

Make Your Home Care-Free! 35 Pages

# POPULAR MECHANICS

SEPT. 1962

35 CENTS

*11-14-62 7-20-62  
6609  
FLEXIBLE*

**Sunny Garden Inside the House**



**A Lazy Man's Lawn for Any Lot**  
**50 Money-Stretching Tips for Home Buyers**  
**Playable Children's Furniture: Complete Plans**

Материал опубликован авторским правом

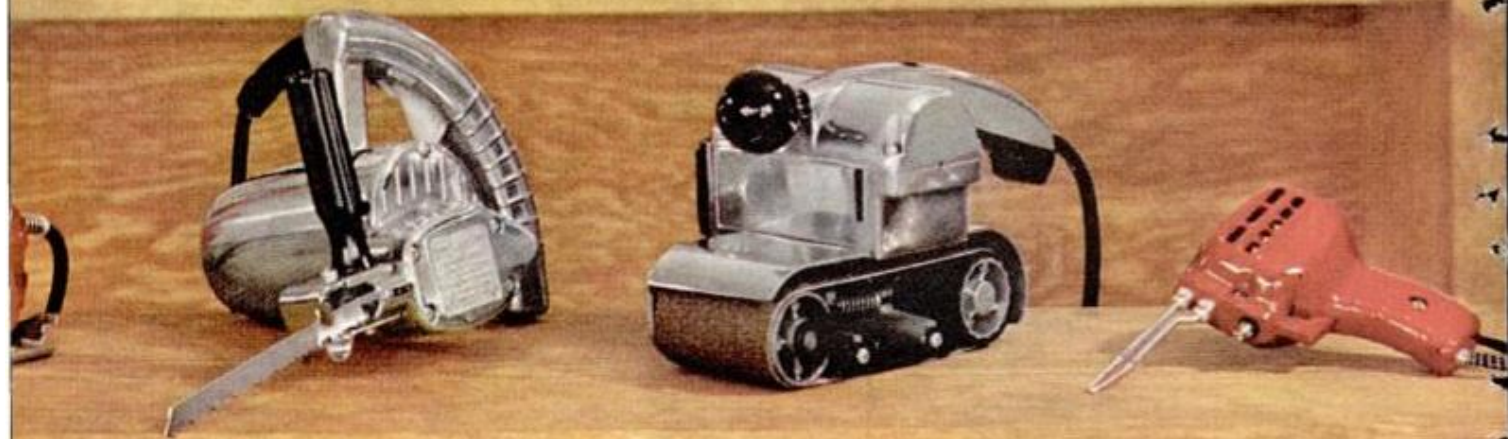
**WEN****POWER**

### **FAST FREEHAND VERSATILE "ZIPP SAW"**

Gets into hard-to-reach places. Makes flush wall and floor cut-outs. UL "Industrially Rated," 1/3 HP motor. Seven blades included to cut any material from 6" logs to delicate patterns to heavy gauge metal and pipe. Model 920.

**\$44.95.**

### **LOWEST PRICED 3-INCH BELT SANDER**

Nothing on the market to equal this sander at a price even close. Sands coarse or smooth surface. Almost dustless, weighs only 7 lbs. Open on one side for flush work. Belt turns at 850 Surface Ft. per Min. Includes 3 belts, coarse, medium, fine. Model 910. **\$44.95.**

### **QUALITY SOLDER GUNS CHOSEN BY PROFESSIONALS**

Four models from slim 100 watt model, to the professional's standby at 250 watts for all-purpose heavy-duty work. All guns heat in 2½ to 5 seconds and work with a variety of changeable tips. Built-in spotlights focus on work. **\$5.95 to \$15.95.**

Материал, защищенный авторским правом



### **3/8" DOUBLE DUTY 2 SPEED DRILL**

No other drill like it! Genuine Jacobs chuck handles big jobs easily. Change speed in a jiffy; 3000 RPM for drilling thin metal and wood . . . 1000 RPM for thick metal, wood, plaster, masonry. Burnout-proof motor gives peak performance—even under load. Model 808. **\$29.95.**

### **SOUPED UP 1/2 HP "ALL SAW"**

Industrially rated—does everything a pattern saw will do—more than a circular saw or chain saw—all with precision versatility. Cuts a 6" log, pipe, sheet metal . . . fine scrollwork, too. Complete with 7 blades, rip guide, circle cutter. Model 909. **\$44.95.**

### **STRAIGHT-LINE VIBRATOR SANDERS**

3 sizes—each perfect for furniture refinishing, fine wood-working. Rugged molded plastic cases. Magnetic motors drive 14,400 strokes per minute. Extra power to ease work load. **\$13.95 to \$19.95.**

# Fresh Ideas for Easy Maintenance

- Redecorate Your Kitchen With Hardware
- Does Your School Have Safe Football Gear?
- We're Losing the Second Battle of Midway
- Stop Those Car Stalls ● Soldering Savvy



# TOOLS... BEST BUY FOR YOUR MONEY

People everywhere know that dependable Wen tools offer far more for their money. More in brilliant design and engineering... new features to make doing a good job easier. Important advantages like 2-position handles on the "Double Duty" Drill and the Belt Sander to make your work more comfortable... unseen advantages like spot welded burnout proof armatures to give your Wen tool longer life and greater efficiency. You get more basic quality, too... better materials to meet exacting professional specifications—yet built so efficiently that Wen tools fall well within the budget of the hobbyist and home fixer. Next time you need a power tool, buy a Wen. You'll not find a better.

**Every 35 seconds**  
*...24 hours a day... 365 days a year*  
**Someone buys a Wen tool**

## **ROTARY ELECTRIC SHAVER**

A precision product of unusual quality. Larger contoured shaving surface adds speed to traditional rotary comfort. Hollow-ground self-sharpening cutters shear whiskers cleanly without pinching. Brush and commutator motor adds years of effective life. **\$19.95.**



**WEN** PRODUCTS, INC., 5810 Northwest Highway, Chicago 31, Illinois

Материал, защищенный авторским правом



## Firestone's New Nylon Farm & Commercial Truck Tire!

**Firestone Rubber-X gives it longer mileage!** The new Firestone Farm & Commercial truck tire has built-in performance features never available before at such a low price. ■ Examples: A Shock-Fortified nylon cord body for maximum protection against impact and moisture deterioration. Torque-toughened Firestone Rubber-X for longer tire life. A new tread design geared for superior wear and traction for all kinds of hauling. Plus another Firestone ex-

clusive: a cooler running, mileage-adding tire-shoulder design. ■ Whatever your hauling operation, Firestone has the Farm & Commercial truck tire for you priced so low, you'll think the price tag is wrong. New Farm & Commercial tires are available now in all popular sizes at your Firestone Dealer or Store—you can charge them or buy on easy terms. Remember, *you know what you're getting when you buy Firestone.*

Most Firestone Dealers and Stores are open weekday evenings until 9 o'clock for your shopping convenience.

**Firestone**  
YOUR SYMBOL OF QUALITY AND SERVICE

# BE READY WHEN YOU'RE SET TO WORK

With a Weldwood "Fix and Finish" shelf in your workshop

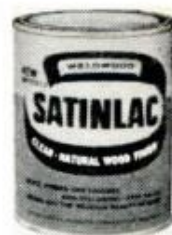

**Make a coffee table.** Basket weave Weldwood Flexible Wood-Trim®. Match or mix birch, oak, walnut, mahogany, Korina®. Apply on plywood top with Presto-Set Glue. Brush on and wipe Deep Finish Firzite. Cover with glass.



**Repair favorite books** dried out over the winter. Fix broken spines and attach torn-off covers with Weldwood Presto-Set® Glue. Won't stain, dries fast. Bellows-action squeeze bottle with spreader top makes work fast and easy.



**For a lovely "hand-rubbed" effect** without sweat, use Weldwood Deep Finish Firzite®. This versatile new sealer-finish also gives floors a tough, durable finish, seals all woods for paint, enamel, varnish.

Don't be stymied by lack of materials when you find the time and have the inclination to tackle some household projects. Set up a basic Weldwood® Fix and Finishes shelf in your workshop with Weldwood Deep Finish Firzite. Weldwood Presto-Set, Contact Cement, Plastic Resin, Epoxy, and Resorcinol Glue will handle any gluing job. Get these and Putty Stiks®, Flexible Wood-Trim at almost any lumber yard, paint, or hardware store.



*Products of United States Plywood*

# POPULAR MECHANICS®

SEPTEMBER 1962

VOL. 118

NO. 3

INTERNATIONAL EDITIONS • SPANISH: Mexico-Caribbean, Southern Hemisphere • FRENCH •

## Features of Special Interest

Those Do-Anything Foamed Plastics - - - - -	85
Falcon Lifts the Lid on Its Convertible - - - - -	91
Should YOUR Son Play Football? - - - - -	94
The SECOND Battle of Midway - - - - -	102
Two New Hulls Meet Two Old Problems - - - - -	110

## HOUSING '62

Strange Shapes in Housing - - - - -	120
New For Your Home—And Easy to Care For - - - - -	124
Have a Lazy Man's Lawn - - - - -	126
PM's House of Care-Free Living - - - - -	137
Sandwich House Slips Together - - - - -	146
50 Money-Stretching Tips for Home Buyers - - - - -	148
Hardware Showcase - - - - -	150
Tile Ceiling Interlocks on Metal Furring - - - - -	156

## For the Craftsman

Play-Furniture From Sweden - - - - -	158
Modeling the "Delta Queen" - - - - -	168
Add a Convertible Top to Your Boat - - - - -	182
When Your Car Stalls - - - - -	190
Soldering Savvy - - - - -	202

Address communications to: 575 Lexington Ave., New York 22, N. Y. SUBSCRIPTION SERVICE: Mail all subscription orders, changes of address, correspondence concerning subscriptions, and Postmaster notices of undeliverable copies to Popular Mechanics, 250 West 55th St., New York 19, N. Y.

Published by Popular Mechanics Company, RICHARD E. BERLIN, *President*

CLIFFORD B. HICKS  
*Editor*

RICHARD E. DEEMS  
*Executive Vice-President*

JOSEPH R. BUELL, JR.  
*Publisher*

*Managing Editor:* DON DINWIDDIE  
*Assistant Managing Editor:* JOHN A. LINKLETTER  
*Shop and Crafts Editor:* WAYNE C. LECKEY  
*Eastern Editor:* RICHARD F. DEMPEWOLFF  
*Western Editor:* THOMAS E. STIMSON  
Suite 1003, 3460 Wilshire Blvd., Los Angeles 5, Calif.  
*Art Director:* HENRY M. NEHRBASS  
*Automotive Editor:* JAMES R. WHIPPLE  
*Associate Editors:* W. CLYDE LAMMEY, WALLACE MYERS  
*Electronics Editor:* BYRON G. WELS

*Assistant Editors:* JAMES BIERY, KEVIN V. BROWN  
R. B. KIRKPATRICK, ARTHUR MIKESSELL  
BIL TOMAN, RICHARD WILLIFORD  
*Editorial Assistant:* JOHANNA L. PUGNI  
*Assistant Art Director:* LEO R. WEEKS  
*Art Editor:* RICHARD A. POTTS  
*Chief Photographer:* FRANK P. FRITZ  
*International Editor:* HEINZ P. SCHLICHTING  
Ritterstrasse 26, Karlsruhe/Bd., Germany  
*Advertising Director:* L. PARK BENJAMIN  
*Advertising Production:* DOROTHY M. WINER  
*Director, Service Bureau:* ALLAN CARPENTER



If you wish additional sources of information for the articles in this issue, or if you wish the name and address of the manufacturer of a particular product shown here, write to Bureau of Information, Popular Mechanics, 575 Lexington Ave., New York 22, N.Y. Ask for the free "Where-to-Find-It-List" for this issue.



**Safe Gear  
For Football**  
page 94

**DANISH • SWEDISH • GERMAN • PORTUGUESE • DUTCH**

## Departments

Over the Editor's Desk - - - -	12
Pentagon Sidelight - - - -	16
Science Overseas - - - -	20
Tune In on the Inventors - - -	22
Items From All Outdoors - - -	24
Science Bulletins - - - -	26
Sidelights on Aviation - - - -	28
Worth Writing For - - - -	41
On the Market - - - -	56
Spotlight on the Checker Wagon -	80
Shopping for Tools - - - -	84
Detroit Listening Post - - - -	100
What's New for Your Home - - -	124
Solving Home Problems - - - -	166
Clinic for Homemakers - - - -	208



**Midway Defeat?**  
page 102



**Playable  
Furniture**  
page 158

## Next Month . . .

THEY'RE LONGER and livelier but are they any better? Read what PM's auto editor has to say about the 1963 cars, after driving them around test tracks, prying up hoods and trunk lids and giving them a real "what-they'll-be-like-to-live-with" inspection. Also from the October PM, puzzled parents can learn how valid IQ tests really are, and craftsmen can try out five clever ways to bend wood.

### NOTE OUR NEW ADDRESS!

ADVERTISING OFFICES—New York: 575 Lexington Ave., MUrray Hill 8-8500; Chicago: 740 Rush St., Whitehall 4-0100; Detroit: General Motors Bldg., TRinity 5-8711; Cleveland: Hanna Bldg., 1422 Euclid Ave., PRespect 1-0456; Los Angeles: 3460 Wilshire Blvd., DUnkirk 2-8458; San Francisco: 111 Sutter St., YUkon 2-0823.



**Arrow Fishing**  
page 174



**Soldering Savvy**  
page 202

Published monthly by Popular Mechanics Company, 575 Lexington Ave., New York 22, N. Y. Richard E. Berlin, President; Richard E. Deems, Executive Vice-President; Fred Lewis, Vice-President and General Manager; John R. Miller, Vice-President; Joseph R. Buell, Jr., Vice-President; G. O. Markuson, Treasurer; R. F. McCauley, Secretary. Single copy in the United States and Canada, 35 cents. Subscription prices: United States and Possessions, \$4.00 for one year; \$7.00 for two years; \$9.00 for three years. Canada, add \$0.50 for each year. Pan-American Postal Union countries, add \$1.00 for each year. All other countries, add \$2.00 for each year. If you plan to move, notify us at least 30 days in advance so you will not miss an issue. Give both your old and new addresses. Second-class postage paid at New York, N. Y., and at additional mailing offices. Authorized as second class mail by the Post Office Department, Ottawa, and for payment of postage in cash. Registered as Second Class Matter at the Post Office at Mexico, D.F., Mexico, June 20, 1950. © 1962 by Popular Mechanics Company. All rights reserved. Printed in the United States of America.

This One



21R7-LSQ-RBFA

Материал, защищенный авторским правом

BUY DIRECT FROM OUR FACTORY

SAVE 80%

ON THIS AMAZING **AMCO**  
8" TILT ARBOR  
POWER SAW

RUGGED ... HEAVY DUTY ... PROFESSIONAL QUALITY ... LIFETIME ENGINEERED

GUARANTEED TO DO THE  
WORK OF \$50 BENCH SAWS

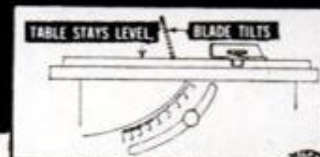
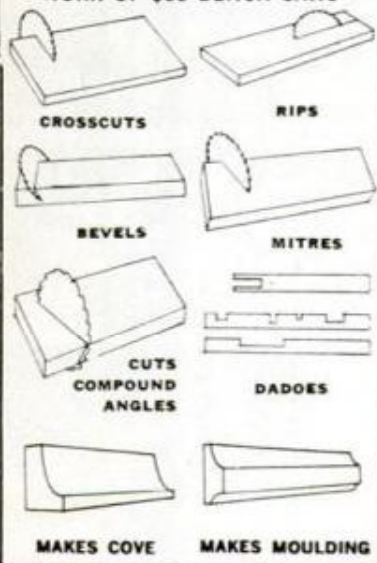

TAKE THE WORK  
OUT OF WOODWORK  
... AND ONLY ...

\$995

Wt. 25 lbs.  
Exp. Coll.

UNCONDITIONAL  
10 YEAR  
GUARANTEE

Complete as shown, less blade, rip fence. Incl. precision miter gauge, ground cast iron table. If desired, RIP FENCE for easier work alignment, \$3.50 additional.

REVOLUTIONARY NEW PATENTS ... NEW DESIGN

REVOLUTIONARY PATENTS DECREASE COSTS, INCREASE EFFICIENCY. Top quality full scale power tools of heavy duty 100% cast iron and steel. Streamlined design features such as perforations on table tops reduce weight, cut material costs, cut polishing and grinding time—reduce production costs. Special patents provide added efficiency, accuracy, savings. Nothing left out but expensive gingerbread. Parts made, assembled, tested and packed in our own factories, shipped direct to you. No retail store handling or profits to add to your cost.

TABLE STAYS LEVEL, BLADE TILTS

Patented motor mount takes any standard 1/4 to 1/2 h.p. motor ... keeps belt tight, assures perfect alignment at any angle, transmits full power. Table stays level—blade tilts, locks securely at any angle to 50°, raises, lowers 0" - 2 1/4". Patented tilt mechanism has accurate etched scale. Takes standard blade, saw insert removes easily for insertion of any STANDARD dadoe heads, cutters, etc. Accessories, table extensions, when wanted, at factory prices.

CLIP AND MAIL  
THIS MONEY SAVING  
COUPON TODAY!

BUILD  
ALL  
THESE

INDOOR  
FURNITURE

OUTDOOR  
FURNITURE

SHELVES  
& CLOSETS

CHILDREN'S  
TOYS

ALL HOME  
IMPROVEMENTS

AND SAVE  
AS YOU  
SAW

American Machine & Tool Co. Dept. PM-92 Royersford, Pa.

- Send 8" Tilt Arbor Power Saw at \$9.95
- Incl. Rip Fence at \$3.50 (both for 13.45)
- Payment in full enclosed \$..... or
- \$3 dep. enclosed, balance C.O.D. I MUST BE FULLY SATISFIED OR WILL RETURN WITHIN 10 DAYS FOR FULL REFUND, no questions asked.
- Please send free catalog of America's greatest power tool values.

NAME \_\_\_\_\_

ADDRESS \_\_\_\_\_

CITY \_\_\_\_\_ ZONE \_\_\_\_\_ STATE \_\_\_\_\_

(Please print \_\_\_\_\_)

NO RISK TO YOU

Also ideal for boy scout troops, clubs and other groups. Share one with your neighbor.

10 DAY  
MONEY BACK  
GUARANTEE

You must be completely satisfied or return 8" power saw for full refund. Fair enough?

SEND FOR YOURS  
TODAY!

AMERICAN MACHINE & TOOL COMPANY  
DEPT. PM-92, ROYERSFORD, PA.

RUGGED, VERSATILE  
PERFORMANCE PROVED  
BY MORE THAN  
500,000 USERS!!

Send for our FREE catalog of America's greatest power tool values.

POPULAR MECHANICS

# END HIDDEN DANGERS OF FRONT-END SAG



"Bottoming" on bumps and potholes is eliminated by Front Load-Leveler stabilizing units.

Rolling on sharp turns and "wind sway" ended with stability of Front Load-Levelers.

Wheel shimmy at high speeds is ended with Front Load-Levelers holding wheels in alignment.

## WITH NEW MONROE *FRONT* Load-Leveler® STABILIZING UNITS

Front-end sag takes its toll on *every* car. It begins when springs take a "set," and changes the entire geometry of your steering system. Wheels continually get out of line, and shimmy at high speeds. Tires are virtually destroyed. Steering becomes difficult. Control of your car is dangerously reduced. Now you can end front-end sag, without costly spring repair, make your car ride *better* than brand new, and prolong tire life with new Front Load-Leveler

stabilizing units by Monroe. Installed in place of your present front shock absorbers, Front Load-Levelers give firm support to sagging springs and compensate for "set." They give your car extra stability, for sure-footed cornering and a safer, more comfortable, more economical ride. You'll marvel at the improved roadability you'll get with new Monroe Front Load-Levelers. Have a set installed in less than thirty minutes where you have your car serviced.



**LOOK FOR THE MONROE DEMONSTRATOR BARREL!**

World's largest maker of ride control products including Monroe-Matic® shock absorbers.

MONROE AUTO EQUIPMENT COMPANY, Monroe, Michigan • In Canada, Monroe-Acme Ltd., Toronto, Ont. • In Mexico, MEX-PAR, Box 28154, Mexico City

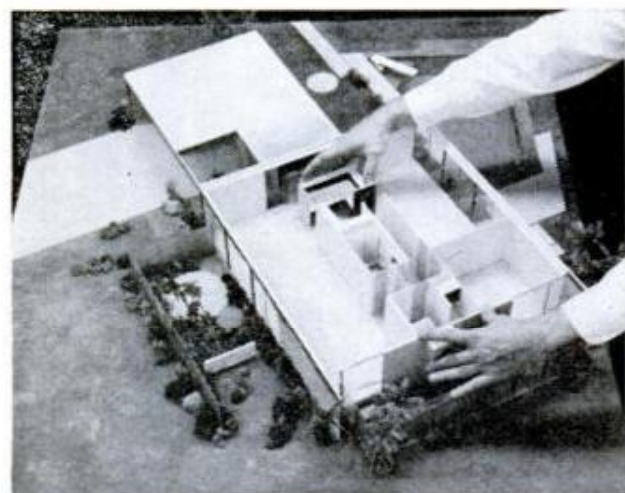

## Pre-Built Home of Steel

Basic structural element of new prefabricated metal homes is a 3½-inch-thick modular steel sandwich panel with a fiberglass-and-dead-air insulating core and a gypsum wallboard inside surface. Assembly starts around a prefab utility core. The three-bedroom home can be assembled in three days.

Prototypes of the house, designed to utilize the curtain-wall method of construction, are now on display in Palm Springs, Calif., and Palm Beach Gardens, Fla.

Designed by Wexler & Harrison of Palm Springs, Calif., the homes are built by Rheem Manufacturing Co., New York 22.

# CLEAN YOUR CARBURETOR RIGHT ON THE ENGINE

Stop engine stalling, hard starts, rough idling and gas waste caused by a dirty carburetor. For **immediate** results, clean your carburetor the fast, professional way with GUMOUT and the easy-to-use Clean-Out Kit. Or, simply add GUMOUT to your gas tank. Either way you'll get improved engine performance and better gas mileage. Clean your carburetor at least twice a year this modern way. You'll save many dollars in repair and operating costs. There's nothing like GUMOUT for quick, positive results. Get GUMOUT at your favorite service station or auto supply store.



**GUMOUT** DIVISION, PENNSYLVANIA REFINING COMPANY  
CLEVELAND 4, OHIO

**\$2.49**  
Carburetor  
Clean-out kit

**\$1.69**  
Gumout  
Pint Can



# WHO ELSE WANTS A BIG RAISE IN PAY?

**"My salary has increased 400% as a direct result of my LaSalle studies"**



Rudolph Urbatis,  
Port Chester, N.Y.

**"Salary more than doubled since enrolling"**



William T. Black,  
Canoga Park, Calif.

**"Income has increased 100 per cent since graduation"**



James L. Yonning,  
Manhattan, Kansas

**"Salary in little over 3 years increased \$3,000.00"**



Dale E. Updegraff,  
Richmond, Ind.

**Stuck in a rut? Tired of your dead-end job? Here's proof you can step up to a high-salary position with prestige and security through LaSalle spare-time training.**

**J**UST LOOK at these enthusiastic letters. Have you ever seen anything like them? They are just a few of many hundreds of similar statements in letters that come from LaSalle students week after week, month after month, year after year.

LaSalle students have one ambition in common—to get out of the ranks of the untrained and earn big money, prestige and security in a key job. Isn't that your goal too?

Without interfering with your present work—and by devoting only a little of your spare time—you too can qualify rapidly for a profitable career of your choice through LaSalle home study. The cost is surprisingly low.

LaSalle has been an acknowledged leader in home education for more than half a century. It has provided training in business, high school and technical subjects for more than 1,000,000 ambitious men and women. Its distinguished faculty includes some of the country's most distinguished authorities. That is why your LaSalle diploma is a credential recognized and respected everywhere.

Check the subject you are interested in—then send the coupon below for FREE booklet. No obligation. Mail to LaSalle, 417 South Dearborn Street, Chicago 5, Ill.



## LASALLE EXTENSION UNIVERSITY

An Approved Correspondence Institution • Dept. 09-105, 417 South Dearborn St., Chicago 5, Ill.

Please send me, without cost or obligation, FREE catalog and full information on the field I have checked below:

### ACCOUNTING

- Complete Accounting with CPA Training
- Basic Accounting
- Cost Accounting
- Federal Income Tax
- Accounting Systems
- Auditing Procedure
- Controllership
- CPA Training
- Modern Bookkeeping

### LAW TRAINING

- Bachelor of Laws Degree
- American Law and Procedure
- Business Law
- Law of Contracts
- Insurance Law

- Claim Adjusting Law
- Law for Police Officers
- Real Estate Law
- Law for Trust Officers

### BUSINESS MANAGEMENT

- Complete Business Management
- Basic Management
- Sales Management
- Sales Training
- Advertising and Sales Promotion Management
- Production Management
- Business Financing
- Credits and Collections
- Office Management
- Business Correspondence

- Personnel Management
- Foremanship Training

### TRAFFIC & TRANSPORTATION

- Complete Traffic and Transportation
- Organization and Management
- Transportation Law
- Classification, Rates and Tariffs

- Transportation Agency and Services

### TECHNICAL COURSES

- Auto Body Fender
- Refrigeration-Air Conditioning
- Diesel
- Drafting
- Welding
- Motor Tuneup

### HIGH SCHOOL

- High School Diploma
- Commercial Course
- College Preparatory
- Secretarial Course

### CAREERS FOR WOMEN

- Machine Shorthand (Stenotype)
- Dental Assistant
- Secretarial
- Accounting
- Law

Name.....Age.....

Address.....County.....

City & Zone.....State.....

# BURIED ALIVE!



SIX YEARS ON THE SAME JOB WITH NEVER AN ACCIDENT... AND THEN ONE MORNING...

2 A CAVE-IN PUT ME SIX FEET UNDER FOR SIX LONG MINUTES



3 IN THE HOSPITAL, I HAD PLENTY OF TIME TO THINK



4 I'D PASSED OVER DOZENS OF I.C.S. ADS IN POPULAR MECHANICS. BUT I SAW THIS ONE IN A NEW LIGHT



# FREE!

## I.C.S. CAREER KIT

Send coupon now...  
get all three books

INTERNATIONAL CORRESPONDENCE SCHOOLS  
BOX C4419J SCRANTON 15, PA.

HOW'S IT GOING, DARLING?

FAST! I'M INTO HYDRAULICS ALREADY. AND I THOUGHT I WAS TOO OLD TO LEARN

5 SIGNING UP FOR THAT I.C.S. COURSE WAS THE SMARTEST THING I EVER DID

6 ONE MONTH LATER...

GOOD TO SEE YOU BACK ON YOUR FEET, JIM. IT'LL BE AWHILE BEFORE YOU'RE BACK IN THE FIELD. SO WE'LL FIX A TEMPORARY DESK FOR YOU IN THE OFFICE WHEN YOU'RE READY

I'M READY NOW, MR. WALSH

7 THEY GAVE ME SOME SIMPLE ASSIGNMENTS... AND I SURE SURPRISED THEM!

SAY, WHERE DID YOU LEARN ABOUT PUMPS?

SAME PLACE YOU DID, JOE... I. C. S.

8 THEN A FEW DAYS LATER, MR. WALSH CALLED ME IN...

JIM, I'M KEEPING YOU HERE AND PUTTING YOU ON SALARY. YOU'LL BE GETTING ABOUT \$20 MORE A WEEK. AND AT THE RATE YOU'RE GOING, I EXPECT I'LL HAVE TO RAISE THAT IN SIX MONTHS

9 THAT EVENING, JANE AND I WENT HOUSE HUNTING

OH, JIM! IT'S A DREAM HOUSE!

AND THANKS TO I.C.S. IT'S A "DREAM" THAT CAN COME TRUE!

MODEL HOUSE

HERE'S WHERE YOU COME IN! LET I.C.S. SHOW YOU THE WAY TO MORE PAY, RAPID ADVANCEMENT, REAL JOB SECURITY! MAIL THIS COUPON TODAY!

- 1 "HOW TO SUCCEED" A 32-page gold mine of ideas
- 2 CAREER CATALOG Opportunities in the field that interests you most
- 3 SAMPLE LESSON (MATH) Shows the famous step-by-step I. C. S. teaching method



# INTERNATIONAL CORRESPONDENCE SCHOOLS I C S

Box C4419], Scranton 15, Penna. (In Hawaii: P. O. Box 418, Honolulu. In Canada: I. C. S. Canadian, Ltd., Montreal.)

Without cost or obligation, rush me FREE Success Kit, with 3 valuable booklets: (1) How to Succeed; (2) opportunity booklet about the field I've checked below; (3) Sample I.C.S. Lesson.

- |   |   |  |   |   |   |
|---|---|--|---|---|---|
| <p><b>ARCHITECTURE and BUILDING TRADES</b></p> <ul style="list-style-type: none"> <li><input type="checkbox"/> Air Conditioning</li> <li><input type="checkbox"/> Architecture</li> <li><input type="checkbox"/> Arch. Drawing</li> <li><input type="checkbox"/> Building Contracting and Estimating</li> <li><input type="checkbox"/> Carpentry &amp; Millwork</li> <li><input type="checkbox"/> Heating</li> <li><input type="checkbox"/> House Planning</li> <li><input type="checkbox"/> Painting</li> <li><input type="checkbox"/> Plumbing</li> </ul> <p><b>ART and DESIGN</b></p> <ul style="list-style-type: none"> <li><input type="checkbox"/> Commercial Art</li> <li><input type="checkbox"/> Fashion Illustrating</li> <li><input type="checkbox"/> Interior Decorating</li> <li><input type="checkbox"/> Magazine Illustrating</li> <li><input type="checkbox"/> Show Card &amp; Sign</li> <li><input type="checkbox"/> Painting</li> <li><input type="checkbox"/> Sketching and Painting</li> </ul> <p><b>AUTOMOTIVE</b></p> <ul style="list-style-type: none"> <li><input type="checkbox"/> Auto Body Rebuilding</li> <li><input type="checkbox"/> Auto Electric Technician</li> <li><input type="checkbox"/> Automobile Mechanic</li> <li><input type="checkbox"/> Engine (Gas &amp; Diesel)</li> <li><input type="checkbox"/> Engine Tune-Up</li> </ul> | <ul style="list-style-type: none"> <li><input type="checkbox"/> Transmission Specialist</li> </ul> <p><b>AVIATION</b></p> <ul style="list-style-type: none"> <li><input type="checkbox"/> Aero Engineering</li> <li><input type="checkbox"/> Aircraft Drafting</li> <li><input type="checkbox"/> Aircraft Mechanic</li> </ul> <p><b>BUSINESS</b></p> <ul style="list-style-type: none"> <li><input type="checkbox"/> Accounting</li> <li><input type="checkbox"/> Cost Accounting</li> <li><input type="checkbox"/> Public Accounting</li> <li><input type="checkbox"/> Bus. Administration</li> <li><input type="checkbox"/> Executive Training</li> <li><input type="checkbox"/> Marketing</li> <li><input type="checkbox"/> Personnel-Labor Relations</li> <li><input type="checkbox"/> Programming for Digital Computers</li> <li><input type="checkbox"/> Purchasing Agent</li> <li><input type="checkbox"/> Real Estate</li> <li><input type="checkbox"/> Salesmanship</li> <li><input type="checkbox"/> Sales Mgmt.</li> <li><input type="checkbox"/> Small Business Mgmt.</li> <li><input type="checkbox"/> Traffic Mgmt.</li> </ul> <p><b>CHEMICAL</b></p> <ul style="list-style-type: none"> <li><input type="checkbox"/> Analytical Chemistry</li> <li><input type="checkbox"/> Chem. Engineering</li> <li><input type="checkbox"/> General Chemistry</li> </ul> | <ul style="list-style-type: none"> <li><input type="checkbox"/> Lab. Technician</li> <li><input type="checkbox"/> Nuclear Energy</li> <li><input type="checkbox"/> Plastics</li> <li><input type="checkbox"/> Pulp, Paper</li> </ul> <p><b>CIVIL ENGINEERING</b></p> <ul style="list-style-type: none"> <li><input type="checkbox"/> Civil Engineering</li> <li><input type="checkbox"/> Construction Engng.</li> <li><input type="checkbox"/> Highway Engineering</li> <li><input type="checkbox"/> Reading Structural Blueprints</li> <li><input type="checkbox"/> Sanitary Engineering</li> <li><input type="checkbox"/> Structural Engineering</li> <li><input type="checkbox"/> Surveying &amp; Mapping</li> </ul> <p><b>DRAFTING</b></p> <ul style="list-style-type: none"> <li><input type="checkbox"/> Architectural</li> <li><input type="checkbox"/> Electrical and Electronic</li> <li><input type="checkbox"/> Mechanical</li> <li><input type="checkbox"/> Sheet Metal</li> </ul> <p><b>ELECTRICAL</b></p> <ul style="list-style-type: none"> <li><input type="checkbox"/> Elec. Appliance Servicing</li> <li><input type="checkbox"/> Electrical Engineering</li> <li><input type="checkbox"/> Elec. Eng. Technician</li> <li><input type="checkbox"/> Elec. Motor Repairman</li> <li><input type="checkbox"/> Industrial Electronic Technician</li> </ul> | <ul style="list-style-type: none"> <li><input type="checkbox"/> Industrial Telemetering</li> <li><input type="checkbox"/> Instrument Technician</li> <li><input type="checkbox"/> Practical Electrician</li> <li><input type="checkbox"/> Practical Lineman</li> </ul> <p><b>ELECTRONICS</b></p> <ul style="list-style-type: none"> <li><input type="checkbox"/> Automation</li> <li><input type="checkbox"/> Basic Electronics</li> <li><input type="checkbox"/> Electronic Computers</li> <li><input type="checkbox"/> Electronics Technician</li> <li><input type="checkbox"/> Hi-Fi Stereo and Sound Systems</li> <li><input type="checkbox"/> Industrial Electronics</li> <li><input type="checkbox"/> Ultrasonics</li> </ul> <p><b>ENGINEERING (Professional)</b></p> <ul style="list-style-type: none"> <li><input type="checkbox"/> Chemical</li> <li><input type="checkbox"/> Civil</li> <li><input type="checkbox"/> Electrical</li> <li><input type="checkbox"/> Mechanical</li> </ul> <p><b>ENGLISH and WRITING</b></p> <ul style="list-style-type: none"> <li><input type="checkbox"/> Better Business Writing</li> <li><input type="checkbox"/> Introductory Technical Writing</li> <li><input type="checkbox"/> Short Story Writing</li> </ul> | <ul style="list-style-type: none"> <li><input type="checkbox"/> Practical English</li> </ul> <p><b>HIGH SCHOOL (Diploma)</b></p> <ul style="list-style-type: none"> <li><input type="checkbox"/> High School General</li> <li><input type="checkbox"/> High School Math</li> <li><input type="checkbox"/> High School Secretarial</li> <li><input type="checkbox"/> High School Vocational</li> <li><input type="checkbox"/> College Preparatory</li> </ul> <p><b>MECHANICAL and SHOP</b></p> <ul style="list-style-type: none"> <li><input type="checkbox"/> Gas and Electric Welding</li> <li><input type="checkbox"/> Industrial Engineering Instrumentation</li> <li><input type="checkbox"/> Machine Design</li> <li><input type="checkbox"/> Machine Shop Practice</li> <li><input type="checkbox"/> Mechanical Engineering</li> <li><input type="checkbox"/> Reading Shop Blueprints</li> <li><input type="checkbox"/> Tool Design</li> <li><input type="checkbox"/> Toolmaking</li> <li><input type="checkbox"/> Safety Engineering</li> </ul> <p><b>SECRETARIAL</b></p> <ul style="list-style-type: none"> <li><input type="checkbox"/> Clerk-Typist</li> <li><input type="checkbox"/> Professional Secretary</li> </ul> | <ul style="list-style-type: none"> <li><input type="checkbox"/> Shorthand</li> <li><input type="checkbox"/> Stenographic</li> <li><input type="checkbox"/> Typist</li> </ul> <p><b>STEAM and DIESEL POWER</b></p> <ul style="list-style-type: none"> <li><input type="checkbox"/> Boiler Inspector</li> <li><input type="checkbox"/> Power Plant Engineering</li> <li><input type="checkbox"/> Stationary Diesel Engineering</li> <li><input type="checkbox"/> Steam Engineering</li> </ul> <p><b>SUPERVISION</b></p> <ul style="list-style-type: none"> <li><input type="checkbox"/> Foremanship-Suprv'n</li> <li><input type="checkbox"/> Industrial Personnel-Lab. Rel'n's</li> </ul> <p><b>TV-RADIO</b></p> <ul style="list-style-type: none"> <li><input type="checkbox"/> Radio and TV Servicing</li> <li><input type="checkbox"/> Radio-Telephone License</li> <li><input type="checkbox"/> TV Technician</li> <li><input type="checkbox"/> Practical Radio-TV Engineering</li> </ul> <p><b>MISCELLANEOUS</b></p> <ul style="list-style-type: none"> <li><input type="checkbox"/> Railroad</li> <li><input type="checkbox"/> Textile</li> <li><input type="checkbox"/> Other (please specify)</li> </ul> |
|---|---|--|---|---|---|

Name \_\_\_\_\_ Age \_\_\_\_\_ Sex \_\_\_\_\_

Home Address \_\_\_\_\_

City \_\_\_\_\_ Zone \_\_\_\_\_ State \_\_\_\_\_

Occupation \_\_\_\_\_

Employed by \_\_\_\_\_ Working Hours \_\_\_\_\_

Special low rates to members of U. S. Armed Forces!

# Over the editor's desk

## Mystery Plane Pegged

I was Field Manager at Newark Airport from 1928 to 1937. The mystery plane (page 10, June PM) was built by Vincent J. Burnelli at Red Bank, N. J., brought to Newark Airport, and test flown one Sunday afternoon. It flew low over the field for newsreel pictures. The ailerons started to flutter and one came off. The ship cartwheeled end-over-end and landed right side up. The pilot climbed out on top of the fuselage unhurt but the engineer with him was hurt badly. The ship was taken from the field and I don't know what became of it after that.

Bronx, N. Y.

THOMAS J. DONNELLY

*The majority of the many letters received from PM readers agreed that the plane was a Burnelli UB-14 powered by two 675-hp. radial engines. Individual writers also pointed out that it was only one of several Burnelli designs, several of which were flown successfully, one carrying a piano and one an automobile.*

## Inside-Out Tires

I have tried to find someone who knows how to turn tires inside-out and scallop



them, as per the enclosed picture. Would one of your readers know?

Indiantown, Fla.

P. C. ZINN

*Not having tried it, we can't be sure, but it looks as if the bead has been cut from one sidewall so the tire could be turned inside out by squashing it edgewise and then twisting. Perhaps other PM readers who have tried this can give you some help.*

## Hazel Is a Corker

My son and I built this *Hazel I* from the *Swish* 15-foot sports runabout plans in your March through May, 1958 issues. She rides rough water like a cork and we have been all over Panama Bay in all kinds of



weather. She is an excellent fishing boat without the back seat.

I use a 30-hp. 1956 Johnson and with three adults aboard she moves out at 23-25 m.p.h. on smooth water. Thanks to the plastic fiberglass I painted the hull with, its upkeep has been positively nothing. She looks like she did the first day we put her in the water.

Balboa, Canal Zone

ROBERT W. BLADES

## Horrendous Goof

Your May '62 PM was very interesting. In 220 pages, I found only one typographical error—a record, I'm sure, to be proud of. You had 174,240 chances and I only caught one error. On page 217, column two, line nine, you said "It's" when you meant "Its" with no apostrophe . . .

Spokane, Wash. EDWARD W. STOLLERY, II

*We did indeed, Ed. Prostrate apologies to all for being overly apostrophic.*

## Backpat for Backpackers

Congratulations on your June backpacking story. I have read too many articles on backpacking by "would-be professionals" that were actually 20 years behind the times. Your writers, Bob and Wilma Knox, are the exception as they are certainly real experts on the latest equipment and techniques. As any experienced backpacker knows, a good pack is the most important part of his equipment and I was disappointed that there was not more comment made by the Knoxs' on the pack briefly mentioned in their story and shown in the mountain picture. This Kelty pack has become almost standard equipment with mountaineering and hiking clubs here and in Alaska. It is a fabulous piece of equipment and certainly worth more than a vague reference. I have traveled about 3000

(Continued to page 14)



# How to 'take charge' of a highly-paid job

## in AIR CONDITIONING & REFRIGERATION

Are you interested in a better job, big money and a secure future? Do you prefer work that is interesting, a challenge to your imagination, and loaded with opportunities to go in business for yourself? Then why not consider a career as mechanic or technician in the Air Conditioning and Refrigeration industry!

You see, Air Conditioning is now America's finest opportunity field. The government reports that during the past 12 years, production increased 400%. *No other industry did better!* The fact is, 8,200,000 domestic and industrial units are produced annually. Already 150,000,000 are in use. Experts say that 20,000 technicians must be trained each year to match industry growth! You can qualify for a top-pay job. How? *Train at home in spare time.* The CTI method is easy, practical and resultful. Quick, too. For full information, *mail coupon below.*

### Many CTI graduates go in business



It is relatively easy to start a repair business in the Air Conditioning and Refrigeration field. Armed with up-to-date knowledge, seasoned with skill acquired through practice on kits, and equipped with tools and gauges, many graduates start out on their own. Some expand into retail stores. Others have contracts to service taverns, restaurants, food stores and commercial buildings. The more resourceful become contractors. Conditions for success are excellent.

### Many students earn cash as they train

The average CTI student is eager to put his skill to profitable work, on a part-time basis. Though most students prefer to tie up with local dealers and repair establishments, a surprising number are independents. The extra cash helps meet training cost. Often there's enough to bank, or invest in more equipment.



### Letters prove efficiency of training



"I have a business of my own servicing domestic and commercial refrigerators."—*Paul Humphrey, Colo.* "I made \$1,000 while training, and am now a refrigeration man for a dairy."—*Giles Minton, N. C.* "I opened a little shop and am swamped with work."—*Charles Corley, Kan.* "Doing service work on a part-time basis the past 10 months, I earned \$2,400. Have a nice business."—*Renos Johnson, Ind.* "My firm advanced me to field superintendent."—*Milburn Dougan, Ark.* You can do as well as these graduates!

You train at home with real equipment

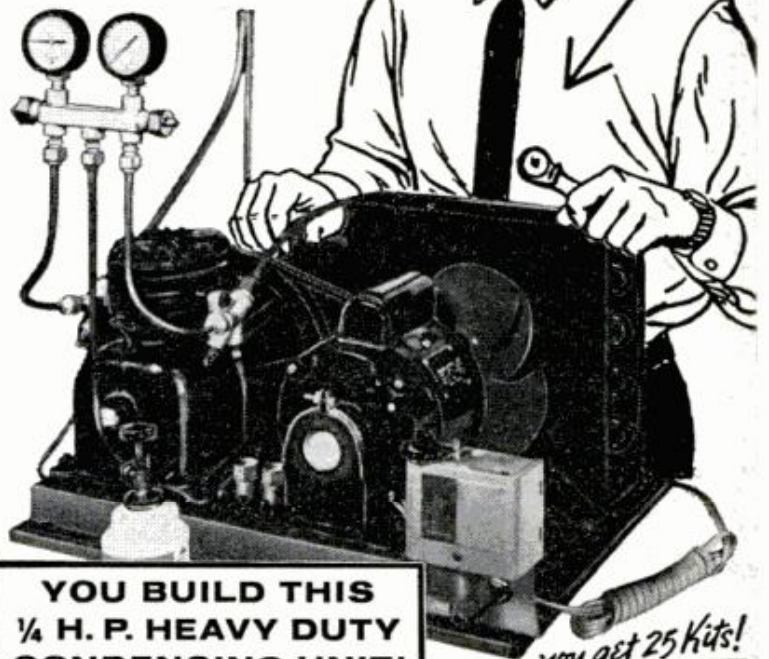

**YOU BUILD THIS  
1/4 H. P. HEAVY DUTY  
CONDENSING UNIT!**

*you get 25 Kits!*

An exclusive feature of CTI training is that you get parts to build a 1/4 h.p. commercial-type condensing unit (above). You also receive mechanic's tools and gauges (right). After unit is assembled, you can build an air conditioner, freezer, refrigerator or milk cooler. Only CTI sends working kits.



### Learn by practicing—Get valuable experience

The modern way to train is to gain skill and experience *with* knowledge—not *after* you graduate. From CTI's simple picture-lessons, you master elemental theory. From experiments and building with kits, you develop skill. In other words, you learn by practicing, pick up solid experience much like on the job. That's the interesting, relaxing way to train after a day's work on your present job. CTI training is exciting!

### Send for fact-filled booklets—Mail coupon now

Exactly what are your opportunities in Air Conditioning and Refrigeration? How does CTI train men for success? Get detailed, accurate answers to these and many more questions by filling out and mailing the coupon below. No obligation. —Commercial Trades Institute, Chicago 26, Ill.

**COMMERCIAL TRADES INSTITUTE**  
1400 GREENLEAF AVENUE DEPT. R-125  
CHICAGO 26, ILLINOIS

Please rush me your opportunity booklet, *Success in Air Conditioning and Refrigeration*, and Lesson Samples. Both free.

NAME \_\_\_\_\_ AGE \_\_\_\_\_

ADDRESS \_\_\_\_\_

CITY \_\_\_\_\_ ZONE \_\_\_\_\_ STATE \_\_\_\_\_

Accredited by National Home Study Council



# The PIPE SMOKER'S Miscellany

TIDBITS, TIPS AND  
TRIVIA ON THE  
ART OF PIPESMANSHIP

## WHEN PIPE-CLEANERS WON'T WORK...

You've got a pretty well clogged-up pipe there. Here's what you do.

Hold the bowl over the spout of a boiling kettle and let the steam pass through it. Then dry thoroughly with pipe-cleaners, and leave a dry one in stem and shank overnight.

P.S. Remember to take it out before your next smoke, or you may find yourself starting this whole rigmarole over again.

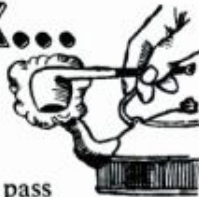

NO MORTAL CAN BOAST SO NOBLE A  
TOAST AS A PIPE OF ACCEPTED TOBACCO.



## THE PIPE TOBACCO THAT STAYS LIT



Bond Street Pipe Tobacco keeps burning because of its old English cut—a combination of flakes for even-burning and cubes for slower-burning. You'll like its aroma of fine imported and domestic tobaccos, too.



Your wife and dog  
may desert you, but  
your pipe—never!

# BOND STREET

A product of Philip Morris Inc.

miles with my Kelty Pack and feel it is the finest piece of equipment I own.

Los Angeles, Calif.

DON REEVES

There was more information on the Kelty and other types of packs, Don but we had to trim some out to make our space requirements. Perhaps if enough PM readers request it, we could work up a Shopper's Guide article on various types of packs for a future issue.

## Editor Takes a Nip

Supplementing last month's item about the hazards a PM author encountered in digging a story out of Mummy Cave in Arizona, the photo below shows PM's aviation editor, Kevin Brown, using the forearm method of greeting a gooney bird on



Midway Island (see story on page 102). Before Kevin mastered this technique, one of these ridiculous birds had given his bare hand a nasty nip.

Nor was this all. Later, while photographing a gooney which had built its nest directly in front of an ammunition dump and directly under a sign, "Danger! Keep Out," Kevin failed to notice the alert Navy guard who took a dim view of picture taking in such sensitive areas. Kevin spent a brief time in the island brig while (1) he explained that it was his sense of humor, not any attempt to violate security, that prompted him to take the picture, and (2) the Navy explained that they would like to keep the gooney birds away from restricted areas, too, but the silly birds just won't listen.

The Editors

POPULAR MECHANICS

Aluminum Company of America, 885-J  
Alcoa Building, Pittsburgh 19, Pa.

Please send me a FREE, 32-page book-  
let on mobile-home living.

Name \_\_\_\_\_

Address \_\_\_\_\_

City \_\_\_\_\_ Zone \_\_\_\_\_ State \_\_\_\_\_

Send this →  
coupon, learn  
what every  
family should know today about



mobile-home living  
(come on, now, aren't you curious?)

and reasons why Champion offers  
all you'd ever want inside →

...stays Care-free outside  
(less work, more time  
for yourself) ↓



...because it's aluminum, this metal asks so little of you



Entertainment at Its Best... **ALCOA PREMIERE**  
with Fred Astaire as Host... Tuesday Evenings, **ABC-TV**

# Pentagon sidelights

By William R. Kreh

**Anchoring buoys** in water up to three miles deep is being done by the Coast Guard to mark the exact positions of its ocean rescue stations in the Atlantic. The project is at the request of the Federal Aviation Agency which wants a precise radar survey of the transatlantic airways to show how well the airliners are sticking to their flight patterns. To make the necessary observations for this purpose, the Coast Guard vessels must know very precisely where they are—thus the buoys. Each buoy will be a light, plastic doughnut six feet in diameter. It will be anchored by a polypropylene line—a plastic lighter than water that will not exert any downward pull on the buoy.

**German missile scientists** are influencing even the Pentagon press room where the wire service teletype machines clack out the day's news. Witness this recently posted sign:

**ACHTUNG! Alles Lookenspeepers**  
Das teletypenmachines is nicht for gefingerpoken und mittengrabben. Is easy schnappen der springenwerk, blownfusen, und poppencorken mit spitzensparken. Ist nicht fur gerwerken by das dumkopfen. Das rubbernecken sightseeren keepen hands in das pockets—relaxen und watch das blinkenpaper.

**The term "aerospace"** is slowly and quietly being substituted for "air" in Air Force unit designations. For example, it's now the 92d Strategic Aerospace Wing. Aerospace, as the Air Force sees it, is the earth's atmosphere and the space above it and the service insists its operating area extends from the earth's surface out in a continuous field.

**Radar on wheels**, designed to track storms as far as 400 miles away and monitor movements of radioactive clouds from nuclear bursts, is now being tested by the Army weather unit. It is housed in a standard 26-foot Army trailer and features a power-erected antenna mount that rises through the van's roof. The system can be put into operation in less than an hour.

**Walk-around oxygen** in a miniature self-contained rebreather device has been developed at the Naval School of Aviation Medicine. With it, air crewmen may now leave the main oxygen supply source when necessary and move around within the aircraft. The device can supply oxygen for periods up to one hour.

**A battlefield searchlight** half the size but with twice the range and intensity of any now in use has been developed by Army Engineers. Its main use will be to illuminate large sections of a combat area under surveillance by aiming its beam low over the area and bouncing the light off the atmosphere with a sort of indirect lighting effect. The light has 450-million candlepower and can operate continuously for up to nine hours.

**Sleeping rats** invariably wake up immediately when exposed to tiny doses of radiation, Navy tests show. They not only wake up in hurry but their heartbeats quicken, indicating, Navy scientists say, that radiation may have a stimulating effect on the nervous systems of animals. And this raises the question whether animals have sense organs for radiation that no one has yet discovered.

**Normal vision** is seriously impaired under the forces of acceleration. More than 250 runs in the Navy's huge whirling centrifuge at its acceleration laboratory have demonstrated that acceleration greatly cuts the ability of the human eye to see differences in brightness. And almost all vision depends on being able to tell this. Early indications show, the Navy says, that pressure breathing may reduce this effect.

**An ionic purifier** is being tested by the Coast Guard in hopes it can be used to successfully de-salt sea water so remote lifeboat stations won't have to rely on rainwater as they do now. The gadget, which can turn out about 2000 gallons of nearly pure water a day, works this way: A vat is divided by two plastic membranes into three compartments. Sea water is pumped into the middle compartment and an electric charge is applied across the vat. The charge and the chemical structure of one membrane are such that sodium ions are pulled out through the membrane into one of the outer compartments. The other compartment, oppositely charged, pulls chlorine ions out from the center, leaving the water in the center compartment nearly pure.

## "OWN a Business" Coupon

**DURACLEAN CO.** 2-169 Duraclean Bldg., Deerfield, Ill., U.S.A.

Without obligation to me, send booklet and letter giving full details. Tell me how I may OWN a growing business of my own built upon satisfied customers.

Name \_\_\_\_\_

Address \_\_\_\_\_

City \_\_\_\_\_ State \_\_\_\_\_

Start Now  
while  
employed



# Are You The Man?

If you have longed for the prestige and financial independence of YOUR OWN business, you can now realize this goal . . . if you can qualify for a Duraclean dealership. We are now enlarging this world-wide chain of independently-owned service dealerships.

You must however be reliable, honest, diligent and able to make a small investment in a business we assist you in establishing. It's a profession we will personally and quickly teach you. We will help finance you. You can build your business

while still employed.

This is a sound, lifetime business that grows from REPEAT ORDERS and customer RECOMMENDATIONS.

Alert dealers, using national price guide, can gross an hourly profit of \$9 on own service plus \$6 on EACH service man.

We want to assure your success. A Duraclean dealer will train and assist you. He'll reveal his successful plan of building customers. He will work with you. This business is easy to learn . . . quickly established. Coupon will bring full details.

### You are Trained in a New Profession . . . to Revive, Clean, Protect Home Furnishings

Duraclean's growth to a worldwide service resulted from the safer, quick-drying ABSORPTION process rendered in-the-home by courteous, trained craftsmen. Aerated foam created by the electric Foamovator vanishes dirt, grease and many unsightly spots.

Customers appreciate upholstery and floor coverings cleaned with a new consideration for life and beauty. No more soaking, harsh scrubbing, or strong soaps. Instead of scrubbing soil down into upholstery or rug pile, it is REMOVED.

Customers tell friends how Duraclean eliminates the customary soaking and breaking of fibers . . . how the mild quick-action foam, lightly applied, revives colors and enlivens fibers . . . how fabrics look fresher, brighter and cleaner . . . how furnishings are back in use in a few hours. Customers become your best salesmen.

### You Have 6 Complete Services

**DURASHIELD**, applied to new or freshly cleaned fabric, retards soil and stains . . . retains the fresh, new look MONTHS longer.

**DURAPROOF** kills moths and carpet beetles. It makes upholstery, rugs, blankets, clothing repellent to both. 6-YEAR WARRANTY.

**DURAGUARD** flameproofs . . . prevents fire starting from cigarettes, candles, etc. Reduces fire damage in homes, theaters, hotels.

**SPOTCRAFT** safely removes most stubborn spots and stains.

**TUFTCRAFT** enables you to repair cigarette burns, moth damage.

### We'll work WITH You . . . No Shop Needed

You'll have a close relationship with our staff and with other dealers. We see our dealers often at regional meetings, training schools and conventions. We all work together . . . exchange ideas and swap experiences. We show you effective ways to bring customers to you.

You will have pre-tested newspaper and yellow-page ads, store display cards, radio and TV commercials, folders, sales materials and a complete mailing program. Magazine ads explain the superior merits of YOUR modern services and develop customer confidence in YOUR business. Your services are backed by Parents' Magazine Seal, the Use-Tested approval of McCall's and recommendations of textile manufacturers.

You not only have the opportunity to quickly increase your income . . . the growing dealership value is increasing your net worth. G. F. Monroe, after 12 months, sold his Texas dealership for 10 times his cost. Leo Lubel after 30 months sold for \$8,308 above cost. If for any reason you should want to sell your dealership, we maintain a resale service.

Almost every building houses a customer. Furniture stores, department stores, interior decorators, upholsterers and carpet stores secure jobs from their customers. Auto dealers have used cars Duracleaned and take orders for you. Some dealers have shops or offices . . . others operate from home with no overhead expense.

We prefer that you have no cleaning experience so you don't have to "unlearn" old scrubbing methods. We and an experienced dealer will show you everything you need to know to succeed and build your dealership.

A few hundred dollars establishes your business . . . pay balance from sales. We furnish electric machines, sales aids, and enough materials to return your TOTAL investment. This may be your life opportunity.

Just mail the convenient coupon today. There is no time like the present to find out whether this is the business that will increase your income and secure your future. We'll send you all the facts with no obligation whatever. Then, if you decide you would like to become a Duraclean dealer, you can mail your application and, if you qualify for acceptance, we'll have you actively operating in a few days.

### FREE Booklet . . . Send for it NOW

Our first letter and illustrated booklet will explain everything . . . modern services, waiting market, how business grows, your large profit and territory. Mail coupon today while you can still get a dealership in YOUR location.

### What Dealers Say

**L. Lawson:** "National advertising is tops, creates leads. In September, working alone, jobs totaled \$1,475."

**Ed Kramsky:** "In 2 years, I now have two assistants, a nice home and real security for my family."

**John Jaffe:** "There's a huge demand for good carpet and upholstery cleaning. If you tell enough people about Duraclean, you have to make good."

**Hiram L. Brown:** "Made \$105 in one day cleaning sorority house."

**Thomas C. Mason:** "Cleaned two rooms for a stock broker. He was so impressed he had 7 jobs lined up for me and from those seven came 4 more."

**Russel C. Blue:** "Customer called a prominent competitor. They said they could not clean her badly soiled furniture . . . to contact me because 'if anyone could get it clean, I could'."

**Ward Whitbeck:** "In my fifth year am making as much as \$225 in one day."

**L. Broersma:** "Have now completed 5 years with Duraclean. We have never had one complaint."

OWN  
a Growing  
BUSINESS



FREE  
Booklet  
tells how

Duraclean Co.  
2-169 Duraclean Bldg.  
Deerfield, Ill.

# Science overseas

By William Kreh

Some birds not only know which way is up, they also know which way is around!

Italian scientists say some birds may navigate by detecting mechanical forces resulting from Earth's rotation.

They put tiny electrodes in the brains of pigeons, placed the birds on a slowly rotating table, and found that the birds measured small differences in acceleration. The tests show that the homing variety of pigeons react to the changes; the nonhoming breeds do not.

The force of a grasshopper's jump can be measured by a tiny, sensitive springboard developed by zoologists in Great Britain.

Slam your car into reverse while it is going forward? You may be able to in a few years, if you really want to.

A one-pedal car, able to go forward and backward with no clutch, differential or gear box is under test in England. The car, a Triumph Herald, carries a new hydrostatic transmission system designed at the National Engineering Laboratory, East Kilbride, Scotland.

A normal gas engine drives a high-pressure oil pump which rides where the gear box used to be. Oil from the pump is carried to two hydrostatic motors mounted in the trunk. These motors, controlled by the amount and direction of oil flowing through their whirling vanes, drive the back wheels.

When the pedal, pivoted at its center, is pushed forward with the toe, the car goes forward. Pushing back on the heel reverses oil flow and the car can be slammed immediately into reverse while still going forward.

Myth or monster? Modern science is finally being turned out to search for the legendary Loch Ness monster in Scotland. British scientists are sounding the Loch with Norwegian echo sounders and other electronic gear.

A knotty knitting problem has been solved (unraveled?) by the Australian Council for Scientific and Industrial Research.

Sales of knitting yarn have been falling off and wool producers blamed this on the

fact that hand-knitters couldn't keep yarn at an even tension and that their final products weren't always the right size and shape because of it.

The scientists came up with a gadget which fits on a knitter's fingers and controls the tension of the wool yarn like the disks on a sewing machine. The device makes it possible to turn out uniform knitting with the desired number of stitches to the inch. It can be adjusted easily to shape a garment and even make complicated patterns.

The oldest curse on record may have been uncovered recently, when a 3000-year-old earthenware dish was dug up near the Dead Sea.

Archeologists found a magician had scratched the name of a city backwards as a curse to evoke the wrath of the gods on the place and its residents. He did it six times, spelling out the name of "Arad"—an ancient Hebrew city—backwards each time.

Most everything's coming in coin-operated machines—even postal money orders. By putting the proper amount of money in a test machine in Paris, one can get—push-pull, click, click—a money order ranging in denomination from ten cents to two dollars. The fee is about four cents for the service.

The largest blast furnace in the world, so its builders say, has blazed into action in Japan. It turns out pig iron at the rate of 3000 tons a day.

Peel me a grape! A Canadian agricultural scientist has invented an infrared oven which allows skin to be peeled from tomatoes, plums, apples and peaches just as easily as you peel the skin from a banana. He gives the fruit a four-second blast of 3000-degree heat.

Seals wearing corsets that measure their heartbeats have been diving in a special tank, and in the open sea, to aid British scientists.

The research should determine how the deep-diving seal can go through its antics without being afflicted with the bends, such as plague the human diver.

Girls so inclined can check their pearls for quality more accurately than ever before. Japanese technicians have come up with a glossmeter that measures the lustre of pearls. They also say the meter could be used by industry to measure the gloss on ball bearings or other curved surfaces.

GET READY FOR THE SPACE and SCIENCE ERA! SEE SATELLITES, MOON ROCKETS CLOSE UP

# AMAZING SCIENCE BUYS

for FUN, STUDY or PROFIT



See the Stars, Moon, Planets Close Up!

## 3" ASTRONOMICAL REFLECTING TELESCOPE



60 TO 180 POWER!  
Famous Mt. Palomar Type!  
An Unusual Buy!

See the Rings of Saturn, the fascinating planet Mars, huge craters on the Moon. Equatorial Mount with lock on both axes. Aluminized and overcoated 3" diameter high-speed f/10 mirror. Telescope comes equipped with a 60X eyepiece and a mounted Barlow Lens. Optical Finder Tripod included. Hardwood, portable tripod. FREE with Scope: Valuable STAR CHART plus 272-page "HAND-BOOK OF HEAVENS" plus "HOW TO USE YOUR TELESCOPE" BOOK.

BOOK OF HEAVENS" plus "HOW TO USE YOUR TELESCOPE" BOOK.  
Stock No. 85,050-H ..... \$29.95 Postpaid  
4 1/4" REFLECTING TELESCOPE—Up to 255 Power.  
Stock No. 85,105-H ..... \$79.50 F.O.B., Barrington, N.J.

## BUILD A SOLAR ENERGY FURNACE

A fascinating new field. Build your own Solar Furnace for experimentation—many practical uses. Easy! Inexpensive! Use scrapwood! We furnish instructions. This sun powered furnace will generate terrific heat—2000° to 3000°. Fuses enamel to metal. Sets paper aflame in seconds. Use our Fresnel Lens—14" diameter . . . f.l. 14".

Stock No. 70,130-H ..... Fresnel Lens ..... \$6.00 Postpaid  
11" Sq. Fresnel Lens F.L. 19".  
Stock No. 70,533-H ..... \$4.75 Postpaid

## SPELLBINDING EXPERIMENTS with SILICON SOLAR CELL AND SUN BATTERY!



Experience endless fascination in converting sunlight into electricity to power small motors, amplifiers, etc. (See July '61 Popular Science article—"The Boat That Runs on Sunlight" for latest techniques). Plastic case 1 1/8" x 1 1/8" x 3/16". Produces .3 to .45 volts—10-16 milliamperes. 24-page Handbook gives full data on 12 pat experiments.

Stock No. 60,216-H ..... \$2.25 Postpaid  
Selenium Photocell. Lower power, lower price than Silicon Cell.  
Stock No. 30,411-H ..... \$1.50 Postpaid  
Solar Cell and Photocell Handbook. Fascinating 112-page Handbook on Silicon-Cell and Selenium projects, demonstrations, etc. Explains photo-voltaic theory, performance. Gives infrared and ultra-violet applications. Paperbound, 6"x9".  
Stock No. 9230-H ..... \$2.00 Postpaid

## MINIATURE WATER PUMP



Wonderful for experiments, miniature waterfalls, fountains, Christmas gardens, HO gage railroad backdrops, hobbyists, labs, schools. Pumps continuous flow of water etc. Tiny (2 5/8" x 1 3/4") electric motor and pump ideal for hobbyists, labs, schools. Pumps continuous flow of water at rate of one pint per minute at a 12" head. With 2 D Batteries in series will pump to 24" high. Works in either direction. Stock No. 50,345-H ..... \$2.25 Postpaid

## NOW . . . EXCITING NEW COLOR EXPERIMENTS for AMATEURS

### AMAZING DIFFRACTION GRATING SAMPLE KIT!

Miracle of light diffraction! Wonder material of the 20th century. Now you can develop spectacular color-coordinated schemes . . . produce iridescent decorative effects inside and outside the home . . . convert old, unwanted costume jewelry—earrings, cufflinks, pins, pendants and bracelets—into excitingly different, ever-glowing pieces of adornment. Yes, now you can bounce light off reflecting Diffraction Grating Replicas in all the scintillating brilliance of rainbow colors. Kit contains 8 1/2" x 5 1/2" pieces of transmission (see through) and reflecting type grating, mounted circular grating, unmounted transmission and reflecting type, gratings, round pieces of mounting glass, double-faced mounting tape, stereo viewer; Edmund Diff. Grating Idea Book.

Stock No. 70,563-H ..... \$5.00 Postpaid.

## OPAQUE PROJECTOR



Projects illustrations up to 3" by 3 1/2" and enlarges them to 35" x 30" if screen is 6 1/2 ft. from projector; larger pictures if screen is further away. No film or negatives needed. Projects charts, diagrams, pictures, photos, lettering in full color or black-and-white. Operates on 115 volt, A.C. current. 6-ft. extension cord and plug included. Operates on 60 watt bulb, not included. Weight 1 lb., 2 oz. Plastic case with built-in handle.

Stock No. 70,199-H ..... \$7.95 Postpaid

ORDER BY STOCK NUMBER—SEND CHECK OR MONEY ORDER—SATISFACTION GUARANTEED  
**EDMUND SCIENTIFIC CO., BARRINGTON, N. J.**

## 'FISH' WITH A MAGNET

### Go Treasure Hunting On The Bottom

Great idea! Fascinating fun and sometimes tremendously profitable! Tie a line to our 5-lb. Magnet—drop it overboard in bay, river, lake or ocean. Troll it along the bottom—your "treasure" haul can be out board motors, anchors, fishing tackle, all kinds of metal valuables. 5-lb. Magnet is war surplus—Alnico V Type—Gov't. Cost—\$50. Lifts over 125 lbs. on land—much greater weights under water. Order now and try this new sport.  
Stock No. 70,571-H 5 lb. Magnet . . . \$12.50 Postpaid



## USE THIS AIR FORCE BUBBLE SEXTANT

ANYWHERE—Land or Sea  
ANYTIME—Night or Day



Lighted bubble makes "any-time, anywhere use" possible. Employ as straight sextant to measure elevations referenced to bubble or horizon; or measure elevations with self-contained clock-driven mechanism that shows degrees and minutes of elevation averaged through a two minute sighting on a dial counter. Besides bubble, and swinging prism (for use with natural horizon), sextant contains astigmatizing lens, sun shades, adjustable focus, rubber-padded eyepiece. Extras: suspension hook, spare bulbs, rheostat-controlled battery case. Measures 120 degree angle from -10 degrees to +110 degrees. Vernier drum reads to 2 minutes. May be interpolated to 1 minute. In late use by U.S.A.A.P.  
Stock No. 70,574-H Used good condition . . . \$32.50 Postpaid

## LARGE SIZE OPAQUE PROJECTOR

Ideal for photographers, this low-cost unit projects 3 1/2 ft. sq. image at 6 ft.—7 1/2 ft. sq. image at 12 ft. Projects photos, drawings, sketches, clippings, any opaque copy up to 6" x 6"—larger pieces in sections. Lenses are 2 plano-convex, 3 1/2" dia. mounted in 3 1/4" barrel. Projector is 11 1/2" high, 13 1/4" wide. 9" front to back, pressed steel in black wrinkle finish, bakelite handle. Uses two 200 watt bulbs—not included. Complete with side platform to hold illustrations, 6 ft. elec. cord, heat resist. plate glass mirror.  
Stock No. 80,066-H ..... \$42.00 Postpaid



## SPECIAL PURCHASE—SAVE \$7 ON THIS PROFESSIONAL MECHANICAL DRAWING SET

Made to Sell for \$19.95—OUR PRICE ONLY \$12.95. Precision-made for professionals, yet priced within low-budget range. We bought all available stock from one of West Germany's famous instrument makers to bring you this super bargain. Every instrument real chromium on brass—not brass nickel. Wonderful gift for anyone in need of drawing equipment. Set includes: 6" detail (Swede) pen; 6" divider; 6" hinged divider with pen, pencil and extension; two 5 3/4" ruling pens; 4 1/2" bow divider with center wheel, bow pencils with center wheel; and bow pen, all precision type; 4 1/2" drop compass with pencil and pen attachment; spare parts box; screwdriver for adjusting extra lead box; polishing cloth. All metal parts rust free. Two-flap velvet lined case.  
Stock No. 70,440-H ..... \$12.95 Postpaid

## 6x30 WAR SURPLUS AMERICAN-MADE BINOCULARS

Big savings—brand new. Crystal clear viewing—6 power. Optics fully coated. Individual focus. Exit pupil 5mm. Approx. field—445 ft. at 1000 yds. Excellent for spectator sports, races, hunting, etc. Normally costs \$100 up. Complete with carrying case and strap.  
Stock No. 963-H ..... \$33.00 Postpaid  
7 x 50 BINOCULARS—a Terrific Buy.  
Stock No. 1544-H ..... \$74.80 Postpaid (tax incl.)

## WOODEN SOLID PUZZLES

12 Different puzzles that will stimulate your ability to think and reason. Here is a fascinating assortment of wood puzzles that will provide hours of pleasure. Twelve different puzzles, animals and geometric forms to take apart and reassemble, give a chance for all the family, young or old, to test skill, patience, and best of all to stimulate ability to think and reason while having lots of fun. Order yours now.  
Stock No. 70,205-H ..... \$3.00 Postpaid



Order by Stock No.—Send Check or M.O.—Money-Back Guarantee  
**EDMUND SCIENTIFIC CO., Barrington, New Jersey**

## MAIL COUPON FOR FREE CATALOG "H"

160 Pages! Over 1000 Bargains!

EDMUND SCIENTIFIC CO., Barrington, N. J.  
Please rush Free Giant Catalog "H"

Name .....

Address .....

City..... Zone..... State.....



Guaranteed against burn-out

**AIROGRATE**

**YELLO-BOLE**

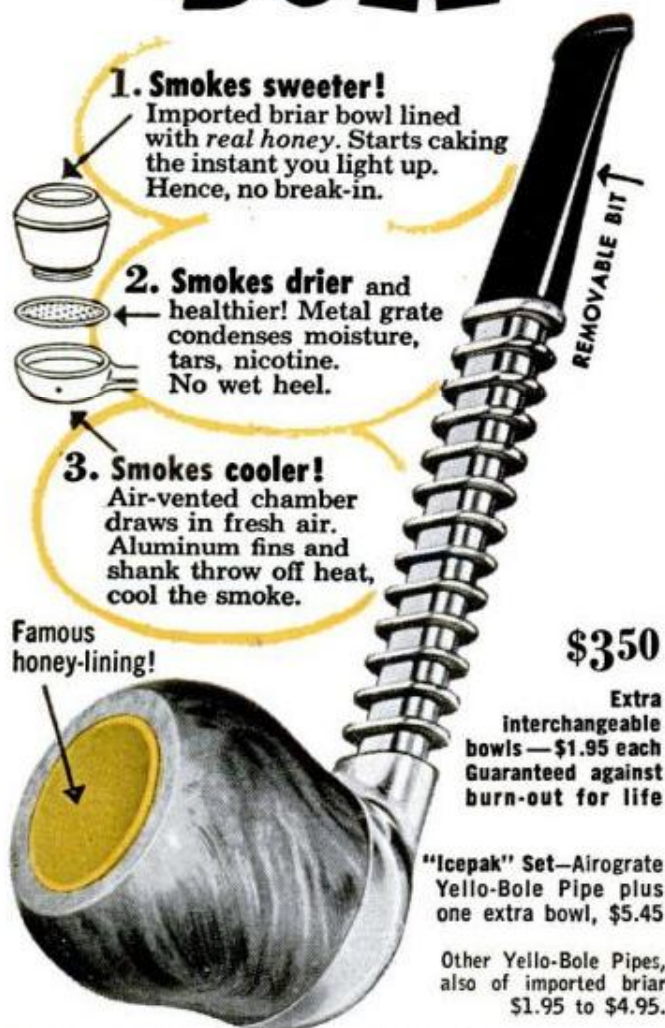

**1. Smokes sweeter!**

Imported briar bowl lined with *real honey*. Starts caking the instant you light up. Hence, no break-in.

**2. Smokes drier and healthier!**

Metal grate condenses moisture, tars, nicotine. No wet heel.

**3. Smokes cooler!**

Air-vented chamber draws in fresh air. Aluminum fins and shank throw off heat, cool the smoke.

Famous honey-lining!

**\$350**

Extra interchangeable bowls—\$1.95 each  
Guaranteed against burn-out for life

"Icepak" Set—Airograte Yello-Bole Pipe plus one extra bowl, \$5.45

Other Yello-Bole Pipes, also of imported briar \$1.95 to \$4.95.

Send for FREE FOLDER, YELLO-BOLE PIPES, Inc., Dept. Y6, N.Y. 22

**RUPTURED**

**BE FREE FROM TRUSS SLAVERY**

Surely you want to THROW AWAY TRUSSES FOREVER, be rid of Rupture Worries. Then Why Do you put up with wearing a griping, chafing and unsanitary truss the balance of your life? If you do, it will NOT be through necessity but through choice on your part.

Now there is a new modern Non-Surgical treatment that is designed to permanently correct rupture. These Non-Surgical treatments are so dependable, that a Lifetime Certificate of Assurance is given. Write today for our new FREE BOOK that gives facts that may save you painful, expensive surgery. Tells HOW and explains WHY NON-SURGICAL Methods of Treating Rupture are so successful today. No obligation.

Excelsior Medical Clinic  
Dept. H6125, Excelsior Springs, Mo.

**Tune in on the inventors**

By J. L. Pugni

Diamond dust, accelerated to meteoric speeds, is being used to study corrosive damage to spacecraft caused by impact with tiny dust particles. The diamond particles are injected into a high-vacuum suspension chamber where a single particle is charged by a high-energy beam of argon ions. The charged particle is extracted from the chamber, accelerated to meteoric speeds by an electric field, and then slammed into the surface of the material being tested. Alexander J. Dessler of Palo Alto, James F. Vedder of Los Altos, and Martin Hertzberg of Sunnyvale, Calif. were granted patent No. 3,036,213 for the process.

☆☆☆

Mildew-proofing garments by chemically treating fibers and fabrics is the method that was awarded patent No. 3,034,957 for James L. Smith and Robert C. Harrington, Jr., Kingsport, Tenn., who assigned rights to Eastman Kodak Co. One of the chemicals used, 3,4,4'-trichlorocarbanilide, effectively retards the growth of mildew-producing microorganisms.

☆☆☆

A longer firing life for a gun barrel is possible by jacketing the bullet area that normally touches the gun barrel rifling with Teflon (polyeterafluorethylene). The technique, developed by William A. Zisman, Silver Spring, Md., and Vincent G. Fitz Simmons of McLean, Va., received patent No. 3,040,662.

☆☆☆

Visible, infrared or ultraviolet light is used by a proximity detector to determine the presence and relative speed of a missile or aircraft in space. Current detectors either rely on radar and are complex systems or they use passive radiation and are less dependable and not portable.

☆☆☆

Slowing jet planes, which touch the runway at speeds of about 160 miles per hour, with a drag parachute that automatically retracts into the plane's fuselage won patent No. 3,036,795 for Gordon R. Sinclair of Fallston, Md.

Copies of the original patents may be ordered for 25 cents each from the Commissioner of Patents, Dept. of Commerce, Washington 25, D. C.



# JOIN MEN LIKE THESE

## Who Now Make **BIG PROFITS** From America's Electric Appliance Boom!

Here's a report on six of NRI's typical successful graduates who earn \$3 to \$5 and more an hour — spare time or full time — enjoying their work as qualified Appliance Service Technicians...\*

### Make \$3 to \$5 an Hour... FIXING Electric Appliances!

**STOP AND THINK** for a minute about YOUR present job and future. Are YOU making enough money? Are you happy in your work? Can you bank on a steady income, good times or bad?

Now you can have the answer to these money and job worries, once and for all. Get in "on the ground floor" of a booming industry — Servicing Electrical Appliances. The coming of the auto created a multi-million dollar service industry, the auto repair business. Now it's happening in the electric appliance field. But with this important difference: anybody with a few simple tools can get started in it!

### Why the Boom in Appliances Means Money in Your Pocket

In addition to the 400 MILLION appliances already in use, this year alone will see sales of 76 million new appliances! For example, 4,750,000 coffee makers, 2,000,000 room air conditioners, 1,425,000 clothes dryers. A nice income awaits the man who can service such appliances. That man can be you! Even if you don't know a volt from an ampere now, you can soon be making \$3 to \$5 an hour in your spare time.

The NRI training in Servicing Electric Appliances is thorough — right from the basic fundamentals about electricity. And your training will cost less than 20¢ a day.

### Your Skill Always in Demand — "Set Up Shop" Anywhere

People need their appliances fixed in good times or bad. Once word gets around that you are trained to service them properly, you'll have plenty of work.

You need only the few basic tools that you may already have — and an Appliance Tester which we provide at no extra charge. You can work in a corner of your basement or garage. If you like, you can open your own shop. And you can save money by fixing your own appliances. Mail coupon for Free Book telling how you can "cash in" on the big opportunities that are waiting for the man who knows how!

### FREE BOOK and SAMPLE LESSON

Our 24-page Free Book tells about America's "Electric Appliance Boom" — how we train you to "cash in" on it. Free Sample Lesson shows how simple our instruction is — how it can quickly prepare you for a profitable future. Mail coupon to: National Radio Institute, Dept. AJ2, Washington 16, D. C. (No obligation — and no salesman will call on you.)



### Earn While You Learn With this Precision Appliance Tester — Yours At No Extra Charge!

Along with the NRI course in Electric Appliance Repair you receive — without extra charge — this precision Appliance Tester. In kit form, which enables you to locate short circuits, faulty cords and poor connections, check fuses and circuit breakers, test for open circuits, check thermostats, line voltages, wattage drain, take resistance measurements. This instrument helps you track down trouble in every appliance from table lamps to room air conditioners — and make up to \$5 an hour doing it!



**EARL G. REID, RFD 1, Thompson, Ohio** reports that he took in \$648 in one month, of which \$510 was clear — and he was only working part-time!

**JAMES CARTER, 872 Franklin St., Rocky Mount, Va.** states some of the single lessons in the course are worth the entire cost — now owns and operates the Fixit Shop in his own home town.



**NRI Graduate CHESTER M. SIEMS, 2326 Corbin St., Melvindale, Mich.** tells that he saved big money just keeping his own major electric appliances in repair. Says he would recommend the course to anyone.

**CARL BOEHMKE, 636 Grove N.E., Albuquerque, N. Mex.,** lost his job through pneumonia. His NRI diploma got him a job with an Appliance Service Center where he's doing the kind of work he enjoys, and the climate is much better for his health.



**FRANK S. NETTNAY, 827 N. 7th St., Vincennes, Ind.** gets all the spare-time appliance repair work he can handle from hardware store where he has a regular job.

Now that **ERNEST B. FARRAR, RFD 1, Mountain Home, Ark.** has retired at age 67, he has opened his own appliance Repair Service.



\* Letters on file

### MAIL NOW FOR FREE BOOKLET AND SAMPLE LESSON

Mr. J. M. Smith, President  
NATIONAL RADIO INSTITUTE  
Dept. AJ2, Washington 16, D. C.

Please send me Free Book about NRI Electrical Appliance Repair training program and a free Sample Lesson. I am particularly interested in:

- Spare time earnings  Business of my own  Better job

I understand there is no obligation on my part; and no salesman will call.

Name.....

Address.....

City..... Zone..... State.....

Accredited Member National Home Study Council



# FREE!



## Trial lesson in **DRAFTING & DESIGN**

### LEARN AT HOME IN SPARE TIME

Check the want ads in any newspaper — SEE the big-pay opportunities open to you as a draftsman. What's more, you can learn this well-paid, prestige profession at home — quickly, easily! No special talent needed! Get complete, step-by-step Chicago Tech lessons in the mail, spend a few pleasant hours studying each week. In a short time you'll be a well-trained draftsman, ready to take your pick of many good jobs. Act now!

### FREE INFORMATION—MAIL COUPON TODAY!

Get FREE TRIAL LESSON plus information about C.T.C. practical training. Learn what successful Chicago Tech graduates say about high pay and opportunities in drafting. No charge, or obligation.

Est. 1904 Accredited National Home Study Council

### CHICAGO TECHNICAL COLLEGE

M-200 Tech. Bldg., 2000 So. Michigan Ave.,  
Chicago 16, Illinois

Mail me FREE Lesson with information about big opportunities in DRAFTING.

Name..... Age.....

Address .....

City..... Zone..... State.....

B11

## WANT TO BE A LOCAL BRIKCRETE\* MANUFACTURER?

\*Guaranteed to Contain No Clay

High income can be earned operating a Brikcrete plant, because Brikcrete — world's most modern masonry — gives more value for less cost to building owners without sacrifice of profits. Huge savings by local production makes possible low prices and high income potentials.

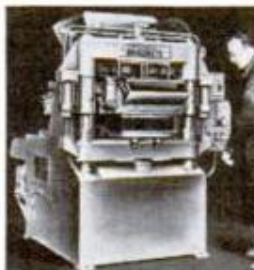

### Choice Territories Open

Broad markets are waiting because Brikcrete is popular for every type of residential, commercial and industrial construction. Ultra modern in design, size, proportion. Cost less than lumber. Wide color range. Combines all the features that make for large consumer acceptance. More local plants are needed. Exclusive privileges in franchise-protected territories. Mark-up averages 100% on basic cost. Machine available on long-term payments. Write for Brikcrete Book No. 2 and tentative reservation of territory.

Brikcrete Associates, Inc., 402 W. 25th, Holland, Mich.

## Items from all outdoors

Thanks for livening the summer around PM's editorial offices with stacks of letters in response to our March article "Bitter Battle of the Waterways." There were hundreds of them, every one interesting, and almost all made it clear that, with a little common sense and courtesy, there's plenty of water to go around. Try it.



And a special thanks to our letter-writing readers from Eleanor Stephens, a graduate student at the University of North Carolina, who borrowed the stacks of letters to use in writing a thesis on usage of public waters. She reports that they were a big help. We believe it was in a good cause, since recreational waters need planning and management, not laws and enforcement, to stay useful to everyone.



Best story to come of all that correspondence was the one about the water skier who buzzed a bank fisherman twice, annoying him no end with the boat's wake. On the third pass, the fisherman picked up a fist-sized rock and threw a perfect strike on the skier, who then lost his balance and fell, suffering a broken leg in addition to rock damage about the head. Skier sued fisherman, but the judge threw it out of court on the grounds that the skier had asked for it. A Solomon. But don't throw rocks, please.



Next item could have gone in the Tune in on the Inventors column as well as this one, but it ties in nicely with Marc Michaelson's article on school football safety (page 94). Mr. Neal Parsons, superintendent of schools in Weeping Water, Neb., has invented a cleat for football shoes that won't damage the man you're stepping on. He demonstrates them by letting you put on the shoes and walk on his hands. Secret of the new cleat, which looks much like the old square cleat of several years ago, is that it's made of resilient urethane plastic. The plastic cleats grip like hard cleats—better than the hard ones on frozen ground—but give enough to make them safe in the worst pileup. They're not much more dangerous to players than tennis shoes would be.

*Dick Liepatrik*

POPULAR MECHANICS

Материал, защищенный авторским правом

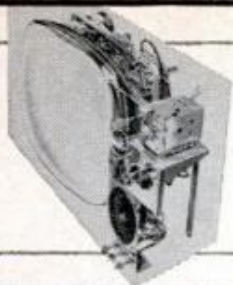

**TELEVISION  
SERVICING**

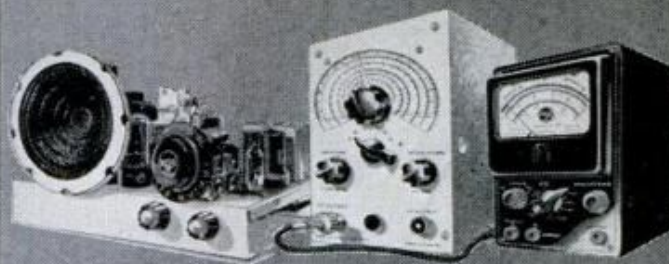

**ELECTRONIC FUNDAMENTALS**

**COLOR  
TELEVISION**

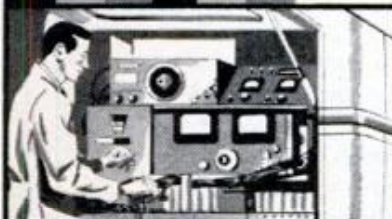
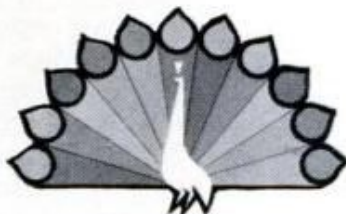

**COMMUNICATIONS  
ELECTRONICS**

**RCA INSTITUTES  
OFFERS A COMPLETE  
SELECTION OF  
HOME TRAINING  
COURSES IN  
ELECTRONICS**

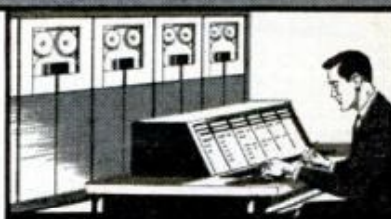

**COMPUTER  
PROGRAMMING**



**TRANSISTORS**



**AUTOMATION  
ELECTRONICS**

Prepare yourself for an exciting and profitable career in electronics. You need no special technical background to start your training. Even if you do not have high school training, you can start your training at home under the guidance of RCA Institutes. Choose from RCA Institutes' wide selection of courses including Electronic Fundamentals, TV Servicing, Color TV, Communications Electronics, Automation Electronics, Computer Programming, Transistors. Practical work starts with the very first lesson. You get

prime quality equipment that you keep and can later use on the job. You never have to take apart one piece of equipment to build another. Perhaps most important, RCA's liberal Voluntary Tuition Plan is the most economical home study method because you pay only for lessons as you order them. If you should interrupt your training at any time, you do not owe one cent. No other obligations. No installment payments required! Licensed by the New York State Department of Education. Approved for Veterans.

**Act today! Send for this 64-page career book FREE!**

**CLASSROOM TRAINING**

Classroom Training in New York City and Los Angeles. Day and Evening Classes start four times a year. In addition, Radio Corporation of America offers a limited number of basic courses in Chicago, Philadelphia, and Cherry Hill, N. J. (near Camden). Detailed information on request.

**RCA INSTITUTES, INC. Dept. PM-92**

A Service of the Radio Corporation of America  
350 W. 4th Street, New York 14, N. Y.  
610 S. Main St., Los Angeles 14, Calif.



**The Most Trusted Name in Electronics**

To save time, paste coupon on postcard

**RCA INSTITUTES, INC. Dept. PM-92**  
A Service of the Radio Corporation of America  
350 West 4th St., New York 14, N. Y.

Please rush me your FREE illustrated 64-page book describing your home training programs. No obligation. No salesman will call.

Name \_\_\_\_\_ Age \_\_\_\_\_  
(please print)

Address \_\_\_\_\_

City \_\_\_\_\_ Zone \_\_\_\_\_ State \_\_\_\_\_

**CANADIANS**—Take advantage of these same RCA courses at no additional cost. No postage, no customs, no delay. Send coupon to: RCA Victor Company, Ltd., 5581 Royalmount Ave., Montreal 9, Quebec



Earn big pay as a

# TRAFFIC AND Transportation Expert

LA SALLE WILL TRAIN YOU  
IN SPARE TIME AT HOME

Get out of a dead-end job—take advantage of today's demand for men trained in Traffic and Transportation management. Unlimited opportunities with national manufacturers, transcontinental and overseas shippers, leading transport lines. LaSalle helps you become an expert on Rates, Classifications, Tariffs, Routing, Methods of Shipping, Claim Adjusting, Government Regulations, etc. You learn Motor-Truck Traffic Management, Air Transportation, Railroad-ing, Water Transportation. Tuition cost is low. Send for free booklet. LaSalle, 417 S. Dearborn, Chicago 5.

## LA SALLE EXTENSION UNIVERSITY

An Approved Correspondence Institution

417 S. Dearborn St., Dept. 09-069, Chicago 5, Ill.

Please send me your free booklet "Opportunities in Traffic and Transportation."

Name..... Age.....

Address..... County.....

City & Zone..... State.....

5-MINUTE CAR WASHER is portable, inexpensive to make. Instructions on Plan Sheet B509, 25c. Popular Mechanics Service Bureau, 740 N. Rush St., Chicago 11, Ill.

**\$6.44 AN HOUR** IN YOUR OWN BUSINESS

**STEP INTO THIS BOOMING  
\$19 BILLION A YEAR INDUSTRY**



Hundreds of accidents and losses will happen this year in your community.

We'll show you how to investigate and adjust these losses for insurance companies, railroads, government offices. You buy NO tools or equipment. You do NO selling. You need NO prior

experience or higher education. And you can operate out of your own home. Right

now independent Accident Investigators average \$6.44 an hour. We'll train you quickly to do the same. Start part-time if now employed. Fill the need for an Accident Investigation specialist in your area. Colorful booklet explains everything. Absolutely no obligation on your part. No salesman will call. Write TODAY for FREE Booklet.

UNIVERSAL SCHOOLS, PM-9, 6801 Hillcrest, Dallas 5, Texas

## Science bulletins

Some day a salesman on TV may brag that his company makes the *slowest-acting* pills in town. However, he probably won't drop one in water to substantiate his claim. It might take three years to dissolve!

Experiments underway at the Naval Medical Research Institute are calculated to make such long-lasting capsules a reality. Lts. Judah Folkman and David M. Long, Jr., are enclosing chemicals in a unique silicon rubber capsule that lets minute amounts of the chemical seep out for as long as three years from a half-inch capsule, but will let nothing seep in.

Possible uses for such capsules are in providing chemicals to regulate heart action, insulin for diabetics and, of course, in making the one-a-year vitamin pill.

Give a cloud a hotfoot, and it will give you rain. The U.S. Atomic Energy Commission proposes that heat from nuclear or ordinary fuels be applied to clouds or moist air masses from airplanes or balloons, saying such action "may alter the natural precipitation in a given geographical region."

Not eating at all, if you want to reduce, is better than going on low calorie diets. The reason, says Dr. Garfield Duncan of the University of Pennsylvania, is that when no food at all is eaten the fat person loses his appetite, whereas he becomes intolerably hungry on 900 to 1000 calories a day.

The catch is that this program—of making fasts as long as 10 days to lose more than two pounds a day—is not for all of us. Only those people who have had a thorough physical, and take their fast under a doctor's supervision, can perform the voluntary hunger strike safely.

Readers of PM's December, 1960, article, "The World's Greatest Atom Gun Blasts Off," will be interested to know that the gun—the giant atom smasher at Brookhaven National Laboratory—has blasted four neutrinos from the core of the atom. It had been thought that each atom had only two of the ghostlike particles.

James Biery

POPULAR MECHANICS



# Earn **HIGH WAGES** as a **HEAVY EQUIPMENT OPERATOR**



**FIELD-TRAIN  
AT NATIONAL ON  
DIESEL-ENGINE MACHINES**

Learn Operation,  
Maintenance and  
Safety

## **RUGGED OUTDOOR MEN**

up to 56 years old can qualify!

**NO PREVIOUS  
EXPERIENCE NECESSARY**  
No Special Education Needed



High wages and security NOW and in the years to come are yours as a trained heavy equipment operator. Your chance is TODAY . . . your opportunity is HERE, if YOU will but take advantage of it! The world's fast-growing multi-billion dollar construction industry needs men NOW for work in this country and overseas — you can be one of them!

As a heavy equipment operator you will "move the earth" on aerospace projects, highway building, and industrial construction. Learn HOW at National, the original school of heavy equipment operation, through actual field training on the same kind of diesel-engined bulldozers, rubber-tired scrapers, motor-graders, and cranes now in use by the industry.

National School is NOT a correspondence school . . . if your application is accepted, you will field-train on its huge proving ground in the beautiful Piedmont area of North Carolina. Full training courses, VA approved, payment plans available. AND, National maintains its own Job Advisory and Counselling Department with a full-time Director for the exclusive use of its graduates!

Make up your mind NOW that you are interested in high wages and security and mail the coupon TODAY for FREE illustrated school catalog . . . you are not obligated in any way.

Even if you are presently taking a "course" in heavy equipment operation, write for our free catalog (there is no obligation), and compare the "training" you are receiving with ours.

**MAIL TODAY**  
For **FREE** Illustrated School  
Catalog and complete information

**NATIONAL SCHOOL OF HEAVY EQUIPMENT OPERATION**  
Dept. D-32  
P. O. Drawer 1686, Charlotte, N. C.

Please send one **FREE** illustrated school catalog and complete information about how I can become a Heavy Equipment Operator. I understand there's no obligation.

Name \_\_\_\_\_ Age \_\_\_\_\_

Address \_\_\_\_\_

City \_\_\_\_\_ Zone \_\_\_\_\_ State \_\_\_\_\_

# Television RADIO-ELECTRONICS Electricity ELECTRONICS IN NEW SHOP-LABS OF COYNE

## TRAIN QUICKLY! OLDEST, BEST EQUIPPED SCHOOL of ITS KIND in U.S.

Get practical training in New Shop-Labs of Coyne. Prepare for a better job and a successful future in a top opportunity field. Advanced education or previous experience not needed. Employment service to graduates.

### Enroll NOW—Pay Later

Finance Plan and Easy Payment Plan. Also Part Time Employment help for students.

**FREE BOOK** Clip coupon or write to address below for Free Illustrated Book. "Guide to Careers"—Describes all training offered. No obligation and No Salesman Will Call. Act NOW.

B. W. Cooke, Jr., President

**COYNE**  
ELECTRICAL SCHOOL  
1501 W. Congress Pkwy., Chicago 7, Ill. Dept. 62-5

CHARTERED  
NOT FOR PROFIT  
Established 1899  
1501 W. Congress Pkwy.  
Chicago, Dept. 62-5

COYNE Electrical School  
1501 W. Congress Pkwy., Chicago 7, Ill.  
Dept. 62-5

Send FREE book "Guide to Careers" and details of all training you offer.

NAME.....

ADDRESS.....

CITY.....STATE.....

## TELLS HOW TO SELL YOUR INVENTION

If you have an invention that you believe has merit, write us at once for copy of copyrighted booklet "How to Go About Selling Your Invention." We work with manufacturers, and booklet reveals present markets, qualities of a saleable invention, current royalty rates being paid by manufacturers. Booklet is FREE, is offered to encourage new ideas we might submit to manufacturers. Just send name (no drawings, please) to Kessler Sales Corporation, Dept. D-59, Fremont, Ohio

## IDEAL LAWNMOWER 900 SHARPENER

"Two-Way" Grinding Option means bigger profits for you!

The Ideal sharpens any reel-type mower by either "Hook" or "Straight-Line" methods. No limitations, every job perfect with no hand filing. Ruggedly built, screw adjustments can't slip, 1/2 hp. motor.

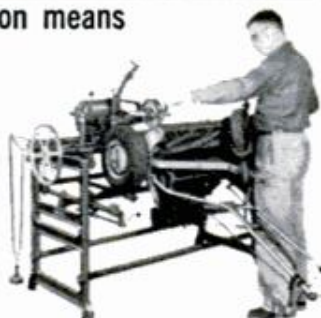

Write for Full Details

The Fate-Root-Heath Co., Dept. PM-9, Plymouth, Ohio

## Sidelights on aviation

In the beginning there were only three, the 707, the 880 and the DC-8.

Today, the casual browser of airline schedules could easily become lost among the morass of numbers surrounding what are really only three big jets.

The 707, for instance, has at least 15 numbered versions, everything from the basic 707, to the 720, the VC-137 and the 707-32B.

The 880, besides the usual model numbers, has a sister ship called the 990.

And the DC-8 is into its fifth series of changes, up to and including model number DC-8F-54.

It's enough to confuse a computer.

If all this weren't enough, the airlines which use the Big Three are prone to ignore the numbers altogether and call identical planes by such Madison-Avenue creations as *Astrojets*, *StarStreams* and *V-Jets*.

When is a 707 not a 707?

Well, when is a Buick not a Buick? When it's a station wagon?

Besides station wagons, the boys in Detroit also make two-doors, four-doors and convertibles, and they make improvements on all of them from time to time.

Is it so unreasonable that the aircraft makers could also turn out several different models of the same basic aircraft and make improvements on them periodically?

In Detroit, it's easy to name the new models—1963 Buick, 1962 Ford, 1961 Dodge, etc. On the West Coast, it's harder. The new models are not part of a program of planned obsolescence, but of specific models for specific customers. Some airlines fly medium-range flights, some the long overseas routes; some want extra cargo space, some extra passenger space.

Basically, these are the only model numbers worth remembering:

Boeing makes the long-range 707 and the intermediate-range 720. A "B" before or after either model number indicates fan-jet engines.

Convair makes the medium-range 880 and the intercontinental 990.

Douglas makes the DC-8.

All other model designations of any of them indicate wing modifications, fuel capacity, range and other technical differences of interest only to those in the trade.

Kevin V. Brown

POPULAR MECHANICS



**MANUFACTURING**



**ADMINISTRATIVE**

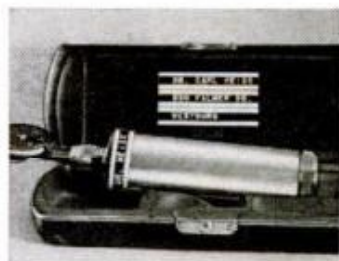

**PROFESSIONAL**

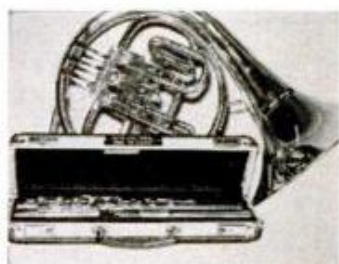

**MUNICIPAL**

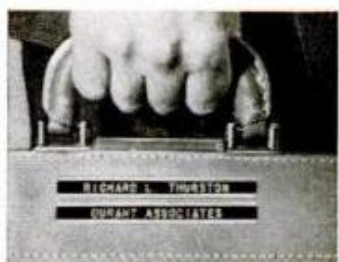

**PERSONAL**

**RAISED LETTER LABELS**

**MADE ON THE SPOT**

If it can be mistaken, mislaid, misfiled, misused, misanything — label it with Dymo. See for yourself how easily you can make handsome, raised-letter labels for 1001 applications.

Embossed labels take seconds to make, cost pennies, stick permanently to almost any surface. Vinyl tape in 10 colors, five striped tapes, six metal

tapes. Five Dymo Tapewriter models, from \$24.95.

Send the coupon for a free booklet "1001 Applications" for manufacturing, administrative, inventory, personalizing, professional, electrical, municipal, schools, electronics, and many more — along with a name badge personalized with your name.

Embossed letters provide maximum permanent legibility, quality appearance.



*Prices slightly higher in Canada*



**WRITE FOR FREE BOOKLET "1001 APPLICATIONS" AND YOUR SAMPLE NAME BADGE**

Dymo Industries, Inc., Department PM -9  
P.O. Box 1030, Berkeley 1, California

Please send me free booklet "1001 Applications" and my name badge as follows.

Name \_\_\_\_\_ (PLEASE PRINT)  
 Title: \_\_\_\_\_ Firm \_\_\_\_\_  
 Product or Service \_\_\_\_\_ Tel. \_\_\_\_\_  
 Address \_\_\_\_\_  
 City \_\_\_\_\_ Zone \_\_\_\_\_ State \_\_\_\_\_

# EARN MORE - LEARN AUTO DIESEL MECHANICS

OR TRAIN WITH OTHER GREER DIPLOMA COURSES

- |   |   |
|---|---|
| <input type="checkbox"/> AUTO MECHANICS       | <input type="checkbox"/> REFRIGERATION        |
| <input type="checkbox"/> DIESEL MECHANICS     | <input type="checkbox"/> AIR CONDITIONING     |
| <input type="checkbox"/> BODY & FENDER REPAIR | <input type="checkbox"/> MACHINIST-TOOL & DIE |
| <input type="checkbox"/> GAS, ARC WELDING     | <input type="checkbox"/> AUTOMATIC            |
| <input type="checkbox"/> HELIARC WELDING      | <input type="checkbox"/> TRANSMISSIONS        |
| <input type="checkbox"/> DRAFTING             | <input type="checkbox"/> MOTOR TUNE-UP        |

Civ. or  G.I.

Skilled men are needed in every part of the country. Earn top pay in established shops or start your own business. Greer's expert instruction and actual shop training teaches you how. You learn by doing—quick, easy courses using the latest tools and equipment. Day, evening and part time instructions available.

Job placement aid and convenient living accommodations are yours while training. Contact GREER'S FREE JOB PLACEMENT SERVICE when you enroll if you wish part time or full time employment assistance.

## TECHNICIAN COURSES

- DIESEL AUTOMOTIVE TECHNICIAN—21 MONTHS
- REFRIGERATION & AIR COND. TECHNICIAN—17 MONTHS
- WELDING TECHNICIAN—14 MONTHS

Please rush me free literature on the trade indicated at no obligation.

NAME \_\_\_\_\_ AGE \_\_\_\_\_

STREET \_\_\_\_\_

TOWN \_\_\_\_\_ ZONE \_\_\_\_\_ STATE \_\_\_\_\_

Established 1902

# GREER SHOP TRAINING

Box 1, 2236 S. Michigan Ave. Chicago 16, Ill.

## EXCLUSIVE DOUBLE-BEARING HEAVY DUTY PUMPS

IRRIGATE • DRAIN • CIRCULATE • SPRAY  
Use 1/4 HP motor or larger . . . 1 HP for up to 5,200  
GPH; 1,000 GPH 60" high; or 3,000 GPH from 25"  
well. 1 1/4" inlet; 1" outlet. Stainless shaft.

TYPE X—2 oil-less bronze bearings. **\$10.95**  
Won't rust . . . . .  
TYPE XB—Ball bearing model. **\$12.95**  
Best for belt drives . . . . .  
Postpaid if cash with order.

Don't delay—send for yours today!

**MONEY BACK GUARANTEE**

Centrifugal and Gear Pumps in All Sizes  
LABAWCO PUMPS, Belle Mead 2, N. J.



C-14



## COLORCRETE CAN BE YOUR OPPORTUNITY

All over the country, men are making money as applicators of Colorcrete—the beauty treatment for old, drab, time-worn masonry surfaces. Stucco, concrete and the like can be transformed in brief time and at relatively low cost into surfaces that gleam in colorful beauty. Colorcrete is good for homes, stores, schools, motels, garages, service stations and other public and commercial buildings. Range of 16 colors.

Every community can support a Colorcretor — and many territories are still available. Investment required is very moderate. Write at once for Opportunity Book.

**COLORCRETE INDUSTRIES, INC.**  
570 Ottawa Avenue, Holland, Mich.



## MY SPARE TIME HOBBY MAKES ME \$5<sup>00</sup> an hour CASH PROFIT

—Grover Squires



### START YOUR OWN SPARE TIME BUSINESS

You can turn your spare time into Big Cash Profits with your own COMPLETE SHARPENING SHOP... Grind saws, knives, scissors, skates, lawn mower blades... all cutting edges. Your Own Cash Business with no inventory right at home... no experience needed. FREE BOOK tells how you can start your own spare time business while you are still working at your regular job. Low Cost—time payments only \$15.00 a month. Send postcard today.

BELSAW SHARP-ALL CO, 713 Field Bldg., Kansas City 11, Mo.



## STOP FRONT DRIVE DRAG AND WEAR ON 4-WHEEL-DRIVES!

# WARN HUBS

Free-wheeling 2-wheel drive with Warn Hubs means big savings in gear, engine, tire wear, gas—plus more pep, performance, power in high, and easier steering. Rugged, dependable, proven, with over 400,000 in use. Iron-clad guarantee. Choose Lock-O-Matics that change drive as you shift, or manual Locking Hubs. Models for all 4-w. ds. at dealers, or write for literature.

**WARN MFG. CO.** Riverton Box 6064-A  
Seattle 88, Wash.

## JEEP OWNERS

RE-POWER NOW WITH A V-8 OR 6 CYL. ENGINE — USE FORD—CHEV.—MERCURY—GMC—PONT—STUDE—DODGE OR PLYMOUTH In Jeeps, Jeepsters, Sta-Wgn, trucks, Kaiser & H. J. cars. Conversion Kits \$45.35 to \$56.90. Want fast action? Give us full information, send \$15.00 Dep. and we will ship correct kit. Bal. COD. Send full amount for prepaid shipment. Wire, phone or write today. Details FREE.

**HOOSIER MACHINE PRODUCTS CO.**  
312 S. E. 6th St. Phone CR 6-3442 Pendleton, Oregon

## TURN 58c INTO \$6.00 CASH PROFIT AT HOME IN SPARE TIME—METALIZING

Now you can invest 58c in material and get back \$6.95 and make \$6.00 for your time in this fascinating home business. Hundreds make good extra money in sideline work. So Easy—so much Fun! "Eternalize" baby shoes, other keepsakes. Big market everywhere. No face-to-face selling. Write for facts FREE, plus financing plan. No obligation. No salesman will call. **WARNER ELECTRIC, 1512 Jarvis, Dept. M2K Chicago 26, Ill.**

## MEN PAST 40

### Afflicted With Bladder Trouble, Pains in Back, Hips, Legs, Nervousness, Tiredness.

If you have these troubles, particularly bladder trouble, then your condition may be traced to Glandular Inflammation . . . a constitutional disease. Neglect of this condition often leads to premature old age and sometimes incurable conditions.

The Excelsior Medical Clinic has a New Free Book that tells how thousands of men have been successfully treated here at Excelsior Springs for Glandular Inflammation by **NON-SURGICAL METHODS**. They found soothing relief and a new outlook in the future of life.

This Free Book may prove of utmost importance in your life. Write Today. There is no obligation. **Excelsior Medical Clinic, Dept. B6129, Excelsior Spgs., Mo.**

POPULAR MECHANICS



# FIX CARS FASTER!

with **MOTOR'S** great

## 2-IN-1 AUTO REPAIR MANUAL

① Famous MANUAL pages show how you can

## FIX ANY PART OF ANY CAR

Quick, Easy, Right the first time  
Any Car, 1955-1962, including all Compacts

### ② TROUBLE-SHOOTER

section spots 2300 car troubles for you immediately  
... leads you to exact repair needed

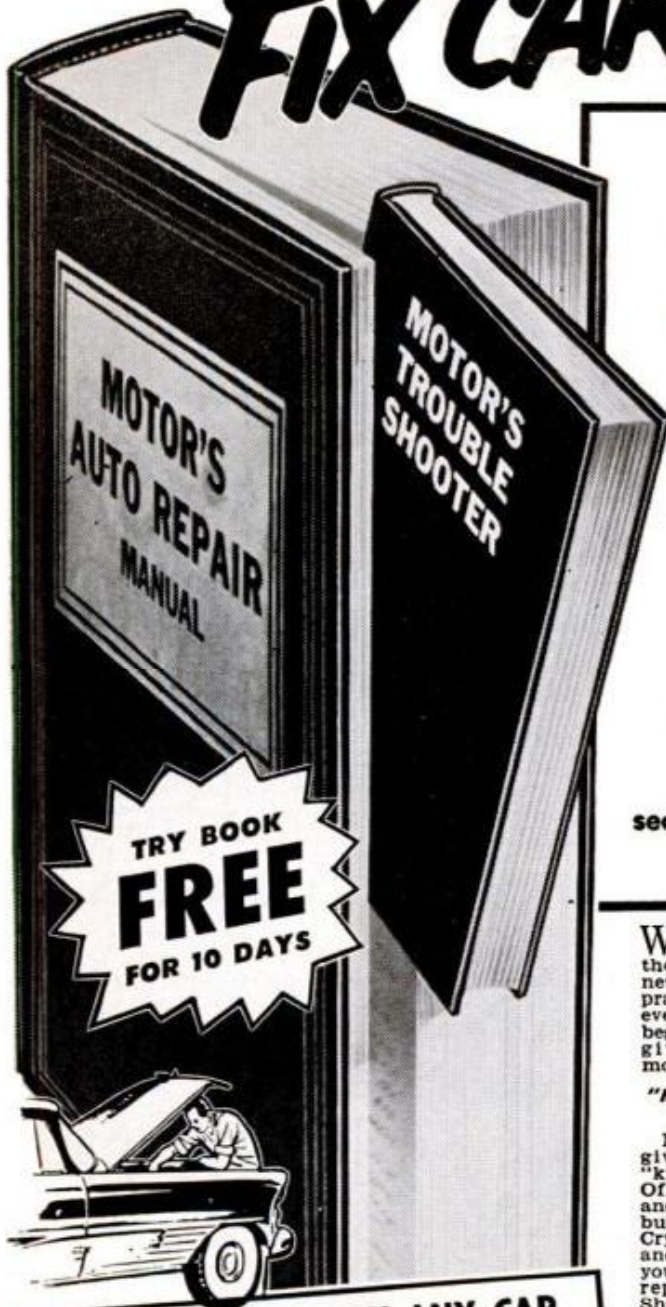

TRY BOOK  
**FREE**  
FOR 10 DAYS

WANT TO FIX ANY PART OF ANY CAR — fast, easy, right — the first time you try? MOTOR's new 2-in-1 Auto Repair Manual practically does it for you. Makes every job easy as A-B-C. Turns beginner mechanics into experts. Gives experts real time- and money-saving tips.

No wonder over FOUR MILLION copies of MOTOR's Manual have already been sold! No wonder it is used by U.S. Army and Navy, thousands of garages and repair shops.

#### "Meat" of 176 Official Shop Manuals

MOTOR's Manual gives you a wealth of "know-how" from 176 Official Shop Manuals and hundreds of factory bulletins. No guesswork! Crystal-clear directions and big pictures guide your hands thru every repair job. "Trouble-Shooter" section spots any of 2,300 car troubles fast — leads you to exact repair needed. Then famous Manual pages show you where to start, what tools to use, how to use them. Every job is made so easy you CAN'T go wrong!

USE  
**MOTOR'S**  
AUTO REPAIR  
MANUAL  
**FREE**  
FOR 10 DAYS

MAIL COUPON BELOW  
NOW — WITHOUT MONEY!

#### Here's What You Get

NEW, REVISED, ENLARGED edition covers more than 2,219 popular-make models since 1955, including all the new compacts. Over 1,100 pages. 2,850 pictures. 195 easy-to-read charts. 30,000 repair specs. 225,000 service and repair facts. PLUS adjustment tables, tune-up charts, tables of measurements and clearances, overhaul and replacement facts, tune-up data for 40 foreign car makes, much more.

#### Try Book FREE 10 Days

Just mail coupon. We'll rush Manual to your home or shop. USE it for 10 days. If it doesn't pay for itself in this time, return it and pay nothing. Mail coupon TODAY to: MOTOR, Book Dept., Desk 219, 250 West 55th St., New York 19, N. Y. (SCHOOLS, BOOKSTORES: write for discounts.)

### FIX ANY PART

Ignition  
Alternator  
Generator  
Generator  
Regulators  
Starting Motors  
Carburetors  
Fuel Pumps  
Engines

Automatic Transmissions  
Overdrive  
Suspensions  
Differentials  
Brakes  
Steering  
Dash Gauges  
Starter Switches

### FIX ANY CAR

Buick  
Buick  
Special  
Cadillac  
Chevrolet  
Chevy II  
Chrysler  
Comet  
Continental  
Corvair  
Corvette  
Dart  
DeSoto

Dodge  
Edsel  
Falcon  
Ford  
Fairlane  
Imperial  
Jeep  
Lancer  
Lark  
Lincoln  
Mercury  
Mercury  
Meteor

Nash  
Oldsmobile  
Olds F-85  
Plymouth  
Pontiac  
Pontiac  
Tempest  
Rambler  
Rambler  
American  
Studebaker  
Thunderbird  
Valiant

**AMAZED HIMSELF AND HIS FRIENDS**  
"I amazed myself and my friends, too. Now do auto repair jobs that stumped me before."  
—Michael Baliczky, Newark, N. J.

**HAS PAID FOR ITSELF TIME & AGAIN**  
"Doesn't take schooling to read it. It's easy to see pictures of every part. Has paid for itself time and again."  
—Paul Pemper, Wisconsin

#### Same 10-Day FREE OFFER on New TRUCK REPAIR MANUAL

Covers 98% of all trucks, 1952 thru 1962, including new "Mid-gets." Over 2,000 illustrations; 300,000 facts. Easy to use. Covers all gasoline engines, plus OM, Cummins, Mack & Int'l Diesels, 822 pages. For 10-day FREE Trial, check box in coupon.

#### MAIL COUPON NOW FOR 10-DAY FREE TRIAL (Attach to Postcard for Fast Action)

MOTOR BOOK DEPT., Desk 219, 250 W. 55th St., New York 19, N. Y.

Rush to me at once the book(s) I have checked below:

**MOTOR'S NEW AUTO REPAIR MANUAL.** If O.K., I will remit \$2 in 10 days, \$2 monthly for 2 months and a final payment of \$2.95 (plus 45¢ delivery charges and sales tax) one month after that. Otherwise I will return the book postpaid in 10 days.

**MOTOR'S NEW TRUCK REPAIR MANUAL.** If O.K., I will remit \$3 in 10 days, \$3 a month later, then \$2 monthly for 2 months, plus 45¢ delivery charges and sales tax with final payment. Otherwise I will return book postpaid in 10 days.

Name.....Age..... (PLEASE PRINT)

Address.....

City.....Zone.....State.....

Check box and save 45¢ shipping charge by enclosing WITH coupon entire payment of \$8.95 for Auto Manual (or \$10 for Truck Manual) plus sales tax. Same 10-day return-refund privilege.

# AUDELS GUIDES

No. 1	AUTOMOBILE MECHANICS GUIDE. 1132 Pages	\$ 6.00
No. 2	HOME APPLIANCE SERVICE GUIDE. 864 Pages	6.00
No. 3	TV & RADIO SERVICE LIBRARY. 2 Book Set	8.00
No. 4	HANDY BOOK OF ELECTRICITY. 1052 Pages	5.00
No. 6	PLUMBERS & STEAMFITTERS GUIDES. 4 Book Set	9.00
No. 7	PAINTING & DECORATING MANUAL. 585 Pages	4.00
No. 8	CARPENTERS & BUILDERS GUIDES. 4 Book Set	9.00
No. 10	WELDERS GUIDE. 608 Pages	4.00
No. 11	MATHEMATICS MADE EASY. 672 Pages	4.00
No. 12	MACHINISTS & TOOLMAKERS HANDBOOK. 1250 Pages	6.00
No. 14	REFRIGERATION & AIR CONDITIONING. 1360 Pages	6.00
No. 15	ELECTRIC LIBRARY. 10 Volume Set	22.50
No. 26	MASONS & BUILDERS GUIDES. 4 Book Set	9.00
No. 27	ELECTRIC MOTOR GUIDE. 1056 Pages	5.00
No. 29	SHEET METAL PATTERN LAYOUTS. 1152 Pages	7.50
No. 43	DO-IT-YOURSELF ENCYCLOPEDIA. 2 Book Set	8.95
No. 44	NEW MECHANICAL DICTIONARY. 712 Pages	6.95
No. 46	WATER SUPPLY AND SEWAGE. 436 Pages	4.00
No. 47	PRACTICAL CREATIVE PHOTOGRAPHY. 416 Pages	3.95
No. 48	GAS ENGINE MANUAL. 480 Pages	4.00
No. 49	OUTBOARD MOTORS & BOATING GUIDE. 400 Pages	4.00

### 7-DAY FREE EXAMINATION

SEND NO MONEY—Pay the postman nothing! We'll send you any of the Audel Guides for FREE examination. If you decide to keep the books you pay for them under our easy-pay plan of only \$2 a month.

### HERE IS ALL YOU DO

IT'S EASY TO ORDER: In the No-Risk Mail Order Coupon below draw a circle around the number of Guides you want. We will send them to you at once. If you are not completely satisfied, return the books to us.

## MAIL THIS COUPON TODAY!

THEO. AUDEL & CO. — Self Improvement Publishers Since 1879  
49 W. 23rd Street, New York 10, N.Y. P9

Please mail me for 7 days' FREE EXAMINATION the books I have circled below. I agree to mail \$2 in 7 days on each book or set ordered, and to further mail \$2 a month on each book or set ordered until I have paid the purchase price, plus shipping costs. If I am not completely satisfied with my Audel Guides I may return them.

NAME \_\_\_\_\_

ADDRESS \_\_\_\_\_

EMPLOYED BY \_\_\_\_\_

1 2 3 4 5 6 7 8 9 10 11 12 13 14  Check Here for Free Complete Catalog  
15 23 24 27 29 43 44 46 47 48 49

SAVE SHIPPING COSTS! Check here if you enclose complete payment with order. We pay postage charges. You have same return privilege.

## SAMURAI SUICIDE WARRIORS KARATE!

## JUDO BOXING! MUSCLEBUILDING! YOGA! STRONGMAN STUNTS! STRENGTH & ENDURANCE! HANDBALANCING! ETC.

YOU GET ALL THESE COURSES! \*20 illustrated KARATE blows \*SAVATE foot fighting \*Secret NERVE CENTER and ANATOMY charts \*20 lethal JUDO throws \*20 terrific STRONG-MAN STUNTS \*Complete MUSCLE-BUILDING course \*Ancient YOGA secrets \*HANDBALANCING stunts \*Complete BOXING course. Secrets of ENDURANCE \*WRESTLING holds \*WEIGHTLIFTING \*Giant wall charts. All picture packed. No C.O.D. Canadian 50c.

FOR ONLY **35¢**

Huge KARATE PRACTICE DUMMY K-MAN life like! Shows attack points, nerve centers, weak spots. 15c with 35c order only. Total 50c. **15¢** you get the lot! Plus FREE 16 Page Book

OXFORD STUDIO, 44A7 Bromfield St., Boston 8, Mass.

NAME (print) \_\_\_\_\_  35c Program  
Address \_\_\_\_\_  
City \_\_\_\_\_ State \_\_\_\_\_  50c with K-man

## "\$7,108<sup>50</sup> NEW!"

### FIRST YEAR Cleaning-Repairing RADIATORS."



—Hank Konter, Newcastle, Wyo.

Make \$6,000-\$9,000 a year servicing auto-truck-tractor radiators with Inland's new 1-Piece Radiator Shop. Easy to do entire job — TEST, CLEAN and REPAIR radiators. Only 11' 7" long. Inland, world's largest radiator equipment manufacturer, trains you free. Small down payment starts you. Easy-pay plan lets you pay from profits. Proved merchandising assures volume. Profitable department for garage or service station. Many set up Radiator Shop in garage at home, make good money working evenings. Write.

INLAND MFG. CO., Dept. PM-9, 1108 Jackson St., Omaha 2, Nebr.

## At Last a New Amazingly Simple GAS TURBINE JET ENGINE

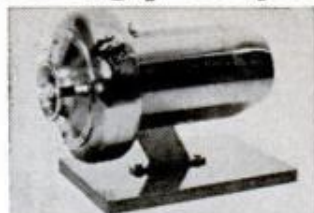

Build from easy to follow plans. Length 15", Dia. 8 1/2". Wt. 15 Lbs. Fuel—Gasoline or Kero.

'Screamin Demon' develops 20 H.P. Ideal project for serious-minded hobbyists, students; scientific and industrial arts classes. Make on 9" metal cutting lathe with milling attachment. For use on small racing boats, midget cars, etc. Full size assembly drawings with critical dimensions, bill of materials and photos.

Price \$5.00. No C.O.D. Dealer Inquiries Invited. SAVOY SCIENTIFIC, Box 1398, SANTA MONICA, CALIF.

## get into operating or repairing EARTH MOVING EQUIPMENT

Men needed now for good paying jobs in booming road and construction work. Learn operating or repair-rebuilding of heavy road machinery, cranes, bulldozers, earth carriers, etc. Actual "on the job" training. 5 to 13 1/2 week courses. Classes start every Monday. Reserve your space now. Complete catalog and reservation facts FREE. Approved for veterans. Write

**Greer TECHNICAL INSTITUTE**  
Attn.: P. K. Hutch, Box 368, Braidwood, Ill.

## Learn PACKAGING!

Make to 2500% PROFITS at Home. WITHOUT SELLING!

Package products at home for nation-wide sales force. You package bulk items in your own home. We do your selling coast-to-coast. FREE "No Selling Plan" reveals thousands full, spare time big profit opportunities for beginners in self-service packaging, contract packaging, gift wrapping. We guide you step by step. Everything furnished. Write today for FREE "10-STEP PACKAGING PROFIT PLAN", and full details. No salesman will call.

HOME PACKAGING CO., Dept. A-251, 807 Sunset Blvd., Los Angeles 12, Calif.



## CAR DECALS

4 1/2 x 6 1/2 inches

"You've got a Hole in the Head"

\$1.00 Each Postpaid

ART SOUTHWEST P. O. BOX 4822  
Dallas 6, Texas

## REAL ESTATE BE A BROKER

PAYS BIG! SEND FOR FREE, BIG, ILLUSTRATED CATALOG NOW! Graduates report making substantial incomes. Start and run your own business quickly. Men, women of all ages, learn easily. Course covers Sales, Property Management, Appraising, Loans, Mortgages, and related subjects. STUDY AT HOME or in classrooms in leading cities. Diploma awarded. Write TODAY for free booklet! No obligation.

FREE BOOK TELLS HOW

Approved for World War II and Korean Veterans  
WEAVER SCHOOL OF REAL ESTATE (Est. 1936)  
3521P Broadway Kansas City, Mo.

COMPLETE ADDRESSES of manufacturers, inventors, and sources of information for items mentioned in the editorial pages of this issue are listed in the free WHERE-TO-FIND-IT list. Send self-addressed, stamped envelope to

SERVICE BUREAU  
200 E. Ontario, Chicago 11, Illinois

**PROCESSING OF KODACHROME** (Licensed by Eastman Kodak)

also: EKTACHROME ANSCOCHROME KODACOLOR

KODACHROME I & II  
8mm Roll or 35mm 20 Exp. Mtd. **\$1.00**

8mm MAGAZINE ..... .75  
35mm 36 EXP. MTD. .... 1.75

SEND FOR FREE MAILERS and our big FREE 25th Anniversary CATALOG of Film and Processing, Splicers, Titlers, Screens, Viewers, Cameras, Projectors at low discount prices.

**SOLAR** CINE PRODUCTS, Inc.  
4247 S. Kedzie • Chicago 32, Ill. • DEPT. PM

*SOLAR 25th Anniversary*

**HELP WANTED—SPARE TIME**

SENSATIONAL NEW LONGER-BURNING LIGHT BULB. Amazing Free Replacement Guarantee—never again buy light bulbs. No competition. Multi-million dollar market yours alone. Make small fortune even spare time. Incredibly quick sales. Free sales kit. MERLITE (Bulb Div.), 114 E. 32nd, Dept. C-15Y New York 16, N.Y.

*In Canada: Mopa Co., Ltd., 371 Dowd St., Montreal 1, P.Q.*

**LAW FREE BOOK** **THE LAW TRAINED MAN**

Write today for a FREE copy of Illustrated law book, "THE LAW-TRAINED MAN," which shows how to earn the professional Bachelor of Laws (L.L.B.) degree through home study of the famous Blackstone Law Course. All necessary books and lessons provided. Moderate cost; convenient monthly terms. Write for FREE law training book today.

**Blackstone School of Law, 307 N. Michigan Ave.**  
Founded 1890 Dept. 56, Chicago 1, Illinois

**make your own Gems** **36.50** F.O.B.

The Gem Maker comes complete with all necessary equipment, including a super-charged diamond blade for sawing, and all the wheels for grinding, shaping and polishing; also complete instructions. The complete equipment as shown, less motor and belt for only \$36.50, f.o.b. Burlington, Wisconsin. Write today for information and literature.

**B&I MANUFACTURING CO.**  
Dept. P, Burlington, Wis.

**FROM Spain**

**FOR MEN WHO KNOW STYLE**

The new—the different—imported footwear, in a handsome variety for street, dress, casual wear. Sizes 5 to 13; A to EEE. From \$12.95 to \$19.95.

MADE ON AMERICAN LASTS

**Eleganza imports** 1062 Freight St. Brockton, Mass.

**Write for FREE catalog TODAY!**

#2031 — AUTHENTIC FLAMENCO DANCING BOOT

# Learn Electronics Radio-Television

## by Practicing at Home in Your Spare Time

**WITHOUT EXTRA CHARGE** you get kits to make training easier, faster.

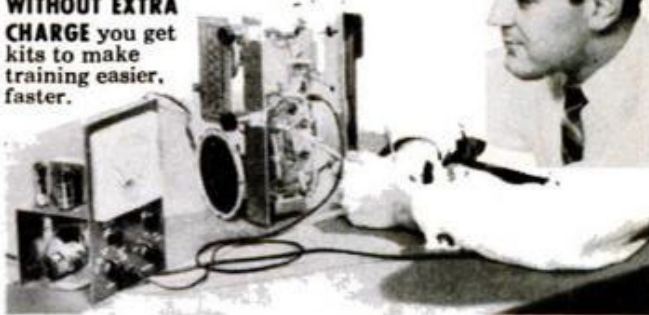

## Fast Growth Offers Prestige High Pay—Bright Future

Above average jobs with bright futures await men with Electronics training . . . jobs for which YOU could qualify through NRI. Train right at home in spare time, while you hold your present job. Earn high pay in jobs with TV and Radio Stations, industrial plants, or in a profitable business of your own.

### Train with the Leader

#### NRI TRAINED THESE MEN



**Own Business:** I could hardly make ends meet. Now I have my own service business. **J. HILLENBRAND,** Bklyn., N. Y.

**Broadcasting:** "I am now chief engineer of Station WARA. NRI was the foundation." **R. ARNOLD,** Attleboro, Mass.



**Industrial:** "Four months after starting your course I went to work at Raytheon. Now I am an engineering assistant in Microwave Power Tube Research." **L. J. BLOOM,** Newton Centre, Mass.

For 45 years NRI has featured the best Radio-TV Electronics training for beginners—for men without high school diplomas or previous experience. NRI is the oldest and largest home-study Radio-TV Electronics school. NRI "learn-by-doing" training is supplied at low cost. It's the easy way to get into the field of Electronics.

### Start Soon to Earn More

Soon after enrolling, NRI shows you how to earn extra money in your spare time repairing sets. Many start a profitable business this way. Others get good paying jobs within a year. Take the first step to a new career NOW. Mail coupon for descriptive catalog. National Radio Institute, Washington 16, D.C.

**64 PAGE CATALOG FREE**



### MAIL THIS COUPON NOW

**NATIONAL RADIO INSTITUTE, Washington 16, D.C. 2JA**  
Send me full information without cost or obligation. No salesman will call. (Please print)

Name.....Age.....

Address.....

City.....Zone.....State.....

Accredited Member National Home Study Council

Some make more, some less;

F.E.DORAN  
reports:

**\$1050**  
gross in single  
**MONTH**  
in my own business



**Start your own business!**

• Here's YOUR chance to start a money-making, year 'round business of your own and make the success you've dreamed about.

G. R. Adcock took in \$102 in one day. O. W. Hare landed a \$750 hotel job. J. S. Corbit grossed \$279.50 his first month. Homes, hotels, offices, clubs, offer you big profit possibilities. Auto upholstery also.

**NO SHOP NECESSARY** • You clean upholstered furniture with efficient **PORTABLE ELECTRIC DETERGER** on customers' premises. No hauling, no high rents; you operate from your home. Supplies cost little; what you take in is mostly profit.

If you want to be your own boss—free from layoffs, we will help you to start and work with you for your success.

**OURS IS NOT A LEASE ARRANGEMENT** • You are free to operate in an independent manner. You sign no contract. You own the detergent outright and are always your own boss... and every dollar you take in is yours to keep... you pay no fees, or dues, or royalties to anyone. And you take no risk. Your detergent is fully guaranteed and enough supplies come with it to return far more than your investment. Many earn the cost of the detergent in a week or two. It costs nothing to get the details... write **TODAY**.

**MAIL COUPON TODAY FOR FREE BOOK**

**VON SCHRADER MFG. CO.**  
910 "D" Pl., Racine, Wisconsin

Without obligation rush your **FREE** booklet about how I can start my own permanent and profitable electric Upholstery Cleaning business.

Name \_\_\_\_\_

Address \_\_\_\_\_

City \_\_\_\_\_ Zone \_\_\_\_\_ State \_\_\_\_\_

## Britannica ACADEMY FOR ADULTS

a division of Encyclopaedia Britannica Films Inc.

**A NEW CONCEPT IN EDUCATION  
AT HOME... FASTER... EASIER**

EARN YOUR HIGH SCHOOL DIPLOMA the modern way. Only Britannica Academy offers the "automated learning" math you've read about in national magazines, plus new, up-to-date material in every subject. A member of the Encyclopaedia Britannica family, the Academy assures you a fine education and meaningful diploma. Take individual subjects or complete courses up to full 4 years credit. Progress at your own pace. Many complete years' work in months. Moderate tuition, terms. Write for catalog. No salesman will bother you with calls.

**BRITANNICA ACADEMY FOR ADULTS • Dept. PM 92**  
14 EAST JACKSON BLVD. • CHICAGO 4, ILLINOIS



## TV Aids Navigators

Latest electronic aid to small boatmen, the Coast Guard's **RATAN** (Radio and Television Aid to Navigation) incorporates television into the navigation system for the first time.

Undergoing tests at Sandy Hook, N. J., the new system transmits a UHF television picture of a high-definition shore radar station's screen. The skipper of the receiving boat locates himself on the screen and gets a continuous position fix, plus a track on all other vessels in his vicinity. Cost will only be around \$200 for the boat's set.



# A Few Months Spare-time Study Earns You UP TO \$6.50 AN HOUR IN THIS EXCITING CAREER!

No selling required. Only an average education needed. Let me show you how easy it is to get into one of today's most profitable new professions. Increasing auto accidents create scores of new openings for accident claim investigators every week! Pick your location. Car expenses paid. Work as an independent investigator or for an insurance company. We train you at home in spare time. Pay for course right out of earnings. Write for FREE Booklet; complete details. No obligation. Chance of lifetime! Address Dept. 99, Liberty School of Claim Investigating, Libertyville, Illinois. (State approved as a Business Correspondence School.)



## 6-IN-1 ONLY MACHINE OF ITS KIND! UNIMAT

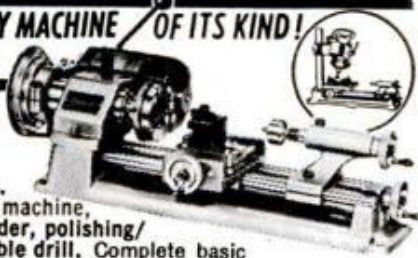

Compact workshop for all metal, plastic, wood. Precision lathe, milling machine, drill press, surface grinder, polishing/grinding machine, portable drill. Complete basic unit, \$139.50 WRITE FOR FREE CATALOG. AMERICAN EDELSTAAL, INC., DEPT. GJ, 350 BROADWAY, N. Y. 13, N. Y.

## DON'T QUIT SMOKING

... Before Giving My Pipe a Trial!

New principle that contradicts every idea you've ever had about pipe smoking. I guarantee it to smoke cool and mild hour after hour, day after day, without rest without bite, bitterness or sludge. To prove it, I'll let you try a new Carey Pipe. Send name today for my FREE complete trial offer. Write to: E. A. CAREY, 1920 Sunnyside Ave., Dept. 252-K, Chicago 40, Ill.

**\$47,983.06 ORDERS FROM 12 WORD CLASSIFIED AD.** Amazing—Startling—but TRUE. Terrific story sent free. Request must be made on business letterhead. F. W. Johnson, Classified Adv. Manager, 740 Rush St., Chicago 11, Ill.



## WANT MORE MONEY? GET INTO PHOTOGRAPHY

Coast-to-coast, high-paying jobs in photography are waiting for people with the "know-how" to fill them. You can quickly, easily qualify at home with the world-famous NYI Learn-by-Doing Method. Write today for free catalog. Also resident training in N. Y. Our 52nd Year. Approved for Veterans.

NEW YORK INSTITUTE OF PHOTOGRAPHY  
Dept. 49 10 West 33 St. New York 1, N. Y.



## First Miniaturized TWO-WAY RADIO!

**\$24.88**  
each postpaid with batteries  
Two for \$44.88

SPACEPHONE—FITS IN POCKET! Latest two-way American made Walkie-Talkie sending and receiving set. Completely wireless. Each unit contains microphone — loud-speaker, 9-volt transistor radio battery, 48" collapsible antenna. Latest transistorized transmitting and receiving circuits. Range 1/2 mile. Citizen's band—NO LICENSE, NO EXAM, ANY AGE. For hunting, boating, fishing, hiking, farms, ranches.

IN DO-IT-YOURSELF KIT FORM \$17.88 ea. Two for \$29.88. All parts, components, photograph identification sheet, manual, circuit board, case, antenna all complete.

Produced by leading space satellite company. Spacephone does same job as equipment costing from \$89 to \$195 per pair. TO ORDER: Enclose check, cash or M.O. for postpaid shipment. \$5 deposit per unit for C.O.D. 10-day money-back guar. Dealers inquire. Calif. res. add 4% state tax.

Mission House 730 San Fernando Road San Fernando, 106 California

## 94.6% OF BAILEY GRADUATES ARE EMPLOYED AT TOP PAY IN THE FIELDS WHICH THEY WERE TRAINED!



## DIESEL-AUTO MECHANICS DESPERATELY NEEDED!

We have a far greater demand for our students than we can fill!

We can show you an actual waiting list of leading companies throughout the world who have tried Bailey graduates — found them outstanding, and are coming back for more!

Bailey Graduates are Successful . . . RECEIVE BIG PAY — HAVE SECURE FUTURE!

The Famous Bailey Course prepares you for BOTH Diesel and Gasoline Mechanics.

This is a must—due to the advent of using Diesel principles, such as 'Fuel Injection' on passenger cars . . . use of gasoline engines for starting Diesel engines, etc. You learn all this at Bailey in the amount of time ordinarily required to learn just one of these subjects, ALL FOR THE PRICE OF ONE.

Don't be satisfied with a 'futureless', one-type job — learn how you can make big money now! Write today for Free Booklet that takes you on a step-by-step camera tour through our spacious, modern shops — See Bailey students in action as they Learn-by-doing with the Famous Bailey Method of training!

We provide you with housing and part time jobs while in school, plus nationwide placement service for graduates.

## BAILEY Technical SCHOOLS

1634 S. GRAND ST. LOUIS 4, MO.

### MAIL TODAY!

Please mail immediately this free booklet without obligation.

FREE BOOKLET



Name.....

Address.....

City..... State.....

APPROVED FOR VETERAN . . . NON-VETERAN



# FREE **EICO**<sup>®</sup> CATALOG

**Build Your Own Hi-Fi, Radios, Ham Gear, Test Instr.,—Save 50%**

Get started in **ELECTRONICS** the easy **EICO** way. No technical knowledge needed to build **EICO** kits. Simple, step-by-step "Beginner-Tested" pictorial instructions guide you all the way. 106 beautiful kits to choose from. Mail coupon now!

**EICO Electronic Instrument Co., Inc.**

3300 Northern Blvd., L. I. C. 1, N. Y. PM-9

Please send free catalog and name of local dealer.

Name.....

Address.....

City..... Zone..... State.....

## FINISH HIGH SCHOOL AT HOME

# MAKE MORE MONEY

High school graduates get better jobs, more money—average almost \$30 a week more than non-graduates. More job security, too. Don't let lack of diploma hold you back any longer. Complete high school now—at home, in spare time. Simplified step-by-step lessons, plus personal attention and help.

Full credit for courses already completed. It's quick, easy. Men and women of all ages have done it . . . so can you! If 17 or over and not in school, send coupon for

Free Book, "Graduate to Success," and full information. No obligation. Do it now!

Accredited Member—National Home Study Council

**WAYNE SCHOOL of LA SALLE EXTENSION UNIVERSITY**

A Correspondence Institution—Established 1908

417 S. Dearborn St., Dept. 09-523, Chicago 5, Illinois

Please send Free Book, "Graduate to Success," and information on high school training.

NAME..... AGE.....

ADDRESS.....

CITY..... STATE.....

ZONE & COUNTY.....

## PROFIT IN YOUR SPARE TIME



**FIX Small Gasoline Engines**

**OUTBOARD • POWER MOWER • CHAIN SAW • TRACTOR**

Harry F. Peters, Spokane, Wash., says:  
". . . your Course led me into a very profitable and enjoyable business."



Be a small engine expert . . . earn **EXTRA MONEY** . . . own your own business. Easy-to-learn **LINCOLN** Home Study method qualifies you. Write for full particulars.

**LINCOLN TECHNICAL INSTITUTE**

Suite 9-E, 472 Market St., Newark 5, New Jersey

# WE'VE MOVED!

*Our NEW Address is*

## 575 Lexington Ave., New York 22, N. Y.

**We're excited about our move!**

For generations, PM's readers have been vitally interested in the latest developments of science, in new industrial processes, in fascinating new home products, in new shop techniques, in dozens of new ways to use leisure time profitably and enjoyably!

And these are the very interests that are expanding most rapidly today.

In order to serve you better, in order to expand our coverage of these fields, we're moving to brand-new quarters. We'll have new automotive and electronic test equipment, a bigger shop, finer facilities for testing new products.

We're making the move to develop an even bigger and better magazine during the exciting years ahead!

## Get Yourself FIXED FOR LIFE in the Big Pay Shoe Business!

It's no trick at all to make big money— FULL OR SPARE TIME—with the only shoe line featuring baby shoes in addition to shoes for all the family with new Family Discount plan. Lifetime security. Amazing new "Spring-Step" cushion invention proves it by actual demonstration. Only ORTHO-VENT has it! There is no other shoe in the world like it. Repeat orders are sure, steady. One try and a customer is sold for life. Profits are BIG. Orders are sure and easy with the most amazing 1-minute demonstration in the history of the shoe business. No experience needed. No investment to make. Everything, including actual cut-a-ways, furnished free! Be the big-pay ORTHO-VENT man in your territory. Write TODAY!

**ORTHO-VENT SHOE COMPANY**  
1129 BRAND RD. SALEM, VIRGINIA



WE GIVE  
PRODUCERS  
THEIR OWN  
SHOES AS  
A BONUS!

## SHORTHAND IN

Famous SPEEDWRITING shorthand. 120 words per minute. No strange symbols; no machines; uses ABC's. Learn at home or through classroom instruction. Low cost. 500,000 graduates. For business and Civil Service. TYPING AVAILABLE. 39th Year. Schools in 443 cities. Write for FREE booklet.

**Speedwriting**  
Dept. 1509-2,  
55 W. 42 St., N. Y. 3, N. Y. (R)

# 6 WEEKS



Transistor Radio with Battery \$1.96  
17-Jewel Watch \$2.87  
Derringer Pistol \$5.74

## HOME-IMPORT BUSINESS—Make Big Profits

New Drop Ship Plan offers you first day profits! Deal direct with overseas sources at prices shown. Dazzling bargains with no investment. Full or spare time. Write for FREE BOOK today to...

MELLINGER, 1554 S. Sepulveda, Dept. D259 Los Angeles 25



100  
POUND  
SET  
\$12.80

Extra Plates Only 12c Pound

## BARBELLS

140-Pound, CHROME DELUXE Barbell-Dumbbell set only \$19.80. This is our feature set and is the finest ever manufactured.

Training with adjustable weight is the BEST way to keep fit; the ONLY way to develop great strength and a perfect body. As the oldest and best equipped barbell company, BUR gives value and prices no one can equal.

SEND FOR FREE CATALOG  
**BUR BARBELL CO.**  
Lyndhurst 9, New Jersey

## MONEY IN WORMS

Success for you! 5000 of our hybrid red wiggler fishworms produce 5,000,000 in one year using our successful method of worm raising. Read our success story in LIFE MAGAZINE, Dec. 28, 1959 issue. Let us teach you our secrets of success. Write today for FREE INFORMATION on how to raise and sell fishworms and crickets.

Special Today—Hybrid Red Wigglers—3000—\$5.95. 5000—\$8.95. 10,000—\$16.95. Postpaid.  
**CARTER WORM RANCH, PLAINS, GEORGIA**

## 75 POWER TELESCOPE \$3.98

NEW 3 in one telescopes. 3 variable 25X 45X-75X magnification. Brass bound. 25 power for ultra bright images 45 & 75 power for long range. Guaranteed to bring distant stars, moons, objects, sports 75 times closer. Most powerful scope sold anywhere near this amazing low price. American made, 5 sections. Opens 36" closes 1 ft.; contains 4 ground & polished lenses. Can also be used as powerful compound microscope. Mass production enables us to offer telescope complete at \$3.98 postpaid. Money back guarantee.  
**CRITERION CO., Dept. PMB-4, 331 Church St., Hartford, Conn.**

# FREE CAREER BOOKLET



To guide you to a  
successful future in

## METALLURGY MECHANICAL ENGINEERING AIR CONDITIONING INDUSTRIAL TECHNOLOGY

This interesting pictorial booklet tells you how you can prepare for a dynamic career as a Mechanical Engineer or Engineering Technician in such rewarding fields as:

**DEVELOPMENT • RESEARCH • SELLING  
PRODUCT DESIGN • PURCHASING  
QUALITY CONTROL • TIME STUDY**

Get all the facts about job opportunities, length of study, courses offered, degrees you can earn, scholarships, part-time work — as well as pictures of the Milwaukee School of Engineering's educational and recreational facilities. No obligation — it's yours free.

## MILWAUKEE SCHOOL OF ENGINEERING

### MAIL COUPON TODAY!

**Milwaukee School of Engineering**  
Dept. PM-962, 1025 N. Milwaukee St., Milwaukee, Wis.  
Please send FREE "Your Career" booklet  
I'm interested in  Metallurgy  Air Conditioning  
 Industrial Engineering  Mechanical Engineering  
 Electrical Engineering.

Name \_\_\_\_\_ Age \_\_\_\_\_  
PLEASE PRINT

Address \_\_\_\_\_

City \_\_\_\_\_ Zone \_\_\_\_\_ State \_\_\_\_\_

I'm eligible for veterans education benefits.  
Discharge date \_\_\_\_\_

MS-118

this

ANNUAL  
REPORT

tells so many... so much...

Magazine publishing companies are like other manufacturing businesses. They design and manufacture products they hope will gain customer acceptance. They rely upon annual reports as a measurement of success.

There is a difference, however. In most businesses quality of product and customer loyalty are reflected in profit and loss statements. Thanks to the Audit Bureau of Circulation, the unquestioned source of circulation data, magazines can measure reader enthusiasm and loyalty by the number of copies of a magazine readers pay for. In effect, ABC

measures the "wantedness" of a magazine. It measures the size of a magazine's audience. It measures the success of a magazine, in serving its readers.

Here at PM, for example, our editors spend every moment searching for, creating and preparing features of interest to a special group of men interested in the mechanics of modern living. Through ABC reports, we know that, today, more men are interested in mechanical things.

We know that, because more men are reading Popular Mechanics. What better way of staying on the beam with over 1,400,000 men who buy



**POPULAR  
MECHANICS**



# Magic Mail Plan—Make up to \$5 an Hour!



**THIS MAN...**

... is taking out of the machine a Plastic Sealing Job—ordered by mail—only 11¢ in material cost brings back \$2.58 in cash by mail. Capacity of machine: \$25.00 profit per hour of operation.

Get **ORDERS** and **CASH** from your mailman—do work in **SPARE TIME** at home—or expand into **FULL TIME** business. Send coupon for Free facts about the newest and most fascinating of all home operated businesses. For the first time a simplified machine brings the fabulous profits of **Plastic Sealing** and **Plastic Laminating** within the reach of the small operator. Anyone can learn to operate the machine with a few minutes practice—then with our **Magic Mail Plan** can get mail orders pouring in daily with cash in every envelope. **No canvassing—no selling.** We even

**Get into PLASTIC LAMINATING at home**

**WE'LL EVEN HELP FINANCE YOU**

supply the circulars you mail to bring back cash and orders, financing help, too. Rush name. We'll send you **FREE** and postpaid, pictures, prices, details, finance plan, all the facts you need. Mail coupon or send name on postcard. No charge. Warner Electric Co., 1512 Jarvis Av., Dept. L-2-K, Chicago 26, Ill.

## Make Thousands of Beautiful Art Creations

**COSTUME JEWELRY • CIGARETTE BOXES TRAYS • CANDLESTICKS • COASTERS LAMP BASES • BOOK ENDS...ALL IN SPARKLING COLORED PLASTIC**



**WARNER ELECTRIC CO., 1512 Jarvis Av. Dept. L-2-K, Chicago 26, Ill.**

At no cost to me, please rush full details and financing plan, postage prepaid. No obligation.

Name \_\_\_\_\_  
Address \_\_\_\_\_  
City \_\_\_\_\_ Zone \_\_\_\_\_ State \_\_\_\_\_

Would You Like to Make **\$1,000 A MONTH?**



That's what Stanley Hyman made selling the amazing new **Presto Fire Extinguisher!** Many others "cleaning up"—so can you! Amazing tiny new extinguisher ends fires fast at 2 seconds. **Guaranteed for 20 years!** Sells for only \$4.95. Write for Free sales kit.



Merlite Industries, Inc., Presto Div., 114 E. 32nd St., Dept. P-15Y, New York 16, N. Y.



## MANUFACTURE this BEAUTIFUL OUTDOOR FIREPLACE in YOUR OWN BACKYARD

\$4.00 worth of sand and cement produces this attractive fireplace. Sells on sight from \$60 to \$80. Easy to start your own profitable business in your backyard. No experience necessary. Big profits. Exclusive manufacturing territories. Write immediately for full details. General machines sold to U.S. Government. Dealer inquiries invited.

**GENERAL ENGINES CO., INC.** Dept. MF-92 Rt. 130, Thorntone, N. J.



## CARTOONING IS EASY NOW

Famous System of Manual Training brings a complete new conception in Art Instruction at home... **Cartooning** is a wonderful profession that offers Men and Women a wide field rich in unequalled opportunities to make good money. It is worth while to get the facts. Ask for free information today.

**Continental Schools, Inc.** DEPT. E-222, 4201 S. BROADWAY, LOS ANGELES 37, CALIF.

## New Publication "HOW TO MAKE MONEY in MAIL ORDER"

Complete plan revealed to you for just a dollar bill. Shows men, women how to start full or spare time home mail order business without experience or product investment. Reveals plans on how and where you get best products... how you pocket profits in advance... how you get **FREE** ads. **Absolute MONEY BACK GUARANTEE.** Rush dollar today! Address to **MAILCO**, Dept. D259, 1554 So. Sepulveda, Los Angeles 25, Calif.



## HP means High Pay to men who are trained in Auto Mechanics

America needs 100,000 mechanics, 25,000 repair shops. Earn big money, work steady. Train at home in spare time. Practical CTI course includes 30 Job Experience Projects, 15 kits of tools and instruments (Volt-Ampere, Tach Testers, etc.) Extra instruction in Body-Fender or Diesel Mechanics. CTI offers more! Mail coupon today for valuable free booklet.

**COMMERCIAL TRADES INSTITUTE** DEPT. A-270  
1400 GREENLEAF AVE. • CHICAGO 26, ILL.

Name \_\_\_\_\_ Age \_\_\_\_\_  
Address \_\_\_\_\_  
City \_\_\_\_\_ Zone \_\_\_\_\_ State \_\_\_\_\_

# LEARN MEAT CUTTING AT NATIONAL Pay After Graduation

The steady dependable trade of Meat Cutting taught easily in 8 short weeks. **YOU LEARN BY DOING** under actual meat market conditions in big modern school at Toledo.

For beginners or men with experience. Get a profitable store of your own. Remember. **PEOPLE MUST EAT!** Big pay jobs. Free employment help. Thousands of successful graduates.

Buying, cutting, percentage, pricing, advertising, selling, etc. A complete retail meat education. National School established 39 years. Get National training now. Pay your tuition in easy monthly payments after you graduate. Send coupon for **FREE** 40 page school catalog — **TODAY G.I. approved.**

**National School of Meat Cutting, Inc., Dept. 50-J, Toledo 4, Ohio**

Send me your **FREE** school catalog on National Training at Toledo in Meat Cutting, Meat Merchandising and Self-Service Meats. No obligation. No salesman will call.

Name \_\_\_\_\_ Age \_\_\_\_\_  
Address \_\_\_\_\_  
City \_\_\_\_\_ State \_\_\_\_\_

Approved for Veterans

# EARN \$125 A WEEK AND UP

## BE AN AUTO DIESEL EXPERT—LEARN A TRADE YOU LIKE

You learn fast in our shops because you learn with tools on real equipment. Students short of money may earn most of their expenses by doing part-time work. Experienced instructors explain WHY and show you HOW, then you DO IT YOURSELF. Many of our graduates earn \$125 a week and up. Approved for veterans. Day and evening classes. Free bulletin-write today.

MAIL THIS COUPON TODAY!

**NASHVILLE AUTO-DIESEL COLLEGE**  
226 7th Ave., No., Dept. 86, Nashville, Tenn.  
Please send without obligation free catalog.

NAME \_\_\_\_\_  
(please print or write plainly)

ADDRESS \_\_\_\_\_

CITY \_\_\_\_\_ STATE \_\_\_\_\_



## ARTISAN ORGAN "King of Kits"

- The ultimate in organ tone & styling
- Skip dealer profits and factory labor
- Pay as you build & play as you build
- No previous technical skill required
- The original build-it-yourself organ

- Choice of models from \$1750 to \$5500
- Write today for details

4949-Po York Blvd., Los Angeles 42, Calif.



## NEW HI-FI PERFORMANCE

The Exciting NEW  
MODEL 422 **BENJAMIN**  
CO<sub>2</sub> 10-SHOT SEMI-AUTOMATIC

**.22 PELLET PISTOL**

EFFICIENT—SAFE—  
DEPENDABLE—CONVENIENT  
Famous BENJAMIN Quality

\$24.00

Ask Dealer  
for Demon-  
stration

AT LAST—an Amazing New Handgun that incorporates the Characteristics Wanted for Serious Training, Plinking and Match Competition—Indoors and Outdoors—at LOWEST SHOOTING COSTS! Handsome, Dynamic, Mechanically Reliable, MODEL 422 combines Traditional BENJAMIN PEAK POWER and ACCURACY with Incredible Firing Speed—Smooth JAM-PROOF ACTION (no ramrod for cleaning pistol bore required)

WITH  
EXTRA MARGIN  
BENJAMIN'S Unique  
DOUBLE SAFETIES

Press Trigger Safety "OFF"  
Release Hammer Safety as Illustrated.



KEEPS SHOOTING & SHOOTING & SHOOTING & SHOOTING  
AS FAST AS YOU CAN SQUEEZE THE TRIGGER!

FREE Write today! Complete Catalog Benjamin Rifles & Pistols—Single Shot & Repeaters—88 or 177 or 22. Also, Special Offer on Hunting Knives. Use Benjamin H-C Pellets in Model 422 for Accurate, Jam-Free Shooting.

BENJAMIN AIR RIFLE CO. 896 MARION ST., ST. LOUIS 4, MO.

# DOLLS!

learn world's  
most fascinating  
business



We teach you to make, repair, and sell all kinds of Dolls and accessories. Study at home. Excellent money making opportunities in every locality. Start a business part or full time. Easy to learn. Low monthly payments—many pay for their course out of earnings made while learning. We show you how. May we send FREE and without obligation our informative booklet? No salesman will call. For an exciting future, ACT NOW!

**NORM and SUE MORRIS**  
**LIFETIME CAREER SCHOOLS**  
Studio M-92, 11824 San Vicente Blvd.,  
Los Angeles 49, California



## ACCORDIONS UP TO 1/2 OFF

Save up to 1/2 off retail prices of comparable accordions •  
**5-DAY FREE TRIAL** •  
Buy DIRECT from world's Largest Exclusive Dealer! Compare our Importer-to-You prices! See how you save! Over 30 models—finest genuine Italian makes! New, easier terms! 5-Day Free Home Playing Trial with satisfaction 100% assured. Bonus Gifts Free. Rush name and address for FREE Color Catalogs and direct Importer-to-You prices—FREE. Write TODAY! Accordion Corporation of America • 2003 W. Chicago Av., Dept. P-92, Chicago 22 •

## MAKE MONEY! REPAIR HYDRAULIC JACKS



Earn While You Learn At Home  
Make up to \$5 an hour, full or part-time, in the competition-free field of Hydraulic Jack Repair. Millions of jacks in auto service stations, truckers, body shops, riggers, farms, need servicing. We show you HOW. Easy step-by-step directions.

Write for Folder PM-9 and Free Bonus Offer

**Institute of Hydraulic Jack Repair**

P. O. BOX 50 • BLOOMFIELD, N. J.

A Correspondence School Licensed by N.J. Bd. of Ed.

ADD an enclosed cab to your pickup truck for camping, hunting, vacations. Instructions and diagrams on Plan Sheet B510, 25c from Popular Mechanics Service Bureau, Room 533, 740 Rush St., Chicago 11, Ill.

## POLICE

START your gun collection with an authentic replica of a .38 Colt Cobra. Solid cast aluminum..... \$3.95 each p.p.d.



LYTLE Novelty Co.,  
Box 2146, Whittier, Calif., Dept. PM1

## CAM-DWELL INDICATOR

Quickly and Accurately solve all CAM DWELL problems on any car, truck, or boat engine in just minutes!

No need to remove the distributor for accurate point setting. Can be used anywhere, on car, at work bench, in bay, or at pumps. Eliminates feeler gauges. Points set by Cam Dwell assures proper coil buildup time for smoother and surer hot spark. Complete with steel case and instructions.. \$3.95



**M&E SALES COMPANY Dept. PM**  
P.O. Box 51  
Springfield, N.J.

\$3.95

# POPULAR SHOPPING

"Body and Mind in Harmony," a book by Sophia Delza, recently published by David McKay Company, Inc., 119 West 40th St., New York 18, N. Y., discusses an ancient Chinese way to exercise in order to achieve health and tranquility through T'ai Chi Ch'uan, a system of activating the body for the development of physical, emotional and mental well-being. Four full chapters explain and diagram 108 basic forms done continuously with a flowing movement. The author teaches this system at the United Nations. Valid for all age groups, the book is available for \$3.98.

Russian and other foreign technical literature, particularly in the fields of science, engineering, technology and medicine can be obtained easily through "Technical Translations," a semi-

monthly journal announcing all new translations put out by the Nation's two major sources of foreign material in English, the Office of Technical Services and Special Libraries Association Translations Center. Subscriptions are \$12 a year from the Superintendent of Documents, U.S. Government Printing Office, Washington 25, D.C. The American Geological Institute and several other organizations use this publication to announce their own translations.

**Anglers Club!** Add a touch of permanence and prestige to your Big Catch. Whether you catch a single big fish, a good string, an unusual species or any fish under extraordinary circumstances, if you verify that you caught your "catch of a lifetime" with an Arbogast lure, you will



receive a goldplated model of the Jitterbug or Hula Popper lure—as pins or tie tacks for men and as brooches or charms for women. Also, you'll receive a membership card. It's all free. Write Dick Kotis when you're ready for membership application at Fred Arbogast Company, Inc., 313 W. North Street, Akron 3, Ohio.

**GUARANTEED TO ATTRACT DEER!**  
NATIONAL  
**BUCK SCENT**  
TWIN PACK

To get your deer this season sprinkle a few drops of these 2 powerful scents on brush, rocks, etc. One whiff and your trophy buck will be charging in. 2 compelling scents deer can't resist—their favorite food and the ever lovin' sweet smell of sex. Money-back guarantee! Works in any climate or place—won't freeze, no heating required. Only \$2 ppd. For rush overnight air-mail special delivery add \$1. Sorry no C.O.D.'s.

**FREE** 32-page booklet on how to train a dog and use scents in hunting, trapping, fishing.

**NATIONAL SCENT CO.**  
10660 Stanford Avenue • Garden Grove 8, California

**FAST! NEW**

**WAY TO INSTALL BACKBOARDS**

Amazing new supports help you install his basketball backboard in minutes . . . NO CUTTING, FITTING OR PAINTING. Adjusts to any roof slope. Heavy duty, rust resistant, angle iron. Supports kit includes everything for easy installation. \$9.95 prepaid. Satisfaction guaranteed. No C.O.D.'s. Send check or money order NOW to:

**DALCO PRODUCTS**  
1438 Lakewood Drive, Bettendorf, Iowa

**PLAY RIGHT AWAY!**

**ANY INSTRUMENT—** even if you don't know a single note now!

**FOR BIG OR TALL MEN ONLY!**

We specialize in Large Sizes Only! Sizes 10 to 16; Widths AAA to EEE. Dress, sport, casual, golf shoes, insulated boots, sox, slippers, jackets. Also dress and sport shirts with bodies cut full 4" longer than usual. Slacks, raincoats and sweaters, too! Sold by mail only; Satisfaction Guaranteed! Write for FREE Style Book today! King-Size, Inc., 6222 Forest St., Brockton, Mass.



**Make Money in Art**

Learn Commercial Art for Only 20c a Day!

ENJOY glamorous high-pay career or profitable hobby this easy, proven way. Learn Painting, Commercial Art, Cartooning, Fashion, TV Art, etc., at home in your spare time—for only 20c a day! TWO 22-piece art outfits (worth \$25) included at no extra cost. Cash in on demand for trained artists. Be your own boss or high-pay staff artist. Write for FREE Book describing easy Course. No obligation. No salesman will call. So write TODAY to: **WASHINGTON SCHOOL OF ART**, Studio 149, Port Washington, N. Y. (Est. 1914)

NOW it's EASY to learn ANY instrument. No boring exercises. Even if you don't know a single note now you can play delightful pieces—from your FIRST lesson! BY NOTE. Make amazing progress. No special "talent" needed. Learn at home in spare time. Without a teacher. Low cost! Soon you can play popular music, hymns, classical and any other music. Over 1,000,000 students, all over the world.

**FREE BOOK.** Fill in ad, send to: **U. S. SCHOOL OF MUSIC**, Studio 309, PORT WASHINGTON, N. Y. (No obligation, no salesman will call.) Chartered by N.Y. State Education Dept.

Name.....  
Address.....  
Include Zone No., if any.

# ENGINEERING



Heald's Micro-wave and Radar Laboratory Equipment.

**ENROLL NOW FOR NEW TERM**

## HEALD Engineering College

Van Ness at Post, Dept. PM

San Francisco, California

NAME \_\_\_\_\_

STREET \_\_\_\_\_

CITY \_\_\_\_\_

STATE \_\_\_\_\_

**AMERICAN INDUSTRY NEEDS TRAINED ENGINEERS NOW**  
**BACHELOR OF SCIENCE DEGREE, 30 MONTHS**

**SAVE 2 YEARS' TIME**

**B.S. Degree Courses:**

- Electronic Engineering
- Mechanical Engineering
- Electrical Engineering
- Civil Engineering
- Architecture

**Diploma Courses:**

- Radio-Television Plus Color **TECHNICIAN**
- Architectural Drafting
- Electronic Technician
- Mechanical Drafting
- Structural Drafting

**APPROVED FOR VETERANS**

Send for **FREE** Information

A chance to make extra money at home.

**Be your own watchmaker! You can replace round waterproof crystals in 60 seconds! Special Offer:**

The easy to operate SUC Rocket Watch Crystal Remover and Inserter tool with special base... plus 144 SUC AW Round crystals... complete size range... A \$37.95 value.

**YOURS FOR ONLY \$27.95**

Standard Unbreakable Watch Crystals, 123 E. 144 St., N.Y. 51, N.Y.



DAN LURIE  
World's Most Famous  
Body-Builder,  
TV Strongman

**A BODY LIKE MINE IN SHORT TIME with famous DAN LURIE BARBELLS!**

SEND FOR NEW GIANT CATALOG

Factory Prices	Cast Iron	Semi-Steel	<b>\$9.48</b>
50 lb. Set.	\$9.48	\$10.48	
100 lb. Set.	15.98	18.98	
150 lb. Set.	23.48	27.48	

Extra Wts. 166 lb., 186 lb., \$10 Course

**MONEY BACK GUARANTEE—Send 50% in check or money order P.O.B. Plant Brooklyn, New York. Balance C.O.D.**

DAN LURIE BARBELL CO. 1661-M9 Utica Ave., Dept. 259J, Brooklyn 34, N.Y.

## NEW MAGIC RADIO WALKIE TALKIE!



**TALK TO ANYONE ANYWHERE BY RADIO!**

Sends your voice to any car or house radio. Works up to 1-2 miles from car to car or 1-5 or more blocks house to house depending on local conditions. Just Push Button to Talk—No Complicated Hookups or Wires—Anyone can use it. Transistor powered by flashlight batteries. No License or Permits Needed. Guaranteed to Work. 1 yr. Service Guarantee. Should Last for Years!

**SEND ONLY \$3.00** (cash, ck, mo) and pay postage or send \$12.99 for postpaid delivery. Ready to operate, with clear instructions. Order your Radio-Talkie today—Now!  
WESTERN RADIO, Dept. TPM-9, Kearney, Nebr.

"the shoes that made comfort famous"



**ALWAYS GET GENUINE DUNHAM'S TYROLEANS®**

**AT BETTER STORES EVERYWHERE**

write for name of nearest dealer



**DUNHAM'S, BRATTLEBORO, VT.**

## \$3 Worth of FUN MAKERS, \$1 JOKES & TRICKS for \$1

**SPECIAL OFFER!** America's oldest & largest novelty company wants YOU as their customer. We are so anxious to get our catalog into your hands, we offer you a **BARGAIN SURPRISE PACKAGE** for \$1.00. This "Get Acquainted" Special includes 10 new & different novelty articles and our big new catalog of 2500 novelties. Total value is three times as much! Nothing more to pay or buy. Money back guarantee. Limit one to a person. Send \$1.00 now!

**JOHNSON SMITH & CO.**  
Dept. 157, Detroit 7, Michigan



## BUY FACTORY DIRECT!

**WREN** by BIRD engineering **\$99.95**

Send 25c for brochure



**\$10.00 Down**  
**\$5.00 a Month**  
Complete with Clinton 2 1/2 H.P. engine, ready to run!

Bird Engineering, 206 S. 19. Dept. PM-W3 Omaha, Nebr.

## SAVE MONEY! MAKE MONEY! WITH PORTABLE CEMENT MIXER!

It's easy, fast, fun to do your own work with the MIXAL Mixer. Build barbecues, patios, sidewalks for yourself, for others! Mixes 3' x 8' sidewalk every hour! Uses any 1/4 HP motor. Thousands used by contractors! Try it on **MONEYBACK GUARANTEE!** Send for **FREE HOW-TO-DO-IT CEMENT MIXING BOOKLET.** Dept. PM-9.



**KOL, INC., 2323 Ellis Ave., St. Paul, Minn.**

W. of Rockies

## TOOLS WHOLESALE

**SELL TOOLS** to your friends and neighbors, or buy tools for your own use and **SAVE MONEY \$\$\$.** Send **\$1.00** for your **WHOLESALE CATALOG TODAY!!**

**A MILLION DOLLAR INVENTORY AT YOUR FINGERTIPS. NO STOCK TO CARRY. ORDER AS YOU NEED IT.**

**BUY AT WHOLESALE PRICES.** Extra \$25.00 profit on your accumulated purchases. \$1.00 refund on first purchase or refunded if you are not 100% satisfied.

**THOUSANDS!!** of Nationally Advertised items of Hand Tools, Power Tools, Machinist Tools, Tool Chests, Paint Sprayers, Light Fixtures, Appliances, Guns, Gifts, Toys and other items too numerous to mention.

**WE SHIP COAST TO COAST** White. Disc. up to 50% off

**SILVO HARDWARE CO., Dept. PM-9 107 Walnut St., Phila. 6, Pa.**

## LICKITY LOG SPLITTER

**Ends Wood Splitting Drudgery**

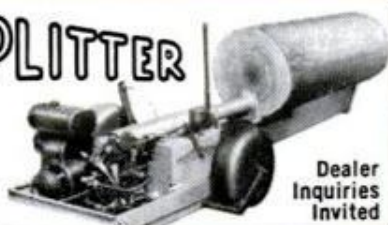

Dealer Inquiries Invited

Smooth 18 ton hydraulic power splits big profits for you from the toughest woods, including American Elm. 7 HP trailer unit squats under own power to receive large logs without "dead" lift. Has 2 speeds, auto-shift and auto-stroke. 26" ram travel splits up to 34" lengths, any diameter—or, with extended frame and adjustable wedge, splits up to 52" lengths, any diameter. Write for details.  
**THE WACO AIRCRAFT CO., Dept. D, Troy, Ohio**

**Underwater photography**, surf riding, water skiing, and competitive diving are some of the topics in Arthur Liebers', "The Complete Book of Water Sports," illustrated with action photographs and published this year by Coward-McCann, Inc., 200 Madison Ave., New York 16, N.Y., for \$4.50. Its 13 chapters are aimed at those readers who want to derive greater enjoyment from invigorating water sports as well as physical education teachers and professional pool and likefront instructors.

**Gunmen** will value the first annual edition of "Handloader's Digest," which sets a precedent as a comprehensive encyclopedia for rifle, pistol and shotgun reloaders. Published this year by the Gun Digest Association and edited by John T. Amber. Included in its 260 pages are original articles by the foremost gun authorities, plus a complete catalog of reloading equipment

with the latest prices. Other sections cover metallic cartridges, bullet swagging and shotshells, with an additional feature: "Maximum Loading Tables." The price is \$2.95. Write the publisher, Dept. 6, 4540 W. Madison St., Chicago 24, Ill.

**Pocket calendars** for the blind are available in a condensed braille version which covers 12 months and the day of the week on which the first day of each month falls. An ordinary braille calendar would be much too large to carry continuously. The compact calendar is free upon request to blind people from the American Foundation for the Blind, Inc., 15 West 16th St., New York 11, N.Y.—an organization which has helped thousands to compensate for lack of sight.

**Bathrooms** can be unusually attractive as well as functional. "Plan-A-Bath Color Guide" of-

fers you a selection chart with full-color photos illustrating color in bathrooms and washrooms, plus a series of floor plans showing fixtures, vanity and counter arrangements. Send 10 cents to Plan-A-Bath, Kohler Co., Kohler, Wis.

*Additions to past "Worth Writing For" items:*

May 1962 issue: "Arco Workshop Companion," Arco Publishing Co., is \$2.50.

July 1962 issue: "Driving Safety," William Frederick Press is 25 cents, not 15 cents.

July 1962 issue: "Information Free," Arnold Hagen requires 25 cents handling charge.



## NO SANDING

CHIP FREE, SATIN SMOOTH CUTS WITH NEW **DADO & MOLDING CUTTERS**  
Now For all HOME WORKSHOP TABLE SAWS. Dewalt, Pow-R-Kraft, Comet, Craftsman, Delta, Shopsmith and others.

The famous JET industrial woodworking cutters are now available in a complete line of smaller (appr. 1" width) sizes for home workshop use. All Jet Jr. cutters PRECISION GROUND AND CASE HARDENED. Guaranteed to out perform any cutters now made for home or light industry use. Up to 20 times the life of stamped or die-cast cutters! DOUBLE LOCKED—Cannot fly out (patented). Now you can use the choice of professional Cabinetmakers and quality picture frame mfrs.—JET! Turn out professional quality work on home equipment.



**JET TOOL, INC.** 7952 North Ave., Lemon Grove, Calif.



## JET CUTTERS

CUTTER HEAD \$9.95 ppd.  
(includes adapters for all table saws mentioned.)

**JET CUTTERS \$3.90 pr.** (your choice) See cutter shapes at top of page. Dado cutters 1/4" to 1 3/16" **5 PAIR OF JET CUTTER \$17.95** (your choice)

**PROFESSIONALS** Send for JET CATALOG on senior woodworking line. Have your favorite cutters CARBIDE TIPPED.

**FREE CATALOG** • JET PRECISION HOLE CUTTERS AND OTHER SPECIAL TOOLS **ORDER BY MAIL:** Enclose 1/2 for C.O.D. shipment. 10-day money back guarantee plus warranty. Free information on request. Jet Senior equipment handled by over 500 mill supply outlets for over 15 years.

**MEN!! HEAVY EQUIPMENT**

**EARN UP TO \$4.50 PER HOUR!**

Learn to operate Bulldozers, Motor Scrapers, Loaders, Graders, Shovel, Drag Line, others. Training includes ACTUAL EXPERIENCE on heavy equipment at our field training center. Free employment guidance. Write Today!

**TRAINING SERVICES**  
120-P City Line Center Philadelphia 51, Penna.

**IDEAS for HANDICRAFTERS**

**FREE 112 page CATALOG from AMERICAN HANDICRAFTS CO.**

Worlds Largest Suppliers of Handicrafts  
Box 1643-PM Fort Worth 1, Texas

**High School at Home**

**MANY FINISH IN 2 YEARS**

No classes. No time wasted going to and from school. Progress as fast as your time and abilities permit. Standard H.S. texts supplied. Thousands enroll each year in this 65-year-old school. Send for FREE descriptive booklet.

**AMERICAN SCHOOL, Dept. H645**  
Drexel at 58th St., Chicago 37, Ill.

Without obligation, please send FREE descriptive booklet.

Name \_\_\_\_\_

Address \_\_\_\_\_

Accredited Member National Home Study Council

**ONLY \$135 complete with accessories**

**You can make Big Money with this low cost arc welder!**

**HOBART BROTHERS CO., BOX M-92, TROY, OHIO, U.S.A., Ph. 332-1223**

EASY TO USE "Trojan" 180 amp. welder fabricates parts, ornamental railings, furniture. Makes repairs on the spot. Hardsurfaces machinery, tools. Solders leaks. Brazes fenders. Heats metal for bending. Has no moving parts. Permanently quiet operation. Line switch disconnects power. Light weight, compact (23" h. 13 3/4" w. 13 1/2" d.). Meets REA power line requirements. Provides 18 welding heat steps. Complete package includes electrode holder; 15' ground cable, clamp; 20' electrode cable; headshield, lens; 8' power connection; electrodes Write for data sheet A-521-F today.

battery charger attachment optional

# IDEA PROJECT INFORMATION CENTERS

CHECK THIS LIST FOR THE ONE NEAREST YOU

**LOOK FOR THIS SYMBOL**  
*on their door or window*

**IDEA PROJECT**

MINIMUM MAINTENANCE  
FOR MAXIMUM LIVING  
POPULAR MECHANICS

**CENTER**

The lumber and building supply dealers listed below, who display the Idea Project symbol, are the best sources in your area for additional information and materials needed in home improvement and remodeling projects. They can suggest ideas and materials that offer "minimum maintenance for maximum living." We highly recommend their services to you.

## ALABAMA

**Jasper**  
North Alabama Lumber Co.  
201 West 22nd St.

## ALASKA

**Anchorage**  
Spenard Builders Supply, Inc.  
4412 Lois Drive

## ARIZONA

**Scottsdale**  
Hamman McFarland Lumber Co.  
6425 East Thomas Road

## ARKANSAS

**Crossett**  
Pierce-Grassi Lumber Co., Inc.  
503 West 1st Avenue

## CALIFORNIA

**Bell**  
Atlantic Lumber Co.  
6327 S. Atlantic Blvd.

**Citrus Heights**  
Sylvan Lumber Co.

**Culver City**  
Betts-Sine Lumber Co.  
8770 Washington Blvd.

**Marysville**  
Speckert Building Supplies, Inc.

**Montebello**  
Willis Cashway Lumber Co.  
1919 Whittier Blvd.

**San Bernardino**  
Gibson Lumber Co.

## COLORADO

**Durango**  
Federal Lumber Co.

**Grand Junction**  
Harbert Lumber Co.  
204 North Avenue

**Ignacio**  
Wiseman Hdw. & Lumber

**Littleton**  
Littleton Lumber Co.  
5250 South Santa Fe

**Sterling**  
Broadway Lumber Co.  
101 Broadway

**Wheatridge**  
Wheatridge Lumber Co.  
8995 West 44th

## CONNECTICUT

**Hamden**  
Centerville Lumber Inc.  
2308 Whitney Ave.

## FLORIDA

**Sarasota**  
Shepard Lumber Co.

**West Palm Beach**  
Butler Bros. Lumber Co.  
601 Roseland Drive

## HAWAII

**Lihue, Kauai**  
Hale Kauai Ltd.

## IDAHO

**Caldwell**  
McNeel's  
1024 Arthur St.

**Idaho Falls**  
Bonneville Lumber Co.

## ILLINOIS

**Belleville**  
Signal Hill Lumber & Hardware  
9300 West Main

**Bellwood**  
Republic Home Modernizing Co.  
St. Charles & Mannheim Rds.

**Bloomington**  
Schwulst Lumber & Coal Co.  
416 S. Robinson St.

**West Side Coal & Lumber Co.**  
1111 West Market St.

**Blue Island**  
Mathieu Building Center, Inc.  
14300 South Western Ave.

**Blue Mound**  
Blue Mound Lumber Co.

**Cambridge**  
Clifford & Clifford

**Caseyville**  
Steck Lumber Co.  
10505 Lincoln Trail

**Chicago**  
Gee Lumber Company  
2600 West 79th St.

**Joseph Lumber Co.**  
2001 N. Narragansett

**Republic Lumber Co.**  
5584 Northwest Highway

**Star Lumber Co.**  
201 W. 87th St.

**Evanston**  
Evanston Builders Lumber Co.  
1001 Sherman Ave.

**Fulton**  
Brinkman & Pessman Lumber Co.  
R. R. 1

**Harrisburg**  
Harrisburg Lumber Co.  
Vine St.

**Harwood Heights**  
Republic Home Modernizing Co.  
4646 N. Harlem Ave.

**Jacksonville**  
Henry Nelch and Son, Co.  
725 East College

**Joliet**  
I. N. R. Beatty Lumber Co.  
North Broadway & Chaney

**Cash & Carry Lumber Co.**  
816 South Gardner St.

**Kankakee**  
Troup's Building Center  
111 East Oak St.

**Marseilles**  
I. N. R. Beatty Lumber Co.  
322 Main St.

**Morris**  
I. N. R. Beatty Lumber Co.  
824 Liberty Street

**Mossville**  
Hunter Lumber Co.

**Mt. Olive**  
Ervin J. Niemann Lumber Co.  
500 East 1st South Street

**Oak Lawn**  
I. N. R. Beatty Lumber Co.  
9537 South 52nd Avenue

**I. N. R. Beatty Lumber Co.**  
5187 West 95th Street

**Orland Park**  
I. N. R. Beatty Lumber Co.  
9730 143rd Street

**Peoria Heights**  
Peoria Heights Lumber Co.  
838 East Glen

**Pontiac**  
I. N. R. Beatty Lumber Co.  
703 East Howard Street

**Rock Falls**  
Cashway Lumber Co.  
405 Emmons Ave.

**South Holland**  
Wausau Lumber & Coal Co.  
236 East 161st Place

**Tinley Park**  
I. N. R. Beatty Lumber Co.  
6721 North Street

**Tuscola**  
F. H. Jones Lumber Co.  
100 N. Parke

**Waukegan**  
Mackemer & McBroom  
123 West Walnut

**Wilmingon**  
I. N. R. Beatty Lumber Co.  
Kankakee Street

## INDIANA

**Aurora**  
The Wright Lumber Yard  
Third St. & B & O R.R.

**Chesterton**  
Dunes Lumber & Supply Co.

**Columbia City**  
Columbia City Builders Supply Co.  
414 South Line St.

**Columbus**  
Wendel's, Inc.  
1416 Sycamore St.

**Decatur**  
Arnold Lumber Co., Inc.  
425 South Winchester St.

**East Chicago**  
Indiana Harbor Lumber & Coal Co., Inc.  
3440 Watling Street

**Frankfort**  
Kramer Brothers Lumber Co.  
608 West Washington St.

**Ft. Wayne**  
South Side Lumber Co.  
4928 South Hanna

**Gary**  
Grant Street Lumber & Supply Co.  
3883 Grant Street

**Greentown**  
Hamer Lumber Co.

**Indianapolis**  
Builders Lumber Co.  
1560 Massachusetts Ave.

**Lowell**  
Lowell Lumber Co.

**Michigan City**  
Frey Bros. Lbr. Co.

**Middletown**  
Middletown Lumber & Builders Supply  
107 South 8

**Morgantown**  
Stockton Co. Inc.

**Portage**  
Willow Creek Lumber Co.

**Rensselaer**  
The Lumber Co. of Rensselaer, Inc.  
Cullen & Vine

**St. John**  
Standard Lumber Co. of St. John, Inc.

**South Bend**  
Eckler Lumber Co.  
1406 South Franklin St.

**Valparaiso**  
Smith-Nuppau Company  
360 Indiana Avenue

## IOWA

**Algona**  
Ready Mix Concrete & Lumber Co.

**Carroll**  
Kanne Lumber & Supply Co.  
814 West Ninth

**Keokuk**  
Streeter Lumber Co.  
320 Des Moines St.

**Marshalltown**  
Marshall Lumber  
312 South 1 Avenue

**Waterloo**  
Shepherd Lumber Co.  
1162 East Fourth

## KANSAS

**Abilene**  
Central Lumber Co.  
511 N.W. 2nd

**Argonia**  
Mack-Welling Lumber & Supply Co.

**Axtell**  
Meyer Lumber & Hardware Co.

**Bogue**  
Mack-Welling Lumber & Supply

**Collyer**  
Mack-Welling Lumber & Supply Co.

**Garnett**  
Star Grain & Lumber Co.

**Horton**  
Horton Lumber Co., Inc.

**Hutchinson**  
Kightlinger's  
1301 East Fourth

**Kansas City**  
Logan-Moore Lumber Co.  
47th & Mission Road

**Mack Lumber Co., Inc.**  
26th & Metropolitan Ave.

**Lawrence**  
Logan-Moore Lumber Co.  
(Continued to page 46)



### Steam Tamer

Torrid auto radiators are tamed by this plastic radiator cap cover that promises no more burned or scalded hands.

It stands heat up to 250° F. and has a diameter one and a half times larger than the metal cap it covers. This overhang deflects steam and boiling water downward.

Handy for service station men, or it snaps on permanently. 59¢ ppd. from McCamey & Co., 803 14th St., Orange, Tex.

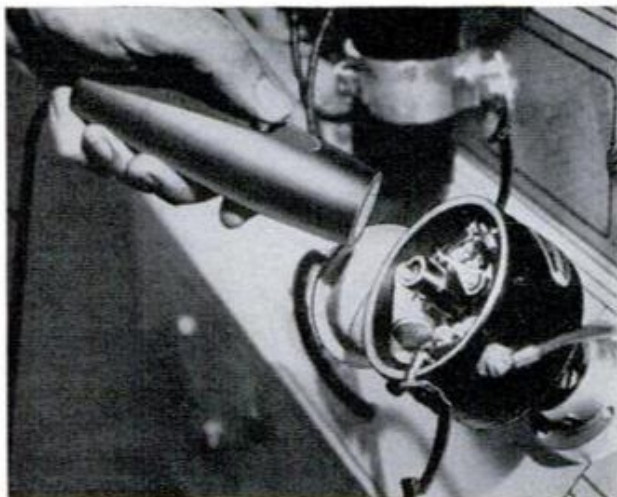

### Remote-Control Starter

Tune-up men and Saturday mechanics alike will welcome this remote-control engine starter that eliminates the need for a helper in the vehicle to press the starter.

When the mechanic wants to turn the engine over, he presses the button on the side of the case. When the button is pressed, a miniature work light also illuminates underhood areas. Switch contacts are double silver-plated for reliability and the connecting leads are heavy duty, according to the maker: Kal-Equip Co., of Otsego, Mich.

SEPTEMBER 1962

# FREE

## FOR '63

## LAFAYETTE RADIO ELECTRONICS



1963 CATALOG  
NO. 630

**388  
GIANT-SIZE  
Pages**

*The Largest Catalog in  
Our 42-Year History*

**It's New - It's Big - It's Better Than Ever  
It's from the "World's Hi-Fi &  
Electronics Shopping Center"**

Here it is—the exciting, all-new 1963 Lafayette Catalog. 388 giant-sized pages with thousands of items for the audiophile, experimenter, technician, hobbyist, engineer, student, serviceman . . . fully illustrated . . . hundreds of manufacturers.

#### CHECK THESE LAFAYETTE BENEFITS

- ✓ **LARGEST STOCK.** Everything in Hi-Fi and Electronics — C.B., Tape Recorders, Hi-Fi Stereo, Ham and Amateur, Radio & TV Accessories, and much more.
- ✓ **EXCLUSIVE LAFAYETTE KITS.** The best value for your money.
- ✓ **SATISFACTION GUARANTEED OR MONEY REFUNDED**
- ✓ **LOWEST PRICES**

Buy the EASY-WAY with EASY-PAY

**NO MONEY DOWN, UP to 24 MONTHS TO PAY**

**Mail the Coupon Today for your  
FREE 1963 Lafayette Catalog**

LAFAYETTE RADIO, Dept. LI-2  
P.O. Box 10, L.I., N.Y.

Please send me the FREE 1963 388  
giant-size page Lafayette Catalog.

Name \_\_\_\_\_

Address \_\_\_\_\_

City \_\_\_\_\_ Zone \_\_\_\_\_ State \_\_\_\_\_



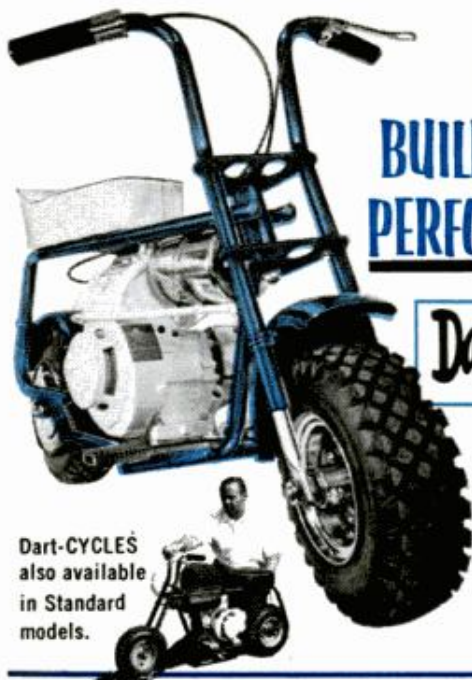

for  
**BUILD, LOOKS,  
PERFORMANCE**

**Dart-CYCLE**  
BY RUPP

Builder of the  
Championship  
Dart-KART

only  
**\$19950**  
no extras  
except the fuel

Dart-CYCLES  
also available  
in Standard  
models.

The all-NEW Dart-CYCLE is rugged, yet beautifully designed . . . for fun, sport or any handy-economical transportation. Weighs only 69 lbs.—carry it in your car, plane or boat . . . use it anywhere. 2½ HP, 4-cycle Lauson engine (3 HP optional at small additional cost) gets you away and keeps you going—Fairbanks-Morse clutch gives you perfect control, and 5" Internal Expanding brake assures maximum safety.

Send 25¢ for full color Rupp Catalog of Cycles, Karts and Carriers and accessories.

Rupp Mfr., Inc., Cycle Dept., 1776 Airport Road, Mansfield, Ohio

**POOL TABLE PLANS** with extra two-face top for table tennis and model railroad. Featured earlier this year in Popular Mechanics. Blueprints B1209 and building instructions, \$3.50. Popular Mechanics Service Bureau, 740 Rush St., Chicago 11, Ill.

**LEARN TO EARN**

**HIGH WAGES**  
AS A HEAVY EQUIPMENT  
OPERATOR OR MECHANIC

- **WORLD'S ONLY CONTRACTOR OWNED AND OPERATED SCHOOL**
- **MODERN EQUIPMENT, HIGHLY QUALIFIED INSTRUCTORS**
- **V.A. APPROVED FOR GI TRAINING**

Learn to operate bulldozers, draglines, cranes, back hoes, scrapers and motor graders  
**ON ACTUAL CONSTRUCTION PROJECTS!**

Learn by **doing** . . . no impractical correspondence courses.

**WESTERN SCHOOL  
OF HEAVY EQUIPMENT  
OPERATION**

WRITE TODAY  
FOR FREE  
SCHOOL  
CATALOG

DEPT. B-21, BOX 510  
WEISER, IDAHO  
PHONE 549-1112



Member American Road Builders Association  
Associate Member Associated General Contractors

- Lucas**  
Mack-Welling Lumber & Supply Co.
- Luray**  
Mack-Welling Lumber & Supply Co.
- Marion**  
Mack-Welling Lumber & Supply Co.
- Natoma**  
Mack-Welling Lumber & Supply Co.
- Palco**  
Mack-Welling Lumber & Supply Co.
- Plainville**  
Mack-Welling Lumber & Supply Co.
- Pratt**  
W. R. Green Lumber Co.  
803 North Main St.
- Quinter**  
Mack-Welling Lumber & Supply Co.
- Russell**  
Mack-Welling Lumber & Supply Co.  
122 East Seventh Street
- Tribune**  
Tribune Lumber Co., Inc.
- KENTUCKY**
- Ashland**  
Patton Lumber Co.  
53rd Winchester Avenue
- Burlington**  
Burlington Lumber & Building Supply, Inc.  
#2 East Park Drive
- Pikeville**  
Pauley Lumber Co.
- LOUISIANA**
- New Orleans**  
Simon Streiffer Co.  
2026 Metairie Road
- St. Francisville**  
Jos. Rinaudo & Son
- MICHIGAN**
- Adrian**  
Fridd Lumber Co.  
402 College Ave.
- Ann Arbor**  
Fingerle Lumber Co.  
617 South Fifth Ave.
- Battle Creek**  
Troxel Lumber Co.  
18 Ansell St.
- Birmingham**  
Erb-Restrick Lumber Co.  
425 South Eton
- Boyns Falls**  
Boyns Falls Log Homes
- Cheboygan**  
Cheboygan Lumber Co.  
892 North Huron St.
- Coldwater**  
Woodward Building Materials  
120 West Chicago St.
- Detroit**  
Atlas Lumber Co.  
10300 West Fort
- Mohawk Lumber & Supply Co.  
East Side Yard  
11500 East Eight Mile Rd.
- Mohawk Lumber & Supply Co.  
West Side Yard  
14525 West Chicago Ave.
- Escanaba**  
Stegath Lumber Co.  
1812 Ludington Street
- Gaylord**  
The Otsego Lumber Co.  
123 S. Indiana
- Gladstone**  
Sterling Building Supplies  
1122 Delta Ave.
- Jasper**  
Jasper Lumber & Supply  
M S 2
- Lincoln Park**  
Mohawk Lumber & Supply Co.  
2172 Dix Avenue
- Livonia**  
Mohawk Lumber & Supply Co.  
33600 Plymouth Road
- Merrill**  
Boutin Lumber Co.
- Muskegon**  
Keene Lumber Co.  
346 W. Laketon Ave.
- Ontonagon**  
Hawley Lumber Co.
- Port Huron**  
Foster Builders Supply Co.  
951 Water St.
- Rochester**  
Nowels Lumber & Coal Co.  
412 Water Street
- Roseville**  
Mohawk Lumber & Supply Co.  
26640 Gratiot Ave.
- Royal Oak**  
Erb-Restrick Lumber Co.  
803 South Main
- Tecumseh**  
Tecumseh Lumber Co.  
2800 E. Monroe Road
- Unionville**  
Unionville Lumber Co.
- Wyandotte**  
Williamson Lumber Co.  
651 Vinewood
- MINNESOTA**
- Barnesville**  
J. H. Fisch Co.
- Bigfork**  
Westby Lumber Co.
- Butterfield**  
W. E. Schrader Lumber Co.
- Hastings**  
Hastings Lumber Mart, Inc.  
3rd & Bailey Sts.
- Hopkins**  
Justus Lumber Co.  
2 Excelsior Avenue, East
- Kasson**  
Kasson Lumber Co.
- Litchfield**  
Ideal Lumber Co.
- Madelia**  
S. Hage Lumber Co.  
24 Center Ave., N.
- Minneapolis**  
Crystal Lumber & Millwork Co.  
5353 Lakeland Ave.
- Lowry Lumber Co.  
111 Lowry Avenue
- Stewart**  
Stewart Lumber Co.
- St. Paul**  
Lexington Lumber Co.  
997 N. Lexington Pky.
- S. Berglund Lumber Co.  
1171 North Snelling Ave.
- South St. Paul**  
Farmers Supply Company  
1030 North Concord
- Wells**  
Wells Lumber Co.
- MISSOURI**
- Butler**  
Logan-Moore Building Material Co.
- Carrollton**  
J. E. Waddill Lumber Co.  
110 East Benton
- Kirksville**  
Adair Lumber Co.  
122 South Elson
- La Belle**  
La Belle Lumber Co.
- La Plata**  
La Plata Lumber Co.
- Lewiston**  
Lewiston Lumber Co.
- Maryville**  
Maryville Lumber Co.  
315 North Market
- Milan**  
Charles Rice Lumber Co.
- Monett**  
Wilks Lumber Co.
- Salisbury**  
Logan-Moore Lumber Co.
- Slater**  
Sailor Lumber Co.  
164 West Front St.
- St. Louis**  
Melcher-Schene Hardware & Lumber Co.  
4800 Natural Bridge
- Tarkio**  
Atchison County Lumber Co.  
1st & Main Street
- Vandalia**  
White Lumber Co.  
310 South Main
- MONTANA**
- Missoula**  
Wright Lumber Co.  
Hiway #10 West
- NEBRASKA**
- Burwell**  
Burwell Lumber Co.
- Holdrege**  
Kingsley Lbr. & Redimix Concrete Co.  
(Continued to page 48)



## Quake Is Earth-Shaker

The earth vibrated up and down one one-thousandth of an inch every 20 minutes for several months following the large Chilean earthquake of May, 1960.

Although vibrations resulting from earthquakes have been studied for some time, the low-frequency, 20-minute vibration has only recently been detected.

According to Dr. G. J. F. MacDonald of the University of California, the vibration could be described as the earth alternately taking the shape of a pancake and then a football to the extent of one one-thousandth of an inch.

## "Test-Tube" Grass

A new "test-tube" grass has been developed to help restore California's grasslands denuded by fire.

Developed by Professor B. Lennart Johnson of the University of California, the grass is a sterile hybrid—a cross between Indian rice grass and a needle grass. Fertility in the seeds was induced by dipping the roots in a drug, colchicine, making possible a fertile plant that could be grown and tested over several generations.

Experts will test the grass to determine its value as a forage crop and an erosion control on burned-over wildlands.

## Ocean Bottom Mostly Bumpy

Some of the most rugged terrain on Earth lies at the bottom of the sea. According to Henry W. Menard, professor of geology at the University of California, as much as 60 percent of the Pacific Basin floor is covered by millions of small hills averaging half a mile in height and five miles in diameter.

The Basin also contains such great geological features as trenches seven times as deep as the Grand Canyon, submerged mountain chains the size of the Rockies, fracture zones 3000 miles long, and perhaps 10,000 volcanoes, both active and extinct.

## New Model 161 UTILITY TESTER® FOR REPAIRING ALL ELECTRICAL APPLIANCES MOTORS·AUTOMOBILES·TV TUBES

As an electrical trouble shooter the Model 161

• Will test Toasters, Irons, Broilers, Heating Pads, Clocks, Fans, Vacuum Cleaners, Refrigerators, Lamps, Fluorescents, Switches, Thermostats, etc.



• Will test all TV tubes (including picture tubes) for open filaments and burned out tubes.

• Measures A.C. and D.C. Voltages, (both 110 Volt and 220 Volt lines).

• Will measure current consumption (amperes) while the appliance under test is in operation.

• Incorporates a sensitive direct-reading resistance range which will measure all resistances commonly used in electrical appliances, motors, etc.

As an Automotive Tester the Model 161 will test:

• Both 6 Volt and 12 Volt Storage Batteries • Generators  
• Starters • Distributors • Ignition Coils • Regulators • Relays  
• Circuit Breakers • Cigarette Lighters • Stop Lights • Condensers  
• Directional Signal Systems • All Lamps and Bulbs  
• Fuses • Heating Systems • Horns • Also will locate poor grounds, breaks in wiring, poor connections, etc.

Model 161 comes complete including 36-page book... Only

**\$22.50**

**SEND NO MONEY WITH ORDER—  
PAY POSTMAN NOTHING ON DELIVERY**

Try it for 10 days before you buy. If completely satisfied then send \$5.00 and pay the balance at the rate of \$5.00 per month until the total price of \$22.50 (plus small P.P. and budget charge) is paid. If not completely satisfied, return to us, no explanation necessary.

ACCURATE INSTRUMENT CO., INC.

Dept. B-212, 911 Falls St., New York 39, N.Y.

Please rush Model 161. I will pay on terms specified. Otherwise I will return tester.

Name \_\_\_\_\_

Address \_\_\_\_\_

City \_\_\_\_\_

Zone \_\_\_\_\_ State \_\_\_\_\_

All prices net, F.O.B., N.Y.C.

## JOBS WAITING

WE TRAIN YOU IN NEW YORK CITY

• AUTO MECHANICS • DIESEL • AUTO BODY  
& FENDER REPAIR • WELDING • FURNITURE  
UPHOLSTERY • SLIPCOVERS—DRAPES

Practical shop training. Day or eve. classes. Free job placement. Skilled men earn \$5-\$6 per hour. 30,000 students trained. Mail coupon.

**FREE  
JOB  
BOOK**

ROBERTS TECHNICAL AND TRADE SCHOOL  
517 W. 57th Street, Dept. PM-1, New York 19, N. Y.

Please Mail Me Free Job Booklet:

Name \_\_\_\_\_ Age \_\_\_\_\_

Address \_\_\_\_\_

City \_\_\_\_\_ State \_\_\_\_\_



**LINCOLN  
WELDERS**

## PORTABLE POWER PLANT AND WELDER COMBINED!

Sells for price of power generator alone—only **\$680.00\***

New Lincoln "WELANPOWER 225" combines 225-amp welder with 5000-watt power generator. Be prepared for power shortage. Have power for field jobs. WELANPOWER supplies power for lights, tools, machinery, farm equipment, home appliances. Pays for itself in daily use as a welder... welds, cuts, heats, brazes, solders, hardsurfaces. Dozens of uses including thawing frozen pipes. Get the facts from your Lincoln dealer today listed under Welders, Arc, in the telephone yellow pages. The Lincoln Electric Company, Dept. 4732, Cleveland 17, Ohio.

\*Including all accessories you need to weld. Undercarriage extra. \$20 higher in 11 Western States.

The World's Largest Manufacturer of Arc Welding Equipment and Electrodes



**NEW LOW PRICES  
ON LINCOLN  
180 and 225-AMP  
SHOP WELDERS**

AC-180-S—\$125

AC-225-S—\$140



You can make money in

# WATCH REPAIR

Learn at home the low cost Sweazey Way

Watch repairing pays up to \$6 an hour, part time watch makers report on survey. Unique and modern Sweazey home study System starts you making repairs right away on Swiss and American watches. Professionally prepared training. No previous experience needed. Special tools provided for practice. Tuition only \$5 a month. Diploma Awarded. Free sample lesson and opportunity book give all facts. Write today. No obligation.

**CHICAGO SCHOOL OF WATCHMAKING**  
2330 N. Milwaukee Avenue, Dept. 192, Chicago 47, Illinois

## FREE BOOK and SAMPLE LESSON

CHICAGO SCHOOL OF WATCHMAKING  
2330 N. Milwaukee Ave., Dept. 192, Chicago 47, Illinois  
Please rush FREE BOOK and Sample Home Study Lesson.

Name \_\_\_\_\_ Age \_\_\_\_\_  
Address \_\_\_\_\_  
City \_\_\_\_\_ Zone \_\_\_\_\_ State \_\_\_\_\_

## boaters! sea-vue hood



### FOR DEPTH FINDERS

Get distinct readings, from your present Depth Finder. Sight-engineered to eliminate glare, etc. Installs in seconds.

Send check or money order to:  
**projects unlimited, inc.** Only \$9.95 ppd.  
P. O. Box 1426 Northridge Station Dayton 14, Ohio

## Train The ALLIED WAY For Security - Good Pay

HOME STUDY or  
RESIDENT

**DRAFTING** ALL BRANCHES

**TOOL & DIE** DESIGNING & MAKING

**ENGINEERING**

**AIR CONDITIONING**  
HEATING & REFRIGERATION

**AUTO MECHANICS**

For Jobs Not Affected  
by AUTOMATION

Automation can never replace the Draftsman, Tool & Die Designer, Tool & Die Maker, Engineer, Air Conditioning and Refrigeration Serviceman, and Automotive Mechanic. In fact, these trained men are more in demand than ever. Allied training is endorsed by industry, accredited by National Home Study Council, and approved for Veterans training.

Send For FREE Books

ALLIED INSTITUTE OF TECHNOLOGY  
1338-42 South Michigan Ave., Dept. PM-92, Chicago 5, Ill.

Send me without obligation information on your courses:

Drafting—All Branches  Air Conditioning  
 Tool & Die Designing & Refrigeration  RESIDENT  
 Tool & Die Making  Auto Mechanics  HOME STUDY  
 Engineering

Name \_\_\_\_\_ Age \_\_\_\_\_

Address \_\_\_\_\_

City \_\_\_\_\_ County \_\_\_\_\_ State \_\_\_\_\_

**Lincoln**  
Johnson Cashway  
Lumber Co.  
1820 "R" St.  
**Millard**  
Millard Lumber & Grain  
Co.  
305 South Fifth  
**Neligh**  
Neligh Lumber, Grain &  
Coal Co.  
**North Platte**  
Field-Birge Co.  
101 West Front Street  
Waltemath Lumber Co.  
800 East Front  
**Ogallala**  
S. E. Martin Lumber Co.  
East Highway 30

### NEW JERSEY

**Belmar**  
Stern Coal &  
Lumber Co.  
12th & R.R. Aves.  
**Flemington**  
C. Tereshko Lumber Co.,  
Inc.  
Copper Hill  
**Fords**  
Fords Coal & Lumber Co.  
922 King George Rd.  
**Hackensack**  
Fairmount Coal &  
Lumber Co., Inc.  
Johnson Ave. &  
Lawton St.  
**Old Bridge**  
Discount Building Mate-  
rial Center  
Route 9, Madison Twnshp.  
**Plainfield**  
Plainfield Lumber &  
Supply Co.  
403 Berckman St.  
**Trenton**  
De Graaf Roofing & En-  
gineering Co., Inc.  
1240 Princeton Ave.  
**Wayne**  
Circle Building Supply  
Co., Inc.  
Route #23  
**West New York**  
West New York Lumber  
& Supply Co.  
Park Ave. & 52nd St.

### NEW MEXICO

**Carlsbad**  
D & B Lumber, Inc.  
**Hobbs**  
Hobbs Lumber & Supply  
Co., Inc.  
706 West Marland  
**Hollywood**  
C & L Lumber & Supply

### NEW YORK

**Baldwinsville**  
Tappan Lumber Corp.  
East Genesee St.  
**Bronx**  
Square Lumber Supply  
Co., Inc.  
115 Westchester Square  
**Brooklyn**  
Alco Lumber Co.  
5815 Bay Parkway  
Gem Lumber Co.  
286 Ninth Street  
John J. Doody & Son Inc.  
Ave. Y & East 17th St.  
**Elmont**  
Village Lumber  
1 Elmont Road  
**Medina**  
Lake Shore Lumber Co. of  
New York, Inc.  
222 Commercial Street

### NORTH CAROLINA

**Carrboro**  
Fitch Lumber Co.  
309 Greensboro Street  
**Dunn**  
Nu-Home Builders Supply  
Co., Inc.  
**Durham**  
Coman Lumber Co.  
912 Ramseur St.  
**Greensboro**  
Hodgin Roofing & Sup-  
ply Co.  
923 West Lee St.  
**Kinston**  
Grady's Building Supply  
& Hardware, Inc.  
512-514 East Vernon Ave.  
**Rose Hill**  
Herring Supply Co.

### NORTH DAKOTA

**Anamoose**  
Heringer Lumber Co.  
**Bismarck**  
W. T. Jennings Lumber  
Co., Inc.  
**Grand Forks**  
Ireland's Lumber Yard  
123 North Sixth Street  
**Jamestown**  
M. Mooney Lumber Co.

### OHIO

**Canton**  
The DeVillie Lumber Co.  
1225 Gross Avenue, N. E.  
**Cleveland**  
The West End Lumber Co.  
7517 Lorain Ave.  
The West End Lumber Co.  
4123 Pearl Road  
The West End Lumber Co.  
4520 West 130th Street  
**Conneaut**  
Lake Shore Lumber Co. of  
Ohio, Inc.  
360 Sandusky St.  
**Coshocton**  
Muskingum Valley  
Lumber Co.  
1247 East Main Street  
**Hamler**  
Panning Lumber Co.  
625 Belton Street  
**Maumee**  
Maumee Lumber & Sup-  
ply Co.  
707-717 Conant St.  
**Painesville**  
Lake Shore Lumber Co. of  
Ohio, Inc.  
284 Richmond St.  
**Uniopolis**  
Shaw Lumber Co.  
**Willoughby**  
Lake Shore Lumber Co. of  
Ohio, Inc.  
3884 Church St.

### OKLAHOMA

**Enid**  
Bank Lumber Co.  
302 East Maine  
**Ponca City**  
J. W. Dutton Lumber Co.  
339 S. Pine St.  
**Tulsa**  
Dale Carter Lumber Co.  
4459 South Sheridan Rd.  
Dickason Goodman  
Lumber Co.  
2712 West 40th St.  
Robert W. Dickson  
5249 South Peoria

### OREGON

**Baker**  
Builders' Supply  
2701 Court St.  
**Klamath Falls**  
Swan Lake Molding Co.  
**Milton-Freewater**  
J. E. Olinger & Sons  
216 S. Columbia  
**Pendleton**  
Van Petten Lumber Co.  
604 S.W. Dorion  
**Portland**  
King Building Supply  
4310 S.W. Beaverton-  
Hillsdale Highway

### PENNSYLVANIA

**Allentown**  
Anchor Bldg. Supply Co.  
7th St. Pike & Grape St.  
**Cecil**  
Desmet Lumber &  
Supply Co.  
**East Stroudsburg**  
R. C. Cramer Lumber Co.  
320 North Courtland St.  
**Erie**  
Lake Shore Lumber Co. of  
Pa., Inc.  
21st and East Ave.  
**Nicholson**  
Nicholson Lumber Co.  
**North East**  
Lake Shore Lumber Co. of  
Pa., Inc.  
45 Smedley St.  
**Sharon**  
Johnson-Sizer Co.  
369 South Dock Ave.  
**Union City**  
Mullen's  
5 Market St.

**TEXAS**

- Amarillo**  
E. B. Burgess Lumber  
418 Tyler  
Lumber & Supply Co.  
2601 East Third  
Seale Amerson Lumber &  
Building Co.  
4201 N.E. 8th Street
- Austin**  
Texas Lumber Co.  
1313 East 6th St.
- Bridge City**  
Fields Lumber Co.  
355 West Round Bunch  
Road
- Ft. Worth**  
Chickasaw Lumber Co.  
2701 West Vickery  
Jefson Lumber Co.  
3300 West Seminary  
Drive  
Sabine Valley Lumber Co.  
4329 East Belknap St.
- Houston**  
Maynor Lumber Co.  
6316 Mykawa Road  
Olshan Lumber Co.  
2600 Canal
- Midland**  
Andy's Lumber Co.  
1801 West Industrial
- New Braunfels**  
Richards & Krueger Co.  
674-686 S. Seguin Ave.
- Orange**  
West End Lumber Co.  
McArthur Drive
- Port Arthur**  
Wyde Lumber Corp.  
1205 Ft. Worth Ave.  
Wyde Lumber Co.  
3333 25th St.
- San Angelo**  
Armstrong Brothers  
Lumber Co.  
801 South Oakes
- San Marcos**  
Tuttle Lumber Co.  
228 South Guadalupe St.
- Shepherd**  
Beeson's Builders Supply  
Co.
- UTAH**
- Salt Lake City**  
Lillywhite Building  
Supply, Inc.  
3025 E. 33rd St.
- Midvale**  
Midvale Lumber & Hdw.  
Co.  
114 N. Main Street
- VIRGINIA**
- Abingdon**  
Miller & Bradley, Inc.
- Chatham**  
McLaughlin Supply Co.  
Main Street

- Harrisonburg**  
R. S. Monger & Sons,  
Inc.  
265 Cheaspeak Ave.
- Virginia Beach**  
Virginia Beach Lumber &  
Supply  
Birdneck Road

**WASHINGTON**

- Mt. Vernon**  
J. W. Copeland Lumber  
Co.
- Olympia**  
Hyak Lumber &  
Millwork, Inc.  
408 Olympia Ave.  
Lumbermens Mercantile  
Co.  
502 Custer Way
- Sunnyside**  
Home Lumber Inc.  
213 State Highway
- Yakima**  
Sears Lumber Market  
2318 South 1st St.

**WEST VIRGINIA**

- Charleston**  
Wright-Bachman Lumber  
Co. of W. Va.  
**South Charleston**  
Evans Lumber Co.  
**Weirton**  
The Weirton Lumber Co.  
914 Cove Road

**WISCONSIN**

- Beaver Dam**  
Roedl-Jacobs Lumber Co.  
114 East Third Street
- Fort Atkinson**  
The Hoffman Lumber Co.  
10 Madison Ave.

- Kenosha**  
Andrews Lumber Co., Inc.  
4800 75 Street

- Racine**  
Weeks Lumber Co.  
2000 Douglas Ave.

- Sheboygan**  
Ebenreiter Lumber Co.  
1221 Erie Ave.

- Wabeno**  
Twin City Lumber & Fuel  
Co.

- Wausau**  
Schuette Builders Co.  
1330 South 11th Ave.

**WYOMING**

- Laramie**  
Otto Builders Supply Inc.  
463 West Garfield

- Lusk**  
Frontier Lumber Co.

- Powell**  
Powell Lumber Co.  
206 South Absaroka

- Sheridan**  
Vickere Lumber Co.  
135 North Gould

**BE A  
REAL ESTATE  
BROKER**

**FOR SALE  
YOUR  
NAME  
HERE**

**PAYS BIG! SEND FOR FREE, BIG, ILLUSTRATED CATALOG NOW!** Graduates report making substantial income. Start and run your own business quickly. Men and women of all ages, learn easily. Course covers Sales, Property Management, Appraising, Loans, Mortgages, and related subjects. **STUDY AT HOME** or in classrooms in leading cities. Diploma awarded.

**FREE  
BOOK  
TELLS  
HOW**

*Approved for World War II and Korean Veterans*

**WEAVER SCHOOL OF REAL ESTATE (Est. 1936)**  
3523 R Broadway, Kansas City 11, Mo.

Please send me the Free Book, without obligation. I am interested in learning how the Weaver School trains men and women for Real Estate.

NAME \_\_\_\_\_  
ADDRESS \_\_\_\_\_  
CITY \_\_\_\_\_ ZONE \_\_\_\_\_ STATE \_\_\_\_\_

Send for your free WHERE-TO-FIND-IT list giving sources of supply or further information on articles in this issue.

**POWERFUL NEW INVENTION, ONLY 2" LONG  
SHOOTS THRU 100  
PAGES-THIS BOOK!  
'B-B SHOT'**



MAKE THIS TEST... Load your 'BB Shot' and fire against this magazine. Notice that it drives BB's through more than 100 pages. Though only 2" long x 1" in diameter, this pocket-size device has amazing power and accuracy. Use it for targets, pests and hunting. Scientifically designed for high power, operating ease and safety.

**FREE!** Get the 'BB Shot' now—we'll include an extra Velocity Cone and FREE Target, BB's and Automatic BB Dispenser... all for only \$1.98 ppd. 3 for \$5.00 ppd. Money Back Guarantee. Not sold to N. Y. C. residents or minors

**GRAYSON CO. • Dept. B-99, 210 Fifth Ave., N. Y. 10**

**MONEY-BACK  
GUARANTEE** Name.....  
Address.....  
City..... State.....

**\$198  
ppd.**

**LEARN  
UPHOLSTERY**  
in your spare time  
run your own  
business  
AT HOME

**FREE BOOK  
with  
sample  
lessons**

**With Course  
You Make**

**SLIPPER  
CHAIR**

**CLUB  
CHAIR**

**OTTOMAN**

**PLUS  
SLIP COVERS  
Yours to Keep  
or Sell**

**FREE TOOLS  
WITH COURSE**

**BE YOUR OWN BOSS**  
Earn more from the start in spare time. STOP worrying about layoffs, enjoy a steady growing income and independence for life in the booming field of Custom Furniture Upholstery. Right off, you start upholstering with the tools, complete frames, fabrics and materials, included FREE with N. Y. State-approved UTS Home Study Course. You learn skilled professional custom upholstery, reupholstery, furniture finishing, repairs, how to make valuable custom slip covers, cushions and draperies EARN WHILE YOU LEARN, in your spare time AT HOME... the UTS easy way.

**FREE ILLUSTRATED BOOK—FREE SAMPLE LESSON** Get ready for well-paid job and big profits, from steady work, as your own boss, running your own business. Training in N.Y. School also available. Mail coupon NOW for FREE BOOK!

**VET APPV'D. ACCREDITED BY N.H.S.C.**

**UPHOLSTERY TRADES SCHOOL  
TO-310, 721 B'way, N. Y. 3, N. Y.**

Please send me FREE book, "Your New Way to a Successful Career," and FREE sample lesson. No obligation—no salesman will call.  
 Home Study  Training in N. Y. School

Name .....  
(Please Print Plainly)  
Address .....  
City ..... Zone ..... State .....

Check if Korean Veteran



## Just Half Size

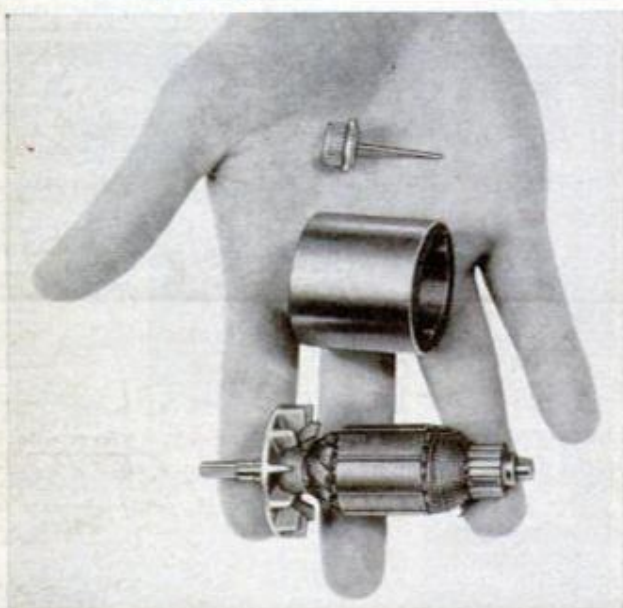

NOW COMES THE smallest portable electric drill of  $\frac{1}{4}$ -in. capacity. It's not just a handful like its contemporaries. It's less, as you can see from the photo above—only about twice as long as your index finger, from the very tip of the chuck jaws to the back of the motor housing. And note also the comparisons in the lower photo with the present average-size  $\frac{1}{4}$ -in. drill and the old. Yet this new mite is industrially rated  $\frac{1}{4}$ -in. capacity and the weight has been held to just 27 ounces.

The lifetime guaranteed permanent-magnet stator, center photo, is a solid unit, no wire windings. There are no electrical connections from the stator to any other parts of the drill. There are no soldered leads in the armature. They are welded to immunize motor construction from the effects of heat. The pistol grip is of plastic and the switch is adjustable to suit individual touch. The chuck turns at a free, or no-load, speed of 1250 r.p.m. on 115-v. alternating current. A diode circuit converts a.c. input to direct current within the tool itself. For this reason the drill can be operated only on alternating current. Drills  $\frac{1}{4}$ -in. holes in metals;  $\frac{3}{4}$  to 1-in. holes in wood. It's priced at \$32.50 with cord and chuck wrench by Thor Power Tool Co., 175 N. State Street, Aurora, Ill.

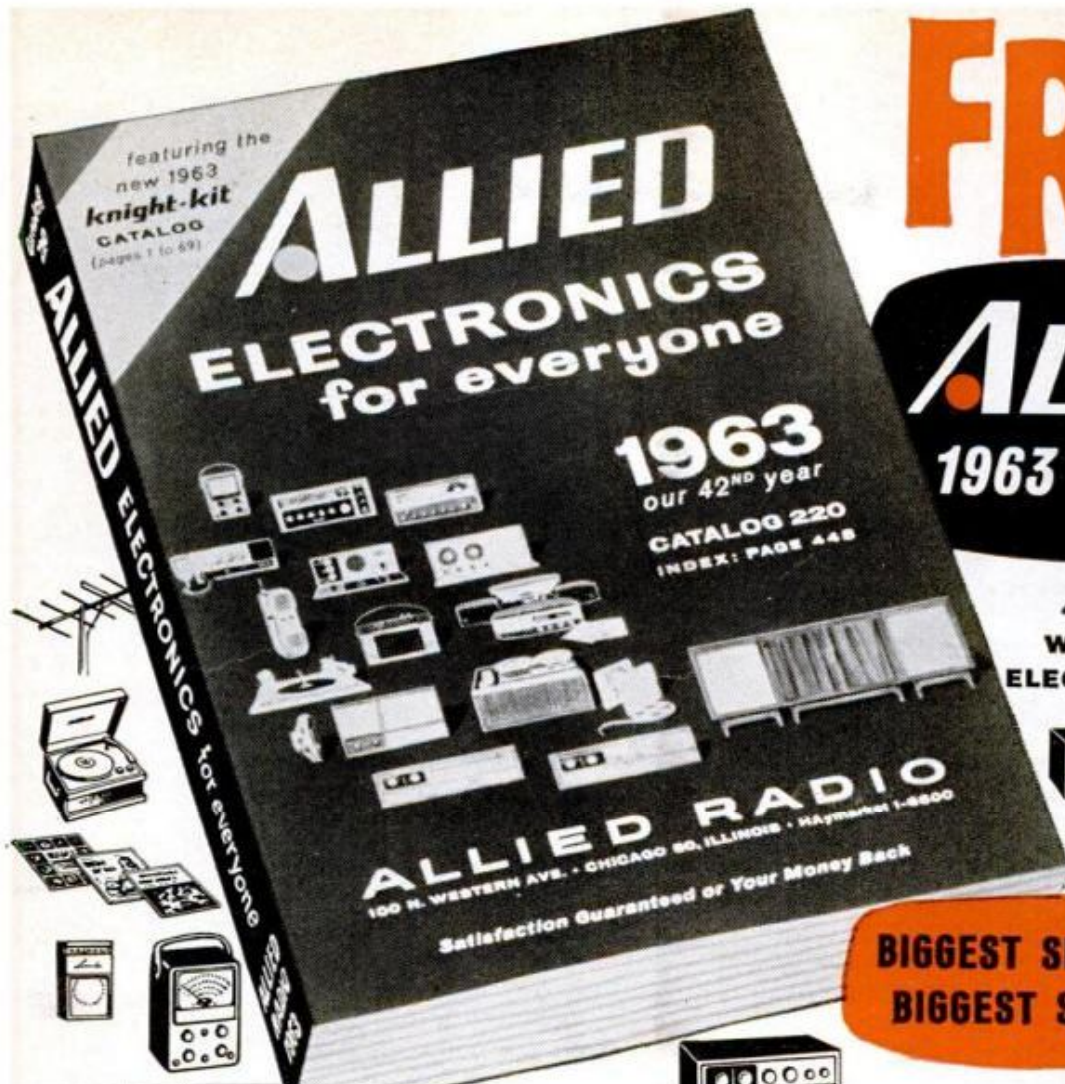

# FREE

## ALLIED 1963 CATALOG

**464 PAGES  
WORLD'S LARGEST  
ELECTRONICS CATALOG**

**BIGGEST SELECTION  
BIGGEST SAVINGS!**

see what's new in  
**STEREO HI-FI**

top buys in  
**TAPE RECORDING**

latest values in  
**CITIZENS BAND &  
SHORTWAVE RADIOS**

exciting build-your-own  
**knight-kits**

**NO MONEY DOWN:** Over 50% More  
Buying Power with your  
Allied Credit Fund Plan!

*Satisfaction guaranteed or your money back*

**ALLIED RADIO**  
The World's Largest Electronic Supply House

SEPTEMBER 1962

### SAVE MOST ON:

- Everything in Stereo Hi-Fi
- New All-Transistor Stereo
- KNIGHT® Super-Value Hi-Fi
- Tape Recorders & Tape
- Citizens Band 2-Way Radios
- Transistor & FM-AM Radios
- Phonographs & Records
- Ham Station Equipment
- PA Systems, Intercoms
- Latest Test & Lab Instruments
- TV Tubes, Antennas, Accessories
- Parts, Tubes, Transistors, Books, Tools

### ALLIED EXCLUSIVES:

See special products  
and values available  
only from Allied—plus  
all the famous makes!

**FREE**

**SEND FOR YOUR COPY TODAY!**

ALLIED RADIO, Dept. 2219J  
100 N. Western Ave., Chicago 80, Ill.

Send FREE 1963 ALLIED Catalog

Name \_\_\_\_\_  
PLEASE PRINT

Address \_\_\_\_\_

City \_\_\_\_\_ Zone \_\_\_\_\_ State \_\_\_\_\_





**PM TEST SHOOTER** Ken Warner demonstrates the sitting position that proved steadiest for field shots

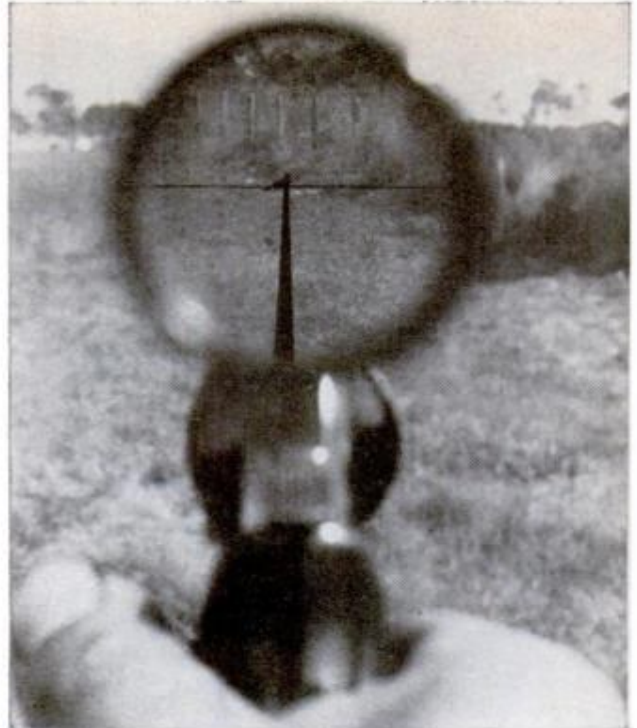

**THAT'S A CROW** in Ken's sight at 60 yards—a ten-to-one chance ordinarily; a sure thing with the scope

## 'Scope Sight Turns Handgun Into "Pocket Rifle"

**HANDY AS IT IS** for carrying, the handgun has never been popular for long-range plinking and varmint shooting because only a few experts could score on distant targets with pistol iron sights. Now, however, with 'scope mounts available for many handguns, they can be fitted with low-power, long eye-relief telescopic sights, and transformed into a plinking and pest-shooting tool almost equal to an equivalent rifle—and a lot handier.

PM's test rig matched a Smith & Wesson K-22 Masterpiece revolver in .22-Magnum caliber with a Weaver K2.5 sight, using a

stock Buehler mount made for the K-series weapons. The conversion took just a few minutes, with only a screwdriver.

In the field, the new rig proved good enough for crow shooting at 100 yards. It delivered hand-sized groups at that range, and quarter-sized groups at 50 yards or less. The sight permitted the shooter to take advantage of the .22 Magnum's inherent accuracy for the first time. The entire outfit, loaded, weighed only 50 ounces.

The only problem was in holding the gun steady. You must use a braced two-handed position or fire from a rest.—Ken Warner

**ATTACHING THE SCOPE** was easy with this equipment, but usually requires drilling one hole on any handgun

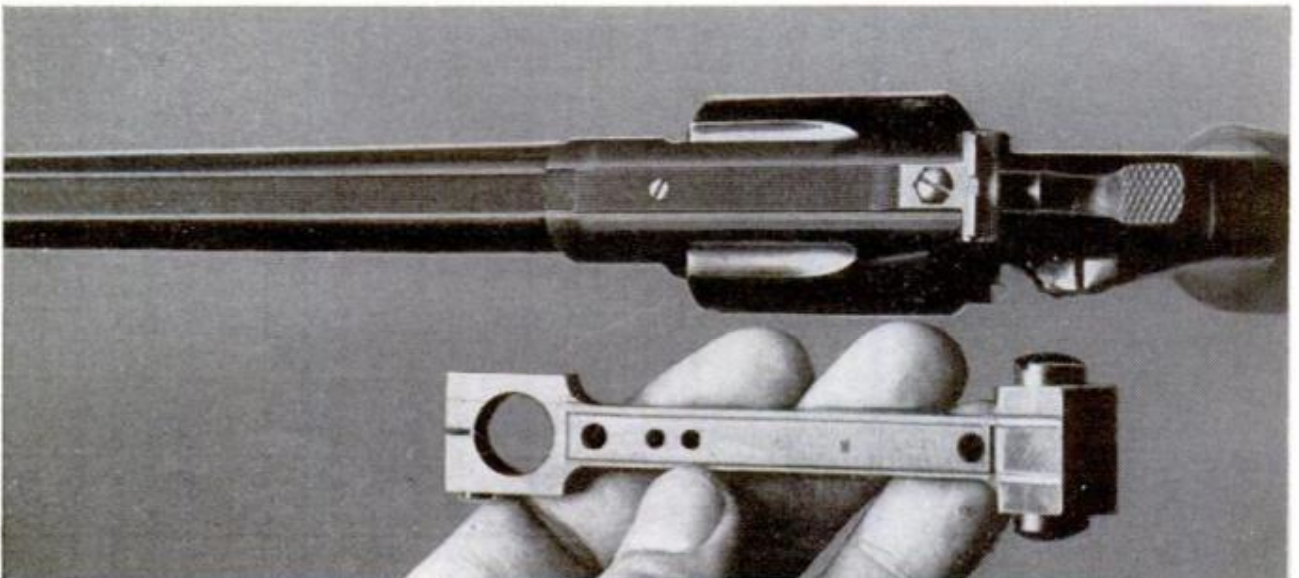



## POPULAR MECHANICS

Books for the Farmer

- to reduce work
- protect and improve livestock
- increase profits



### New Ed. Veterinary Guide for Farmers

Written by farm expert, G. W. Stamm, this amazing book has sold more than a quarter million copies . . . now completely revised with most modern discoveries and methods fully discussed. Adopted by the U. S. Government for farm training. Used by farmers everywhere to diagnose and treat livestock diseases. Covers virtually every farm animal ailment and tells how to tell one from another; explains treatment or best procedure until the vet arrives. Includes a special, invaluable 12-page diagnostic chart that helps you locate symptoms in short order. A special chapter is devoted to artificial insemination and tells how this breeding method can improve the quality of your herd as well as increase your profits. Noted authorities proclaim: this book the finest and most complete guide of its kind

**\$3.95**



### New Edition Farm Manual

Helps you step up farm efficiency, improve property appearance and values, increase farm production and income. Every member of the farm family will find something in this book he or she can use to great advantage in farm operation, maintenance and improvement . . . from the building and care of equipment to painting the farm home and fast freezing of fruit and vegetables. Covers every aspect of farm machinery maintenance . . . includes detailed plans for building essential equipment from scrap and discarded materials. Even suggests how to mix and pour concrete that will last longer! Here is a book brimming with short cuts, labor-saving ideas and methods that will simplify farm chores and save you money as well. Adopted by State Farm Training Programs. Hundreds of pictures and clearly drawn diagrams.

**\$3.00**



### Artificial Breeding and Livestock Improvement

Now—the secrets of the key to better livestock revealed by farm editor, G. W. Stamm! The first book in ten years to cover the up-to-date principles and practices of Artificial Breeding . . . and written in words every farmer and stockman can understand easily and follow surely. This astonishing book presents the true, approved facts on inbreeding, line-breeding and cross-breeding, plus sections on timing, heat periods, how to pick a good dairy cow, how to choose a herd sire, what to do when a bull fails to perform, what's ahead in the field of frozen semen and many other topics of equal interest. Included is a 13-page directory of semen producers, the areas they serve and the breeds of bulls in their studs. If you are a modern livestock producer interested in the best methods and top profits, you simply cannot afford to be without this book for regular reference.

**\$3.95**



### Developing a Profitable Dairy Herd

Here, in a single, practically written book is everything you want and need to know about profitable dairy herd management. Written by Carnation Farms' Merton L. Moore and E. M. Gildow, D.V.M., there is complete information on feeding values, fertilization of pastures, silo practices, breeding, production, pedigrees, management problems and operating economies, vitamins and many other vitally important subjects. A most interesting chapter covers the showing and selling of cattle. Hundreds of charts, photos, drawings and diagrams leave nothing to the imagination. Whether you raise just a few cows or maintain a huge operation involving hundreds of animals—you'll profit from using this book.

**\$3.50**



### Hog Profits for Farmers

Hog raising can be highly profitable for the farmer . . . if proper management and feeding methods are employed. Even if you raise only a few hogs you can make a much bigger profit by applying the suggestions and ideas contained in this outstanding Popular Mechanics book. Written by Dr. W. N. McMillen, it offers down-to-earth, practical money-making information on care and management, feeds and feeding, equipment, marketing, breeds and breeding, judging, showing and sales tips. Contributors include many well-known agricultural experts and renowned college instructors. Only a mere 15 minutes of reading time will show you how to apply the six high points of profitable hog raising to improve your profits immediately.

**\$3.00**

Satisfaction Guaranteed or Your Money Refunded.  
Place your order now. Use coupon below.



POPULAR MECHANICS PRESS, Dept. 962

740 Rush St., Chicago 11, Illinois

RUSH books I have checked below. If not pleased, I can return in good order within seven days for full refund.

Remittance enclosed. Send prepaid.

Veterinary Guide     Farm Manual     Artificial Breeding  
 Profitable Dairy Herd     Hog Profits

Name \_\_\_\_\_

Address \_\_\_\_\_

P.O. \_\_\_\_\_

State \_\_\_\_\_



## FOR BIG PAY JOBS ON DIESEL AND HEAVY EQUIPMENT

Qualified, trained men are needed NOW to operate, service, repair the Diesel and Heavy Equipment used in the fast-growing highway building, trucking, transportation, etc. industries. If you are mechanically inclined Interstate can help you qualify for these unusual job and advancement opportunities. Get information today about Interstate's internationally recognized General and Cummins-approved Diesel home-training programs. No obligation. Free advisory placement service for trainees. Men are needed NOW!

**GET THE FACTS TODAY!**

**FACTORY TRAINING**  
for Qualified Men

**INTERSTATE TRAINING SERV.**

Dept. A-3, Portland 12, Oregon  
Rush information on I.T.S. Diesel Courses, Factory Training and Diesel Job Opportunities.

Name \_\_\_\_\_ Age \_\_\_\_\_

Address \_\_\_\_\_

City \_\_\_\_\_ Zone \_\_\_\_\_ State \_\_\_\_\_

Shop PM Ads for Exciting  
Direct-Mail Offers

## "I Earn Two Incomes Now"



Says John Bennie, Pittsburgh, Pennsylvania

"Thanks to your wonderful training, I have been able to earn \$1300 a year extra doing little locksmith jobs at home. This is the best trade a man can take up."

## Be a LOCKSMITH



Add 50% - 100% to YOUR INCOME with easy spare time earnings. Cash in on nationwide shortage . . . in good times and bad. Quickly step into a big-pay opportunity job - high profit shop of your own.

**Earn Extra Money RIGHT AWAY! All Special Tools, Supplies Furnished FREE.**

Age, education, minor physical handicaps don't matter in this growing trade. You can quickly qualify as a skilled locksmith. Study at home as little as one hour a week. Gain practical experience through well-illustrated lessons. Do real jobs on car locks, house locks, padlocks and safe locks, under guidance of experts.

**FREE Illustrated Book**

For a future as your own boss or in a high-pay job, send for FREE book and sample lesson pages. Only school of its kind. Lic. State of N.J. Acc'd NHSC. Vet. App'd. Locksmithing Institute (Div. of Tech. Home Study Schools). Dept. 109-2, Little Falls, N.J.

**MAIL COUPON NOW!**

Please send, without obligation, FREE Book, "Big Money in Locksmithing," and Sample Lesson Pages. No Salesman will call.

LOCKSMITHING INSTITUTE, Dept. 109-2  
Little Falls, New Jersey

Name \_\_\_\_\_  
(Print here)

Address \_\_\_\_\_

City \_\_\_\_\_ Zone \_\_\_\_\_ State \_\_\_\_\_

Check if Veteran

# On the market

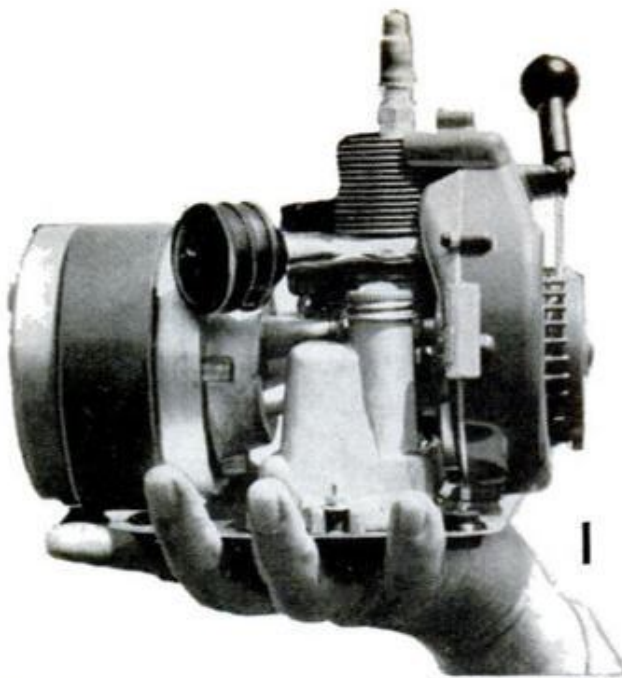

**1. TINY TIGER MOTOR-GENERATOR** delivers 350 watts of 115-volt electric current for two hours with one filling of outboard-motor fuel. With this 9-lb. unit you can perk coffee, fry bacon and eggs, run an electric drill, shave and do sundry other chores. Available in three types. Made by Gadco Electra, 2325 Wilshire Blvd., Santa Monica, Calif.

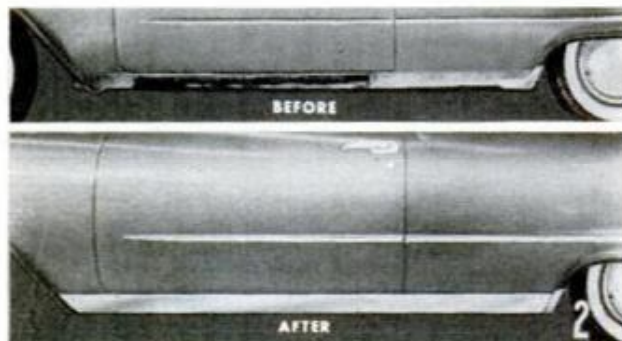

**2. NEW ROCKER PANEL** dress-up and repair kit is made of heavy-gauge stainless steel with aluminum step plates. Simple snap-in installation requires no shop facilities. Available for 1957-59 Plymouth, Dodge, DeSoto and Chrysler, 1955-59 Fords and 1956-59 Chevrolets. MoPar Parts and Accessories, Chrysler Motors Corp., P. O. Box 1718, Detroit 31, Michigan



**3. AUTO SAFETY KIT** contains essential items you need for road emergencies. Included is a tire sealer with enough air to inflate tire, two flares and extinguisher; antifog and mist cloth for windshields and a first-aid manual. Packed in cardboard carrying case with built-in handle. Price \$3.99. Metron Industries, 128-30 14th Ave., College Point 56, N. Y.

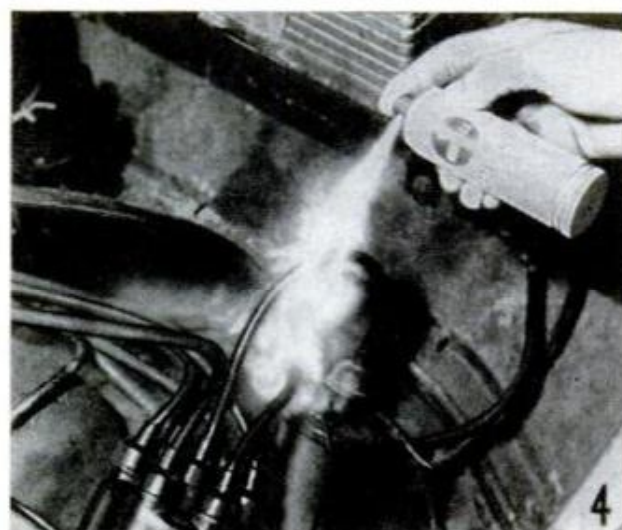

**4. SPECIAL MULTIPURPOSE COMPOUND** penetrates scale, dirt and corrosion to remove moisture; lubricates and seals against future corrosion. Removes moisture from ignition systems in a matter of minutes plus many other uses in homes, shops and industry. Available in 2 and 12-oz. spray and 1-gal. containers. Peerless Tube Co., 58 Locust Ave., Bloomfield, N. J.

**5. HAND WOVEN CANE** in a variety of patterns is sealed between layers of rigid plastic to provide new charm for interior decoration. Use it for panels, doors, screens, window treatment or novel lighting. Standard sheets are 4 x 8 ft. clear or opal plastic. Others can be had on special order. Polyplastex United, Inc., 870 Springfield Ave., Union, N. J.

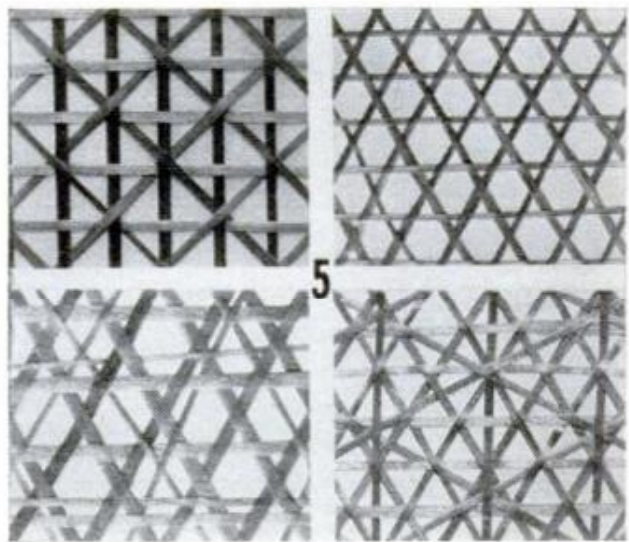



**MADE IN ENGLAND**

**SET OF THREE MICROMETERS**  
OUTSIDE & DEPTH - FROM 0 TO 2 INCHES

SCALED TO .001"  
Complete with vinyl case

**\$9.95**  
ONLY PREPAID

**FECIL**  
1640 N. E. 123 ST., N. MIAMI, FLA.

## ARE YOU MOVING?

**SIX WEEKS IS REQUIRED to change your magazine address.**

A new regulation of the Post Office effective January 10, 1962 requires that you pay the extra postage if copies of POPULAR MECHANICS are forwarded to you at your new address. Copies will not be forwarded free and we cannot replace lost copies. To insure delivery at your new address please notify us at least six weeks in advance of your moving. Send us your old and new address and if possible the address label from your last issue . . . include your postal zone number. Thank you.

Write to:

**POPULAR MECHANICS**  
Subscription Dept.  
250 West 55th St., New York 19, New York

## Shrinks Hemorrhoids New Way Without Surgery Stops Itch - Relieves Pain

For the first time science has found a new healing substance with the astonishing ability to shrink hemorrhoids and to relieve pain - without surgery.

In case after case, while gently relieving pain, actual reduction (shrinkage) took place.

Most amazing of all - results were so thorough that sufferers made astonishing statements like "Piles have ceased to be a problem!"

The secret is a new healing substance (Bio-Dyne®) - discovery of a world-famous research institute.

This substance is now available in suppository or ointment form under the name Preparation H®. Ask for it at all drug counters.

SEPTEMBER 1962

**ENGINEERING  
SCIENCE  
MATH** **B.S. DEGREE  
IN 36 MOS.**

**U.S. NEEDS 50,000 NEW ENGINEERS EVERY YEAR**  
EARN ACCREDITED B.S. DEGREE in Science or Engineering in 36 months—year-round program optional. 27-month engineering diploma also available. Classes start September, January, March, June. QUALITY EDUCATION. Graduates employed throughout U.S. and foreign countries. Government approved for veteran training. Students from 50 states, 40 countries, 20 buildings; dorms, gym, Campus. New library and laboratories. Employment help provided. SAVE TIME AND MONEY.

Write for catalog and complete information.

## INDIANA TECHNICAL COLLEGE

1612 E. Washington Boulevard, Fort Wayne 2, Indiana

Please send free information on accredited B.S. Degree programs in Engineering and Science as checked:

- |   |  |
|---|--|
| <input type="checkbox"/> Aeronautical Engineering | <input type="checkbox"/> Mechanical Engineering    |
| <input type="checkbox"/> Chemical Engineering     | <input type="checkbox"/> Metallurgical Engineering |
| <input type="checkbox"/> Civil Engineering        | <input type="checkbox"/> Physics                   |
| <input type="checkbox"/> Electrical Engineering   | <input type="checkbox"/> Chemistry                 |
| <input type="checkbox"/> Electronic Engineering   | <input type="checkbox"/> Mathematics               |

Name \_\_\_\_\_

Address \_\_\_\_\_

City \_\_\_\_\_ State \_\_\_\_\_

## A PERFECT HOLIDAY GIFT IDEA (Rocket Viewer can be worn with glasses. Keeps both hands free.)

A precision stereoscopic magnifier complete with 3 interchangeable lens strengths. Ideal for: Hobbyists, Doctors, Chemists, Artists, Dentists, Machinists, etc. Standard Unbreakable Watch Crystals, 123 E. 144 St., N.Y. 51, N.Y.



\$12.50

## CAREER TRAINING FOR GAS TURBINE JET ENGINE MECHANICS

Learn how you can cash in on the fabulous future for jet/gas turbines

Worldwide conversion to jet aircraft plus coming use of gas turbine power for cars, trucks, tractors, boats—here is the opportunity of a lifetime for a career offering high wage potential, job prestige and long-term security.

**MAIL  
COUPON  
NOW**

Learn how Jetma can train you for only a few dollars a week. Budget terms. Free placement service for graduates.

NOT just a home study course.

JETMA TECHNICAL INSTITUTE Dept. PM 92  
103 So. Airport Blvd., So. San Francisco, Cal.

Please rush free bulletins on gas turbine course.

Name \_\_\_\_\_

Address \_\_\_\_\_

City \_\_\_\_\_ Zone \_\_\_\_\_ State \_\_\_\_\_



57



**NOW YOU CAN  
BUILD A FINE**

*Schober Organ*

**FOR ONLY  
\$550**

You can assemble this new Schober Spinet Organ for \$550 — or half the cost of comparable instruments you have seen in stores. The job is simplicity itself because clear, detailed step-by-step instructions tell you exactly what to do. And you can assemble it in as little as 50 hours.

You will experience the thrill and satisfaction of watching a beautiful musical instrument take shape under your hands. The new Schober Electronic Spinet sounds just like a big concert-size organ — with two keyboards, thirteen pedals and magnificent pipe organ tone. Yet it's small enough (only 38 inches wide) to fit into the most limited living space.

You can learn to play your spinet with astounding ease. From the very first day you will transform simple tunes into deeply satisfying musical experiences. Then, for the rest of your life, you will realize one of life's rarest pleasures — the joy of creating your own music.

For free details on all Schober Organs, mail the coupon now. No salesman will call.

THE *Schober Organ* CORPORATION

43 West 61st Street, New York 23, N. Y.  
Also available in Canada and Australia.

**MAIL THIS COUPON TODAY**

The Schober Organ Corporation, Dept. PM-8  
43 West 61st Street, New York 23, N. Y.

- Please send me FREE booklet and other literature on the Schober Organs.
- Please send me the Hi-Fi demonstration record. I enclose \$2 which is refundable when I order my first kit.

Name.....

Address.....

City.....Zone...State.....



**How This can be the  
TURNING POINT in your life**

**Own Your Own Business  
... Be Independent ...  
Every Dollar You Make is  
Yours ... No One Can  
Lay You Off!**

Your neighbors, stores, barber and beauty shops, supermarkets, hospitals, everybody needs sharpening service. The TREYCO Method of grinding

knives, seissors, clippers, tools and saws brings you cash customers. Make as much as \$6.00 an hour, spare or full time! We don't leave you high and dry—you get FREE Instruction and Marketing Manuals, signs, display and mailing cards, newspaper and yellow page ads to help you get started and build up your business. Personal instruction course also available. Take advantage of your ability and earning power. Write for the TREYCO plan.

**TREYCO PRODUCTS 375 Old Falls Blvd.  
N. Tonawanda, N. Y.**

**GET INTO ELECTRONICS**

V.T.I. training leads to success as technicians, field engineers, specialists in communications, guided missiles, computers, radar, automation. Basic and advanced courses. Electronic Engineering Technology an ECPD accredited Technical Institute curriculum. Assoc. degree in 20 mos. B.S. obtainable. G.I. approved. Start Sept., Feb. Dorms, campus. H.S. graduate or equivalent. Catalog.

**VALPARAISO TECHNICAL INSTITUTE**

DEPT. D VALPARAISO, INDIANA



**Given to men who want to get into  
CRIME DETECTION  
FINGER PRINT IDENTIFICATION**

Train at home, spare time. Join hundreds of I.A.S. graduates now employed by police and identification bureaus in every state. Learn finger print identification, crime investigation, firearms identification, police photography, other subjects vital to qualifying for good pay, secure, interesting jobs. "Blue Book of Crime" and details free. Must state age.

**Institute of Applied Science, Dept. 1356**

A Correspondence School Founded in 1916  
1920 Sunnyside Ave., Chicago 40, Ill.

**FREE GUIDE Reveals 200 Ways  
to Make Extra Money**

YOU can turn your spare hours into cash (\$25 to \$100 a week) by selling products and services to friends and others. Famous *Salesman's Opportunity Magazine* shows you how. Contains hints, plans, hundreds of offers. No matter what your age, experience or occupation—write TODAY for next 5 issues—absolutely FREE. Send no money just name. OPPORTUNITY, 850 N. Dearborn, Dept. 547, Chicago 10, Ill.

**EARN MORE be a TAX CONSULTANT**

Our students earn lucrative fees in 3 month busy tax season preparing income tax returns in spare time—and operate profitable Business Tax Service yielding steady monthly fees of \$10-\$50 per client, year 'round. Enjoy professional standing in dignified full or part time home-office business. No experience necessary. We train you at home and help you start. Write today for free literature. No agent will call. State Approved Course.

**UNION INSTITUTE, Lakewood, Q20, New Jersey**

**New Table Top Invention Puts You In...**

**PROFITABLE RUBBER  
STAMP BUSINESS**

**Home Operators now make  
\$9.20 AN HOUR in Business  
once monopolized by  
a few big companies**

Special rubber stamps bring high prices—cost only pennies to make on new, low-cost table top machine. Take 27 cents worth of material, make perfect stamps, the kind businesses and offices now buy by the dozen at \$1.80 each. Make up to \$9.20 an hour. Start in spare time in your own home. Run machine on kitchen table using ordinary electrical outlet. Make any kind of stamp. We'll send you free information without obligation about this established, highly profitable business. **We'll even help finance your start.** For free information send name and address today on a postcard to: Rubber Stamp Div., 1512 Jarvis Ave., Dept. R-2-K, Chicago 26





# CLASSIFIED ADVERTISEMENTS



Advertisements in this section \$1.35 per word, each insertion, minimum 10 words, payable in advance. To be inserted under proper classification, copy must be in our office the 18th of the second month preceding date of issue  
F. W. Johnson, Manager, Classified Advertising  
Popular Mechanics, Classified Adv. Dept., 740 Rush St., Chicago 11, Illinois

## YOU'LL PROFIT

By reading and answering the classified ads in this section. Hundreds of opportunities for you to make and save money

### AUTOMOBILES, MIDGET CARS

**AUTOMOBILE** Literature, antique, modern; catalogs, photos, manuals. Monthly bulletin. Non-profit organization. Free information. Enthusiasts, Box 451B, Mount Clemens, Mich.

### AUTO SUPPLIES AND EQUIPMENT

**STEAM** Automobile conversion kit. Financially responsible franchises open. Shaw, Box 1144, Palo Alto, Calif.

**TIRES.** Spectacular savings. National brands. All types for farm equipment, auto, trucks. Write today: Romar Tire, 10 Penn St., Woodbury, N. J.

**JEEP Parts!** For military and civilian. At great savings. Largest inventory. Catalog for owners and dealers. Inquiries invited. American Auto Parts Co., 1830-PM Locust, Kansas City, Mo.

**NEW** And used parts at savings. Complete guaranteed parts service for all models cars and trucks. Largest in the West. Jeep and army parts specialists. Newest type shifting hubs for all jeep and all military and latest production front end drive vehicles. \$27.50 and up. Also, foreign car parts. Write, Pioneer Auto and Truck Parts Co., 734 W. 13th Avenue, Denver 17, Colo.

**PARTS.** Model "A." List 25¢. (Refundable) Matco, Box 135, San Pedro, Calif.

1909-1934 **FORD** Parts illustrated catalogs 75¢. Mark Auto, Layton, N. J.

**RING-Valve** job while driving, \$6.00 postpaid. Guaranteed! Nothing like it! Used by mechanics! Motaloy, Grantham, Penna.

**SAVE** Up to 50% on auto parts, accessories! Get new 356-page illustrated catalog, just out. Over 100,000 items to renew, rebuild, renovate all makes, models domestic, foreign cars, trucks, sports cars, from 1920 to 1962's; '28 to '31 Model A! Latest Hollywood accessories, custom and hi-speed equipment. Rush 25¢ for postage, handling—refundable on first order. Whitney, 1919 FM-9 Archer, Chicago 16.

**AUTO** Shop welding repair training in world's largest non-profit welding school. Low tuition. Free booklet. Hobart Welders, Box M-921, Troy, Ohio.

**ELECTRONIC** Spark intensifier changes ignition spark to fireball. Patent pending. Amazing! Simple installation! Increases efficiency and point life. \$10.95 postpaid. State car voltage, compression. Raybin, 10908 Crenshaw, Inglewood, Calif.

**CRANKSHAFT** Grinder, hand operated. Makes bearings fit without taking engine apart. \$5.00. Literature. L. D. McOee, 719 Cascade, Wenatchee, Wash.

**GEM** Brilliance for your car. Unique multi-safety light. Also magna-sighter. Free details. Quality Products, 217A, Huntington, Utah.

**STOP,** Oil pumping \$4.95. Ready Sales, 16161 Mark Twain, Detroit 35, Mich.

**TRANSFIRE** Transistor electronic ignition. Points, plugs last longer. Top performance, economy. Kits from \$34.95. Parts. Literature. Palmer Electronics, P27M, Carlisle, Mass.

**SELL** America's sensational patented new auto alarm. Ingenious mechanical mechanism. Fabulous profits! Sells fast. Demonstrator \$4.95 postpaid. Gregory, 2440-A Euclid, Cleveland 15, Ohio.

**JEEP** Owners — V8 conversions. Read Jeep Owners ad, page 30.

**NEVER** Run out of gas. Amazing reserve fuel container snaps into spare tire. For Volkswagen, Mercedes, Porsche. Literature free. Midwest Imports, P.O.B. 988M, Chicago 90.

### AUTO TRAILERS

**BUILD** Camping travel trailers. Illustrated circulars 20¢. Kamcraft, Box 1153, Milwaukee 1, Wis.

**PICKUP** Campers. Pre-cut Kits. Blueprints. Supplies. Literature 10¢. Comstock Trailers, Parsons, Kansas.

### MOTORCYCLES, BICYCLES, MOTORSCOOTERS AND SUPPLIES

**MOTORIZED** Your bicycle. Plans \$1.00. Kits \$69.95: Go-Byk, Fergus Falls, Minnesota.

**GO** Cart \$10. Cushman \$15, less engines. Engines \$2 up. Servicycle \$25, motorbike motor \$15. (Mailorder only). Send 25¢ (35¢ for First Class Mailing) for 32-page Directory-Catalogue Number 109, listing these and hundreds of other bargains in go-carts, motorscooters, homebuilders plans, parts, etc. Midget Motors Directory, Athens, Ohio.

**MOTORCYCLE** Parts. New, used. List 25¢. Ballak, 811 N. 9th, St. Louis 1, Mo.

**TRAVELALL** Scooter for farm, fun, street and trail. Literature 10¢. Ansa, 2202 Tulare, Burbank, Calif.

**MINI-BIKE,** Go-kart parts, accessories frames, engines. Free catalog. Box 511, Janesville, Wisconsin.

**HARLEY-Davidsons** — Used bargains. New, used parts, accessories, all models. Bulletin 25¢. Knuth's (Factory Dealer), 1753 Muskego, Milwaukee, Wis.

**RECONDITIONED** Motorcycle motors. Large stock Indian Cushman Vespa Mustang NSU parts. Indian Motorcycle Sales, Kansas City 27, Missouri.

### AVIATION

**NEW** Light Aero engines \$89 and up. 30 H.P. 2 cyl. opposed 4-cycle O.H.V. 2100 R.P.M. Aircooled 71 lb. "Zenta" aviation engines, complete, ready to fly \$129. Fabulous new 4 cylinder, 2-cycle Alan Radial "X" 35/40 H.P. super-light engines \$175. 3 cyl. radial 45 H.P. Zentas—\$188., 4-cylinder in-line 50 H.P. Skyskouts \$245. 15/18 H.P. "Aero-Outboard" 2 cyl. self-feathering autostart glider engines from \$89. All are new current production aviation quality, fully guaranteed. (No conversions). Send 10¢ for circular or \$1 (returnable) for big complete detailed data book just published, and used/rebuilt/trade-in lists, other data. Low-cost prop's, instruments, accessories. Aeromotive Engineering, 1746 West Van Buren, Phoenix, Arizona.

**PROPELLERS.** Plans, supplies for airboats, snowplanes, 125 h.p. Lycopom engines. Prompt delivery. Catalog 25¢. Banks-Maxwell Propeller Co., Box 3301E, Ft. Worth 5, Texas.

**AEROBATIC** Handbook. Illustrated, descriptive. \$1.00. Urshanair, Box 250, San tee, California.

### BATTERIES, GENERATORS

**REBUILD** Batteries! Complete manual \$3.00. Chrysler Corp. Alternator Guide \$3.00. C. O. D. accepted. Bayer Publications, 938 Betty Avenue, Neenah, Wisconsin.

**BATTERY** Reconditioning kit, molds, instructions. Old batteries like new. Apex, 1127 Auzerals, San Jose, Calif.

### ELECTRICAL SUPPLIES

**LAMP,** Electrical parts, wholesale. Thousands of items for repairing, converting. Catalog 35¢. Brown Lamp, Box 305, Clayton 5, Missouri.

**LAMP** Parts. Catalog, prices, wiring instructions. 50¢. Refunded first order. Gyro, 5208P N.W. 35 Ave., Miami 42, Fla.

**LAMP**—Appliance—vacuum parts wholesale. Illustrated catalogue 25¢. Your one stop supplier. Seco, 112 South 20th Street, Birmingham 3, Alabama.

### WELDING, SOLDERING, PLATING

**ARC** Welder manual. Only 50¢. Regular \$1.00 value. Tells how to weld every job. Emerson Electric, 8100 Florissant, Dept. PM-9, St. Louis, Missouri.

**FREE** Welder catalog. Kits, build 350-ampere welder using aircraft generator, plans. 25¢. LeJay, Minneapolis 20, Minn.

**CHROME** Plating equipment, supplies. All other finishes. Home workshop and production sizes. Send \$1.00 (refundable) for formulas, operating data, equipment guide and catalog. HBS Equipment Division L50, 3445 Union Pacific Avenue, Los Angeles 23, Calif.

**WELDERS, 110/220, \$39.50. Morris, 1070 Inner Drive, Schenectady 3, New York.**

**ACETYLENE** Outfits, new \$59.50; used \$40.00. Arcwelders \$69.50. Eagle Welding, Dept. PM, 5085 Broadway, Chicago 40, Ill.

### MACHINERY, TOOLS, SUPPLIES

**NEW Surplus—12 different tools, only \$3.50. Send for list. Salme Enterprises, 40 Greendale Avenue, Worcester 6, Mass.**

**NEED Compressed air?** Build your own small compressor. New, simple construction. Booklet, drawings, photograph, \$1. Robert Vaughn, Vau hn Apartments, Greensboro, North Carolina.

**RADIUS** Cutter demonstrators, responsible franchises open. Shaw, Box 1144, Palo Alto, Calif.

**HYDRAULIC**, Air, repair kits for jacks, lifts, benders, rams, presses, pumps, valves, guns, etc. Anything using cups, packing, O. rings, chevrons. Send make, model or old part. 50¢ for price list, instructions. Interstate Mfgs., 8724 So. Main St., Los Angeles 3, Calif.

**40 NEW** Machinist tools. Campbell Tools, 1424 Barclay, Springfield, Ohio.

### ENGINES, MOTORS, DYNAMOS

**¾ H.P.** Midget diesel engines \$23.50 complete, aircooled, full diesel, burn all fuels, easy starting. New. Governed or varispeed to 4,000 R.P.M. Lightweight-compact. "Kitty-Powrr" brand. 300 watt A.C. generators, 115 volt 60 cyc. new \$19.75. Complete with regulators, 3,600 R.P.M. ½" shaft. Self-excited. Ready to use. Both above units, coupled, mounted on 10 hr. capacity cast fuel-tank base forming complete "Kitty-Watt" unit \$49. Circulars 25¢. Foreign dealers (only) wanted. Houghton Motor Mfg. Co., 1746 West Van Buren, Phoenix (7), Arizona.

**REWIND** Motors yourself. Complete instructions, \$1.00. Lewis Manufacturing, Howell, Michigan.

**WINDING** Data. 275 motors, single and three phase \$1.10. Data Company, 512 Kensington, Kansas City 24, Mo.

**REWIND** Motors yourself. Free booklet. Modern, Box 8715, Kansas City 14, Mo.

### GOVERNMENT SURPLUS

**U.S. Government surplus—Jeeps, \$264.00, radios, \$2.53, guns, typewriters, cameras, tools, thousands of items. Fabulously low surplus prices. Complete information sent immediately. Send \$1.00 to—Surplus, P.O. Box 50512, Dept. E, New Orleans 50, Louisiana.**

**BUY** Surplus direct from government. Complete guide—50¢. Satisfaction guaranteed. Janecek, 373 East 155th Street, New York 55-PM, N. Y.

**JEeps \$111.68. Airplanes \$75.20. Boats \$6.14; Many others direct from U.S. Government. For complete "Directory" send \$1.00 to Quality Surplus, Box 22163R, Indianapolis, Indiana.**

**JEeps \$223.83. Typewriters \$4.15. Boats \$6.18. Radios \$2.65. Televisions, guns, recorders. Typical surplus prices. Free exciting details. N. Y. Enterprises, Box 402-X3, Jamaica 30, New York.**

**GOV'T** Surplus how and where to buy in your area. Send \$1.00. U.S. Surplus Headquarters, Box 187, Abbottstown, Penna.

**JEeps, \$278; Airplanes, \$159; boats, \$7.88; generators, \$2.68; typewriters, \$8.79 are typical government surplus sale prices. Buy 10,001 items wholesale, direct. Full details, 627 locations and procedure only \$1.00. Surplus, Box 177-C16, Abbottstown, Penna.**

**GUARANTEED** Latest and up-to-date list of government surplus sales \$1.00. Surplus, Dept. MP, P.O. Box 1931, Fort Myers, Fla.

**PAINT** Sprayers. Stainless steel tanks. Bargains. Free folder. Imsco, 1829 S. State, Chicago 16, Ill.

**GOV'T** Surplus. How and where to buy in your area. Send \$1.00. Surplus Information, PM, Headquarters Building, Washington 6, D. C.

**GOVERNMENT** Surplus, radios, jeeps, walkie talkies, etc. Buy direct. Locations and procedures \$1.00. Satisfaction guaranteed. Delta, Box 227, El Paso, Texas.

**JEeps, Boats, airplanes, helicopters, walkie-talkies, radar, tents, typewriters, tires, tools, cameras. Individuals can buy now direct from government. "U.S. Depot Directory & Procedure" \$1.00. Brody, Box 425-PM, Nanuet, N. Y.**

### BOATS, OUTBOARD MOTORS

**BOAT** Owners, write for our new cinch ramp and winch brochure. Dealers wanted. Vine, Hill & Co., Box 35P, Swanton, Ohio.

**CANOE** Kits. Size and model for every canoeing need. Easily assembled in one weekend. Write: Dept. 46, Schneider Boats, 3133 Lisbon, Milwaukee 8, Wis.

**INCREASE** Outboard speeds 20-30%. Same boat, motor. No cost. Results guaranteed. \$1.00. Boats, Box 21-M, Cambridge, Maryland.

**CAMPERBOAT.** Light, unsinkable, seats 4, sleeps 2. Cartop carried. Send \$1.00 for detailed drawings. Erdco, Box 162, Tarzana, Calif.

**FULL** Size, cut-to-shape boat patterns, blueprints, 7½-38 feet. Big new illustrated "Build a Boat" catalog of 64 designs, including catamarans, cruisers, runabouts, skiffs, outboard boats, sailing, racing, houseboats, 50¢. "How to Build a Boat" booklet, \$2.50. Cleveland Boat Blueprint Co., Box 1651, Cleveland, Ohio.

**FIBERGLASS**, Resins. Repair, cover boats. Best source. Customize, repair automobiles. Thousand uses. Free catalogue. Plastic Kolor Co., P.O. Box 8531, Houston 9, Tex.

**FULL** Size, cut-to-shape boat patterns, blueprints, 7½-38 feet. Big new 88-page illustrated "Build a Boat" catalog of naval architect-designed catamarans, cruisers, runabouts, skiffs, outboard boats, sailing, racing, houseboats, 50¢. "How to Build a Boat" booklet, \$2.50. Cleveland Boat Blueprint Co., Box 1651, Cleveland, Ohio.

**NEW**, Used, rebuilt marine motors. Marine conversions, fittings. Free catalog. Stokes Marine Supply, Dept. 24, Coldwater, Michigan.

**MARINE** Conversions. Ford, Chevrolet, Jeep engines. Catalog 25¢. Lehman Manufacturing Company, 800 Elizabeth Avenue, Linden 4, N. J.

**FIBERGLAS** Your old wooden boat. Make it waterproof. Repaint over fiberglass, wood, or metal with new Poly-Aqua Epoxy paint. Free literature. Ajax Plastic Co., Dept. 6, P.O. Box 1323, Ft. Worth, Texas.

**MARINE** Conversions and gears for all popular automotive engines. Send 25¢ coin for complete catalogue. Barr Marine, 2706A Castor Ave., Philadelphia, Penna.

**BOAT** Plans, frame kits, full-size patterns prepared specially for amateurs. Send 50¢ for new 80-page catalog illustrating over 40 build-it-yourself power boats from 7' to 28'. Glen Designs, 9152 Rosecrans, Bellflower, Calif.

**BUILD** Your own boat from our large-scale blueprints. Books of plans give how-to-build help. Hundreds of professional designs—motor, sail or auxiliary—for amateur builders. Free catalog. MoToR Boat-in-G, 959 Eighth Ave., Dept. RS, New York 19, N. Y.

**STOP** Paying ridiculous prices for your boats interior. Finest, latest style plastics, foam rubber, tools. Send for free brochure. La Scala Textile, Box 1490, Albany, New York.

**KAYAKS \$39.95.** Rugged, stable, lightweight, safe. Years of fun guaranteed. \$59.95 assembled. Literature 10¢. Klondike Kayaks, Box 63P, Corte Madera, Calif.

**I Want to send you proof of the wonderful pulling power of Popular Mechanics classified pages. What's your proposition? Write me today. Include literature if possible. F. W. Johnson, Manager Classified Advertising, Popular Mechanics Magazine, 740-G Rush St., Chicago 11, Ill.**

### ATHLETIC EQUIPMENT, BODY BUILDING COURSES

**DEVELOP** Powerful arms, chest, shoulders, legs! Complete course, \$1.00. Keystone. Box 206, Pottsville, Pennsylvania.

**BIG** Muscles fast—gain up to 4" on arms, 10" on chest in just 7 weeks. Free details. Sinkram Body Builders, Dept. ME-6, Box 11, Brooklyn 36, N. Y.

**"GIANT** Arms." Dr. Young's, D.C. revolutionary discovery. \$2. Satisfaction or refund. Gaucho, Box 9309-S7, Chicago 90.

**"MUSCULAR** Arms." Learn how author developed 19" arms. \$1.00. H. Fox, 1303 E. State, Olean, N. Y.

### SPORTING GOODS, GUNS, FISHING, SKIN DIVING, ARCHERY

**GUNS** All kinds below wholesale. Send 25¢ for bargain guide. 2057 Mesa Way, Santa Rosa, Calif.

**THREE** Hands! New fishing rod holder attaches belt. \$1.00. World-Wide Gift Prod., Box 307, Laurel, Maryland.

**FLASH!** Klein's \$1.00. Big all-new, all-sports bargain catalog has been price cut to 25¢. Order today! Klein's, Dept. PM, 227 West Washington St., Chicago 6, Illinois.

**FREE—Wholesale** catalog. Beads, Spinners. Lure parts, Sinker molds, Jigs, Reels. FinnySports (ME), Toledo 14, Ohio.

**BIG** Money raising crickets and 12 inch African fishworms. Free literature. Carter Ranch, Plains, Georgia.

**MOLDS** For fisherman's sinkers, jigs, squids, casting and spinning lures. Free catalog. Sweet's Molds, Tonawanda 1, New York.

**JAP** Rifle altering to 30-06, \$6.00. Japshells, \$3.95. Catalog 10¢. T. P. Shop, West Branch 11, Mich.

**JAP** Rifle altering to 30-06, \$6.00. Japshells, \$3.95. Gunsmithing catalog 10¢. T. P. Shop, West Branch 11, Mich.

### CAMPING EQUIPMENT AND TENTS

**CAMPING** Equipment, tents, world's largest selection. Send 25¢ for new giant catalogue—handbook—camp site directory (print name—address). Morsan Tents, 10-21R 50th Ave., Long Island City 1, New York.

### BINOCULARS, TELESCOPES, MICROSCOPES, MAGNIFIERS

**BUILD** Your own reflector telescopes. Complete kits: mirrors, eyepieces, tripods, all other accessories. Request free illustrated literature. Criterion Manufacturing, Dept. KPM-92; Hartford, Connecticut.

**CUSTOM** Telescopes, lens, tripods, equatorials, and accessories, UPSCO, Sunbury, Penna.

**DYNASCOPE.** Amazing world-famous reflector telescope. Request free brochure. Criterion, Dept. DP-95; Hartford, Connecticut.

**MICROSCOPES**, Accessories, prepared slides, supplies, etc. Free brochure. New England Science Service, Westmoreland, New Hampshire.

**MICROSCOPES** Varimex brand (European). Educational, research, industrial, other. Scientific catalog 25¢. Magnification Instrument, 2 East 45th, New York 17. OX 7-8978.

**SPECTROSCOPE** And instruction book \$7.00. Kuttingson, 875 Arastradero, Palo Alto, Calif.

**BARGAINS!** Zoom binoculars! Rifle scopes! Telescopes! Microscopes! Free catalog. Adventure Company, Box 2133, San Diego 12, California.

**TELESCOPE Kits**—Direct from manufacturer. Other optical hobby kits. Large selection. Free booklet. Esco Products, Oak Ridge, N. J.

**SCIENCE Bargains!** Lenses, telescopes, binoculars, microscopes, kits, parts, war surplus. Send \$1.00 for beginner's 10-lens kit with instruction booklet. Order Stock 2-CH. Request free 144-page Catalog CH. Edmund Scientific Co., Barrington, New Jersey.

**FAMOUS Optical goods.** Free discount catalogue. University Optics, Box 1205-M, Ann Arbor, Michigan.

### EARTHWORMS, CRICKETS, FROGS

**AMAZING Profits** in worms. Send long self-addressed stamped envelope for free informative letter. Hillaire, Northville, Mich.

**BIG Money** raising fishworms and crickets. We teach you how to raise and where to sell. Free literature. Medium redworms, 3000, \$5.95; 10,000, \$16.95. Carter Redworms, Plains, Georgia.

**FROG Raising.** Young frogs and giant breeders. Stock your lakes, ponds. Nu-Tex Frog Farm, P.O. Box 4029, Corpus Christi, Texas.

**HYBRID Redworms.** Live delivery guaranteed. 1000—\$4.00, 5000—\$16.50. Bedrun 2500—\$4.95, 5000—\$8.95, 10,000—\$16.85. Postpaid. Free literature. Hall Farm, Hilton, Georgia.

**MEN!**—Women! Make money raising bait at home for us! We buy your crop! Details free. Red Wigglers, Warsaw 45, Indiana.

**EARN Money** raising fishworms for us! Exciting details free! Oakhaven—56, Cedar Hill, Texas.

**HYBRID Redworms** 1000/\$3.00; 2000/\$5.00; 5000/\$8.00; 10,000/\$14.00; Postpaid with raising instructions. Live delivery guaranteed. Brazos Bait Farm, 60 Lincoln, Waco, Texas.

**FISHWORM Hatcheries** that can produce 10,000,000 bait size Giant Africans between May and September. Write Associated, 3620 N. Meridian, Okla. City 12, Oklahoma.

**AZTEC Red wigglers.** Texas' largest worm grower. Satisfaction guaranteed. Circle J Farms, Box 4056P, Waco, Texas.

**FREE Literature.** Earthworms, books. Denton Enterprises, Box 348, Hattiesburg, Mississippi.

### PLANTS, SEEDS, BULBS, NURSERY SUPPLIES

**GINSENG** Bringing \$14 pound. Have seeds, plants. Goldenseal. Full information. K. Collins, Viola, Iowa.

### GARDEN EQUIPMENT & SUPPLIES

**LAWN Sweeper.** Make it yourself from old mower parts. Plan sheet 35¢, includes instructions and drawings. Popular Mechanics Service Bureau, 740 Rush St., Chicago 11, Ill.

### PETS—DOGS, BIRDS, HAMSTERS, ETC.

**BABY Raccoons, monkeys, skunks, snakes, lizards, turtles, birds.** Catalogue 10¢. Thompson Zoo, Clewiston, Fla.

**PETS** Of every description. Catalog \$1 (refundable). Jungland, Florida 5, Alabama.

**HAWKS, Reptiles, raccoons, skunks, squirrels.** Catalogue 25¢. Trails End Zoo, St. Stephen, S. C.

**PETS.** Hamsters, mice, rabbits, squirrels, chipmunks, guinea pigs, skunks, raccoons. Picture catalog twenty-five cents. Moore's Hamster Ranch, Shepherdstown 25, West Virginia.

**HAMSTERS.** Ideal pets. \$2.95 pair. Booklet 10¢. Jer-Fre's Hamstery, 1447 Apple, Muskegon, Michigan.

### RABBITS—FUR BEARING ANIMALS

**MINK Raising** information free. Complete. Lake Superior Mink Farm, Superior. EE1, Wisconsin.

**RAISE Rabbits** successfully by knowing facts. 48 page book. 38 illustrations describing 25 breeds. Housing. Breeding. Feeding. Markets and Marketing. Bulletin etc. 25 cents. American Rabbit Association, 36 ARBA Building, Pittsburgh, Penna.

**EARN \$10,000** Yearly raising Angora rabbit wool for us. Information 25¢ coin. American Angora Company, Malta 12, Montana.

**RAISE Rabbits** on \$500 month plan. Free details. White's Rabbitry, Mt. Vernon, Ohio.

### FARMS, FARM LANDS, REAL ESTATE

**CANADIAN Lands,** seized and sold for taxes. Our 45th annual series of lists describe many choice properties, situated from coast to coast, acquired by us through tax sale. Priced as low as five dollars per acre, guaranteed perfect title, small monthly payments, no mortgage. Beautifully situated hunting and fishing camps, where there is real sport; summer cottage sites, heavily wooded acreages. Now is the time to invest in Canada's minerals, forests and farms. Write today for free twenty page booklet with full explanation. Tax Sale Service, Room 411-D, 1173 Bay St., Toronto 5, Canada.

**FREE Strout catalog!** Farms, homes, businesses, resorts, retirement properties. Over 3,000 values coast-to-coast. 62 years service. World's largest! Write Strout Realty, 7-CJ S. Dearborn, Chicago 3, Ill.

**ON River!** Huge spring! Picturesque 55 acres has nearly 1/2 mile frontage on fishing river plus mammoth Ozark spring which feeds large branch. 20 acres tillable bottom land is ideal for converting into fish lakes. 35 wooded acres. On all-weather private road, 2 miles highway. 3 village. Rustic 2-year-old log cabin has 3 rooms, wood paneled interior. Buy of a lifetime at \$5,900, only \$1,500 down! New free illustrated Fall-Winter catalog, bargains coast to coast! United Farm Agency, 2825-PM Main St., Kansas City 41, Mo.

**FLORIDA Campsites**—deep in the heart of the great Ocala National Forest. Abundance of game, best fishing. Warranty deed. Unrestricted—pitch tent, park trailer, build lodge. Free maps and photos. Howard Vernor, DeLand, Florida, AD60068(Q-O).

**\$5 MONTHLY Buys 5 acres**—near clear-water lake. Price \$125. Excellent fishing, good cabin sites. Free list. Box 425-P, Carthage, Mo.

**CANADIAN Vacation lands:** Full price \$385.00. 40 acres. \$10 month. Suitable cottage sites, hunting, fishing, investment. Free information. Land Corporation, 3768-C Bathurst, Downsview, Ontario, Canada.

**MONTANA**—Fishing, hunting, cabin sites and campsites on beautiful Kootenai River in Montana Rockies. \$595 at \$10 down and \$10 a month. Mountain Empire Company, Box 203-P, Libby, Montana.

**FLORIDA, 100x280 Highway frontage** 3 miles from Suwannee River. \$995, only \$25 monthly. Also, 1 1/4 acres 960 ft. from highway \$295, only \$10 monthly. All high, wooded. Actual photo. Hurry! Gilchrist, P.O. Box 163-Q, Miami 37, Fla.

**FREE Fall-Winter catalog!** America's greatest bargains! Actual property photos! Safe-Buy Real Estate Agency, 5514-PM West Markham, Little Rock, Ark.

**CAROLINA Coast**—\$5 down, \$5 monthly, buys large homesite, 70x150, in beautiful Boiling Spring Lakes. Satisfaction guaranteed. 16,000 acres. 50 freshwater lakes. Excellent fishing, hunting. Free literature. Boiling Spring Lakes, Southport 1-B, North Carolina.

**FLORIDA.** Big beautifully wooded tracts on prominent highway, famous Green Hills pleasure resort area 28 miles north Panama City. Also choice 1/4-acre lakeside homesites. \$10 monthly. Free maps, photos. Owen Wood, Fountain 15, Florida, AD62005 (K-O).

**BAHAMA Island sunswept homesites** (125'x80'). Sandy beach, fishing, water sports. \$895. No taxes. \$10 month. Suitable investment, vacationing, retirement. Free information. Bahama Estates, 3768-F Bathurst, Downsview, Ontario, Canada.

### FARM MACHINERY AND SUPPLIES

**3 HP HOEING Machine.** Hoes between plants, rows. Depth adjustable 0-6". Women operate easily. Self-propelled. Month trial. Year warranty. Discount. Autohoe, West De Pere 22, Wis.

### PROFITABLE OCCUPATIONS

**UNBELIEVABLE?** Enter concrete drain tile business on profitable, competitive basis for less than \$500. Durable Marvel. Best and still lowest-priced of drain tile machines. Pays for itself with two weeks production. Data and industry's most thorough info on making concrete drain tile 25¢. CMC, Inc., Drawer 99, Hickory 12, N. C.

**INVESTIGATE Accidents.** Earn \$750 to \$1,000 monthly. Men urgently needed. Car furnished. Business expenses paid. No selling. No college education necessary. Pick own job location. Investigate full time. Or earn \$6.44 hour spare time. Write for free literature. No obligation. Universal, CPM-9, 6801 Hillcrest, Dallas 5, Texas.

**BARGAINS!** Buy wholesale! Save money! Free catalog! Norris, 273-K Merrick Road, Lynbrook, N. Y.

**REDWORM Raising** profitable. Free literature. Hall Farm, Hilton 1, Georgia.

**REPAIR Hydraulic jacks.** Easy, profitable. Write: Hydraulics, Box 4104, El Paso, Tex.

**\$2.00 WEEKLY** Selling books by mail. Box 51-PA, Des Plaines, Illinois.

**AUCTIONEERING**—Home study course. Diploma granted. Auction School, Ft. Smith, Ark.

**VENDING Machines.** No selling. Operate a route of coin machines and earn amazing profits. 32-page catalogue free. Parkway Machine Corporation, Dept. #25, 715 Ensor Street, Baltimore 2, Maryland.

**BAKE** New greaseless doughnuts in kitchen. Sell stores. Free recipes. Michael, 3605 South 15th, Minneapolis 7, Minn.

**BIG Money** raising fishworms and crickets. Free literature. Carter Wormery, Plains, Georgia.

**BECOME Independent** with your own franchise business. Thousands earning handsome incomes. Request interesting facts today. National Franchise Reports, PM-528, 333 North Michigan, Chicago 1.

**EARN \$240.00** A month at home, spare time, doing only two \$5.00 invisible mending jobs a day. Big money paid for service that makes cuts, tears disappear from fabrics. Steady demand. Details free. Fabricon, 1586 Howard, Chicago 26, Ill.

**EARN Money** raising fishworms for us! Write: Oakhaven—58, Cedar Hill, Texas.

**SHARPEN Scissors, pinkers, clippers.** Inexpensive machines, supplies. Black-hawks, Sheldahl, Iowa.

**FREE Report:** "609 Unusual, Successful Businesses." Box 1001-PT, Evanston, Ill.

**WHOLESALE.** Magazine subscriptions highest commissions. Bonus! Qualified Agencies. 451TA Kingston, Brooklyn 23, New York.

**INVESTIGATE** Auto accidents. Earn up to \$750 monthly. Investigators needed in every state. No selling required. Car furnished; expenses paid. Or start a business of your own. Associate with interesting, important people. We train you at home. You hold present job until ready to switch. Get free information. No obligation. Write Liberty School, Dept. C-94, 1139 West Park, Libertyville, Illinois.

**CHROME** Plating. Instructions, equipment and supplies. Platers' Supply, P.O. Box 565, Lugo Station, Los Angeles, Calif.

### BOOKS, PERIODICALS, PICTURES, POSTCARDS

**NATIONAL** Geographic magazines. 1888-1960, any issue. Periodical Service, Box 465-PM, Wilmington, Delaware.

**100,000 BOOKS!** Bargains! Catalog—dime. Treasure-Site, 6990 Aberdeen, Upper Darby, Penna.

**MISSILE** Photos. Actual color reproductions. 15 cards \$1.00. Missile book \$1.00. Carlo Company, Box 616, Winter Park, Florida.

**BOOKS** Located! You name it—we find it. Book Mark, 89A Macomb, Mt. Clemens, Mich.

**FREE** Catalog. Self-help books. Write Wilshire, 8721 Sunset, Los Angeles 69P.

**BOOKHUNTERS!** Scarce, miscellaneous books supplied! Atlantic Book Service, Cedar Street, Charlestown 29, Mass.

**BRITISH** Book bargains—Any subject. Catalogues free. Transatbooks, Wantagh, N. Y.

**BOOKFINDERS!** All subjects. Send wants! Jaher Book Service, 183 Hazelwood Drive, Westbury, N. Y.

**BOOKS.** All kinds. Write for list. State Interests, Wallace, Dept. 39, Box 628, Montreal, Canada.

**BOOKFINDING** Our specialty. Try us. Babcock, 412 Lulu, Wichita 11, Kansas.

**SAVE** To 84% on books, records. Free catalogue. Discount Reader's Service, MI-5435 Upland Way, Philadelphia 31.

**THREE** Books postpaid worth 30¢ to \$3.00 for 30¢. Lund's Book Shop, 2772 East 79th, Cleveland 4, Ohio.

**PROPHET** Elijah coming before Christ. Wonderful book free. E. Megiddo Mission, Rochester 19, N. Y.

**OLD** Books, magazines. Coutant's Antiques, RFD 4, Scotia, N. Y.

### GAMES, TOYS, NOVELTIES

**COWBOY** Trick rope, \$1.00 postpaid, instructions. Box 1058, Putnam, Texas.

**CHIVALRY** Playing cards. New game just patented. 8.88 plus 4% sales tax. M. J. Tynio, 4816 Franklin Street, Harrisburg, Penna.

**GET** Your novelties, tricks, gags wholesale. Sell friends. Big catalog. 50 gag samples 25¢. Dohn-SE-Marks, Broadview, Illinois.

### MAGIC TRICKS, PUZZLES, JOKER NOVELTIES

**WORLD'S** Finest professional magic. Joker novelties. Giant illustrated catalog 10¢. Top Hat, Evanston 12, Illinois.

**500 TRICKS.** New 1962 edition, famous Douglas catalog of magicians tricks and supplies now available just 10¢. Fastest service. Douglas Magicland, Dept. 61, Dallas, Texas.

**SMOKE** Bombs 25¢, 7 for \$1.00. Terrific! 6703-N Eleventh, Philadelphia 26.

**WORLD'S** Finest magic catalog, \$2.50 (\$2.00 magic included free). 3000 tricks, pocket, stage (408 pages). Kanter's, M-200 South 13th, Philadelphia 7.

**VENTRILLO** Voice thrower 25¢. Ventriloquist's puppet 75¢. Box 971-PM, Philadelphia 5.

**FLAME** Thrower! 36" flashes at fingertips! \$1.00. Harmless! Ariane, Philadelphia 44.

**HOUSE** Of 1000 mysteries! World famous! Professional magic! Pocket tricks! Jokes! Puzzles! Secrets! Illusions! Gimmicks! Giant surplus catalog! Latest edition! Astonishing contents! Special for Sept. 10¢. Vick Lawston, Dept. PM9C-62, Trumbull, Conn.

**CATALOG.** Free tricks, 25¢. (1,500,399 tricks, jokes, novelties.) Magico, 7408-P, San Antonio 7, Texas.

**PROFESSIONAL** Catalog. 175 pages, 25¢. Williams, 900 Plymouth, Ellwood City, Penna.

**MAGIC** Cards, tricks, dice! Sixty different decks! Catalog, free trick, 15¢. Poules, 437 Brittain, Akron 5, Ohio.

**LEARN** Magic. Introductory lesson of four excellent tricks \$1.00. C. B. Orr, 58 Dodge, Akron 2, Ohio.

### ANTIQUES, RELICS, INDIAN GOODS, CURIOS

**6** ARROWHEADS. Archaic knife, scraper, \$2.00. Smith, 841 N. Tacoma, Indianapolis 1, Indiana.

**GENUINE** Oregon obsidian arrowheads. Introductory offer—3 perfect birdpoints \$1.00. Strobeck, 724A Williamette, Eugene, Ore.

**ISHKABILE!** Have fun, make money collecting and selling antique relics of all sorts, and guns. Send 35¢ for large listing circular. Wooden Indian, Wenona, Illinois.

**SELLING** 20,000 Ancient arrowheads, spearheads, etc. List free. Lear's, Glenwood, Arkansas.

### COINS, TOKENS, CURRENCY

**PROOF** Sets. 1961-\$2.90. 1962-\$2.60. Tom Norman, Corinth, Mississippi.

**100** FOREIGN Coins for \$2.00. Fairfat, Box 6350-M, Phoenix 5, Arizona.

**UNCIRCULATED** 1935 Silver pony express commemorative medal \$1.00. Coin lists free. Sayers, 1000 Unaka, Johnson City, Tennessee.

**5** INDIAN Cents \$1.00; 6 Liberty nickels \$1.00. Doktor, P.O. Box 35151, Los Angeles 35, Calif.

**COINS** Bought. Catalog 25¢ refundable. Lacheen, Box 1355, Philadelphia, Penna.

**LINCOLN** Cents for sale: 15¢ each. 1909, 1914, 1917D, 1918D, 1918S, 1919D, 1919S, 1920D, 1920S, 1925S, 1926D, 1927D, 1928D, 1929D, 1929S, 1930D, 1930S, 1931, 1934D, 1935D, 1935S, 1936D, 1936S, 1937D, 1937S, 1938D, 1939S. Dennis, Box 3555, Toledo 8, Ohio.

**TWENTY-Four** page 1963 retail price list of USA and Canadian coins 10¢. Our selling prices on thousands of coins and coin collectors' supplies. Bryson Incorporated, 612A White, Toledo 5, Ohio.

**ALASKAN** 49th state gold dollar. Removed from circulation 31 December 59. Are a collectors item. \$5.00 each. Coin-service, 6 Pastor's Walk, Monroe, Connecticut.

**SAVE** Your slick nickels where date is worn off. Order a bottle of Coin Date. It will bring the date out on Buffalo, V. Shield nickels. It's easy to use. Satisfaction guaranteed. \$1.00 postpaid. Box 276-F, Mooresville, No. Carolina.

**LINCOLNS**—100 Different in Whitmans \$5.00. Houdelette, 10011 Arden, Tampa 12, Fla.

**BARBER** Quarters: 10 different \$3.95, 15 different \$5.95. Large cent \$1.75, 4 different \$5.95, many bargains! Modern Coin Shop, 109 West Grace, Richmond 19, Virginia.

**COIN** Bargain list 25¢. Refundable first order. Stroud's Coins, Kinston, N. C.

**CURRENCY.** Bolivia 5-50-100 Bolivianos 25¢; Jolie, Roslyn Heights, New York.

**LINCOLNS:** 40 Different 1909-1940 plus 1960D small date \$1.95, 25 different "S" including rare 1955S \$1.50. Harris, Box 9011, San Francisco 29, California.

**LINCOLNS** For sale. 1909VDB, 1916DS, 1917DS, 1918DS, 1919DS, 1920DS, 1921S, 1923S, 1924S, 1925DS, 1926D, 1927DS, 1928DS, 1929DS, 1930DS, 1931P, 1932P, 1933P, 1934D, 1938DS, 1939PDS, 1955S, G-F. Only \$7.50. Postpaid. Guaranteed. Hyles Sales, Box 9566, Dallas 14, Texas.

**FREE** List. Coin accessories. Althor, 2301 Benson Ave., Brooklyn, N. Y.

**RARE** Unc. 1899 Philadelphia silver dollar, \$5.00. Butts, Torrington, Wyo.

**RARE** Uncirculated 1885 Carson City dollar \$19.50. Beautiful uncirculated \$20.00 gold \$57.50, 3 different types \$163.50. Book "Gold is Going Higher" by Baxter \$1.00. Pope John Vatican set \$4.25. Pony Express medal \$1.25. Bebee's, 4514 North 30th, Omaha 11, Nebraska.

**BARGAIN** Pricelist, coins, supplies, 10¢ (refundable) Ron Farley, Metamora, Illinois.

**ANY** Four Roosevelt dimes \$1.00. Traycee, 25 Quinlan, Staten Island 14, New York.

**1963** RED Guidebook \$1.75. Blue handbook \$1.00. Gray, 506-15th, Moline, Illinois.

**SEATTLE** World's Fair official trade dollars! Uncirculated! \$1.50. Ball, Dept. A-4, 301 E. Thomas, Seattle 2, Washington.

**TEN** Different Indian cents \$2.50. Two different large cents \$2.50. With lists. Hutchinson's, Box 6256, Philadelphia, Penna.

**12** DIFFERENT Lincolns before 1921 \$1.00. 24 before 1931 \$1.50. Gene Carlton, Chandler, Okla.

**LINCOLN** Cents, 1941 thru 1961, in folder, \$2.95. O'Malley, Box 592, West Covina, Calif.

**FREE** Coin supplies! Giant coin list 10¢ (refundable). Economy Sales, Mansfield, Massachusetts.

**LARGEST** Coin magazine. 288 pages, 50¢. Scrapbook, 7320-J Milwaukee, Chicago 31.

**NUMISMATICS** Largest newspaper. Semi-monthly. Sample 25¢. \$2.00 yearly. Numismatic News, Box 452, Iola, Wis.

**RARE** 1878 CC mint dollar uncirculated \$5.00. 100pg. catalogue 50¢. Shultz, Salt Lake City 10, Utah.

**BARGAIN** List! U. S. coins, accessories. Stamp please. Hugh's, Hickory, N. C.

**40** PAGE Illustrated United States and Canadian coin list 10¢. Stoney, 260 Washington, Boston 8, Mass.

**COIN** Collector's magazine. On your newsstand or direct. Sample 35¢. \$3.00 yearly. Coins Magazine, Box 274, Iola, Wis.

**WORLD'S** Greatest coin magazine and wooden nickel 10¢. Lawrence's, Anamosa, Iowa.

**GIANT** Illustrated catalog listing hundreds of bargains in coins and supplies, only 25¢. Ben's Coin Company, 31 North Clark, Chicago 2.

**TRUE** Value American coins. Booklet 25¢. Deimonte, 314H Main St., Ft. Lee, N. J.

**STARTER** Collections. 15 Indian cents, \$3.50. 12 Liberty nickels \$3.50. 18 Barber dimes, \$7.50. 15 Barber quarters, \$10.00. 15 Barber halves, \$20.00. Postpaid. All different. Folders, Good, Herman Prager, 470 27th Avenue, San Francisco, Calif.

**LINCOLN** Cents: 1923S, 24S, 21SP, 16SD, 17SD, 18SD, 19SD, 20SD, 25SD, 29SD, 30SD, 28SD, 27SD, 1955S, 54SP, 32D, 33P, 39SD. Good to fine. Complete lot \$7.50. Rolls 1955S \$10.00 fine to X fine, 1949S \$3.00. Berry, Box 306, Westminster, Calif.

**INTERESTING** Set latest Kenya coins \$2.00. Greaves, Box 676, Kitale, Kenya.

### STAMP COLLECTING

**FREE!** 25 Egypt, 10¢ handling. Approvals. Bellet, Mapledale, Hazel Park, Michigan.

**MINT** U.S. at face! Older commemoratives only. Send 25¢ for all different packet. Limit one with mint U.S. approvals. Western, Box 1689P, Salinas, California.

**U.S.** Stamps. Giant discount catalog 25¢. Raymax, 37-VZ Maiden Lane, NYC 38.

**FOUR** Different sets! 10¢! Approvals. Reda, 6350 Leonard, Philadelphia 49, Pa.

**LOOK!** \$1.00 value 25¢ for approval applicants. Packet contains many mint sets, old U.S., 1939 World Fair stamp, and many other valuable stamps. Write to: Richard W. Huebner, 3570 South 19th, Milwaukee 21, Wisconsin.

**WOW! 110 all different Germany 10¢!** Zeppelins, semi-postals, airmails, high values, etc. Giant catalog, bargain lists included with beautiful approvals. Jamestown Stamp, Dept. A92PM, Jamestown, N. Y.

**DEALERS—Wholesale list.** Postage 4¢. Frank, 5031 Queensberry, Baltimore 15, Maryland.

**HISTORY In The Making issues!** 65 different U.S. stamps, including airmails, special delivery, postage dues, high denominations, etc., some over 75 years old! Only 10¢ with approvals. Offer to adults only. Littleton Stamp Co., Littleton, B1, N. H.

**115 DIFFERENT 10¢, 50 Australia 25¢.** Pop Harris & Griggs, Oklawaha, Florida.

**BRITISH Colonial sets at wholesale.** Fischer, 1530 Metropolitan, New York 62, N. Y.

**105 DIFF. U.S. only 25¢.** Approvals included. Shelton, P.O. Box 187-KP, Hempstead, N. Y.

**FREE! North America plus 87 foreign flag stamps.** Big valuable collection of all-different, genuine stamps from Greenland (North Pole), St. Pierre, Newfoundland, Canada—picturing Eskimos, Indians, scarce 1867 Confederation, Northern Territories, Nova Scotia, United Nations, U.S.—Ancient 19th Century; first Ship and Plane; rare Whooping Crane; Pony Express; etc. Also, complete set Colonial and Civil War commemoratives. Plus colorful flag stamps of 87 foreign countries. Extra! Big bargain catalog. Approvals. Send 10¢ for mailing. Kenmore, Milford EF-385, New Hampshire.

**FREE! Giant bargain catalog.** New edition listing thousands of bargains including U.S. and B.N.A. stamps, packets, mixtures, albums accessories and supplies; sent with beautiful approvals. Jamestown Stamp, Dept. E92PM, Jamestown, N. Y.

**TERRIFIC Stamp bargain!** Israel, Iceland, San Marino, plus triangle set, plus Antigua, Borneo, Virgin, Scots, Congo, Russia, plus large stamp book. All four offers free. Send 10¢ for mailing cost. Empire Stamp Corporation, Dept. PM, Toronto, Canada.

**25 LARGE American commemoratives 10¢.** Accompanying approvals. Free perforation gauge. Linstamps, St. Catharines 101, Ontario.

**WEIRD Diamond shape coffee stamps.** Lively flower triangle! First American big commemorative. Greenland, Idol Dancer, etc. 10¢ with approvals. Capital Stamp Co., Ferrysburg 2, Michigan.

**101 DIVERSIFIED British Commonwealth 10¢.** Approvals included. Niagara Stamps, St. Catharines 501, Ontario.

**BARGAINS.** 100 U.S. commemoratives \$1.00. 100 large foreign pictorials \$1.00. 12 mint sets \$1.00. All three \$2.50. Jeski, 5404 Patton Terrace, Falls Church, Virginia.

**"OLD Glory" in flaming colors!** U.S.A. flag giant beauty from Honduras. Enormous United Nations Mexican stamp. Plus strange gorilla issue. Duke of Windsor, Morocco lovely Macao flowers, wild buffalo stamp and others, 10¢ with approvals. Sunny Stamp, Apopka 2, Fla.

**FREE Premium packet.** Approvals accompany. Patton's, 660 California, Boulder City, Nevada.

**OBSOLETE:** Mint plate blocks, 1½¢ Sante Fe, 65¢, 1½¢ Mt. Vernon 50¢, 2½¢ Bunker Hill 60¢. Harry Rainess, Box 43, Kens. Sta., Brooklyn 18, N. Y.

**UNITED STATES 19th Century and early 20th Century approvals.** Great variety to adult collectors only. Limarc Stamps, 148 Wilbur, Bergenfield, New Jersey.

**GERMANY:** 104 Old and new different stamps with complete airmail set. 10¢ approvals included. Boger, Box 152, North Wales, Penna.

**OLD Scarce U.S. seconds on approvals.** Slight imperfections, lowest prices. Hernefield, Clintonhill Sta., Newark 8, N. J.

**BAHAMAS And West Indies;** 51 different stamps. Send \$1.00. White, PM092, Box 106, Nassau, Bahamas.

**WHOLESALE Bulletin.** Fantastic bargains. Send 4¢ stamp. Lowell Donald Co., Box 837, Rutlands, Vermont.

**FREE! 55 Different triangles, pictorials, others.** Colorful, low-priced approvals. L. Baird, PM-5, Box 8128, Portland 7, Oregon.

**BEAUTIFUL Mint C9 Vietnam airmail cat.** \$2.50 for 25¢ coin to approval customers. I. J. Stamps, Box 644, Bloomington, Ill.

**FREE! Congo triangle set!** Boy Scout beauty! 25 others. Approvals. Cambridge, Box 411, Cambridge, Ohio.

**FALL Special 1000 worldwide stamps \$1.00.** 3500, \$3.00. No approvals follow. Harrison's Stamps, 1435 First Ave., Oakland 6, Calif.

**1948 U.S. Mint plate blocks.** 5 for \$1.00. Wetterhahn, Box 43074, Los Angeles 43, Calif.

**INEXPENSIVE Approvals.** Thousands available. Worldwide bargains! Carling's, BB-902, Howard City, Michigan.

**FREE.** Five beautiful sets, approvals. Liberty Company, 5105 Avers, Chicago 25.

**150 STAMPS, Ten cents.** Worldwide approvals. Swan, 3191 "R", Lincoln 3, Nebraska.

**EXCHANGE.** Send 100-200 different stamps with 20¢. Receive different. Patterson, Lancaster 10, New York.

**200 DIFFERENT!** Includes pictorials. 10¢ with approvals. J-B Stamps, 2319 Fenwick, Dallas 28, Texas.

**50 BRITISH Empire 15¢.** Approvals. RHN Stamps, Box 1633, Memphis 1, Tennessee.

**FREE Wonderful Vatican set with approvals.** Beverini, Manno 2/12, Ge-Sestri, Italy.

**25 AUSTRALIAN Commemoratives 15¢.** Approvals. Cooper, Box 75053, Los Angeles 5, California.

**50-75% OFF Catalogue.** Worldwide. Additional discounts. Golovin, 11 Feldberg, Monticello, N. Y.

**PRICE List U.S., foreign.** No approvals. Stamps, 5000 Miami, St. Louis 9, Mo.

**FREE 100 Worldwide with penny approvals.** 10¢ Handling. Skytop, Box 1022-PM, Binghamton, N. Y.

**FREE Korea set, request approvals.** Harrish, Box 177, New York 13, N. Y.

**COLORFUL Maps set free, approvals.** Jerry Hoffmann, 3016 Delaware Avenue, Kenner, La.

**222 WORLDWIDE Collection!** 25¢. Approvals. Zampino, 2055 West Tenth, Brooklyn 23.

**50, LATIN, British, Orient: 10¢.** Approvals. Thiese, 9320-B San Juan, South Gate, California.

**PHILATELIC Jungle 10¢.** Fifteen zoological specimens. Approvals included. Free watermark detector. Crown Stamps, Virgil 301, Ontario.

**"LEARN How to collect Stamps" free by mail.** Stamp album, watermarks, detector, magnifier glass, stamp nippers, perforated gauge, stamp hinges, as well as interesting method and biography for the learner. For additional information write to: Carril's Stamp Club, P.O. Box 479, Main Office, Union City, N. J.

**WRITE For list.** British Colonial, foreign lots. Thomas Drew, Box 325A, Deep River, Ontario, Canada.

**AFRICA Independent nations.** Fascinating collection butterflies, flowers, masks, birds, fish triangles only 25¢. Approvals. Berchtold, Troy, Ohio.

**25 LARGE Stamps free with foreign approvals.** Centennial Stamp Company, Box 1587C, Anniston, Alabama.

**VALUABLE Limited offer!** 4 unusual Japanese, 11 others. Worldwide approvals. 10¢. Postmark, Box 542M, Great Neck, N. Y.

**START A profitable approval business.** New easy plan. Free information. Stark, 14321 Wentworth, Chicago 27, Illinois.

**FREE! Shepard astronaut commemorative!** 25 others different. Approvals. White, Box 485, Flemington, New Jersey.

**NEW Issue set free with approvals.** Rhoden, 903P Leland, Chicago 40, Illinois.

**FREE Mint surprise packet.** Approvals. Tellico, Box 4127, Sunnyside 4, N. Y.

**CHEVROLET Antique automobile stamps 10¢ with approvals.** Uram, Amherst, N. H.

**RYUKYU Islands.** Flower stamp free with approvals. Lee Hoover, Box 3594, Portland 8, Oregon.

**FREE—50 different stamps, with approvals.** Fahsing, Dept. PM, Atascadero, California.

**FREE! Beautiful pictorial packet!** Approvals. Conklin, Box 388-PM, Osage, Iowa.

**203 DIFFERENT Stamps 25¢ with approvals.** Arlo Bones, 126 Southeast 24th, Portland 14, Oregon.

**333 DIFFERENT Triangles, sports, topicals etc.** Worth \$8. Only 25¢. Approvals. Jayto Stamps, Box 246B, East Syracuse, New York.

**300 DIFFERENT.** Includes pictorials. 25¢. Knopp, Box 1381, Bristol, Conn.

**DISCONTINUING Stamp business.** Tremendous values! \$2.00. Conglomeration includes mixtures, packets, sheets. Norge, Ho-Ho-Kus, N. J.

**EXTRAORDINARY! Free! 20 different Finland to those requesting approvals.** Rosenberg, Box 1303, Chicago 90, Ill.

**NEW ZEALAND 20 different, including giant Christmas and centennials 10¢.** Approvals. Reinhardt's, Box 93MI, Troy, Michigan.

**FREE.** Price lists with over 500 illustrations, sets, singles, at low price. Guy Desjardins, C.P. 153 Delorimier, Montreal 34, P. Q.

**GIANT Stamp collection including: astronauts, satellites, moonrocks, Boy Scout issue, complete UN set, recent Olympic and sport issues from many countries, etc.; Plus big stamp dictionary and approvals.** Everything 10¢! Stampex, Box 47-LM, White Plains, N. Y.

**GLORIOUS Bathing beauty.** Miss Universe stamp. Nine sparkling colors. "Photonotes" subscription. Free! While they last, with approvals. Philatelics, RM, New Paltz, New York.

**FREE! Surprise "Mystery" packet.** Approvals. Premiums. Dancer, 75-P36, Mansfield, Ohio.

**START Approval business.** Details 25¢. Steele, Box 553-PR, Pacific Grove, Calif.

**100 DIFFERENT Stamps, \$1.00.** Grace Clabaugh, 10546 Debra Ave., Granada Hills, Calif.

**FANTASTIC Fish triangles! Valuable "Ben Franklin" on Canal Zone! Flaming bi-colored volcano triangle! Lovely Olympics triangle! Plus icy Greenland, weird wild beast issue and others.** 10¢ with approvals. Roseland Stamps, Spring Lake 2, Michigan.

**TEN Different nudes on stamps: Only two dimes.** Twenty-eight different: \$1.00. Approvals. Stamp Farm, MN48, Oxford, Wis.

**FIRST Day cover approvals!** Included free, valuable airmail cover. Myers, Coopersburg, Penna.

**FREE—25 large beauties with request for approvals.** Al Gray, 506-15th St., Moline, Illinois.

**UNUSUAL Old U.S., defectives.** Bargain prices. K. Swartz, Malden Bridge, New York.

**FREE! Antique autos! Complete! 10¢ handling.** Approvals included. W. Shaver, 3075 Vamana, Pomona, California.

**25 DIFFERENT U. S. commemoratives, 1893 up, 10¢ approvals.** K & B Stamp Co., Box 70, Brooklyn 23, N. Y.

**50 DIFFERENT Central and South America, 10¢ with worldwide approvals.** Cole, Box 223-A, Buffalo 21, N. Y.

**21,000 ALL Different, only pennies a day using our systematic payment plan.** Details free. Sjoquist, 1435 Cherrydale, San Jose 25, California.

**U.S. Fully illustrated catalog 10¢ deductible.** Simmy's, 45 Bromfield, Boston 8, Massachusetts.

**FREE! 25 Different Portuguese; colorful, inexpensive approvals.** Elkhart, Box 33, Elkhart, Indiana.

FREE Mint Africa set with approvals. Lithor, Box 51, Canoga Park, Calif.

FREE 30 Large U. S. commemoratives with approvals. 10¢ handling. Jack Clancy, Box 2187, Portland 14, Oregon.

FREE Sample. Interesting, informative. Illustrated. National Stamp News, Anderson, South Carolina.

OVER \$20.00 Catalog value for just \$1.00. 1000 different worldwide. Approvals included to adults only. Universal, Box 6, Kenosha 5, Wisconsin.

200 STAMPS, 25¢ With approvals. Smith, 508A Brooks, College Station, Texas.

FREE! 222 worldwide. 10¢ handling. Penny approvals. Jung, 1601 North Stanley, Los Angeles 46.

U.S. Mint specials! Flag set, complete \$1.00; 1¢, 2¢, 3¢ famous Americans (21 different) \$1.00. Free list. Brooks, 2323 Avenue X, Brooklyn 35, New York.

TWO \$5.00 United States stamps. 20 others 10¢ with United States approvals. Irwin, Box 1105, Brooklyn 30, New York.

80 DIFF. U. S. stamps includes 19th Century commemorative. High values. Plus 1943 flag stamp of occupied nations. All for only 25¢. Approvals included. Willett Co., Box 338-C, Yorktown Heights, N. Y.

UNITED Nations 15th anniversary sheet with first day cancel, as commemorated by Russia. Free! While they last, with approvals, Philatelics, R-J, New Paltz, N. Y.

25 COLUMBIA 10¢. Approvals included. Reed, Box 980, Chicago 90, Illinois.

INTRODUCING Our better United States approvals we offer 15 United States stamps including Columbian, Bi-Centennials, famous American, airm, others; only 10¢. Ocean Stamps, Box 64-PM, Brooklyn 29, New York.

PENNY Approvals. Thousands. Bargains for pennies. Gifts with purchases. Penny Stamps, Orange, California.

UNITED States commemorative collection containing 33 different—10¢. Approvals. White, 516-A Avenue L, Brooklyn 30, New York.

AMAZING OFFER! 200 United States stamps — including commemoratives, airmails, high denominations to \$1.00. Only 10¢ to approval applicants! Illustrated bargain lists free. Mystic Stamp Co., Dept. 80, Camden, New York.

100 OLD United States between 1861 and 1935, \$1.00. Roush Stamps, 51 Chestnut, Mansfield, Ohio.

FREE Monaco nudes. Approvals. Stamp Ranch, 902 Addison, Chicago 13, Ill.

PENNY Approvals! Regardless catalogue! Kloster, 4164—52nd St., San Diego 5, Calif.

60 DIFFERENT U. S. (30 commemoratives) 25¢. No approvals. Seidenberg, Appleton, Wisconsin.

225 STAMPS For only 10¢! This mammoth value includes airmails, pictorials; stamps from strange countries cataloging up to 25¢ each! Also approvals. Mystic Stamp Company, Camden 80, New York.

FREE 50 Worldwide, mailed with inexpensive approvals. University Stamps, P.O. Box 44-592, Miami 44, Florida.

100 DIFFERENT United States commemoratives, 1/2¢ to 10¢ values—used \$1.00; Mint \$4.95. No approvals. Gil's, Box 12BA, Brooklyn 29, N. Y.

215 DIFFERENT Worldwide 25¢. Plume, Korea, Laos, Russia, Transvaal. Approvals. Bobb's, Box 3045, Saint Louis 30, Missouri.

MILLION Foreign stamps! 2¢ each! Send for thrilling, giant approvals! ABC Stamps, Box 6000-MB, San Francisco 1, Calif.

14,000 DIFFERENT! Amazing new plan builds your collection systematically, country by country. Only 50¢ weekly. Free details. L. G. Ware, Monroe 75, Conn.

200 DIFFERENT U. S. only \$1.00 with approvals. Winchester Stamps, 45 Winchester Rd., Mansfield, Ohio.

ZOWIE! U.S. commemorative collection free. 33 different, plus gift, approvals, 10¢ handling. Russell Stamps, Jamestown 5, Rhode Island.

FREE Mint set! Approvals accompany. Stampco, Box 737, Memphis 1, Tenn.

PENNY Foreign stamps, neatly mounted in jumbo books in Scott order. Bullot Approvals, 1359 Coney Is. Ave., Brooklyn 30, N. Y.

701 U.S.A. — 25¢. Plenty commemoratives. Request approvals. Horace Gatewood, Winston-Salem, N. C.

FREE—When you buy our foreign approvals, you receive absolutely free stamps equaling your purchases. Coast, 1609 S. Park, Santa Ana, California.

1000 DIFFERENT, \$1.00 With approvals. Louis Golden, 6721 Eastwood, Philadelphia 49, Penna.

25 U.S. Free with approvals. Collier, Box 265, Chamblee, Ga.

BEAUTIFUL Set latest Kenya stamps. Unused. \$10.00. Greaves, Box 676, Kitale, Kenya.

50 DIFFERENT U.S. commemoratives 25¢. Peters Stamps, Box 645, Arlington 16, Va.

SELL Stamps to our readers. Your ad in this space will be read by thousands of stamp buyers. I'll prove that to you. Write now for Folder "S." F. W. Johnson, Classified Advertising Manager, Popular Mechanics, 740-ST Rush St., Chicago 11, Ill.

## HOBBIES AND COLLECTIONS

AMAZING Introductory offer. Collect regulation medals with ribbons; Five different French, \$3.00; Four British, \$3.00; Five German, \$3.00. Catalog 25¢ (refundable). Insignias, Box 71-M, Rockaway 94, New York.

COLLECT Shells, 25 different \$1.00. 50 diff. \$3.00. Lyles, 1531 N.W. 34th Ave., Miami, Fla.

SEND Me a list of your hobbies with \$1.00 and receive interesting ideas and latest information about your hobbies. John W. Slawen, List Compiler, 39 Main St., Ayer, Mass.

COLLECTORS Matchbook covers. 100 different unused, \$1.00. Catalog 25¢. Charles Edelman, 1311-C East 84, Cleveland 3, Ohio.

AMERICAN Newspaper, complete, original, dated before 1860, \$1.50. 25¢ stamps brings catalogue. D. R. Spaight, Book-seller, Tall Timbers 1, Maryland.

50 JUNGLE Butterflies \$2.00. Haas, Box 2466, New York 8, New York.

## PRECIOUS STONES, MINERALS

SEMI-Precious uncut gems. Ten different for \$1.00. Request list 28. Prospectors Shop, 201 San Francisco, Santa Fe, New Mexico.

EARTH Science. Rockhound's National Magazine. Subscription \$2.50. Sample 35¢. Box 1357-PM, Chicago 90, Ill.

FREE Gold! Blackhills gold ore, sawed specimen, 4 square inches. You can see the gold, \$1.00 plus postage. Lyman J. Carr, Onida, South Dakota.

100 SPECIMEN Mineral collection, complete \$5.00. Colorful, rare, educational. Labelled. Wilderness Originals, Canyon, Calif.

ROCKHOUND—Gem cutters — jewelry makers. New free catalog just off the press! Biggest supplier to hobbyist and craftsman offers you tools, materials, equipment, introductory bargains and know-how. Free catalog. Write: Grieger's, Dept. C-11, 1633 E. Walnut, Pasadena, California.

KNOW Your planet. Geology is fascinating and educational. Send \$1.00 for two authentic marine fossil prints in limestone. Blount Fossil Studies, P. O. Box 98, Elmwood Station, Syracuse 7, N. Y.

20 GEMSTONES \$1.00 collectors and jewelry making. Eberles, 2727 West Slauson, Los Angeles 43, Calif.

FREE Bargain gem list. New lapidary and silversmith tool catalog, 50¢. O'Brien's, 116B Wilcox, Hollywood 38, Calif.

ROCKHOUNDS! Four gold nuggets in authentic miniature gold pan. \$1.50. Mag-nifier free! Nuggets, P.O. Box 1194, Seattle 11, Wash.

## PHOTOGRAPHY, CAMERAS, PHOTO SUPPLIES

FREE! Send now for circular of new and used photographic bargains. Dept. 1-H-9, Central Camera Company, 230 So. Wabash Ave., Chicago, Illinois.

\$1.00 BRINGS Discount catalogue. Sterling's, P.O. Box 246, Easton, Pennsylvania.

PHOTOGRAPHY For pleasure or profit. Learn at home. Practical basic training. Long established school. Free booklet. American School of Photography, 835 Diverser Parkway, Dept. 345C, Chicago 14, Illinois.

## PHOTO FINISHING

COLOR Movie fans! Low cost—high quality processing our specialty, 8mm. just \$1 (or \$3 with fresh film). Mailed back next day. Craftsmanship guaranteed. Send exposed reel or request free mailers and price list of complete photo-finishing services. Direct Mail Photo, Box 8352-PM, Pittsburgh 18, Penna.

2 BLACK And white prints from each picture on roll. 8 exposures 45¢; 12 exposures 60¢. Forty-two years of satisfied customers. Quick service. Lens Photos, Dept. J-4, Janesville, Wis.

A FREE Kodak roll returned with each black and white or Kodacolor developed and printed, fast service, lowest prices, guaranteed quality send for free mailers. Economy Photo Service, Dept. P. M., Box 1111, Albany 1, N. Y.

FAST, Hi-quality finishing. Kodacolor rolls: eight jumbo prints \$1.98. Twelve \$2.49. Twenty \$3.49. Reprints 15¢. Also low B&W prices. Custom Quality Studio, Box 4838, Chicago 80.

KODACOLOR Developed and each print charged \$1.75. Black and white 30¢, up to 12 exp. Kodachrome 8mm. movies or 20 exp. slides 79¢. Send film now or write for free mailers, circular, and free Kodak film offer. Prompt service. Photo King, Box 7185, Dept. 238, Jersey City 7, N. J.

EKTACHROME-Anscochrome 35mm. 20 exp. 620, 120, 127, developed, mounted, \$1.00. Exceptional low prices on Kodacolor films. Prompt service. Complete price list-free mailers. Write Trycolor, P.O. Box 123, So. Windsor, Conn.

WITH This ad only. Kodacolor films processed and printed, including new film roll. 8 exp. \$2.50; 12 exp. \$2.95. MBG Photo, Box 537-A, Toledo 1, Ohio.

8MM, 16MM. Movie subjects. Silent, sound. New, used. 2"x2" color slides. Biggest selection anywhere! Free each month, big 24-page newspaper-size catalog. Blackhawk Films, Davenport 14, Iowa.

8x10, 20¢ WITH This advertisement. Don's Photos, Box 84, Brooklyn 19, N. Y.

## MOTION PICTURES AND SOUND EQUIPMENT

8MM. Valentino, Fairbanks, Keaton, others. 16mm. sound features, shorts, silent classics. Large assortment. Entertainment Films Co., 236 W. 55th, New York City.

16MM. Films—projector parts. Gordon, 28-53 Steinway Street, Long Island City, N. Y.

5,000 8-16 MM. Movie films. Free catalogues. International, Greenvale, N. Y.

MOVIE Camera film: 8mm. roll \$1.50. 16mm. 100' \$3.00. Free processing. Better Films, 742 New Lots, Brooklyn, N. Y.

MOVIE Film! Free catalog! ESO-R, 47th Holly, Kansas City 12, Missouri.



**FREE Catalog!** Save on 8/8mm.-16mm. film and supplies. Superior, 448 N. Wells, Chicago 10.

**16MM.** Sound, projectors, films. Sale, rental, exchange. Stereo Tapes. Rental and sale. Visit store or write for catalog. National Cinema, 71 Dey St., New York City.

### COLOR SLIDES

**TRANSPARENCIES** Wanted. Up to \$500.00 each. For information write American Color, P.O. Box 46372, Hollywood 46, Calif.

**LINCOLN** Story in 500 color slides: Hogdenville, Knob Creek, Gentryville, Rockport, New Salem, Springfield, Washington, Gettysburg, statues, memorials, etc. Sample slide 35¢. Catalogue free. Willems, Box 1515-A, Chicago 90.

### MUSIC & MUSICAL INSTRUMENTS

**SONGWRITERS** Handbook—only \$1.00. Valuable information. Songwriters Service, 1619-D Broadway, New York 19.

**POEMS** Wanted for musical setting and recording by America's largest song studio. Send poems. Free examination. Five Star Music Masters, 630 Beacon Building, Boston.

**SONGPOEMS** Wanted for musical setting. Free examination. Get "The Nashville Sound" in your songs and records. Send poems: Music City Songcrafters, 6145-N, Acklen Station, Nashville, Tenn.

**ELECTRIC** Guitars, amplifiers, wholesale. Free catalog. Carvin, PMM, Covina, Calif.

**LOW** Quotes: Stereo tapes, components, recorders. HiFi, Roslyn 6, Penna.

**SONGPOEMS** And songs wanted! Mail to: Tin Pan Alley, Inc., Box 405, Radio City Station, New York 19, N. Y.

**POEMS** Wanted for musical setting and recording. Send poems. Free examination. Crown Music Company, 49-C West 32 Street, New York 1.

**GUITAR** Making books, plans, imported woods, tools. List 10¢. Satinwood, 510 East 11th Street, New York 9, N. Y.

**SONGS** Wanted. Pays royalties. Enclose postage. Olenik Records, Mount Morris, Michigan.

**ACCORDION-O-RAMA**, 874 Broadway, New York 3, N. Y. Tremendous discounts. Top brands. Free brochure.

**SEND** Songpoems. Needed immediately for songs and recordings. Free professional appraisal. TV-Soundcrafts, Box 550-G, Radio City, New York 19, N. Y.

**POEMS** Wanted to be set to music. Brightens dull, lifeless TV picture tubes. Reduce high repair bills! Fits all makes. Safe, easy to install. Only \$9.95. Money back guarantee. Christie's, P. O. Box 1211, Denver, Colorado.

**PIANO** Tuning quickly learned with home study course. Diploma granted. American Tuning School, Gilroy, Calif.

**SONGS** Poems wanted for publishing recording consideration on royalty sharing basis. Ted Rosen, 17 Longwood Road, Quincy, Massachusetts.

**SONGPOEMS** Wanted! Collaborate with professional songwriters on equal basis. Share royalties. Songwriters Contact Co., 1619-D Broadway, New York 19.

**GOSPEL** Quartet records. Sample \$1.00. PAC, Box 157-ACS, Gadsden, Ala.

**TRANSPOSE** Easily. New plastic musical slide rule—only \$1.00. "Transpos-A-Chord," Box 189PM, Hollywood 28, California.

**SONGPOEMS** Needed immediately. Nashville Music Institute, Box 532-M, Nashville, Tennessee.

**POEMS** Wanted. Surprising offer. Free recordings. Successful songs. 6 North Street, Danbury, Conn. Phone 748-6603.

**POEMS** Wanted to be developed into new songs for recording and promotion. Send poems today for free examination. Buddy Bregman Music Productions, Dept. 42, Box 2066, Culver City, California.

**ACCORDIONS**, Guitars, chord organs! Save 1/2. Famous makes. Free home trial. Easy terms. Trades. Free catalogs. Mention instrument. International Music Mart, Dept. R, 2003 Chicago Avenue, Chicago 22.

**LYRICS** Revised, prepared for publication, recording. Lee Ice, Marietta, Ohio.

**SWISS** Musical movements. Mechanical-electrical. Spielman, 131 West 42nd, New York 36.

**BANJO** Making. Money-back guaranteed instructions, patterns, parts price list, \$2. List only, 10¢. Musicraft, 823-A Foster, Evanston, Ill.

**PIANO** Rolls. Old and new. Free lists. A. Schmidt, 455 Belden, Chicago 14.

**ACCORDIONS**, Piano, chromatics, butontype, concertinas. Wholesale catalogs free. Italian Accordion Mfg. Co., 7600-C Cottage Grove, Chicago 19, Illinois.

**ACCORDION** Exchange plan. Catalog terms. Accordion Import Center, 7120 Galli Dr., San Jose 29, Calif.

### RADIO, TELEVISION AND ELECTRONICS

**LEARN** While asleep with amazing "Electronic Educator" endless tape recorder. Details free. Research Association, Box 24-PX, Olympia, Wash.

**GOVERNMENT** Surplus radios, parts. Picture catalog 10¢. Meshna, Maiden 48, Mass.

**FIX** Your own TV. Save 80%! Send for free illustrated chart showing how! We'll include giant electronics catalog. Zalytron, 220-M West 42 St., New York City.

**TAPE** Recorders hi-fi components. Sleep learning equipment, tapes. Unusual values. Free catalog. Dressner, 1523M Jericho Tpke, New Hyde Park, N. Y.

**SAVE** Dollars on radio, TV-tubes, parts at less than manufacturer's cost. 100% guaranteed! No rebrands, pulis. Request bargain bulletin. United Radio, 1000-M, Newark, N. J.

**PORTABLE** Taperecorders with same features as other American name brands, but at new low price of \$29.95. No c.o.d. Floyd Stanford, Box 124, Lawtell, La.

**SAVE** 30% Up! Blank-stereo recorded tape-recorders-Norelco speakers. Saxitone, 1776 Columbia Road, Washington 9, D. C.

**CONVERT** Radio to versatile intercom. Parts—complete instructions only \$20.00. Futronics, 585 Winthrop, Taunton, Massachusetts.

**RADIO** Course only \$14.95. Includes all tubes, parts, tools, instructions. Write for full information. Progressive "Edu-Kits" Inc., Dept. 575B, Hewlett, N. Y.

**NEW!** Miracle electronic power booster. Brightens dull, lifeless TV picture tubes. Reduce high repair bills! Fits all makes. Safe, easy to install. Only \$9.95. Money back guarantee. Christie's, P. O. Box 1211, Denver, Colorado.

**GUARANTEED** 4 Transistor tape recorders including accessories \$19.88 postpaid. Details free. Peter Pan Promotions Corp., Time & Life Building, Rockefeller Center, New York 20, N. Y.

"**LISTEN-In-Coil**" picks up any telephone conversation in vicinity. No connection to telephone necessary. Easily concealed. \$2.98 complete. Acoustical Research, Dept. 73, 512 East 80, NYC 21, N. Y.

**QUALITY!** Tape: 73% discount! Pre-recorded; Accessories. Catalog: Tape King, 2028 Garth, Los Angeles 34, California.

### BUSINESS OPPORTUNITIES

**REAL** George hot dog siltter. It's new, all you do is twist it thru—then barbecue, boil, broil. Sell \$1.00. Samples 2 for \$1.00. Circumscribe your hot dogs. George T. George, 4447 Simpson, North Hollywood, Calif.

**OUTSTANDING** Income from nationally famous Travelmats, placemats, books, and fund raising programs. \$2 kit includes everything needed to make \$100 commission per day. Box 28P, Prairie du Chien, Wis.

**DO** It with "Power-Packs", the new national sandwich sensation. Ten million sold. P.O. Box 936 (P), Wichita, Kansas.

**FREE** Cop! "Inside Secrets Mailorder Importing." Victor, Box 944-A, Kingsport, Tennessee.

**MAIL** Order items that sell. Seven complete offers. Orders drop shipped. Beginners-established dealers welcomed. Emm-Ess Company, Dept. SK-9, Linden, New Jersey.

**INTERNATIONAL** Mailorder business made easy. Complete setup service, not just instructions. Hermes, 152 West 42, New York City 36.

**GOLD**, Silver, platinum; refining, testing, make alloys, solders, etc. Learn wonderful business. Frank J. Herman, Metallurgist, 1529 Liberty Street, Los Angeles 26, Calif.

**IMPORT** Export, represent manufacturers. International directory covers 150 countries. Monthly bulletins. Book 25¢. Benko, Box 186-A, New York 21, N. Y.

**MAILORDER** To motels, churches, institutions. Individual setup. Not just instructions. Hermes Advertising, 152 West 42, New York City 36.

**FRFE** "Franchise Profit Letter" tells how unique NFR service is helping thousands seeking profitable businesses. Write today. National Franchise Reports, W-528, 333 North Michigan, Chicago 1.

**START** A business spare or full time immediately repairing small electrical appliances. Free literature. M & L Appliance Parts, Dept. A, 1507 W. 69th St., Chicago 36, Illinois.

**BUSINESSES**, Resorts, motels, investment property, ranches. Our special service dept. at your disposal. No obligation. World's largest. 62 years service. Strout Realty, 7-MB S. Dearborn, Chicago 3, Ill.

**SELL** Books by mail. Moneymaking system. Amazing profits. Details free. American Distributors, Box 409, Niles, Michigan.

**EARN** \$10,000 Selling books by mail. Box 51-BY, Des Plaines, Ill.

**OPERATE** Mailorder bookshop. Free details. Ballard, 1834 Edgeland, Louisville 4, Ky.

**MAKE** Money making leathersgoods. 1148 ideas. Free information. Tandy Leather Co., Box 791-Q3, Fort Worth, Texas.

**IMMEDIATE** Profits with no capital or experience. Take orders for all magazine subscriptions. Friends and neighbors are your prospects. Write now for complete, free kit. McGregor Magazine Agency, Dept. CB2, Mount Morris, Illinois.

**HOW** And where to obtain capital. Reliable Service, Rome City, Ind.

**SELL** Champion, AC, Autolite spark plugs. Reconditioned, electroplated, guaranteed 10,000 miles. 100% profit. Free sample. Lee Plugs, 1608-A Roberts, Houston 3, Texas.

**VENDING** Machines. No selling. Operate a route of coin machines and earn amazing profits. 32-page catalogue free. Parkway Machine Corporation, Dept. #27, 715 Ensor Street, Baltimore 2, Maryland.

**BIG** Money raising fishworms and crickets. Free literature. Carter Farms, Plains, Georgia.

**TO \$100.00 Weekly.** Sparetime, home operated mailorder business. Successful beginner's plan. Everything supplied. Lynn, 10420-M National, Los Angeles 34.

**PIANO Tuning** learned quickly at home. Tremendous field! Musical knowledge unnecessary. Information free. Empire School of Piano Tuning, Champaign, Ill. (Founded 1935).

**OPERATE Profitable** mail order business. Write Walter Service, 4159A East 112th, Cleveland 5, Ohio.

**BAKE New** greaseless doughnuts in kitchen. Sell stores. Free recipes. Montgomery, 3605 South 15th, Minneapolis 7, Minnesota.

**MAKE \$46** From square foot plywood: jigsaw necessary. Free details. Woodart, Bridgewater, Mass.

**\$400.00 MONTHLY** Raising giant fishworms. Soilless method. Charlie Morgan, Bushnell, Florida.

**PLASTERCRAFT** Molds, liquid rubber, plasters, flocks, candle supplies. Catalog and manual free. Blue Rapids Supply, Blue Rapids, Kansas.

**WORLD'S Largest** wholesale supply. Buy from 679 American, European, Japanese wholesalers. Tailormade suits from Hongkong. 123 dropship catalogs. Rock-bottom prices. Free details. International Buyers, 216-MM Jackson, Chicago 6, Ill.

**MANUFACTURE** Polishes, cleaners, cosmetics, anything. Literature, stamp. Neiko, 3462 Merchandise Mart, Chicago 54.

**11,000 NEW** Prospects daily. Baby record books, shoes, albums. Sell mailorder. Use our literature. Write: No-Co-Ro, Capitola, Calif.

**OPERATE** Home mailorder business. Vosacek Printing, 4444AI Ute, San Diego, 17, Calif.

**COLORGLAZED** Concrete pottery made without molds. Patented method. Cemetery products, novelties, tiles. Basement leak-sealing. Money-making projects. Booklet, details free. Men only. National Potteries Company, Grand Rapids, Minnesota.

**WANT** To make big money at home? \$10.00 profit in an hour possible with invisible mending. Make tears, holes disappear from clothing, fabrics. Steady year-round demand from cleaners, laundries, homes. Details free. Fabricon, 1585 Howard, Chicago 26, Ill.

**EARN** Money raising fishworms for us! Write: Oakhaven-38, Cedar Hill, Texas.

**LEARN** Sewing machine repairing. To \$125 weekly. Sparetime. Supplies. Add to present business. Write today! Taylor Service, Box 484, Cupertino, Calif.

**MAKE** Money from old tires. Operators clearing \$400 weekly. Equipment costs \$800. Get facts. S & S Patents, Inc., 3511 N. Lincoln, Chicago 13.

**DRIED** Mushrooms \$4.50 pound for large canning company. Receiving warehouse in United States. Growers wanted on contract, everything supplied. Dehydrated Products & Chemicals, No. 548, Calgary, Alberta, Canada.

**VENDING** Machine catalog. Rakes, 609P Spring Garden, Philadelphia 23, Penna.

**BRONZE** Baby shoes. Genuine electroplating process. Equipment, mountings, instructions. Send \$1.00 for valuable book "Your Guide To Success" bronzing baby shoes, plus complete catalog. Hollywood Bronze Supply, Dept. B60, 3445 Union Pacific Avenue, Los Angeles 23, California.

**RAISE** Rabbits on \$500 month plan. Free details. White's Rabbitry, Mt. Vernon, Ohio.

**\$200.00 MONTHLY.** Spare time. With tablesaw, bandsaw or jigsaw. Write. Holiday House, A3800 Harney, Vancouver, Washington.

**SHARPEN** Saws and lawnmowers the profitable way. Send for free literature. Max Manufacturing Company, 138 Stockton Avenue, San Jose 26, California.

**SIMPLE.** Pleasant mailorder can net \$12,000 year. Write: Rutward, 2010 Bryant, Columbia Station, Ohio.

**\$34.70 TWO** Hours manufacturing concrete products. No selling. Castings #3, Box 1721, Rapid City, South Dakota.

**LAUNCH** Profitable mailorder business. Write: Kozar, 159 Belleville, Belleville, N. J.

**GARDEN** Golf. Start amusement center. Invest now. Brockway, Box 3762, Portland 8, Oregon.

**LARGE** Profits manufacturing, selling own brands. Andrews, East 3823 Liberty, Spokane 27, Wash.

**EVERYBODY** Likes fine candy and popcorn specialties. Make professionally home. (Our 50th year.) Ragsdale Candies, B107 East Orange, New Jersey.

**PROFITABLE** Mailorder business! Write: Vikari, 468-P Third Avenue, Salt Lake City 3, Utah.

**MAKE** \$1,858.50 Yearly with \$89.95 investment. Yearly contracts. Hubbard, 3757 Wilshire, Los Angeles 5.

**MAKE** Money with Lechler, dropship beauty cosmetics. Free art, copy, layout-circulars available. Wholesale prices. Lechler Laboratories, 560-G Broadway, New York.

**10,000 PROFITABLE** Formulas, recipes, trade secrets. Details free. Colen, 7731-M9 Yates, Chicago 49.

**WORK** At home packaging merchandise. Very profitable. No selling. Everything supplied. Details free. D'Amico, 209 W. Jackson, Chicago 6.

**SELL** Greeting cards. Make extra money. Christmas, all occasion assortments, stationery, gifts, jewelry, name imprinted Christmas cards. Experience unnecessary. Salable samples on approval. Free catalog. Write Hedenkamp, 361 Broadway, Dept. PM-81, New York.

**OPERATE** Profitable low-cost mail order business. Details free. Liberty, 210 Fifth Avenue, New York 10, N. Y.

**MAKE** Durable building plastic easily. Waterproof, fireproof, economical. Bays Laboratory, Cedaredge, Colorado.

**SECRETS!** Secrets! Mail order success revealed by internationally famous expert who discovered how to make home business fortunes. Beginners: Get free copy "How to Make Money in Mail Order." Disclosed free advertising, profitable products, everything! No obligation. Write Mallico, 1554 Sepulveda, Dept. D709, Los Angeles 25.

**BIG** Money—Operate your own fix-it shop. Service all household appliances: irons, fans, refrigerators, automatic washer-dryers, etc. Do house wiring, commercial writing. Rewind motors of all sizes. Sharpen mowers, skates, saws. Buy needed spare parts wholesale. Free book. Christy Trades School, A-2903, 3214 W. Lawrence, Chicago 25.

**PROFIT** With Popular Mechanics' subscription plan. No investment, no experience needed. Earnings begin immediately when you obtain subscriptions for Popular Mechanics, Good Housekeeping and others. High commissions, bonus. No experience needed. Deal directly with the publisher. Write Popular Mechanics, Room 9B, 250 West 55th St., New York 19, N. Y.

**DOLLS!** Dolls! Dolls! We teach you to make, repair, dress and sell. Study at home. Earn while learning. Free booklet. Doll Hospital School, Studio MC-92, 11826 San Vicente Blvd., Los Angeles 49, Calif.

**LEARN** Landscaping and the growing of plants. Start a profitable business part or full time. Free information without obligation. National Landscape Institute, Dept. MC-92, 11826 San Vicente Blvd., Los Angeles 49, Calif.

**BECOME** Tax consultant. Graduates earn \$1,000-\$3,000 every tax season preparing returns evenings. State approved. Union Institute, Lakewood Q-2, N. J.

**MAKE** Telephone surveys spare time! Free home-business details. No selling, choose your own hours. Telephone Institute, Dept. HC-179, 1038 So. La Brea, Los Angeles 19.

**EXPORT-Import** opportunity, profitable, world-wide, mail-order business from home, without capital; or travel abroad. Established world trader ships instructions for no-risk examination. Experience unnecessary. Free details. Mellinger, D709, Los Angeles 25.

**START** Your own business on credit. Your own boss, 1199 dealers sold \$5,000 to \$25,500 in 1961. We supply stocks, equipment on credit. 200 home necessities. Sales experience unnecessary. Pleasant, profitable business backed by world-wide industry. Write Rawleigh, Dept. I-U-PPM, Freeport, Ill.

**MAKE** Extra money. Big steady earnings, repeat business. Sell advertising book matches, full or part time. New 1962 line. Show glamour girls, colorama, tenorama; dozens more. All sizes. Free master outfit, sales helps, leads, no experience necessary, no investment. Write today. Superior Match, Dept. MX-962, 7530 Greenwood, Chicago 19, Ill.

**MANUFACTURE** Products—400% profit. Sell mailorder. Catalogue free. "International," 6347 Parnell, Chicago 21, Illinois.

**PEST CONTROL.** Start own part, full time business. Charge \$10.00 hour! Elston, 4035 Lake-Cook, Northbrook 1, Illinois.

**HOW** To start profitable small diner, lunchroom. Home training. Details free. Restaurant Business School, Dept. EC-92, 1920 Sunnyside, Chicago 40.

**EARN** Extra money. Own your own business. Amazing business manual tells how. Literature free. Hodgson's Mail Order Co., 10 Chaplin Rd., Bristol 5, England.

**HONEST** Help for home mailorder. \$1000 monthly possible. Write: Murrey's, Litchfield, Maine.

**MOLD** Statuary, pottery, tiles, novelties. 5¢ materials makes dollar sellers! Particulars free. Marbleizing Service, Edwardsville, Illinois.

**\$50-\$100 WEEK** Possible with herbs. Grow inside-outside or gather wild. Free details. Whitlow, Dept. A-8, 726 Fairwood, Dallas 32, Texas.

**AVOID** Trouble. Order latest mailorder business "Legal Guide." Explains all about licenses, taxes, etc. \$2.00. Neil H. Tasker, Shamokin, Pennsylvania.

**PACKAGE** At home for profit! We supply everything. No selling. Free home business details. HPC 2212BW, Jesse Street, Los Angeles 23.

**EARN** \$100.00 Weekly. Unusual home business. Fourteen magic methods. Derco, Box 494-B, Muncie, Indiana.

**NEW** Snow cone machines. All prices. P.O. Box 26410, Dallas, Texas.

**SELL** Books by mail. 400% profit. Royal, Box 450-X, Cleveland 27, Ohio.

**MOLDING** Rubber. Free information. Chaney's, 5415-A San Jose Blvd., Jacksonville 7, Fla.

**FREE** Necklace kit offered by Modern Craft under Home Craftsmen.

**NEW** Snow cone machines. All prices. P.O. Box 26410, Dallas, Texas.

**STOP** Throwing away box-tops! They're worth money! Some, 25¢! Inquire: Box-tops-MB, Cedar Hill, Texas.

**INVESTIGATE** New mail order drop shipment plan. OPO, 13389 23rd Place, Golden 2, Colorado.

**BIG** Cash easy. Details. Send 4¢. EKO, 213 Kalaniana'olep, Hilo, Hawaii.

**FREE** Book: "609 Unusual, Successful Businesses." Box 1001-PX, Evanston, Illinois.

**\$100.00 WEEKLY.** Sparetime home mail order business. Successful beginners plan. L&D, 109 W. 42nd, New York City 36.

**CANDLE** Making kit, wax metal mold, color, wicking, instructions \$8.95 prepaid. The Candle House, 4900 CY Ave., Casper, Wyo.

**MOLDS** For concrete bird baths, benches, flower urns, animals, statuary items, etc. Buy durable aluminum molds direct from top manufacturer. 96-page manual complete instructions, product illustrations, mold prices, \$2.00. Concrete Machinery Company, Inc., Drawer 99, Hickory 12, N. C.

**THE** Franchise boom is the way to a business of your own in your area. Write for complete list of exclusive franchise opportunities. Partake, Inc, Dept. PM, Oak Brook Mall, Oak Brook, Illinois.

**RAISE** Nightcrawlers, redworms easy soilless method. Three Oaks Ranch, Dresden, Tenn.

MAIL Order beginner's booklet 50¢. Haven, 3620 Lindermann, Racine, Wisconsin.

\$1,000 MONTHLY! Operate home mail-order business. Immediate profits! Free details on new, unique business plans. Fulker Research, 1212 S.W. 4th Ave., Portland 4, Oregon.

BE Successful. Read "Success"! Results guaranteed. \$1. Box 2025, Orcutt, California.

HOME Producers needed desperately in exploding new plastics business. Sell your spare time. No selling. Most territories still open! Hurry. NPC, Box 23321, Los Angeles 23.

LOVE Pays. Bronze baby shoes. Free booklet. Box 5036A, Inglewood, California.

BUY Direct from factories. Appliances, cameras, watches! Free details! Cam Co., 436 P.M. Bloomfield Ave., Verona, N. J.

CANDLE Making, decorating supplies, molds, tools, equipment. Largest selection, lowest prices. Also complete illustrated home study course on candle making and decorating. Ideal for making professional candles for holidays, special occasions. Send 25¢ today for big new catalog, applied to first order. General Supplies, Dept. G-226, Fallbrook, Calif.

### MONEYMAKING OPPORTUNITIES

CASH In on your knowledge! Know true values of all U.S. coin. Rarities, appraisal techniques and dealer's buying prices all in two latest illustrated professional numismatist's references; the "Bluebook" \$1.00, the "Greenbook" \$1.75. Both \$2.50 postpaid. D. Wood, 2572 Carswell, Omaha 47, Neb. American Numismatic Assn. 42452.

HANDWRITING Analysis for fun and profit. Yours plus information one dollar. Lois W. Reading, 1731 New Hampshire Ave. N.W., Washington 9, D. C.

SUGGESTIONS. 100 Ways to make money through your plant suggestion plan. Booklet with sketches and examples, \$1.00. Suggestions, P.O. Box 2541, Mansfield, Ohio.

FIVE Mailorder winners. Circulars for mailing free. Box 936, Wichita, Kansas.

\$100.00 WEEKLY Raising redworms. Free literature. Hall Farm, Hilton 10, Georgia.

OPERATE Collection service. Send \$3.00 for equipment. You'll make money immediately, or money back. Creditors Service Company, Murphy, North Carolina.

MAKING Beautiful plastic products, per our easy instructions, your greatest money-making opportunity. Write for proof. Plaston Company, Box 105, Grove City, Penna.

\$7.50 HOUR Home spartime. Experience unnecessary. New printing method. Daltons, 5922 Metro. Station, Los Angeles 55, California.

"1000 NEEDED Inventions." Make your fortune! Details for stamp. Box 51-Y, Oakford, Penna.

\$35-\$65 WEEKLY Assembling artificial lures at home for stores. Materials supplied free. Write: Lures, Box 1280, Fort Walton Beach, Fla.

ELECTRIC Blankets easily repaired. Free information. Blanket Co., Hubbard 2, Texas.

\$500.00 TO \$1000.00 Profit per house for furnishing and installing aluminum siding on houses in your town. Complete instructions. All tools furnished without charge. Material delivered by motor freight direct to your door or your customer's door. Excellent part-time business. \$349.95 cash investment in inventory to get started. Send \$1.00 for samples, dealer application, and complete information. Aluminum Industries, Department PM-9, Kansas City 11, Missouri.

CONCRETE Drain tile. Want to make them? We have the machine. Thorough data 25¢. CMC, Drawer M99, Hickory 12, N. C.

HOME Mailorder "manufacturing." Everything supplied. Glenso Products, 184 Oakview, Winnipeg 15, Manitoba.

WORK From home. Free details. Jess & Gerald Enterprises, Box 11203, Indianapolis 1, Ind.

START Your own mail order business from home, featuring personalized gifts. No merchandise to stock. \$1.00. Refundable. Harfam Products, Box 775200, Los Angeles 7, California.

MAKE Money in mail order. 25¢ brings details. Barg Sales, Box 957, Evanston 9, Illinois.

HOW To sell cars. \$10. Money-back guarantee. Free details. Dept. PM, Box 130, Scarborough, Ontario, Canada.

DOES Well-paying research interest you? Or operating telephone answering service? Write: Murray's, Litchfield, Maine.

FREE Necklace kit offered by Modern Craft under Home Craftsman.

FABULOUS Profits raising earthworms. Picture folder free. Excello, Kosciusko 6, Mississippi.

BIG Money raising fishworms. Free literature. Downeast, Box 149, Bangor, Maine.

MAILORDER. Five practical plans and only \$1.00. L. G. Carlson, 4538 N. 40 St., Omaha 11, Nebraska.

HOW To win prize sweepstakes, drawings, contests. Lesson 50¢. Winner, Box 304, Columbia City, Indiana.

EARN \$10 Daily, spare time. Full particulars. Write Springer, 5031 First N.W., Washington 11, D. C.

I'LL Send you full-size famous Blair home products for free trial, to help you make more money, spare time or full time. Show friends, neighbors, take easy big orders, make generous profits. Write Blair, Dept. 31FS, Lynchburg, Va.

EARN \$240.00 a month at home, spare time, doing only two \$5.00 invisible mending jobs a day. Big money paid for service that makes cuts, tears disappear from fabrics. Steady demand. Details free. Fabricon, 1532 Howard, Chicago 26, Illinois.

MEN - Women! Start money-making plastic laminating business at home in spare time. Material that costs 11¢ brings back \$2.58. No canvassing or selling but mail orders brings in \$20 a day. Write for full particulars free. Rush name on postcard to Warner, Room CL-2-H, 1512 Jarvis, Chicago 26, Ill.

BECOME A notary public! Win extra income, prestige, business contacts. Details free. Stationers Exchange, Box 552-P, Kermit, Texas.

EARN Money evenings, copying and duplicating comic cartoons for advertisers. Adservice, Argyle 1, Wisconsin.

MAKE Plastic novelties for extra income. Low cost home training now available. Write for free booklet. Interstate Training Service, Dept. D-3, Portland 12, Oregon.

BAKE New greaseless doughnuts in kitchen. Sell stores. Free recipes. Melvin, 3605 South 15th, Minneapolis 7, Minn.

CIGARETTES—Make 20 plain or filter- tip for 9¢. Facts free. Moberly, Box 4012, Owensboro, Kentucky.

MINK Raising information free. Complete. Lake Superior Mink Farm, Superior, Eel, Wisconsin.

VENDING Machines. No selling. Operate a route of coin machines and earn amazing profits. 32-page catalogue free. Parkway Machine Corporation, Dept. #26, 715 Ensor Street, Baltimore 2, Maryland.

EARN Money raising fishworms for us! Write: Oakhaven—59, Cedar Hill, Texas.

YOUR Own, easy-to-start, home mail-order business, spartime. Fascinating; profitable! Information free. Alfano, 19-PM Pine, Closter, N. J.

BIG Money raising fishworms and crickets. Free literature. Carter Hatchery, Plains, Georgia.

AMAZING Successes through franchises! Become exclusive franchise holder your territory. Information rushed. National Franchise Reports, MP-528, 333 North Michigan, Chicago 1.

LEARN The secrets of repairing junk batteries, generators, starters, profitable, easy, at home. Free particulars. Batteryman, 3465 Forrest, Santa Clara, Calif.

EASY To start rubber stamp business at home in spare time. Make up to \$9.80 an hour without experience. Facts free. Write Roberts, 1512 Jarvis, Room CR-2-H, Chicago 26.

GROW Miniature dwarf trees in your home. Proven process. Fully explained in detail. Send \$3.00. Dwarf Trees, Box 309, Akron, Ohio.

THIS Is it. Increase your income easily. Full or part time. Positively proven method. No gimmicks. For information send \$2.00 to The Imhotep Co., P.O. Box 844, Cleveland 22, Ohio.

### EXPORT - IMPORT

JAPAN: Direct mail-order 26 page catalogue: dolls, novelties, business information, manufacturers' names, addresses, \$1.00; Japan's Trade Directory, 3000 companies, \$3.00. Send cash. Clarence Yamagata, 814 Toginburi, Marunouchi, Tokyo.

HAND-MADE Salad set from Kenya \$4.00. Pearl necklace \$1.00. Delftware ashtray from Holland \$2.50. Japanese lighter \$1.50. Charles Marchand, 295 Albert St., Rawdon, Quebec, Canada.

6 WORLD Import wholesale directories combined \$3.00. Baker Enterprises, 313-E. Harrison, Sullivan, Illinois.

BEER Steins, carvings; Mail self stamped envelope: Gonzalez, 3100 Gaston, Dallas 26, Texas.

### SCIENCE & CHEMISTRY

MICROSCOPISTS, Microbiological slides. Sample \$1.00. Micro, Box 19, Staten Island 10, New York.

AMAZING New book of science experiments, formulas, and catalogue of laboratory supplies. Only 35¢. National Scientific Co., 13 S. Park Avenue, Dept. PM-9, Lombard, Illinois.

SUN Battery, converts sunlight directly into 1/2 volt at 5 MA. Instructions for powering radios, making light meters, etc., included. Bargain priced \$1.00 each, 5 for \$4.00 postpaid. Custom Service, 5071 Pico Blvd., Los Angeles 19, Calif.

SEND For free experimenter's dream catalog, for advanced amateurs in all sciences. Ohioans: Visit our unusual science store. Frey Scientific, 273 Orange, Mansfield 6, Ohio.

TERRIFIC Seller. Genuine oil portraits. Just take orders. 4 sales pay \$100.00 to \$150.00 profits. Beautiful sample makes easy sales. Amazing offer free. Nichols, Box 1054, Coral Gables 34, Fla.

BIG Money. Sensational new plan taking orders on trial basis for guaranteed hosiery. Write Lee Co., P.O. Box 486, Arlington Heights, Illinois.

SELL Beautiful unusual foreign art to stores. Big income. Free information. Fruitland Traders, Fruitland, Maryland.

EARN Up to 50% profit. Tremendous profits with beautiful gifts and novelty items. For details and free color catalog, write Royal of America, Dept. 77, Providence, R. I.

ROCKET Amateur supplies. Chemicals, engines, instruments. Big new catalog 25¢. Central Rocket Co., Waupaca, Wis.

CHEMICALS And apparatus for industrial, analytical, and private laboratories. Catalog 35¢. Dept. M-50, Biological Supply Co., 1176 Mt. Hope Ave., Rochester 20, N. Y.

ILLUSTRATED Catalog: Chemistry, mineralogy, biology 25¢. Tracey Laboratories, Evanston, Illinois.

UNUSUAL Chemistry books, courses, kits! Rare chemicals, cheap! Catalog 25¢. NSC, Box 11133, Palo Alto, Calif.

LABORATORY Conversion charts with bigger catalogue—25¢. Hagenow Laboratories, Manitowoc, Wisconsin.

### FORMULAS, PLANS, ETC.

UNUSUAL Formulas, home businesses. Write Southland, 401-C E. Jackson, Orlando, Florida.

FORMULAS For latest money-making discoveries. New! Good! Valuable literature free! Miller, Chemist, 1517-D, Tampa, Florida.

10,000 PROFITABLE Formulas, recipes, trade secrets. Details free. Colen, 7731-MI Yates, Chicago 49.

**FORMULAS**—All kinds. Amazing big catalog, 10¢. Kemxal, Park Ridge, Ill.

**LATE**, Modern manufacturing formulas. List free. Moon Chemical, Martville, New York.

**BLEACH** Formula \$1.00, stamped self-addressed envelope. Wolz, 3201 So. Wayne Rd., Wayne, Michigan.

## PLASTICS

**NEW** Liquid casting plastic, clear, colors. Embed real flowers, butterflies, photos, coins. Send 25¢ for two handbooks, "How to Cast Liquid Plastics" and "How to Make Extra Money at Home." Castolite, Dept. K-101, Woodstock, Illinois.

**NOW!** Plastic vacuum forming machines. Hobby. Easy. Profitable. Details. Burr, 7645 Oakland, Kalamazoo, Michigan.

**PLASTIC** Embedding and molding made easy with new instruction manual, \$1.00. Catalog 25¢. Castcraft Corp., Dept. M-962, P.O. Box 555, Palo Alto, Calif.

**NEW** Bowling jewelry. Free literature. Pinfred's, 1502 Las Vegas Blvd. So., Las Vegas, Nevada.

**LIFE** Lasting fiberglass signs 3¢ square inch up. Boettger, 961, Dorothy, N. J.

**BOXES**, Plastic. 200 sizes. Free list. Althor, 170 Bay 23 Street, Brooklyn, N. Y.

## AGENTS WANTED

**CHRISTMAS** Cards. Earn bigger commissions with this exceptional line. Price range: \$4.75 to \$14.25 for 25 cards, with customer's name imprinted. Album contains 85 personal and business designs that are "different." Inexperienced salespeople can earn up to \$600 and more this season, even in spare time. Experienced Christmas card salespeople can earn up to \$1,800 from now 'til Christmas. Sales kit includes expensive sample album and easy selling instructions. If you want really big commissions from this higher-priced line, send for kit now! Write Process Corp. (our 41st year), Dept. Y-2, 3450 S. 54th Ave., Chicago 50, Illinois.

**SELL** Greeting cards. Make extra money. Christmas, all occasion assortments, stationery, gifts, jewelry, name imprinted Christmas cards. Experience unnecessary. Salable samples on approval. Free catalog. Write Hedenkamp, 361 Broadway, Dept. PM-80, New York.

**WILL** You test new items in your home? Surprisingly big pay. Latest conveniences for home, car. Send no money. Just your name. Kristee 125, Akron, Ohio.

**MAKE** \$50.00 Selling 25 boxes of our personalized Christmas cards. 49 exclusive designs. Free album. No obligation. Write Elmcraft, Dept. EC-15, 5930 So. Western, Chicago 36, Ill.

**AMAZING** Christmas card profits! Make 75¢—not 50¢—on popular \$1.25 assortments; \$75.00 on 100. Gift bonuses. 250 money-makers. Exciting personal seal stationery. 53 personalized samples free; approval assortments free with first order. Creative, 4401 Cermak, Dept. 507-C, Chicago 23.

**MAKE** Most extra cash with world's biggest line Christmas cards, wrappings, gifts. Introduce friends, neighbors to 150 Christmas, everyday box assortments, 600 big money-making novelties. Pocket up to 50% profit plus liberal bonus. Free giant color catalog; samples on approval. Arrow Greetings, 513 Fourth Ave., S., Dept. 83-T, Minneapolis, Minn.

**EXTRA** Cash aplenty! Show 'em and you'll sell 'em—sensationally beautiful, handpainted plastic photo enlargements, personalized compacts, costume jewelry. Take orders—collect 40% commission. Self-selling sales kit free. Novelco, 3343 North Avenue, Chicago 47.

**EXOTIC** Earrings! Details free. Pair \$1.00. OHGA, PM-378, Sigakenkusatu, Japan.

**IMPORTED** Artificial flowers. Sensational sellers. Free details. Mae Jung Imports, 2917 E. Robinson, Fresno 3, Calif.

**BUSINESS** Kit free! Postcard puts you in business! Complete line 230 shoe styles, jackets! New discoveries pay big commissions. No investment. Send for free kit. Mason, Chippewa Falls K-436, Wisconsin.

**AUTOMATIC** Bed warming sheet, you sleep on, not under. Outsells electric blankets 10 ways, costs less. Generous profits. Patented Products Corp., Dept. PM-92, Danville, Ohio.

**WHOLESALE** Catalogue! Appliances, cameras, watches. Associated Distributors, Box 1481-C, Denver 1, Colo.

**RUN** A spare-time greeting card and gift shop at home. Show friends samples of our new 1962 Christmas and all-occasion greeting cards and gifts. Take their orders and earn to 100% profit. No experience necessary. Costs nothing to try. Write today for samples on approval. Regal Greetings, Dept. 7, Ferndale, Mich.

**MAKE** Up to \$50.00 a day soliciting delinquent accounts. Terrific commissions. Write today. National Credit, 304Y Pickwick Bldg., Kansas City 6, Mo.

**YOUR** Own business—Used suits \$1.50; overcoats 65¢; mackinaws 35¢; shoes 12½¢; ladies' coats 30¢; dresses 15¢. Enormous profits. Catalog free. Nathan Portnoy Associates, 2109-AA Roosevelt Road, Chicago 8, Ill.

**PRINTING**. Advertising salesmen—Excellent moneymaking sideline selling decalcomania name plates, small quantities. Automobile initials, sign letters. Free samples. Raico, XL, Boston 19, Mass.

**CHRISTMAS** Cards wholesale. Take orders and earn up to 160% profit. Samples on approval. Write Astra Enterprises, 31868 6th Ave. S.W., Federal Way, Washington.

## BUY IT WHOLESALE

**APPLIANCES**. Cameras, toys, typewriters, watches. Coded wholesale catalogue! The Robinson Co., 15468 Hiway 80, El Cajon, Calif.

**100,000 PRODUCTS** Wholesale! Terrific bargains! Wholesalers, 1265-MR Broadway, New York 1, N. Y.

**HANDMADE** Western boots. Free catalogue. Sellers Co., 8830M Alameda, El Paso, Texas.

**ASSORTMENT** Of wholesale catalogs. Nationally advertised products. Everyday necessities. Dollar deposit. Refund with order. Matthews-Haynes, Box 512, Rialto, Calif.

**WHOLESALE** Offers! Importing! Dropshipping! Trade journals! Mail order business opportunities! Write: Importico-2, Enka, North Carolina.

**OVERHEAD** Door parts. Wholesale prices. List. Door Supply, 101 County Street, Somerset, Massachusetts.

**350,000 ITEMS** Below wholesale! Many free! Goldmine, Planetarium Station, New York City 24.

**CHAIN** Saws \$89.00. Buy wholesale, karts, engines, garden equipment. Literature 50¢. Sepeco, 5071 National Road East, Richmond, Ind.

**LARGEST** Wholesale supply source in U.S.! 15 free catalogs. Furniture, clothing, appliances, housewares, tools, sporting goods, hobby supplies, farm equipment, imports, new products, bargain merchandise. Free details. Associated, Box 108-DD, Lincoln 1, Nebr.

**SAVE** To 70%. Five free factory catalogs, tools, machinery, ladders, paint, brushes, wood screws, etc. Send 25¢, cost of handling. Factory Outlet, P.O. Box 172-PM, Norwalk, Conn.

**GARDEN** Rotary tiller and tractor combination. Universal Mfg. Co., 324 West Tenth, Indianapolis 2, Indiana.

**BUY** Direct from factories! Appliances, cameras, watches! Free details! Cam Company, 436PA Bloomfield Ave., Verona, N.J.

**WORLD'S** Largest wholesale supply. Buy from 679 American, European, Japanese wholesalers. Tailormade suits from Hongkong. 123 dropship catalogs. Rockbottom prices. Free details. International Buyers, 216-M Jackson, Chicago 6, Illinois.

**NEW** Deluxe below wholesale catalog. Automobile catalog and others. Furniture, clothing, housewares, appliances, refrigerators, freezers, washers, dryers, television, radios, luggage, binoculars, hi-fi, stereo, phonographs, recorders, cameras, projectors, musical instruments, sporting goods, toys, tools, typewriters, watches, jewelry. Huge discounts on thousands of name brand items. For free specimen list of actual factory prices—postcard: Selbyco, Decatur 15, Illinois.

**FREE!** Name brands catalog! Your own high profit business. Sell name brands, full or part time. No inventory, no investment. More than 2,000 name brand items; lowest wholesale prices. Watches, jewelry, cameras, hi-fi, stereo radios-phonos, appliances, housewares, hardware, power tools, luggage, musical instruments, garden equipment, sporting goods, toys, many others. 8 floors of name brands. Million dollar inventory. Orders shipped complete in 24 hours! Send for free, beautifully illustrated catalog now! Separate wholesale price list. H. B. Davis Corp., Dept. PM, 145 W. 15 St., New York 11, N. Y.

**USED** And new watches \$2 up. Free list. Southern Watches, 5-PM So. Wabash, Chicago 3.

**ELECTRIC** Guitars, amplifiers, wholesale. Free catalog. Carvin PMW, Covina, Calif.

## SALESMEN—DISTRIBUTORS

**EARN** Big commission full or part time. Build profitable business of your own selling America's largest line low priced business printing and advertising specialties. 360 page catalog samples hundreds of items used daily by business people. Imprinted ball pens low as \$7.95 for 100. Big line low priced union label political printing included. Free sales kit. National Press, Dept. 8, North Chicago, Illinois.

**MAKE** Up to \$50.00 a day soliciting delinquent accounts. Terrific commissions. Write today. General Finance, 304V Pickwick Bldg., Kansas City 6, Mo.

**MAKE** Extra money selling advertising matchbooks. Free catalog and sales outfit. Matchcorp, Dept. PM-82, Chicago 32.

**IF** You're interested in making money in selling, see the hundreds of exceptional opportunities in Salesmen's Opportunity Magazine. Send name for your copy, absolutely free. Tell us what you're selling now. Opportunity, 848 N. Dearborn, Dept. 17, Chicago 10, Illinois.

**GET** New shirt outfit free! \$90 weekly on 5 average orders a day. Famous quality made-to-measure dress and sport shirts at \$4.50 up, sell to all men. No experience needed. Full or part time. Write: Packard Shirt Co., Dept. 616, Terre Haute, Indiana.

**CALENDARS**, Novelties. Full or part time. Liberal commissions. Fleming, 6535-A Cottage Grove, Chicago 37.

**HIGH** Commission and bonus. Earn \$100 to \$300 weekly. 30 year old company has openings. List delinquent accounts for collection. Experience not necessary. Permanent. Write Merchants Protective Agency, Dept. PM-9, 1015W Walnut, Kansas City, Mo.

**MAKE** Big money taking orders for Stark dwarf fruit trees. Everybody can now grow giant size apples, peaches, pears in their yards. Also shade trees, shrubs, vines, roses, etc. Outfit free. Stark Bro's, Desk 30193, Louisiana, Missouri.

**MAKE** Extra money. Big steady earnings, repeat business. Sell advertising book matches, full or part time. New 1962 line. Show glamour girls, colorama, tenorama; dozens more. All sizes. Free master outfit, sales helps, leads, no experience necessary, no investment. Write today. Superior Match, Dept. M-962, 7530 Greenwood, Chicago 19, Ill.

**\$1,000.00** A Month for making dramatic 3-second demonstration of amazing lightweight Presto fire extinguisher. New chemical used by Airforce snuffs out fires instantly. Only \$4.95. Terrific commissions. Millions want it. Free kit. Merlite, 114 E. 32nd, Dept. P-66Y, New York 16.

**ADVERTISING** Specialty men: Big cash bonus extras for vacation and other needs, plus regular generous commissions! No quotas needed! The Gerbert Company, 902 33rd, Dept. P8, Galveston, Texas.

**SELL** Our playing cards and other novelties. Free samples and wholesale price list. Nina, 624 So. Michigan, Chicago 5.

**GIANT Profits.** Automatic short flush toilet control. Saves water, cesspool pumping. Ends jiggling, running toilets. Retail \$4.95. Conserve Products, Tujunga, Calif.

**SWEDISH Products.** Steady repeat items. High earnings. Write immediately to Lindstroms, 48 Boylston, Cambridge, Mass.

**GAG Posters** for restaurants, bars. Samples 60¢ (refundable). Kohr Enterprises, Box 111-J, Clearwater, Fla.

**SENSATIONAL** New longer-burning light bulb. Amazing free replacement guarantee. Never again buy light bulbs. No competition. Multi-million dollar market yours alone. Make small fortune even spare time. Incredibly quick sales. Free sales kit. Merlite (Bulb Div.), 114 E. 32nd, Dept. C-74Y, New York 16.

**SELL** New inexpensive mailing machine to offices. Excellent commissions. OPCO, 13389 23rd Place, Golden 4, Colorado.

**HAND-MADE** Genuine leather billfolds. Assorted designs; \$11.00 dz. \$120.00 gross. Write for free pamphlet. Southeastern Leather Co., P. O. Box 573, La Grange, N. C.

**EARN** To \$3000 by Christmas. Sell "Sno-Thaw" (Chemical de-icer). Sells in large quantities. Every business a prospect. No investment. Liberal weekly commissions. Full or part time. Distributors wanted. Sno-Thaw, Box 8505 Nashville 11, Tennessee.

**FREE** Details! Big profits! Sell sensational new kitchen tool. Slade Gorton Co., 2H9, 96 Central, Boston, Mass.

### EMPLOYMENT INFORMATION

**MERCHANT** Marine. Men and women. Top wages. Travel. Information. Captain, Box 501-P, Reading, Massachusetts.

**FOREIGN** Employment. Construction, other work projects. Good paying overseas jobs with extras, travel expenses. Write only: Foreign Service Bureau, Dept. PM, Bradenton Beach, Florida.

**CALIFORNIA** Employment. \$2.00 monthly subscription brings weekend classifieds. Graham, Box 1031, Lompoc, California.

**FOREIGN** Employment information. Europe, Africa, Asia, South America. Free transportation. Up to \$1600.00 monthly. Sensational opportunities. Construction workers, clerks, truck drivers—every occupation. Complete information, application form, sent immediately by return mail. Satisfaction guaranteed. Only \$2.00 (\$2.25 airmail) (C.O.D.'s accepted) to: Jobs, P.O. Box 50512, Dept. E, New Orleans 50, Louisiana.

**CIVIL** Service jobs. Overseas, U.S.A. Mechanical, clerical, professional. List \$1.00. Civil Service Bulletin, 115F Haypath Road, Plainview, New York. Satisfaction guaranteed.

**MERCHANT** Marine. Men and women. Job information. Top wages. Travel. Complete information only 25¢. Helimco, Box 124-P, Pendleton, Indiana.

**TREMENDOUS** Opportunities. U.S.A.-Overseas. Choose jobs, locations, transportation. Free details. International Occupations, International Airport, Box 100C-2, Jamaica 30, N. Y.

**WEST** Coast boom! Government employment opportunities. All occupations. Current list \$3.00 airmail. Satisfaction guaranteed. Careers, 3534 N. Meridian, Fresno 3, Calif.

**THOUSANDS** Of government jobs available. Details free. Globe, Box 814-U, Macon, Georgia.

**MANY** Jobs in New York City. Men and women needed. Skilled, unskilled, professionals. Complete report \$1.00. EAB Enterprises, Box 3898 Grand Central Station, New York 17, N. Y.

**USA** And foreign jobs, up to \$1600.00 monthly. All occupations. Benefits. Transportation paid. Complete report only \$2.00 (\$2.50 airmail). Satisfaction guaranteed. International Opportunities, Dept. 33C, 152 W. 42, New York 36, N. Y.

**JAPAN!** Exotic Orient. Many hi-paying jobs available. Complete, detailed reports \$2.00. Japan Reports, Box 2202-C, Newport Beach, California.

**DIRECTORY** Reports. Construction, aviation, shipping, oilfields, government, manufacturing, trucking, etc. Foreign-stateside. Helpful information plus job-getting tips on preparing application letters. Unconditional money-back guarantee of satisfaction. Act today. Only \$3.00. \$3.25 airmail. (C.O.D.'s accepted). Research Services, Meramec Building, St. Louis 5-PM, Missouri.

**RESUME** Preparation kit. Complete. \$2.00. Planatrol, Box 434, Ft. Wayne, Indiana.

**UNIQUE** Resumé service. With special employment opportunities. Free details. International, Dept. 6T, Box 621, San Jose 6, Calif.

### SPECIAL SERVICES

**INFORMATION** On anything. Ferguson Research Specialists, 59 Lent Ave., Hempstead, N. Y.

**INFORMATION** Concerning any matter. Folborg Research Agency, Wyckoff Heights, Brooklyn 37, New York.

**RESEARCH** Service. Any subject! Product information. Jake Barraco, 478 Gardner, South Beloit, Illinois.

**INFORMATION.** All subjects. Reports, research, translations. Quality! Reasonable. Pokrass, Central Valley, New York.

**I.Q.** Can now be accurately and inexpensively tested in your home. Individuals needed to supply data to facilitate research program. Find out your I.Q. Write Uri Test, Dept. 9, Stanford University Post Office Box 6744, Stanford, California.

### EDUCATIONAL AND INSTRUCTION

**MASTER** Watch making at home. Free sample lesson. Chicago School, 2328-YJ Milwaukee, Chicago 47.

**"HOW To Train Horses."** A book everyone who likes horses or ponies should have. Free. No obligation. Simply address Beery School, Dept. 1109, Pleasant Hill, Ohio.

**OUR** Diploma can mean \$1,500 a year to you! Yes, high school graduates make more. Get diploma now, at home, in spare time. Personalized help from fully accredited school. Write for free book, read about our Guarantee of Success. Wayne School, Dept. 09-519, 417 S. Dearborn, Chicago 5, Illinois.

**LEARN** Fascinating, profitable invisible reweaving at home. \$10.00 earnings in an hour possible making tears, holes disappear from clothing, fabrics. Steady demand from cleaners, laundries, homes. Details free. Fabricon, 1534 Howard, Chicago 26, Illinois.

**BROADCASTING:** Learn announcing, newscasting sportscasting. Closed circuit radio-TV. Professional broadcasting staff. Dormitories. Co-ed. Placement. Write Secretary, Cambridge School, 687 Boylston Street, Boston, Massachusetts.

**INTERIOR** Decoration: Approved supervised home study training. Fine starting point for career. No classes. Text and work kit furnished. Diploma awarded. Low tuition and payment. Send for free booklet. Chicago School of Interior Decoration, 835 Diversey Pkwy., Dept. 3436, Chicago 14.

**DRAFTING** Pays big money. Leads to position in automotive, aeronautical, construction, mechanical fields. Learn at home in spare time. All equipment supplied. Pay later plan. Free book. Christy Trades School, D-6303, 3214 Lawrence, Chicago 25, Ill.

**OIL** Coloring photographs. A fascinating hobby or profitable sideline for those with artistic talent. Learn at home. Easy simplified method. Free booklet. National Photo Coloring School, 835 Diversey Parkway, Dept. 3436, Chicago 14.

**NEW** Self-teaching course in memory helps you achieve greater success in business and social world. Free booklet. Memory Studies, 835 Diversey Parkway, Dept. 3436, Chicago 14.

**COMPLETE** Your high school at home in spare time with 65-year-old school. Texts furnished. No classes. Diploma. Information booklet free. American School, Dept. X645, Drexel at 58th, Chicago 37, Illinois.

**GUARANTEED** America's finest and most complete line of slide rules. Wholesale prices. You save 30 to 50%. Post card brings our catalog. Lewis M. Crawford & Sons, Joanna, South Carolina.

**ENGINEERING** And Art degrees earned through home study. Electronics, Mechanical, Liberal Arts. When writing specify course desired. Pacific International College of Arts & Sciences, primarily a correspondence school. Resident classes also available. 5719-B Santa Monica Blvd., Hollywood 36, California.

**LEARN** How to write sales letters for yourself or others. Collection of 100 profit-producing letters teaches how. Free facts. Graham, 2952 Marlboro Road, Oceanside 2, New York.

**PENMANSHIP** Corrector. Improve poor penmanship quickly. Details free. Ozment, Box 665-34, St. Louis 88, Mo.

**ELECTRONICS.** Mathematics. No obligation. Pay as you learn. Free brochure. Indiana Home Study, 64 Hemenway Road, Framingham 1, Mass.

**GOOD** Paying jobs open! Operate, repair heavy earth moving equipment! Learn "on the job" operating latest cranes, bulldozers, earth carriers! V.A. approved. Free catalog. Write K. P. Hutch, Greer Technical Institute, Braidwood, Illinois.

**INVESTIGATOR'S** Course. Credentials, diploma. Free information. Southwestern Institute Criminology, Box 201, Geronimo, Oklahoma.

**LEARN** Civil and criminal investigation at home. Earn steady, good pay. State age. Institute Applied Science, 1920 Sunnyside, Department 166, Chicago 40, Ill.

**SPEAK.** Sing with power. Self-training records. Canfield, 2018-A Fifth Avenue South, Minneapolis 4, Minnesota.

**REPAIR** Door closers. Used on store doors, schools, homes, offices, factories. Lifetime trade. At home, or full time business. Big demand. Big profit. Details free. Eagle Company, 1906 Taylor, Columbia, South Carolina.

**HIGH** Pay, security; prepare now for job with future. Thousands of trained men needed now in earthmoving field. Complete home study course now available! Diploma and free employment assistance to our graduates. Free details. Write Canaveral Institute, Box 901A, Cocoa Beach, Florida.

**PHYSICAL.** Culture and massage pays big profits. Learn at home. Free catalog. Write National Institute, Dept. A-1, 874 N. Wabash, Chicago 11, Ill.

**DENTAL** Technician's home study student's kits. Instruments, plastic, etc. Illustrated instructions. Write for free lesson. Grant Laboratory, Haas Bldg., Los Angeles 14, Calif.

**BIG** Money as computer writer. Course outline dollar. Computer Institute, 562 E. Wheelock Pkwy., St. Paul, Minn.

**FREE** Catalog. Self-improvement books. BID, 2630 Midvale, Los Angeles 64, California.

**MASTER** Secrets of the ages. Key to success. Dynamic formula! Free literature. Leavitt Science, Clinton, Illinois.

**FREE** Literature, self-help books, sleep learning. Fletcher, 2407-PM Catherine, Dallas 11, Texas.

**TEACHING-MACHINES,** programed instructions, sensational scientific discovery, free catalogue, all subjects. Ace Corp., Eatontown, N. J.

**GET** A British degree. Divinity, Philosophy, Radionics, Biochemistry. 35 courses. Prospectus free. Brantridge Forest School, "Lodge", Brantridge, Balcombe, Sussex, England.

**INVESTIGATOR** Training. Free booklet covering approved home-study plan. Write National Detective Academy, 12812 Hazel Ave., Garden Grove, Calif.

**PROFITABLE** National Camera Repair School training at home! 174PM, Englewood, Colorado.

**AIRLINE Careers. Adventure! Prestige!** Promotion! Four-week course. Free placement service with 35 airlines. G. I. approved. Free catalog B. McConnell Airline School, 1030 Nicollet, Minneapolis, Minnesota.

**NEW Trade? Electronic, Mechanical Drafting** pays \$150 week. Send \$2 first lesson, complete home study course \$25. Prior Inc., 23-09 169 St., Whitestone 57, New York.

**BE A Real Estate Broker.** Insure security for yourself and your family. Study at home. Prepare for state examination. GI approved. Write for free book today. Weaver School of Real Estate, 3519P Broadway, Kansas City, Missouri.

**SWEDISH Massage.** Foot technique. Post graduate. Home study. Residential. Diploma. Dr. Swanson's Illinois Licensed School, 3809-PL Alta Vista, Chicago 13.

**USED Correspondence courses and books** sold and rented. Money back guarantee. Catalog free. (Courses bought.) Lee Mountain, Pisgah, Alabama.

**HIGH School diploma at home.** Licensed teachers. Approved materials. Southern States Academy, Station E-16, Atlanta, Ga.

**WOODWORKING** And cabinetmaking course for beginning and advanced home craftsmen. Only complete low-cost home training program available. Write for free booklet. Interstate Training Service, Dept. G-3, Portland 12, Ore.

**WANT A diesel job? Higher pay? Advancement?** We can help you qualify! Complete diesel, tractor and heavy equipment and Cummins Diesel Engine Shop-method home-training courses available. Write today. Interstate Training Service, Dept. B-3, Portland 12, Ore.

**BOOKKEEPERS.** Operate your own "Dollar-A-Week" system. Ellis, Box 200, Cedar Grove, North Carolina.

**LEARN Asleep or awake!** Records, tapes, equipment! Free catalog! Drawer PM-697, Ruidoso, New Mexico.

**MEN Wanted.** Earn \$125 a week and up. Master a trade with a future. Learn auto diesel mechanics in our shops. You learn with tools on real equipment. Earn while you learn. Many of our graduates earn \$125 a week and up. Write for free bulletin: Dept. 256, Auto Diesel College, Nashville 3, Tenn.

**FINGERPRINTING** And identification taught at home. Diploma. Details free. Alabama School of Fingerprinting, Fairfield, Alabama.

**LEARN Auctioneering.** Free catalog. Missouri Auction School, 1330 Linwood, Kansas City 9-X3, Mo.

**LEARN Ventriloquism.** Amazing-entertaining! Easy! Details free. B. Davis, B-38, Safety Harbor, Florida.

**LEARN While asleep** with your recorder, phono. Details, catalog free. Sleep-Learning, Box 24-PX, Olympia, Wash.

**PROFESSIONAL Investigator.** Home study. Lapel pin, certificate, future. Box 41197-F, Los Angeles 41, California.

**OPERATE** Collection agency. Little gold mine. Franklin Credit, Roanoke, Virginia.

**LEARN Real Estate business fast.** Economical homestudy. Literature free. Howard Schools, Box 8394-A, Kansas City 5, Missouri.

**PIANO Tuning** pays. Learned easily at home. GI approved. 59th year. Free booklet. Niles Bryant School, Dept. P, 3731 Stockton, Sacramento 20, Calif.

**LEARN Profitable art.** Make cement lawn ornaments, plaster craft. Catalogue, instructions, sample free. Wooley, 1915A North Peoria, Ill.

**USED Courses! Books! List 10¢.** Smith's, 124 Marlborough, Salem, Mass.

### PLAYS, STORIES, MANUSCRIPTS

**WRITERS** Send your books, articles, stories, plays for free evaluation, screening and sale. Write today! Literary Agent Mead, 915 Broadway, New York City 10.

**WANT Your book published?** Learn how we publish, advertise, promote, distribute. Many successes. Free booklet PM. Vantage, 120 West 31, New York City. Or 6253 Hollywood Blvd., Hollywood 28, Calif.

### ADVERTISING AGENCIES, ADV. SERVICE, MAILING LISTS

**YOUR** Circulars, sales letters mailed. \$2.50 to \$4.50 1000. Mailing lists \$5.00 up 1000. Many classifications. Free information. Occupant lists. Stephens Distributing Co., Box 1434, Atlanta 1, Ga.

**MAILORDER Dealers.** Write own sales letters. Save expert fees. Adapt from over 100 profit-producing examples. Free details. Graham, 2952 Mariboro Road, Oceanside 1, New York.

**FREE! Red-hot book** — "More Profit From Your Advertising." Lists best mail-order magazines, newspapers. Adservice, 516B Cornelia, Chicago 13.

**ADVERTISING Ratebook** leading newspapers, magazines, free. Chicago Advertising Agency, 28-E Jackson, Chicago 4.

**MAILING Lists** most all kinds 1000 \$5.00. Free folder. Your circulars mailed \$4.00 1000. Dixie Malters, King, N. C.

**AMAZING New Book**—"Profits From Classified Advertising." Tells how and what to advertise. Be sure to read this book before you invest one cent in advertising. Write for your copy now. F. W. Johnson, Classified Advertising Manager, Popular Mechanics, 740-PR Rush St., Chicago 11, Illinois.

### TYPEWRITERS, DUPLICATORS, OFFICE DEVICES

**RECONDITIONED** Typewriters, mimeograph, printing presses \$25.00 up. Write Dixiegraph, King, N. C.

### RUBBER STAMPS AND OFFICE SUPPLIES

**3 LINES** Rubber stamp \$1.00. 25 cents each additional line. Whitney's Rubber Stamp Shop, 18 Washington Ave., Chatham, N. Y.

**POCKET 3 Lines** \$1.00. Guaranteed. Catalog free. W. J. Specialty, 8464 Manhattan, Detroit 11, Michigan.

**POCKET Stamps 3 lines** \$1.00. Office stamps, \$1.50. Duane Vaught, Box 905, Bloomington, Ind.

**3 LINES** \$1.00. Free wholesale brochure. Luke Wood, Saranac Lake, New York.

**FREE CATALOG:** Rubber stamps, printing, labels; Business cards, \$3.50. Martin, 1425 Major, Jefferson City, Missouri.

**THREE-Line** pocket rubber stamp, self-inking, plastic case, \$1.00. L. Watson, P.O. Box 162, St. Charles, Illinois.

**3 LINE** Rubber stamp 50¢. Repco, 7232 N. Western Ave., Chicago 45, Illinois.

**FREE 32-page** rubber stamp catalog. Stock stamps, pads, ink. Signature stamps \$3.50. Notary seals & embossers, business cards, labels. Youngers Stamp Shop, Princeton, Iowa.

**FREE—Illustrated** rubber stamp catalog. Low prices! Hildreth, 1047-A Inner, Schenectady 3, New York.

**STAMP Makers' supplies.** Lowest prices. O'Brien's, 421 Jackson, Toledo 4, Ohio.

### CARTOONING, COMMERCIAL ART, SHOWCARD & SIGN PAINTING, TATTOOING

**WANTED—Cartoonists.** Amateurs, professionals. Over 200 markets. Inquire. Maler-9PM, 11620 Lansdowne, Detroit 24, Michigan.

**PAINT Signs!** Letter patterns, hundred selections. Paulow Signs, Crystal Falls, Michigan.

**"HOW To Make Money** with Simple Cartoons." A book everyone who likes to draw should have. It is free; no obligation. Simply address Cartoonists' Exchange, Dept. 99, Pleasant Hill, Ohio.

**PAINT Signs!** Using patterns! Trial alphabet \$1.00. Harwell's, PM-962, Byrdstown, Tennessee.

**CARTOONERAMA** Teaches you cartooning in a new 24 lesson course. Free brochure. CFA, Box 263-E7, Branford, Conn.

**YOU** Can entertain with chalk talks. Catalog 10¢. Balda the Cartoonist, Oshkosh, Wis.

**LEARN Sign painting** at home. Free talent test. Ben Kerns, Box 812-PM, Greenville, S.C.

**LEARN Sign painting** with fascinating system. Straley, 410 S. Western, Springfield, Ohio.

**LEARN Profitable** magazine cartooning. Free details. Hartman, Box 3097, Lincoln 10, Nebraska.

**PAINT Artistic** showcard-signs by new number method. Free Strok-O-Graph and details. Idea clipbook \$1. Midwest School of Art, 103 East Main, Fort Wayne, Indiana.

### PRINTING, MULTIGRAPHING, MIMEOGRAPHING, GUMMED LABELS

**250 8 1/2 x 11 MODERN** Designed Hammermill letterheads \$2.95. Envelopes same. Samples! Davis's, 7609 Spruce Road, Baltimore 22, Maryland.

**BUSINESS Cards,** stamps, printing. Reasonable. Martin, 2736 Canary Drive, Dallas 16, Texas.

**LABELS,** Blank. Self-adhesive. Stock sizes. Free list. Althor, 2301 Benson Ave., Brooklyn, N. Y.

**WHOLESALE** Business forms, \$2.95 thousand. Samples. Post-Age Industries, Brazil, Indiana.

**SAVE On** mimeographing. Samples. Fuesing's, 6522 West Center, Milwaukee 10, Wisconsin.

**250—8 1/2 x 11 HAMMERMILL** letterheads \$2.75. 250—Envelopes \$2.75. Samples. Patton, Box 248G, South Haven, Mich.

**QUALITY** Photo offset. Samples, price list. Horizon Offset Press, 5205 So. Ashland, Chicago 9.

**PERSONALIZED** Correspondence cards, white or colored, neatly printed, 100 \$1.25; 1000 business cards \$3.95, postpaid. May Printers, Box 1703, Gary, Indiana.

**OFFSET,** Letters, booklets, statements. Free estimates. Powell, 2917 W. Kiowa, Colorado Springs, Colorado.

**BRASS** Social Security identification \$1.00. 1,000 name, address labels \$1.00. Post paid. Juanita, Route 3, Lincolnton, North Carolina.

**BUSINESS Cards** \$3.00 thousand. Post paid. Agents wanted. Mauney's, 1103 Fern Street N.W., Washington 12, D. C.

**PRINTED** Scotch tape. Free price sheet. Kavanagh, 607 Knickerbocker Ave., Brooklyn 21, N. Y.

**MIMEOGRAPHING,** Offset printing. Free samples. Pennway, Drawer 1340, Scranton, Penna.

**1000 NAME-Address** labels 75¢. Hallows, 14 Drexel, Cahokia, Illinois.

**1000 BUSINESS** cards, raised letters. \$3.75 postpaid. Samples. Routh, PM-9, 3910 Kipling, Greensboro, N. C.

**1000 EMBOSSED** Business cards \$3.00 postpaid. Samples. Northgate Printing, 5210 Cornell, El Paso, Texas.

**FREE** Catalog salesbooks, snaper forms. Printed Business Forms, Box 1, Bronx 72, N. Y.

**OVERNITE** Offset printing 1000 8 1/2" x 11"—\$6.50. Postage extra. Evergreen, 9420 Trumbull, Chicago 42.

**AMAZING** Business printing values. Samples. Print Shop, Box 576, Greenville, R. I.

**FREE** Catalogs postpaid printing. Rubber stamps. DM Press, Sebastopol, Calif.

**FAST** Method photo reproduction printing, from clear drawings, maps, typewritten, catalogue sheets, black and white copy. 1000, 8 1/2 x 11, \$6.95. Photo copies, 50¢ each. 1000 business cards \$3.95. Cash with order. Hopkins, 532 South Western Avenue, Los Angeles 5, California.

**OFFSET** Printing. 100 8 1/2 x 11 \$2.49. Additional 100's 43¢—add shipping. Parks, 1879 Dover, Wantagh, New York.

**ADS** Running under this heading sell printing. Ask me for proof. I'll gladly send you amazing facts. Ask for Folder "P." F. W. Johnson, Popular Mechanics, 740-P Rush St., Chicago 11, Ill.

## PRINTING OUTFITS AND SUPPLIES

NEW 1962-63 Illustrated printing equipment and supply catalog. This 9"x12", 336-page book is the most complete catalog of the century. Contains everything used in the graphic arts industry including thousands of offset, letterpress, bindery, rubber plate and stamp, composing room, silk screen, art and engraving supplies and equipment. Includes paper cutters, folding machines, printing and proof presses, padding presses and many more. Send \$2.00 to cover mailing. Refund with first order. Also available is our latest 184 page type catalog—add \$1.00. American Printing Equipment & Supply Co., Dept. PM 42-25 Ninth Street, Long Island City 1, N. Y.

**SICKNESS** Forces sale sixteen hundred dollars worth brand new printing equipment for six hundred cash. Write Rathbun, Rt. 8, Box 785, Jacksonville 17, Florida.

**TYPE** And supplies for printers and rubber stamp makers. Buy direct from foundry and save! Send \$1.00 for big 96 page catalog and free tweezers, deductible from first order. Acme Type, 633 Plymouth Court, Chicago 5, Ill.

**TYPE Cases.** Manufacturer. Catalog. King McKay Company, 23179 Telegraph, Southfield, Michigan.

**HARD Type** for rubber stamp making, printing. Introductory offer 10 or 12 pt. 20th Century Medium caps or L.C. \$2.50. Free catalog. Barco Type, 232 Evergreen, Bensenville, Ill.

**MAKE** Your own self-molding rubber stamps and printing cuts. Plexirubber, Argyle 1, Wisconsin.

**RUBBER** Stamp presses, hydraulic operated, electrically heated. Sizes 5"x8", 8"x12", 10"x15". Starting outfits, supplies. Printing presses. Custom Manufacturing, 1464-P East Commercial, Springfield, Missouri.

**DO** Your own printing. Save money. Simple rules. We supply everything. Print for others; good profit. Raised printing like engraving too. Have home shop. Details free. Kelsey Presses, V-11, Meriden, Connecticut.

**RUBBER** Stamp outfits, supplies. Klewlet, 2025 Barney Road, Kalamazoo, Mich.

**SILK** Screen dry photo stencils. Photo, art service. Boettger, 960, Dorothy, N. J.

**FREE** Rubber stamp press. Postpaid stamp materials. Duckman, Avoca, Ark.

## FOR INVENTORS

**PROFESSIONAL** Searches of the Patent Office. Dependable—reliable \$6.00 including airmail report and related patents. For free protection forms and "Patent Information" write Trans-World Patent Service, 500 Walker Building, Washington 5, D. C.

**PATENT** Searches including full, airmail report and closest patent copies. \$6.00. Quality searches, expertly administered. Free protection forms and "Patent Information." Write Professional Patent Office Search Bureau, 709 Albee Building, Washington 5, D. C.

**SAVE** High fees! Prepare your patent application yourself! New "do-it-yourself" patent kit now makes it easy. Free "Registration Form." Miss Blaine, 306 Carry Building, Washington 5, D. C.

**PATENT** Searches, professional patent development of inventions by licensed professional patent engineer and U.S. Patent Office former examiner with staff of engineering specialists in all fields of inventions. Expert searches performed in the U.S. Patent Office. Your inventions and ideas engineered for maximum patent protection and greatest commercial value. Inventions developed by us negotiated for cash or royalties with our nationwide contacts. Send for free protection "Invention Certificates" and further interesting, valuable patent information. George Spector, Licensed Professional Patent Engineer, U.S. Patent Office Former Examiner, Woolworth Building, New York.

**PATENTS** Skillfully prepared for maximum commercial value, with useful product development. High record of success in proving and claiming patentability. Valuable market service. Patent prepared for a fee as low as \$200.00. Send for self-protecting record of invention forms free. Patent search with valuable engineering report \$10.00. Foreign patents filed at low cost. Thirty years established. Joseph O'Brien, Patent and Development Engineer, 132 Nassau St., New York 38, N. Y.

**PATENT** Searches, prompt complete \$6.00. Patent office copies of related patents airmailed. For free "Protection Forms" and "Patent Information" write to Anne Hamilton, 711 14th Street N. W., Suite 507, Washington 5, D. C.

**PATENT** Searches, \$6.00, including official patent office copies of related U. S. patents. Certified, airmailed! For free "Invention Record" and "Patent Information," write: United States Inventors Service Company, 1311 "G" Street NW, Washington 5, D. C.

**PROFESSIONAL** Patent searches, \$6.00, including official copies of related U.S. patents. Prompt, dependable airmail service! For free "Invention Record Folio" and "Information Every Inventor Should Have," write: Congress Invention Institute, 210 McKim Building, Washington 5, D. C.

**U.S. Patent office** searches—\$5.00. Free invention record. Patents engineered. Patent Office Searchers, 233 Broadway, Room 3615, New York.

**PATENT** Searches, including copies of nearest patents, \$6.00. Reports airmailed within 48 hours. More than 200 registered patent attorneys have used my service. For free invention protection forms, write Miss Ann Hastings, P. O. Box 176, Washington 4, D. C.

**WE** Have the markets if you have the ideas. Harvey Engineers, Cambridge 1 Maryland.

**INVENTORS:** Test the commercial value of your patented or unpatented inventions, quickly and inexpensively. Write for free information. Institute of American Inventors, Dept. 40-B, 635-F St., N.W., Washington 4, D. C.

**MANUAL** For inventors. All necessary information to help you make money with your ideas and inventions. Developing, promoting, advertising, patents, market surveys, etc. Send for manual, \$2. Product Promotion Development, Little Building, Boston 16, Mass.

**INVENTIONS** Needed immediately for manufacturers. For additional information write Kessler Corporation, C-59-FI, Fremont, Ohio.

**INVENTORS.** Write for free literature "Your Inventions Are Our Business." Inventors & Manufacturers Service, 3852 First Ave., San Diego 3, Calif.

**PATENTS** Through corporate trust of officers. Royalties. Peter Michalsky, 197 Cambridge Avenue, Garfield, New Jersey.

**PATENTS** Professionally prepared for maximum commercial value. Patent searches including report \$6. Valuable market service. Cash or royalty sales. 10 years dependable service. For free self-protective Record of Invention forms write: H. Lawrence Blasius, 19 Park Row, New York 38, N. Y.

**INVENTORS!** Searches of the patent office \$6.00 including airmail report, related copies. Free protection forms, "Patent Information." Washington Patent Office Search Bureau, 1426 G Street, N.W., Washington 5, D. C.

**INVENTORS!** Consider our offer first before selling or licensing your invention on a cash or royalty basis. Patented. Unpatented. Write Wall Street Invention Brokerage, 79 Wall Street, New York 5, New York.

## INVENTIONS WANTED

**INVENTORS**—If you have an invention for sale, patented or unpatented, write for free brochure outlining manufacturer's requirements, royalty rates. Kessler Corporation, C-59-IW, Fremont, Ohio.

**INVENTION** Engineers have manufacturers waiting for patented, unpatented inventions. Inventors Creative Service, 354 South Spring, Los Angeles 13, Calif.

**INVENTIONS** Wanted immediately. Patented; unpatented. Nationwide manufacturers listings. Metro Company, Box 151, Oak Park, Illinois.

**ATTENTION** Inventors! Find out how you can sell your invention to manufacturers and investors. No commission. G. Daoust, 3138 Wilson, Chicago 25, Ill.

**TOY** Inventions needed by agent with toy manufacturing contacts. Write: Creative Items, Box 322, Pacific Palisades, California.

**INDUSTRY** Needs inventions immediately. Inventions for industry, organized to discover and assist new inventors. Write Delmar Mason, Chairman Investigating Committee, 3021 Monroe Street, Toledo, Ohio. Free details.

**NATIONAL** Mailorder catalog needs quality products. Galleon, 27 School, Boston 8, Massachusetts.

**INVENTIONS** Sold, licensed. Outright, royalty basis. Inventions International, Box 560, Wall Street, New York 5, N. Y.

**INVENTIONS** Wanted. Patented; unpatented. Tremendous manufacturers lists. Global Marketing Service, 2420 77th, Oakland 5, California.

**INVENTORS:** Hundreds of manufacturers have requested our assistance in locating marketable new products. Complete information free. Institute of American Inventors, Dept. 40-D, 635-F St. N.W., Washington 4, D. C.

**ARE** You interested in offers from reliable manufacturers for your invention? Patented, unpatented. Harvey Engineers, Cambridge, Maryland.

**INVENTORS!** Outright cash sale or royalties for your inventions. Patented. Unpatented. Constant demand from our client manufacturers. Write: United States Invention Brokerage, 78 Wall Street, New York 5, N. Y.

**INVENTORS** Needing help with any problem, financial, development, securing manufacturer, obtaining patent. Write the organization that delivers action and results—not promises. Pioneer Invention Institute, 150 Broadway, New York 38, N. Y.

**INVENTORS!** Sell your invention for cash or royalties! Our manufacturers constantly seeking new items. Patented. Unpatented. For free information write Gilbert Adams, Patent Broker, 80 Wall Street, Financial District, New York, N. Y.

**INVENTIONS** Promoted-for cash-royalty sales with manufacturer contacts. George Spector, Licensed Invention Engineer, Woolworth Building, New York.

**SELL** Your invention for cash. No commissions. Milburn, Burlington, Kentucky.

**CASH** Or Royalties for inventions! Consider our offer first before licensing or selling your patented or unpatented invention. Write Aladdin Industries, 80 Wall St., New York 5, N. Y.

## PATENTS FOR SALE

**SHAVING** Attachment for electric shavers for trimming hairs from nostrils and ears. Pat. 2,783,533 royalty or outright. Send \$1.00 for copy of patent and complete information. Mack Wilson, 5050 Arsenal St., St. Louis 39, Mo.

## MANUFACTURING

**MODELS**—Small lot manufacturing. Metals, plastics, etc. Milburn, Burlington, Kentucky.

**LATHE** And drillpress work Single or multiplicable parts made to specifications. Henry Meunier, 18022 Hubbell, Detroit 35, Michigan.

## MODELS—SHIPS, TRAINS, PLANES, ETC.

**STEAM** And gasoline engines, accessories. One of the oldest, largest and best stocked firms catering to the model engineer. Illustrated 100-page catalog \$1.00. Cole's Power Models, Ventura, Calif.

**LIVE** Steam engine castings kits; marine, walking beam, mill engines, boilers, from \$7.45. Some machined, finished. Illustrated catalog 35¢. H.P.K. Models, P.O. Box 34, Centuk Station, Yonkers, N. Y.

"**WHITE** Heat V." Radio-controlled model hydroplane featured June 1962 Popular Mechanics. Full-size plans, patterns, accessories, and engine available. Literature for stamped addressed envelope. Ocutra Models, 8144 N. Milwaukee Ave., Niles 48, Ill.

**STEAM** Engines, tractors, boilers, castings, prints. Catalog \$1.00. Tiny Power, Junction City, Oregon.

**MODEL** Hobbyists! Send 10¢ for catalog. Our 70 powered model plane and boat kits, many radio-control operated, also accessories. Sterling-M, 501 Wister, Philadelphia 44, Penna.

**FREE** Plan for miniature steam engine included in new illustrated comprehensive Model Engineering supplies catalog; largest selection model gasoline, steam-engine casting kits; 1962 catalog 35¢. Ocutra Models, 8148 Milwaukee Ave., Niles 48, Ill. Dept. FPM.

**SHIP** Models. Kits, fittings, plans, books, tools, engines, motors. Big illustrated catalog 50¢. James Bliss & Co., Dept. SM, 342 Atlantic Avenue, Boston 10, Massachusetts.

**SHIP** Model kits and fittings: clippers, frigates, etc. Catalog paint-tool list, book list, 35¢. Model Shipways, Box 85, Bogota, N. J.

**SHIP** And yacht model fittings; blueprints. Send 40¢ for illustrated catalog listing hundreds of items. A. J. Fisher, Inc., 1002-1 Etowah Ave., Royal Oak, Mich.

"**POWER** Drives Handbook"—36 pages illustrating many types motor drives for model autos, boats, displays, turntables, etc. Mail 25 cents cash, returnable first order \$3.00 or more. Wilson's of Cleveland, Dept. PM, P.O. Box 8995, Ft. Lauderdale, Fla.

## ENGINEERING SERVICES

**INVENTION** Development. Industrial research: machinery, electronics, chemistry. Specific inquiries invited. Todd Consulting Engineers, 430 West 119th, New York 27.

## HOME CRAFTSMEN

**FREE.** New catalog. 2447 plans, patterns. World's greatest selection things to do, make. Fun. Profit. Craftplans, 18250 Harwood, Homewood, Ill.

**VENEERS**, 1/28" Thick. Send \$1.50 for two square feet each of cherry, mahogany, maple, oak and walnut. Catalog of wood-working supplies 10¢. Barap Specialties, P.O. Box 2044, Dept. P-17, Chicago 9.

**GRANDFATHER** Clock movements, case plans, kits. Catalog 25¢. Mason-Sullivan, Osterville 7, Mass.

**POOL** Tables. Build; repair. Plans, cushions, cloth, balls, cues, all materials available. Catalog 25¢. Campbell Billiard, 1607 W. Lawn Ave., Milwaukee 9, Wisconsin.

**FREE** Necklace kit with new jewelry supply catalog. 25¢. Designs, kits, instructions. Big profits! Easy to make and sell! Modern Craft, Box 11088-R29, Saint Petersburg 33, Florida.

**SAVE** On Cherry, Maple, Poplar, etc. Lumber, blocks, squares. Kiln dried, direct from sawmill. Joseph Gribus, Springboro, Penna.

**REFRIGERATOR.** Sink, lavatory, made like new for \$2.50. Amazing coating. White. 24 colors. Free color chart. Plastic Kolor Co., P.O. Box 8531, Houston 9, Tex.

**THE** Inexpensive Metl-Former makes useful, decorative articles from flat, sheet or round metals. Intricate designs are easy. Free literature from Metl-Former, 29 1/2 N. 8th St., Richmond, Indiana.

**WOODWORKERS** Interested in a product for a part time business. Write Box 1225, Boston 4, Mass.

**101 PATTERNS** Of smart gifts, novelties, shelves, action windmills plus "Make Money Jig Sawing." \$1.00. Mastercraft, 95M, 7041 Olcott, Chicago 31.

**PLANS** For pool table with extra two-face top for table tennis and model railroad. Blueprints B1209 and building instructions \$350. Popular Mechanics Service Bureau, 740 Rush St., Chicago 11, Ill.

**BUY** Picture frame moldings at wholesale. All styles and widths. Necessary tools, too. Free deliveries in U.S.A. Free 1962 catalog. Chesapeake Picture Frame Company, 414-A East Baltimore St., Baltimore 2, Md.

**UNPAINTED** Sparkling figurines, shell-craft samples 25¢. Shopper's Delight, Garden Plain, Kansas.

**FOUNDRYETTE**, 2400° F., 1 1/2 to 48 lb. capacity. Descriptive circular; send 10¢ for postage. Kansas City Specialties Co., Dept. P-9 Marysville, Kans.

**FREE** "Do-It-Yourself" leathercraft catalog. Tandy Leather Company, Box 791-A46, Fort Worth, Texas.

**PICTURE** Frame moulding, squares and lumber. Kiln dried walnut, cherry, silver maple. Midland Lumber Company, Box 262, Savannah, Mo.

**SKIL-CRAFTS** New 62-63 catalog. Largest and finest selection of leathercraft, artist, hobbycraft supplies in the world. Free gift with first order. Send 50¢. Refundable with first order. Skil-Crafts, Box 167-P, Joplin, Missouri.

**FREE!** Leathercraft catalog. Hundreds of new items. Write MacPherson Bros. Leather Company, Dept. E, 730 Mission St., San Francisco 3, Calif.

**SAVE.** Raw picture frame moulding from manufacturer. Ash, poplar, walnut, cherry, mahogany, all styles. Bauerle Cabinet Wks. Inc., Hammond, La.

## WATCHES, OLD GOLD, JEWELRY

**CASH** Immediately for old gold, jewelry, gold teeth, watches, diamonds, silverware, spectacles, platinum, mercury. Free information. Rose Industries, Heyworth Building, Chicago 2.

**SWISS** Watch factory offering striking novelty: Five watches in one. Ref. 432 the beautiful Lady's Interchangeable Watch. 5 differently colored bezels and straps in luxurious box, \$18.50 postage paid. The watch to match the dress! Send money order or check. Manufacturers: Itraco Watch Co. Ltd., Zurich 27 Switzerland.

**WATCH** And clock repairing books. Free catalog. North American, 2320-AW Milwaukee, Chicago 47, Illinois.

**HIGHEST** Cash for gold, teeth, jewelry, rings, diamonds, watches, silver, platinum. Mail articles today. Free gift with information. Chicago Gold & Precious Metals, 6 E. Monroe, Dept. 4358, Chicago 3.

**WATCHMAKERS'** Tools, materials, supplies, watches. Catalog. Gales, Box 1000, Chicago 90, Ill.

**TOP** Cash for jewelry, diamonds, watches. Write Ali Oken's, Box 87, Balboa Heights, Panama Canal Zone.

**FREE** Necklace kit offered by Modern Craft under Home Craftsmen.

**RHINESTONES.** Jewelry findings. Reduced prices. Free catalog. Sexton's, 416 Potomac, Buffalo 13, N. Y.

**FREE** Watchmaking course! Wholesale catalogue, details, 25¢. Bengal's, Culver City, California.

## TOBACCO, SMOKERS' SUPPLIES

**BLACK** Watch pipe tobacco. 20¢ for sample. Vottis Blenders, 19 Stella Lane, Amsterdam, N. Y.

## DO IT YOURSELF

**TERMITES?** U-Do-It! Inexpensive! Arab, Box 55585, Indianapolis, Indiana.

**INSTANT** Laminating: photos, cards. Self-adhesive plastic. Sample, details. Hughes Company, PM, Middletown, Conn.

**SAVE** Money. Fix your leaky faucets, easily with guaranteed precision tool. Free literature. Kenite Products, P.O. Box 3618, Santa Barbara, California.

**YOU-Do-It** prints, originals, appealing, decorative, useful. Details. Daco Mfg. Co., Woodsville, N. H.

**EXERCISE** At home on build-it-yourself physical fitness equipment, including bicycle exerciser, rowing machine, belt massager, and abdominal board. Send \$2.50 for blueprints B1208 and instructions. Popular Mechanics Service Bureau, 740 Rush St., Chicago 11, Illinois.

**RESILVER** Mirrors; plate. Literature catalog 25¢. Mirrocraft, 18518 Winthrop, Detroit 35.

**CONCRETE** Bird baths, animals, etc. Want to make them? We have the molds, instructions and prices \$2.00. Concrete Machinery, Drawer 99, Hickory 12, N. C.

**THE** Inexpensive Metl-Former makes useful, decorative articles from flat, sheet or round metals. Intricate designs are easy. Free literature from Metl-Former, 29 1/2 N. 8th St., Richmond, Indiana.

**CREATE** U.S. map 6'x4' on floor. Use 9x9 tile. Lay bricks like an expert. Use Sigl Masonry Spacers, 603 Elmwood Ave., Buffalo 22, N. Y.

**FREE** Check-list covering more than 500 classifications of projects, plans, instructions, service and repair information detailed in Popular Mechanics famous series of instructional booklets, books, patterns, and blueprints. List covers an extremely wide variety of do-it-yourself data on home remodeling, repair and improvement, hobbies, crafts, boating, games, lawn and garden, and hundreds of others. For your free copy of this helpful list, write: Service Bureau, Popular Mechanics, 575 Lexington Ave., New York 22, New York.

## RAZORS, BLADES, SHARPENING

**AMAZING** Success due to ingenious packaging and forty excellent double-edge razor blades. Sells for \$1. Cost 50¢. Wonderful door-opener. Send \$1 for two samples. See unique packaging, then sell samples to experience quick sales. Earn \$5 hour. Such seller seldom around, act on it. Comp. Blade, 3 Hoover, Inwood, L. I., N. Y.

## OF INTEREST TO WOMEN

**CANDLEMAKING** And decorating. Terrific hobby. Great business: Learn fascinating molding, dipping, creating and decorating candles for year-round demand—holidays, birthdays, weddings, anniversaries. All events. Spare time fun and extra income now; expand to colorful candle shop later. No age limit. Write for free facts on home instruction method. Candle Institute, Dept. X-756, Fallbrook, Calif.

**SELL** Fine fabrics. Get yours wholesale. Box 863, Norwalk, Conn.

**WOMEN!** Make big money at home. \$10.00 profit in an hour possible with invisible mending. Make holes, tears disappear from clothing, fabrics. Steady year-round demand from cleaners, laundries, homes. Details free. Fabricon, 1533 Howard, Chicago 26, Illinois.

**LEARN** Expert cake decorating, candy making. Free details on home instruction method. Candy & Cake, Dept. D-357, Fallbrook, California.

**HOUSEWIVES.** Teachers, students, office workers. If you need extra cash each week but household or other duties prevent you from taking a part-time job, learn how you can earn by accepting orders to Popular Mechanics, Good Housekeeping and all other magazines. No experience needed. Write Popular Mechanics, Room 9W, 250 West 55th St., New York 19, New York.



## PERSONAL

**BIBLE** Questions answered. Stamped envelope. Bylon, 17167 Bentler, Detroit 19, Michigan.

**LOANS** By mail, \$100-\$600. Anywhere. Confidential. Write Union Finance, Dept. PM, 323 E. Camelback, Phoenix, Arizona.

**LOANS** By Air Mail, \$100-\$600. Anywhere. Confidential. Easy payments. Write Security Finance Co., 898 Van Ness Ave., Dept. PM, San Francisco 9, Calif.

**DEVELOP** Mind power, personality while asleep. Details free. Research Association, Box 24-N, Olympia, Washington.

**NEW!** Borrow \$1000. Anywhere. Increased loan limit. Air mail service. Postal Finance, 374 New Brotherhood Building, Dept. 17-D, Kansas City, Kans.

**MY** Remailing experience in a copy-right book sent postpaid for \$1. Ross Hancock, 83 Bellhaven Rd., Toronto 8, Canada.

**INVESTIGATORS**, Free brochure, latest subminiature electronic listening devices. 11500-P NW 7th Ave., Miami 50, Florida.

**NEED** Money? Borrow \$100-\$1,000 by mail. Confidential, repay in 24 months. Free loan application. Budget Finance Co., Dept. OB-212, 114 So. 17th, Omaha 2, Nebraska.

**BORROW** \$100 to \$1,000 by mail. Quick. Easy, private. No co-signers. Repay in 24 small monthly payments. For the amount you want write today to Dial Finance Co., 410 Kilpatrick Bldg., Dept. J-1, Omaha 2, Nebraska.

**STAMMERING**. Corrected myself. Could help you. Dipple, 103 Church, Detroit 3.

**TOP** Loans on jewelry, diamonds, watches. Write Ali Oken's, Box 87, Balboa Heights, Panama Canal Zone. Strictly confidential.

**"HOW** To Wake Up Life-Changing Winning Ability" free. Write President, Box 1924-W, Louisville 1, Ky.

## REMAILING SERVICE

**LOS** Angeles, Hollywood, San Fernando Valley 25¢ single, \$3.00 monthly. Confidential, 10437 Lanark, Sun Valley 3, Calif.

**CONFIDENTIAL** New York City mailing, receiving, forwarding address. Business personal mail \$3.00 month. Remails 25¢. Details free. Birnhan, 152 West 42, New York City 36.

**RENO**, Nevada, confidential remails, 25¢. Monthly \$3.00. Garakontie, Box 2876-A.

**REMAILS** 25¢. New York phoned messages \$1. Bagley's, 158-18 Riverside Drive, New York 32.

**CHICAGO** Address \$3.00 month. Details. Continental, 64 E. VanBuren, Chicago 5.

**PALM** Beaches remailing 25¢. Evco, 1630 44th St., West Palm Beach, Florida.

**IRISH** Reairmails \$1.00. 2 postcards \$1.00. Write for other services. C. O'Donnell, Dysart, Letterbarrow, Donegal, Ireland.

**SECRET** Mail address. \$3 month. Hedg-peth, Box 830, Alhambra 23, California.

**LETTERS** Remailed, forwarded 25¢. Robert Carter, Box 742, Los Angeles 53, Calif.

**NATION'S** Capitol. Remails 25¢. Monthly \$3.00. Mailon, Box 7166, Washington 4, D. C.

**LETTERS** Remailed 25¢. Six 50¢. Permanent address, anniversary, other services. Morris, 1613 Bradley, High Point, N. C.

**HAWAII** Secret address. Receiving-forwarding 25¢, \$3.00 monthly. Postcards. Coe, Box 984, Kailua, Hawaii.

**CONFIDENTIAL** Receiving-forwarding system. Letter 25¢, monthly \$3.00. Free information. Bellis, 26766 Hillview, Highland, California.

**RELIABLE** Receiving-remailing, confidential address, \$3.00. Box 53, Wilmington, California.

**PERSONAL** Letters remailed from Washington, D. C., 25¢ each. Caldwell, Box 7716, Washington 4, D. C.

**SECRET** Mail receiving-forwarding system. Lipps, 941 Mouton, New Orleans 24, Louisiana.

**MOSCOW** Remails 50¢ each. D. A. Durocher, P.O.B. 2292, Station A, Cumberland, Maryland.

**SECRET** Address professionals 25¢-\$3.00. De Graff, 8765 Innsdale, Spring Valley, California.

**CONFIDENTIAL** Mail service. Lowest rates. Remails 25¢. Johnson, Box 1890, Long Beach, California.

## TREASURE FINDERS

**METAL** Locator kits and assembled models from \$39.90. Terms. Transistorized and underwater models available. Free catalog. Electronic Applications, Dept. M, Box 8, Arlington 10, Virginia.

**GOLD**, Silver, coins, Civil War relics, treasures. Choice 5 locators. Established 1933. Free literature. Write The Goldak Company, 1541 W. Glenoaks Blvd., Glendale 1, California.

**TREASURE**, Gold, silver, relics. Find them with new Detectron instruments. Free information. Raytron, Box 715, North Hollywood, California.

**FUN** And profit finding buried treasure, relics with transistor m-scope. Booklet, interesting customer comments free. Terms. Fisher Research, Dept. AX, Palo Alto, Calif.

**TREASURE** Signs, Indian symbols. Copy \$1.00 postpaid. R. O. Morgan, Box 344, Inyokern, Calif.

**TRANSISTORIZED** Treasure finder locates deep buried, sunken treasures. Easily, inexpensively built without previous electronic experience. Step by step illustrated plans, details, \$2.00. Dee Designs, Box 7263-A, Houston 8, Texas.

## WANTED-MISCELLANEOUS

**BUY**, Swap, sell anything that can be moved. Details for 10¢. Refundable. Hilton's, Box 7-B, Glendive, Montana.

**QUICKSILVER**, Platinum, silver, gold. Ores analyzed. Wholesale Terminal, Norwood, Mass.

**CASH** For used paper backed books. The American Company, Merrick 7, N. Y.

## FOR SALE-MISCELLANEOUS

**FREE** Money-saving catalog. Surplus and newly manufactured equipment and tools for workshop, home, boats, farm, factory. Write: Groban, 1139 So. Wabash, Chicago 5, Ill.

**EYE** Visors, unique! Stop that glare on glasses. Two types: Snap on 50¢; with temples wear over glasses or without \$1.00. Sparks Eye Visors, 4561 Covington Hy., Decatur, Ga.

**HEARING** Aid batteries wholesale. Free list. Habs, Box 51, York, Penna.

## MISCELLANEOUS

**EARN** Money raising fishworms for us! Write: Oakhaven-60, Cedar Hill, Texas.

**CIGARETTES**-Make 20 plain or filter-tip for 9¢. Facts free. Moberly, Box 785, Owensboro, Kentucky.

**SEND** Us wool for blankets. Write El-Dorado Woolens, Eldorado, Texas.

**WANT** Your name with 1000 mailers? 25¢ lists your name year with our mailings every month. Dixie Mailers, King, N. C.

**50 ALL** Different mail order publications \$1.00. Harddings's, McLoud, Oklahoma.

**BOOKS** On antiques and their prices. Free circular! P. Warman Publishers, Uniontown, Penna.

**SUPER** Memory overnight! Success guaranteed! Bijou, Box 1727-M, Hollywood 28, California.

**AUTHENTIC** Guamanian "stick" dolls made by Chamorro natives. \$2.00 postpaid. Giant African snail shell from Guam \$1.00 postpaid. Air mail money to: Guam Rehabilitation and Workshop Center, Inc., Box 2113, Agana, Guam.

**ANTIQUES!** Fact-filled illustrated monthly magazine tells how to know, use antiques. Special bonus offer! Write Antiques Journal, Uniontown, Penna.

**OUTHOUSES**, Septic tanks, cesspools, clogged drains, filter beds, restored to newness by miracle crystal pellets. New discovery. Do-it-yourself. Easy-to-follow instructions. Free literature and testimonial letters. Electric Sewer Cleaning Co., Boston 34, Mass.

**BUCKSKIN** Jackets, gloves, moccasins, etc. Deerskins tanned. Send 50¢ for Buckskin money poke and catalog. Berman Buckskin, Minneapolis 1, Minnesota, Dept. 42.

**"GOLDEN** Ray" ink powder. Letters pop up when you write. Stephen Sidella, Pottsville, Penna.

**AT Last!** Hearing aids only \$28.95. Free trial, terms. Write Cary-B Sales, Inverness, Fla. Salesmen wanted.

**KEEP** Your mail box loaded. Get listed 10¢. Frankland Enterprises, P.O. Box 112, Chicago 17, Ill.

**SEE** Color on your TV. Amazing device brings glorious thrilling color pictures. Free details. Gay-Dol Co., 937 Ludlow St., New Bedford, Mass.

**FREE!** Exciting new catalog—Western wear, saddles, riding accessories. Western Saddlery, Box 1864-V3, Fort Worth, Texas.

**PRIMITIVE** Sculptures, oriental art. Wholesale prices. L. B. Myers, Box 1268, Twentynine Palms, California.

**CALENDARS**, Ancient, present, future, A.D. 1 to 2399, any year. \$1.00. Bixler, Benson Avenue, Frankfort, Kentucky.

**RETRACTABLE** Pens, guaranteed, 20 for \$1.00. Maclean, 312 Belanger, Houma, Louisiana.

**MARRIAGE** Certificate. Suitable for framing, in two colors, 8x10"-\$1.00. Harvey's, Box 1402-C, Englewood, Colo.

**RECEIVE** Gifts, samples, magazines, catalogs, opportunities, 10¢. Directory, Adkins, Texas.

**TAILOR**—Alters shirts by mail. Sides tapered, sleeves shortened. Write: Francis Nation, 210 N. West, Perryville, Mo.

**HARPSICHORD** In kit form for home workshop assembly \$150. Write for brochure: Zuckermann Harpsichords, Dept. 2, 115 Christopher St., New York 14, N. Y.

**NOVELTIES** For men. Illustrated list 4¢. Novelties, 9420 Trumbull, Chicago 42.

**"STAMMER**, Stutter, No More." (Dr. Young.) Write: Gaucho, Box 9309-S7, Chicago 90.

**VERY** Old finest Netsuke ivory animals, all kinds, fowls, birds, \$16.00 each. Meier, Church St. Annex, P.O. Box 302, New York 8, N. Y.

**UNUSUAL** Gifts whole family. Free catalogue. Jordan's, 743 South Dorrance St., Philadelphia 46, Pa.

# BLACK & DECKER TOOLS REPAIRED

- ✓ FULL GUARANTEE on all recommended repairs
- ✓ NEW PRICE POLICY saves you money
- ✓ FAST REPAIRS in 24 hours or less
- ✓ GENUINE FACTORY PARTS made for your B&D tools
- ✓ ALL REPAIRS MADE by tool experts
- ✓ FREE REPAIR ESTIMATE on request

OVER 100 REPAIR CENTERS. Check the Yellow Pages under "Tools Electric" or write for address of nearest service station.



**Black & Decker®**

Towson 4, Md.

QUALITY TOOL SERVICE

NOW! COPPER SWEAT JOINTS  
**THE EASY WAY!**

**SWIF SOLDER**

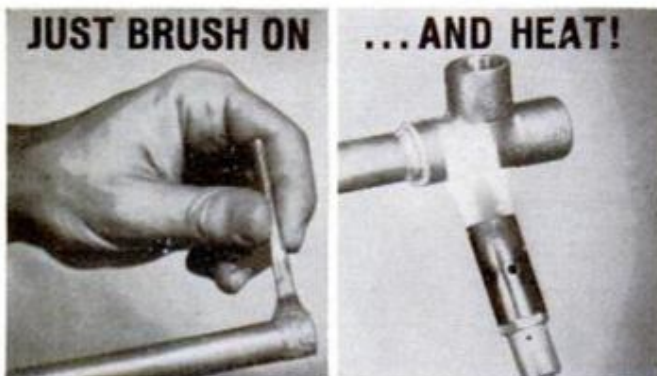

Make perfect leak-proof sweat joints every time with Hercules SWIF Solder, the real 50/50 tin-lead solder pre-mixed with flux in easy-to-use paste form. Save time and money, too. Just brush on, join, and heat for neat, strong joints. SWIF solders all common metals (except aluminum) and works with a torch, soldering iron, or soldering gun. This grade available in economical 4 oz., 1/2 lb., 1 lb., and 3 lb. cans at your plumbing supply or hardware dealer. See for yourself how easy any soldering job is when you use SWIF.

Write for free do-it-yourself soldering folder.



Hercules Chemical Co., Inc., 416 B'way, N.Y. 13



## Handwritten Telephone Calls

Part of a new "data phone" series of machines which permit instant transmission of printed material by telephone, the Series 600 system sends handwritten messages.

A normal telephone call between two offices makes the connection, and, while both receivers are rested, the message is written on one electric-writing machine and is simultaneously reproduced on a similar machine.

Other series do similar work. Some of them can send and reproduce up to 1600 words a minute. The data-phone system was developed by the American Telephone & Telegraph Co.

NEW CATALOG

# WOOD

Everything for the Craftsman  
Over 1,500 Items  
Finest Domestic and Imported Woods...  
Kits...Ornaments  
...Tools...Special Hardware...Tile.  
**LOW MONEY-SAVING PRICES**  
Stanley Power Tools  
—Big Discounts!



**Workshop Supplies, Equipment**  
Send for Craftsman's NEW 112-page catalog... get big discount prices on Stanley Power tools! Finest kiln-dried domestic and imported woods, wood and metal legs, ornaments. Over 1,500 items! Big values on tools, craftsman hardware, Mosaic Tile, upholstery supplies, lamp parts, Glue Injectors. Send 25¢ to help pay postage and handling.  
**Craftsman Wood Service, Dept. A-9**  
2729 S. Mary St., Chicago 8, Ill.

**MAIL COUPON NOW!**

**CRAFTSMAN WOOD SERVICE CO., Dept. A-9**  
2729 South Mary Street, Chicago 8, Illinois  
Enclose find 25c. Rush new CRAFTSMAN Wood Catalog.

NAME .....

ADDRESS .....

CITY ..... ZONE ..... STATE .....

POPULAR MECHANICS

YOU'LL ENJOY SHOOTING MORE WITH A  
MODEL **K4 WEAVER SCOPE**



Model K4  
(4-power) with  
Weaver-Detachable  
Top Mount. Scope, \$45; Mount,  
\$9.75. Other K Models from 1- to 10-  
power, priced from \$34.50 to \$59.50.

**better vision • easier aim • greater accuracy**

A Model K Weaver-Scope makes shooting more fun because it lets you shoot more accurately. Precision optics give a big, bright view of your target; sturdy construction and all-weather sealing make K Models dependably accurate. See the Model K Weaver-Scopes at your dealer's, there's one to fit your needs and your budget.

© 1962 W. R. Weaver Company

SEND FOR **FREE** 36-PAGE CATALOG

Name \_\_\_\_\_

Address \_\_\_\_\_

City \_\_\_\_\_ Zone \_\_\_\_\_ State \_\_\_\_\_

**W. R. WEAVER CO.**  
Dept. 91 El Paso, Texas

**THE WORLD'S MOST USED, MOST PROVED SCOPES**

**FREE AMAZING NEW BOOK**  
**"HOW TO ANSWER ADS"**



Never before have you seen anything like this. Tells you in simple language the correct way to answer ads. Gets you quicker replies—better results, and greater satisfaction. Will save you time and money and it's **ABSOLUTELY FREE**. No obligation whatever. Every reader of advertising should have this booklet. Send a postcard for your copy **NOW**. F. W. JOHNSON, Popular Mechanics Magazine, 740 Rush St., Chicago 11, Ill.

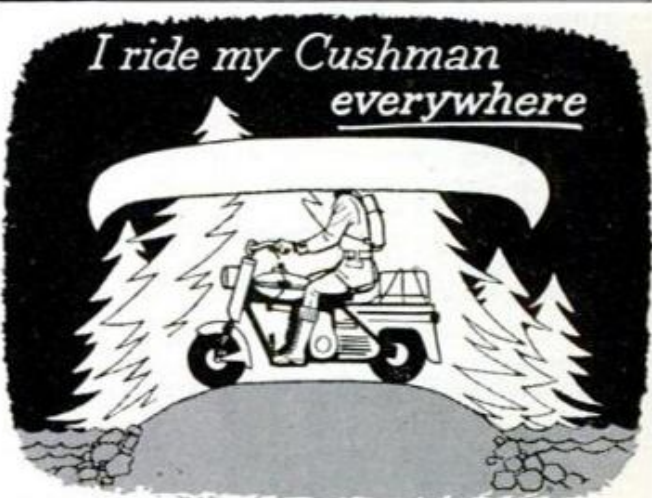

*I ride my Cushman  
everywhere*

A sleekly styled Cushman Scooter is today's way to get there. It's superbly engineered for dynamic performance. It's economical, too—up to 100 mpg.

**CUSHMAN**  
**Super Eagle**

Famous for rugged roadability, now with new seat suspension, new brake action.

See your dealer or write for booklet.



**CUSHMAN MOTORS**  
Division of Outboard  
Marine Corporation  
951 No. 21st  
Lincoln, Nebraska

NAME \_\_\_\_\_  
ADDRESS \_\_\_\_\_  
CITY \_\_\_\_\_ STATE \_\_\_\_\_

**DRAFTY?**

**CAULK with RUTLAND**

Seal cracks in concrete, masonry, around doors, windows. **KLIP-TIP\*** gives 3 sizes from one spout.  
\*Reg. & Pat. Pend.

other quality  
**RUTLAND PRODUCTS**  
Glazing Compound  
KEX Spackling  
Patching Plaster  
Concrete Patcher

**RUTLAND FIRE CLAY CO., Rutland, Vt.**

**"MADE \$1200  
ON ONE JOB"**

*Some make more, some less...*

**We help you start Your Own All-Year Business**

**Make BIG Money!** With our easily operated, highly efficient wall washer, G. H. Jones made \$1200 on one school job. E. L. Goss took in more than \$10,000 in one year. E. C. Taber wrote, "I made \$400 gross in two weeks." And no wonder... this machine washes walls 6 times faster and better than by hand—with no mess... no drop cloths.



**Your Money-Making Opportunity •**

We want more men to go into this profitable business for themselves and enjoy independence—freedom from layoffs and bosses. Customers everywhere—homes, offices, schools, churches, hotels, etc. How much you earn depends largely on you, but we help you to start and work with you for your success. What you take in is mostly profit. No need to rent shop or office; operate from home. Can start spare time until your full time is justified.

**OURS IS NOT A LEASE ARRANGEMENT •** You are free to operate in an independent manner. You sign no contract. You own the detergent outright and are always *your own boss*... and every dollar you take in is *yours* to keep. You pay no fees, or dues, or royalties to anyone. And you take no risk. Your detergent is fully guaranteed and enough supplies come with it to return far more than your investment. Many earn the cost of the detergent in a week or two. It costs nothing to get the details... write **TODAY**.

**Lose No Time — Send Coupon Today for All the Facts**

**FREE BOOK! MAIL COUPON TODAY!**

• **VON SCHRADER MFG. CO.** •  
 • 910 "W" Pl., Racine, Wisconsin •  
 • Send at once (no obligation) your **FREE** booklet •  
 • containing information about your **WALL WASH-** •  
 • **ING MACHINE** and how I can start *my own* •  
 • permanent, profitable business. •  
 • Name \_\_\_\_\_ •  
 • Address \_\_\_\_\_ •  
 • City \_\_\_\_\_ Zone \_\_\_\_\_ State \_\_\_\_\_ •  
 • ..... •

● Among the Jivaro Indians of South America, a father repeatedly recites the family's hatreds to his son to make him an aggressive head hunter. The Indians believe that if a man fails to add a new shrunken head to his trophies periodically, he will become prey to illness and witchcraft.

**MEET YOUR CELL BOSS**

**THE CHEMICAL** that tells the cells in your body when to get busy and reproduce themselves—or when to knock off work for a while—has been found by two biologists who were busily examining, of all things, the cells of the pea plant!

A protein called histone is the key decision maker, according to Dr. James Bonner and Dr. Ru-Chih C. Huang of the California Institute of Technology. Histone turns on and off the activity of the genes, the tiny bits of matter that carry hereditary information and regulate the processes of life.

It is important in developing the specialized tissue of the body—for example, skin, hair or red blood cells.

The genes, controlled by histone, carry the information by which new generations of animals and plants are duplicated. Every one of the millions of cells in every person's body contains a complete blueprint of that person. This blueprint consists of perhaps 100,000 genes, grouped in chains called chromosomes. A portion of the blueprint is for making the protein structure found in every cell, and another portion is for making specialized proteins such as brain or bone.

However, every gene in every cell is not active all the time. If genes were that active, then all the cells would try to produce all of the proteins. If they did so, there would not be any human beings, because humans have specialized cells.

And that's where histone, which Dr. Bonner and associates found at work in cells of embryo pea stems, comes in. Chromosomes consist of two kinds of genes—those covered with histone and those not covered. The *uncovered ones*—in the case of the pea, this was only 20 percent of the genes—do all the work.

Histone, itself, is a small, simple protein molecule composed of about 150 amino acid building blocks. There are 20 different kinds of these blocks and they are assembled into proteins by being strung together in chains. Histone is said to be simple because it is composed principally of only two of the 20 amino acids, lysine and alanin.

Because the histone units are small, several are required to cover one gene.

Dr. Bonner said that human cancer cells have been found to contain less histone than normal. This could mean that too many of their genes are "turned on" which could account for a distinguishing feature of cancer cells—the apparent loss of their ability to specialize. ★★★

# NEW SONY STEREO TAPE DECK



Now, for less than the cost of a good record changer, you can add a versatile new dimension to your hi fi system. ■ The Sony 262-D tape deck has a 4 track stereo erase head and 4 track stereo record/playback head. Heads are wired to six output and input facilities for connection of external electronics to play and record four track stereo. This is the same quality mechanism used in the most expensive Sony Superscope tape recorders.

**\$89<sup>50</sup>**



**NOW AVAILABLE!**

Complete your 262-D stereo system: the long-awaited Sony SRA-2 stereo recording amplifier provides instant connection to the Sony 262-D stereo tape deck for complete 4-track stereophonic and monophonic recording. 2 Recording level indicators track selector switch, record safety interlock, microphone and radio inputs. No modifications necessary.

**\$89<sup>50</sup>**

For literature or nearest dealer, write: Superscope, Inc. Dept. 9 Sun Valley, California.

**SUPERSCOPE**

The Tapeway to Stereo

All Sony Stereorecorders are Multiplex ready!

# EVERY LITTER BIT HURTS

Don't be a litterbug! Drop every litter bit in the litter basket. Carry a litterbag in your car. That's how you can help KEEP AMERICA CLEAN AND BEAUTIFUL.



Published as a public service in cooperation with The Advertising Council.

SEPTEMBER 1962



**BUILD**  
this famous  
engine...  
The Visible  
Airplane Engine  
...it's a handsome  
showpiece...  
and it really works

Replica of the Pratt & Whitney "Wasp". Transparent housing permits clear view of the nine radially mounted cylinders, valves, rocker arms, connecting rods, cams and gears as they synchronize with the electric firing of the spark plugs. Variable pitch propeller. Complete with motor, stand and manual. **\$14.95**  
1/4 size scale

**RENWAL**

**FREE** Write for copy of "Getting a Jump on the Future with a Renwal Hobby"

NAME \_\_\_\_\_  
ADDRESS \_\_\_\_\_  
CITY \_\_\_\_\_ ZONE \_\_\_\_\_ STATE \_\_\_\_\_

SEND TO: RENWAL, MINEOLA, N.Y., DEPT. PM-1

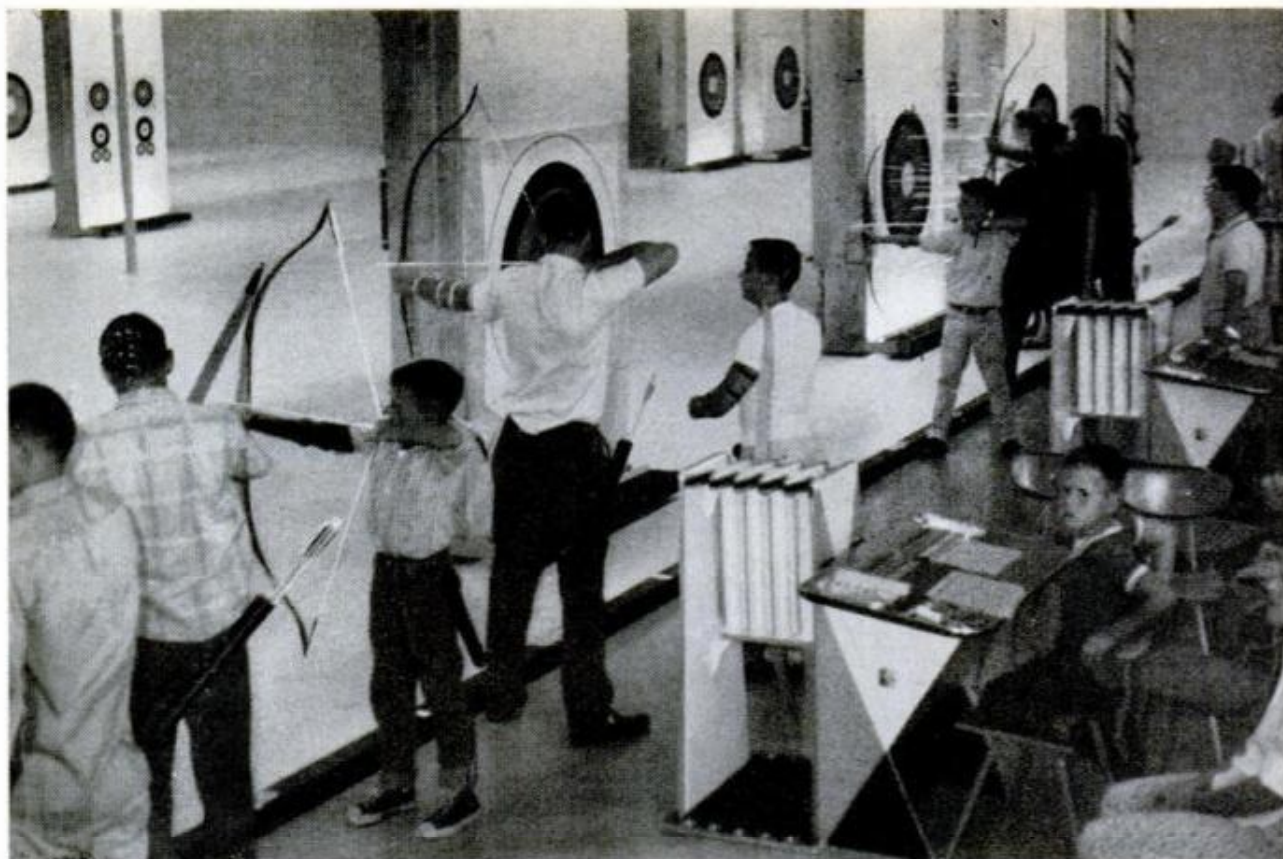

**AUTOMATED ARCHERY** makes its debut as bow and arrow enthusiasts try the indoor range of the nation's first electronically operated archery center in Seattle, Wash. The push-button equipment adjusts the position of a target at any interval between 20 feet and 30 yards, automatically picks up and returns any fallen arrows to the archer, and brings the target to the shooting line for inspection



**who needs it?**

**(you do)**

Why? Because now, right under your hood, a dirt-clogged air filter may be robbing your car of up to 3c a gallon on gasoline. Call the cops? No, call in at your favorite service station. Have your dirty air filter replaced with a fresh Fram "Wear-Guard" Air Filter. Change it at least every 10,000 miles. A Fram "Wear-Guard" Air Filter screens out airborne dirt that could chew up engine parts—cleans the 9,000 gallons of air your engine mixes with every gallon of gasoline. Then you get all the pep and power you pay for—save up to 3c a gallon on gasoline. Fram Corporation, Providence 16, R.I.

**FRAM**  
WEAR-GUARD FILTERS

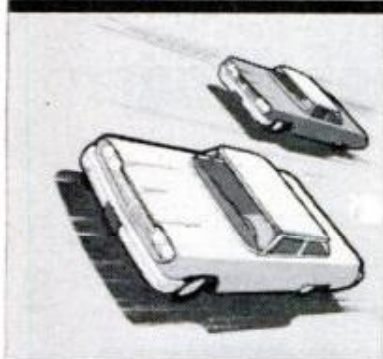

PERFECT CIRCLE PISTON RINGS  
ARE INSTALLED AS ORIGINAL  
FACTORY EQUIPMENT IN 95  
BRANDS OF VEHICLES AND ENGINES



## WHY THE "PROS" PREFER PERFECT CIRCLE PISTON RINGS

**THE DOCTOR OF MOTORS**  
Skilled mechanics the  
world over prefer and install  
Perfect Circle piston rings

Engine "pros" know that one reason for the long life of Perfect Circle rings is the thick, solid chrome surface. Chromium has been tested and proved the hardest, longest-wearing surface material currently available.

Perfect Circle pioneered chrome rings and PC's chrome surface is finished with watchmaking precision that assures truest fit and eliminates tedious break-in.

In addition, PC oil rings have uniformly-applied tension that automatically compensates for wear, maintains positive oil control.

For like-new power, smooth performance and lasting oil control — always install Perfect Circle piston rings. Ask for dependable PC's — the rings preferred and specified by so many leading vehicle and engine manufacturers, race drivers, fleet operators and mechanics the world over.



**PERFECT  CIRCLE**

PISTON RINGS • PRECISION CASTINGS • SPEEDOSTATS • ELECTRONIC PROGRAMING EQUIPMENT  
Hagerstown, Indiana • Don Mills, Ontario, Canada

Материал, защищенный авторским правом



**ALTHOUGH BRED** for city streets, Checker's cab-based wagon corners with solid control; has good clearance

## Spotlight on the Checker Station Wagon

By Jim Whipple

**C**AN AMERICA'S best-known taxicab bring happiness to a suburban family while masquerading as a station wagon?

This question is not nearly as facetious as it sounds. There is a solid, six-passenger four-door wagon based on America's only exclusively taxicab-built automobile. So, to find the answer PM borrowed a wagon from the maker and gave it a family-style road test.

When you buy a Checker passenger car, you are getting a "civilian" version of the tall, solid, square cabs found in every major U.S. city, minus, of course, the meter, roof-light and gaudy war paint.

By reversing the logic that has led to adaptation of so many Ford, Chevy, Plymouth or Studebaker sedans for taxicab work, the Checker taxi has been turned into a private passenger car.

The Checker is made in Kalamazoo, Mich., by the Checker Corporation, a firm exclusively devoted to taxicab manufacture for the past 40 years.

Checkers are not, incidentally, adaptations of some other manufacturer's light truck chassis.

The Checker is designed from the ground up to handle the round-the-clock, year-round slam-bang of big city cab operation.

This fact, we soon discovered, is the key to the Checker's total design and the reason for its somewhat unique driving characteristics.

A cab operator wants two main attributes in any taxi that he buys for his fleet; first the cab must be one that people find comfortable to ride in and easy to get in and out of.

Secondly, the operator wants his vehicle to roll up tremendously high mileage before he is forced to replace it. Further, of course, this mileage must be put on at minimum cost and with the least possible downtime for repairs.

A car designed for such requirements is, we discovered, pretty much of a solid, no-nonsense vehicle. Annual styling changes, so important to sale of private passenger cars, are almost unknown to Checker, which has been virtually unchanged for seven years.

Far more important than the style of a Checker's fenders is the fact that all four of them can be unbolted from the body structure for easy replacement. In conventional passenger cars, rear fenders are integral parts of the body and must be welded in as replacements.

The Checker wagon looks bigger than its 199 inches over-all length and 76-inch width because it is 62 inches high compared to the 55-inch height of most other station wagons.

This extra height pays off in the passenger compartment, providing a flat-floored, tunnel-free rear compartment, seats that are a comfortable 13 inches off the floor, and "hat's on" type headroom in front and rear compartments.

As a cargo carrier, we found the Checker less roomy than its ample height led us to expect. Its cargo volume is 93 cubic feet, a measurement that excludes the area of the driver's seat. This compares with the 87 cubic feet of the '62 Chevrolet wagon which is 10 inches longer but 7 inches lower.

However, the Chevy has 10.5 more cubic

(Continued to page 82)



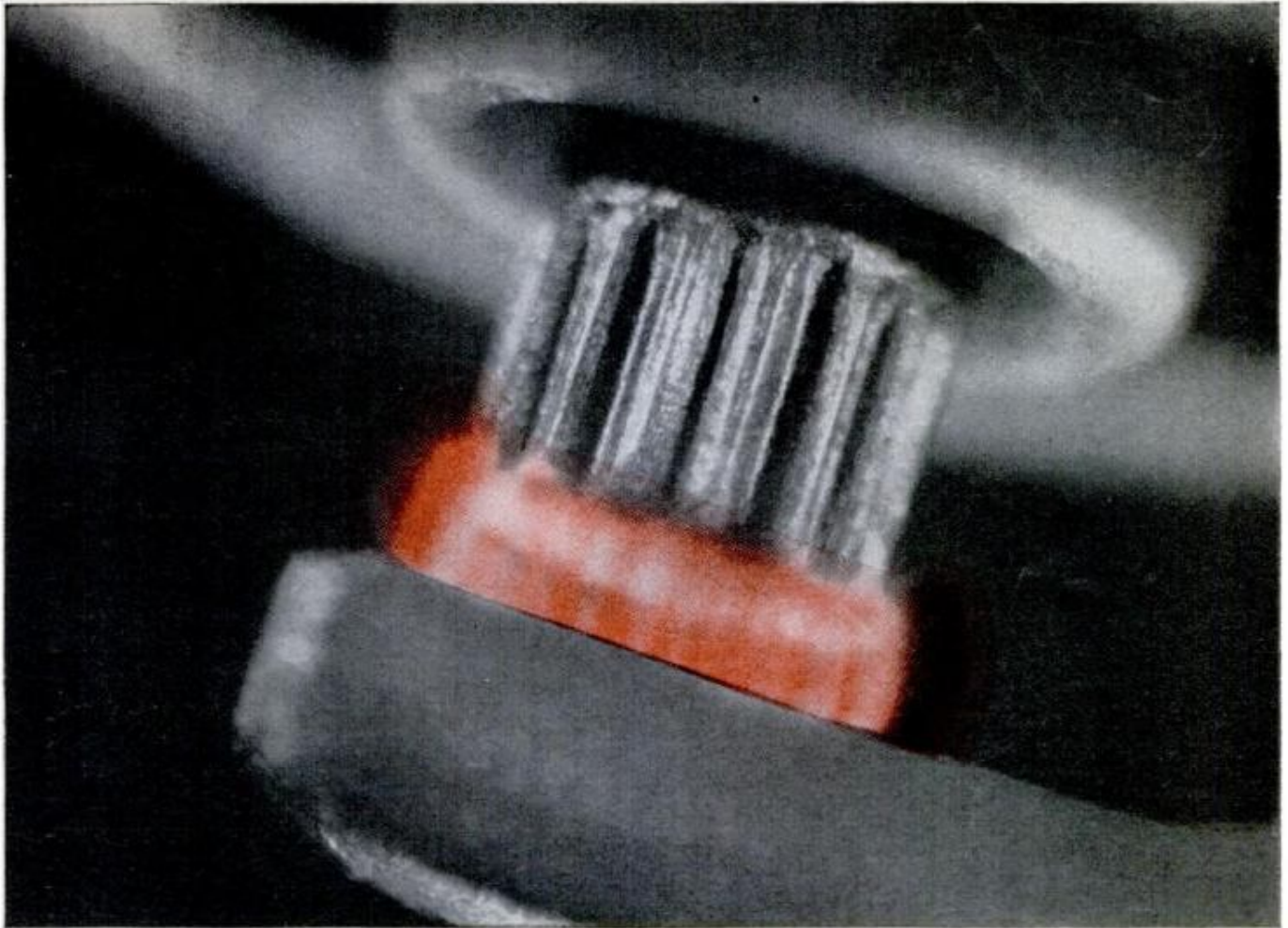

## AC's Fire-Ring spark puts more punch into your car's performance

Here is AC's famous "Ring of Fire" — the potent spark that gets maximum power and performance from every drop of gasoline. It's a benefit you get only from AC's exclusive precision-ground knurled center electrode. Due to its flat surface and sharper edges, you get crisper, more evenly distributed spark for more efficient combustion under all operating conditions. Also, because the spark is not concentrated at a single "high spot," as with spark plugs that do not have precision-grinding, AC electrodes wear down slowly and maintain

proper gap size longer. So — when you buy new spark plugs — ask for ACtion, ask for AC. They keep sparking better, longer.



**FIRE-RING  
SPARK PLUGS**

AC SPARK PLUG  THE ELECTRONICS DIVISION OF GENERAL MOTORS



**FLAT FLOOR**, wide doors, high seats, make for easy entry, comfort

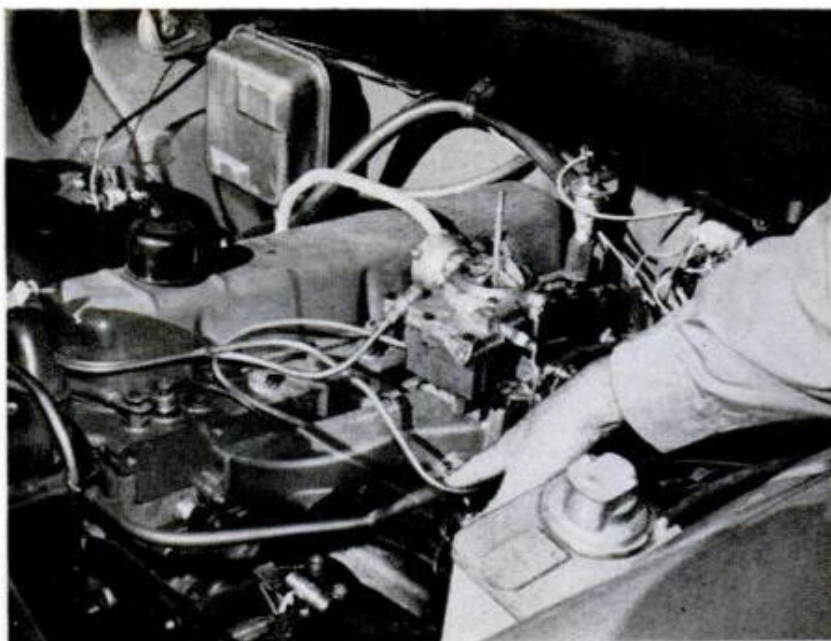

**HOT WATER** from cylinder head warms, further vaporizes fuel on its way to engine via water-jacketed intake manifold; exhaust is on other side

feet in a locker below the cargo floor. This space contains the folding rear seat on nine-passenger models.

The Checker wagon, incidentally, comes only as a six-passenger model. If you want to carry more than six people the Checker sedan is better with its stool-like "jump seats" in the forward end of the rear compartment. The rear seat in Checker sedans is almost a foot farther back in the body (to provide for jump seats space). This makes for fabulous legroom.

Rear seat legroom in the wagon is also good and entry through the tall, square door openings is very easy. Distance between the wheelwells in the Checker's cargo compartment is 49 inches, while the length from back of front seat to rear of extended tailgate is 109 inches (compared to Chevrolet's 118). So 4 x 8 foot sheets of plywood or wallboard fit in with room to spare.

On the road Checker has a solid serenity, due to a combination of 3700-plus pounds of weight and a firm suspension system (coil-springs up front, leaf springs at the rear).

There is little lean or roll in cornering and there is little flex or shake in the body on rough roads, due to the heavy "X" type frame which appears to have been borrowed from the bridge-building section of the Army Engineers. In fact the whole undercarriage of the Checker is heavy-duty, built to withstand the beating of rough city streets for 150,000 miles which is the mileage life demanded of a cab.

Checker has two passenger car lines. The Superba (standard trim) and the Marathon (deluxe). Either line may be optioned with

one of two different Continental six cylinder engines. The first of these is a side valve, or "L-head" powerplant developing 80 horsepower. For about 56 dollars more a buyer may option a 141-horsepower, overhead-valve version of the same engine. Both engines have bore and stroke of 3.3 x 4.37 inches for a displacement of 226 cubic inches.

The lesser of these two engines is intended primarily for economy and its performance will be found wanting by many.

PM's test wagon had the larger engine, an automatic transmission (three-speed and torque converter type), power steering and power brakes. Its performance was adequate if not startling.

An honest 85 mph seemed about tops and acceleration from standstill to 60 mph required 18 seconds. The wagon cruised comfortably and without strain or undue noise at 65-70. But passing on two-lane roads is no power show; it takes some planning.

In light of the unexciting level of performance, fuel economy was disappointing. Over-all mileage was 13.7 for mostly over-the road operation.

All in all we think the Checker is an honestly designed fairly easy to drive, and quite comfortable automobile, even over the roughest of roads. It is priced at over \$3700 (factory suggested, or "sticker" price) including radio, heater, whitewalls, power steering and brakes, automatic transmission and power tailgate window. If you're the type of driver who runs up mileage, the Checker's built-in extra margin of durability might justify the cost.

★ ★ ★



Ask for  
**Seymour's  
 Aluminum Enamel**  
 in the new  
**24-oz spray can**

---

made with pigments  
 from *ALCOA*

Of all the ways we know to relax—gardening, golfing, gambling—nothing beats spray-painting with aluminum. It's so downright satisfying just to push a button and add new sparkle and beauty to almost anything—lamps, trays, baskets, appliances, vases, garden furniture and tools, dingy attics, home shop areas. It's a long list.

Next trip to your paint dealer, pick up one of the good brands like Seymour's Vinyl Enamel, made with Alcoa® Aluminum Pigments. Now available in big, economical 24-oz spray-pack cans, Seymour's Aluminum Enamel dries to touch

in minutes. That means smooth, dust-free results.

Aluminum paint is durable; a tough film of metal resists wear, cuts the maintenance nuisance. Aluminum has great hiding power; one coat covers soiled or stained surfaces (aluminum pigment is opaque). Aluminum paint is attractive; it looks clean—it's easy to keep clean.

**Alcoa does not make aluminum paint,** but Alcoa Pigments are used in the best brands. Available in either spray cans or conventional containers, brands like Seymour's are at dealers everywhere. Send coupon for our booklet.

## ALCOA ALUMINUM

PIGMENTS, PASTES & POWDERS

Entertainment at Its Best . . . **ALCOA PREMIERE**  
 with Fred Astaire as Host . . . Tuesday Evenings, ABC-TV

SEPTEMBER 1962

Aluminum Company of America  
 1743-J Alcoa Building, Pittsburgh 19, Pa.  
 Please send your free booklet, *Painting With Aluminum*.

Name \_\_\_\_\_

Address \_\_\_\_\_

City \_\_\_\_\_ Zone \_\_\_\_\_ State \_\_\_\_\_



**MIRROR, TOOL CHEST** and blackboard combination can be hung in any room in the home. Comes complete with eight basic home repair tools in knotty pine or maple finished cabinet. Size is 2 $\frac{3}{4}$ " x 14" x 17". Price \$14.95 express collect or in unfinished kit form \$10.95 ppd. Yield House, No. Conway, N. H.

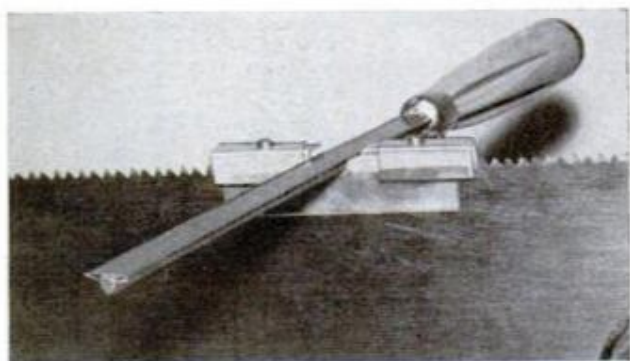

**SAW-FILING GAUGE** and guard permits anyone to get perfect results on rip or crosscut hand saws. It gives all teeth exact and uniform pitch, bevel and depth for precise sharpening. Price of unit without the file is \$1.50 ppd. With 6-in. file is 50c extra. Watro Mfg. Co., 156 Muir Ave., Hazelton, Pa.

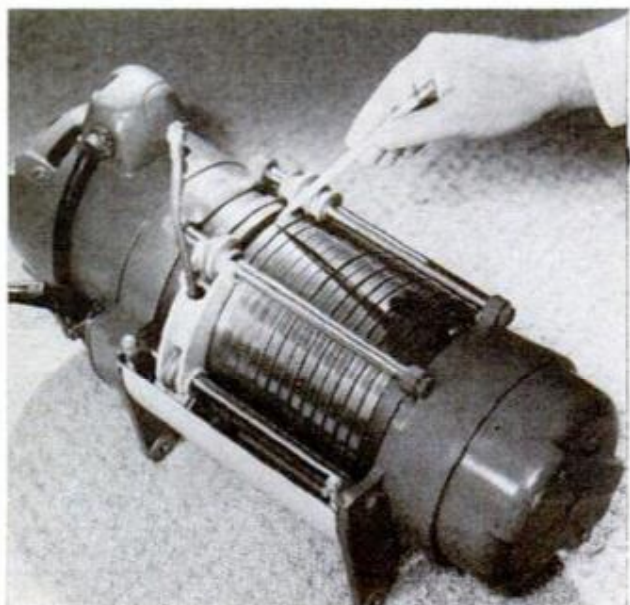

## Shopping for tools

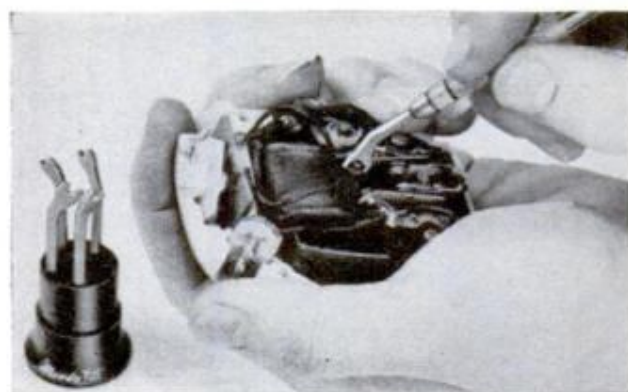

**TINY OFFSET OPEN-END WRENCH SET** consists of five interchangeable wrenches and a chuck-type, knurled steel swivel handle. Availability in two set combinations provides a range of eight wrench sizes from  $\frac{5}{64}$  in. to  $\frac{5}{16}$  in. Made by Moody Machine Products Co., Inc., 42-46 Dudley St., Providence 5, R.I.

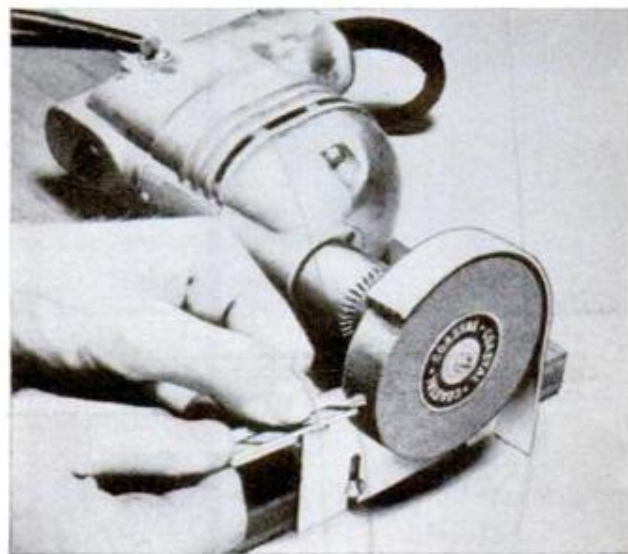

**ACCESSORY KIT** for electric drills sharpens twist drills and other tools to a keen, professional edge. Kit consists of 3-in. aluminum oxide grinding wheel, guard, drill holder, tool rest and high-speed bit. Priced at \$2.00. Coastal Abrasive & Tool Co., 42-33 Northern Blvd., Long Island City 1, N. Y.

**NEW UNIVERSAL HOIST** incorporates a unique and highly desirable positive antifouling mechanism which prevents backlash and provides orderly reel-in on the drum. Contains 15 ft. of  $\frac{1}{4}$ -in. cable capable of a 1400-lb. load. AiResearch Mfg. Co., of Los Angeles, 9851 Sepulveda Blvd., Los Angeles, Calif.



## KEEP YOUR CHEVY the CHEVY-EST\* with Genuine GM Chevrolet replacement parts

The Chevrolet engineers who designed your car know what's best for it. That's why, to keep that Jet-smooth ride, they recommend genuine Chevrolet replacement shock absorbers. They're quality built by Delco to fit right and work right with the Chevrolet suspension system. They're available through your local Chevrolet dealer and through leading independent garages and service stations. Get long, trouble-free service—keep your Chevy the Chevy-est—be sure to ask for genuine GM Chevrolet parts by name. . . . Chevrolet Division of General Motors, Detroit 2, Michigan.



*\*Chevy-est: all Chevy with new-car reliability maintained part by part.*



# Pall Mall's natural mildness is so good to your taste!

**So smooth, so satisfying, so downright smokeable!** For flavor and enjoyment you just can't beat Pall Mall's natural mildness. It's so good to your taste. Never too strong. Never too weak. Always just right! Enjoy satisfying flavor...so friendly to your taste. **Outstanding...and they are Mild!**

**COMPARE ALL THREE!**

Regular	
Filter-Tip	
PALL MALL	

Smoke "traveled" through fine tobacco tastes best. Pall Mall's famous length travels and gentles the smoke naturally . . . over, under, around and through the finest tobaccos money can buy. Makes it mild but does not filter out that satisfying flavor!



# Those Do-Anything Foamed Plastics

STATUES, moon bases, just about everything is made of plastic foam. This huge figure weighs but 40 pounds

*From sculpture to sailboats,  
instant huts to underwear, these  
amazingly adaptable plastics  
find new careers every day*

**By Betty Lou Raskin**

Head of plastics research and development, Johns  
Hopkins University Radiation Laboratory, Baltimore

**O**NE NIGHT LAST WINTER, several colleagues and I took part in an experiment which caused motorists a few miles away to report having seen a miracle.

By putting two syrupy liquids through a gas turbine smoke generator, we produced a white cloud of tiny, gas-filled particles of plastic foam. As the cloud floated hundreds of feet above us, a Skyjector crew focused its enormous slide projector on this holey smoke screen. The pictures that appeared on the screen looked as if they had been carved out of colored marble, with the

# Making It Is Like Baking a Cake

velvet-black sky serving as a backdrop.

Skyjector pictures on foamed plastic smoke are more than just a spectacular new advertising technique. They also may become an important aid to education, especially in areas where adequate teaching facilities are lacking. A teacher lecturing into a loudspeaker about the lesson shown on a foamed screen could turn a clearing in a woods into an outdoor night school for thousands of students.

This projection screen is only one of many uses for foamed plastic compositions which are turning out to be one of the most versatile and fastest-growing families of synthetics. Less than 20 million pounds of these expanded plastics were produced in the U.S. in 1956. Last year the figure reached 200 million pounds. James M. Margolis, head of Chemical Marketing and Research Co., N. Y., predicts the figure will expand to 750 million pounds by 1965.

## Slabs, Powders and Liquids

They've caught on fast and are being turned out as factory-made slabs, tubing and sheets which can be cut, sewed, heat-sealed or cemented. They come as expandable molding powders, and as liquids which will produce a foam adhering to almost any surface anywhere—including Outer Space.

There's even a *space parachute* in the works. Engineers at General Electric's Missile and Space Vehicle Dept., Philadelphia, are working on a way for an astronaut to foam a protective chute around himself, like a cocoon, should he have to abandon ship.

The originator of this idea, John H. Quilinan, explained to me how the chute would work. To return to Earth, the astronaut would step out of his ship, taking along his retro rockets, oxygen supply, recovery aids and survival gear. Over his space suit, he would wear a plastic bag shaped properly for his re-entry; it would have tanks of foamable plastic and a mixer attached. To foam himself home, he would first fire the rocket to head earthward. Then he would inflate the bag, and fill the space between himself and the bag with the foamed plastic. During re-entry into the atmosphere a hard dense foam would serve as a heat shield and a more sponge-like foam would form a shock absorbent landing cushion. At about 30,000 feet, a parachute would release and, at the same time, pull cords which would strip the foam from around his hands and arms. After landing, he would free himself completely from the foam and remove his em-

bedded survival kit. If he landed on water, the foam could also serve as a raft.

There are so many other worthwhile uses for expanded plastics that military men, manufacturers, and buyers alike are going after them as if they were free money. Foams are going into everything from powder puffs to pipe insulation, from bassinets to ballistic missiles. Because of these foams we now have shoes for walking on water, paperlike wrappings which keep chocolates from melting, and picnic coolers which retain temperatures so well that they have carried steamed Chesapeake Bay crabs, piping hot, from Baltimore, Md., to London, England.

There is no single, all-purpose foam. But all plastics can be expanded by gas, so there are hundreds of plastic compositions from which foams can be made. The fundamental principle involved is similar to that for baking a cake. A gas is bubbled through a liquid plastic resin to increase its volume; before the foamy mass collapses, it is hardened by heat or by chemicals.

There are five ways to put gas into the resin: 1. adding a chemical blowing agent which acts like baking powder in cake dough; 2. forcing gas under pressure into the resin; 3. whipping air or gas into it; 4. boiling a volatile liquid through it under reduced pressure; 5. mixing two highly reactive chemicals which produce a plastic mass and gas.

## Fluffy or Rigid

By selecting the gas, plastic resin (there are 14 basic types) and expansion technique, chemists can prepare foams which are as fluffy as absorbent cotton, as resilient as a pillow, as shock-absorbing as an astronaut's couch, or as rigid as timber.

The mechanical strength of an expanded plastic is largely dependent on the percentage of gas it contains. The more a foam is blown, the less dense and more fragile it becomes. Most of the foam's other properties are determined by the chemical composition of the plastic and its cell structure. For example, open-celled, air-filled vinyl foams absorb water and sound, and provide cushioning. On the other hand, close-celled, gas-filled, rigid silicone foams float on water, and provide excellent electrical insulation and heat resistance up to 700 degrees F.

Although foam-making chemistry is complex, many fabricating techniques are simple. In our laboratory we used a kitchen-type mixer to prepare a ureaformaldehyde foam which looked like a pie meringue and weighed only one-half pound





**SAILBOAT** has foamed hull, polyethylene sail, is 11 feet long, weighs 50 pounds but supports 500 pounds

per cubic foot. We put two cupfuls of water containing a resin and other chemicals into a three-quart mixing bowl and whipped in air until the foam filled the bowl. Then we added a small amount of an acid curing agent, mixed it well and quickly removed the foam before it stuck to the bowl. This mixing technique, with the right materials, produces excellent results.

At DuPont's Elastomers Laboratory near Wilmington, Del., I saw two liquids squirted through a special mixing gun. Out frothed a urethane foam like shaving cream from an aerosol can. This composition was poured between two thin four by eight-foot aluminum sheets. A few minutes later it had expanded to a volume 30 times that of the liquids, completely filling the four-inch-wide space, and firmly adhering to the

SEPTEMBER 1962

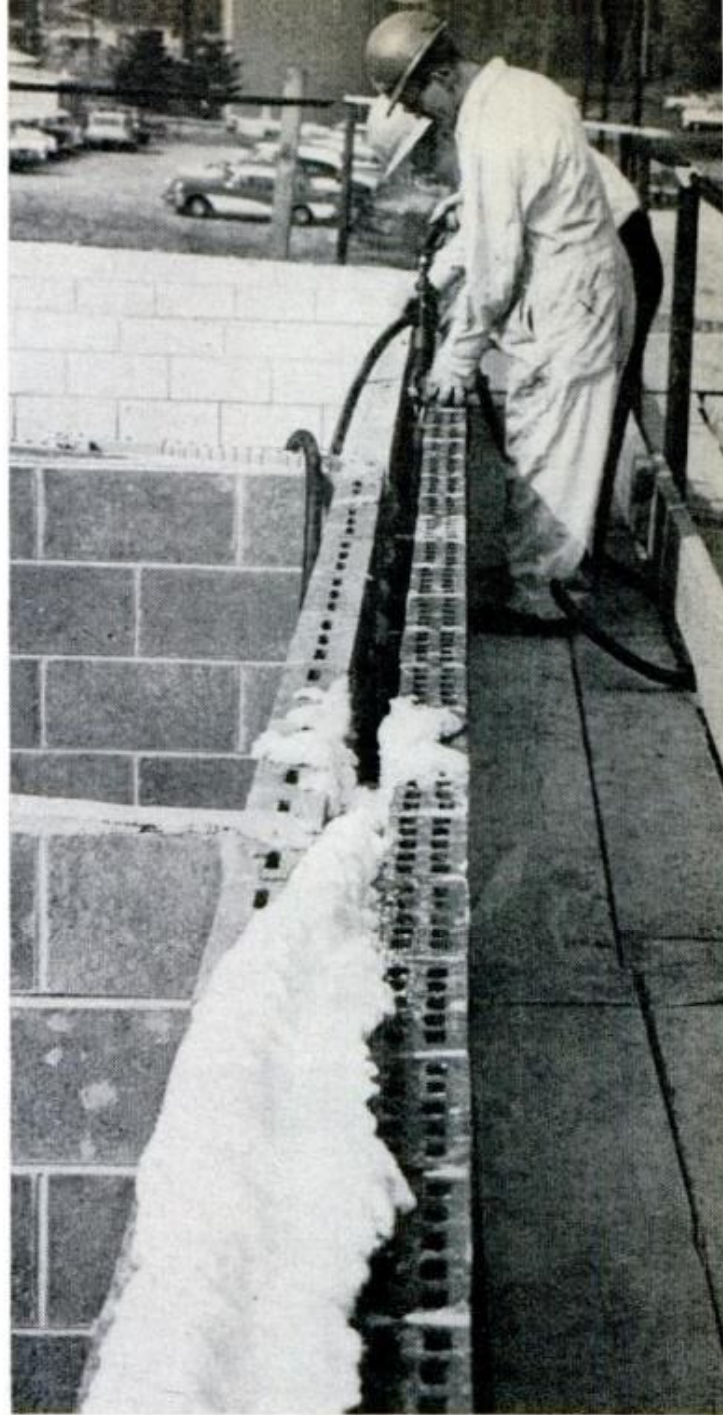

**SEALING**, and filling, masonry wall cavity with urethane foam gives insulation and moisture resistance

aluminum. The foam was so hard that 10 men stood on the panel without deflecting it.

The foams already are in competition with conventional materials. For example, a urethane foam containing trichloromonofluoromethane gas has twice as good a low-temperature insulation value as the fibrous glass used in refrigerators. Therefore, only half as much of this foam is needed to produce the same insulation as glass fiber. The result is about 25 percent more storage space in present-size refrigerators.

G. S. McCloy, manager of engineering at Westinghouse's major appliance division, told me: "As technological improvements make it possible to deliver cold to areas as small as a dime or as large as a wall, these—combined with foam—mean that a home-

87

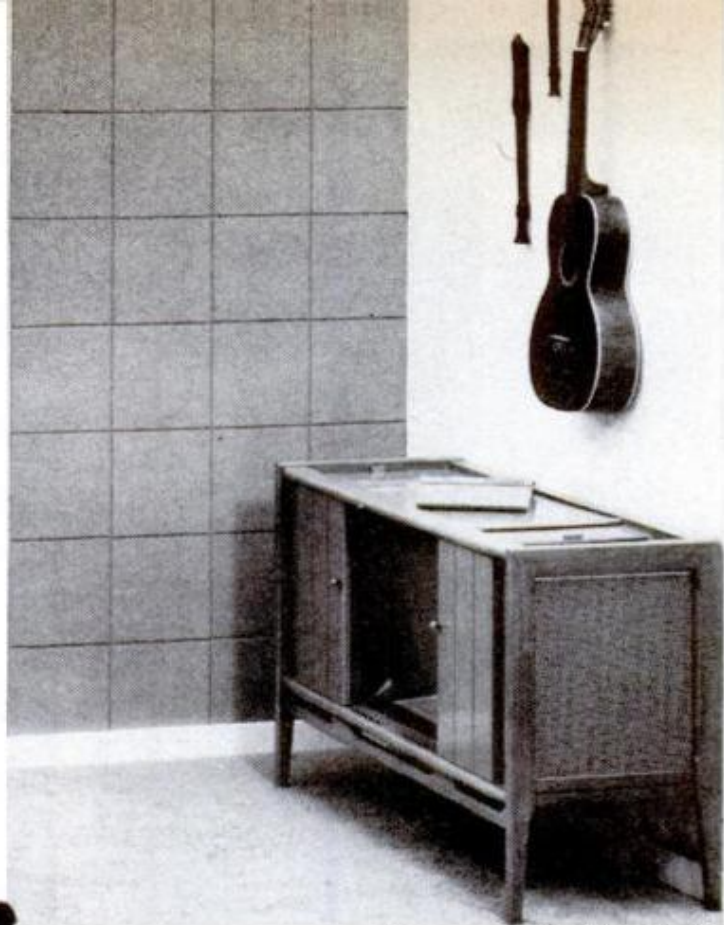

**SOUND OF MUSIC** in record room is improved when wall tile is made of the sound-absorbing plastic foams

## *They'll Withstand*

maker can have a refrigerated drawer, cabinet, box or closet anywhere in her home."

In Watertown, N. Y., I saw a dramatic example of how a wafer-thin layer of urethane foam can save lives by reducing the icing and deterioration of highway bridges. Workmen sprayed a film of the expandable plastic on the underside of a bridge's southbound lanes. Northbound lanes were not sprayed. Almost instantaneously the sticky coating swelled up into a one-inch thickness of foam weighing only three ounces per square foot, yet having the same thermal effect as two to five feet of earth. Representatives of the state's Department of Public Works and the Allied Chemical Corp., developers of the insulation, conducted tests on the two decks during two winter seasons. They found the uninsulated deck became hazardous to travel, while the foam-coated one remained virtually clear of ice, snow, or heavy frost formation. The foam showed no weathering during five years of study.

Foams also are making a big splash on water—in the form of floating toys and boards, and rescue boats for the Coast Guard. And buoys that can be shot at by

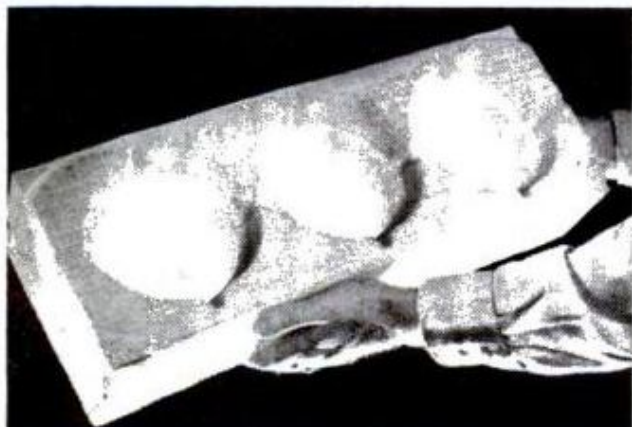

**MASK AND BOTTLE.** Urethane mold, above fits on tail lamp of sports car to protect glass from heat during painting. Baby's bottle also is kept warm in foam



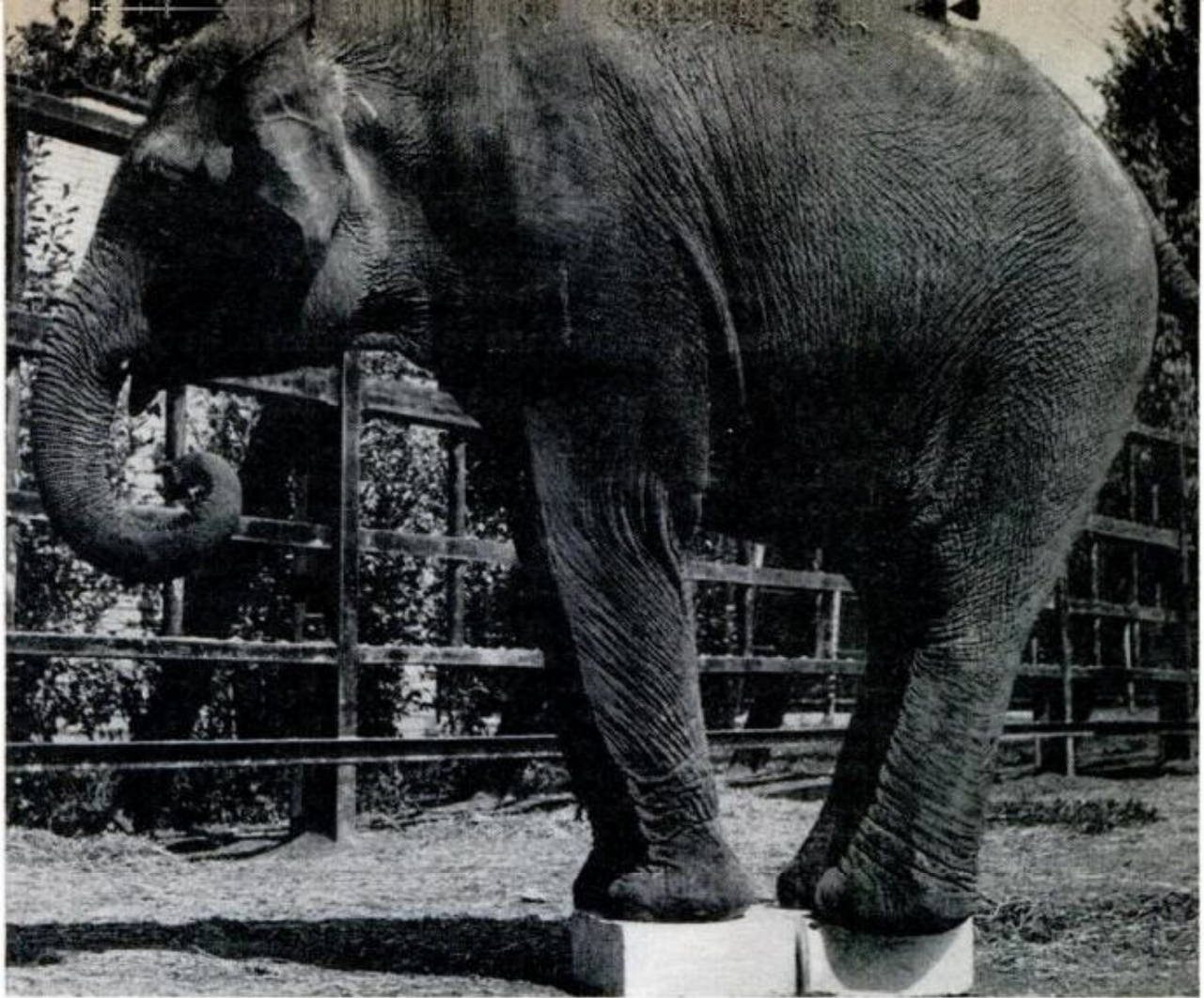

**PACHYDERM** does not flatten the blocks of expandable polystyrene foam. Such foam, sandwiched between other materials such as aluminum and plywood, binds them tightly and provides a new building material

## *Sound, Hold Heat, Cold or Elephants*

pranksters or even rammed by boats without sinking.

Expanded plastics package all kinds of fragile items. The Boeing Aircraft Co. used to deliver a delicate missile part by human courier. Now the part is packed in a resilient, polyethylene foam and shipped by air parcel post.

At the National Plastics Exposition in New York last year I saw Royal typewriters being packed in a urethane foam made right in a corrugated shipping carton. The typewriter is put into a plastic bag and then into the carton. When the foam-making ingredients are poured into the remaining space, the foam billows up, fills the box and rapidly hardens. Cost of this package: one-fourth that of wooden containers, one-half that of all-plastic containers.

Sculptors also are benefiting from the foam. At a recent American Bowling Congress in Detroit there was a 15-foot, 120-pound statue of a giant carved from slabs of plastic foam and covered with a layer of gold-painted plaster. This was the most inexpensive way of producing a figure of this size and complexity.

Another example of the properties of

these new synthetics can be seen in mattresses. A crib mattress of urethane foam weighs less than the average newborn baby; a double-bed size weighs 16 pounds, about one-third the weight of an inner-spring mattress. Economical (about 40 percent less expensive than foamed rubber) and easy to turn, these urethane mattresses are made in controlled degrees of firmness, have excellent chemical resistance, are long-lasting and sterilizable.

Largest uses for flexible foams are in furniture and automotive cushioning. Vinyl-foam coated fabrics with the look and feel of fine leather—at about one-third the cost—are used in handbags, shoes, jackets, belts, gloves and upholstery. In 1958, 20,000 yards of this material, 54 inches wide, were sold in the U.S. Last year the amount had risen to 34,000,000 yards.

Garment interlinings of urethane foam also are popular. Made of about 97 percent air and 3 percent plastic, they are laminated to almost any material—even jerseys and lacy knits. Foam-backed fabrics are soft, comfortable to wear, wrinkle-resistant, and keep their shape well. They provide so much extra warmth that now almost any

# Buildings From Bags and Barrels

material can be used in outerwear—even light-weight cottons. Foam backings also are used in winter underwear, shoe linings, slip covers, sleeping bags, and rugs.

Automobile manufacturers, already using foams for cushioning, crash-padding and filters, are trying them out in door panels and roofs of cars to cut down noises and vibrations and to make the cars warmer in winter and cooler in summer.

The greatest potential for foamed plastics is in building construction. Already there are nearly 200 different trade names for the rigid foams. In Washington, D. C., the Smithsonian Institution's new \$30,000,000 Museum of History and Technology has been insulated with a flame-retardent polystyrene foam in board form produced by the Koppers Co.

Recently a British firm made a hut to house eight people and a laboratory for Sir Edmund Hillary to use on his Himalayan expeditions. Made of about 100 interlocking panels of polystyrene foam covered with plywood, the hut can be erected and dismantled at any location to keep the explorers warm—even at subfreezing temperatures.

Thicker foam panels covered with metal, wood, asphalt, reinforced concrete or reinforced plastic are used in the construction of curtain walls, partitions, roofs, floors, door cores and perimeter insulation. Sev-

eral firms are developing interchangeable panels in which the plumbing, heating and electrical lines are already built into the foam.

In masonry-wall construction, when a urethane foaming composition is poured between inner and outer walls, the foam rises, fills all cracks and corners and forms a strong seamless core. Structural tests show the bursting strength of a urethane foam-filled masonry cavity wall to be two-and-one-quarter times that of comparable unfilled walls. This means that less structural steel will be needed in new masonry buildings made using this technique. The savings in structural steel can be sufficient to offset the installed cost of the urethane foam, which is several times that of conventional materials used in residential construction. In time the price of the foam should drop, due to widespread development work in this field.

A method for spraying this foam into uninsulated homes is being worked on by several chemical firms. Providing superior insulation with half the thickness of conventional materials, this foam, like other foams used as building insulation, has a density of two pounds per cubic foot; it is also verminproof, virtually moistureproof, and won't deteriorate or mildew.

(Continued to page 244)

**FOAM, SWEET HOME.** Huts rise in a hurry when foam's sprayed over inflated balloon. Door is cut with saw



# Falcon Lifts the Lid on Its Convertible

By Jim Whipple



**CUTE IS THE WORD** many folks will use to describe '63 Falcon convertible. No changes have been made in the basic sheet metal. A new and better grille plus thick spear-like side molding alters the car's appearance

**H**AS SUCCESS spoiled Falcon? Not so you could notice it after looking at the 1963 version.

Ford has elected to stick with the basic styling that has marked Falcon since October 1959 and is seen on more than 1,200,000 units now rolling on U.S. roads. There is, of course, the new grille distinctive "spear" side trim, and T-Bird roof line.

Biggest visible change in the Falcon for '63, then, is the addition of a convertible to the Futura line.

When purchased in "standard" trim, the convertible will carry five passengers on conventional bench seats. However, an optional seating package consisting of two bucket-type seats and a center console with parcel locker is available.

Surprisingly, Falcon does not join the GM compact convertibles (Chevy II, Corvair, Tempest, F-85 and Buick Special) in the economy trend toward spring-counterbalanced tops that are raised and

lowered manually. Falcon's convertible gets the electrically-powered, hydraulically-operated raising and lowering mechanism as standard. Tops are vinyl and come in black, white or blue to match or contrast with body colors.

In place of zippers at the sides of the clear vinyl rear window there are strips of magnetic-type adhesive—one on the inner edge of the top opening, the other on the outer (concealed) edge of the window panel. The weight of the entire panel is carried by a simple, straight-line zipper across the top of the vinyl "window." To close the sides tightly you merely press the "sticky" strips together like a self-sealing envelope.

A small, but worthwhile improvement in convertible-top design appears on the '63 Falcon; the top material is anchored to each roof bow to prevent the unhappy "ballooning" of top fabric caused by the lift effect of air passing over the roof at higher speeds.



**FORD TRADEMARKS** are Falcon's two bull's-eye tail lamps changed for '63 by addition of "deep-dish" chrome rings. America's handsomest exposed gas cap graces filler panel; it's door-knob-sized and solid chrome

Ford has come up with another real innovation in convertible-top design that should soon make its way around the industry.

The "stickiness" itself is made up of literally thousands of hook-ended nylon bristles—very much like cocklebur material laid flat. It's a whole lot easier to press sides together than trying to thread a zipper down in the lower corner of the window while the window flops on top of your arms.

Now, if someone will only perfect a flexible rear window that stays clear for the life of the car, the real trouble area in a convertible would be eliminated. We've always thought that it's a lot easier to raise or lower the entire top manually than to struggle with that back window.

With the convertible's chrome-edged side windows in production, it is somewhat surprising, to us at any rate, that no true hardtop appears in the Futura series, particularly now that the Falcon two-door Futura can be had with a very elegant vinyl-covered "Thunderbird" roof.

Making a real pillarless hardtop when you have both convertible windows and a top that is tailored for the job is, in our opinion, not much tougher than rolling off a log. Not taking advantage of all these parts in hand is rather like serving strawberries without cream.

In the area of styling, all Falcon sedans have the Thunderbird roof line which was introduced this spring on the Futura two-door. The rounded backlight, which, after three years, had become as much a part of

Falcon as its bull's-eye tail lamps, has disappeared.

The new roof, with its "blind" quarters behind the rear door windows (an area known as the "C" post), is vinyl-covered only on the Futura two-door. When painted to match the body color, the new roof, coupled with Falcon's new convex grille and spear side trim makes a considerable appearance change. Nobody will mistake a '63 Falcon for a '60, '61 or '62 model.

On the other hand no one will have any trouble in spotting the '63 model as a bird from the same nest as the other three.

However, under the familiar sheet metal that spells Falcon a block away, there have been some changes made in the interest of comfort and serviceability.

As a result of some brutal rough road testing of the suspension—service that not more than one in a hundred Falcon owners would give their cars—Ford has beefed up the suspension system. There's a  $\frac{3}{4}$ -inch stabilizer strut (formerly  $\frac{5}{8}$ ) at each front wheel to take care of rearward forces on the front wheel as well as a heavier bracket.

To reduce transmission of vibration from the front springs, rubber pads have been placed between the upper end of the coils and their bearing places in the fenders. Rear shock absorber brackets have been beefed up to handle the roughest roads.

Brakes are now self-adjusting, using a ratchet and cable mechanism that operates (if needed) whenever brakes are applied in reverse. This same device has been used



**REAR WINDOW** is sealed at the sides by merely pressing together the novel strips of nylon "cockleburrs"

on other Ford products for the past several years.

Brake drums themselves are now subjected to a honing process that smooths them down and, it is claimed, will eliminate the squeal that worries owners long before the linings are worn down. Parking brake cable conduits leading from the underbody to the rear wheels are nylon-lined on the new model.

The low-friction and self-lubricating characteristics of the nylon eliminate a need for lubrication in an area that is almost universally neglected by owner and serviceman alike. The nylon inner sleeve should do much to prevent freezing of cable to the spiral steel conduit in very cold weather. So next winter will be the critical test at the hands of new owners.

Also on trial for '63 Falcon owners will be 30,000-mile chassis lubrication interval accomplished by the same sort of sealed fittings on suspension and steering parts as were introduced on the 1961 Fairlane and Galaxie Fords.

The familiar pair of six-cylinder engines of 144 and 170 cubic inches displacement are continued with an improved carburetor for automatic-transmission equipped cars—it has a dashpot piston to prevent stalling on deceleration. Also standard is the posi-

tive crankcase ventilation system which valves crankcase fumes into the air cleaner.

There are new, and according to Ford, improved engine mounts to eliminate more vibration.

Ford has taken the great leap forward in making the minimum engine service interval a full 6000 miles. Both oil and oil filter are to be changed at 6000 miles. Fuel filter is now booked for a 30,000-mile run while the coolant is intended for two years of service without changing winter or summer.

Carburetor and ignition tuneups should fall in the 6000-mile interval, as will spark plug cleaning and changing.

The 6000-mile oil (and oil filter) change interval is in opposition to the conservative thinking of many other manufacturing divisions (outside Ford Motor Company) whose consensus is that oil should be changed every two months in warm weather, every 30 days in average winter service with a 4000-mile top limit on miles between changes.

A four-speed fully synchronized manual floor-shift transmission will be optional on all Falcons for '63. Ratios are 3.16 to 1 for 1st, 2.21:1 for second, 1.41 for third and 1.00 for fourth gear. ★ ★ ★

# Should Your Son Play Football?

*How safe is the equipment? Are coaches more interested in the boys—or in the win-loss record? Scientific research has turned up some facts that may affect your decision*

**By Marc Michaelson**

Sports Writer, *Chicago's American*

**P**ARENTS ACROSS THE COUNTRY are taking long, hard looks at their teen-age sons, and are asking: "Shall I allow *my* boy to play football this fall?"

The question is a sound one. A total of 21 of the 720,000 high-school football players died last season. The number could increase this season. Will your boy be in danger? Could a gridiron fatality occur in your town? Is something being done to make this popular "fun" game safer?

There are no simple answers. While 21 preps died last season, only seven were stricken the year before, and eight the year before that. The

**FULL SET** of equipment offering adequate protection for a high-school player costs about \$125, or \$4000 for a team

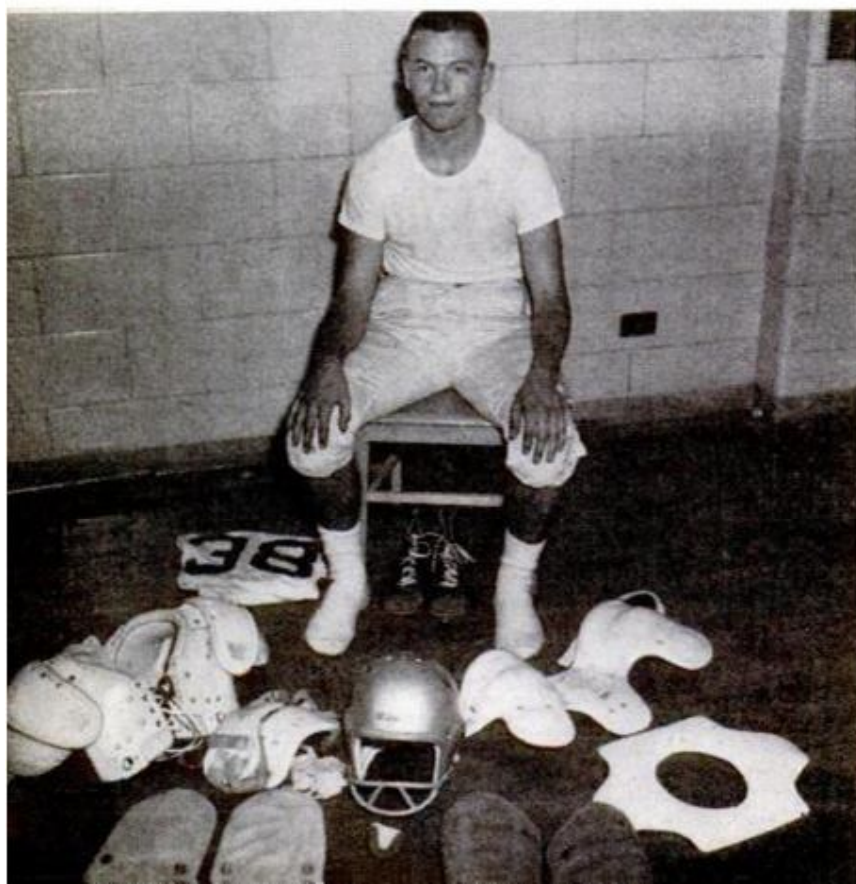

**FACE GUARD**, above, while valuable protection for the face and teeth, may also be a handy grip for an opponent. Guard should fit the face as close as possible; if it extends forward too far, it may provide a lever by which the neck can be forced backward excessively, causing neck injury

**CORRECT** shoulder method of tackling is contrasted with dangerous nose-on-the-ball technique. In the latter method, the tackler aims his face mask at the ball in an attempt to knock it from the runner's hands; tackler's helmet is forced back against base of his skull and top of spine





Chicago's American photographs

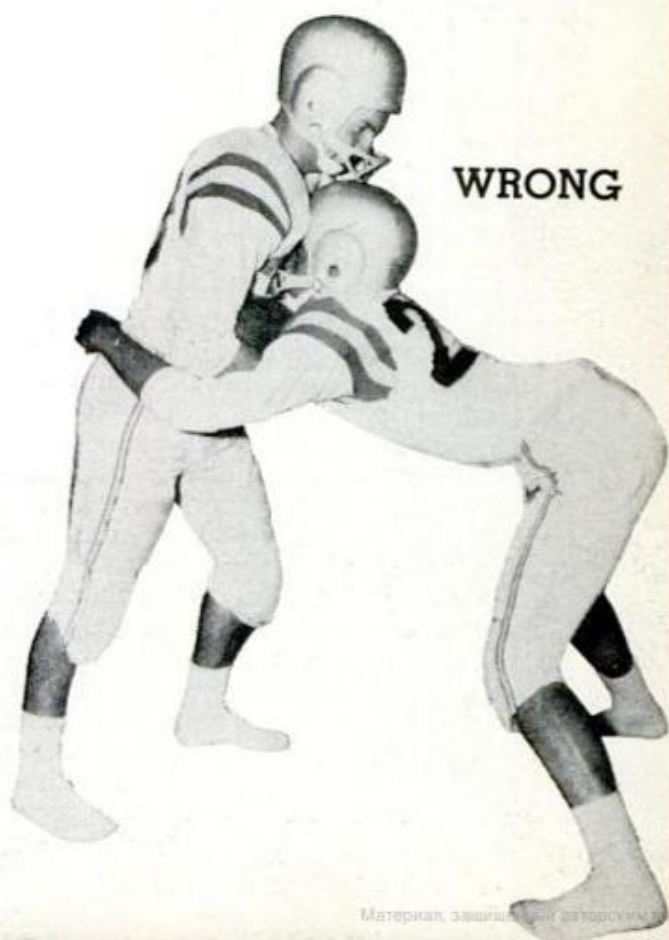
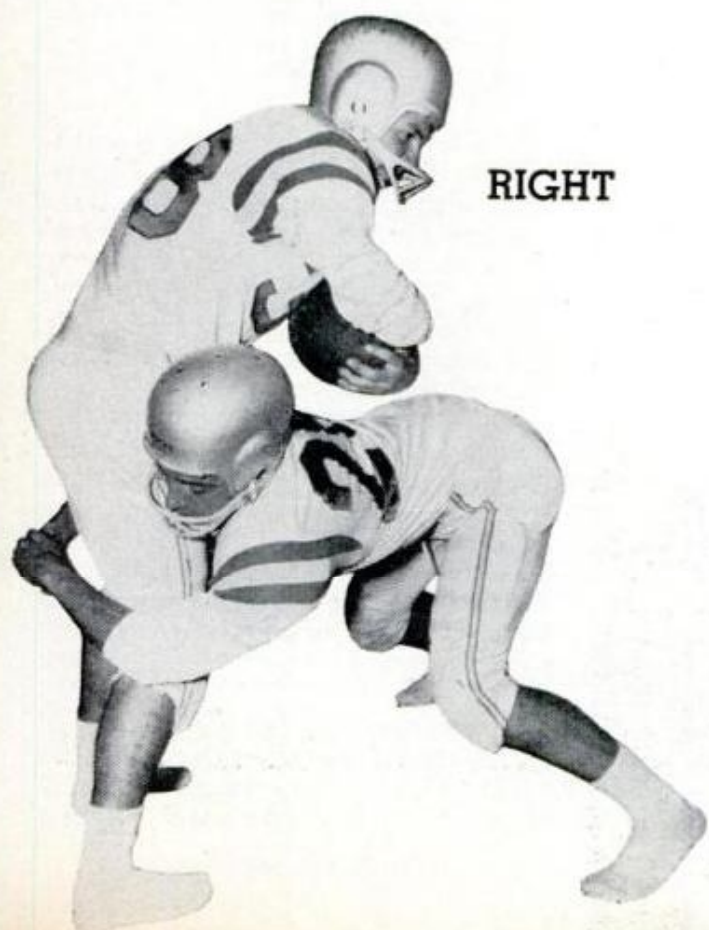

## New helmet designs, neck rolls and mouth



**NECK ROLL**, made of polyethylene foam, can be worn by player with a neck injury or to prevent whiplash



**CUTAWAY** of new helmet, left, contrasts with commonly used suspension type. Speckled material in new helmet is Koppers polystyrene; white material is vinyl foamed plastic. Black cloth pad is for comfort

equipment seems to be the same . . . the boys are the same . . . the game appears to be the same. Why then the rise in the death rate?

Searching for the answer, we interviewed the top experts in the field, doctors, coaches, manufacturers of athletic equipment, university research departments, and even conducted our own examination of the existing equipment.

The most popular "solution" was to blame the new hard-shell plastic helmets. But the easy answer is not always the best one. Our findings, on which we shall go into greater detail later, show that the plastic helmet is superior to anything used before. However, like everything else, it should be improved, and will be.

Many feel that the new techniques of the game, much as tackling with the "nose on the ball" (often called "spearing") and head blocking are responsible for the tremendous rise in neck and spine injuries.

Dr. Stephen Reid, Northwestern University team physician and former All-American, who is also engaged in a helmet research project for the American Medical Association, claims:

"Head and neck injuries increased with the adoption of the bar guard across the face. Boys are putting their heads where they have no business being."

How about the coaching? Some people think some unscrupulous coaches are teaching their boys to play dirty, while others say the coaches just aren't teaching anything. Penn coach John Stiegman charged last fall that blockers are smashing their forearms into the chins and under the face guards of their opponents. He said, "Somebody's got to be teaching it to these kids."

Walt Verson, coach at the University of Illinois, Chicago (Navy Pier), claims the boys just don't have the techniques:

"There are too many men coaching who

## *pieces are armor against gridiron injuries*

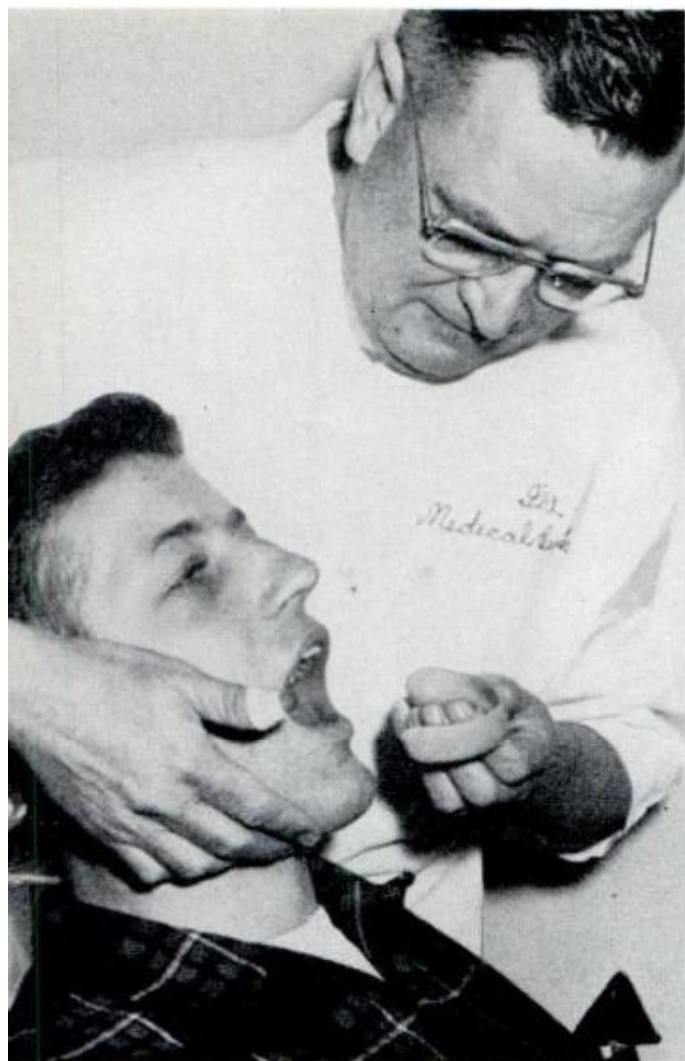

**PLASTIC MOUTHPIECE** is a new type tested by Indiana University squad. Design allows players to talk easily, is less likely to fall out than previous types



**BACK EXTENSION PAD** for helmet helps reduce whip-lash injuries to neck when player's head snaps or the helmet is slammed against back of his neck

just don't know enough to train their boys properly. A boy who doesn't have the techniques, who doesn't know how to block, for instance, is asking for trouble. You see too many boys going in with their heads held so low that they cannot brace themselves for the shock of the tackle."

Somewhere in all of the views—and also in charges that some coaches put winning above all else and that conditioning, or lack of it, is a factor—lies the reason for the upsurge of fatalities.

What can the parent do to help keep his boy as safe as possible? The American Medical Association says that with proper physical conditioning, careful coaching, good officiating, proper equipment, and proper medical care, football injuries can be kept to a minimum.

Let's start by taking a look at the equipment. According to the National Alliance football rules under which most high schools operate, a player needs a head pro-

tector, a face protector, knee pads and numbers on his jersey. That's all the "law" required in the past. This season a mouth-and-tooth protector has been added to the list.

Thus, the individual coach has a great deal of responsibility in choosing the protective equipment which his team will wear. There are no standards to which he can refer in trying to make up his mind.

The American Medical Association and several other agencies are working on minimum standards for helmets, but none have yet been established.

Much of the furor raised has been directed at this most vital piece of equipment, the helmet. Last year, the majority of fatalities were caused by head and neck injuries.

Some of the 1961 case histories bear this out. Here are a few:

A football player at Tell City, Ind., was a big boy for a 16 year old, 6 feet, 3 inches and 220 pounds. He was engaged in a tackling drill when helmets met with a glancing

## Ingenious radio-fitted helmet will

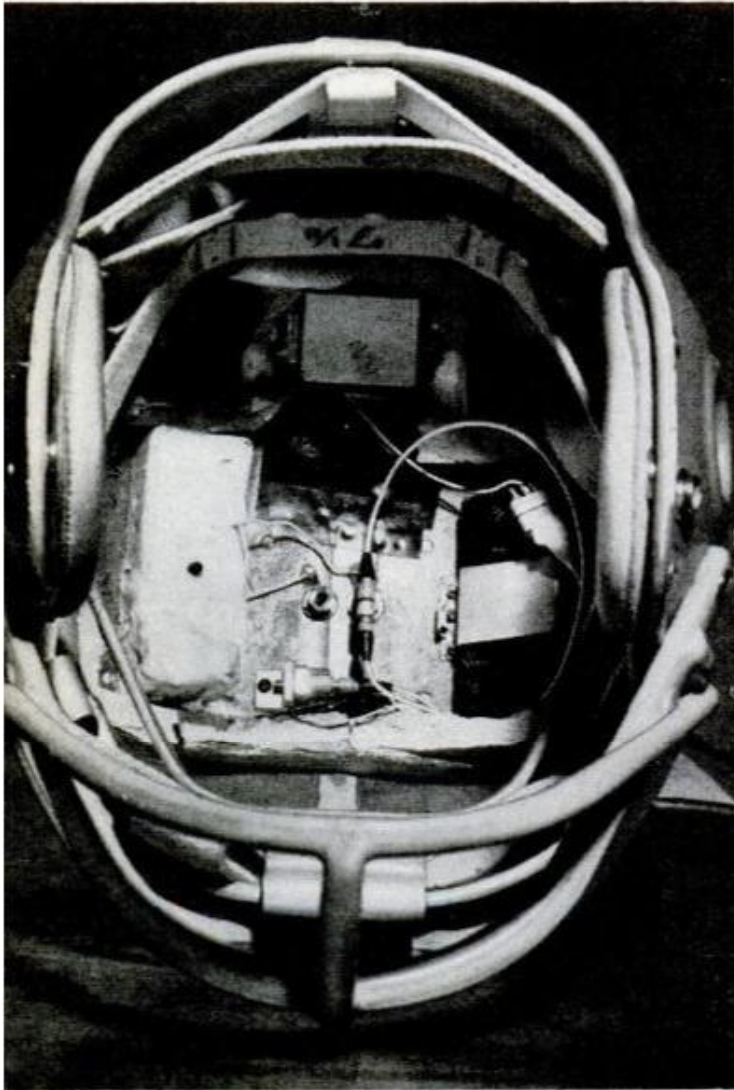

**TRANSMITTER** inside Northwestern University helmet is designed to broadcast brain and impact data

blow. The tackle was completed, and he withdrew from the drill. He died the next day from contusion and laceration of the brain.

Was the hard helmet to blame? Would a layer of padding on the outside have saved him?

Another player of Manor High in Clymer, Penn., had two head injuries. He was sidelined by a suspected concussion on August 26, certified fit by his doctor September 11, and died of an intracranial hemorrhage on September 16.

Every time a new death or serious injury is reported, a great number of people join the "anti-plastic helmet" band wagon. However, many doctors, equipment makers, and coaches don't feel this way. They feel that the material out of which you make the helmet is not as important as its design. They agree, however, that the plastic helmet should, and will, be improved.

What's the difference between the pres-



**"NECKTIE" TACKLE** graphically illustrates type of head and neck jolt that helmet must protect against

ent-day leather and plastic helmets? Very little. If you choose the top grade of either, it should give good protection. Many plastic helmets are now padded inside as are leather helmets, and both also have some sort of an internal suspension to cradle the head and keep it away from the wall of the helmet.

Oddly, when many top coaches criticize the plastic helmet, they don't concern themselves with its ability to protect the wearer. They complain about its hardness and how many players use its hard surface as an offensive weapon as they smash full tilt into their opponents.

This objection can be overcome if the schools will have the outside of the helmet padded with one of the "slow recovery" foam pads which all of the major makers have available.

If not the helmet, what is the villain? Many people think it is the face mask. One of the most outspoken is University of Iowa

## *transmit data during a game*



**RADIO-EQUIPPED HELMET** on Northwestern University fullback is part of experiment aimed at broadcasting and recording data on impacts and brain activity during game. Goal is to learn minimum needs for safe helmet

Athletic Director Forest Evashevski, who states:

"Give a kid a car, and tell him to drive it 90 miles an hour, and you know he'll soon be in trouble with his reckless daring. That's the same idea, putting a helmet on him that has a face mask, and telling him he can now do anything with his head. The head isn't made for blocking or tackling, but the idea that they're now safe is making kids and coaches reckless."

Manufacturers agree that there is some failing in the face guard. They already have research underway which will bring the guard closer to the face where it will serve to protect the mouth, but not be as much of a lever.

Almost more important than *what* equipment you choose, is how well you *fit* what you buy. A loose-fitting helmet serves to intensify any blow to the head in that the helmet becomes a striking surface rather than a protecting one.

Modern helmets can be filled out with shims until the fit is exact. The fit, however, should be checked from time to time, since even a haircut could change the fit.

A full set of equipment which will offer adequate protection for high-school athletes costs around \$125, or about \$4000 for the average team. Many small schools feel that they can't afford such an outlay because receipts don't warrant it, and they cut corners. But there is no degree of protection that a boy should have except the best. As one authority declared:

"If a school can't afford to give its football players the best protection available, then it should not risk the lives of its boys. It should give up the sport.

What can you do to make sure your boy is as safe as any youngster can be who participates in a rugged contact sport like football?

The American Medical Association feels

(Continued to page 230)



By Jim Whipple



## To Grease or Not to Grease — a Tragicomedy. Now, Filtered Fuel for a Cleaner Tank

There are two sides, we've found, to almost every question, including the one concerning "service-free" vs. "see-your-dealer-every-1000-miles" type automobiles. We'd like to relate an experience that may shed even more confusion on a subject already clouded with as yet unproved claims.

Recently we took our pride and joy (even auto writers occasionally buy new cars) down to the station for its very first lube job. The maker of our little dream belongs to the "grease-as-you-go" school. (We, however, are fence-sitting this one out.)

The station was a gleaming, almost anti-septic, member of a really big chain. Bright-eyed, if not bushy-tailed, lads in starched denims swarmed around our sturdy little Six. We stood watching, feeling considerable kinship with the legion of mothers who take their first-born sons to be first shorn at the barbershop. The shearing was not long in coming either!

What we watched reminded us of the nightmarish croquet game that Alice played with the Red Queen in Wonderland. Four fairly vital grease fittings on the front suspension were passed up.

They missed the clutch and gearshift fittings, which might as well have been in outer space. No one consulted the crisp new lube charts on the wall. No one looked at the steering gear box. This worried us as we'd once taken delivery on a new car whose steering box was bone dry.

For a finale, the service-with-a-smilers forgot to record the mileage and date of this momentous event with the customary sticker on the left front door frame.

At this point we felt like spending the \$1.75 we had paid to see this comedy of errors, on a telegram to the manufacturer's chief engineer urging an immediate running change to sealed fittings and molydisulfide grease.

Before you nod your head in complete agreement, please hear us out. All the votes are not yet in.

One item that the crew-cut grease monkeys did not ignore was the filler plug of the manual transmission case. One of the lads found that the assembly plant had put less than a pint of gear lube around a set of

gears requiring two pints. There were no traces of leakage. After the correct amount of SAE 90 was added the improvement in the synchomesh action was most gratifying.

Had this been a "lifetime" fitting instead of a spot requiring regular checking, the story could have had an unhappy and expensive ending—a new transmission instead of some gears that got lapped in a might quicker than intended.

So ends our tale, which is no isolated happenstance. Hardly a week passes in which we don't hear of some service goof-up. Our own checkbook bears scars of two sets of universal joints replaced in the past 18 months. These were joints that we'd previously ordered (but not watched) a service station pack.

We'd like to come up with an answer—a way out of this bucket of worms. But we can only suggest our own solution—a dandy little Swiss-made hand grease gun and half an hour a month with our back on the garage floor.

For every brickbat, there's usually a balancing bouquet, and this month we have one. The American Oil Company operating service stations from coast to coast, has been busily installing a device they call "Final Filter" on all their pump hoses.

Final Filter is an 11½-inch-long tube of aluminum and plastic containing a perforated cartridge which holds a pleated filter of impregnated paper. The paper is capable, says American, of blocking particles of micron (.000039-inch) dimension.

In short, Final Filter is a giant version of the plastic (or metal) cased filters that some carmarkers have inserted in the fuel line between pump and carburetor. What it does is prevent entry of dirt and rust particles, seemingly an unavoidable by-product of transport and bulk storage of gasoline, into your fuel tank and lines. Such particles, if unhindered, have a way of plugging up jets and wedging open the needle valve from its seat. The net results are familiar—flooding, poor idle, flat spots, uneven power and poor mileage.

American Oil deserves thanks for what amounts to putting a filter on everybody's car and keeping it changed, and all for free.

## Mirror Teaches Golf

For the golfer who has everything except a pro to help him groove his swing and develop consistent form, a new training aid provides the next best thing—a good view of himself. Called Swing Image, it's a 13-inch convex optical-glass mirror on an adjustable aluminum stand. The golfer sees himself reflected against a set of guide lines which provide reference points at ground and shoulder level and a vertical line for orientation.

Placed on the floor or ground and adjusted to the height of the golfer, the mirror permits him to watch his body and club through the entire swing without moving his eyes more than a few inches from the ball. The Swing Image mirror sells for \$14.95, from Swing Image Corp., 329 Commonwealth Bldg., Louisville 2, Ky.



## B-u-u-m-m-p-p-y R-i-i-d-e

To study the reaction and performance of crews when exposed to high aircraft vibrations, volunteers have been subjected to vibrations at simulated speeds of more than 450 miles per hour.

The vibrations, produced by hydraulic equipment, show that pilots have difficulty in reading some aircraft instruments accurately, many find it difficult to operate certain controls during high-frequency vibrations, and some suffer from severe nose itching, skin flutter and eyelid motion.

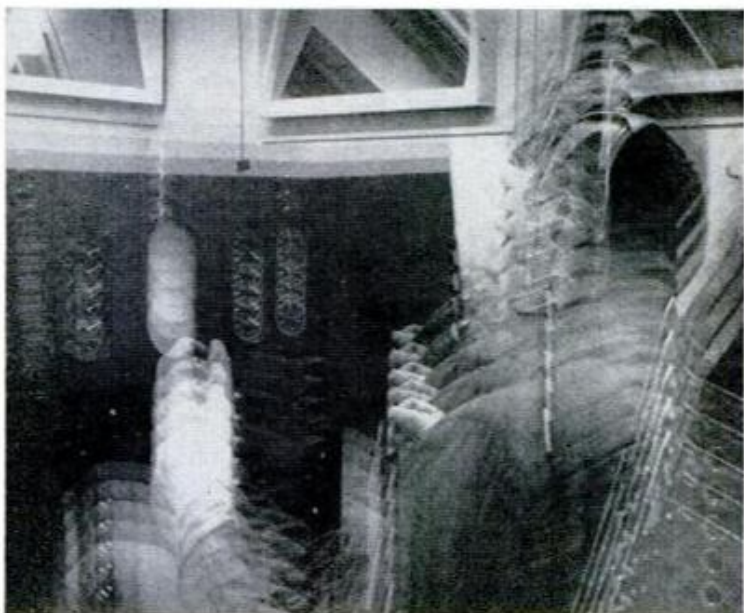

## Maintenance Reminder

Motorists can be reminded when to lubricate a car and change oil, points and spark plugs by a new dashboard indicator with eight movable dials and two sweep hands. When the speedometer shows the corresponding mileage for each maintenance change, the motorist knows it's time to act.

The magnetized chrome sticks tight and will not vibrate loose from the dashboard. It costs \$2, and is made by Centurian Motor Products, Inc., 718 Atlantic Ave., Brooklyn, N.Y.

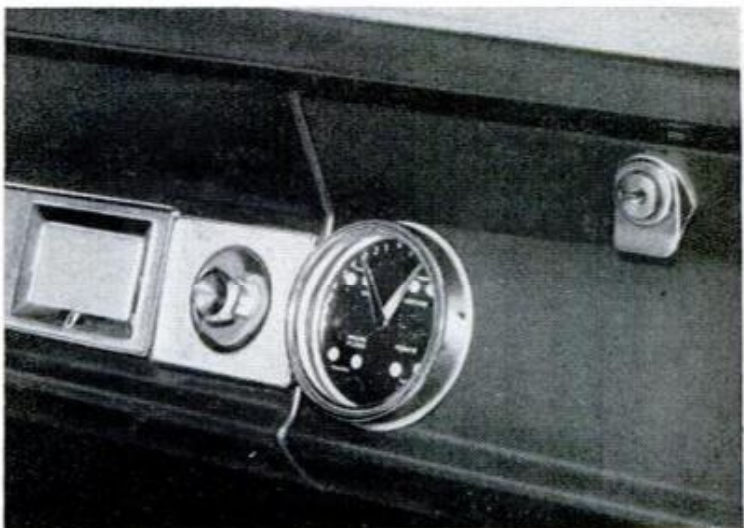

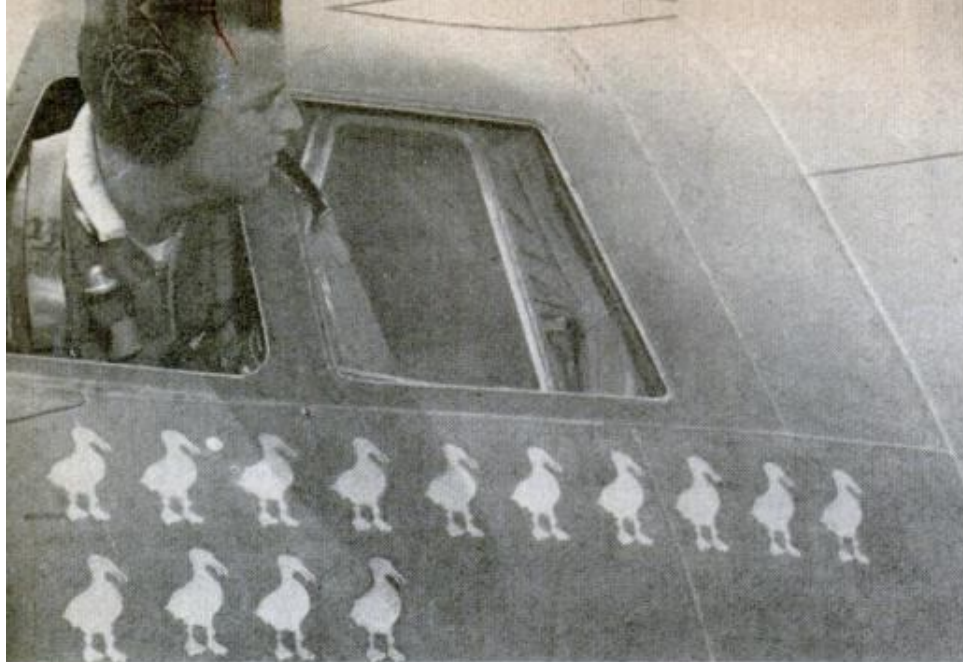

NAVY PILOT displays 14 "victories" over gooney birds of Midway. He knows better, however. The birds are ahead in this wacky battle

# The gooney birds are winning **THE SECOND** **BATTLE** **OF MIDWAY**



MIDWAY ISLANDS include Sand (foreground), Eastern and coral reef. Planes operate from Sand. Shaded portion of east-west runway shows newly paved areas which discourage birds from soaring there. Dotted lines enclose triangle Navy would like to cover. Inset shows radar flight range

BIRD STRIKES cripple aircraft, slow down Cold War and threaten crews. But gooneys love to soar, planes must fly, the two collide and strange battle continues

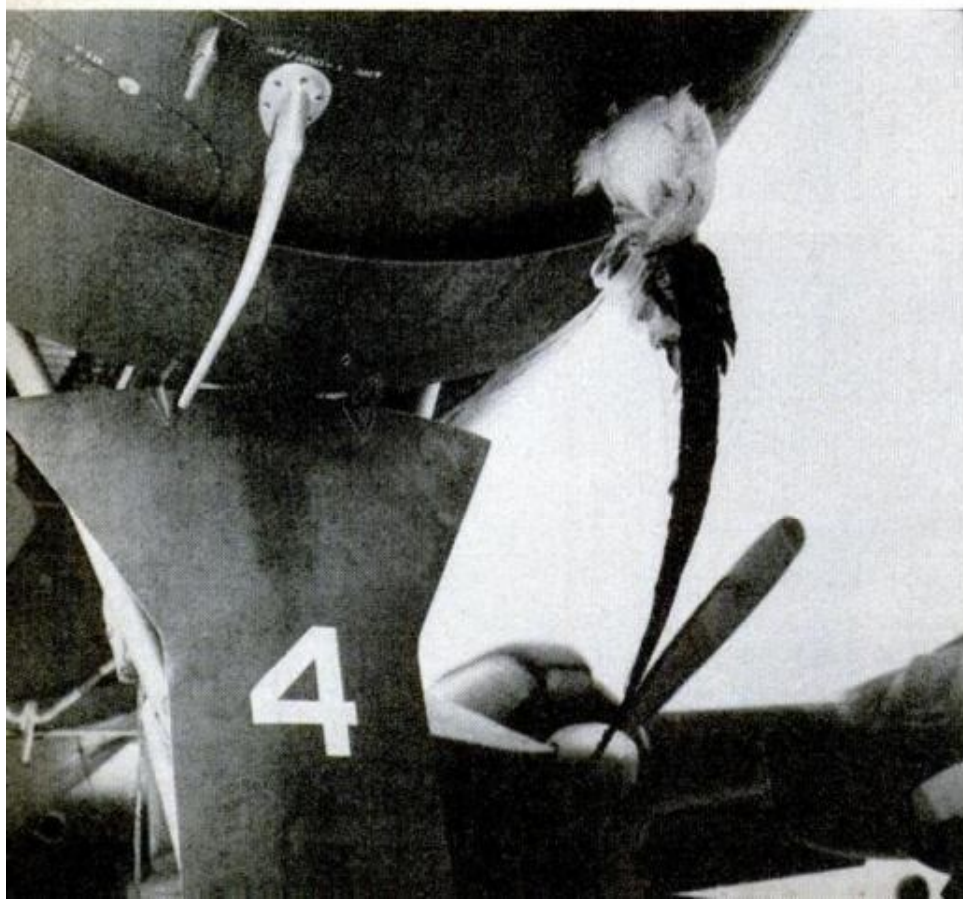



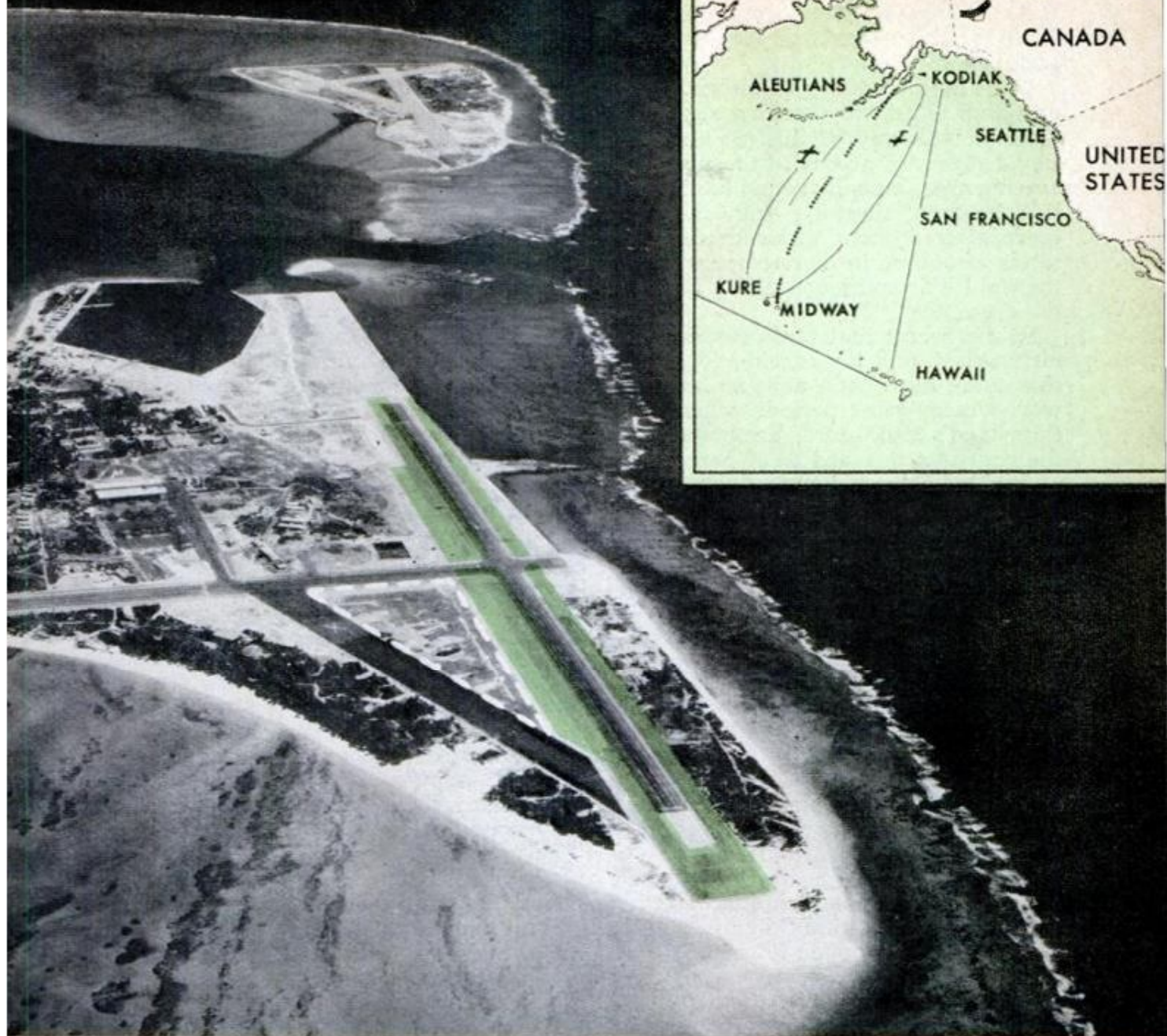

**By Kevin V. Brown**

**W**HEN I LANDED on Midway, my Navy escort, Lt. Al Dobbs, gave me a friendly greeting, a tour of the base and all kinds of advice on how to get along with the gooney birds.

"Don't pet them with your bare hand," he said. "Wear gloves. Better yet, use a stick. They'll bite that and, when they get tired, you can shorten up gradually until you're close enough to use your hand.

"Above all," he warned, "if one does grab you, don't yank back. That curved beak can tear a hole in you."

I found a two-foot twig and a sweet-faced gooney sitting on a nest. I offered it soothingly, but the gooney ignored it, squawked suddenly, reached out and grabbed my bare hand; I screamed, yanked back, the blood poured and Al Dobbs roared with laughter.

That was my introduction to the gooney birds of Midway, the most irrational, unreasonable, stubborn, clumsy, ridiculous, senseless and useless birds in the world.

And among the most dangerous.

And probably the most lovable.

As Al Dobbs said, "They are frustrating as hell, but you can't stay mad at them."

My purpose in going to Midway was not to pet a gooney bird (and get bit in the process), but to find out for *Popular Mechanics* the reasons behind all this frustration. Midway is an important link in a radar chain that extends across the top of the North American continent all the way to the British Isles. It is tied in with the North American Air Defense Command (*PM*, August, 1962), the joint Canadian-American network to provide early warning of manned attack over the Polar route.

U.S. Navy radar planes, operating out of Midway, fly continuously between there and Alaska.

Unfortunately, the gooney birds also operate out of Midway, and they are not impressed with any of this. So their traditional rights of access to the nesting and soaring areas on and around the island collide head-on, literally, with the heavily laden aircraft, causing hundreds of thousands of dollars in damage, slowing down the Cold War and jeopardizing the lives of the crews.

It's no secret that birds can cause fatal air crashes, and it's considered a miracle that there have been none so far on Midway. During peak periods, when most of the island's 25,000 birds are hovering over the runways, as many as 40 percent of the planes have been struck during takeoffs and landings.

If a crash ever does occur, it will be heard all the way to Washington, D.C. The planes—Lockheed WV-2 *Warning Stars*, the souped-up military version of the commercial airlines' *Super Constellation*—are loaded down with 8000 gallons of fuel for up to 20 hours of flight, electronic gear that is the equivalent of an entire radar site, and more than 20 highly skilled crewmen.

To prevent such a crash, the Navy has been trying frantically for years to persuade the birds to leave the island. The gooneys, thank you, are staying, and their colossal indifference to the Navy's best-laid "get lost" plans has produced some of the most hilarious and humiliating episodes in the history of military dignity. While the Cold War was going on in the skies, something resembling a *Keystone Cops* comedy was going on down below.

If anything, the gooney birds are winning the Second Battle of Midway.

**NAVY'S ATTEMPTS** to chase birds were pure slapstick. Lt. Dobbs shows how gooneys ignore flare



Midway, located 3200 miles from San Francisco, is the second last in a 1200-mile chain of islands that begins with Hawaii and ends with Kure. Midway is actually Midway Islands, in the plural. It consists of a coral reef which rings a large lagoon and two major islands, Sand and Eastern.

Sand is the larger, about two miles long and a mile wide. It's from here that the Pacific Barrier flights are made and where all the collisions occur. Eastern, east of Sand, has gooneys, too, but flights are made there only to maintain electronic facilities and it has no further significance.

Historically, Midway was discovered in 1859 and claimed for the United States. The gooneys were there then, and God alone knows how long before that. The Navy was given jurisdiction in 1903—a jurisdiction it still holds—and the reason is sheer irony. Now trying desperately to get rid of the birds, it was sent there originally to protect the islands from poachers who killed the birds for their feathers.

Man has been on the island ever since, and this is the point of frustration. In the normal course of civilization, when man moves in, animals move out. The gooney birds stayed . . . and stayed . . . and stayed . . .

Let's face it, they're still there.

While remaining socially aloof even to this day, they seemed to enjoy the comforts of civilization. Sand Island, once a barren waste of sand and brush, is today relatively lush. Cable crews, who leased facilities on the island during cable-laying operations across the Pacific, imported trees and coarse grass, and both flourished.

The gooneys loved it, building their nests in the grass and sitting in the shade of the trees. Today, you can still see some on sandy nests along the beaches, but most

**NESTING GOONEYS** express disdain for loudspeaker. Frisky non-nesting birds squawk right back at box





**WARNING STAR** takes off on 15-hour flight through flock of soaring gooney birds, who couldn't care less

prefer "downtown" locations—alongside the administration buildings, on front lawns in the residential sections, near the hangars, in front of the base exchange, outside the laundromat, under gun placements, in the ammunition dump, even adjacent the brig.

The gooney birds are actually albatrosses. The Marines, who occupied Midway during World War II (the *first* Battle of Midway, a turning point in the war, was fought almost within sight of the island), are often credited with giving the birds their nickname. However, naturalists referred to them as gooneys prior to 1900. Best guess is that the birds were too goofy

and too looney to be called one or the other, hence gooney.

What makes a gooney bird gooney?

Well, you can start almost anywhere. The gooney-bird "season" begins in mid-October when the birds start returning from a three-month sojourn at sea. By November they're all over the place.

Once settled, they start dancing. First, they bow to one another, then circle around, nodding constantly. After this do-si-do, they move in close for a friendly fencing match, feinting from side to side and pecking one another's neck. Then, while one tucks its head under a wing, the other steps back and clacks its beak. The

grand finale consists of one, or both, standing on tippy-toes and, with beak thrown high, squawking a prolonged "aw-w-w-wk!"

What does it all mean? No one really knows, but naturalists relate it to a mating ritual. The sailors call it "choosing up sides." Trouble is, it's not uncommon to see three or four gooneys all dancing together, with more standing around watching. And the non-nesting birds, or "unemployed bachelors," continue dancing all season long. Also, it's extremely difficult to tell whether it's always a male and female dancing together, and some observers aren't even sure the gooneys can tell the difference either. They just seem to keep trying until they . . . well, never mind, it could be of no possible interest to anyone but another gooney bird.

The mated birds mate for life, but do not necessarily increase in wisdom while nesting. Midway jokesters swear the stupid birds will sit on anything. To prove it, they've stolen eggs and replaced them with rocks, tennis balls, beer cans, anything handy, and the birds go right on sitting. One ingenious resident replaced an egg with a light bulb and strung the cord back to his living room. Every so often he'd turn the light on. The bird would stand it just so long, then jump off the hot bulb and scold its "egg." When it cooled off, it would try again. When the prankster finally tired of his prank, the silly bird was still trying to incubate a light bulb.

The downtown birds pose an additional problem. Primarily soaring birds, gooneys

**BIOLOGIST ROBBINS** grabs gooney to check its leg band. Typically, gooney offers hardly any resistance



**LAWN MOWER** fascinates, but doesn't disturb, nesting gooney bird. They also ignore dogs and children

don't have enough power in their seven-foot wings to get off the ground from a standing start. They need "runways." Since it's so congested downtown, they usually walk to the beaches—and they don't walk, they waddle. So it's not uncommon to see a Navy vehicle tawdling along a Midway road, its driver with his hand slapped over his face, muttering to himself, while a gooney bird—oblivious to the truck, the traffic, the world—hogs the road and waddles along in front of the truck, all the way to the beach.

The birds reach the heights of hilarity during their takeoffs and landings. On breezy days, they do all right, spreading their long wings, heading into the wind, paddling a few steps, and away they go.

On calm days, however, it's a panic. When there is no wind, they spread their wings, run like mad, leap into the air, and fall flat on their faces, turning complete somersaults. Unabashed, they jump up and try again, almost always with the same result. Landing, they invariably turn cartwheels.

Even on good days, they can't avoid slapstick. Birds that nest near the hangars use downhill slopes toward the ramps for their takeoffs. One mechanic told me about a bird that headed down the slope, leaped into the air, soared across the ramp—and crashed into a parked plane.

"It lay there about five minutes," he said. "Finally, it shook itself off, waddled up the hill and started right back down



**FUZZY BABIES** are friendlier than adults, sometimes becoming pets. But, because they leave the island when old enough to fly and don't return for five years, they forget old friends and come back aloof old birds

again. That crazy bird hit the plane almost at the same spot it hit the first time."

Incidents like this—and they are not isolated, since others have crashed into hangars, utility poles, even people—keep the men on the island from "staying mad" at the gooneys, but in a very real sense they highlight the Navy's problem.

If these silly birds are too stupid to get out of the way of a plane that is standing still, what will they do when the plane is coming at them at close to 150 m.p.h. during the critical moments of takeoff?

The answer, of course, is nothing. So the birds and the planes collide.

To repeat, the Navy considers it a miracle that there have been no fatal crashes on Midway, although the birds have struck—with sickening thuds—the wings, windshields, fuselages and engines of as many as two of every five planes that take off. The air crews call it Russian roulette, gooney-bird style—some of the planes are going to be hit, but which ones?

A few years ago, when these collisions were at their worst, when some of the damaged planes were out of action for months, when the coverage of the Pacific Barrier was seriously hindered, the Navy decided that the birds just had to go.

And the comedy of errors began. . .

First, of course, they tried scarecrows. Sailors collected scraps of junk, discarded mattress stuffings, bailing wire, whatever was handy and, with American ingenuity, created some of the most hideous monsters since Frankenstein. Were the birds fright-

ened? Nonsense, they were fascinated. They examined the strange creatures carefully, discovered the straw, pecked it out strand by strand and carried it back to line their nests until there was nothing left of the ghouls but steel skeletons. End of scarecrows.

Next, the Navy tried burning old tires. The birds didn't mind the smell, but it was making the men sick. The fires were drenched.

Next, they tried smoke. They set off sulphurous flares, lit smoke pots, fired rockets into the air. Like the man said, through the rockets' red glare you could see the gooneys were still there. They hadn't budged.

Next, they tried noise. They lobbed mortar shells along the beaches, fired bazookas over their heads, lit fire crackers. Did it have any effect? It certainly did. The nearby birds turned to watch, and those out at sea flew back to the island to find out what all the noise was about. So there were more birds than ever milling around.

Next, they set up loudspeakers. Maybe the birds, like dogs, could hear only ultra-high frequencies. They fed some horrendous screams and screeches into the amplifier and dashed out to watch the results. The birds gathered around the speakers in semicircles and, while flapping their wings, were screaming right back at the noise in some of the most cocophonous community sings this side of Mitch Miller.

The Navy was getting desperate. Not

(Continued to page 222)



### Light by the Foot

Short lengths of fluorescent tubing, encased in a longer clear plastic tube, permit novel lighting effects and new applications.

The many small fluorescent units are enclosed in waterproof flexible vinyl which comes in a wide range of colors. The line of lights can be bent around a two and one-half inch radius without collapsing.

In addition to their decorative uses, the lamps have numerous practical applications. They can be used to outline safety areas, to indicate pathways, and can also be employed underwater for lighting swimming pools and fountains.

The lamps are available in two types, Model 44 having four equally spaced lamps per foot and Model 74 having seven. The lights are activated by a generator which produces a radio frequency to operate 196 feet of the 44 line or 100 feet of the 74. Cost of the lights is about \$3.75 per foot. The manufacturer is Etzon Corp. 3141 West Century Blvd., Inglewood, Calif.



### Lighted Gloves Signal Traffic

Nighttime traffic signals are given at a flick of the finger with new motoring gloves fitted with a light on the back which also serves as a reflector.

The light switches on when two button-like contacts in the thumb and index finger are pressed together; motorists can easily see the light from behind. Flashing signals can be given by pressing and releasing the contacts. The gauntlet of the glove contains the battery.

The gloves are made by Electro Plastics, Kent, England.

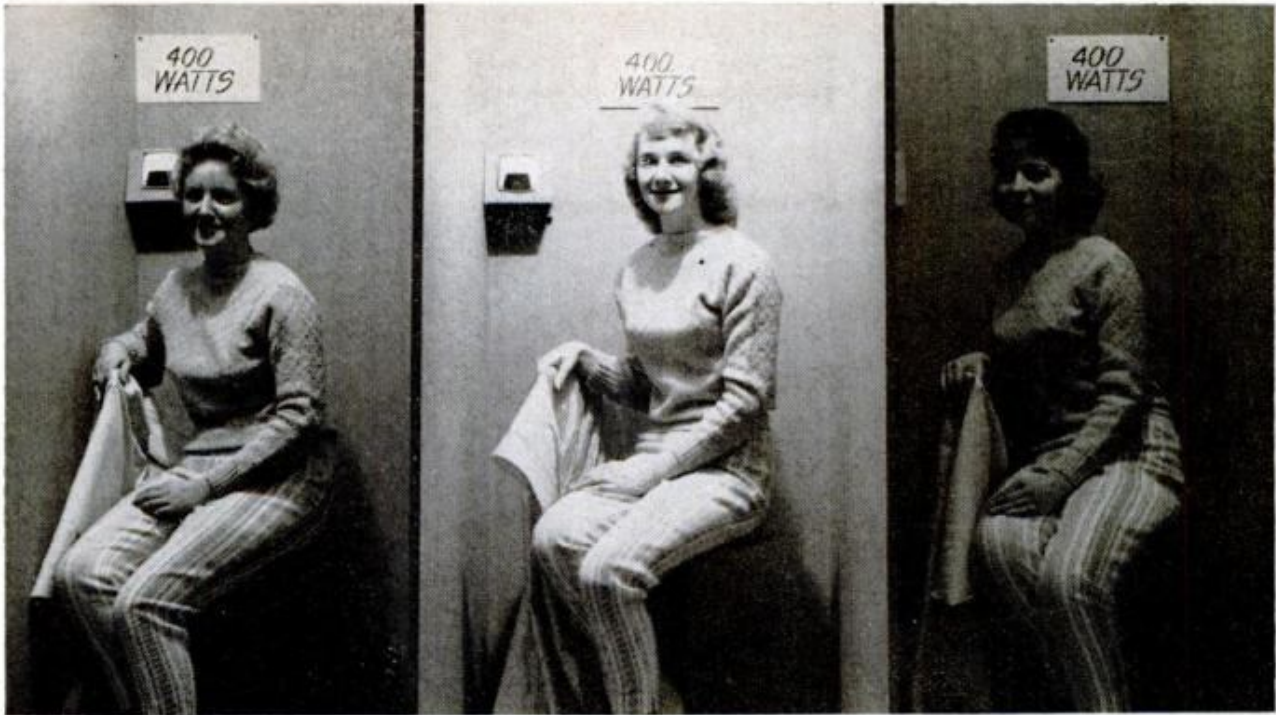

## Metallic-Vapor Lamp Gives More White Light

Lighting of streets, highways and large indoor areas such as shopping centers and arenas may be done more efficiently with a new metallic-vapor lamp. It is nearly five times as efficient as conventional incandescent lighting and of comparable whiteness, according to the General Electric Co.

The new lamp has up to twice the efficiency of mercury lighting. It uses small quantities of metallic elements other than mercury, including sodium and thallium. Above, at the same power levels, are a mercury lamp, left, the new lamp, center, and incandescent lighting, right.

## Bank Gives Kids Great Big Boost

Children rise in the banking world when they step on a Kiddie Vator. The young customer touches a black button on the railing and is raised to the teller's window. A touch of a red button lowers the unit.

Weight capacity of the elevator is 200 pounds. Maximum height of the lift is 34 inches.

All moving parts are enclosed in a heavy neoprene covered fabric boot. The electrically operated unit is made by Arverow Specials Co., 546 Avenue A, Hutchinson, Kans.

### QUOTE:

*"It is . . . advisable to avoid naive faith in what teaching machines can accomplish. People using machines wisely, not people looking to machines to do their jobs for them, will be the ones who most effectively improve the educational milieu of the 1960s."*

DR. HAROLD G. SHANE, Dean  
Indiana University  
School of Education





## Two New Hulls





## HYDROPLANES... Family Thunderboats

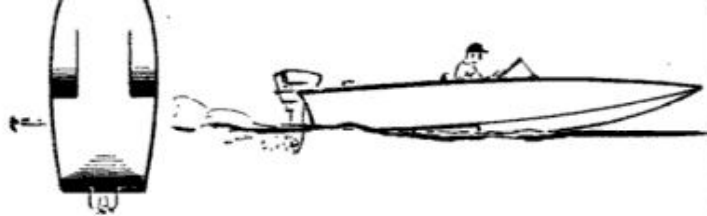

**B**IGGEST hull development in small boats since fiberglass and multihulls, the hydroplane runabouts bursting onto the market this season are direct descendants of the familiar racing hydros—the thunderboats of Gold Cup fame.

The reason for their development—and success—is the same as their antecedents, too. They're faster without sacrificing stability. In this case, "faster" can mean more speed with maximum power, better speed with minimum power, and more economy with either, since speed is economy in a boat. By lifting the hull until it supports itself partly on air and partly on water, the hydros produce this improved performance by reducing the amount of bottom being dragged over the water—"wetted area" the designers call it. The bottom shape divides the remaining wetted area into three (and in at least one case, four) supporting "points," to provide very good stability, even at high speeds. The "tunnel" between those points creates a venturi which traps

and compresses the air passing under the bottom, keeping it in position for maximum aerodynamic lift.

What's new about stepped hydroplanes? Nothing, really—they've been around for years. The first patent for a planing stepped hull was awarded in 1912, but was a commercial success only in its application on stepped seaplane hulls. The next big step was a three-pointer patented in 1937 by Arno and Adolph Apel. Arno eventually built the famous Ventnor racing hydroplanes in the middle Forties.

Since the evolution of lightweight, high-performance outboard power during the past ten years, several designers have worked toward a hydroplane runabout. Most prominent were Hank Canazzi of Custom-Craft, Dick Cole for Thunderbird, and Kenneth Pyle of Hydrocraft. New materials, especially the moldable plastics, helped greatly in producing the difficult hull shapes economically. Custom-Craft,

(Continued to page 112)

## Meet Two Old Problems

### DEEP Vs Anywhere, Anytime

**AS THE** stepped hydros were bred in the thunder and spray of closed-course racing, the biggest thing in small boats for big water has grown out of another type of racing—a series of spectacular wins in the tough 180-mile grind of the annual Miami-Nassau powerboat race. But unlike the hydros, the forbears of the "Deep V" boats were the stable, comfortable deep-water V hulls which have plied East Coast waters for generations as displacement hulls. No one ever tried to plane a V-bottom, or at least no one talked much about it. Everyone knew that a fast boat must have a flat hull aft, and that the flat-planing hulls were rough riders.

Fortunately, one man didn't think so. C. Raymond Hunt, one of the country's finest naval architects, worked out the complicated mathematics of designing a full V hull that would plane. He calculated precisely the necessary angles and planes on the bottom, then added full-length strakes



both to help lift the hull and to act as bilge keels and spray strips. The result added another creative design credit to Hunt's already-impressive list.

With the lift generated by his carefully-calculated plane surfaces and the strakes, plus the great thrust of modern high-performance engines, Hunt found that his planing V hull was very fast despite its apparent large wetted area, but that it still retained the seakindliness and soft-riding qualities of its more dignified ancestors.

What's more, the new boat showed no tendencies to yaw or broach in heavy seas—the hull grooved on its course as if it were on rails. With the chines well above the water line at speed, there was no digging in on turns; the hull banked perfectly with no side-slipping at all. With much of the wetted hull below the surface, a generous beam, and the stabilizing effect of the strakes, the boat didn't roll as its critics had

(Continued to page 113)

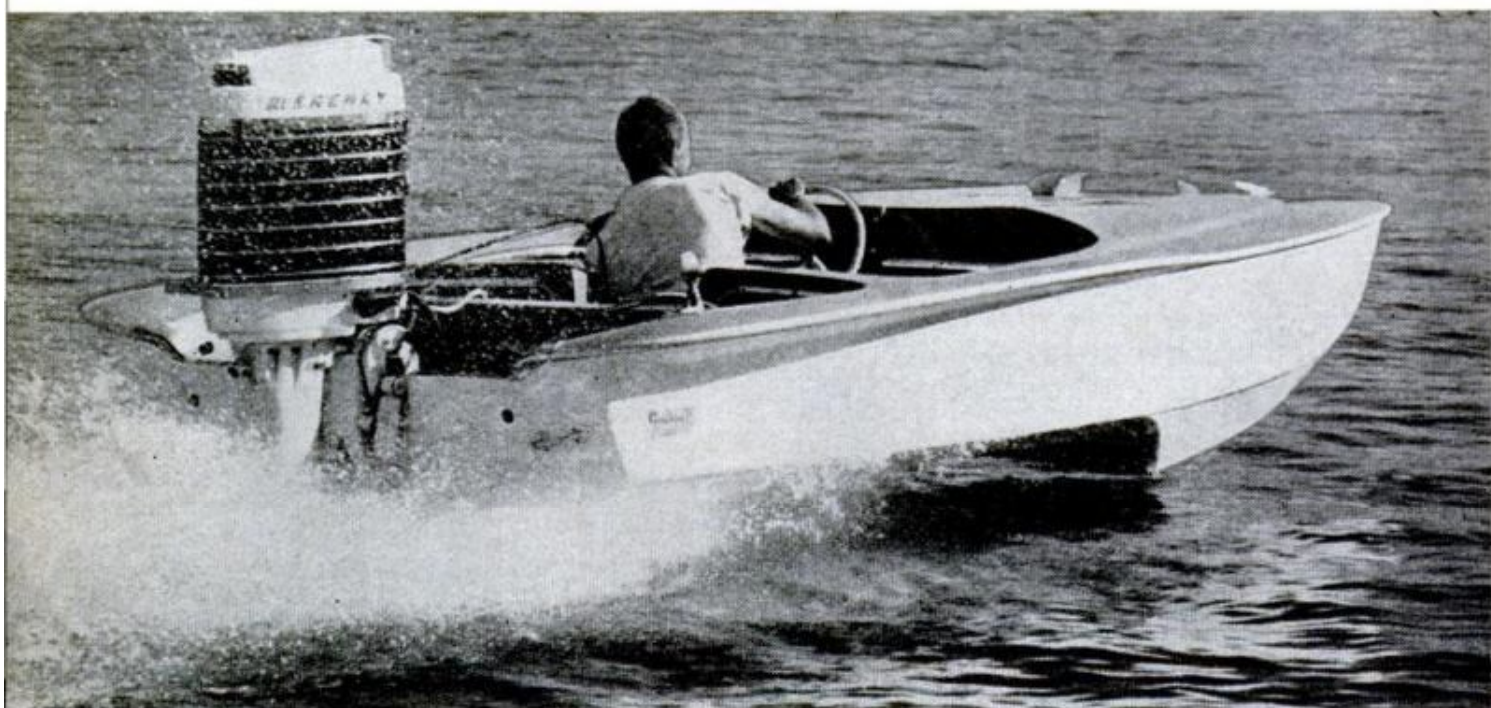
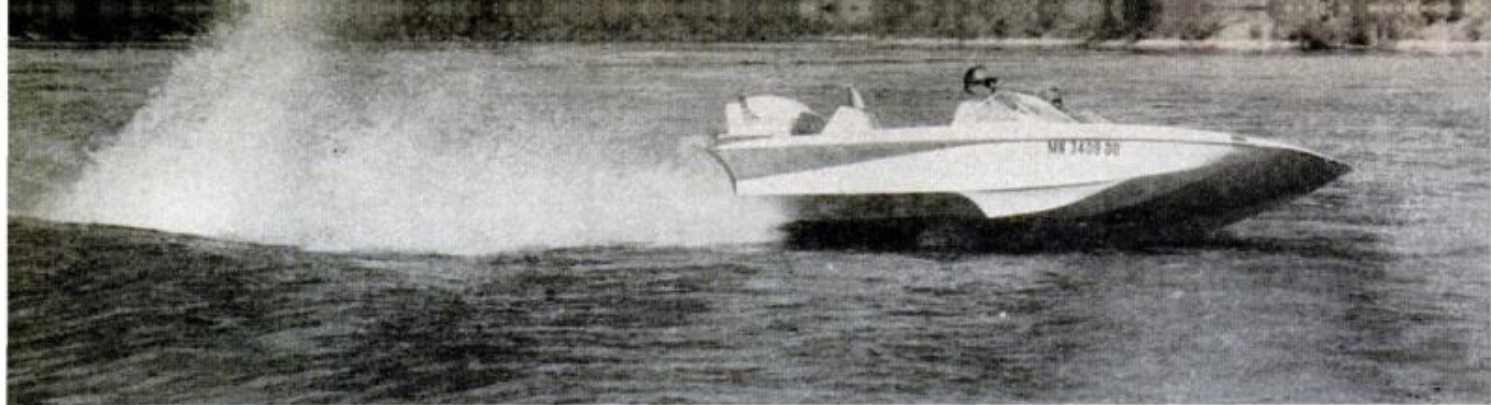

**SCOTT'S** hydro runabout, flat out near 50 m.p.h., demonstrates daylight under its super-planing hull. One bonus; this may be the prettiest production model boat on the market

**HYDROCRAFT'S** Fantasy runabout may be the fastest family three-pointer at 57 m.p.h. with the 80-horsepower Mercury outboard. It's cleaning up West Coast stock racing events

### HYDROPLANES (continued)

Hydrocraft, Glass Magic and Thunderbird brought out commercial models in the 1960 season and the race to the market was on. Early this year saw the introduction of a real bomb, the Switzer-Craft U-4. This is a four-point catamaran that's technically a runabout, but which has been cleaning up on the outboard racing circuit (PM, April '62) in the pleasure-craft divisions.

At the early '62 boat shows, hydroplane runabouts were introduced by two motor manufacturers, Outboard Marine Corp. and Scott Division of McCulloch Corp. Each marketed a three-pointer, the OMC 17 and the Flying Scott Custom. They stole the shows from more conventional craft, and cemented the position of hydroplane runabouts on the American boating scene.

A comparison of the OMC and Scott boats gives a good picture of the two sides of hydroplane boating. OMC's 17-footer (top, page 110) is big and stable, holds five adults with ease, and carries them at around 30 m.p.h. with its fuel-injected, two-

cycle 80-horsepower stern drive unit (PM, August '61, February '62). It'll push 40 with a minimum load. Following the trend of most recreational hydros, it runs on three hull points—two sponsons forward and a section of the hull at the transom.

The Scott boat, however, retains the true three-point pattern of the racing hydro. At speed, the hull comes clear of the water, and the boat rides on two forward sponsons and the propeller, which becomes the third supporting point. That created a problem—the prop needed to be low for maximum thrust at low speeds, but high for maximum speed on the points. The Scott engineers solved it by installing a hydraulic lifting device on the motor mount; it's adjustable from the cockpit. And there's speed aplenty—it's factory-rated at 50.

Drawbacks? Not many if you're after sports-car performance in a family boat. The hydros are a little hard-riding in rough water, but they aren't sold as a rough-water boat. For *that* solution, see the section on Deep Vs.



**JIM WYNNE**, Volvo outdrive designer, with his 17-foot sports runabout. Powered with a 100-horsepower Volvo unit, it hit 45 m.p.h.; won the 1961 Orange Bowl Endurance Race

**ALIM "STEP LIFT"** design produces a snappy 20-footer with a single 80-horsepower outdrive unit; speeds are "over 30" despite soft ride and great stability and capacity

### DEEP Vs (continued)

predicted, either. Despite the relatively deep draft, the hull planed flat, leaving a flat wake with no roster tail.

Richard Bertram, Miami sportsman and broker, obtained a 31-foot model of the Hunt design, named it *Moppie*, and entered it in the 1960 Miami-Nassau Power Boat Race. Already twice winners in the three-year-old contest, Bertram and his ace driver, Sam Griffith proved Hunt's hull spectacularly, winning the '60 race—in the roughest weather in its short history—setting a new course record. Second place went to a 25-foot version of the same hull.

Bertram began manufacturing the "Hydrolift" hulls in 31 and 25-foot sizes in five models. The 31-footers turn in 38-40 m.p.h. with big twin Chrysler inboards; the smaller boats hit the mid-30's with dual Volvo-Penta outdrive units (bottom, page 110).

The rest is history. Bertram and Griffith and succeeding *Moppies* repeated their Miami Nassau win in '61, then had to settle for

second place in '62 because of engine trouble (though the MerCruiser-powered winner was a 25-foot Bertram). The '62 race stilled the reports that the Bertram boats were *only* fast in rough water. The course was as smooth as a mill pond.

Working from Hunt's research, other designers and manufacturers began exploring the Deep V principle; this year's Miami boat show turned up 11 Deep-V brands. Among the more successful designers are Jim Wynne, designer of the Volvo-Penta outdrive, and Howard Weiler of Miami. Both have won the Miami-Nassau race in lower-powered divisions. Others, now on the market, are Carl Moesly's Seacraft, John Allmand's Citation, Alim Marine's V-20 Step Lift, Glastron's Gulfstream, and models by Aztec and Scottie-Craft.

Deep V drawbacks? Not many here, either. A relatively deep draft and the need for a boat at least 18 or 20 feet long seems to be about all. For a relatively small boat on big water, the Deep Vs will be hard to beat.

★ ★ ★



## Lawncomber Grooms Turf

Back-breaking hand-raking is a task of the past with a new lawncomber that rakes, thins heavy lawns, and removes grass clippings, thatch and choking grasses. Equipped with a multiblade rotor of free-swinging

blades, the unit breaks clods, levels ridges caused by night crawlers and turns in fertilizer after tilling.

It costs \$255. Made by Rental Equip. Mfg. Co., 57 E. Powers Ave., Littleton, Colo.

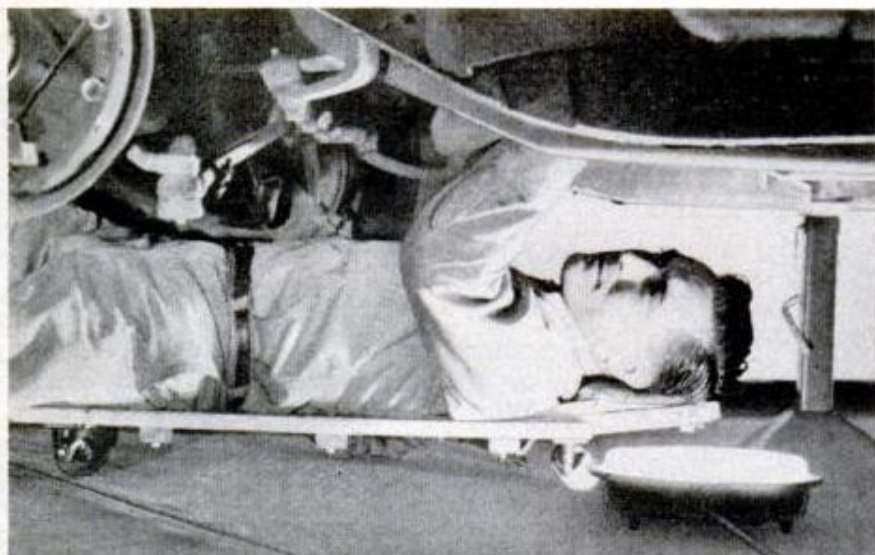

## Glare-Free, Versatile Trouble Light

Eyestrain and glare of conventional drop-cord lights is said to be eliminated with Blackhawk Mfg. Co.'s. (Milwaukee 46, Wis.) Shop-Lite. A large area is clearly but softly lit by its circular, long-lasting fluorescent bulb. The maker claims that 5-lb.,

2-oz. lamp's special fittings will allow it to stand or hang almost anywhere. It has a special shatterproof, grease-resistant lens, 25-ft. heavy-duty cord and an auxiliary power tool outlet. Heavy gauge metal case has molded bumper guard. Price: \$19.95.

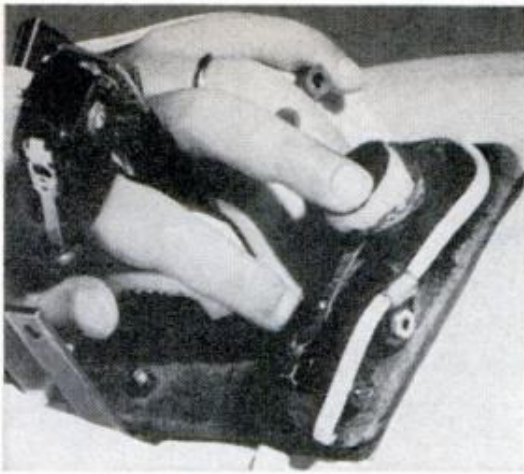

### Paralytic Reads, Writes

Paralyzed by polio from the neck down, a former engineer, with the help of a rig operated by electric snap-action switches, is now able to read and write.

Able to use only the thumb and middle finger of the left hand, he reads books by using an electric page turner and writes by dictating into a tape recorder, both operated by the feather-touch switches. He has already written a television play and two books.

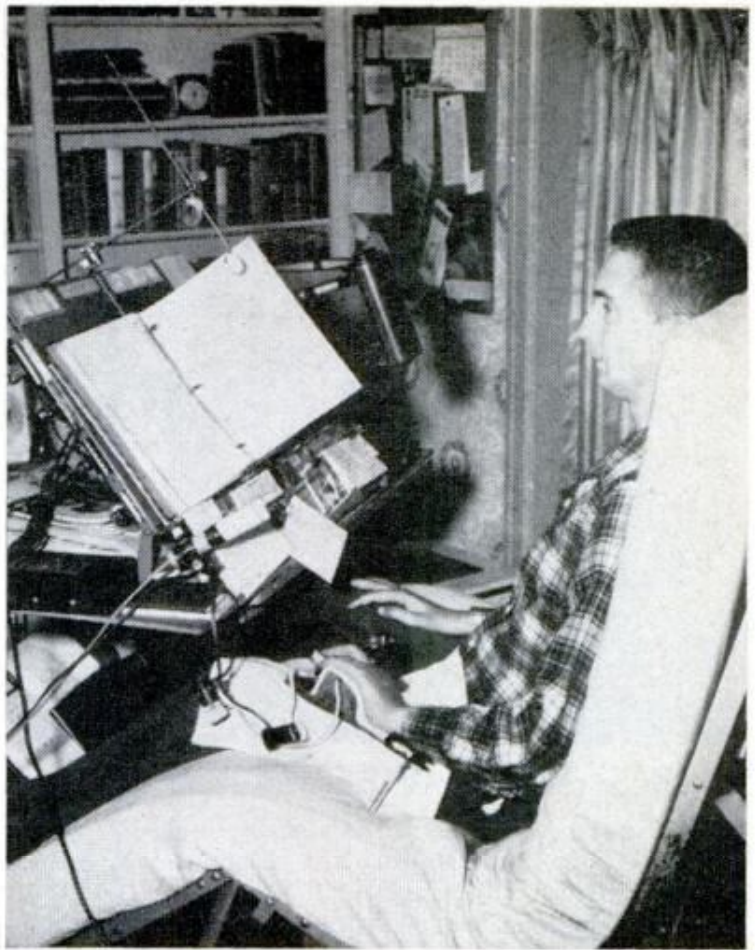

### Auto Travel Tray

Tricky balancing of food and beverages in the lap or on the dashboard while eating in a car is eliminated by a new travel tray that fits over the front seat.

The tray can also be used as a drawing surface for children or as a writing top for passengers while traveling. The unit folds compactly when not in use.

It costs \$2.98 and is made by Marsh Allen Mfg., Co., 1971 W. 85th St., Cleveland, Ohio.



### Pupil-Counter Panel

School principals can determine the attendance in every classroom just by glancing at a new electronic panel.

A teacher reports classroom attendance by touching a button at her desk; the number of pupils in each room is then indicated on the tabulating panel in the principal's office.

The Minneapolis-Honeywell panels also indicate the location of key school personnel, whether classrooms are full or empty and the room temperatures in the school.

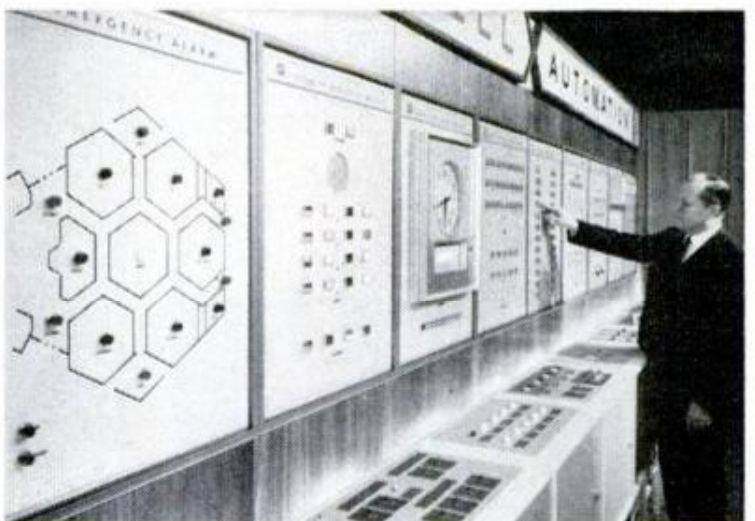

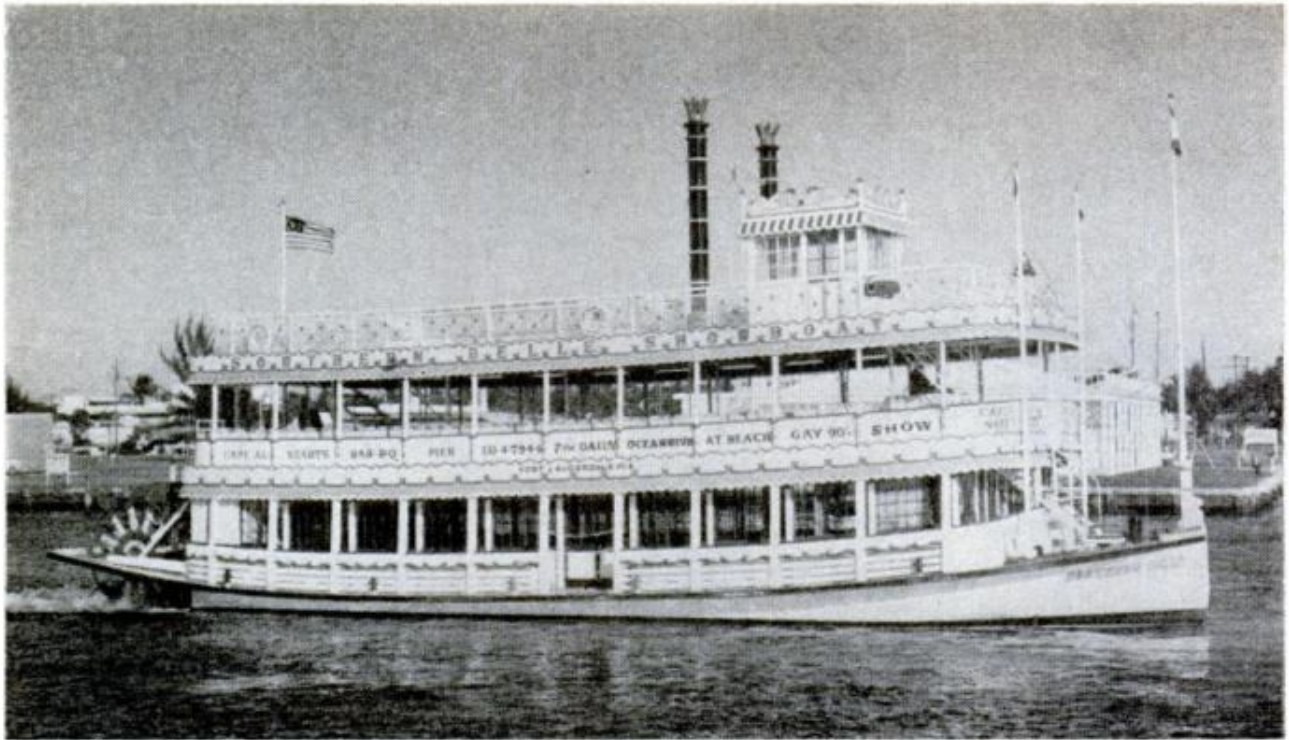

## Replica of Stern-Wheeler Has Modern Conveniences

Near-perfect replica of the stern-wheeler riverboat on the outside, but completely modern inside, Capt. Al Starts' new excursion boat cruises Fort Lauderdale waterways with all the modern conveniences. The 80-foot, 80-ton boat is made of steel,

powered by twin 200-horsepower diesel engines, and steered in tight places by bow-mounted water jets. Fully loaded, with its capacity of 310 passengers aboard, the \$400,000 boat will do 16 knots in only 54 inches of water.

## Wrench Shifts Weight of Indy Cars

Ace Indianapolis race-car builder A. J. Watson has developed a novel, adjustable gravity control for Indy cars that maintains the machine's balance using a standard ratchet wrench.

The "Weight Jacker" is a familiar Proto ratchet wrench mounted just behind the driver's left knee. Through three extensions and universal joints, it controls the right rear wheel's torsion bar which receives a bit more twist with each click of the wrench, thus shifting the car's weight to the left.

This enables a driver to control his car's balance as fuel is used up, to shift up to 100 pounds of the car's weight to the left, and to do so at high speed with merely the twist of his wrist. This makes the car handle about the same with its fuel tank full or empty.

Watson developed the weight-jacker idea back in '55 when it was used on winner Bob Sweikert's car. This year, 15 Watson-built cars, among them those of Rodger Ward and Len Sutton which finished 1-2, ran the 500-mile grind equipped with the jack.

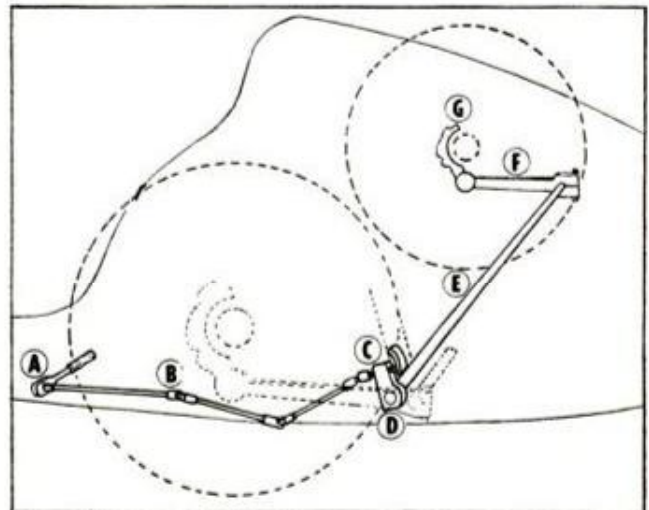
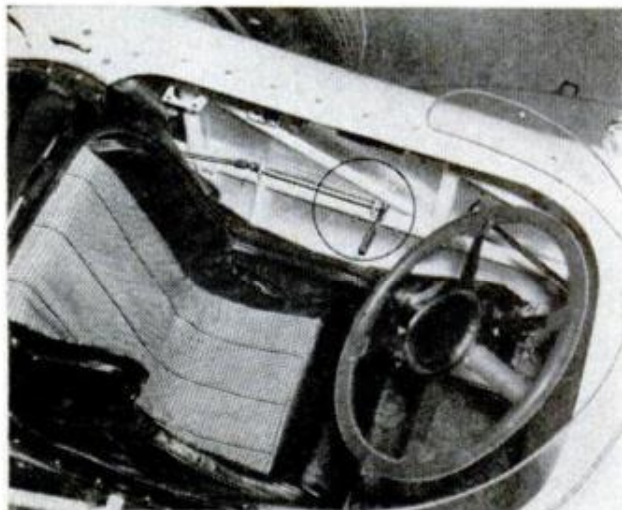

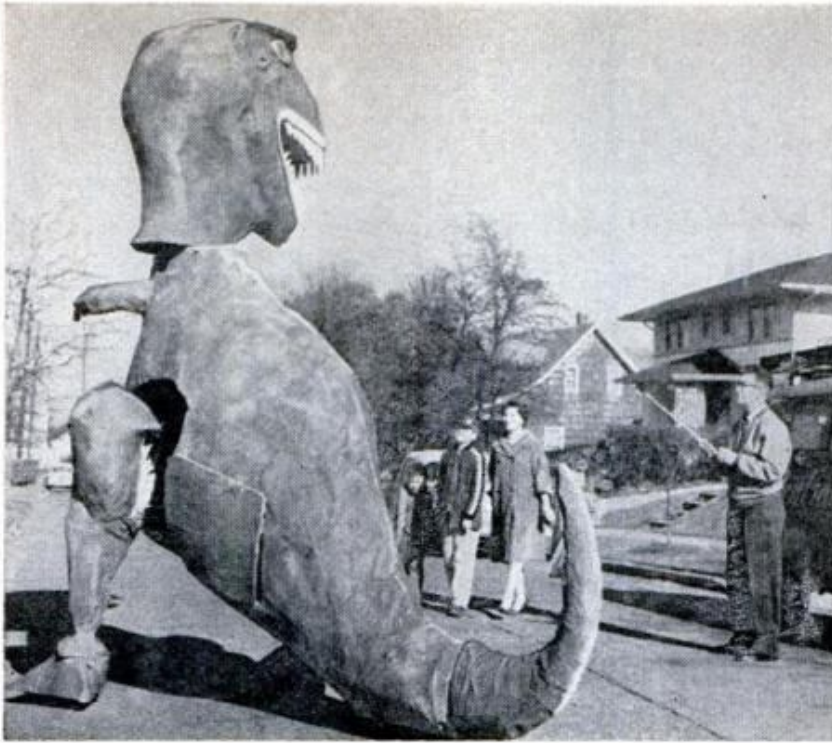

## He Creates Walking, Talking Dinosaurs

Frankenstein created monsters. Frank Abbott of Seattle, Wash., creates walking dinosaurs.

His *tyrannosaurus*, a prehistoric meat-eating lizard, is the first of several he plans for a park exhibition. Thirteen feet high, it

consists of aluminum tubing for bones, covered over with chicken wire which is sprayed with a plastic coating.

Each leg can be moved by remote control through a small motor powered by a 12-volt battery. The dinosaur also "talks" on tape.

## Instant Noise

An electric compressor supplies instant pressure to new auto horns which don't use a conventional air-storage tank or pressure gauge. Chrome-plated for exterior mounting, the triple horns stand six to nine inches high, yet will fit behind a car's grille and are powerful enough to give a piercing, high-pitched blast.

Installations for 6 or 12-volt systems include tubing, brackets and an electric relay. A separate switch or the car's horn button may be used. Made by Grover Products, 1221 S. Hope St., Los Angeles 15.

## Table Linen Rolls Away

Restaurant waitresses can produce fresh linen for their customers by simply rolling the old linen out of the way.

A new system for restaurant counters uses a roll of fresh linen which is threaded over the counter. When one customer has been served and the dishes cleared, the soiled linen is automatically rolled away by pulling a cord which also rolls fresh linen into place. When the full roll, which is hidden under the counter, has been used, it is replaced by a freshly laundered roll of white linen.





## "Spider" Money Bag Grips Thief's Hand

Thievery becomes more complicated with the introduction of a "beat-the-bandit" money bag. It was recently demonstrated in London.

When the bag is snatched by a thief, causing the messenger to release his thumb from a button on the handle, a trigger is released. After a time delay of two seconds (to give the thief ample time to get a good grip) the handle clamps viselike on the thief's hand. Three steel telescopic arms shoot out—six feet in three different directions—to prevent a getaway by car.



## Supermarkets on Wheels For Small Neighborhoods

Fifty trailer trucks fan out daily from a central warehouse in Mexico City to bring fresh food to poor sections that could not support a permanent supermarket.

Following regular routes and schedules, the trucks stop at the same spot at the same hour every day in more than 200 fringe neighborhoods. Two-man crews unfold mechanical stairs, turn on air-conditioning, indirect lighting and tape music for the customers.

Everything is packaged to sell for one peso (8 cents) per package. Customers serve themselves.

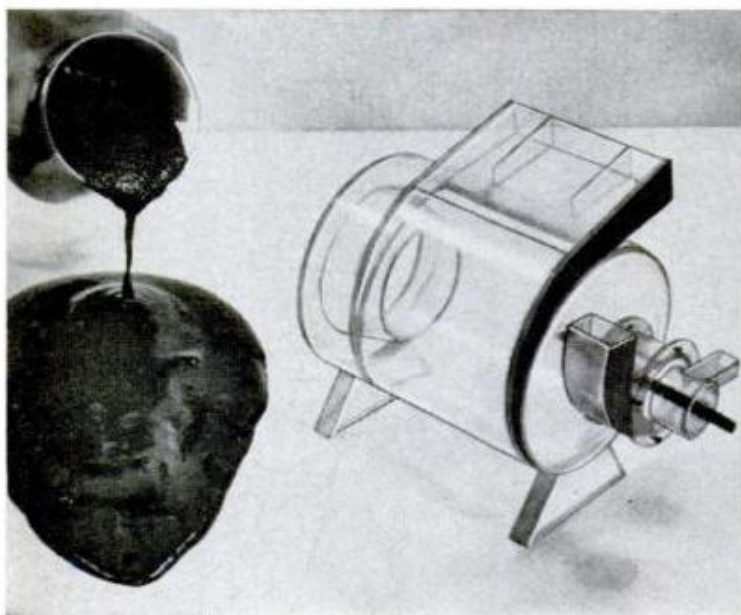

## Revolving Furnace Burns Pipeline Coal

Coal slurry—a 70-percent coal, 30-percent water mixture—can be transported by pipeline and burned directly in giant electric utility boilers.

The slurry is shown next to a plastic model of the new Babcock & Wilcox Cyclone furnace.

The fuel, which enters the furnace through the pipe at the hub, is whirled around and the water is vaporized by heated air. Coal particles are ignited and burned at more than 3000 degrees F.

The hot gases formed are discharged by the furnace to generate steam in boiler tubes.



# Housing '62

A SPECIAL 35-page section on your home, new houses and ideas for every home. We proudly feature in color PM's own House of Care-Free Living, a low-maintenance home that's built around a sunlit garden open to the sky.

PLUS a stimulating feature on landscaping, "Have a Lazy Man's Lawn," packed with minimum-maintenance ideas for the outdoors; unusual new houses (turn the page); easy-care home products; new construction techniques; a wealth of tips for home buyers; and a showcase of the unusual new hardware you can use to facelift your own home.

Strange Shapes in Housing . . . . .	page 120
New for Your Home—Easy to Care For . .	page 124
Have a Lazy Man's Lawn . . . . .	page 126
PM's House of Care-Free Living . . . . .	page 137
Sandwich House Slips Together . . . . .	page 146
Money-Stretching Tips for Home Buyers . .	page 148
Hardware Showcase . . . . .	page 150
Tile Ceiling Interlocks on Metal Furring . .	page 156

# STRANGE      SHAPES

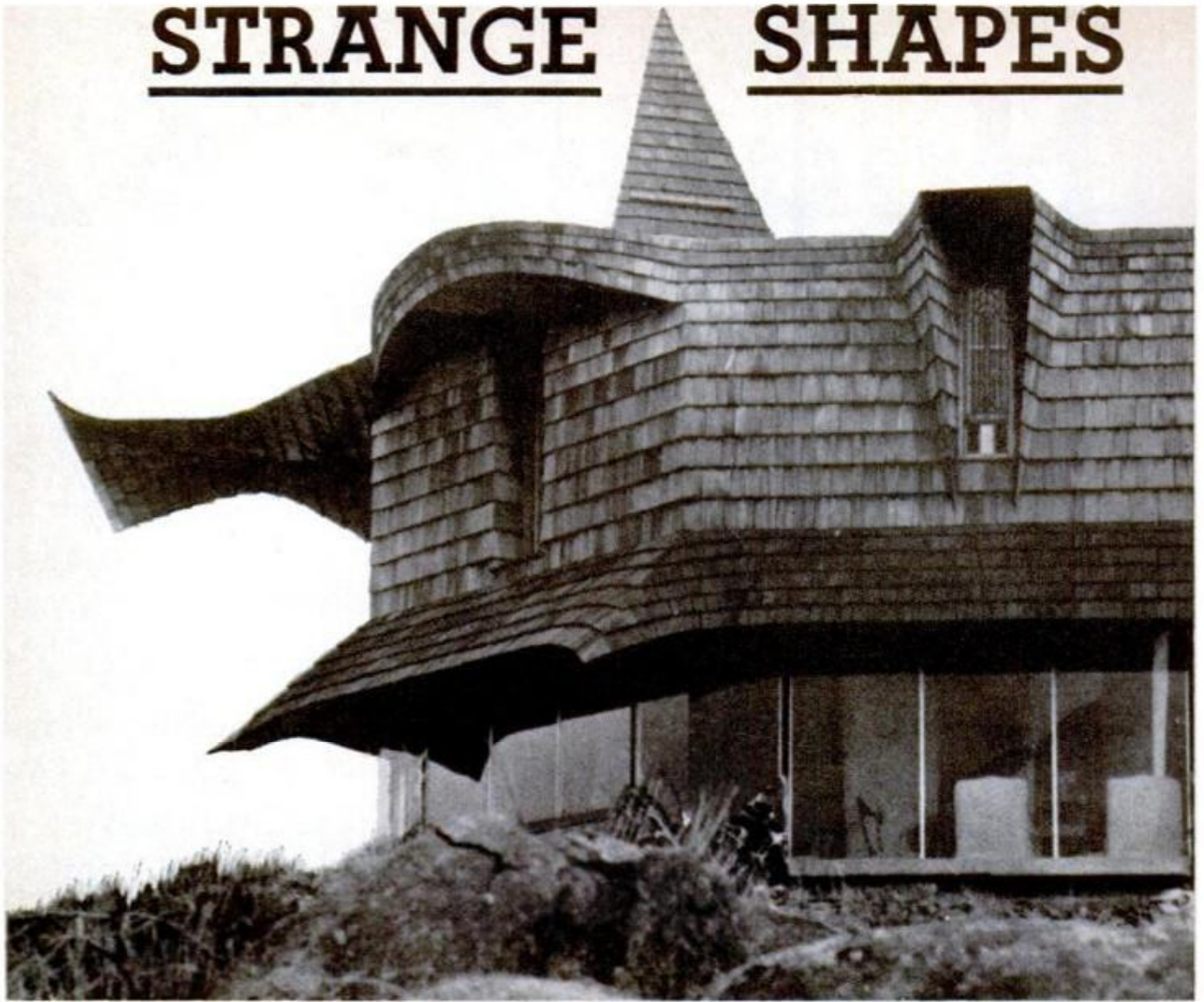

CEDAR AND GLASS home in Snyder, Okla., is called a blend of "sleek modernity and massive antiquity"

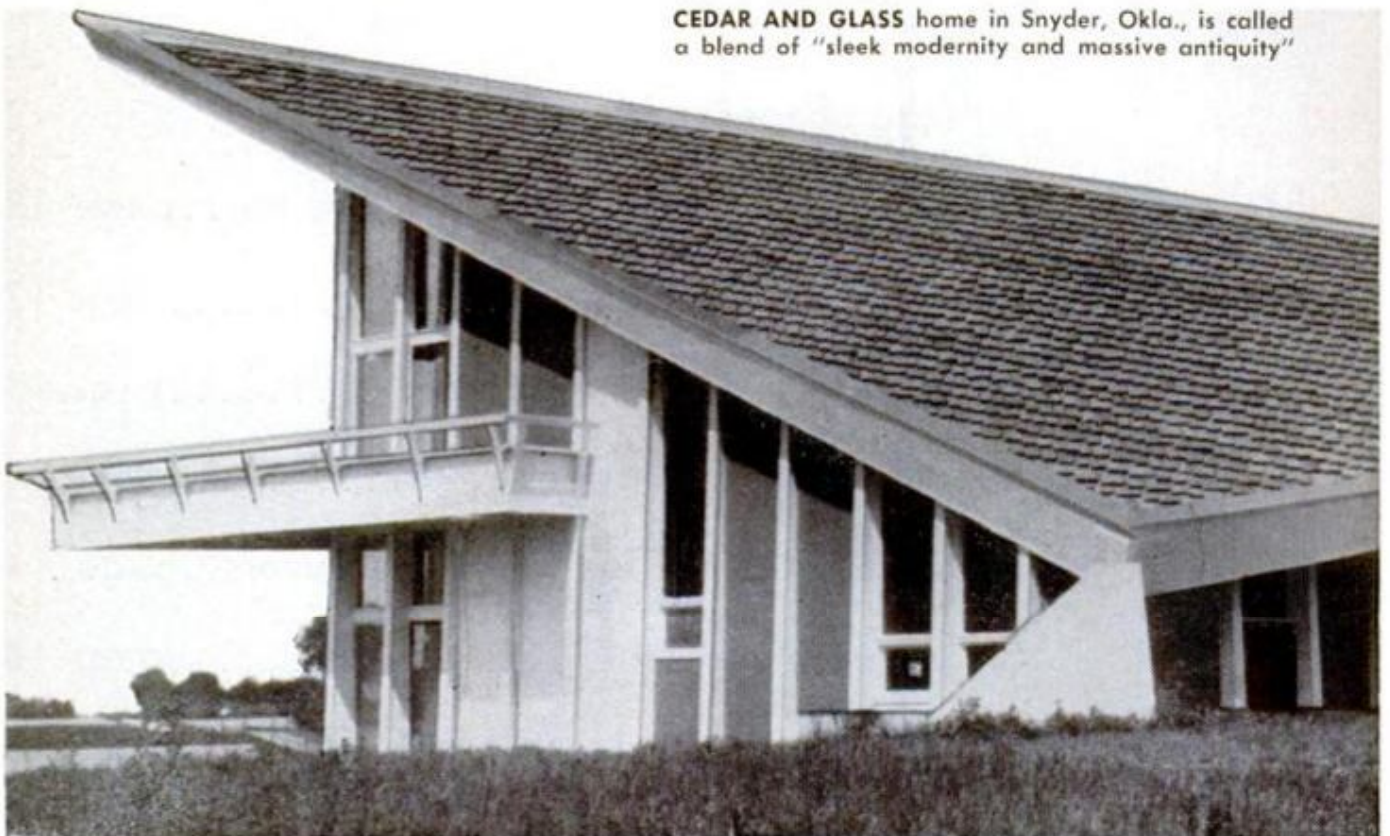

# IN HOUSING

TRIANGLES, hexagons, serrations and free-form shapes are popping up in today's houses in sharp contrast to more conventional forms.

Most of the unusual shapes take advantage of particular building lots, materials or views.

Interiors, too, are imaginative. The dart-shaped house, below, is unexpectedly oriental in its interior decor. But it has such non-oriental features as an electric heat pump, push-button control of indoor climate, an electronic air cleaner and electrically operated water faucets.

The aluminum house on page 123, which was displayed at an international design exhibition, has a serrated, folded-plate roof structure made of the same aluminum-and-foamed-plastic panels that make up the walls.

The steel house on that page also utilizes panels. They are insulated double steel wall panels that form a 3½-inch-thick curtain wall.

The hexagonal shape of the house at the bottom of the same page depends on the lightness and strength of plywood.

Strange shapes and textures, today's architects are developing!



INTERIOR of triangular house is blend of modern (such as push-button mixing of hot and cold water) and Japanese shibui. Family room features chairs hung from ceiling

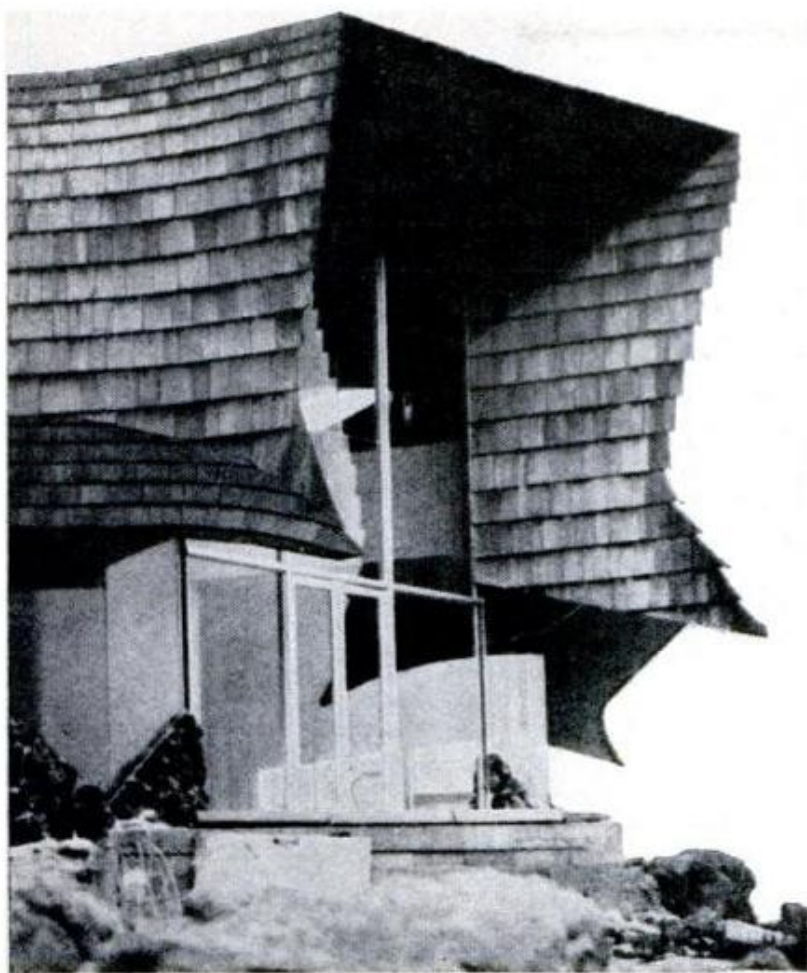

TWO GIANT TRIANGLES form the roof of this Aurora, Ill., showcase house. Roof sections, covered with cedar shakes, rest on two concrete buttresses; there are no load-bearing walls

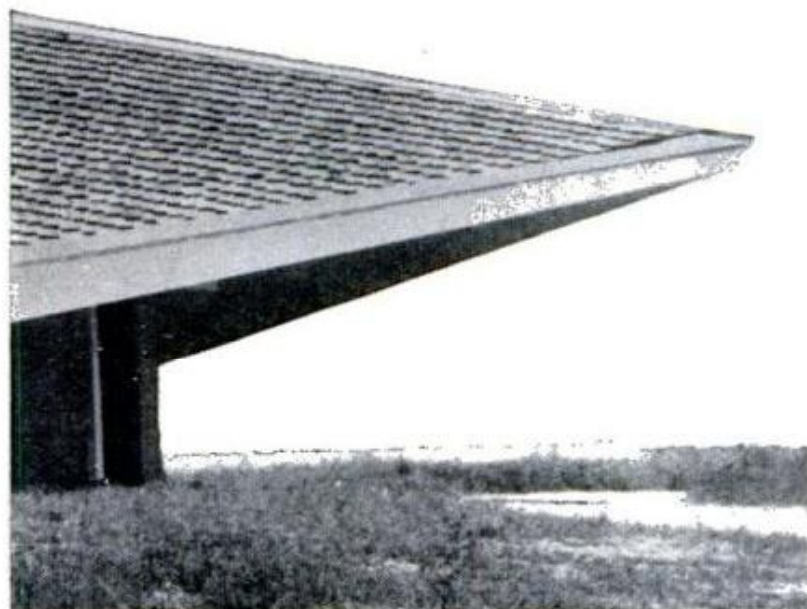

# Triangles

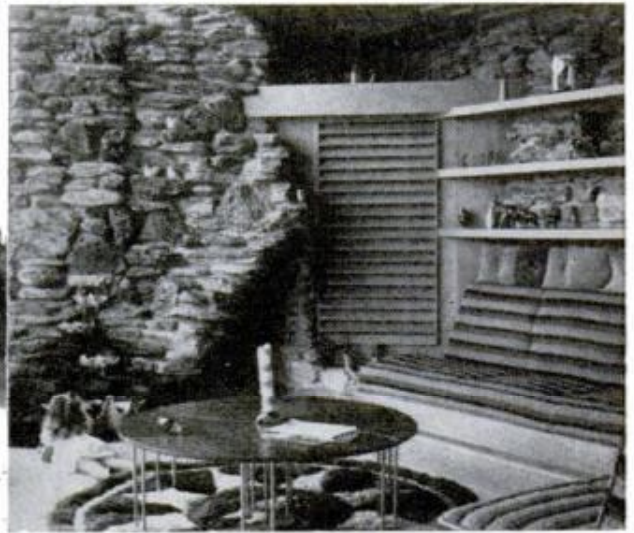
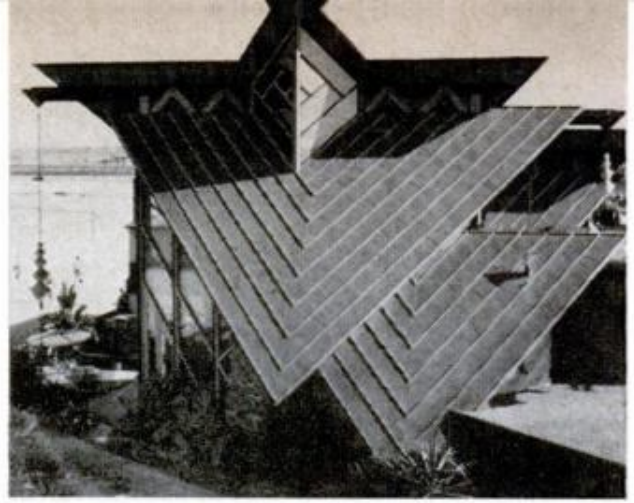

**TRIANGULAR LOT** helped determine shape of San Diego, Calif., beachside house, above. The front, which faces beach, is made almost entirely of glass. Steep triangular roofs, made of copper, form a strong geometric pattern, and the interior repeats the triangle motif

**STEEL HOUSE**, top right, has steel wall and roof panels and stone veneer. **Entry**, far right, displays steel structural elements. Home is in Los Angeles. **ALUMINUM HOUSE**, right, built for exhibition, is made of aluminum-and-foamed-plastic-sandwich panels set in aluminum channels

**SEVEN HEXAGONS** make up this Naples, Fla., house which was designed to take advantage of its site. Stressed-skin plywood roof is supported on steel and concrete columns, and the walls are nonload-bearing curtain walls. Much of the furniture is built-in to fit unusual room shapes

# Hexagons

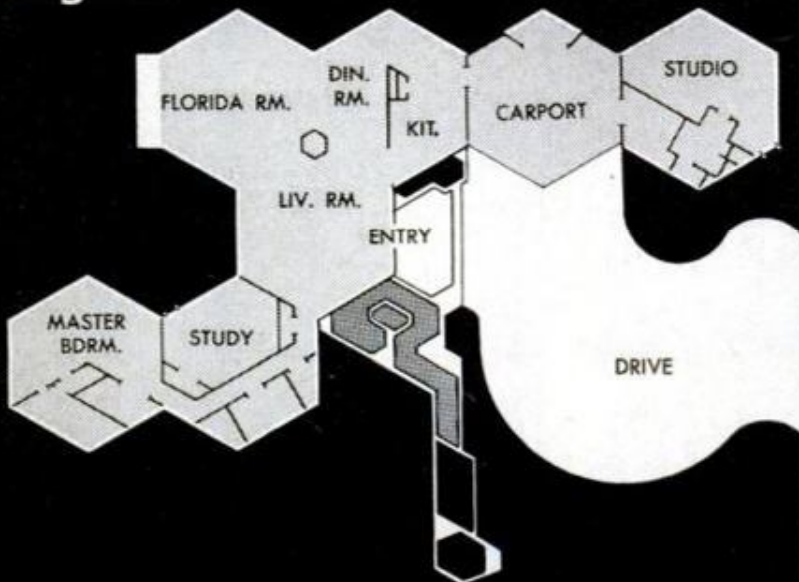

Steel



Aluminum

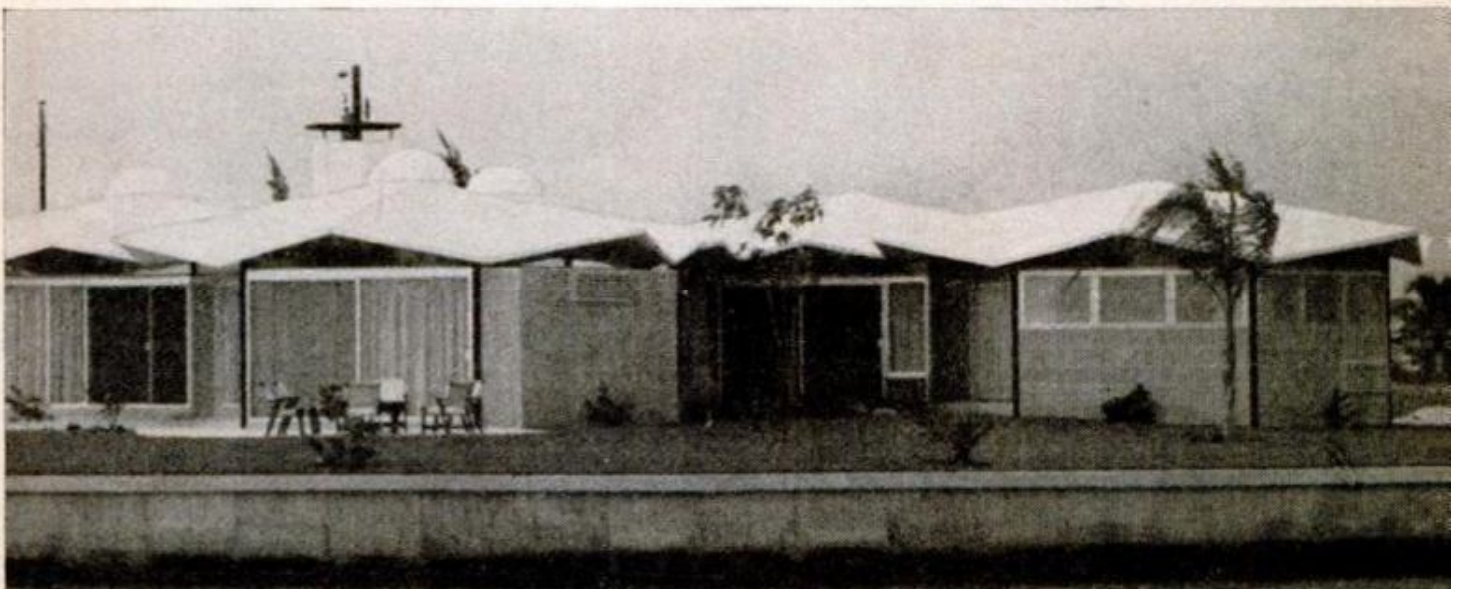



**TRAVELING THERMOSTAT** with rabbit-ear antenna broadcasts impulses to heat source for optimum comfort in any part of the house. Minneapolis-Honeywell Regulator Co. predicts this model will be a thermostat of the future

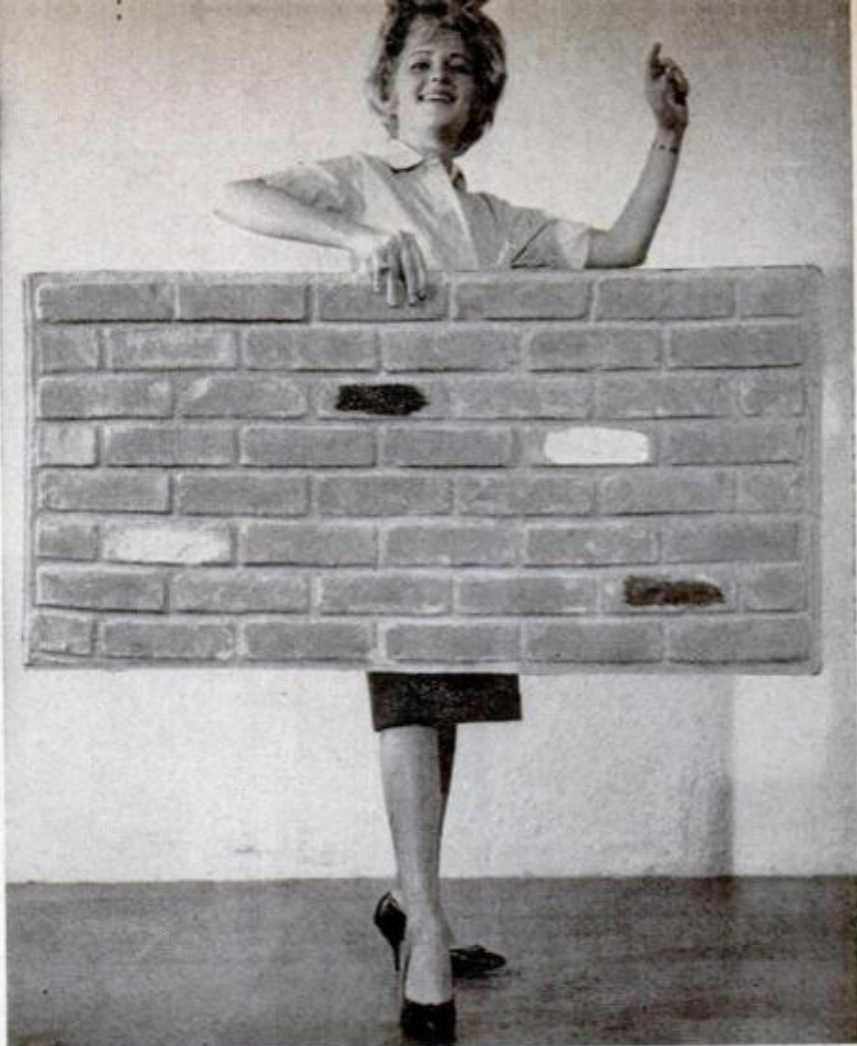

**THREE-DIMENSIONAL FIBERGLAS PANELS** look like real masonry and can be applied to any wall surface with hammer and saw. They're made in four designs by Deko Products, E. 69 Gillett St., Hartford 5, Conn.



**PLASTIC FILM**, laminated to wood or metal siding, will not peel, chip, or crack. It lasts up to 30 years without upkeep. The new Du Pont product is available in white and three color shades

## New For Your Home— **AND EASY**

**HEATING-PLANT HUMIDIFIER** has revolving mesh screens which give maximum evaporation and stir water to eliminate lime and mineral deposits. The water reservoir (clear plastic in this demonstrator) is stainless steel. Hamilton Humidity, Inc., Merchandise Mart, Chicago 34, Ill.



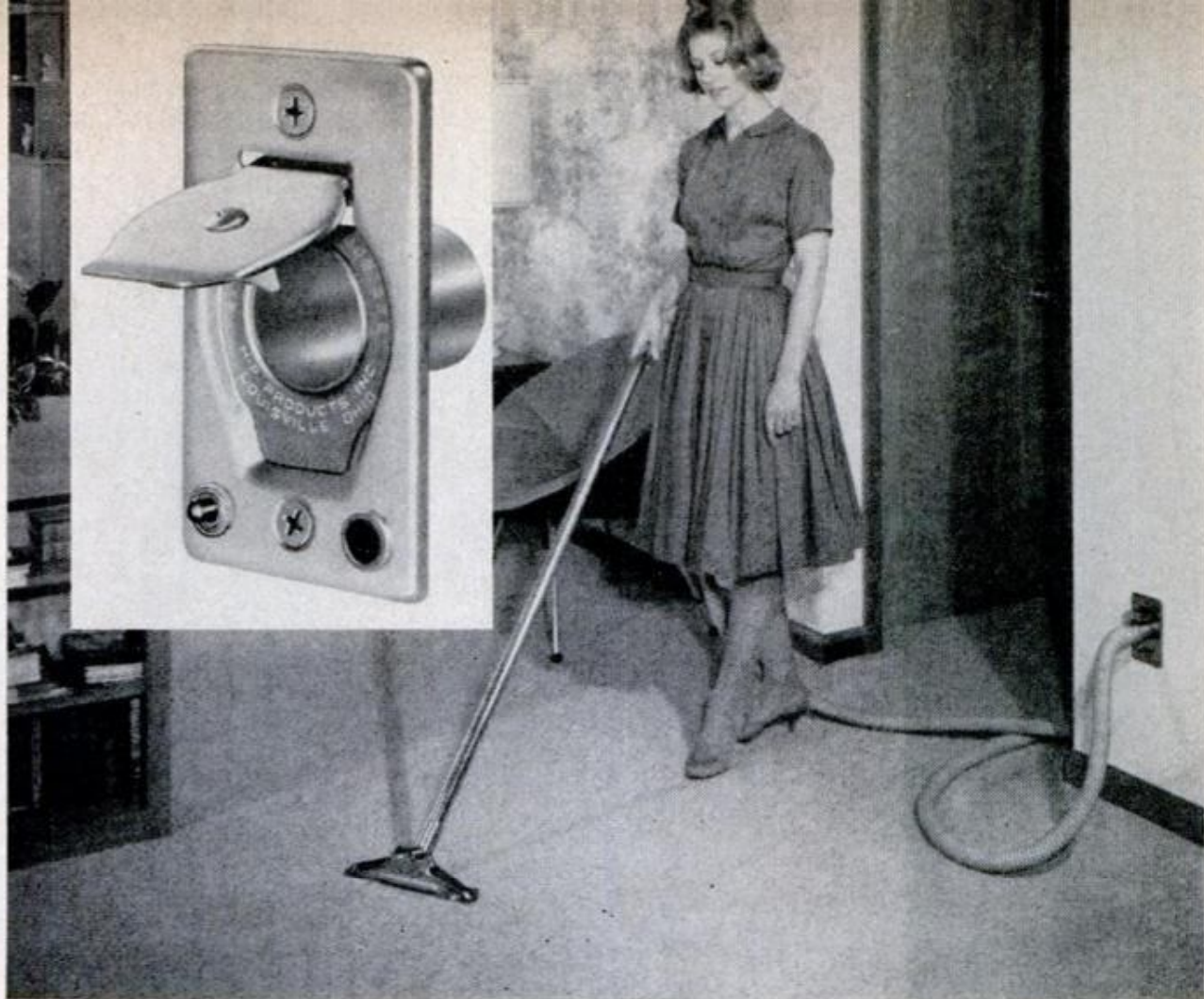

**TRIPLE-DUTY BUILT-IN VACUUM** incorporates fire detector and prowler protection. A thermostat triggers alarm in case of fire. Pressing a button on the wall valve rings alarm loudly to frighten burglars; the alarm also may be used as a household "intercom" system. Unit is made by H-P Products, Inc., Louisville, Ohio

## TO CARE FOR

**THERMAL KITCHEN COMPARTMENT** has ventilating hood with fan and an infrared oven for keeping food hot or for quickly thawing frozen food. Unit also serves as wall cabinet. Made by Aubrey Mfg., Inc., Union, Ill., it's available in 30, 36 and 42-inch widths. Starts at \$189

**WASHABLE CEILING TILE** absorbs noise, resists dirt and its vinyl coating can be cleaned with a detergent. It's made by U. S. Gypsum

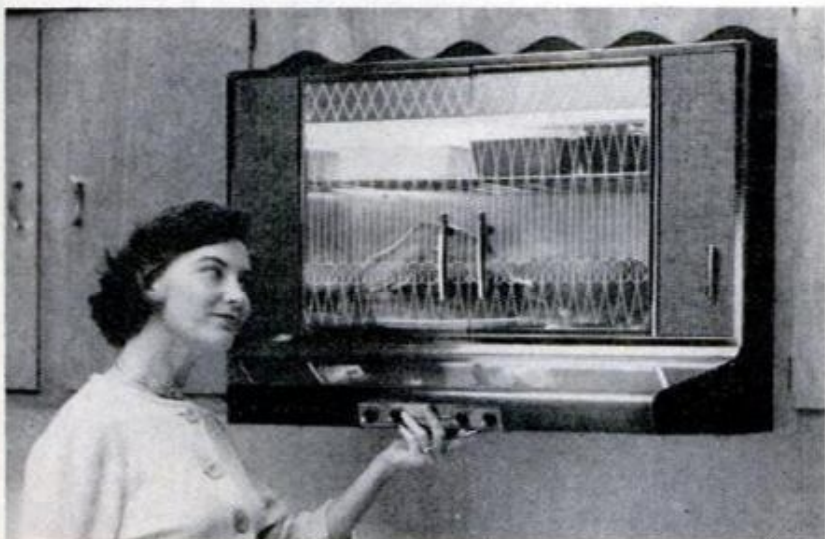

X389

# HAVE A LAZY MAN'S LAWN

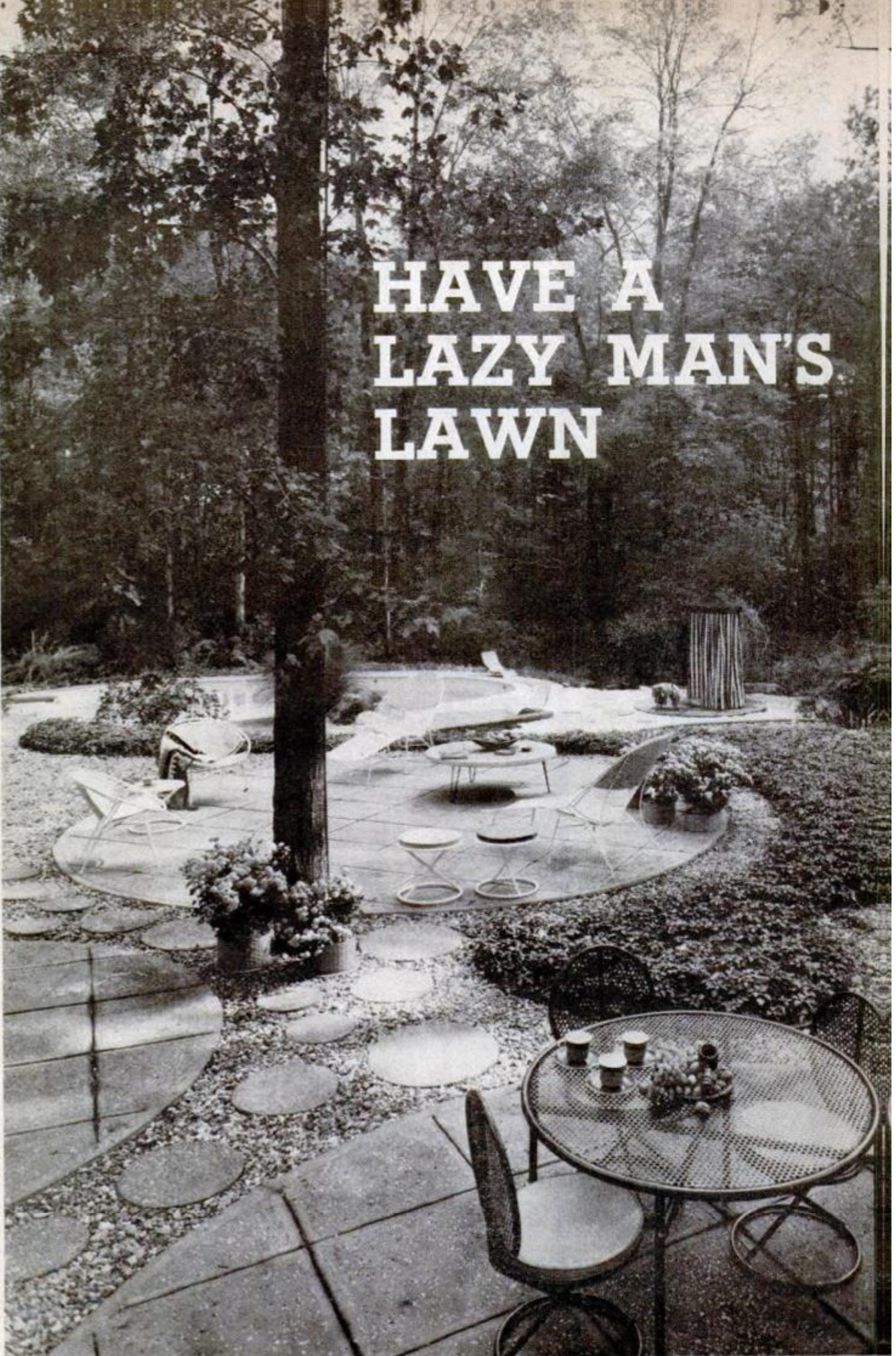



# A professional landscape architect shows how you can have an easy-care — and unusually beautiful — yard

By Clayton W. Steen  
Landscape Architect

**H**UMAN NATURE being what it is, most home owners today would like their private real estate to resemble a nursery exhibit at the National Flower Show. But the care of this neatly manicured arboretum mustn't interfere with golf, sailing, social engagements or family vacations! Briefly, it should take care of itself. Is this wishful thinking? Not entirely. The answer, like many in our complex modern civilization, is neither black nor white.

Whatever is said about landscaping, one thing is certain: Maintenance is never *completely* eliminated. Plants, whether grass, trees or shrubs, are living, growing things. As such, they require feeding, weeding, spraying and pruning. Fortunately, however, many plants are sympathetic to the demands made upon harassed modern man and are able to put on a good show without much help (see chart, page 228). Whether you think in terms of lawn or plantings, the job is to separate for use the best performers demanding the least attention. Those shown on the list, chosen from some 25,000 shrubs and trees, have all the necessary "easy maintenance" qualifications:

1. Neat growth habit.
2. Relatively free of disease and insect attack.
3. Seasonal interest.
4. Hardy resistance to temperature change or drouth.
5. Slow-growing, or easily restricted.

By choosing such plants carefully, employing a few tricks

**PEBBLES, CONCRETE AND GROUND COVER** turned a woodland lot into a graceful low-maintenance garden built from the plan shown below

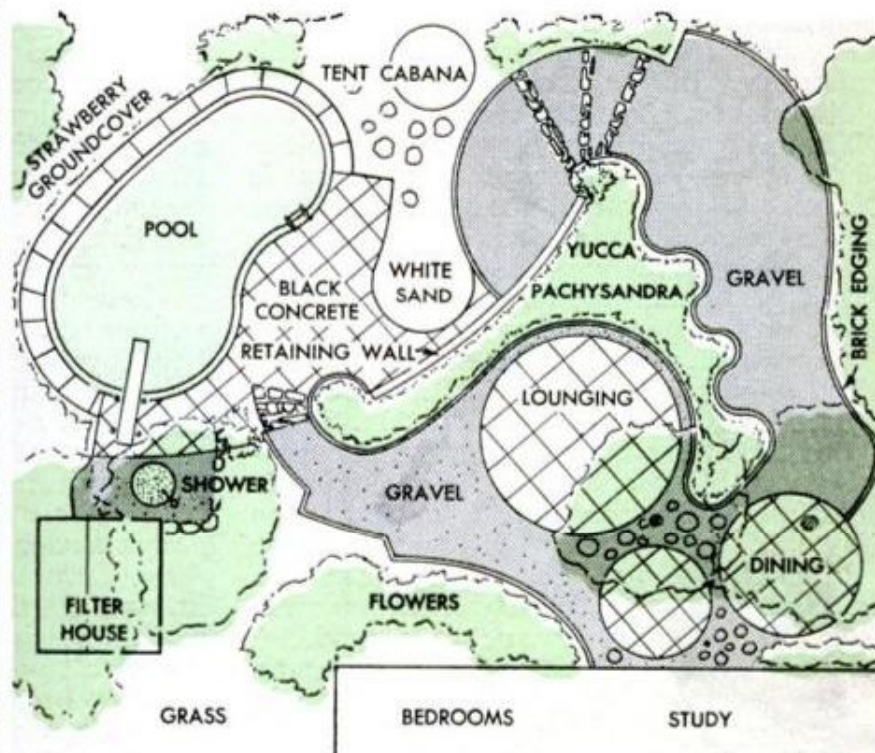



**TERRACING** with low walls divides yard areas, creates pleasing effects and permits use of decorative steps. Minimum lawn area is edged with brick to eliminate all tedious trimming of grass, cutting maintenance time

in the planning of beds, and restricting lawn areas with sweeping, maintenance-free patio spaces, no one need be a slave to a weedy jungle.

The job of creating easy maintenance landscape on any site, however, begins with planning. This is a must. No two sites are alike, nor are the needs of any two families. Whatever else it may be—from showplace to eyesore—the area around any house is for people to use and enjoy. It should be designed with this in mind.

One of my recent problems involved a retired gentleman and his wife with a small house on two acres. They wanted freedom to play golf, fish and travel. They weren't interested in decorative settings, but the place had to look perpetually tidy. So we preserved the site's natural, irregular contours with interesting rocks and gnarled old trees. A farmer cuts the meadow-type lawn three times a year. With maintenance slashed to the bone, these people can take a slow boat around the world and come home to find the landscape unchanged.

Another family with three energetic youngsters in a new tract house, presented a different problem. They wanted decor, easy maintenance, a place for the kids to

play, "practically no lawn to mow, please—and do something about the swamp." Today you enter this home via a spacious court of screened bluestone and rectangular flag stepping stones, contained by long, low railroad tie walls that terrace an embankment rock garden. A steep bank on the far end is cloaked in a blanket of evergreen periwinkle that never needs trimming. A king-size area beside the house is paved in asphalt and marked out for games. A drainage ditch beyond it takes the ex-swamp water off into a winding brooklet behind the house. Here, long, curving gravel areas with circular concrete stepping stones embedded at random, surround a circular concrete patio and terraced gravel picnic area. A graceful weeping willow shades the patio, and evergreen shrubs soften hard lines. With little to maintain, these people can devote their time to family activities, and a rock garden they enjoy.

So, once the needs of the family are known, the first thing to do is to make a scale plan sketch of house and site, positioning all existing trees, rock outcrops and slopes. Before you start pushing the ground around, remember that many existing shrubs, trees, ground cover, rocks and



**STEPPING STONES** of concrete, planted at random through a gravel "lawn," serve a definitely practical as well as a decorative purpose by providing firm footing for high heels that would sink in the loose pebbles

terrane may be worked into your plan as is. The danger to root systems of major trees, possible erosion resulting from grade changes—and cost—are sound reasons to think twice before "shaping" a site to fit a theoretical plan. You can exploit rocks in the garden areas, and plan patio areas in the shade of existing trees, for instance.

Don't overlook the pleasing effect of low terracing to divide areas. Nearly every plot has a grade change of at least eight inches somewhere. That's enough to terrace. The slope can be banked with railroad ties, old brick, or dry stone walls. With the areas established—for lounging, outdoor eating, garden, play—you can "dress up" for easy maintenance.

The majority of landscape maintenance problems hinge on three things—drainage, lawn and plantings. Solutions for each must be thought of in relation to the others, plus things like driveways and walks.

**Drainage:** An area improperly drained can provide a perpetual maintenance headache by causing constant erosion or by creating a soggy bog too wet for lawn or plantings. Erosion of gentle slopes is easily controlled with lawn. If the grade is too steep, try a heavy planting of ground

covers such as Hall's honeysuckle, English ivy, creeping junipers or the Memorial Rose. Often the best and most pleasing effect is to interrupt a steep slope with terracing, using a series of those low retaining walls. Another solution is to rip-rap the embankment with stone, and to plant the areas between rocks with rock garden plants or ground covers.

One hint for planting embankments: Cover the tilled slope with jute matting or burlap, pegged to the earth before the plants are set. Make a small cut for each plant. This will retard soil washout until roots are established.

Boggy areas aren't so easy, but are even more important to correct. High water tables flood septic systems. The hydrostatic pressure they induce can crack and tumble retaining walls, heave terraces and driveways. The best solution is a curtain drain along one side of the property, with lateral drains leading into it. You may find it less expensive to raise low areas with porous fill. The important thing to remember is that most plants won't tolerate wet feet.

**Lawns:** The biggest beef I hear regarding care and upkeep of landscape is: ". . . if only I could eliminate the mowing, trim-

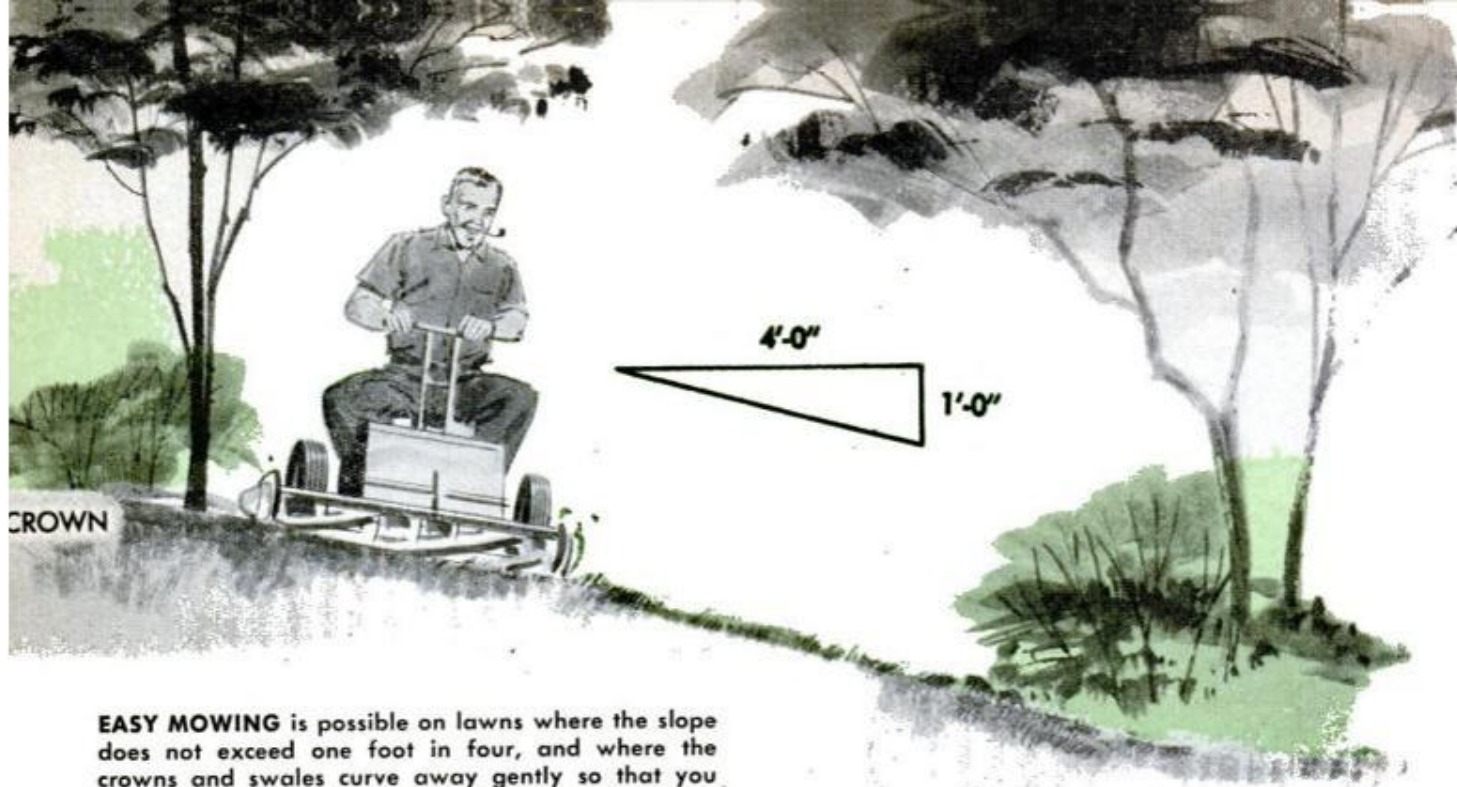

**EASY MOWING** is possible on lawns where the slope does not exceed one foot in four, and where the crowns and swales curve away gently so that you can avoid "scalping" the turf with the mower blades



**STEEP SLOPES** are hard to mow but are easily maintained under groundcover, or broken into stepped terraces with retaining walls of stone, brick or block

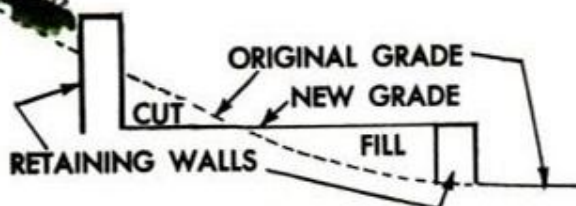

**EXISTING TREES** often may be worked into your landscape plan by providing shade for a lounging area, or they may create a spot for ground-cover beds



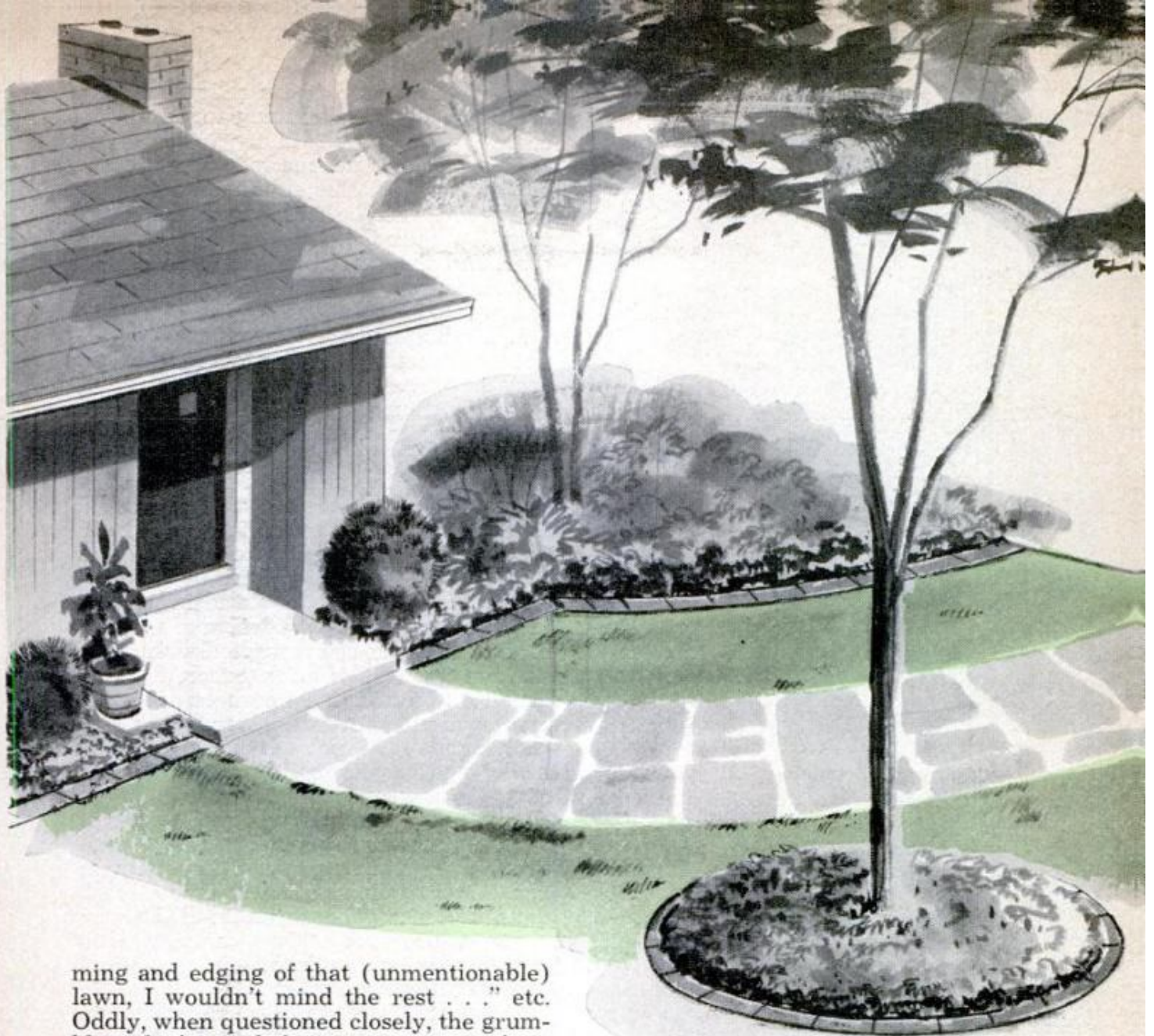

ming and edging of that (unmentionable) lawn, I wouldn't mind the rest . . ." etc. Oddly, when questioned closely, the grumblers don't mind the mowing as much as the trimming and edging!

The fact is that well-established lawn—provided there isn't too much of it—is one of the best low maintenance covers going. It is also the least expensive solution to ground stabilization and beautification. When worked into a landscape plan judiciously in conjunction with other substi-

**MOWING STRIPS** of brick or tile separating all grass areas from gravel and planting beds help to eliminate trimming. Set bricks on their flat side

**NATURAL ROCK** outcrops left intact create no mowing problem if they are dressed with rock plants or gravel and edged with curbing

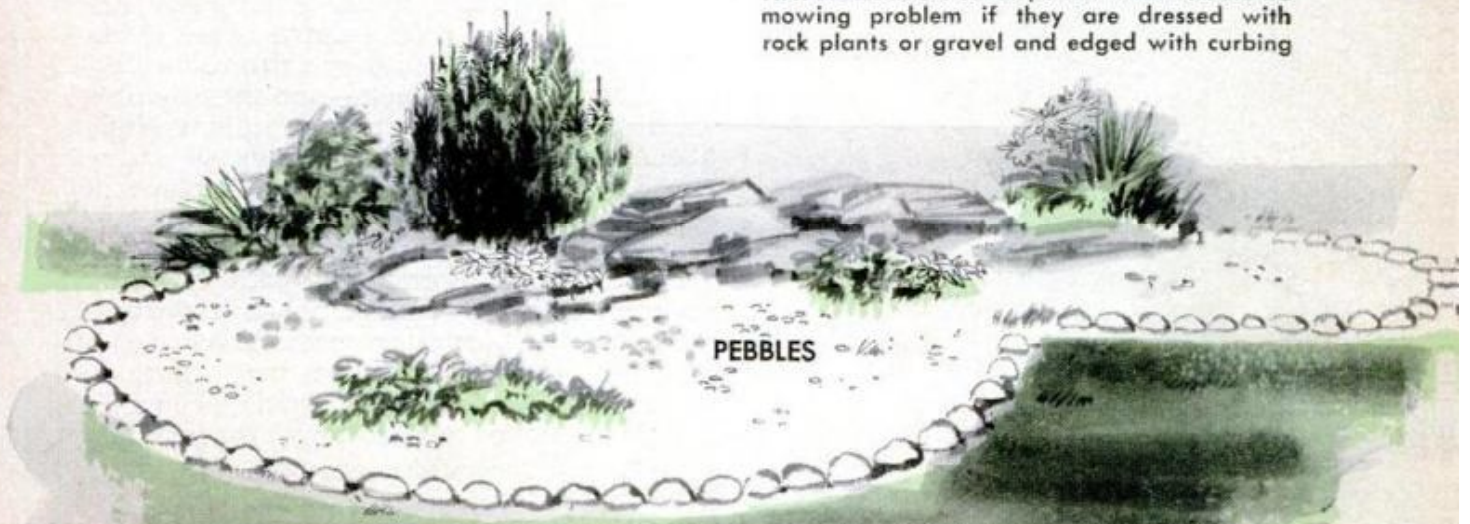

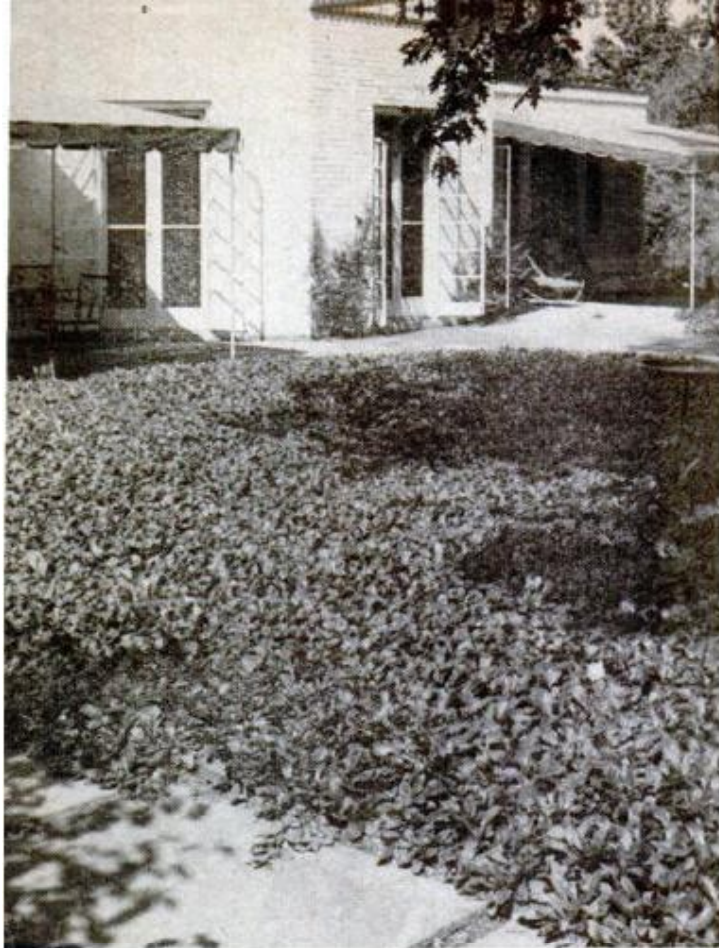

**LAWN SUBSTITUTE** requiring little or no care can be achieved under proper conditions with a variety of ground cover such as a bed of Ajuga—a low, leafy plant, used effectively in the garden above

**SHADY AREAS** like the one shown below lend themselves to beds of ground cover such as this evergreen pachysandra that never grows any taller, needs little trimming, thrives without any sun



tutes we'll come to, it can relieve severity of line and add a softening touch of cool color.

Most of us are not ready to accept green asphalt as a suitable substitute for grass, even if it must be crab grass. There are ways to reduce the size of lawn areas, however, and they will be considered after a few hints on where grass *should* be used, and how to prepare for it.

1. Limit grass to level areas and slopes—not exceeding a rise of one foot in four—for easy mowing.

2. Use ground cover, such as pachysandra or myrtle, under shade trees where grass is difficult to maintain. If you'd like to lounge in the shade of favorite trees, spread out a two-inch layer of builder's sand as a cushion for a brick or flagstone terrace. Do not mortar the joints. Water and air must get to the roots!

3. Much work can be saved in mowing lawn and preserving the design of a garden if all grass areas are restricted with a border mowing strip of brick, concrete or tile. Be sure to avoid sharp corners not easily maneuvered with a mower. The strip should be wide enough so the mower blade laps it without having the wheels slip off the edge (see sketch).

4. Prepare the seed bed with generous amounts of humus for good moisture retention. Seed in late August and early September. Water established lawns every 7 to 10 days, unless supplied by rainfall. This encourages deep roots. Two complete feedings a year are sufficient—in mid-March and early September.

5. Select grass varieties suited to the demands made upon it. *Poa Trivialis* is good for wet, shady areas while *Chewing Fescues* are good where it is drier and partly shaded. *Kentucky Bluegrass*, especially the *Merion* variety, is excellent in full sun—or where a playproof turf is required. Farther south *Meyer Zoysia* is a good all-purpose lawn grass.

6. Checking weeds and grubs with chemicals the first year will eliminate trouble.

**Lawn substitute areas.** Many materials can be used to reduce lawn area. When thoughtfully handled they can produce attractive, unusual effects—and they involve little upkeep. Proven materials include beach pebbles, pit gravel, crushed stone, sand, tanbark, wood chips, buckwheat hulls. For one client, whose yard is pictured here, we used ½-inch screened multi-colored gravel in sweeping patterns to integrate his deeply shaded two-level garden. Set into the gravel are cross-hatched circles of concrete for eating and lounging terraces. Random size circular concrete stepping stones are scattered through the

(Continued to page 229)

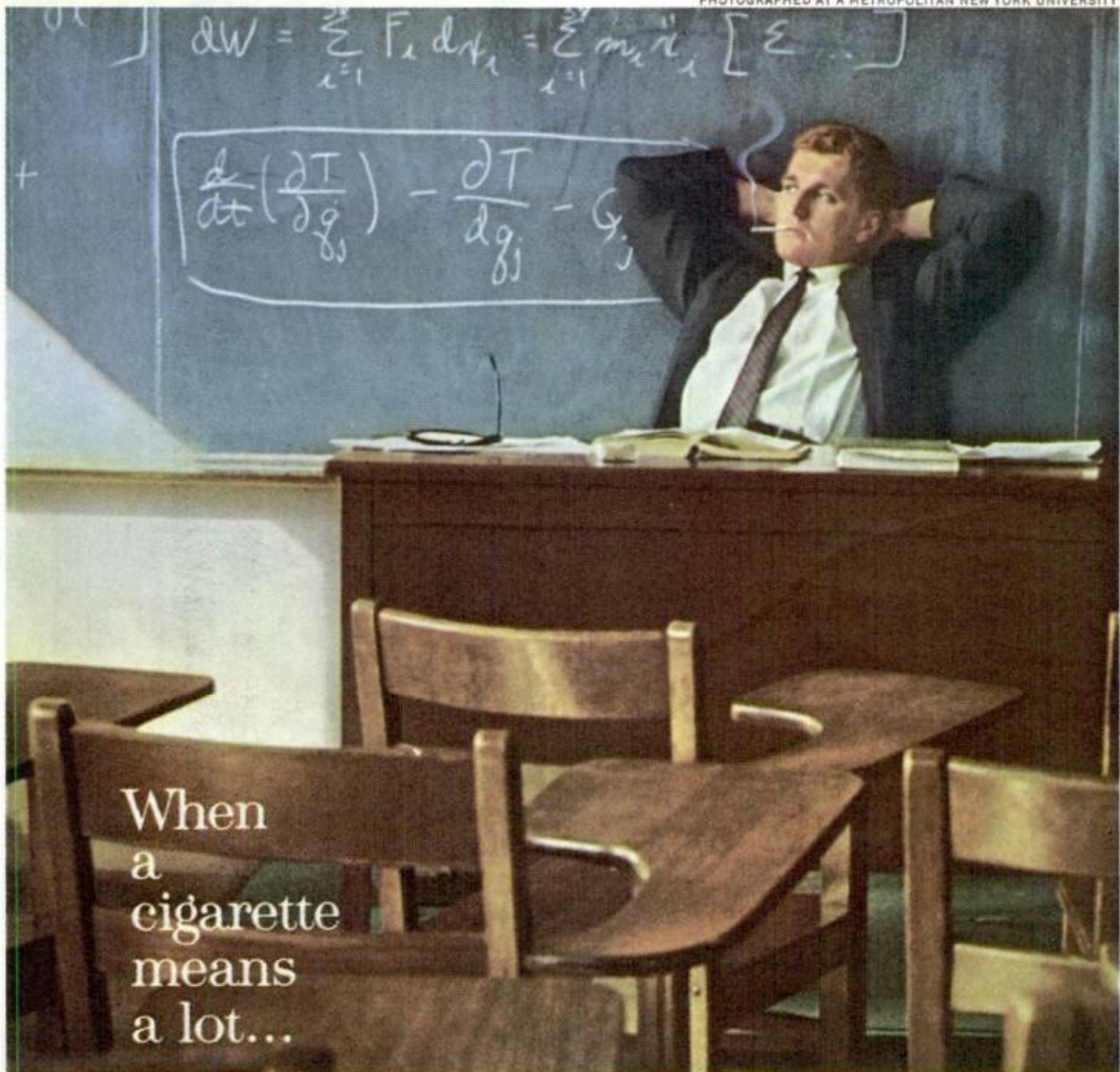

## you get Lots More from L&M

**more body in the blend**... there's a special rich-flavor leaf — and more of it — among L&M's choice tobaccos.

**more flavor in the smoke**... every puff is heartier, for L&M has more longer-aged, extra-cured leaf than even some unfiltered cigarettes.

**more taste through the filter**... for full pleasure. And with L&M's modern filter — the Miracle Tip—only pure white touches your lips.



**It's the rich-flavor leaf that does it!**

# For "minimum maintenance"

## *The dependable family of FRIGIDAIRE APPLIANCES*

Planning a new kitchen or remodeling an old one? Whatever you're looking for—styling, features, colors, convenience—you'll find it in the Frigidaire family of dependable appliances. Sizes and models to fit any kitchen, any budget. Features that stretch small kitchens—make old kitchens young again. Plus Frigidaire dependability for maximum enjoyment, minimum maintenance. Don't pinch yourself! It's your dream kitchen all right—and the Frigidaire Appliances make it come true.

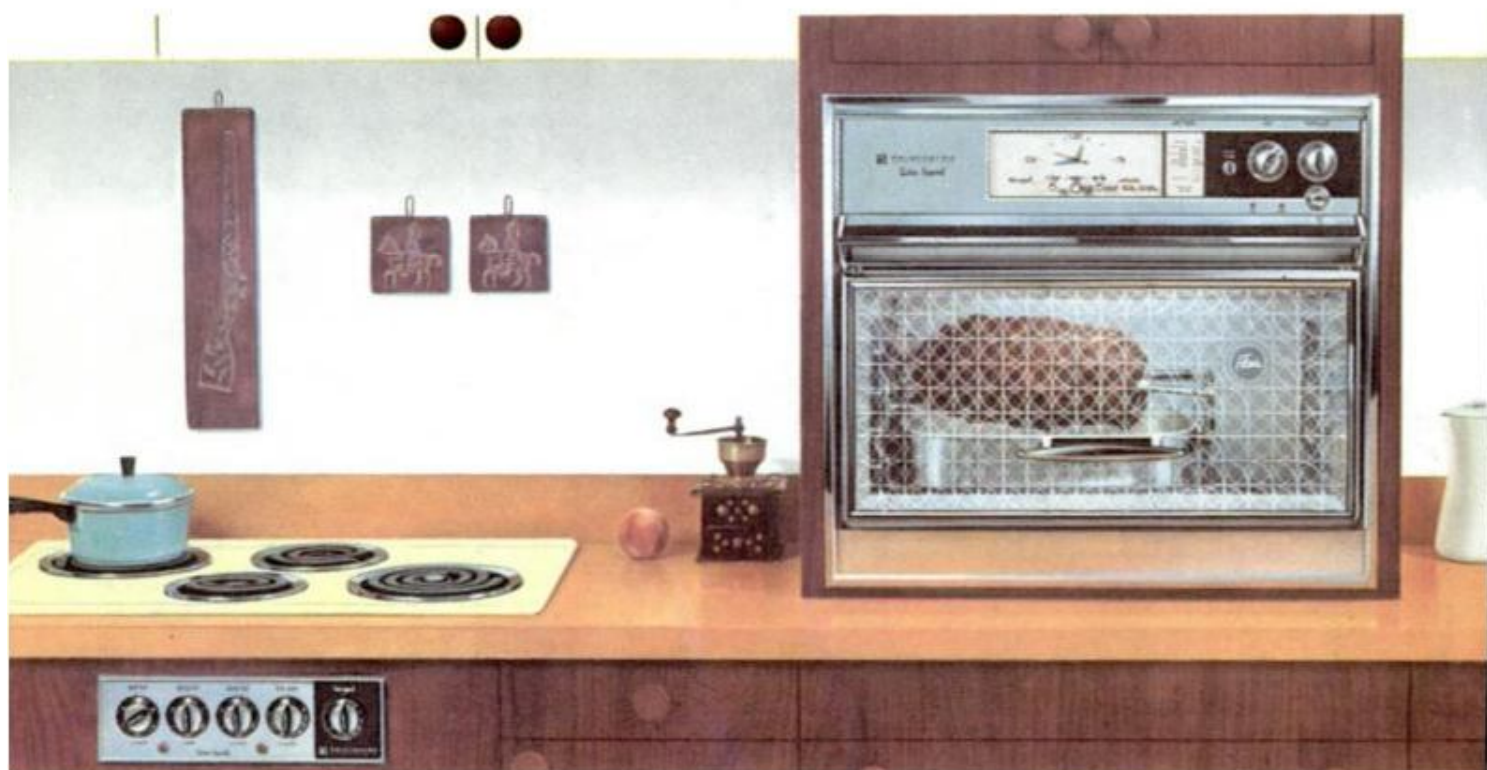

**Cooking without watching!** Even unwatched bacon won't burn on the Cooking Top Heat-Minder unit. Speed-Heat unit gets red hot in seconds. 4 models.

**No stooping or bending for cooking, looking, or cleaning!** Frigidaire Flair Wall Oven (above right) with exclusive Glide-up Glass Door. Fits standard 33" cabinets. Other Wall Ovens to fit 24" cabinets. Single and double ovens. Drop-Leaf and French Doors. Pull 'N Clean lower oven for easiest oven cleaning. Cook-Master control cooks while you're away.

**Luxury cooking in a small space!** New Frigidaire Compact 30". Big 23" wide oven. Easiest to build-in range ever. Complete single-package cooking center.





# in your New Kitchen—

No more dishwashing! Push a button to wash, rinse and dry a full day's dishes for an average family of 4. Uses water too hot for hands to get dishes cleaner, more sanitary than handwashing ever could. Dishmobile and other mobile models. Quiet Frigidaire Food Waste Disposer, too.

No defrosting ever! Exclusive Frigidaire Frost-Proof system does away with all defrosting. Door shelves hold even half-gallon milk bottles. And only Frigidaire offers you the Flip-Quick Ice Ejector. Empties entire tray at the flick of a lever.

Colors! Aztec Copper, Mayfair Pink, Sunny Yellow, Turquoise, Snowcrest White, and Brushed Chrome—on most models.



Breeze through washday with sturdy Frigidaire Washers and Flowing Heat Dryers! New 12-lb. capacity. Rapidry Spin removes more water than any other automatic. Exclusive "Three-Ring Agitator" washing action. Wonderfully gentle Flowing Heat drying is safer than sunshine. Clean the no-stoop lint screen in less than a minute.

SEPTEMBER 1962



**FRIGIDAIRE**

PRODUCT OF GENERAL MOTORS

FACTORY-TRAINED SERVICEMEN EVERYWHERE



Send for colorful new 24-page Kitchen Ideas Booklet —only 25¢

Mail 25¢ today to "Frigidaire Kitchen Ideas," P.O. Box 124, Dept PMX, Dayton 1, Ohio.

NAME \_\_\_\_\_

STREET \_\_\_\_\_

CITY \_\_\_\_\_ ZONE \_\_\_\_\_ STATE \_\_\_\_\_

Offer limited to U.S.A. and possessions. Void wherever taxed, prohibited or restricted.

Материал, защищенный авторским правом

## PLANNING A BASEMENT RECREATION ROOM?

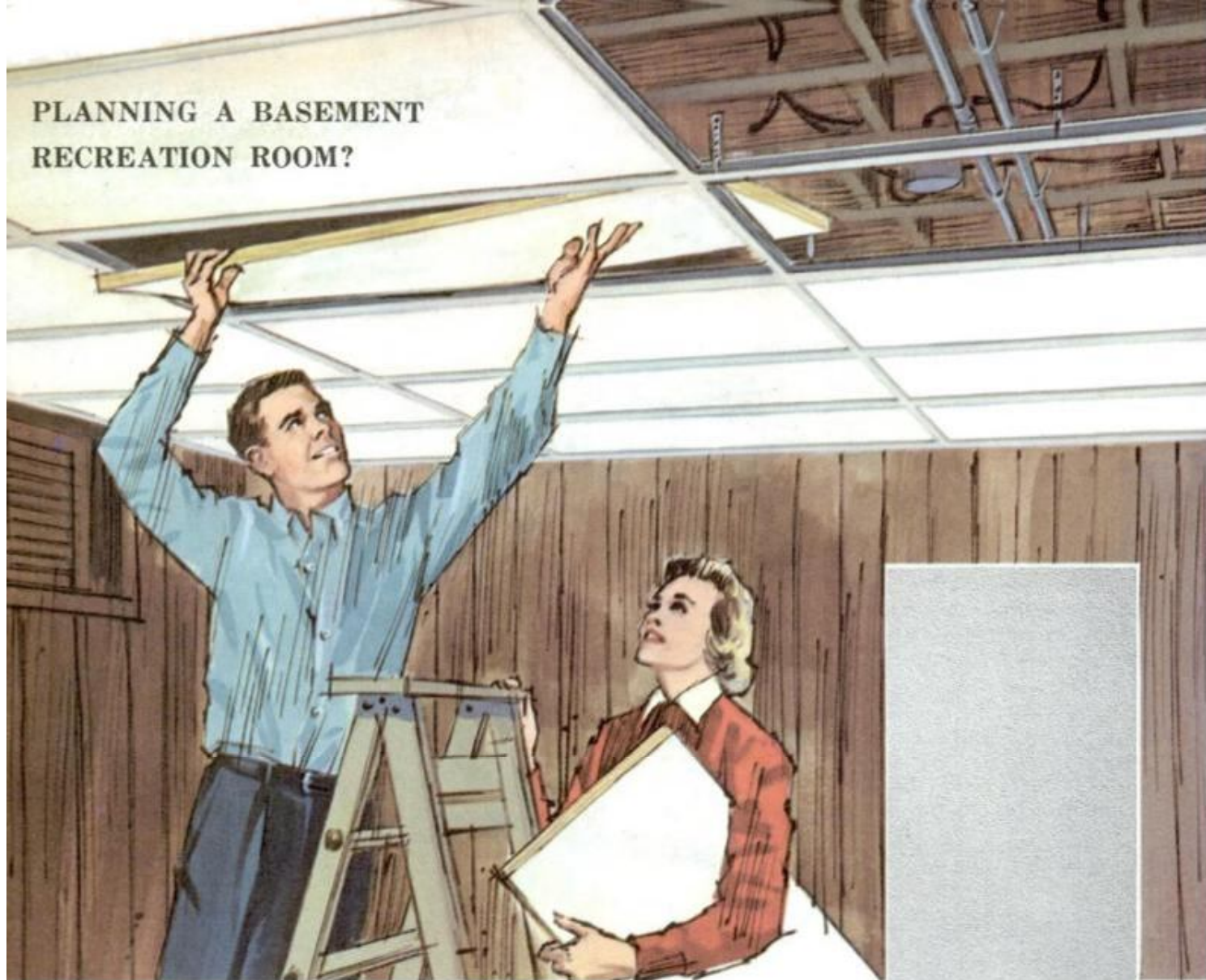

### Hide ducts, pipes and wires with new, removable G-B Vinyl Faced Ceiling Boards

Here's a simple, economical way to cover unsightly mechanical equipment in your basement ceiling. Install a suspended ceiling system, using G-B Vinyl Faced Ceiling Boards. After supporting members are attached to the joists at the desired level, slip G-B Vinyl Faced Ceiling Panels into place. No messy adhesives! No furring strips!

G-B Vinyl Faced Ceiling Panels are made of semi-rigid fiber glass boards, covered with an embossed vinyl film. They are flexible enough to bend during installation . . . rigid enough to remain flat after installation. Their fiber glass construction makes them easy to cut and fit . . . pleasant to handle. G-B Vinyl Faced Ceiling Boards won't

crumble or break—no waste material. The off-white vinyl film is completely washable—never discolors, never needs painting. Once installed, the panels are easily removed to provide access to the equipment above the ceiling.

G-B Vinyl Faced Ceiling Panels are high in acoustical efficiency, absorbing up to 75% of all noises. They have a light reflection rating of 80%. G-B Vinyl Faced Ceiling Boards are available in 2' x 2' and 2' x 4' modules, 1" thick. They are a product of Gustin-Bacon Mfg. Co., a pioneer in the fiber glass industry. Write today for complete information to Gustin-Bacon, 294 W. 10th St., Kansas City, Mo.

**GUSTIN-BACON**  **FIBER GLASS**

*Around a Sunny Garden*

## PM'S HOUSE OF CARE-FREE LIVING

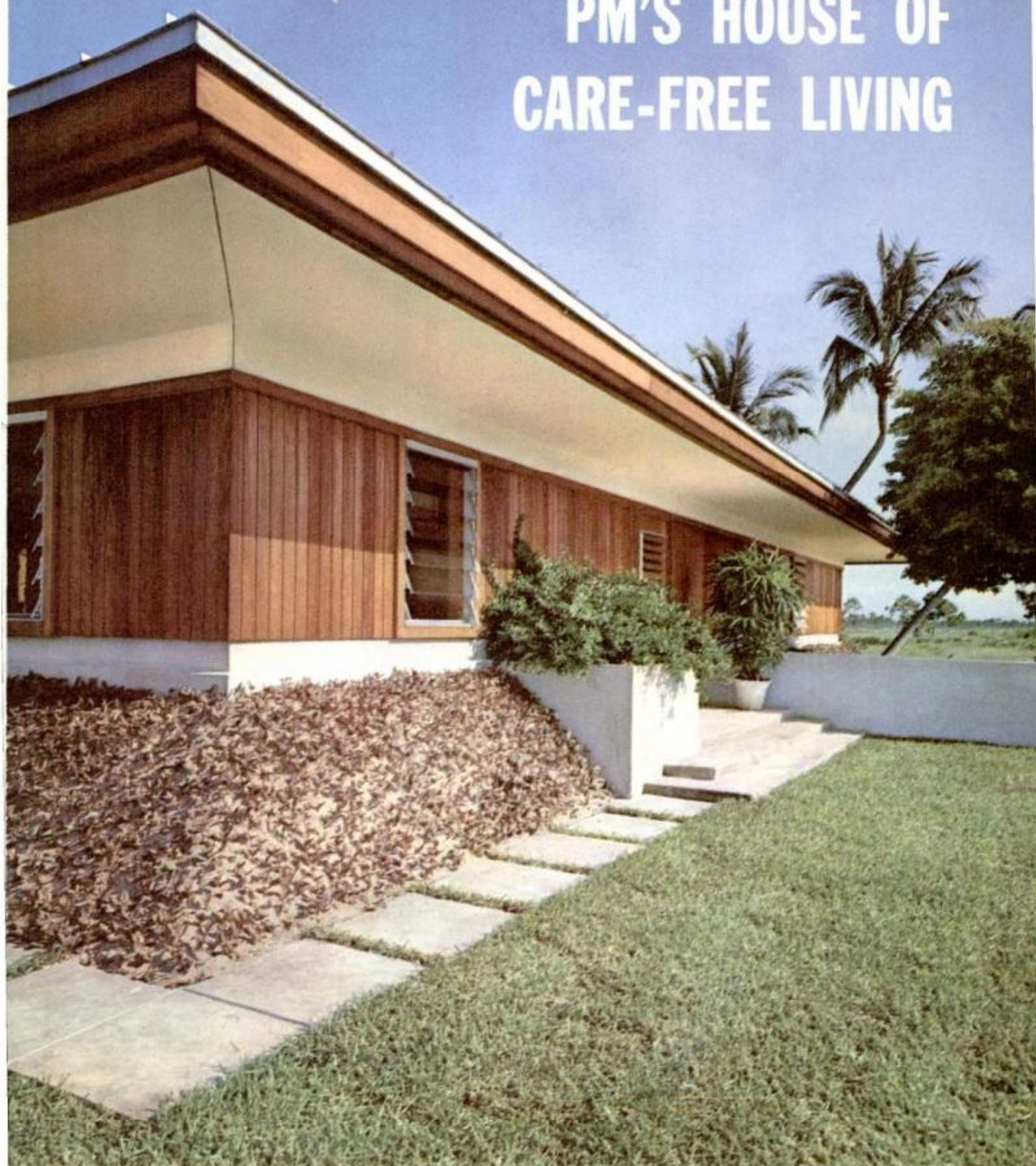

*Easy living — from the inviting, protected entry out front to the sun-filled atrium in the center of the house — that's PM's 1962 low-maintenance home for care-free living*

*Text begins on page 141*

*Peak of gracefully sloped roof is open, allowing air and sunlight into atrium. In the Florida pilot model, only screens are needed; in cold climates there's a closure*



*Sunlight brightens grass-floored atrium in views, below, toward master bedroom. Located near P.G.A. headquarters, owner turned center into putting green. However atrium could have a swimming pool or garden*

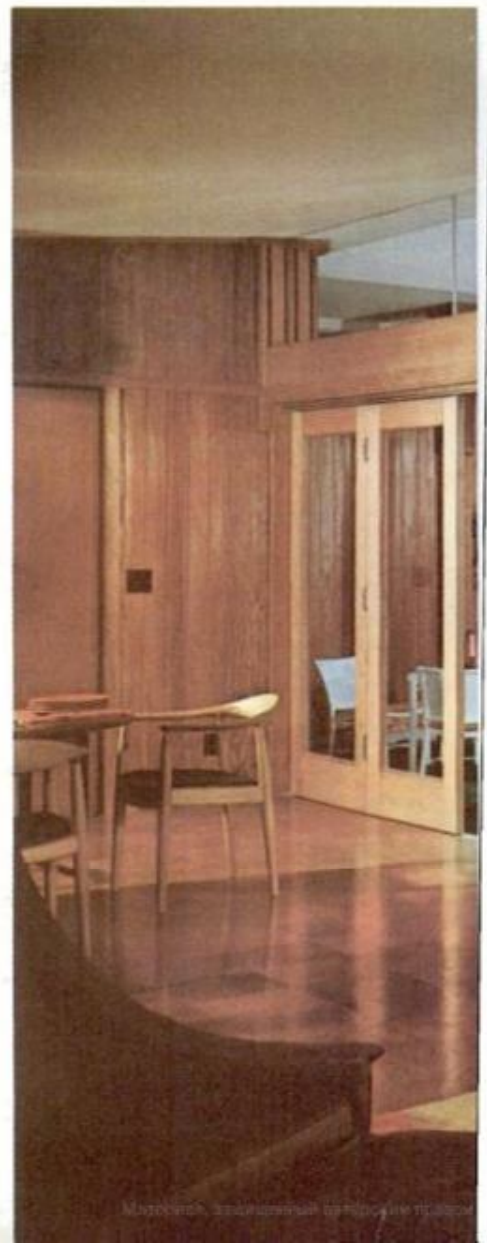





*Spacious living-dining area, with easy-to-care-for coated-cork floor and redwood-paneled walls, has lots of room for entertaining*

*Master bedroom, open to the atrium during the day, is quickly closed off for privacy with glass doors and sliding drapes*



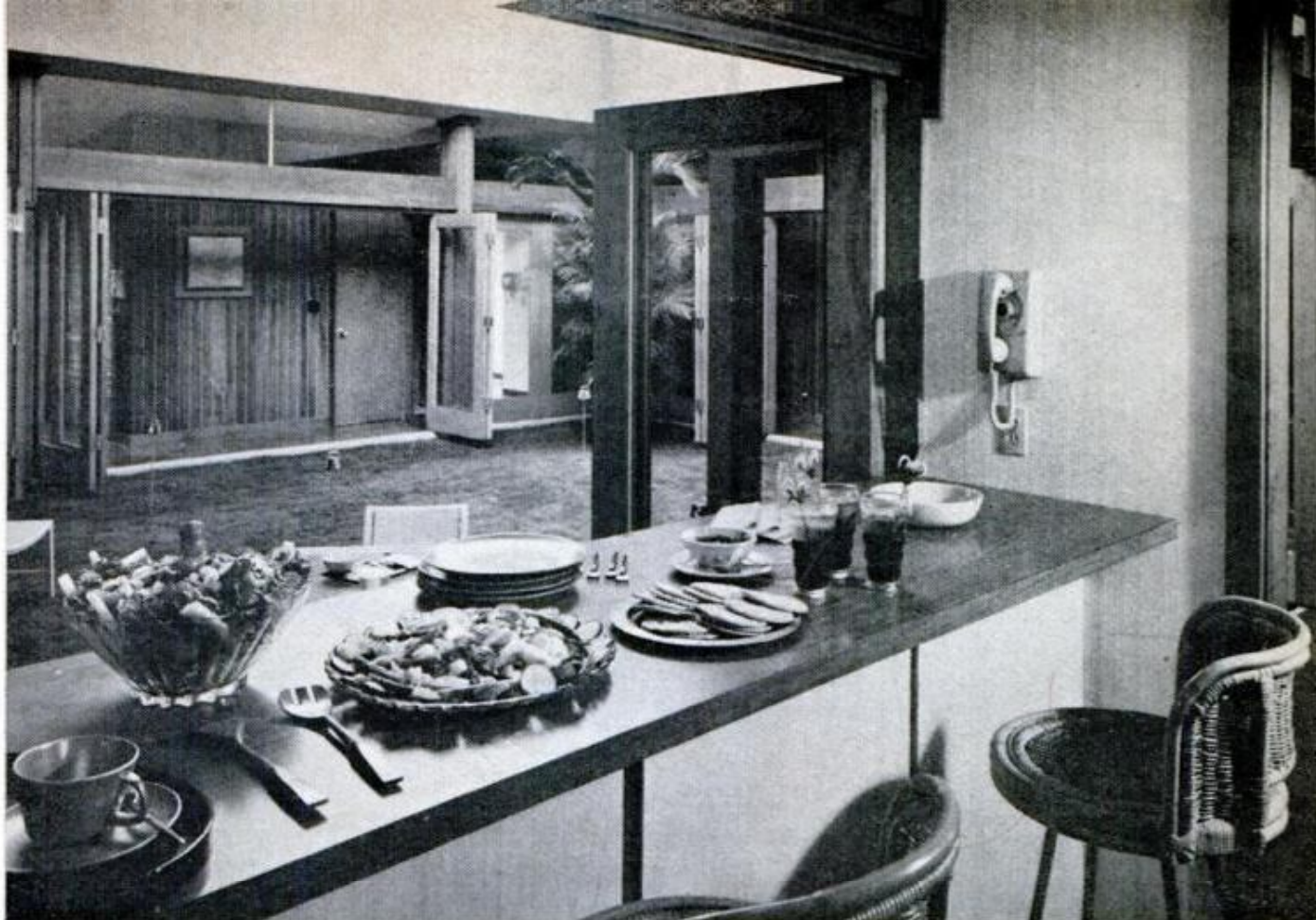

*Breakfast bar, between kitchen and atrium, is nine feet long. It doubles as a serving counter when the family entertains in the garden*

## For Care-Free Living, Just Move in — and Relax

**I**T'S A HOUSE of care-free living—and lots more. It's a house of gracious living . . . of family living . . . a house of outdoor living indoors.

PM's House of Care-Free Living is the happy solution to a problem we posed over a year ago to the nationally prominent Miami, Fla., architect, Alfred Browning Parker. "Give us a house that's easy to care for, that's truly different and that all of us would really *like* to live in," we asked.

With the help of Pritikin Construction of Miami, he created a home in Palm Beach Gardens that is all of these.

The focal point of the house—and a feature that adds light and space to practically every room in the dwelling—is an atrium. It's a centuries-old idea: the Romans developed the atrium as the main court in the center of a home, open to the sky.

Those old Romans would feel at home in our atrium during a modern-day barbecue, since cooking was the earliest use they made of the open court. However, they'd

[\(Text continues on page 144\)](#)



*U-shaped kitchen has laminated-plastic cabinet fronts, splashbacks and counter tops*

**Atrium at the center gives  
space, light to all rooms**

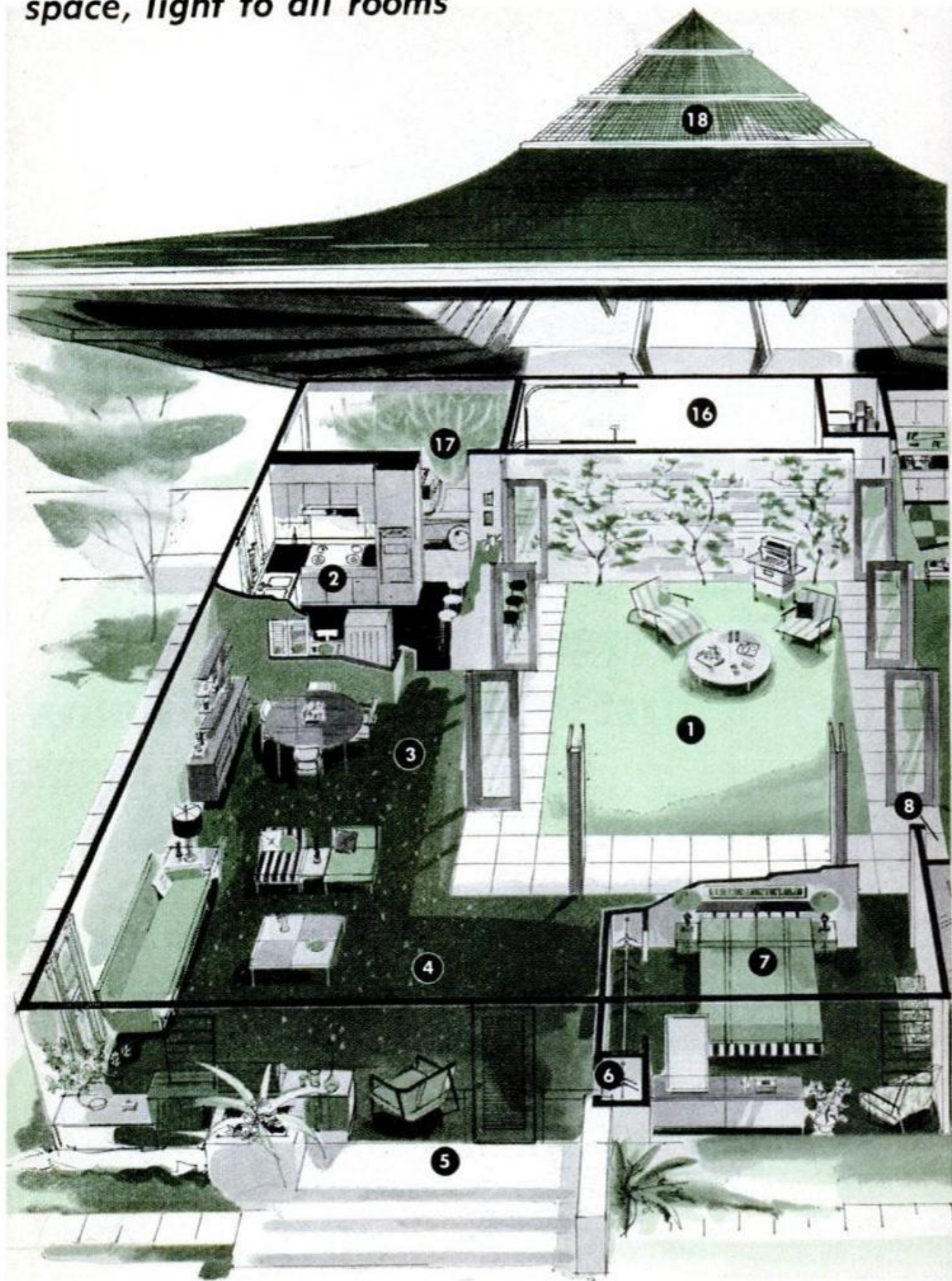



*In alternate four-bedroom version, laundry is fourth bedroom, carport becomes utility room with half bath, and garage becomes double carport, opening on far side. There are also options for fireplace, basement and roof closure*

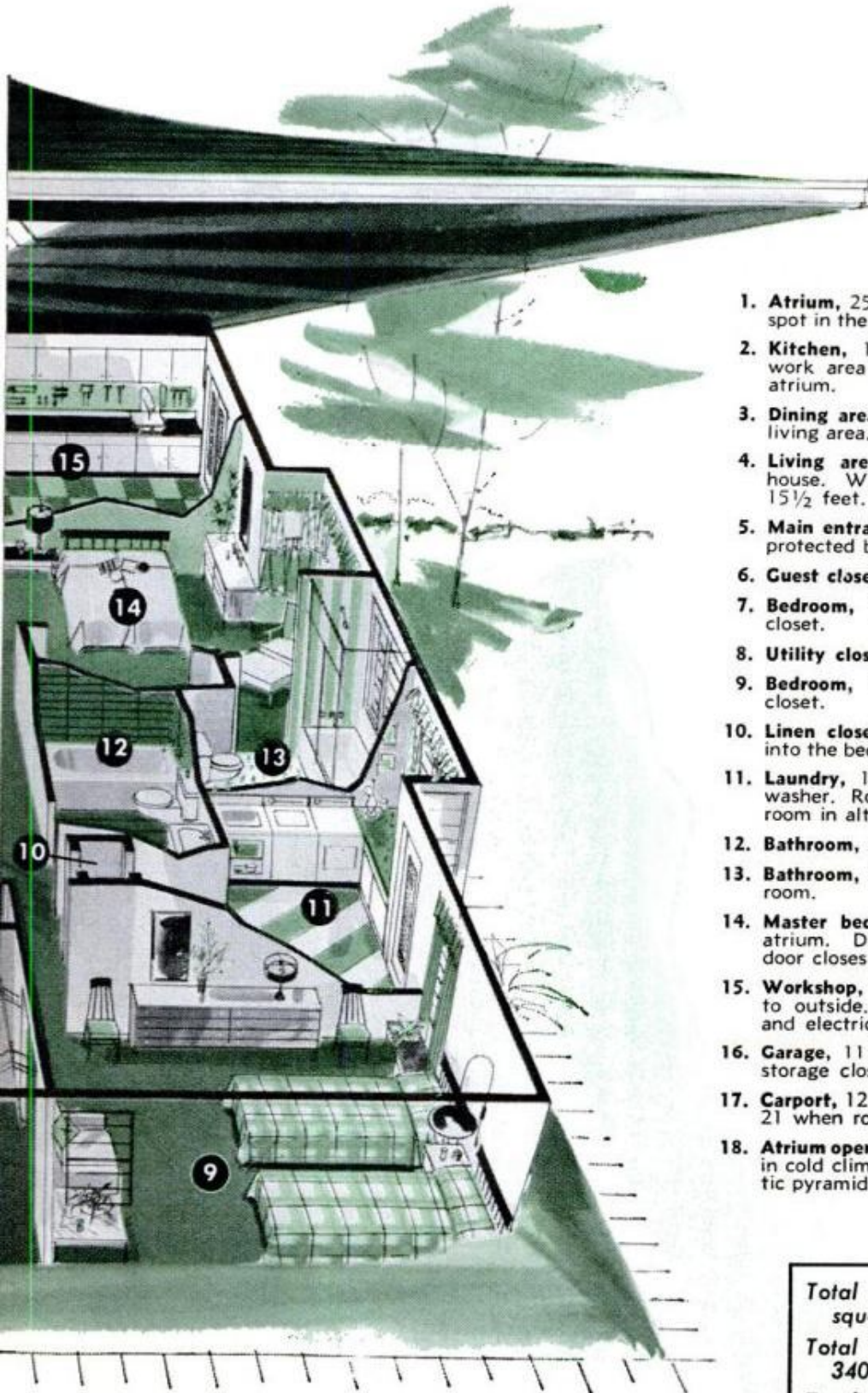

1. **Atrium**, 25 by 29 feet, is a sunlit garden spot in the center of the house.
2. **Kitchen**, 12 by 15½, has a U-shaped work area; its breakfast bar opens onto atrium.
3. **Dining area** forms 32 by 24-foot L with living area. Entire area opens onto atrium.
4. **Living area** includes main entrance to house. Width of living-dining space is 15½ feet.
5. **Main entrance**, reached by three steps, is protected by wide overhang of roof.
6. **Guest closet** holds visitors' wraps.
7. **Bedroom**, 11½ by 11½, has 7½-foot closet.
8. **Utility closet** opens on bedroom hallway.
9. **Bedroom**, 11½ by 15, has 8½-foot closet.
10. **Linen closet** opens into the laundry and into the bedroom hallway.
11. **Laundry**, 10 by 14, has sink alongside washer. Room can also be a fourth bedroom in alternate version of house.
12. **Bathroom**, 5 by 9, serves bedroom area.
13. **Bathroom**, 6 by 8½, is for master bedroom.
14. **Master bedroom**, 15 by 18, opens onto atrium. Drapes cover glass doors and door closes in hallway for privacy.
15. **Workshop**, 11½ by 15, has double doors to outside. Heating and cooling plants and electrical entrance are in this room.
16. **Garage**, 11½ by 20, has 4½ by 8-foot storage closet between it and workshop.
17. **Carport**, 12 by 16, is actually about 17 by 21 when roof overhang is included.
18. **Atrium opening**, 10½ by 10½, is screened; in cold climates it is covered with a plastic pyramid or sections of glass.

**Total area under roof: 4523 square feet.**

**Total living and working area: 3409 square feet.**

**Total enclosed living area: 1919 square feet.**

## Long life and easy maintenance are

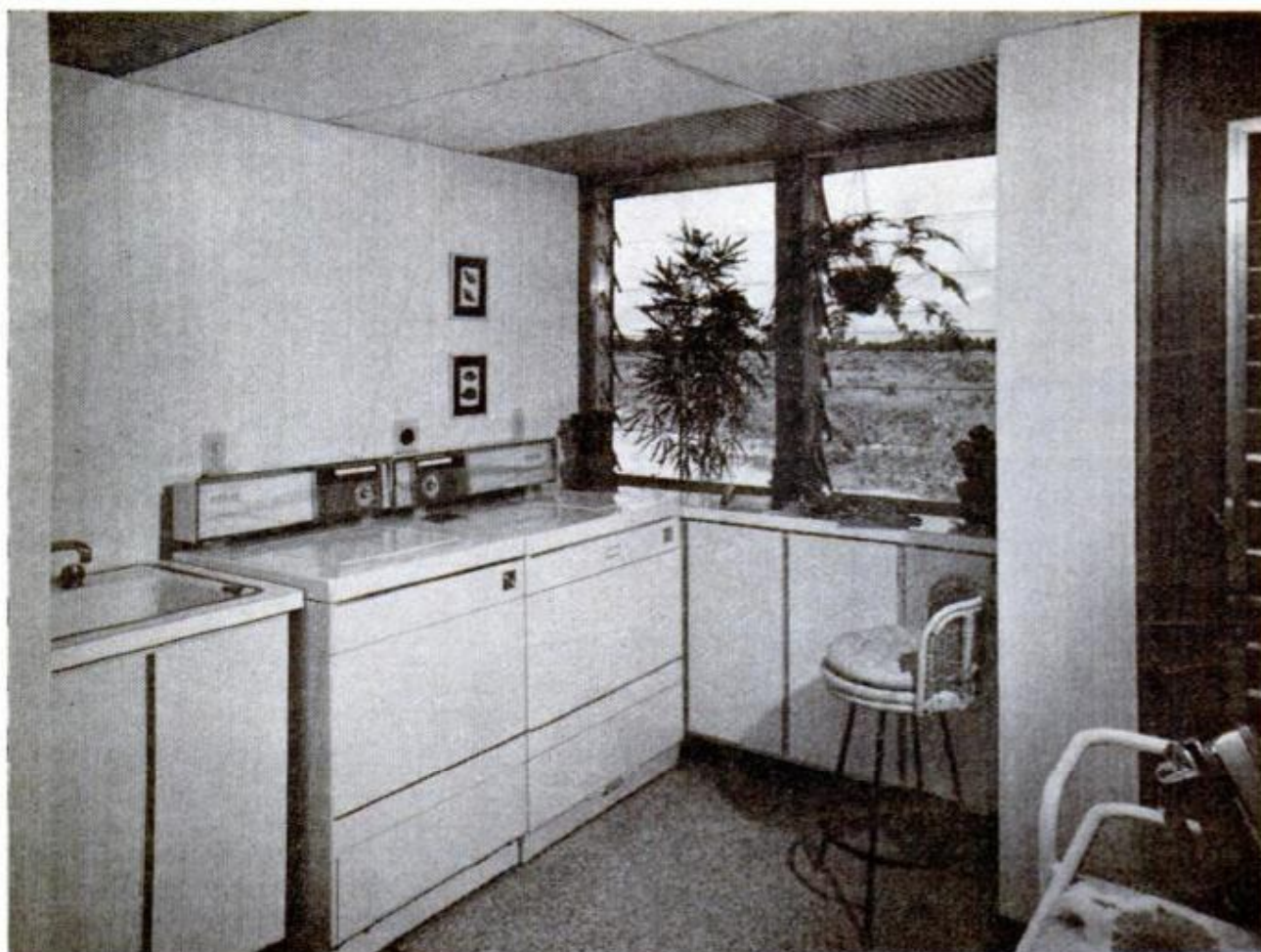

**Bright laundry room has counter tops and cabinets for folding and storing clothing, plus room for ironing and sewing. Door, at right, opens outdoors**

never understand the putting green—complete with cups and rolling terrain—that went into the Florida house. This golfer's paradise is a "natural," as the house stands alongside the new site of the Professional Golfers' Association headquarters and golf course.

In PM's house, the opening above the atrium is at the peak of a roof that slopes gracefully upward on four sides to a point in the center. In Florida's mild climate, only maintenance-free fibreglas screening covers the atrium opening, allowing sunshine and rain to fall on the grass below. (And if grass isn't your cup of tea, you can do several other things with the area: Pave it, put in a decorative garden, or add a swimming pool.)

In a cold climate, the center is capped with a plastic closure or glass sections that can be opened during warm months.

Plate-glass French doors inside the house surround the atrium, enabling the area to be closed off from the rest of the house.

But whether those glass doors are open or closed, there are many sweeping interior views across the garden, such as that from

the master bedroom—a view that takes in the atrium, kitchen, dining and living rooms and bedroom hallway. (For privacy, there are sliding drapes along the glass doors that close off the master bedroom.)

Commenting on the design of the house, the architect described it as "looking inward, thus assuring not only privacy for the family without the maintenance problems of draperies, etc., but also eliminating a lot of the dust that might blow into a house. By the use of the atrium the screening required to keep the home free of insects is reduced to an absolute minimum. And the location of the inward wall of French doors reduces the heat loss of the building and makes cleaning of the glass much easier than would be a similar amount of glass used in outside windows.

"Even though the house looks inward for family privacy," he continued, "it has a 'friendly' exterior—that is, it doesn't look walled and aloof—and fits well in a neighborhood of homes."

The main entrance to the house is, as are all its entryways, inset and sheltered under the wide overhang of the roof. Such

## standards for materials in the PM house



*Linen closet conveniently opens from both the laundry side and the hallway*



*Workshop features a sturdy, folding bench on each side of radial-arm saw*

protected entryways help cut down the amount of dirt tracked into a house, relieving the housekeeper of extra cleaning.

Upon entering, you step onto polyurethane-coated cork tile, the flooring that is used throughout most of the house. Its tough, lustrous surface is another easy-keep feature.

The warmth of redwood paneling domi-

nates the view from the front door. Wood paneling covers the walls of the living-dining area, the walls of the hallway, the master bedroom—even the wall between the atrium and garage. The posts, beams and doors are also redwood, which, in addition to its pleasing appearance, offers a high degree of resistance to rot and to insect attacks.

(Continued to page 240)

### PM'S HOUSE OF CARE-FREE LIVING

### FOR PLANS

### ANOTHER MODEL

**Architect:** Alfred Browning Parker, FAIA, 2921 Southwest 27th Avenue, Miami 33, Florida.

**Builder of Pilot Model:** Pritikin Construction, 6700 Northeast Fourth Court, Miami 38, Florida.

**Furnishings and Decoration:** Burdine's of Miami, Florida.

**Location of Pilot Model:** 9901 Military Trail, Palm Beach Gardens, Florida.

(From the West Palm Beach exit of the Sunshine State Parkway, go north on Military Trail.)

**Photography:** William Maris, Ezra Stoller Associates, Kirby Lane North, Rye, New York.

**Complete plans** including specifications for the PM House of Care-Free Living, as it was built and shown here, are available. The plans will include drawings of the four-bedroom alternate and the optional basement, fireplace and closure for the atrium. The cost for each set of plans is \$50. Order from Plans Department, Popular Mechanics, 575 Lexington Avenue, New York 22, New York.

Burt & Lee Builders of Houston, Texas, have adapted the Easy-Living theme in a model which may be seen at 2502 Dauphin Court, Swan Lagoon Addition, Houston, Texas. Furnishing and decoration were done by Hart's of Houston. Watch for the local announcement of its opening date.

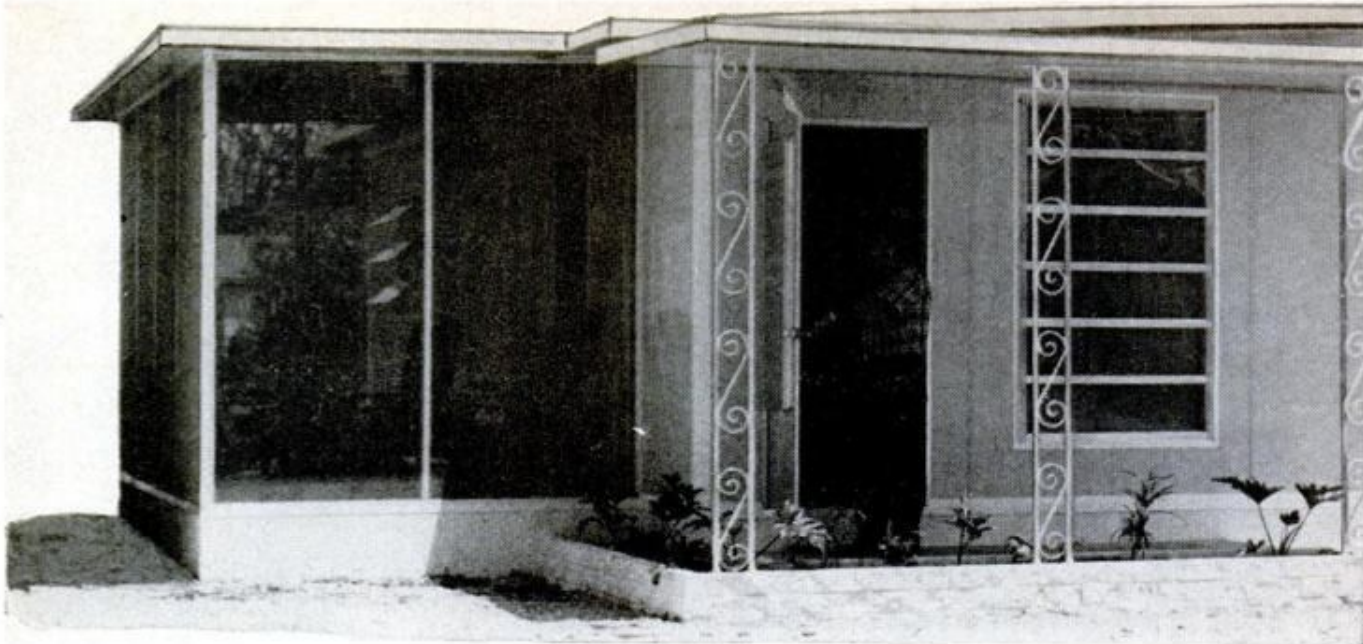

# Sandwich House Slips



**ALUMINUM PANELS** are easily slid into place by one or two men. Panel joint (below) slides down to lock both crimped edges of each panel

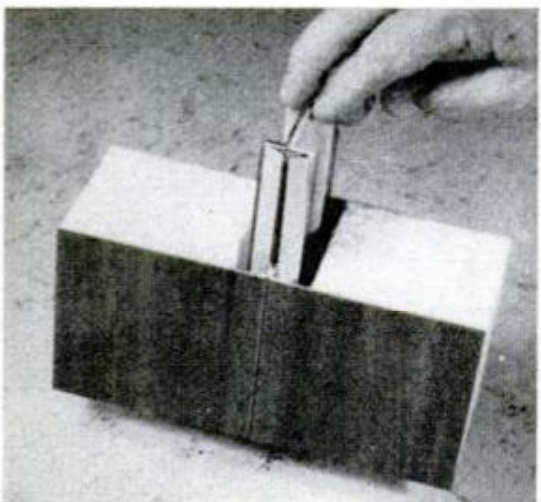

**P**REFABRICATED aluminum homes can now be put together by the owner by sliding the panels in place. The joints are then double locked by driving a special vinyl strip down the full length, pulling the panels tightly together and eliminating caulking. The aluminum siding and leakproof joints make the homes care-free.

The three-foot panels are a sandwich of three-inch-thick polystyrene, which serves as insulation, bonded between sheets of prefinished aluminum. The exterior sheets are finished in a variety of stains and baked-on enamel, and the interior sheets are in imitation wood or leather textures in an assortment of colors.

The homes are available in 15 different models, from one-room vacation homes to three-bedroom deluxe versions that include a screened porch and carport. A two-bedroom model is shown above.

Built on a slab or conventional foundation, they use no rafters, studs, ceiling joists or other framing materials. Necessary tools include level, electric drill, screwdriver and wrench.

Priced from \$4000 to \$11,000, the homes include all plumbing, electric wiring and fixtures, plus heater, kitchen appliances and bathroom fittings. The manufacturer, National Panel Corp. of St. Petersburg, Fla., also claims:

That the homes can be dismantled and moved to another location as easily as they can be put together.

That the special joint locks make the walls and roof completely leakproof.

That the insulation material has the same insulation qualities as 24 inches of concrete.

That the walls when erected properly can withstand winds up to 135 m.p.h.

That they will give 10 years of maintenance-free use.

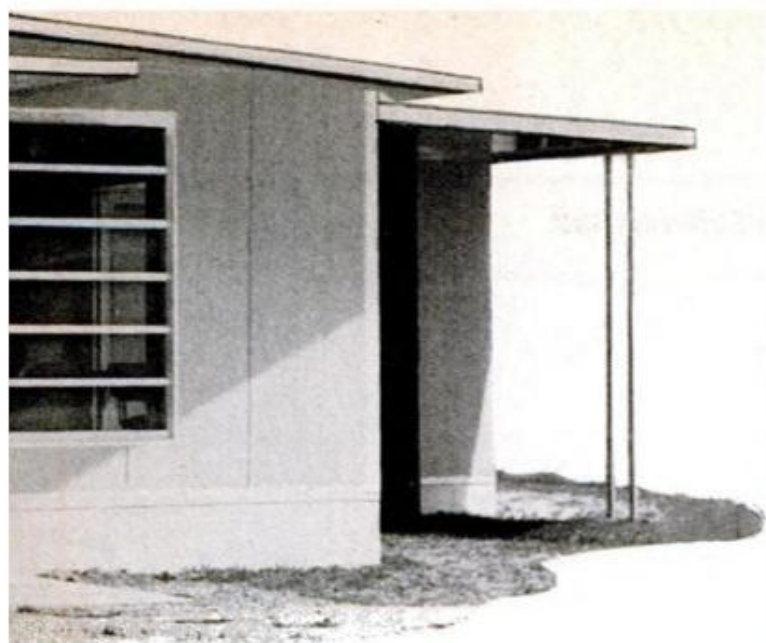

# Together

**PANEL PLUG**, prefabricated to fit, slides in above window, fitting neatly with large wall panels



**INTERIOR PANELS** for inside walls have similar construction to outside panels, except that both aluminum sheets have interior decorative finishes. They are installed in same manner as outside walls, without studs

**ROOF PANELS** also have construction similar to wall panels and are slid together and locked in place. Manufacturer claims lock makes roof leak-proof without need for caulking. Some models have screened porches

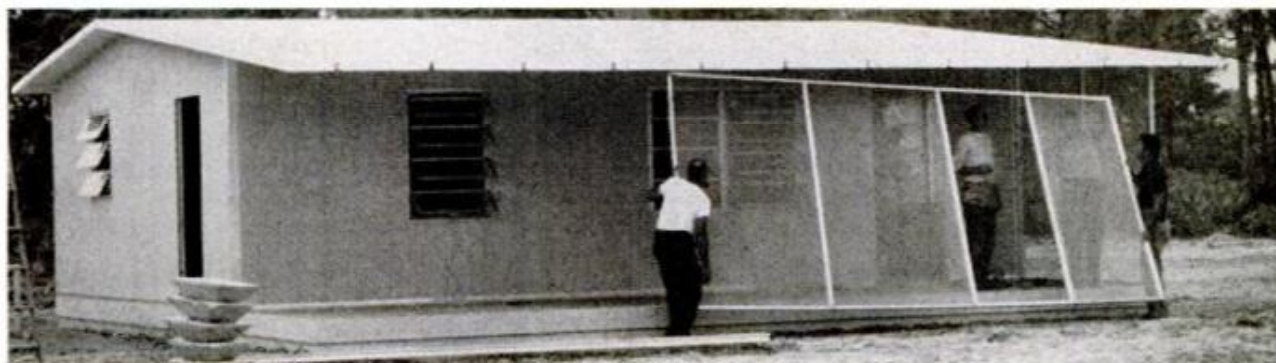

# 50 Money-Stretching



THE BETTER THE NEIGHBORHOOD you select, the less depreciation your home will have over the years

By Richard Nunn

**I**T'S A BUYER'S YEAR so far as new housing goes, with most of the nation's builders offering bargains they've never offered before.

Houses—especially development houses in smaller cities and towns—are better built, better designed and need less maintenance.

To find what you should look for and expect when you go house hunting this fall, *Popular Mechanics* went into the field and talked to the leaders in the home-building industry. Here are their tips for getting more long-lasting value from the money you spend.

## Neighborhood

After you've carefully analyzed your family's needs and narrowed down the field of subdivisions, make this check:

- You like the neighborhood now, but will you like it five years from now? The better the neighborhood, the less depreciation your home will have over the years.
- Are you close to schools and churches? The school superintendent or a PTA officer will give you enrollment figures and how they compare with room space, and tell you whether classes are on split sessions as well as future expansion plans. If space is inadequate now, you'll be taxed for a new building.
- Are you close to public transportation and shopping areas? If not, you can count on extra driving costs—or a second car.
- Does the subdivision have land set aside for recreational purposes? Many builders

are including extra value in community swim clubs, playgrounds and so on.

- Beyond the boundaries, is it industrial or residential? Too much industry can devalue your property. Are there zoning codes? You can get the zoning information from the city building department or city engineer. Your lending agency will probably help, too, since it will be interested in maintaining the value of its investment.

- How about police and fire protection? If you have city protection, see if there's a fee for the service. It can run as high as \$200 per call. The city clerk can give you figures on the cost of police and fire protection both inside and outside the city.

- When comparing city and noncity taxes, remember that the generally higher city tax may include such services as garbage pickup (which usually costs about \$3 a month on a contract basis).

- If the builder has other, older subdivisions, visit them. Are they well kept or slummy? This often gives you an insight into the future of your area and the consequent future value of your investment.

- Is the builder reputable? Check the local office of the National Association of Home Builders or the Chamber of Commerce. A reputable builder will be interested in protecting his good name by building good houses.

- Are the streets paved, well-marked and lighted? If not, you'll be assessed for improvements later.

- Are the storm drains and fire hydrants in? They, too, are costly later.

# Tips for Home Buyers



**DOOR PLACEMENT** may involve special furniture

## Plan and Site Arrangement

The plan and site arrangement of the house should be your next consideration. Look outside first and check:

- Has the lawn been seeded or sodded and landscaped? If not, it will cost you a minimum of \$150 to do the job after you move in.
- Does the lot have proper drainage away from the house? Local codes generally specify the slope; a good general rule is one percent for every two feet. Bad drainage can cause costly basement flooding.
- Trees closer than 10 to 15 feet from the house can cause trouble with the roof, gutters and foundation.
- How adequate are the storm sewers? In getting this answer, you should consult the city engineer. Basement flooding or an assessment for new sewers may be the result of an inadequate system.
- Is the driveway concrete or blacktop? Blacktop needs renewing every few years, at an average cost of \$150. Garage floors and driveways should be metal reinforced to prevent cracking and breaking. They should also be thick enough—about five inches—to withstand the weight of trucks. To check, insert a wide scraper between the sod and driveway and press away the dirt to expose the thickness of the concrete.
- Are the sidewalks in? You can be assessed for them later.
- Is the lot adequate in size? Less than 75 to 80 feet of frontage is considered inadequate by subdivision standards. By buying a lot that's too small, you may devalue the house. The house should fit the lot with room for later additions.



**MANY BUILDERS** show framing methods, materials

## Plan of the House

The plan of the house is its most important feature. The house should be designed so the traffic flow isn't through the living room. There are other design faults, too, which may be overlooked at the time of purchase. These faults may become merely annoying later on—or they may lead to expensive remodeling to correct them.

Young home buyers should consider purchasing a home that can be expanded for a growing family. Other points include:

- Do the walls in the living areas conform to easy furniture arrangement? King-sized windows and odd placement of doors often involve furniture specially made to fit. In effect, this will raise the cost of the house.
- Are the bathrooms conveniently located so that you don't have to walk through the living room to reach them?
- Do the bathrooms appear to be large enough for your family? Shower areas should be tiled shower-head high with ceramic or plastic tile. Plastic tile can't take the cleaning punishment that ceramic does. There should be storage space for towels, washcloths and toiletries.
- Is there a closet near the entrance for guests' wraps? Or will guests have to go into a bedroom to store them?
- Are bedrooms large enough for accessories such as night stands and chests?
- Is there adequate closet space for your family's clothing? Inside depth should be no less than 22 inches—or 24 inches for heavier outer garments.

(Continued to page 216)

**DRAWER PULLS AND KNOBS**

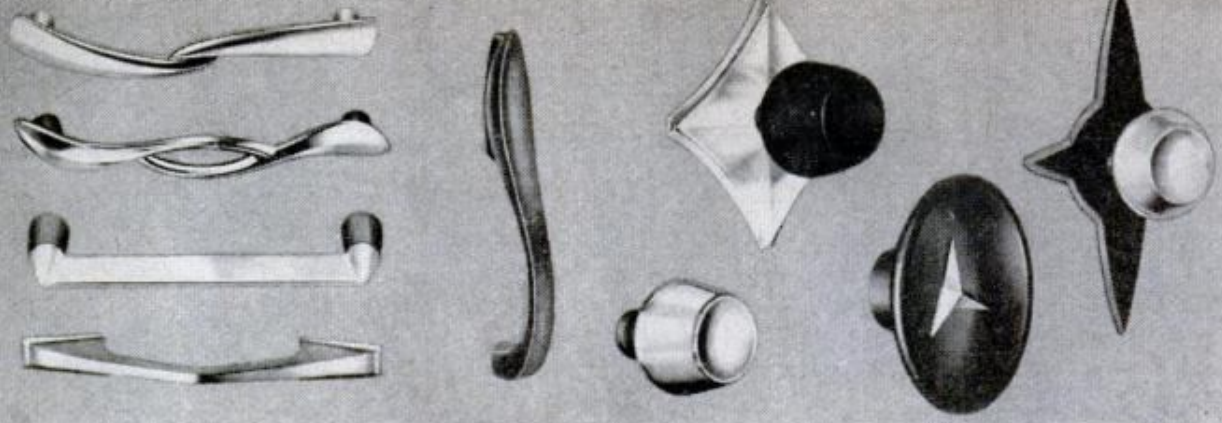

**DRAWER PULLS**

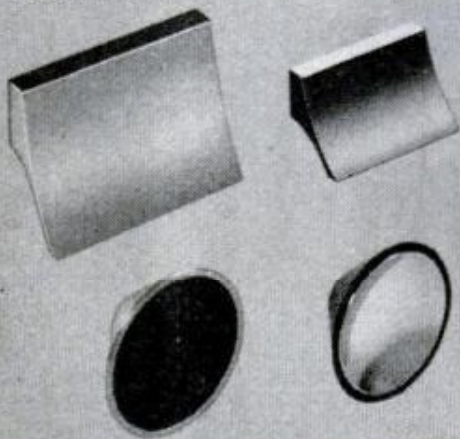

# HARDWARE SHOWCASE

Thinking of remodeling the kitchen? This capsule look will give you an idea of what your hardware dealer has in the way of common and special items to make the kitchen the smartest and handiest room in the house

**SURFACE HINGES**



IN BLACK AND COPPER

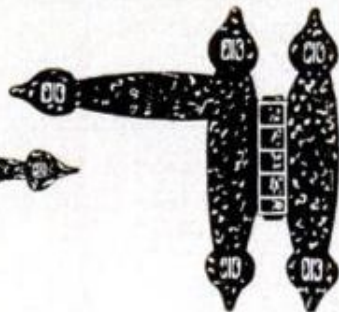

TWO-TONE  
IN BRASS, BLACK  
AND COPPER



OFFSET



IN CHROMIUM  
BRONZE AND COPPER



FLUSH



SEPARATE STRAP

**NOVELTY PULLS**







**By E. R. Haan**

**B**EFORE YOU install kitchen cabinets and built-ins or modernize old installations for better appearance and added convenience, you'll want to have a look at the latest hardware for the handy homeowner.

Accompanying details and photos on these pages give you a good idea of the variety in smart knobs and pulls now available. Regular finishes are satin or polished chrome, copper, brass and black. Back plates of knobs as well as the knobs often are interchangeable so that you can have a certain type and size knob on the particular back plate you may prefer. Most knobs and pulls are attached with machine screws driven from the back of doors and drawers, except some, such as colonial style pulls, which are screwed on from the front.

Magnetic catches are highly popular. They are small and have no moving parts that wear out, and are made for single and double doors. Those for two doors are slightly longer, having two pairs of magnets. Some magnetic catches have a floating action to assure maximum contact. Another bullet-type magnetic catch fits in a  $\frac{5}{8}$ -in. blind hole and so is out of the way. Cases differ in design to suit various mounting positions.

Some mechanical catches, such as the touch catch, not only hold the door closed but propel it outward a few inches when the door is pressed lightly. This is an advantage on flush cabinet doors having no pulls or knobs, nor recessed finger holds. There also is a combined pull and spring-action catch which is reversible for right or left-hand doors. The catch releases by finger pressure on the upper end of the pull. The polyethylene friction catch with a ball-head wood screw for silent action comes at low cost and is quite efficient for small doors. Noiseless catches have a spring-cushioned rubber roller which cradles in the strike and prevents the door from striking against the frame. Another smooth-operating, silent catch is similar but has two rubber rollers that move with a floating finger action to grip and release the strike. There's also a cabinet door closer which closes small doors automatically. It's illustrated on page 152.

Exposed hinges should match other door hardware in color and design, especially the colonial style hinges. Some

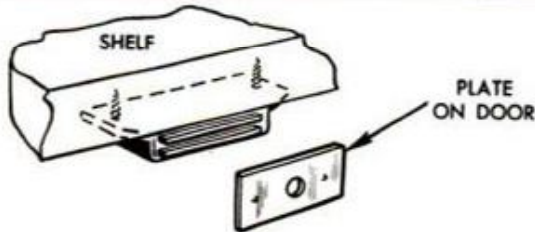

**MAGNETIC CATCHES**

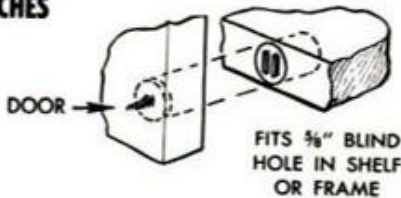

TOUCH CATCH

**MECHANICAL CATCHES**



POLYETHYLENE CATCH



PUSH-BUTTON CATCH  
COMBINED WITH  
DOOR HANDLE



NOISELESS CATCH  
WITH SPRING-  
CUSHIONED RUBBER  
ROLLER



DOUBLE-ROLLER CATCH  
WITH FLOATING-FINGER  
ACTION

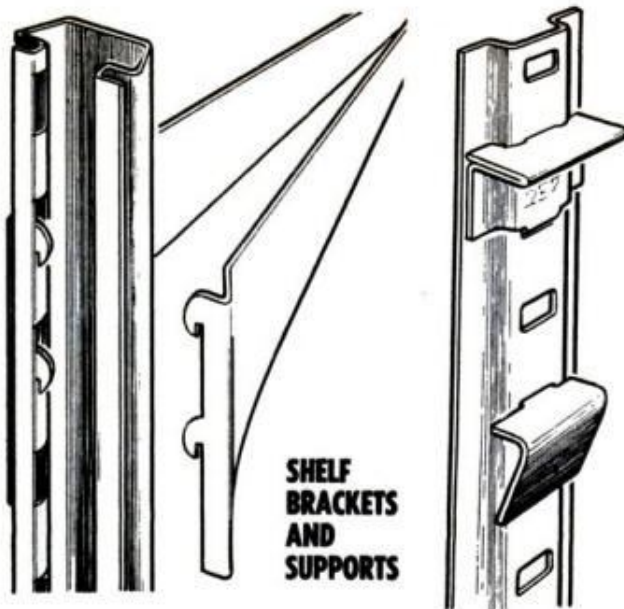

**WASTE SPACE** can now be utilized, either on the wall or in a cabinet by using easily installed shelf brackets and shelf supports. Just screw the metal strips to wall and snap the brackets or supports in desired place

### SEMI-CONCEALED HINGES

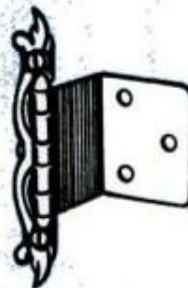
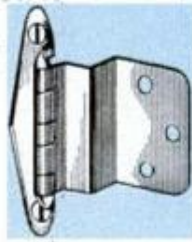

**NOW YOU** can buy tiny hydraulic closers for kitchen cabinet doors. Saves time and finger wear on doors



**CABINET-DOOR CLOSER**

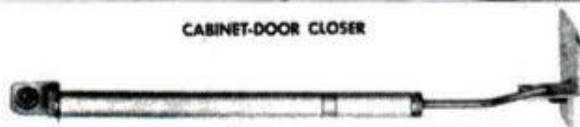

of these have a separately attached strap. Many hinges are made to fit various types of doors—overlapping doors, overlapping-rabbeted doors, and flush doors. The variation in the methods of hanging are shown in details above and on facing page.

Most cabinet hinges are reversed to fit either right or left-hand doors. Non-reversible hinges are purchased for right or left-hand doors as for example the various types of partially or wholly concealed hinges. Some are made for attachment to the top and bottom corners of doors. A shallow mortise in the door edges produces maximum concealment. One type requires a small slot in the door so that only the pivot end is visible. Some are completely concealed.

Sliding cabinet doors of glass or of other material require tracks to hold them in

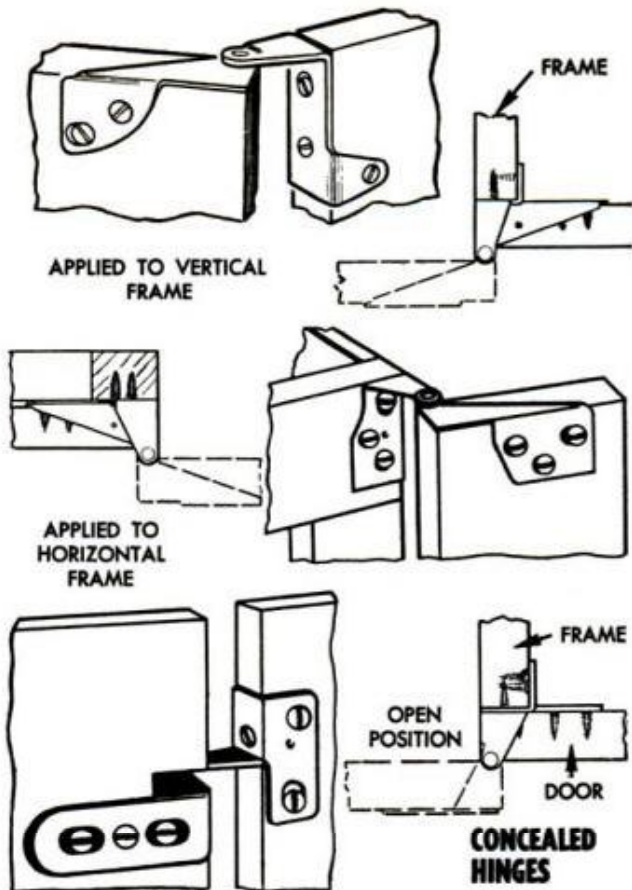

position and to permit bypassing with sufficient clearance. For lightweight doors you can use wood, plastic or metal tracks, shown below, but for heavier doors tracks with rollers or ball bearings are best.

Heavily loaded drawers that are difficult to open and close can be transformed into easy-sliding, fingertip-control drawers by using specially designed guides and rollers now available, page 155. Some guides have plain rollers and others have ball-bearing rollers. One design is such that when drawers are released when still open a few inches they will close automatically. Guides on drawers are either installed at the sides or underneath, and require a specified



### ALUMINUM SLIDING-DOOR AND PANEL TRACK

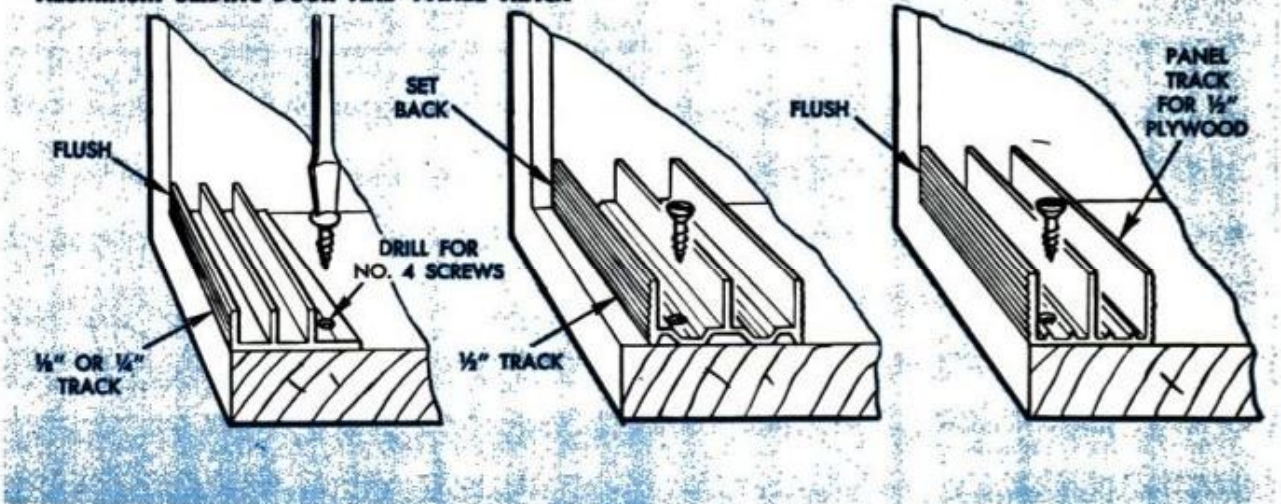

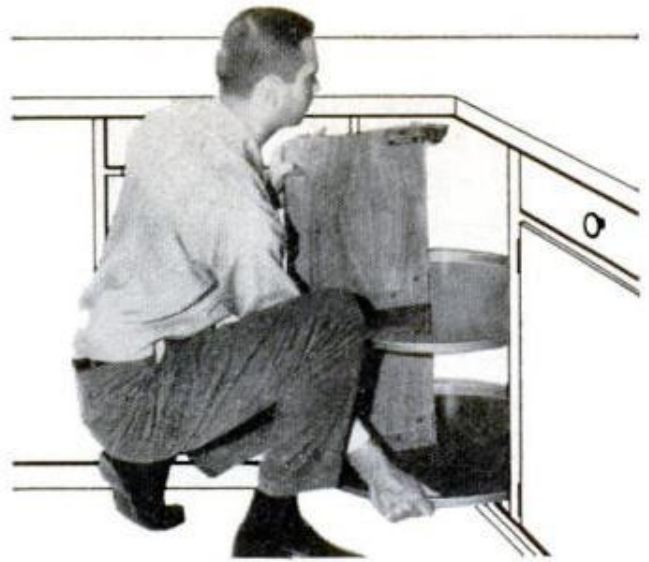

**CORNER SUSANS** are of two types; one fits across corner and is concealed by a door as in left-hand photo above. Other fits into a right-angle corner, carries its own closures. Closed, it appears as corner of cabinet



**APPLIANCE SHELF** operates just like typewriter shelf that closes into desk. Shelf folds into cabinet below

**TOWEL RACK**, pan rack, waste-container rack slide into cabinet when not in use; are easily installed



clearance between drawer and framing. One type consists of a single guide installed centrally under a drawer, and two rollers installed on the frame. Another type carries the drawer entirely on rollers. All these units have variously styled mountings to suit different drawer installations. You'll get installation instructions with all cabinet and door units.

One good way to utilize waste space is to install adjustable shelves, using adjustable brackets and supports like those on page 152. These units are easy to install; just screw to the room wall or inside a cabinet. A sliding waste-basket holder, a sliding pan rack, and a sliding towel rack are shown at the left and below. A swing-up shelf for food mixer also is pictured.

As a substitute for permanent shelves in corner base cabinets, where stored articles are usually hard to reach, you can install rotating shelves, or concealed Lazy Susans. There are three methods of installation. Where the corner is accessible through a single door set at an angle, circular metal shelves carried on brackets on a rotating column are used. The same type brackets and column are used where the installation must be made in cabinets that corner at a 90-degree angle. In this case a segment is cut out of each shelf, and two vertical doors set at right angles are fastened to the shelves. The doors fit flush with the cabinet front when the Susan is closed and move inside the cabinet as the shelves turn. In the first arrangement it is also possible to rotate the shelves on small individual rollers which are mounted on blocks screwed to the frame. Regular shelves can be arranged to slide outward from other base cabinets, by using easily-installed metal shelf slides. ★★★

# DOUBLE-TRACK DRAWER SLIDE

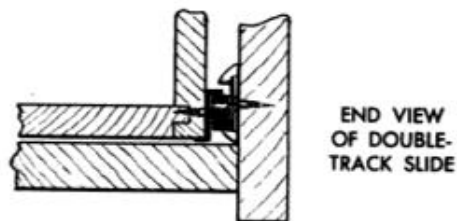
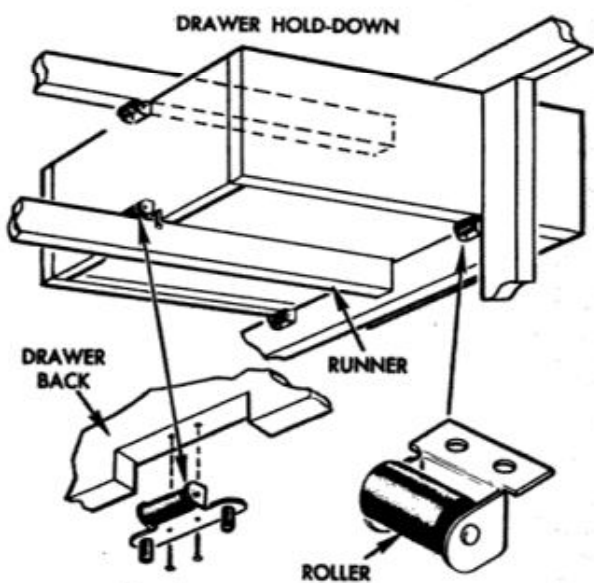
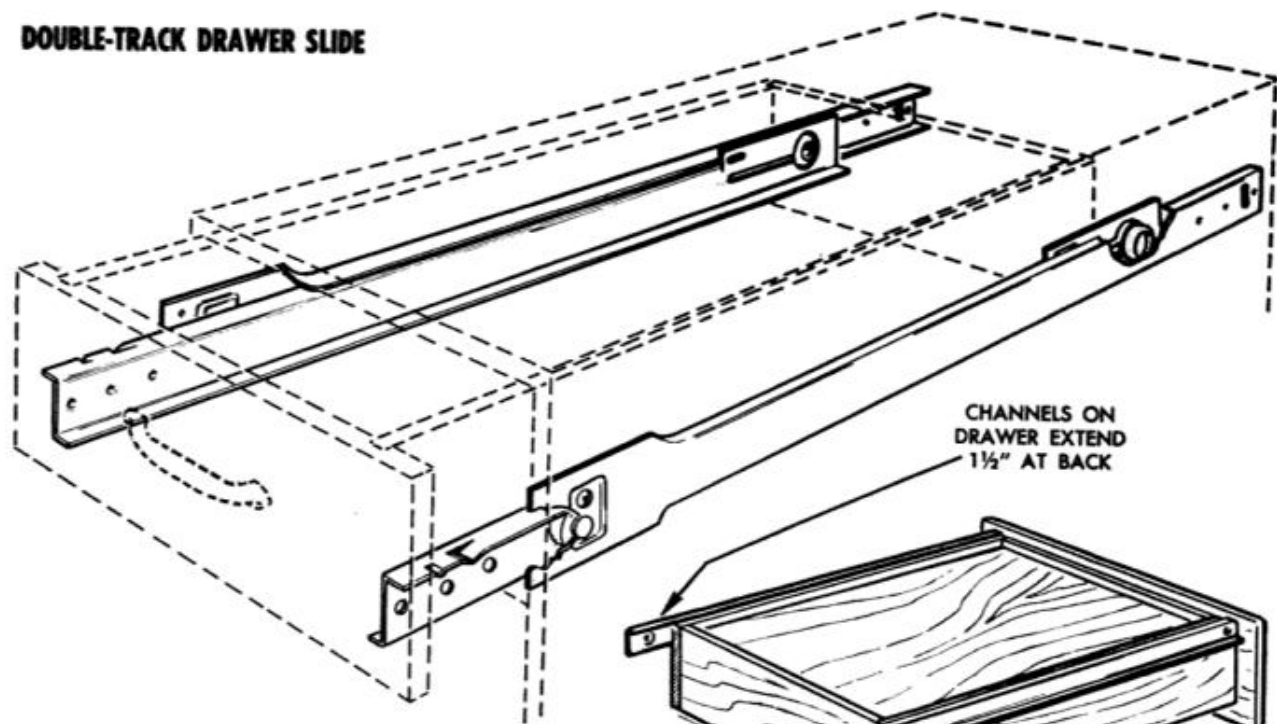

# TRI-ROLLER DRAWER SLIDE

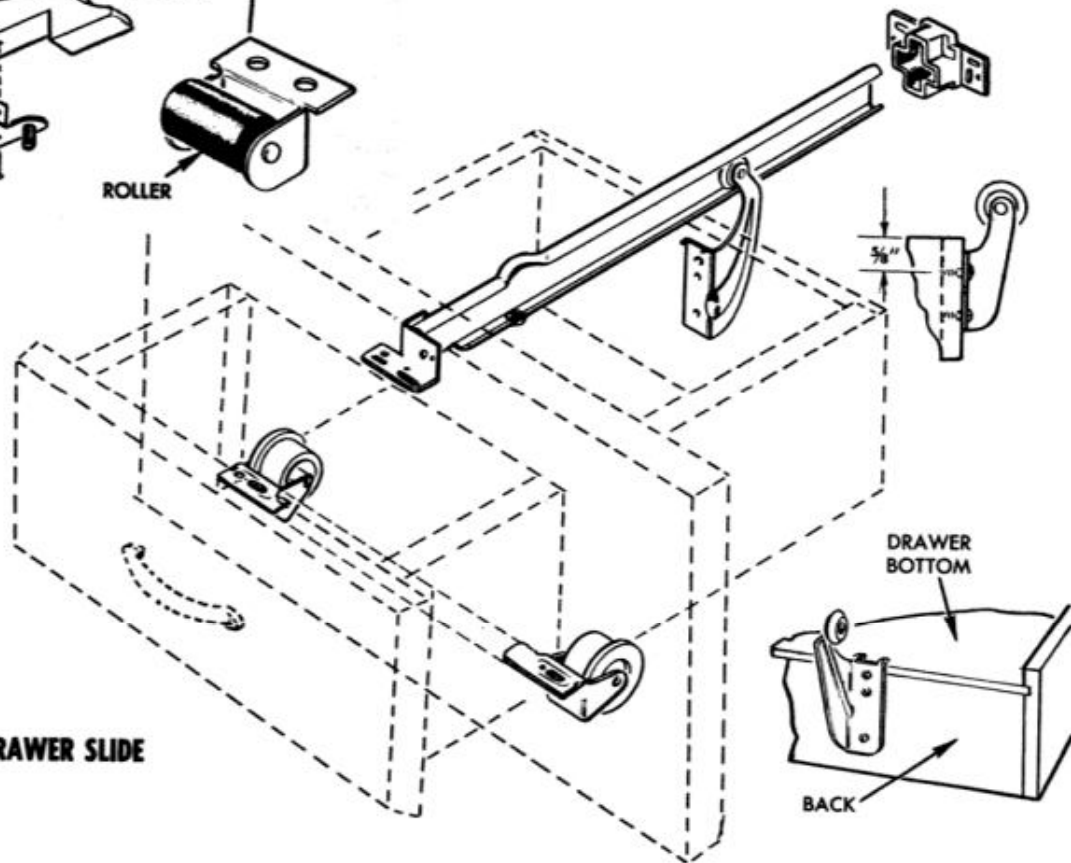



**INSTALLATION** of lightweight metal furring strips is much easier than nailing ordinary wood furring



**TONGUE-AND-GROOVE** joint between tiles conceals the flange of metal Z-strip from which ceiling is hung

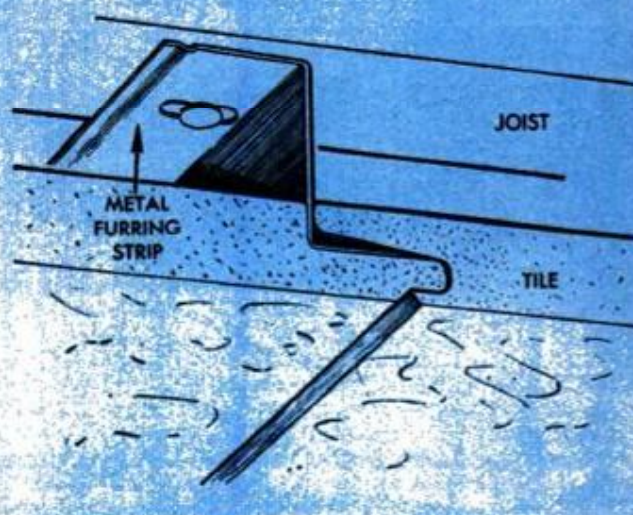
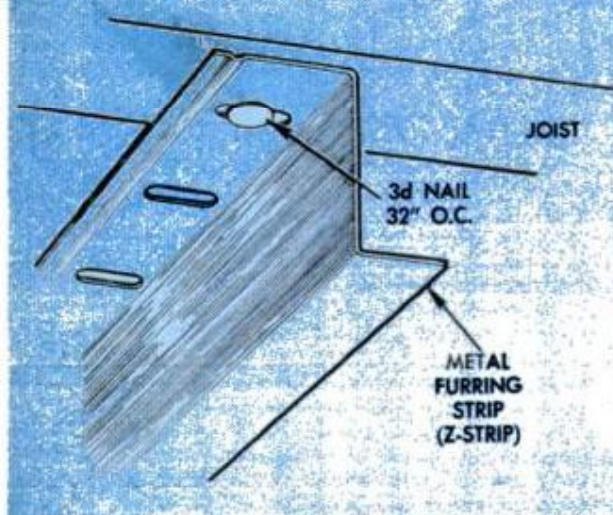

## Tile Ceiling Interlocks On Metal Furring

DO YOUR remodeling plans include a new ceiling? If they do, you'll be interested in a new and almost foolproof system for installing ceiling tile that takes much of the work and worry out of the job. The key to this whole system is the use of lightweight metal Z-strips in place of the standard wood furring strips. Instead of stapling, or nailing the tiles in place you simply slip the lip on one side of the tile into the notch of the preceding tile and rest the lip on the opposite side over the flange of the metal Z-strip. When the next row of tiles is installed the flange will be concealed.

Since the metal Z-strips are much lighter and easier to handle than wood furring, you'll find that the job of aligning them will be less difficult. In addition, the way in which the tiles interlock provides fast and

accurate alignment in both directions. As you see in the detail on the opposite page a plastic cove molding snaps into the metal edge strips for that professional finishing touch, at the walls. It's so simple that you can install the molding for an entire room in a matter of minutes.

The metal furring and tile shown here are manufactured by the Insulite Division of Minnesota and Ontario Paper Co., 500 Investors Bldg., Minneapolis 2, Minn. Other manufacturers are making a similar new ceiling system. Available in both decorative and acoustical types, the tile has a minimum edge bevel to make the joints less obvious and create a more unified effect. Both types of tile can be purchased in a variety of textures, patterns and colored designs suitable for any ceiling. ★ ★ ★



**METAL EDGING STRIPS** mounted around outside of room will hold snap-in plastic cove molding

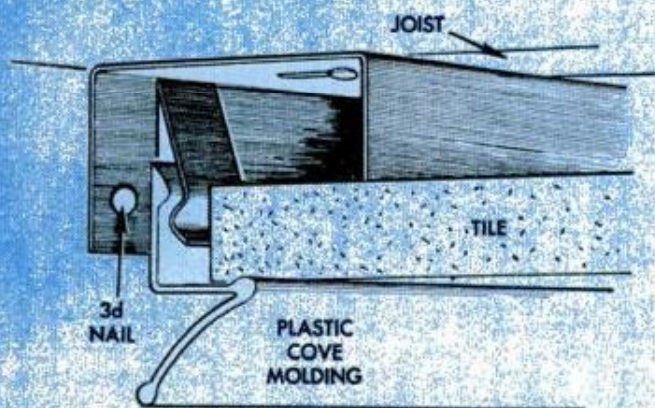

**COVE MOLDING** goes up with minimum effort, slipping into notches in the metal edging strip



SEPTEMBER 1962



## Bevel-Siding Saver

This L-shaped bar is used by a wrecker who specializes in salvaging parts of old structures intact. It's made from  $\frac{1}{8}$ -in. flat steel bent to a right angle and having the ends shaped as in the detail. Driven under a siding board near the nailing point it will lift the board without splitting or damaging the edges.—*G. E. Hendrickson*

## Boxes Steady Door

Here's a trick that one carpenter uses to hold a door upright while planing the edge to cure sticking. Clamp a wooden packing crate to each end of the door on opposite sides, and you'll find that this holds the door perfectly steady. Use a pad between the C-clamp and door to prevent marring the finish.—*B. W. Draper*

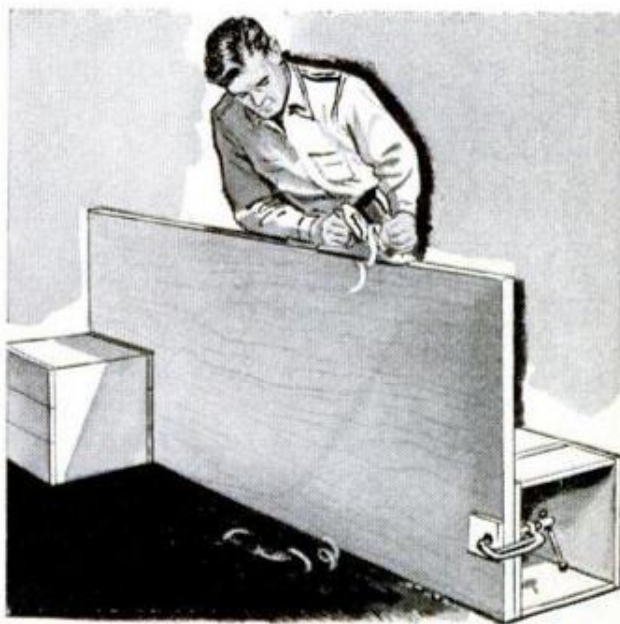

157



Elis Borg

## **PLAY-FURNITURE FROM SWEDEN**

*In these nine pieces Swedish designers and craftsmen have used their skills to achieve a rare combination of newness, freshness, and simplicity of line sure to delight the eye of moppets and grownups alike*

### **PART I**

**D**ESIGNED WITH nothing but fun in mind, this fresh new approach to the wonderful world of make believe is Sweden's answer to simple, imaginative play-furniture. Featuring take-apart, folding, rolling and rocking action, it gives the imaginations of lively youngsters full reign in originating new and exciting play.

In cooperation with *Good Housekeeping Magazine* who first pictured this exciting collection in color in their May issue, *Popular Mechanics* in this first of a two-

part article, now shows its readers how to build it.

#### **Work-Play Table**

You see the work-play table pictured above and detailed on page 162. Note that it contains sixteen "drawers" in two sizes which serve not only as drawers when placed in the table, but also as tote boxes or stack boxes for play or storage. After a good look at the features of this table you Dads might even be tempted to build it grownup-size for a shop bench. In tot-size





Ellis Borg



Evy Westerberg-Levander



Evy Westerberg-Levander

Nils Johansson

Evy Westerberg-Levander



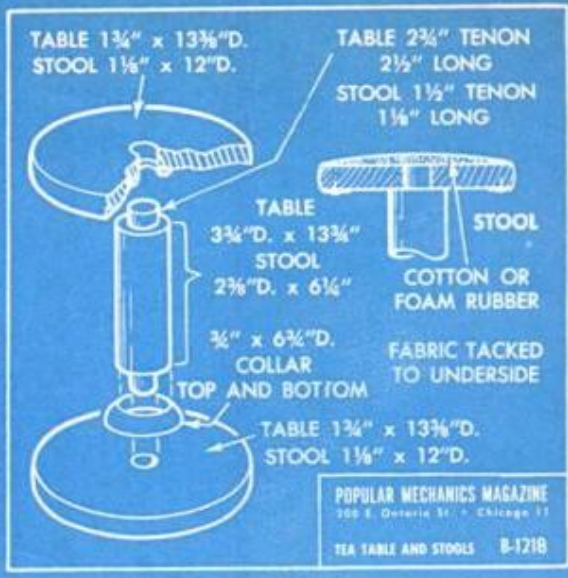

it's built all of selected white pine, although you can, of course, use other woods, such as poplar or birch if this is desirable. The drawer corners are joined with box dovetails, or box joints, as this joinery is sometimes referred to. To get the width of the top and end pieces which form legs you'll have to dowel and edge-glue a couple of standard widths of stock. In the construction of this piece the mark of the

craftsman is in the painstaking sanding of the wood, skillful joinery and finally, in the softened edges of all exposed parts ("softened" being the craftsman's term for smoothly and uniformly rounded edges).

### Tea Table and Stools

Although you can build this cute set with hand tools, using a square column with stopped chamfers and mitered collars, it

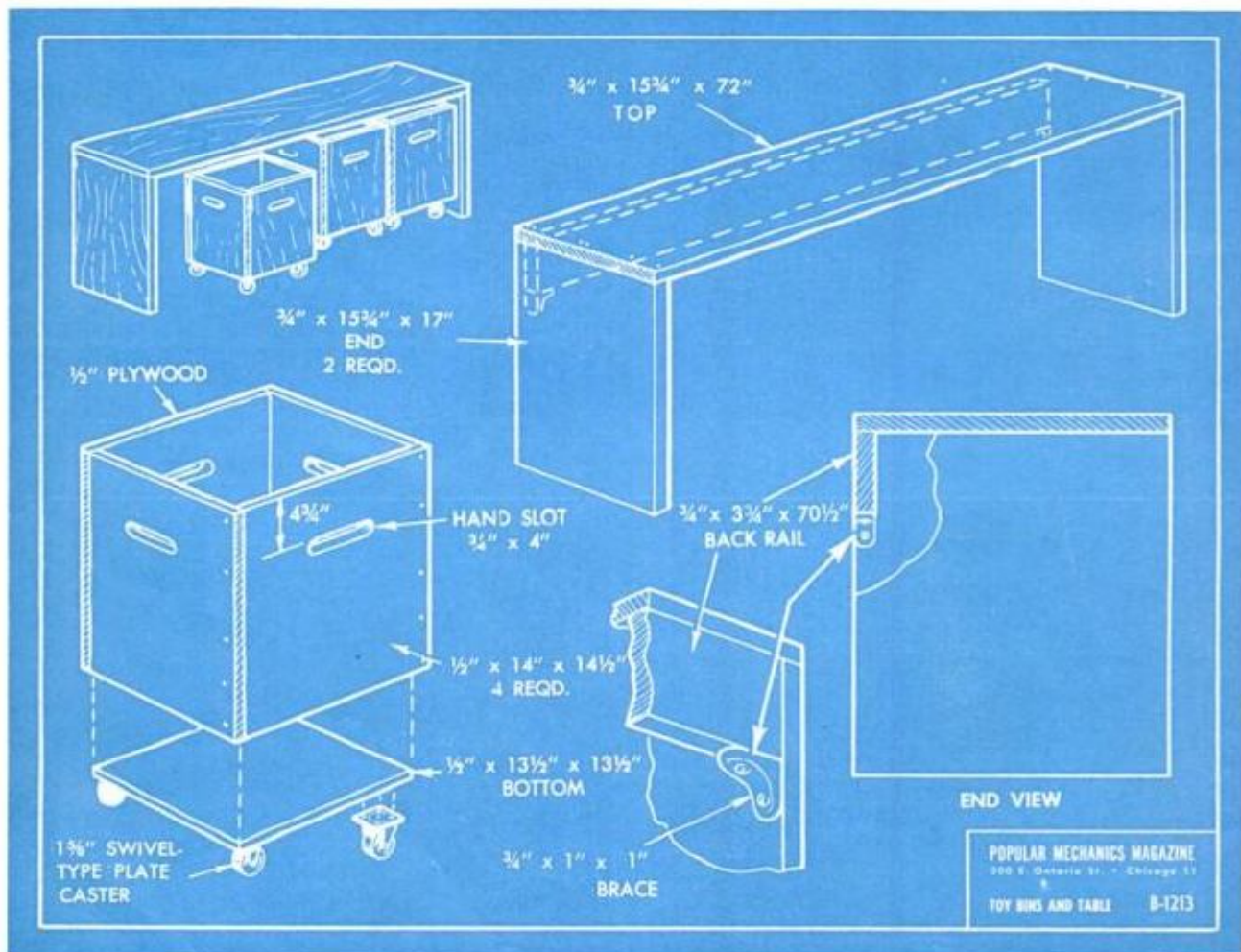

takes a wood lathe to duplicate it as detailed. Clear, white pine is used for all parts of both table and stools. Note that the parts of each are identical, that is, the bases, tops and columns of the stools are the same size, as are the top and base of the table. Tops of the tiny stools are upholstered, with cotton or foam rubber being used under a fabric covering, the edges of which are tacked to the undersides of the tops as detailed. Be careful to stretch the covering uniformly.

### Toy Bins and Table

Four rolling bins and a four-board table of the simplest construction combine in this novel unit, in which you see common design features carried a step further. For example, each bin has four hand slots instead of two, as would be the usual practice. The table, unlike others, has only a single rail which serves the twofold purpose of a stop for the bins, lining them up when rolled into storage position, and also as a sturdy brace for the table ends, or legs. The top and legs are simply panels made by doweling and edge-gluing two 1 x 8s of clear white pine. The toy bins are made of 1/2-in. plywood. Here again, good crafting calls for careful elementary joinery and softened edges on all exposed parts. This gives the work that finished look.



SLATS which form the seat, or saddle, of the horse cart are spaced and attached with screws and glue

### PLANS AVAILABLE

Large 17 x 22-in. blueprints detailing construction of each of these nine pieces are available at 50 cents each. Simply address Blueprint Department, Popular Mechanics Magazine, 200 East Ontario Street, Chicago 11, giving the plan number of each blueprint desired.

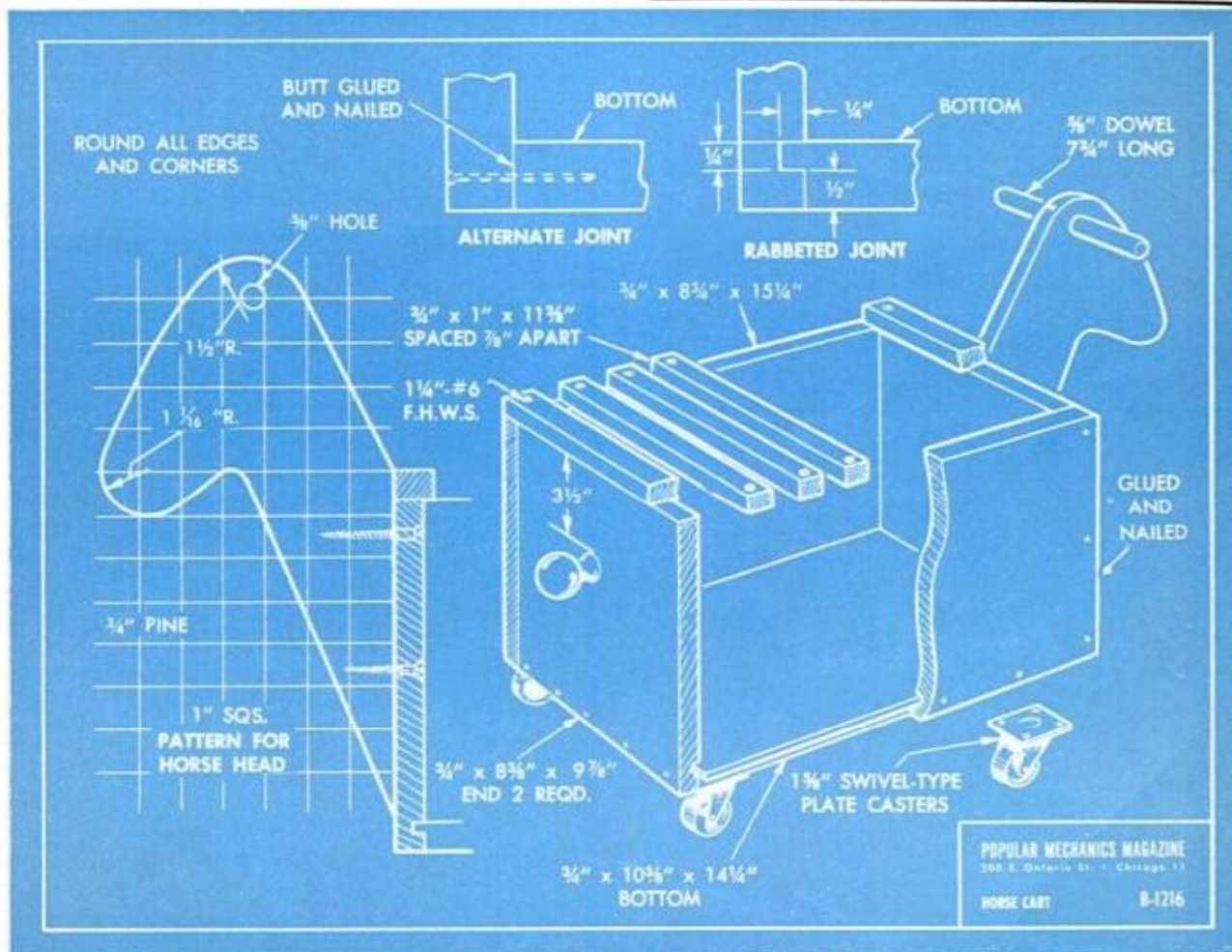



**WORK-PLAY TABLE** is oil finished in natural color of wood. No stain is used, as oil finish darkens wood slightly. All parts of table are of clear white pine

### Horse Cart

The horse cart is just a box with a spaced slat top which provides a seat, or saddle, an attached head and neck with the ears serving as handles, four swiveling casters and a wooden drawer pull for a tail. Maybe you can't get a horse out of that, but we'll venture to say the kids will; they'll just climb aboard and go off for a ride. Note that in this detail, page 161, you are directed to round all edges and corners and that you have a choice of two methods of joining the bottom to the sides and ends. Also, the slats are attached with screws rather than nails.

### Stools and Plank

These three-legged stools could be thought of as a playroom gym. No? Then take another look at the upper left-hand photo on page 159. The stool has other uses. As an example, for TV viewing there's nothing quite like them for tots, teens and grownups too. And you'll be especially taken with the top of each stool. It's heart shaped; it's not hinged, nailed or screwed in place, yet it can't tip, slide or tilt sideways. The plank, of course, is just that, a plank. But the stool is a bit more detailed in construction than the other projects. Study the details closely before you cut your stock or drill any holes. Note that one

leg, B, is shorter than the other two, A, by a trifle more than the thickness of the top. Use 1½-in. hardwood dowels for the legs and ¾-in. dowels for the stretchers, or rungs. Notice also how you drill the holes in the legs to the required angle by using witness marks on the end of a wooden V-block you make especially for the purpose. Test the accuracy of the V-block on a waste piece before you trust it with any of the stock you have cut to size. Glue the rungs in place in the holes and make sure before the glue hardens that the piece sets level and that no part is misaligned. The top is shaped from two pieces of white pine which have been doweled and edge-glued. By duplicating parts you can turn out these stools by the dozen if you like.

Finish? The originals you see pictured were oil-finished in the natural color of the wood with only two exceptions, the bins of the toy bins and table and the blackboard coming in Part II and pictured in the lower left-hand photo on page 159. If you feel that paint or enameled finishes are more desirable, then be sure to use a finish containing a nontoxic pigment of the type compounded especially for finishing toys. Although you can handle enamels with a brush, spray finishing gives the more uniform job.

*(continued next month)*

**STOOL** can be built in duplicate, by the dozen if you like. Lift-off top is held in place by wrap-around notches which drop over ends of the two longer legs



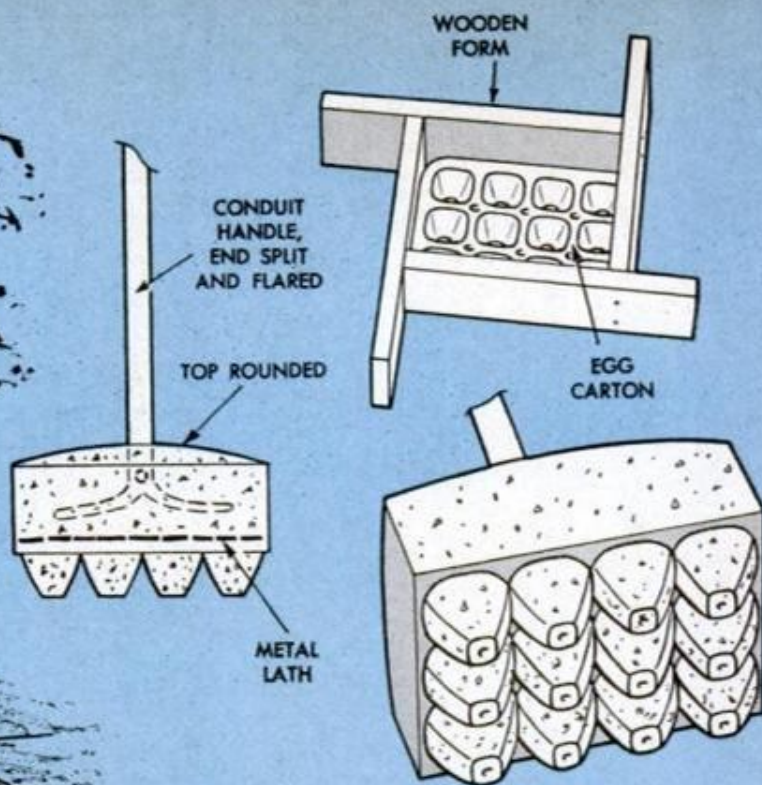

## SHEEP'S-FOOT TAMPER

For compacting dirt fill you can't beat this concrete tamper. The form is made from 1 x 6s, the inside measurements taking a one-dozen egg carton. Prepare a handle by slitting one end of a 5-ft. length of conduit, bending the halves outward and drilling for a spike. Have a piece of metal lath at hand, cut to size. Pour a stiff mix, placing reinforcement and handle while pouring. Trowel the surface to a contour and support the handle until the concrete sets.

—George A. Healy

## Rub-Down With Solvent Renews Old Varnish Finish



Checks and fine scratches in an old varnish finish often can be eliminated simply by rubbing the surface lightly with a cloth moistened with a lacquer reducer. Only enough reducer is applied to soften the surface of the varnish as otherwise you may remove the finish to the bare wood. While in the softened state the varnish can be smoothed and blended by rubbing lightly with the moistened cloth.—Walter E. Burton

Extending the life of a blacktop driveway may be done by leveling the surface periodically. One homeowner, after it rained, circled all the water-filled areas with chalk. When surface dried, he built up the circled areas with a ready-mix asphalt.

# TIN-CAN LAMP

TWO LARGE juice cans,  $\frac{1}{8}$ -in. threaded pipe, standard lamp parts and a shade of your choice assemble into this modern decorator lamp. Two juice cans, placed open end to open end and fitted with a long and short length of pipe joined with an elbow, form the base. After locating the pipe with the ends projecting through holes drilled or punched in the bottom of the top can and in the side of the lower can about 1 in. from the bottom, solder the cans together. Cut an opening in the bottom of the top can with a beer-can opener and pour in plaster of paris until both cans are full. Fish lamp cord through the pipe and run down locknuts on the projecting ends. Finally, measure and cut the fabric covering for the base, allowing an excess of material all around. Coat the base and fabric. Allow to dry, then press into contact, and trim off the excess.—R. Treves

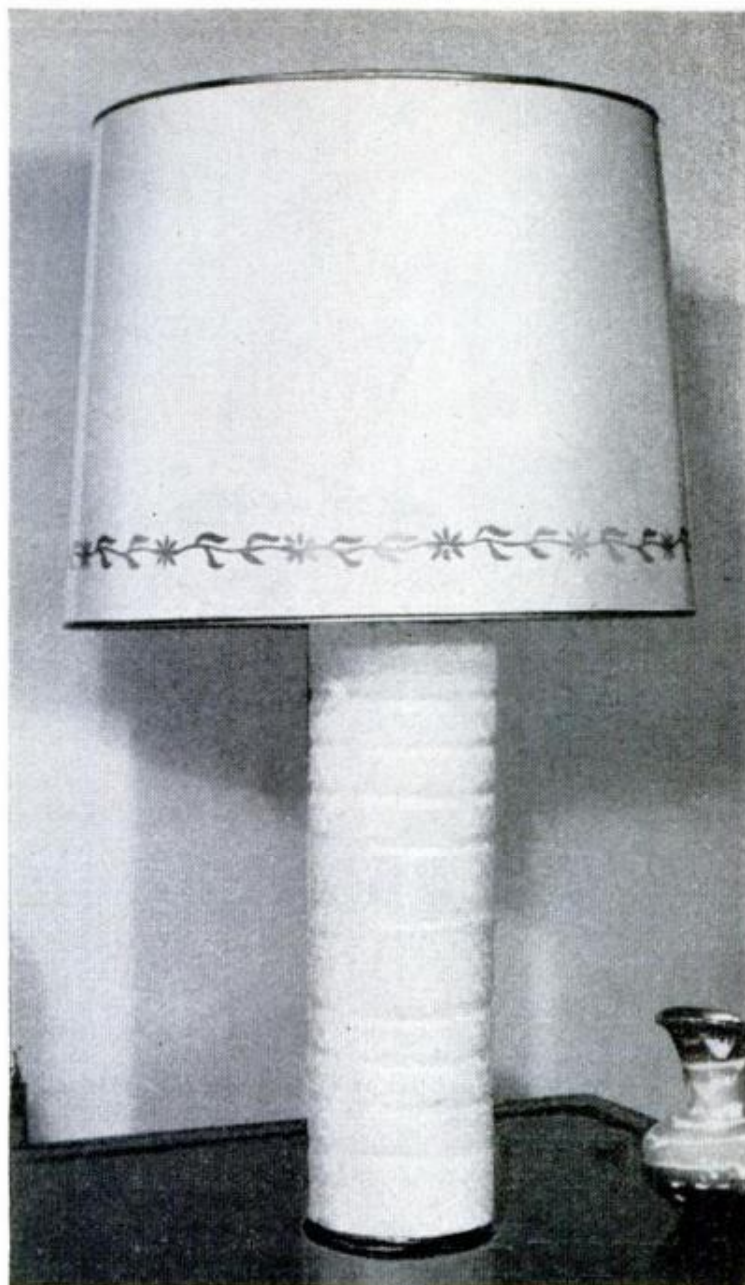

**BLADE GUIDED** along edge of bottom layer of overlap, above, produces butt seam. Below, pipe is seated in place, ends projecting

**BEFORE APPLYING** fabric covering, base is coated with cement which is allowed to set tacky. Be sure to apply cement uniformly

**APPLY FABRIC** to top of base first and trim away excess material. Remove all lint and loose threads. Then press fabric into full contact



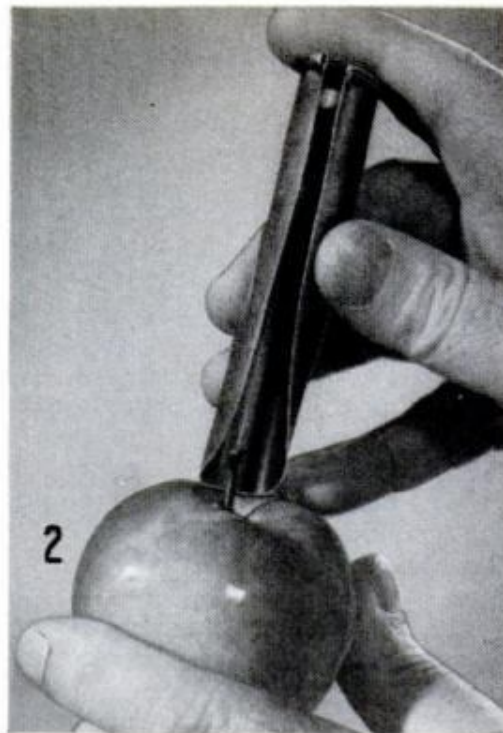
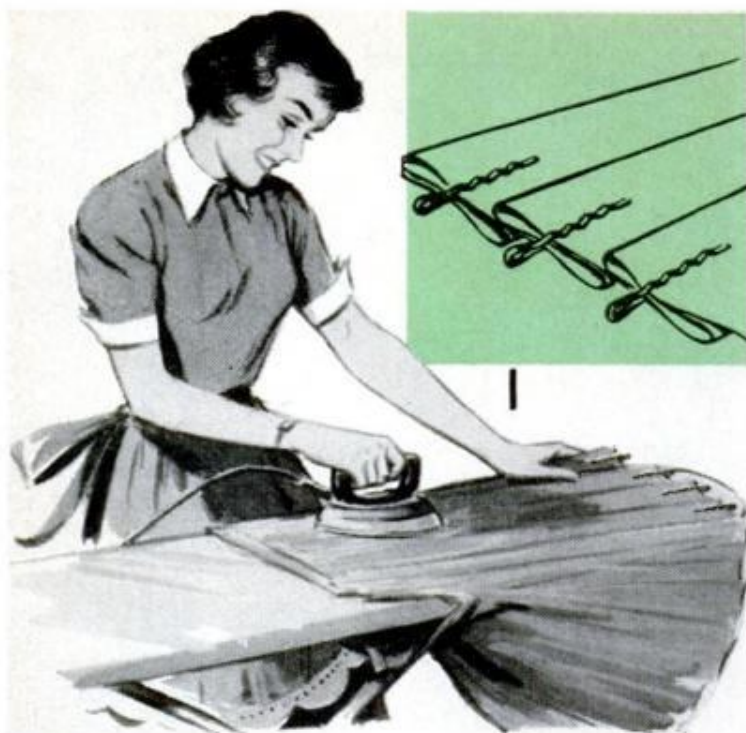

# Solving HOME PROBLEMS

**1. PRESSING PLEATS** in a skirt will take much less time if bobby pins are used to hold them in place. They may be left in position while pressing all but the hem and then removed to complete the job. It's simpler than using pins which might damage fabric

**2. APPLE CORER** can easily be made from a strip of metal obtained from a tin can. Simply cut a 2½-in. strip from the can, retaining the crimped upper edge, and round the bottom corners as illustrated. To shape it, bend the strip around a ¾-in. dowel

**3. NEEDLE HOLDER** for a spool of thread is just a small square of ordinary waterproof adhesive tape placed over the hole in the spool. None of the adhesive will adhere to the needle when you pull it out, and the needle will be kept clean and bright

**4. STACKED TUMBLERS** often stick together and are difficult to separate. To avoid this annoyance, drop a toothpick into the bottom of each tumbler before inserting the next one. The toothpick will support the upper tumbler and keep it from sticking in place

**5. TOOL HOLDER** is especially handy when you're working from a ladder or on the roof. The next time you run into such a job, borrow Junior's western holster. Most of these are large enough to carry three or four small tools easily. It's a real step-saver

**6. GLAZIER'S POINTS** are difficult to hold in place while being driven into the sash. A drop of linseed oil will hold the points to the glass and turn the job into a simple one-hand operation. This is particularly helpful when you're working from a ladder

**7. KITCHEN KNIVES** will dull quickly when you keep them in a drawer with other cooking tools. To protect that sharp edge, push the blade through two slits cut in a piece of cardboard. For extra-long knives, use a larger piece of cardboard with three slits cut in it

**8. PENCIL POINTS** have a way of breaking off when the pencil is carried in a shirt or jacket pocket. To protect the point and prevent it from making a hole in your pocket, slip a short length of rubber tubing over the end. The tubing must fit tightly on the pencil

**9. WHEN WORKING** with quick-drying materials (glue, wood putty etc.) the container must be kept covered. You can avoid having to pry off the lid each time more material is needed if you attach a knob to the container cover with a small wood screw

**10. FREQUENTLY USED** pages from catalogs and instruction booklets often become torn or wrinkled. To prevent this, apply strips of masking tape to top and side edges. If you extend the top strip to form a tab, these sections will be much easier to locate



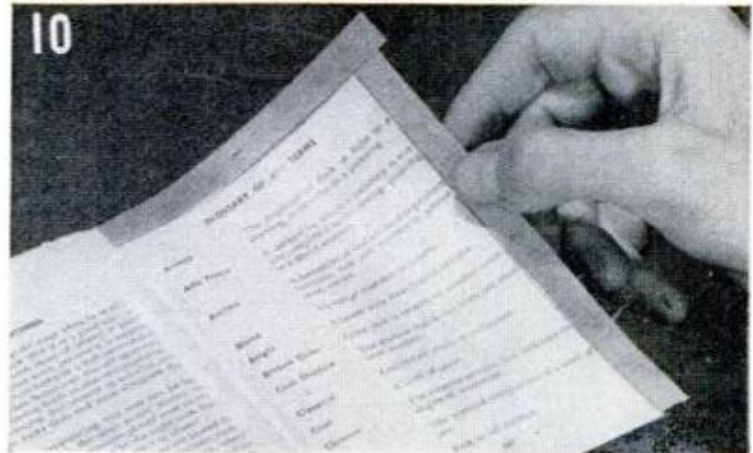
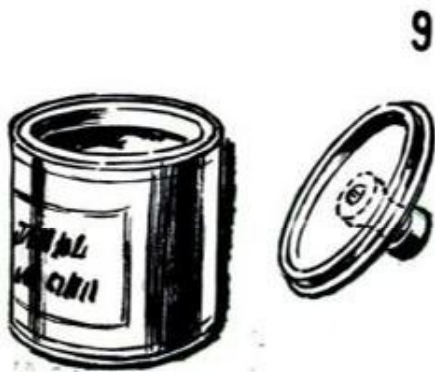
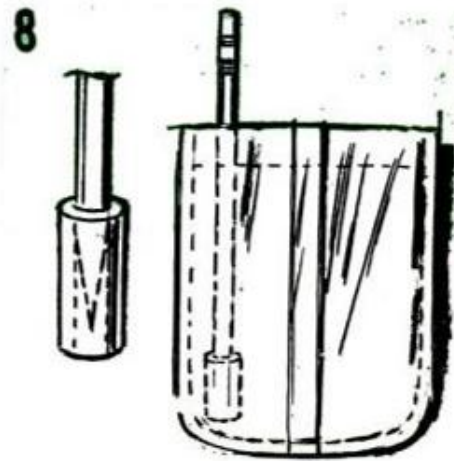
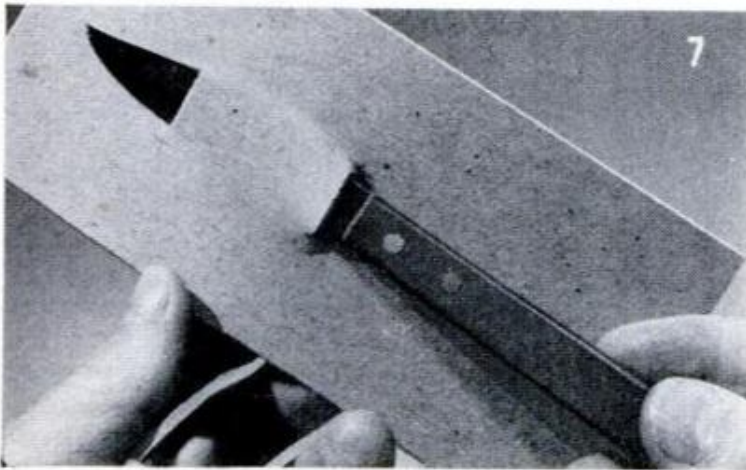
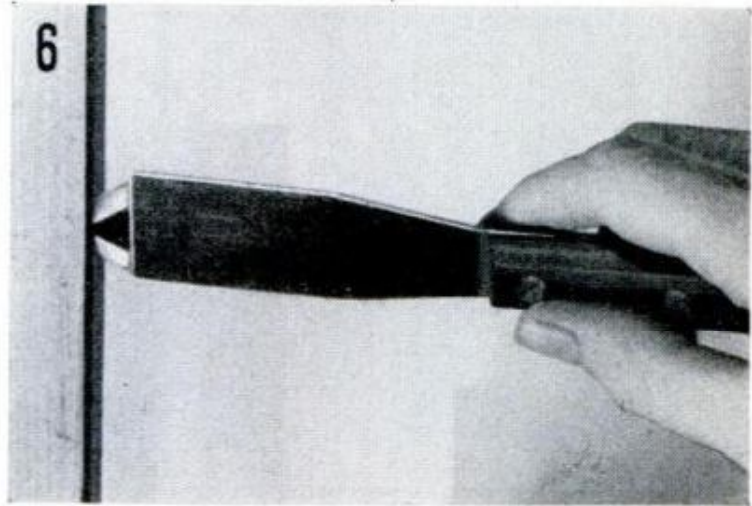
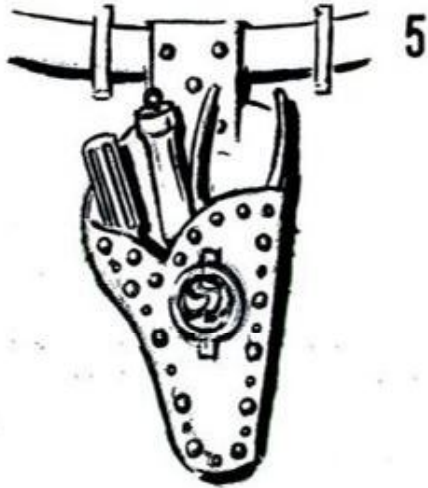
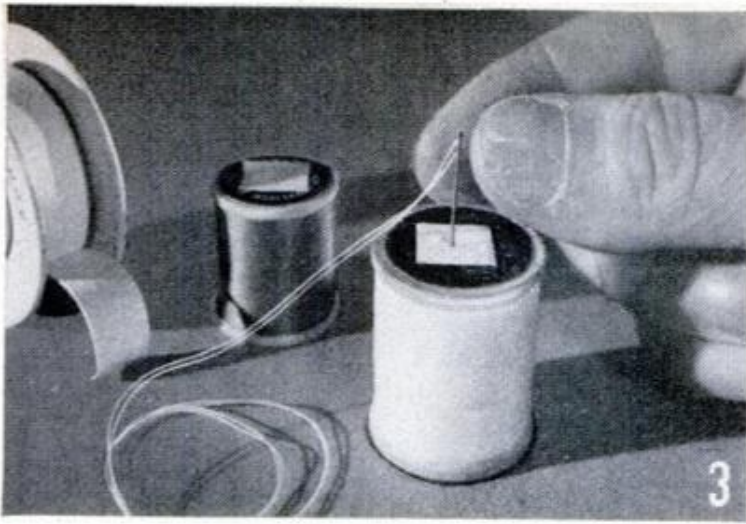

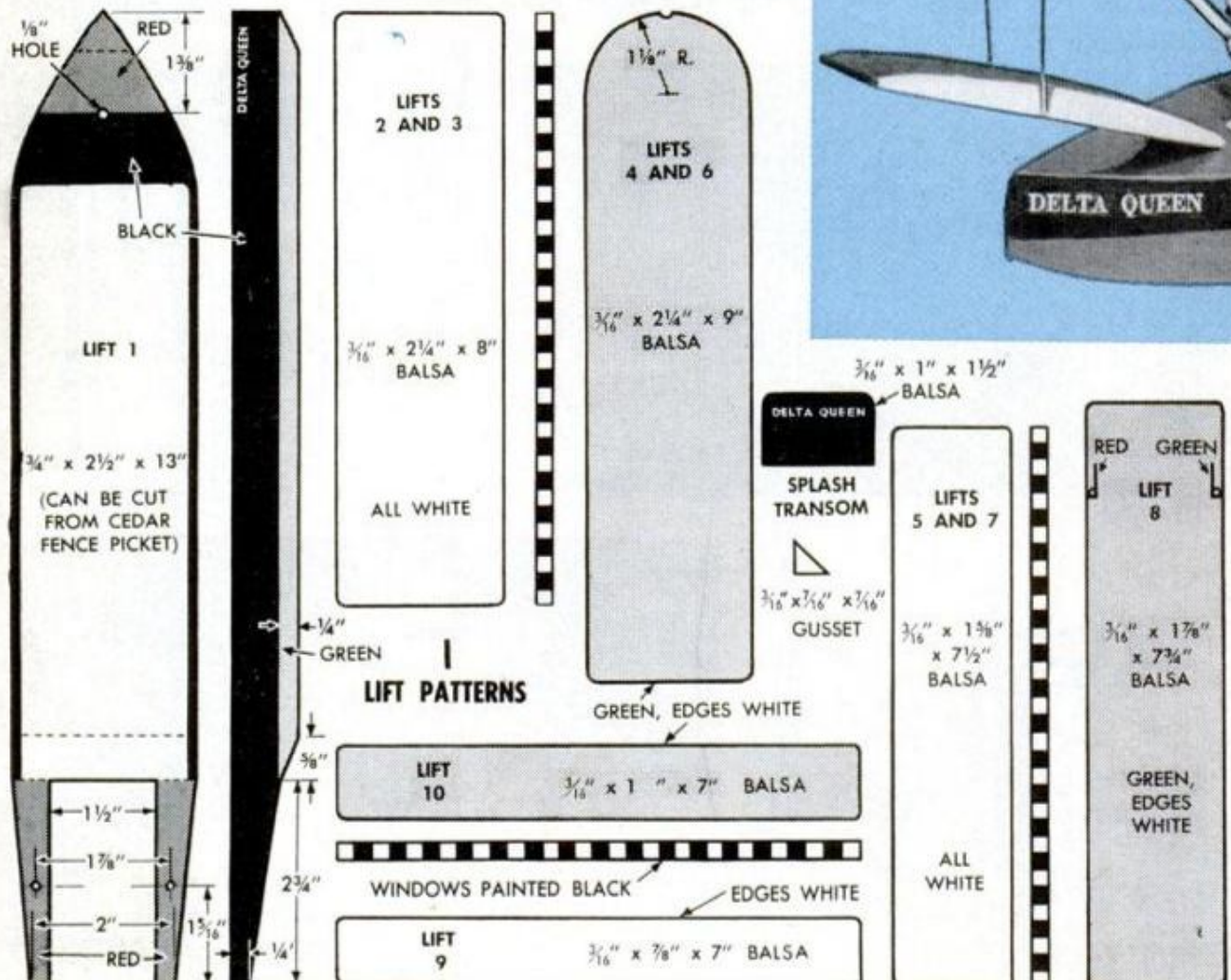
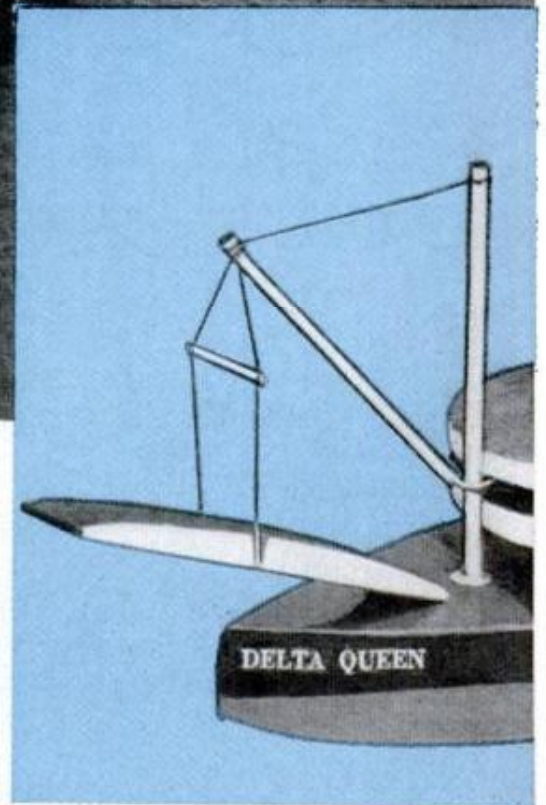
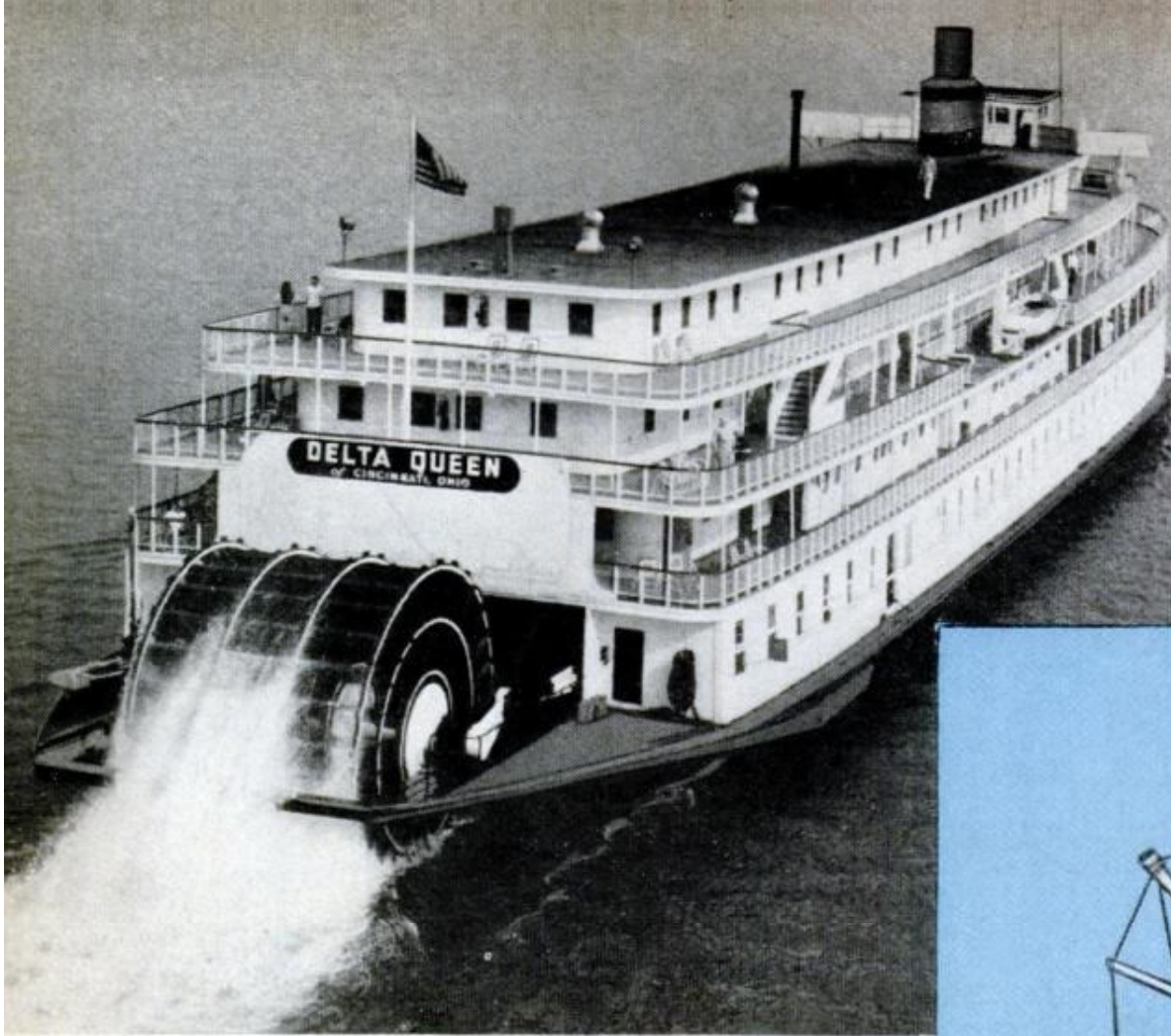

# Modeling the DELTA QUEEN

*Last of the Mississippi overnight passenger steamboats, this 285-ft. stern-wheeler carries vacationers on leisurely 10-m.p.h. river cruises*

**T**HIS 13-IN. MODEL of the huge old queen of the rivers should delight any junior river pilot. It's small paddle wheel turns just like the 24-ft. original, but instead of being driven by steam, it's powered by a rubber band. Complete even to the tiny steam pipes of the calliope, you can cut, assemble and paint this model in an evening or two. The main part of the hull, lift 1, is made from a cedar fence picket, so

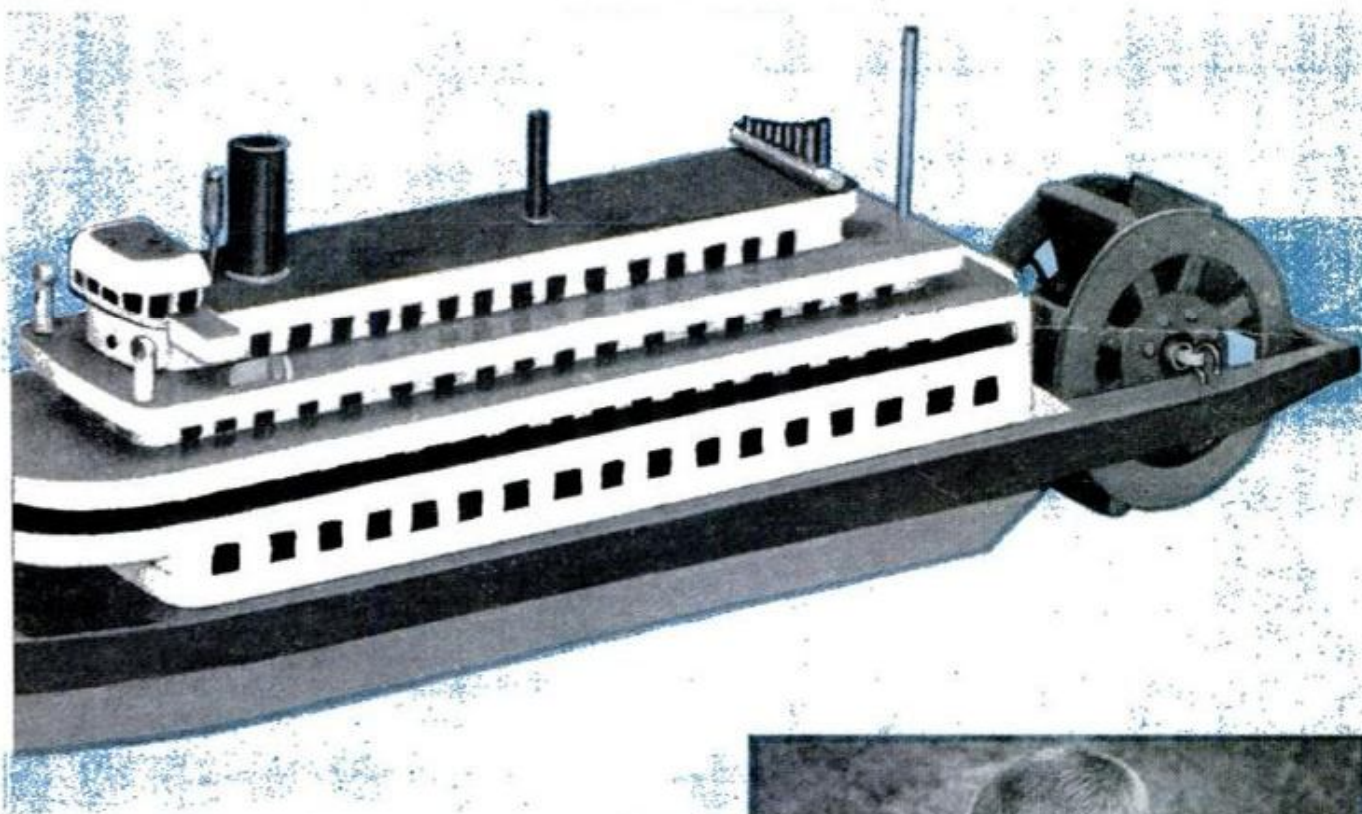

that a minimum of shaping is necessary.

You can obtain balsa of the proper thicknesses at most model or hobby shops. In order to simplify the project, cut and paint each of the 10 lifts making up the hull itself before assembling the boat, Fig. 1. The stern gussets and splash transom are also installed at this time. Since the end grain of balsa is particularly open, you'll have to fill it with wood putty and sand lightly to achieve a smooth surface for painting. Use regular model enamel, following the indicated color scheme, and put in the lettering with a fine artists' brush.

After assembling the basic hull, you are ready to add the details which give this model its authentic appearance, Fig. 3. Make the calliope by gluing different lengths of  $\frac{1}{16}$ -in. dowel to a short length of  $\frac{1}{8}$ -in. dowel and mounting this assembly near the after end of lift 10. For extra real-





ism, give the calliope a coat of metallic paint before mounting.

Both the galley chimney and whistle are pieces of  $\frac{1}{8}$ -in. dowel, while the stack is a  $\frac{3}{4}$ -in. length of  $\frac{7}{16}$ -in. dowel. Color the stack and chimney black, but use metallic paint on the whistle. The ship's bell mounted on lift 6 is simply the pendant from a lighting-fixture pull chain. Assemble the mast, boom and landing stage as shown, and after painting, mount this unit on the fore deck. The bridge, pilot house, searchlights and running lights go on next. Finally, glue the flagstaff in place.

The paddle wheel, Figs. 2 and 4, consists of eight paddle buckets mounted around a brass tube and held in place by two rubber washers on each side. The rubber band passes through the tube and is secured with a pin inserted when assembling the wheel. Slip the ends of the rubber band over two screw eyes on the legs of the stern. ★ ★ ★

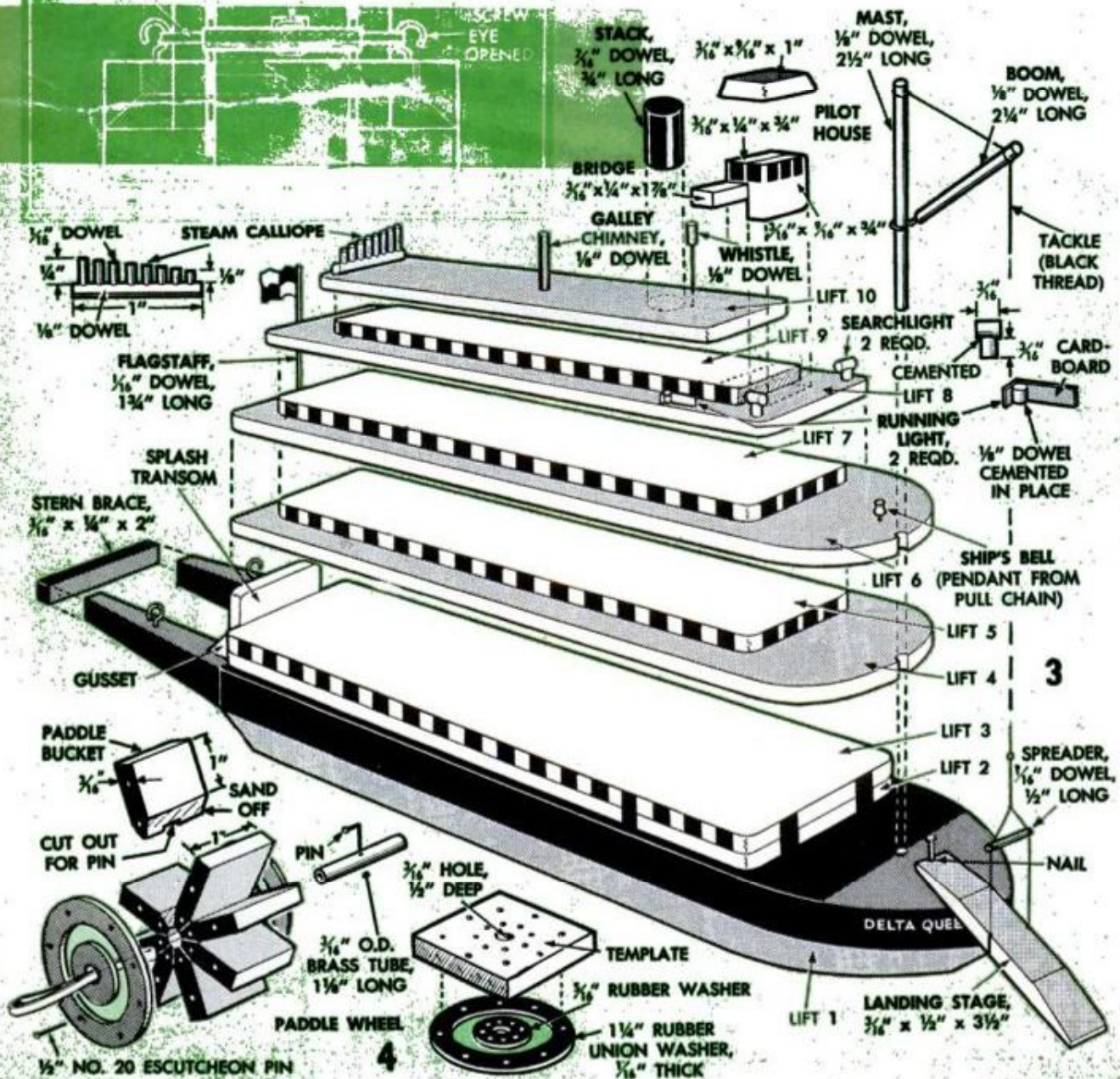

## Ride 'Em Stools for TV Tots

Each youngster of the family can have his own "box seat" in front of TV with these tin-can straddle stools which will hold an after-school snack and even serve as a desk. One gallon antifreeze or motor-oil cans with the ends intact are preferred, but common 1-gal. paint cans with covers will do. Each stool requires three cans which are sandwiched between three pieces of  $\frac{1}{2}$ -in. plywood and the whole unit is held together with three lengths of  $\frac{1}{4}$ -in. threaded rod. Two rods are required in the front section to prevent the desk top from twisting, but only one is needed for the seat.

Drill  $\frac{1}{4}$ -in. holes through the plywood and punch matching holes in the ends of the cans. Then temporarily assemble the unit and cut the rods so that the ends are just below the surface of the plywood. Counterbore the holes for a 1-in. flat washer and a nut. After final assembly, fill the counter-bored holes with wood putty and sand smooth before painting.—*Fred Bryce*

Your next house party can be a riot with a fortune or consequence punchboard, particularly when you make it yourself. Filled with crazy "fortunes" or ridiculous stunts which the guests must enact, such a game-of-chance, will keep any party from getting dull. To make such a board obtain a scrap of  $\frac{1}{4}$ -in. perforated hardboard having  $\frac{1}{8}$ -in. holes. Glue paper over the holes on one side, then type one-line fortunes on paper and cut into  $\frac{1}{4}$ -in.-wide strips. Roll the strips tightly and insert them in the holes in the board. Finally glue paper over the holes on the face side. A wooden peg is provided to punch out the fortunes.

—*Kenneth Murray*

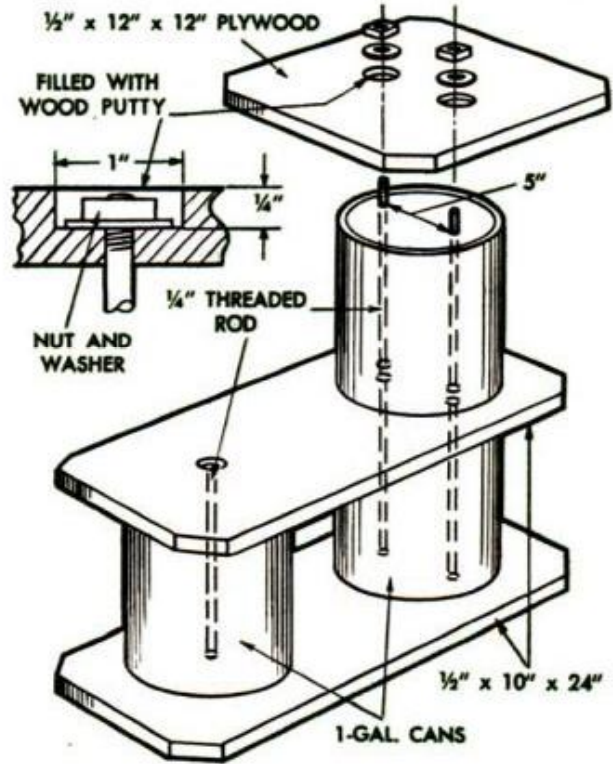

## Hang Tool Panel and Save Drilling Holes

What's the simplest way to mount a tool panel on a basement wall without drilling holes in the masonry? — hang it. That's what I did and here's how: I used a piece of perforated hardboard for the tool panel which measured 3 x 4 ft. Then I ripped three  $\frac{3}{4}$ -in.-sq. wood strips for hanging the panel to the overhead floor joists, making them long enough to hold the panel at a convenient height. Next I placed the three strips on the back of the panel and positioned them between the rows or holes so they would not block any hole and would be spaced consistent with the standard 16-in. spacing of the joists. After this all I had to do was nail the upper ends of the wood strips to the face of the joists, seeing that the panel was level and flat against the wall. Besides saving the job of drilling holes, the wood strips provided clearance for the wire tool hangers.—*Don Honick*

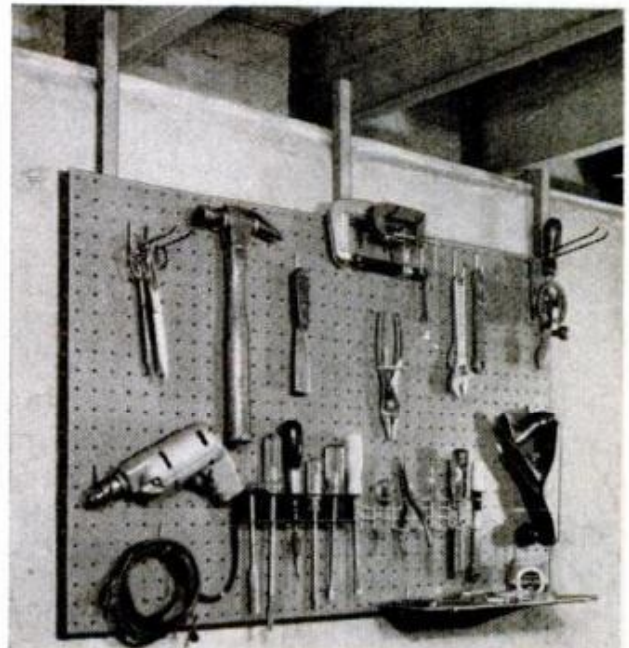

## Bench Converts Back Seat for Sleeping

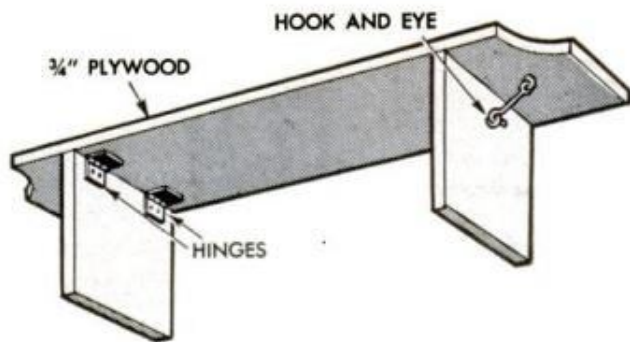

How many times have you wished for a station wagon so that the kids would have a place to stretch out and go to sleep during long drives or at the drive-in? This folding bench fits between the back of the front seat and the cushion of the rear seat making the back seat into a roomy bed. It's made of  $\frac{3}{4}$ -in. plywood, padded with foam rubber and covered with plastic fabric. When taking measurements, be sure that the front seat is in the driver's favorite position and allow  $1\frac{1}{2}$ -in. clearance all around.—*Eugene S. Weiss*

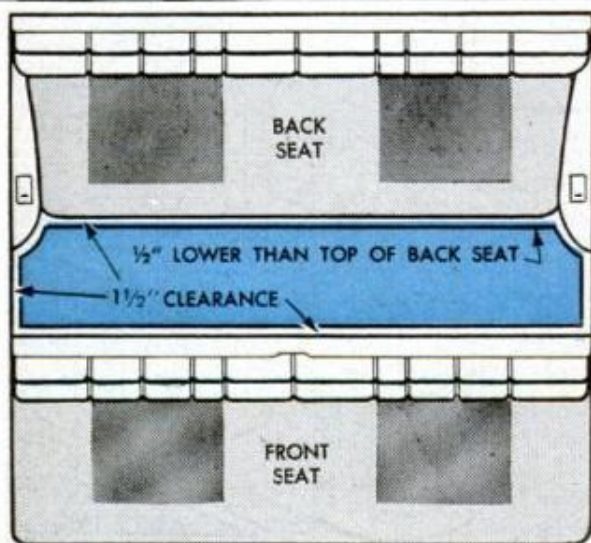

**Thread-cutting taps** can be protected when not in use by wrapping them with pipe cleaners so as to shield the sharp cutting edges. Apply a couple of drops of oil to each tap before wrapping to prevent the formation of rust. Such protective wrapping is especially important when you must store taps loose in a box with other tools.—*Francis R. Young*



## The Right Slant

Attach a common drawer pull to the upper edge of your drawing board and it becomes a convenient carrying handle. The pull can also do double duty as a hook for use with a notched lift to elevate the upper part of the board and hold it at one of three angles. Make the vertical support of  $\frac{1}{2}$ -in. plywood and cut notches at an angle of 30 deg. Use a short length of 1 x 2 for the base, securing the notched upright to it with angle brackets.—*Henry Hanscom*

**Windproof cigarette lighters** don't work as efficiently when the wick begins to fray, spread or lie against the shield. You can prevent this from happening by cutting the head off a common pin and forcing the pin down through the center of the wick. Not only will the wick light more easily, but it will also last much longer.

—*Burton L. Wollenzien*

# Underwater Light for Skindivers

FOR EXPLORING underwater caves, shipwrecks or the bottom of the big drink much more than ten fathoms down you need a light, a good, reliable one that can spot danger or treasure in the murky depths. It must be watertight, battery-operated, have a handle for one-hand operation and it must be quick-detachable from a belt.

This light, made by a diver, meets these requirements at a cost of five or six dollars for parts and materials plus a few hours' workshop time. In the photos you see the light attached to its quick-detachable belt (all diving gear should be easy to get out of) and detached and hand-held. The details below show how the original was made. The sealed-beam lamp is sandwiched between two circular  $\frac{3}{8}$ -in plywood cutouts of the inner and outer dimensions given and measuring 7 in. over the ears for the hanger bolts. Use brass hanger bolts of the type used for attaching a toilet bowl to the floor. The handle is made from a select 7-in. length of 2 x 4, shaped as shown and mortised for the cord from the switch to the lamp and a two-pole toggle switch as indicated. To assure watertightness a rubber gasket is fitted between the handle and the lamp. The hole in the handle for the 4-ft. length of cord from battery to switch should be sealed with wax after the parts are in place. Turn a brass screw eye into the handle near the top to form a ring for the belt snap. The battery is placed in a tin can and the latter filled with hot tar. The cord is then taped to the can with plastic electrician's tape, which also holds the wire belt loop.

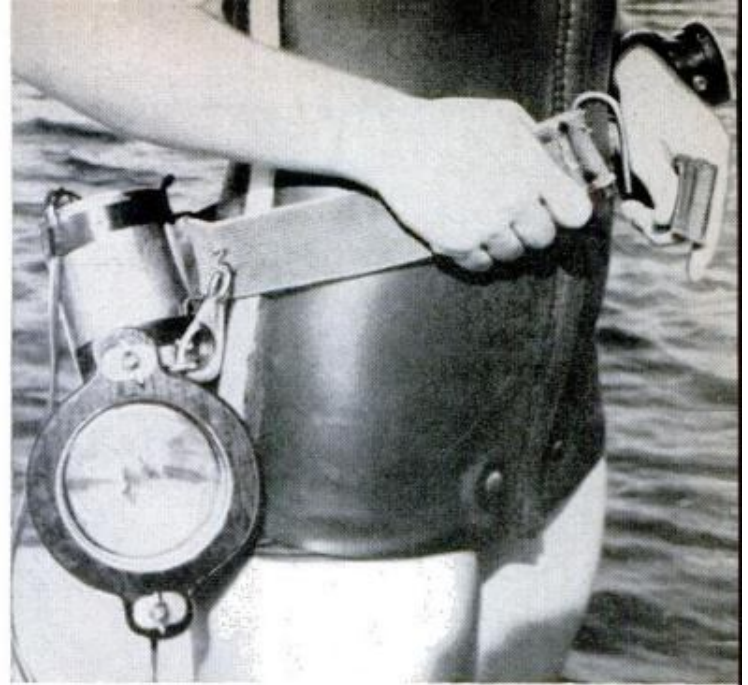

**LIGHT AND BATTERY** are carried on a quick-detachable belt. Unit is easily handled, instantly available

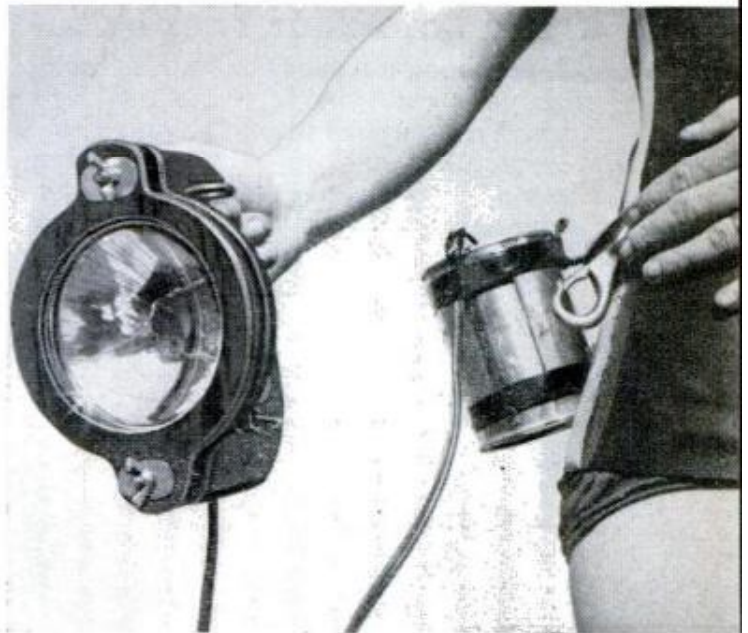

**SAW-HANDLE GRIP** gives positive control when light is detached from belt. Ballast helps to steady beam

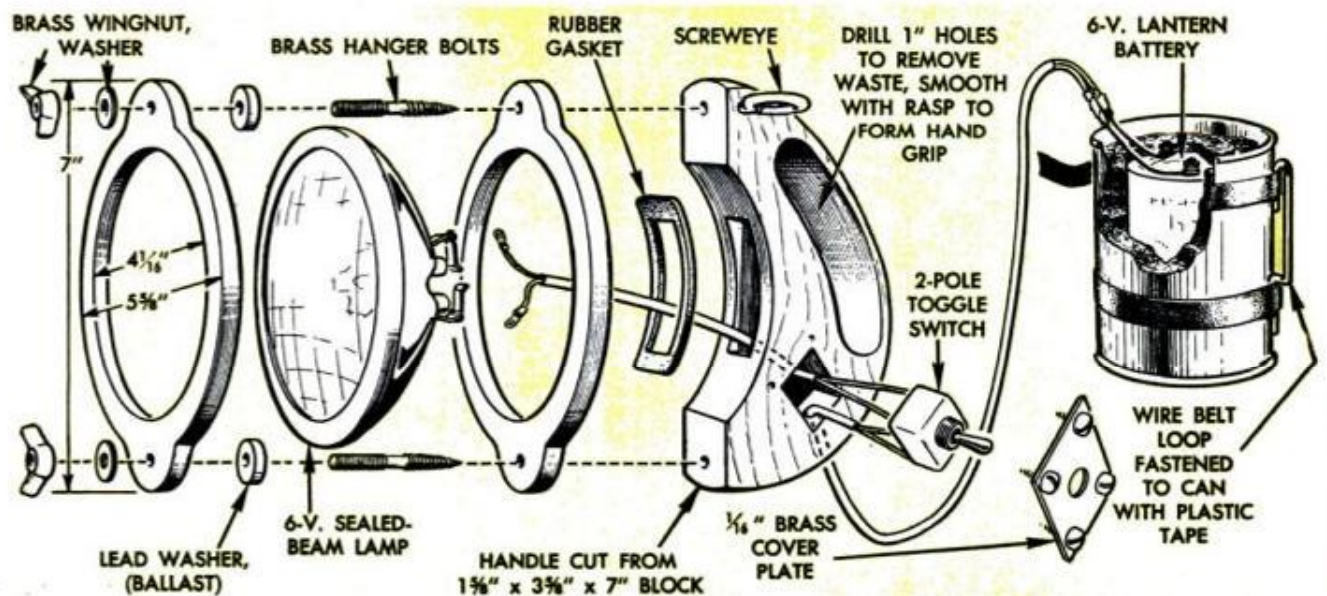

## FISHING HINTS



### If You Lose Your Tackle . . .

If you hook a fish big enough to make off with your rod, you have no use for this kink. But keep it in mind as an aid to salvage should you drop your rod overboard. Keep a toy balloon, a length of line and a heavy sinker in the tackle box. When you lose the rod inflate the balloon, tie the balloon and sinker to the line and throw overboard as a marker while you go for help to retrieve the rod.—*G. E. Hendrickson*

### Or Need Minnows for Bait

Some fishermen are called lucky because they don't just fish; they catch fish. The luck comes from knowing all the tricks—stashing away in memory everything to be learned from other fishermen. Here's one to remember: When you need minnows for bait run over into shallow waters and sprinkle a bit of corn meal on the surface. Then scoop 'em up with a minnow net. So says one fisherman to another!

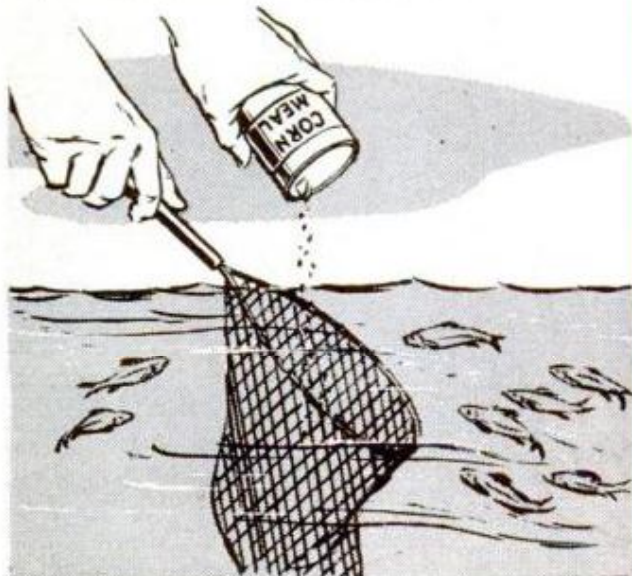

## Spare the Rod and Use the Arrow

THIS STUNT might be dubbed "spin fishing with a bow, using the arrow as a hook," or something like that. Check first with your local warden to find out if he and your state approve such goings on. If you get the nod—and likely you will—you're in for some exciting sport. Even when the season on game fish is closed to you, you can try this on the trash fish such as carp and gar. Of course, you have to be a reasonably competent archer, but beyond that requirement everything you need to know is shown in the details below and in the photos on the opposite page. Use fiberglass arrows as you'll need the extra weight. The "spin reel" is a tin can attached to the bow as detailed. Fit the arrows with fishing points and if you fasten the line to the arrow point, take a half-hitch around the nock end of the arrow before you let go at a fish, as otherwise you've got trouble. To fly true, the arrow should bear the drag of the line at the trailing end, just behind the flight guides, or fletching. Plastic or rubber flight guides also are available and last longer than feather fletching in the repeated duckings. If you fashion your own arrow points, the barb should be made either removable or reversible. Use a nylon line from 30 to 50 ft. in length.—*Frank A. Tinker*

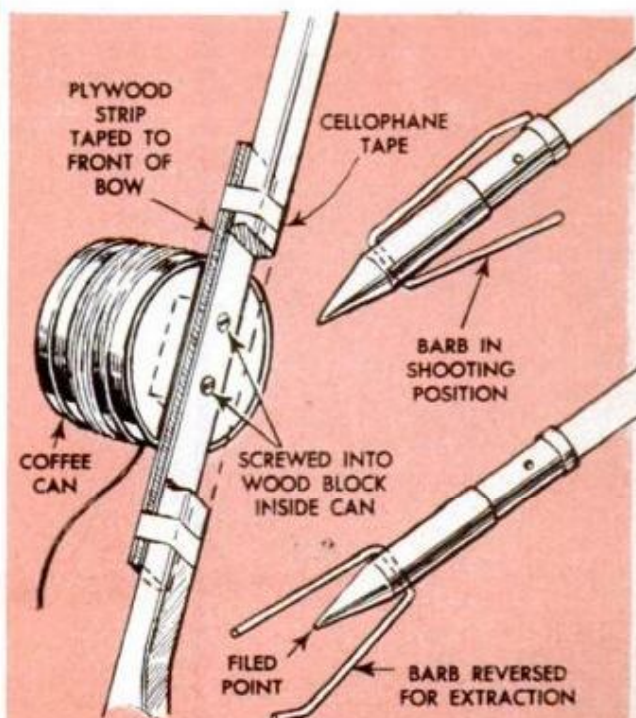



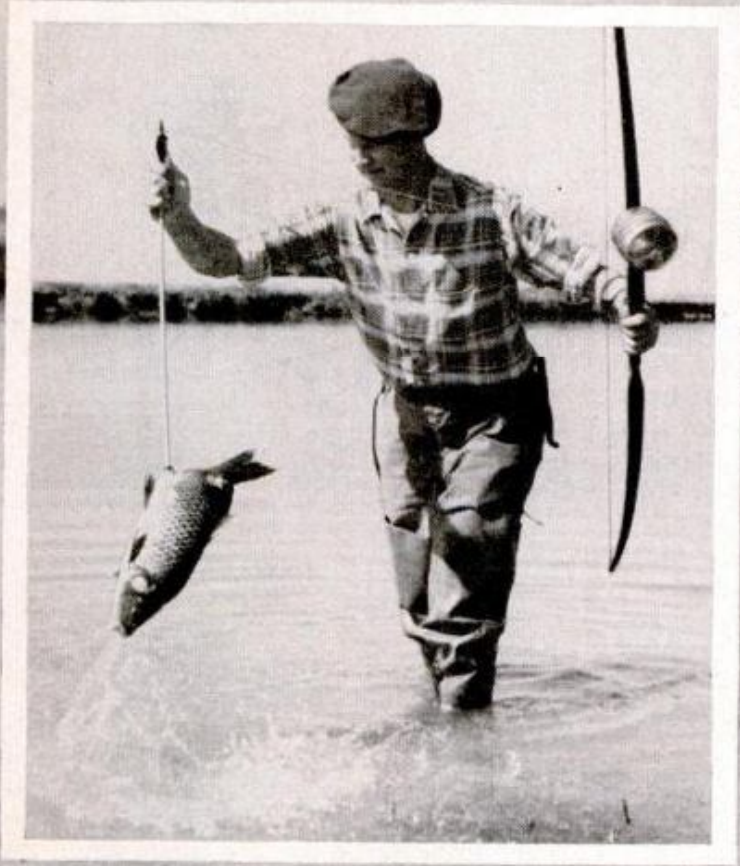



# "Wow!" yelled Lil

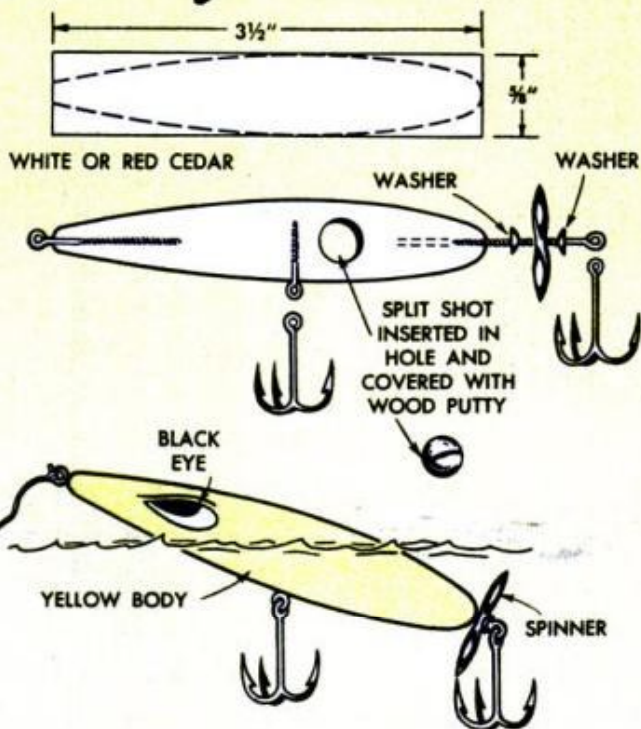

LIKE A piece of a huge mirror, the still water reflected the shadowy shore line of the lake as the hot summer sun began to dip into the west. There was the swish of a line through the air and a light splash as a hook-decorated lure hit the surface.

Tiny waves, in spreading circles, wrinkled the glassy water, then it was still again. Lil, my wife and angling companion, slowly raised the tip of her casting rod and twitched the lure slightly, making it look like a dying minnow gasping for air.

From beneath a nearby stump, a big bass emerged and slid silently toward the bait. He paused a moment to set his sights on the struggling morsel of free lunch, then tore upward with a rush. The water erupted in a shower of foam as the gray-green fish rammed skyward, his red gills flashing and the tiny wooden lure jammed between his jaws.

"Wow!" yelled Lil as she hauled back on her rod and began cranking the reel like mad. The old blockbuster bass ripped the surface three more times before he finally came to rest in the landing net . . . and joined a cousin on the stringer.

The fish held by Lil, five and six pounders, respectively, were just two of over eight hundred bass we have taken in the last four years on hand-whittled surface lures . . . lures made from about a dime's worth of materials.

In the southland they are called "pencil baits" because they look like fat pencils with a couple of treble hooks. Here in Illinois we call 'em "dolly lobbers" . . . for no good reason I know of . . . and the painted ones, yellow and black, are tabbed with the

name of "Ol' Black-Eye." We have experimented and found that lures 3 1/2 in. long, shaped as shown in the details, give a more realistic dying minnow action than the plain pencil shape.

We make some with a spinner added to the tail section, and some without. The spinner gives a more erratic, splashy retrieve which seems to wake up the bass quickly, although there are times when the lure without the spinner is more effective.

We make the lures out of both white and red cedar and even redwood shingle material. Usually half of the lures are painted yellow with an evil-looking black eye and the rest are just left natural wood color and given several coats of varnish. Over the years we have found that the natural wood lures have taken slightly more bass than the painted ones which would seem to bear out the theory that bass are more interested in shape and action than in color.

We have had best results by casting near such well-recognized bass haunts as old stumps, brush piles and weed beds. Allow the bait to rest, then give it a twitch. If nothing happens, make it zigzag for about three feet over the surface and then rest quietly. If Mr. Bass doesn't latch onto it then, retrieve it back to the boat with a series of short jerks so that it skips from side to side on top.—Bob Cary



## FOR SHUTTERBUGS

**1. AN 8-mm. SOUND PROJECTOR**, complete with compact recording and amplifying units, is now available. Unit permits recording, erasing and superimposing voice, music and other sound effects. Included is a microphone jack for an outside amplifier, a tape recorder and speaker extension unit. Less than \$200. Mansfield Industries, 1227 W. Loyola, Chicago, Ill.

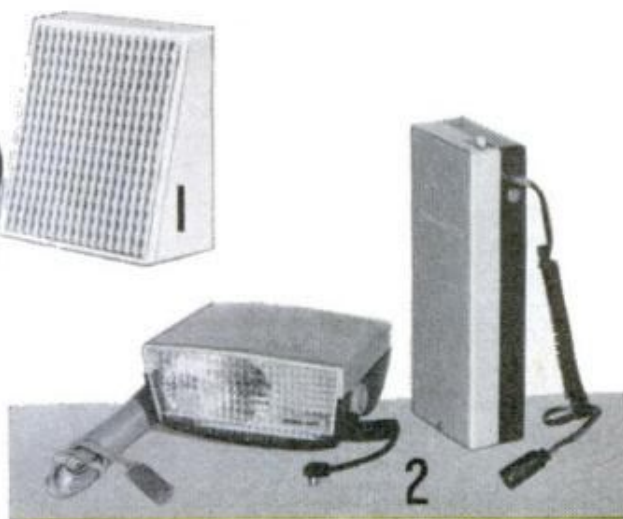

**2. PORTABLE ELECTRONIC FLASH GUN** has flash tube good for 50,000 shots. The a.c. gun has a rapid recharging time of about six seconds. Head measures a compact 4½x3x2 in. and weighs only 12 oz. Open-flash test button. Using Kodachrome II film, it has a guide number of 40. Spiralite gun sells for \$12.95. Spiratone Inc., 135-06 Northern Blvd., Flushing 54, N. Y.

**3. WITH A THROUGH-THE-LENS** electric eye this reflex movie camera reads only what is actually seen by the lens, adjusting instantly to differences in light values. The 3-to-1 zoom lens is activated at a touch of the power button atop the camera. Partial fades may be achieved through manual control of photocell. Bell & Howell, 7100 McCormick Rd., Chicago 45, Ill.



**4. RETINETTE 35-mm. CAMERA** is said to operate with snapshot ease and carries a budget-size price tag. A hinged back makes loading easy. For fast focusing, there are three click-stop markings for close-ups, groups and scenes. The shutter is synchronized for bulbs and electronic flash. Priced at less than \$45 by The Eastman Kodak Company, Rochester 4, N. Y.

**5. ROLLAKIT PORTABLE LAB** permits processing black-and-white films without a darkroom. Kit includes a film-loading compartment, a bottle of single-solution developer, fixer, a special processing tank and two film clips. Critical temperature controls are unnecessary. Complete kit, \$12.95. Cormac Chemical Corp., 34-22 35th St., Long Island City 6, N. Y.



## DARKROOM HINTS



### Keeping Cotton Handy

With cotton being used so often in the darkroom it is wise to buy it in large rolls and one of the best dispensers you can make to keep it clean and handy is a glass jar with a screw cap. Simply cut a hole in the cap so you can pull out the cotton as you need it. There will always remain a tuft to grasp the next time. Should there be a period of a week or more when the cotton is not used, the exposed portion can be pulled out and discarded to be assured of clean cotton.

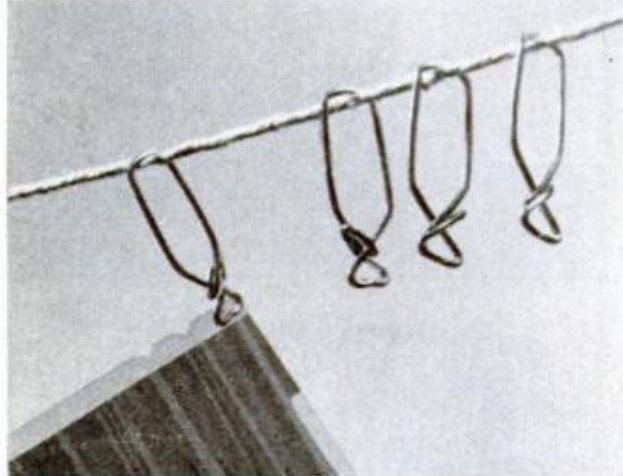

### Free Film Clips

When you get clothes back from some dry cleaners there is an identification tag clipped to each article. Save the clips and in time you will have a supply of film drying clips that cost you nothing. Thread a length of strong cord through the large loop and knot it to each clip. This will keep the clips separated and prevent them from bunching up and the film touching. The clips are strong enough to hold any size film and the ends, or jaws, being parallel, will not pierce it.—Wayne Floyd

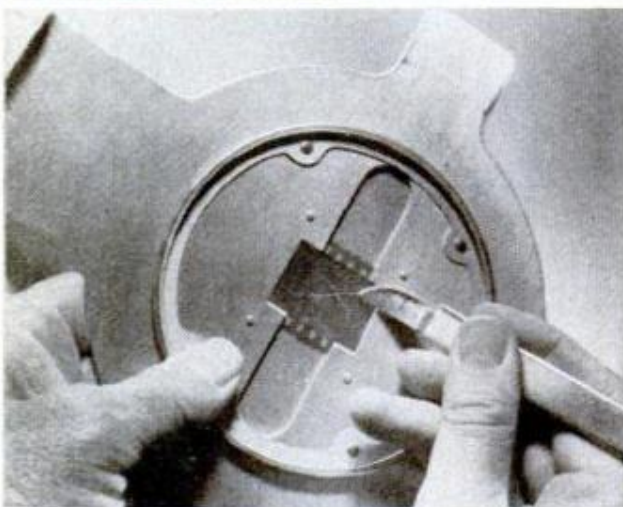

### Sharp Prints From Scratch

Focusing an enlarger sharply with a dense negative is always a problem and all the more so with a cold-light-type enlarger. One sure-fire way to do it is to first focus the enlarger with a "focusing negative." To make such a negative pick an extra-dense negative you no longer need and scratch an X on the emulsion side with a pointed instrument. When placed in the enlarger, the scratch on the negative will make it easy to get a sharp image on the easel, after which the enlarger is locked and the focusing negative is replaced with the negative you wish to print.—Eugene M. Hanson



### There's Film in the Tank

If an important phone call or other business takes you away from the darkroom while in the process of loading a developing tank with roll film, don't run the chance of forgetting during your absence that you already have loaded the tank and later remove the cover. As a reminder in such cases, take the backing paper from the film and wrap it around the tank before you leave. Not only will this tip you off that there is film in the tank but it will also indicate the type of film so you can give it the correct development time and even select the preferred developer.

# Pressure-Sensitive EASEL

**PRESS IT DOWN**, expose and peel it off. That's all it takes to make full, borderless (bleed) prints with this gelatincoated enlarger easel. It holds the paper nice and flat, doesn't stain the back and retains its pressure-sensitive surface indefinitely when kept dust free. The easel, Fig. 1, is a simple affair consisting of a plain picture frame fitted with a piece of hardboard. The face of the hardboard insert is coated with a pressure-sensitive adhesive, permitting you to press the paper lightly into contact and then peel it off after exposure.

Fit the piece of  $\frac{1}{8}$ -in. hard board into the rabbeted back of a 15 x 18-in. picture frame with the smooth face up. Drive wire brads into the frame to hold the hardboard in place, Fig. 2. Place the frame on a flat surface and check it with a level, Fig. 4, shimming up the edges of the frame with tape if necessary. This is important as you must have a level surface for the printing paper. The adhesive is a treated gelatin composition used in office duplicators and is available at most stationery stores. It comes in jelly form, which when heated becomes liquified and when dry it is sticky to the touch. You will need two standard cans of this material. Remove the caps from the gelatin containers and place in boiling water until the solution liquefies, Fig. 3. Pour onto the easel as in Fig. 5. Tilt the easel to flow the liquid uniformly over the surface. Then allow it to dry at least twelve hours before using. To use, place the printing paper on the easel and lightly touch the four corners to insure contact. Make the exposure, then peel the paper from the easel. If at first the easel surface is overly sticky, condition it by pressing a sheet of ordinary paper into full contact, then peeling it off.—*William Farrell*

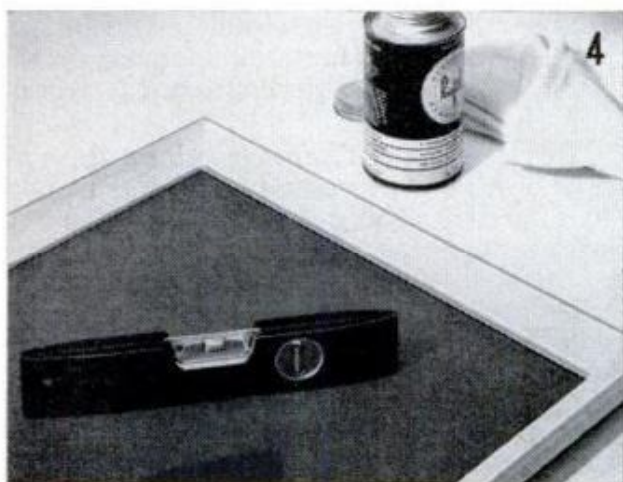
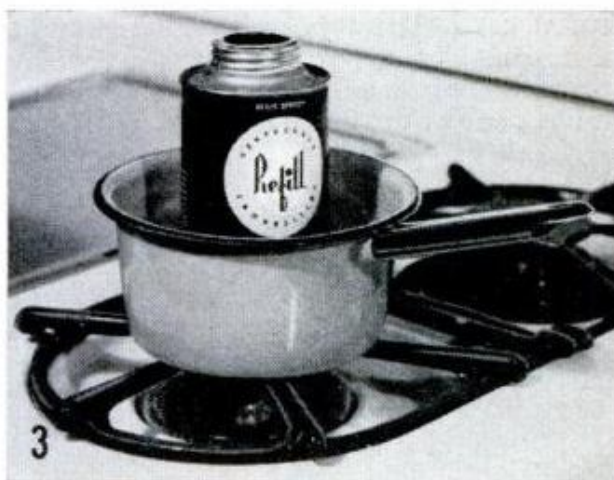
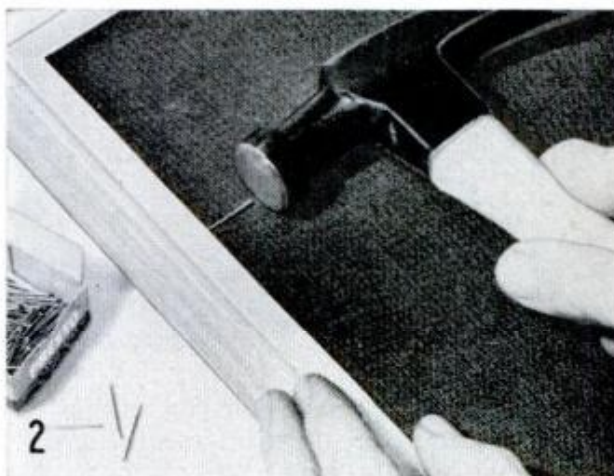
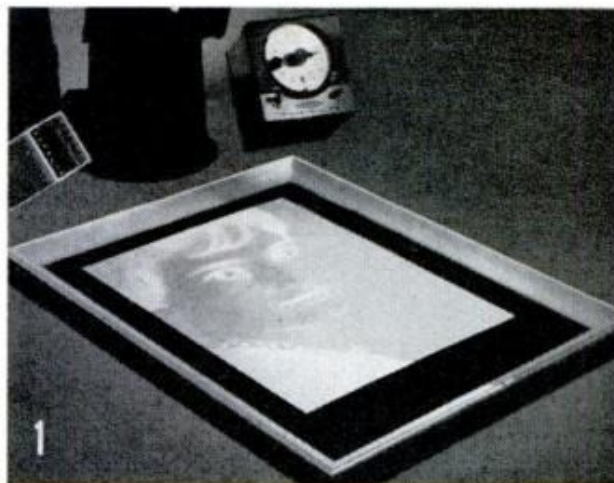

## Day-and-Night Skylight for Windowless Areas

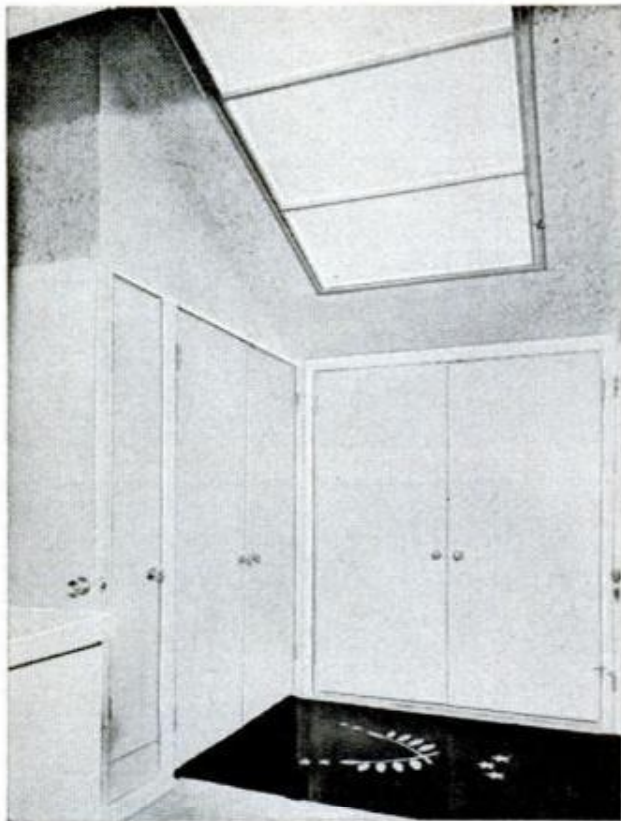

Sunlight brightens the area under this skylight during the day and on sunless days and at night fluorescent lights sandwiched between fibreglas panels give a soft, diffused glow. The top, or weather panel is the corrugated type, fitted into the roof and protected by flashing. The lower panel is a flat pane of the same material, fitted into



a frame which is hinged so that it may be lowered for replacing bulbs as in the right-hand photo. A skylight made in this manner is especially effective in a hallway. The materials needed are the necessary framing, fluorescent fixtures and fibreglas panels in "seashell white." Framing should be finished to match existing woodwork.

## Rubber Band Holds Inserted Rivet in Place



Holding an inserted rivet in place while you get the work into position for peening can get to be a pretty irksome job, more so when riveting a length of tubing made from sheet metal. Remember this trick when you're confronted with the problem: Insert the rivet, hold it in place and snap a rubber band around the tube. Slide the band up against the rivet, then pull, or stretch, it sidewise so that it maintains tension on the rivet. A bit crude, perhaps, but it works.

Working small-diameter tubing through a wall or floor presents two problems, how to feed the tubing smoothly and surely, without bending it and how to keep dirt out of the open end. In most instances you can solve both simply by turning a round-headed screw into the end of the tube. A round-headed metal screw usually is just the thing, as the large head serves to guide the tubing through small openings and keeps out dirt.

# Reducing Outboard Static



*Some tips on gagging that electronic villain lurking on the transom*

THE SIMPLEST WAY to solve an outboard static problem is to shut off the motor whenever you want to use the radio. However, for those who don't want to drop anchor every time they check the weather forecast, there are several other less drastic measures which will alleviate the interference problem.

Static-producing impulses from the ignition system reach the radio in two ways: Radiation (through the air) and conduction (along control cables, power cables, etc.). The metal cowling used on some outboards provides a certain amount of shielding and reduces radiated impulses. Some manufacturers offer special kits to cut down radiated impulses. Newest of these, and fairly typical, is Mercury's kit consisting of special resistor cables and distributor cap. The big-six version sells for \$21.75.

**DISTRIBUTOR CAP** provided in one new radio noise suppressor kit is designed to provide extra shielding

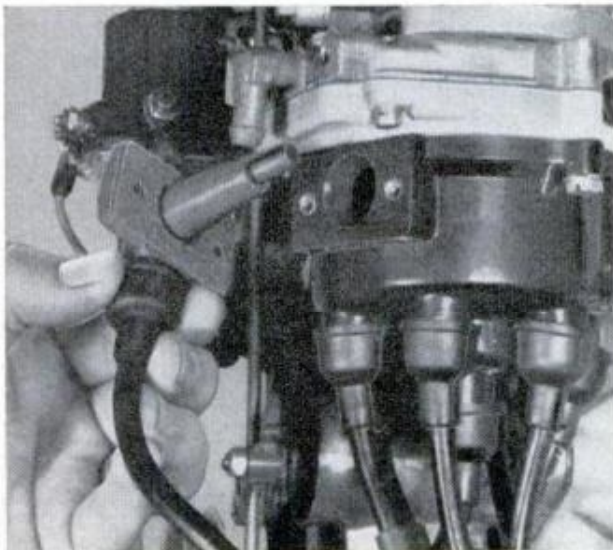

Proper grounding also is particularly important. To avoid electrolysis problems, use negative ground even though a separate battery is connected to the radio. If your radio has a removable cover, it should be grounded at close intervals. Likewise, the antenna lead should be shielded and the shield grounded. Be sure that all grounds terminate at one point.

Select an antenna suitable for the frequency for which it is intended to operate and install it as far as possible from the engine and remote-control cables. If you have a small boat, it may be impossible to mount the antenna far enough away from the motor to reduce the interference picked up by radiation to any substantial degree. In such cases, locate the antenna as far away as you can and make doubly sure that everything is properly grounded.

**RESISTOR CABLES** help to reduce the radiation of static-producing impulses from the ignition system

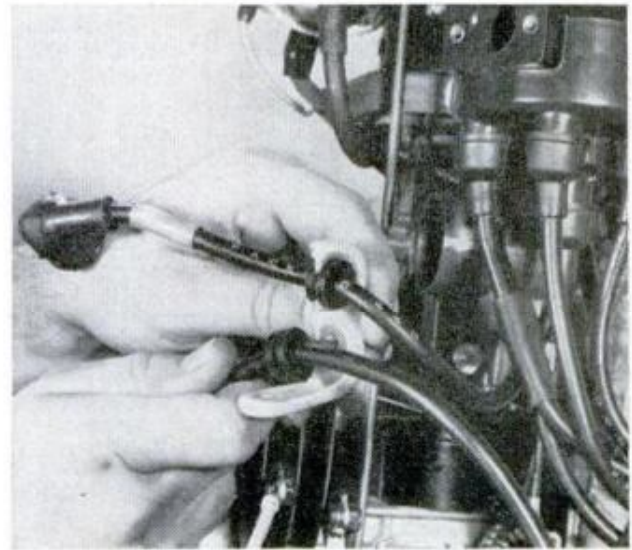

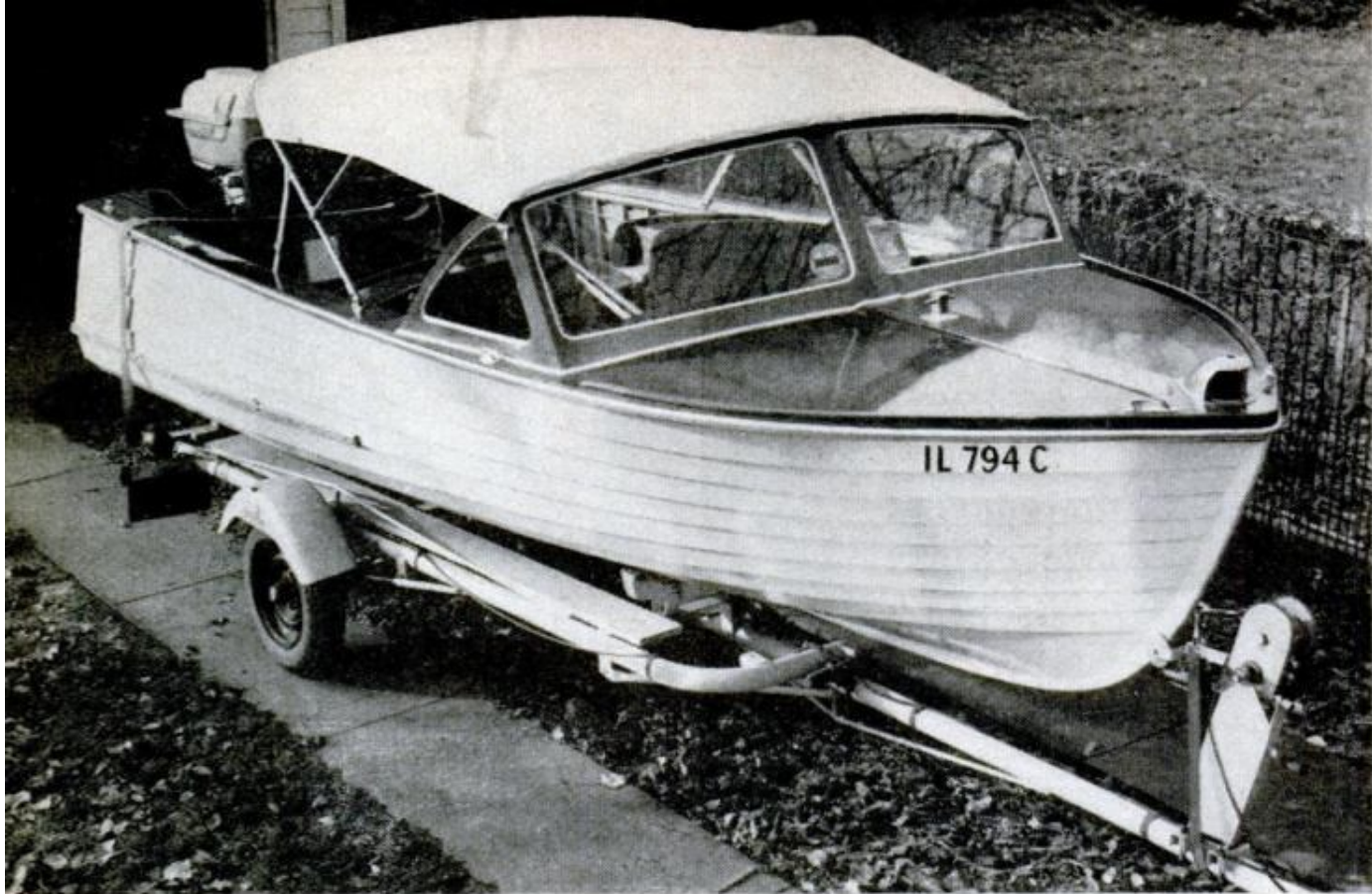

CONVERTIBLE TOP for this boat may look like a million, but canvas and framing materials came to just \$15

# For Cruising Comfort—Add a CONVERTIBLE TOP

By Herb Schneider

**T** IRED OF baking in the sun and shivering in the rain? Decide now to fit your boat with a convertible top. You can make a custom-fitted canvas top that will rival the appearance of expensive commercial jobs. The ventilating slot, Fig. 1, is a comfort-plus feature that provides for better circulation of air behind the windshield, but it's strictly optional.

Use 10.10-oz. treated duck for the cover itself, since this is light enough to be handled on a home sewing machine. Make the framing from either thin-wall conduit or aluminum tubing. The aluminum fittings can easily be cut and formed in your shop. However, before you go ahead with the project, take a look at some commercial tops at a marina or dealer's showroom so that you'll have an idea of how a top is made.

The top illustrated here was designed for a 16-ft. boat with a 6-ft. beam and a 15-in. windshield. In changing the dimensions to fit your boat, don't try to gain a great deal

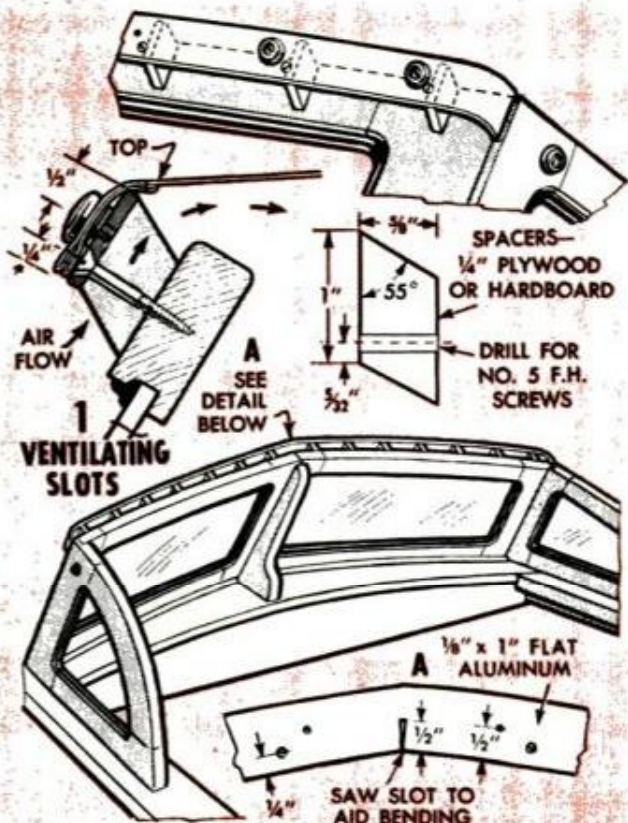





**TOP FOLDS DOWN** for easy storage either over dash, behind windshield or on deck ahead of windshield

of extra height or length for this may alter the boat's profile so much so that it has an awkward appearance. Also, if the top is made too long, it will sag and collect rain water since the use of lightweight fabric requires that supports be located relatively close together. Remember that when your boat is running at 25 m.p.h., the effect on the top is like that of a 25-m.p.h. breeze on a tent. Proper support is needed to keep it from flapping, and while you could solve the problem by using heavier material, this would make sewing much more difficult.

Begin by making a pattern for the top bows from old pipe, heavy wire or any other material which can be bent easily and retain its shape. Make this pattern in three pieces—a top curve with two legs taped to it—so you can adjust the height. Place the legs of the pattern bow on the gunnels and prop up the unit at an angle of about 45 deg. The bow must be approximately 38 in. above the seat cushion to provide adequate headroom for the average person. The top of the bow, which marks the rear edge of the cover, should be about 5½ ft. from the windshield in order to assure full protection for the front seat.

Fold the bow forward, pivoting it on the ends of the legs without moving them. When folded, the frame should lie on the dashboard behind the windshield where it won't be in the way when not in use. Adjust the legs so that the bow just misses the top and wings of the windshield, keeping the top as wide as possible within these limitations. If this storage position won't work with your windshield, you may mount the bows so that the top folds flat on the deck forward of the windshield or even rests on the upper edge of the windshield.

A trial setup will give you an approximate idea of how the top will look when it's completed so you can judge the appearance of the profile. String a cord across the garage **at the same height** as the back bow

## 2 SEAM DETAILS

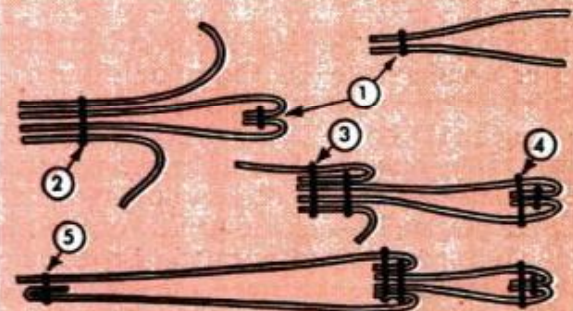
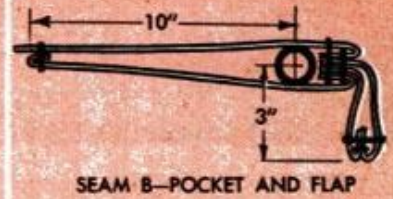
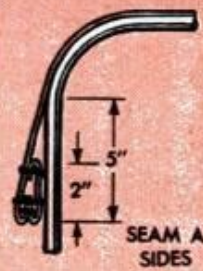
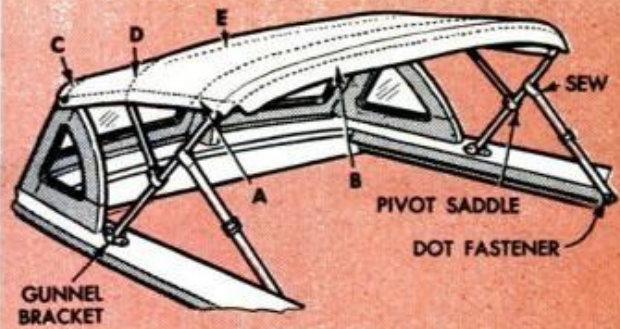

FIVE SEWING STEPS AT SEAM B



SEAM D—GORE

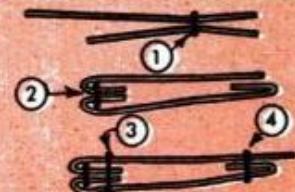

FOUR SEWING STEPS AT SEAMS A AND C

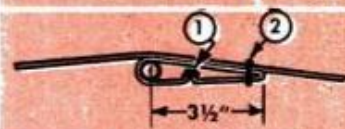

E—POCKET FOR TOP BOW

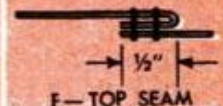

F—TOP SEAM

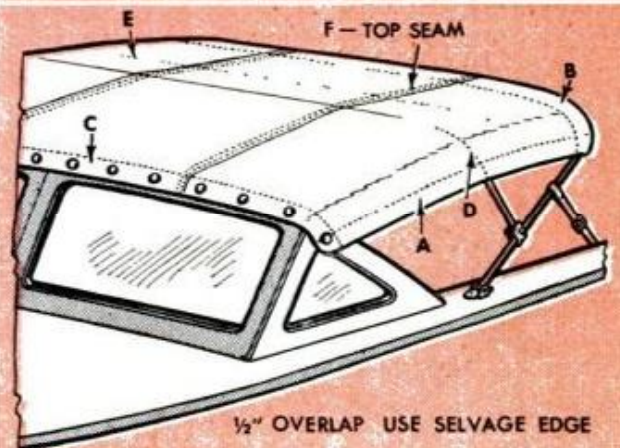

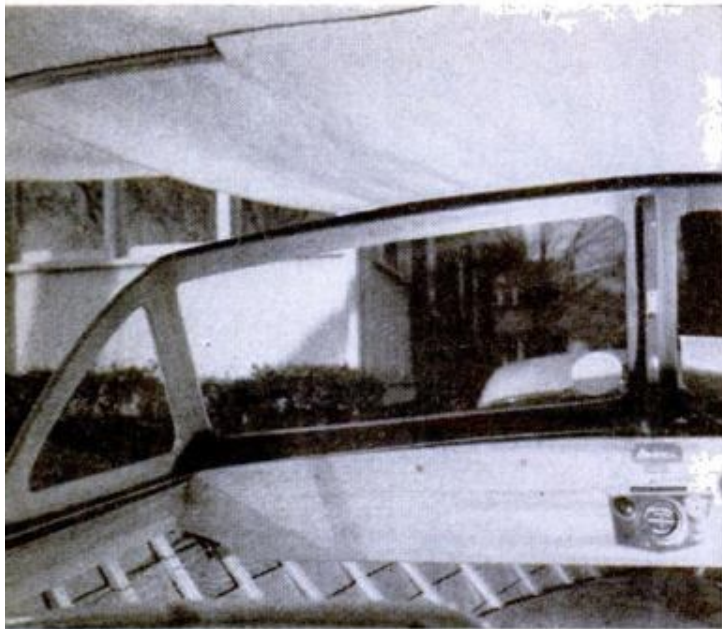

**CENTER BOW** fits into a 38-in. sleeve, and positioning of sleeve is the last step in making the top

and about 26 in. aft of the windshield to act as a substitute for the middle bow. If you're working outside, clamp light battens to the coaming and string the cord between these. Tape a large piece of brown paper or an old sheet to the rear bow and windshield to give you an idea of the profile of the top.

If you are satisfied with the appearance of this setup, use the temporary back bow as a pattern to make the bending jig for the rear and middle bows. Lay it on a large sheet of paper and trace the curve along the outer edge, then fold the paper in half with the outline on the outside and select the half with the smoothest curve. Since

this line marks the outside of the tubing, you'll have to draw a second line inside the first a distance equal to the diameter of the tubing used. Cut the paper along this inside line while folded, unfold it and you have a symmetrical pattern for the jig.

The tubing used in the pilot model was  $\frac{3}{4}$ -in. o.d. aluminum with a .050 wall. This is about the minimum size, since anything lighter won't stand up to rough usage. To prevent kinking when bending, fill the tubing with dry, tamped-in sand and cork both ends. Measure the pattern bow in order to get the length of tubing required and add about 6 in. Locate the middle of this piece of tubing on the centerline of the jig and bend the tube around the form. After bending both sides, take the bow off the jig and reverse the direction. This will show up any irregularities, which can then be corrected by hand.

Form the middle bow in the same way. The length of tubing required will be about 18 in. shorter than that for the rear bow, but you can determine the exact length by attaching the pivot saddles and propping the bow in position. When the frame is folded, the bows should lie one atop the other for easy storage. To complete the frame, cut and bend the gunnel fittings, then secure them in the proper locations.

The ventilating slot, Fig. 1, is made by bending a strip of  $\frac{1}{8}$  x 1-in. aluminum to follow the upper front edge of the windshield. Mount it with wood screws running through  $\frac{1}{4}$ -in. plywood spacers on 5-in. centers, then attach the dot fasteners which

(Continued to page 210)

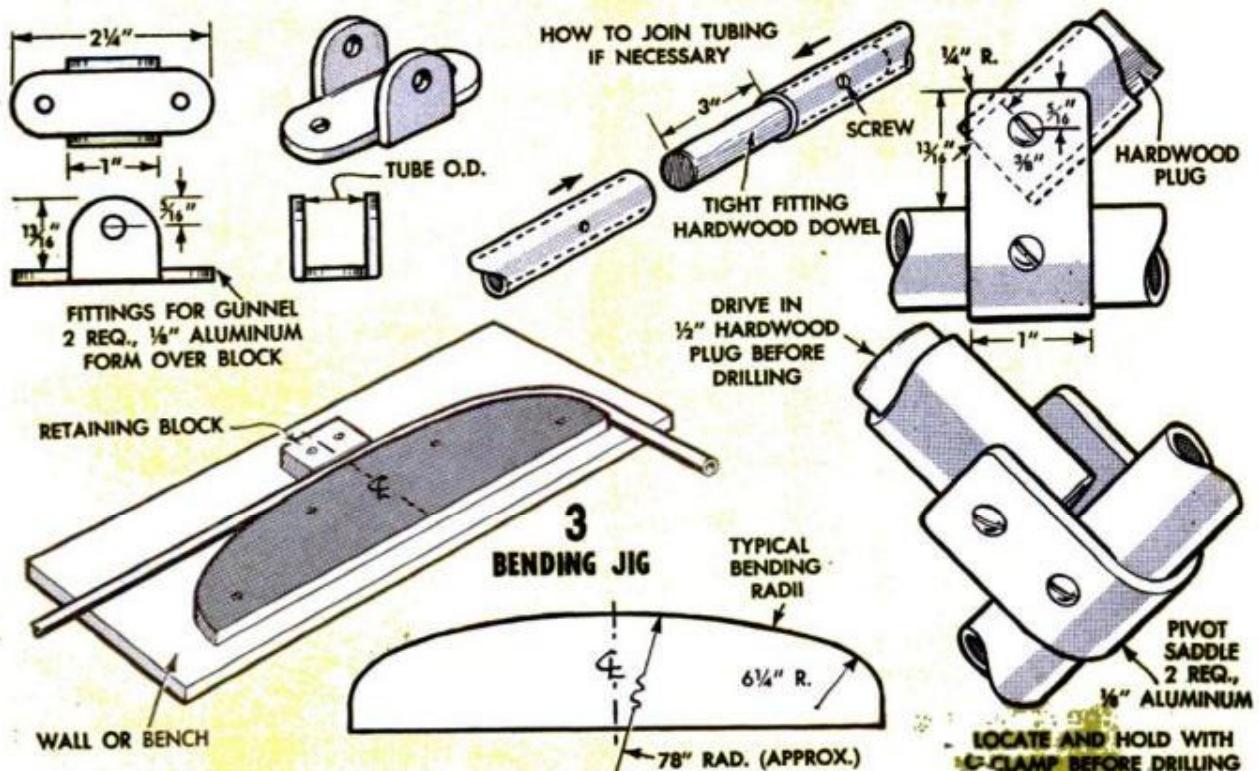

LOCATE AND HOLD WITH C-CLAMP BEFORE DRILLING

# NEW FOR BOATERS

**1. STREAMLINED** fender cleat utilizes spring-loaded top to eliminate projections which snag lines, sails and clothing. Measuring  $\frac{7}{8} \times \frac{7}{8} \times 3\frac{3}{8}$  in., the heavy chromed fitting takes lines up to  $\frac{3}{8}$ -in. dia. and is adjustable for height by using a series of loops or knots. Priced at \$3.50 per pair, or two pair for \$6.75, these streamlined cleats are available from Safety Boat Cleat Co., 644 Diversey Parkway, Chicago, Ill.

**2. TRANSISTORIZED** tachometer works with all types of engines but diesels, takes triggering pulse across distributor points. Range switch on back of housing selects either 0-4000 or 0-8000 r.p.m. range. Brushed, anodized, die-cast aluminum case with ball-and-socket mounting may be attached either above or below the dash. Tachometer is available in kit form for \$22.95 f.o.b. Heath Co., Benton Harbor, Mich.

**3. AUTOMATIC** trolling plate allows large motors to operate at higher, more efficient r.p.m. rate while traveling at low speed. Automatically locks into position behind prop at low speed to exert spoiling effect. More throttle causes plate to swing up behind cavitation plate for minimum drag. Made by Norcoa, North Coast Products Corp., 333 W. Superior St., Duluth 2, Minn., the trolling plate is priced at \$14.95

**4. EPOXY REPAIR** and resurfacing kit includes all the necessary materials, applicators and mixing implements. Senior size (shown below) sells for \$5.75 and contains 1 lb. of epoxy resin, 1 pt. of resin cleaner, a large bag of fixative powder and a 2-ft. length of glass cloth 4 in. wide. Junior size is approximately one fourth as large and costs \$2.50. Manufactured by Nehi Protective Coatings, Inc., Lindenhurst, N. Y.

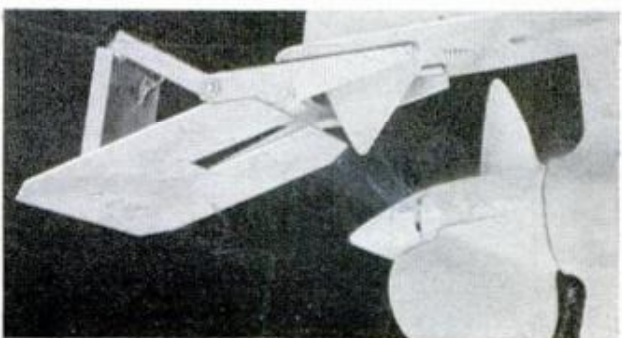
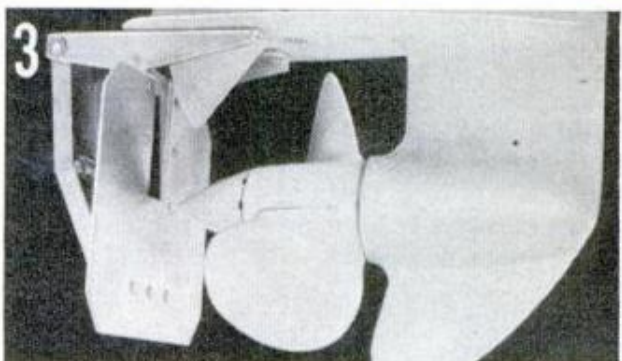
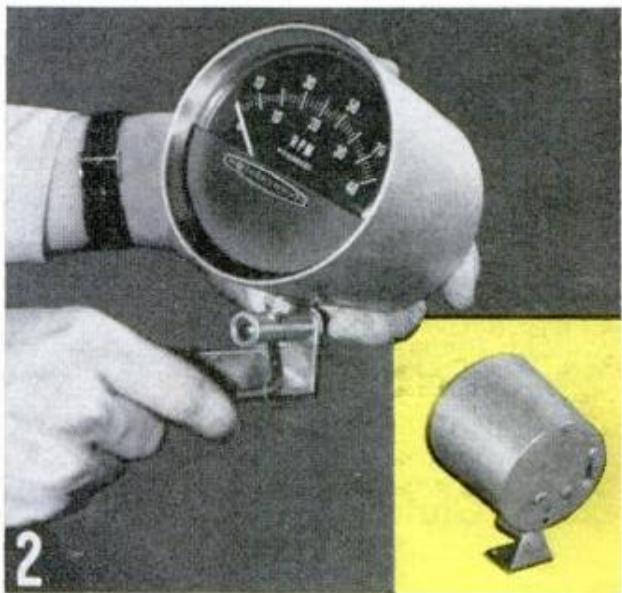

# X139 Glue-Caning



## Butter-Pat Spear

In one restaurant where butter pats are served from an iced crock the head waiter bent (with the manager's permission, of course) the two outer tines of a fork back on themselves as detailed. His purpose was twofold; to make it easier for waitresses to spear a pat of butter and at the same time to devise a means of inviting them to replace the fork.—*Russel E. Leitch*

## Screw Clutch

Haven't you often wished for some way to hold the screw to the screwdriver while you drove it with one hand? Here is a simple solution that will help you start a screw almost anywhere. Slip the screwdriver blade into one end of a short piece of rubber tubing and push the screw head into the other. This will hold them together until the screw is started. When not being used slip the tubing up onto the shank.

—*H. Hanscom*

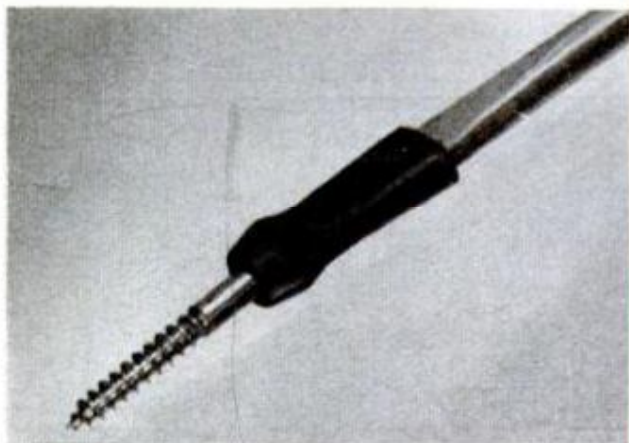

**1. PLASTIC-COVERED** electrical cord serves as a binder under clamping pads. Cord is tacked in place

**THREADING** strand cane through the holes of a chair seat in weaving a new bottom is a time-consuming job, hard on the hands as well as the back. Now there's an easier way, thanks to the strong holding power of white plastic-resin glue. Instead of weaving a seat which takes hours, you buy prewoven cane webbing and simply glue it on. The result is an exceptionally strong seat, tight as a drum head.

To obtain a good surface for glue-caning, remove all the old cane seat and sandpaper the area between the holes and the inner edges of the frame members. This done, mark a center line across the front and back members of the frame with chalk. These

**2. CHAIR SEAT**, of prewoven cane, is cut roughly to size and held in place with clamps until glue dries

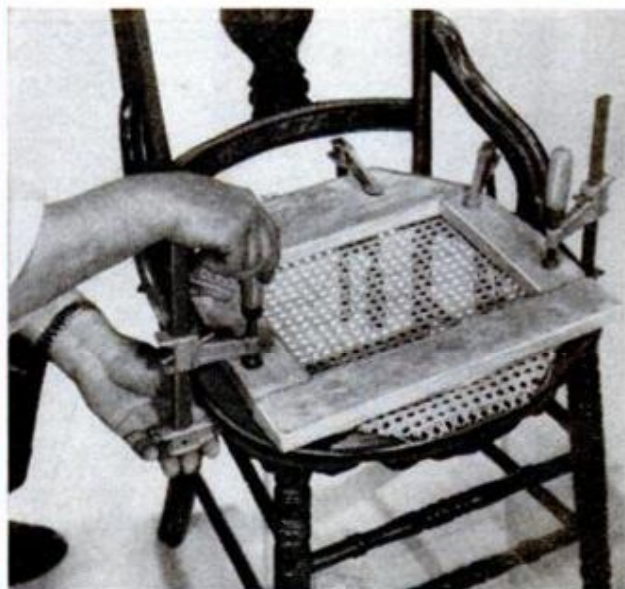

# Chair Seats

lines will serve as guide lines for placing the prewoven cane seat squarely in position with the double strands running from front to back. Next, obtain and fit a length of heavy, plastic-insulated two-wire electrical cord around the frame with the outer edge of the cord directly over the outer edges of the holes in the frame. The cord is shown being tacked in place in Fig. 1. Make sure the cord is shaped to the contour of the row of holes in the seat frame.

Cut the prewoven cane webbing to a size roughly 1 in. larger than the actual finished size of the seat to allow for trimming. Place in hot water and allow to soak for at least 20 minutes. In the meantime run a line of white glue around the sandpapered portion of the seat frame as in Fig. 3. Rub into the wood with your finger. Remove the rough-cut cane seat from the water and shake off the excess water. Wipe the underside dry. Place over the chair frame and clamp in place. Turn the chair over and run a pencil mark around the inner edge of the seat frame, marking the outline lightly on the cane. Remove the seat, run a line of glue onto the cane just inside the pencil line. Spread the line carefully so that it will just cover the sandpapered area on the seat frame when the seat is replaced in position. Next spread a new line of glue over that already applied to the frame. Now, place the cane seat and tack the shaped cord over it as in Fig. 1, making sure the cane seat is just tight enough to prevent it from sagging. Then, quickly before the glue sets, place a number of clamping pads, or wood cauls, on top of the electrical cord as in Fig. 2 and draw them down with C-clamps.

**4. AFTER GLUE** is dry and cauls are removed, trim the rough-cut seat to final size. Cord is still in place

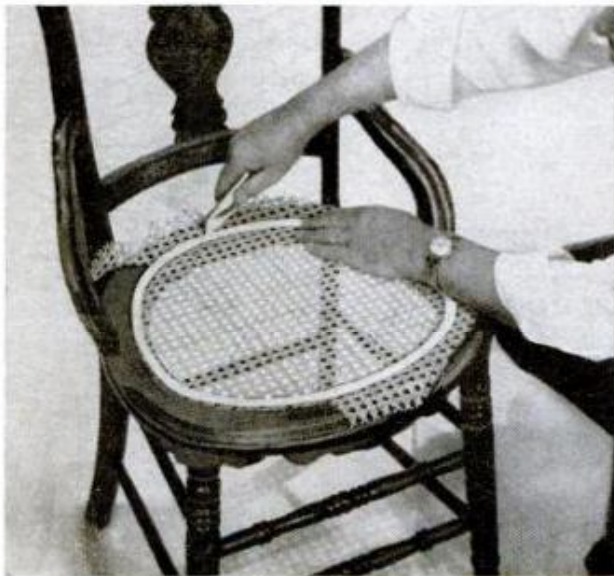

SEPTEMBER 1962



**3. SPREAD GLUE** around seat frame, keeping glue line in area between holes and inner edge of frame

When the glue has dried—give it plenty of time—remove clamps and cauls and trim away the cane waste as in Fig. 4. When dry, the cane will be drum-tight. Now carefully pry the cord up and remove. The edge of the seat is then finished with a binding in the regular way as in Fig. 5. Finally, coat both sides of the cane seat with a high-grade varnish.—Gustav W. Stamm

**5. SEAT IS FINISHED** with binding in conventional manner. Then coat both sides with high-grade varnish

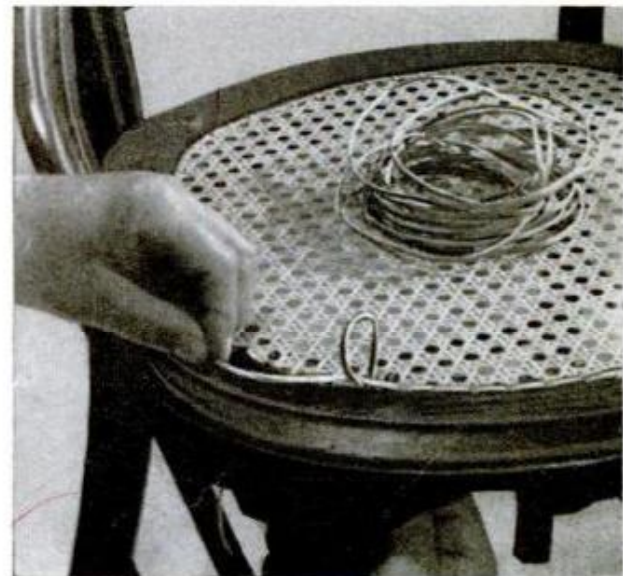

187

# "Show Biz" Makeup Mirror



SHOW PEOPLE know the importance of controlled light in applying makeup and friend wife will feel like a star herself in front of this lamp-studded, back-stage dressing mirror. Controlled from full bright to warm glow by a dimmer switch, the mirror will let her apply her makeup to suit the particular lighting mood. All you need is a fancy picture frame, a dozen or more pin-type plastic sockets with bulbs and a dimmer switch known as Luxtrol.

Replace the picture in the frame with a mirror, then on a center line penciled on the back of the frame lay off equal spacings of the sockets. About 4 in. is a good average spacing. Drill holes through the frame on these centers, the holes slightly under-size so that each socket is a press fit. For neatness and ease of wiring take pains to press each socket in to the same level so that all will project the same distance at the back of the frame and present a pleasing symmetry on the front face when the bulbs are in place. When placing the wires be sure that the socket caps are turned to a uniform tension with the wrench supplied so that the points will penetrate the insulation and make contact with the wires.

The control switch is designed to be installed in a two or four-wire outlet as in details A and B below. Switch capacities start at 200 watts so use this as a value when calculating the total wattage. ★ ★ ★

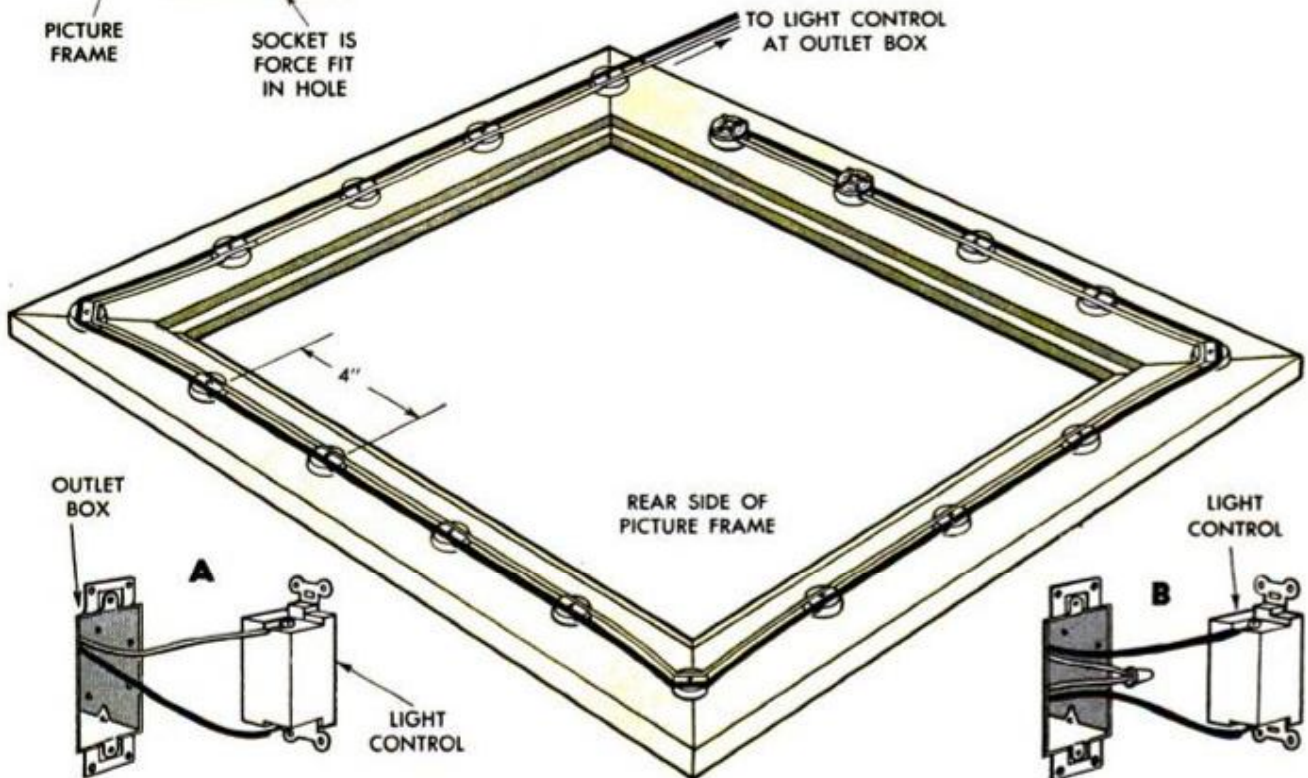
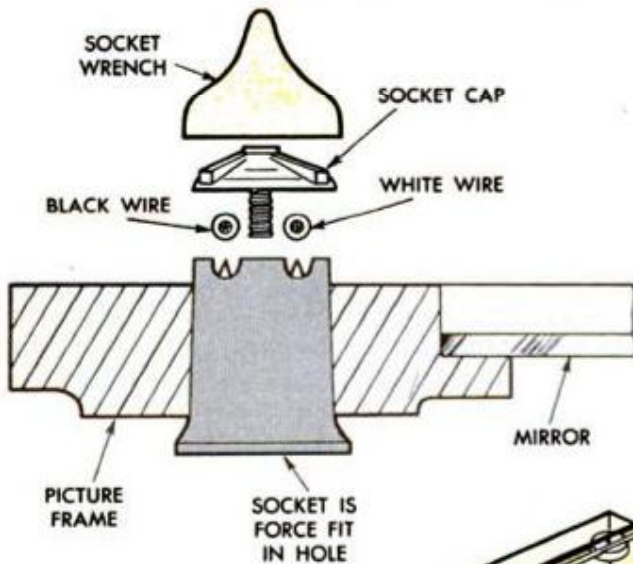

## SHOP SHORT CUTS

### Wrench-Sized Cap

Large pipe caps, such as those on oil-tank filler pipes, require use of a pipe wrench for removing and replacing. Not everyone has a pipe wrench handy when needed for such a job. One homeowner, after encountering this special problem, had a 1/2-in. nut welded to the cap. This permits use of any small end wrench or adjustable wrench when removing or replacing the cap. To prevent the nut from filling with water and rusting, turn a bolt of the same diameter into the nut, cut it off flush and peen over.—*John Krill*



### Self-Holding Stop

A permanent magnet of the bar type is just the thing to use as an adjustable cut-off stop on your jigsaw. Say you need to cut a number of equal lengths from a small strip. Place a rule on the table, measure the required distance from the side of the blade and drop the permanent magnet on the table with its edge at the measured point. Then place the workpiece with the end against the edge of the magnet and move into the blade. Be sure to hold the workpiece firmly so that it cannot shift sidewise.—*G. E. Hendrickson*

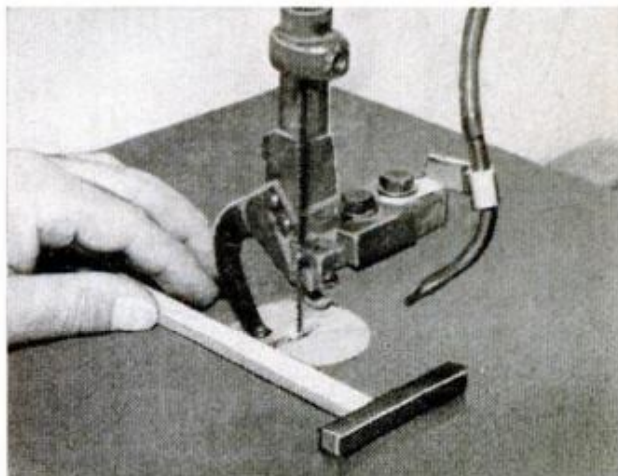

### Ready-Made Demagnetizer

You don't need to build a demagnetizer to demagnetize small tools such as screwdrivers. You have one right in your tool kit. Just connect your soldering gun, close the switch and insert and withdraw the blade of the screwdriver between the two arms that form the tip.—*Ken Patterson*



Use a permanent magnet to pick up small tools from your workbench before dusting. One pass of the magnet will pick tiny drills, screwdrivers, screws, right out of the chips.

### Rivets Are the Answer

Hinging doors or swinging panels of thin materials such as 1/4-in. plywood and perforated hardboard, is difficult and often impossible because screws won't hold. Rivets solve this problem nicely. Just use ordinary aluminum rivets and rivet washers. Drill holes in plywood for the rivets to exact size so that you gain the support of the material when peening. After inserting the rivets and placing the washers, cut them to length with nippers or side-cutting pliers, leaving sufficient material projecting for peening. This should be done with care to avoid tilting the rivets.—*Jackson Hand*

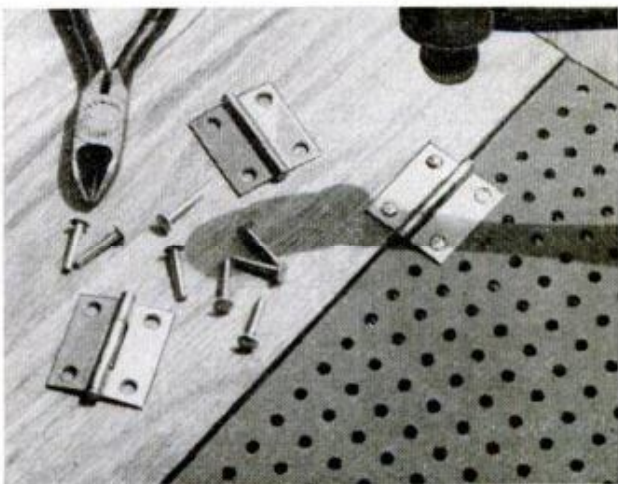

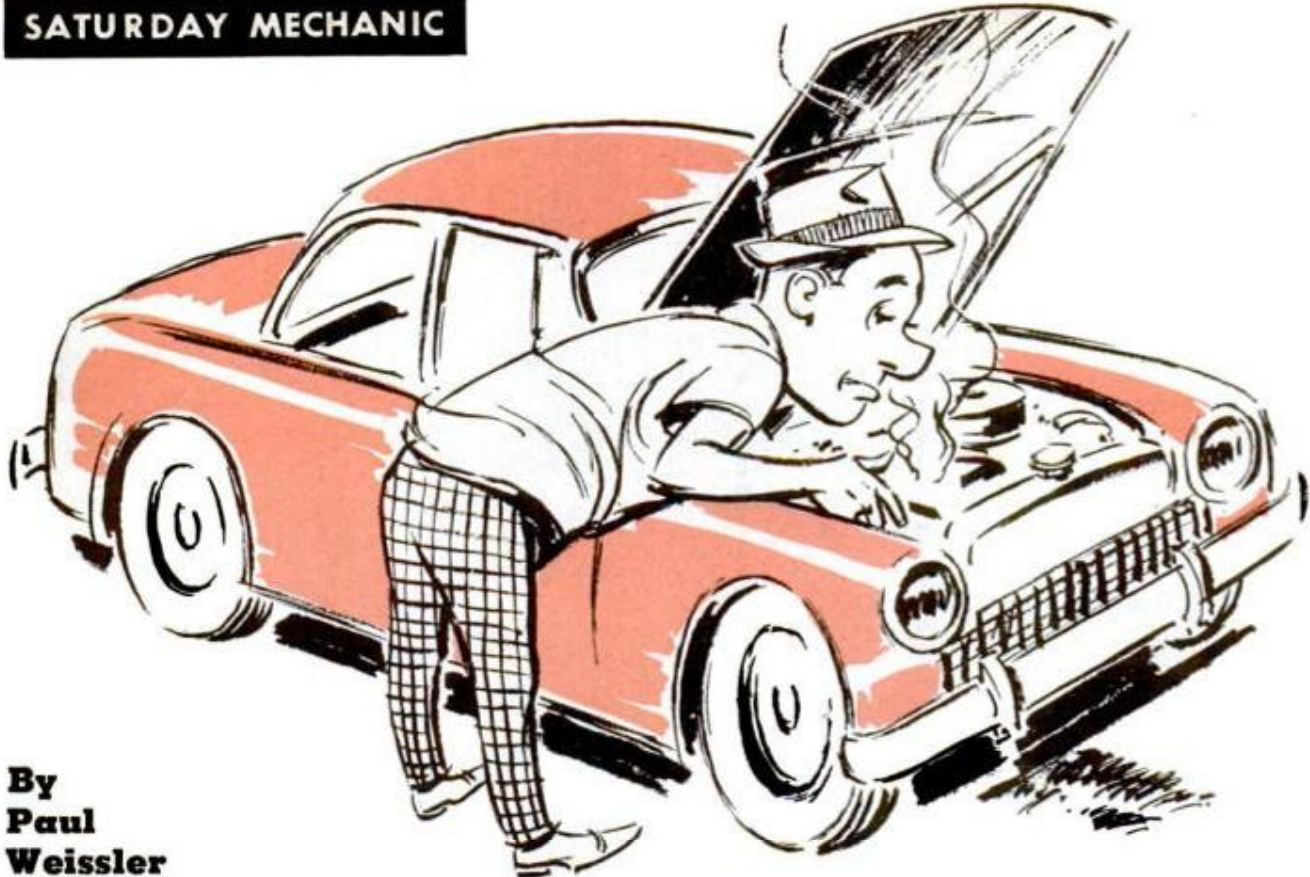

By Paul Weisser

# When Your Car Stalls

*flooring the accelerator may or may not get you started again. An expert tells you how to prevent stalling by correcting the causes*

**K**NOWING THE cause and what to do about it when something goes wrong with the car is the mark of the good Saturday mechanic. But usually the trouble is already half cured when you are able to read the performance signs beforehand.

That's especially true of the tendency of a car to stall at the lights or in stop-start traffic. You don't get much warning; but if you are a sharp observer and a good listener, you won't be taken completely by surprise.

**1. DEFECTIVE FLOAT** and needle valve cause flooding, difficult starting, loss of power and waste of fuel

**2. NEEDLE AND SEAT** can be cleaned with solvent but if either show any scores, both should be replaced

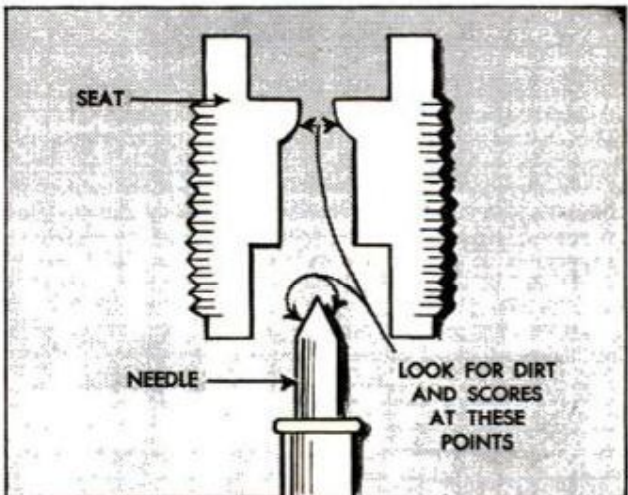
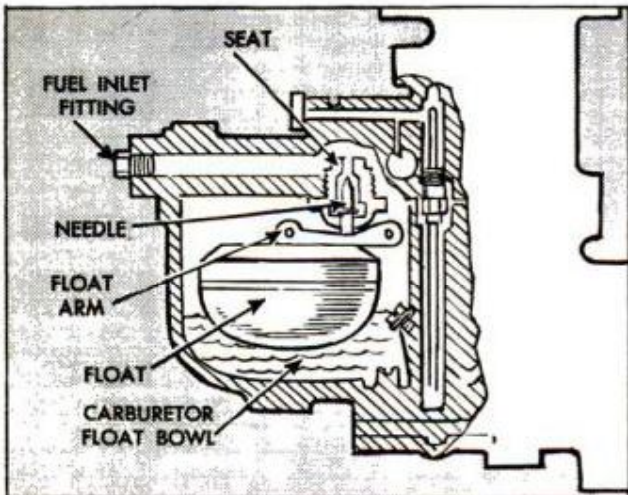

Материал, защищенный авторским правом



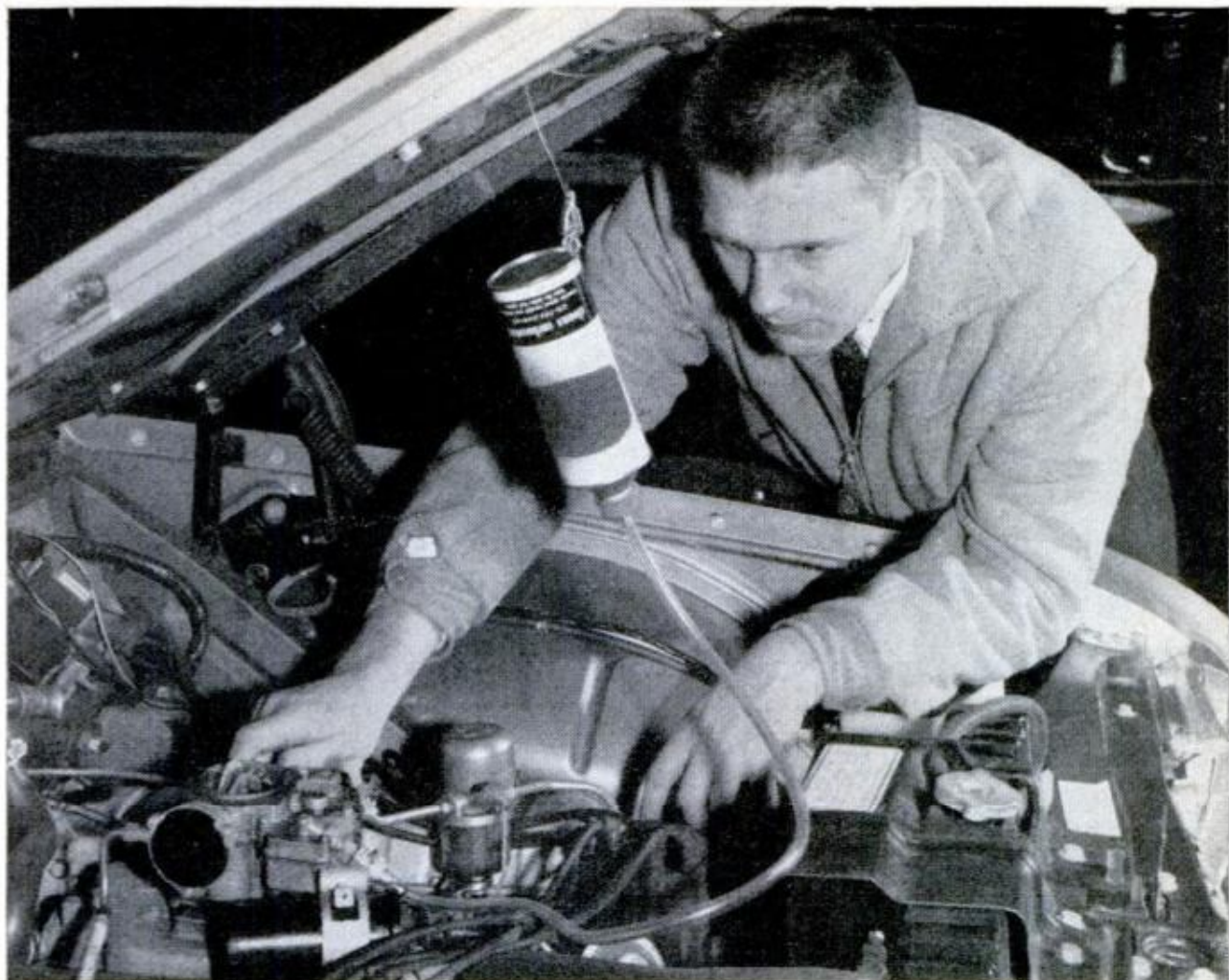

**3. ON-THE-CAR** cleanout kit is effective cleaner for carbs in good mechanical condition. Solvent removes dirt and gums that may restrict air bleeds and affect needle and float action. Kit is inexpensive

A rough idle with the engine warm usually—but not always—is an indication of a carb malfunction which generally conditions the car for a stall. If the engine won't hold a smooth idle after an idle-screw adjustment, it's generally pretty safe to guess that the carb needs working over. If the engine stalls in traffic and you have to floor the gas pedal to get started again—you

hope—there are two fair guesses: Either the float needle is sticking, Fig. 1, or the idle-adjustment screw doesn't "adjust." A reminder before you take things apart: Be sure to make some arrangement to keep parts in order so that when it's time to put them together again you'll know which goes where. Even the experts get fooled sometimes!

**4. STAKING, OR RESEATING,** needle in its seat with light tap of hammer is a fairly common practice

**5. WHENEVER FLOAT** is removed always shake it vigorously. If there's fuel inside, it indicates a leak

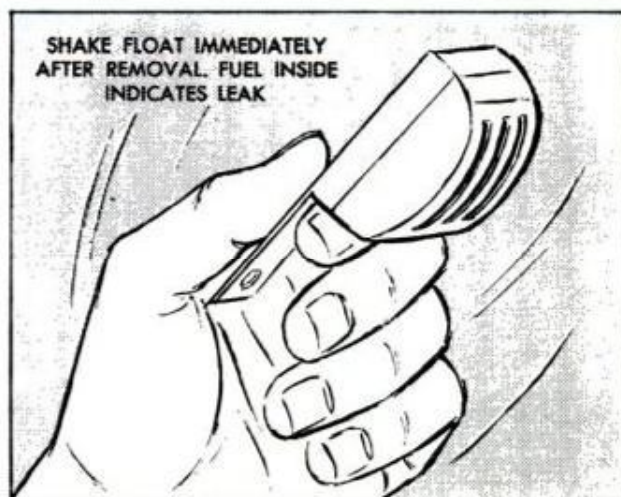
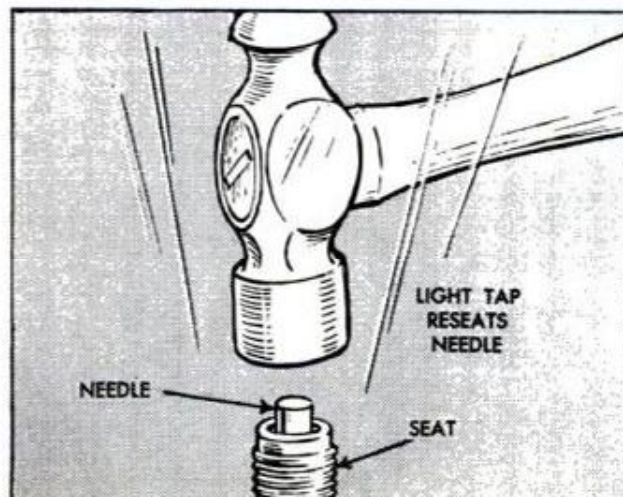



**6. YOU CAN** tell by this comparison photo which is the clean air filter. A semiclogged filter wastes gas

Now, while you're removing the carbowl cover and maybe investigating the adjustment screw, keep several other more remote possibilities in mind, mainly the chance that the carb float itself may have sprung a leak. If this happens, it simply sinks to the bottom of the carb bowl and stays there—and you don't start. So, whenever the float is removed for any reason remember to shake the thing immediately as in Fig. 5. If you hear any rattles or sloshes, throw it away.

Usually the needle or the seat, or both, are at fault rather than the float. Fig. 1—like all the other accompanying sketches—is only representative of what you will find inside a carb as all are not alike. Examine

**8. EXCESSIVE FUEL-PUMP** pressure can be a cause of flooding. Check it out for sure with a pressure gauge

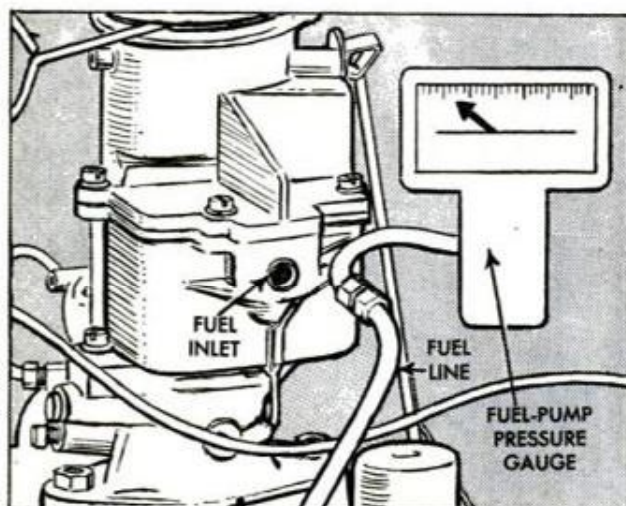

**7. IN-THE-LINE** fuel filters can trap most microscopic particles before they reach the carburetor

the needle and the seat, Fig. 2, closely. If you see dirt and an accumulation of gum at the points indicated, remove with a solvent and take another look. If you see a ring score on either the needle or seat, or both, replace the parts.

Some experienced mechanics go all the way with suspected carbs and install a complete repair kit which includes the needle and seat, replacement gaskets, float-level gauge, Fig. 10, accelerator pump, Fig. 11, and an instruction sheet with specs for setting the float level. In addition, the whole unit gets a close examination and a thorough cleaning with solvents.

Before reinstalling a used needle and a seat still in good condition, or a new set,

**9. DIRT AND GUMS** that build up gradually in the air bleeds can prove an unsuspected cause of flooding

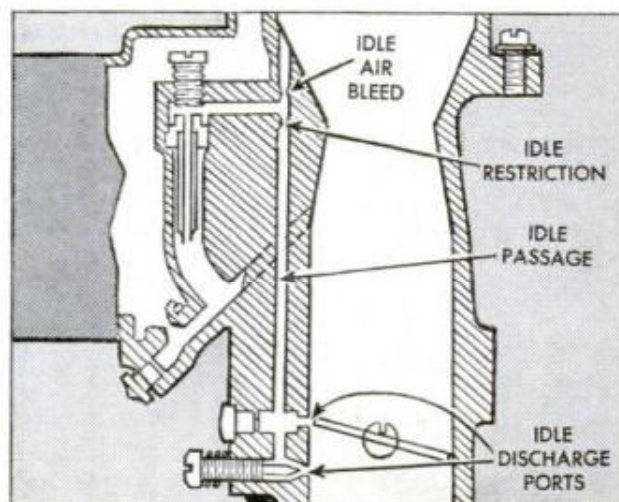

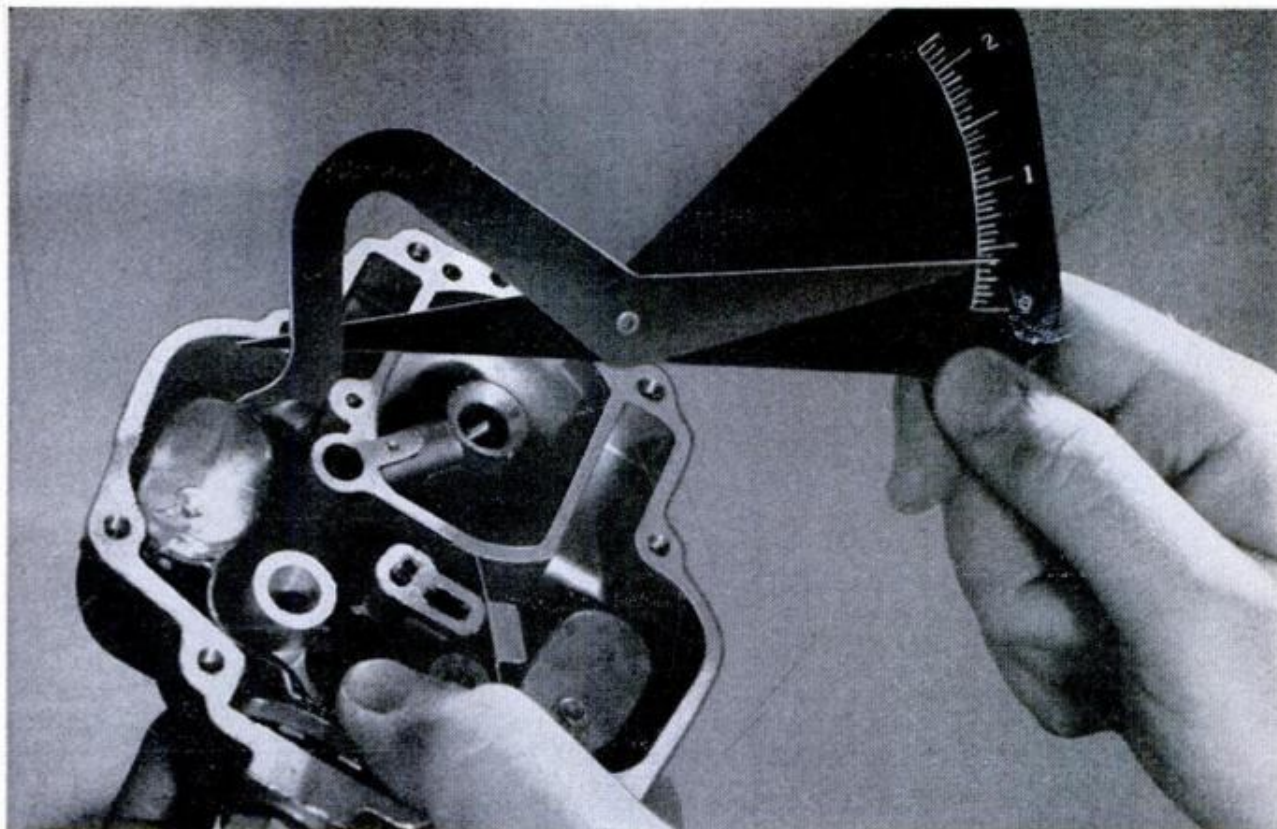

**10. FLOAT LEVELS** can be checked out with a rule but it's better to run this check and set the float to specs for your carb with the gauge that comes with the carb kit or with a gauge of the universal type

many mechanics reseal, or stake, the needle so it will seat properly. Although there are some who do not approve this practice it is still quite common. It's done by placing the seat upright on a clean, flat surface, inserting the needle in the seat and giving the needle a single, light tap with a hammer as in Fig. 4. Just one light tap does it. More will ruin the needle and seat.

Float level is usually taken to mean the height the float reaches when the needle is fully seated. As a rule this is given in the specs as fractions of an inch. You can set the float by measuring with a rule, gen-

erally from the top of the bowl to the top of the float with the needle seated, or from the bottom of the float to the flat surface of the bowl cover. But it's better to set the float with a gauge, using either the one that comes with the carb kit, following the instructions furnished, or with a universal gauge which is available. As a rule you can make any small adjustment necessary simply by bending the float arm or by means of an adjusting tab which may be found on the arm. If you do make an adjustment, be sure that the float can move

(Continued to page 212)

**11. ACCELERATOR-PUMP PISTON** should be checked when carb is disassembled. Replace defective piston

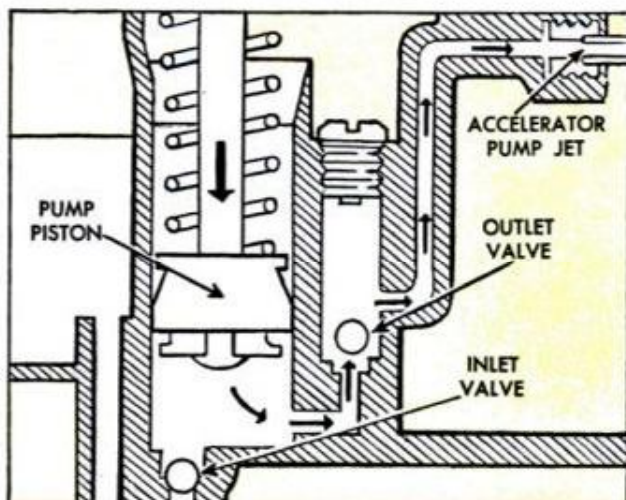

**12. AUTOMATIC CHOKES** can stick and possibly cause flooding, also sluggish performance and fuel waste

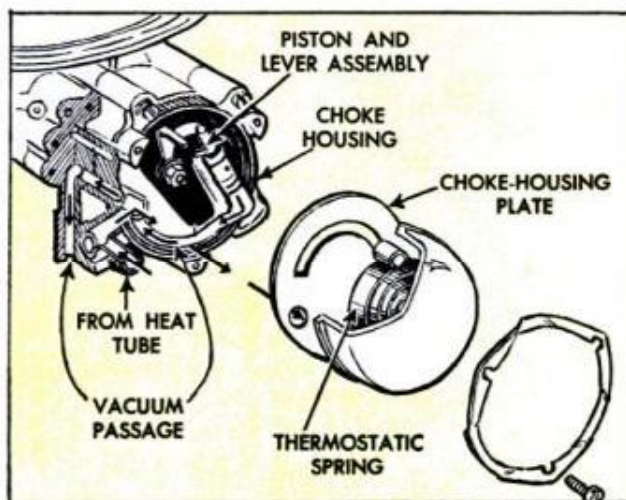

# Better CARKEEPING

● **REPAIRING A HOLE** in a gas tank often can be done without removing the tank from the car. After draining the tank, place a metal washer over a round-headed sheet-metal screw and turn the screw through a piece of gasket material. Coat gasket and area around leak with gasket cement, then drive the screw into the hole

● **TO REDUCE GLARE** of the sun reflecting off the hood of your car and into your eyes, give the hood a heavy coat of wax but don't polish it to a high gloss. The dull wax will greatly reduce glare. Of course, the hood can be polished later. It's especially helpful for long vacation drives when the glare often produces headaches

● **HEAVY COIL SPRINGS** which must be stretched to install, such as those on the hood or foot pedals, will no longer be a problem if you flatten the points of several large nails and drive them between the coils. When the spring is lengthened sufficiently, pull out all of the nails and spring will snap into proper tension

● **WHEN LOOSENING** a capscrew in a cramped location where a wrench will only give an eighth of a turn or so, cut a slot in the head with a hacksaw and turn it out as you would a screw. You also can drive the screw with the screwdriver, and while you'll still have to use a wrench for final tightening, it will be easier and faster

● **NOISY SPEEDOMETERS** are often difficult to oil, but here's a way to simplify the operation. Remove the speedometer cable to expose the cable connection. Then slip the small end of a discarded rubber sparkplug shield over the nozzle of a small pump oil can, push the end of the plug shield over the speedometer connection

● **TRACING OIL LEAKS** sometimes seems almost impossible, but you can track down most leaks in a very short time by using a little ingenuity. Clean the suspected areas thoroughly. Then dust lightly with talcum or tire talc, using a garden duster. Wait a few moments, and you'll find that leaks show up clearly on the white powder



● **EXTRA LIGHT** for loading or unloading the trunk of your car at night will be available automatically if you connect the wiring of the trunk light to that of the back-up lights as shown. Once these two circuits are linked, the back-up lights will come on whenever you raise the trunk lid, lighting up the interior. While this will also cause the trunk light to come on each time you put the car in reverse, the extra current drain will be negligible, and since the average car is in reverse for relatively short periods of time, this feature shouldn't hinder you from making the installation. Don't leave the car parked in reverse gear

● **AFTER EXPERIENCING** aching leg muscles in driving his Renault 4CV on long road trips, one sports-car owner gained extra legroom by adding an auxiliary foot pad to the standard button accelerator. Positioned forward and to the right of the original accelerator as shown, the extra pedal, besides giving a more solid footrest, provided additional leg reach to make highway driving less tiring. The auxiliary pedal consists of a strap hinge screwed to a wood block which is bolted to the floor panel as pictured

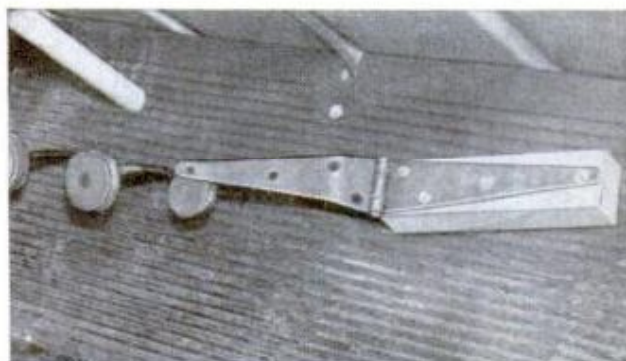

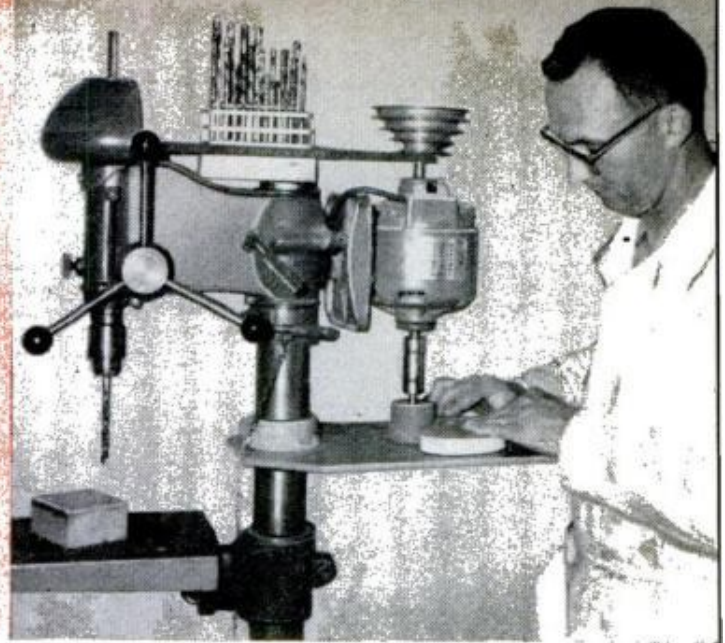
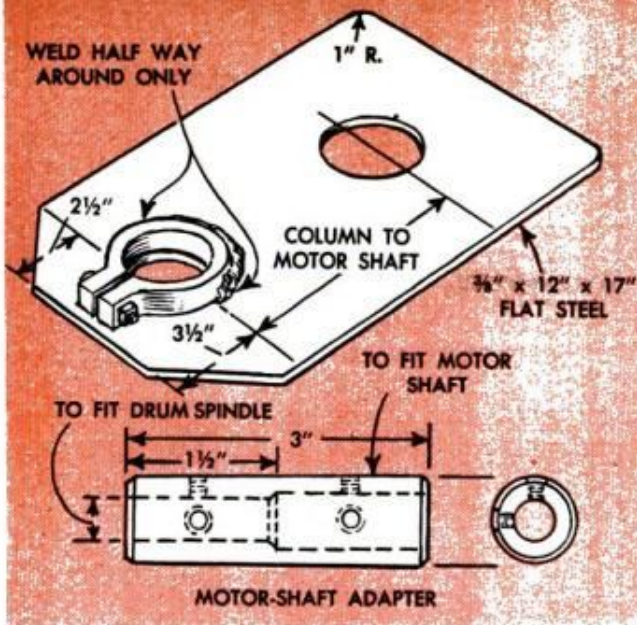

## Drill Press Doubles as Spindle Sander

If your drill-press motor has a double shaft, you can add this handy spindle sander simply by making an adapter from 1 or 1½ in. round steel and fitting a sanding table on the drill-press column as pictured. The table clamps to the column, permitting it to be moved up or down to utilize all the abrasive surface of the drum. Holes for the column and drum can be flame-cut at a local welding shop. The hole

for the drum should be about ¼ in. greater in diameter than that of the drum. Likely the same shop can make the clamp and weld it to the table at nominal cost. You may have to do some close filing to assure a good fit of the clamp. When tightened on the column the surface of the sanding table will always be at right angles to the spindle. The unit does not interfere with use of the drill press.—Charles A. Haugk

## Punch Press

You can use not only the drill press but the drill bit as well to punch holes in light sheet metals. Just grind the end of the drill-bit shank at an angle of about 12 degrees. This serves as the punch. With the same bit, drill a hole through a piece of flat steel, drill and countersink two holes for screws, attach to a drilled block of hard wood and there's your die. This basic idea can be carried further by using a strip of tool steel ⅛ or ¼ in. thick and drilling a row of holes along a center line, each of a different diameter, to form a multiple die. Corresponding drill bits used as punches have the shank ends ground at a 12-degree angle. Such a punch and die is useful only for punching holes in nonferrous metals such as aluminum, brass and copper. For punching holes in steel the die should be made from tool steel and hardened. Short lengths of drill rod also can be used as punches.—Louis Hochman

Sometimes, due to lack of space, it is necessary to keep edge tools in a drawer and, of course, the main problem is to keep them from getting nicked. Individual sheaths, plastic pockets and such, take up a lot of space. There's another, simpler way to protect the edges. Cover each cutting edge with a strip of masking tape. Double the thickness when necessary.

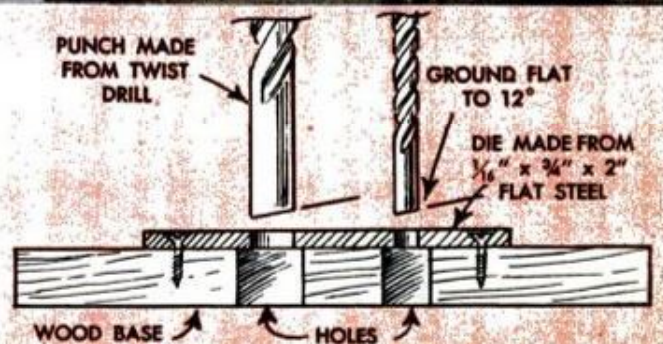
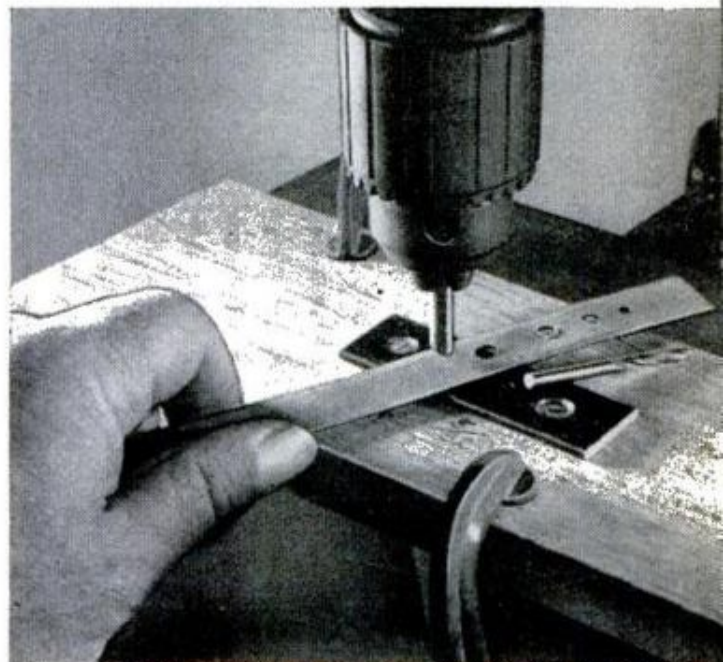

## See-Through Guide Aids In Glass Salvage

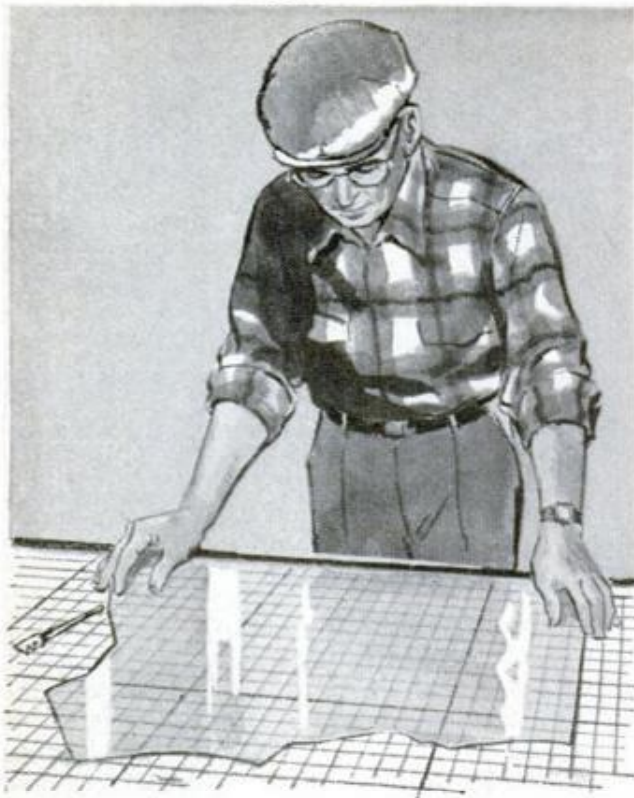

Let's say you have a number of pieces of glass, originally of a given size, which have been chipped along the edges, or several panes which have sizable pieces broken away. How to salvage what's left? Easy. Rule 1-in. squares on a piece of wallboard larger than the largest pane. Stick a length of tape along one edge, the edge of the tape flush with the first rule line. Lay one straight edge of the glass along the tape and you can see at a glance just what you can get out of it. Of course, the same ruled board makes the perfect surface on which to cut undamaged glass to any size.

—Ann Zawistowski

Scoring a rod with a pipe or tube cutter will assure a square cut with the hacksaw. The blade will follow the score all the way through. The same kink is also useful where it is desirable to square the end of a pipe or tube without deburring, as would be necessary if the cutter were used to cut the wall of the pipe or tube clear through. Just score lightly with the cutter and saw through with the hacksaw.—R. Hanscom

## Drill Holes at Any Angle With This Guide

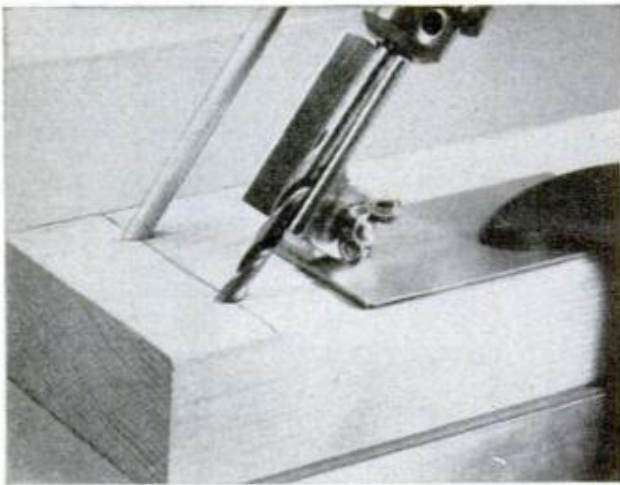

You've tried it—tried to manage a drill-press-accurate hole with a portable electric drill. You came close, but not quite close enough. That's why it's good to have this simple drilling jig, or guide, handy when the job calls for something better than free-hand accuracy. It's a simple affair consisting of a drill guide, a base and two angle lugs gripped by a single screw and tightened by two lock washers and a wing nut. The guide is a length of steel angle to which one of the lugs is welded. The second lug is welded to the metal base. The guide can be made any size required. As dimensioned it's suitable for use with a 1/4-in. portable drill. In use you simply set the guide to the angle desired, 45 to 90 degrees, clamp it to the work or handhold it, lay the drill bit in the angle guide and away you go.

—Robert Micals

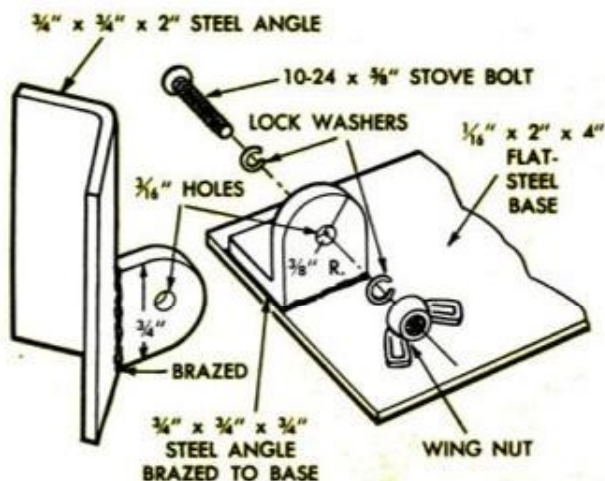

When you need to store small pieces of steel, either partially finished or unfinished, for long periods of time, exposure to temperature variations in a basement workshop may result in a badly rusted stock of materials. Grease or oil is out of the question since it coats not only the materials but everything with which they come in contact. Paint's the answer. Spray-paint the pieces, taking care to coat the surfaces uniformly. They'll remain rust-free for months, or even years. Take the paint off with a remover when ready to use.

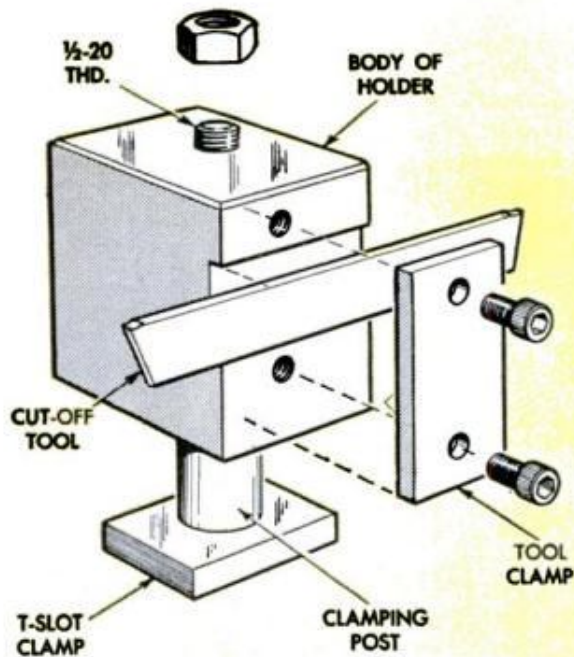

# Chatter-Free Cutoff Tool

ONE OF THE problems in cutting off, or parting, operations on a metal-working lathe is getting a smooth, chatter-free cut. One sure way to solve the problem of the smooth cut is to mill a mounting block for the cutoff tool from cold-rolled steel stock. This block carries the tool in a milled groove and clamps to the tool-post seat on the compound, replacing the tool post.

Dimensions given for the over-all size of the holder, or block, should be checked carefully with your lathe, particularly the dimension to the top of the groove A. You may have to alter the over-all size of the block slightly from that given. Mill the groove A to the exact width of the parting tool, or mill it just slightly under and file or grind the tool to a close fit. The depth of the groove should be slightly less than the thickness of the parting tool. Drill and tap the block for the socket-head screws which hold the tool clamp. The latter was made from 1/8-in. cold-rolled stock, but you can use 1/4-in. stock for greater rigidity.

Next, machine the clamping post and the T-slot clamp and drill and counterbore the block to take this unit. As you finish all these parts, break (chamfer) all corners except those on the flange of the post and the T-slot clamp. The finished unit is clamped in place on the toolpost seat with a single hex nut as in the detail above.

—C. W. Woodson



EXTREME RIGIDITY and ease of setting are features that make this parting-tool mount a standout among similar lathe tool mountings. Before cutting stock take careful measurements to be sure it fits your lathe

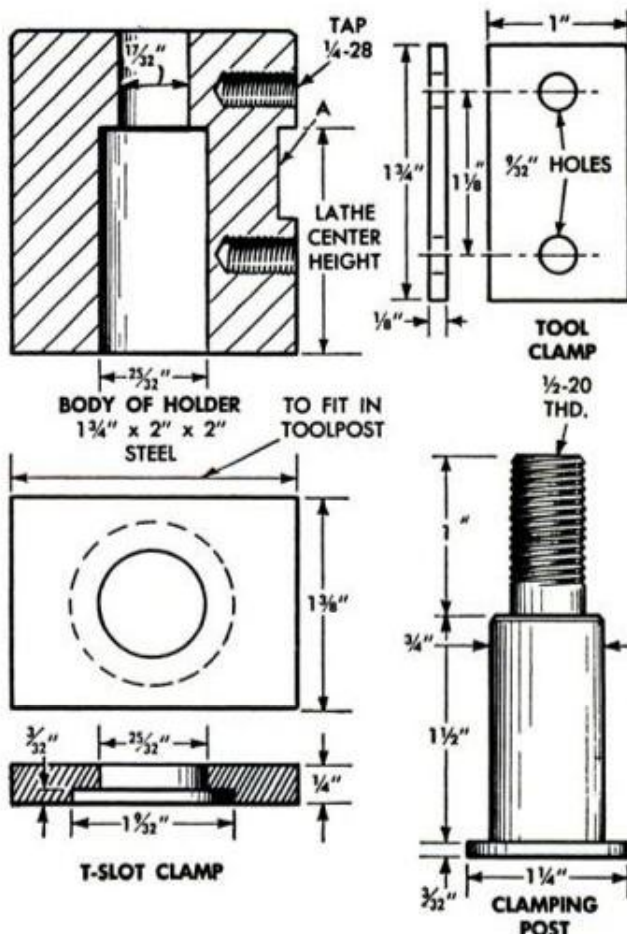

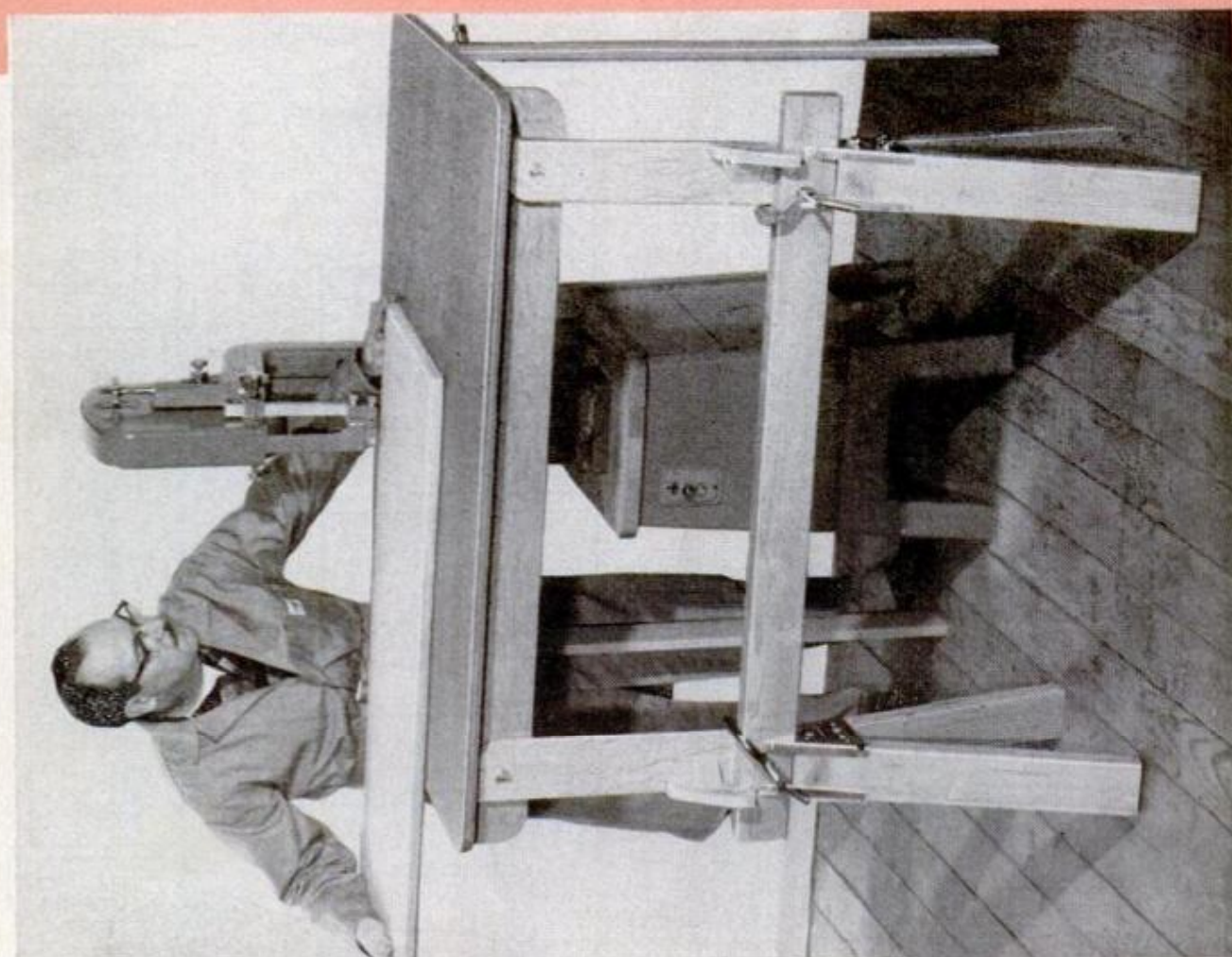
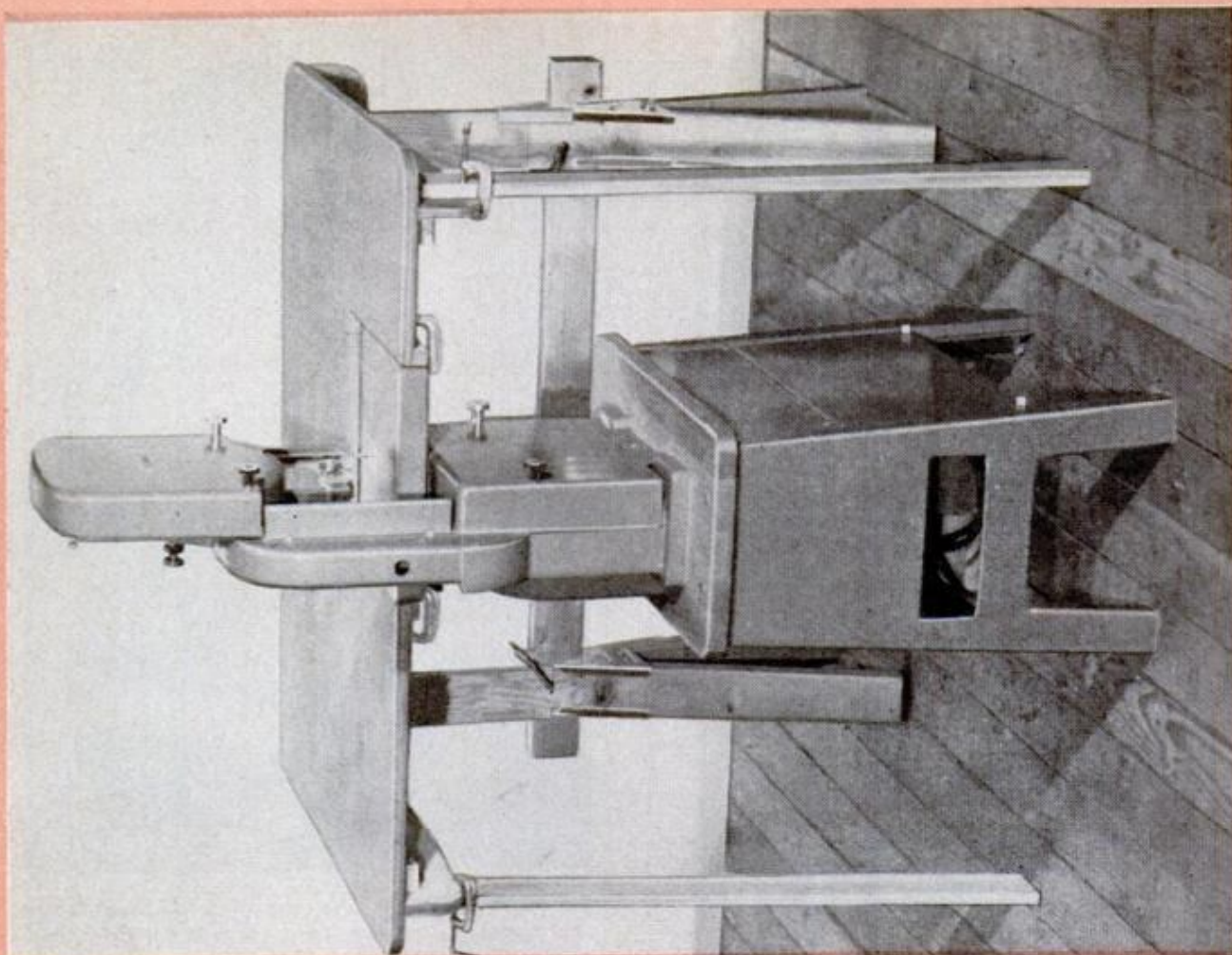



# Resize Your Bandsaw

*This 3 x 4-ft. auxiliary plywood table gives any small bandsaw real big-machine capacity*

YOUR 12 or 14-in. bandsaw will cut anything you can get under the blade guide. The problem is to support and guide a large workpiece while it is being cut. This auxiliary table is designed for jiffy installation. It sets up ready for use in about a minute and takes down and folds for storage in even less time. Note the two photos above and then go over the detail at the right, remembering that here the table is shown upside down. The outboard side of the table is supported on short folding legs which rest on the beam of a sawhorse. In the original the tongue cut on the lower end of each folding leg fits between the halves of the metal sawhorse leg brackets. Cleats around the auxiliary-table opening provide a means of clamping the auxiliary to the machine table.

First of all, check the height of the sawhorse to be used. Subtract this value from the height of the bandsaw table to get the distance from the top of the auxiliary table to the bottom of the notch in the bearing blocks which are attached to the short front legs. The latter are cut about 4 in. or so longer to permit the lower ends to be clamped to the sawhorse beam. Each short leg is held by a bolt and wing nut, the latter being loosened to permit the leg to fold. The notched blocks can be attached permanently to the legs or can be attached by the alternate method detailed (shown right side up) which permits the blocks to be adjusted.

Cut the auxiliary table to size, rounding the corners as detailed, attach three aprons in the positions shown and cut the opening for the bandsaw table; try for fit over the bandsaw table, then screw three clamping cleats around the opening. Use 1 x 4s for the legs and cut and attach the short legs first. The rear legs should be cut just a trifle short of the measurement from the floor to the underside of the table so that you have a little room for adjustment. Don't cut any stock to the dimensions given until you are sure the parts will fit your bandsaw.—*Manly Banister*

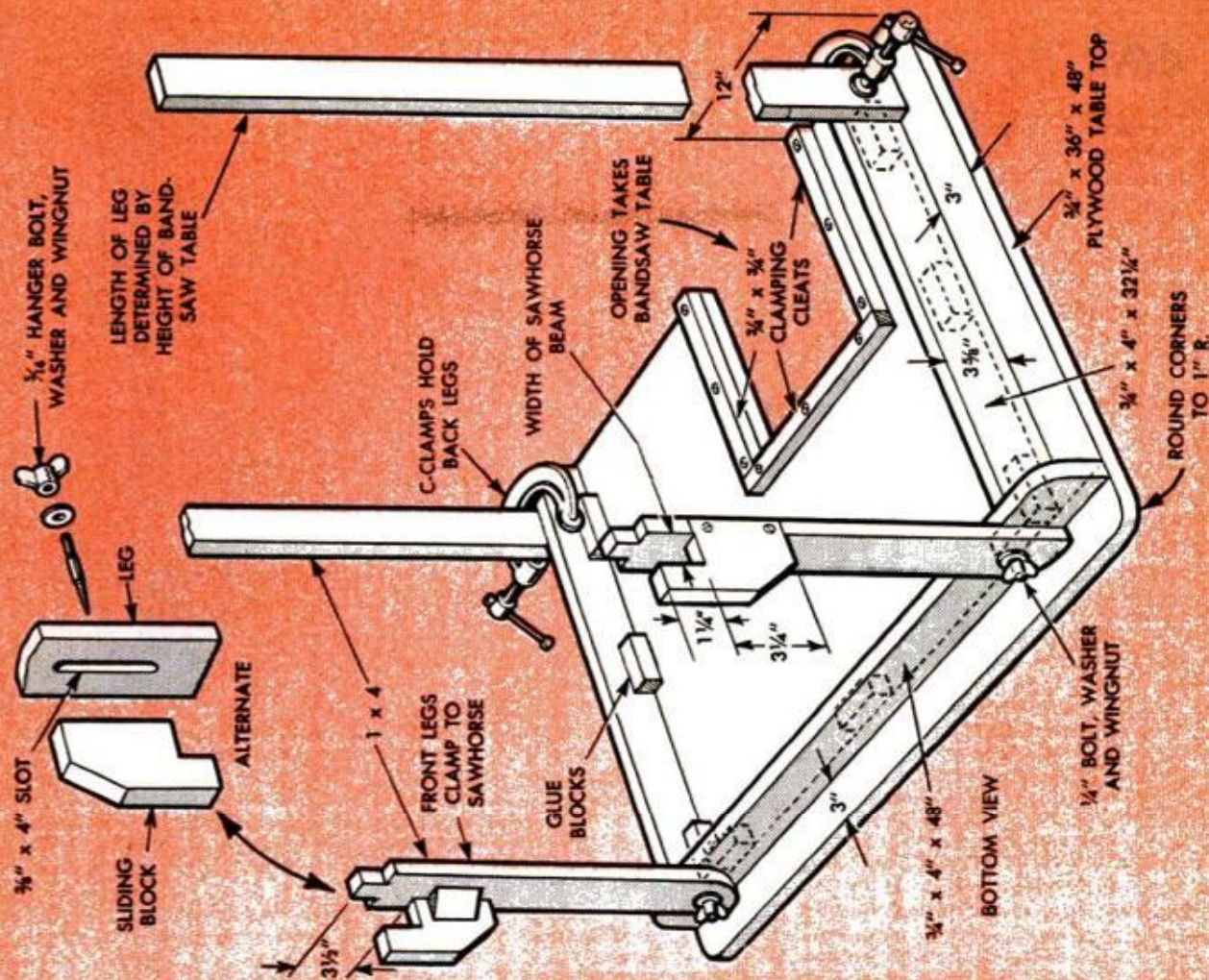

## COMING UP NEXT . . .

**ACCORDIO-ORGAN.** Buy a used accordion, fit it into a floor-type, airtight cabinet you build yourself, add volume control and electric blower and there's your spinet-type accordio-organ, like that pictured. And if you like the novel, the unusual, the beautiful, in musical instruments, be sure to see the October PM.

**HALLOWEEN CAPERS.** Soon witches will be riding high and Jack-O-Lanterns shining low. Treat the trick-or-treaters to a bit of individual art, show 'em what you can do in the way of arting up a pumpkin, instead of just slashing holes for eyes, nose and mouth. Watch for this bewitching story in the October PM.

**BENDING WOOD.** Probably you've looked at a fine bent wood chair with the thought, "Now if I could only bend wood like that." You can. Heat it, soften it, laminate it so it will bend almost like rubber and without breaking. October PM carries a shop feature on how to bend wood with the simplest equipment.



## Vise Jacks

Gripping a workpiece off-center, or of necessity at the very edge of the jaws, can seriously damage your precision drill vise or milling-machine vise. Unless, of course, you take the time to make these tiny vise jacks. Each jack consists of a tapped sleeve having two milled or filed flats 180 degrees apart, and an ordinary capscrew of the same thread size and having the hex head turned round and drilled transversely for insertion of a pin punch or a length of  $\frac{1}{8}$ -in. drill rod. In use, you place the workpiece in the vise and tighten lightly, place the jack on the opposite side between the jaws and back the screw until the jack tightens. Then simply tighten the vise jaws and the jack simultaneously, using the jacks for the sole purpose of equalizing the pressure on the vise jaws.

—Walter E. Burton

Is your oilstone coated and discolored with the grime of years of use? One way to do a fairly thorough job of renewing it is to dip a pad of fine steel wool in carbon tetrachloride and give it a good scrubbing. The carbon tet will loosen the dirt and oil and make it look almost new again. Avoid inhaling fumes from carbon tet.

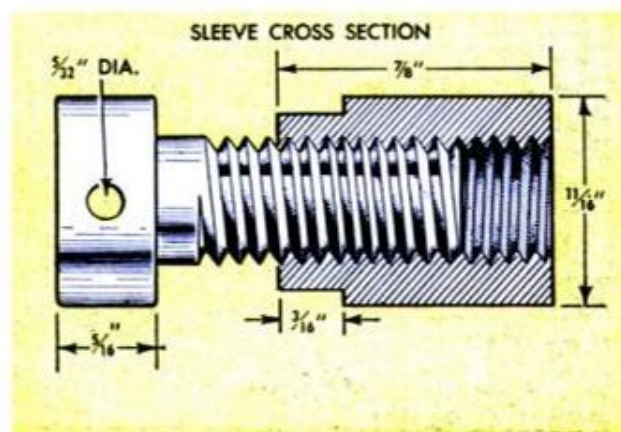
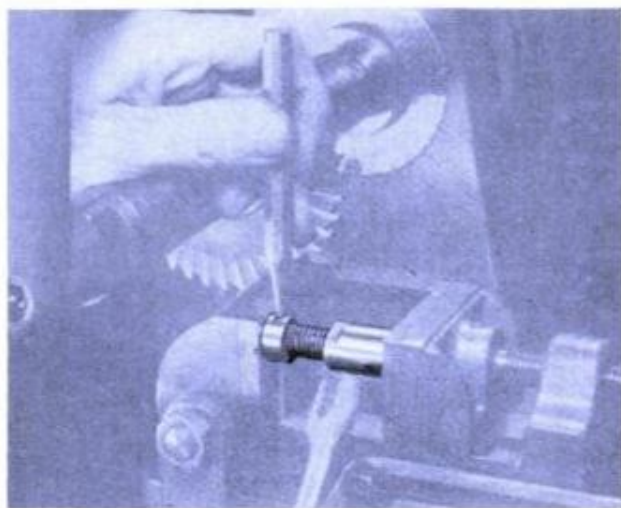

POPULAR MECHANICS

# RADIO TV HI-FI

ELECTRONICS

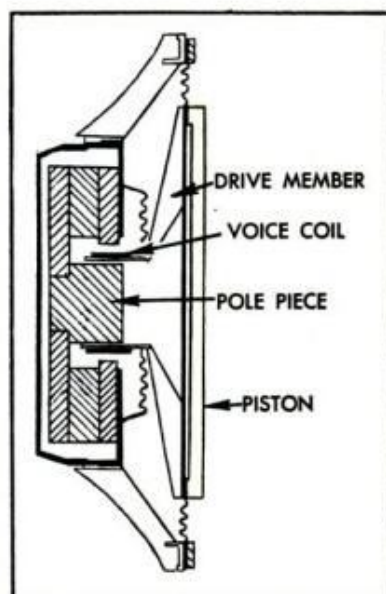
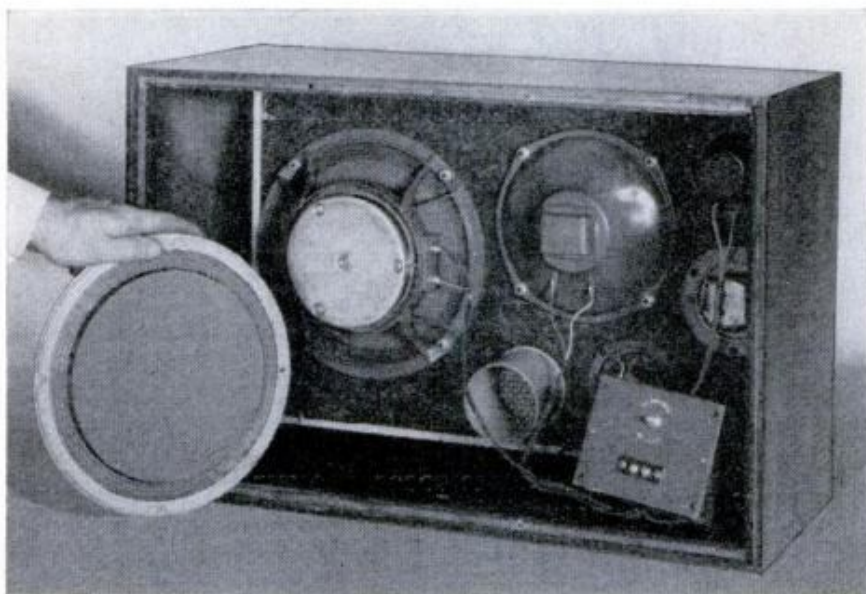

## Speaking of Speakers . . .

Shown above is the business end of a Jensen 3P/3 loudspeaker system. The speaker being supported by the hand is perhaps the most unique innovation in loudspeakers since the invention of the permanent magnet type. The heart of this unit is the solid plastic face called a piston radiator, which is used instead of the standard cone. The radiator has excellent low-frequency response. Additional in-

formation on the piston speaker is available from Jensen Mfg. Co., 6601 S. Laramie Ave., Chicago 38.

The speaker in the inset below was built completely from the disassembled kit. The instruction book actually instructs the builder in the assembly steps—and the reasons behind them. The 8-in. kit is \$15.95, the 12-in. kit \$19.95. Radio Shack, Boston 17, Mass.





**THIRD HAND?** You can actually hold solder between your teeth while hands are busy. Use pliers or clips on component wires to draw off damaging heat

You can banish the leading causes of electronic ailments by studying this distillation of "old pro"

# Soldering Savvy

**A** LARGE MAJORITY of the kits sent to manufacturers for repairs have nothing more wrong with them than such simple wiring faults as a cold solder joint. This is one in which the solder fails to form one smooth, solid fillet binding wire and lug together.

In some cases, the cure is simple. In all cases, it is easy to avoid the problem if you learn how the experts tackle a soldering job. Here's the way they do it.

**Preparing the Tools.** Soldering guns or irons which range from 60 to 100 watts are good for work on small radios. Too much heat may damage a component, so use only enough heat to make the solder liquefy completely. Too little heat will result in a cold solder connection where the solder has partially softened but not melted. You

**WHERE SEVERAL WIRES** are connected to one lug before soldering it's wise to "lock" mechanical connection as at left. Note in 3, below, from left to right: Good connection with smooth solder fillet; rough, partly dull, cold solder joint caused by insufficient heat; far right, too little solder and insulation

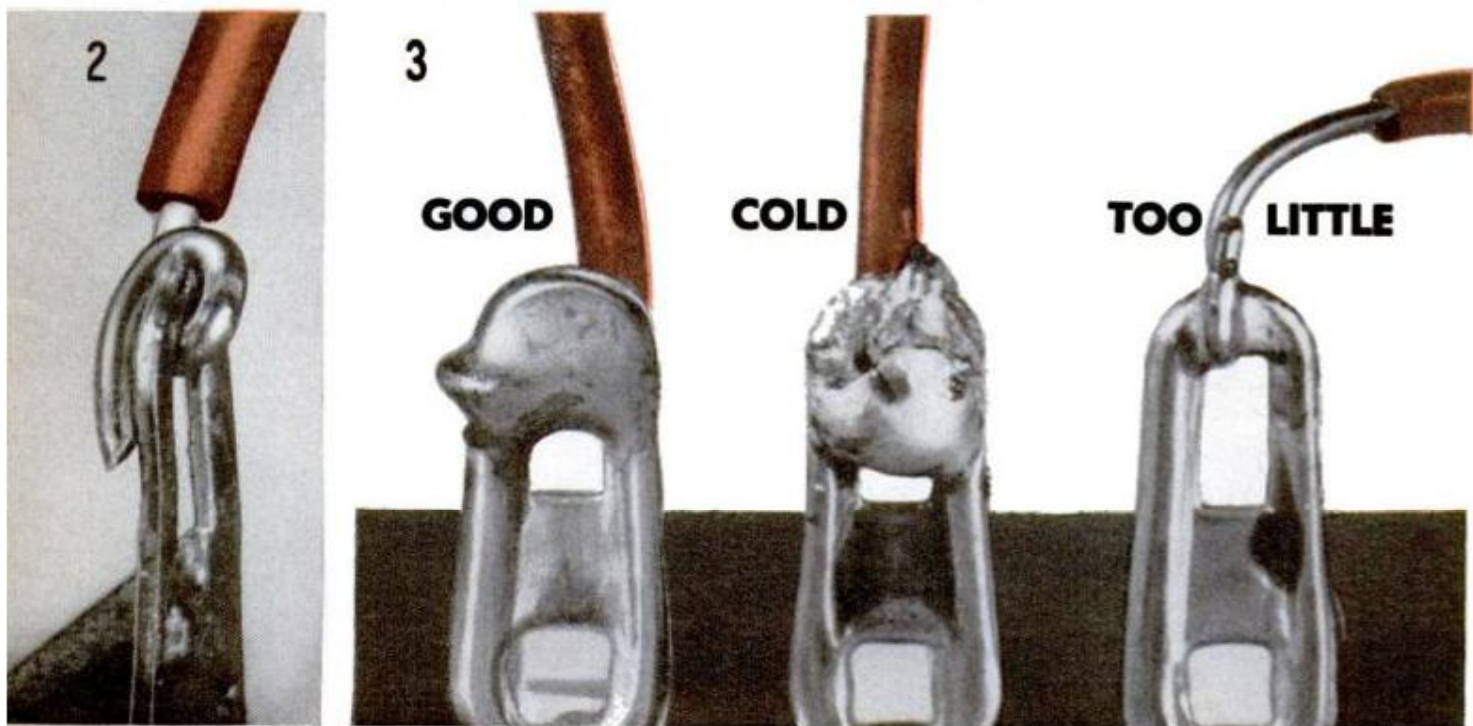

can also make a cold joint by pulling on the wire before the solder has cooled completely.

Curing a cold solder joint is easy, however. Simply reheat the joint until the solder flows evenly, withdrawing the excess solder on the tip of the soldering gun. The resulting joint should be neat and very shiny, dulling gradually as it cools.

If your soldering tool has a plain copper tip, file it to dress down all oxide pockets, then apply a little solder to the tip, and wipe with a rag, leaving the tip's surface clean and lightly coated with solder. This process is called "tinning" the iron. Irons with silver- or gold-plated tips, should not be filed. Simply apply a little solder and wipe the excess away.

**Preparing the Wire.** The two types of wire which you will work with the most are the stranded and solid. To remove insulation without nicking or breaking the inner wire conductor, you can use any one of numerous tools called "wire strippers" (Fig. 6). If you don't have one, hold the edge of a sharp knife blade against the insulation at right angles. Then press the wire into the knife with your thumb and pull the wire at right angles to the knife blade.

If the wire is stranded, twist the strands together tightly and lay the wire across your soldering iron. Place a drop of solder over the heated strands and the solder will flow through the wire, bonding it into a single easy-to-work conductor. This is called "tinning the wire."

**Preparing the Connection.** With about 1/4-inch of wire exposed from its insulation, grasp the wire at about the 1/8-inch point with long-nose pliers, (Fig. 8), bend the hook through the terminal lug, and crimp the hook against the lug with the pliers. Where you will make several connections before soldering and don't want the wire jostled loose until you solder it, you can lock the wire in place by bending the end of the wire back over the lug once again (Fig. 2). In any event, a good mechanical connection must precede any soldering in order to make a sound joint.

**Soldering.** The trick in good soldering is to use enough heat. Molten solder flows downward, so place your iron somewhat below the joint, with a flat side of the tip contacting as much of the terminal lug and the wire as possible (Fig. 9). Then apply the solder, not to the iron, but to the heated joint.

The iron heats the joint, the joint melts the solder. When enough solder has flowed in place to form a smooth, well-shaped solid fillet between the joint and the wire, remove the solder coil from the joint. But

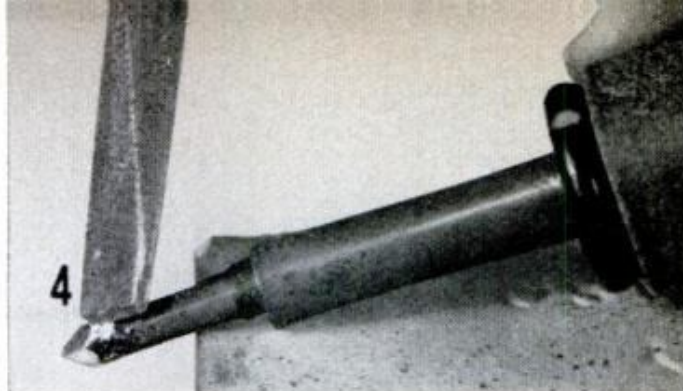

**TO PREPARE IRON**, rest on heatproof surface, dress down with medium-fine file to remove oxide pockets



**TIN THE IRON** by melting solder over dressed tip, then remove excess with soft cloth or steel wool

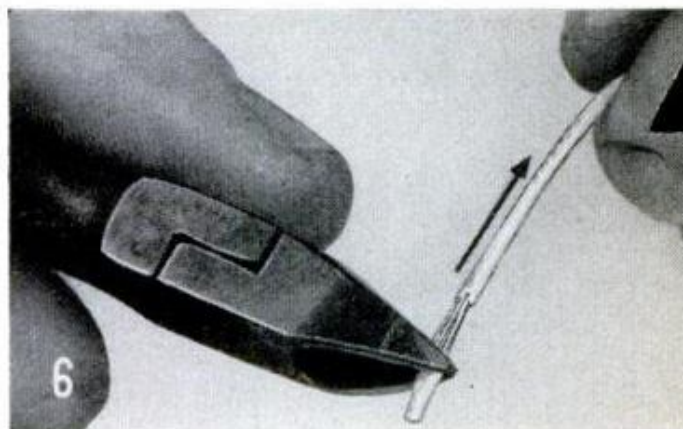

**OLD PRO TRICK** for stripping. Grasp insulation with cutters, pull wire quickly. Don't squeeze handles

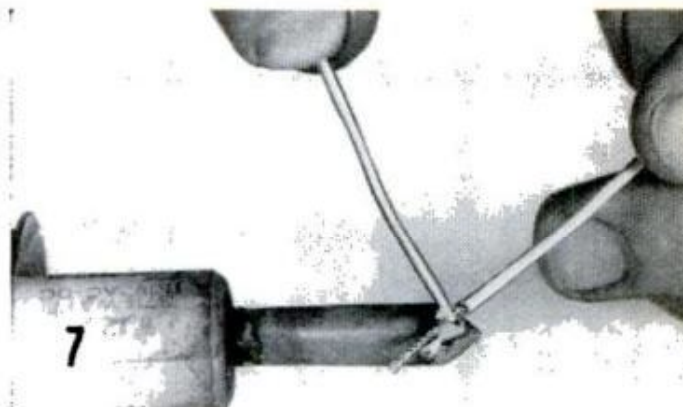

**STRANDED WIRE** should be twisted into single strand, then tinned by flowing solder over twisted strands

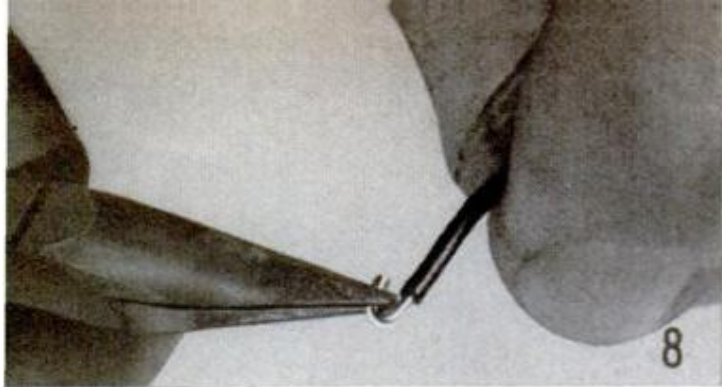

**STRIP INSULATION** back  $\frac{1}{4}$  inch, then form neat hook for mechanical connection before soldering

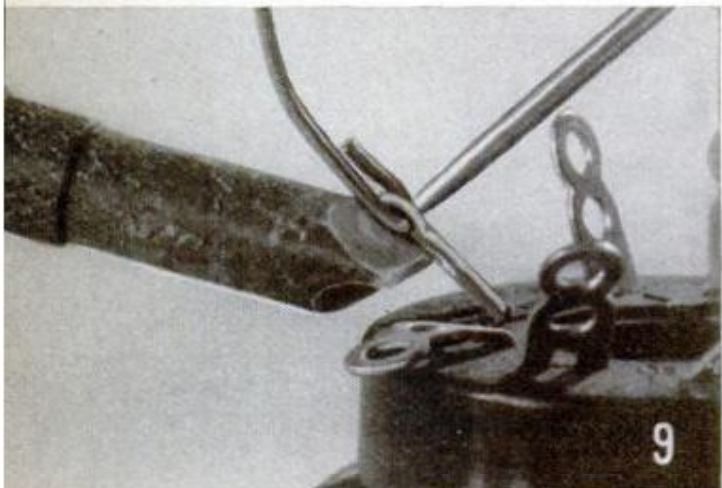

**NOTE POSITION** of iron, terminal, wire and solder (upper right). Idea is to heat terminal, let solder flow from above over it and preconnected wire



**MOST KIT BUILDERS** don't apply enough heat to printed circuit board connections. Make sure solder flows

**FOR MULTIPLE CONNECTIONS** (below) organize all mechanical connections first. Solder whole joint at once

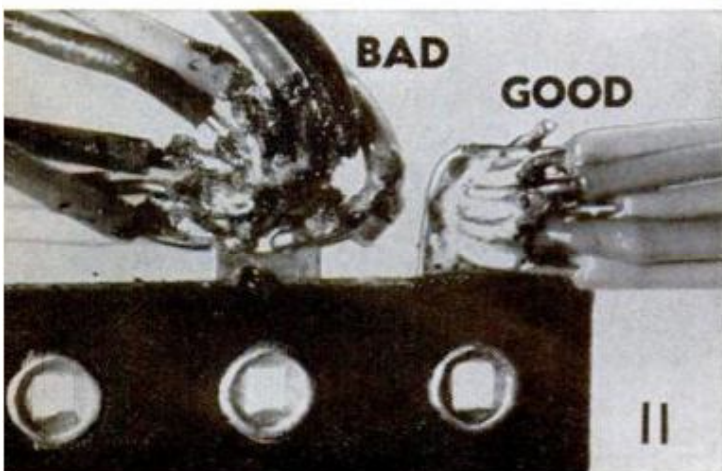

keep the iron in place for another moment to be sure the solder has completely liquefied. Then remove the iron, but do not disturb the joint. It must not be moved until the solder has cooled and set or a cold joint will result.

**Printed Circuit Boards.** In their anxiety to avoid burning foil conductors away from the plastic of a printed circuit board, many people fail to use sufficient heat. The result is poorly soldered connections, cold solder joints, and much unhappiness all around. Use an iron in the 100-watt range, and touch it to both the conductor and the wire. Be sure the solder flows completely before removing the heat! If you use a gun, be sure the tip is hot enough to flow the solder before applying it to the board to prevent damage.

**Heat Sinks.** Very often, you have to solder to components which are sensitive to heat. Some diodes, transistors and thermistors could easily be damaged by excessive heat. To protect these units during soldering, temporarily attach pliers, an alligator clip or a forceps between the solder joint and the component. Clamp this heat sink to the wire lead, and the excess heat from the soldering iron will be directed away from the delicate component and into the heat sink.

**Multiple Connections.** When connecting more than one wire to a terminal, make all the mechanical connections first before soldering. Arrange the wires from the terminal so they will lay in the proper direction along the chassis. This is called "dressing" the wires.

If the wires are to run in a bundle (called a cable), then dress them all in the same direction with no tangling (Fig. 11). When soldering a multiple connection, it is important that solder flow completely in and through each wire in the connection. After cooling, check each wire by tugging gently; it should not move on the lug. ★ ★ ★

**TOO MUCH SOLDER** on tube-socket terminal flows into block hole. To correct, reheat from below, shake

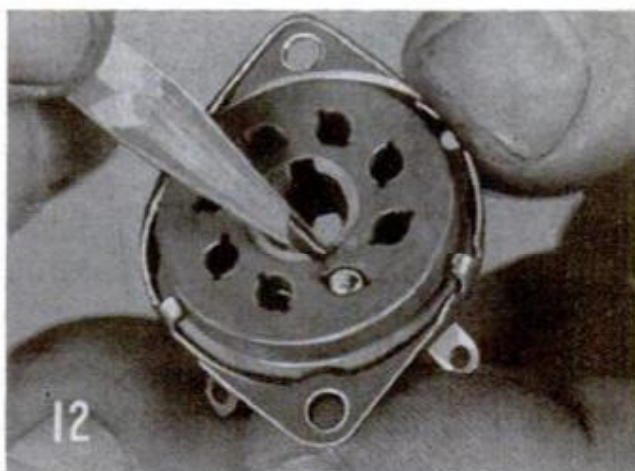



## Now you can paint your house in color and be sure it will last . . . with new "Dutch Boy" Latex House Paint

Now there's a new kind of paint that ends all the old problems of conventional colored paints. It's "Dutch Boy" Latex House Paint. Use it and your house will stay looking bright and fresh for years. Made with "Dutch Boy's" own acrylic resins, tests have shown it to be outstandingly resistant to sunlight and oxidization. In fact, this new paint retains its color so well you can come back and touch it up years afterwards, and not see the difference. When it's time for a new paint job, you'll only have to repaint the weathered side. Keep the same color and you may never have to paint your whole house at one time again!

"Dutch Boy" Latex House Paint is probably the most convenient paint ever developed for the weekend painter. You don't have to wait for ideal weather. Use it right after a rainstorm if you like. And you can stop and start anywhere. Lap marks won't show.

It's easier to use, too. "Dutch Boy" Latex House Paint flows off the brush, without paint drag. And this one paint is all you need for almost any surface—wood, stucco, brick and even composition shingles.

More advantages: Brushes and equipment clean up with just soap and water. And you can eliminate most of the blistering and peeling problems that used to be caused by trapped interior moisture. "Dutch Boy" Latex House Paint breathes—allowing moisture to escape, yet sealing out the weather.

If you'd like to find out more about this remarkable paint, check with your nearest "Dutch Boy" dealer, listed in the Yellow Pages. Or write for informative free booklet to: NATIONAL LEAD COMPANY, General Offices, 111 Broadway, New York 6, N. Y.

**Dutch Boy**  
LATEX HOUSE PAINT®



# *New* **KODAK CAROUSEL Projector** *Machine-gun action...* *80 slides at a clip!*

**Fast-loading . . . automatic . . . won't jam!** If you appreciate fine mechanisms, this new KODAK CAROUSEL Projector is for you. The first few times you run it, you'll catch yourself watching the way it works with as much interest as you watch the amazingly bright image on the screen!

The round tray loads in a jiffy with 80 slides. Slides need no special mounts. Locking ring keeps them from spilling out. Snap the tray on the projector and start the show. Slides feed by gravity. No jams.

You *could* show all 80 slides in 75 seconds! But that's just showing off. There are three other ways to do it: (a) Set the projector for *automatic* showing at 5-, 10-, or 20-second intervals. Then sit back and be a guest. (b) *Remote-control* the show by push button from the end of a 12-

foot cord. You can advance and reverse slides at any speed, any time . . . even fine-tune focus, all from across the room. Or (c) you can advance and reverse slides by push button at the projector's keyboard console.

The console also lets you select high or regular lamp brightness. You can stop the show anywhere and spin the numbered tray to any slide you want. You can pluck out a slide and drop in another any time during the show.

Take some of your better color slides to your Kodak dealer's. Any 2 x 2 slide in cardboard or thin-glass mount. Watch the way the KODAK CAROUSEL Projector handles them. This is something to see . . . today! KODAK CAROUSEL Projector, less than \$150 with 5-inch *f*/3.5 lens and one 80-slide tray.

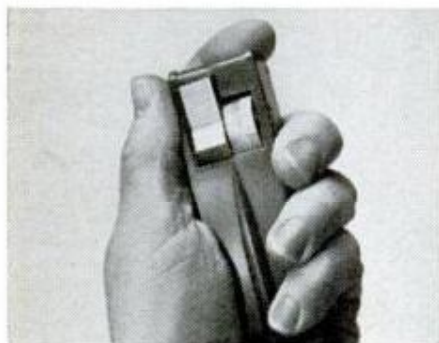

◀ **REMOTE CONTROL** • Make slides go forward and back, as fast or as slowly as you want. Fine-tune the focus. 12-foot cord.

**KEYBOARD CONSOLE** • All manual controls, plus selectors for high-low lamp brightness. "Select" button lets you spin numbered tray to any slide—for viewing or quick replacement.



## **EASTMAN KODAK COMPANY,**

POPULAR MECHANICS



**Kodak**  
TRADE MARK



**LOADS FAST** • Slides drop into tray as easily as pennies into a piggy bank! No slide holders needed.

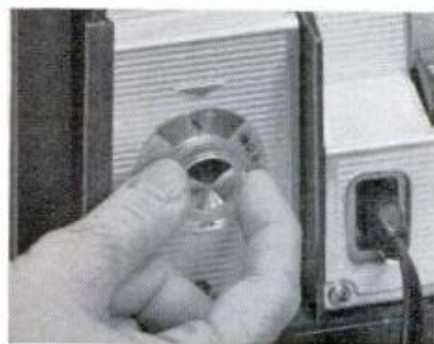

**AUTOMATIC TIMER** • Set it for slide-changing at 5-, 10-, or 20-second intervals, and the whole 80-slide show proceeds automatically . . . no hands! Great for continuous operation at exhibits, for displays, etc.

**NEW "LIBRARY" SLIDE STORING** • Each 80-slide tray comes in its own indexed case. Fits upright like a book on your library shelves. Handy, space-saving, slide-saving.



**Rochester 4, N. Y.**

SEPTEMBER 1962

*Price subject to change without notice.*

Enjoy Walt Disney's "Wonderful World of Color" Sunday evenings, NBC-TV

# CLINIC FOR HOMEOWNERS

## Painting Stone Masonry

*Q—Last spring we purchased an older home, and my project for this coming winter is making a recreation room in the basement. However, the basement walls are natural stone and the surface is quite irregular. My question is: Will an ordinary paint adhere to the stones, or is there some special type of paint required?*

*—A.S., Mass.*

*A—For such below-grade application, we recommend that you use masonry waterproofer. This flat finish is available in a wide range of pastel colors, and one of them should fit in with the color scheme you plan to use in your rec room. However, before going ahead with this project we would suggest that you give careful consideration to simply cleaning the surface with a wire brush to remove loose particles and applying a coat of clear masonry water-proofer. The texture of a stone wall can be quite attractive, and it might be possible to fit this into your decorative scheme.*

## When to Roll the Lawn

*Q—A friend of mine dropped in last spring while I was rolling the lawn, and he said that this job should be done in the fall. According to him, spring rolling packs the soil and prevents it from absorbing water, causing the lawn to dry out. On the other hand, if the lawn is rolled in the fall, freezing and thawing during the winter will break up the hard crust caused by rolling. He almost has me talked into going over the lawn again this fall, but I wanted to check with you first. Is he right?—S.K., Ohio*

*A—Your friend's logic is good, but he seems to have forgotten that the main purpose of rolling a lawn is to level out those irregularities caused by frost action and press any dislodged grass roots back into contact with the soil. Actually, the proper time for rolling a lawn depends more on its general condition than on season or custom. Among the factors which you should consider are: Age of the sod, type of soil, relative mildness or severity of the preceding winter, moisture content of the soil at the time of rolling and thickness of the turf. Established lawns which have been carefully maintained probably won't require rolling every season, especially when growing in fairly light soil with good drainage.*

*Never roll the lawn when the soil is*

*wet. However, rolling new seeding levels high spots, firms the loosened soil and presses the seed into contact with soil.*

## Defective Plaster

*Q—We recently bought a new home, and right after moving in I discovered that something is apparently wrong with a large section of plaster in the living room. It's soft and breaks into very fine particles when rubbed lightly. Could you tell me what causes this, and what I can do to correct it? We've had to put off decorating this room because of it, and I wondered whether I could just give the wall a coat or sealer or undercoater to bind the loose particles so that paint could be applied safely.—G.V., Wis.*

*A—If we judge correctly from your description, this chalking can probably be traced to some condition which has delayed the setting of the materials in the plaster itself. It might be that the water in the plaster mix was permitted to evaporate too quickly at the time of application. This would prevent proper setting and produce a soft, crumbly surface. Plasterers often correct this condition by moistening the surface with a fine spray of water and keeping it moist with repeated applications for several hours, or until the plaster sets.*

## Pump Trouble

*Q—We live on a farm, and our water is supplied by a pressure water system. The water pressure has been dropping steadily for the past three months though there seems to be plenty of water in the well and the pump apparently is operating properly. I've looked for leaks but can't find any. What's wrong?—S.J., Del.*

*A—Have you checked the air-inlet valve? This valve is supposed to admit a small amount of air at each stroke of the pump so as to maintain that correct air-water ratio in the pressure tank. Air-inlet valves seldom give any trouble, but from your description it seems likely that the valve has been damaged or is jammed in the closed position. We suggest that you examine the valve and replace it if it is found to be defective.*

As a service to Popular Mechanics readers in solving the hundreds of problems pertaining to a home—inside or out—you are invited to present your problems to The Clinic Editor for his helpful advice. Address your questions to The Clinic Editor, Popular Mechanics Magazine, 575 Lexington Ave., New York 22, N.Y.



## BEAUTIFUL MARLITE PANELING

wash-and-wear walls you can install yourself

You can finish a room with Marlite this weekend—and eliminate redecorating for good! Marlite's melamine plastic finish is *baked on*, so it's smooth and durable as the surface of a refrigerator. It takes abuse that would spoil other finishes, then wipes clean with a damp cloth. And Marlite's simple to install in new rooms or old. Choose from a handsome array of Trendwood® reproductions, beautiful patterns and decorator colors—in large sheets or easy-to-handle Plank and Block. See your building materials dealer.



Tongued-and-grooved Marlite Random Plank (16" x 8" x 1/4") goes up fast over furring strips or solid backing with no waste, muss or fuss.

**Marlite**®  
plastic-finished paneling

Marlite Division of Masonite Corporation  
Dept. 942, Dover, Ohio

Please send full-color building and remodeling folder on Marlite Paneling.

Name \_\_\_\_\_

Address \_\_\_\_\_

City \_\_\_\_\_ Zone \_\_\_\_\_ State \_\_\_\_\_



ANOTHER QUALITY PRODUCT OF MASONITE® RESEARCH

## Convertible Top

(Continued from page 184)

hold the fore edge of the canvas top to this strip. If an aluminum strip isn't available, you may use hardboard, but you'll have to add shaped blocks to round off the ends and an additional spacer under the joint in the middle.

To make a pattern for the canvas top, cover the frame with brown paper, using masking tape as necessary. Be sure to keep the dimensions on both sides of the centerline as nearly equal as possible. Once you have assembled this paper cover over the frame, it should look exactly like the finished top. The pattern must come down over the windshield about 1 1/8 in. and conform to the general outline shown in Fig. 2.

Using a crayon, mark the location of the gore over the corner of the middle bow. This gore should run all the way around the curve of the bow. Draw a line on the paper along the outside of the rear bow, and for reference, mark the centerline of the top on the pattern. If your wife will be doing the sewing, let her take a look at the pattern stretched over the frame so that she will have an idea of how the top should look when it's completed. While the location of seams will depend on the size of the top and the width of the material used,

follow the general layout and seam details shown in Fig. 2.

When the sewing is completed, install one dot fastener in the center of the fore edge of the canvas. Then slip the rear bow through its sleeve and mark the locations of the other fasteners, being careful not to stretch the fabric when laying out these positions as it will shrink slightly in time.

Once you have attached the dot fasteners, erect the top again and install two additional fasteners on the coaming for the two tie-downs. Finally, pin the 38-in. sleeve for the middle bow in position, then remove the top and sew the sleeve in place. ★ ★ ★

## Solar Heat Warms Pool

Made from vinyl plastic, a swimming-pool cover heats the pool water by using the energy from the sun.

Rolled over the top of the pool and held in place with sandbags, the cover also keeps out dirt. Tests show that the cover can warm the pool even on cloudy days and keep the heat in at night. Heat passes through a top layer of clear plastic and is absorbed by a bottom layer of dark plastic. Air space separates the two layers.

The cover, depending on pool size, is priced from \$98.38 to \$209.67. It is sold by Capri Manufacturing, Burbank, Calif.

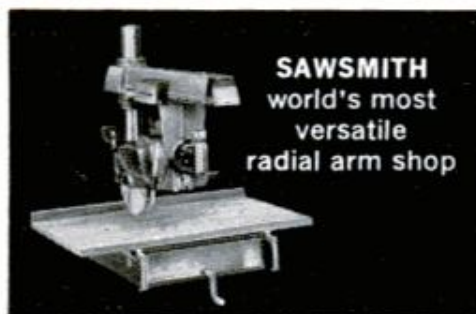

**SAWSMITH**  
world's most  
versatile  
radial arm shop

Here's your passport to happy, hobby evenings: detailed instructions for completing useful, attractive items in one evening apiece. Pick up your free copy at your nearest power tool dealer or Montgomery Ward store. Ask about Free Dream Shop contest. See SHOPS MITH and SAWSMITH in action while you're there.

# "Practical POWER TOOL PROJECTS" FREE at your SHOPS MITH and SAWSMITH Dealer (Limited time offer)



**SHOPS MITH**  
the only complete  
5-in-1 power shop

SHOPS MITH is the only complete multi-purpose home power shop: saw, lathe, horizontal drill, vertical drill press and sander... ALL IN ONE. Fits in a bicycle's parking spot.

SAWSMITH is the world's most versatile radial arm shop. Performs 14 basic woodworking operations with 7-speed power selection. Gives built-in precision for every job!



**AMERICAN CORPORATION**  
Interstate 75—Evendale, Cincinnati 15, Ohio

Seal  
up for  
Winter  
with  
**DAP**®



seal up cracks, holes and leaks that lead to costly heat loss, water damage or repair work with these quality **DAP products**

Do-it-yourself with DAP. Make your house snug and comfortable—keep out drafts, dirt and insects—prevent heat loss, water damage, rusting and rotting of building materials. Get ready for winter now. Get nationally advertised DAP caulking-glazing-sealing compounds at leading hardware, paint or building supply dealers.



Use DAP CAULKING to seal cracks and joints in wood, metal and masonry . . . around window and door frames, porches and steps, in wood or metal siding, along flashings. Buy DAP Caulk in cartridges, cans or tubes. Apply with gun, knife or from tube.



Use DAP "33" GLAZING COMPOUND to replace broken glass . . . dried-out putties that leak air, water at windows. DAP "33" outlasts ordinary putties. Get DAP "1012" Aluminum Gray Glazing Compound for aluminum sash—needs no painting.



Use DAP KWIK-SEAL to seal cracks in joints around tubs, sinks and lavatories. For pointing or resetting tiles, too. Squeeze Kwik-Seal from the tube—use finger to smooth and finish—works quickly, easily. Waterproof—dries white, stays "rubbery."



Use DAP ROPE CAULK for scores of do-it-yourself jobs—a fine, easy-to-use weatherstrip around windows or window air conditioners; seals joints or cracks in most materials. Apply with fingers—no tools! Stops air, water leaks; takes paint.



Use DAP vinyl paste SPACKLING for easy patching of cracks, holes and breaks in plaster. Seals dry wall panel joints. Good for wood, too! Use right from can. Creamy smooth—sticks tight, sands to a feather-edge. Easy to paint. No priming needed.

**DAP**®

DAP inc.,  
General Offices: Dayton 31, Ohio  
Manufacturers of nationally-advertised DAP Glazing, Caulking, Sealing and Spackling Products; Duratite Wood and Metal Fillers, Glues and Adhesives.

**EASY  
DOES  
IT!**



## **CHAN NEL LOCK**

You'll do every gripping job the easy way with a Channellock worksaver plier. Powerful parallel jaw grip . . . tremendous leverage . . . patented, smooth-working can't-slip adjustments. Your choice of five jaw capacities:  $\frac{1}{2}$ ,  $\frac{7}{8}$ ,  $1\frac{1}{2}$ , 2 and  $2\frac{1}{4}$  inches. *Be sure it's a genuine Channellock. Look for the trademark on the handle. Write for catalog showing complete line of pliers. Made Only By Champion DeArment Tool Company, Meadville, Pennsylvania.*

## **When Your Car Stalls**

*(Continued from page 193)*

freely within the limits of its travel without touching any part of the bowl and without binding at any point.

On some regular carbs the bowl cover forms a part of the air horn. If the cover gasket does not completely seal this part of the joint, fuel can spill into the horn and cause flooding of the engine. When re-assembling your carb don't use the old gasket unless it is in exceptionally good condition. Reuse of old gaskets is always a questionable practice. Also, check that portion of the bowl cover that forms part of the air horn. Although the probability of the cover being warped is remote, the possibility should never be overlooked. Should the cover be even slightly warped, no gasket, either new or old, can be relied on to hold fuel. When you install a gasket, either new or old, always note its position in relation to the float. If it projects into the bowl on carbs having the float pivoted on the cover, it may restrict movement of the float. Trim if necessary to assure ample clearance. And don't forget to tighten the cover screws to a uniform tension.

### **Fuel-Pump Pressure**

A less frequent cause of flooding is excessive fuel-pump pressure—pressure sufficient to edge the float needle right out of its seat, maybe even bend the float arm. If you have any reason to suspect the pump, check it out with a reliable fuel-pump pressure gauge, Fig. 8. Replace the spring or, if necessary, the pump, if the pressure is significantly excessive.

Flooding can be caused by an insufficient volume of air. Among the possible causes are a partially clogged air cleaner, Fig. 6, automatic choke sticking in the closed position and restricted idle air bleeds, Fig. 9. The idle circuit of the carb (assuming that the float assembly is functioning properly) can figure in this picture only at the idle and low road speeds, that is, under 20 or 25 miles per hour. If there's a noticeable lack of go at the higher speeds, it's fair to assume that the automatic choke and the air cleaner are, one or both, at fault. A badly clogged air cleaner, or filter and a stuck-solid choke plate can, of course, result in frequent flooding, also in between times produce a condition in which the engine is fed a too-rich fuel mixture continuously.

Some carbs are equipped with a mechanical unloader linkage which will open a sticking choke mechanically when the accelerator is floored. But if, due to an accu-

*(Continued to page 214)*

# Look at page 62 of last month's Popular Mechanics.

## We agree!

If you haven't got page 62 of last month's issue, send this coupon to us. We have plenty. **VOLVO**

Volvo, Inc.  
452 Hudson Terrace  
Englewood Cliffs, N. J.



Name \_\_\_\_\_

Address \_\_\_\_\_

City \_\_\_\_\_ State \_\_\_\_\_

# Test your automotive I.Q!

## QUICK QUIZ BY QUAKER STATE

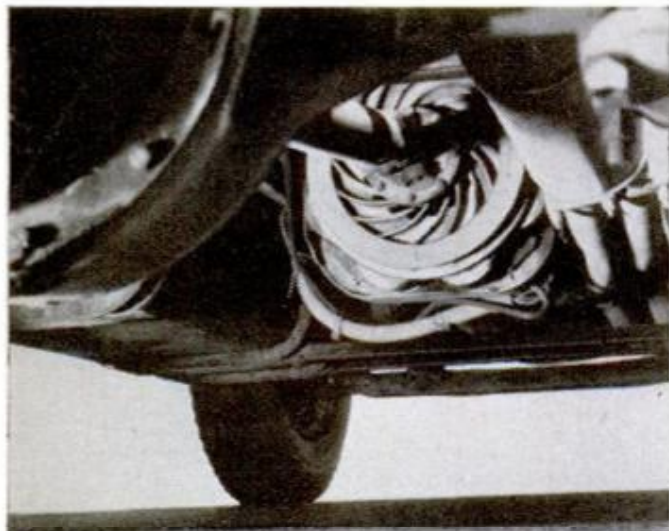

1. Can you name this device often found on trucks and buses?



2. What does this symbol stand for?

The device at top is an electromagnetic retarder for extra braking action. The life preserver is the symbol of Quaker State Motor Oil—because it is the best engine life preserver. Made from 100% pure Pennsylvania Grade Crude Oil, Quaker State gives every car longer-lasting lubrication and complete protection. Always get the best engine life preserver—Quaker State.



QUAKER STATE OIL REFINING CORP., OIL CITY, PA.

mulation of dirt or a mechanical fault, the choke resticks itself in the closed position the over-rich-fuel-mixture, insufficient-air condition will not be corrected.

Clean the air-cleaner filter element regularly according to the instructions or replace it periodically. If a check shows the piston and lever assembly of the choke to be free, Fig. 12, and the choke plate still fails to open fully when the engine warms up, check the thermostatic spring and choke tube. Usually it's the spring that's at fault and if so, there's only one thing to do, replace it. When you reset the choke after re-assembly follow manufacturer's instructions in all details.

Flooding caused by clogged air bleeds, Fig. 9, is something you rarely hear about but it has happened. Usually it's the other way around, that is, the clogged bleeds pose lean-mixture problems. If you're experiencing more or less regular stalls due to flooding and a change in the idle-mixture adjustment results in no appreciable change in idle-circuit performance, then clogged bleeds may be indicated. If dirt and gum have clogged the bleeds, the problem can be solved by use of an on-the-car carb clean-out kit, Fig. 3, which permits gravity feeding of the solvent into the carb with the engine running. After using the solvent remove the float (compressed air can cause it to collapse) and blow out the idle circuit. If this procedure doesn't give the desired result, then it's advisable to replace the carb with a rebuilt job. And finally, after you've taken all the preventive measures possible of practical application by Saturday Mechanics, you might consider installing an in-the-line fuel filter like that pictured in Fig. 7. It will greatly extend the effective life of a new or rebuilt carb, as it can remove particles as small as ten microns from the fuel. ★ ★ ★

### QUOTE: Promising Laggards

*"I feel that the most important subject in the entire course of study in the elementary and college preparatory years is the English language. I have some younger physics colleagues who obviously write with difficulty. They are promising scientists who love to work in the laboratory but they are laggards when it comes to writing papers to describe their results. But what good are research results unless they are properly described in a well-written report?"*

*"Also, it is most important that a scientist or engineer be able to get on his feet and speak clearly about his work."*

W. W. WATSON, Chm., Physics Dept.  
Yale University



# END NUT and BOLT HANGOVERS

**DOT Teenuts**



Can't Slip... Steel Threads in Wood  
Flush-Mounted... Strong... Versatile!

The **One Nut That Makes Sense!**



Ideal for permanent work or where easy "knock-down" feature is wanted. Available to fit standard thread bolt sizes: 6-32, 8-32, 10-24, 10-32, 1/4-20, 5/16-18, 3/8-16. Available at

hardware dealers. If not, send \$1 for special mail order package and name of nearest distributor. Specify size.

**COLUMBIA FASTENER COMPANY**

3229 South Ashland Ave. • Dept. PM • Chicago 8, Illinois

WORLD'S MOST EXCITING LOWEST PRICED CAR  
**KING MIDGET** FOR 1962

Drive it for 75c a week.  
Rider Agents Wanted.  
Send 25c for 32 page book, full details, dealer price. Or send \$1 (refunded first order) for this plus Service and Repair Manual and 16 5x7 photos of car and factory.

**MIDGET MOTORS CORP.**  
ATHENS 1, OHIO



1-1/3 MILLION STROKES and still like new!

**WRIGHT Quality RATCHET** 1/2" dr. model

THE HEART OF EVERY WRIGHT SOCKET SET

- Oil-proof, non-slip rubber grip
- Short handle swing for tight places
- Popular prices--professional quality

At leading dealers--or write:

**WRIGHT TOOL AND FORGE CO.**  
Dept. PM 92 Barberton, Ohio



Works in seconds!



**Loosens Rusted Bolts**  
nuts, screws, "frozen" parts!

**LIQUID WRENCH**  
SUPER-PENETRANT

The super-penetrating rust solvent that quickly loosens rust and corrosion.

**AT ALL HARDWARE AND AUTO STORES**

RADIATOR SPECIALTY COMPANY  
CHARLOTTE, N. C.



**NOW! A REAL 6/12 VOLT BATTERY BOOSTER**

Now you can own a genuine **SCHAUER** 6 & 12 volt battery booster at a low, low price! The Model H612 is *positively not just a battery "warmer"*, as are so many "economy" models on the market! It delivers a full 1 1/4 amps of power at BOTH voltages, that will charge car, boat, motorcycle and lawnmower batteries. Has full-wave Selenium rectifiers... *automatic* circuit breaker... 6 or 12 volt selector switch... rugged steel case with handsome red finish. Money-back guarantee. Buy yours now. If your dealer can't supply, send check or money order.

Automotive Division

**SCHAUER MANUFACTURING CORP.**  
4532 Alpine Avenue, Cincinnati 42, Ohio

ONLY **\$9.95**

Postpaid Model H612



**NEW FROM PRATT & LAMBERT**

**"6-T-1"**

**HOUSE PAINT**

**GIVES OIL PAINT GLOSS and PROTECTION PLUS WATER THINNABLE EASE**

Give your home beautiful oil paint luster, and enjoy convenient, easy water clean-up of new P&L "6-T-1" House Paint.

An exclusive Pratt & Lambert formulation with linseed oil in solution, "6-T-1" House Paint brings you all these advantages and more...

"6-T-1" House Paint brushes on easier and sets up faster than ordinary oil paint. It can be applied over chalked old paint in otherwise good condition without using a prime coat. "6-T-1" resists blistering... can even be applied while surface is damp. "6-T-1" House Paint can be thinned when necessary with plain tap water. And brushes and equipment wash out in a jiffy with ordinary soap and water.

Next time you paint, make it easy on yourself, and give your home that bright new look with "6-T-1" House Paint, from your nearest Pratt & Lambert dealer.

**PRATT & LAMBERT-Inc.**

NEW YORK • BUFFALO • CHICAGO  
FORT ERIE, ONTARIO

*The paint of professionals for over a century*



## Tips for Home Buyers

(Continued from page 149)

- The more dead-ended bedrooms there are, the better noise is curbed.
- Is kitchen storage adequate? There should be six square feet of shelf space for each member of the family.
- Are the refrigerator, sink and range handy? They should form a rough triangle with the units from four to seven feet apart.
- Are the countertops hard-surfaced and easy to clean? Linoleum tops wear fairly quickly; ceramic-tile tops break and chip china dishes. Ideally, there should be counter space beside the refrigerator, the range and on both sides of the sink.
- Is the kitchen floor linoleum or tile for easy cleaning?
- Are appliances the top line of well-known manufacturers? Brand-name manufacturers have low-priced merchandise that often has to be replaced in a few years. Off brands present repair problems: you often can't get parts. If appliances are included, pin down the answer to the repair problem *before* you make your decision.
- Is there adequate work area? Ask this question as you look at the shop and the sewing and laundry areas. For example, there should be a space at least three feet, eight inches wide and three feet, six inches deep in front of a washer or drier; with the laundry units side by side, the space should be five feet, six inches wide.
- Is there adequate play area?
- Is there adequate storage area for your garden equipment, out-of-season clothing, screens, storm windows, bikes, play equipment and outdoor recreation equipment?

### Construction Features

Construction features and component parts, or units, of a house generally have to comply to local building codes and FHA standards. As the house is completed, each phase—framing, wiring, plumbing, etc.—is inspected by a building inspector. If it is rejected, the builder must redo the work before he can continue. If your area has a code system—and most do—you can count on the house being constructed at least up to code standards.

In the last few years great strides have been taken to improve the building product. For example, component building—roof trusses, wall panels, window units, plumbing trees, bathroom and kitchen cores—has been developed to speed building, thus cutting the price you pay for a home. If these methods were not used, a house costing, say, \$15,000, would cost

roughly from \$17,500 to \$20,000 by the old, piece-by-piece assembly technique.

Are components just as good? In most cases, better. They give the builder control over his product by allowing him to pre-fabricate in his shop where conditions are the very best.

When buying a new house, it's impossible to look in back of the wallboard or plaster to see if the studs are on 16-inch centers or whether they're top-quality lumber. You can determine stud placement by sounding the walls with your fist. Start tapping at the corner. Solid. Move inward. Hollow. At about 16 inches, the tapping should become solid again. Many builders have display areas in their model homes that show framing techniques and materials used. If not, ask the builder to show you the blueprint of the house.

Or you can ask about these points:

### The Roof

- What kind of roofing does the house have? Average is 210-pound asphalt strip shingles with a lifespan from 10 to 15 years. A slate, aluminum or copper roof, though more expensive at the outset, requires little, if any, maintenance and lasts more than a lifetime. Wood shingles may jump the fire-insurance premiums on the house.
- Are gutters adequate to carry water away from the foundation? Galvanized-steel gutters don't have the life that aluminum, copper, or nickel-coated ones have.

### Exterior Materials

- Painted wood siding has to be repainted about every five years. The average-size house costs about \$300 to \$450 to do. Best woods are redwood, cedar and cypress.

Brick eventually needs cleaning; the joints need tuckpointing about every 10 to 15 years.

Aluminum siding is about as maintenance-free as any. It will dent if struck hard.

Hardboard siding is tough; it has to be repainted every five years or so.

Asbestos-cement shingle siding is an excellent material. Some comes pre-painted with fade-resistant paints. Broken shingles are easy to replace in single units.

Cement block is a rugged material. It can be painted with special paints. Maintenance runs about five years.

Stucco has to be repainted about every five years. Damage isn't too difficult to repair.

### The Foundation

Whether the foundation leaks is very difficult to tell in a new house. Several things to look for are:

(Continued to page 218)

## Another power tool tip from **DISSTON**

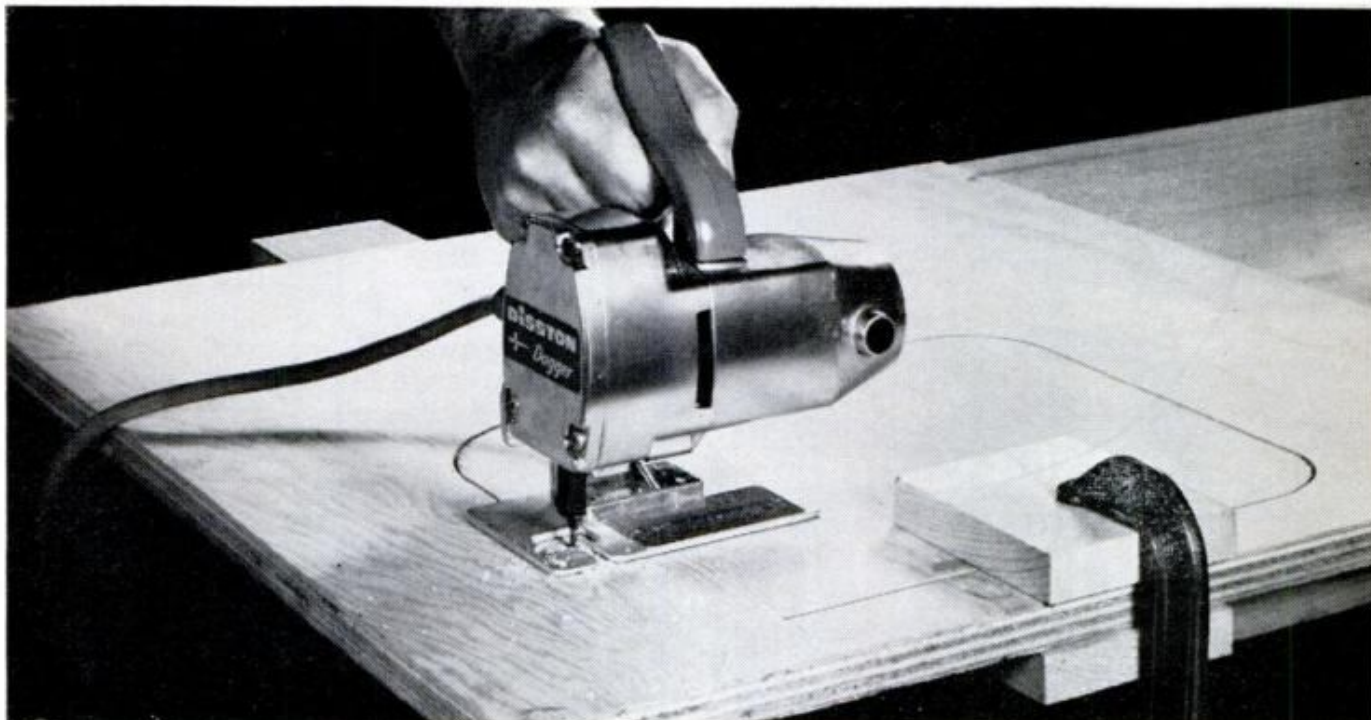

### Why you need a back-up block for piercing work

When a back-up block extends the full length of the cut-out, it eliminates any chance that the fall-out piece will bind or snap the blade, or ruin your work.

To protect the work and give added support, clamp a smaller block on top.

Another thing, it's much easier to concentrate on your work when you don't have to worry about a falling cut-out.

You'll find the Disston Dagger Sabre Saw perfect for almost any cutting job.

It cuts straight lines, circles and bevels in wood, plastic and metal. Cuts steel plate up

to  $\frac{1}{4}$  inch, makes bevel cuts up to  $45^\circ$  in 2-inch lumber.

The Dagger cuts 15 to 50 per cent faster than other saws of its type. "Orbite" blade action prevents drag and back-cut, permits longer blade life.

What's more, you'll like the Dagger's comfortable handle—designed to help give you firm control over the tool.

See the Disston D-20 Dagger at your favorite hardware or department store. It's a whole shop-full of saws in one compact, quality tool. Suggested retail price \$54.50.

**DISSTON**—Master Toolmaker since 1840. Disston Division, H. K. Porter Company, Inc., Porter Building, Pittsburgh 19, Pa.

### See Disston's full-line of power tools, including:



D-25 Disston Dirk  
 $\frac{1}{4}$ " Power Drill



D-1 Disston Dot  
 $\frac{1}{4}$ " Power Drill



D-650 Disston Defender  
 $6\frac{1}{2}$ " Circular Saw



D-600 Disston Discus  
 $6\frac{1}{2}$ " Circular Saw

**PORTER**

**DISSTON DIVISION**  
**H. K. PORTER COMPANY, INC.**

# FREE!

## 6" CHROME CLAD® RULE

### \$270 VALUE

# WHEN YOU BUY ANY STANDARD 1" LUFKIN MICROMETER



This C2110R rapid-reading 6" Chrome Clad rule is machine divided in 16ths, 32nds and 64ths. It's yours, free, with the purchase of any standard 1" Lufkin Micrometer\*. . . the micrometer that has 5 to 7 fewer parts than other makes . . . less to get out of adjustment! One-piece frame and hub simplifies wear adjustment. Easy-to-read markings. Nonglare Chrome Clad finish, cam lock and ratchet stop top are optional features.

Get them at leading Industrial Distributors and Tool Dealers.

\*Offer expires October 31, 1962

- Cracks in mortar joints.

Big cracks in poured concrete foundations—especially around windows and corners.

Cracks between the floor and foundation. Water marks along cracks.

Water. (Don't let the builder tell you he just hosed down the floor!)

Termites are a problem in the South. Most progressive builders have licked this problem with special chemically-treated lumber. Also, there is a new chemical on the market that can be sprayed along foundation walls and in crawl spaces to keep out the critters. If the builder hasn't used it (chances are that he has), the job can be done very cheaply.

### Framing

Studs, which are 2 by 4s, are generally on 16-inch centers, although some codes allow them to go on 24-inch centers, especially in garage framing.

Joists, too, are generally on 16-inch centers. They are braced with bridging, usually 1 by 3s or 1 by 4s that form Xs between the joists. You can check joist framing from the basement or by climbing into the attic. If the floor or ceiling is finished, use the sounding technique described earlier.

- Lumber should be seasoned (dry) before it's used. Green lumber often warps and sags. You can tell the difference—usually—by sticking a knife blade into the stock. If it feels spongy, it has a lot of moisture in it.

- Sheathing can be boards, plywood sheets, or insulating fiberboard. The latter has the best R factor. (The R factor is a measure of the resistance of a material to heat transmission, therefore its insulation value.) Typical R factors:

Insulation-board sheathing (25/32-inch): R 2.06.

Insulation-board sheathing (1/2-inch): R 1.32.

Lumber (1-inch): R 0.98.

Gypsum (1/2-inch): R 0.45.

Plywood (5/16-inch): R 0.39.

- Insulation goes between studs and ceiling joists. Its rating depend on the amount used. Types include blanket, batt, reflective, and loose-fill. Thickness is generally three inches, except for reflective. Insulation can save you 15 percent or more on your heating and cooling bill.

### Heating

- Gas rates vary from five cents a therm in the Southwest to 16 cents and up in the Northeast.

Oil runs about 15 cents per gallon.

Both gas and oil are measured in BTUs,

(Continued to page 220)

# Choose from these useful POPULAR MECHANICS BOOKS

*order direct at catalogue prices*

## HOME IMPROVEMENT

- 102 HOME IMPROVEMENT GUIDE \$2.50
- 103 HOME PLUMBING GUIDE \$3.50
- 104 LAWN AND GARDEN BOOK \$2.50
- 105 OUTDOOR LIVING ROOMS \$2.95

## CRAFTSMEN

- 106 CONCRETE HANDBOOK \$2.00
- 107 DO-IT-YOURSELF MATERIALS GUIDE \$2.95
- 108 GADGETS GALORE \$2.95
- 109 GETTING STARTED WITH POWER TOOLS  
Basic to every home workshop. What you should know in selecting and operating power tools. Accepted safety measures. A real handbook for getting the most from your power tools. 160 pages. \$1.95

- 110 PORTABLE ELECTRIC TOOLS AND HOW TO USE THEM \$2.00
- 111 YOU CAN MAKE A "STRADIVARIUS" VIOLIN \$2.00
- 112 TOYS YOU CAN MAKE \$2.00
- 113 HANDBOOK OF AMERICAN WOODS \$2.75

## SPORTS

- 114 ALL ABOUT BOATS \$2.95
- 115 HOW TO TEMPT A FISH \$2.00
- 116 GUIDE TO GOOD HUNTING AND TRAPPING \$2.95

Merely list the numbers of the books you'd like to receive, and send this order form to us with your check or money order for the total amount of the books ordered.

## YOUNG PEOPLE'S

- 117 THERE'S ADVENTURE IN ASTRONAUTICS \$2.95
- 118 THERE'S ADVENTURE IN ATOMIC ENERGY \$2.95
- 119 THERE'S ADVENTURE IN AUTOMOBILES \$2.95
- 120 THERE'S ADVENTURE IN CHEMISTRY \$2.95
- 121 THERE'S ADVENTURE IN CIVIL ENGINEERING \$2.95
- 122 THERE'S ADVENTURE IN ELECTRONICS \$2.95
- 123 THERE'S ADVENTURE IN GEOLOGY \$2.95
- 124 THERE'S ADVENTURE IN JET AIRCRAFT \$2.95
- 125 THERE'S ADVENTURE IN MARINE SCIENCE \$2.95
- 126 THERE'S ADVENTURE IN METEOROLOGY \$2.95

## PM Books Make Good Gifts

- 128 THERE'S ADVENTURE IN ROCKETS \$2.95
- 129 MR. WIZARD'S SCIENCE SECRETS  
By Don Herbert  
264 pages of fascinating entertainment for children of all ages. Hundreds of scientific experiments that mystify and capture the imagination. \$3.95
- 130 BUILD-IT-YOURSELF BOOK FOR BOYS \$2.95
- 131 GOLF FOR BOYS AND GIRLS \$3.95
- 132 THE BOY SCIENTIST \$3.95
- 133 THE BOY MECHANIC \$3.95

## SCIENCE

- 134 SEVEN INTO SPACE \$3.95
- 135 SCIENCE MILESTONES \$4.95
- 136 OUT OF THIS WORLD \$3.95
- 137 VOCABULARIO TECNICO, INGLES-ESPAÑOL \$2.95
- 138 FIFTY YEARS OF POPULAR MECHANICS \$5.00
- 139 ALBUM OF AVIATION \$3.00

## RADIO, TV, ELECTRONICS

- 140 ELECTRONICS MADE EASY (Revised) \$4.95  
The first edition of this basic book sold over 250,000 copies. Completely revised, it includes over 25 do-it-yourself projects, tips on radio servicing and the latest on hi-fi and stereophonic systems.
- 141 A GUIDE TO STEREO SOUND \$4.95
- 142 THE SOUND OF HIGH FIDELITY \$4.95
- 143 FIX-IT-YOURSELF TELEVISION MANUAL \$3.00

## FARM

- 144 VETERINARY GUIDE FOR FARMERS  
By G. W. Stamm  
The correct methods of diagnosis, new facts on treatment, and information on preventative measures in the diseases of farm animals. A mighty valuable book. 384 pages of useable information. \$3.95
- 145 ARTIFICIAL BREEDING AND LIVESTOCK IMPROVEMENT \$3.95
- 146 DEVELOPING A PROFITABLE DAIRY HERD \$3.50
- 147 FARM MANUAL \$3.00
- 148 HOG PROFITS FOR FARMERS \$3.00

## AUTOMOBILES

- 149 AUTO ALBUM \$3.00
- 150 HOW TO RESTORE ANTIQUE AND CLASSIC CARS \$3.50
- 151 MANUAL FOR CHEVROLET OWNERS (1950-58) \$3.95
- 152 MANUAL FOR FORD OWNERS (1950-58) \$3.95
- 153 MANUAL FOR PLYMOUTH OWNERS (1950-57) \$3.95

### ORDER TODAY!

USE THIS CONVENIENT ORDER FORM FOR QUICK DELIVERY.

Popular Mechanics Books  
740 Rush St.,  
Chicago 11, Illinois

PM-9

Gentlemen: Please send to me at the address below the PM books numbered as follows: \_\_\_\_\_

I am enclosing my  check or  money order to cover the entire cost of this order.

NAME \_\_\_\_\_

ADDRESS \_\_\_\_\_

CITY & STATE \_\_\_\_\_

ORDER THESE POPULAR MECHANICS BOOKS NOW — at low catalogue prices.

# GRAVELY MAKES LEAVES VANISH!



Ride or guide your Gravelly Tractor with Leaf-Away attachment and watch leaves vanish! One of 31 tools for the 6.6-HP, all-gear drive Gravelly. See how Gravelly power and versatility make *all* your tough jobs easy. For free copy of booklet, "Power vs. Drudgery," write now. *Finance plan available.*



**GRAVELLY TRACTORS**  
DIVISION STUDEBAKER CORPORATION  
P. O. BOX 601-J DUNBAR, W. VA.

# SHOOT A STAPLE WHEREVER YOU'D DRIVE A NAIL!

Some Machine  
uses 6  
Staple  
Sizes . . .



"ONE  
SQUEEZE  
AND YOU'VE  
NAILED IT!"

WITH  
AN

**ARROW**  
Brooklyn 12, N. Y.

**No. T-50 All-Purpose STAPLE GUN**

Available at Hardware, Building, Lumber and Stationery Dealers Everywhere.  
ARROW FASTENER CO., INC. 1 Junius St., Brooklyn, N. Y.

or British Thermal Units of heat content. A therm of gas has 100,000 BTUs. A gallon of oil has 138,000 BTUs. Compare the difference in your area before you decide on gas or oil heat. The difference may be very slight.

Electric heat is the most expensive, at least in most areas. This may change in five years or so. Power companies are now working to cut prices, and builders are learning how to build better electrically heated houses. Again, it might pay you to check your local utility for comparison.

- Heat registers should be on outside walls under windows.
- Water heaters should have at least a 40-gallon capacity to take care of normal household activity. Glass-lined heaters last longest. Metal-lined tanks have to be replaced every eight years or so at a cost of about \$100.

(A family of four should have at least a 30-gallon water heater. A large family—or any home with automatic laundry equipment—requires a 50-gallon tank. These figures apply to tanks heated by gas or oil; electric heaters generally have slower recovery and should be larger.)

## Plumbing

- Copper tubing and cast-iron drains are your best buy. Steel pipe doesn't last as long. Plastic pipe is good, but most codes don't yet permit it.
- Cleanouts should be accessible.
- The basement and garage should have a floor drain.

## Wiring

- A 100-ampere, three-wire system is now considered minimum. You can tell the rating by checking the entrance box; it is labeled.
- There should be at least three double convenience outlets in the living, dining and bedrooms. Depending on local codes, this may vary. (Some houses have outlets every 10 feet, which adds to the cost.)
- The kitchen should have multiple outlets on the countertops for mixers, toasters, fry pans, etc. And the bathroom should have at least two outlets for shaving, hair dryers and so on.
- Check for outlets in the basement, garage and outside the house. Having them installed after you buy the house can run into real money—from \$1 to \$2 per foot from the power source.

Before you finally buy the house, it may pay you to consult an architect or an appraiser, especially if you're in doubt. The fee they charge is usually about \$20.

But if you've checked all the points listed above, you'll be a savvy home buyer who will get his money's worth. ★ ★ ★

# GET REMODELING IDEAS AND PLANS

## Join Masonite's Home Improvement Club

You can improve your home, inside and out, with easy-to-follow plans when you join Masonite's home improvement club. You get weekend home improvement project plans every other month, plus a 16-page, full-color booklet with ideas for almost every room in the house.

With these complete plans and quality Masonite hardboard products, remodeling your home can be fun, easy and rewarding.

Join up now! The low cost of only 50 cents a year takes care of postage and mailing.

 **MASONITE** shows the way!  
Masonite is a registered trademark of Masonite Corporation



This month's plan—Garage Interior Remodeling with storage platform, cabinets and drop-down worktable.

### MASONITE CORPORATION

Dept. PM-9, Box 777  
Chicago 90, Illinois

Enroll me in Masonite's Home Improvement Club sending first month's plan and Ideas Book. I enclose fifty cents.

Name \_\_\_\_\_

Address \_\_\_\_\_

City \_\_\_\_\_ Zone \_\_\_\_\_ State \_\_\_\_\_

Piano-hinge top, two drawers and tote tray. 20x9x9 1/2 steel box in blue finish.

At Hardware Stores or Write:

**HUOT MFG. CO.**  
555 N. Wheeler St.  
St. Paul 4, Minn.

Deluxe hip-roof tool-saver

**HUOT TOOL BOX**

FOB \$ 18<sup>00</sup>  
St. Paul



Model 110

**GYM EQUIPMENT BLUEPRINTS** featured in Jan. and Feb. Popular Mechanics. Includes bicycle exerciser, rowing machine, belt massager and abdominal board. Send \$2.50 for prints B1208 to Popular Mechanics Service Bureau, 740 N. Rush St., Chicago 11, Ill.

## DO MORE PLANING JOBS WITH LOW COST BELSAW



Exclusive MONEY-MAKING Features: Full 12 1/4" x 6" capacity • Power feeds at 14" to 34" a minute • Provides for Grinding Knives in the Cutter-head • Attachments for Jointing, Rabbeting, Tongue, Matching, Groove. Convert low cost rough lumber into high priced stock. Easy to make flooring and popular patterns. Send Today for FREE Literature and Prices.

Belsaw Machinery Co., 2053 Field Bldg., K.C. 11, Mo.

LOW DOWN  
PAYMENT  
EASY TERMS

## HANDLE LOOSE?

fix it quick with



# PLASTIC WOOD®

Handles like putty-hardens like wood!

SEPTEMBER 1962

priced from \$109.50...

**HAND-HELD, MOBILE, BASE STATION**

## 2-WAY RADIO

**VIKING MESSENGERS**

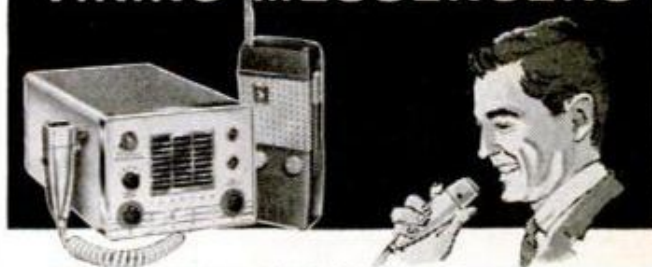

Now, 3 feature packed Johnson Messengers...  
outperforming everything else in the field!

Compact, hand-held 100 milliwatt or 1 watt "Personal Messengers". Rugged and reliable—11 transistors, 4 diodes! Superheterodyne receiver and exclusive tuned RF amplifier gives twice the sensitivity and 40% more range than similar units with conventional circuitry—more output than similar units with same rated inputs!

For mobile or base stations—performance proved Viking "Messenger" punches your signal across the miles! High efficiency design makes full use of maximum allowable legal power. Excellent receiver sensitivity and selectivity. Automatic "squench" control—5 channel coverage. Only 5 1/2" x 7" x 1 1/2", easy to install anywhere!

**WRITE TODAY**  
for  
Information packed  
4 Color Catalog...



**E. F. JOHNSON COMPANY**

1407 10th Ave. S.W., Waseca, Minnesota

Please rush "Messenger" details to:

NAME \_\_\_\_\_

ADDRESS \_\_\_\_\_

CITY \_\_\_\_\_ STATE \_\_\_\_\_

Manufacturers of the world's most widely used personal communications transmitters.

221



## THERE'S A REMARKABLE DIFFERENCE IN SPRAY-O-NAMEL®

For decorating, remodeling, protection, or hobby work, no other aerosol has near the quality of new Spray-O-Namel. Complete, super-opaque coverage in one coat; super fast drying in less than five minutes. Goes twice as far as ordinary spray paints. See the difference, feel the difference for yourself.

**WORTH DOING WELL?**

**WORTH SPRAY-O-NAMEL®**

At quality paint and hardware stores

ILLINOIS BRONZE POWDER CO. • CHICAGO 16, ILL.

## EVERLITE\* World's THRIFTIEST Light Plants

(Item 869-10T)



\*Trade-Mark Registered

### NEW TRANSISTOR ALTERNATOR REPLACES GENERATOR

Now a Service Free Light Plant built with a transistorized alternator. Offers 30% greater efficiency—more power for less fuel. Terrific service life—no brushes to arc and burn. No more commutator to wear, no collector ring trouble. And best of all it costs no more to "go modern with Ever-lite." Thrifty 1000 watt, 115v. AC plant powered by a rugged easy starting 4 cycle engine—leader priced. Model 869-10T. Wt. 65 lbs. as illustrated

**\$179.50**

fob factory

All sizes available—can finance. Write for catalog. Special models for public utilities—Approved for Civil Defense. Write.

**MASTER MECHANIC MFG. CO., Dept. A-962, Burlington, Wis.**

Southern Customers write Dept. A962, Box 65, Sarasota, Florida

## DYNAMIC INDUSTRIAL TYPE TRANSFORMER WELDER

WELD-CUT-BRAZE-SOLDER-HEAT  
IRON-STEEL-BRONZE-BRASS  
ALUMINUM AND OTHER METALS



Professional Electric Arc Welder. Ideal for Home, Shop, Farm or Industrial use. The handiest tool in your workshop. Weld, Braze, Solder, Cut, Bend all metals. Do expert work on your first job. Build or repair Boats, Trailers, Auto Bodies, parts, fenders, metal and ornamental iron furniture, fixtures, farm equipment, garden tools, bicycles, toys, etc. Operates on any properly wired 110 V. A.C. line. Complete with helmet, arc torch, electrode holders, flux, rods, cables, instruction book. **FULL YEAR GUARANTEE**, 10 day money back trial. **ONLY \$38.50 f.o.b.**

Only \$38.50 f.o.b. Send only \$6.00 check or m.o. Pay postman balance plus charges. **EASY PAY PLAN.** Low down payment. Pay as you weld.

**DYNAMIC WELDER CO. 1808 SOUTH FEDERAL STREET Dept. D2-J, CHICAGO 16, ILL.**

## The Second Battle of Midway

(Continued from page 107)

only were its planes and crews in danger, but its dignity was in jeopardy.

Ah-ha, they decided, if we can't drive them off, let's carry them off. So a test group of gooneys was captured and loaded aboard three aircraft. One batch was flown 2000 miles to the Aleutians and released, another handful 3200 miles to the islands near Seattle, and the third 4200 miles to the Philippines. All of the birds had been tagged so that, just in case they were ever found again, they could be identified.

They were found all right—right back on Midway. It took the swiftest only 10 days to find their way home, while the slow-pokes didn't show up for two months. They not only returned to Midway, but to the exact same nests. And record books now list the flight from the Philippines as the long-distance record for birds.

### Ugly Answer

The Navy was beating its head against the palm trees. What could it possibly do that it hadn't already done? The answer, an ugly one, became obvious.

So the order went out: Kill the birds.

Sailors armed with lead pipes, baseball bats and other blunt instruments waded through the nesting grounds near the runways, slashing out at the birds, breaking bones, decapitating some, crushing others. The gooneys, who have no sense of fear, clacked their bills pathetically, but offered no other resistance. Several thousand were slain.

One of the participants told me, "Some of the boys got drunk before they went out, and the rest got drunk when they came back."

When word of the slaughter got back to the States, the screams from animal lovers were cosmic. The Navy issued a pious statement that it was "in complete sympathy with the desire to conserve our wildlife," but restrained from pointing out that none of the complainers showed any compassion for the crews whose lives were in danger nor for the fact that the Cold War was a serious business.

It was a sad affair, and sadder still because it was wasted. The gooney birds, like the mythical Greek who got up stronger every time he was knocked down, became more dangerous than ever. When the birds that had been out at sea came back and found their mates dead, they abandoned the nests and took to the air. And now there were more birds than ever soaring over the runways.

(Continued to page 224)



# How to be a WRECK-LESS driver... by *Vip*

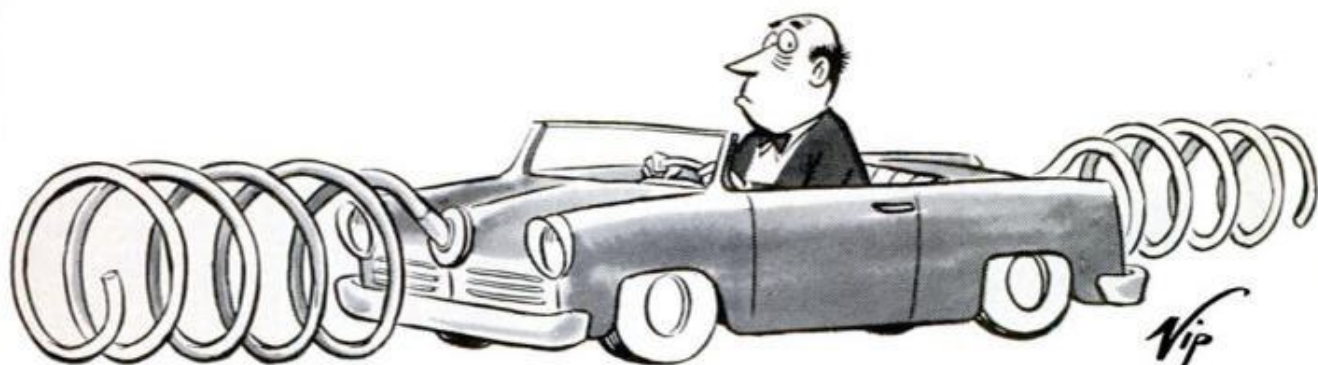

A more practical way to safeguard your life is with good shock absorbers. Wornout shocks cause dangerous swaying . . . loss of braking and control by allowing your tires to leave the road. Have your shocks checked regularly. For the safest, most comfortable ride of all . . . insist on Gabriel Shock Absorbers.



**CHECK UP BEFORE  
YOU CRACK UP...  
see your Gabriel  
dealer now!**

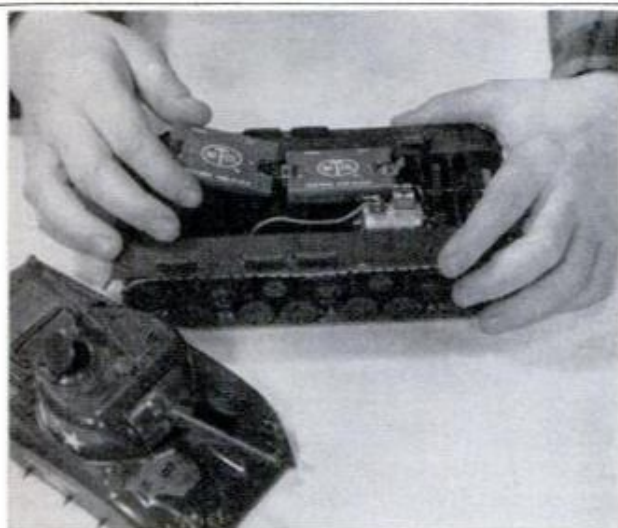
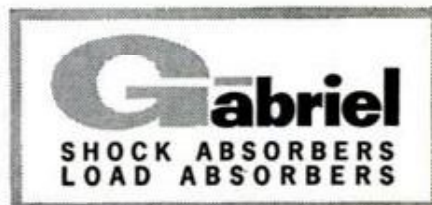

## Miniature Battery for Toys

Designed specifically for toys, a tiny battery saves space and weight but provides sufficient power to operate a variety of moving models, even airplanes.

Invented by a scientist at the California Institute of Technology, the Mi-T-Cel is manufactured by National Automated Industries of Inglewood, Calif.

It is available in five sizes, from  $\frac{1}{8}$  ounce to a full ounce.

A major feature is its long shelf life. It is a deferred-action power unit that remains inactive until dipped in water.

SEPTEMBER 1962



## What's New in High Fidelity

by Fred Honig

Former Editor of Hi Fi Guide, well-known writer and authority on high fidelity

## Music Throughout Your Home

You'll work better in your shop—have more fun in your playroom or greenhouse, out on your patio, relax more at bedtime—with the right kind of music throughout your home. From a central control point—perhaps located in your living room—a compact stereo/high fidelity music system will bring you the true realism and depth of the music you want to hear, where and when you want it. This arrangement is also ideal for the kids' playroom, since it keeps them out of the living room, yet lets them enjoy the music they want—superbly reproduced. Besides great flexibility, components offer economy, too, because the need for several installations is eliminated.

Through components, a single stereo system with FM tuner, record player, tape recorder, amplifier and speakers as required for your needs can easily provide music for your entire home. Mail the coupon below for a free booklet.



**Institute of High Fidelity Manufacturers, Inc.**  
Dept. H-32—516 Fifth Avenue, New York 36

Please send me the free booklet about  
High Fidelity Components.

NAME \_\_\_\_\_

ADDRESS \_\_\_\_\_

CITY \_\_\_\_\_ ZONE \_\_\_\_\_ STATE \_\_\_\_\_

# Why borrow? Speedy Sprayer

now only \$39<sup>95</sup>

Slightly higher Denver West



New! Speedy Sprayer Outfit complete with motor, ready to plug in and spray! Pays for itself on your first big paint job. Does an hour's work in minutes—spray fences, screens, shutters, furniture, rough walls, floors, etc. Smooth, flawless finish. A real professional tool! Ask for "Compact" 404. Write for "How to Spray" and folder.

**W. R. BROWN CORP.**

Specialists in Portable Sprayers Since 1921

2635 North Normandy Avenue • Chicago 35, Illinois

## STOP WATER DAMAGE...

Wood  
Plywood  
Shingles  
Asbestos siding  
Concrete blocks  
Concrete  
Mortar  
Stucco  
Linoleum  
Plaster  
Brick  
Paint  
Wallboard  
Tile  
Canvas  
Leather  
Fabrics



**Prevents warping, swelling, mildew, mold, water stains, seepage, dampness, rot.**

**Keeps moisture out 5 years and longer.**

Use on all woodworking jobs, boats, patio furniture, planter boxes, shutters, screen doors, window sash, shingle roofs. Stops seepage in basement walls, concrete silos, foundations. Waterproofs canvas, tarps, tents, awnings, leather boots, shoes, outdoor clothing. Won't harden or crack leather or fabrics. Perfect underseal for oil base or alkyd paints. Deep penetrating, colorless. Apply by brush, spray or roller. At paint or hardware stores or order direct. 16 oz. spray can \$1.89, Qt. \$1.75, Gal. \$5.35, 5 Gal. \$25.25, ppd., tax incl. Send check or money order to **E. A. Thompson Co** 1365 Market St., San Francisco 3, Calif. No COD's please. (Since 1929.) Dealer and jobber inquiries invited.

The Navy gave up. It began a series of communications through channels that eventually reached, and were signed by, the then Chief of Naval Operations, Admiral Arleigh (Thirty-One Knot) Burke. It was all very official. There were the usual copies for CHINFO, COMFOURTEEN, CINCPACFLT and all the other commands. They were written in official navalese, referring to "loss of Barrier integrity" and attempts to "alleviate the hazard," but what it all really amounted to was that the United States Navy—the scourge of the seas, the most powerful fleet ever created—was throwing up its hands to the heavens, to whatever guardian angel watches over it, and crying aloud:

*"Help! Help! Somebody please help us!"*

Its cries of anguish were heard by dedicated wildlife groups, plus the usual assortment of crackpots. One New Jersey fisherman, explaining that he had discouraged sea gulls from spoiling his boat by painting the boat red, suggested that the Navy—no, not paint the runways red—but paint the whole island red.

A sweet old lady from a Midwest bird-watching group, noting that the gooney birds never collided with other gooney birds, suggested that the Navy paint pictures of gooney birds all over the sides of the airplanes. The boys in the officer's club, while swirling their swizzle sticks, allowed as how this might have some merit, but offered a switch. Since they were trying to get rid of the birds, they reasoned, and since the gooneys didn't collide with other gooneys and they did collide with airplanes, why not paint airplanes on the sides of the birds?

### Scientific Studies

Well, enough of that. Several universities and wildlife groups sent teams of naturalists to the Island to make serious studies. After much trial and error, one suggestion bore fruit. The birds' soaring habits showed they preferred portions of the busy east-west runway adjacent large sand dunes where, apparently, warm updrafts created conditions favorable to soaring. So sand dunes at the west end of the runway were leveled and covered with blacktop, in effect widening the runway at that point.

It worked. Many nests were destroyed but the number of bird strikes was reduced. (It's now down to about seven percent.) The Navy would like additional blacktop in a triangular area formed by the two runways and a taxiway. The area is one of the most dangerous nesting grounds because the birds have to cross the runway to get to sea. Also, the blacktop could catch rainwater; surrounded by the Pacific, Midway

depends on rain for drinking and cooking water.

Two more suggestions have been discussed. Since the birds require uncluttered areas for takeoffs and landings, setting up stakes or fence baffles in strategic spots might discourage them. Also, spreading chicken wire over the ground would eliminate nests.

Fences have been tried individually with the usual comic results. Residents who fenced off their yards found that the birds who had nested there the year before paced up and down outside the fence until someone came along to open the gate, then scampered in and built their nests as usual.

A team from the U.S. Fish and Wildlife Survey, headed by biologist Chandler Robbins, was on the island during my visit. He explained some of the birds' habits, some not entirely understood today and almost all completely misunderstood when the Navy began its slapstick efforts to get rid of them.

When the eggs are hatched (and 95 percent hatch successfully), the dark fuzzy chicks stay close to the nest until May when they are fat and ready to fly. By July they leave the island with the adults.

#### Five-Year Disappearance

This is the strange part. While the par-

ents return to the same island to lay more eggs year after year, the young birds don't return for at least five years, and it's not certain they all return to the island of their birth. No one knows where they go, but best guess is that they just stay at sea, soaring or riding the waves. When they do pick an island, however, nothing can dissuade them from returning annually.

"I've found birds nesting within four feet of the spot they nested the year before," Chandler told me.

His field studies show that the youngest nesting birds are seven years old, so most of the "unemployed birds" are five and six-year olds.

The significance of all this is that the gooney birds have remarkable homing instincts and, however clumsy they are on the ground, they are truly beautiful and indefatigable soaring birds. Any attempt to get them lost at sea is futile and, because of their unique life cycle, no attempt to slaughter them on land will ever work unless carried on for at least five years, with success not assured even then. The young birds stay at sea for five years, the five and six-year olds are on and off the island, and half the mated birds are always away from the nest seeking food. Also, even if all the Midway birds were destroyed, there is no

(Continued to page 226)

## only **PROTO** makes screwdrivers like this

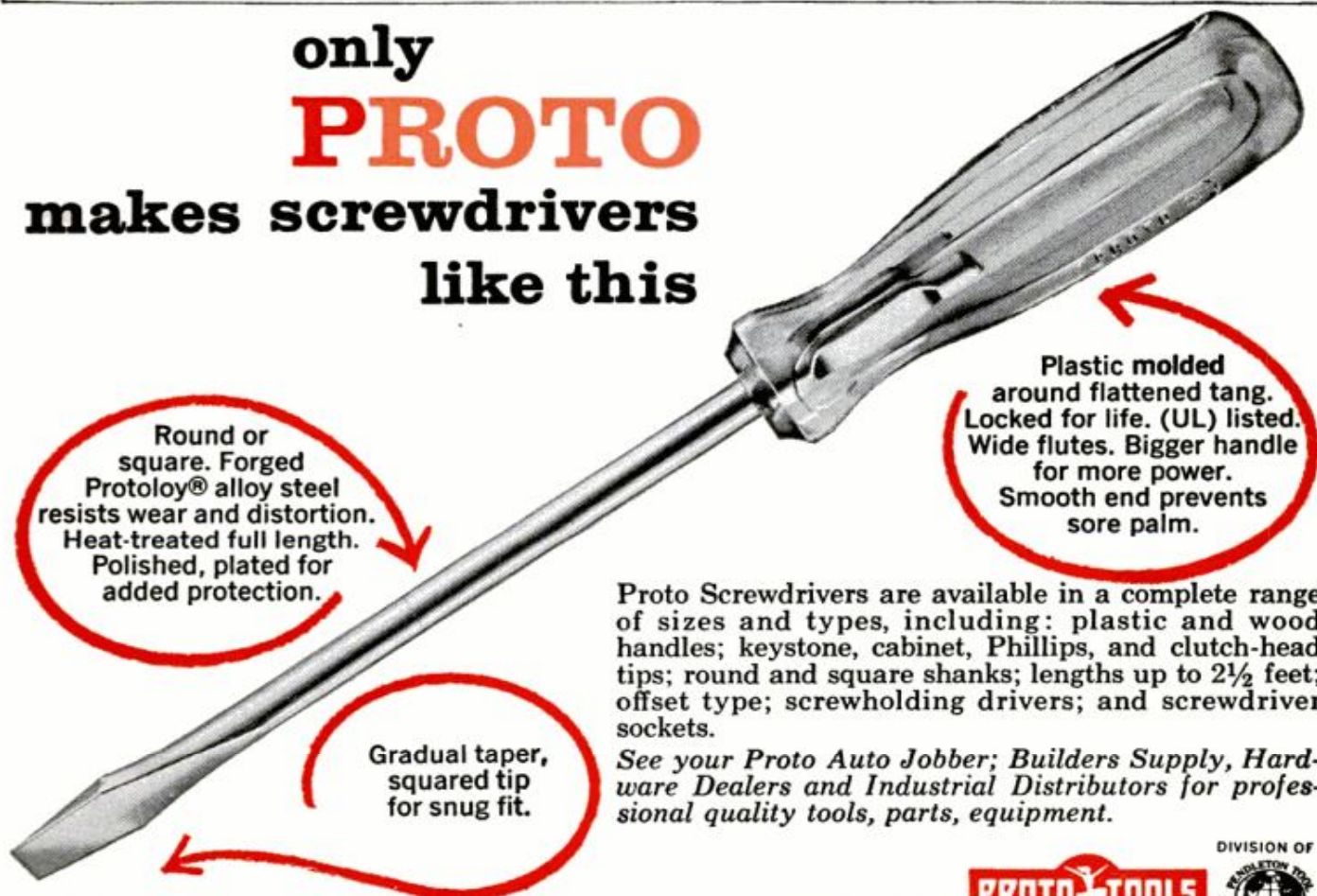

Round or square. Forged Protoloy® alloy steel resists wear and distortion. Heat-treated full length. Polished, plated for added protection.

Gradual taper, squared tip for snug fit.

Plastic molded around flattened tang. Locked for life. (UL) listed. Wide flutes. Bigger handle for more power. Smooth end prevents sore palm.

Proto Screwdrivers are available in a complete range of sizes and types, including: plastic and wood handles; keystone, cabinet, Phillips, and clutch-head tips; round and square shanks; lengths up to 2½ feet; offset type; screwholding drivers; and screwdriver sockets.

See your Proto Auto Jobber; Builders Supply, Hardware Dealers and Industrial Distributors for professional quality tools, parts, equipment.

**PROTO TOOLS**  
PROFESSIONAL QUALITY TOOLS



Send 25¢ with your name and address for fully illustrated Catalog of over 2300 Proto Tools.

2202 Santa Fe Ave., Los Angeles 54, Calif • 502 Allen St., Jamestown, N.Y • 1702 Oxford East, London, Ontario, Can.

## DO-IT-YOURSELF NEWS!

**DAVOL**

### RESP-R-AID MASK

T. M.

**Filters Your Breathing Against  
Dusts . . . Sprays . . . Pollens**

Protects against common home workshop dust, non-toxic paint sprays, garden insecticides and allergy pollens.

Lightweight Resp-R-Aid has washable filter, foam cushioning, adjustable strap.

At Your Drug or Hardware Store  
**DAVOL RUBBER COMPANY**

PROVIDENCE 2, R. I.

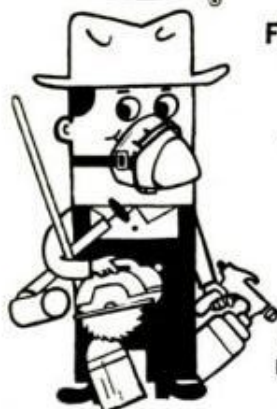

FOR QUALITY LUBRICATION CHANGE TO

## KENDALL MOTOR OILS

KENDALL REFINING COMPANY • BRADFORD, PENNA.

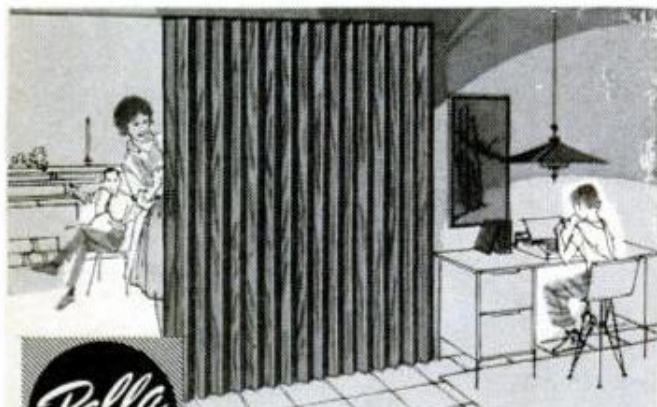

## WOOD FOLDING DOORS

Stop dreaming about extra rooms! Make them with PELLA WOOD FOLDING DOORS that come in veneers of nature's own AMERICAN WALNUT, BIRCH, PINE, OAK, ASH or PHILIPPINE MAHOGANY. We'll finish them at the factory or you can finish them at home. Available in Canada, too.

—THIS COUPON ANSWERED IN 24 HOURS—

**ROLSCREEN COMPANY, Dept. NC-89, PELLA, IOWA**  
Please send color pictures of PELLA WOOD FOLDING DOORS.

NAME \_\_\_\_\_

ADDRESS \_\_\_\_\_

CITY & ZONE \_\_\_\_\_

STATE \_\_\_\_\_

MAKERS OF PELLA WOOD WINDOWS, WOOD FOLDING DOORS AND PARTITIONS,  
ROLSCREENS AND WOOD SLIDING GLASS DOORS

guarantee that young birds born on other islands in the chain might not later choose Midway for their home. The cycle seems endless.

So that's the gooney-bird story, parts of it serious, parts of it sad, but most of it hilarious. The birds have never had a natural enemy until the Navy landed on Midway, which may account for their complete indifference to man. They are neither afraid nor friendly. The Navy is both.

I'm just friendly—but from a distance. I've still got the scar where the gooney bird bit me, and it may be permanent. But I was warned, and I can't stay mad. They are the silliest things I have ever seen.

Silly or not, the Navy still has the problem of learning to live with them. It has given up trying to get rid of them. And the second Battle of Midway continues.

Next month, when the birds return from sea, and come skidding in on their faces, the crews will watch the show with mixed emotions—genuine amusement at the birds' ridiculous antics, and fear for the next round of Gooney Bird Roulette.

Their commanding officer, in his report to his superiors, could well sum up their feelings by rewording a message made famous on another island in another war:

"The gooney birds have landed. The issue is still in doubt." ★ ★ ★

## Update "Modern" Plants

Stiff competition and customer demand are forcing some American businesses to spend vast sums of money to modernize plants which are already up-to-date. For example, Robert L. Hershey, a DuPont vice-president says, "The pressure on DuPont from our competitors and from the market place is enormous. Our customers keep pressing for lower prices, higher quality, greater varieties. . . ."

In answer to customer demand and hungry competitors, DuPont has had to replace and improve equipment and plants which are in good shape and often very modern. As an example, the Sabine River Works was the world's most modern nylon-intermediates plant in 1947. In 1955, the plant was torn down and rebuilt even though it was capable of many more years of productivity. The end products remained the same, but with the installation of modern equipment and the newest technological processes, the new plant produced products at a lower cost and of a higher quality.

" . . . What the customer sees is exactly what he's always seen—but we've spent an enormous amount of money to make sure he can buy it at a competitive price," Hershey pointed out.

**CRUISERS \$369 UP: 18, 20, 22 FT.**



48 Models, 12-22 ft. \$104 up.  
FIBERGLASS OR PLYWOOD  
Runabouts, ski-models, fishing, cruisers.  
Anyone easily assembles. Equal factory  
finished at savings of 1/2 to 2/3.

HOUSEBOAT  
CRUISER  
22 FT.  
Sleeps 6. \$224 Dn.



EASY  
TERMS  
1/4 DOWN

FREE CATALOG  
**LUGER BOAT KITS**  
Dep't B-9 9200 BLOOMINGTON FRWY., MINNEAPOLIS 20, MINN.

**WOODS W CONSTANTINE'S**

Whether you work with wood for fun or profit, you're sure to find *everything* you need in the World's most Complete Source for rare, imported and domestic woods, in veneer, lumber and plywood... inlays, pre-cut picture kits, furniture hardware, finishing and upholstery supplies, tools, BIG ALL-NEW CATALOG and MANUAL, 132 value-packed pages, many in full color, of exciting new items. Over 2,000 in all. Send 25c for Big Catalog and Manual today... NOW!  
**ALBERT CONSTANTINE & SON, Inc.**  
2050 Eastchester Rd., Dept. M-5, New York 61, N.Y.



**Solves Repair Problems**

Durham's fills cracks and holes in plaster, wood and tile. Won't shrink or fall out. Economical, easy to use. Big 4-lb. can, only \$1.40 at lumber, paint and hardware dealers, or shipped direct postpaid in U. S. for \$1.75. Money-back guarantee. Order now. Donald Durham Co., Box 804-T, Des Moines, Iowa.

screens, upholstery, carpets...

hundreds of other uses.

You name 'em!



**Swingline 101 Staple Gun**

Staples practically anything. Exclusive push-button loading and built-in staple extractor. At your stationery, department or hardware store.

only **4<sup>95</sup>**

FREE! New 8-page

SEND FOR YOURS TODAY! "TIPS FOR TACKING" Booklet... shows you how to save time, money and effort — with a SWINGLINE AUTOMATIC STAPLE GUN



**Swingline INC.**

32-00 Skillman Ave., Long Island City 1, New York

**HERE'S A MONEYMAKER FOR YOU!**

make from \$3 to \$6 an hour with the FOLEY SAW FILER

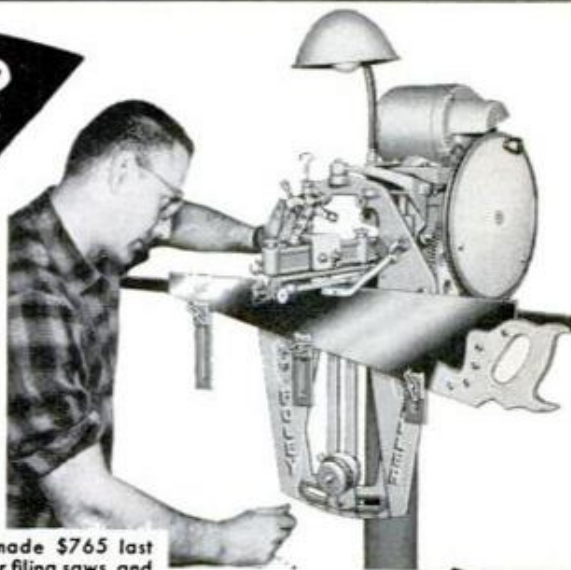

Ask yourself these three questions: 1. Do I really want to get ahead *faster*? 2. How can I do it? 3. Am I willing to use my spare time? If you answer "Yes" to questions 1 and 3—then we have a positive answer for you on No. 2. Men make from \$3 to \$6 an hour sharpening hand, band and circular saws with Foley Saw Filers. No experience needed, to turn out sharp, smooth-cutting saws with this automatic machine. Start in spare time—no canvassing.

**HERE'S THE WAY TO START**

Read "Money Making Facts"—shows you how others have added hundreds or thousands of dollars to their incomes in this steady, repeat, CASH business. Start your *own* business in your basement or garage, no overhead, small investment. With *Time Payment Plan* the Foley can more than pay for itself out of profits. Send for "Money Making Facts"—mail coupon now. No salesman will call.

**HERE'S PROOF**

"When Mr. Patrick got his Foley Saw Filer in March 1946 he made a good and wonderful investment. He has done so well that we bought a house and paid for it; bought a new car, built an addition to our house. Nicest of all, it's all paid for." Mrs. Leslie Patrick.

"I made \$765 last year filing saws, and it sure comes in handy. I do this work in my spare time." —James B. Williams

"Last year's profit amounted to \$3,000. Not so bad for a one-man outfit." —Charles C. Hough.

"I have done 4 or 5 thousand saws in my spare time in the 4 1/2 years since I got the outfit, and they are all coming back with repeat orders." —Len Crego.



FOLEY MFG. CO., 916-2 Foley Bldg., Minneapolis 18, Minn.  
Send me free book "MONEY MAKING FACTS" and Time Payment Plan.  
NAME \_\_\_\_\_  
ADDRESS \_\_\_\_\_

# PLANT MATERIAL FOR EASY MAINTENANCE

GROUND COVER	Height Inches	Decid-uous	Ever-green	Sun	Shade	Remarks
English Ivy	6-8		X	X	X	Use on north and east exposures.
Bar Harbor Juniper	8-12		X	X		Good on dry, sunny slopes and rocky areas. Prefers sandy soil.
Sargents Juniper	12		X	X		Same as Bar Harbor Juniper.
Pachysandra	8		X	X	X	Four to five rooted cuttings per sq.ft. Mulch in sunny areas.
Memorial Rose	12	X		X		Use on steep, sunny slopes.
Periwinkle (Myrtle)	6		X	X	X	Best all-purpose ground cover with flowers.
<b>CLIMBERS</b>	(feet)					
Bower Actinidia	20	X		X	X	Twiner. A good fence cover.
Five-leaf Akebia	12-30	X	X	X	X	Twiner. Refined vine for near house.
English Ivy	20-30		X	X	X	Does best on north and east exposures.
Hall's Honeysuckle	30		X	X	X	Twiner. Use on banks away from desirable plantings.
Boston Ivy	30-50	X		X	X	Good for large masonry walls.
Low's Japanese Creeper	10	X		X	X	Good for small masonry walls.
<b>SHRUBS</b>						
Azaleas	1-10	X	X	X	X	Acid loam: foundation and neutralizing.
Japanese Barberry	6	X		X	X	Neutral soil. Use for natural and sheared hedges and borders.
Warty Barberry	2		X	X		Good for foundation and rock garden.
Rock Cotoneaster	3	X		X		Sandy loam, rockeries, massed for light ground cover.
Redvein Enkianthus	15	X		X	X	Combines with azalea, rhododendron.
Forsythia	7-9	X		X	X	Weeping types on walls and slopes; others on borders.
Hydrangea	3-15	X		X	X	Likes moisture: good for summer color in borders.
Japanese Holly	10		X	X	X	Excellent foundation; planting and/or in contrast with the texture of rhododendron.
Convexleaf Holly	8		X	X	X	
Heller Holly	4		X	X	X	
Pfitzer Juniper	6-8		X	X		On sunny slopes where unrestricted.
Mountain Laurel	8		X	X	X	Acid loam, foundation, banks, neutralizing.
Beauty Bush	8-10	X		X		Specimen, or behind borders.
Regel's Privet	6	X		X	X	Foundation, hedge, borders.
Blueleaf Honeysuckle	12	X		X		Rear of borders or specimen.
Morrow Honeysuckle	8	X		X		Rear of borders or specimen.
Mountain Andromeda	5		X		X	Acid loam, foundation, with rhododendron.
Japanese Andromeda	6-7		X	X	X	Same as Mountain Andromeda.
Firethorn	20	X	X	X		Neutral soil, espallier, hedge, tree.
Rhododendron	4-15		X	X	X	Acid loam, dwarf and hybrid types for foundation; others borders.
Father Hugo Rose	7	X		X		Natural hedge, borders, specimen.
Spirea Vanhoutte	5-6	X		X		Natural hedge, borders, specimen.
Chenault Coralberry	5	X		X	X	For banks and shady areas.
Korean Spice Viburnum	4-6	X		X		Neutral soil, foundations, borders.
Jap. Snowball Viburnum	10	X		X		Neutral soil, specimen, borders.
Dwarf Winged Euonymus	6-8	X		X	X	Neutral soil, foundations, borders, rosy-red color in fall.
<b>TREES</b>						
Japanese Maple	15-20	X		X		Specimen for terrace or lawn.
Sugar Maple	60-100	X		X		Shade tree, brilliant fall foliage.
Katsura Tree	60	X		X		Columnar form, good for screening.
Yellowwood	40-50	X		X		Rich, moist soil, fragrant white flower, good specimen tree.
Flowering Dogwood	25-30	X		X		Light acid soil, well drained; best all-purpose small tree.
Kousa Dogwood	25-30	X		X	X	Same as above; blooms later.
Moraine Locust	75-100	X		X		Fine-textured shade tree; hardy.
Sargents Crab-Apple	6-8	X		X		Best flowering crab for small plot.
Sourwood	25-30	X		X		Moist, acid soil, pyramidal, fall flowers, scarlet fall color.
White pine	75-100		X	X		Best pine for sheared screens and hedges.
Austrian Pine	60-70		X	X		Dense, dark; good screen and sea-shore tree.
Mugho Pine	4-6		X	X		Good foundation and rockery plant.
Swiss Stone Pine	20-30		X	X		Compact, pyramidal, use near house.
Pin Oak	75-80	X		X		Lawn, shade tree; moist acid soil.
Canadian Hemlock	90		X	X	X	Screen and hedge; best in part shade.
Spreading English Yew	2-3		X	X	X	Low, spreading for foundations.
Pacific Yew	2-3		X	X	X	Same as above, plus low hedges.
Upright Japanese Yew	8-40		X	X	X	Good accent tree in foundation.
Hatfield Yew	3-10		X	X	X	Best medium-to-high hedge plant for foundation planting.

## Have a Lazy Man's Lawn

(Continued from page 132)

gravel to make walking easy for high heels.

On irregular land with rocky outcrops, pea-size gravel can be used to eliminate difficult-to-cut grass areas. And in heavy shade where grass won't grow, it can be highly dramatic when used in combination with beds of pachysandra or myrtle.

**Warning!** Unless your plan is strictly geometric, large areas of gravel without compensating areas of grass, ground cover or shrubbery, may look austere. And unless you run to straight lines and rectangles, bold, sweeping curves are more pleasing than tight corners and circles where one area joins another.

Don't get the idea that gravel and crushed stone are entirely maintenance free. Seeds sift between stones, grow into weeds, and must be plucked. But it's not as bad as it sounds, either. Weed growth can be controlled in one of two ways. If the roots of desirable shrubs and trees are not in the area, an arsenic solution may be sprayed over the pebbles each spring to kill any weeds that are sprouting, otherwise, heavy tarpaper or polyethylene film can be spread over the ground before the gravel is laid.

**Shrubs and plant materials.** Next up on the maintenance gripe list are plant materials selected to beautify the grounds. Too often, those cute little plants from the supermarket grow to tree-like proportions—right in front of the picture window.

We have listed a variety of ground cover, vines, shrubs and trees that are well adapted to form the backbone of any garden scheme. Farther south the list may vary so consult your local nurseryman.

There is one all-important piece of advice in regard to foundation plantings: **UNDERPLANT.** It is always easier to add another plant than to remove an overgrown, misplaced one. Those selected should, for the most part, be evergreen and slow growing. If you're in a hurry for that "finished" look, buy larger plants—not twice as many.

The maintenance ogre need not rob you of the pleasures of home ownership if planning is done before spending. The money saved in avoiding mistakes can buy an automatic lawn sprinkling system, so you can golf with no concern about the lawn burning up. Then, you will always be assured of having lawn to mow in a few small areas, and you'll never need feel unneighborly when you see everyone else on the block sweating over his less cleverly planned patch of paradise. ★ ★ ★

SEPTEMBER 1962



As versatile as they are powerful, Wiss Snips are an all-purpose cutting tool no home work bench should be without. Sizes from 7" to 17" in aviation, combination, solid steel and inlaid steel styles. At hardware stores.

### WISS SNIPS CUT EVERYTHING!



**J. WISS & SONS CO., NEWARK 7, N. J.**

World's Largest Manufacturer of Shears, Scissors, Pinking Shears, Skalloping Shears, Metal Cutting Snips and Garden Shears

229

## CATCH FISH in the WEEDS



## Should Your Son Play Football?

(Continued from page 99)

that injuries and fatalities can be held to a minimum "through good coaching, proper physical conditioning, careful officiating, proper protective equipment, and careful medical care of players."

To begin with, the parent should realize that his boy is not engaged in kindergarten activities. As Dr. Joseph H. Burnett, who runs the medical end of the Boston High School football program, one of the safest in the country, says:

"Injuries in football are inevitable. It should be the aim of all concerned to try to reduce the number of injuries and, at the same time, minimize their severity. I have long since become reconciled to the fact that most of these injuries can be catalogued as a hazard of youth, because whether they play football or any other sport, a percentage of them get hurt."

Although it is impossible to remove all of the hazards from sports, measures can be taken to prevent injury.

What can you do? Plenty.

### Parents Can Set Policies

Parents are potentially the strongest force in determining school athletic policies. You can make certain that sports are conducted chiefly for the good of the players, not a coach's win record. This does not mean that winning is undesirable, but victory should not be gained at the expense of the health of the players.

Dr. Fred V. Hein of the American Medical Association staff said, "Remember, the coaches' attitudes and practices are often a reflection of the community. Unfortunately, coaches are sometimes hired primarily to win games; and it is made known to them in no uncertain terms that the job depends on a winning record. Is it any wonder that the interests of the boy become secondary under these conditions?"

Should your boy be playing at all? Does he have the drive and desire to make him get in proper shape? Or is he playing because his dad was a player and wants him to follow in his footsteps? Or because the coach needed some more boys to fill out the squad and pulled him out of the hall?

Once it has been determined that your boy will play, see to it that he gets a complete medical examination. If the school doctor is not as thorough as you think he might be, have a doctor of your own choosing examine him. Choose a doctor who knows something about sports.

Such a doctor would appreciate that a

(Continued to page 232)

## NEW! PIPE - BENDING PROTRACTOR and LEVEL

HERE is a precision gauge that will level and plumb anything vertically or horizontally. Sets anything to a specific degree of angle. Precision-ground magnet base assures positive accuracy. For Electricians, Appliance and Furnace Servicemen, Pipe Fitters and Plumbers, Machinists, Millwrights etc., and has many uses in Home Workshop. Comes packed in attractive plastic box for easy carrying in pocket. Fully guaranteed against defects.

Price \$2.25 postpaid.

P. B. PROTRACTOR AND LEVEL, Box 5064, Roanoke, Va.

MORE THAN 600 specific craft, home and shop problems solved with Popular Mechanics' do-it-yourself instructional materials. For a free Service File listing by subject, write Service Bureau, Popular Mechanics, 740 Rush St., Chicago 11, Ill.

<b>JET-DRI</b>		
<p>paint toys</p> <p>PLAY with them 15 minutes later!</p>	<p>paint boats</p> <p>LAUNCH it 15 minutes later!</p>	<p>paint equipment</p> <p>USE it 15 minutes later!</p>
<p>paint your floor</p> <p>WALK on it 15 minutes later!</p>	<p>paint your wall</p> <p>HANG pictures 15 minutes later!</p>	<p>paint storm windows</p> <p>HANG them 15 minutes later!</p>
<p>paint furniture</p> <p>USE it 15 minutes later!</p>	<p>paint your cabinet</p> <p>USE it 15 minutes later!</p>	<p><b>JET-DRI</b> DRIES IN <b>15</b> MINUTES</p>
<p>In Spray Cans, Qts., or Gallons wherever paints are sold For new "Profitable Paint Ideas" booklet, write— <b>CONSOLIDATED CHEMICAL &amp; PAINT CORPORATION</b> 442 Driggs Ave., Brooklyn 11, N.Y.</p>		



# SURPLUS SALE

GOVT. SURPLUS  
EXCESS INVENTORY  
BANKRUPT STOCK



## HYDRAULIC SURPLUS BARGAINS

- Great savings. Build loaders, diggers, presses, etc. Brand new equipment.
- \$95 Pump, 1000 lb., 10 gpm. . . . \$33.95
- 12-v Battery Hyd. Pump . . . . . 18.49
- Hand Hyd. Pump . . . . . 10.95
- \$39 Hyd. Cyl., 3x8" 2-way . . . . . 19.70
- Hyd. 2-way 1000-lb. Valve . . . . . 18.00



## 115-V A-C GENERATORS

- Many other Surplus Plants.
- Item # 626. Brand new 3-wire heavy duty 1,200 rpm 115-v 60-c 3000-4000-w/ball-bearing generator. Wt. 260 lbs. Govt. cost over \$800. SALE . . . . . **\$139.50**

## HYDRAULIC SPEED REDUCER

- Item #1311. 1 h.p. transmission. Variable 0 to 350 rpm. Instantly reversible. Ideal for lathes, midget cars, etc. Roller bearings. Complete except motor. Use your own single or 3 phase motor. Equipped with pulley. Easy to mount motor. Size 21"x9"x20". Wt. 200 lbs. Govt. cost over \$900. SALE . . . . . **\$79.50**



## STORAGE BATTERY WINCHES—HOISTS



Many other types battery winches—hoists.

- Item #311. 12-v Govt. reversible, ball bearing 2000-lb. capacity winch. Holds 40' 1/4" cable. For trucks, docks, boats, etc. 55 lbs. Cost over \$250. SALE . . . . . **\$49.95**

## AC-DC ELECTRIC GENERATOR



Wt. 55 lbs. Cost over \$250. SALE . . . . . **\$15.85**

- Item # 675. New Govt. unit. Generates 115-v (800 cycle) AC (1200-w) and 30-v up to 200 amps DC.
- Use for 115-v AC lights or stove or for DC 200-amp welder. Size 14"x8"x6".

## AIR COMPRESSOR EQUIPMENT

- Make your own outfit. For painting, tires, shop use, etc. Save to 60%.
- Compressor, \$21.50. Govt. Tank, \$10.95. Gauge, \$1.75. Paint Gun, \$11.50. Auto switch, \$4.75. Air Regulator, \$3.95.

## DIAL TELEPHONE

- Item # 716. Std. phone, same used on all phone systems. Use as extension to main phone and on private systems. Directions furnished. Wt. 8 lbs. Cost \$25. SALE . . . . . **\$7.95**



## SPECIAL OF THE MONTH!

### 12-V BATTERY ELECTRIC CAR MOTOR

- Item #564. Powerful gear motor. Hi torque. Build boy's car, golf-cart, winch elevators, etc. Runs on 12-v battery. Reversible. Gear ratio 24 to 1. 100-150 rpm. Ball bearings. Shaft 1 1/16" diam. Size 17"x6". Wt. 36 lbs. Govt. cost \$295. SALE . . . . . **\$18.95**
- Reversing switch for above motor, \$3.95



### ARMY CAPSTAN WINCH

- Item #325. Just rec'd Govt. award. New Army worm gear capstan winches. Designed for front end mtg. on trucks & jeeps. Ideal for boats. Has input shaft which can be driven thru flexible coupling to fan pulley shaft. Also easily adapts to 12-v battery motor drive. Size 14"x12"x9". Wt. 39 lbs. Govt. cost over \$100. SALE . . . . . **\$33.95**



### EXAMPLE BARGAINS IN 1962 CATALOG

- \$112 Level-Transit, brand new . . . \$84.00
- \$55 Finest 7x50 Binoculars . . . . . 24.15
- \$67 Surveyor's Level, rod, tripod . . . 50.25
- \$12 Fish-Worm Shocker . . . . . 3.49
- \$13 115-v AC Pump . . . . . 7.97
- \$80 Govt. Turbine Pump (finest) . . . 19.49

ALL ITEMS THIS AD FOR LINCOLN Write today for large 1962 catalog.

**SURPLUS CENTER**  
DEPT. 811 LINCOLN, NEBR.

## NEW JET DRIVEN BOAT KIT

KIT INCLUDES BOAT and JET FOR AUTO ENGINE

FREE CATALOG \$22375 \$3804 DOWN PER MO.

CONSTRUCTION DRAWINGS \$2.00

**TAFT MARINE WOODCRAFT**  
DEPT. PM-962 • 636 39th Ave. N. E. MINNEAPOLIS 21, MINNESOTA

## FOR TOP VALUE... INSIST ON

**Folding Wood RULES**

**Steel White TAPES**  
with belt holsters  
6 ft. to 100 ft.

**Evans** RULE CO. 400 Trumbull Street, Elizabeth, N. J.

## Print Your Own

Cards, Stationery, Advertising, Circulars, labels, photo and movie titles, church work, tags, etc. Save money. Sold direct from factory only. Raised printing like engraving, too.

**Own a Printing Business**

Print for Others, Good Profit. Have home shop. Junior press \$15; Senior \$35 up. We supply everything. Easy rules. Pays for itself in short time. Write now for free details.

**KELSEY PRESSES, Z-37 Meriden, Conn.**

## Fill Flaws In Plywood

Handles like putty. Hardens like wood.

# PLASTIC WOOD

The *Genuine* - Accept No Substitute.

## NO JOB WORRIES

PLASTEX INDUSTRY needs manufacturers on small scale for big production of Lamps, Clock Stands, Art Goods, Novelties in Plastic Marble imitation. No Experience necessary. 1/2c material makes regular 10c store sellers. Moulds furnished for fast production. Small investment brings good profit. Big wholesale orders now being placed. Ambitious men have chance for real prosperity and job security. Our NEW FREE booklet will interest and benefit you.

**PLASTEX INDUSTRIES, Dept. A**  
3400 Third Ave. New York 56, N. Y.

**Backyard Blues?**

**Good News!**



AMERICA'S FINEST BASEMENT DOOR

Here's the way to add amazing new beauty and convenience to your home. Replace that troublesome wood door with a modern Bilco. All steel, permanent, watertight, opens and closes at a touch. A new Bilco Door will do wonders for your home . . . and for you!

The Bilco Co., Dept. R-69, New Haven 5, Conn. Please send me your free illustrated folder and name of local dealer.

Name \_\_\_\_\_  
Address \_\_\_\_\_  
City \_\_\_\_\_ Zone \_\_\_\_\_ State \_\_\_\_\_

nearsighted boy, for example, could play the center of the line, while he would be unfit for a backfield or end position.

Of the high-school players who died last year, several should not have been playing in the first place.

One fatality in Pennsylvania died of heart failure due to exertion complicated by a congenital defective heart. This was a condition he was born with, but not detected in examination.

A footballer of Crowell, Tex., died of a ruptured organ doctors said was defective from birth. Another Texas boy collapsed during a warmup. He had had no contact for three days. Reports say the boy previously had several fainting spells, and should not have been playing. However, he wanted to play so badly that his mother gave in and let him play.

Another player of Grand Blanc, Mich., died of a ruptured artery in his brain which doctors say may have been due to congenital weakness.

How many of these boys might have been saved by a more complete physical examination?

#### Doctor Should Be on Field

Not only should a doctor see your boy before the start of the season, but a doctor should be on hand at all games. It's just as important to have a doctor on the field as it is a referee.

The A.M.A. reports that in Bellaire, Ohio, on September 23, three players were overcome by heat stroke in a game played under a blazing sun. The Bellaire team physician, Dr. Peter Lancione, stopped the game.

"Why jeopardize a boy's life?" he asked. The three were hospitalized and nine others treated at a hospital and released.

Insist that your boy be in top shape, able to withstand the hard knocks of football. You can encourage him to work out during the summer and report to fall drills in sound, solid condition.

What kind of conditioning drills is your boy receiving? Ask questions. Conditioning activities should include running, calisthenics, and combination of drills, stunts, and contests.

"Preseason conditioning exercise to develop muscle tone is absolutely necessary," says Dr. Augustus Thorndike of Harvard.

Conditioning has three main purposes: 1. Prevent injury, 2. Improve performance, and 3. Increase enjoyment in participation. Often adequate conditioning is neglected in favor of emphasizing game techniques and strategy.

See to it that your boy is not only outfitted with high-grade protective equipment, but that care is taken in custom

fitting it to his body. Your boy should have his own personal helmet, and not just one picked up on the sidelines as he gets ready to enter the game.

One of the major equipment problems comes from the practice of filtering substandard equipment, considered no longer suitable for varsity use, down to the "hamburgers," the scrubs. The boys who in most cases are *more* in need of protective equipment since they do not as yet have the techniques of the game to protect them.

A good deal of research is under way to improve the existing protective equipment, and some dramatic results can be expected. One of the most important may be that carried on at Northwestern University by Dr. Stephen Reid, the Wildcats' team physician, and Dr. James Aagard, professor of electrical engineering.

#### Radio in Helmet

In their experiment, they are putting tiny instruments into a football helmet which are designed to radio back to the sidelines data on both impact and brain activity (electro-encephalograph).

They hope to be able to come up with minimum requirements for a safe helmet, something which no one has yet done. Dr. Reid says:

"Normal tests on the helmet are done by placing it on a dummy, and subjecting it to blows on the top. This determines the breaking point of the shell. This would be fine if we were concerned with skull fracture. We are not; concussion is the major problem. Hence, we want to see what goes on in the brain upon contact."

Dr. Francis Murphy of Memphis, a member of the A.M.A. committee on the medical aspects of sports, and a neurosurgeon with a special interest in head injuries, has asked that helmet research cover the improvement of protection against injuries of the neck as well as the head.

His request was answered by one of the major equipment makers (Wilson) which has developed a back extension pad for the helmet which should reduce the chance of whiplash injury. Test helmets so equipped were used by Purdue University last season as a special use test. The pads are now on the market.

The American Medical Association's Committee on the Medical Aspects of Sport which has been one of the most active groups in the country seeking an answer to the problem of football safety, called together 50 of the nation's top experts this summer. Here is a recap of their findings:

They felt that the "hard-shelled plastic

(Continued to page 234)

# DU PONT M.O.A. GUARDS YOUR CAR ENGINE AGAINST DANGERS YOUR OIL INDICATOR DOESN'T SHOW!



**Exclusive Du Pont development prevents harmful sludge formation...helps keep oil passages open...saves costly engine repairs**

Sludge is your engine's worst enemy. It doesn't register on your oil-pressure gauge or trigger your warning light until it's too late. But whenever you drive, sludge can form . . . blocking oil passages, clogging key engine parts, robbing your engine of vital lubrication. Result: valves become noisy, rings stick, engine wear increases . . . and repair bills rise.

Du Pont M.O.A. added to your motor oil prevents sludge from forming. Just one can of M.O.A. at each oil change keeps your engine cleaner, quieter and smoother-running, under all driving conditions.

Don't let deadly engine sludge give you low performance and high repair bills. Add Du Pont M.O.A. to your crankcase regularly. Available at service stations or wherever auto supplies are sold. Just \$1.65.\*

\*Suggested retail price

**Results of  
48,000-mile  
road test**



OIL SCREEN WITH M.O.A.



OIL SCREEN WITHOUT M.O.A.



**DUPONT No "7" PRODUCTS**

BETTER THINGS FOR BETTER LIVING . . . THROUGH CHEMISTRY

SEPTEMBER 1962

233

# PAINTING IS A PLEASURE

WITH  AERO-DYNE "PAINT—ENAMEL—LACQUER

INSECTICIDES—WEED KILLERS  
GARDEN SPRAYS



**\$19<sup>95</sup>**

PREPAID  
Add 30c Denver and West



### New Aero-Dyne Sprayer Outfit

Self-pressurizing unit has no electric cords or air hoses. Pressure tank sprays gallons of oil or water soluble liquids. Easy to use and convenient as an aerosol bomb. Built-in Aero Jet ends nozzle cleaning problems. Light weight and quiet. Professional results on your first spray job.

### AERO-DYNE SPRAY OUTFIT

Includes: Sprayer handle with push-button nozzle; Pressure Tank filled with Propellant; Refillable Paint Tank (24 oz.) and Nozzle; Fan Spray Pistol Nozzle; Instruction Booklet and "How to Spray Paint" Suggestions.

PATENTS  
PENDING  
MODEL  
J100A-44

ASK YOUR HARDWARE DEALER FOR FREE DEMONSTRATION  
OR FILL IN THIS ORDER BLANK AND MAIL TODAY.



### AERO-DYNE CORPORATION

Box 247-PM — Emmetsburg, Iowa

NAME (Print) \_\_\_\_\_

ADDRESS \_\_\_\_\_

CITY \_\_\_\_\_ STATE \_\_\_\_\_

I enclose \$19.95 (Check or Money Order) for Sprayer Outfit with FREE Adjustable Insecticide Nozzle.

I enclose \$1.95 for Extra Pressure Tank (Prepaid).

Please Send Illustrated Literature.

For that extra  
Quality you can  
actually feel...



The choice of men who make their living with tools. A complete line of sockets, handles, flat wrenches, pliers and adjustable wrenches. Sold by better dealers everywhere.

FREE POCKET CATALOG of S-K Lectrolite wrench sets and individual tools. Send this coupon today.

S-K/Lectrolite Tools—Dept. A  
Chicago 32, Illinois

Name \_\_\_\_\_

Address \_\_\_\_\_

City \_\_\_\_\_ State \_\_\_\_\_



helmet currently in general use is superior to previously used models constructed of other substances."

The superiority of the plastic helmet was derived from completed and continuing research in which the shock-absorbing capacities of various materials have been measured, and from comparison of head and neck injury rates since the advent of the hard-shelled plastic helmet with the incidence of such injuries in the past.

The practice of "spearing," or using the helmeted head as a battering ram in either blocking or tackling, was strongly condemned. Professional football teams do not employ these tactics, considering them too dangerous. This conclusion was strongly supported by Clark Shaughnessy, defensive coach of the Chicago Bears, who attended the conference.

### Face Guard Is Valuable

The face guard now commonly used provides valuable protection against injuries to the face and teeth, the committee concluded. However, it should be fitted as close to the face as possible while still providing optimum protection. Records show that injuries to the face are cut by more than 70 percent with the use of a properly fitted face guard.

The committee pointed out that it is a logical assumption that a face guard extending too far forward, providing a lever by which the neck may be forced backward excessively, could be a factor in neck injuries.

Mouth or tooth guards, which will be mandatory under high-school football rules this year and recommended at the college level, were termed "an important new protection."

Proper conditioning of the athlete, particularly the muscles of the neck, is a significant factor in preventing neck and head injuries. Team physicians, athletic trainers, and researchers all agree that a strong neck "splinted" by well-conditioned neck muscles is a valuable protection against neck and head injuries.

Continuing research on head protection was urged by the committee to determine the impact from a blow to the head that the player can absorb without harm.

"Once these values are known, the engineers and the manufacturers of protective devices can develop equipment to take up the difference," the committee said.

Now you know the problem and the solutions proposed by the nation's top experts in the field. Should your boy play? Well, that's a question that can only be answered by you. ★★★



*"Art, we're rich! Think of it, we've created Mac's Cooling System Cleanser for car radiators. Now all we have to do is invent automobiles and service stations and we'll clean up!"*



## GENUINE ALNICO MAGNETS

**AMAZING. PERMANENT. NON-ELECTRIC. HIGHLY PRACTICAL.** Conduct interesting experiments. Hundreds of uses. Retrieve valuable steel items such as guns, tackle from fresh or salt water; tools from tanks & drains. **GUARANTEED.** Try any magnet one week.

Money back if you are not well-pleased.

M-90 (Wt. 5 oz.) Has pull of 15 lbs. on steel block.....	\$ 3.50
M-500 (Wt. 13 oz.) Has pull of 50 lbs. on steel block.....	\$ 5.00
M-575 (Wt. 18 oz.) Has pull of 75 lbs. on steel block.....	\$ 7.00
M-625 (Wt. 20 oz.) Has pull of 100 lbs. on steel block.....	\$ 10.00
M-710 (Wt. 53 oz.) Has pull of 225 lbs. on steel block.....	\$18.00
M-44 Rod Magnets for Electric Guitars 1/4" Dia. x 1 1/4". 12 for	\$ 4.00
M-47 Hot Pad Magnets. 10 for \$1.00.....	\$ 4.87
M-35 Science Experiment Kit of 8 magnets.....	\$ 2.00

Send M.O. or check. We pay postage. Sorry no C.O.D.'s.  
**MIAMI MAGNET COMPANY, 3240 N.W. 27th Ave., Miami 42, Fla.**



"That little voice in our ear used to be our conscience. Now it's a transistor radio."

YOU need  
**BALANCED RIDE CONTROL**  
for your car



Balanced Ride Control is the big motoring benefit you receive when you equip your car or truck with Air Lift Adjustable Air Springs. They are the only sure way to keep your car level at all times, regardless of road or load conditions.

Cornering is improved, side-sway greatly reduced, **A LEVEL CAR IS A SAFE CAR.**

Air Lift Adjustable Air Springs are unexcelled if you carry heavy loads or haul a trailer—just add a little AIR and you're on your way in 10 seconds with a LEVEL . . . SAFE car.

Air Lift Air Springs save money, too, by improving tire wear . . . keeping wheels in alignment and reducing vibration.

Available at leading garages and service stations or write to:



**AIR LIFT COMPANY**

LANSING 2, MICHIGAN



BE READY FOR ANY ROAD PROBLEM

### WITH A HULL AUTO COMPASS

Handsome, accurate, easy to install. Seven colors. Save time, gas dollars. Boat models, too. \$5.95 to \$7.50. At your dealer or write for lit.



**HULL MFG. CO. • Box 246-D-9 • Warren, Ohio**

**GUNK®** removes grease  
-- scourfully!  
cleans -- degreases -- freshens



- power mowers • engines
- cement floors • kitchen walls • ovens • exhaust ducts
- paint brushes • furnace filters • barbecue grills
- implements • machinery

**AT AUTO SUPPLY, FARM & HARDWARE STORES!**

GUNK CHICAGO CO., River Forest, Illinois  
serving the Midwest and Southeast  
RADIATOR SPECIALTY CO., Charlotte, N.C.  
serving the East, Southeast and far West

# Furniture Finish Remover



**Free-flowing Klean-Strip** takes the mess and work out of removing old furniture finishes. It spreads easily, penetrates several coats quickly, lifts the old finish off in a clean, non-gummy film. Non-flammable, non-poisonous and needs no neutralizing. For vertical surfaces and water-rinse use get Heavy-Bodied Klean-Strip.

At paint and hardware stores everywhere.

## KLEAN-STRIP PAINT REMOVERS

The Klean-Strip Co., Inc. Memphis 6, Tennessee—Winnipeg, Canada



Men who know  
**WOOD SCRAPERS**  
say the **BEST** are  
**Red Devil Tools.**

### UNUSUAL TOOLS BY MAIL



#### DRILL GRINDER

Sharpens round shank drills like new with hand or power grinders. \$2.95 ppd.



#### EASY SAW FILER

No. 11 Gives correct height, depth, pitch, bevel to any 6" to 10" hand or circular saw with no side pull. Includes 8" file. \$9.95 ppd.



#### #44 CORNER CLAMP & MITER BOX COMBINED

Adjustable to any angle. Accurate cuts with any handsaw from 0° to 180°. Full 3" capacity. Sides exposed for nailing and gluing. \$2.75. No. 33 corner clamp, only, \$1.75 ppd.

#### SAW SET

automatically sets teeth at 10° or more \$2.95 ppd.



#### WRITE FOR FREE CATALOG

A. D. McBURNEY, 5908. Hollywood Blvd., Hollywood 28, Cal. Dept. A-92

### DRAINS cellars, cisterns, wash tubs; \$7.95 IRRIGATES - CIRCULATES - SPRAYS



1,001 uses. Stainless shaft. Won't rust or clog! Use 1/6 HP motor or larger . . . 3/4 HP for up to 2,400 GPH; 450 GPH 80' high; or 1800 GPH from 25' well. 1" inlet; 3/4" outlet. Coupling included free. \$7.95. HEAVY DUTY BALL-BEARING PUMP. Up to 5,200 GPH; or 3,000 GPH from 25' well. 1 1/4" inlet; 1" outlet. \$12.95 Postpaid if cash with order. MONEY BACK GUARANTEE

Centrifugal and Gear Pumps in All Sizes

LABAWCO PUMPS, Belle Mead 7, New Jersey

## WAR SURPLUS AND OTHER BARGAINS SAVE UP TO 90%

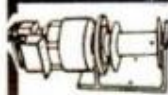

### DELUXE ELECTRIC STORAGE BATTERY WINCH

Handles 250' of 1/4" cable. Operates on 6 and 12 V. battery. 160-1 gear reduction. Lift cap. 2500 lbs. Heavy-duty mounting base with outrigger bearing and spool support. Rugged construction. Heavy-duty. Dim. 22" L x 9" W x 8" H. For jeeps, trailers, boats, trucks, campers. Shpg. wt. 80 lbs. Approx. GOVT. COST \$490. NEW. Model E-D. \$69.50.

**MODEL E** Same as above but without heavy-duty base and outrigger support. Spool cap. 70'. 1/4" cable. NEW. \$49.50



### BUILD YOUR OWN ARC WELDER, LIGHT PLANT OR BATTERY CHARGER \$39.50

Kit incl. 1 Navy NEA-5 Gen. combination AC-DC type. AC 115 V. DC 24 V., 200-300 Amps. 2 complete generators in 1, yet no larger than reg. gen. Ideal for home, shop and farm lighting plants. Delivers 1200 Watts AC. DC side for charging batteries, welding and operating war surplus motors. Also in kit: 1 DC Voltage Reg., Reverse Current Relay, 1 Voltmeter, Rheostat, Electrode Holder, Toggle Switch, Welder's Shield, Wiring Diagram for kit. Wt. under 100 lbs. Approx. GOVT. COST \$650. Kit—\$39.50. Navy NEA-5 Gen. as above, purchased separately, \$23.50



### U.S. NAVY SEXTANT (AN 5851)

Adjustable bubble and nite lite, built-in averaging device. Both artificial and natural horizon. Used with or without bubble. Used by many power squadrons. All units tested for tolerances. Complete with built-in filters, astigmatizer, carrying case and instruction book. Approx. GOVT. COST \$586. Like NEW. \$16.95



### RESERVE YOUR COPY NOW!

Send 25c in coin for amazing new catalog with 1000's of bargains in hydraulics, electrical, precision tools, marine items, automotive, etc. for hobbyists or industrial — off the press soon! Or order from this ad and receive a free copy. All prices FOB Culver City, Calif. 50% dep. for COD. Send check, cash or money order. Order today!

**AIRBORNE SALES CO., INC DEPT. PM962**  
8501 Stellar Drive, Culver City, Calif.



# 10,000 Things Electronic To Enjoy—10,000 Ways to Save in Famous **RADIO SHACK CORPORATION'S**

## Brand New 1963 Electronics Catalog

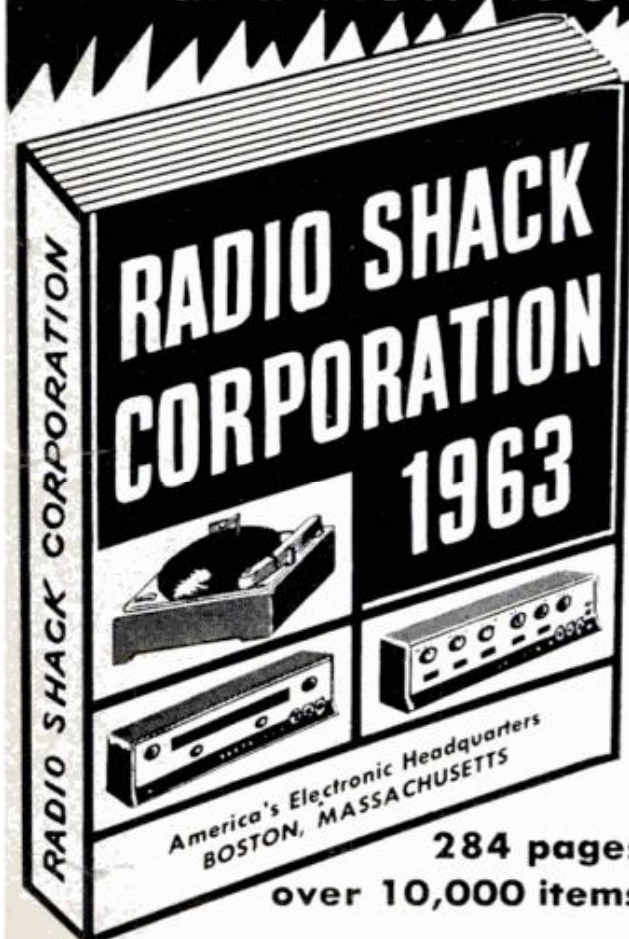

**284 pages  
over 10,000 items**

### Partial List of Products in our New 1963 Catalog

- Amateur Radio
- Antennas
- Batteries
- Books
- Capacitors
- Controls
- Hi Fi
- Microphones
- Needles
- Phonographs
- Public Address
- Radios
- Resistors
- Tape Recorders
- Test Equipment
- Tools
- Transformers
- Transistors
- Tubes
- Wire

**NO MONEY DOWN CREDIT TERMS**  
Take up to 2 Years to Pay

# **RADIO SHACK CORPORATION**

**BOSTON, MASSACHUSETTS**  
America's Electronic Headquarters

SEPTEMBER 1962

# FREE

## for You & 2 Friends Mail Card Today

### The Radio Shack Story

Radio Shack Corporation of Boston, Massachusetts is one of America's big 3 distributors of things electronic to the general public, industry, craftsmen and hobbyists. We offer a complete selection of precision built products by mail, through stores, and direct to manufacturers. Our exclusive REALISTIC® line of electronic products is famous nationwide for its high quality, dependable service and fine values. Our selection of national brand products is the largest in the country.

Radio Shack Corporation has been serving the nation since 1923—from the very beginning of the electronic age. This year over 2,000,000 people—music devotees, ham operators, amateurs and professionals—will shop from our catalog because they get the most value for every penny they spend on their favorite products . . . they will buy on the easiest terms, cash or credit . . . they are assured by our guarantee of getting the most satisfaction on every purchase. Radio Shack Corporation invites you and your friends to get your share of these savings and satisfaction by mailing the card opposite for your FREE catalog.

<b>RADIO SHACK CORPORATION</b>		Dept. 62J3C
730 Commonwealth Ave., Boston 17, Mass.		
Without obligation send me Free and Postpaid, your New Electronics Catalog plus every new issue for one full year.		
Your name _____		
Address _____		
City, State _____		
▶ Name of a friend _____		62J3D
Address _____		
City, State _____		
▶ Name of a friend _____		62J3E
Address _____		
City, State _____		



## Flecto Varathane Outlasts Varnish 2 to 1

Flecto Varathane is a remarkable new clear plastic finish

that dries dust-free in minutes, and lasts *twice* as long as varnish.

Flows right on *any* kind of wood, inside or out. Needs no sealer. Put it on siding, floors, kitchen cabinets, furniture, even boats. Comes in glossy or satin finish, regular can or easy-to-use aerosol container for quick touch-ups.

Note to users: Clean brush and equipment with mineral spirits. First coat covers 500 sq. ft. per gallon. Second coat covers 600-800 sq. ft.

If your nearby paint, hardware or building supply dealer doesn't carry it yet — or for free brochure — contact...

The Flecto Company, Dept. P. M., Box 84, Berkeley 2, Calif.  
Flecto Coatings, Ltd., 8850 Selkirk, Vancouver, B. C.

### Briggs & Stratton — Clinton New Gas Engine Sale

Never before and perhaps never again—this offer of brand new genuine Clinton and Briggs & Stratton engines including 1 yr. factory warranty *at less than cost*. Perfect power for go-carts, scooters, tractors, mowers, generators, pumps, sprayers, etc. We bailed out 3 big factories who needed cash and the savings are yours while quantities last. *Act fast.*



Clinton 2 1/2 hp, Mdl. A400—Re-coil starter Std. 3/8 shaft w. keyway—ready to go. Reg. price \$49.50 Special (item 1002)

**\$29.95**

2 for ..... \$57.50  
6 for ..... \$150.00

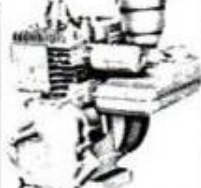

Briggs & Stratton 2 hp, Mdl. 60101 Rope start, std. 3/8 shaft w. keyway. Sturdy 4 cycle power. Regular price \$49.80 Special (item 106a)

**\$29.75**

2 for ..... \$57.40  
6 for ..... \$149.50

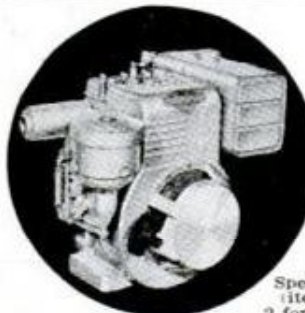

**\$67.50**

**5 3/4 hp.**

**Briggs  
&  
Stratton**

Briggs & Stratton 5 3/4 hp, Mdl. 143302. Re-coil start. Std. 1" shaft w. keyway, aut. choke & throttle control—a rugged big engine ready to tackle any job.

Regular price .. \$92.60

Special (item 1059) ... **\$67.50**

2 for \$130.00 6 for \$350.00

Remember these engines are absolutely perfect and standard and under factory warranty. Money back guarantee. Order now while stocks are complete. Factories—write us on any new items that are surplus to your needs.

Send 10c for 100 page catalog.

**MASTER MECHANIC MFG. CO., Dept. A-962, Burlington, Wis.**

Southern Customers write Dept. A-962, Box 65, Sarasota, Florida

## PM's House

(Continued from page 145)

Inside and out—there's redwood paneling on the top half of the exterior walls—the wood has been finished with a preservative oil that further adds to its long life.

In the kitchen, cabinet fronts, counter tops and splashbacks are made of damage-resistant plastic laminate which easily wipes clean. Other work-saving features of the kitchen include a dishwasher and disposer.

Along the atrium side of the kitchen is a nine-foot eating bar which will seat a family of five. It also doubles as a serving counter when the family entertains in the atrium.

A doorway from the kitchen leads to the carport. Ahead of the carport is a garage which has a lightweight overhead door made of low-maintenance fiberglass.

Between the garage and workshop is a storage room for garden equipment.

The shop itself has a set of double doors opening to the outside, enabling the owner to move large pieces of material or large projects in and out with ease. In the pilot model, the main tool is a radial-arm saw, flanked by workbenches that can be dropped flat against the wall in the event that more floor space is wanted in the shop. The shop floor is prefinished wood parquet.

On the inside wall of the shop are located the heating-cooling plant, with an electrostatic precipitator to cut down household dust, and the water heater.

### Three Bedrooms

The three bedrooms of the home are to the right of the main entry. In addition, the laundry is located in the bedroom area, close to the "origin" of most of the dirty clothing. There's an outside entry through the laundry room, enabling the housewife to turn that easily cleaned room into a mud room for youngsters coming into the house in soiled clothing or dirty shoes.

The spacious master bedroom has its own bath, which is completely walled in easy-care ceramic tile, including window sills.

A second ceramic-tile bath draws light from the atrium; a clear glass "window" lets natural light into the space above the bathroom's luminescent ceiling.

Both baths have the translucent fiberglass ceilings, and in both the toilets are wall-hung, allowing easy cleaning of the floors around them.

How about the exterior?

The roof, which has no valleys for leaks or ice dams to form in, is covered with a metal alloy that's maintenance-free for

(Continued to page 242)



## A Business or Sideline YOU can Enjoy...

... we think you want a profitable, enjoyable hobby; a rewarding sideline; or an interesting business that is all YOURS. Manufacture and Sell Ornamental Concrete Items. Grow from the profits and have a good time in the process.

We manufacture and sell on a direct basis the industry's best molds. Durable, Dependable, High Quality, and of Aluminum. 96-pg. "How To Turn Concrete Into Gold" includes 29 pgs. of priceless instructions for professional results. Describes and Prices over 300 molds for Bird Baths, Benches and Tables, Flower Urns, Statues, Animals, Religious Items, and many more from 2" to 68" high. It gives the full story. Order yours TODAY—Rushed to you by First Class Mail. It's only \$2.00.



No. 100 Pee Wee Mold makes complete Concrete Bird Baths 11" high, 17" diameter. Price of Mold on \$45.00. And there are over 300 other molds to select from.

HOW TO TURN CONCRETE INTO GOLD

SEND \$2

Manufacture And Sell Your Own Ornamental Concrete Items OVER 300 DIFFERENT DESIGNS

**Concrete Machinery Co., Inc.**

839 Lenoir Road, N. W. • Hickory 2, N. C.

**SERVICE FILE**—FREE listing of books, booklets, blueprints, patterns and plan sheets by subject. Write Service Bureau, Popular Mechanics, 740 Rush St., Chicago 11, Ill.

## ELECTRIC WELD - BRAZE & CUT

REPAIR MOST EVERYTHING MADE OF METAL

Home Appliances, Auto parts. Make and repair lawn chairs, tables, ornamental iron work, gates, wagons, etc. Solder, heat, bend, and straighten, with terrific heat from arc torch. Cut and weld up to 1/4" steel plate. A million uses for Home, auto, farm, inventors, factories, etc. Works from any home 110 volt plug-in. Complete with dark welder's mask, arc torch, supply of carbon steel welding and brazing rods and complete Welding Instruction Book, 1 year guarantee.

**SEND ONLY \$3** (cash, ck. mo.) and pay postman \$11.95 plus COD postage on arrival or send \$14.95 and we will send postpaid. Ideal gift for mechanically minded, relatives, friends. Order now. Available only from: **MIDWAY WELDER, Dept. DPM-9, Kearney, Neb.**



## HOW-TO Remove Wallpaper

You can remove your wallpaper fast and efficiently with the Hyde ES99 All-Electric Wallpaper Steamer. Automatic features include shut-off valve on pan, steam pressure control and low water shut-off. Operates off 110-120 volt AC on 15 amp. fuse. Rent from your local paint, hardware and lumberyard dealer, or write Hyde with name of your dealer.

WRITE FOR FREE CATALOG



**HYDE TOOLS**

SINCE 1875

SOUTHBRIDGE, MASS. U. S. A.

## Cabinet hardware



by **Amerock**

Building, remodeling, or painting? New cabinet hardware will give your job that professional look. Amerock offers a style and finish for every decor. Modern, Provincial, Colonial, Contemporary. Ask your dealer to show you these outstanding patterns . . . and look for the Amerock Emblem of Quality.



**FREE!** New idea folder "Beautify Your Home" . . . send coupon

**AMEROCK CORPORATION**  
DEPT. PM29, Rockford, Illinois

Send to \_\_\_\_\_

Address \_\_\_\_\_

City and State \_\_\_\_\_

## NEW GLOG-PROOF TOP



The Borden Chemical Company, 350 Madison Ave.,  
New York 17, N.Y. (Available in Canada.)



"A man is like  
a tack—he  
can only go as  
far as his head  
will let him."

<p><b>U.S. ARMY pailey's SAVE!</b></p> <p><b>SIGNAL CORPS FIELD PHONES</b> 17.95 EACH 32.50 SET</p> <p>Two-way ringing telephone system built for rugged in-the-field use up to 5 miles. Uses standard flashlight batteries. Generator has ringing crank. Up to 10 phones can be hooked together. Ideal in mountains, on farm, camp, etc.</p>		<p><b>STANDARD DIAL PHONES</b></p> <p>Will make ideal intercoms by using 6-volt batteries... or use for standard extension telephones. Operates up to 1-mile without amplification. Cost Government approx. \$25.00 each... <b>NOW 5.95 EA. 10.95 PAIR</b></p>	
<p><b>400 GPH PUMP</b></p> <p>A vane type fuel pump, but can be used as water pump. Delivers 400 GPH at up to 20 PSI. Relief valve adjusts to give up to 40 PSI oil pressure. Ports are 3/4" standard pipe... Cat. No. H-P95U-400 <b>4.95</b></p>		<p><b>1500 PSI HYDRAULIC CYLINDER</b></p> <p>Designed for use in multiple banks or series. Bore is 1 1/2", stroke 4-7/8", shaft 1-1/8", length 10". Ports are 3/8" AN(9/16" - 18 thread). Cost Gov't approx. \$60.00 Cat. No. H-565U... <b>3.95</b></p>	
<p><b>HYDRAULIC GEAR PUMP &amp; MOTOR</b> No. HPU-6 12ZE</p> <p>Delivers 3-1/2 GPM at 600 PSI. Motor is 1-1/2 HP, 24 V., DC - will operate on 12 or 32 volts. Has built-in relief valve. Ports: 3/4" inlet, 1/2" outlet. Use on portable loaders, etc.</p>		<p><b>No. H-84 - Double Action Cylinder</b> Cost the Gov't approximately \$68.00 For pressure to 1500 PSI. Bore - 1-1/2", shaft 9/16", stroke adjustable 1-3/16" to 4-3/8", length 14-1/2". A Real Buy at <b>ONLY 4.95</b></p>	
<p><b>HIS CATALOG!</b> <b>260 PAGES OF BARGAINS</b> Includes: Hand &amp; Power Tools, Sports &amp; Outdoor Equip., Electric Motors &amp; Generator's, New and Used Hydraulic Equip. of all types</p>		<p><b>HER CATALOG!</b> <b>64 PAGES OF GIFTS</b> Featuring Gift and Decor items from 'round the World, Primitive carvings from Africa, brassware from India, art objects from Italy, fantasies and furniture from the Orient PLUS budget priced gift items from the U.S.</p>	
<p><b>SEND ONLY 50¢ AND GET BOTH CATALOGS!</b> to cover the cost of handling and mailing the catalogs!</p>			
<p><b>TO ORDER:</b> Send check or M.O. 1/2 dep. with C.O.D.'s. All items sent freight or postage collect.</p>			
<p><b>pailey's</b> 2263 E. VERNON AVE., Dept. P.M.-92 LOS ANGELES 58, CALIFORNIA</p>			

years, even in the corrosive salt-air climate of the Florida coast. It needs no paint, though it will take it well.

There are no gutters around the eaves to bother with. Rain, distributed evenly by ridges on the roof, drops onto a splash-block walk around the entire house. The wide overhang of the roof keeps water away from the siding and windows, thereby cutting down on window maintenance and on weather damage to the siding.

The lower base of the house is made of waterproofed concrete with earth banked against it. The earth bank is covered with groundcover which needs virtually no care. Since the wood framing of the house starts more than 30 inches above the finish floor, there's little danger of termite damage; additional protection against the insects is provided by a reinforced band of concrete which separates wall framing from the masonry wall and by solutions and membranes.

### Threaded Nails

Laminated wood beams support the roof, and they, in turn, rest on steel beams. Nails in the building are threaded so that they won't pull out of the wood.

For those who need more than three bedrooms, there's an alternate plan with four—plus an additional half bath near the kitchen. In this version, the laundry becomes a bedroom, and the carport is closed in to make a utility room and bath. The garage is then converted into a double carport which opens along the present outside wall of the garage.

Another option is a basement located under the master bedroom, baths and laundry. There's also room (and a plan) for a freestanding fireplace; it is designed to go just to the left of the main entry in the living room.

The House of Care-Free Living is a home in which you'd never feel confined—either by maintenance jobs, which have been designed out of it, or by walls and roof, which have been designed to let the outdoors in.

★ ★ ★

Additional ideas and building materials which offer "Minimum Maintenance for Care-Free Living" can be obtained from cooperating Lumber Dealers listed on page 44 this issue.

For the firm nearest you,  
check this list.

IDAHO WHITE  
PINE

PONDEROSA  
PINE

LODGEPOLE  
PINE

SUGAR PINE

LARCH

WHITE FIR

DOUGLAS FIR

ENGELMANN  
SPRUCE

RED CEDAR

INCENSE  
CEDAR

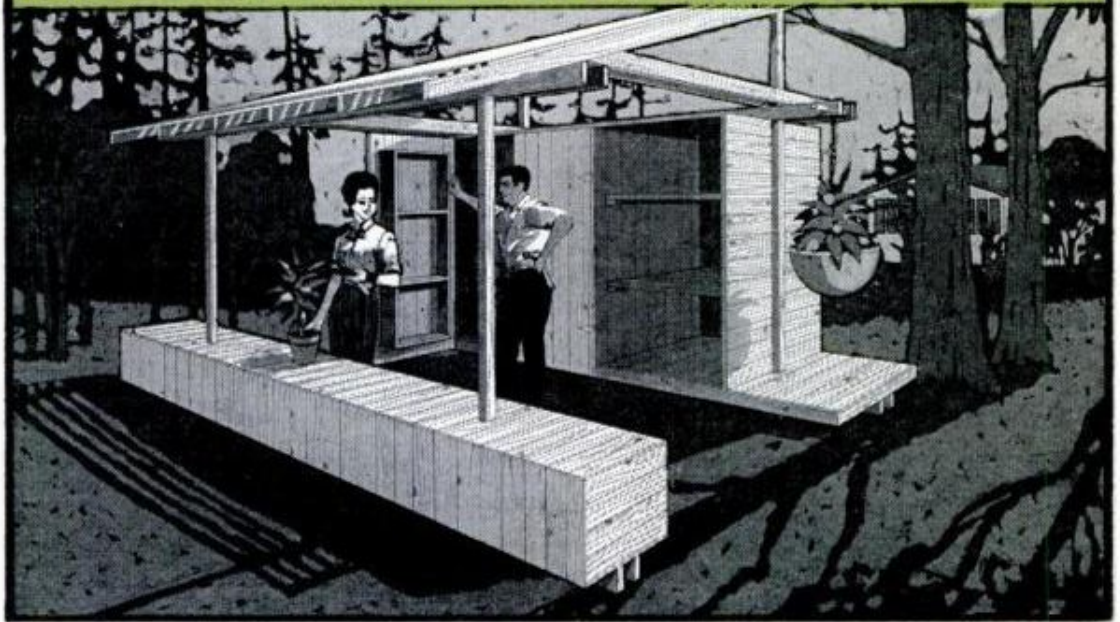

**Find inspiration in this FREE Booklet** (available now at your building supply dealer's). Improve your property with an easily-built center for storing garden tools, lawn furniture and other items. Combine storage space with a playhouse for your children. Here are easily-followed construction plans, how-to-do-it tips and materials specifications. If your dealer is unable to supply you with this booklet, send 10c to the address below.

**Western Pine Region Solid Lumber** will provide lasting assurance of a job well done. These remarkable woods have no equals for sawing, shaping, sanding and finishing:



**WESTERN PINE ASSOCIATION**  
Dept. M-10 Yeon Bldg., Portland 4, Oregon

**Quality Graded Lumber**

## Those Foamed Plastics

(Continued from page 90)

### What Are the Drawbacks?

"Like all materials, expanded plastics have their strong points and their limitations," says Dr. Albert G. H. Dietz, Professor of Building Engineering at M.I.T. "Any of the plastic foams can be destroyed by fire, although quite a few can be formulated to be flame-resistant so that they will not support their own combustion or add fuel to the flames. Since the foams are light in weight, their strength properties are not outstanding, but when the foams are united with small amounts of heavy but strong materials, a combination can result which has great strength and stiffness with much less weight than would otherwise be possible."

An economical process for using boards of polystyrene foam as a form for concrete in thin shell roof construction has been developed by the Dow Chemical Co., in conjunction with Purdue University. As an offshoot of this work, the foam is placed over sculptured earth; reinforced concrete is cast over it, and the finished roof lifted into place. The 268-foot diameter domed roof of the International Convention Building at the Church of God headquarters, Anderson, Ind., was made by this method and lifted 22 feet into place. Experts note that such thin shell construction with foamed plastics will allow more for unlimited architectural freedom in creating graceful, flowing structures, and more spheric or paraboloid shapes.

### Bag and Barrel Building

At present the Army is experimenting with instant housing for field use. In Natick, Mass., at the Quartermaster Research and Engineering Command, I saw one of the "buildings from a barrel." Expandable plastic was sprayed over a large inflated balloon. After the foam had expanded and hardened, the balloon was deflated, leaving a structure firmly bound to the ground and suitable for use as a mess hall, barracks or field hospital. Light enough to be picked up and moved to a new site, it also can be cut into pieces and glued back together again with more foam. A 10 x 20 x 45-foot structure can be built by three men in three hours!

"Buildings from a bag" also are on the way. Made of preshaped flexible skins with foaming components inside, they can be erected in a few minutes after the membrane separating the highly reactive chemicals is broken.

At the Goodyear Aircraft Corp., in Ak-

ron, Ohio, I saw how a similar technique could be used in space to rigidize an inflatable solar concentrator made of aluminized plastic film. The foam ingredients will be mixed in the factory, immediately frozen, and then put between the two thin skins of the concentrator. After the unit is rocketed into space, the heat of the sun will cause the foaming reaction to take place.

Goodyear aircraft engineers also showed me a space station 30 feet in diameter which could be packaged, shot into space, inflated, and rigidized with liquid foaming ingredients. In a simulated space chamber the liquids expanded far more than they do under atmospheric pressure.

In Philadelphia, Dr. I. M. Levitt, Director of the Fels Planetarium at the Franklin Institute, showed me the Moon Room in the Institute's new space science section. Constructed and furnished almost completely of foamed plastics, the room is a sample of the type of housing which explorers might establish in a cave on the moon. With foam-producing chemicals taken to the moon initially the pioneers could fabricate everything quickly on the spot.

As Dr. Levitt says: "Foamed plastics may provide the key to the establishment and perpetuation of a civilization on the moon." Apparently, man's imagination, not the sky, is the limit for these fantastic materials. ★ ★ ★

---

## Smokey Has Live Namesake

A famous cartoon character, Smokey the Bear, introduced in 1945 and dedicated to forest fire prevention, has a real-life counterpart to help with his work.

Rescued from a New Mexico forest fire in 1950, a badly burned bear cub was nursed back to health and sent to the National Zoo, Washington, D. C. Appropriately, the cub was named Smokey after the cartoon character.

The live Smokey gave added appeal to the cartoon character, who has become the symbol for forest fire prevention through the media of publications, posters and television.

Organized youth groups, Boy and Girl Scouts, Camp Fire Girls, 4-H Clubs and even Smokey Bear Clubs have teamed up to help Smokey with his campaign.

Smokey's efforts have contributed to the saving of an estimated \$10,000,000,000 from forest fire damage despite a tenfold increase in forest usage.



First propeller-driven boat to break the 200 m.p.h. mark: Miss U.S. 1, sparked by silvery-plated Champions!

200.4195 mph—another world's record set with Champion spark plugs! Wherever power and performance are vital—on land, water, or in the air—Champions are the overwhelming first choice. Why settle for less in your car?





# This man is a "security risk"!

Age, 29. Married. Two children. High school education. Active in local lodge, church, veterans' organization. Employed by large manufacturing concern. Earns \$95 a week.

SOUNDS like an Average Joe. And he is. Too average! He's got a job. It pays fairly well. He's satisfied.

But here's the catch. With the right kind of training, this young

man could step into a better job. He could be making \$8-10,000 a year. He could be cashing in on those spare-time hours he now wastes.

As it stands now, he's stuck in his job. Can't seem to make any headway. He's reluctant to try. So he just hangs on.

This man is a "Security Risk" to his wife and children.

His family probably will never enjoy the comforts, the prestige, the good living that could be theirs. If hard times come, they are almost sure to be hurt. For an Average Joe can't expect to compete with trained men when the chips are down.

A man like this would do well to start a planned program of self-improvement. In his spare time. In a field related to his interests and abilities. Right NOW!

One good way to start—a way proved by hundreds of thousands of once-Average Joes who are making good today—is to enroll for special training with a recognized correspondence school. One like I.C.S., the oldest and largest in the world.

Don't you be a "Security Risk." Mail the coupon for full, free details while there is still time.

Clip coupon here—and take your first big step to real success! I.C.S., Scranton 15, Penna.

Fully Accredited Member  
National Home Study Council

## INTERNATIONAL CORRESPONDENCE SCHOOLS

Box J5419J, Scranton 15, Penna.

(In Hawaii: P. O. Box 418, Honolulu. In Canada: I. C. S. Canadian, Ltd., Montreal.)

Without cost or obligation, rush me FREE Success Kit, with 3 valuable booklets: (1) How to Succeed; (2) opportunity booklet about the field I've checked below; (3) Sample I.C.S. Lesson.

### ARCHITECTURE and BUILDING TRADES

- Air Conditioning
- Architecture
- Arch. Drawing
- Building Contracting and Estimating
- Carpentry & Millwork
- Heating
- House Planning
- Painting
- Plumbing

### ART and DESIGN

- Commercial Art
- Fashion Illustrating
- Interior Decorating
- Magazine Illustrating
- Show Card & Sign
- Painting

### Sketching and Painting

- AUTOMOTIVE
- Auto Body Rebuilding
- Auto Electric Technician
- Automobile Mechanic
- Engine (Gas & Diesel)
- Engine Tune-Up

- Transmission Specialist

### AVIATION

- Aero Engineering
- Aircraft Drafting
- Aircraft Mechanic

### BUSINESS

- Accounting
- Cost Accounting
- Public Accounting
- Bus. Administration
- Executive Training
- Marketing
- Personnel-Labor Relations
- Programming for Digital Computers
- Purchasing Agent
- Real Estate
- Salesmanship
- Sales Mgmt.
- Small Business Mgmt.
- Traffic Mgmt.

### CHEMICAL

- Analytical Chemistry
- Chem. Engineering
- General Chemistry

- Lab. Technician
- Nuclear Energy
- Plastics
- Pulp, Paper

### CIVIL ENGINEERING

- Civil Engineering
- Construction Engrg.
- Highway Engineering
- Reading Structural Blueprints
- Sanitary Engineering
- Structural Engineering
- Surveying & Mapping

### DRAFTING

- Architectural
- Electrical and Electronic
- Mechanical
- Sheet Metal

### ELECTRICAL

- Elec. Appliance Servicing
- Electrical Engineering
- Elec. Eng. Technician
- Elec. Motor Repairman
- Industrial Electronic Technician

- Industrial Telemetering
- Instrument Technician
- Practical Electrician
- Practical Lineman

### ELECTRONICS

- Automation
- Basic Electronics
- Electronic Computers
- Electronics Technician
- Hi-Fi Stereo and Sound Systems
- Industrial Electronics
- Ultrasonics

### ENGINEERING (Professional)

- Chemical
- Civil
- Electrical
- Mechanical

### ENGLISH and WRITING

- Better Business Writing
- Introductory Technical Writing
- Short Story Writing

### Practical English

- HIGH SCHOOL (Diploma)
- High School General
- High School Math
- High School Secretarial
- High School Vocational
- College Preparatory

### MECHANICAL and SHOP

- Gas and Electric Welding
- Industrial Engineering
- Industrial Instrumentation
- Machine Design
- Machine Shop Practice
- Mechanical Engineering
- Reading Shop Blueprints
- Tool Design
- Toolmaking
- Safety Engineering

### SECRETARIAL

- Clerk-Typist
- Professional Secretary

- Shorthand
- Stenographic
- Typist

### STEAM and DIESEL POWER

- Boiler Inspector
- Power Plant Engineering
- Stationary Diesel Engineering
- Steam Engineering

### SUPERVISION

- Foremanship—Suprv'n
- Personnel—Lab. Rel'n's

### TV-RADIO

- Radio and TV Servicing
- Radio-Telephone License
- TV Technician
- Practical Radio-TV Engineering

### MISCELLANEOUS

- Railroad
- Textile
- Other (please specify)

Name \_\_\_\_\_ Age \_\_\_\_\_ Sex \_\_\_\_\_  
 Home Address \_\_\_\_\_  
 City \_\_\_\_\_ Zone \_\_\_\_\_ State \_\_\_\_\_  
 Occupation \_\_\_\_\_  
 Employed by \_\_\_\_\_ Working Hours \_\_\_\_\_

Special low rates to members of U. S. Armed Forces!

# NEW



## Ready for a radial?

If you haven't already added that radial saw you've been thinking about, you're lucky. Now you can own the **BRAND NEW DELTA SUPER 990!** It backs up horsepower with *cutting* power. It gives you *useful* features, not gadgets. And it's a versatile, one-tool workshop you'll want to see for yourself. So see your Delta Dealer (listed under **MACHINERY** in the Yellow Pages)—you'll like the deal.

Rockwell Manufacturing Co., Delta Power Tool Division  
5021 N. Lexington Ave., Pittsburgh 8, Pa.

Please send me **FREE FOLDER** with all the facts on  
Delta's new **SUPER 990** Radial Saw.

Name

Address

City  Zone  State

**DELTA POWER TOOLS**

another fine product by

**ROCKWELL**



Manufactured in the U.S.A.

# WINSTON TASTES GOOD...

## LIKE A CIGARETTE SHOULD!



© 1964 REYNOLDS TOBACCO CO. WINSTON SALEM, N.C.

It's what's up front that counts...  
**FILTER-BLEND**



TRY AMERICA'S BEST-SELLING,  
BEST-TASTING FILTER CIGARETTE.

Up front, ahead of a modern filter, only Winston gives you **FILTER-BLEND**—mild, flavorful tobaccos specially selected and specially processed for the best taste in filter smoking.