

**Your Vacation Home**

**1962 Plymouth  
Owners Report:**

# POPULAR MECHANICS

FEB. 1962  
35 CENTS

**Build It  
NOW in  
Your  
Basement**



**Assemble It  
This Summer**



- **Shopper's Guide: Portable Electric Drills**
- **Bizarre Weapons in Today's Little Hot Wars**
- **Clean-Line Furniture You Can Make From Metal**

# TOOLS—BEST BUY FOR YOU



**400 Strokes  
Minute**



**BEST QUALITY  
FINE FINISH SANDERS**

Straight-line lightweight sanders essential in furniture finishing, woodworking. Choose from models—handy 14 sq. in. economy model at \$13.95, in a pal kit with extra paper at \$16.95, or heavy-duty model in big 20-inch sanding surface, metal kit with extra paper, at \$19.95. All have strong molded plastic housings with exclusive patented super-power magnetic motors driving 14,400 strokes per minute. Perfect for professional & amateur alike!



**2 Professional  
Speeds**  
**3/8" Jacobs Chuck**

**DOUBLE-DUTY DRILL  
MOST VERSATILE TOOL  
IN YOUR WORKSHOP**

No other drill like it! 3/8" Jacobs geared chuck handles big jobs easily, yet drill is lightweight—easy to handle. Change speed in a jiffy. 3000 RPM for drilling thin metal and wood... 1000 RPM for thick metal and wood, plaster and masonry. Handles every job at the correct speed—polish, sand, grind, wire brush, mix paint, drive screws—you name it. \$29.95



**NEW...AND EXTRA SPECIAL!!  
WEN ROTARY SHAVER**

A really BIG shaving head to cover large areas and provide a super-fast shave in addition to traditional rotary comfort. Domed shape fits the contour under the chin. Hollow-ground self-sharpening cutters working close to the outer edge make upper lip shaving a cinch. It's the fastest, smoothest, lightest, quietest shaver on the market. \$19.95

STRATED, PLAYBOY, ESQUIRE, POPULAR SCIENCE, POPULAR MECHANICS.

Материал, защищенный авторским

# MONEY!

**NEW\*** EXTRA POWERFUL—  
ALMOST DUSTLESS  
NEW INDUSTRIALLY RATED  
3" BELT SANDER AT  
HOME WORKSHOP PRICE

\*Introduced only last Fall and already in world-wide demand. Firmly established as the finest product of its kind. If the buying rush has caused a shortage in your area, ask your dealer to order a sander for you. You'll be glad you waited.

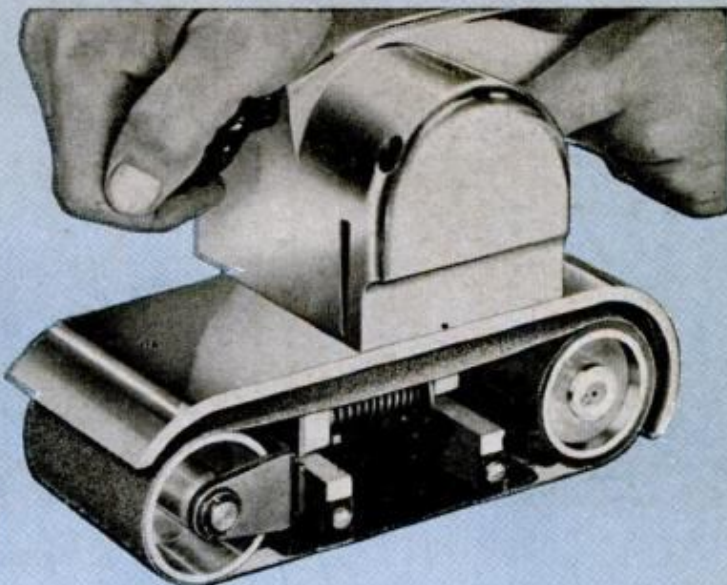

Finally, the complete answer to home-workshop sanding . . . and finally at a sensible price. Exclusive casting design combines with forced air currents to cause dust to accumulate at rear—keeps work clean, easy to see. Cool-running  $4\frac{1}{4}$  amp. motor turns belt at 850 surface ft. per min. Balanced weight—7 lbs—and contour grip handle minimize fatigue. Includes 3 belts: coarse, medium, fine. \$44.95.

## WEN

PRODUCTS INC. 5810 NORTHWEST HIGHWAY CHICAGO 31, ILL.

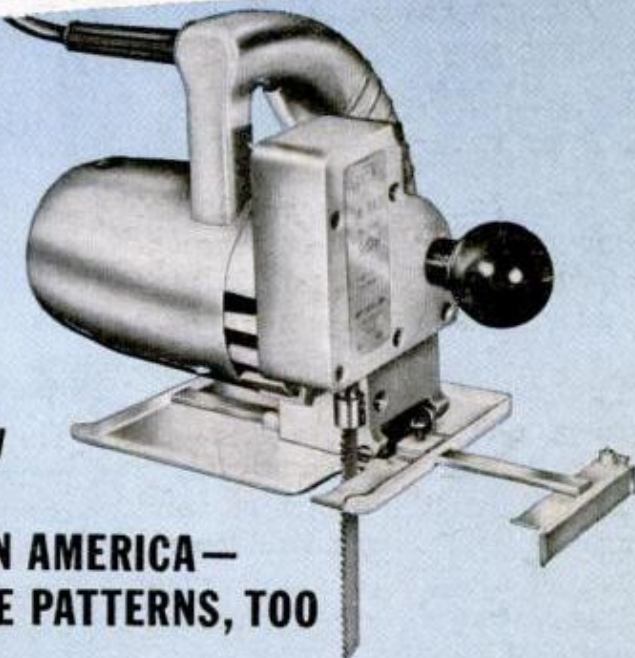

**The Famous Industrially  
Rated ALL-SAW  
BEST SELLING SAW IN AMERICA—  
CUTS A 6" LOG—FINE PATTERNS, TOO**

Powerful  $\frac{1}{2}$  HP motor—Industrially Rated—yet comfortable to hold . . . easy to use. Does everything a pattern saw will do . . . more than a circular saw . . . many things a band saw or nibbler will do . . . and much that until now only a chain saw could do. Cuts a 6" log—yet cuts delicate patterns in any material normally cut with saw or knife. Complete with 7 blades, rip guide, circle cutter. \$44.95

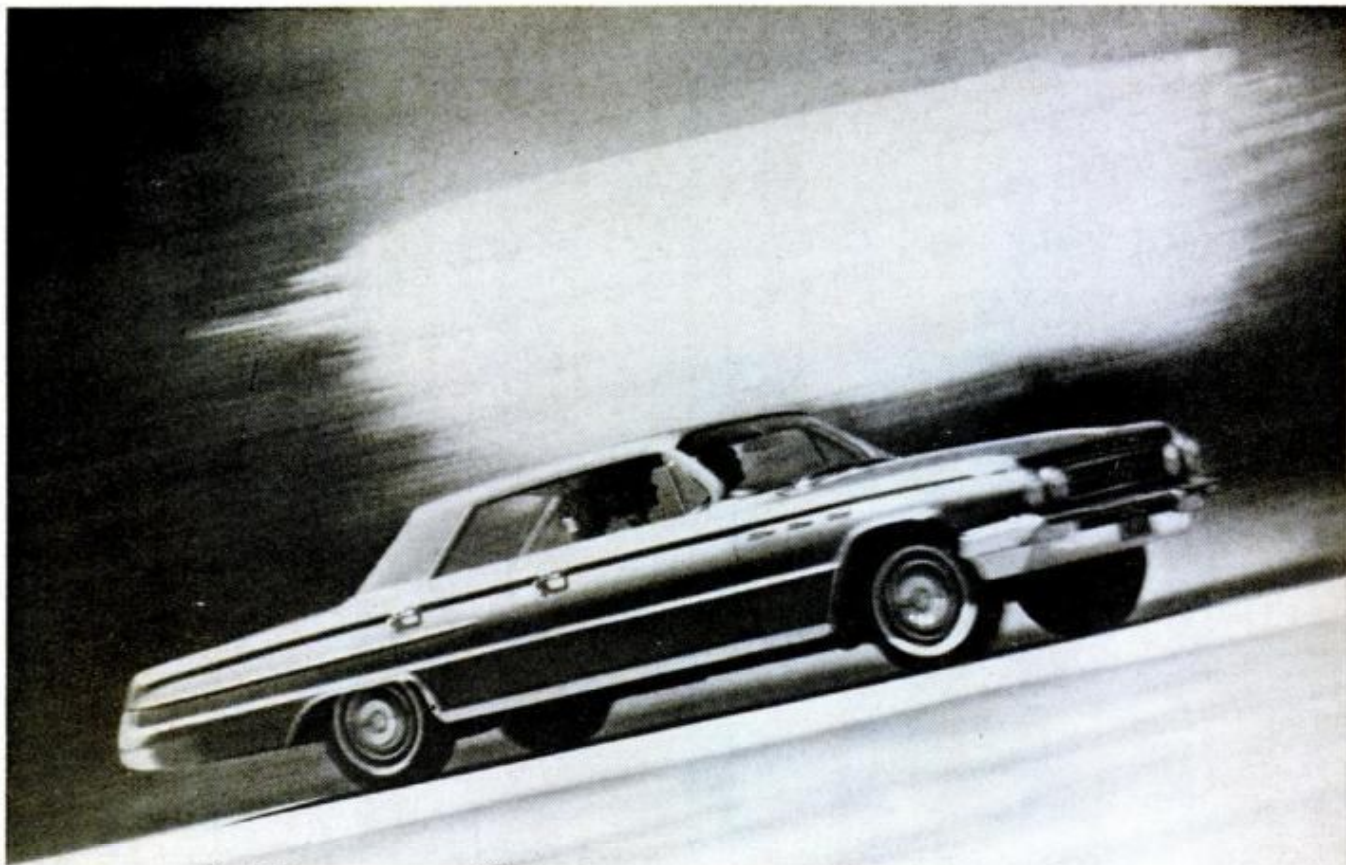

## THE BIG DIFFERENCE IN '62

# ADVANCED

# THRUST

**WHAT IT IS:** A completely new concept in engine mounting and front-end suspension design. Advanced Thrust positions the mighty Wildcat V-8 and Turbine Drive forward over the front wheels. Placing more weight over these wheels enables them to resist being turned from their course by side winds. It takes advantage of the principle that the center of wind pressure against a moving car is toward the front end . . . and that more weight *ahead* of this center of wind pressure improves directional stability.

**WHAT IT DOES:** To begin with, Advanced Thrust makes your Buick track truer and straighter. But it also has other effects you'll appreciate. Snappier wheel

response and return. Less road shock up the steering column. Flatter cornering because the front-end frame has been made wider. And, with the engine moved forward, the front floor's gone nearly flat.

**WHY YOU'LL LOVE IT:** Advanced Thrust makes your driving safer, smoother, more relaxed. Your Buick stays right on course—even in gustiest crosswinds. Going is surer on ice, snow, wet roads. And with the new flatter floor, middle passengers have more room for legs, knees and feet. Feel the *big* difference in the '62 cars—drive the Advanced Thrust '62 Buick. Now at your Buick dealer's. Buick Motor Division — Gen-  
eral Motors.

# '62 BUICK

POPULAR MECHANICS

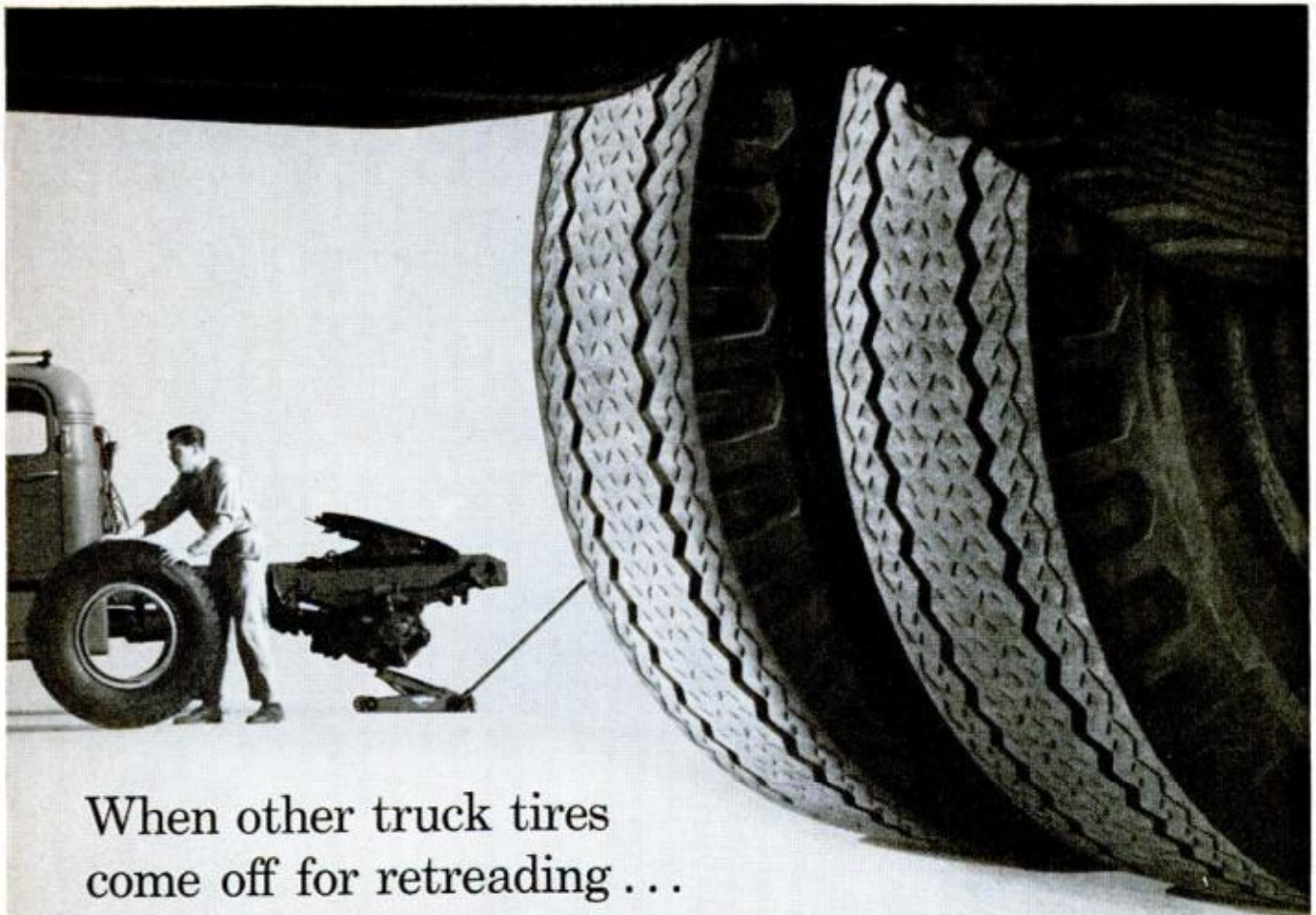

When other truck tires  
come off for retreading . . .

# Firestone

## *TRANSPORT-100's*

are still on the road!

OUTSTANDING ALL-POSITION TRUCK TIRE PERFORMANCE . . .  
YIELDS EXCEPTIONAL MILEAGE GAINS ON DRIVE WHEELS!  
That's what *independent* fleet owners reported after millions of miles of hauling  
on Firestone Transport-100's. One reason why: The Transport-100's new  
broad center rib minimizes squirming and scuffing. Its wide flat tread face  
improves grip and gives maximum traction. And you get all this at *no* increase  
in prices! Order Transport-100's in nylon or Tyrex® rayon cord, tubeless or  
tubed—at your Firestone Dealer or Store this week. *Always Specify Firestone  
Tires on New Trucks and Trailers*

Copyright 1962, The Firestone Tire & Rubber Company

MEMBER  AMERICAN TRUCKING INDUSTRY

®T. M. of Tyrex, Inc.

Transport® T. M. Firestone

This One



OYGH-9HN-BXT7

FEBRUARY 1962

# POPULAR MECHANICS®

FEBRUARY 1962  
VOL. 117 NO. 2

INTERNATIONAL EDITIONS • SPANISH: Mexico-Caribbean, Southern Hemisphere • FRENCH •

## Features of Special Interest

Start Your Vacation Home at Home—Part I	87
Owners Report on the Plymouth	95
Skytyping	100
Space-Age World's Fair	102
Bizarre Weapons for the Little Wars	106
There's Adventure in Your Crankcase	116
Supersound Moves Out of the Lab	122
PM Shopping Guide: Portable Drills	126
Saltwater Anglers Hit the Jackpot	138
Science Climbs the Mountain Peaks	146

## For the Craftsman

Clean-Line Metal Furniture	156
Snow Fort of Precast Blocks	162
Home Fitness Gym—Conclusion	168
Triple-Top Fun Table—Part III	176
Prefab Ice-Fishing Shanty	186
Appliance Fix-It File: Food Mixer	188
When It's Time to Reline Brakes	190
Shop-Built Router Guide	200
Outdoor Antenna for Fallout Shelter	204
Everyone Needs a Panic Button	205

Address communications to: 200 E. Ontario St., Chicago 11, Illinois. **SUBSCRIPTION SERVICE:** Mail all subscription orders, changes of address, correspondence concerning subscriptions, and Postmaster notices of undeliverable copies to Popular Mechanics, 250 West 55th St., New York 19, N. Y.

Published by Popular Mechanics Company, **RICHARD E. BERLIN**, *President*

**CLIFFORD B. HICKS**  
*Editor*

**RICHARD E. DEEMS**  
*Executive Vice-President*

**JOSEPH R. BUELL, JR.**  
*Publisher*

*Managing Editor:* DON DINWIDDIE  
*Assistant Managing Editor:* JOHN A. LINKLETTER  
*Shop and Crafts Editor:* WAYNE C. LECKEY  
*Automotive Editor:* JAMES R. WHIPPLE  
*Associate Editors:* W. CLYDE LAMMEY, WALLACE MYERS  
*Electronics Editor:* BYRON G. WELS  
*Assistant Editors:* JAMES BIERY, KEVIN V. BROWN  
ROBERT L. HERING, R. B. KIRKPATRICK  
ARTHUR MIKESELL, BIL TOMAN, RICHARD WILLIFORD  
*Advertising Production:* DOROTHY M. WINER

*Art Director:* HENRY M. NEHRBASS  
*Art Editor:* RICHARD A. POTTS  
*Chief Photographer:* FRANK P. FRITZ  
*Eastern Editor:* RICHARD F. DEMPEWOLFF  
959 Eighth Ave., New York 19, N. Y.  
*Western Editor:* THOMAS E. STIMSON, JR.  
Suite 1003, 3460 Wilshire Blvd., Los Angeles 5, Calif.  
*International Editor:* HEINZ P. SCHLICHTING  
Ritterstrasse 26, Karlsruhe/Bd., Germany  
*Advertising Manager:* FRANK R. DUPUY  
959 Eighth Ave., New York 19, N. Y.  
*Director, Bureau of Information:* ALLAN CARPENTER

If you wish additional sources of information for the articles in this issue, or if you wish the name and address of the manufacturer of a particular product shown here, write to Bureau of Information, Popular Mechanics, 200 E. Ontario St., Chicago 11, Ill. Ask for the free "Where-to-Find-It-List" for this issue.

DANISH • SWEDISH • GERMAN • PORTUGUESE • DUTCH

## Departments

Over the Editor's Desk - - - -	12
Spotlight on the Travelall - - - -	16
Pentagon Sidelights - - - -	24
Tune In on the Inventors - - - -	30
Worth Writing For - - - -	38
Science Bulletins - - - -	44A
Science Overseas - - - -	46
Sidelights on Aviation - - - -	68
Shopping for Tools - - - -	76
Items From All Outdoors - - - -	80
On the Market - - - -	82
Detroit Listening Post - - - -	105
What's New for Your Home - - - -	144
Solving Home Problems - - - -	164
Better Carkeeping - - - -	194
Clinic for Homemakers - - - -	210

## Next Month . . .

Owners of new Ramblers and Chevy IIs tell you what they think of their new purchases. . . . Tape recorder buyers learn practical store-testing techniques. . . . How-to fans have a field day with such fine projects as: a water jet boat that goes anywhere; a guest room in a table; a banjo; a coil-winding machine and a portable workshop power tower.

ADVERTISING OFFICES—Chicago: 200 E. Ontario St., Whitehall 4-0100; New York: 959 Eighth Ave., Columbus 5-7300; Detroit: General Motors Bldg., TRinity 5-8711; Cleveland: Hanna Bldg., 1422 Euclid Ave., PRospect 1-0456; Los Angeles: 3460 Wilshire Blvd., DUNkirk 2-8458; San Francisco: 111 Sutter St., YUKon 2-0823.

Published monthly by Popular Mechanics Company, 200 E. Ontario St., Chicago 11, Ill. Richard E. Berlin, President; Richard E. Deems, Executive Vice-President; Fred Lewis, Vice-President and General Manager; John R. Miller, Vice-President; Joseph R. Buell, Jr., Vice-President; G. O. Markuson, Treasurer; R. F. McCauley, Secretary. Single copy in the United States and Canada, 35 cents; subscription rates in the United States and possessions, 1 year \$3.50; 2 years, \$6.00; 3 years, \$8.00. In Canada, add 50 cents per year. In countries of the Pan-American Postal Union, 1 year \$4.50; 2 years \$8.00; 3 years \$11.00. In all other countries 1 year \$5.50; 2 years \$10.00; 3 years \$14.00. If you plan to move, notify us at least 30 days in advance so you will not miss an issue. Give both your old and new addresses. Second-class postage paid at Chicago, Illinois, and at additional mailing offices. Authorized as second class mail by the Post Office Department, Ottawa, and for payment of postage in cash. Registered as Second Class Matter at the Post Office at Mexico, D.F., Mexico, June 20, 1950. © 1962 by Popular Mechanics Company. All rights reserved. Printed in the United States of America.



Oil Hunting  
Risks-p. 116



Oops-Buggies  
p. 130

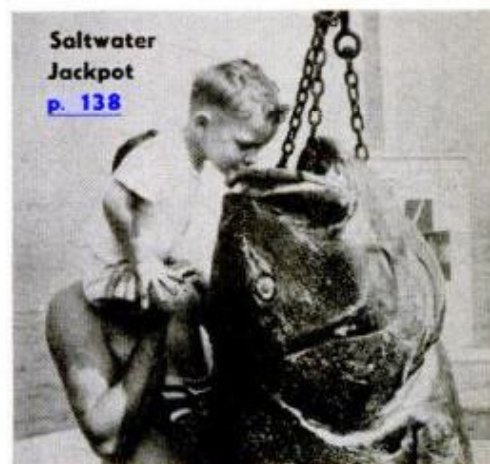

Saltwater  
Jackpot  
p. 138

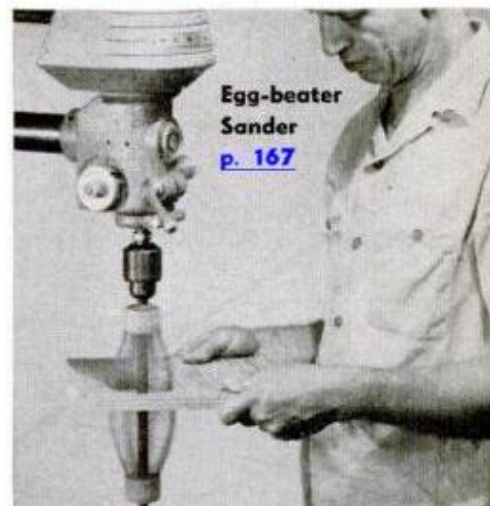

Egg-beater  
Sander  
p. 167

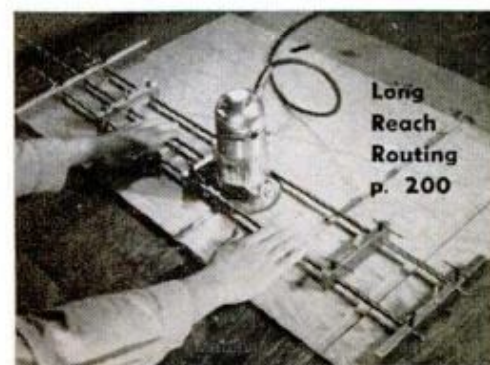

Long  
Reach  
Routing  
p. 200

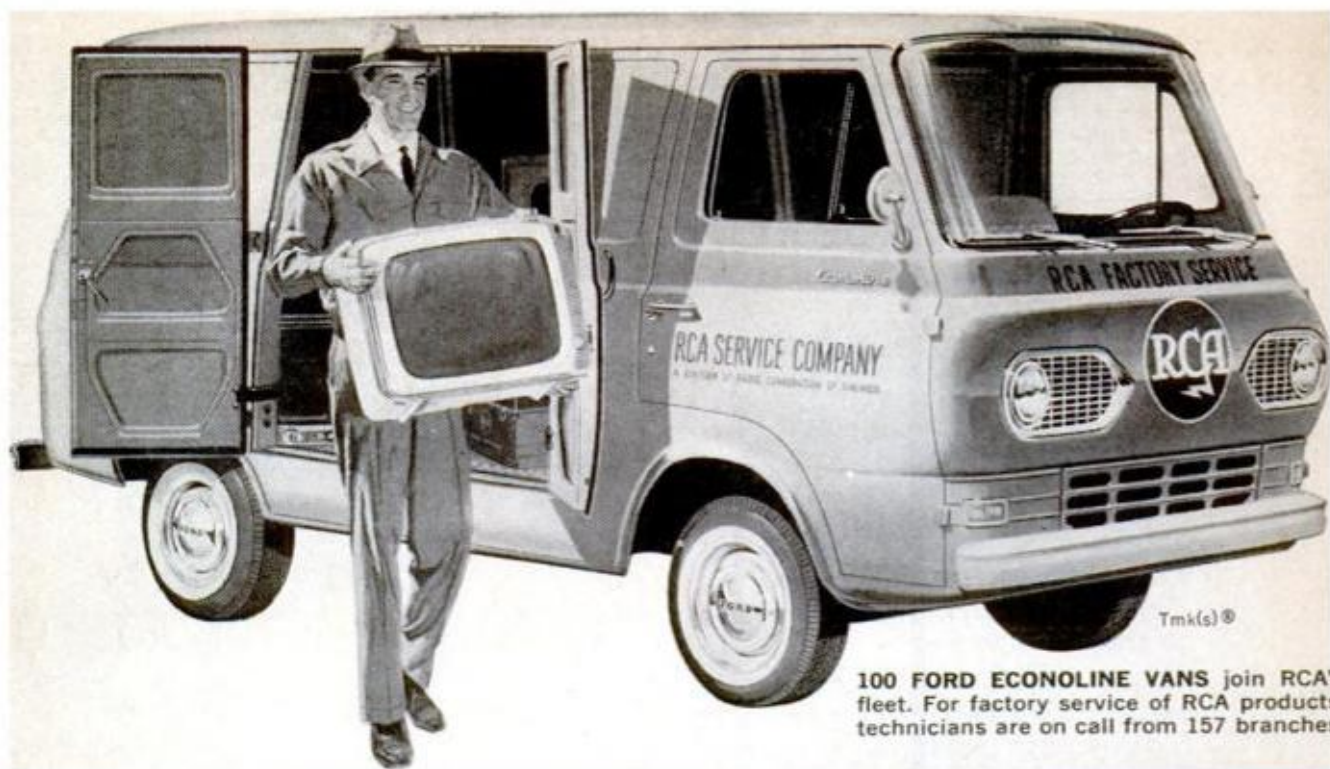

100 FORD ECONOLINE VANS join RCA's fleet. For factory service of RCA products, technicians are on call from 157 branches.

## RCA tries 1...adds 100 Ford Econolines !

### Solid testimony that Ford's full-time economy only starts with low price !

"Starting last February, we've shifted our initial Econoline from branch to branch," says Jack H. Thompson, Fleet Maintenance Manager of RCA Service

Company, "and it's a truck that everybody likes. In the 8 months since, we've been averaging better than 20 miles per gallon and have had no repair costs."

Not all buyers come back for 100 more, but all will tell you how you save with Ford's new Van. You save with a price well below any popular conventional panel. Save on gas. Save on oil—go 4,000 miles between

changes. Save on maintenance, save on tires—even on licensing!

All told, savings on operating costs every 16,000-mile year can top \$100! The facts, from independent tests, are in Ford's Certified Economy Reports. See how you can save . . . full time!

### FORD TRUCKS COST LESS

SAVE NOW...SAVE FROM NOW ON!



FORD'S ECONOLINE VAN HAS A FLAT FLOOR, front to rear, because the engine's up front where it belongs. Big 204-cu. ft. loadspace, up to 80 cu. ft. more than panels; ¾-ton payloads! 4-ft. doors rear and curbside.

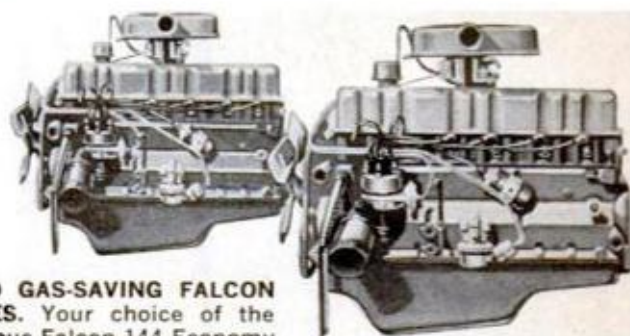

TWO GAS-SAVING FALCON SIXES. Your choice of the famous Falcon 144 Economy Six . . . or an optional new 170 High Performance Six!



TIRE-SAVING SUSPENSION. Unlike some other types, Econoline's truck suspension keeps front tires tracking true, makes them last longer!

PRODUCTS OF MOTOR COMPANY





# How Long Since You've Had a REAL Raise?

**Are you just marking time in your job while others move ahead? Here's what you can do about it.**

A man may work for years at his job, and still be worth only a clerk's pay. Without special training, those hoped-for raises come in dribbles.

You can command a much bigger salary than you are now earning—with prestige and privileges to go with it—by getting out of the ranks of the untrained. You can become an expert in the kind of work you like—and employers will seek you out. For in today's vastly expanded business activity, there are more key jobs than there are trained men to fill them.

Without interfering with your present work—and by devoting only a little of your spare time—you can qualify rapidly for the career opportunity of your choice through LaSalle home study.

LaSalle has been an acknowledged leader in home education for 53 years. It is the only accredited correspondence University in the country. It has provided training in business, high school and technical

subjects to more than 1,500,000 ambitious people.

More than 5,300 Certified Public Accountants today are LaSalle alumni. LaSalle's famed Law Library, especially prepared for its own Law course, is now a much used reference work in offices and resident colleges. And LaSalle has earned similar distinctions in all its other departments. Its faculty is college-level and includes some of the country's foremost practicing specialists and instructors. That's why your training is in good, experienced hands...why your LaSalle diploma will be respected by every employer.

Mailing the coupon below may be the start of a whole new future for you... may be the first step in getting a more important job, higher pay, all of the good things that go with success. Simply check the program in which you are interested, and receive a valuable free booklet describing the opportunities in that field. LaSalle, 417 S. Dearborn, Chicago 5, Ill.



## LASALLE EXTENSION UNIVERSITY

An Accredited Correspondence Institution • 417 South Dearborn St., Dept. 2-048, Chicago, Ill.

Please send me, without cost or obligation, FREE catalog and full information on the field I have checked below:

### ACCOUNTING

- Modern Bookkeeping
- Basic Accounting
- Practical Accounting
- Principles of Acctg.
- Cost Accounting
- Federal Income Tax
- Accounting Systems
- Business Law
- Auditing Procedure
- Controllorship
- CPA Training
- Complete Accounting

### TRAFFIC & TRANSPORTATION

- Organization & Mgt.
- Classifications, Rates & Tariffs
- Transportation Agency & Services
- Transportation Law & Regulation

- Rate Making & Rate Cases
- Complete Traffic & Transportation

### LAW

- Law of Contracts
- Insurance Law
- Claim Adjusting Law
- Law for Trust Officers
- Law Enforcement
- Business Law
- General Law
- First Year Law
- American Law and Procedure (LL.B. Degree)

### BUSINESS MANAGEMENT

- Principles of Management
- Psychology in Business
- Selling & Sales Management

- Advertising and Marketing
- Production Problems
- Business Financing
- Credits and Collections
- Office Management
- Managing Men
- Accounting & Statistical Control
- Business Correspondence
- Organization & Reorganization
- Legal Problems
- Complete Business Management

### MANAGEMENT COURSES

- Basic Management

- Production Management
- Sales Management
- Advertising & Sales Promotion
- Financial Management
- Personnel Management
- Sales and Executive Training
- LaSalle Sales Training
- Foremanship Training

### HIGH SCHOOL

- General Business Course
- High School Diploma
- Commercial Course
- Secretarial Course
- Home Management Course

- General Culture Course
- Science Course
- Mechanical Course

### DENTAL ASSISTANT

- Dental Assistant
- ### TECHNICAL COURSES
- Auto Body Fender
  - Refrigeration-Air Conditioning
  - Diesel
  - Drafting
  - Welding
  - Motor Tuneup

### STENOTYPE

- Machine Shorthand

Name ..... Age.....

Address..... County.....

City & Zone..... State.....

# "I SAW MYSELF 10 YEARS FROM NOW!"



IT WAS PAYDAY. THERE WAS FRED, LOOKING A LITTLE RUN-DOWN. ON THE SAME JOB 10 YEARS. NICE GUY. MARRIED. TWO CHILDREN.

FRED AND I WALKED AWAY FROM THE PAY WINDOW TOGETHER. HE SEEMED DEPRESSED, UNHAPPY.

EACH WEEK I FEEL I'M LETTING THE KIDS DOWN. CAN'T SEEM TO AFFORD THINGS THEY NEED. I'M JUST NOT GETTING AHEAD.



FRED'S WORDS HIT ME ALL OF A SUDDEN. I COULD SEE MYSELF SAYING THE SAME THING—**10 YEARS FROM NOW!**

WILL I HAVE THE SAME OLD JOB 10 YEARS FROM NOW? SAME THIN PAY CHECK? MONEY WORRIES... LIKE FRED'S?



THAT NIGHT, STILL THINKING ABOUT FRED, I SAW AN I.C.S. AD ABOUT HOW I.C.S. TRAINING OPENS JOB OPPORTUNITIES. HOW PEOPLE LIKE ME CAN WIN PROMOTIONS, MORE PAY.



THIS LOOKS LIKE JUST THE THING I NEED TO DO SOMETHING ABOUT GETTING AHEAD!

I MAILED THE I.C.S. COUPON THAT NIGHT. MY BOSS SOON LEARNED I WAS AN I.C.S. STUDENT. HE MOVED ME OFF THE LINE. AND TWO RAISES LATER...

GEE, FRED, THESE I.C.S. COURSES ARE GREAT! YOU OUGHT TO SIGN UP, TOO!

WELL...MAYBE SOME DAY...

FRED'S STILL ON THE SAME OLD JOB. STILL HOPING FOR THE "BREAK" HE'LL NEVER GET WITHOUT TRAINING. ONE DAY THE BOSS CALLED ME IN...

YOU'RE BEING PROMOTED TO ASSISTANT SUPERVISOR. AND A GOOD RAISE GOES WITH THE JOB!

THANKS TO THOSE PRACTICAL I.C.S. COURSES!

# FREE! I.C.S. CAREER KIT

SEND COUPON NOW...  
GET ALL THREE BOOKLETS

- 1 "HOW TO SUCCEED," 32-PAGE BOOKLET OF CAREER TIPS
- 2 "CAREER CATALOG," OPPORTUNITIES IN YOUR JOB FIELD
- 3 SAMPLE LESSON (MATH) SHOWS I.C.S. METHOD



For Real Job Security—Get an I. C. S. Diploma!

I. C. S., Scranton 15, Penna.

Accredited Member, National Home Study Council

## INTERNATIONAL CORRESPONDENCE SCHOOLS



BOX 89419B SCRANTON 15, PENNA.

(In Hawaii, reply P.O. Box 418, Honolulu)

(Partial list of courses)

Without cost or obligation, send me "HOW TO SUCCEED" and the opportunity booklet about the field BEFORE which I have marked X (plus sample lesson):

### ARCHITECTURE and BUILDING CONSTRUCTION

- Air Conditioning
- Architecture
- Arch. Drawing and Designing
- Building Contractor
- Building Estimator
- Carpenter Builder
- Carpentry and Millwork
- Heating
- Painting Contractor
- Plumbing
- Reading Arch. Blueprints

### ART

- Commercial Art
- Magazine Illus.
- Sign Painting and Design's
- Sketching and Painting

### AUTOMOTIVE

- Automobile
- Auto Body Rebuilding and Refinishing
- Auto Engine Tuneup
- Auto Electrical Technician
- Diesel Engines

### AVIATION

- Aero-Engineering Technology
- Aviation Engine Mech.
- Reading Aircraft Blueprints

### BUSINESS

- Accounting
- Advertising
- Bookkeeping and Cost Accounting
- Business Administration
- Business Management
- Clerk Typist
- Creative Salesmanship
- Managing a Small Business
- Professional Secretary
- Public Accounting
- Purchasing Agent
- Real Estate Salesmanship
- Salesmanship
- Salesmanship and Management
- Traffic Management

### CHEMICAL

- Analytical Chemistry
- Chemical Engineering
- Chem. Lab. Technician
- General Chemistry

- Oil Field Technology
- Pulp and Paper Making

### CIVIL ENGINEERING

- Civil Engineering
- Construction Engineering
- Highway Engineering
- Professional Engineer (Civil)
- Reading Struc. Blueprints
- Sanitary Engineer
- Sewage Plant Operator
- Structural Engineering
- Surveying and Mapping
- Water Works Operator

### DRAFTING

- Aircraft Drafting
- Architectural Drafting
- Drafting & Machine Design
- Electrical Drafting
- Electrical Engineer Drafting
- Industrial Piping Drafting
- Mechanical Drafting
- Sheet Metal Drafting

### ELECTRICAL

- Electrical Appliance Servicing
- Electrical Engineering

- Electric Motor Repairman
- Elec. Engr. Technician
- Elec. Light and Power
- Practical Electrician
- Practical Lineman
- Professional Engineer

### HIGH SCHOOL

- Good English
- High School Diploma
- High School General
- H. S. College Prep. (Eng'g & Science)
- High School Math
- High School Science
- Short Story Writing

### LEADERSHIP

- Industrial Foremanship
- Industrial Supervision
- Personnel-Labor Relations
- Supervision

### MECHANICAL and SHOP

- Diesel Engines
- Gas-Elec. Welding
- Heating and Air Conditioning
- Industrial Engineering
- Industrial Instrumentation

(plus sample lesson):

- Industrial Safety
- Machine Shop Practice
- Mechanical Engineering
- Plumbing and Heating
- Professional Engineer
- Quality Control
- Reading Shop Blueprints
- Refrigeration and Air Conditioning
- Tool Design
- Tool Making

### RADIO, TELEVISION

- General Electronics Tech.
- Industrial Electronics
- Practical Radio-TV Eng'g
- Radio-TV Servicing
- TV Technician

### RAILROAD

- General Railroad

### STEAM and DIESEL POWER

- Combustion Engineering
- Power Plant Engineer
- Stationary Diesel Engr.
- Stationary Steam Engines

### TEXTILE

- General

Name \_\_\_\_\_ Age \_\_\_\_\_ Home Address \_\_\_\_\_

City \_\_\_\_\_ Zone \_\_\_\_\_ State \_\_\_\_\_ Working Hours \_\_\_\_\_ A.M. to P.M. \_\_\_\_\_

Occupation \_\_\_\_\_

Canadian residents send coupon to International Correspondence Schools, Canadian, Ltd., Montreal, Canada. . . . Special low monthly tuition rates to members of the U. S. Armed Forces.

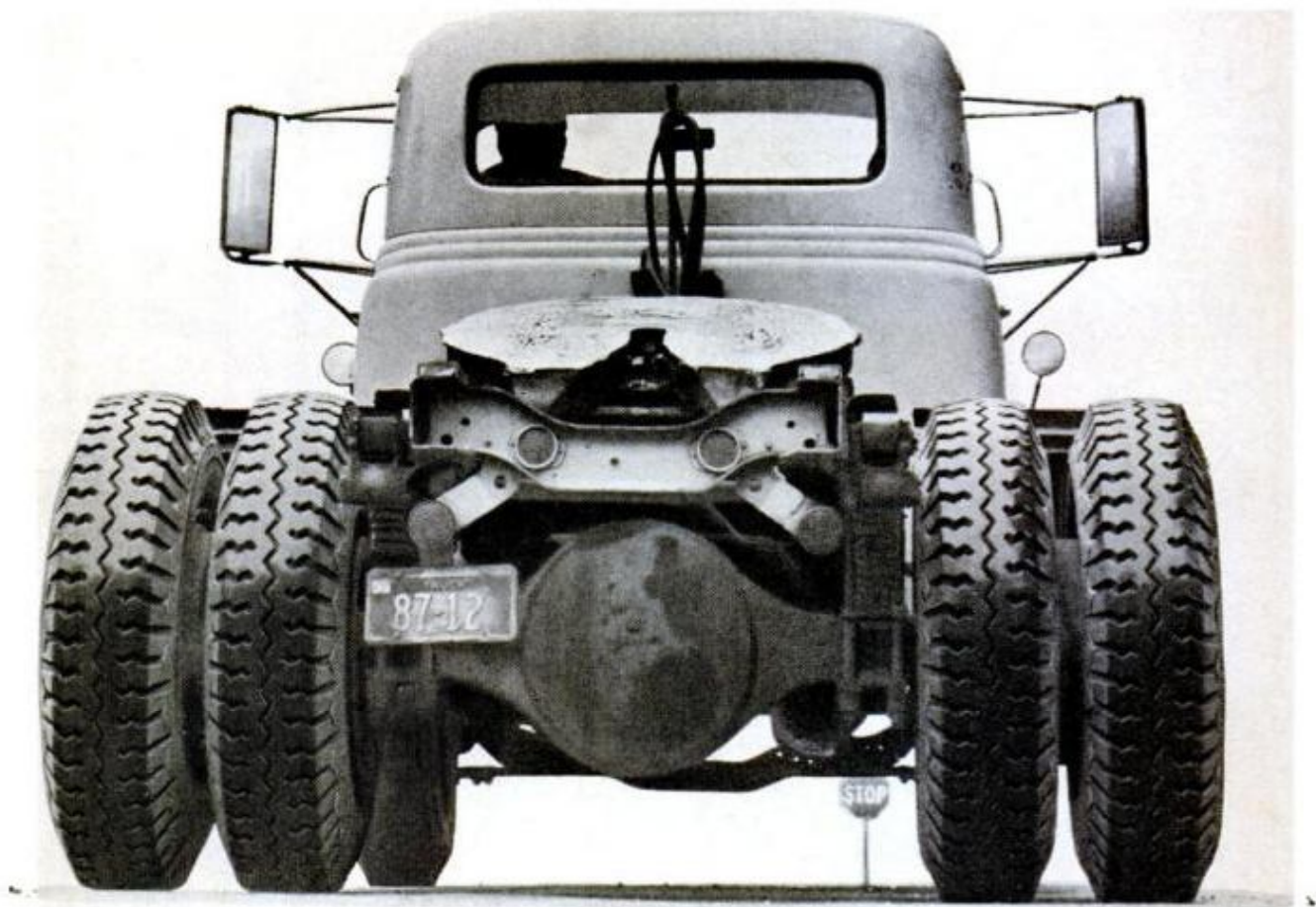

## New! Tires that double drive-wheel mileage!

Yes! Double the mileage! *Twice* as much as you get from ordinary truck tires on drive wheels!

We call this new truck tire the Super Cross-Rib. And with it come many advances in tire design.

Example: "Dual compounding." This brings together a soft, resilient inner tread with a super-toughened outer tread for long mileage. Heat buildup is lower and tire body life is longer.

We redesigned the tread, too. Its depth is 60% greater than that of ordinary tires, with a center groove which has many more biting edges. That means better traction — sideways, as well as forward and backward.

Anytime you can get double the mileage of another tire, you're way ahead. Super Cross-Rib is the way. Goodyear, Akron 16, Ohio.

**MORE TONS ARE HAULED ON GOODYEAR TRUCK TIRES THAN ON ANY OTHER KIND**

**GOOD**  **YEAR**

# Great NEW Idea from CTI

...to help you get and hold a fine job  
(or start a business of your own) in  
**Air Conditioning and Refrigeration!**

"Practice" Your Way  
to Bigger Pay!



Here Is Your  
"Training Shop"

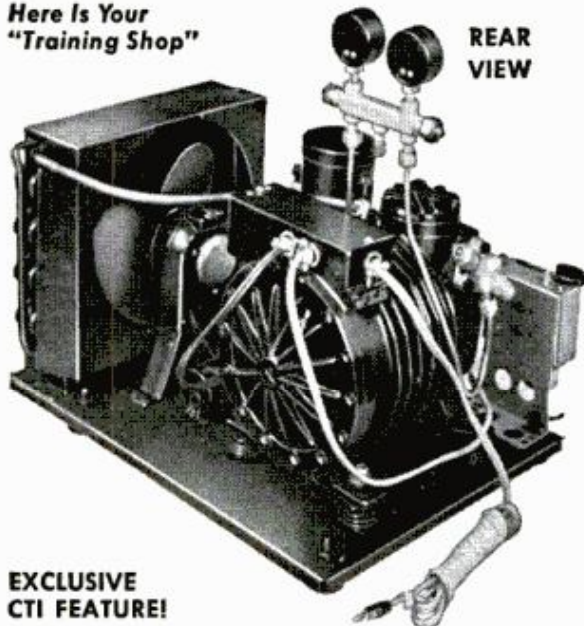

REAR  
VIEW

EXCLUSIVE  
CTI FEATURE!

## 25 KITS—20 SHOP PROJECTS

Illustrated above is a view of the new CTI condensing unit, fully assembled. This is a commercial-type, heavy-duty, 1/4 h.p. unit. You build it from 25 kits of parts (and with tools) that CTI sends without extra cost. In addition, CTI includes 20 Shop Projects, which simulate the kind of problems you are likely to encounter in the field. After assembling your condenser, you may then build an air conditioner, freezer, refrigerator or milk cooler.

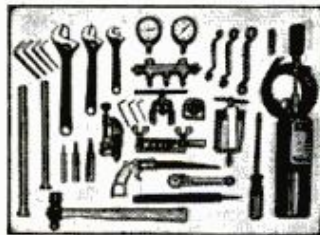

### Tools Are Included

You receive wrenches, tube flaring tools, hammer, tubing, fittings, gauges and many other items used by the experienced mechanic. Everything is of professional quality. Best of all, CTI trains you to use tools with speed and skill.

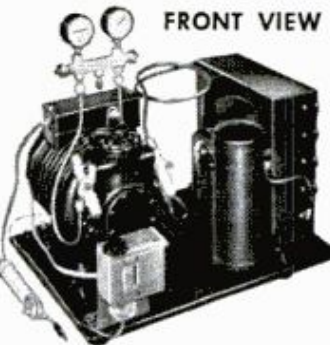

FRONT VIEW

### Go in Business



Because air conditioning and refrigeration is expanding so rapidly all over the nation, opportunities to go in business are plentiful. Many CTI graduates have accomplished this high aim. Start in a small way, from your own home, and gradually expand. In time you may wish to add a sales division. Manufacturers offer attractive franchises, including merchandising aids, to ambitious, qualified men.

### You learn by practicing with operating equipment

Thousands once learned this rewarding craft just by completing home study lessons. But CTI goes a step farther—and an important step it is! CTI also sends you 25 kits of tools and parts. You build these parts into an operating unit. It's a practical method because you get experience as you train.

### Earn Cash in Spare Time

Soon after enrolling, many CTI students earn money in spare time. Some handle servicing on a monthly fee basis for food stores, restaurants, taverns and office buildings. Many work part time at local dealers. Quite a number of CTI students have a full-time business going by the time they graduate. CTI kit training gives you the practice and experience you need to step from lesson study to actual field work.

## 3 FREE BOOKLETS

Get complete information—read it—and then decide. The facts are free. Mail coupon for 3 opportunity booklets. Act today.



### PROOF FROM GRADUATES

CTI has prepared a fascinating, new booklet called "Proof from Graduates." In their own words, CTI graduates tell you how training has helped them to better jobs, higher pay, or a business of their own. Send coupon for your copy.

COMMERCIAL TRADES INSTITUTE CHICAGO 26, ILLINOIS  
A Non-Profit Organization • Accredited by National Home Study Council



### COMMERCIAL TRADES INSTITUTE

1400 GREENLEAF AVENUE  
CHICAGO 26, ILLINOIS

Dept. R-56

Send me your 3 free booklets: Success in Air Conditioning & Refrigeration; Proof from Graduates; and Lesson Samples.

NAME \_\_\_\_\_ AGE \_\_\_\_\_

ADDRESS \_\_\_\_\_

CITY \_\_\_\_\_ ZONE \_\_\_\_\_ STATE \_\_\_\_\_



# Over the editor's desk

## Krick Critic

Read your article on weather about the predictions of Irving P. Krick (Oct. PM). I kept a tab on the weather locally, area and nation, and if the maps shown in the article are his predictions, he sure was all wet . . .

Greendale, Wis. JOHN R. OBERHOFER

*Forecaster Krick has promised us a full report on the "batting average" of his long-range forecasts, in time for the next issue of POPULAR MECHANICS.*

## Radiation Instrument

Where can I get an instrument to measure fallout radiation? I don't want to stay in my bomb shelter any longer than necessary . . .

Annandale, Va. GEORGE A. BIRDSALL

*There's a source for an approved commercial unit listed on page 77 of our last issue (January '62 PM).*

## Hood for Grandfather



I made this grandfather clock from a print which appeared in your April '56 PM—with this difference: It has a detachable hood (see photos) so it is easy to make any adjustments needed on the movements. This 7½-foot-high clock is made of solid Missouri walnut.

Leadwood, Mo. IVAN E. FORSHEE

## 1700 Portholes

To get this 54-inch model, I enlarged your building plans for the 36-inch model liner U.S.S. United States. My model required 6½ years to build, has a laminated basswood hull and is completely hollow all the way up to the smokestacks.

The superstructure is fabricated brass and the 64-feet of railing are made of sol-

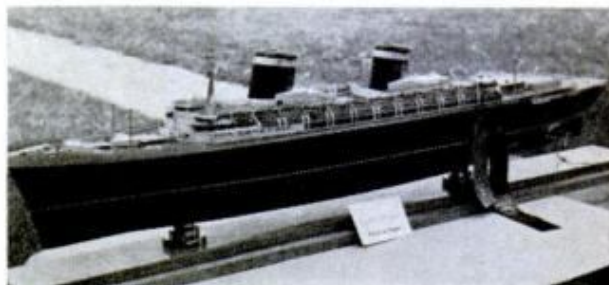

dered copper wire. I cast all anchors and screws by the lost wax process with fine results.

Lifeboats, cargo booms and radar tower are aluminum-foil covered. There are 1700 portholes in the hull. The model won the purple Sweepstakes ribbon this year at the Minnesota State Fair.

Duluth, Minn. RALPH W. ANDRES

## Soccer Versus Football

Obviously the author of your November article, *Football's Fabulous Foremen*, has never seen a game of pro soccer. He claims that football is probably the fastest paced, most varied and consistently thrilling of all sports. Soccer is faster paced and requires more skill and courage than football—a good soccer team could run circles around a football team.

Except for the backfield, football is strictly a game of brute strength. On a good soccer team, every man is of equal importance.

Westtown, Pa. ERNEST FOSS III

*Any football fans care to make a line plunge into this argument?*

## Jerky Pemman

Got quite a kick out of your formula for pemman (p. 24, Nov. PM). Maybe that is the government formula, but try to sell it to an Indian and he'd have your scalp.

The main ingredient in pemman is jerky, the salted and dried flesh of almost any game animal. Plains Indians used buffalo; others used venison or antelope. White pioneers used beef or even horse meat.

(Continued to page 14)

# Learn Radio-Television Electronics

## by Practicing at Home in Your Spare Time

WITHOUT EXTRA CHARGE NRI provides special kits that bring to life things you study. Makes learning easy, interesting, fast. All equipment yours to keep.

## Spare Time



## Fast Growth Offers You High Pay, Prestige, Bright Future



From Radio-TV Servicing and Broadcasting to missile launching sites like Cape Canaveral, NRI graduates share in the gigantic Electronics industry. Interesting jobs await you in studios, on ships and planes, in your own business. Mail coupon today for NRI catalog.



Many NRI graduates help build, install, operate and service automated electronic equipment for the new "Space Age" we live in—equipment used in offices, factories, the military. Others have important jobs as inspectors, laboratory technicians, etc., or hold essential civilian posts with the Government and Armed Forces.



**J. M. SMITH**  
President

If you check the classified advertisements in your local newspaper, you will undoubtedly see more job opportunities available for men with Electronics training than for any other field. Hardly without exception, these are better than average jobs, with bright futures . . . jobs for which YOU could qualify through NRI training. Thousands of men like yourself—most of them without a high school diploma—have moved up to good pay and enjoy greater prestige in jobs with TV and Radio broadcasting stations, in industrial plants making Electronic equipment or in businesses of their own where they sell, install and service Radio and TV sets.

### Train With The Leader

Join the many NRI graduates now taking advantage of career opportunities in this amazing Electronic Age. For 45 years, NRI has featured the best Radio-TV Electronics training for beginners—for men without previous experience. Throughout the U.S. and Canada, successful NRI graduates are proof that it's practical to train at home, in your spare time, at your own pace. Keep your present job while training. NRI supplies this training at low cost because it is

### NRI Trained These Men



I was working in a textile factory trying to make ends meet. Now I own one of the most modern service shops in this section. **ARGIE C. TAYLOR**, Glasgow, Ky.



After graduating I was a shipboard radio operator. Now I am chief engineer at Station WARA. **RAYMOND D. ARNOLD**, Attleboro, Mass.



Thanks to NRI I am in a top position with the Federal Aviation Agency in the Navoids Electronic Section. **JOE DUCKWORTH**, Fort Worth, Texas.



Four months after starting your course I left my job in a hardware store to work at Raytheon Manufacturing. Now I am an engineering assistant in Microwave Power Tube Research and Development Laboratory. **LEONARD BLOOM**, Newton Centre, Mass.



the oldest and largest home-study Radio-TV Electronics school. In every respect, you will find the Electronics field a profitable one for the ambitious man. And the NRI "learn-by-doing" method is the most practical way for you to get into this exciting field quickly.

### Start Soon to Earn More

NRI training can bring prompt financial return. Soon after enrolling, NRI shows you how to earn \$10, \$15 and more a week extra fixing sets in your spare time. This can lead to a profitable Radio-TV business of your own. Others have found good paying jobs within a year after enrolling.

Mail the coupon below TODAY for our FREE CATALOG. It tells in words and pictures about the amazing field of Electronics. Read success stories. See the equipment you get. Find out about the NRI 60-day free trial enrollment offer and convenient monthly terms. National Radio Institute, Washington 16, D. C.

GET 64 PAGE  
CATALOG  
FREE

MAIL THIS  
COUPON NOW



National Radio Institute

Washington 16, D. C.

2BA

Send me full information without cost or obligation. No representative will call. (Please print.)

Name.....Age.....

Address.....

City.....Zone.....State.....

ACCREDITED MEMBER NATIONAL HOME STUDY COUNCIL

Pemmican is made by pounding the meat to a pulp and adding such roots, herbs and berries as are at hand.

Jerky itself is a good survival food, but one would want more than 10½ ounces of water a day to go with it as it is very salty. I lived four days on a piece of jerky no larger than your fist and came out none the worse for the experience.

Golden, Col. ORVILLE BALL

PM Outdoor Editor Dick Kirkpatrick also disagrees with the government version of pemmican. The first he ever ate was made of venison, bear grease and wild blueberries, looked like a gray-blue candy bar and tasted pretty good. Some Minnesota squaws made it to sell to fishermen and and tourists (the men and their families preferred Spam and beans).

### Hold It, Tom

I implore Tom Killmon not to rebuild the early man-powered helicopter he has (p. 8, Oct. '61 PM). Many readers may remember that the Langley aerodrome was rebuilt and flown, but the new parts used invalidated its claim to priority over the Wright brothers. Any new parts added to the Ingoldsby helicopter would give rise to the suspicion it would not fly in its original form.

Mr. Killmon could build a replica, as

nearly as possible of the same materials, using the original gears as patterns in casting new ones. Then, if the replica flies, it proves the practicality of the original.

Pelham, N. Y.

LAURANCE F. STUNTZ

### Rewarding Results

The handsome new plaque hanging on our office wall is the National Safety Council's Public Interest Award for 1961. We're proud to have earned it. And we're equally proud of other 1961 awards which have been made, individually, to two of the *Popular Mechanics* editors.

One was the Annual Citation for Aviation Writing given to PM's Aviation Editor, Kevin Brown, by the Illinois Wing of the Air Force Association. The other was a Writer's Award for Outstanding Journalistic Service made to PM's Outdoor Editor, Richard B. Kirkpatrick, by the American Power Boat Association.

We knew that Dick's special articles in the March boating issue and Kevin's special aviation section in June were worthy of such recognition. Your letters in response to them had already confirmed their value.

For telling our boys how much you appreciated their material, then, here's a hearty thanks from all of

*The Editors*

## STEWART-WARNER ELECTRIC FUEL PUMPS

No stalling! No flooding! No vapor lock! Stewart-Warner Electric Fuel Pumps provide positive delivery of fuel instantly, under all conditions, all temperatures. This means quick, sure starts on the coldest winter days or when temperatures soar. Stewart-Warner Electric Fuel Pumps are available for engines with 6 or 12-volt electrical systems. See them at your nearby service station, garage or automotive parts store today!



*always on the job  
when your engine  
calls for fuel!*

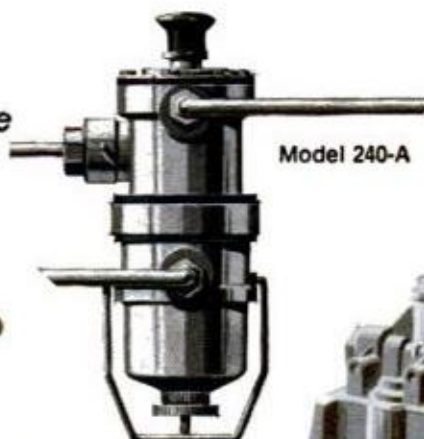

Model 240-A



Model 220-A

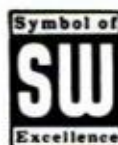

INSTRUMENT DIVISION  
**STEWART-WARNER**  
CORPORATION

Dept. C-22  
1840 Diversey Parkway  
Chicago 14, Illinois

POPULAR MECHANICS



# SAVE **AS MUCH AS 80% ON** POWER TOOLS

**GUARANTEED TO DO THE WORK OF \$40, \$60, \$80 UNITS**

- **SAVE! BUY DIRECT FROM FACTORY**
- **PROFESSIONAL QUALITY, LIFETIME ENGINEERED**
- **UNCONDITIONAL 10-YEAR GUARANTEE**

REVOLUTIONARY PATENTS DECREASE COSTS, INCREASE EFFICIENCY. Top quality full scale power tools of heavy duty 100% cast iron and steel. Streamlined design features such as perforations on table tops reduce weight, cut material costs, cut polishing and grinding time—reduce production costs. Special patents provide added efficiency, accuracy, savings. Nothing left out but exp've gingerbread. Parts made, assembled, tested and packed in our own factories, shipped direct to you. No retail store handling or profits to add to your cost.

**\$995**

Exp. Coll.



**8" TILT ARBOR POWER SAW**

Complete as shown, less blade. Incl. precision mitre gauge, ground cast iron table. If desired, RIP FENCE for easier work alignment, \$3.50 add'l.

**DOES THE WORK OF \$50 BENCH SAWS!**

CROSS-CUTS, RIPS, BEVELS, MITRES, DADOES, CUTS COMPOUND ANGLES. Patented motor mount takes any standard 1/4 to 1/2 h.p. motor . . . keeps belt tight, assures perfect alignment at any angle, transmits full power. Table stays level—blade tilts, locks securely at any angle to 50°, raises, lowers 0"-2 1/4". Patented tilt mechanism has accurate etched scale. Takes standard blade, saw insert removes easily for insertion of any STANDARD dadoe heads, cutters, etc. Accessories, table extensions, when wanted, at factory prices. Versatile, rugged performance proven by almost a half-million users.

**UNCONDITIONAL 10 YEAR GUARANTEE**

**DOES THE WORK OF \$60 UNITS**

Now, at little more than a hand tool price, a guaranteed professional quality precision machine which does same work as skilled hand planing . . . much faster, more accurately. Make accurate glue joints; rabbeting cuts for doors, window frames, table drawers; square taper cuts for chair legs; extremely accurate beveling. Helps amateurs produce quality work—with the sweat eliminated.



**TOP QUALITY FEATURES SPEAK FOR THEMSELVES**

- Precision ground cast iron tables, adjustable for depth of cut
- Rigid cast iron base
- New patent-pending design holds clearance between knives and tables at any depth
- Rabbet depth 3/8"
- Hardened, ground high speed steel knives
- Patent-pending fence adjustable to any position, any angle 0°-50°
- Patent pending lift-off guard (nothing to loosen!)
- Balanced steel cutter head. **UNCONDITIONAL 10-YEAR GUARANTEE.**

**FULL 22" LONG, 4 1/8"**  
**JOINTER-PLANER**

**NOW \$1995**

Complete as shown

100% precision ground cast iron and steel. Exp. Coll.

**HIGH SPEED TILT ARBOR BENCH SABRE SAW**



**TAKES THE PLACE OF \$100. BAND SAW—**  
Zips through thick stock effortlessly. Makes outside and inside cuts a breeze. Cuts circles, curves, any angle 0°-45°. Ideal for intricate jobs as well as ripping and crosscutting. Multipurpose saw almost a complete workshop in itself! Free-cutting blade eliminates pull up of work piece. This cutting action, unlike conventional portable sabre saws, reduces friction, blade stays cool, breakage and dulling are minimized. Even the most inexperienced do-it-yourselfer can turn out professional work the very first time. Takes any standard 1/4 h.p. motor or larger.

**\$1995** **UNCONDITIONAL 10-YR. GUARANTEE!**

**6" SWING 3-FT. LATHE**

**\$985**



**DOES THE WORK OF \$40 UNITS—**This sturdy all cast iron power tool will turn wood or plastics with the precision and speed of machines selling for 4 times as much. Has tubular steel bed, ball thrust cup center, spur center. T-Rest assembly, lever action tail stock. 2 speed pulley. Fits any motor. Perfect for the home or professional workshop, garage or farm. **UNCONDITIONAL 10 YEAR GUARANTEE.**

Complete as shown  
Exp. Coll.

**BENCH DRILL PRESS**

**DRILLS TO CENTER OF 10" CIRCLE—** Rugged, dependable . . . all cast iron and steel. Table to 1/2" handtite chuck; max. 13 1/2". Spindle has combination ball and bronze bearings. Adjustable stop for repetitive drilling. Precision ground cast iron table. Table assembly fully adjustable on column. **UNCONDITIONAL 10 YEAR GUARANTEE.**



**\$1995** Less Belt  
Exp. Coll.

**MAIL COUPON TODAY!**

American Machine & Tool Co., Dept. PM-22, Royersford, Pa.  
Please send me the units checked. Payment in full enclosed \$..... or \$3 deposit each item enclosed, balance C.O.D. I must be fully satisfied or will return unit within 10 days for full refund. No questions asked.

8" Saw \$9.95     8" Saw & Rip Fence \$13.45     Lathe \$9.85  
 Sabre Saw \$19.95     Jointer-Planer \$19.95     Drill Press \$19.95

NAME.....

ADDRESS.....

CITY..... ZONE..... STATE.....

(please print)

**10 DAY MONEY BACK GUARANTEE**  
You must be satisfied or money refunded, no questions asked.

**AMERICAN MACHINE & TOOL COMPANY**  
Dept. PM-22, Royersford, Pa.



THE ENTIRE FIRST GRADE of the Bartlett, Illinois school (28 kids) lines up in front of the Travelall wagon.



Below, all 28 youngsters fit into the wagon. Those on the tailgate could have ridden in front seat as it was empty when this photograph was taken

## SPOTLIGHT on the TRAVELALL

By Jim Whipple

**M**ANY OF US OLDSTERS (over 30) can remember the high, boxy station wagons of the 1930's and 40's, with their latticed, varnished wood panels and fabric roofs. They jolted and creaked along at 50 m.p.h. or so, and in a stiff cross wind the driver felt a strong kinship with the helmsman of an offshore schooner.

Squeaky, drafty old crates they were, but they could really haul the goods. I remember helping a friend move his belongings in a faithful old wagon that we called the "Plywood Playground." We heaved barrels of china and books onto the tailgate and slid them into the cavernous body.

After World War II stylists "discovered" the station wagon and rapidly transformed it from a high, wooden ark to a low, jelly-bean-shaped vehicle of steel and glass.



Over-all height plummeted from a stately six feet to near sedan levels of 56 inches.

Among these passenger-car adaptations International Harvester's Travelall is unique. It was designed to bridge the gap; to provide a roomy, comfortable station wagon no bigger than the smaller family cars (not compacts) yet be capable of hauling far heavier and larger loads than any passenger-car station wagon.

When you first walk up to a Travelall it looks huge. You will be surprised, as we were, to learn that its over-all length is only 202 inches bumper to bumper, and that it's a modest 75 inches wide. It is 70 inches tall, however, which makes it, until more than International's current rate of 5000-6000 per

**Remember  
how great  
cigarettes  
used to taste?  
Luckies  
still do**



***Change to Luckies and get some taste for a change***

© A. T. Co.

*Product of The American Tobacco Company - "Tobacco is our middle name"*

FEBRUARY 1962

Материал, защищенный авторским правом

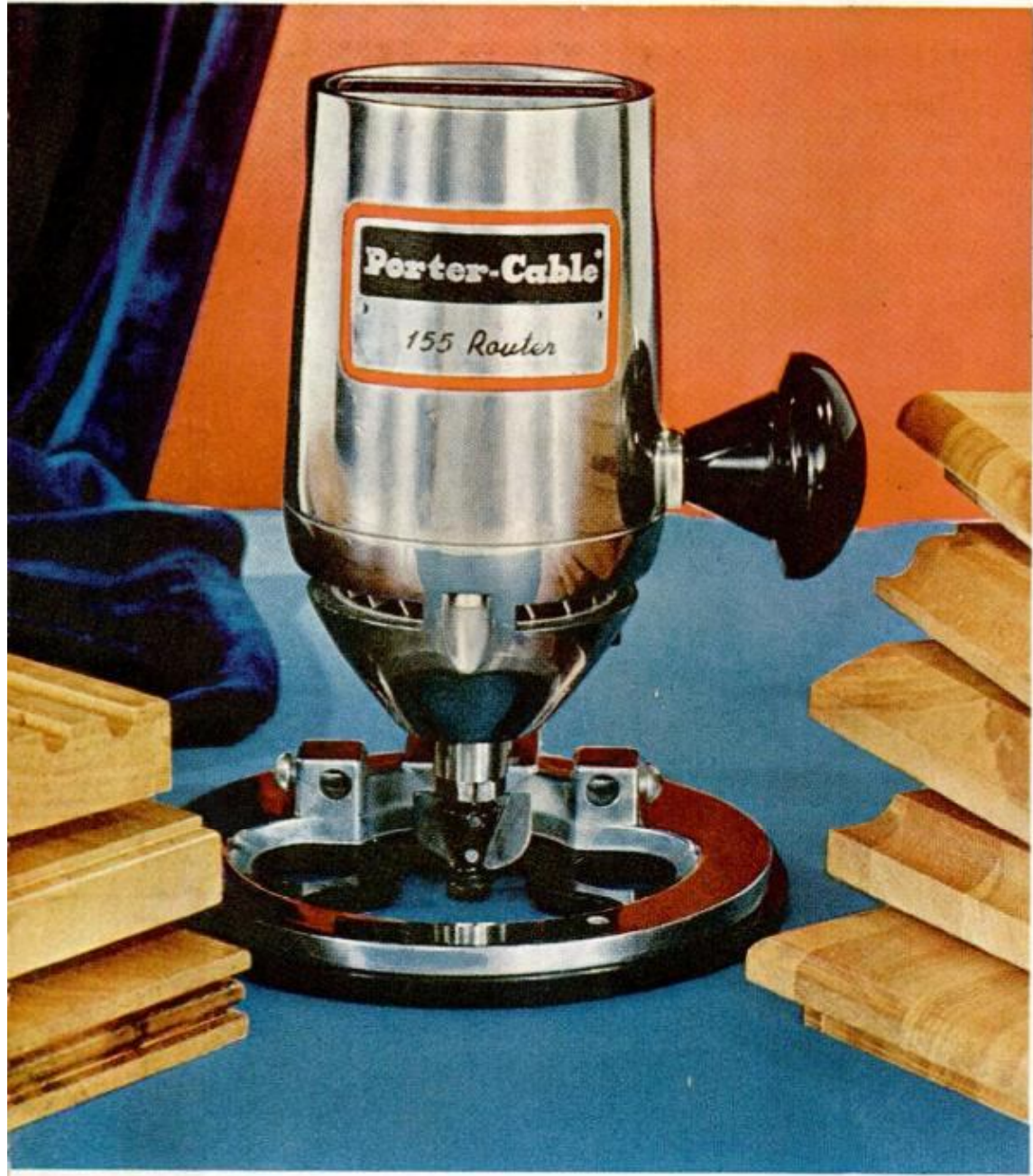

SCROLL SAW



SANDER



SHAPER



POWER PLANE

# This new Router will be the busiest tool in your shop

Versatility with a capital "V"—that's what you get when you add this handsome 5-in-1 Router to *your* workshop! A single 4-amp, 23,000-RPM motor unit powers the tool as a Router, Power Plane, Shaper, Scroll Saw and Finishing Sander. And thanks to famous Porter-Cable precision engineering, you can change from one tool to another quickly, easily—in a matter of seconds.

Your Porter-Cable dealer will gladly show you how this exciting new portable tool makes plain and fancy woodworking a real "snap." Ask him for a demonstration now.

**WRITE FOR FREE FOLDER** describing the 5-in-1 Router and name of dealer nearest you: Porter-Cable Machine Company, Subsidiary of Rockwell Manufacturing Company, 502 B North Lexington Avenue Pittsburgh 8, Pennsylvania.

*In Canada: Porter-Cable, Ltd., Box 817, Kingston, Ontario, Canadian prices slightly higher.*



year are sold, the easiest car to find in any parking lot.

This height really pays off, you'll find, as it gives some features that you just can't get in a conventional U.S. passenger car—such as 8.6-inch ground clearance; seat cushions that are 15 inches off the floor and a roof that's 38 inches above the seats. The middle seat folds forward to make an enclosed load space well over six feet long.

The cargo area is 42 inches high, from the deck to headliner, and 49 inches wide between the wheel wells. An optional third seat can be attached to the body floor and will hold three adults with 34 inches of headroom.

The tailgate is counterbalanced and has a rear window powered by an electric motor that slides down neatly into it.

Total interior load space behind the front seat is 124 cubic feet, 50 percent more than in a Buick Special or Olds F-85 wagon, for example.

Load carrying capacity is 1550 lb. including passengers. And that's figuring it conservatively.

Travelall's ride is on the firm side, like many imported cars, but its torsion bar independent suspension makes it stable and keeps it from swaying in spite of its height. Travelall just doesn't bounce. Small bumps such as expansion joints jiggle its solid structure but soft seat cushions absorb this nicely. Cushions, incidentally, are foam rubber covered by durable nylon fabric which is breathable and a great hot weather boon compared to sticky plastic in the typical wagon.

Vision is great on all sides. The driver sits high and surveys the traffic beneath him with a clear view of all corners of the wagon. For this reason, among others, my wife took to the Travelall immediately, finding it easier to guide into a parking slot than our own lighter car.

### Manual Shifting a Workout

Travelall's steering is slow but precise and easy as long as the car is rolling. For those who plan to do much driving in congested traffic, power steering is available. Manual transmission and clutch are built for long life and heavy loads and operating them can get tiresome in traffic. Three-speed and overdrive, or four-speed synchromesh transmissions are available. My wife preferred very strongly the automatic transmission with which one of PM's test Travelalls was equipped. This one also had the 155-horsepower V8 engine which made a smooth, relatively quiet combination that my wife found very pleasant to drive around our small country town.

FEBRUARY 1962



**WIDE REAR OPENING** makes Travelall a real hauler. Its cargo space swallows nearly all of 4 x 8-foot plywood sheets and takes furniture up to 35 inches high

She found it hard to believe that this pleasant, practical vehicle, was neither more nor less than a skillfully modified truck chassis. Reasonable cruising speed for this model was about 70 miles per hour.

PM also tested a manual transmission model with six-cylinder engine of 220 cubic inches rated at 112 horsepower. Teamed with three-speed manual transmission and a 3.73 to 1 axle ratio this engine moved the heavy Travelall briskly up to 60 m.p.h. in 16 seconds from a standing start.

Comfortable cruising speed for this unit was 60 to 65. Above this speed the engine became noisy.

This wagon was equipped with Power-Lok limited-slip differential which gave it positive traction on both rear wheels. Thus equipped, the Travelall handled boat-launching chores on the muddy banks of a lake with eye-opening assurance.

### Jungle Buggy?

If you plan to explore South American jungles or work the Texas oil fields with your Travelall, four-wheel-drive is available. However, this equipment will cancel out the easy riding and steering.

In a combined usage pattern of small town stop-and-go driving and high-speed cross-country runs the stick shift Travelall scored 17.5 miles per gallon over-all, a commendably low rate of consumption for a wagon in the 4000-lb. class.

At \$2797 factory retail for the wagon with manual transmission and Deluxe interior trim, Travelall isn't cheap. But its rugged character, tremendous capacity and docile road manners make it a natural for a large family or anyone with the kind of out-of-the-ordinary transportation needs for which this wagon is ideally suited. ★ ★ ★

# FREE!

## TRIAL LESSON



# Trial lesson in DRAFTING



### LEARN AT HOME IN SPARE TIME

Check the want ads in any newspaper — SEE the big-pay opportunities open to you as a draftsman. What's more, you can learn this well-paid, prestige profession at home — quickly, easily! No special talent needed! Get complete, step-by-step Chicago Tech lessons in the mail, spend a few pleasant hours studying each week. In a short time you'll be a well-trained draftsman, ready to take your pick of many good jobs. Act now!

### FREE INFORMATION—MAIL COUPON TODAY!

Get FREE TRIAL LESSON plus information about C.T.C. practical training. Learn what successful Chicago Tech graduates say about high pay and opportunities in drafting. No charge, or obligation.

Accredited National Home Study Council

## CHICAGO TECHNICAL COLLEGE

B-200 Tech. Bldg., 2000 So. Michigan Ave.  
Chicago 16, Illinois

Mail me FREE Lesson with information about big opportunities in DRAFTING.

Name..... Age.....

Address.....

City..... Zone..... State.....

## ENGINEERING SCIENCE MATH

## DEGREE IN 27 or 36 MOS.



B.S. degree — 36 mos. • B.E. degree — 27 mos.

ACCELERATED YEAR-ROUND PROGRAM prepares for early employment in fields of SCIENCE AND ENGINEERING. Regular 4-year program for B.S. Degree completed in 36 months, special engineering degree program in 27. Classes start — March, June, July, Sept., Jan. QUALITY EDUCATION. Graduates employed from coast to coast. Government approved for veteran training. Students from 50 states, 40 countries. 20 buildings; dorms, gym, Campus. SAVE TIME AND MONEY. EARN BOARD while studying. Write for catalog and complete information.

## INDIANA TECHNICAL COLLEGE

522 E. Washington Boulevard, Fort Wayne 2, Indiana  
Please send me free information on Bachelor's Degree Programs in Engineering and Science as checked below:

- |   |  |
|---|--|
| <input type="checkbox"/> Aeronautical Engineering | <input type="checkbox"/> Mechanical Engineering    |
| <input type="checkbox"/> Chemical Engineering     | <input type="checkbox"/> Metallurgical Engineering |
| <input type="checkbox"/> Civil Engineering        | <input type="checkbox"/> Physics                   |
| <input type="checkbox"/> Electrical Engineering   | <input type="checkbox"/> Chemistry                 |
| <input type="checkbox"/> Electronic Engineering   | <input type="checkbox"/> Mathematics               |

Name.....

Address.....

## DOLLARS for DIMES

Earn \$\$\$\$\$ AT HOME with New VELVETIZING PROCESS

You can earn up to \$20 per hour spare time. Amazing new Velvetizing Process instantly makes any object (Lamps, Radio & TV Cabinets, Figurines, Signs, Auto dash boards, Toys, furniture, draperies—anything) worth expensive Dollar Prices... Velvetizing offers a thousand ways to multiply your income, gain security and financial independence.

UP TO \$500 PROFIT FROM \$20 IN MATERIALS

Materials cost only 3c per square foot. In just 15 minutes and only 3-4c in materials, an average TV or radio cabinet can be beautifully Velvetized with a startling new 3-dimensional Velvet finish. You charge at least \$10.00 for this.

FANTASTIC HOME BUSINESS... BIG CITY, SMALLTOWN, FARM

End your money troubles forever. Add "Velvetizing" spare time profits to give you 2 incomes at once. Then use the profits to develop your full time business. Start anywhere, any time... Corner of Garage, Basement or Service Porch. Investigate today—be first in your area! Actual sample in Radiant color, Booklet of 50 Home Business Opportunities and complete confidential Details all sent free! Send no money. Write: Coast Industries, Los Angeles 61, Calif., Dept. B-2.

## NEW Improved Accurate Scope-Shot

Price Complete with 50 DISINTEGRATING PELLETS \$1.95 P.P.  
They crack like a rifle when they hit—leave mark—puff of smoke!

Big Bag of 250 EXTRA Pellets 98c P.P.  
Millions Sold! Patent No. D-178,837

World's Finest Precision SLINGSHOT Scope-type sight!  
Pure gum rubber slings. Beautifully polished cast aluminum stock.  
Pistol grip. So powerful it kills small game. Fits pocket perfectly!  
Guaranteed. FREE shooting manual.

Order NOW from: GENERAL SPORTS  
4184-MB Apple Street, Cincinnati 23, Ohio



KELSEY PRESSES

## Print Your Own

Cards, Stationery, Advertising, Circulars, labels, photo and movie titles, church work, tags, etc. Save money. Sold direct from factory only. Raised printing like engraving, too.

### Own a Printing Business

Print for Others, Good Profit. Have home shop. Junior press \$15; Senior \$35 up. We supply everything. Easy rules. Pays for itself in short time. Write now for free details.

KELSEY PRESSES, Z-37 Meriden, Conn.

## earn as TAX EXPERT

\$15 HOUR  
Our students earn as much as \$3,000 in 3 short months preparing income tax returns in spare time. Also operate lucrative year-round Business Tax Service. Dignified home-office business. Experience unnecessary. We train you; help you start. State approved home training program. Write today for free prospectus.

UNION INSTITUTE, Lakewood H-20, N. J.

## MAKE BIG MONEY—ALL PROFIT—AT HOME

## INVISIBLE MENDING

Pays up to \$10 in an Hour!  
Make moth holes, cigarette burns, tears, rips, disappear from all fabrics. Little-known craft pays extra spare-time profits at home. Write today for exciting details FREE!

FABRICON, 1555 Howard St.  
DEPT. 322, CHICAGO 26, ILLINOIS



## Marshall's NEW PHOTO PAINTING PENCILS

Check this easy way to turn free time into extra cash. There's a big market for hand colored photos, snap shots and Polaroid Land prints. No special talent needed. Send for FREE instructions or \$1.98 for Complete Coloring Kit of 8 Pencils. MARSHALL'S, 149 N. 9th St., B'klyn 11, N. Y. At photo, art, hobby, drug & stationery stores.



# WHAT ALL AUTO MECHANICS WANT TO KNOW

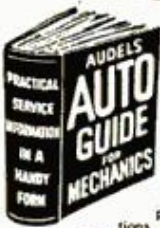

This Big Practical Book gives full information, with working diagrams, covering the principles, construction, ignition, service and repair of modern cars, trucks and buses.

**Air Conditioners, Hydramatic & Fluid Drives Fully Explained.**

A complete guide of 1132 Pages, with over 1000 Illustrations showing inside views of working parts, with instructions for service jobs. Completely up-to-the-minute! Priced at only \$6.

CIRCLE No. 1 IN COUPON

## HOW TO FIX HOME APPLIANCES

REFRIGERATORS WASHERS TOASTERS DRYERS IRONERS RANGES VACUUMS FREEZERS

Many other GAS AND ELECTRIC APPLIANCES



Handy Reference for Electric & Gas Servicemen, Mechanics, Dealers and Homeowners. Explains clearly and simply how to locate troubles, how to test, reassemble and connect. Wiring diagrams, 1000 Facts. Easy to read. Answers ALL your questions. 864 Pages. Illustrated. Only \$6.

CIRCLE No. 2 IN COUPON



## TV TELLS HOW TO ANSWER RADIO RADIO T.V. QUESTIONS SERVICE LIBRARY

HERE IS LATEST INFORMATION IN A HANDY FORM FOR RADIO AND TELEVISION REPAIRMEN, SERVICEMEN AND STUDENTS

TWO COMPLETE VOLUMES - 1568 Pages - 1085 Illustrations and Diagrams. 1001 Important Facts and Figures on Modern T.V. Radio. Electronic Devices. INCLUDES TRANSISTORS & Transistor Circuits, Rectifiers, Record Changers, P.A. Systems, Phonograph Pick-ups, F.M., Auto Radio, Short Wave.

Basic principles, Construction, Installation, Operation, Troubleshooting. How to get Sharp, Clear T.V. Pictures. Install Aerials. How to Test. Explains COLOR SYSTEMS, Methods of Conversion, Terms, etc. Includes Ultra High Frequency. Quick ready reference or use as a home study course. Only \$8 for BOTH volumes.

CIRCLE No. 3 IN COUPON

## OIL BURNERS

New, complete, explaining in detail both domestic and industrial oil burners. Includes electrical hook-ups and wiring diagrams. Fully covering the theory, construction, installation, operation, testing, servicing and repair of all equipment. Indexed for ready reference. Over 416 Pages. 320 Illustrations and Diagrams. Only \$2.50

CIRCLE No. 28 IN COUPON



## ALL TYPES OF BLUEPRINT READING

How to read scales, the standard symbols, detail and assembly prints, working drawings, short cuts, hints and suggestions. THE MAN WHO CAN READ BLUEPRINTS IS IN LINE FOR A BETTER JOB. This book gives you the secret language, step by step in easy stages. 448 Pages. Very Fully Illustrated. Priced at \$3.

CIRCLE No. 25 IN COUPON

## PLUMBERS AND STEAMFITTERS GUIDES

Practical Trade Assistant & Reference Set. Explains in plain language and by clear illustrations, diagrams, charts, graphs and pictures the principles of modern plumbing practice including Pipe Fitting and Air Conditioning. 4 Vols. - 2624 Pages - 3642 Diagrams & Illustrations. Only \$9 for the complete set of 4 vols. Sold individually \$2.50 each.

CIRCLE No. 6 IN COUPON

## 7-DAY FREE EXAMINATION

SEND NO MONEY - Pay the postman nothing! We are glad to send you any of the Audel Guides for absolutely FREE examination in your own home. We take all the risks and leave all the decisions up to YOU. There is no obligation! If you decide to keep the books of your choice you may pay for them under our astounding easy-pay plan of only \$2 a month.

### HERE IS ALL YOU DO

IT'S EASY TO ORDER: In the No-Risk Mail Order Coupon at the right just draw a circle around the number of Audel Guides you want to send you for FREE EXAMINATION. We will send them to you at once to help you build a brighter future by increasing your SKILL. If for any reason at all you are not COMPLETELY satisfied, return the books to us, and that will end the matter! NO STRINGS OR CATCHES TO THIS OFFER.

**THEO. AUDEL & CO.**

49 West 23rd Street, New York 10, N.Y.

## GAS ENGINE MANUAL

Just off the press! A helpful, practical guide for mechanics, students and homeowners. Maintenance and repairs of modern gas engines of all types and sizes used in almost every field, from motor transportation, to appliances around the home. Includes marine and aircraft engines.



FOR THE EXPERT OR THE DO-IT-YOURSELFER

THE FIRST PART explains the operating principles of various types of gas engines, and the function of engine parts and accessories: carburetors, fuel injection methods, cooling and lubrication systems, etc. THE SECOND PART covers trouble-shooting, modern service operations and engine tune-up procedures. Ignition system items are fully listed and illustrated. 48 pages. Only \$4.

CIRCLE No. 48 IN COUPON

## PAINTING AND DECORATING MANUAL

NEW TITLE gives the practical know-how you have been looking for. Concise and late information on the many phases of house painting and decorating. Complete from A to Z. INSIDE TRADE INFORMATION!

Outside and inside work, how to mix paints, preparation of surfaces, paper-hanging, wood finishes, tools and their proper use, synthetic paints; where and how to use them, the brush care, spray painting, scaffolds, rigging, costs, estimating, better methods and a dictionary of trade terms. Over 585 Pages. Fully illustrated. Only \$4.

CIRCLE No. 7 IN COUPON

## MASONS & BUILDERS GUIDES

A PRACTICAL ILLUSTRATED 4 VOL. SET - Explaining in clear, simple language and profuse illustration, principles, advances, short cuts, trade secrets, based on modern practice - including how to figure and calculate various jobs. Vol. 1 - Brick work, bricklaying, bonding, designs. Vol. 2 - Brick foundations, arches, tile setting, estimating. Vol. 3 - Concrete mixing, placing forms, reinforced stucco. Vol. 4 - Plastering, stone masonry, steel construction, blueprints. 4 Vols. 1440 Pages. 2067 Illustrations. Complete Set only \$9.

CIRCLE No. 26 IN COUPON Sold individually \$2.50 each.

## MATHEMATICS MADE EASY

A COMPLETE HOME STUDY COURSE - Starting with the first principles of arithmetic, advancing step by step through the various stages of mathematics, including the rules and calculations for mechanical and electrical problems. New EASY correct methods. Includes plane and solid geometry, trigonometry, algebra, calculus, etc. Practical tests, reference tables and data. How to use slide rule. 672 Pages. 550 Illustrations. Priced at only \$3.

CIRCLE No. 11 IN COUPON

## NEW MACHINISTS AND TOOLMAKERS HANDBOOK

MODERN MACHINE SHOP PRACTICE - For every Machinist, Toolmaker, Draftsman or Student. Tells how to set up and operate lathes, screw and mulling machines, shapers, drill presses and all other machine tools. A COMPLETE INSTRUCTOR AND REFERENCE BOOK 1250 Pages. Fully Illustrated. Priced at only \$5.

CIRCLE No. 12 IN COUPON

## ELECTRIC MOTORS

THIS GUIDE covers the construction, hook-ups, control, maintenance and trouble shooting of all types of motors. Includes armature winding. Explains entire subject in great detail in simple language. Over 1056 Pages of information. 617 Diagrams. All types of motors fully illustrated and indexed for ready reference. Priced at only \$5.

CIRCLE No. 27 IN COUPON

## REFRIGERATION & AIR CONDITIONING

FOUR BOOKS IN ONE - basic principles, servicing, operation, repair of: 1. Household Refrigeration. 2. Special Refrigeration Units. 3. Commercial & Industrial Refrigeration. 4. Air Conditioning Systems. A GOLD MINE of essential information. Completely up-to-date. 1360 Pages. Fully Illustrated and Indexed. Priced at only \$5. CIRCLE No. 14 IN COUPON

# CARPENTERS AND BUILDERS GUIDES



PRACTICAL STOREHOUSE OF MODERN CONSTRUCTION INFORMATION (4 vol. set) for carpenters and all woodworkers. Explains in easy language and by profuse illustration principles, advances, short cuts, trade secrets, all based on the NEWEST information. Vol. 1 - Tools, steel square, saw filing, joinery, furniture, etc.; Vol. 2 - Builders mathematics, drawing plans, specifications, estimates, etc.; Vol. 3 - House and roof framing, laying out, foundations, etc.; Vol. 4 - Doors, windows, stair building, millwork, painting, etc. 4 vols. 1904 Pages. 3700 Illustrations. Whole set only \$9. CIRCLE No. 8 IN COUPON

## PRACTICAL ELECTRICITY

A COMPLETE HANDBOOK - Quick, simplified, ready reference. Complete instruction and practical information on the rules and laws of electricity - Maintenance of Machinery - A.C. and D.C. Motors - Armatures - Wiring Diagrams - House Lighting - Power Wiring - Meters - Batteries - Transformers - etc. Simple to understand. 1052 Pages. 2600 Illustrations. Priced at \$5. CIRCLE No. 4 IN COUPON

## DIESEL

ALL THERE IS TO KNOW ABOUT MODERN DIESEL ENGINES - Basic principles, starting valves, timing, fuel pumps, fuel injection compressor, air compressors, piston, cylinders, lubrication, cooling systems, etc. Answers on operation, calculations. 640 Pages. Fully Illustrated. Priced \$3.

CIRCLE No. 9 IN COUPON

## THE NEW ELECTRIC LIBRARY

A COMPLETE ENCYCLOPEDIA explaining in the simplest terms the fundamental principles, rules and applications of applied electricity.

A COMPLETE COLLEGE EDUCATION! Fully illustrated with diagrams and sketches, calculations and tables for ready reference. Questions and answers. Trial tests for practice study and review. All based on the most modern theory.

- Vol. 1 - Principles and rules of electricity, magnetism, armatures, repairs. No. 15
- Vol. 2 - Dynamos, DC Motors, construction, installation, maintenance, etc. No. 16
- Vol. 3 - Testing instruments and tests, storage battery constr. and repairs. No. 17
- Vol. 4 - Alternating current, power factor, alternators, transformers. No. 18
- Vol. 5 - A.C. Motors, windings, maintenance, converters, switches, fuses, etc. No. 19
- Vol. 6 - Relays, condensers, regulators, rectifiers, meters, switchboards, etc. No. 20
- Vol. 7 - Wiring, house light and power, circuits, high tension, plans, code, etc. No. 21
- Vol. 8 - Railways, signals, elevators, ignition, etc. No. 22
- Vol. 9 - Radio, telephone, telegraph, television, motion pictures. No. 23
- Vol. 10 - Refrigeration, illumination, welding, x-ray, electrical appliances, Index. No. 24

6,000 fully illustrated pages. Priced at only \$22.50 for the ENTIRE SET. Also sold individually for \$2.50 each.



## ADDITIONAL IMPORTANT TITLES

The following Audel Guides are all the best in their fields, written in clear simple fashion, all lavishly illustrated. Circle the numbers wanted in the MAIL ORDER COUPON below. All books are sent for FREE EXAMINATION.

- No. 5 TRUCK & TRACTOR GUIDE, 1376 Pages \$5.00
- No. 7 WELDERS GUIDE, 608 Pages 3.00
- No. 13 WIRING DIAGRAMS (Light & Power), 304 Pages 2.50
- No. 29 SHEET METAL PATTERN LAYOUTS, 1152 Pages 7.50
- No. 30 SHEET METAL HANDY BOOK, 448 Pages 2.50
- No. 31 MECHANICAL DRAWING GUIDE, 192 Pages 2.50
- No. 32 MECHANICAL DRAWING & DESIGN, 410 Pages 3.00
- No. 33 ELECTRONIC DEVICES, 304 Pages 3.00
- No. 34 ELECTRICIANS EXAMINATIONS, 272 Pages 2.50
- No. 35 ELECTRIC POWER CALCULATIONS, Page 480 3.00
- No. 36 ELECTRIC DICTIONARY, 9000 Terms 3.00
- No. 37 POWER PLANT ENGINEERS GUIDE, 1568 Pages 5.00
- No. 38 ENGINEERS AND FIREMANS EXAMS, 544 Pages 2.50
- No. 39 OPERATING ENGINEERS LIBRARY, 3 Book Set 12.00
- No. 40 PUMPS, HYDRAULICS AND AIR COMPRESSORS, 1750 Pages 6.00
- No. 41 HOUSE HEATING GUIDE, 966 Pages 5.00
- No. 42 MILLWRIGHTS & MECHANICS GUIDE, 1248 Pages 5.00
- No. 43 DO-IT-YOURSELF ENCYCLOPEDIA, 2 Book Set 8.95
- No. 44 NEW MECHANICAL DICTIONARY, 712 Pages 6.95
- No. 45 MAGIC OF LANDSCAPING, 128 Pages 1.49
- No. 46 WATER SUPPLY & SEWAGE DISPOSAL, 436 Pages 4.00
- No. 47 GUIDE TO CREATIVE PHOTOGRAPHY, 400 Pages 3.95

## MAIL THIS NO-RISK COUPON TODAY!

THEO. AUDEL & CO. - Self Improvement Publishers Since 1879 - P2

49 W. 23rd Street, New York 10, N.Y.

	1	2	3	4	5
Please mail me for 7 days' FREE EXAMINATION the books I have circled at right.	6	7	8	9	10
I agree to mail \$2 in 7 days on each book or set ordered, and to further mail \$2 a month on each book or set ordered until I have paid the purchase price, plus shipping costs. If I am not completely satisfied with my Audel Guides I may return them.	11	12	13	14	15
	16	17	18	19	20
NAME _____ AGE _____	21	22	23	24	25
ADDRESS _____	26	27	28	29	30
CITY _____ STATE _____	31	32	33	34	35
EMPLOYED BY _____	36	37	38	39	40
<input type="checkbox"/> SAVE SHIPPING COSTS! Check here if you enclose complete payment with order. We pay postage charges. You have some return privilege.	41	42	43	44	45
	46	47	48		

THIS VALUABLE BOOK IS

*free*

TO AMBITIOUS  
MEN WHO WANT TO  
SUCCEED IN BUSINESS

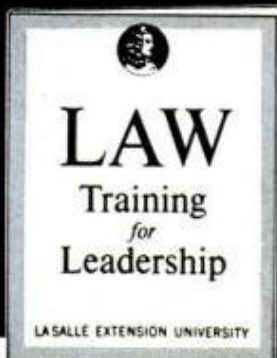

## Study LAW at Home

### Earn an LL.B. Degree from LaSalle

The Law-trained man wins rapid promotion, big income, great personal influence and prestige in any line of business activity. Leading corporations seek out such men for key positions. Under supervision of LaSalle's distinguished Law faculty, you can master Law thoroughly and enjoyably in your spare time. You work with actual legal cases, acquiring real experience. *Famed LaSalle Law Library of 14 volumes given to you as part of course. Mail coupon today.*

#### LA SALLE EXTENSION UNIVERSITY

An Accredited Correspondence Institution

Dept. 2-036, 417 South Dearborn, Chicago 5, Ill.

Please send me your free illustrated book  
"Law Training for Leadership."

Name ..... Age.....

Address.....County.....

City &.....

Zone.....State.....

more run for your money!



## WARN HUBS

on your 4-WHEEL DRIVE

That goes for your vehicle as well as Warn Hubs. The hubs stop front end drag in 2-wheel drive, save gears, gas, tires, give your vehicle more life, greater handling ease. And the hubs are the most dependable you can own. Ask your dealer!

WARN MFG. CO.

Riverton Box 6064-A  
Seattle 88, Washington

## JEEP OWNERS

RE-POWER NOW WITH A V-8 OR 6 CYL. ENGINE — USE FORD—CHEV.—MERCURY—GMC—PONT—STUDE—DODGE OR PLYMOUTH

In Jeeps, Jeepsters, Sta-Wgn, trucks, Kaiser & H. J. cars. Conversion Kits \$45.35 to \$56.90. Want fast action? Give us full information, send \$15.00 Dep. and we will ship correct kit. Bal. COD. Send full amount for prepaid shipment. Wire, phone or write today. Details FREE.

HOOSIER MACHINE PRODUCTS CO.

312 S. E. 6th St. Phone CR 6-3442 Pendleton, Oregon

## GET INTO ELECTRONICS

V.T.I. training leads to success as technicians, field engineers, specialists in communications, guided missiles, computers, radar, automation. Basic and advanced courses. Electronic Engineering Technology an ECPD accredited Technical Institute curriculum. Assoc. degree in 2 1/2 mos. B.S. obtainable. G.I. approved. Start Feb., Sept. Dorms, campus. H.S. graduate or equivalent. Catalog.

VALPARAISO TECHNICAL INSTITUTE

DEPT. D VALPARAISO, INDIANA

## 6-IN-1 ONLY MACHINE OF ITS KIND!

### UNIMAT



Compact workshop for all metal, plastic, wood. Precision lathe, milling machine, drill press, surface grinder, polishing/grinding machine, portable drill. Complete basic unit, \$129.50. WRITE FOR FREE CATALOG.

AMERICAN EDELSTAAL, INC., DEPT. GB 350 BROADWAY, N.Y. 13, N.Y.

# INVESTIGATE ACCIDENTS

Train quickly in your own home for repeat income in the exciting, secure Claim Investigation and Claim Adjusting field. Our students and graduates are already earning \$4, \$5, \$6 an hour extra SPARE TIME — and up to \$10,000 a year Full Time. You need NO prior experience or higher education. Your age does NOT matter.

### HERE IS YOUR CHANCE FOR ACTION AND REAL JOB SECURITY

As a trained Claim Investigator you will (1) INVESTIGATE FACTS and (2) DISTRIBUTE MONEY as the representative of wealthy organizations.

No other business offers you greater opportunities for success and security. Here's why: The huge, rapidly expanding Claim Investigation and Adjusting Profession right now distributes more money than any other service industry. And it's growing fast. Over 200 MILLION ACCIDENTS must be investigated this year for Insurance Companies, Airlines, Railroads, Steamship Lines, and Government Offices.

### MAIL NOW for FREE BOOK

SEND TODAY for Big, FREE, Illustrated Catalog. Learn the exciting facts about Universal Schools' low cost training. No obligation. No salesman will call. GI APPROVED.



#### UNIVERSAL SCHOOLS

6801 Hillcrest Ave.  
Dept. PM-2, Dallas 5, Texas

Please rush me your FREE book on Claim Investigation. This does not obligate me and no salesman will call.

Name ..... Age.....

Address.....

City.....Zone.....State.....

Approved by Government for Korean Veterans





# MAN GOING PLACES

He's building a money-making, lifetime business as a Duraclean dealer. He could be your neighbor—or he could be *you*.

This man is an expert in one of the most profitable businesses of all—carpet and furniture cleaning in the home. Duraclean trained him, provided all his special equipment and cleaning materials, and backs him with a powerful national advertising campaign.

Duraclean shows him how to get customers, too. They're easy to find. Every homeowner is a potential client. Every theater, church, office building, hotel, school and business is a prospective customer.

The market is there, and Duraclean's unique cleaning process lets the dealer take full advantage

of it. Duraclean cleans by absorption. That is, it literally lifts the dirt from fabrics—leaves them bright, fresh, really clean.

This Duraclean dealer works full time performing Duraclean service. That's only one way to begin in this business. You also can start part-time or you can hire others to do the servicing. There's little overhead, no shop needed, because the work is done in the customer's home or place of business. Three average jobs a day can gross a dealer \$22,500 a year.

For the enterprising man, for the man interested in going places, a Duraclean dealership offers a lifetime of financial security. Interested? Mail the coupon below.

## JOIN THESE SUCCESSFUL DEALERS



**Ed Kramsky (Ill.)** "In two years I now have two assistants, a nice home and real security for my family."

**Ward Whitbeck (Conn.)** "On one hotel job I made \$400.88. In my fifth year am making as much as \$225.00 one day."



**John Kalita (Ind.)** "Instead of making \$2.00 an hour working for someone else, I average \$7.00 to \$9.00 an hour with Duraclean. It's the best investment I ever made."

RUSH THIS COUPON TODAY

Duraclean Company, Dept. 2-162  
Duraclean Building  
Deerfield, Illinois  
Please send me all the facts about Duraclean.

Name .....

Address .....

City ..... State .....



BUY DIRECT! IMPORTER-TO-YOU

**SAVE UP TO 1/2**  
**ON MUSICAL INSTRUMENTS**



## ACCORDIONS

Famous Italian Makes—35 Models

Get our low **Importer-to-you discount prices!** A. C. A. saves you up to 1/2 off prices of comparable accordions. Brilliantly performing new 1962 models for students and professionals. Standard or electronic. Many colors. Trades welcomed—big allowances. Low down payment, easy terms. Money back guarantee. Bonus Gifts **FREE!** Coupon brings **FREE Color Catalogs.**

## Electric Chord Organs

Play at Sight  
—No Lessons

Low as \$99.00

Amazing tone and performance. Play in minutes, without lessons. **FREE MUSIC.** Finest Italian hand-crafted workmanship. Lovely cabinetry. All types: Portable, Consoles, Piano Keyboard Models too! **E-Z Terms.** Money back guarantee. Rush coupon **TODAY.**



5-DAY FREE TRIAL

**ACCORDION CORP. OF AMERICA, Dept. R-22**  
2003 W. Chicago Ave., Chicago 22, Ill.

**FREE BONUS GIFTS**  
for promptness

**5-DAY FREE HOME TRIAL**

**FREE COLOR CATALOGS**  
and discount sale prices

**ACCORDION CORPORATION OF AMERICA, Dept. R-22**

2003 West Chicago Avenue, Chicago 22, Illinois  
Rush **FREE** color catalogs and Importer-to-You discount prices.  
Check Instrument preferred:  Accordion  Chord Organ

Name \_\_\_\_\_  
Address \_\_\_\_\_  
City \_\_\_\_\_ State \_\_\_\_\_  
 I have an Instrument to trade-in.

## Curious Coins!

ODD PAPER MONEY!

Worth \$1 — But Yours

**FREE!**

to get names for our mailing list

**SEND** for this valuable packet of odd and curious coins, paper money—an exciting introduction to fast growing hobby! You'll find coins from Formosa (Free China—our ally), Belgium, neighboring Mexico, far-off Pakistan, etc. Actual value at least \$1—but yours **Free** on this special offer!

**JOIN THE FUN RIGHT AWAY**

Get your **FREE** packet of coins and money—plus \$100,000 Confederate Money **bonus**—together with lists of rare coins available and other valuable offers for inspection. No obligation to buy. Just send your name and address now, with 10c to help cover shipping, to:

**LITTLETON COIN CO., Dept. 2-PM,**  
Littleton, New Hampshire



**ALSO FREE!**



**\$100,000 in CONFEDERATE "MONEY"!**

These lots-of-fun facsimiles are yours for promptness while the supply lasts.

## learn more . . . earn more

Industry demands graduates. Major corporations regularly visit us to interview and employ seniors. Enroll for higher income . . . advancement.

## engineering degree in 27 months

Earn B.S. faster here. IN 36 MONTHS B.S. in Business Administration. Small classes. *Low costs.* Enter Mar., June, Sept., Jan. Write J. E. McCarthy for Catalog and Career Book.

## TRI-STATE COLLEGE

422 College Avenue • Angola, Indiana

## TELEPHONE



## HANDSETS

Use as inter-house phone, talk house to garage, as loud speaker system, etc. You receive transmitter, receiver, 3 conductor cord and simplified, illustrated installation diagrams. Handsets are guaranteed to be the same as used in our great National Telephone System. Price delivered \$2.95. **TWO FOR \$5.00!**

**PRIVATE TELEPHONE SYSTEMS** for offices, factories, motels and drive-in restaurants information on request.

**TELEPHONE REPAIR AND SUPPLY CO.**  
DEPT. PM-140 1760 Lunt Ave., Chicago 26



## BIG EARNINGS WAITING

Learn to **REPAIR, REBUILD, RESELL**  
**TYPEWRITERS, All makes—At home**

Get industry-proved training in spare time! Earn while you learn with real typewriter, sub-assemblies, professional tools, illus. lessons. **FREE BOOK** shows money-making opportunities. Write **TODAY** to Typewriter Repair School, Div. Tech. Home Study Schools, Dept. B-13, 150 Park Ave., E. Rutherford, N. J. (Lic'd N. J. Dept. of Educ.)



## MAGIC TRICKS

**IT'S FUN To Do MAGIC**

Be popular! Amaze—mystify—entertain! For 40 years Douglas has satisfied customers all over the world. Now, you can enjoy this fascinating hobby. Only 10c brings our New 1962 Catalog 500 Tricks, containing brand new tricks for pocket, parlor, stage. Join in the fun—send 10c today!

**DOUGLAS MAGICLAND**  
Dept. M-7, Box 274, Dallas 21, Texas

Processing of **KODACHROME** (Licensed by Eastman Kodak)

## AT DISCOUNT PRICES

KODACHROME I & II } \$1.00  
8mm ROLL OR }  
35mm 20 EXP. MTD. }  
8mm MAGAZINE ..... .75  
35mm 36 EXP. MTD..... 1.75

**SEND FOR FREE MAILERS** and our big **FREE CATALOG** of Processing, Film and Equipment at **DISCOUNT PRICES!**



**SOLAR** CINE PRODUCTS 4247 S. Kedzie Dept. ME  
Chicago 32, Ill.

# new home-import business...

Now you can get exciting Imports at trifling cost abroad and sell them by mail order, or to friends and stores. New Plan starts you in full or spare time without capital or previous experience. Just imagine the *huge profit* you could make on this 17-jewel watch you can get for only \$2.87 in Europe—the 16-mm camera at just \$2.30, the transistor radio or the hunting rifle. Mellinger globe-trotting couriers discover and show you how to get fast-selling imports just like these—Show you how you can deduct your profit in advance, even *before* ordering merchandise.

## Famous World Trader Guides You

You'll receive personal step-by-step guidance from B. L. Mellinger, one of the most famous international traders the world has ever known. Mr. Mellinger even shows you how to put experience you have gained through jobs, hobbies and interests to work making extra import profits for you.



Hand carved Clock Germany 63c



Spinning Reel with spare spool 96c



Hunting Rifle Italy \$3.24

Sim. Pearl Necklace Japan 4 1/2c



Stainless Steel Dinner Service. 50 pieces \$3.54



Motorcycle Norway \$110.00

16mm Camera Magazine load, with case and hand strap. Uses standard 16mm film Japan \$2.30



Tape Recorder with mike. Germany \$13.50



Derringer Pistol Germany \$5.74

**MELLINGER CO.,**  
Dept. D252 • 1554 S. Sepulveda • Los Angeles 25, California

Tailor made Suit. Silk or Wool Hong Kong \$17.50



Transistor Radio with battery. Japan \$3.02



Binoculars Germany \$1.00



Lighter Japan 17c

NEW PLAN SHOWS YOU HOW AND WHERE TO GET DAZZLING BUYS LIKE THESE FOR BIG PROFIT U. S. SALES. PRICES SHOWN ARE DIRECT FROM SUPPLIERS ABROAD. DO NOT ORDER FROM US...

17-Jewel Watch France \$2.87

Fishing Fly hand tied 1 1/4c

## You Keep ALL the Profits

This is a NEW idea for making money. Not a catalog "scheme" or franchise distributor "deal" where you buy catalogs and imports from others and watch them turn the *real* wealth of your labor into luxuries for themselves. *Mellinger puts you in direct contact with the ORIGINAL OVERSEAS SOURCE!* He makes no profit on your imports. The profits are all yours. On one of the lower priced products shown here, an importer following the Mellinger Plan has already taken in a *half million dollars!* You, too, can cash in on the big demand for imports, if you know this method.

## Free Samples—CONTACTS ABROAD

Following the Mellinger Home-Import Plan you receive FREE imports—and membership in International Traders, a world-wide organization of Importers and Exporters which helps beginners to a fast start. You will receive confidential monthly bulletins revealing names and addresses of actual overseas suppliers. You are shown how you can easily deal with foreign suppliers, how to get samples, how to make big savings on your own purchases.

## Rush Coupon for FREE Details

Start now to exciting cash profits in the new Import boom. Mail coupon for FREE BOOK, "Success Stories in World Trade," which will change your whole idea of the money you can make, full or spare time, in your own Home Import Business. No salesman will call. Airmail reaches us overnight.

Send for FREE Book!

MELLINGER CO., Dept. D252  
1554 S. Sepulveda, Los Angeles 25, Calif.

Show me how these amazing buys abroad can give me my own big profit Home Import Business. Rush book and details without obligation. ALL FREE!

NAME \_\_\_\_\_  
ADDRESS \_\_\_\_\_  
CITY & ZONE \_\_\_\_\_ STATE \_\_\_\_\_

You wouldn't stand for  
a hose like this . . .



## But what about your engine?

That's right—your automobile engine can be every bit as leaky as a leaky hose if the engine bearings are worn. The only difference is you can't see the leak; but you can tell it's there if you're using a lot of oil.

### Insist on a complete overhaul

When you have your engine overhauled, don't stop at the rings. For the fact is, not even brand-new rings can handle excessive oil thrown off by worn bearings. Bearings are designed to distribute a controlled amount of oil to help the engine function properly. Naturally, an engine will run like new only with new engine bearings.

### Insist on *Fm* Job-Tailored bearings

So while you're at it, insist on Federal-Mogul engine bearings, the very best you can buy. They are designed specifically to work best in your particular engine, from V-8 to straight-8, from overhead-4 to pancake-6. There's a size

and type for even the grand old-timers. Insist on Federal-Mogul Job-Tailored engine bearings.



# FEDERAL-MOGUL SERVICE



Division of Federal-Mogul-Bower Bearings, Inc. • Detroit 13, Michigan

# Pentagon sidelights

By William R. Kreh

An unexpected package arrived in the mail recently for an ex-Navy man.

In it were some personal articles of his which had spent more than 19 years at the bottom of Cavite Bay in the Philippines. The seaman served in the submarine USS *Sealion* when she became the first submarine to be sunk in World War II. When the *Sealion* was raised for scrap recently, his belongings were found. Among the items returned was a message to him announcing his daughter's birth. His daughter is now 20 years old.



**Here's an absolutely rainproof raincoat.** In recent Army tests, a cotton coat treated with a new repellent stood continuous 24-hour laboratory rain, at the rate of an inch per hour, for more than a week. The new raincoats will become standard equipment for soldiers stationed in areas where rain is heavy, as in the tropics.



**A torture chamber** has been opened by the Army Signal Corps at Fort Monmouth, N. J., to test production samples of some 20 million dry batteries bought every year for all the armed forces.

The new unit's job will be to "torture" the batteries—exposing them to heat, humidity, cold, shock vibration and similar punishment. And some of the punishment is pretty severe. The Navy, for example, requires its batteries to operate efficiently even after being shot 40 feet by an air cannon.



**Invisible dust** may tell us more about the weather in a project being followed closely by the Office of Naval Research.

Scientists have strung 30 miles of wire in central Illinois in order to put a uniform charge on tiny particles of dust. Natural dust has a mixture of charges. The dust will rise up to about 7000 feet and be tracked by special airborne and ground instruments to reveal air movements better than smoke can. It's hoped the project will show why some clouds produce rain and some do not, what causes cloud droplets to grow into drops of rain, and what effect electrical forces have on rain.

**Sea lions bark under water.** The Navy just found it out in experiments on the West Coast. It means one more up-to-now-unidentified sound can be ignored by sailors listening on sonar for enemy submarines.

**Breath can be measured** by a machine installed by the Air Force at Wright-Patterson Air Force Base in Dayton, Ohio. So sensitive it can measure thrust as gentle as the force of human breathing, it will be used to measure precisely the thrust of ion rocket engines and other propulsion systems designed for space ships.

**Bird watchers** around Boston aren't having much to do with the Navy these days.

It seems the Massachusetts Audubon Society not long ago started spraying sea gulls with red dye to help trace their nesting habits. But then too many reports of red gulls started coming in. Investigation showed that the Navy Hydrographic Office was using the same red dye as the gull painters to study tides off Portsmouth, N. H. The birds swam in the dyed water and came out red.

**A coat of special wax** is given transport planes of the Military Air Transportation Service after every 1000 hours of flying time. Officials say the wax enables the plane to pick up five to ten knots in air speed by cutting friction, also saving fuel.

**Cloud seeding in the Arctic** may help the Army "weather" in the enemy if any future war is fought there. Recent polar tests have shown that seeding clouds with dry ice from an airplane can result in a good snowstorm. A test plane seeded an eight-mile path, using about five pounds of dry-ice pellets per mile. Twenty minutes after seeding, there was an intense snowfall. Visibility was cut from 12 miles to about an eighth of a mile within the snow area and the cloud ceiling dropped from 1200 feet to about 300 feet. The snow continued for 15 minutes.

**Salt water and garbage** can be converted to electricity by a new Navy bacterial battery. Bacteria are supplied with organic matter for food and sea water for oxygen. Their life processes create an electrical current that can be led off on wires. The experts say that many kinds of wastes, including sewage, would make suitable foodstuff or "fuel" for the microscopic generators.

The Navy's not saying what its bacteria will eat, but has confirmed that a laboratory model of a bug battery has been producing current for a year and will soon get a working test at sea. ★ ★ ★

# LEARN UPHOLSTERY

in your spare time  
run your own  
business  
AT HOME

FREE TOOLS WITH COURSE!

**FREE BOOK**  
with sample lessons  
WITH COURSE YOU MAKE  
SLIPPER CHAIR  
CLUB CHAIR  
OTTOMAN  
WITH SLIP COVERS  
Yours to Keep or Sell

**BE YOUR OWN BOSS**

Earn more from the start! Set up your own profitable business, in your own home. STOP worrying about lay-offs and retirement. Enjoy steady income, independence for life in the booming field of Furniture Custom Upholstery. Right off, you start learning AT HOME with tools, complete frames, fabrics and materials—ALL included FREE with your UTS Course.

Now the practical N. Y. State-approved UTS Home Study Course is available to you right at home under the personal supervision of top notch upholsterers, the same fine professionals who teach in our N. Y. School.

You learn professional custom upholstery, reupholstery, furniture finishing, repairs, how to make beautiful slip-covers, window cornices, cushions and draperies, and quickly become a skilled craftsman.

Best of All You EARN WHILE YOU LEARN, in your spare time . . . the UTS easy way. Many Upholstery

Trades School students earn enough doing spare time upholstery to end their money worries. What they have done—YOU CAN DO!

**FREE ILLUSTRATED BOOK AND SAMPLE LESSON SHOWS YOU HOW**

Accept this **FREE SAMPLE LESSON**—With this lesson you'll be able to repair the bottoms of chairs, couches, webbed benches, stools, dozens of things!

**FREE DELUXE 36 page PICTURE BOOK** (108 illustrations) "UPHOLSTERY—Your New Way to a Successful Career." Tells you all about this expanding, big opportunity field . . . 17 ways to MAKE MONEY in upholstery!

AT HOME prepare NOW for a well-paid job, big profits, from steady work, as your own boss, running your own business. Training in N. Y. School also available. Accredited Nat'l Home Study Council, Vet. Approved. Mail coupon NOW! No obligation. Upholstery Trades School, Dept. TB-310, 721 Broadway, N. Y. 3, N. Y.



Paul de Vita, former Auto Mechanic says "Doubled my income—am my own boss thanks to UTS Training."

**Send for FREE Illustrated Book**

**FREE SAMPLE LESSON**

**Upholstery Trades School**

Dept. TB-310, 721 B'way, N.Y. 3, N.Y.

Please send me at no cost your big illus. FREE book, "your Future in Custom Upholstery," and FREE sample lesson—no obligation, no salesman will call.

I am interested in:

- Home Study Training.
- Training in N. Y. School.

Name . . . . . (Please print plainly)

Address . . . . .

City . . . . . Zone . . . . . State . . . . .

Check if Korean Veteran.





# PLAY RIGHT AWAY ANY INSTRUMENT

— even if you don't know a single note now!

**N**OW it's EASY to learn ANY instrument. No boring exercises. Even if you don't know a single note now you can play delightful pieces — from your FIRST lesson! BY NOTE. Make amazing progress. No special "talent" needed. Learn at home in spare time. Without a teacher. Low cost! Soon you can play popular music, hymns, classical and any other music. Over 1,000,000 students, all over the world.



**FREE BOOK.** Send this ad with your name and address filled in below, to: **U. S. SCHOOL OF MUSIC, Studio 302, PORT WASHINGTON, N. Y.** (No obligation, no salesman will call.)

Chartered by N. Y. State Education Dept. Est. 1898.

Name .....

Address .....

Be Sure to Include Zone No., if any.



## ... TURN CONCRETE INTO GOLD!

### MAKE UP TO \$75 A DAY IN YOUR OWN BUSINESS

If you want to have your own business — to start a business on your own — here's your big opportunity! New high speed, low cost General block machine produces up to 1,000 concrete blocks a day. Sell all you make to builders, supply houses, and others for homes, factories, buildings, garages. Cash in on the building boom! You can make profits of 100% to 150% — up to \$75 a day! General block machine equipped with 1/2 h.p. electric motor — or can be supplied with gasoline engine — works anywhere, in little space, indoors or out. Operates from ordinary house light socket. Simple, foolproof 3 step operation — so easy a child can do it. Makes superior 3 core blocks any size from 4" to 12". Also makes chimney, sash, corner and other types. Blocks meet any building code anywhere in the country. Materials — sand, water, cement, available anywhere. Simple illustrated operating instructions and mixing formulae for cement and cinder blocks supplied with each machine. Write for FREE folder with full information.

**MOTOR DRIVEN**

R. L. T. of New York City reports: "MY GENERAL BLOCK MACHINE PAID FOR ITSELF IN FIRST 2 WEEKS!" Hundreds now in use the world over! Write for FREE details today!

**EXTRA**

Amazing illustrated book gives floor plans for 6 sensational concrete block bungalows. Tells how to lay blocks, lay out building lines, mix concrete, build steps, porch and concrete floors all at great savings. Written by experts. Can save many times the cost of the machine! Get it now! No strings attached. Send \$1.

BOOK SENT FREE IF YOU BUY MACHINE.  
\$1 REFUNDED IF YOU BUY LATER.

**GENERAL ENGINES CO.**  
DEPT. PB-22, ROUTE 130, THOROFARE, N. J.



## PROFIT IN YOUR SPARE TIME



FIX Small Gasoline Engines  
OUTBOARD • POWER MOWER • CHAIN SAW • TRACTOR

Harry F. Peters, Spokane, Wash, says:  
"... your Course led me into a very profitable and enjoyable business."



Be a small engine expert . . . earn EXTRA MONEY . . . own your own business. Easy-to-learn LINCOLN Home Study method qualifies you. Write for full particulars.

**LINCOLN TECHNICAL INSTITUTE**  
Suite 2-E, 472 Market St., Newark 5, New Jersey

## REAL ESTATE BE A BROKER

**PAYS BIG! SEND FOR FREE, BIG, ILLUSTRATED CATALOG NOW!** Graduates report making substantial incomes. Start and run your own business quickly. Men, women of all ages, learn easily. Course covers Sales, Property Management, Appraising, Loans, Mortgages, and related subjects. **STUDY AT HOME** or in classrooms in leading cities. Diploma awarded. Write TODAY for free booklet! No obligation.



Approved for World War II and Korean Veterans  
**WEAVER SCHOOL OF REAL ESTATE (Est. 1936)**  
2020V Grand Avenue Kansas City, Mo.

## BLUE BOOK OF CRIME FREE!

Given to men who want to get into **CRIME DETECTION FINGER PRINT IDENTIFICATION**

Train at home, spare time. Join hundreds of I. A. S. graduates now employed by police and identification bureaus in every state. Learn finger print identification, crime investigation, firearms identification, police photography, other subjects vital to qualifying for good paying, secure, interesting jobs. "Blue Book of Crime" and details Free. Must state age.

**Institute of Applied Science, Dept. 1352,**  
A Correspondence School Founded in 1916  
1920 Sunnyside Ave., Chicago 40, Ill.

## MONEY in WORMS

Sell 20,000 fishworms per week @ \$4 per 1000 from a bed 3 feet wide and 8 feet long. We teach you how to raise and where to sell fishworms and crickets. Write for free literature.

**CARTER WORM RANCH, PLAINS, GEORGIA**  
Read our success story in LIFE MAGAZINE, December 28, 1959 Issue

## EARN Mechanical Engineering DEGREE

You can earn an A.S.M.E. degree at home. College level HOME STUDY courses taught so you can understand them. Continue your education, earn more in the highly paid Mechanical Engineering field. Drafting, machine and tool design, automatic, electro-mechanics, etc. Over 27,000 graduates now employed. Resident school available at our Chicago Campus. Founded 1934. Free catalog. Catalog on Electronics A.S.E.E. Degree course also available on request.

**AMERICAN INSTITUTE OF ENGINEERING & TECHNOLOGY**  
1145 West Fullerton Parkway — Chicago 14, Illinois

## RUPTURED

**BE FREE FROM TRUSS SLAVERY**

Surely you want to THROW AWAY TRUSSES FOREVER, be rid of Rupture Worries. Then Why Do you put up with wearing a griping, chafing and unsanitary truss the balance of your life? If you do, it will NOT be through necessity but through choice on your part.

Now there is a new modern Non-Surgical treatment that is designed to permanently correct rupture. These Non-Surgical treatments are so dependable, that a Lifetime Certificate of Assurance is given. Write today for our new FREE BOOK that gives facts that may save you painful, expensive surgery. Tells HOW and explains WHY NON-SURGICAL Methods of Treating Rupture are so successful today. No obligation.

**Excelsior Medical Clinic**  
Dept. H6125, Excelsior Springs, Mo.



# 6 REASONS WHY RCA TRAINING IN ELECTRONICS

can be the smartest investment  
you'll make in your *entire lifetime!*

**1. You get the finest training-at-home** under the supervision of the RCA INSTITUTES, experts in technical training for over 50 years. The very name "RCA" means dependability, integrity, and scientific advance.

**2. You get comprehensive training** in your choice of many complete up-to-date Courses . . . including Radio and Electronic Fundamentals, TV Servicing, Color TV, Transistors, Automation Electronics, Communications Electronics, Computer Programming.

**3. You get Theory, Experiment, and Service Practice** starting with the very first lesson . . . a complete training package throughout the course. No special technical background is required.

**4. You get prime quality equipment** as a regular part of your Course . . . equipment that you keep and use on the job. You never have to take apart one piece to build another.

**5. Voluntary Tuition Payment Plan.** You pay for each lesson only when you order it. If you interrupt your course *at any time, for any reason*, you owe nothing more unless you resume. You *never* have to pay for the whole course if you don't complete it.

**6. You get top recognition —** Graduates of RCA Institutes now work for leaders in the electronics field; many have their own businesses. This record is true tribute to the high quality of RCA Institutes training.

Send for this  
64-page Home  
Study Catalog  
**FREE!**



RESIDENT SCHOOL Courses in New York City and Los Angeles offer comprehensive training in Television and Electronics. Day and Evening classes start four times each year. Detailed information on request.

## RCA INSTITUTES, Inc. Home Study School, Dept. PM22

A Service of Radio Corporation of America  
350 West Fourth Street, New York 14, N. Y.

Please rush me your FREE illustrated 64-page book "Your Career in Electronics," describing your home training programs. No obligation. No salesman will call.

Name .....  
please print

Address .....

City ..... Zone ..... State .....

Korean Vets! Enter discharge date .....

**CANADIANS** — Take advantage of these same RCA courses at no additional cost. No postage, no customs, no delay. Send coupon to: RCA Victor Company, Ltd., 5581 Royalmount Ave., Montreal 9, Quebec.

Guaranteed against burn-out

**AIR GRATE**

**YELLO-BOLE**

**1. Smokes sweeter!**

Imported briar bowl lined with *real honey*. Starts caking the instant you light up. Hence, no break-in.



**2. Smokes drier and healthier!** Metal grate condenses moisture, tars, nicotine. No wet heel.

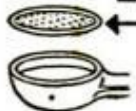

**3. Smokes cooler!**

Air-vented chamber draws in fresh air. Aluminum fins and shank throw off heat, cool the smoke.

Famous honey-lining!

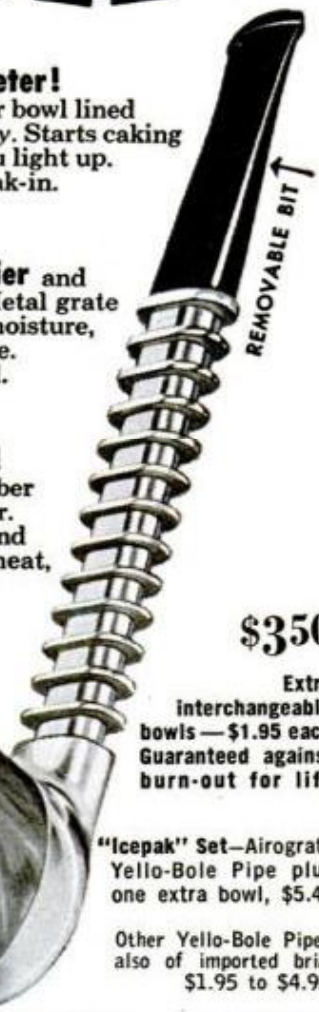
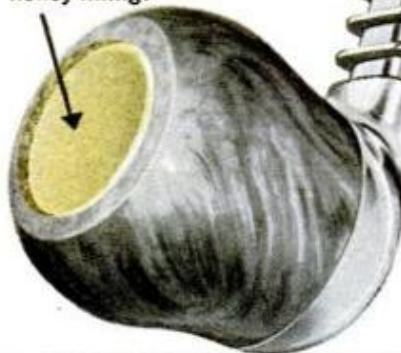

**\$350**

Extra interchangeable bowls — \$1.95 each  
Guaranteed against burn-out for life

"Icepak" Set—Airograte Yello-Bole Pipe plus one extra bowl, \$5.45

Other Yello-Bole Pipes, also of imported briar \$1.95 to \$4.95.

Send for FREE FOLDER, YELLO-BOLE PIPES, Inc., Dept. Y54, N.Y. 22

**\$40 for 1½ DAY'S SPARE TIME WORK GRINDING LAWNMOWERS**

Yes, J. H. B. writes, "not bad for a 76 year old young fellow earning \$40 for a day and a half's work" . . . and others are making even bigger money with the Universal Model B Lawnmower Grinder. You too, can make good spare or full time profits in your own business in your garage or basement. We furnish everything you need. Write today. No cost or obligation. Dept. M-22.

**ROGERS**  
MANUFACTURING CO.  
LINDSEY, OHIO



**Tune in on the inventors**

The INVENTIONS WANTED sign is out again at the National Inventors Council, with a new list of inventions wanted by the armed forces and other government agencies. Here's a selection of interesting possibilities from the 83 suggestions listed:

- . . . A method of preventing snow and ice accumulations on airfield runways.
- . . . A self-driving anchor stake for guy wires on radio antennas and towers.
- . . . A relief valve that will vent gases from rocket fuels in zero gravity without letting the liquid fuel escape.
- . . . A wind force and direction sensor that won't foul in ice, snow and extreme cold.
- . . . A wind-measuring system that will report both horizontal and vertical air movement.
- . . . A wind force and direction meter that works reliably without moving parts.
- . . . A method for keeping birds off—and away from—the tracks used for high-speed rocket sleds, without interfering with the track or the sled. (This one would be worth real money in a lot of places besides the government, too.)

For the complete list of inventions wanted, plus an outline of NIC's operations, write for the Inventions Wanted bulletin to the National Inventors Council, U.S. Dept. of Commerce, Washington 25, D. C., or see any Department of Commerce field office.



Another valuable government service to inventors and businessmen is the Products List Circular published monthly by the Small Business Administration. It lists hundreds of new products and processes to help small businessmen find new fields or ways to improve their present methods. The privately-owned inventions are available through arrangement with the inventors; the government-owned patents can be licensed on a royalty-free but non-exclusive basis.

The current issue, available at any office of the SBA or by mail from the Small Business Administration, Washington 25, D. C., lists ideas ranging from a pinless diaper and a keepsake baby spoon to a pavement-breaking bulldozer attachment and a hay tedder. By the way, how many people do you know who know what a hay tedder is? We didn't. ★ ★ ★



# Are you the kind of guy who loves to "tinker" with things?

And are you completely satisfied with your present kind of work, income, prospects? If these questions "hit home," here's a big fact to realize: **OVER 400 MILLION electrical appliances are in use in American homes — and are increasing by 76 MILLION a year! Men trained to service them are cashing in on this "Electrical Appliance Boom" — making \$3 to \$5 an hour, spare time or full time. It will pay you to send for the FREE BOOK telling how you can quickly and easily get into this profitable field.**



**YOU'RE NOT TOO HAPPY** in your present job — right? Not enough money. Work not interesting enough. Don't like the people you work with.

What you *really* enjoy is putting around the house, getting things shipshape. Fixing that doorbell or squeaky hinge. Putting a new washer in that leaky faucet. Getting the motor of that balky power lawn mower to run smooth as silk.

And sometimes you wonder, "Why can't I do something like this all the time? Why can't I get PAID for doing what I really enjoy — instead of what bores me? Why can't I start some sort of little home business that would be fun and profitable?"

## This is "Made to Order" for You

If that's the kind of fellow you are, here's a little business that's "made to order" for you. Servicing Electrical Appliances. No big investment or elaborate equipment needed. A few simple hand tools are all you need — and a corner of your basement or garage to work in.

Plenty of money to be made — \$3 to \$5 an hour, in spare time or full time. At that rate, you may soon find it will pay you to open up your own Appliance Repair Shop. Then you're completely your own boss. Maybe even end up having other fellows work for you!

## Why the Boom in Appliances Means Money in Your Pocket

In addition to the 400 MILLION electrical appliances *already* in use in American homes, this year alone will see sales of 76 million *new* appliances! For

## CASH IN ON THE BIG BOOM IN ELECTRICAL APPLIANCES

The coming of the auto created a multi-million dollar service industry, the auto repair business. Now — with 400 MILLION electrical appliances in American homes — the same thing is happening in *that* field. No wonder that men who know how to service them properly are making \$3 to \$5 an hour — in spare time or full time!

example, 4,750,000 new coffee makers, 2,000,000 new room air conditioners, 1,425,000 new clothes dryers. And now that Americans have become so absolutely dependent on these electrical aids, they are dependent on the men who can service them. As a trained Appliance Service Technician, you will be needed — respected — well paid.

Don't worry about how little you may now know about electricity. That's where we come in. We'll train you at home, in your spare time, using methods proven successful for over 45

years. We start from scratch, TELL you clearly and SHOW you in pictures everything you need to know. Your training will cost you less than 20¢ a day — and you can earn while you learn.

## FREE BOOK and Sample Lesson

Our 24-page Free Book will open your eyes to a whole world of new opportunities. Tells how you can "cash in" on America's "Electrical Appliance Boom" — the money our students are making, what they say about us.

Free Sample Lesson shows how simple and clearly illustrated our instruction is — how it can quickly prepare you for a profitable future in this big field. Just mail coupon, letter, or postcard to: National Radio Institute, Dept. AB2, Washington 16, D.C. (No obligation — and no salesman will call on you.)



### Earns \$510 in One Month's Spare Time

"In one month I took in approximately \$648 of which \$510 was clear. I work only part time. I do a lot of service calls on ranges, dryers, and other major appliances. The NRI course has been priceless to me." — Earl Reid, RFD 1, Thompson, Ohio.



### Business A Success

"Since taking your course I have opened up a small repair shop. At present I am operating the shop on a spare time basis — but the way business is growing it will be a very short time before I will devote my full time to the shop." — J. G. Stinson, 1506 Poinsettia St., Long Beach, Cal.



### More Than Doubled Cost of Course

"I had practically no knowledge of any kind of repair work. Now I am busy almost all my spare time — and have more and more repair work coming in. I have my shop in basement. I have made more than double the cost of training." — John D. Pettis, 172 N. Fulton, Bradley, Illinois.

### NATIONAL RADIO INSTITUTE Dept. AB2, Washington 16, D.C.

Tell me how I can "cash in" on the "Electrical Appliance Boom." Send me your illustrated FREE BOOK that outlines the whole NRI Course, tells what opportunities are open to me, answers my questions, describes success of other students, and much more. Also send me the FREE SAMPLE LESSON so I can see how clear and easy your instructions are. I am particularly interested in:

- Spare Time Earnings  Business of My Own  Better Job

I understand there is no obligation on my part; and no salesman will call on me.

Name.....

Address.....

City.....Zone.....State.....

Accredited Member National Home Study Council

Especially  
for  
**APPLIANCE REPAIRMEN!**  
YOU NEED **ELECTRIC APPLIANCE  
SERVICE NEWS**

**EASN**—now in its 12th year—is the Only Publication Serving the ENTIRE Appliance Repair Field.

**EASN LISTS** sources of supply for parts on all types of household electric appliances, such as washing machines, dryers, irons, vacuum cleaners, ranges, sewing machines, toasters, irons, mixers, coffeemakers, and so forth.

**EASN OFFERS** a "Buyers' Guide," listed alphabetically by product name, to help you get the parts you need.

**EASN ADVERTISERS** send free mailings of catalogs and other pertinent market data to readers from time to time.

**EASN BRINGS NEWS** of appliance repair schools and clinics in your area.

**EASN OFFERS** editorial material covering industry news with articles on techniques used by service firms, technical information, and industry trends.



ONLY PUBLICATION SERVING THE ENTIRE APPLIANCE REPAIR FIELD

505 N. LA SALLE ST.

CHICAGO 10, ILL.

**TRIAL OFFER**

**ELECTRIC APPLIANCE SERVICE NEWS** (Published Monthly)  
505 N. La Salle St., Chicago 10, Ill.

GENTLEMEN: Enclosed find  Check  Money Order  Stamps  
 Cash to cover my subscription as I have indicated below:  
 \$1.00 for 4 months trial subscription, or  
 \$2.00 for 1 year  \$3.00 for 2 years  \$4.00 for 3 years

By (Individual) .....

Firm Name .....

Street .....

City..... Zone..... State.....

(Please enclose your business card or letterhead stationery) PM

*The little box that keeps you in touch*

**WALKIE-TALKIE CITIZENS BAND TRANSCEIVER #740**  
Kit \$54.95      Wired \$79.95  
Complete with      Carrying Case with  
battery and charger      Shoulder Strap \$3.95

Hold it easily in the palm of your hand—slip it into your jacket pocket (weighs a mere 19 ounces, measures 7 1/4" x 2 5/8" x 1 5/8") . . . send and receive up to 1 1/2 miles over land; 10 miles over water; no license needed; no age limit; battery supplied lasts up to 2500 operating hours; crystal controlled transmit and receive; beginner-tested instructions for complete kit building ease and assurance; U. S. made; an original product of EICO research.

Write for free EICO catalog and name of nearest EICO dealer to:

**EICO® ELECTRONIC INSTRUMENT CO., INC.**  
Dept. PM-2 3300 N. Blvd., L.I.C. 1, N.Y.

(add 5% in West)

New Table Top Invention Puts You In...  
**PROFITABLE RUBBER STAMP BUSINESS**

Home Operators now make **\$9.20 AN HOUR** in Business once monopolized by a few big companies

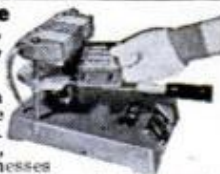

Special rubber stamps bring high prices—cost only pennies to make on new, low-cost table top machine. Take 27 cents worth of material, make perfect stamps, the kind businesses and offices now buy by the dozen at \$1.80 each. Make up to \$9.20 an hour. Start in spare time in your own home. Run machine on kitchen table using ordinary electrical outlet. Make any kind of stamp. We'll send you free information without obligation about this established, highly profitable business. **We'll even help finance your start.** For free information send name and address today on a postcard to: Rubber Stamp Div., 1512 Jarvis Ave., Dept. R-2-B, Chicago 26

**CONCRETE BLOCK HOME PLANS**

**\$1600 RANCH HOME**



QUALITY PLANS SINCE 1953

Folder, "How To Build Your Own Block Home", plus Plan Folder 10c. BAILEY BUILDERS, 201-B Cherokee, Little Rock, Arkansas

Build your own 24'x40' Ranch Home complete for \$1600. Liv. Room, Kit., two bedrooms, bath, Fireplace, slab or basement, carport or garage. Blueprints, instructions, and material list \$3.00 ppd. Money back guarantee. Other plans—\$600 and \$1000 Cottages, \$1200 Garage Apt., \$1900 and \$3000 Duplexes, \$2500 and \$3800 Ranch Homes, \$4800 Split Level, New Nuclear Ranch Home. Illustrated

**DOLLS!**

Learn to make, repair, dress, and sell dolls. Study at home. Excellent money making opportunities. **FREE BOOKLET.** No obligation! **NORM & SUE MORRIS'** DOLL HOSPITAL SCHOOL Studio M-22 11826 San Vicente Blvd., Los Angeles 49, Calif.

**ASSOCIATE In SCIENCE DEGREE in 90 Weeks**



- ARCHITECTURAL DRAFTING
- INDUSTRIAL TECHNOLOGY
- TOOL AND GAUGE DESIGN

Complete training in less than two years. Free placement service for life. Many excellent positions available to graduates. Start any Monday.

**LAIN TECHNICAL INSTITUTE**

TWO SCHOOLS: 603 N. Delaware St., INDIANAPOLIS, IND.  
821 E. Division St., EVANSVILLE, IND.



**Thumbnail Amplifier**

This amplifier, easily supported on a man's thumbnail, five years ago would have had to be the size of a typewriter. The manufacturer, Lear, Incorporated of Santa Monica, California, used miniature components to produce a unit which does not sacrifice quality.

# Don't wish you were a **WATCH REPAIRMAN...**

## **Be one NOW!**

Opportunities for full or part time earnings are the best in years

*Make rapid progress the Sweazey Way*



## **CHICAGO SCHOOL OF WATCHMAKING** *will train you at home in your spare time*

Get set now for lifetime security or a business of your own. Have a second trade for emergencies or after retirement. Watch repairing is light, clean, fascinating. It frees you from the dull drudgery of tiresome or back breaking work. It offers excellent opportunities now for full or part time earnings.

### **Complete professional instruction for only \$5 a month**

No need to leave home or job. Learn in spare time. Chicago School of Watchmaking's exclusive Sweazey System shows you step by step how to repair all types of Swiss and American watches. It's practical, shop method training. You work with watches from your very first lesson. You need no previous experience. Age is no barrier. Diploma awarded. Send today for free sample lesson and complete information. No obligation, of course. No salesman will call.

**CSW has been training men and women for this trade since 1908**

Why not be one of our successful graduates? Learn how Chicago School's streamlined home training can speed *your* success.

**MAIL COUPON TODAY!**

**CHICAGO SCHOOL OF WATCHMAKING**

*Founded 1908*

**2330 MILWAUKEE AVE., CHICAGO 47, ILL.**

### **SPECIAL TOOLS PROVIDED**



This set of tools is offered in your course at no extra tuition cost. They enable you to start repairing right away.

## **FREE SAMPLE LESSON**

### **CHICAGO SCHOOL OF WATCHMAKING**

2330 N. Milwaukee Avenue, Dept. 122, Chicago 47, Illinois

Please rush **FREE SAMPLE LESSON** and full information to tell me how I can learn watch repairing at home.

NAME \_\_\_\_\_ AGE \_\_\_\_\_

Address \_\_\_\_\_

City \_\_\_\_\_ Zone \_\_\_\_\_ State \_\_\_\_\_

# EARN \$125 A WEEK AND UP

## BE AN AUTO DIESEL EXPERT—LEARN A TRADE YOU LIKE

You learn fast in our shops because you learn with tools on real equipment. Students short of money may earn most of their expenses by doing part-time work. Experienced instructors explain WHY and show you HOW, then you DO IT YOURSELF. Many of our graduates earn \$125 a week and up. Approved for veterans. Day and evening classes. Free bulletin-write today.

MAIL THIS COUPON TODAY!

**NASHVILLE AUTO-DIESEL COLLEGE**  
226 7th Ave., No., Dept. 86, Nashville, Tenn.  
Please send without obligation free catalog.

NAME \_\_\_\_\_  
(please print or write plainly)

ADDRESS \_\_\_\_\_

CITY \_\_\_\_\_ STATE \_\_\_\_\_

# 95% PROFITS YEAR 'ROUND

Be your own boss. Operate a **SIMPLEX** lawn-mower sharpening service in your community.

One compact machine grinds all mowers, sharpens cutlery. Low investment, 95% profit. Pays for itself in average month.

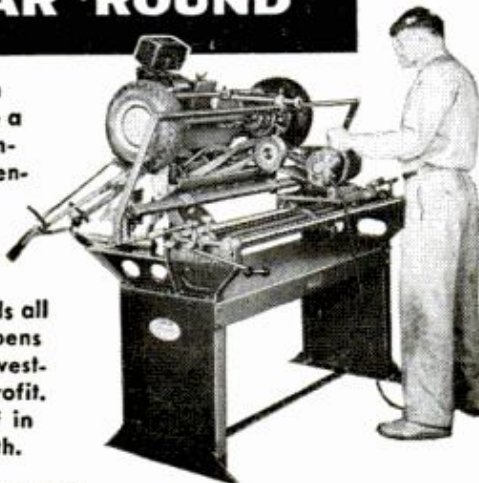

## SIMPLEX—4 Machines in One!

- **Reel Grinder**—sharpens any mower reel in or out of mower.
- **Rotary Blade Grinder**—hollow grinds any rotary mower blade.
- **Bed Knife Grinder**—grinds with either round wheel or cup wheel.
- **Cutlery Knife Grinder**—sharpens cutlery, tools, scissors.

Send for free, money-making details!

The Fate-Root-Heath Company, Dept. PM-2, Plymouth, Ohio

## Direct from England!

### 115 DIFFERENT BRITISH COLONIALS 24¢

Famous "Export Parcel" includes scarce old Classics, modern Pictorials, Regionals, Electronic issues! You get: Great Britain 1864 **QUEEN VICTORIA**; W. Australia 61 yr. old "SWAN"; 58 yr. old **QUEENSLAND**; unusual regionals for **ULSTER, SCOTLAND**; **GHANA INDEPENDENCE**; First 2 Electronic Stamps — with graphite on back; mint Queen & Sultan Issues from scarce colonies — **KEDAH, GILBERTS, NAURU, TRISTAN, ASCENSION, MALACCA**. Many others. Total 115 different. Regularly \$1.68 — bargain export price 24¢ to introduce overseas approvals.

**IMPORT DIRECT — SAVE 20-60%**. Buy direct — where dealers buy. Exciting offers, low prices, yours from London the easy 14 day approval way. Satisfaction Guaranteed. **SEND 24¢ IN UNUSED U.S. STAMPS (NO COINS)**. Ask for Lot ZN-3.

**BROADWAY APPROVALS LTD., 50 Denmark Hill, London S.E. 5, England**



## FREE OUTFIT STARTS YOU IN BIG MONEY SHOE BUSINESS!



Run your own profitable "shoe store" business from home! Represent fast growing million dollar firm in spare or full time. We give you—**FREE**—complete Starting Outfit that makes you **\$217 EXTRA each month for just 2 easy orders a day**. Feature 195 fast-selling dress, sport, work shoe styles for men, women. Air-cushion shoes, many special features! Sizes 2½-15—AAAA to EEEE. Sell to friends and folks where you work. Rush postcard for **FREE Outfit!**

**MASON SHOE, Dept. H-236, Chippewa Falls, Wisconsin**



## New ALVA ALLEN Power Punch Press HANDBOOK Catalog

100 pages. Shows 1 to 25 Ton Capacity Punch Presses in hundreds of different model combinations. Full of general detail information on Punch Presses. Gives information on accessories as—Feeds, Punch Units, etc. Most complete Punch Press and Accessories Handbook Catalog. \$1.00 postpaid. **Alva Allen Industries, Dept PM, Clinton, Mo.**

## Secrets of VENTRILOQUISM Now Revealed!



Easy to learn in 60 to 90 days with our Home Study Course. **RESULTS GUARANTEED** Make Money! Be Popular! Have Fun! Big Opportunity! Radio, Television, Stage Appearances! For **FREE** Information regarding price and terms **WRITE**. You must state your age. Dummy Catalog 25c. **MAHER HOME COURSE OF VENTRILOQUISM** Box 36, Studio PM-2, Kensington Station Detroit 24, Michigan

# ONLY \$1.00

## TO START YOUR OWN BUSINESS

Sample, Automatic Fire Alarm, complete with Battery, postpaid to you for only \$1.00. You can make \$1000.00 a month and more. **WE GUARANTEE LEADS FOR YOU**. Send today for your Alarm, and complete details... this should be the opportunity you've been looking for.

**WE  
GUARANTEE  
LEADS**

**"FIRE KING"**

819 "FIRE KING" BLDG., ENGLEWOOD, COLORADO

POPULAR MECHANICS

# Get into... PLASTIC LAMINATING AT HOME!

Sensational New:  
**"ONE MAN BUSINESS"**  
...pays \$10 to \$20 profit for each dollar of cost.

Make Up to \$5 an Hour by our **MAGIC MAIL PLAN**... get orders and cash from your mailman!



Here's the newest and most fascinating of all home-operated businesses. For the first time, a simplified machine brings the fabulous profits of Plastic Sealing and Plastic Laminating within the reach of the small operator. Can be

operated in a corner of the kitchen, basement, or garage. And any man or woman, regardless of age, education, or experience—can learn this interesting work in a few minutes of reading—can turn out professional jobs after one hour's practice.

## TWO EXCITING FIELDS FOR BIG PROFITS!

No house-to-house canvassing. No face-to-face selling. We not only supply the equipment you need for the work, but also show you exactly how to cash in big daily profits from two big demand fields.

### A FORTUNE IN PLASTIC SEALING

Millions of people want to protect valuable cards, photographs, documents and papers against wear, soil, and damage. By our MAGIC MAIL Plan you get this business through the mails. Open envelopes, take out money and orders. Details of plan will amaze you. It will be sent free. We even furnish financing help. Just mail coupon.

### ENORMOUS PROFITS IN LAMINATING

A creative, artistic business. Gift shops sell your entire output. Just a few of thousands of giftwares illustrated on this page. Beautiful colors. Endless designs. Exclusive "one of a kind" appeal brings sales at ten to twenty times the cost of materials. Beautiful illustrations and instructions for making these artistic novelties sent free.

The opportunities in Plastic Laminating are so big that space here does not permit even skimming the surface. To get any idea

**FREE** at all of the size of these markets and your place in this sensational business you must read the details. See for yourself how easy it is to do the work—how you can put plastic sheets into your machine and take out a fortune—how money and orders come to you in the mail—how gift shops clamor to get more and more of your creations—how you can start with one machine and build up a big production plant with others doing the work—how you can get money and business from every State in the Union—how you can achieve independence without study or experience.



### Cash Money Comes to You in the Mail

By our MAGIC MAIL Plan you sit at home, send out mail, and get back money and orders. Additional profits in supplying lifetime protection for **SNAPSHOTS—IDENTIFICATION CARDS—DISCHARGE PAPERS—DRIVERS' LICENSES—SOCIAL SECURITY CARDS—VOTERS REG. CARDS—MENUS—BIRTH CERTIFICATES—CREDIT CARDS—BIRTH AND WEDDING ANNOUNCEMENTS—PASSES—DOCUMENTS.**

Lifetime protection. See how laminating prevents soiling, wear, and moisture damage with flexible, plastic covers.



**RUSH COUPON**

Never before has such an opportunity been offered the small, home-operator—an opportunity to gain complete personal independence in a big money business of your own. Don't lose a minute. Get the facts at once. All information, fully illustrated with pictures, is free. Send the coupon—or send your name and address on a postcard. There is no charge now, or at any other time. Send for the information on this exciting opportunity today.

**NO MONEY—  
Just Send Name!  
We'll Even Help  
with Financing!**

**WARNER ELECTRIC CO.**

1512 Jarvis, Dept. L-2-B, Chicago 26, Illinois

## Thousands of Beautiful ART CREATIONS

Made by Laminating as explained in our Free information. Send coupon for list and pictures of **COSTUME JEWELRY—JEWELS—CIGARETTE BOXES—CUFF LINKS—NOVELTY BUTTONS—TRAYS—CANDLESTICKS—COASTERS—CLOCK CASES—LAMP BASES—PICTURE FRAMES—BOOK ENDS—CHARMS—ADVERTISING SIGNS—NAME PLATES—BELT BUCKLES—CHECKERS—PAPER KNIVES—CHESSMEN—BOOKMARKS—TIE RACKS—KEEPSAKES OF ALL KINDS.**

**WARNER ELECTRIC CO.,** Dept. L-2-B  
1512 Jarvis Avenue, Chicago 26, Illinois

Please mail, postage prepaid, complete information with illustrations showing the things I can make and the money possibilities in Plastic Laminating. All free. No Salesman is to call. Also, tell me your Financing Plan and how I get orders and money by the MAGIC MAIL Plan.

NAME \_\_\_\_\_  
ADDRESS \_\_\_\_\_  
CITY \_\_\_\_\_ ZONE \_\_\_\_\_ STATE \_\_\_\_\_

# EARN MORE - LEARN AUTO DIESEL MECHANICS

OR TRAIN WITH OTHER GREER DIPLOMA COURSES

- |   |   |
|---|---|
| <input type="checkbox"/> AUTO MECHANICS       | <input type="checkbox"/> REFRIGERATION        |
| <input type="checkbox"/> DIESEL MECHANICS     | <input type="checkbox"/> AIR CONDITIONING     |
| <input type="checkbox"/> BODY & FENDER REPAIR | <input type="checkbox"/> MACHINIST-TOOL & DIE |
| <input type="checkbox"/> GAS, ARC WELDING     | <input type="checkbox"/> AUTOMATIC            |
| <input type="checkbox"/> HELIARC WELDING      | <input type="checkbox"/> TRANSMISSIONS        |
| <input type="checkbox"/> DRAFTING             | <input type="checkbox"/> MOTOR TUNE-UP        |

Civ. or  G.I.

Skilled men are needed in every part of the country. Earn top pay in established shops or start your own business. Greer's expert instruction and actual shop training teaches you how. You learn by doing—quick, easy courses using the latest tools and equipment. Day, evening and part time instructions available.

Job placement aid and convenient living accommodations are yours while training. Contact GREER'S FREE JOB PLACEMENT SERVICE when you enroll if you wish part time or full time employment assistance.

## TECHNICIAN COURSES

- |   |
|---|
| <input type="checkbox"/> DIESEL AUTOMOTIVE TECHNICIAN—21 MONTHS         |
| <input type="checkbox"/> REFRIGERATION & AIR COND. TECHNICIAN—17 MONTHS |
| <input type="checkbox"/> WELDING TECHNICIAN—14 MONTHS                   |

Please rush me free literature on the trade indicated at no obligation.

NAME \_\_\_\_\_ AGE \_\_\_\_\_

STREET \_\_\_\_\_

TOWN \_\_\_\_\_ ZONE \_\_\_\_\_ STATE \_\_\_\_\_

Established 1902

# GREER SHOP TRAINING

Box B, 2236 S. Michigan Ave. Chicago 16, Ill.

## Learn BAKING At Home

Baking is one of America's high industries in wages. Nearly depression-proof. Thorough basic home course lays sound foundation. If you have aptitude, write for FREE BOOKLET, "Opportunities in Commercial Baking." National Baking School, 835 Diversey Pkwy., Dept. 1352, Chicago 14, Illinois



# GARDENCRETE CENTER



GC-1

## A New Business Opportunity for Men of Modest Capital

Gardencrete Center denotes a new wayside industry, covering the making and selling of decorative masonry. It sparks latent possibilities into practical opportunities. Opens up new horizons for a business potentially huge but long neglected. It is a low-investment franchise operation, with exclusive privileges in protected territories. A timely business with fascination, interest, and opportunity for expansion. Markets are broad; profit possibilities are generous. Practically every home owner is a prospective customer. No experience or special building required. We supply complete equipment, as well as manuals covering manufacturing and selling. Thousands of good territories are available, but those who act quickly get the choice of the select.

- Bird Baths
- Lawn Seats
- Flagstones
- Screen Blocks
- Flower Boxes
- Vases & Urns
- Brick & Stone for building
- Planters
- Walks
- Patios
- Etc.

Write at once for prospectus "The Gardencrete Center Idea".



COLORCRETE INDUSTRIES  
726 Ottawa Avenue  
HOLLAND, MICHIGAN



# FREE SAMPLE NEW WONDER AUTO GLAZE

with Miracle Methyl  
Silicone Fluids



Given to show how you can clear up to \$55.00 a day profit on your own exclusive route!

**GUARANTEED** to outshine, outlast and outperform ANY wax polish on the market today—or money back!

**FAST REPEAT SELLER!** Needed by 45,000,000 car owners. Demonstrates like magic. Just apply, wipe off. No hard rubbing. Keeps car and chrome like new for months!

**OVER 175% PROFIT!** Retail \$2.00 pint (year's supply). Your profit can be over \$1.35 pint—more on gallons!

**FREE SAMPLE** sent to try on your car. Rush name for FREE sample and FREE money-making details. No obligation!

ROYALTONE PRODUCTS CORP., Dept. PM-2  
1035 E. 10th St. • Brooklyn 30, N. Y.

FREE SAMPLE

# TOOLS WHOLESALE

\$100  
PUTS YOU IN  
BUSINESS

Start your own business, sell tools to your friends and neighbors, or buy tools for your own use and **SAVE MONEY \$\$\$**

A MILLION DOLLAR INVENTORY AT YOUR FINGERTIPS. NO STOCK TO CARRY. ORDER AS YOU NEED IT.

**BUY AT WHOLESALE PRICES.** Extra \$25.00 profit on your accumulated purchases. \$1.00 refund on first purchase or refunded if you are not 100% satisfied.

**THOUSANDS!!** of Nationally Advertised items of Hand Tools, Power Tools, Machinist Tools, Tool Chests, Paint Sprayers, Light Fixtures, Appliances, Guns, Gifts, Toys and other items too numerous to mention.

**WE SHIP COAST TO COAST** Wholesale. Disc. up to 50% off

SILVO HARDWARE CO., PM-2 107 Walnut St., Phila. 6, Pa.

# FREE GUIDE Reveals 200 Ways to Make Extra Money

YOU can turn your spare hours into cash (\$25 to \$100 a week) by selling products and services to friends and others. Famous *Salesman's Opportunity Magazine* shows you how. Contains hints, plans, hundreds of offers. No matter what your age, experience or occupation—write TODAY for next 5 issues—absolutely FREE. Send no money just name. OPPORTUNITY, 850 N. Dearborn, Dept. 448, Chicago 10, Ill.

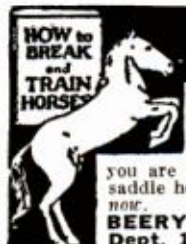

SEND FOR THIS FREE!

Make money. Know how to break and train horses or ponies. Write today for this book FREE, together with special offer of a course in Animal Breeding. If you are interested in Gaiting and Riding the saddle horse, check here ( ). Do it today—NOW.

BEERY SCHOOL OF HORSEMANSHIP  
Dept. 1102-D Pleasant Hill, Ohio

# Would YOU Like to Make \$1 000 A MONTH?



That's What Stanley Hyman  
Made Selling PRESTO

## Amazing Midget Fire Extinguisher

Sensational! Presto does job of bulky extinguishers costing 4 times as much. Ends fires fast as 2 seconds; fits palm of hand. Never corrodes; guaranteed 20 years! Sells for only \$4.95. Show it to owners of homes, cars, boats, farms, etc., and to stores for re-sale—make good income. Write for FREE Sales Kit.



Stanley Hyman

MERLITE INDUSTRIES, Presto Div.  
114 East 32nd St. • Dept. P-15P • New York 16, N. Y.  
In Canada: Mopa Co., Ltd., 371 Dowd St., Montreal 1, P. Q.

POPULAR MECHANICS

# Special Invitation to Inventors

If you have an invention or an idea for an invention, whether patented or unpatented, that you wish to sell outright or on a royalty basis, the booklet we offer free in the coupon below may be very valuable in saving you both time and money.

We are specialists in representing inventors and submitting their inventions and ideas to manufacturers. We work continuously with scores of manufacturers seeking new products, and we have connections from coast to coast and in foreign countries. We are well informed which manufacturers may be especially interested in your particular kind of invention. Hundreds of these manufacturers have written us descriptions of the types of inventions they want.

Our service is designed to do all the many things the average inventor does not have the time or facilities for doing, or who lacks knowledge of the proper markets. When you appoint us to represent you, we prepare sales material that points up your invention, its advantages, its construction, its market potential and profit possibilities.

For presenting your invention to selected manufacturers we charge a modest fee (which is refunded if we handle the sale of the invention for you) and the customary commission. We are a Nationally known concern, with an impeccable reputation for ethics and integrity. We believe ours is the finest service offered inventors.

We are not patent attorneys. However, if you have need for a patent attorney and do not know one, write us and we will tell you how to obtain the names of all U. S. Patent Attorneys in your area, and you can make your own choice.

To encourage inventors, whether their inventions are patented or unpatented we have prepared a booklet entitled "How to Go About Selling Your Invention." This booklet contains such information as current royalty rates being paid by manufacturers, discusses various types of inventions and the markets for them, and tells the most effective methods you can use in presenting your invention for sale, whether you employ us or do it yourself.

You can obtain a copy of this booklet merely by mailing the coupon below. It will be sent to you with our compliments, free, without any obligation whatever. If you wish to write us for comments about your invention, please do so. We make no charge for consultation. But please do NOT send blueprints or models. Just describe your invention briefly, its nature and purpose.

**REFERENCES:** Your own bank, attorney, or Chamber of Commerce.

**K. O. Kessler, President**  
**KESSLER SALES CORPORATION**  
Accredited as a Corporation  
Under the Laws of Ohio  
**FREMONT, OHIO**

## MAIL THIS COUPON FOR FREE BOOKLET

**Mr. K. O. Kessler, President**  
**Kessler Sales Corporation, Dept. D-52, Fremont, Ohio**

Please mail me a copy of your FREE Booklet, "How to Go About Selling Your Invention," which reveals many points about selling inventions and explains your service. It is understood that there is no charge for this booklet now or at any other time and I am not obligated in any way.

MY NAME .....

STREET ADDRESS .....

CITY..... ZONE..... STATE.....

# POPULAR SHOPPING

worth  
writing  
for...



## Make Money in Art

Learn Commercial Art for Only 20c a Day!

ENJOY glamorous high-pay career or profitable hobby this easy, proven way. Learn Painting, Commercial Art, Cartooning, Fashion, TV Art, etc., at home in your spare time — for only 20c a day! TWO 22-piece art outfits (worth \$25) included at no extra cost. Cash in on demand for trained artists. Be your own boss or high-pay staff artist. Write for FREE Book describing easy Course. No obligation. No salesman will call. So write TODAY to: **WASHINGTON SCHOOL OF ART, Studio 142, Port Washington, N. Y. (Est. 1914)**



**Walt Kelly**, the comic-strip artist, has written and illustrated a "Pogo Primer for Parents (TV Division)." It contains some helpful do's and don't about television watching and sets some guide lines to help parents select their children's television fare. It costs 20 cents and can be ordered from the Supt. of Documents, Government Printing Office, Washington 25, D. C.

**Model railroaders** will find details of railroad construction in this booklet. It is a 1914 record of construction issued by the Baldwin Locomotive Works and contains 18 steam locomotive pic-

tures, text and complete information about each engine. Cost is \$2 from Harry P. Albrecht, 40 Wilton Ave., Clifton Heights, Pa. **Painters** who tackle jobs having a variety of exposure conditions will find helpful information in "Lead Pigments Technical Letter No. 15—Red Lead Based Paint Systems." It is available free from the Lead Industries Assn., 292 Madison Ave., New York 17, N. Y.

**Photographic films** or prints stored or kept for any length of time in a humid atmosphere may develop fungus growth on either the emulsion surface or back of the film. The Sales Service Div., Eastman Kodak Co., Rochester 4, N. Y., has prepared a free folder, "Prevention and Removal of Fungus on Processed Films (E-22)," to solve this problem.

**Sewing machines**—domestic and imported—are explained for the do-it-yourself repairman. Highly illustrated sections on repair, checkup and maintenance analyze the working parts of all current models, from spool pin to motor. "The Complete Sewing Machine Repair Book" also includes a buyer's guide. It is available for \$3.50 from Arco Publishing Co., 480 Lexington Ave., New York 17, N. Y.

**Spray painting** has its secrets exposed in a 14-page booklet, "How To Paint Like a Pro With a Sprayer." It is available from Burgess Vibrocrafters, Inc., Grayslake, Ill.



**FREE! AIRMAILS**  
Fabulous collection of all-different genuine foreign Airmail Stamps from remote corners of the world — Africa, Europe, Exotic Orient, everywhere! World's Largest Airmail, Flying Doctor, Bomber, \$2.00 Helicopter, many others. PLUS Collection of thrilling Space-Age stamps... Sputniks, Jets, fantastic Moon Rocket stamps. Both of these remarkable collections — containing stamps worth up to 25c each! — for only 10c to cover mailing costs. Extra: Other sensational stamps for your free examination, plus Big Bargain Catalog. Rush 10c today to: **Jamestown Stamp Co. Dept. F22PM Jamestown, N. Y.**

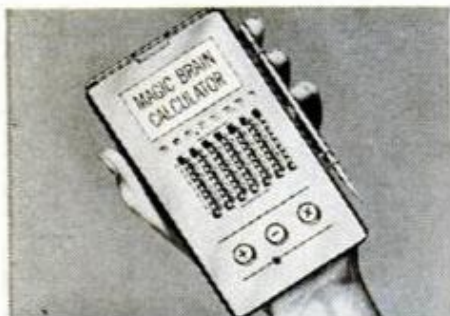

## Magic Brain Calculator, 98¢

Pocket adding machine does all your math problems with ease. Adds—subtracts—multiplies to 99,999,999. **MAGIC BRAIN CALCULATOR** balances check books, adds grocery tapes, bridge scores, children's schoolwork, income tax statements, car mileage. Gives the answer in seconds! Simple to use... all steel mechanism works fast. **Money-back guarantee!** **MAGIC BRAIN CALCULATOR**, only 98¢, postpaid. Order from **Sunset House, 278 Sunset Building, Beverly Hills, Calif.**

## UNUSUAL TOOLS BY MAIL

**44 CORNER CLAMP & MITER BOX COMBINED**

Holds the wood. Holds your saw. Accurate cuts with any handsaw from 0° to 180°. Full 3" capacity. Sides exposed for mailing and gluing. \$2.75 ppd. No. 33. Same as No. 44 without saw guide attachments. \$1.75 ppd.



**EASY SAW FILER**

No. 11 Gives correct height, depth, pitch, bevel to any 6" to 10" hand or circular saw with no side pull. Includes 8" file. \$9.95 ppd.



**SAW SET**

automatically sets teeth at 10° or more \$2.95 ppd.



**DRILL GRINDER**



Sharpens round shank drills like new with hand or power grinders. \$2.95 ppd.

**MONEY BACK GUARANTEE**  
**A. D. McBURNEY, 5908 Hollywood Blvd., Hollywood 28, Cal. Dept. A-22**

## RUPTURE-EASER

T.M. Reg. U.S. Pat. Off. (A Paper Brace Product)



Double...\$5.95  
Right or left  
Side \$4.95  
No Fitting Required

A strong form-fitting washable support for reducible inguinal hernia. Back lacing adjustable. Snaps up in front. Adjustable leg strap. Soft, flat groin pad. No steel or leather bands. Unexcelled for comfort. Also used as after operation support. For men, women, children. Mail orders give measure around lowest part of abdomen and state right or left side or double. We prepay postage except on C.O.D.'s.  
**PIPER BRACE CO.**  
811 Wyandotte Dept. PM-22 Kansas City 5, Mo.



**MAKE YOUR OWN NATURE TILES With Colorful Leaves, Flowers, Butterflies, Permanently Preserved in Castoglas.**

**Pours Like Honey—Sets Like Glass!** The pansy shown in this photograph was embedded in crystal-clear Castolite in 1946. It is as lovely now as the day we picked it in our garden. NOW—a greatly simplified method enables you to do the same with Castoglas on wood, hardboard, metal or between layers of glass mat.

**What Can You Do With Tiles!** A good example is the way a dark and outmoded kitchen was converted into a bright and cheerful room at surprisingly modest cost. Castoglas was used in three ways: for making the decorative glass screen, for the tiles with embedments of leaves and butterflies, and for "glassing" the countertop. Castoglas is waterproof, heat- and acid-resistant and easily cleaned. You can also make table tiles, coasters, trays, wall decorations and embed photos, coins, sea shells and many other things. No tools, no heat required.

New illustrated booklet explains in easy-to-follow directions how to do it. Please mail 25c to Dept. 1-B.

**THE CASTOLITE CO., Woodstock, Ill.**

**MANUAL 25c**

**GET YOURSELF FIXED FOR LIFE IN THE BIG PAY SHOE BUSINESS**

**WE PUT UP THE MONEY!**

It's no trick at all to make big money—FULL OR SPARE TIME—with the only shoe line featuring baby shoes in addition to shoes for all the family with new Family Discount Plan, Lifetime security. Amazing new "Spring-Step" cushion invention proves it by actual demonstration. Only ORTHO-VENT has it. There is no other shoe in the world like it. Repeat orders are sure, steady. One try and a customer is sold for life. Profits are BIG. Orders are sure and easy with the most amazing 1-minute demonstration in the history of the shoe business. No experience needed. No investment to make. Everything, including actual cut-aways, furnished free! Be the big-pay ORTHO-VENT man in your territory. Write TODAY!



**WE GIVE PRODUCERS THEIR OWN SHOES AS A BONUS**

**ORTHO-VENT SHOE COMPANY**  
1122 Brand Road, Salem, Virginia

**ROCK HOUNDS THUMLER'S TUMBLER**

- Imparts gem-like polish to 3 to 10 lb. rocks.
- Simple—guaranteed—no better at any price.
- If your dealer can't supply, order direct \$18.95 postpaid. (Set of 2 grits, 1 polish, \$1.20 additional.)



**TRU-SQUARE METAL PRODUCTS, INC.**

(CHECK OR MONEY ORDER ONLY)  
P.O. BOX 375, AUBURN, WASH.

Send for your free WHERE-TO-FIND-IT list giving sources of supply or further information on articles in this issue.

**SAVE BY MAIL... DISCOUNTS UP TO 40%!**

1,001 famous U.S. products for workshop, garden, boat, paint jobs—all in our valuable, 68-page Catalog of discounts. Name brands from cover to cover. Satisfaction guaranteed. Send for your copy today, enclosing just 25 cents.

**GATES GENERAL CORPORATION**  
P.O. BOX 355 PM • FARMINGTON, CONNECTICUT

**SAMURAI SUICIDE WARRIORS**

# KARATE!

**JUDO BOXING! MUSCLEBUILDING! YOGA! STRONGMAN STUNTS! STRENGTH & ENDURANCE! HANDBALANCING! ETC.**

**YOU GET ALL THESE COURSES!** #20 illustrated KARATE blows #SAVATE foot fighting #SECRET NERVE CENTER and ANATOMY charts #20 lethal JUDO throws #20 terrific STRONGMAN STUNTS #Complete MUSCLE-BUILDING course #Ancient YOGA secrets #HANDBALANCING stunts #Complete BOXING course. Secrets of ENDURANCE #All picture packed. Super wall charts. (surplus 1961 printing). No C.O.D.'s. Canadian orders 50c.

**K-MAN KARATE PRACTICE DUMMY.** Life like! Shows attack points 15c with 35c order only. Total 50c.

**35c** you get the lot!

Oxford Studio, 44R Bromfield, Boston, Mass.

**DRAFTING!**  
The STARTING POINT OF ALL PRODUCTION



**Train At Home In Spare Time for BIG EARNINGS**

**Learn Mechanical Drafting—Aeronautical Drafting—Architectural Drafting—Machine Drafting—Construction Drafting—Electrical Drafting—Statistical Chart Drawing—Highway Drafting—Map Making—Plumbing Layouts.**

Christy Trades School gives you complete basic training that prepares you for specialization in the field of your choice!

CTS uses interesting Low-to-training methods. You learn by drawing, work on actual projects. You help create things.

**PAY AS YOU LEARN PLAN**

Receive CHRISTY PROFESSIONAL TRAINING, drafting instruments, equipment, supplies, portable drafting table, lesson manuals, etc. on our special Pay-As-You Learn Plan. Rush name for FREE BOOK, pay later form. CHRISTY TRADES SCHOOL, Dept. D-5603, 3214 W. Lawrence Ave., Chicago 25, Ill.

# WANTED!

**Mechanically Inclined  
Men to Qualify for  
BIG PAY JOBS  
AND SPECIAL FACTORY  
TRAINING IN DIESEL**



"We need qualified repairmen, operators, mechanics NOW!" say Diesel Manufacturers, Highway Builders, Truck Line Operators in every corner of America. Can you qualify for these High Pay Jobs? We can help you! Interstate's General Course and Cummins-approved Diesel home-training courses are internationally recognized. Advisory placement service for trainees. Don't wait. Men are needed NOW!

**Get the Facts Today!**

**WRITE INTERSTATE TRAINING SERVICE**

Dept. A-3, Portland 12, Oregon

Rush information on I.T.S. Diesel Courses, Special Factory Training and Diesel Job Opportunities.

Name \_\_\_\_\_ Age \_\_\_\_\_

Address \_\_\_\_\_

City \_\_\_\_\_ Zone \_\_\_\_\_ State \_\_\_\_\_

**FREE**  
**MUSCLE BUILDING**  
**INFORMATION**  
Sensational New Methods  
Less Time—Less Effort—Better results  
**BODY-TONE**, Box 638, North Miami 61, Fla.

**Draw**  
**CARTOONS**

**EARN BIG MONEY...  
LEARN AT HOME IN SPARE TIME**

You don't need previous training or art ability with the "Famous System of Manual Training!" With this modern streamlined method, you learn rapidly and easily...start to cartoon immediately, without tedious study or exercises.

Wide Demand for Cartoonists—Earn While You Learn...Magazines, newspapers, movies, television, ad agencies—all are searching for new cartoon ideas and talent. As a successful, Continental-trained Cartoonist, your earnings are not limited.

Many of our students start earning after first few lessons. A wonderful pastime, too.

We Supply Everything...As our student, you receive FREE of extra cost a big 15-piece Professional Kit containing all equipment and materials you need, and valuable Articulated Model that helps you draw any human pose.

Get All the Facts FREE...Big, colorful Free catalog gives all details plus pages of useful information. FREE for the asking. Use coupon.

\*U.S. Pat. Applied For

**Continental Schools, Inc.**  
4201 S. BROADWAY, LOS ANGELES 37, CALIF.

Continental Schools, Inc.  
Dept. E-125, 4201 S. Broadway, Los Angeles 37, Calif.  
Please rush me your Free Catalog and other information by return mail. No charge or obligation.

NAME \_\_\_\_\_

ADDRESS \_\_\_\_\_

CITY \_\_\_\_\_ ZONE \_\_\_\_\_ STATE \_\_\_\_\_

SEND  
COUPON FOR  
FREE BOOK

Here is Your Opportunity  
to Build a Successful  
Business of  
Your Own

At Home  
in Your  
Spare Time

**BIG PROFITS IN  
MOSAIC TILE**

Go into this year around business. Big profits making Serving Trays, Jewel Boxes, Bric-a-Brac Shelves, Sewing Boxes, Table Pieces—customers come to you. Complete Business Outfit tells how to sell to Department Stores, Variety Stores, Gift Shops. Use in homes, for walls, table tops, floor patterns. Finest quality imported Tile, Trivets, Glue, Grout, at Wholesale Prices. No previous experience necessary—with our visual aid training do professional looking work in 2 or 3 hours. Opportunity to start earning right away. Send now for Booklet telling how to get started..... **50c**

**STARK'S DISTRIBUTING CORPORATION**  
1601 S. Canal St., Dept. PM-22, Chicago 16, Illinois

**Learn Profitable Profession  
in few months at Home**

**MEN AND WOMEN, 18 TO 60**

\$4.00 to \$5.00 for 1-hour treatment is the established charge for a skilled operator. Easy to learn and do. Diploma awarded. Open your own office or earn good income from Doctors, Hospitals, Clubs and other health or recreational centers. Wonderful part-time profession. Low monthly payments. Write today for free Anatomy Charts and catalog. No obligation.

**ANDERSON SCHOOL OF SCIENTIFIC MASSAGE**  
Dept. B1, Princeton, Illinois



**Delta-Wing for Snow Flying**

Shaped like a jet plane, a new sled also banks like an airplane to make turns. Made of a single piece of heavy-gauge steel, the sled has a central runner on the bottom plus a control louver built into each "wing" tip. When the sled is banked, the louvers cause it to turn.

Made by TransCraft, 11705 Detroit Ave., Cleveland, Ohio, SnowWing costs \$8.95.

## "I Have My Own Shop Now!"



Says **FREEMAN J. JEFFRESS**, Oklahoma City, Okla.

"Your course is so good, I wouldn't take back the money I paid for it. I have a nice little shop set up in my home and it has already paid for itself!"

Just a few of the many professional tools supplied FREE for use with course.

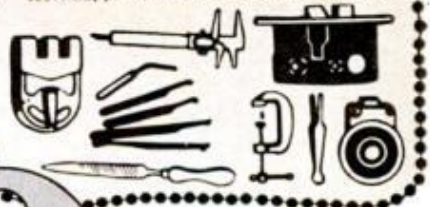

# Be a LOCKSMITH

### Train at HOME—Earn While You Learn

Add 50%—100% to YOUR INCOME with easy spare time earnings. Cash in on the nation-wide shortage—trained locksmiths are in demand! Quickly step into a big pay opportunity job or start a high-profit shop of your own.

**Earn Extra Money RIGHT AWAY!** All Special Tools, Supplies Furnished FREE.

Age, education, minor physical handicaps don't matter in this growing trade. You can quickly qualify as a skilled locksmith. It's like a fascinating hobby. Study at home as little as one hour a week. Gain practical experience through well-illustrated lessons. Do real jobs on car locks, house locks, padlocks and safe locks, under the guidance of experts.

FREE illustrated book, write now.

**LOCKSMITHING INSTITUTE, Dept. 102-2**  
(Div. Tech. Home Study Schools)  
150 Park Avenue, E. Rutherford, N. J.

**SEND FOR FREE BOOK!**

**PROFESSIONAL TOOLS SUPPLIED FREE FOR USE WITH COURSE**

**APPROVED FOR VETERANS**

**MAIL COUPON FOR FREE BOOK.**

For a future as your own boss or in a high-pay job, write now for FREE illustrated book. Only school of its kind. Licensed by State of New Jersey.

Accredited,  
Nat'l Home Study Council

**MAIL COUPON NOW!**



**LOCKSMITHING INSTITUTE, Dept. 102-2**  
150 Park Avenue, East Rutherford, N. J.

Please send without obligation the FREE illustrated book, "Your Opportunities in Locksmithing." I understand no salesman will call.

Name.....  
(Print Here)  
Address.....  
City.....Zone.....State.....

**Wooded, High-ground HOMESITE (70 x 150)**  
on CAROLINA Coast!

**\$500 DOWN \$500 A MONTH**

14,000 acres—50 freshwater lakes  
... 40 miles of finished roads ...  
fishing, hunting, golf.

**FREE LITERATURE!**  
BOILING SPRING LAKES, Southport 15, N. Car.

**WHOLESALE Electric Guitars - Parts - Factory to You**  
Professional electric solid body Spanish guitars, amplifiers, electric bass, double-necks, triple-necks, tone changers, double-neck Spanish, electric mandolin, pickups. Parts to outfit your own 1962 Models wholesale — Free catalog.

**CARVIN CO.,** Box 287, PM-2, Covina, Calif.

## Learn CARBURETOR and IGNITION



### SCIENTIFIC MOTOR TUNE-UP

Train at home for a career in this well-paying interesting field. Learn testing and adjusting with latest type scientific equipment. The demand for qualified men in this field is increasing due to greater number of cars on the road today.

#### FREE SAMPLE LESSON

Get in line for a raise—or more profits in your own shop. The field is wide open and highly inviting.

**SEND TODAY FOR FREE CATALOG AND SAMPLE LESSON**

Accredited Member, National Home Study Council

**UTILITIES ENGINEERING INSTITUTE**  
417 South Dearborn, Dept. 02-563 • Chicago 5, Illinois

Get Into One Of Today's TOP OPPORTUNITY FIELDS

# ELECTRICITY —ELECTRONICS TELEVISION RADIO · ELECTRONICS

**COYNE** Train in the New Shop-Labs of Oldest, Best Equipped School of Its Kind in U.S. Founded 1899

in Chicago—Electrical and Electronic Center. Prepare for a better job and a successful future. Train on real equipment — no advanced education or previous experience needed. Lifetime employment service to graduates. Part time employment help to students. Finance Plan—enroll now, pay most of tuition later.

**FREE BOOK**— Mail Coupon or write to address below for Big Free Illustrated Book—"Guide to Careers."

Information comes by mail. No obligation and NO SALESMAN WILL CALL.

### COYNE ELECTRICAL SCHOOL

Chartered as an Educational Institution Not for Profit  
1501 W. Congress Pkwy., Chicago 7, Ill., Dept. 22-3C

**COYNE ELECTRICAL SCHOOL, Dept. 22-3C**  
1501 W. Congress Pkwy., Chicago 7, Ill.

Send FREE Book, "Guide to Careers" and details of all training you offer. I am especially interested in

Electricity  Television  Both Fields

Name.....  
Address.....  
City.....State.....

(I understand no salesman will call)

# ATTENTION! YOUNG MEN

## WE OFFER YOU IMMEDIATE TRAINING IN

# HEAVY EQUIPMENT OPERATION

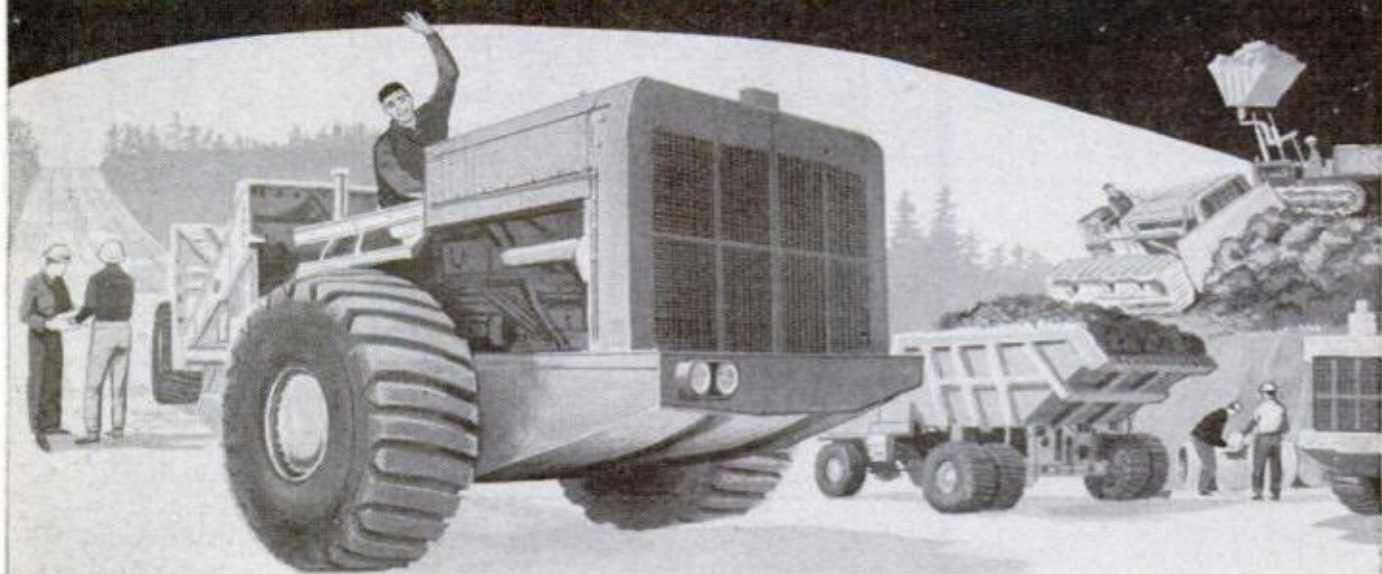

What you are looking at are the wonder tools of a new age, mechanical monsters that are changing the face of the world we live in. The BULL DOZER . . . the LOADER . . . the GRADER . . . the EARTH-MOVER—these have made possible today's complex civilization. But as mighty as they are these giants are lifeless without the men to operate them. Only under the guidance of a man's hand can these machines throw bridges over wide rivers, create dams to turn wasteland into lush fields, ribbon the broad face of our country with super-highways. Only because there are men at the controls are schools, factories, office buildings, hospitals reaching toward the sky.

This is an industry which is spending billions of dollars—yet even as it builds it is unable to meet the demand. This is an industry which is charged with supplying facilities for the explosive increase in population—here and all over the world. This is an industry which offers bright futures to MEN! And these men must come from somewhere!

Would *you* like to get training for HEAVY EQUIPMENT OPERATION? Our home study—resident training program can be the first step. You need not interrupt your present schooling or job. And read this carefully: Your training will be completed on the same big, modern machines that are used on the job.

But there is one thing that is vitally necessary: You must have a sincere interest in heavy equipment operation. These announcements are interesting men all over the country and thousands are writing in. Our represent-

**DON'T DELAY.** To learn about this training without obligation, use the postage paid card facing this announcement. If someone has already used the card, just write a note to HEAVY EQUIPMENT TRAINING, DEPT. H-36, NORTHWEST SCHOOLS, 730 THIRD AVENUE, NEW YORK 17, N.Y. Give your name, address, age, nearest phone, working hours. You will get full information.

atives simply do not have time to visit those who are merely curious. They ask you for no obligation or commitment except this: *You must have a serious interest.* Whether or not you later decide to go ahead is strictly up to you.

The man who will call on you will help you. He will explain to you the future of heavy equipment operation. You can make up your mind from what you learn from him whether heavy equipment training is for you. To many men—men like you—the Northwest representative was an enormously important visitor. He may be the same for you.

The men in enviable heavy equipment careers took that first step . . . to get TRAINING. *The next step is yours.* Get information about age and other requirements which must be met to qualify for employment in this giant industry. Fill in the card facing this page and drop it in the mail. No stamp is needed . . . we pay the postage. Then the next move will be ours. Good luck to you.

THE OPPORTUNITY  
OF A LIFETIME  
MAIL POSTAGE FREE CARD

# Science bulletins

**It's official:** "Unintelligibility" is a characteristic of the female voice. This flaw, according to Air Force researchers, is due to a lack of harmonics or overtones of appropriate vibration rate, and may rule women out as broadcasters of routine transmissions for aircraft communication systems. However, the female voice could be useful in broadcasting warning transmissions, the researchers concluded, since it has a "natural priority in commanding a man's attention."

**An Ohio farmer** harvests cattle feed every day, says the American Iron and Steel Institute. Using hydroponics—a method of blending water, nutrient chemicals, proper light, temperature and humidity—he's growing supplemental feed in steel trays. The crop grows an inch daily.

Before this experiment he needed two acres of land to sustain five cows. He now feeds the five on one acre with the addition of his hydroponics-grown food.

**Used-up uranium** is flying high. Plane builders have found it is an excellent material for use as counterweights in wing tips and tailpieces of commercial jet planes; it has a higher density and costs less than sintered tungsten and is available in large quantities. Depleted uranium contains less than the natural concentration of U-235. The Atomic Energy Commission since the first of the year let depleted uranium be used for this purpose by countries other than Soviet-bloc nations.

**Attention, young science** and engineer graduates: The Guggenheim Foundation, 120 Broadway, N. Y. 5, N. Y., has 18 fellowships for graduate study in rockets, jet propulsion, space flight and flight structure available. Candidates must file by March 1, this year, and be citizens of either Canada or the U. S.

The hope is to find potential astronautic and aeronautic leaders.

*James Biery*

FEBRUARY 1962

MY SPARE TIME HOBBY MAKES ME

**\$5<sup>00</sup>** an hour  
**CASH PROFIT**

— Grover Squires

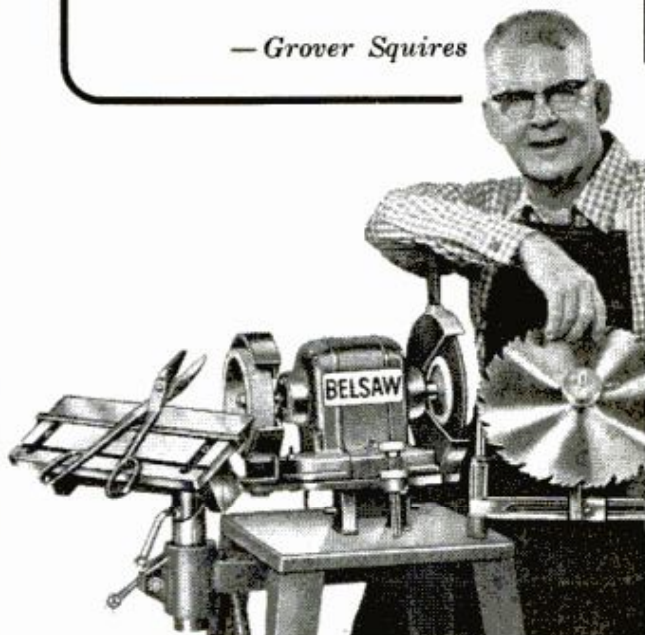

**START YOUR OWN SPARE TIME BUSINESS**



You can turn your spare time into Big Cash Profits with your own **COMPLETE SHARPENING SHOP**... Grind saws, knives, scissors, skates, lawn mower blades... all cutting edges. Your Own Cash Business with no inventory... right at home ... no experience needed.

**FREE BOOK** tells how you can start your own spare time business while you are still working at your regular job. Low Cost—time payments only \$15.00 a month. **Send coupon today.**



**BELSAW SHARP-ALL CO**  
712B Field Bldg.,  
Kansas City 11, Mo.

Send Free Book "LIFETIME SECURITY". No obligation.

Name \_\_\_\_\_

Address \_\_\_\_\_

City \_\_\_\_\_ State \_\_\_\_\_

44A

**MAKE YOUR HOME WORKSHOP PAY OFF**  
in spare time or full time income  
**ELECTRICAL APPLIANCE REPAIR**



Turn spare hours into cash profits. Millions of Home Appliances need fixing. Every home is your market for Full-Time Career or Spare Time "Second" Income.

Costs Less Than \$1.50 A Week. All you need is a workbench, spare time and N.T.S. Home-Training in Electrical Appliance Repair. You get a professional appliance tester, tools, and easy-to-learn, practical instructions, fully illustrated. Start earning early in course. Mail coupon now. No obligation. No salesman will call.

**NATIONAL TECHNICAL SCHOOLS**  
WORLD-WIDE TRAINING SINCE 1905

4000 So. Figueroa Street  
Los Angeles 37, Calif., U.S.A.

**FREE BOOK and ACTUAL LESSON**

**NATIONAL TECHNICAL SCHOOLS**  
Los Angeles 37, California

HB22

Name \_\_\_\_\_ Age \_\_\_\_\_

Address \_\_\_\_\_

City \_\_\_\_\_ Zone \_\_\_\_\_ State \_\_\_\_\_

**These Pictures taken within 2 minutes**



can mean up to \$1,000.00 in a MONTH to you!

**Make Big Money with Sensational Invention . . . SEALS PUNCTURE & INFLATES FLAT TIRE in 2 minutes . . . without tools!**



Amazing new REPAIR 'n AIR is gobbled up by motorists and fleet owners when they learn it seals puncture flats and reinflates the tire (either tube or tubeless) in 2 minutes or less . . . without jacking up car, without changing wheel, without tools! Just show astounding Independent Laboratory Test Report to prospects, take easy, fast orders spare time or full time. Make up to \$1,000.00 and more in a month!

**Get Automatic Repeat Orders from Stores!**

Taxi companies, police, fire depts., other fleet owners order up to 12 and more at a time. You make over 100% profit on every REPAIR 'n AIR they buy. Your profit's so big you can sell to gas stations, garages, auto supply, hardware stores, gift shops, drug stores for re-sale, and get automatic repeat orders.

**FREE!** Get big Illustrated Sales Kit, with complete money-making details, sensational Laboratory Test Report, Guaranteed Special Starting Offer—all FREE, no obligation. Rush name, address TODAY to:

**NATIONAL DYNAMICS CORP., Dept. 10FK**  
222 E. 23rd St., New York 10, N. Y.

**MEN!! TRAIN NOW FOR A BIG PAY FUTURE**



**Be a Trained Diesel Man**

- Diesel Construction
- Diesel Engine Repairman
- Diesel Operator
- Industrial Maintenance
- Auto Engine Rebuilding
- Bus & Truck Maintenance



Go places with DIESEL! Farms, factories and power plants, trains, ships, trucks, busses all use DIESEL POWER . . . all need DIESEL-trained men! You can start your DIESEL training at home, in spare time, with tested, proved UEI training. Skilled instructors. You learn the operation, maintenance, servicing of all types of DIESEL engines, PLUS Scientific Motor Tune-up.

**ACT NOW!** If you have mechanical ability, YOU'LL LIKE DIESEL!

Write now for FREE book.

Accredited Member, National Home Study Council  
**UTILITIES ENGINEERING INSTITUTE**

421 So. Dearborn Street, Dept. 02-556 Chicago 5, Illinois

**LAW FREE BOOK THE LAW TRAINED MAN**

Write today for a FREE copy of illustrated law book, "THE LAW-TRAINED MAN," which shows how you can learn quickly at home the basic principles of all law topics through the famous Blackstone Law Course. All necessary books and lessons provided. Moderate cost; convenient monthly terms. Write for FREE law training book today.

**Blackstone School of Law, 307 N. Michigan Ave.**  
Founded 1890 Dept. 52, Chicago 1, Illinois



**WANT MORE MONEY? GET INTO PHOTOGRAPHY**

Coast-to-coast, high-paying jobs in photography are waiting for people with the "know-how" to fill them. You can quickly, easily qualify at home with the world-famous NYI Learn-by-Doing Method. Write today for free catalog. Also resident training in N. Y. Our 52nd Year. Approved for Veterans.

**NEW YORK INSTITUTE OF PHOTOGRAPHY**

Dept. 49 10 West 33 St. New York 1, N. Y.

**\$6.00 OR 2 FOR \$11.00!**

With 40 ft of wire. Additional wire 3c ft. **TESTED AND GUARANTEED.** Write for free list of all types of telephones. Shipments FOB Simpson, Pa.  
**TELEPHONE ENGINEERING CO., Dept. 2B2, Simpson, Penna.**

**LEARN TO BE A DENTAL MECHANIC**



**SECURITY • PRESTIGE • GOOD PAY**

Learn at home, in your spare time, to make Crowns, Plates, Bridgework, etc. Dental Mechanics are employed by Dentists, Dental Laboratories or open your own shop, full or spare time. **FULL EQUIPMENT OF TOOLS AND MATERIALS INCLUDED WITH COURSE.** Low tuition. Easy Terms. Write for FREE BOOK about this money-making profession that's not affected by automation.

**McCARRIE SCHOOL OF MECHANICAL DENTISTRY**  
207 No. Broad St., Dept. 29, Philadelphia 7, Pa.

**PELLET FIRING LUGER AUTOMATIC**

- MAGAZINE LOADING CLIP
- OVER 15 MOVING PARTS
- FULLY AUTOMATIC

Automatic full size model of a Luger Automatic pistol—contains over 15 moving parts. Loads 8 complete rounds which snap into the hard butt simulating a Luger. Fires 8 bullet shaped pellets Has automatic slide action.

**MOST AUTHENTIC MODEL GUN WE'VE EVER SEEN**  
Comes to you with working parts disassembled with cleverly engineered springs, full instructions, supply of pellets and specially designed belt holster. Full Money Back Guarantee. Simply send \$1.98 plus 27c shipping charge or order C.O.D. From:  
**HONOR HOUSE PROD. CORP., Dept. LL-95, Lynbrook, N.Y.**

**ONLY \$198**

# Here's the "STRAIGHT DOPE" on HOW TO FIX ANY PART OF ANY CAR

## from the Men Who Build 'Em!

Engineers from every American car factory put their know-how at your fingertips in this giant 1,100-page, picture book!  
COVERS ALL THESE MAKES — 1955 thru 1962!



**PLUS** Buick Special, Comet, Corvette, Lancer, Lark, Olds F-85, Pontiac Tempest, Rambler American

BRAND-NEW EDITION!

MOTOR'S  
AUTO  
REPAIR  
MANUAL

TRY BOOK

**FREE**  
FOR 10 DAYS!

Now — the "meat" of 176 shop manuals makes practically any car repair or service job child's play for beginner or expert mechanic!

Now you can "breeze thru" the toughest car repair jobs — in **DOUBLE-QUICK** time. If you're a beginner mechanic you can tackle jobs you never dreamed you could handle. And if you're already an expert, you'll save yourself hours of back-breaking work... and save money, to boot!

It's easy with the big brand-new Edition of famous MOTOR'S Manual. You get the expert help of 176 Official Factory Shop Manuals — the time and work-saving methods developed by factory engineers in every auto plant in America for their own motor car lines—boiled down in one handy, indexed book.

### Factory Experts Practically Guide Your Hands

NO guesswork! NO false starts! MOTOR'S Manual starts you from

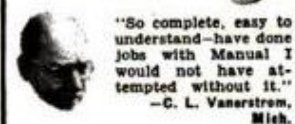
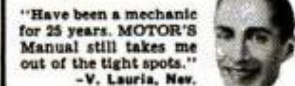
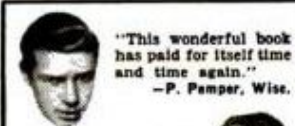

"scratch" — expert "know-how" guides your hands through every step of practically every job. With clear illustrations and 1-2-3 instructions, these experts show you how to "polish off" any repair on any car listed—1955 thru 1962, including all the new compacts.

NEW, REVISED Edition gives you everything you need to know to repair 2,219 models. Over 1100 giant-size pages, 2,850 "this-is-how" pictures and diagrams, 195 "Quick-Check" Charts, 30,000 essential repair specifications, 225,000 Service and Repair FACTS. Instructions and pictures so clear you CAN'T go wrong!

Here's how to make fast, expert repairs on Automatic Transmissions, Engines, Ignitions, Carburetors, Steering Gears, Generators, Alternators, Distributors, Power Steering and Brakes, Starter Motors, Starter Switches, and much, much more. No wonder **THREE AND A HALF MILLION** copies have been sold. No wonder it's used by the U.S. Armed Forces.

### Try It FREE 10 Days

**SEND NO MONEY!** Just mail coupon. (Paste it to a postcard for faster action.) Use the Manual for 10 days, free. If you don't agree that it is the greatest time-saver and work-saver you've ever seen—return book in 10 days, pay nothing. Mail coupon today! MOTOR Book Dept., Desk 212, 250 West 55th St., New York 19, N. Y. (Schools, Bookstores; Write for discounts.)

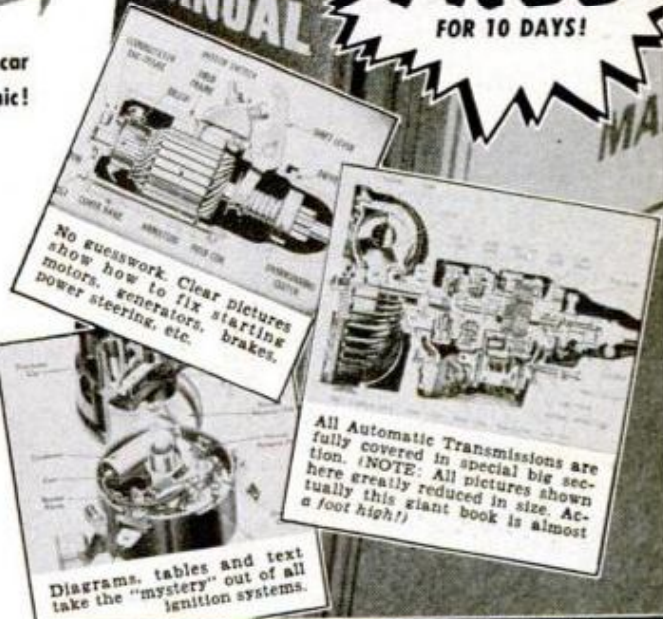

MAIL COUPON NOW FOR 10-DAY FREE TRIAL  
(Attach to postcard if more convenient)

MOTOR BOOK DEPT.  
Desk 212, 250 W. 55th St., New York 19, N. Y.

Rush to me at once (check box opposite book you want):

MOTOR'S New AUTO REPAIR MANUAL. If O.K., I will remit \$2 in 10 days, \$2 monthly for 2 months and a final payment of \$2.95 (plus 45¢ delivery charges and sales tax) one month after that. Otherwise I will return the book postpaid in 10 days.

MOTOR'S New TRUCK REPAIR MANUAL. If O.K., I will remit \$2 in 10 days, \$2 a month later, then \$2 monthly for 2 months (plus 45¢ delivery charges and sales tax with final payment). Otherwise I will return book postpaid in 10 days.

Print Name.....Age.....

Address.....

City.....Zone.....State.....

Check box and save 45¢ shipping charge by enclosing WITH coupon in envelope entire payment of \$8.95 for Auto Repair Manual (or \$10 for Truck Repair Manual) plus sales tax. Same 10-day return/refund privilege applies.



Same FREE 10-Day Trial on TRUCK REPAIR MANUAL  
Covers every job on every popular make truck, 1952 thru 1962, including Chevy, Ford & International "Midgets," plus GM, International, Mack, Cummins Diesels, Engines, fuel systems, ignition systems, starters, generators, transmissions, axles, brakes. For FREE TRIAL, check box in coupon.

## FREE Key Machine

Kind master locksmiths use. Sells for \$125, but yours FREE with Locksmithing Course



## You Can Learn To Be A LOCKSMITH

in your spare time

There's a big demand for skilled locksmiths. You can earn big money either full or part-time in your own home. Be your own boss; earn steady, year 'round income with no layoffs. The BELSAW INSTITUTE training, recommended by professional locksmiths, teaches you to make keys, open and repair locks on homes, cars and buildings. Easy, step-by-step illustrated lessons complete with all tools and supplies. We tell you how to get servicing jobs, how much to charge, how to earn while you learn and how to build a secure cash profit business.

Mail Coupon for FREE Book Today!

BELSAW INSTITUTE, 102 Field Bldg., Kansas City 11, Mo.  
Send FREE book, "Keys To Your Future!"  
No obligation. No salesman.

Name.....

Address.....

City..... State.....

## A BIG BUSINESS OF YOUR OWN!

MAKE BIG, EASY PROFITS

THIS BULB  
OUTLASTS  
10 TO 13  
ORDINARY  
BULBS

Make up to \$10 an hour. Earn \$100, \$250, \$500 in spare time—more full time. Work when you want! Supply homes, stores, offices, factories with Sunmaster's guaranteed 5-year light bulb—outlasts 10 to 13 ordinary bulbs—saves your customer at least \$2.00 per bulb on replacement costs. That's why sales come easy—profits come fast—up to 108% on each sale! Write today for FREE Sales Outfit and 30-Day No-Risk Offer.

IT'S  
GUARANTEED  
FOR 5 YEARS

Sunmaster Electric Products Dept. PM-22  
366 Fifth Ave., New York 1, N. Y.

Send FREE Sales Kit and No-Risk Profit Plan.

Name.....

Address.....

City..... Zone..... State.....

(In Canada, 539 King St. W., Toronto, Ont.)

## SHORTHAND IN 6

Famous SPEEDWRITING shorthand. 120 words per minute. No symbols; no machines; uses ABC's. Learn at home or through classroom instruction. Lowest cost. For business and Civil Service. 500,000 graduates. Typing available. 39th year. Write for FREE booklet.

6  
WEEKS  
© 1961

**Speedwriting**  
Dept. 1502-2, 55 W. 42 St., New York 36

## Free! NORTH AMERICA PLUS 87 FOREIGN FLAG STAMPS!



SENSATIONAL GET-ACQUAINTED OFFER. Big valuable collection of all-different genuine postage stamps from Greenland (North Pole), St. Pierre, Newfoundland, Canada — picturing Eskimos, Indians, scarce 1867 Confederation, Northern Territories, Nova Scotia, United Nations. U.S. — ancient 19th Century; first Ship & Plane; rare Whooping Crane; Pony Express, etc. Also, Complete set of Colonial & Civil War commemoratives. PLUS colorful flag stamps of 87 foreign countries. EXTRA! Big bargain catalog; How To Recognize Rare Stamps; other exciting stamp offers for free inspection. Send 10c for mailing.

KENMORE STAMP COMPANY, Milford EF 346, N. H.

## 1000 TRICKS 10¢

AMAZE! ENTERTAIN! START NOW!

BIG EXCITING MAGIC & FUN  
CATALOG! 160 Pages! Tricks,  
Jokes, Magic, Illusions, Secrets!  
Puzzles, Stunts, etc.! Rush name,  
address and only 10¢.

FREE MAGIC TRICK GIVEN

House of 1000 Mysteries • Dept. PM2-62 • Trumbull, Conn.



FREE  
BOOKLET

## Be a JEWELER

We teach you at home to buy, grade, appraise and sell all kinds of gems and jewelry. Full or part time opportunities everywhere. Easy to understand assignments, detailed illustrations. We supply you with actual diamonds to teach you accurate appraising. GIA training can be your stepping stone to prestige and recognition in this well paying field.

FREE INFORMATION and full color  
gem illustrations. Dept. M-22

GEMOLOGICAL INSTITUTE OF AMERICA  
**GIA** 11940 San Vicente Blvd.  
Los Angeles 49, Calif.

## Shrinks Hemorrhoids New Way Without Surgery Stops Itch - Relieves Pain

For the first time science has found a new healing substance with the astonishing ability to shrink hemorrhoids and to relieve pain — without surgery.

In case after case, while gently relieving pain, actual reduction (shrinkage) took place.

Most amazing of all — results were so thorough that sufferers made astonishing statements like "Piles have ceased to be a problem!"

The secret is a new healing substance (Bio-Dyne®)—discovery of a world-famous research institute.

This substance is now available in suppository or ointment form under the name Preparation H®. Ask for it at all drug counters.





# Earn **HIGH WAGES** as a **HEAVY EQUIPMENT OPERATOR**



**FIELD-TRAIN  
AT NATIONAL ON  
DIESEL-ENGINE MACHINES**

Learn Operation,  
Maintenance and  
Safety

## **RUGGED OUTDOOR MEN** *up to 56 years old can qualify!*

**NO PREVIOUS  
EXPERIENCE NECESSARY  
No Special Education Needed**

High wages and security NOW and in the years to come are yours as a trained heavy equipment operator. Your chance is TODAY . . . your opportunity is HERE, if YOU will but take advantage of it! The world's fast-growing multi-billion dollar construction industry needs men NOW for work in this country and overseas — you can be one of them!

As a heavy equipment operator you will "move the earth" on aerospace projects, highway building, and industrial construction. Learn HOW at National, the original school of heavy equipment operation, through actual field training on the same kind of diesel-engined bulldozers, rubber-tired scrapers, motor-graders, and cranes now in use by the industry.

National School is NOT a correspondence school . . . if your application is accepted, you will field-train on its huge proving ground in the beautiful Piedmont area of North Carolina. Full training courses, VA approved, payment plans available. AND, National maintains its own Job Advisory and Counselling Department with a full-time Director for the exclusive use of its graduates!

Make up your mind NOW that you are interested in high wages and security and mail the coupon TODAY for FREE illustrated school catalog . . . you are not obligated in any way.

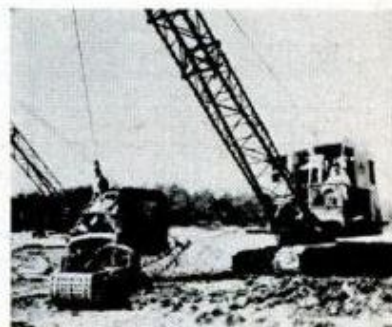

Even if you are presently taking a "course" in heavy equipment operation, write for our free catalog (there is no obligation), and compare the "training" you are receiving with ours.

**NATIONAL SCHOOL OF HEAVY EQUIPMENT OPERATION  
Dept. D-25  
P. O. Drawer 1686, Charlotte, N. C.**

Please send one FREE illustrated school catalog and complete information about how I can become a Heavy Equipment Operator. I understand there's no obligation.

Name \_\_\_\_\_ Age \_\_\_\_\_

Address \_\_\_\_\_

City \_\_\_\_\_ Zone \_\_\_\_\_ State \_\_\_\_\_

**MAIL TODAY**  
**For FREE Illustrated School  
Catalog and complete information**

## AVIATION CAREER

A solid education is your only key to success in the world of aviation.



A non-profit, private institution of higher education.

### Director of Admissions

Embry-Riddle Aeronautical Institute  
Aviation Building, Miami 52, Florida

Without obligation, please send me your Free 80-page Book and full particulars about the course(s) checked.

Print Name .....

Address .....

City .....

- Executive Pilot—Bachelor of Science Degree
- Business Pilot—B.B.A. Degree
- Aeronautical Engineering—B.S. Degree
- Aircraft Maint. Engr.—B.S. Degree
- Aircraft Maint. Engr. Tech.—A.S. Degree
- Aeronautical Engineering Technology

3A-PM-22

**MAIL THIS COUPON TODAY**

Learn to **MOUNT BIRDS**  
**Tan SKINS, Make Up FURS**  
 Be a Taxidermist. We teach you at Home.  
 Mount Birds, Animals, Pets, Game Heads, Fish  
 Save your hunting trophies; decorate home  
 and den. **MAKE MONEY**. Mount and Krome-  
 tan for others. Big spare-time profits.  
**FREE BOOK** 100 game pictures  
 48 pages - Hunters,  
 get this wonderful book. It's Now Free.  
 Send postcard **TODAY**. State AGE.  
**NORTHWEST TAXIDERMIST SCHOOL**  
 Dept. 2502, Omaha, Nebraska

**STEP UP to BENJAMIN'S** TRADITIONAL EXCELLENCE!  
 DISCOVER the BIG DIFFERENCE that EXPERT CRAFTSMANSHIP can Make in Your SHOOTING PERFORMANCE and FUN!  
 25 MODELS - SINGLE SHOT and REPEATERS - FIRST CHOICE of SHOOTERS who want SAFETY - CONVENIENCE - ECONOMY including HIGHEST QUALITY MATERIALS to Assure Them OUTSTANDING POWER - ACCURACY - DEPENDABILITY!

**World Famous AIR GUNS and CO<sub>2</sub> GUNS**

No. 2600 BENJAMIN Super 35-Shot BB Gas Pistol. Safe—No Pumping—Uniform Hi-Power. For Target & Small Game. \$18.95  
 No. 2620 BENJAMIN 20-Shot Cal. 22 Gas Pistol. Economical. \$20.95  
 No. 1300 50-Shot BB Air Pistol \$23.50  
 No. 1320 BENJAMIN 35-Shot Cal. 22 Air Pistol \$25.50

No. 3600 BENJAMIN Super 100 Shot BB Gas Rifle. Non Toxic—Safe—Convenient—Uniform Hi-Velocity Power. \$19.95  
 No. 3620 BENJAMIN Super 85 Shot Cal. 22 Gas Rifle. . . . \$21.95  
 No. 3100 Super 100 Shot BB Air Rifle. Adj. Shooting Force \$24.95  
 No. 3120 BENJAMIN Super 85 Shot Cal. 22 Air Rifle. . . . \$26.95

**FREE** Catalog All Models Benjamin Single Shot & Repeaters—Cal. BB or 177 or 22. Also, Special Hunting & Fishing Knife Offer.

**BENJAMIN AIR RIFLE CO., 896 MARION ST., ST. LOUIS 4, MO.**  
**You Can DEPEND on... BENJAMIN**

**"\$7,108<sup>50</sup> NEW!"**

FIRST YEAR  
**Cleaning-  
 Repairing  
 RADIATORS."**



—Hank Konter, Newcastle, Wyo.

Make \$6,000-\$9,000 a year servicing auto-truck-tractor radiators with Inland's new 1-Piece Radiator Shop. Easy to do entire job—TEST, CLEAN and REPAIR radiators. Only 11' 7" long. Inland, world's largest radiator equipment manufacturer, trains you free. Small down payment starts you. Easy-pay plan lets you pay from profits. Proved merchandising assures volume. Profitable department for garage or service station. Many set up Radiator Shop in garage at home, make good money working evenings. Write.

**INLAND MFG. CO., Dept. PM2, 1108 Jackson St., Omaha 2, Nebr.**

## BRONZE FOUNDRY

Since 1935

Schools • Home Workshops • Inventors



Make your own castings of aluminum, copper, bronze, silver. Foundry sets are available in six sizes, capacity 1½ lb. to 48 lb. of red brass. 2400 Deg. F. blast furnace included with each. Write for Free Circular.

**KANSAS CITY SPECIALTIES CO. DEPT. P-2 MARYSVILLE, KAN.**

Now Many Wear

## FALSE TEETH

With More Comfort

**FASTEETH**, a pleasant alkaline (non-acid) powder, holds false teeth more firmly. To eat and talk in more comfort, just sprinkle a little **FASTEETH** on your plates. No gummy, gooey, pasty taste or feeling. Checks "plate odor" (denture breath). Get **FASTEETH** at drug counters everywhere.



"Well, that takes care of those rust spots on the car!"

POPULAR MECHANICS

Not everyone does as well, but T. N. CODY, who started a business of his own, reports...

For 12 months I've averaged

**\$800 PER MONTH INCOME**



**—most of it clear profit for me!**

Many men have discovered how to be independent, to be free of layoffs and bosses. C. G. Naples grossed more than \$200 his first week. A father-son combination grossed \$44,000 their second year. H. Lemon says, "I netted \$133 in one 8-hour day."

How much you make depends largely on you. You need no special skill, no large investment. Start part time if you wish.

**NO SHOP NECESSARY** • Our Electric Deterger shampoos rugs, carpets right on floor—removes dirt and grime and helps to show their natural color and beauty. So efficient and safe it is used by largest railroads and hotels.

► **This is not a lease proposition. You own the machine, you work when and where you please and all the money you take in is your own. You take no risk. Machines fully guaranteed.**



**MAIL COUPON TODAY FOR FREE BOOK**

**VON SCHRADER MFG. CO.**  
210 "R" Pl., Racine, Wisconsin

Without obligation send me **FREE** booklet about your RUG DETERGER and tell me how I can start my own permanent, profitable business.

Name \_\_\_\_\_

Address \_\_\_\_\_

City \_\_\_\_\_ Zone \_\_\_\_\_ State \_\_\_\_\_

**Portable Power Tower** with shelf space for power tools and multiple outlets so the cords won't get tangled. Wheels around to any location where it is needed. The March issue of PM will carry plans.



**DRAINS** cellars, cisterns, wash tubs; **\$7.95**  
**IRRIGATES - CIRCULATES - SPRAYS**

1,001 uses. Stainless shaft. Won't rust or clog! Use 1/6 HP motor or larger... 3/4 HP for up to 2,400 GPH; 450 GPH 80' high; or 1800 GPH from 25' well. 1" inlet; 3/4" outlet. Coupling included free. **\$7.95.**  
**HEAVY DUTY BALL-BEARING PUMP.** Up to 5,200 GPH; or 3,000 GPH from 25' well. 1 1/2" inlet; 1" outlet. **\$12.95**  
Postpaid if cash with order. **MONEY BACK GUARANTEE**  
Centrifugal and Gear Pumps in All Sizes  
LABAWCO PUMPS, Belle Mead 7-P-XB, New Jersey

## LEARN MEAT CUTTING AT NATIONAL

Pay After Graduation



The steady dependable trade of Meat Cutting taught easily in 8 short weeks. **YOU LEARN BY DOING** under actual meat market conditions in big modern school at Toledo.

For beginners or men with experience. Get a profitable store of your own. Remember, **PEOPLE MUST EAT!** Big pay jobs. Free employment help. Thousands of successful graduates.

Buying, cutting, percentage, pricing, advertising, selling, etc. A complete retail meat education. National School established 39 years. Get National training **NOW.** Pay your tuition in easy weekly

payments after you graduate. Send coupon for **FREE** school catalog—**TODAY.** G.I. approved.

**National School of Meat Cutting, Inc., Dept. 50-B, Toledo 4, Ohio**

Send me your **FREE** school catalog on National Training at Toledo in Meat Cutting, Meat Merchandising and Self Service Meats. No obligation. No salesman will call.

Name..... Age.....

Address .....

City..... State.....

Approved for Veterans

# ENGINEERING

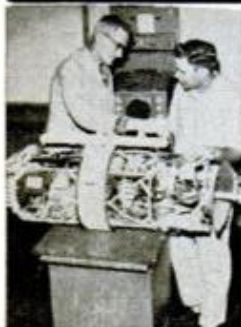

AMERICAN INDUSTRY NEEDS  
TRAINED ENGINEERS NOW

**BACHELOR OF SCIENCE  
DEGREE, 30 MONTHS**

SAVE 2 YEARS' TIME

**B.S. Degree Courses:**

- Electronic Engineering
- Mechanical Engineering
- Electrical Engineering
- Civil Engineering
- Architecture

**Diploma Courses:**

- Radio-Television Plus Color **TECHNICIAN**
- Architectural Drafting
- Mechanical Drafting
- Electronic Technician
- Structural Drafting

APPROVED FOR VETERANS

Send for **FREE** Information

**HEALD Engineering College**

Van Ness at Post, Dept. PM San Francisco, California

NAME \_\_\_\_\_  
STREET \_\_\_\_\_  
CITY \_\_\_\_\_ STATE \_\_\_\_\_

## Transistor Radio

Size of cigaret package, yet thrilling performance. Weighs only 3 ounces. Listen to music, news, sports programs, etc., on your personal portable set. Modern plastic case, ivory and blue with gold metal grille. Complete broadcast band. On-off switch one end. Uses standard penlight cells (included). Guaranteed. Complete, ready for \$4.95 immediate playing. Postpaid Only. . . . Johnson Smith Co., Dept. 124, Detroit 7, Mich.



## New Jet Engine Burns Gasoline



Powerful continual thrust for models: boats, cars, planes. No moving parts. Easy to start. Runs on regular gas. 6-in. long. Complete. Only \$1.49  
JOHNSON SMITH COMPANY, Dept. 124, Detroit 7, Mich.

## Catalog of 2900 Novelties 10c

New Send 10c for amazing catalog of novelties, live animals, scientific supplies, hobbies, funmakers, planes & boats, looms, magic tricks, joke articles, unusual seeds, gadget timesavers, cameras, optical goods, projectors, movies, lucky jewelry, religious novelties, disguises, musical instruments, stamps, coins, puzzles, fortune tellers, radios, auto & bike accessories, telescopes, magnifiers, compasses, banks, smokers' gadgets, artists' supplies, printing sets, engines, motors, shockers, knives, billfolds, guns, rifles, sports, books, games, plants etc. Send 10c.

JOHNSON SMITH COMPANY, Dept. 124, Detroit 7, Mich. Here's 10c.

Rush catalog to: \_\_\_\_\_  
Address \_\_\_\_\_

## MAGNETS

TSX-15 Magnet Assembly (150 lb. pull) Each....\$9.50  
TSX-14 Magnet Assembly (100 lb. pull) Each.... 7.25  
TS-1 Magnet Assembly (50 lb. pull) Each.... 2.95  
TS-2 Alnico 5 Pot Holder Magnets 50 for \$3.50, 20 for 1.50  
TS-5A Rectangular U's (4 lb. pull) 10 Magnets..... 3.25  
TS-6 Sample Magnets & Catalog (over 200 sizes listed)..... 25c  
**Money Back Guarantee**—Send check or money order, sorry, no C.O.D.'s  
TERRY SALES CORP., 1045 Silver Beach Rd., Riviera Beach, Fla.

44H

## DON'T PAY FOR THESE GREAT BOOTS!



8" Boot—  
Quilted,  
Air Cushioned,  
Thermal-Insulated

GET THEM WITHOUT COST  
AS A REWARD — PLUS THE CHANCE  
TO "BE BOSS" OF YOUR OWN  
\$10,000 A YEAR SHOE BUSINESS!

Brand new plan! You can earn marvelous new boots instead of paying for them... and develop an extra income for life! Sell friends new Work, Dress, Casual Shoes and Boots in spare time. Amazing Vylt Sole guaranteed the life of the shoe or boot or replaced **FREE!** Also earn Advance Commissions up to \$10.00 a pair, plus big Bonus. No experience. Samples supplied. Write for new Selling Outfit — without obligation.

**CHARLES CHESTER SHOE MFG. CO.**

Dept. B-623 Brockton, Mass.

## ADDING MACHINE

\$1.98 or 2 \$3.69  
ea. for

+ — × ÷  
ADD — SUBTR. — MULT. — DIVIDE

Does all 4 operations. Handles 9 columns of numbers. Settle for no less. Leatherette case. Lowest price adder made in America. Beware of cheapened foreign imitations. Money back guarantee. Agents wanted. \$1.98 add 4% tax in Pa.

**TOM THUMB** P. O. BOX 276 BETHAYRES, PENNA. DEPT. F-12



**FREE CATALOG!**

**TREMENDOUS SAVINGS ON HUNDREDS OF SURPLUS AND NEWLY MANUFACTURED ITEMS!**

New 1961 edition contains over 50 pages of tools and equipment for farm, home, workshop, factory. Hydraulic equipment, pumps, motors, construction and diesel equipment and parts! Write for your **FREE CATALOG** Today.

**GROBAN SUPPLY COMPANY**

1139 South Wabash Ave., Dept. 6-1 Chicago 5, Ill. WEbster 9-3793

*After the city,  
Before the state  
The ZONE keeps your mail  
From being late*

★ ★ ★

The Post Office has divided 106 cities into postal delivery zones to speed mail delivery. Be sure to include zone number when writing to these cities; be sure to include *your* zone number in *your* return address — after the city, before the state.

POPULAR MECHANICS

Just a Few Months **NEW** and Already One of the **HOTTEST** Money-Makers for Men Everywhere—even Spare Time!

**HOW HOT?**  
Read how great these men are doing!

**MERLITE Longer-Life Light Bulbs—the Only Bulbs in the World Backed by this SENSATIONAL GUARANTEE:**

**ONCE YOU BUY MERLITE LIGHT BULBS—YOU NEVER HAVE TO BUY BULBS AGAIN—NEVER!**

**Daring NO-TIME LIMIT FREE REPLACEMENT GUARANTEE**  
Does the selling **FOR YOU—MAKE** up to \$1,000.00 in a MONTH!

It's fantastic—14 magic words (**ONCE YOU BUY MERLITE LIGHT BULBS—YOU NEVER HAVE TO BUY BULBS AGAIN—NEVER!**) are making it easy for men everywhere to make a "small fortune"—as much as \$1,000.00 and more in a month, spare time or full time! No demonstrations, no fast-talking sales pitch needed. Almost everyone jumps at the chance to buy Merlite Bulbs with the iron-

clad Guarantee (packed with each bulb) that unconditionally offers to replace **FREE** any burned-out Merlite Bulbs, no matter when they burn out—in 5 years, 10 years—**NO TIME LIMIT!** And the Guarantee applies to all Merlite Bulbs purchased or replaced! Every home needs 12 to 24 Merlite Bulbs to replace old-fashioned short-life non-guaranteed bulbs. Make up to 120% profit, easily make \$50 in few spare hours. Merlite men are doing this now!

**Averages \$12 an Hour**

"Merlite Bulbs are the answer to a salesman's prayers. They're fantastically easy to sell. Working only part time, I have averaged \$12.00 per hour."  
*Philip Smith, Maine*

**Sold 178 Bulbs First Afternoon**

"The first afternoon I sold 178 bulbs. Am very pleased with reception we get from customers. Please ship my next order at once."  
*W. E. Foust, Arkansas*



**Makes \$8.20 an Hour in Just Spare Time**

"These guaranteed Merlite Bulbs surely sell. I've averaged \$8.20 per hour for the time I've spent with them. That makes a nice income and wish I could give full time to the job."  
*L. C. Benedict, Virginia*



**FREE Money-Making Details**  
**Amazing No-Risk Offer**

Find out for yourself how much money you can make with the sensational Guaranteed Merlite Long-Life Light Bulb. We'll send you—**FREE** and without obligation—complete money-making Illustrated Sales Outfit and an astounding offer which helps you get started making money without risking a penny. Mail coupon **TODAY!**

**Merlite Industries, Inc., Dept. C-15P**  
(Bulb Div.) 114 East 32nd Street, New York 16, N.Y.

Merlite Industries, Inc., (Bulb), Dept. C-15P  
114 East 32nd Street, New York 16, N.Y.  
Rush complete money-making illustrated Sales Outfit and No-Risk Starting Offer—**FREE** and without obligation.

Name \_\_\_\_\_  
Address \_\_\_\_\_  
City \_\_\_\_\_ Zone \_\_\_\_\_ State \_\_\_\_\_  
In Canada: Mops Co., Ltd., 371 Dowd St., Montreal 1, P.Q.



**BARBELLS**

140-Pound, **CHROME DELUXE** Barbell-Dumbbell set only \$19.80.  
This is our feature set and is the finest ever manufactured.

Training with adjustable weight is the **BEST** way to keep fit; the **ONLY** way to develop great strength and a perfect body. As the oldest and best equipped barbell company, BUR gives value and prices no one can equal.

**SEND FOR FREE CATALOG**  
**BUR BARBELL CO.**  
Lyndhurst 9, New Jersey

100 POUND SET  
**\$12.80**  
Extra Plates Only 12c Pound

**HYDRAULIC JACK REPAIRS**



**Earn While You Learn at Home**  
Millions of jacks in gas and auto-service stations, truckers, body-shops, riggers, factories, farms need servicing. We show you **HOW**—easy step by step directions—what tools to use. **EARN UP TO \$5 an hour**, in spare time, in your own basement or garage. Start your own business **NOW**.  
Write for folder PM2 and free bonus offer.

**INSTITUTE OF HYDRAULIC JACK REPAIR**  
P. O. BOX 50 • BLOOMFIELD, N.J.  
A Correspondence School Licensed by N. J. Bd. of Ed.

**High School at Home**

**MANY FINISH IN 2 YEARS**

No classes. No time wasted going to and from school. Progress as fast as your time and abilities permit. Standard H.S. texts supplied. Thousands enroll each year in this 65-year-old school. Send for **FREE** descriptive booklet.

**AMERICAN SCHOOL, Dept. H245**  
Drexel at 58th St., Chicago 37, Ill.

Without obligation, please send **FREE** descriptive booklet.

Name \_\_\_\_\_  
Address \_\_\_\_\_  
Accredited Member National Home Study Council

© 1962 A.S.C.



**PAY 2 or 3¢ on the DOLLAR**  
for 1000's of Useful Items of  
**U. S. GOV'T SURPLUS**

**AT THE AMAZING PRICES PAID AT GOV'T SURPLUS SALES**

Autos.....\$78 Tractors.....\$68  
Trucks.....\$212 Motors.....\$99  
Boats.....\$5.90 Typewriters \$6.80  
Compressors \$9.69 Generators \$8.78

You **BUY DIRECT** from U. S. Government at **TREMENDOUS** savings. Eliminate middlemen—Save **BIG MONEY!** Pay as **LOW** as 2¢ on the dollar. Our **DIRECTORY** Gov't Surplus Sales lists 100's Army, Navy, Air Force Surplus Depots all over the world. **BUY JEEPS**, sports equipment, hunting, fishing and photographic equipment and supplies, radio, electronic and electrical equipment, trucks, boats, airplanes. Plumbing, hardware, office equipment & supplies. Tools, machinery, furniture. This 1962 book tells how to buy Gov't Surplus **DIRECT**. No dealer profits to pay. Get on the **gravy train NOW!** Send \$1 **TODAY** for "Gov't Surplus **DIRECTORY**" to **AVIATION SURPLUS INC., Box 789-PM2, York, Pa.**

# AMAZING SCIENCE BUYS

OVER 1000 ITEMS

## WAR SURPLUS AMERICAN-MADE 7x50 BINOCULARS

Big savings! Brand new! Crystal clear viewing—7 power. Every optical element is coated. An excellent night glass—the size recommended for satellite viewing. Individual eye focus. Exit pupil 7mm. Approx. field at 1,000 yds. is 376 ft. Carrying case included. American 7 x 50's normally cost \$274.50. Our war surplus price saves you real money.



Stock No. 1544-H. only \$74.80 postpd. (Tax included)  
6 x 30 Binoculars—similar to above and a terrific bargain.  
Stock No. 963-H. . . . . \$33.00 postpd. (Tax included)

## CIRCULAR DIFFRACTION GRATING JEWELRY

A DAZZLING RAINBOW OF COLOR

Shimmering rainbows of gem-like color in jewelry of exquisite beauty—made with



CIRCULAR DIFFRACTION GRATING REPLICA. Just as a prism breaks up light into its full range of individual colors, so does the Diffraction Grating.  
Stock #30,349-H Earrings . . . . . \$2.20 Ppd.  
Stock #30,350-H Cuff Links . . . . . \$2.20 Ppd.  
Stock #30,372-H Pendant . . . . . \$2.20 Ppd.  
Stock #30,390-H Tie-Clasp . . . . . \$1.65 Ppd.  
Stock #40,519-H Bracelet (six 3/4" Gratings) . . . . . \$7.70 Ppd.

## OPAQUE PROJECTOR



Projects illustrations up to 3" by 3 1/2" and enlarges them to 35" x 30" if screen is 6 1/2 ft. from projector; larger pictures if screen is further away. No film or negatives needed. Projects charts, diagrams, pictures, photos, lettering in full color or black-and-white. Operates on 115 volt, A.C. current. 6-ft. extension cord and plug included. Operates on 60 watt bulb, not included.

Size 12" x 8" x 4 1/2" wide. Weight 1 lb., 2 oz. Plastic case with built-in handle.  
Stock No. 70,199-H . . . . . \$7.95 Postpaid

Remove Your Retaining Rings—Disassemble Lenses, Cameras, etc.



## ADJUSTABLE SPANNER WRENCH

Made for U.S. Air Force—available at a fraction of Government cost. A top grade, versatile tool that every instrument and camera repair man or just plain tinkerer should own. Adjustable for 1/2" to 12" diameter retaining rings. Complete with six different pairs of points to fit all types of slots and holes. 3", 6", and 12" main bars. All steel and nicely plated. The finest tool we have ever come across for this type of retaining ring work AND a real bargain at our low price.  
Stock No. 70,355-H . . . . . \$12.50 Postpaid

## 'FISH' WITH A MAGNET

Go Treasure Hunting On The Bottom

Great Idea! Fascinating fun and sometimes tremendously profitable! Tie a line to our 5-lb. Magnet—drop it overboard in bay, river, lake or ocean. Troll it along the bottom—your "treasure" haul can be out-board motors, anchors, fishing tackle, all kinds of metal valuables. 5-lb. Magnet is war surplus—Alnico V Type—a terrific bargain. Lifts over 125 lbs. on land—much greater weights under water. Order now and try this new sport.

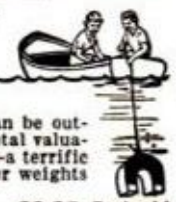

Stock No. 70,183-H. 5-lb. Magnet. . . . . \$9.95 Postpaid

## NEW! CIRCULAR SLIDE RULE!

Pocket Size—Fast—Easy to Use!



Multiplies, divides, figures fractions, percentages, squares, cubes, roots, proportions, circumferences, areas, prices, fuel consumption. Faster, easier to learn and use. Directions included.

Stock No. 30,336-H . . . . . \$4.95 Postpaid

Order by Stock No.—Send Check or M.O.—Money-Back Guarantee  
**EDMUND SCIENTIFIC CO., Barrington, New Jersey**

Clip and Hand to a Friend . . . or Leave for the Next Reader of this Issue!

## MAIL COUPON For FREE CATALOG "H-1"

160 Pages! Over 1000 Bargains!

EDMUND SCIENTIFIC CO., Barrington, N. J.

Please rush Free Giant Catalog—"H-1"

Name . . . . .

Address . . . . .

City . . . . . Zone . . . . . State . . . . .



# Science overseas

By William Kreh

There's \$280,000 awaiting the inventor of a silent, road breaking pneumatic drill. A group of British manufacturers, joining the London Noise Abatement League campaign, will pay at least this much for the right to make the quiet drill.

Radioactive roadblocks? Space vehicles will have to pick their way through masses of radiation, just as terrestrial ships do through icefields, speculates Russian Air Force General G. I. Pokrovsky.

The U.S.S.R., he adds, has already compiled a map of radiation zones in outer space so that this can be done.

Radiation news, by the way, is not all bad. Male radiographers in Japan have more boys than girls, and the evidence is that radiation-caused mutations in sex chromosomes leads to this occurrence. That's the theory of Katsumi Tanaka, professor of human genetics at Tokyo Medical and Dental University, backed up by research into radiation effects on fruit flies.

A survey of 5733 X-ray technicians revealed that 53.86 percent of their offspring born after they took up X-ray work were male, compared to 51.32 percent for the rest of the population.

Paper tires? Perhaps. The Chemical Institute of Canada says the crude rubber content of tires can be reduced 10 to 40 percent by substituting lignin, a waste product of paper manufacture. Lignin has been used in carcass and tread of experimental nylon-cord tires.

Frozen rats, stiff as boards, have been revived without apparent harm in experiments which may lead to successful preservation of whole body organs for long periods without loss of function.

Dr. Audrey U. Smith, of London's National Institute for Medical Research, says that by slowly freezing rats she was able to reduce their internal body temperatures to the freezing point and even a little below. After keeping them at these temperatures for an hour or more, she said, she revived them by quick rewarmings.

Milk can be stored for four weeks without refrigeration or change in flavor or color, if it has been treated by a new Swedish process.

Temperature of the milk is raised to 140 degrees C. by jets of steam and is then chilled quickly in a vacuum chamber. The whole process is done in ultra-sterile equipment, eliminating the bacteria that cause milk to sour.



**Woomera Rocket Range**, in central Australia, will be used as the launching site for a new international space program. Great Britain and seven West European nations plan to launch a satellite from the range in 1965. Great Britain's Blue Streak rocket will be the first stage; the second stage will be French-made and the third will be built in West Germany.



**Avalanches will trip** themselves up in British Columbia. Wires will be strung across avalanche paths that cross the Trans-Canada Highway. When a wire is broken by pushing snow and ice, a radio transmitter will send out a signal, alerting road crews where to come to clear the highway.



**Hypertense people** behind the Iron Curtain are getting treatment in a biotron—a chamber which regulates "temperature, relative humidity, barometric pressure, oxygen content, and ionic content."

This therapy, says a Soviet report, restores "the defensive forces and reserves of the human organism without the use of any chemotherapeutic agents."

Five hundred edgy Russians have been restored by this treatment.



**And the sea gave up fresh water.** Israel is operating the first of a new type of salt-water converter. About the size of a small household oven, it has a capacity of 250 gallons a day and can make drinking water from underground salt water—drawn about 10 miles south of the Dead Sea and some 1200 feet below that fabled body of water. Salt is removed by means of electricity and membranes.



A "window" in the top of the tuna's head interests Canadian scientists. Nova Scotia Fisheries' Department says this tiny hole, covered by a transparent tissue, may mean the fish's migrations are the result of seasonal sunlight changes. The hole is connected to a tube leading to the traveling tuna's brain. ★ ★ ★

**AMAZING SCIENCE BUYS** OVER 1000 ITEMS

See the Stars, Moon, Planets Close Up!  
**3" ASTRONOMICAL REFLECTING TELESCOPE**  
60 TO 180 POWER  
Famous Mt. Palomar Type!  
An Unusual Buy!



See the Rings of Saturn, the fascinating planet Mars, huge craters on the Moon. Equatorial Mount with lock on both axes. Aluminized and overcoated 3" diameter high-speed f/10 mirror. Telescope comes equipped with a 60X eyepiece and a mounted Barlow Lens. Optical Finder Telescope included. Hardwood, portable tripod. FREE with Scope: Valuable STAR CHART plus 272-page "HANDBOOK OF HEAVENS" plus "HOW TO USE YOUR TELESCOPE" BOOK.

Stock No. 85,050-H ..... \$29.95 Postpaid  
4 1/4" REFLECTING TELESCOPE—Up to 255 Power.  
Stock No. 85,105-H... \$79.50 F.O.B., Barrington, N. J.

**NEW! SCIENCE FAIR PROJECT KITS**

Edmund Kits are carefully planned to give any boy or girl the fun and excitement of discovering science facts. Such carefully planned projects can lead the student to awards or scholarships. Adults too will find them an excellent introduction to the various fields of science.



Write for Free Bulletin 47-H  
"Your Science Project" covering all phases of Science Fair projects

**MOLECULE AND CRYSTAL MODELS KIT**—Rods and balls to make atomic models, plus directions.  
Stock No. 30,413-H ..... \$2.50 Postpaid

**SOIL TESTING KIT**—Basis for many fascinating experiments regarding growth of plants, etc.  
Stock No. 60,118-H ..... \$2.00 Postpaid

**CRYSTAL GROWING KIT**—Grow breathtaking display of large crystals with this set.  
Stock No. 70,336-H ..... \$9.50 Postpaid

**MAGNETISM KIT**—Based on magnetism demonstrations developed by UNESCO.  
Stock No. 70,325-H ..... \$3.75 Postpaid

**SCIENCE TREASURE CHESTS**

Extra-powerful magnets, polarizing filters, compass, one-way-mirror film, prism, diffraction grating, and lots of other items for hundreds of thrilling experiments, plus a Ten-Lens Kit for making telescopes, microscopes, etc. Full instructions included.

Stock No. 70,342-H ..... \$5.00 Postpaid

**Science Treasure Chest DeLuxe**—Everything in Chest above plus exciting additional items for more advanced experiments including crystal-growing kit, electric motor, molecular models set, first-surface mirrors, and lots more.  
Stock No. 70,343-H ..... \$10.00 Postpaid

**MINIATURE WATER PUMP**



Wonderful for experiments, miniature waterfalls, fountains, Christmas gardens, HO gage railroad backdrops, etc. Tiny (2 3/4" x 1 3/4") electric motor and pump ideal for hobbyists, labs, schools. Pumps continuous flow of water at rate of one pint per minute at a 12" head. With 2 D Batteries in series will pump to 24" high. Works in either direction. Stock No. 50,345-H ..... \$2.25 Postpaid

**BUILD A SOLAR ENERGY FURNACE**



A fascinating new field. Build your own Solar Furnace for experimentation—many practical uses. Easy! Inexpensive! Use scrapwood! We furnish instructions. This sun powered furnace will generate terrific heat—2000° to 3000°. Fuses enamel to metal. Sets paper aflame in seconds. Use our Fresnel Lens—14" diameter . . . f.1. 14".  
Stock No. 70,130-H . . . Fresnel Lens . . . \$6.00 Postpaid.

Order by Stock No.—Send Check or M.O.—Money-Back Guarantee  
**EDMUND SCIENTIFIC CO., Barrington, New Jersey**

**MAIL COUPON for FREE CATALOG "H"**  
160 Pages! Over 1000 Bargains!  
EDMUND SCIENTIFIC CO., Barrington, N. J.  
Please rush Free Giant Catalog-H.

Name.....  
Address.....  
City..... Zone . . . State . . .



# HOME PACKAGING

"MADE TO ORDER"  
FOR FOLKS WHO  
DON'T LIKE TO SELL



An Amazing New Kind of Home Business That Can Bring You a Big **STEADY INCOME**

Profits up to 2500%. Greatest one-man or man and wife team opportunity you ever heard of. Start spare time or full time anywhere—kitchen, basement, garage. We supply everything you need—guide you step-by-step. If you don't like house-to-house selling, this is the type of work you will really go for. Free "no selling plan" reveals big profit spare, full time opportunities. Get complete information in my new book "10 STEP PACKAGING PROFIT PLAN"—sent free and postage prepaid.



## FREE! Mail Coupon Now

A. J. Abarsi, Pres., Home Packaging Co., 2212 E. Jesse St., Los Angeles 23, Calif.  
Dear Mr. Abarsi: Please send me your new book "10-STEP PACKAGING PLAN" and details of how I can get started in my own home. Everything you send me now is free and no salesman will call. Dept. R-255

NAME \_\_\_\_\_  
ADDRESS \_\_\_\_\_  
CITY \_\_\_\_\_ ZONE \_\_\_\_\_ STATE \_\_\_\_\_

## POWERFUL NEW INVENTION, ONLY 2" LONG SHOOTS THRU 100 PAGES—THIS BOOK! 'B-B SHOT'



MAKE THIS TEST... Load your 'BB Shot' and fire against this magazine. Notice that it drives BB's through more than 100 pages. Though only 2" long x 1" in diameter, this pocket-size device has amazing power and accuracy. Use it for targets, pests and hunting. Scientifically designed for high power, operating ease and safety.

**FREE!** Get the 'BB Shot' now—we'll include an extra Velocity Cone and FREE Target, BB's and Automatic BB Dispenser... all for only \$1.98 ppd. 3 for \$5.00 ppd. Money Back Guarantee. Not sold to N. Y. C. residents or minors.

GRAYSON CO. • Dept. B-71, 210 Fifth Ave., N. Y. 10

**MONEY-BACK  
GUARANTEE**

Name.....  
Address.....  
City..... State.....

**\$1.98**  
ppd.

## WELD - BRAZE - SOLDER - CUT

REPAIR MOST EVERYTHING MADE OF METAL



Home Appliances, Auto parts. Make and repair lawn chairs, tables, ornamental iron work, gates, wagons, etc. Solder, heat, bend, and straighten, with terrific heat from arc torch. Cut and weld up to 1/4" steel plate. A million uses for Home, auto, farm, inventors, factories, etc. Works from any home 110 volt plug-in. Complete with welding mask and complete Welding Instruction Book. 1 year guarantee.  
**SEND ONLY \$3** (cash, ck. mo.) and pay postman \$14.95 plus COD postage on arrival or send \$14.95 and we will send postpaid. Ideal gift for mechanically minded, relatives, friends. Order now. Available only from:  
**MIDWAY WELDER, Dept. DPM-2, Kearney, Neb.**

## GHANA COLLECTION



### MULTICOLORED ALL-PICTORIAL STAMPS!

You get this FREE Ghana collection which pictures: United Nations, African flags and maps, sports, mystic jungle "Talking" drums, manganese mine, castle, Independence provisionals albatross and more! Also FREE, a "Philatelic PhotoNotes" subscription. All yours, with colorful sets for your 30-day examination. Adults only, write now. Say: "Rush me my special offers".

PHILATELICS UNLIMITED

Department K-16 New Paltz New York

## HALF-FLUSH—WATER SAVER



**New—Save Water and Your Cesspool!**

Why use 5 gals. when 1 to 2 gals. will flush fluid waste? HALF-FLUSH used at least 6 times to 1 full flush. Flush any amount you want. Pays for itself 1st month. Lasts for years. Full flush works same as always. Put on in 5 minutes. Instructions incl. \$1.50 ppd. Crandall Mfg. Co., Box 284, Dept. B, Sunland, Calif.

## DO IT YOURSELF BUT DO IT BETTER WITH THE RIGHT MATERIALS!

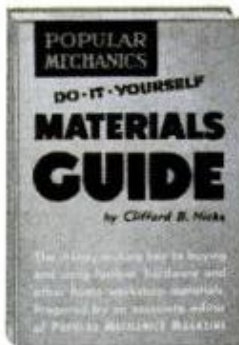

Get Popular Mechanics **DO-IT-YOURSELF Materials Guide**



The Key to Buying and Using Lumber, Hardware and Other Home Workshop Materials

### You Need This

How to select and how to use—Lumber, mill-work, plywood and hard-board—Exterior wall and roof materials—Hardwood floors and floor coverings—Wall and ceiling materials—Doors, windows, screens and weather stripping—Glass, the material of tomorrow—Plumbing pipes and fittings—Electrical equipment—Nails, screws, bolts, etc.—Hinges, locks and other hardware—Paints and miscellaneous products.

192 Fact filled pages.  
667 how-to-do-it pictures

The right lumber. The right grade. The right fastenings, nails, screws, glue and other hardware. These are all just as important as the right design and the right kind of workmanship. It's true, whether you're fixing up the house, making a fine piece of furniture or knocking out a time-killing gadget. Get Popular Mechanics Materials Guide. Fills a long-felt need of home owners and home workshop fans. Has how-to-do-it information too. Send only \$2.95 for postpaid delivery. Money back if you want it in 5 days.

Popular Mechanics Press, Dept. 262, 200 E. Ontario St., Chicago 11



Earn \$5 per hour in your own

## LAWN MOWER SHARPENING SERVICE

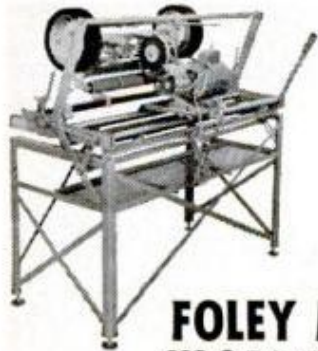

Earn extra money right from the start—average \$5.00 per hour. Full or spare time opportunity. The Modern Lawn Mower Sharpener is a complete shop in one machine. You don't need experience to start—anyone can operate it, and turn out perfect jobs. All operations are done quickly, easily and accurately. Write for full money making details.

**FOLEY MFG. COMPANY**  
293-2 Foley Bldg., Minneapolis 18, Minn.

**NO MONEY DOWN!**

**FLORIDA** <sup>1/4 ACRE</sup> *Only \$395* FULL PRICE

**A SUBURB OF OCALA!** Choice 1/4 acre homesites. Pay just \$10 a month • Guaranteed high and dry—gently rolling land • City of Ocala 3 miles — with shopping, churches, schools • Hunting and fishing — 400 nearby lakes • Unbeatable location • Free color photos and plat. Dept. 9

**OCALA RIDGE, Box 1718, Ocala, Fla.** AD 61079 (Q-Q)

**FREE CATALOG**



**MAKE YOUR OWN RODS AND LURES**

Send for FREE Wholesale Catalog. The most complete and fully illustrated catalog of reels, rods, heads, spinners, jigs, lure bodies and parts, sinker molds, feathers, tools, hooks, rod blanks, rod parts, swivels, wire, etc. Over 170 pages.

**FINNYS SPORTS**

2062X SPORTS BUILDING TOLEDO 14, OHIO

## NO JOB WORRIES

PLASTEX INDUSTRY needs manufacturers on small scale for big production of Lamps, Clock Stands, Art Goods, Novelties in Plastic Marble imitation. No Experience necessary. 1/2¢ material makes regular 10¢ store sellers. Moulds furnished for fast production. Small investment brings good profit. Big wholesale orders now being placed. Ambitious men have chance for real prosperity and job security. Our NEW FREE booklet will interest and benefit you.

**PLASTEX INDUSTRIES, Dept. A**  
3400 Third Ave. New York 56, N.Y.

## Make Money with Your Telephone

**NEW HOME BUSINESS.** Men, women — no experience needed. No selling! Choose your own hours, full or spare time. We show you everything—tell you who to call, what to say, how to make money without ever leaving your telephone. **Free Copy**, "How to Make Big Profits by Phone," full details, write **TELEPHONE INSTITUTE, Dept. H172**  
1038 S. La Brea - Los Angeles 19, California

FREE COPY

## NEW BENSEN GYRO-COPTER



Plans and kits for one-man "Spirit of Kitty Hawk" now available. Easy to build and fly. 3-view drawings, specs, photo \$2 or simpler Copter Glider \$1. Order today!

**BENSEN AIRCRAFT CORP., Dept. PM-22**  
Raleigh-Durham Airport, Raleigh, N.C.  
NAME  
ADDRESS

## 94.6% OF BAILEY GRADUATES ARE EMPLOYED AT TOP PAY IN THE FIELDS WHICH THEY WERE TRAINED!

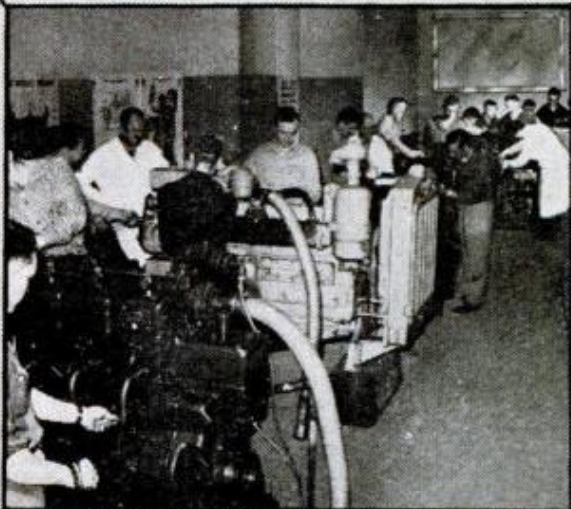

## DIESEL-AUTO MECHANICS DESPERATELY NEEDED!

We have a far greater demand for our students than we can fill!

We can show you an actual waiting list of leading companies throughout the world who have tried Bailey graduates — found them outstanding, and are coming back for more!

**Bailey Graduates are Successful . . . RECEIVE BIG PAY — HAVE SECURE FUTURE!**

The Famous Bailey Course prepares you for BOTH Diesel and Gasoline Mechanics.

This is a must—due to the advent of using Diesel principles, such as 'Fuel Injection' on passenger cars . . . use of gasoline engines for starting Diesel engines, etc. You learn all this at Bailey in the amount of time ordinarily required to learn just one of these subjects, **ALL FOR THE PRICE OF ONE.**

Don't be satisfied with a 'futureless', one-type job — learn how you can make big money now!

Write today for Free Booklet that takes you on a step-by-step camera tour through our spacious, modern shops — See Bailey students in action as they Learn-by-doing with the Famous Bailey Method of training!

We provide you with housing and part time jobs while in school, plus nation-wide placement service for graduates.

## BAILEY Technical SCHOOLS

1634 S. GRAND ST. LOUIS 4, MO.

### MAIL TODAY!

Please mail immediately this free booklet without obligation.

FREE BOOKLET



Name.....

Address.....

City..... State.....

APPROVED FOR VETERAN . . . NON-VETERAN

Sworn statement from CHAS. LEMMING reads:

**"After starting my own business**



**I've averaged \$100 A DAY —most of it clear profit!"**

• If you want to be independent—free from lay-offs, bosses—start profitable, year 'round business of your own. Ours is NOT a lease proposition. You own the machine, you work when and where you please, and all the money you take in is your own. FREE book tells you how.

Not everyone does as well...

Mr. Lemming owns two machines

In city of less than 50,000, Mr. Lemming started his own business after filling in coupon like one below. He averaged \$100 a day during first year, some days \$200. F. E. Doran grossed \$1050 in single month. Geo. Held grossed \$300 in one week.

How much you earn depends largely on you. No special skill, no large investment required for our electric upholstery cleaning machine. Start spare time until full time justified. Hire helpers as needed.

**NO SHOP NECESSARY** • You clean upholstered furniture on customers' premises—homes, hotels, motels, etc. Auto upholstering, too. No hauling; operate from your home. Watch business grow as satisfied customers tell friends. Supplies cost little, profits high.

**MAIL COUPON TODAY FOR FREE BOOK**

**VON SCHRADER MFG. CO.**

210 "D" Pl., Racine, Wisconsin

Without obligation rush your FREE booklet about how I can start my own permanent, profitable electric Upholstery Cleaning business.

Name \_\_\_\_\_

Address \_\_\_\_\_

City \_\_\_\_\_ Zone \_\_\_\_\_ State \_\_\_\_\_

**IS HE TALKING ABOUT YOU?**

A. Ribicoff, U. S. Secretary of Health, Education and Welfare, is alarmed by the number of high school students who never earn their high school diplomas. He points out that the unemployment rate for people with less than a high school education is nearly double the rate for those with a high school diploma.

**NOW! HELP YOURSELF TO A MORE SECURE FUTURE**

**EARN HIGH SCHOOL DIPLOMA AT HOME AT YOUR OWN SPEED**

a program now offered by one of the nation's largest educational organizations



Learn fast! Earn more! Enter college, professional or technical schools. Advance socially. Live a happier, fuller life. Individual courses or complete 4 year schooling. Moderate tuition. Write for School Catalog.

**ACADEMY FOR ADULTS**

Division, Encyclopaedia Britannica Films, Inc.  
30 W. Washington, Dept. PM-22, Chicago 2, Illinois

**GOVERNMENT OIL LEASES LOW AS \$1 PER ACRE**

You do no drilling, pay no taxes, may realize a king-size profit without ever leaving home. Write for free map and literature.

**AMERICAN OIL SCOUTS, Dept. PM**  
619 Cascade Bldg. Portland 4, Oregon



**get into operating or repairing EARTH MOVING EQUIPMENT**

Men needed now for good paying jobs in booming road and construction work. Learn operating or repair-rebuilding of heavy road machinery, cranes, bulldozers, earth carriers, etc. Actual "on the job" training. 5 to 13 1/2 week courses. Classes start every Monday. Reserve your space now. Complete catalog and reservation facts FREE. Approved for veterans. Write

**Greer TECHNICAL INSTITUTE**  
Attn.: P. B. Hutch, Box 368, Braidwood, Ill.

**New Isotronic Training Method LEARN TV REPAIR IN ONE SHORT WEEK!**

Now, after 5 year's research—a streamlined training system that obsoletes all others! In just 7 days you may earn \$150 weekly, without paying up to \$250 for training, studying long months! Developed by electronic scientists in cooperation with major TV mfr's., the new Isotronic method is the most practical ever devised! For conclusive proof, write for details and FREE SAMPLE LESSON. Use it on your own set or a friend's—repair it—convince yourself you can make big money immediately in your own TV business! Hurry—Free Lesson supply limited. Write:

**TV SERVICING SYSTEMS, Dept. H-172**  
1038 South La Brea, Los Angeles 19, California



# CLASSIFIED ADVERTISEMENTS



Advertisements in this section \$1.35 per word, each insertion, minimum 10 words, payable in advance.

To be inserted under proper classification, copy must be in our office the

18th of the second month preceding date of issue

F. W. Johnson, Manager, Classified Advertising

Popular Mechanics, 200 East Ontario Street, Chicago 11, Illinois

## YOU'LL PROFIT

By reading and answering the classified ads in this section. Hundreds of opportunities for you to make and save money

### AUTOMOBILES, MIDGET CARS

**FIBERGLASS** Bodies, will fit karts with 17"-19" frames. Ideal for children's auto. \$5.00. Send stamped, self-addressed envelope for dimensions. Naefly Plastics Inc., Madison 4, Wis.

**AUTOMOTIVE** Fiberglass repair manual. Start new career. Save repair costs. \$2.50. RPS Publications, D140 1844 No. Beverly Dr., Beverly Hills, Calif.

**VOLKSWAGEN** Owners. This new Deutch defroster will rapidly clear 80 percent more of the windshield, winter and summer. Attaches without tools. Guaranteed. Only \$4.98. Free details. Multi-Products, Box 261M, Oakmont, Penna.

**OVER 300** Model cars, table top racing sets, parts, tools and exclusive items available only by mail. Send 25¢ for spectacular 72 page catalog! Auto World, Box 961PM, Scranton, Penna.

**FORD T and A** parts? Try best source old model parts, all makes. Wisneski Auto, Milwaukee 4.

**SAVE** Money on your new car purchase. Dealer costs exposed on any American car, including accessories, \$1.00. cost analysis on all 14 makes, \$6.50. K&C, 7120 Liberty Road, Solon, Ohio.

**AUTOMOBILE** Literature: Catalogs, photos, manuals. Antique, modern. Monthly bulletin; non-profit hobby club. New members get free premium. Write. Auto Enthusiasts, Box 451B, Mt. Clemens, Mich.

### AUTO SUPPLIES AND EQUIPMENT

**NOTICE**—Dismantling 1,100 old American and foreign cars for parts. Write: "Parts," P.O. Box 207, Woodbridge, Va.

**HYDRAULIC** Jack repair kits. Free catalog. Free "Silent-Salesmen" with each kit. Hydraulic Jack Packing & Tool Co., P.O. Box 50, Bloomfield, N. J.

**AUTO** Shop welding repair training in world's largest non-profit welding school. Low tuition. Free booklet. Hobart Welders, Box M-221, Troy, Ohio.

**AIR** Conditioner for your car. Build it yourself for \$37.50. This is new. Just out. Not an evaporator but real refrigerated air. Use in your car and sell them. Easy plans \$5.00. P.P.P. Co., 1957 S. St. Aubin, Sloux City, Iowa.

**KEYHOLE** Antifreeze \$1.00. S. Shacket, P.O. Box 4840, Chicago 80, Illinois.

**JEEP** Owners — V8 conversions. Read Jeep Owners ad, page 20.

**STOP** Oil pumping. 10,000 mile guarantee \$2.95. Park, 16161 Mark Twain, Detroit 35, Mich.

**BUY** Wholesale, automobile accessories—merchandise. Catalog 25¢. Matthews (5-A8). New York City 38.

**NEW** And used parts at savings. Complete guaranteed parts service for all models cars and trucks. Largest in the West. Jeep and army parts specialists. Newest type shifting hubs for all jeep and all military and latest production front end drive vehicles. \$27.50 and up. Also, foreign car parts. Write. Pioneer Auto and Truck Parts Co., 734 W. 13th Avenue, Denver 17, Colo.

**PARTS**, Model "A." List 25¢. (Refundable) Matco, Box 135, San Pedro, Calif.

**JEEP** Parts! For military and civilian. At great savings. Largest inventory. Catalog for owners and dealers. Inquiries invited. American Auto Parts Co., 1830-PM Locust, Kansas City, Mo.

**1909-1934 FORD** Parts illustrated catalogs 75¢. Mark Auto, Layton, N. J.

**AUTOMATIC** Transmissions our factory rebuilt exchange. Any car \$89.50. Guaranteed. Transpareco, 5525 Chicago, Chicago 51, Ill.

**RING-Valve** job while driving, \$6.00 postpaid. Guaranteed! Nothing like it! Lasts 100,000 miles! Motaloy, Grantham, Penna.

**JUST** Out! New 324-page, illustrated catalog offering savings up to 50% on over 100,000 auto parts and accessories, everything to renew, rebuild, renovate '28-'31 Model "A" Fords. All makes (1920 to 1962 models), trucks, foreign and sports cars. Hollywood accessories, custom styling, hi-speed equipment. Send 25¢ for postage, packing. Refundable on first order. Whitney, 1919 PM-2 Archer, Chicago 16, Ill.

**230 NEW "A" Parts**. List 10¢. Box 423, Bensenville, Ill.

### AUTO TRAILERS

**BUILD** Expanding eight foot trailer. Accommodates five. Literature 10¢. Fra-Mar Company, Wilmington, Mass.

### MOTORCYCLES, BICYCLES, MOTORSCOOTERS AND SUPPLIES

**MOTORCYCLE** Supplies, bulletin 25¢, factory dealer. Les Myers, 813 Ohio, Wichita Falls, Texas.

**GO-CARTS**, motorbikes, parts, tires. Wholesale catalog 25¢. Loren Products, Danville, Illinois.

**GO** Cart \$10, Midget car \$20, motosecot \$30, minibike \$60. Whizzer engine \$4. (Mailorder only). Send 25¢ (35¢ for first class mailing) for 32-page directory-catalogue Number 105, listing these and hundreds of other bargains in midget cars, go carts, engines, homebuilders parts, plans, etc. Midget Motors Directory, Athens, Ohio.

**SEND** \$1.00 For complete plans on "How to Motorize Your Bicycle." Mounting bracket kit with clutch \$19.95, less engine. Go-Byk Industries, Fergus Falls, Minn.

**RECONDITIONED** Motorcycle motors. Chrome accessories. Complete stock Indian parts. Expert rebuilding. Fast service. Indian Motorcycle Sales, Kansas City 27, Missouri.

**HARLEY-Davidsons** — Used bargains. New, used parts, accessories, all models. Bulletin 25¢. Knuth's (Factory Dealer), 1753 Muskego, Milwaukee, Wis.

### AVIATION

**SURPLUS** Airplanes \$159, helicopters, McCullough Drone engines \$63, components, wheels, etc., all sold at giveaway prices direct to you by U. S. Gov't. Complete details only \$1.00. Surplus Trader, Box 8M, Thomasville, Penna.

**PROPELLERS**, Plans, supplies for airboats, snowplanes. 125 h.p. Lycoming engines \$135.00. Prompt delivery. Catalog 25¢. Banks-Maxwell Propeller Co., Box 3301E, Ft. Worth 5, Texas.

**AIRLINE** Careers. Adventure! Prestige! Promotion! Four-week course. Free placement service with 35 airlines. G. I. approved. Free catalog B. McConnell Airline School, 1030 Nicollet, Minneapolis, Minnesota.

**BE** A government licensed aviation mechanic. Write for free booklet. Aero Mechanics School, Municipal Airport, Kansas City, Missouri.

**HOME**BUILT Helicopter handbook \$1.00. Directory \$1.00. Urshanair, Box 197, Santee, California.

### BATTERIES, GENERATORS

**PROFIT!** Repair batteries! Complete manual \$3.00. C.O.D. accepted. Bayer Publications, L938 Betty Ave., Neenah, Wisconsin.

**START** Your own battery business. Manufacture, rebuild, repair. Easy with large 121-page manual. No job worries. Batteries, P.O. Box 341, New Castle, Penna.

### ELECTRICAL SUPPLIES

**WASHING** Machine, dryer parts! Illustrated catalog. All makes, models. Save, order direct—pumps, kits, agitator, gears, etc., at discounts; Free "trouble diagnosis chart" included, 25¢, refundable on first order. Jonsal Co., Dept. PM, 291 Atlantic Ave., Massapequa Park, New York.

**APPLIANCE** Lamp vacuum parts wholesale. Catalogue 25¢. Seco, 112 South 20th Street, Birmingham 3, Alabama.

**ELECTRO-SCRIBE!** Engraves all metals, \$2.00. Beyer Mfg., 10511-H Springfield, Chicago 55.

**LAMPS.** 25¢ Brings parts catalog. Refunded first order. Gyro, 5208P N.W. 35th Ave., Miami 42, Florida.

**LAMP,** Electrical parts, wholesale. Thousands of items for repairing, converting. Catalog 35¢. Brown Lamp, Box 305, Clayton 5, Missouri.

### WELDING, SOLDERING, PLATING

**WELDERS,** 110/220, \$39.50. Morris, 1070 Inner Drive, Schenectady 3, New York.

**ACETYLENE** Outfits \$59.50; arcwelders \$69.50. Eagle Welding, Dept. PM, 5085 Broadway, Chicago 40, Ill.

**FREE** Catalog, welders, kits. Build 350-ampere welder using aircraft generator, plans 25¢. Dunbar, Minneapolis 8, Minn.

**PLATING** Equipment and supplies. Save 50% and more on new fiberglass tanks, DC power units, 50 amp, 6 volt DC power supply \$97.50; 100 amp, 6 volt \$145; other sizes from 5 amps to 250 amps. Easy terms. Mix your own solution and save. Send \$1 for newest formulas and operating data for all types of plating, equipment guide and catalog. HBS Equipment Division, Dept. L5, 1624 E. First St., Los Angeles 33, Calif.

### MACHINERY, TOOLS, SUPPLIES

8 **DOUBLE** Wrenches 13/64" to 7/16". Box 191, Arlington 74, Mass.

**ALL** Purpose tool kit. 25 pieces packed in plastic pouch. Wonderful for home and shop. Price \$3.99. Weight 2 lbs. Grosvenor Co., Box 357, Hayfield, Minn.

**UNUSUAL** And hard-to-find quality tools for the woodworker. Send 10¢ for Catalog M. Woodcraft Supply Co., 14 Washington St., Boston 14, Mass.

**FREE** New catalog showing only complete line of work holding tools available anywhere. Drill press vises, angle and swivel machine vises, rotary tables, production and heavy duty angle vises. 68 different models, fully described with prices. Palmgren Products Co., 8365 South Chicago Ave., Chicago 17, Illinois.

### ENGINES, MOTORS, DYNAMOS

**INSTALL** Your 220V 3-phase motor on 220V 1-phase line. Information available for \$2.50 by return mail. No gimmicks, ballasts, condensers, rewinding, or reconnecting. Just technical know-how. Strang Elec. & Eng. Co., P.O. Box 555, Hawthorne, Calif.

**ELECTRIC** Motor repairing simplified. Free details. Modern, Box 8715, Kansas City 14, Mo.

10 & 20 KW AC generators, 60 cycle, 110/220 volts, belt drive. Diesel engines, generators, parts. Rent, sell. New, used, government surplus. Save 50%! Guaranteed. Portable power is our business. Midwest Diesel Power, Inc., 4120 Belmont, Chicago 41, Illinois.

**DIESEL** Injector parts and fuel pumps wanted. GM51-71-110. Bares, 2093 East 19 Street, Cleveland 15, Ohio.

**REWIND** Motors yourself. Complete instructions, \$1.00. Lewis Manufacturing, Howell, Michigan.

**WINDING** Data. 275 motors, single and three phase \$1.10. Data Company, 512 Kensington, Kansas City 24, Mo.

### GOVERNMENT SURPLUS

**JEEPS** \$223.83, Typewriters \$4.15. tires \$1.33, radios \$2.45, televisions, guns, recorders. Typical surplus prices. Free exciting details. N. Y. Enterprises, Box 402-X, Jamaica 30, New York.

**JEEPS,** Boats, airplanes, helicopters, walkie-talkies, radar, tents, typewriters, tires, tools, cameras. Individuals can buy now direct from government. "U.S. Depot Directory & Procedure" \$1.00. Brody, Box 425-PM, Nanuet, N. Y.

**SAVE** Money. Thousands of government surplus items; tremendously reduced prices. Procedures, depots, \$1.00. Associated Reporters, P.O. Box 1008, Miami 1, Florida.

**GOVERNMENT** Surplus, radios, jeeps, walkie talkies, etc. Send for "Depot Locations and Procedures." Satisfaction guaranteed. \$1.00. Delta, Box 2262-M, Dallas 21, Texas.

**JEEPS** \$278, Airplanes \$159, boats \$7.88, generators \$2.68, typewriters \$8.79 are typical government surplus sale prices. Buy 10,001 items wholesale, direct. Full details, 627 locations and procedure only \$1.00. Surplus, Box 789-C35, York, Penna.

**BUY** Surplus direct from government. Complete guide—25¢. Janacek, 373 East 155th Street, New York 55, N. Y.

**TENTS.** Government surplus. Hexagonal, Pyramidal. Cost \$140. Our price \$39.50. \$225 paint spray unit, \$44.50. Free folder. Imasco, 1829 S. State, Chicago, Ill.

**GOV'T** Surplus. How and where to buy in your area. Send \$1.00. Surplus Information, PM, Headquarters Building, Washington 6, D. C.

**U.S.** Government surplus—jeeps, \$264.00; radios, \$2.53; guns; typewriters; cameras; tools; thousands of items. Fabulously low surplus prices. Complete information sent immediately. Send \$1.00 to: Surplus, Box 512-E, New Orleans 12, Louisiana.

### BOATS, OUTBOARD MOTORS

**FULL** Size, cut-to-shape boat patterns, blueprints, 7 1/2-38 feet. Big new 88-page illustrated "Build a Boat" catalog of naval architect-designed catamarans, cruisers, runabouts, skiffs, outboard boats, sailing, racing, houseboats, 50¢. "How to Build a Boat" booklet, \$2.50. Cleveland Boat Blueprint Co., Box 1651, Cleveland, Ohio.

**BOATS!** 18 models prams to cruisers. Not kits but factory built unpainted at low kit prices. Save 2/3 retail. Free catalog. Hawk Boat Co., 10 Flynn St., Natick, Mass.

**SAVE!** Save! Save! World's finest boat kits 25% less! Satisfaction guaranteed! Write for free color catalog. Dept. PM262, Taft Marine Woodcraft, 636 39th Ave., N.E., Minneapolis, Minnesota.

**OUTSTANDING** Clothing and equipment for boat owners. Many not obtainable elsewhere. All guaranteed. Outstanding in quality and value. Free catalog. Write: Captain Bill, 262 Mechanics Street, Longbranch, Washington.

**FIBERGLASS** Boat covering. Wholesale prices. Free literature and sample. Seifert's, Box 1206-M, Green Bay, Wis.

200 **BOAT** Plans to 42 feet, patterns, kits. Catalog: Powerboat \$1.00. Sailboat 25¢. Marinecraft, Box 161-M, Brighton, Mass.

**WORLD'S** Largest selection of boat plans and patterns, frame kits, boat kits, marine fiberglass, hardware and accessories. Three, full, new, exciting catalogs, covering all of the above, available now for \$1. Send to: Custom Craft, Mail Order Division #1L, Buffalo 7, New York.

**FIBERGLAS** Your old wooden boat. Make it waterproof. Repaint over fiberglass, wood, or metal with new Poly-Aqua Epoxy paint. Free literature. Ajax Plastic Co., Dept. 6, P.O. Box 1323, Ft. Worth, Texas.

**BOAT** Plans, frame kits, full-size patterns prepared specially for amateurs. Send 50¢ for new 80-page catalog illustrating over 40 build-it-yourself power boats from 7' to 28'. "Inboard Motor Installations In Small Boats"—hardcover illustrative book on "how to" of inboard installations—\$6 ppd. Glen Designs, 9152 Rosecrans, Bellflower, Calif.

**NEW.** Used, rebuilt marine motors. Marine conversions, fittings. Free catalog. Stokes Marine Supply, Dept. 24, Coldwater, Michigan.

**BUILD** Your own boat from our large-scale blueprints. Books of plans give how-to-build help. Hundreds of professional designs—motor, sail or auxiliary—for amateur builders. Free catalog. MoToR Boat-ing, 572A Madison Ave., New York 22, N. Y.

**MARINE** Conversions and gears for all popular automotive engines. Send 25¢ coin for complete catalogue. Barr Marine, 2706A Castor Ave., Philadelphia, Penna.

I want to send you proof of the wonderful pulling power of Popular Mechanics classified pages. What's your proposition? Write me today. Include literature if possible. F. W. Johnson, Manager Classified Advertising, Popular Mechanics Magazine, 200 E. Ontario St., Chicago 11, Ill.

### ATHLETIC EQUIPMENT, BODY BUILDING COURSES

**PHYSICAL** Perfection. Reducing, gaining, muscles, longevity. Mail 25¢ for all 4 courses, (Guaranteed) to Sids System, PM-2, 8421-C Evergreen, Southgate, California.

**SECRET** Of great strength—Running, for happier life. 25¢. Harold Ashworth, Heuvelton, N. Y.

**PROF.** Wong's Karate Kung-Fu. For health and self-defense. \$9.95. Prof. T. Y. Wong, 142 Waverly Place, San Francisco 8, Calif.

"**GIANT** Arms." Dr. Young's, D.C. revolutionary discovery. \$2. Satisfaction or refund. Gaucho, Box 9309-S7, Chicago 90.

**OUTSTANDING** Physical development! Any age. New guaranteed discovery uses only a rope! Strength, health, muscles. Gain—reduce. Free booklet. Roperise, 4834 Art, San Diego 15, California.

### SPORTING GOODS, GUNS, FISHING, SKIN DIVING, ARCHERY

**PLASTIC** Lure bodies. World's famous flattish complete kit 25 for \$3.25. Spinning reels open and closed face \$3.25. Free circular. Quaker City Mfg., 3514-24 N. Lawrence, Philadelphia 40, Penna.

**MOLDS**—For casting your own fishing sinkers. Free illustrated booklet. Reading Instrument Co., Box PM78, Reading, Penna.

**FREE**—Wholesale catalog. Beads. Spinners. Lure parts. Sinker molds. Jigs. Reels. Finnyports (ME), Toledo 14, Ohio.

**BIG** Money raising crickets and 12 inch African fishworms. Free literature. Carter Ranch, Plains, Georgia.

**MOLDS** For fisherman's sinkers, jigs, squids, casting and spinning lures. Free catalog. Sweet's Molds, Tonawanda 1, New York.

**NOBODY** Undersells Kleins'! 144 page all-sports bargain catalog free. Kleins-PM, Chicago 24, Illinois.

**SPORTING** Goods. Wholesale. Information. \$1.00 refundable. Berkshire Wholesale Sporting Goods, Six Lakes, Michigan.

**SMOKE** Fish, game. Build inexpensive electric smoker. Instructions, recipes \$1.00. Eddie Thom, Hope, Idaho.

**WANT** To catch pan and game fish? Send only 35¢ for your copy of "Fishing Secrets" to Lucky Fishing, Box 3694, Whitefish Bay, Wis.

**MODERN** Military rifles \$7.95. New revolvers \$9.95. Bargain catalog 25¢. Armsco, Box A, Santa Rosa, Calif.

154 **PAGE** Catalog—A real dream book for fishermen. It's free. Neicraft Company, Dept. B-2, Toledo 13, Ohio.

**METAL** Gun racks for pick-ups, station wagons. Free information. Enterprises, 334 Junction Hy., Kerrville, Texas.

**GUN Rack**, solid pine, holds 3 guns. Postpaid \$3.50, two \$6.00. Redi-Cut, 4733 W. Center, Milwaukee 10, Wisconsin.

**FREE "Record Casts and Catches"** and facts about fisherman's pliers—15 tools in one that save time, temper and tackle. Send postcard now. Miscos, Box 15D, Paramount, California.

### CAMPING EQUIPMENT AND TENTS

**SALESMEN** Wanted. Apache two wheel aluminum camping trailers, world's largest producer. Some territories available. All new on-ground, off-ground models. Send for details, four color catalog. Vesely Manufacturing Co., Box P.M., Lapeer, Michigan.

**CAMPING Equipment**. Send 25¢, giant catalogue. Morsan, 10-21R 50th Avenue, Long Island City 1, New York.

**BUILD** Your pickup camper. Blueprints and supplies. Literature 10¢. Comstock Trailers, Parsons, Kansas.

**PORTABLE** Kitchen-pantry. Approved by university camping clinics, outdoor writers and veteran campers. Plywood construction. Plans \$1.00. Specify station wagon or sedan. Literature 10¢. Campers Kitchen Company, Box 6062, San Antonio 9, Texas.

### EARTHWORMS, CRICKETS, FROGS

**HYBRED** Redworms 1000, \$3.00; 2000, \$5.00; 5000, \$8.00 postpaid with raising instructions. Brazos Bait Farm, 60 Lincoln, Waco, Texas.

**EARN** Money raising fishworms for us! Exciting details free! Oakhaven—56, Cedar Hill, Texas.

**BIG** Money raising fishworms and crickets. We teach you how to raise and where to sell. Free literature. Medium redworms, 3000, \$5.95; 10,000, \$16.95. Carter Redworms, Plains, Georgia.

**\$1,000 MONTHLY** Possible, raising earthworms—African giants! Backyard, garage, basement. Complete illustrated booklet, explains raising, feeding, packing, marketing. Send 25¢! Ozark Worm Farm-J, Willow Springs, Missouri.

**TRAP** Thousands nightcrawlers, earthworms. Easy building instructions, drawings, \$1.00. Eddie Thom, Hope, Idaho.

### BINOCULARS, TELESCOPES, MICROSCOPES, MAGNIFIERS

**AMAZING** New Zoom binoculars! Telescopes! Microscopes! Riflescopes! Free catalog. Adventure Company, Box 2133, San Diego 12, California.

**BUILD** Your own reflector telescopes. Complete kits: mirrors, eyepieces, tripods, all other accessories. Request free illustrated literature. Criterion Manufacturing, Dept. KPM-85, Hartford 1, Connecticut.

**REFLECTING** Telescope, 60X, completely assembled. Guaranteed observatory clearness. Free information. Skyscope, P.O. Box 55, Brooklyn 28, N. Y.

**MICROSCOPES**, Surveying, recorders. Everything Japanese. Catalog 25¢. Magnification Instrument, 2 East 45th, New York 17.

**SCIENCE** Bargains! Lenses, telescopes, binoculars, microscopes, kits, parts, war surplus. Send \$1.00 for beginner's 10-lens kit with instruction booklet. Order Stock 2-CH. Request free 144-page Catalog CH. Edmund Scientific Co., Barrington, New Jersey.

**BINOCULARS**, 7x35 Coated lenses \$10.95. Free catalog. Aaron Wheeler, 7088 Whitaker, Detroit 9, Mich.

**DYNASCOPE**. Amazing world-famous reflector telescope. Request free brochure. Criterion, Dept. DP-88, Hartford 1, Conn.

### PLANTS, SEEDS, BULBS, NURSERY SUPPLIES

**GINSENG** Bringing \$14 pound. Have seeds, plants. Goldenseal. Full information. K. Collins, Viola, Iowa.

**LOW** As 20¢. Latest mountain grown, hardy, heavy-bearing peach and apple trees. Pears, plums, cherry, berries, plants. Grapevines 8¢. Shrubs 18¢. Evergreens 25¢. Catalogue free. Benton County Nursery, Box 542A, Rogers, Arkansas.

**COMPLETE** Line of insect eating plants and supplies; unusual and atomic mutated seeds. Peter Pauls Nurseries, Bldg. 2, Canandaigua, New York.

### PETS—DOGS, BIRDS, HAMSTERS, ETC.

**RAISE** Profitable guinea pigs. Free details. Diamond J. Rabbitry, Colborne, Ontario, Canada.

**HAMSTERS**—Ideal pets, \$2.95 pair. Free booklet. Jer-fre's Hamstery, 1447 Apple, Muskegon 13, Michigan.

**PETS**—Hamsters, mice, rabbits, squirrels, chipmunks, guinea pigs, skunks, raccoons. Pricelist dime. Picture catalog twenty five cents. Moore's Hamster Ranch, Shepherdstown 25, West Virginia.

**HAWKS**, Reptiles, raccoons, skunks, squirrels. Catalogue 25¢. Trails End Zoo, St. Stephen, S. C.

**MAKE** Money raising chinchillas, mink, rabbits, cavies for us. Free catalog. Keeney Brothers, New Freedom 2, Penna.

**SEA** Horses mated pair guaranteed live arrival and live 12 months. Food, salt instructions. \$3.50 complete. No COD's. Send check or money order. He and She Sea Horses, P.O. Box 44-632, Miami, Fla.

### RABBITS—FUR BEARING ANIMALS

**MINK** Raising information free. Complete. Lake Superior Mink Farm, Superior, E.E.1, Wisconsin.

**RAISE** Rabbits successfully by knowing facts. 48 page book, 38 illustrations describing 25 breeds. Housing. Breeding. Feeding. Markets and Marketing. Bulletin etc. 25 cents. American Rabbit Association, 36 ARBA Building, Pittsburgh, Penna.

**EARN** \$10,000 Yearly raising Angora rabbit wool for us. Information 25¢ coin. American Angora Company, Malta 12, Montana.

**RAISE** Rabbits on \$500 month plan. Free details. White's Rabbitry, Mt. Vernon, Ohio.

**RAISE** Rabbits. Make money. Information and prices sent free. Write Johnson, 683, Kansas City, Missouri.

### FARMS, FARM LANDS, REAL ESTATE

**CANADIAN** Tax sale lands. Our 45th annual series of lists, just begun, describe farms, timber lots, hunting and fishing camps. Average price five dollars an acre; small monthly payments, guaranteed titles. Write today for free sixteen-page booklet containing full information. Tax Sale Service, Room 411-D, 1173 Bay Street, Toronto 5, Canada.

**NORTH** Florida lots beautiful Suwannee County, 50x100. \$295.00 full price. \$5.00 down and monthly. No interest. Free literature and maps. Casper Corporation, 3970 NW 177th St., Carol City, Miami, Florida.

**FLORIDA** Campsites—deep in the heart of the great Ocala National Forest. Abundance of game, best fishing. Warranty deed. Unrestricted—pitch tent, park trailer, build lodge. Free maps and photos. Howard Vernor, DeLand, Florida, AD60088(Q-O).

**OPPORTUNITIES!** Government land. U. S., Alaska, Canada. Sledge Surveys, Macon, Mississippi.

**CAROLINA** Coast. \$5 down, \$5 monthly buys large homesite, 70x150, in beautiful Boiling Spring Lakes. Satisfaction guaranteed. 16,000 acres. 52 freshwater lakes. Excellent fishing, hunting. Free literature. Boiling Spring Lakes, Southport 1, North Carolina.

**\$5 MONTHLY** Buys 5 acres—near clear-water lake. Price \$125. Excellent fishing, good cabin sites. Free list. Box 425-P, Carthage, Mo.

**LOOK!** Under \$10,000! Only \$1,000 down buys fine duplex and private swimming pool! Beautifully situated on good-sized lot, nestled beneath mighty oaks, shielded from street by bamboo hedge. Right in city 15,000 population. Compact-type swimming pool built for both children and adults. Good building; upstairs apartment with entrance porch, living room, 3 bedrooms, bath with new colored fixtures, large kitchen, built-ins, electric stove and refrigerator. Downstairs apartment has large living room with 10-ft. stone hearth, wood-burning fireplace, bath, 2 bedrooms, Florida room at side entrance, big kitchen with stove and refrigerator. Bask in the Florida sunshine while enjoying self-sustaining retirement at \$9,950, only \$1,000 down. New free illustrated Spring Catalog, bargains coast to coast! United Farm Agency, 2825-PM Main St., Kansas City 41, Mo.

**FREE** Strout catalog! Farms, homes, businesses, resorts, retirement properties. Over 3000 values coast to coast. 61 years service. World's largest! Write Strout Realty, 7-CJ S. Dearborn, Chicago 3, Ill.

**CANADIAN** Vacation lands: Full price \$385.00. 40 acres, \$10 month. Suitable cottage sites, hunting, fishing, investment. Free information. Land Corporation, 3768-C Bathurst, Downsview, Ontario, Canada.

**OZARKIAN** Contentment! Improved acreage \$15 monthly. Descriptions free. Armstrong, Wappapello, Mo.

**FLORIDA**—For sale: ¼ acre homesite in Florida—private lake, free country club privileges, white sandy beaches right at property. Fishing pier, club house, dock site, lovely homes, hard-paved roads under construction, electricity, phones, tested pure water—all available. Certified high, dry land only 2½ miles from healthful bubbling waters of Rainbow Springs. Only \$10.00 monthly. Total cost \$795, no hidden extras. Free photos, booklet. Write to Rainbow Lakes Estates, Dept. B-28, 817 Silver Springs Blvd., Ocala, Florida.

**FLORIDA** Quality riverfront 3 bedroom home and extra lot on wide Caloosahatchee. Colonel Dueker, RFD 4, Box 238, Fort Myers, Florida.

**FLORIDA** Hillside lots restricted at Ocala National Forest, three miles from Saint John's River. \$495. \$10 monthly. Write Victor Roepke, Route 3, DeLand, Florida.

### FARM MACHINERY AND SUPPLIES

**3 H.P.** Hoeing machine. No other like it. Uproots all weeds in row and between plants. Very simple. Very sturdy. Women operate easily. Also tills. Depth adjustable 0-6". Self-propelled. Buy direct at discount. 30 day trial. One year warranty. Write Autohoe, West De Pere 22, Wis.

### PROFITABLE OCCUPATIONS

**INVESTIGATE** Auto accidents. Earn \$750 to \$1,000 monthly. More investigators urgently needed. Car furnished; business expenses paid. No college education necessary. No selling of any kind. Pick your own job locality. Meet interesting, important people. We train you at home in spare time. You keep present job until ready to switch. Write for free booklet. No obligation. Liberty School, Dept. C-91, Libertyville, Illinois.

**MAKE** Money writing short paragraphs. Information free. Barrett, Dept. C-27B-N, 7464 No. Clark, Chicago 26.

**BUY** Below wholesale! Thousands of nationally advertised products. Drugs, clothing, housewares, cameras, jewelry, hardware, sporting goods, etc. Postcard brings price list showing actual factory cost. Buy-Rite, 310 Main, Bennington 1, Vermont.

**AUCTIONEERING**—Home study course. Diploma granted. Auction School, Ft. Smith, Ark.

**VENDING** Machines. No selling. Operate a route of coin machines and earn amazing profits. 32-page catalogue free. Parkway Machine Corporation, Dept. #25, 715 Ensor Street, Baltimore 2, Maryland.

**BAKE** New greaseless doughnuts in kitchen. Sell stores. Free recipes. Michael, 3605 South 15th, Minneapolis 7, Minn.

**BIG** Money raising fishworms and crickets. Free literature. Carter Wormery, Plains, Georgia.

**BECOME** Independent with your own franchise business. Thousands earning handsome incomes. Request interesting facts today. National Franchise Reports, PM-528, 333 North Michigan, Chicago 1.

**HOME Mailorder** business. Simple, enjoyable. Net \$15,000 year. Write: Mail-order, Box 512-E, New Orleans 1, La.

**SAVE** Those boxtops! They're worth money! Inquire: "Boxtops-MA," Cedar Hill, Texas.

**START A** magazine subscription business. Earn generous commissions on Popular Mechanics, Good Housekeeping and all others. Best commissions, bonus, all materials sent free. No experience needed. Write Popular Mechanics, Room 2-P, 250 West 55th St., New York 19, N. Y.

**INVESTIGATE** Accidents. Earn \$750 to \$1,000 monthly. Men urgently needed. Car furnished. Business expenses paid. No selling. No college education necessary. Pick own job location. Investigate full time. Or earn \$6.44 hour spare time. Write for free literature. No obligation. Universal, CPM-2, 6801 Hillcrest, Dallas 5, Texas.

**POSSIBLE** \$4.00 Hour selling bronzed baby shoes. Kitsap Bronzing, 818 Merrill, Bremerton, Wash.

**EARN** \$240.00 A month at home, spare time, doing only two \$5.00 invisible mending jobs a day. Big money paid for service that makes cuts, tears disappear from fabrics. Steady demand. Details free. Fabricon, 1586 Howard, Chicago 26, Ill.

**COLOR** Photographs at home. Learn from expert. \$1.00. Phototint, Box 372, Pleasant Hill, Calif.

**EARN** Money raising fishworms for us! Write: Oakhaven-58, Cedar Hill, Texas.

**SHARPEN** Scissors, pinkers, clippers. Industrial machines, supplies. Black-hawks, Sheldahl, Iowa.

**WHOLESALE** Magazine subscriptions. Highest commissions. Bonus! Qualified Agencies, 451LA Kingston, Brooklyn 25, N. Y.

**FREE** Book "990 Successful, Little-Known Businesses." Work home! Plymouth-57T, Brooklyn 4, New York.

**FREE** Report: "609 Unusual, Successful Businesses." Box 1001-PT, Evanston, Ill.

**THE Private eye!** Exclusive booklet, direct from files of internationally known private investigator. Reveals who! Why! When! Where! and How! to become private investigator! Send name, address and \$2.98 for postpaid copy today! Or will rush C.O.D. plus mailing costs. "The Private Eye," Dept. PMC-2, P.O. Box 96, Oklahoma City 1, Oklahoma.

**BECOME** A research expert. Complete instructions \$1. Janacek, 373 East 155th Street, New York 55, N. Y.

## BOOKS, PERIODICALS, PICTURES, POSTCARDS

**BOOKHUNTERS!** Exciting! Unusual world wide books! Catalog 10¢. United Sales, Box 57M, Dyker Hts., Brooklyn 28, N. Y.

**75¢ BOOKS.** Cars, hotrods, karting, stamps, coins, rocks, science: pocket-novels, all subjects, discounts. Catalogue 5¢. Fairfax, Box 4283, Panorama City, California.

**FREE** Catalog. Self-help books. Write: Wilshire, 8721 Sunset, Los Angeles 46P.

**BOOKFINDERS!** All subjects. Send wants! Jaher Book Service, 183 Hazelwood Drive, Westbury, N. Y.

**NATIONAL** Geographic magazines, 1888-1960, any issue. Periodical Service, Box 465-PM, Wilmington, Delaware.

**BOOKS** Located fast. Out-of-print, scarce. Lowest prices without obligation. Book Mark, 51A Walnut, Mt. Clemens, Mich.

**BOOKHUNTERS!** Scarce, miscellaneous books supplied! Atlantic Book Service, Cedar Street, Charlestown 29, Mass.

**BRITISH** Book bargains—Any subject. Catalogues free. Transatbooks, Wantagh, N. Y.

**FREE** List of 90 "How To Do It Yourself" books on hobbies, home improvement, gardening, cooking, sports. \$2.50 each. Jeb's Books, Waverly, Missouri.

**PHOTOGRAPHS** Passenger ships. List 10¢. Scozafava, 1648 59th St., Brooklyn 4, N. Y.

**132 PAGE** Catalog—10¢. All subjects. Bookmaster, Box 17273-H, Salt Lake City 17, Utah.

**TERRIFIC** Book bargains! Free catalog. Write: Marich, 3452 Massachusetts St., Gary, Indiana.

**1000 INTERESTING** Books, catalogs 10¢. Starlight, 170-05E Baisley Blvd., Jamaica 34, New York.

**THOUSANDS OF** subjects. Catalogs 25¢ (refundable). Adirondack Printers, Saranac Lake, New York.

## MAGIC TRICKS, PUZZLES, JOKER NOVELTIES

**84 PAGES.** Completely illustrated catalogs, 25¢. Manhattan Magic, Box 334-P, New York City 11.

**CATALOG.** Free trick, 25¢ (1,500,399 tricks, jokes, novelties). Magico, #4037-P, San Antonio 7, Texas.

**WORLD'S** Finest professional magic. Joker novelties. Giant illustrated catalog 10¢. Top Hat, Evanston 12, Illinois.

**3000 TRICKS.** Pocket, parlor, stage. World's finest magic catalog (408 pages), \$2.50. Kanter's, M-1311 Walnut, Philadelphia 7.

**2700 NOVELTIES.** Jokes, tricks, fun-makers, hobbies. World's biggest gadget catalog 10¢. Johnson-Smith, D-549, Detroit 7.

**PROFESSIONAL** Catalog, 175 pages, 25¢. Williams, 900 Plymouth, Ellwood City, Penna.

**500 TRICKS.** New 1962 edition, famous Douglas catalog of magicians tricks and supplies now available just 10¢. Fastest service. Douglas Magicland, Dept. 61, Dallas, Texas.

**400 LAUGH** Lines plus professional comedy catalog. \$1. Orben Publications, Hewlett, N. Y.

**GET** Your tricks, gags wholesale. Sell to friends. Big catalog. 50 gag samples 25¢. Dohn-OX-Marks, Broadview, Illinois.

**BOOK** Of 279 tricks—15¢. Bookmaster, Box 17273-K, Salt Lake City 17, Utah.

**BE** A magician! Latest tricks. Large professional catalog \$1.00. (refundable with order). Ireland, C-109 North Dearborn, Chicago 2.

**FREE!** World's greatest fun and professional magic catalog. 1000 tricks, jokes, magic! 160 pages! Send 10¢ to cover postage-handling. House of 1000 Mysteries, Dept. PM2C-62, Trumbull, Conn.

## COINS, TOKENS, CURRENCY

**NUMISMATISTS.** Price list valuable gift, 40¢. Coin Investment—unprecedented, invaluable to small investor—booklet \$1.00. Vanderman, Box 9161, Suitland, Maryland.

**FREE** Bargain lists. The RJR Coin Company, Astoria 1, Oregon.

**COINS & supplies,** Lincoln cents our specialty. Catalogue free. Hyles Sales, Box 9566, Dallas 14, Texas.

**UNCIRCULATED** 1935 silver pony express commemorative medal \$1.00. Coin lists free. Sayers, 1000 Unaka, Johnson City, Tennessee.

**HIGHEST** Prices paid for United States coins. Send 10¢ for our buying lists. Wilmot's, 1067-A Bridge, Grand Rapids 4, Michigan.

**COINS,** Supplies: Lists 20¢. Lund, 200 So. Sycamore, North Platte, Nebraska.

**LARGEST** Coin magazine. 288 pages, 50¢. Scrapbook, 7320-J Milwaukee, Chicago 31.

**NUMISMATICS** Largest newspaper. Semi-monthly. Sample 25¢. \$2.00 yearly. Numismatic News, Box 452, Iola, Wis.

**WE'LL** Pay \$9,000.00 to \$18,000.00 for 1913 Liberty Head nickel. Certain dates: Lincoln cents before 1956—\$250.00; Indian cents \$1,750.00; Flying Eagle cents \$950.00; Dimes before 1943—\$5,250.00; Quarters before 1933—\$5,250.00; Half dollars before 1939—\$7,500.00. Thousands of others worth \$10.00 to \$15,000.00. Such as certain dates: halfcents, large cents, 2¢ pieces, 3¢ pieces, halfdimes, Shield nickels, Buffalo nickels, 20¢ pieces, commemorative coins, paper money, foreign coins, etc. Thousands of persons have sold us coins totaling over \$250,000.00. For complete information, before sending coins, purchase our large illustrated complete guaranteed buying-selling catalog \$1.00. Worthycoin Corporation (K-528-C) Boston 8, Massachusetts.

**RARE** 1878 CC mint dollar uncirculated \$5.00. 100pg. catalogue 50¢. Shultz, Salt Lake City 10, Utah.

**BARGAIN** List! U. S. coins, accessories. Stamp please. Hugh's, Hickory, N. C.

**40 PAGE** Illustrated United States and Canadian coin list 10¢. Stoney, 260 Washington, Boston 8, Mass.

**25 BEAUTIFUL** Coins from 25 countries. Mostly uncirculated. Terrific assortment. \$1.00. Hindley, Box 708, Aurora, Illinois.

**RARE** Unc. 1899 Philadelphia silver dollar, \$5.00. Butts, Torrington, Wyo.

**GIANT** Illustrated catalog listing hundreds of bargains in coins and supplies, only 25¢. Ben's Coin Company, 31 North Clark, Chicago 2.

**COIN** Collector's magazine. On your newsstand or direct. Sample 35¢. \$3.00 yearly. Coins Magazine, Box 274, Iola, Wis.

**INTRODUCTORY:** Confederate coin and foreign paper money, coin-medal catalog, send 50¢, postage, handling; American military medal and catalog, 50¢; amazing values. Collectors Club, Box 71-C, Rockaway 94, New York.

**TWENTY-Four** page 1962 retail price list of USA and Canadian coins 10¢. Our selling prices on thousands of coins and coin collectors' supplies. Bryson Incorporated, 612A White, Toledo 5, Ohio.

**88-PAGE** Illustrated 1962 foreign coin-currency catalog—35¢ (refundable). Jolie, Roslyn Heights, N. Y.

**SIX** Different Indian cents with lists. \$1.00. Hutchinson's, Box 6256, Philadelphia, Penna.

**GOLD** Sale: Bright U.S. twenty-dollars gold \$55; ten-dollars gold \$33; five-dollars gold, \$22. Lincoln cents uncirculated 1941 to 1961 complete 57 pcs. \$20. Lawrence Lake, Clarence, N. Y.

**COINS** Bought. Illustrated catalog 25¢. Hutchinson's, Box 6256, Philadelphia, Penna.

**TOPS!** Fascinating coin collection from Camaroon, Formosa, Vatican, etc., and foreign banknote. Catalog price over \$1.50! Only 10¢ with exciting coin approvals! Littleton Coin Company, Littleton T1, New Hampshire.

**LEARN** About coins the right way! Special offer! U. S. coin guide book, coin premium handbook, "Coin World" weekly newspaper. Current issues. \$3.25 value, postpaid, only \$2.00. International Guild, Englewood, O.

**COINS,** Closeout prices. List 15¢. Lee's, 525 Mt. Curve, St. Paul 16, Minn.

**BRILLIANT** Unc. 1909VDB cent \$3.50 each, 10 for \$32.50, 50 for \$155. Lincoln price list 50¢. Beacon Hill Coins, 43 Bromfield, Boston 8, Mass.

**CC** Silver dollars 1885 B U \$13.25. Emory Evans, Westminster, Md.

**15 DIFFERENT** Lincolns before 1921. \$1.00. Gene Carlton, Box 336, Chandler, Oklahoma.

**JAPANESE** Giant tempo coin, \$1.00. Kornegay, 531 Terry, Fayetteville, North Carolina.

**THIRTEEN** Different nice Liberty nickels \$2.50. Buying Indians 12¢. Pratali, 165 Aster Drive, New Hyde Park, N. Y.

**FRENCH** Coins, fine, 150 old francs \$1.00. Singles. Send list. Callahan, 121, Flushing 65, N. Y.

**25 UNCIRCULATED** Coins, 25 countries, \$1.00. Newcomers, Box 91, Atlantic 71, Mass.

LINCOLN Cents 23-S, 21-S-P, 24-S, 16-S-D, 18-S-D, 19-S-D, 20-S-D, 55-S, 34-D, 28-S-D, 27-S-D, 38-S-D, 29-S-D, 25-S-D, 09-P, 30-S-D, 32-D, 33-P, 39-S-D, 31-P. Good to fine complete lot \$7.25. Rolls of 55-S Lincoln cents fine to A.U. \$6.50. Berry, Box 306, Westminster, Calif.

RARE 1881-CC dollar uncirculated \$17.50. Liberty \$5.00 gold very fine \$17.50. Paying "top" cash for \$1.00 to \$50.00 gold, 1903-0 silver dollar. World's greatest bargain catalogue \$1.00. (Deductible first \$10.00 order.) Bebee's, 4514 North 30th, Omaha 11, Nebraska.

SENSATIONAL New presidential bronze medals, (half dollar size). Kennedy, Lincoln or Washington. \$2.50 each, postpaid. International Guild, Englewood, Ohio.

NEWFOUNDLAND Coins, 1¢-50¢, 11 different, \$5.00. Collis, Green, Newburyport Mass.

LINCOLNS For sale 50¢ each: 1921-S, 1923-S, 1924-S, 1932-D, 1933. \$1.50 each: 1910-S, 1913-S, 1922-D, 1926-S, 1933-D. John Gardner, Box 408, Colorado Springs, Colorado.

BUFFALO Nickel, 1923-S \$2.95, 1916, 1917, 1918 40¢ each (almost fine). Large cent \$1.75, half dime \$1.25. Vacoin, Box 10, Richmond 1, Va.

GENUINE Connecticut notes 1790. Two different \$3.00. Abraham Slopak, Calchester, Conn.

WASHINGTON Carver commemorative 50¢ uncirculated. \$2.00 prepaid. Stroud's Coins, Kingston, N. C.

25% DISCOUNT! Coin supplies. List 10¢. Kaplan, Box 115, Hollis 23, New York.

DISPOSING Of private coin collection; details for stamp. Evans, Box 303, Jamaica, N. Y.

AMAZING "All Coin" counts, wraps and stacks all U.S. coins. Use any paper or wrapper. \$1.00 PP. Don Baylor Enterprises, 5235 N. Cumberland Ave., Chicago 31, Illinois.

MEXICAN Silver dollars. Brilliant, uncirculated. Three for \$1.00. M. Ogden, Box 13404, Ft. Worth, Texas.

LINCOLNS 40 Different 1909-1940 plus 1960D small date, \$1.95. 25 different "S," including rare 1955S \$1.50. Harris, Box 611P, Cupertino, California.

HANSEL Profit's booklet "5 Coins for Quick Profit" only \$1. White, Box 10342, Knoxville 19, Tennessee.

## STAMP COLLECTING

50% PROFIT By return on your money — if you aren't more than delighted with our value parade of 1,700 genuine stamps consisting of: Ghana's first stamps, the coveted Prov. Independence Commem. Beautiful collections from: Germany Empire & Republic incl. World War II Occupation, Hungary sets, pictorials, etc. France, excellent, Belgium, fine, Czechoslovakia, excellent, would retail alone for \$2.00. Italy, outstanding. Oceania Zoological Collection. "Mystery Lot" an original full quarter pound of stamp mixture still on paper, just as received from Asia, Europe, Australia, etc. Fun galore. Belgian East Africa wild animals, San Marino superb 16th & 18th century hunting scenes, Giant Lourdes Commem. Fine general collection—British Empire past & present, fine! Disregarding cost, we offer the entire collection, catalogue value \$50.00, as a get-acquainted special for only \$1.00! Adults only. A fine selection for your inspection will also be enclosed. Satisfaction guaranteed or return it intact and we will send you \$1.50 for your \$1.00. Frasek Co., P.M., White Plains, N. Y.

FREE! Giant bargain catalog—new edition listing thousands of bargains including U.S. and B.N.A. stamps, packets, mixtures, albums, accessories and supplies; sent with beautiful approvals. Jamestown Stamp, Dept. E22PM, Jamestown, N. Y.

BEAUTIFUL Laos elephants free. Approvals accompany. Fred Easley, Sterling, Alaska.

U.S. Commemoratives, 60 different, 25¢. 500 U.S. mixture with 35 stamps—\$1.00. Postpaid U.S.A. Wessbecher, 7116 Oakland, St. Louis 17, Missouri.

508 DIFFERENT World-wide from Formosa, Morocco, Indonesia, etc., cataloging over \$15, only 35¢. Offer to adults only. Approvals. Littleton Stamp Co., Littleton Q1, New Hampshire.

CANADIAN Sports set complete 10¢. Approvals. Valley Stamps, Little Valley, New York.

STANDARD Cachets. Sample, next 4¢ release 10¢. Stanets, 1548, Highland Ind.

FREE: 50 Different. Approvals. Greene, 1833 19th Ave., San Francisco 22, Calif.

FIRST U.N. set. Among world's prettiest. Only 10¢. Approvals. Welles, Box 1246-R, New York City 8.

CANADA Totem dollar and Jamaica Royal Visit only 25¢. Approvals. Rheume, 6591 11th Ave., Montreal 36, Canada.

2000 WORLDWIDE \$1.00. Bargain approvals. Carson, Box 396, Lawrence, Kan.

FREE! 30 Different Australia. Plus, world's only octagonal stamp. Plus Abyssinia Red Cross set; to those requesting approvals. W. Cleaveland, 806 North Humphrey, Oak Park, Illinois.

FREE 50 Different colorful foreign pictorials with world-wide approvals. Brand, 125 Virginia Ave., BayShore, N. Y.

200 DIFFERENT U.S. stamps \$1.00. Approvals included. Shelron, Box 907-K, New York 8, N. Y.

50 DIFFERENT Central and South America, 10¢ with worldwide approvals. Cole, Box 223-A, Buffalo 21, N. Y.

SURPRISE Collection! Exotic mint British colonials, absolutely free with approvals. Viking, Great Neck 8, N. Y.

21,000 ALL Different, only pennies a day using our systematic payment plan. Details free. Sjoquist, 1435 Cherrydale, San Jose 25, California.

35 AMERICANS 10¢. Approvals. Jonas, 1340 Southwest 60 Court, Miami, Florida.

ZEPPELIN Flight covers 8 different \$3.00. Nelson Angelino, Box 264, Joinville, St. Catarina, Brazil.

WOW! 110 All different Germany 10¢! Zeppelins, semi-postals, airmails, high values, etc. Giant catalog, bargain lists included with beautiful approvals. Jamestown Stamp, Dept. A22PM, Jamestown, New York.

INDONESIA, 50 Different for 25¢ with approvals. R. B. Griffiths, 29761 MacIntyre, Livonia, Michigan.

GIGANTIC Collection free. Includes triangles, early United States, animals, commemoratives, British Colonies, high value pictorials, etc. Complete collection plus big illustrated magazine all free. Send 5¢ for postage. Gray Stamp Company, Dept. PM, Toronto, Canada.

NO Gimmicks. No gadgets. No giveaways. Just attractive approvals at attractive prices. Sunny Stamps, Apopka 2B, Florida.

AMERICAN Historical collection! Enormous George Washington beauty, F. D. Roosevelt diamond, giant Abe Lincoln U.S.A. flag commemorative, plus midget soldier. Latin orchid issue, old IPNI overprint, etc. 10¢ with approvals. Roseland Stamps, Spring Lake 2A, Mich.

1847, FIRST USA variety! Goliath foreign beauty shows Ben Franklin in this outstanding issue! Plus Congo freedom stamp, unused 1/2 inch midget stamp freak, real cigar issue, icy Greenland, Free China Bomber airmail giant, etc. only 10¢ with approvals. Capital Stamp Co., Ferrysburg 2D, Mich.

50, LATIN, British, Orient: 10¢. Approvals. These, 9320-M San Juan, South Gate, California.

500 FINE Mixed U.S. 15¢. Wright, 201M Mealey, Hagerstown, Maryland.

\$12.50 CATALOGUE For \$1.00. Every stamp catalogs 10¢ or higher. Approvals. Payne, 307 Helena, Salina, Kansas.

POLAND Airmails C41-51 (used) \$5.00. Stanley Borkowski, 175 Strauss St., Buffalo 11, N. Y.

700 STAMP Collectors from twelve different countries want to exchange stamps with you. \$1.00 brings you lists. J. Castonguay, 6805 21st Avenue, Montreal 36, Canada.

U.S. Mint #929-1190 face plus 1¢ each: #907-928 face plus 2¢ each. Stamps over 4¢ plus 2¢. Postage extra. Wilhelm, 16566 Mendota, Detroit 21, Michigan.

U.S. Fully illustrated catalog 10¢ deductible. Simmy's, 45 Bromfield, Boston 8, Massachusetts.

500 MIXED U.S. various issues 25¢. Monjar, Fairmount, Cincinnati 14, Ohio.

START Approval business. Details 10¢. Steele, Box 553-PK, Pacific Grove, Calif.

PRICE List U.S., foreign. No approvals. Stamps. 5000 Miami, St. Louis 9, Mo.

BRITISH Colonial sets at wholesale. Fischer, 1530 Metropolitan, New York 62, N. Y.

ARGENTINA, 300 Interesting different, \$1.00. Evenden, Box 5001, Eugene, Oregon.

30,000 DIFFERENT! Only pennies a day builds collection. Free particulars. Holtzman, 95 Terrace Road, Levittown, Penna.

REAL Old U.S. seconds. Bargain prices. K. Swartz, Malden Bridge, New York.

CANADIAN 100 Different 50¢, 150—\$1.00, 200—\$2.75. Down's, Box 1316, Rosetown, Saskatchewan.

12,000 PENNY Approvals waiting for you. Many from exotic countries, pictorials, airmails, new issues. Tilbury, Box 862, Newark 1, N. J.

BEAUTIFUL 1962 Price list, 132 pages, U.S., B.N.A., U.N., etc. Send 30¢, refundable \$3.00 purchase. Beacon Stamp, 44 Bromfield, Boston 8, Mass.

OLDER U.S. used. 260 different. \$4.00. Satisfaction guaranteed. Stoess, Washington, Washington.

EXTRAORDINARY Free. 20 different Finland to those requesting approvals. Risenborg, Box 1303, Chicago 90.

BECOME A stamp dealer. We wholesale stamps. Write: Doyle Philatelics, P.O. Box 11102, Kansas City 19, Missouri.

100 LARGE Pictorials 25¢. Approvals. Knopp, Box 1381, Bristol, Conn.

LIQUIDATION Bulletin #14, U.S.-foreign. Free. Taaffe, P.O. Box 226, Los Angeles 53, Calif.

25 DIFFERENT Stamps free to adult approval applicants. Gilmar Stamps, 308 Somerset Street, San Francisco 24, Calif.

AUSTRALIAN, Canadian free. Approvals. Koppes, Box 74, Humboldt, Saskatchewan, Canada.

115 DIFF. 10¢. 5000 Mixed \$4.00. Pop Harris, Oklawaha, Florida.

52 MINT Pairs \$1.00. King, 330 Alexander, Kamloops, B. C., Canada.

500 MIXED U.S. 25¢. Arthur Sibley, Box 222, Uxbridge, Mass.

KILO Mixtures over 100 different kinds. Ask for our pricelist prepaid for U.S. in dollars. Allow four weeks for shipping. Rolf Gummesson A.B., Kungsgatan 55, Stockholm, Sweden.

JAPAN 48 Different beautiful commemoratives \$1.00. Government sealed mixture 1/2 pound \$4.00. List free. Miss Fumiko Takamura, 1-567 Tozuka Shinjuku-Ku, Tokyo, Japan.

10 DIFFERENT Civil War United States and representative Confederate States stamps plus pricelist 10¢. Minuteman, 127 Lincoln, Lexington 73, Mass.

ILLUSTRATED Worldwide new issue brochures. Samples 10¢. Comcco Stamps, Box 56, Brooklyn 29, N. Y.

WONDERLAND Fish, flower, sputnik, sports diamond, beast, many more, bonuses, 10¢! Approvals. Bakers, Thomaston, Connecticut.

SPECIAL Collection: 75 different Denmark (Catalog \$2.50) 10¢ with unique, worldwide approvals 1/2¢ up. Stamp Studio, Box 171M, New York 24, N. Y.

51 DIFFERENT. Catalog value over \$4.00—25¢. Approvals. Terra Nova, Box 276, Cathedral Station, New York 25, N. Y.

FREE—United Nations catalogue. Great Western, Box 3777, New York 17, N. Y.

125 DIFFERENT U.S. 30¢. Rayworth, 321 South Cicero Ave., Chicago 44.

FREE! Five mint sets; approvals. Bergman, 78 Dorchester, Worcester, Mass.

310 DIFFERENT Stamps, 25¢! Country packet lists. Bargains! Carling, 262-A, Howard City, Michigan.

U.S. Mission mixture. Guaranteed unpicked. 2 lbs. \$4.00; 5 lbs. \$8.50. Skytop, Box 1022PM Binghamton, N. Y.

EXCHANGE Duplicates. Successful plan. Write: Exchange Club, 6036B Dartmouth, Bradenton, Florida.

UNITED Nations bargain list free. Conquistador, 2627A Troy Road, Schenectady 9, N. Y.

CANADA Totem dollar 20¢. Approvals. Dalett, Box 832, Moncton, New Brunswick.

PENNY. Two and three cent approvals by country. William Hicks, 61 McLean, Wilkes-Barre, Penna.

**TREASURE** Hunt for rare stamps! We pay up to \$30,000.00 each for certain rare varieties. We are searching for rare United States and foreign postage stamps and will pay high prices for rarities. We offer for just \$1 our new large completely illustrated buying catalog of rare stamps. This quality catalog gives detailed information and complete descriptions of the stamps we want to buy. Everything you need to know to sell stamps for large profits. Each and every stamp listed is clearly illustrated, making identification easy. Sample high buying prices: Certain United States 5¢ stamps, up to \$10,000.00; certain United States 2¢ invert, up to \$1000.00; certain United States 24¢ invert, up to \$2000.00; certain British Guiana 1¢, up to \$30,000.00; certain Mauritius 2¢, up to \$3000.00; certain Hawaii 2¢, up to \$5000.00; dozens of others. Complete information is in our catalog. Purchase catalog before sending stamps. If you have any old United States or foreign stamps, old letters, postcard, etc. This catalog may be very valuable to you. Only catalog of its kind. Guaranteed reliability. Send \$1 today. Immediate refund when you sell us stamps. Jaymar Corporation, Stamp Department 404-A, Johnson City, N. Y.

**FREE!** Mystery packet. Approvals. Premiums given. Dancer, 75-P30, Mansfield, Ohio.

**1,000 WORLDWIDE Beauties** only \$1.00. Stamps, Box 738, Sioux Falls, So. Dakota.

**U.S. Approvals.** Low prices. Eagle Stamps, Romine Ave., Pittsburgh 26, Penna.

**NEW Ethiopia animals set complete, 10¢!** Approvals. Elmer Swanson, Niagara, North Dakota.

**GABON, Poland, Bulgaria beautiful new** topics plus 50 different 10¢. Approvals. Berchtold, RFD 1, Troy, Ohio.

**500 DIFFERENT British Empire \$2.** Erv. Knott, Box 31, Helmer, Indiana.

**PROFESSIONAL Gambler's lot \$2.00.** Heisler, Valley Circle Lane, Hamburg, N. Y.

**SPAIN 50 Different 10¢ with approvals.** Stamps Universally, Cardwell, Missouri.

**U.S. Price list to approval applicants.** Include want list. Bogle, Avondale, Mo.

**GHANA, Malaya, Nigeria.** 30 different 10¢. Approvals. Erickson, 736 Cottage, St. Paul 6, Minnesota.

**SPECIAL Stamps, 50¢ per 2" line.** Free folder. Tabco, Tomkins Cove, New York.

**SCREWBALL Fish in natural colors;** Pan the goat man; Egypt, Mother's Day; Crawley bugs set; jets; Somaliland flower garden; French model; U. S. Revolutionary War; others free while purchasing approvals. Stamp Farm, MS-41, Oxford, Wis.

**FREE! 25 Different Portuguese; colorful,** inexpensive approvals. Elkhart, Box 33, Elkhart, Indiana.

**FREE Mint Africa set with approvals.** Lithor, Pox 51, Canoga Park, Calif.

**GAMBLER'S Packet, 25¢, with approvals.** Kennedy, Box 9497, San Diego 9, Calif.

**300 DIFFERENT Given free with approvals.** Particulars. Windsor Stamps, P.O. Box 735, Santa Clara, California.

**FREE! Exotic mint Polynesian hula girl stamps!** Giant bargain lists included with approvals. Aloha Stamps, 1019-PM Tarryall Drive, Dallas 24, Texas.

**STAMP Collecting outfit, includes packet** worldwide stamps, package hinges, watermark detector, millimeter gauge. Everything 10¢ with approvals. Loraine Brown, Marion, Michigan.

**FREE 30 Large U. S. commemoratives** with approvals. 10¢ handling. Jack Clancy, Box 2187, Portland 14, Oregon.

**WINTER Special, 1000 worldwide stamps** \$1.00. 3500, \$3.00. No approvals follow. Harrison's Stamps, 1435 First Ave., Oakland 6, Calif.

**FREE Sample.** Interesting, informative, illustrated. National Stamp News, Anderson, South Carolina.

**FREE. 33 Greenland, Congo, Ruanda,** others. Approvals. Keating, 2520-P Boulevard, Jersey City 4, New Jersey.

**FREE! 25 Egypt, 10¢ handling.** Approvals. Bellet, Mapledale, Hazel Park, Michigan.

**200 STAMPS, 25¢ With approvals.** Smith, 508A Brooks, College Station, Texas.

**1,000 DIFFERENT Worldwide for approval** buyers only. Jacobsen, Crompond, N. Y.

**TRADE Your duplicates toward our** approvals! (Foreign only.) Complete information, 10¢. Variety Stamps, Box 98-P, Newton Highlands 61, Mass.

**FREE! 222 worldwide, 10¢ handling.** Penny approvals. Jung, 1601 North Stanley, Los Angeles 46.

**TERRIFIC Value.** Eight complete mint sets 10¢ with approvals. Beatties, Box 4503, Fort Lauderdale, Florida.

**U.S., U.N., Confederate states catalog** free. Stone, 260 Washington, Boston 8, Mass.

**U.S. Mint specials! Flag set, complete** \$1.00; 1¢, 2¢, 3¢ famous Americans (21 different), \$1.00. Free list. Brooks, 2323 Avenue X, Brooklyn 35, New York.

**SPUTNIKS, Rockets, space stamps free** with sparkling approvals. Cambria Stamps, Box 2205, Anaheim, California.

**TWO \$5.00 United States stamps, 20** others 10¢ with United States approvals. Irwin, Box 1105, Brooklyn 30, New York.

**25 DIFFERENT Large American** commemoratives. 10¢ with approvals. Linstamp, St. Catharines 101, Ontario.

**80 DIFF. U. S. stamps includes 19th** Century commemorative. High values. Plus 1943 flag stamp of occupied nations. All for only 25¢. Approvals included. Willett Co., Box 338-C, Yorktown Heights, N. Y.

**107 DISTINCT British Colonial stamps,** 10¢. Approvals. Linstamp, St. Catharines 401, Ontario.

**UNITED Nations 15th anniversary sheet** with first day cancel, as commemorated by Russia. Free! While they last, with approvals. Philatelics, R-J, New Paltz, N. Y.

**25 COLUMBIA 10¢. Approvals included.** Reed, Box 980, Chicago 90, Illinois.

**105 DISSIMILAR British Colony stamps,** 10¢. Approvals. Crown Stamp Company, Virgil 601, Ontario.

**INTRODUCING Our better United States** approvals we offer 15 United States stamps including Columbian, Bi-Centennials, famous American, airs, others; only 10¢. Ocean Stamps, Box 64-PM, Brooklyn 29, New York.

**PENNY Approvals. Thousands. Bargains** for pennies. Gifts with purchases. Penny Stamps, Orange, California.

**GIANT Approvals, thousands different,** 1¢ and 2¢ each. Wahl's Stamp Exchange, 7008P Farragut, Chicago 31, Ill.

**UNITED States commemorative collection** containing 33 different—10¢. Approvals. White, 516-A Avenue L, Brooklyn 30, New York.

**103 DIVERSIFIED British Empire** stamps, 10¢. Approvals. Niagara Stamps, St. Catharines 501, Ontario.

**SELL Your surplus good grade stamps.** Write, describing fully what you have. Vanroy Shirk, Lebanon, Pennsylvania.

**AMAZING OFFER! 200 United States** stamps — including commemoratives, airmails, high denominations to \$1.00. Only 10¢ to approval applicants! Illustrated bargain lists free. Mystic Stamp Co., Dept. 80, Camden, New York.

**100 OLD United States between 1861** and 1935, \$1.00. Roush Stamps, 51 Chestnut, Mansfield, Ohio.

**UNITED States price list, 116 pages,** price 25¢. Mark Hanna, 335 Fifth Ave., Pittsburgh 22, Penna.

**STAMP Jungle including Zabu, kooka-** burra, koalabear, kangaroo, rhinoceros, 10¢. Approvals. Crown Stamp Company, Virgil 301, Ontario.

**FREE Monaco nudes. Approvals. Stamp** Ranch, 902 Addison, Chicago 13, Ill.

**PENNY Approvals! Regardless cata-** logue! Kloster, 4164—52nd St., San Diego 5, Calif.

**60 DIFFERENT U. S. (30 commemora-** tives) 25¢. No approvals. Seidenberg, Appleton, Wisconsin.

**307 WORLDWIDE Different stamps only** 25¢. Approvals. Niagara Stamps, St. Catharines 201, Ontario.

**225 STAMPS For only 10¢! This mam-** moth value includes airmails, pictorials; stamps from strange countries cataloging up to 25¢ each! Also approvals. Mystic Stamp Company, Camden 80, New York.

**FREE 50 Worldwide, mailed with inex-** pensive approvals. University Stamps, P.O. Box 44-592, Miami 44, Florida.

**FREE Mint set! Approvals accompany.** Stampco, Box 737, Memphis 1, Tenn.

**150 DIFFERENT U. S. 50¢, many older** issues. Approvals. Winchester Stamps, 45 Winchester Rd., Mansfield, Ohio.

**111 WORLDWIDE. Includes airs, mid-** gets, triangles. 10¢. Approvals. Premiums. Faith, 20½ Bushnell, Alhambra, Calif.

**100 DIFFERENT United States** commemoratives, 1½¢ to 10¢ values—used \$1.00; Mint \$4.95. No approvals. Gil's, Box 12BA, Brooklyn 29, N. Y.

**1065 DIFFERENT Stamps \$1.00 to ap-** proval applicants. Klondike, Harrisburg, Illinois.

**LATIN America. More stamps for less** money. Packet including elusive issues \$1.00. M. Garcia, Box 71, Bronxville, N. Y.

**FREE—All volumes Scott's International** albums. Scott's 1962 catalogues—even master global albums free—when you buy our sensational foreign approvals. Bargain Stamps, Redlands, California.

**701 U.S.A.—25¢. Plenty commemora-** tives. Request approvals. Horace Gatewood, Winston-Salem, N. C.

**1000 DIFFERENT Worldwide stamps** \$1.00. Valued over \$20.00. To adults only requesting our popular packet approvals. Universal, Box 6, Kenosha 5, Wisconsin.

**SUPERIOR Worldwide mission mixture.** Amazing variety! Five ounces \$1.60. Pound \$4.50. Bay Nielsen, 4545B Harvard, Montreal 28, Canada.

**EXCHANGE. Send 100-200 different** stamps with 15¢. Receive different. Patterson, Lancaster 10, New York.

**FREE Macao mint set, approvals.** Coretta, G.P.O. Box 1546, New York 1.

**SELL Stamps to our readers. Your ad** in this space will be read by thousands of stamp buyers. I'll prove that to you. Write now for Folder "S." F. W. Johnson, Classified Advertising Manager, Popular Mechanics, 200 E. Ontario St., Chicago 11, Ill.

**FIFTY Fine stamps 5¢ with approvals.** Ransom, 1333 Pontiac St., Ann Arbor, Mich.

**GIGANTIC Surprise packet, contains** hundreds—only 15¢. Approvals accompany. Dresel, Box 128-M, West Englewood, New Jersey.

**SEVENTY Different United States. Ob-** solete and current. 25¢. Ed. Keller, Library, Penna.

**FREE Stamps to buyers of worldwide** approvals. Enormous selection. Fair prices. Handy Stamps, 460 Handy, Orange, Calif.

**FREE—Airmails, Complete sets. Sing-** gles. Fifteen different countries. Handling 10¢. Approvals. Boger, Box 152, North Wales, Penna.

**215 DIFFERENT Worldwide 25¢. Flume,** Korea, Laos, Russia, Transvaal. Approvals. Bobb's, Box 3045, Saint Louis 30, Missouri.

**BATHING Beauty, spacemen packet—** 10¢ with approvals. Nugget, 2408 Gillen, Racine, Wisconsin.

**UNITED Nations. Five different 10¢.** Approvals. Anderson, 1234 Delaware, Santa Cruz, California.

**FREE! World's largest! Strange, valu-** able 7"x14" beauty. Send 15¢ handling now! Norrisco, Milwaukee 7, Wis.

**PENNY Approvals, 1,000 foreign stamps** mounted in Scott order. No assorting! Bulloet Approvals, 1359 Coney Is. Ave., Brooklyn 30, N. Y.



250 DIFFERENT World wide 25¢, colorful. Better-Bilt, 25625 Koontz, Roseville, Mich.

ROCKETS! Satellites! 10¢ with approvals. Schaefer, Californiastrasse 16, Wiesbaden, Germany.

FREE Animal set with approvals. Collier, Box 265, Chamblee, Ga.

FREE Surprise set to approval applicants. Wayout Peachtree, Box 9875, Atlanta 19, Ga.

500 MIXED Worldwide 25¢. Brookside, R.F.D. Box 242, Mendon, Mass.

FREE—When you buy our foreign approvals, you receive absolutely free stamps equaling your purchases. Coast, 1609 S. Park, Santa Ana, California.

MINIATURE Collection Queen Elizabeth mint sets (Antigua, Caymans, Mauritius, Montserrat, Virgins, St. Kitts)! 21 lovely pictorials, only 25¢! Attractive approvals! Gannon Stamps, Box 931, Canton 1, Ohio.

### ANTIQUES, RELICS, INDIAN GOODS, CURIOS

ILLINOIS: Gesundheit! Selling hundreds of historical, Confederate, Revolutionary, Civil War, Indian War muskets, carbines, revolvers, swords, bayonets, powderhorns, canteens, bullet molds, duelling pistols, holsters; 50,000 collector's cartridges; 110,000 Stoneage Indian relics, arrowheads, deerheads, steerhorns, bowwood, military insignias, coins, mineral specimens, fossils, frontiers, Confederate money. Large listing, send 35¢ (refundable). Heike's Relics, Wenona, Illinois.

STRANGE, Unique items catalog 10¢. The unusual and rare. Black Magic Shop, Dept. C, Box 4318, Minneapolis 18, Minn.

6 ARROWHEADS, Archaic knife, scraper, \$2.00. Smith, 841 N. Tacoma, Indianapolis 1, Indiana.

50 CHOCTAW Bone warpoints \$3. William Hardy, Box 547, Englewood, New Jersey.

SELLING 20,000 Ancient arrowheads, spearheads, etc. List free. Lear's, Glenwood, Arkansas.

GENUINE Oregon obsidian arrowheads. Special. 3 perfect \$2.00. Strobeck, 724 Willamette, Eugene, Oregon.

### PRECIOUS STONES, MINERALS

SEMI-Precious uncut gems. Ten different for \$1.00. Request list 28. Prospectors Shop, 201 San Francisco, Santa Fe, New Mexico.

FREE Bargain gem list. 1961 lapidary and silversmith tool catalog. 50¢. O'Brien's, 1116B Wilcox, Hollywood 38, Calif.

EARTH Science. Rockhound's National Magazine. Subscription \$2.50. Sample 35¢. Box 1357-PM, Chicago 90, Ill.

GOLD. Native nuggets, \$2.00. Lester Lea, 942 PM, Mt. Shasta, California.

U.S. And foreign mineral specimens, lists 10¢. Minerals, Winston, New Mexico.

JUST Released! Lost and buried treasure map of Great Southwest. Ideal for framing. \$1.00 postpaid. Tomac Research, Ltd., 3268-PM Rosecrans, San Diego, Calif.

### HOBBIES AND COLLECTIONS

ADVERTISING Free. Distinctive Hobby Monthly. Dime. Bobbies Hobbies, Quincy 1, Illinois.

HAVE Fun! Collect picture postcards. 100 assorted \$1. Card Shop, 1500-44 Ave., San Francisco 22, Cal.

DISBANDING Collection of foreign and American military medals, embroidered insignia, armbands; list for stamp. Evans, Box 303, Jamaica, N. Y.

COLLECTORS Matchbook covers. 100 different unused, \$1.00. Catalog 25¢. Album \$3.00. Charles Edelman, 1311-C East 84, Cleveland 3, Ohio.

COLLECT Timepieces? Free folder. Nawco, Box 8824, Pittsburgh 21, Penna.

CLEARANCE Sale, foreign medals: Iron Cross \$1.00, S.S. Medal \$1.50, German General staff embroidered, 30¢. Catalog 20¢. International, Box 303, Jamaica 31, N. Y.

AMERICAN Newspaper, complete, original, dated before 1860, \$1.50. 25¢ stamps brings catalogue. D. R. Spaight, Book-seller, Tall Timbers 1, Maryland.

### PHOTOGRAPHY, CAMERAS, PHOTO SUPPLIES

PHOTOGRAPHY For pleasure or profit. Learn at home. Practical basic training. Long established school. Free booklet. American School of Photography, 835 Diversey Parkway, Dept. 3451, Chicago 14, Illinois.

FREE! Send now for 64 page book of new and used photographic bargains. Dept. 1-AR-2, Central Camera Company, 230 So. Wabash Ave., Chicago, Illinois.

### PHOTO FINISHING

FAST, Hi-quality finishing. Kodacolor rolls: eight jumbo prints \$1.98. Twelve \$2.49. Twenty \$3.49. Reprints 15¢. Also low B&W prices. Custom Quality Studio, Box 4838, Chicago 80.

SENSATIONAL Offers. Free mailers. Flash Photo Service, Box 3035, Atlanta 17, Georgia.

TWELVE Exposure rolls 59¢. Wallets 20 for \$1.25. Lincoln Studios, Dept. K, Box 13, Lincoln, Neb.

EKTACHROME-Anscochrome 35mm. 20 exp. 620, 120, 127, developed, mounted, \$1.00. Kodachrome 8mm. and 35mm., low prices, prompt service. Complete price list—free mailers. Write Trycolor, P.O. Box 123, So. Windsor, Conn.

COLOR Movie fans! Low cost—high quality processing our specialty, 8mm. just \$1 (or \$3 with fresh film). Mailed back next day. Craftsmanship guaranteed. Send exposed reel or request free mailers and price list of complete photo-finishing services. Direct Mail Photo, Box 8832-PM, Pittsburgh 21, Penna.

A FREE Kodak roll returned with each black and white or Kodacolor developed and printed, fast service, lowest prices, guaranteed quality send for free mailers. Economy Photo Service, Dept. P. M., Box 1111, Albany 1, N. Y.

PHOTOGRAPHIC Murals wall size from your slides or our negatives. Brochure 50¢. Al Greene Stage 3, 1333 South Hope, Los Angeles 15, Calif.

### MOTION PICTURES AND SOUND EQUIPMENT

1962 PASADENA Rose Parade. Color movies and color slides. 8mm 50' reel, \$4.95. 8mm 200' reel, \$19.95. 16mm 400' reel, \$40.00. 2x2 color slides, 12 for \$2.75, 24 for \$5.00, 80 for \$14.95. Kolor Kade Productions, 5880 Hollywood Blvd., Hollywood 28, Calif.

USING 8mm Movie camera? Make \$9.50 hourly. Bulletin \$1.00. Lagene's, Pocasset, Mass.

BARGAINS 16M.M. sound films, list. Bedner, 5300 So. Talman, Chicago.

FREE 1962 Film and equipment catalog. Tremendous stock 8mm, 16mm features, shorts, all subjects. Bargains. Imperial, 34 Park Row, New York 38.

ROSE Parade 1962. 8mm color movies—slides. 50' \$4.95, complete 200'—\$19.95. 35mm slides, set 12—\$2.75, 24—\$5.00, 72—\$14.95. Free bonus! 3 extra slides with slide orders. LP record or 1/4" tape describing 200' 8mm and 72 slides \$3.95 each. Satisfaction guaranteed. Rose Parade Movies, 7266-M Melrose, Hollywood 46, Calif.

SAVE Money on B&W, color, 8mm., 16mm. film and supplies. Send 10¢ for bargain catalog. Superior, 448 N. Wells, Chicago 10

5,000 8-16 MM. Movie films. Free catalogues. International, Greenvale, N. Y.

MOVIE Camera film: 8mm. roll \$1.50. 16mm. 100' \$3.00. Free processing. Better Films, 742 New Lots, Brooklyn, N. Y.

MOVIE Film! Free catalog! ESO-R, 47th Holly. Kansas City 12, Missouri.

16MM. Sound, projectors, films. Sale, rental, exchange. Visit store or write for catalog. National Cinema, 71 Dey St., New York City.

8MM. Home movies. Free catalog. Midwest Enterprises, P. O. Box 2062, Milwaukee, Wisconsin.

LADY Wrestling. Movies, photos. Free list. Peerless, Box 171-M, New York 13, N. Y.

EVERYTHING Photographic: 30-75% off list. Every item brand new. Over 77 brands of cameras, projectors, film, etc. Sound features \$9.97 up. Catalog \$1.00 (refundable). Pearlman's, 420 East 55th, New York City.

### COLOR SLIDES

8MM., 16MM. Movie subjects. Silent, sound. New, used. 2"x2" color slides. Biggest selection anywhere! Free each month, big 24-page newspaper-size catalog. Blackhawk Films, Davenport 14, Iowa.

TRANSPARENCIES Wanted. Up to \$500.00 each. For information write American Color, P.O. Box 46372, Hollywood 46, Calif.

10 OLDEST City historical color slides \$2; 60 linen or 30 kodachrome post cards \$1. Florida Souvenir Company, Box 494, St. Augustine, Florida.

ALASKA Color slides. All areas and peoples. Free catalogue. Write: Machetanz Productions, Kenton, Ohio.

### MUSIC & MUSICAL INSTRUMENTS

ACCORDIONS, Chord organs, guitars! Buy direct—save to 1/2. Famous makes. Free home trial. Easy terms. Trades. Free catalogs. Mention instrument. International Music Mart, Dept. R, 2003 Chicago Avenue, Chicago 22.

SONGWRITERS—Outstanding, ethical offer free. Hibbler, C-5, 6808 Oleander, Chicago 31.

SONGWRITERS—Send poems. Honest, sincere offer. Free recording. Successful Songs, Box 608, Danbury, Conn.

POEMS Wanted by America's largest song and recording studio. Free examination. Five Star Music Masters, 630 Beacon Bldg., Boston.

1962 ACCORDIONS at 60% off! Save middleman's profits. 20 models to choose from. Money back guarantee—5 day free trial! 40 bass electric chord organ \$99.00. Waltham Importers, Box 3862, Detroit 5, Michigan.

ACCORDION-O-RAMA, 874 Broadway, New York 3, N. Y. Tremendous discounts. Top brands. Free brochure.

PLAYER Piano rolls, supplies, parts, books, service. Literature dime. Rodgers, 16381 Shelby, Cleveland 30, Ohio.

ACCORDIONS—All sizes. Free home trial. Color catalog. Save 1/2. Terms. Accordion Import Center, 7120 Galli Dr., San Jose 29, Calif.

SONGPOEMS And songs wanted! Mail to: Tin Pan Alley, Inc., Box 405, Radio City Station, New York 19, N. Y.

POEMS Wanted for musical setting and recording. Send poems. Free examination. Crown Music Company, 49-C West 32 Street, New York 1.

POEMS Needed immediately for new songs and records. Free examination and appraisal. Send poems: Songcrafters, Acklen Station, Nashville, Tenn.

GUITAR Making books, plans, imported woods, tools. List 10¢. Satinwood, 510 East 11th Street, New York 9, N. Y.

SONGS Wanted. Pays royalties. Enclose postage. Olenik Records, Mount Morris, Michigan.

SONGPOEMS Wanted! Collaborate with professional songwriters on equal basis. Share royalties. Songwriters Contact Co., 1619-D Broadway, New York 19.

NEW Song "Old Miner Joe" sheet music & records. Floyd Davis, Bethesda, Ohio.

VIOLINMAKERS. Repairers. Fine tone woods and supplies. Also headquarters for violins, guitars (regular and electric) double basses. Send for wholesale price lists. International Violin Co., 414-MPM E. Baltimore Street, Baltimore 2, Maryland.

LYRICS Revised, prepared for publication, recording. Lee Ice, Marietta, Ohio.

## RADIO, TELEVISION AND ELECTRONICS

**SILENCE TV's** annoying commercials. Scraps make armchair control. Instructions \$1.00. M. Ryan, Greenbush Drive, Poughkeepsie, N. Y.

**RADAR King** plans \$1.00. Kits \$19.95. Wired units \$29.95. Wardell Smith, 65 Glenwood Rd., Upper Montclair, N. J.

"**RADIO Explained**." 64 page book—15¢. Bookmaster, Box 17273-F, Salt Lake City 17, Utah.

**FREE Confidential list** electronic components. Unbeatable prices. Knapp, 3174 1/2 8th Ave., S.W., Largo, Florida.

**TRANSISTOR Radios** repaired. \$5.00 covers parts, labor, return postage. Mail radio and \$5.00 to: Mannington TV, 23 Pyles Ave., Mannington, W. Va. Guaranteed.

**LEARN** While asleep with amazing "Electronic Educator" endless tape recorder. Details free. Research Association, Box 24-PX, Olympia, Wash.

**DON'T Buy hi-fi** components, kits, tape, tape recorders until you get our low, low return mail quotes. "We guarantee not to be undersold." Wholesale catalog free. Easy time payment plan. 10% down—up to 24 months to pay. Hi-Fidelity Center, 220-M E. 23 St., New York 10, N. Y.

**RECORDERS, Hi-fi.** Free wholesale catalogue. Carston, 125-Y East 88, N. Y. C. 28.

**GOVERNMENT Surplus** radios, parts. Picture catalog 10¢. Meshna, Maiden 48, Mass.

**FIX Your own TV.** Save 80%! Send for free illustrated chart showing how! We'll include giant electronics catalog. Zalytron, 220-M West 42 St., New York City.

**TAPE Recorders hi-fi** components. Sleep learning equipment, tapes. Unusual values. Free catalog. Dressner, 1523M Jericho Tpke, New Hyde Park, N. Y.

**CRYSTAL Radio kit** \$1.00. Amplifier and speaker for same \$4.95. Catalogue. Clearco, Box 1638, Stuart, Florida.

**SAVE Dollars** on radio, TV-tubes, parts at less than manufacturer's cost. 100% guaranteed! No rebrands, pulls. Request bargain bulletin. United Radio, 1000-M, Newark, N. J.

## BUSINESS OPPORTUNITIES

**IMMEDIATE Profits** with no capital or experience. Take orders for all magazine subscriptions. Friends and neighbors are your prospects. Write now for complete, free kit. McGregor Magazine Agency, Dept. CB2, Mount Morris, Illinois.

**OFFICE Homework, privacy, spare-time.** Refundable moneymaking business instructions 50¢. Interstate, 37 Besch, Albany 9, N. Y.

**OPERATE Profitable home mailorder** business. Details free. Alto Distributors, Box 253, Palo Alto, California.

**RAISE Rabbits** on \$500 month plan. Free details. White's Rabbitry, Mt. Vernon, Ohio.

**\$70.00 WEEKLY**—Home, spare time. Simplified mail bookkeeping. Immediate income—easy. Auditax, 3474A, Los Angeles 34.

**LIQUID Molding** rubber, free sample. Shellcraft supplies, Chaney's, 1907-A East Road, Jacksonville 16, Fla.

**BUY Direct** from factories. Appliances, cameras, watches! Free details! Cam Co., 436 P.M. Bloomfield Ave., Verona, N. J.

**\$200.00 MONTHLY.** Spare time. With tablesaw, bandsaw or jigsaw. Write, Holiday House, A3800 Harney, Vancouver, Washington.

**SHARPEN Saws** and lawnmowers the profitable way. Send for free literature. Max Manufacturing Company, 138 Stockton Avenue, San Jose 26, California.

**FRANCHISES** Make profits! Operate your own exclusive franchised business. Write today for free interesting details. National Franchise Reports, W-528, 333 North Michigan, Chicago 1.

**SELL Champion, AC, Autolite** spark plugs. Reconditioned, electroplated, guaranteed 10,000 miles. 100% profit. Free sample. Lee Plugs, 1608-A Roberts, Houston 3, Texas.

**VENDING Machines.** No selling. Operate a route of coin machines and earn amazing profits. 32-page catalogue free. Parkway Machine Corporation, Dept. #27, 715 Ensor Street, Baltimore 2, Maryland.

**BUSINESSES, Resorts, motels, investment** property, ranches. Our special service dept. at your disposal. No obligation. World's largest. 58 years' service. Strout Realty, 7-MB S. Dearborn, Chicago 3, Ill.

**BIG Money** raising fishworms and crickets. Free literature. Carter Farms, Plains, Georgia.

**TO \$100.00 Weekly.** Sparetime, home operated mailorder business. Successful beginner's plan. Everything supplied. Lynn, 10420-M National, Los Angeles 34.

**PIANO Tuning** learned quickly at home. Tremendous field! Musical knowledge unnecessary. Information free. Empire School of Piano Tuning, Champaign, Ill. (Founded 1935).

**COPUBLISH Mail Sale Advertiser,** leading mail order paper. Details, latest copy, dime. Vanroy Shirk, Lebanon, Penna.

**OPERATE Profitable mail order** business. Write Walter Service, 4159A East 112th, Cleveland 5, Ohio.

**BAKE New greaseless** doughnuts in kitchen. Sell stores. Free recipes. Montgomery, 3605 South 15th, Minneapolis 7, Minnesota.

**EXCEPTIONALLY Profitable** opportunity in tape recording! Free information. Baron's, Lynden, Washington.

**MARKETS Everywhere.** Make artistic concrete birdbaths, pottery. Best coloring. Home workshop. Hundred varieties. Free pictures. Hollywood Cementcraft, 8527-S Wonderland, Hollywood 46, California.

**MAKE \$46** From square foot plywood: jigsaw necessary. Free details. Woodart, Bridgewater, Mass.

**\$400.00 MONTHLY** Raising giant fishworms. Soilless method. Charlie Morgan, Bushnell, Florida.

**HOW And where** to obtain capital. Write: Reliable Service, Rome City, Ind.

**SELL Books** by mail. 400% profit. Royal, Box 368-X, Cleveland 27, Ohio.

**PLASTERCRAFT** Molds, liquid rubber, plasters, flocks, candle supplies. Catalog and manual free. Blue Rapids Supply, Blue Rapids, Kansas.

**WORLD'S Largest** wholesale supply. Buy from 679 American, European, Japanese wholesalers. Tailormade suits from Hongkong. 123 dropship catalogs. Rock-bottom prices. Free details. International Buyers, 216-MM Jackson, Chicago 6, Ill.

**MAILORDER.** America's most unique no cost beginner's plan. Armstrong's, 154-A Darrington S.W., Washington 24, D. C.

**EARN \$3 hourly,** spare, full time, looking up information at your local library. Operate research bureau. Details free. Service, 81C Knickerbocker Station, New York.

**RE-CAST Junk** batteries into new. Latest achievements. Battery Laboratories, Bayou LaBatre, Alabama.

**11,000 NEW Prospects** daily. Baby record books, shoes, albums. Sell mailorder. Use our literature. Write: No-Co-Ro, Capitola, Calif.

**SELL By mail.** Mail order specialist shows how to start on low capital. Modern merchandising methods, not crackpot schemes. Free details. Larry's Specialties, 97-06 63rd Drive, Rego Park 74, New York.

**SIGNS.** Sell restaurants, bars, etc. Samples \$1.00. Box 9563, Jackson, Miss.

**INTERNATIONAL Mailorder** business made easy. Complete setup service, not just instructions. Hermes, 152 West 42, New York City 36.

**OPERATE Home mailorder** business. Vosacek Printing, 4444A Ute, San Diego, 17, Calif.

**MAILORDER:** Extra income, spare time. Easy. Write: American Distributors, Box 409, Niles, Michigan.

**PROSPERITY** In garden golf. Invest now. Details, Brockway, Box 3762, Portland 8, Oregon.

**COLORGLAZED** Concrete pottery made without molds. Patented method. Cemetery products, novelties, tiles. Basement leak-sealing. Money-making projects. Booklet, details free. Men only. National Potteries Company, Grand Rapids, Minnesota.

**BUSINESS Guidance:** Select the business you want. We help you setting it up. Free details. Hermes Company, 152 West 42, New York City 36.

**FREE Report:** "609 Unusual, Successful Businesses." Box 1001-PR, Evanston, Illinois.

**SELL By mail!** Rare opportunity! Fascinating facts! A. Nelson, 210 Fifth Avenue, New York 10, N. Y.

**BIG Profit!** Learn to operate auto and iron salvage yard. Box 806, Mason City, Iowa.

**\$10.00 HOUR:** Painting signs with our patterns. Carlayne, 1803 Fremont, Rapid City, South Dakota.

**MUSHROOMS** Quicker, easier, cheaper. Spawn (seed) plus newest manureless growing, various processes, marketing. \$1. Free literature. Luxur, 641 South 19th, Newark 3, N. J.

**MAKE Durable** building plastic easily. Waterproof, fireproof, economical. Bays Laboratory, Cedaredge, Colo.

**CANDIED** Popcorn and potato chip equipment. Eakins, Box 933-A2, Springfield, Ohio.

**FREE.** Spare time dollars. Flocking. 1517 Log Cabin Avenue, Rockford, Illinois.

**MAKE Money** making leathers. 1148 ideas. Free information. Tandy Leather Co., Box 791-F2, Fort Worth, Texas.

**GROW Orchids** at home. Profitable, fascinating. Successful home grower explains special light, temperature and humidity conditions orchids need. Free—full details. Orchids, 100 S. Vermont, Los Angeles 4, Calif.

**NEED Help** to make money, start a business? Ask for experienced advice. Send \$5. Business Counselors, 441 S. Division, Grand Rapids, Mich. Limit 5 questions answered.

**MADE \$10,000.00** Typing at home. Guaranteed profit.—Amazing information 15¢. Lenore Feigen, 30 Washington, Oak Park, Ill., Dept. PM.

**WANT To make big money** at home? \$10.00 profit in an hour possible with invisible mending. Make tears, holes disappear from clothing, fabrics. Steady year-round demand from cleaners, laundries, homes. Details free. Fabricon, 1585 Howard, Chicago 26, Ill.

**LEARN Sewing** machine repairing. To \$125 weekly. Sparetime. Supplies. Add to present business. Write today! Taylor Service, Box 484, Cupertino, Calif.

**AMAZING!** "Famas Plan." \$12,000 year earnings. No selling! Free details. National Systems (Dept. 72) 101 Capri Lane, San Antonio 1, Texas.

**MAKE Extra money**—Big cash commission plus premiums for you and your customers. Sell advertising book matches. Sensational new tenorams, glamour girls, hill billies; dozens others. All sizes. Quick daily sales; big repeat business. Free master kit makes selling easy. No experience necessary. Superior Match, Dept. MX 262, 7530 Greenwood, Chicago 19.

**10,000 PROFITABLE** Formulas, recipes, trade secrets. Details free. Colen, 7731-M2 Yates, Chicago 49.

**RE-REFINE** Used oil. Drawings, instructions, \$3.00. Pacific, Box 311, Gresham, Oregon.

**EARN Money raising fishworms for us!** Write: Oakhaven—38, Cedar Hill, Texas.

**BIG Money — Operate own fix-it shop.** Service household appliances, motors, mowers, saws, skates, etc. Free book. Christy Trades School, A-2103, 3214 Lawrence, Chicago 25.

**START Your own business on credit.** U.S. only. Your own boss. 1344 dealers sold \$5,000 to \$25,500 in 1960. We supply stocks, equipment on credit. 200 home necessities. Sales experience unnecessary. Pleasant, profitable business backed by World-wide industry. Write Rawleigh's, Dept. B-U-PPM, Freeport, Ill.

**DOLLS! Dolls! Dolls!** We teach you to make, repair, dress and sell. Study at home. Earn while learning. Free booklet. Doll Hospital School, Studio MC-22, 11826 San Vicente Blvd., Los Angeles 49, Calif.

**LEARN Professional TV servicing in one week!** Fabulous new simplified system. No big expense. No studying. No tools or equipment. Spare, full time. Own your own big profit business! Save! Amazing but true! Free sample lesson, illustrated "How To" booklet. Write, TV Systems, Dept. FC-172, 1038 So. LaBrea, Los Angeles 19, Calif.

**BECOME Tax consultant.** Graduates earn \$1,000-\$3,000 every tax season preparing returns evenings. State approved. Union Institute, Lakewood H-2, N. J.

**\$250.00 WEEK Spare time profit possible.** Earn at home with new fascinating printing method. \$5 starts you—send no money now. Free confidential facts and valuable sample. Screen-Print, FY, Los Angeles 61.

**SECRETS! Secrets!** Mail order success revealed by internationally famous expert who discovered how to make home business fortunes. Beginners: Get free copy "How to Make Money in Mail Order." Disclosed free advertising, profitable products, everything! No obligation. Write Malco, 1554 Sepulveda, Dept. D702, Los Angeles 25.

**IMPORT-Export opportunity, profitable, world-wide, mail-order business from home, without capital; or travel abroad.** Established world trader ships instructions for no-risk examination. Experience unnecessary. Free details. Mellinger, D702, Los Angeles 25.

**\$1.00 BRINGS you \$18.00 spare-full time home business opportunity!** Amazing new velvet-spray transforms old cheap lamps, TV-radios, figurines, furniture, anything, into valuable products! Free samples. 50 business opportunities booklet. Send no money. Flok-Kraft, FY Los Angeles 61.

**WE'LL Finance the right party in your area in spare time business keeping retail stores supplied.** No selling. Just \$24 down starts you in fast-growing rack jobbing business, pays you good hourly earnings. For information, no obligation, write Novo, 3855 Lincoln, Dept. P-85, Chicago 13.

**OPERATE Profitable mail order business.** Write: Wayne's Service, 3016-J Channing, Washington 18, D. C.

**DRIED Mushrooms \$4.50 pound for large canning company.** Receiving warehouse in United States. Growers wanted on contract, everything supplied. Mushroom Salt Co., No. 548, Calgary, Alberta, Canada.

**FREE Book "990 Successful, Little-Known Businesses."** Work home! Plymouth-572T, Brooklyn 4, New York.

**START Profitable bookkeeping service without previous experience.** R. I. Systems, 1645 Warwick Avenue, Warwick 3, Rhode Island.

**RAISE Tomatoes year-round.** 20¢ for plans and information. Jefferson Company, Box 416, Jefferson, Oklahoma.

**SENSATIONAL New folio, \$1.00. Dozen \$5.00. Hundred \$35.00. Thousand \$250.00.** Rush \$1.00 for sample. Further details free. Hamilton, Box 184, Flushing 52, N. Y.

**AMAZING Manufacturing opportunity.** Free list of manufacturing formulas. Presler Oil Co., Box 788P, Fostoria, Ohio.

**LEARN Landscaping and the growing of plants.** Start a profitable business part or full time. Free information without obligation. National Landscape Institute, Dept. MC-22, 11826 San Vicente Blvd., Los Angeles 49, Calif.

**EVERYBODY Likes fine candy and popcorn specialties.** Make professionally home. (Our 50th year.) Ragsdale Candies, B107 East Orange, New Jersey.

**"MAILORDER Laws and Regulations."** Explains licenses, taxes, legal requirements, etc. \$2.00. Play safe. Order today. Neil H. Tasker, Shamokin, Pennsylvania.

**PROFITS In plastics.** Incredible new "table-top" machine manufactures over 15,000 saleable products. Also laminates, encases, moulds and plates in bronze, chrome, or copper, in 30 seconds. 20¢ materials produce \$3.00 products. Free confidential details and home-business plan. Plasti-Form, Dept. FY, Gardena, Calif.

**FREE Necklace kit with jewelry supply catalog.** 25¢. Designs, kits, instructions. Big profits! Easy to make! Modern Craft, Box 11088-R22, Saint Petersburg 33, Fla.

**\$34.70 TWO Hours manufacturing concrete products.** No selling. Castings #3, P.O. Box 1721, Rapid City, South Dakota.

**MAKE Money from old tires.** Operators clearing \$400 weekly. Equipment costs \$800. Get facts. S & S Patents, Inc., 3511 N. Lincoln, Chicago 13.

**MONEY! Yours now.** No selling, no waiting, no investment. Send 25¢ for details. Thomas, Mount Wilson 8, California.

**\$100 WEEKLY.** Sparetime home mail order business. Successful beginners plan. Everything furnished. L&D, 109 W. 42nd, New York City 36.

**OWN And operate a collection agency.** Complete instructions \$1. Janeczek, 373 East 155th Street, New York 55, N. Y.

**AUTO Mechanics.** Be your own boss. Grind crankshaft journals with Sunnen portable crankshaft grinder right in the car. Many Sunnen grinder operators earn over \$50 a day. Why not get into this profitable business? Write for details. Sunnen Products Company, 7954 Manchester Avenue, St. Louis 17, Missouri.

**MAKE And sell concrete step stones, parking curb, park benches and many other specialty products at home or factory.** Spare or full time. Instructions, 24-page catalog, 25¢. Concrete Specialty Forms, Box 4167-S, Columbus 7, Ohio.

**FREE Books "707 Latest Moneymaking Ventures" — "Profits 1935-1968."** Work home! Haylengs, Carlsbad, Calif.

**OPERATE Home factory.** Make fast selling products. Private labels furnished. Tremendous profits. Research, 1735 Kildare, Indianapolis 18, Ind.

**BRONZE Baby shoes; Instructions, equipment and mountings for genuine electroplating process.** Largest supplier of all plating equipment, supplies. Free catalog. Hollywood Bronze Supply, Dept. B-3, 3445 Union Pacific, Los Angeles 23, Calif.

**MAKE Telephone surveys spare time!** Free home-business details. No selling, choose your own hours. Telephone Institute, Dept. HC172, 1038 So. La Brea, Los Angeles 19.

**LIFETIME Home business bottling fabric softener.** Details. Morgan's, Coldspring Street, Norwalk, Conn.

**YOUR Own importing business.** Opportunity for beginners. Also wagon, crewmen, salesmen, mailorder operators. Make money without stock investment. No importing experience required. Overseas suppliers will drop-ship direct to your customers. \$15,000.00 yearly not unusual. Not a study course, but your own 400% profit, world-wide drop-ship importing business. Mail 2 dimes, get details and trade coupon worth \$2.00. Overseas, Box 13364, Houston 19, Texas.

**CAN You enjoy independence and high income? Obtain a guaranteed program for business planning.** \$2.98. Business Address, P.O. Box 91, Niagara Falls, N. Y.

**PROFITABLE Catalog mailorder business!** Vikari, 468-PM3 Third Avenue, Salt Lake City 3, Utah.

**PACKAGE At home for profit!** We supply everything. No selling. Free home business details. HPC, 2212BF Jesse Street, Los Angeles 23.

**PLACE Gift displays in stores.** \$500.00 investment required. Big profits! Robbins, 170-G Fifth Ave., New York City 10.

**MAKE \$50,000 Or \$100,000 a year possible.** New clean way in glass. "Suregrow" dried plant food not dusty. Revives new life in old lawns, flowers, gardens, trees, fruit trees, shrubs, etc. Millions homes can become customers. Sell from your home to thousands homes in your district and neighborhood. Free sample and catalog. Suregrow Company, 1019-6th North, Seattle, Wash.

**CANDYMAKING.** Profitable home business. Easy. Amazing course, \$1.00. Ideal, Park Ridge, Illinois.

**GROW Mushrooms.** Cellar, shed, chicken houses, caves, tunnels, etc. First class mushroom spawn. Spawn to plant 50 square feet \$10.50, to plant 100 square feet \$16.00, to plant 250 square feet \$22.00, to plant 500 square feet \$37.00, to plant 1,000 square feet \$67.00. Planting instructions are sent with each order free. Send full cash payment with the order for prompt prepaid shipment. Thomas Company, 1019-6th North, Seattle, Wash.

**MOLD Statuary, pottery, tiles, novelties.** 5¢ materials makes dollar sellers! Particulars free. Marbleizing Service, Edwardsville, Ill.

**NEW Prefab house with concrete frame saves labor, materials.** World wide opportunities building, selling, manufacturing parts for New American Home, P.O. Box 7026, Tampa 3, Fla. Details 25¢.

## MONEYMAKING OPPORTUNITIES

**MAKE Plastic novelties for extra income.** Low cost home training now available. Write for free booklet. Interstate Training Service, Dept. D-3.

**BAKE New greaseless doughnuts in kitchen.** Sell stores. Free recipes. Melvin, 3605 South 15th, Minneapolis 7, Minn.

**NEW Infra-red defroster by Quik Products sells itself with simple demonstration.** Defrosts refrigerators, freezers in minutes. Place 20 per day on free home trial plan, call back to take orders. No selling experience required. Make over \$250 first week. Like no other product. Sold with 1 year guarantee. Send for complete details. Dept. PM2, Quik Products, Glen Cove, N. Y.

**FABULOUS Profits raising earthworms.** Picture folder free. Excello, Kosciusko 6, Mississippi.

**MAKE \$5,000 Yearly sparetime raising mink, chinchillas, nutria, etc.** Free booklet reveals proved plans. Write: Furs, 588 Mt. Pleasant Road, Toronto 1, Canada.

**ATTENTION—Aluminum concrete yard ornament molds—donkey cart planters, beautiful bird baths, urns, etc.** Prices slashed. Write for information. Knapp's, 4257 Josephine Street, Denver 16, Colorado.

**EARN Money raising fishworms for us!** Write: Oakhaven—59, Cedar Hill, Texas.

**WIN Contest money.** General Contest Bulletin gives hundreds of tips. Lists current contests, rules. Sample magazine 25¢. General Contests, 1609½ East 5th, Duluth 12, Minnesota.

**MAILORDER Business.** Work home. Sample, details. Nationwide, 96 Reservoir, Butler 1, New Jersey.

**TEAR Out this ad, and mail with name.** address for big box of home needs and cosmetics for free trial, to test in your home. Tell your friends, make money. Rush name. Blair, Dept. 31PB, Lynchburg, Va.

**START A profitable subscription business in spare time!** We need men and women (young and old) as representatives for all leading national magazines. Liberal commissions on all subscriptions. Supplies free. No experience needed. Send this ad with your name and address to: Popular Mechanics, Room 2-O, 250 W. 55th St., New York 10, N. Y.

**MAKE Big easy profits making costume jewelry at home in spare time!** Quick, easy to make, easier to sell! Details free! Don-Bar, 2934W Fullerton, Dept. B-202, Chicago 47, Illinois.

**LEARN Jewelry making at home.** Inexpensive art metalcraft course teaches how to make all types cuff links, earrings, tableware, etc. of silver, gold, copper. Send postcard for free booklet. Interstate Training Service, Dept. L-3, Portland 12, Oregon.

**WANTED—Cartoonists.** Amateurs, professionals. Over 200 markets. Information free. Markets-M2PM, 11620 Lansdowne, Detroit 24, Michigan.

**ENJOY Quick extra income using new tested ideas.** Free details. Price, 409 First, Genoa, Ill.

**MONEY In your mail! Exciting! Revealing!** Hirsch's, 1301 Hoe, New York City 59.

**MAKE Money with "Moneymaking Ideas."** Published monthly. Sample 35¢. 907 Birch, Eau Claire, Wisconsin.

**MEN, Women**—get in on the huge profit plastic bonanza. Work home. No direct selling. Send \$1.25 or for free literature. Specialty Sales, Box 365, Haysville, Kan.

**\$50-\$100 WEEK** Possible with herbs. Grow inside-outside or gather wild. Details free. Whitlow, Dept. A-2, 403 No. Westmoreland, Dallas 11, Texas.

**\$35-\$65 WEEKLY** Assembling artificial lures at home for stores. Materials supplied free. Write, Lures, Lake Village 9, Arkansas.

**SECRETS** Of success explained. Send 25¢ to: Miracle Book Co., Box 816, Laredo, Texas.

**HOW** To win prize sweepstakes, drawings, contests. Lesson 25¢. Winner, Box 304, Columbia City, Indiana.

**MAILMAN** Brings us \$150 daily. Operate home mailorder business. Write: Elias, Box 222, Toronto 5, Canada.

**MAKE** Up to \$8,500 a year sparetime. Complete data \$1, refundable. Janeczek, 373 East 115th Street, New York 55, N. Y.

**SIMPLIFIED** Mailorder programming \$2.25. D. W. Knoepfel, P.O. Box 67, Webster Groves, Mo.

**\$1000 THREE** Months, sell trophies. Penningtons, 10932 South 71, Kansas City 37, Mo.

**BIG** Profits raising redworm night-crawlers. Redworm soilless, odorless method. Three Oak Ranch, Dresden, Tenn.

**10,000 SECRETS** And ideas for home operated, moneymaking businesses! (Free brochures.) Berthold's, 739-PM, Sylvania Avenue, Toledo 12, Ohio.

**CIGARETTES**—Make 20 plain or filter-tp for 9¢. Facts free. Moberly, Box 4012, Owensboro, Kentucky.

**MINK** Raising information free. Complete. Lake Superior Mink Farm, Superior, E.E1, Wisconsin.

**VENDING** Machines. No selling. Operate a route of coin machines and earn amazing profits. 32-page catalogue free. Parkway Machine Corporation, Dept. #26, 715 Ensor Street, Baltimore 2, Maryland.

**EARN** Money evenings copying and duplicating comic cartoons for advertisers. Adservice, Argyle 1, Wisconsin.

**YOUR** Own, easy-to-start, home mail-order business, sparetime. Fascinating; profitable! Information free. Alfano, 19-PM Pine, Closter, N. J.

**BIG** Money raising fishworms and crickets. Free literature. Carter Hatchery, Plains, Georgia.

**READ** "Progressive Mailtrade." the magazine that tells how to make money by mail. Quarter brings sample and special offer. Progressive Mailtrade, Box 357, Sheboygan, Wisconsin.

**AMAZING** Successes through franchises! Become exclusive franchise holder your territory. Information rushed. National Franchise Reports, MP-528, 333 North Michigan, Chicago 1.

**LEARN** The secrets of repairing junk batteries, generators, starters, profitable, easy, at home. Free particulars. Batterymen, 3465 Forrest, Santa Clara, Calif.

**\$25-\$50 WEEKLY** Possible, re-writing news items, jokes, poems, recipes, for publishers. Some worth \$10 each. Details free. Service, 81-D, Knickerbocker Station, N.Y.C.

**MAILORDER** Business learned easily. Write: Easco, Box 323, Grand Rapids 1, Michigan.

**PIANO** Tuning learned at home quickly. Tremendous field! Be independent! Information free. Empire School, Dept. P, Champaign, Ill. (Founded 1935.)

**MASSIVE** Cash profits with this little known money-making opportunity, making gravestones for pets. Easy to make, small investment, large returns, work home, no selling, free details. Laneville, 5420-B Home Gardens Dr., Reno, Nevada.

**EARN** \$240.00 A month at home, spare time, doing only two \$5.00 invisible mending jobs a day. Big money paid for service that makes cuts, tears disappear from fabrics. Steady demand. Details free. Fabricon, 6251 Broadway, Chicago 40, Ill.

**EASY** To start rubber stamp business at home in spare time. Make up to \$9.80 an hour without experience. Facts free. Write Roberts, 1512 Jarvis, Room CR-2-A, Chicago 26.

**MEN**—Women! Start money-making plastic laminating business at home in spare time. Material that costs 11¢ brings back \$2.58. No canvassing or selling but mail orders brings in \$20 a day. Write for full particulars free. Rush name on postcard to Warner, Room CL-2-A, 1512 Jarvis, Chicago 26, Ill.

**MAKE** Money writing short paragraphs! No tedious study. I tell you what to write, where and how to sell; and supply list of editors buying from beginners. Many small checks add up quickly. Write to sell, right away. Send for free facts. Benson Barrett, Dept. C-27A-N, 7464 Clark, Chicago 26.

### EXPORT — IMPORT

**JAPAN:** Direct mail-order 26 page catalogue: dolls, novelties, business information, manufacturers' names, addresses, \$1.00; Japan's Trade Directory, 3000 companies, \$3.00. Send cash. Clarence Yamagata, 814 Toginbiru, Marunouchi, Tokyo.

**YOUR** Own import mail order business. Deal with over 400 manufacturers exporters of the world. Complete import procedures, international dropship methods. Capitol unnecessary. Details 10¢ refundable. Associated, Box 108-EI, Lincoln 1, Nebraska.

**WATCHES!** Airmailed from Switzerland. Free catalog. K-P Imports, 511 Glenwood, Buffalo 8, N. Y.

**WORLDWIDE** Dropship and import directory \$1. Janeczek, 373 East 155th Street, New York 55, N. Y.

**"FOREIGN** Bargains Directory." \$1.00. L. J. Finn Company, 140 Virginia Park, Detroit 2, Michigan.

### SCIENCE & CHEMISTRY

**AMAZING** New book of science experiments, formulas, and catalogue of laboratory supplies. Only 35¢. National Scientific Co., 13 S. Park Avenue, Dept. PM-2, Lombard, Illinois.

**ROCKETS** Available now: Powerful new 2-stage model spacecraft! Kits, cones, engines, chemicals. Bigger 1962 catalog 25¢. Central Rocket Company, Waupaca, Wis.

**"CHEMISTRY** Explained." 64 page book —15¢. Bookmaster, Box 17273-G, Salt Lake City 17, Utah.

**MESSAGES** (Return addressed) placed in our watertight drift-bottles and cast overboard in mid-Atlantic, Indian, Mediterranean or Pacific areas. Only \$1. Position, time, wind and sea data reported to you. Johnson Exploration, Berth 78, San Pedro, California.

**ILLUSTRATED** — Pyrotechnics Manual. Contains formulas and data on fulminates, explosives, fuses, and other fireworks including stars. \$1.00 postpaid. Kel-Tec Laboratory, Box 194, Brockton 69, Massachusetts.

**SPECTROSCOPE** For quick analysis \$3.00. Kuttingson, 875 Arastradero, Palo Alto, Calif.

**SPINTHARISCOPE**, Sparkles continuously by alpha particles from its contained radium. Full charges post paid U. S. and Canada \$1.35 per instrument. Rock Shop, Box 405, Argus, California.

**BIG** Chemistry catalog 25¢. Bargain lists. Laboratory Sales, Box 161-A, Brighton, Mass.

**SOLAR** Energy collectors—30" dia. parabolic mirror. Other types. Details free. Cope, Box 71A, West Chester, Penna.

**CHEMICALS** And apparatus for industrial, analytical, and private laboratories. Catalog 35¢. Dept. M-50, Biological Supply Co., 1176 Mt. Hope Ave., Rochester 20, N. Y.

**SCIENCE** Treasure chest. Do hundreds of experiments. Order No. 70.342-CZ—\$5.00 postpaid. Request free Catalog—CZ. Edmund Scientific Co., Barrington, New Jersey.

**NEW** Concept of atomic structure. Nuclear theory challenged. 30 pages, 25 cents ppd. C. F. Krafft, 4809 Columbia Road, Annandale, Virginia.

**232 PAGE** Catalog \$2.00. Laboratory Materials, 7319 Vincennes, Chicago, Ill.

**WORLD** Rocket flights. Price list 4¢. Captain Peters, Interlachen, Florida.

**ILLUSTRATED** Catalog: Chemistry, mineralogy, biology 25¢. Tracey Laboratories, Evanston, Illinois.

**UNUSUAL** Chemistry books, courses, kits! Rare chemicals, cheap! Catalog 25¢. NSC, Box 11133, Palo Alto, Calif.

**"EXPERIMENTER'S** Booklet" and bigger catalogue—25¢. Hagenow Laboratories, Manitowoc, Wisconsin.

**ROCKETS:** New illustrated catalog 25¢. Kits, cones, tubes, engines, etc. Estes Industries, Penrose 2, Colorado.

### FORMULAS, PLANS, ETC.

**AUTO** Engine overhaul compound formula \$1. Other auto service formulas included free. Janeczek, 373 East 155th Street, New York 55, N. Y.

**10,000 PROFITABLE** Formulas, recipes, trade secrets. Details free. Colen, 7731-MB Yates, Chicago 49.

**FORMULA** Trade secrets, 10,000 to choose from. Information free. Norris Sales Co., Alpine 3, Tennessee.

**FORMULAS**—All kinds. Amazing big catalog, 10¢. Kemixal, Park Ridge, Ill.

**ANTI-FREEZE**, Waterless handsap, resilvering mirrors, all \$1.00. Nelko, Box 3462, Merchandise Mart, Chicago 54.

**LATE**, Modern manufacturing formulas. List free. Moon Chemical, Martville, New York.

**FORMULAS** For latest money-making discoveries. New! Good! Valuable literature free! Miller, Chemist, 1517-D, Tampa, Florida.

### PLASTICS

**PLASTIC** Laminating, photos, anything to 2½ x 3½ inches, 49¢. Pacific, Box 311, Gresham, Oregon.

**NEW!** Plastic vacuum forming machines. Hobby. Easy. Profitable. Details. Burr, 330 East Center, Kalamazoo, Mich.

**NEW** Liquid casting plastic, clear, colors. Embed real flowers, butterflies, photos, coins. Send 25¢ for two handbooks "How to Cast Liquid Plastics" and "How to Make Extra Money at Home." Castolite, Dept. B-101, Woodstock, Illinois.

**CREATE** Original artistic gifts now. New instruction manual tells how to do plastic embedding and molding. Manual \$1.00, catalog 25¢. Castacraft Corporation, Dept. M-262, P.O. Box 555, Palo Alto, California.

**BOXES**, Plastic. 200 sizes. Free list. Althor, 170 Bay 23 Street, Brooklyn, N. Y.

### AGENTS WANTED

**EARN** \$50 Weekly in sparetime. New unusual way to earn extra money in your spare-time. No investment necessary! No sales experience needed. Get merchandise on credit. Work your own hours! If you'd like complete details on how to earn money this interesting way, write Greetings Unlimited, Park Square, Room 2-679, St. Paul, Minnesota.

**NEW** Cosmetic! Excellent commissions. Sample 10¢. National Consolidated, Saranac Lake, New York.

**BIG** Profit selling chamois to service stations, car lots. Steady repeat business. Free details. Inka Industries, 717-H Fairview, Houston 6, Texas.

**MAKE** Extra money during spare time! Show colorful catalog with toys, jewelry, all-occasion cards, gifts and household gadgets. Fill orders. Work your own hours. No experience necessary. No investment necessary. Excellent for direct selling or parties. For free money-making catalog, write: North Star, Dept. 2-492, 251 East Fifth Street, St. Paul 1, Minnesota.

**STRANGE** Dry window cleaner. Replaces messy rags, liquids. Simply glide over glass. Samples sent on trial. Kristee 123, Akron, Ohio.

**SEEKING** New products? Get my outfit 47 money-making specialties. Latest conveniences for home, car. Send no money. Just your name. Kristee 123, Akron, Ohio.

**SELL** Greeting cards. Make extra money. Guaranteed all occasion assortments, Easter, valentines; stationery, gifts, wrappings, toys, jewelry. Experience unnecessary. Salable samples on approval. Free catalog. Free gift offer, details. Write—Hedenkamp, 361 Broadway, Dept. PM-71, New York.

**MAKE \$55 A day** clear profit! Sell nationally advertised Royaltone Auto Glaze to car owners, dealers, jobbers. Exclusive territories. Rush name for free sample, details. Royaltone, Brooklyn 30, N. Y.

**IF** You're interested in making more money, send for our moneymaking offers. Foster, 14 Horatio, New York City 8.

**FAST** Selling novelty ball pens, 6 different samples, \$1.00. Robbins, 170-P Fifth Avenue, New York City 10.

**BUSINESS** Kit free! Postcard puts you in business! Complete line 230 shoe styles, jackets. New discoveries pay big commissions. No investment. Send for free kit. Mason, Chippewa Falls K-403, Wisconsin.

**MAKE** Most extra cash with world's biggest line everyday greeting card assortments, gifts. Introduce friends, neighbors, to over 150 assortments, 500 big moneymakers. Pocket up to 100% profit plus big cash bonus. Free giant color catalog; samples on approval. Write Arrow Greetings, 513 Fourth Ave., S., Dept. 83-K, Minneapolis, Minn.

**AGENTS**—300% Profit selling genuine gold window letters; stores and offices. Free samples. Metallic Sign Letter Co., 1217-D West Newport, Chicago.

**EXOTIC** Earrings! Details free. Pair, \$1.00. Ohga, PM-329, Sigakenkusatu, Japan.

**RUN** A spare-time greeting card and gift shop at home. Show friends samples of our wonderful new 1962 all-occasion greeting cards and gifts. Take their orders and earn up to 100% profit. No experience necessary. Costs nothing to try. Write today for samples on approval. Regal Greetings, Dept. 67, Ferndale, Michigan.

**GOOD** Profits, repeats, selling exclusive, gorgeous, handmade rugs (\$7.00 value) \$24.00 dozen. Sample material free. Wilson, Box 8, Strasburg, Virginia.

**3-1 SANITARY** Mops dries from inside but cost no more. Christie Mop Co., Knoxville 19, Tenn.

**QUICK** Demonstration sells folding safety steps to homes, trades and industry. Liberal discount. Anderson Mfg. Co., Norway, Michigan.

**SELL** Champion, AC, Autolite spark plugs. Reconditioned, electroplated, guaranteed 10,000 miles. 100% profit. Free sample. Lee Plugs, 1608-E Roberts, Houston 3, Texas.

**FREE** Sample. Beautiful curios! Sell on sight! Apartado 9036, Mexico City.

**PRINTING.** Advertising salesmen—Excellent moneymaking sideline selling decalomania name plates, small quantities. Automobile initials, sign letters. Free samples. Ralco, XL, Boston 19, Mass.

**YOUR** Own business—Used suits \$1.50; overcoats 65¢; mackinaws 35¢; shoes 12½¢; ladies' coats 30¢; dresses 15¢. Enormous profits. Catalog free. Nathan Portnoy Associates, 2109-AA Roosevelt Road, Chicago 8, Ill.

**MAKE** Up to \$50.00 a day soliciting delinquent accounts. Terrific commissions. Write today. National Credit, 304Y Pickwick Bldg., Kansas City 6, Mo.

**BIG** Profits. Stamp social security plates, key protectors. Sample 50¢. Catalog free. General Products, 11 No. Pearl St., Albany 7, N. Y.

**MAKE** Profitable men's-women's wear. Sample free. Sunmade, Brockton 64, Mass.

**WAGON** Jobbers, route men, \$100.00 extra per week. Guaranteed sales. Revolutionary new tool holder sells on sight for \$1.98. Makes hooks, peg board obsolete. Information Drawer J, Blue Bell, Penna.

**YOUR** Ad in this space will get some good agents for you. Yes, I'll prove it. Write for Folder "A" right now. F. W. Johnson, Classified Advertising Manager, Popular Mechanics Magazine, 200 E. Ontario St., Chicago 11, Ill.

**BE** Independent. Your own business full or part-time wholesaling our home, shop need products through drug, grocery, department stores. Protective territory your area. For franchise, all details, mail \$2.00 now, refundable, to Chris Hickman, Mgr. CHA, 730 Northwest Welder, Portland, Oregon.

## BUY IT WHOLESALE

**GUARANTEED** Handmade western boots. Free catalog. Sellers Co., 8830 Alameda, El Paso, Texas.

**LOOKING** For something? Buyers Service, 9325-E Menard, Oaklawn, Illinois.

**FREE** Gifts. Lowest wholesale prices. Catalog 25¢. Information 4¢. George Fitch, 4415-P Edgebrook, Wheaton, Maryland.

**JUST** Out! 356-page catalog—save to 50% on auto parts, accessories. All makes, models. Send 25¢—refundable on first order. Whitney, 1919 PA-2, Archer, Chicago 16.

**BARGAINS.** Closeouts, specials, 32 pages of genuine wholesale prices. Variety store items. Free catalog. Egyptian, Box 168, Anna, Ill.

**FREE!** Name brands catalog! Your own high profit business. Sell name brands, full or part time. No inventory, no investment. More than 2,000 name brand items; lowest wholesale prices. Watches, jewelry, cameras, hi-fi, stereo radios-phonos, appliances, housewares, hardware, power tools, luggage, musical instruments, garden equipment, sporting goods, toys, many others. 8 floors of name brands. Million dollar inventory. Orders shipped complete in 24 hours! Send for free, beautifully illustrated catalog now! Separate wholesale price list. H. B. Davis Corp., Dept. PM, 145 W. 15 St., New York 11, N. Y.

**BUY** Below wholesale! Thousands of nationally advertised products. Drugs, clothing, housewares, cameras, jewelry, hardware, sporting goods, etc. Postcard brings price list showing actual factory cost. Buy-Rite, 310 Main, Bennington 2, Vermont.

**NEW** Deluxe multicolor below wholesale catalog, automobile catalog, and others. Housewares, appliances, refrigerators, freezers, washers, dryers, television, radios, furniture, clothing, luggage, binoculars, phonographs, recorders, cameras, projectors, tools, typewriters, watches, jewelry. Name brands. Huge discounts to 70%. Postcard: Selbyco, Decatur 15, Ill.

**WORLD'S** Largest wholesale supply. Buy from 679 American, European, Japanese wholesalers. Tailormade suits from Hongkong. 123 dropship catalogs. Rockbottom prices. Free details. International Buyers, 216-M Jackson, Chicago 6, Illinois.

**USED** And new watches \$2 up. Free list. Southern Watches, 5-PM So. Wabash, Chicago 3.

**WHOLESALE** Specials. Closeouts. Catalog \$1 deposit. Loeber, 224-A Wyatt, Lincoln, Ill.

**LARGEST** Wholesale supply source in U.S.! 15 free catalogs. Furniture, clothing, appliances, housewares, automobiles and accessories, tools, sporting goods, hobby supplies, farm equipment, imports, new products, bargain merchandise. Free details. Associated, Box 108-DD, Lincoln 1, Nebr.

**BARGAINS!** Buy retail at wholesale prices. Catalog free. C. Ayres, 1427 Pickens, Columbia, S. C.

**BUY** Wholesale—why pay more. Thousands items. Tremendous savings. Watches, jewelry, household appliances, toys, radios, many more. Details. Free catalog. Write: Ward Sales Company, Woodford 1, So. Car.

**BELOW** Wholesale! Tools, shavers, housewares, toys, etc. Free catalog. Lant Distributors, 718 Myrtle, Albany, N. Y.

**FIVE** Wholesale catalogs free! Savings up to 80% on name brand merchandise. Send \$1.00. Refundable. McCullough, 3316 W. Adams St., Chicago 24.

**BIG** Bargains. Wholesale. Hundreds practical items. Large illustrated catalog. 10¢. Gifts, Box 330-A2, Fort Dodge, Iowa.

**BUY** Cameras, projectors, below wholesale. All photography products. Kodak, Polaroid, etc., factory sealed cartons. Free price list. Adco Pop. Photo Supply, 333 Mamaroneck Ave., Mamaroneck, N. Y.

**BARGAINS!** Name brands. Catalog 25¢ (refundable). National Wholesalers, Saranac Lake, New York.

**BUY** Wholesale. Hundreds necessities. Surprising bargains. Amazing low prices. Free catalog. Willnor Distributors, Box 629-M, New Haven 3, Conn.

**FREE** Catalog. Tremendous bargains! Offers, 8440 West Michigan, Detroit 10, Michigan.

**REAL** Wholesale prices. Big variety. Free catalog. Ateep, Box 66, Teaneck, N. J.

## SALESMEN—DISTRIBUTORS

**GET** New shirt outfit free! Make \$90 weekly on 5 average orders a day. Famous quality made-to-measure dress and sport shirts, \$4.50 up, sell fast to all men. No experience needed. Full or part time. Write: Packard Shirt Co., Dept. 512, Terre Haute, Indiana.

**WILL** You test new items in your home? Surprisingly big pay. Latest conveniences for home, car. Send no money. Just your name. Kristee 151, Akron, Ohio.

**MAKE** Extra money selling advertising matchbooks. Free catalog and sales outfit. Matchcorp, Dept. PM-22, Chicago 32.

**MAKE** Extra money—Big cash commissions plus premium for you and your customers. Sell advertising book matches. Sensational new tenorrama glamour girls, hillbillies; dozens others. All sizes. Quick daily sale; big repeat business. Free master kit makes selling easy. No experience necessary. Superior Match, Dept. M262, 7530 Greenwood, Chicago 19.

**BIG** Money! Cash in on big demand for Negro cosmetics. Build permanent business. Free sample. Write Valmor, Dept. YQ, 2451 Michigan, Chicago 16.

**UP** To \$1,000 monthly introducing amazing new invention. Seals puncture, re-inflates tire in 2 minutes without changing wheel. Fleets order dozen or more, every motorist needs. Millions already sold. Sales guaranteed. Free details. National Dynamics, 216 East 23rd., Dept. 60FA, New York 10.

**SENSATIONAL** New longer-burning light bulb. Amazing free replacement guarantee—never again buy light bulbs. No competition. Multi-million dollar market yours alone. Make small fortune even spare time. Incredibly quick sales. Free sales kit. Merlite (Bulb Div.), 114 E. 32nd, Dept. C-74P, New York 16.

**NEW** Money-making silicone water repellent. Free facts. GK Company, 230-21st, S. E., New Philadelphia, Ohio.

**MONEL** Rings. Masonic, initial, fraternal. Every man a prospect. Free sales outfit. Bonnett Mfg. Co., Biloxi 1, Miss.

**NEW!** Washable pictures. Huge profits (brochure). Rustic Art Sales, Wallace, Mich.

**\$1,000.00** A Month for making dramatic 3-second demonstration of amazing lightweight presto fire extinguisher. New chemical used by airforce snuffs out fires instantly. Only \$4.95. Terrific commissions. Millions want it. Free kit. Merlite, 114 E. 32nd, Dept. P-66P, New York 16.

**EARN** Big commission full or part time. Build profitable business of your own selling America's largest line low priced business printing and advertising specialties. 360 page catalog samples hundreds of items used daily by business people. Imprinted ball pens low as \$7.95 for 100. Big line low priced union label political printing included. Free sales kit. National Press, Dept. 8, North Chicago, Illinois.

**SALESMEN** To sell transparent mirrors and novelties made on Catalina Island. Ye Olde L.A. Press Club, 9026 So. Orchard Avenue, Los Angeles 44, Calif.

**EXPERIENCED** Magazine men, no turn in. Cars, crews furnished. Apply Mark Steele (Magazine King), Steele, Missouri.

**PATENTED** Bottle caddy! Every car door needs one. Send \$1.25 for samples and price list. Taylor-Garner Corp., 1113 Healey Bldg., Atlanta 3, Ga.

**AMAZING** Opportunity. New low priced fire alarm protects homes, farms, offices, factories, etc. No wiring—hangs like picture. Pays up to \$1,100 a month. Free kit. Merlite (Alarm Div.), 114 E. 32nd St., Dept. F-66P, New York 16, N. Y.

**MAKE** Big money taking orders for Stark dwarf fruit trees. Everybody can now grow giant size apples, peaches, pears in their yards. Also shade trees, shrubs, vines, roses, etc. Outfit free. Stark Bros., Desk 30122, Louisiana, Mo.

**HIGH** Commission and bonus. Earn \$100 to \$300 weekly. 30 year old company has openings. List delinquent accounts for collection. Experience not necessary. Permanent. Write Merchants Protective Agency, 1015F Walnut, Kansas City, Mo.

I'LL Send you free stocking sample new-est advancement in hosiery since nylon. Patented, full-length. Stays up over-the-knee without supporters, without girdle! Nationally advertised price \$1.95. Make money introducing to friends at \$1.00 pair. American Mills, Dept. 720, Indianapolis, Indiana.

LONG Needed invention. Men to contact service stations. Huge profits. Cyclo Mfg., 3816 Dahlia, Dept. 117, Denver 1, Colo.

MAKE Big money taking orders Campbell's Gro-Green Liquid and 100% soluble crystal fertilizer concentrates. Saves time, money, labor. Feeds foliage, soil. Field proven over 10 years. Increases protein, mineral content grains, forage. Free sample. Selling outfit. Credit given. Ideal for corn and feed men. Campbell Co. (Est. 1928), Rochelle 52, Illinois.

BIBLE Profit 130% — why make less? Literature free. Bible, 4813A Hurford, Chester, Penna.

PART TIME Automatic fire extinguisher salesman. Out-O-Matic, 1737J East 31st, Denver 5, Colorado.

MAKE Up to \$50.00 a day soliciting delinquent accounts. Terrific commissions. Write today. General Finance, 304V Pickwick Bldg., Kansas City 6, Mo.

IF You're interested in making money in selling, see the hundreds of exceptional opportunities in Salesmen's Opportunity Magazine. Send name for your copy, absolutely free. Tell us what you're selling now. Opportunity, 848 N. Dearborn, Dept. 17, Chicago 10, Illinois.

FOG Shield — Stops fogging instantly cars, mirrors, windows. Keeps ice off windshields. Will last 2 or 3 years — sold money back guarantee. Incredibly quick sales. This is no fly by night deal. Distributors wanted. Send \$1.00 for sample to: Fog Shield, P.O. Box 27, Baker, La.

## EMPLOYMENT INFORMATION

CALIFORNIA Jobs. Aircraft, missiles, construction, sales. Many others. Send \$2.00 for latest listings. Airmail. California Opportunities, Box 2463, San Bernardino, Calif.

WORK In sunny Arizona. Information and job listings, \$1.00. Thompson Enterprises, Box 5651, Phoenix 5, Arizona.

SENSATIONAL Employment listings. \$2.00. Diamond Publications, Box 6133, Spokane, Wash.

\$1,600.00 MONTHLY Possible! With "Employment Information." \$1. International, 100 Airport, San Antonio 12, Texas.

DIRECTORY Reports. Construction, aviation, shipping, oilfields, government, manufacturing, trucking, etc. Foreign-stateside. Helpful information plus job-getting tips on preparing application letters. Unconditional money-back guarantee of satisfaction. Act today. Only \$2.00 (\$2.25 airmail). (C.O.D.'s accepted). Research Services, Meramec Building, St. Louis 5-PM, Missouri.

FOREIGN Employment information. Europe, Alaska, Africa, Asia, Canada. Travel, adventure. Up to \$1,600 monthly. Construction workers, truck drivers, clerks, teachers, professionals, etc. Sensational opportunities — most complete information, application form sent immediately by return mail. Send \$2.00 to: Jobs, Box 512-E, New Orleans 12, Louisiana.

MERCHANT Marine jobs. Men and women. Top wages. Travel. Captain, Box 501-P, Reading, Massachusetts.

OVERSEAS Employment information. High salaries. All occupations, professions. Tremendous opportunities. Complete listings, \$2.00. Associated Reporters, P.O. Box 1008, Miami 1, Florida.

JOBS On ships. Age 18 to 55. Experience not required. National Seafaring, Box 71881-B, Los Angeles 1, California.

JOB-Getting resumes easily prepared. "Effective Resume Guide" shows you how, makes it simple, step by step. Sample resumes included. Send \$3.00. Richton Company, Dept. A, 1020 Broad, Newark, New Jersey.

U.S.A. And foreign jobs, up to \$1600.00 monthly. Construction, clerical, supervisory, etc. Skilled, unskilled. Free transportation. Unusual opportunities. Complete information plus worldwide project listings. Only \$2.00 (\$2.25 Airmailed). Satisfaction guaranteed. International Opportunities, Dept. 66G, 109 W. 42, New York 36, N. Y. or Dept. 66H, Box 621, San Jose 6, California.

EUROPE Overseas. High paying jobs. Full details \$2.00. North Sea Export (PF), POB 548, Amsterdam, Holland, Europe.

TREMENDOUS Opportunities. U.S.A., overseas. Choose your job, your location. Bonuses. Free transportation. Free details. International Occupations, International Airport, Box 100C-3, Jamaica 30, N. Y.

FLORIDA Job opportunities. Work in Land of Sunshine. Current classified list skilled, unskilled jobs available. Send \$1.50. Advertiser, Dept. 3P, 6910 Sheridan Road, Melbourne, Florida.

FOREIGN Employment. Construction, other work projects. Good paying overseas jobs with extras, travel expenses. Write only: Foreign Service Bureau, Dept. PM, Bradenton Beach, Florida.

CALIFORNIA List of industries hiring in all fields, \$1.00. Hughes Enterprises, 109 East Etiwanda, Rialto, California.

EXCELLENT Employment. Nationwide-newest listings. All occupations. \$1. Employment Surveys, 2908 Gawthorne, Oroville, California.

JOBS On ships. Employment directory \$1. Janacek, 373 East 155th Street, New York 55, N. Y.

THOUSANDS Of job openings. Nationwide-Worldwide, Box 12, Detroit 13, Mich.

LOOKING For a high-paying job! Free, proven result-getting information. Current openings, men-women all trades, anywhere in United States and abroad. Write: Worldwide, Dept. B20, 155 N. Franklin St., Hempstead, N. Y.

INDUSTRY Commissions Dr. Sterling B. Davis's staff find all types applicants, even technical, executive. Local foreign. Apply direct. No fees. Box 205, Houston, Texas.

## SPECIAL SERVICES

TECHNICAL Writing professionally done. MILSpec, patent, promotional. Send data for quote. Technical Publications, Glen Burnie, Md.

INFORMATION On anything. Ferguson Research Specialists, 59 Lent Ave., Hempstead, N. Y.

## EDUCATIONAL AND INSTRUCTION

LEARN Fascinating, profitable invisible reweaving at home. \$10.00 earnings in an hour possible making tears, holes disappear from clothing, fabrics. Steady demand from cleaners, laundries, homes. Details free. Fabricon, 6255 Broadway, Chicago 40, Ill.

SPEAK, Speak with power. Self-training records. Amazing! Canfield, 2018-A Fifth Avenue South, Minneapolis 4, Minn.

USED Correspondence courses and books sold and rented. Money back guarantee. Catalog free. (Courses bought.) Lee Mountain, Pisgah, Alabama.

BECOME A personal problem counselor. Enter dignified profession. Instructions \$1.00 refundable. Hermansen, Box 808, Grand Central Station, New York 17, N. Y.

WOODWORKING And cabinetmaking course for beginning and advanced home craftsmen. Only complete low-cost home training program available. Write for free booklet. Interstate Training Service, Dept. G-3, Portland 12, Ore.

BE A Real Estate Broker. Insecure security for yourself and your family. Study at home. Prepare for state examination. GI approved. Write for free book today. Weaver School of Real Estate, 2018 P Grand, Kansas City, Missouri.

WANT A diesel job? Higher pay? Advancement? We can help you qualify! Complete diesel, tractor and heavy equipment and Cummins Diesel Engine Shop-method home-training courses available. Write today. Interstate Training Service, Dept. B-3, Portland 12, Ore.

HIGH School diploma at home. Licensed teachers. Approved materials. Southern States Academy, Station E-16, Atlanta, Ga.

BOOKKEEPERS. Operate your own "Dollar-A-Week" system. Ellis, Box 200, Cedar Grove, North Carolina.

OWN Collection agency. Little "gold mine." Franklin Credit, Roanoke, Va.

LEARN Asleep or awake! Records, tapes, equipment! Free catalog! Drawer PM-697, Ruidoso, New Mexico.

MEN Wanted. Earn \$125 a week and up. Master a trade with a future. Learn auto diesel mechanics in our shops. You learn with tools on real equipment. Earn while you learn. Many of our graduates earn \$125 a week and up. Write for free bulletin: Dept. 256, Auto Diesel College, Nashville 3, Tenn.

PIANO Tuning pays. Learned easily at home. GI approved. 59th year. Free booklet. Niles Bryant School, Dept. P, 3731 Stockton, Sacramento 20, Calif.

SWEDISH Massage, physical culture and weight reduction pay big profits. Men and women. Learn at home. Diploma course. Free catalog. National Institute, Desk 4, 165 E. Ontario, Chicago 11, Illinois.

INVESTIGATORS Course. Credentials, diploma. Free information. Southwestern Institute Criminology, 510-A Iowa, Geronimo, Okla.

FINGERPRINTING And identification taught at home. Diploma. Details free. Alabama School of Fingerprinting, Fairfield, Alabama.

LEARN Auctioneering. Free catalog. Missouri Auction School, 1330 Linwood, Kansas City 9-X3, Mo.

LEARN Ventriloquism. Amazing-entertaining! Easy! Details free. B. Davis, B-38, Safety Harbor, Florida.

SECRET Investigations. Experience unnecessary. Investigators particulars free. George Wagner, M125 West 86th, New York City 24.

LEARN Real Estate business fast. Economical homestudy. Literature free. Howard Schools, Box 8394-A, Kansas City 5, Missouri.

DENTAL Technician's home study kit!! Instruments, plastic, etc. Write for free illustrated instructions. Grant Laboratory, Haas Bldg., Los Angeles 14, Calif.

LEARN While asleep with your recorder, phono. Details, catalog free. Sleep-Learning, Box 24-PX, Olympia, Wash.

ELECTRONICS, Drafting, gunsmithing, auto-mechanics, building trades. Earn AAS degree in 2-yrs. Public, coeducational college established 1925. Technical and engineering levels offered. Moderate costs. Adequate housing. Trinidad State Junior College, Trinidad, Colorado.

BOOKS, Free general catalog, 100 pages. Text, vocational, educational, instructional subjects. Millions of volumes, new and used. Bargain prices. Books bought. Est. 1902. Long's College Book Co., Dept. PM, Columbus 1, Ohio.

PENMANSHIP Corrector. Improve poor penmanship quickly. Details free. Ozment, Box 665-34, St. Louis 88, Mo.

BEGINNER'S Home training course in drafting. Chickris Engineering, Liberty Building, Rock Island, Illinois.

PROFESSIONAL Investigator. Home study. Lapel pin, certificate, future. Box 41197-F, Los Angeles 41, California.

PIANO Tuning pays. Big money in spare time. Learn at home in 30 days. No musical knowledge necessary. Phonograph, records, tools and instructions furnished. Electronic tuning also taught. Free catalog. Capital Tuning School, 3160 S.W. 16th Court, Ft. Lauderdale, Fla.

MEMORY Training. Memorology offers adequate instruction. You can master it. Information free. Memorology Studio, 1958 Sunnyside, Chicago 40, Ill.

EARN \$150 Weekly Mechanical, Electronic Drafting. Send \$2 first lesson, \$25 complete home study course. Prior, Inc., 23-09 169 Street, Whitestone 57, New York.

FREE Investigator course as bonus with purchase of 1962 National Detective Directory. Write for full information to: American Detective Association, P.O. Box 478, Santa Ana, California.

**FINISH** High school at home. No classes. Texts furnished. Diploma awarded. If 17 or over and have left school, write for free assignment and catalog. Wayne School, Dept. 02-521, 419 S. Dearborn, Chicago 5, Ill.

**"REVIEWING Trigonometry"** by Dressler-Rich. Step-by-step self-study paperback. Clear, simple, thorough. (For beginners too.) 277 pages. 173 worked-out examples. Includes logarithms. Money back guarantee. Send \$1.50 to Peter Paperback, Box 614, Flushing 52, N. Y.

**GOOD** Paying jobs open! Operate, repair heavy earth moving equipment! Learn "on the job" operating latest cranes, bulldozers, earth carriers! V.A. approved. Free catalog. Write T. B. Hutch, Greer Technical Institute, Braidwood, Illinois.

**LEARN** Civil and criminal investigation at home. Earn steady, good pay. State age. Institute Applied Science, 1920 Sunnyside, Department 162, Chicago 40, Illinois.

**MASTER** Watch making at home. Free sample lesson. Chicago School, 2328-YB Milwaukee, Chicago 47.

**ENGLISH** Course for adults. With my new self-correcting method you can stop making mistakes—speak & write effectively. 15 minutes a day at home. Free 32 page booklet. D. O. Bolander, Career Institute, Dept. 27705A, 30 E. Adams St., Chicago 3, Illinois.

**OIL** Coloring photographs. A fascinating hobby or profitable sideline for those with artistic talent. Learn at home. Easy simplified method. Free booklet. National Photo Coloring School, 835 Diversey Parkway, Dept. 3432, Chicago 14.

**DRAFTING** Pays big money. Leads to position in automotive, aeronautical, construction, mechanical fields. Learn at home in spare time. All equipment supplied. Pay later plan. Free book. Christy Trades School, D-5503, 3214 Lawrence, Chicago 25.

**"HOW To Train Horses"**—A book everyone who likes horses or ponies should have. Free. No obligation. Simply address Beery School, Dept. 1102-C, Pleasant Hill, Ohio.

**COMPLETE** Your high school at home in spare time with 65-year-old school. Texts furnished. No classes. Diploma. Information booklet free. American School, Dept. X245, Drexel at 58th, Chicago 37, Illinois.

**ENGINEERING** Capability test, prepared specifically for individuals interested in engineering; gives you an insight into your engineering potential. Send \$2.00 to Engtrst, Box 371, Denton, Texas.

**HOME-Study** Bible course. Write for free information. 2119 Monroe Street, Fort Myers, Florida.

**52 COLLEGES** Offer college, high school, elementary correspondence courses! Directory \$1.00. Soave, Box 5188, Mount Vernon, New York.

**JOIN** Hundreds finding "Wilson's Legacy" best handbook for success in sixties! \$1.00. Personal Publications, Box 6947, Baltimore 16.

**LEARN** By ear with Dormiphone. While you slumber, the amazing new scientific Dormiphone tools give you a shortcut to learning languages, correct speech; memorizing facts, figures; relaxation, habit training. Saves you time, effort. So simple to use, children benefit. Used by educators, psychologists. Write today for fascinating free book. No obligation. Modernophone, Inc., 320-022 Radio City, New York 20.

**ENGINEERING** And Art degrees earned through home study. Electronics, electrical, mechanical, civil, physics, liberal arts. When writing, specify course desired. Pacific International College of Arts & Sciences, primarily a correspondence school. Resident classes also available. 5719-B Santa Monica Boulevard, Hollywood 38, California.

**LIP-READING.** Fascinating! Profitable! Guaranteed lessons \$25.00. Trial \$2.00. Guyer, Miami 45, Florida.

### PLAYS, STORIES, MANUSCRIPTS

**WRITERS!** Free list of top-notch U.S.A. markets for short stories, articles, books and plays. Write for your free copy today! Literary Agent Mead, 915 Broadway, New York 10.

**PUBLISH** Your book! Join our successful authors; publicity advertising promotion, beautiful books. All subjects invited. Send for free manuscript report and our detailed booklet. Carlton Press Books, Dept. PMB, 84 Fifth Avenue, New York City 11.

**WANT** Your book published? Learn how we publish, advertise, promote, distribute. Many successes. Free booklet PM. Vantage, 120 West 31, New York City. Or 6253 Hollywood Blvd., Hollywood 28, Calif.

### ADVERTISING AGENCIES, ADV. SERVICE, MAILING LISTS

**FREE** Radio advertising! Nationwide. Complete procedure \$1. Janeczek, 373 East 155th Street, New York 55, N. Y.

**ADVERTISE:** 24 Words, 75 Canadian newspapers, \$5.50. Lists free. Advertising Bureau, 10511-C Springfield, Chicago 55.

**ADVERTISING** Ratebook leading newspapers, magazines, free. Chicago Advertising Agency, 28-E Jackson, Chicago 4.

**MAILING** Lists most all kinds 1000 \$5.00. Free folder. Your circulars mailed \$4.00 1000. Dixie Mailers, King, N. C.

**NOW Ready:** New, amazing Classified Advertising Record Book—prepared especially for classified advertisers. Here is a book that tells you instantly whether or not your advertising in any publication is paying you real results. You can tell immediately how many inquiries each publication produced—how much cash received from every ad. Spaces are provided for the name and address of the publication, date of issue, space used, rate, cost of ad, key number, etc. You have a complete record of each publication right before your eyes. Plenty of space to keep accurate record of 28 separate publications. You can have a copy by sending only 10¢ to cover postage and handling. Send for your copy now. W. F. Johnson, Classified Adv. Mgr., Popular Mechanics Magazine, 204 E. Ontario Street, Chicago 11, Illinois.

**AMAZING** New Book—"Profits From Classified Advertising." Tells how and what to advertise. Be sure to read this book before you invest one cent in advertising. Write for your copy now. F. W. Johnson, Classified Advertising Manager, 202-210 East Ontario Street, Chicago 11, Illinois.

### TYPEWRITERS, DUPLICATORS, OFFICE DEVICES

**RECONDITIONED** Typewriters, mimeograph, printing presses \$25.00 up. Write Dixigraph, King, N. C.

### RUBBER STAMPS AND OFFICE SUPPLIES

**STAMP** Makers' supplies. Lowest prices. O'Brien's, 421 Jackson, Toledo 4, Ohio.

**THREE** Line rubber stamp. Economy mount. Resembles printing. 65¢. Additional lines 15¢. Las Stamp Manufacturers, Box 733PM Campbell, Calif.

**BEAUTIFUL** Script or print. Deluxe 3 or 4 lines \$1.50 airmailed. Free folders. Kirksey, 6614 Hesperia, Reseda, Calif.

**FREE** Catalog. Introductory bargain, 3 lines, \$1.00. Guaranteed. Jackson's, 1327 Wellington, Chicago, Ill.

**DISCOUNTS!** Rubber stamp catalog 25¢ (refundable). Adironack Printers, Saranac Lake, New York.

**RUBBER** Stamps 4 lines \$1.25. Office printing reasonable. Kays, 172 W. 34th St., Riviera Beach, Fla.

**FREE**—Illustrated rubber stamp catalog. Low prices! Hildreth, 1047-A Inner, Schenectady 3, New York.

**CATALOG**—Rubber stamps, daters, business cards, printing. Martin, 1425 Major, Jefferson City, Missouri.

**FREE** 32-Page rubber stamp catalog. Stock stamps, racks, pads, Christmas stamps, signature stamps \$3.50. Youngers Stamp Shop, Princeton, Iowa.

**3 LINES** \$1.00. Extra lines 25¢. Cushioned mount, knob handle. One day service. Wallace, Box 146, Hanover, Penna.

**THREE** Line rubber stamp—50¢. Offers, 8440 Michigan, Detroit 10, Michigan.

**SUPERIOR** Rubber stamps, labels, printing. Low prices! Catalogue. Johnson, 443 MacDonough, Brooklyn 33, N. Y.

**SPECIAL**—3 Lines 65¢; signature \$2.50. Economy, 4719 Wisconsin, Milwaukee 8.

**SIGNATURE** Stamps \$3.00. Pocket stamps \$1.00. Free literature. Sav-mor Stamps, Adams City, Colorado.

### CARTOONING, COMMERCIAL ART, SHOWCARD & SIGN PAINTING, TATTOOING

**SIGN** Painting outfit! Complete instructions, supplies! Oilboard, hardboard, plywood letter patterns, 1" to 8". Paulow Signs, Crystal Falls, Michigan.

**LEARN** Sign painting. Easy method. Ellis, 10533 121 Ave. N., Largo, Florida.

**YOU** Can entertain with chalk talks. Catalog 10¢. Balda the Cartoonist, Oshkosh, Wis.

**LEARN** Sign painting at home. Free talent test. Ben Kerns, Box 812-PM, Greenville, S.C.

**LEARN** Sign painting with fascinating system. Straley, 410 S. Western, Springfield, Ohio.

**LEARN** Profitable, fascinating tattooing. Illustrated information \$1. Zels, 728-C Leslie, Rockford, Illinois.

**"HOW To Make Money With Simple Cartoons."** A book everyone who likes to draw should have. It is free; no obligation. Simply address Cartoonists' Exchange, Dept. 92, Pleasant Hill, Ohio.

**CARTOONERAMA** Teaches you cartooning in a new 24 lesson course. Free brochure. CFA, Box 263-C8, Branford, Conn.

**WANTED**—Cartoonists. Amateurs, professionals. Over 200 markets. Information free. Cartoon Markets-2PM, 11620 Lansdowne, Detroit 24, Michigan.

### PRINTING, MULTIGRAPHING, MIMEOGRAPHING, GUMMED LABELS

**OFFSET** Printing. Free prices, samples. Harrison Litho, 248 South Hackett, So. Beloit, Illinois.

**AMAZING** Business printing values. Samples. Print Shop, Box 576, Greenville, R. I.

**250**—8½x11 BOND Letterheads \$2.75. 250 envelopes \$2.75. Samples. Patton, Box 248B, South Haven, Mich.

**DISTINCTIVE** Printing, proofs, cuts, mats, artwork. Writers', office supplies. Logan Enterprises, 6801-A Onyx, St. Petersburg 3, Florida.

**MIMEOGRAPHING**—Letters, pricelists, formulas, instructions. Lowest prices. Lem's Letter Shop, 5710 Stanton, Detroit 8.

**ADS** Running under this heading sell printing. Ask me for proof. I'll gladly send you amazing facts. Ask for Folder "P." F. W. Johnson, 200 E. Ontario St., Chicago 11, Ill.

**FREE** Catalogs postpaid printing. Rubber stamps. DM Press, Sebastopol, Calif.

**1000** NAME-Address labels 88¢. Rubber pocket stamp 88¢. Printing, rubber stamp catalog. Jordan's, 552 West O'Connor, Lima, Ohio.

**BUSINESS** Cards \$2.75 thousand postpaid. Free samples. Kavanagh, 607 Knickerbocker Ave., Brooklyn 21, N. Y.

**YOUR** Name—address printed on 100 correspondence postcards \$1.00 postpaid. Hallows, 14 Drexel, Cahokia, Illinois.

**BUSINESS** Cards. 1000—\$2.95. Quality guaranteed. Box 8304, Kansas City, Missouri.

**LETTERPRESS.** Offset, mimeographing. Lowest prices. Barsketis, 6540 S. Western, Chicago 36.

**PRINTING**—Reasonable prices, fast service, catalog free. Cannon, Box 77F, Commack, New York.

**250** LETTERHEADS (8½x11 Hammermill) \$2.95 postpaid. Envelopes same. Samples. Davis, 7609 Spruce Road, Baltimore 22, Maryland.

**OFFSET** Printing. 100 8½x11 \$2.49. Additional 100's 43¢. Add postage. Parks, 3823 Merrick, Seaford, N. Y.

**PRINTING**—Samples, prices. Fred the Printer, Box F-623, Independence, Mo.

**FAST** Offset printing. Reasonable prices. Victor, 4660 Lexington, Los Angeles 29, Calif.

1000 ASSORTMENT Printings \$7.50. Samples. Stamp please. Kormoczy, 230 Broadway East, Seattle 2, Washington.

1000 BUSINESS Cards, raised letters. \$3.75 postpaid. Samples. Routh, PM-2, 2633 Randleman, Greensboro, N. C.

FREE Case—1,000 embossed business cards \$3.95, two colors \$4.95. Quality letterheads, statements, billheads, envelopes. Postpaid, samples. Medallion, 356 E. Alondra, Gardena, California.

OUTSTANDING Printing. Free estimates, samples. Elanem, 1116 Inwood, Plainfield, N. J.

YOUR Name or initials printed on 50 match books \$2.00 postpaid. Hallows, 14 Drexel, Cahokia, Illinois.

MIMEOGRAPHING. Offset printing. Samples, prices. Pennway, Drawer 1340, Scranton, Penna.

### PRINTING OUTFITS AND SUPPLIES

RUBBER Stamp presses, hydraulic operated, electrically heated. Sizes 5"x8", 8"x12", 10"x15". Starting outfits, supplies. Printing presses. Custom Manufacturing, 1464-F East Commercial, Springfield, Missouri.

MAKE Your own self-molding rubber stamps and printing cuts. Plexirubber, Argyle 1, Wisconsin.

DO Your own printing. Save money. Simple rules. We supply everything. Print for others; good profit. Raised printing like engraving too. Have home shop. Details free. Kelsey Presses, V-11, Meriden, Connecticut

RUBBER Stamp outfits, supplies. Kiewiet, 2025 Barney Road, Kalamazoo, Mich.

PRINTING Presses, type, supplies. Lists 44. Turnbaugh Service, Mechanicsburg, Penna.

TYPE Case catalog. Manufacturer. King McKay Company, 23179 Telegraph, Southfield, Michigan.

HARD Type for rubber stamp making, printing. Introductory offer 10 or 12 pt. 20th Century Medium caps or L.C. \$2.50. Free catalog. Barco Type, 232 Evergreen, Bensenville, Ill.

### FOR INVENTORS

PROFESSIONAL Searches of the Patent Office. Dependable—reliable \$6.00 including airmail report and related patents. For free protection forms and patent information write Trans-World Patent Service, 500 Walker Building, Washington 5, D. C.

PATENT Searches including full, airmail report and closest patent copies, \$6.00. Quality searches, expertly administered. Free protection forms and patent information. Write Professional Patent Office Search Bureau, 709 Albee Building, Washington 5, D. C.

INVENTORS! Outright cash sale or royalties for your inventions. Patented. Unpatented. Constant demand from our client manufacturers. Write: United States Invention Brokerage, 78 Wall Street, New York 5, N. Y.

INVENTORS! Consider our offer first before selling or licensing your invention on a cash or royalty basis. Patented. Unpatented. Write: Inventions on Demand, 79 Wall Street, New York 5, N. Y.

PATENT Searches, including copies of nearest patents, \$6.00. Reports airmailed within 48 hours. More than 200 registered patent attorneys have used my service. For free invention protection forms, write Miss Ann Hastings, P. O. Box 176, Washington 4, D. C.

WE Have the markets if you have the ideas. Harvey Engineers, Cambridge 1 Maryland.

INVENTORS: Test the commercial value of your patented or unpatented inventions, quickly and inexpensively. Write for free information. Institute of American Inventors, Dept. 40-B, 635-F St., N.W., Washington 4, D. C.

INVENTORS! Searches of the Patent Office administered professionally. \$6.00 including airmailed comprehensive report and related patent copies. For free invention protection forms, dependable service, write Washington Patent Office Search Bureau, 1426 G Street N.W., Washington 5, D. C.

U.S. Patent office searches—\$5.00. Free invention record. Patents engineered. Patent Office Searchers, 233 Broadway, Room 3615, New York.

INVENTORS! Sell your invention for cash or royalties! Our manufacturers constantly seeking new items. Patented. Unpatented. For free information write Gilbert Adams, Patent Broker, 80 Wall Street, Financial District, New York, N. Y.

PATENTS Skillfully prepared for maximum commercial value, with useful product development. High record of success in proving and claiming patentability. Valuable market service. Patent prepared for a fee as low as \$200.00. Send for self-protecting record of invention forms free. Patent search with valuable engineering report \$15.00. Foreign patents filed at low cost. Thirty years established. Joseph O'Brien, Patent and Development Engineer, 132 Nassau St., New York 38, N. Y.

SAVE High fees! Apply for your patent yourself. New do-it-yourself Patent Kit now makes it easy! Free "Registration Form." Miss Susan Bialue, 306 Carry Building, Washington 5, D. C.

CASH Or Royalties for inventions! Consider our offer first before licensing or selling your patented or unpatented invention. Write Aladdin Industries, 80 Wall St., New York 5, N. Y.

PATENTS Professionally prepared for maximum commercial value. Patent searches including report \$6.00. Patents prepared as low as \$195.00. Valuable market service with cash or royalty sales. 10 years dependable service. For free self-protecting Record of Invention forms write: H. Lawrence Blasius, Patent and Development Engineer, 19 Park Row, New York 38, N. Y.

INVENTORS: Save time and money. Prepare and file your own patent application. Our complete "Patent Kit" makes it easy. Includes detailed instructions and all necessary material. Only \$8.95. Money back guarantee. Don't delay. Send check or money order today to National Inventors Service, Box 88, Benjamin Franklin Station, Washington, D.C.

INVENTIONS Wanted immediately for promoting on cash or royalty. Patented, unpatented. Free booklet outlines royalty rates, requirements. Write Kessler Corporation, C-52-FI, Fremont, Ohio.

INVENTORS: If your idea hasn't cleared search, write to Mr. Von Anderson, 4522 Loring Street, Philadelphia 36, Penna., for free information on how he can help make your idea clear search.

IRAMCO Invention research and marketing corp. For your patents and ideas. Write: 401 S. 15th St., San Jose 12, Calif.

PATENT Searches professional patent development of inventions by licensed professional patent engineer and U.S. Patent Office former examiner with staff of engineering specialists in all fields of inventions. Expert searches performed in the U.S. Patent Office. Your inventions and ideas engineered for maximum patent protection and greatest commercial value. Inventions developed by us negotiated for cash or royalties with our nationwide contacts. Send for free protection "Invention Certificates" and further interesting, valuable patent information. George Spector, Licensed Professional Patent Engineer, U.S. Patent Office Former Examiner, Woolworth Building, New York.

QUALITY Patent searches, \$6.00. Complete patent office report forwarded. Free "Protection Certificate." American Patent Search Co., 422 Washington Bldg., Washington 5, D. C.

WRITE For information about our new concept in developing and promoting ideas and inventions. Taylor-Garner Corp, 1113-B Healey Bldg., Atlanta 3, Georgia.

SELL Your patent, inventions through Business Counselors, 441 S. Division, Grand Rapids, Mich.

### INVENTIONS WANTED

WE Develop and promote your product or ideas. Write for information. Product Promotion Development, Little Building, Boston 16, Mass.

INVENTIONS Wanted. Patented: unpatented. Tremendous manufacturers lists. Global Marketing Service, 2420 77th, Oakland 5, California.

INVENTORS: Hundreds of manufacturers have requested our assistance in locating marketable new products. Complete information free. Institute of American Inventors, Dept. 40-D, 635-F St. N.W., Washington 4, D. C.

ARE You interested in offers from reliable manufacturers for your invention? Patented, unpatented. Harvey Engineers, Cambridge, Maryland.

INVENTORS! Outright cash sale or royalties for your inventions. Patented. Unpatented. Constant demand from our client manufacturers. Write: United States Invention Brokerage, 78 Wall Street, New York 5, N. Y.

INVENTORS! Consider our offer first before selling or licensing your invention on a cash or royalty basis. Patented. Unpatented. Write: Inventions on Demand, 79 Wall Street, New York 5, N. Y.

INVENTORS Needing help with any problem, financial, development, securing manufacturer, obtaining patent. Write the organization that delivers action and results—not promises. Pioneer Invention Institute, 150 Broadway, New York 38, N. Y.

INVENTORS! Sell your invention for cash or royalties! Our manufacturers constantly seeking new items. Patented. Unpatented. For free information write Gilbert Adams, Patent Broker, 80 Wall Street, Financial District, New York, N. Y.

INVENTIONS Promoted-for cash-royalty sales with manufacturer contacts. George Spector, Licensed Invention Engineer, Woolworth Building, New York.

INVENTIONS Wanted for national promotion. Write: Prometheus, Box 1341, Akron 8, Ohio.

SELL Your invention for cash. No commissions. Milburn, Burlington, Kentucky.

INVENTIONS Wanted immediately for promoting on cash or royalty. Patented, unpatented. Free booklet outlines royalty rates, requirements. Write Kessler Corporation, C-52-IW, Fremont, Ohio.

WORTHY Patented inventions promoted free. Porter, 12 Morgan, Rockland, Mass.

CASH Or Royalties for inventions! Consider our offer first before licensing or selling your patented or unpatented invention. Write Aladdin Industries, 80 Wall St., New York 5, N. Y.

INVENTIONS Sold, licensed. Outright, royalty basis. Inventions International, Box 560, Wall Street, New York 5, N. Y.

### MODELS—SHIPS, TRAINS, PLANES, ETC.

STEAM Engines, tractors, boilers, castings, prints. Catalog \$1.00. Tiny Power, Junction City, Oregon.

LARGE Selection! Gasoline, steam engines, boilers, fittings, books. Miniature hexagon head bolts and nuts. Comprehensive 100 page catalog #18, \$1.00. Chas. Cole, Ventura, Calif.

HO Supermart. Catalog and sale bulletins. 35¢. Trainland, U.S.A., Box 452, Dept. PM, Easton, Penna.

MINIATURE Gasoline and steam engines—easily machined using our castings and blueprints. Fascinating hobby. Illustrated catalog 35¢. Octura Models, 8148-PM Milwaukee, Niles 48, Ill.



**LIVE Steam powered backyard railroads!** All sizes. Complete "bolt-together-kits", and rough castings. Excellent drawings. 100 page catalog \$1.00. Little Engines, Lomita, Calif.

**SHIP Model kits and fittings:** clippers, frigates, etc. Catalog paint-tool list, book list, 35¢. Model Shipways, Box 85, Bogota, N. J.

**LIONEL Trains.** Big discounts bulletin 10¢. Catalog 25¢. Mack-Bros., 2043P. Chicago Ave., Chicago 22.

**SAVINGS To 50%.** Lionel, Gilbert, Althearn, etc. New trains accessories. Hobby Surplus, P.O. Box 1106, New Britain, Connecticut.

**SHIP And yacht model fittings:** blueprints. Send 40¢ for illustrated catalog listing hundreds of items. A. J. Fisher, Inc., 1002-1 Etowah Ave., Royal Oak, Mich.

**"POWER Drives Handbook"**—36 pages illustrating many types motor drives for model autos, boats, displays, turntables, etc. Mail 25 cents cash, returnable first order \$3.00 or more. Wilson's of Cleveland, Dept. PM, P.O. Box 8995, Ft. Lauderdale, Fla.

**MODEL Hobbyists!** Send 10¢ for catalog. Our 70 powered model plane and boat kits, many radio-control operated, also accessories. Sterling, 501 Wister, Philadelphia 44, Penna.

**SHIP Models.** Kits, fittings, plans, books, tools, engines, motors. Big illustrated catalog 35¢. James Bliss & Co., Dept. SM, 342 Atlantic Avenue, Boston 10, Massachusetts.

**ROCKETS!** Five complete blueprints. Plus easy instructions for parachute, instrumentation, electronic ignition, 2-stage, fuels. \$1.00. Rocketry, Box 4708, Washington 20, D. C.

**BREATHAKING!** 49" Radio controlled Mustang plans, \$1.75. List, bonus plan, specials, 50¢. Special Edition Plans, Massena, N. Y.

**BUILD Balsa wood model boats.** 22 models, \$1.29 to \$17.95. Send 25¢ for catalog. Dumas Products, Box 6093, Tucson, Arizona.

### ENGINEERING SERVICES

**DESIGNING.** Model making, development work, blueprints. Write: Martin, Martindale, Penna.

**SMOLEY'S Users.** Master Smoley's with 80 page simplified "Key to Smoley's," \$1.50 each. G. Wolters, Box 475, Ormond Beach, Florida.

### MANUFACTURING

**FOR Inventors.** Model building. Manufacturing. Research. William Parker, 32 Westminster, Worcester 5, Mass.

**MODELS**—Small lot manufacturing. Metals, plastics, etc. Milburn, Burlington, Kentucky.

### HOME CRAFTSMEN

**89 JIG Saw patterns** of shelves, novelties, lawn ornaments, animal figures, etc. Only \$1.00. Mastercraft, 24M, 7041 Olcott, Chicago 31.

**FREE!** Giant new do-it-yourself catalog. Leather, mosaics, all popular handicrafts. Larson, Dept. 1927, 820 S. Tripp, Chicago 24.

**101 PATTERNS** Of smart gifts, novelties, shelves, action windmills plus "Make Money Jig Sawing," \$1.00. Mastercraft, 25M, 7041 Olcott, Chicago 31.

**16 LAWN Chairs,** 22 tables, benches, trellises. Plans and necessary patterns. \$1.00. Mastercraft, 23M, 7041 Olcott, Chicago 31.

**WOODWORKING Catalog and manual.** Brand new 150th Anniversary edition! World's largest selection of domestic, imported woods—materials, tools, supplies, do-it-yourself plans, projects. 132 pages, many full color. More than 2,000 items. Send 25¢ for postage and packing. Act now! Constantine, 2050 Eastchester Road, Dept. B-101, New York 61, N. Y.

**KNOCKDOWN Cedar chests and lumber.** Catalog 25¢. Bedford Lumber Company, A-1, Shelbyville, Tennessee.

**HARDWOOD Turnings, furniture parts.** Information, prices. Robert Flick, Bridgton, Maine.

**HARDWOOD Lumber, turning stock free list.** Joseph Gribus, Springboro, Penna.

**KNOCKDOWN Cedar chests, also over fifty kits.** Catalog 25¢. Giles Kendall Co., Huntsville 2, Alabama.

**FREE! Leathercraft catalog.** Hundreds of new items. Write MacPherson Bros. Leather Company, Dept. E, 730 Mission St., San Francisco 3, Calif.

**SKIL-CRAFTS**—All new '62-'63 catalog. Largest and finest selection of leathercraft, artist and hobbycraft supplies in the world. Free goods gift with first order. 25¢ for latest catalog. Skill-Crafts, Box 167-P, Joplin, Mo.

**PICTURE Frame moulding, squares and lumber.** Kiln dried walnut, cherry, silver maple. Midland Lumber Company, Box 262, Savannah, Mo.

**FREE, New catalog.** 2447 plans, patterns. World's greatest selection things to do, make. Fun. Profit. Craftplans, 1322-A Wabash, Chicago 5.

**LEATHERCRAFT.** Send 10¢ for catalog. Saxcrafts, Inc., 1101 N. 3rd, Milwaukee, Wisconsin.

**GRANDFATHER Clock movements, case plans, kits.** Catalog 25¢. Mason-Sullivan, Noroton 7, Conn.

**FREE "Do-it-yourself" leathercraft catalog.** Tandy Leather Company, Box 791-042, Fort Worth, Texas.

**ALL-PURPOSE Putty powder** keeps indefinitely. Mix with water, dries rock-hard in 1 hour. Does not shrink. Repairs cracks, dents, holes in wood, plaster, etc. Sand it, saw it, drill it, polish it, paint it. Imbed loose screws; make molds and models. Used extensively in arts, crafts and hobbies, in shell and tile imbedding. Handiest item in home or shop. Send \$1.00 for over 3/4 pound, complete instructions and handy applicator. Postpaid in U.S. Somay, 4301 N.W. 35th Ave., Miami, Florida.

**NOW! Make your own exotic musical instruments.** Earn big money interior decorators, gift shops, department stores. Authentic actual size plans for historic Gypsy Violin, Japanese Samisen, Old Moon guitar, Teardrop lyre. \$1 each plan, 3 for \$2. Specify model. Money back guarantee. Bud Greer Industries, Dept. A-1, 734 Ceramic Lane, Fallbrook, California.

### DO IT YOURSELF

**RESILVER Mirrors; plate.** Literature catalog 25¢. Mirrocraft, 18518 Winthrop, Detroit 35.

**BUILD Your own tractor plans.** Free information. Eltraco, Dept. A, Camptonville, Calif.

**FREE List "How To Do It Yourself"** books, also home study Civil Service guides. Harry's Book Shop, 4415-PD North 13th St., Tacoma 6, Wash.

**BUILD Bongo drums.** Complete plans \$1.25. R. Cormier, Box 297, So. Swansea, Massachusetts.

**CONVERT Your car or truck generator to 110 V AC; up to 1000 watts.** Plans \$1.00. Radio 185, Princeton, Mo.

**ADOBE Builds hut or hacienda, all regions, to any masonry building plan at fractional cost.** Spanish-Indian adobe making details—soil types, binders, mixing, molding, curing. Drawings, building tips. \$1.00. Steele, Box 403, San Angelo, Texas.

**MAKE Hydrogen—Inflate balloons.** Make your own generator. Plans \$1.00. P.P.P., 1957 S. St., Aubin, Sioux City, Iowa.

**SHELTERS Fallout, stronger—our Insulcrete with your stone.** Specifications—M. \$1.00, with plans, \$5.00. Box 4176, Miami Beach, Florida.

**BICYCLE Sidecar, detachable, inexpensive.** Plans \$1.00. Rexray, 5509 Gary, Alexandria, Virginia.

**INSTANT Laminating; photos, cards.** Self-adhesive plastic. Sample, details. Hughes Company, Middletown, Connecticut.

**FREE Check-list** covering more than 500 classifications of projects, plans, instructions, service and repair information detailed in Popular Mechanics famous series of instructional booklets, books, patterns, and blueprints. List covers an extremely wide variety of do-it-yourself data on home remodeling, repair and improvement, hobbies, crafts, boating, games, lawn and garden, and hundreds of others. For your free copy of this helpful list, write: Service Bureau, Popular Mechanics, Room 520, 200 East Ontario, Chicago 11, Ill.

### WATCHES, OLD GOLD, JEWELRY

**CASH Immediately** for old gold, jewelry, gold teeth, watches, diamonds, silverware, spectacles, platinum, mercury. Free information. Rose Industries, Heyworth Building, Chicago 2.

**WATCH And clock repairing books.** Free catalog. North American, 2320-AP Milwaukee, Chicago 47, Illinois.

**HIGHEST Cash** for gold, teeth, jewelry, rings, diamonds, watches, silver, platinum. Mail articles today. Free gift with information. Chicago Gold & Precious Metals, 6 E. Monroe, Dept. 3658, Chicago 3.

**LEARN Watch cleaning, repairing.** Illustrated. Excellent earnings. Kester, Deckerville, Michigan.

### FOR THE HOME

**HEAT Your home** for almost nothing. Interesting details. Ottaquechee Products Company, Quechee, Vermont.

### OF INTEREST TO WOMEN

**LEARN Expert cake decorating, candy making.** Free details on home instruction method. Candy & Cake, Dept. D-160, Fallbrook, Calif.

**CANDLEMAKING & decorating.** Terrific hobby. Great business. Learn fascinating molding, dipping, creating & decorating candles for year-round demand—holidays, birthdays, weddings, anniversaries, all events. Spare time fun & extra income now, expand to colorful candle shop later. No age limit. Write for free facts on home instruction method. Candle Institute, Dept. X-628, Fallbrook, California.

**STAMPED Linens** for embroidery or painting, yards and kits for knitting, crocheting, weaving, rug making supplies. Send for free catalog. Merrilee Corp., Dept. 463, 16 West 19th St., New York 11, N. Y., or 2729 West 7th St., Fort Worth 7, Texas.

**SELL Fine fabrics.** Get yours wholesale. Box 863, Norwalk, Conn.

**DRESSES 24¢.** Shoes 39¢. Men's suits \$4.95. Trousers \$1.20. Better used clothing. Free catalog. Transworld, 164-G Christopher, Brooklyn 12, N. Y.

**WOMEN! Make big money at home.** \$10.00 profit in an hour possible with invisible mending. Make holes, tears disappear from clothing, fabrics. Steady year-round demand from cleaners, laundries, homes. Details free. Fabricon, 6253 Broadway, Chicago 40 Ill.

**STOP Throwing away boxtops!** They're worth money! Some, 25¢! Inquire: "Box-tops-M," Cedar Hill, Texas.

**PERSONALIZED Home study.** Doll Hospital School, Studio MC-22A, Los Angeles 49, Calif.

**TYPISTS.** Earn cash typing for others. Instructions \$1. Refundable. Nationalco, Southmountain, Millburn PM-1, N. J.

**HOW To make money typing at home.** 17 proven ways! Detailed instructions \$1 (refundable). Rycos Service, 210-A Fifth Ave., New York 10, N. Y.

## PERSONAL

**LOANS** By mail, \$50-\$600 for any purpose. Confidential. 2 years to repay. Free loan application. Write: American Loan Plan, Dept. PM-1252, City National Bldg., Omaha 2, Nebraska.

**BORROW \$100 To \$1,000** by mail. Quick, easy, private. No co-signers. Repay in 24 small monthly payments. For the amount you want write today to Dial Finance Co., 410 Kilpatrick Bldg., Dept. B-1, Omaha 2, Nebraska.

**BIBLE** Questions answered. Stamped envelope. Bylon, 17167 Bentler, Detroit 19, Michigan.

**LOANS** By mail, \$100-\$600. Anywhere. Confidential. Write Union Finance, Dept. PM, 323 E. Camelback, Phoenix, Arizona.

**LOANS** By Air Mail, \$100-\$600. Anywhere. Confidential. Easy payments. Write Security Finance Co., 898 Van Ness Ave., Dept. PM, San Francisco 9, Calif.

**NEW!** Borrow \$800. Anywhere. Increased loan limit. Air mail service. Postal Finance, 374 New Brotherhood Building, Dept. 17-C, Kansas City, Kansas.

**DEVELOP** Mind power, personality while asleep. Details free. Research Association, Box 24-N, Olympia, Washington.

**"HOW To Wake Up Life-Changing Winning Ability"** sent free. Write: President, Box 1924-W, Louisville 1, Ky.

**MY** Personal experience with personality development explained. Satisfaction or money refunded, \$1.00. Russell, 324 Billeve, Chelmsford, Mass.

**UNDETECTABLE** Hairpieces for men. Free booklet. Write George Robinson, 256 South Broad Street, Mobile, Alabama.

**UNUSUAL** Bargains! 1000 embossed business cards \$3.40, samples. Booming Wichita classifieds, 50¢. Talk on phone with hands free, details. Rare books. Send stamped envelope for list and sample booklets. Avery, 112 S. Elizabeth, Wichita 13, Kansas.

## REMAILING SERVICE

**YUKON** Territory postcards, 4 for \$1.00. Write message and return to us for remailing. Monthly forwarding service \$3.00. Other remails, 25¢. Yarter, Box 177, Watson Lake, Yukon Territory, Canada.

**CANARY** Islands. Reairmails \$1. Regular 50¢. Evrard, Apartado 554, Las Palmas, Canary Islands.

**CHICAGO** Remails 25¢. Five \$1.00. M. Lyons, 2240 Wilson, Chicago 25.

**REMAIL** 25¢, \$3.00 Monthly. Confidential. Henry, 512 Quincy, Dept. 9, San Antonio 15, Texas.

**REMAILING** Service 25¢. Confidential. M. Breden, 4133 Warbler, Dallas 27, Texas.

**WONDERFUL** Copenhagen reairmails \$1. Special services available. Holmes, Aeginavej 16, Copenhagen S, Denmark.

**LETTERS** Reairmailed \$1.00. Latiff, 86 Albert Street, Durban, South Africa.

**SECRET** Mail receiving-forwarding system. Hedgpath, Box 830, Alhambra 23, California.

**SECRET** Remails 25¢. \$3.00 month. De Graff, Box 14156, San Diego, California.

**SWITZERLAND** Reairmails \$1. Postcards 50¢. Parlat, 27 Riantmont, Lausanne, Switzerland.

**ALASKA** Remails \$5.00 month, 50¢ single. Reliable. Confidential, Box 2173, Fairbanks, Alaska.

**HAWAII** Remails 25¢. Information free. Coe, Box 984, Kailua, Hawaii.

**LETTERS** Reairmailed 25¢. Confidential. Robert Carter, Box 742, Los Angeles 53, Calif.

**CONFIDENTIAL** New York City mailing, receiving, forwarding address. Business personal mail \$3.00 month. Remails 25¢. Details free. Birnhan, 109 West 42, New York City 36.

**SECRET** Mail address, \$3 month. Wolfe, 7604 Mack, Detroit 14, Mich.

**REMAILS**, Receiving, forwarding, \$3.00 monthly, 25¢ single. 10437 Lanark Street, Sun Valley 3, California.

## TREASURE FINDERS

**EXCITING** Adventure locating hidden loot, treasure, relics, etc., with powerful, electronic M-scope locator. Lightweight. Guaranteed. From \$59.50. Easy terms. Send for free booklet, interesting customer reports. Fisher Research, Dept. AY, Palo Alto, Calif.

**METAL** Locator kits and assembled models from \$39.90. Terms. Transistorized and underwater models available. Free catalog. Electronic Applications, Dept. M, Box 8, Arlington 10, Virginia.

**GOLD**, Silver, coins, Civil War relics, treasures. Choice 5 locators. Established 1933. Free literature. Write The Goldak Company, 1541 W. Glenoaks Blvd., Glendale 1, California.

**TREASURE**, Gold, silver, relics. Find them with new Detlectron instruments. Free information. Raytech, Box 715, North Hollywood, California.

**AMERICAN** Treasure map \$1.00. Wimbrow, 634 West 36, Norfolk 8, Virginia.

## WANTED—MISCELLANEOUS

**QUICKSILVER**, Platinum, silver, gold. Ores analyzed. Wholesale Terminal, Norwood, Mass.

## FOR SALE—MISCELLANEOUS

**JUST** Out! 356-page catalog—save to 50% on auto parts, accessories. All makes, models. Send 25¢—refundable on first order. Whitney, 1919 AA-2, Archer, Chicago 16.

**EYEGLASS** Frames, repaired refinished like new. \$3.00. Satisfaction guaranteed. Certified Opticians, 1920 Washington Ave., New York 57.

**\$1.00 FRAMES** 60 QSL or scenic cards in individual pockets of plastic wall packets. Three 20-card packets \$1.00 ppd. Tenn. Box Co., Gallatin, Tenn.

**FREE** Money-saving catalog. Surplus and newly manufactured equipment and tools for workshop, home, boats, farm, factory. Write: Groban, 1139 South Wabash, Chicago 5, Illinois.

## MISCELLANEOUS

**INDEPENDENCE**, Prosperity possible. Details for dime. Goding Specialty, Gambrills, Md.

**EARN** Money raising fishworms for us! Write: Oakhaven—60, Cedar Hill, Texas.

**SEPTIC** Tanks, cesspools, clogged drains restored to newness by powerful crystal chemicals. Pumping unnecessary. Details. Testimonials. Chemicals Cesspool & Drain Cleaning Co., Allston 34, Mass.

**5" HEEL** Shoes. Illustrated catalog, \$1.00. Monique, Box 85151-R, Hollywood 27, Calif.

**HOSE**, Heels, net and rubber garments catalog, \$1.00. Renee, Box 2804-R, Hollywood 28, Calif.

**S T A M P** Collections, accumulations. Eagle Stamp Co., 2221 Romine, Pittsburgh 26, Penna.

**NEW** Ultrasonic sirens—110 AC-DC high intensity output. Limited surplus quantity. \$50.00. Information available. Sonitrol Corporation, 2710 Pendleton Avenue, Anderson, Indiana.

**RECEIVE** Import catalogs! Circulars! Foreign business opportunities! Get listed 25¢. Importico, Enka, North Carolina.

**RECEIVE** Amazing offers from manufacturers, publishers, dealers, everywhere. Get listed 25¢. Roricks, Box 26086-P, Cincinnati 26, Ohio.

**GUARANTEED** Handmade western boots. Free catalog. Sellers Company, 8830-M Alameda, El Paso, Texas.

**BABY'S** Photo, lock of hair; plastic sealed, \$1.98. Keepsake House, Bloomfield, Conn.

**"MEMORY-LOCK"** (Dr. Young.) For self-advancement. Clarion, Box 9309-S7, Chicago 90.

**BOOKS** On antiques and their prices. Free circular! P. Warman Publishers, Uniontown, Penna.

**CIGARETTES**—Make 20 plain or filter-tip for 9¢. Facts free. Moberly, Box 785, Owensboro, Kentucky.

**SUPER** Memory overnight! Success guaranteed! Bijou, Box 1727-M, Hollywood 28, California.

**WANT** Your name with 1000 mailers? 25¢ lists your name year with our mailings every month. Dixie Mailers, King, N. C.

**100,000 PRODUCTS** Wholesale—Free catalog! Send postcard: Econ-O-Mart, Whippany 15, New Jersey.

**SEND** Us wool for blankets. Write Eldorado Woolens, Eldorado, Texas.

**STAMMER**, Stutter, no more. (Dr. Young.) Write: Gaucho, Box 9309-S7, Chicago 90.

**AMAZING** Bargains for whole family. Tremendous useful items. Big catalog free. Kelly, 2110 Brown, Flint 3, Mich.

**MEN** And women—Interested in full or part time selling? Your name on our mailing lists one year, free. Avers, Box 22, Forest Park, Ill.

**GOLD** Monogram kit. 200 initials that go on anything. Never tarnish. \$1.00. Box 46457, Dept. PM, Los Angeles 46, Calif.

**"HOW To Wake Up Life-Changing Winning Ability"** sent free. Write: President, Box 1924-X, Louisville 1, Ky.

**FIRE** Prevention and safety kits for table-top demonstrations. Easily built. Amazing new devices. Assures safety. Used by fire departments and civil defense. Excellent science projects. Free details. I. Anderson, P. O. Box 332, Rialto 2, California.

Information not listed on articles in this issue often is given in the WHERE-TO-FIND-IT list, available at no cost from the SERVICE BUREAU, POPULAR MECHANICS, 200 E. Ontario, Chicago 11, Ill.



## Industrial-Age Bells

Children within three miles of a mission school in Rangmatia, East Pakistan, are summoned to class by a bell toolled from a steel I-beam by Bethlehem Steel Co. engineers. They toiled in Pennsylvania to find the best toll for the mission's pastor. He had written that his first bell was being drowned out by another bell two miles away.

A wide-flange beam, properly proportioned (for example: 12 inches by 5 feet, weighing 135 pounds), suspended vertically, and struck with an 8-pound sledge gave a far-reaching sound—E flat below middle C. The company shipped off the beam and it's rung happily ever after.

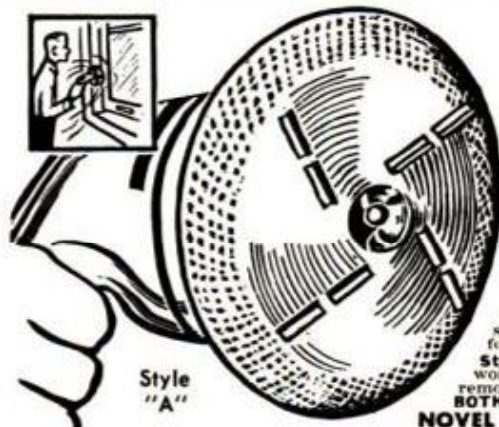

## ROTARY SANDER and PAINT REMOVER

**5 in 1 ★ SANDER ★ PLANING ★ RASPING ★ TRIMMING**  
**TOOL ★ PAINT REMOVER ★** **\$1.00**

Use indoors or outdoors—Boats—On Rock Hard Paint & Varnish. Asphalt Tiles—Wood—Aluminum—Fiber glass—Etc. Will save hours of back breaking labor. Precision made imported tool attaches to any electric power drill. Scientifically designed large 4 3/4" metal disk will not clog, scratch or deface surface. Quickly pays for itself. Cheaper, faster and safer than blow torch or dangerous chemicals. Will do everything and more than tools selling up to \$20.00 or your money back. A comparable \$3.00 value now specially priced at only \$1.00 plus 25¢ for postage and handling. Sorry, no C.O.D.'s.

**Available—Style A—Professional heavy duty combination scraper and sander. Eight non clog scraper bars which project from face. Rapidly scrape away hard paint with razor blade like action. Outer rim then used for sanding, smoothing, etc. Only \$1.00**

**Style B—An all around, fine, multi purpose tool recommended for all home work shops. Use where fine sanding and smoothing action is wanted. Will remove up to 5 coats of paint easily and quickly. Only \$1.00**  
**BOTH only \$2.25 postpaid.**

**NOVEL MFG. CORP., Dept. T-4165, 31 Second Ave., New York 3, N.Y.**



## New Model 161 UTILITY TESTER® FOR REPAIRING ALL ELECTRICAL APPLIANCES MOTORS·AUTOMOBILES·TV TUBES

As an electrical trouble shooter the Model 161

• Will test Toasters, Irons, Broilers, Heating Pads, Clocks, Fans, Vacuum Cleaners, Refrigerators, Lamps, Fluorescents, Switches, Thermostats, etc.



• Will test all TV tubes (including picture tubes) for open filaments and burned out tubes.

• Measures A.C. and D.C. Voltages, (both 110 Volt and 220 Volt lines).

• Will measure current consumption (amperes) while the appliance under test is in operation.

• Incorporates a sensitive direct-reading resistance range which will measure all resistances commonly used in electrical appliances, motors, etc.

As an Automotive Tester the Model 161 will test:

• Both 6 Volt and 12 Volt Storage Batteries • Generators • Starters • Distributors • Ignition Coils • Regulators • Relays • Circuit Breakers • Cigarette Lighters • Stop Lights • Condensers • Directional Signal Systems • All Lamps and Bulbs • Fuses • Heating Systems • Horns • Also will locate poor grounds, breaks in wiring, poor connections, etc. **\$22.50**

Model 161 comes complete including 56-page book... Only

**SEND NO MONEY WITH ORDER—  
PAY POSTMAN NOTHING ON DELIVERY**

Try it for 10 days before you buy. If completely satisfied then send \$5.00 and pay the balance at the rate of \$5.00 per month until the total price of \$22.50 (plus small P.P. and budget charge) is paid. If not completely satisfied, return to us, no explanation necessary.

ACCURATE INSTRUMENT CO., INC.

Dept. B-174, 911 Falls St., New York 39, N.Y.

Please rush Model 161. I will pay on terms specified. Otherwise I will return tester.

Name.....

Address.....

City..... Zone..... State.....

All prices net, F.O.B., N.Y.C.

## RUPTURE!

An amazing Air-Cushion Invention allows body freedom at work or play. Light, neat, cool, sanitary. Durable, cheap. Day and night protection helps Nature support weakened muscles gently but surely. No risk. Sent on Trial! Write NOW for free Booklet and Proof of Results. All correspondence confidential.



**Brooks Company, 143-E State St., Marshall, Mich.**



## Choose an AIRLINE CAREER

**ADVENTURE! PRESTIGE! PROMOTION!**

You can train for opportunity with the airlines. Four-week course for men 18-35, H.S. graduates. Free placement service with 35 airlines. Station Agent—Operations Agent, Ticket Agent, Reservationist.

**WRITE TODAY FOR FREE INFORMATION**

**McCONNELL AIRLINE SCHOOL**

1030 Nicollet Ave., Room P-22, Minneapolis, Minn.

Name..... Age.....

Address..... State.....

SEND FOR  
YOUR

# ALLIED

## MONEY-SAVING 1962 ELECTRONICS CATALOG

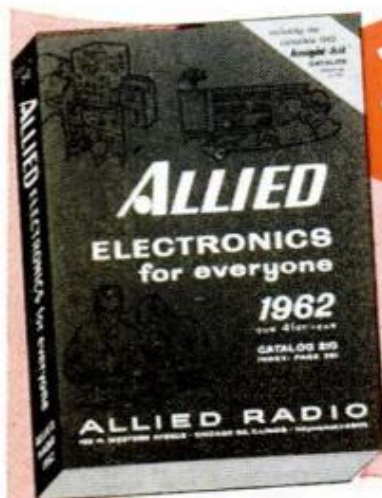

# Free

**444 PAGES**  
World's Biggest  
Most Complete!

...  
**NO MONEY DOWN**  
New Credit Plan  
Gives You 50% More  
Buying Power!

SAVE MOST ON

### EVERYTHING IN ELECTRONICS

world's largest selection of famous name brands

Send today for this **FREE** Catalog—the world's biggest, featuring *everything* in Electronics for modern living. Largest selection of all famous name brands, including products and values available only from **ALLIED**. Whether you're a kit builder, experimenter, hi-fi fan, Amateur, technician or student, you'll save most on:

- **KNIGHT-KITS®**—Best in Build-Your-Own
- Everything in Stereo Hi-Fidelity
- New Multiplex Stereo FM
- New All-Transistor Stereo Hi-Fi
- **KNIGHT®** Super-Value Stereo Hi-Fi
- Tape Recorders & Phono Equipment
- Citizens Band 2-Way Radios
- TV Tubes, Antennas, Accessories
- Parts, Tubes, Transistors, Tools, Books
- Amateur Station Equipment
- Public Address & Intercom
- Latest Test & Lab Instruments

**SAVE MOST** on everything in Electronics at **ALLIED**—the world's largest electronic supply house. Get fastest service, expert personal help, easiest-pay terms. Send coupon today for **FREE** 1962 **ALLIED** Catalog.

**Satisfaction Guaranteed  
or Your Money Back**

## ALLIED RADIO

ALLIED RADIO, Dept. 41-82  
100 N. Western Ave., Chicago 80, Ill.

Rush **FREE** 1962 **ALLIED** Catalog.

Name \_\_\_\_\_  
PLEASE PRINT

Address \_\_\_\_\_

City \_\_\_\_\_ Zone \_\_\_\_\_ State \_\_\_\_\_



# Free CATALOG



## Sidelights on aviation

Air prophets are again dusting off their shopworn predictions about the big boom in private flying. By 1970, they say, more than 100,000 noncommercial aircraft will fill the skies. More than half of these will be for business use and another 25 percent for pure pleasure.

Their predictions are based primarily on the fact that only 12 percent of the 3000 top industrial firms in the U.S. fly their own aircraft, leaving an untapped reservoir of 88 percent, or more than 2600 large firms; also, they say, thousands of professional men and small business firms could use aircraft profitably.

▼ ▼ ▼  
**A plastic airplane?** Piper Aircraft Corp., which built the famous Cub, is working on one and it's due to fly this spring.

The wings, fuselage and tail will all be made of plastic, reinforced with glass-fiber cloth and paper honeycomb. Each major component will be built by joining two halves that have been formed in molds.

The two-place aircraft will probably cost in the same price range as current light planes, around \$5000. It will cruise about 130 miles per hour.

▼ ▼ ▼  
**Despite the secession** of its Air Corps, which broke off to form the independent Air Force in 1947, the Army still has a considerable fleet of aircraft.

Most of them are used for reconnaissance, and require short, and sometimes vertical, takeoff and landing characteristics. The Army's newest airplane, now under construction, will be a VTOL jet capable of vertical takeoff and forward speeds up to 500 miles per hour.

Two jet engines will drive lift fans mounted horizontally in the wings. The fans will provide lift for vertical maneuvers and, more important, for hovering. For forward speed, the power of the jets will be diverted rearward for conventional thrust.

▼ ▼ ▼  
**"Made in Japan"** will be imprinted on a unique new helicopter scheduled for tests next summer. Few details are available, but it will have three-bladed counter-rotating rotors mounted inside a ducted shield. The teardrop-shaped cockpit will seat one or two persons. It will cruise at 65 miles per hour.

Kevin V. Brown

POPULAR MECHANICS



### Instant Home Movies

Packaged in a special plastic cartridge by the processor, 8-mm. home movies can be shown instantly by inserting the cartridge into a new movie projector.

The cartridges can be labeled and stored individually, eliminating storage cans. The movie starts the moment a cartridge is snapped into the projector. No extra reels or rewinding is necessary. Projector and cartridges are made by Technicolor Corp., 6331 Romaine, Hollywood, Calif.

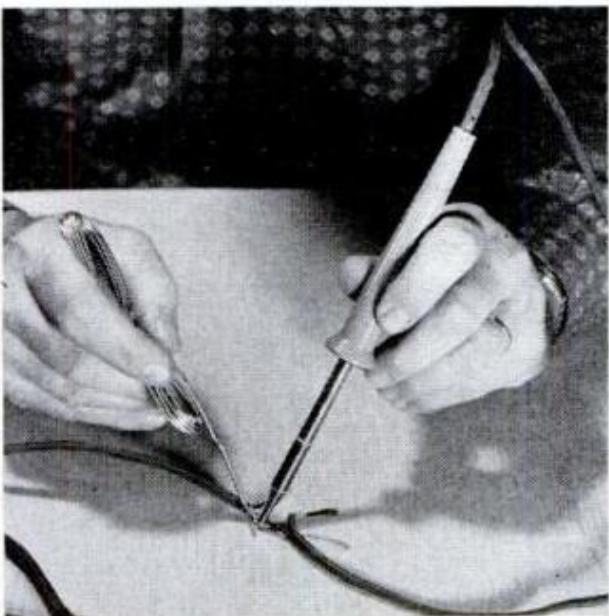

### Small Iron With Spare Parts

Small and lightweight, a new electric soldering iron has interchangeable plug-in tips and heater assemblies.

Available in 30-, 40-, and 45-watt ratings, the Penline-120 was developed by General Electric for industrial use, though the firm points out that it is also suitable for home use. Price of the soldering iron is about \$8.

FEBRUARY 1962

# FREE CAREER BOOKLET

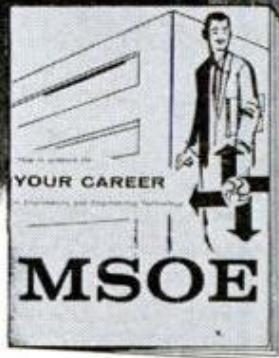

To guide you to a successful future in

## ELECTRONICS RADIO-TV COMPUTERS ELECTRICAL ENGINEERING

This interesting pictorial booklet tells you how you can prepare for a dynamic career as an Electrical Engineer or Engineering Technician in many exciting, growing fields:

**MISSILES • AVIONICS • AUTOMATION  
SALES • DEVELOPMENT  
ELECTRICAL POWER • ROCKETRY  
RADAR • RESEARCH**

Get all the facts about job opportunities, length of study, courses offered, degrees you can earn, scholarships, part-time work — as well as pictures of the Milwaukee School of Engineering's educational and recreational facilities. No obligation — it's yours free.

### MILWAUKEE SCHOOL OF ENGINEERING

#### MAIL COUPON TODAY!

**Milwaukee School of Engineering**  
Dept. PM-262, 1025 N. Milwaukee St., Milwaukee, Wis.  
Please send FREE "Your Career" booklet  
I'm interested in  
 Electronics     Radio-TV     Computers  
 Electrical Engineering     Mechanical Engineering

Name..... Age.....  
PLEASE PRINT  
Address.....  
City..... Zone..... State.....  
 I'm eligible for veterans education benefits.  
Discharge date..... MS-117



**FREE!** ★  
100  
WORLD-WIDE  
STAMPS  
...just  
released!

HURRY! SEND TODAY for new, FREE collection of 100 Worldwide stamps. Get new issues of past 12 months . . . Pakistan Khyber Pass, Queensland "Victoria", Central African Butterfly, Argentina Llama, Mozambique "Arms", many others. Wonderful new additions to your collection. All different, all genuine, topicals, pictorials, mint and used. Many in limited circulation, so get them first. Send today for this new, FREE collection, other stamp offers for approval. Rush name, 10¢ for handling, postage. GARCELON STAMP CO., Dept. 2PMX, Calais, Maine.

GARCELON STAMP CO., Dept. 2PMX  
Calais, Maine. Rush FREE 100 Different Stamps, other offers.  
Enclosed 10c for handling. (PLEASE PRINT).

**Dazzling new!**



### BSA SUPER ROCKET

New outstanding power and acceleration matched with new improved brakes. Truly one of the most beautiful motorcycles ever made—now with brilliant metallic red tank, chrome tank panels, chrome fenders, and dozens of other highly chromed parts to dazzle its way into your heart.



*The most popular motorcycle in the world*

Write to the nearest address for a colorfully illustrated free catalog of the new 1962 models.

Catalog offer limited to U. S. residents only.

West:

**HAP ALZINA**  
Dept. P62  
3074 Broadway  
Oakland, California

East:

**BSA INCORPORATED**  
Dept. P62  
639 Passaic Ave.  
Nutley, New Jersey



### Machine Makes Metal Folds

Sheets of aluminum, brass, copper, or stainless steel can be passed through a new metal-folding machine and be folded into numerous patterns, creating corrugated stock suitable for making such products as heat exchangers and electronic wave guides and for less technical items, such as decorative screens for the home.

Cam-controlled dies in the machine move in both vertical and horizontal planes to produce the unusual patterns. Using three rolls of stock, the machine can form a different pattern for each at the same time. This is a product of Twin Coach Co., Buffalo 25, N. Y.



POPULAR MECHANICS

## Build This CAMPER

Save Time and Money with our Plans, Material List and Instructions — \$15

Dealers Wanted

Write for: Price List on Factory Built Units.



**Vi-King Camper Co.** 14123 Holly Rd., Hopkins, Minn.

**NEW JET DRIVEN BOAT KIT**

KIT INCLUDES BOAT and JET FOR AUTO ENGINE

FREE CATALOG \$223.75 DOWN PER MO. \$38.04

CONSTRUCTION DRAWINGS \$2.00

**TAFT MARINE WOODCRAFT**

DEPT. PM-262 • 636 39th Ave. N. E. MINNEAPOLIS 21, MINNESOTA

## BEAUTIFY YOUR HOME

with Pikes Peak Low Cost Quality Plantings  
SEND TODAY FOR SPRING CATALOG

**PIKES PEAK Nurseries**

801 WATER STREET INDIANA 11, PA.

**"POP" SAYS:**

**Mechanics**

"I've heard an awful lot of fish stories I'd like to throw back!"

## LEARN WHILE YOU SLEEP!

Hypnotize with your recorder, phono. Details, catalog free!  
Sleep-Learning Research Ass'n. P. O. Box 24-A Olympia, Wash.

## MAKE BIG MONEY

**MAKING COSTUME JEWELRY AT HOME!**

Thrilling spare-time, MONEY-MAKING hobby! Make newest, beautiful jeweled earrings, necklaces, bracelets, pins, pendants, cuff links, tie clips! Quick, easy to make—easier to sell to friends, neighbors, stores, at big profit! Details FREE!

**DON-BAR CO., Dept. B192**  
2934 W. Fullerton Ave., Chicago 47, Ill.



**BLASTS MOLESTERS ...THUGS!**

**Amazing TEAR GAS PENCIL**

100% PROTECTION!

Discharges tear gas to instantly stop, stun and incapacitate the most vicious man or beast. Effective substitute for firearms; leaves no permanent injury. No selling experience needed. Handle as profitable sideline, soon you'll sell it full time. Start now, 5 easy sales net \$25.00 a day up. Send \$5.95 for demonstration kit of Automatic Tear Gas Pencil, 10 demonstrators and 3 Tear Gas Cartridges. NOT SOLD TO MINORS. State age with order.

**HAGEN SUPPLY CORP., Dept. PM22, St. Paul 1, Minn.**

**BIG PROFITS, SELLS EASY TO GAS STATIONS, NIGHT WORKERS, MOTORISTS, NURSES, STORES, BANKS, HOMES**

# MEN PAST 40

**Afflicted With Bladder Trouble, Pains in Back, Hips, Legs, Nervousness, Tiredness.**

If you are a victim of these symptoms, your trouble may be due to Glandular Inflammation. A constitutional Disease that requires special types of medical treatment. Neglect of such Inflammation causes men to grow old prematurely and often leads to Incurable conditions.

Most men, if treatment is taken in time, can be successfully NON-SURGICALLY treated for Glandular Inflammation. If the condition is aggravated by lack of treatment, surgery may be the only chance.

## NON-SURGICAL TREATMENTS

The NON-SURGICAL New Type treatments used at the Excelsior Medical Clinic are the result of discoveries in recent years of new techniques and drugs, plus over 20 years research by scientific technologists and doctors.

Men from all walks of life and from over 1,000 communities have been successfully treated here at Excelsior Springs. They found soothing and comforting relief and new health in life.

### EXAMINATION AT LOW COST

When you arrive, our Doctors, who are experienced specialists, make a complete examination. You then decide if you will take the treatments needed, which are so mild, hospitalization is not needed—a considerable saving in expense.

### RECTAL-COLON DISORDERS

Are often associated with Glandular Inflammation. These disorders, we can treat at the same time we treat Glandular Inflammation.

### REDUCIBLE HERNIA

Is also amenable to a painless Non-Surgical treatment that we have developed. Full details of this treatment given in our Free Book.

### Write For FREE BOOK

The Excelsior Medical Clinic has published a New FREE Book that deals with diseases peculiar to men. It could prove of utmost importance to your future life. Write today. No obligation.



**EXCELSIOR MEDICAL CLINIC**  
Dept. B 6151  
Excelsior Springs, Mo.

Gentlemen: Kindly send me at once, your New FREE Book. I am interested in full information. (Please Check Box)

- Glandular Inflammation       Hernia  
 Rectal-Colon

Name.....

Address.....

City..... State.....

# Free!



## BRAND NEW LAFAYETTE ELECTRONICS 1962 CATALOG 620

It's Bigger and Better  
Than Ever!

340 giant-sized page catalog from the world's leading supplier of electronics and stereo hi-fi equipment.

### 340 PAGES

It's a complete shopping center for audiophiles, technicians, engineers, students, hobbyists, servicemen and dealers. Thousands of items at lowest money-saving prices — featuring LAFAYETTE KITS . . . the best value for your money any day.

**SPECIAL! NO MONEY DOWN**

with Lafayette's **NEW EASY-PAY PLAN.**

**MAIL THE COUPON TODAY FOR YOUR FREE CATALOG**

**LAFAYETTE LOCATIONS**

JAMAICA • BRONX • NEW YORK CITY  
NEWARK • PLAINFIELD • PARAMUS • BOSTON

Lafayette Electronics Dept. LB-2  
P.O. Box 10, Syosset, L. I., N.Y.

Send me the FREE 340-pg. 1962 catalog 620.

Name \_\_\_\_\_

Address \_\_\_\_\_

City \_\_\_\_\_ Zone \_\_\_\_\_ State \_\_\_\_\_

## 1 1/4 ACRE Including Easements FLORIDA COUNTRY ESTATES

FLORIDA HIGHLANDS

**\$895**

ONLY

Complete Price

**\$10** DOWN  
MONTHLY

30 Day Money-Back  
Guarantee

FREE: Warranty Deed  
Title Insurance

In the very heart of Florida's beautiful "Blue Grass" area, 16 miles from Ocala. Graded roads are in ready to be maintained by purchaser. **YOU CAN DRIVE TO YOUR PROPERTY NOW.** Each estate can be divided into 4 homesites, each 75' x 135'. Buy for future retirement, vacations, or as an unsurpassed investment in "Space-Age" Florida.

**HIGH, DRY, BEAUTIFUL LAND AT  
LESS THAN THE PRICE OF A HOMESITE ALONE**

Florida Realty Center, Inc., Broker Dept. E2-2

520 N. E. 79th St., Miami 38, Florida

Please send full information without obligation.

Name \_\_\_\_\_

Address \_\_\_\_\_

City \_\_\_\_\_ Zone \_\_\_\_\_ State \_\_\_\_\_

AD 61094

Shop PM Ads for Exciting  
Direct-Mail Offers



### Featherweight Ceiling

So light that each 12 by 12 by 1/2-in. tile weighs only 2/3 ounce, a ceiling and wall tile mounts on almost any surface with an adhesive developed by the manufacturer.

The polystyrene tile is available in a variety of patterns and colors.

Manufacturer is Arvey Corp., 3500 North Kimball Ave., Chicago 18.

## RAMBLERS and CHEVY IIs

Are the owners of these 1962 cars satisfied with performance, fuel mileage and quality control? How do they rate their purchases, after driving them for months? You'll find the answers in two frank and revealing Owners Reports, both appearing in the

### MARCH Popular Mechanics



# EAT ANYTHING WITH FALSE TEETH



EASY TO USE STRIPS

Trouble with loose plates that slip, rock or cause sore gums? Try Brimms Plasti-Liner. One application makes plates fit snugly without powder, paste or cushions. Brimms Plasti-Liner adheres permanently to your plate; ends the bother of temporary applications. With plates held firmly by Plasti-Liner, **YOU CAN EAT ANYTHING!** Simply lay soft strip of Plasti-Liner on troublesome upper or lower. Bite and it molds perfectly. Easy to use, tasteless, odorless, harmless to you and your plates. Removable as directed. Money-back guarantee. At your drug counter. \$1.50 reliner for one plate; \$2.50 for two plates. Plasti-Liner, Inc., Dept. PM-2, 1075 Main Street, Buffalo 9, New York.

**BRIMMS PLASTI-LINER**  
THE PERMANENT DENTURE RELINER

## FREE AMAZING NEW BOOK "HOW TO ANSWER ADS"



Never before have you seen anything like this. Tells you in simple language the correct way to answer ads. Gets you quicker replies—better results, and greater satisfaction. Will save you time and money and it's **ABSOLUTELY FREE.** No obligation whatever. Every reader of advertising should have this booklet. Send a postcard for your copy NOW. **F. W. JOHNSON, Popular Mechanics Magazine, Room 600-A, 204 East Ontario Street, Chicago 11, Ill.**

make it with 60c worth of sand & cement!

## SELL IT FOR \$2000

every home a prospect for these "LIFETIME"

## CONCRETE INCINERATORS

Make big profits manufacturing rust proof, fire proof, almost indestructible concrete incinerators in your own backyard or garage... full or part time. Sell to home-owners, hardware, department and garden supply stores. Phila. manufacturer doing big volume with Sears, Roebuck; large department stores. Easy to follow instructions and all needed equipment supplied. Exclusive protected franchise—No competition! Territories going fast. Write immediately for full details.



**T. C. TOR, Dept. PM-22**  
318 Rancocas Ave., Delanco, N. J.  
Gentlemen:  
Rush full information about your concrete incinerator protected franchise offer.

Name \_\_\_\_\_

Street No. or R.D. \_\_\_\_\_

City \_\_\_\_\_ Zone \_\_\_\_\_ State \_\_\_\_\_

# INSURED SAVINGS

EARN HIGH DIVIDENDS

# 5%

Current Rate  
Dividends  
Compounded  
Semi-Annually

You can be safe and sure when mailing your Account to First Union where all Accounts are Insured (up to \$20,000.00) by Security Financial Insurance Corp. Deposits postmarked by the 20th earn dividends from the 1st.



Write today for your free Booklet of VALUABLE FREE GIFTS

## FIRST UNION SAVINGS & LOAN, INC.

\*\*\*\*\* POSTAGE PAID BOTH WAYS \*\*\*\*\*  
 \* Dept. 112 \*  
 \* FIRST UNION SAVINGS & LOAN INC. \*  
 \* 6901 Belair Rd., Baltimore 6, Maryland \*  
 \* NAME..... \*  
 \* ADDRESS..... \*  
 \* CITY..... ZONE..... STATE..... \*  
 \*\*\*\*\*

# Shopping for tools

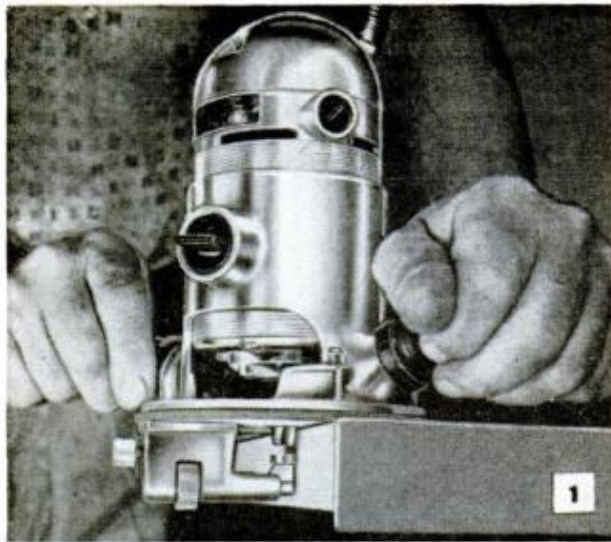

**1. VENEER TRIMMING EQUIPMENT** features a new trim guide designed for accuracy in finishing veneers and laminates. Guide is spring-loaded; when once set, trim adjustment will not vary. Used for flush and bevel trimming. Kit sells separately for \$15.95. The ½-hp. router, including trim kit, is priced at \$69.95. The Stanley Works, New Britain, Conn.

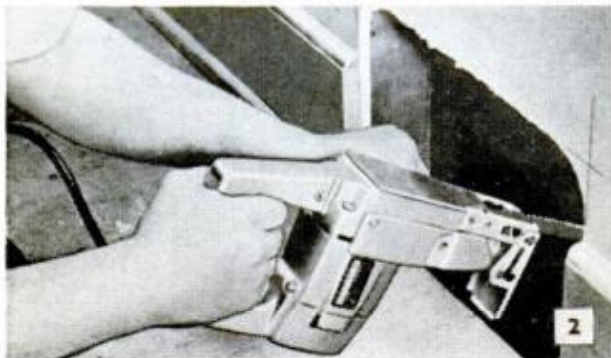

**2. RECIPRO SAW CUTS** anything from thinnest plastic sheets to steel and heavy lumber. May be used to make flush cuts even into corners and pocket cuts in walls and floors. Blade is adjustable for cutting in any one of four directions. Blower keeps line of cut clean of sawdust. Priced at \$49.95 by Skil Corp., 5033 Elston Ave., Chicago 30, Ill.



**3. MULTIFACED HAMMER** has replaceable tips of varying hardness. The five tips are made of plastic and secured in steel collars. Shock absorbers inside the head reduce rebound, making blows more effective. Especially good for electronic and automotive use. Hammer sells for \$10.50. Total weight is two pounds. Ramset Fastening System, New Haven, Conn.

**4. C-CLAMP** with threadless spindle provides fast clamping action. A special bracket converts clamp for use as bench vise. Flats, rounds and most irregular shapes are easily held. Clamps come with either anvil or V-spindles in 2, 4, and 6-in. sizes. The 4-in. size sells for \$8.45. United Associates, 1605 North Hercules Ave., Clearwater, Fla.

**5. DELTA NINE-INCH RADIAL SAW** features an up-front elevating handle for convenience and safety. Threaded shaft permits use of right-hand drill and router bits. Developing up to two hp. under load, powerful motor reduces chance of bucking during heavy cuts. Retail \$249. Rockwell Mfg. Co., Power Tool Div., 400 N. Lexington Ave., Pittsburgh 8, Pa.

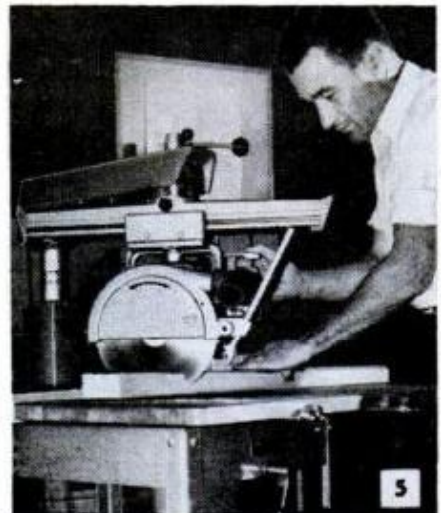
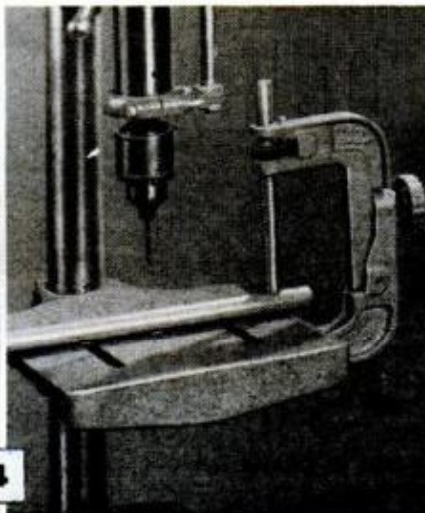



## Local Drain Tile Plants Can Earn High Incomes

Ready-made markets await local manufacturers of concrete drain tile. Every year demand is much greater than production.

With a Champion machine you can convert \$28.05 worth of sand and cement into 1000 4" superfine concrete drain tile, and at \$90.00 you can undersell ordinary clay tile. You have both quality and price in your favor. The Champion makes all sizes from 3" to 12" diameters; 1-man operation with automatic feeder. Requires no special building—no skilled labor. Moderate investment; time payments if desired. Write at once for the Champion Book.



W. E. DUNN MFG. CO. • 522 W. 24th St., Holland, Mich.



Regular Price of a Slide Rule \$4 and Up

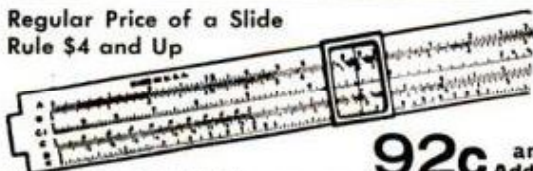

If you can use a pencil, you can use this Slide Rule

92c and this Ad Add 8c Postage

**SLIDE RULE with FREE 28-Page Inst. Book**

For students, accountants, mechanics, hobbyists, salesmen, everybody. Simplifies mathematics for everybody. Easy to calculate instantly, accurately. Multiplying, proportions, division, roots, etc. "High Vision" Clear View Slide. Full 10" Rule, A, B, C, D, C1 and K Scales. Money back guarantee.

LARCH, 118 East 28th Street, Dept 62-A, New York 16, N. Y.

## NEED EXTRA CASH SHOW CARDS, GIFTS

New money-making ideas in cards, gifts and gadgets. No investment. Free catalog. . . Write today to: North Star Dept. 2-455, 251 E. 5 St., St. Paul, Minn.



### Professional Ski Patrol & Ranger WALKIE-TALKIE TWO WAY RADIOS

**\$19.88** Each Ppd. Two for \$29.88 Ppd. Latest Spring 1962 Models. All-transistorized Channel 14 Citizens' Band (27MC) two way transceivers IN DO-IT-YOURSELF KIT FORM COMPLETE, all parts, chart & manual. Takes one ordinary 9-volt transistor radio battery. 48" antenna included. Excellent range, fidelity and volume. Invaluable for outdoor sports, hunting, boating, scouting, construction jobs, coaching. Used by ski patrols, rangers, timber cruisers, sheriff deputies. FOR SAME UNIT FACTORY ASSEMBLED add \$7.50 each. (one for \$27.38, two for \$44.88.)



### TRANSISTORIZED INTERCOMS

Both for **\$29.88** ppd. New model, big and rugged. 6" x 5" x 2 1/2" Master and slave set. Completely assembled, not a kit. Cabinet allows in-the-wall installation or simple hook mount. USE FOR CAB-TO-CAMPER, with 12 volt car battery hook-up, self-contained flashlight batteries or dry cells. Range to 1 mile. Instructions included. Use upstairs to basement, house to garage, infant's room to kitchen. 1000 uses. **TO ORDER ANY ITEM:** Send check or money order. \$5 deposit for C. O. D. 90-day warranty. California residents add 4% state tax.

Bargains from the "Heart of the Electronics World"



**Mission house**  
15336 Roscoe Blvd., Van Nuys 25, Calif.



OVER 100,000,000 PROSPECTS

Millions of electrical appliances used daily . . . in factories, homes, office buildings, on farms. All eventually need adjustment and repairs.

**EARN \$5.00 to \$6.00 PER HOUR WHILE LEARNING**

It is not unusual for appliance men to charge on that basis. We teach you how to secure business, make repairs, what to charge, how to buy spare parts wholesale, etc.

**EASY TO LEARN**

If you are mechanically inclined you will enjoy CHRISTY Training Manuals written in simple, easy to follow instructions, fully illustrated and CHRISTY Testing Equipment which helps you quickly locate troubles.

**CHRISTY FINANCES YOU!**

CTS Shop Method Home Training Program can be had on a Pay as you Learn Plan. Send today for FREE book and special form.



**EARN WHILE YOU LEARN ELECTRONIC KIT FURNISHED You!**



## CHRISTY TRADES SCHOOL

Dept. A-2003, 3214 W. Lawrence Ave., Chicago 25

**Send FOR FREE BOOK**

CHRISTY TRADES SCHOOL, Dept. A-2003 3214 W. Lawrence Ave., Chicago 25. Send me your FREE book on Electrical Appliance Repairing and instructions for paying later from EARNINGS WHILE LEARNING.

Name . . . . . Age . . . . .  
Address . . . . .  
City . . . . . Zone . . . . . State . . . . .

# THE PIPE SMOKER'S Miscellany

*Tidbits, Tips and Trivia on the Art of Pipesmanship*

## The Secret of Ideal Puffing

(For beginning pipe-smokers)



Whatever you do, avoid the hard puff — it's harsh on the tongue.

Don't be long-winded either. Short and easy on the draw does it.

And don't blow through your pipe to keep it lit. This upsets your evenly packed bowl and causes hot spots.

The secret? Make your smoke a succession of light, even puffs that flow as naturally as your breathing.

*The pipe draws wisdom from the lips of the philosopher, and shuts up the mouth of the foolish.*

THACKERAY

## THE PIPE TOBACCO THAT STAYS LIT



Bond Street Pipe Tobacco keeps burning because of its old English cut — a combination of flakes for even-burning and cubes for slower-burning. You'll like its aroma of fine imported and domestic tobaccos, too.

It's a virtuous son who inherits his father's pipe.

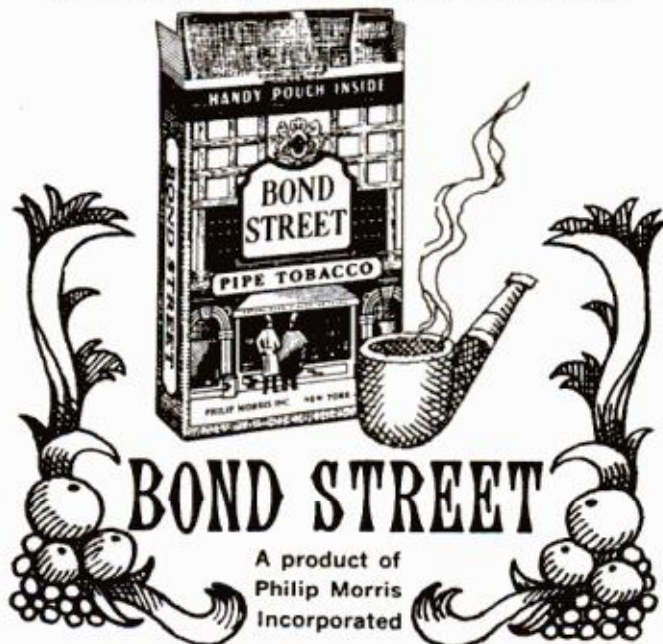

## No-Hands Carrier Landings

Ten Navy aircraft carriers will have an automatic landing system installed that will permit hands-off landings under adverse weather conditions.

The system, developed by Bell Aerosystems Company, electronically guides an approaching aircraft to the deck without the pilot being required to touch pitch-and-bank controls or even to make visual contact with the carrier, as in fog.

The system assumes control of an aircraft when it is several miles from the carrier. Precision radar tracks the airplane and relays its position to a computer. The computer compares the aircraft's position with that of the carrier and generates control commands which are radioed to the aircraft's automatic pilot. The automatic pilot, in turn, controls the aircraft, holding it on a proper flight path.

A land-based version has been studied for possible commercial application.

## Probe to Peek at Mars

Is there any life on Mars?

By 1964 we may have an answer. A program to send a space probe with a telescope to photograph the planet by visible and infrared light is under way. The probe could reveal if organic molecules—the building blocks of living forms—are present.

The probe would circle to within 20,000 miles of Mars. Mars is 48 million miles from Earth. Previous infrared spectroscopy done with the 200-inch Mount Palomar telescope indicates that these molecules could exist on Mars, but the evidence from that distance is not clear-cut.

## Super-Slow-Speed Motor

Featuring a controlled speed range without gearing of from 500 revolutions per minute down to  $\frac{1}{60,000}$  r.p.m. (one revolution every 41½ days), a hydraulic motor may have applications all the way from machine tools to space vehicles.

Another outstanding characteristic is its high-response rate. From 100 r.p.m. it will stop, reverse direction and accelerate to 100 r.p.m. within  $\frac{15}{10,000}$  of a second.

Originally developed by the Cimtrol Division of Cincinnati Milling Machine Co. of Cincinnati, Ohio, as a positioning drive for its machine tools, the motor may ultimately be used for controlling the orientation of large, precise instruments such as a satellite-tracking antennae, for optical-maser aiming, for navigation, for chemical control, or for missile guidance.

The completed motor weighs 138 pounds, and measures 12½ inches by 6 inches deep. It's called the Acradrive/22.



## PROFESSIONAL INVESTIGATORS WANTED!

**NORTH AMERICAN INSTITUTE OF POLICE SCIENCE**

WILL IMPROVE YOUR SKILL.  
ONLY THE SKILLED INVESTIGATOR CAN EXPECT A BETTER JOB AND HIGHER SALARY.

NOW YOU CAN TRAIN BY MAIL FOR HIGHER POSITIONS IN DETECTIVE POLICE OR INVESTIGATIVE FIELDS UNDER THE GUIDANCE OF MEN OF PROVEN ABILITY. ALL IMPORTANT PHASES OF INVESTIGATIONS COVERED BY SUCH NOTEWORTHY EXPERTS AS CAPTAIN JOHN I. HOWE (former Captain of Police, Chicago, and lecturer at various Police schools) AND PAUL D. NEWBY (former Chief, State's Attorney's Police, Cook County, Illinois; and Federal Agent). GRADUATES CAN BECOME PAID CORRESPONDANTS, AS NEEDED AND IF DESIRED, IN THE INTERNATIONAL NETWORK OF NORTH AMERICAN DETECTIVE AGENCY'S FORCE. FOR INFORMATION ON THE 20 WEEK COURSE AND CERTIFICATE,

WRITE: 608 S. Dearborn St., Suite 863, Chicago 5, Ill

# Worship together this week



*You need not walk alone!*

RELIGION IN AMERICAN LIFE, INC.

Published as a public service in cooperation with The Advertising Council.

## CONCRETE BIRD BATHS AND OVER 250 OTHER MONEY MAKING ITEMS



You've seen them all over the country . . . concrete bird baths, garden seats, flower boxes, appealing statuary, and many other items that add charm around the house and lawn. They're made by enterprising people, just like you, from our COPYRIGHTED ALUMINUM MOLDS. It's easy. It's fun. It's profitable.

Send \$2.00 today for this 82-page "How to" book. 20 pages of clear instructions. Valuable trade secrets. Over 250 items beautifully pictured (with description, dimensions, and prices of molds). Rushed to you by first class mail.

CONCRETE MACHINERY CO., INC.  
HICKORY 2, NORTH CAROLINA

Name \_\_\_\_\_

Address \_\_\_\_\_

**HOW TO  
TURN  
CONCRETE  
INTO  
GOLD**

## WINEGARD ELECTRONIC TV ANTENNA INVENTION

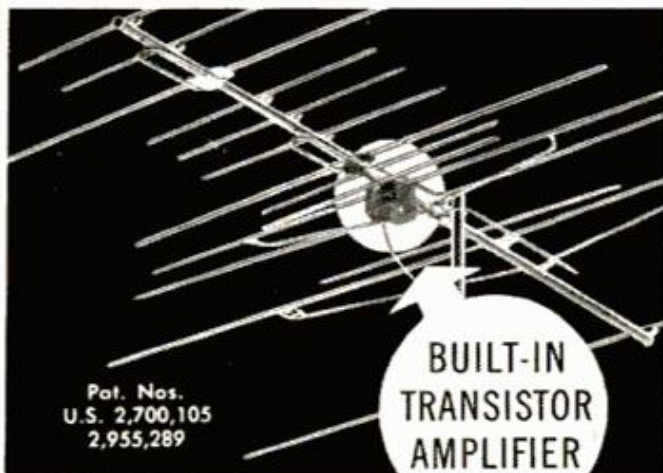

Pat. Nos.  
U.S. 2,700,105  
2,955,289

### GIVES YOU POSITIVE TV IMPROVEMENT

clears up snow and interference,  
increases reception distance.

The Winegard Powertron is a new *electronic* antenna that will make a big improvement in your TV reception. For instance, for long distances, the Powertron will pull in TV pictures hardly visible with an ordinary antenna.

There are two reasons for this unusual performance: The Powertron has a patented Electro-Lens system that intercepts and focuses TV signals on the collector element. Here the signal is *amplified* by a built-in transistor. The result: In most cases, you can enjoy more channels. Pictures that were poor to fair become sharper . . . brighter. Snow and interference is reduced. Excellent for color or black and white.

Besides being electronically superior, the Powertron is mechanically strong and will deliver fine performance for years. It has a lustrous gold anodized finish that won't corrode or turn dull. If you and your family want better reception, the Winegard Powertron is a wise investment. See your TV dealer, or for more information, send coupon for booklet.



**Winegard**  
ANTENNA SYSTEMS  
3001-2 Kirkwood • Burlington, Iowa

Winegard Co., 3001-2 Kirkwood, Burlington, Iowa

- Send FREE booklet on Powertron
- Send folder on easy way to install TV antenna plug-in outlets in each room in my house.
- Send information on long distance FM reception.

Name \_\_\_\_\_

Address \_\_\_\_\_

City \_\_\_\_\_ State \_\_\_\_\_

My nearest TV station is \_\_\_\_\_ miles away

NOW! COPPER SWEAT JOINTS  
**THE EASY WAY!**

**SWIF SOLDER**

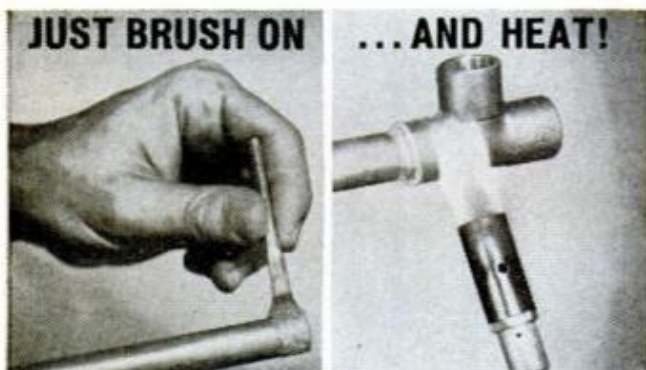

Make perfect leak-proof sweat joints every time with Hercules SWIF Solder, the real 50/50 tin-lead solder pre-mixed with flux in easy-to-use paste form. Save time and money, too. Just brush on, join, and heat for neat, strong joints. SWIF solders all common metals (except aluminum) and works with a torch, soldering iron, or soldering gun. This grade available in economical 4 oz., 1/2 lb., 1 lb., and 3 lb. cans at your plumbing supply or hardware dealer. See for yourself how easy any soldering job is when you use SWIF.



Write for free do-it-yourself soldering folder.

Hercules Chemical Co., Inc., 416 B'way, N.Y. 13

**START A BUSINESS**  
this quick way



with these 2 machines  
you can sharpen  
**ALL HAND AND POWER  
LAWN MOWERS**

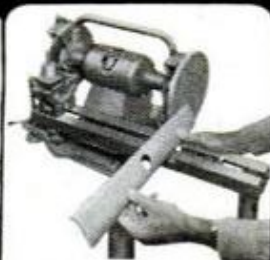

**FOR ROTARY POWER  
MOWER BLADES**  
The Foley 314 Grinder  
puts a perfect cutting  
edge on all rotary power  
mower blades.

Here's a business you can start in spare time, and begin to make a CASH PROFIT right away. The Foley Lawn Mower Sharpener handles up to 3 or 4 reel type mowers per hour. Prices run \$2.00 to \$3.00 for hand mowers, \$5.00 to \$8.00 for power mowers. You get 99¢ profit out of each dollar.

With the Foley Grinder you can sharpen rotary power mower blades, rip, cross-cut and combination circular saws, dado heads, ice skates, knives, scissors, shears, all sharp-edged tools.

**FREE PLAN** tells how to put yourself right into a home business that will pay you \$3 to \$6 an hour. Send coupon today for **FREE BOOK** on how to sharpen power mowers and Special Combination Money Saving Offer. No obligation—no salesman will call.



**FOLEY MFG. CO.**  
207-2 Foley Bldg., Minneapolis 18, Minn.  
Send Free Plan on lawn mower business and  
Special Combination Offer.

NAME \_\_\_\_\_

ADDRESS \_\_\_\_\_

**Items from  
all outdoors**

Does your boat still carry a fire extinguisher that uses carbon tetrachloride, chlorobromomethane (there's a mouthful), or some other toxic vaporizing liquids? Though such types are fast disappearing from the scene, many are still around on boats. But the first of January was the cutoff date for their use under Coast Guard regulations—they're now illegal. Better check your extinguisher. The three legal types are chemical foam, CO<sub>2</sub>, and dry chemical.

As this issue goes to press, PM's outdoors editor returns from a visit to Outboard Marine Corporation's test station at Naples, Florida. There I had a chance to test drive OMC's long-awaited three-point boat (see page 115). And, true to their promise, the designers proved that their radically-new hull has everything they predicted. It's fast (over 30 m.p.h. easily with four adults aboard), runs dry and level, comes up on a plane quickly and stays up at very low speeds. In short, it is easily the most stable, best-handling multikeeled boat I've ever driven. What's more, while more familiar multikeels are notoriously rough riders in a chop, the new boat smoothes out the bumps surprisingly well. By the time they're available this spring, their 80-horse two-cycle powerhead will be optionally-equipped with *direct fuel injection* for better acceleration, smoother performance and an estimated 30 percent cut in fuel consumption.

One of the big problems in correcting bad golf form is finding out where you're hitting the ball with the club face. It's impossible to tell by watching the impact—it all happens too fast for your eye to see. But a new training aid called Spot-Shot does the job. It's an adhesive tab that sticks over the club face and retains the impression of the ball after you've hit it. Since most topping, skying, hooks and slices are caused by hitting the ball with the wrong area on the club face, you can quickly spot your trouble and work to correct it. You get three tabs, each one good for 100 erasable impressions, and an indexed instruction book for \$1.25. It's made by the Spot-Shot Co., Box 158, West Covina, Calif.

*Dick Kirkpatrick*

POPULAR MECHANICS

# DEMING, NEW MEXICO

## A RANCHETTE OF YOUR OWN

### In The Healthiest, Sunniest Climate In All America

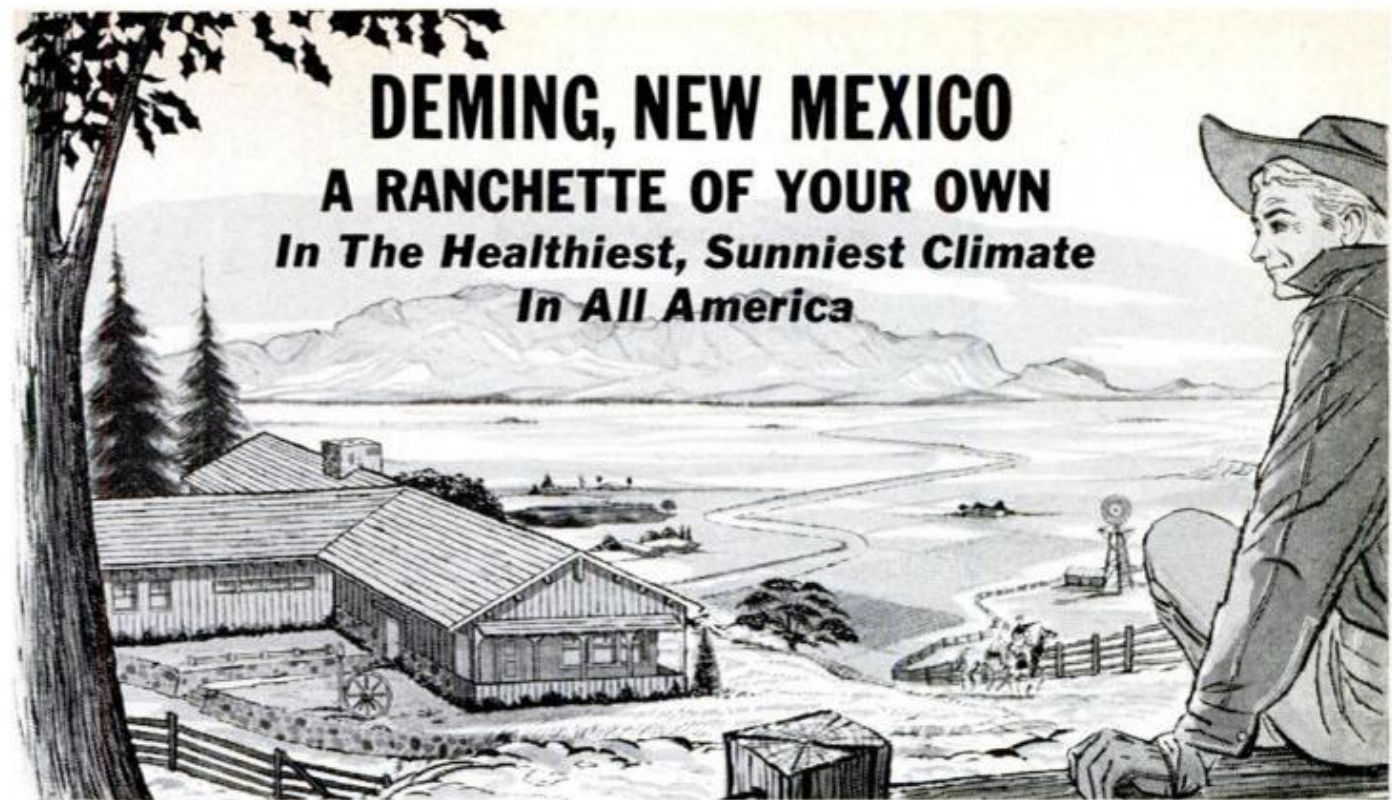

**\$199 PER HALF ACRE**

**\$5 DOWN \$5 PER MONTH**

There is a broad ribbon of highway that begins in the heart of Savannah, Georgia and winds for 3000 miles to its terminus in exciting Los Angeles. This ribbon is mighty Route 80—the most travelled all-weather highway in the U.S. Millions of Americans have followed it to the West, coursing through the rich hills of Georgia and Alabama, passing through the heart of Mississippi and Louisiana and entering into the plains of Texas. Gradually the scenery begins to change. Texas begins to roll; distant hills become higher. Then suddenly one emerges into "The Land of Enchantment." New Mexico's wonders erupt in a blaze of color and majesty. The mighty mountains thrust themselves, tree-topped, into the unimaginable blue of the sky. Dust and smoke have vanished from the air and the lungs drink in great delicious draughts in heady delight. If it is wintertime snow may cap the lofty mountains. If it is spring or summer or fall the unspoiled air touches the skin softly and the feeling of well-being is nowhere else equalled. But winter or summer, it is almost certain the sun will be shining in New Mexico—the sunniest, healthiest state of all 50. Yet great 80 is just beginning to take you through the sunshine wonderland of America. In the tropical southwestern pocket of our country you glide through towns like Las Cruces and Deming. A short while westward and you are in Tucson and Phoenix, Arizona, and from there the West Coast beckons. But nowhere in this enchanting Southwest is there a more beautiful area than the mountain-rimmed, pure-aired New Mexico region of Las Cruces and Deming.

DEMING RANCHETTES is blessed with water which is called "America's finest drinking water, 99.99% pure." (Almost every shop in Deming displays this proud claim in its window.) Home building has already begun in DEMING RANCHETTES and electric lines and telephone connections await you. Schools, hospitals, churches, shops, theaters, golf course, tennis courts—these are close by in the charming growing city of Deming. Fertile soil is yours for the planting, and wait until you see the stunning landscape of cotton fields in bloom. Fruit trees... apple, peach, pear and plum... do not grow better anywhere.

And the price of your Ranchette? Just \$199 complete for a half-acre, \$5 down and \$5 monthly. That's the complete price—no extras, no interest, no taxes! At this moment you may reserve as many half-acre sites as you wish but please bear this in mind: DEMING RANCHETTES is not an enormous development and land such as this goes fast. At these prices you may want your Ranchette to be larger—one, two—even five acres. An immediate deposit will guarantee that your half-acres will adjoin each other (this may not be so in the near future). And you take no risk in sending your deposit. Your \$5 per half-acre will definitely reserve your land but does not obligate you. You have the unqualified right to change your mind 30 days after we send you your Purchaser's Agreement, Property Owner's Kit, Maps and Photographs—30 full days to go through the portfolio, check our references, talk it over with the family. If, during that time, you should indeed change your mind your reservation deposit will be instantly refunded. (Deming and Albuquerque Bank references.)

Ten years ago, in nearby Las Cruces, a comparable fertile half-acre such as we offer in DEMING RANCHETTES could have been bought for \$199. Today it's up to \$2000! Experienced realtors predict the same future for Deming—in a much shorter time! If this makes sense to you your next act is mailing the coupon below. And one more thing: we promise that no salesman will annoy you. Thanks, sincerely, for your attention.

To live anywhere in New Mexico is to live better. The superb climate, naturally air-conditioned in the summer and brilliantly sunny in the winter—the breathtaking beauty of a lavish Nature—the young vigor of a state that is causing an unprecedented business and investment boom—the record which shows that one lives longer, that health improvement is almost miraculous—these are the reasons that tens of thousands of Americans already have come here to live, and hundreds of thousands of others will be following in the immediate years ahead.

Consider then: Here in the center of this miraculous climate and beauty are towns which have grown amazingly in the last 10 years. Las Cruces, for example: In 1950 it had 12,000 people. By 1960, 37,000... a rise of 300% in 10 years! (How about your town? Has it grown 3 times its size in 10 years?) Like Tucson and Phoenix, this area is a beautiful semi-tropical paradise where palm trees and long staple cotton-fields flower the landscape. Statistics show the same 85% of possible sunshine, summer and winter; these same figures reveal even purer, drier air than in Phoenix or Tucson.

A few minutes from the flavorful city of Deming (population 8,000) is a 5,000 acre Ranch, picture-framed by the breathtaking Florida Mountains. So real, so beautiful, so typically the romance of the Southwest is this valley Ranch that it has been photographed for the covers of many magazines including the official publication of the State of New Mexico. What better way to describe its Southwestern flavor than to tell you that when the producers of the movie THE TALL TEXAN sought an authentic locale for their picture, they chose the very land we are now sub-dividing into the DEMING RANCHETTES. THE TALL TEXAN was filmed on our ranch, the same place where you may have a Ranchette of your very own!

This is the lovely basin of land where heavy equipment is now at work constructing wide roads facing every DEMING RANCHETTE. Every Ranchette will have direct access to avenues leading to three major highways surrounding our property—U.S. Highways 80, 70 and State Highway 11.

DEMING RANCHETTES DEPT. L-6  
112 West Pine Street, Deming, New Mexico

Gentlemen: I wish to reserve the following site in Deming Ranchettes:

- ½ acre for \$199. I enclose \$5 as a deposit.
- 1 acre for \$395. I enclose \$10 as a deposit.
- 1½ acres for \$590. I enclose \$15 as a deposit.
- 2½ acres for \$975. I enclose \$25 as a deposit.
- 5 acres for \$1925. I enclose \$50 as a deposit.

Please rush complete details, including my Purchaser's Agreement, Property Owner's Kit, Maps, Photographs and all data. It is strictly understood that I may change my mind within 30 days for any reason and that my deposit will be fully and instantly refunded if I do.

NAME.....

ADDRESS.....

CITY..... ZONE..... STATE.....



# On the market

**1. ALL-PURPOSE PATCHING PLASTER** with vinyl combines durability of plaster with resiliency and bonding strength of vinyl. Material can be troweled on as thin as paint or, when mixed with sand, used as economical fill for large areas. It is especially effective as joint cement for wallboard. Plaster-All Products, 5150 N. Western Ave., Chicago 25, Ill.

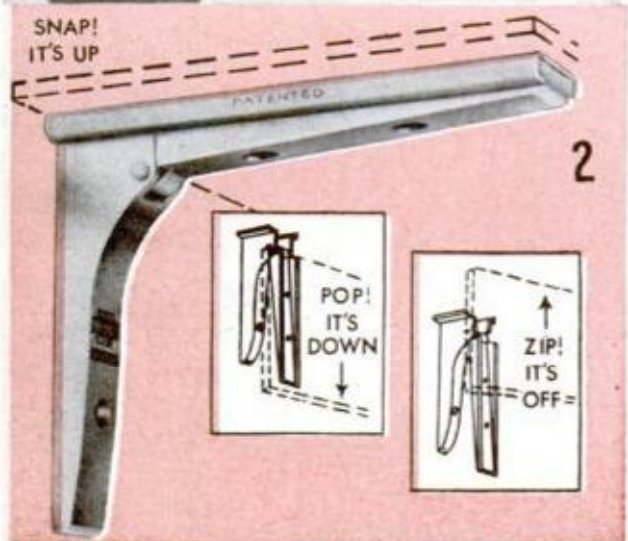

**2. REMOVABLE FOLDING BRACKET** is ideal for shelves, tables, seats, and counters where floor space is at premium. Shelf may be removed for storage or quickly replaced by another shelf on same brackets—especially useful in boats and house trailers. Price of brass bracket is \$4.98. Standard-Keil Hardware Mfg. Co., 2581-85 Atlantic Ave., Brooklyn 7, N. Y.



**3. VINYL SLATE TILE** combines the character of quarried slate with the advantages of vinyl asbestos. Suitable for on, or below-grade installations, material is warm and resilient underfoot. It is available in five realistic stone colors—with the colors and pattern going all the way through for maximum wear. B. F. Goodrich, 800 Second Ave., New York 17, N. Y.

**4. EPOXY CEMENT** in a two-component package solves the problem of mixing small quantity of this fast-drying material. Catalyst and resin are sealed in vacuum-formed plastic container—one in center, other in separate concentric ring. Stick is used to push down center; then components are mixed directly. Plastic Assoc., Box 36, Laguna Beach, Calif.

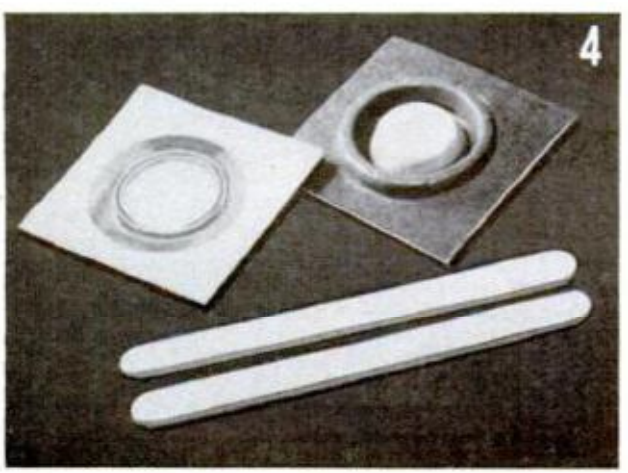

**5. PLASTIC ELECTRICAL TAPE** is now available with a taping dispenser in a new economy size. The tough, black tape can be cut easily and cleanly on the cutting edge which forms part of the dispenser. Also, the position of the end tab makes the tape convenient for instant use. Marketed by the Minnesota Mining & Mfg. Co., 900 Bush Ave., St. Paul 6, Minn.

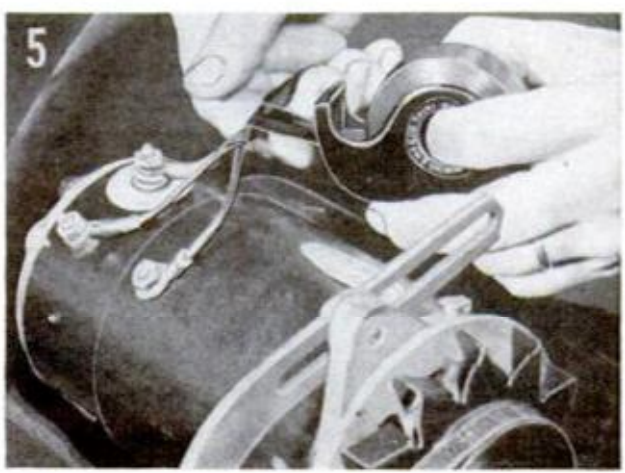



(Advertisement)

A number of one-man mail order enterprises are paying their owners an income of \$40,000 to \$50,000.

## SPECIAL OPPORTUNITIES

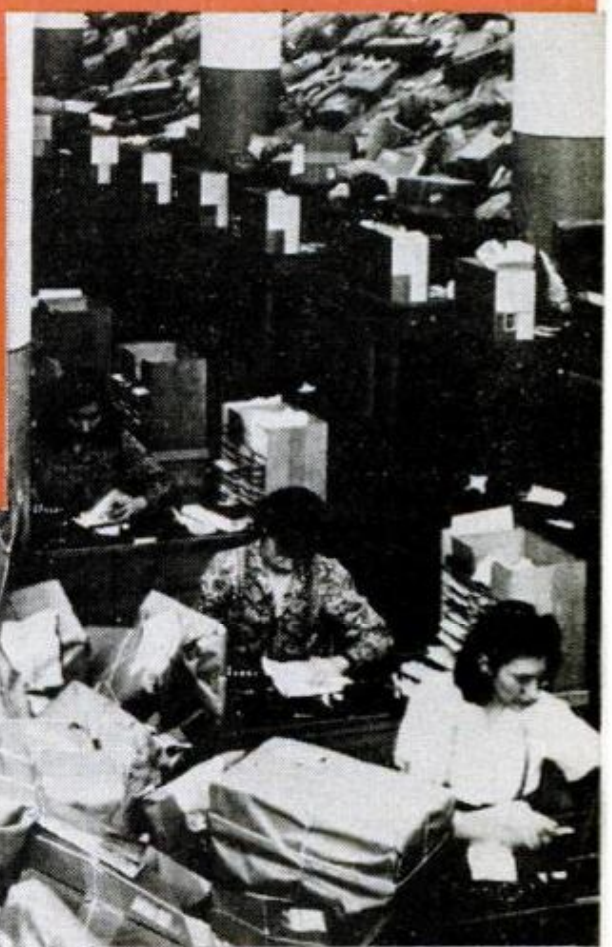

Mail order is big business. Annual catalog sales volume of Sears, Roebuck and Co. is over 700 million dollars!

### HOW TO START

# Your Own Mail Order Business

You can make a fortune by mail. New firms will set you up in a fabulous mail order business of your own! They'll make up your catalogs, prepare your advertising, supply mailing lists and even ship your products for you!

### By Robert Stephenson

When Anthony Sambati injured his back and was laid off from work he never dreamed it would be a blessing in disguise. Bedridden for weeks, he decided to start a small mail order business. This was something he could run right from his own home and required very little capital to begin. In fact, Sambati started with less than \$85.00.



After a short time in mail order, Sambati soon had a beautiful home with all the luxuries of a successful businessman.

He figured that a small mail order business might provide a temporary income to support his family until he got back on his feet. His first step was to obtain a franchise from a large wholesale mail order firm which supplied him with all the necessary catalogs and mailing literature. It wasn't long until his spare-time venture blossomed into a booming enterprise. Drawing a small salary and pouring the rest of the profits back into the business, he soon had others working for him! Today he owns a large retail store, his own warehouse and a beautiful home with all the luxuries of a successful businessman.

Sambati's story is typical of a number of men and women who began a small mail order business with absolutely no previous experience, and made a huge success of it. These 'little' people are quietly pocketing big profits every day—many content to keep the business small . . . spending an hour or two each day in the privacy of their own home. No bosses, time clocks or small pay envelopes. No door to door selling, in fact, you never even meet your customers face to face.

Yes, a small one-man mail order business is ideal for anyone wanting a chance to gain financial security and independence. Yet thousands try mail order each year and fail, simply because they don't learn the few simple secrets of success early in the game.

Take the case of Bud Sheer who had been working for a theatre in a small New Jersey town. With only a few hours spare-time to spend each morning, he tried mail order to supplement his regular income. Like many beginners in this field, Sheer was faced with the problem of finding good mail order items which would have a high mark-up and repeat sales potential. But the biggest obstacle was the expense of printing a catalog.

Then he heard about the A. J. Statile Co. of Hillsdale, New Jersey — an organization set up to aid the small mail order beginner.

He wrote to A. J. Statile Co. for full information, sent in his application for a franchise and within a short time the cash began rolling in. Today Bud Sheer *owns* the theatre he once worked for. Sheer attributes his success in mail order to the A. J. Statile Co. Actually, the theatre he owns has become a side investment.

He still uses the beautiful 300 page mail order catalogs supplied by A. J. Statile Co.

How does the Statile Co. help the beginner get a sound start in mail order? Very simply. Just as Henry Ford made automobiles within the reach of the general public—by mass production and large volume.

Let's take a few specific examples:

(1) All franchised dealers of A. J. Statile are offered ready to mail catalogs and sales literature. Each mailing piece has the dealer's name and address printed right on it. By printing millions of catalogs, Statile is able to offer these at a fraction of their regular cost. The artwork and layout costs for these catalogs would run into thousands of dollars for the beginner if he were starting from 'scratch'.

(2) Since all mailing material and catalogs contain your name and address, all orders come directly to you. Yet you don't have to invest one penny in inventory. All merchandise is stocked for you. In fact Statile has over \$3 million dollars worth of mail order merchandise at your disposal.

(3) All packaging and shipping is done for you. You simply send a shipping label to Statile together with the wholesale cost of the items, and the merchandise is shipped directly to your customers under your own shipping label.

(4) A consultation service is provided to answer any questions you may have. You receive a secret list of over 100 national magazines which run free ads. You'll be shown how to obtain free publicity on your own mail order items. In addition, you obtain trade names and addresses of over 150 other mail order wholesalers who drop-ship top mail order items for you. You'll also be given all the government laws and regulations pertaining to a home operated mail order business. These laws are a 'must' for all beginners.

All this valuable information is covered in the Statile Mail Order Survey which every new franchised dealer receives from Statile before they begin. Formerly sold for \$25.00, this survey has become the 'bible' of the trade. Mr. J. M. of Baltimore, Md., writes, "To tell the truth, all the information in regard to obtaining free ads is alone worth the \$25.00 I paid you . . ." J. D. of Kalamazoo, Mich.,

(Advertisement)

states, "Just a personal note to say I am most satisfied with my \$25.00 investment. Your sales plan is simple and well organized . . ." These are only a few of the many testimonials received praising the Statile Mail Order Survey.

(5) The catalogs and mailing literature offered by Statile Co. cover every conceivable mail order item. You select the field you are interested in . . . BABY ITEMS, TOYS, APPLIANCES, VITAMINS, BOOKLETS AND



The thrill of receiving money in your morning mail is one you'll never tire of.

MAIL ORDER COURSES, you name it, Statile has the catalog or mailing piece. Select your market, order your mailing literature and you're in business.

(6) You'll be told how to compile your own mailing lists—and this is the most important part of your business. Many a beginner has fallen by the wayside simply because he mails his catalogs to a poor list of names. Suppose, for example, you offered a beautiful scale model of a 40' Chris-Craft cabin cruiser by mail. You would probably make your mailings to boating enthusiasts and the chances are that nine times out of ten your mailings would show a loss instead of a profit. How would Statile help you solve this particular mailing list problem? He would show you where to get the names and addresses of *actual owners* of 40 foot Chris-Craft cabin cruisers! Surely every owner would like to have a scale model of his own boat. Strange as it may seem, such a mailing list is available to anyone. The secret is where to find it. This is just one example of how an experienced mail order expert giving you personal advice, may mean the difference between success and failure!

This same method of obtaining selective specialized mailing lists may be applied to practically any market . . . selling baby items to new mothers, selling toys to young children, etc., etc.

So much for starting your own mail order business. Now, a word of caution. **OBTAIN YOUR MAIL ORDER FRANCHISE FROM A**

**REPUTABLE MAIL ORDER FIRM.** Unfortunately, during the past few years a number of ads have appeared in newspapers and magazines offering to start people in mail order. The ads are grossly misleading. Many imply that you can become a millionaire over night if you use their catalogs. Beware! Particularly if they operate their own mail order business direct to the consumer. These firms compete with their own franchised dealers! They could just as well mail all the catalogs themselves. They don't need you.

Other shady firms fail to drop-ship your orders promptly, thereby losing customers for you. In mail order, prompt shipment is an absolute requirement for a successful operation.

Deal only with firms whose business is preparing catalogs and shipping merchandise. They operate on a strict wholesale basis for franchised dealers exclusively. Such a firm is the A. J. Statile Co. Letters from successful franchised mail order dealers speak for themselves. A woman from Milwaukee writes, "It has been better than my expectations." A gentleman from California states "we are quite pleased with the response we are receiving." Another man from Wisconsin writes, "To say the least, I am more than satisfied."

Yes, a small mail order business offers you an opportunity to earn a second income, or—if you work at it in earnest, a chance to strike it rich. The young housewife in St. Louis may be content to make an extra \$20.00 a week . . . the office worker in Los Angeles may be aiming for \$150.00 weekly full time business . . . and the ambitious schoolteacher in Newark may reach \$20,000.00 a year. What is your objective? Set your own goal, pick your own hours, and the sky is the limit.

Even a government report stated that a number of the most successful one-man mail order enterprises make as high as \$40,000 to



**Big firms will carry all stock for you. They ship orders direct to your customers using your own shipping labels.**

(Advertisement)

# Your Own Catalogs of Top Mail Order Items!



• NAME BRAND GIFTS, BABY ITEMS

• CATALOGS OF TOYS, MERCHANDISE

• CORRESPONDENCE COURSES

**A. J. Statile Co. will prepare your catalogs, write your sales letters, supply mailing lists and even ship merchandise for you, using your own shipping labels!**

\$50,000 a year! But frankly, this is the exception rather than the rule. Most mail order operators are content to earn a comfortable living doing little physical work, but enjoying their work thoroughly! We don't say you'll be a mail order millionaire or another Sears & Roebuck, but if you're looking for a business of your own with financial security, the answer is mail order. If you've already tried mail order with little or no success, don't give up! Try to analyze what went wrong. Success comes only to those who keep trying and learn from their own mistakes. Again we emphasize, deal only with a reputable firm.

The A. J. Statile Co. has been in business for over twelve years.

They gladly furnish bank or trade references upon request. They are probably one of the largest mail order wholesalers in the country. Whether it be toys, gifts, vitamins or appliances—they've got it ready to ship under your label **WITHIN 24 HOURS!**

Firmly convinced that no other business offers the tremendous opportunities of mail order, A. J. Statile, president of the firm, is an outspoken advocate of the man or woman who wants to start in business for himself. As Statile puts it, "by all means, start your own business and start **NOW!** If you want a chance at security and financial independence make your choice mail order. There's nothing like it. Absolutely nothing!"

## FOR FREE DETAILS

**Mail coupon below — no obligation**

A. J. Statile Co., Dept. 28 • Statile Building • Hillsdale 28, N. J.

Dear Mr. Statile:

Please send me complete **FREE** details telling me how I may obtain a franchised mail order dealership with your firm. I understand I am under no obligation and no salesman will call on me.

NAME..... AGE..... SEX.....

ADDRESS .....

CITY..... ZONE..... STATE.....

PREVIOUS EXPERIENCE, IF ANY.....

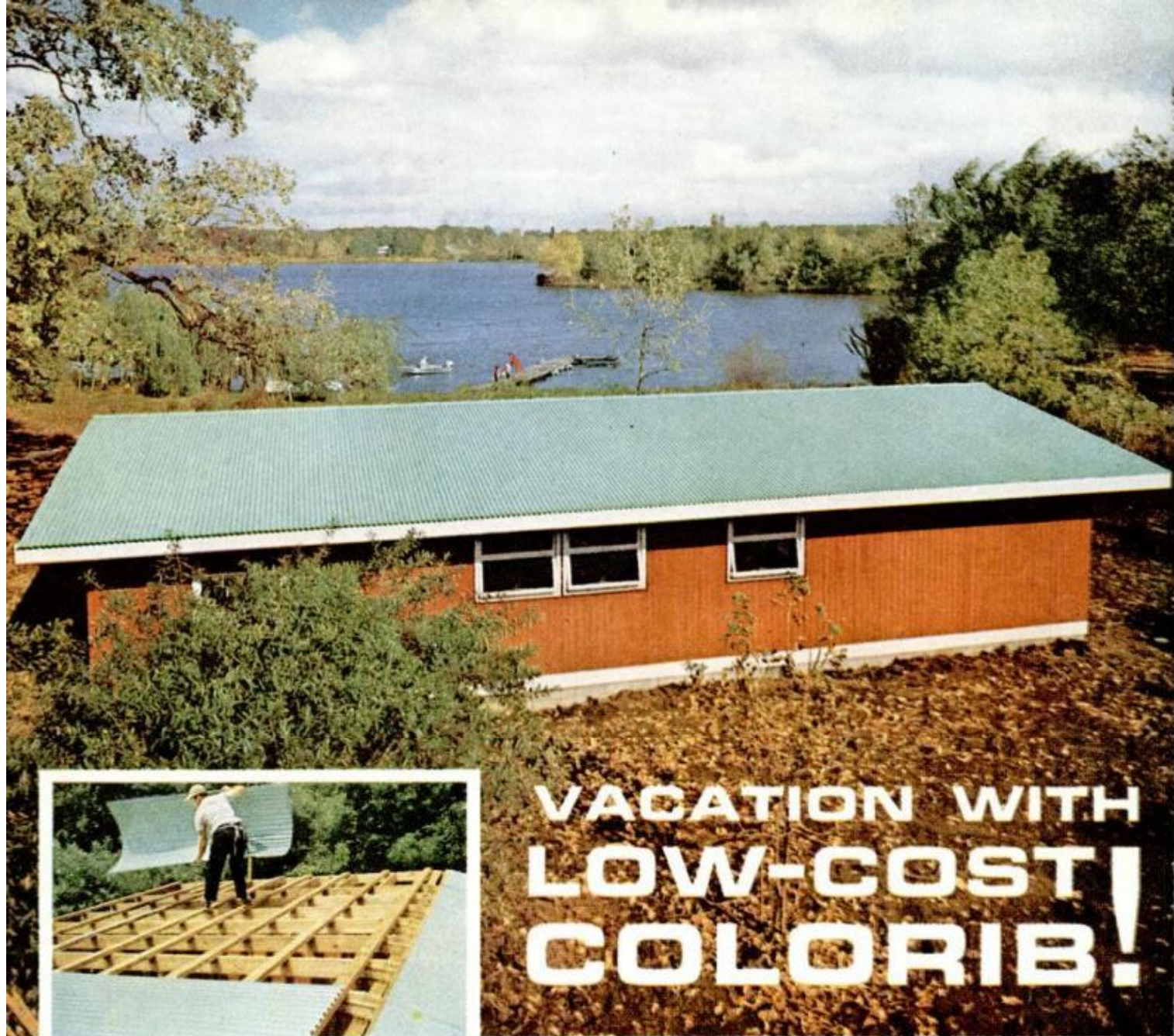

# VACATION WITH LOW-COST! COLORIB!

**BUILD** patios, fences, boathouses and vacation homes with Alcoa® Aluminum Colorib® Panels.

**GOES UP FAST AND EASY**—Use simple hand tools. Heavy-gage yet lightweight, covers fast.

**ONCE UP, NO UPKEEP**—Won't rust, rot or warp.

**TOUGH AND HANDSOME**—Finish won't chip, crack, flake, peel or blister. Baked enamel Colorib Panels stand up to wind, rain and snow.

**WRITE IN TODAY**—for Colorib Panel Idea Folder and where you can get **FREE PROJECT PLANS**. Send handy reply card, or write: Aluminum Company of America, 891-B Alcoa Building, Pittsburgh 19, Pa.



## ALCOA PANELS IN 7 BRIGHT COLORS

Entertainment at Its Best . . . **ALCOA PREMIERE**  
with **Fred Astaire** as host Tuesday Evenings, ABC-TV

FROM:

NAME \_\_\_\_\_

ADDRESS \_\_\_\_\_

CITY \_\_\_\_\_ ZONE \_\_\_\_\_ STATE \_\_\_\_\_

1st CLASS  
PERMIT  
No. 1174  
Pgh., Pa.

### BUSINESS REPLY MAIL

No Postage Stamp Necessary if Mailed in the United States

6¢ postage will be paid by

ALCOA COLORIB PANELS  
ALUMINUM COMPANY OF AMERICA  
891-B ALCOA BUILDING  
PITTSBURGH 19, PA.



**ALCOA ALUMINUM**

COLORIB PANELS

*You can light either end!*

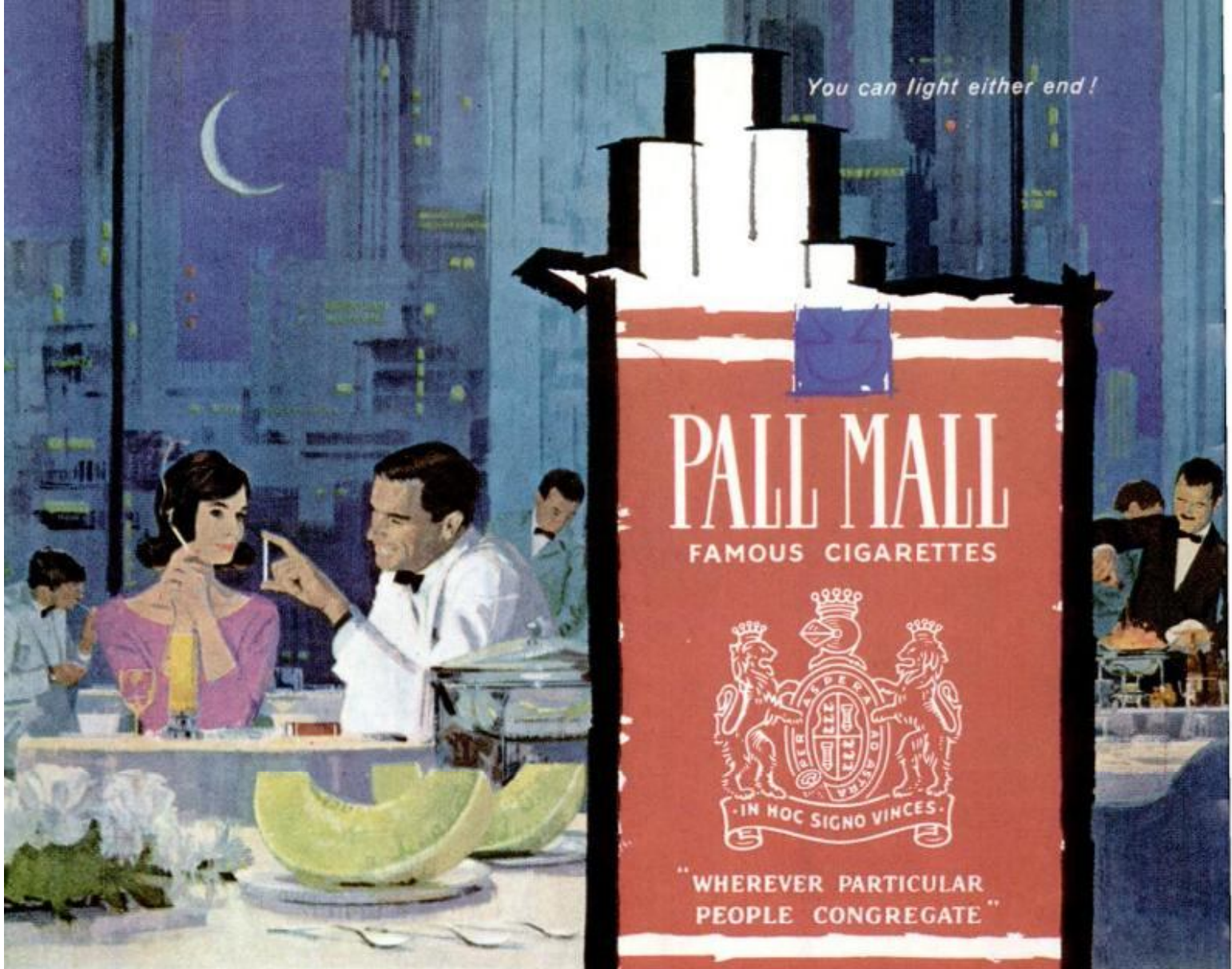

**PALL MALL**  
FAMOUS CIGARETTES



"WHEREVER PARTICULAR  
PEOPLE CONGREGATE"

*"Wherever particular people congregate"*

## Pall Mall's natural mildness is so good to your taste!

**So smooth, so satisfying, so downright smokeable!**

See how Pall Mall's famous length of fine tobacco travels and gentles the smoke naturally—makes it mild—but does not filter out that satisfying flavor. Never too strong. Never too weak. Always just right! Enjoy satisfying flavor...so friendly to your taste.

**Outstanding...**  
and they are **Mild!**

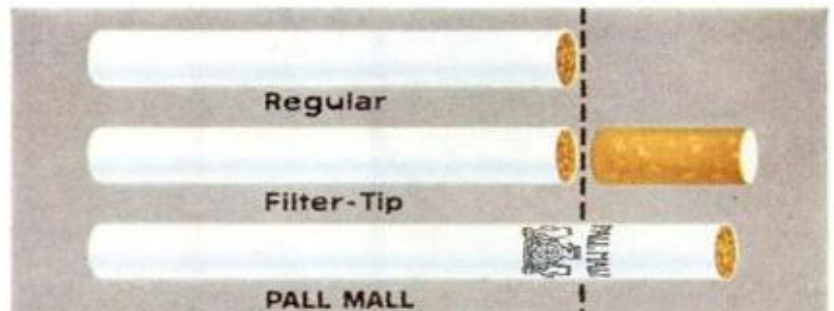

Compare all three! Smoke "traveled" through fine tobacco tastes best. See the difference! With Pall Mall, you get that famous length of the finest tobaccos money can buy. Pall Mall's famous length travels and gentles the smoke naturally... over, under, around and through Pall Mall's fine, mellow tobaccos. Makes it mild... but does not filter out that satisfying flavor!

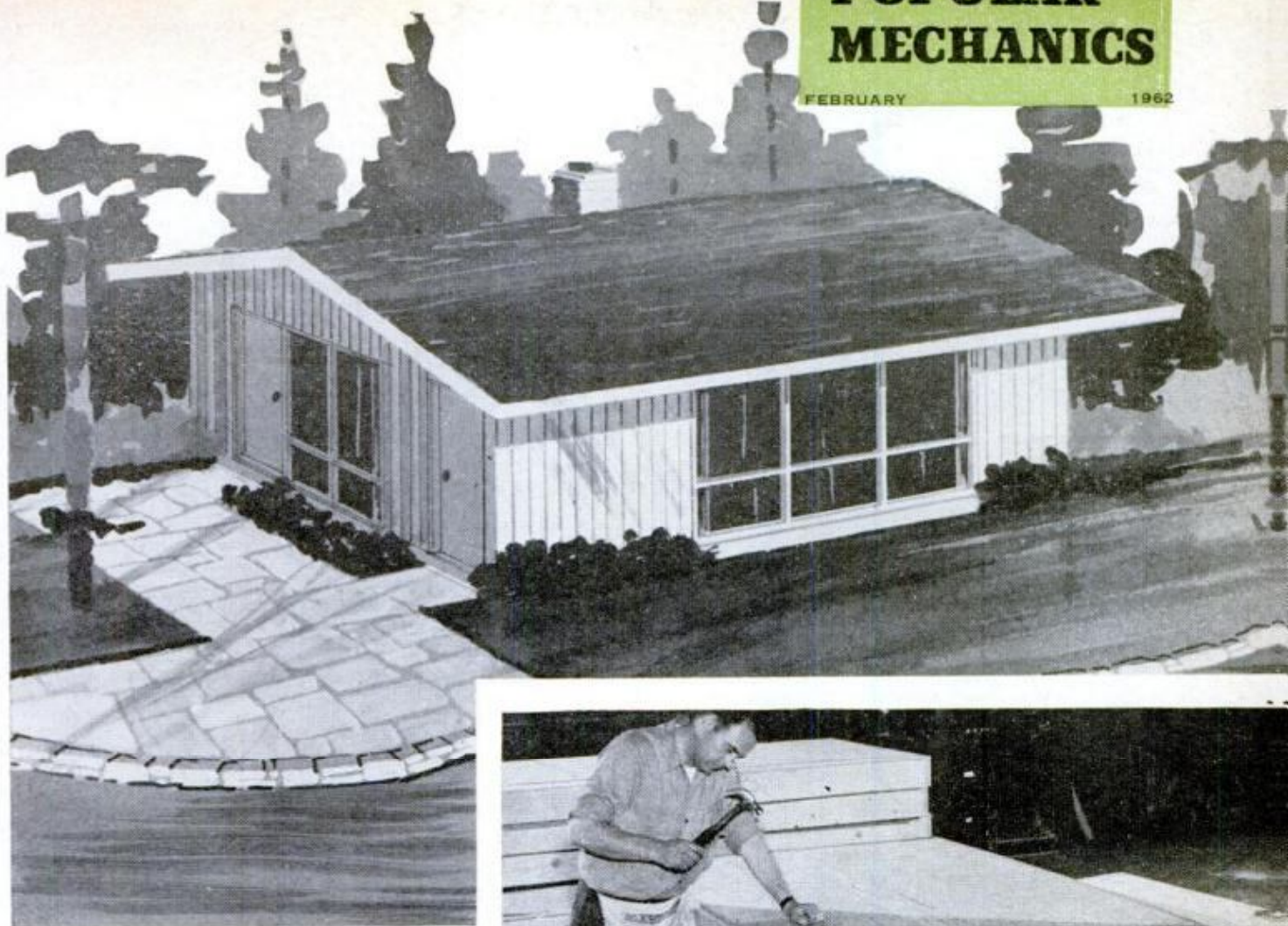

**START  
YOUR  
VACATION  
HOME  
at Home**

*Prefab construction lets you build it in your basement during the winter, ready for trucking to a lakeside building site next spring*

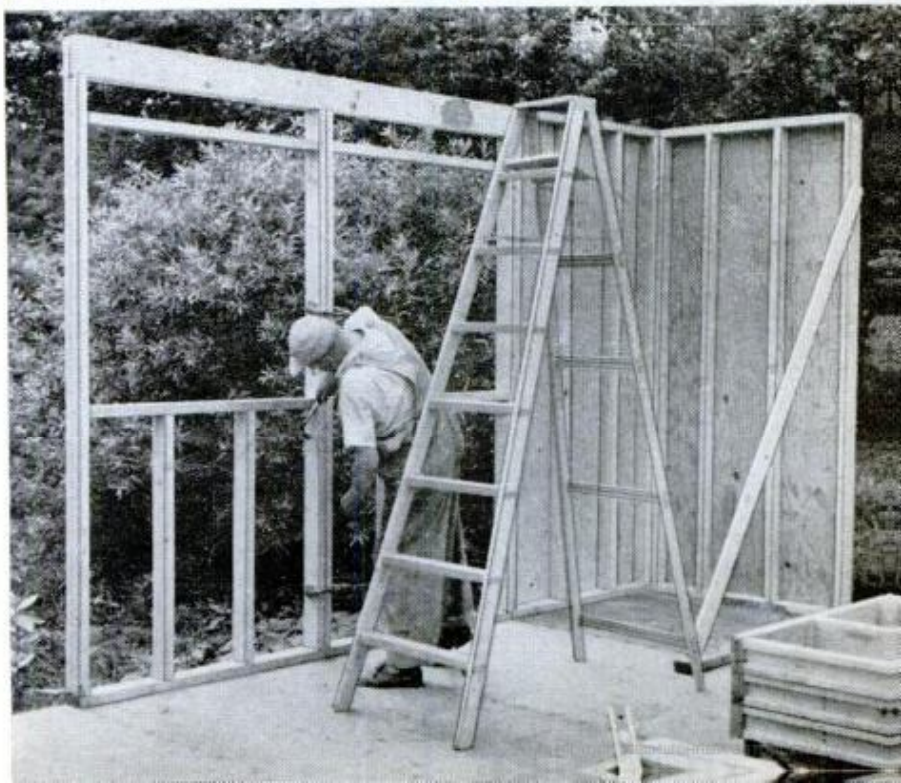
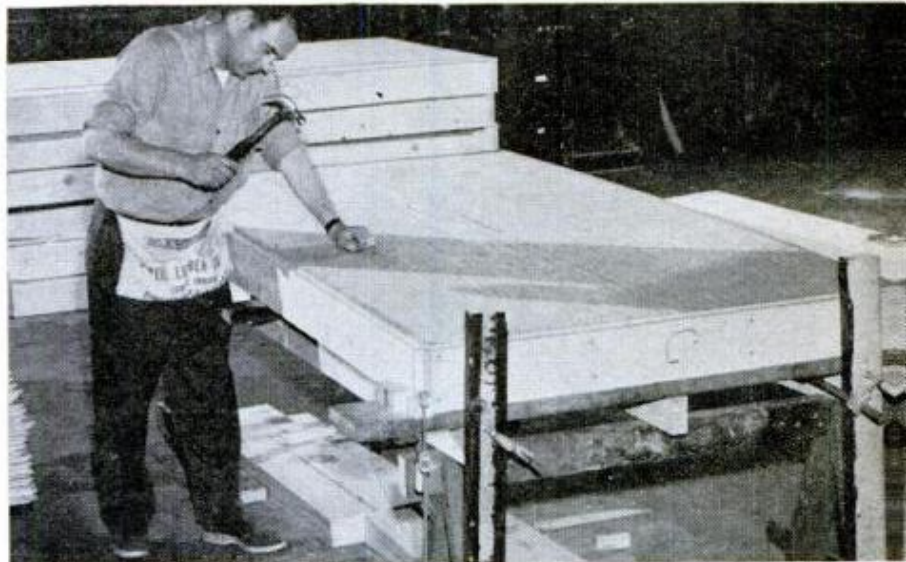

STAGE 3

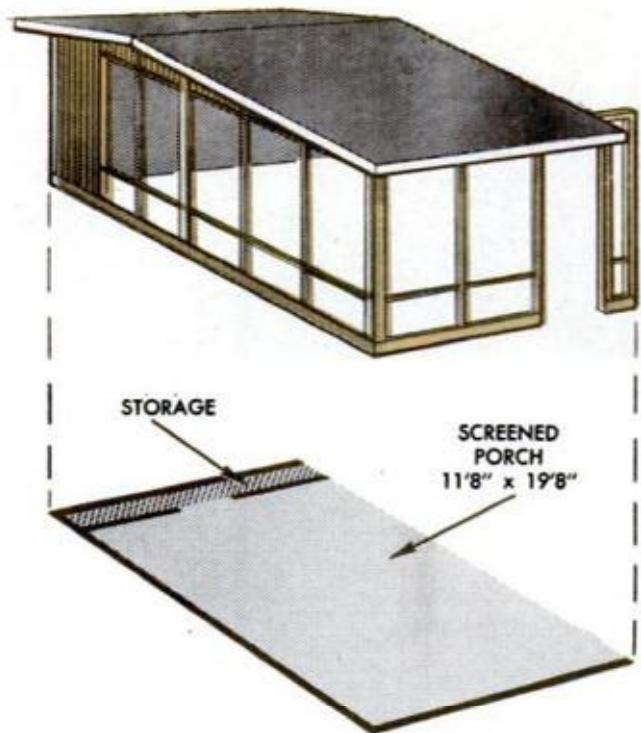

PART I

**E**VER THOUGHT you'd like to build your own vacation home? You probably have the very spot already picked out, a choice site overlooking a beautiful lake where the family could spend a carefree summer and you the week ends, plus your vacation.

But who has the time to build his own vacation home? Traveling back and forth would leave little time for working, it would take forever to build it, it's just too big a project to ever consider as a spare time project.

Building a vacation home at some distant spot week ends is out of the question to be sure. But suppose you could get a head start by building at least half of it at home in your basement or garage?

In building such a home within your home *Popular Mechanics* editors knew that almost everyone would be faced with a shortage of time. The answer, obviously, was a simple modular affair, the floors and walls of which could be prefabbed at home in standard 4-ft. sections, stockpiled until spring and carted to the building site where they could be erected by the builder within a two-week vacation period. With this idea in mind, the editors commissioned Home Planners, Inc. to design such a vacation home, stressing that it should be built of stock dimensional materials and that it should go together like a set of toy building blocks. In addition, it was to be designed to grow with the builder's future needs.

The vacation home you see here incorporates these basic requirements. Designed as a three-stage,



**FOOTING FORMS** are 2 x 4s, set on grade, then dug out for an 8-in. poured footing



**STUB TIE-INS** are laid at corners of basic foundation when future addition is planned

**FOUNDATION GOES FASTER** when several concrete blocks are buttered at same time





## STAGE 1

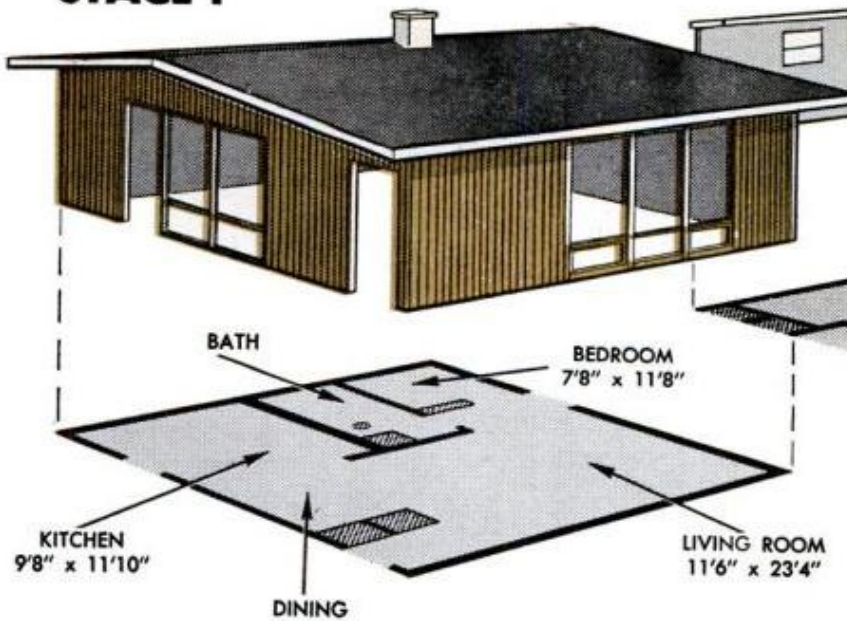

## STAGE 2

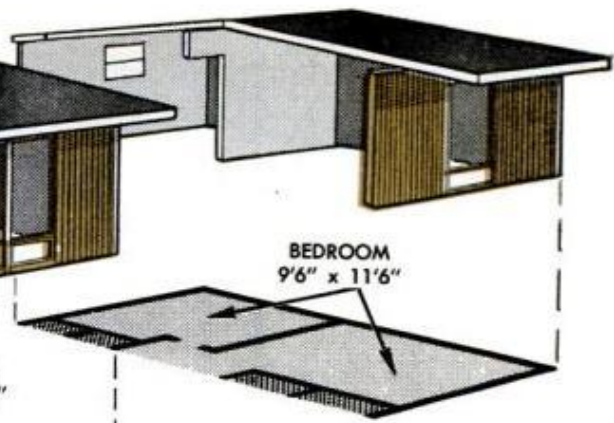

add-on affair, the modest basic unit has a modular floor plan measuring 24 x 24 ft., or a total of 576 sq. ft. It features a living room, a kitchen, a bedroom and bath, large enough to sleep and house a vacationing family of four. While the basic unit alone may very well fill your needs, both family-wise and budgetwise, the house is designed so it may be expanded at any future time with a minimum of work and expense. For example, if you find you need more sleeping area than the basic unit provides, a 12-ft. two-bedroom addition can be added. This involves little more than hitching on more 4-ft. prefabbed floor, wall and roof sections to the basic unit and cutting a doorway through the existing end wall. If

**HERE'S WHAT** your vacation home will look like when the add-on sections are attached to the ends of the basic unit, giving a total of 1152 sq. ft. of area

### IF YOU WOULD LIKE TO KNOW

what the material cost will be to build this economy vacation home in your locality, the name and address of the lumber and building-supply dealer nearest you is listed on page 244. He is prepared to provide you with costs and further information on building the PM vacation home.

in time you feel a need for a porch and the storage it provides, here again it's a case of simply hooking on another 12-ft. addition to the opposite end of the basic unit, over the existing patio slab. In each case, the wall and roof line is not disturbed, only a few roof shingles would have to be removed to tie in with the new, plus the fascia boards on the gable ends. The third stage gives you a total floor area of 1152 sq.

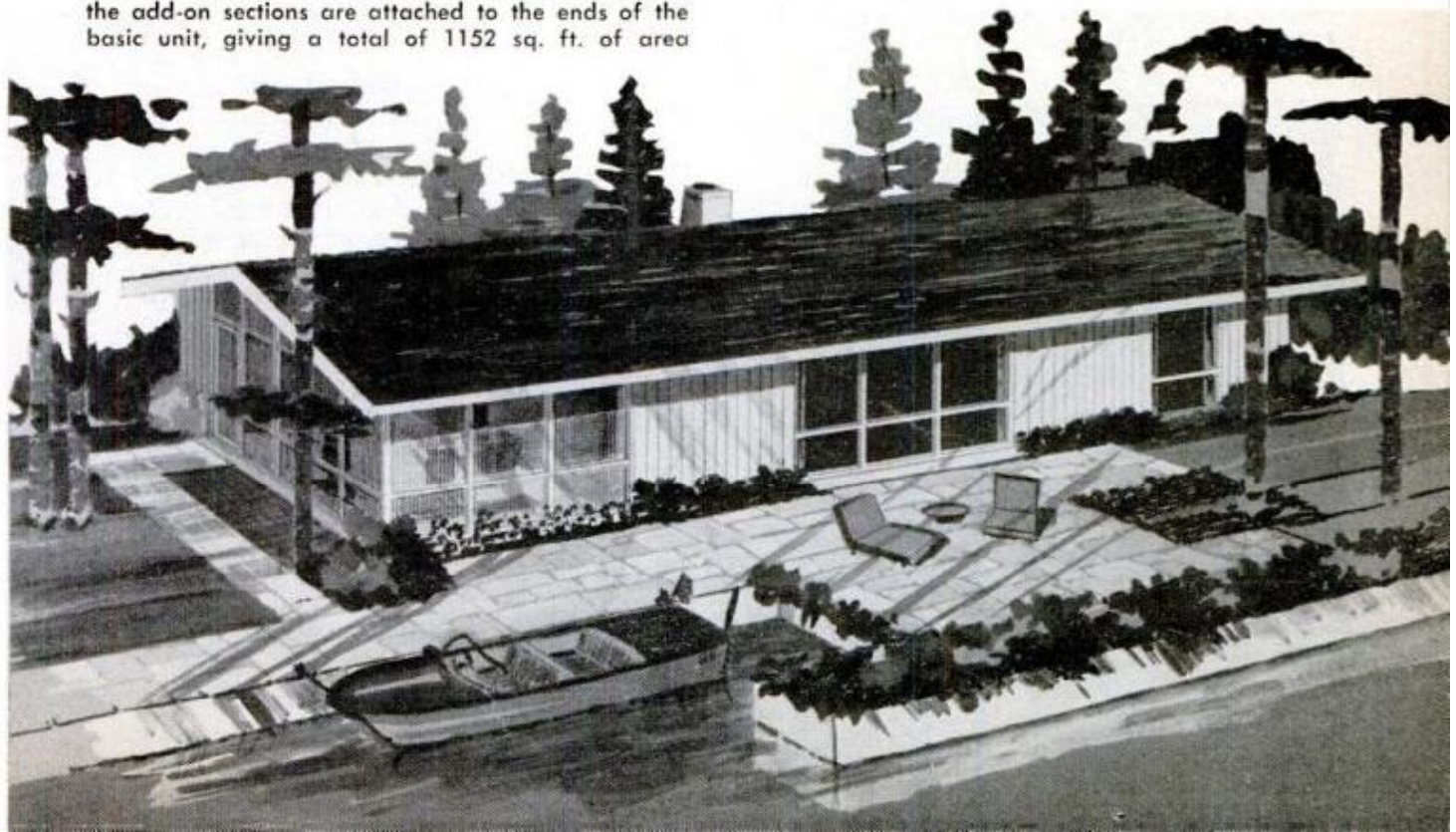

## ELEVATIONS OF BASIC UNIT

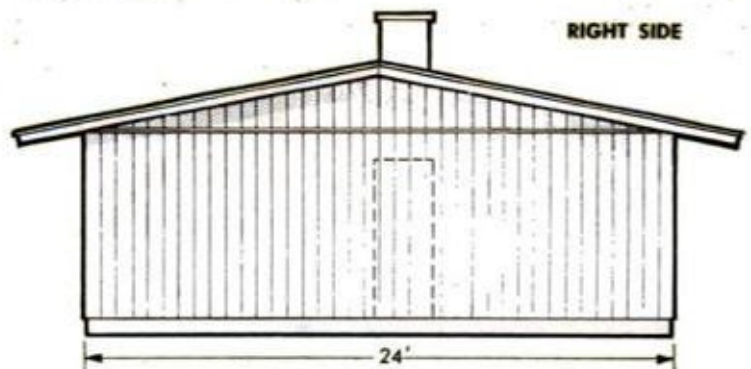
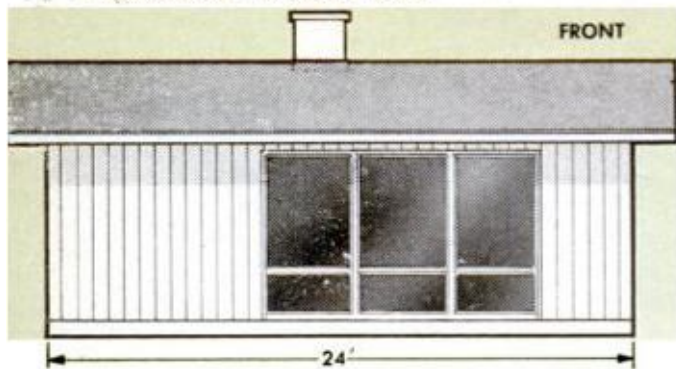

## ELEVATIONS OF ADDITIONAL UNITS

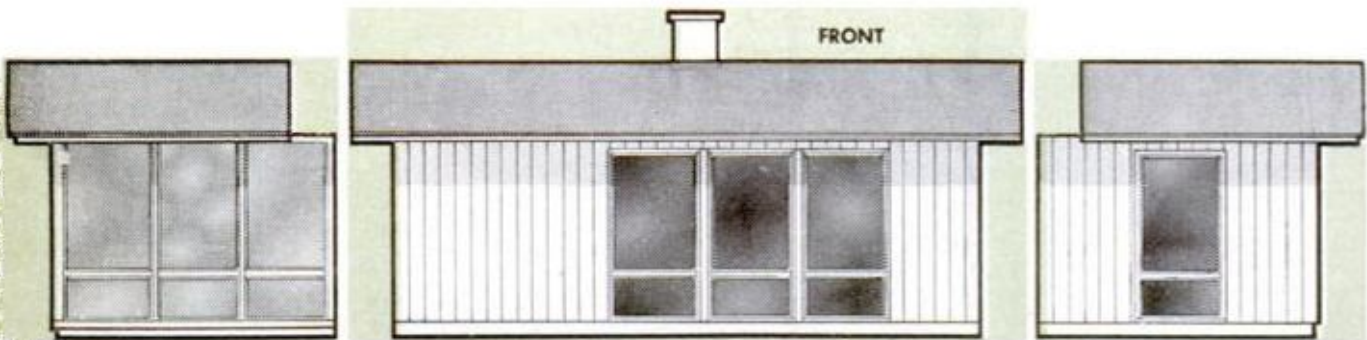
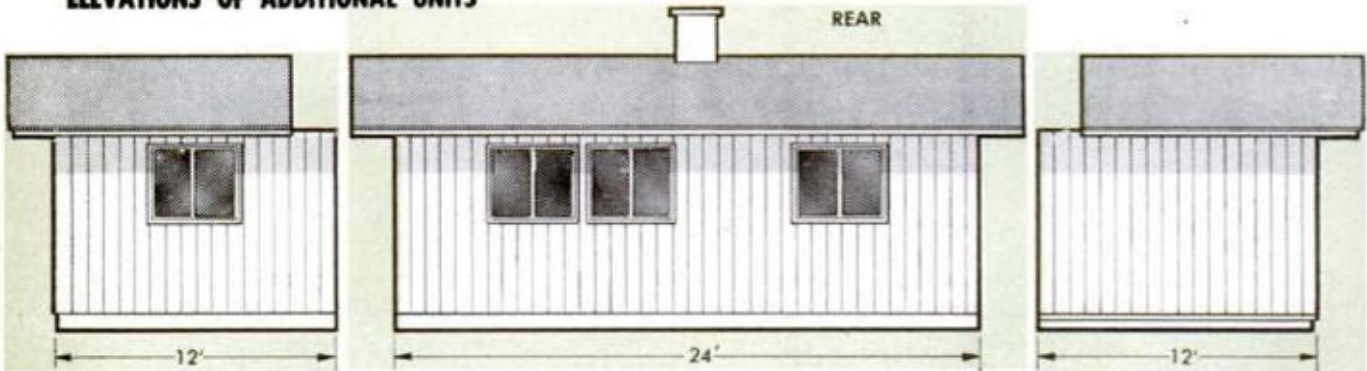

**HOLES IN WALL PLATES** are located for anchor bolts in foundation by placing 2 x 8 members against bolts and using try square to mark position of the bolts



ft., sufficient for even year-round living.

Now, can you actually build this home yourself? In the strict sense, no. Working alone you'll have the problem of lifting the heavy and bulky prefabricated panels. This will be less of a problem at home where friend wife can give you a hand in wrestling with the panels. However, when it comes to erecting them and framing the roof, you'll need a helping hand. There's the problem, too, of a well, a septic system and of getting the crawl space bulldozed. Actually, it makes sense to have the footing and block foundation laid for you so that when you are ready to take over, this part of construction is already done. In the case of the foundation it might be well to weigh the future possibility of building stage II. If so, you will be ahead to have the footing for the bedroom addition laid at

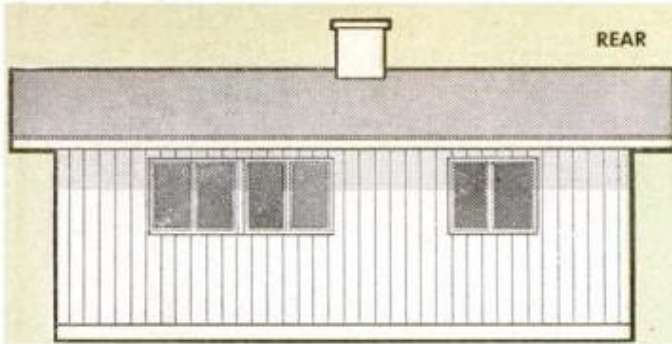

REAR

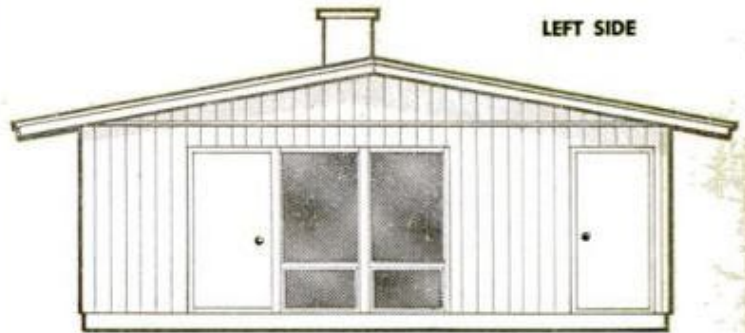

LEFT SIDE

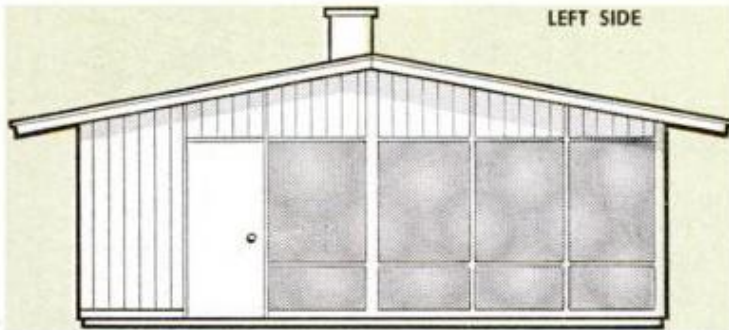

LEFT SIDE



RIGHT SIDE

### COMPLETE PLANS

including a material list, are available for the PM Vacation Home. Each set contains 14 sheets which detail the basic home as well as the add-on units. Floor alternates are included for the builder who may wish to follow conventional joist construction rather than pre-fabricating sections. The cost of the plans is \$20.00 for one set, \$35.00 for four sets. Each additional set is \$5.00 when ordered with the initial set. Order from Plans Department, Popular Mechanics Magazine, 200 East Ontario Street, Chicago 11, Illinois.

the same time as the footing for the basic unit and to have a portion of the foundation wall extended. Such long-range planning not only will save you money but will also provide foundation stubs for tying-in the new wall. Both footing and stub walls can be graded over and uncovered later.

What will the house cost? Materials for the basic unit will run about \$3000.00. This figure is based on material costs in a high-cost area and could very well be less in your particular locality. To this you will have to add the cost of the lot, the cost of a well, septic system and whatever additional labor you will have to hire.

Construction procedure is to be presented in a series of four articles, dealing with the building of the basic unit only. Since you will need several sets of regular builders' plans, which is customary, not

**EACH PILASTER** in the foundation wall of the basic unit is built up with a 4-in. block backed with a common 8-in. block in each course of the wall



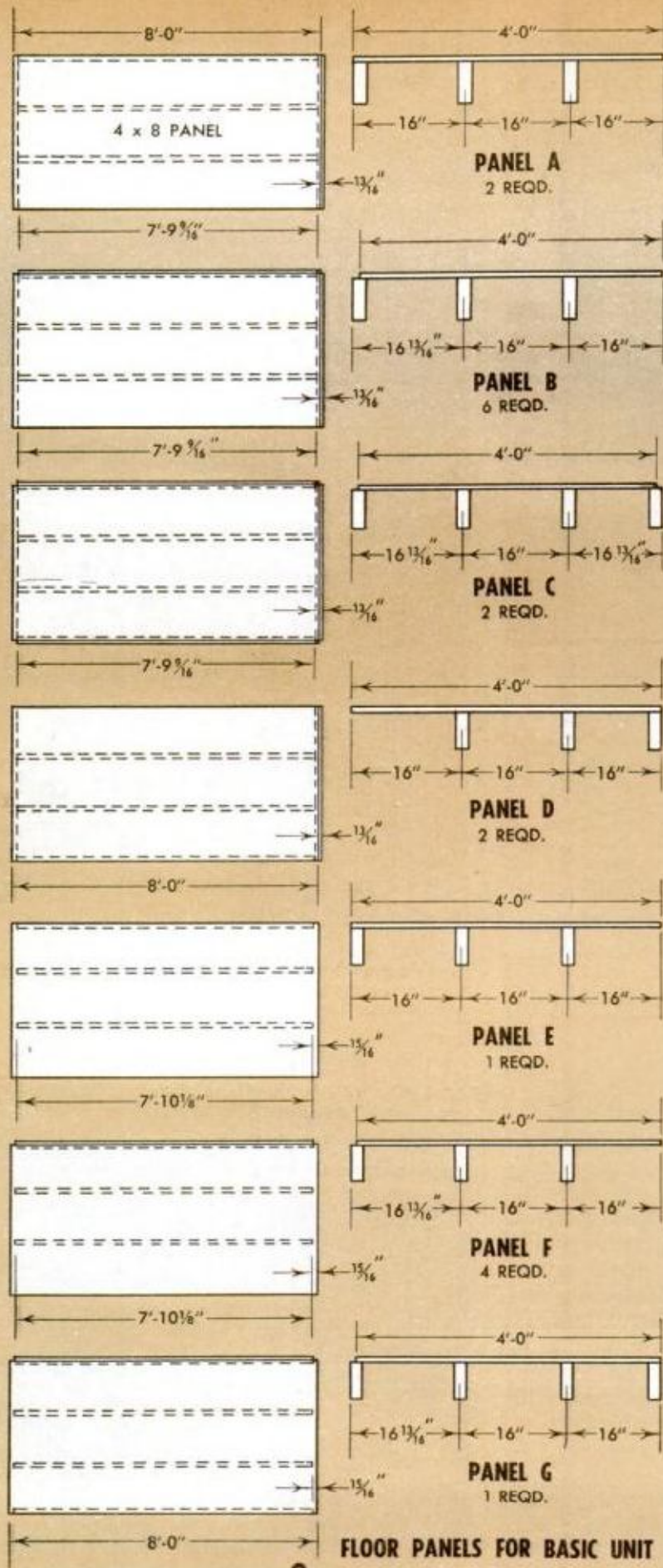

FLOOR PANELS FOR BASIC UNIT

2

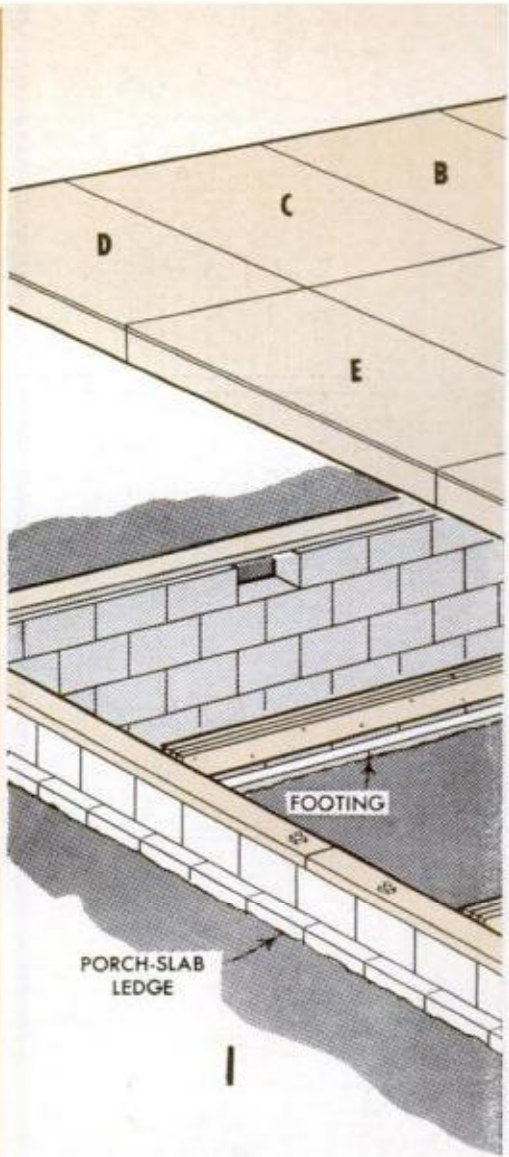

only to follow in building the home but for obtaining a building permit, finance loan, etc., the details in the magazine article serve only to acquaint you with the general construction. The builders' plans are presented in much greater detail and cover construction of the basic as well as the add-on units. In addition to a complete material list, the plans give the builder a choice between a prefabricated floor, a conventional joist floor and a concrete slab.

What tools will it take? The perfect power tool for mass-cutting duplicate members to the exact same length is a radial-arm saw. But it doesn't mean you have to own

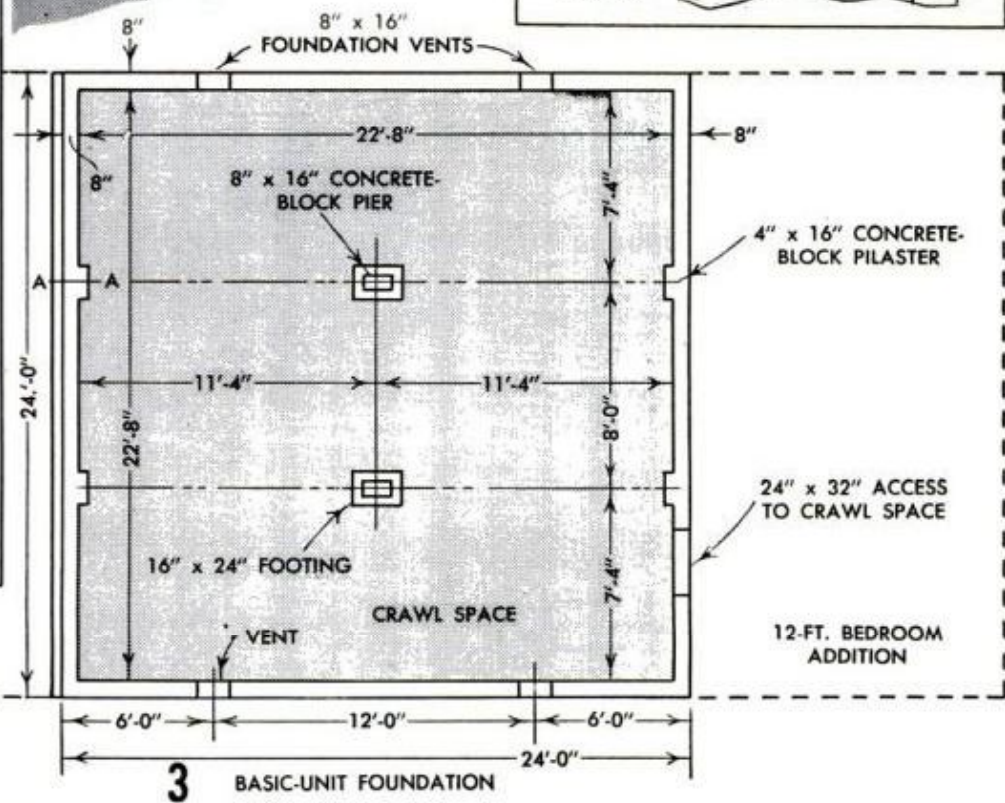
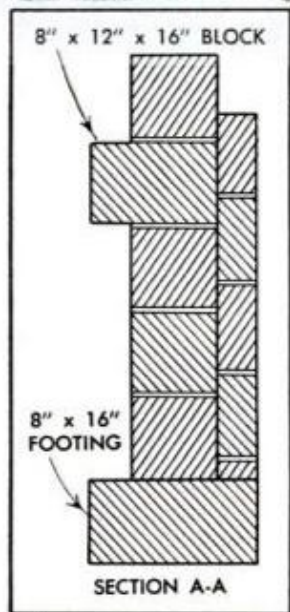
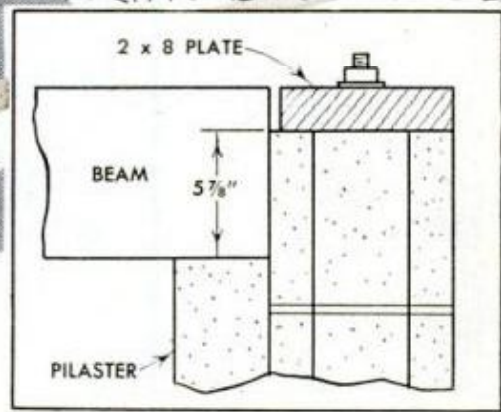
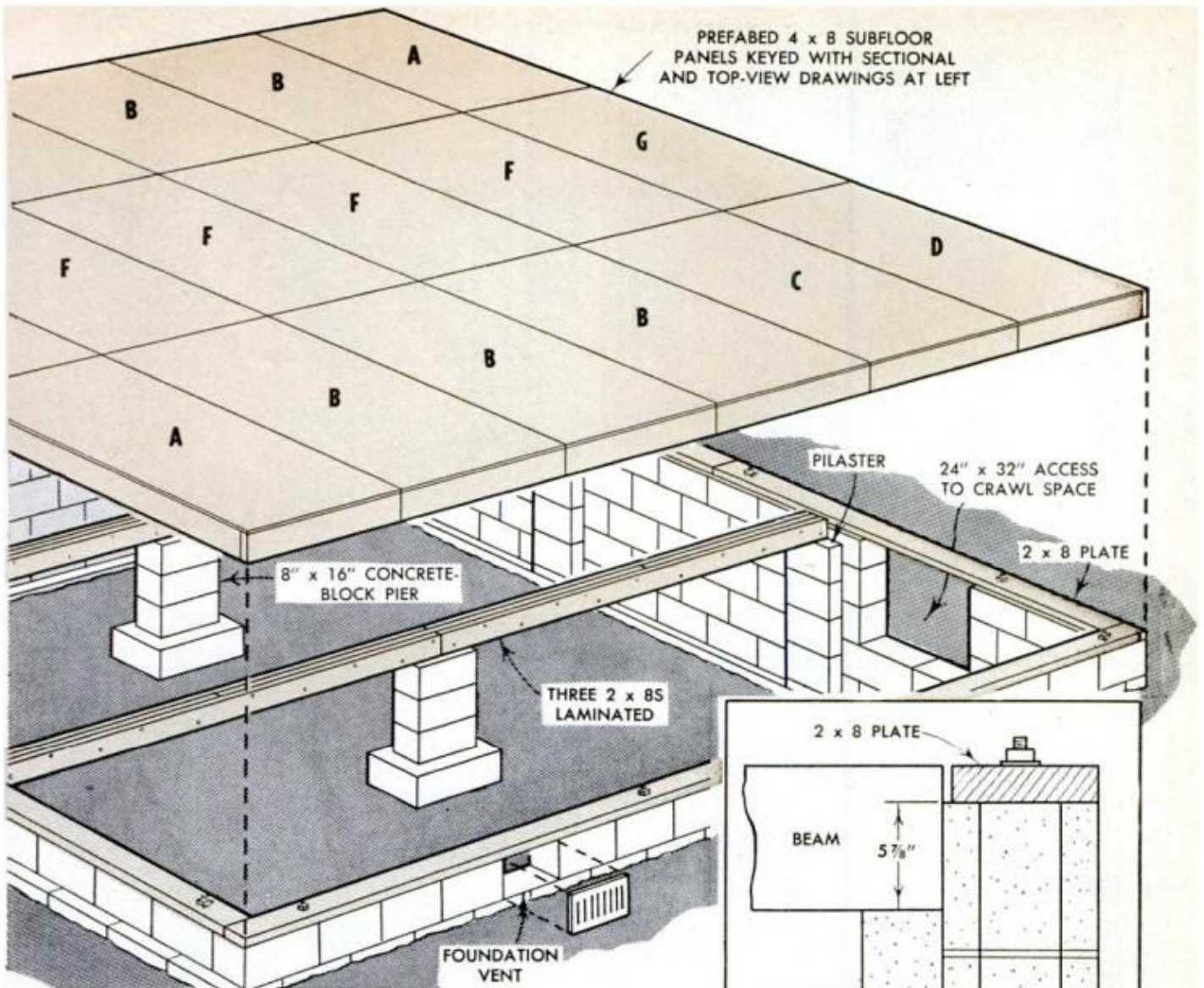

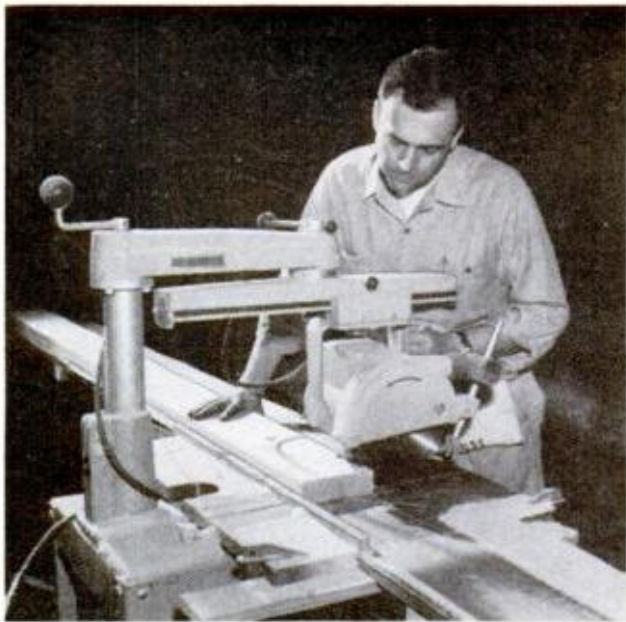

**RADIAL-ARM SAW** makes play of cutting duplicate floor members squarely and to exact same length



**STOP BLOCKS** automatically position longitudinal members in nailing jig in fast assembly-line operation

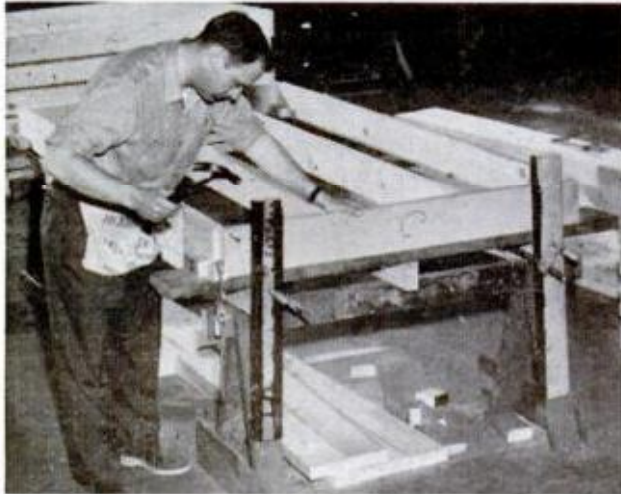

**UPRIGHT STOPS ON JIG** quickly position closure members for nailing to ends of longitudinal members

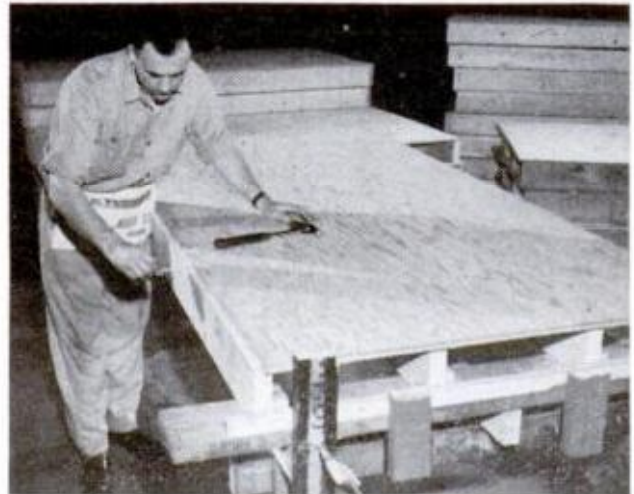

**SHEETING ON SOME** floor units center on edges of 2 x 6s to provide nailing ledges for adjacent units

such a saw. In fact, if you've got what it takes, musclewise, to whip through 2-in. lumber with a handsaw, you can build this home with a minimum of common carpenter's hand tools. On the other hand, if you're not so good at hand sawing, it will pay you to invest in, or rent at least a portable electric saw. It is important that the members be cut squarely, so the prefabricated sections will fit together accurately.

Now to go to work. Prefabbing the floor is your first step. Based on a module of 4 ft., the floor of the 24 x 24-ft. basic unit requires eighteen 4 x 8-ft. sections. In studying Figs. 1 and 2 you'll notice they are not all alike, although several of the group are made in duplicate. For example, 6 of (B) are made alike, 4 of (F), 2 of (A) etc. All require 4 x 8-ft. panels of  $\frac{3}{8}$ -in. material which are nailed to a framework of 2 x 6s placed on edge. Here, even though a couple of the sections require only one

of a kind to be fabricated, you'll find it will pay to take the time to make a nailing jig. Rigged up on a couple of horses and fitted with stop blocks to position duplicate parts uniformly, such a jig will make the work go faster in an assembly-line manner. Some of the assemblies are left open at the ends, others are closed at one or both ends. In some cases the 4 x 8-ft. sheets are kept flush with the 2 x 6 members, in other cases the sheets are centered on the 2 x 6s to provide nailing ledges for the adjoining sections. Use 8d coated nails spaced 6 in. apart to fasten the  $\frac{3}{8}$ -in. material, 16d nails to nail the 2 x 6s. As each section is completed, letter it so you will know the order in which it joins the others. If you lack the space to store the completed sections indoors, stockpile them outside on a level surface and cover with a protective tarp.

Figs. 2 and 3 will give you an idea of how

(Continued to page 254)

POPULAR MECHANICS

**OWNERS  
REPORT**

A NATIONWIDE SURVEY

Based On 603,902  
Owner-Driven Miles



OWNERS FAVOR FRONT END over rear—due to grille and sloping hood—but tend to approve over-all styling

# Smaller Plymouth Wins Greater Owner Approval

*Marginal and boldface comments by Jim Whipple, PM's Auto Editor*

There has been a lot of tightening up on quality control at Chrysler, since the publication of PM's last Plymouth Owners Report, on the 1960 model. Like the current model, the 1960 car was brand-new—Chrysler's first year with a unit construction body and slant Six engine.

Owners rated that 1960 Plymouth 50.9 percent Excellent, 38.2 percent Average and 10.9 percent Poor. Twenty percent of

all the owners reporting then complained of poor workmanship.

In contrast, owners of the new 1962 Plymouth rate the car 66.6 percent Excellent, 28 percent Good, 3.1 percent Fair and 1.9 percent Poor. And complaints of poor workmanship have dropped to 8.8 percent.

The real payoff comes when we compare the owners' desire to buy another Plymouth. Of all 1960 owners reporting, only

## OWNERS LIKE . . .

Sure, easy handling  
Soft yet steady ride  
Lively performance

## OWNERS DISLIKE . . .

Poorly finished details  
Scant legroom, headroom  
Air leaks at windows

**For the 1962 Owners Reports, PM's rating system has been expanded from Excellent, Average and Poor to Excellent, Good, Fair and Poor. This new four-category breakdown is intended to provide a more accurate reflection of owner's opinions of their cars.**

**Weight reduction on the '62 has made steering even easier than on previous models—and that's without power.** →

33.5 percent said they would buy one again. But this year, a solid 85.3 percent say that they want another Plymouth.

Obviously, Plymouth production engineers, who knew the problems (and their solutions) in 1960, are really getting results in improved quality of product today.

If our sample of 1962 Plymouth owners is as representative as we think it is, over 71 percent of the buyers of new Plymouths are getting V8s, and over 28 percent are buying Sixes.

To back up this report, PM tested a '62 Plymouth Belvedere Six sedan with automatic transmission. Constant-speed fuel mileage readings were taken, with the following results:

27.7 miles per gallon at 30 m.p.h.

25.5 miles per gallon at 40 m.p.h.

22.8 miles per gallon at 50 m.p.h.

21.8 miles per gallon at 60 m.p.h.

18.7 miles per gallon at 70 m.p.h.

Over-all fuel mileage obtained, including warmup, acceleration and driving on country roads and in city traffic, was 20.6 m.p.g.

To get down to cases, here in order of their frequency of mention are owner statements on the six best-liked features of the '62 Plymouth.

"We like the wonderful way the car handles in traffic."—Nebraska bank teller.

"It handles like a small car, has a quiet ride and no rattles—after 7000 miles."—Maryland cab driver.

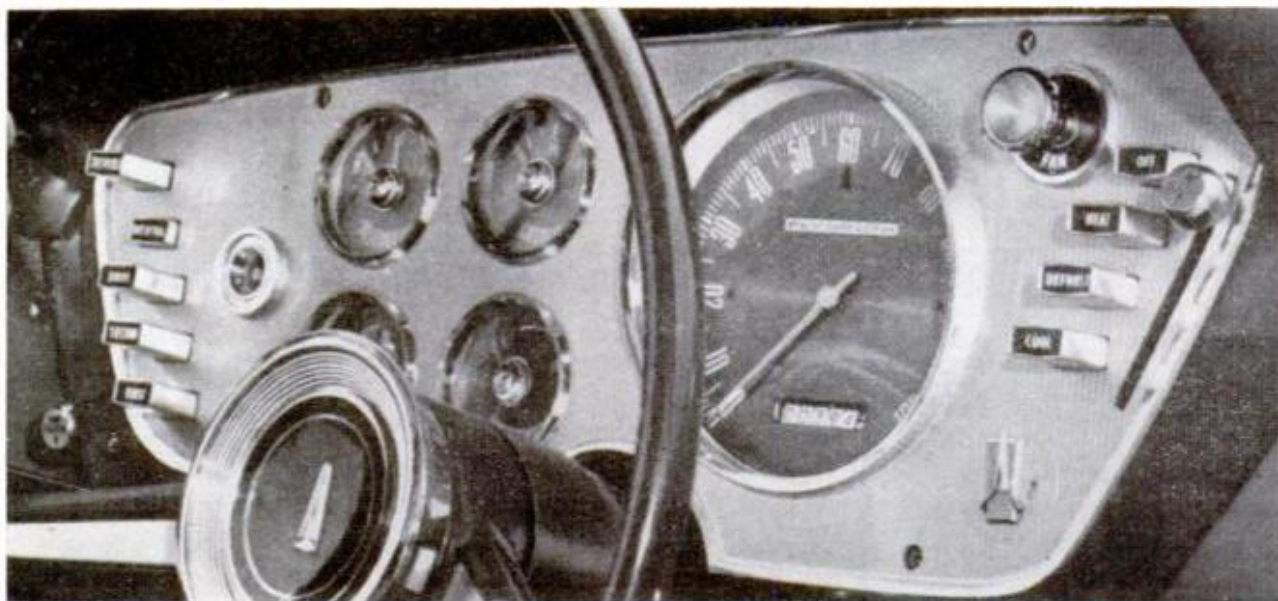

**OWNERS LIKE HUGE,** easily-read speedometer just below eye level, and well-lighted, sensibly-grouped controls and gauges. Below, curbside comparison shows roomy new Plymouth is smaller than other late models







**DOOR FRAME CORNERS** can scratch, snag clothes, some owners said. Right, rear door has full exit room but sill is high

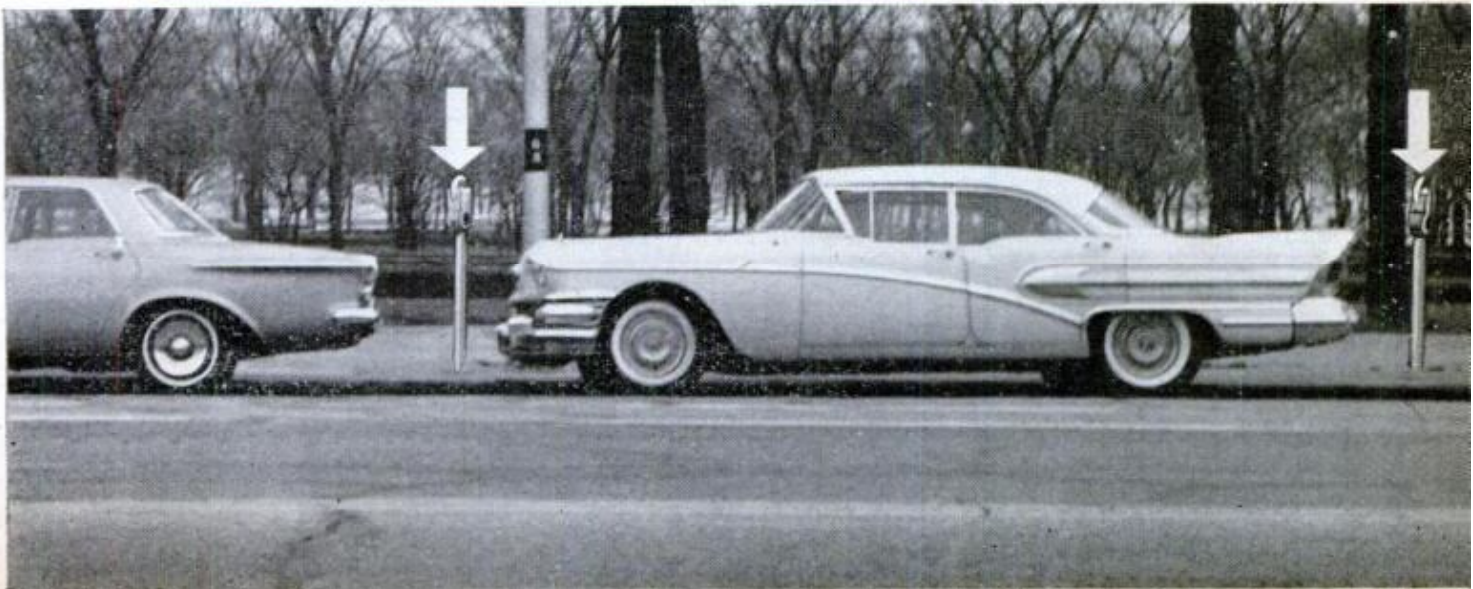
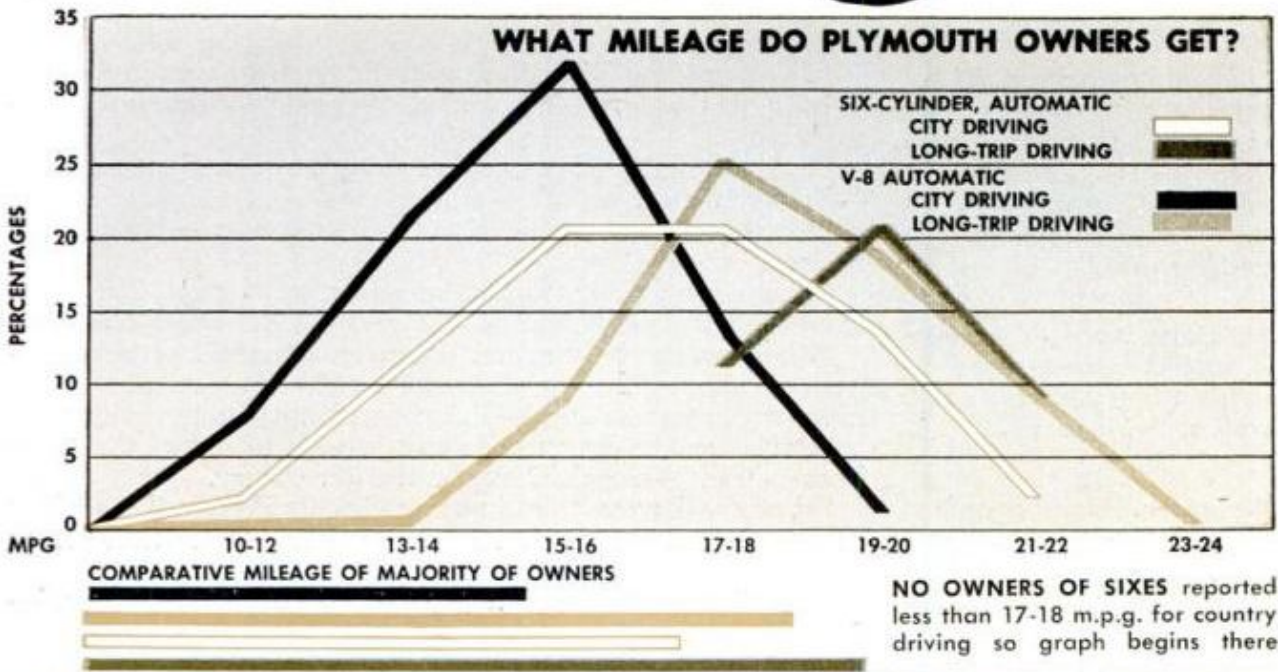



**PLYMOUTH'S TRUNK** holds nine bags plus flat-mounted spare, but you must lift them high to clear the rim



**LOWER TUNNEL** shows real efforts to cut it down in '62; owners' beefs are fewer than on '60 Plymouth

**His enthusiasm is understandable. Plymouth's excellent ride is becoming a tradition.** →

**Plymouth's standard, 318-cubic-inch V8 option comes with low numerical rear axle ratio, efficient automatic transmission. His mileage is common on long trips.** →

**PM's test Six with its efficient, three-speed automatic accelerated as well as Fairlane V8.** →

**We agree. Many people don't like the '62 Plymouth right off the bat because of its different styling approach.** →

**He may have to switch to premium fuel when he gets a little carbon in that engine!** →

**It's not hard to mistake Plymouth's low-effort steering for power on six-cylinder models.** →

"I like the ease with which it handles and parks; I can almost turn on a dime."—Minnesota retiree.

"I had a compact previously, and in comparison the Plymouth rides like a Cadillac."—Maryland salesman.

"Rides every bit as well as our '60 Chrysler Windsor."—Utah engineer.

"The powerful V8 with automatic transmission gives surprising gas mileage—19 m.p.g. over-all."—Alabama salesman.

"I've got plenty of power and get good gas mileage (V8)."—Texas farmer.

"Plenty of power for a six-cylinder car."—New York retiree.

"The six-cylinder engine has plenty of pep. I'm most satisfied with the power of this car."—Ohio press operator.

"It's amazing how much the performance has been improved compared to my '60, and my '62 averages about two more miles per gallon."—Nebraska county commissioner.

"Performance far exceeds any similar '62 car of the same horsepower."—South Carolina theater owner.

"Frankly, I wasn't too impressed with Plymouth's styling this year, but I find it a functional design—one that grows on a person after a time."—New York accountant.

"The lines are clean cut and there's just enough trim."—Florida retiree.

"Our 20 m.p.g. was over mountain roads, about 100 miles in 2nd gear in a snow storm—a real blizzard!"—Wyoming rancher.

"I can use regular gasoline in my 270-hp. V8 without loss of power."—Pennsylvania camp director.

"Steering qualities are excellent. The car doesn't seem to fall away on curves."—Pennsylvania millwright.

"It steers easier (manual steering) than my last one and its wonderful to drive on the highway."—Minnesota salesman.

"A bonus surprise to me was the ease with which I can maneuver the car in tight situations (no power steering)."—Nebraska musician.

*As usual, there are complaints, too. Let's examine them, numbers one through five in order of frequency of mention.*



**BULKHEAD WIRING CONNECTOR**—a good idea, but PM test car's horn wire and starter lead each loosened



**STEERING WHEEL POSITION** pleases owners. Front seat is roomy for all, including longest-legged drivers

"The body seems slapped together."—Virginia heavy-equipment operator.

"The factory didn't finish the inside. It was a very messy job."—Iowa farmer.

"Door handles fall off; radio grille falls off; chrome trim comes loose—poor inspection at factory."—Texas dairyman.

"The finish had bubbles and knots around the whole car and the factory representative authorized repainting of the

(Continued to page 246)

**Here's that old bugaboo quality control again.**

← **A car may operate perfectly, but what a disappointment to the owner if it looks sloppy.**

**SUMMARY OF OWNERS REPORT:**

**EXCELLENT**  
66.6%

**GOOD**  
28.4%

**FAIR**  
3.1%

**POOR**  
1.9%



<b>Satisfied with automatic economy?</b>	
About as expected.....	44.9%
Better .....	43.7
Not as good.....	11.4
<b>Satisfied with manual economy?</b>	
About as expected.....	56.5
Better .....	39.7
Not as good.....	3.8
<b>Best-liked features</b>	
Handling ease .....	53.4
Riding comfort .....	37.5
Power, performance .....	31.6
Styling .....	14.1
Economy .....	12.8
Steers easily .....	9.7
Size, compactness .....	9.4
Roadability .....	7.5
Brakes .....	5.9
Solid, rattle-free .....	5.9
<b>Most frequent complaints</b>	
Poor workmanship .....	8.8
Lack of leg, headroom.....	5.3
Windows .....	4.1
Doors .....	4.1
Glove compartment .....	3.8
Water leaks .....	3.4
<b>Had mechanical trouble?</b>	
No trouble .....	78.7
Some trouble .....	19.1
Considerable trouble .....	2.2
<b>What was trouble?</b>	
Automatic transmission .....	3.1
Alternator .....	2.5
Water pump .....	2.2

<b>Best-liked exterior features</b>	
Hood .....	13.4%
Front end .....	12.2
Grille .....	11.9
Absence of fins, gingerbread..	5.0
Low, streamlined styling.....	5.0
Simplicity, Continental look...	3.1
Smaller size .....	2.8
Paint job .....	2.8
Colors .....	2.5
<b>Least-liked exterior features</b>	
Rear end .....	12.2
Rear window .....	5.3
Hood .....	4.4
Trunk .....	3.8
Taillights .....	3.1
<b>Best-liked interior features</b>	
Dashboard, instrument panel...	36.3
Seats .....	14.1
Upholstery .....	12.2
Roominess, head and legroom...	8.4
Small transmission hump.....	3.1
Heater, heater controls.....	3.1
<b>Least-liked interior features</b>	
Glove compartment .....	10.9
Lack of room, roof too low....	7.5
<b>Did consider another car in Plymouth's price range?</b>	
Plymouth's price range?.....	50.0
Chevrolet .....	41.8
Ford .....	34.4
Dodge .....	10.0
Rambler .....	4.4
Ford Motor compacts.....	1.8
GM compacts .....	3.2
Chrysler Corp. compacts.....	1.8

<b>Is Plymouth only car in family?</b>	
Yes, it is.....	62.5%
No, it is not.....	37.5
<b>Make of other car?</b>	
Plymouth .....	13.4
Other Chrysler Corp. make....	11.6
Chevrolet .....	3.4
Other GM make.....	4.1
Ford .....	5.3
Other Ford Motor make.....	0.9
Other U.S. make.....	2.5
<b>Decision to buy Plymouth based on:</b>	
Performance .....	68.1
Economy .....	43.8
Style .....	40.0
Size .....	32.8
<b>How is dealer service?</b>	
Excellent .....	68.2
Average .....	26.0
Poor .....	5.8
<b>Make of car traded in:</b>	
Plymouth .....	55.0
Other Chrysler Corp. make....	13.7
Ford .....	8.4
Other Ford Motor make.....	1.6
Chevrolet .....	5.3
Other GM make.....	4.0
Other U.S. make.....	1.2
Foreign make .....	0.9
<b>Would buy another Plymouth?</b>	
Yes, would buy.....	85.3
No, would not buy.....	5.3
Undecided, don't know.....	9.4

# Skytyping

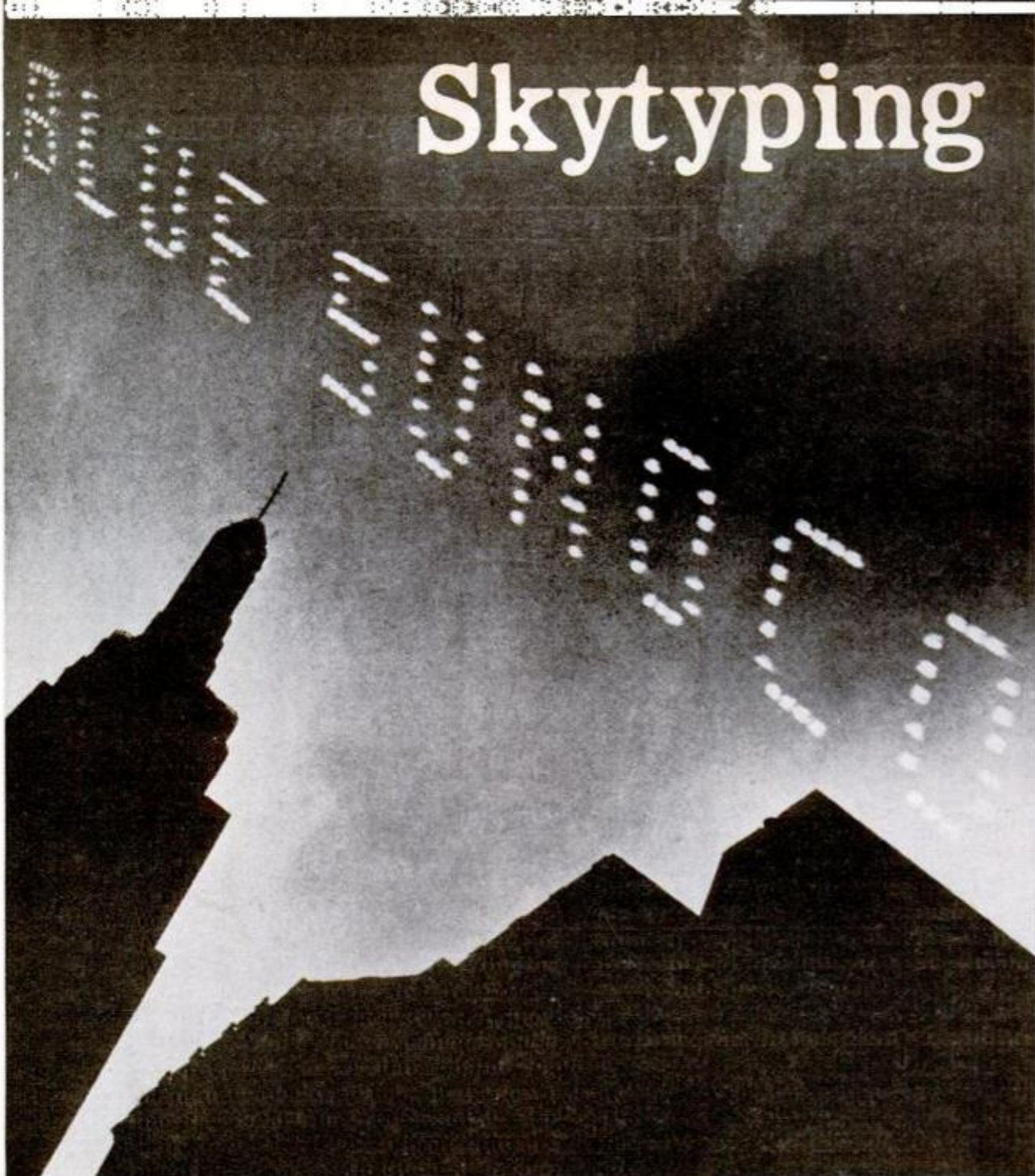

**SEVEN-PLANE FORMATION** now "types" message formerly sky "written" by a one-man, one-plane artist

**A**S AUTOMATION came clicking onto the scene, few industries escaped the revolution. Skywriting, a familiar sight to most Americans, was no exception. The lazy, cotton-white messages of years ago quickly became a series of puffs—orderly lines of tiny, man-made clouds that create words in a fraction of the time it took to do the same job in "longhand."

The new method? Skytyping! The technique has gained acceptance as the number of capable skywriters diminishes. At last count, there were only about six of these pioneers of "the lazy loop" still practicing their skillful art.

With the need for speed (when a sky-typed message is completed, the first word

is still legible) and more efficient methods increasing, skytyping has come into its own.

Skytyping is actually a simple idea. Five airplanes take up their positions wing-tip. First, of course, they must locate a smooth, draftless area if the message is to stay in position for any amount of time.

Then, they move out in a straight line. The center plane carries a radio transmitter which automatically operates the smoke valves in all five planes. In this way, the puffs can be released according to a predetermined plan as the five-plane group moves across the sky.

While these puffs appear tiny from the ground, each one is several hundred feet in diameter. No rolling, looping movements



**SKY SMOKE** is discharged from specially designed tube mounted along fuselage of each plane in group



**JOB "STRIP,"** mounted vertically in lead-plane cockpit, corresponds to pattern flown by formation

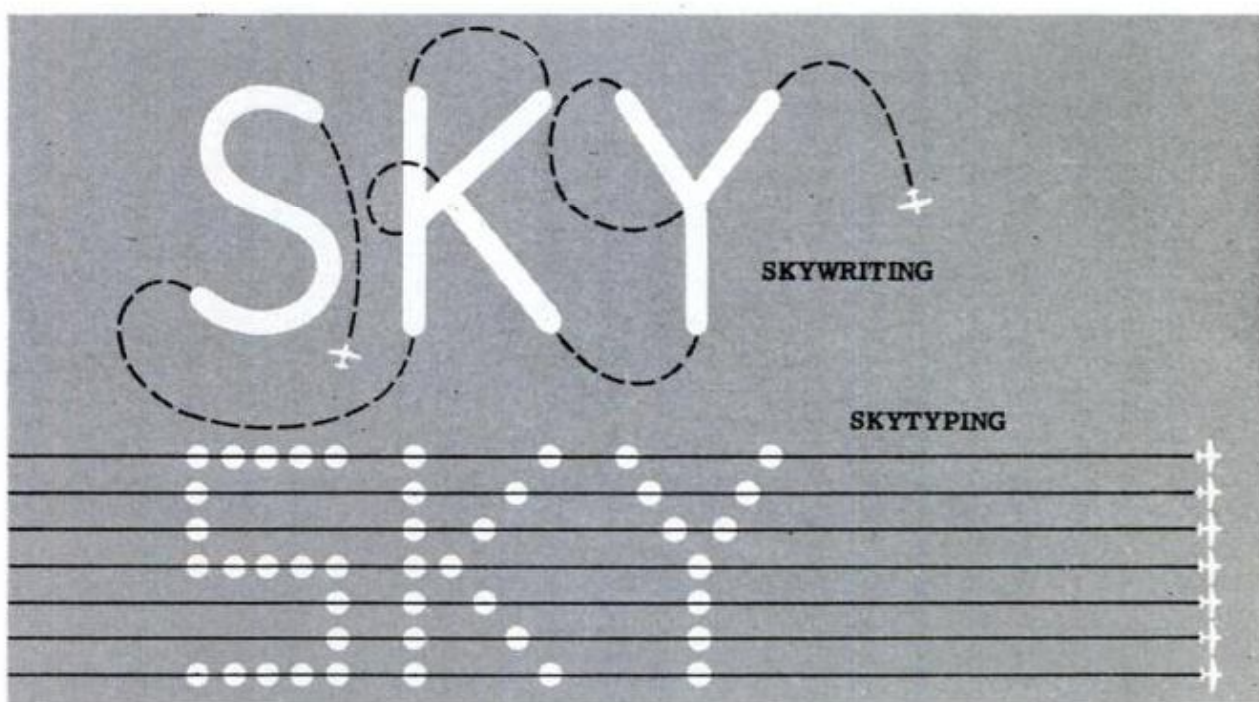

**DIFFERENT TECHNIQUES** are shown in diagram. Skywriting involves precision turns, takes much longer

are necessary as was the case in skywriting. Thus, the message is quickly "typed" across the sky. It remains intact much longer than the longhand messages did even in a slightly windy sky.

Skytyping can cost as little as \$400 for a small word of uncomplicated design and as high as \$3500 for a skytyping assignment involving the five planes. Companies such as Chrysler, Ford, Oldsmobile, Sunoco and Pepsi-Cola are customers for this unusual advertising medium. Generally, it is used to introduce a new product or service because of the large number of people who can be reached with the message in a short period of time.

Reservists, retired pilots and regular

pilots with extra time make up the precision crews that type messages.

In skytyping, as in skywriting, the same chemical formula is used to produce the smoke. A carefully prepared oil is combined with a paraffin wax and placed under pressure in tanks aboard the planes. On command from the pilot, the mixture is released across the plane's exhaust pipes and, on contact with the red hot metal, bursts into a fluffy white smoke.

With millions of people inhabiting the ground below—a ready audience for the skytyped message—and the technique of skytyping firmly established, Americans can look forward to new innovations in the skies above.—*Robert A. Kelly*

# Space-Age World's Fair

By Thomas E. Stimson

THERE'S A SPECIAL BONUS for tourists this year in the Pacific Northwest. In addition to national parks, mammoth dams and snow-capped mountains, Seattle is holding America's first World's Fair in 23 years. It is called the first "space-age World's Fair" and will run from April 21 through October 21, 1962. Its theme: Civilization in the years ahead. Its name: Century 21 Exposition. It will be located only a mile from downtown Seattle. Visitors can walk or, if they are in a hurry, board an overhead monorail train that gets them there in 95 seconds.

Towering over the exposition grounds is a steel and glass "Space Needle" 600 feet tall, with an observation deck and the Eye-of-the-Needle Restaurant, seating more than 200 people, at its top. The entire top of the needle rotates one turn every hour. Without moving from their seats, diners will be able to overlook much of Puget Sound, then view Seattle with Mt. Rainier in the background and, as the restaurant continues to turn, look toward the Cascade Mountains to the east and north. High-speed glass-walled elevators will whisk visitors to the top of the needle and back again. (It is rumored in Seattle that a second restaurant, called the "Chicken-Out Inn," will be built at the base of the skyscraping tower.)

In the exhibition halls, visitors will preview a thousand wonders that science and industry foresee for the future. There will be a working model of a home computer that can plan your meals, remind you of dental appointments and other engagements and do many other mental chores. One exhibit will feature an electronic lawn mower that guides itself untended over your lawn, another

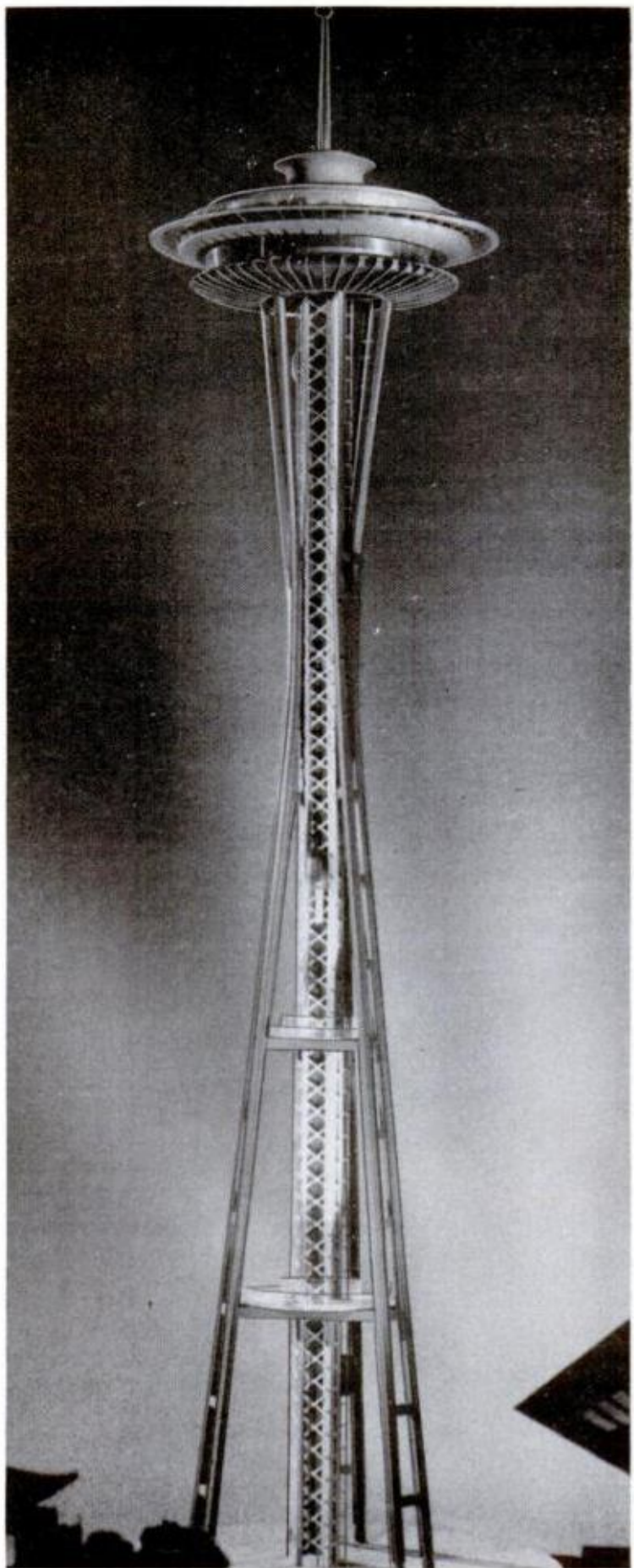

STRUCTURAL SYMBOL of the Century 21 Exposition will be the 600-foot "Space Needle," with a restaurant and observation deck on its rotating crown. Served by two 800-foot-per-second elevators—or two 832-step stairways if you prefer to walk, the tower will also house the world's largest carillon

*800-foot-per-minute*

*(see APRIL 1962, p. 8)*

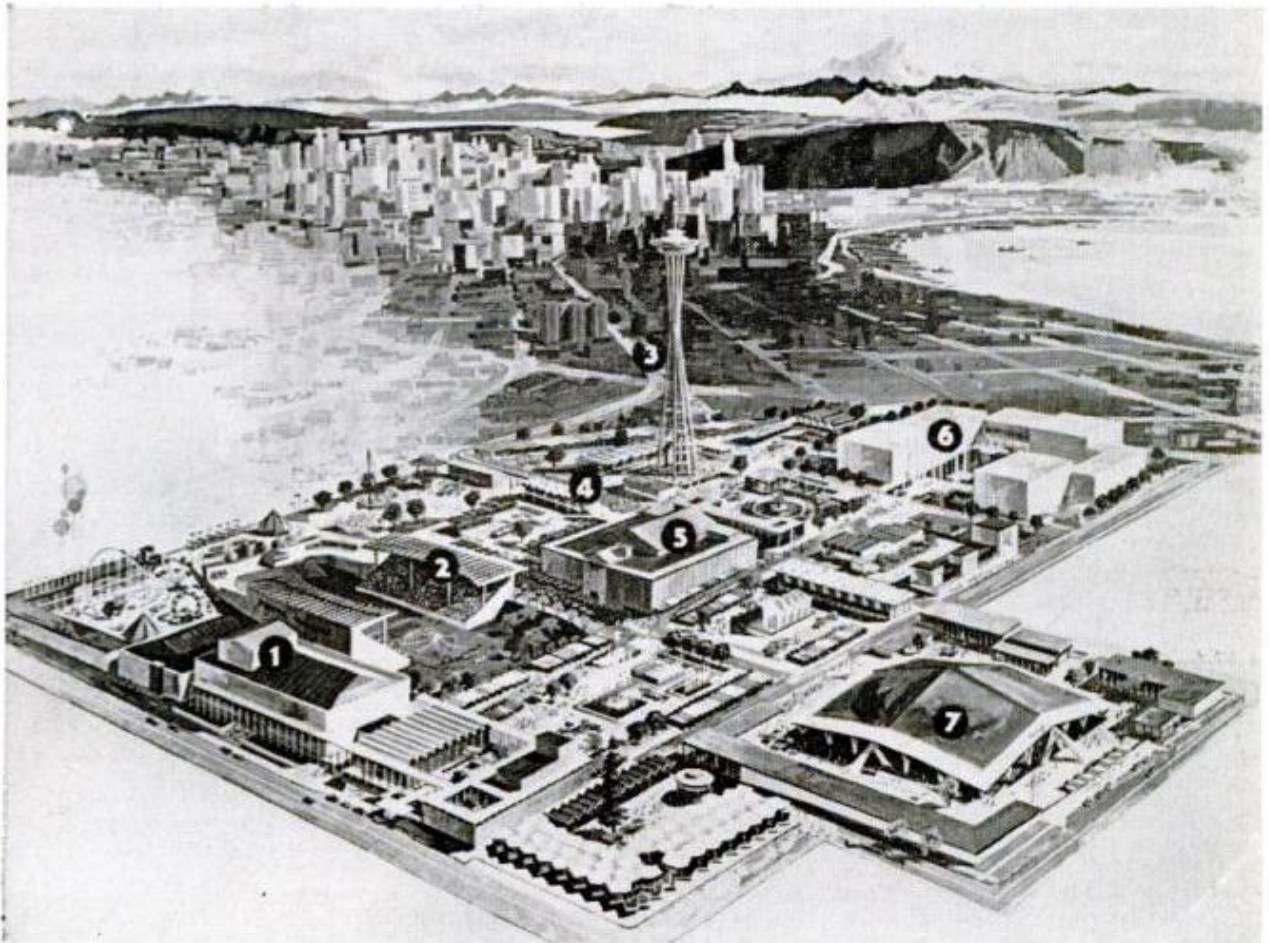

**VIEW FROM THE NEEDLE**, above, covering Seattle, Puget Sound and the surrounding mountains, will be a major attraction. Below, an architect's rendering of the site, looking southeastward toward Seattle. Numbered attractions are: (1) Fine Arts Area, (2) Stadium, (3) Space Needle, (4) Monorail Terminal, (5) Food Circus, and (6) Federal Science Pavilion. After the fair, 90 percent of the buildings will remain to form one of the nation's largest civic centers, with facilities for huge conventions, major sporting events, and public attractions

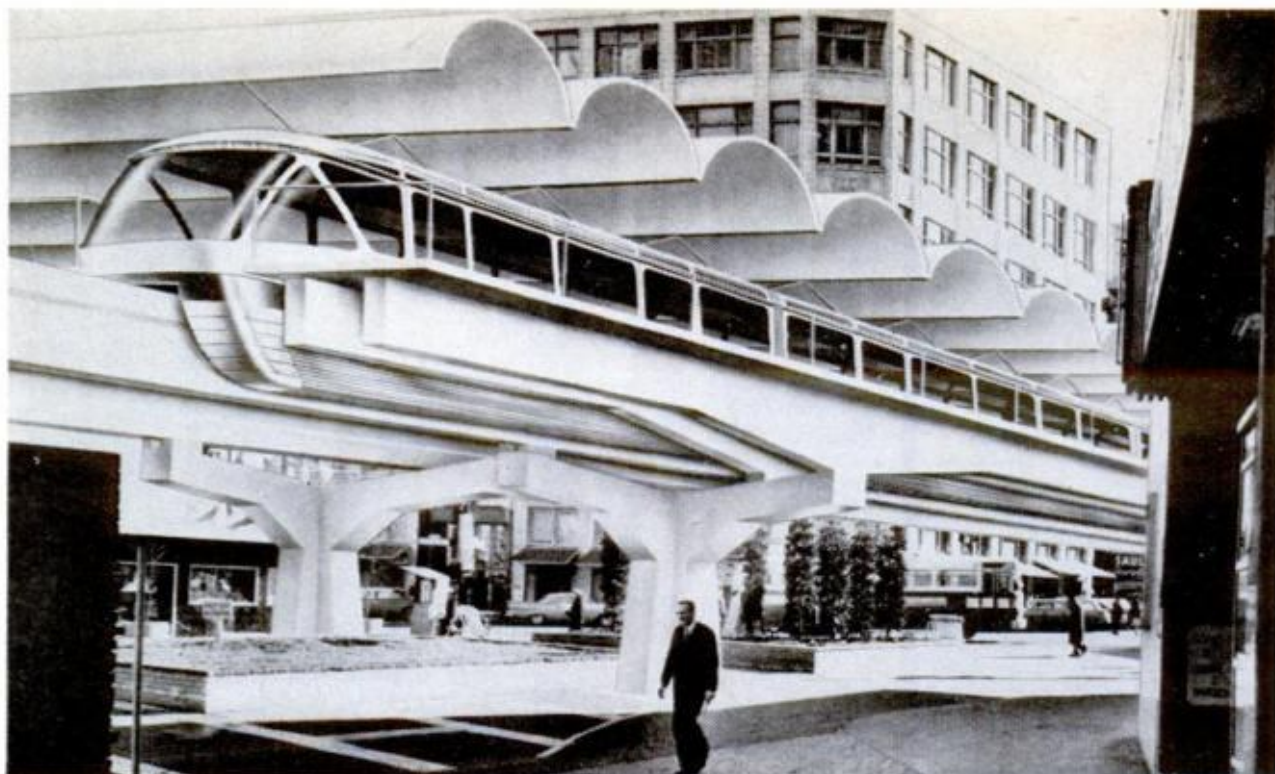

**NATION'S FIRST** commercial high-speed monorail system will go from downtown Seattle to the exposition grounds, 1.2 miles in 95 seconds. It will serve as an example of the coming thing in public transportation

will specialize in cordless home appliances, a third will show an experimental automobile designed to operate on electric-lane-controlled highways. There will be home telephones that close your windows, water your lawn and turn on your oven on remote-dialed command. There will be

video phones, and phones that remember often-called numbers and dial them automatically when you press one or two buttons. Cordless telephones will be on display, as will others that transmit information at the rate of 3000 words per minute.

(Continued to page 216)

**CONCRETE MUSHROOMS**, cast together to form a multiple hyperbolic paraboloid roof, form sheltered walkways in the International Exhibit Area. Workman standing on truck roof gives an idea of their impressive height







By Jim Whipple



## Cool First Reaction to Family-Size Cars. Compacts Flunk Chicago Police Trial

First rumble of public reaction to the new-sized autos—PM calls them “family-sized”—with 115-116-inch wheelbase, comes from two sources: **Dodge** and **Plymouth**. (Due to late on-sale dates there hasn't been much recorded reaction on **Ford Fairlane** and the new **Mercury Meteor** as we go to press.)

There have been reports from Dodge dealers who say that the new '62 products of 202-inch over-all length have received a cool reception from the public because the car is “too small.”

Also, in PM's Owners Report on the '62 **Plymouth** (page 95) there were a lot of traders of large '58, '59 or '60 **Plymouths** who generally liked their smaller-sized cars, but wished they were “a little longer.”

What we may have here is a case of early-season buyers who are loyal “repeaters” on a given make and are a bit startled by the sudden decrease in size. Remember that when cars grew to their present “full size” from the “old” size (116-inch wheelbase, 200-inch over-all length), the growth was gradual, from 1955 to 1960.

But, when the automakers planned today's “new” sizes back in '58 there was nothing but hue and cry throughout the land against the bigness of the “insolent chariots.” So automakers pushed their well-worn panic buttons and, after two or three years' lead time, out came these four intermediate, family-sized cars.

Wouldn't it be ironic if the public had already divided itself into two camps, compact devotees and “full-sized car” fans, and the very practical-sized **Fairlane**, **Plymouth**, **Dodge** and **Meteor** missed the boat? It's too early in the model year to raise more than a wetted finger so we won't stick our editorial neck out just yet.

A vote for big cars comes from the Chicago Police Department after a six month trial of 125 compacts for patrol duty. George Rupprecht, CPD's director of automotive maintenance, said that men on patrol for eight hours in the compacts had to slouch, could not wear their hats and complained of backaches and cramped muscles.

He also said that the compacts were ineffective for pursuit because, “they do not

hold the road well at high speeds.” Tests were a fair sampling involving **Ramblers**, **Larks**, **Valiants**, and **Falcons**.

But we can leave the compacts on an up-beat. Even though compacts were turned down by Chicago's finest, we can expect to see wider use of compacts in the car-rental industry according to a top executive of **Avis Rent-a-Car System**. Right now compacts make up about 20 percent of rental fleets.

Most of the agony involved in bringing out new models centers around the problems of eliminating bugs that weren't found on engineering test prototypes but show up in early batches of full-scale production models.

For example, prototype **Ford Fairlane Sixes** had annoying vibration stemming from drive line that drummed through the body on stick shift models. A “fix” in the form of a vibration damper was added to crankshaft pulley as production started.

**Fairlane's** brand-new 221-cubic-inch V8 wasn't delivering as much power at rear wheels as Ford engineers had anticipated from test runs on the dynamometer. Solution to the problem was relatively simple—larger exhaust manifolds and piping.

Sometimes mechanical innovations work out A-OK from the start, like **Rambler American's** new oil-pressure-engaged automatic clutch, the E-Stick. According to an unusually candid source at **American Motors** their factory service people have yet to receive a complaint on this option which is being fitted to 20 percent of all **American** production at this time.

Over at **Chrysler** they've had some problems with alternators due to failure of the diodes that rectify the a.c. current output changing it to d.c. They've crash-programmed a manufacturing cure for this, so all should soon be tranquil.

**Bucket-seat coupes** are booming in '62 as they did in '61. Now there's a **Mercury Meteor** version called the “S-33,” numerically a notch above the **Comet S-22**. Checking **Plymouth** we find 40 percent of **Valiant** production going into their sporty-looking **Signet**, while at **Oldsmobile** the luxury bucket-seated **Starfire** is accounting for 13 percent of the product mix. ★ ★ ★



**NEW CHEMICALS**, sprayed from helicopter, can denude trees and reveal Red Guerrillas to the Allied soldiers



# Bizarre Weapons for the Little Wars

By S. David Pursglove

**H**OW CAN THE United States give its little 95-pound allies in Southeast Asia more antiguerrilla firepower without weighting down the spunky but small fighters with heavy guns and ammunition?

America's answer: Fill their pockets with dozens of tiny, lightweight, rocket-powered "darts" more devastating than the heaviest .30 caliber bullet. Replace their 9-pound rifles with gun barrels the size of soda straws to use as launching tubes, and each Vietnamese or Laotian antiguerrilla fighter becomes a running, jumping, hiding, attacking missile battalion.

This is just one new weapon that Pen-

**RUGGED TERRAIN** of Southeast Asia (left) makes useless usual techniques and equipment of warfare

**FLAME THROWER**, still a good jungle weapon, is often too heavy for undersized Asian soldier to carry

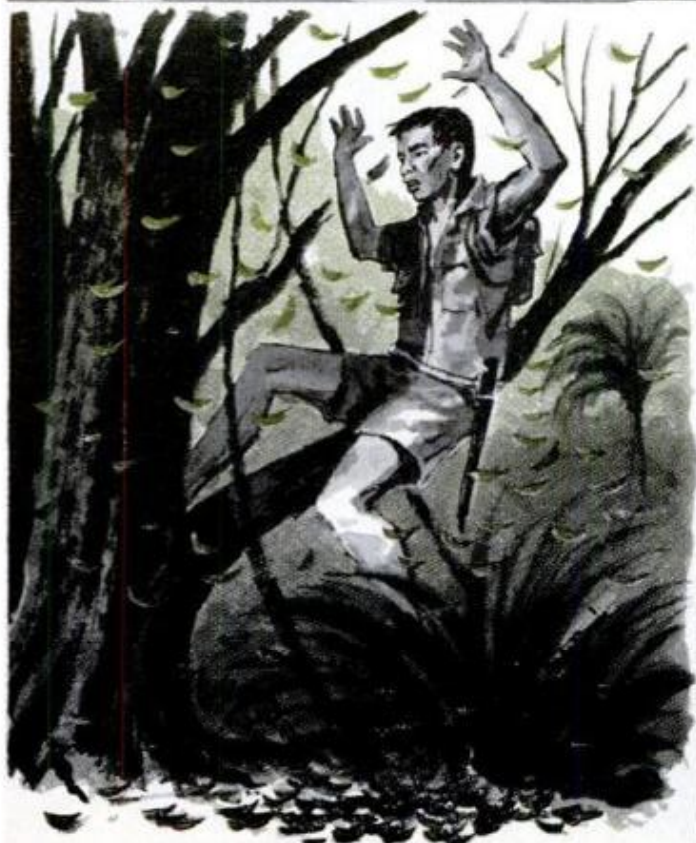

FEBRUARY 1962

107





**NAPALM MINES**, made of gasoline and thickening powder, are buried and ignited with new fuse, spraying enemy troops with flaming liquid



**TINY BOMBLETS**, rained from aircraft, are deadlier than strafing

tagon scientists are developing to help our allies and our own "brushfire war" troops defeat Communist guerrillas, infiltrators and riot-inciters on their own ground. One of the dirtiest, but most effective, weapons that the Reds use against our Asian allies (nails) is now met by a new defense: A swamp tennis shoe with a steel insole.

We can spray a band of jungle around villages under frequent Communist attack with new chemicals that drop the leaves from brush and trees, robbing guerrilla raiders of foliage protection and exposing sniper nests.

Night raiders who masquerade as harmless rice farmers by day are exposed by

sprays of dyes that they cannot wash off.

New aids to better vision at night, when most guerrillas operate—are being made smaller, lighter, and simpler for guerrilla warfare.

New guerrilla-fighting tactics and better ways of dealing with natives whose support we need are getting expert attention. One result may be to overturn the time-honored principle that "a guerrilla lives off the land." Our roving forces may start getting more and better-delivered air drops, leaving only the Communists to rob food from the very natives they count on for support.

Many Vietnamese and other Southeast

**REMOVABLE STEEL INSERT** protects Allied fighting man from guerrillas' nastiest booby-trap—a buried plank with sharpened 7-inch nails buried just under surface of jungle trails. Canvas tops resist swamp rot; leather doesn't



# Bizarre Bazooka

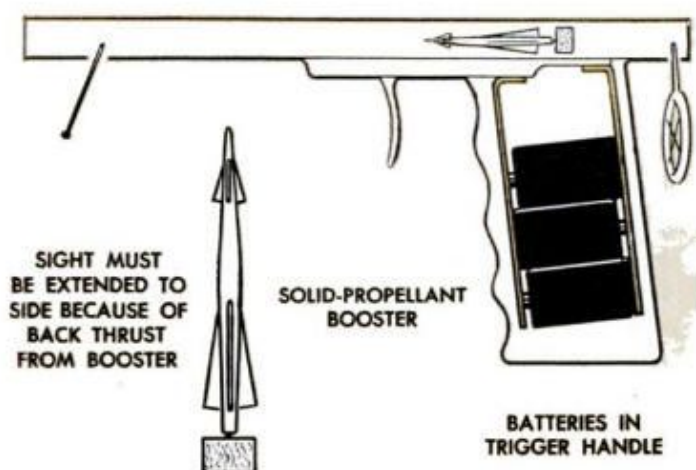

**BIZARRE HAND GUN** is a miniature bazooka. It fires tiny but powerful rocket through barrel the size of soda straw

Asian troops and certain local groups elsewhere in Asia, Africa, the Middle East, and Latin America now look to U.S. military groups for advice and help. These "indigenous forces" (native troops) are the mainstay of our new determination to stop the Communist hacking away of the free world, a piece here, a bit there. They are the bulk of the force that fights the undeclared wars. And they will be the good right hands of American troops fighting the "limited wars" of the foreseeable future.

For them, the Defense Department is developing radical new weapons and is vastly improving some of the reliable stand-bys of nonnuclear war. One of the newest and most radical—the "Microjet" rocket—is a hard nylon needlelike projectile about one inch long. Nobody in the Pentagon can con-

firm details, but the microjet apparently is very much like a toy missile sometimes found as premiums in Crackerjack boxes. But somebody in the Pentagon has added to this "toy" a tiny solid-propellant rocket.

The weapon can be fired accurately from soda-straw size plastic or aluminum tubes for several hundred yards with a speed nearly twice that of a standard .30-caliber military rifle bullet. The almost noiseless projectile will penetrate thick plaster walls and small tree trunks.

Microjet definitely will be a guerrilla weapon. One fighter can discard his rifle

**M-60 MACHINE GUN** is handled easily by husky American, but is too awkward for 100-pound Asian



and move lightly with just the small plastic straw and a pocketful of rocket-darts. Also, a number of launching straws can be grouped together to fire a devastating barrage, still controlled by just one man.

Although many modern weapons are very sophisticated, it is still the very simple problems that cause us the most trouble. A seven-inch nail driven through a board has caused much anguish in the swamplands of Southeast Asia. Viet Cong Communist guerrillas would drive the nails through boards, sharpen and barb the points, and bury them like land mines in muddy trails.

This weapon was as effective as any anti-personnel mine and could not be detected. It explains why a Vietnamese soldier does not actually lift his bare feet when he "runs." He slides them instead, to feel for the nails. He cannot wear the leather combat boots that we tried to force on him for many years because they, and his feet in

them, would soon rot in the humid swamps.

Then about three years ago, our Army developed a light canvas shoe that would not confine water around the feet and would let them "breathe." It had a rubber sole containing a steel plate that the barbed nails could not penetrate. Thousands of the swamp tennis shoes were shipped to Vietnam from Japan where they were produced. They proved effective, but the steel plate hampered walking on hard or rocky ground where the nails cannot be used.

So now at Natick, Mass., the Army Quartermaster Corps is putting the finishing touches on a new swamp boot with a detachable plate. The steel insole can be removed for action on high ground, and can be inserted into the boot when there is danger of barbed nails.

From large atomic bombs for strategic warfare to very tiny bombs to fight guerrillas—that's the Air Force arsenal. It has



**HELICOPTER DROP**, without parachutes, is accomplished by sliding fully equipped soldiers down rope. In hit-and-run warfare of Southeast Asia such quick dispersal of troops becomes critical



## FARMERS OR GUERRILLAS?

**CHEMICAL WARFARE** may end duplicity of guerrillas who pose as farmers during daylight. Sprays dropped on enemy positions during night maneuvers will leave stains on them that will identify them as Red soldiers

recently developed a "bomblet" made of cast iron, weighing only a few ounces, and just 2½ inches long. Because of its bomb shape, the small hunk of metal, called *Lazy Dog*, straightens its path and falls toward targets with tremendous speed and power.

Strafing a guerrilla camp with a 20-mm. cannon requires several passes, exposes the plane to danger, and uses a large amount of very expensive ammunition. Now tactical fighters can make a single high altitude pass, dropping thousands of cheap bomblets with an effect equal to strafing. *Lazy Dog* offers a psychological advantage,

too. Its silent killing will strike terror into an unsuspecting guerrilla band.

What has happened to make us want such unusual weapons? In recent years, America's ability to cope with brush fires—Korea, Laos, and Lebanon-type actions—has slid downhill while most of the money and effort has gone into nuclear weapons.

The communists, meanwhile, pick jungles, swamps, mountains and deserts for their battlefields, and we have not been equipped to fight there.

This problem is so serious that the Penta-

(Continued to page 236)

## HOW THE RED GUERRILLA FIGHTS

The Viet Cong communist guerrilla does not have any modern weapons and equipment. However, he has the advantage of being on the offensive, picking the time and place for battle. The element of surprise is on his side. His task is much simpler—just destroy—where the Allies task is to build, protect and preserve.

The Viet Cong soldier has no uniform. He wears the dress of the native population. When about to do battle, when he must be identifiable to his own troops, he ties a colored band around his arm or fastens a sash around his waist. Only if he is fortunate does he have a firearm, then it will be almost any rifle that could be captured and for which he can scrounge some ammunition. Most of his comrades either use crossbows with poison-tipped arrows, or devote themselves to digging the effective "panji" traps. Only the elite Viet Cong forces that move into an area for the kill and consolidation after local subversives have prepared the way will be equipped with the Red Chinese grease-gun or the Russian light-weight rifle, mortars, and other equipment. They seldom

are seen since the local subversive national guard-type units usually have emptied the area of our Allies.

Panji traps, more important weapons than rifles, are camouflaged pits. Needle-sharp bamboo stalks are shoved upright in the bottoms. The sharpened points are coated with human body waste, manure, remnants of decaying animals and even a prepared culture which will produce fatal infection or tetanus. Sometimes, the Viet Cong also rig the traps with grenades.

Panji traps are not dug in paths where they would be suspected. Instead, they are dug among the best cover and shelter surrounding the area where our allies will be attacked. As the Vietnamese jumps for cover, he falls into the trap.

Viet Cong camps always are completely surrounded by panji traps. They act as sentinels. A Viet Cong unit consists of five squads and in bivouac each squad beds down 25 yards from other squads. Each squad area is protected by earthworks about 18 inches high. Beyond the small walls are the panji traps.



## Steel Feet for Leathernecks

Armored boots with a six-inch "sole" of stainless steel beveled to deflect blast fragments will help protect Marines from injury by wartime land mines.

The boots, developed by a Naval research laboratory, are scheduled to be issued to the Marines this year. Prototypes were made by the International Latex Corp.

Medical records indicate that feet and lower limbs are the most common casualties from land mines. The boots were developed to protect against those injuries.

### QUOTE:

*"Space has great military potential. While Russia is many thousands of miles away, our satellites have made more than 50,000 orbits of the earth, some of them only 100 miles up. That's pretty close."*

**MAJ. GEN. LEIGHTON I. DAVIS**  
 Commander, Air Force  
 Missile Test Center  
 Cape Canaveral, Fla.

## Packaged Bathroom Comes Ready for Installation

Molded as a plastic shell with the tub integrally cast in place, a new modular bathroom—complete with framing that also serves as a shipping crate—arrives at a building site ready for installation.

Available in a choice of colors, the six-by-eight-foot unit includes a wall-hung toilet, lavatory set into a counter, shelves

and sliding mirror above the counter, electric heater and lights.

The floor, wall and ceiling shell is made of fiberglass reinforced with vibrin polyester resin. Counter tops are laminated plastic, and the floor is covered with vinyl.

It's made by Modular Components Corp., Chula Vista, Calif.







## Big Brother Keeps 'Em Rolling in Detroit

Traffic along a 3.2-mile stretch of the John C. Lodge Freeway in Detroit, Mich., is watched and directed by an operator in a control center who views 15 closed-circuit TV monitors. As traffic situations develop, the operator can control use of

lanes and speeds by overhead signs on the expressway; he can also close entrance ramps.

The cameras in the experimental General Electric system can be tilted and panned, and the lenses switched for close-ups.

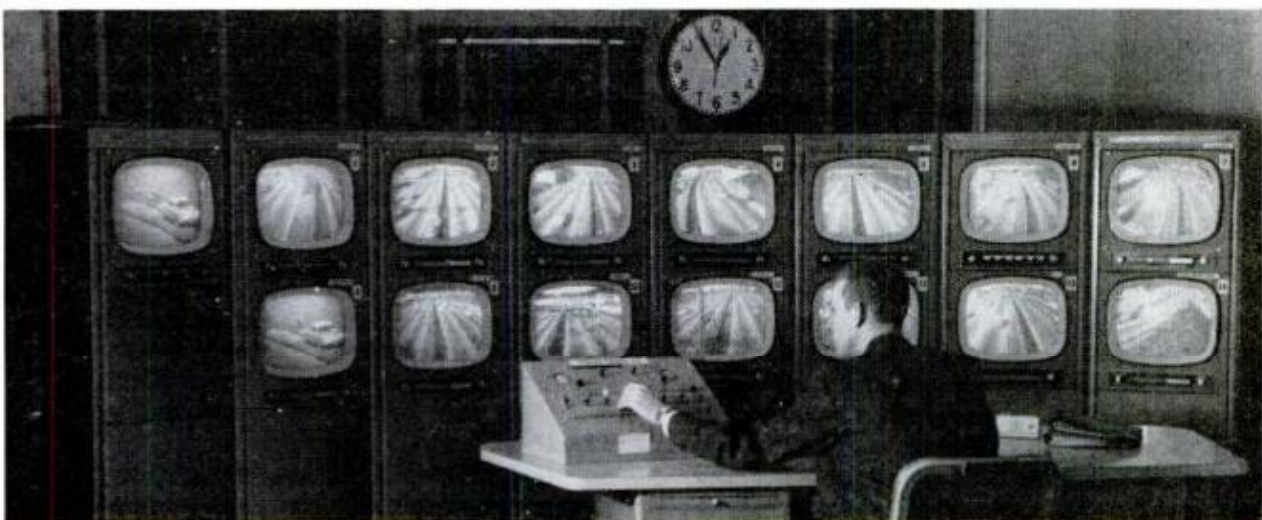

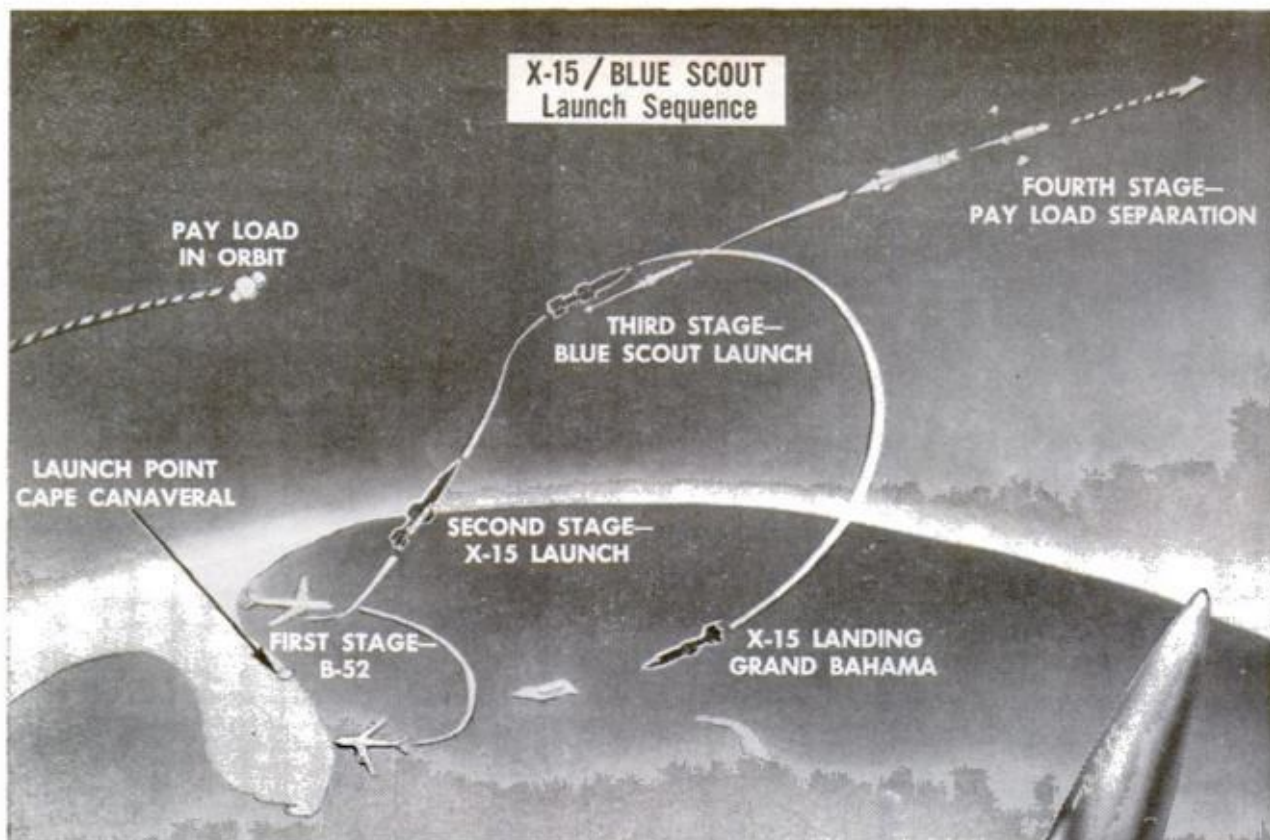

## Piggy-Piggyback Satellite

Not one, but two manned boosters may be used to put a rocket into orbit as a satellite or send it into a deep space probe.

The system would include an Air Force B-52 bomber with an X-15 rocket airplane strapped beneath its wing. The X-15, in turn, would have a Blue Scout research rocket tucked beneath its fuselage.

In the proposed system, the B-52 will launch the X-15 at 50,000 feet and the X-15 will launch the Scout at 156,000 feet. Both the B-52 and X-15 would then return for landings, thus recovering both the first and second stages. This has not been possible with other satellites and space probes.





## Unique Inboard Runabout Designed for Stern Drive Unit

First three-point inboard pleasure runabout, and maybe the first boat to be designed specifically for an inboard-outdrive power system, the new OMC 17 combines the Outboard Marine Corporation's V-4, 80-horsepower stern drive unit (PM, August '61) with a unique 17-foot fiberglass hull designed to provide maximum performance without sacrificing comfort or stability. The

unusual three-keeled hull employs a thin center "fin" hull between the two main hull sections, which are stepped like a racing hydroplane. The design, developed by the OMC design section, is the product of over two years' research, during which over 40 hulls were built, tested and rejected. The boat will sell, fully equipped, for about \$3500, or in a utility version, about \$2800.

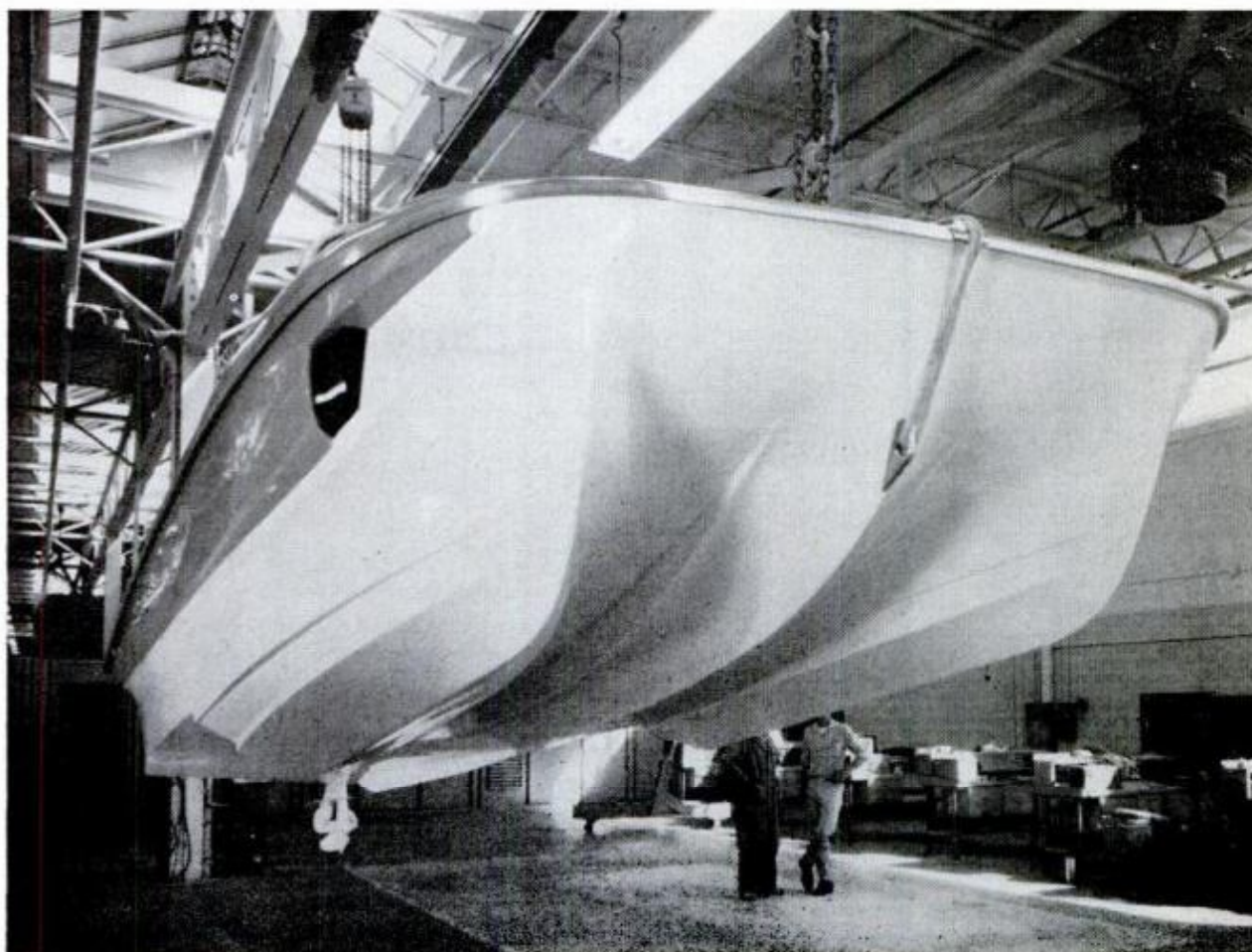

# There's Adventure In Your Crankcase

By Kevin V. Brown

**S**EISMIC CREWS who invaded the virgin mountains of northern Alberta have been chased by a mammoth race of grizzlies that was believed to be extinct as long ago as the Civil War.

Geologists in Libya send out scouts armed with mine detectors to clear a path ahead of the major party, because more than three million unexploded World War II mines are still buried beneath the sands.

Drilling crews working in northern Canada have watched their trucks, rigs and heavy equipment — even their roads — sink out of sight in a black, smelly muck called muskeg—a goo so cancerous that it has spread across a half-million square miles, devouring everything in sight.

Some oil crews climb mountains, others dive to the floor of the sea. Some work throughout the frigid winters above the Arctic circle. Some invade the steaming jungles of South America. Others tread uninhabited Middle Eastern deserts where there is no life and temperatures rise as high as 130 degrees F.

And they do it all looking for oil they might never find. But often the hard work and the dangers do pay off.

Imperial Oil Company geologists, for instance, used a helicopter to hop from peak to peak in the Canadian Rockies. Pack mules would never have made it. Then, on foot, they scrambled along the almost vertical sides of the mountains, with sheer drops below them of several thousand feet, to collect samples of rock that helped them piece together the story of a large oil basin that lies beneath the Canadian Rockies.

In Utah's wild, deserted southeastern section, near the four-state junction with Arizona, New Mexico and Colorado, seismic crews of Pan American Petroleum Corporation toured the towering Orange Cliffs and their deep, deceptive gorges, using special portable drilling and recording equipment that could be hooked to a helicopter and airlifted from one site to another. It



**MINE DETECTOR** moves ahead of oil party in North Africa to seek out deadly relics of World War II





**LAND MINE** is exploded so heavy equipment can be sent through gap and oil search can go on. In Louisiana bayous (below), gargantuan wheels of "swamp buggy" pull crews and equipment over land, water

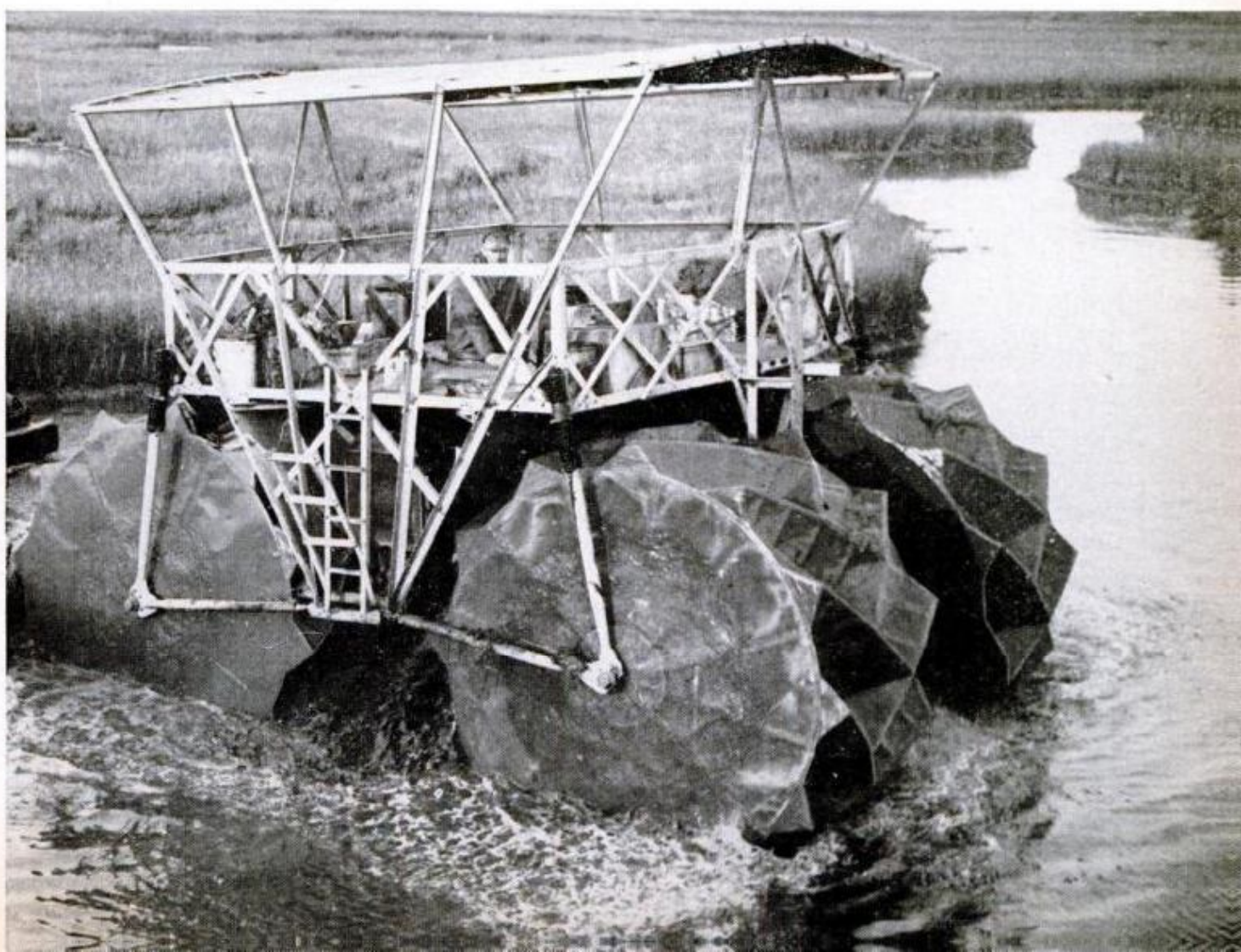

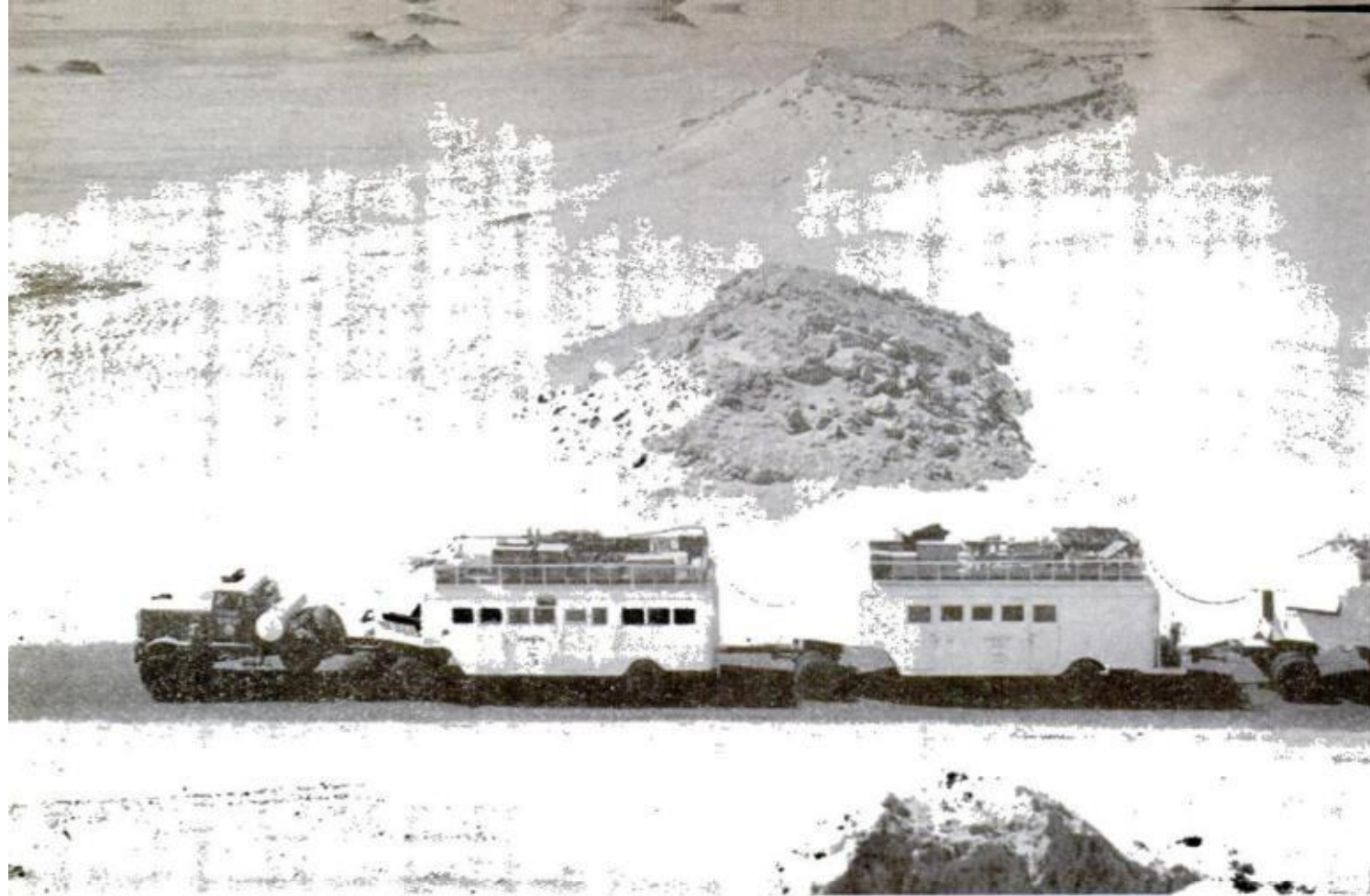

**OIL CARAVAN** of air-conditioned trailers heads into torrid heat of *Rub' al-Khali*, Saudi Arabian desert

not only saved time, but made the whole operation possible, because there were no roads to this remote and elevated area and trucks were useless.

Meanwhile, other oilmen are heading in the opposite direction, drilling for oil on the ocean's floor. Underwater drilling requires a stationary barge that can be installed above the surface of the water, with legs reaching down to the ocean floor. A typical drilling barge may measure 200 by 100 feet, with a drilling rig at one end and a helicopter landing platform at the other. Inside might be air-conditioned quarters for 50 men, a power plant and a distillation unit for converting sea water into fresh water.

The barge, which floats, is anchored in place by lowering up to six retractable legs to the ocean floor by hydraulic jacks. When the legs reach rock bottom, the jacks continue to operate, lifting the barge clear of the water.

Pan American had to float such a barge all the way to the Persian Gulf from Galveston, Texas. A large, Dutch ocean-going tug did the towing job, and the trip, nearly half way around the world, took nearly four months. The voyage was necessary because there were no barges available in the area and the cost of building a new one (up to \$7 million) was prohibitive.

The British Petroleum Company, which

brought in two wells in the Persian Gulf, one at 5500 feet below the Gulf floor and another at 9600 feet, needed a permanent land base near its crew to supply them with food and equipment. Otherwise they would have to service them out of a port in Saudi Arabia, nearly 170 miles away.

The land nearest the drilling operations was Das Island, a mile-long strip of sand and rock inhabited only by sea birds, scorpions and turtles. Before they could set up a base, construction crews watered and rolled 4000 feet of the sand into a reasonable airstrip on which two-engine aircraft were able to land. And, until a harbor was built (by quarrying rock from the island itself and using it to make a breakwater), most of the heavy supplies were brought in by a military tank-landing craft, which was able to run right up on the beach and throw open its bow doors to unload.

All of this is in addition to the preliminary problems of locating a likely site, taking the necessary samples and making the necessary tests—at the bottom of the sea. Deep-sea divers and, more recently, skin-divers have brought new techniques to the old routine of searching for oil.

While new techniques can solve the underwater problems, new machines are needed to cope with others encountered above and on the surface. In the Louisiana bayou country, for instance, oilmen devel-



**PLAINS GRIZZLIES**, believed extinct, were a hazard in Canadian mountains



**RUGGED OILMEN** waded through inundated forest, carrying all their equipment by hand. Clothing was taped to keep out leeches

**ROCK SAMPLES** are chipped from the sheer face of a mountainside in Canada



**ARCTIC WINTERS** are best time for oil exploration. In spring and summer rivers run high and muskeg becomes too mushy to cross



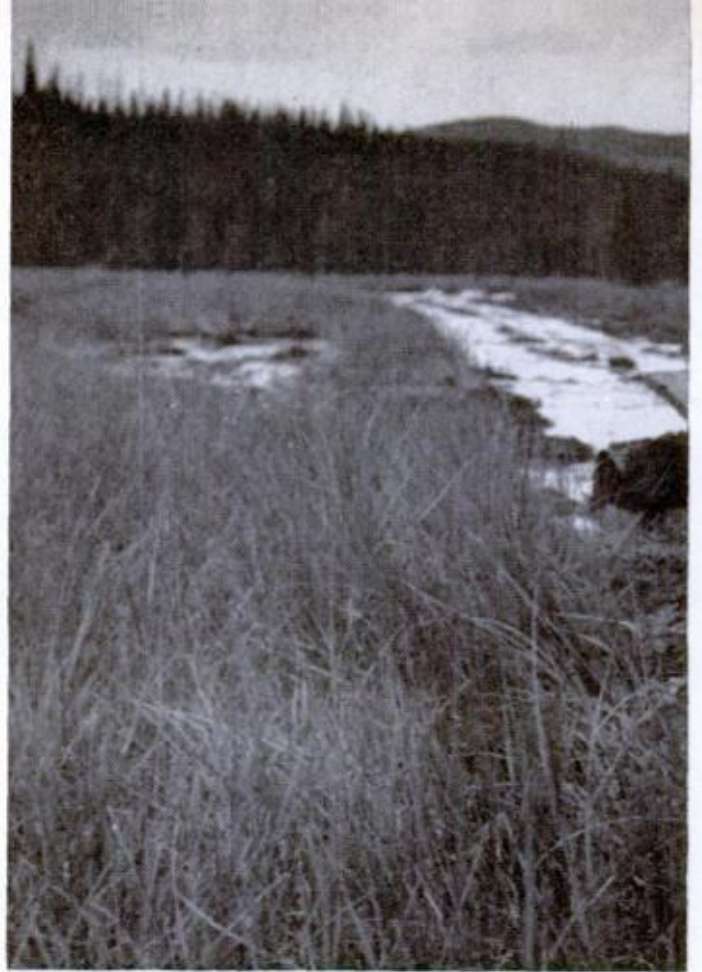

**HELICOPTER** (left) carries crews to inaccessible areas of oil-rich mountains. Far from home, oilman (below) can still enjoy some of its finer comforts







**MUSKEG BUGGY** sloshes its way through shallow area of muskeg. Normal vehicles would disappear in muck

oped an outlandish-looking vehicle called a swamp buggy to carry men and equipment through that eerie area that is half water and half land and not really one or the other. The buggy has four gargantuan wheels with quilted tracks that can float through the water and grind through the mud.

Another machine was borrowed from another industry. Cities Service Company, exploring the fabulous area of oil-soaked sands along the Athabasca River in northern Alberta, found that the most efficient device for the task was a giant mining wheel built by German engineers for digging coal in the Ruhr Valley. These Athabasca oil sands, by the way, cover 30,000 square miles and contain an estimated 40 billion barrels of hydrocarbon reserves, the world's largest deposits. But the sands are at or near the surface, so ordinary oil-drilling methods do not apply. Strip-mining methods, familiar in the coal industry, are used.

The German mining machine has buckets, fastened to a huge wheel, which dig into the ground and drop their loads onto a conveyor belt. The belt transports the sand to an extraction unit, which returns the clean sand to the ground and forwards the extracted liquid hydrocarbons to a mobile refinery nearby.

While some special equipment can be

borrowed and some developed over a period of years, other equipment must be improvised. In one case Sinclair Oil Company crews produced two self-propelled landing barges for operations in Somalia, Africa, because the nearest port was 350 miles away.

Each barge had two outboard engines that could be tilted when the vehicles neared the shore, and had ramps at the other end that could be lowered by hand winches for unloading. More than 4000 tons of equipment—drilling rigs, trucks, air-conditioners, house trailers, etc.—were transferred from ships in the Indian Ocean to the homemade barges and then to the shore. Somalia is on the Equator, incidentally, and has the world's highest average annual temperature—88 degrees.

Oilmen seem to work in areas where Mother Nature is at her meanest. One of these areas is *Rub' al-Khali*—"the empty quarter" of Saudi Arabia that even the natives avoid. Here temperatures rise above 130 degrees in summer, and a man alone could not survive more than 24 hours. The oil crews survived with the help of air-conditioned trailers, mounted on huge sand tires and grouped like wagon-train camps of the Old West. Geological crews operate out of these base camps, setting up outlying tent bases for day work, but return to

(Continued to page 228)

# Supersound Moves

## Soldering

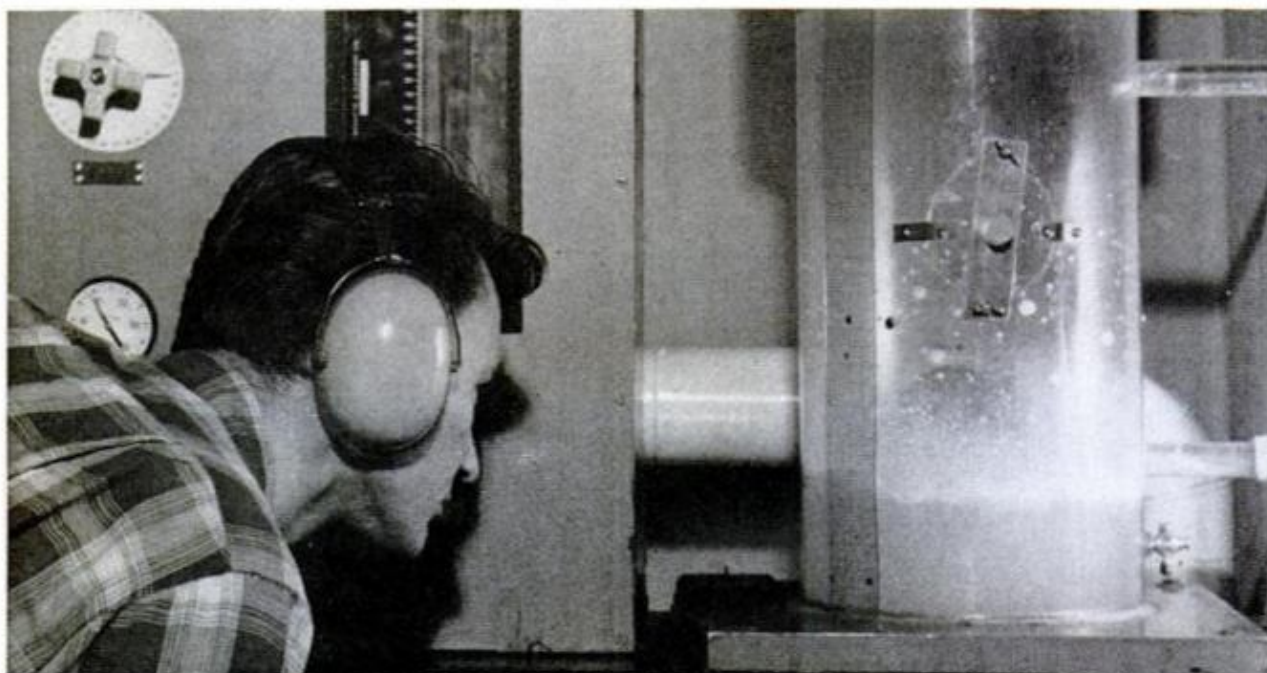
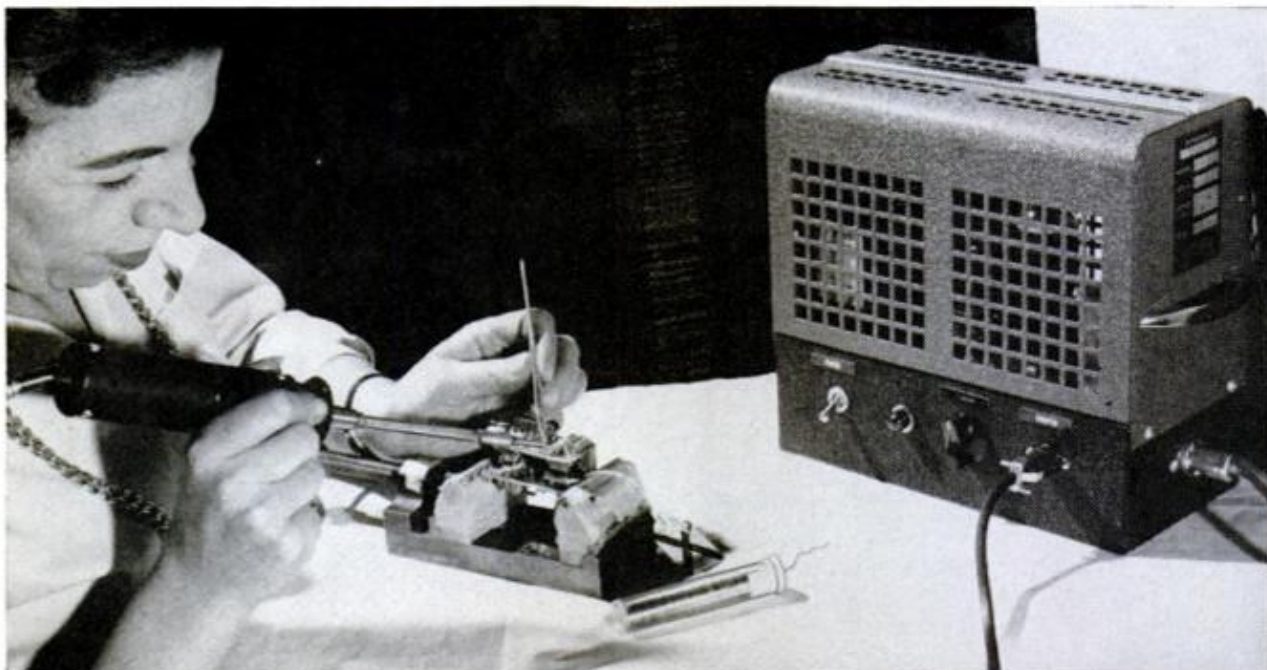

## Defoaming

SOUND WAVES pitched at more than 20,000 cycles per second—quite beyond human hearing—are performing miracles on production lines. They bore complicated designs into glass, solder materials without using flux and, among other things, quickly scrub hard-to-clean metals bright.

The vibrations of supersound are formed by transducers, which (like certain ceramics) vibrate when subjected to electric

current or (like sheets of thin nickel alloy in a coil) expand and contract, setting up vibrations in a radiating plate.

In the ultrasonic drill, the vibrations are imparted to a tool which does not cut materials (even glass!) directly, but transmits energy to a fine abrasive powder of slurry, producing a fast chipping action.

In ordinary welding, heat pushes molecules of two different objects into so much

# Out of the Lab

## Welding



**TIP** of soldering iron, opposite page, heats work in normal manner till solder flows; ultrasonic waves are then switched on, vibrating tip, causing solder to bond immediately. Ultrasonic welder, left, will spot or seam weld aluminum foil in thicknesses down to .00025 inch



**TRAPPED AIR** bubbles are removed from liquids, opposite page, by ultrasonic whistles; sound waves force the bubbles out. Drill, left, leaves no machine marks while vibrating at 20,000 cycles per second. One hundred grains of abrasive between drill and work cut about two million chips per second

## Drilling

activity they flow together. Ultrasonics causes this flow cold, by rapid supersound vibration, making it possible, for example, to weld hermetic seals in foil containers holding food or drugs. Another benefit: Ultrasonic welders on the processing line can turn out a seam in seconds.

The ultrasonic soldering iron has its heating tip linked to a transducer, allowing the soldering of aluminum, for instance, which

has an oxide film that normally would interfere with tinning. The vibrations rip away this film, permitting the solder to bond to the surface of the aluminum. Obviously flux is unnecessary.

Ultrasonic cleaning is in wide use. A transducer vibrates detergent-filled water, causing bubbles to form then to implode (or collapse), releasing energy that cleans with crackling speed.



### First Aid Via TV

Paris policemen televise close-ups of a victim at the scene of an accident to doctors who are then able to give first-aid advice even though far from the site. The portable TV camera is a new design.



### Fresh Air for Sale

By inserting a 10-yen coin (about three cents) in a slot machine, shoppers in downtown Osaka, Japan, can get 20-seconds of refreshing oxygen. Individual sanitary paper funnels are placed over the dispenser.

### Lighted Rubber Tubes Automatically Mark Traffic Lanes

Internally illuminated, automatic-rising traffic markers make it possible to change traffic patterns without the hazards of manual distribution of lane markers.

Made of silicone rubber, the markers are contained in housings which can be buried

in a street without the need of trench excavations. Individual holes are dug for the markers. They operate electrically, activated by remote control. Manufacturer is Nationwide Traffic Engineering Products Corp., Glenside, Pa.





### Primitive Caveman? Nope—He's Electronic

Starting from a small sketch or a film strip, a Chicago firm builds and animates three-dimensional reproductions of cartoon characters for animated displays. The larger-than-life model of Fred Flintstone

was molded by Silvestri Art Mfg. Co., cast in fiberglass, hand painted, dressed in real fur, left, then equipped with electronic and mechanical innards, right. A pre-programmed tape controls his actions.

### Runaway Air Force Jets Snagged by Nylon Cable

Similar to systems used on aircraft carriers to halt landing Navy planes, a cable system for snagging Air Force jets in danger of overshooting the runway is being tested.

A nylon cable is wound around two

drums buried on each side of the runway. When a jet hooks the cable, the cable spins the drums which drive hydraulic pumps. The hydraulic pressure operates on two aircraft wheel brakes which slow down the drums.



# PM Shopping Guide



**TAKE TIME** to check drills and accessories. Your dealer can give you suggestions, catalogs

**B**EFORE YOU BUY a portable electric drill answer this question: What do I intend to do with it now and what am I likely to need it for later on? A portable electric drill with accessories designed to be chuck-driven is almost a complete power workshop. Let's say that first you need the power unit for drilling holes in wood or metal. You buy the drill for that purpose. Later you have a sanding job. You buy either a disk or orbital-sander accessory, and you're in business. Or you have a polishing job coming up, on the car or the furniture. You buy the polishing pad and you're all set to handle this chore. Acquiring a power workshop piece by piece from your local

**CORDLESS DRILL** is new. It's battery operated and works anywhere at full-rated power

**NOTE HOW CLOSE** this drill works to horizontal 2 x 4. Chuck is at right angles to motor

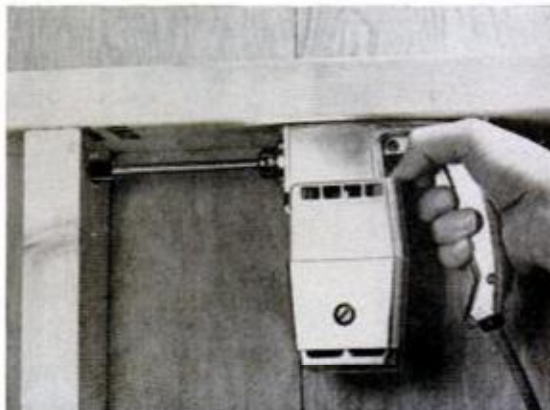

# Portable Drills

dealer is as simple as that. Get the drill first, then buy accessories as the need develops.

And before you buy the drill learn about all the accessories available. Most of these are chuck-driven and can be operated with any drill. Others are quick-locked to the drill in driving position and can be used only with the drill for which they were designed. Know which is which and how they work before you buy.

Now the drill itself. It's the basic unit of the power shop and you should know what you're getting before you put your money on the barrelhead. Pictured at the right are four common types of grips, or handles, you'll find on portable drills. No one can tell you which is best for you. You'll have to judge that yourself. Heft the drill, get the feel of the grip in normal operating positions, overhead, horizontally and straight down. One of the first three types will probably suit you. On the fourth, with the spade handle, you ordinarily do not have a choice. You get the spade handle with nearly all  $\frac{1}{2}$ -in. drills.

Size in a portable drill is the chuck capacity. A  $\frac{1}{4}$ -in. drill comes with a chuck which takes a  $\frac{1}{4}$ -in. twist-drill bit or a  $\frac{3}{4}$  or 1-in. wood bit, or auger, with a  $\frac{1}{4}$ -in. shank. This is the maximum size bit shank the chuck will handle. The same is true of the  $\frac{3}{8}$  and  $\frac{1}{2}$ -in. drills. Obviously all three units will handle twist-drill bits from about  $\frac{1}{16}$  in. (fractional size) up to the maximum size. Of course, the maximum woodboring-bit capacity will be much higher, up to  $1\frac{1}{2}$  in. for some  $\frac{1}{2}$ -in. drills rated heavy-duty. Chucks A, B and C, illustrated on a following page are those commonly available. The geared chuck, C, is preferred.

Now study the cutaway view of a typical portable drill with a pistol-grip handle and the features keyed A, B, C and so on. Go over these closely, noting the chuck offset, G, which determines how closely you can work to a vertical or horizontal surface, and

TYPES OF HANDLES



PISTOL GRIP



SAW-HANDLE GRIP

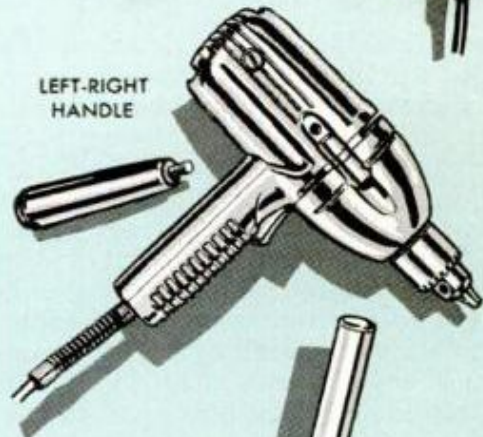

LEFT-RIGHT HANDLE

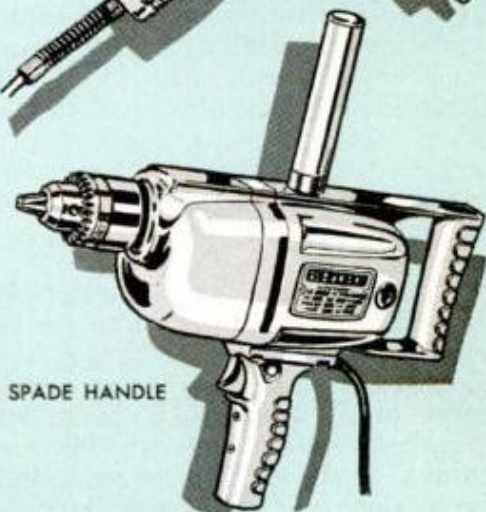

SPADE HANDLE

# PM Shopping Guide

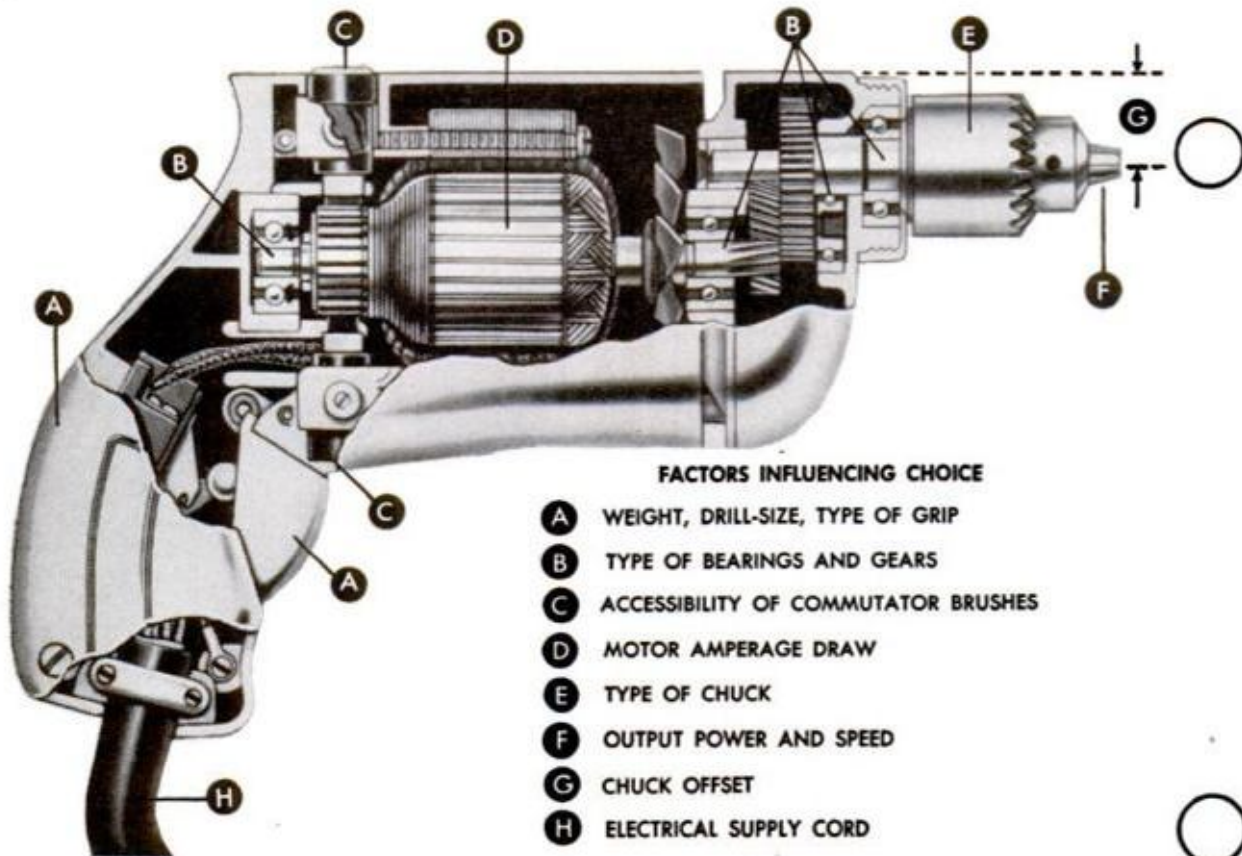

## FACTORS INFLUENCING CHOICE

- A WEIGHT, DRILL-SIZE, TYPE OF GRIP
- B TYPE OF BEARINGS AND GEARS
- C ACCESSIBILITY OF COMMUTATOR BRUSHES
- D MOTOR AMPERAGE DRAW
- E TYPE OF CHUCK
- F OUTPUT POWER AND SPEED
- G CHUCK OFFSET
- H ELECTRICAL SUPPLY CORD

also the helical pinion drive and the ball bearings, B. This drill might be described as full-ball-bearing construction, that is, all rotating parts, armature, gear train and chuck, are mounted on ball bearings which reduce friction to the minimum. Such a drill might have a heavy-duty rating which normally means that it can be operated continuously at full capacity. A lower-priced drill of the same chuck capacity might be fitted with oilless sleeve bearings and be designed for intermittent duty only. Such drills are designed for homeowners and others who normally do not operate the unit continuously over long periods of time.

You'll find the amps. or amperage draw, D, on the nameplate of the drill. On  $\frac{1}{4}$ -in. units this ranges from 2.5 to 3 amps., and is a measure of the power of the unit. Some  $\frac{3}{8}$ -in. and  $\frac{1}{2}$ -in. heavy-duty drills will be rated 5 amps. or more. On the nameplate you'll also find the no-load speed. The load speed will be considerably

lower and the manufacturer's literature usually gives both. On a  $\frac{1}{4}$ -in. drill rated standard or intermittent duty the no-load speed might be given as 2500 r.p.m. and the load speed, which is the chuck speed under load, might be given as 1600 r.p.m. This is not a fault; it is a characteristic of all series (universal a.c.-d.c.) motors with which portable drills are normally fitted. On a  $\frac{3}{8}$ -in. heavy-duty unit the no-load speed may be as low as 600 r.p.m. and the load speed 375 r.p.m. Drills with the lower speeds are designed for heavy-duty jobs such as boring large diameter holes in hardwood, driving large hole saws and the like. Some small drills are designed to be operated at two load speeds. The high-speed drill, which you as a homeowner will have more use for, does have some advantages over the slower speed unit. While such units do not have the power, or lugging ability, of the heavy-duty slower-speed drills, you just can't beat them for high-speed drilling in



# Portable Drills



**THIS DRILL** is driven by power pack attached to user's belt. Operates at full power

wood or metal and for sanding or polishing with a lamb's-wool pad.

If you must compromise, then buy either the  $\frac{3}{8}$ -in. heavy-duty drill or the  $\frac{1}{2}$ -in. standard-duty unit. You can use most of the accessories for the  $\frac{1}{4}$ -in drill and the larger drills will handle any heavy-duty job. ★★

**PORTABLE DRILL** with nylon housing is shock-proof. Otherwise it's regular in size, weight

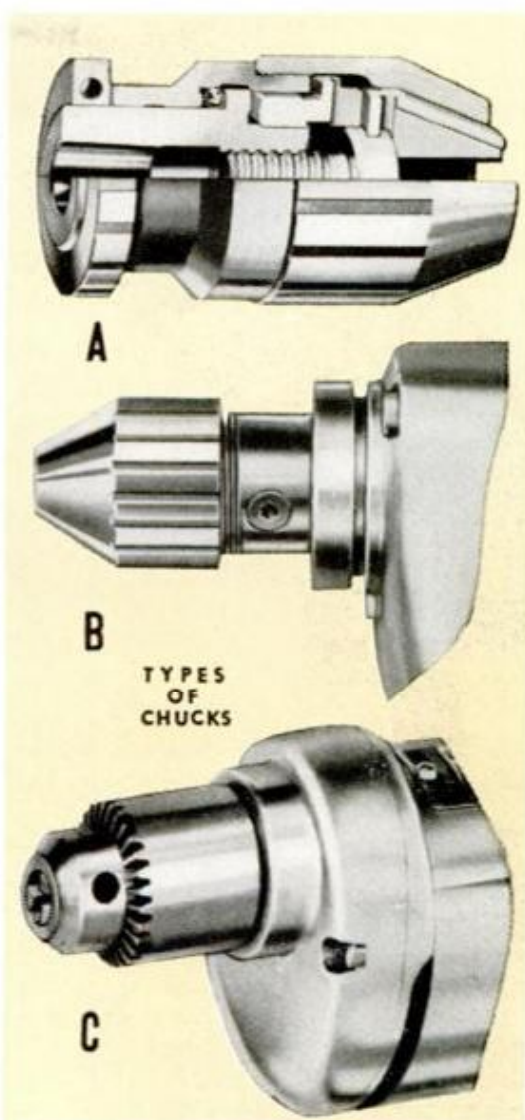

TYPES OF CHUCKS

**THREE TYPES** of chucks supplied on portable drills. Geared chuck, C, is most widely used

**PORTABLE DRILLS** come with 3-wire cords. Use adapter with ground in all two-wire outlets

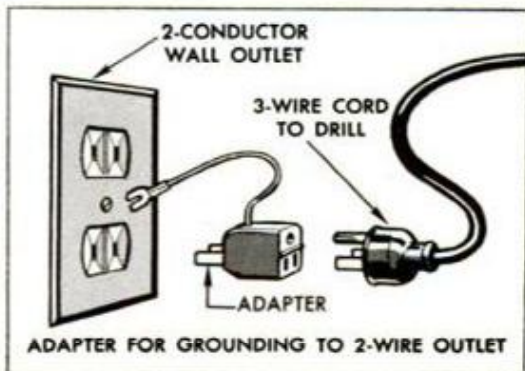



# OOPS!

**UP AND OVER!** Dune Riders' buggies—all hand fashioned—hit 70-mile-per-hour speeds on the rolling sands

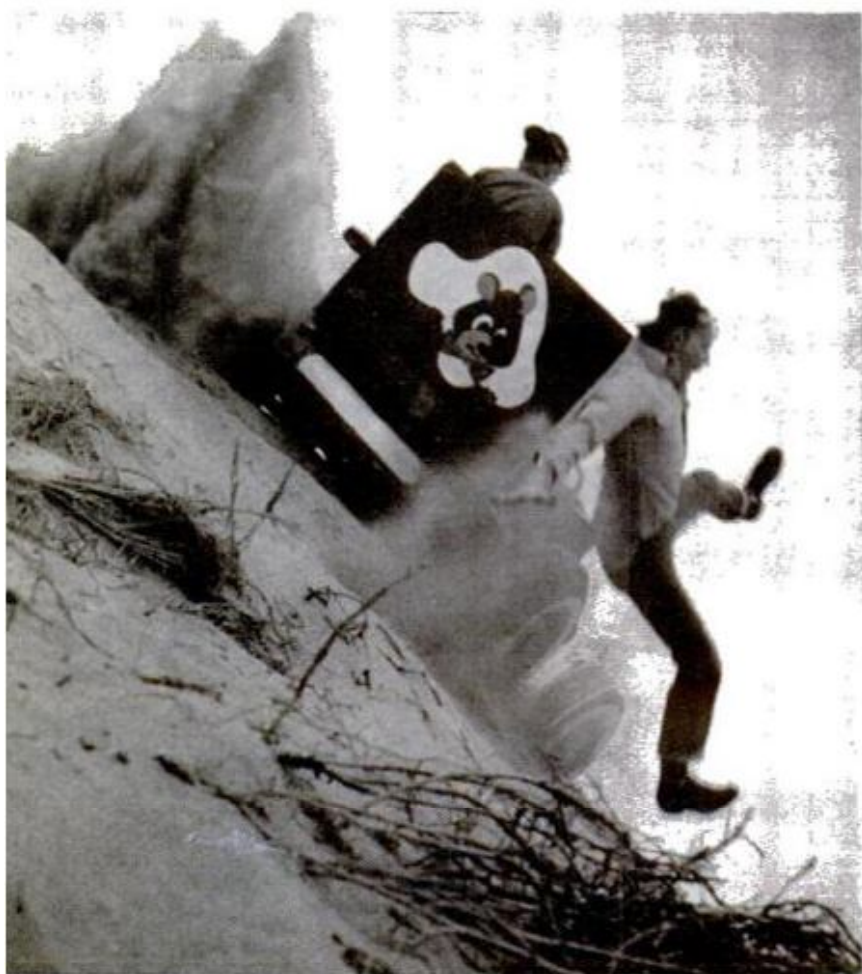

**ROARING** over dunes around Arroyo Grande, a village south of San Francisco, Calif., 73 members of the Dune Riders club tear Sunday afternoons into dizzying, sand-spitting auto games. What autos! What games!

Action starts with a 50-mile-per-hour game of follow the leader when the pace car plunges down the 75-foot-high sides of a natural amphitheater. The drivers—housewives, breadwinners, young and old—bank into a dizzy whirl. Losing altitude, they peel off, gunning toward the bowl floor to shoot—oops!—over the lip on the opposite side.

Drivers build their buggies on shortened Model-A frames, for the most part. Rear-wheel rims are split and widened with nine-inch inserts. Front widths are standard; all tires are buffed smooth to keep tread from digging into sand. V8 engines are hopped up and set back so the center of gravity allows buggies to “fly” atop the sand.

**CONTACT.** As car crashes to earth after leap over dune, passenger takes a spill

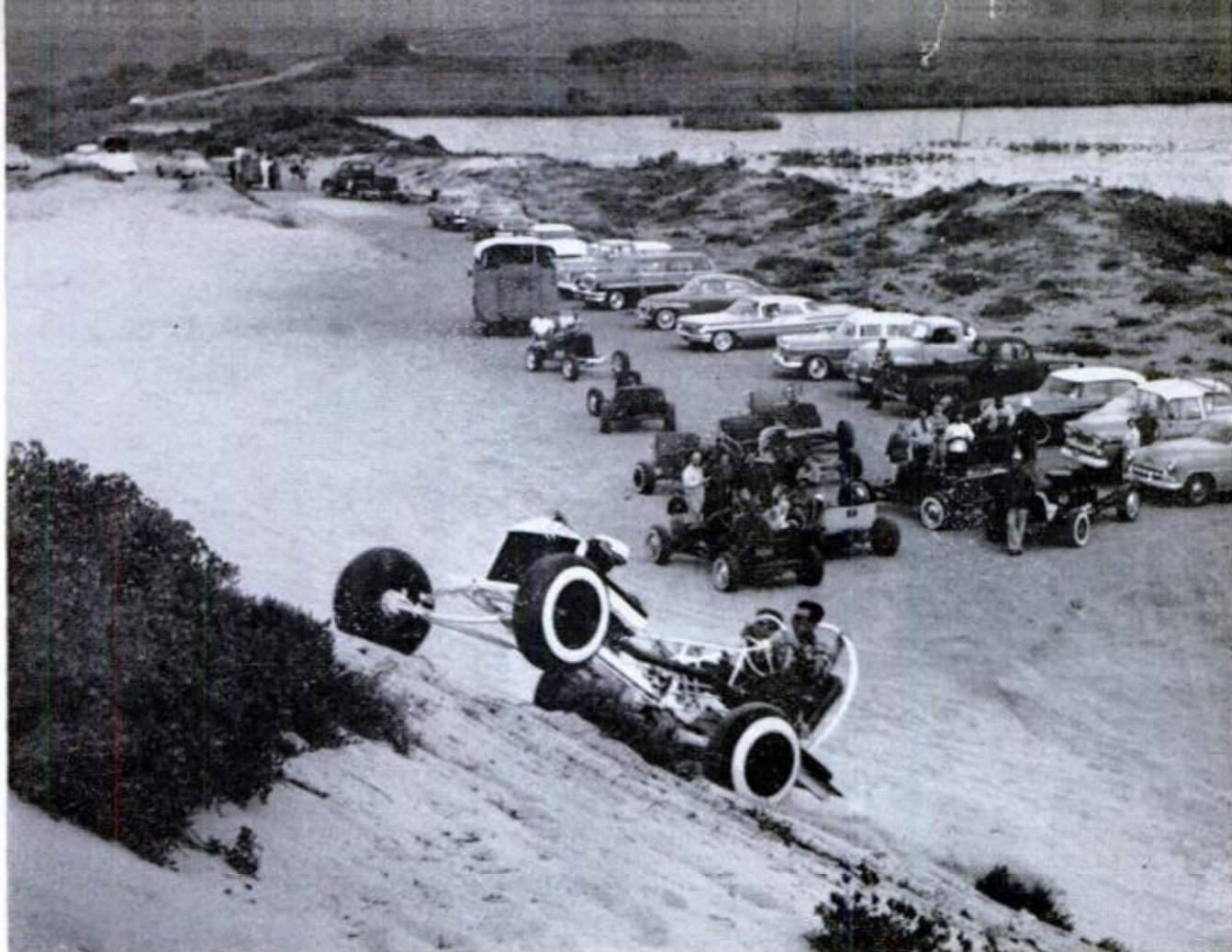

**SETTING** for high-speed games is near Osa Flaco Lake. Club members aid drivers who get in trouble

**SETUP** for buggy can look like this: shortened Model-A frame, stick shift with 1939 Ford box, V8 engine, Chevy or Model-A steering gear. Some builders attach an extra rear seat (shown) to fight gravity

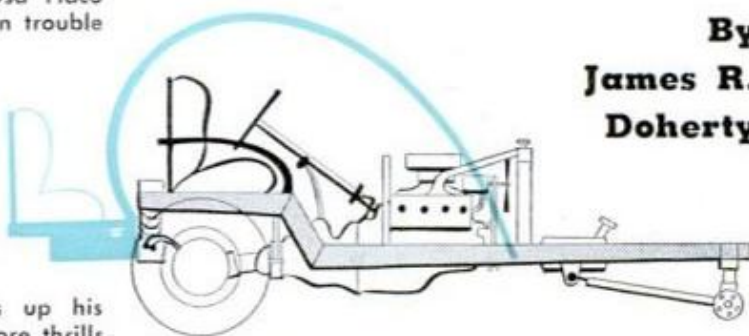

**By  
James R.  
Doherty**

**CLUB PRESIDENT**, Chuck Johnson, whips up his Chrysler V8 engine for higher speed and more thrills



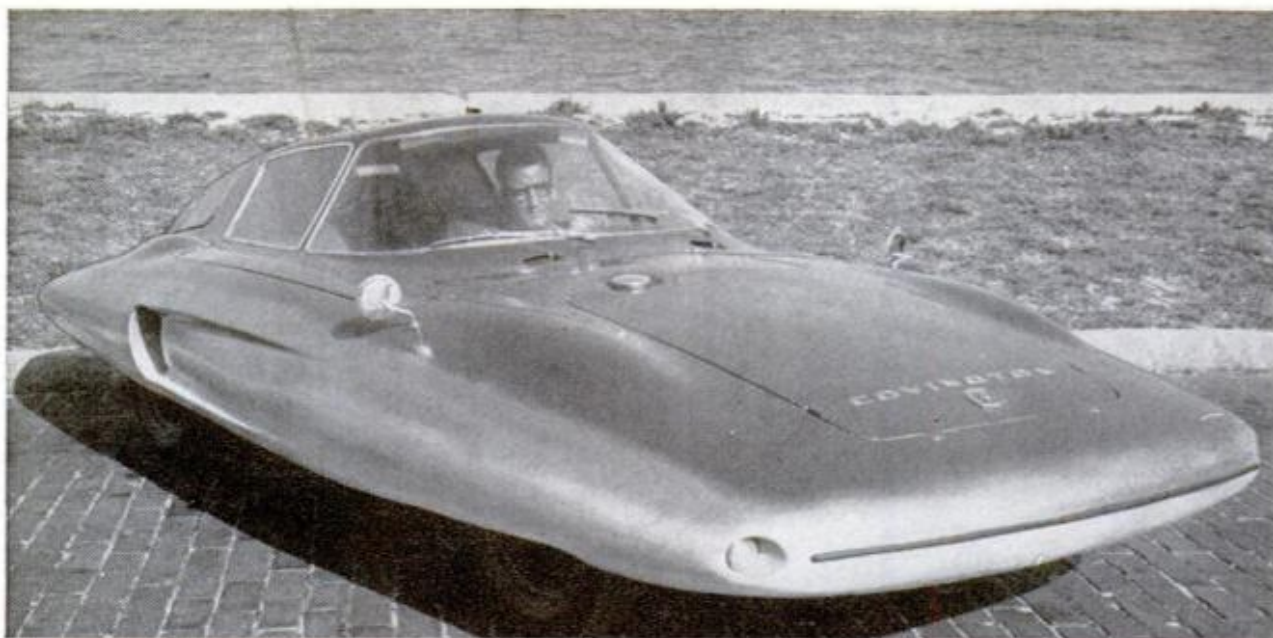

### Sharklike Custom Body Is for Rear-Engine Cars

Aerodynamic principles received first consideration in the design of a sleek, 140-pound fiberglass body shell for use on any rear-engine car with approximately 80-inch wheelbase and 48-inch tread. Designer Henry Covington, St. Petersburg, Fla., says

that his car's 20-horsepower air-cooled engine moves it along at 80 miles per hour.

While over six years and \$4000 were invested in the development of this shell, he believes that bodies can be produced from the same mold to sell for \$400.

### Aluminum and Concrete Bridge Spans Highway

Going into use at Amityville, Long Island, are two highway bridges that utilize aircraft-type aluminum members. Triangular-shaped beams bolted together edge-to-edge form the roadway base. Each beam is a cell fabricated from sheets of alumi-

num and stiffened inside with aluminum extrusions. Standard concrete paving was poured directly on the deck.

The bridges are 212 feet long and 86 feet wide; each has four spans made up of 76-foot and 30-foot beams.

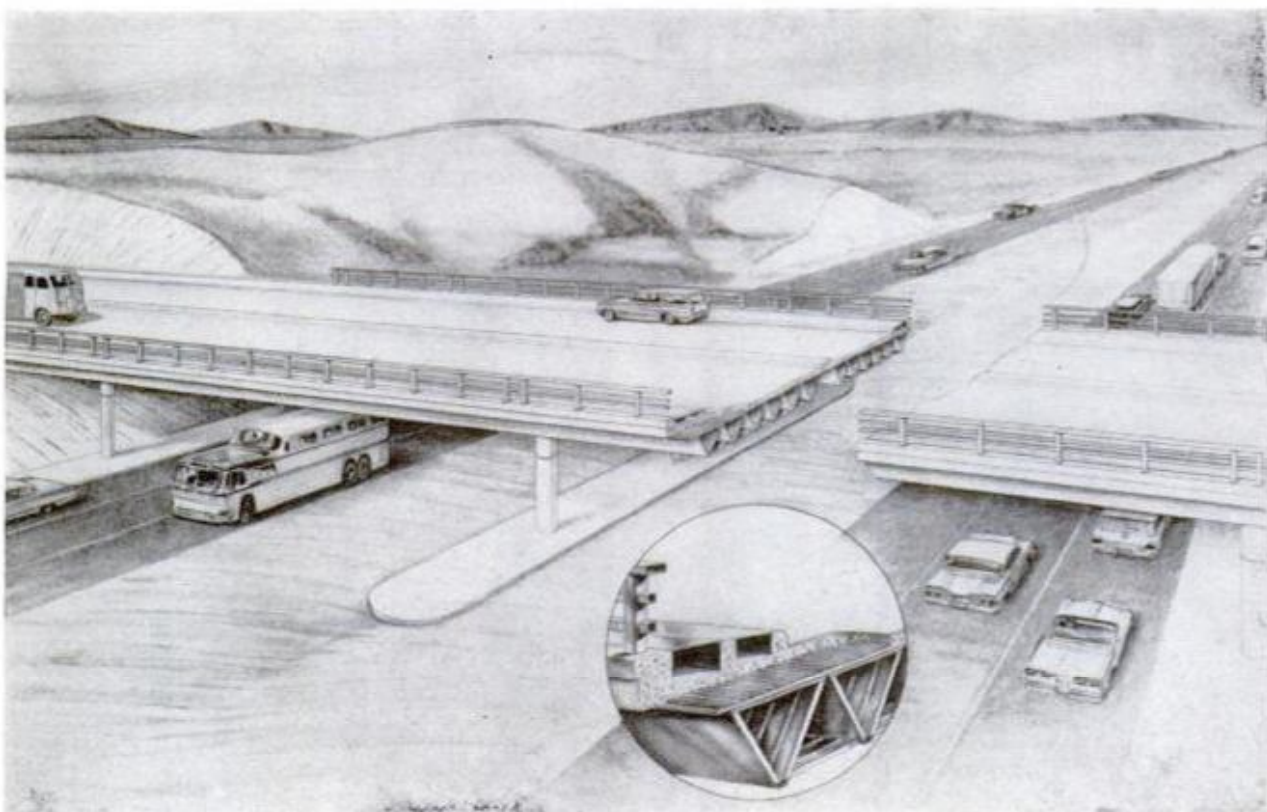



### **Air Boat Skims Over Water at 75 Miles Per Hour**

Powered by two aircraft engines, an air boat rides an eight-inch cushion of air and is capable of 75 miles per hour. One engine drives a reversible-pitch propeller mounted on the tail assembly, which includes a rudder. Another 160-horsepower engine forces air through jets on the underside of the craft, lifting it from the water on a cushion of air. The craft is owned by Reynolds Metals Co.

der. Another 160-horsepower engine forces air through jets on the underside of the craft, lifting it from the water on a cushion of air. The craft is owned by Reynolds Metals Co.

### **Hey, Stop the Countdown—It's a Truck**

Looking as though it were set to take off into the sky, a truck dumping its load of wood chips at a pulp mill near North Bend,

Ore., runs up a ramp which is punched skyward by a long-fingered hydraulic lift. It tilts the truck as if it were a toy.



# Now It's Used-House Dealers

By Jack B. Kemmerer

LAND CLEARING for Southern California's booming construction projects has produced an entirely new business in the last few years—the used-house lot. Like a used-car lot, it's a place where homes, displaced from their original sites, can be purchased, usually at surprisingly low prices.

Home movers once bought such houses, sold them where they stood, then moved them to the buyer's lot. But pressing construction schedules forced faster action than that, and the used-house lot was born. There are a dozen now in Southern California, and with 50,000 houses scheduled for moving in 1962, they may become commonplace across the nation.

Most used houses are less than 10 years old, but buyers find such bargains as two-bedroom homes for \$3500 to \$3900; three-bedroom models for \$5500 to \$5900, delivered to the buyer's lot. Even though installation costs range around \$1500, it's possible to buy a \$20,000 home for as little as \$8000 to \$10,000, depending on the cost of the lot.

**WATER TRANSPORTATION** is ideal for houses; it's comparatively less expensive and eliminates problems with traffic and street obstructions. This one was part of a group of eight homes moved 100 miles by barge

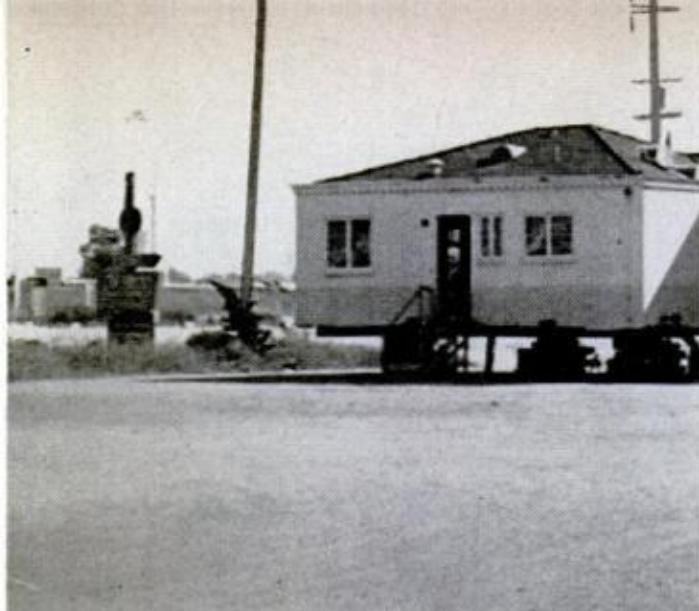

**PROSPECTIVE BUYER** shops in a Los Angeles used-house lot. Duplex at left is priced at \$7000; two bedroom house at center, \$4000; house at right, \$3900. Duplex has been cut in half for easier handling

**ATTRACTIVE** three-bedroom home in Hollywood shows no sign of its travels from another suburb. This big, new three-bedroom house required two nights for moving, which boosted the total cost to \$15,000

**OFF TO THE LOT,** a big two-story stucco house leaves its original footings. Moving tall houses is more expensive because of the cost of moving power and telephone lines enroute; this one cost about \$10,000







### Motor-Driven Bar Bell Vibrates the Muscles

Twin electric motors in the bell ends vibrate a bar bell which can be used as a muscle relaxer or a spot massager. A pad is included for massaging.

The bar bell weighs 12 pounds and, when plugged in, vibrates the muscles as they

are exercised. It is designed to appeal to women as well as men—and to older men with heart conditions because it gives them a workout without all that work.

It retails at \$44.50. Manufacturer is Central Stamping & Mfg. Co., Polo, Ill.

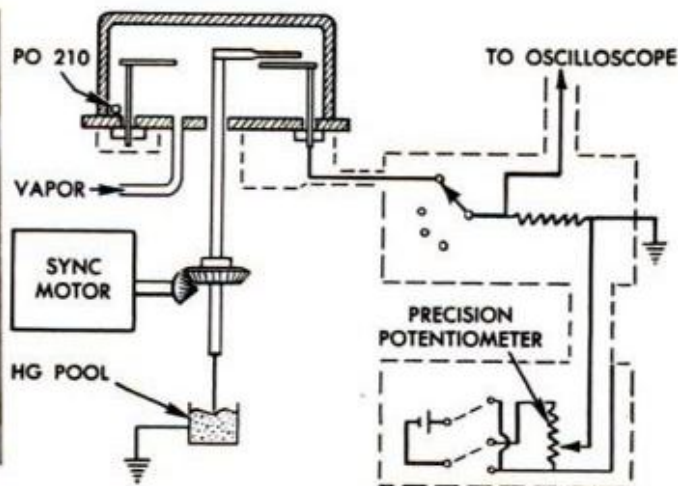

### Electronic Nose Sniffs Differences Between Smells

Odors can be measured, and the differences between them plotted by an electronic sorting apparatus. It uses common chemical substances—such as salt or egg albumin—to adsorb odor particles in a gold-lined chamber, creating an electrical impulse that can be read on an oscilloscope.

Dr. Andrew Dravnieks, consultant to Armour Research Foundation, Chicago, constructed the odor reader. He utilized the adsorbers, such as the salt, to simulate the way the moist membrane in the human nose picks up odors and creates electrical impulses to be "read" by the human brain.



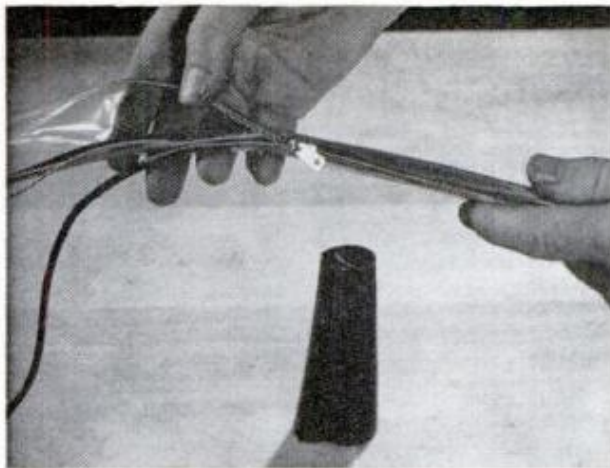

### Zip-On Plastic Tubing

Plastic conduit, tubing or sheathing can be zipped around wires, cables or ropes with an ordinary slide fastener built into a new plastic strip. Called Zippertubing, it can be zipped on and off easily for temporary shielding, or sealed into a permanent tube with a liquid sealer. It's available in 20 sizes and types, even tapered joint sections, from the Zippertubing Co., 13000 S. Broadway, Los Angeles 61.



### Child's Chair Tips and Rocks

Made of the same durable material as a football helmet, with a seat insert of polystyrene, a child's chair spins, rocks, tips and twirls. The Tip-N-Rok is listed at \$9.75 (for ages 1 to 6) and \$12.95 (7-12) by Tip-N-Rok Sales Co., 137 Kennedy St., N.W., Washington 11, D. C.

FEBRUARY 1962

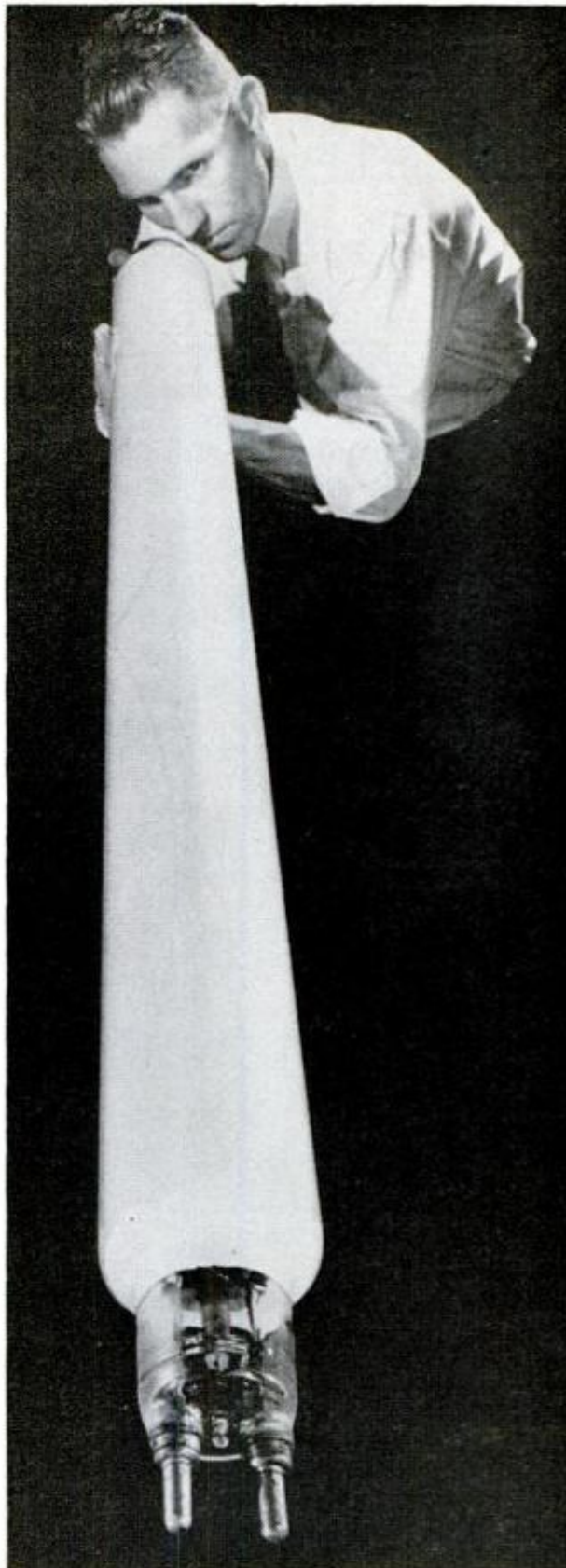

### King-Size Floodlight

Four inches in diameter and five feet long, a new mercury-fluorescent lamp contains a mercury arc tube which produces high-intensity light. A phosphor coating on the outer casing improves color, quality. List price of the 330,000-lumen GE lamp is \$425.

137

# Thanks to Shifting Ocean Currents..... Saltwater

By Frank A. Tinker

**B**ACK IN 1957, after a nine-year cold spell, the waters off our West Coast suddenly warmed. Although this warming amounted to only a few degrees, to oceanographers the shift was spectacular. To sport fishermen at ports like Long Beach and Monterey, it was even more so. Fish which had not been caught in respectable numbers for a decade became abundant. By 1959, 26 species had been reported far north of their usual range and 11 of these were the farthest north they had ever been found. Eastern anglers may some day observe the same phenomenon on an even more spectacular scale.

**PARTY BOATS** and private craft share the same water as West Coast fishermen enjoy their boom. Below, barracuda comes in the hard way

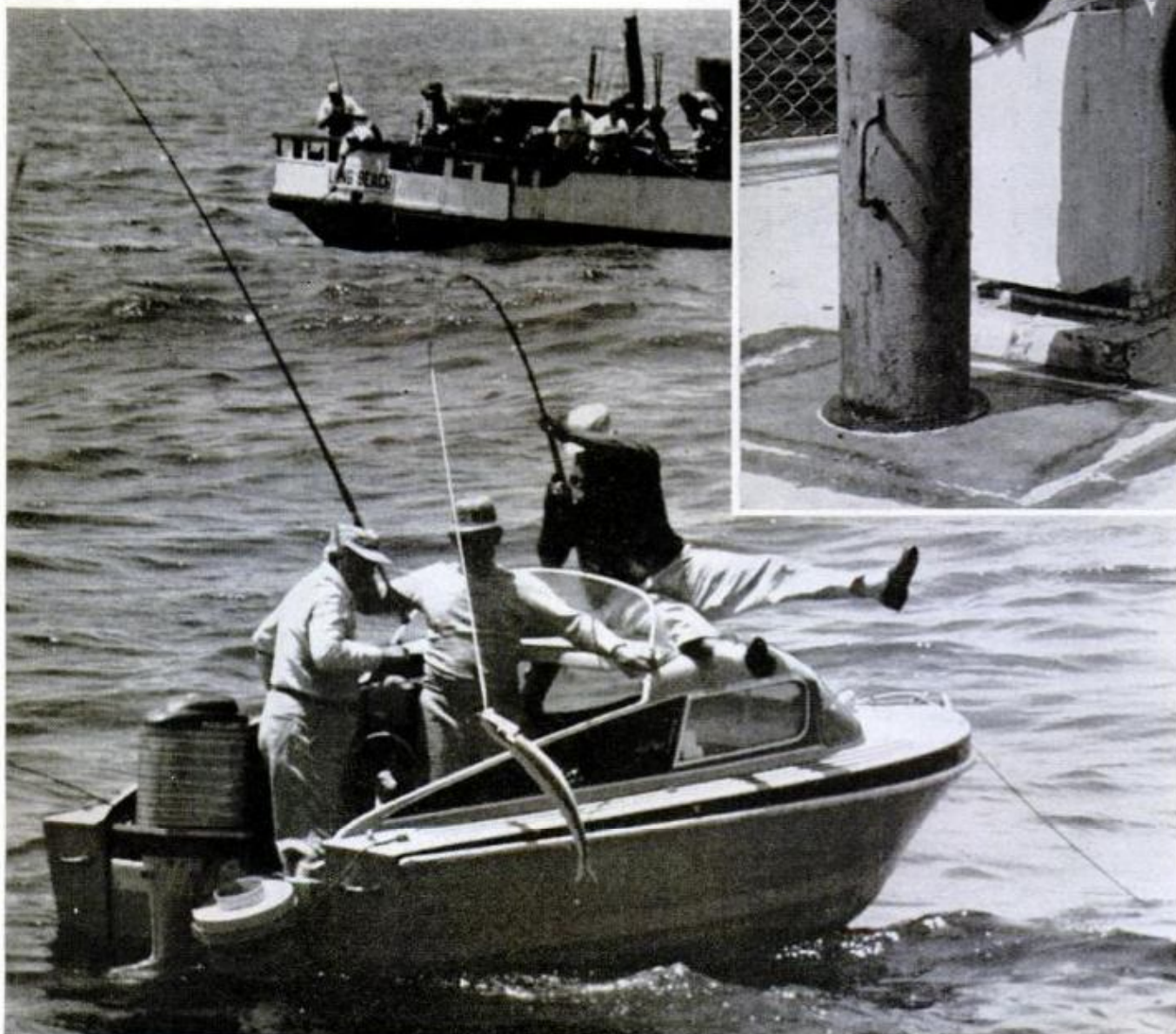

# Anglers Hit the Jackpot



**FAST ACTION** aboard a party boat as four happy anglers play fish at the same time. Fifth angler, foreground, is unhooking his fat albacore. Dense schools of this tuna cousin provide plenty of thrills

The California catch of barracuda, for instance, had dropped to a mere 87,000 by 1956. But the next year, the first of the warm water, it jumped to more than 500,000 and has remained at or above this figure. These tigers of the sea, commonly associated with more southerly climes, are being hauled in by fishermen not only in California but off Oregon and Washington. They have even been taken by commercial trawlers off Alaska!

The wonderful yellowtail, who at ten pounds will outfight salmon twice his weight, rebounded from a yearly average catch of about 30,000 to nearly 200,000. Ling

and rock cod, some of them weighing 25 pounds, are now being caught with almost embarrassing ease, particularly off Monterey. White sea bass, which had retired to Mexican waters, has returned in force to the same area.

Perhaps the most spectacular invasion for the sport fisherman was that of the dolphin. This tropical favorite, cohabitor with the sailfish, was caught only rarely off the coast before the present influx, the largest number since 1947—only twelve—being hooked in 1954. In five years of the previous decade none were taken at all. But in 1957, over 3000 dolphin were hooked.



**JUNIOR-SIZE** fisherman inspects the gaping maw of his dad's catch, dwarfed by the giant black sea bass

In the same way, the tropical skipjack have become abundant all the way to Oregon. Striped bass, which in the west are usually caught in inland waters, became a surf fish on the West Coast during this warm-water period.

Marlin and sailfish have been sighted all along the coast by commercial fishermen, and swordfish have been taken frequently off Monterey.

Fortunately for the visiting angler, this return—or visit—of the southern fishes has inspired a revival of the sport fisheries here which surpasses anything known before. The number of private boats docked has soared, and coastal communities have been forced to enlarge their mooring facilities. Yet harbor space remains scarce in some



**PARTY BOAT** heads home after a good day, and two lady anglers show off their share of the yellowtail catch

ports. For the angler who has neither the opportunity nor the desire to float his own craft, nearly every dock has party-boat skippers or launch owners ready to oblige.

In Monterey, where idle sardine canneries stand as mute memorials to the wayward ways of that little fish, the new sporting industry has taken up some of the slack. Launches began seining for these "fire-crackers" and small squid as bait when the white sea bass returned four years ago.

#### **Explaining the Warmup**

As for the warming of the West Coast waters, Mr. John Radovich, oceanographic expert of the California Fish and Game Service, explains it thus:

"We should realize that the 'normal' situ-



**BOTTOM FISHERMAN**, using a multiple-hook, heavy-duty rig, brings in a double—a matched pair of rock cod

ation is controlled almost entirely by the several sea currents and fairly constant winds which transport great masses of water into and out of the fishing grounds. To raise the water temperature even these few degrees would have required the completely efficient burning of more than half the world's oil reserves. Certainly solar radiation—the only oceanic source of heat—was insufficient to bring about this change in such a short time."

Thus the gist of the scientific deductions both here and in such authoritative offices as the Scripps Institution of Oceanography at La Jolla is that the water did not actually warm as it lay along the coast, but was warm to begin with and moved into the area from elsewhere. Yet both of the currents which make this potentially one of the finest sport fishing waters in the world are cold. The California Current, which

sweeps down from the Aleutians, is part of the great clockwise surface movement of the north Pacific. Running about 650 feet below it, ordinarily, is the Davidson Current, which proceeds in the opposite direction. Both these currents are considerably colder than the water farther offshore and both are rich in the phosphate nutrients which eventually feed all marine life.

During the winter, the lower Davidson Current rises to the surface near the California coast. In addition, the prevailing winds provide an offshore movement of the surface waters, thus bringing an upwelling from deeper regions where the temperature is even lower. The year-long effect of this system is to provide the West Coast with a relatively cold belt of water which separates it from the warm waters of the central Pacific.

The speed of this protective surface Cali-

# The World's Ocean Currents Lead . . . .



**MAJOR OCEAN CURRENTS** which affect fishing. Circled area shows the area enjoying the warmup, as the southbound California current slows to let warm eastbound Pacific water into range of West Coast fishermen

fornia Current as it proceeds down the coast is only a little over half a mile per hour. And apparently some of this speed is due—or related—to the prevailing winds. An almost permanent low-pressure zone is located just off the Aleutians.

During the past "cold" decade, these winds kept the California Current moving southward at its ordered pace. In addition, they provided enough offshore movement to bring up the cold water from below. Then, about the latter part of 1956, something shifted. The Aleutian "low" moved closer to the continent and enlarged, and the winds slowed.

When the winds died down, the California Current meandered, and in moved a part of the waiting, warmer Central Pacific mass. Samples of zooplankton taken along the coast show definitely that the new water is not from the south, although its accompanying fish are. Further, the increased salinity and higher oxygen content are typical of the Central Pacific waters. Thus the West Coast has, in effect, been moved

out into the ocean a critical distance and the fish schools, ever on the alert for better feeding and spawning grounds, have moved in to take advantage of the situation.

The warmth itself has not exceeded six degrees Fahrenheit, which boosted the temperature at Monterey to a consistent summer level of about 70 degrees. At the Scripps Oceanographic Institution, the average annual sea temperature during 1955 was 61.7 degrees and in 1957 raised to 63.2, certainly not a startling change to anyone but a fish. However, the warmer months were the most important, since they included the spawning season.

The warming caused by this intrusion of the water mass from the west extended down just over 300 feet in 1957, somewhat deeper since, and this has affected the sport fishing most of all. Species which are normally caught here are surface feeders who spend most of their time in this upper layer. The commercial fish run deep, and between the two are other types which strangely go unharvested.

## . . . . Fish—and Fishermen—Follow



**MORE PARTY-BOAT ACTION**—above, good-sized barracuda on his way to an unexpected landing in the boat

Of course, mixed with the good effects of the warming are others not so pleasant. While the bonito fishing off Oregon and Washington has improved, the coastal salmon catch in some of these areas has declined. After the first warm year, the albacore came in on their annual shoreward trek 150 miles north of their usual habitat. Although this had been predicted by the oceanographers, much of the commercial fishing fleet went to their traditional grounds—and were skunked.

What of the future? Is the California coast destined to become a happy extension of the Mexican sport-fishing wonderland? Will marlin and other tackle-busters be hunted off Oregon? All this is very doubtful. In fact, those who want to share this bonanza would do well to get in their licks soon.

This is not the first time the warm water has moved in, nor will it be the last, although it is the longest such trend on record. In 1926, 1931, and 1941 the temperature of the water rose similarly, and Mr. Radevich recently dug up old records

which showed that in each case the angler success followed the temperature upward.

But after each such cycle of warmth there has been a period of cold—and a resultant dearth of good fishing. The last such subnormal period, from 1949 to 1957, was the longest cold stretch in the sketchy history of these waters. From recent studies by agencies in the California Cooperative Oceanic Fisheries Investigations (CCOFI), comes information which may possibly signal the waning of warmth and its attendant fishing boom for California. For at the same time the water warmed here, it cooled off near Japan, apparently from a cold-water mass intruding in much the same fashion as its warm counterpart did off our shores. Such a cold mass began a slow march directly across the Pacific in 1957 and was first scheduled to reach here in 1958. Fortunately, it slowed and the arrival date was moved ahead to the spring of 1960. But then the mass halted completely, about 800 to 1500 miles off the coast, where it remained until 1961. Readings

(Continued to page 218)

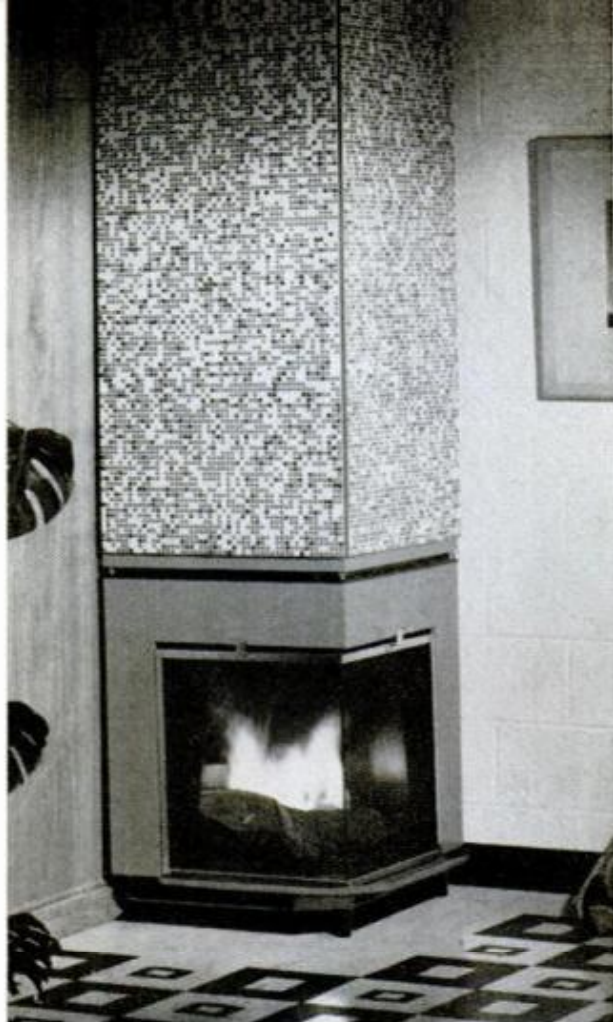

**FREESTANDING FIREPLACE** fits into a corner. Inner and outer walls of fireplace are heavy-gauge steel; the outer jacket is lined with fiberglas. Price is about \$255 from Dura-Vent Corp., Redwood City, Calif.

## WHAT'S NEW FOR

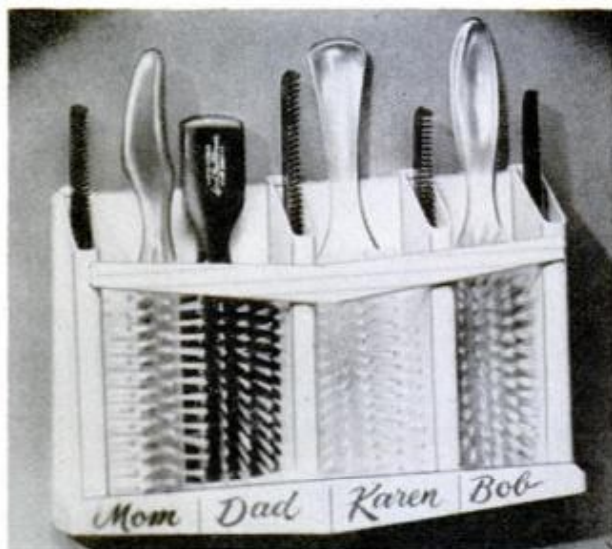

**BRUSH AND COMB HOLDER** attaches to wall. Plastic case cleans easily with a damp cloth. Personalized unit sells for \$2.50 (plus 10 cents postage) from Crown-Craft Products, 3-5 Mt. Hope Pl., New York 53

**SLACK AND SKIRT HANGER** operates like giant clothes-pin to hold garments securely. It's made of plastic and metal. Sold three for \$1.98, the hanger is manufactured by Mission Industries, Escondido, Calif.



**LIGHT BULBS and fuses** are neatly stored in plastic rack that mounts with screws on wall or cupboard. Price is \$1 (plus 25 cents postage) from Harold Franzen & Co., 171 King Bldg., Flanagan, Ill.

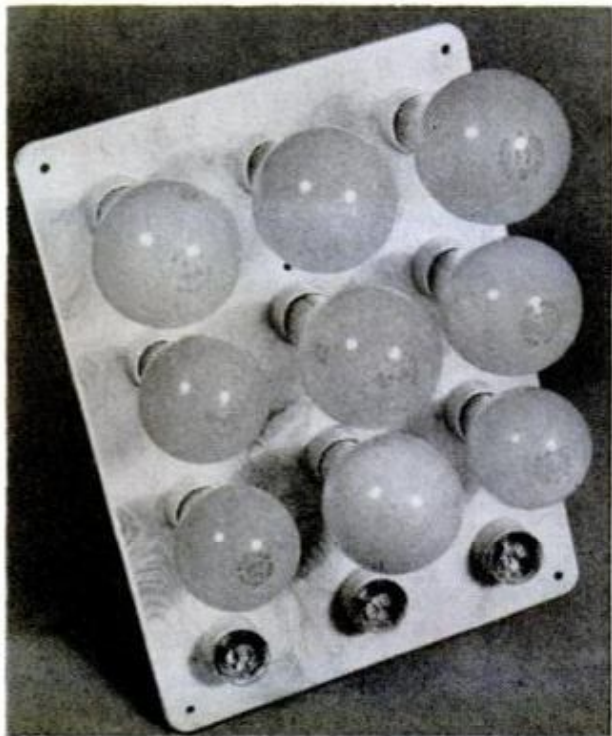





**AIR-CONDITIONED RANGE** whisks odors away through slot in range cover; when cover is closed, it provides extra counter space. Manufacturer is Jenn-Air Products, 1102 Stadium Dr., Indianapolis 7, Ind.



**WATER TEMPERATURE** for shower or tub can be selected and maintained by thermostatic control. Price of Hydroguard control is \$60. The manufacturer is Powers Regulator Co., 3400 Oakton St., Skokie, Ill.

**TELESCOPING DESIGN** of shutters enables homeowner to fit them to any size window. Made of steel or aluminum, Adjust-A-Shutters fit heights from 27 to 70 inches. By Addison Products Co., Addison, Mich.



FEBRUARY 1962

**LETTER SCALE** determines amount of postage. Worldwide postal rate booklet included. Scale that weighs up to two ounces sells for \$2.95; up to 10 ounces, \$3.95, from Apalt Specialties, Box 431, Oakdale, N.Y.



145

# Science Climbs the Mountain Peaks

By  
Richard Dempewolff



HANDIEST WAY to Sonnblick Observatory, in Austrian Alps, is by helicopter

**T**HROUGHOUT THE WORLD, scientists have been setting up shop in the sky. To reach their stratospheric eyries perched on rocky pinnacles above the clouds, they dangle over alpine peaks on aerial cableways. They grind upward in cog rail cars through tunnels and shafts carved in the living rock of 18,000-foot mountains. They hairpin their way up jagged snow-swept slopes in tracked vehicles and multiwheeled lorries, and ski along razor-edged rims of breath-taking

cols that drop away in sheer 3000-foot cliffs to white altiplanos below.

Halfway to the stratosphere, where most of some 50 modern, well-equipped high altitude laboratories (7500 to 18,000 feet up) are perched today, the cold, thin air doesn't lend itself to human comfort. But it is an ideal place, for instance, to study cosmic particles pouring in from outer space before most of them collide with gas nuclei in the air, and explode into totally different particles. Some of these cosmic



GLACIER



ICE PALACE  
CARVED IN GLACIER

TUNNEL TO  
ICE PALACE

COG RAILWAY TUNNEL  
CUT THROUGH  
FIVE MILES OF ROCK

*Sky-high observatories studying cosmic rays and high-altitude living are helping to sketch in our plans for exploring outer space*

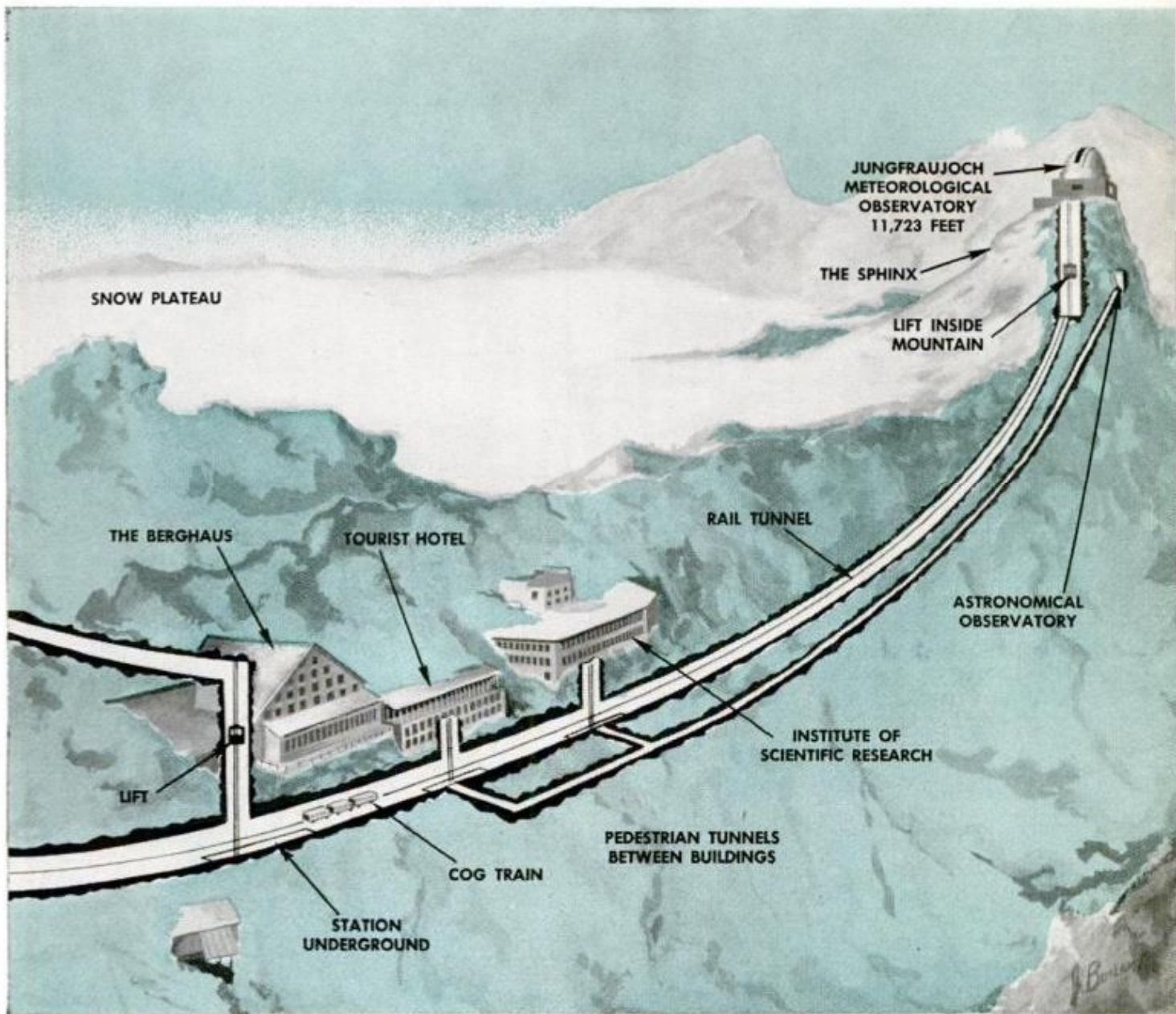

**SWITZERLAND'S JUNGFRAUJOCH** Observatory, some 12,000 feet up, is reached by railroad that tunnels five miles

radiations—from the sun and from exploding stars far out beyond our solar system—make the radiations in the Van Allen Belt pale to insignificance. If for no other reason than manned space flight, it is vital to know about them.

"If intense cosmic radiation storms can be predicted," one observer points out, "tomorrow's astronauts may be able to find refuge behind the Earth or the moon until the bombardment subsides."

In their high-flung labs, astronomers

view the night sky unhampered by distortions of the two miles of dust and moisture-laden lower air. Radio astronomers set up electronic ears and listen to cosmic radiations without picking up a cacophony of man-made background noise. Meteorology, solar radiation, sky glow, glaciology, magnetic field studies, geology, botany, astrophysics and even physiology are among many fields for which whole new vistas have been opened by development of these sky-high observatories.

*Swiss scientists study snow control;  
Austrians live among active glaciers*

In the crystal air 11,134 feet above the Pacific Ocean, for example, scientists on the slopes of Mauna Loa have been examining the solar radiations reflected from the surface of Mars. By analyzing them with spectrograph, they hope to measure the planet's moisture content and determine the ability of Martian climate to sustain life.

The International Geophysical Year, 1956-57, really put the spotlight on high altitude research. It was in the high-flung laboratories that many dramatic discoveries were made. From mountain stations in the far north, and from observatories on the two-mile-high Antarctic icecap, came proof that auroras appear simultaneously over both poles. The labs contributed data about new fields of cosmic radiation high above the earth. And it's still going on. Through the big telescopes on Mt. Wilson and Mt. Palomar, Dr. Jesse Greenstein recently identified what appears to be either a brand new star, or a whole new universe composed of elements that appear to be different from any known to man. And at the observatory atop Pic du Midi, in France, Air Force scientists are making an intensive study of the moon. By analyzing the changing shadows around the boundary between the dark and sunlit sides as it moves across the moon's surface, they are creating a highly precise moon map. Reason: To prepare complete details of that area of the lunar surface where the first space ships are most likely to land.

Highest of the skybound research stations is Dr. Ismael Escobar's 18,000-foot-high meteorological hut of the Chacaltaya Cosmic Ray Laboratory, some 20 miles from La Paz, in Bolivia. Up here, the temperature drops below freezing every day of the year. And the atmosphere, only half the pressure of air at sea level, is so thin that even men conditioned to high mountain air must work in shifts. At the end of three days, they are forced to return to lower altitudes to catch their breath.

Clinging 12,000 feet high on the side of Mount Fujiyama, in Japan, is a weather station where scientists are delving into the formation of rime ice. This is the ice formed from droplets of super-cooled water that builds up on airplane wings and destroys their lift. At the 10,000-foot Sonnblick Observatory in Salzberg, Austria, glaciologists live with neighboring active glaciers, studying their movement and their effect on the terrain.



**SNOW FENCE**, an experimental avalanche retainer, is one of variety tested at Weissfluhjoch, Switzerland

**HIGH IN** the German Alps, a weatherman takes a wind reading atop Zugspitze Observatory (at right)





Hans Truul photos

**WEISNFUJOCH LAB**, 9000 feet high, investigates effect of sunlight on paint, among other things, for industry. But a primary job is to prevent avalanches with fences. To test, they start small ones with exploding shells

**PROMENADE DECK**, under construction at Zugspitze, will look like this when finished sometime this year. In foreground is entrance for cable car. Three men staff the observatory which concentrates on Alpine meteorology



## *From the top of the Alps to the Clouds of Colorado:*



**MEN OF WEISSFLUHJOCH** measure snow pressure and density on instruments spaced around three miles of mountainside. Right, avalanche researcher monitors precipitation meter; it registers snowfall electronically

In Switzerland, on the 8,737-foot horn of the Weissfluhjoch, some 20 sunburned scientists of the Swiss Institute for Snow and Avalanche Research study the prevention of disastrous snow slides. Their experimental devices, for holding cubic miles of snow in place, stud the slopes. Vast arrays of instruments measure snow density and movement as the avalanche-producing spring thaws set in. Rescue teams, working with the Weissfluhjoch station, can be brought to the scene by dialing 11 on any telephone in the area. The laboratory keeps a team of 143 "avalanche dogs" trained and ready to help find people caught under tons of snow. Recently, one dog smelled out a pair of tourists who had been buried under an avalanche for more than two hours. They were still alive when dug out.

At the University of California's White Mountain laboratories, where a series of camps are spotted at heights up to 14,246

feet, you're likely to find all kinds of odd things going on. For one whole season, the University's Dr. Leo Delsasso fired a cannon from one peak and recorded its sound, via microphone, on another peak a mile and a half away. Object: To study the characteristics of sound traveling at high altitude. And for a time, the 12,500-foot Barcroft Laboratory on White Mountain had a menagerie of dogs, sheep, chickens, turkeys and mice, used in experiments involving high altitude metabolism. The chickens soon lost a third of their body weight and quit laying eggs. But turkeys, raised on the heights from day-old chicks, developed larger hearts and blood volume than normal, and thrived. Oddly, such adaptiveness doesn't always last. A colony of mice bred on White Mountain quickly adjusted and raised a rapid series of families. But after several generations, reproduction dropped, growth was stunted and the creatures developed liver troubles. As

## Research to control environment or to live with it



**JET PILOTS** climb treadmills 14,000 feet up at Mt. Evans, Col., to build tolerance for high-altitude work. Photometer, right, measures sky glow, a phenomenon of outer atmosphere, from Fritz Peak, Colorado

soon as the colony was returned to sea level, the mice became normal within one generation.

What it all means, no one is sure yet. But with man stepping across the thresholds of space, it grows increasingly important for him to know the limits of physical endurance and the adaptability of his physical machine to unfriendly environments. At San Nicholas, in Peru, the Institute of Andean Biology has an isolated outpost laboratory on an Andean peak 16,500 feet above the coastal city of Lima. For years, a group of Peruvian scientists under Dr. Carlos Monge, the Institute's Director, and Dr. Alberto Hurtado, Director of Research, have been studying the effects of altitude on people. Here, where the Andes soar out of the sea to precipitous heights of 20,000 feet, the Institute has established four laboratories—one at sea level in Lima and three in the mountains.

Scientists reach the mountain stations

by way of the Central Railway of Peru, short-cutting through 80 tunnels, and clinging to precipices where there's scarcely room for a mountain goat. Or, they may drive up the road that weaves through deep gorges, snakes through clouds, and hems the rims of mile-high vertical palisades, while an overworked supercharger gulps the thin air with an endless sigh.

At Morococha, after 90 tortuous miles, even rugged men unaccustomed to the rarified air in the mining town, pant from the exertion of getting out of the car at the 14,900-foot altitude, flop weakly into chairs and complain of light-headedness. Often their demoralization is made complete by the sight, through the lab's big windows, of Peruvian miners racing around outside in a vigorous game of soccer.

These mountain Indians, with barrel-like chests and stocky legs set far apart, are peculiarly adapted to life at high altitude. They are the primary reason for



**FROSTED DECORATION** atop this 10,188-foot Austrian peak is Sonnblick Observatory. Two staff men live here

these Andean labs. In the stone and glass station at Morococha, these mountain men sit for long periods in a huge, spherical altitude chamber, where atmospheric pressures are raised and reduced while scientists study a battery of instruments to observe reactions. X-rays of native lungs and rib cages are taken. A five-foot, three-inch mountain Indian has the chest of a sea-level six-footer. Indians work out on a treadmill while their oxygen intake and metabolism are studied. In one experiment, Dr. Hurtado took a group of sailors up the mountain. The men had managed 30 minutes to an hour on the treadmill at sea level. After a month of adapting themselves to Morococha's altitude, they could stay on the mill only four minutes. Indians who had lived on the mountain since birth kept the treadmill turning for up to 96 minutes. What the scientists want to know is why?, how?, what happens in the body tissues? And does heredity play a part in this ability?

The work has turned up some interesting facts. The mountain man's bone marrow turns out many more oxygen-carrying red blood cells than is normal for sea-level people; sea-level dwellers *do* adjust to high altitude and their body systems learn to compensate gradually over periods of years, though they may suffer periodic headache, nausea, and weight loss. In one year at Morococha, Dr. Hurtado lost 32 pounds.

Are Peruvian mountain men designed by heredity to tolerate stratospheric heights? Dr. Hurtado doesn't think so. "The high altitude tolerance acquired by newcomers," he says, "is based on respiratory, circulatory and blood changes, while the tolerance present in a man born and raised on the heights is chiefly to tissue adjustments. These are deep-rooted adjustments and we are trying to determine more about them."

Actually, the ability of men to adjust to high altitude is important for more immediate reasons than future space plans. At the 14,000-foot Inter-University Laboratories on Mt. Evans in Colorado, Air Force scientists have been running jet pilots through a series of rugged tests to study the effects of accelerated breathing and oxygen starvation. The work began, according to the Air Force's Dr. Bruno Balke, because of several unexplained airplane accidents at high altitude.

Pilots from the Air Force's School of Aviation Medicine in San Antonio, spent weeks climbing a tilted treadmill whose slope was increased every 60 seconds. They pedaled a stationary bicycle with a braking device to make the work progressively tougher. They went mountain-climbing, carrying loads of rocks. With oxygen masks, they sat in a mockup pilot seat, handling controls as oxygen supply was diminished until their breathing came

(Continued to page 220)





**EASILY** installed remote TV listener permits you to hear TV silently. Switch and volume control on remote unit permits normal set operation as well. \$8.91, Telex Inc., Telex Park, St. Paul, Minnesota

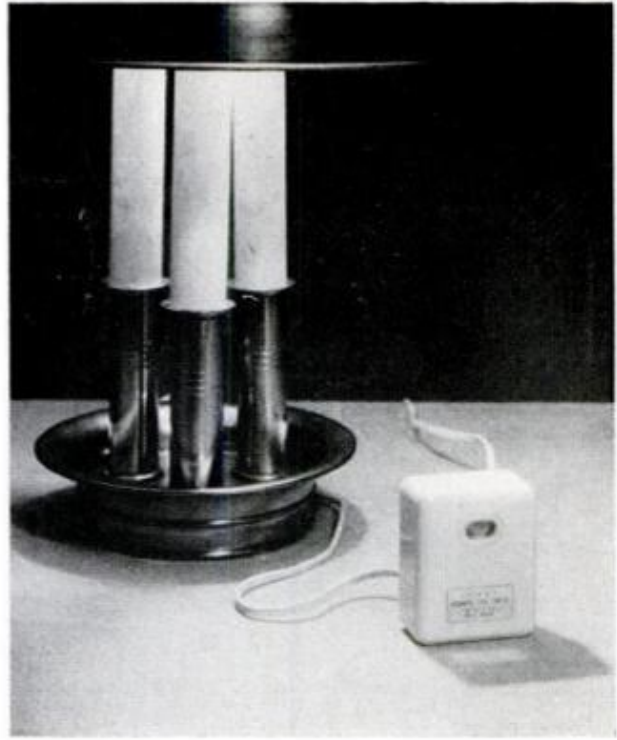

**PHOTOELECTRIC** night light automatically turns a lamp on at dusk, turns it off again at dawn. Plug lamp into unit, plug unit into wall. \$9.95, Sampson, Inc., 2244 S. Western Ave., Chicago, Illinois



**CAN YOU FIND** the speakers? Actually, there are two in the picture. One is hung on the wall, the other disguised as a set of books. The units can be used with stereo equipment, phonographs or TV sets. Each component is equipped with a 25 foot length of cord. \$14.95 and up, Sears Roebuck & Co.



**NOW YOU** can see your tape recordings! Immerse a piece of recorded tape in the special solution, and you can inspect it under special lens to get closeup view (inset). Excellent check for head alignment and tape editing. Called Magna-See, kit sells for \$12, Reeves Soundcraft Corp., Danbury, Conn.

## New in Electronics

(see APRIL 1962, p. 8)

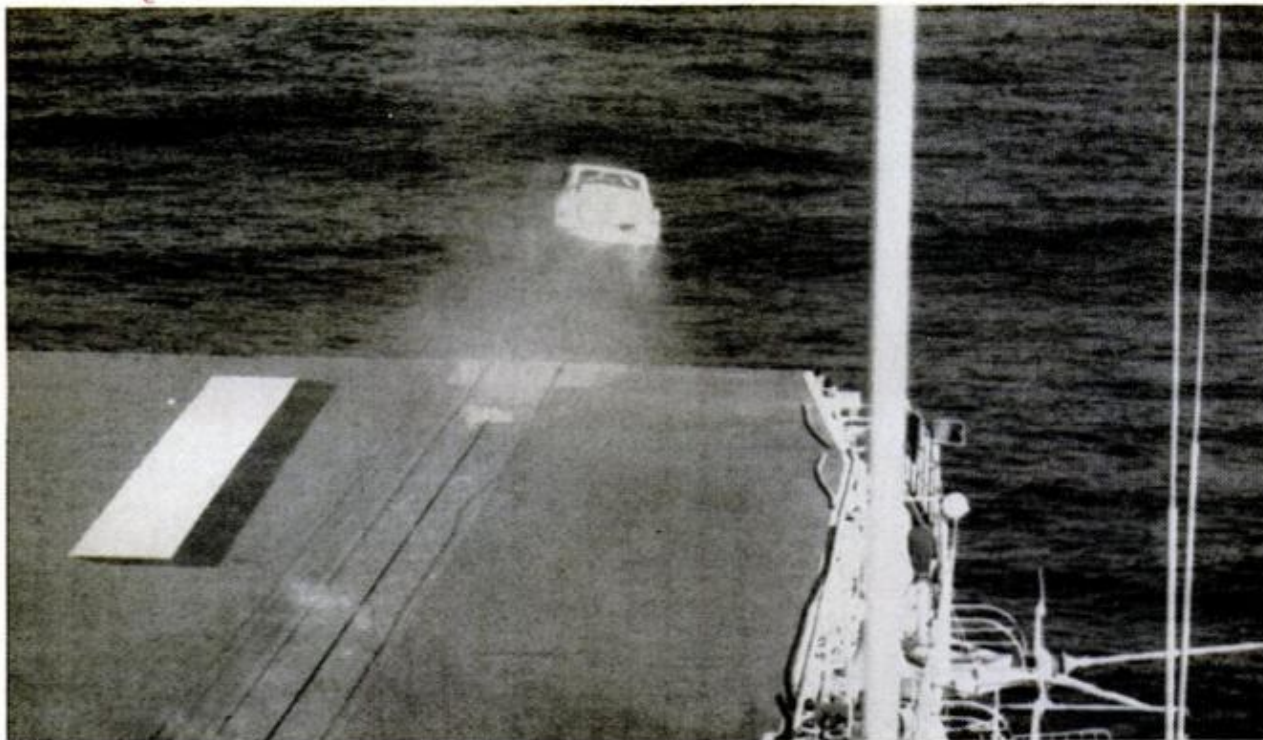

### For That Trip to Davy Jones' Locker, Travel by Car

When someone got the bright idea of disposing of junked automobiles by sending them to the bottom of the sea, someone else asked the bright question, "Who's going to drive them?" The bright answer: "No one. Just catapult them off the deck of an aircraft carrier.

Actually, it was all part of a program cooked up between the National Safety Council and the Navy. The idea was to help rid the nation's highways of unsafe automobiles by sending them, as the Navy sometimes does its discarded ships, on that long voyage to Davy Jones' locker.

### Mechanical Fencing Master Drills Students

"Trained" to duplicate the defensive response of a live fencer, a spring-loaded mechanical swordsman drills fencing students for instructor Bela de Tuscan, of Fort Lauderdale, Fla. Designed to spare the teacher the routine task of defending himself while a student practices offensive

movements, the mechanism provides realistic drills in beat attacks and disengaging and binding movements. Knobs control the spring tension in shoulder and elbow joints, allowing the instructor to provide slow responses for beginners, or lightning-quick movements for more advanced students.

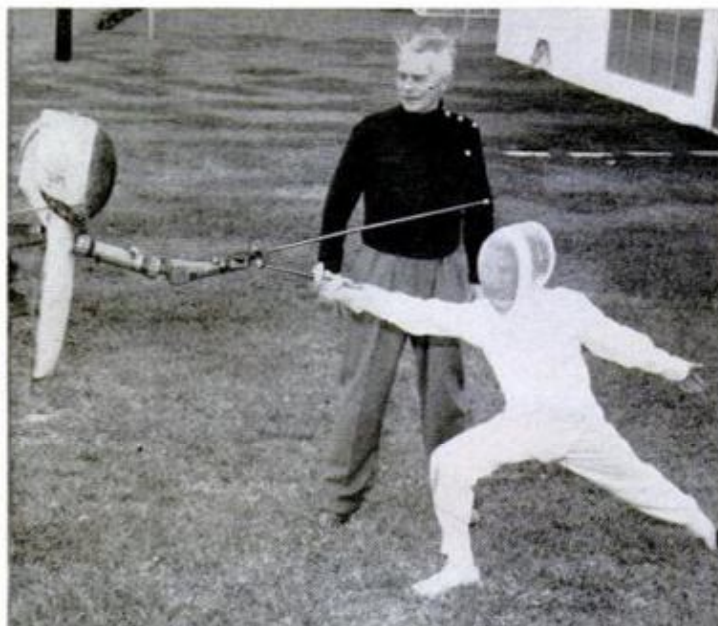



### Golf, Groceries, Gardening — Three-Wheeler Handles 'Em All

Put a large market basket on the front of a new three-wheeled scooter and it can be used for trips to the store. Attach a lawn mower and use it for grass cutting, or attach a trailer for rubbish hauling; put on the sulky seat and there's room for two. At the golf course, the golf bags attach to

brackets on the steering column and the handle holds golf balls, tees, score cards, pencils and other objects. On flat courses, it will transport two golfers.

The scooter, manufactured by the Flinchbaugh Co., 390 Eberts Lane, York, Pa., can be stowed in the trunk of an automobile.

### Dig This Crazy Building! It Was Built Down Instead of Up

Sidewalk superintendents in Geneva, Switzerland, had a rare treat recently—a building that sank as fast as it was built.

A steel cutting edge was at the base of the circular seven-story garage, and on top of it was a hollow concrete ring divided into chambers. If one side of the building sank

faster than the other, the high chambers would be filled with water, weighing that side down. As more stories were added and the building sank—about four feet per day—excavators hauled away soil from the center. The garage was built underground so it could double as an emergency shelter.

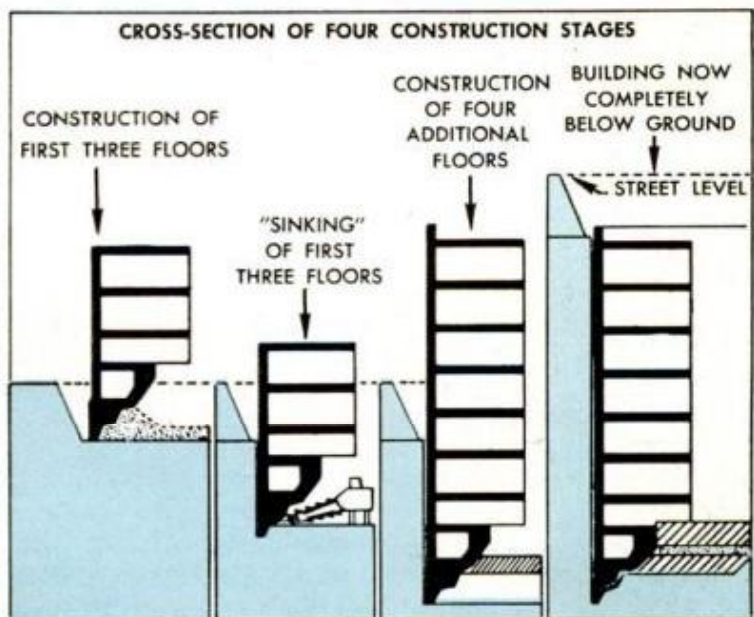
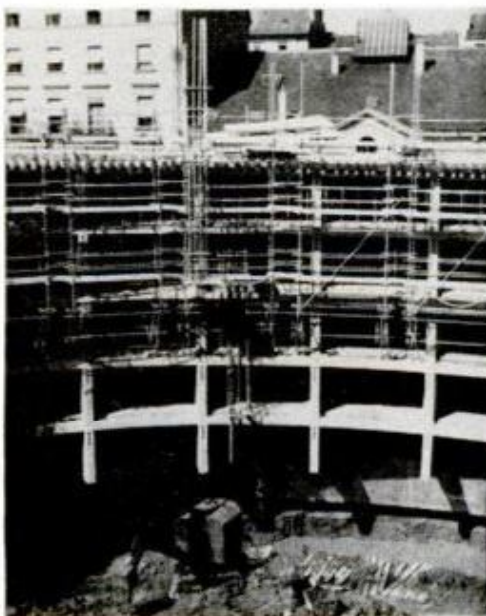



## Clean-Line Metal Furniture

By Arne O. Vidstrand

**Y**OU'D PAY a pretty penny in a store for this smart contemporary metal furniture. Made in your workshop it will cost little more than the price of the material, especially if you have a home welder. If welding is something you can't do, a local welding shop will do it for you for a nominal fee. The metal parts of all three pieces,

the desk, arm chair and ottoman, are made from  $\frac{3}{4}$ -in.-square seamless steel tubing and  $\frac{3}{4}$ -in. steel angle. Additional  $\frac{1}{2}$ -in. steel angle is needed to support the expanded-metal shelf for the desk,  $\frac{1}{8}$  x  $\frac{3}{4}$ -in. flat steel for the chair, and except for the chair arms which are walnut, all the rest of the wood parts are cut from  $\frac{3}{4}$ -in. fir plywood.

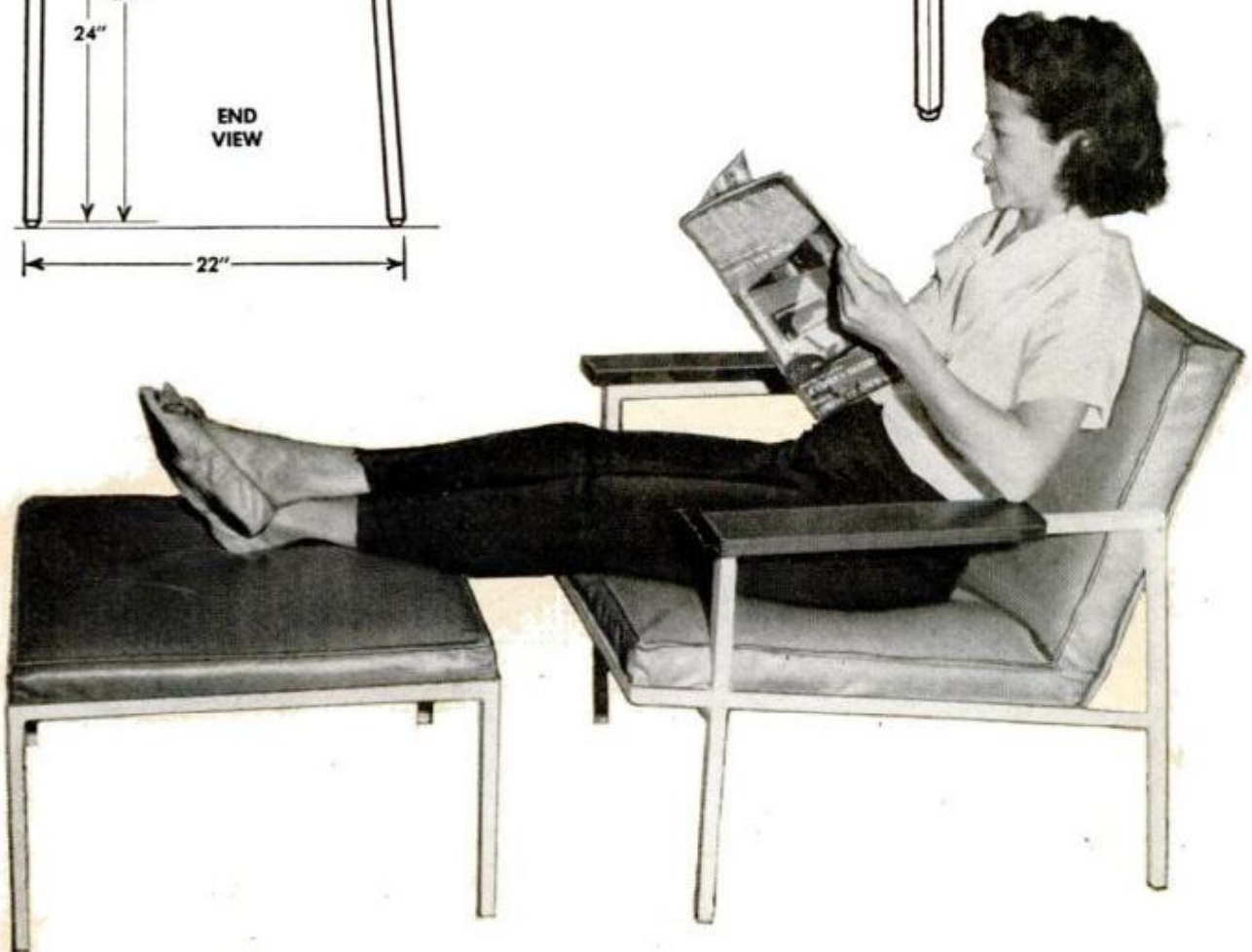
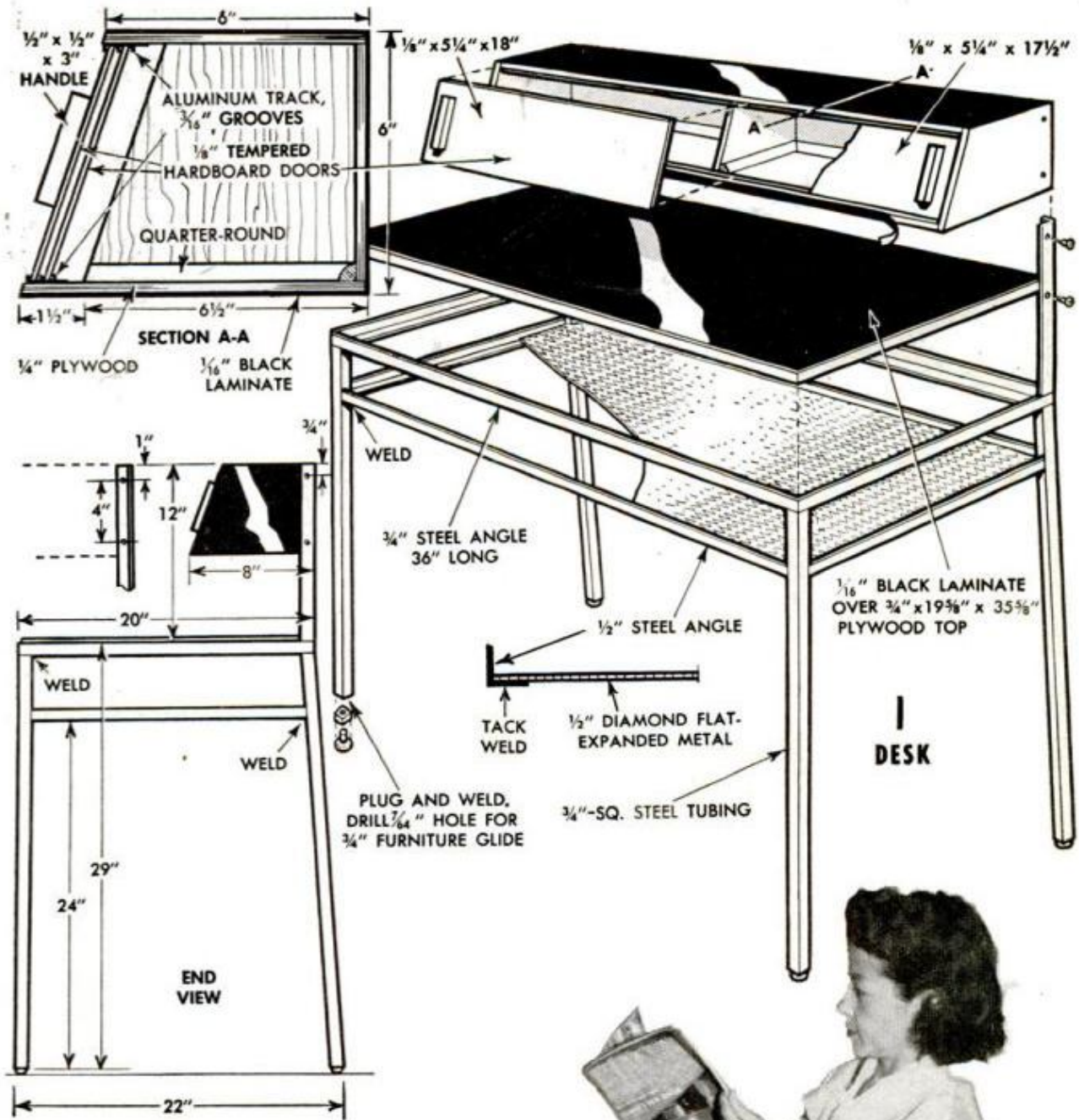

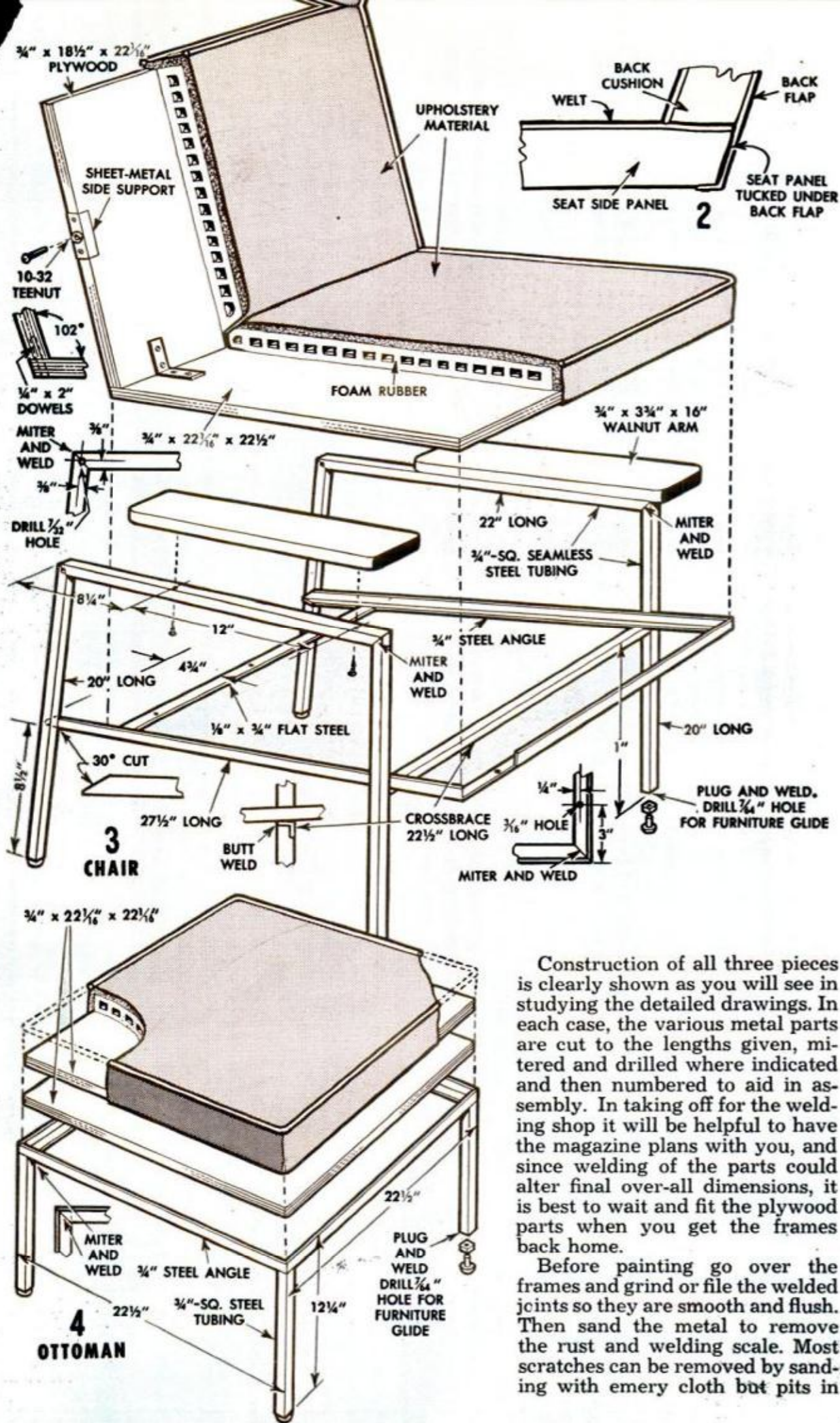

Construction of all three pieces is clearly shown as you will see in studying the detailed drawings. In each case, the various metal parts are cut to the lengths given, mitered and drilled where indicated and then numbered to aid in assembly. In taking off for the welding shop it will be helpful to have the magazine plans with you, and since welding of the parts could alter final over-all dimensions, it is best to wait and fit the plywood parts when you get the frames back home.

Before painting go over the frames and grind or file the welded joints so they are smooth and flush. Then sand the metal to remove the rust and welding scale. Most scratches can be removed by sanding with emery cloth but pits in



the metal may have to be filled with plastic auto-body filler. Give the frames a final wet sanding with No. 280 sandpaper and water, followed by washing with vinegar.

The original frames were sprayed with two coats of white auto lacquer. Begin by applying two coats of lacquer primer, sanding after each coat with No. 320 wet or dry paper, using water as a wetting agent. Then apply the lacquer, again sanding between coats. The frames are completed by inserting  $\frac{3}{4}$ -in. dome glides in the ends of the legs and cementing with epoxy cement.

The desk writing surface, Fig. 1, as well as the sliding-door cabinet, is finished by covering the exposed wood surfaces and edges with black decorative laminate. The

(Continued to page 212)

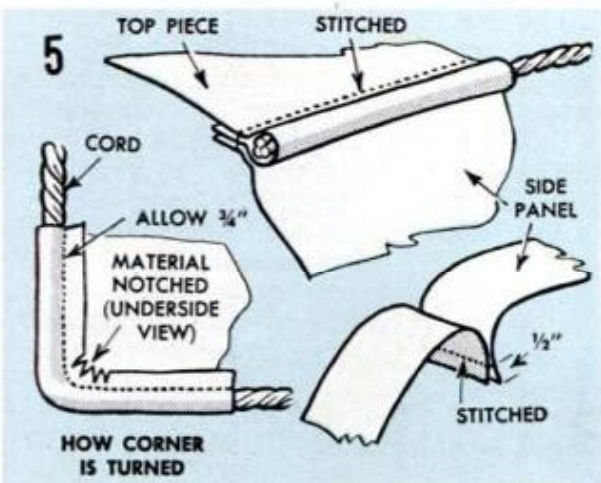

FEBRUARY 1962

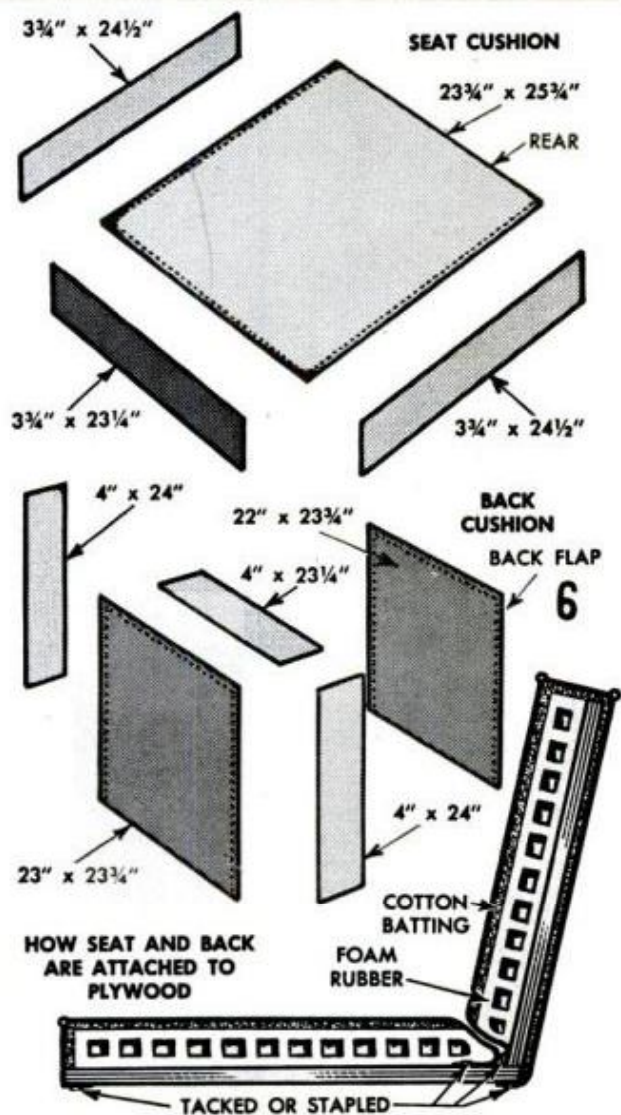

159

# X795



## WHITTLER'S PETS

*Have fun whittling these figures with a pocket knife*

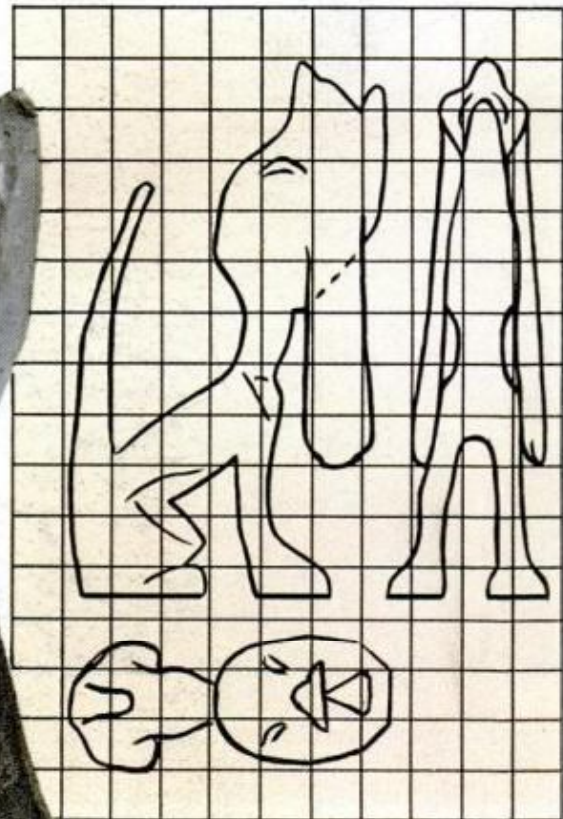

**FOR WHITTLING** use narrowest blade of your knife and hone to a razor edge. Lay out hound pattern on  $\frac{3}{8}$ -in. squares

**WHEN YOU FIRST** try this kind of whittling you're in for a surprise. Notice how strongly the comic character and individuality of these whittler's subjects have been brought out by just a few short, 45-degree knife cuts on the square corners of a jigsawed profile. You lay out a pattern on  $\frac{3}{8}$  or  $\frac{1}{2}$ -in. squares, using the cross-hatched profiles of any of the figures pictured, place the pattern on a piece of  $1\frac{1}{8}$ -in. clear white pine, trace it and saw on the lines. Then take successive short knife cuts on the corners and note how your cutout begins to take on the form and character of a likeness almost immediately.

Take the skunk, lower detail on the oppo-

site page as an example. Lay out the pattern on  $\frac{1}{2}$ -in. squares, and saw to the rough profile shown in the detail. Now, make light 45-degree cuts on the corners of the cutout and see how close you are to the finished figure in the photo. A couple of controlled V-cuts define the tail and body, three light curved cuts form the head and ears, two V-cuts separate the legs, and there you are.

The burro and hound take much the same procedure, except that you drill holes at the high point between the legs and ears and saw out the waste. On the hound, V-cuts form the haunches and toes and you have to pare down the tail to proportion from the profile block. The body and head of the bird are somewhat different, but the procedure is still the same; you simply round over the corners of the cutouts until the widening series of cuts meet at the center lines. Colors can be anything that suits your fancy, a few spots on the hound, an over-all color on the burro, and a white streak on the skunk.—*Hi Sibley*



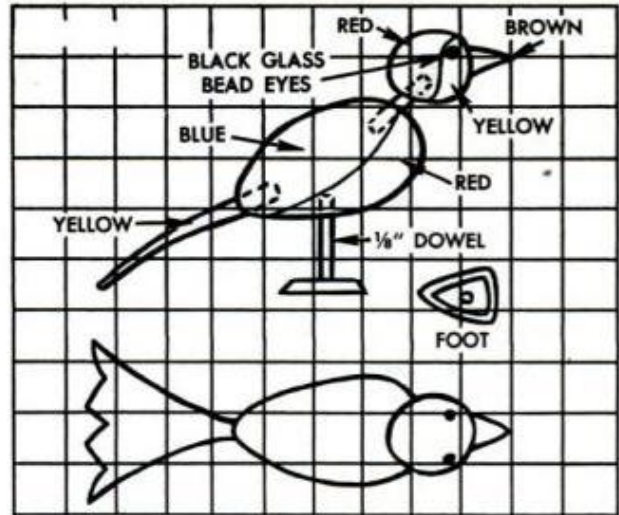
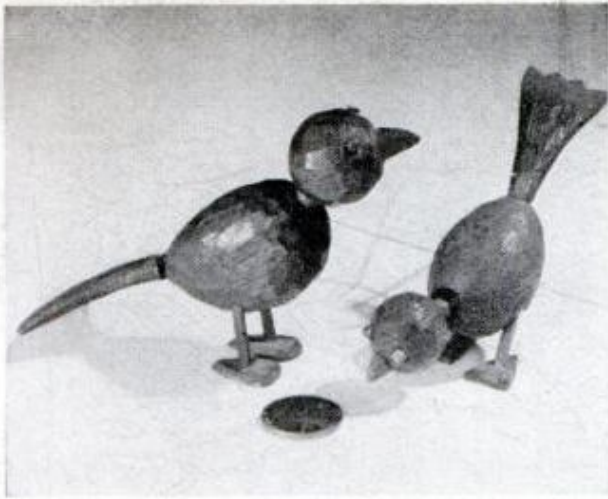

**BIRD** can be whittled in either pose, or stance. Procedures are the same. Simply change angle of legs

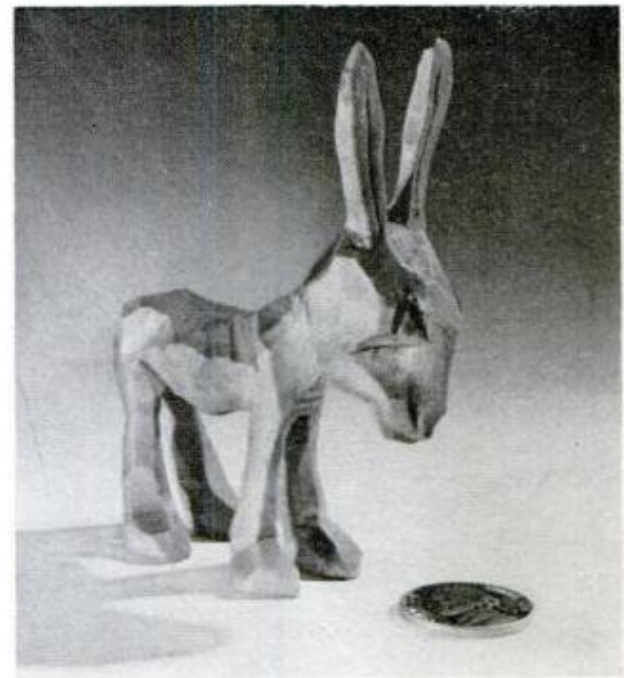
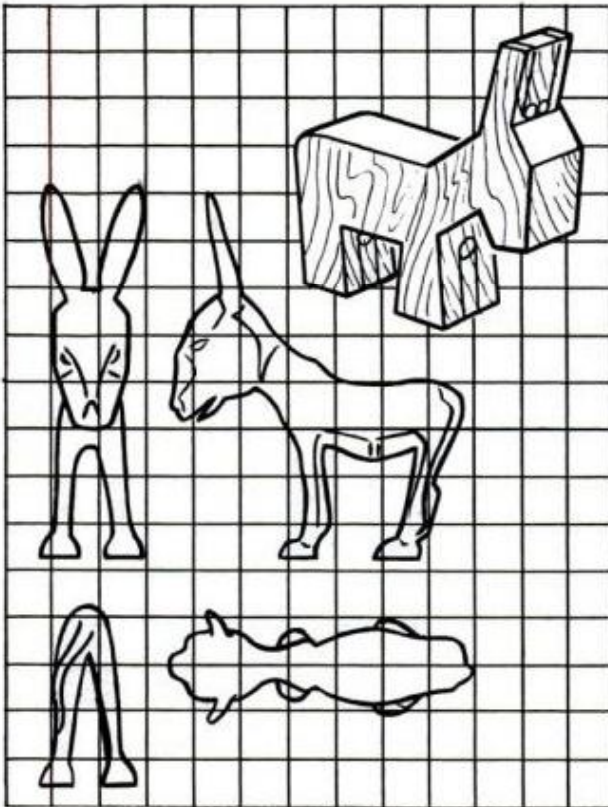

**BURRO PATTERN** is laid out on  $\frac{1}{2}$ -in. squares. Drill holes and pare out waste to separate ears and legs



**SKUNK** is perhaps simplest of all to whittle. Easy paring cuts and controlled V-cuts form the contours

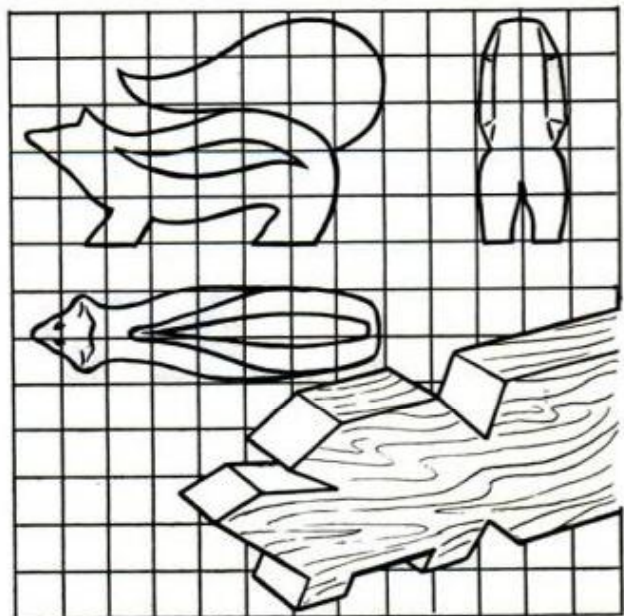

# FORT SNOW

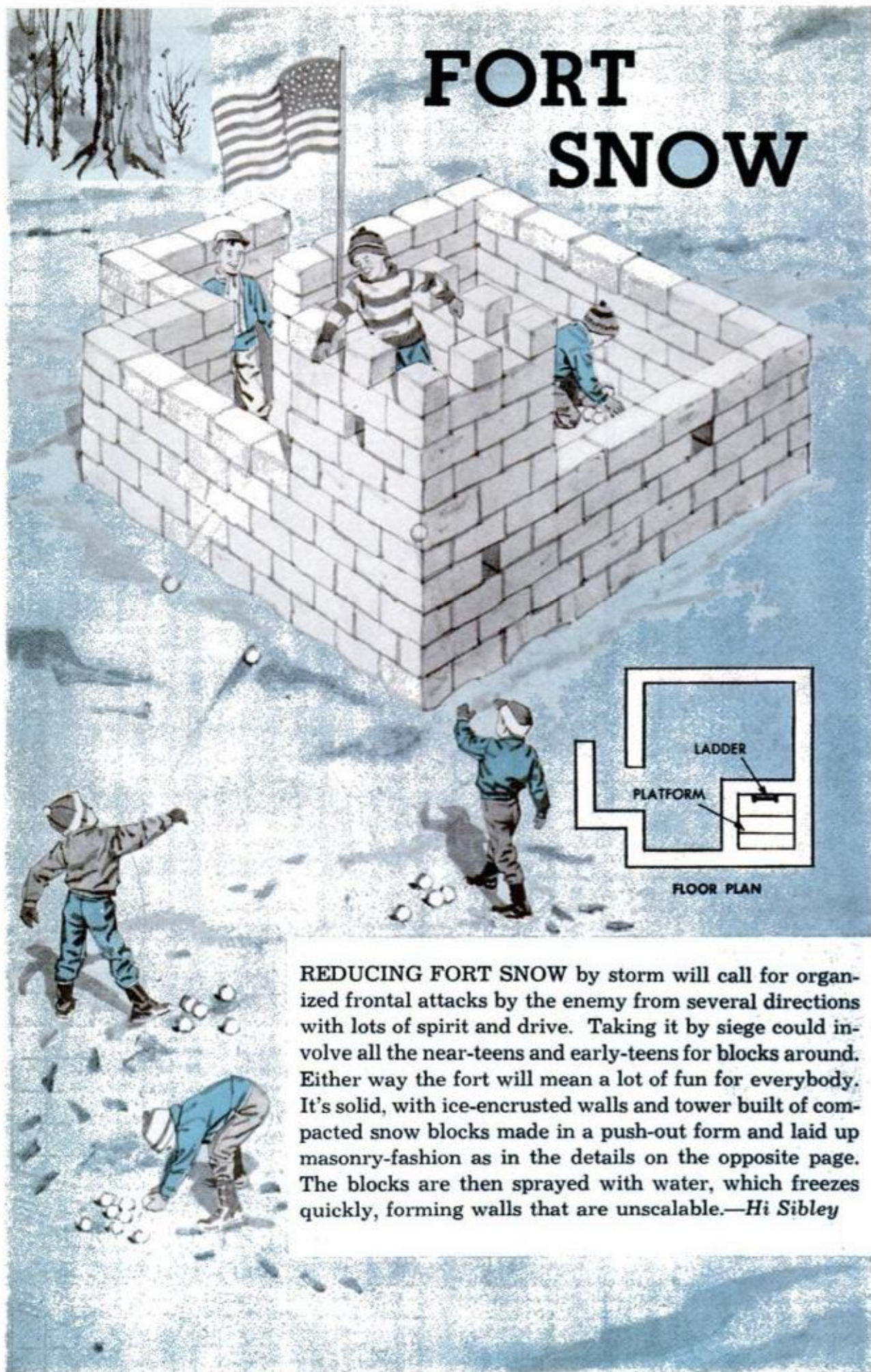

**REDUCING FORT SNOW** by storm will call for organized frontal attacks by the enemy from several directions with lots of spirit and drive. Taking it by siege could involve all the near-teens and early-teens for blocks around. Either way the fort will mean a lot of fun for everybody. It's solid, with ice-encrusted walls and tower built of compacted snow blocks made in a push-out form and laid up masonry-fashion as in the details on the opposite page. The blocks are then sprayed with water, which freezes quickly, forming walls that are unscalable.—*Hi Sibley*

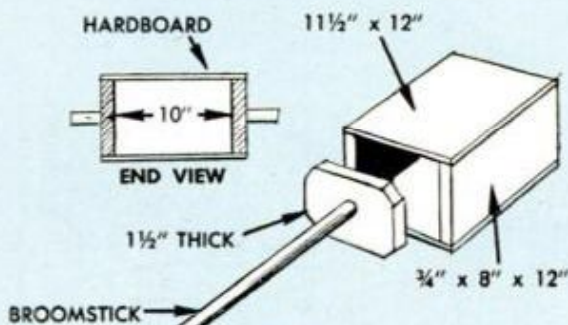

BOX IS PLACED ON FLAT SURFACE AND FILLED . . .

THEN SNOW IS TAMPED WITH PLUNGER . . .

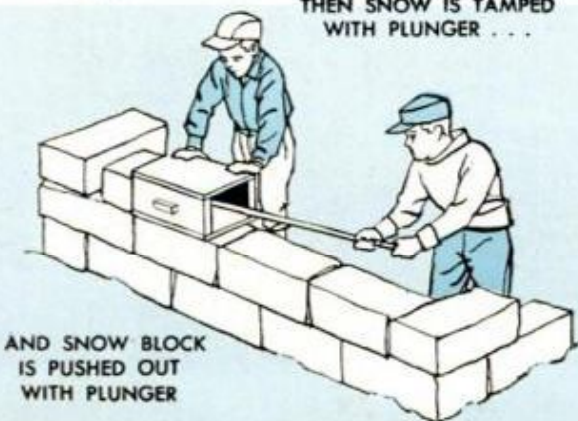

AND SNOW BLOCK IS PUSHED OUT WITH PLUNGER



### Shoe-Polish Ink

Corrections and additions on blueprints are easily made with white liquid shoe polish instead of blueprint ink, whenever the latter is unavailable. White polish also makes an ideal ink for writing on the dark areas of photographs or on other dark surfaces. Regular penpoint may be used as a printing and ruling point for line work. On larger areas, a brush is an advantage.

### Nuts and Bolts Chart

Owners doing repair and maintenance work on their cars will find a chart, listing the sizes of bolts and nuts commonly used, eliminates need for trial and error when choosing the proper size wrench. The chart, which might also list the proper torque for such fittings, is glued on the inside cover of the box. Pasted over the chart, a sheet of cellophane helps protect it.—R. Hanscom



# Solving HOME PROBLEMS

**STAINS** made by coffee or tea on the inside of plastic dinner cups will vanish in an instant if you rub them vigorously with a little silver polish on a soft cloth

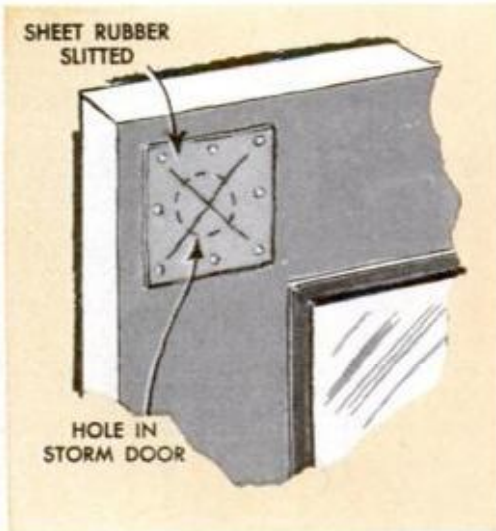

**STORM DOORS** which are difficult to open or close because of air pressure can be vented with a valve cut from an inner tube

**RUBBER GLOVES** will always be within your wife's reach when she needs them if you glue a spring clothespin to the door or an inner wall of the sink cabinet

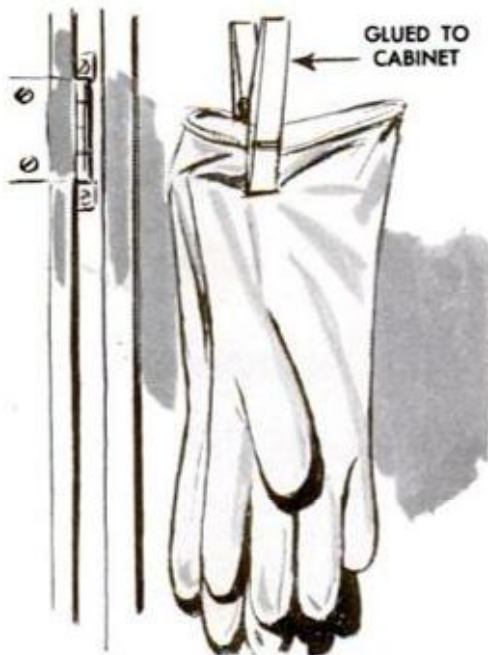

**EXTRA SHELF SPACE** to hold small items such as cups, saucers and condiments can be obtained by suspending shelves of 1/4-in. tempered hardboard on long L-hooks between widely spaced shelves of your cabinets. Paint shelf to match cabinet interior



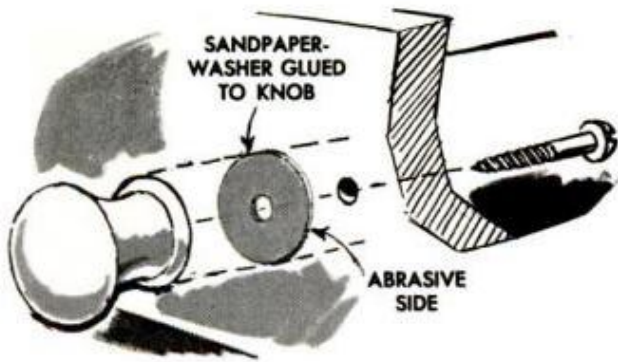

**DRAWER PULLS** and the handles of cabinet doors that work loose will hold tightly if you insert a sandpaper washer between the handle and face of the drawer. Glue the washer in place, then tighten screw

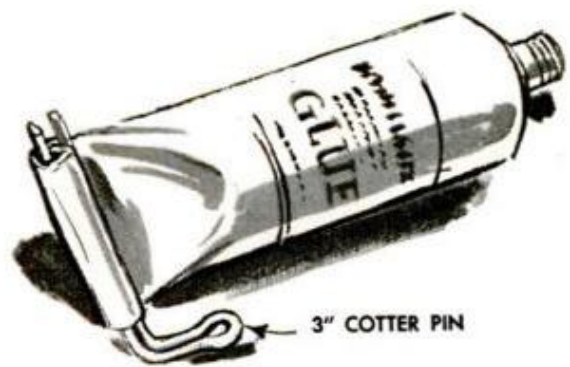

**COLLAPSIBLE TUBES** of glue, shaving cream, tooth paste, etc., can be emptied completely by using a crank made from a 3-in. cotter pin. Bend the head as shown above. Remove and reuse when tube is empty



**HUNTING BOOTS** will last longer if properly dried after each wearing. A reusable cloth bag of calcium chloride tossed into each boot will do the trick



**THREAD DISPENSER** is easily made by cutting a short slit in one side of a plastic pill bottle. Thread will be kept clean, free of tangles and ready for use

**WASTED SPACE** at the bottom of your closet can be converted into extra storage space if you construct a simple boxlike frame to hold a storage drawer

**STAIR STRINGERS** which seem to be weak and springy can be given new life by reinforcing them with a pair of 2 x 4s nailed inside, flush with bottom edges

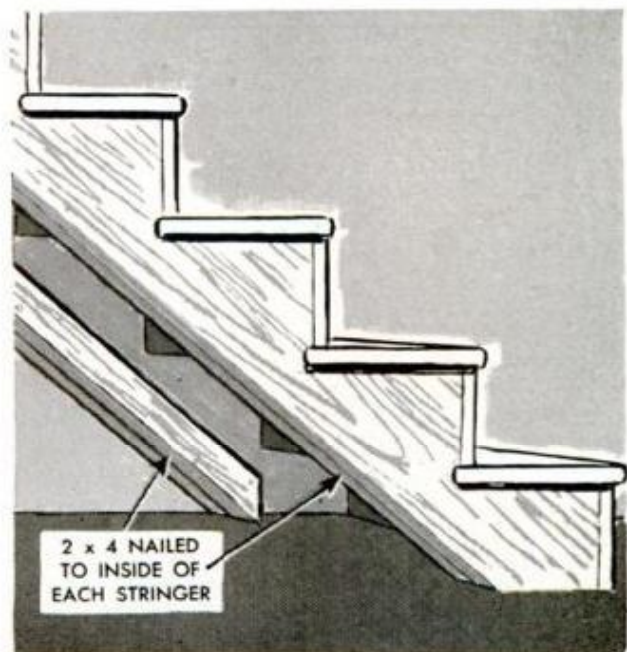



## WORTH REMEMBERING

### Snow-Shovel Skid

Here's the easy way to get your trash can over the snow to the curb without straining your back. Bend a length of heavy wire into the shape shown so that it may be attached to the handles of the can to serve as a bail. Drive a screw hook into the handle of your snow shovel to engage the loop in the bail and prevent the can from sliding. By keeping the handle low the shovel can be used to skid heavy loads.

—G. E. Hendrickson

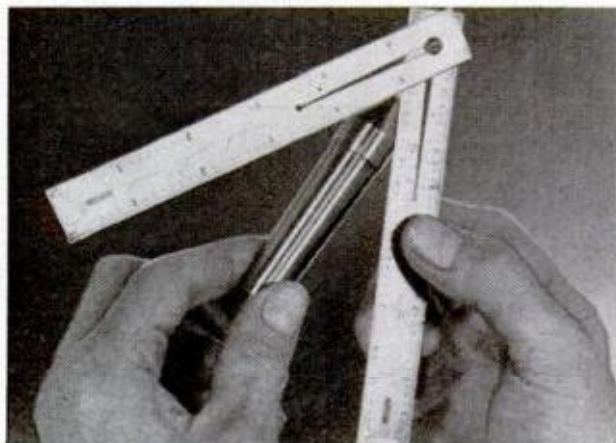

### The Right Angle

It's easy to make an angle gauge from two 6-in. rules which have tapered wire-gauge slots. Simply fit a small bolt through the large ends of the slots so that the rules can be clamped together. A small lock washer fitted under the nut will provide sufficient tension to retain a setting. If you don't have such slotted rules, solid rules can be drilled to accommodate the bolt. The angle gauge can be used for regular measuring work by closing the two rules together.—R. Hanscom



### Pie-Tin Reel

If you've been storing your trouble light by looping the cord tightly and hanging it from the nearest handy nail, try using this pie-tin reel which holds the cord in regular loops and protects the bulb. Drill a hole near the rim of a metal pie tin or an old shallow kitchen pan. Screw or nail the pan to the garage or basement wall, making sure that the hole in the rim is at the top. The sides of the pan hold the cord loops, and the lamp guard is hung by its hook from the hole in the rim.—Bil Toman

☞ A large earthenware flower pot makes an efficient and inexpensive hibachi. Just line the pot with aluminum foil and add a small round grill purchased at the dime store.

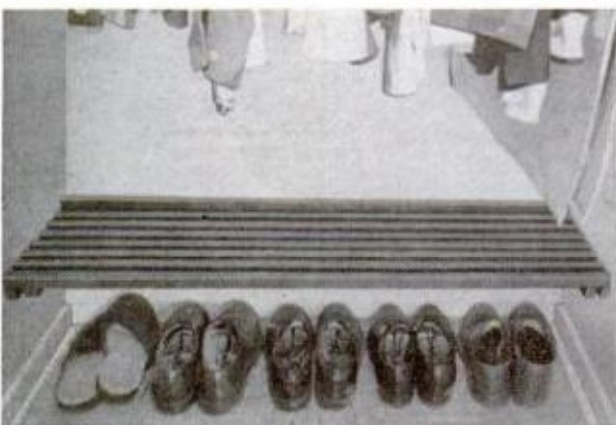

### Duckboard Shoe Shelf

Your bedroom closet will take on a neater look and be much easier to clean if you keep shoes off the floor. Not only do they gather dust and have little chance for airing, but must all be removed when running a dust mop in the closet. A simple solution is to place the shoes on a duckboard shelf supported 10 in. or so off the floor. This is nothing more than slat affair, consisting of  $\frac{3}{4}$  x 1-in. strips spaced  $\frac{1}{2}$  in. apart and nailed to end cleats. Toggle bolts hold the shelf.—Edward J. Kolb

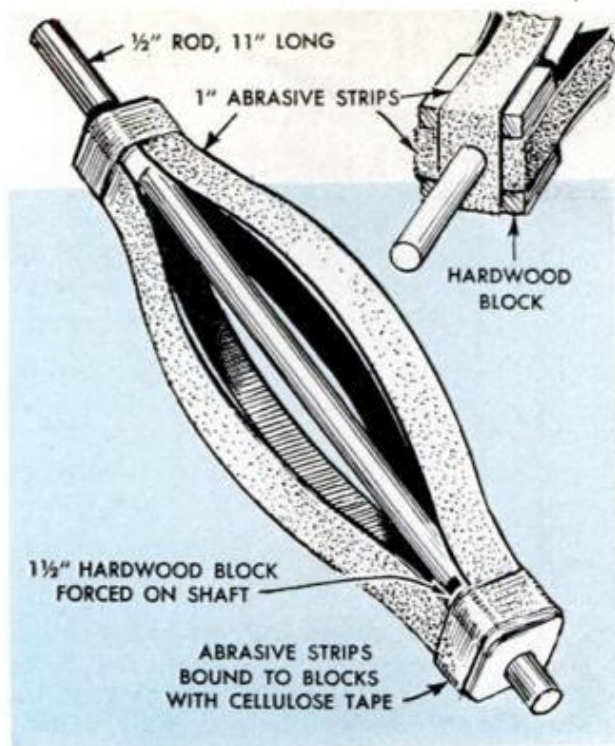

## Hole Sander Makes Like an Egg Beater

If you have ever tried to sand a large-diameter hole in wood of any common thickness, you know what a tricky, time-consuming job it can be. Especially if you're particular about the edges being sharp and the walls of the hole smooth all the way around. Here's the centrifugal sanding

head, roller, eggbeater, or what have you, that will do it in a few seconds. The detail shows how to make it for sanding a 2 to 2 1/2-in. hole but it can be made smaller or larger, using a 1/2-in. steel rod to fit the drill-press chuck. Run the drill press at the third-step speed.—*John J. Maendel*

## In-Line Sander

Sanding out the tiny ridges and hollows in a straight wood turning can be done, of course, by looping a strip of sandpaper around the work. A faster way is to thumb-tack the strip of sandpaper to a square of wood and slide the abrasive side along the tubing in the manner pictured, using the tool rest as a support. This method smooths out all irregularities in a few passes of the sander. Set the tool rest so that its edge just clears the work.—*J. C. Roby*

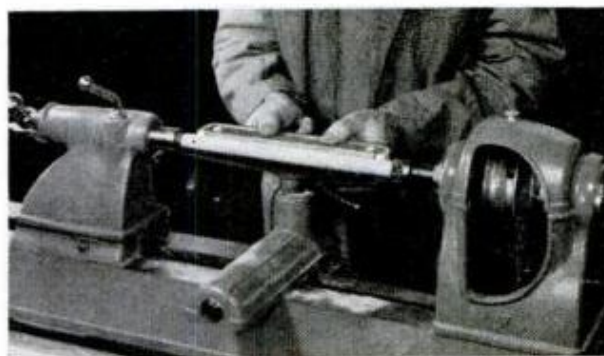

## Blade Clamp

If you should happen to tighten the arbor nut a trifle too tight or if the saw blade should jam in a cut, the nut may be difficult to remove. If this happens take time to make this blade clamp. It consists of a strip of plywood with one edge cut straight and a portion of the other sawed to a radius slightly greater than that of the blade. The clamping strip is ripped from solid stock to a width of about 1 1/2 in. and cut to a length that will span the insert opening. Drill two holes through both pieces for 1/4-in. stove bolts and provide wing nuts and washers.

—*R. Hanscom*

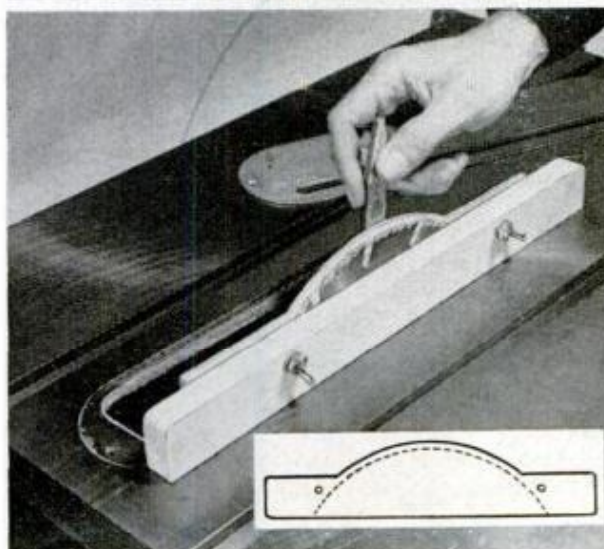

# HOME FITNESS GYM

## Conclusion

**Y**OUR FAMILY FITNESS GYM won't be complete without the old standby — the belt massager. A ten-minute workout after a hard day at the office will make you feel like a new man, completely relaxed. Tired muscles will give way to its soothing massaging action and before long you'll wind up with a trimmer and healthier figure.

Like the bike exerciser and the rowing machine which were described last month, the belt massager is made of common, easily obtained parts. The important thing in a belt massager is sturdiness, it has to be

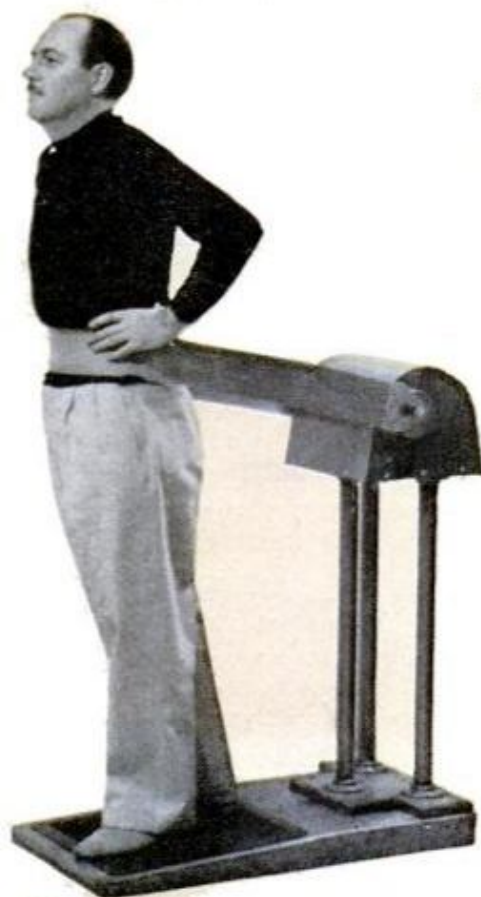
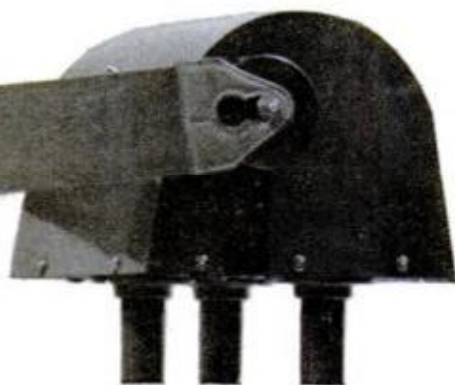

Designed by Manly Banister



heavy enough to stay put. The machine pictured below weighs about 80 lb., operates quietly, without vibration. Start by making the platform detailed in Fig. 5. The top of it is 1½-in. plywood. If this is difficult to obtain, glue and clamp a ¾ and a ¾-in. thickness together. Cut the plywood to its over-all size, 17 x 34¼ in., and then cut a 14-in. piece from one end. Tilt your saw 4 deg. and take a shaving cut from the end of the larger piece. The two-piece top is supported on three sides by 2 x 2s which likewise are tapered 4 deg. and center braced with a 1 x 5-in. member. The latter is beveled across the leading edge to match the slant of the tapered side rails. Use glue and screws to rigidly assemble the 2 x 2s, the cross brace and the plywood top, driving the screws in the latter up from the bottom. Finally, glue a ½-in.-thick facing to three sides of the base, keeping it even with the top of the plywood. Note that the facing does not rest on the floor. Round all edges and corners and sand smooth. Bore a hole through the rear of the platform for a motor cord.

The motor pedestal consists of three 27-in. lengths of 1¼-in. steel pipe fitted with heavy-duty flanges. All three pipes are cut exactly the same length and threaded farther than normal to let the pipes seat deep in the flanges and be even with the bottom. The lower flanges are solidly an-



ALL SHARP EDGES of the belt-massager platform should be rounded to avoid slivers, and then sanded

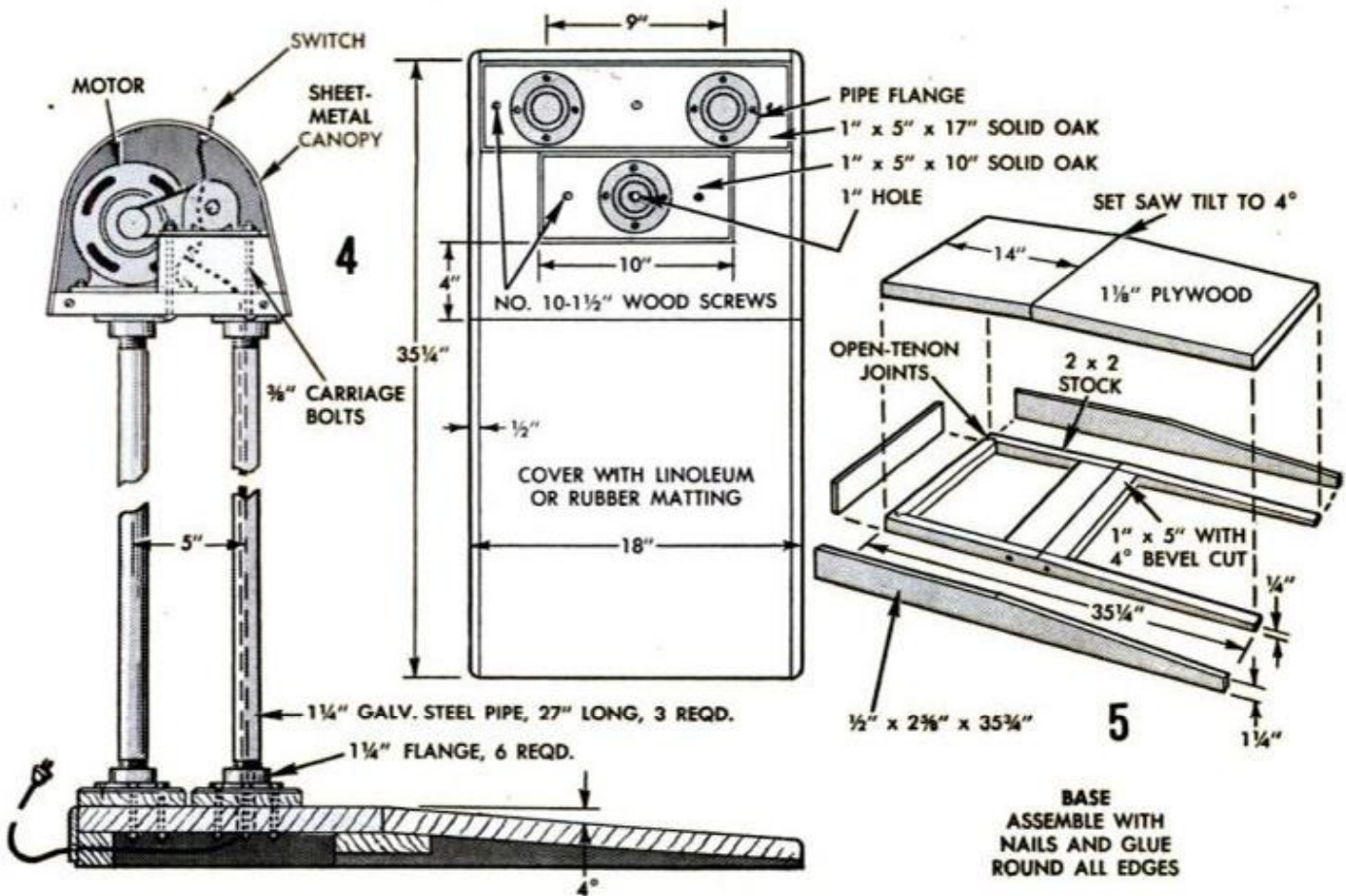

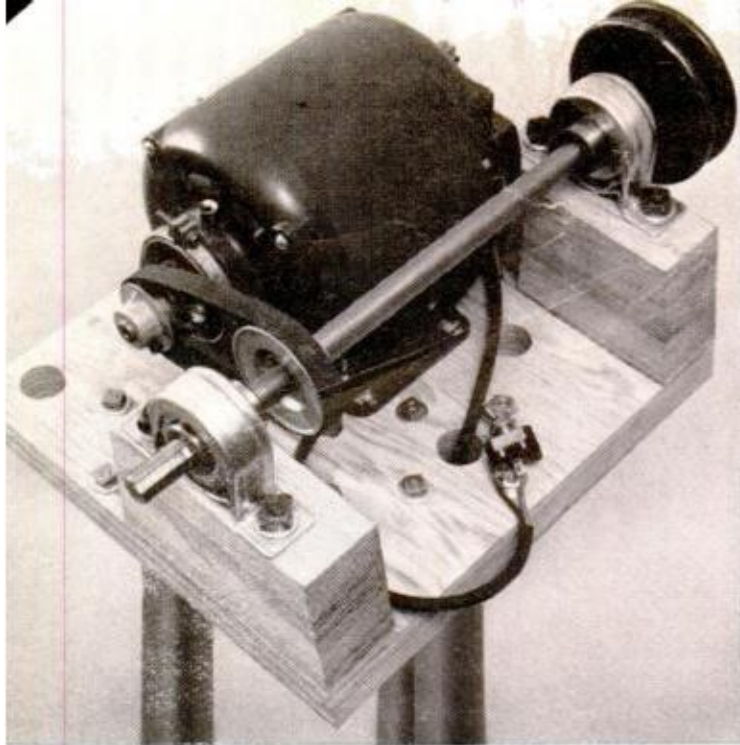

THIS IS THE POWER HEAD with hood removed. Note how motor cord runs through pipe pedestal

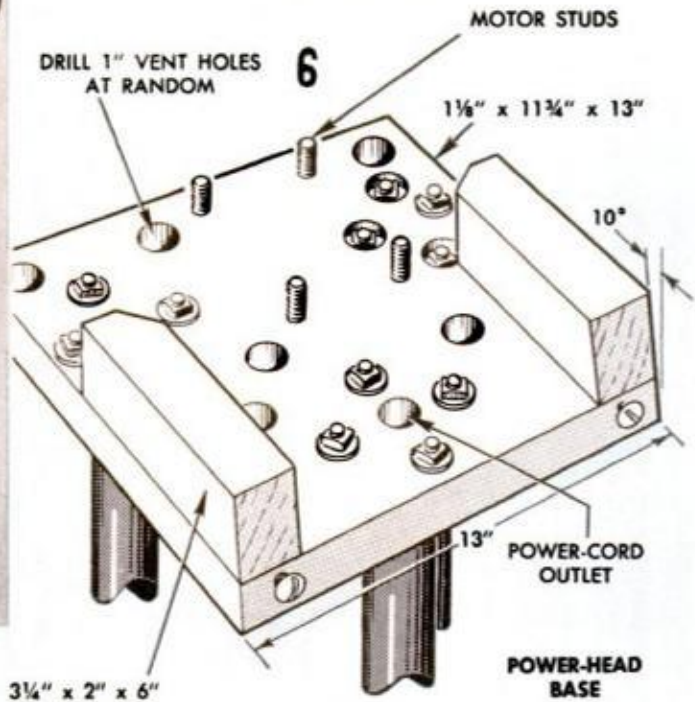

chored to 1-in. oak pads glued and screwed to the rear of the platform as shown in the plan view, Fig. 4. Note that the two rear flanges are located 9 in. center to center. The third flange is centered between the two and 5 in. forward, center to center. All three flanges are anchored securely with  $\frac{1}{4}$  x 3-in. flathead stove bolts which pass through both the oak pads and the plywood. Use lock washers under the nuts. Bolts

cannot be used in the rear holes of the rear flanges because of the 2 x 2 member. Husky wood screws are used here instead. Note that the front flange is mounted over a 1-in. hole drilled through the platform which permits the power cord to pass up through the pipe.

Fig. 6 details the wooden motor platform of the power head, and the photo at the left of Fig. 6 shows how the motor is belted to a crankshaft turning in pillow-block bearings. Any used  $\frac{1}{4}$ -hp. (1750 r.p.m.) washing-machine motor will do and it in turn will determine the over-all size of the motor platform. Like the lower platform, the motor platform is made of  $1\frac{1}{2}$ -in. plywood. After seeing that the flanges on the upper ends of the pipe columns are all turned down to precisely the same level,

### PLANS AVAILABLE

To fulfill requests for plans for building this home exercising equipment after the magazine article is out of print, we have prepared a set of large-size plans, plus an instruction booklet which may be purchased by writing Popular Mechanics Magazine, Blueprint Dept., 200 East Ontario St., Chicago 11, and enclosing \$2.50.

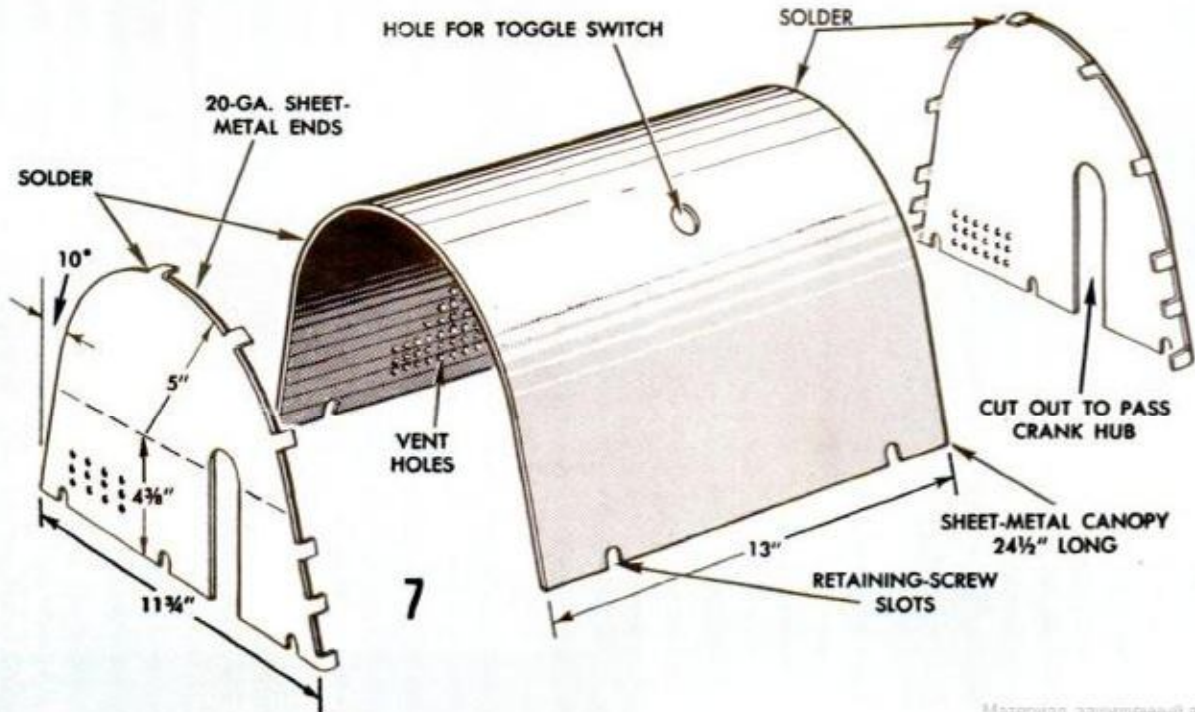

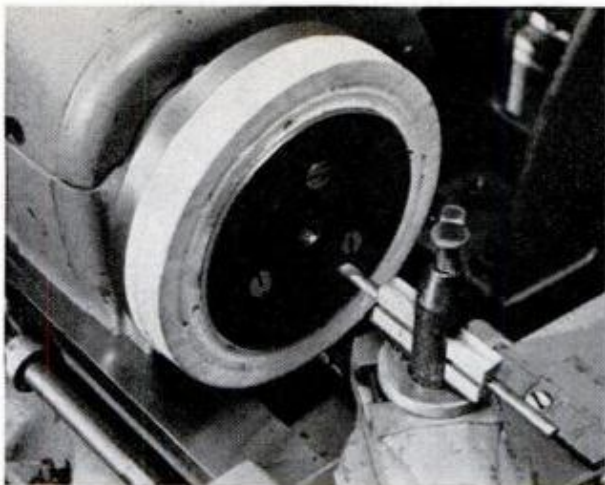

**CRANKPLATES** which bolt to face of V-pulleys are screwed to wood facing on faceplate and turned true



**WITH SLOT ALIGNED** with pulley keyway, crankplate is clamped to pulley and holes are drilled through

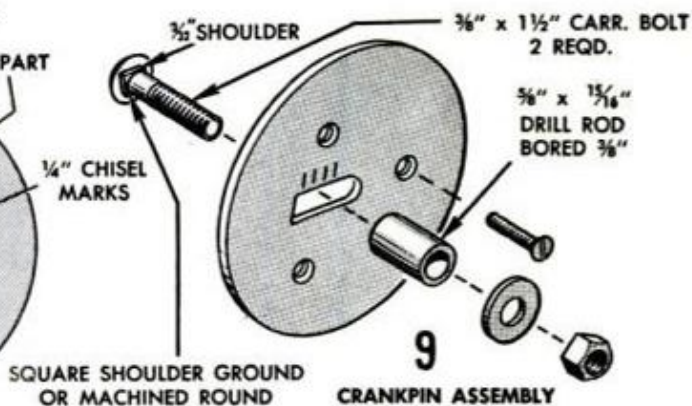
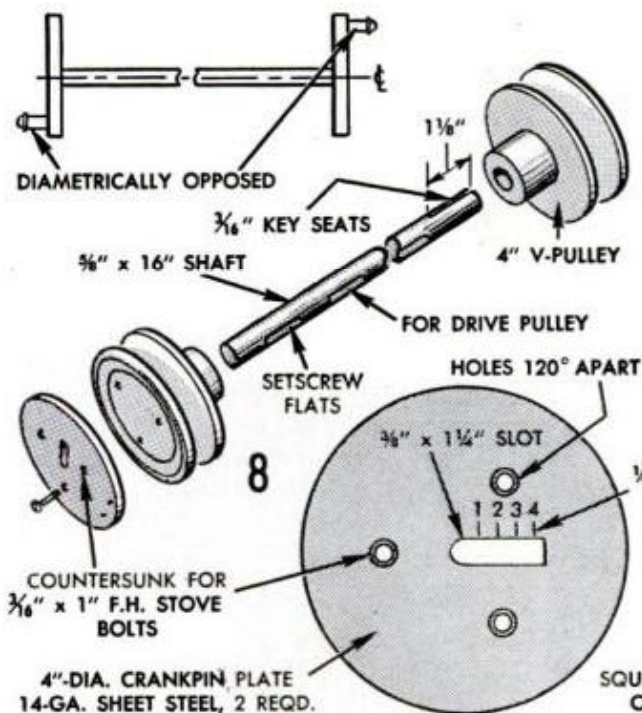

**END COVERS** of hood are neatly cut out with jigsaw fitted with metal-cutting blade. Note soldering tabs

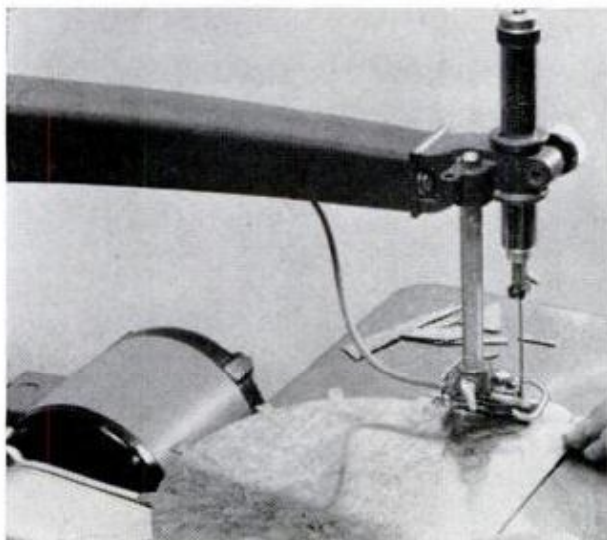

**COMPLETED HOOD** shows how it fits over crank heads at ends. Machine takes 64-in. massaging belt

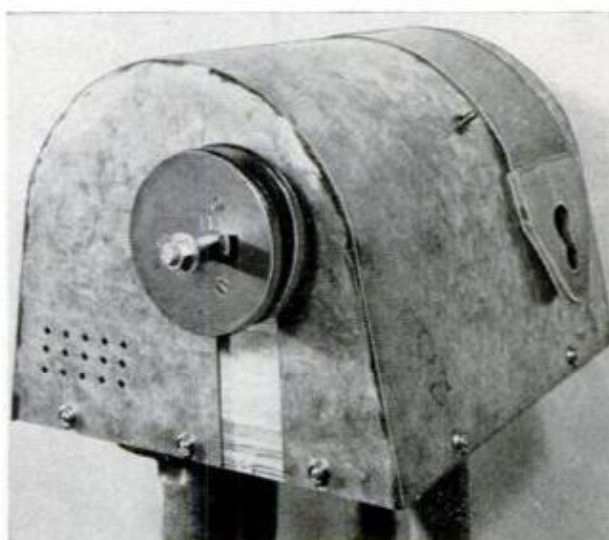

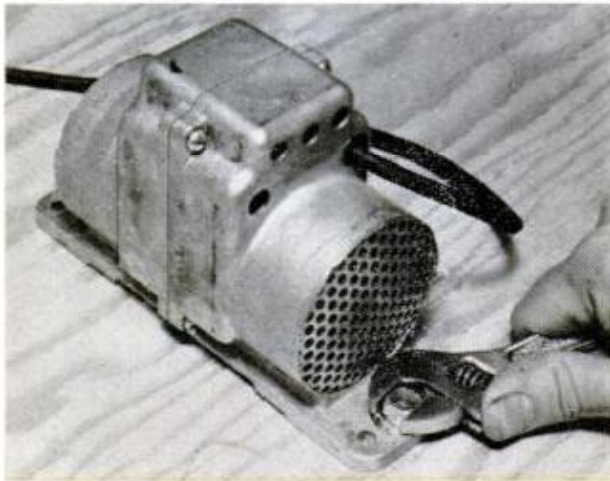

**VIBRATOR MOTOR** bolted to bottom of abdominal board eases fatigue, adds pep like nothing else

place the motor platform in position on the flanges and mark the flange bolt holes. Note in Fig. 6 that holes which fall under the motor base are counterbored on the top side so as not to interfere. Bolt holes for anchoring the motor, vent holes and a hole for the power cord are all made in the wooden base before bolting it to the flanges. Oak blocks for the pillow-block bearings are added next. Holes for mounting the bearings are drilled all the way through the motor platform and  $\frac{3}{8}$ -in. carriage bolts are used to anchor all three, the bearings, oak blocks and platform at one time.

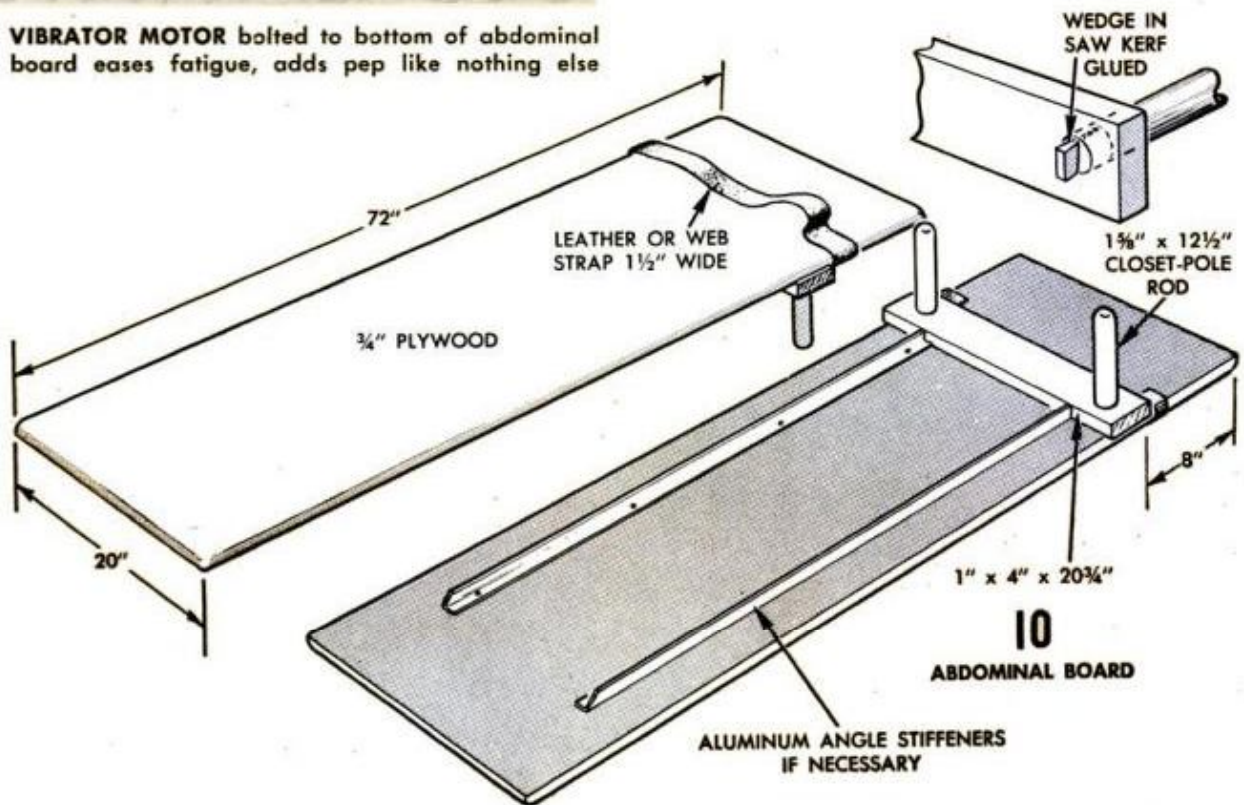

The crankshaft, detailed in Fig. 8, is a length of  $\frac{5}{8}$ -in. steel shafting 16 in. long. To spot the pulley-setscrew flats on the shaft, place the shaft temporarily in the bearings and at the same time slip a  $2\frac{1}{2}$ -in. V-pulley and belt on the shaft. Place a  $1\frac{1}{2}$ -in. V-pulley on the motor. A center-to-center spacing of  $4\frac{1}{4}$  in. between the motor shaft and the crankshaft will permit a 15-in. V-belt to be used. With the same amount of shaft extending at each bearing, align the shaft pulley with the motor pulley and turn down the setscrew in the shaft pulley hard so it will mark the shaft. Do the same thing



**LEG AND HIP** exercises are done from a standing position, raising weights with foot at count of one, two



Designed by William Walker

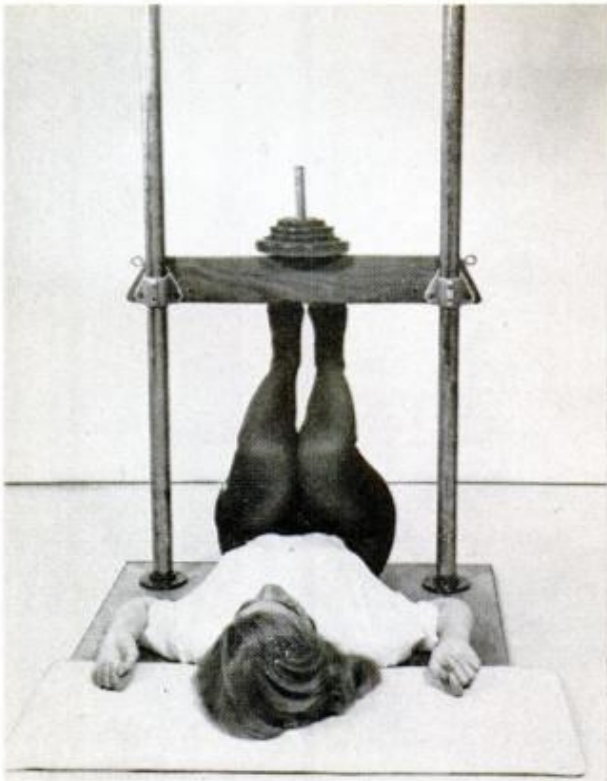

**LYING ON BACK**, weighted slide bar is raised by the feet by the numbers in another helpful leg exercise



**RAISING AND LOWERING** body by sitting on inclined board with knees held by strap helps flatten waist

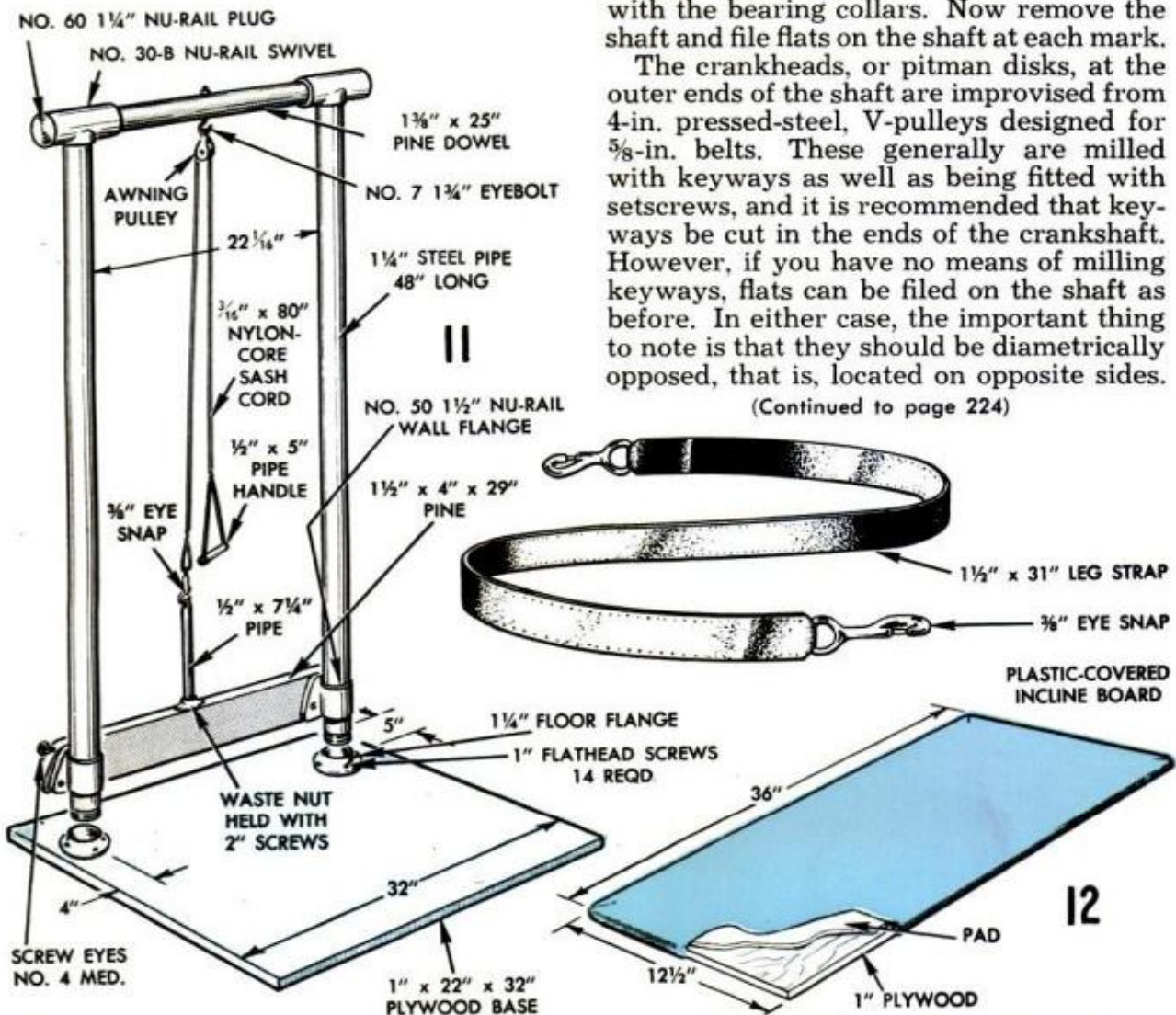

with the bearing collars. Now remove the shaft and file flats on the shaft at each mark.

The crankheads, or pitman disks, at the outer ends of the shaft are improvised from 4-in. pressed-steel, V-pulleys designed for 5/8-in. belts. These generally are milled with keyways as well as being fitted with setscrews, and it is recommended that keyways be cut in the ends of the crankshaft. However, if you have no means of milling keyways, flats can be filed on the shaft as before. In either case, the important thing to note is that they should be diametrically opposed, that is, located on opposite sides.

(Continued to page 224)

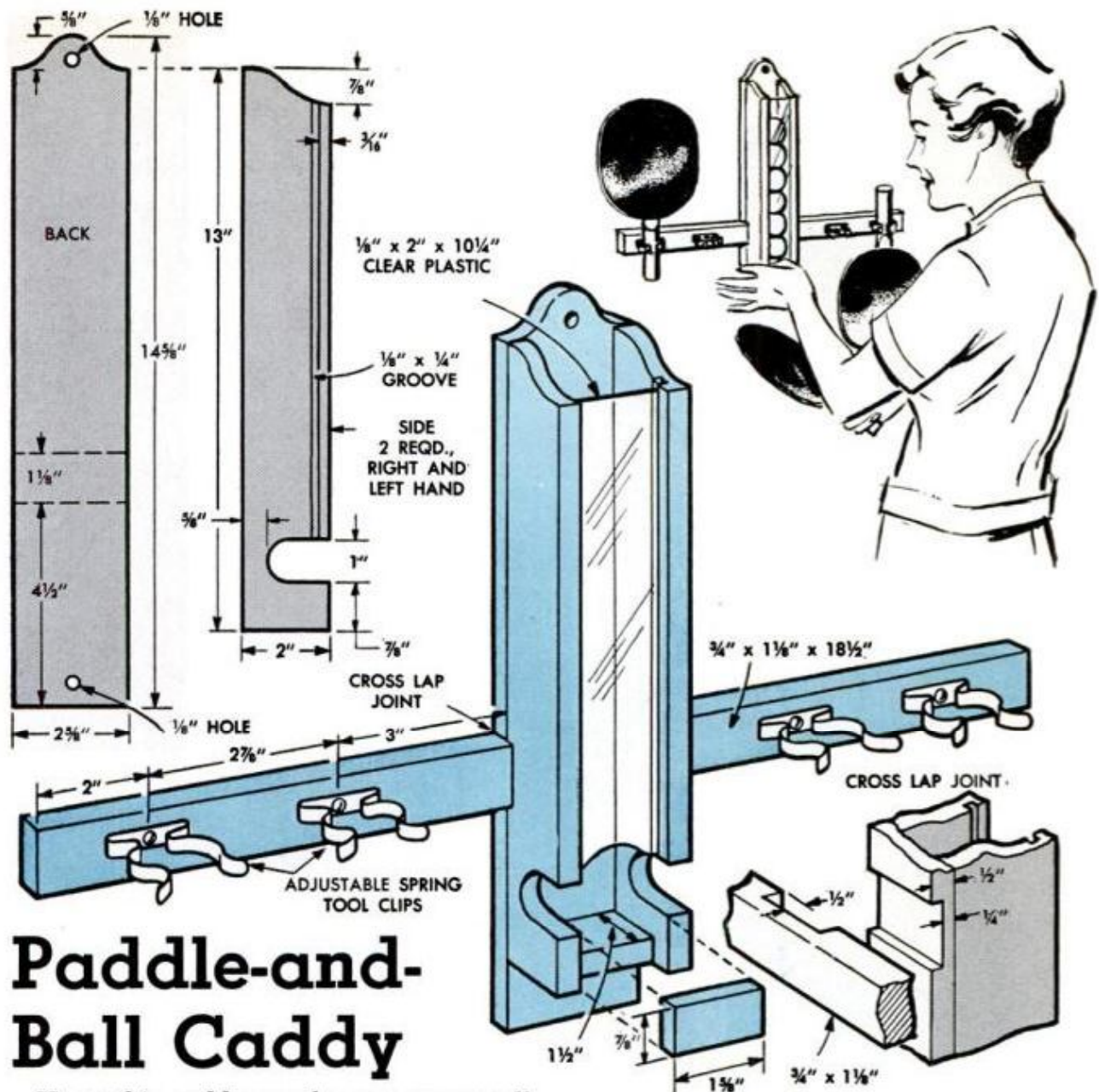

## Paddle-and-Ball Caddy

Hang this caddy on the rec-room wall near the tennis table and you end that periodic search for balls and paddles. One evening's work in the shop gets out the parts ready for assembly. A second evening puts them together and finishes the caddy ready for hanging. If you use a hardwood such as

mahogany, walnut or curly maple, the caddy becomes an attractive wall decoration. As you can see, it stores and dispenses balls one at a time and the horizontal bar racks four paddles in neat array.

—Howard R. Schramm

## End-Rabbeting Setup

Cheek cuts on end-rabbets should be run with the stock standing vertically against the rip fence for best results. Run the shoulder cuts first on all pieces. Then, to make the cheek cut, set the rip fence to give the exact rabbet-depth required. Screw a length of stock to the miter gauge of a width equal to or greater than the height of the fence. The right-hand end of this piece should just clear the fence, as it serves as a follower. Set the blade to the correct depth, then stand the stock on end and run the cut as pictured.—Jackson Hand

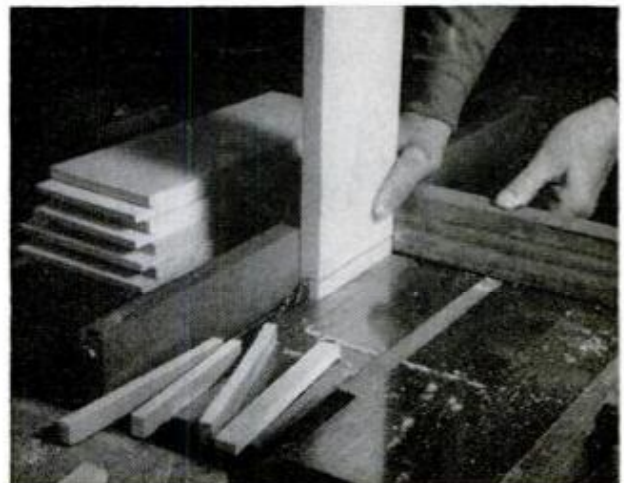

## Making the Base for the Triple-Top

# FUN TABLE

### PART III



28

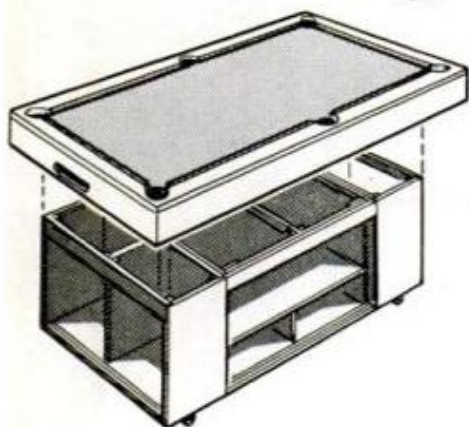

By John Jefchak

*Under-the-table space wasted in most pool tables is put to use in the form of storage compartments for chucking playing equipment and other game-room clutter*

**N**OW THAT YOU HAVE completed the pool-table top of the fun table, construction of which was described in the December and January issues, you are ready to start building the supporting base which features roomy storage compartments for stowing the lift-off props of the model-train setup, pool and table-tennis equipment, as well as other game-room paraphernalia.

The storage unit assembly measures  $20\frac{3}{4} \times 36\frac{1}{2} \times 80\frac{1}{2}$  in. and can be separated into three units for transportation, Fig. 28. The two end, or leg, cabinets are identical and serve as the legs as well as a support for the center unit. The base of the leg cabinet is  $\frac{3}{4}$ -in. plywood, Fig. 29, part F, with a  $\frac{3}{8}$ -in. stopped dado  $11\frac{3}{8}$  in. long at the center. Run this cut on the table saw, stopping just

short of the required dimension. Finish the cut with a wood chisel. Then run  $\frac{3}{16} \times \frac{1}{4}$ -in. door grooves, or tracks, 1 in. in from the front edge of the material.

The two sides, made right and left, come next. Notice that the parts A and B in Fig. 29, have  $\frac{3}{8} \times \frac{3}{8} \times 11\frac{3}{8}$ -in. stopped dados and that there are  $\frac{3}{8} \times \frac{3}{4}$ -in. rabbets on two edges of both pieces. The  $\frac{3}{8} \times \frac{3}{4} \times 2\frac{3}{4}$ -in. corner rabbets are laid out and cut with a wood chisel.

The center divider, part C, Fig. 29, requires a dado located  $11\frac{1}{4}$  in. from the top edge on both faces. Cut a  $\frac{3}{8}$ -in. tongue (tenon) on the lower edge, and a  $\frac{3}{8}$ -in. notch at the front edge. The  $\frac{1}{2} \times \frac{3}{4}$ -in. notch near the upper front corner receives the upper track for the sliding doors. Detail A, Fig.



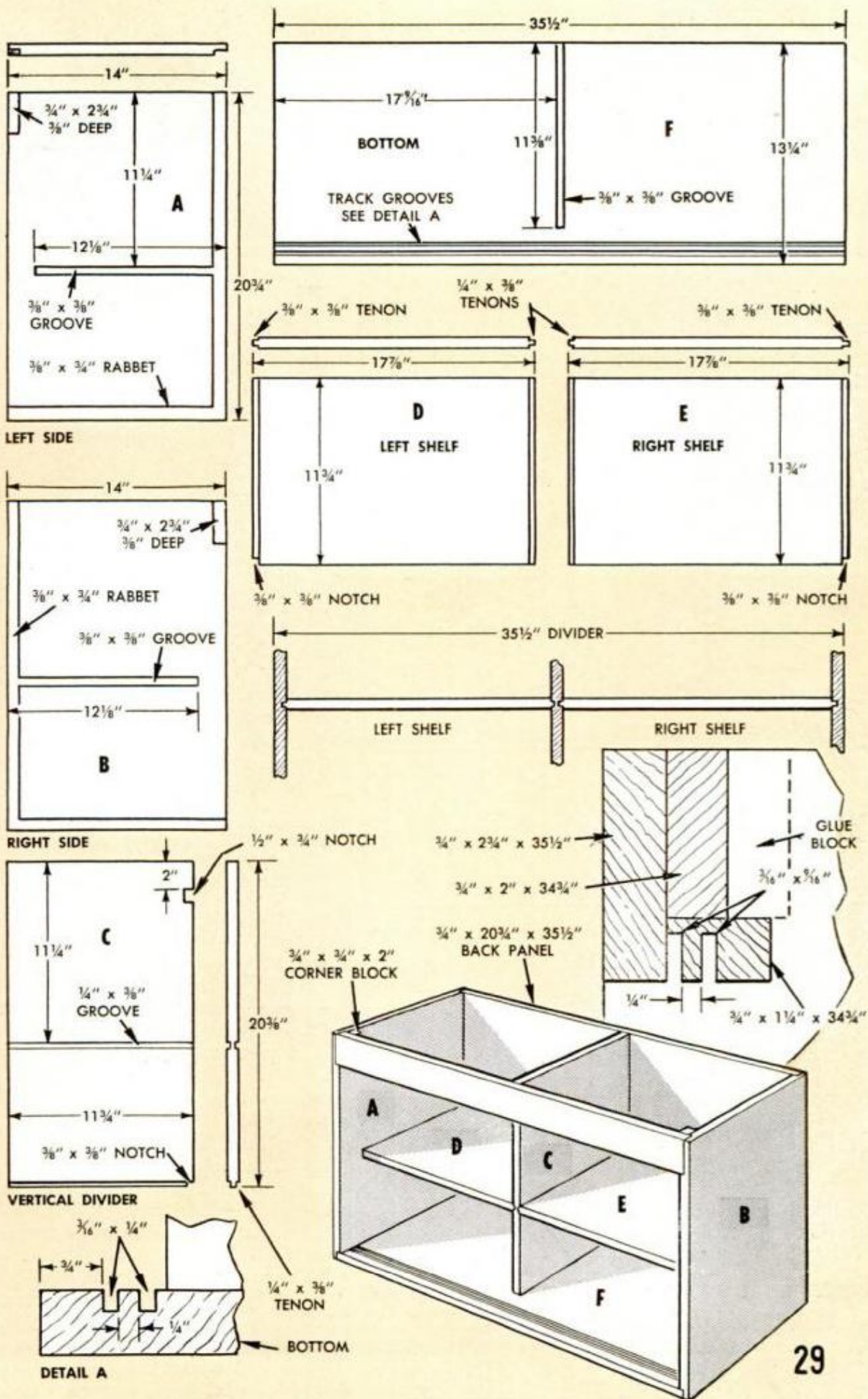

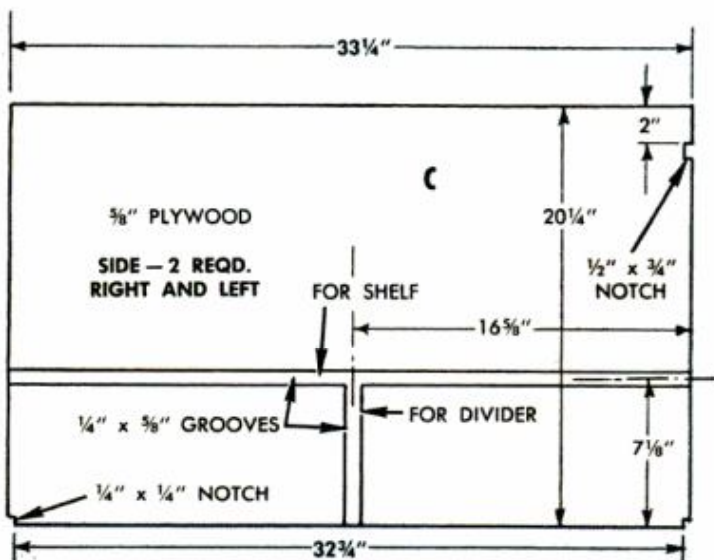
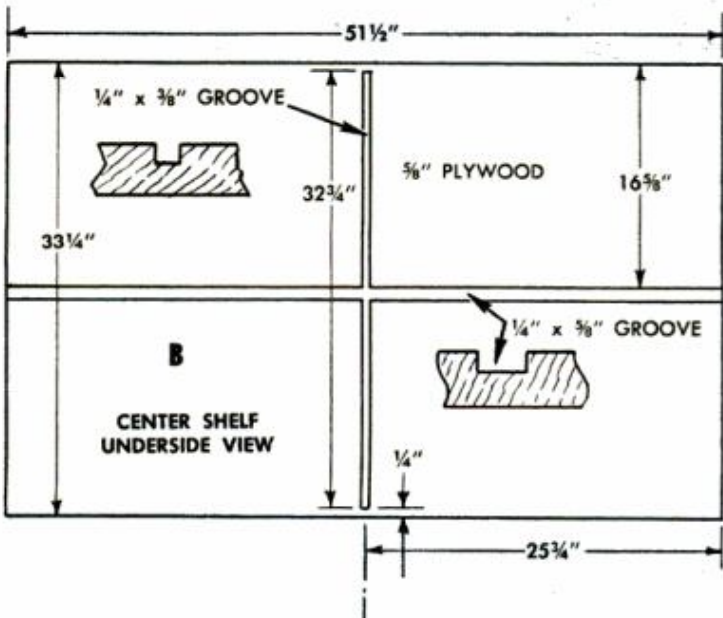
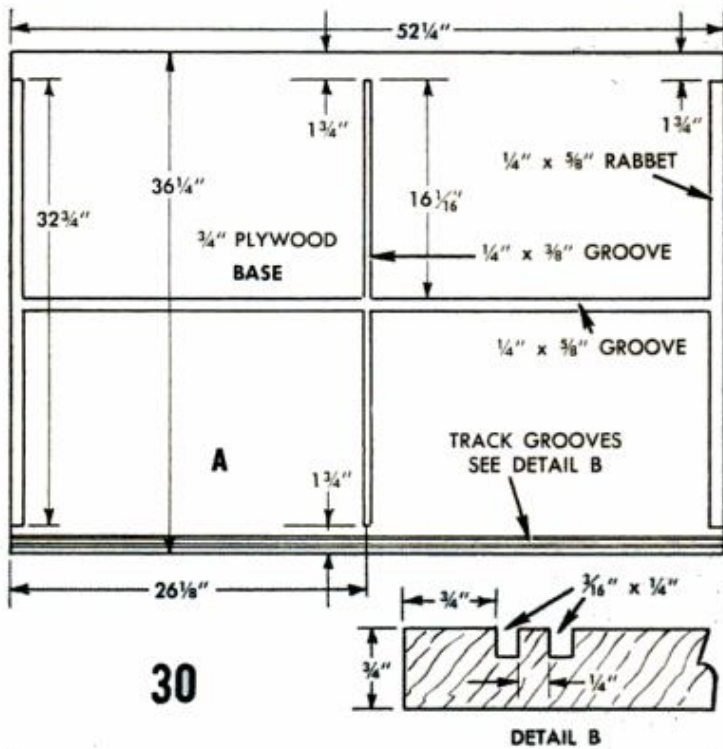

29, shows the lower tracks. Note that upper tracks are cut deeper. Two shelves, parts D and E, Fig. 29, have ends tenoned to fit into the dados in parts A, B, and C. Note the difference in tenon sizes.

The back panel requires no cutting other than the over-all size given. A front piece, or rail, forms a part of the upper sliding-door track assembly, as in the sectional view, Fig. 29. Study the drawing before making any cuts. Behind this rail is a backing strip, a grooved track and two corner blocks. Take extra care in constructing the upper grooved track since it must line up precisely with the grooves in the base. Duplicate all pieces as there are two end, or leg, units. Prime (with glue) all edge grain, apply glue over the priming, and nail. Set the nails and fill with a patching compound.

The base, shelf and end pieces of the center storage unit, parts A, B, and C, are detailed in Fig. 30 and the unit is shown assembled in Fig. 32, including the additional parts E, and F, Fig. 31. Note that only the bottom is of 3/4-in. plywood. The bottom tracks detail B, Fig. 30, are identical to those on the end cabinets. Note that two sides are required, one left and one right. The shelf dado is easy to cut on the table saw all the way but you may have to finish cutting the divider dado with a chisel. Notice the two 1/4-in. x 1/4-in. notches in the lower corners. On the shelf the dados, or grooves, are centered each way; one is stopped, the other goes through to the edges.

The long divider, part F, Fig. 31, is rabbeted on both edges and grooved on both sides at the center to take the inner end of the dividers, parts E, Fig. 31. Note that in the front corners of dividers E the tenons are cut back 1/4 in.

Sectional dimension and assembly of the upper track, Fig. 31, will be seen in detail C, Fig. 32. This member is 52 1/4 in. long. Cut duplicate 3/4 x 2 3/4-in. facing strips, and 3/4 x 2-in. backing strips. These will be assembled as in the sectional view, Fig. 31. The parts are cut from solid stock. Finally you'll need one spreader, and eight glue blocks, each 3/4 x 1/2 x 2 in.

Now, trial-fit all the parts of the three-unit base. Make any adjust-

ments necessary, then begin assembling, starting with the leg cabinets. Use glue in all the joints and be sure to strike nailing guide lines so that you know where to center nails into edges that are concealed in the assemblies. Use bar clamps to draw parts tightly together before nailing. Wipe off excess glue with a damp cloth.

Place the end units in position against the center cabinet, line up accurately, and clamp in position. Mark off on the inside ends of the center cabinet, and drill eight holes in each side as indicated. Counter-sink and drive 1 1/4-in. No. 10 F.H. wood screws—8 on each side. This results in a

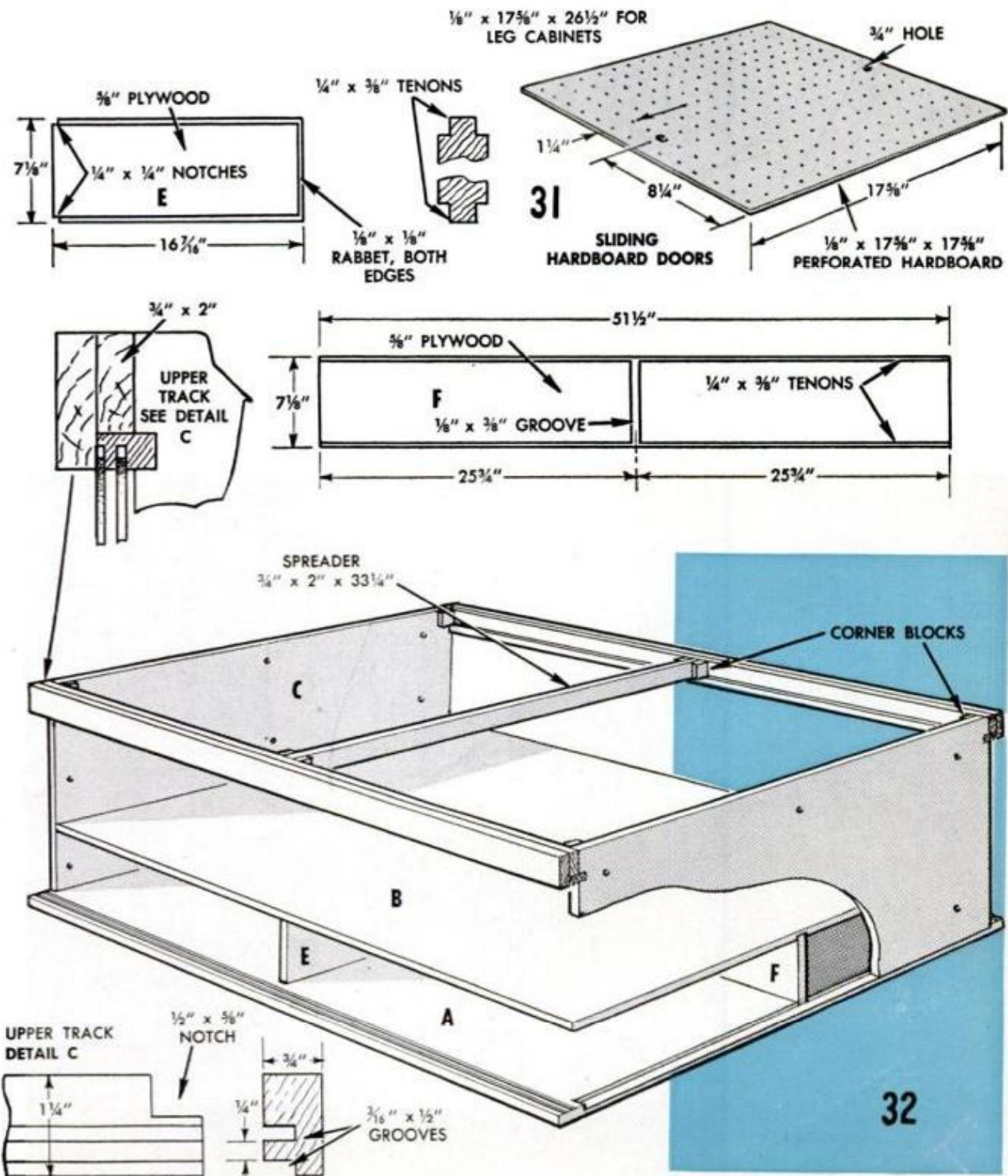

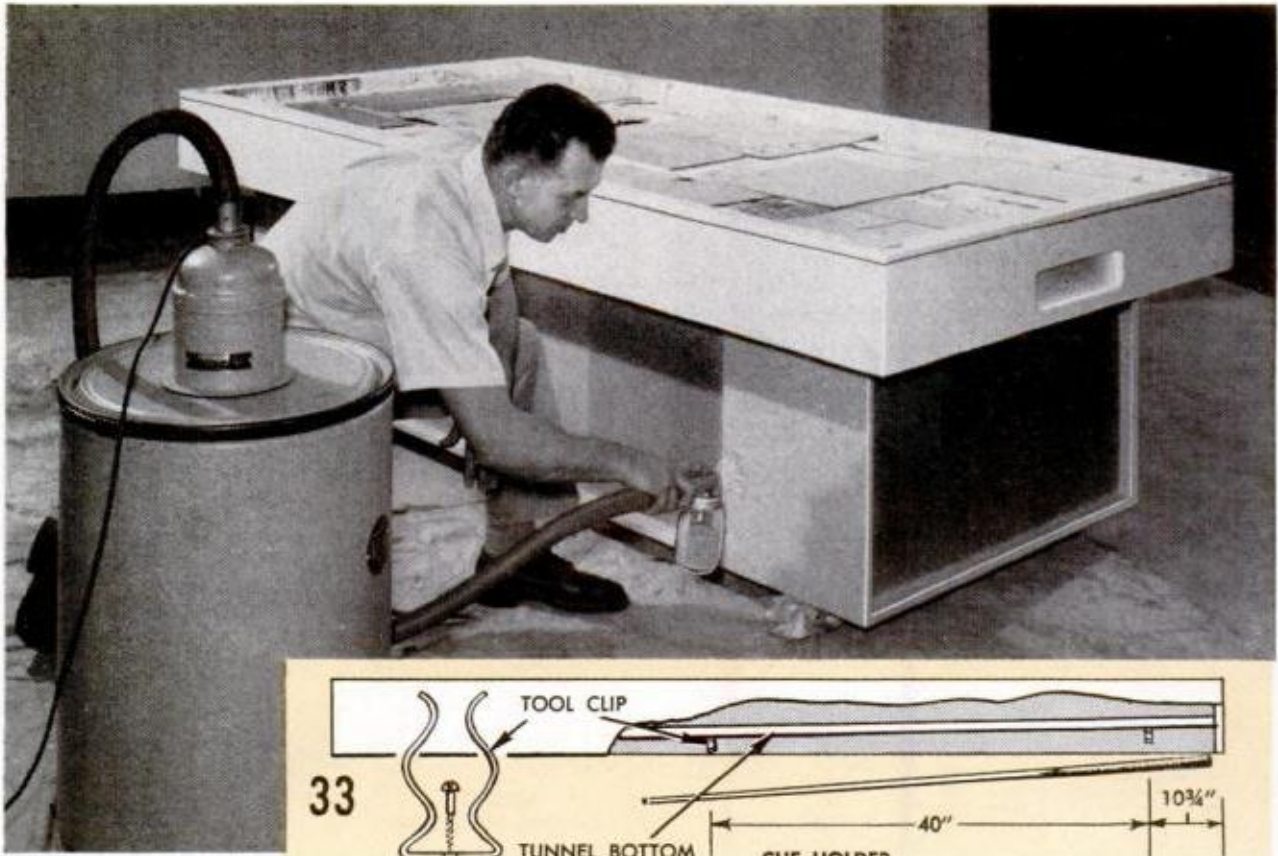

**PAINTING TABLE**, the final operation, is done with a sprayer of the type attached to vacuum cleaner. Here shop vacuum supplies air pressure. Details shows how cues are racked to underside of ball tunnel



simple, rigid assembly of the three-part base. Now, to add the casters, take the three units apart, place the two end cabinets back to back, clamp together temporarily and turn the combined units over, bottom up.

The assembled table rolls on four 2-in. rubber or plastic-wheel casters (two with brakes), which are of the type fitted with a  $\frac{3}{4}$ -in. threaded stud and generally used on power-tool stands. Locate longitudinal center lines on the bottom of each end cabinet. Plates for the casters are made from heavy clothesline hooks of the type having mounting plates, or bases, like those in Fig. 34. Remove the hooks. Enlarge the hole in the center of each plate to take the caster stud. Then attach the plates to the casters, drawing

(Continued to page 214)

**SWIVEL CASTERS**, two with brakes, are attached to leg cabinets as in photo at left and center detail. Right-hand detail shows how levelers are attached to leg cabinets. Four identical levelers are needed

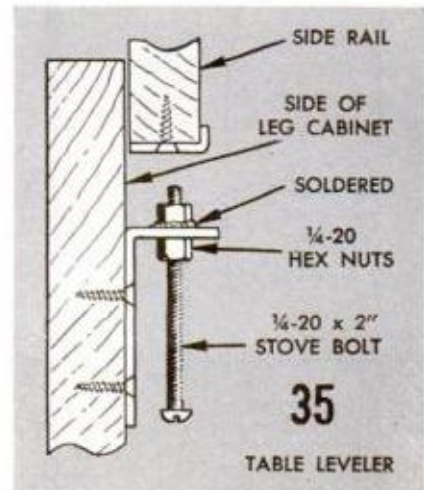
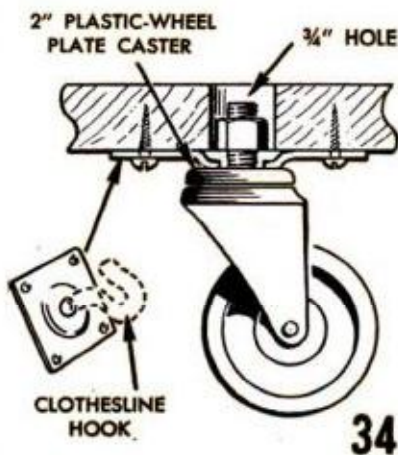

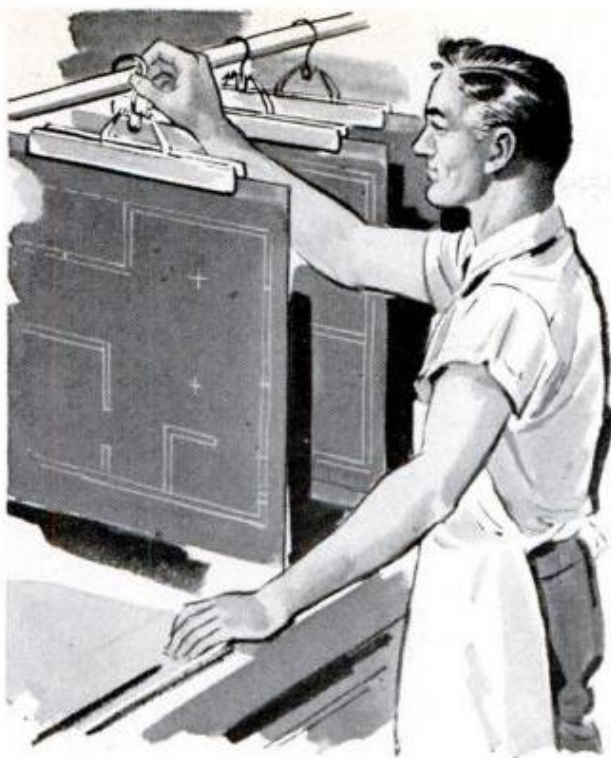

## No-Roll Storage

Small blueprints, shop drawings and tracings will remain flat and dust-free indefinitely if you clamp one or more in a trouser hanger and hang on a wire or clothes-closet pole. If prints have been rolled, clamp a second trouser hanger to the bottom edges to serve as a weight.

## Wandering Compass

When a draftsman's compass is fully extended it can get a little wobbly, especially if you're using the extension arm. A full circle reveals any deflection right away but you're not always sure of accuracy when drawing a segment. Clamp two  $\frac{1}{4} \times \frac{1}{2}$ -in. hardwood strips to the legs with a  $\frac{1}{8}$ -in. bolt and wing nut as pictured. This gives the compass all the rigidity and reliability of a trammel.—*H. Hanscom*

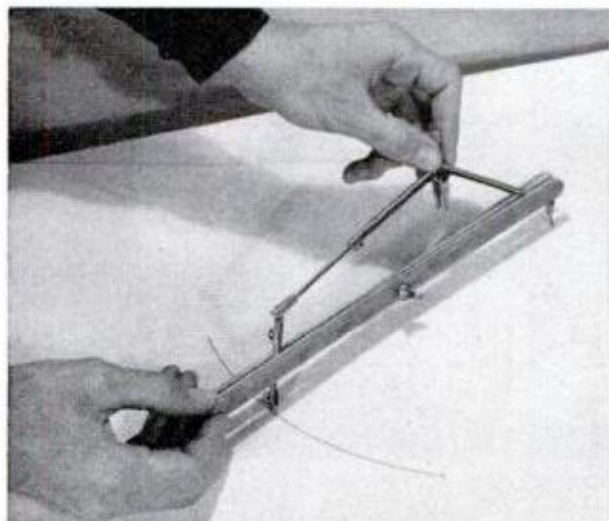

FEBRUARY 1962



## Label It

EXOTIC wine labels from famous vineyards throughout the world, beautifully printed in multicolors, provide an unusual touch of contemporary decoration. Most appropriate for adding a splash of color to game-room walls, bar front or snack area; labels also may be applied to ice buckets, trays, wastebaskets, table tops, etc. May be applied with glue or rubber cement. You can get 30 for \$2.00 from Heritage House, 529 Firethorn Drive, Monroeville, Pa.



181



## T-Square Sleeve

Students who on occasion carry a drawing board and T-square back and forth to school will find that the T-square can be carried more conveniently if slipped into a sleeve attached to the back of the board. Being nothing more than a length of lightweight cardboard folded and lapped at the seam, the sleeve interferes in no way with the regular use of the board and therefore can be permanently attached with glue or tacks. Form the sleeve by lapping the edges of the cardboard about  $\frac{1}{2}$  in. and fastening with staples. In addition to keeping both T-square and board together, the sleeve also affords protection for the ruling edges of the blade.—*Richard Hanscom*

**¶**To avoid marring a surface when working with a compass, try using a flat transparent plastic garment button as a pivot block. Coat the underside lightly with beeswax so it won't slip and prick-punch the face for a center.

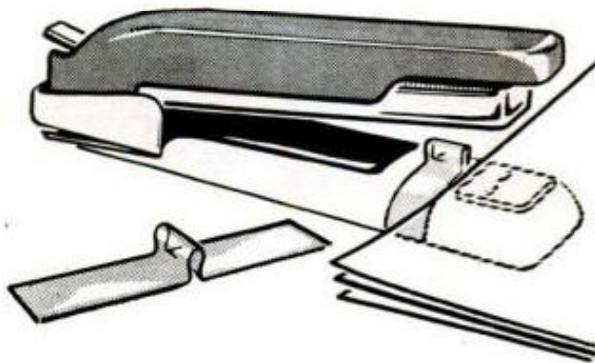

## Stapler Stop

A folded strip of gummed tape attached to your desk stapler will serve as a practical depth stop when stapling papers. The upright, creased part of the tape serves as the stop and assures that all staples will be located the same distance from the edge of the paper. The stop is easily attached and can be removed when it interferes with regular use.—*G. E. Hendrickson*



## Soap Shapes Brush

The chisel edge on an artist's lettering brush may be maintained by shaping the edge on a wet bar of soap before putting the brush away. The soap will dry almost immediately and hold the bristles in shape until the next job. When the brush is needed again, you need only wash the soap out with water and it is ready for use. This will work equally well with small touch-up brushes used around the home.

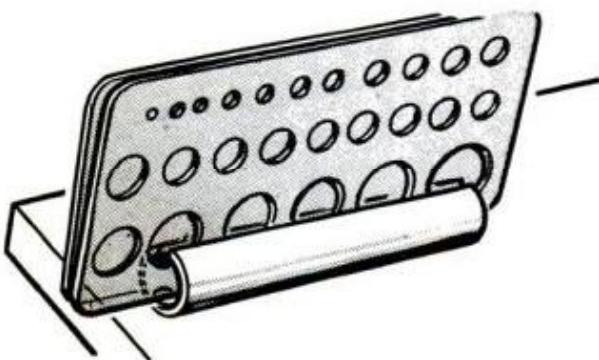

## Tube Holds Templates

Draftsmen and artists can keep their lettering guides, templates and angles within easy reach on the drawing board by standing them in a section of mailing tube. To make it, simply cut a  $\frac{1}{4}$ -in. slot lengthwise in one wall of a 6-in. piece. Use two thumb-tacks to attach the holder to the drawing board, inserting one tack at each end of the tube.—*William B. Eagan*

# NEW FOR SHUTTERBUGS NEW

**UNIQUE PROJECTOR SCOPE** makes viewing and editing movies possible without setting up a screen—even viewing in daylight is practical. Scope resembles a television picture tube. With 8-mm. scope, movies may be previewed at any time. You simply insert unit into lens opening in place of projector lens. Priced at \$14.95. Hudson Photo Industries, S. Buckhout St. & Station Rd., Irvington-on-Hudson, N. Y.



**CAROUSEL SLIDE PROJECTOR** features 80-slide revolving tray which can be set for continuous, automatic operation at intervals of 5, 10 or 20 sec., or for manual control. All-in-one remote-control switch permits operator to change slides, hold slides, or reverse them. Unit has continuous motorized focusing. Slides are accessible for instant editing. Less than \$140. Eastman Kodak Co., Rochester 4, N. Y.



**A 4-IN-1 ENLARGING EASEL** provides fast, trouble-free printing in four of the most popular sizes of paper (8 x 10, 5 x 7, 4 x 5, 2½ x 3½). Magnetic latching eliminates the use of springs, but always provides positive paper holder. Nonslip rubber feet hold easel in place. Both sides of easel have white focusing base. Priced at \$8.95, easel is marketed by Photo Materials Co., 2450 Estes Ave., Elk Grove, Ill.

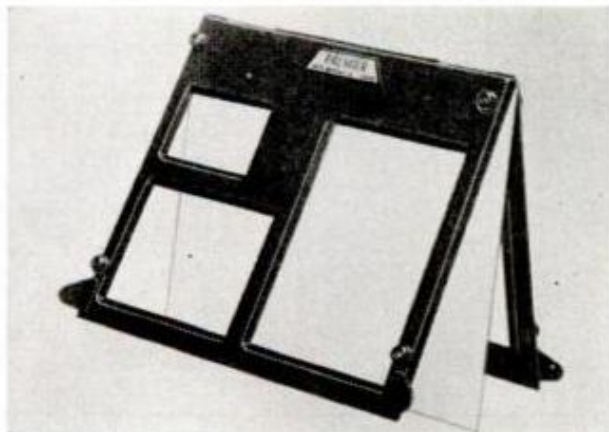

**SLAVE FLASH UNIT** is automatically fired by light from flash on camera. Weighing less than 6 oz., the lightweight, cordless flash unit permits using additional light sources with great ease. Gun may be shot up to 25 ft. from small flash units accepting midget bulbs. Mechanical safety button prevents the premature flashing by other flash guns. Price: less than \$20. Eastman Kodak Co., Rochester 4, N. Y.



# Electric Tank Agitator

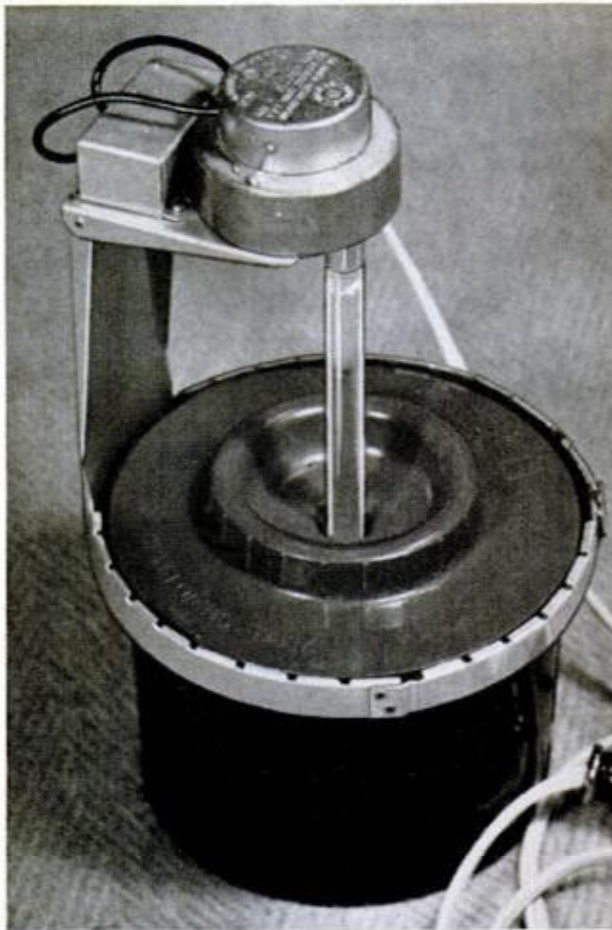

Motor-support bracket clamps to developing-tank cover to hold agitating rod in line with film reel in tank

SPENDING ten to fifteen minutes manually agitating the tank each time you develop a roll of film is silly when this little electric agitator will do it for you automatically and continuously. The heart of the unit is a 10-r.p.m. advertising-display motor which slowly rotates the tank reel by a plastic-tube shaft extension coupled to the motor. This was done in the original by turning a headless machine screw part way into a hole already tapped in the end of the motor shaft and then threading the tubing over the end of the projecting screw. A tight-fitting plastic sleeve forced over the motor shaft and the tubing would be another way. A spring-tensioned sheet-metal bracket, designed to clamp around the tank cover, supports the motor and agitator shaft in line with the filler opening. Patterns, made to fit the tank at hand, are cut from sheet aluminum (such as a cookie sheet) and bent along the dotted lines. Eyelets or small machine screws can be used to fasten the motor platform to the frame. The motor and a switch-fitted cord are wired to a terminal strip.—*Ted Strader*

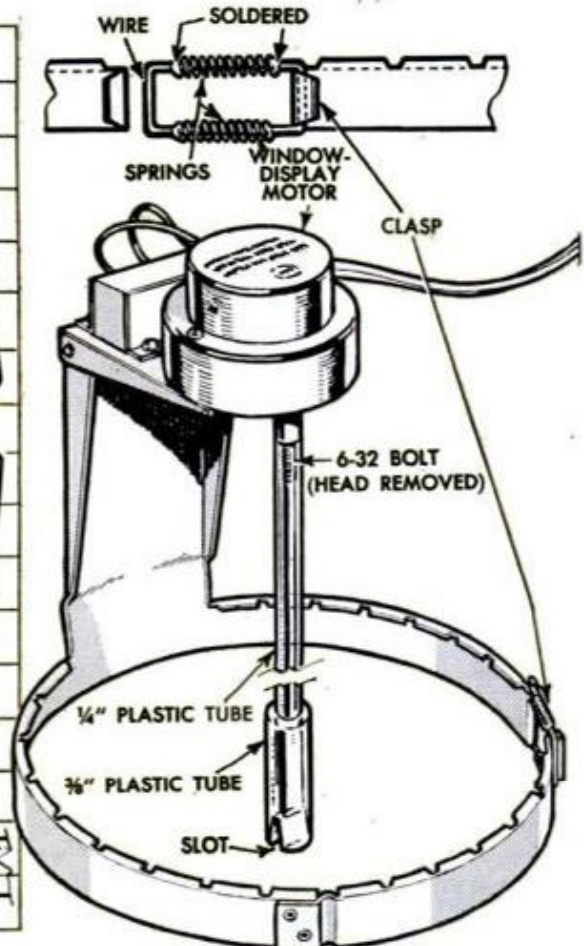
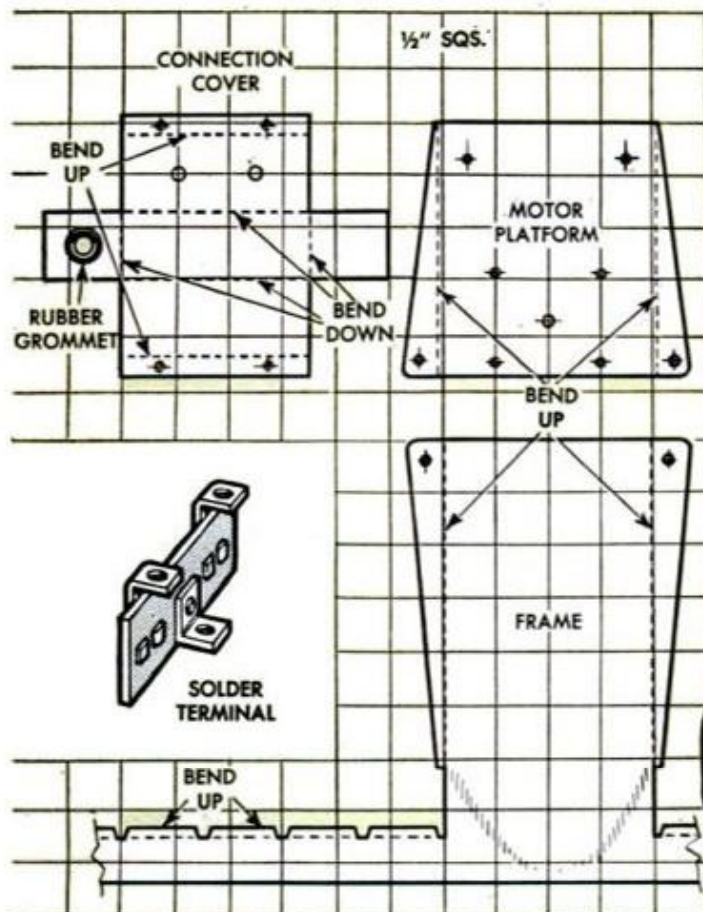



## FOR CAMERA BUGS

### Extension Flash Adapter

Designed to fit the terminal rod of a collapsible light stand, this universal adapter provides a flash unit with a secure base on which it can be adjusted and locked in any position. This makes it an indispensable accessory for indirect bounce, multiple and supplemental lighting. Also when you want the single main light off the camera for those unusual or dramatic pictures.

Cut three lengths of strap aluminum for each adapter; the longest is 8 in. for the stand clamp, 3 in. for the light mount and 1½ in. for the rod stop. To make it easier, drill all the holes before bending and drill those for the rivets with the pieces clamped together to be sure the holes line up. Sharp 90-deg. bends can be made in the aluminum by clamping the parts between the jaws of a vise and tapping the metal lightly at the points of bend with a hammer. Start forming bends in the upper end of the 8-in. piece.

The captive screw, available in camera shops, is a standard-base screw which fits the tripod socket in the camera. The center hole in the aluminum disk, which provides a base for the flash unit, is drilled oversize to clear the threaded captive screw. The thumbscrew can be made from a wing nut run down and soldered to the head of a stove bolt. Finally, for appearance give it a brushed finish with a wire wheel chucked in an electric drill.—*Manly Banister*

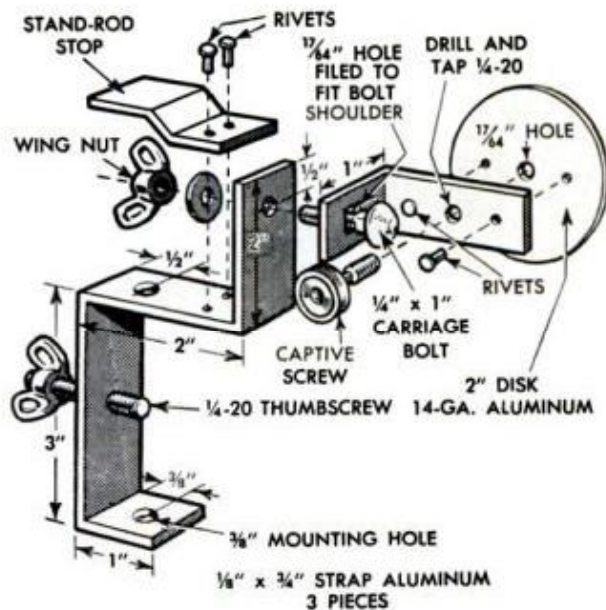

### Steady Does It

If you left the house without a tripod and would like to get into the picture with the rest of the folks, a table lamp will solve your problem. Also, if you don't own a tripod, this will be a fair substitute to get sharper pictures than you would holding the camera. The difference will be especially noticeable in enlargements. You'll find that after removing the lamp finial and shade, the ¼-20 stud will fit all standard camera tripod sockets. This idea is best for small cameras as a large one is apt to make the lamp top heavy.—*Bil Toman*

There is no need to be fumbling around for the darkroom foot switch when it's so easy to expose it without risk of fogging your paper. Simply stick two or three short pieces of luminous tape across the sides and up over the top edges. A glance will show you the switch when you're ready to make an exposure and put an end to the usual delay while you groped around searching for it with your foot.

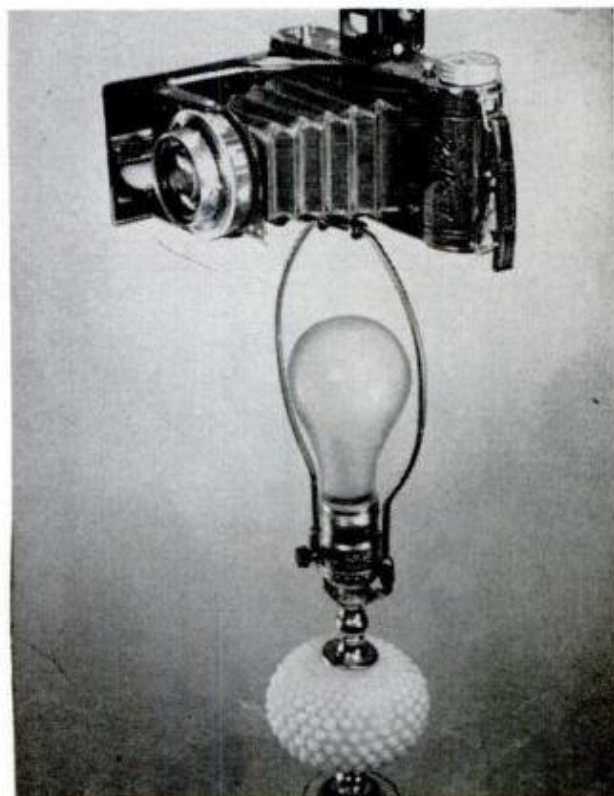

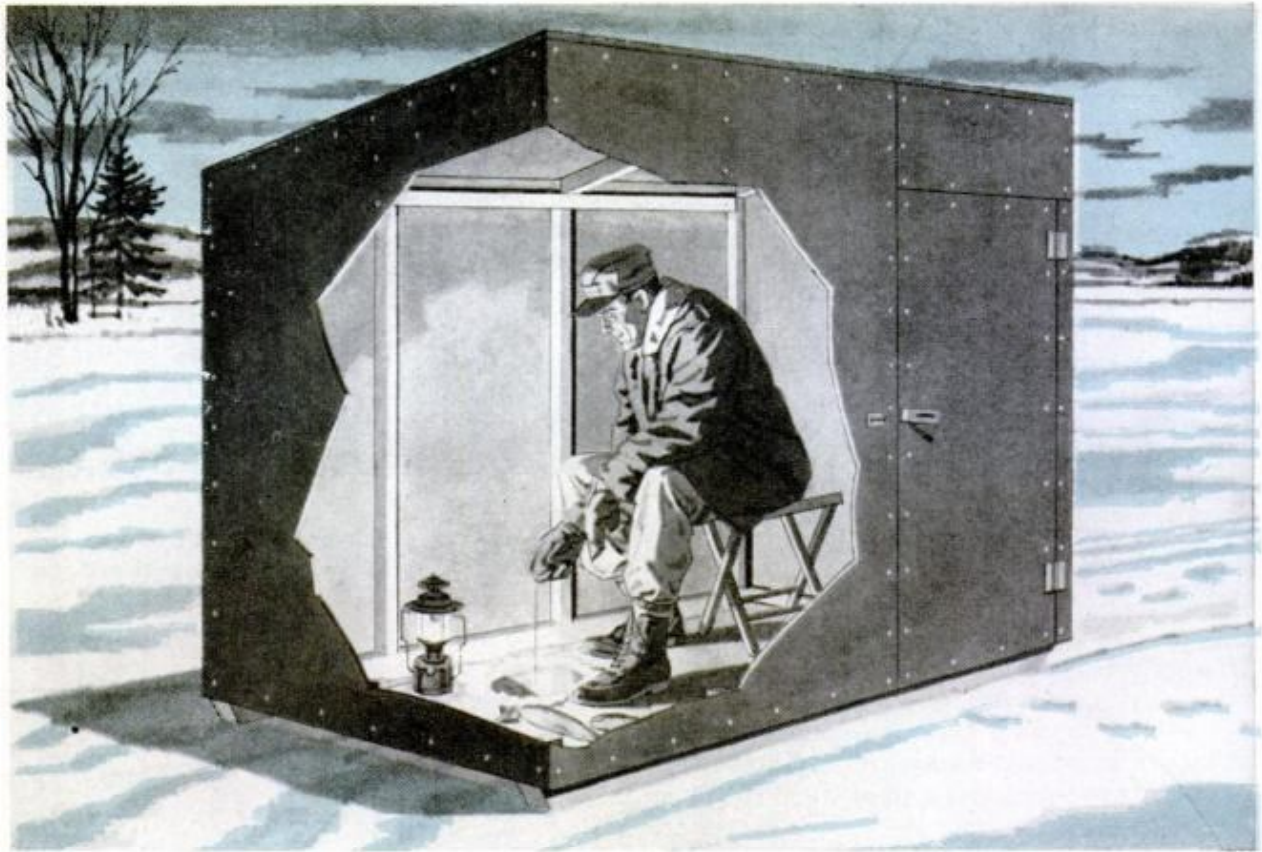

## Prefab Ice-Fishing Shanty

**F**OR LESS THAN \$25 and only four or five hours work you can own a snug portable ice-fishing shelter which may be pushed along like a sled from one site to another. Afterwards, double-headed (scaffold) nails may be pulled and the house dismantled for carting back home.

Drawings below and on the opposite page detail construction of the five panels. These can be cut and assembled at home, perhaps in a garage, and then hauled to a lake or river and nailed together with the nails

mentioned. The two end studs in the front and rear panels should be cut 2 in. shorter than the inside studs to permit the notched corners of the side panels to rest on top of the 2 x 6 skids. Six sheets of asphalt-coated, insulated sheathing are needed: The six diagrams show how to cut these numbered pieces. Roll roofing may be precut and tacked in place at the site. The asphalt-coated sheathing requires no paint; but for a different color, finish with a poly-vinyl acetate-base paint.

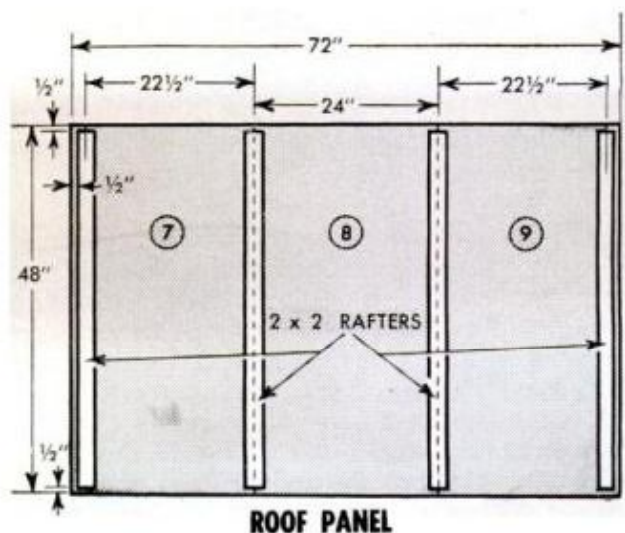
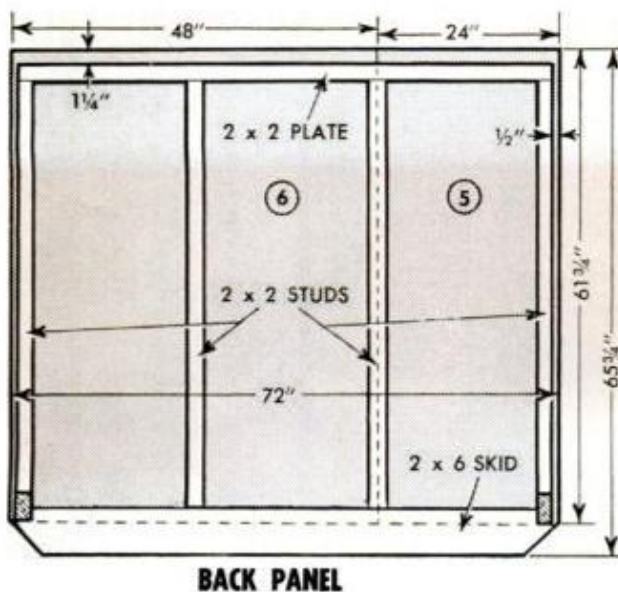

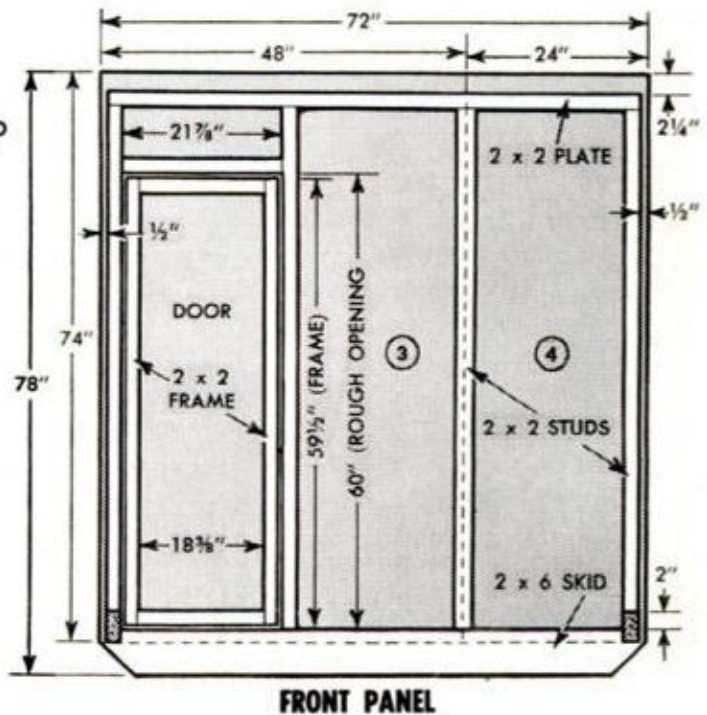
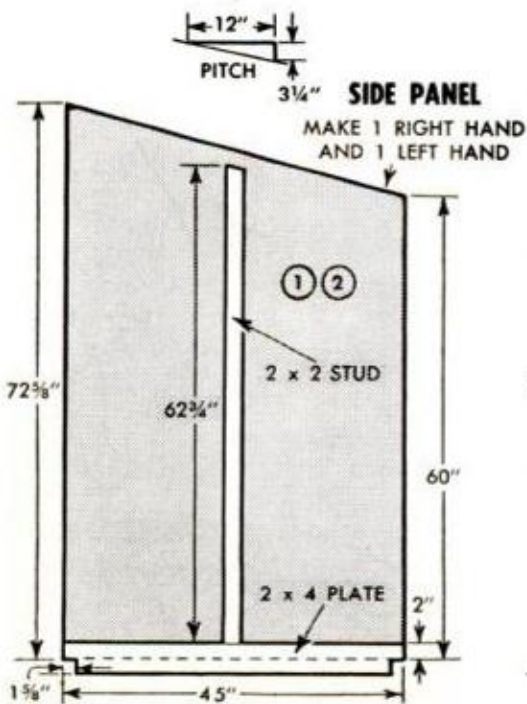
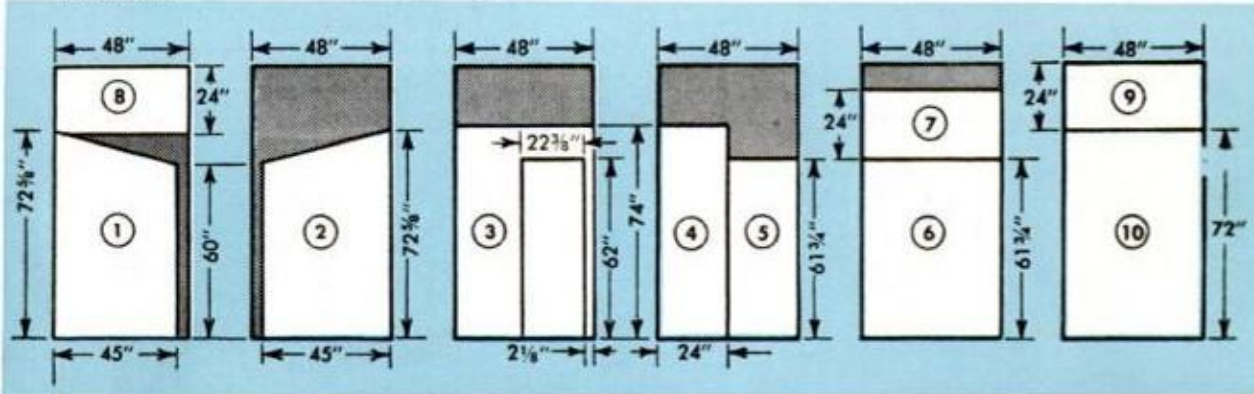
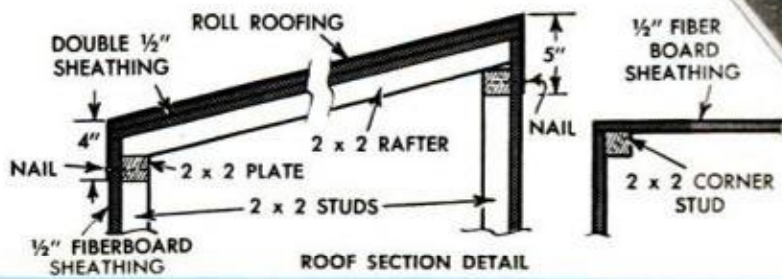
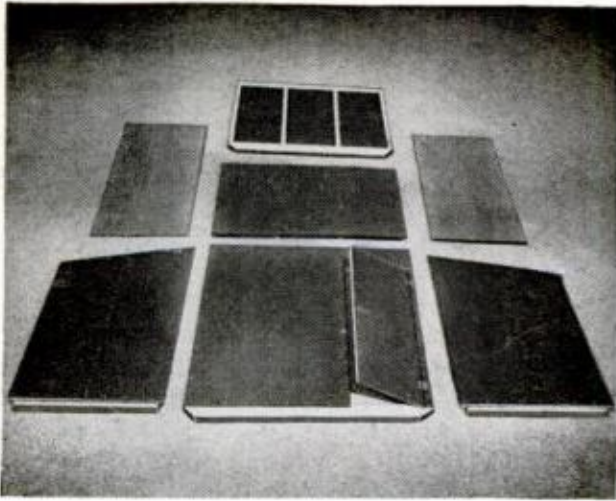

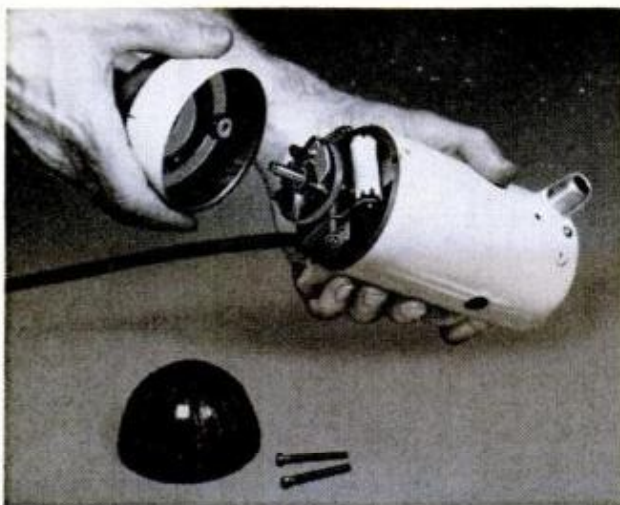
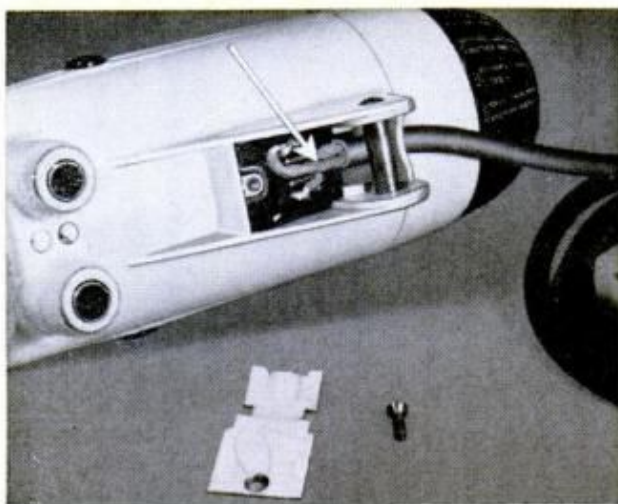

**I**F YOU ever drop your electric mixer, it's well to keep in mind the possibility that one or both the motor brushes may have been shattered in the fall. Brushes in a mixer motor will take years of ordinary wear, but the shock of a fall from the table to the floor may break one or both. It's always well to remove both brushes and inspect them before starting the motor. The center photo at the left shows what the brushes look like. To take them out you unscrew the holder, or retainer, which projects through an opening on each side of the motor housing. There's a screwdriver slot in each holder. Go light on the screwdriver and remember that the brushes are spring loaded. They'll pop out on the floor unless you grasp the holder as you unscrew it. If both brushes are okay, replace them. Be sure, and we'll repeat for emphasis—be sure they are marked so you can replace them exactly as they were originally. Also, if the brushes are badly worn or chipped, they should be replaced with new ones.

The cord on a mixer gets rough usage. If the plug end of the cord appears to be okay, take off the access plate on the underside of the motor (usually it's between the legs of the bracket) and examine the terminals, indicated by the arrow in the upper left photo. Brush away any lint that may have collected. If the cord insulation is cracked or shows other signs of wear and deterioration, it's a good idea to replace it.

Tiny motors of electrical appliances collect an astonishing

# Appliance Fix-It File

amount of lint and dust and this makes it advisable to take the motor apart periodically for cleaning. Removal of the speed-control cone, or wheel, and the access plates gives you a good look at the inside of the motor, lower photo on the opposite page. Clear away dust and lint with a soft-bristle brush. Somewhere inside you'll find a capacitor, or condenser, arrow in the upper photo, right. If your mixer causes radio interference when running, then this part should be replaced.

You've already removed the brushes so now you can remove the bearing plate as in the center photo, right. In most mixers this permits you to pull out the armature as in the lower right-hand photo. Again, be careful. Don't pull things apart until you've made sure you can put them back in the same order. Brush away all lint and dust from the armature and field coils inside the motor. You'll see the brush track on the commutator, which is a part of the armature. If the commutator is smooth with no indication of grooving at the edges of the brush track, merely wipe off the loose carbon. You can polish the commutator lightly with very fine sandpaper (8/0) if you wish. Wipe clean to remove any abrasive. Clean the worm at the end of the armature shaft and relubricate, using a lubricant approved by the manufacturer.

Reassemble all parts in the reverse order. Recoil bearings sparingly, also apply oil at any other point that may be indicated by the word "oil."

—John Pennington

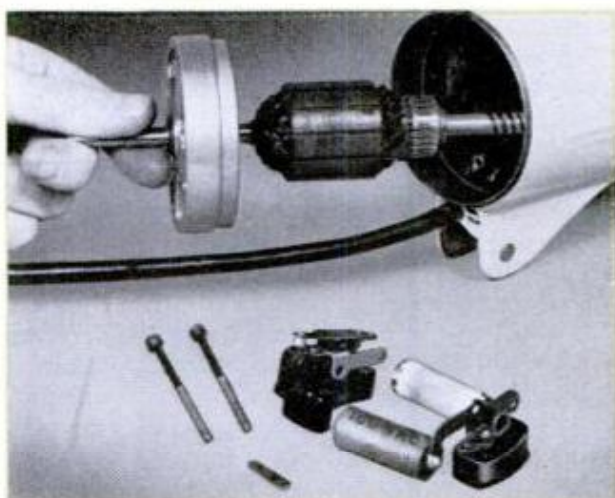
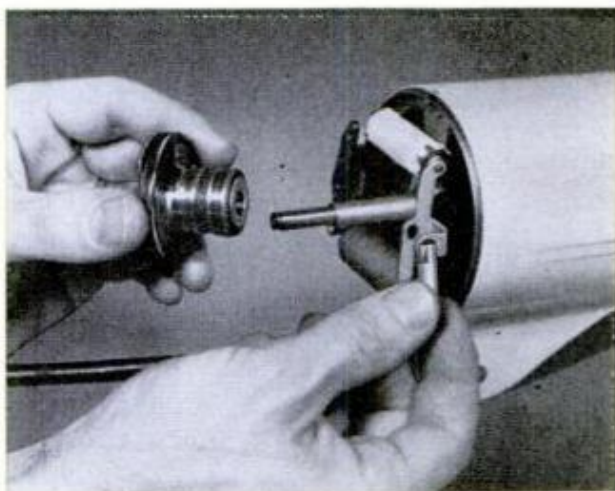
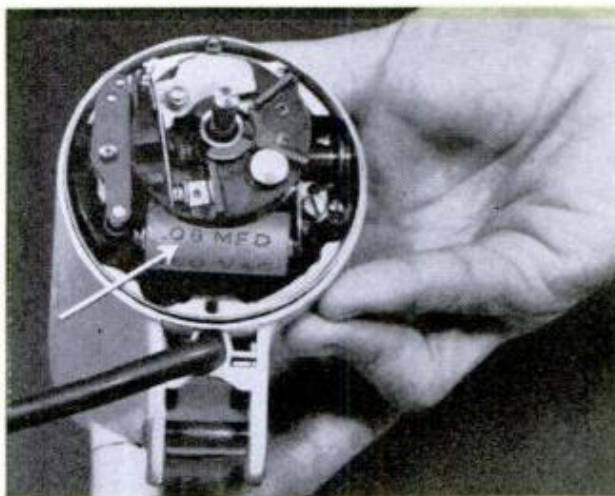



1. BRAKE DRUMS that may be defective should be checked by your parts dealer with a brake micrometer

## When It's Time to Reline Brakes

*Everyday service, a few panic stops, mountain driving, hard braking at the lights can make a good reline job something more than adding new linings*

**By William J. Hector**

**I**T'S ALMOST safe to say car brakes never really fail, they're that good. But they do wear down slowly, with a proportional lessening in stopping power. Before brake wear gets to the danger point drivers usually get ample warning of that approaching time when the brakes on the car need relining.

Of course, it would be simpler and easier to just turn the job over to your serviceman and let him handle it all the way, deliver the car back to you with its brakes relined, readjusted and ready for the road again. But you learn he's very, very busy with people who want this or that done at once—can't possibly handle the job until sometime next week, if then. This opens the way for you to take the load off his back by doing a brake-reline job yourself. Tomorrow is Saturday, so why not give it a try?

If you have followed the series of articles

on various phases of brake servicing beginning in the July 1961 issue of *Popular Mechanics* you already have much of the equipment and know-how, which will come in handy on this major step in the complete overhauling of the brake system. A complete overhaul is generally thought of as shoe relining, drum turning if necessary, hydraulic-system overhaul and a major adjustment. Normally the four steps are carried out at one time.

In the accompanying photos you'll see Bendix brakes pictured. Chrysler car owners can refer to the September 1961 issue of *PM* for information on adjusting Chrysler brakes. You should experience no trouble with the reline job on these brakes if care is used in reassembling the parts in the same sequence as they were removed.

Start the reline job by placing a wooden block under the brake pedal to prevent it

from being depressed. Then mark the wheels and drums so that you can return them to the same locations. Loosen the lug nuts on all wheels before you jack up the car and place it on car stands or on square, stable wooden blocks. Release the emergency brake. Now remove the wheels, remembering the suggestion in a previous article to place the lug nuts in the hub caps so that none are lost. From this point on keep everything clean so that no dust, grit, or grime gets into bearings. Clean the outside of the drum and the back plate. Then remove the drums, using the puller pictured in Fig. 10 on the rear axle so that you do not risk damaging the differential. Clean the shoe assemblies and inner faces of the back plates as described in preceding articles. Then remove the shoes, using the brake tools pictured in Figs. 6, 8 and 9. Chalk identifying marks on the assemblies and keep with the individual drums, Fig. 5.

Examine each of the drums for defects described in the chart on page 192. The first three are quite easily detected by feel and a close examination. If the working surface of the drum (that surface against which the shoes seat) is exceptionally smooth or is rough in spots or all the way around the circumference, it will pay to have the drum trued up on a brake-drum lathe, Fig. 2. This gives a new braking surface with just the right tooth and corrects any minor out-of-roundness.

Slightly bell-mouthed or egg-shaped drums are more difficult to detect by examination alone. The first term, bell-mouthed, describes a condition in which the wear surface of the drum has become beveled slightly in relation to the axis of the drum, that is, it is flared outward slightly, back to front. An egg-shaped drum, of course, is

#### TOOLS

Bendix brake spring tool or  
Chrysler brake spring pliers  
Box wrenches  
Wheel lug wrench  
Brake spoon for Bendix adj. screw  
Open end wrenches  
Brake cylinder clamps  
Large screwdriver  
Water-pump pliers

#### MATERIALS

New brake shoes  
Lubriplate  
Wheel-bearing grease  
New cotter pins  
New wheel-bearing seals

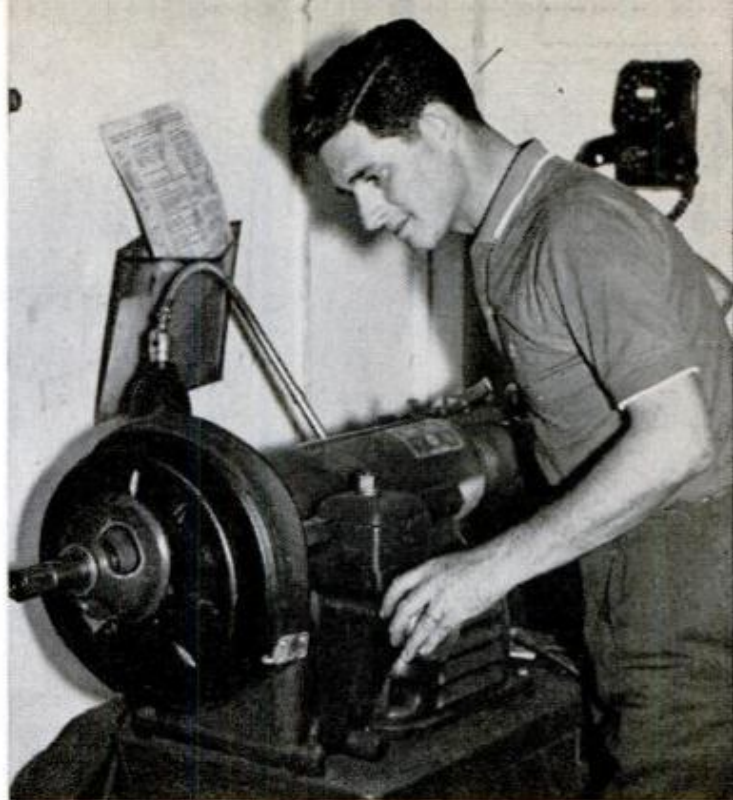

2. TRUING BRAKE DRUMS on a brake-drum lathe is advisable if you suspect that drums are out of round

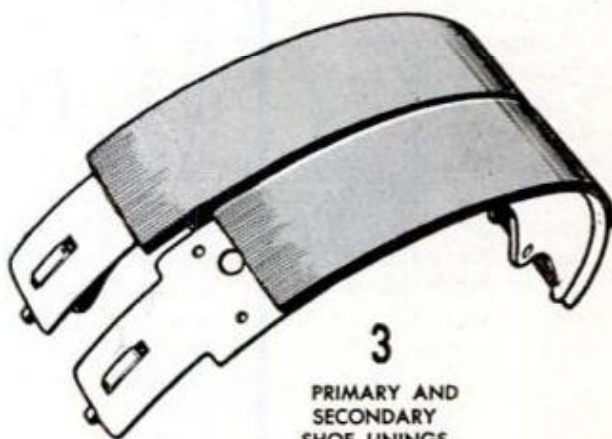

3  
PRIMARY AND  
SECONDARY  
SHOE LININGS

4. BRAKE-SHOE LININGS are arced to concentricity with drums on a machine designed for the purpose





**5. CHALK-MARK** all parts of each brake unit as they are removed and replaced to keep them in sequence

simply out of round. If either condition is readily discernible, then the chances are that the drum cannot be reclaimed.

In any case, it's always good practice to take the drums and shoes to your local auto-parts dealer for replacement of the shoes and a check of each drum with a brake-drum micrometer, Fig. 1. This instrument will detect minor and major defects in the drums and also will determine the required thickness of the replacement brake shoes, Fig. 3. If the micrometer check of the drums indicates that more than .060 in. will have to be removed by the lathe, it usually is recommended that the drum be replaced. Replacement drums for most cars are not unduly expensive and sometimes it's less trouble and expense to replace a drum than it is to recondition the original. Keep in mind that if you replace front-wheel drums, you will have to remove the hubs from the old ones and install them



**6. SPECIAL BRAKE TOOLS**, made for the purpose, will save a lot of time when removing or installing shoes

in the replacements. Replace the studs also.

Now comes the question of which to use—bonded or riveted linings? Both are good so it's generally best to use the type recommended for your car. Proper installation of either type should prove entirely satisfactory from the service standpoint. Either way, have the new shoes arced (ground) on a special grinding machine to fit the drums, Fig. 4. This unit grinds the surface of each shoe to perfect concentricity with the drum. Be sure you keep each pair of shoes with the drum to which they were fitted. It's a good idea to chalk-mark them as in Fig. 5, just to make sure you don't miss when you reassemble the individual brake units. Should you get them mixed you could have trouble, as diameters of the drums may vary somewhat. Another thing to be sure of will be noted from Figs. 3 and 7. Be sure that you have the shoes placed with the short, or primary, shoes in exactly

## CHECK BRAKE DRUMS

### ARE THEY

#### SCORED?

They will abrade the new linings, cutting down on the life of the lining.

#### SLICK?

They will not give the friction of a freshly turned drum. Turning on a brake-drum lathe cuts a new surface in the drum, smoothing any irregularities and correcting minor out-of-round conditions.

#### SCORCHED?

Possibly too many panic stops in a short space of time. Also, drum thickness might be too thin for adequate heat dissipation.

#### BELL-MOUTHED?

Gives inadequate contact area. Caused generally by ill-fitting internal brake parts, worn parts and hard braking over long periods of time.

#### EGG-SHAPED?

Excessive pressure may have been applied to the foot pedal. Also, too-hard application of parking brake on hot brake drums.



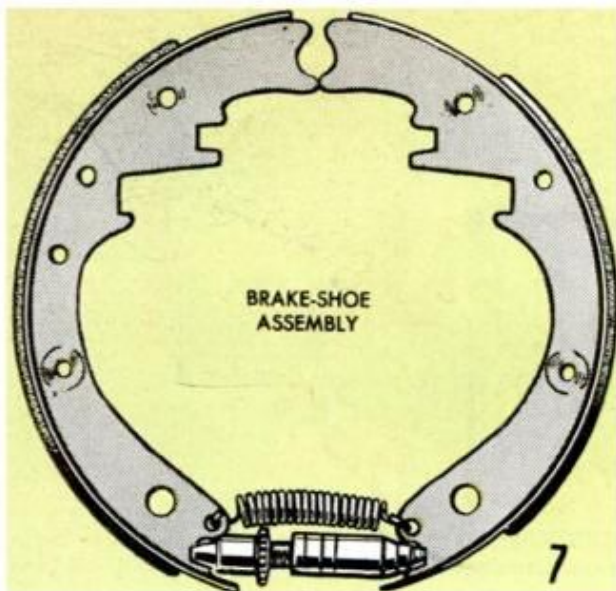

the same position as were the originals.

From here on you should take every precaution to prevent oil or grease, or any grime containing either lubricant, from getting on the working surfaces of the drums or the linings. This is especially important, as only a drop of oil or a smear of grease can cause faulty operation of the brakes even though they are properly adjusted after assembly. Even a fingerprint on the working surface of the drum can result in the immediate formation of a rust spot.

Again dust off the back plates and apply a thin film of the proper lubricant (Lubri-plate) to the anchor-pin thread and the shoe-bearing surfaces, or platforms, on the back plate. Then assemble the brake shoes in matching pairs with the adjusting screw and spring, Fig. 7. Don't attempt to place the shoes individually on the back plate, but place on the plate assembled in pairs, (front wheels first) making sure that you have the primary shoe in the position specified for your car. Also, be sure that the notches in the adjusting screw line up with the adjustment opening in the back plate. Place the hold-down springs in position and replace the anchor-pin plate. Then, using the brake-spring tool, replace the brake-shoe return springs, primary shoe first. On the rear wheels, assemble shoes on the plates and attach the emergency brake lever to the shoes, lubing the bolt position very lightly. Then place the emergency-lever shoe separator in position, making sure it is returned to the same position as originally. Replace the brake drum and repeat the sequence on the other rear wheel.

Now make a major brake adjustment on all four units (see the August 1961 issue of PM) and then give the car a road check. If you were careful with all the details, your brakes should work like new. ★ ★ ★

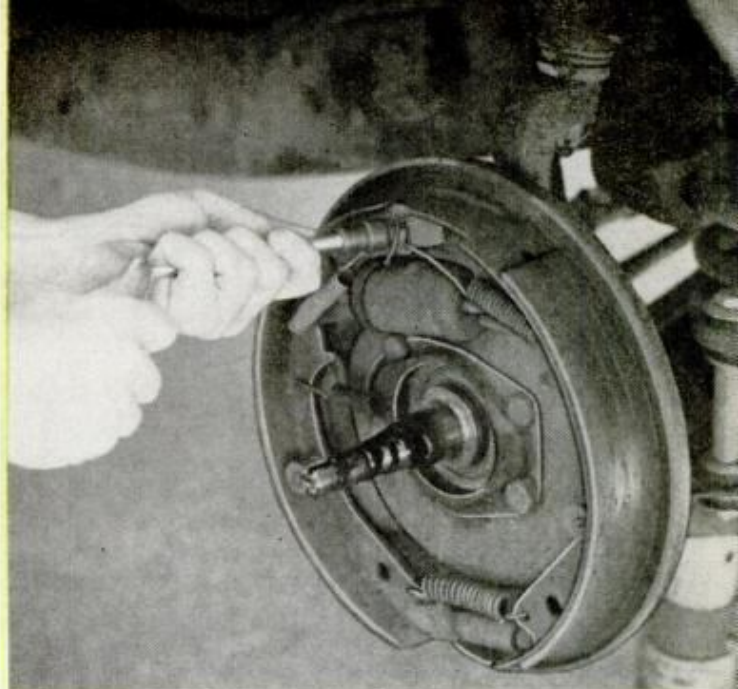

**8. HERE'S WHERE** the right tool can save time, possible hand injury and even damage to brake-shoe parts

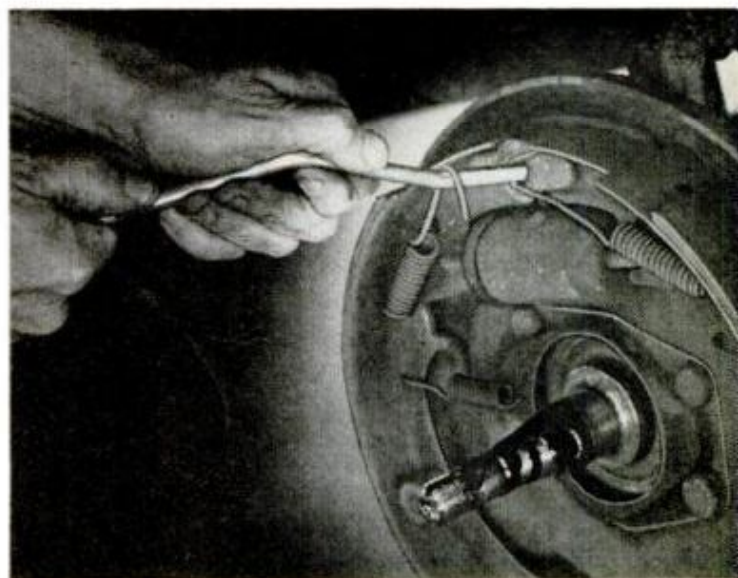

**9. TRICKY JOB** on Bendix brake is removing and replacing retracting springs. This tool does it easily

**10. SPECIAL PULLER** of this type assures easy removal of parts without damage to rear axle or differential



# Better CARKEEPING

● **INSTALLATION** of a new cover on the steering wheel of your car can be made much easier by dipping the cover in water so that it will stretch a bit. The dampness helps the cover grip the wheel, and when it dries the cover will shrink to its original size on the wheel assuring a neat, snug fit

● **TIE-DOWNS** for lumber or other materials carried for short distances on the top of your car can be kept from marring the paint if you slip a length of old garden hose over the wire or rope wherever it touches the car body. The pieces of hose can be stored in the trunk or garage for reuse

● **WHEN CHANGING** an oil-filter cartridge, put new oil in the filter case at the same time. If there happen to be any leaks, they will show up the moment the engine is started. In addition to this advantage, the oil in the case will provide instant lubrication for your engine the first time you start it

● **SPARK-PLUG** overheating, generally associated with using plugs of too hot a heat range or over-advanced ignition timing, also can be caused by insufficient fuel-pump pressure. This lack of pressure causes a lean fuel mixture at high speed and may bring about overheating of both plugs and valves

● **TO CONVERT** degrees to distance on a flywheel of any diameter, multiply the diameter in inches by 3.1416 and divide this figure, the circumference, by 360. If your car's flywheel has starter teeth, divide 360 by the number of teeth in the flywheel ring gear for the degree value of each tooth

● **HYDRAULIC VALVE** lifters can be cleaned effectively by using a synthetic rubber battery syringe. Simply draw clean solvent into the syringe, fit it to the lifter stem and force the liquid through. After all residue has been removed the ball will make a sharp click when the lifter unit is shaken

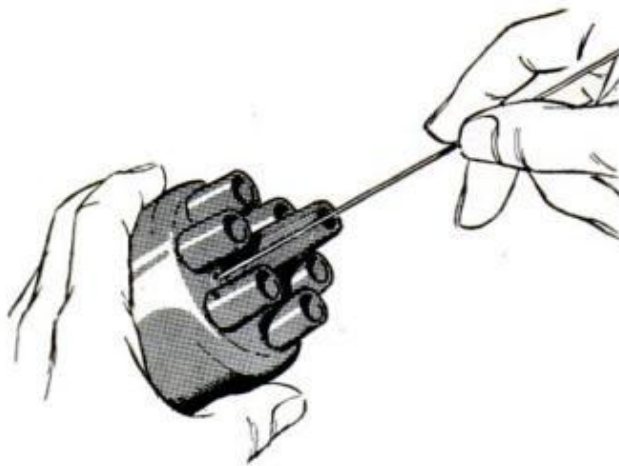

**ORDINARILY** you don't find a vent hole in distributor caps. Usually it's in the housing, but it's a good idea to check the cap when servicing the distributor. It's important that the vent be open to eliminate corrosive gases formed inside by high-tension current

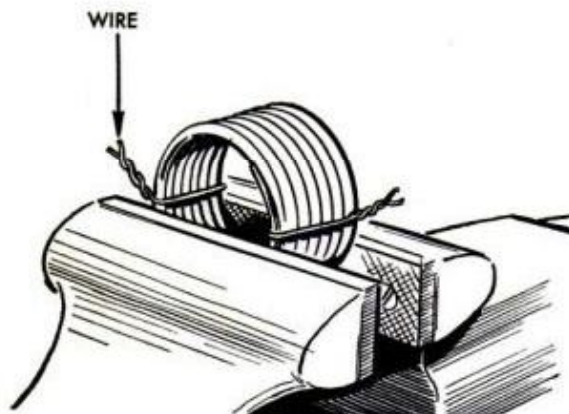

**VALVE SPRINGS** are easy to replace if you compress each one in a vise and keep it compressed by means of two short pieces of wire, one on each side. When the spring has been installed and the valve keyed, you can remove the two pieces of wire with pliers

**WHEN REPLACING** the carburetor after repair, it is sometimes difficult to attach fuel and vacuum lines. Try setting the carburetor on the mounting studs without nuts and starting all lines, then place nuts on the mounting studs and tighten all connections

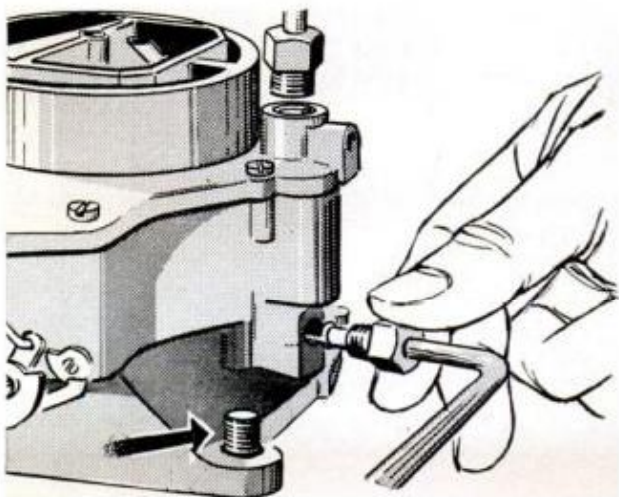

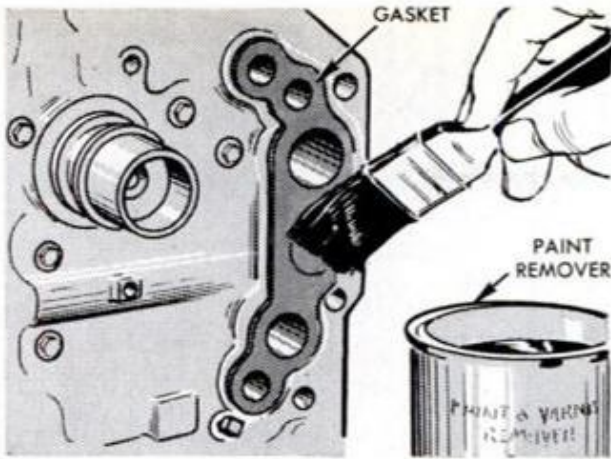

**REMOVING GASKETS** cleanly when overhauling an engine is always quite a problem. However, if you paint the gasket with ordinary paint and varnish remover and let it soak in for a few minutes, you'll find that the gasket will strip off cleanly every time

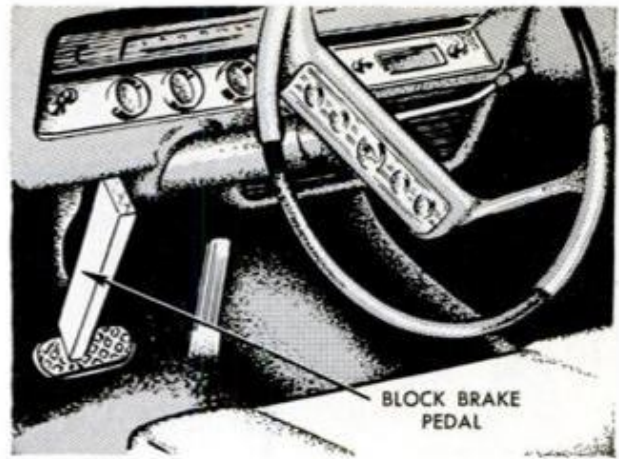

**AFTER INSTALLING** a new master cylinder you can bleed the system without help by making all connections but one, then depressing pedal to floor and holding it with a wedged stick. After connecting last line, fill cylinder and work pedal slowly to displace air



**A ROUGH IDEA** of the number of miles of use your spark plugs have seen since they were last serviced can be obtained by measuring the gap across the electrodes. Engineers have found that electrodes in the average plug wear about .001 in. for each 1000 miles

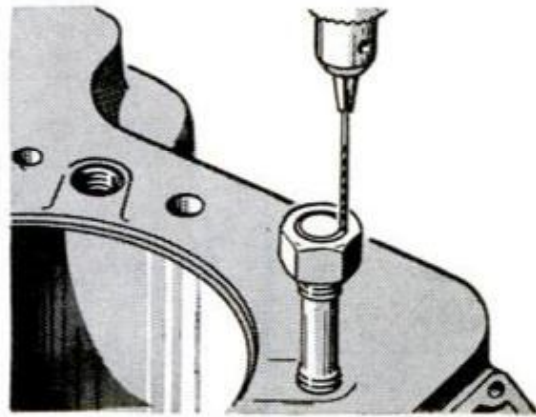

**TO REMOVE** a stud without damaging threads with a wrench, run a nut down until it's flush with the top of the stud, centerpunch a mark at the threads, drill a small hole and insert a pin. The pin will lock the nut so you can turn out the stud by the nut

**TAIL PIPE** can be replaced without damaging the muffler if you place a wood block between the car frame and muffler, then set a jack directly under the block below the muffler. Put just enough pressure on the jack to hold the muffler in place while you work

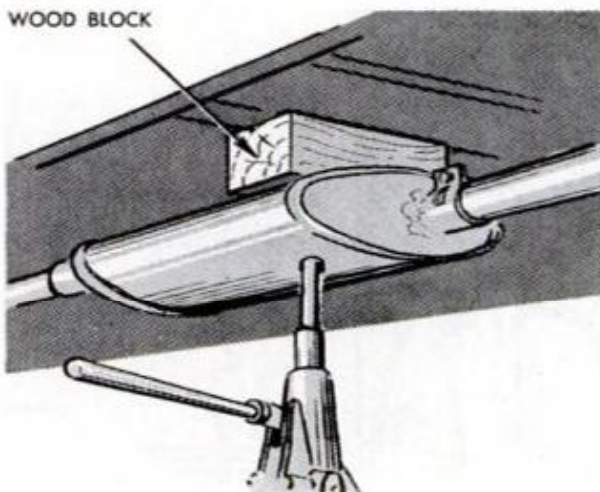

**SPRING-TYPE HOSE CLAMPS** on lower radiator connections are difficult to hold open when connecting hose. However, if you squeeze the clamps open and force a short length of 1/2-in. copper tubing over the ends as shown here it will hold the clamp open

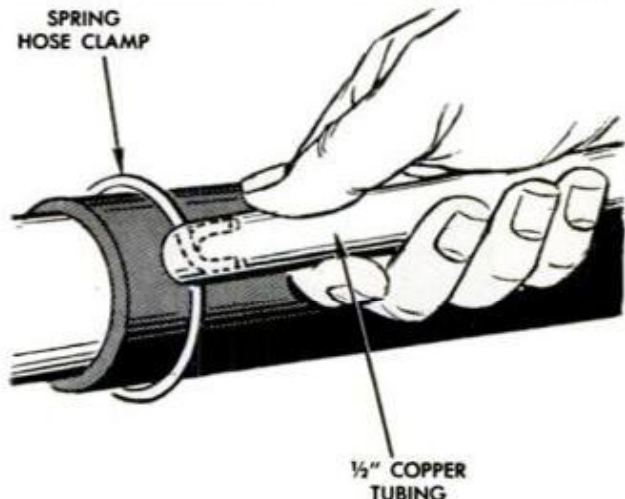

# MR. DO-IT AND BLUNZLE

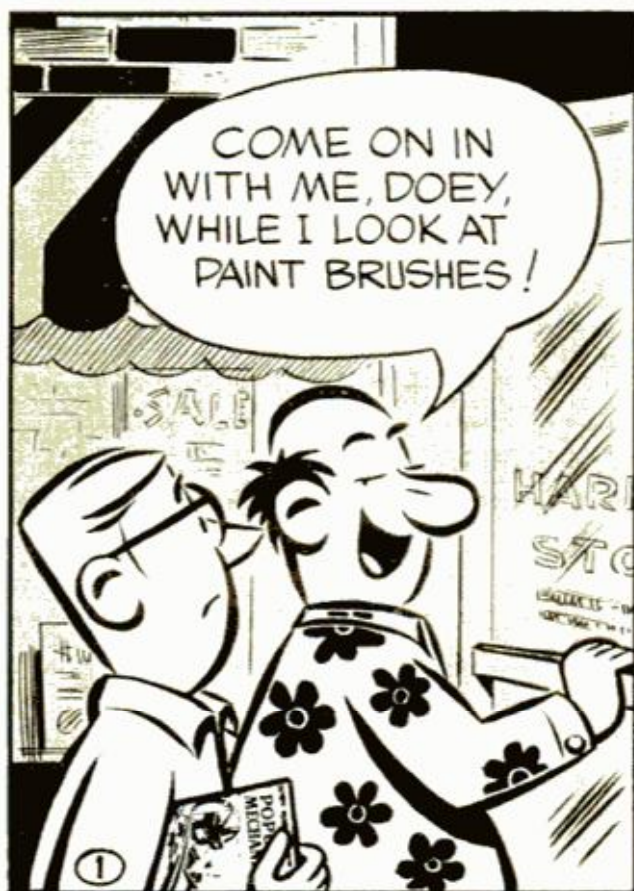

**When a helpful clerk tries to tell Bungle how to recognize a good paintbrush, he discovers that what's really needed is a high-quality brush-off**

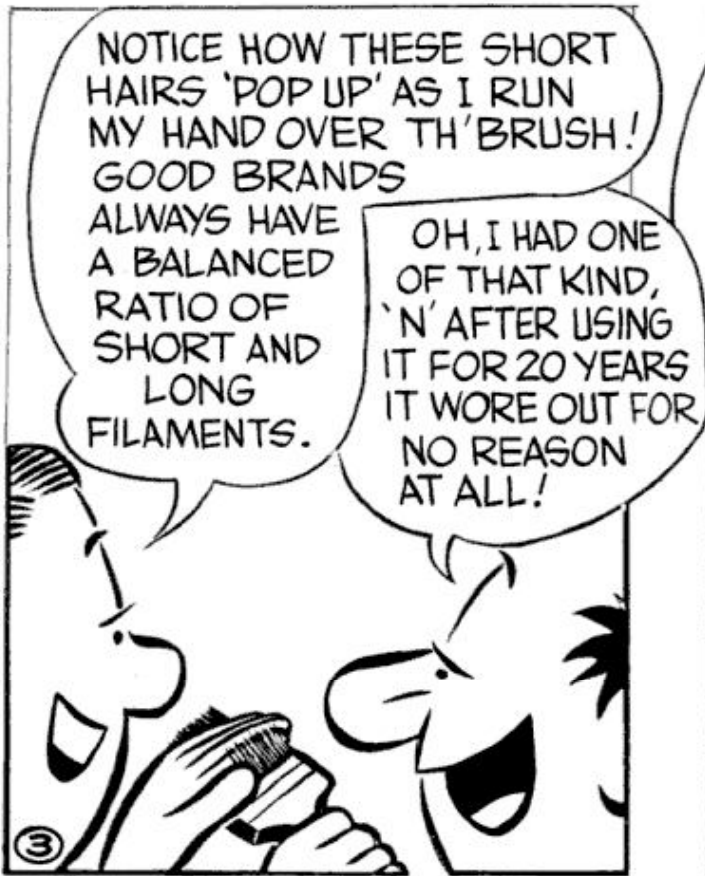

## Coming Up Next . . .

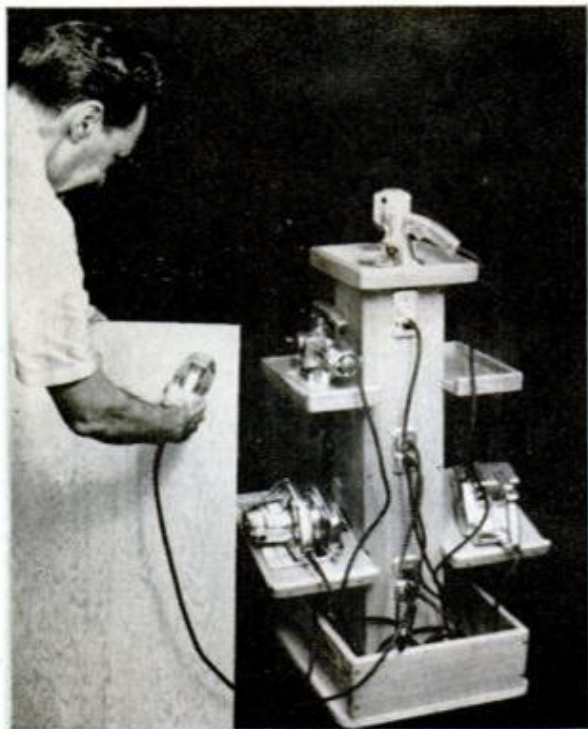

**MOBILE POWER TOWER.** And that's just what it is, the handiest caddy ever for portable power tools. There's a place for power cords, shelves for the individual tools and a plug-in panel. You can make one like it in the March PM.

**JET-POWERED BOAT.** The PM boat of the year, powered by the newest thing in boat propulsion—the turbojet. Two-part construction story completely details the hull and engine and pump installation. Be sure to look for it in the March issue.

**DUAL-PURPOSE TABLE.** Not only serves as a chairside table but a place to park a roll-away bed. Clever out-of-sight place to store a stand-by bed for an extra guest, it's ideal, too, for one-room apartments. You build the table, buy the bed. See how it's done in the March issue.

**MAKE YOUR OWN BANJO.** Excellent musical instrument at a fraction of the store price. Precut kit provides materials, solves problem of hard-to-get parts, lets you take over and complete it. It's a craft special for March.

**COIL WINDER.** Winding a coil on this unit is like winding a bobbin on a sewing machine and just as fast. Motor driven with foot control, automatic counter, it's the shop project for next month.



### Safe Anchor for Pipe

Fairly long lengths of pipe can be hauled safely in a pickup truck if you keep them from rolling about with this anchor consisting of a C-clamp and a webbing strap with a buckle. Just tighten the clamp on the endgate and strap the pipe tightly to the clamp.—G. E. Hendrickson

### Out of the Doghouse

Rover — if that's his name — is going to appreciate this ventilator for his one-room apartment. The ventilator itself is ready-made as it's simply a downspout elbow turned upside down and fitted tightly in a hole cut in the back of the house.



## SHOP SHORT CUTS

### Quick Brush-Off

Drillstands have a way of collecting a coating of oil and dust which soon obscures the marks indicating drill-bit sizes. Cleaning is something you put off because of the time it takes to remove the drills, clean the stand and replace them. Next time the stand needs cleaning, dip a bottle brush in cleaning fluid (remember the fire hazard) and run the brush through the spaces between the rows of drills. A few strokes in each space do the job.—Walter E. Burton

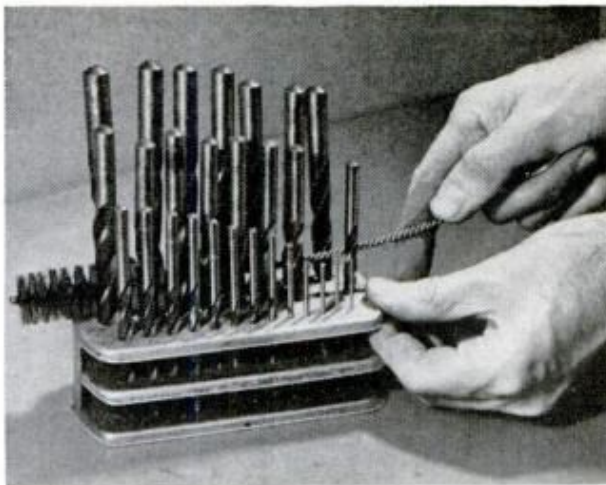

### Rough and Ready

To save time changing sandpaper sheets on his pad sander one craftsman makes an extra sanding pad by cementing a sheet of the desired grade of abrasive paper to a piece of inner tube cut to the exact size of the pad-sander platen. He uses the coarse grade of paper on the platen and when the work is ready for finish sanding he places the extra pad on the work and the sander on the pad and proceeds with the finish sanding without any time lost changing sheets. It is not necessary to attach the rubber-backed sheet to the sander pad.

—H. Hanscom

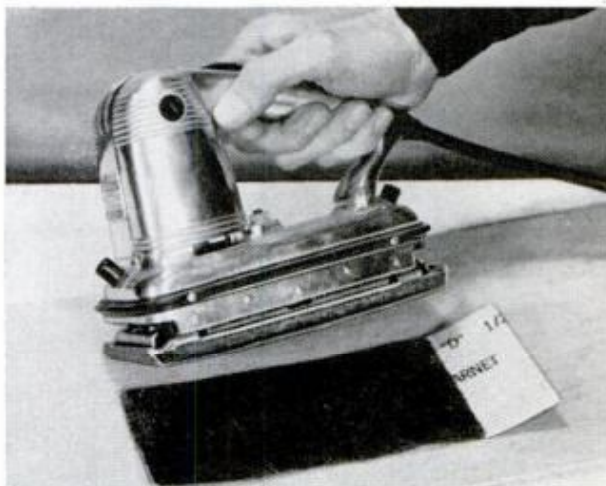

### Hold Everything

Remember this useful shortcut the next time you find it necessary to hand-hone the knives of your 4 or 6-in. jointer. Each knife can be held easily at the proper angle for honing the bevel as well as for oil-stoning the flat side to remove the wire edge, simply by clamping it between the blade and the cap iron, or chipbreaker, of your hand plane. The double plane iron provides a reasonably comfortable grip, sizeable enough to give the necessary control better than any other improvised arrangement except, of course, a jig which is especially made for the purpose of grinding and honing jointer knives.

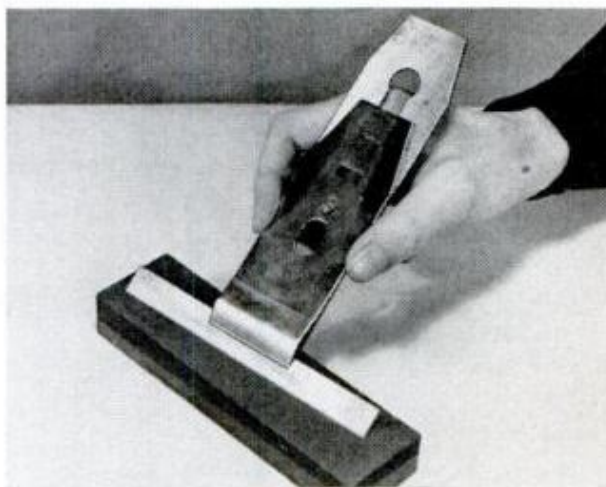

### Square Edges

Squaring the edge of the stock perpendicular to the face with a hand plane is a neat trick if you can bring it off successfully. But with this guide attached to your hand plane it's no problem at all. Cut a piece of  $\frac{3}{8}$ -in. plywood to the length of the frame of the plane and then cut a wide rabbet on one edge, the depth about  $\frac{3}{16}$  in. and the width equal to the height of the plane frame at its highest point. Trim the rabbeted edge to the approximate contour of the plane frame and then clamp to the side of the frame as pictured.

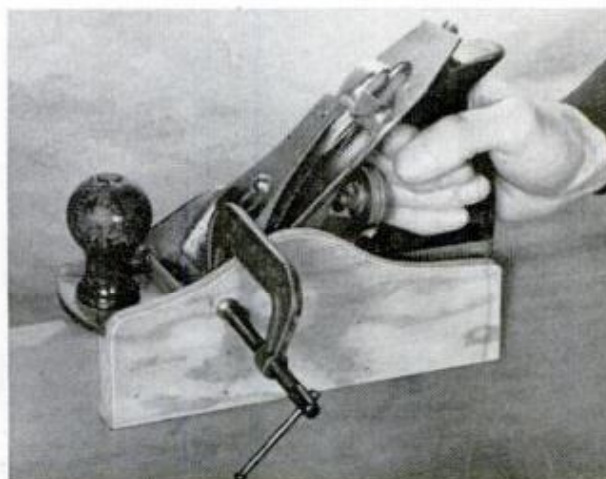

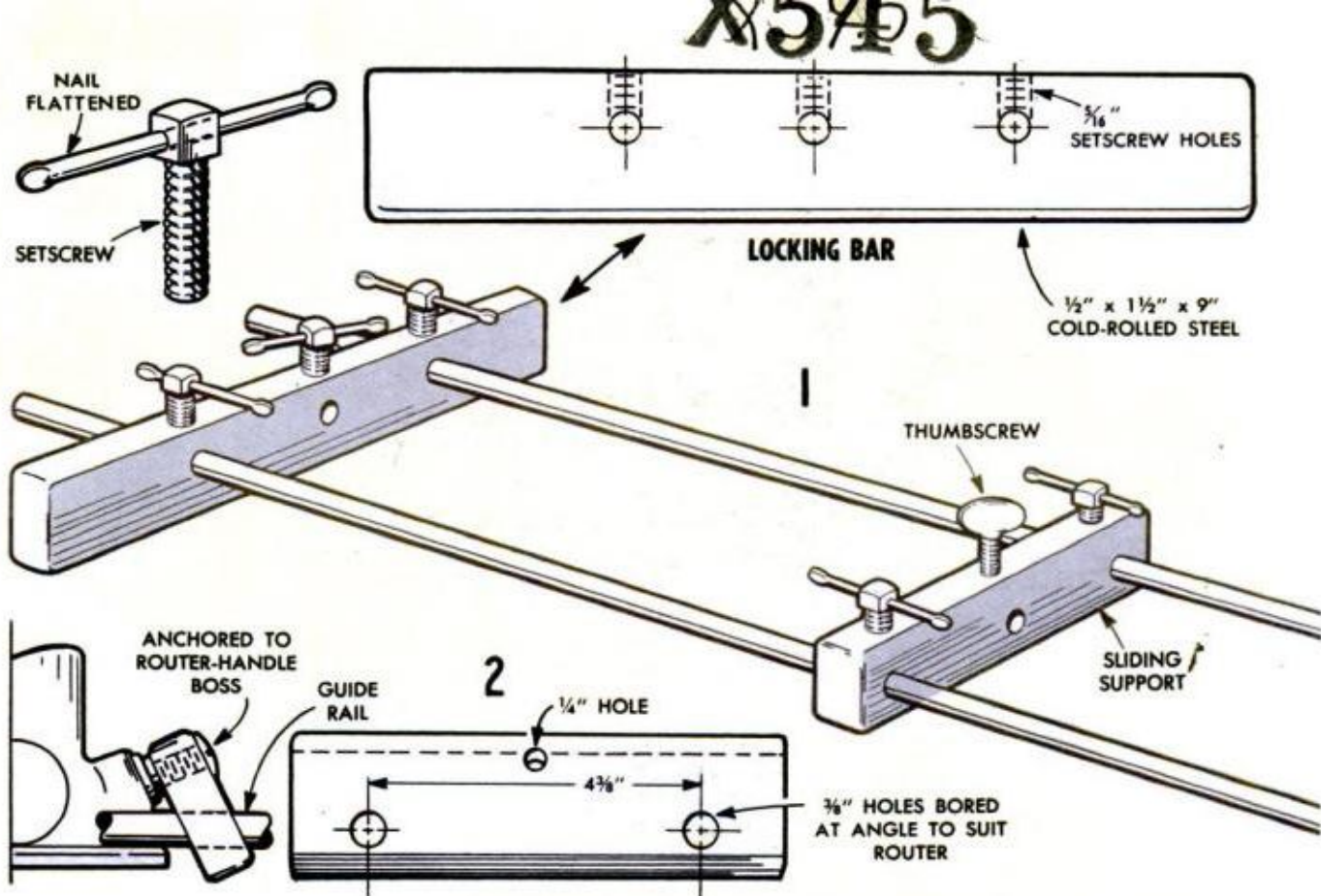

# Shop-Built Router Guide

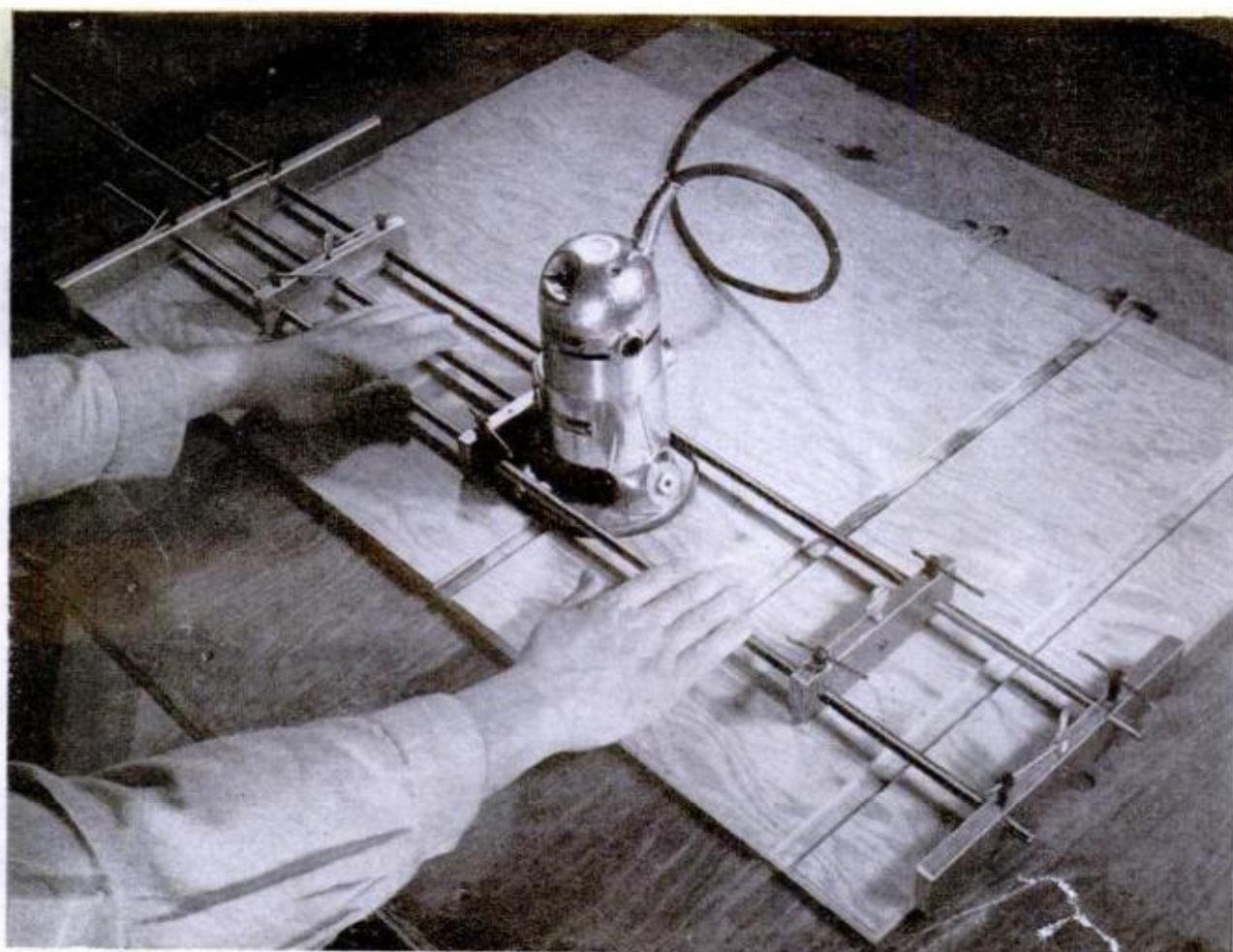



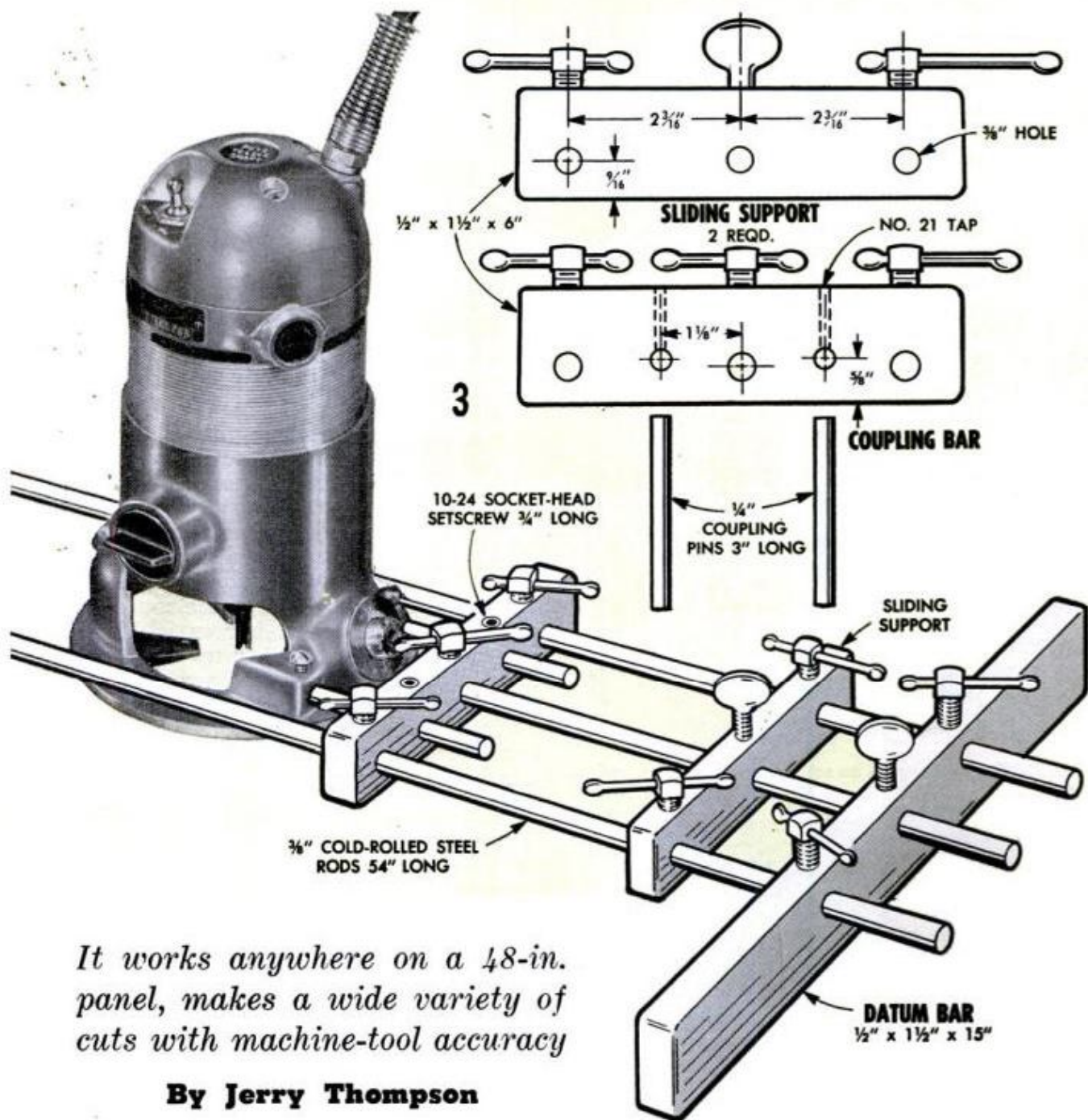

*It works anywhere on a 48-in. panel, makes a wide variety of cuts with machine-tool accuracy*

**By Jerry Thompson**

**O**NE LOOK at the guide detailed in Figs. 1, 2 and 3 and you get a good idea of how it extends the range of a portable electric router. Or drop your eye to the job pictured in the photo on the opposite page. You could very well have some difficulty handling this job on an industrial-size circular saw. But the router, mounted in this guide, buzzes those dados across the panel in seconds per cut.

Basically, the guide consists of three 3/8-in. steel rods (drill rod is best) and five sliding members cut from 1/2 x 1 1/2-in. cold-rolled steel. The third rod is the same length as the other two but is not shown full length in Fig. 1. Routers of the type and size pictured are supported by a sliding coupling bar and pins detailed in Fig. 3. The pins enter holes in the router base,

Figs. 1 and 4, which normally take the rods supporting the regular guide for straight and curved work which is supplied as a router accessory by the manufacturer.

Note that all five bars have three holes drilled on 2 3/16-in. centers. In the hole layout it's important that this spacing be maintained as otherwise the bars will bind on the rods when moved close together, as is necessary in some types of work. All the bars are drilled and tapped for 5/16-in. setscrews. Instead of the handled setscrews detailed, you can, of course, use 5/16-in. thumbscrews, three of which are shown in Fig. 1. The only exceptions are the two socket setscrews which hold the coupling pins in the coupling bar. Spacings of the holes for the pins may have to be changed to suit different makes of routers.

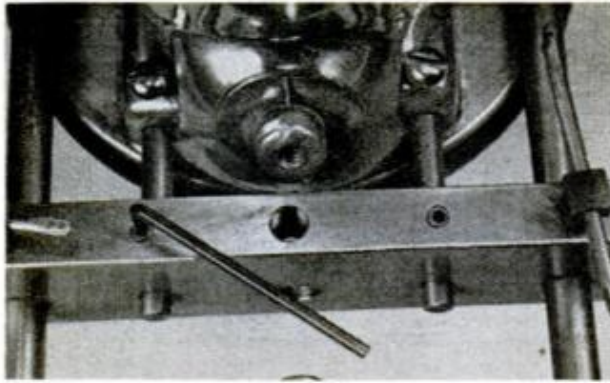

**4. BASES OF SOME** portable routers permit mounting by means of a coupling bar and short coupling pins

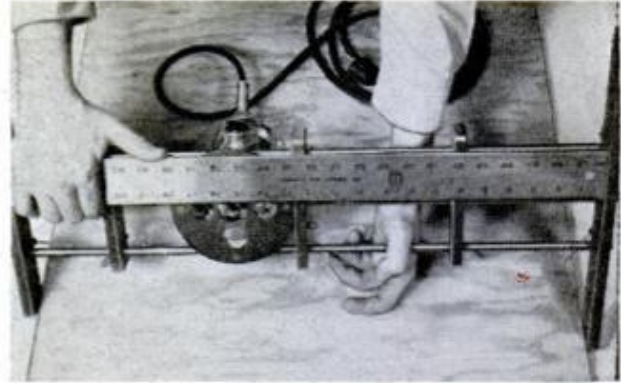

**5. TO SET** for spaced cuts measure from face of datum bar to side of router bit. Then lock coupling bar

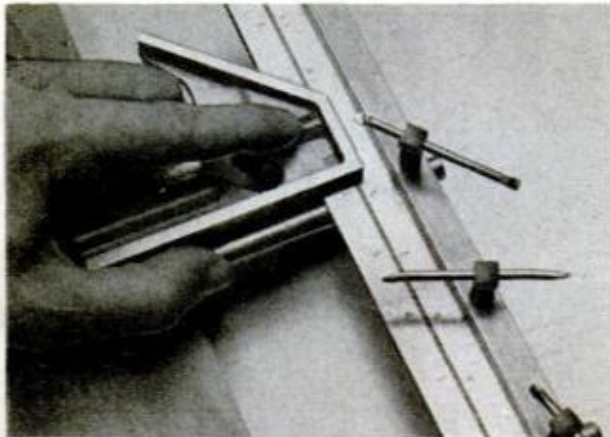

**6. DATUM BAR** should be set square with guide rods then locked to guide bars. Normally it is not reset

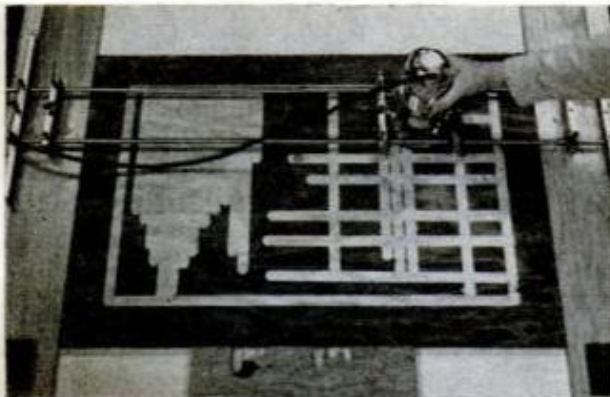

**7. HERE** router is supported clear of recessed surface by second coupling bar attached to handle boss

**8. NOTCHED GUIDE STRIPS** are used to hold work for diagonal spaced cuts. Slide supports ride guides



In use, make sure when you set the datum bar, or stop, that it is square with the rods, Fig. 6. Once set, it normally is not changed. Then to run a cut a given distance from the inner face of the datum bar you simply measure the required distance from the face of the bar, which rides the edge of the workpiece, to the side of the router bit nearest the face of the bar as in Fig. 5. Then bring the locking bar up to the opposite edge of the stock and away you go.

When making parallel cuts  $2\frac{1}{2}$  in. and less from the edge of the work, the width of the work must be increased by placing 3-in. fill-in strips along each edge, Fig. 7, to provide additional crosswise travel of the router, for the stop and datum bars to ride. Here also you will note that the router itself is supported above and clear of the surface by a second coupling bar, Fig. 2, which is attached to the opposite side of the router base. As detailed, the second coupling bar not only is drilled to travel on the guide rods but is drilled at an angle near the edge for a screw which is turned into the tapped boss which holds the router handle. Guide strips also are used for the job pictured in Fig. 8. In this instance the guide strips are notched to take the diagonal corners of the work. In Fig. 9 spaced dados are being worked in two directions. ★ ★ ★

**9. SPACED DADOES**, run in two directions, complete a pattern on face of stock. Note that stopblock is used

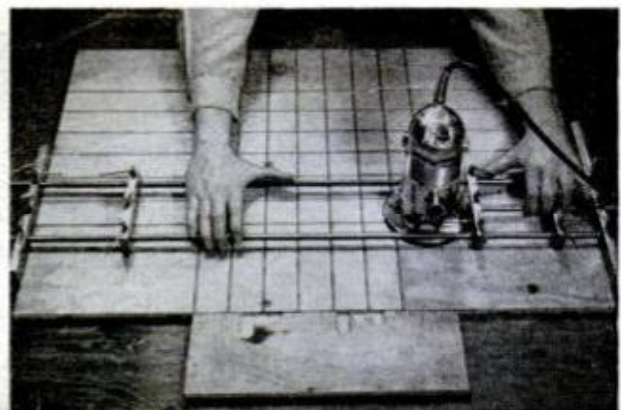



**DID YOU EVER** wonder why certain stories appear first in some magazines and are then seen later in others? Here's a good example:

One of *Popular Mechanics'* editors had an idea for a new kit for PM readers. He discussed it with a manufacturer of electric guitars. The manufacturer was enthusiastic and, in less than three months, had pre-production models ready.

The manufacturer now has a new product, PM has another exclusive story and readers can obtain a fine electric guitar by assembling it from a kit. The guitar is equal in every way to a commercially manufactured \$75 instrument.

The kit is easy to assemble as the body comes cut, glued, sanded and presealed.

The white plastic border on top and bottom is already installed, and all that is left for you to do is finish and assemble. Use the three large screws to attach the prefinished neck and fingerboard. Mask the fingerboard and either lacquer, enamel or varnish the presealed wood to your own taste. Attach the prewired controls and pickup along with the plectrum shield. Assemble the patent head, the tailpiece and the bridge. Add the strings, tune up and you are ready to plug into any amplifier, tape recorder or phono, and play. If you want to hear real quality, plug it into the magnetic phono input of your hi-fi. The electric guitar is available at \$41.80 from McMurray Music, 10201 Page Blvd., St. Louis 32, Mo.

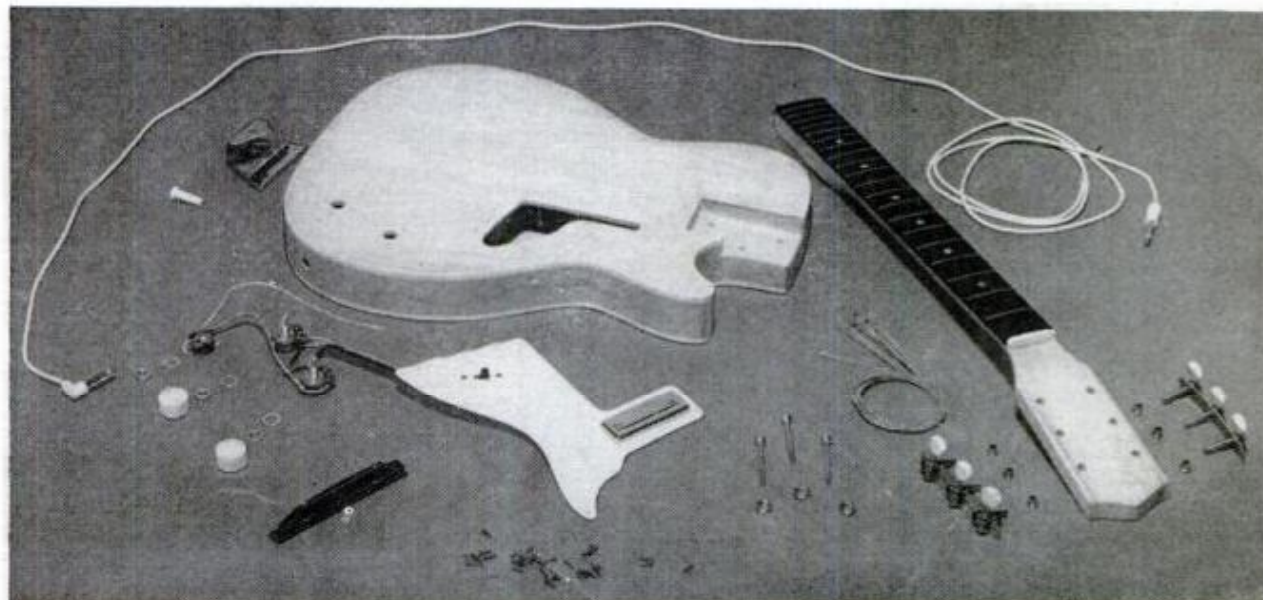

# Outdoor Antenna for Fallout Shelter

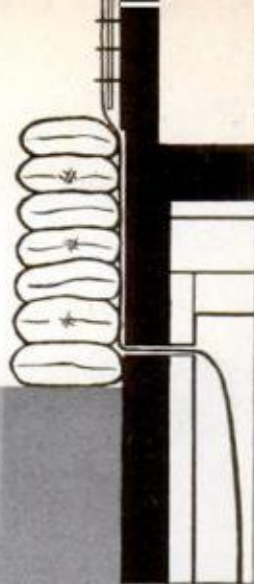
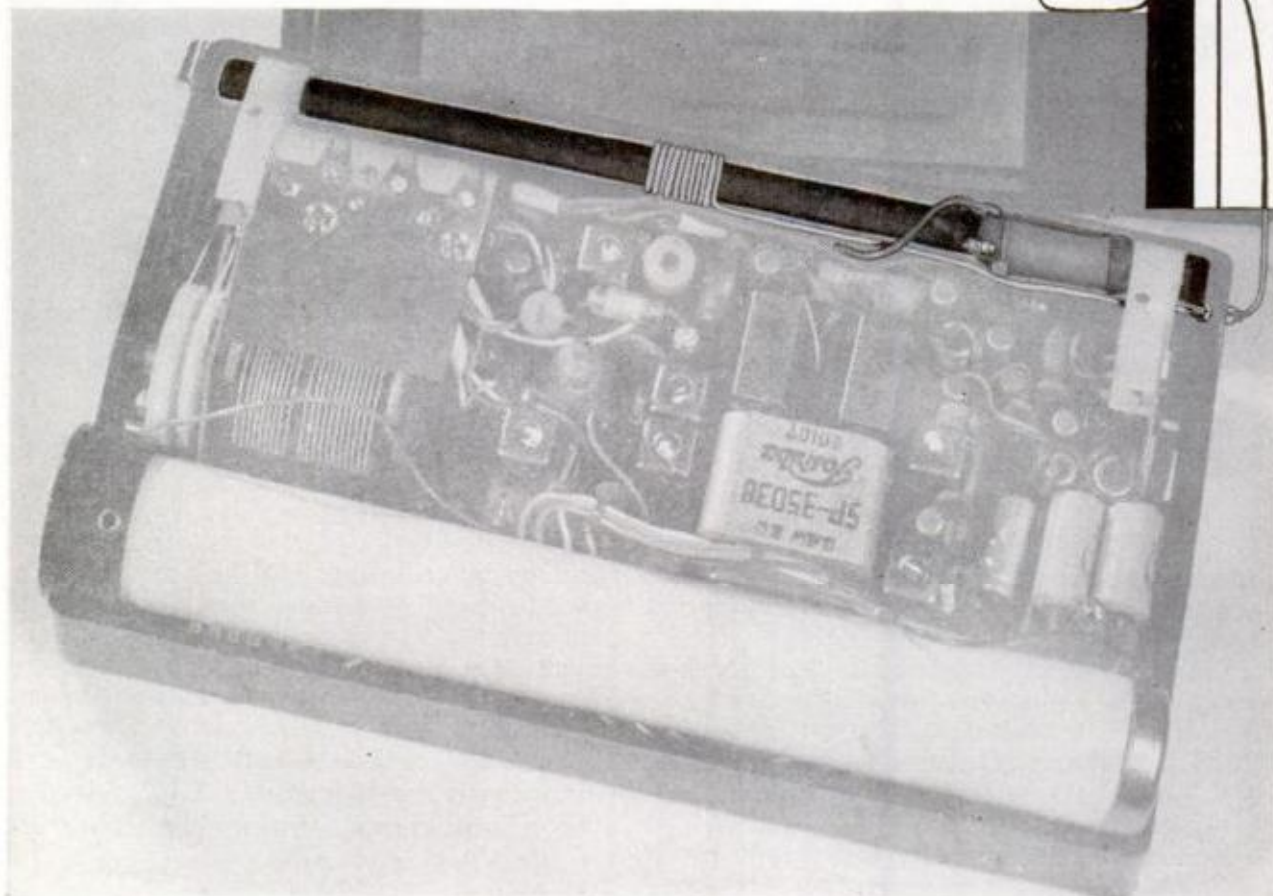

A SHELTER which shields you from fallout may also shield a good part of those important Conelrad civil defense announcements—your key link with the outside world.

The Office of Civilian Defense and Mobilization has suggested an outdoor antenna system using a loop antenna to transfer maximum signal to the indoor radio. While this will work very well with older radio sets using flat loop antennas, if your radio is a transistor type with a ferrite rod antenna, there's a better way of beefing up reception.

Form a coil of enamel-insulated wire, about 18 gauge. The coil should contain five to ten turns of wire and use a few drops of polystyrene "Q" dope or plastic cement to hold the coil in shape. Connect one lead from the coil to a small phono jack which you mount at the side of the case.

Bring your outside antenna wire into the shelter and plug it into the jack. Turn the radio on and tune to a weak station, as close as you can to either 640 or 1240 kc., which are the Conelrad civil defense frequencies. Slide the antenna coil along the ferrite rod until you hear an increase in volume. At this point, fix the coil to the rod with a drop of cement.

This improves transistor radio reception, whether the radio is used for a fallout shelter or a playroom. The single connector can easily be removed so you do not sacrifice portability. For sets with flat or oval ferrite antennas, make the coil slightly larger, and squeeze to fit. ★ ★ ★

When your TV picture begins to look dim, remove the front from the set and clean the tube face and glass shield with a wax-free spray type glass cleaner.

# Everyone Needs a . . . . .

Are your bills still due from three months ago? Is the boss glaring at you whenever he walks past your desk? Wife threatening to leave? Relax. Build a panic button!

This fun-for-all gadget uses a bicycle horn, or you can take a battery-operated fire alarm apart to get the horn-bracket-battery combination, as we did for this one. The entire assembly fits neatly into a miniature cabinet box, with the horn exposed at the front. The doorbell switch mounts on top. When things get too deep, simply push the button. The result is a loud, albeit sympathetic "BLAA-AA-AAT"!

Measure the required front hole for the horn, and after punching this hole, set the bracket for the 1½-volt flashlight battery in place. This is mounted through the bottom with two screws. The button is wired through a small hole in the top, and using the case as ground, only one wire needs to be passed through.

When the unit is completely wired (see diagram right) place it on the corner of a desk and watch while your visitors enjoy the fun.

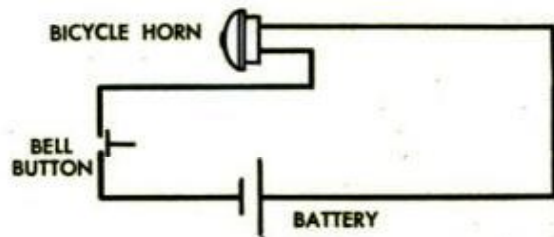

---

## Wall-Mounted Loudspeakers

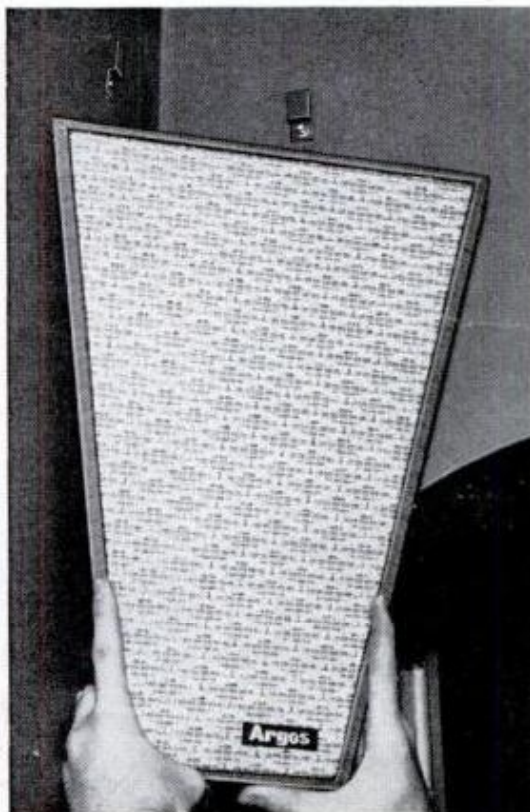

Many technicians will recall the problem of installing wall-mounted speaker enclosures. You had to work on a ladder, often with hot soldering iron clenched between your teeth while you struggled with screwdriver and balky bolts.

The new clips shown here mount on the wall first, using the pattern sheet as a guide. After the clips are secured in place, the cabinet itself is carried up the ladder and slipped over the clips. Simply pull it down to secure. After the speaker has been mounted to the inside of the front grille, it is wired and then the lead is brought above and behind the enclosure. Slip the top of the grille into its notch, press the bottom in place and fasten the one wood screw which holds it all together.

The units are available in a wide assortment of styles and sizes. Argos Products, Genoa, Ill.

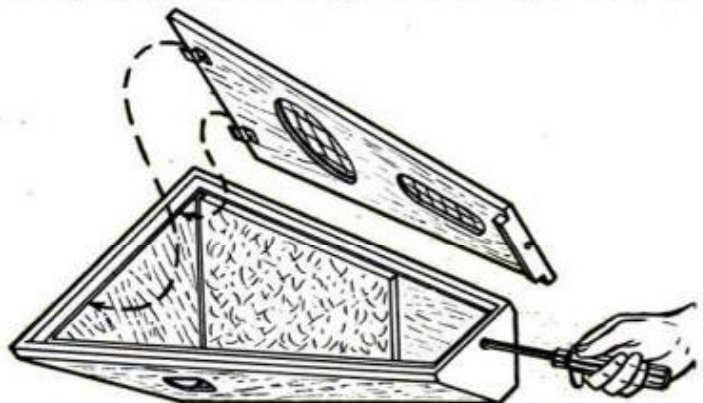

# Electronically New



**CHANGE YOUR TV ANTENNA** rotator from manual to fully automatic operation. Device is installed by transferring three wires and cutting and taping the fourth. When you set desired direction, antenna follows. \$32.95, Channel Master, Ellenville, N. Y.



**NEW MAGNETIC RING** is fitted to earpiece of hearing-aid eyeglasses. Permits user to remove glasses easily in only two seconds by decoupling from the earpiece. Ring disconnects from earpiece which remains in ear. Zenith Radio, 6001 W. Dickens, Chicago

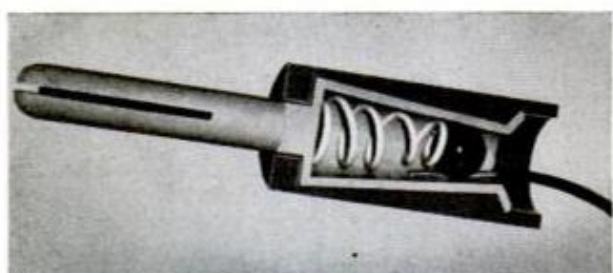

**CONNECTOR FROM GERMANY** utilizes conical aperture with metal ball and coiled spring. Press the wire into rear hole to make contact; spring and ball hold wire in place. Insert toothpick or pencil to release. Kaye Text Products, Lichtenstein, Germany



**PEOPLE DEPRIVED OF THEIR VOCAL CHORDS** due to operations need not be embarrassed. What appears to be a high-grade pipe contains a voice generating circuit, which "pipes" the sound through the stem and into mouth. Ticchioni, 14 Durini Street, Milan, Italy

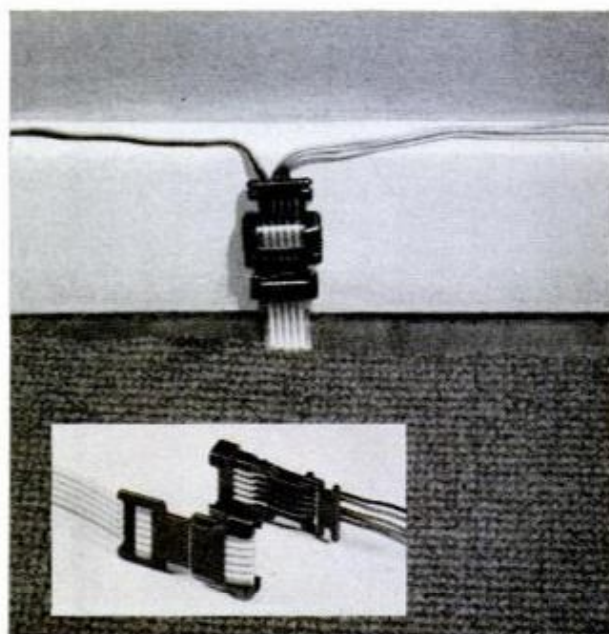

**DID YOU EVER** try running wires under a rug? The unsightly bulge that usually results can be eliminated by use of flat, multiple ribbons and adaptors to connect to regular wires. Great for your stereo speakers. Thomas & Betts, Elizabeth, N. J.

# YOU'RE ALWAYS READY TO DO A BETTER JOB

With a Weldwood Fix  
and Finishes shelf  
in your workshop

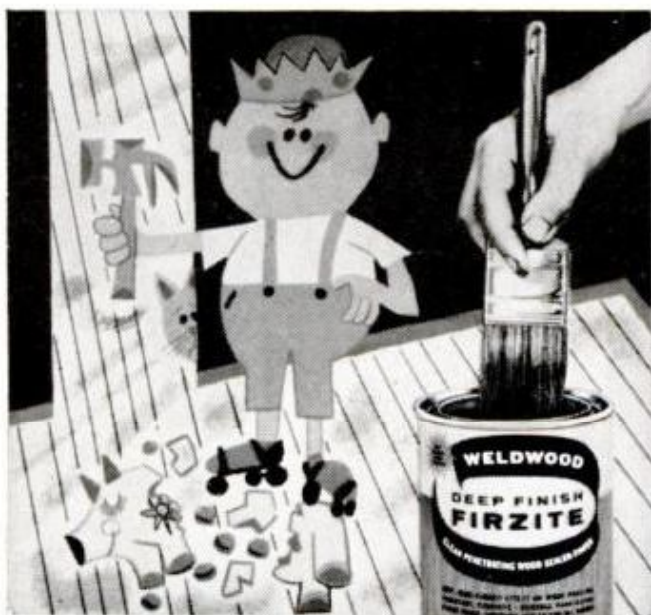

**Super-tough floor finish.** New Weldwood Deep Finish Firzite® penetrates the wood fibers producing a low-luster finish with outstanding resistance to wear, moisture, and stains.



**For a bond that holds!** Weldwood Plastic Resin Glue makes joints even stronger than the wood itself. Mixes instantly, is water-resistant. Bonds leather, hardboard, plastics, too.



**Hide scratches** with crayon-like Weldwood Putty Sticks®. You can fill nail holes and other wood blemishes after the wood has been finished and waxed. Assorted colors to match almost any finish.

Smart idea! Set aside a shelf in your workshop for the Weldwood® glues and finishes you'll need in the coming months. You'll save time and trouble—and do a better job, too—because you'll always have the *right* materials on hand when you need them. Suggestions: Weldwood Plastic Resin and Presto-Set® Glues, new Deep Finish Firzite, Satinlac® self-sealing natural finish, Weldwood Putty Stiks, and Flexible Wood-Trim® for edging plywood. At lumber yards, paint and hardware stores.

**FREE-8-PAGE BOOKLET!** "Professional Gluing And Wood Finishing Guide." For free copy, write: United States Plywood, Dept. PM 2-62, 55 W. 44th St., New York 36, N. Y.



*Products of United States Plywood*

Now  
you'll have to  
listen 17% harder  
to hear a  
Galaxie  
whisper



**Its silence whispers quality . . .** for there is no surer proof of the care with which a car is built than the quiet with which it runs. A decibel meter in the

front seat revealed a 1962 Galaxie is 17% quieter than last year; the built-in protection of twice-a-year—or 6,000 mile—maintenance insures it will *stay* quiet.



**How did America's quiet car get even quieter? It took a "tuned" frame, a nylon dot, a fiber sandwich—and new advances in Ford's new science of automatic quality.**

It is perfectly true that last year's Galaxie was so astonishingly quiet it made the \$10,000 cars of only a few years ago seem crude by comparison. But it also is perfectly true that *this* year's Galaxie is substantially quieter . . . 17% quieter in the front seat, 21% quieter in the rear seat.

No one big invention made the difference. These cars move like a silk banner in a summer breeze because hundreds of little things were improved, because Ford's quality control is now the highest in the industry . . . and because Ford has made silence *automatic* by ingenious design techniques.

A tiny blob of nylon is one example of this new approach. You see it illustrated on the finger at right: a "sleeve nut" that connects a rod and lever in the door latch. In 1961 this connection was made by a metal spring clip; no matter how carefully made or fitted there was always the possibility of wear . . . and a faint little vibration. Now the rod snaps into a hole in the soft nylon nut, the nylon snaps into the lever . . . and

there is no possibility of metal-to-metal contact.

We also have taken one of the largest things in a Galaxie, the frame, and "tuned" it by designing in a minute degree of flex. Thus it becomes a giant spring, over 16 feet long, that blots up road noises that get past tires, springs and shock absorbers.

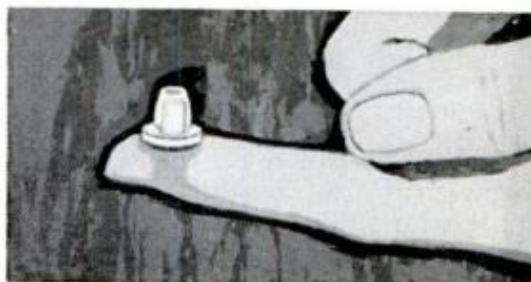

New nylon "nut" helps soundproof doors.

The "fiber sandwich" is a ½-inch thick batt of textile fibers that runs from the top of the toe board on down under the front seat. When you realize this is sandwiched between a double-ply layer of waffle felt deadener *and* a thick jute blanket *and* covered by the floor mat you stop wondering why any Galaxie engine is so hard to hear.

These are merely three examples from thousands, all devoted to the single aim of making a Galaxie quiet. It would take a library to tell the whole story, to even begin to sum up Ford's standards of craftsmanship . . . but the *result* is beautifully, silently obvious the moment you take the wheel.



# *Galaxie by Ford*

# CLINIC FOR HOMEMAKERS



As a service to our readers in solving the hundreds of problems pertaining to a home—inside or out—editors of Popular Mechanics invite you to present your problems to The Clinic Editor for help and advice. Address your questions to The Clinic Editor, Popular Mechanics Magazine, 200 East Ontario Street, Chicago 11, Ill.

## Oil Stains on Concrete

**Q**—We use our garage as a playroom for the children when the weather is bad, but they get into the grease and oil on the concrete floor. Is there an easy way of removing these stains?—S. K., Mo.

**A**—You'll have to work at it, but here is one way of cleaning oil from concrete. If you need the floor only clean enough so the kids can play without ruining their clothes—and not spotless—your job will be simplified. Also, by removing the stains as soon as possible, the work will be easier.

With a wide scraper, remove the thickened crust of grease and dirt as best you can. This should be followed by a good scrubbing with a stiff brush dipped in gasoline (be careful to follow safety precautions). Then, the surface should be scrubbed again with detergent and warm water. Usually this treatment is all that's needed to clean a floor. But where appearance is important and the stain has penetrated deeply into the concrete, it will require more attention.

On deep stains, use a 10 percent solution of muriatic acid to scrub the remaining spots (avoiding contact with skin). And for those extremely stubborn blotches, use



the bandage method: Pads of absorbent cloth are saturated with chemicals, laid over the spots, and covered with glass. Finally, rinse with clear water.

## Too Much Humidity

**Q**—We own a new brick home with aluminum storms and aluminum windows. The windows are excellent, but in winter we have trouble with moisture collecting on the metal window frames. Water keeps running onto the sills. How can we correct this problem?—H. B., Penn.

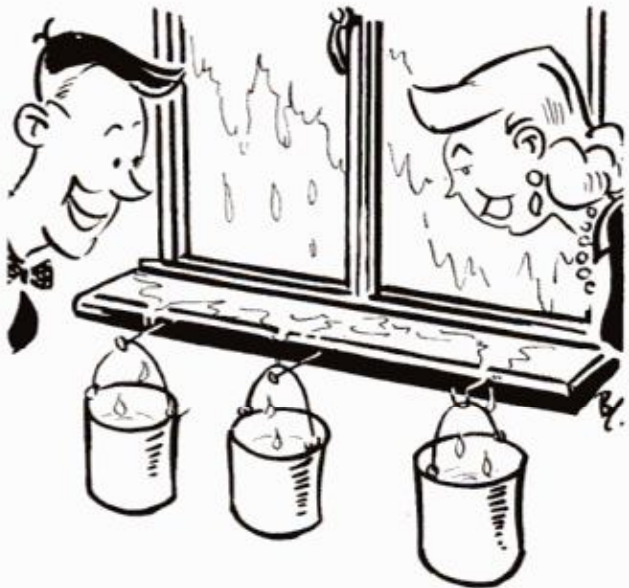

**A**—Unlike the loosely built homes of a few years ago, modern, tightly constructed homes with vapor-sealed walls and weather-stripped doors and windows are practically airtight. From such homes it's difficult for water vapor to escape. The dew-point temperature at which vapor condenses varies with the temperature and amount of water in the air. Condensation principle is illustrated by a sweating glass of ice water.

During winter, when outside temperatures are low, windows provide cold surfaces on which water vapor may condense. Condensation usually is confined to glass areas; but, when metal sashes are used, the inside surfaces have more of a tendency to sweat and frost than do wooden ones. Sweating should be a warning to reduce inside moisture.

The quickest way of reducing water vapor is to open a few windows. Exhaust fans installed in kitchen, utility, and bathrooms, however, are the most satisfactory method of ventilating, especially during the winter. The second way is to eliminate some of the sources of water vapor. Bathing, washing, and cooking produce most of the vapor within a well-constructed house. Finally, an electric dehumidifier is a highly efficient way of reducing water vapor. ★ ★ ★

# GRAVELY & YOU—power partners!



**GRAVELLY**  
doesn't give  
up  
when the  
going gets  
tough!



Performance—Power (6.6 hp)—Productivity . . . that's what your Gravelly power partner gives you. The satisfaction of seeing your place kept perfectly, the garden green and growing clean . . . every tough job licked with power! You'll be proud of your partner, proud of your place, proud of yourself.

You get performance. No pushing, pulling or pampering. You just ride it or guide it. Your Gravelly partner powers 30 different tools and attachments. Tools designed for maximum power and performance at the job. When you have a Gravelly, you get the job done better, faster, easier. (Optional electric starter, too.)

Get the facts before you buy—from Gravelly's big 24 page "Power Vs. Drudgery" booklet. See how Gravelly proves it's best for you before you buy! Write now!



ROTARY  
MOWER



SNOWBLOWER

## GRAVELLY TRACTORS

DIVISION STUDEBAKER-PACKARD CORPORATION

P. O. BOX 601-B

DUNBAR, W. VA.



Sold & Serviced by Authorized **GRAVELLY DEALERS**—our 40th year!

**Skilled  
Machinists  
Prefer  
South  
Bend**

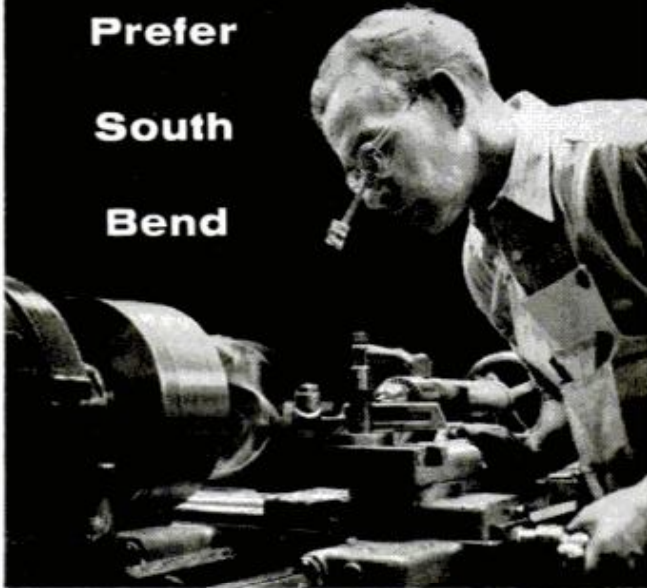

Photo from Learcal Division, Lear, Inc., Los Angeles

The day of the precise craftsman is not past. You should see how some of the nations finest workmen go about doing their jobs with painstaking accuracy.

Such accuracy is absolutely vital in the manufacture of many of the precision components that make this "Space Age" possible.

To get the accuracy and fine finish so necessary on precision parts, skilled machinists choose South Bend 16" Lathes.

- Dependable—Trouble-Free
- Spindle bearings designed specifically for precision work.
- Quiet running—No Vibration—No Gear Marks—Delivers parts with extremely fine finish.

Prices of South Bend 16" Lathes start at \$2591 f.o.b. factory

Write for catalog of South Bend Lathes, Milling Machines, Shapers, Drill Presses and Pedestal Grinders

# SOUTH BEND

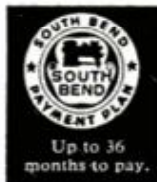

## LATHE

**SOUTH BEND 22, INDIANA**  
BUILDING BETTER TOOLS  
SINCE 1906

## Danish-Style Metal Furniture

(Continued from page 159) •

hardboard doors and the interior of the cabinet are sprayed white, after which regular aluminum door track is installed. Screws driven from below through holes in the steel angle anchor the desk top in place.

After cutting the plywood panels for the arm chair and ottoman, Figs. 3 and 4, fasten the chair back to the seat with 2-in. angle brackets. Then add the sheet-metal side supports to opposite edges of the chair back to align with the holes in the arm rails. Upholstering the chair and ottoman is comparatively easy, both being fitted with foam-rubber cushions. In the case of the chair, seat and back cushions are worked up separately, then attached to the panels. When cutting the 2-in. foam rubber, add an extra inch all around to allow for compressing. The original cushions were made of a plastic fabric called Naugahyde and require 2 yards, 54 in. wide. Measure and cut the fabric to the sizes given, Fig. 6, and sew the welt cord into the seams in the manner detailed in Fig. 5.

### Cotton Added First

Begin actual upholstering by adding cotton batting to the rear side of the chair back, stapling or tacking it here and there to hold it in place. The chair and the ottoman require about 3 yards of cotton batting. Next place the foam rubber in position and cover with a layer of cotton. Follow by the cushion cover and staple the back flap across the lower edge of the plywood panel. Do not fasten the lower outside flap at this time. The seat is upholstered in much the same way. Staple the rear flap across the rear edge of the seat panel, place the foam rubber in position and cover with cotton. Pull the cover on over the cotton, check for low spots and add more cotton where necessary. Finally, staple or tack the cover and as a last step draw the lower flap of the back cover under the seat and tack, Fig. 2.

To add the cushions to the chair, punch holes through the fabric where it covers the sheet-metal side supports and attach to the arm rails with  $\frac{3}{16}$ -in. machine screws turned into 10-32 Tee nuts. After this, turn the chair upside down and attach the seat cushion to the seat rails with round-headed wood screws. Finally, the prefinished walnut chair arms are attached with screws.

The ottoman, detailed in Fig. 4, can be made to serve also as a small coffee table by having an extra top handy to replace the cushion. In either case, the cushion, as well as the extra top, merely rest in the recess of the steel-angle frame. The extra top can be covered with laminate. ★ ★ ★

# AConomize on Gasoline

Get more miles per dollar—install an AC ACon-O-Mizer between your fuel pump and carburetor. Reduces flooding and stalling . . . tailors fuel pressure—precisely and instantly—to every driving condition from idle to full throttle. The best answer yet to real gasoline economy!

suggested retail price

**\$7.95**



At Your Nearby Service Station, garage or General Motors Dealer

**ACon-O-Mizer**

AC SPARK PLUG  THE ELECTRONICS DIVISION OF GENERAL MOTORS

## KROIL LOOSENS RUSTY FROZEN PARTS



Frozen bolts, pipe threads, bearings, etc., yield to Kroil, the chemical lubricant that creeps into millionth inch spaces, dissolves rust and dried grease. Harmless to metal or skin — used by 25,000 shops for 20 years. Now available in half-pint spout cans, 65c at your dealer.

LABORATORIES, Nashville 11, Tennessee



### Before You Buy a Power Tool ...

SEND FOR 180 PG. FACT-PACKED BOOK . . . "HOW TO CHOOSE AND USE POWER TOOLS." One quarter invested now can pay big dividends. Let an expert show you how to get the best results at the least cost. Send 25c today: The Black & Decker Mfg. Co., Dept. D-022, Towson 4, Md.

## King Midget FOR 1962

Drive it for 75c a week.

Rider Agents Wanted. Send 25c for 32 page book, full details, dealer price. Or send \$1 (refunded first order) for this plus Service and Repair Manual and 16 5x7 photos of car and factory.



WORLD'S MOST EXCITING LOWEST PRICED CAR

MIDGET MOTORS CORPORATION, Athens 1, Ohio

## OUTWORKS THEM ALL



Pat'd. & Pats. Pend.

Prepares the toughest soils in one operation. All-purpose tiller-tractor tills to 12" deep -12" to 40" wide. Chain drive delivers equivalent of 2 extra hp! 4 models; rotors, tractor tools for all jobs and soil conditions. Optional reverse. Send for details.

## MERRY TILLER

Northern Life Building, Box 1829, Seattle 11, Wn.

# CRESTOLOY MINIATURE PLIERS

with BOX JOINTS

ROUND NOSE

No. 21

CHAIN NOSE SIDE CUTTER

No. 622

No. 22

SHORT CHAIN NOSE

No. 942

DIAGONAL CUTTER

Forged from CRESTOLOY Steel, these fine pliers have precision-fitted box joints that assure perfect jaw alignment and smooth operation under long, hard usage. Excellent balance, combined with broader handles reduces worker fatigue. All are electronically hardened. Cutting pliers have tested edges. Finished with polished heads and gun metal handles.

Sold by hardware dealers everywhere

**CRESCENT TOOLS**

*Give Wings to Work*

Crescent is our trade-mark, registered in the United States and abroad, for wrenches and other tools. Sold by leading distributors and retailers everywhere and made only by

**CRESCENT TOOL COMPANY, JAMESTOWN, N. Y.**

## Triple-Top Fun Table

(Continued from page 180)

the nuts up tightly. Now drill  $\frac{3}{4}$ -in. holes on the center line penciled on the bottom of each end cabinet. These holes take the studs as in Fig. 34 and must be located so that when the caster is in place, the outer edge of the plate will be  $\frac{1}{4}$  in. in from the edge of the cabinet. Locate the casters with brakes on opposite corners to prevent the table from moving while play is in progress.

Four table levelers are necessary to assure a perfectly level pool-table bed. These

### MATERIALS LIST

(All dimensions actual sizes in inches)

- 2 pcs.— $\frac{3}{4}$  x  $13\frac{1}{4}$  x  $35\frac{1}{2}$ —Base of end unit
- 4 pcs.— $\frac{3}{4}$  x  $14$  x  $20\frac{3}{8}$ —Sides of end unit (2 R. and 2 L.)
- 2 pcs.— $\frac{3}{4}$  x  $11\frac{3}{4}$  x  $20\frac{3}{8}$ —Center divider
- 4 pcs.— $\frac{3}{4}$  x  $11\frac{3}{4}$  x  $17\frac{7}{8}$ —Shelves—end unit (2 R. and 2 L.)
- 2 pcs.— $\frac{3}{4}$  x  $2\frac{3}{4}$  x  $35\frac{1}{2}$ —Face spreader for end unit
- 4 pcs.— $\frac{3}{4}$  x  $\frac{3}{4}$  x  $2$ —Corner blocks—end unit
- 2 pcs.— $\frac{3}{4}$  x  $2$  x  $34\frac{3}{4}$ —Back strip, upper-track assembly (end unit)
- 2 pcs.— $\frac{3}{4}$  x  $1\frac{1}{4}$  x  $34\frac{3}{4}$ —Upper grooved track—end unit
- 1 pc.— $\frac{3}{4}$  x  $36\frac{1}{4}$  x  $52\frac{1}{4}$ —Center-unit base
- 2 pcs.— $\frac{5}{8}$  x  $20\frac{1}{4}$  x  $33\frac{1}{4}$ —Center-unit sides (1 R. and 1 L.)
- 1 pc.— $\frac{5}{8}$  x  $33\frac{1}{4}$  x  $51\frac{1}{2}$ —Center-unit shelf
- 1 pc.— $\frac{5}{8}$  x  $7\frac{1}{8}$  x  $51\frac{1}{2}$ —Center unit—long divider
- 2 pcs.— $\frac{5}{8}$  x  $7\frac{1}{8}$  x  $16\frac{7}{16}$ —Center unit—short dividers
- 2 pcs.— $\frac{3}{4}$  x  $2\frac{3}{4}$  x  $52\frac{1}{4}$ —Face spreader, upper track, center
- 2 pcs.— $\frac{3}{4}$  x  $2$  x  $52\frac{1}{4}$ —Back strip, upper track, center unit
- 2 pcs.— $\frac{3}{4}$  x  $1\frac{1}{4}$  x  $52\frac{1}{4}$ —Upper-track strip, center unit
- 1 pc.— $\frac{3}{4}$  x  $2$  x  $33\frac{1}{4}$ —Spreader, center unit
- 8 pcs.— $\frac{3}{4}$  x  $1\frac{1}{2}$  x  $2$ —Corner blocks, center unit
- 4 pcs.— $\frac{1}{8}$  x  $17\frac{3}{8}$  x  $26\frac{1}{2}$ —Doors for leg cabinet
- 4 pcs.— $\frac{1}{8}$  x  $17\frac{3}{8}$  x  $17\frac{3}{8}$ —Doors for center cabinet
- 16 — $\frac{1}{4}$  x  $10$  F.H. wood screws (fasten units together)
- 8 — $\frac{3}{4}$  x  $10$  F.H. wood screws (table levelers)
- 4 — $2$  x  $\frac{1}{4}$  x  $20$ —R.H. stove bolts (levelers)
- 8 —Hex nuts for  $\frac{1}{4}$ — $20$  bolts (levelers)
- 4 — $\frac{5}{8}$  x  $2\frac{1}{2}$  x  $2\frac{1}{2}$ —Steel corner plates (levelers)
- 4 — $\frac{3}{4}$  x  $8$  F.H. wood screws (strike plate, levelers)
- 4 —Spring tool holders—2 for  $1\frac{1}{4}$  D. and 2 for  $\frac{1}{2}$  D. (cue holders)
- 4 —R.H. wood screws—2 ·  $1$  x  $10$  R.H. 2 ·  $\frac{5}{8}$  x  $8$  R.H. (cue holders)
- 4 —Rubber or plastic-wheel casters (two with brake)
- 4 —Clothesline hooks (casters)
- 4 —Lock washers (caster stud)

are made from L-shaped steel mending plates (inside-corner type). Cut a 1-in. length from one leg of each plate and bend a  $\frac{1}{4}$ -in. lip on one end of each of the cut pieces. Run a nut on each of four  $\frac{1}{4}$  x 2-in. stove bolts. Enlarge the hole in the short leg of each of the mending plates. Pass the stove bolt through the enlarged hole. Run a second nut down on the bolt and solder (or attach with epoxy cement) the second nut to the plate. This latter assembly is attached to each side of each leg cabinet on the center line and about 1 in. below the lower

edge of the table side rail as in Fig. 35. Then attach the strike plates to the edges of the side rail directly above the end of the stove bolt and you end up with four assemblies like that in Fig. 35 which enable you to level the table easily.

Cues are stored under the ball tunnel as in Fig. 33. Spring tool clips are attached to the bottom of each ball tunnel at the positions indicated, the larger clip at the high end and the smaller one, which holds the cue tip, 40 in. distant.

Use  $\frac{1}{8}$ -in. perforated hardboard for the sliding doors. In laying out, remember to evenly space the holes from the outside edges, Fig. 31. Note the variations in sizes of the doors. Locate and drill two  $\frac{3}{4}$ -in. finger holes on each door. Smooth and slightly round all edges. In a final installment next month you will be told how to make the flip-over piggyback top which serves as a table-tennis table on one side and a model-railroad layout on the other. Complete painting and finishing instructions also will be given.

## Spacemen Will Be Mechanics, Not Dashing Adventurers

Man will play second fiddle to machines in the Space Age.

"Instrumentation systems which will be built up to perform vital space functions will become so complicated and expensive that we will need men in the very inglorious role of a maintenance and repair man for complex television and communication satellites, or to the complex astronomical observatories in space," says Dr. S. F. Singer, University of Maryland physicist.

After all, he said, man is "the only non-linear, 150-pound servomechanical system which can be mass produced by unskilled labor."

## "Flies" Planes on Ground For Instrument Check

By simulating flight conditions and correcting and calibrating an aircraft's instrumentation before takeoff, an analog-to-pressure converter insures near-perfect altimeter and airspeed readings once the plane is airborne.

Previously, the lowest margin of error achieved by such testing was .3 percent. The new Moletronics APC unit reduces this margin to .025 percent.

Usable on both commercial and military aircraft, the new safety device is no larger than a week-end suitcase. It also has potential in other industries.



PERFECT CIRCLE PISTON RINGS ARE INSTALLED AS ORIGINAL  
FACTORY EQUIPMENT IN 94 BRANDS OF VEHICLES AND ENGINES

## WHY THE "PROS" PREFER PERFECT CIRCLE PISTON RINGS

The superior craftsmanship that goes into Perfect Circle piston rings pays off in longer lasting oil control. Leading vehicle and engine manufacturers, race drivers, fleet operators and mechanics the world over have proved it in billions of miles of use.

Perfect Circle oil rings are plated with thick, solid chrome to protect them against wear. Uniformly applied tension is additional assurance of extended, positive oil control. Special design provides unobstructed drainage which resists clogging. And, Perfect Circle rings are made to a standard of precision that's measured in millionths of an inch.

To bring back the oil control and power your engine delivered when it was new, visit your Doctor of Motors—your skilled mechanic. He'll respect your judgment when you ask for the rings the "pros" prefer—Perfect Circle.



**PERFECT *PC* CIRCLE**

PISTON RINGS • PRECISION CASTINGS • SPEEDOSTAT  
ELECTRONIC PROGRAMING EQUIPMENT  
HAGERSTOWN, INDIANA • DON MILLS, ONTARIO, CANADA

**THE DOCTOR  
OF MOTORS—**  
your skilled mechanic  
—is the "pro" to  
see to get superior  
Perfect Circle  
performance

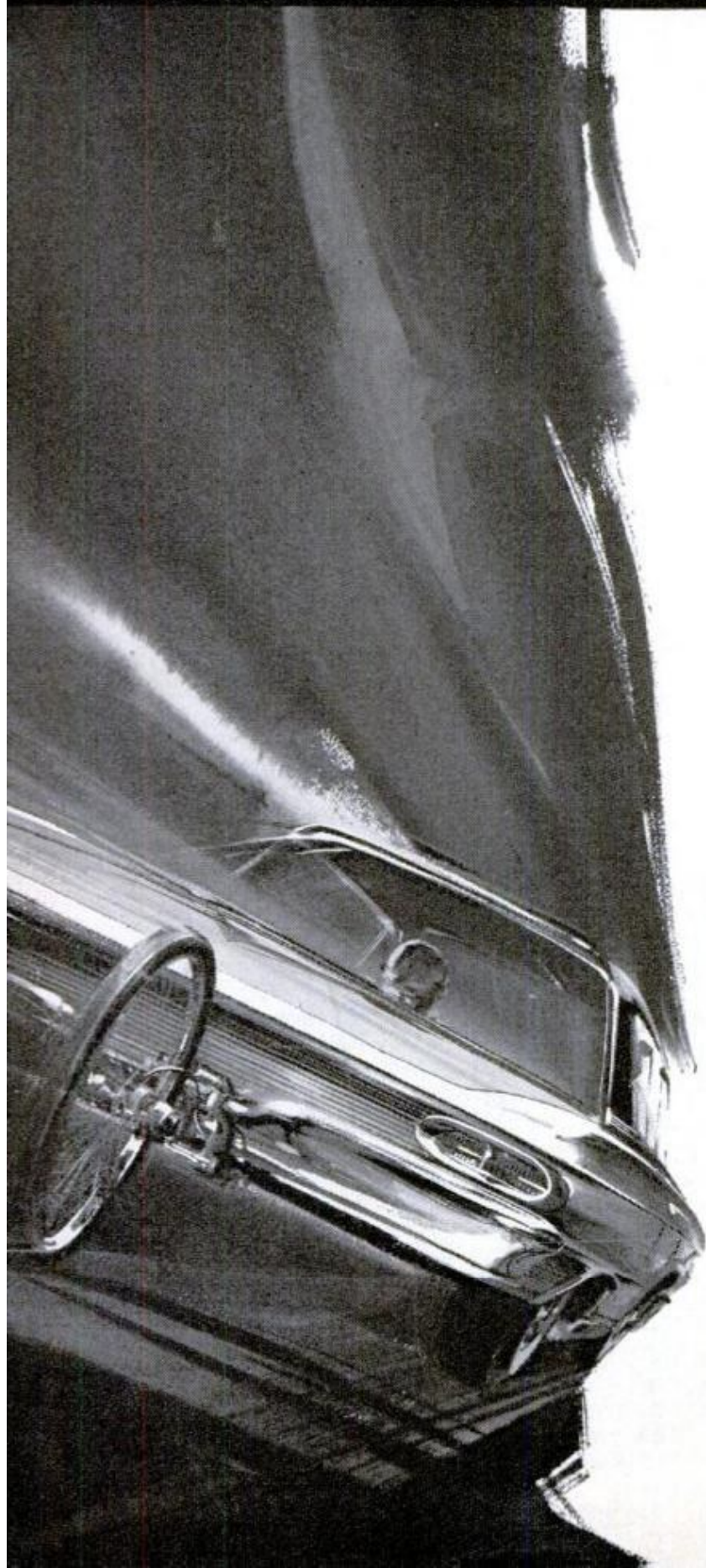

## Space-Age World's Fair

(Continued from page 104)

One exhibitor will display an ion emission microscope so powerful that a mass consisting of only nine atoms can be detected. Magnified to the same degree, the head of a pin would cover two and a half square miles! Another exhibit is planned to demonstrate the use of air walls to provide indoor comfort in outdoor living spaces. Others include closed-circuit TV systems by which you can play chess with a distant opponent, full-wall TV screens, and heating devices woven into rugs or installed in the walls of a room.

Some of these exhibits will be displayed in the cubed facades of a "floating city" suspended inside Coliseum Century 21, a four-acre building whose massive 11-story roof has no interior supports. Entering the coliseum at ground level, visitors will ascend in a 100-passenger "bubble-ator" to the exhibit area, then stand on moving sidewalks that carry them past the displays.

### ... Even a Space Trip

An awe-inspiring spectacle never before created will be a simulated trip through a portion of the universe, a two-billion-light-year "travelogue" condensed into a 12-minute show.

Spectators on the ride through space will stand inside a dome 78 feet in diameter and 39 feet high that serves as a motion picture screen completely surrounding the viewers. In effect the spectators will be on board a space ship and will watch the earth recede from them as the ship slides past the moon on a "ride" through intergalactic space and other star systems. This spacearium color film will be a combination of regular photography, animation and stop motion. The film is projected to all sides of the dome by means of an ultra-wide-angle lens system that is mounted on top of a projection booth centrally located on the spacearium's floor. Floor slants in one direction to help focus attention on the central point of the show.

The spacearium structure is one of several buildings that make up the United States Science Pavilion, the \$9 million complex sponsored by the Federal Government. In the first building, the House of Science, visitors will watch a film that traces the history of science and shows how modern scientists perform their tasks.

The second building contains exhibits that show the development of science, different aspects of nature, the role of mathematics and, finally, the classic experiments on which modern science is based. The

third building, Vistas of Space, contains the spacearium. Next comes the Methods of Science building, in which are shown modern scientific methods. Next, the Horizons of Science depicts the ways in which science fits in with civilization.

Still another part of the Science Pavilion is a laboratory in which visitors will be guided in performing their own scientific experiments. The final structure is a science theater in which popular scientific lectures and films will be presented.

### Something for Everyone

Century 21 Exposition is to have numerous other attractions aside from those of science. A fine arts exhibit has been assembled that includes 70 of the most famous paintings and art objects owned by top U.S. and Canadian museums. Famed orchestras, ballet companies, theatrical productions and individual artists from many nations will perform. To house these performances, an 800-seat playhouse and a 3100-seat opera and concert hall have been built.

Other entertainment, in a 5500-seat arena and a 12,000-seat stadium, will include performances by the Mexican Motorcycle Police team and in which spectacular sharpshooting exhibitions will be given, kite fighters and boxers from Thailand, the Voladores de Papantla of Mexico who swing from the top of a 100-foot pole, Chinese acrobats and the Royal Canadian Mounted Police.

Like all other fairs, Century 21 Exposition will have a gayway amusement area. A sky wheel, a bobsled ride, a Le Mans sports car course and a score of other thrilling entertainments will be available in the four acres given over to the fun zone. Off-shore, the famous French line *Liberte*, will serve as a floating hotel for 1500 people.

### City Prepares for Crowds

Seattle expects that more than five million people, possibly twice that number, will visit its World's Fair this year. Among them will be the finalists from thousands of high school contests entered in the annual National Science Fair competition. If you plan to visit and want to know more about it, write to Public Information, Century 21 Exposition, Seattle 9, Wash.

The permanent structures that have been built for the fair—90 percent of the planned construction—will comprise Seattle Center when the Fair is over. It is expected that they will still be in use when the 21st Century actually rolls around for, after all, it's only 38 years away. But you can get a preview in Seattle this year. ★★★





PRUNING TO DO?  
Spray On New **STANLEY PRUNING PAINT** and **WOOD PRESERVATIVE**



PAINT-HARDENED BRUSHES?  
Spray On New **STANLEY BRUSH SOFTENER** and **PROTECTOR**



WINDOWS STICKING?  
Spray On New **STANLEY SLIDE LUBRICANT**

## JUST SPRAY 'EM ON . . .

Hundreds of uses  
for home and shop!



GREASY MOTORS?  
Spray On New **STANLEY DEGREASER** and **CLEANER**



NEW CAR?  
Protect Trim With New **STANLEY CLEAR PLASTIC LACQUER**



RUSTED SCREWS, NUTS, BOLTS?  
Spray On New **STANLEY RUST PENETRATOR**



GLUE WON'T DO?  
Spray On New **STANLEY SPRAY ADHESIVE**. Sticks On . . . Peels Off



RUSTY TOOLS . . . GUNS?  
Spray On New **STANLEY ANTI-RUST OIL**

# NEW STANLEY CHEMICAL TOOLS

Each of these new Stanley Chemical Tools will do dozens of jobs around the home or shop . . . use them in the workshop, garage, outdoors. **JUST PRESS BUTTON** and **PRESTO** . . . the job's done! Quickly and conveniently. **ONLY \$1.39 EACH** at your hardware dealers.

**SEND FOR FREE SPRAY HANDLE—50¢ Value.** Converts any spray can to spray gun in seconds . . . keeps hands clean. Write, enclosing "Special Offer" sticker or Number cut from front of can label, to Stanley Tools, Division of The Stanley Works, 622 Elm Street, New Britain, Connecticut.

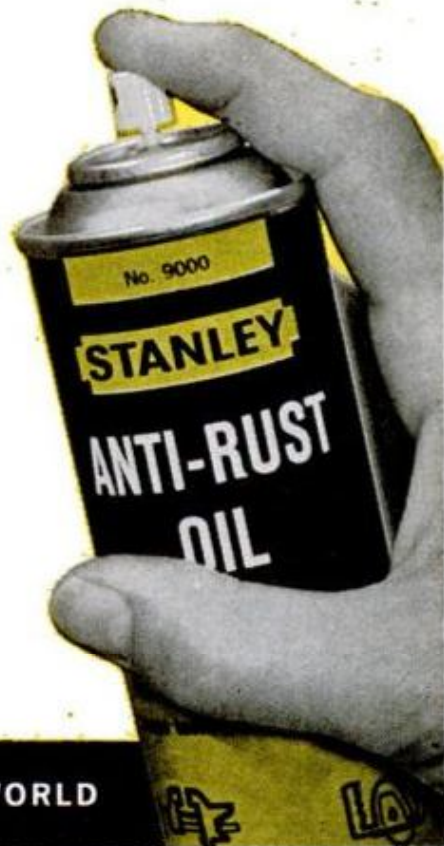

# STANLEY

THE TOOL BOX OF THE WORLD

# CRUISERS \$369 UP

CATALOG  
FREE

1/4 Down 2 Years to Pay

SAVE UP TO \$1700



20 FT. ISLANDER



22 FT. CARIBBEAN



## 22 FT. HOUSEBOAT-CRUISER \$699

Cruiser performance with houseboat space and facilities. V-bottom design. Planes with 40 HP to 20 MPH. Inboard or outboard power. 6 1/2 ft. headroom. Galley, toilet, lounge, sundeck. Sleeps 4 in comfort. Free catalog explains how anyone easily assembles this cruising houseboat.

## FIBERGLASS \$299 UP

RUNABOUTS 14, 16 FT.

WRITE TODAY

ASSEMBLE IN ONE EVENING

3 factory-molded sections interlock; bond into 1-piece molded fiberglass boat. Colors molded in. With Luger's patented method, anyone assembles boats exactly like factory-finished models in one evening. Brush and screwdriver only tools. A scientific triumph of simplicity and ease never known before in boat construction.



SAVE  
\$300 to \$500

FREE CATALOG



## PLYWOOD RUNABOUTS

40 MODELS, 8-16 FT.  
\$41.75 Up, Save 1/2-2/3

EASY  
PAYMENTS

styling. Equal factory-finished boats in appearance and performance. 8 ft. dinghy \$41.75; 12, 14, 16 ft. fishing boats \$59.95 up; Runabouts 12 ft. \$104 up, 14 ft. \$139 up, 16 ft. \$189 up. Also low mail order prices on fiberglass supplies, accessories, trailers, paint, hardware.

## FREE CATALOG LUGER BOAT KITS

Dep't. B-2, 9200 Access Road, Minneapolis 20, Minn.

ALL  
NEW!

## 150th Anniversary Issue! 1962 Edition of Constantine's WOODWORKING CATALOG & MANUAL

WOODS, TOOLS, HARDWARE, ETC.

Get the biggest Constantine Catalog & Manual—2,000 items! World's largest source since 1812 for rare imported and domestic woods in veneers, lumber, plywoods, bandings, inlays, mouldings, carvings . . . hard-to-find hardware, new solid brass hardware, wood finishing and upholstery supplies, patterns, tools, woodworking materials—at bargain prices! Also exclusive Inlaid-Wood-Picture Kits . . . Identification Chart of 60 rare woods in color . . . Inspiring projects, plans, etc. For all-new 1962 Catalog & Manual, send 25c for postage and mailing. Write today!

ALBERT CONSTANTINE AND SON, INC  
2050 Eastchester Rd., Dept. B-5  
New York 61, N. Y.

2,000 Items  
Greatest selection, inspiring ideas, low prices. Write for your copy now!

## Anglers Hit the Jackpot

(Continued from page 143)

now indicate summer temperatures may not rise as high in succeeding years. Even should the cooling trend persist, the effects of the warm-water years between 1957 and 1960 will still be sufficient to provide good fishing in 1962, far superior to that which existed before. Catches of the strictly tropical fish, like barracuda, may fall, but it will take several more years to dissipate the influence of the warmth completely.

### East Coast Prospects?

And what about the East Coast? Could similar currents here, shifting in some manner, bring about comparable changes? They certainly could, and with even more drastic results.

The Gulf Stream is usually considered a tropical affair, since it is most evident as it sweeps up out of the Caribbean and passes Florida. But, although its speed of four knots has dropped to the point that the main stream divides and meanders at Cape Hatteras, it is still a significant factor far to the north. In fact, its warmth helps create the great natural fishery at the Newfoundland Banks, where the current is still proceeding at 10 miles a day.

While still at a significantly higher temperature than the surrounding ocean, the Gulf Stream proceeds along the entire East Coast only a short distance offshore. The only thing intervening is a narrow counter-current called the Cold Wall by mariners and fishermen. If this cold current slackened or were overridden by the Gulf Stream, the coastal states here would be washed by water which is truly tropical. Fishing would become an amazing sport, both in the success ratio and the types caught.

Further, if this Cold Wall were somehow dispersed, exactly the same thing could happen here as happened on the West Coast—the warmer waters of the mid-ocean could move inshore, thus vitally affecting the whole situation. As for the Gulf Stream itself, Prof. J. Berknes of the University of California has found recently that this tremendous sea-going river has warmed five degrees in the last 60 years. The increase in the Stream's temperature since the turn of the century, according to Prof. Berknes, is directly related to the increase in the Bermuda High, a semipermanent high-pressure area located off these Atlantic islands. If this trend continues another few decades, its abundant tropical marine life will be carried farther and farther north.

Marlin fishing out of New York City? Not impossible. ★ ★ ★

CHOOSE A POCKET-SIZE

**Kirsten**  
"COMPANION"  
PATENTED "RADIATOR" STEM MEANS  
Cool Smoking!

**\$3.95**  
POSTPAID

WEIGHS ONLY 1 OUNCE!

WRITE FOR FREE CATALOG  
other pipes 5.00-7.50-10.00

Write to: **Kirsten** PIPE CO. Seattle 7, Wash. Dept. C

**BUY GREAT NECK HAND TOOLS**  
... for long-lasting performance

**Precision Balanced NAIL HAMMER**

One-piece, forged steel, rubber-cushioned, no-slip grip

**GREAT NECK SAW MFRS., Inc.**  
MINEOLA, N. Y. — SEE YOUR LOCAL STORE

**Satisfaction**

Enjoy the satisfaction that comes from using a genuine Gerstner Chest. Free Catalog to toolmakers and machinists.

**GERSTNER TOOL CHESTS**  
462 Columbia St. • Dayton 7, Ohio

**PAGE FOR TILLING PLOWING MOWING**

A FULL LINE — 2 to 9 HP  
with complete gear drive and reverse  
FREE CATALOG • LOW PRICES • EASY TERMS  
Over 40 years experience  
OVER 60 ATTACHMENTS AVAILABLE!

**PAGE** Richfield 4 Wisconsin DEALERS WANTED

fast, lasting repairs

**Magic**  
FIXES EVERYTHING!

Magic Plastic Aluminum • Epoxy Glue  
Magic Rubber • Fix-All Porcelain  
Tub 'N Tile Sealer • Magic Wood  
Woodblend Putty Pencils

at all stores

**Magic** Iron Cement Co., Inc.  
Cleveland 28, Ohio

29¢ to \$1

space age hobby

**BUILD-YOUR-OWN ELECTRONICS**  
FOR MODERN LIVING

IT'S FUN...IT'S EASY WITH MONEY-SAVING

**knight-kits** **K**  
A PRODUCT OF ALLIED RADIO

featured in the 444 page

1962 **ALLIED**  
ELECTRONICS CATALOG

**free** send for it!

Select from more than 70 exciting Knight-Kits! See—Stereo hi-fi, including new Multiplex Stereo tuners and all-transistor amplifiers, short-wave radios, intercoms, Citizens Band radios, electronic science labs, test instruments—all easy to build and a pleasure to own! Send today for your FREE 1962 ALLIED Catalog!

Dozens of new hobbyist kits, including amazing Electronic Science Lab—over 100 projects!

Everything in Stereo hi-fi components; new Multiplex Stereo FM tuners

New—tachometer kit and outstanding test instruments

New all-transistor intercom; many other kits for modern living

**SAVE ON EVERYTHING IN ELECTRONICS**

Get the most for your money in: Stereo hi-fi systems and components • Recorders and tape • Citizens Band radios • Amateur station equipment • TV tubes, antennas, accessories • Electronic parts, tubes, transistors, tools, test instruments, books. Send today for your FREE 444-page 1962 ALLIED catalog!

**NO MONEY DOWN**  
Easiest Terms

**FREE CATALOG**

**ALLIED RADIO**

ALLIED RADIO, Dept. 24-B2  
100 N. Western Ave., Chicago 80, Ill.

Rush FREE 1962 ALLIED Catalog

Name \_\_\_\_\_  
PLEASE PRINT

Address \_\_\_\_\_

City \_\_\_\_\_ Zone \_\_\_\_\_ State \_\_\_\_\_

**WORLD'S BIGGEST**

**FOR  
YOU  
WHO  
WANT  
THE  
BEST**

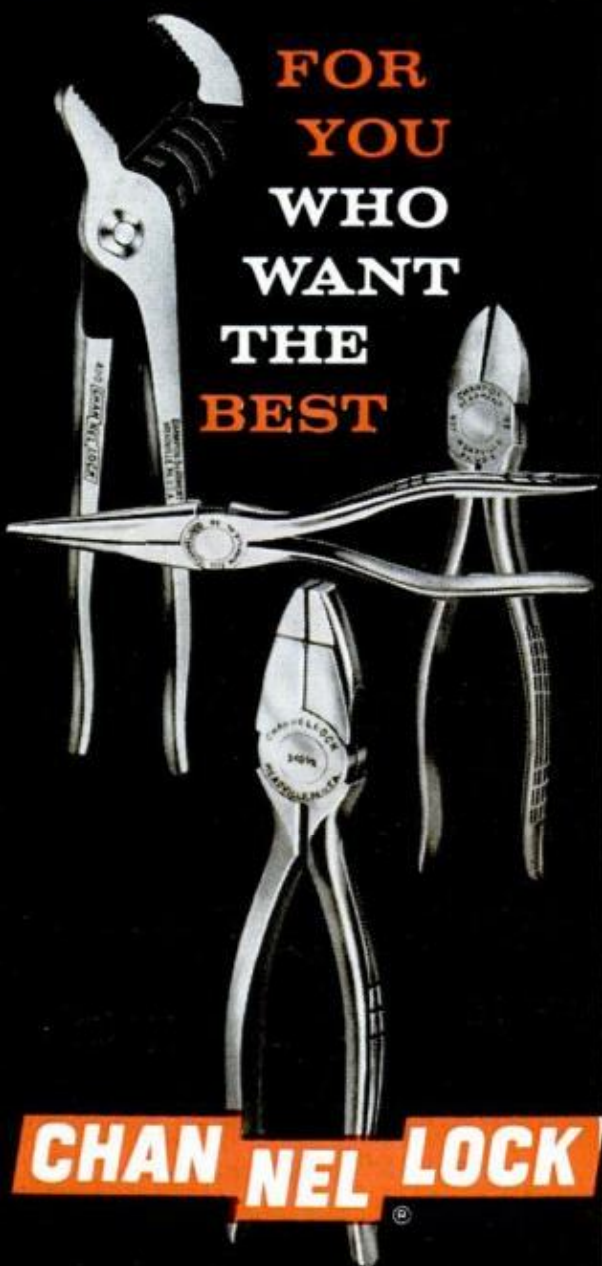

**CHAN NEL LOCK**

Surgical instrument quality at no extra cost . . . yours with Channellock. Drop forged of highest grade steel. Precision machined jaws. Hand-honed cutting edges. Full polished finish. A full line of standard and special styles to choose from. For you who want the best, your choice of pliers—as with thousands of craftsmen—will be Channellock.

*A copy of our catalog showing the complete Channellock Plier line is yours for the asking. Write to: Champion DeArment Tool Company, Meadville, Pennsylvania.*

## Science Climbs the Peaks

(Continued from page 152)

hard and fast. Batteries of instruments checked things like blood pressure, pulse rate, breathing rate and reaction time. The result, according to Dr. Blake, indicated that routine conditioning may raise the allowable ceiling for pilots by several thousand feet.

### Most Spectacular Laboratories

Probably the most spectacular of all the high-altitude laboratories are those hanging on the towering pinnacles of the European Alps. One of the most unbelievable is the cosmic ray lab of the International Institute of Scientific Research, crowning a spire of black rock known as "The Sphinx" atop the snowclad heights of Switzerland's Jungfrau. Surface approach to these ram-parts consists of nearly vertical rock walls, falling away in sheer drops of thousands of feet. Even cableways are impractical here. To reach the top, visitors ride a railroad that chugs up a breathtaking roadbed until it is swallowed by a yawning tunnel from which it never emerges until the return trip.

Winding upward for five miles through the black interior of the mountain, the train arrives at an underground station carved in the rock beneath the foundations of the Berghaus, a huge ski lodge. From here, the tunnel proceeds through the inside of the mountain top to a point some 500 feet beneath the Sphinx. Here, met by Herr Hans Wiederkehr, of the Institute, the visitor enters a lift. The shaftway bores up through the peak to the 11,723-foot level of a laboratory that caps the entire surface of the pinnacle like a dome on a minaret.

### Precise Blasting

Herr Wiederkehr, who for 25 years has repaired and maintained everything from the Institute's telescopes and cosmic ray counters to its plumbing, watched the four-story laboratory and outbuildings grow from a wooden hut cabled to a rock ledge. He'll tell you that the last 100 feet of the lift shaft is almost as wide as the Sphinx itself. To carve it out of the rock, experts had to drill and blast with incredible precision. One poorly calculated charge could have ruptured the thin walls and brought down the entire pinnacle in an avalanche of crumbled rock.

Just as hair-raising is the Bavarian Zugspitze, a 9721-foot peak crowned by Germany's highest meteorological observatory, the *Münchner Haus*. To reach this

(Continued to page 222)

## 90 DAY SPECIAL OFFER!

**WRIGHT** Professional Quality  
**SOCKET SET**



**998**  
12-pc set

FOR THE HOME  
... THE CAR  
... ON THE JOB

- Ratchet
- 7 sockets (3/8" to 3/4")
- 13/16" spark plug socket
- 2 extensions
- Metal box

Guaranteed against defects in material and workmanship.

- 3/8" DRIVE
- MILLION STROKE RATCHET
- OIL-PROOF RUBBER GRIP
- HOT FORGED ALLOY STEEL FULLY HARDENED
- POLISHED CHROME PLATE

Sold by dealers only. Write for name of nearest dealer.

**WRIGHT** TOOL AND FORGE COMPANY  
42 East State St. — Barberton, Ohio

INVEST IN—



U.S. SAVINGS BONDS

SAFE AS AMERICA

## ADDS BEAUTY TO ALL WOOD FINISHES

**PRIMES • SEALS • CONDITIONS**

Best start for a better finish! Dries fast, seals thirsty wood tack-free in minutes. Sands without gumming. Insures lightest possible natural wood finish; increases coverage and lustre of top coats.

Pierce & Stevens Chemical Corp., Buffalo 3, N. Y.  
Made by the makers of famous **FABULON**

**PRYME**  
FIRST-COATER and LIGHTENER.

screens, upholstery, carpets...  
hundreds of other uses.  
You name 'em!



## Swingline 101 Staple Gun

Staples practically anything. Exclusive push-button loading and built-in staple extractor. At your stationery, department or hardware store.

only **4<sup>95</sup>**

**FREE!** New 8-page "TIPS FOR TACKING" Booklet  
... shows you how to save time, money and effort — with a SWINGLINE AUTOMATIC STAPLE GUN

tips FOR TACKING

**Swingline INC.**  
32-00 Skillman Ave., Long Island City 1, New York

## 4-WAY WELDER \$14.95

WELD • BRAZE • SOLDER • CUT

NO OTHER WELDER AT THIS PRICE  
Complete with SAFETY FOOT SWITCH, FULL FACE SHIELD, twin carbon arc torch, welding rod holder, clamp, carbons, welding & brazing rods, flux, fuses, instruction book. **FULL YEAR GUARANTEE.**

More than a quarter million in use in homes, garages, farms, shops, factories. NOW anyone can weld, braze, solder, cut, heat, without experience. Does 1001 jobs on all metals. Save & earn money. Make & repair auto bodies, parts, fenders, trailers, boats, metal furniture, fixtures, ornamental iron, farm equipment, garden tools, bicycles, toys, etc. Operate on any properly wired 110 V AC line. **SEND ONLY \$2.** Pay postman \$12.95 plus C.O.D. charges. Ideal lifetime gift for hobbyist, mechanic, hot rodder, homeowner. Order on 10-day money-back guarantee.

**FOUR WAY WELDER CO.** DEPT. F2-B, 1810 S. FEDERAL ST. CHICAGO 16, ILL.

**Exclusive Double-Bearing HEAVY-DUTY PUMPS**  
IRRIGATE • DRAIN • CIRCULATE • SPRAY  
Use 1/4HP motor or larger . . . 1 HP for up to 5,200 GPH; 1,000 GPH 60" high; or 3,000 GPH from 25' well. 1 1/4" inlet; 1" outlet. Stainless shaft.

**TYPE X**—2 oil-less bronze bearings. Won't rust. . . . **\$10.95**

**TYPE XB**—Ball bearing model. . . . **\$12.95**

Postpaid if cash with order. Rush your order today

**MONEY BACK GUARANTEE**  
Centrifugal and Gear Pumps in All Sizes  
**LABAWCO PUMPS, Belle Mead 2, N. J.**

**LICKITY LOG SPLITTER**

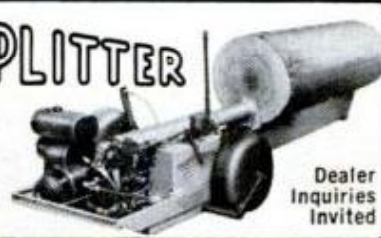

Ends Wood Splitting Drudgery

Dealer Inquiries Invited

Smooth 18 ton hydraulic power splits big profits for you from the toughest woods, including American Elm. 7 HP trailer unit squats under own power to receive large logs without "dead" lift. Has 2 speeds, auto-shift and auto-stroke. 26" ram travel splits up to 34" lengths, any diameter—or, with extended frame and adjustable wedge, splits up to 52" lengths, any diameter. Write for details.

**THE WACO AIRCRAFT CO., Dept. D, Troy, Ohio**



# MULTI-DUTY POWER TOOL



SAWS



PLANES



MOLDS

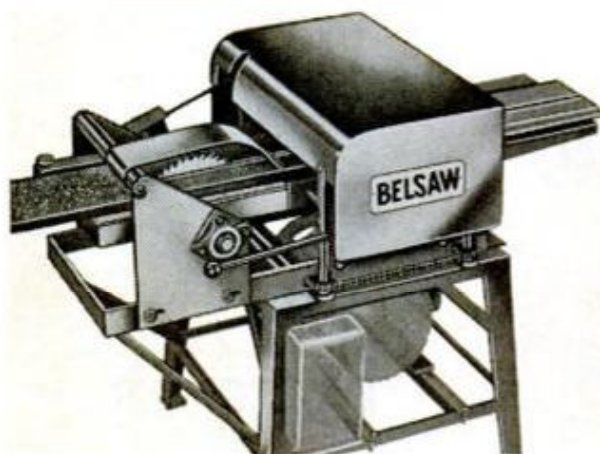

Now you can use this **ONE power feed** shop to turn rough lumber into high-value moldings, trim, flooring, furniture... **ALL** popular patterns.

**RIP... PLANE... MOLD...** separately or all at once by power feed... with a one horse-power motor. Use 3 to 5 HP for high speed commercial output.

**LOW COST...** You can own this **MONEY MAKING POWER TOOL** for only... **\$30<sup>00</sup>** down payment

Send coupon today

## BELSAW POWER TOOLS

902 Field Bldg., Kansas City 11, Missouri

Send me complete facts on the **MULTI-DUTY Power Tool**. No obligation.

Name \_\_\_\_\_

Address \_\_\_\_\_

City \_\_\_\_\_

State \_\_\_\_\_



cabin-in-the-sky, a cog railway carries visitors from the famous *Garmisch-Partenkirchen* winter sports center up a one-in-four gradient, past the azure *Eibsee* lake and into a three-mile tunnel terminating at *Schneefernerhaus*, a resort hotel. From here to the *Zugspitze* peak, cableway cars, dangling above crags and bottomless valleys, hoist people the remaining 1035 feet to the summit. Right now, men with jackhammers are drilling into the tough granite to anchor a pair of gigantic towers—one near the peak, and another near the lake village of *Eibsee*, 6000 feet below. Between them, these two towers will support a cableway 13,000 feet long. Early in 1962, two cablecars, each with a capacity of 45 passengers, will begin swinging their way back and forth along this high wire, making a one-way trip in nine minutes.

### Promenade Deck

At the terminal on the peak, sometime in 1963, passengers will find themselves in a vast, enclosed promenade deck with lounge, restaurant and other plush facilities overlooking some of the most spectacular scenery in the world.

For years, most high-altitude laboratories were unknown except to a handful of scientists with a special interest in astronomy and related fields. It was in 1930, while establishing two Andean cosmic ray stations, that Dr. Korff became aware of the general lack of information about the stratospheric camps, and made his worldwide survey of them.

### Daring Scientists

Many of the 46 he has listed have no permanent staff, no water, heat or power. But one place at 7000-foot altitude in Kodaikanal, India, lists a staff of 37. Another observatory in Kole Kole, Hawaii, has a single staffer who is listed as a "jack of all trades." Hazards of high, rockbound stations are listed, too. Several have a somber record. At *Sonnblick* Observatory, one resident meteorologist died in a fall on his way to the valley, some 10,000 feet below the station. Another, *Joseph Rupitsch*, succumbed to a blizzard in 1945 when he tried to save his wife who was returning up the dizzy trail from the valley. Both were found dead of exposure only 300 yards from the observatory. Until the first manned space laboratory goes into orbit, these hardy, daring men, and their spectacular Earth-bound observatories, will continue to play a heavy role in the accumulation of cosmic knowledge.

You'll be hearing more and more about them. ★★★



# SPECIAL OFFER!

**POPULAR  
MECHANICS**

# VACATION HOME CONSTRUCTION AID MANUAL AVAILABLE NOW!

**H**ERE IT IS—complete in one book—step-by-step construction information on the Popular Mechanics Vacation Home. It includes the full story on the vacation home, plus many more how-to-do-it pictures and construction suggestions.



When used in conjunction with the plans for the PM Vacation Home, the Construction Aid Manual simplifies the completion of your home . . . its step-by-step approach will save you time (and help you avoid errors!)



Included in the Manual is an extensive source list of companies and associations who offer plans and/or further information on other types of vacation homes. This is an invaluable aid in planning your vacation home!



The entire Manual is printed on heavy, water-proof paper—you can use it in your shop, at the construction site of your home—even drop it in water—without serious damage.



Popular Mechanics will see that you are provided with information from many manufacturers concerning the types of products to be used in your home. The material will come directly to you — with many, many ideas on minimum maintenance features, conveniences, and new products!



If you should decide to buy the plans for the Vacation Home from Popular Mechanics, the cost of the Construction Aid Manual will be deducted from the cost of the plans!

**Make sure you get your copy of the PM Vacation Home Construction Aid Manual early! Fill in and mail the coupon below today!**

**POPULAR MECHANICS**  
Dept. VHM, 200 East Ontario  
Chicago 11, Illinois

Enclosed is \$1.00 for my copy of the PM Vacation Home Construction Aid Manual. Please rush it to me postpaid as soon as it is available. (Complete plans also available—see page 89.)

(Please Print)

Name .....

Address .....

City and State .....

## Home Fitness Gym

(Continued from page 174)

Crankplates, Fig. 9, come next. These are disks of 14-ga. steel or 1/8-in. brass which are turned to the same diameter as the pressed-steel pulleys and then drilled and bolted to them. To make the crankplates, first saw them out roughly on a jigsaw, then turn to the proper diameter. Bore a 3/8-in. hole dead center through the disk and lay out and drill three 3/16-in. holes 120 deg. apart on a 1-in. radius. Countersink the latter holes for 1-in. flathead stove bolts. Now form the center hole into a 3/8 x 1/4-in. adjustment slot. This can be done on the jigsaw or by drilling a series of overlapping holes and working out the waste with a file.

### Attaching Crankplates

The holes in the crankplates are used as a guide in spotting and drilling registering holes through the faces of the pulleys. To do this, align the slot in the disk with the keyway in the pulley and clamp both together. Then, with the pulley supported over an open drill-press vise, carefully drill each hole. By aligning the slots with the keyways, the crankheads will automatically be offset 180 deg. from each other. Before the crankheads can be permanently bolted to the pulleys they must be fitted with crankpins, Fig. 9. These are made from bright-finish 3/8-in. carriage bolts slightly altered by chucking and turning down all but about 3/2 in. (the thickness of the crankplate) of the square shank. This lets the shouldered bolt head seat securely in the adjustment slot. Sleeves are made by boring 5/8-in. drill rod lengthwise with a 3/8-in. drill bit. A nut and washer draw the crankpins up tight. Chisel marks spaced 1/4 in. apart along the adjustment slot and numbered 1, 2, 3 and 4, will serve to vary the stroke of the massage belt from a mild to a vigorous action. In bolting the crankplates to the pulleys draw up the bolts so they draw the disks slightly concave. Use lock washers on the bolts. Polish the crankplates and pins with emery cloth followed by crocus cloth.

A lift-off sheet-metal hood, or canopy, lets you get at the motor and belt by loosening wood screws driven in the edge of the wooden base. Fig. 7 shows how the hood is made, the end covers being laid out on 20-ga. sheet metal. Tabs are left around the top edges, slots are formed along the bottom to slip under the screw heads mentioned, vents holes are drilled as indicated and cutouts are made to clear the ends of the crankshaft. You can cut out the end covers neatly by chucking a metal-cutting blade in your jigsaw. The center part of

the hood can be of lighter (26-ga.) sheet metal. Like the end covers, screw slots are formed along the lower edges, a hole is made for a toggle switch and the metal is rolled to the same curvature of the end covers. The covers are soldered to the center section with the tabs placed on the inside. Then the seam is filled on the outside with epoxy mastic. When the latter is filed smooth and the hood painted, the joints will be as neat as can be.

After cementing rubber matting to the platform, your belt massager is completed and ready to try out. The machine is designed for a regular 64-in. commercial belt having conventional leather ends. In using the machine, abdomen, hips and upper thighs are treated in a standing position, facing toward or away from the power head. To massage sore muscles in chest or upper back, sit on a stool placed on the platform. To massage the lower thighs, calves and feet, place the stool alongside the platform. Then detach the belt from the far crankhead and wrap the belt around the calf or foot. Take up the slack by holding the free end and start the motor.

### Abdominal Board

The abdominal board is nothing more than a board inclined at one end on which the person lies on his back, head down and the feet hooked under a strap at the head of the board. Exercising consists of touching the toes with the hands from a sitting position, then lying on the back to a rhythmic count. The easiest of all your equipment to make, Fig. 10 shows how you start off with a plywood board 20 in. wide and 72 in. long. All edges are rounded and sanded smooth. Stiffeners of aluminum angle or 1 x 2 strips are screwed to the underside, a cleat with dowel legs attached is screwed to one end and a leg strap attached. The latter can be of anything handy; a length of web belting is fine. It is tailored to the person by passing it across the ankles while sitting on the board and then securing the ends to the underside with washers and screws. An optional but worthwhile feature of the board is a vibrator motor. This is bolted to the underside of the board with the nuts flush in counterbored holes. Ten minutes spent relaxing stretched out on the abdominal board with the vibrator plugged in will make you feel like you're floating on air.

Fig. 11 details still another piece of equipment for your home fitness gym. This simple exerciser makes use of weights to condition the body from a standing, sitting or lying position. As shown, it features a slide bar which is weighted with bar-bell

(Continued to page 226)





They're all 'keepers'

Compact cluster: from left, Corvair, Rambler, and Falcon surround the new Sea-Horse 18, 5½ and 10'

## NEW JOHNSON COMPACTS

slim, smart, simple...dependable as only a Sea-Horse can be

Look again at those Sea-Horse motors. They're smaller, sleeker, smarter-looking.

They're the new '62 Johnson *Compacts*. Compact size and styling. No frills or fancy do-dads. They fit the fisherman and the way he travels . . . on and off the water.

There's plenty of piston displacement plus cushion hub prop protection. Corrosion proofing and thermostatic cooling. Full gear-shift and six gallon fuel tank.

It's all standard equipment . . . and all

yours at your Johnson dealer's. Look in the Yellow Pages. See Electramatic 75's and 40's (outboarding's first truly automatic transmission), the new "in-between" 28 and the famous 3. Send for free '62 catalog.

Johnson Motors, 1237 Pershing Rd., Waukegan, Ill., Div. of Outboard Marine Corp.



Well over two million quiet Sea-Horse motors prove **JOHNSON DEPENDability**

*It's as*

**E  
A  
S  
Y**

*as*

**to**



## Find the Answer

If you've been putting off that do-it-yourself project because you're not quite certain how to proceed, here's a handy reference guide that tells you where to find the answer to more than 600 home, shop, and craft problems. Popular Mechanics has compiled a SERVICE FILE listing, by subject, all of the projects covered in the famous PM books, booklets, blueprints, and patterns. Whether you're building a dinghy or dinette set, a water wheel or a weathervane, a retaining wall or a rocking horse, PM's SERVICE FILE tells you where to find easy-to-follow instructions.

**Send for Your  
FREE  
SERVICE FILE  
TODAY!**

POPULAR MECHANICS, Service Bureau, Room 529  
200 East Ontario St., Chicago 11, Illinois  
Please send your free SERVICE FILE TO:

Name .....

Address .....

City..... Zone..... State.....

disks and used as a leg exerciser from a prone position by raising the bar with the feet. Weights at the end of a pulley-and-cord arrangement provide beneficial leg, back and arm exercises from both a standing and sitting position. And when equipped with a padded board elevated at one end by resting it on the slide bar, the exerciser has its own abdominal board. Fence fittings called Nu-Rail wall flanges are attached to the ends of the slide bar and slip over regular 1 1/4-in. pipe standards which screw into common pipe flanges attached securely to a plywood base. A length of wooden closet pole with an eyebolt through it to hold an awning pulley is supported at the top by fence parts called swivels. A spindle to hold the weights on the slide bar consists of a waste nut and a pipe nipple. A second spindle which is used free of the bar consists of the same parts but with the end of the nipple flattened and drilled for attaching to a length of cord fitted with a snap. The cord is passed over the pulley and a hand and foot yoke are formed at the end by passing the cord through a 5-in. section of 1/2-in. pipe. Screweyes at each end of the slide bar permit a knee strap to be snapped to them for use with the abdominal board. ★ ★ ★

### Is Cancer Related to Area?

Cancer seems to occur more often in residents of regions where radiation is higher—due to radioactive rocks—than normal.

Government geologists, surveying Washington county, Md., found distinct differences in radioactivity of rock masses. Some rocks were 10 times more radioactive than others in the county.

The higher readings seemed to be in populated areas where the cancer rate was higher than normal.

### High-Speed X-Ray Movies

X-ray motion pictures with exposure times of less than a millionth of a second taken at 1/4000 of a second intervals can now chronicle the actions of burning missile fuels and other contained high-speed phenomena.

The system developed by Zenith Radio Research Corp., Chicago, produces optically visible images that may be viewed directly, transferred to a closed-circuit TV monitoring screen, or photographed by motion-picture cameras using conventional photographic film.

Previously, ultra-high-speed shadow-graphic pictures could only be taken several minutes apart.

**ONLY  
\$175.00**

*less motor*

The Atlas 6" is the world's greatest precision lathe value.

It is the only compact lathe to give you the accuracy of Timken tapered roller bearings — bed ways precision ground to within .001" in all planes — 8 to 96 threading range — 16 spindle speeds, 54 to 3225 rpm — V-belt drive — reversible automatic longitudinal power feeds.

Perfect for making prototypes of your designs, inventions — starting a business of your own — or for relaxation.

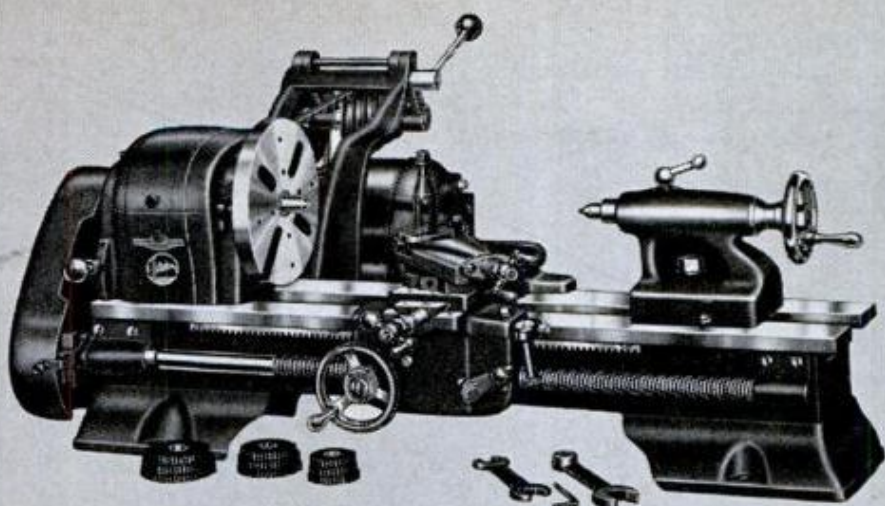

**Atlas 6"** Back-geared  
Screw-cutting **LATHE**  
...for turning **Metal - Plastics - Wood**



Get the complete details—Write for a catalog today

**ATLAS PRESS CO.** 2-24 N. Pitcher St.  
KALAMAZOO, MICHIGAN

373



### New Shape in the Air

Looking like a giant spool in flight, a new flying toy will rise in a wind of five miles an hour or more. It can be manipulated in flight by slight turns on a stick held by the operator; two lightweight lines run from the stick to flying arms on each side of the foamed-plastic toy.

The Space Wing is launched with a spinning motion, and it continues to spin in flight, enabling the airfoil cross piece to lift it. The wing sells for \$4.98; manufacturer is Aeroplastics, Inc., Venice, Calif.

FEBRUARY 1962

Save Money on **WOOD**

**POWER TOOLS • HARDWARE • KITS  
WORKSHOP SUPPLIES • EQUIPMENT**

**NEW LOW PRICES!**



**Hardwoods, Veneers, Plywoods,  
Mouldings, Mosaic Tile, Tools,  
Lamp Parts, Upholstery Supplies**

Your complete wood and workshop buying guide—new 140 page edition now ready. Many pages in full color! Startling new savings on everything you need! Craftsman is your best and most complete source of the finest quality kiln-dried domestic and imported hardwoods. Beautiful wood inlays, bandings, matched plywoods, carved ornaments, modern & traditional furniture legs.

**NEW!**  
**140 PAGE  
CATALOG  
SEND FOR IT  
TODAY**

**Discounts on Stanley Power Tools**

Craftsman offers startling savings on top name power tools, hard to find cabinet hardware, lamp and upholstery materials. More than 1,500 items. Packed with new patterns, projects. Enclose 25c to help pay mailing and handling costs.

**CRAFTSMAN WOOD SERVICE CO.**  
2729 S. Mary St., Dept. A-2, Chicago 8, Ill.

**CRAFTSMAN WOOD SERVICE CO., Dept. A-2,**  
2729 South Mary St., Chicago 8, Illinois  
Rush giant new Craftsman WOOD Catalog. I enclose 25c to help cover mailing cost.

Name \_\_\_\_\_  
Address \_\_\_\_\_  
City \_\_\_\_\_ Zone \_\_\_\_\_ State \_\_\_\_\_

227

# NOW . . . BRAND NEW HOLLEY REPLACEMENT CARBURETORS FOR CHRYSLER-BUILT CARS!



*Holley "PEP" carburetors are  
factory-new, original equipment  
quality—not rebuilds*

You can give your car new Pep, Economy and Performance with a brand new Holley PEP Carburetor. One Holley single bore, downdraft model for all 1960-1962 six-cylinder Chrysler-built cars, including Dodge, Lancer, Plymouth, Valiant. Holley PEP Carburetors are brand-new . . . *not rebuilds*. They are made to the same *original equipment quality* specifications as carburetors Holley is supplying for 1962 Chrysler-built sixes, and are factory inspected and sealed. See your Authorized Holley Distributor or Dealer today. Give details on car-year and engine model.

★ ★ ★

Holley Carburetor Company has been a supplier of original equipment carburetion and ignition for over 55 years. For genuine Holley parts for American Motors, Chrysler, and Ford cars, see your Holley Authorized Holley Distributor or Dealer, listed in the Yellow Pages. He carries a complete stock of Holley carburetor and ignition repair kits and parts, plus brand-new Holley PEP Carburetors . . . all *original equipment quality*.

ORIGINAL EQUIPMENT MANUFACTURERS  
**HOLLEY**  
Carburetor Co.

OF CARBURETION  
AND IGNITION PRODUCTS  
FOR OVER 55 YEARS

C-8

11955 E. Nine Mile Road, Warren, Michigan

## Adventure in Your Crankcase

(Continued from page 121)

the trailers at night. Even so, the men can work in the desert only four weeks at a stretch, taking a week off to "dry out" at a port city before returning to the scorching sands of the "empty quarter."

### Jungles Too Cold

An ironic twist occurs in the steaming South American jungles, where it is simply not hot enough. Pan American crews in Argentina and Richmond Exploration Company crews in Venezuela have to set up intermediate heater stations along pipelines because the oil there is too thick and heavy to flow smoothly between the wells and the port where it is loaded on tankers. It has to be warmed to about 180 degrees to make it fluid enough to pump.

This irony has its parallel in the Arctic regions where oilmen have to wait for the coldest weather to get their best work done. In summer, the ground thaws and becomes too mushy to use and, if there are any rivers to cross, they are usually too wild and high from the winter snows. Drilling time usually starts after January 1, and it sometimes takes three winters to complete a job.

### Bridges of Ice

Even in winter, when the ground is frozen solid, rivers still have to be reckoned with. Pan American solved this problem in its Beaver River project in northern British Columbia, across the border from Yukon Territory where the lowest temperature in North America (81 degrees below zero) has been recorded. To move heavy equipment to the well site, two rivers had to be crossed, both swift and a half-mile wide. So ice bridges were built by flooding water over 60-foot logs laid side by side on the rivers. After January 1, the rivers and the bridges froze solid.

Behind — or, more accurately, beneath the problem of waiting for winter to drill in northern Canada is the frightening nature of the ground itself when unfrozen. More than a half-million square miles — more than the total area of France and both Germanies — consists of a spongy, treacherously deep mixture of water and dead vegetation that supports nothing, spreads like cancer, and devours everything. It is called muskeg. The heavier the load, the more apt it is to sink out of sight, as engineers building the Alaskan highway found as they watched ton after ton of fill disappear. Perhaps the most surprising thing about muskeg is that it hasn't been used by Hollywood as the basis of a horror film. Muskeg,

POPULAR MECHANICS

more than the cold, has bogged down the development of northern Canada and, if it didn't freeze once a year, the area would be totally undeveloped today. Yet there is oil beneath all that goo, and Imperial crews have helped pioneer trails through some of the thinner layers of muskeg (which can run as deep as 30 feet). They use helicopters as advanced scouts and recently developed muskeg buggies as ground vehicles. Currently the "Musk-Ox," a 20-ton monster with tracks 10-feet wide, is the most practical muskeg vehicle, being able to haul up to 15 tons of equipment over the mush.

### Vanishing Islands

Muskeg has a cousin in the "vanishing islands" of South America. Royal Dutch/Shell Company crews in Columbia have been dismayed to find their operations on islands in the Magdalena River disrupted by another freak of Nature. At floodstage, the river eroded the islands completely, moving them several miles downstream and creating an altogether new topographical arrangement.

Using "Dutch mats," an idea borrowed from the Netherlands where the mats are used to keep the dikes in place, the oilmen kept their islands from traveling by braiding huge 80-by-50-foot mats from brushwood and covering the banks with them, with part of the mats extending into the river. The mats were then weighted down and completely covered with rocks. The rocks on the bank were then covered over with gravel and sand, while those below the water were covered with asphalt.

The sturdy Dutch mats kept the over-all contours of the islands intact, and were flexible enough to hug the shores after any minor erosions.

### Giant Grizzlies

Imperial Oil crews, however, probably had the most unusual encounter with Nature, when they entered a pocket valley in the relatively untouched and highly inaccessible Swan Hills of northern Alberta. Here they stumbled upon the last survivors of a race of giants—the plains grizzlies that swarmed over much of the West before civilization drove them into isolation. Hiding for more than a century, they were understandably perturbed at this new trespass upon their domain and, second in size only to the Alaskan Kodiak bear, they had the equipment to put up a protest.

Many oilmen scurried for cover at the sight of these bears and many bears had to be shot in self-defense—including the "King of Goose Mountain," a half-ton colossus measuring 10 feet from nose to hind paws.

(Continued to page 234)

## "HANDY HELPERS" FOR HOME REPAIRS



REPAIR  
WALL CRACKS  
PERMANENTLY

TRADEMARK  
**Dexall**  
PATCHING PASTE

- Ready mixed, ready-to-use
- Easy, fast way to fill cracks, holes, joints and gouges in plaster or wood
- Won't crack, water resistant, dries fast

WATERPROOF  
SEALER

**Dexall**  
TUB AND TILE CAULK



- Tough, elastic sealer that sticks to tile, glass, wood, plastic or metal
- Handy tube with applicator nozzle eases work around sinks, bathtubs and showers
- Will not chip, crack or shrink



DIRT-DISSOLVING  
**Dexall** Waterless  
HAND CLEANER

- Removes grease, grime, paint, varnish, tar, crayon, ink and adhesive instantly
- Contains lanolin and hexachlorophene... leaves hands soft and clean

Look for the name

**Dexall**

at paint and hardware stores everywhere  
Deshler Products, Inc., Deshler, Ohio

# the FUN and EASE

## OF ELECTRONIC LIVING

yours at half  
the price with

# HEATHKIT®

**Kits for every member of the family—  
over 250 from which to choose**

The big Heathkit Catalog has over 100 pages filled with kits priced from \$7.95 to \$945.00. There are Educational Kits, Hi-Fi/Stereo Kits, Marine Kits, Ham Radio Kits . . . and a host of work saving "electronic servants" for every room in your house.

**Save up to One-Half the Price  
on all the luxuries you want**

Yes, truly elegant living can be yours at prices you can afford. This is possible because with Heathkits you have the fun, the pride of building your own and eliminate the problem of paying high ready-made equipment prices. Save as much as 50%.

**Easy terms—buy now, up to 18 months to pay**

Why wait to add the equipment you want for your home! With Heathkit's new, easy terms, you can order today using the no-down-payment terms in the catalog. Enjoy the pleasure of building and having your Heathkit as you pay for it.

**Satisfaction Guaranteed—your money back  
if you cannot build a Heathkit successfully**

This amazing guarantee is made possible by Heathkit's experience in supplying "do-it-yourself" electronic kits to millions of customers. If you follow our check-by-step instruction manuals, we know you will be another satisfied Heathkit builder.



### SPECIAL OFFER FOR BEGINNERS

**ORDER NOW— Complete with Tool Kit!**

only \$21.95



See How Easily Heathkits Can Be Built—with This 6-Transistor Portable Radio. Two top items for the price of one! Assemble the radio under our money-back guarantee and begin an exciting hobby that will save you hundreds of dollars in the years ahead.

**GR-151 Radio plus  
Tool Kit . . .  
5 lbs . . . \$21.95**

# check these money-saving, pleasure-giving HEATHKITS only a few of the hundreds you can build



## RADIO-CONTROLLED GARAGE DOOR OPERATOR

For all overhead Track, Jamb & Pivot type doors up to 8' high. Operates door from house or car. Easy to assemble and install.

**GD-20 Mechanism, Transmitter & Receiver . . . 65 lbs. . . . . \$109.95**



## HANDS-FREE TELEPHONE TALKS

Talk & listen hands free! Amplifier has built-in speaker & volume control. All-transistor circuit operates up to 100 hours on a single 9 v battery.

**GD-71 Telephone Amplifier  
2 lbs. . . . . \$19.95**

## WORLD NEWS—WHEN IT HAPPENS



## SHORT WAVE LISTENERS RADIO

Four bands, 550 kc — 30 mc; lighted dial & meter; circuit board for easy

assembly; flywheel tuning; bandspread. 4-tubes & silicon rectifier.

**GR-91 Radio . . . 9 lbs. . . . . \$39.95**

## SAFER CRUISING WITH A DEPTH FINDER

All-transistor, battery powered; depth 0-100'; transducer incl. Accurate & dependable.

**MI-10 Depth Finder  
9 lbs. . . . \$69.95**



## 50 WATT HI-FI STEREO AMPLIFIER

Deluxe . . . superbly styled in luggage-tan vinyl-clad cabinet. 5 stereo inputs; versatile controls. Power response,  $\pm 1$  db 30 cps to 15 kc @ 25 watts per channel.

**AA-100 Stereo Amplifier . . . 31 lbs. . . . . \$84.95**



## BASIC TRANSISTORS "LEARN-BY-DOING" KIT

Teaches basic transistor theory. Finished product is a two-station intercom. Perform interesting experiments while learning. Easy-to-understand text.

**EK-3 Basic Transistors  
. . . 4 lbs. . . . \$16.95**

## WALKIE TALKIE COMMUNICATOR RANGE 1 MILE

4-transistor; crystal-controlled; super-regenerative receiver; 36" whip antenna. Easy circuit board assembly. Only  $5\frac{3}{8}$ " H x  $3\frac{1}{8}$ " W x  $1\frac{1}{2}$ " D.

**GW-31 Walkie Talkie . . .  
2 lbs. ea. \$24.95**



Ordering instructions: Fill out the order blank, include charges for parcel post according to weights shown. Express orders shipped delivery charges collect. All prices F. O. B. Benton Harbor, Mich. A 20% deposit is required on all C.O.D. orders. Prices subject to change without notice. Dealer and export prices slightly higher.

ITEM	MODEL	PRICE

Ship  P.P.  Ex.  C.O.D.  Best way



**HEATH COMPANY**  
Benton Harbor 17, Michigan

Yes, send me my free 1962 Heathkit catalog

NAME \_\_\_\_\_

ADDRESS \_\_\_\_\_

CITY \_\_\_\_\_

ZONE \_\_\_\_\_ STATE \_\_\_\_\_

Garage  
Basement  
Shed, Shop  
Barn

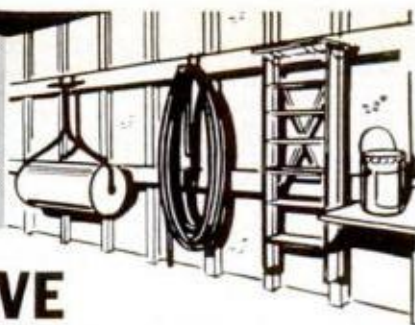

## SOLVE STORAGE PROBLEMS

startling  
NEW

## HERCULES HOOKS

Patent applied for

obsoletes every other method of HEAVY DUTY WALL STORAGE

These giant steel hooks are approx. 1/4" thick. They fit over the common 1" x 4" wood board. Simple to put up. NO perforated wallboard is used.

Hold the heaviest tools, equipment, shelves, etc. HOLDS EVERYTHING. Ask for them by name at your dealer. HERCULES HOOKS!

Sample hook sent direct to you. Enclose 10c for mailing.



8 DIFFERENT STYLES

**K** Literature FREE!  
**THE KERR WIRE PRODUCTS CO.**  
937 N. Cicero Avenue • Chicago 51, Illinois

## LAUNCHING'S a Breeze

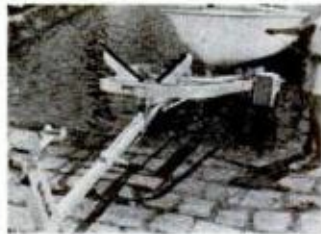

with  
**AUTO-LAUNCH EASE!**

### Exclusive in Gator Boat Trailers!

And before you buy . . . Compare these work-saving GATOR Features with any other trailer on the market . . .

- **AUTO-LAUNCH** . . . a system of rollers and cradles that give your boat maximum protection in transit and automatic launching at the ramp.
- **LOADING GUIDE** . . . overcomes boat drift caused by wind and water current . . . makes loading a cinch.
- **3-SPEED HEAVY-DUTY WINCH** . . . designed to let you "shift" gears to handle loads up to 2500 lbs. Three gear ratios that take the work out of trailer loading.

Gator is the trailer choice of veteran and novice boatmen everywhere. **SOONER OR LATER YOU'LL GO GATOR** . . . the trailer with features designed by boatmen.

See a full line of economy Champ trailers at your **GATOR-CHAMP DEALER.**

FOR INFORMATION, WRITE DEPT. PM-62-2A

## PETERSON BROS., INC.

1925 East Beaver Street, Box 51, Station G, Jacksonville 6, Florida

(Continued from page 229)

A conservationist finally convinced the crews that they were destroying the last remnants (about 400 left) of one of Nature's rare breeds. Now the oilmen help spot and tag the bears—capturing them in homemade steel-culvert traps, knocking them out with liquid ether, weighing them and tagging their ears—in a cooperative effort with conservationists. And, to ward off sadistic bear hunters, the Alberta government has placed the Swan Hills area off limits.

Man, not nature, created the most dangerous oil hunt of all by starting World War II. During it more than four million land mines were buried in the North African desert by the armies of Rommel and Montgomery. Today more than three million of them are believed to be still there, waiting to be stepped on. It's in this area, specifically northern Libya, that crews of Esso Standard gingerly tiptoed looking for oil.

### Leaping Mines

Armed with mine detectors, they moved in on foot, clearing safe lanes for the heavier equipment by finding and exploding mines which, buried beneath the dry sand, were as deadly as the day they were set nearly two decades ago. Included among them were British antitank mines and German antitroop mines (which leap three feet in the air before exploding to spread their splinters of shrapnel over a much larger area). These will kill or wound everything within a 200-yard radius. Crewmen also located glass and plastic mines extremely difficult to find because they have only one piece of metal—a pin—to which the detectors are sensitive.

Libya, again only incidentally, had the highest official recorded temperature in history, 136 degrees F. at El Azizia.

Heat, cold, mountains, valleys, above the water and below it, into areas and dangers few men have encountered before—these are all part of an oilman's life. So next time a drop of oil drips from your car's crankcase, remember it took some adventure to get it there. ★★★

### QUOTE:

*"The engineering of our day is far ahead of our science. In general, we are at the point of exhausting our fundamental knowledge, and the engineers are on the tail of the research scientist every day."*

DR. WILLARD F. LIBBY,  
Nobel Prize Winner for Chemistry,  
Professor of Chemistry at the  
University of California at Los Angeles



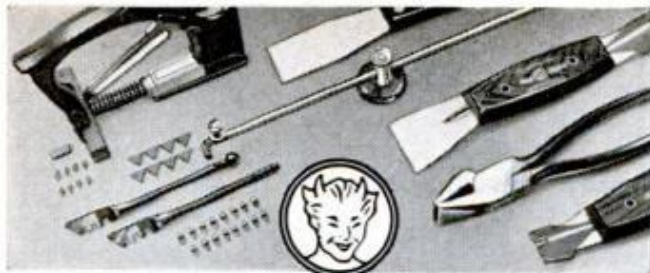

Men who know  
**GLAZIERS' TOOLS**  
say the **BEST** are  
**Red Devil Tools.**



## G E A R S

**In Stock - Immediate Delivery**

Gears, speed reducers, sprockets, thrust bearings, flexible couplings, pulleys, etc. A complete line is carried in our Chicago stock. Can also quote on special gears of any kind. Send in your blueprints and inquiries.

Send for Complete Catalog No. 10  
**CHICAGO GEAR WORKS**  
440-50 N. Oakley Blvd., CHICAGO 12, ILL.

BUY DIRECT  
• SAVE ON •  
TILLERS • TRACTORS

Full line of attachments for  
mowing, gardening, farming  
2-3-4 H.P. TILLERS 12"-16" CUT.

FREE CATALOG  
& PRICE LIST

5-6-7-9 H.P.  
2 wheel &

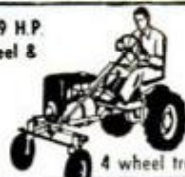

4 wheel tractors

**RED-E TRACTOR CO.**

4th Street  
RICHFIELD, WISCONSIN



"One of the best  
things built  
in a workshop  
is a pleasant  
personality."

**BUILD FINE GRANDFATHER CLOCK NOW**

The simple sensible **SPEEDE Red-i-Kut** way as thousands have - **FOR YOURSELF OR SELL AT A GOOD PROFIT. SAVE HUNDREDS OF DOLLARS. SHOP TESTED PLANS "SPIRIT OF THE CENTURY"** Narrow waist 33" tall or stately straight side **"SPIRIT OF AMERICA."** **EASY-TO-FOLLOW photopack PLANS & LIFE SIZE PATTERNS** tell all—plus **MOVEMENT BROCHURE \$40 up**, of heavy brass weight (Kuempel original) Westminster, tube **BELL** chime, movements, **gorgeous bronze-silver MOVING MOON** dials, 3/4" solid-mahogany **Jiffy Joint-Kwik-Bit** case kits. **Send \$1.00 today - Both plans RUSH \$1.50** as folks have for over forty years.

Kuempel Chime Clock Works, 15 Kuempel Bldg., Minneapolis 16, Minn.



Works in seconds!  
**Loosens Rusted Bolts  
nuts, screws, "frozen" parts!**

**LIQUID  
WRENCH**  
SUPER-PENETRANT

The super-penetrating rust solvent that quickly loosens rust and corrosion.

**AT ALL HARDWARE  
AND AUTO STORES**

RADIATOR SPECIALTY COMPANY  
CHARLOTTE, N. C.



FEBRUARY 1962



# WHY TOY AROUND

WITH MOTOR OILS THAT DO NOT GIVE YOU

# THE ECONOMY OF

LOWER OPERATING COSTS  
BEST PERFORMANCE THROUGH

# KENDALL QUALITY

MOTOR OILS REFINED FROM THE CHOICEST  
100% PENNSYLVANIA CRUDE OIL



KENDALL REFINING COMPANY - BRADFORD, PENNA.

Lubrication Specialists Since 1887

# STOP WATER DAMAGE...



Wood  
Plywood  
Shingles  
Asbestos siding  
Concrete blocks  
Concrete  
Mortar  
Stucco  
Plaster  
Brick  
Paint  
Wallboard  
Tile  
Canvas  
Leather  
Linoleum  
Fabrics

**Prevents warping, swelling, mildew, mold, water stains, seepage, dampness, rot.**

**Keeps moisture out 5 years and longer.**

Use on all woodworking jobs, boats, patio furniture, planter boxes, shutters, screen doors, window sash, shingle roofs. Stops seepage in basement walls, concrete silos, foundations. Waterproofs canvas, tarps, tents, awnings, leather boots, shoes, outdoor clothing. Won't harden or crack leather or fabrics. Perfect underseal for oil base or alkyd paints. Deep penetrating, colorless. Apply by brush, spray or roller. At paint or hardware stores or order direct. 16 oz. spray can \$1.89, Qt. \$1.75, Gal. \$5.35, 5 Gal. \$25.25, ppd., tax incl. Send check or money order to E. A. Thompson Co 1355 Market St., San Francisco 3, Calif. No COD's please. (Since 1929.) Dealer and jobber inquiries invited.

## 20 WAYS To Use An **ARROW T-50** HEAVY DUTY STAPLE GUN

Only  
**\$12.50**



Uses 6  
staple sizes:  
1/4", 5/16", 3/8", 1/2"  
9/16" and CEILTILE

- Install ceiling tile
- Install insulation
- Weatherstrip doors and windows
- Reupholster furniture
- Staple wire fencing to posts
- Repair window and door screens
- Fix loose wiring to floors, walls
- Replace worn window shades
- Tack down carpets
- Lay new linoleum
- Attach vines to trellis
- Affix plywood panels to walls
- Wrap and staple young tree trunks
- Line kitchen and closet shelves
- Hang drapes and curtains
- Make decorative cornices
- Cover valences with material
- Put up Christmas decorations
- Staple down building felt
- Quickly repair odd wood-working jobs

**ALSO No. JT-21 Junior TACKER \$4.95**  
For Light Duty Tacking Chores

ARROW FASTENER CO., INC. 1 Junius St., Brooklyn, N.Y.

At Hardware, Building, Lumber and Stationery Dealers Everywhere.

**CUT THIS OUT AS A HANDY CHECK LIST**

## Weapons for the Little Wars

(Continued from page 111)

gon last Spring created a Limited Warfare Systems Office to cope with it. It has already made over 100 recommendations for improvement.

Vehicles must be more at home in swamps than on highways, says the Limited Warfare Systems Office. Thus, the Navy is developing a new armor-plated swamp boat; the Army is modifying some of its equipment until it can come up with new designs. Supply planes have to land in small clearings rather than on long, paved runways. For this reason, some of the first of the new Canadian-built Caribou transports have been rushed from the factory directly to Vietnam. The Caribou carries 24 paratroopers or three tons of supplies. It lands and takes off on very short, crude runways.

The helicopter can be used to spray jungles with newly developed defoliants. These agents cause trees and shrubs to drop their leaves within two or three days after spraying. So far, the Chemical Corps has developed three or four effective defoliants, all based on commercial weed killers. One use would be to spray wide areas—many miles—to discourage guerrilla activity by stripping away the protective cover of leaves. Another use is to create leafless protective rings around villages and cities.

Chemical Corps scientists are working hard now to improve the defoliants. They seek an agent that can be used in small quantities over wide areas, yet strip leaves in just a few hours.

Another spray has an entirely different use. Many Red guerrillas are raiders by night, but farmers or laborers by day. They may even be persons trusted by the anti-guerrilla forces. How do you spot them?

### The Telltale Stain

During night raids, guerrillas will be attacked with flame throwers, modified to squirt water with an indelible dye added. The next day, antiguerrilla forces will search for persons stained with bright dye. It cannot be washed off. The Chemical Corps has also developed "invisible" dyes similar to those used by police to mark money for tracing. Supply dumps, bridges and other equipment or structures that are possible sabotage targets are painted with the dyes. Following trouble, suspects' hands are exposed to ultraviolet light and examined for traces of the dye.

One of the most effective weapons against guerrillas is fire—burn them out of the

(Continued to page 238)

## UNHAPPY WITH YOUR KITCHEN? TURN IT INTO A BIG, BRIGHT FAMILY CENTER

It's easy . . . when you plan your new kitchen around Andersen Windows. They open effortlessly . . . to capture sunshine and fresh air. Close weathertight to seal out dust, dirt and storms.

Get many more remodeling ideas free! Just mail the coupon below. For additional planning help, see your lumber or mill-work dealer.

**Andersen**  
**Windowalls**  
TRADEMARK OF ANDERSEN CORPORATION



**REMODELERS!** If you win BETTER HOMES & GARDENS' remodeling contest—and use Andersen Windows in your entry—we will refund the retail price of your windows.

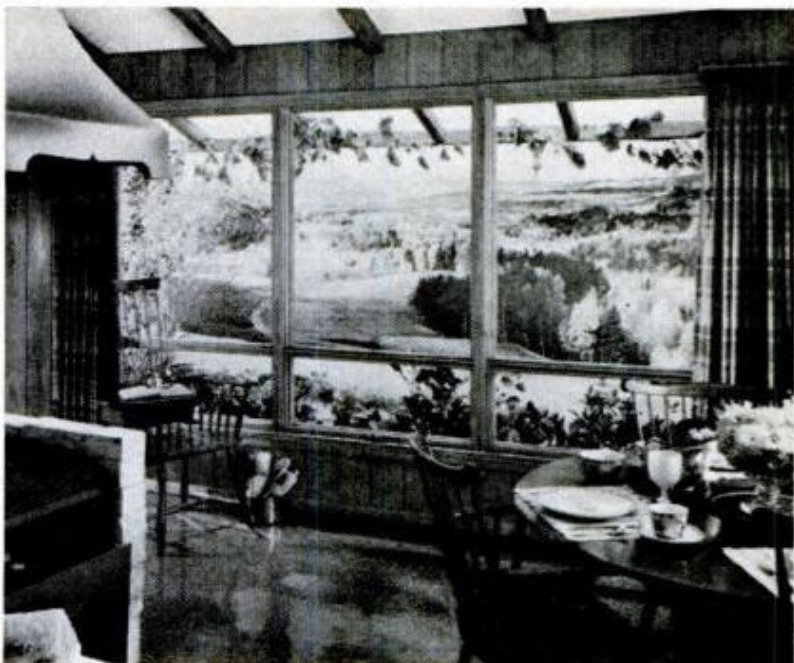

CLIP AND MAIL TODAY

FREE! Remodeling Ideas Book...   
Ideas for Window Beauty...  Check one or both

Andersen Corporation, Bayport, Minnesota

NAME \_\_\_\_\_

ADDRESS \_\_\_\_\_

CITY \_\_\_\_\_ ZONE \_\_\_\_\_ STATE \_\_\_\_\_

PM-22

## CAMPING TRAILER KITS AS LOW AS \$269.50

SAVE! Assemble it yourself!

Sleeps 5! Same high quality parts and convenience features found in trailers costing twice as much!

BOAT TRAILER KITS ALSO AVAILABLE  
Write for illustrated catalog today! Please enclose 10c for postage and handling.



TRAILER PRODUCTS, INC. Dept. PM-22, P.O. Box 176 Kingsport, Tenn.

Table Stores the Guest Bed if you follow the building instructions in the March Popular Mechanics for an attractive end table which holds a comfortable folding bed inside.

The second most important tool...  
for every  
woodworking shop

A VERSATILE

**W&H**

**MOLDER-PLANER**

is second only to a saw . . . it molds, planes and rabbets.

Models from \$89.95

From \$27.50 down & \$6.00/mo.

SEND FOR  
FREE BROCHURE

WILLIAMS & HUSSEY MACHINE CORP.  
CLINTON ST., MILFORD, NEW HAMPSHIRE



# Hot Fishing Tips!



How Experts do it...

Discover how experts catch more fish. New Heddon Deluxe Catalog is full of these tips, tackle to use, pictures, records, etc. Details on outstanding new Heritage Total Free Spool and Scandia Audio-Touch Control reels.

James Heddon's Sons  
369 West Street, Dowagiac, Mich.

- Here's 25c. Rush 1962 Deluxe 64-page Catalog.  
 Send FREE 32-page pocket catalog.

**Heddon**

Name \_\_\_\_\_ (please print)

Address \_\_\_\_\_

City \_\_\_\_\_ State \_\_\_\_\_

In Canada: James Heddon's Sons Canada Ltd., Preston, Ont.



**There's an easier way—  
with Reynolds Corner Post!**

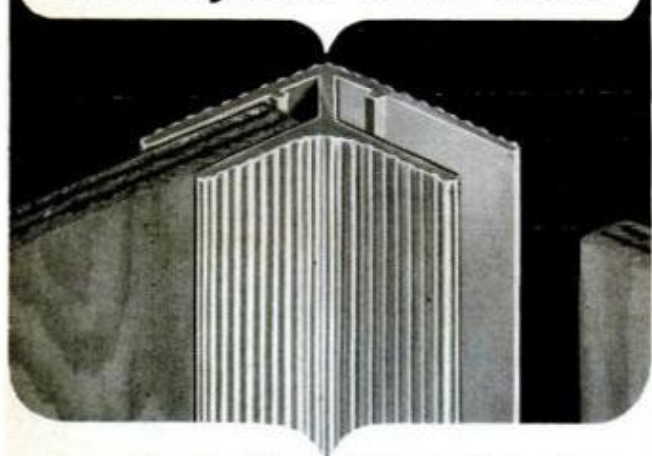

Reynolds Aluminum Corner Post gives you perfect corner fittings everytime . . . no need for exacting angle measurements, butting of joints or elaborate corner finishing. Just slip the paneling material (peg board, plywood, masonite, etc.) into the side openings and glue or screw them together.

Corner Post is available in 8 ft. lengths for materials  $\frac{1}{4}$ ",  $\frac{1}{2}$ " or  $\frac{3}{4}$ " thick. And Corner Post is strong enough to support weight, serve as cabinet legs, etc.

You need no special equipment; the ordinary woodworking tools you already own are all it takes for any Reynolds Do-It-Yourself Aluminum. Get Reynolds Corner Post at hardware departments everywhere.

Watch Reynolds exciting TV programs on NBC: The Dick Powell REYNOLDS ALUMINUM SHOW every other Tuesday; SAY WHEN, weekdays; ALL-STAR GOLF—in living color—every Saturday.

**REYNOLDS METALS COMPANY  
RICHMOND 18, VIRGINIA**



brush. Almost any American or Allied fighting unit usually has on hand plenty of gasoline and packets of a thickening powder developed by the Chemical Corps. When a small amount of powder is added to a large quantity of gasoline, the liquid thickens to a jelly called napalm. This is often used in emergencies in five-gallon cans rigged as antipersonnel mines. Or napalm-filled drums are rolled toward an enemy and exploded, sending flying sheets of flame in every direction.

The napalm is easy to come by; the problems are in fusing it for use. Field forces use all sorts of tricks to make the containers explode and spread the flaming napalm—sticks of TNT, blasting caps, windings of primacord and even delicately balanced hand grenades. Much of the time, these field-rigged napalm weapons do not work; often they are as dangerous to the makers as to the enemy. The Chemical Corps has developed a small, lightweight exploding stick to be used in field-rigged napalm weapons.

The incendiary burster is 12 inches long and contains two plastic tubes of explosives that can be safely detonated by ordinary fuses or blasting caps. It bursts the napalm containers, ignites the fuel and scatters flames over a wide area. The bursters are small, light and rugged enough for anti-guerrilla units constantly on the move.

### **New Forms of Cats' Eyes**

The Army Corps of Engineers has developed a new type of image intensifier that needs no electrical input, and does not use infrared. The problem with infrared devices is that an enemy with infrared goggles can clearly see each of our devices. The problem with electronic image intensifier tubes, such as the widely publicized "cat eye," is that they require a heavy, bulky power supply for their operation.

A new "cascaded image intensifier" tube operates in much the same manner as the cat eye, but it draws its power from moonlight, starlight or even just "skyglow." The Engineer Research and Development Laboratories near Washington, D.C., is now working to make the system small enough to mount on a weapon in place of the infrared sniper scope. This will be a device designed specifically for fast-moving night action against guerrillas.

### **3-D Maps**

Another development is now ready for use by Special Forces and our Allies. It is a three-dimensional plastic map that can be rolled or folded to fit a pocket. A map where the hills actually stick up and the

(Continued to page 240)

# ECONOMY POWERFUL! TRACTOR

Thousands in Use!

Since  
1946

## UNEQUALLED LOW PRICE! TERRIFIC VALUE!

America's finest tractor. Ruggedly built. Easy to operate. 790 lbs. Borg-Warner clutch, trans. and diff. 140 to 1 reduction. 40% more drawbar pull than ordinary tractors. 9 H.P. engine. 20 quick change implements. HOOD-FENDERS.

Write for Catalog.

Engineering Products Co.  
1005 K-2 Anoka Avenue  
Waukesha, Wisconsin



**Make your own Gems 36<sup>50</sup>**  
FOR

The Gem Maker comes complete with all necessary equipment, including a super-charged diamond blade for sawing, and all the wheels for grinding, shaping and polishing; also complete instructions. The complete equipment as shown, less motor and belt for only \$36.50, f.o.b., Burlington, Wisconsin. Write today for information and literature.

**B&I MANUFACTURING CO.**  
Dept. P, Burlington, Wis.

## Keep Tools in Tip-Top Condition

Lubricate • Clean • Prevent Rust

## 3-IN-ONE® OIL

REGULAR—OIL SPRAY—ELECTRIC MOTOR

Jump Drum, a kiddies' bounce tumbler made from an old tire and plastic clothesline. See it in the March PM.

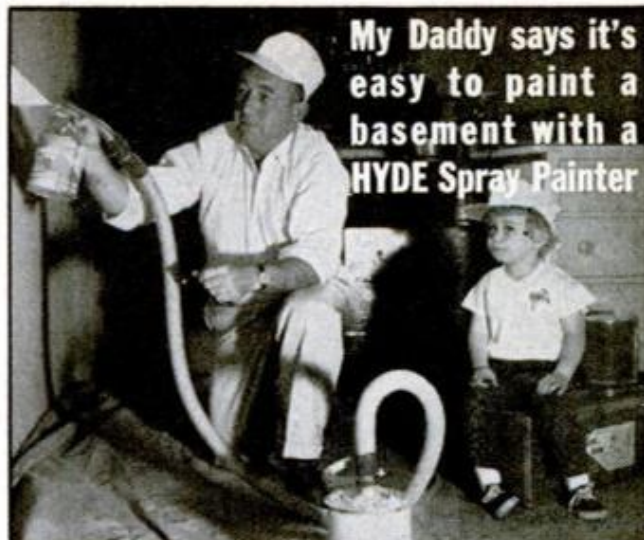

My Daddy says it's  
easy to paint a  
basement with a  
HYDE Spray Painter

It's easy to spray-paint basement walls, floors, outside of houses, boats, swimming pools, equipment, fences, shutters, outdoor furniture with the Hyde Spray Painter. A Low Pressure System, sprays all paints right from manufacturer's quart paint can. Gun fastens to exhaust outlet of canister or tank-type vacuum cleaner or Hyde Electric Air Blower. Spray Painter retails for \$12.95. Steel carrying case with Spray Painter and Hyde Electric Air Blower, complete for \$73.40. See Hyde's complete selection of Putty Knives, Wall Scrapers, Paint Scrapers and other Take It Off—Put It On Paint Tools in paint, hardware, building supply and lumber yard stores. Write for Free Pocket Catalog and How-To Book.

## HYDE TOOLS

SINCE 1875

Dept. PM 2

SOUTHBRIDGE, MASS., U. S. A.

Buy Your

# WINCH

as Carefully as  
You Buy Your

# TRUCK!

Buy the *right* winch for the *right* truck. Buy a BRADEN Winch and be sure. BRADEN... considered the leader in winch manufacturing... has pioneered more improvements in winch design than any other company. BRADEN'S Oil Cooled, Fully Automatic Safety Brake, for example, has never been equalled for quality and safety. If you buy your winch as carefully as you buy your truck, you'll insist on BRADEN.

Look in the Yellow Pages for name of your BRADEN Winch distributor, or write direct to the factory for complete information.

Nation-wide Service Available on all BRADEN Winch Products

## BRADEN WINCH

DIVISION OF  
NAUTEC CORPORATION

LYNN LANE AND DALLAS AVE. • BROKEN ARROW, OKLAHOMA

# BRADEN

Your BEST Winch Buy



**UPRIGHT MODELS** — Designed for behind cab mounting. Capacities from 8,000 to 100,000 lbs.

**UNDERSLUNG MODELS** — Range from 8,000 to 30,000 lbs. capacity. For front end mounting.

**FRICTION CLUTCH MODELS** — Capacities range from 5,000 to 16,000 lbs. Ideal for small trucks.

**SPECIAL MODELS** — Constant load, constant speed model specially designed for electric utility and telephone industry application.



don't say "darn"...say

**DAP**<sup>®</sup>

**KWIK-SEAL**<sup>®</sup>



New rubber-like sealer makes it easy for you to put a neat, white, waterproof joint around tub, sink, shower, lavatory. Resets loose or broken tiles, too. Handy squeeze tube. Get DAP Kwik-Seal for longer-lasting jobs.

DAP inc. • Dayton 31, Ohio

## Make \$20 to \$30 a Week EXTRA MONEY!

With the high prices of food, clothing and everything else, just think what you could do with extra money every week! Turn your spare time into CASH—sharpening saws with a Foley Automatic



Saw Filer pays from \$3 to \$6 an hour. Start in your basement or garage—no experience necessary. "The first saw I sharpened with my Foley Filer came out 100%"—writes Clarence E. Parsons. No canvassing—"I advertised in our local paper and got in 93 saws—says M. L. Thompson. With a new model 200 Foley you can file all hand saws, also band and both combination and crosscut circular saws.

### FREE BOOK Shows How to Start

It explains how you can get business from home owners, farmers, carpenters, schools, factories, etc. "I get work from 20 and 30 miles away"—says Charles H. Smith. Free Book, "Money Making Facts," tells how to start. **Time Payment Plan.** Send coupon today—no salesman will call.

Send Coupon for **FREE BOOK**

**FOLEY MFG. CO.**  
216-2 Foley Bldg., Minneapolis 18, Minn.

Send **FREE BOOK**—"Money Making Facts,"  
and Time Payment Plan.

Name

Address



valleys are real depressions is a great help to poorly educated native troops. Such maps had existed only at high headquarters since they could not be folded.

The new map can be rolled or folded for travel. When unfolded, the plastic mountains pop right back into place.

The Army's research and development office is now studying several designs of "floating wheelbarrows." These will be man-powered, one-wheel carts capable of being pushed easily over any kind of terrain and floated over swamps. The lightweight wheelbarrows will solve the problem of transporting heavy loads where vehicles cannot move.

The R & D office also seeks an all-purpose adhesive that can be used to fasten demolitions to any surface, wet or dry. It will mean that Special Forces demolitions specialists will carry only one adhesive instead of several.

### Tactics Changing

One major change may be in guerrilla-fighting tactics. Now, counter-guerrilla groups are roving bands that catch guerrillas where they find them.

New tactics call for independent, self-contained groups of about 50 men each. The groups would be spread through guerrilla-infested country and operate as follows:

A guerrilla-infested part of the country is marked off and divided into sections. Each section is patrolled by one of these units, but all are in contact with a central headquarters, which in turn has a reserve force at its disposal. Upon contacting guerrillas, a patrol alerts headquarters and adjacent patrols. As the latter converge, headquarters dispatches paratroops or helicopter transports behind the enemy, who is surrounded and destroyed. Once an area is pacified, the government consolidates its control and moves its forces on to the next section of land to be cleared.

The keys to success here are constant patrols, good communication facilities, rapid mobility, and capacity for rapid concentration.

The guerrilla's traditional way of living off the countryside may be on the way out. Chinese Communist boss Mao Tse-tung contends that guerrillas are like fish and the local population is the sea in which the fish must swim. With the new Allied tactics the 50-man detachments will be well-supplied by air, leaving nothing to be drawn from the native population.

With new tactics and new weapons, the Allies are at last finding ways to fight the small brush wars—and win. ★ ★ ★

## END NUT and BOLT HANGOVERS

**DOT Teenuts**

Can't Slip ... Steel Threads in Wood  
Flush-Mounted ... Strong ... Versatile!  
The **One Nut That Makes Sense!**



Ideal for permanent work or where easy "knock-down" feature is wanted. Available to fit standard thread bolt sizes: 6-32, 8-32, 10-24, 10-32, 1/4-20, 5/16-18, 3/8-16. Available at

hardware dealers. If not, send \$1 for special mail order package and name of nearest distributor. Specify size.

**COLUMBIA FASTENER COMPANY**  
3229 South Ashland Ave. • Dept. PM • Chicago 8, Illinois

## GUNK® removes grease like no detergent can!



Cleans power mowers, engines, garage floors, kitchen walls, ovens, exhaust ducts, paint brushes, furnace filters, bar-b-q grills, machinery! At auto supply, farm, or hardware stores!

GUNK CHICAGO CO., River Forest, Ill.  
serving the Midwest and Southwest  
RADIATOR SPECIALTY CO., Charlotte, N.C.  
serving the East, Southeast and far West

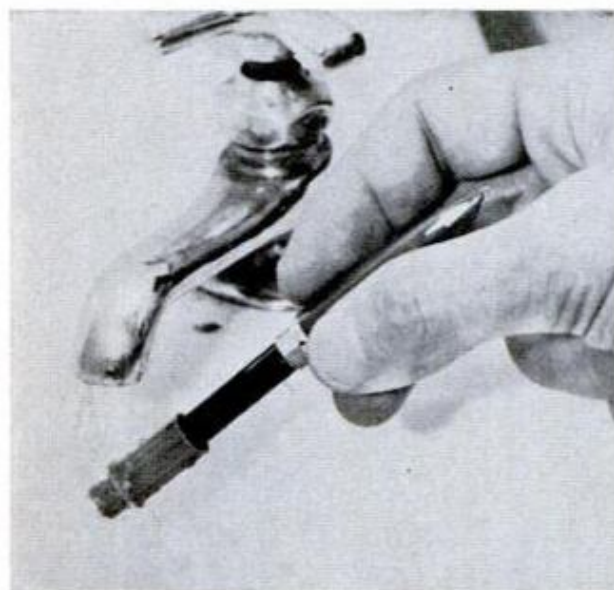

### Instant Ink! Just Add Water

Just dip a fountain pen into a glass of water, or hold it under a faucet, and in 30 seconds you have a full pen.

A new instant-ink capsule holds an ink concentrate sandwiched between thin sponge layers. When water is drawn through it, the capsule dissolves, producing a solution of ink.

Capsules are sold at three for 29 cents for Parker Pen's 61 models.

FEBRUARY 1962

**2  
New**

## RIGID Tubing Cutters

Give you Grooved Rollers  
for close flare cut-offs ...  
no waste! Also, Enclosed  
Feed Mechanism • Spare  
Cutter Wheel in Handle •

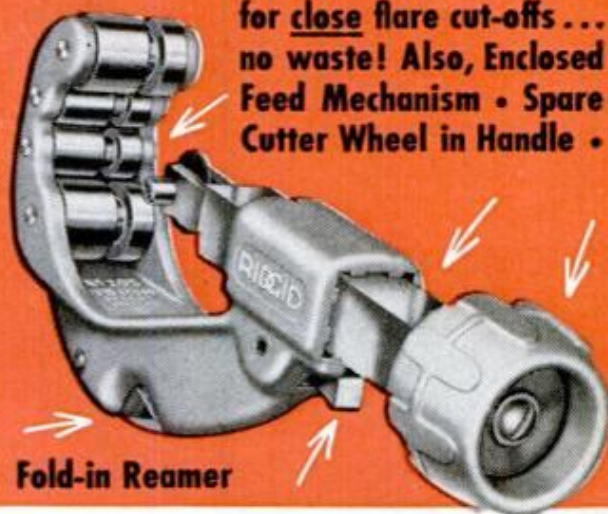

Fold-in Reamer

### RIGID No. 205 Tubing Cutter

Time-Saving, Slide-to-Size 1/8" to 2 3/8" O. D. Capacity

Made of lightweight, high-strength cast aluminum alloy, you'll find these new RIGID Tubing Cutters extra handy. Slight push on handle of large-size-range RIGID No. 205 snugs cutter wheel against tubing ... locks it in position until released. Feed screw fully protected and enclosed ... always feeds into tube with easy handle turn ... can't jam with chips or dirt. Wheel gives quick, clean cuts of copper, brass, aluminum tubing and thin-wall conduit ... no burr. Grooved rollers give easy flare cut-offs without tubing waste. Tubing always turns freely on 2 of 4 Rollers. Rollers smooth tubing ready for soldering. Fold-in reamer always handy. Spare Cutter wheel in handle. Wheel for plastic and aluminum pipe available for No. 205 only.

Conform to Fed. Spec. GGG-C-771b Type II—  
Class I—enclosed feed mechanism

### RIGID No. 105 Tubing Cutter



Protected Feed  
Screw Always  
Easy-Turning  
1/8" to 1 1/8" O.D.  
Capacity

Save time on home main-  
tenance and workshop proj-  
ects; get a RIGID Tubing  
Cutter from your Dealer today!

## RIGID

The Ridge Tool Company • Elyria, Ohio, U.S.A.

241

You've never seen a  
**THE *NEW***



**\$30<sup>00</sup>**

Only a nickel  
more than the  
next best drill



# power drill like it before: **DISSTON 1/4" DIRK!**

"The unusual design makes sense. With your hand directly behind the bit, you can drill straighter, apply more muscle on tough boring jobs and eliminate the wobble that breaks bits and gives you oval holes," says a well-known handyman's magazine.

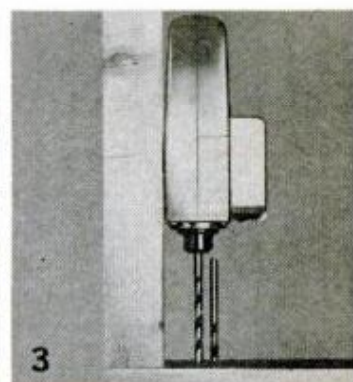
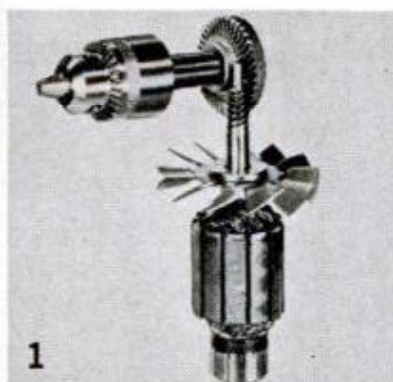

**1. POWER.** The Disston Dirk has a full 3-amp motor (1800 rpm) with Spiroid® gearing. It's one of the most powerful drills in its price class. These gears have more teeth in simultaneous contact than any other right angle gears. Plus, the Disston drill also has a built-in chip blower — and a three-wire safety cord.

**2. EXCLUSIVE! A STAND-UP BASE.** It's the only drill with a stand-up base, makes it easier to change bits. Drill bits won't break or bend when you set the unit aside because the Dirk is always in an upright position.

**3. YOU CAN SNEAK IT INTO CORNERS.** It's the only drill with an offset motor and a recessed Jacobs chuck. This gives the working end the slimmest profile available. You can also work between joists and get closer to floors and ceilings. (Note bit clearance required by conventional drills.)

Look for the new Disston Dirk 1/4-inch drill in your local hardware store. It's priced at \$30.00, only a nickel more than the next best drill. When you see it and try it, you'll want to buy it. The Dirk, made in Danville, Virginia, is another fine product from Disston, master toolmaker since 1840.

**PORTER**

**DISSTON DIVISION  
H. K. PORTER COMPANY, INC.**

**FOR COMPLETE COST AND PRODUCT INFORMATION  
ON THE PM VACATION HOME . . .**

## **VISIT THESE POPULAR MECHANICS COOPERATING IDEA PROJECT INFORMATION CENTERS**

**IDEA PROJECT**

**MINIMUM MAINTENANCE  
FOR MAXIMUM LIVING  
POPULAR MECHANICS**

**CENTER**

**WATCH FOR THIS SYMBOL ON THE DOOR**

The lumber and building supply dealers listed below, and who display the Idea Project symbol, are the best sources in your area for further product and cost information on the PM Vacation Home. We highly recommend their services to you—for this and other Idea Projects you'll see in Popular Mechanics during the coming year.

- |  |   |  |  |
|--|---|--|--|
| <p><b>ALABAMA</b><br/>Jasper<br/>North Alabama Lumber Co.<br/>201 West 22nd St.</p> <p><b>ARIZONA</b><br/>Scottsdale<br/>Hamman McFarland Lumber Co.<br/>6425 East Thomas Road</p> <p><b>CALIFORNIA</b><br/>Marysville<br/>Speckert Building Supplies, Inc.</p> <p><b>COLORADO</b><br/>Sterling<br/>Broadway Lumber Co.<br/>101 Broadway</p> <p><b>Wheatridge</b><br/>Wheatridge Lumber Co.<br/>8995 West 44th</p> <p><b>CONNECTICUT</b><br/>Hamden<br/>Centerville Lumber Inc.<br/>2308 Whitney Ave.</p> <p><b>IDAHO</b><br/>Idaho Falls<br/>Bonnevillie Lumber Co.</p> <p><b>ILLINOIS</b><br/>Blue Mound<br/>Blue Mound Lumber Co.</p> <p><b>Cambridge</b><br/>Clifford &amp; Clifford</p> <p><b>Chicago</b><br/>Gee Company<br/>2600 West 79th St.</p> <p><b>Fulton</b><br/>Brinkman &amp; Pessman Lumber Co.<br/>R. R. 1</p> <p><b>Joliet</b><br/>Cash &amp; Carry Lumber Co.<br/>816 South Gardner St.<br/>I. N. R. Beatty Lumber Co.<br/>North Broadway &amp; Chaney</p> <p><b>Marseilles</b><br/>I. N. R. Beatty Lumber Co.<br/>322 Main St.</p> <p><b>Morris</b><br/>I. N. R. Beatty Lumber Co.<br/>824 Liberty Street</p> <p><b>Mt. Olive</b><br/>Ervin J. Niemann Lumber Co.<br/>500 East 1st South Street</p> <p><b>Oak Lawn</b><br/>I. N. R. Beatty Lumber Co.<br/>9537 South 52nd Avenue<br/>I. N. R. Beatty Lumber Co.<br/>5167 West 95th Street</p> <p><b>Orland Park</b><br/>I. N. R. Beatty Lumber Co.<br/>9730 143rd Street</p> <p><b>Pontiac</b><br/>I. N. R. Beatty Lumber Co.<br/>703 East Howard Street</p> <p><b>Tinley Park</b><br/>I. N. R. Beatty Lumber Co.<br/>6721 North Street</p> <p><b>Watska</b><br/>Mackemer &amp; McBroom<br/>123 West Walnut</p> | <p><b>Wilmington</b><br/>I. N. R. Beatty Lumber Co.<br/>Kankakee Street</p> <p><b>INDIANA</b><br/>Decatur<br/>Arnold Lumber Co., Inc.<br/>425 South Winchester St.<br/>East Chicago<br/>Indiana Harbor Lumber &amp; Coal Co. Inc.<br/>3440 Watling Street</p> <p><b>Frankfort</b><br/>Kramer Brothers Lumber Co.<br/>608 West Washington St.</p> <p><b>Gary</b><br/>Grant Street Lumber &amp; Supply Co.<br/>3883 Grant Street</p> <p><b>Portage</b><br/>Willow Creek Lumber Co.</p> <p><b>Valparaiso</b><br/>Smith-Nuppenau Company<br/>360 Indiana Avenue</p> <p><b>IOWA</b><br/>Algona<br/>Ready Mix Concrete &amp; Lumber Co.</p> <p><b>Carroll</b><br/>Kanne Lumber &amp; Supply Co.<br/>814 West Ninth</p> <p><b>Marshalltown</b><br/>Marshall Lumber<br/>312 South 1 Avenue</p> <p><b>Waterloo</b><br/>Shepherd Lumber Co.<br/>1162 East Fourth</p> <p><b>KANSAS</b><br/>Argonia<br/>Mack-Welling Lumber &amp; Supply Co.</p> <p><b>Bogue</b><br/>Mack-Welling Lumber &amp; Supply</p> <p><b>Collyer</b><br/>Mack-Welling Lumber &amp; Supply Co.</p> <p><b>Garnett</b><br/>Star Grain &amp; Lumber Co.</p> <p><b>Horton</b><br/>Horton Lumber Co., Inc.</p> <p><b>Kansas City</b><br/>Logan-Moore Lumber Co.<br/>47th &amp; Mission Road</p> <p>Mack Lumber Co., Inc.<br/>26th &amp; Metropolitan Ave.</p> <p><b>Lawrence</b><br/>Logan-Moore Lumber Co.</p> <p><b>Lucas</b><br/>Mack-Welling Lumber &amp; Supply Co.</p> <p><b>Luray</b><br/>Mack-Welling Lumber &amp; Supply Co.</p> <p><b>Marion</b><br/>Mack-Welling Lumber &amp; Supply Co.</p> <p><b>Natoma</b><br/>Mack-Welling Lumber &amp; Supply Co.</p> <p><b>Palco</b><br/>Mack-Welling Lumber &amp; Supply Co.</p> | <p><b>Plainville</b><br/>Mack-Welling Lumber &amp; Supply Co.</p> <p><b>Pratt</b><br/>W. R. Green Lumber Co.<br/>803 North Main Street</p> <p><b>Quinter</b><br/>Mack-Welling Lumber &amp; Supply Co.</p> <p><b>Russell</b><br/>Mack-Welling Lumber &amp; Supply Co.<br/>122 East Seventh Street</p> <p><b>KENTUCKY</b><br/>Ashland<br/>Patton Lumber Co.<br/>53rd Winchester Avenue</p> <p><b>Burlington</b><br/>Burlington Lumber &amp; Building Supply, Inc.<br/>#2 East Park Drive</p> <p><b>Pikeville</b><br/>Pauley Lumber Co.</p> <p><b>MICHIGAN</b><br/>Birmingham<br/>Erb-Restrick Lumber Co.<br/>425 South Eton</p> <p><b>Detroit</b><br/>Mohawk Lumber &amp; Supply Co.<br/>East Side Yard<br/>11500 East Eight Mile Rd.<br/>Mohawk Lumber &amp; Supply Co.<br/>West Side Yard<br/>14525 West Chicago Ave.</p> <p><b>Escanaba</b><br/>Stegath Lumber Co.<br/>1812 Ludington Street</p> <p><b>Lincoln Park</b><br/>Mohawk Lumber &amp; Supply Co.<br/>Lincoln Park Yard<br/>2172 Dix Avenue near Southfield</p> <p><b>Livonia</b><br/>Mohawk Lumber &amp; Supply Co.<br/>Livonia Yard<br/>33600 Plymouth Road</p> <p><b>Roseville</b><br/>Mohawk Lumber &amp; Supply Co.<br/>Roseville Yard<br/>26640 Gratiot Avenue</p> <p><b>Royal Oak</b><br/>Erb-Restrick Lumber Co.<br/>803 South Main</p> <p><b>Unionville</b><br/>Unionville Lumber Co.</p> <p><b>MINNESOTA</b><br/>Bigfork<br/>Westby Lumber Co.</p> <p><b>Butterfield</b><br/>W. E. Schrader Lumber Co.</p> <p><b>Hopkins</b><br/>Justus Lumber Co.<br/>2 Excelsior Avenue, East</p> <p><b>Kasson</b><br/>Kasson Lumber Co.</p> <p><b>Litchfield</b><br/>Ideal Lumber Co.</p> | <p><b>Minneapolis</b><br/>Crystal Lumber &amp; Millwork Co.<br/>5353 Lakeland Ave.<br/>Lowry Lumber Co.<br/>111 Lowry Avenue</p> <p><b>St. Paul</b><br/>S. Berglund Lumber Co.<br/>1171 North Snelling Ave.</p> <p><b>South St. Paul</b><br/>Farmers Supply Company<br/>1030 North Concord</p> <p><b>MISSOURI</b><br/>Butler<br/>Logan-Moore Building Material Co.</p> <p><b>Carrollton</b><br/>J. E. Waddill Lumber Co.<br/>110 East Benton</p> <p><b>Kirksville</b><br/>Adair Lumber Co.<br/>122 South Elson</p> <p><b>La Belle</b><br/>La Belle Lumber Co.</p> <p><b>La Plata</b><br/>La Plata Lumber Co.</p> <p><b>Lewiston</b><br/>Lewiston Lumber Co.</p> <p><b>Maryville</b><br/>Maryville Lumber Co.<br/>315 North Market</p> <p><b>Milan</b><br/>Charles Rice Lumber Co.</p> <p><b>Salisbury</b><br/>Logan-Moore Lumber Co.</p> <p><b>Vandalia</b><br/>White Lumber Co.<br/>310 South Main</p> <p><b>MONTANA</b><br/>Missoula<br/>Wright Lumber Co.<br/>Hiway #10 West</p> <p><b>NEBRASKA</b><br/>Burwell<br/>Burwell Lumber Co.</p> <p><b>Millard</b><br/>Millard Lumber &amp; Grain Co.<br/>305 South Fifth</p> <p><b>North Platte</b><br/>Field-Birge Co.<br/>101 West Front Street<br/>Waltemath Lumber Co.<br/>800 East Front</p> <p><b>NEW MEXICO</b><br/>Hollywood<br/>C &amp; L Lumber &amp; Supply</p> <p><b>NEW YORK</b><br/>Brooklyn<br/>Gem Lumber Co.<br/>286 Ninth Street<br/>(Between 4 and 5 Avenues)</p> <p><b>NORTH CAROLINA</b><br/>Carrboro<br/>Fitch Lumber Co.<br/>309 Greensboro Street</p> <p><b>Dunn</b><br/>Nu-Home Builders Supply Co., Inc.</p> |
|--|---|--|--|

**NORTH DAKOTA**

**Anamoose**  
Heringer Lumber Co.

**Grand Forks**  
Ireland's Lumber Yard  
123 North Sixth Street

**Jamestown**  
M. Mooney Lumber Co.

**Sharon**  
Johnson-Sizer Co.  
369 South Dock Avenue

**OHIO**

**Canton**  
The DeVille Lumber Co.  
1225 Gross Avenue, N. E.

**Cleveland**  
The West End Lumber Co.  
7517 Lorain Ave.

The West End Lumber Co.  
4123 Pearl Road  
Cleveland, Ohio

The West End Lumber Co.  
4520 West 130th Street

**Coshocton**

Muskingum Valley  
Lumber Co.  
1247 East Main Street

**Hamler**

Panning Lumber Co.  
625 Belton Street

**Uniopolis**

Shaw Lumber Co.

**OKLAHOMA**

**Tulsa**  
Dale Carter Lumber Co.  
4459 South Sheridan Rd.

**PENNSYLVANIA**

**East Stroudsburg**  
R. C. Cramer Lumber Co.  
320 North Courtland St.

**TEXAS**

**Amarillo**  
Lumber & Supply Co.  
2601 East Third

Seale Amerson Lumber &  
Building Co.  
4201 N.E. 8th Street

**Ft. Worth**  
Chickasaw Lumber Co.  
2701 West Vickery

**Houston**  
Maynor Lumber Co.  
6316 Mykawa Road

**Midland**  
Andy's Lumber Co.  
1801 West Industrial

**Orange**  
West End Lumber Co.  
McArthur Drive

**San Marcos**  
Tuttle Lumber Co.  
228 South Guadalupe St.

**Shepherd**  
Beeson's Builders Supply  
Co.

**VIRGINIA**

**Virginia Beach**  
Virginia Beach Lumber &  
Supply  
Birdneck Road

**WEST VIRGINIA**

**South Charleston**  
Evans Lumber Co.

**WISCONSIN**

**Beaver Dam**  
Roedl-Jacobs Lumber Co.  
114 East Third Street

**Kenosha**  
Andrews Lumber Co., Inc.  
4800 75 Street

**Wabeno**  
Twin City Lumber & Fuel  
Co.

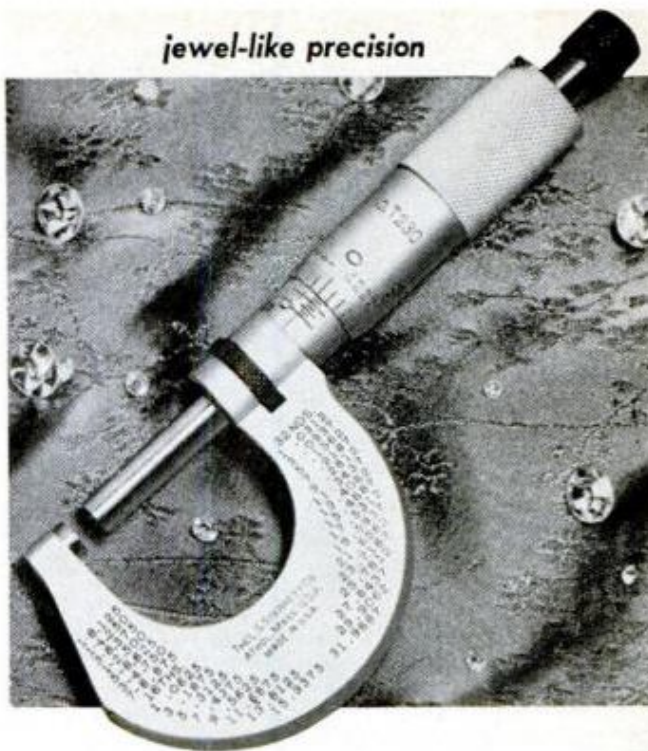
*jewel-like precision*

# Starrett®

## SATIN-CHROME MICROMETERS

Like jewels, Starrett SATIN-CHROME Micrometers have superior design and gem-like sparkle in detail and finish.

Precise, easy readability is assured with crisp, black, straight-line graduations and figures.

The knurled ring-type locknut securely locks the spindle without disturbing the setting or distorting the spindle.

Lapped, high-micro finish on the anvil and spindle, together with hardened and ground threads on the one-piece spindle, are added features assuring the highest degree of accuracy and lasting precision.

Ask your Industrial Supply Distributor or tool dealer to demonstrate these and many other precision features . . . or write for Catalog No. 27. Please use the coupon.

**STARRETT TOOLS** are carried by  
leading Industrial Supply Distributors  
and Hardware Tool Stores.

THE L. S. STARRETT COMPANY  
Dept. AP, Athol, Massachusetts, U. S. A.

Please send my free copy of Starrett Catalog  
No. 27 describing Starrett SATIN-CHROME Micro-  
meters and over 3000 other fine precision tools.

Name \_\_\_\_\_

Occupation \_\_\_\_\_

Address \_\_\_\_\_

City \_\_\_\_\_ Zone \_\_\_\_\_ State \_\_\_\_\_

## Valances Are Air Conditioners

Copper sheet with built-in tubing is the basis of the new Reflectotherm heating and cooling system originated by Dr. Clarence Mills of the University of Cincinnati. It has been tested in a home and an office for three years.

Decorative valance strips made of Revere Copper Tube-in-Strip carry warm and cold water for radiant heating and cooling. Fresh, clean air is introduced under low pressure by a separate ventilating system.

Winter comfort was achieved at air temperatures 8 to 10 degrees below those needed for warm-air-heated structures with a fuel saving of 40 percent, according to the tests.

## Mobile Vans for Heart Exams

Similar to the vans that travel from community to community giving free chest X rays to discover tuberculosis, new mobile vans may give "assembly line" heart tests.

A program proposed by International Business Machines would involve making mass tape recordings of heart sounds, which would then be fed into a computer and analyzed.

The chief benefit of the program, as in the TB tests, would be to discover unsuspected heart abnormalities. Those who have them could then be referred to the family doctor or heart specialist. A pilot study showed four of every 1000 children had undiscovered heart defects.

# FREE PLAN tells how to start your own business FILING SAWS

Here is a steady repeat CASH business you can start in your own basement or garage in your spare time and make up to \$3 or \$6 an hour. You can file hand, band and both combination and cross-cut circular saws on the Foley Saw Filer. No eyestrain—no experience needed.

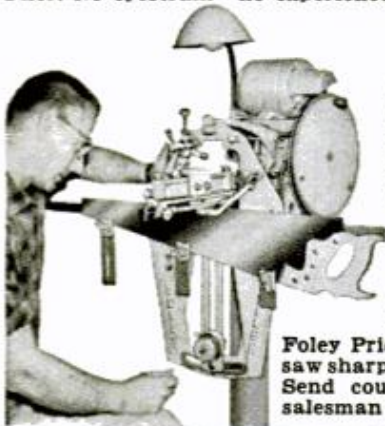

"The first saw I sharpened with my Foley Filer came out 100%"—writes Clarence E. Parsons.

Every saw you sharpen with the Foley Saw Filer brings you more customers. "I rented a two-car garage and have all the work I can do"—Charles H. Smith.

## FREE BOOK Shows How to Start

Foley Price Guide gives saw sharpening charges. Send coupon today. No salesman will call.

Send Coupon for **FREE BOOK**

**FOLEY MFG. CO.**  
243-2 Foley Bldg., Minneapolis 18, Minnesota.  
Send **FREE BOOK**—"Money Making Facts,"  
and Time Payment Plan.

Name.....

Address.....



## palley's FALL-OUT SHELTER BUYS

### PORTABLE 2000 WATT POWER PLANT

An efficient and dependable power source for Fall-out Shelters, Farms, Garages, etc. Will supply all electric power needs up to 2000 Watts. Generator rated at 28 V. DC, at 70 Amps at 3600 RPM. Comes equipped with a voltage regulator and a volt meter. Rope start or push button start with a 24 volt battery (battery not included). Engine is a single cylinder, air-cooled 2-cycle type and is direct coupled to the generator. Size: 21-1/4" x 8-1/2" x 18-1/2". Entire unit easily portable. Originally made for the U.S. Air Force. SAVE No. HLM-2000 .....



**NOW  
89<sup>00</sup>**

### Stainless Steel TANKS for FALL-OUT SHELTER • JEEP • TRUCK • FARM or GARAGE • IDEAL FOR WATER • AIR • OXYGEN or CHEMICALS

Type G-1 - An excellent storage tank for emergency drinking water, fuel, etc. Has 1/4" ports. Capacity 2100 cubic inches or 9 gallons. Tested to 400 PSI.

Order No. G-1 Excellent condition ..... **1195<sup>EA</sup>**

Type J-1 Large Volume TANKS - Same as above but holds 18,000 cu. in. of air or 77 gallons of liquid. Size: 45" long x 24" dia. 400 PSI test. No. J-1 - worth \$400 **9500**



### WORLD'S MOST AMAZING CATALOG

**260 PAGES of GOV'T SURPLUS**

Factory Closeouts and Hard-to-Find Bargains!

From EVERYWHERE Palley's bring you products of every description and at lower-than-wholesale 'DISCOUNT' prices. Here you'll find bargains in Hand & Power Tools, Electric Motors & Generators, Sports & Outdoor Equipment, "Gadgets," Aircraft Instruments & Hardware, Winches & Hoists - PLUS World's largest on-the-shelf stocks of Hydraulic Cylinders, Pumps, Valves, Motors, etc. at **SAVINGS up to 85%**. Order Your Copy TODAY and SAVE!

**Only 50c** Your 50c will be refunded with your first order of \$1.00 or more.

TO COVER HANDLING & MAILING

TO ORDER: Send check or M.O. 1/2 dep. with C.O.D.'s. All items sent freight or postage collect.

**palley's** 2263 E. VERNON AVE., Dept. PM-22  
LOS ANGELES 58, CALIFORNIA

## Owners Report on the Plymouth

(Continued from page 99)

car." — Alabama wire-weaving supervisor.

"The top is entirely too low. The windshield is entirely too close to passengers." — South Dakota farmer.

**For some yes, but that 43-degree slope cuts wind resistance and saves gas at turnpike speeds.**

"For use in my funeral business, my wagon is about 12 inches too short from behind the driver's seat to the top of the tailgate." — New Jersey funeral director.

**Perhaps Plymouth engineers would rather accommodate their live customers!**

"My taxi customers complain about low headroom." — Vermont taxi owner.

**They gripe about Plymouth's competitors too. Its headroom is about average.**

"I'd like a couple more inches of back-seat room because I keep the front one entirely back." — Pennsylvania music teacher.

**Here we go again—back to the behemoths —inch by inch!**

"Rubber around the ventilator windows isn't wide enough. The wind whistles around the glass all the time." — New York nurse.

"Weather stripping on windows doesn't fit too good, especially on the vent windows." — Illinois carpenter.

**This seems to be one of the big quality-control problems for the first few months of production on a new body design. The only real answer seems to be—stabilize your design.**

"A front side window doesn't fit properly and lets lots of air in when you're driving." — Texas teacher.

"The doors make too harsh a sound when closing." — Illinois salesman.

"Sharp point on the front door comes close to your eyes when you open it." — North Carolina architect.

"The doors still don't fit right—air comes in on both sides." — New Mexico government worker.

"I had to have door locks replaced." — Illinois TV serviceman.

"Water leaks in around the doors." — Michigan auto mechanic.

**Some day we may see precision-molded plastic door seals that will fill all uneven gaps.**

**Here are additional best-liked features, ranking seven through twelve in their order of mention.**

"It is small enough to park almost any place in the city without any trouble." — Montana logger.

"It has achieved a good compromise between inside seating space (3-seat wagon) and outside bulk and size." — Michigan librarian.

(Continued to page 248)

# NEW FROM ALADDIN



## B-I-Y

### ALADDIN'S NEW B-I-Y SYSTEM

combines the basic principles of the Readi-Cut Home with the most advantageous techniques of Custom-Built, Component, and Pre-Assembled construction methods.



This beautiful Aladdin Home is just one of 112 different styles and designs available from Aladdin. Prices range from \$3,000 to \$10,000, freight prepaid.

**ALADDIN . . .** the world's oldest and largest manufacturer of Readi-Cut Homes, now presents the most advanced concept in individual home construction yet developed . . . **ALADDIN'S NEW B-I-Y SYSTEM.** The B-I-Y System is another result of Aladdin's continuing creative research efforts . . . efforts dedicated to finding new ways of supplying "better homes for less money."

B-I-Y combines the basic principles of Aladdin's famed **READI-CUT HOME** with the most practical aspects of Custom-Built, Component, and Pre-Assembled construction methods. This combination of the best qualities of four different methods into one *simplified system* has produced a home-building concept far superior to any yet developed for the individual home builder.

### MAIL COUPON

for further information. You will receive the big new 1962 Aladdin "Book of Homes" . . . 72 pages filled with valuable home-building suggestions.



Aladdin B-I-Y was developed so *you can have a quality home for less* whether built by yourself or erected by others. It has been *field tested and publicly accepted.*

### SAVE TIME!

*Outside walls and inside partitions erected, and outside walls sheathed, in 50% less time;*

*Inside rough door openings completed (frame, trim, door, and hardware applied) in 30 minutes.*

### SAVE MONEY!

These, and many other savings, are yours with our new *place and nail* system.

### QUALITY MATERIAL THROUGHOUT

Build the Aladdin B-I-Y way—save up to \$5,000.

**THE ALADDIN COMPANY**  
BAY CITY, MICHIGAN

62-20

Please send 1962 "BOOK OF HOMES" with complete information about the new Aladdin B-I-Y Home-Building System. Enclosed is 25¢.

NAME \_\_\_\_\_

ADDRESS \_\_\_\_\_

CITY \_\_\_\_\_

ZONE \_\_\_\_\_ STATE \_\_\_\_\_

(Please Print Carefully)

**Bore 35 standard holes  
with just one tool**

**New IRWIN  
Expansive Bit**

*lets you dial your size*

Just turn the dial and you're set to go with this new Irwin Expansive bit. No hunting for the size you need. Fits all hand bit braces. Clean, fast, accurate boring action from  $\frac{7}{8}$ " to 3"—35 standard hole sizes in all!

And what a really fine precision tool to own. It's drop-forged from special bit steel, heat treated full length, machined for accuracy and sharpness, highly polished, too. Two cutters supplied with each bit. Model No. 21 with  $\frac{5}{8}$ " to 1 $\frac{3}{4}$ " boring range also available. Ideal for home handyman, professional woodworker, or farm. See your independent hardware dealer soon.



**No. 22  
Micro  
Dial  
only  
\$4.00**  
 $\frac{7}{8}$ " to 3"  
boring  
range

**IRWIN**

Wilmington, Ohio

the original solid  
center auger bit  
screw drivers  
screw driver bits



**CLIK-STOP**  
Adjustable  
Wrench

**AUTOMATICALLY  
LOCKS AT  
EVERY SETTING**

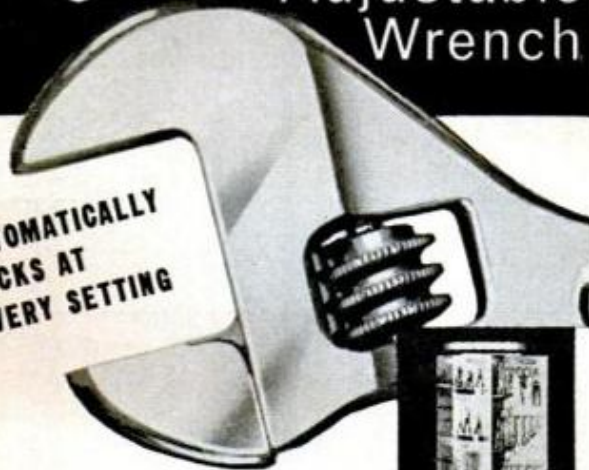

No levers . . . no gadgets . . . it won't slip or work loose . . . ever! You can yank it, bang it, even on the toughest jobs the jaws will never work loose. Available in both chrome or industrial-black finish in sizes from 4" to 20".

Send 10c for descriptive P&C Tool Catalog.



Look for the colorful  
P&C Merchandisers  
in over 12,000 stores.

**P & C TOOL COMPANY**

Portland 22, Oregon • subsidiary of Pendleton Tool Industries, Inc.

"It is large enough on the inside and by cutting off some of the length it is easy to park and fits in my garage."—District of Columbia government engineer.

"This is a full-size car trimmed down some—less weight."—Pennsylvania investment manager.

*Its size should suit most logical motorists, yet 5.3 percent complain of lack of head or legroom.*

"Holds the road on old pavements like a heavy car."—Missouri insurance agent.

"I like the cornering and roadability—best handling car I've ever owned."—New Mexico airman.

"Handles well; fine balance; no sway on curves or at high speeds (60-65 m.p.h.)."—Michigan city assessor.

*PM's Plymouth Six was stable at 85 m.p.h. traveling on uneven black top.*

"It holds the road better than any light car I have ever driven."—Tennessee farmer.

"I like the self-adjusting brakes and their straight, swift, sure stopping power."—New York toxicologist.

*Brakes are new on '62 Plymouth—a different design—but one that's had plenty of testing time on other cars.*

"Quick, smooth stopping."—Oklahoma teacher.

"Quality is excellent; fit of the chrome is good—no mismatch. Tight, no body rattles."—Michigan engineer.

"The improved fit of the trim is what I like. Things actually fit together for a change!"—Iowa timekeeper.

*Like many other loyal Plymouth owners he's noticed that something new has been added—quality.*

"Six-cylinder motor is silent."—Ohio retiree.

"I like the comfortable seats; you sit up straight as in a chair."—Michigan photo-engraver.

"There's an improvement in seating comfort in the rear seat as well as the front."—New York foreman.

*Seats are comfortable but the degree of improvement depends on what you were driving before.*

*Getting back to the gripes, here are representative complaints on items six through nine in order or frequency.*

"You must lift things too high to place them in the trunk."—Pennsylvania plant guard.

"Don't like the construction of the luggage compartment which requires lifting any object placed in it as high as the top of the car."—Illinois office manager.

*If you don't have this high "transom" area say the engineers, you must have double (inner) trunk walls, hence less space inside.*

(Continued to page 250)

# SURPLUS SALE

GOVT. SURPLUS  
EXCESS INVENTORY  
BANKRUPT STOCK



## GOV'T SURPLUS A-C POWER PLANTS

Wonderful buys in fine Govt. plants and generators. Save 40% to 70%.

- 1000-w 115-v 60-c ..... \$172.50
- 2500-w 115-v 60-c ..... 269.50
- 3500-w 115/230-v ..... 329.50
- 5000-w 115/230-v ..... 479.50
- 3000-w AC generator ..... 139.50

## HYDRAULIC SURPLUS BARGAINS

- Great savings. Build loaders, diggers, presses, etc. Brand new equipment.
- \$95 Pump, 1000 lb., 14 gpm. .... \$41.60
- 12-v Battery Hyd. Pump ..... 18.49
- Hand Hyd. Pump and Cylinder .... 27.95
- \$39 Hyd. Cy. 3x8" 2-way ..... 19.70
- Hyd. 2-way 1000-lb. Valve ..... 18.00



## AIR COMPRESSOR EQUIPMENT

- Make your own outfit. For painting, tires, shop use, etc. Save to 60%.
- Compressor, \$21.50. Gov't Tank, \$10.95. Gauge, \$1.75. Paint Gun, \$11.50. Auto Switch \$4.75. Air Regulator \$3.95.

## DIAL TELEPHONE

Item #716. Std. phone, same used on all phone systems. Use as extension to main phone and on private systems. Directions furnished. Wt. 8 lbs. Cost \$25.00. SALE... **\$7.95**



## STORAGE BATTERY WINCHES—HOISTS

Item #311. Expensive 12-v Gov't. reversible, ball bearing 2000-lb. capacity winch. Holds 40' 1/4" cable. For trucks, docks, boats, etc. Cost over \$250. SALE... **\$49.95**



Many other types battery winches—hoists.

## FARMERS—CONTRACTORS PUMPS—PIPE

Item #204. Self priming Timken bearings, 1 1/2" size, use for irrigation, swimming pools, boats, cellar drains, etc. Wt. 32 lbs. Gov't. cost, \$80.50. SALE... **\$19.49**



## SPECIAL OF THE MONTH!

### U. S. ARMY FIELD TELEPHONES

Item #756. Limited quantity of these efficient compact phones, wonderful for contractors, farmers, Boy Scouts, foresters, builders, etc. Complete units, require only single pair wire between stations. Has own signal generator, bell, etc. Talk over any distance up to 20 mi. Gov't. cost over \$30. SALE Two for **\$24.95** ..... **\$13.97** each.



### EXAMPLE BARGAINS 1962 CATALOG

- \$12 Fish & Worm Shocking Generator... \$3.49
- \$155 Telephone Audio Amplifier... 14.91
- 30e G-Pr. Buried-Aerial Cable... 5c ft.
- \$30 Linesmen's Belt & Safety Strap... 10.29
- \$35 Motor Driven Sweep Floodlight... 7.95
- \$40 Fire-Burglar Alarm System... 12.95
- \$29 0-120 AC Motor & Transformer... 8.39
- \$17 Immersion Heater 800-w 115-v... 3.31
- \$250 Welding Generator 200 amp... 14.95

ALL FOB LINCOLN

Write today for large 1962 catalog.

## SURPLUS CENTER

DEPT. 804, LINCOLN, NEBR.

# INCREASE HOME VALUE—MAKE NEEDED IMPROVEMENTS NOW

**\$25.95**

POSTPAID

## NEW 1/4 H.P. bench grinder

- FINGER-TIP ADJUSTABLE TOOL RESTS
- 80-GRIT 6-INCH WHEEL
- CUSHION RUBBER FEET
- DIE-CAST ALUMINUM HOUSING
- HEAVY-DUTY CAPACITOR MOTOR
- 46-GRIT 6-INCH WHEEL



### MONEY-BACK GUARANTEE—

You save over 40% on this top-quality, 1/4 hp bench grinder. If not satisfied, return prepaid in 10 days for full refund. Full 90-day warranty. Underwriters' listing... Send check or money order; no C.O.D.'s, please.

ORDER BY MAIL  
**SAVE OVER 40%**

HUNTER DIVISION, ROBBINS & MYERS, INC.,  
P. O. BOX 3775-B, MEMPHIS, TENN.

## MANUFACTURE THIS BEAUTIFUL CONCRETE OUTDOOR FIREPLACE

Right In Your Own Backyard

**\$4.00 Worth of Sand & Cement produces this Attractive Fireplace.**

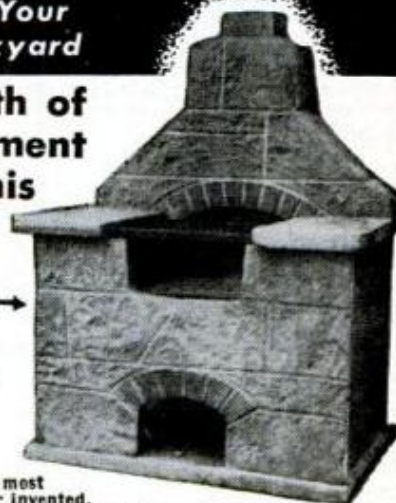

**Sells on Sight from \$60. to \$80. Easy to start your own Profitable Business.**

The General Fireplace Molds and Process are the most amazing and foolproof ever invented. Simple to operate. Two men can produce five fireplaces a day.

### BIG DEMAND!!

Sell all you produce to Department Stores, Homeowners, Parks, Nurseries and Picnic Groves. Fireplaces sell on sight. No experience necessary. We supply full operating instructions and equipment plus the know-how that spells **BIG PROFITS**. This is an outstanding opportunity for men of vision and small capital to get into a busy rich paying field. Don't delay, be the only exclusive manufacturer in your own home town. Mail coupon at once for full details as to how you can reserve your territory. **Molds sold only on exclusive franchise.**

**GENERAL ENGINES CO., Inc., Dept. MF-22**  
ROUTE 130, THOROFARE, N. J.

Mr. Tor of Philadelphia writes: Sold 250 in first 4 months. Selling to Sears Roebuck, John Wanamaker, and Gimbel Bros. in Philadelphia area.

Name .....  
Address .....  
City ..... Zone .....  
State .....



## PIPE THAWER TRINDL ARC WELDER

**THERM-O-TRON PIPE THAWER**, the original, tried & tested way to safely, easily, electronically thaw frozen pipes. All voltages. Portable complete with cables - clamps, instr. Just **\$98.50**. Also **BRAZE - SOLDER - SWEAT COPPER PIPES**. Indispensable for farmers - plumbers - homes - industry - etc.

Do your own metal work... **WELD - BRAZE - SOLDER - CUT** Thrifty & expertly. World-Famous **125A TRINDL WELDER**, 110/220 V marvel gives 16 heats, 20-125 amps. Handles 1/16" - 5/32" rods & 1/2" metal. Only **\$98.50** complete. TRINDL mfg'rs. range of heavier models.



GUARANTEED full year for CONTINUOUS OPERATION. WRITE for details, also time payment plan. Dealer inquiries invited.

**TRINDL PRODUCTS, LTD. Dept. T2-B 1807 South Clark Street Chicago 16, Illinois**

this message to  
**AUTO MECHANICS** contains  
**FACTS EVERY CAR OWNER**  
**OUGHT TO KNOW ABOUT**  
**THE BEAR®**

# LINE-UP OF PROGRESS

## FACT 1. 7 OUT OF 10 CARS ARE OUT OF ALINEMENT!

50% Tire Waste due to misalignment is common. Quickest test for both front and rear wheels: *The Bear Drive-Over Scuff Check*. As soon as your wheels pass over the platform, your car is checked. Quick-as-a-wink, the *New Tire Waste Forecaster*, tells you exactly how much tire life you are wasting!

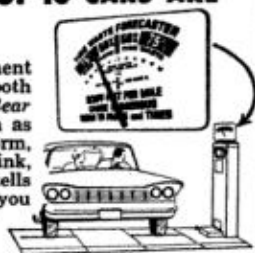

## FACT 2. CAR FACTORY APPROVED SETTINGS ASSURED WITH CHECK-O-MATIC AND TELAMATIC SYSTEMS.

Now, both the mechanic and the car owner can see AT-A-GLANCE whether wheel alignment meets car factory specifications both BEFORE AND AFTER CORRECTION! Special templates for each model car assures perfect settings of caster and camber!



## FACT 3. MISALIGNMENT WEARS OUT TIRES AND PARTS; CAUSES UNSAFE, FATIGUING STEERING!

Wheel shimmy, hard, see-saw steering, road wander, accidents! All these are the results of misalignment. So easily and accurately is it detected and corrected with Bear Equipment that costs for this service are most reasonable.



## FACT 4. BEAR LEADERSHIP IN PRECISION EQUIPMENT, BEAR SCHOOLS, BEAR SIGN OF PROGRESS.

In Bear's *Line-Up of Progress* are the newest developments in shop equipment for wheel alignment, balancing, body repair, brake, headlight and steering service. Superior adjustments are assured through use of this equipment by BEAR SCHOOL TRAINED MECHANICS. Look for the BEAR SIGN, the sign car owners look to with confidence. No wonder more shops display the BEAR SIGN and use Bear Equipment than all others combined!



PASTE ON A POSTCARD AND MAIL WITH YOUR NAME & ADDRESS TO:  
**BEAR MFG. CO., Dept. P-10, Rock Island, Illinois**

I'm interested in  CAR OWNER FACTS BOOKLET  
 BEAR SCHOOL  BEAR SERVICE AS A BUSINESS OPPORTUNITY

"I am disappointed in the gasoline mileage (12 m.p.g. with V8, automatic transmission), however, I am assured by the dealer that it can be improved."—Iowa banker.

"I'm getting poor gas mileage. My '59 V8, same motor but a four-door, averaged 20 m.p.g. on the road and 18 in the city."—Arizona army officer.

"Padding on the instrument panel has a glossy finish that reflects on the windshield as you drive into the sun and tremendously impairs visibility."—Colorado clerk.

"Dash glare in the windshield on sunny days is very bad."—Montana physician.

"I cannot see any part of the rear of the car when backing up, but I'm getting used to it."—Colorado petroleum worker.

**This is a real problem for short-waisted people who sit low in their cars. You can't see the rear "corners" of the car.**

"I am unable to see the right front corner and the rear from the driver's seat."—Arizona auditor.

"With the windshield and rear window smaller, vision is not as good as previously."—New York minister.

**And here are the final favorable comments in order of mention, numbers thirteen through eighteen.**

"I like being able to see the road over the engine while driving."—Colorado retiree.

"I like the easy-to-view instrument panel and the compact control center."—Alabama electrical engineer.

**If prizes were given out for new instrument panel designs of '62, Plymouth would have itself a blue ribbon.**

"Plenty of room for the three six-footers in our family."—Michigan salesman.

"High back on second wagon seat makes a 'playpen' in the rear area."—Colorado housewife.

"The new second gear is what I like. It gives a faster getaway."—Maryland plant guard.

**For a final short list of complaints, here are items ten through twelve as they occur in frequency.**

"I'd like to have the windshield a few inches farther forward."—North Dakota advertising salesman.

"Too much wind noise through vent window."—Missouri clerk.

**This seems to be result of an accumulation of "off" tolerances in door structure, window frames and sealing rubber that all add up in the wrong direction.**

"The location of the spare tire takes up too much room."—Florida expediter.

"The spare tire is in a very poor place, right in your way."—Indiana tool and die maker.

★★★



# CUT-TO-FIT HOMES CUT COSTS UP TO 40%

Save labor cost up to 100%, reducing completed home cost up to 40%. You can assemble any of 57 designs from easy-to-follow plans. No measuring or cutting . . . every piece precision machine pre-cut and marked. **BUY DIRECT FROM MILL.** Eliminate all between overhead, profit and labor

costs. Nothing to plan or figure. Complete with all lumber, hardware, paint, nails, glass, roofing, etc. Sterling Home quality material throughout. Freight paid most areas. Write today. Send 25c for illustrated, color catalog, floor plans and details.



PRICED FROM \$2295 UP

CHOICE OF 57 DESIGNS

FIVE EASY-PAYMENT PLANS

INTERNATIONAL MILL & TIMBER CO. Bay City, Michigan, DEPT. PM22

## Mobile Snow Melter

Melting snow at the rate of about 300 gallons a minute, a mobile unit can, in one hour, rid a city's streets of an amount equal to 40 truck loads.

The snow melter, developed by Esso Research and Engineering Co. of Linden, N.J., consists of a melter mounted on a trailer drawn by a truck tractor. A tank containing highly agitated water heated to about 45 degrees receives the snow dumped in by front-end loaders. Using the principle of submerged combustion, the device melts the snow almost instantaneously and the water drains into the sewer system.

## Oil Is Alaska's Top Resource

No oil was produced in Alaska until three years ago, but production for 1961 was an estimated six million barrels. It may have succeeded gold as the state's largest mineral resource.

The first oil discovery was made on the Kenai Peninsula in July, 1957, and all production has taken place in that area. One company plans to build a \$20,000,000 refinery there.

Wildcat activity is spreading, however, and 13 companies have geologists working at the northern edge of the continent.

## The 'All-Purpose' Oil For Home Workshops

Cleans • Lubricates • Prevents Rust

## 3-IN-ONE® OIL

REGULAR—OIL SPRAY—ELECTRIC MOTOR

## EVERLITE\* World's THRIFTIEST Light Plants

(Item 869-15T)



1500 watt amazing new alternator. Most efficient trouble-free light plant ever made. Rugged new transistor circuit eliminates commutator and armature—all the old headaches of generators gone. Output is standard current—115v., AC—operate oil burner, freezer, lights, TV, power tools or anything that requires up to 1500 watts. Powered by sturdy fast starting 3 hp Briggs engine guar. for 1 full year. Price is unbelievable, only \$209.50 F.O.B. factory for the finest 1500 w. plant made.

\*Trade-Mark Registered Everlite 1500 watt, Item 869-15T Wt. 60 lbs. . . . . \$209.50

### STANDARD DIAL PHONES WITH BELL

Western Electric dial phones same as used by all telephone companies. Easily installed as extension phones. Also ideal for private phone system. (Please specify). Merely dial to ring other party—Local and clear even at long distances. Needs 2 cond. wire for private line. Item 855, Wt. 8 lbs., each phone . . . . . \$8.95 Wire—4 cond. 22 gage, 250 ft. coil . . . . . \$4.95 Wire—4 cond. 19 gage (for distances over 500 ft.) 250 ft. coil . . . . . \$7.95



Fast delivery—10 day money back guarantee. All prices f.o.b.

MASTER MECHANIC MFG. CO., Dept. A-262, Burlington, Wis. Southern Customers Order from Dept. A262, Box 65, Sarasota, Florida

## \$47,983.06 ORDERS FROM 12 WORD CLASSIFIED AD.

Amazing—Startling—but TRUE. Terrific story sent free. Request must be made on business letterhead. F. W. Johnson, Classified Adv. Manager, 200 E. Ontario St., Chicago 11, Ill.

## HANDIEST SAW YOU EVER HELD! Cuts Wood -- Metal -- Plastic -- up to 4 1/4" thickness with Finger-Tip Control

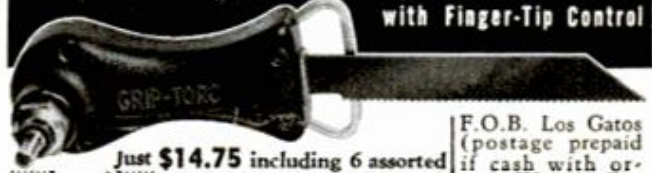

Just \$14.75 including 6 assorted blades, lubricant and wrench (postage prepaid if cash with order). Wt. 2 1/2 lbs. GRIP-TORC Saw gives YOU control of the blade because of its right angle pivoting on electric drill. Compact 6 1/4" length gets at hard-to-reach places . . . cuts squares, circles, bevels, and close to wall or floor. Reversible blade for right or left hand use, with push or pull movement. Provides unexcelled cutting speeds. Unconditionally guaranteed. Order today!



tools 17480 SHELburnE WAY LOS GATOS, CALIFORNIA

## THAW FROZEN WATER PIPES FAST.



Thaw pipe without digging or creating fire hazards. Just plug this low cost PORTA-THAW into a regular 110/220v AC power line. It's completely safe. Has no connection between power line and output terminals. Provides low, medium, high currents. Clears lines in 5 to 20 minutes. Complete with power cable, plug, receptacles, two thawing cables. Ask for data sheet TH-3-10.

HOBART BROTHERS COMPANY, BOX M-22, TROY, OHIO, PH. FE: 2-1223

## DC WELD • RUN AC TOOLS



New low cost welder/power combination furnishes DC current for welding and 110/220 v. AC power. Runs lights, tools, motors, pumps, sprays, etc. Can be invaluable as an emergency power source for brooders, milking machines, furnaces, etc. Ask for data sheet A-279-J.

	
Has the face of our house changed!	We used to have this old basement door.
	
Till we heard about all-steel Bilco.	And replaced our old door.
Spring balanced Bilco Doors open at a touch . . . lock securely . . . are weathertight, cost so little! The door used on thousands of new homes!	
The Bilco Co., Dept. RJ2 New Haven 5, Conn. Please send me your fully illustrated folder and name of local dealer.	
 <b>AMERICAS FINEST BASEMENT DOOR</b>	
Name _____ Address _____ City _____ Zone _____ State _____	



### Robot Bank Teller

Customers may insert blank deposit slips in an automatic machine that accepts coins, currency and checks — and receive validated deposit slips in return.

The machine is expected to speed up rush-hour service in bank buildings. In addition, banking service can be extended beyond the building by placing machines in shopping centers and remote locations.

Employing electronic and electromechanical techniques, the Bankograph makes a microfilm record of the deposits to insure accuracy and packages each deposit separately. It is made by Reflectone Electronics of Stamford, Conn.

 **YOU NEED THIS**

**FREE GIANT B-A CATALOG**



- SAVE UP TO 50% ON B-A SELECTED KITS
- HI-FI AND STEREO SYSTEMS & COMPONENTS
- TOP VALUES IN POWER AND HAND TOOLS
- 30 PAGES OF BARGAINS NOT IN ANY OTHER CATALOG

**BURSTEIN-APPLEBEE CO.**  
Dept. PM, 1012 McGee St., Kansas City 6, Mo.  
 Rush me New 1962 B-A Catalog No. 621

Name \_\_\_\_\_  
Address \_\_\_\_\_  
City \_\_\_\_\_ State \_\_\_\_\_

**SEND FOR IT TODAY**

**The Clown Who Winks**

his eyes in tempo with the music. Watch for this clever radio receiver project in the upcoming March issue of

**POPULAR MECHANICS**

**WAR SURPLUS AND OTHER BARGAINS SAVE UP TO 90%**

**DC JET GENERATOR ARC WELDING KIT** Complete with GE Type CM-77 Generator (30 volts D.C., 400 Amp., 3000 RPM up; ampere rating is for continuous duty, intermittent amperage is 500 to 600 amps.), also 2 rheostats, 1 voltage reg., 1 voltmeter, 1 electrode holder, 1 welder's mask, 1 toggle switch, 10 lb. vacuum packed 1/4 in. welding rods, pair welder's gloves & spline coupling. All units guaranteed pre-tested. Wt. 110 lbs. Approx. GOVT. COST \$700. All items, now only **\$64.50**.

\*G.E. Generator noted above can be purchased separately. Makes deluxe heavy-duty welder comparable to the finest commercial welders available. Wt. 90 lbs. Approx. GOVT. COST \$600. Gen. alone—\$49.50.

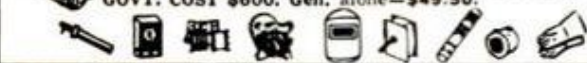

**ELECTRIC STORAGE BATTERY WINCH**

New, improved model contains heavy-duty, 2-way drum switch. Fully reversible heavy-duty, two-speed motor, 160 to 1 gear reduction. Ball bearing construction throughout. Drum will handle 70' of 1/4" cable. Can be used on 6, 12, 24 V. battery. Lift cap. 2000 lbs. plus. Ready to install & operate. 19" long x 9" wide x 8" high. For jeeps, trailers, boats, trucks, etc. Complete with mounting flange safety load locking brake. Shpg. Wt. 60 lbs. Approx. GOVT. COST \$400. NEW. Model E. **\$49.50**.

**"SUPER 9" 200 AMP WELDING KIT** With Deluxe accessories consisting of one 200 AMP. Gen., adjustable helmet, electrode holder, ammeter and shunt, rheostat, toggle switch, voltmeter, voltage reg., 1 pr. heavy-duty welder's gloves and 30' cable. All units guaranteed pre-tested. Approx. GOVT. COST \$500. Most items new—all perfect, **\$27.50**.



**SOUTH WIND HEATER & ACCESSORIES**

Manufactured for govt. antarctic expeditions for jeeps and half-tracks. Heating unit puts out over 20,000 B.T.U.'s. Late recirculating type. Burns any type gas. 12 volt system. Fuel consumption extremely low, 1 gal. per 8 hrs. Terrific for trucks, etc. With service & installation manuals & many components. Approx. GOVT. COST \$550. Shpg. wt. 50 lbs. NEW. **\$39.95**. Limited quantity.

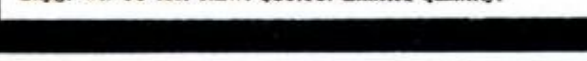

**R1 GENERATOR—300 AMP.** Make your own arc welding and battery charging unit. Terrific source of power for all 24-32 V. equipment. Simple installation with our wiring diagram. All generators pre-tested in our own shop. Approx. GOVT. COST \$400. Like NEW. **\$16.50**.

**ELECTRIC PUMP WITH CONTROL UNIT**  
Runs on 12 or 24 V. Centrifugal type. Draws 5.2 AMPS. Has built-in removable filtering screen. Great for bilge, circulating or sump pump... bait tanks, etc. Pumps 400 GPH. Complete with on and off switch rheostat. Shpg. Wt. 7 lbs. Approx. GOVT. COST \$195. NEW **\$8.95**.

**DELUXE ELECTRIC STORAGE BATTERY WINCH**  
Handles 250' of 1/4" steel cable. Operates on 6, 12, 24 V. battery. 160-1 gear reduction. Lift cap. 2500 lbs. Contains heavy-duty mounting base with outrigger bearing and spool support. Rugged construction. Heavy-duty dual speed motor with safety load-locking brake. Dim. 24" long x 9" wide x 8" high. Great for jeeps, trailers, boats, trucks & campers. Shpg. Wt. 80 lbs. Approx. GOVT. COST \$490. NEW. Model E-D. **\$69.50**.

**FRESH WATER SYSTEM PUMP**—For boats, campers & trailers. Output 10 to 200 gal. an hr. Variable rheostat controls output. 1/2" pipe thread into bronze impeller housing. 12 V.D.C. Radio noise filter. 5.2 amp. draw. Explosion-proof const. Shpg. wt. 11 lbs. Complete with mounting instructions & wiring diagram. Approx. GOVT. COST, \$200. NEW. **\$10.95**.

**225-1 REDUCTION GEAR** For beaching boats, winches, hoists. Ideal motor in golf or boy's electric car. DC motor and clutch. Easily reversible wiring diagram furnished. Hi torque. 105 RPM. Runs on 6-12 or 24-32 V. 65 lbs. gross. Approx. GOVT. COST \$300. **\$13.50**. Matched splined gear—\$3.00 ea.

**NEW 1962 CATALOG!** Tremendous catalog—our biggest ever—fully illustrated—1000s of bargains in war surplus & other items. Send 25c in coin for your copy today or free copy with order. Where ppd, indicated applies to US only. Other prices FOB Culver City, Calif. Send cash, check, money order, 50% deposit for COD.

**AIRBORNE SALES CO., INC. DEPT. PM262**  
8501 Stellar Drive, Culver City, Calif.

**WHERE-TO-FIND-IT LIST**

WHERE-TO-FIND-IT List for this issue, free on request, gives sources of supply or further information on all editorial items for which this information is available. Send a stamped, self-addressed envelope to



**SERVICE BUREAU**

200 E. Ontario Chicago 11, Illinois

**SAVE MONEY... EARN MONEY**

with the **MET-FORMER**

**ROLLS • FORMS • BENDS**

Make screen door guards, wall hangings, plant shelves, room dividers... anything you want in light wrought metal and with a truly professional appearance. Form rod, tubing or flat metal.

**\$34.95** PREPAID including material

Write for information and free project folder. **SWAYNE, ROBINSON & CO.** Dept., A. 228 E. MAIN ST., RICHMOND, IND.



**POWERFUL**

**SAFE!**  
No chain to grab or whip

**FREE PLANS**

10,000 cutting strokes per minute

**WRIGHT POWER BLADE SAW**

The most useful gasoline-powered saw you can own. Rugged power for felling 20" trees, smooth cut for carpentry or pruning, perfect for firewood. Safe to use, even on a ladder. Send coupon today for free plans, literature and the name of your nearest dealer.



Plans for log cabin also shows how to build duck blind, rustic furniture, boat dock, fences, etc.

**HOW TO BUILD A LOG CABIN**



THOMAS INDUSTRIES INC., Wright Saw Div. Dept. PM-2, 207 E. Broadway, Louisville 2, Ky.

Name \_\_\_\_\_  
Address \_\_\_\_\_  
City \_\_\_\_\_ Zone \_\_\_\_\_ State \_\_\_\_\_

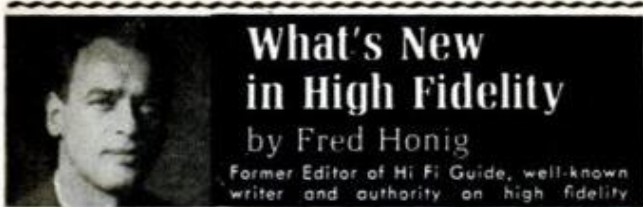

## What's New in High Fidelity

by Fred Honig

Former Editor of Hi Fi Guide, well-known writer and authority on high fidelity

### Music Throughout Your Home

You'll work better in your shop—have more fun in your playroom or greenhouse, out on your patio, relax more at bedtime—with the right kind of music throughout your home. From a central control point—perhaps located in your living room—a compact stereo/high fidelity music system will bring you the true realism and depth of the music you want to hear, where and when you want it. This arrangement is also ideal for the kids' playroom, since it keeps them out of the living room, yet lets them enjoy the music they want—superbly reproduced. Besides great flexibility, components offer economy, too, because the need for several installations is eliminated.



**DYNACO's**  
FM-1 Dynatuner  
Kit, \$79.95  
Semi-kit, \$99.95  
Pre-assembled,  
\$119.95

For example, FM tuners (stereo or monaural) built specially for component systems, incorporate the latest electronic advances, and can act as the source for radio signals heard throughout your entire home. Teamed with other components of your music system, a tuner such as shown will provide radio listening of a quality obtainable only through components.

Records are a wonderful source of high fidelity music, and one record player can serve the entire home. The sound of your records depends upon the engineering of the record player which must track sensitive cartridges for a wide range performance without undesirable effect. This demands precision turntables, motors and tone arms. Some units (as shown) are automatic.



**GARRARD**  
Type A  
Automatic Turntable  
(Dynamically Balanced  
Tone Arm)  
\$79.50



**ALTEC-LANSING**  
Model 605A  
"Duplex" Speaker  
\$177.50

Whatever the sound source, what you ultimately hear is the speaker. Full range speaker units, such as that shown, can reproduce the full spectrum of sound undistorted. Yet they offer great versatility, since they can be incorporated into any room or area, either built-in or within suitable enclosures which you can buy complete or build yourself, according to your abilities and interests.

Through components such as these, a single stereo system with FM tuner, record player, tape recorder, amplifier and speakers as required for your needs can easily provide music for your entire home. Mail the coupon below for a free booklet.

**Institute of High Fidelity Manufacturers, Inc.**  
Dept. B-32—516 Fifth Avenue, New York 36

Please send me the free booklet about  
High Fidelity Components.

NAME \_\_\_\_\_

ADDRESS \_\_\_\_\_

CITY \_\_\_\_\_ ZONE \_\_\_\_\_ STATE \_\_\_\_\_



## Start Your Vacation Home

(Continued from page 94)

the floor sections will eventually rest on the foundation of the basic unit. Supported by two beams which are built up of 2 x 8s to rest on concrete-block piers and pilasters, the floor sections are toenailed to a 2 x 8 plate atop the foundation wall. The plate is anchored here and there with bolts mortared in the cores of the top course of blocks. In addition to being toenailed to the plate, the floor sections are nailed to each other from under the crawl space, as well as being nailed along the lapped joints. Next month you'll see how the side walls are prefabricated and how the roof is framed.

**Go-Anywhere Boat.** For the first time, you can build a boat designed for water jet propulsion, and enjoy piloting it through those snag-filled water inlets that are too shallow for prop operation. Watch for the plans in the March Popular Mechanics.

## Ink Isn't What It Used to Be

Before letters, diaries and other original papers of historical significance can be sealed permanently in plastic, the paper must be treated chemically to halt deterioration. This works fine for early documents, but the ink floats right off 20th-century papers. Today's inks are water soluble; old ones were not.

Washington State University is studying the problem, investigating various misting and atomizing processes. The school's library is custodian of more than a half million documents pertaining to the history of the Pacific Northwest, and most of the papers are less than 70 years old.

## Jupiter's Spot Is Stuck

The red spot on planet Jupiter does not float. It is the top of a fluid column of poisonous atmosphere confined above a surface peak by whirling winds, says British astronomer Dr. Raymond Hide.

First seen in 1878, the spot now appears brown. It is estimated to be 25,000 miles long and 8000 miles wide.

Dr. Hide discounts the long-held theory that the spot floats because it remains in the same latitude, even though it rotates at a different rate than does the planet.

The rotation difference is caused by Jupiter's atmosphere, he says, which is so thick it can move solid parts of the planet, and thus change the rotation rate of that part.

New... and best for you...

# ROTUNDA QUALITY PARTS!

...made better to fit right and last longer!

Now, as near as your closest Ford Dealer or selected service outlet, you can get quality Rotunda Parts. Rotunda Parts are made to the same exacting specifications set for FoMoCo Genuine Parts... to fit right, last longer and keep maintenance at a minimum. Ask for Rotunda Oil Filters, Shock Absorbers, Fan Belts and other parts by name, *to be sure*. You'll find Rotunda Parts ideal for universal use on cars and trucks.



Rotunda Depth-type Oil Filters with 2-step action offer twice the life of many surface-type oil filters... provide maximum filter protection for engines in trapping particles as small as 39 millionths of an inch—finer than talcum powder.



Rotunda Shock Absorbers keep internal friction and wear to a minimum... give positive two-way action without bypass leakage for more uniform ride control.



NOW... TWO TOP QUALITY LINES OF PARTS AVAILABLE THROUGH FORD DEALERS AND SELECTED SERVICE OUTLETS



PRODUCTS OF  MOTOR COMPANY

# PUZZLE: FIND AL

Al's got himself lost in his job.

He does his work. He draws his pay. He gripes, and hopes, and waits. But the big breaks never seem to come.

You have to hunt hard for Al. He's in a rut!

Then, who's the figure standing out in the picture? That's Tom. Tom grew tired of waiting. He decided to act. He took three important steps:

1. Wrote to I.C.S. for their three famous career books.
2. Enrolled for an I.C.S. job-related course.
3. Started to apply—on the spot—what he was learning.

The others began to say, "Ask Tom, he knows." The supervisor began to take notice. The boss began to receive reports on Tom's progress. *And Tom began to move!*

It's a fact worth remembering: An I.C.S. student always stands out!

**P.S.**—You'll find men like Al everywhere—griping, hoping, waiting—reading this and skipping on. But forward-looking fellows like Tom will take time to investigate, will mark and mail the coupon and get the three valuable career books free. They're men of action. And a few short months from now, you'll see them start to move!



For Real Job Security—Get an I. C. S. Diploma! I. C. S., Scranton 15, Penna.

Accredited Member,  
National Home Study Council

## INTERNATIONAL CORRESPONDENCE SCHOOLS



**BOX 03419B SCRANTON 15, PENNA.**

(In Hawaii, reply P.O. Box 418, Honolulu)

(Partial list of courses)

Without cost or obligation, send me "HOW to SUCCEED" and the opportunity booklet about the field BEFORE which I have marked X (plus sample lesson):

### ARCHITECTURE and BUILDING CONSTRUCTION

- Air Conditioning
- Architecture
- Arch. Drawing and Designing
- Building Contractor
- Building Estimator
- Carpenter Builder
- Carpentry and Millwork
- Heating
- Painting Contractor
- Plumbing
- Reading Arch. Blueprints

### ART

- Commercial Art
- Magazine Illus.
- Sign Painting and Design'g
- Sketching and Painting

### AUTOMOTIVE

- Automobile
- Auto Body Rebuilding and Refinishing
- Auto Engine Tuneup
- Auto Electrical Technician
- Diesel Engines

### AVIATION

- Aero-Engineering Technology
- Aviation Engine Mech.
- Reading Aircraft Blueprints

### BUSINESS

- Accounting
- Advertising
- Bookkeeping and Cost Accounting
- Business Administration
- Business Management
- Clerk Typist
- Creative Salesmanship
- Managing a Small Business
- Professional Secretary
- Public Accounting
- Purchasing Agent
- Real Estate Salesmanship
- Salesmanship
- Salesmanship and Management
- Traffic Management

### CHEMICAL

- Analytical Chemistry
- Chemical Engineering
- Chem. Lab. Technician
- General Chemistry

- Oil Field Technology
- Pulp and Paper Making

### CIVIL ENGINEERING

- Civil Engineering
- Construction Engineering
- Highway Engineering
- Professional Engineer (Civil)
- Reading Struc. Blueprints
- Sanitary Engineer
- Sewage Plant Operator
- Structural Engineering
- Surveying and Mapping
- Water Works Operator

### DRAFTING

- Aircraft Drafting
- Architectural Drafting
- Drafting & Machine Design
- Electrical Drafting
- Electrical Engineer Drafting
- Industrial Piping Drafting
- Mechanical Drafting
- Sheet Metal Drafting

### ELECTRICAL

- Electrical Appliance Servicing
- Electrical Engineering

- Electric Motor Repairman
- Elec. Engr. Technician
- Elec. Light and Power
- Practical Electrician
- Practical Lineman
- Professional Engineer

### HIGH SCHOOL

- Good English
- High School Diploma
- High School General
- H. S. College Prep. (Eng'g & Science)
- High School Math
- High School Science
- Short Story Writing

### LEADERSHIP

- Industrial Foremanship
- Industrial Supervision
- Personnel-Labor Relations
- Supervision

### MECHANICAL and SHOP

- Diesel Engines
- Gas-Elec. Welding
- Heating and Air Conditioning
- Industrial Engineering
- Industrial Instrumentation

- Industrial Safety
- Machine Shop Practice
- Mechanical Engineering
- Plumbing and Heating
- Professional Engineer
- Quality Control
- Reading Shop Blueprints
- Refrigeration and Air Conditioning
- Tool Design
- Tool Making

### RADIO, TELEVISION

- General Electronics Tech.
- Industrial Electronics
- Practical Radio-TV Eng'g
- Radio-TV Servicing
- TV Technician

### RAILROAD

- General Railroad

### STEAM and DIESEL POWER

- Combustion Engineering
- Power Plant Engineer
- Stationary Diesel Engr.
- Stationary Steam Engines

### TEXTILE

- General

Name \_\_\_\_\_ Age \_\_\_\_\_ Home Address \_\_\_\_\_

City \_\_\_\_\_ Zone \_\_\_\_\_ State \_\_\_\_\_ Working Hours \_\_\_\_\_ A.M. to P.M. \_\_\_\_\_

Occupation \_\_\_\_\_ Canadian residents send coupon to International Correspondence Schools, Canadian, Ltd., Montreal, Canada. . . . Special low monthly tuition rates to members of the U. S. Armed Forces.

# WEN

# POWER TOOLS

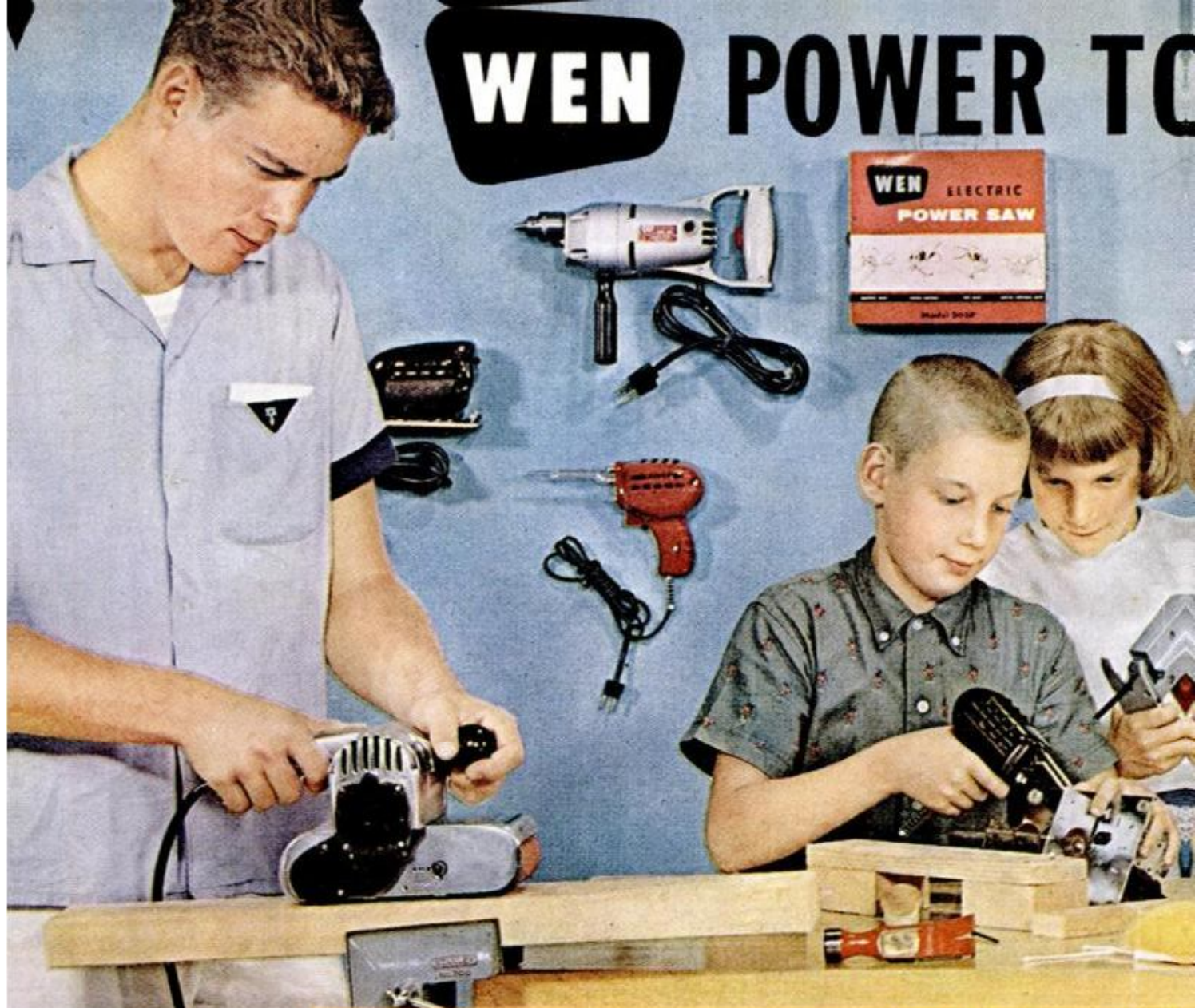

**Quick to Heat  
Easy to Use**

### WORLD'S BEST SELLING SOLDER GUNS

Choose from 4 guns, 2 gun kits— from feather-light slim 100 watt model to heavy-duty 250 watt model standard among professionals. All guns are heated, ready to use in 2½ to 5 seconds . . . quick to cool. Built-in spotlights focus on work. Housings are shatterproof plastic. Long-reach, long life tips are replaceable and interchangeable with special purpose tips. \$5.95 to \$15.95

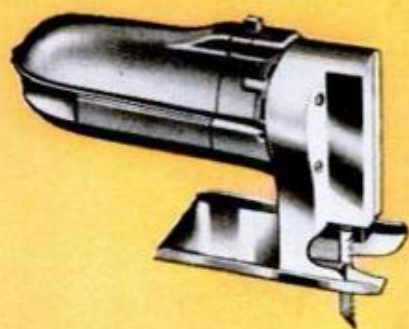

**2650 5/8" Strokes  
Per Minute**

### LIGHTWEIGHT ALL-PURPOSE SABRE SAW

Extremely versatile and easy-to-handle, this fine saw is excellent for scrollwork and patterns. Slices through 2x4's in seconds. Cuts through wood, metal, plastics, composition boards, hard rubber, leather. Air stream clears dust from work. You get a true cut every time. It's a must in your workshop . . . the finest of its kind. \$26.95

**14  
Pes**

Str  
—  
fin  
3  
ea  
me  
\$1  
wi  
in  
\$1  
pl  
po  
me  
mi  
an

... AS ADVERTISED IN LIFE, POST, NEWSWEEK, TIME, TRUE, SPORTS ILLU

# What Plymouth Buyers Like and Dislike How Many Are Choosing V8s or Sixes?

- Science on the Mountain Peaks
- Ocean Currents Bring a Fishing Bonanza
- Router Guide with a Long Reach
- Mold for Building Super Snow Forts

Second Year—Add Bedrooms

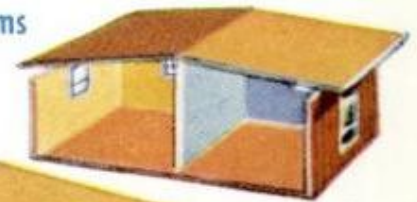

First Year—Basic Home



Third Year—Add Stretch-Out Space

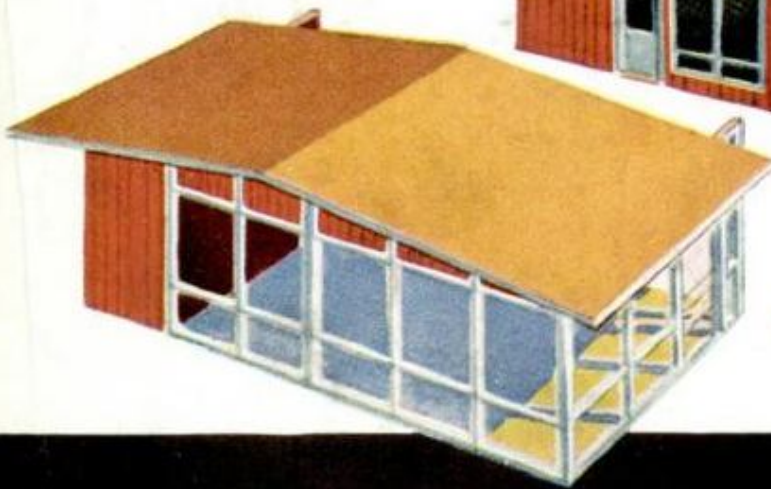



# 500,000 Families In Debt To Doctors and Hospitals

One of the best-liked features of the White Cross Plan is its ability to arrange the point at which P... the bills to

## MEDICAL COSTS CLIMB HIGHER

...ages that you need and are lower be-  
A pa... wk... by... dent... thr... Me... pe... to... ul

## Millions Need More Health Insurance!

Money, to help pay surgical bills and doctors' calls, is made available by Policy P-12, "Family Medical Policy" (also for individuals). The generous schedule of benefits...

# HOW TO GET THE HEALTH INSURANCE PROTECTION YOU NEED and SAVE MONEY

Newspapers and magazines shout the warning of rising costs of hospital and medical care. When sickness or accident strikes, thousands of families are shocked to find their health insurance covers only a fraction of the bills. Many go deeply into debt to pay the hundreds of dollars their insurance didn't provide!

**DO YOU HAVE THE PROTECTION YOU NEED?** To safeguard yourself and your family from the possibility of financial disaster, chances are you need additional protection. But you want

to choose coverage that is built to meet your needs, that fits your budget and gives you this needed protection at the lowest possible cost.

**FIND OUT THE ANSWERS NOW.** We invite you to mail the handy reply card and get the actual facts on How You Can Save Money On Your Health Insurance. This information answers your questions about health insurance so you can decide on the kinds of protection you and your family should have. For example, you may want to know about *Income Protection*, or *Major Medical Insurance*, a type of plan you hear so much about today. You owe it to yourself to clearly understand all the different types of policies available . . . including *Hospitalization*, *Medical Surgical*, *Major Medical*, *Income Protection*, *Extra Money*, and others.

**SEE HOW YOU CAN SAVE MONEY, TOO.** You want the security of a sound, safe health insurance program. But you don't want to pay a penny more than you need to. With the facts in hand, you will learn that the low-cost policies, available under the WHITE CROSS PLAN, can be tailored to your needs and budget. By avoiding needless duplication, these flexible, individualized policies may offer you a chance to increase your security and save money.

**MAIL POSTAGE-FREE CARD TODAY.** No cost, no obligation. You will receive all the facts on How To Save Money On Your Health Insurance. It can be worth thousands of dollars to you and your family. Just print your name and address on the card and drop it in the mail box.

Find out How You Can  
**SAVE MONEY**  
On Your **HEALTH INSURANCE**  
and enjoy the protection you need to meet today's  
**HIGH MEDICAL COSTS**

Send for  
**FREE**  
information

Get the **FACTS** Now . . .  
**DETACH AND MAIL POSTCARD**  
No Postage Needed



**BANKERS LIFE AND CASUALTY CO.**  
offering policies of the **WHITE CROSS PLAN**  
An Old-Line Legal Reserve Stock Company  
HOME OFFICE: Chicago 30, Illinois

**MOUNTAIN RESCUE EXPERT** Robert Byhre risks his life — without pay — to save people in distress high in the mountains. A long-time Camel smoker, Bob says Camels seem to taste even better to him today than when he started smoking. They give him the satisfaction he wants — every time he lights up!



Are you smoking more now but enjoying it less?

Have a real cigarette - **CAMEL**

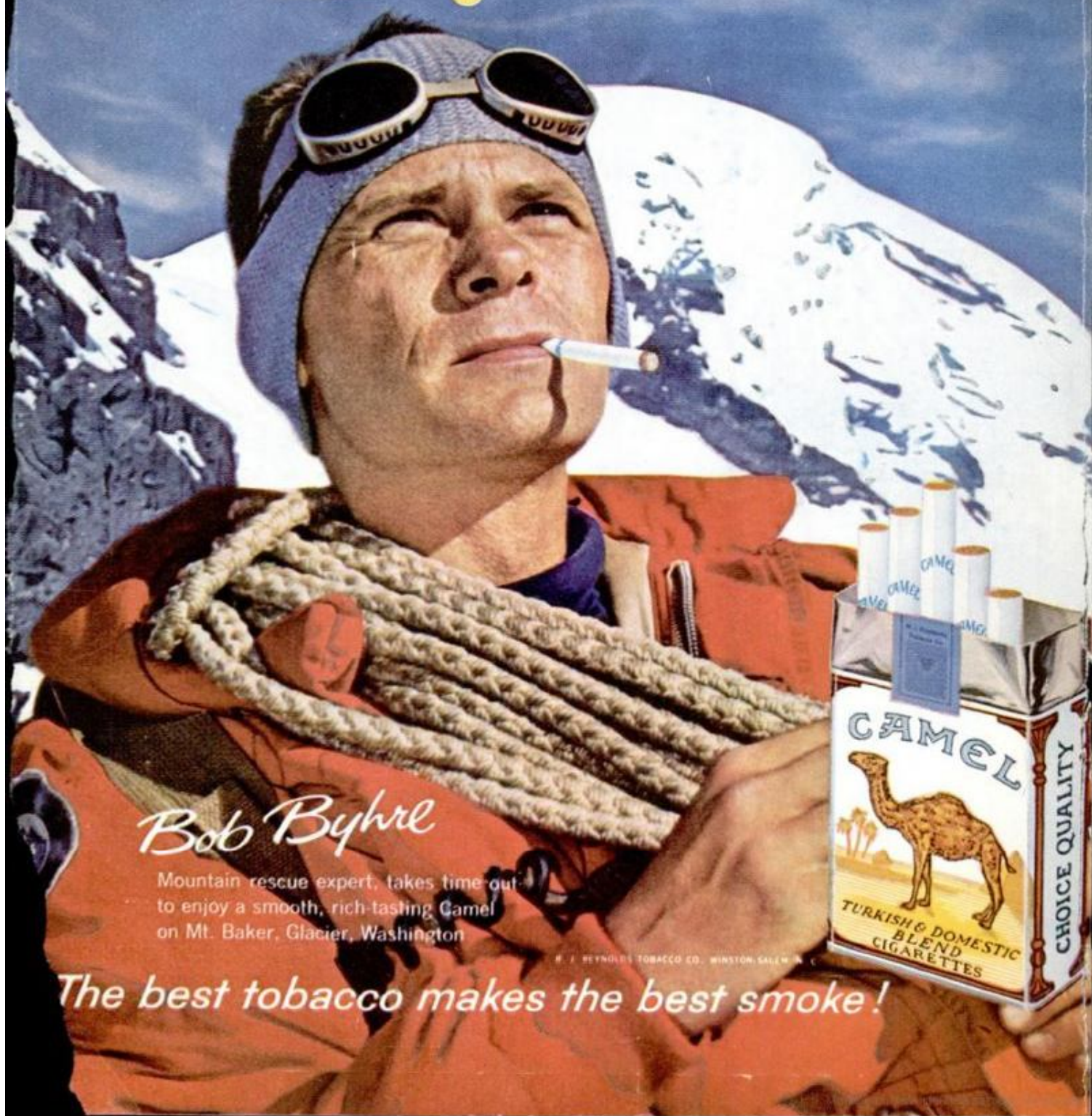

*Bob Byhre*

Mountain rescue expert, takes time out to enjoy a smooth, rich-tasting Camel on Mt. Baker, Glacier, Washington

© 1987 REYNOLDS TOBACCO CO., WINSTON-SALEM, N.C.

*The best tobacco makes the best smoke!*