

THE WONDERFUL WORLD OF MODELS

POPULAR MECHANICS

DEC. 1960

35 CENTS



**17 PAGES OF CHRISTMAS GIFTS
AND DECORATIONS YOU CAN MAKE**

World's Greatest Atom Gun Blasts Off

Christmas Savings

DELTA HOME WORKSHOP SALE

on two of the most useful power tools you can own



Cat. No. 34-005
Delta Homecraft 9"
Tilling Arbor Circular
Saw equipped with
Extension Wings
and Steel Stand.

SAVE \$22.05

Reg. price \$144.95

SALE price 122.90

YOU SAVE \$22.05

Take advantage of this special holiday offer on the Delta 9" Circular Saw. Ideal for starting (or improving) your workshop, it's the tool you'll use most often on any job—makes precision cutting faster and easier. So get big enjoyment and enjoy a big \$22.05 savings*



Cat. No. 49-576 Delta Dust
Collector complete with
motor and hose.

SAVE \$10.00

Reg. price \$59.95

SALE price 49.95

YOU SAVE \$10.00

This new, improved Delta Dust Collector is really tops in versatility! It can be used with almost any woodworking power tool, adapted for paint spraying, general clean-up and a dozen other helpful jobs. To add more convenience to your shop, add this practical tool—you'll appreciate the practical \$10.00 Christmas savings* you get.

*Prices and savings slightly higher in the West

HURRY-OFFER LIMITED!

See your Delta Dealer (listed under "TOOLS" in the Yellow Pages) or visit leading Department, Hardware or Building Supply Stores. Rockwell Manufacturing Company, Delta Power Tool Division, 502M N. Lexington Ave., Pittsburgh 8, Pa.

DELTA POWER TOOLS

another fine product by

ROCKWELL



You can make professional-looking inlays this easy way



1. Make game board of plywood with birch and walnut
WELDWOOD FLEXIBLE WOOD-TRIM



2. Bring out the real wood beauty with
WELDWOOD SATINLAC



3. Keep the finish beautiful with
WELDWOOD PASTE WAX

WELDWOOD® FLEXIBLE WOOD-TRIM®, real wood, paper-backed, in handy 8' rolls. For inlay work and edging plywood, lumber. Comes in 6 different woods. Apply with Weldwood Presto-Set® Glue.

WELDWOOD SATINLAC®, self-sealing finish gives glowing, soft-sheen luster, brings out the wood's natural beauty without "plate-glass" shine. For extra light finishes, use first coat of Weldwood Satinlac® Lightener.

WELDWOOD PASTE WAX is easy to use, self-cleaning. Puts on the finishing touch for lasting wood beauty. Resists water-spotting, won't harm wood, protects as it beautifies.

WELDWOOD—the people who know what's good for wood... makers of prefinished wood paneling.

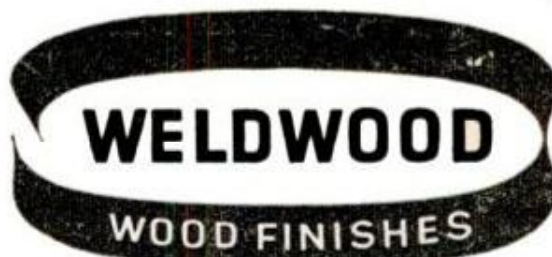

Products of United States Plywood

This One



NDF-04K-067W

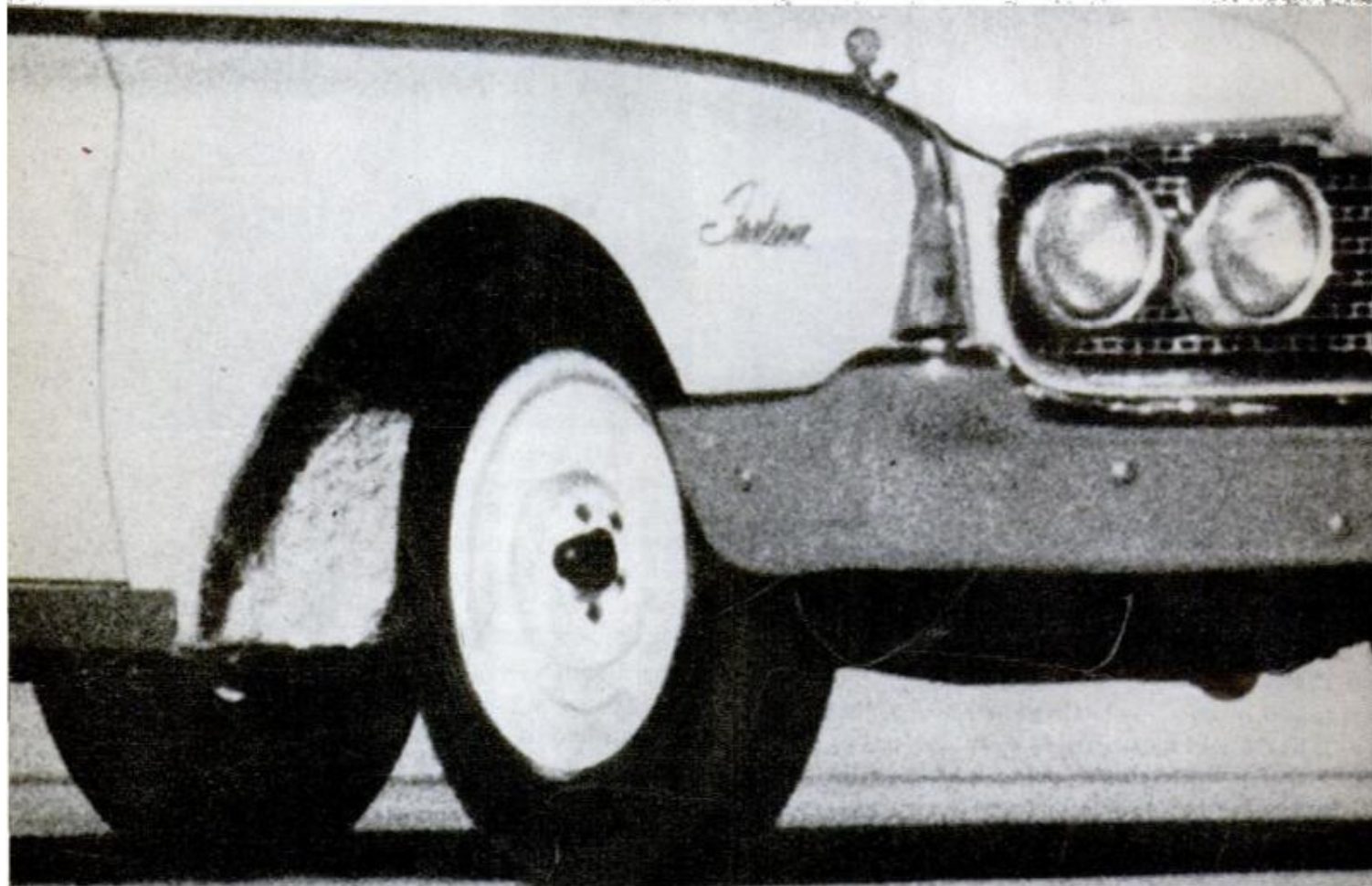
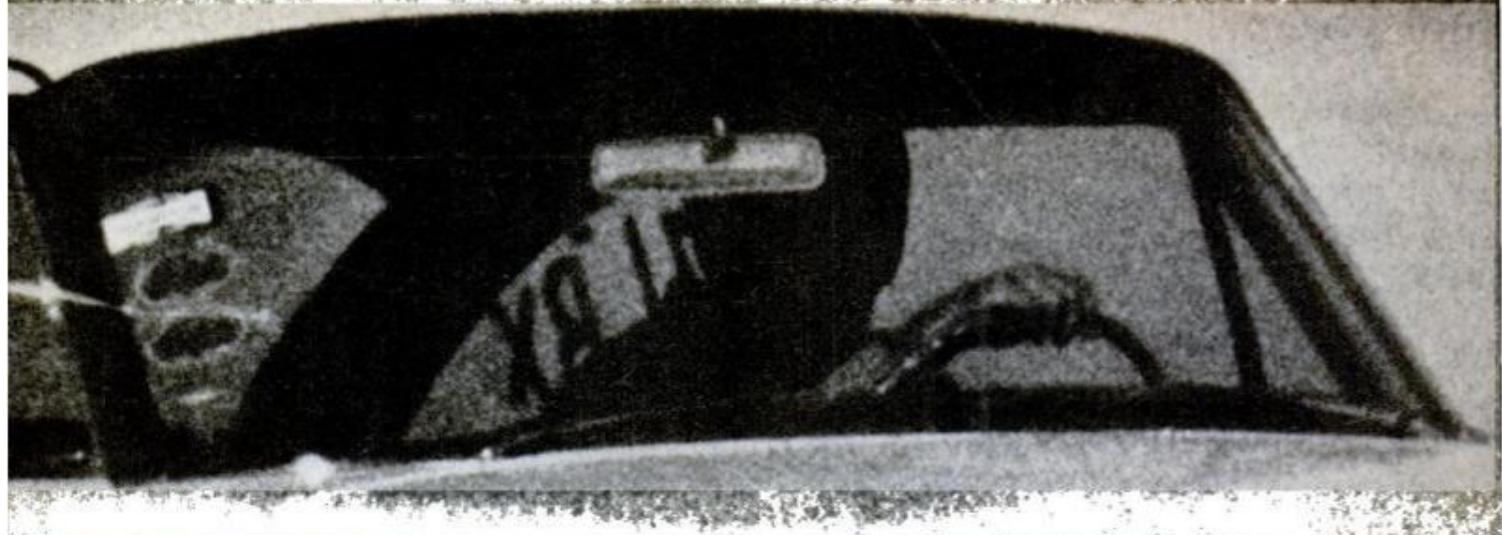

Ford Starliner, driven by Karol Miller, races across Bonneville Salt Flats.

Ford Starliner sets record of 157.9 m.p.h. with Champion spark plugs!

This is a lot faster than *you'd* want to drive. But it shows you the kind of performance Champion spark plugs deliver.

This was a *standard* Ford—the kind you can order from your dealer. It used gas you can buy at the pump. And it was sparked by the plugs—Champions—most dealers recommend for *your* car.

Winners of 9 out of 10 major races use Champion spark plugs. Twice as many car manufacturers specify them. New Champions will make *your* car perform better (and save money on gasoline), too! Put in a set every 10,000 miles!

CHAMPION



POPULAR MECHANICS®

Address communications to: 200 E. Ontario St., Chicago 11, Illinois. **SUBSCRIPTION SERVICE:** Mail all subscription orders, changes of address, correspondence concerning subscriptions, and Postmaster notices of undeliverable copies to Popular Mechanics, 250 West 55th St., New York 19, N. Y.

Editor
RODERICK M. GRANT

Executive Vice-President
RICHARD E. DEEMS

Publisher
JOSEPH R. BUELL, JR.

Managing Editor
CLIFFORD B. HICKS

Shop Notes and Crafts Editor
WAYNE C. LECKEY

Associate Editor, General Features
JOHN A. LINKLETTER

Associate Editor, Automotive
JAMES R. WHIPPLE

Associate Editors, Shop Notes and Crafts
W. CLYDE LAMMEY, EARL WOBECK

Radio-Television, Electronics Editor
BYRON G. WELS

Assistant Editors, General Features
GUERRINO F. AMATI, JAMES BIERY
KEVIN V. BROWN, R. B. KIRKPATRICK

Assistant Editor, Shop Notes and Crafts
ROBERT L. HERING

Assistant Editors, Production
WALLACE MYERS, JEAN KAVANAUGH

Art Staff
FRANK BEATTY, Director
HENRY NEHRBASS, Assistant Director
RICHARD A. POTTS, Art Editor

Eastern Editor
RICHARD F. DEMPWOLFF
959 Eighth Ave., New York 19, N. Y.

Western Editor
THOMAS E. STIMSON, JR.
Suite 1003, 3460 Wilshire Blvd.
Los Angeles 5, Calif.

Advertising Manager
FRANK R. DUPUY
959 Eighth Ave., New York 19, N.Y.
Director, Bureau of Information
ALLAN CARPENTER

Advertising Offices
Chicago: 200 E. Ontario St., Whitehall 4-0100;
New York: 959 Eighth Ave., Columbus 5-7300;
Detroit: General Motors Bldg., TRinity 5-8711;
Cleveland: Hanna Bldg., 1422 Euclid Ave.,
PRospect 1-0456; Los Angeles: 3460 Wilshire,
DUNKirk 2-8458; San Francisco: Russ Bldg.,
235 Montgomery St., YUKon 2-0823.

Published monthly by Popular Mechanics Company, 200 E. Ontario St., Chicago 11, Ill. Richard E. Berlin, President; Richard E. Deems, Executive Vice-President; Fred Lewis, Vice-President and General Manager; Robert F. MacLeod, Vice-President; John R. Miller, Vice-President; G. Harry Chamberlaine, Vice-President; G. O. Markuson, Treasurer; R. F. McCauley, Secretary. Single copy in the United States and Canada, 35 cents; subscription rates in the United States and possessions and Canada, 1 year \$3.50; 2 years, \$6.00; 3 years, \$8.00. In countries of the Pan-American Postal Union, 1 year \$4.50; 2 years \$8.00; 3 years \$11.00. In all other countries 1 year \$5.50; 2 years \$10.00; 3 years \$14.00. If you plan to move, notify us at least 30 days in advance so you will not miss an issue. Give both your old and new addresses. Second-class postage paid at Chicago, Illinois, and at additional mailing offices. Entered as Second Class Matter at Post Office Dept., Canada. Registered as Second Class Matter at the Post Office at Mexico, D.F., Mexico, June 20, 1950. © 1960 by Popular Mechanics Company. All rights reserved. Printed in the United States of America.

DECEMBER 1960

INTERNATIONAL EDITIONS

SPANISH: Mexico-Caribbean, Southern Hemisphere
FRENCH, DANISH, SWEDISH, GERMAN, PORTUGUESE, DUTCH

Volume 114

DECEMBER 1960

Number 6

In This Issue...

Modelmakers in a Tizzy - - - - -	81
The World's Greatest Atom Gun Blasts Off -	92
Skin Diving for Gold - - - - -	98
Bonneville's Magnificent Trials—and Errors -	101
The Magic Box That Reads Russian - - -	109
What's New for Dinner? - - - - -	122
Train Your Own Horse - - - - -	132
The Metric System—Pro and Con - - - -	138
The Engine That Was Born Again - - - -	146

For the Craftsman...

Leaf Wall Decor - - - - -	150
Things to Make for Christmas - - - - -	160
You Can Overhaul Your Carburetor - - -	180
Strong Plug Sparks Mean Top R.P.M.'s - -	182
The Fine Points of Cutting Glass - - - -	188
Handy Tips for Welding Shops - - - - -	194
How to Cut, Nail and Tape Plasterboard -	198
Radio, TV and Electronics - - - - -	204

Regular Departments...

GUIDE TO THIS ISSUE - - - - 6

On the Market - - - - -	16	Pentagon Sidelights - - - - -	32
Science Bulletins - - - - -	17	Know This Old-Timer! - - - - -	33
Tune In on the Inventors - - - - -	20	Shopping for Tools - - - - -	72
Items From All Outdoors - - - - -	24	An Eye on Space - - - - -	87
What's Up in the Air - - - - -	26	Detroit Listening Post - - - - -	90
Keeping Up With the Atom - - - - -	28	Solving Home Problems - - - - -	158
Spotlight: Hillman Husky - - - - -	30	Clinic for Homemakers - - - - -	212

Turn to detailed index on page 6. Sources of additional information on items in this issue are shown on the Where-to-Find-It List, available without charge by writing the Bureau of Information, Popular Mechanics, 200 E. Ontario St., Chicago 11, Ill.

Next Month...

HERE COMES the annual automotive issue—almost 50 pages on cars, cars, cars. You'll see a "Gallery of Classics"—America's all-time great autos—in full color. Also, photos and complete specifications on the 29 most popular imports, and an engineer's analysis of all the latest developments in transmissions, chassis and engines . . . Plus a long line-up of other fascinating features

HORSEPOWER THAT MAKES SENSE FOUR CYLINDERS TO SAVE GAS! THE NEW SWEET RUNNING TROPHY 4 ENGINE FROM PONTIAC PERFORMANCE SPECIALISTS!

The new Trophy 4 engine puts real performance in the Tempest and cuts gasoline bills to boot. This new baby is *eager to move out* for safe passing. Holds the going pace on any expressway. Breezes up steep hills in high gear. This new 195 cubic inch displacement, 45° inclined, short stroke, 4 cylinder engine has a wide range of h.p. ratings. With single-barrel carburetor and stick shift: 110 h.p. (regular gas) or 120 h.p. (premium gas). With the same carburetor and extra cost automatic shift: 130 h.p. (regular gas) or 140 h.p. (premium gas). Want still more? Order the 4-barrel carburetor with the automatic and get **155 h.p.** (Or buy the 155 h.p. aluminum V-8 option.)

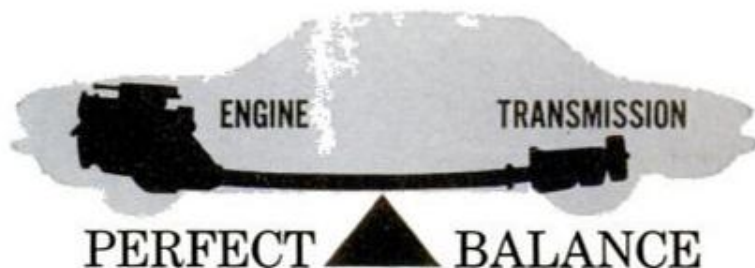

Rear axle drive and transmission are combined (a trans-axle). Flexible shaft from front engine delivers smooth, quiet power. Perfect 50-50 balance gives a flat, level ride that no other new-size car can touch. *Rides like the big ones!* An equal load on every wheel. Steering is light and easy! Better braking and improved traction in snow, sand or mud! *Independent suspension at all wheels.* Swing axles keep Tempest on an even keel over bumps, ruts, dips and holes! *112" wheelbase.* Long enough for a cradled ride—short enough to handle like a sports car. *Big 15" wheels.* Good road clearance. Long tire life. (13" compact wheels turn about 4900 more times to go 100 miles.) *Seats six men.* The big transmission hump is gone. The middle man can stretch out size 12 brogans! *Wide-Track, too!* The track is up to 3 inches wider than most compacts. Less lean. Less sway. Better cornering. *Pontiac dealers have it—and they have it now!* A four-door sedan . . . a station wagon . . . a full line-up of accessories. Try the Tempest out for an hour—you'll want in for keeps! It's priced with the compacts!

PONTIAC MOTOR DIVISION • GENERAL MOTORS CORPORATION

THE
HOT TOPIC
IS THE
NEW
TEMPEST!



QUALITY NEW/COMER FROM PONTIAC!

TEMPEST

AMERICA'S ONLY FRONT ENGINE ↔ REAR TRANSMISSION CAR.
155 H.P. FROM FOUR CYLINDERS! *
PRICED WITH THE COMPACTS!

*WITH 4-BARREL CARBURETOR AND AUTOMATIC TRANSMISSION, EXTRA-COST OPTIONS

South Bend Vertical MILLING MACHINE

**Now with Power Feed
Table and Head**

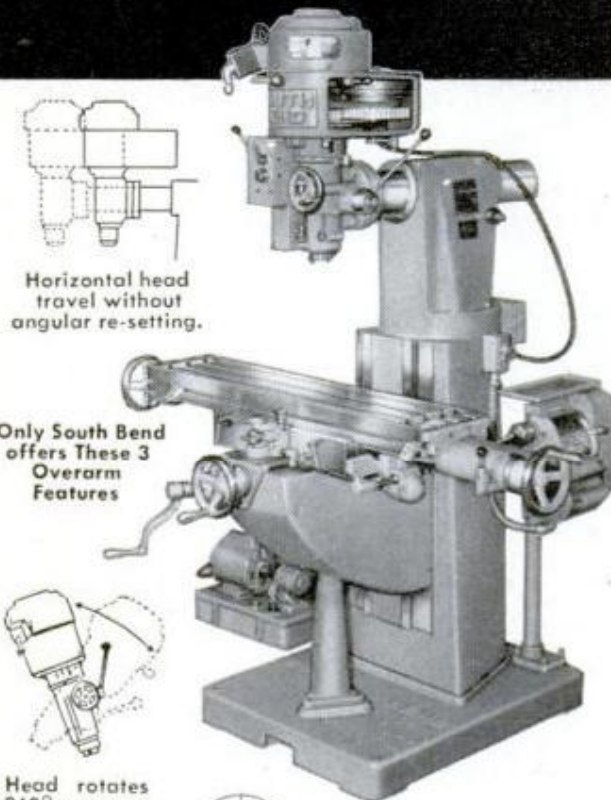

Horizontal head travel without angular re-setting.

Only South Bend offers These 3 Overarm Features



Head rotates 360°, overarm does not turn.



Adjustable tapered gib in keyway prevents play. More bearing surface.

- ✓ 30 feeds to table, 1/4" to 15" per min.
- ✓ Infinitely variable feed to head, 0 to 25" per minute.
- ✓ Mills, bores, drills, reams at any angle.
- ✓ Easy accessibility simplifies job set-ups and tooling changes.
- ✓ 32" or 42" table with 20" or 30" travel.

Prices start at \$2429 f.o.b. factory.

SOUTH BEND



LATHE

SOUTH BEND 22, INDIANA

Builders of Lathes, Milling Machines, Shapers, Drill Presses and Pedestal Grinders.

GUIDE TO THIS ISSUE

With Sources of New Products

Paint roller	16
Patching material	16
Waxless floor coating	16
Matching switch plates	16
Repair kit for Venetian blinds	16
Can-cover garlands	18
Scientists won't give up: insist man can fly like a bird	18
Cycloid sawing action	72
Radial saw	72
Tape rule	72
Universal drill-press table	72
Miter box on miter gauge	72
6-in. long-bed jointer	72
Right-angle drive	74
Portable paint-spraying unit	74
Pantograph	74
Tool holder	74
Guard, eye shield and tool rest	74
Snap-lock mechanism	76
Economy model of radial saw	76
Tool kit for hobbyists	76
Flexible-shaft machine	76
Soldering gun	76
Five tools driven by one motor	78
Portable jigsaw	78
Pocket-size sanding block	78
Shaper cutters	78
Elevator hoists boats on cradle	88
Air force B-70 will fly three times speed of sound	89
Hot dog! (EMKA Metallwerkenfabrik A.G., 100 Postbox, Luedenscheid, West Germany)	89
Sub made from water tank	89
Fingerprints the easy way (Chance Vought Aircraft Corp., Dallas, Texas)	97
Tear-off top for can	97
Windbreak unfolds from sled	97
Skin diving for gold	98
Aquarium saddles (Moonglow Plastic Jewel Corp., 106-10 Dunkirk St., St. Albans 12, New York)	100
Driving school on a table top (Allgaier Shops, 4004 Fifth Road North, Arlington 3, Va.)	100
Suspension bridge for conveyor belt	100
High chair collapses into bed (A. Corinni, 54 Rue Andre Tessier, Fontenay-sous-Bais [Seine] France)	107
Portable hangar for helicopters	107
Converted fuel tank stores Texas grain (Johnson Grain Co., Dallas, Texas)	108
Fastest gun in Texas (Chance Vought Aircraft Corp., Dallas, Texas)	108
Mammoth elbow suppresses jet noise	113
Huge machine rolls right over trees	113
Windjammers still soil	114
Flying automobiles (Mr. H. L. Trautman, San Marino, Cal.)	116
My most exciting moment	117
Knife sharpener	118
Spray-scrubber	118
Grapefruit knife	118
Electric shaver	119
Triple-deck bunk bed	119
Bottle thermometer	119
Outdoor torches	119
Plastic bags in rolls	119
Test stand for the powerful F-1 space engine rises in desert	120
Mapping lightning flashes helps predict weather	120
Turbocharged diesel engine for pleasure boats	121
"Flying saucer" cafeteria	127
Pilots practice getting dunked	128
Underwater television	128
Tent fits on station wagon (Morsan Tents, 10-27 50th Ave., Long Island City, N. Y.)	128
Wins pistol crown the hard way	130
Man baits dog	130
Organ plays through radio	130
Soldier improvises beauty shop	130
Army catamaran clears San Francisco Bay of debris	131
Inflatable sailing catamaran (Bletico Ltd., Altona Works, Lisburn, N. Ireland)	137
Giant missile-tracking camera	137
The metric system—pro and con	139
Ice skating rink built into downtown apartment (Alan Murray, 213 West 58th St., New York, N. Y.)	140

(Continued to page 8)

Are You "STANDING STILL" on your job?

You can justify a real pay raise and a better position—by making one simple move—the move that opens the way to more earnings and promotions—*practical training.*

If YOU are "standing still" on your job—no promotions—only token increases in pay—then you had better do something about it. You know that if you are untrained, your chances of getting ahead are slim. **NOW IS THE TIME TO PREPARE.**

WILL RECOGNITION COME?

The only answer, as you know, is that success *does* come to the man or woman who is really *trained*. LaSalle has provided the "key to success" for many thousands of ambitious people who have sought our training for more than fifty years.

Get all the facts. Investigate the opportunities in your chosen field. It costs you nothing to learn about LaSalle's proven and tested accredited correspondence courses in the major fields of business as well as high school and technical courses. You can train in the

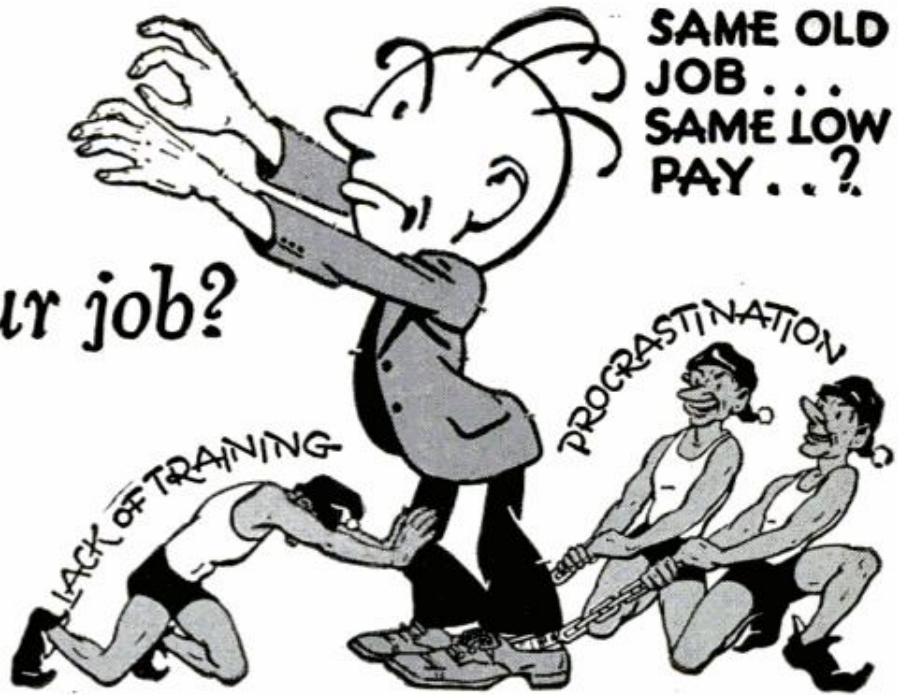

privacy of your own home, progressing at your own rate. You lose no time from work, and your instructors guide you every step along the way through our famous Practical Problem Method. Low cost—easy terms.

Don't let promotions pass you by—do something **TODAY** about your future.

The coupon below is for your convenience. Simply mark the program in which you are most interested, and mail at once. We'll send you, without obligation, free booklets describing that field together with the opportunities and what you must know to be a success.

ACCREDITED MEMBER, NATIONAL HOME STUDY COUNCIL

LaSalle Extension University, A Correspondence Institution, Dept. 1264X, 417 S. Dearborn, Chicago 5, Ill.
Please send me, without cost or obligation, **FREE** catalog and full information on the field I have checked below:

ACCOUNTING

- Modern Bookkeeping
- Basic Accounting
- Practical Accounting
- Principles of Acctg.
- Cost Accounting
- Federal Income Tax
- Accounting Systems
- Business Law
- Auditing Procedure
- Controllship
- CPA Training
- Complete Accounting

TRAFFIC & TRANSPORTATION

- Organization & Mgt.
- Classifications, Rates & Tariffs
- Transportation Agency & Services

- Transportation Law & Regulation
- Rate Making & Rate Cases
- Complete Traffic & Transportation

LAW

- Law of Contracts
- Insurance Law
- Claim Adjusting Law
- Law for Trust Officers
- Business Law I
- Business Law II
- General Law
- First Year Law
- American Law and Procedure (LL.B. Degree)

BUSINESS MANAGEMENT

- Principles of Management
- Psychology in Business
- Selling & Sales Management
- Advertising & Marketing
- Production Problems
- Business Financing
- Credits & Collections
- Office Management
- Managing Men
- Accounting & Statistical Control
- Business Correspondence
- Organization & Reorganization
- Legal Problems
- Complete Business Management

MANAGEMENT COURSES

- Basic Management
- Production Management
- Sales Management
- Advertising & Sales Promotion
- Financial Management
- Personnel Management
- Sales & Executive Trng.
- LaSalle Sales Training
- Foremanship Training

HIGH SCHOOL

- High School Preparatory
- General Business Course
- High School Diploma
- Commercial Course
- Secretarial Course

STENOGRAPHY

- Stenotype (machine shorthand)
- Home Management Course
- General Culture Course
- Science Course
- Mechanical Course

DENTAL ASSISTANT

- Dental Assistant

TECHNICAL COURSES

- Auto Body Fender
- Refrigeration-Air Conditioning
- Diesel
- Drafting
- Welding
- Motor Tuneup

Name.....Age.....
Address.....
City, Zone, State.....

**CHECK THIS COUPON AND MAIL
TODAY... SURE!**

The Miracle of Transistors Brings You



110 AC FROM BATTERIES

ESB
PACKAGED POWER

ACTIVERTER

©1960

Dependable Power for Hundreds of Uses

Now — using a totally new concept in electronic design — the ESB engineers have developed a revolutionary, fully transistorized inverter-charger, the ESB ACTIVERTER. This major breakthrough in "packaged power" means that you can now have the convenience and the utility that 110 Volt AC current can bring, and you can have it wherever you can take a 12 Volt storage battery!

Just connect the ESB ACTIVERTER to a battery and you can have 110 AC instantly, anywhere, for many hours. You can plug in portable electric power tools, an electric blanket, electric lights, even a television set! A flick of a switch and the ESB ACTIVERTER fast or slow charges 6 or 12 Volt batteries.

Compact, Rugged, Truly Portable

The compactness of the ESB ACTIVERTER design makes it possible to have a 12 Volt storage battery, an inverter, and a battery charger all in one self-contained and portable package. One PAK-O-POWER ACTIVERTER model provides a source of 110 Volt AC, with an output rating of 500 Watts, in a package the size of a portable picnic cooler! Because solid-state electronic components are used throughout, ACTIVERTERS are both rugged and lightweight. There are no moving parts, no vibrators.



4 Sizes — from 150 to 500 Watts

MODEL I-152 INVERTER — Inverter only, operates from direct connection to 12 Volt battery or through cigarette lighter socket of cars with 12 Volt systems. Output ratings: Intermittent Use — 150 Watts, 1.5 Amps. AC... Continuous Use — 125 Watts, 1.2 Amps. AC. Shipping Weight: 8 lbs.

MODEL IC-252 ACTIVERTER — Inverter-Charger operates from direct connection to 12 Volt battery. Output ratings: Intermittent Use — 250 Watts, 2.3 Amps. AC... Continuous Use — 200 Watts, 1.8 Amps. AC. Shipping Weight: 15 lbs.

MODEL IC-202P PAK-O-POWER — Inverter-Charger with compartment for 12 Volt battery. Completely self-contained unit. Output ratings: Intermittent Use — 250 Watts, 2.3 Amps. AC... Continuous Use — 200 Watts, 1.8 Amps. AC. Shipping Weight less battery: 22 lbs.

MODEL IC-506S PAK-O-POWER — The Multi-Service Inverter-Charger-Car Start unit, with large 12 Volt battery compartment and Car Start leads. Completely self-contained with built-in fast and slow charger — Charging rate: 60 Amps. for 6 Volt, and 40 Amps. for 12 Volt batteries. Output ratings: Intermittent Use — 500 Watts, 4.0 Amps. AC... Continuous Use — 300 Watts, 2.5 Amps. AC. Shipping Weight less battery: 55 lbs.

ESB

THE ELECTRIC STORAGE BATTERY CO.

Makers of

PACKAGED POWER

Willard - Exide - GRANT - WISCO - Jordan

The Electric Storage Battery Co.
Automotive Division — Dept. PM-2
P.O. Box 6266 - Cleveland 1, Ohio

I want to use 110 Volt 60 Cycle AC for _____

Please send me ESB ACTIVERTER information without obligation.

Name _____

Street _____

City _____ Zone _____

State _____

Suitcase folds up like high silk hat (Barrow Hepburn & Gale Ltd., Orange Mills, Bermondsey, London, S.E.1, England)	140
Sub comes up after 20-year dive	141
Mosaic house	142
Frogmen televise fish from undersea craft	144
Fingerprints cast in plastic for improved identification	144
Self-propelled lifter unloads piggybacks (Travelift & Engineering, Inc., Sturgeon Bay, Wis.)	145
Chair folds out to become gentleman's gentleman (George Jensen, 667 Fifth Ave., New York, N. Y.)	145
Delicate touch	149
Luminous chair (Laverne, Inc., Space 6-162, Merchandise Mart, Chicago 54, Ill.)	149
Russia claims world's largest helicopter	149
Rack those extra golf tees	153
Cotter pin masonry anchor	153
Faucet washer locks turn button	153
Replacement terminals	153
You may need extra fishhooks	153
Easy way to hull walnuts	153
Fun on runners	154
Candles light your doorstep	156
Socket repair	157
Sanding block	157
Brush storage	157
Brad holder	157
Medicine bottle located easily	158
Automobile windows and windshield kept from fogging	158
Mailing coins	158
Caked pigment brought back to uniform suspension	158
Opening paint cans	158
Linens kept sweet smelling when stored	159
Cleaning a ready-made bow tie	159
Redecorating your home	159
How to open locked bathroom door from outside	159
Crossarm on light stand increases usefulness	177
Display your salon photos on a folding screen	177
Clamp-on reflector has own cord reel	177
Tripod projector table	178
Eraser polishes convex forms in drill press	179
Lathe attachment is aid in turning half sphere	179
You can overhaul your carburetor	180
Go easy on masking tape	186
Knife switch for electric toys	186
Cement anchors shingle tabs	186
Ladder serves as work support	186
Pipe clamp is bench top aid	186
Spring-back binders protect clippings	187
Save bottle-cap inserts	187
Chuck adjusted with screwdriver	192
Lubricant fed to drill bit	192
Short power cords for convenience	192
Backing stiffens hacksaw blade	192
Chuck supports tubular work on tail center	193
Flexible battery carrier serves as motor lifter	193
Lathe toolpost grinder handles bench work	193
Eight handy tips for welding shops	194
True readings with magnifier	196
Ball-point pen serves as stylus	196
Pipe bar clamps get bigger bits	197
New kits for Christmas	204
Decoy missile fools enemy air defenses	219
Weather warning system charts lightning static	222
Hydrogen gun bombards material being tested for spaceship use	235
Treated corn needs less water	235

NOTICE—It is the intention of this magazine to provide its readers with information regarding the latest developments in the mechanical arts. Except where otherwise indicated, this magazine has no information as to any unexpired patents in respect of the developments reported herein. In the event that commercial use is to be made of any of the developments reported herein, it is suggested that legal counsel be consulted to avoid liability for patent infringement. It is not the purpose of this magazine to encourage patent infringement but, as indicated, it is the intention of this magazine to report on the latest developments in the mechanical arts.

Cooler Supplies Heat as By-Product

Another use of the heat-exchanging principle has harnessed waste heat for dairy farmers. A new unit uses the heating power of the refrigerant in a mechanical refrigeration unit to provide "free" hot water for the farmer, who can use the once-wasted heat from his milk cooler to give him more hot water or enable him to use a smaller water heater at a lower cost than before.

Learn Radio-Television Electronics

by Practicing at Home in Your Spare Time

WITHOUT EXTRA CHARGE NRI provides special kits that bring to life things you study. Makes learning easy, interesting, fast. All equipment yours to keep.

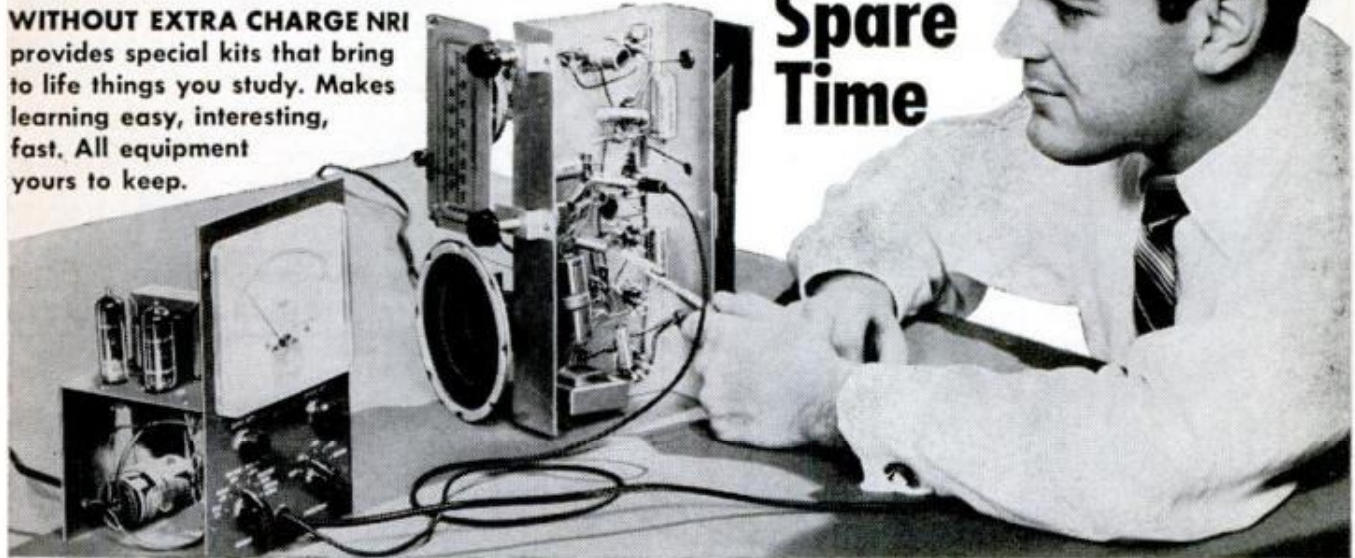

Fast Growth Offers You High Pay, Prestige, Bright Future



From Radio-TV Servicing and Broadcasting to missile launching sites like Cape Canaveral, NRI graduates share in the gigantic Electronics industry. Interesting jobs await you in studios, on ships and planes, in your own business. Mail coupon today for NRI catalog.



Many NRI graduates help build, install, operate and service automated electronic equipment for the new "Space Age" we live in—equipment used in offices, factories, the military. Others have important jobs as inspectors, laboratory technicians, etc., or hold essential civilian posts with the Government and Armed Forces.



J. M. SMITH
President

If you check the classified advertisements in your local newspaper, you will undoubtedly see more job opportunities available for men with Electronics training than for any other field. Hardly without exception, these are better than average jobs, with bright futures . . . jobs for which YOU could qualify through NRI training. Thousands of men like yourself—most of them without a high school diploma—have moved up to good pay and enjoy greater prestige in jobs with TV and Radio broadcasting stations, in industrial plants making Electronic equipment or in businesses of their own where they sell, install and service Radio and TV sets.

Train With The Leader

Join the many NRI graduates now taking advantage of career opportunities in this amazing Electronic Age. For 45 years, NRI has featured the best Radio-TV Electronics training for beginners—for men without previous experience. Throughout the U.S. and Canada, successful NRI graduates are proof that it's practical to train at home, in your spare time, at your own pace. Keep your present job while training. NRI supplies this training at low cost because it is

NRI Trained These Men

I was working in a textile factory trying to make ends meet. Now I own one of the most modern service shops in this section. **ARGIE C. TAYLOR**, Glasgow, Ky.

After graduating I was a shipboard radio operator. Now I am chief engineer at Station WARA.

NRI was a wonderful foundation. **RAYMOND D. ARNOLD**, Attleboro, Mass.

Thanks to NRI I am in a top position with the Federal Aviation Agency in the Navoids Electronic Section. **JOE DUCKWORTH**, Fort Worth, Texas.

Four months after starting your course I left my job in a hardware store to work at Raytheon Manufacturing. Now I am an engineering assistant in Microwave Power Tube Research and Development Laboratory. **LEONARD BLOOM**, Newton Centre, Mass.

the oldest and largest home-study Radio-TV Electronics school. In every respect, you will find the Electronics field a profitable one for the ambitious man. And the NRI "learn-by-doing" method is the most practical way for you to get into this exciting field quickly.

Start Soon to Earn More

NRI training can bring prompt financial return. Soon after enrolling, NRI shows you how to earn \$10, \$15 and more a week extra fixing sets in your spare time. This can lead to a profitable Radio-TV business of your own. Others have found good paying jobs within a year after enrolling.

Mail the coupon below TODAY for our FREE CATALOG. It tells in words and pictures about the amazing field of Electronics. Read success stories. See the equipment you get. Find out about the NRI 60-day free trial enrollment offer and convenient monthly terms. National Radio Institute, Washington 16, D. C.

GET 64 PAGE CATALOG FREE

MAIL THIS COUPON NOW



National Radio Institute

Washington 16, D. C. ONA

Send me full information without cost or obligation. No representative will call. (Please print.)

Name.....Age.....

Address.....

City.....Zone.....State.....

ACCREDITED MEMBER NATIONAL HOME STUDY COUNCIL

CUTS A
FANCY
CORNER—

HANDLES
"BIG TOOL"
PROJECTS



Dremel moto-shop

Versatile, multi-purpose tool for every workshop — and one the whole family can use. Handles delicate scroll work, or "big tool" projects. Moto-Shop is basically a 15-inch jig saw with a power take-off. It has a powerful ball-bearing motor — cuts through 1 3/4" wood, light metal, tile, plastics. Table tilts to 45° for angle and bevel cuts, raises and lowers to new, sharp blade area. 4-way blade holder permits cutting in any direction. Moto-Shop is self-contained — no belts or pulleys. Unique blade guard makes it safe for the whole family.

Model 571 Moto-Shop — 15-inch Jig Saw with disc sander attachment.....\$33.95

Model 572 Deluxe Moto-Shop — 15-inch Jig Saw with disc sander, grinding wheel and guard, wire and cloth buffing wheels, 30" flexible shaft and a 12 piece accessory set.....\$49.95

Ask your dealer for a demonstration — or
WRITE FOR POWER TOOL CATALOG

Dremel MOTO-SAW



Cuts the most intricate and delicate scroll designs accurately at 7,200 strokes per minute. Handles 3/4" wood, light metal, plastics, floor and wall tile. Model 203... \$6.85

Quality Power Tools Since 1934

DREMEL MFG. CO., Dept. 110-M, Racine, Wis.

Over the Editor's Desk



To the Editor:



I thought you might like to know of the success I had with an outdoor animated (Christmas) display which I made from your November 1958 issue. Your article said "It's the animated display that gets the real attention and enthusiastic comment." —and so it did! Thanks.

Paul B. Lacy III
(aged 13)
Covington, Va.

☆☆☆

To the Editor:

I noted with interest a picture on page 167 of your June issue regarding one power mower pulling another to speed up lawn cutting.

The enclosed picture will give you an idea of the hookup I have been using. I mounted the throttle of my towed mower on the side of the motor so I could more easily remove the handles and put them back on when I use the smaller mower for trimming around shrubs.

The front and rear towing bars and their

(Continued to page 12)

Did you give up too soon?

Did you quit school too soon? Are you stuck with a low-pay job just because you don't have a technical education? Millions of unskilled men are in the same boat. But, unlike the others, you can do something about your future. You can train at home in spare time for a better job, higher pay and lifelong security. Opportunities are best in the Air Conditioning and Refrigeration field. So rapidly is the industry expanding that 20,000 service technicians must be trained each year. Let CTI qualify you for a rewarding career!

To men who want to make a fresh start

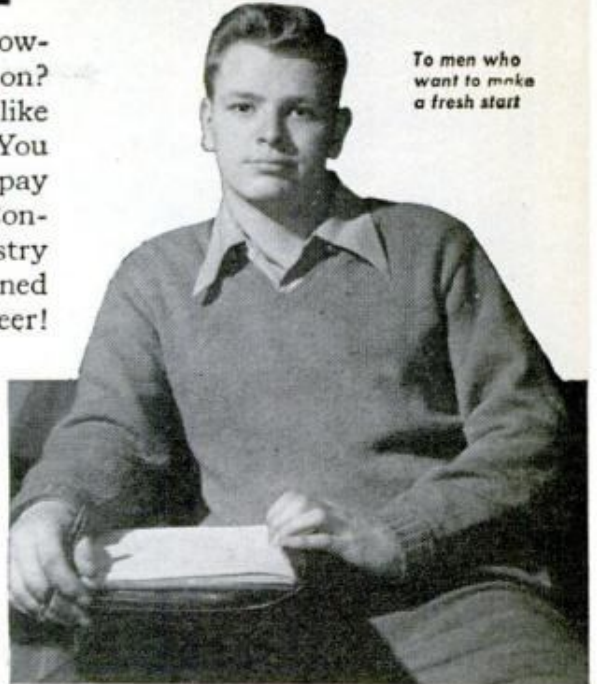

Opportunities are great for success in **Air Conditioning and Refrigeration—** Train at home in spare time

YOU BUILD THIS
1/4 H.P. HEAVY DUTY
CONDENSING UNIT!



As part of your training, you receive all parts to build a 1/4 h.p. heavy-duty, commercial-type condensing unit. You also get a set of professional quality mechanic's tools and gauges. You experiment with this equipment, get practical experience as you train, before you graduate. After unit is assembled, you may build an air conditioner, freezer, refrigerator or milk cooler. Only CTI sends operating kits. No extra charge!

Air Conditioning is now America's finest opportunity field. The government reports that during the past 12 years, production increased 400 per cent. No other industry did better! Over 8,200,000 domestic and industrial units are produced annually. Already 150,000,000 are in use. Despite this fabulous growth, Air Conditioning is said to be in its infancy! There are more opportunities for advancement—and less competition for good jobs—than perhaps in any other field. You are needed.

Get experience as you train

A famous "mechanics" magazine made a survey of home study school graduates. The editors found that 90% got pay raises, 42% earned promotions, and 17% started businesses of their own. CTI home study offers other advantages. You keep your present job as you train. You live with your family. You set your own pace, select study hours most convenient for you. You also get truly personalized instruction. Best of all, CTI sends practical training kits—to help you get experience as you learn!

Earn money as you learn

The typical CTI student is eager to put his skill to profitable work on a part-time basis. Though most students prefer to tie up with local dealers and repair establishments, a surprising number are independents. The extra cash helps meet training cost. Often there's enough to bank, or invest in more equipment.

Start a business—Be the boss

Armed with knowledge, seasoned with skill acquired through practice on kits, and equipped with tools and gauges, many graduates start out on their own. Some expand into retail stores. Others contract to service taverns, restaurants, food stores and commercial buildings. The more ambitious become air conditioning contractors.

Get the facts—Then decide

Do you have a mechanical inclination to learn Air Conditioning and Refrigeration repair? What are your opportunities for success? How does CTI train men to become qualified technicians and mechanics? What do students think of training? Get detailed, accurate answers to these and many other questions by filling out and mailing coupon below. No obligation. Facts are free. Act today!

These students are making good—Why not you?

"I have a business of my own servicing domestic and commercial refrigerators."—Paul Humphrey, Colo. "I made \$1,000 while training, and am now a refrigeration man for a dairy."—Giles Minton, N. C. "I opened a little shop and am swamped with work."—Charles Corley, Kan. "Doing service work on a part-time basis the past 10 months, I earned \$2,400. Have a nice business."—Renos Johnson, Ind. "My firm advanced me to field superintendent."—Milburn Dougan, Ark.



COMMERCIAL TRADES INSTITUTE
A Non-Profit Organization
CHICAGO 26, ILLINOIS

COMMERCIAL TRADES INSTITUTE

1400 GREENLEAF AVENUE
CHICAGO 26, ILLINOIS

DEPT. R-826

Please rush me your opportunity booklet, *Success in Air Conditioning and Refrigeration*, and Lesson Samples. Both free.

NAME _____ AGE _____

ADDRESS _____

CITY _____ ZONE _____ STATE _____



Accredited by National Home Study Council

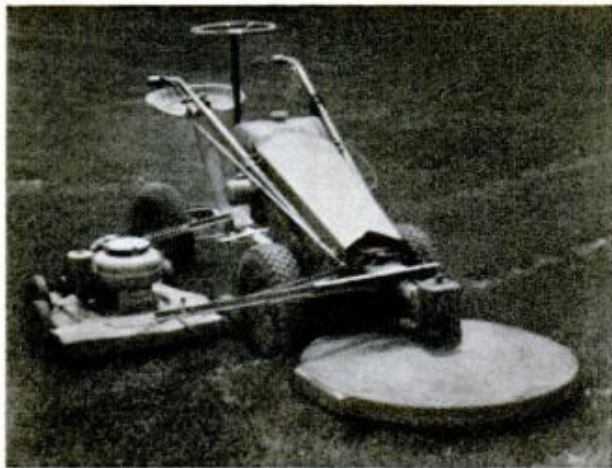

braces are firmly attached to the towing mower. The chains pulling the other mower are a bridle arrangement in front and a single chain at the rear. The chains should be adjusted so they are tight when the mower is standing still on a level surface. The rear of the mower being pulled should be directly under the rear tow bar. This is what keeps it in its proper position on turns and while in reverse. The longer towing chains in front allow the mower to ride up and down over bumps.

These two mowers have a total cutting width of 51 inches.

E. J. E. Mitchell
Ottawa, Ontario

To the Editor:

Enclosed are some shots of the better part of four years of my life.

Once a '31 Ford roadster, I've passed her off as everything from Maserati to '31 Thunderbird. Inside is a modified flathead Merc. coupled to a 26-tooth Lincoln with overdrive leading out to a two-speed rear end. No lack for gears.

You might say she's more sports car than rod, having all the luxuries, radio, heater, defroster, bucket seats, a ride that amazes all passengers and, my pride and joy, no rattles! Done with a big cross member and interlocking door latches.

Also standard equipment are coil overloads in front, a rumble-seat type trunk,

(Continued to page 14)



DON'T DECIDE YOUR FUTURE UNTIL YOU HAVE READ

How To Make Big Money Fast in the Accident Investigation & Adjusting Field



A. J. Allen earned over \$2,000 in ten weeks. Gary Williams doubled his former salary. Jessie Hill says "Had I not learned of Universal Schools' Accident Investigator Course I would still be just another time card puncher; but today I have a wonderful position, and I receive \$3.00 an hour plus an expense allowance."

RIGHT NOW the Accident Investigation and Adjusting Field offers you a tremendous future. Here's why: *This vital business distributes more money than any other service industry.* Last year alone over 200 MILLION ACCIDENTS had to be investigated for Insurance Companies, Airlines, Railroads, Steamship Lines, and Government Offices — and the need for trained men is booming!

You can investigate full time for one company — or earn \$3 to \$10 an hour in *your own business*. No prior experience or higher education needed. And age is no barrier. Here is a field wide open to men 18 to 60.

NOW! FREE Book Gives You All the Facts

Send TODAY for new, illustrated Book mailed FREE. Learn how you can prepare at home in just a few weeks for excellent full time or spare time income. See for yourself how others have doubled and even tripled their earnings. Let us show you how Universal Schools has trained hundreds of men in their own homes spare time — and then helped them add thousands of dollars to their incomes. Absolutely no obligation on your part. No salesman will call. Write at once to me, M. O. Wilson, Universal Schools, 6801 Hillcrest Ave., Dallas 5, Texas.

Mr. M. O. Wilson, Dept. PM-12
Universal Schools, 6801 Hillcrest Ave.,
Dallas 5, Texas

Send me free book on Big Money in Accident Investigating & Adjusting Field. No salesman will call.

Name.....Age.....

Address.....

City.....Zone.....State.....



We Really Mean It...When We Say

You **DON'T** Need

A High School Diploma

Previous Electronics Experience



to prepare **AT HOME** the DeVry way for a job that
Pays **REAL MONEY** in **Electronics!**

LET US TELL YOU WHY!

OUR INTEREST IN YOU... MAKES THE BIG DIFFERENCE!

preparing you at home for a profitable job in the billion dollar opportunity field of electronics, DeVry Tech is more interested in your **DESIRE TO GET AHEAD** than we are in what you know about the field now. DeVry's training is thorough and practical. No previous electronic experience is required. We train you even if you don't know how to splice a lamp cord.

Our thorough training, with its many exclusive features such as home movies, has produced many graduates so well-trained, they have been employed by some of today's best-known firms and by scores of Radio and TV stations across the continent. DeVry Tech graduates are in demand. There are many job opportunities for them.

Becoming a DeVry Tech man in itself is a big lift. We have found during the past 29 years that by understanding a man's problems... by encouraging him in every way possible, we usually help him get the break he wants. It helps him do things he cannot do alone.

Another important benefit of becoming a DeVry Tech man is knowing you are part of an institution that not only trains you and helps you get started... but an organization that stands behind you on the job. It is such things as these that make DeVry Tech graduates **DIFFERENT**... it makes them **PREFERRED** men by so many employers.

Why don't you send the coupon below for 2 **FREE** booklets... Mailing that coupon could be a big step forward... toward greater heights... better pay!

Exclusive
training
movies help
you learn **FASTER!**

**DeVry Sends You Actual
Equipment You Need
At No Extra Cost!**

DeVry Tech, in addition to its exclusive training movies, sends you the practical "Electro-Lab" system which includes 16 shipments of equipment to work more than 300 learn-by-doing projects in your own home. We know of nothing more effective than DeVry Tech's tool-in-hand training.



Send for these

**2 FREE
BOOKLETS**

Accredited member of National Home Study Council

We Have Residential Training for High School Graduates

MILITARY SERVICE We have valuable information for every man of draft age.	EARN WHILE YOU LEARN Practical training shows you how to earn good money in spare time.	RESIDENT TRAINING DeVry Tech has modern training centers in Chicago and Toronto.
---	---	--

WORK IN THESE EXCITING FIELDS WHEN TRAINED!

Radar • Guided Missile Control • Television • Radio
Micro-Waves • Communications • Industrial Electronics
Computers • Automation Electronics • Broadcasting
Remote Control Systems • Your Own Service Shop

**DeVRY TECHNICAL
INSTITUTE
CHICAGO • TORONTO**

DeVRY TECHNICAL INSTITUTE
4141 Belmont Avenue • Chicago 41, Illinois • Dept. PM-12-Q

Please give me your two free booklets, "Pocket Guide to Real Earnings" and "Electronics in Space Travel"; also include details on how to prepare for a career in Electronics. I am interested in the following opportunity fields (check one or more):

- | | |
|--|--|
| <input type="checkbox"/> Space & Missile Electronics | <input type="checkbox"/> Communications |
| <input type="checkbox"/> Television and Radio | <input type="checkbox"/> Computers |
| <input type="checkbox"/> Microwaves | <input type="checkbox"/> Broadcasting |
| <input type="checkbox"/> Radar | <input type="checkbox"/> Industrial Electronics |
| <input type="checkbox"/> Automation Electronics | <input type="checkbox"/> Special "Short Courses" |

Name _____ Age _____

Address _____ Apt. _____

City _____ Zone _____ State _____

Check here if you face military service.

Canadian residents: Write DeVry Tech of Canada, Ltd.,
970 Lawrence Avenue West, Toronto 19, Ontario 2078

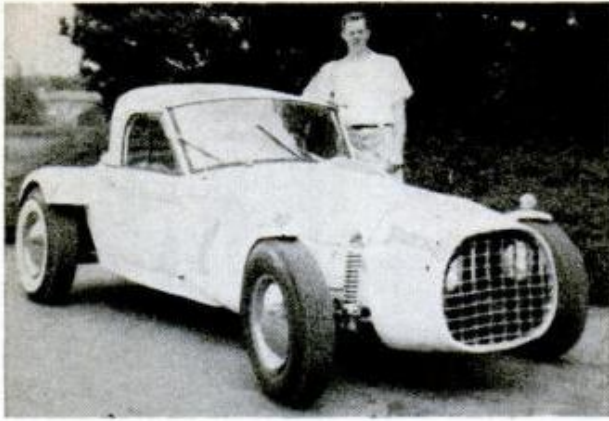

electric wipers, and two other objects of considerable pride, windows in the doors and a convertible hard top. Enough leg room so that not even a six footer can touch the fire wall.

Jim Curtice
Corvallis, Oregon

☆☆☆

POPULAR MECHANICS has available free for readers an informative folder entitled "What You Should Know About Patents." The folder gives complete information on what protection a patent provides, who can apply, costs, how to find a reliable patent attorney and steps in preparing an application. For your free copy write *Popular Mechanics, Bureau of Information, 200 E. Ontario St., Chicago 11, Illinois.*

ONE OF THE feature articles in our October issue was "Mr. Rescue and His Bloodhounds," the story of Russ Cone of Los Gatos, Calif. We regret that Mr. Cone did not live to read the story of which he was the hero. He was struck by an automobile in September and died just about the day our October issue appeared on the newsstands.

☆☆☆

To the Editor:

Here is a miniature American LaFrance fire truck I built. Seeing it running around town, people wondered why the borough bought such a small truck so they put it in the newspaper to set people straight.

Roland C. Bower
Berwick, Pa.

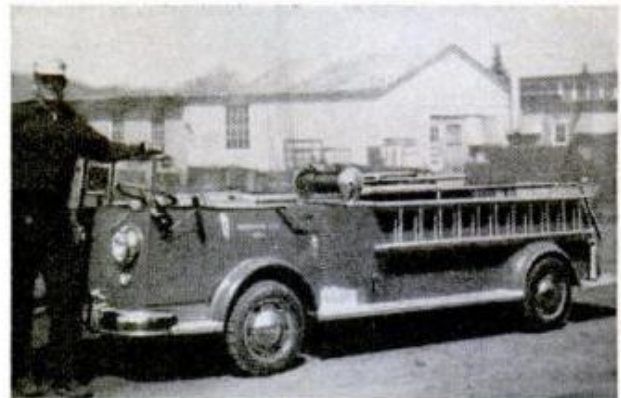

Enjoy
Velvet-Smooth Smoking
-the whole bowl
through!

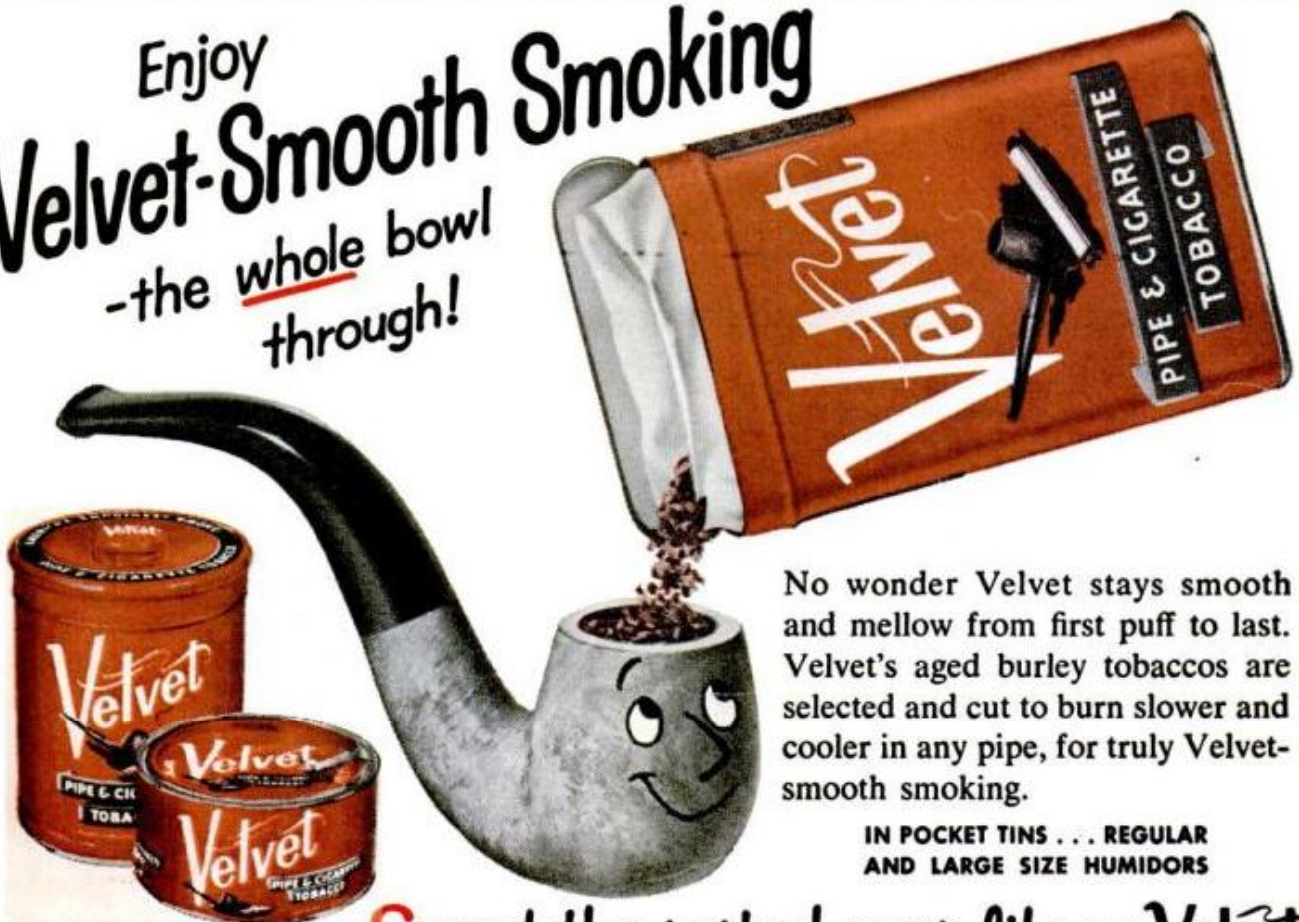

No wonder Velvet stays smooth and mellow from first puff to last. Velvet's aged burley tobaccos are selected and cut to burn slower and cooler in any pipe, for truly Velvet-smooth smoking.

IN POCKET TINS . . . REGULAR
AND LARGE SIZE HUMIDORS

Spend the rest of your life on Velvet!

© 1959 LIGGETT & MYERS TOBACCO CO.

WHAT ALL AUTO MECHANICS WANT TO KNOW

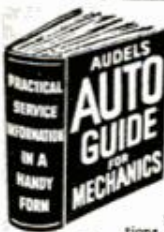

This Big Practical Book gives full information, with working diagrams, covering the principles, construction, ignition, service and repair of modern cars, trucks and buses.

Air Conditioners, Hydraulic & Fluid Drives Fully Explained.

A complete guide of 1132 Pages, with over 1000 Illustrations showing inside views of working parts, with instructions for service jobs. Completely up-to-the-minute! Priced at only \$6.



CIRCLE NO. 1 IN COUPON

HOW TO FIX HOME APPLIANCES

REFRIGERATORS WASHERS TOASTERS DRYERS IRONERS RANGES VACUUMS FREEZERS

Many other GAS AND ELECTRIC APPLIANCES



Handy Reference for Electric & Gas Servicemen, Mechanics, Dealers and Homeowners. Explains clearly and simply how to locate trouble, how to test, reassemble and connect. Wiring diagrams, 1000 Facts. Easy to read. Answers ALL your questions. 864 Pages. Illustrated. Only \$6.

CIRCLE NO. 2 IN COUPON



TV TELLS HOW TO ANSWER RADIO AND T.V. QUESTIONS SERVICE LIBRARY

HERE IS LATE INFORMATION IN A HANDY FORM FOR RADIO AND TELEVISION REPAIRMEN, SERVICEMEN AND STUDENTS

TWO COMPLETE VOLUMES - 1568 Pages - 1085 Illustrations and Diagrams. 1001 Important Facts and Figures on Modern T.V., Rad-0, Electronic Devices. INCLUDES TRANSISTORS & Transistors Circuits, Rectifiers, Record Changers, P.A. Systems, Phonograph Pick-ups, F.M., Auto Radio, Short Wave,

Basic principles, Construction, Installation, Operation, Troubleshooting, How to get Sharp, Clear T.V. Pictures. Install Aerials, How to Test. Explains COLOR SYSTEMS, Methods of Conversion, Terms, etc. Includes Ultra High Frequency. Quick ready reference or use as a home study course. Only \$8 for BOTH volumes.

CIRCLE NO. 3 IN COUPON

OIL BURNERS

New, complete, explaining in detail both domestic and industrial oil burners. Includes electrical hook-ups and wiring diagrams. Fully covering the theory, construction, installation, operation, testing, servicing and repair of all equipment. Indexed for ready reference. Over 416 Pages. 320 Illustrations and Diagrams. Only \$2.

CIRCLE NO. 28 IN COUPON



ALL TYPES OF BLUEPRINT READING

How to read scales, the standard symbols, detail and assembly prints, working drawings, short cuts, helps, hints and suggestions. THE MAN WHO CAN READ BLUEPRINTS IS IN LINE FOR A BETTER JOB. This book gives you the secret language, step by step in easy stages. 448 Pages. Very Fully Illustrated. Priced at \$3.

CIRCLE NO. 25 IN COUPON

PLUMBERS AND STEAMFITTERS' GUIDES



Practical Trade Assistant & Reference Set. Explains in plain language and by clear illustrations, diagrams, charts, graphs and pictures the principles of modern plumbing practice including Pipe Fitting and Air Conditioning. 4 Vols. - 2624 Pages - 3642 Diagrams & Illustrations. Only \$8 for the complete set of 4 vols.

CIRCLE NO. 6 IN COUPON

7-DAY FREE EXAMINATION

SEND NO MONEY - Pay the postman nothing! We are glad to send you any of the Audel Guides for absolutely FREE examination in your own home. We take all the risks and leave all the decisions up to YOU. There is no obligation! If you decide to keep the books of your choice you may pay for them under our astounding easy-pay plan of only \$2 a month.

HERE IS ALL YOU DO

IT'S EASY TO ORDER: In the No-Risk Mail Order Coupon at the right just draw a circle around the number of Audel Guides you want us to send you for FREE EXAMINATION. We will send them to you at once to help you build a brighter future by increasing your SKILL. If for any reason at all you are not COMPLETELY satisfied, return the books to us, and that will end the matter! NO STRINGS OR CATCHES TO THIS OFFER.

THEO. AUDEL & CO.
49 West 23rd Street, New York 10, N. Y.

DECEMBER 1960

CARPENTERS AND BUILDERS GUIDES



PRACTICAL STOREHOUSE OF MODERN CONSTRUCTION INFORMATION (4 vol. set) for carpenters and all woodworkers. Explains in easy language and by profuse illustration principles, advances, short cut, trade secrets, all based on the NEWEST information. Vol. 1-Tools, steel square, saw filing, joinery, furniture, etc.; Vol. 2-Builders' mathematics, drawing plans, specifications, estimates, etc.; Vol. 3-House and roof framing, laying out, foundations, etc.; Vol. 4-Doors, windows, stair building, millwork, painting, etc. 4 vols. 1904 Pages. 3700 Illustrations. Whole set only \$8. CIRCLE NO. 8 IN COUPON

PRACTICAL ELECTRICITY

A COMPLETE HANDBOOK-Quick, simplified, ready reference. Complete instruction and practical information on the rules and laws of electricity-Maintenance of Machinery -A.C. and D.C. Motors-Armatures-Wiring Diagrams-House Lighting-Power Wiring-Meters-Batteries-Transformers-etc. Simple to understand. 1052 Pages. 2600 Illustrations. Priced at \$5. CIRCLE NO. 4 IN COUPON

DIESEL

ALL THERE IS TO KNOW ABOUT MODERN DIESEL ENGINES-Basic principles, starting valves, timing, fuel pumps, fuel injection compressor, air compressors, pistons, cylinders, lubrication, cooling systems, etc. Answers on operation, calculations. 640 Pages. Fully Illustrated. Priced \$3. CIRCLE NO. 9 IN COUPON

MASONS & BUILDERS GUIDES

A PRACTICAL ILLUSTRATED 4 VOL. SET-Explaining in clear, simple language and profuse illustration, principles, advances, short cuts, trade secrets, based on modern practice - including how to figure and calculate various jobs. Vol. 1-Brick work, bricklaying, bonding, designs. Vol. 2-Brick foundations, arches, tile setting, estimating. Vol. 3-Concrete mixing, placing forms, reinforced stucco. Vol. 4-Plastering, stone masonry, steel construction, blueprints. 4 Vols. 1440 Pages. 2067 Illustrations. Complete Set only \$8.

CIRCLE NO. 26 IN COUPON

MATHEMATICS MADE EASY

A COMPLETE HOME STUDY COURSE-Starting with the first principles of arithmetic, advancing step by step through the various stages of mathematics, including the rules and calculations for mechanical and electrical problems. New EASY correct methods. Includes plane and solid geometry, trigonometry, algebra, calculus, etc. Practical tests, reference tables and data. How to use slide rule. 672 Pages. 550 Illustrations. Priced at only \$3.

CIRCLE NO. 11 IN COUPON

NEW MACHINISTS AND TOOLMAKERS HANDBOOK

MODERN MACHINE SHOP PRACTICE - For every Machinist, Toolmaker, Draftsman or Student. Tells how to set up and operate lathes, screw and milling machines, chapers, drill presses and all other machine tools. A COMPLETE INSTRUCTOR AND REFERENCE BOOK. 1250 Pages. Fully Illustrated. Priced at only \$6.

CIRCLE NO. 12 IN COUPON

ELECTRIC MOTORS

THIS GUIDE covers the construction, hook-ups, control, maintenance and trouble shooting of all types of motors. Includes armature winding. Explains entire subject in great detail in simple language. Over 1056 Pages of information. 617 Diagrams. All types of motors fully illustrated and indexed for ready reference. Priced at only \$5.

CIRCLE NO. 27 IN COUPON

REFRIGERATION & AIR CONDITIONING

FOUR BOOKS IN ONE - basic principles, servicing, operation, repair of: 1. Household Refrigeration. 2. Special Refrigeration Units. 3. Commercial & Industrial Refrigeration. 4. Air Conditioning Systems. A GOLD MINE of essential information. Completely up-to-date. 1360 Pages. Fully Illustrated and Indexed. Priced at only \$6. CIRCLE NO. 14 IN COUPON

New MECHANICAL DICTIONARY

THE AUTHORITATIVE WORD BOOK FOR MECHANICS TECHNICIANS AND STUDENTS

With the revolutionary progress being made today in all mechanical fields, new words and phrases come into use. Any mechanic who wants to be up to date must know this new trade language.

Audels New Mechanical Dictionary gives you all these new words and also the old. Every mechanic will find his job made easier if he knows the exact meaning and use of technical words that come up every day at work. It is an engineer's shop companion and a student's guide.

TABLES, FORMULAS, PROCESSES AND PRACTICAL SUGGESTIONS

Constant use of Audels New Mechanical Dictionary will increase your knowledge and skill in a matter of days without any conscious effort on your part. The right word at the right time is like the right tool - be sure you have it and use it! Defines 17,000 words - terms phrases - rules and formulas, 712 pages only \$6.95.

CIRCLE NO. 44 IN COUPON

THE NEW ELECTRIC LIBRARY

A COMPLETE ENCYCLOPEDIA explaining in the simplest terms the fundamental principles, rules and applications of applied electricity.

A COMPLETE COLLEGE EDUCATION! Fully illustrated with diagrams and sketches, calculations and tables for ready reference. Questions and answers. Trial tests for practice study and review. All based on the most modern theory.

Vol. 1-Principles and rules of electricity, magnetism, armatures, repairs. No. 15

Vol. 2-Dynamos, DC Motors, construction, installation, maintenance, etc. No. 16

Vol. 3-Testing instruments and tests, storage battery constr. and repairs. No. 17

Vol. 4-Alternating current, power factor, alternators, transformers. No. 18

Vol. 5-A.C. Motors, windings, maintenance, converters, switches, fuses, etc. No. 19

Vol. 6-Relays, condensers, regulators, rectifiers, meters, switchboards, etc. No. 20

Vol. 7-Wiring, house light and power, circuits, high

tension, plans, code, etc. No. 21

Vol. 8-Railways, signals, elevators, ignition, etc. No. 22

Vol. 9-Radio, telephone, telegraph, television, motion pictures. No. 23

Vol. 10-Refrigeration, illumination, welding, x-ray, electrical appliances, Index. No. 24

6,000 fully illustrated pages. Priced at only \$30 for the ENTIRE SET. Also sold individually for \$2 each.



WELDERS GUIDE - Covers Electric, Oxy-acetylene, Thermit, Unionmelt welding for sheet metal, spot and pipe welds, pressure vessels and aluminum, copper, brass, bronze and other metals. Airplane work, surface hardening, hard facing, cutting, brazing, etc. 608 Pages. Fully Illustrated. Only \$3.

CIRCLE NO. 10 IN COUPON

ADDITIONAL IMPORTANT TITLES

The following Audel Guides are all the best in their fields, written in clear simple fashion, all lavishly illustrated. Circle the numbers wanted in the MAIL ORDER COUPON below. All books are sent for FREE EXAMINATION.

No. 5 TRUCK & TRACTOR GUIDE. 1376 Pages	\$5.00
No. 7 PAINTING & DECORATING MANUAL. 417 Pages	3.00
No. 13 WIRING DIAGRAMS (Light & Power). 304 Pages	2.00
No. 29 SHEET METAL PATTERN LAYOUTS. 1152 Pages	7.50
No. 30 SHEET METAL WORKERS HANDBOOK. 448 pages	2.00
No. 31 MECHANICAL DRAWING GUIDE. 192 Pages	2.00
No. 32 MECHANICAL DRAWING AND DESIGN. 410 Pages	3.00
No. 33 ELECTRONIC DEVICES. 304 Pages	3.00
No. 34 ELECTRICIANS EXAMINATIONS. 272 Pages	2.00
No. 35 ELECTRIC POWER CALCULATIONS. Page 480	3.00
No. 36 ELECTRIC DICTIONARY. 9000 Terms	3.00
No. 37 POWER PLANT ENGINEERS GUIDE. 1568 Pages	5.00
No. 38 ENGINEERS AND FIREMANS EXAMS. 544 Pages	2.00
No. 39 OPERATING ENGINEERS LIBRARY. 3 Book Set	12.00
No. 40 PUMPS, HYDRAULICS AND AIR COMPRESSORS. 1760 Pages	6.00
No. 41 HOUSE HEATING GUIDE. 966 Pages	5.00
No. 42 MILLWRIGHTS & MECHANICS GUIDE. 1248 Pages	5.00
No. 43 DO-IT-YOURSELF ENCYCLOPEDIA. 2 Book Set	8.95

MAIL THIS NO-RISK COUPON TODAY!

THEO. AUDEL & CO. - Self Improvement Publishers Since 1879 - P-12 1 2 3 4 5 6
49 W. 23rd Street, New York 10, N. Y.

Please mail me for 7 days' FREE EXAMINATION the books I have circled at right. I agree to mail \$2 in 7 days on each book or set ordered, and to further mail \$2 a month on each book or set ordered until I have paid the purchase price, plus shipping costs. If I am not completely satisfied with my Audel Guides I may return them.

NAME _____ 17 18 19 20 21

ADDRESS _____ 22 23 24 25 26

OCCUPATION _____ 27 28 29 30 31

EMPLOYED BY _____ 32 33 34 35 36

SAVE SHIPPING COSTS! Check here if you enclose complete payment with order. We pay postage charges. You have same return privilege. 37 38 39 40 41
42 43 44

On the MARKET for Do-It-Yourselfers



1. PAINT ROLLER has a built-in sleeve ejector that can save a lot of time when you're decorating with several colors. Just press a release and the roller pops off the holder. Replace with a clean roller and you're ready to go again in half a minute. Rollers are available in the popular 7 and 9-in. sizes

Rollers By Baker, Inc., Brandon, Vt.

2. PATCHING MATERIAL is fast setting, is especially formulated to handle unusual and difficult leakage problems in masonry walls. It will stop the flow of water leaking through cracks or breaks in a masonry wall even though applied when the water is seeping in. Anchors bolts and hooks to masonry

The Reardon Co., St. Louis 14, Mo.

3. WAXLESS FLOOR COATING is self-polishing, produces a bright, long-lasting luster on linoleum, asphalt tile, rubber and vinyl tile and similar resilient floor coverings. Applies easily with a cloth or applicator. No rubbing. Dries in minutes without any streaks. Goes on white, but dries clear

Price & Stevens Chemical Corp.,
710 Ohio St., Buffalo 3, N. Y.

4. MATCHING SWITCH PLATES for wood-paneled walls are available in the popular paneling woods and are made from solid stock with the grain running vertically. Plates are smooth-sanded, ready for finishing. Made for single or multiple switch, outlet, jack box. Combinations also are available

Superior Panel Plate Co.,
606 Mead Ave., Sheboygan, Wis.

5. REPAIR KIT for Venetian blinds contains 12 plastic slot supports, or ladders, which are installed without sewing and without dismantling blinds. Simply lift fallen slot, insert plastic ladder, push fasteners through tapes into the ends of the ladder. Takes less than a minute to replace a single ladder

Slat-Fix Co., 72 Spruce St., Hicksville, L.I., N.Y.



2



3

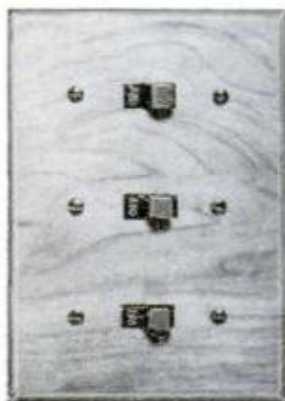

4

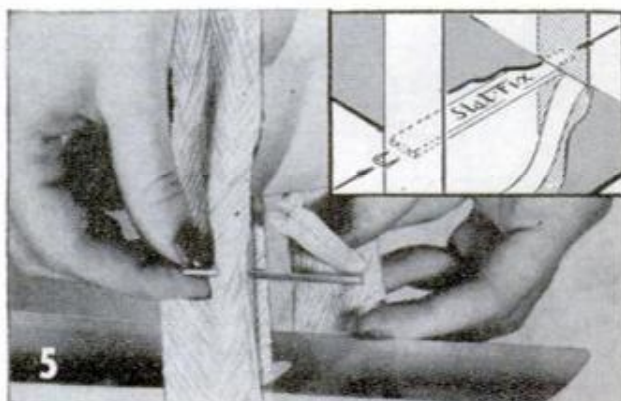

5

By James Biery

MULTIPLE SCLEROSIS, the crippling disease resulting from degeneration of the sheathlike covering that surrounds nerve fibers in the brain and spinal cord, may be linked to cosmic rays. Dr. John S. Barlow, Harvard University neurologist, says a statistical study of the occurrence of the disease shows it varies with latitudes in the same way as does the occurrence of cosmic rays. The disease thus is more common in northern parts of Europe and North America than in southern areas. It is rare in the Orient, South America, Africa, the Tropics. Other scientists have suggested that the mystery of distribution of multiple sclerosis might depend on the amount of radiation from the sun, or trace elements in the soil. If positive links are found between cosmic radiation and incidence of the disease, says Dr. Barlow, protection may be effected by chemical agents known to lessen biological effects of radiation.

Minute quantities of radioactive tracers are used to measure blood loss in patients undergoing extensive heart operations at University of Michigan Medical Center. A small amount of the patient's blood is "tagged" with radiation, then replaced. A sample taken before the operation shows by the amount of dilution of the radioactive blood just what the patient's normal supply of blood is. A second sample, taken after the operation, indicates whether the supply is back to normal. Such a test is an aid to surgery, says Dr. Edward A. Carr, Jr., one of the innovators of the technique, because a patient's recovery after surgery is greatly aided if his total blood volume can be controlled accurately by the surgeon. Previous to use of the tracer technique, methods of determination could be off as much as three pints.

What do vitamins do? Experiments at the Long Island, N. Y., Jewish Hospital have revealed that one vitamin, A, maintains the sense of taste. Laboratory animals deprived of the vitamin were unable to distinguish between regular tap water and ultrasour quinine water. Chief sources of vitamin A are milk, egg yolk, yellow fruits and the yellow and dark-green vegetables. ★★

UNUSUAL BARGAINS EXCELLENT XMAS GIFTS!

See the Stars, Moon, Planets Close Up!

3" ASTRONOMICAL REFLECTING TELESCOPE

60 to 180 Power — Famous Mt. Palomar Type! An Unusual Buy! Assembled—Ready to use! You'll see the Rings of Saturn, the fascinating planet Mars, huge craters on the Moon, Star Clusters, Moons of Jupiter in detail. Galaxies! Equatorial mount with lock on both axes. Aluminized and overcoated 3" diameter high-speed f/10 mirror. Telescope comes equipped with a 60X eyepiece and a mounted Barlow Lens, giving you 60 to 180 power. Low-cost accessory eyepiece available for higher powers. An Optical Finder Telescope, always so essential, is also included. Sturdy, hardwood, portable tripod. FREE

with Scope:—Valuable **STAR CHART** plus 272 page "**HANDBOOK OF HEAVENS**" plus "**HOW TO USE YOUR TELESCOPE**" BOOK.

Stock No. 85,050-H \$29.95 postpaid

4 1/4" Astronomical Reflector Telescope! Up to 255 Power. New Vibration-Free Metal Pedestal Mount.

Stock No. 85,105-H \$79.50 F.O.B.



SCIENCE TREASURE CHESTS

Extra-powerful magnets, polarizing filters, compass, one-way-mirror film, prism, diffraction grating, and lots of other items for hundreds of thrilling experiments, plus a Ten-Lens Kit for making telescopes, microscopes, etc. Full instructions included.

Stock No. 70,342-H \$5.00 Postpaid

Science Treasure Chest DeLuxe—Everything in Chest above plus exciting additional items for more advanced experiments including crystal-growing kit, electric motor, molecular models set, first-surface mirrors, and lots more.

Stock No. 70,343-H \$10.00 Postpaid

War Surplus American-Made 7x50 Binoculars

Big savings! Brand new! Crystal clear viewing — 7 power. Every optical element is coated. An excellent night glass — the size recommended for satellite viewing. Individual eye focus. Exit pupil 7mm. Approx. field at 1,000 yds. is 376 ft. Carrying case included. American 7 x 50's normally cost \$195. Our war surplus price saves you real money.

Stock No. 1533-H only \$55.00 postpd. (Tax included)



Terrific Buy! American Made! OPAQUE PROJECTOR

Projects illustrations up to 3" x 3 1/2" and enlarges them. No film or negatives needed. Projects charts, diagrams, pictures, photos, lettering in full color or black-and-white. Operates on 115 volt, A.C. current. 6-ft. extension cord and plug included, operates on 60 watt bulb, not included. Size 12" x 8" x 4 1/2" wide.

Weight 1 lb., 2 oz. Plastic case with built-in handle. Stock No. 70,199-H \$7.95 Postpaid



ANALOG COMPUTER KIT

Demonstrates basic analog computing principles—can be used for multiplication, division, powers, roots, log operations, trig problems, physics formulae, electricity and magnetism problems. Easily assembled with screwdriver and pliers. Operates on 2 flashlight batteries. Electric meter and 3 potentiometers are mounted on die-cut box. Answer is indicated on dial. Computer is 20" long, 9" wide, 2" deep.

Stock No. 70,341-H \$14.95 Postpaid

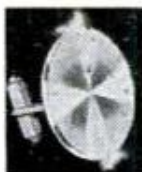

CIRCULAR DIFFRACTION GRATING JEWELRY

A DAZZLING RAINBOW OF COLOR
Shimmering rainbows of gem-like color in jewelry of exquisite beauty—made with CIRCULAR DIFFRACTION GRATING REPLICAS. Just as a prism breaks up light into its full range of individual colors, so does the Diffraction Grating.

Stock # 30,349-H Earrings \$2.75 Ppd.
Stock # 30,350-H Cuff Links \$2.75 Ppd.
Stock # 30,372-H Pendant \$2.75 Ppd.
Stock # 30,390-H Tie-Clasp \$2.75 Ppd.

Order by Stock No.—Send Check or M.O.—Money-Back Guarantee
EDMUND SCIENTIFIC CO., Barrington, New Jersey

MAIL COUPON for FREE CATALOG "H"

144 Pages! Over 1000 Bargains!

EDMUND SCIENTIFIC CO., Barrington, N. J.
Please rush Free Giant Catalog-H.

Name

Address

City Zone State



FREE!

TRIAL LESSON



Trial lesson in **DRAFTING**



LEARN AT HOME IN SPARE TIME

Check the want ads in any newspaper — SEE the big-pay opportunities open to you as a draftsman. What's more, you can learn this well-paid, prestige profession at home — quickly, easily! No special talent needed! Get complete, step-by-step Chicago Tech lessons in the mail, spend a few pleasant hours studying each week. In a short time you'll be a well-trained draftsman, ready to take your pick of many good jobs. Act now!

FREE INFORMATION—MAIL COUPON TODAY!

Get **FREE TRIAL LESSON** plus information about C.T.C. practical training. Learn what successful Chicago Tech graduates say about high pay and opportunities in drafting. No charge, or obligation.

Accredited National Home Study Council

CHICAGO TECHNICAL COLLEGE

5-218 Tech. Bldg., 2000 So. Michigan Ave.
Chicago 16, Illinois

Mail me **FREE Lesson** with information about big opportunities in **DRAFTING**.

Name..... Age.....

Address

City..... Zone..... State.....



Make Money with **MULTICRETE**

Get into the garden masonry business — where manufacturing is easy, where the market is broad, and where income potentials are highly attractive.

Multicrete is a line of concrete masonry for building many things around house and garden — patios, walks, terraces, steps, barbecue pits, lattice walls, piers, planters, and many more. There's a place for Multicrete around almost every home.

The new Multicrete machine is compact and self-contained. Easy to operate because of hydraulic movements and automatic controls. Requires very little space. High production with low labor costs. Requires only moderate investment, with time-payments where desired. Write for free literature.

W. E. DUNN MFG. CO.
401 W. 24th Street
HOLLAND, MICH.



M-2

Patio Stones
Screen Block
Brick, etc.



Can-Cover Garlands

Shiny tops and bottoms of tin cans decorate a large spruce at Christmastime in the yard of Lauren Cahill in Denver, Colo. The ends of the cans are punched near the rims, strung on heavy cord and draped on the tree. At night the tree is lighted by two foreground floodlights. Sunlight brings out striking reflection patterns during the day. To space the lids on the cord and prevent them from sliding together, the end of the cord is passed through the hole in the lid, looped over the rim and then passed through the hole a second time. After stringing, the ends of the cord are tied to the branches near the top.—K. E. Althoff

Scientists Won't Give Up: Insist Man Can Fly Like a Bird

Long before the Wright brothers proved they could fly in machines, men were trying to fly like birds—using flapping wings. Now two scientists at the University of Chile are renewing the argument, claiming that, simply by using the mechanical, biological, electrodynamic and aerodynamic similarities of birds and insects, man can strap on a pair of wings and take off. A 154-pound man, for instance, would need wings about 10 feet long with a flight surface of 60 square feet. To maintain a speed of 45 to 50 miles per hour, he should flap his wings 35 times a minute or about once every two seconds. They estimate this would require about as much energy as walking up a flight of stairs at 30 steps a minute. Depending on conditions, he could keep it up from 5 to 30 minutes. Much of their theory is based on the availability of new materials, both metals and plastics.

**Courses in Radio and
Electronic Fundamentals –
TV Servicing – Color TV –
Electronics for
Automation –
Transistors**



RCA Institutes, one of the leading technical institutes in the United States devoted exclusively to electronics, offers the finest training-at-home. The very name "RCA" means dependability, integrity, and scientific advance. Practical work with your very first lesson. Pay as you learn. *No monthly installment payments.* You pay for your next study group only when you order it. Remember, in electronics, the more you know the higher you go! Licensed by the New York State Education Dept.



RCA INSTITUTES, INC.,
A Service of Radio Corporation of America
350 West Fourth Street, New York 14, N. Y.

**The Most Trusted Name,
in Electronics**

Resident School Courses in Los Angeles and New York City offer comprehensive training in Television and Electronics. Day and Evening classes. Free Placement Service. Catalog free on request.

SEND FOR THIS FREE 64-PAGE BOOK TODAY!

RCA INSTITUTES, INC., Home Study School Dept. PM-DO
350 West Fourth Street, New York 14, N. Y.

Please rush me your FREE illustrated 64-page book describing your electronic training programs. No obligation. No salesman will call.

Name _____ Age _____

(please print)

Address _____

City _____ Zone _____ State _____

Korean Vets: Enter discharge date _____

Canadians—Take advantage of these same RCA Institutes courses at no additional cost. No postage, no customs, no delay. Send coupon to: RCA Victor Company, Ltd., 5581 Royalmount Ave., Montreal 9, Quebec

**"MADE \$1200
ON ONE JOB"**

Some make more, some less...

We help you start Your Own All-Year Business Make BIG Money! With our easily operated, highly efficient wall washer, G. H. Jones made \$1200 on one school job. E. L. Goss took in more than \$10,000 in one year. E. C. Taber wrote, "I made \$400 gross in two weeks." And no wonder...this machine washes walls 6 times faster and better than by hand—with no mess...no drop cloths.



Your Money-Making Opportunity • We want more men to go into this profitable business for themselves and enjoy independence—freedom from layoffs and bosses. Customers everywhere—homes, offices, schools, churches, hotels, etc. How much you earn depends largely on you. What you take in is mostly profit. No need to rent shop or office; operate from home. Start spare time until full time is justified.

Lose No Time — Send Coupon Today for All the Facts

FREE BOOK! MAIL COUPON TODAY!

VON SCHRADER MFG. CO.
W10 "W" Pl., Racine, Wisconsin

Send at once (no obligation) your **FREE** booklet containing information about your **WALL WASHING MACHINE** and how I can start my own permanent, profitable business.

Name

Address

City Zone State

If you take

Color Pix

8mm • 16mm • 35mm 127 • 120 • 620

You must get our **MONEY SAVING**

Free Catalog

Listing all popular **KODAK** and **ANSCO** Film Type and Sizes . . . **WRITE TODAY!**

SOLAR CINE PRODUCTS, Inc.

"Direct-by-Mail" Film and 4247 S. Kedzie Chicago 32,
Processing Specialists for almost a quarter century" Dept. ME

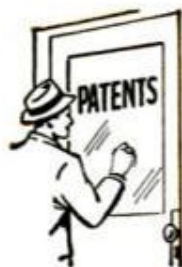

**TUNE IN ON THE
INVENTORS**

By John Linkletter

NO 3-D GLASSES or wide screens are needed to produce the three-dimensional images of a new two-screen motion-picture system. Separate filmings are made of foreground action and background settings. For viewing, the foreground is projected onto a wire mesh screen; the background is rear-projected onto a screen behind the mesh. Between the screens, a neutral density filter keeps the background image from striking the front screen or the foreground image from getting to the rear screen. Alvin M. Marks, Whitestone, N. Y., Mortimer M. Marks, Beechhurst, N. Y., and Satiris Fasoulis, Clifton, N. J., received patent No. 2,952,182 for the system.

An afterburner apparatus for purifying auto exhaust won patent No. 2,953,898 for George W. Cornelius of Portuguese Bend, Calif. He assigned the patent to Holley Carburetor Company.

Frost can't get at fruit trees covered by a polyethylene bag invented by George J. Nelson of Milwaukee, Wis. The inventor found that the bag's .003-inch thickness allows sunlight to enter to mature fruit. Vents let air circulate. The device was awarded patent No. 2,953,870.

A paint pail invented by Garth Showers of Tannersville, N. Y., has a place for everything needed in painting. Bins and trays on the sides hold brushes and other tools, and a disposable paper liner keeps the pail clean. Because of its shape, the bucket lies flat against the side rails of a ladder.



GET A LOAD OF

THIS!

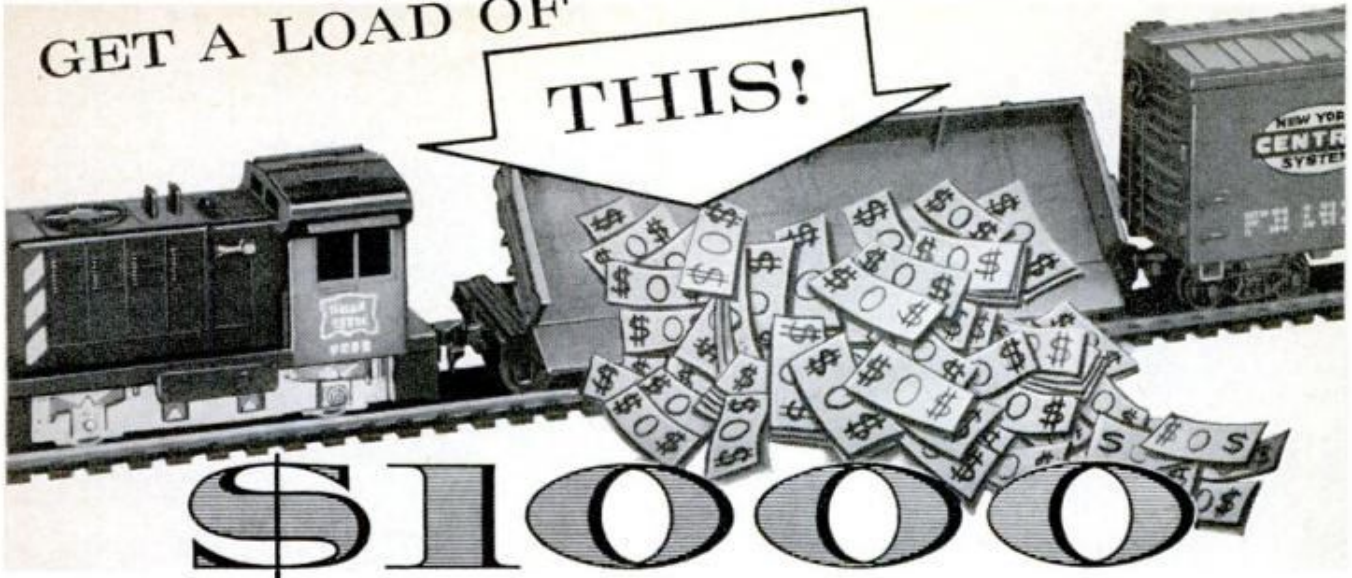

\$1000

can be yours...in the big new
**LIONEL RAIL ROAD COMPANY
TRACK LAYOUT CONTEST!**

\$1,000 IN CASH > \$500 IN CASH > \$250 IN CASH > PLUS 500 OTHER PRIZES

IT'S EASY...IT'S FUN!...HERE IS ALL YOU DO!

1.

Pick up a free
Lionel catalog,
wherever Lionel
trains are sold.



2.

Turn to the contest
pages in the catalog
and choose one of
three track layouts...
Junior, Intermediate
or Advance.

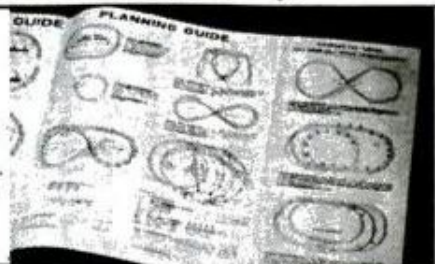

3.

Use your imagination and
put together the best-
looking, most exciting
layout you can. Using
Lionel track, trains and
accessories (either Super "O",
"O27" or HO.)



4.

Take a snapshot
of your finished
layout and send the
photo to Lionel as
your contest entry.
(Address below)



RULES:

1. Winners will be chosen on the basis of originality and interest.
2. Rolling stock and accessories must be made by Lionel. Merchandise used to "dress-up" your layout can be of your own choice or making.
3. Enter as often as you wish. But remember: each entry must be a photograph of a different layout.
4. Contestants must be no older than 16 years of age.
5. Entries must be postmarked no later than midnight, Jan. 31, 1961.
6. Decisions of the judges are final, and no entries may be returned.
7. Send entries to—LIONEL RAIL ROAD CO. Box 202, N. Y. 10, N. Y.

EXTRA PRIZES!

Each entrant will become an honorary stockholder in the Lionel Rail Road Company. You will receive your own stockholder's certificate . . . and the right to vote for the Board of Directors, and help select next year's trains and accessories.

TO ENTER...GET YOUR LIONEL CATALOG NOW! CONTEST CLOSES JANUARY 31, 1961

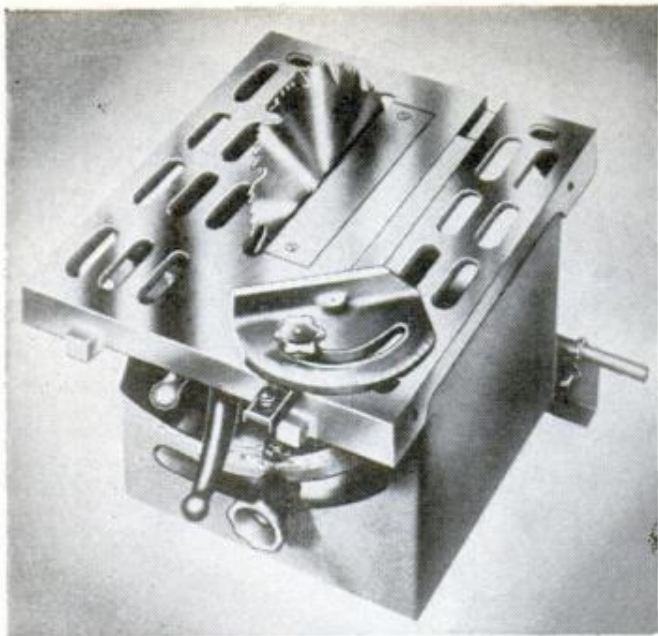

Power Saw only \$9.95 Don't question the price! Don't doubt the value! Don't try to beat it! You can't! We operate large foundry—own patents—sell direct. Blade tilts, table stays level. All cast iron and steel construction. Precision ground cast iron table. Massive cast iron mitre gauge. Patented motor drive fits any motor. Does everything accurately and quickly—as a saw costing 5 times as much. Cross cuts, rips, bevels, dados, cuts compound angles. Adjustable depth of cut 0 to 2¼. Exactly as shown less blade.

Send cash or check for \$9.95. Or, send \$2 deposit for C.O.D. All machines sent express collect. We will give you your money back immediately if you are not completely delighted. 480,000 now in use. See for yourself. Order right now.

AMERICAN MACHINE & TOOL CO.
Royersford 9, Pa.

engineering degree in 27 months

Share rewards awaiting college men . . . higher income . . . advancement. Important firms visit Tri-State campus to interview seniors. *Bachelor of Science Degree in 27 Months* in Electrical Engineering (Electronics or Power major), Mechanical, Civil, Aeronautical, Chemical Engineering. *In 36 Months* a B.S. in Business Administration (General Business, Accounting, Motor Transport Management majors). For earnest, capable students. Small classes. More professional class hours. Well-equipped, new and modernized, buildings, labs, dorms. *Modest costs.* Year-round operation. Enter January, March, July, Sept. Founded 1884. Write *J. E. McCarthy, Director of Admissions, for Catalog and "Your Career in Engineering and Commerce" Book.*



TRI-STATE COLLEGE

4120 College Avenue Angola, Indiana

IT'S EASY TO ROLL OUT THIN LINES with

Master[®] PAINT STRIPER

You can do professional striping on furniture, boats, autos, bikes, plywood, etc. Master Striper rolls out uniform lines on wood, glass, plastic, ceramics, almost any surface with paint, temperas, glue, textile-paint or underglaze; also used in industry.

TYPE M Tool with 1/16" roller tip.	\$1.50
Other size Tools (1/64", 1/32", 3/64", 5/64", 3/32", 1/8")	2.00
Extra Roller Tips, Sizes above, ea.	1.00
Extra Roller Tips, 1/4" ea.	1.25
Special complete set with 7 tips, only	5.50
DOUBLE STRIPE KIT—5 combinations	3.50
(COD's. Postage Collect)	

MAKES CLEAN, STRAIGHT OR CURVED LINES; VARIOUS WIDTHS AVAILABLE.



WENDELL MFG. CO., 4234 LINCOLN AVE. DEPT. 44 CHICAGO 18, ILL.

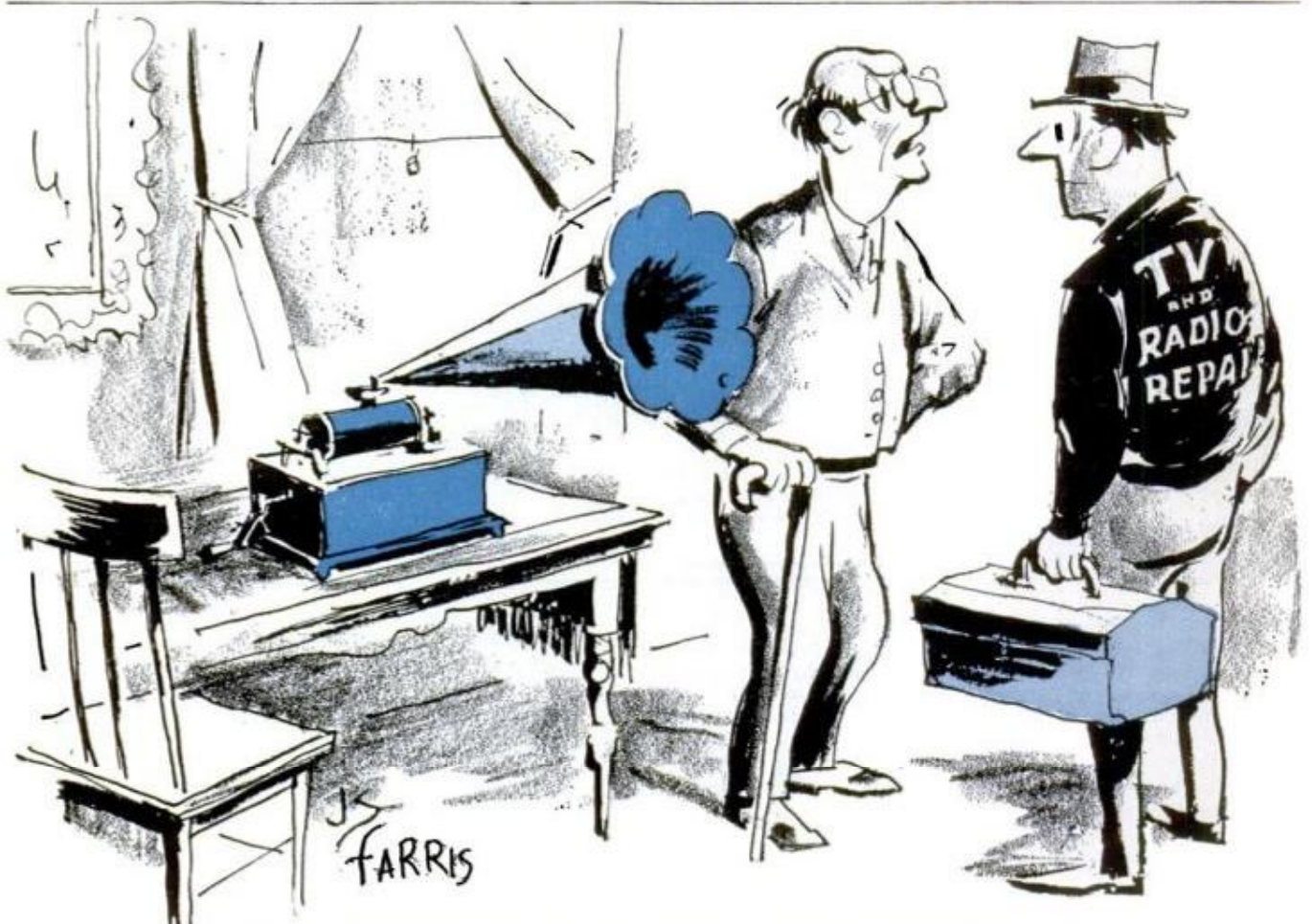

"What kind of service do you call that—no parts available!"

RENEW! Redecorate! MANUFACTURE!

REPAIR! WITH Spray-on Suede!

FANTASTIC NEW HOME BUSINESS FOR BIG CITY, SMALL TOWN, FARM...

End your money troubles forever. Add "Spray-On Suede" spare-time profits to give you 2 incomes at once. Then use the profits to develop full-time financial security. Start anywhere, any time. Corner of Garage, Basement or Service Porch is room enough. Few hours a week can bring money miracles!

Join these Men in the **BIG MONEY** up to **\$500 PROFIT** FROM \$20 WORTH OF MATERIALS (FREE FRANCHISE - RUSH COUPON!)



Some earn less, but here are reports from a few Flook-Krafters:
\$10,000 A YEAR

"I earned \$10,000 a year for spare-time start."
G. H.—California

\$100 JOB 1st DAY
"Got a \$100 job my first day... promises of several more."
C. E.—Maryland

FREE SAMPLES MAIL COUPON

HUGE DEMAND AMONG BOTH NEW & USED CAR DEALERS

QUICK \$140 ORDER
"Got quick \$140 order from store... lined up 5 others in half a day."
H. R.—Wisconsin

Learn in Few Hours - Make Money Right Now
No long-drawn-out study or practice. Simple step-by-step illustrated instructions qualify you almost overnight. No expensive equipment. No previous experience needed. Few hours of practice makes you an expert. Beautify a few articles around your own home and orders from neighbors alone may keep you busy for weeks. We show you how to get orders, what to charge—everything!

WE FURNISH EVERYTHING YOU NEED TO START PROFITS COMING IN FAST
A big Kit of Spray-on Suede supplies starts you off fast. Additional supplies available at low wholesale prices. Material costing you 50¢ turns discarded radio, TV, etc. into decorator's piece to fit in most luxurious home. Get \$10 easy for such a half-hour job!

COVER & BEAUTIFY FABRICS, GLASS, WOOD, PLASTER, PAPER—ANY SURFACE
Over 5000 possible uses. Put green suede top on card tables. Beautify lamps, handbags, toys. Enrich entire wall surface of rooms. Makes worn objects look better than new. Often doubles value of brand new products. Works on any material and any shape—flat, square, round, anything!

ORDERS COME FROM HOMES, STORES, FACTORIES, ETC.—OR MANUFACTURE YOUR OWN LINE OF SUEDE PRODUCTS
Every office, every building, almost every person is a prospect. Get your share of this coming multi-million dollar business. Make and sell your own products nationwide by mail—realistic animal toys, suede belts, greeting cards. We provide ideas & know-how.

RAINBOW COLORS—EVEN FLUORESCENT
Suede materials come in dozens of colors, from soft pastels to brilliant and glowing Fluorescents. Colors for every purpose and to suit every taste. Costs only pennies, pays off in \$\$\$!

COAST INDUSTRIES, DEPT. B-12, 15127 So. Broadway, Los Angeles 61, Calif.



\$13 AN HOUR
"Made \$52.50 in 4 hours doing auto trunks. That's \$13 an hour!"
J. O.—Missouri

BIG PROFITS IN FINISHING FIGURINES, ART OBJECTS



EXPECT \$1000 A MONTH PROFIT—PERMANENT—BIG FUTURE
Exciting profits today—even bigger earnings soon, as news about your much-needed service spreads around your community. Don't stand by carelessly and watch someone else get this "gravy." Start NOW. Airmail Coupon TODAY!



RESTORE BEAUTY OF SOILED OR DAMAGED UPHOLSTERY
Picture shows "before" and "after" view of grease-soiled and torn inside door panel. Finished job looks like new, greatly increases car's value. Millions of old cars need this service. Owners always delighted.



SPRAY AUTO TRUNK INTERIORS
Every car owner welcomes the velvet-soft protection of Spray-On Suede in his luggage compartment. Even the most expensive cars are not fully lined, lower priced are rough steel that ruins valuable traveling bags or other items. You can Suede-finish every inch of surface inside an auto trunk in 15 to 30 minutes. Standard charge is \$7.50. Just one big used lot alone might give you more spare-time work than you can handle!



TURN ANY CAR INTO AN EXCITING SPORT JOB WITH "SPRAY-ON" LEOPARD SKIN FINISH!

ALL 3 FREE plus FREE FRANCHISE

Mail Coupon below for FREE Confidential Details, 50 FREE Home Business Ideas, actual FREE Samples of Suede-Surfaced Materials for you to see and feel the wonder of this fantastic product. Coupon will also reserve a FREE FRANCHISE long enough for you to decide!

NO CHARGE FOR FRANCHISE; MANY OPENINGS NOW, BUT GOING FAST
Don't delay. Be the first in your area to cash in on this amazing development. Many firms with such a sensational money-making invention would charge hundreds of dollars just for this license to use it—but Suede-Finish Franchises are FREE to those who act NOW!



LIMITED FREE OFFER—AIRMAIL COUPON NOW! FREE

COAST INDUSTRIES (Home Business Division) Dept. B-12 15127 So. Broadway, Los Angeles 61, California

I want to know more about your FREE FRANCHISE and the opportunity to make extra money. Please rush the Spray-On Suede Samples, Confidential Details & 50 Home Business Ideas. All FREE & POSTPAID, without obligation on my part. (No salesman will call, now or ever.)

Name _____ Age _____
Street _____
Town _____ Zone _____ State _____

Our reference: Your local Bank or Trust Co. We are members of the Los Angeles Chamber of Commerce.

FREE PLAN

tells how to start your own business

FILING SAWS

Here is a steady repeat CASH business you can start in your own basement or garage in your spare time and make up to \$3 or \$6 an hour. You can file hand, band and both combination and cross-cut circular saws on the Foley Saw Filer. No eyestrain—no experience needed. "The first saw I sharpened with my Foley Filer came out 100%"—writes Clarence E. Parsons.

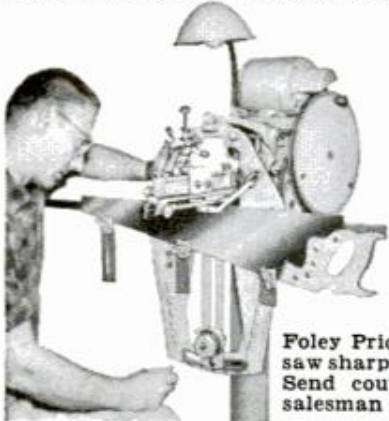

Every saw you sharpen with the Foley Saw Filer brings you more customers. "I rented a two-car garage and have all the work I can do"—Charles H. Smith.

Charles H. Smith.

FREE BOOK

Shows How to Start

Foley Price Guide gives saw sharpening charges. Send coupon today. No salesman will call.

Send Coupon for FREE BOOK

FOLEY MFG. CO.
1216-O Foley Bldg., Minneapolis 18, Minnesota.
Send FREE BOOK—"Money Making Facts," and Time Payment Plan.

Name.....

Address.....



... TURN CONCRETE INTO GOLD!



MAKE UP TO \$75 A DAY IN YOUR OWN BUSINESS

If you want to have your own business — to start a business on your own — here's your big opportunity! New high speed, low cost General block machine produces up to 1,000 concrete blocks a day. Sell all you make to builders, supply houses, and others for homes, factories, buildings, garages. Cash in on the building boom! You can make profits of 100% to 150% — up to \$75. a day! General block machine equipped with 1/2 h.p. electric motor — or can be supplied with gasoline engine — works anywhere, in little space, indoors or out. Operates from ordinary house light socket. Simple, foolproof 3 step operation — so easy a child can do it. Makes superior 3 core blocks any size from 4" to 12". Also makes chimney, sash, corner and other types. Blocks meet any building code anywhere in the country. Materials — sand, water, cement, available anywhere. Simple illustrated operating instructions and mixing formulae for cement and cinder blocks supplied with each machine. Write for FREE folder with full information.

MOTOR DRIVEN

R. L. T. of New York City reports: "MY GENERAL BLOCK MACHINE PAID FOR ITSELF IN FIRST 2 WEEKS!" Hundreds now in use the world over! Write for FREE details today!

EXTRA

Amazing illustrated book gives floor plans for 6 sensational concrete block bungalows. Tells how to lay blocks, lay out building lines, mix concrete, build steps, porch and concrete floors all at great savings. Written by experts. Can save many times the cost of the machine! Get it now! No strings attached. Send \$1.

BOOK SENT FREE IF YOU BUY MACHINE.
\$1 REFUNDED IF YOU BUY LATER.

GENERAL ENGINES CO.

DEPT. M-120, ROUTE 130, THOROFARE, N. J.



ITEMS FROM ALL OUTDOORS

By Dick Kirkpatrick

TOURISTS HEADED SOUTHWARD this winter have a chance to visit and use a unique public park, the Key Largo Coral Reef Preserve, a 75-square-mile beauty spot that is completely under water. Strange? Not if you've ever dived into the kaleidoscopic wonder that is a tropical coral reef. To preserve the coral, underwater vegetation, and myriad tropical fish that swim among them, the Florida and federal governments have worked together to stop the depredations of commercial collectors of fish, coral and shells, and the free-diving spear fishermen.

The preserve extends offshore for about four miles to the drop-off of the continental shelf, and parallels Key Largo from Carysfort Reef to Molasses Reef, including The Elbow, Key Largo Dry Rocks, and French Reef—21 miles of prime fishing, diving, and sightseeing water, and it's all yours. Plans are under way to run glass-bottomed excursion boats over the area from Key Largo.

If you're stuck for something unusual in the line of a Christmas gift for an outdoor type, there's something really new on the market. Sports-In-Sound, Inc., of 211 West 58th St., New York 19, N. Y., has produced two 12-inch, 33 $\frac{1}{3}$ r.p.m. records, one on field-dog training and another on shotgun shooting. They give your man the equivalent of an evening with the expert in both fields. One, titled "Training Your Dog to Hunt, Point, Retrieve," is by Henry P. Davis, veteran sporting dogs editor and the only man who has been asked to judge every major bird dog field trial in this country and Canada. The other, "Wing, Trap, and Skeet Shooting," is by Jimmy Robinson, another distinguished outdoor editor known internationally as "Mr. Trap and Skeet." First of a series of platters on sports topics, they are available both at record outlets and sporting goods stores.

Best new product across the outdoor desk this month: The new Weaver "V8," 2 $\frac{1}{2}$ to 8-power variable telescopic sight, first variable scope with an unobstructed scope tube, no turret, no power-change ring, and no joints in the scope tube. It fits the standard Weaver-Detachable Top Mount, available for over 150 rifles.

Superior's New Model 70 UTILITY TESTER®

FOR REPAIRING ALL ELECTRICAL APPLIANCES MOTORS • AUTOMOBILES • TV TUBES



As an electrical trouble shooter the Model 70:

- Will test Toasters, Irons, Broilers, Heating Pads, Clocks, Fans, Vacuum Cleaners, Refrigerators, Lamps, Fluorescents, Switches, Thermostats, etc.
- Will test all TV tubes for open filaments, inter-element shorts, burned out tubes, etc.
- Measures A.C. and D.C. Voltages, A.C. and D.C. Current, Resistances, Leakage, etc.
- Will measure current consumption while the appliance under test is in operation.
- Incorporates a sensitive direct-reading resistance range which will measure all resistances commonly used in electrical appliances, motors, etc.
- Leakage detecting circuit will indicate continuity from zero ohms to 5 megohms (5,000,000 ohms).

As an Automotive Tester the Model 70 will test:

- Both 6 Volt and 12 Volt Storage Batteries • Generators • Starters • Distributors • Ignition Coils • Regulators • Relays • Circuit Breakers • Cigarette Lighters • Stop Lights • Condensers • Directional Signal Systems • All Lamps and Bulbs • Fuses • Heating Systems • Horns • Also will locate poor grounds, breaks in wiring, poor connections, etc.

IT'S SO EASY!!



With tester's cord in outlet, current consumption of appliance is read direct on meter when line cord is connected to receptacle on panel. This typical iron takes 7 amperes (Good).

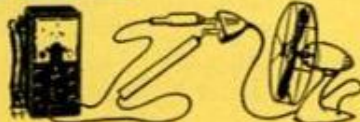

Small electric fan motor indicates 50 ohms (normal resistance).



Control circuits of most furnaces use 24 volts obtained from step-down transformer. Here's how to check room thermostat to see if wires to it are live.



Manual supplied with Model 70 shows meter needle moves to right when test leads are connected to pins 3 and 4 of this 6AU6 tube. Procedure for testing all tubes used in TV are detailed in manual.



Test Generators

Test Auto Fuses

Test Storage Batteries

Test Circuit Breakers

READ THIS!

READ THIS!

READ THIS!

You don't pay for the Model 70 until AFTER you have examined it in the privacy of your home! Model 70 is

SHIPPED ON APPROVAL

NO MONEY WITH ORDER — NO C.O.D.

Try it for 10 days before you buy. If completely satisfied then send \$3.85 and pay balance at rate of \$4.00 per month for 3 months—No Interest or Finance Charges Added! If not completely satisfied, return to us, no explanation necessary.

MOSS ELECTRONIC INC.

Dept. D-830 3849 Tenth Ave., New York 34, N. Y.

Please rush me one Model 70. If satisfactory I agree to pay \$3.85 within 10 days and balance at rate of \$4 per month until total price of \$15.85 plus postage is paid. If not satisfactory, I may return for cancellation of account.

Name _____

Address _____

City _____ Zone _____ State _____



INCLUDED FREE!!

This 64-page book—practically a condensed course in electricity. Learn by doing.

Just read the following partial list of contents:

- What is electricity? • Simplified version of Ohms Law • What is wattage? • Simplified wattage charts • How to measure voltage, current, resistance and leakage • How to test all electrical appliances and motors using a simplified trouble-shooting technique.
- How to test all TV tubes; also simple procedure for determining which specific tube (or tubes) is causing the trouble.
- How to trace trouble in the electrical circuits and parts in automobiles and trucks.

Model 70 comes complete with above book and test leads. Only ...

15⁸⁵

FREE Selection guide of Christmas Gifts for Sportsmen



Save time, save money with this 12-page catalog of famous Mossberg sporting firearms. Make your selection easily, comfortably; then see your Mossberg dealer.

Best way to a happy gift selection. And for your own Christmas gift, it's a helpful guide to those wondering what to give you.

O. F. Mossberg & Sons, Inc.
9712 St. John St. • New Haven 5, Conn.
SIRS: Please send catalog of Christmas gift suggestions.

NAME _____
STREET _____
CITY _____ ZONE _____
STATE _____

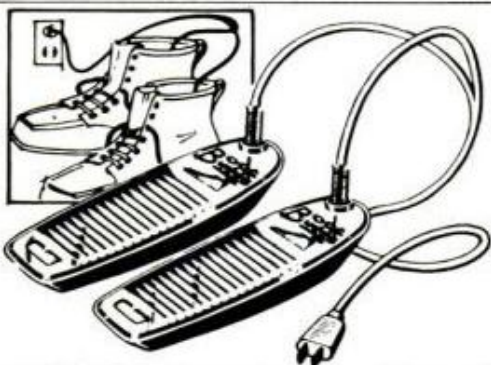

BOOT BUDDY dries and warms all types of footwear (ski and hunting boots, shoes, boots), from teen age thru adult sizes. Plugs into any 115 volt outlet. Mild, uniform heat can't harm leather. Light weight rugged construction, vented for air circulation, built-in element with cord. Guaranteed. Money refunded if not fully satisfied. Order now for Christmas! Pair, complete, \$7.95 postpaid. Check or money order.

OLYMPIC PRODUCTS, INC.
DEPT. D-5

2732 Upton Ave. So. • Minneapolis 16, Minn.

WHAT'S UP IN THE AIR



By Kevin V. Brown

AT SUPERSONIC SPEEDS, parachutes produce a pumping action that bounces their cargo dangerously. Instead of parachutes, astronauts may be glided back through the atmosphere to Earth in a flexible "paraglider." Wind-tunnel tests show that a glider made of nonporous material such as aluminum alloy would slow re-entry much better than a conventional parachute. It has a flexible wing with rigid leading edges. The wing folds up and remains completely folded until needed. The capsule, with the astronaut inside, would be suspended from the glider.

A Pan American World Airways plane set some sort of new record recently. It carried 15,000 passengers from Tokyo to California, all on one flight. The passengers—all females—were canaries destined for cages in living rooms throughout the United States.

A Ph.D. degree in Outer Space?

Cranfield College of Aeronautics at Bedfordshire, England, has opened what may be the first postgraduate course for space scientists. Aim of the year-long class is "to stimulate an interest in the subject and to provide training suitable for future workers in the field." Fee: £75 (\$210).

And while we're in outer space, have you ever wondered what might happen to the astronaut if he comes back to Earth and it's raining? This problem is the subject of a study to find an effective method of removing rain from the windshield of re-entry vehicles. Results indicate that several of the methods tested could provide satisfactory visibility under inclement re-entry conditions but, as the boys in Detroit will testify, no method devised yet is perfect, whether for automobiles or space ships.

Astronauts may look like human flies in their spaceships if they wear shoes recently constructed for them. The shoes, operating on a low-voltage power supply, have electromagnetic soles and a microswitch which interrupts the magnetic circuit each time either heel is raised. The wearer can walk on the walls, floor or ceiling at will, as easily as walking to the corner drug-store. ★ ★ ★

THIS MAN IS ON THE WAY UP

-and you can be too,
with *training*

Get ahead in **HEAVY EQUIPMENT OPERATION**

through quick, intensive home study *plus* actual experience on modern equipment. Train on easy budget terms, while holding present job.

Without obligation, you can find out how to quickly and thoroughly "broaden the base" of your technical and engineering experience. Men already in the heavy equipment field, with the training and "push" to rise higher, are needed to carry on the enormous multi-billion dollar highway and building programs now under way all over America. Thousands of bigger jobs, higher-pay jobs, opening constantly. They will be filled by men with skills, training, eagerness to get ahead. *Many will be graduates of this school.* Northwest graduates are filling some of these bigger jobs now.

NEW TRAINING PROGRAM INCLUDES COVERAGE OF:

Engineering Fundamentals	Blueprint Reading
Highway Construction	Operating Controls
Grade and Grade Stakes	Estimating
Actual Work on Equipment	Field Maintenance



ACCEPT FREE OFFER: Send now for low tuition rates, easy budget plan and complete information, plus an interesting booklet with stories typical of what our graduates are doing. No obligation. No red tape. You will be personally interviewed. **WRITE NOW.**



NORTHWEST SCHOOLS

PORTLAND • HOLLYWOOD • CHICAGO

A National Training Institution — Founded 1946

HEAVY EQUIPMENT TRAINING
Northwest Schools, Inc. Dept. M-11
1221 N. W. 21st Avenue, Portland 9, Oregon

Name _____

Address _____

City _____ State _____

County _____ Phone _____

Education _____ Age _____



GOT "LATE TO WORK" NERVES?

IS GETTING THERE ONE OF YOUR PROBLEMS?
DO YOU GET UP EARLIER TO BE ON TIME? . . .

Beat the rush hours and the late arrival jitters by joining the thousands of joyous SUPER CUB owners. . . To work, to the market, or to the beach. . . The HONDA Super Cub is amazing and it's the "MOST RIDDEN LIGHT-WEIGHT IN THE WORLD" . . . Electric "Push Button" starting the CA-102 gives you over 200 m.p.g., features 3 speed trans and automatic clutch. Its famous 50 cc Over-Head valve engine rates as the finest 4 stroke ever engineered. . . It's real easy to ride, economical. . . AND IT'S FUN!

SUPER CUB

\$245 P.O.E.



Electric Starter
\$30 additional

• 8 Models available (50 cc thru 305 cc).
Electric starters.
East of Mississippi
\$10.00 extra.

AMERICAN HONDA MOTOR CO., INC.

4077 West Pico Boulevard, Dept. PM-12, Los Angeles 19, California

GET THESE FREE FACTS ON MAINTENANCE WELDING

New
144-Page
Pocket-Sized
Maintenance



Welding Data Book

from EUTECTIC

originators of the Low Heat Input process

Handy pocket guide filled with welding and soldering information:

- Torch and arc techniques
- Settings and amperages
- How to choose the right alloy
- Meanings of welding terms
- How alloying takes place
- Descriptions of rods and electrodes
- Tips on color matching
- Tips on machinable deposits
- Ways to save on weld metal

Completely indexed and cross-indexed . . . everything you need to know. Send for your copy today.



EUTECTIC WELDING ALLOYS CORP.
40-40 172nd Street, Flushing 58, New York

Keeping up with the ATOM

By James Biery

ONE OF THE DANGEROUS products of atomic fission is going harmlessly to work for the weatherman. Strontium-90, which, under certain conditions, can cause cancer, will power electronic sentries to flash weather information from remote mountain posts. As the radioactive strontium disintegrates into stable zirconium it releases atomic particles and heat; the heat will run the electric generator. The sentries will use a compound of strontium that is insoluble, and thus cannot be absorbed by living organisms, and, because the fuel is long-lived, they should run for at least two years without servicing. First job for the sentries: to pass along information on temperature, wind speed, barometric pressure.

Since radioactive strontium is part of the fallout debris from nuclear tests, the U.S. Food and Drug Administration is investigating its content in food and is exploring ways to lower human exposure to the danger. Dr. Edwin Laug, chief of the physiochemistry branch, says fruits carry a lower level of strontium-90 than do vegetables. He attributes this to their relatively smooth skins from which particles of fallout tend to fall; also, most fruits grow on stems, branches or vines and thus are removed from direct contact with contaminated soil. Best way to reduce fallout in the diet, he suggests, is to peel skins of tubers, remove outer leaves of vegetables or shell the legume variety and thoroughly wash all fruits and vegetables before preparation.

Radioactive clouds from nuclear tests may be having some effect on feathers of some birds, say scientists at St. Bartholomew's Hospital and Medical College, London, England. Ornithologists have spotted birds with out-of-season color in England and Africa. The birds, which had come from northern Europe and Russia, were discovered during the past year. One, tested at the British Atomic Energy Authority's Harwell center, was found to be radioactive. The St. Bartholomew group has since found they can artificially change the color of a bird's feathers by submitting it to radiation.

Here's the "STRAIGHT DOPE" on HOW TO FIX ANY PART OF ANY CAR from the Men Who Build 'Em!

Engineers from every American car factory put their know-how at your fingertips in this giant 1,000-page, picture book!
COVERS ALL THESE MAKES, OVER 1,967 MODELS—1953 thru 1960!



BRAND-NEW EDITION!



Now — the "meat" of 176 shop manuals makes practically any car repair or service job child's play for beginner or expert mechanic!

NOW you can "breeze thru" the toughest car repair jobs — in DOUBLE-QUICK time. If you're a beginner mechanic you can tackle jobs you never dreamed you could handle. And if you're already an expert, you'll save yourself hours of back-breaking work . . . and save money, to boot!

It's easy with the big brand-new Edition of famous MOTOR'S Manual. You get the expert help of 176 Official Factory Shop Manuals — the time and work-saving methods developed by factory engineers in every auto plant in America for their own motor car lines—boiled down in one handy, indexed book.

Factory Experts Practically Guide Your Hands

NO guesswork! NO false starts! MOTOR'S Manual starts you from

"scratch" — expert "know-how" guides your hands through every step of practically every job. With clear illustrations and 1-2-3 instructions, these experts show you how to "polish off" any repair on any car listed—1953 thru 1960!

NEW, REVISED Edition gives you everything you need to know to repair 1,967 models. Over 1,000 giant-size pages, 2,850 "this-is-how" pictures and diagrams, 195 "Quick-Check" Charts, 30,000 essential repair specifications, 225,000 Service and Repair FACTS. Instructions and pictures so clear you CAN'T go wrong!

Here's everything you need to know to make fast, expert repairs on Automatic Transmissions, Engines, Ignitions, Carburetors, Steering Gears, Generators, Distributors, Power Steering and Brakes, Starter Motors, Starter Switches, and much, much more. No wonder THREE MILLION copies have been sold. No wonder it's used by the U.S. Armed Forces.

Try it FREE 7 Days

SEND NO MONEY! Just mail coupon. (Paste it to a postcard for faster action.) Use the Manual for a week, free. If you don't agree that it is the greatest time-saver and work-saver you've ever seen—return book in 7 days, pay nothing. Mail coupon today! MOTOR Book Dept., Desk 01Y, 250 West 55th St., New York 19, N. Y. (Schools, Bookstores: Write for discounts.)



No guesswork. Clear pictures show how to fix starting motors, generators, brakes, power steering, etc.

All Automatic Transmissions are fully covered in special big section. NOTE: All pictures shown here greatly reduced in size. Actually this giant book is almost a foot high!

Diagrams, tables and text take the "mystery" out of all ignition systems.

MAIL COUPON NOW FOR 7-DAY FREE TRIAL (Attach to postcard if more convenient)

MOTOR BOOK DEPT.
Desk 01Y, 250 W. 55th St., New York 19, N. Y.
Rush to me at once (check box opposite book you want):
 MOTOR'S New AUTO REPAIR MANUAL. If O.K., I will remit \$2 in 7 days, \$2 monthly for 2 months and a final payment of \$1.95 (plus 45¢ delivery charges) one month after that. Otherwise I will return the book postpaid in 7 days. (Foreign price, remit \$10 cash with order.)
 MOTOR'S New TRUCK REPAIR MANUAL. If O.K., I will remit \$3 in 7 days and \$2 monthly for 3 months, plus 45¢ delivery charges, with final payment. Otherwise I will return book postpaid in 7 days. (Foreign price, remit \$11 cash with order.)

Print Name.....Age.....

Address.....

City.....Zone.....State.....

Check box and save 45¢ shipping charge by enclosing WITH coupon in envelope entire payment of \$7.95 for Auto Repair Manual (or \$9 for Truck Repair Manual) plus sales tax. Same 7-day return refund privilege applies.



Some FREE 7-Day Trial on TRUCK REPAIR MANUAL
Covers every job on every popular make truck made since 1952, including GM, Mack, Cummins Diesels. Engines, fuel systems, ignition systems, starters, generators, transmissions, axles, brakes, steering, etc., etc. For FREE TRIAL, check box in coupon.

Some make more, some less;

F.E.DORAN
reports:

\$1050
gross in single
MONTH
in my own business



Start your own business!

Here's YOUR chance to start a money-making, year 'round business of your own and make the success you've dreamed about.

G. R. Adcock took in \$102 in one day. O. W. Hare landed a \$750 hotel job. J. S. Corbit grossed \$279.50 his first month. Homes, hotels, offices, clubs, offer you big profit possibilities. Auto upholstery also.

NO SHOP OR OFFICE NECESSARY - You clean furniture on customers' premises. No hauling, no high rents. Supplies inexpensive; you operate from your own home. What you take in is mostly profit.

If you want to be your own boss—free from lay-offs and strikes, we will help you to start and succeed.

This is not a lease proposition. You own the machine, you work when and where you please and all the money you take in is your own.

Mail
Coupon
Today
for
FREE
Book

VON SCHRADER MFG. CO.
W10 "D" Pl., Racine, Wisconsin
Without obligation rush your **FREE** booklet about how I can start my own permanent, profitable electric Upholstery Cleaning business.

Name _____

Address _____

City _____ Zone _____ State _____



Get Ahead Fast... with **TOP PAY!**

Learn to Operate Big Construction Equipment

Send for Free Personal Qualification Form Today

You can be one of America's high-pay operators of giant earth-moving equipment! Road building, irrigation, leveling, building erection and other exciting fields. Learn the **SURE WAY** by **DOING!** Operate our bulldozers, draglines, cranes, back-hoes, scrapers, graders, etc. Practical residence courses of 220 to 440 hours (depending on equipment chosen) give you the actual practice you need. You work with experts who show you how. Machines of major makes used. Budget Plan available. Ask about GI benefits.

Others do it, so can you! Act now! Write for free details and personal checkup form (no obligation)!

NATIONAL SCHOOLS OF CONSTRUCTION, Inc.

10852 W. Wisconsin Ave., P. O. Box 192, Dept. M
Milwaukee 13, Wisconsin

Spotlight on the

HILLMAN HUSKY

By Jim Whipple

ONE OF THE most likable and practical of all imported cars is the British-made Hillman Husky station wagon. The single model, a two-door, lists at \$1679 delivered at East Coast ports. For Midwest delivery you must pay \$35 additional freight. This price includes all basic necessities excepting the heating and ventilating system which costs \$55 extra.

The Husky has a remarkable amount of useful space in a body that's only 12 feet 8 inches long, and just 5 feet wide. It will hold four adult passengers; two in the individual, bucket-type front seats and two on the folding rear seat.

For family use, the rear seat will hold three average-sized six-to-ten-year-old children. Behind the rear seat there is still room for luggage in a space 33 inches high, 52 inches wide and 29 inches long between the seat back and the one-piece, side-hinged rear door.

When filled completely to the roof, this works out to 18 cubic feet of extremely usable space. Even without loading above the top of the rear seat back, this area will hold two large double suitcases plus two week-end cases. To load more than this while carrying the full passenger complement you must pile luggage up so that it obstructs vision through rear window.

As a total cargo carrier the Husky delivers 40 cubic feet of space when you swing the rear-seat cushion forward and lower the rear-seat back to make a steel-shod luggage deck 50 inches in length.

Access for loading and unloading through the rear door is good. Dimensions of the door are: width 37 inches, height 30 inches. This opening compares favorably with that of the largest U.S.-built station wagons.

Actual load space of 40 cubic feet is just

(Continued to page 34)



New Table Top Invention Puts You In...
**PROFITABLE RUBBER
 STAMP BUSINESS**

Home Operators now make
\$9.20 AN HOUR in busi-
 ness once monopolized by
 a few big companies

Special rubber stamps bring high prices—cost only pennies to make on new, low-cost table top machine. Take 27 cents worth of material, make perfect stamps, the kind businesses and offices now buy by the dozen at \$1.80 each. Make up to \$9.20 an hour. Start in spare time in your own home. Run machine on kitchen table using ordinary electrical outlet. Make any kind of stamp. We'll send you free information without obligation about this established, highly profitable business, now open to individuals for the first time. For free information send name today on a post card to
Rubber Stamp Div., 1512 Jarvis, Dept. R-2-P, Chicago 26, Ill.



TELEPHONE



HANDSETS

Use as inter-house phone, talk house to garage, as loud speaker system, etc. You receive transmitter, receiver, 3 conductor cord and simplified, illustrated installation diagrams. Handsets are guaranteed to be the same as used in our great National Telephone System. Price delivered \$2.95. Two for \$5.00!

TELEPHONE REPAIR AND SUPPLY CO.
 DEPT. PM 133 1760 Lunt Ave., Chicago 26

LEARN WHILE YOU SLEEP!



Experiment in this fascinating, educational new field. Use your phono, recorder or amazing new "Electronic Educator" endless tape recorder. Free catalog lists over 200 unusual tapes, records, equipment for sleep-learning & hypnosis experimenters. Sleep-Learning Research Ass'n., Box 24-A, Olympia, Wash.

MAKE YOUR FORTUNE



Sell famous Spring-Step Cushion Shoes for all the family—men, women, children and babies! Earn big money daily plus Cash Bonus and Retirement Income with amazing 2-minute demonstration that sells on sight. Big repeat business. Full or spare time. America's Biggest Selection of Shoes for all the family. Free outfit given. No investment ever. Write today.

ORTHO-VENT Shoe Co., Inc.
 11012 Brand Road Salem, Virginia

RUPTURED

BE FREE FROM TRUSS SLAVERY

Surely you want to THROW AWAY TRUSSES FOREVER, be rid of Rupture Worries. Then Why Do you put up with wearing a griping, chafing and unsanitary truss the balance of your life? If you do, it will NOT be through necessity but through choice on your part.

Now there is a new modern Non-Surgical treatment that is designed to permanently correct rupture. These Non-Surgical treatments are so certain, that a Lifetime Certificate of Assurance is given. Write today for our New FREE Book that gives facts that may save you painful, expensive surgery. Tells how non-surgically you may again work, live, play, love and enjoy life in the manner you desire. There is no obligation.
 Excelsior Medical Clinic, Dept. H6124, Excelsior Springs, Mo.

Learn at Home
in your spare time
**to Fix Electric
 Appliances**



Better Pay—More Opportunities

Get into a field where there is important work and opportunity for the trained man. Millions of electric appliances are sold every year. Every wired home now has an average of 8. Many of them need service and repair. Owners pay well to have them fixed quickly, properly. This is your opportunity for a better job, your own part time or full time business. NRI can give you the training you need, at home, in your spare time.

Spare Time Earnings Start Soon

Soon after starting you will be able to earn extra cash fixing toasters, clocks, fans, vacuum cleaners, etc., for neighbors and friends. Keep your job while learning and earning. Put spare time to work for you. Work in your basement garage, spare room. You'll be amazed how easily, quickly you, too, can start earning many extra dollars. NRI shows you how. Even before you finish training your spare time earnings may pay for the course and equipment.

NRI Sends Tester to Learn and Earn

You need proper equipment to service today's automatic appliances. With this course you get parts to build professional type, multi-use Appliance Tester. You learn to use it. Takes guess work out of servicing. Mail coupon for FREE book and Sample Lesson. See how easy it is to learn. Find out about NRI—a school that for more than 40 years has been training men, through home study, for success, good pay jobs. Our reputation, record, experience back up this course. Write now to: National Radio Institute, Dept. AN0, Washington 16, D. C.



FREE Lesson and Book
Mail this NOW!

NATIONAL RADIO INSTITUTE

Dept. AN0, Washington 16, D.C.

Send me Lesson and Book Free. No salesman will call.

Name _____ Age _____

Address _____

City _____ Zone _____ State _____

ACCREDITED MEMBER NATIONAL HOME STUDY COUNCIL



Sidelights from the PENTAGON

By William R. Kreh

SMALL-BOAT OWNERS may benefit from Coast Guard experiments with a talking radio-beacon at Cape May, N. J. It's a microwave transmitter that simultaneously broadcasts a rotating light beam and a voice message from a revolving tape. Tape and beam are so synchronized that when the beam points south, the tape announces "Cape May 00." By the time the beam has swung three degrees, the tape has revolved to the point where the message is "Cape May 03," and so on. The announcements, like the light, go all the way around, changing messages at three-degree intervals. It's estimated that a book-sized microwave receiver would cost a boater about \$50. The experimental transmitter is good for 12 miles, but advanced models could broadcast up to 20 miles.

"One-minute car wash" techniques have been adapted by the Marines to cleanse their amphibious vehicles of salt water after each ocean-going maneuver. The briny liquid could corrode the machines if not rinsed off promptly, and cleaning by hand-hosing was too time-consuming. A specially designed rack gives the vehicles a high-pressure shower as they're driven through.

An Air Force B-47 has been hung by the Navy, but it's not as ignominious as it sounds. The huge jet bomber is suspended between two tall towers at the Naval Ordnance Test Station at China Lake, Calif. The purpose is to test missile fuses at various positions on and around the plane to check their firing ability at each spot.

Throwing bottles into the sea with messages is as old as fiction, but the Navy is going the story-tellers one better. It's burying bottles in an underwater gulch near Port Hueneme, Calif. The idea is to check underwater sand slides. The bottles will wash free and float to the surface whenever one occurs.

S/Sgt. T. P. Conway studied actual case histories of emergency ditching or abandoning of aircraft and decided that survival equipment often was too difficult or impossible to recover from the plane. His solution was to assemble a compact kit that each crew member could carry on his person. Using discarded tobacco tins, he is able to stuff into each one: 100 feet of nylon line, eight feet of snare wire, two packs of first-aid gauze, two packs of matches, three fishing hooks, two fishing flies, a bottle of water purification tablets, two fatigue tablets, four bouillon cubes, three sewing needles, two candles, a bottle of iodine and a razor blade. He water-proofs the tins by sealing them with tape.

Sky-writing jets may soon run out of ink. Air Force engineers have developed a way to eliminate vapor trails left by high-flying aircraft. It reduces the size of water particles left by the burning jet fuel by mixing tiny dustlike particles in the engine exhaust.

And here's more good news for Junior! His breakfast cereal not only makes him an All-American but it's also useful in the jet age. Recently 375 servings of a dry cereal were spread on a runway to see how much of it a jet would pick up in its engine intakes when running at full power. The cereal represented normal debris that a jet would expect to encounter on runways. Later more damaging articles will be used to see just how much a jet engine can absorb.

How long can a missile be stored? An Army Redstone was successfully fired recently after resting on the launch pad more than two years.

Homing pigeons carrying tiny radio transmitters may reveal navigational secrets useful to military aircraft. The Office of Naval Research is attaching transmitters weighing less than two ounces to the birds with a light harness. The transmitters emit signals over a range of 20 miles. The signals, picked up by receivers on the ground, track the individual birds to their destinations. Over a period of weeks, deviations in routes and speed may reveal how the pigeons are able to detect, identify and navigate toward a given target.

The Navy has discovered a powder that takes the heat out of fires and puts out gasoline and oil fires twice as fast as ordinary extinguishers. It's called "Purple K Powder" and it consists of very finely powdered potassium bicarbonate. In tests it extinguished an oil fire in 11 seconds. The last smoke drifted away in 16 seconds. ★ ★ ★

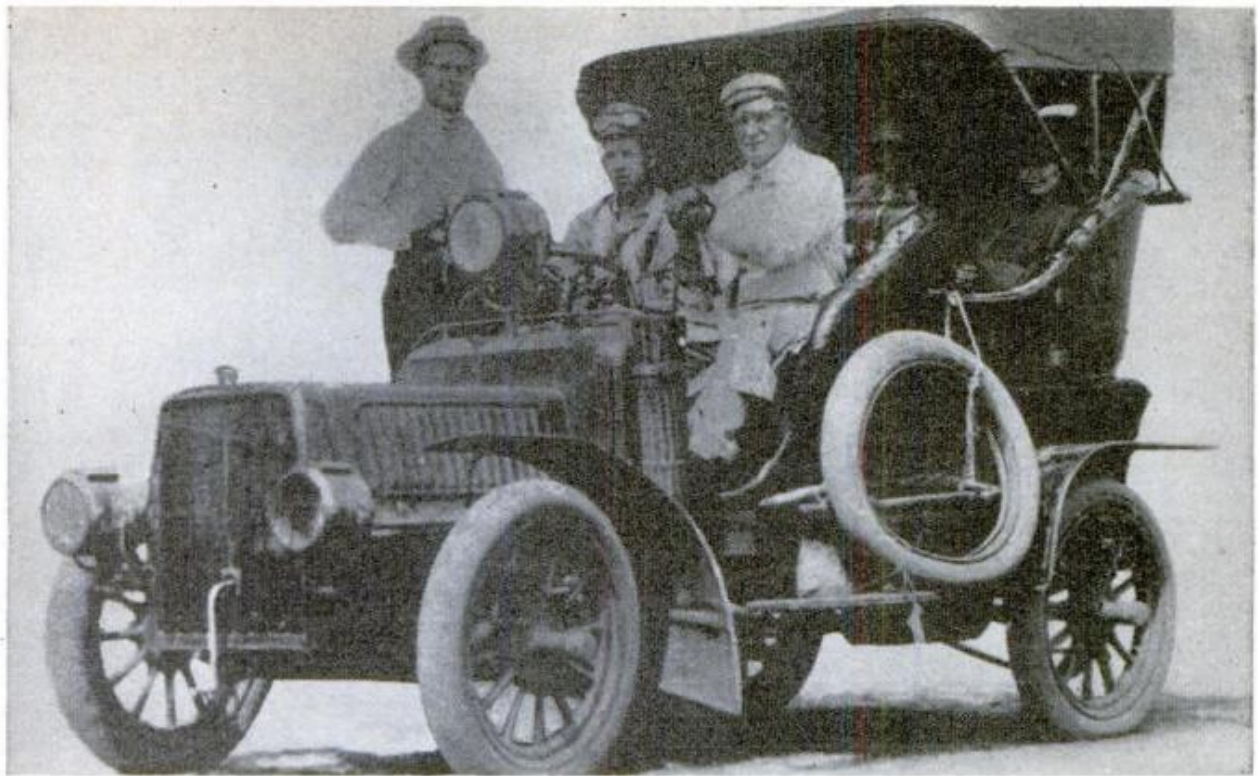

DO YOU KNOW THIS OLD-TIMER?

Influence of European design on American cars is nothing new, as witness this turn-of-the-century dreadnaught with right-hand drive and landau top. It was

probably a sensation in its day, having wooden wheels and what were then the latest in tires—pneumatics (without treads). If you can't name it, see page 250.

—NOW IN JUST 4' OF SPACE—

LET YOUR FAMILY ENJOY THE REAL THRILL OF PHOTOGRAPHY

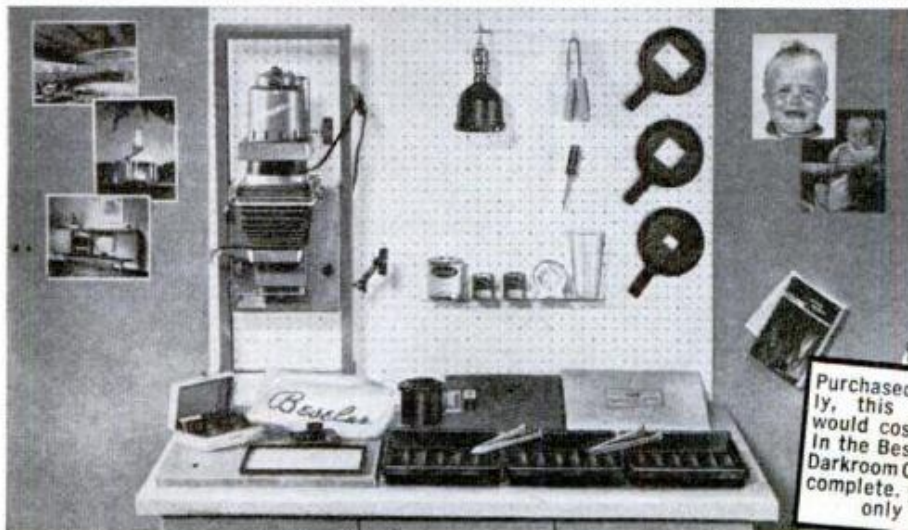

COMPLETE BESELER HOME DARKROOM!



Start tonight!

Just unpack the box — and only 4 feet of space in your bathroom, basement or closet becomes a fully equipped, modern home darkroom!

The world famous Beseler 23C Enlarger is the "heart" of the Dream Darkroom Outfit. It's so versatile and precisely engineered that you can make enlargements as big as you want them—even mural size—in black and white or full, brilliant colors from 8mm up to 2¼ x 3¼ size negatives. Beseler 23C is the very same enlarger used in thousands of small studios and advanced amateur darkrooms. Yet, it works so simply that you'll produce big, beautiful prints the first time you try it.

And with this precision enlarger you receive everything else you need to set up your darkroom—25 pieces of custom matched equipment.

MAKES AN IDEAL LIFETIME GIFT FOR THE ENTIRE FAMILY . . . WRITE FOR FREE BOOKLET

CHARLES BESELER COMPANY
 210 South 18th Street, East Orange, New Jersey
 Please send FREE booklet, "Fun In The Darkroom"

Name _____
 Address _____
 City _____ Zone _____ State _____



You can make money in

WATCH REPAIR

Learn at home the low cost Sweazey Way

Watch repairing pays up to \$6 an hour, part time watch makers report on survey. Unique and modern Sweazey home study System starts you making repairs right away on Swiss and American watches. Professionally prepared training. No previous experience needed. Special tools provided for practice. Tuition only \$5 a month. Diploma Awarded. Free sample lesson and opportunity book give all facts. Write today. No obligation.

CHICAGO SCHOOL OF WATCHMAKING
2330 N. Milwaukee Avenue, Dept. 1120, Chicago 47, Illinois

FREE BOOK and SAMPLE LESSON

CHICAGO SCHOOL OF WATCHMAKING
2330 N. Milwaukee Ave., Dept. 1120, Chicago 47, Illinois
Please rush **FREE BOOK** and Sample Home Study Lesson.

Name _____ Age _____

Address _____

City _____ Zone _____ State _____



Exclusive Double-Bearing HEAVY-DUTY PUMPS

IRRIGATE • DRAIN • CIRCULATE • SPRAY

Use 1/4 HP motor or larger 1 HP for up to 5,200

GPH: 1,000 GPH 60' high; or 3,000 GPH from 25' well.

1 1/2" inlet; 1" outlet. Stainless shaft.

TYPE X-2 oil-less bronze bearings. Won't rust. \$10.95

TYPE XB-Hall bearing model. \$12.95

Postpaid if cash with order. Rush your order today

MONEY BACK GUARANTEE

Centrifugal and Gear Pumps in All Sizes

LABAWCO PUMPS, Belle Mead 2, N. J.

NEW PLASTI-FORM MYSTERY MACHINE

turns Kitchen Table into Manufacturing Plant!

UP TO \$25 AN HOUR Spare Time

CANDLE HOLDERS

TOYS

RELENER CASES

SIGNS

JEWELRY

WALL MASKS

MODELS

BOOK ENDS

LAMINATES • FABRICATES MOULDS • PLATES • ENCASES

Sensational new device with endless applications. Sets up on any small table, does more than a dozen machines 10 times its size. Anyone can operate, even teen-agers or grandparents. Most exciting home-business development in 50 years!

MAKE 10 ITEMS WITH MATERIALS COSTING 50¢

From any small model, your Plasti-Form Machine moulds thousands more for pennies each, even if original cost \$10 or more. Bronzes baby shoes for 1/4 usual cost. Laminates practically anything in permanent plastic seal—every rainbow color, or chrome, silver plate, etc. Wall plaques selling up to \$15 in stores duplicated for 50¢. Makes over 15,000 items to sell below market prices, and still make huge profits!

Get Orders by Mail... We help Finance You!

Complete "Business-by-Mail" Plan brings cash orders from everywhere, no matter where you live - from families, stores, factories. Don't hold back if short of money. Cost is small & we help finance you. Write for **FREE** Plasti-Form Booklet, Table-Top Mfg. Ideas & Home Mail-Order Plan.

PLASTI-FORM CO. Dept. F-12
15125 SO. B'WAY, GARDENA 61, CALIF.

FREE!

ALL THREE

- 1 Complete Revealing Plasti-Form Machine Booklet
- 2 Confidential Table-Top Manufacturing Ideas
- 3 Special Home Mail Order Plan Details



Family of five plus luggage fits happily in Husky

about half that of the full-sized American wagons such as Ford and Chevrolet. However the Husky's 86-inch wheelbase is almost three feet shorter and its over-all length is five-and-a-half feet less than that of the big jobs.

In spite of its squarish silhouette and ultra-compact dimensions, the Husky wagon is an attractive vehicle with clean lines and pleasing contours. The designers who styled the Husky have done a skillful job in creating the illusion of greater length.

Seating in the Husky is quite comfortable with the driver's bucket-type seat adjustable over a four-inch range. There's adequate leg and foot room for the six-foot-plus driver who is quite comfortable except for the fact that the accelerator pedal thrusts way out from the fire wall and forces his right leg into a cramped position.

This isn't as objectionable to a driver of average stature, but in all cases the throttle pedal doesn't provide rest for the right foot which must be held tensely pivoted on the heel in a position that's awkward and tiring. However, it shouldn't be too difficult to install a conventional, treadle-type throttle.

Seats are built up of foam rubber and covered with pleated vinyl that looks much like leather and, speaking from experience, has been found to wear very well.

One of the really enjoyable features of the new Husky, (the current model has been available since late last summer), is the excellent all-around vision. The windshield is very wide and deep and in addition has relatively thin corner pillars. The hood is smooth and slopes forward quite sharply to the front permitting a view of the road very close to the front of the car.

(Continued to page 36)

HOME IMPORT BUSINESS

MEN... WOMEN... MAKE BIG PROFITS... Buy dazzling bargains abroad. Sell to friends, stores or mail order. New Drop Ship Plan puts you in *direct contact* with *overseas sources*—starts you full or spare time, without product investment or previous experience. Complete details **FREE**. Write today!



17-Jewel Watch \$2.87



Derringer Pistol \$5.24



Tape Recorder with Mike \$13.50

MELLINGER CO., Dept. C25C
1717 Westwood, Los Angeles 24, Calif.

... Plan shows where you get bargains like these for big profit sales. **DO NOT ORDER FROM US**

ADDING MACHINE

\$1.98 ea. or 2 for \$3.69

+ — × ÷
ADD — SUBTR. — MULT. — DIVIDE

Does all 4 operations. Handles 9 columns of numbers. Settle for no less. Leatherette case. Lowest price adder made in America. Beware of cheapened foreign imitations. Money back guarantee. Agents wanted. \$1.98 add 4% tax in Pa.



TOM THUMB P.O. Box 5066, Dept. D-10, Philadelphia 11, Pa.

GOVERNMENT OIL LEASES LOW AS \$1 PER ACRE

You do no drilling, pay no taxes, may realize a king-size profit without ever leaving home. Write for free map and literature.

AMERICAN OIL SCOUTS, Dept. PM
8350 Santa Monica Blvd. Los Angeles 46, Calif.



MECHANICAL DENTISTRY

A profession offering unlimited opportunities. Most modern and complete course embracing every branch from Plate to Porcelain Work, which prepares you to work for Dentists or start your own business. Individual instruction—practical training in day or night school. No books—no classes. Catalog upon request.

McCARRIE SCHOOL OF MECHANICAL DENTISTRY
207 N. Broad Street Dept. 107 Philadelphia 7, Penna.

JEEP OWNERS

RE-POWER NOW WITH A V-8 OR 6 CYL. ENGINE — USE FORD—CHEV—MERCURY—GMC—PONT—STUDE—DODGE OR PLYMOUTH In Jeeps, Jeepsters, Sta-Wgn. trucks, Kaiser & H. J. cars. Conversion Kits \$45.35 to \$56.90. Want fast action? Give us full information, send \$15.00 Dep. and we will ship correct kit. Bal. COD. Send full amount for prepaid shipment. Wire, phone or write today. Details **FREE**

HOOSIER MACHINE PRODUCTS CO.
312 S. E. 6th St. Phone CR 6-3442 Pendleton, Oregon

27 YEARS IN BUSINESS AT THE SAME ADDRESS.

Beat the high cost of new tires.

EXTRA MILEAGE TOP GRADE Tires, ANNIVERSARY SPECIAL. SEND AD

WHY PAY MORE? UP TO 15,000 MI.

Our entire stock of good used tires.

600-16	\$4.72	670-15	\$4.72	700-15(8)	\$10.92	750-20(8)	\$12.22
600-16(6)	7.92	710-15	4.72	750-16(8)	11.02	825-20	19.92
650-16(6)	8.82	760-15	4.72	700-17	10.72	900-20	19.92
750-14	4.72	800-15	4.72	750-17	10.92	1000-20	19.92
800-14	4.72	820-15	4.72	850-14	4.72	1100-20	19.92
750-16(6)	10.02	700-16(6)	10.02	700-20	10.92	1000-20	20.92

SNOW TIRES \$7.82 AND \$6.00 ANY SIZE
BLACK WALL PASS.

SUBURBANITE OR TOWN & COUNTRY TREAD

Thousands of tires shipped all over the U.S.A. All tires shipped F.O.B. Phila. Send Check or M.O. with this ad. Dept. 2 No C.O.D.

STANDARD 834 N. Broad St., Philadelphia 30, Pa.

prepare for your career in

ELECTRONICS ELECTRICAL ENGINEERING RADIO-TV COMPUTERS

At MSOE, you can equip yourself for a career in many exciting, growing fields: **MISSILES • RADAR • AVIONICS AUTOMATION • RESEARCH DEVELOPMENT • ELECTRICAL POWER • ROCKETRY**

When you graduate from the Milwaukee School of Engineering, you are prepared for a dynamic career as an Electrical Engineer or Engineering Technician. Under a faculty of specialists, you gain a sound technical education in modern, completely equipped laboratories and classrooms. As a result, MSOE graduates are in great demand and highly accepted by industries nationally.

At MSOE, you will meet men from all walks of life and all parts of the country — some fresh out of high school or prep school, others in their twenties — veterans and non-veterans.

You can start school in any one of four quarters and begin specializing immediately. Engineering technicians graduate in 2 years with an Associate in Applied Science degree. For a Bachelor of Science degree in Engineering, you attend 4 years. A 3-month preparatory course also is available.

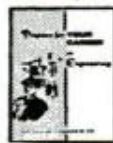

FREE CAREER BOOKLET!

If you're interested in any phase of electronics, radio or television, be sure to look into the programs of study offered by the Milwaukee School of Engineering. Just mail the coupon.

MILWAUKEE SCHOOL OF ENGINEERING

Dept. PM-1260, 1025 N. Milwaukee St. Milwaukee, Wisconsin

Please send FREE Career Booklet. I'm interested in

- Electronics Electrical Power Television
 Mechanical Engineering Radio Computers
 Electrical Engineering Industrial Electronics

PLEASE PRINT

Name _____ Age _____

Address _____

City _____ Zone _____ State _____

I'm eligible for veterans education benefits

MS-125

**EARN \$125
A WEEK AND UP**

**BE AN AUTO DIESEL
EXPERT — LEARN
A TRADE YOU LIKE**

You learn fast in our shops because you learn with tools on real equipment. Students short of money may earn most of their expenses by doing part-time work. Experienced instructors explain WHY and show you HOW, then you DO IT YOURSELF. Many of our graduates earn \$125 a week and up. Approved for veterans. Day and evening classes. Free bulletin-write today.

MAIL THIS COUPON TODAY!

NASHVILLE AUTO-DIESEL COLLEGE
226 7th Ave., No., Dept. 86, Nashville, Tenn.
Please send without obligation free catalog.

NAME _____
(please print or write plainly)

ADDRESS _____

CITY _____ STATE _____

your customer saves gas, and

**HELPFUL HINTS
FOR MECHANICS**

Want the answer to poor gas mileage complaints? A good tune-up usually will solve the problem — IF the job includes a MILEAGE MINDER. Only with MILEAGE MINDER can you safely set carburetor float at lowest recommended point. Result? Spillage from float bowl is stopped; flooding and stalling are ended; your customer saves gas; and you look good. See your distributor, or write:

MILEAGE MINDER
3380 — 17th ST. SAN FRANCISCO 10, CALIF.

**YOU CAN BE
A REAL
HE-MAN!**



CHARLES ATLAS

DON'T let anybody tell you that you're just "naturally" skinny . . . flabby . . . soft. I'll show how you can have the handsome muscle-mighty HE-MAN BODY that Nature meant you to have! In just 15 minutes a day I can make you a NEW MAN! I'll build — smooth, powerful layers of muscle wherever you want 'em — arms, chest, stomach, back, legs, etc. — send wonderful new pep and energy surging through your whole body! **WRITE FOR FREE BOOK.** Tells about famous "Dynamic Tension," the NATURAL way I built my own famous body. How I've built up other fellows. What I can do for YOU. Address: **CHARLES ATLAS, Dept. 812, 115 E. 23rd St., New York 10, N.Y.** In England: Chitty St., London, W1

Send for **FREE BOOK**



Rear compartment side windows are long yet have no pillar. There are sliding glass panels for rear compartment ventilation.

Another delightful feature of the new Husky is its short-stick gearshift control, acting on a four-speed synchromesh transmission. Synchronization is on second, third and top ratios which are the ones used in 95 percent of all driving. The action of the gearshift can give the Husky a considerable sports car flavor if the driver is practiced and well coordinated.

The Husky's engine is a lately improved version of the sturdy, smooth-running four that's powered all Rootes Motors products for the last several years. This engine with its pushrod-operated overhead valves has a bore and stroke of 3.0 x 3.0 inches, displaces 85 cubic inches and is rated at 51 horsepower. Compression ratio is a conservative 8 to 1 which will allow you to use the lowest-priced gasolines.

The Husky's engine provides what can best be described as "briskly satisfactory" performance. It will accelerate to 60 miles per hour in 18.2 seconds, which is pretty commendable when you consider that the Ford Falcon compact with an engine of 144 cubic inches will make 60 m.p.h. in 15 or 16 seconds. The Husky has no trouble in keeping up with fast-moving expressway traffic.

Fuel economy for 764 miles of combined city, high-speed turnpike and country road driving averaged out to 25.2 miles per gallon. This might seem strange for a car as compact as the Hillman Husky until its weight of 2080 pounds is considered.

This weight is the result of extremely solid construction which makes the Husky virtually immune to squeaks, rattles, or vibration. The name Husky is well chosen, as the little wagon gives every indication of being able to stay on the road indefinitely as far as durability of body structure is concerned.

The Husky's ride is typical of British small cars, taut and well controlled with remarkably little rolling or pitching on smooth-surfaced yet uneven roads. On rough surfaces the Husky's ride is firm and inclined to some jiggling.

Handling is uniformly good as the Husky has new, low-friction recirculating-ball steering gear that makes traffic and winding country roads almost a pleasure to cope with.

Considering its really compact size and small engine, the Husky is an exceedingly useful and capable little car. It's ideally suited for household stop-and-go hauling, yet there should be no hesitation in taking it on long trips as long as there aren't many passengers in the rear seat. ★ ★ ★

NEW WESTERN HAIG

**.12 CALIBER
SPECIAL FACTORY
OFFER!**



\$3.00
post-paid

USES POWDER CHARGE

This small bore gun shoots .12 cal. lead bullets fired by small 4.4 mg. powder charge. Not a CO₂ gun! You'll like the handsome lines, grip, and balance. Western in style, but patented ball and cap action allows this low price. 9 3/4" steel barrel cased in knurled styrene stock, overall 13 1/2". Develop pistol form, accuracy at a fraction of cost of large caliber pistols. Comes with 50 lead bullets. Satisfaction guaranteed. Send \$3 to: HAIG MFG. CO., Box 30-F, San Gabriel, Calif.



get into operating or repairing EARTH MOVING EQUIPMENT

Men needed now for good paying jobs in booming road and construction work. Learn operating or repair-rebuilding of heavy road machinery, cranes, bulldozers, earth carriers, etc. Actual "on the job" training. 5 to 13 1/2 week courses. Classes start every Monday. Reserve your space now. Complete catalog and reservation facts FREE. Approved for veterans. Write

Greer

TECHNICAL INSTITUTE
Attn.: P.O. Hutch, Box 368, Braidwood, Ill.

75 POWER TELESCOPE

\$6.00

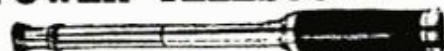

A must in a missile or bomb attack.

Space conquest—very powerful scope. Sells several times as much as this scope—manufactured in America. It has polished lenses—75 Power for Long Range—30 Power for Bright Images. Brings the distant moon and stars much closer. Large production enables us to offer this scope at \$6.00 postpaid. Guaranteed.

DRISCOLL SALES & SERVICE, 536 — 12th Street, Denver, Colorado

LEARN PLASTICS



**COMPLETE LOW COST SHOP METHOD
HOME TRAINING NOW AVAILABLE**

Get in on Big Money opportunities in Plastic molding, casting, forming, carving, etc. Earn as you learn with Interstate's professionally prepared course. All plastic materials furnished.

**WRITE FOR
FREE
BOOKLET**

INTERSTATE TRAINING SERVICE
DEPT. C-3, PORTLAND 12, OREGON

Shrinks Hemorrhoids New Way Without Surgery Stops Itch — Relieves Pain

For the first time science has found a new healing substance with the astonishing ability to shrink hemorrhoids and to relieve pain — without surgery.

In case after case, while gently relieving pain, actual reduction (shrinkage) took place.

Most amazing of all — results were so thorough that sufferers made astonishing statements like "Piles have ceased to be a problem!"

The secret is a new healing substance (Bio-Dyne®)—discovery of a world-famous research institute.

This substance is now available in suppository or ointment form under the name Preparation H®. Ask for it at all drug counters.

MY SPARE TIME HOBBY MAKES ME

\$5.00 an hour
CASH PROFIT

— Grover Squires

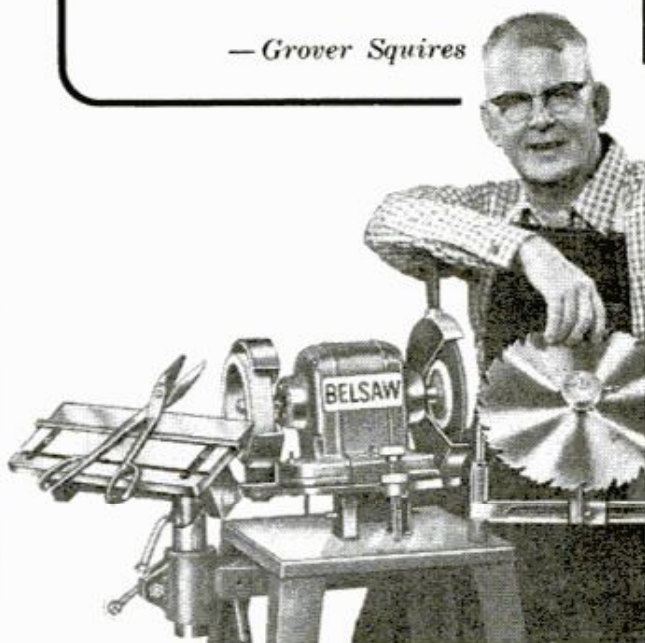

START YOUR OWN SPARE TIME BUSINESS



You can turn your spare time into Big Cash Profits with your own **COMPLETE SHARPENING SHOP**... Grind saws, knives, scissors, skates, lawn mower blades... all cutting edges. Your Own Cash Business with no inventory... right at home... no experience needed.

FREE BOOK tells how you can start your own spare time business while you are still working at your regular job. Low Cost—time payments only \$15.00 a month. **Send coupon today.**



BELSAW SHARP-ALL CO
711 Field Bldg.,
Kansas City 11, Mo.

Send Free Book "LIFETIME SECURITY". No obligation.

Name _____

Address _____

City _____ State _____

ENGINEERING SCIENCE MATH

DEGREE IN
27 or 36 MOS.



ACCELERATED YEAR-ROUND PROGRAM prepares for early employment in fields of SCIENCE AND ENGINEERING. Regular 4-year program for B.S. Degree completed in 36 months, special engineering degree program in 27. Classes start — January, March, June, July, Sept. QUALITY EDUCATION. Graduates employed from coast to coast. Government approved for veteran training. Students from 50 states, 40 countries. 20 buildings; dorms, gym. CAMPUS. SAVE TIME AND MONEY. EARN BOARD while studying. Write for catalog and complete information.

INDIANA TECHNICAL COLLEGE

5120 East Washington Boulevard, Fort Wayne 2, Indiana

Please send me free information on Bachelor's Degree Programs in Engineering and Science as checked below:

- | | |
|---|--|
| <input type="checkbox"/> Aeronautical Engineering | <input type="checkbox"/> Mechanical Engineering |
| <input type="checkbox"/> Chemical Engineering | <input type="checkbox"/> Metallurgical Engineering |
| <input type="checkbox"/> Civil Engineering | <input type="checkbox"/> Physics |
| <input type="checkbox"/> Electrical Engineering | <input type="checkbox"/> Chemistry |
| <input type="checkbox"/> Electronic Engineering | <input type="checkbox"/> Mathematics |

Name _____

Address _____

Catalog of 2900 Novelties 10c

Send 10c for amazing catalog of novelties, live animals, scientific supplies, hobbies, funmakers, planes & boats, toms, magic tricks, joke articles, unusual seeds, gadget timesavers, cameras, optical goods, projectors, movies, lucky jewelry, religious novelties, disguises, musical instruments, stamps, coins, puzzles, fortune tellers, radios, auto & bike accessories, telescopes, magnifiers, compasses, banks, smokers' gadgets, artists' supplies, printing sets, engines, motors, shockers, knives, billfolds, guns, rifles, sports, books, games, plants, etc. Send 10c.

JOHNSON SMITH COMPANY Dept. 481 Detroit 7, Michigan

Would YOU Like to Make \$1,000 A MONTH?

That's what Stanley Hyman made selling the amazing new PRESTO Fire Extinguisher!



Amazing new kind of fire extinguisher. Tiny "Presto" does job of bulky extinguishers that cost 4 times as much, are 8 times as heavy. Ends fires fast as 2 seconds. Fits in palm of hand. Never corrodes. Guaranteed for 20 years? Sells for only \$4.95! Over Three Million Sold!



STANLEY HYMAN

Show it to civil defense workers, owners of homes, cars, boats, farms, etc. and to stores for resale—make good income. H. J. Kerr reported \$20 a day. C. Kama, \$1,000 a month. Write for FREE Sales Kit. No obligation.

MERLITE INDUSTRIES, Presto Div., Dept. P-15Y

114 East 32nd Street, New York 16, New York

IN CANADA: Mopa Co., Ltd., 371 Dowd Street, Montreal 1, P.Q.



Eastern Case Co., 65 South 11th St., Brooklyn, N.Y.

Bowling Ball and Shoe Case Has Built-In Elevator

Built of the same foam-cored plastic being used in boat hulls, a new bowling ball case locks firmly around the ball, then when the case is opened, raises the ball up within easy reach. Racks keep shoes and ball separated. The entire case weighs only three pounds.

STATEMENT REQUIRED BY THE ACT OF AUGUST 24, 1912, AS AMENDED BY THE ACTS OF MARCH 3, 1933, AND JULY 2, 1946 AND JUNE 11, 1960 (74 STAT. 208) SHOWING THE OWNERSHIP, MANAGEMENT, AND CIRCULATION OF Popular Mechanics published monthly at Chicago, Illinois, for October 1, 1960. 1. The names and addresses of the publisher, editor, managing editor, and business managers are: Publisher, Popular Mechanics Company, 200 E. Ontario St., Chicago 11, Ill.; Editor, Roderick M. Grant, 200 E. Ontario St., Chicago 11, Ill.; Managing editor, Clifford B. Hicks, 200 E. Ontario St., Chicago 11, Ill.; Business manager, Joseph R. Buell, Jr., 290 E. Ontario St., Chicago 11, Ill. 2. The owner is: Popular Mechanics Company, sole stockholder, The Hearst Corporation, 100 West Tenth Street, Wilmington, Delaware. All of the stock of The Hearst Corporation is held by the following Voting Trustees, namely: Richard E. Berlin, 959 Eighth Avenue, New York, New York; Harold G. Kern, 5 Winthrop Square, Boston, Massachusetts; G. O. Markuson, 959 Eighth Avenue, New York, New York; Charles Mayer, Third and Market Streets, San Francisco, California; William Randolph Hearst, Jr., 959 Eighth Avenue, New York, New York; Randolph A. Hearst, 270 North Canon Drive, Beverly Hills, California; David W. Hearst, 270 North Canon Drive, Beverly Hills, California; J. D. Gortatowsky, 57th Street at Eighth Avenue, New York, New York and Herbert W. Hoyea, 410 Park Avenue, New York, New York, under Voting Trust Agreement dated as of February 28, 1958; the beneficial owners of the stock deposited under the aforesaid Voting Trust are The Hearst Foundation, Inc., the William Randolph Hearst Foundation, William Randolph Hearst, Jr., Randolph Apperson Hearst, David Whitmire Hearst, George Hearst, John Randolph Hearst, Jr., Joanne Hearst Herndon, William Randolph Hearst II and Deborah Hearst. 3. The known bondholders, mortgagees, and other security holders owning or holding 1 percent or more of total amount of bonds, mortgages, or other securities are: None. 4. Paragraphs 2 and 3 include, in cases where the stockholder or security holder appears upon the books of the company as trustee or in any other fiduciary relation, the name of the person or corporation for whom such trustee is acting; also the statements in the 1st paragraph show the affiant's full knowledge and belief as to the circumstances and conditions under which stockholders and security holders who do not appear upon the books of the company as trustees, hold stock and securities in a capacity other than that of a bona fide owner. 5. The average number of copies of each issue of this publication sold or distributed through the mails or otherwise, to paid subscribers during the 12 months preceding the date shown above was: (This information is required by the act of June 11, 1960 to be included in all statements regardless of frequency of issue.) 1,345,166. J. R. Buell, Jr. (Signature of business manager.) Sworn to and subscribed before me this 29th day of September, 1960. Harry P. Cera (My commission expires March 7, 1964).

MAKE EXTRA CASH

SHARPENING LAWN MOWERS THE MODERN WAY

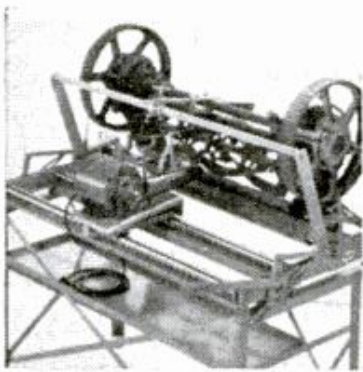

Start your own shop! Full or spare time. Earn many dollars in a short time... average \$5.00 per hour. Many mowers need sharpening. With MODERN'S Extra Heavy Duty LAWN MOWER SHARPENER AND BED KNIFE GRINDER you have 6 machines in one. All operations are done quickly and easily. You make money from the start. Write for free details.

MODERN MFG. CO.

160 N. Fair Oaks Ave. Dept.
Pasadena, California 10-10

PERFECT to give or get

AUTHENTIC CIVIL WAR GUNS

Real collector's pieces—cast barrels, brass fittings, wood parts cut to shape, complete instructions.



No. 1125 James — smoothbore cannon \$7.50
No. 1126 Napoleon — 12 lb. howitzer \$7.50
No. 1127 Parrott — 10 lb. rifled cannon \$7.50
No. 1128 Whitworth — 12 lb. rifled cannon \$8.50

Send 10c for Catalog — a treasury of ship model and gun information.

MARINE MODEL CO., INC. Dept. 960, Halesite, L. I., N.Y.

LAW FREE BOOK

THE LAW TRAINED MAN

Write today for a FREE copy of illustrated law book, "THE LAW-TRAINED MAN," which shows how to earn the professional Bachelor of Laws (LL.B.) degree through home study of the famous Blackstone Law Course. All necessary books and lessons provided. Moderate cost; convenient monthly terms. Write for FREE law training book today.

Blackstone School of Law, 307 N. Michigan Ave.

Founded 1890

Dept. 59, Chicago 1, Illinois

REAL ESTATE BE A BROKER

PAYS BIG! SEND FOR FREE, BIG, ILLUSTRATED CATALOG NOW! Graduates report making substantial incomes. Start and run your own business quickly. Men, women of all ages, learn easily. Course covers Sales, Property Management, Appraising, Loans, Mortgages, and related subjects. STUDY AT HOME or in classrooms in leading cities. Diploma awarded. Write TODAY for free booklet! No obligation.

FREE BOOK TELLS HOW

Approved for World War II and Korean Veterans
WEAVER SCHOOL OF REAL ESTATE (Est. 1936)
2020R Grand Avenue Kansas City, Mo.

BUILD FINE GRANDFATHER CLOCK NOW

The simple sensible SPEEDE Red-i-Kut way as thousands have — FOR YOURSELF OR SELL AT A GOOD PROFIT. SAVE HUNDREDS OF DOLLARS. SHOP TESTED PLANS "SPIRIT OF THE CENTURY" Narrow waist 33" tall or stately straight side "SPIRIT OF AMERICA." EASY-to-FOLLOW photopack PLANS & LIFE SIZE PATTERNS tell all—plus MOVEMENT BROCHURE \$40 up, of heavy brass weight (Kuempel original) Westminster, tube BELL chime, movements, gorgeous bronze-silver MOVING MOON dials, 3/4" solid-mahogany Jiffy Joint-Kwik-Bilt case kits. Send \$1.00 today — Both plans RUSH \$1.50 as folks have for over forty years.

Kuempel Chime Clock Works, #9 Kuempel Bldg., Minneapolis 16, Minn.

NO JOB WORRIES

PLASTEX INDUSTRY needs manufacturers on small scale for big production of Lamps, Clock Stands, Art Goods, Novelties in Plastic Marble imitation. No Experience necessary. 1/2c material makes regular 10c store sellers. Molds furnished for fast production. Small investment brings good profit. Big wholesale orders now being placed. Ambitious men have chance for real prosperity and job security. Our NEW FREE booklet will interest and benefit you.

PLASTEX INDUSTRIES, Dept. A
3400 Third Ave. New York 56, N.Y.

MEN PAST 40

Afflicted With Bladder Trouble, Pains in Back, Hips, Legs, Nervousness, Tiredness.

If you are a victim of these symptoms, your trouble may be due to Glandular Inflammation. A constitutional Disease that requires special types of medical treatment. Neglect of such Inflammation causes men to grow old prematurely and before their time.

Most men, if treatment is taken in time, can be successfully NON-SURGICALLY treated for Glandular Inflammation. If the condition is aggravated by lack of treatment, surgery may be the only chance.

NON-SURGICAL TREATMENTS

The NON-SURGICAL New Type treatments used at the Excelsior Medical Clinic are the result of discoveries in recent years of new techniques and drugs, plus over 20 years research by scientific technologists and doctors.

Men from all walks of life and from over 1,000 communities have been successfully treated here at Excelsior Springs. They found soothing and comforting relief and new health in life.

EXAMINATION AT LOW COST

When you arrive, our Doctors, who are experienced specialists, make a complete examination. You then decide if you will take the treatments needed, which are so mild, hospitalization is not needed—a considerable saving in expense.

RECTAL-COLON

Are often associated with Glandular Inflammation. These disorders, we can successfully treat for you, at the same time we treat Glandular Inflammation.

REDUCIBLE HERNIA

Is also amenable to a painless Non-Surgical treatment that we have developed. Full details of this treatment given in our Free Book.

Write For FREE BOOK

The Excelsior Medical Clinic has published a New FREE Book that deals with diseases peculiar to men. It could prove of utmost importance to your future life. Write today. No obligation.



EXCELSIOR MEDICAL CLINIC

Dept. B6151

Excelsior Springs, Mo.

Gentlemen: Kindly send me at once, your New FREE Book. I am interested in full information. (Please Check Box)

Glandular Inflammation

Hernia
 Rectal-Colon

Name _____

Address _____

City _____ State _____

LEARN UPHOLSTERY

in your spare time
run your own
business AT HOME



FREE BOOK
SAMPLE
LESSON

WITH COURSE
YOU MAKE
SLIPPER
CHAIR

CLUB
CHAIR

OTTOMAN

PLUS
SLIP COVERS

BE YOUR OWN BOSS

Earn more from the start while learning! Set up your own profitable business at home, enjoy steady income, independence. You're in demand, in the booming field of Custom Furniture Upholstery.

EARN WHILE YOU LEARN . . . the easy UTS way. Right off you start with tools, complete frames, fabrics, materials, ALL FREE with your practical, N. Y. State-approved UTS Home Study Course. You learn skilled professional custom upholstery, re-upholstery, furniture finishing, repairs; to make slip covers, window cornices, cushions, draperies in your spare time.

Send for **FREE Illustrated Book, Sample Lesson** Get ready for well-paid job, steady work and big profits as your own boss. Also Training in N. Y. School, VET. APPROVED. Accredited by N.H.S.C.

MAIL COUPON TODAY. No obligation.

UPHOLSTERY TRADE SCHOOL
Dept. MX-310, 721 Broadway, N. Y. 3, N. Y.

Please send me **FREE** book with **FREE** Sample Lesson. No obligation—no salesman will call.

Home Study Training in N.Y. School

Address _____
Name _____
City _____ Zone _____ State _____

Check if Korean Veteran

FIBERGLASS or PLYWOOD

\$41.95 Up: EASY TERMS Write Now

FREE CATALOG

50 Models 8-22 ft.

Cruisers, houseboats, runabouts, convertibles, fishing, sailing. Pre-assembled, pre-formed units anyone easily assembles. Equal factory-built. Save 1/2 to 2/3. Free catalog has all details, color photos, paint, accessories, Fiberglass supplies, trailers. **WRITE TODAY.**



LUGER BOAT KITS

Dept. B-12, 9200 Access Road, Minneapolis 20, Minn.

High School Course at Home

Many Finish in 2 Years

Go as rapidly as your time and abilities permit. Course equivalent to resident school work — prepares for college entrance exams. Standard H. S. texts supplied. Diploma. Credit for H. S. subjects already completed. Single subjects if desired. High school education is very important for advancement in business and industry and socially. Don't be handicapped all your life. Be a High School graduate. Start your training now. Free Bulletin on request. No obligation.

American School, Dept. H945, Drexel at 58th, Chicago 37

AUTO MECHANICS

Experts say that "America needs 100,000 auto mechanics and 25,000 repair shops." Good jobs everywhere. Steady work. High pay plus opportunity to go in business. Train at home. Earn money spare time as you learn. Mechanic's tools and test instruments sent. Diesel or Body Rebuilding lessons included. Facts are free. Be sure to mail coupon today.



COMMERCIAL TRADES INSTITUTE
1400 GREENLEAF AVE. • CHICAGO 26, ILL. A-85

Name _____ Age _____

Address _____

City _____ Zone _____ State _____



Reuse That Christmas Tree

When it's time to take the Christmas tree down after the holidays, don't throw it away. Rather follow the tip from this dairyman: Trim away all the lower branches, leaving the smaller twigs near the tip and you have the perfect broom for getting between the floor joists to remove the dust and cobwebs that are the bane of every dairyman who endeavors always to keep the milking section of the barn clean. If you live in town, this improvised broom works just as well in your basement.

—Wally E. Schultz

\$6.00 OR 2 FOR \$11.00!

With 40 ft. of wire. Additional wire 3c ft. **TESTED AND GUARANTEED.** Write for free list of all types of telephones. Shipments FOB Simpson, Pa.

TELEPHONE ENGINEERING CO., Dept. 1280, Simpson, Pa.

KEEP YOUR... ON

BENJAMIN

Largest Selection in the World
Single Shot & Repeaters
for Every Shooter's Needs! • 25 MODELS

Hi-COMP AIR GUNS AND POWERFUL CO2 GUNS

No. 3600 \$19.95

You Can **DEPEND** on **BENJAMIN . . .** for Safety — Power — Accuracy — Convenience — Economy



No. 2600 BENJAMIN Super 35-Shot BB Gas Pistol. Safe—No Pumping—Uniform Hi-Power. For Target & Small Game. \$18.95

No. 2620 BENJAMIN 20-Shot Cal. 22 Gas Pistol. Economical. \$20.95

No. 1300 50-Shot BB Air Pistol \$23.50

No. 1320 BENJAMIN 35-Shot Cal. 22 Air Pistol \$25.50

No. 3600 BENJAMIN Super 100 Shot BB Gas Rifle. Non Toxic—Safe—Convenient—Uniform Hi-Velocity Power.

No. 3620 BENJAMIN Super 85 Shot Cal. 22 Gas Rifle . . . \$21.95

No. 3100 Super 100 Shot BB Air Rifle. Adj. Shooting Force \$24.95

No. 3120 BENJAMIN Super 85 Shot Cal. 22 Air Rifle . . . \$26.95

FREE Catalog All Models Benjamin Single Shot & Repeaters—Cal. BB or 177 or 22. Also, Special Hunting & Fishing Knife Offer.

BENJAMIN AIR RIFLE CO., 896 MARION ST., ST. LOUIS 4, MO.

Magic Mail Plan—Make up to \$5 an Hour!



THIS MAN ..

... is taking out of the machine a Plastic Sealing Job—ordered by mail—only 11c in material cost brings back \$2.58 in cash by mail. Capacity of machine: \$25.00 profit per hour of operation.

Get **ORDERS** and **CASH** from your mailman—do work in **SPARE TIME** at home—or expand into **FULL TIME** business. Send coupon for Free facts about the newest and most fascinating of all home operated businesses. For the first time a simplified machine brings the fabulous profits of **Plastic Sealing** and **Plastic Laminating** within the reach of the small operator. Anyone can learn to operate the machine with a few minutes practice—then with our **Magic Mail Plan** can get mail orders pouring in daily with cash in every envelope. **No canvassing—no selling.** We even

Get into PLASTIC LAMINATING at home

supply the circulars you mail to bring back cash and orders. Don't waste a minute. Rush your name. We'll send you **FREE** and postpaid, pictures, prices, details, and all the facts you need to start. Mail coupon or card name on postcard. No charge. Warner Electric Co., 1512 Jarvis Av., Dept. L-2-P, Chicago 26, Ill.

Make Thousands of Beautiful Art Creations

COSTUME JEWELRY • CIGARETTE BOXES TRAYS • CANDLESTICKS • COASTERS LAMP BASES • BOOK ENDS...ALL IN SPARKLING COLORED PLASTIC



WARNER ELECTRIC CO., 1512 Jarvis Av. Dept. L-2-P. Chicago 26, Ill.

At no cost to me, please rush complete details postage prepaid. I am under no obligation.

Name _____

Address _____

City _____ Zone _____ State _____

Draw CARTOONS



... for a wonderful pastime or excellent earnings. Master cartooning at home in a few short weeks without waste of time or effort through the Famous System of Manual Training. Send for Big, Illustrated **FREE** Catalog!

CONTINENTAL SCHOOLS, INC., Dept. A-12
4201 South Broadway, Los Angeles 37, California

LEARN TO MOUNT BIRDS



ANIMALS, FISH, PETS

Be a Taxidermist. Save your hunting **TROPHIES**. Have a fine home-museum. Hunters, save and **MOUNT** your beautiful **DUCKS, QUAIL, DEER, TAN** skins and **FURS**. **Great Fun. Spare-time PROFITS.**

FREE BOOK Tells ALL about it. 100 fine wild-game pictures. 48 pages.

Send **TODAY**, don't delay. Get this **WONDERFUL FREE BOOK, MEN AND BOYS**. Learn Taxidermy. Double your hunting pleasure. Rush letter or **POSTAL** today. **STATE AGE.** N.W. SCHOOL OF TAXIDERMY, Dept. 2512. Omaha, Neb.

**IS OUR
ATOMIC
STOCKPILE
DANGEROUS?**

Read this special article
NEXT MONTH
and decide for yourself whether
it's safe to have our planes fly-
ing daily with atomic bombs
aboard

ELECTRONICS

Train in the
new shop-labs of
the world famous



COYNE

ELECTRICAL SCHOOL
on a quarter of a million dollars worth
of equipment or learn at home in your
spare time with Coyne's modern tele-
vision training.

Use this coupon to get our **FREE BOOK**
"GUIDE TO CAREERS"

COYNE ELECTRICAL SCHOOL training training
1501 W. Congress Pkwy. at Coyne at home
Dept. of Electronics 2K, Chicago 7, Ill.

NAME _____

ADDRESS _____

CITY _____

STATE _____

Unlike most other schools, we do not employ salesmen.

Gay Holiday Wreath Made From Nut Cups

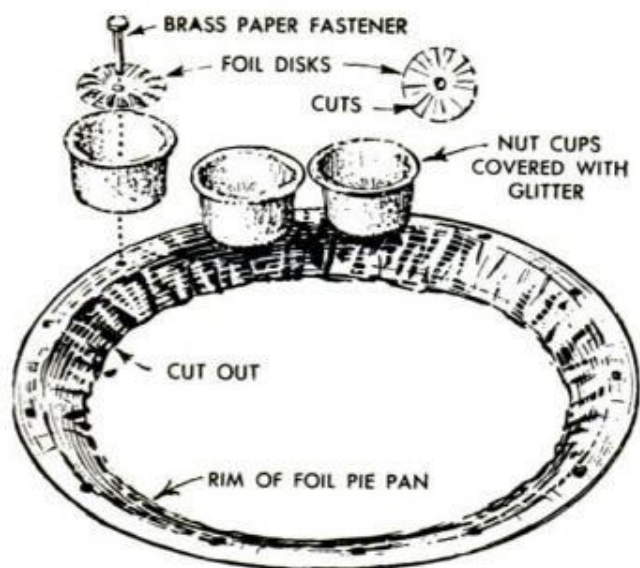

An aluminum-foil pie plate with the center section cut out makes the frame for this attractive Christmas wreath. Nut cups are spaced around the plate rim, and these are covered with red glitter on the inside and green glitter on the outside. The nut cups are attached to the rim of the pie pan by means of brass paper fasteners. To make the glitter adhere to the nut cups, a clear adhesive is spread over the cups with a small brush. Then the glitter is sprinkled on the surface while the adhesive is wet. Allow one color to dry before applying the next one. A circular piece of foil, cut as shown in the illustration, fits into the center of each cup and is held in place by the brass paper fastener. Disks may be cut from either silver or gold foil, depending on the color desired. The wreath is finished by taping a red-ribbon bow to foil-pan rim.

—A. B. Joselyn

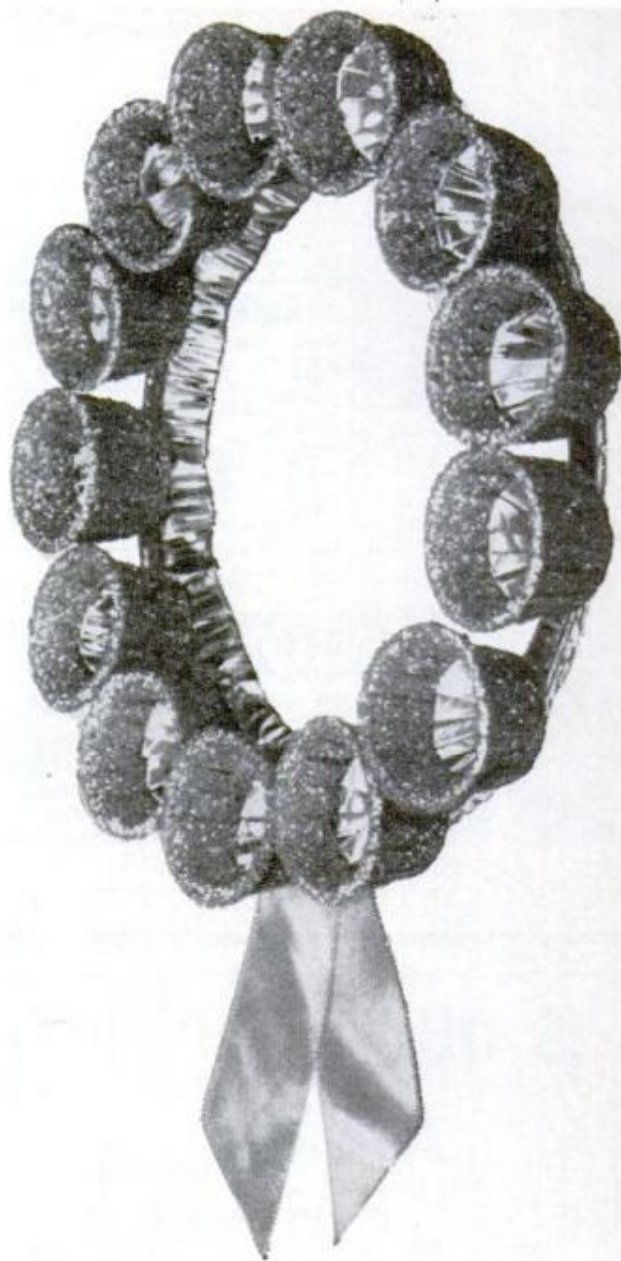

Colorful Christmas Scroll for Your Fireplace Mantel

Yarn and common hardware cloth combine to make this clever Christmas scroll. First the $\frac{1}{4}$ -in.-mesh wire is painted white. Then the letters of the word 'Noel' are blocked out with green yarn, making the body of the letters two mesh squares wide. An in and out weaving technique is used with knots being formed on the rear side. The area surrounding the letters is filled in with white yarn in a manner similar to weaving the letters. In both cases, two strands of yarn are used to fill each square of the mesh, one passing over and the other under the wire. The ends of the hardware cloth are bent like a scroll and then the outer edge of the wire mesh is wrapped with a border of red yarn.

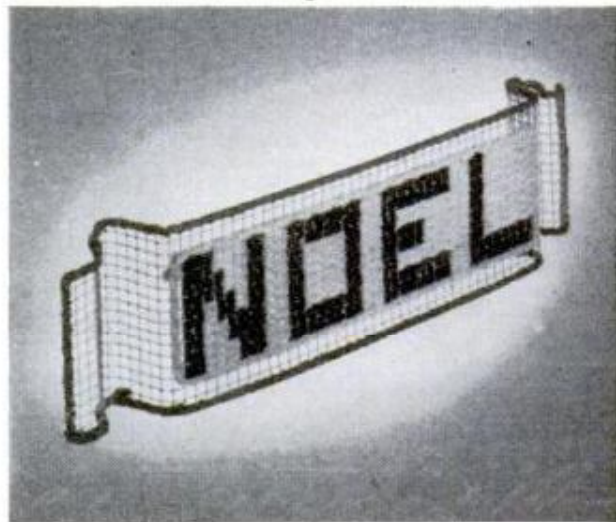

WHAM-O \$1.50 40-LB. PULLY

HITS LIKE A RIFLE—KILLS RABBITS, SQUIRRELS. Powerful, silent, accurate. For hunting, target, routing pests. Sportsman's choice sold world over.

NEW! Surgical quality pure gum rubber. 275 heavy extra steel balls. 40 heavy steel balls, extra rubber. Heavy duty 7' ash stock. target, adapter for shooting arrows. GUARANTEED: Professional model of Nat'l Slingshot Assn. At dealers, or write WAMO MFG. CO., Box E-15, San Gabriel, Calif. FREE catalog on crossbows, knives, games, pistols, etc.

HUNTING SLINGSHOT

WOODWORKING



LOW COST HOME TRAINING COURSE FOR BEGINNERS & ADVANCED CRAFTSMEN

Make money. Learn skills and secrets of fine woodworking and tool use. Professionally prepared shop method training tells and shows how. Covers everything. Easy to master.

Write for Free Booklet

INTERSTATE TRAINING SERVICE
DEPT. F-3, PORTLAND 12, OREGON

FREE AMAZING NEW BOOK "HOW TO ANSWER ADS"



Never before have you seen anything like this. Tells you in simple language the correct way to answer ads. Gets you quicker replies—better results, and greater satisfaction. Will save you time and money and it's ABSOLUTELY FREE. No obligation whatever. Every reader of advertising should have this booklet. Send a postcard for your copy NOW. F. W. JOHNSON, Popular Mechanics Magazine, Room 600-A, 204 East Ontario Street, Chicago 11, Ill.

PLAY RIGHT AWAY!

Even If You Don't Know a Note of Music Now

Now it's EASY to learn any instrument. No boring exercises. Start playing real pieces by notes right away. Amazing progress at home, in spare time. No teacher. Few cents per lesson. 1,000,000 students! Write for FREE BOOK. U. S. School of Music, Studio 3012, Port Washington, N. Y. No salesman will call. (Est. 1898.)



YOUR POSTMASTER, SUGGESTS:

Avoid the Avalanche of Last Minute Holiday Mailings!

To assure prompt delivery of all Christmas parcels and greeting cards before the holiday—

MAIL EARLY!

FOR DISTANT OUT-OF-TOWN POINTS, MAIL BY DECEMBER 10, 1960

FOR DELIVERY IN YOUR LOCAL AREA, MAIL BEFORE DECEMBER 16, 1960

ENGINEERING



AMERICAN INDUSTRY NEEDS TRAINED ENGINEERS NOW BACHELOR OF SCIENCE DEGREE, 30 MONTHS

SAVE 2 YEAR'S TIME

B.S. Degree Courses:

- | | |
|---|---|
| <input type="checkbox"/> Electronic Engineering | <input type="checkbox"/> Mechanical Engineering |
| <input type="checkbox"/> Electrical Engineering | <input type="checkbox"/> Civil Engineering |
| | <input type="checkbox"/> Architecture |

Diploma Courses:

- | | |
|---|---|
| <input type="checkbox"/> Radio-Television Plus Color TECHNICIAN | <input type="checkbox"/> Architectural Drafting |
| <input type="checkbox"/> Electronic Technician | <input type="checkbox"/> Mechanical Drafting |
| | <input type="checkbox"/> Structural Drafting |

APPROVED FOR VETERANS

Send for FREE Information

HEALD Engineering College

Van Ness at Post, Dept. PM San Francisco, California

NAME _____
STREET _____
CITY _____ STATE _____



BIG MONEY OR EXTRA INCOME Home Appliance Repair

Wide-open field for men of all ages. Millions of Home Appliances need fixing... Every home is your market for Full-Time Career or Spare-Time "Second Income" opportunities. Save on your own repairs. N.T.S. Shop-Tested HOME TRAINING is streamlined, modern, low-cost, practical. Qualifies you fully and you start earning early in your course. Includes Tools and Appliance Tester. Send for FREE Opportunity Book and actual lesson. No Obligation. No Salesman Will Call!

LEARN TO EARN MORE... QUICKLY AND EASILY!

NATIONAL TECHNICAL SCHOOLS Dept. HB-120
Los Angeles 37, California

Name _____ Age _____
Address _____
City _____ Zone _____ State _____

FREE BOOK

Learn LANDSCAPE GARDENING

AND GROWING OF PLANTS. Latest information on propagation, soil-testing, plant growth regulators, garden design. Start a profitable business or wonderful hobby. Unique and modern home study course—accredited. Earn your certificate at home. May I send FREE, and without obligation, my informative Booklet? **NORM MORRIS NATIONAL LANDSCAPE INSTITUTE**
DEPT. M-120, 11826 SAN VICENTE BLVD., LOS ANGELES 49, CALIF.

Print Anything You Want In Seconds...

Now you can print anything you wish quickly and easily with this completely new printing outfit. Sensational "BASE LOCK" sets have complete alphabet of rubber letters and numerals which set FLAT AND TIGHT in rubber tongue and groove holder to give clean, sharp impressions every time. Used by leading firms all over the country. Now for the first time available to you at this moderate price.

\$3.95 POSTPAID No C.O.D.

Introductory set contains all of the following:
• More than 250 letters and numbers
• Type tweezers • Stamp pad
• 3-line type holder
and FREE, one extra holder. Order now!



1001 Different Uses

PATERSON STAMP WORKS
P. O. Box 1321
Paterson, N. J.

**94.6% OF BAILEY
GRADUATES ARE EMPLOYED
AT TOP PAY IN THE FIELDS
WHICH THEY WERE TRAINED!**



**DIESEL-AUTO MECHANICS
DESPERATELY NEEDED!**

We have a far greater demand for our students than we can fill!

We can show you an actual waiting list of leading companies throughout the world who have tried Bailey graduates — found them outstanding, and are coming back for more!

Bailey Graduates are Successful . . . RECEIVE BIG PAY — HAVE SECURE FUTURE!

The Famous Bailey Course prepares you for BOTH Diesel and Gasoline Mechanics.

This is a must—due to the advent of using Diesel principles, such as 'Fuel Injection' on passenger cars . . . use of gasoline engines for starting Diesel engines, etc. You learn all this at Bailey in the amount of time ordinarily required to learn just one of these subjects, **ALL FOR THE PRICE OF ONE.**

Don't be satisfied with a 'futureless', one-type job — learn how you can make big money now! Write today for Free Booklet that takes you on a step-by-step camera tour through our spacious, modern shops — See Bailey students in action as they Learn-by-doing with the Famous Bailey Method of training!

We provide you with housing and part time jobs while in school, plus nation-wide placement service for graduates.

BAILEY Technical SCHOOLS

1634 S. GRAND ST. LOUIS 4, MO.

MAIL TODAY!

Please mail immediately this free booklet without obligation.

FREE BOOKLET



Name _____
Address _____
City _____ State _____
APPROVED FOR VETERAN . . . NON-VETERAN

OWN a BUSINESS

Be a Specialist in Booming Industry



Get in on the ground floor of a booming \$750 million a year industry. Fill the need in your area for safe, effective "on location" cleaning of carpets and upholstery. Every home houses a customer! We'll train and establish you in YOUR OWN lifetime business! Start part-time if employed. You'll be trained by a nearby dealer and at 50-hr. school to get you quickly established. You provide 6 services to multiply profits. No shop needed. Just 2 jobs a day nets \$8,750.00 first year. We back you with 27 services: counseling, nat'l advg. . . McCall's, Parents, etc., conventions, advg. kits, others. Booklets explain everything — no obligation, no salesman will call. Send for Free Booklets.
DURACLEAN COMPANY
O-16D Duraclean Bldg., Deerfield, Ill.

**SCIENCE
ENGINEERING**

Bachelor's degree in 27 or 36 months
Accelerated year-round program: Aero., Chem., Civil, Elec., Mech., Metal., Math., Chemistry, Physics. Modest rate. Earn board. New classes Jan., March, June, July, Sept. Catalog. 1612 East Washington Blvd., Fort Wayne 2, Indiana

INDIANA TECHNICAL COLLEGE

75 POWER TELESCOPE 25X-45X-75X \$3.98

NEW 3 in one telescopes, 3 variable 25X, 45X-75X magnification. Brass bound, 25 power for ultra bright images 45 & 75 power for long range. Guaranteed to bring distant stars, moons, objects, sports 75 times closer.
Most powerful scope sold anywhere near this amazing low price. American made, 3 sections. Opens 36", closes 1 ft.; contains 4 ground & polished lenses. Can also be used as powerful compound microscope. Mass production enables us to offer telescope complete at \$3.98 postpaid. Money back guarantee.
CRITERION CO., Dept. PMB-88, 331 Church St., Hartford, Conn.



Print Your Own

Cards, Stationery, Advertising, Circulars, labels, photo and movie titles, church work, tags, etc. Save money. Sold direct from factory only. Raised printing like engraving, too.

Own a Printing Business

Print for Others, Good Profit. Have home shop. Junior press \$15; Senior \$29 up. We supply everything. Easy rules. Pays for self in short time. Write now for free details.

KELSEY PRESSES, Z-37 Meriden, Conn.

Here's the Offer No Other Radio-TV School DARES MAKE

**ALL FINANCED
WITHOUT INTEREST
OR CARRYING
CHARGES**

RADIO-TV TRAINING SCHOOL
815 E. Rosecrans Ave. Dept. PM 128
Los Angeles 59, California

RTS will train you at low cost and when you graduate will help you open a service shop of your own and will supply all of the equipment you need plus a full inventory of parts and supplies.

NO SALESMAN WILL CALL ON YOU!!!

Helps You Overcome

FALSE TEETH

Looseness and Worry

No longer be annoyed or feel ill-at-ease because of loose, wobbly false teeth. FASTEETH, an improved alkaline (non-acid) powder, sprinkled on your plates holds them firmer so they feel more comfortable. Avoid embarrassment caused by loose plates. Get FASTEETH at drug counters everywhere.

WORLD'S
BEST
WANT-AD
MEDIUM

CLASSIFIED ADVERTISEMENTS



Advertisements in this section \$1.30 per word, each insertion, minimum 10 words, payable in advance.
To be inserted under proper classification, copy must be in our office the
18th of the second month preceding date of issue
F. W. Johnson, Manager, Classified Advertising
Popular Mechanics, 200 East Ontario Street, Chicago 11, Illinois

YOU'LL PROFIT

By reading and answering the classified ads in this section. Hundreds of opportunities for you to make and save money

AUTOMOBILES, MIDGET CARS

FIBERGLASS Midget racer bodies. Two section type. Make your own racer or kart. List price \$62.00. Selling out at \$7.50 per set, as long as supply last. Send for picture and dimension. Naefly Plastics, 4909 Midmoor Rd., Madison 4, Wis.

VOLKSWAGEN—New! Delivered U. S. by German dealer. Save domestic mark-up. Fast delivery, safe, easy and several hundred dollars cheaper. Details \$1.00. Bill Woods, 8442 Otis Street, South Gate, California.

OLD Car magazine. Free sample copy. Franson's Motor News, Box 1568, San Diego 12, California.

HISTORICAL Record of 1960 U.S. and foreign cars, fully illustrated. Detailed specifications on all models. 160-page "Car Facts Book, 1960," \$1.00. Service Bureau, Room 517C, Popular Mechanics, 200 E. Ontario, Chicago 11, Ill.

CATALOGS—Automobile, old, modern, foreign; dealer books, service manuals, glossy photographs; motor magazines. Non-profit organization. Write for free information. Auto Maniacs C, Box 451, Mt. Clemens, Michigan.

HOT Rod racing book reports 1959 races, trials, drags. Expert advice on hopping up engines, tuning the stock Corvette, supercharger selection. Send 75¢ (85¢ in Canada) to Service Bureau, Room 517D, Popular Mechanics, 200 E. Ontario, Chicago 11, Ill.

AUTO SUPPLIES AND EQUIPMENT

HUB-O-MATIC Gyro-stabilizer. Proven safety device assures easier handling, better control, longer tire wear. Easily installed on wheels following simple instructions. Only \$7.95 pair prepaid. Front and rear pair recommended. Send money order or check with year and make of car (no compacts). General Supply Company, 1920 McGee, Kansas City, Mo.

GREATEST Auto parts catalog. Thousands racing and restyling accessories for all cars. Only 25¢ (refundable). Newhouse Automotive Industries, 5805-PM12, Beverly, Los Angeles 22, Calif.

AUTO Shop welding repair training in world's largest non-profit welding school. Low tuition. Free booklet. Hobart Welders, Box M-1201, Troy, Ohio.

CORROSION Resistant plated brass license plate bolts. Set \$1.00. Raydie, 246 Interstate, Addison, Illinois.

DON'T Miss the "Earn \$8,000 to \$10,000 "Salesman Wanted" ad. Mr. Herman.

CRANKSHAFT Grinder. Hand operated. Makes bearings fit without taking engine apart. \$4.00. Literature. L. D. McGee, 719 Cascade St., Wenatchee, Wash.

JUST Out: New 404-page, illustrated catalog offering savings up to 50% on over 100,000 auto parts and accessories, many hard-to-get. All makes (1920 to 1960 models), trucks, foreign and sports cars. Also Hollywood accessories, custom styling, hi-speed equipment. Send 25¢ for postage, packing—refundable on first order. Whitney, 1919 PM-12 Archer, Chicago 16, Ill.

HYDRAULIC Jack repair kits. Free catalog. Free "Silent—Salesmen" with each kit. Hydraulic Jack Packing & Tool Co., P.O. Box 50, Bloomfield, N. J.

NYLON Shoulder harness for sports cars, etc. \$4.00. 24 hr. aircraft clocks with sweep hands \$17.50. Crash helmets \$9.75. Lew Leibe, Selma, Calif.

NEW "Float-A-Long" car cushion. World's most comfortable! Prevents tiredness—\$29.80 prepaid anywhere in continental U.S. Give width of front seat, name and year of car, and we'll have you riding in comfort you never dreamed possible. Factory to you unconditionally guaranteed! Float-A-Long Seat Cushions, 818 Lewis St., Flint 3, Michigan.

NOW Hear this! Free Bulova watches, transistor radios, Ronson lighters — with purchase of Iskenderian, Edelbrock, Mallory, Hedman, Scheifer and other popular equipment. Ledbetter Enterprises, 1015 17th, Texarkana 4, Texas.

UNIQUE Supercharging method. Details free. Atlas Kart, 122 Park Place, Schenectady, New York.

STOP Rear axle, transmission noise by perfect lubrication. \$3.00 postpaid. Bailey's Staylube, 814 Lyngrove Drive, Houston 18, Texas.

JEEP Owners—V8 conversions. Read Jeep Owners ad, page 35.

VOLKSWAGEN Fuel gage system \$8.95. Longmire, Box 97, Goleta, Calif.

PARTS, Model "A." List 25¢. (Refundable) Matco, Box 135, San Pedro, Calif.

FREE! New catalog. Speed, power, mileage increasing equipment. Discounts! Almqvist Engineering, Milford PM5, Penna.

JEEP Parts! For military and civilian. At great savings. Largest inventory. Catalog for owners and dealers. Inquiries invited. American Auto Parts Co., 1830-PM Locust, Kansas City, Mo.

RING-Valve job while driving. \$6.00 postpaid. Guaranteed! Nothing like it! Lasts 100,000 miles! Motaloy, Grantham, Penna.

TUCKER Automobile literature. Pictures. \$1.00. Jerry Moore, P.O. Box 657, Grand Rapids, Mich.

JEEP Tops. Free catalog. Mor-Nan, Box 141, Beverly, Mass.

NEW And used parts at savings. Complete guaranteed parts service for all models cars and trucks. Largest in the West. Jeep and army parts specialists. Newest type shifting hubs for all jeep and all military and latest production front end drive vehicles. \$27.50 and up. Also, foreign car parts. Write. Pioneer Auto and Truck Parts Co., 734 W. 13th Avenue, Denver 17, Colo.

MONA-TONE Guttled mufflers for car owners, hot-rod fans. More power! More mileage! Rich, mellow tone! Fits all cars. \$5.95 plus COD and postage. Give year, make, model. Universal, Box 7823M, Nashville 9, Tennessee.

SPARK Plugs. Factory reconditioned, 10,000 mile guarantee, new seals, plated. Box of 8 prepaid in U.S.A. \$2.95. Include make and model. Craft Tool, 1573 Boy Scout Rd., Caro, Michigan.

1909-1934 FORD Parts. Illustrated catalogue 75¢. Mark Auto, Layton, N. J.

AUTO TRAILERS

BUILD Your pickup camper. Blueprints and supplies. Literature 10¢. Comstock Trailers, Parsens, Kansas.

BUILD Expanding eight foot trailer. Accommodates five. Literature 10¢. Framar Company, Wilmington, Mass.

MOTORCYCLES, BICYCLES, MOTORSCOOTERS AND SUPPLIES

LAMBRETTA Parts supply. Oden's, 4000 East 131 Street, Cleveland 5, Ohio.

GO Cart \$50. Child's car \$25. Whizzer motor \$12. Cushman motorscooter \$40. (Mailorder only). Send 25¢, (35¢ for first class mailing) for 32 page Directory-Catalogue Number 98 listing these and hundreds of other bargains in go carts, motorscooters, homebuilders parts, plans, etc. Midget Motors Directory, Athens, Ohio.

BICYCLE Supplies. Goodyear tires. Free delivery. Attleboro Cycle, County Street, Attleboro, Massachusetts.

MOTORCYCLE Parts. New, used. List 25¢. Ballak, 811 N. 9th, St. Louis 1, Mo.

RECONDITIONED Motorcycle motors. Chrome accessories. Complete stock Indian parts. Expert rebuilding. Fast service. Indian Motorcycle Sales, Kansas City 27, Missouri.

HARLEY-Davidsons — Used bargains. New, used parts, accessories, all models. Bulletin 25¢. Knuth's (Factory Dealer), 1753 Muskego, Milwaukee, Wis.

AVIATION

AERIAL Balloon camera. Any camera takes amazing airphotos. Complete plans, giant balloon, \$3.98. Aero-Cam, 2936 Emerson, Altadena, California.

HELICOPTER: Completely engineered. Assembly drawings and parts available. Send \$2.00 for 3 view drawing, photo illustrated booklet, price list and specifications. Send additional \$2.00 for book "Basic Helicopter Aerodynamics," uses our helicopter for complete performance calculations. Helicopter Research Co., Box 121 (M), La Mirada, Calif.

PROPELLERS, Plans, supplies for airboats and snowplanes. Latest designs, prompt delivery. Catalog 25¢. Banks-Maxwell, Box 3301E, Ft. Worth 5, Texas.

AVIATION Surplus bargain catalogue. One dime. Box 22PM, Thomasville, Penna.

AIRLINE Careers. Adventure! Prestige! Promotion! Four-week course. Free placement service with 35 airlines. G. I. approved. Free catalog B. McConnell Airline School, 1030 Nicolet, Minneapolis, Minnesota.

HELICOPTERS Are our business, not our sideline. A-W, originators of home-built helicopters (not autogyros) sells more kits, plans than all others combined. Learn why! Booklet with 3-view drawings, complete prices, regulations, specifications, photos sent postpaid, 25¢. Adams-Wilson Helicopters, Lakewood 14, Calif.

BATTERIES, GENERATORS

STORAGE Batteries: New-rebuild. New treatise teaches everything. Free details. Batteries, Box 341-A, New Castle, Penna.

ELECTRICAL SUPPLIES

PLAY Safe. Check electricity with Test-wire voltage tester. Writes too. \$1 postpaid. Empire Electric, Box 11, Bethpage, New York.

LAMP. Electrical parts, wholesale. Thousands of items for repairing, converting. Catalog 25¢. Brown Lamp, Box 305, Clayton 5, Mo.

LAMPS. 25¢ Brings parts catalog. Refunded first order. Gyro, 5208P N.W. 35th Ave., Miami 42, Florida.

ELECTRO-Scribe! Engraves all metals, \$2.00. Beyer Mfg., 10511-H Springfield, Chicago 55.

WELDING, SOLDERING, PLATING

FREE Catalog. Welders, welder kits, supplies. Build 350-ampere welder using aircraft generator, plans 25¢. LeJay Co., Minneapolis 20, Minnesota.

WELDERS, 110/220, \$39.50. Morris, 1070 Inner Drive, Schenectady 3, New York.

PLATING Equipment, supplies. Complete line of anodes, solutions. Home workshops, industrial sizes. Hollywood Bronze Supply, Dept. C, 1624 East First, Los Angeles 33, California.

FREE Catalog. welders, welder kits. Build 350-ampere welder using aircraft generator, plans 25¢. Dunbar Manufacturing, Minneapolis 8, Minnesota.

MACHINERY, TOOLS, SUPPLIES

REDUCE Machine tool reconditioning costs. Circular. Machine Tool Publications, 215-E Commerce Bldg., St. Paul 1, Minn.

FREE New catalog showing only complete line of work holding tools available anywhere. Drill press vises, angle and swivel machine vises, rotary tables, production and heavy duty angle vises. 68 different models, fully described with prices. Palmgren Products Co., 8365 South Chicago Ave., Chicago 17, Illinois.

AMAZING New combination sharpener (for knives, scissors, mowers, etc.) and glass cutter! Special \$1.00, postpaid! Patented! Free instructions! Easy to use! Griffith, 259 Radcliffe, Strafford, Penna.

NEW Import from Switzerland, air bubble Reba level in plexiglass. Accurate, light, compact. M. L. Vickery, P.O. Box 601, West Monroe, La.

FREE Money-saving catalogue. Bargains, 510 S. Clinton, Dallas, Texas.

SHEET Metal brakes: 3ft., 4ft., 5ft., \$80.00. Shears, benders, folders. Free catalog. Vyke Co., P4158 Jason, Denver 11, Colo.

TOOL Bargains. Save to 90%. H.S. cutters, bearings, abrasives, \$3.50 dozen. Many more. List 10¢. Salme Enterprises, 40 Greendale Avenue, Worcester 6, Mass.

HIGH Speed drills—17 piece set 1½" to 1". Big savings. See advertisement Graff Machine Tool Company. Page 241.

POWER Tools wholesale. Free catalog. Roberson, 14 Brooks Drive, Austell 3, Ga.

ENGINES, MOTORS, DYNAMOS

MOTOR Rewinders specification manual and wholesale parts catalog \$1.00. Modern, Box 8715, Kansas City 14, Mo.

REWIND Motors yourself. Complete instructions, \$1.00. Lewis Manufacturing, Howell, Michigan.

WINDING Data. 275 motors, single and three phase \$1.10. Data Company, 512 Kensington, Kansas City 24, Mo.

DIESEL Injector parts and fuel pumps wanted. GM51-53-71-110. Bares, 7120 Carnegie, Cleveland 3, Ohio.

BOATS, OUTBOARD MOTORS

MONEY-Saving boat supplies. Color catalog—35¢. Boat Equipment Unlimited, Oceanport 8, N. J.

BUILD An air propelled marine bobbed for real fun. Plans \$7.50, drawing \$1.00. International Engineering, Box 5223E, Atlanta 7, Ga.

12 VOLT Remote compass kit, complete—all cables, etc., for any boat \$37.50; 24 hr. aircraft clocks, SS hands \$17.50. Lew Leibee, Selma, Calif.

PLANS And full size patterns for canoes, skiffs, fishing boats, outboard racers, runabouts, cruisettes, sailboats. Catalog 35¢. Write: Modern Designs, Dept. 42, 9809 W. Grantosa, Wauwatosa 16, Wis.

300 BOAT Plans, kits. Catalogs: Powerboat \$1.00. Sailboat 25¢. Trailer kits, Marinecraft, Box 161-M, Brighton 35, Mass.

FRAME Kits, plans or full-size patterns for 35 inboards and outboards. Prepared for amateur builders. New 80 page illustrative catalog. 50¢. Glen Designs, 9152 Rosecrans, Bellflower, Calif.

BUILD Your own boat from our large-scale blueprints. Books of plans give how-to-build help. Hundreds of professional designs—motor, sail or auxiliary—for amateur builders. Free catalog. MoToR Boat-in-G, 572A Madison Ave., New York 22, N. Y.

MARINE Conversions. Ford, Chevrolet, Jeep engines. Catalog 25¢. Lehman Manufacturing Company, 800 Elizabeth Avenue, Linden 4, N. J.

NEW, Used, rebuilt marine motors. Marine conversions, fittings. Free catalog. Stokes Marine Supply, Dept. 24, Coldwater, Michigan.

FULL Size, cut-to-shape boat patterns, blueprints, 7½-38 feet. Big new 88 pg. illustrated "Build a Boat" catalog of naval architect-designed Catamarans, cruisers, runabouts, skiffs, outboard boats, sailing, racing, houseboats, 50¢ "How to Build a Boat" booklet \$2.50. Cleveland Boat Blueprint Co., Dept. A-66, Box 1651, Cleveland, Ohio.

FAST Planing sailboats. 12' scows \$495. 14' surfboards \$295. Dacron sails included. Brochure free. Laurents, Route 1, Largo, Florida.

I Want to send you proof of the wonderful pulling power of Popular Mechanics classified pages. What's your proposition? Write me today. Include literature if possible. F. W. Johnson, Manager Classified Advertising, Popular Mechanics Magazine, 200 E. Ontario St., Chicago 11, Ill.

PROPELLERS, Plans, supplies for airboats, snowplanes. Catalog 25¢. Banks-Maxwell, Box 3301F, Ft. Worth 5, Texas.

ATHLETIC EQUIPMENT, BODY BUILDING COURSES

KARATE! Judo! Yoga! Muscles! Boxing! Stunts! 125 individual, illustrated lessons. All for \$1.00. Scientific instructions, deadly secrets. Charts! Diagrams! Sanson Institute, 44N Bromfield, Boston 8, Mass.

4 MUSCLE Courses 25¢. 12 large courses \$2.00. Big deal \$3.00 (guaranteed). Agents wanted. Sid's System, PMC4, 8421-C Evergreen, Southgate, California.

OUTSTANDING Physical development! Any age. New guaranteed discovery uses only a rope! Strength, health, muscles. Gain—reduce. Free booklet. Ropercise, 4834 Art, San Diego 15, California.

"**BIG** Muscles. The Quick Way." Dr. Young's revolutionary discovery. Free information. Gaucho, Box 9309-S7, Chicago 90.

FREE Muscle building information. Body-Tone, Box 638B, North Miami, Florida.

SPORTING GOODS, GUNS, FISHING, SKIN DIVING, ARCHERY

154 PAGE Catalog—A real dream book for fishermen! It's free! Netcraft Company, Dept. B-12, Toledo 13, Ohio.

GUNS. All kinds. None over \$20.00. Bargain list 25¢. Miller's-PA, 5201 Gordon Drive, Sacramento, Calif.

FREE—Wholesale catalog. Beads, Spinners, Lure parts, Sinker molds, Jigs, Reels, FinnySports (ME), Toledo 14, Ohio.

UNDERWATER Fuse, 10 ft.—\$2.00. Special Services, 7036 Rising Sun Avenue, Philadelphia 11, Penna.

MINNOW Graders. Free circular. Crescent Mfg., Box 3303, Ft. Worth, Texas.

MOLDS For fisherman's sinkers, jigs, squids, casting and spinning lures. Free catalog. Sweet's Molds, Tonawanda 1, New York.

MOLDS—For casting your own fishing sinkers. Free illustrated booklet. Reading Instrument Co., Box PM78, Reading, Penna.

BIG Money raising crickets and 12 inch African fishworms. Free literature. Carter Ranch, Plains, Georgia.

AMAZING Wholesale sporting catalog. Save 70%. Tremendous selections. Econ-O-Mart, Whippany 2, New Jersey.

KILL Submersed water weeds which foul up motor propellers, tangle fishing gear, with R-H Weed Rhap-20, Granular 2.4-D. Inexpensive, easy to use, sure results. For free information write Reasor-Hill Corporation, Box 36PM, Jacksonville, Arkansas.

JAP Rifle altering to 30-06, \$6.00. Jap-shells, \$3.95. Catalog 10¢. T. P. Shop, West Branch 11, Mich.

10,000 GUNS. Antiques, moderns, swords, armour. Every description. Giant catalog \$1.00. Agramonte's, Yonkers 2 G, N. Y.

CAMPING EQUIPMENT AND TENTS

CAMPING Equipment, tents, world's largest selection. Send 25c for new 160 page catalogue—handbook—camp site directory. (Print name, address). Morsan Tents, 10-21R 50th Ave., Long Island City 1, New York.

EARTHWORMS, CRICKETS, FROGS

FROG Raising for pleasure and profit. We ship "Nufond" giants. Broel-A, Box 506, New Orleans 1, Louisiana.

BIG Money raising fishworms and crickets. We teach you how to raise and where to sell. Free literature. Medium redworms, 3000, \$5.95; 10,000, \$16.95. Carter Redworms, Plains, Georgia.

FREE Picture folder, "How to Make \$3,000 Yearly, Sparetime, Backyard, Raising Earthworms!" Oakhaven-56, Cedar Hill, Texas.

RAISE Fishworms and rabbits on \$500 month plan. Free details. White's Rabbitry, Mt. Vernon, Ohio.

FAT Redworms 1000—\$2.75; 2000—\$4.50; 5000—\$8.00. Postpaid. With raising instructions. Brazos Bait Co., 60 Lincoln, Waco, Texas.

CRICKETS—Worms. Hy-bred. Wholesale, retail. Fischer's Bait Barn, Rt. 4, Box 17, Robstown, Texas.

BINOCULARS, TELESCOPES, MICROSCOPES, MAGNIFIERS

MICROSCOPES, Radios, surveying, everything Japanese. Catalog 25¢. Magnification Instrument, 2 East 45, New York City 17.

DYNASCOPE — Amazing world-famous reflector telescope. Request free brochure. Criterion, Dept. DP-74, Hartford 1, Conn.

SATELLITES Seen easily. Imported telescopes, binoculars, microscopes. Free lists. Butts, Torrington, Wyo.

20 x 50 **BINOCULARS**. New war surplus at a fraction of the original cost. Post paid, \$8.00. Guaranteed. Driscoll Sales Service, 536—12th Street, Denver 4, Colorado.

BUILD Your own reflector telescopes. Complete kits: mirrors, eyepieces, tripods, all other accessories. Request free illustrated literature. Criterion Manufacturing, Dept. DPM-71, Hartford 1, Conn.

TELESCOPE Kits—Direct from manufacturer. Other optical hobby kits. Large selection. Free booklet. Esco Products, Oakridge, N. J.

REFLECTING Telescope, 60X, completely assembled. Guaranteed observatory clearness. Free information. Skyscope, P.O. Box 55, Brooklyn 28, N. Y.

BINOCULARS, Telescopes, microscopes: Terrific values, \$3.98 up! Request free money-saving catalogue. Criterion, Dept. P-97, Hartford 1, Conn.

WAR Surplus bargains: Millions of lenses, instruments, telescopes, binoculars, components and complete line of astronomical telescope items. World's greatest optical market-place! Send only \$1.00 for beginner's 10-lens kit and big instruction booklet Stock 2-CH. Write for Catalog CH free! Edmund Scientific Co., Barrington, New Jersey.

BARGAINS, Binoculars, telescopes, microscopes. Free catalog. Adventure Sales, Box 2133, San Diego 12, California.

AMAZING Prices precision binoculars. Folder "Binocular Selecting," catalog free. Prentiss Importers, Mercury Bldg., West Los Angeles 25, Calif.

CELESTIAL Reproductions of observatory photographs. Free catalogue. Astro Murals, 33 W. 60 St., N. Y. 23, N. Y.

PLANTS, SEEDS, BULBS, NURSERY SUPPLIES

GREENHOUSE For your own home. Low as \$186. Send for free literature. Metropolitan Greenhouse Mfg. Corp., 1875 Flushing Ave., Brooklyn 37, N. Y.

GROW Dwarf trees! Instructions and seeds, 35¢. Mail Order Specialties, 1439-PM-L, Sabraton Ave., Morgantown, W. Va.

PETS—DOGS, BIRDS, RABBITS, HAMSTERS, ETC.

EARN \$10,000 Yearly raising Angora rabbit wool for us. Information 25¢ coin. American Angora Company, Malta 12, Montana.

GOLDEN Hamsters—Pedigreed breeders \$3.85 pair. Albino Whitebands. Literature. Moore's Hamster Ranch, Shepherdstown 25, West Virginia.

MAKE Money raising chinchillas, mink, rabbits, cavies for us. Free catalog. Keeney Brothers, New Freedom 2, Penna.

RAISE Rabbits on \$500 month plan. Free details. White's Rabbitry, Mt. Vernon, Ohio.

HAMSTERS—Ideal pets, \$2.95 pair. Free booklet. Jer-fre's Hamstery, 1447 Apple, Muskegon 13, Michigan.

SKUNKS, Reptiles, hawks, raccoons. Illustrated catalogue, 25¢. Trails End Co., St. Stephen, S. C.

RAISE Rabbits successfully by knowing facts. 48 page illustrated book describing 25 breeds. Housing, feeding, breeding, marketing, etc. Plus bulletin, 25 cents. American Rabbit Association, 36 Arba Building, Pittsburgh, Penna.

TRIPLE Profits. Raise mutation hamsters. Professional color breeding handbook, \$2.95. Selmar, Box 63, Sugar House, Salt Lake City 6, Utah.

HAMSTERS. Free literature. Winch's Hamstery, Box 582, Fort Wayne 6, Ind.

FUR BEARING ANIMALS

MINK Raising information free. Complete. Lake Superior Mink Farm, Superior, EEL, Wisconsin.

FARMS, FARM LANDS, REAL ESTATE

\$5 MONTHLY Buys 5 acres—near clear-water lake. Price \$125. Excellent fishing, good cabin sites. Free list. Box 425-P, Carthage, Mo.

FLORIDA Homesites (high and dry) near national forest \$345 at \$10 monthly. Folder free. Howard Vernor, DeLand, Florida.

FREE Strout catalog! Farms, homes, businesses, resorts, retirement properties. Over 3000 values in 36 states. 60 years service. World's largest! Write Strout Realty, 7-CJ S. Dearborn, Chicago 3, Ill.

CANADIAN Vacation lands: Full price \$285.00. 40 acres. \$10.00 month. Suitable cottage sites, hunting, fishing, investment. Free information. Land Corporation, 3768-C Bathurst, Downsview, Ontario, Canada.

ARMSTRONG'S, Shook, Missouri. Sell Ozark lands. Write them. Listings mailed free, quarterly.

FLORIDA—Silver Springs area. ¼ acre waterfront homesites. \$795.00. \$10.00 month. Free color photos. Write: Smith Lake Estates, Box 5681, Belleview, Florida.

OPPORTUNITIES! Government land, U. S., Alaska, Canada. Sledge Surveys, Macon, Mississippi.

FLORIDA 5 Acres full price \$695—\$10 month no interest. Send \$1 for contract and full information on this amazing tropical Collier County land offer. You must be convinced this best land bargain in Florida or deposit promptly refunded. Webb Realty Corporation, 11575 N.W. 7th Ave., Miami 50, Florida. AD59621(c)(7).

FREE Literature. Most desirable retirement, recreation development in South. Twenty square miles with fifty beautiful fresh-water lakes. Near Carolina coast. Best fishing, boating, hunting. Golf course, country club, ocean beach club and yacht basin planned. \$4 down, \$4.40 monthly buys large, beautiful, shady homesite priced \$395. Offer limited. Write Boling Spring Lakes, Southport 1, N. C.

FLORIDA Homesites; at Ocala National Forest, near St. John's River, Daytona Beach. \$495. \$10 monthly. Write Victor Roepke, Route 3, DeLand, Florida.

BE Your own boss! 549-acre farm, only \$12,000! Stretch your farm purchase dollar to the limit! Well-improved Missouri stock setup handles 100 head. Pond, 3 springs, creek, 75 acres cropland. Modern 4-bedroom house, 5-room tenant house. Two barns, 30x40 and 30x30, silo, shop, garage, poultry house. Excellent hunting and fishing nearby. On county road, 18 miles town. Aged owner offers practically unheard of bargain at only \$12,000, half down! Free Fall-Winter catalog, the nation's biggest, 184 pages, 1,250 photos, bargains coast to coast! United Farm Agency, 2825-PM Main St., Kansas City 41, Mo.

BEWARE! Real estate financing pitfalls. Be informed. "Home Buyers & Sellers Guide." \$2.00. Counsel Publications, Box 206, Carmichael, Calif.

FLORIDA Properties: Write for free list. Chambers & Chambers, Wauchula, Florida.

FLORIDA 2¼ Acres, near Gulf, 50 foot elevation. \$795.00; \$15.00 down and month. Russell Hancock, Realtor, Brooksville, Fla.

FLORIDA: Large 100' by 300' retirement lot, 25 miles north of Panama City at Fountain, \$750.00. John H. Ashley, Box 254, Ware Shoals, S. C.

FARM MACHINERY AND SUPPLIES

ELECTRIC Welders. New, heavy-duty, 180 amp. Free trial. Dealerships open. 20 year warranty. 8159 South Pleasant Department A1, Minneapolis 20, Minn.

POULTRY, FARM SUPPLIES

RARE, Fancy, ornamental chicks. Bantams, ducklings, goslings, guineas, turkeys, capons. Free catalog. Stromberg's, Fort Dodge 25, Iowa.

PROFITABLE OCCUPATIONS

BAKE New greaseless doughnuts in kitchen. Sell stores. Free recipes. Michael, 3605 South 15th, Minneapolis 7, Minn.

BIG Money raising fishworms and crickets. Free literature. Carter Wormery, Plains, Georgia.

VENDING Machines. No selling. Operate a route of coin machines and earn amazing profits. 32-page catalogue free. Parkway Machine Corporation, Dept. #25, 715 Ensor Street, Baltimore 2, Maryland.

GROW Mushrooms. Cellar, shed and outdoors. Spare, full time, year round. We pay \$4.50 lb. dried. We have 29,000 customers. Free book. Mushrooms, Dept. 99, 2954 Admiral Way, Seattle, Wash.

SHARPEN Scissors, pinkers. Inexpensive machine. Clipper sharpener. Black-hawks, Sheldahl, Iowa.

BECOME Independent with your own franchise business. Thousands earning handsome incomes. Request interesting facts today. National Franchise Reports, PM-528, 333 North Michigan, Chicago 1.

MAILORDER Beginner's manual. 25¢. Carnahan Bros., 9610 Acacia, Fontana, Calif.

EARN Big money. Sell imports. Catalog and details only 10¢. Gateway, Box 327, Forest City, N. C.

MAKE Money writing short paragraphs. Information free. Barrett, Dept. C-27B-X, 7464 No. Clark, Chicago 26.

FREE Book "990 Successful, Little-Known Businesses." Work home! Plymouth-7P, Brooklyn 4, New York.

WHOLESALE Magazine subscriptions. Highest commissions. Bonus! Qualified Agencies. 451TA Kingston, Brooklyn 25, N. Y.

JUST 1 Hour a day. Earn up to \$1870 per month. Experience not required. No age limit. Send \$1.00. Refundable coupon sent. George Thacker, 11007 Maple Avenue, Bloomington, California.

BOOKS, PERIODICALS, PICTURES, POSTCARDS

30% DISCOUNT Off on all books. (Few exceptions.) Prepaid insured transportation to any point in U.S.A. (1) Deduct 30% from retail price on trade books. (2) Deduct 10% from retail price on text and technical books. (3) Special for December, Pope Pius XII—his voice and life with 45 colorful photos, plus an actual recording of His Solemn Papal Benediction. Price \$4.95—Our special (while they last) \$1.00 each. Send check or money order with your order. NYC res. add 3% sales tax. Banner Book Service, Inc., P.O. Box 2, Canal St. Station, New York 13, N. Y.

WILDCRAFTERS Sportsman's trading post. Send stamp (or 5¢ coin) for copy. Wildcrafters-M, 1001 North 13th, Terre Haute, Indiana.

MILLIONS Of back date magazines. Fast service. Midtown Magazines, 1105B 6th Ave., New York 36.

BEAUTIFUL Nature paintings. Photos, samples. Helen Ashworth, Heuvelton, N. Y.

FINE Art, craft books. Big savings. Free list. Artcraft, Baldwin, Maryland.

BOOKS Located fast. Out-of-print, scarce. Lowest prices without obligation. Book Mark, Box 68A, Mt. Clemens, Mich.

OUT-Of-print books at lowest prices! You name it, we find it! Fast service. No obligation. International Bookfinders, Box 3003-PM, Beverly Hills, Calif.

BRITISH Book bargains—Any subject. Catalogues free. Transatbooks, Wantagh, N. Y.

FREE Catalog. Self-help books. Write! Wilshire, 8721 Sunset, Los Angeles 46P.

BOOKFINDERS! All subjects. Send wants! Jaher Book Service, 183 Hazelwood Drive, Westbury, N. Y.

NATIONAL Geographic magazines, 1888-1960, any issue. Periodical Service, Box 465-PM, Wilmington, Delaware.

LOCATE Any book. No obligation. Aardvarks, Box 734, La Mesa, Calif.

SPARETIME Repeat profits taking magazine subscriptions. Special offers. Cassell Agency, Boynton Beach, Florida.

BIBLES, Books, magazines bound. Price list free. Norris Bookbinders, Greenwood, Miss.

BIBLES, Books, bargains. Free catalog. Price, 4813 Hurford, Chester, Penna.

MAGIC TRICKS, PUZZLES, JOKER NOVELTIES

FREE Trick and magic catalog 25¢. Castle Magic, Box 92-PM, Jamaica 35, New York.

3000 TRICKS, Pocket, parlor, stage. World's finest magic catalog (408 pages), \$2.50. Kanter's, M-1311 Walnut, Philadelphia 7.

BE A magician! Large professional catalog of latest tricks, 35¢. Ireland, C-109 North Dearborn, Chicago 2, Illinois.

WORLD'S Finest professional magic. Joker novelties. Giant illustrated catalog 10¢. Top Hat, Evanston 12, Illinois.

CATALOG, Free trick, 25¢. (1,500,399 tricks, jokes). Magico, Box 4373-P, San Antonio 7, Texas.

500 TRICKS, Famous Douglas 120 page catalog number 33 now available. Complete catalog-magic tricks-equipment just 10¢. World's fastest service. Magicland, Dept. 14, Box 274, Dallas, Texas.

3100 NOVELTIES, Jokes, tricks, gadgets, funmakers, hobbies. Big catalog 10¢. Johnson-Smith, D-494, Detroit 7.

PROFESSIONAL Catalog, 175 pages, 25¢. Williams, 900 Plymouth, Ellwood City, Penna.

25,000 PROFESSIONAL Comedy lines. Catalog 10¢. Orben Publications, Hewlett, N. Y.

MAGICAL Stage tricks, illusions, jokes. Sensational handcuff escapes. Free catalog. Write: Magician Heaney, Oshkosh, Wisconsin.

GET Your tricks, gags wholesale. Sell to friends. Big catalog, 28 gag samples 25¢. Dohn-ND-Marks, Broadview, Illinois.

"VENTRILOQUISM Selftaught." Complete book 25¢. Greenview, Box 61-B, Whitestone 57, New York.

BIG 160 Page professional magic catalog! World's greatest collection of over 1000 tricks, jokes, magic, illusions, secrets, mysteries! Special Christmas offer 10¢ with free trick! House of 1000 Mysteries, Dept. PM12C, Trumbull, Conn.

COINS, TOKENS, CURRENCY

DIFFERENT Liberty nickels 15, \$3.00; 11, \$2.00; 6, \$1.00. I. Doktor, P.O. Box 35151, Los Angeles 35, Calif.

RARE Unc. 1899-P silver dollar, each \$5.00. Free price lists. Butts, Torrington, Wyo.

GET Profit and pleasure in collecting old coins. Send 25¢ for 68-page illustrated coin catalog. You'll be delighted with it. Send for it now. B. Max Mehl, Box 750-B, Costa Mesa, Calif. Oldest rare coin establishment in U.S. Established 59 years.

NEW 1961 Giant U. S. coin catalogue 25¢. Ace, 107 N. Dearborn, Chicago 2.

SIX Different Indian cents \$1.00. Free list. Collector's Bargains, New Hope, Penna.

32 PAGE U.S. coin list 10¢. Contains almost 100 illustrations; over 5,000 delightful bargains. Stoney, 260 Washington, Boston 8, Mass.

FREE List! U. S. coins. Lowest prices! Hugh's Coins, Hickory, N. C.

OLD Money wanted. Will pay \$5,000.00 for nickel of 1913 with Liberty head (not buffalo). We pay cash premiums for all rare coins. Send 5¢ for large coin folder. May mean much profit to you. Numismatic Co., Box 750-A, Costa Mesa, Calif.

FREE Bonus offer! U. S. bargain list, 10¢ (refundable). Economy Sales Company, Mansfield, Massachusetts.

LARGEST Coin magazine, 200 pages, 50¢. Scrapbook, 7320-J Milwaukee, Chicago 31.

NUMISMATICS Largest newspaper. Semi-monthly. Sample 25¢. \$2.00 yearly. Numismatic News, Box 452, Iola, Wis.

RAREST CC mint dollar, 1885. Uncirculated, \$10.00. 100pg. coin catalogue, 50¢. Shultz, Salt Lake City 10, Utah.

COINS: Price lists 10¢. Lund, 200 So. Sycamore, No. Platte, Nebraska.

LINCOLN Cents: 1923-S; 1921-S; 1924-S; 1916-S-D; 1927-S-D; 1928-S-D; 1920-S-D; 1909-P; 1925-S-D; 1938-S-D; 1930-S-D; 1955-S; 1917-S-D; 1918-S-D; 1919-S-D; 1920-S-D; 1934-D; 1931-P. Good to fine. Complete lot \$3.95. Berry, Box 306, Westminster, Calif.

INDIAN Cent, foreign coin, plus bargain lists 10¢. Hutchinson's, Box 4747, Philadelphia 34, Penna.

WE Sell pennies, nickels, dimes. Bargain prices. Free list. Send self-addressed stamped envelope. Ben's Coins, 31 North Clark, Chicago 2.

EIGHT Indianhead pennies \$1.00. 7 large Canadian cents \$1.00. Frank Herget, 2884 Bailey, Buffalo 15, N. Y.

U.S. Large cent and 2¢ piece, only \$1.95. Bargain list included. Vacoin, Box 10, Richmond 1, Va.

GENUINE Ancient bronze—Constantine the Great 60¢. Jolie, Roslyn Heights, New York.

TWENTY Page 1961 retail price list of USA and Canadian coins for 10¢. Our selling prices on thousands of coins and coin collectors supplies. Bryson Incorporated, 612A White, Toledo 5, Ohio.

GOLD, Uncirculated: \$20, \$42.50; \$10, \$23.95. Cook, Box 181, Jackson 5, Miss.

LINCOLNS: 25 Different 1909-1930 \$1.45. 40 different 1909-1940 \$1.85. 25 different "S" \$1.50. Pricelist 10¢ (free with order). Buying list 25¢ (refunded). Harris, 1457 Moreno, Oceanside, California.

25 DIFFERENT Coins from 25 foreign countries. \$1.00. Bargain. Hindley, Box 808, Mt. Vernon, Ohio.

WANTED! Indian, Lincoln cents, other coins. Sky-high prices paid! New list, 25¢ (refundable). Evans, 7620 Bertram, Hammond, Ind.

COINS From Formosa, Vatican, plus foreign banknote, 10¢ with coin approvals. Littleton Coin Co., Littleton 51, N. H.

BUYING Indian cents \$7.00 per hundred. Frank DiMambro, 459 Van Rensselaer, Utica, N. Y.

CARSON City silver dollars, \$3.00. Uncirculated silver dollar, \$2.00, 5 different Barber half dollars, \$4.50, 5 different Barber quarters, \$2.50, 5 different Barber dimes, \$1.50, 10 different Liberty nickels, \$2.00, 10 different Indian cents, \$1.50, 50 different Lincolns 1909-1939, \$4.00. Complete set Lincolns 1941-1960, \$2.50. Complete set Jefferson nickels 1938-1960, \$10.00. Free souvenir. Ed Nelson, Box 4176, North Las Vegas, Nevada.

LINCOLNS 1922D, 1926S, 1931D \$1.00, 1910S, 1913S, 1915S \$1.50, 1912S, 1914S \$2.00 each. United, 348 Grotto, Providence, R. I.

LINCOLNS: 50 Different dates 1909-1940 including 1909VDB in Whitman folder. Only \$2.50 plus 35¢ postage. Will accept C.O.D. Earl Kammerzell, 207 Cleveland, Pullman, Washington.

COINS Wanted. List of prices paid, 25¢. Wayne Coin, 1205 California Ave., Ft. Wayne, Indiana.

LINCOLNS 1955S Unc. 29S, 36P, 37P, 39P, 39S, 40S, 41S—\$2.00. Coinwallace, Hayden Lake, Idaho.

NEW Coin Album holds 800 pennies, nickels, dimes, quarters. Gives number minted and approximate value each coin. Postpaid \$2.50. Lesco, Box 6023A, Arlington, Virginia.

INDIANHEADS, 10 Different in album \$2.00. DeWolf, 508 S. Hill, Oceanside, California.

HAWAII, Alaska statehood medals 95¢ each. Both in plastic holder \$3.95. 1960 proof set \$4.85. 20 different Lincolns before 1929 \$1.25. 8 different Indian cents \$1.00. 6 different Liberty nickels \$1.00. G Distributors, Box 35123, Los Angeles 35, California.

1960 Proof Set \$5.85; or set encased in glittering lucite cube paper-weight \$10.75. Beautiful uncirculated \$20.00 gold \$49.00; 2 different types \$95.00. Premium handbook, \$1.00. Retail guidebooks—U.S. \$1.75; Canada \$1.75. Bebee's, 4514 North 30th, Omaha 11, Nebraska.

WE Buy all rare coins. Complete catalogue 50¢. Fairview, Box 1116-WW, New York City 8.

LINCOLNS, 65 Diff. dates, good to uncirc., \$3.95 ppd. Farmer, 6739 Hollywood Blvd., Hollywood, Calif.

WONDERFUL Bargains! 30 different foreign coins, including older and larger pieces \$1.00; 8 different worldwide before 1900—\$1.00; 20 different Asia and Africa, \$1.00; 20 different Latin America, \$1.00. Alfred Szego, Box 187, Jackson Heights 72, New York.

FREE Bonus offer. Illustrated Buying Guide; plus monthly bargain bulletin 25¢. Richer, Box 9017, Schenectady 1, N. Y.

SELLING Genuine Mexican gold 2 pesos, \$2.75; 2 1/2s, \$3.50; 5s, \$6.50; 10s, \$14.00; 20s, \$25.00; 50s, \$50.00, XF/UNC; BU 1960-D, small, large date Lincolns, \$1.00 set, 5 sets, \$3.00; 1960 mint sealed proof sets, \$5.50. Buying fine plus U.S. gold: 5s, \$12.00; 10s, \$17.50; 20s, \$37.00. Send insured, immediate cash. Richard Brewer (ANA #33413), 641 Saint Paul, Los Angeles 17, California.

TWO Plastic coin notebook sheets; holds twenty coins, four sizes. \$1.00. Raydie, 248-R Interstate, Addison, Illinois.

FILMS—Developed and printed 50¢—127, 620, 120 film. Color film developed and printed, save 25 to 33½ discount on all color work. World's finest quality. Send for mailers—price list. Apex Photo, Box 511, Paoli, Penna.

A Roll of fresh Kodak film returned to you absolutely free for each roll of black and white or Kodacolor sent in for developing and printing. Fast service, low prices, guaranteed quality. Send for free mailers. Economy Photo Service, Dept. PM, P.O. Box 1111, Albany 1, New York.

HAVING Trouble finding those just right Christmas cards? Thoughtful personal cards from your photo or negative in the all new slim-line style. Samples, information from Holiday Photos, Box 666, Dept. 16, Denver, Colo.

BEAUTIFULLY Tinted 8x10 enlargement. Negative or photo, \$1.00. 3 alike, \$2.00. Dick's Photo, Louisville 12, Ky.

MOTION PICTURES AND SOUND EQUIPMENT

WORLD'S Largest selection of 8mm. silent and sound films at discount prices. New and used—features and shorts from Castle, Official, AAP, NTA, etc., including "Old Time Movies," "Collectors Items." New 8mm. magnetic sound films available. Free Bargain Bulletin (specify size). Write to Peerless Camera Stores, 415 Lexington Ave., New York, Dept. M18.

8MM Movies, 50', comedies, cartoons, travel, airplanes, hunting, fishing. Limited offer. Send \$1.00 each. MovieLand, Box 10-M, Van Nuys, Calif.

16MM SOUND—8mm films. New, used. Free list. Entertainment films, 236 W. 55, N. Y. C.

16MM. Sound feature films \$20.00. Bedner, 5300 So. Talman, Chicago 32.

16MM. Sound Shorts. Tremendous assortment features. \$18.50 up. Used 16mm. sound projectors, \$79.50 up. Catalog. Abbe Films, 417 West 44th Street, New York 36, N. Y. Plaza 7-2219.

5,000 8-16 MM. Movie films. Free catalogues. International, Greenvale, N. Y.

8MM-16MM Color and B & W film and supplies. Save money. Free catalog. Superior, 448 N. Wells, Chicago 10.

FREE Every month. Blackhawk's newspaper-size catalog 8mm., 16mm. movies, 2"x2" color slides. Biggest selection in USA. Bargains in used 16mm. sound films, projectors. Blackhawk Films, Davenport 14, Iowa.

MOVIE Camera film: 8mm. roll \$1.50. 16mm. 100' \$3.00. Free processing. Better Films, 742 New Lots, Brooklyn, N. Y.

16MM. Sound films. Bargain bulletin. Duquette, 97-T Snow, Fitchburg, Mass.

MOVIE Film! Free catalog! ESO-R, 47th Holly, Kansas City 12, Missouri.

16MM. Sound, projectors, films. Sale, rental, exchange. Visit store or write for catalog. National Cinema, 71 Dey St., New York City.

ENTIRE Life of Christ. 8mm, silent, 16mm. narrated, sacred music for sale. Hemenway Film Co., 424 Little Building, Boston 16, Mass.

SPECIAL Entertainment—8 mm. b&w, 50 feet \$12.00. 16 mm., b&w, 100 feet, \$20.00. Tex, Box 368, Terminal A, Toronto, Canada.

COLOR SLIDES

ALASKA Wildlife in color. Slides, 8mm., 16mm. movies. 3 sample slides \$1.00. Alaska Film, Box 5-621, Mt. View, Alaska.

LINCOLN Story, complete in 500 color slides. Catalogue and sample. 35¢. Willems, Box 1515-A, Chicago 90.

TRANSPARENCIES Wanted. Up to \$500.00 each. For information write: American Color, 1008 N. Stanley Ave., Hollywood 46, Calif.

WESTERN Listings and five Colorado slides for \$1.00. Quality Approvals, 711 Columbia Road, Colorado Springs, Colo.

TITLES, Travel and wildflower slides. 8mm. titles. Free catalog. Title-Color, Box 35521T, Dallas 35, Texas.

SOUTHSEAS—Hawaii, Samoa, Fiji, Tahiti, New Zealand, Australia. Six color slides for \$1.00. Catalogue, sample, 20¢. Avery, Box 8261, Honolulu 15, Hawaii.

MUSIC & MUSICAL INSTRUMENTS

SWISS Musical movements (finest) \$2.50. Electrical \$6.50. Spielman, 131 West 42nd, New York 36.

SONGWRITERS! A publishing house for amateurs. Songs published, recorded. Free music. Free lyric course. Amateur Songwriters Association, 1356 Hancock Street, Quincy, Mass.

1961 ACCORDIONS, Factory to you! 23 shifts \$395.00, 2 shifts \$145.00. 20 models to choose from. 40 Bass electric chord organ \$99.00. Money back guarantee. Waltham Accordion Company, Box 3862, Detroit 5, Michigan.

CHORD Organs. Save ½. Italian craftsmanship. Play without lessons! Terms. Free trial! Free catalogs. Philharmonic Importers, Department R, 2003 Chicago, Chicago 22.

SONGPOEMS And songs wanted! Mail to: Tin Pan Alley, Inc., Box 405, Radio City Station, New York 19, N. Y.

POEMS Wanted for musical setting and recording by America's largest song studio. Send poems. Free examination. Five Star Music Masters, 630 Beacon Building, Boston.

POEMS Wanted for musical setting and recording. Send poems. Free examination. Crown Music Company, 49-C West 32 Street, New York 1.

POEMS Needed immediately for new songs and records. Free examination and appraisal. Send poems: Songcrafters, Acklen Station, Nashville, Tenn.

GUITAR Making books, plans, imported woods, tools. List 10¢. Satinwood, 510 East 11th Street, New York 9, N. Y.

ELECTRIC Guitars, amplifiers, wholesale. Free catalog. Carvin, PMM, Covina, Calif.

ACCORDIONS! Direct from importer—savings to 50%. Free home trial. Trades accepted. Easiest terms. Famous makes. Free 1961 catalog. Accordion Corporation, Dept. R, 2003 Chicago, Chicago 22.

POEMS Wanted! Best songs recorded free with 7-piece orchestra. Melodies written. Send poems, free examination. Songmakers, 1472-M Broadway, New York 36.

PIANO Tuning. Home study course. Diploma granted. American School of Tuning, Box 707, Gilroy, Calif.

SONGWRITERS—Send poems. Honest, sincere offer. Free recording. Successful Songs, Box 608, Danbury, Conn.

ACCORDIONS. Buy direct! 120 bass, 8 switches—\$125. Write for brochure. Alias Accordion, 874 Broadway, New York City 3.

SONGWRITERS. See your name and song on new idea. Write to Top-Ten Button Co., 22 Hazelwood Ave., Buffalo 15, N. Y., for sample and information.

VIOLIN Making supplies. Free catalog. Fred Artindale, Box 71992, Los Angeles 1, Calif.

SWISS Musical movements, \$1.90. Helax, 218 W. 72nd St., New York City 23.

BONGOS—Hand made. Three inch. Double, \$3.95. Triple, \$5.95. Five set, \$8.95. Postpaid. Tabu, 2401 Kalakaua, Honolulu 15, Hawaii.

ACCORDIONS—Organs! From importer. Save ½. Free trial. Terms. Trades welcome. Free catalog. Dept. PM-12. Accordion Import Center, 7120 Galli Drive, San Jose, Calif.

ACCORDION Repair Guide \$3.00. How To Build Accordions, \$5.00. Complete charts. Satisfaction guaranteed. Fischer, Box 402, Bellingham, Wash.

RADIO, TELEVISION AND ELECTRONICS

FREE! 1961 Catalogs for newest, best electronic bargains available. Stereo, hi-fi, ham radio, 1000 other items. Alco Electronics, Lawrence 2, Mass.

FREE! Giant wholesale catalog on electronics, hi-fi, transistor, scientific, hobby, optics, photographic, housewares, jewelry, tools, novelties, toys. Write: Lektron, 131M Everett Ave., Chelsea 50, Mass.

GOVERNMENT Surplus radios, parts. Picture catalog 10¢. Meshna, Malden 48, Mass.

TAPE Recorders, Hi-Fi components, sleep learning equipment, tapes. Unusual values. Free catalog. Dressner, 69-02M, 174 St., Flushing 65, N. Y.

LEARN While asleep with amazing "Electronic Educator" endless tape recorder. Details free. Research Association, Box 24-N, Olympia, Washington.

ELECTRIC Guitars, amplifiers, wholesale. Free catalog. Carvin, PMR, Covina, Calif.

RADIO And TV tubes at manufacturer's prices! 100% guaranteed! Brand new! No re-brands or pulls! United Radio, Box 1000-M, Newark, N. J.

HI-FI Components, recorders. Free wholesale catalogue. Carston, 125-Y East 88, N. Y. C. 28.

FIX Your own TV. Save 80%! Send for free illustrated chart showing how! We'll include giant electronics catalog. Zalytron, 220-M West 42 St., New York City.

LOW Quotes. Hi-Fi equipment. Stereo tapes. Catalog. Hi-Fi, Roslyn 6, Penna.

STEREOPHONIC Phonographs, radios, recorders. Wholesale catalog free! Towers, Box 3022, Philadelphia 50.

CRYSTAL Radio kit \$1.00. Amplifier and speaker for same \$6.95. Catalogue. Clearco Crystal Company, 2966 No. 4th, Milwaukee 12, Wisconsin.

FREE 444-Page 1961 Allied Electronics catalog! See products and values available only from Allied. See everything in stereo hi-fi systems and components; latest money-saving build-your-own Knight-Kits; tape recorders; TV accessories; public address systems; world's largest stocks of parts, tubes, transistors, test instruments, tools, books. Only \$2 down on orders up to \$50. Write for value-packed Free catalog! Allied Radio, 100 N. Western Ave., Dept. 96-M, Chicago 80, Ill.

DON'T Buy hi-fi components, kits, tape, tape recorders until you get our low, low return mail quotes. "We guarantee not to be undersold." Wholesale catalog free. Hi-Fidelity Center, 1797M First Avenue, New York 28, N. Y.

NO Television is complete without our remote sound control, making it possible to adjust volume from your easy chair. Each unit has earphones for "silent" listening. \$9.95. Deluxe model includes padded earphones and remote control power cord. \$12.95. Check or money order. Shipped postpaid. Penn Valley Products Co., Box 64, Wynnwood, Pennsylvania.

ELECTRONIC Surprise package! 5 pounds assorted parts. \$25.00 value. Only \$2.98. KPJ Sales, Box 1252-C, Studio City, California.

TRANSISTOR Antennae. Trailerites, campers, homes. 1000 mile range. \$6.95. Clinton Industries, 4801 Ave. V, Birmingham, Ala.

VARIABLE Tone control box. Improves tone quality and reduces interference on radios, phonographs, etc. Mounts in minutes! \$4.50 p.p.d. Marvin Electronic Accessories, Box 532, Stow, Ohio.

\$1.00 FULL Price. Will rid you of loud raspy commercials without leaving your chair. Operates any set or money back. Remote Control Co., Box 1661, Manhattan Beach, Calif.

6 TRANSISTOR Radios with 3 short-wave bands \$19.00. Details free. Elmer Block, Sarcoxie, Mo.

HI-FI From Japan. Finest imported tuners, amplifiers, recorders, etc. Free catalog. KPJ Sales, Box 1252-C, Studio City, California.

BUSINESS OPPORTUNITIES

INVISIBLE Reweaving: \$5-\$10 per job possible reweaving burns, tears, moth-holes. Spare-full time. Free details. Skill-Weave, Dept. RC-1612, 335 W. Madison, Chicago 6, Illinois.

EARN \$100.00 Week upholstering dinette chairs. Instructions 50¢. Simplcraft, 2338 Elston, Chicago 14.

"HOW To Write Letters That Sell." Compact manual by expert brings you powerful weapon for success in any field. Only \$2.95 postpaid, money back guaranteed. Literature free. Helinger, East Syracuse 10, N. Y.

EXPORT-Import business made easy. Individual setup service. Not just instructions. Hermes, 152 West 42, New York City 36.

MONEY Daily—Selling by mail. Everything furnished. Irvin, Box 1052, Oklahoma City 1.

REPAIR Hydraulic jacks. Easy and profitable. Write: Hydraulics, Box 4104, El Paso, Texas.

UNIQUELY Different magazine. \$4,500 profit possible! Dignified business. Operate from home! Sample, complete instructions \$1.00. Free details. HBD, GPO, Box 972-PM, New York 1.

FLORIDA—25 Different profitable businesses. Self operated, low investments, big profits. Florida Business Guide \$1.00. Research, Box 1891, Jacksonville, Florida.

MAKE Money at home! Respectable field. Experience unnecessary. No public contact. Nothing to grow or make. Excellent profit potentials! Free expert guidance helps you achieve success. Complete plan, details, \$1.00 (refundable). Columbia, 45-09-PY Broadway, Long Island City 3, New York.

FRANCHISES Make profits! Operate your own exclusive franchised business. Write today for free interesting details. National Franchise Reports, W-528, 333 North Michigan, Chicago 1.

FREE! Name brands catalog! Your own high profit business. Sell name brands, full or part time. No inventory, no investment. More than 2,000 name brand items; lowest wholesale prices. Watches, jewelry, cameras, hi-fi, stereo radios-phonos, appliances, housewares, hardware, power tools, luggage, musical instruments, garden equipment, sporting goods, toys, many others. 8 floors of name brands. Million dollar inventory! Orders shipped complete in 24 hours! Send for free, beautifully illustrated catalog now! Separate wholesale price list. H. B. Davis Corp., Dept. 11, 145 W. 15 St., New York 11, N. Y.

DISTRIBUTE Lowest priced wholesale catalog. Felix, 160-04-16th, Whitestone 57, N. Y.

WANT To make big money at home? \$10.00 profit in an hour possible with invisible mending. Make tears, holes disappear from clothing, fabrics. Steady year-round demand from cleaners, laundries, homes. Details free. Fabricon, 6234 Broadway, Chicago 40, Ill.

LEARN Sewing machine repairing. To \$125 weekly. Sparetime. Supplies. Add to present business. Write today! Taylor Service, Box 2126, San Bernardino, Calif.

IMMEDIATE Profits with no capital or experience. Take orders for all magazine subscriptions. Friends and neighbors are your prospects. Write now for complete, free kit. McGregor Magazine Agency, Dept. 6B, Mount Morris, Illinois.

FREE Picture folder, "How to Make \$3,000 Yearly, Sparetime, Backyard, Raising Earthworms!" Oakhaven-38, Cedar Hill, Texas.

VENDING Machines. No selling. Operate a route of coin machines and earn amazing profits. 32-page catalogue free. Parkway Machine Corporation, Dept. #27, 715 Ensor Street, Baltimore 2, Maryland.

BIG Money raising fishworms and crickets. Free literature. Carter Farms, Plains, Georgia.

BUSINESSES, Resorts, motels, investment property, ranches. Our special service dept. at your disposal. No obligation. World's largest. 58 years' service. Strout Realty, 7-MB S. Dearborn, Chicago 3, Ill.

TO \$100.00 Weekly. Sparetime, home operated mailorder business. Successful beginner's plan. Everything supplied. Lynn, 10420-M National, Los Angeles 34.

PIANO Tuning learned quickly at home. Tremendous field! Musical knowledge unnecessary. Information free. Empire School of Piano Tuning, Champaign, Ill. (Founded 1935).

I want to send you proof of the wonderful pulling power of Popular Mechanics classified pages. What's your proposition? Write me today. Include literature if possible. F. W. Johnson, Manager Classified Advertising, Popular Mechanics Magazine, 200 E. Ontario St., Chicago 11, Ill.

COPUBLISH Mail Sale Advertiser, leading mail order paper. Details, latest copy, dime. Vanroy Shirk, Lebanon, Penna.

11,000 NEW Prospects daily. Baby record books, shoes, albums. Sell mailorder. Use our literature. Write: No-Co-Ro, Capitola, California.

BRONZE Baby shoes: Instructions, equipment and mountings for genuine electroplating process. Largest supplier of all plating equipment, supplies. Free catalog. Hollywood Bronze Supply, Dept. B-3, 1624 East First, Los Angeles 33, Calif.

OPERATE Profitable mail order business. Write: Walter Service, 4159A East 112th, Cleveland 5, Ohio.

EARN Good money sharpening chain saws, scissors, cutters, knives. Free manual. Treyco, North Tonawanda, N. Y.

BAKE New greaseless doughnuts in kitchen. Sell stores. Free recipes. Montgomery, 3605 South 15th, Minneapolis 7, Minnesota.

\$3.00 HOUR—Home, sparetime, assembling pump lamps. Easy. Free details. Ogor. Caldwell, Arkansas.

RAISE Rabbits on \$500 month plan. Free details. White's Rabbitry, Mt. Vernon, Ohio.

\$400.00 MONTHLY Raising giant worms. Odorless soilless method. Charlie Morgan, Bushnell, Florida.

LIQUID Molding rubber, free sample. Shellcraft supplies. Chaney's, 1907-A East Road, Jacksonville 11, Fla.

VENDING Machine catalog. Rakes, 609P Spring Garden, Philadelphia 23, Penna.

PLATE Baby shoes, jewelry, gifts, bronze and colored pearl. We finance. Free booklet. Platex, 11029 South Vermont, Los Angeles 44

RECAST Junk batteries into new. Latest achievements. Battery Laboratories, Bayou LaBatre, Alabama.

\$34.70 TWO Hours. Manufacturing concrete products. No selling. Castings #3, 2907 Dundee, Rapid City, South Dakota.

CANDIED Popcorn and potato chip equipment. Eakins, Box 933-AO, Springfield, Ohio.

BUY Direct from factories. Appliances, cameras, watches! Free details! Cam Co., 6810PM-20th Ave., Brooklyn 4, N. Y.

PROSPER By selling "The World's Most Usable Bible." Sales quick, easy and highly profitable. To start earning a better living, write today. International Book Company, Department M., Box 118, Wichita 1, Kansas.

MAIL Order, home workers, dealers, hobbyists opportunities. Part time or full. Earn extra income. Details. Sterling, Box 626-PM, Dania, Florida.

MAILORDER Beginners no cost plan. Armstrong's, 154 Darrington S.W., Washington 24, D. C.

PLASTERCRAFT Molds, liquid rubber, plasters, flocks, candle supplies. Catalog and manual free. Blue Rapids Supply, Blue Rapids, Kansas.

SELL Books by mail. 400% profit. Royal, Box 368-X, Cleveland 27, Ohio.

EARN \$10,000 Yearly raising Angora rabbit wool for us. Information 25¢ coin. American Angora Company, Malta 77, Montana.

\$70 WEEKLY—Home, spare time. Simplified mail bookkeeping. Immediate income—easy! Auditax, 34757A, Los Angeles 34.

EVERYBODY Likes candy and popcorn specialties. Learn to make professionally home. (Our 50th year.) Ragsdale Candies, B-107, East Orange, New Jersey.

OPERATE Home mailorder business. Vosacek Distributors, 4444A1 Ute, San Diego 17, Calif.

EXCEPTIONALLY Profitable opportunity in tape recording! Free information. Baron's, Lynden, Washington.

MAKE Money from old tires. Operators clearing \$400 weekly. Equipment costs \$640. Get facts. S & S Patents, Inc., 1307 N. Clark, Chicago 10.

"HOW To make money by mail." Write: American Distributors, Box 409-P, Niles, Michigan.

MAKE \$46 From square foot plywood; jigsaw necessary. Free details. Woodarts, Bridgewater, Mass.

MAIL Order franchise. No experience needed. Spencer Gifts, a well-established and successful mail order firm, starts you in business. Supplies catalogs with your own name imprinted. No investment in stock. No shipping merchandise. Catalog items pre-tested for salability. Initial investment of less than \$50 can get you started. Write for free information kit. Spencer Gifts, EZ-54 Spencer Building, Atlantic City, N. J.

INCREDIBLE New "table-top" machine manufactures over 15,000 saleable products. Also laminates, encases, moulds and plates in bronze, chrome, or copper. 20¢ materials produce \$10.00 products. Free confidential details and home-business plan. Plasti-Form, Dept. PM-12, Gardena, Calif.

TERRITORIES Open for "Auto-Moly" Lubricant (doubles engine life). Small investment, build future state franchise. Pacific Lubricants, 5808-PM12 Beverly, Los Angeles 22, Calif.

NEW Home-import mail order profitability! Your mailbox stuffed with money! No selling. No experience. No investment. We supply everything. Free details. Mail Order Distributors (Import Division) Dept. B5CC, 15201 South Broadway, Los Angeles, Calif.

\$1.00 BRINGS You \$18.00 spare-full time home business opportunity! Amazing new velvet-spray transforms old cheap lamps, TV-radios, figurines, furniture, anything, into valuable products! Free samples, 50 business opportunities booklet. Send no money. Flok-Kraft DR, Los Angeles 61.

\$250.00 WEEK Spare time profit possible. Earn at home with new fascinating printing method. \$5 starts you—send no money now. Free confidential facts and valuable sample. Screen-Print, DR, Los Angeles 61.

MAKE A move to big money: A happy healthy, future. No worries, doctors bills or pressure. Beautiful climate. Unlimited business opportunities. Full employment. A paradise for children and adults. Send \$1.00. A.N.Z. Report, Box 522, Monterey, Calif.

FREE! Beautiful Mexican curios! Rush 30¢ stamps (refunded). Sylviako, Apartado 9036, Mexico City.

\$1.00 GETS Our "Blue Book" on battery repairing. Little Pal, 1105 5th Ave., McKeesport, Penna.

PROFIT With Popular Mechanics' subscription plan. No investment, no experience needed. Earnings begin immediately when you obtain subscriptions for Popular Mechanics, Good Housekeeping and others. High commissions, bonus. No experience needed. Deal directly with the publisher. Write Popular Mechanics, Room 12B, 250 West 55th St., New York 19, N. Y.

A Real money making franchise opportunity. Add hundreds of dollars to your present income with the imported products of the Waltham Company, in beautiful "right selling" display cases. We are appointing distributors in your area, where we shall select and stock locations with these imported products. Your activities will be to service each location, collect and restock. You do no selling. This is a dignified independent business of your own, without interfering with your present employment, takes only a few hours per week. May be expanded to full time if desired. All merchandise fully guaranteed, both to dealer and consumer. Inventory 100% exchangeable. We will get you started right. Minimum investment \$1192.50 cash necessary. Your investment covers distributorship, inventory and display units. You may earn back the entire original investment through our reorder bonus plan. Applicants who can qualify will be appointed as local distributors, must be responsible, a permanent resident, have use of car. Write today giving name, address and phone number to Time Industries, 170 West 74 Street, New York 23, N. Y. Dept. #33.

Liquid Rubber, models, free sample. Lavin Novelties, Box 296F, Leavittsburg, Ohio.

BIG Money—Operate own fix-it shop. Service household appliances, motors, mowers, saws, skates, etc. Free book. Christy Trades School, A-9703, 3214 Lawrence, Chicago 25.

LEARN Landscaping and the growing of plants. Start a profitable business part or full time. Free information without obligation. National Landscape Institute, Dept. MC-120, 11826 San Vicente Blvd., Los Angeles 19, Calif.

YOUR Own vitamin business without risk. Over 200% profits. Free details. Hollywood Health Aids, 5880 Hollywood Boulevard, Hollywood, California.

PACKAGE At home for profit! We supply everything. No selling, ready market. Free home business details. HPC, 2212BN Jesse Street, Los Angeles 23.

START Your own business on credit (U.S. and Canada). Your own boss. 1396 dealers sold \$5,000 to \$25,500 in 1959. We supply stocks, equipment on credit. 200 home necessities. Sales experience unnecessary. Pleasant profitable business backed by world-wide industry. Write Rawleigh's, Dept. L-U-PPM, Freeport, Ill.

JAPAN Directory. 145 Japanese manufacturing exporters. Japan and Hong Kong trade journal information. Asia opportunities. Just \$1.00 today. Nippon Annai, Box 1150-P, Spokane 10, Wash.

IMPORT-Export opportunity, profitable, world-wide, mail-order business from home, without capital; or travel abroad. Established world trader ships instructions for no-risk examination. Experience unnecessary. Free details. Mellinger, C70C, Los Angeles 24.

MONEYMAKING Franchise can be exclusively yours. For free current franchise reviews information write Franchise Newsletter, F, 9 South Clinton, Chicago 6.

START Successful mailorder business without inventory, packaging, delivery headaches. Dropship Buyers' Guide reveals how. Send for free details. Rutward, 117 Bryant Ave., Columbia Station, Ohio.

MAKE Extra money—Big cash commissions plus premiums for you and your customers. Sell advertising book matches. Sensational new tenor, glamour girls, hillbillies; dozens others. All sizes. Quick daily sales; big repeat business. Free master kit makes selling easy. No experience necessary. Superior Match, Dept. MX-1260, 7530 Greenwood, Chicago 19.

\$128 PROFIT From \$10 material. Information. Simpson Enterprises, 170 Ellis, Peshtigo, Wis.

COLORGLAZED Concrete pottery made without molds. Patented method. Cemetery products, novelties, tiles. Basement leak-sealing. Money-making projects. Booklet, details free. Men only. National Potteries Company, Grand Rapids, Minnesota.

MAKE Fabulous weekly profits clipping newspaper items for publishers. Some clippings worth \$5.00. Particulars free. National, 81-PM, Knickerbocker Sta., New York City.

PRACTICAL Mailorder. Start small. Money-maker 126, 722 East Silver Spring, Milwaukee 17, Wisconsin.

MAILORDER Business of your own. \$3.00 starts you in business. Free details. Write: Milwaukee Mills, 1618 W. North Ave., Milwaukee, Wis.

BECOME Tax consultant. Graduates earn \$1,000-\$3,000 every tax season preparing returns evenings. State approved. Union Institute, Lakewood 2T, N. J.

INDICATEUR de L'Horlogerie. Authentic 1961 Swiss watch manufacturers, exporters directory in English! 250 addresses! Information on products; custom and exchange quotations. Get immediate samples, offers! Postpaid \$1.00. Specialty Trading Company, P.O.B. 323-C, New York 21.

MARKETS Everywhere. Make artistic concrete birdbaths, pottery. Best coloring. Home workshop. Hundred varieties. Free pictures. Hollywood Cementcraft, 8527-S Wonderland, Hollywood 46, California.

CASH From sawdust, tin-cans, newspapers. Over 200 methods. Instructions \$1.00. Charles Company, 42-GPR, Norwood, Ohio.

MAILORDER Techniques, rules, laws, regulations, do's, don'ts. Complete "how-to" mailorder manual, \$1.00. Dean Products, Box 40-PM, Elberton, Georgia.

FREE Report: "609 Unusual, Successful Businesses." Box 1001-PMC, Evanston, Ill.

"WORLD'S Easiest Mailorder Business." Completely explained. Published especially for beginners. \$1.00 postpaid. Neil H. Tasker, Shamokin, Pennsylvania.

MAIL Advertising Ideas! Business-building manuscript helps increase sales. ReGal, 904 North Labrea, Inglewood 3, Calif.

MANUFACTURE Fishing lures. None better. Start now. Send \$3.50 25 samples complete. Quaker Lure Manufacturing, 3514-24 N. Lawrence, Philadelphia 40, Penna.

SPARETIME Home moneymaking business—Easy! Trotta, Pla-2036—66th, Brooklyn 4, New York.

700% PROFIT. Selling mailorder folios. Dean's, Box 40-PM, Elberton, Georgia.

I Got rich in the dry cleaning business with no investment, so can you. Free details. Write: Imperial School of Dry Cleaning, 1700 Touhy Avenue, Chicago 26, Illinois.

FREE Book "990 Successful, Little-Known Businesses." Work home! Plymouth-72P, Brooklyn 4, New York.

\$480.00 PER Month raising nightcrawlers, redworms. Soilless method. Write Three Oaks Ranch, Dresden, Tenn.

WANTED: Home producers, to be subcontractors. Cast plastic products for manufacturers in our clearing house service. Thousands of easily made items required. Cash in at home, without previous experience. Plastic Service Associates, Dept. 12-PM, East Boston 28, Massachusetts.

LOOKING For financial independence? Get my plan! No manufacturing; No selling! High earnings possible! Dime brings details. Kenilworth, Box 2086-Z, Potomac, Alexandria, Va.

TYPISTS! Start profitable business at home. \$1 tells all. Local Bulletin, Box 193, Feeding Hills, Mass.

PHYSICAL Therapy and massage. Home training. Practice privately or work with doctors and hospitals. Free catalogue. National Institute, Desk 4M, 159 E. Ontario, Chicago, Ill.

BUY Direct from factories. Appliances, cameras, watches. Discounts to 80%. Free details! Cam, 116 Malden Street, Worcester 6, Mass.

YOUR Own business. Dye carpets and furniture in customer's home. Exclusive sales and service territories. Earn up to \$200.00 per day. Training available. Armstrongs, Box 1447, Chicago 90, Illinois.

BE Independent, be secure, have your own big money mail order business. Earn \$10,000 and up annually. Start from home. Start small and grow big. We set you up—show you how—guarantee results. You never invest one cent in inventory. All orders shipped for you. Collect cash in advance. Exciting details free. National Mail Order Corp., Dept. 1B, P.O. Box 828, Wayne, N. J.

BIG League earnings \$100 to \$1000 per sale. You don't sell—dignified work by appointment. Interview "live" leads for "Push Button Pizza Route Distributorships," multi-million dollar field. Distributors invest \$500 to \$10,000 & service taverns, bowling alleys, etc., with fully prepared pizzas and miniature ovens that bake in minutes. They refill & collect, part or full time. No truck, shop or experience necessary. We supply everything. No investment or inventory for you. Your advance commissions range from \$100 to \$1000 per deal. Sell "Income" the world's greatest commodity. Complete details & simple instructions if accepted. Prepared Snak Inc., Dept. M., 6 Xavier Drive, Yonkers, N. Y.

HOMEWORKERS, What can you make? We sell all type Craft products through nationwide markets. Produce and ship to our customers. We pay you cash. Crafters Marketing Service, Box 1534, Birmingham 4, Alabama.

MONEYMAKING OPPORTUNITIES

NEW Magazine shows you how to operate profitable mail order business. Free details. Mail Order Business, Dept. P-102, 550 Fifth Ave., New York 36.

MAKE \$5,000 Yearly sparetime raising mink, chinchillas, nutria, etc. Free booklet reveals proved plans. Write: Furs, 588 Mt. Pleasant Road, Toronto 1, Canada.

MAKE Fabulous weekly profits clipping newspaper items for publishers. Some clippings worth \$5.00. Particulars free. National, 81-PM, Knickerbocker Station, New York City.

PLATE Baby shoes, jewelry, gifts, bronze and colored pearl. We finance. Free booklet. Platex, 11029 South Vermont, Los Angeles 44.

NEW Small stamping tool. Stamp dog tags, identification bracelets and social security plates. Everything furnished. Maurer Metal Specialties, Box 934, Springfield, Ill.

NEW Magazine shows you how to make mail order pay. Free details. Mail Order Business, Dept. P102 550 Fifth Ave., New York 36.

SELL Yourself aluminum siding, awnings, shutters. Factory-wholesale! Save. Write Groff, Box 10446, Tampa, Florida.

17 PROVEN Ways to make money typing at home! Detailed information \$1 (refundable). Rycos Service, 210-G Fifth Ave., New York 10.

YOU Need only a mimeograph machine and a ruler to put yourself into a business that will make you financially independent. Details free. The Graphic Garret, Box 9312, Arlington 9, Virginia.

MAKE Money writing short paragraphs! No tedious study. I tell you what to write, where and how to sell; and supply list of editors buying from beginners. Many small checks add up quickly. Write to sell, right away. Send for free facts. Benson Barrett, Dept. C-27A-X, 7464 Clark, Chicago 26.

NEW! Plastic sealing machine. Hobby. Easy, profitable. Details. Burr Sealing, 330 East Centre, Kalamazoo, Mich.

\$2,000,000.00 FUTURE. 6% royalty paid from three inventions sales for \$200.00; 3%, \$100.00. Send check, references. Inventions, Investments, 210 5th Ave., Suite B-106, New York 10, New York.

PLATE Baby shoes. Make jewelry, novelties. Start with \$3.00 refundable investment. Free details. JO-CA, 468-D Northwest 79th Street, Miami 50, Florida.

BUILD Plastic signs. Complete revised instructions \$3.00. No experience necessary. Big demand. McMaster Sign Co., 730 State St., Bellingham, Wash.

MAKE Money. Government surplus jeeps, \$223.00; trucks, \$212.00; boats, \$7.58; typewriters, \$7.10; motors, \$1.00. Tools, clothing. Typical surplus prices. Buy direct. List of depots, procedure, full details, only \$1.00. New York Enterprises, Wall Street Box 402-X3, New York 5.

GET 25¢ Orders by mail. Keep the quarters and fill all orders yourself! Rush 25¢ for three ad copies selling mailorder information and how to fill the orders you receive. A. C. Fitzgerald, Box 1764, Longview, Texas.

MAILORDER. Latest fantastically profitable proposition. Harper, Box 1224-P, Clarksburg, W. Va.

OPERATE Profitable mailorder business! Gilbert Risdien, 1461 Hubbard, Detroit 9, Mich.

GIFTS On jigsaws, bandsaw, lathe. Also earn profits. Details. Majots, Michigan City, Indiana.

CIGARETTES. Make 20 plain or filter-tips for 9¢. Facts free. Moberly, Box 821, Owensboro, Kentucky.

IN 1952 I was unemployed, broke. Today own \$18,000 home, drive Cadillac, have bank account. Anyone can do this. Write Norris Cole, 217 West 49th, Bradenton, Florida.

WIN Contest money. General Contest Bulletin gives hundreds of tips. Lists current contests, rules. Sample magazine 25¢. General Contests, 1609½ East 5th, Duluth 12, Minnesota

EASY To earn extra money! Free 100 page catalog. Tandy Leather Company, Box 791-T37, Fort Worth, Texas.

100% PROFIT. No investment. Stamp brings samples, details. Miller, Box 584, Brooklyn 1, New York.

MINK Raising information free. Complete. Lake Superior Mink Farm, Superior, EEL, Wisconsin.

VENDING Machines. No selling. Operate a route of coin machines and earn amazing profits. 32-page catalogue free. Parkway Machine Corporation, Dept. #26, 715 Ensor Street, Baltimore 2, Maryland.

GROW Mushrooms. Cellar, shed and outdoors. Spare, full time, year round. We pay \$4.50 lb. dried. We have 29,000 customers. Free book. Mushrooms Dept.: 173, 2954 Admiral Way, Seattle, Wash.

EARN Money evenings copying and duplicating comic cartoons for advertisers. Adservice, Argyle 1, Wisconsin.

YOUR Own, easy-to-start, home mail-order business, sparetime. Fascinating; profitable! Information free. Alfano, 19-PM Pine, Closter, N. J.

BIG Money raising fishworms and crickets. Free literature. Carter Hatchery, Plains, Georgia.

READ "Progressive Mailtrade," the magazine that tells how to make money by mail. Quarter brings sample and special offer. Progressive Mailtrade, Box 357, Sheboygan, Wisconsin.

MAKE Big money with fast-selling line self-help manuscripts, many titles! Imprints available; drop shipments if desired! Complete details to established mailorder dealers only! Economy, Box 2580-PM, Greensboro, North Carolina.

SPARETIME Homework. Typewriter required. Moneymaking instructions 50¢, refundable. Interstate, 37 Besch, Albany 9, N. Y.

MEN — Women! Start money-making plastic laminating business at home in spare time. Material that costs 11¢ brings back \$2.58. No canvassing or selling but mail orders bring in \$20 a day. Write for full particulars free. Rush name on postcard to Warner, Room CL-2-L, 1512 Jarvis, Chicago 26, Ill.

EASY To start rubber stamp business at home in spare time. Make up to \$9.80 an hour without experience. Facts free. Write Roberts, 1512 Jarvis, Room CR-2-L, Chicago 26.

SIZEABLE Profits, buying, selling antique items locally. Information free. O'Rourke, 201B Arlington, Jersey City 5, New Jersey.

WANT A second income? Write: Wagner, 110 Callodine, Buffalo 26, New York.

UNUSUAL Profits in pocket change. Giant, illustrated guide of wanted coins, plus amazing free offer, only 25¢. Albetco, Box 843, Union, New Jersey.

DYNAMIC Mail order plans. Everything furnished. Details 25¢. Donovan, 79-PM Greenbelt, Levittown, New York.

SELL Perfume. Wholesale list, sample. Geller, 2089P Matthews, New York 62, New York.

EVERYBODY Cuts own hair! Sample \$2.00. Easytrim, 2325A Bonair, Montreal 35, Canada.

MONTHLY Puzzle contests. Cash prizes! Science, Box 11569, St. Petersburg, Fla.

START Big-pay business at home in spare time. No experience needed to operate little table-top machine for bronzing baby shoes. Make \$5.46 profit on every pair. Full particulars free. Send postcard to Mason, 1512 Jarvis, Room CM-2-L, Chicago 26, Ill.

\$50 WEEKLY—Spare time, home operated. Sharpening all types scissors and pinking shears. Details free. Serr-Edge, 4469 West 160 Street, Cleveland 35, Ohio.

LEARN The secrets of repairing junk batteries, profitable, easy, at home. Free particulars. Batteryman, 3465 Forrest, Santa Clara, California.

\$600.00 PROFIT! Mailing catalogs! Sample, instructions 25¢. GPO, Box 972, New York 1.

WANT To make \$5,000 yearly or more in respectable, easily learned and operated mailorder business? Experience unnecessary. Valuable help given. Rush \$1.00 (refundable) for complete plan, details. Columbia, 45-09-PX Broadway, Long Island City 3, New York.

\$200.00 MONTHLY. Spare time. With tablesaw, bandsaw or jigsaw. Write. Holiday House, Box 1825 A, Vancouver, Washington.

AMAZING Successes through franchises! Become exclusive franchise holder your territory. Information rushed. National Franchise Reports, MP-528, 333 North Michigan, Chicago 1.

EXPORT — IMPORT

SOURCE List import items. Mid-East, Europe, India, \$1.00. Porter, 2230 Field, San Angelo, Texas.

FOREIGN Import Directory \$1.00. Lists 400 exporters. Tech Publications, Box 821, Logan, W. Va.

JAPAN: Direct mail-order. 26 page catalogue, kimono, dolls, novelties, gifts, business information, manufacturers' names, addresses. Send \$1.00. Clarence Yamagata, 814 Toginbiru, Marunouchi, Tokyo.

RELIABLE Worldwide import/export contacts supplied, \$1.00 monthly. Send details, self-addressed postcard per each inquiry. Imports Unlimited, 5916 California, San Francisco 21.

SCIENCE & CHEMISTRY

CHEMISTRY Catalog, 25¢. Expendibles kit free with \$15.00 order. Laboratory Sales, Box 161-A, Brighton, Mass.

MICROSCOPE Slides, anatomical. Free list. Bay, 409 Roosevelt, San Francisco 14, California.

CHEMICALS And apparatus for industrial, analytical, and private laboratories. Catalog 25¢. Dept. M-50, Biological Supply Co., 1176 Mt. Hope Ave., Rochester 20, N. Y.

ILLUSTRATED Catalog: Chemistry, mineralogy, biology 25¢. Tracey Laboratories. Evanston, Illinois.

ROCKET Supplies for amateur rocketry. Catalog 25¢. Mervin Hill Company, R.D. #1, Seward, Penna.

POPULAR Mechanics book, "Science Year," illustrated survey of last year's developments in science. Covers rockets, medicine, astronomy, electronics, etc. Send \$1 to Service Bureau, Room 517E, Popular Mechanics, 200 E. Ontario, Chicago 11, Illinois.

UNUSUAL Chemistry books, courses, kits! Rare chemicals, cheap! Catalog 25¢. NSC, Box 11133, Palo Alto, Calif.

EXPERIMENTERS: New! Bigger catalog and "Experiments Booklet." Only 25¢. Hagenow Laboratories, Manitowoc, Wis.

AMAZING New book of science experiments, formulas, and catalogue of laboratory supplies. Only 35¢. National Scientific Co., 13 S. Park Avenue, Dept. PM-12, Lombard, Illinois.

MICROSCOPISTS, Bacteriological slides. Micro, Box 19, Staten Island 10, N. Y.

232 PAGE Catalog \$2.00. Laboratory Materials, 7319 Vincennes, Chicago, Ill.

60 PAGE Booklet, "Beginners Astronomy," 10¢. Franks, 3121 South Racine, Chicago 8.

CHEMICALS In small quantities, complete apparatus. Catalog 25¢. Winn Chemicals, 124 West 23, New York 11.

ROCKET Chemical apparatus catalog 25¢. Keefe Scientific, 159-10 Hillside, Jamaica, New York.

EXPERIMENTERS! Electro mineral unit sends code many feet with 25 drops of water! Science demonstrations. Unlimited possibilities. Guaranteed. \$1.50 post-paid. Bonus for circuits submitted. Shoffner's, Box 335, Hamilton, Montana.

FORMULAS, PLANS, ETC.

FORMULAS For 10,000 products \$4.95. Ervin Sales, Box 366, Roseburg, Ore.

FORMULAS; All kinds. Latest, best. Literature free. Kemixal, Park Ridge, Ill.

RESILVER Mirrors. Plus ten other formulas—\$1. D. C. Dykes, 904 Sunset Drive, St. Joseph, Missouri.

FORMULAS For latest money-making discoveries. New! Good! Valuable literature free! Miller, Chemist, 1517-D, Tampa, Florida.

RESILVER Mirrors—make one-way mirrors. Both \$1.00. Kem-Mir, Park Ridge, Illinois.

LATE, Modern manufacturing formulas. List free. Moon Chemical, Martville, New York.

PLASTICS

PLASTICS — Plexiglas, clear, colored, flat, corrugated; Polyesters clear casting, laminating, coating; Fiberglass, cloth, mat, tape; Acetate; Vinylite; supplies. Manufacturers' distributor for sheets, rods, tubes, liquids. Yes—Epoxy! Large, small quantities. Complete instructive catalog. 25¢. Gem-O-Lite, 5529-A Cahuenga, North Hollywood, Calif.

PLASTIC Vacuum-forming machine. Hobby. Easy. Profitable. Details. Burr, 330 East Center, Kalamazoo, Michigan.

PLASTIC And supplies for laminating. Colamco, 12 Center, New Haven, Conn.

BOXES, Plastic. 200 sizes. Free list. Althor, 170 Bay 23 Street, Brooklyn, N. Y.

NEW Liquid casting plastic, clear, colors. Embed real flowers, butterflies, photos, coins. Send 25¢ for two handbooks "How to Cast Liquid Plastics" and "How to Make Extra Money at Home." Castolite, Dept. P-101, Woodstock, Illinois.

CELLULOID scrap. Sheets, state thickness, colors. Box 333, Kearny, N. J.

MAKE Your own plastic jewelry, castings and embeddings. Introductory jewelry kit \$3.95 or send 25¢ for catalog. Castacraft Corp., Dept. M-12, Box 555, Palo Alto, Calif.

PLEXIGLAS— $\frac{1}{8}$ " \$1.25 sq. ft. Sheets, rods, tubings; fabricating, models made. Catalog 15¢. Plastic Shop, 2025 Nevada, Butte, Montana.

MONEY. 1250% Profit. Plastic laminating the machineless way. Circular free. Johnson Supply, 2611 Harriet, Minneapolis 8, Minn.

AGENTS WANTED

NEW Sleeping comfort means generous profits with Electro-Warmth. Beat electric blankets 10 ways, costs less. Adds no top covering you sleep on it. Best season starting. Patented Products Corp., Dept. PM-1260, Danville, Ohio.

AGENTS—300% Profit selling genuine gold window letters; stores and offices. Free samples. Metallic Sign Letter Co., 1217-D West Newport, Chicago.

SEEKING New products? Get my outfit 47 money-making specialties. Latest conveniences for home, car. Send no money. Just your name. Kristee, 78, Akron, Ohio.

DAMASCENE Earrings! Exotic orientalism. Huge profit Ohga, PM-211, Sigan-kenkusatu, Japan.

FREE! Beautiful Mexican curios! Rush 30¢ stamps (refunded). Sylviak, Apartado 9036, Mexico City.

MEN! Women! 60% profit on cosmetics. Famous nationally advertised Hollywood cosmetics pay 60%. Make \$25 day up. Hire others. For free samples, details, write Studio Girl, Glendale, California, Dept. 12012J.

DON'T Miss the "Earn \$8,000 to \$10,000 Salesman Wanted" ad Mr. Herman.

ENJOY \$7,200 Extra showing exclusive multi-use crib. Jane Trent, Dept. PM, Menlo Park, New Jersey.

AMAZING, Fast, easy seller. Quick repeater. Sample dozen blue standard ink refills for ball point pens, individually stamped 49¢, envelopes, \$1.50. Postpaid. Cumbers, 5909 Lords Ave., Sarasota, Fla.

"FOG-STOP" Windshield cloth. Instantly removes blurry mist, frost, sleet, snow. Stops windshield fogging. Samples sent on trial. Kristee 75, Akron, Ohio.

FAST-Selling specialties—Jewel Cleaner, Bouquet-Magic, many others. Excellent profits. Free catalog, special offer. Shaklee Products, 300 12th St., Oakland 7, Calif.

YOUR Own business—Used suits \$1.50; overcoats 65¢; mackinaws 35¢; shoes 12½¢; ladies' coats 30¢; dresses 15¢. Enormous profits. Catalog free. Nathan Portnoy Associates, 2109-AA Roosevelt Road, Chicago 8, Ill.

PRINTING, Advertising salesmen—Excellent moneymaking sideline selling decalomania name plates, small quantities. Automobile initials, sign letters. Free samples. Ralco, XL, Boston 19, Mass.

SELL Champion, AC, Autolite spark plugs. Reconditioned, electroplated, guaranteed 10,000 miles. 100% profit. Free sample. Lee Plugs, 1608-E Roberts, Houston 3, Texas.

START Making money now. Earn top commissions taking orders for all magazine subscriptions. Friends and neighbors are your prospects. No experience needed. Write for free money-making kit. McGregor Magazine Agency, Dept. 5A, Mount Morris, Illinois.

MAKE Up to \$50.00 a day soliciting delinquent accounts. Terrific commissions. Write today. National Credit, 304V Pickwick Bldg., Kansas City 6, Mo.

BIG Profits. Stamp social security plates, key protectors. Sample 50¢. Catalog free. General Products, 11 No. Pearl St., Albany 7, N. Y.

MAKE Profitable men's-women's wear. Sample free. Sunmade, Brockton 64, Mass.

SELL Amazing glow-in-dark pictures. Big profits. Samples free. Madison Mills, 303 Fourth Ave., New York 10, N. Y.

YOUR Ad in this space will get some good agents for you. Yes, I'll prove it. Write for Folder "A" right now. F. W. Johnson, Classified Advertising Manager, Popular Mechanics Magazine, 200 E. Ontario St., Chicago 11, Ill.

NEW Product. Sells on sight. Every home prospect. Sample \$1.00 or write for free information. Bath Aid Mfg. Co., Box 484, Mitchell, So. Dak.

AGENTS—Dealers—Farmers—up to \$250 weekly. Represent highly rated, well established firm your area. Products nationally advertised, needed by every farmer. Proven sales plan. No investment. Free sample. Ideal proposition for seed corn and feed men. Farm Products, 248 No. Main, Rochelle, Ill.

BUY IT WHOLESALE

FREE Catalog. General merchandise. Amazing! Fidelity Mercantile Agency, Roanoke, Virginia.

RAISED, 7/16" Metal letters, numerals. Black; white; gold. 150, \$3.95. RNG Sales, PM, Wildomar, California.

2,000 PAGES Wholesale catalogs! Write: Mosaser, Box 47-B, Newark, Ohio.

FREE! Wholesale toy catalog! Big savings on hundreds of nationally advertised toys for Christmas. Housewares Distributors, 1216-AB West 79th St., Chicago 20, Illinois.

BOOTS. Handmade western styles. Free catalog. Austin Boot Co., Box 5303-J, El Paso, Texas.

WORLD'S Largest wholesale supply. Buy from 679 American, European, Japanese wholesalers. Tailormade suits from Hongkong. 123 dropship catalogs. Rockbottom prices. Free details. International Buyers, 216-M Jackson, Chicago 6, Illinois.

ELECTRIC Guitars, amplifiers, wholesale. Free catalog. Carvin, PMW, Covina, Calif.

WHOLESALE: 850,000 Items. Supply source directory 25¢. Idealer, Park Ridge, Illinois.

LARGEST Wholesale supply source in U.S.! Furniture, clothing, appliances, housewares, automobiles and accessories, tools, sporting goods, hobby supplies, farm equipment, imports, new products, bargain merchandise. Free details. Associated Wholesalers, Box 2068-DD, Sioux City 4, Iowa.

USED And new watches \$2 up. Free list. Southern Watches, 5-PM So. Wabash, Chicago 3.

100,000 PRODUCTS Wholesale! Terrific bargains! United Wholesalers, 1265-M Broadway, New York 1, N. Y.

NEW DeLuxe Multicolor wholesale catalog, automobile catalog, and others. Nationally advertised merchandise. Housewares, appliances, refrigerators, freezers, washers, dryers, television, radios, rugs, furniture, sewing machines, clothing, luggage, binoculars, phonographs, musical instruments, recorders, cameras, projectors, typewriters, power tools, toys, notions, sporting goods, watches, jewelry, novelties, vitamins, drug sundries, cosmetics, books, school supplies, practically everything. Famous brands. Huge discounts up to 40 to 70%. Postcard: Selbyco, Decatur 5, Illinois.

BELOW Wholesale most merchandise. Write: Factory Buyer, 446, Jacksonville, Illinois.

LADIES Nylon hosiery, house slippers, earrings. Tested Products, Box 393, Radio City Sta., New York 19, N. Y.

APPLIANCES, Cameras, radios, watches—wholesale! Free catalog. Shortridge Co., Mt. Vernon, Ohio.

VITAMINS, Wholesale. Gift wrapped for Xmas. Drop shipped anywhere. Free details. Hollywood Health Aids, 5880 Hollywood Blvd., Hollywood, Calif.

BARGAINS! Bargains! On appliances, tools, toys, gifts, etc. Huge savings. Catalog 25¢. (Refunded on first order). Write today. Vance Sales Co., 515 Hill Place, National City, Calif.

900,000 ITEMS Wholesale. Practically everything. Latest, illustrated, 3000 pages, 14 lbs., largest catalogs in USA: \$1.00. Transair Distr., Dept. PM-S, P.O. Box 1463, Seattle 3, Wash.

SALESMEN—DISTRIBUTORS

BIG Money. New sensational plan. Fleets and farmers buy huge quantities. Free details. Conklin, Inc., 5626 Nokomis Station, Minneapolis 17, Minn.

BIG Profits selling homes, factories 6-in-1 pocket workshop. Sample \$1.00. Gam Corporation, Lancaster, Penna.

MAKE Up to \$50.00 a day soliciting delinquent accounts. Terrific commissions. Write today. General Finance, 304V Pickwick Bldg., Kansas City 6, Mo.

IF You're interested in making money in selling, see the hundreds of exceptional opportunities in Salesmen's Opportunity Magazine. Send name for your copy, absolutely free. Tell us what you're selling now. Opportunity, 848 N. Dearborn, Dept. 17, Chicago 10, Illinois.

MONEYMAKING Opportunity in fast growing market selling attractive outdoor advertising pennants. Write: Radder Products, Box 31, Colvin Station, Syracuse 5, New York.

MAKE Extra money—Big cash commissions plus premium for you and your customers. Sell advertising book matches. Sensational new tenor glamour girls, hillbillies; dozens others. All sizes. Quick daily sales; big repeat business. Free master kit makes selling easy. No experience necessary. Superior Match, Dept. M-1260, 7530 Greenwood, Chicago 19.

MAKE Extra money selling advertising matchbooks. Free catalog and sales outfit. Matchcorp, Dept. PM-120 Chicago 32.

WILL You test new items in your home? Surprisingly big pay. Latest conveniences for home, car. Send no money. Just your name. Kristee 104, Akron, Ohio.

STEADY Profits. Made to - measure shirts. Free sales kit. Dept PM-12, Henlein, Cincinnati 2, Ohio.

WILL You wear new suits and topcoats without one penny cost and agree to show them to friends? You can make up to \$30.00 in a day even in spare time, without canvassing. Stone-Field, 532 South Throop St., Dept. P-926, Chicago 7, Ill.

SENSATIONAL new longer-burning light bulb. Amazing Free replacement guarantee—never again buy light bulbs. No competition. Multi-million dollar market yours alone. Make small fortune even spare time. Incredibly quick sales. Free sales kit. Merlite (Bulb Div.), 114 E. 32nd, Dept. C-74Y, New York City 16.

"YES, We're Open" sign sweeping the country. Sells on sight for \$1.50. Sample dozen \$4.40. You pocket \$18.00. Write for complete line. Advance Press, Addison, Ill.

EARN \$8,000 To \$10,000 first year selling replacement auto parts to car dealers, garages, fleets for top rated nationally known manufacturer-distributor. Personal, in-the-field training at company expense. Paid vacation, bonuses, fringe benefits. Tremendous income and professional growth potential. For personal interview write full facts: Mr. Herman, 1130 E. 222 St., Cleveland 17, Ohio.

MONEY-Making opportunity: Take big profit orders for world famous patented varieties fruit trees. Also flowering shrubs, roses, vines. Big sales outfit free. Stark Bro's, Desk 30161, Louisiana, Missouri.

EARN Big commission full or part time. Build profitable business of your own selling America's largest line low priced business printing. 360 page catalog samples hundred of items used daily by business people. Imprinted ball pens low as \$8.95 for 100. Big full color catalog low priced advertising specialties included. Free sales kit. National Press, Dept. 8, North Chicago, Illinois.

FREE Start! Your own business! Private labels! Big easy profits! Free sample. VitaMins Wholesale, 2908-P Beverly, Los Angeles 57.

PRINTING Salesmen. Sell plastic bound receipt books. 25% commission. Re-order protection. Free catalog. Mendelson Forms Co., 756 W. Adams St., Jacksonville, Fla.

EARN \$12,000 Yearly. Sell only two drums daily. New fireproof degreaser-cleaner now replaces dangerous solvents in most industries. Get demonstrator, leads, and immediate repeat commissions franchise, \$3.95. Elgene, Mount Vernon, N. Y.

\$1,000.00 A Month for making dramatic 3-second demonstration of amazing light-weight Presto fire extinguisher New chemical used by Airforce snuffs out fires instantly. Only \$4.95. Terrific commissions. Millions want it. Free kit. Merlite, 114 E. 32nd, Dept. P-66Y, New York 16.

EMPLOYMENT INFORMATION

LIVE, Work, in Arizona. Averages 230 days sunshine. Information, job listings, \$1.00. Thompson Enterprises, Box 6561, Phoenix, Arizona.

LIST Of names—addresses. 100 American contractors with large overseas projects. Only \$1.00. Contractor Services, Meramec Building, St. Louis 5, Missouri.

WANT That promotion—better job? Details free. Publications, 1601 Ninth St. N.E., Roanoke, Virginia.

U.S.A. Foreign jobs, up to \$1600.00 monthly. Construction clerical, supervisory, etc. Skilled, unskilled. Free transportation. Unusual opportunities. Complete information plus world-wide project listings. Only \$2.00 (\$2.25 airmail). Satisfaction guaranteed. International Reports, Dept. 4A, 109 W. 42, New York 36, N. Y.

HIGH Paying jobs. World wide. Alaska, Japan, South America, Europe. Skilled and unskilled. Thousands of positions open, and jobs on ships. For free information, write to International Employment, P.O. 115, Boston 27, Mass.

JOBS: High pay. Foreign countries, U.S.A. All trades. Write Dept. 55C, National Employment Information, 1020 Broad, Newark, N. J.

100s GOVERNMENT Jobs. Civil Service security. Overseas, in States. West Point-Annapolis entrance. Learn how to come out high in exams. \$1 starts you. Tole House, Box 2521M, Hollywood 28, Calif.

FOREIGN Employment information. Work overseas. Travel, adventure. Europe, Africa, Asia, Canada, Alaska. Earn as much as \$1,600 monthly. Construction men, truck drivers, clerks, teachers, professionals, etc. Fabulous opportunities. Most complete information, application blanks, etc. Sent by return mail same day received. Send \$2.00 to Dept. PM, Foreign Bureau, P.O. Box 512, New Orleans, Louisiana.

FREE Information—U.S.A., overseas jobs. High pay, transportation. Futures. Dent. M, 215 West 34th Street, New York City 1.

FOREIGN Jobs—Latin America, Alaska, Canada, up to \$1500 monthly. Up-to-date 1960 foreign service directory gives complete information; hot list of firms hiring for military and civilian construction, aircraft, oil, exporters-importers, mining. How-when-where to apply. 12th successful year. \$1.00. Global Reports, Box 8873-S, Los Angeles 8, Calif.

DIRECTORY Reports. Construction, aviation, shipping, oilfields, government, manufacturing, trucking, etc. Foreign-stateside. Helpful information plus job-getting tips on preparing application letters. Unconditional money-back guarantee of satisfaction. Act today. Only \$2.00 (\$2.25 airmail). (C.O.D.'s accepted). Research Services, Meramec Building, St. Louis 5-PM, Missouri.

HIGH Pay overseas domestic jobs. Men, women. Generous benefits. Companies pay transportation. For information write: World Wide, Dept. B6, 149 N. Franklin St., Hempstead, N. Y.

JOBS, Immediate openings, Germany, Great Britain, Sweden, Switzerland. Information \$2.00. Charles Erikson, 6857 Franklin Avenue, Los Angeles 28.

GOOD Salaries. Petroleum, construction, manufacturing, teaching, etc. Technical, professional personnel. Travel paid, living allowances, bonuses, U.S. tax exempt. Information \$2.25 air mailed. Colombian Opportunities, Apartado Aéreo 14448, Bogotá, Colombia.

SPECIAL SERVICES

\$2.00 BRINGS List of manufacturer's for anything. Air mailed same day. National Listing Systems, Box 5173, Amarillo, Texas.

INFORMATION On anything. Ferguson Research Specialists, 43-11 64 St., Woodside 77, N. Y.

EDUCATIONAL AND INSTRUCTION

BECOME A personal problem counselor. Enter dignified profession. Instructions \$1.00. Hermansen, Box 808, Grand Central Station, New York 17, N. Y.

INVESTIGATOR Training—Free booklet covering approved home-study plan. Write National Detective Academy, Dept. E, 722 West Chapman Avenue, Orange, Calif.

PIANO Tuning pays. Big money in spare time. Learn at home in 30 days. No musical knowledge necessary. Phonograph, records, tools and instructions furnished. Electronic tuning taught also. Free catalog. Capital Piano Tuning School, 3160 S.W. 16th Court, Fort Lauderdale, Fla.

ENGINEERING And art degrees earned through home study. Electronics, electrical, mechanical, civil, physics, liberal arts. When writing, specify course desired. Pacific International College of Arts & Sciences, primarily a correspondence school. Resident classes also carried. 5719-B Santa Monica Boulevard, Hollywood 38, Calif.

BE A Real Estate Broker. Insure security for yourself and your family. Study at home. Prepare for state examination. GI approved. Write for free book today. Weaver School of Real Estate, 2018 P Grand, Kansas City, Missouri.

LEARN Auctioneering. Free catalog. Missouri Auction School, Box 9252X3, Kansas City, Missouri.

LEARN World interlanguage approved by UNESCO. Textbook 25¢. Esperanto, Middleton, Wis.

HIGH School diploma at home. Licensed teachers. Approved materials. Southern States Academy, Station E-16, Atlanta, Ga.

WANT A diesel job? Higher pay? Advancement? We can help you qualify! Complete diesel, tractor and heavy equipment and Cummins Diesel Engine Shop-method home-training courses available. Write today. Interstate Training Service, Dept. B-3, Portland 12, Ore.

DEVELOP Mind power, personality while asleep. Use your phonograph, recorder. Amazing psychological tapes, records now available. Details free. Sleep-Learning Association, Box 24-N, Olympia, Washington.

EARN While you learn. Auto and diesel mechanics master this top paying trade. Many graduates earn \$100 a week and up. Approved for Korean veterans. For free information write Dept. No. 256, Nashville Auto-Diesel College, Nashville 3, Tenn.

PHYSICAL Therapy and massage. Home training. Practice privately or work with doctors and hospitals. Free catalogue. National Institute, Desk 4, 159 E. Ontario, Chicago, Ill.

BOOKS, Free general catalog, 100 pages. Text, vocational, educational, instructional subjects. Millions of volumes, new and used. Bargain prices. Books bought. Est. 1902. Long's College Book Co., Dept. PM, Columbus 1, Ohio.

STRENGTHEN Your voice—for more success in business, social life! Free booklet. (Give age.) PV Institute, Studio EP-2, 210 South Clinton, Chicago 6.

INVESTIGATOR Training—Robert B. Phillips Sr., Founder, former U.S. Government Special Agent. Write to 1917-K North Kenneth, Chicago 39, Ill.

USED Correspondence courses and books sold and rented. Money back guarantee. Catalog free. (Courses bought.) Lee Mountain, Pisgah, Alabama.

BOOKKEEPERS. Operate your own "Dollar-A-Week" system. Ellis, Box 200, Cedar Grove, North Carolina.

ANALYZE Handwriting for profit, pleasure. Free sample lesson, catalog reveals plan. Write IGAS, Inc., Dept. 2, Springfield 4, Missouri.

OWN Collection agency. Little "gold mine." Franklin Credit, Roanoke, Va.

PROFESSIONAL Investigators. Home study. Lapel pin, certificate, future. Box 41197-P, Los Angeles 41, California.

SWEDISH Massage. Home study. Diploma. Illinois Licensed School, 3809 Alta Vista, Chicago 13.

ELECTRONICS. Learn at home. Training equipment furnished. Catalog free. National Radio Institute, Dept. OKAA, Washington 16, D. C.

DANCE! Free lesson proves you can! Castle, 507 Fifth Avenue, New York 17.

SECRET Investigations. Experience unnecessary. Investigators particulars free. George Wagner, M125 West 86th, New York City 24.

CIVIL Service. Learn about this field of work and how you can prepare yourself by home study for a high entrance mark. Private organization. Free booklet. No obligation. Franklin Institute, Dept. W50, Rochester 4, N. Y.

FINGERPRINTING Course \$12.00. Diploma awarded. Details free. Alabama School of Fingerprinting, Box 185, Fairfield, Alabama.

"HOW To Train Horses"—A book everyone who likes horses or ponies should have. Free. No obligation. Simply address Beery School, Dept. 11012, Pleasant Hill, Ohio.

MASTER Watchmaking at home. Free sample lesson. Chicago School, 2328-YM, Milwaukee, Chicago 47.

GAME Warden, government hunter, forestry, park and wildlife service announce job openings regularly. Enjoy outdoor work, good pay real security. Complete information free! Write North American School of Conservation, Dept. 17CB, 810 Dodsworth, Covina, Calif.

BE A locksmith! Earn while you learn. Big opportunities await you in this fascinating, profitable trade. Earn quickly—step into a wellpaid job or start a business of your own, full or part time. Learn easily at home, all materials and special tools supplied. Write for free book today! Locksmithing Institute, Dept. 6712, 150 Park Avenue, East Rutherford, New Jersey.

COMPLETE Your high school at home in spare time with 63-year-old school. Texts furnished. No classes. Diploma. Information booklet free. American School, Dept. X945, Drexel at 58th, Chicago 37, Illinois.

LEARN Asleep or awake! Records, tapes, equipment! Free catalog! Drawer PM-697, Ruidoso, New Mexico.

BLUEPRINT Reading. Learn to read blueprints with confidence in 10 easy lessons. Write: Belton, 1059D North Lawn-dale, Chicago 51.

LEARN By ear with Dormiphone. While you slumber, the amazing new scientific Dormiphone tools give you a shortcut to learning languages, correct speech; memorizing facts, figures; relaxation, habit training. Saves you time, effort. So simple to use, children benefit. Used by educators, psychologists. Write today for fascinating free book. No obligation. Modernophone, Inc., 320-120 Radio City, New York 20.

INVESTIGATORS Course. Credentials, Diploma. Free information. Southwestern Institute Criminology, 510-A Iowa, Geronimo, Oklahoma.

FREE Book "990 Successful, Little-Known Businesses." Work home! Plymouth 71P, Brooklyn 4, New York.

LEARN Civil and criminal investigation at home. Earn steady, good pay. State age. Institute Applied Science, 1920 Sunnyside, Department 169, Chicago 40, Illinois.

McGUFFEY'S Readers. Reprints original 1879 revised editions. Free circulars. Old Authors, PM, Rowan, Iowa.

ANALYZE Handwriting. Big earnings. 12 lessons \$12. \$1 monthly. L. Earnshaw, 430 Thompson, Glendale, Calif.

DENTAL Technicians simplified home study course. Accredited A.C.S.C. Certificate. Write: Denshire School, Box #762, Boston 2, Mass.

DEVELOP Powerful mind, asleep, awake. Free brochure. Troy's Record Service, 173 W. San Fernando, San Jose 13, Calif.

RAFTER Trouble? Condensed professional rafter cutting course \$2.00. E. L. Overstreet, Route 3, Lufkin, Texas.

CORRESPONDENCE Courses, educational books, bought, sold. Lists free. Lohmer, 3605 Clark, P-126, Burbank, Calif.

EARN Degree in business. Modern courses. Fremont College, Yuma, Arizona.

LEARN To sing beautifully. Unlimited opportunities. Inexpensive course. Sunland, 3362 Romeo Bd., Tucson, Arizona.

FREE Booklet tells how you can get money, success, mastery of life. The Sun School, Box 10482, Phoenix, Arizona.

PROFESSION—Correspondence course. Physical therapy, massage. Diploma. Northwestern Institute, Box 368, Rock Falls, Illinois.

LEARN Blueprint reading. Understand schematic wiring diagrams. Self-study drawing courses (mechanical, electronics, architectural, art). Send \$2.25 subject or \$9.00 for eight main chapters. Louis D. Prior, Inc., 23-09 169th St., Whitestone 57, New York.

FREE L. P. record and book gives instructive facts about Sleep-Education and the Audio Educator. The short-cut method to learning and self-development. No obligation. SDRF, Dept. P-12, 104 East 40th Street, New York 16, N. Y.

USED Correspondence courses, books bought, sold, rented. Catalog free. Vernon's, Summerville, Ga.

LEARN Real estate business fast. Economical homestudy. Particulars free. Howard Schools, 320 Glover, Kansas City 5, Missouri.

PLAYS, STORIES, MANUSCRIPTS

PUBLISH Your book! Join our successful authors: Publicity, advertising promotion, beautiful books. All subjects invited. Send for free manuscript report and our detailed booklet. Carlton Press, Dept. MP11, 84 Fifth Avenue, New York City 11.

WANT Your book published? Learn how we publish, advertise, promote, distribute. Many successes. Free booklet PM. Vantage, 120 West 31, New York City. Or 6253 Hollywood Blvd., Hollywood 28, Calif.

CARTOONING, COMMERCIAL ART, SHOWCARD & SIGN PAINTING, TATTOOING

LEARN Sign painting at home. Free talent test. Ben Kerns, Box 812-PM, Greenville, S.C.

LEARN Profitable, fascinating tattooing. Illustrated information \$1. Zeis, 728-C Leslie, Rockford, Illinois.

LEARN Sign painting with fascinating system. Straley, 410 S. Western, Springfield, Ohio.

"HOW To Make Money With Simple Cartoons"—A book everyone who likes to draw should have. It is free! No obligation. Simply address Cartoonists' Exchange, Dept. 912-C, Pleasant Hill, Ohio.

GRAFO Precision air brushes. Write Crag Distributors, 6556 W. Cornelia, Chicago 34, Illinois.

PAINT Signs! Use patterns! Trial alphabet \$1.00. Harwell, PM-1260, Byrdstown, Tenn.

CARTOONERAMA Teaches you cartooning in a new 24 lesson course. Free brochure. CFA, Box 263P, Branford, Conn.

HARDBOARD Cut-out letters, for pattern or original, 2" to 8". Paulow Signs, Crystal Falls, Michigan.

20 LESSONS in cartooning. Enter big cash prize drawing contest \$2.00. Cartoons—M. P.O. Box 545, Dover, N. J.

ADVERTISING AGENCIES, LETTER WRITERS, FOR ADVERTISERS

\$1 FOR Results. Parsons Advertising Agency, 1428 Miller St., Utica, N. Y.

FREE! Red-hot book, "More Profit From Your Advertising." Lists—best mail order magazine, newspapers. Adservice, 516 Cornelia, Chicago 13.

ADVERTISE: 24 Words, 100 Canadian newspapers, \$5.50. Lists free. Advertising Bureau, 10511-C Springfield, Chicago 55.

"AMAZING New Book"—"Profits From Classified Advertising." Tells how and what to advertise. Be sure to read this book before you invest one cent in advertising. Write for your copy now. Just send 10¢ for postage and handling. W. Johnson, Classified Advertising Manager, 202 East Ontario Street, Chicago 11, Illinois.

MAILING Lists most any classification \$5.00 1000. Your circulars mailed with ours \$4.00 1000. Write for our literature. Dixie Mailers, King, N. C.

ADVERTISING Ratebook leading newspapers, magazines, free. Chicago Advertising Agency, 28-E Jackson, Chicago 4.

SAVE! Circulars, brochures, folders, catalogs designed and printed. Samples! Flair, 8 West 45th, New York City 36.

NOW Ready: New, amazing Classified Advertising Record Book—prepared especially for classified advertisers. Here is a book that tells you instantly whether or not your advertising in any publication is paying you real results. You can tell immediately how many inquiries each publication produced—how much cash received from every ad. Spaces are provided for the name and address of the publication, date of issue, space used, rate, cost of ad, key number, etc. You have a complete record of each publication right before your eyes. Plenty of space to keep accurate record of 28 separate publications. You can have a copy by sending only 10¢ to cover postage and handling. Send for your copy now. W. F. Johnson, Classified Adv. Mgr., Popular Mechanics Magazine, 204 E. Ontario Street, Chicago 11, Illinois.

TYPEWRITERS, DUPLICATORS, OFFICE DEVICES

RECONDITIONED Typewriters, duplicating, printing devices. \$25.00 up. Supplies. Appliances. DixieGraph, King, N. C.

WHOLESALE Typewriters, business machines. Free catalog. Continental Distributing Company, Box 71, Temple City, California.

RUBBER STAMPS AND OFFICE SUPPLIES

WOND-R-COPY Paper makes 15 copies on typewriter. No carbons needed. Samples 10¢. American, 3432 Olive, St. Louis 3, Mo.

UP To four lines, indexed, cushioned stamp. \$1.00. Fast. Chambers Company, 8316-1 Hanon, Ft. Worth 8, Texas.

RUBBER Stamps 3 lines \$1.00; additional lines 25¢ each. Adirondack Printers, Saranac Lake 2, New York.

SPECIAL Introductory offer. 3 line pocket stamp 59¢. Junior, Box 227, Valparaiso, Ind.

3 LINES. Rubber stamp \$1.00. 25 cents each additional line. Whitney's Rubber Stamp Shop, 18 Washington Ave., Chatham, N. Y.

HANDY Plastic pocket rubber stamp 3 lines \$1.00. Holland, 132 Grace St., Syracuse 4, N. Y.

AIRMAILED Immediately, 50¢ per line. Zorecki, 5221 Rambo, Toledo 13, Ohio.

PRINTING Outfit (rubber). Change copy anytime, \$2.00. Kem's, 14041 Don Julian, La Puente, Calif.

PERSONALIZED Rubber stamps. 3 lines \$1.65. First quality only. Write for price list. Precision Industries, 262 Farmers Ave., Lindenhurst, N. Y.

HIGHEST Quality rubber stamp. 3 lines \$1.00. Larry Miller, Brooks St., Pontotoc, Miss.

FREE Rubber stamp literature. Stock Stamps, Signature stamps \$3.50. Dating and Numbering Stamps. All size pads. Shipping and business labels (all sizes). Personalized scratch pads. Free business printing catalog. Youngers Stamp Shop, Princeton, Iowa.

THREE Line pocket rubber stamp with pad or office type \$1.00. W. Atherton, Box 61, Randolph, Massachusetts.

PRINTING, MULTIGRAPHING, MIMEOGRAPHING, GUMMED LABELS

1,000 BUSINESS Cards. Raised letters \$3.95. Samples. Pioneer, PM-12, Island Park, N. Y.

1,000 RAISED Letter business cards, \$3.45. Sterling Press, 545-A Fifth Avenue, New York 17, N. Y. Samples.

BUSINESS Cards \$3.25 per thousand. \$1.00 deposit and copy. LaSalle Printing Co., LaSalle, Chicago, Ill.

1,000 EMBOSSED Business cards \$2.95 postpaid. Agents wanted. Elco, Box 101, Sylvania, Ohio.

250 8 1/2x11 BUSINESS Letterheads \$2.95. 250 envelopes \$2.95. Samples! Davis, 7609 Spruce Road, Baltimore 22, Maryland.

HIGH Quality printing. Low prices. Free samples. Gerald Cox, 1004 South N. Midland, Texas.

MIMEOGRAPHING: 100—\$2.45, 250—\$2.95, 500—\$4.20, 1000—\$6.20, 2000—\$10.70 (8 1/2x11" white bond). Delivery 40¢ extra. Excellograph, Box 153, Boston 34, Mass.

EMBOSSED Business cards. Rulon, Box 575, Station A., Richmond, California.

SILK Screen printing, photo stencils, art service. Investigate. Boettger 961, Dorothy, N. J.

BUSINESS Cards—1000, \$2.95. Rubber stamps. Weiss, Box 8304, Kansas City, Mo.

OFFSET Printing. 1000 8 1/2x11, \$5.50. Alpine, Box 676-EA, Cupertino, Calif.

LETTERHEADS: 500—\$4.50. Free sample. Carlayne, 1803 Fremont, Rapid City, South Dakota.

MIMEOGRAPHING—Letters, pricelists, formulas, instructions. Lowest prices. Lem's Letter Shop, 5710 Stanton, Detroit 8.

ADS Running under this heading sell printing. Ask me for proof. I'll gladly send you amazing facts. Ask for Folder "P." F. W. Johnson, 200 E. Ontario St., Chicago 11, Ill.

FREE Catalogs postpaid printing. Rubber stamps. DM Press, Sebastopol, Calif.

COLORED Or white 8 1/2x11 offset. \$6.50—1,000; \$18—5,000. Fast! Flair, 10 West 45th, New York City 36.

PRINTING OUTFITS AND SUPPLIES

TYPE For printers and rubber stamp makers. Complete home printing outfits. Send 25¢ for big new 96 page catalog. Largest selection in U.S. Acme Type, 633 Plymouth Court, Chicago 5, Ill.

RUBBER Stamp presses, hydraulic operated, electrically heated. Sizes 5"x8", 8"x12", 10"x15". Starting outfits, supplies. Printing presses. Custom Manufacturing, 507-P N. Jefferson, Springfield, Missouri.

PRINTING Presses, type, supplies. Lists \$4. Turnbaugh Service, Mechanicsburg, Penna.

RUBBER Stamp presses, supplies. Kiewiet, 2025 Barney Road, Kalamazoo, Mich.

MAKE Your own self-molding rubber stamps and printing cuts. Plexirubber, Argyle 1, Wisconsin.

DO Your own printing. Save money. Simple rules. We supply everything. Print for others; good profit. Raised printing like engraving too. Have home shop. Details free. Kelsey Presses, V-11, Meriden, Connecticut.

FOR INVENTORS

INVENTIONS Wanted for immediate promotion—patented; unpatented! Out-right cash; royalties! Casco, Mills Building, Washington 6, D. C.

OPINIONS Furnished regarding necessity further development and marketability ideas, inventions, patents. Send papers, patents and \$50.00 for services. Umatilla Patent Development Company, Box 54, Hermiston, Oregon.

YOU Can easily apply for patents. Save with complete professional kit, featuring "Exclusive Demonstrator Method" and fill-in forms. Free registration certificate. Patent Associates, 1214 Commonwealth Building, Philadelphia 7, Pennsylvania.

PROFESSIONAL Searches of the Patent Office Records. Dependable. Reliable. \$6.00—For free protective forms write Trans-World Patent Service, 500 Walker Bldg., Washington 5, D.C.

DON'T Pay high fees! Obtain U.S. patent yourself. It's easy with Professional Kit with fill-in forms. Free "Registration Form." Patent Protection Institute, 2000 P Street, N.W., Washington 5, D.C.

INVENTORS' Complete service. Cash-royalties sales. Inventions researched. Patent development engineering. Free invention certificate. George Spector, Licensed Invention Engineer, 3615 Woolworth Building, New York.

INVENTIONS Wanted now by my manufacturer clients. Patented. Unpatented. Write Gilbert Adams, Patent Broker, 80 Wall St., Financial District, New York City.

PATENT Searches, including copies of nearest patents, \$6.00. Reports airmailed within 48 hours. More than 200 registered patent attorneys have used my service. For free invention protection forms, write Miss Ann Hastings, P. O. Box 176, Washington 4, D.C.

WE Have the markets if you have the ideas. Harvey Engineers, Cambridge 1, Maryland.

INVENTORS: Test the commercial value of your patented or unpatented inventions, quickly and inexpensively. Write for free information. Institute of American Inventors, Dept. 40-B, 635-F St., N.W., Washington 4, D.C.

PATENT Searches, including complete copies of nearest patents, \$6.00. Inventors, attorneys, manufacturers use my original world-wide airmail service. "Proof of Invention" protection form and "Information Every Inventor Needs" sent free. Miss Jean Hayward, 1029 Vermont Avenue, N.W., Washington 5, D.C.

INVENTORS! Determine patentability of your invention. Searches of the Patent Office Records administered professionally—\$6.00. For free invention protection forms, dependable service write Washington Patent Office Search Bureau, 1426 G Street, N. W., Washington 5, D. C.

PATENTS Skillfully prepared for maximum commercial value, with useful product development. High record of success in proving and claiming patentability. Valuable market service. Patent prepared for a fee as low as \$200.00. Send for self-protecting record of invention forms free. Patent search with valuable engineering report \$15.00. Foreign patents filed at low cost. Thirty years established. Joseph O'Brien, Patent and Development Engineer, 132 Nassau St., New York 38, N. Y.

INVENTORS! Outright cash sale or royalties for your inventions. Patented. Unpatented. Constant demand from our client manufacturers. Write: United States Invention Brokerage, 78 Wall Street, New York 5, N. Y.

NEW Toy ideas wanted. We have markets for good new toys. Outright purchase or royalty. Will be an Art Linkletter product. Link Research Corp., 9460 Wilshire Boulevard, Beverly Hills, California.

INVENTORS: Save time and money. Our complete "Patent Kit" makes it easy to prepare and file your own patent application. Free "Registration Certificate." National Inventors Service, Box 88, Benjamin Franklin Station, Washington, D. C.

PATENT Searches, \$6.00, complete with comprehensive report and official Patent Office copies of related patents. Certified, airmailed. For free "Invention Protection Form." and "Patent Information," write: U.S. Inventors Service Bureau, Headquarters Building, Washington 6, D. C.

INVENTIONS Needed immediately for manufacturers. For additional information write Kessler Corporation, C-512-F1, Fremont, Ohio.

PATENT Searches \$5.00, including patent copies. Reliable reports. Same accurate search as conducted for attorneys. Free protection forms. 15 years dependable service. Patent Service Institute, 945-A Pennsylvania Avenue, Washington 4, D. C.

PROFESSIONAL Patent searches, \$5.00, complete with report and related patent copies. Complete patent and trademark services. Free forms; write: Congress Invention Institute, 210B, McKim Building, Washington 5, D. C.

SAVE High fees! Apply for your patent yourself. New do-it-yourself Patent Kit now makes it easy! Free "Registration Form." Miss Suzan Blaine, 306 Carry Building, Washington 5, D. C.

FOR The cost of a search, you can prepare and file your own patent application. 50 page instruction book; tear-out signature sheet. \$5.00. Gardena Printing Co., Alondra Station, Gardena, California.

PATENT Searches including copies of closest patents \$6.00. Quality searches expertly administered. Free protection forms. Write Professional Patent Office Search Bureau, 709 Abee Building, Washington 5, D. C.

INVENTIONS WANTED

INVENTORS Needing help with any problem, financial, development, securing manufacturer, obtaining patent. Write the organization that delivers action and results—not promises. Pioneer Inventions, 150 Broadway, New York 38, New York.

INVENTORS! Outright cash sale or royalties for your inventions. Patented. Unpatented. Constant demand from our client manufacturers. Write: United States Invention Brokerage, 78 Wall Street, New York 5, N. Y.

INVENTORS' Complete service. Cash-royalties sales. Inventions researched. Patent development engineering. Free invention certificate. George Spector, Licensed Invention Engineer, 3615 Woolworth Building, New York.

INVENTIONS Wanted: patented, patent pending. 29 years experience promoting inventions. National Service Bureau, 3120 Meramec, St. Louis 18, Mo.

INVENTIONS Wanted now by my manufacturer clients. Patented. Unpatented. Write Gilbert Adams, Patent Broker, 80 Wall St., Financial District, New York City.

INVENTORS: Hundreds of manufacturers have requested our assistance in locating marketable new products. Complete information free. Institute of American Inventors, Dept. 40-D, 635-F St. N.W., Washington 4, D. C.

INVENTIONS Wanted. Patented: unpatented. Tremendous manufacturers lists. Global Marketing Service, 2420 77th, Oakland 5, California.

ARE You interested in offers from reliable manufacturers for your invention? Patented. unpatented. Harvey Engineers, Cambridge, Maryland.

INVENTORS! Don't sell your invention, patented or unpatented, until you receive our offer. Write Universal Inventions, Box 298, Marion, Ohio.

INVENTIONS Wanted for immediate promotion—patented; unpatented! Outright cash; royalties! Casco, Mills Building, Washington 6, D. C.

IF Your invention is adaptable to promoting we will contract for selling on cash or royalty. Free booklet outlines royalty rates, requirements. Kessler Corporation, C-512-IW, Fremont, Ohio.

FRESH Ideas in toys. Leading toy manufacturer, with national distribution and network TV show, seeks unique toy ideas. Interested in pure toy only, whose end is to amuse and fascinate child. Not interested in craft-type items whose end goal is completion. Royalty and per item arrangements. Write for submission forms. Colorforms, New Products Division, Norwood, New Jersey.

INVENTIONS Wanted for manufacturers. Free details. Write Allen, Dept. C., 712 Davis Bldg., Big D, Dallas, Texas.

HIGHEST Cash, royalties. Ideas developed into products, drawings, patent search, protected. Nation-wide manufacturers contacts. Inventors Creative Service, 354 South Spring, Los Angeles 13, Calif.

INVENTORS! Consider our offer first before selling or licensing your invention on a cash or royalty basis. Patented. Unpatented. Write: Inventions on Demand Associates, 79 Wall Street, New York 5, N. Y.

MANUFACTURING

MODELS—Small lot manufacturing. Metals, plastics, etc. Milburn, Burlington, Kentucky.

MODELS—SHIPS, TRAINS, PLANES, ETC.

SCALE Model materials for building model homes and architectural buildings of any type. $\frac{1}{4}$ " and $\frac{1}{8}$ " scale. Send 35¢ for catalog. A & B Model Builders, 454-H Donovan Road, Kansas City, Kansas.

20% DISCOUNT On Lionel train equipment. Catalog 25¢. Tait, Box 194, Winnetka, Ill.

SAVE! Free bargain bulletins: trains, airplanes, boats, cars, radio control, plastics. America's Hobby Center, 146PM West 22nd Street, New York 11, N. Y.

LIONEL Trains. Big discounts bulletin 10¢. Catalog 25¢. Mack-Bros., 2043P. Chicago Ave., Chicago 22.

ROCKETS—Supplies lists 10¢. Hand booklet with 3 model rocket plans 25¢. Two sample 1.1 pound NAR approved rocket motors 75¢. All three \$1.00. Estes Industries, 5505 Tejon, Denver, Colorado.

MODEL Cars, electrified roadways. Electromat Company, Box 13742, Dallas, Texas.

SHIP Models. Most complete line in New England, kits, fittings, plans, books, tools, engines, motors. Illustrated catalog 35¢. James Bliss & Co., Inc., Dept. SM, 342 Atlantic Ave., Boston 10, Mass.

ROCKET Supplies—Nozzles, cones, tubes. Specials also made. Catalog 10¢. Sky Mfg., Mineral Point, Penna.

SHIP And yacht model fittings: blueprints. Send 40¢ for illustrated catalog listing hundreds of items. A. J. Fisher, Inc., 1002-1 Etowah Ave., Royal Oak, Mich.

SHIP Model kits and fittings: clippers, frigates, etc. Catalog, paint-tool list, book list, 25¢. Model Shipways, Box 85, Bogota, N. J.

"POWER Drives Handbook"—36 pages illustrating many types motor drives for model autos, boats, displays, turntables, etc. Mail 25 cents cash, returnable first order \$3.00 or more. Wilson's of Cleveland, Dept. PM, P.O. Box 8995, Ft. Lauderdale, Fla.

DECK Cannon, "Old Ironsides." Authentic, beautifully appointed. Complete $\frac{3}{4}$ scale working drawings. Only \$1.00. Parts or kits available. Howijay & Company, Halesite, New York.

POWER Models. Unusual steam, gasoline and traction engines, fittings, metals. Ultra small socket head set and cap screws. New comprehensive 100-page catalog \$1.00. Chas. Cole, Ventura, Calif.

ROCKETS—Plans for three missiles, fuels, 10¢. Send 25¢ for plans and illustrated catalog. Central Rocket Company, Waupaca, Wis.

HOME CRAFTSMEN

WOODWORKING Catalog and manual. Brand new 1961 edition! World's largest selection of domestic, imported woods—materials, tools, supplies, do-it-yourself plans, projects. 130 pages, many full color. Send 25¢ (refunded first order). Year's subscription to "Chips and Chats" included free. Constantine, 2050 Eastchester Road, Dept. T-101, New York 61, N. Y.

MAKE A battery clock. Runs anywhere one year on flashlight battery. Movement and hands \$10.00. Post China, New Port Richey, Fla.

TREASURE! Buried coins, gold, silverware, relics. Transistorized M-scope locates them! From \$59.50. Easy terms. Free catalog. Fisher Research, Dept. C-1, Palo Alto, Calif.

GOLD-Silver detectors. Latest types. Five models including transistors. Violites for tungsten, etc. Geiger counters. No finer instruments anywhere. Free information. Detectron, Dept. 24, Sylmar, California.

DISCOVER Buried loot, sunken treasure, gold, silver, coins; battlefield and ghost town relics, with powerful transistorized locators pioneered and perfected by Goldak. Low as \$79.50. Free, exciting information; literature on maps. The Goldak Co., 1541 West Glencaks Boulevard, Glendale 1, California.

WANTED—MISCELLANEOUS

QUICKSILVER. Platinum, silver, gold. Ores analyzed. Wholesale Terminal, Norwood, Mass.

WANTED Machinists tools. Rodgers Player Piano Service, 16381 Shelby, Cleveland 30, Ohio.

UNUSUAL Collections or products in any category for exhibition. Box 32, Dania, Florida.

FOR SALE—MISCELLANEOUS

MYSTERY Ash tray. Amazing! Weird! A hit! Literature, dime. North Star Products, Box 112-D, Cedar Grove, New Jersey.

GOVERNMENT Surplus. World's lowest prices. Free catalog. Contractors Surplus Company, Williamstown, Mass.

ERASAFILM Rubber tooth brush. Guaranteed to stop bleeding gums. \$1.00 each, four \$3.50. Erasafilm Co., Box 2002, Alhambra, California.

HEARING Aid batteries, wholesale. Free list. Habs, Box 51, York, Penna.

FREE Money-saving catalog. Surplus and newly manufactured equipment and tools for workshop, home, boats, farm, factory. Write: Groban, 1139 South Wabash, Chicago 5, Illinois.

MISCELLANEOUS

AMAZING New checkwriter, lasts a lifetime, does the work of machines costing up to \$500.00, yet weighs just ten ounces. Only \$9.95. Send check or money order to John T. Benjamin, Box 75637, Sanford Station, Los Angeles 5, California.

PIGEON Trouble? Trap the pests. Free information. Johnson's, Waverly, Kentucky.

75 FREE Items! List of sources 30¢. Martinelli, Box 82, Brooklyn 29, N. Y.

BOOKS On antiques and their prices. Free circular! P. Warman Publishers, Uniontown, Penna.

YOUR Name wanted. We'll send 1000 publishers, mailers, wholesalers your name, on our list one year 25¢. Dixie Mailers, King, N. C.

100,000 PRODUCTS Wholesale—Free catalog! Send postcard: Econ-O-Mart, Whippany 15, New Jersey.

SEND Us wool for blankets. Free literature. West Texas Woolen Mills, 421 Main, Eldorado, Texas.

SUPER Memory overnight! Success guaranteed! Bijou, Box 1727-M, Hollywood 28, California.

CESSPOOLS, Septic tanks, outhouses cleaned, deodorized. No pumping necessary. Free details. Electric Sewer Cleaning Co., Allston 34, Mass.

NEW Sensational rod puppet. Loads of fun. Geppetto Marionettes, Box 2366, Ocean Park, California. \$1.00 ppd.

LOANS Entirely by mail—\$600 or less. Strictly confidential. Repay in 24 monthly payments. Write: Budget Finance Co., Dept. J-110, 114 S. 17, Omaha 2, Nebr.

MAKE 16 Point Christmas stars from paper only. Any size. Beautiful. Can be sold. Weatherproofed. Instructions and samples \$1.50. One sample 25¢. How, P.O. Box 9031, Lansing 9, Michigan.

LIFETIME Listing. Receive valuable free samples. Interesting educational books, moneymaking mailorder opportunities. 25¢. Ply-O-Film, Box 30G12, Berea, Ohio.

CASH From discarded tires. Valuable information \$1.00. Woodson & Shay, 128½ Woodland Rd., Asheville, N. Car.

THE Most liked present. Export and mail orders. C.P.O. Box 508, Tokyo, Japan.

CESSPOOL—Septic tank trouble? Do it yourself. No pumping necessary. Sursolvent opens the ground around the system, allowing the liquids to drain off. Pumping a cesspool is not cleaning it. You have to remove the cause of the system's filling up—soap and grease. Sursolvent restores faulty systems back to a condition approaching newness. Free details. Chemical Cesspool & Drain Cleaning Co., 294 Lincoln St., Allston 34, Mass.

CITRUS Fruit gift packed half bushel \$6.95 prepaid. Varble's, Parkwood, Harlingen, Texas.

SELL Your services and get the job you want. New manual by expert shows how. Only \$2.00. Satisfaction guaranteed. Shaffer, 119 Register Ave., Baltimore 12, Maryland.

RECEIVE Mails, magazines, samples. Your name in numerous mailing lists 25¢. Greenwood, Box 1116-M, New York City 8.

COLORFUL, Imported feather bird pictures in cedar frames. One each of 4x7, 5x11, 9x11, 9x16, 12x22 for \$11.00. Charles Weinholt, 27 Pennsylvania Ave., Shillington, Penna.

FABULOUS New sign kit. Requires no skill. Makes any sign in color. \$19.95 complete. Sign Div., Viking Products, Inc., Box 653, Sioux City, Iowa.

BIG Mail for life 25¢. Fowler Mailers, 585 W. 5th St., Lancaster, Texas.

NEW, Sensational "Santa-Lite" Xmas-tree lights, put on in minutes and in order. No more 3 way plugs. Just plug in cord—you have 8 openings. Fits on top of tree. Doesn't interfere with ornaments (safety). Will not burn. \$3.98. Borandies Industries Inc., M. E. Humphries, Agent, 8426 Frankstown Ave., Pittsburgh 21, Penna.

CIGARETTES. Make 20 plain or filter-tips for 9¢. Facts free. Moberly, Box 915, Owensboro, Kentucky.

ORIENTAL Delicacies—Chocolate covered Ants, Bees, Caterpillars, etc. Free price list. Fredericks, Box 106, Brooklyn 25, New York.

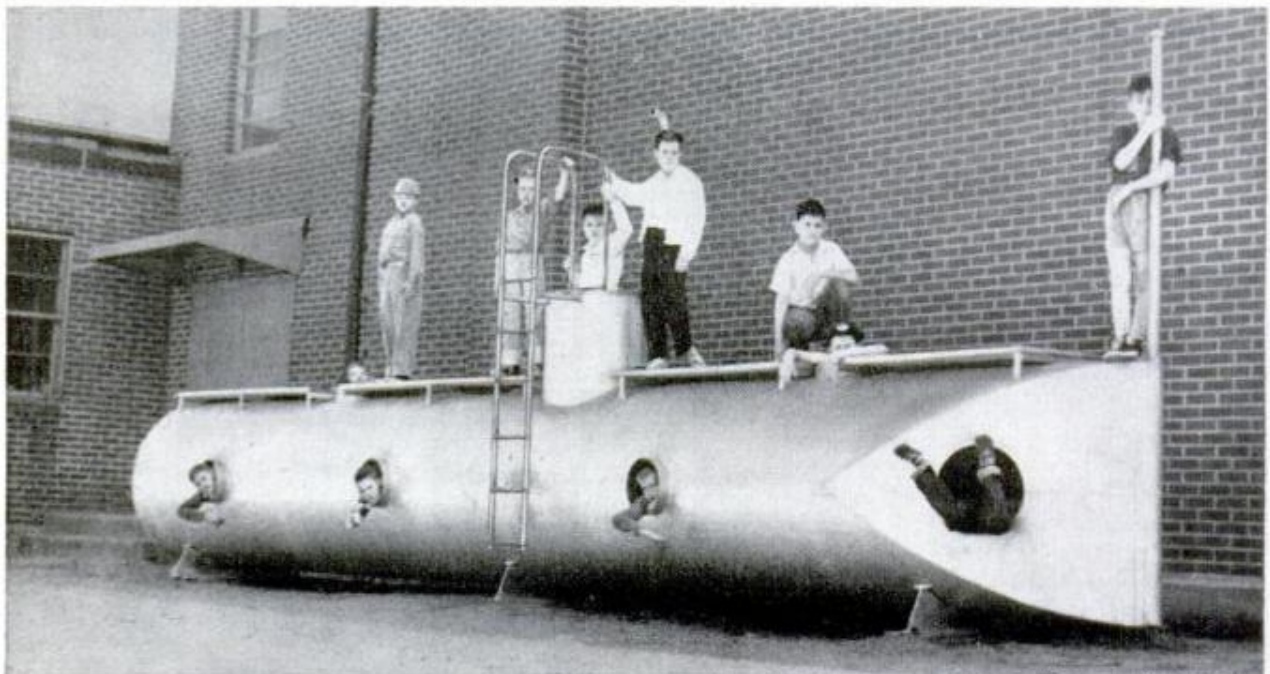

Boys' Clubs of America, 381 Fourth Ave., New York 16, N.Y.

Smokestack Converted to Playground Submarine

Designed by a local architect and constructed by the boys themselves, a copy of a submarine, made from an old smokestack, now is part of the playground equipment at the Boys' Club of Norfolk, Va. Smoothed out inside to prevent injuries, the body of

the "sub" is 38 feet long and 4 feet wide. Portholes were cut into its sides and a catwalk and conning tower added, then the entire structure was mounted on a solid concrete foundation. Its chief asset, however, is its very high "boy appeal."

GEORGE HILL REPORTS

1961

POPULAR MECHANICS'

HOT ROD

ANNUAL 75c

85c IN CANADA



HERE COME THE KARTS
HOPPING UP THE '60 ENGINES



WORLD'S RECORD BATTLE
LATEST SPEED EQUIPMENT

COMPLETE RESULTS FROM
• BONNEVILLE NATIONALS
• AHRA DRAGS
• DETROIT NATIONALS

NOW ON SALE!

Finish HIGH SCHOOL ^{AT HOME}
IN YOUR SPARE TIME

DIPLOMA AWARDED
Learn more! Earn more! Enter professional or technical schools. Advance socially. Live a happier, fuller life. Individual Courses or complete schedule. Write for School Bulletin.

ACADEMY FOR ADULTS
30 W. Washington, Dept. PM-1260, Chicago, Ill.

MONEY in WORMS

Sell 20,000 fishworms per week @ \$4 per 1000 from a bed 3 feet wide and 8 feet long. We teach you how to raise and where to sell fishworms and crickets. Write for free literature.
CARTER WORM RANCH, PLAINS, GEORGIA
Read our success story in LIFE MAGAZINE, December 28, 1959 Issue

95% PROFITS YEAR 'ROUND

Be your own boss, Operate a SIMPLEX lawn-mower sharpening service in your community. One compact machine grinds all mowers, sharpens cutlery. Low investment, 95% profit. Pays for itself in average month.

SIMPLEX

—4 Machines in One!
Reel Grinder—sharpens any mower reel in or out of mower.
Bed Knife Grinder—grinds with either round or cup wheel.

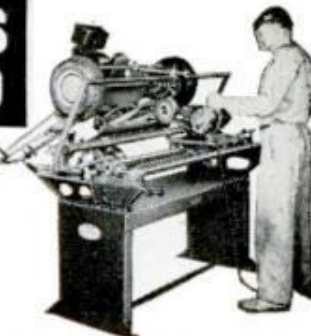

Rotary Blade Grinder—hollow grinds any rotary mower blade.
Cutlery Knife Grinder—sharpens cutlery, tools, scissors.

Send for free, money-making details!

The FATE-ROOT-HEATH Company • Dept. PM-12, Plymouth, Ohio

Millions have done it so can YOU!



Also FREE Photo Book of Strong Men

Stop being **SKINNY** like I was

Quickly **GAIN 25 LBS.** of HANDSOME, POWER-PACKED MUSCLES like I did
Send for these 5 AMAZING PICTURE COURSES

All 5 FREE before \$1 price goes back

1. How to GAIN MIGHTY ARMS
2. How to GAIN A BIG CHEST
3. How to GAIN A MIGHTY BACK
4. How to GAIN POWERFUL LEGS
5. How to GAIN A GRIP OF STEEL

Send 10¢ for postage for all 6 items

Jowett Institute, Dept. PM-012, 220 Fifth Avenue, N. Y. 1, N. Y.

FORTUNES IN DIVING

Train at Home in Spare Time
Write Today for Amazing Free Booklet



Here is one of the greatest opportunities of our time. Make big money fast in Skin and Lung Diving. Trained divers needed in hundreds of industries and by government. Build a successful business of your own. Hourly rates among highest paid in any field. Training program by E. R. Cross, world famous master diver. Get the facts now. Mail coupon for FREE BOOKLET TODAY!

DIVEMASTER, Dept. PM-120
5637 W. 63rd Place, Chicago 38, Ill.

Send me free information about Diving.

Name _____ Age _____

Address _____

City _____ State _____



JUST CLIP THIS AD

Fill in your name and address. Receive giant new

FREE RADIO SHACK

Electronics CATALOG
plus every new issue for full year

See America's finest values in Hi-Fi, Stereo, Ham Radio, Kits and Parts! Over 100,000 electronic marvels for today's enjoyment, exciting gifts, all-year pleasure. Low as \$2 down, pay balance after Christmas.

Mail this ad to **RADIO SHACK, Dept. 60M3**
730 Commonwealth Ave., Boston 17, Mass.

YES! Without obligation mail free catalogs for full year.

See values like this!



Transistor Pocket Radio only \$8.88

Name _____ Address _____

City _____ Zone _____ State _____

KEY OCCUPATIONS—

Law, Accounting, Commercial Art

by B. Richard

The occupations described here will serve as an example of the many professional and administrative job opportunities that can lead to substantial earnings and a secure future for those who are willing to undertake the training and education so necessary in this field.

About half of all those with "white collar" jobs in 1958 were employed in the business professions. These 14 million workers have in common long periods of study, education and training — preparation that has enabled these workers to take their place in the professions, the fastest growing of all major occupational groups.

The trend in this field is toward requiring more education and training than was previously the case. In most states, lawyers, for example, are required to obtain a law degree from a state-approved law school before they are permitted to take their bar examinations. While formal education may not be quite as important in the other occupations described below, training and knowledge are an essential prerequisite for success, and earnings generally increase correspondingly with knowledge and practical experience.

LAW—

One of the advantages to being a qualified lawyer is the opportunity for self employment. Of the 226,000 lawyers in this country practicing in 1958, 80 percent were in private practice. Two-thirds of these private practitioners were in practice by themselves.

After they become established, these private practitioners can accept or reject work as they choose and determine their own workload. Because of this, experienced lawyers can continue to practice well past the usual retirement age if they desire.

Lawyers also have the advantage of being able to attain extremely high earnings. In 1954, for example, lawyers in practice 25 to 29 years had average earnings of over \$11,000 a year, and established lawyers in

large law firms had average annual incomes of over \$36,000.

Before these earnings can be achieved, however, lawyers must ordinarily undertake many years of education and practical training. Before a lawyer can practice in any state, he must either pass the bar examination for that state or, in some states, he is permitted to practice after graduation from certain in-state law schools.

Some states permit graduates of correspondence law schools to take bar examinations, and in other states two or three years of college work and completion of an American Bar Association or state-approved law school is a requirement before an applicant is permitted to take the bar examination.

In many cases, law school graduates find correspondence courses an excellent refresher in their preparation for their bar examinations.

After passing the bar examination for their particular state, lawyers can go into independent practice or they can act as an assistant to an experienced lawyer to acquire additional experience before striking out on their own. Ordinarily, beginning lawyers are not particularly well paid, but their earnings quickly rise as their experience increases.

ACCOUNTING—

Truly a key profession in industry, accounting is one of the major stepping stones to management. It is the second largest field of professional employment for men, and in 1958, 400,000 accountants and auditors were at work in this country.

Because accounting is a highly specialized professional occupation, education and experience play an important part in the advancement of the beginning accountant.

Many fine correspondence courses are available to those desiring a background in this field, and these courses have helped a great many experienced accountants pass

Continued to Page 64

SHORTHAND IN

Famous SPEEDWRITING shorthand. 120 words per minute. No symbols; no machines; uses ABC's. Learn at home or through classroom instruction. Low cost. 500,000 graduates. For business and Civil Service. Typing available. 38th Year. Schools in over 400 cities. Write for FREE booklet.

Speedwriting
Dept 1512
55 W. 42 St., N.Y. 36, N.Y.

6
WEEKS

MECHANICAL PENCIL CALCULATOR

New Invention—Not a Slide Rule



MATH-WIZ pencil calculator gives answers to unlimited addition, subtraction, basic multiplication and square root (up to 10M) problems. (Indirect division.) Easy to operate. Comes in gold anodized sturdy aluminum casing. Unique Xmas gift. Only \$2.95 postpaid. NO COD.
JACK WEISER, Dept. 1, 1233 S. Fairfax Ave., Los Angeles 19, Calif.

LEARN MEAT CUTTING

Train quickly in 8 short weeks at Toledo for a bright future with security in the vital meat business. Big pay, full-time jobs—HAVE A PROFITABLE MARKET OF YOUR OWN! Pay after graduation. Diploma given. Job help. Thousands of successful graduates. Our 37th year! Send NOW for FREE catalog. No obligation. GI approved.
NATIONAL SCHOOL OF MEAT CUTTING, Dept. 50-M, Toledo 4, Ohio

How to Make Money with Simple Cartoons

A book everyone who likes to draw should have. It is free; no obligation. Simply address FREE BOOK
CARTOONISTS' EXCHANGE
Dept. 912-D Pleasant Hill, Ohio

START NOW — EARN TOP PAY

Graduates in Auto Mech., Automatic Transmission, Diesel Mech., Welding, Body & Fender, Refrig., Air-Conditioning, and Mach., Tool & Die earn highest pay. Train in the largest trade school in the world. Day—Evening—Part Time. Free Placement assistance while training and after graduation. Veteran Approved.

Write for details. Box L

GREER shop training

2236 S. Michigan Ave., Chicago 16, Ill.

Share your
Christmas
Joy
Give to
The Salvation Army

DECEMBER 1960

"I Have My Own Shop Now!"



Says Freeman J. Jeffress
Oklahoma City, Okla.

"Your course is so good, I wouldn't take back the money I paid for it. I have a nice little shop set up in my home and it has already paid for itself."

Be a LOCKSMITH

Add 50%-100% to YOUR INCOME with easy spare time earnings. Cash in on nationwide shortage — trained locksmiths in demand! Quickly step into a big-pay opportunity job — high-profit shop of your own. Earn Extra Money RIGHT AWAY! All Special Tools, Supplies Furnished FREE. Age, education, minor physical handicaps don't matter in this growing trade. You can quickly qualify as a skilled locksmith. Study at home as little as one hour a week. Gain practical experience through well-illustrated lessons. Do real jobs on car locks, house locks, padlocks and safe locks, under the guidance of experts.

MAIL COUPON FOR FREE BOOK
For a future as your own boss or in a high-pay job, write now for FREE illustrated book! Only school of its kind. Lic. State of N.J., Accredited NHSC. Locksmithing Institute, (Div. Tech. Home Study Schools)
Dept. 112, 150 Park Ave., E. Rutherford, N.J.

MAIL COUPON NOW!

LOCKSMITHING INSTITUTE, Dept. 112,
150 Park Avenue, E. Rutherford, N.J.

Please send Free Illustrated Book without obligation.

Name _____
(Print here)

Address _____

City _____ Zone _____ State _____

Check if Veteran (No salesman will call.)

FREE!

1961 LAFAYETTE ELECTRONICS CATALOG 610

From the world's leading supplier of electronics and stereo hi-fi equipment.

OUR 40TH YEAR

The biggest and best catalog in our history, featuring the latest equipment from all major manufacturers at prices that can't be beat anywhere.

HUNDREDS OF EXCLUSIVE
LAFAYETTE FINE-QUALITY ITEMS
AVAILABLE IN THIS CATALOG ONLY

The "complete shopping center" for the audiophile, hobbyist, technician, student, engineer, serviceman and dealer. Mail the coupon today for your free copy.

LAFAYETTE LOCATIONS

JAMAICA • BRONX • NEW YORK CITY
NEWARK • PLAINFIELD • PARAMUS • BOSTON

Lafayette Electronics
P.O. Box 190 Dept. LL-6
Jamaica 31, N. Y.

Send me the **FREE** 324-pg. 1961 catalog 610.

Name.....

Address.....

City..... Zone..... State.....

ELECTRIC WELD - BRAZE & CUT

REPAIR MOST EVERYTHING MADE OF METAL

Home Appliances, Auto parts, Farm-garden equipment, toys, Make and repair playground equipment.



lawn chairs, tables, ornamental iron work, gates, wagons, etc. Solder, heat, bend, and straighten, with terrific heat from arc torch.

Cut and weld up to 1/4" steel plate. A million uses for Home, auto, farm, inventors, factories, etc. Works from any home 110 volt plug-in. Complete with dark welder's mask, arc torch, supply of carbon welding and brazing rods and complete Welding Instruction Book. Efficient—durable—1 year guarantee. Wt. only 4 lbs.

SEND ONLY \$3 (cash, ck. mo) and pay postman \$9.95 plus COD postage on arrival or send \$12.95 and we will send postpaid. Ideal gift for mechanically minded home owners, relatives, friends. Order now for early delivery. Available only from: MIDWAY WELDER Dept. DPM-12 Kearney, Nebraska



BARBELLS

140-Pound, CHROME DELUXE Barbell-Dumbbell set only \$19.80. This is our feature set and is the finest ever manufactured.

Training with adjustable weight is the BEST way to keep fit; the ONLY way to develop great strength and a perfect body. As the oldest and best equipped barbell company, BUR gives value and prices no one can equal.

SEND FOR FREE CATALOG
BUR BARBELL CO.
Lyndhurst 9, New Jersey

100 POUND SET \$12.80
Extra Plates Only 12c Pound



CLOSE-OUT!

SUPERSENSITIVE RADIO KIT

It's fun & easy to build! Simple construction. The Magic Wand loopstick tuner is supersensitive. Radar type diode and earphone included. Other low price kits available. Write for Bulletin PM 3

PARTS UNLIMITED INC. 1 State St. Bloomfield, N. J.

Secrets of VENTRILOQUISM Now Revealed!



Easy to learn in 60 to 90 days with our Home Study Course. RESULTS GUARANTEED. Make Money! Be Popular! Have Fun! Big Opportunity! Radio, Television, Stage Appearances! For FREE information regarding price and terms WRITE. You must state your age. Dummy Catalog 25c.

MAHER HOME COURSE OF VENTRILOQUISM
Box 36, Studio PM-12, Kensington Station
Detroit 24, Michigan

1000 TRICKS 10¢

AMAZE! ENTERTAIN! START NOW!

BIG EXCITING MAGIC & FUN CATALOG! 160 Pages! Tricks, Jokes, Magic, Illusions, Secrets! Puzzles, Stunts, etc.! Rush name, address and only 10¢.

FREE MAGIC TRICK GIVEN

House of 1000 Mysteries • Dept. PM12 • Trumbull, Conn.



FREE REFERENCE KEY

Unlock the answers to hundreds of Do-It-Yourself problems with this tremendous Service File list of Popular Mechanics' booklets, books, full-size patterns, and blueprints. Send self-addressed stamped envelope to

SERVICE BUREAU, Popular Mechanics
Room 520D, 200 E. Ontario, Chicago 11, Illinois

their examinations to become certified public accountants (CPA's).

Business schools and colleges offering courses in accounting also provide excellent preparation for those desiring to get started in this field.

Today it is possible for beginning accountants to start at salaries up to \$450 per month, provided they have a good educational background. With experience, accountants can progress to supervisory positions and salaries increase with responsibility. Accountants in industry have the opportunity to progress to highly responsible positions such as company treasurer, and there are more corporation presidents who started their business careers as accountants than through any other profession except for law.

The long run employment outlook for accountants is good because it is expected that business management will make greater use of accounting information in years to come. Complex tax systems, the growth of publicly held business corporations which are required to submit financial reports to stockholders, and the greater use of accounting services by alert small businesses will tend to make the accountant increasingly valuable in future years.

COMMERCIAL ART—

Each time you read a magazine or look at a television commercial, you see the work of the commercial artist. Commercial artists have a wide range of duties including the preparation of advertising layouts, cartooning, lettering and designing.

In 1955 Art Direction Magazine surveyed 2,500 art directors and top commercial artists, and the survey showed that 20 percent earned \$15,000 or more annually. Here is strong evidence of the earning power of experienced artists in the commercial field.

Because business establishments are expected to increase their expenditures for all kinds of visual advertising, the employment outlook for commercial artists is good. However, the trend in the past several years shows that those artists with highly specialized skills and advanced training will be in greater demand than those with only a general background.

Artistic ability is of course the most important prerequisite for success in this field, but training and practical experience are also extremely important. Many successful artists have been trained in specialized art schools or institutes. Courses of study ordinarily take two or three years and cover such fundamentals as perspective, design, composition, etc. Specific skills such as advertising layout, typography and lettering are also covered.

Beginning commercial artists ordinarily are restricted to more routine artwork. As experience is gained, they progress to more skilled and specialized jobs and can enter into a management job in which they have charge of an entire art department. Many experienced commercial artists have found it profitable to work on their own on a free-lance basis.

For more information on other career opportunities, write for your free copy of **SKILLS for AMERICA**. Write Popular Mechanics, Department SFA, 200 E. Ontario St., Chicago 11, Ill.

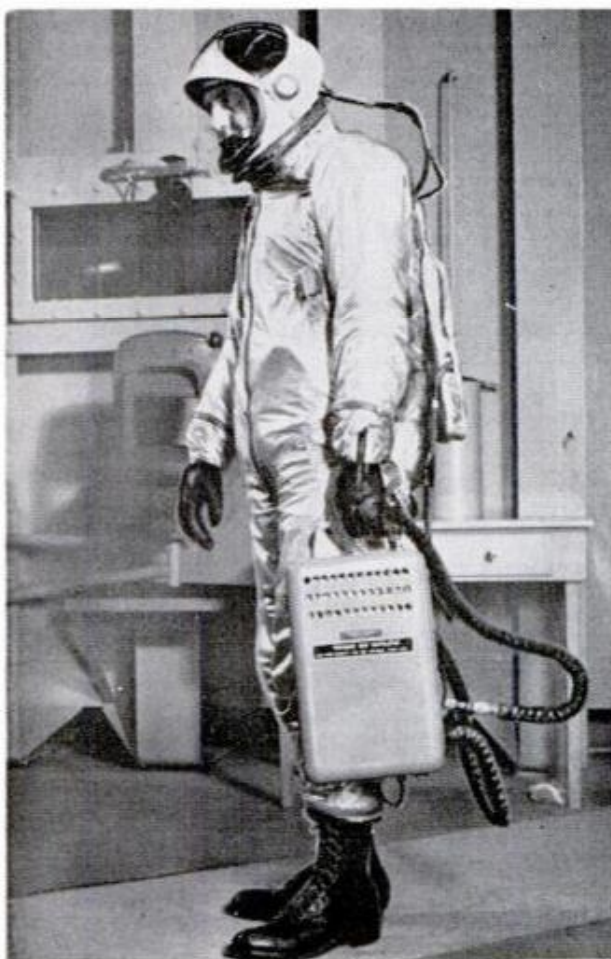

Air Force Flight Test Center, Edwards AFB, Calif.

Portable "Heat Beater" Ventilates Pressure Suit

Pilots for the X-15 space plane wear a special pressure suit that is completely airtight. In flight it is connected to the plane's cooling system, but on the ground it becomes a "sweat box" in the desertlike atmosphere around Edwards Air Force Base, Calif. A portable air conditioner has been designed to relieve the problem. Intended primarily for the X-15 program, the portable device can be used with any type of airtight suit that restricts air circulation and causes physical fatigue.

DECEMBER 1960



REMOVE that GAG from Your VOICE

Don't you often dream of being able to command immediate attention when you speak? Wouldn't it be wonderful to have a voice that RINGS WITH AUTHORITY AND ASSURANCE . . . instead of feeling that your voice is bottled up inside you? Science has demonstrated that VOICE is one of the real secrets of PERSONALITY.

Eugene Feuchtinger has the amazing method for removing that gag from your voice . . . releasing powerful tones that will astonish you and everyone who hears you.

A SCIENTIFIC PROGRAM

Now you can learn how your voice can be made excitingly forceful for both speaking and singing. The success-winning tones you have admired can be yours! Why be handicapped in business and social life? Read Eugene Feuchtinger's new book "Voice Power and Personal Power." It may be the key to your future success. Mail coupon below TODAY!

FREE BOOK on Voice Development



PREFECT VOICE INSTITUTE, Studio MP-2

210 S. Clinton St., Chicago 6, Ill.

Please send me, absolutely free, Eugene Feuchtinger's new book "VOICE POWER and PERSONAL POWER." I understand there is no cost or obligation. No salesman will call.

Name.....
Address.....
City..... State..... Age.....

"MINIATURE MACHINE SHOP

No Bigger Than A Typewriter, Outperforms Machines Many Times its Size!"

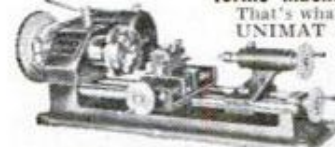

That's what a popular publication says about UNIMAT in their 3 page feature story in the May issue. If you want a reprint of this story plus complete information about this amazing 10 in 1 combination precision tool write to:

AMERICAN EDELSTAAL, Inc.

UNIMAT DIV., DEPT. GL. 350 BROADWAY, NEW YORK 13

NOW! ACCORDIONS UP TO 1/2 OFF retail prices of comparable accordions...



IMPORTER TO YOU!

Buy DIRECT from World's Largest Dealer. Compare our low Importer-to-You prices . . . see how much you save! All famous Italian makes . . . over 30 models . . . latest features, new colors! Small down payment—amazingly E-Z terms. 5-day FREE Playing Trial. 100% customer satisfaction assured.

Free Bonus Gifts for promptness. Trade-ins welcomed—free appraisal. Rush coupon for new color catalogs. No obligation. Write

ACCORDION CORPORATION OF AMERICA
2003 West Chicago Avenue
Dept. R-120 - Chicago 22, Illinois

5 DAY FREE TRIAL

ACCORDION CORPORATION OF AMERICA
Dept. R-120, 2003 W. Chicago Avenue, Chicago 22, Illinois
Rush Color Catalogs and "Importer-to-You" prices on famous-make accordions . . . FREE.

NAME.....
ADDRESS.....
CITY..... Zone..... STATE.....

New 4-Way Tool Offer by VACO®

Midget Driver + Handle with 1/4" Hex Socket + Reversible Blade with 3/16" Regular and No. 1 Phillips Bits

Nestest Tool Trick In Years!

Instrument-type screw driver included FREE with regular VACO DU-11 reversible. Midget driver handle fits into 1/4" socket (piggy-back style) for extra precision control in hard-to-get-at places. Complete set only **\$1.60.**

At Better Stores Everywhere

VACO PRODUCTS COMPANY
317 E. ONTARIO STREET, CHICAGO 11, ILLINOIS

MAKE MONEY! REPAIR HYDRAULIC JACKS

Earn While You Learn At Home
Make up to \$5 an hour, full or part-time, in the competition-free field of Hydraulic Jack Repair. Millions of jacks in auto service stations, truckers, body shops, riggers, farms, need servicing. We show you HOW. Easy step-by-step directions.
Get Folder PM 12 & free bonus offer

Institute of Hydraulic Jack Repair
P. O. BOX 50 • BLOOMFIELD, N. J.
A Correspondence School Licensed by N.J. Bd. of Ed.

SIGN PAINTING

Home-Study Course — Only \$5.95

Teaches you commercial sign painting and sign building as it is being done TODAY in leading shops all over the country. Complete practical course for self-instruction. Shows latest methods of truck lettering, office doors, wood letters, reflecting signs, plastics, sprayed signs, gold leaf, silk screen process, up-to-date alphabets, money-making business information, etc.

SATISFACTION GUARANTEED OR REFUND!

Contains all the instruction of a high-priced correspondence course. Full price, only **\$5.95**, postpaid. Or C.O.D. plus postage. No risk—order today. Satisfaction or money back! Order "Sign Painting Course." **NELSON-HALL CO., 210 S. Clinton St., Dept. 2MP-2, Chicago 6, Ill.**

BUILD YOUR MUSCLES FAST WITH DAN LURIE BARBELLS

Get results as no other method can. See as low as your arms, chest, legs grow like magic. no other method compares. Get \$10.00 BODY MOLD COURSE FREE with order. Results guaranteed. Buy direct and save.

50 lb. set \$ 9.48	100 lb. set \$15.98
150 lb. set \$23.48	200 lb. set \$29.98

Semi-steel sets approx. 10% higher. Extra wts. 15c per lb. Send 50% cash, balance COD., F.O.B. Plant. Order today.
Dan Lurie Barbell Co., 1661-M12 Utica Ave., Dept. 59M, Bklyn. 34, N.Y.

FREE SALES OUTFIT THAT STARTS BIG SHOE BUSINESS FOR YOU

Rush Postcard Today

Get in highly profitable, repeat-order shoe business! Sell amazing line of Air Cushion Innersole comfort shoes to friends, neighbors, fellow workers. Dress, sport, work, safety shoes for men, women. Make \$10 to \$75, as much as \$200 monthly just in spare time. No investment. Send card today for FREE SELLING OUTFIT.
Mason Shoe, Dept. G-714 Chippewa Fall, Wisc.

BRONZE FOUNDRY

Since 1935

Schools • Home Workshops • Inventors

Make your own castings of aluminum, copper, bronze, silver. Foundry sets are available in six sizes, capacity 1 1/2 lb. to 48 lb. of red brass. 2400 Deg. F. blast furnace included with each. Write for Free Circular.

KANSAS CITY SPECIALTIES CO.
DEPT. P-12
MARYSVILLE, KAN.

FINAL OFFER!

FEW REMAINING SETS OF

POPULAR MECHANICS

FAMOUS DO-IT-YOURSELF ENCYCLOPEDIA

We think you'll find this the greatest treasury of do-it-yourself information you've ever seen.

12 volumes, 6 in. by 9 in.,
bound in gold-stamped grease-proof Sturdi-Tan
2,970 pages with over
9,000 illustrations in an
Imported maple book rack

Information straight from Popular Mechanics Magazine, carefully detailing every step necessary for success in almost every home, hobby, shop, sport or travel subject.

This offer is made on the final few sets of this edition. It will be many months before a revised edition is published. We cannot guarantee that our small supply will meet the demand and we reserve the right to return your money if the sets are sold out by the time we receive your order; first checks received will get the few remaining sets.

Please act at once if you want this encyclopedia at this bargain price.

This offer carries a money-back guarantee if upon receipt of the set you find it does not live up to your expectations.

Send JUST \$17.95
Cash, check, or money order

POPULAR MECHANICS, Dept. PA 12
250 W. 55th Street, New York 19, N. Y.

Please send me _____ set(s) of POPULAR MECHANICS DO-IT-YOURSELF Encyclopedia, including my free imported wooden book rack for it. I understand that if I am not satisfied, I may return it within 7 days.

Name

Address

City..... State



DURO-PLASTIC

MENDS EVERYTHING!

but a **BROKEN HEART**
and **THE CRACK OF DAWN**
(Well, just about everything)

You've got a fix-it problem? DURO-PLASTIC has the answer. DURO-PLASTIC ALUMINUM, PLASTIC RUBBER, PLASTIC PORCELAIN REPAIR, Liquid STEEL, rust REMOVER, LOCK-it, E-POX-E GLUE . . . and others in tubes and cans. Available at all better hardware, automotive, paint and variety stores.

In \$1.00 and 59c sizes (in Canada \$1.29 and 69c)



WOODHILL CHEMICAL CO. Cleveland 14, Ohio
IN CANADA: 840 Montee De Liesse Road, Montreal 9, Quebec



Kyoritsu International, Ltd., 12, Shin Ryudo-cho, Azabu, Minato-ku, Tokyo

Crumb Whisker

Following the principle that it's inefficient to swat gnats with a barn door, a Japanese firm has manufactured a small, hand-powered "vacuum cleaner" for use where a normal-size cleaner would be a nuisance. A couple of pushes on a protruding knob spins a blade which whisks bread crumbs and cigarette ashes into a small, easily emptied chamber.

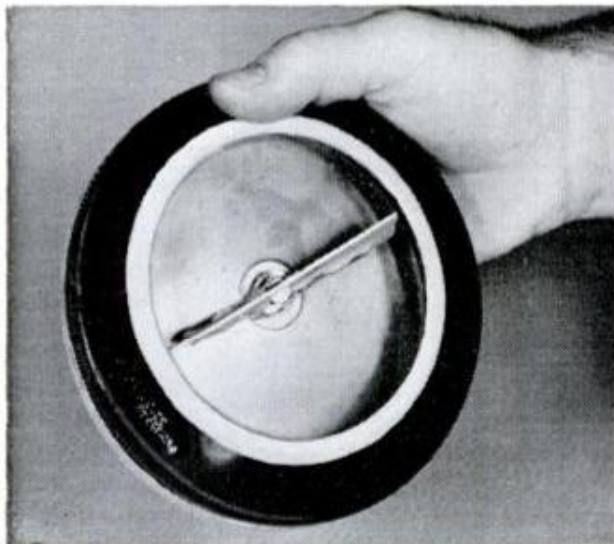

DECEMBER 1960

CONCRETE BIRD BATHS AND OVER 250 OTHER MONEY MAKING ITEMS



You've seen them all over the country . . . concrete bird baths, garden seats, flower boxes, appealing statuary, and many other items that add charm around the house and lawn. They're made by enterprising people, just like you, from our **COPYRIGHTED ALUMINUM MOLDS**. It's easy. It's fun. It's profitable.

Send \$2.00 today for this 82-page "How to" book, 20 pages of clear instructions. Valuable trade secrets. Over 250 items beautifully pictured (with description, dimensions, and prices of molds). Rushed to you by first class mail.

CONCRETE MACHINERY CO., INC.
HICKORY 2, NORTH CAROLINA

Name _____

Address _____

**HOW TO
TURN
CONCRETE
INTO
GOLD**

FREE GIANT 1961 204 PAGE CATALOG



SAVE UP TO
50% ON B-A
SELECTED
KITS

HI-FI AND
STEREO
SYSTEMS &
COMPONENTS

TOP VALUES
IN POWER
AND HAND
TOOLS

30 PAGES
OF BARGAINS
NOT IN ANY
OTHER CATALOG

BURSTEIN-APPLEBEE CO.

Dept. PM, 1012 McGee St., Kansas City 6, Mo.

Send Free 1961 B-A Catalog No. 611

Name _____

Address _____

City _____

State _____

**SEND
FOR IT
TODAY**

67



Working on the railroad, the station wagon serves as a rail inspection car, above, carrying flagging and other equipment for that purpose. It doubles as an emergency ambulance, below



Wagon Rides the Rails

When its retractable railroad wheels are down, an eight-passenger station wagon clicks along the remote right-of-way of the Ontario Northland Railway and serves as ambulance and rail-inspection car. Dashboard buttons operate whistles, lights and other railroad equipment. It converts for road use in a few minutes.

Hydraulic levers operate flanged guide wheels which lower or retract in minutes



cabana marrone



**PLAN YOUR FUTURE NOW...
have a business of your own**

Luxurious, high-fashion fur now being ranch-raised in U.S.A. and Canada. All select, pedigreed, registered stock. Easy and economical to raise in any climate. One pair should produce 10 to 15 young per year. Warranty assures life and production. You may qualify for membership in CNBA (Cabana Nutria Breeders Association), the largest and strongest Nutria association. Free ranch training program. Cabana Marrone Nutria garments nationally advertised.

Cabana Marrone available only through authorized distributors. Write for complete information. Distributor inquiries invited.



CABANA NUTRIA INC.
Dept. 71 636 West Lemon Arcadia, Calif.

**FREE
CATALOG!**

**TREMENDOUS SAVINGS ON
HUNDREDS OF SURPLUS AND
NEWLY MANUFACTURED ITEMS!**

New 1960 edition contains over 50 pages of tools and equipment for farm, home, workshop, factory. Hydraulic equipment, pumps, motors, construction and diesel equipment and parts! Write for your **FREE CATALOG** Today.

GROBAN SUPPLY COMPANY

1139 South Wabash Ave., Dept. G12 Chicago 5, Ill., WEbster 9-3793

**After the city,
Before the state
The ZONE keeps your mail
From being late**



The Post Office has divided 106 cities into postal delivery zones to speed mail delivery. Be sure to include zone number when writing to these cities; be sure to include *your* zone number in *your* return address — after the city, before the state.



Excitement! Security! Good Pay!

CRIME DETECTION

LEARN AT HOME IN SPARE TIME—START NOW!

Crime everywhere is on the rise! Learn now, in your own home, the profitable profession that enables you to track down criminals and bring them to justice! Hundreds of Identification Bureaus employ I. A. S. graduates... trained in finger printing, police photography, handwriting identification, firearms and investigation. Our 44th year! **FREE "Blue Book of Crime"**... packed with crime facts and the full story of famous I. A. S. training. State exact age. No salesman will call. Rush Coupon! *A Correspondence School Founded in 1916.*

**FREE
Blue Book
of Crime
MAIL
COUPON**

INSTITUTE OF APPLIED SCIENCE, Dept. 1359
1920 Sunnyside Avenue, Chicago 40, Ill.
Rush Blue Book of Crime... **FREE!**

NAME.....Age.....
ADDRESS.....
TOWN.....STATE.....

BIG EARNINGS WAITING

**Be a
TYPEWRITER
REPAIRMAN**

Earn while you train AT HOME

Here **AT LAST** your big opportunity to qualify quickly for phenomenal growth field — thousands more trained men are needed.

Now for the **first time** you can get industry-proved training **AT HOME**, learn to **repair all makes of typewriters** easily under expert guidance with clearly illustrated lessons. Real typewriter, sub-assemblies, professional tools supplied.

SEND FOR FREE BOOK—Get vital government facts about urgent need for trained men. Free Book describes big, money-making opportunities. Lic. by N. J. Dept. of Education.

(Div. of Technical Home Study Schools)

MAIL COUPON TODAY!



**FREE
Professional Tools,
Typewriter Supplied**



Typewriter Repair School, Dept. M-10, 150 Park Ave., E. Rutherford, N.J.
Send **FREE** Book, "Opportunities Unlimited", no obligation.

Name.....

Address.....

City.....Zone.....State.....



FREE

**MUSCLE BUILDING
INFORMATION**

Sensational New Methods

Less Time—Less Effort—Better results

BODY-TONE, Box 638, North Miami 61, Fla.



BUSINESSMEN

• **Talk from truck, car, or boat
to your home or business!**

**2-WAY
RADIO**
from \$134.95

The finest Citizens' Transceiver available! Excellent sensitivity and selectivity for maximum range. 23 channel coverage—maximum legal power—built-in squelch—Automatic Volume Control—Automatic Noise Limiter. Easy to install anywhere. With tubes, push-to-talk microphone and crystals for one channel.



SEND FOR FREE COLOR BROCHURE

Send full details on the "Messenger"

NAME.....

ADDRESS.....

CITY.....STATE.....

**VIKING
Messenger**

E. F. JOHNSON CO.

1602 2nd Ave. S. W., Waseca, Minn.

HOW'S YOUR WEATHER IQ?

By Samuel Cabot, Jr.

HERE ARE 20 QUESTIONS about the weather, winds, tides, and other climatic vagaries. Try them and see how you fare; the correct answers are listed on the next page. A score of 10 correct is fair; 12 right, good; 15 correct, you're an expert; 18 right, you're an authority.

- The instrument used to measure the speed of the wind is called an:
 - Ammeter.
 - Anemometer.
 - Anemone.
 - Anomaly.
- If you were to stand on the Tropic of Capricorn at high noon on December 22, 1960, where would you see the sun?
 - Due south, halfway to the zenith.
 - You couldn't see it—it would be below the horizon.
 - Due north, halfway to the zenith.
 - Directly overhead.
- What is meant by the **Roaring Forties**?
 - The zone between 40 degrees and 50 degrees north or south latitude, noted for strong winds.
 - The period, 1944-1949, marked by numerous hurricanes along the Atlantic seaboard of the U.S.
 - Gales on the Grand Banks, which frequently exceed 40 miles per hour.
 - The district in New York City where the Weather Bureau is located.
- At what temperature do Centigrade and Fahrenheit thermometers read the same?
 - 10 degrees below zero.
 - 40 degrees below zero.
 - 120 degrees below zero.
 - No temperature.
- The prevailing wind of India that reverses its direction every six months is called the:
 - Mongoose.
 - Simoon.
 - Monsoon.
 - Macaroon.
- A fine novel that tells the life story of a storm named Maria is:
 - "Low Pressure Area," by James Gould Cozzens.
 - "Batten Down the Hatches," by C. S. Forester.
 - "One Cloud Too Many," by Rumer Godden.
 - "Storm," by George Stewart.
- The **Beaufort Scale** is:
 - A loathsome skin disease common in the Carolina coastal regions, caused by excessive humidity.
 - A system of classifying winds by numbers according to their strength.
 - A device for weighing snow to ascertain its moisture content.
 - A logarithmic thermometer scale.
- Two square flags with black squares in their centers mean:
 - Cold wave.
 - Double-header tomorrow.
 - Hurricane warning.
 - Snowfall of over two inches.
- Some early barometers measured air pressure by water, instead of mercury. How tall a tube of water did they need?
 - 4½ feet.
 - 16 feet.
 - 33 feet.
 - 60 feet.
- When Gabriel Fahrenheit devised his thermometer, he chose for his **zero point**:
 - The freezing point of alcohol.
 - The lowest temperature ever recorded in his home town of Danzig.
 - The lowest temperature available with a mixture of ice and common salt.
 - The freezing point of mercury.
- Those big puffy fair-weather clouds are called:
 - Cirrus.
 - Cerberus.
 - Stratus.
 - Cumulus.
- Chinook** means:
 - The warm spring wind of the Rocky Mountains.
 - A large hailstone.
 - An Apache weather prophet.
 - A typhoon of the China Seas.
- In Arctic circles, explorers often see the aurora borealis. What do they call the phenomenon in the **South Polar regions**?
 - Aurora antarctica.
 - Southern lights.
 - Aurora australis.
 - The same name—aurora borealis.
- Degree day** means what?
 - The anniversary of the founding of the Royal Weather Observatory at Greenwich, England, celebrated as a holiday by weathermen everywhere.

- b. A day on which the temperature falls to one degree below zero, or lower.
 c. Graduation day at the School of Applied Meteorology.
 d. A term used (generally in the plural) to indicate the number of degrees by which the mean temperature of a given day falls below 65 degrees.
15. On a weather map, a line connecting points of equal temperature is called:
 a. An isotherm.
 b. An isobar.
 c. A thermodyne.
 d. A warm front (or cold front).
16. Low tides occurring at the first and last quarters of the moon are called:
 a. Shrove tides. c. Neap tides.
 b. Lammas tides. d. Whitsun tides.
17. When folks in Nova Scotia speak of the bore, they mean:
 a. The chief of the Halifax Weather Bureau.
 b. A cold north wind (the word being a local corruption of **Borealis**).
 c. The high tidal wave of the Bay of Fundy.
 d. The month of April, described by a local poet as "the time of melting slush and oozing mud."

18. What are the doldrums?
 a. Headaches caused by sticky weather.
 b. A zone characterized by weather similar to that of the horse latitudes.
 c. Tropical weather stations.
 d. A type of patent rain gauge.

19. From an airplane, you may often see on a cloud bank the shadow of the plane encircled by a little rainbow. What is this phenomenon called?

- a. Brocken specter. c. Cloud corona.
 b. Solar halo. d. Strato-nimbus.

20. Which of the following is not a wind:

- a. Sirocco. c. Norther.
 b. Harmattan. d. Mistrial.

HERE ARE THE ANSWERS to the weather quiz, **How's Your Weather IQ?**, on facing page.

- | | | |
|-------|-------|-------|
| 1. b | 2. d | 3. a |
| 4. b | 5. c | 6. d |
| 7. b | 8. c | 9. c |
| 10. c | 11. d | 12. a |
| 13. c | 14. d | 15. a |
| 16. c | 17. c | 18. b |
| 19. a | | |

20. d (Mistral is the cold wind of the Rhone Valley; mistrial is a judicial mistake.)

"I brush his teeth with my Wen Sander-Polisher"



Burt Heston

It's a lightweight unit—handy and quiet, but it's a powerful little fellow. It delivers 14,400 straight-line-action strokes per minute . . . perfect for fine finishing and polishing. The pistol-grip case is strong black plastic. Comes complete with 6 assorted abrasives and two polishing pads. The Wen Model 202 is the perfect sander polisher \$13.95 for fine finishing jobs around the home.

YOU CAN ALWAYS DEPEND ON NEWER AND FINER PRODUCTS FROM

WEN

MULTI-PURPOSE 1/2 HP "ALL-SAW"—Makes "one-job" saws obsolete. Does everything a Pattern Saw will do . . . more than a circular saw . . . many things normally done by a hand saw or nibbler—and many things that, until now, only a chain saw could do. UL "Industrially Rated," it cuts anything from a 6" log to intricate patterns in wood, metal, etc. Complete with 7 blades. \$44.95



ALL PURPOSE SOLDER GUN KIT—Feather-light slim gun with 100 watts power. Heats in 2 1/2 seconds. Built-in spotlight focused on work. The kit includes the gun, extra tips for hot-cutting, smoothing, and rosin core solder . . . all in a handy fitted box for neat compact storage. \$7.95



3/8" 2-Speed Power Drill \$29.95
 Lightweight Sabre Saw \$26.95

WEN PRODUCTS, INC., 5810 Northwest Hwy., Chicago 31, Ill.

Christmas

SHOPPING FOR TOOLS



1



2

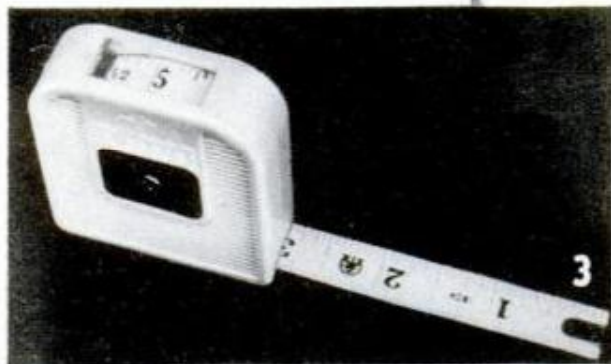

3

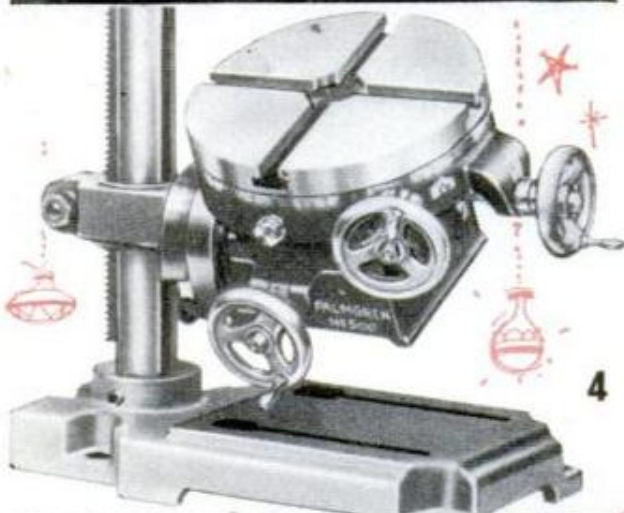

4

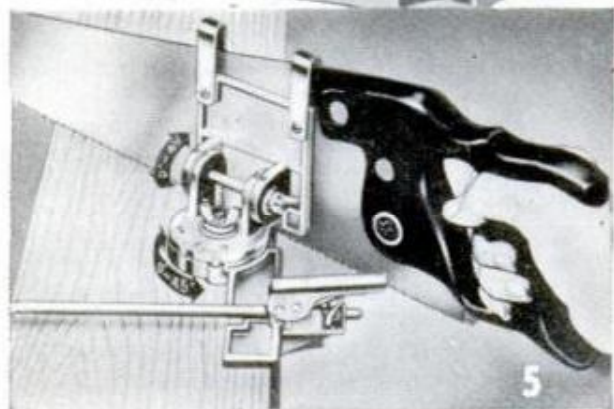

5

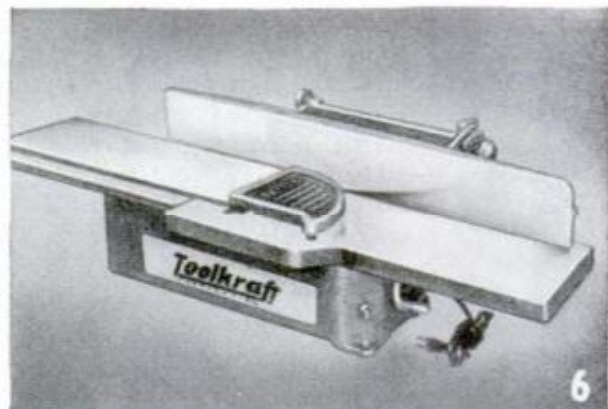

6

1. CYCLOID SAWING ACTION speeds performance of this portable jigsaw to new high levels, clears the teeth at each stroke and produces smoother cuts. Over-motor handle with trigger switch gives positive control

Black & Decker Mfg. Co., Towson 4, Md.

2. RADIAL SAW is engineered for increased portability, convenience and cutting speeds. Features a one-piece yoke mechanism built as an integral part of motor housing. Built-in air stream keeps table clean

Sears, Roebuck & Co., Chicago 7, Ill.

3. TAPE RULE, or pocket tape, has a window in the tough nylon case, through which you take the reading direct and without adding inches for inside measurements as is done with the conventional tape rule

Monroe Sales Co., Box 8021, Seattle 33, Wash.

4. UNIVERSAL DRILL-PRESS TABLE converts a drill press into a light milling machine. Table diameter is 8 in. Transverse, longitudinal travel is $4\frac{1}{4}$ in. Cross-feed dials are graduated in thousandths. Is easily installed

Chicago Tool & Engineering Co.,
8383 S. Chicago Ave., Chicago 17, Ill.

5. MITER BOX, OR MITER GAUGE, clamps to the work, sets at any angle from 90 to 45 degrees and tilts to cut compound miters from 0 to 45 degrees. Any hand-saw can be used. Fits in any tote-type tool box

Nielson Saw & Mfg. Co., 2395 W. 7th Place, Eugene, Ore.

6. 6-IN. LONG-BED JOINTER has built-in $\frac{3}{4}$ -hp. motor. Tables are 43-9/16 in. length over-all; fence is $33\frac{1}{2}$ in. long and $4\frac{3}{4}$ in. high and has positive spring-loaded index pin which locks automatically at angle positions

Toolcraft Corp., 700 Plainfield St., Springfield, Mass.

(Continued to page 74)

NEW! MODERN "LITTLE GEN" MOTOR SCOOTER
(36" Wheelbase—20" to top of Seat)

PORTABLE—Pack It Around In Auto, Boat, or Plane . . . Combination Throttle and Brake Pedal . . . Go or Stop with tilt of the "One Foot Control."
SEND 50¢ TODAY FOR COMPLETE SET OF PLANS AND INSTRUCTIONS ON HOW TO BUILD YOUR OWN . . . KIT includes photos, assembling drawings and instructions with material listings . . . Everything you will need to Build Your Own. (ALSO AVAILABLE IN READY-TO-ASSEMBLE KIT FORM.)

MAIL TO: LITTLE GEN SCOOTER
BOX 292, FORT WAYNE, INDIANA

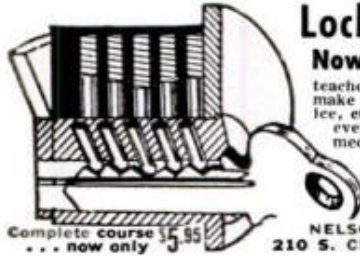

Locksmithing AND KEY MAKING

Now Made Easy! Practical up-to-date course teaches you how to pick locks, de-code, make master keys, repair, install, service, etc. New self-instruction lessons for every handyman, homeowner, carpenter, mechanic, service station operator, fix-it shop, hardware dealer, gunsmith. 53 easy illustrated lessons. Full price only \$5.95 postpaid; or C. O. D. plus postage. Satisfaction or refund guaranteed.

NELSON-HALL CO., DEPT. MP-2
210 S. Clinton Chicago 6, Ill.

Complete course \$5.95
... now only \$3.95

RUPTURE!

An amazing Air-Cushion Invention allows body freedom at work or play. Light, neat, cool, sanitary. Durable, cheap. Day and night protection helps Nature support weakened muscles gently but surely. No risk. Sent on Trial! Write NOW for free Booklet and Proof of Results. All correspondence confidential.

Brooks Company, 143 D State St., Marshall, Mich.



PROFIT IN YOUR SPARE TIME

FIX SMALL GASOLINE ENGINES
Outboard • Powermower • Chain Saw • Tractor
MAKE EXTRA MONEY—or, repair your engines and SAVE. Illustrated, easy-to-understand, Home Study Course. FREE information. Write TODAY!

LINCOLN TECHNICAL INSTITUTE
Suite 12-E, 472 Market Street, Newark 5, New Jersey



IS YOUR HOME HARD TO HEAT?

Skuttle
Dust-ban Filters
can be the answer to high fuel bills

These low-cost, washable, electrostatic filters are built to last for years of service. Each filter is framed in zinc-coated steel. They never need oiling! The electrostatic action of the Skuttle Dust-ban Filter assures the removal of dust, dirt and pollen particles, allowing free flow of air for maximum heating.



FILTER SIZES

10" x 20" x 1" 16" x 25" x 1"
15" x 20" x 1" 20" x 20" x 1"
16" x 20" x 1" 20" x 25" x 1"

\$4.95 ea. f.o.b. factory

GET THIS FREE FILTER GAGE



You get a FREE Filter Gage valued at \$1.95 with the purchase of 2 Dust-ban Filters. This gage is easily installed in the blower compartment of your furnace. When the ball moves up to the SERVICE arrow, it's time to remove the filters and wash them.

On sale at your hardware store, heating dealer or write to:
Skuttle MANUFACTURING COMPANY, Milford, Michigan

Ideas & Inventions
WANTED
by Major Manufacturer

Well-known rubber company wants ideas for new automotive products to be sold through filling stations . . . new products for home and farm to be sold through hardware stores and garden supply centers . . . new products for industry such as power transmission (mechanical, hydraulic, pneumatic), new ways to convey materials, electronic or mechanical devices.

New products can be made of rubber, fabric, plastic, metal, wood, or a combination of these materials. New processes would also be of interest.

If you have an invention or ideas for new products of the kind suggested above, or new processes, merely fill in your name and address on the coupon below and mail it to M. X. Tanner, P.O. Box 3354 Merchandise Mart, Chicago 54, Illinois. When replying, please DO NOT send any sketches, patent files or suggestions for new products, or processes. Upon receipt of the coupon, we will give you full instructions on just how to submit your ideas.

Name _____ (Please Print)
Street Address _____
City _____ State _____ PM _____

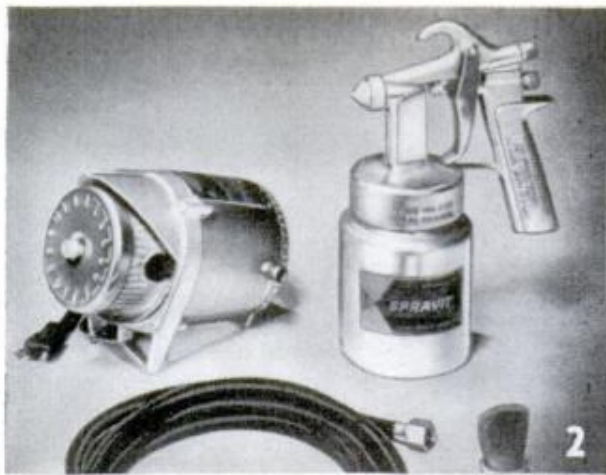

Christmas SHOPPING FOR TOOLS

1. RIGHT-ANGLE DRIVE swivels to any position to operate drill bit, sander or polisher. Reversible—doubles speed for smooth sanding finish or reduces speed by one half for best buffing results and for drilling large diameter holes. Has two-position handle

Stanley Tools, Div. of Stanley Works,
111 Elm St., New Britain, Conn.

2. PORTABLE PAINT-SPRAYING UNIT comes with separate ¼-hp. motor-compressor and an exceptionally lightweight, all-aluminum gun with a range in spray size from the diameter of a dime to more than 10 in. Gun weighs only 1 lb. and has two-finger trigger

Thomas Industries, Elec Sprayit Div., Louisville 2, Ky.

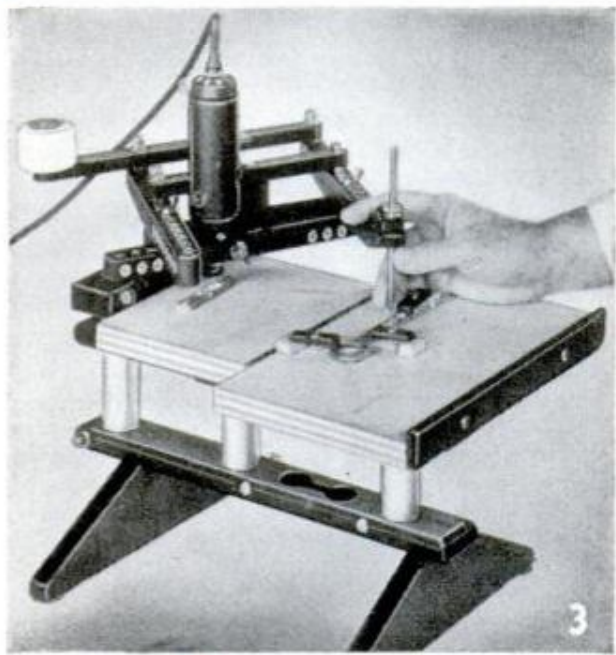

3. PANTOGRAPH utilizes handy grinder motor to carve intricate miniature reproductions from an original. Full ball-bearing equipped, unit operates with ease and precision on all types and ranges of work sizes in either metal or wood. Comes with full instructions

Beitch-Craft, 3011 Starling Lane, Rolling Meadows, Ill.

4. TOOL HOLDER offers both convenience and protection to those who use such striking tools as chisels, star drills and certain types of punches. Has a shock-absorbing plastic handle with a nonslip hand grip. Available in both one-man and two-man models

Rose Mfg. Co., Denver, Colo.

5. GUARD, EYE SHIELD AND TOOL REST units plus a grinding wheel and motor-shaft adapter make a high-speed grinder from any conventional ½-hp. motor. Comes in right or left-hand types for installation on either side of motor. Motor, grinder units bolt to bench

Appliance Engineering Co., 2052 N. Western Ave., Chicago 47, Ill.

(Continued to page 76)

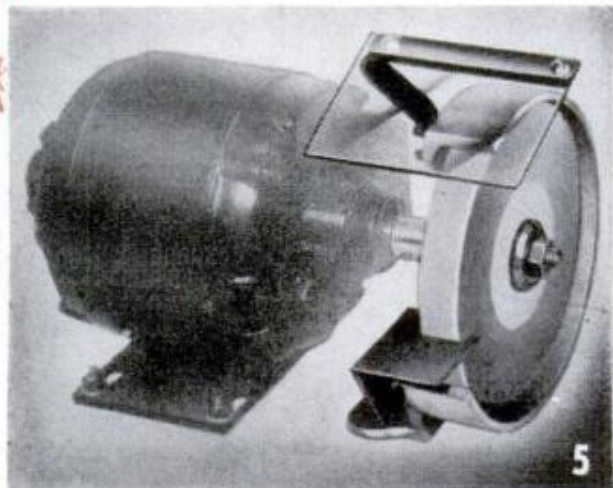

The second most important tool...
for every
woodworking shop

A VERSATILE

W&H MOLDER-PLANER

is second only
to a saw... it
molds, planes and rabbets.
"Your savings pile up as your
shavings pile up."



SEND FOR
FREE BROCHURE

WILLIAMS & HUSSEY MACHINE CORP.
CLINTON ST., MILFORD, NEW HAMPSHIRE

GET INTO ELECTRONICS

V.T.I. training leads to success as technicians, field engineers, specialists in communications, guided missiles, computers, radar, automation. Basic & advanced courses in theory & laboratory. Assoc. degree in 29 mos. B.S. obtainable. ECPD accredited. G.I. approved. Graduates with major companies. Start Feb., Sept. Dorms, campus. H. S. graduate or equivalent. Catalog: VALPARAISO TECHNICAL INSTITUTE
DEPT. D VALPARAISO, INDIANA



"\$7,108⁵⁰ FIRST YEAR SERVICING RADIATORS!"

— Hank Konter, Newcastle, Wyo.

Make good money servicing auto-truck-tractor radiators. Easy to learn. Inland, world's largest radiator equipment mgr., offers complete package — equipment, merchandising, "pays-for-itself" financing, free training. Small down payment on equipment starts you. Profitable dept. for garage or service station. Write

INLAND MFG. CO., Dept. PM-12, 1108 Jackson St., Omaha 2, Nebr.

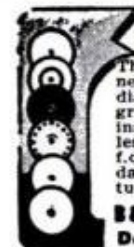

make your own Gems 36⁵⁰

The Gem Maker comes complete with all necessary equipment, including a super-charged diamond blade for sawing, and all the wheels for grinding, shaping and polishing; also complete instructions. The complete equipment as shown, less motor and belt for only \$36.50, f.o.b., Burlington, Wisconsin. Write today for information and literature.

B&I MANUFACTURING CO.,
Dept. P Burlington, Wis.

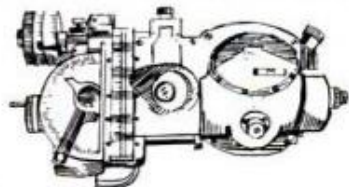

NOW! First Time Ever Offered M9 NORDEN BOMB SIGHTS

THIS IS THE BOMBSIGHT THAT WAS THE MOST CLOSELY GUARDED SECRET OF WWII!!! AMAZING! Complex! Absolutely brand new! Full of gyros & lenses! Cost government \$5000, Ship. wt. 70 lbs. **\$2995**

Send Check or Money Order. U.S. Only. No Canadian Orders.

CHARLOTTE AIRCRAFT CORPORATION
P. O. BOX 9127, CHARLOTTE, N. C.

FREE!

ALLIED MONEY-SAVING 1961 ELECTRONICS CATALOG

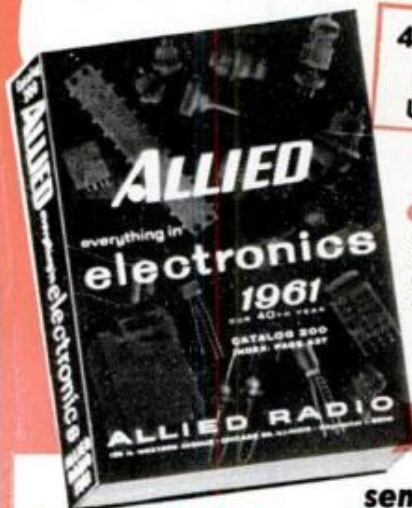

444-PAGES
COMPLETE
UP-TO-DATE

ONLY \$2 DOWN
on orders up to
\$50; only \$5 down
up to \$200; \$10
down over \$200

send for it today!

Largest Selection—Lowest Prices

Send for the leading buying guide to everything in Electronics, including products available only from ALLIED. Builders, experimenters, hi-fi fans, Amateurs, servicemen, engineers—save most on:

- KNIGHT-KITS®—Best in Build-Your-Own
- Everything in Stereo High-Fidelity
- KNIGHT® Super-Value Stereo Hi-Fi
- Tape Recorders & Phono Equipment
- TV Tubes, Antennas, Accessories
- Parts, Tubes, Transistors
- Everything in Tools & Technical Books
- Amateur Station Equipment
- Citizen's Band 2-Way Radio
- Public Address & Paging Systems
- Latest Test & Lab Instruments



SAVE on everything in Electronics at ALLIED. Get every buying advantage fastest shipment, expert personal help, easiest-pay terms, satisfaction guaranteed or your money back. Send today for your value-packed, FREE 1961 ALLIED Catalog.

YOU CAN DEPEND ON THE WORLD'S
LARGEST ELECTRONIC SUPPLY HOUSE

our
40th
year



ALLIED RADIO

SEND FOR
FREE
CATALOG

ALLIED RADIO, Dept. 5-M
100 N. Western Ave., Chicago 80, Ill.

Rush FREE 1961 ALLIED Catalog

Name _____

Address _____

City _____ Zone _____ State _____

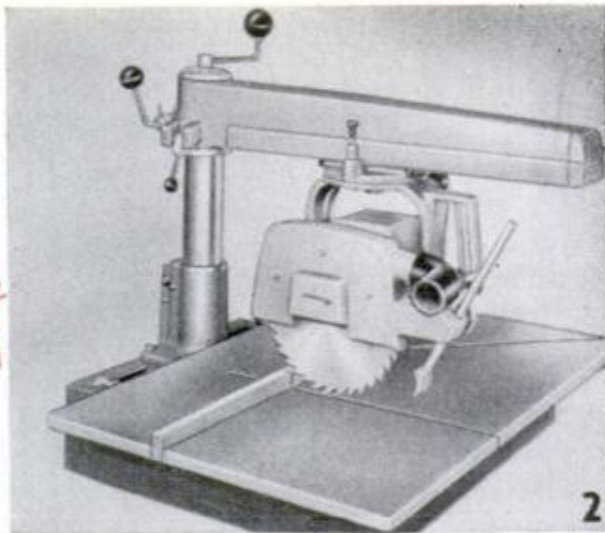
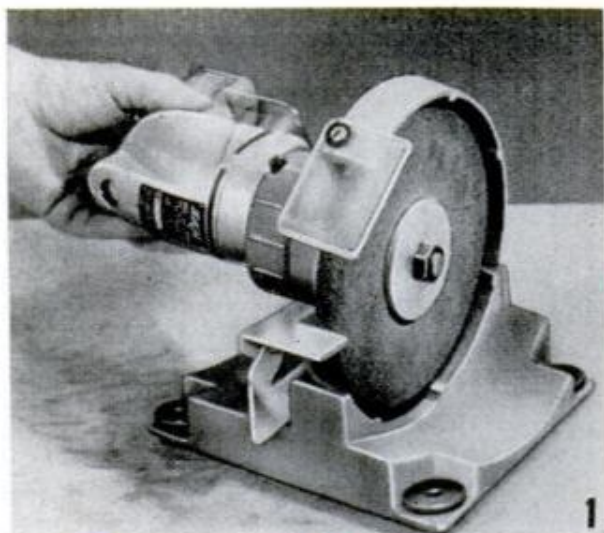

Christmas SHOPPING FOR TOOLS

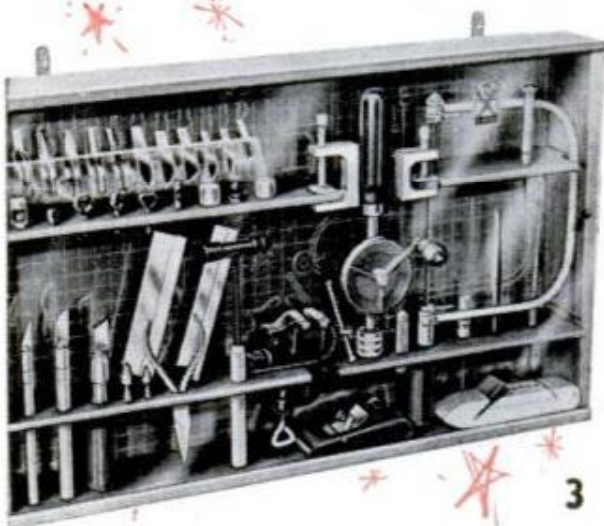

4. FLEXIBLE-SHAFT MACHINE is ideal solution of screwdriving and nut-running problems on delicate production jobs where it is necessary to work in restricted areas. Slim, clean handpiece permits work in places that cannot be reached with regular equipment
 Foredom Electric Co., Inc., Bethel, Conn.

1. SNAP-LOCK MECHANISM attaches the portable drill to this 6-in. bench grinder unit that consists of grinding wheel, base, wheel guard, and eye shield. The grinder is only one of a number of units to which a 1/4-in. portable drill can be attached by snap-locking
 Skill Corp., 5031 Elston Ave., Chicago 30, Ill.

2. ECONOMY MODEL OF RADIAL SAW comes stripped of deluxe features of regular model but retains same custom-built motor and all other basic features of standard radial unit. Has crosscut capacity of 15 in., ripping capacity of 24 in. Depth of cut is 2 1/2 in.
 DeWalt, Inc., Lancaster, Pa.

3. TOOL KIT FOR HOBBYISTS is just about as complete as a hobby tool kit can be made. Includes a wide assortment of holders and detachable blades for carving and similar work. There also are drills, dovetail saws, planes, special hammer, files, tweezers, vise, etc.
 X-acto, Inc., 48-41 Van Dam St., Long Island City 1, N. Y.

5. SOLDERING GUN comes with special alloy tips in three revolutionary types which are adaptable to a wide range of work including ordinary soldering, tile cutting and sealing of plastic containers. Comes in single and dual-heat models. Has built-in spotlight
 Cummins Portable Tool Co., Div. of John Oster Mfg. Co.,
 5055 N. Lydell Ave., Milwaukee, Wis.

(Continued to page 78)

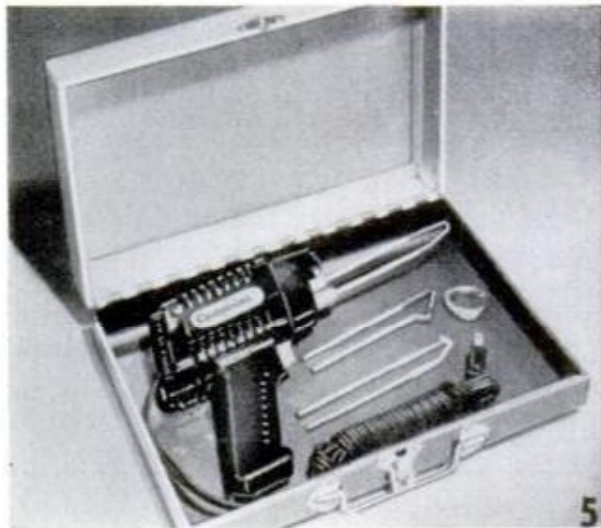
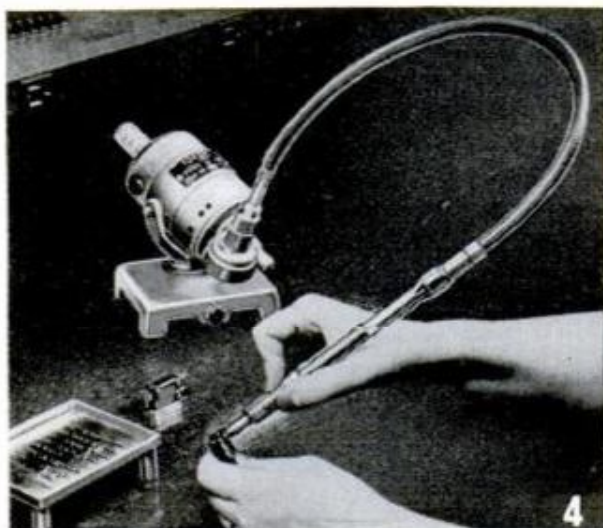

MAGNETS

PERMANENT ALNICO 5, TESTED MAGNETS

For industry, shop, inventors, researchers, hobbyists, fishermen. Retrieve from salt or fresh water, deep tanks, drains, shafts, etc. Salvage valuable tackle, tools, guns, motors, anchors, etc.

Money Back Guarantee. We pay postage. (no c.o.d.s.)

150 LB. PULL
Magnatron
cost govt. \$85
3x3x4 in. / 5 lbs.
No. M150...\$12.75

100 LB. PULL
Assembly
2 1/2 x 4 x 4 1/2 in.
Wt., 7 lbs.
No. R100...\$9.85

55 LB. PULL
Assembly
3x3x2 1/2 in.
Wt., 2 lbs. 6 oz.
No. R55...\$5.75

No. F35 Tackle Box Retriever Assembly / 35 lb. pull / 2x2 1/2 x 2 1/2 in. / Wt. 2 1/4 lbs. \$3
No. H20 Hobbyist Collection / Assortment of 12 powerful small magnets \$2
No. M30 Mighty-Mite, multi-purpose small holder magnets 10 for \$1.

Guaranteed fully magnetized lifetime magnets for all uses
MAGNA MAGNETICS, 7777 Sunset Strip, Los Angeles 46, Calif., Dept. ML

KILLS

MOSQUITOS / MOTHS / MILLERS /
FLIES / GNATS / FISH FLIES / ETC.

USES NO CHEMICALS, GASES, ETC.

No insect recovery. Harmless. Guaranteed. Built to last 25 years. Beautiful outdoor lighting. Plug into any 110 volt socket. Very reasonably priced...

NO AREA CONTAMINATION

Uses up to 200 watt bulb. Grid costs 10¢ per month. Complete with fly attractor. Dead insect catcher, write to SING SING BUG CHAIR, INC. BOX P 3708 / OAK PARK 37, MICH.



FIND BURIED TREASURE

GOLD, silver, coins, jewelry, strong-boxes, battle relics! M-SCOPE transistorized electronic Treasure-Metal Locators detect them all. Used world-wide. Exciting! Rewarding! Guaranteed. Lightweight, super-sensitive. Indestructible fiberglass cases. From \$59.50. Easy Terms. FREE catalog.

FISHER RESEARCH LAB., INC.
Dept. PM-3, Palo Alto, Calif.

AN AIRPLANE CRASH NEED NOT BE FATAL!



There's an organization at Phoenix, Ariz., devoted to helping you walk away safe from a plane accident.

Read about it

in the

JANUARY

POPULAR MECHANICS

DECEMBER 1960

End Skidding and Wheel Spinning!



SKIDMASTER®

DETACHABLE GRIT SPREADER



Revolutionary new grit release device provides "push button" traction!
ONLY \$29.95 INSTALL-IT-YOURSELF!

Napco, leading manufacturer of highway sanders for trucks, trailers, and buses, introduces an entirely new concept in passenger car grit release devices! *Skidmaster* is controlled by a patented new vacuum release valve connected by hose to the windshield wiper line or vacuum spark advance . . . there are no electrical connections . . . no drilling or cutting into car.

Skidmaster more than pays for itself . . . saves damage to transmission from "rocking", eliminates tire wear and wasted gas from "spinning".

Skidmaster helps you climb hills, park alongside of curbs, pass cars; start, slow down, or stop on curves and at intersections.

After simple installation, the outside units are easily removed, stored in trunk and attached in seconds, when needed. You'll never again use costly skid chains, ineffective snow tires and sand bags.

Fits any make or model car or station wagon. Simple installation kit with STEP-BY-STEP INSTALLATION INSTRUCTIONS. If you are not completely satisfied your money will be refunded. Shipped parcel post prepaid.



Flexible bracket fits into window opening, does not interfere with window operation.



Flexible plastic discharge tube slides into pre-adjusted receptacle.

SKIDMASTER SALES CO., Dept. PM
512 Nicollet Avenue, Minneapolis 2, Minnesota

Gentlemen: Enclosed please find \$_____ for _____ set(s) SKIDMASTER GRIT SPREADER(S) @ \$29.95 per complete set, with instructions.

Name _____

Address _____

City _____ Zone _____ State _____

Enclosed: Check Money Order Sorry, no C.O.D.'s.

Christmas SHOPPING FOR TOOLS

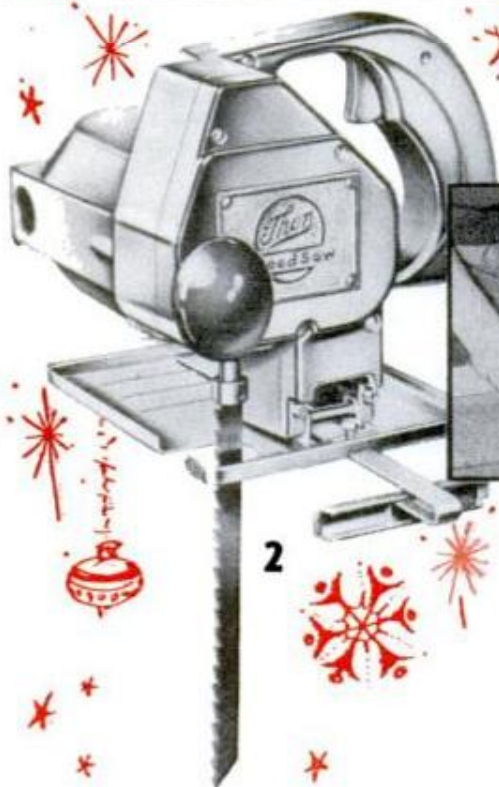

1. FIVE TOOLS driven by one motor make this the combination for home craftsman, hobbyist, builder and carpenter. Motor is a power head, or driver, for sander and scroll-router pictured above, also a power plane and a shaper using a wide range of cutters. Motor operates at speed of about 23,000 r.p.m.
Porter-Cable Machine Co., Marcellus St., Syracuse 1, N. Y.



2. PORTABLE JIGSAW cuts 6-in.-thick stock, handles precision scroll work with fine-toothed blades. Cuts wood or metals with suitable blades. Comes with combination ripping guide and circle cutter, also a protractor permitting angle cuts to 45 degrees. Universal 4.5-amp. motor turns up 2400 strokes per minute. All rotating parts turn on ball and needle bearings
Thor Power Tool Co., Speedway Div., 1421 Barnsdale Rd., La Grange Park, Ill.

3. POCKET-SIZE SANDING BLOCK features three work faces and is wedge-shaped to get into corners, between beads, into flutes, also deep vees. Standard 9 x 11-in. sheet of sandpaper can be cut into four equal refills. Each strip is stretched and then wedged into place by means of a special wedge-shaped end piece
Midwest Abrasive Co., Owosso, Mich.

4. SHAPER CUTTERS with involute relief feature carbide cutting edges which deliver up to 10 times the productive life of ordinary cutters when working plywood and resin-bonded chipboards. Cutters are available in a variety of shapes for cabinet work, also sash, millwork; 1/2, 5/8 and 3/4-in. bores
Boice-Crane Co., 943 Central Ave., Toledo 6, Ohio

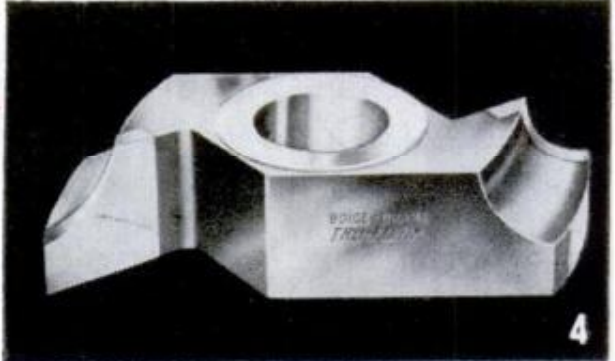
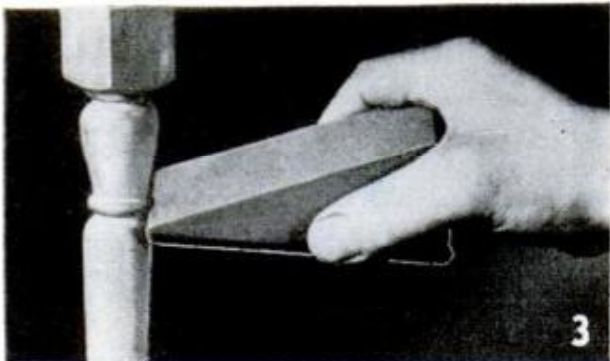



“bargain”

batteries

BAH!

from now on it's a Delco DC-12 for me!

You can try to get by with a “bargain” battery—but a couple of dollars more for a Delco DC-12 Dry Charge can save you time, money and trouble!

What does it cost you to be two hours late for work? Most of us can't afford it, and it's especially annoying when caused by a bad battery. A dependable Delco Dry Charge Battery starts you off on time day after day, in all kinds of weather . . . yet it costs little more than so-called “bargain” batteries.

WHY YOU CAN BE SURE DELCO DC IS 100% FRESH

Delco Dry Charge Batteries stay bone dry until sold . . . can't lose any “zing” on the shelf. Delco DC comes to full, 100% fresh power only when you actually see the dealer add the activator fluid that makes it ready for work . . . thus you can be sure you're getting all the power you pay for!

YOUR DELCO BATTERY DEALER IS A LOCAL BUSINESSMAN

He appreciates your business, and automotive service is his specialty, not a sideline. He knows your car and your driving habits, and can specify the Delco DC battery that suits you best. He is conveniently located a few minutes from home, wants your continuing

DELCO DC-12 . . . Best to START with . . . Best to STAY with

Another reliable General Motors product, distributed nationally through



SEE TWO NEW TV SHOWS FOR DELCO—“Stagecoach West” and “The Islanders” on ABC-TV.

gasoline, oil and service business . . . and wants to be sure that you're satisfied and will come back regularly.

WHY JUST TRY TO GET BY . . . BE SURE WITH DELCO DC-12!

If time or money means little to you, you can afford a “bargain” battery. But if you're in the same boat with most folks, you need the 100% fresh, dependable power that makes Delco America's No. 1 Battery . . . “Designer's Choice” for most new cars, and “Driver's Choice” for replacement, too . . . proved so in surveys year after year. When it's time to replace, ask your dealer for Delco DC-12.





Nomad 6-Passenger 4-Door Station Wagon: hard-working utility with a glamorous flair.

*Here!
A new measure of
your money's worth...*

NEW 1961 CHEVROLET!

Here's clean-as-a-whistle style that'll never cramp yours. No needless bulk or ornamentation on this '61 Chevy. And inside you'll find a full measure of roominess and comfort. Getting in and out is a breeze, thanks to doors that are up to 6 inches wider. And sitting in this new Chevy is pure solid comfort because those new seats are the closest thing you could want to easy-chair height and accommodation. There's also a new kind of deep-well trunk (you can stack baggage 15% higher) for hauling odd-ball objects you used to have to leave home. These are improvements you can see, feel and sit upon—improvements that make Chevy America's Number One new-car investment.



Bel Air 4-Door Sedan: with contemporary-contoured rear deck and canopied roof line.

Now... big car comfort at small car prices

NEW '61 CHEVY BISCAYNE 6

the lowest priced full-sized Chevrolet!

Here's the Chevrolet that gives you everything that makes a big car worthwhile, at a price you'd expect to pay for shaved-down cars that give you a lot less. These new Biscaynes combine all of Chevy's 1961 improvements with the traditional Chevy pluses of solid Body by Fisher, tried and true V8 or six-cylinder dependability, and smooth, sure Full Coil ride. Try a '61 Chevy Biscayne, your budget will love you for it!

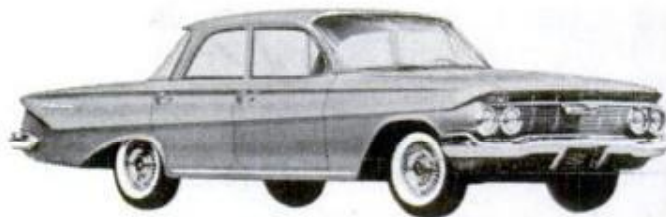

Biscayne 4-Door Sedan.

Modelmakers in a Tizzy

By Carson Kerr

A WEEK AFTER the U. S. Air Force announced its Starfighter jet had set a new altitude record, last December, miniature construction kits of the plane were sold out in stores from coast to coast. Model manufacturers tried hard to step up Starfighter production, but most of them already were behind schedule with many of their other kits. The Christmas season has thrown them into a tizzy for the past 12 years, and keeping up with demand was doubly difficult last year because the women have joined the mil-

Assembling models such as this one of the Explorer I satellite is now the nation's chief hobby





Revell, Inc. photo

1. First step in model production is to make scaled-down plans based on the original's large blueprints



Monogram Models, Inc. photo

2. Skilled craftsmen then create a master model by hand sometimes as much as a year before production

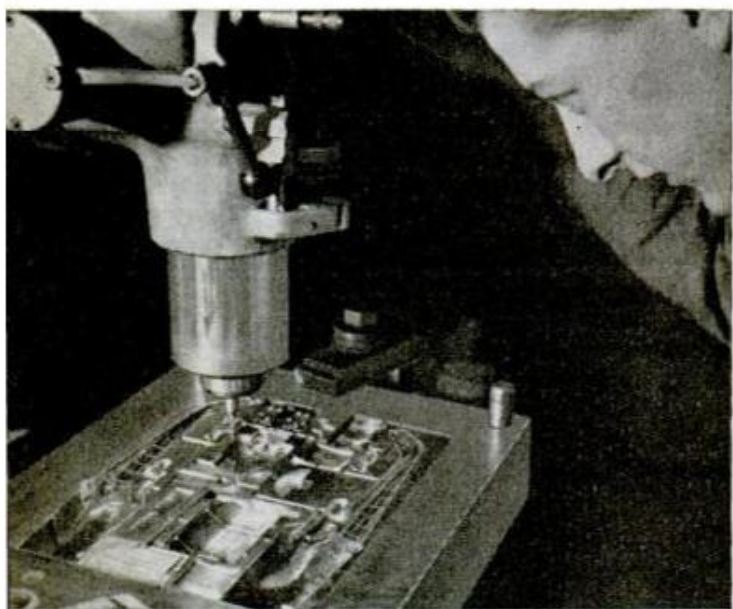

5. Final fitting for mold that will make hundreds-of-thousands of helicopters is a painstaking task



6. Human figures are formed in reduced size by a sculptor using live models, then are further reduced

lions of American males who have taken up modelmaking, an activity that has replaced stamp collecting as the nation's number-one hobby.

Model kits, which sold to the comparatively quiet tune of \$6,000,000 in 1947, reached an annual sale of \$35,000,000 in 10 years, then soared to more than twice that amount in 1959. The 1960 figures will probably top \$100,000,000.

Miniature models have become big business mainly because they no longer are looked upon merely as toys. Apart from recreational value, they're important to education, scientific research, therapy, movie and television production, the manufacture of boats, trains, autos and planes, the settling of court cases, and even as aids

to the foreign policy of the United States.

"The surface of our market hasn't even been scratched," says Lewis Glaser, president of Revell, Inc., the company that has captured about half the world market with annual production in excess of 30 million units. Revell turns out everything from space equipment and atomic power plants to replicas of Walt Disney's *Perri* squirrel. This year the company introduced detailed dollhouse kits, designed by leading architects, expected to attract mothers and daughters as strongly as its new, operating, aircraft engines attract fathers and sons.

Lionel Corp. (with a past reaching back to 1900, when Joshua Lionel Cowen started making miniature electric motors) is keeping pace with the future by offering mili-



3. Pilot models are then broken down to provide patterns for molds of the many parts which go into kits

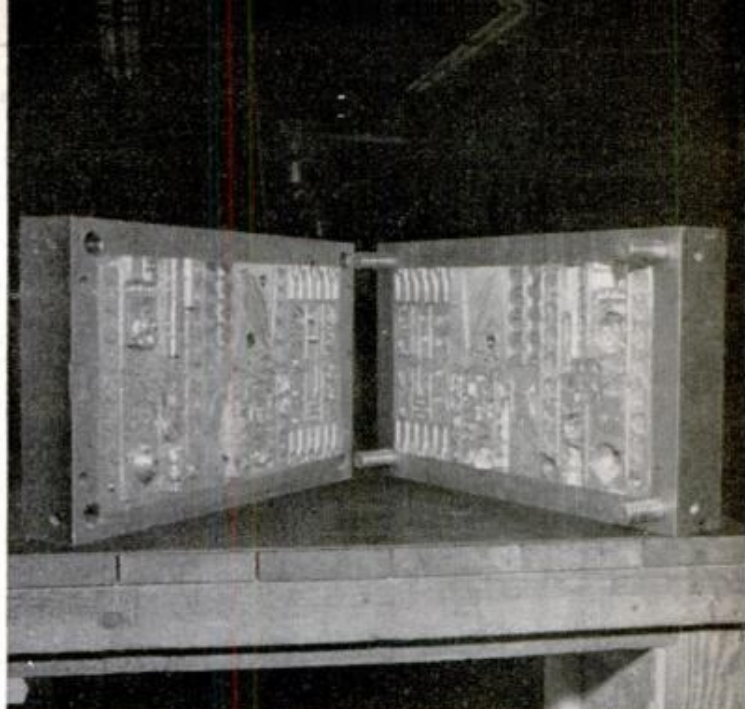

4. Precision molds can be complicated affairs. This one is for half the parts needed to make an engine

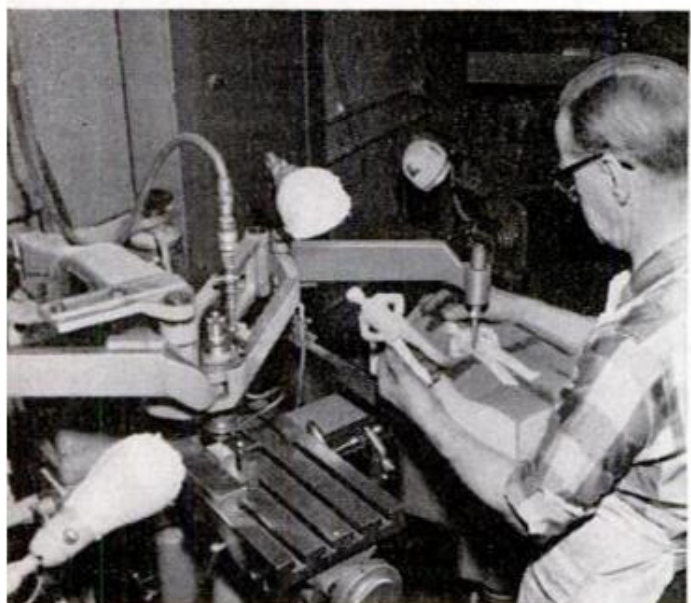

7. Using a pantograph machine, a technician etches a mold in steel from a cast of sailor he is holding



8. Original sculpture, left, and scaled-down reproduction, right. Lifelike accuracy helps sell kits

tary railroad units—radar and missile cars, exploding target cars, helicopter cars with spring-wound launching platforms.

An air-power kit—18 U.S. Air Force planes mounted on wires (scale: 1 inch equals 50 feet)—is a best-seller for Monogram Models, Inc. This company also offers orbital rockets, space taxis and other futuristic models.

"Authenticity is what has made models more than kid stuff," points out Monogram's president, Jack Besser. "Because reasonable facsimiles no longer are acceptable, we carry our efforts to attain realistic detail to a necessary extreme. Authentic human figures have probably added as much interest to modeling as anything else. Our pilots and drivers are fashioned by a

sculptor using live models then successively reduced in size. Though some are only half-an-inch high, we want perfection right down to the dimple in the chin."

The Ideal Toy Co., founded in 1902, although a relative newcomer to the put-together field, has broadened the scope of modelmaking with such innovations as replicas of prehistoric people and animals. Products manager George Belinski reports, "Educators were delighted. They felt that here, at last, was an interesting way of presenting paleontological information."

One of the largest selections of model kits—150 in 17 categories—is offered by Aurora Plastics Corp., specialists in "Winged History" and "Famous Fighters." One of their most popular missile kits is a work-

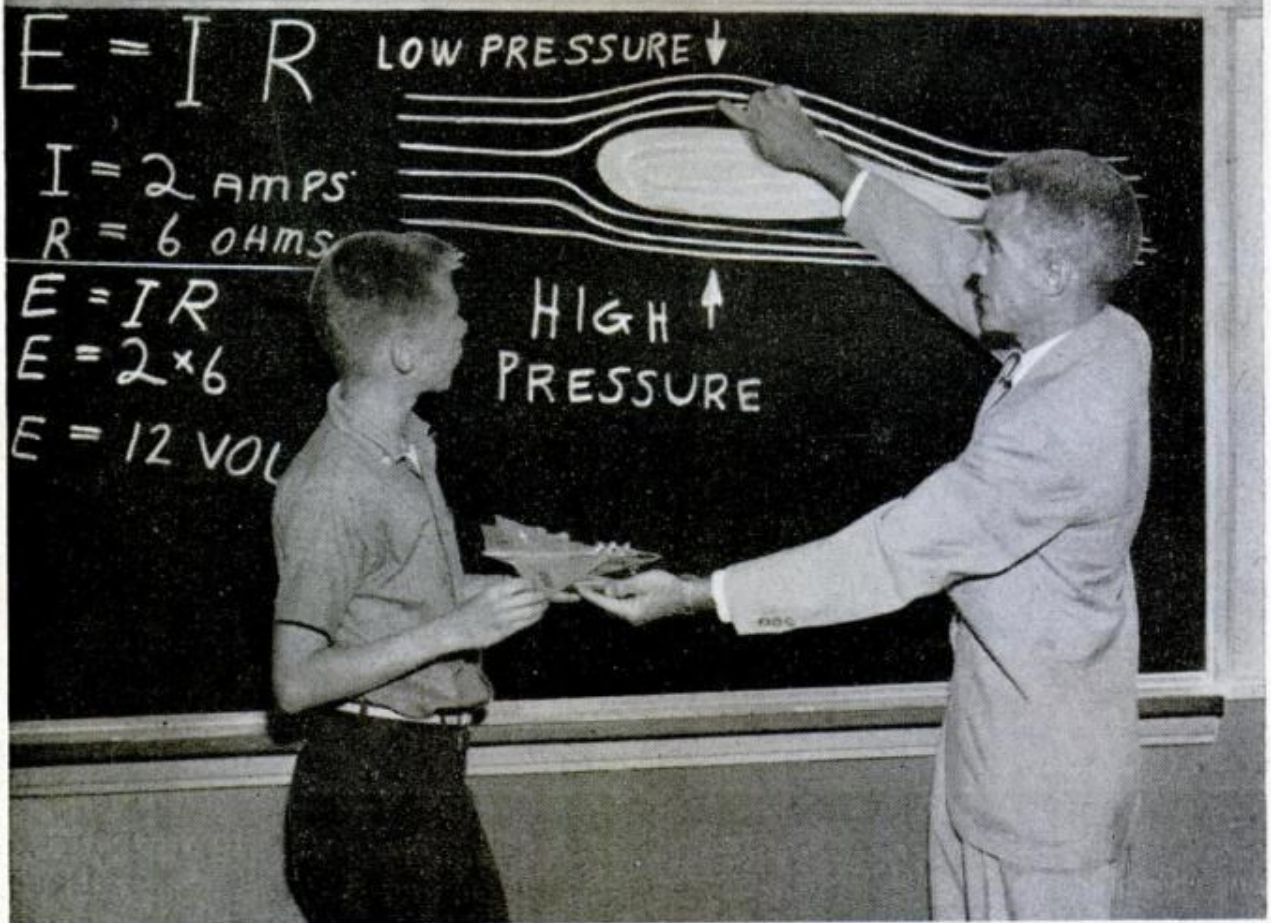

Classroom use of models, like model building, is increasing. Teacher August Macaluse, at Los Angeles Junior High School, shows student Steve Whipple a principle of aerodynamics after Steve built model plane

ing model of Mark III, complete with fuel for 30 launchings. Aurora also has had success with human-figure kits.

Famous for model train accessories, Bachmann Bros., Inc., pioneered in a new direction two years ago by introducing a series of interlocking, paint-by-number bird kits approved by Audubon societies.

Renwal Corp. has clicked with *The Visible Man*, a carefully sculptured human body with a clear lucite outer form showing the circulatory system and revealing organs that can be snapped into position and removed.

Aristo-Craft has come up with lifelike flower kits that are used for both education and decoration.

The Lindbergh line manufactures model planes connected to remote-control sticks that allow budding pilots to make the models assume different flight positions.

Comet Model Hobbycraft, a pioneer model plane maker, and probably the largest manufacturer of plastic, U-control motorized models and balsa flying planes, has contributed to aviation-age education by offering a series of planes, ranging from a simple glider to the newest space craft, that builders can advance to as their skills develop. With some kits, Comet includes an authoritative book, *What Makes An Airplane Fly*.

Authenticity has been a key factor in Revell's success since 1950, when it hit the big time with a faithful reproduction of Jack Benny's Maxwell. Stressing accuracy calls for a lot of research and sometimes also results in some surprising developments. For example models of Russian military equipment are in demand, for they are hard to come by. Preparing a Yak fighter plane kit, Revell designers obtained information on everything but the landing gear. After weeks of studying Russian aviation history, they finally devised the type of gear they figured would have been used. Their studied guesswork later proved to be correct. For a model of Columbus' *Santa Maria*, a researcher combed the Spanish Admiralty archives in Madrid, Spain, and got copies of the original plans. Working on the Starfighter, Revell researchers did such a good job that production of the model had to be held up until clearance from the Air Force could be obtained.

The Wright brothers spent less than \$1000 on their flying machine but it cost Monogram \$25,000 to perfect it in miniature. Wilbur and Orville hadn't worked from blueprints so Monogram designers journeyed to the Smithsonian Institution, in Washington, D. C., to study and photograph the original from all angles.

Scaled-down. This is a replica of the *Tyrannosaurus Rex* dinosaur of 75 million years ago. The 46-piece plastic model was in development for two years

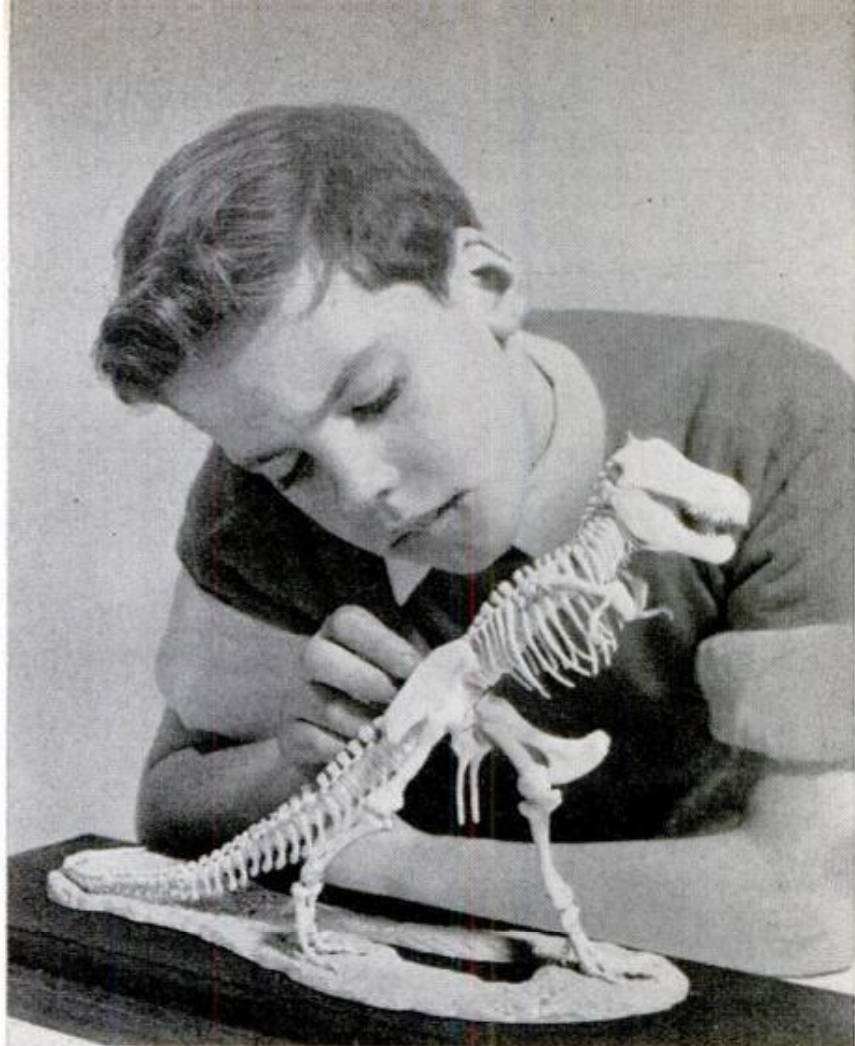

Scaled-up. This bumblebee made from a model kit is eight times real size. It was designed after museum specimens and is assembled from 44 plastic pieces
Ideal Toy Corp. photo





Bachmann Bros. photo

Replica model kits such as one called "Birds of the World" are popular with girls as well as with boys

Assisted by museum curators and other experts, Ideal took *Tyrannosaurus Rex*, a dinosaur that was two stories high and 50 feet long in real life, and scaled the skeleton down to 9 inches in height and 16½ inches in length. The job took two years but the success of the kit made the effort well worthwhile.

Intricate model kits, such as Revell's Westinghouse atomic plant and *Cutty Sark* clipper ship, can take well over a year to perfect and costs can run to \$200,000. Two or three months are spent in preparing true-scale plans. The pilot model is then prepared and is inspected by designers and operators of the original thing whenever possible. Every detail possible to be reproduced in miniature is then made of clay, plaster, wood or metal. Months of mold-making follow.

Strict attention to detail has made models important to the aviation industry, and many modifications have resulted from tests of models, saving a great deal of expense in plane production. When Revell was tooled up to mass produce DC-8 kits, Douglas decided to lengthen the fuselage by two feet. Not one modeler in a thousand would have known the difference, but the molds were changed to keep the model accurate. Small wonder that foreign

pilots being indoctrinated in DC-8 operation tour the Revell plant in Venice, Calif., and pick up kits as part of their course.

Electronic engineers are using miniature planes to test guidance systems, and the time may come when there will be kits for the construction of planes that can be guided electronically. Producing them might be a gamble, but anyone who is afraid of risk won't last long in the model business. Revell, for example, once planned a missile model, only to have the Defense Department scrap the parent project. The company could only follow suit, with a loss of \$75,000.

American models are distributed throughout the world by the U.S. Information Service, and the larger manufacturers also send thousands of kits to underdeveloped countries. Thanks to kits, school children in Ghana, for example, are familiar with the design and operation of modern planes and automobiles although most of them have never seen the real thing. Models of the atomic reactor plant were displayed at the Tunis International Fair last year, and were officially recognized for helping confirm the United States' policy of applying technical atomic knowledge to peaceful purposes. This kit has been ap-

(Continued to page 256)

AN EYE ON SPACE

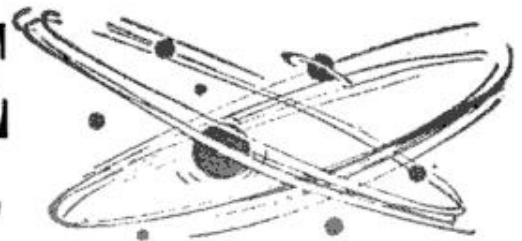

By Dr. Dan Q. Posin

PROFESSOR OF PHYSICS, DE PAUL UNIVERSITY
SCIENTIFIC CONSULTANT AND ADVISOR, COLUMBIA BROADCASTING SYSTEM

WHEN WE LAND ON MARS, we'll dash, panting, to gaze upon the canal regions. But we'll also have some more pressing problems.

The Martian atmosphere is very thin, like ours at about 50,000 feet, and we probably won't be able to breathe without one of those portable breathing units. Furthermore, we may find only about one percent as much oxygen in the Martian atmosphere as we have on Earth, and this oxygen content is not concentrated enough to pump into our breathing units effectively.

We may have to obtain our oxygen by quarrying it. By heating portions of the ground, we may be able to release oxygen which is bonded chemically into Martian soil. Of course, before going, we will want to be pretty sure that the Martian soil will have this trapped oxygen, and for this reason various soils thought to be like those of Mars are being studied now and oxygen is being extracted from them. One type of soil studied is a red sandstone from southern Texas. This soil contains much iron oxide. The second is a lava type like that of the Painted Desert in Arizona. Both of these soils, upon heating, have yielded oxygen, though not enough. Techniques must be improved to make them yield more.

Other studies looking toward Earth-peoples' survival on Mars have led to experiments on growth of bacteria in an atmosphere considered to be Mars-like. Also, to test the effect of breathing and living in a thin atmosphere, colonies of Earth-mice have been subjected to existence in tanks which are progressively evacuated of air.

A group of mice have been quite blasé about it all at the thin air pressure corresponding to 15,000 feet of altitude, and they may get by at 50,000 feet. Peruvian Indians, in the Andes, seem to enjoy life on the 15,000-foot mountain tops, and some of them don't like to go down into the valley, because so much air there gets into their lungs.

The question still remains as to how man would fare in a very thin atmosphere. On Earth we know that many animals native to the high mountains prefer to come down to lower heights to sleep. But this may be for better seclusion and shelter, and to repose in regions warmer than that on the mountain heights at night.

But more about bacteria and vegetation. Research is under way to find out what kinds could exist on Mars. To make studies one must, of course, try to duplicate Martian conditions.

Take temperature, for example. An average summer day on Mars can range from about 77 degrees F. in daytime to about 20 degrees *below zero* at night. On Mars, the atmosphere consists mostly of nitrogen, perhaps 98.5 percent. Most of the remaining small portion consisting of argon, carbon dioxide and oxygen.

In the experiments being carried out at Armour Research Foundation of the Illinois Institute of Technology, a Martian atmosphere is produced in test tubes. Into them are placed certain species of Earth bacteria and several types of vegetation. The question, of course, is can the bacteria survive in the Martian atmosphere and, if so, do they retain their initial vigor?

The vegetation used in a set of studies consists of mosses and lichens, and it will be fascinating to learn which kinds of elementary life can survive in a Martian atmosphere with what is believed to be Martian vegetation. ★ ★ ★



Elevator Hoists Boats on Cradle

Miami marine engineer Raymond Pearlson demonstrates his new "Synchrolift," which provides a fast, easy, inexpensive way to launch and load boats up to 100 tons.

The elevator, with a cradle already in position on its rails, is lowered into the water. The boat pulls in over the cradle and is lifted out and pushed into the yard.

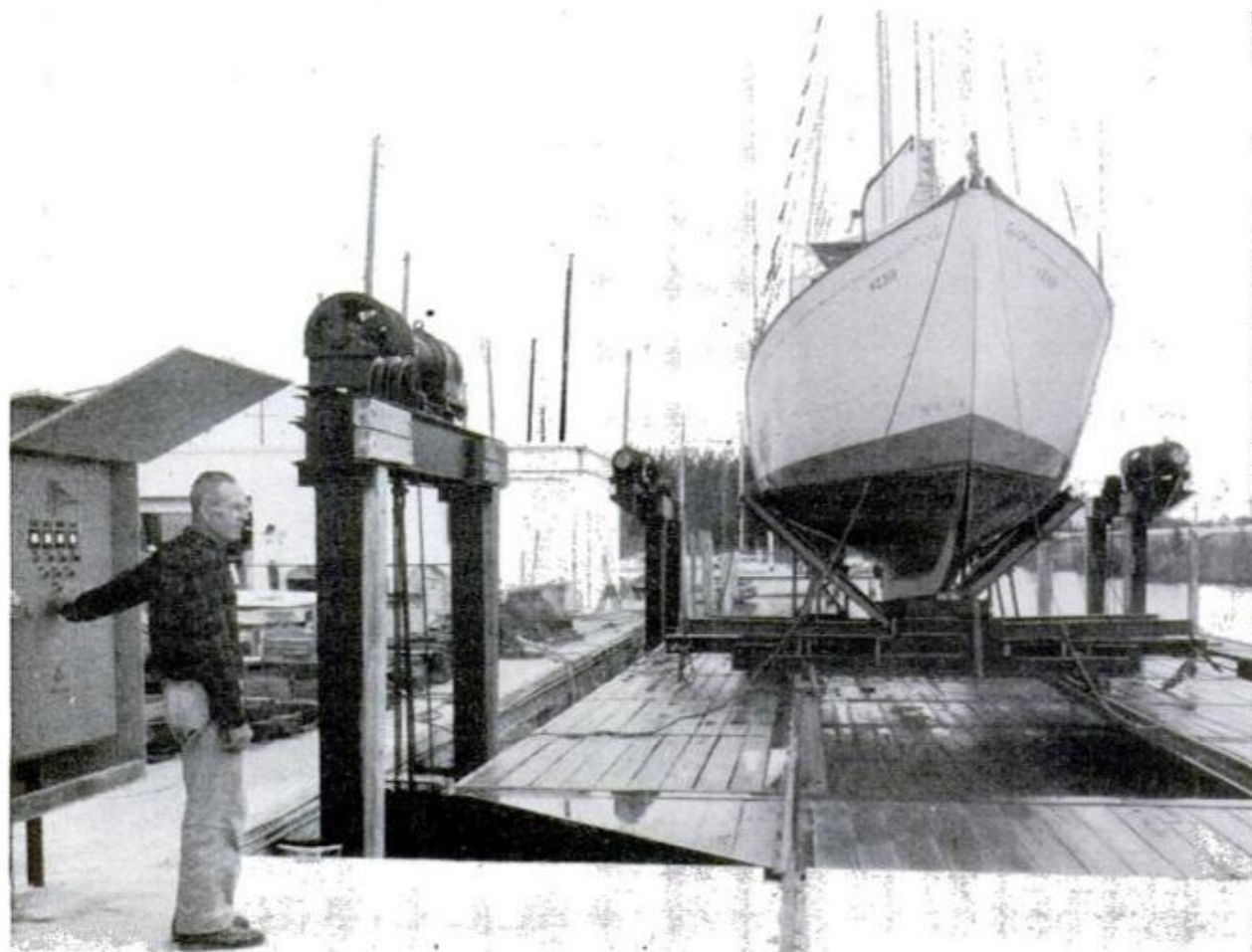

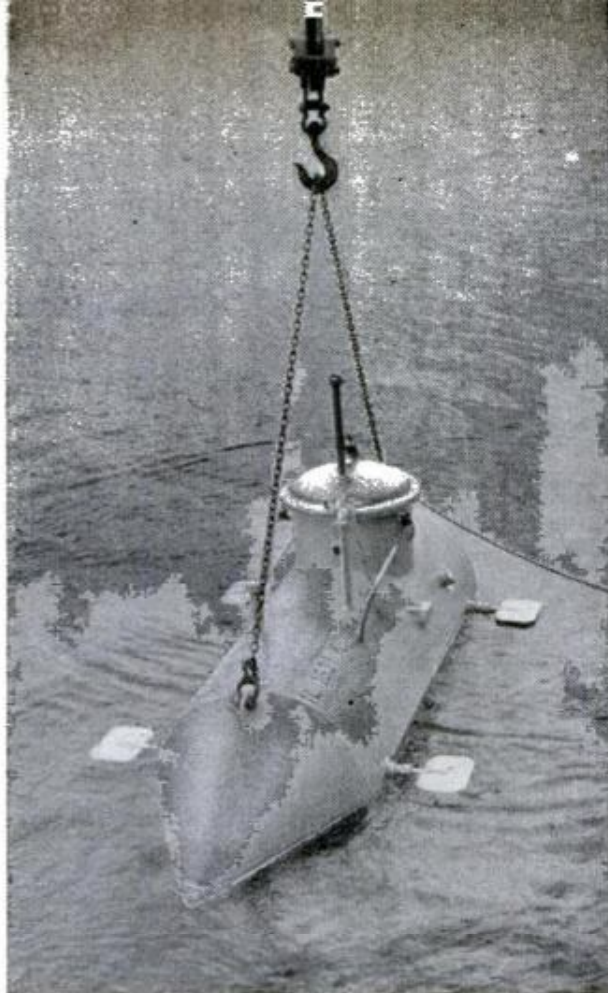

PM photo

Sub Made From Water Tank

Powered on the surface by a five-horsepower engine and underwater by a two-horsepower electric motor, a homemade 13-foot submarine now prowls Lake Michigan. Isadore Portnoff and Jerry Krason of Chicago made the hull from a used 500-gallon water tank. The craft weighs 3000 pounds.



Hot Dog!

How to heat hot dogs without bursting their skins? A West German engineer devised a table-top cooker that brings the red hots to eating warmth by bathing them in steam. Water is placed in a pan at the bottom of the heater and as many as 80 hot dogs can be placed in the glass container.

Air Force B-70 Will Fly Three Times Speed of Sound

Six jet engines will power the B-70, the Air Force's newest bomber being built by North American Aviation, to speeds in excess of Mach 3, three times the speed of sound. Shown in an artist's sketch, the

needle-nosed craft permits its crew to sit well forward in "shirt sleeve" comfort without the need of bulky pressure suits. The huge ship will be able to use runways currently accommodating B-52s.

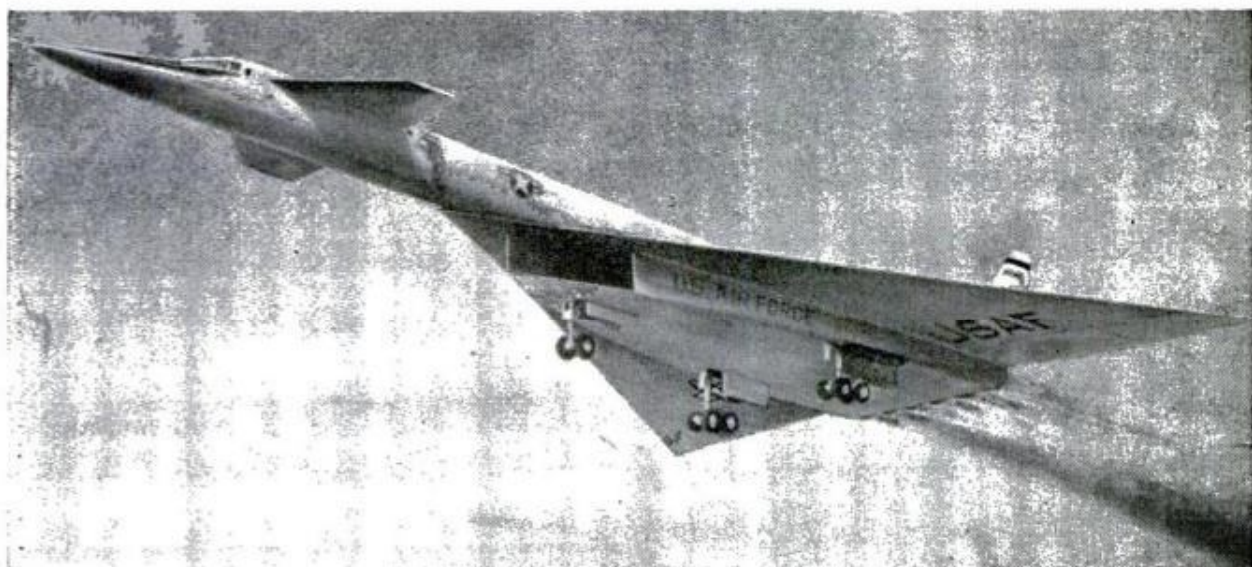



By Jim Whipple



New compacts draw buyers for "big brother" cars. Auto industry puts on the greatest show ever.

Which way will the ball bounce? The new **Buick**, **Olds**, **Pontiac** compacts are in the showrooms. **GM** has placed its big bets and now the wheel of fortune spins. Whether compacts or "full-sized" cars gain in sales, and if so which ones, is still pretty much an open question.

One thing is sure however, **B.O.P.** dealers have profited from the experience of **Chevy** dealers last year. These were the gentlemen whose showroom floors were stocked with accessory-loaded **Corvair 700's** with Federal price stickers showing radios, heaters, automatic transmissions and all the other "goodies" that **Chevy** could bolt on them.

When they saw these prices the conservative buyers of compacts—secretly hoping to find a new car at used-car prices—recoiled and threw up their hands in dismay.

Today's **B.O.P.** dealers aren't making the same mistake. Each showroom has its **F-85**, its **Tempest**, or **Special** in a stick-shift "standard" model with just a heater at a rock bottom sticker price. For **Olds** and **Buick** this comes to just under \$2500 before state and local taxes. **Pontiac's Tempest** is ticketed at a bit over \$2200 with heater.

Some early reports on the sale of new compacts indicate that they are acting as traffic builders, bringing people into the showrooms to look them over. In many cases these lookers wind up buying the "big" car instead of the compact after a real selling job by the dealer.

This, of course, is what happened in **Chevy** showrooms during the 1960-model year. They came to look at the **Corvair** and stayed to buy **Chevy Biscayne Sixes** by the trainload.

If something like this happens to **Buick**, **Oldsmobile** or **Pontiac** dealers, not too many tears will be shed, because there's more money to be made selling the full-sized cars, even at closely figured prices.

An executive of one of the **B.O.P.** divisions remarked happily after reading his first 10 days' sales report: "The big job is going great, it looks as if compact sales will be 'plus' business." In other words if

sales of the newly redesigned big **Buick**, **Olds** or **Pontiac** are good enough, the parent division will have a profitable year even if the compacts do not "take off" like **Falcon** did last year.

A compact to watch in the year ahead is **Valiant**, and possibly its higher-priced **Dodge** counterpart the **Lancer**, as well. **Valiant** sales have been coming up fast in the last few months after a very slow start. The reason given by happy **Chrysler Corporation** people is that the public has discovered that **Valiant** gives them handling, ride and roadability of a high order and plus performance of the 101-horsepower engine at prices very close to the bottom.

A look in at the Forty-Third National Automobile Show in Detroit's great new **Cobo Hall** revealed more cars and more people than had ever been together in one room before. (It's easy to do this, just get a room that measures 725 by 405 feet.)

Surveying the glittering panorama, six-and-one-half acres of shining chrome and glowing color, one couldn't help marveling at the wide choice offered the American car buyer.

The industry is to be congratulated for the scope and magnificence of its show in general and for the "Auto Wonderland" in particular. This last, an exhibit of semi-technical nature, was set up by parts manufacturer groups such as the rubber, brake, spring and electrical component industries.

It was a veritable science museum of the modern auto industry. For those who live within reach of Detroit, the show should be a "must see" next fall.

Ford and **Chevy's** new short-wheelbase light trucks, the **Corvair 95** and **Ford Econoline**, have already attracted a considerable amount of attention.

According to early reports this is not idle window shopping but solid interest backed up by rising order volume.

These useful vehicles are the result of market research (valid for a change) which revealed that most farm and delivery truck users don't carry heavy enough loads to justify the overload capacity and pulling power of today's standard half-ton trucks.

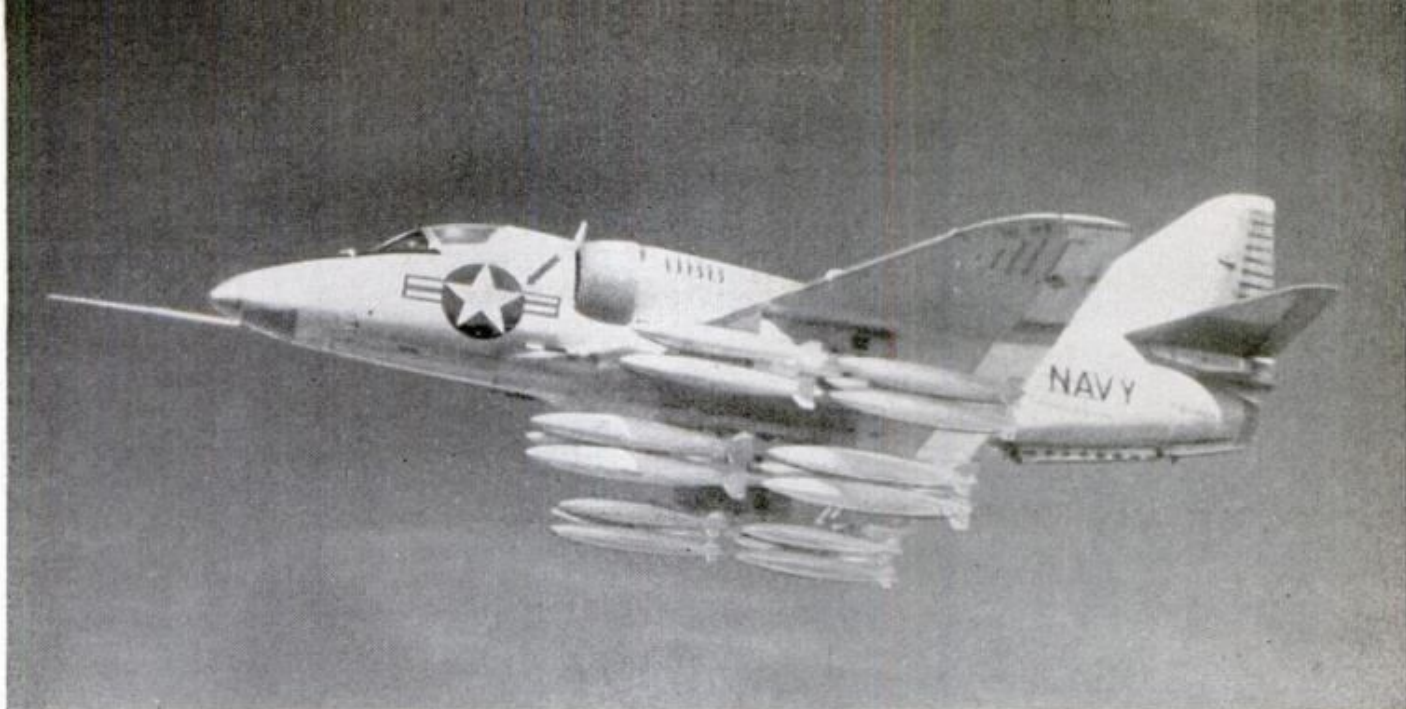

Six times as many bombs can now be carried by the Navy's A4D Skyhawk with the use of a new multiple bomb rack adapter. The bomb-cluster rack system has successfully completed a rigorous testing program which included level, dive, loft and skip bombing. More than 150 bombs were dropped in tests conducted at the Patuxent Naval Air Test Center in Maryland and from the decks of the Navy's attack carrier *Independence*

Barnum's first tour of the Midwest was made famous by the reaction of a prairie farmer seeing his first giraffe—"There ain't no such animal!" And the same farmer, seeing this new British Shortland straddle carrier, would probably have repeated himself. The big machine, designed to lift and carry huge loads of timber, pipe, girders and long bulk loads, is inspected by a giraffe at a circus in Belfast, Northern Ireland





Buried under ten feet of earth and concrete, the tunnel housing the atom gun curves like a half-mile track

The World's Greatest

By Richard F. Dempewolf

IN A CIRCULAR underground tunnel that is half-a-mile long and big enough to accommodate a subway train, groups of technicians move along a curving line of magnets strung down one side like a king-size necklace. Occasionally they stop to inspect one of the racks of electronic tubes set at intervals between the giant chunks of steel.

A hundred feet off the tunnel, in a balcony room housing a high-speed computer and a dial-studded control console, operators peer through windows overlooking an eerie array of equipment. On their right are twin towers of stacked capacitors encased in doughnut-shaped aluminum housings. From this monster, cables reach out through glittering clusters of glass tubes to their instrument console. In front, a 110-foot-long tube, some three feet in diameter, stretches away below them toward the big tunnel like the barrel of a mighty gun—which it is.

At a signal from the safety crew that the tunnel is clear of people, a man at the console throws the switch on a high-voltage generator. Red lights flash in critical areas, raucous buzzers bleat through

the cavernous spaces of this nine-acre honeycomb. Big gates shut and are locked behind retreating technicians and safety crew. The operator throws another switch, activating the "gun."

There is no *bang!* Just the muffled roar of the big generators. But down the length of that 110-foot barrel surges a speeding charge of nuclear bullets. In less than a microsecond they are swept into the huge circular tunnel. Through high vacuum they are speeded up by a series of high voltage "kicks" during each revolution, and are nudged into their circular orbit by staggering magnetic forces. In *one second* on that race course, the "bullets" have spun around the half-mile circuit some 300,000 times—160,000 miles—and are traveling within one-tenth-of-one-percent of the speed of light.

Then, without a sound, a tiny target, or "flag," is thrust into the path of the speeding particles. In one destructive instant, a cataclysm of radiation floods the area as atomic debris flies off in all directions to be counted, photographed in flight and painstakingly analyzed by a battery of scientists.

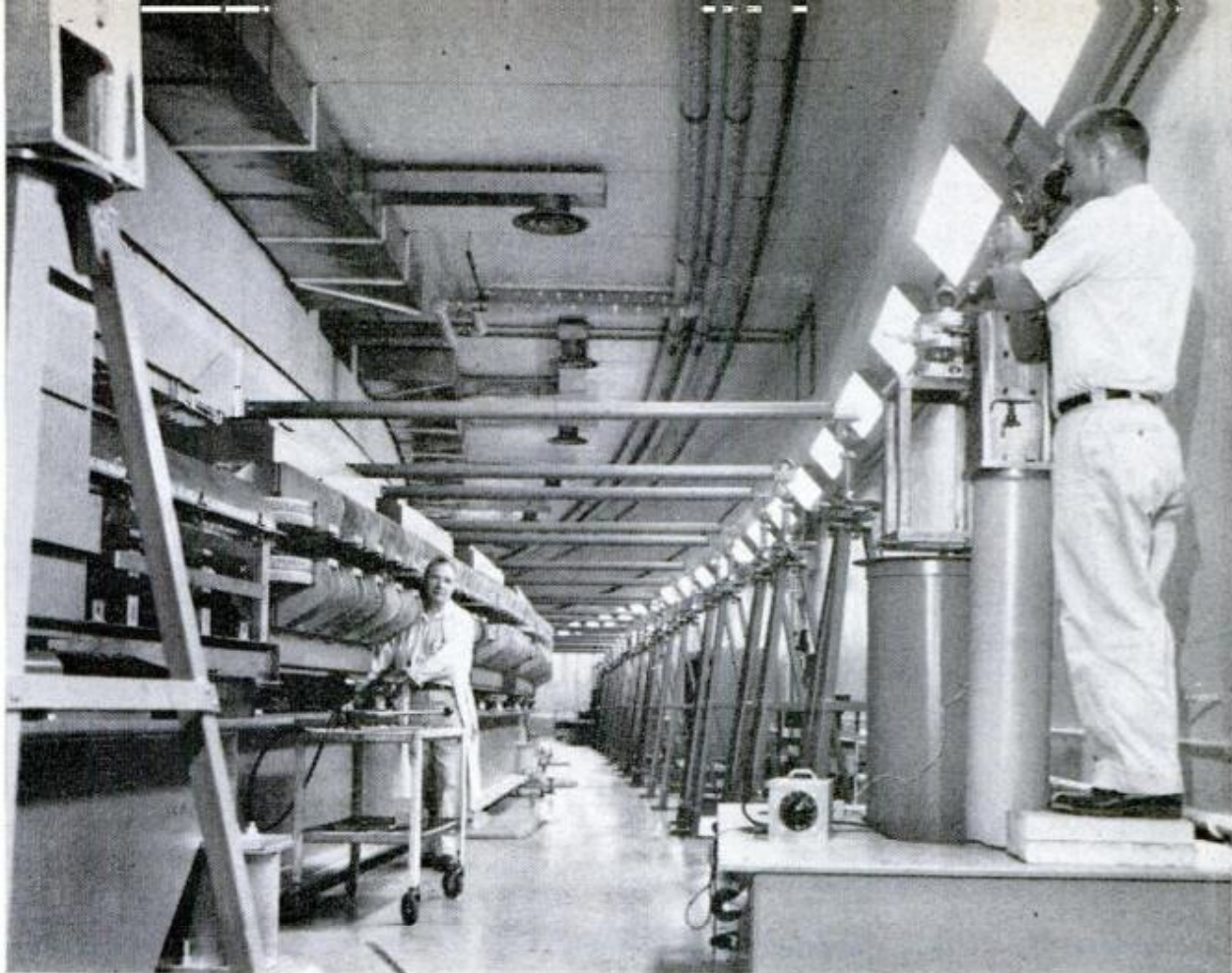

Technicians use surveying instruments to line up magnets, left, that hold proton "bullets" on true course

Atom Gun Blasts Off

Protons speed down this 110-foot-long linear-accelerator, then are pulled onto the raceway by the magnets

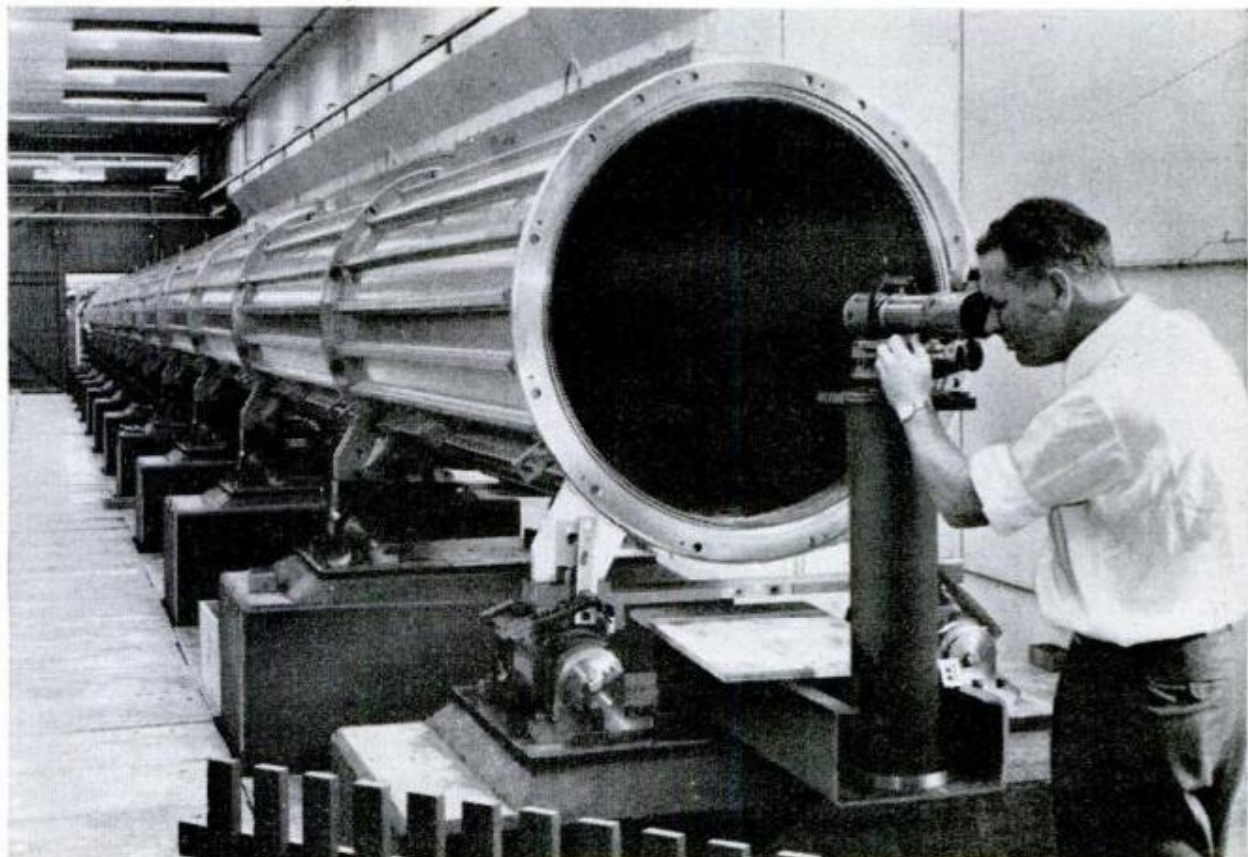

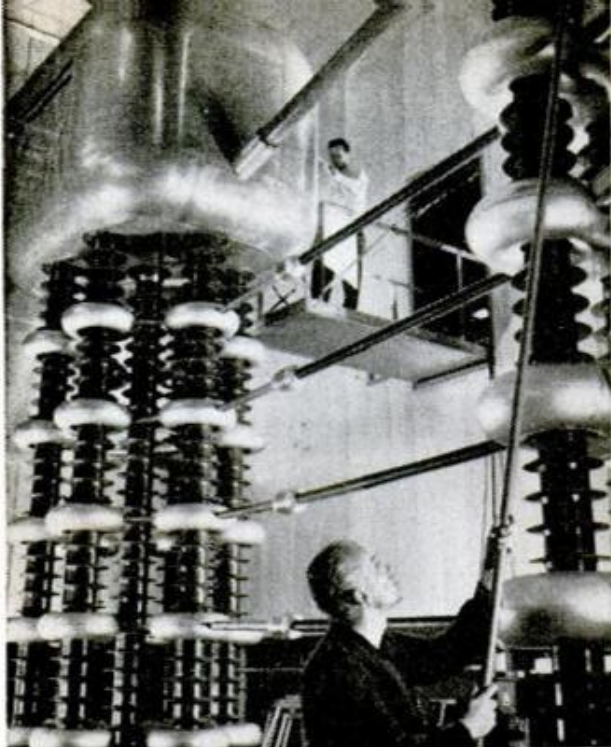

Cockroft-Walton generator gives the proton beam its first kick of acceleration — 750,000 electron-volts

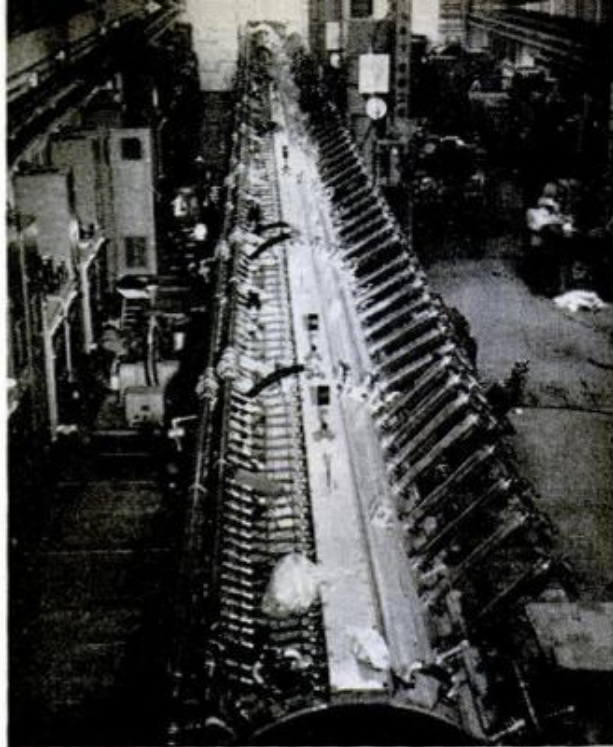

R. A. Abbott photo

This is the second stage of the linear accelerator that boosts beam by some 50 million electron-volts

This is the world's newest, most powerful "atom gun"—the 30-billion-electron-volt Alternating Gradient Synchrotron at Brookhaven National Laboratory, Long Island, N.Y. Construction of the sprawling 4400-ton string of magnets and windings began in 1956. This fall—four years and some \$31,000,000 later—the gigantic machine, known around Brookhaven as "The AGS," began firing strange projectiles at billions of invisible targets. Both bullet and target are among the smallest bits of matter in the universe.

To get an idea *how* small, try the target—an atom's nucleus—for size. In terms of a meter (about three feet three inches), the width of such a target would be about 10^{14} times smaller. That's the figure "one" followed by 14 zeros. The bullets are protons, infinitesimally small nuclei of hydrogen atoms produced in the ion beam, or "flux," created by the AGS' huge Cockroft Walton generator. The Synchrotron fires a stream of these protons at a target material containing billions upon billions of the particular atoms under study.

Construction view of tunnel housing the "gun," or Alternating Gradient Synchrotron. It's heavily shielded

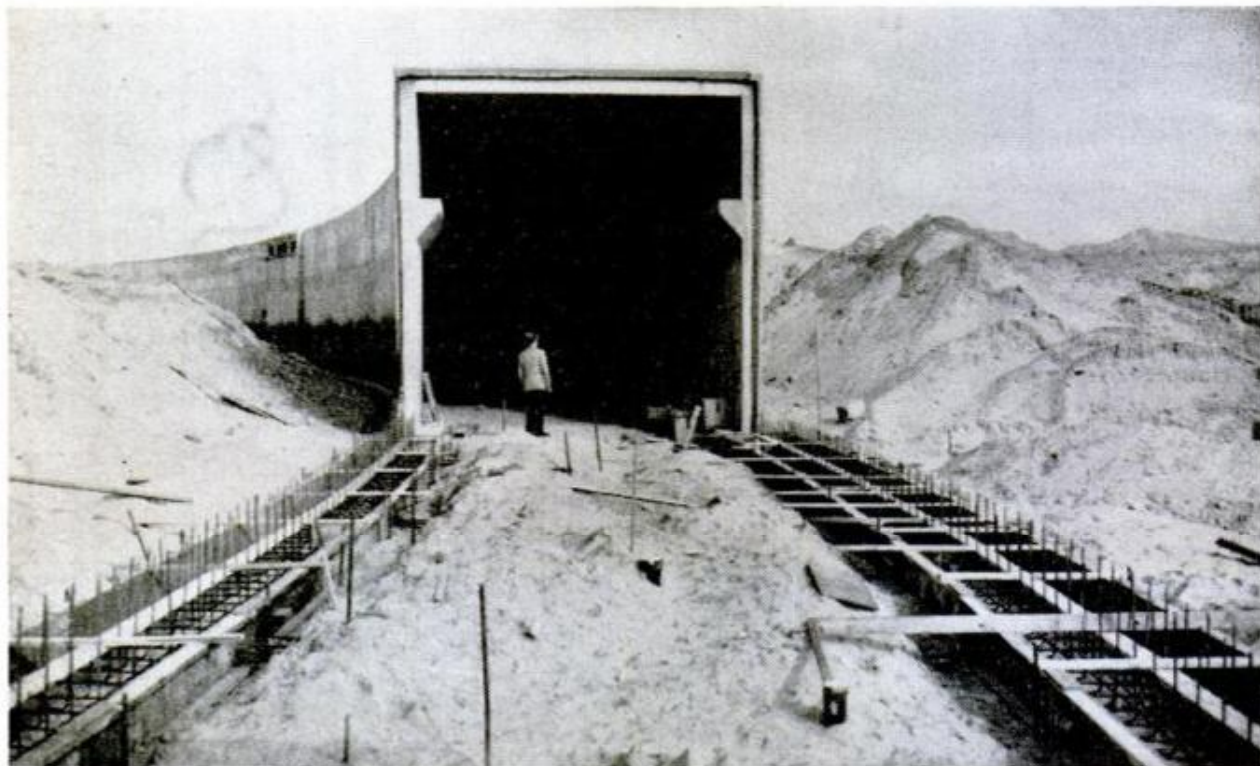

Each of the 240 strong-focusing magnets is made of 2800 laminations of steel plate. With coils each weighs about 16 tons and bends proton beam 1.5 degrees

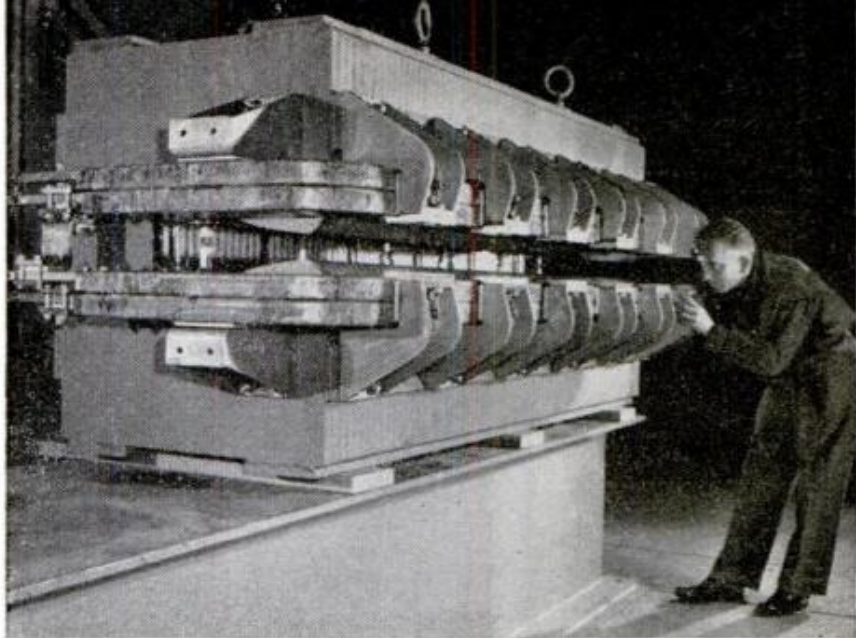

Linear accelerator (it rests on steel beam in center) injects protons into the orbit of the Synchrotron's circular ring of magnets on pedestals at right

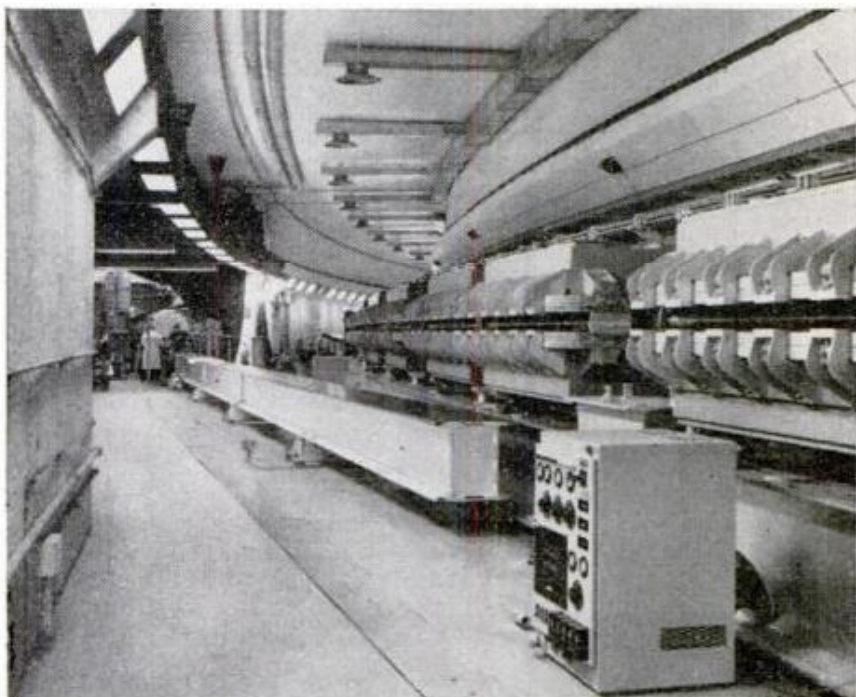

Control console of the Synchrotron is a collection of dials, switches and cathode tubes. Proton beam originates in a dome on the other side of the window



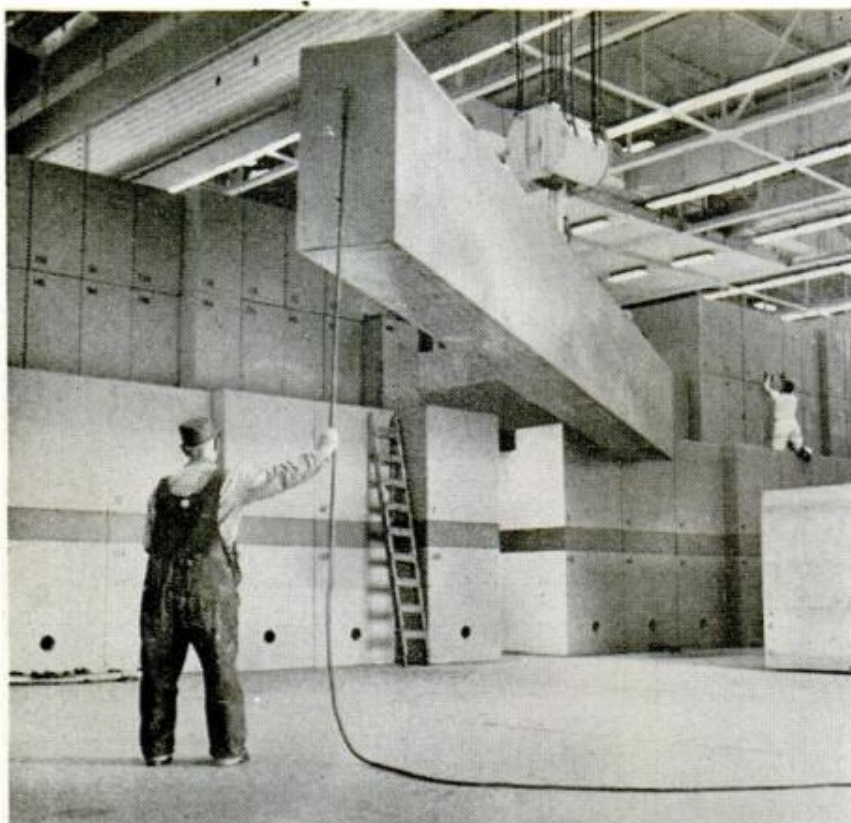

Shielding blocks in the target building are moved into place with 40-ton crane. Some of the concrete blocks weigh 34 tons; 1446 such blocks are required

The "hits" scored by the scatter-gun technique will enable scientists to recreate rare cosmic events that occur naturally only in the far reaches of space. From Brookhaven's yawning tunnel may come new clues to the greatest secrets of the universe.

What is the ultimate particle of matter? Of what is it made? How is it created? What are the cosmic forces that bind all the nuclear particles of an atom into a package so incredibly small that it takes multibillions of them to make a barely visible speck of anything? What is the key to the endless storehouse of fabulous energy that is released in the total annihilation of matter? Does it lie in the weird phenomenon of "antimatter" which, scientists have begun to suspect, was formed in equal quantities with other matter when all things were created? The instant a proton and an antiproton meet, they destroy each other, releasing energy 1000 times greater than that resulting from the fusion reaction of atoms in a hydrogen bomb. A few of these strange particles have been produced for brief instants in powerful atom-smashing predecessors to the new Synchrotron, leading atomic physicists to believe that there exists some tremendous cosmic force holding protons and antiprotons apart in the structure of matter as we know it. What is this force, and how does it work?

Particle accelerators such as the AGS function as sort of "atom microscopes." They make it possible for scientists to construct a picture of what is inside an atom's

nucleus. But the more energy that can be imparted to the proton (or electron) "bullets," the more "events" will occur when they strike a nuclear target. This means that more of the pieces that make up the structure of an atom's nucleus can be "seen" as they fly off following each atomic collision.

The first cyclotron, built in 1930, kicked particles up to about 80,000 electron-volts of energy, and gave physicists their first real look at a few basic bits of the nuclei they shattered. During the 1950's, the three-billion-electron-volt (BEV, for short) Cosmotron at Brookhaven, and the six-BEV Bevatron at the University of California, were able to produce particle beams billions of times more intense than nature's cosmic rays. From these big "guns" came the first discovery of a host of weird new particles—among them, antiparticles.

The "bullets" (the proton beam) for Brookhaven's new "gun" begin as hot hydrogen gas in the Synchrotron's Cockroft-Walton ion generator, which performs somewhat the same function as the booster stage of a rocket. Protons are knocked off hydrogen atoms with a high voltage "kick," and sent on their way with an initial energy start of 750,000 electron-volts. They shoot from the Cockroft-Walton into the "second stage"—the 110-foot-long barrel of a linear accelerator. Here the beam is squirted through 124 "drift tubes," strung down the center of the "gun" barrel in a series of lengthening groups that "bunch"

(Continued to page 248)



Fingerprints the Easy Way

No muss, no fuss—no ink or paper, either—both Texas lawman Bill Decker as he fingerprints himself with the new optical fingerprinter developed by Electronics Division of Chance Vought Aircraft. The unit uses an optical technique which picks up the print directly from his finger and projects it on a screen for immediate observation or recording. An enlargement of the screen's picture forms a background. The device is officially called Precision Recording (Optical) of Fingerprints—PROOF for short.

Windbreak Unfolds from Sled

Warming up with a cup of hot coffee during an ice-fishing session, John Buckingham of Lake Geneva, Wis., shows his unique ice-fisherman's windbreak. Built around the familiar sled that most ice fishermen use as a combination carryall and seat, the light metal framework unfolds and spreads "wings" of heavy clear plastic film. The angler sits in relative comfort on the folding seat, out of the wind but still able to see what's going on around him.

☐ The ladies have forced Boeing to redesign the floors of the 707 jet air liner. Their spiked heels were riddling dimples in the honeycomb-aluminum sandwich floor. Now Boeing is making its floors of corrugated aluminum sheets spot-welded to upper surface skins.

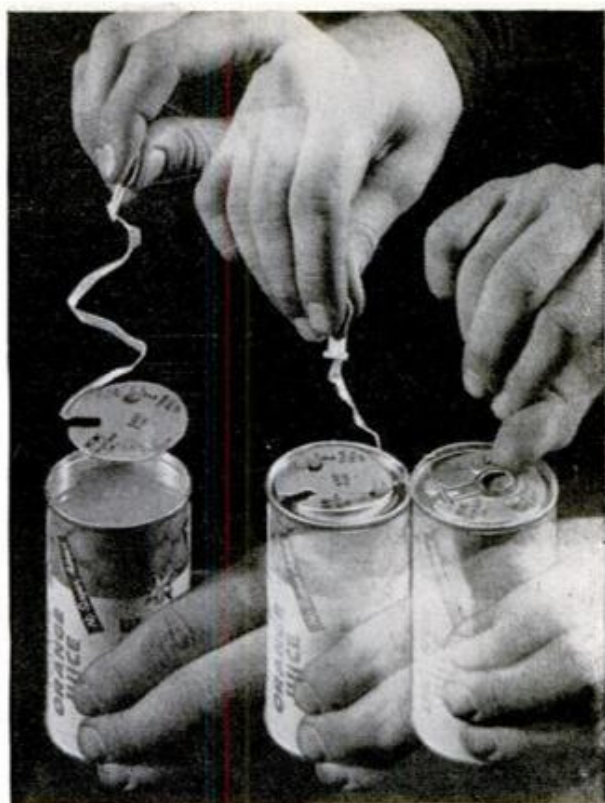

Tear-Off Top for Can

Next time that TV pitchman tells you to "tear off the top and mail it in with your entry" he may be talking about the top of a can. A quick-opening aluminum top is undergoing tests for frozen-juice containers. It has an aluminum tab which, when pulled, tears out a thin, scored strip of aluminum around the circumference of the top. The top comes free at the end of the strip, leaving a smooth, safe opening. Though designed for frozen juice, the makers are confident the tear-top has unlimited application.



SKIN DIVING FOR GOLD

By Bob Hyatt

FIVE THOUSAND gold-hungry prospectors are nothing new to the well-worn hills of California's Mother Lode country, for thousands of Forty-niners grubbed in its hills and panned its creek banks during the gold rush years in the mid-19th century. But now, a hundred years later, a new breed is prospecting those same streams—on the bottom.

Wearing underwater breathing apparatus, they probe the eddies and cracks and pockets along the rocky bottoms, picking up nuggets (two youths took 86 ounces of pure gold—at \$30 an ounce—from under a bridge on the Yuba River). They also are taking out promising muck and gravel with lightweight suction dredges, then run it over a miner's "riffle box," where the heavy bits of gold settle into pockets while the water carries the lighter sand, gravel and dirt back into the stream. There have been some real bonanzas; one man took out \$100,000 in two and a half months, and hundreds of divers pay for their time and equipment at the rate of \$100 a day. Statistics and details are scarce, though. You can't stake a claim on a river bed, so the successful divers learn to keep quiet.

You can go into business for as little as \$25 with mask, snorkel, and a little hand "sucker" to pick up gravel; and really setting up with a dredge, compressor, wet suits (it's cold down there) and breathing gear for something like \$1000.

But the lure is strong—you could take that thousand bucks out of a rich pocket in a few minutes if you're good, or lucky—or both.



Boy-girl diving team works over a rocky river bottom with prying tools and a bag for specimens. Below, Dick Anderson, veteran Los Angeles skindiver, holds his portable dredge. In his left hand is a small "riffle box." California dealers can't keep up with the demand for small-scale dredging gear





Most divers work in teams of at least two, one working the bottom while the other tends the compressor and riffle box. Here, borrowing the old-timers' panning technique, Dick Anderson pans out the take while he takes a breather and thaws out. There's about three ounces of flake and nugget gold in that pan; that's at least 90 dollars' worth. Below, it's not all at dramatic depths. A diver with only his face in the water chips at an underwater crack in a riffle. Air hose leads to compressor, saves carrying and refilling tanks



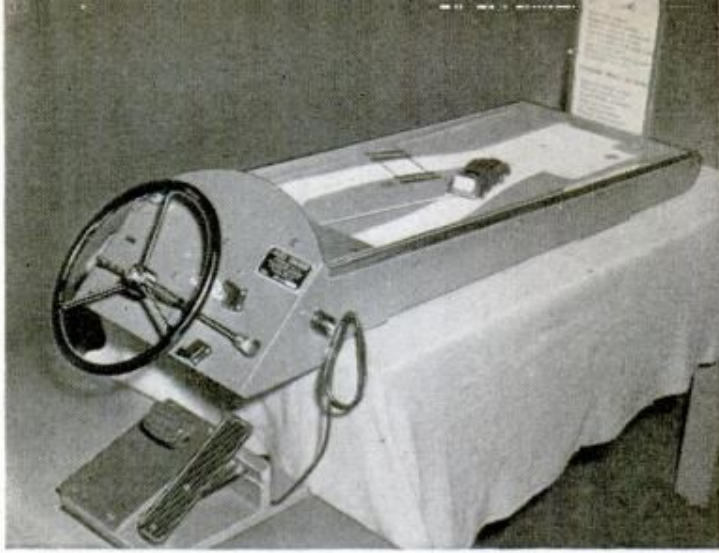

Driving School on a Tabletop

Beginning drivers can practice highway and city driving complete with turns, stops, traffic and even parallel parking on a new automobile trainer. The machine transmits the manipulations of wheel, brake, accelerator and gearshift lever to a model car which runs on a roadway printed on an endless belt. The controls operate a variable-speed motor and reversing switch.



Suspension Bridge For Conveyor Belt

Spanning the Snake River near Pasco, Wash., a 930-foot-long suspension bridge supports a conveyor belt that carries construction material from one side of the river to the other. The belt transports aggregate for the concrete construction of the Ice Harbor Dam being built by the U.S. Army Corps of Engineers to provide 540,000 kilowatts of power and to extend navigation 35 miles up the Snake. If the rock and sand had to be trucked from one side to the other, the shipping distance would be 15 miles. The belt delivers 660 tons an hour from sorting bins on the south shore to the batch plant on the north shore. This aggregate will be used for making up a large portion of the more than one-million cubic yards of concrete that are required to fill in the \$135,000,000 dam and lock. The suspension bridge is supported by steel towers which are 100 feet tall.

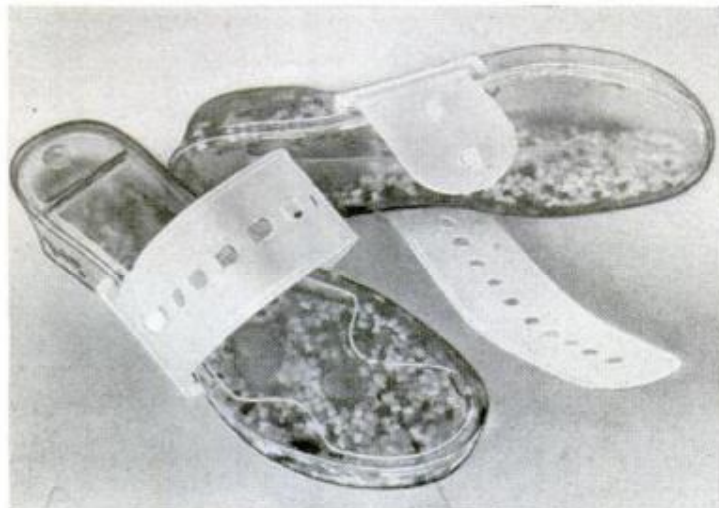

Aquarium Sandals

Plastic sandals with built-in aquariums may be turning up at beaches next season. A plastics fabricator has announced production of a hollow sandal made of transparent acetate plastic and filled with a clear liquid, brightly-colored plastic pebbles, and plastic fish. As the wearer moves or walks, the contents move and the "fish" dart among the "pebbles." Sure to draw attention on or off the beach, the sandals are available in sizes to fit girls from ages 3 to 12.

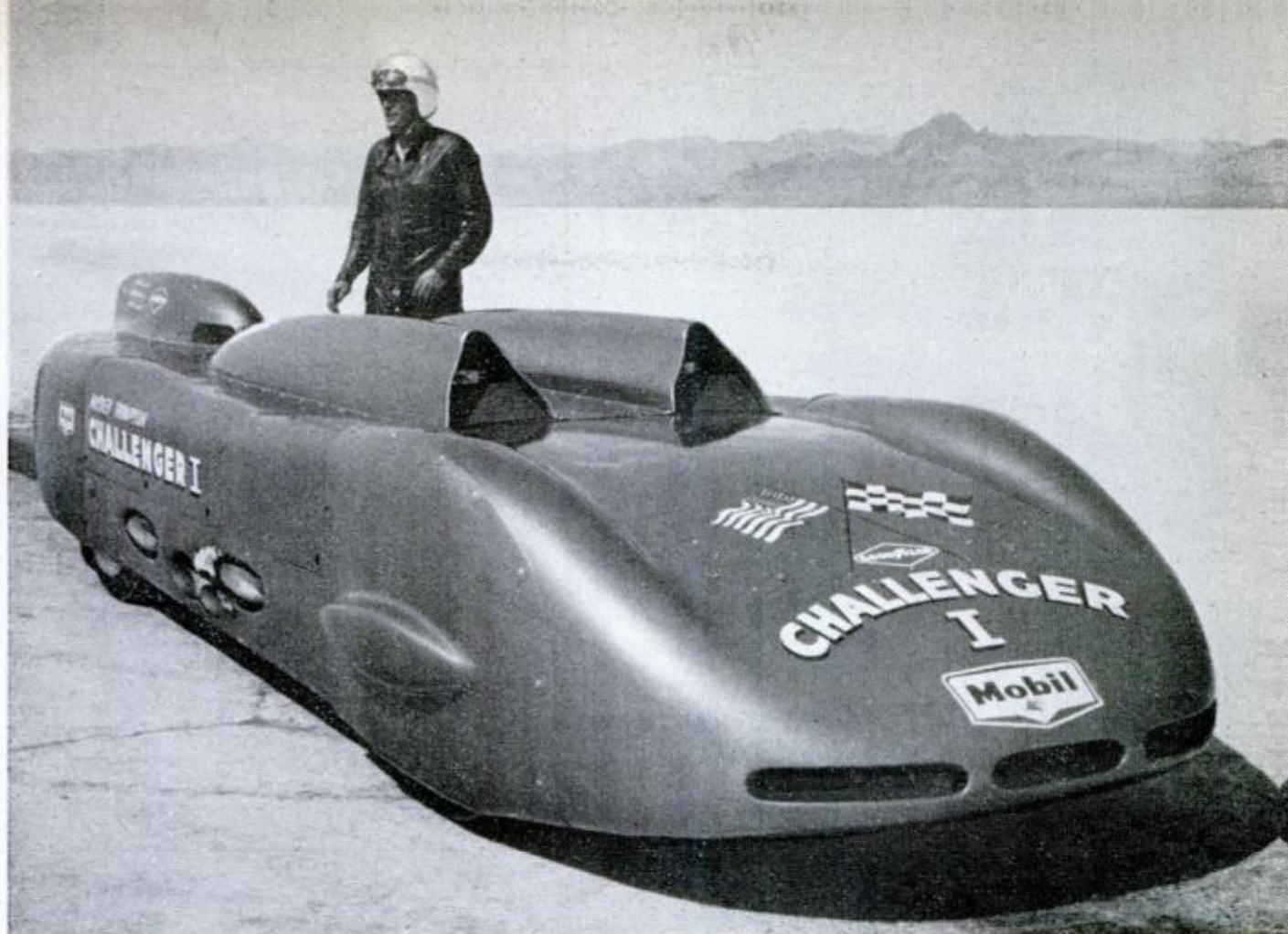

Mickey Thompson and his *Challenger I*, which sped 406.6 miles per hour one way, but broke down on return

By Thomas E. Stimson, Jr.

AS OF NOW, hot rodder Mickey Thompson of California has driven a car faster than any man in history. This fall he was clocked at Bonneville at 406.6 miles per hour, three and a half miles per hour faster than the unlimited one-way speed made by John Cobb of England 13 years ago.

Thompson snapped a drive shaft while shifting into second at 210 miles per hour on his return run and failed to beat Cobb's international two-way land speed record of 394.1 miles per hour.

Bonneville's Magnificent Trials — and Errors

Bluebird on trailer in foreground is followed by English "task force" across salt flats to measured course

PM photos by the author



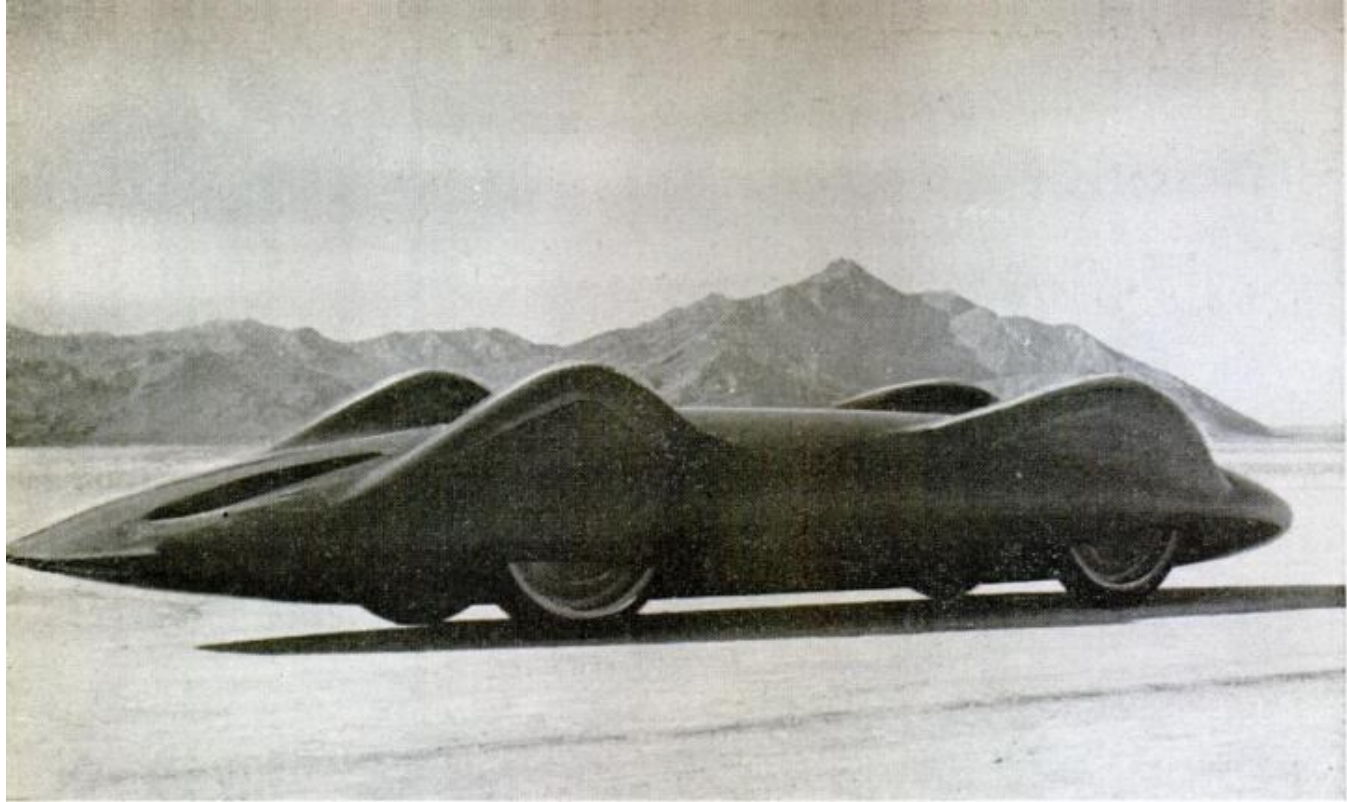

The sleek *Bluebird*, product of more than a million man-hours of work by employees of some 90 British firms, made trial runs on the salt flats before its ill-fated assault on the international land-speed record

In all, five different drivers tried to beat Cobb's old record this past season. One contender, Athol Graham of Salt Lake City, was killed when his Allison V-12-engined car got away from him at around 300 miles per hour and rolled across the salt.

Art Arfons, Akron dragster, burned out the clutch of his Allison-powered vehicle and retired. Dr. Nathan Ostich of Los Angeles was out of the running when his pure jet automobile developed suspension trouble at about 300 miles per hour.

The most ambitious attempt of all was made by Donald Campbell of England whose *Bluebird* automobile represented virtually a national engineering effort by British industry. Ninety different companies participated in building the car and more than a million man-hours of work went into its design and construction.

Campbell's land speed record attempt cost an estimated \$4½ million.

Bluebird was powered by a 4250 horsepower *Proteus* free-turbine jet engine that was modified to deliver its power to all four wheels. The car was expected to be safe and stable at up to 500 miles per hour and might even go faster if a suitable straightaway could be found for it. The car was the most sophisticated and advanced land vehicle ever built.

The experts still don't know exactly what happened to it. In a preliminary run and while accelerating rapidly, the car yawed away from the track. It appeared to lie almost on its side for a moment, then it became airborne. In a series of long bounces and slides it traveled three quarters of a mile before losing its right wheels and coming to rest. The engine was still

Optical system projects readings of *Bluebird's* speedometer and accelerometer as images that appear to be on track surface 100 yards ahead of car. Driver sees figures without moving eyes or changing their focus

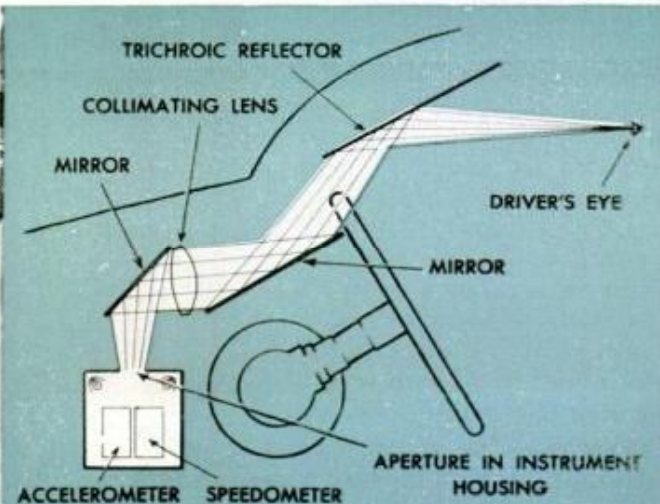

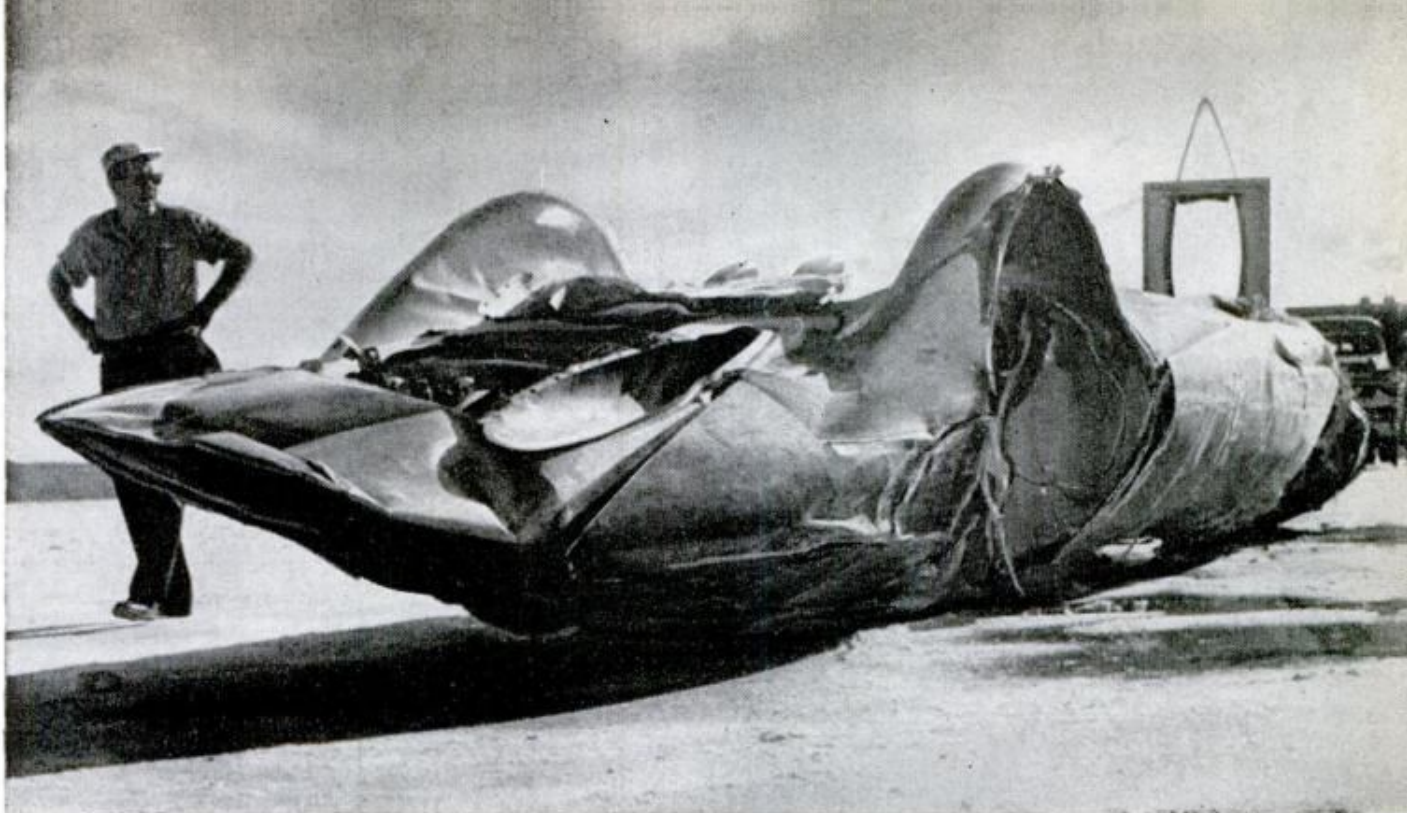

UPI photo

A slight swerve from the course at 325 miles per hour put the *Bluebird* into a skid and a series of bounces that ended current hopes for a new land record. Driver Donald Campbell escaped with minor injuries

running, at idle. Campbell was shaken and bruised and the car was too badly damaged for another attempt this year.

Comparing Mickey Thompson and his *Challenger I* to Campbell and *Bluebird* is like comparing David to Goliath. Thompson's four-wheel-drive car is powered by four reworked and supercharged Pontiac automobile engines and is mostly a "made-by-Mickey" product. Yet Thompson is no novice; he has been running at Bonneville for years and holds many of the all-out speed records. As far back as 1953 he turned 194 miles per hour in a modified coupe.

Last year in *Challenger I* he broke all of John Cobb's old records except for the flying kilometer and the flying mile. He set a U.S. one mile record of 363.6 miles per hour.

His car is 19 feet 7 inches long and weighs approximately 6000 pounds. It is completely unsprung, with all its weight resting solidly on its axles. The four engines burn straight alcohol, develop in excess of 3000 horsepower, and are cooled by ice water circulated from individual tanks. In addition to disk brakes the car uses a drag chute for deceleration.

The driver breathes oxygen and wears shoulder harness. He sits in a semireclining position with his knees higher than his hips in an armored cockpit behind the engines. He has two foot pedals, the right one for acceleration, the left for braking. The brake pedal has a cap at its tip into which the toe of the driver's shoe fits.

Tires have always been a major problem in attempts at new speed records. Cobb's

Campbell, son of the famed Sir Malcolm, dons oxygen mask before seating himself in the *Bluebird*'s cockpit

PM photo by the author



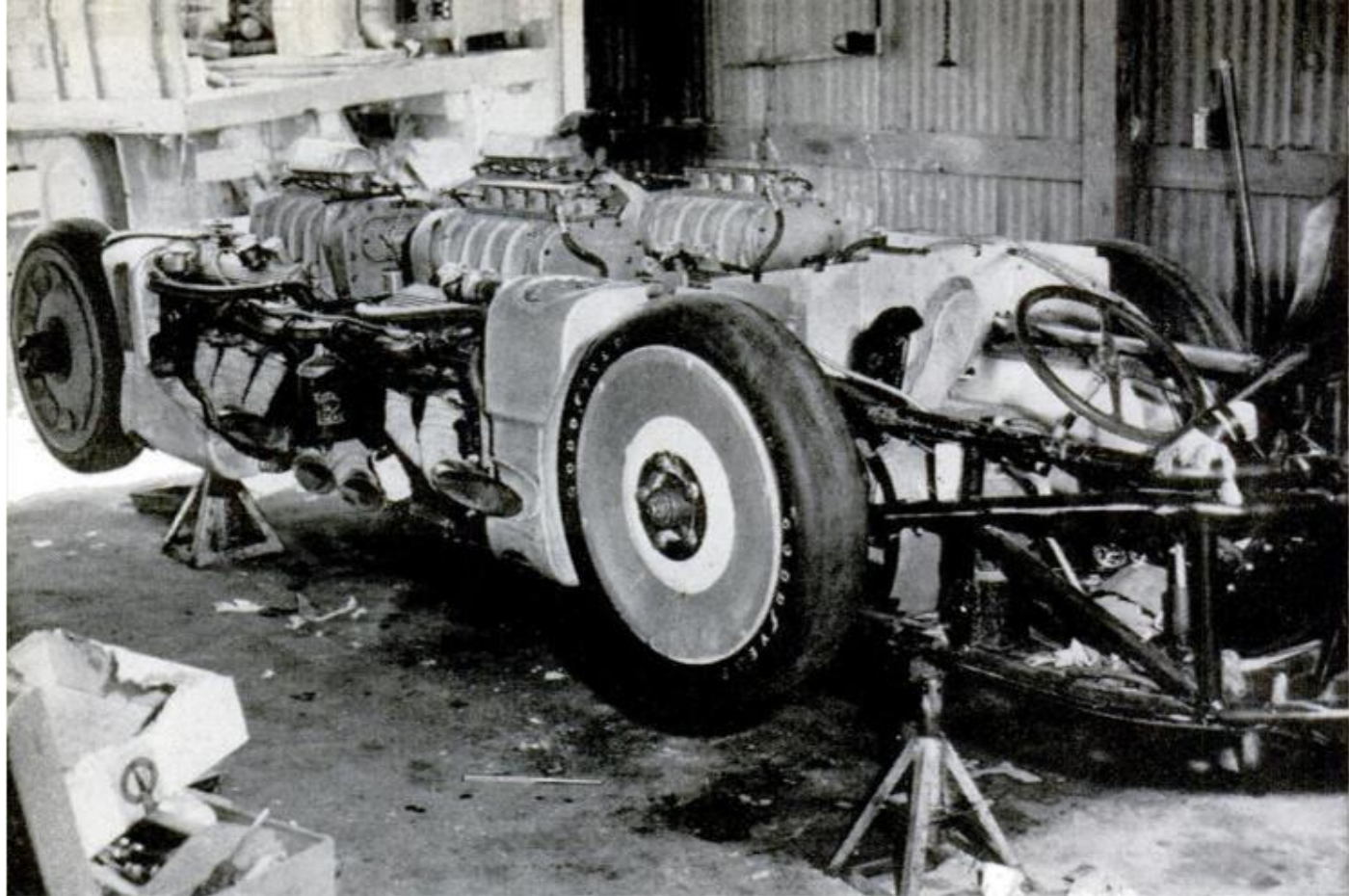

FM photo by the author

Mickey Thompson's car in a garage at Wendover shows its four supercharged Pontiac powerplants. The slick, tubeless Goodyear tires, built for Thompson, have been machine tested at 500 miles per hour under load

tires, the best that could be built in 1947, were in shreds at the end of each run.

Thompson used specially designed tubeless Goodyear slicks, 30 inches in diameter, that were tested under load in excess of 500 miles per hour on Goodyear's multi-stage dynamometer. The tires have a carcass of low angle nylon cord and an outer coating of pure rubber only .020 of an inch thick. They are mounted on 21-inch magnesium wheels, are inflated to 100 pounds per square inch. Normally a "land speed record attempt" tire is changed at the end of each run; Thompson's proved to be so good that in trials he used the same set of tires for more than 100 miles.

Thompson's top speed came at the end of almost a month of test runs during which time the car was modified several times. At first the front wheels were spinning excessively because aerodynamic lift lightened the front of the car. Thompson added 700 pounds to the front end, later installed an air spoiler in the form of an aluminum rib across the front of the body to decrease the lift.

England has held the record for the flying mile for decades and means to keep it if possible. Campbell's father, Sir Malcolm, held the record several times in the past. Campbell himself holds the world speed record on water, having traveled at the rate of 260.35 miles per hour in his *Bluebird* jet hydroplane.

Campbell left as little to chance as pos-

sible when he decided to go after the land speed record. Norris Brothers, Ltd., the big engineering firm that designed the *Bluebird* boat, was put in charge. Five years went into the designing, testing and construction of the car.

The driver breathes oxygen through a mask. His helmet contains a two-way FM radio that connects with the pits. So that he won't have to take his eyes from the course in front of him, the figures that show his speed and rate of acceleration are reflected onto the windshield. Important pressures and temperatures in the vehicle are transmitted by radio to a telemeter truck. Technicians can advise the driver by voice if they see that the oil in a gearbox, say, is reaching a dangerous temperature.

The car is 30 feet long, 8 feet wide and 4 feet 9 inches tall. It weighs four tons and clears the ground by four inches. Its main frame is made up of sheets of aluminum honeycomb sandwiched between aluminum plates. A fully independent wheel suspension system is used.

For the speed record attempt, Dunlop developed a new low-profile tire 52 inches in diameter, of a special low-stretch rayon and coated with a scant one-fiftieth of an inch of rubber. The inner tubes are inflated to 130 pounds per square inch with nitrogen gas and the tires are so stiff that there is no standing wave and virtually no centrifugal distortion at 500 miles per hour, the speed at which they have been tested.

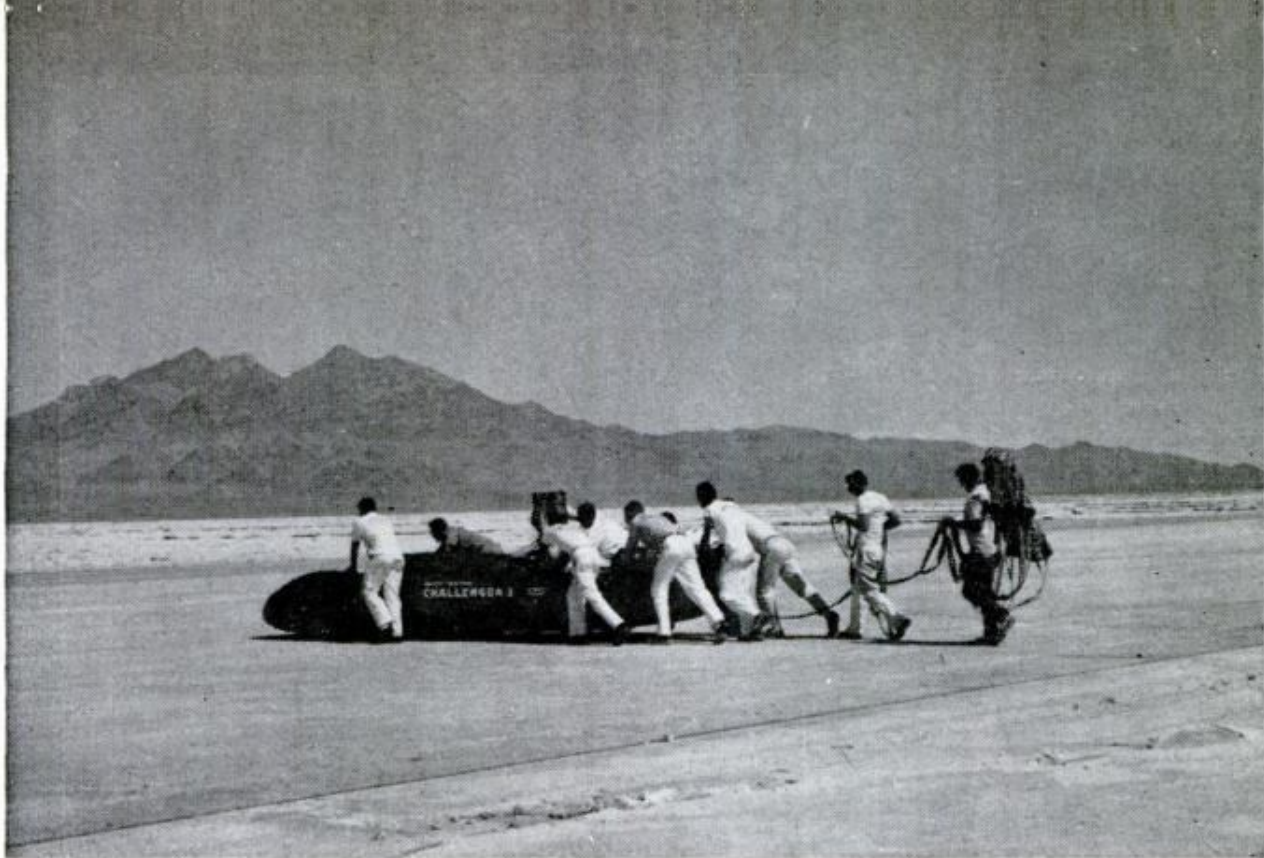

Crew of technicians with Mickey Thompson's *Challenger I*, a car that has traveled faster than any other automobile in history

Thompson in cockpit of his car with shoulder harness, crash helmet and oxygen mask. Helmet fits tightly inside steel shell that is part of the car's body



PM photos by the author

"Unlike the limited record breaking cars of the past, *Bluebird* has no large tail fin to help stabilize it," says K. N. Norris, one of the designers. "A tail fin would need to be so large that it could sway the car violently in side gusts.

"Instead, the big wheels provide considerable stability. Each wheel and tire assembly weighs 400 lb. and at 400 miles per hour is rotating at around 2600 revolutions per minute. This produces a strong gyroscopic effect. The car tends to travel straight ahead.

"In theory the body is aerodynamically

neutral," Norris continues. "Our desire was to carry the car's static weight on its wheels at all speeds. Four of the telemetry circuits in the car are used to measure the angles of the wheel suspension legs, to tell us whether the car is resting too lightly or too heavily on its wheels at any particular speed."

One of the oddities of a fast car is that its front wheels rotate faster than its rear wheels during deceleration. The center of gravity moves forward when the car is being braked, putting more weight on the front tires and depressing them. In effect

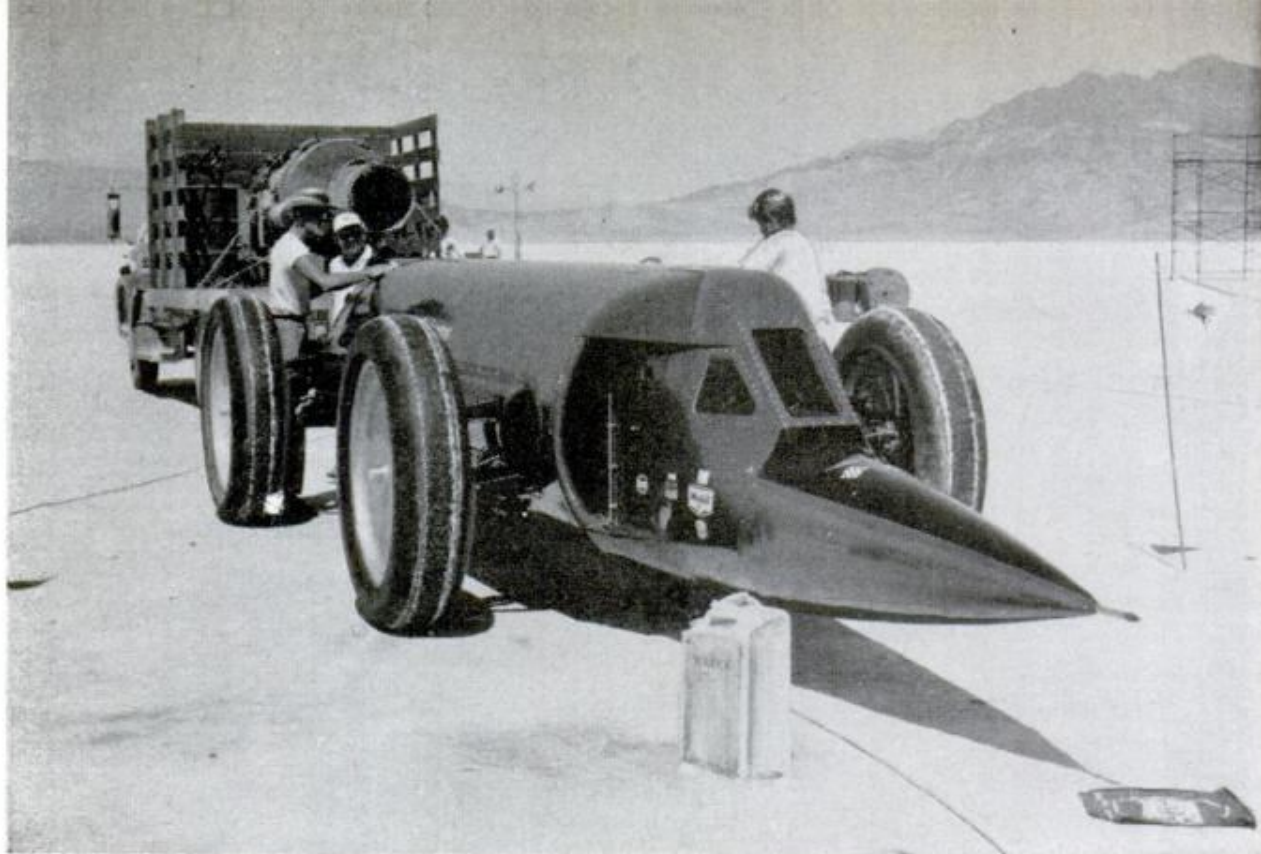

Pure jet racing machine driven by Dr. Nathan Ostich of Los Angeles developed wheel shimmy at 300 miles per hour and did not run for the record. Dr. Ostich plans to change suspension

Art Arfons of Akron, another contender for speed record, had clutch trouble. Here he works over his car's Allison V-12 engine
PM photos by the author

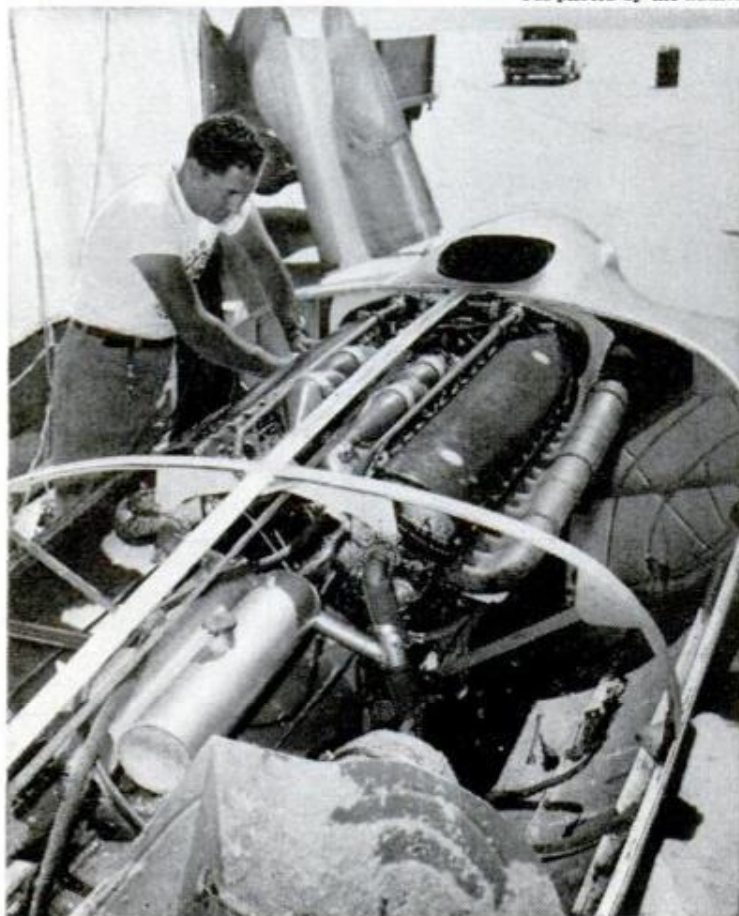

they become smaller and so must rotate faster.

In a four-wheel-drive car with all wheels driven by a single engine this creates a serious problem called "shaft windup." The front wheels try to turn their shafts and gears faster than the engine will allow. To avoid heavy stresses and the chance of a snapped shaft, a free-wheeling device is incorporated ahead of the engine.

From its planned top speed, *Bluebird* was to be decelerated below 400 miles per hour by aerodynamic speed flaps that open into the wind from each side of the rear of the vehicle, then by multiple disk brakes on each wheel shaft. These are mounted inboard on the gear boxes to reduce the amount of unsprung weight. Their friction elements consist of asbestos, powdered metal and additives molded to shape. Under full load the brakes heat up to 2200 degrees, turning red and then yellow with heat. One of the service vehicles carries high-speed fans to cool them at the end of each run.

To bring *Bluebird* to the U.S., an expedition was made up virtually on a task force basis. Tons of spare parts were shipped from England. Eighty tires were packed in separate containers and a dozen extra wheels were turned out. A special trailer was built for moving the

(Continued to page 242)

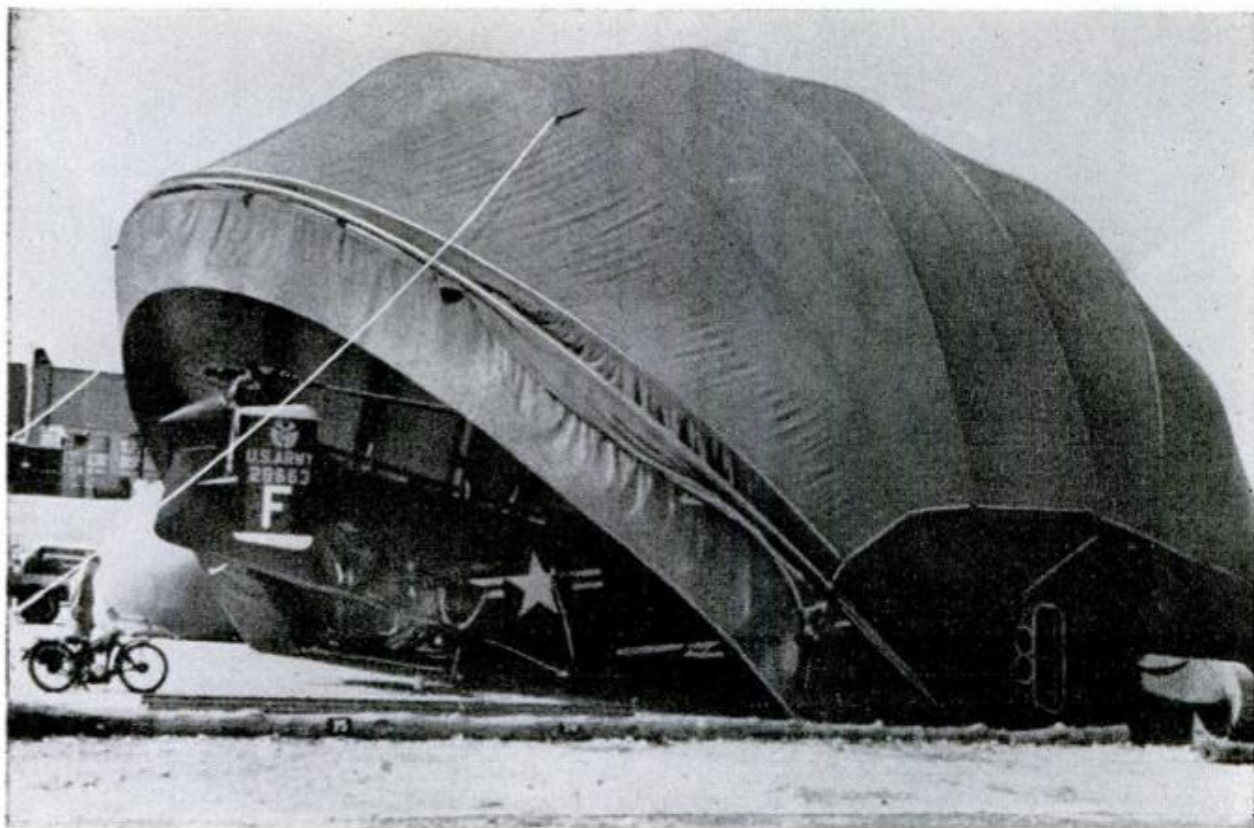

Portable Hangar for Helicopters

Easily moved by truck, an Army hangar may be folded up and transported to advanced areas for housing helicopters. It opens up accordion-fashion, supported by steel ribs, and can be held partly opened to

allow ground crews to work on craft in daylight. When fully closed for complete protection, it is supported by a small blower. The hangar stands 36 feet high and weighs 7400 pounds.

High Chair Collapses Into Bed

Since lunchtime for children is quickly followed by naptime, a French inventor devised a chair for feeding that quickly converts into a bed for sleeping. The chair's

table and footrest fold to form the foot of the bed; the backrest folds back to form the head. The canopy for the day-bed slips into a pocket behind the chair.



French chair that folds into a bed for children stores flat



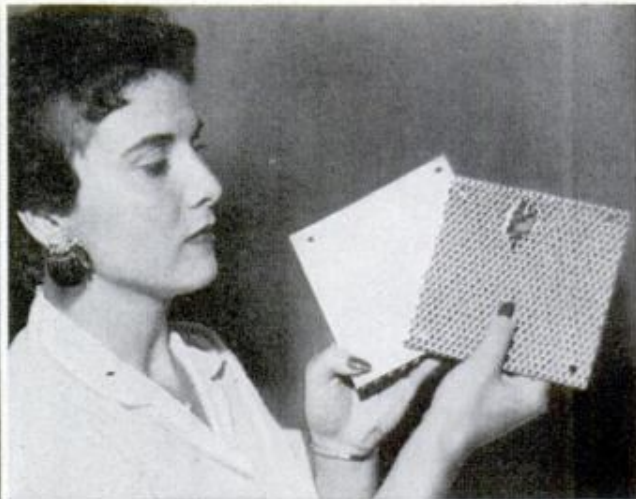
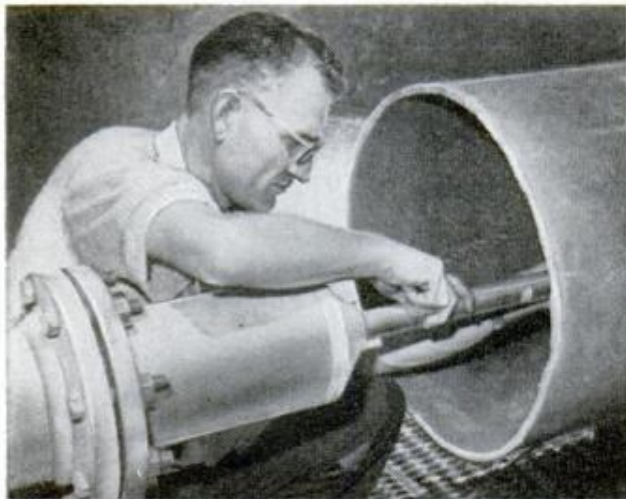

Fastest Gun in Texas for Artificial Meteorites

Colt's frontier handguns, firing their bullets at around 550 miles an hour, were peashooters compared to a "gun" developed by Chance Vought Aircraft engineers in Dallas. Designed to fire tiny artificial meteorites through a vacuum tank and into samples of structural materials for space craft, the gun uses a shaped charge of RDX

explosive to accelerate $\frac{1}{140}$ -ounce pellets of aluminum to velocities of 16,000 miles an hour. Above, left, H. T. Armstrong fits a 1.2 by 3.5-inch charge into the firing tube. Electronic timing grids measure the speed of the pellet. At right, a damaged aluminum "honeycomb" sample after being struck by a tiny "meteoroid" at near-orbital velocity.

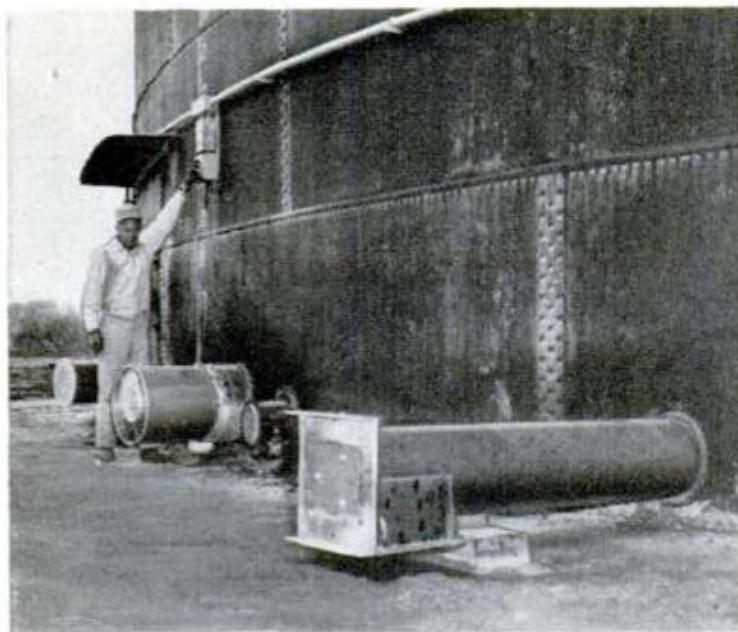

Converted Fuel Tank Stores Texas Grain

Take a quarter-million bushels of grain in need of storage and an unused railroad oil-storage tank, add an ingenious storage engineer, and you get one of the biggest, and perhaps the strangest, grain bins in the business. The Johnson Grain Company, of Dallas, Tex., took over the oil tank at Silsbee, Tex., a 30-foot-high, 144-foot-diameter steel tank. They cleaned it up, added loading and unloading equipment, a ventilating system, and a temperature-control system. The converted tank holds 128 carloads of grain, usually milo-maize, and keeps it in excellent shape awaiting shipment. At left, top, a worker checks for "hot spots" on an electronic thermometer that gives 144 temperature readings from thermocouples spaced every five feet through the interior. Below, another worker checks a vent fan, one of eight five-horsepower electric fans that suck air in through roof vents, circulate it through the grain, and discharge it through four ducts at the base. The large pipe in the foreground of the top photo houses a power auger that can completely unload the tank in about three days.

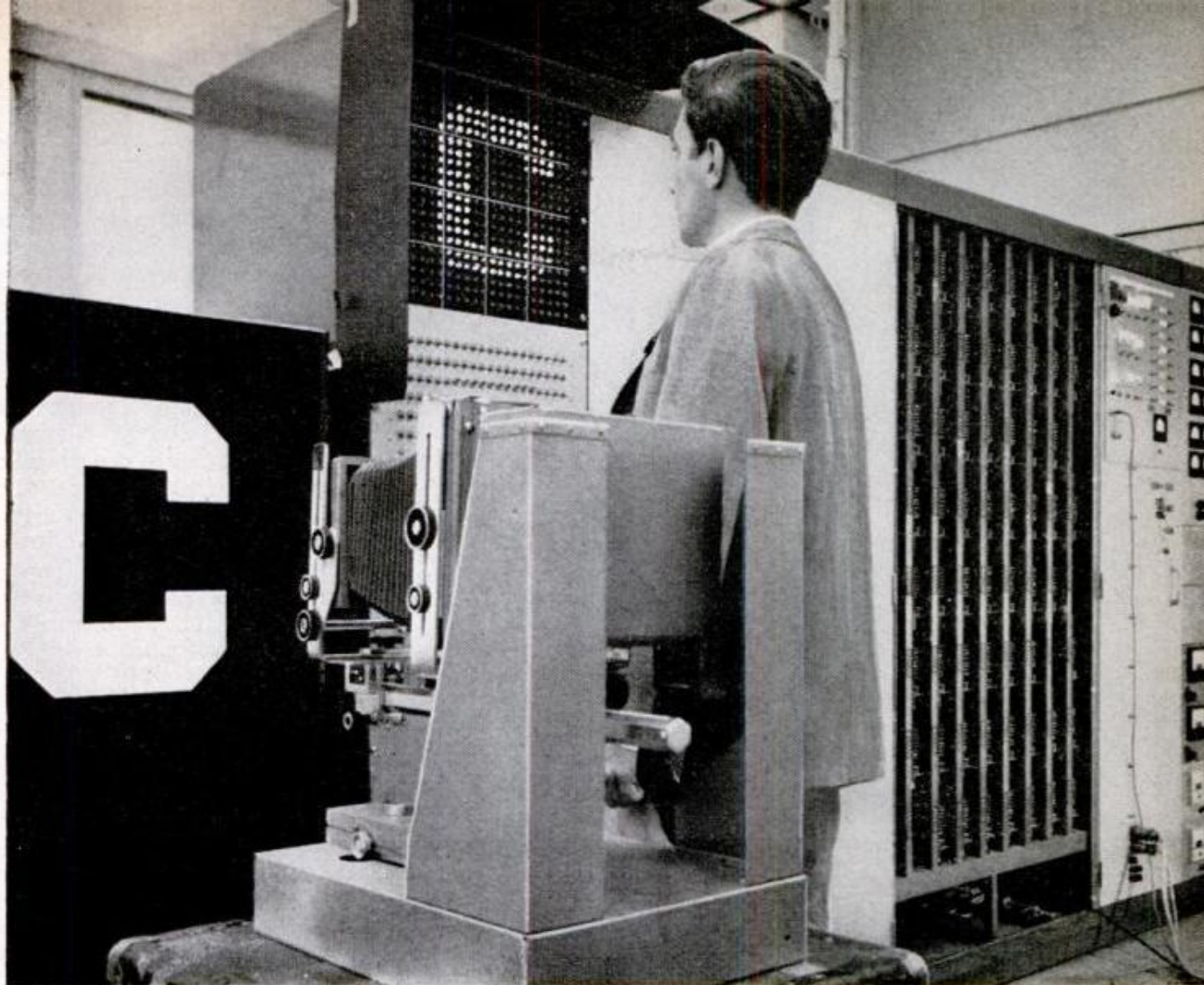

Perceptron identifies C. This type of "reader" will eliminate slower human reader from first step of translating

The Magic Box That Reads Russian

It translates faster than you can read

By Volta Torrey

FIFTY YEARS AGO *Popular Mechanics* pictured a box on the side of a telephone to convert one language into another. More has been done to make such an automatic interpreter possible in the last 10 years than was done in the first 40. Still more will be done in the next 10 years.

Printed words now can be translated faster than a tobacco auctioneer can talk. Next year the U. S. Air Force expects to have an "automatic language translation complex" capable of turning a 300-page Russian book into English words and phrases in an hour.

A machine already is translating the Russian newspaper *Pravda* into English.

Russian-English dictionary looks like phonograph record. Words are in band of tiny streaks near rim





Congressmen consider its output readable, but Dr. Gilbert W. King, director of the International Business Machines Group which developed this machine calls what comes out of it "pidgin English." (It recently translated "Little Red Riding Hood" as "Red Cap.") IBM engineers now consider this machine obsolete, and are building a new transistorized model.

Good machines only do what they are told to do. To produce better translations now, machines must be told how to do more than look up the meaning of words and phrases. They must be instructed in analyzing sentences in one language and synthesizing new sentences in another, which calls for a more complete knowledge of languages.

This is being acquired. Dr. Anthony G. Oettinger of Harvard, for example, recently developed a new technique known as "predictive analysis" which is being used experimentally to unravel some of the complex syntax in Russian sentences.

English, too, has to be understood better, Machine that now converts *Pravda* into English is fed by typist. It translates faster than she can type

Russian newspaper *Pravda* is translated into English. Sample of results is shown here. Experts still consider translations unsatisfactory and are concentrating on improvements in sentence structure

Товарищи депутаты!

Все выступавшие на сессии выразили полное согласие с положениями, выдвинутыми в докладах, и единодушно поддержали предложения Советского правительства об отмене налогов с рабочих и служащих и других мероприятиях, направленных на повышение благосостояния советского народа, и о завершении в 1960 году перевода всех рабочих и служащих на сокращенный рабочий день. В своих выступлениях депутаты единодушно одобряли внутреннюю и внешнюю политику Советского правительства.

Comrade deputy !

All appearing on session expressed full consent with/from positions, advanced in reports, and unanimous supported offer Soviet government about cancellation taxes with/from worker and employee and other measures, directed on increase welfare Soviet people, and about completion in 1960 year translation all worker and employee on abbreviated worker day. In own appearances deputy unanimous approved inside and foreign policy Soviet government.

Comrade Deputies !

All those who spoke at the session expressed complete agreement with the positions advanced in the reports, and unanimously supported the proposals of the Soviet government for abolition of taxes collected from industrial, office and professional workers and for other measures directed at improving the welfare of the Soviet people, and for the completion in 1960 of the transition of all industrial, office and professional workers to a shorter working day. In their speeches the deputies unanimously approved the internal and foreign policy of the Soviet government.

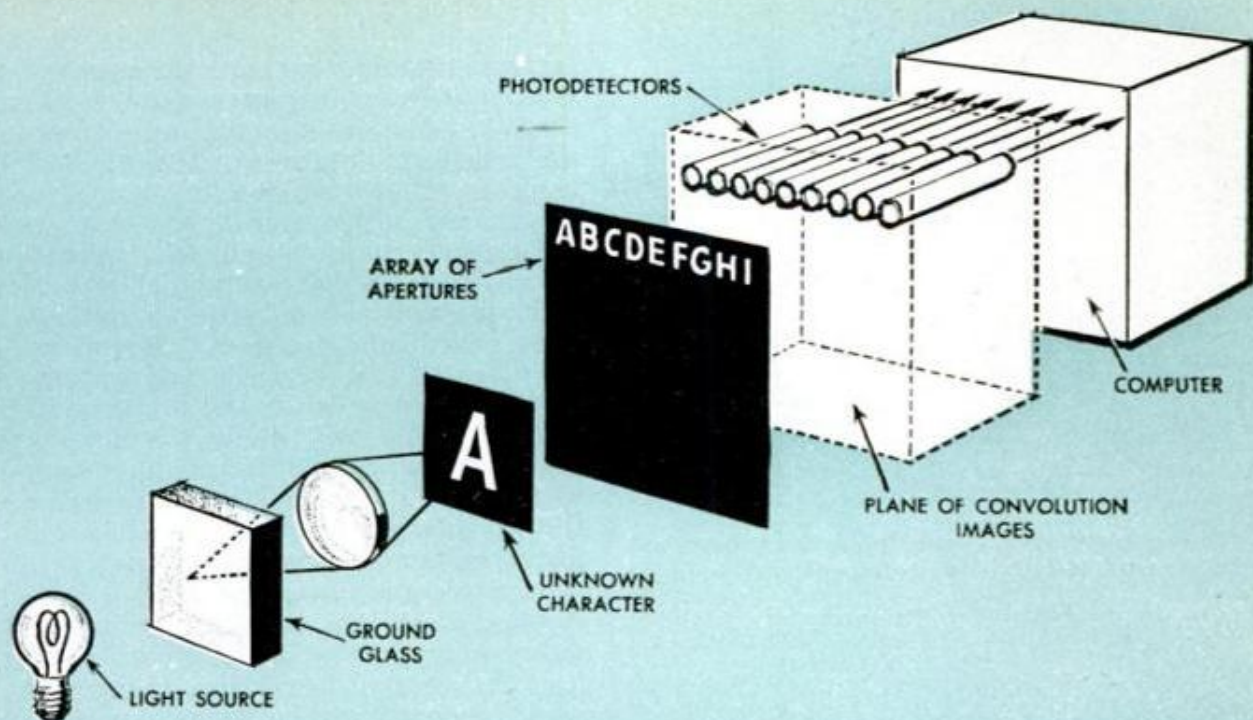

Optical-electronic "reader," now being built, will compare characters to those in its memory, and photodetector will notify computer which letter it has encountered. It will recognize 1000 characters per second

and Dr. Victor H. Yngve of the Massachusetts Institute of Technology recently explained previously puzzling features of our language.

A code for electronic translation of languages was worked out in 1947 at Princeton, and Prof. L. E. Dostert and his associates at Georgetown University demonstrated in 1954 that a machine could turn Russian into English. In that "Kitty Hawk experiment," the machine had a vocabulary of 250 words. The one translating *Pravda* now can use hundreds of thousands of words (Shakespeare used only about 24,000), and Gen. Donald P. Graul of the Rome Air Development Center expects a machine to have a vocabulary of 1,500,000 words next year.

Dr. King's new whirling dictionary makes this possible. It is a 10-inch glass disk that looks like a phonograph record, but is spun at 1400 revolutions per minute rather than 33. Russian and English words are printed in hundreds of tiny tracks in a band less than half an inch wide near its rim. The words in this "photoscopic disk memory" are not printed the way they are in books for people, but are spelled out in a binary code similar to a telegrapher's code. Only two symbols are used in this code: (1) A white space followed by a dark dot, and (2) A dark dot followed by a white space. Each letter of each language's alphabet is represented by a different sequence of these precisely spaced dots. It

In 1910, *Popular Mechanics* suggested that an attachment on telephone would translate foreign languages

AN INTERPRETING TELEPHONE

The reader must not be led to think by the above head that any such wonderful device has yet been invented, or that there is anything but a very distant likelihood of such a device in the future. Yet, every great invention has appeared impossible to the many and difficult to most before its arrival and very simple afterwards.



The interpreting telephone, however, is nothing more or less than the prophecy of a Michigan inventor, who believes the time will come when a person at one end of the line can speak one language and that any language can be heard at the other end. That is, any language the telephone is provided with. The drawing shows the Michigan man's idea of how it is to be accomplished. Attached to the side of an ordinary telephone receiver is a box in which the different languages are stored. If the man answering the phone is Chinese, he will move the indicator opposite the Chinese language, and then some mysterious mechanism yet to be designed will receive the English words coming over the wire and convert them into Chinese.

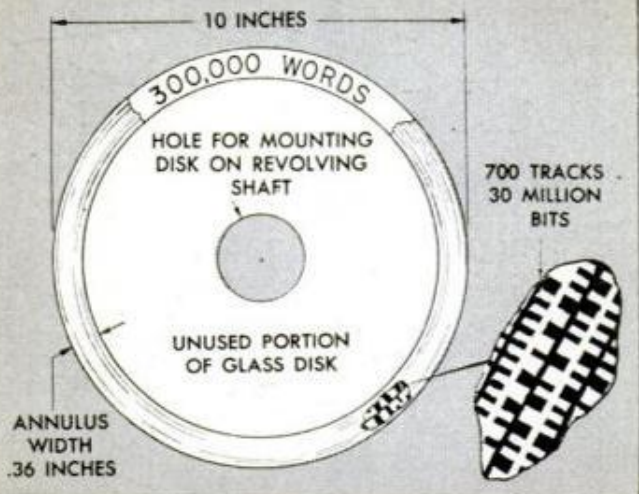

Although packed with words, whirling dictionary can be revised and a new edition brought out overnight

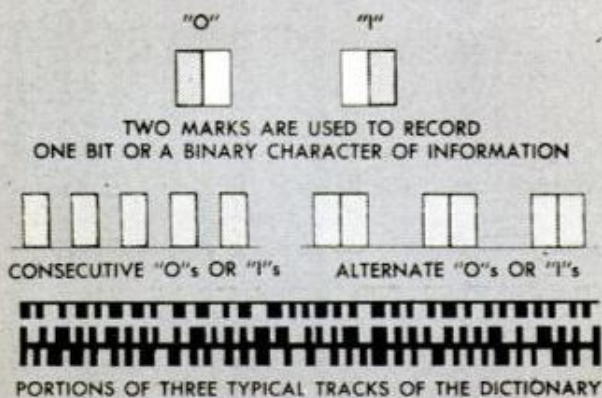

Binary code's two symbols, zeros and ones, combine to form letters. Below: Disk track enlarged 300 times

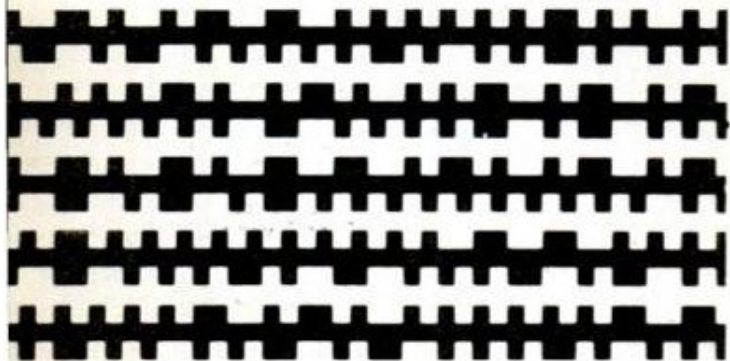

Memory of new reader (page 111) will be type fonts



takes a lot of dots to represent even a short word this way, but each symbol is only 0.00033 inches wide, and there is room on the disk for so many words that the IBM engineers consider this dictionary's capacity virtually unlimited.

To print so finely, the disk's makers had to devise new photographic processing techniques, in which only a little fluid is used, and this fluid is finely filtered.

To read such fine printing, a beam of light darts from one track full of symbols to another, the way you flip the pages when you use an ordinary dictionary, until it finds the right one. The machine then reads the words there with the light beam. English words and phrases are alongside Russian words and phrases.

After English words or combinations of words that can be substituted for those used in Russian have been found in this way, they are typed out by an electric typewriter attached to the machine.

The machine's speed is staggering. It can look up a Russian word's meaning in $\frac{1}{300}$ of a second, and turn out an English version of an 1800-word Russian article in 60 seconds.

Getting the literature into the machine, in fact, now takes longer than translating the words and phrases. Typists feed the IBM translator by punched tapes. A girl can punch out only about 40 words a minute. So this will soon be automatized.

Years of study have gone into efforts to design reading machines. In some systems, the characters are scanned for unique features. Such systems are difficult to adapt to a wide variety of type faces. This difficulty is believed to have been overcome now.

For the translating complex planned by the Air Force, Baird-Atomic, Inc., of Cambridge, Mass., is working on a reading machine that will be able to "remember" how letters, numerals, and punctuation look in different fonts of type. Its memory will consist of an array of English, Cyrillic and Greek letters from various fonts, stored in photographic masks or optical apertures. The machine will compare each letter it finds in the text that it is asked to read with those in its memory.

The makers of this optical-electronic device expect it to feed punched tapes to the translator 60 times as fast as girls could prepare them. But it will not work directly from printed pages the way the girls do. It will require filmed copies of the Russian publications to be translated. The machine has been designed to recognize 1000 Russian characters per second on these films.

Experts still differ about the wisdom of

(Continued to page 254)

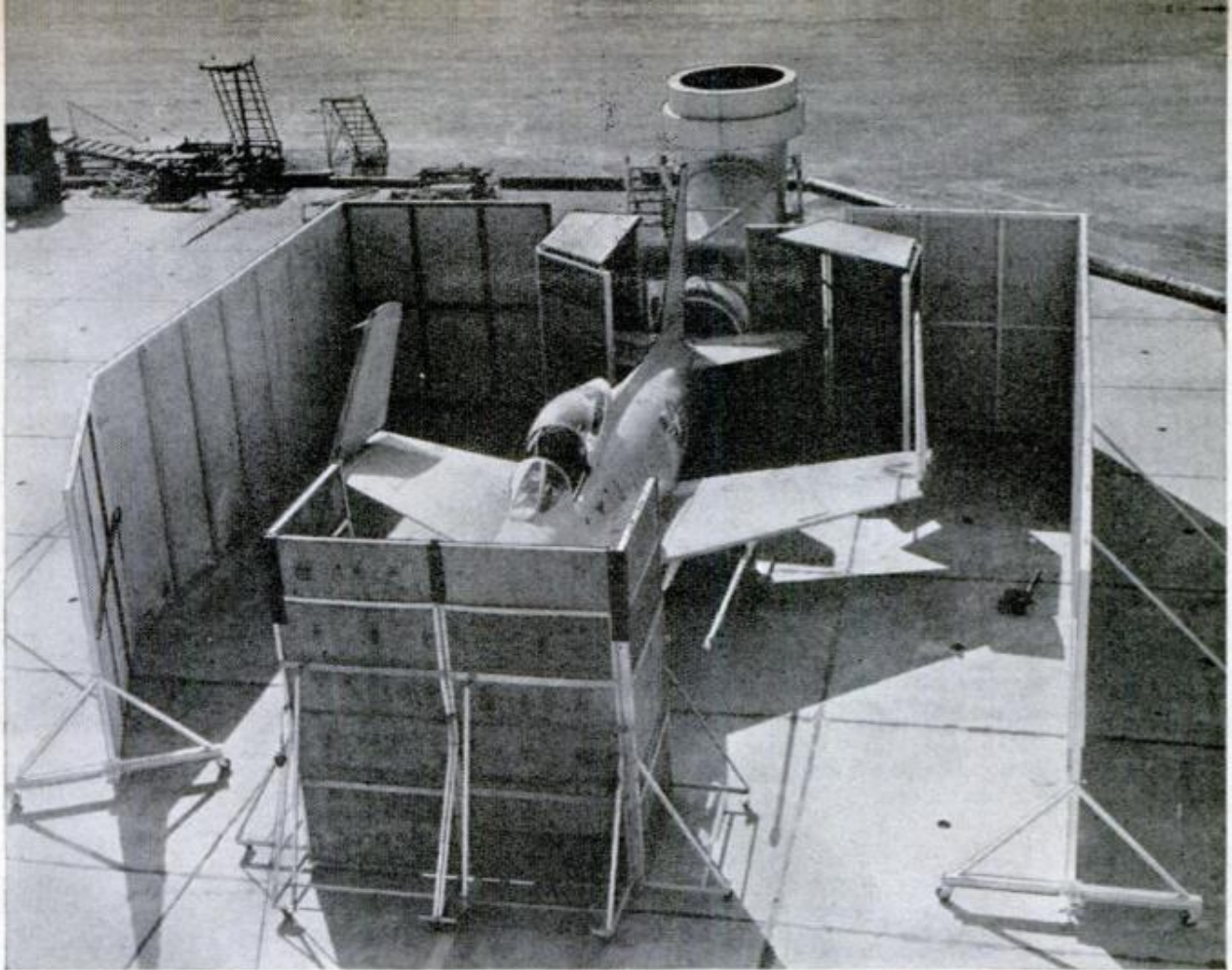

Mammoth Elbow Suppresses Jet Noise

Plumbers could be credited with an assist in developing a noise suppressor for jet engines. The Naval Air Station at Alameda, Calif., is experimenting with a portable

metal screen around a huge elbow. When a jet is to be ground-tested, the screen is moved around the plane and most of the exhaust is absorbed by the elbow.

Huge Machine Rolls Right Over Trees

Crashing through stands of timber on cleated steel drums, a new 130-ton tree-crushing machine chews up wooded areas at a rate even the mythical woodcutter Paul Bunyan would admire. Whereas his famed

Blue Ox merely flayed about, knocking trees down, the machine fells the trees, then compacts the debris into a mat to prevent erosion. The machine levels three acres of woods an hour.

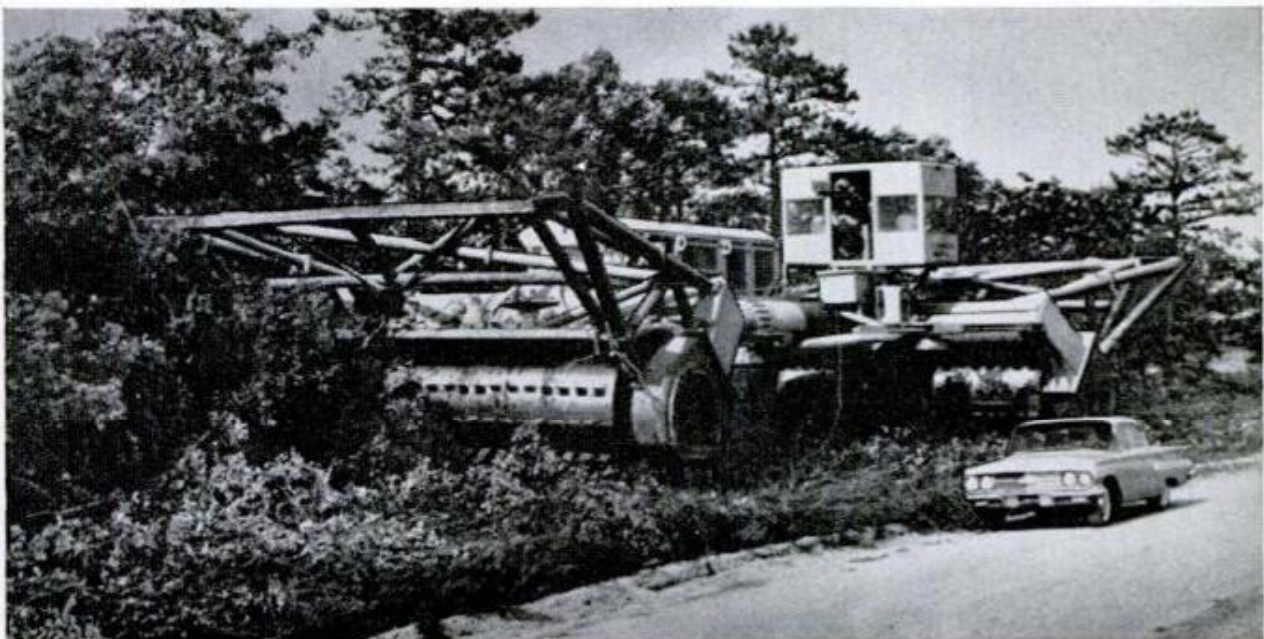



Sail Ho! The training ship *Kaiwo Maru*, proceeding gracefully at left, is one of two run by Japan to prepare men for its merchant marine. At right, its sails whipping in the breeze, is Norway's *Christian Rodich*

Windjammers Still Sail

Aloft, men of the U.S. Coast Guard try their hands at furling the sails on the training ship *Eagle*. Such schooling imparts to them self-confidence, teaches basic seamanship

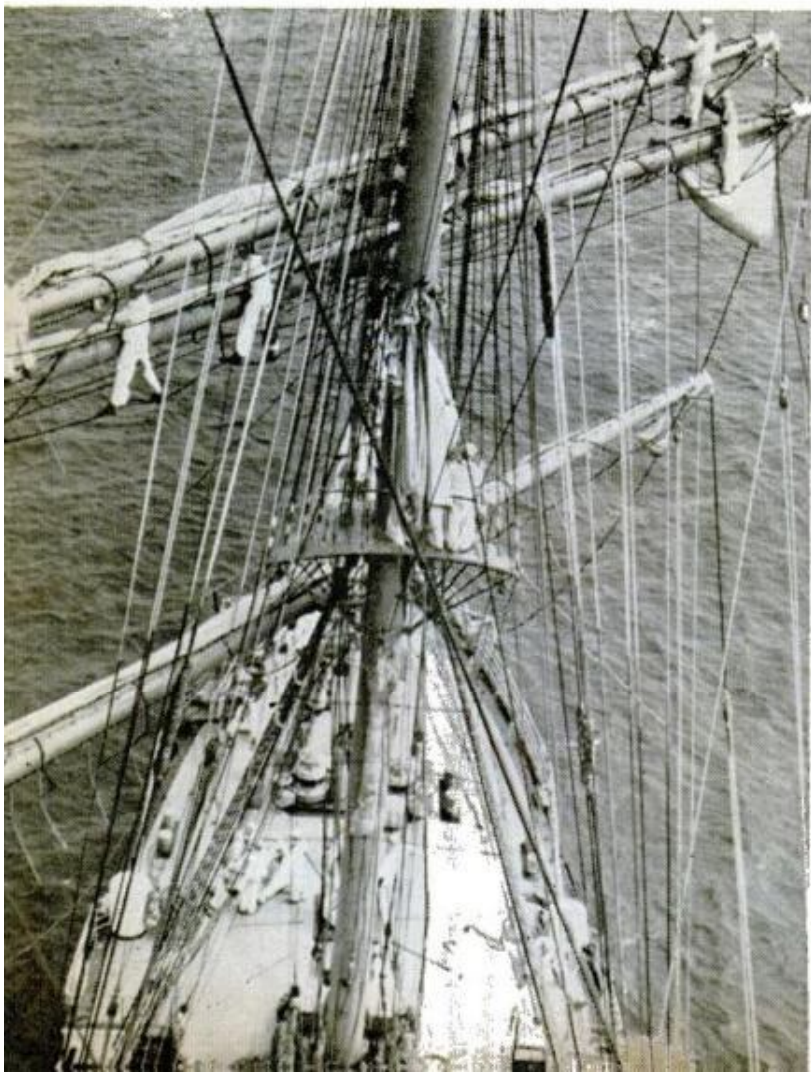

SOMEWHERE on the great oceans a white sweep of sail dips and rises with the rolling swell, and the chant of men hauling on canvas carries in the air. Sailors, as they have for centuries, continue to go down to the sea in sailing ships—a fact that may seem surprising in an age of diesel and atomic power.

But as a result of some 17 nations employing windjammers to school their naval and merchant marine cadets, the number of sailing men and sailing ships has, if anything, tended to increase since World War II. Other countries, agreeing that nothing imparts the feel of the sea so much as sailing under canvas, are embarking on similar programs. Chile, for example, uses a schooner launched in 1952, and West Germany recently took delivery of a 1600-ton bark to replace its training ship *Pamir*, which was lost in a hurricane. Other countries with schools under sail include: Indonesia, Japan, Russia, Italy, Portugal, Sweden, Rumania, Yugoslavia, Denmark, Spain, Finland, Brazil, Belgium, Norway and the United States. Every few years some training vessels are entered in a sailing race from England to Portugal.

On these pages: ships that run before the wind.

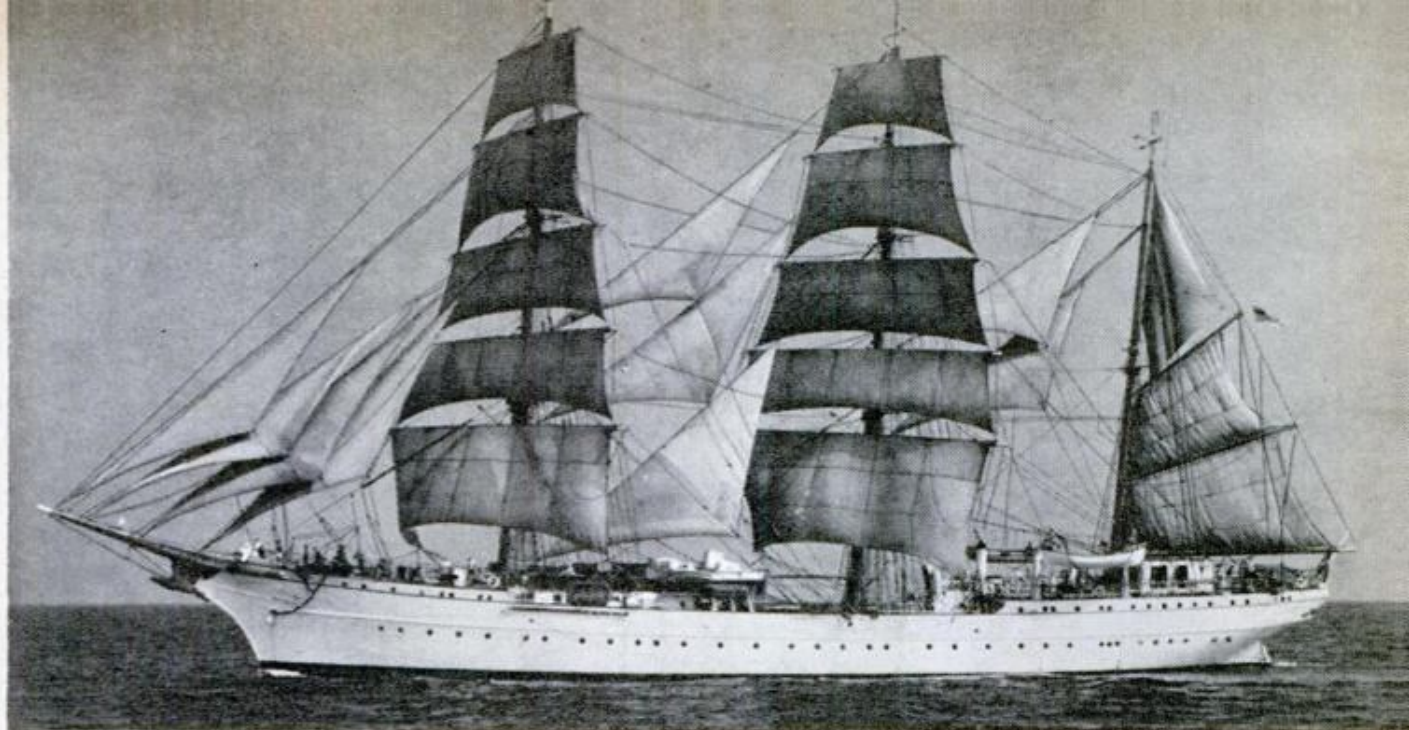

Under two flags. The *Eagle*, formerly a German naval training craft, was acquired by the United States as a war payment

Brazil trains its future naval officers on board the *Almirante Saldanha*, four-masted vessel with plenty of sails to furl



Spanish naval cadets learn the ropes of seamanship sailing the *Juan Sebastian De Elcano*, a striking topsail schooner

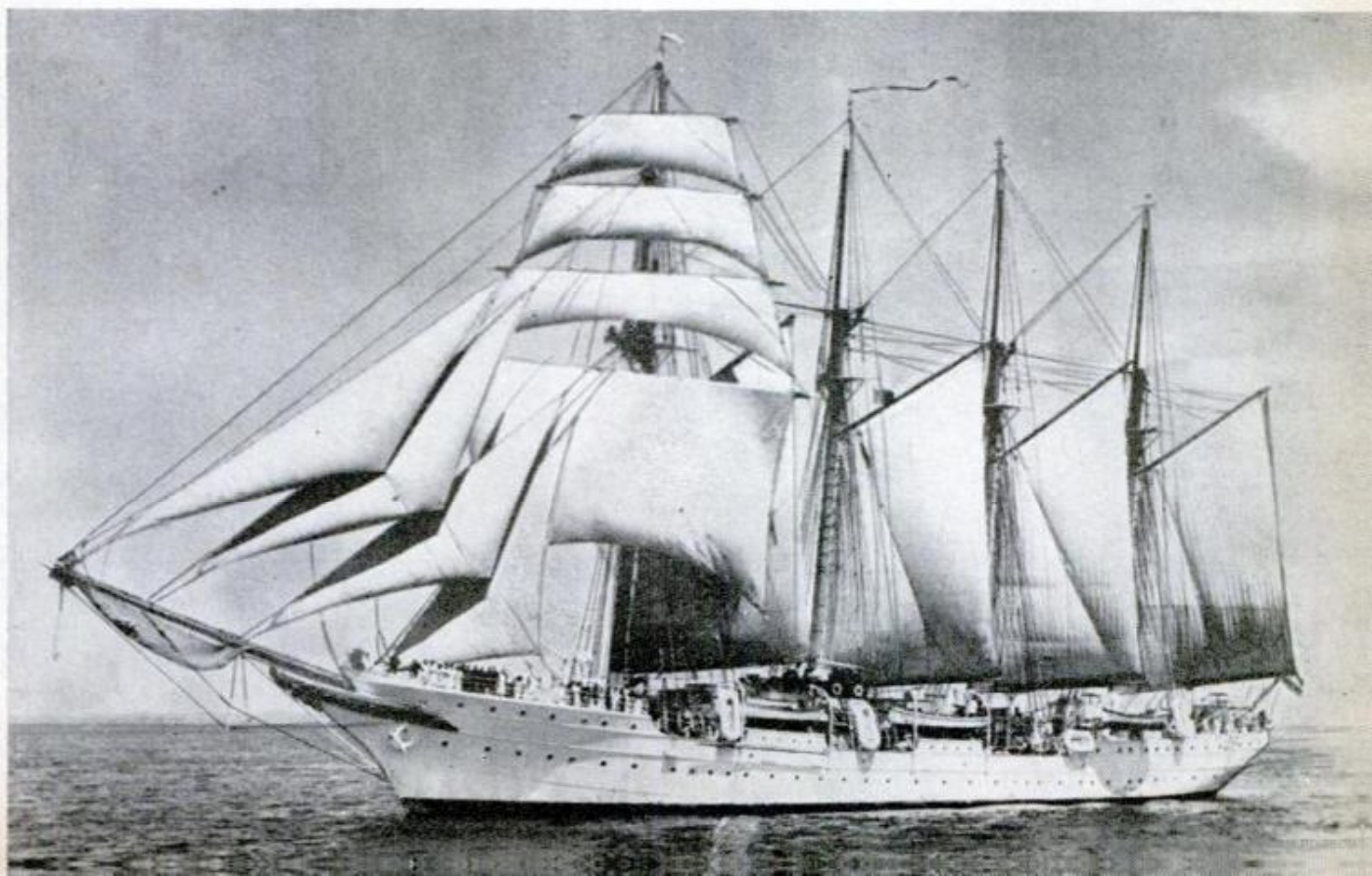

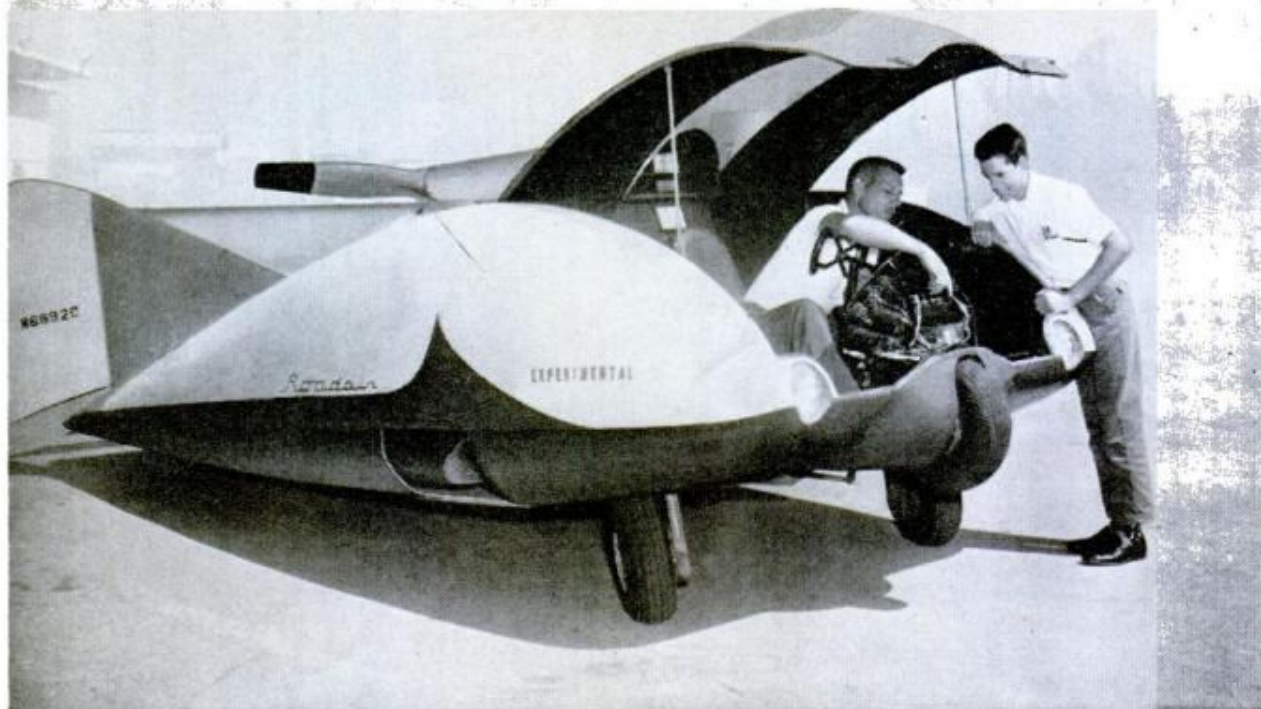

Roadair operates as auto or plane from same controls. Same action moves rudders and wheels. Wings fold up inside body

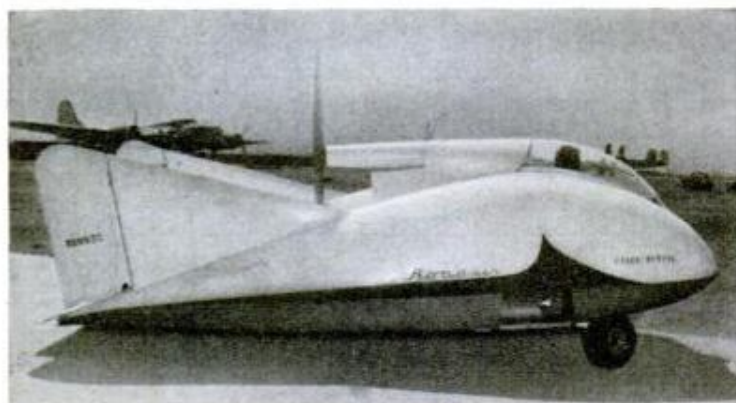

Estimated cruising speeds are 90 miles per hour in air and up to 75 on ground. FAA experimental license has been issued

Flying Automobile

Another flying car has completed its initial flight tests successfully. Called the Roadair, the car has a body 15 feet long and 7 feet 10 inches wide. As an auto, it rides on a tricycle gear, the single rear wheel driven by a small gasoline motor. As an airplane, the wings fold out from the body to a 25-foot wingspread. A 75-horsepower airplane engine drives the single pusher propeller. Twin rudders and elevator are located in the rear. Expected retail price: Approximately \$10,000.

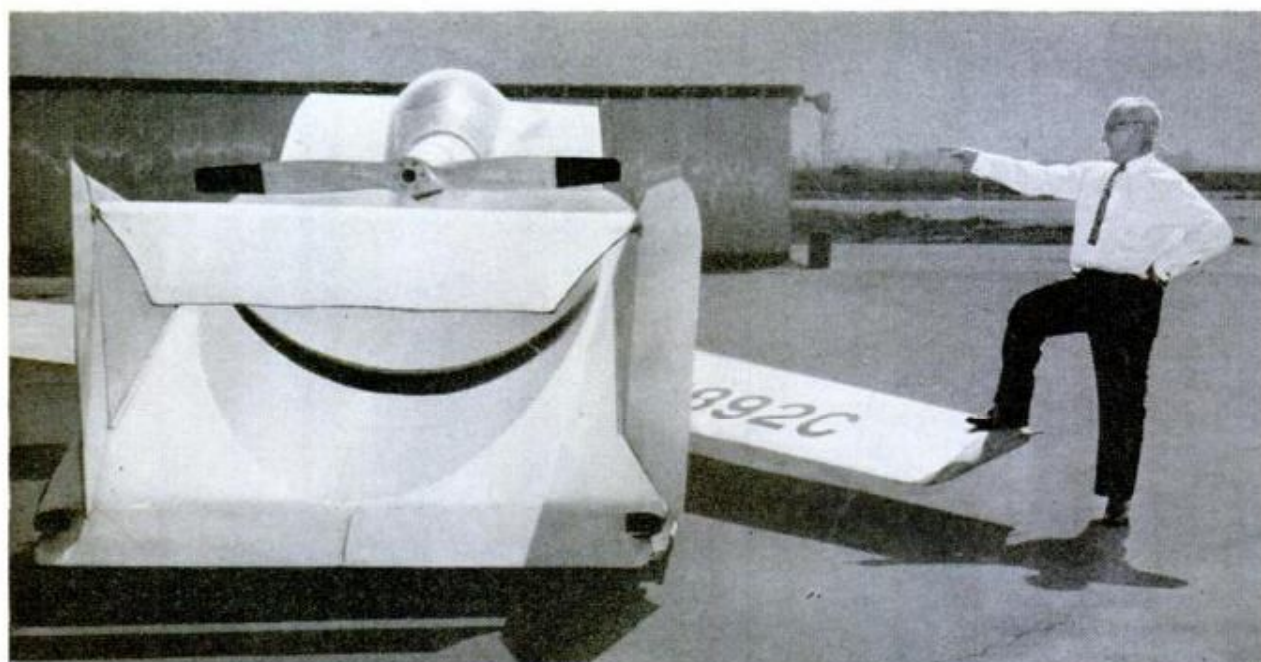

Captain Edward V. Rickenbacker has won equal distinction in the automotive and aviation fields. Prior to World War I, he engaged in experimental work on automobiles, and in racing. During the War, he became a celebrated combat aviator and shot down 22 enemy planes. Afterward he manufactured automobiles, ran the Indianapolis Speedway and entered the field of commercial aviation. He is now Chairman of the Board of Eastern Air Lines, Inc.



My Most Exciting Moment

By Captain Edward V. Rickenbacker

DURING WORLD WAR II, while enroute across the Pacific on a special mission undertaken for the Secretary of War, our plane ran out of gas and crash-landed in the Pacific Ocean.

For more than three weeks, my companions and myself, without food or water, unprotected from the blazing sun and burning salt water, had tossed about on the surface of the ocean. One of our little company of eight had already died. After 24 days together, our three rafts had separated.

It was late afternoon of the 23rd day, when we sighted two planes. We were wild with rapture at the prospect of being rescued at last! I waved as hard as I could with my old hat. But the planes, flying only a few yards off the water, passed within a couple of miles and then disappeared into the setting sun.

Then we heard that wonderful sound of throbbing motors again, this time much closer. The two planes were coming back! One of the planes went off while the other dived right over the raft. We yelled like maniacs. The plane was so low that I could see the pilot's expression. He was smiling and waving.

The plane straightened out and made a cautious landing on the darkened sea. After taxiing within a few yards, the pilot shut off the engine. I paddled up and caught hold of the pontoon. The radioman climbed down to help me. The pilot joined him, and I remember thinking how clean and handsome they were, how proud I was to have them as countrymen!

The pilot, the late Lt. W. F. Eadie, of Evanston, Ill., and the radioman, L. H. Boutte, of Abbeville, La., helped to lift Hans Adamson, whose back was injured, into the high cockpit. The plane had room for only one passenger so I took it for granted that John Bartek and I would be left behind. But our Navy pilot said calmly, "Why, Captain Eddie, you fellows are going too." I looked at the cockpit. "Where?" He smiled and said, "On the wing".

On the way, they gave us the good news that our other companions had been located the previous afternoon. When we finally reached the Navy PT boat, I remember thinking that planting my feet upon the deck of an American boat was the next-best thing to being home.

All that we could say was "This is heaven," and "Thank God," and "God Bless the Navy."

A large, stylized handwritten signature in black ink that reads "Edward V. Rickenbacker". The signature is written in a cursive style with a long, sweeping tail.



WHAT'S NEW FOR

Sun Enterprises, Inc., 3121 Washington Ave. North, Minneapolis 11, Minn.

KNIFE SHARPENER powered by water from the kitchen sink hones up blades with an aluminum-oxide abrasive wheel. The sharpener attaches to the tap and the force of the water turns a nylon turbine which also spins the sharpening wheel. Both are attached to a single stainless-steel shaft and are housed in a plastic case

SPRAY-SCRUBBER, taking power from water coursing through the garden hose, makes it possible to scrub, clean and rinse in one operation. Made of lightweight aluminum tubing, the shaft has a fingertip water-flow control. The 16-inch-long brush has polystyrene bristles set in hardwood and conceals the jet-spray head. For use on smooth or rough surfaces

Titan Sales Corp., Buffalo, N.Y.



GRAPEFRUIT KNIFE has three blades: one is curved, blunt-pointed and serrated so it can be inserted at the edge and worked all the way around the half of the fruit to loosen the peeling; the two other blades, set closely together, are placed to straddle the membrane between segments and thus help to separate the grapefruit from the inedible membrane

Cherry Development Co., P.O. Box 313, Downers Grove, Ill.





Monroe, Hattenbach, 347 Fifth Ave.,
New York City 16

ELECTRIC SHAVER is powered by a battery that stores enough electricity to give 15 shaves on a 20-hour charge, when plugged into a 110-120-volt outlet. The switch, a transparent ring surrounding the shaving head, also lights up the shaving area



Sears Roebuck and Co., 925 S. Homan Ave., Chicago 7, Ill.

TRIPLE-DECK bunk bed made of maple-finished hardwood in Colonial style stands 79½ inches high, features a sliding, straight-hanging ladder and a removable guard-rail. Designed for a growing family, it may be broken down into three twin-size beds when more room becomes available

BOTTLE THERMOMETER slips on and off baby bottles and is held in place for a reading by an elastic cord. It records the temperature when heat is transmitted through a pliable copper band, which conforms to contour of the bottle, and into a sensitive bimetal element

Zinn Originals, 321-A Greenwich St.,
New York 13, N.Y.



OUTDOOR TORCHES for lighting up a patio, lawn or beach party come in sealed, tamperproof cans. The torchhead, in the can, burns from four to six hours, all the while repelling insects. A kit contains six torchheads, six wicks, two five-foot stands and head-holders

Harrison Oil Specialties, Inc.,
Milwaukee, Wis.



PLASTIC BAGS now come in rolls; to use, a bag is unrolled to a heat-sealed separation and the bag is torn along a perforation below this seal. The perforated end becomes the mouth of the bag removed. Handled much like wax paper, a roll holds 25 plastic bags

Jordan Associates, 230 Park Avenue,
New York 17, N.Y.



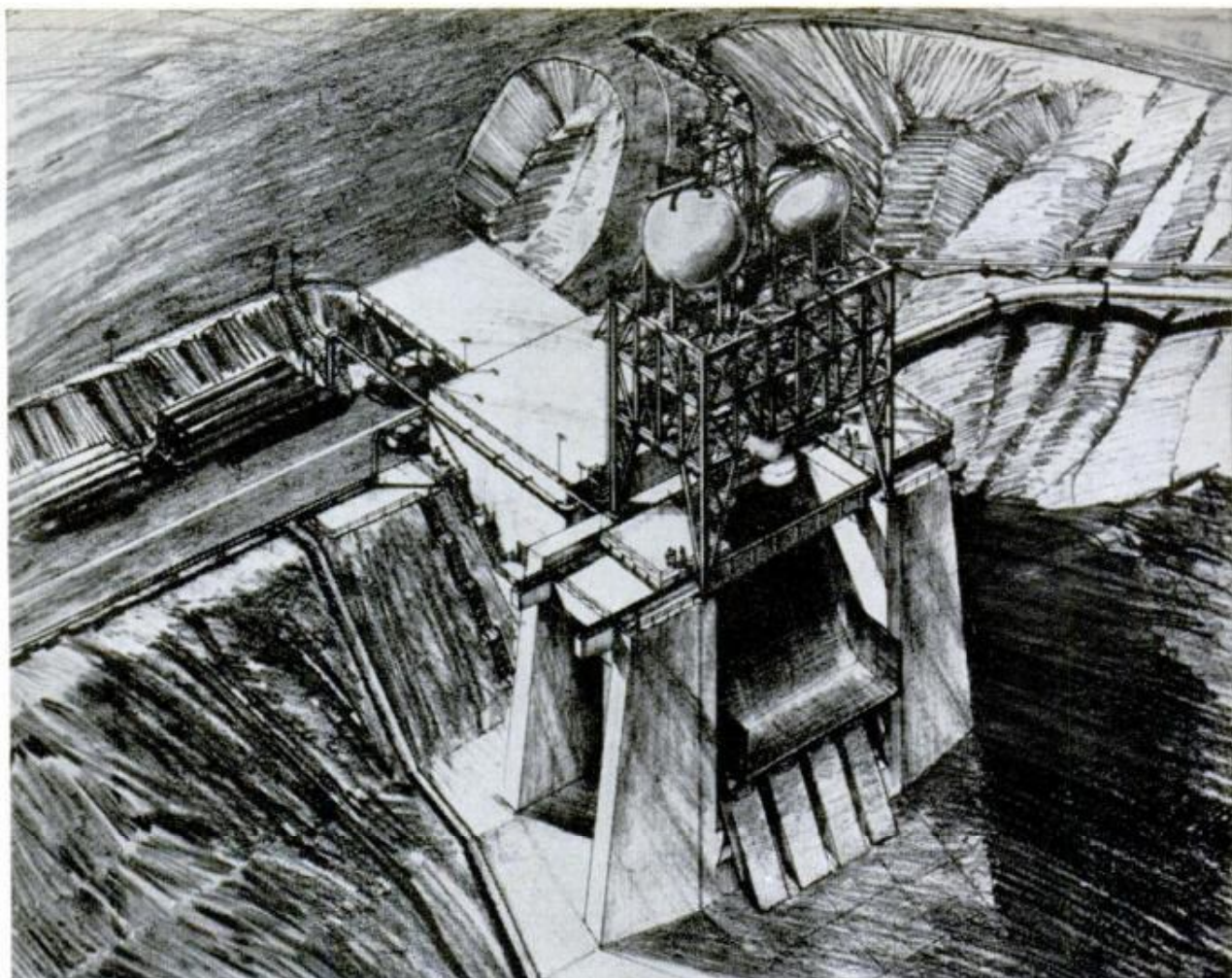

Test Stand for the Powerful F-1 Space Engine Rises in Desert

Rising from the desert at Edwards Air Force Base, Calif., are three huge test stands designed to keep the F-1 space engine tethered while under development. The single-chamber engine is being built

for the National Aeronautics and Space Administration for use, in clusters, to put into orbit a 150,000 pound space laboratory. It develops 1.5-million pounds of thrust, or three times as much thrust as any space

Mapping Lightning Flashes Helps Predict Weather



Lightning spotter stations, positioned in Kansas, Oklahoma, Arkansas, Illinois, Iowa, and South Dakota, are being tested by the Army Signal Corps as an aid to weather prediction and tornado spotting. The detector stations are equipped with special radio receivers which pick up static generated by lightning flashes and relay the information to a central station in Kansas City. The operator can detect heavy lightning in a limited area, which can mean thunderstorms, and can track the storm's position with accuracy.

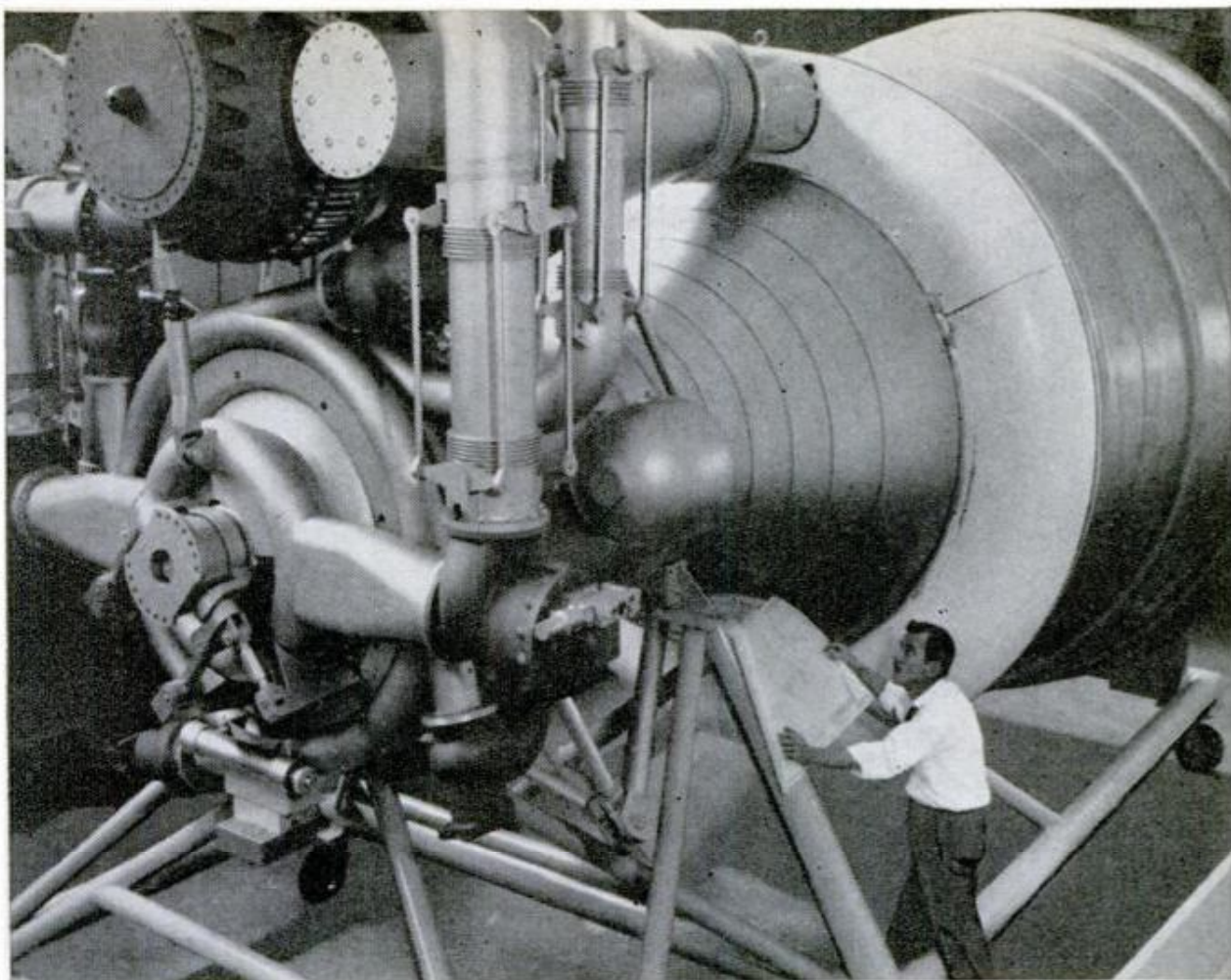

F-1 rocket will look much like this full-scale mockup when it is ready for flight in about four years

engine available today. As a result, the largest test stand, 1-B, is being set into 12,000 yards of concrete. Rising to a height of 230 feet from this base will be a reinforced girder framework to hold the engine

in place while engineers check its performance. To control the exhaust blast, the flames will be directed downward, then outward as they hit a 260-ton water-cooled flame deflector.

Turbocharged Diesel Engine for Pleasure Boats



Safety and economy features of diesel power can be built into inboard pleasure boats with a new series of marine diesels by Caterpillar Tractor Co. of Peoria, Ill. The series features their turbocharging feature, which uses waste power in exhaust gases to boost air intake to each cylinder, raising efficiency and producing a clean exhaust. Available in 130, 180, and 270 horsepower models, the engines burn No. 2 furnace oil in an efficient four-cycle system that can idle indefinitely without carboning or exhaust smoke.



Bread dough leavened with a chemical agent rather than yeast needs no lengthy rising time. One new type of dry mix, when stirred with water and popped into the oven, can produce fresh, crisp loaves in 40 minutes

By Thomas E. Stimson, Jr.

NEARLY HALF of your grocery bill is going for foods that weren't on the market 10 years ago.

Food retailers say that there are about 6000 items on the shelves these days as against the 1500 foods that were available in the late 1940s.

At the corner grocery today you can pick up such new foods as a complete steak or Chinese or Mexican dinner, with all the trimmings, perfectly cooked and then quick-frozen for preservation. You can buy instant tea, dehydrated onions, instant rice and pretrimmed and packaged fresh vegetables. With convenience foods like these a housewife can prepare an elaborate dinner in an hour. Not much more than 10 years ago the same meal took three or four hours to prepare.

A revolution has been going on in the

food industry and yet food scientists are saying that we haven't seen anything yet, that the big revolution in foods is still ahead of us.

They are talking about dehydrofrozen foods and "dry liquids." In the laboratory they are testing new aerosol foods that you spray from a can. Soon they may have canned peas that look and taste like fresh peas.

They have a new table cream that contains vegetable oil in place of butterfat and so can be used by people with heart trouble. They are exploding lima beans and other seeds with high-pressure carbon-dioxide gas to create a whole new family of puffed and popped snacks. They have new ways of tenderizing meats.

Of course, there are very few brand-new foods. Most of the developments that are being studied are concerned with better



Beans cascading from the bottle above have been treated to require no soaking; they can be baked and served in 45 minutes. Below: \$7.50 worth of dehydrated and frozen foods—from soups to chicken dinners

Well, how about cream of olive soup, exploded lima beans and cream that never saw a dairy?

ways of preserving foods, or adding or restoring flavors, or compounding tailor-made foods for people with special food requirements.

For foods that are really new (to most of us), how about a can of fried baby bees? Or a can of candied ants, or fried grasshoppers? You'll find these "delicacies" on the gourmet shelves of some supermarkets. For \$3.50 you can buy a large can of boiled muskrat, if you feel you must, and on the same shelves are cans of roast caterpillar and rattlesnake steaks.

Less exotic, and more palatable to most of us, are some quick-cooking beans that have been developed at Stanford Research Institute in California. Ordinary dry beans need six hours of soaking and three hours of cooking; the new beans bake to perfection in 45 minutes with no soaking at all.

Dr. John P. Nielsen, senior food scientist at SRI, originated the fast-cooking beans after studying the bean's chemistry. He devised a soaking solution that supplements a deficiency in the bean itself. After being



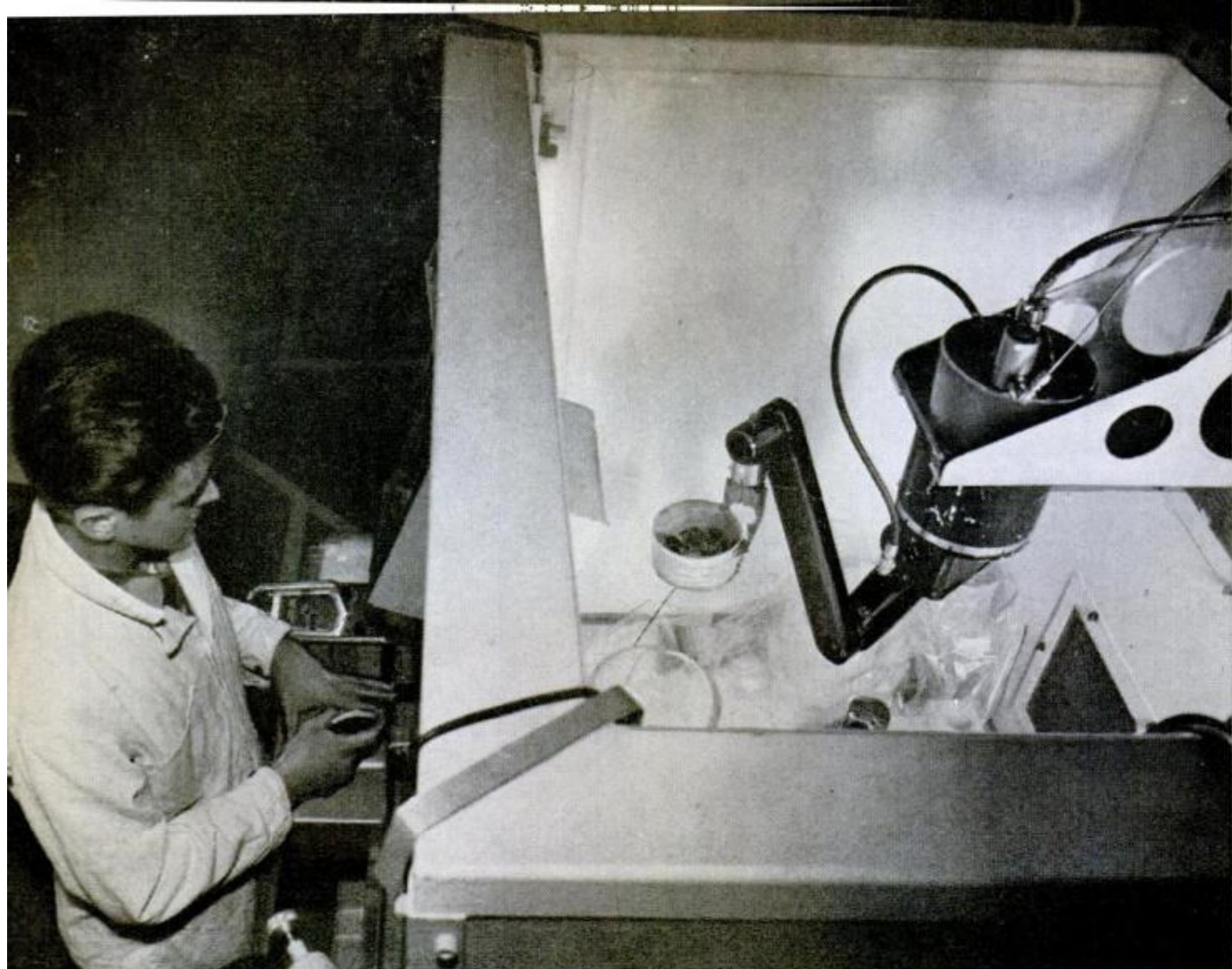

Irradiation of foods is tried at Stanford Research Institute in effort to find better preserving methods

soaked, the beans are dried again and are packaged for the consumer. The process has passed from the laboratory to the pilot plant stage and the beans should be on the market in about a year.

The treated beans are said to have a slightly better flavor and to be somewhat more digestible. Nutrition studies are continuing in the hope that beans can be made to yield an even greater percentage of their food value.

Dr. Nielsen also has been doing studies in which unsaturated vegetable oils are substituted for butterfat in table cream. The vegetable oils help maintain a low blood cholesterol, hence the cream should be popular with people who have circulatory or heart disturbances. The difference in taste is hard to detect and the new cream fools almost everyone when used in tea or coffee or on cereals and fruit. It, too, will be on the market soon.

One of the exciting things that is on this side of the food horizon is "micro-encapsulation." This is a technique by which a liquid is changed into a dry dust and yet is instantly available as a liquid. Each tiny liquid globule is coated with a thin dry film of gelatin or some other soluble and digestible substance.

The coating idea was developed by National Cash Register Company to encapsulate a dye that would become a substitute for carbon paper; scientists now see a big future in it in the field of dehydrated foods.

They are thinking about encapsulating butterfat and adding it to powdered dry nonfat milk. The dry mixture would change instantly into cream or whole milk when water is added. The butterfat would never turn rancid in storage because the coating around each globule effectively prevents oxidation. Later in this article you'll read about another new way of preserving fresh milk; in the long run the method that provides the highest quality at the lowest price will be most widely adopted.

Most natural foods contain up to 90 percent of water. The same food when dehydrated takes up only a fraction of its original space and can be stored for long periods of time. It is restored to its original size and shape by adding water which is allowed to soak in. Powdered eggs, instant coffee, instant mashed potatoes and various soup mixes are among the dehydrated products that enjoy a wide sale.

But relatively few of the dried foods have all the flavor and palatability of the fresh products. Today it seems possible to ex-

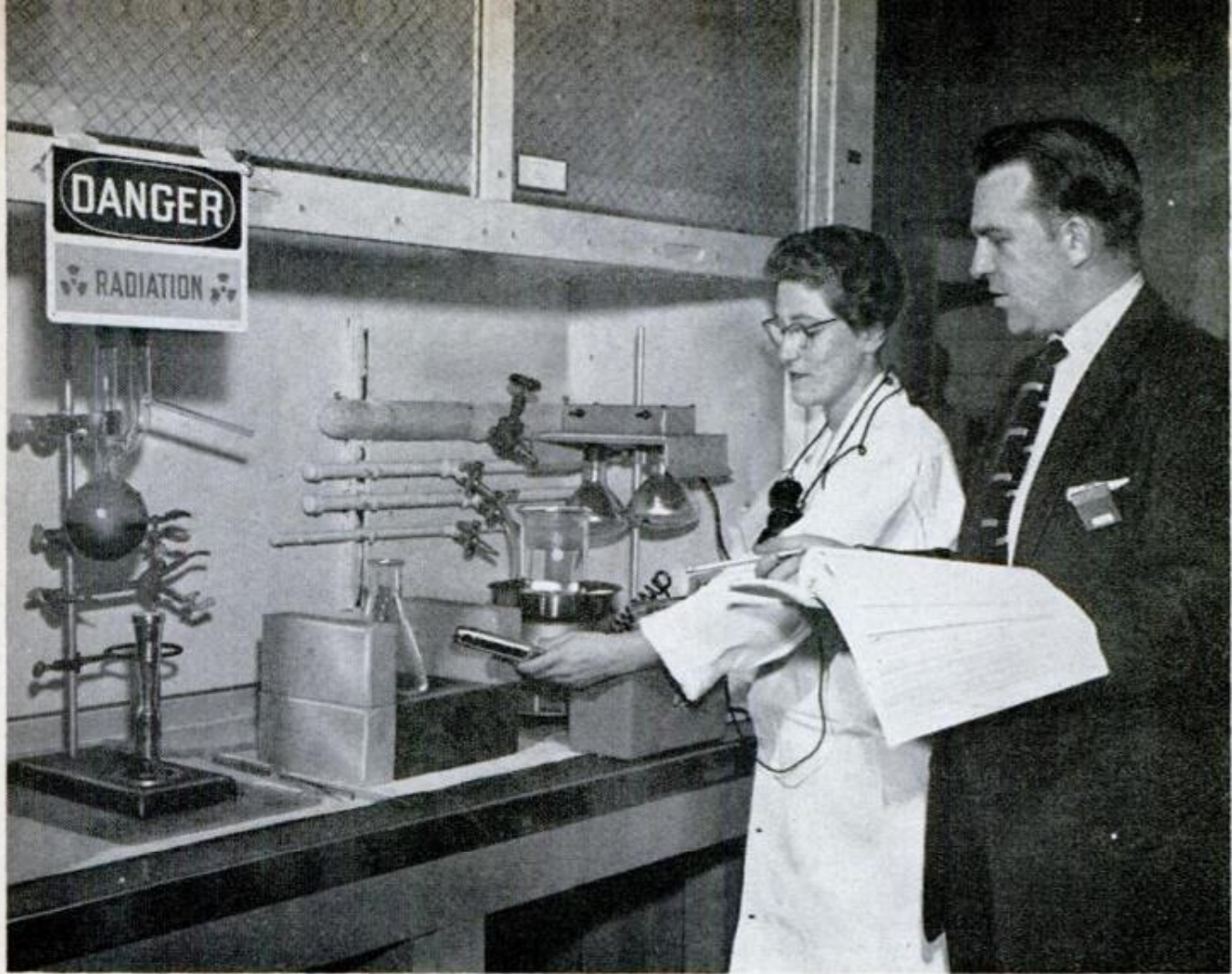

Radioactive isotopes are added to pesticides and detergents used to protect and wash vegetables so a technician equipped with a counter can tell how effective are the new cleaning processes. One uses sound waves

Controls for dryer in Department of Agriculture lab are intricate, but the experimental machine provides valuable information for researchers. It presses dried foods into a dense, thick sheet for packaging



DECEMBER 1960

Centrifugal separator used at the University of California extracts juice from the pulp of such foods as tomatoes. It is used in experiments seeking to find ways to better preserve various pastes, sauces

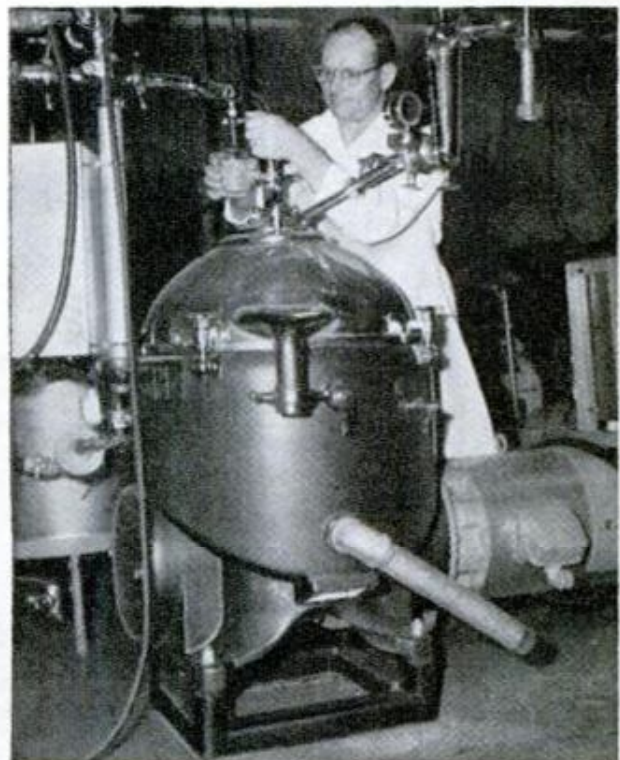

125



Taste tester, isolated in booth at Stanford, blindly reaches for food on which he will pass judgment

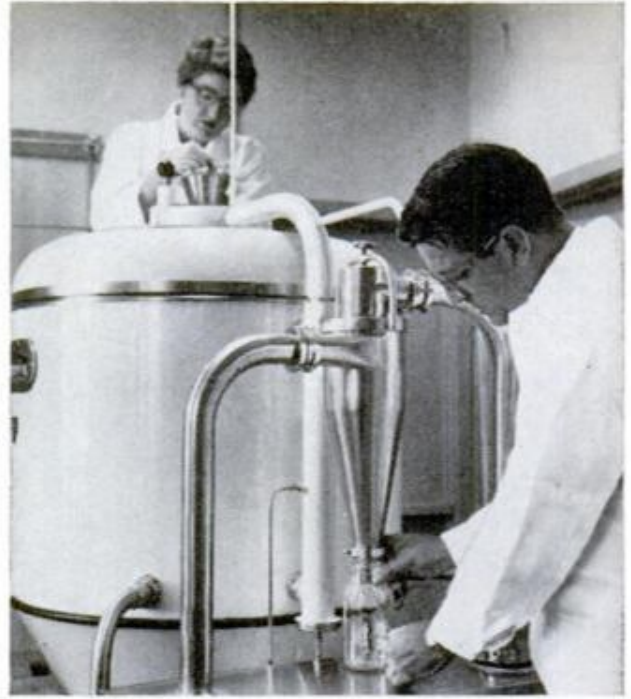

Spray dryer at the Institute converts liquid to dry powder, is used in studies of new food preparations

tract the natural oils from a vegetable, encapsulate them, and add them to the dehydrated product. It may be practical to preserve the food's vitamins the same way. Too, the enzymes that bring out the characteristic flavors are often lost in dehydration. Micro-encapsulation of enzymes may be the best way of regenerating the fresh flavor when water is added to a dehydrated food.

It may be possible, for instance, to encapsulate the aroma-and-flavor-producing ingredients of fresh coffee and add these to the dehydrated "instant" product. For many people this would be a tremendous thing all by itself!

Food scientists have begun to learn a great deal about how to take odors and

flavors apart and to analyze the chemical compounds of which they are composed. The scientists hope to be able to stabilize these essences and return them to the foods, to be retained over long periods of time.

At the Western Regional Laboratory of the U.S. Department of Agriculture, for instance, a technique called gas chromatography is used to determine the things that give fresh bread its appealing flavor and aroma. Surprisingly, it has been found that acids, alcohols and acetones are mostly responsible, although the entire aroma-flavor package contains more than 60 different compounds. The goal of the USDA research is to find a way of preserving these volatile

(Continued to page 238)



Drum dryer is used by a Department of Agriculture researcher in studies that seek to develop an improved, dehydrated mashed potato—another "instant" food

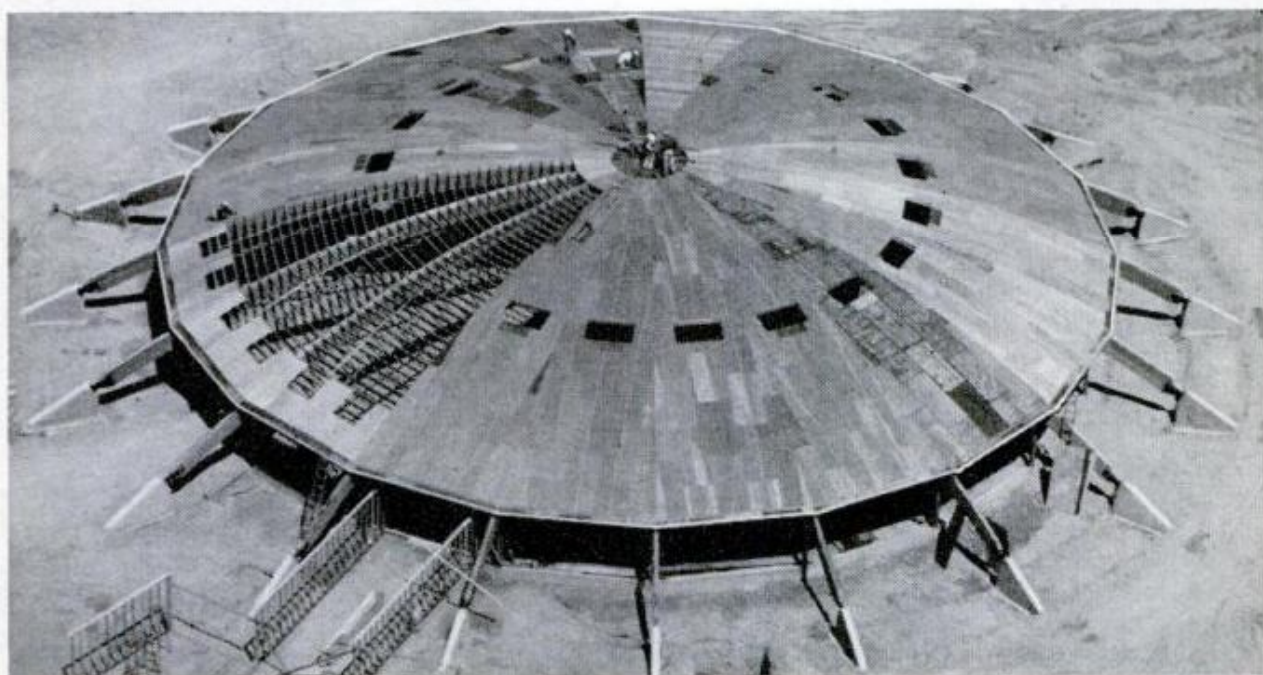
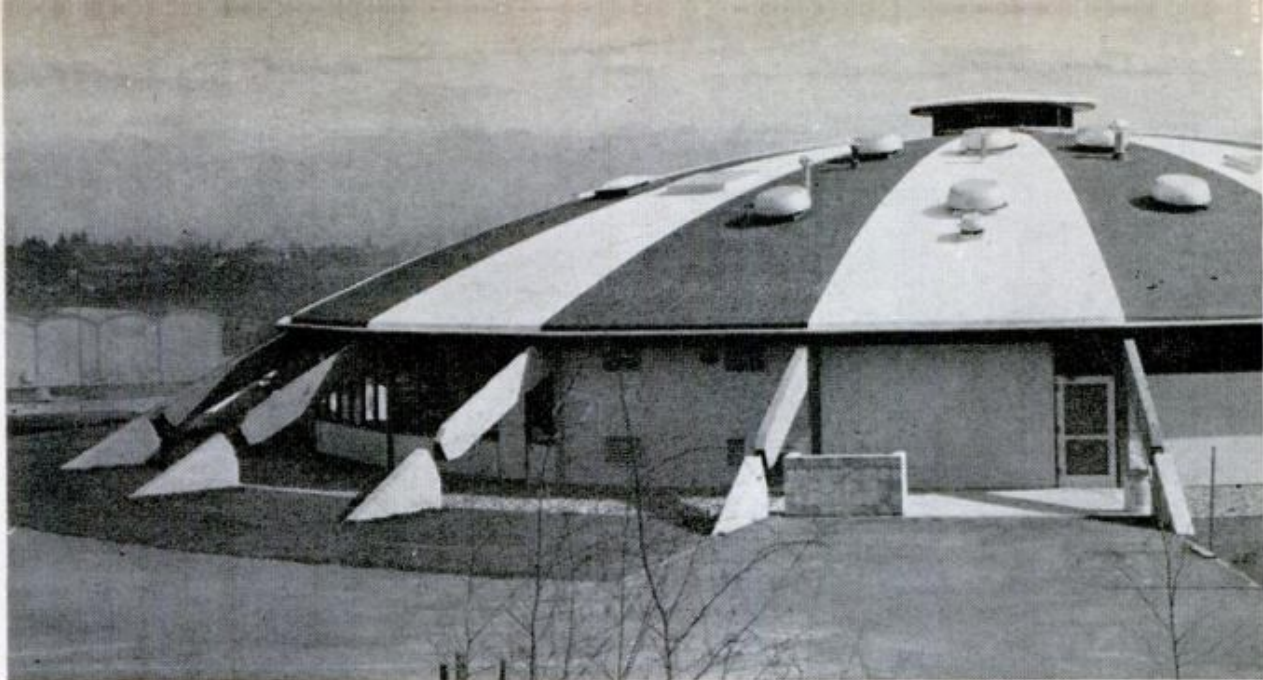

"Flying Saucer" Cafeteria

Although it looks like a flying saucer come to rest on curving, retractable legs, the cafeteria of a new school in Tacoma, Wash., is anchored firmly on laminated beams set in concrete—a technique of great functional value. The 20 beams soar to the center of the building and are tied together. No columns are needed to support the roof, which is made from plywood sheets curved over the beams. The roof spans 144 feet.

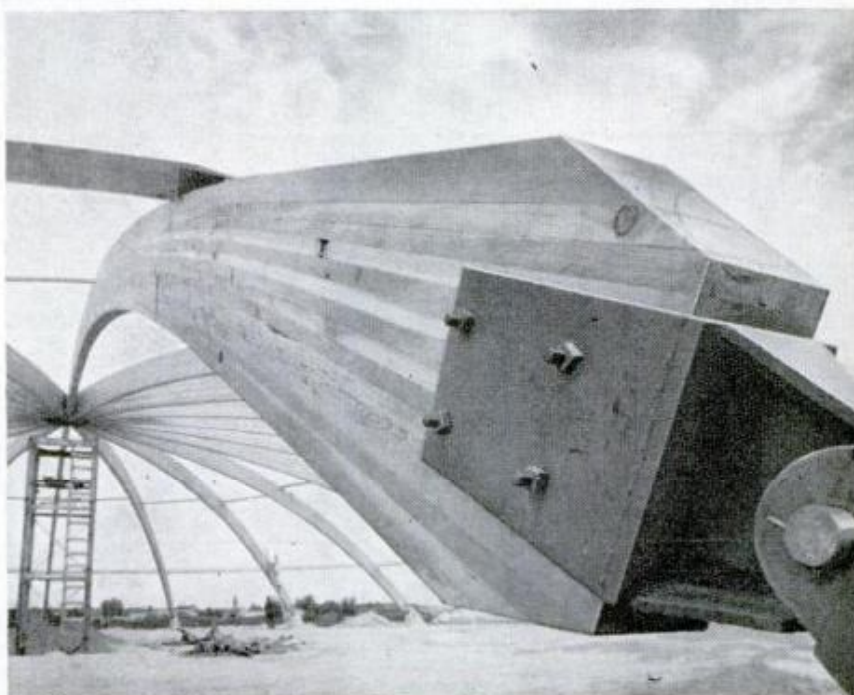

Pilots Practice Getting Dunked

Three hours of a six-hour course in water survival are spent in the water. The Air Force's liquid life-saving program is augmented by a pulley-wire arrangement that simulates a parachute drop and climaxes by dropping the trainee in the pool. The airman first releases a one-man dinghy from his seat pack. It drops into the water where it automatically inflates. Still suspended, he inflates his underarm life preserver and, when his feet touch the water, he releases his parachute harness and drops all the way in. He then swims to the life raft and climbs aboard. Advanced classes practice jumping in groups and swimming, with full regalia, to a four-man raft. The initial jump from the tower simulates the "shock" effect of a parachute opening. The remainder of the test gives the trainees safe experience in ditching at sea, efficiently, quickly and safely.

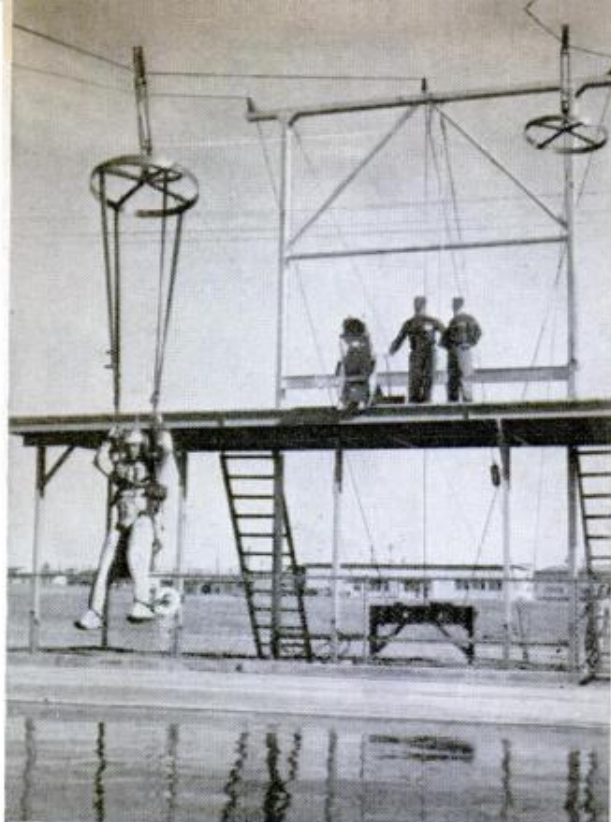

Underwater Television

It looks like a tank or a helicopter, depending on which angle you view it from, but it's actually an underwater machine developed for the Navy for exploring the sea at depths up to 20,000 feet below the surface and five miles from the coast. The RUM (for remote underwater manipulator) has a jointed mechanical arm which can pick up and bring back samples from the ocean's floor or assemble and install instruments for long-range investigations. It has four television cameras on a closed circuit which, via a long coaxial cable reeled out to shore, sends back pictures of the vehicle and its surroundings. The tank tracks allow it to travel on the bottom of the ocean; the helicopter device allows it to swim over rough spots.

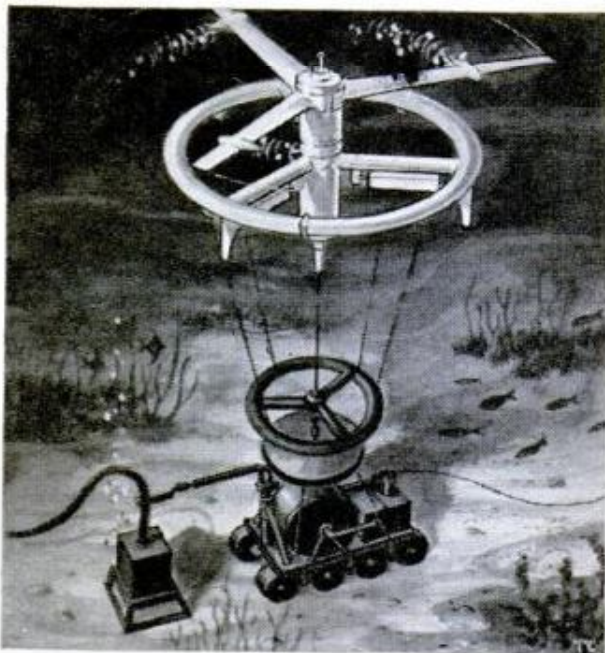

Tent Fits on Station Wagon

Combining the advantages of station wagon camping with the open floor space and head room of an umbrella tent, a new tent opens through the rear panel into the open tailgate of any station wagon. The opening is covered by an awning with side curtains which extends over the rear windows of the wagon body. With the wagon removed, the awning can stay in place to form a "back porch," and a four-foot square of mosquito netting zips over the opening to form another window. In bad weather, the same awning zips down to cover the opening. The tent is nine feet, four inches square and sleeps three easily. Two more can sleep in the wagon bed; the side curtains assure privacy and keep out the light.

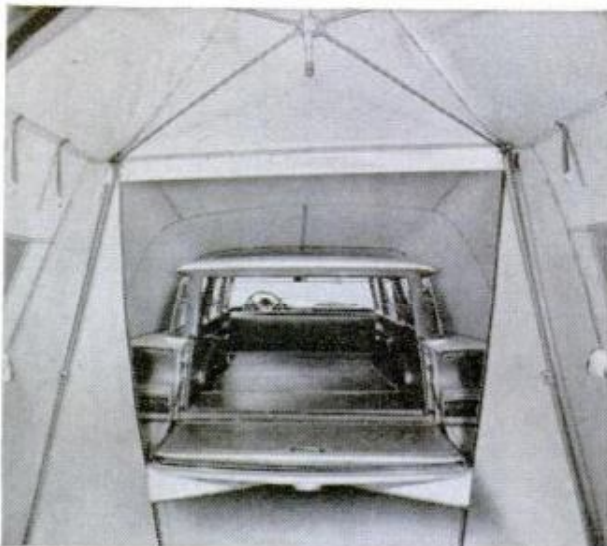

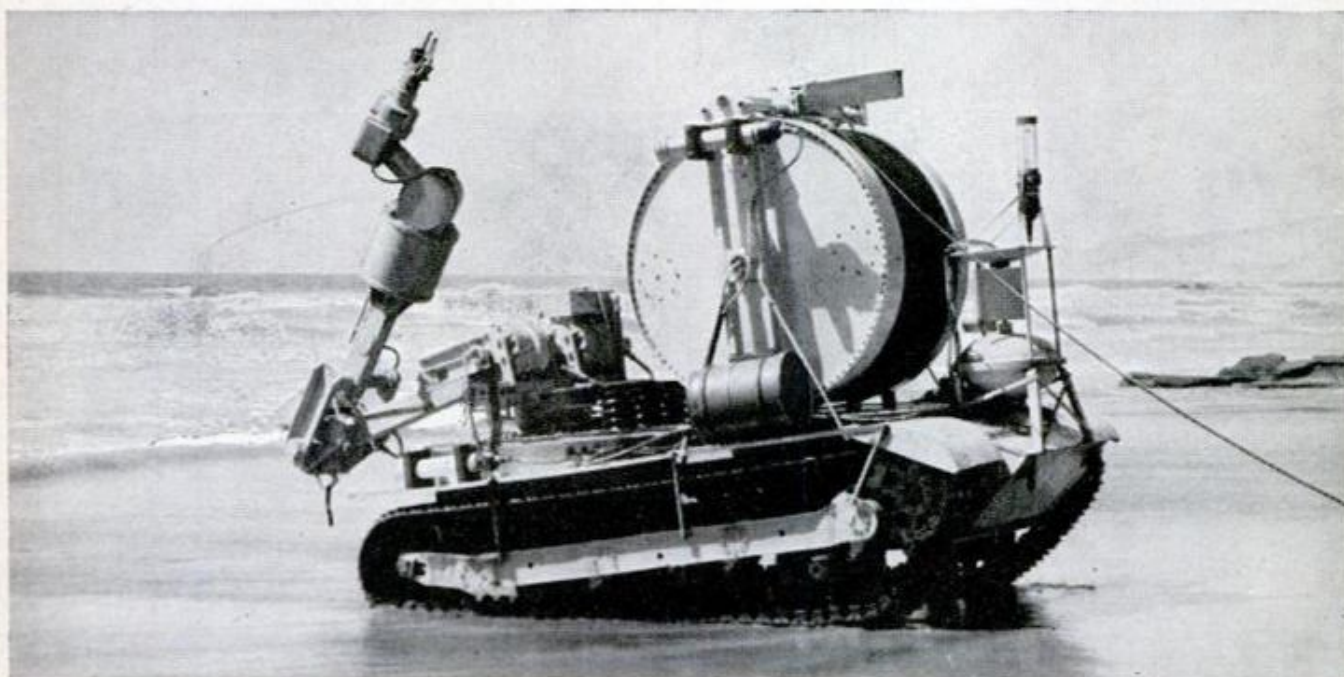



Wins Pistol Crown the Hard Way

When Donald J. Weldon, Navy fire control technician, broke his right hand two months before the finals of the Navy pistol-match championship, he began practicing left-handed. With his right hand still in a brace, he went on to win.



Man Baits Dog

Looks like a man making a sandwich the hard way, but it's really SPCA Officer Odin White, baiting a dog trap at the Hayward, Calif., airport. Traps were used to reduce packs of dogs which created a nuisance chasing rabbits around the runways.



Organ Plays Through Radio

Any radio or electronic amplifying system serves as an audio output for a German "Minichord" organ, demonstrated at the 1960 International Spring Fair in Frankfurt. The keyboard is portable, has a range of four octaves and can be used with any normal speaker system.

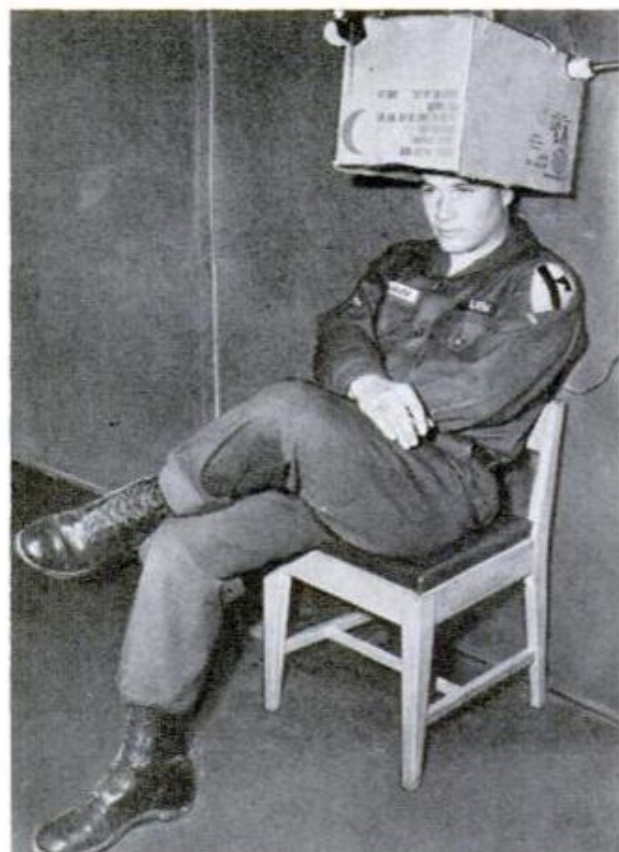

Soldier Improvises Beauty Shop

When it was known in Korea that Pfc. A. L. Frederick had been a civilian hair stylist, he was besieged by Army nurses and USO girls. He improvised a dryer from a C-ration box and four light bulbs. Dowel pins became wave rods, and home-permanent kits became his wave solution.

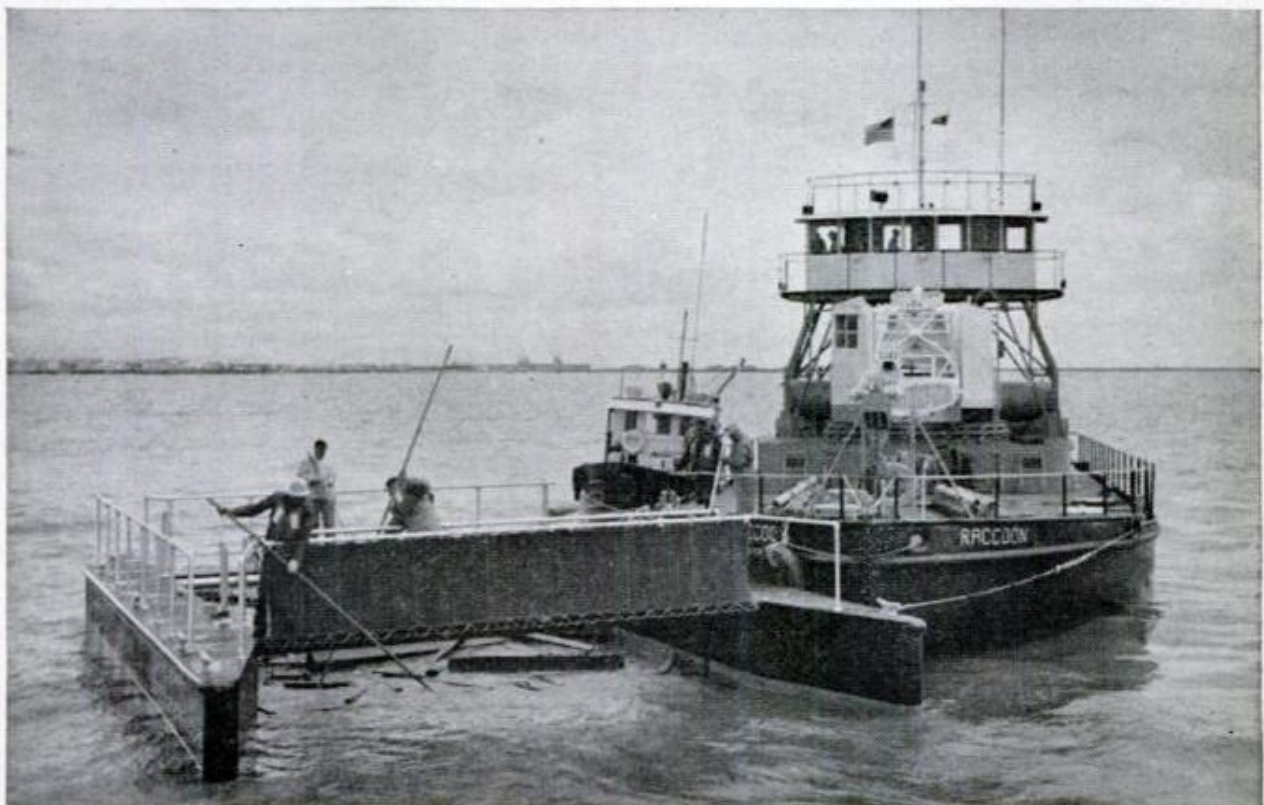

Army Catamaran Clears San Francisco Bay of Debris

Mushrooming construction and redevelopment programs, deteriorating piers and shore structures, thoughtless vandals who deliberately throw trash and garbage into the water, coupled with a smog-abatement program that outlaws any open burning have all created a major navigation problem in the San Francisco Bay area. Float-

ing debris has become a menace to ships and amphibious aircraft. Army engineers met the problem with a catamaran-type vessel that drags a one-ton net between its hulls about three feet underwater. When the net accumulates about 10 tons of debris, it is lifted to the tug and hauled away to be burned in a special incinerator.



Teaching a new colt to lead, Joe Armstrong holds the lead line while Ray Sewell controls a loop around the hindquarters to help. Reluctant now, the youngster will soon get the idea and learn to follow the lead wherever it goes. This first, important step lays the foundation for all the training to come

Train Your Own Horse

By Bob Moulder

THE SADDLE HORSE, long acclaimed by horsemen and trainers as smarter and easier to train than its rider, is growing in popularity, taking its rightful place beside the thoroughbred and harness horse. Why? Certainly not the decline of motorized transportation. Horseback riding and a love of good horseflesh has been a part of the American tradition—and that of our English forebears—for centuries. And for perhaps a hundred years, the horse was more important to the development of our country than motorized transportation is in these times.

But today, with more and more families moving out of the city into the wide open exurbs, families can again own and use riding horses—and they can double their pleasure by training their own.

The saddle horse is not a pet reserved for royalty. It is a working man and sportsman's horse. Owning and riding a good horse is fun. But that is only half the fun. The other half is breaking and training the animal from a colt. When this is done, there is a bond between horse and rider that is as

strong as that between a man and his dog.

You don't know how to train a horse? Relax—there is no magic feat to training your animal. Neither do you have to be a champion cowboy to do the job. All it takes is a liking for horses, patience, and some knowledge of a few fundamentals that have varied only a little in centuries of horse breaking and training.

Professor Carl Williams, of Mississippi State University at Starkville, Mississippi, whose job it is to teach Quarter Horse conformation and training at the university's School of Agriculture, gives seven basic rules for training a saddle horse which will change your colt from a frisky rebel to a gentle servant and companion.

Halter breaking your colt: Breaking the colt to lead is the first step in training any kind of horse. This can be done at any age, but it is easiest when the colt is still nursing. When this is the case, the mother can be used to walk beside the colt as a calming influence. In almost all cases, this is done when the colt is about six to eight months old. The halter-trained colt is much easier

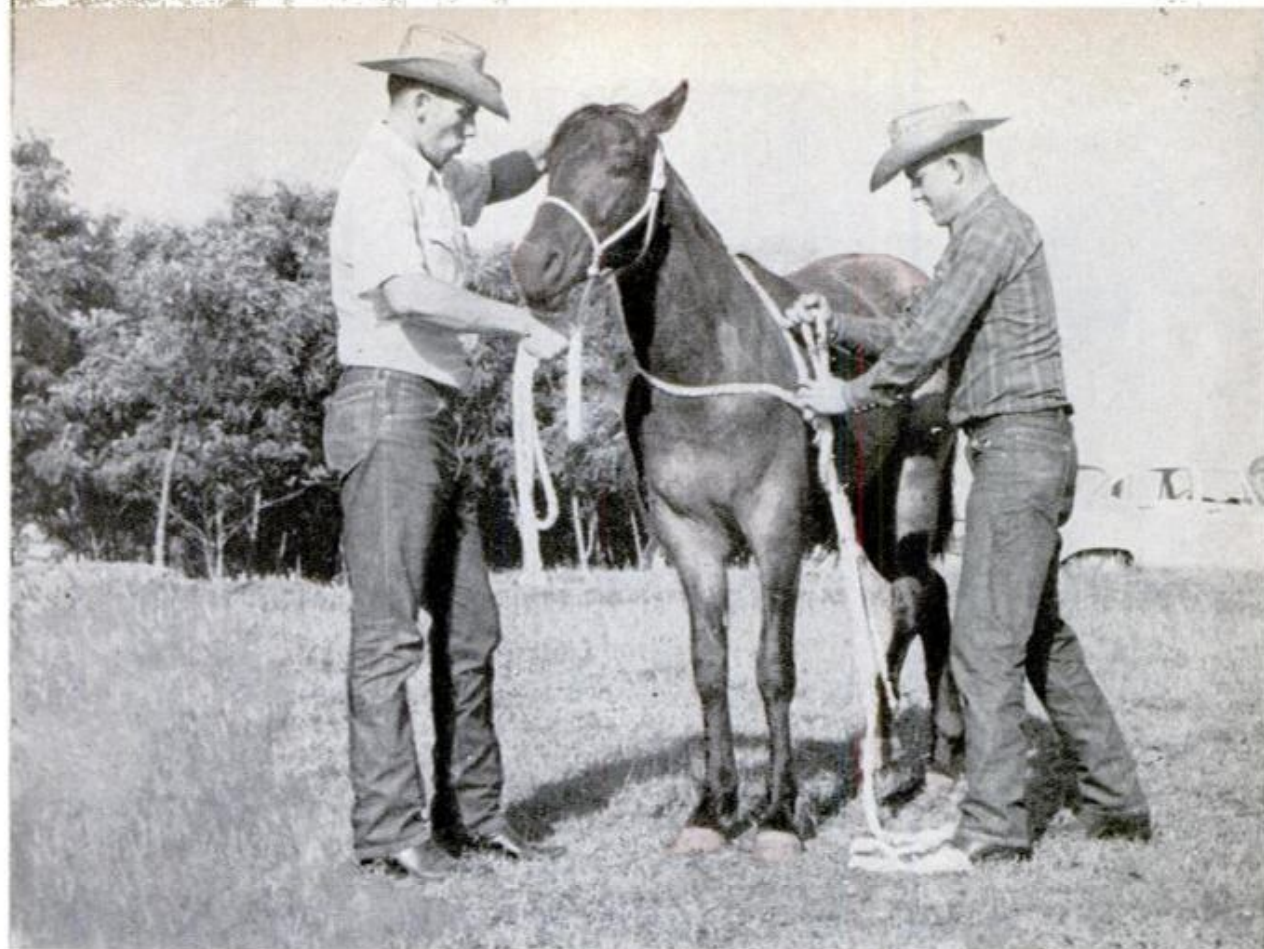

Step two—18 months old, gentled and thoroughly broken to the lead line, the colt is ready for his introduction to the saddle and rider. Joe holds the halter and the colt's ear while Ray runs a rope around his neck and back to a hind leg to discourage jumping during the early stages of the breaking process



Rubbing the blanket and saddle gently across the colt's back for a while assures him that there's nothing to fear, and he soon forgets his resentment. Then it's time to fasten the girth, but loosely

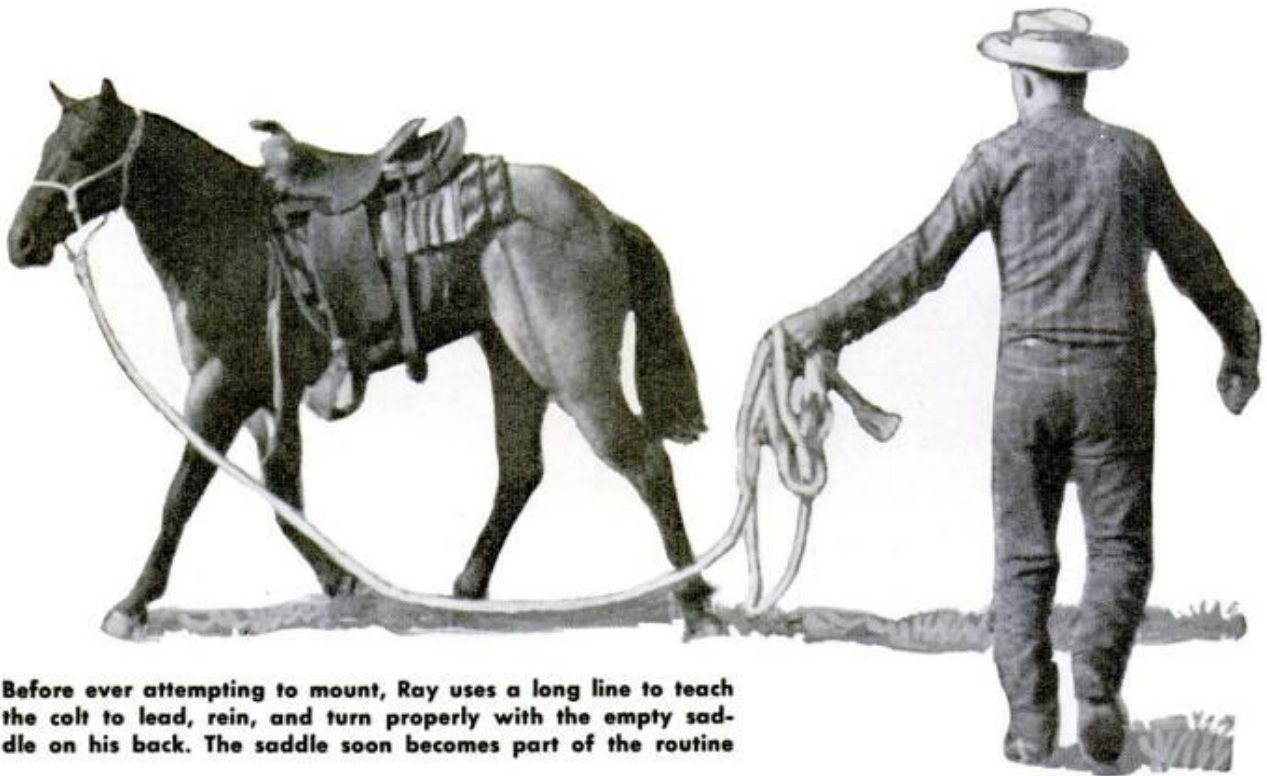

Before ever attempting to mount, Ray uses a long line to teach the colt to lead, rein, and turn properly with the empty saddle on his back. The saddle soon becomes part of the routine

to handle during training. While still a young foal, the colt can be handled quite easily. A little work each day for several days will usually result in a colt that will lead readily.

The best way to begin teaching a colt to lead is by pulling gently on the rope from one side of the colt. When he steps around, give him some slack in the lead rope. Repeat the procedure until he readily turns toward you when you pull on the rope. Then, try getting him to step forward by pulling straight ahead. Always give him some slack when he steps forward. This shows the colt what you want him to do. He'll catch on in a few minutes.

If the colt is reluctant to lead forward, a loop around his hips or rear quarter will

encourage him to move. A loop around his chest, with the rope between his front legs, is sometimes used on older horses. A tug on this rope will usually make the horse move forward.

Older colts that have never been handled are often tied to a fence for a few hours to start the halter breaking process. This teaches the colt respect for the rope and halter and will teach him not to pull back on the rope. The colt then can be taught to follow by using one of the methods mentioned earlier.

Breaking the colt to ride: Breaking usually begins when the colt is around eighteen months old. The animal that is handled easily and made friends with early, is usually much easier to handle. Most horses are

Time to change from the halter to a hackamore, which does the same job but spares the colt's mouth from the occasional but necessary yanks during training



"Back" and "whoa"—important lessons —come next, and are much easier to teach before trying to mount as well as handy during the sometimes-precarious attempts at training from the saddle



First time up. Holding the left rein shorter than the right, so the colt will turn if he starts to move too soon, Joe mounts and dismounts several times to get him accustomed to the new weight



broken to ride gradually today instead of being caught for the first time, saddled and ridden immediately. That "old West" method is hard on both the horse and the trainer.

Training horses has been compared to the basic rules of raising children, being firm, patient, and beginning early. By working gradually, the horse can be gentled and can have time to become accustomed to the blanket and saddle. The blanket and saddle should be patiently rubbed across the horse's back until he loses his fear of the unnatural trappings. As soon as he learns that they are not to be feared, he will not resent them. Only older horses that haven't been worked should need to be restrained to saddle. One way of doing this is by tying one back hoof. If you have someone helping, he can hold the horse by the ear until the foot is tied. This isn't necessary with gentle horses.

Saddle and walk: Give the horse a little time to get accustomed to the saddle on his back, then tighten the girth slightly. He can then be exercised in a walk and trot in a circle on the end of a long line. This will acquaint the horse with the saddle when making various movements. You should also teach him what the command "Whoa" means at this time. Give him the command and then give a short jerk on the line, and he will soon learn what you mean.

The hackamore: Young horses are usually ridden at first with a hackamore. This prevents injury to the mouth while teaching the horse to rein. The hackamore should be adjusted to fit the particular horse; some animals respond better when it is at a different place on the nose.

Back and rein: The next step is to teach the horse to back and to rein. This doesn't come as natural to the horse as moving forward, but it is advisable to teach the horse this movement at an early age. You can also teach him the basic principles of reining before ever mounting the saddle. This can be done by tying the stirrups together under his stomach and running the reins through the stirrups and driving him from behind. You can teach him to turn with his

(Continued to page 236)



Once he accepts the rider on his back, the colt is ridden in irregular figure eights for about an hour a day. It is important not to ride too long or to work the colt too hard

Tall—and at home—in the saddle, Joe and the newly-trained saddle horse enjoy a graduation ride. Time, patience, and gentle, careful handling have paid off in a steady, stable mount



Inflatable Sailing Catamaran

Starting from a package small enough to carry on a car-top rack, a new sailing catamaran inflates and assembles into a 9½-foot sailer that will support three adults. Made of a special waterproofed nylon fabric, the hulls are each divided into four separate compartments. The fabric resists tearing and rotting. The catamaran is manufactured in North Ireland.

Recent tests by the Army at Fort Devens, Mass., showed that the most consistently visible color for clothing was a fluorescent "blaze orange" — much better than the usual red or yellow.

Studies by a University of Wisconsin scientist disclose a maximum heart rate of 1320 per minute and maximum respiratory rate of 1080 per minute for the masked shrew, a mouselike mammal.



Giant Missile-Tracking Camera

ROTI (recording optical tracking instrument) is basically a 24-inch telescope with a 500-inch focal-length lens system mounted on a 70-millimeter camera. Two of these units are used to track missiles fired from Cape Canaveral and record their performance for later evaluation. In the sequence below, 1) a Titan missile blasts off and is photographed about 25 miles above the Cape; 2) the first stage is shown burning out; 3) the first and second stages separate; 4) the second stage ignites; 5) it begins to leave the first stage behind; and 6) it is photographed more than 50 miles from the camera, still climbing and traveling spaceward at nearly 5000 miles per hour. The second stage will continue into outer space where its ballistic trajectory will start downward and the re-entry vehicle will re-enter the atmosphere and into the down-range splash net. The initial part of the trip sets the pattern, however, and the new cameras record how well it performs then.

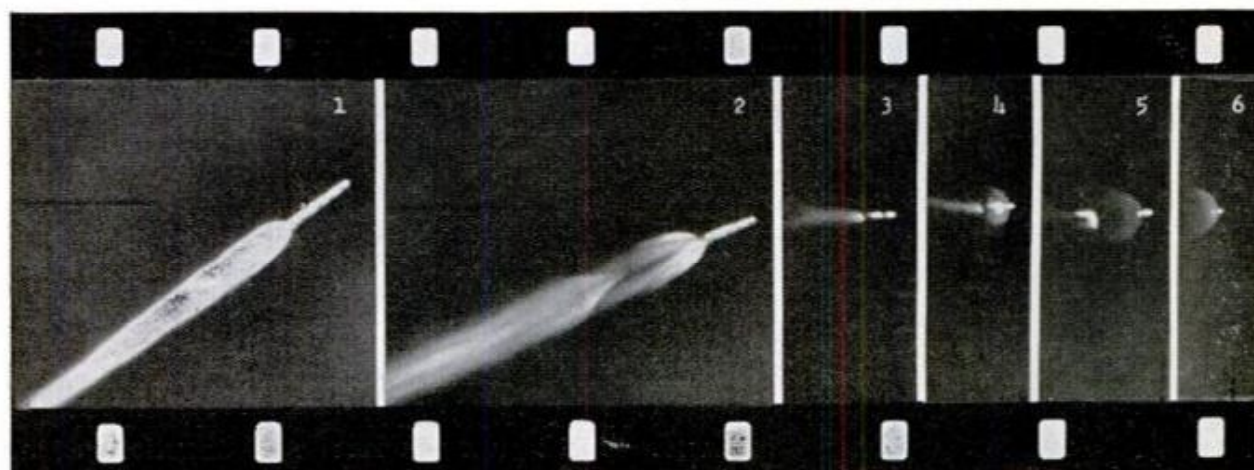
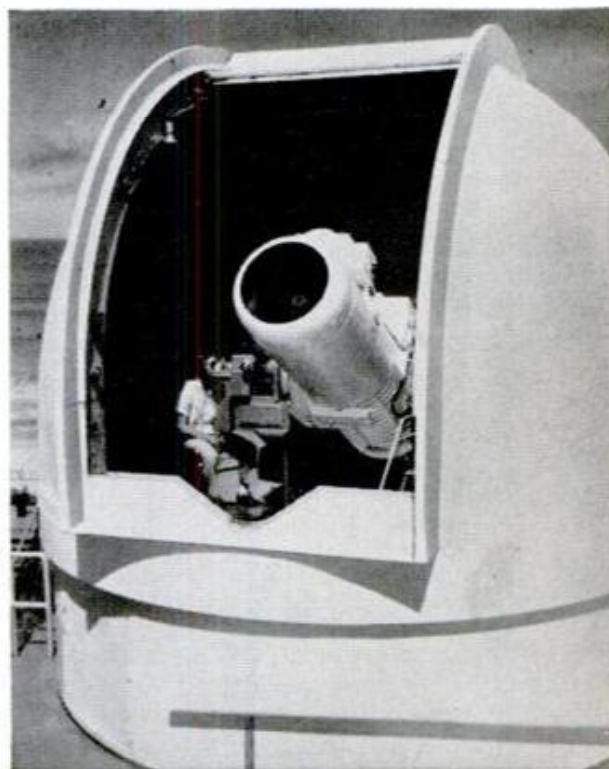

The Metric System - PRO

By **Chauncey D. Leake**

Professor of Pharmacology, The Ohio State University
President of the American Association for the Advancement of Science

THERE ARE 10 good reasons why we should voluntarily and gradually get our weights and measures on the metric system:

(1) It is much more simple and easy to use in computation than the clumsy ancient disorderly English system;

(2) It is an interrelated and coordinated system for linear, volume, mass, energy and electro-magnetic standards;

(3) It is universally used all over the world in scientific studies, and indeed greatly facilitates such studies;

(4) It is in common ordinary daily use all over the world, except in English-speaking countries, which are thus at a disadvantage in communicating on measurement at an international level;

(5) It is commonly used in trade and commercial transactions, except in English-speaking countries, which thus are at a disadvantage in selling abroad;

(6) Its uniformity in standards tends to reduce cheating or deception in trading, or in buying and selling;

(7) Its direct capacity for indefinite extension into the sub-atomic or super-cosmic worlds makes it essential for our modern development of nuclear energy and space exploration;

(8) It easily relates us as humans to our environment, since the meter is about an arm's length, or a long step;

(9) It can quickly and easily be learned in childhood;

(10) It can readily be applied to machine tooling and manufacturing with resulting simplicity of procedure, interchangeability of parts, and uniformity of product.

There are other more subtle psychological reasons for adopting the metric system. Thus it provides a simple and easily understood basis for reaching *agreements* on standards, and thus assuring a method of obtaining world-wide uniformity in measuring, whether for scientific or for commercial reasons. Again, if the agreed-upon physical standards, now in Paris, were ever to be lost, they could be exactly reproduced. Further, the commonly used English-named weights and measures in the United States are legally defined (and thus reproducible) only in terms of the agreed-upon international metric standards. Why not, then, use these metric standards themselves in our every-day business, whether household, scientific, industrial or commercial?

The English lost their physical standards in a fire in the House of Commons in the middle of the 19th Century, and could only reproduce them from historical records. Meanwhile we had defined our standards on the metric standards, even though we continued to use the English terminology. The result is that slight but now significant differences exist between the English standards and ours. This causes much, and will cause more, confusion in technical matters. It would be better for us all to go directly to metric usage.

There are two major objections to our going on metric usage: (1) a commercial factor which traders are reluctant to admit; namely, that variations in standards of measurement permit shrewd traders to learn where to buy long measure (as with long tons, or imperial gallons) and sell short measure, and (2) costs of converting machine tools and manufactured products to metric standards.

The first objection is specious and suggests a resistance to honest trading which is unworthy of our professed ethical ideals. The second objection is superficial, since the change can be made gradually and eventually would result in real economic gain. The American drug industry is gradually converting to metric use in all phases of manufacturing and merchandising, with resulting economy and efficiency in its rapid expansion, especially in world markets.

However, there are subtle psychological objections to the metric system. It is "felt" to be foreign, strange, different, and being of French origin, slightly immoral. These "feelings" are unworthy of intelligent people, but they exist. This sort of quasi-religious, highly emotional, irrational, and semi-superstitious antagonism to the metric system reached its culmination in the successful efforts of an Ohio fanatical astrologer and numerologist, Charles Latima, when his organized opposition prevented legal adoption of the metric system in the United States in 1876.

Recently there was an important international conference on systems of units held under the auspices of the American Association for the Advancement of Science. Except for some questions on the basis of costs, there was unanimous agreement that the full legal adoption of the

(Continued to page 222)

By Ralph M. Drews

Chief Metallurgist, Fabricating Divisions, Republic Steel Corporation

"SHOULD American industry convert to the metric system" is a very old question. At least 40 years ago this question was a subject of lively debate in our schools and newspapers. The popular argument in favor of conversion at that time was supposed simplicity and international usage as well as the fact that our monetary system was a decimal measurement. Proponents of the change made it sound like a simple matter—nothing more difficult than changing from standard to daylight time.

Surely, there is much more to it than that. We must first consider the knowledge of the people with no scientific education, their training and their gradual acclimation to using the metric system. I feel quite sure that, if a poll were taken of the American public, very few persons would have any idea of the relationship of the metric system to itself or to our American system. Yet, most of these people have come in contact with the metric system at some time in their school days. The use of *milli*, *centi*, *deci*, *deka*, *hecto*, *kilo*, *meters*, *grams* and *liters* is no simple language or measurement system to them. It is quite confusing.

Within the steel industry it may not be too difficult to recalibrate our scales and change the headings on our report sheets, but much more sober thinking must be given to the billions of dollars in drawings in our engineering files and of the astronomical number of dollars in operating equipment. To keep this equipment operating requires constant maintenance and replacement of worn parts made to the drawings in our files. All of this has been engineered to the American measurement system. To change now to the metric system would require redimensioning of our entire file of drawings with cumbersome metric decimals, having a large number of figures in order to make new parts fit accurately.

In addition to the making of coke, iron and steel, the steel industry in this country is involved in making numerous so-called finished iron and steel products. These vary somewhat from plant to plant, but may be castings, pipe, tubing, couplings, wire, nails, fencing, bolts, nuts, rivets, roofing, containers, shafting, cold-drawn bars, structural shapes, reinforcing mesh and so on. In this finishing or fabricating field, the steel industry has another astronomical investment in machines, engineered to and mak-

ing products to the U. S. measurement system.

How this change is to be brought about and what benefit it will be to the American producer and consumer becomes quite confusing—at least to me.

If the conversion from inch to centimeter is made by using the metric equivalent of the inch measurement, then we have done nothing more than change existing dimensional figures to probably something more complicated. For instance, the 1-inch measurement is equivalent to 25.4 millimeters—an American standard in use for 25 years—or to 2.54 centimeters; $\frac{1}{2}$ inch (0.500 inch) to 1.275 centimeters; $\frac{1}{4}$ inch (0.250 inch) to 0.635 centimeters or 6.35 millimeters; $\frac{1}{8}$ inch to 0.79375 millimeters; $\frac{1}{16}$ inch to 0.396875 millimeters, and our popular $\frac{1}{1000}$ (0.001 inch) tolerance figure becomes 0.000254 millimeters. After all this conversion is accomplished, we should merely have adopted a much more difficult way of expressing the inch measurement.

Products made to metric system dimensions of simple numbers are in no way interchangeable with products made to the inch system. For example, a 2-centimeter bolt cannot be used in place of a $\frac{1}{4}$ -inch bolt, and standard metric-dimensioned pipe will not interchange with American.

If the conversion is to be made by adopting the existing metric-country standards, which I believe is what most proponents would like for new design, by continuing to manufacture to the inch system for existing requirements we might never get out of the mess. This would mean redesigning all our product standards. It would mean retooling for the entire American industry—not only the steel industry—while at the same time maintaining present tooling and setups for existing equipment and products. It would mean dual stocking of parts from now on. It could even mean producing equipment operating with sections made to both measurements. Of course, to start with, our people would first have to be briefed on the metric system. Obviously, this could produce considerable costly confusion. And what have we gained?

If there is any thought that we can simply "pull the shade down on the inch measurement" and change over abruptly to the metric system, it most likely will be a

(Continued to page 228)



Ice Skating Rink Built Into Downtown Apartment

Midtown Manhattan seems an unusual spot for a private ice skating rink, but at 213 West 58th Street there's a 20 by 32-foot skating area built into the rear of a fashionable apartment building. The owner, Alan Murray, a shoe manufacturer and ice-skating instructor, had the rink built into the site of an unused stable behind the building

so his friends and students could take a turn on the ice without inconvenience or temperature worries. An ice-making machine capable of freezing 10 tons of ice a day keeps the ice in shape, and Mr. Murray's apartment and offices are around and above the rink. Above, the host and his daughter watch the skaters from the apartment.

Suitcase Folds Up Like High Silk Hat

It was made in England, of course, the country most identified with the folding top hat. When folded, it rather resembles an over-size underarm case. When unfolded, it becomes a normal-size suitcase. Made of light-weight canvas, it has two stiffened sides that are swung inward when collapsing the suitcase. When open, the two sides are held in place by clips. The collapsible case, because of the canvas, is relatively light in weight, some sizes weighing less than five pounds. It is available in four sizes, ranging up to 26 by 15 by 7 inches, and priced up to about \$21. When folded, it can be slipped into a canvas envelope for storage, just like a plastic raincoat. The envelope can be carried in the case.



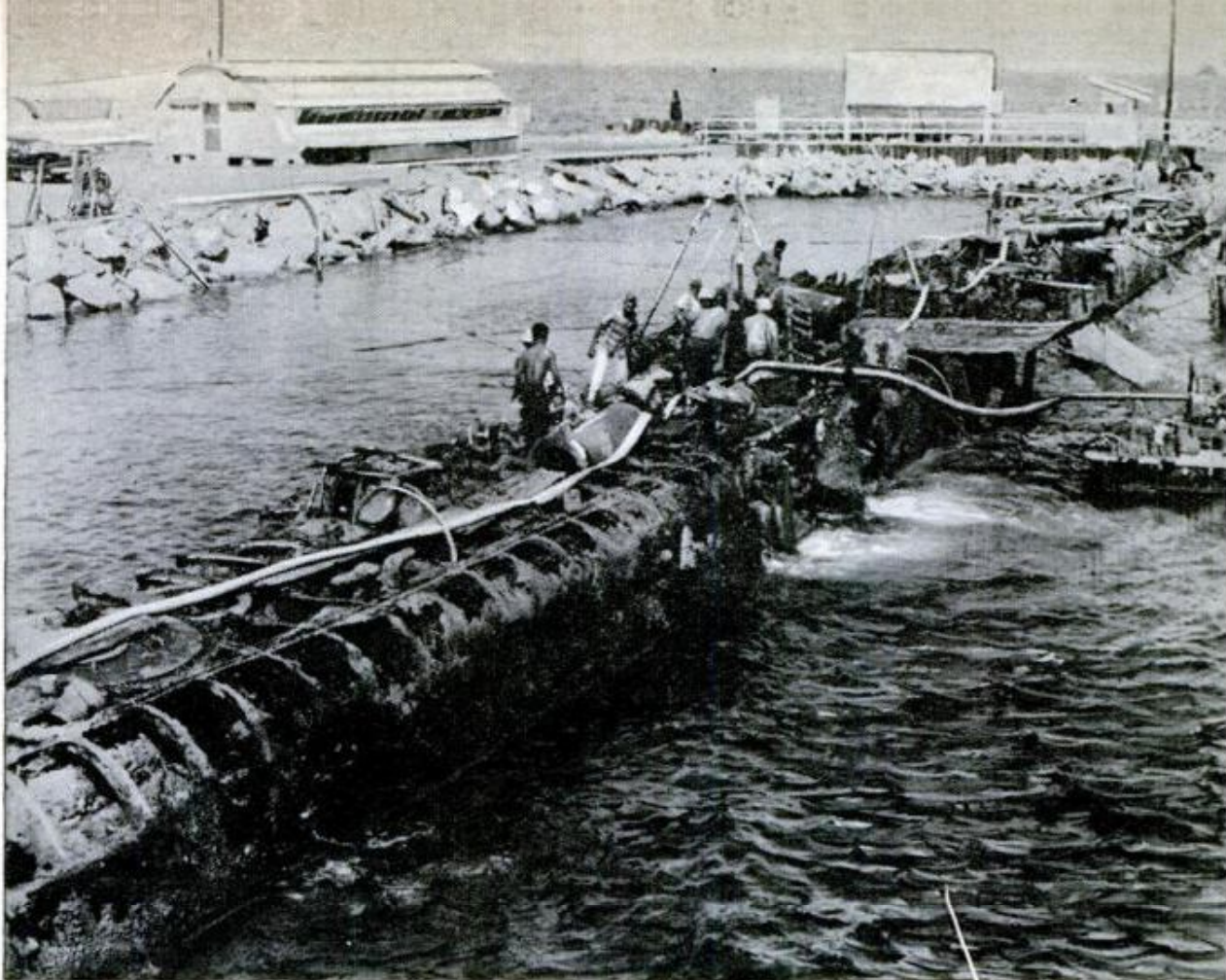

Sub Comes Up After 20-Year Dive

Sunk by Japanese bombs near Cavite in the Philippines during the early days of World War II, the USS *Sea Lion* was raised later by the Japanese, then sunk a second time by American bombers during the recapture of Luzon. After two months' work a Philippine salvage firm raised the twice-sunk submarine by sealing the many holes

in her hull with concrete and pumping water from flooded compartments until the hull was buoyant enough to be raised out of the bottom mud. The operation uncovered one strange mystery: In a crew locker, a U. S. nameplate and medal were found, inscribed "Fred Wroble," though he was never known to be aboard the *Sea Lion*.



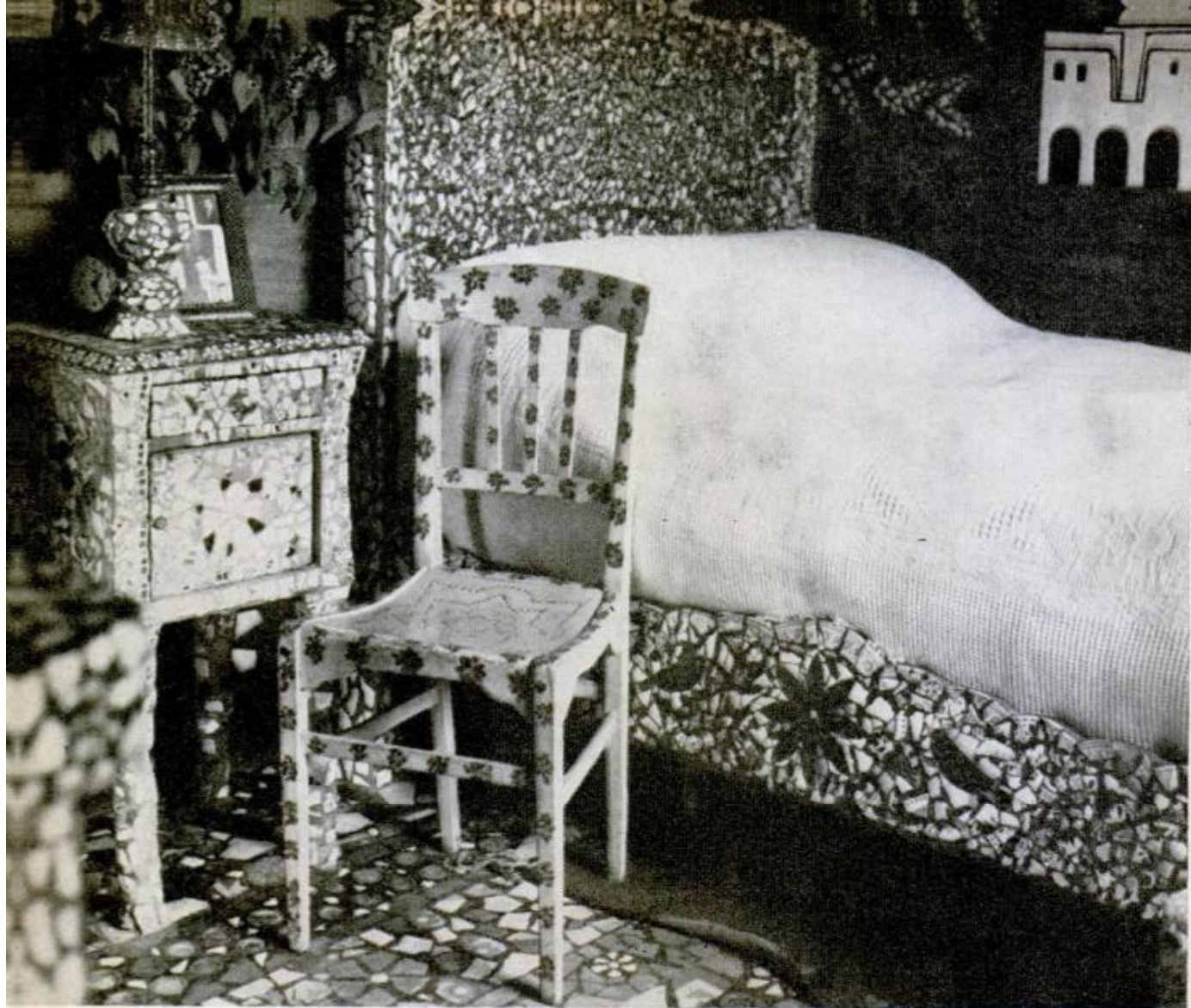

Bedstead, lamp base, nightstand, floor—these surfaces are covered with mosaics made by Raymond Isidore

MOSAIC HOUSE

His beret tilted in the way sported by artists, Isidore touches on paint to a butterfly design he made from bits of broken glass and pottery. With his wife, right, he sits in their mosaic-embellished courtyard





Thirty years of careful work have resulted in Isidore's home becoming a showcase for his mosaic designs

FRENCH STREET CLEANER Raymond Isidore for 30 years has been salvaging bits of glass, china and crockery from the mounds of dust he gathers each day and using them to decorate his house, the wall around it and the patiolike yard. The result is that his home has become a sparkling showplace for mosaic design and a rival, as a tourist attraction, to the famed cathedral in his town of Chartres.

Isidore is himself fond of churches and many of his designs have been fashioned to resemble such well-known cathedrals as the one in Chartres, Notre Dame, Sacre-Coeur and others. Flower designs predominate on the wall around his courtyard and on the floor of the courtyard which itself

holds a display of flowers and plants in mosaic-encrusted flowerpots.

Mrs. Isidore cooks on a stove that has been surfaced with bits of broken crockery, and most of the rest of the household furnishings are similarly covered with the carefully fashioned designs. The exceptions are chairs. These are painted with designs because the cement, in which the mosaic pieces are fitted, would make the chairs too heavy to move about.

The only major part of the house that has not been overlaid with mosaic design is the roof. But Isidore, who has cemented in four million bits of glass and crockery through the years, from time to time studies, reflectively, its artistic possibilities.



Frogmen Televisе Fish From Undersea Craft

Two Coast Guard frogmen who studied fish and fishing practices at Gloucester, Mass., toured around underwater seated in a submarine-like craft made from a Navy bomber fuel tank. It is designed to be filled with water and sink, using a plastic foam material to achieve partial buoyancy. It is equipped with fins and rudder which are operated by one frogman while the other sits facing the stern with an underwater

television camera. The craft is towed by a surface ship which has a television screen for displaying the pictures. In an attempt to learn more about the catching of fish, the towing craft on occasion also tows a net, just in front of the frogmen. One thing they learned was that contrary to general belief, fish sometimes go into the net tail first, apparently not aware that they have been overtaken.

Fingerprints Cast in Plastic for Improved Identification



Instant fingerprints — foolproof, permanent plastic casts of either a whole finger or of a dusted print—are possible with a new method developed by the Army Quartermaster Corps. With the method, liquid plastic is sprayed on a latent print, or a finger is dipped into the plastic, which is peeled off and turned inside out to become a model of the original finger. The resultant print is clearer, more accurate, and easier to handle than the usual rolled-ink prints.



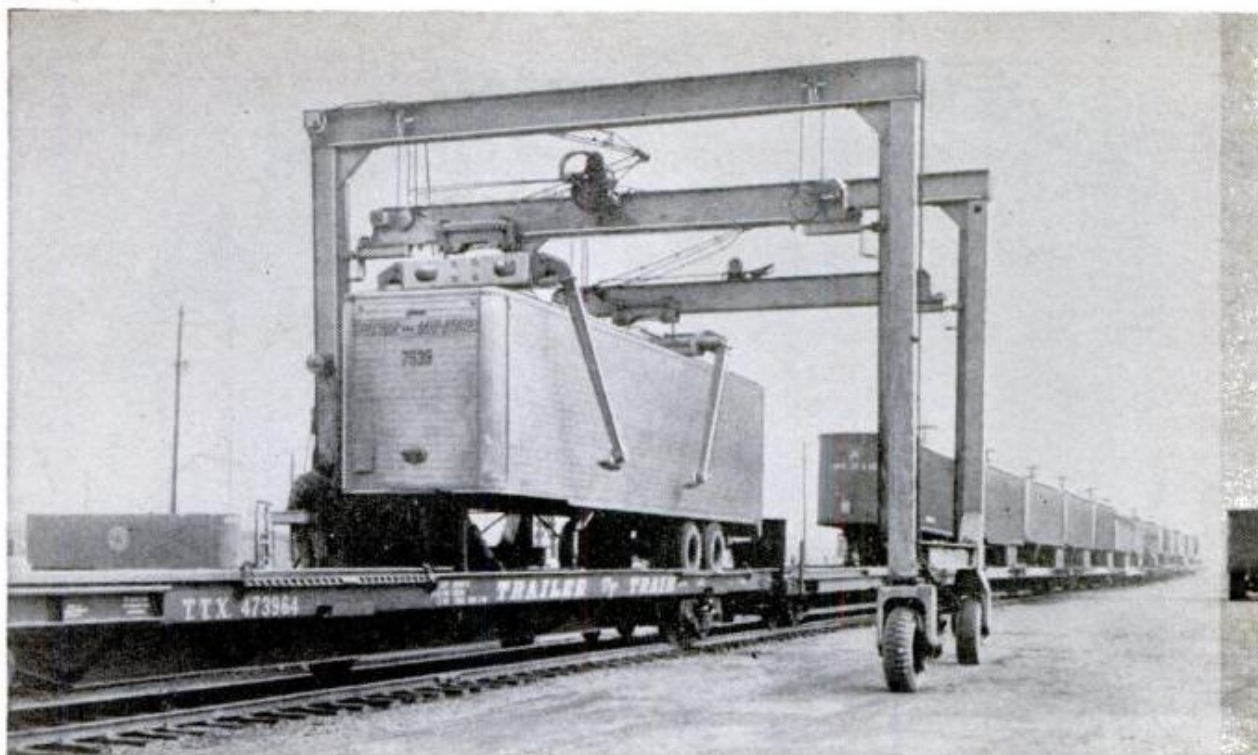

Self-Propelled Lifter Unloads Piggybacks

Big brother of the familiar "straddle carriers," a new vertical lifter is unloading 18 big piggyback trailers an hour in the South Kearney, N. J. rail yards by simply lifting them off their flatbed rail cars.

Straddling the entire train, the big lifter picks up a trailer with its four arms, rolls it across the top beams on trollies, and eases it onto the ground. The one-man operation works with any trailer or container.

Chair Folds Out to Become Gentleman's Gentleman

Danish furniture designers, as most furniture buyers might know, have a talent for the unusual. One of their latest creations is a cherry and teakwood chair that, when not in use, folds out into a valet piece. The

back becomes a coat hanger, the seat is used for draping trousers and the small compartment beneath the seat stores pocket articles. It's designed for either private lounge or executive suite.



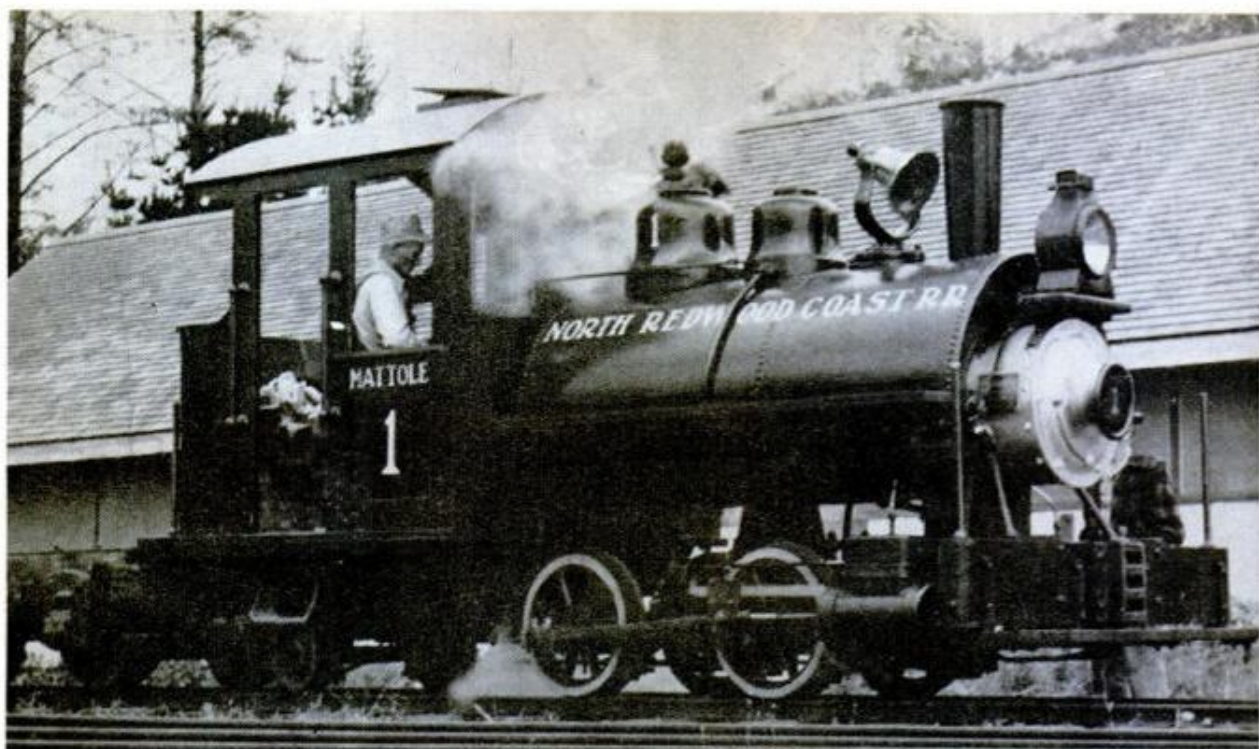

Abandoned and half-buried for 46 years, old Mattole No. 1 rides again—for about 300 feet to nowhere

The Engine That Was Born Again

By Cliff Essex

Photos by Henry Sorensen and Gus Haggmark

Coach was donated by neighbor to give revived engine something to pull. Cupola converted coach to caboose

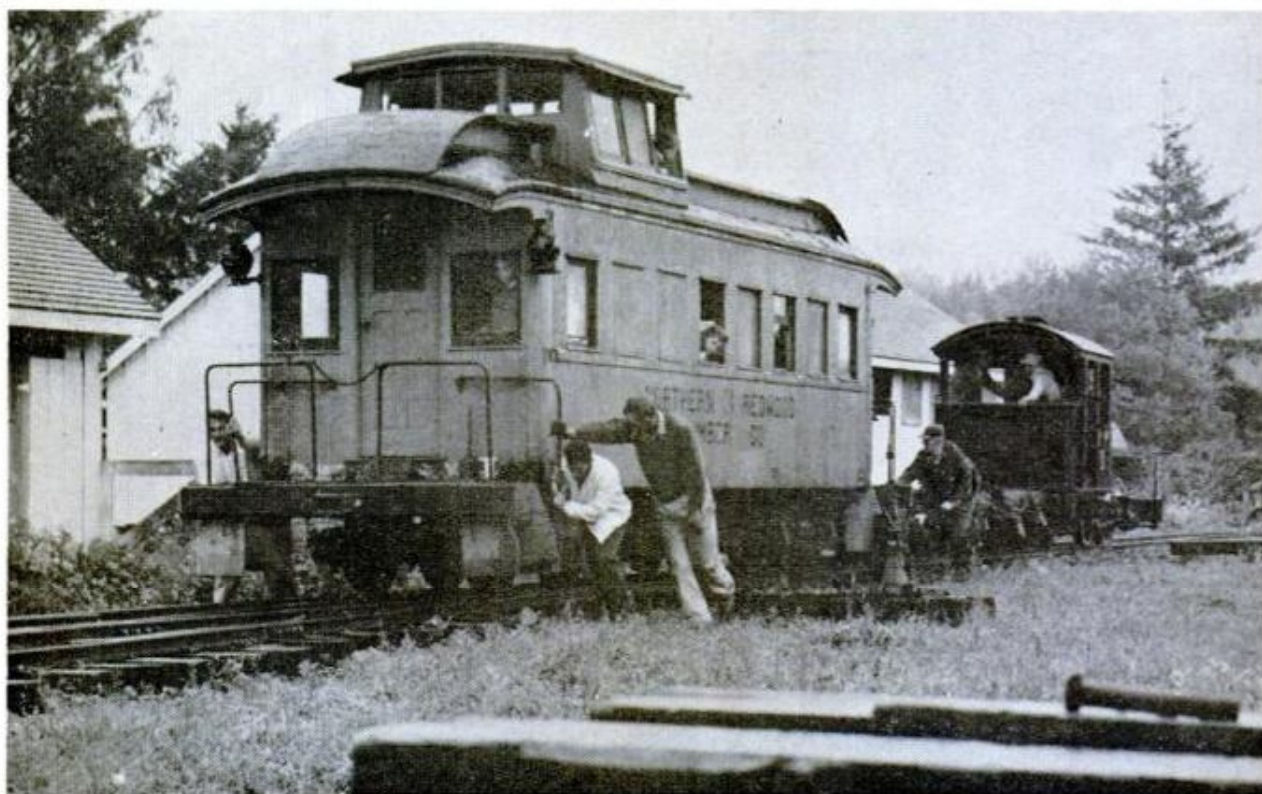

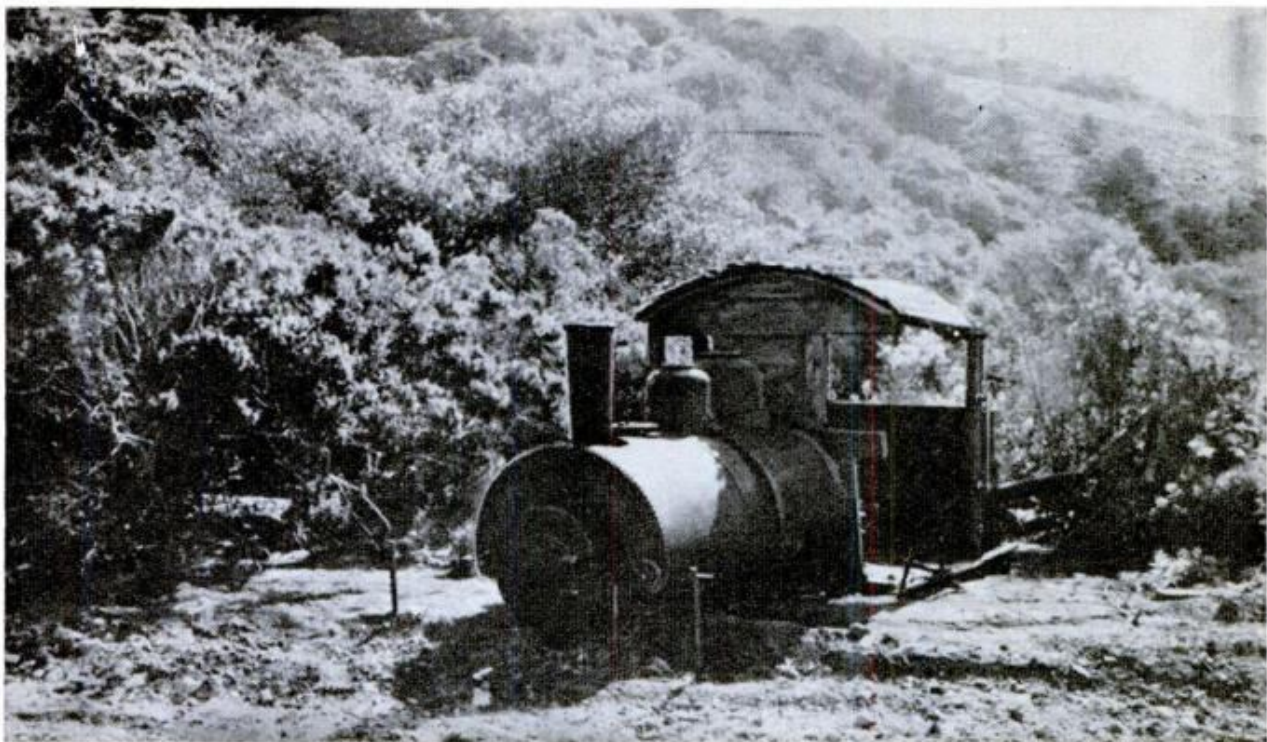

Engine looked like this when found, still riding on buried tracks. Nearly 10 years of work lay ahead

AROUND THE TURN of the century the rough forested hills of northern California's lumber country were laced with hard-working narrow gauge railroads. In time much of this equipment was abandoned and today is highly prized by collectors. Unfortunately it is sometimes impossible to remove this material because of the terrain, or because, in the wet

climate that encourages shaded ferns to grow five feet tall, wood and iron have rusted and rotted beyond use.

Henry Sorensen felt lucky when he found a locomotive near the ocean, away from the forest. But problems were apparent. The engine was buried up to her boiler in the dirt and gravel of a dry stream and would have to be dug out by

Sorensen (l.) and Haggmark (r.) chat with friend



Saddle tank, all repaired, is lowered onto boiler

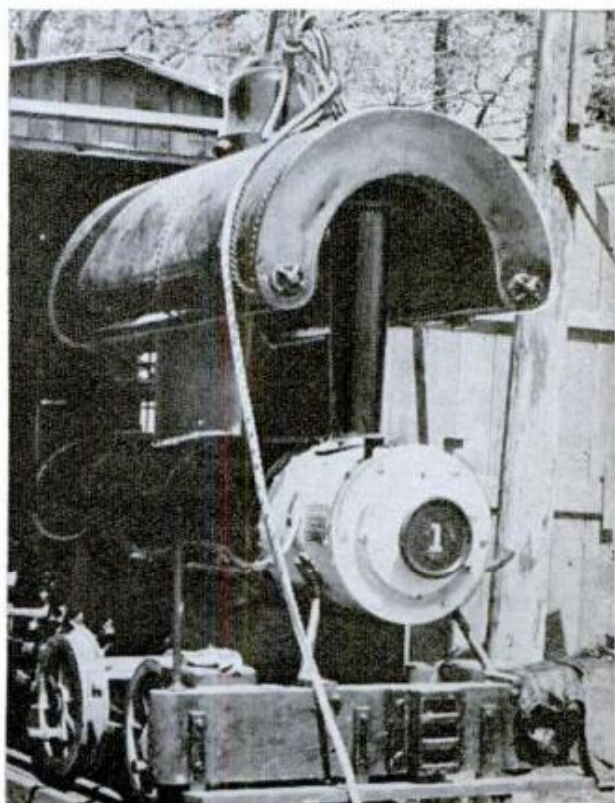



Entire cab had to be rebuilt by hand, since most of it had eroded away. Sorensen (right) took special night class in woodworking to learn how. Most of the engine's instruments and fittings had to be replaced

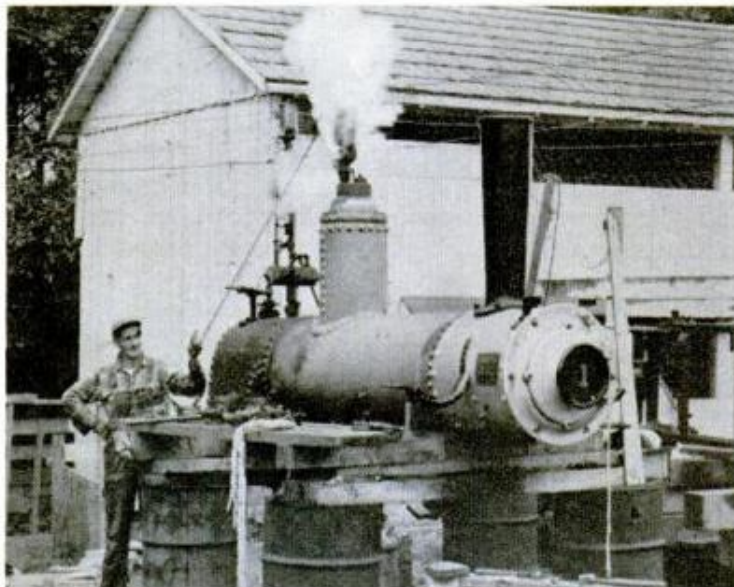

Sorensen estimates it cost him \$2000 to restore the engine. He saved on labor, however, which was mostly donated by friends



hand. Then it would have to be taken across the Mattole river somehow, and certainly an access road would have to be built. All this would have to be done while he was building a new home and running his poultry and dairy ranch 75 miles away to the north.

The relic was actually found by Henry's close friend, Gus Haggmark, who works for Pacific Gas and Electric and shares Henry's enthusiasm for old trains. Gus heard about it from a friend who had stumbled on it while quail hunting.

Investigation showed—and this alarmed Gus and Henry—that title to the old engine was owned by a man in Los Gatos, 300 miles away. He had acquired it in 1940 but lacked the opportunity to work on it, so Henry, for one dollar, became the proud owner on Dec. 29, 1949.

The locomotive had once been used for hauling tanbark from its terminal near the city of Petrolia, to a wharf out in the ocean, terminating at Seal Rock. About three miles long, the route curved around a hill following the Mattole River to its mouth, then along the rocky shore of the Pacific where waves came right up over the rail bed, to the wharf. Freight from the cars was "high-lined" to boats

(Continued to page 226)



Delicate Touch

Atomic scientists at a Hanford, Wash., research plant decorate Christmas trees in an unusual manner. They put the trees in cells where radioactive material is handled. They then place ornaments on them by remote control, using manipulators, getting practice for handling "hot" material.



Luminous Chair

Reading lamps are obsolete in homes furnished with a model from a new line of translucent plastic chairs. The chair itself is luminous and provides sufficient light for reading. A lounge model, it lights up from fluorescent tubing concealed under its foam-rubber cushion.

Russia Claims World's Largest Helicopter

With a gross weight of 84,000 pounds and a capacity of 80 passengers, the Russians have placed their MI-6 helicopter in nomination as the world's largest. Two 4635-horsepower gas-turbine engines drive the five-bladed main rotor and the smaller

four-bladed tail rotor, giving the craft a top speed of more than 165 miles an hour. The fuselage, which is almost as large as a modern airliner, can also carry vehicles which are driven aboard through clam-shell doors at the rear.



**SHOP NOTES
AND CRAFTS**



BRANCH OUT WITH SOMETHING DIFFERENT IN LEAF WALL DECOR

By Louis Pamper

THIS autumn branch of leaves "growing" on the wall of your living room or foyer will leave your friends agog. So real looking, they'll want to take a closer look, only to find that it is fashioned entirely from sheet brass and tubing. A conversation piece to say the least, it makes a striking and most unusual wall decoration.

Begin by making master tracing patterns of the four leaves given. A total of 100 leaves are needed in all, close to 25 of each size. Scribe the patterns on 24-ga. (.020) soft-tempered yellow brass and cut them out with snips. Flatten the curled leaves after cutting and deburr the rough edges with a fine file. Each leaf is embossed to simulate veining. This is done with a metal bar ground to a dull knife edge. Place the leaf on a hardwood block and then strike the embossing tool sharply with a hammer



BRANCHES AND LEAF STEMS are bent to various angles and shapes, giving an artistic, natural appearance



EACH LEAF PATTERN is first scribed on 24-ga. sheet brass and the outline carefully cut with duckbill snips



LEAVES ARE FLATTENED on a solid surface by tapping curled edges with hammer. Then edges are filed smooth



EMBOSSING OF LEAVES is done by striking knife-edge metal sharply while leaf is on hardwood block

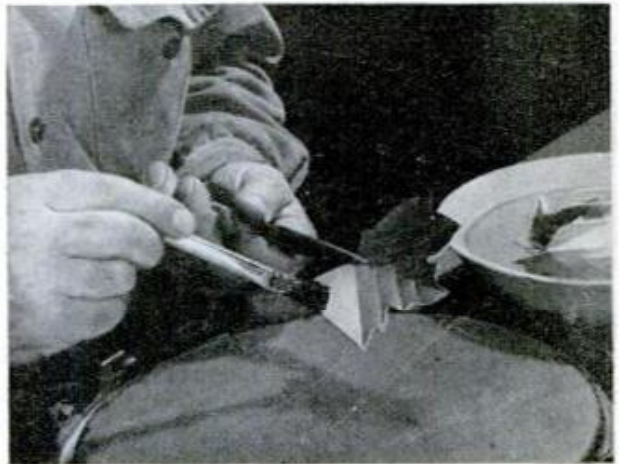

LEAVES ARE COATED with acid flux prior to coloring by dipping in acid few seconds or applying with brush

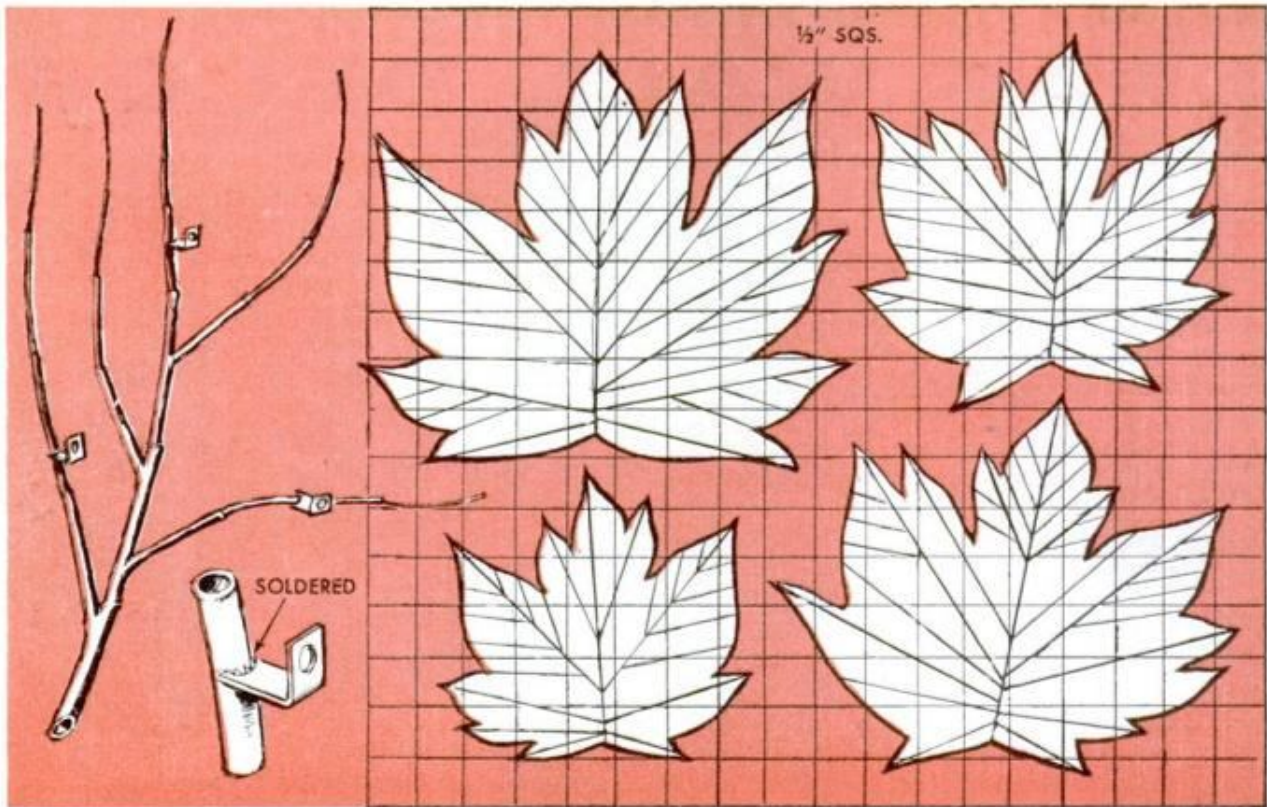

COLOR IS ADDED by playing flame of torch (below) to leaf and then quenching immediately in cold water

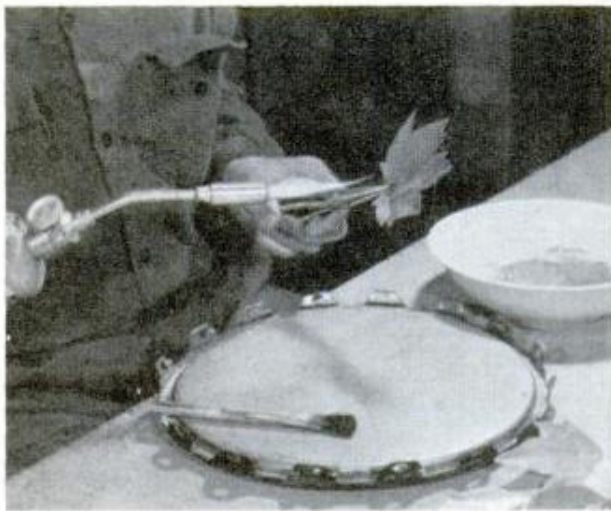

EACH LEAF IS FITTED with a stem soldered to the back. Welding rod cut in 3-in. lengths is used for stems

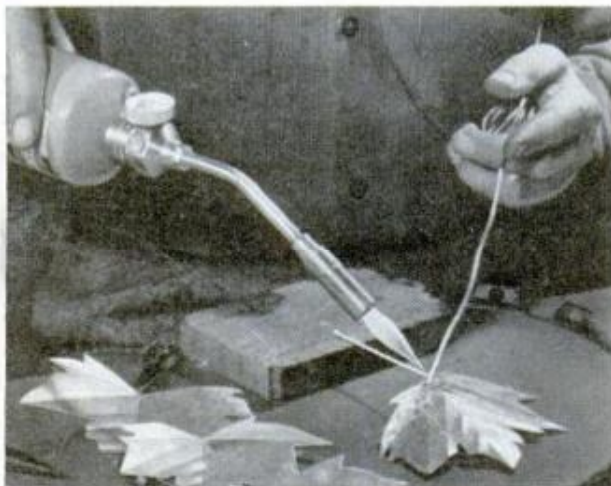

to indent, or upset, the metal. After embossing, the leaves are given an autumn hue by coating them with soldering flux (muriatic acid) and then playing the flame of a torch over them. Several leaves may be dipped in the acid at a time or the acid may be brushed on. Hold each leaf with pliers and heat with the torch until a greenish-blue vapor rises. Then immediately quench the leaf in cold water. With practice you'll learn the right moment to remove the flame. If you don't have a torch, you can heat the leaves over the burner of a gas stove. Acid remaining on the leaves requires neutralizing by immersing in a baking-soda solution, one cup soda to one gallon of hot water. Let the leaves "soak" for one hour, then rinse in hot water.

(Continued to page 230)

TAPERING BRANCHES are formed from telescoping sections of seamless brass tubing which are soldered

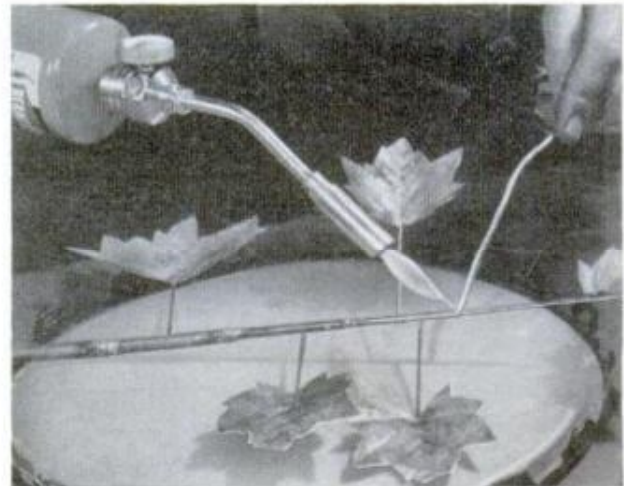

Rack Those Extra Golf Tees

Like a lot of other small items that must be carried about before being put to use, golf tees are easy to lose and hard to find when needed. To keep them in order and always at hand, rack a dozen or so in a piece of corrugated cardboard, the kind that's faced on both sides of the corrugation with heavy brown paper. Then stick the whole thing in your pocket or in your golf bag for safekeeping.

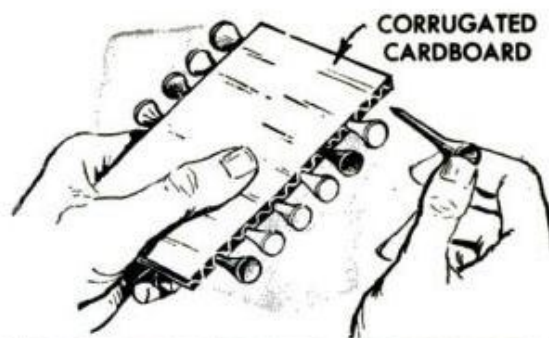

Cotter Pin Masonry Anchor

One of the simplest ways to anchor an eye in a concrete basement wall for supporting a clothesline or hanging a shelf is to use a large cotter pin. The eye is readymade and the pin can be altered so that it will anchor itself solidly. Just drill a hole, cut one leg of the pin shorter than the other, bend the long leg slightly and drive it in.

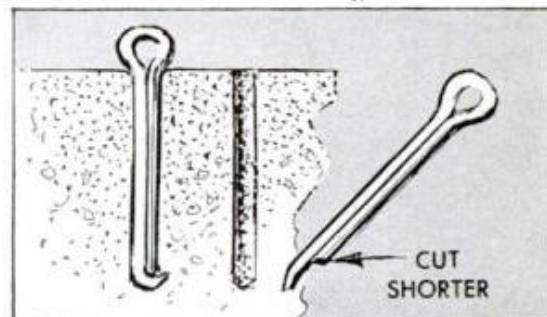

Faucet Washer Locks Turn Button

Turn buttons that hold storm sash and screens have a tendency to turn the screw as they are rotated to release the sash or screen. Because of this the buttons are likely to be quite loose after being released a few times. If you turn the screw down on a rubber faucet washer, you won't have this trouble.

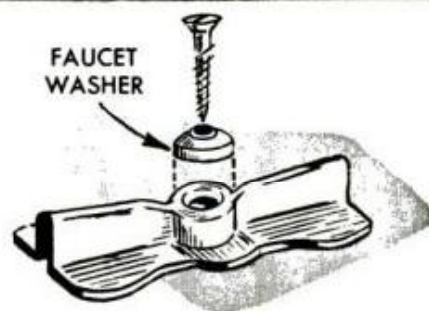

Replacement Terminals

Replacement terminals for electrical connections in the wiring system of your car can be made quickly from copper tubing. Terminals suitable for generator and starter cables, for example, can be made from 5/8-in. lengths of tubing. Simply flare one end of the tube, fit over the bared wire and solder. Then flatten and drill the end as detailed.

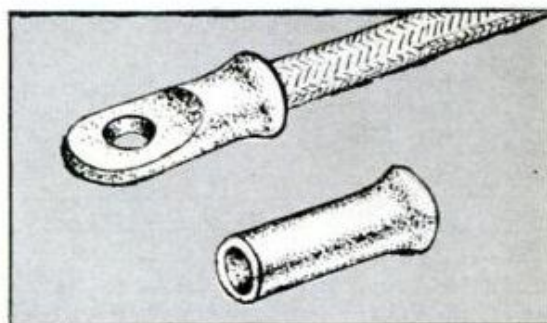

You May Need Extra Fishhooks

Fishermen who work narrow, sluggish creeks for catfish or bullheads don't always bother carrying a complete fishing kit. But should a hook snag irretrievably, an extra hook will be needed to save the fishing day. One way to carry the extras safely is to stick them to the pole with a strip of cellulose tape.

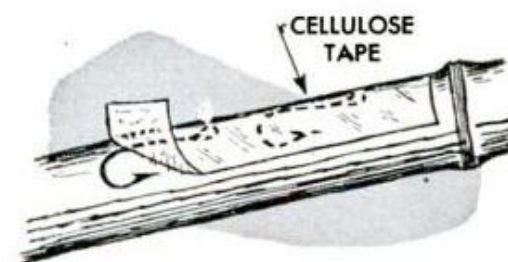

Easy Way to Hull Walnuts

Long before mechanical hullers were heard of grandpa used this method of "shucking" walnuts. And for the fellow with only a bushel or two of walnuts to hull it's still one of the fastest and cleanest hand methods. Just drill a hole through a 2 x 6 near one end, place the nut over it and tap with a hammer or mallet. The nut will go through the hole but the hull will be stripped off cleanly.

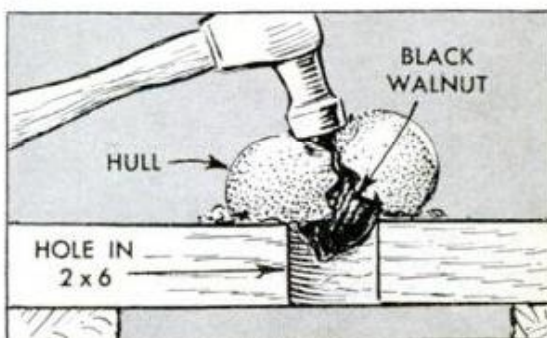

FUN ON RUNNERS

X87

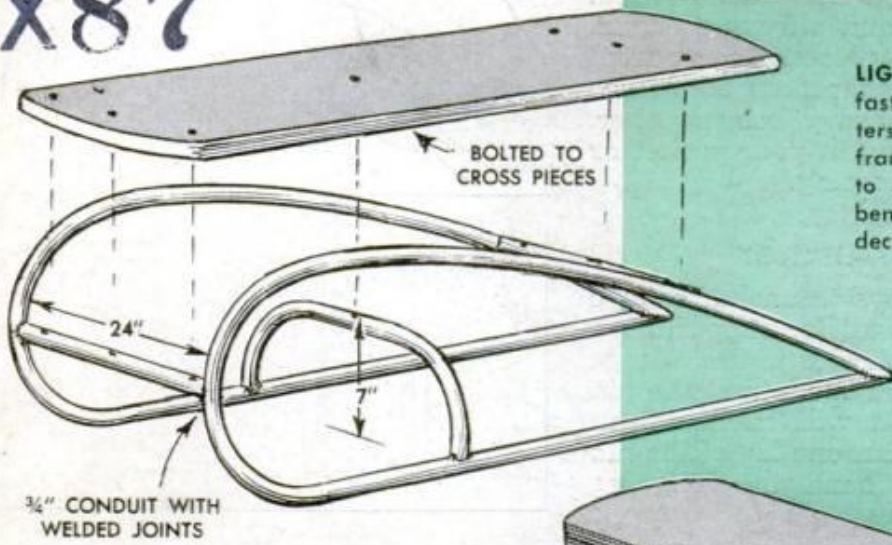

LIGHTWEIGHT COASTER is the fastest thing on runners for sitters or belly floppers. Make the frame of rigid metal conduit bent to shape with an electrician's bending tool. Attach the plywood deck with 1/4-in. carriage bolts

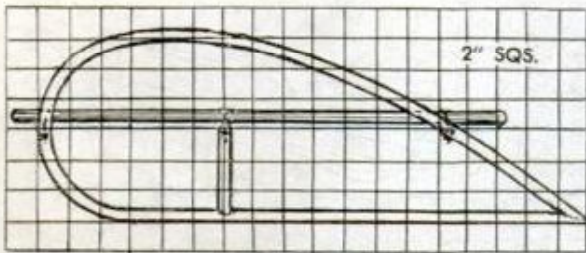

LIGHTWEIGHT COASTER

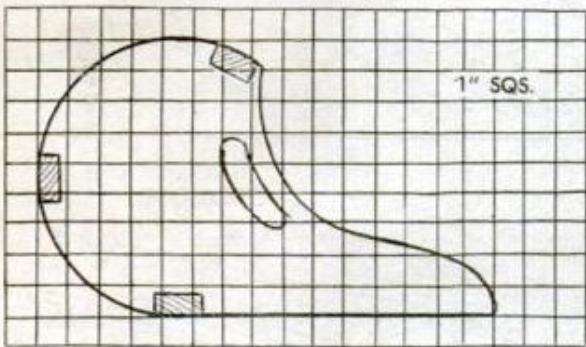

JIFFY TOBOGGAN

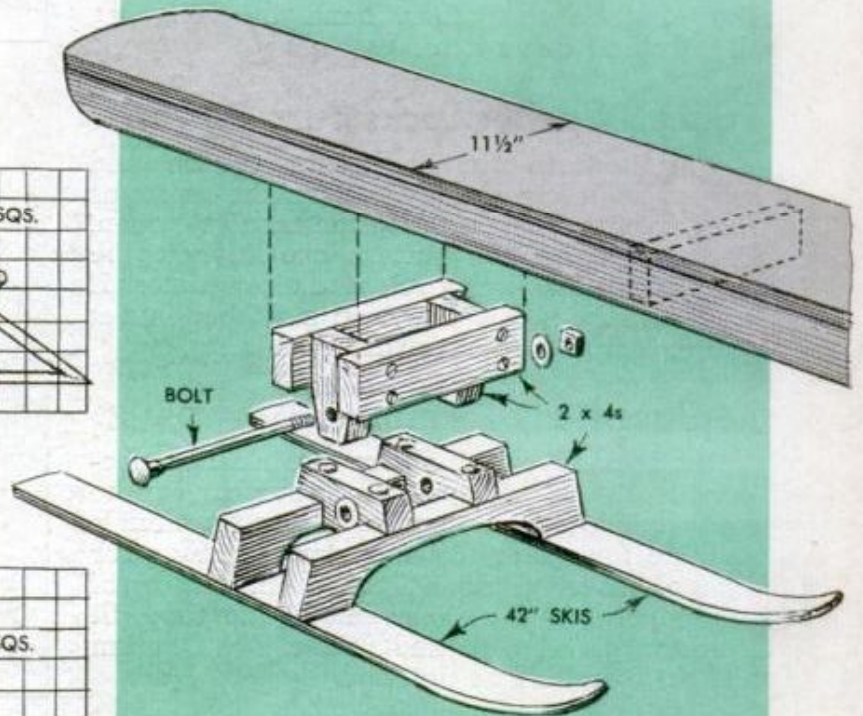

LINOLEUM UNDULATES WITH SLOPE

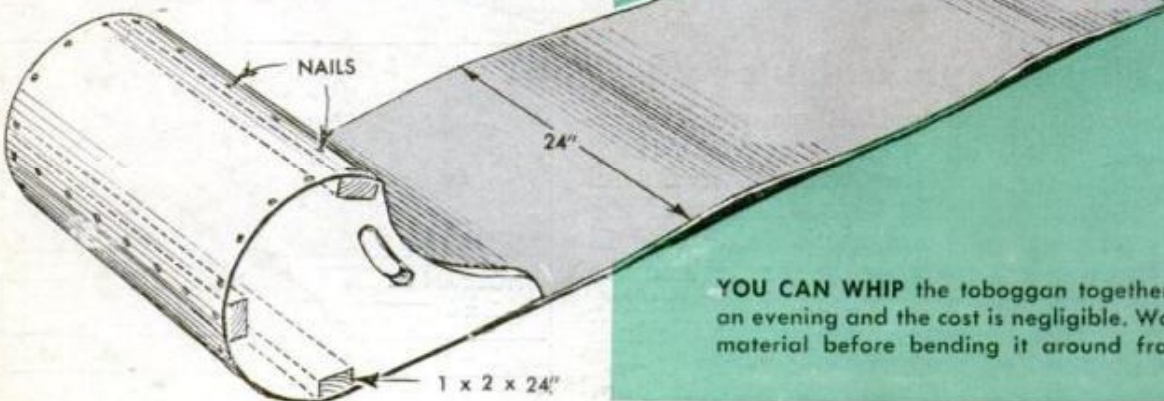

YOU CAN WHIP the toboggan together in an evening and the cost is negligible. Warm material before bending it around frame

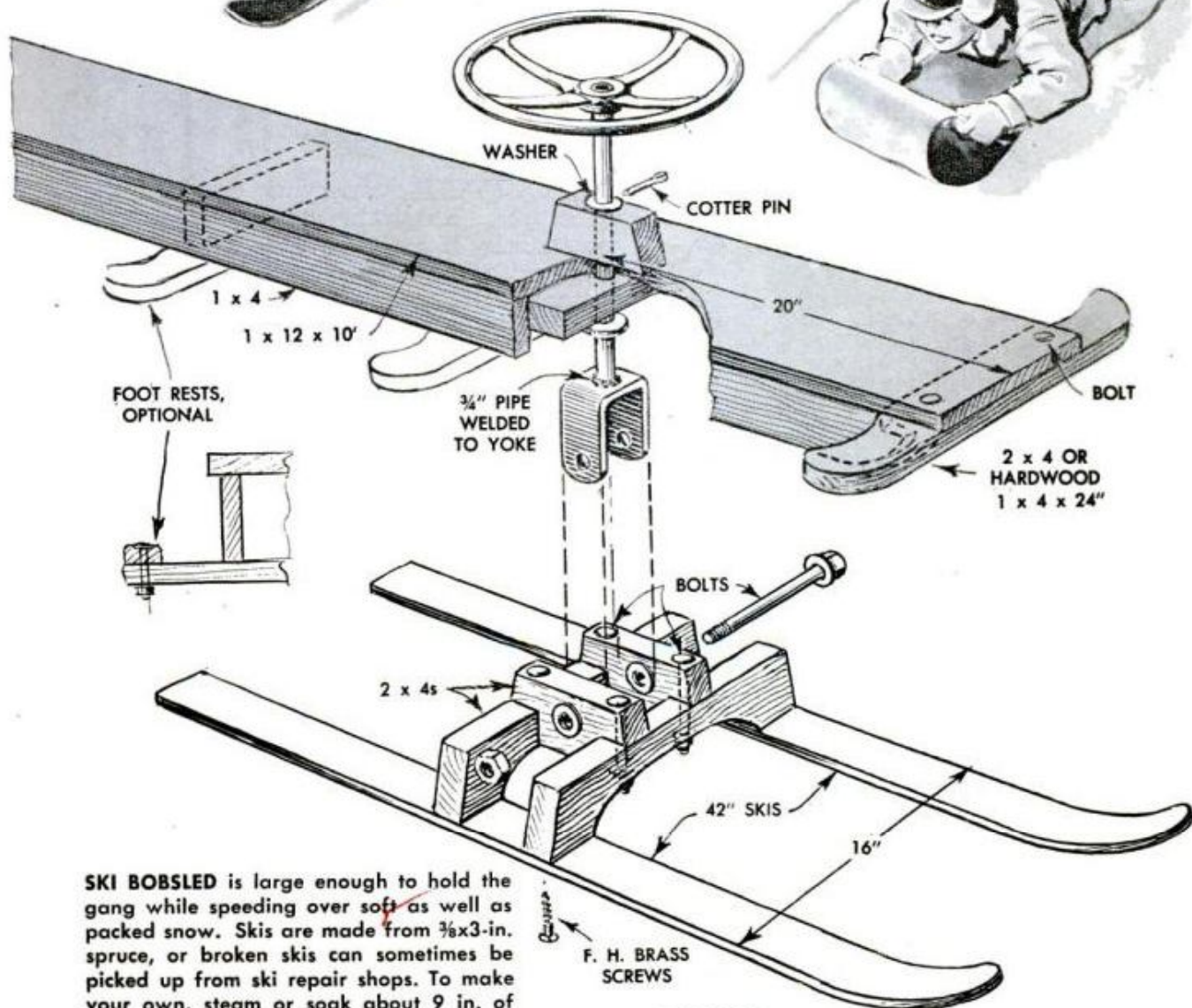

SKI BOBSLED is large enough to hold the gang while speeding over soft as well as packed snow. Skis are made from $\frac{3}{8}$ x 3-in. spruce, or broken skis can sometimes be picked up from ski repair shops. To make your own, steam or soak about 9 in. of the ends and bend them over curved forms

SKI BOB

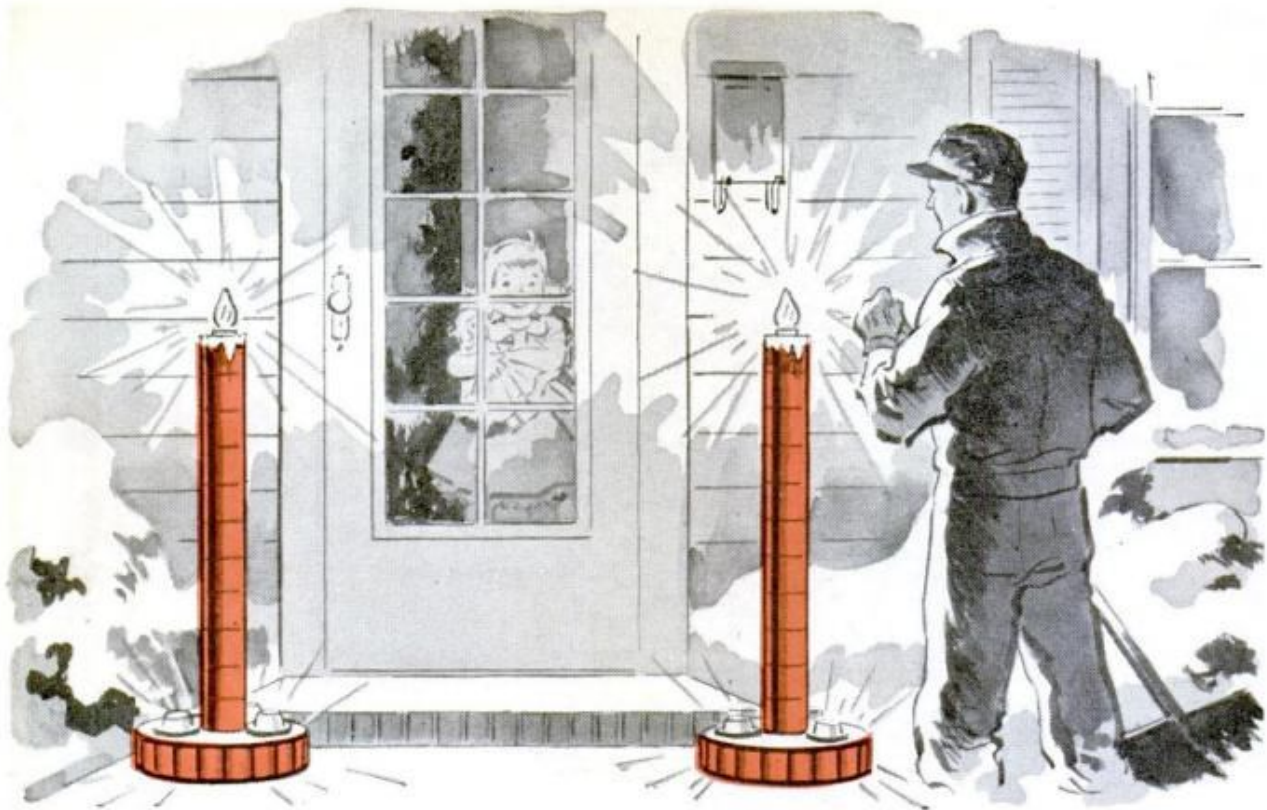

CANDLES LIGHT YOUR DOORSTEP

HOW BETTER can you express the warmth and hospitality of the holiday season than by lighting your doorstep for all to see with these towering candles? A look at the details on the opposite page and you'll see that each candle is made by stacking and soldering eleven 1-lb. coffee cans and then mounting on a base made by assembling two disks of plywood with a 2 1/4-in. wide strip of colored glass fiber between. See the details A and B at the left for construction of the base and sizes of parts. Note also from the detail on the opposite page that the top can is inverted and its top is soldered to the top of the one below it after the base and column, or body, of the candle are assembled. Each of the 11 cans has a 1/2-in. hole centered through the bottom to permit insertion of the anchor wire and lamp cord. The anchor wire holds the base in place as will be seen from the detail. Glass custard cups serve as globes for the three bulbs in the base. Each globe is held in place over the holes bored in the base disk, detail A, by a wooden ring and screws driven up from the bottom of the disk and through faucet washers. When the assembly is complete solder the top coffee can in place, fit the socket and flame lamp and complete the wiring. Add the drip pattern which is glued in place. Then paint the column and base red.—A.L. Mills

use C 9 1/2 Xmas-type bulbs

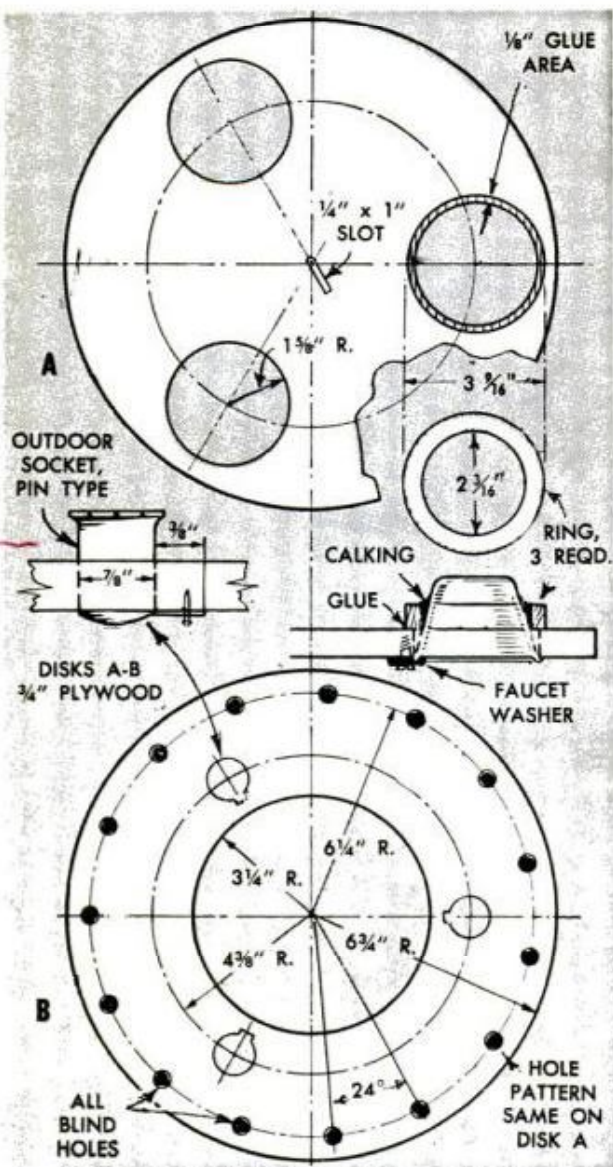

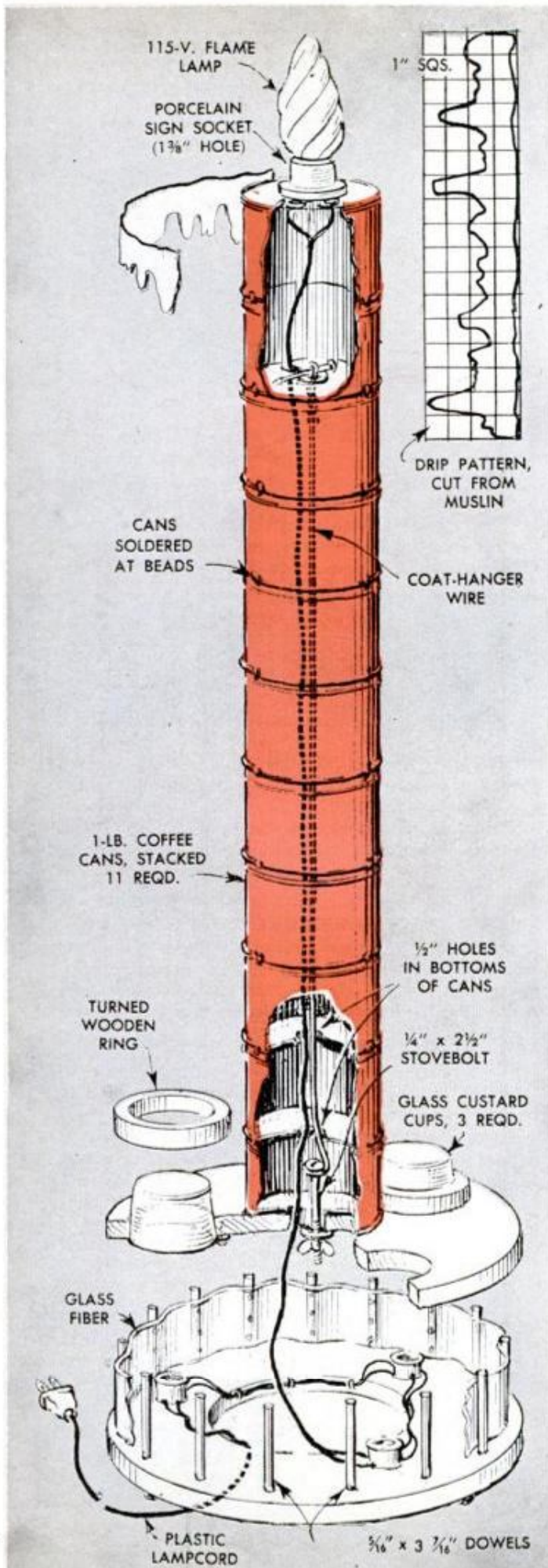

DECEMBER 1960

Socket Repair

To increase the life of Christmas-tree light sockets and prevent entrance of moisture which might short the wiring, fill the open end of each socket with wax. Center the lead wires in the opening so that the wax will flow and level around them.

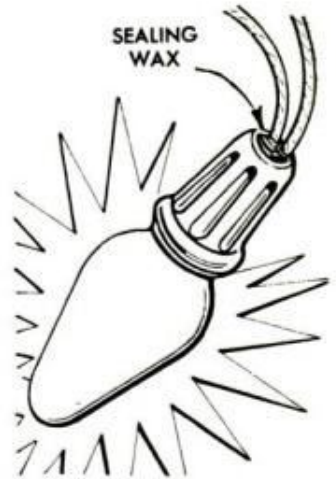

Sanding Block

Sandpaper cemented to a length of cove molding makes the perfect sander for chair legs, clothes poles or any rounded surface. Glue a block to the back of the molding to serve as a convenient hand grip.



Brush Storage

After using a sign painter's or artist's brush, dip it in petroleum jelly to prevent it from hardening in storage. Before using again simply rinse the brush in a solvent to remove the jelly coating. Turpentine is a suitable solvent.



Brad Holder

When driving brads save your fingers by using a bobby pin as a holder. It will hold the brad in the desired position until it is started and there's no danger of injury. A light pull releases the pin and the brad is then driven home.

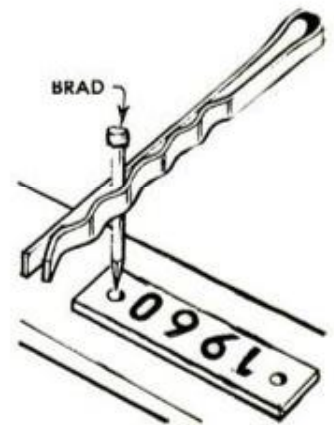

157



A STRIP OF SANDPAPER glued to a bottle of medicine can serve as a warning to anyone in the home other than the person for whom the medication has been prescribed. Use coarse sandpaper so that the bottle is easily located by feel alone, should this ever be necessary. Also, it's a good idea to destroy all prescription medicines after they have served their purpose



MOTORISTS, HERE'S A TIP for those cold winter days when fogged-up windshields and windows make driving difficult and hazardous. Spray the glass surfaces with a regular spray-type window cleaner to which has been added just enough soap flakes to make the solution cloudy. When wiped from the glass, an invisible film will remain to keep the glass clear

SOLVING HOME PROBLEMS

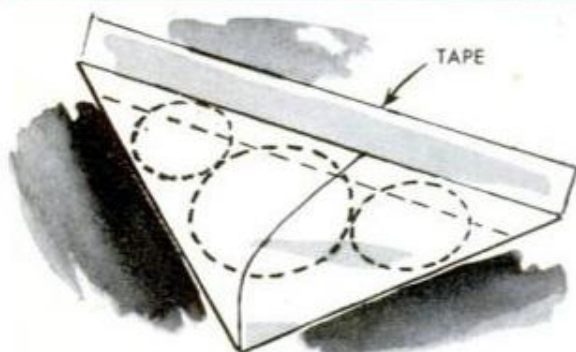

WHEN MAILING COINS, don't place them loosely in the envelope, but try handling them this way: Cut the corner from an old envelope, place the coins inside, tape the open end shut and slip this little container right into the regular mailing envelope

PIGMENT WHICH HAS BECOME CAKED in the bottom of a small container can be brought back to uniform suspension by attaching the container to an ordinary household 60-cycle vibrator, as shown below left. The vibrator's frequency is just perfect for the job

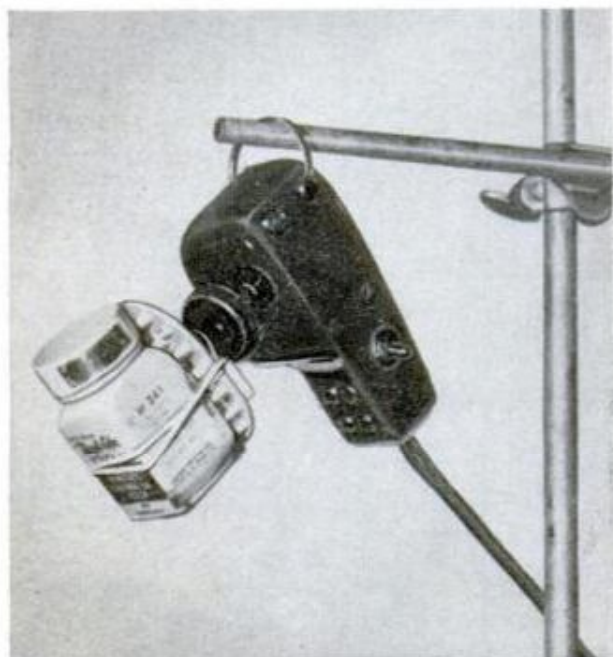

OPENING PAINT CANS, below, is a snap with this handy little device which can be made in a few minutes. Simply drive a large-headed nail into one end of a stick or dowel, slip the nail head under the lid, pry backward and the lid will pop right off



NEWLY WASHED SHEETS, bedclothes and other items are likely to develop a stale, musty odor if left stored in a drawer for any appreciable length of time. One simple, effective and inexpensive way to prevent this is to place a bar of sweet-smelling soap in each drawer



CLEANING A READY-MADE BOW TIE need not be a chore. Simply fill a jar $\frac{1}{2}$ full of home-type cleaning fluid, immerse the tie in this and close the lid tightly. Thirty to sixty seconds of vigorous shaking of the jar will clean the tie thoroughly

REDECORATING YOUR HOME can throw things pretty much into confusion unless you provide beforehand a place for those hooks, screws and other items that are so easily lost. Best way to keep track of them is to cut the bottom corner from a cardboard box and then insert the items into the openings in the corrugations

THERE COMES A TIME in the life of every family when junior locks himself in the bathroom. Foreseeing the possibility of this happening, saw a slot in the end of the key so it can be turned by inserting a small screwdriver through the keyhole

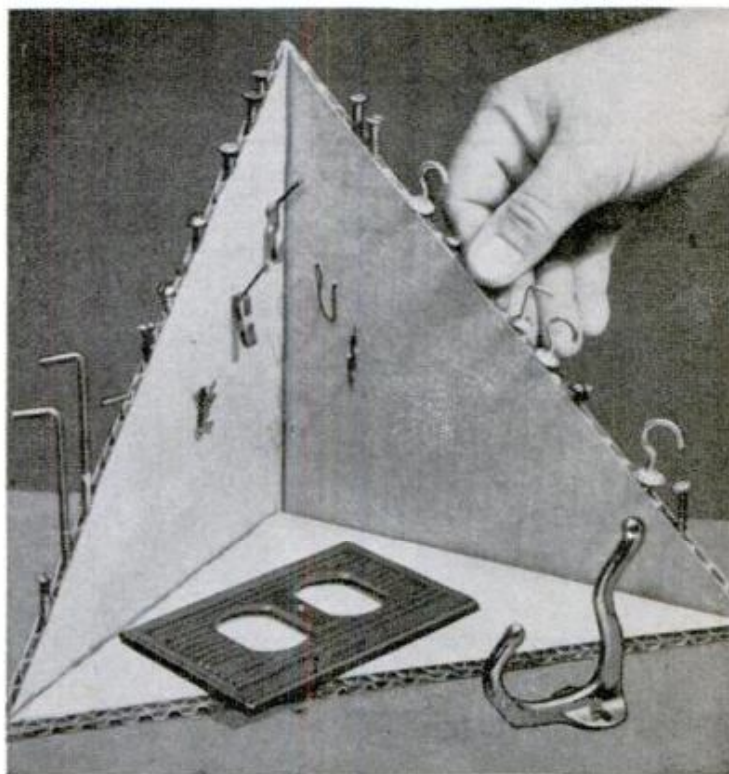
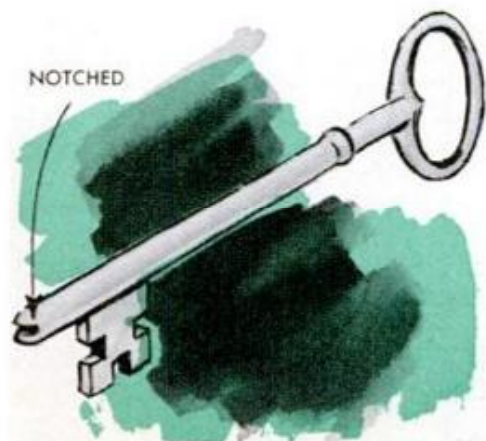

MAKE IT A Merry Christmas



EVERYONE has their special way of making Christmas merry. But the guy or gal who likes to make things has a way all their own of *making it* so. Making someone happy with a gift gives the greatest satisfaction when the gift is the handiwork of the giver. Whether dad is making something for the youngsters or Johnny is making a gift for mom, or the family is decorating the house for the holidays, there's a special kind of merry Christmas that comes only to those who enjoy working with their hands.

The following 16 pages are packed with many clever things to make for Christmas, either as gifts or decorations. All have been carefully selected for their simplicity and uniqueness. Some can be made in an evening, others will take longer. But if you get started now, you'll have ample time to *make it* a MERRY CHRISTMAS.

Glowing Christmas Tree

Strikingly different, this modern version of a Christmas tree is a cone of acetate-coated wire screening, sprayed white and decorated with gold, red and green Rhinglas transfers. When placed over a 100-watt bulb, the translucent tree glows from within and sends a shaft of light out through the top to illuminate a glittering star perched atop. Acetate-coated screening, such as Cel-O-Glas, is the kind used to winterize breezeways, doors, windows, etc., and can be purchased from both Sears and Wards as well as local hardware stores. You can get the transfers at art and paint stores. Cut the coated wire from a paper pattern, using snips or old scissors. Then, before rolling into the conical shape, spray it flat white on the outside and apply the transfers as you would decals. Finally, form it into a cone, cement the seam and cover both seam and edges with gold metallic adhesive tape. The star is made of coated wire, too, covered with glue and sprinkled with gold glitter

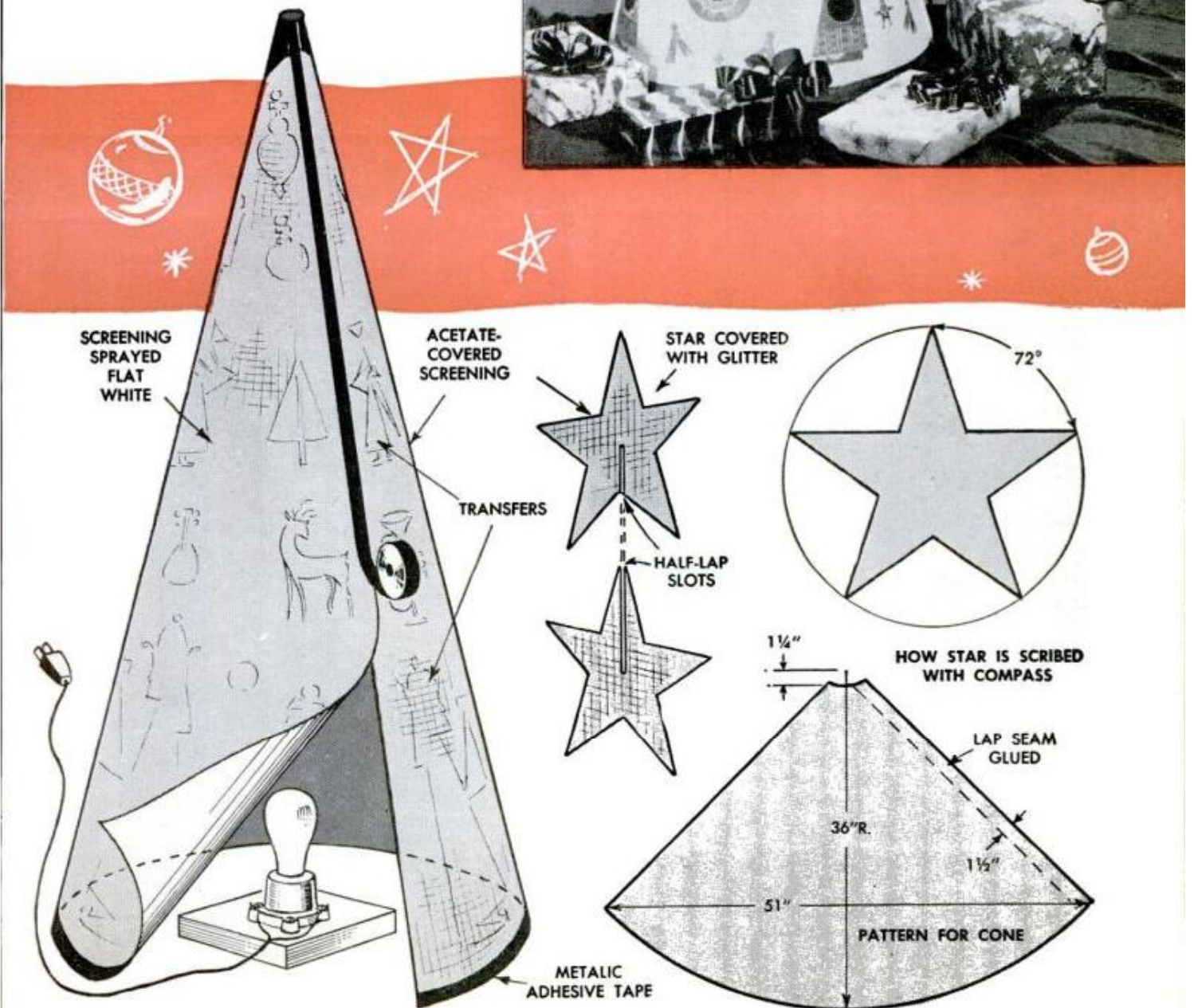



IONS ★ MAKE YOUR OWN DEC

Fanciful and Beautiful

No two of these weird but really beautiful candle centerpieces will be alike since there is no control in forming them. Looking like fairy-tale formations of colored icicles, these unusual Christmas candles are formed by dipping a container of melted paraffin in water quickly and lifting out. Here is how one is made: A dipping rack is first made of wood to fit a pail or other large container; the bathtub will do. Then any glass or foil container, a small pie pan or ashtray are perfect, is placed on the rack and a white or colored candle is supported upright in the container by tying the wick with a string to the handle of the dipping rack. Melted paraffin, to which a little stearin is added, is poured in the container and a few pine cones or small ornaments are placed in the warm wax. The setup is plunged into cold water, in and out quickly. The submerged wax seeks the water level and crystallizes instantly into the most unusual formations. The deeper the water, the taller the formation. The wax, of course, will embed the cones as well as tiny ornaments in a solid mass. Further ornamentation can be added by tying ribbon bows or angel figures to the candles to suit your fancy

★ MAKE A GIFT FOR CHRISTMAS ★ MAKE A



★ MAKE YOUR OWN DECOR



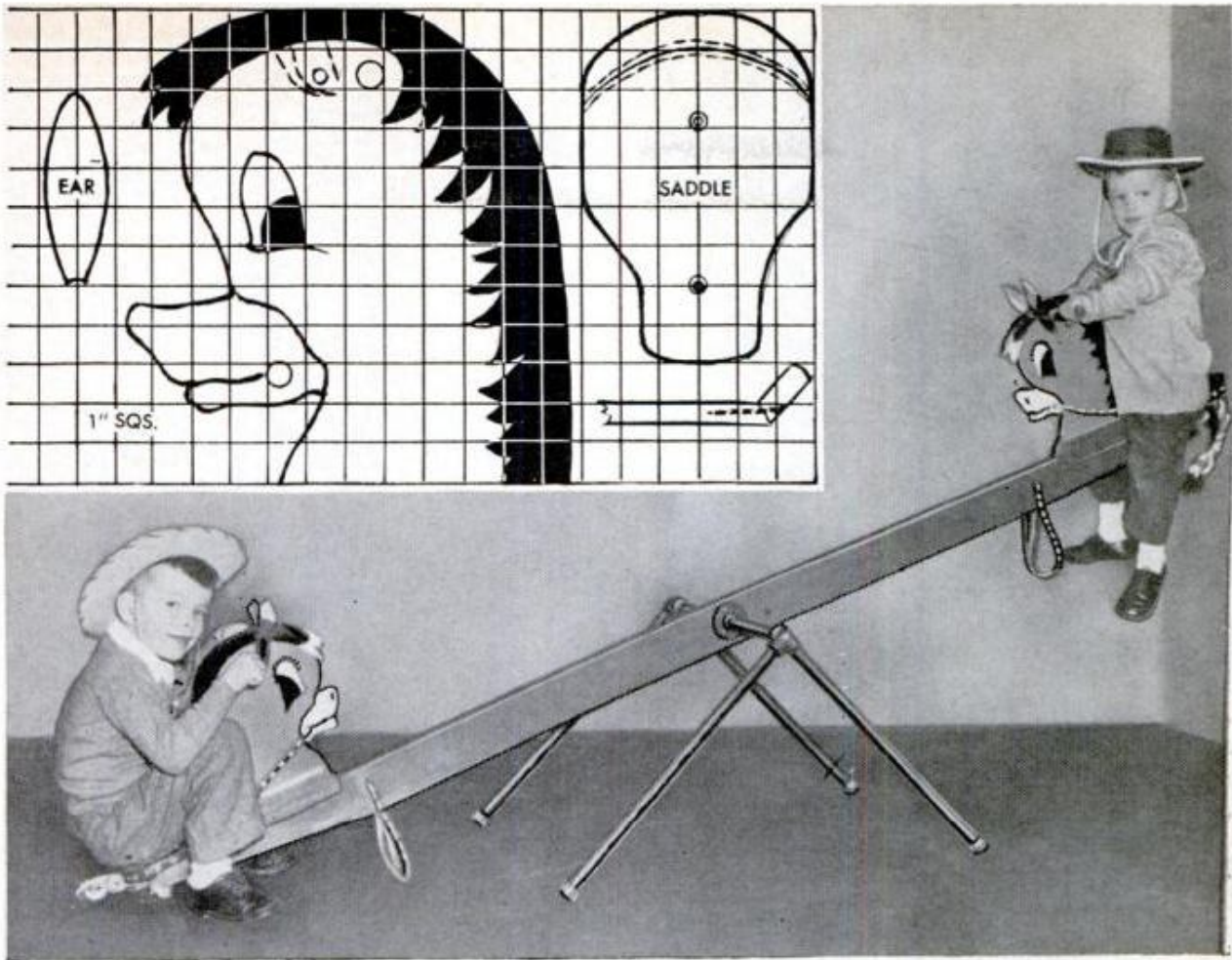

Bronco Buster Packs Rough Ride

Taming the wild ones becomes kid's play on this ride-'em-cowboy seesaw. The beam is a 10-ft. 2 x 4 set on edge and supported by a pipe stand assembled from standard fittings. Two pipe flanges, reamed out to remove the threads and screwed to opposite side of a hole bored through the 2 x 4, provide bearings through which the pivot pipe passes. Horse heads are of plywood for strength, a broomstick or dowel form handholds. Saddles are fashioned from pine and padded. Stirrups and horse tails are hemp rope. Painted bright colors, young riders will whoop it up Christmas morn

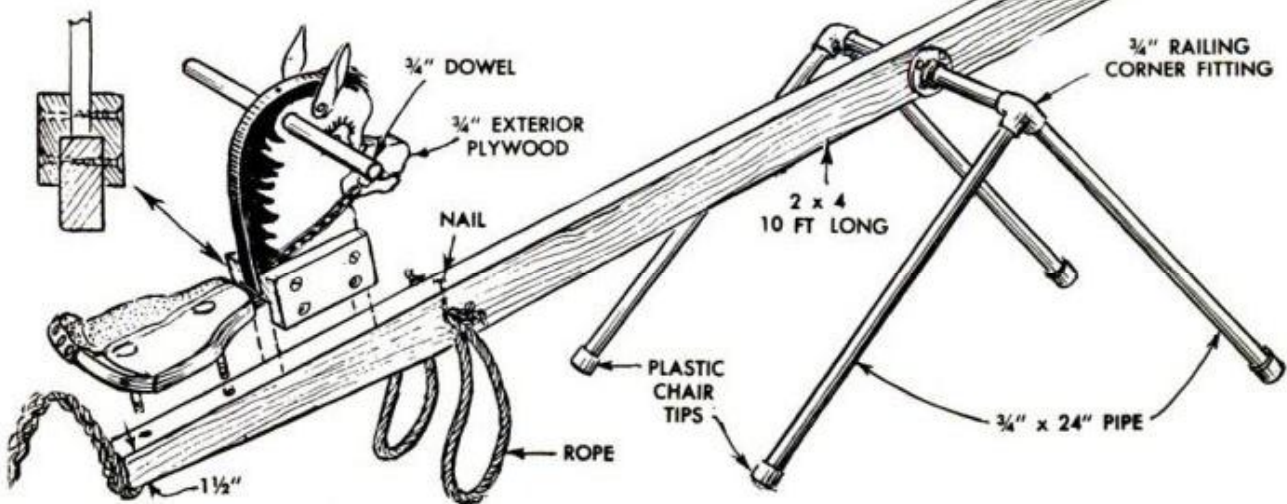
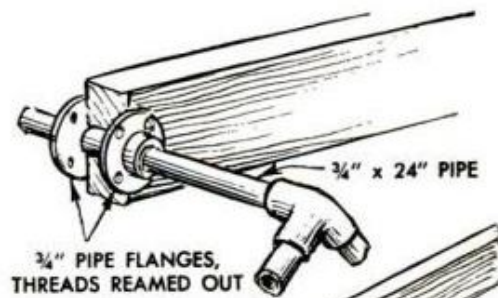



★ MAKE YOUR OWN DECORATION ★

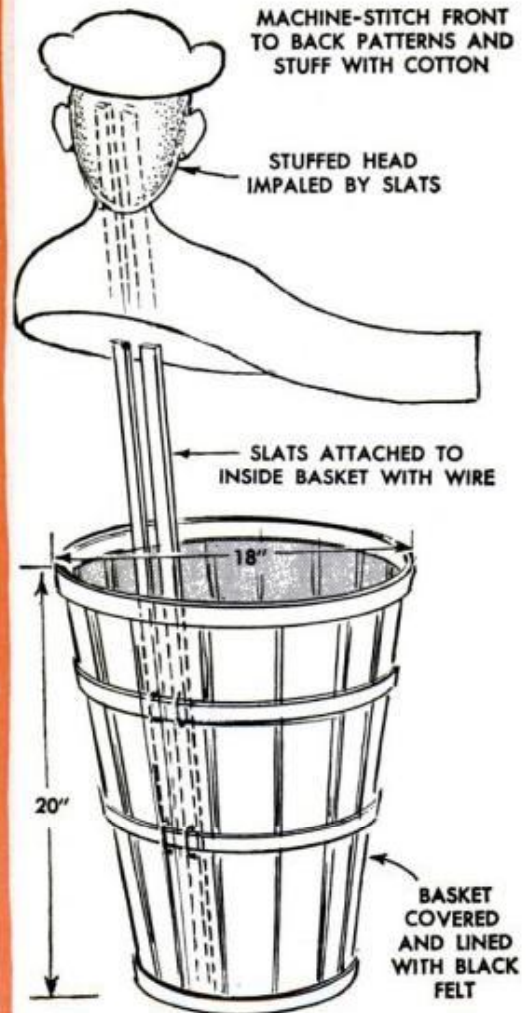

★ MAKE A GIFT FOR CHRISTMAS ★ MAKE A

Pirate's Treasure Trove

Fill it with gifts on Christmas morning, then let it round up toys the rest of the year. This cute idea takes care of the toy clutter in a child's room. Start out with a fruit basket about 20 in. tall and wire two wooden slats 20 in. long to the inside to support the pirate's head. Next sew a double sleeve of black felt so it will pull over both inside and outside of the basket and glue it to the bottom edges. Cover the bottom likewise. The pirate is sewed together as a separate unit, doubling up on the various patterns and stitching them together at the edges but leaving the bottom of the head open so it can be stuffed with cotton. The features are glued in place, after which the stuffed head is forced down over the supporting sticks. The red-felt arms are wrapped around the basket to meet pink hands which are stuck in place with glue. Skull and cross bones are glued to the hat, and the words "Treasure Trove" are cut from white felt and glued to the front. The striped shirt front is made by backing up the openings with white felt. This is done only in the front half of the shirt pattern. Complete the dashing pirate by sewing a plastic curtain ring to one ear and a "diamond" to the ring finger of the left hand

★ MAKE YOUR OWN DECORATION ★

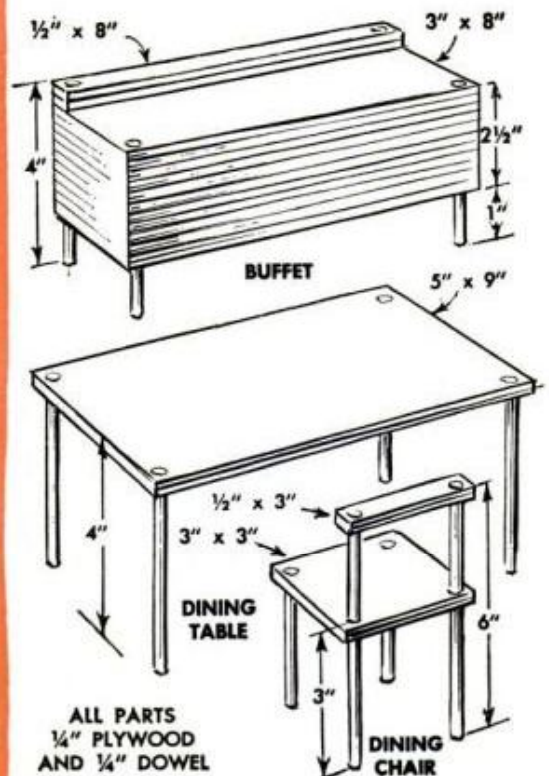

POPULAR MECHANICS

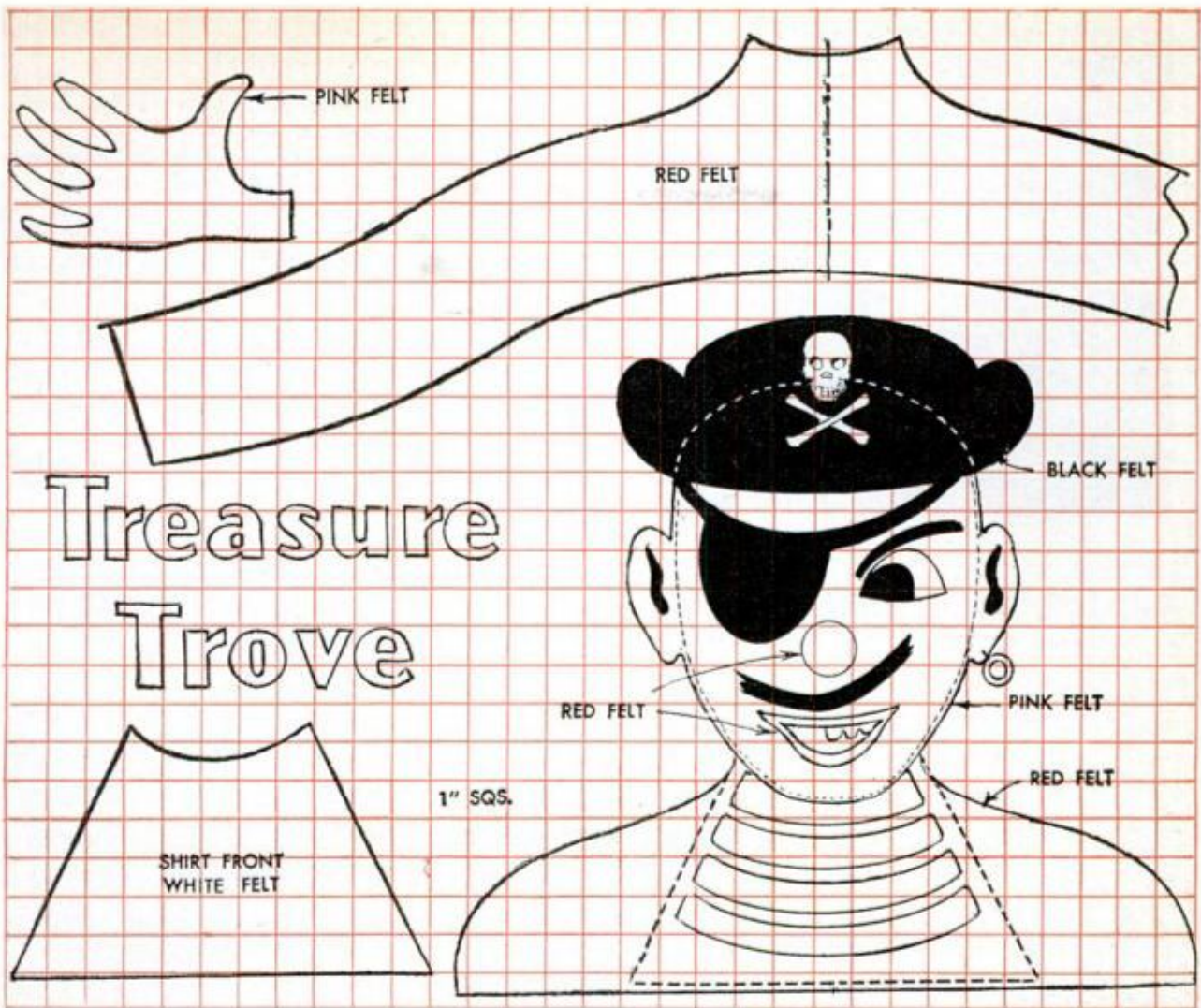

GIFT FOR CHRISTMAS MAKE A GIFT FOR

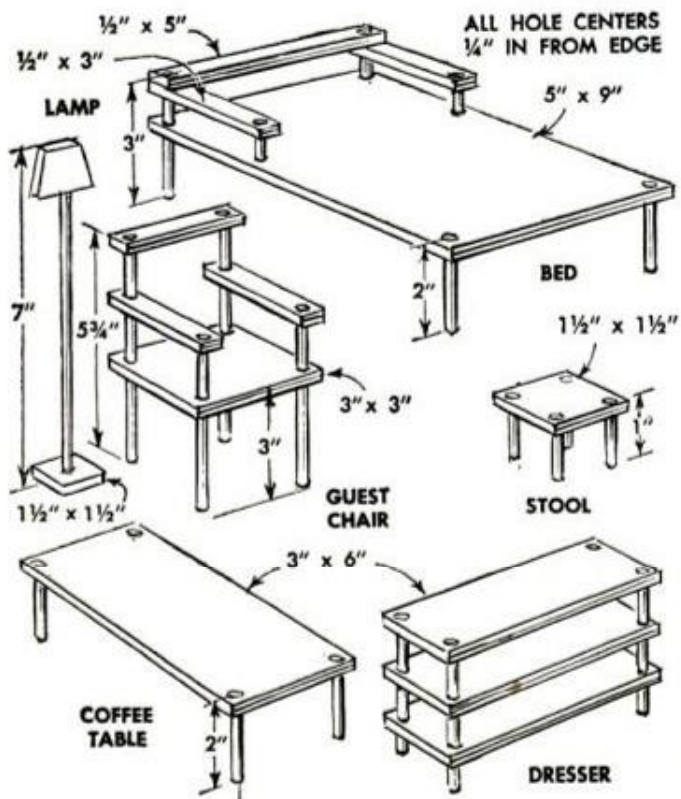

Quickie Doll Furniture

Scraps of plywood, a few short dowels and an evening are all it takes to make this simple set of doll furniture. Holes for the dowels are made slightly undersize so the parts fit snugly. Alignment of holes is assured by drilling two or more parts at one time. Sandwiched parts form the buffet

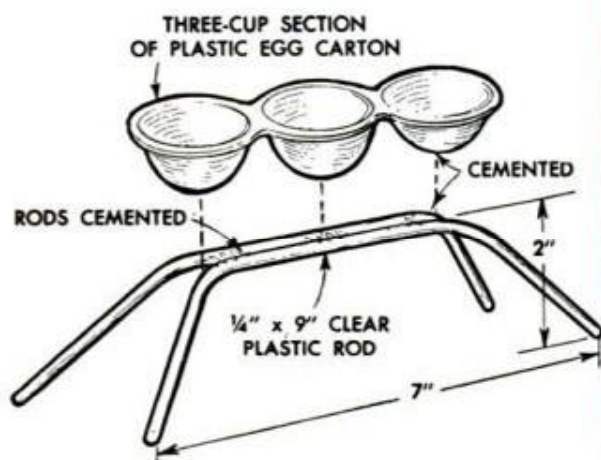

Mini-Candelabra

Plastic egg tray provides cups for candles of this miniature candelabra which are cut from tray with coping saw and cemented to plastic stand. Two extra cups provide mold for casting ball candles. Pouring hole is made in one, string wick inserted and both cups are taped together for pouring each candle

Royal Card Holder

King-size crown fashioned from cardboard paint-bucket liner makes holiday holder for greeting cards. Liner is cut down, painted gold and decorated with red and green sequins



Novel Candlesticks



Firly one at left is bright foil pie plate slitted around edge and curled inward. One below consists of fancy wood block topped with square of clear plastic and fitted with metal candle socket of hammered copper

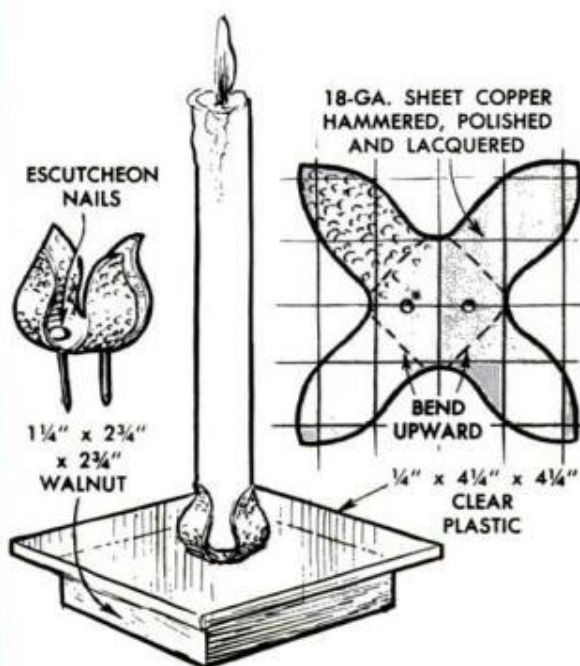

★ MAKE YOUR OWN DEC ★

★ MAKE YOUR OWN DEC ★



Gift-Package "Icing"

Ever think of decorating your gift boxes like a cake? You can do it cleverly with a mixture of snow-like suds whipped up from a handful of soap flakes. Use your cake mixer and add soap and water until mixture stands in snowy drifts. Snowflakes can be formed by putting the

mixture in a cookie press. A pastry tube or plastic squeeze bottle is used to write greetings and form ribbons, using a somewhat thinner soap mixture. If left to dry for a day or two, the snow suds will dry and harden into a permanent decoration that won't brush or rub off

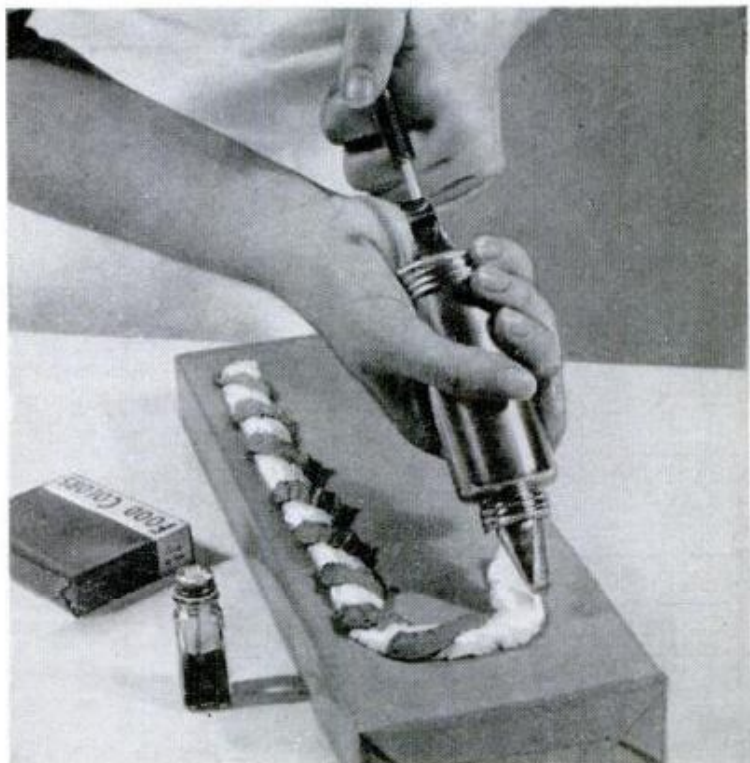
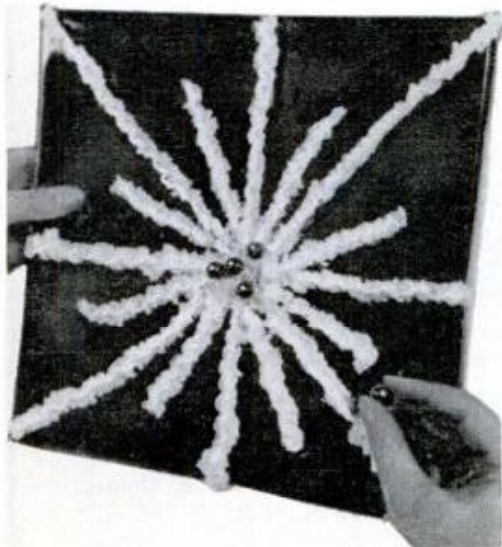



Greeting-Card Tree

Cut tree-shape from a scrap of welded-wire fabric, which normally is used to reinforce concrete, and then trimmed with strands of rope tinsel, this dazzling Christmas tree displays the greeting cards you receive. Floodlighted from below, the tree is set in a wooden "planter" and taped to stand 6 in. out from the wall. The wire mesh is painted white, ball ornaments are hung here and there and small tabs of cellophane tape are used to hold the cards in place

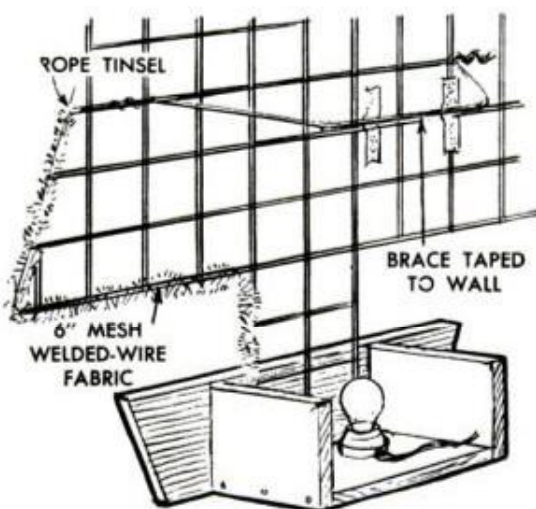

★ MAKE A GIFT FOR CHRISTMAS ★ MAKE A



Lawn Santa Cutout

Your home takes on a holiday mood to passersby when a jolly Santa is stationed outside. Made any size you wish, you can cut him out in a hurry with a portable electric jigsaw. To enlarge the pattern, rule off on wrapping paper the same number of squares as given, drawing them 4 or 4½ in. square. Then with the squares of both patterns numbered for quick reference, the small pattern is enlarged by drawing in the portion of the outline that appears in the corresponding square. Be sure to use exterior plywood and give the cutout a coat of shellac after you cut it out. Paint Santa's suit bright red, boots black, fur and whiskers white. Prop Santa up from behind and put a spotlight on him at night

READY-DRAWN PATTERN AVAILABLE

If you don't feel equal to enlarging the Santa pattern yourself, you can buy a 42-in. pattern ready for tracing. Send 50 cents in-coin to Blueprint Dept., Popular Mechanics Magazine, 200 E. Ontario Street, Chicago 11, and ask for pattern No. 121

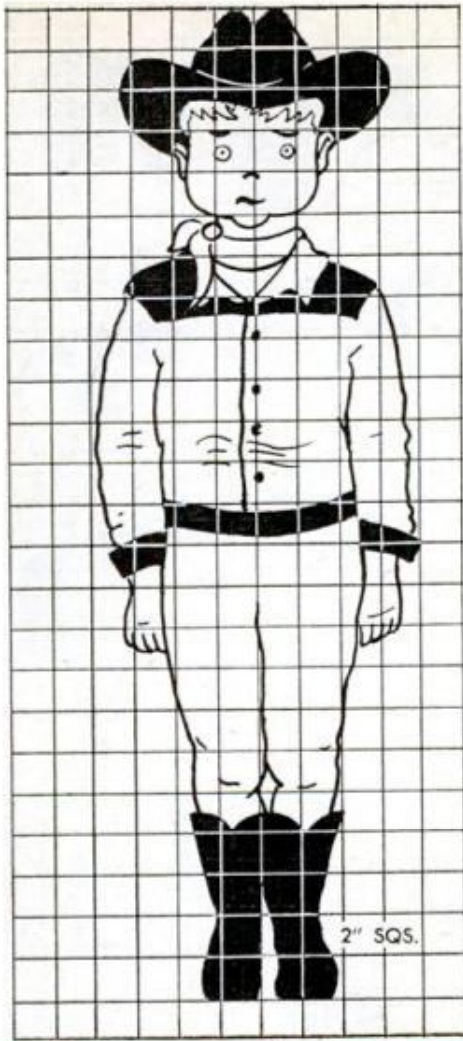

MAKE YOUR OWN DECORATIONS



GIFT FOR CHRISTMAS MAKE A GIFT FOR

Wrap Wrangler

Young cowpokes who can barely reach the stirrups as well as a coat hook will find this western wardrobe rack just the thing to corral stray play clothes. Two cowboy cutouts standing 48 in. tall support a shoe and boot rack at the bottom and a hat shelf and clothes rod at the top. The drawing details the parts. Both cutouts can be jigsawed from a 3 x 4-ft. sheet of plywood, tracing a full-size pattern on $\frac{3}{4}$ -in. material. The magazine pattern is enlarged by ruling off 2-in. squares on wrapping paper. Both cowboys are painted alike: yellow for the hair and shirt, light blue for eyes and pants, white for neckerchief, red for hat and mouth, light tan for face, hands and neck and dark brown for the rest. The backs of the cutouts are painted bright red as is the rest of the parts of the rack. Regular clothes-rod sockets are used to support the pole between the cutouts

DECEMBER 1960

MAKE YOUR OWN DECORATIONS

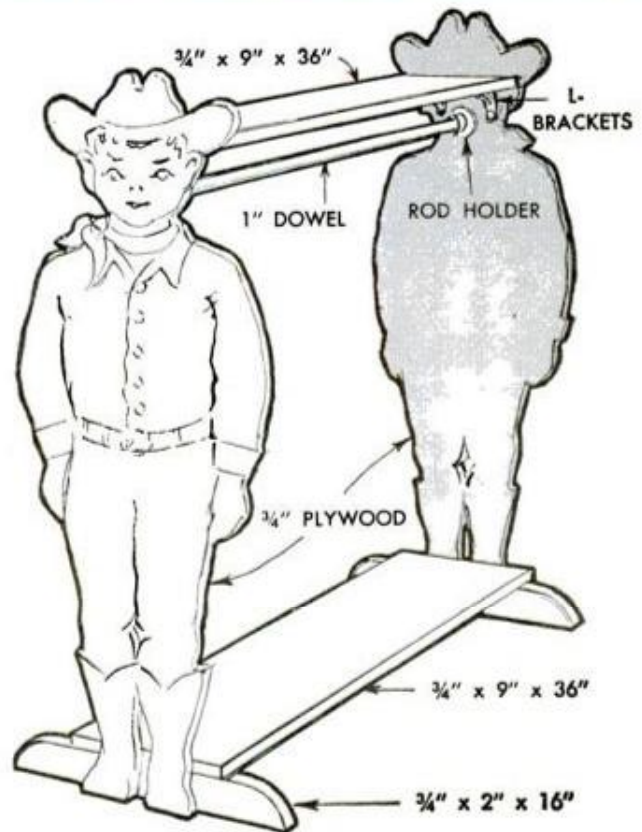

169

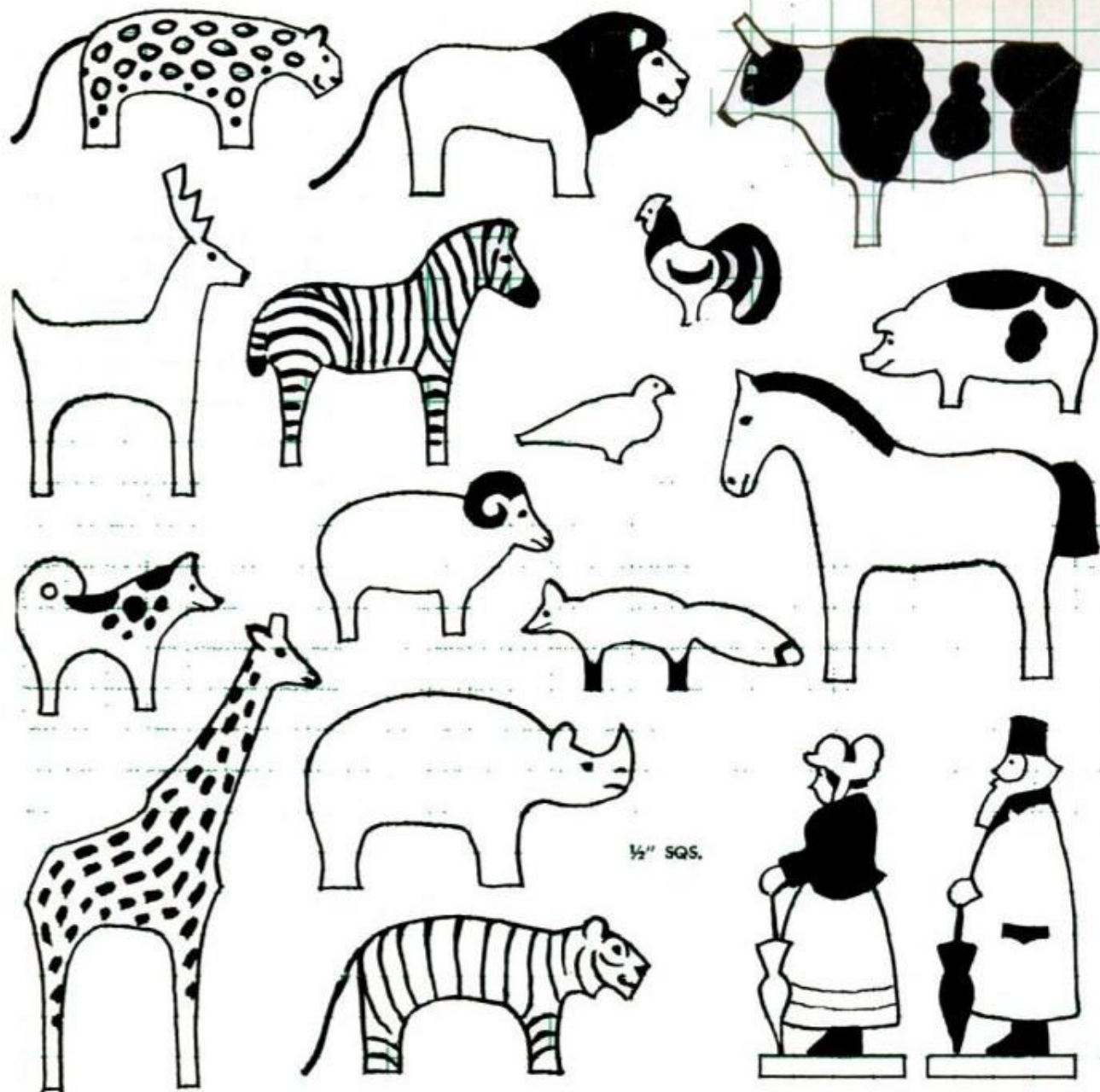

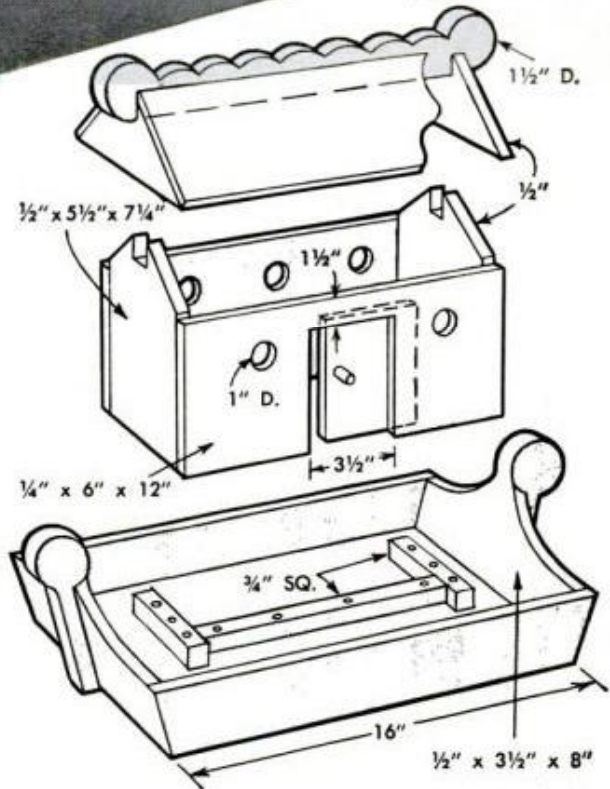
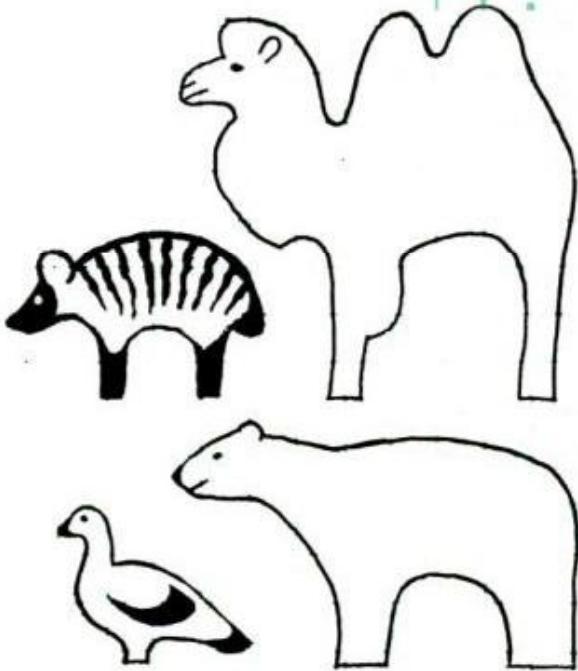
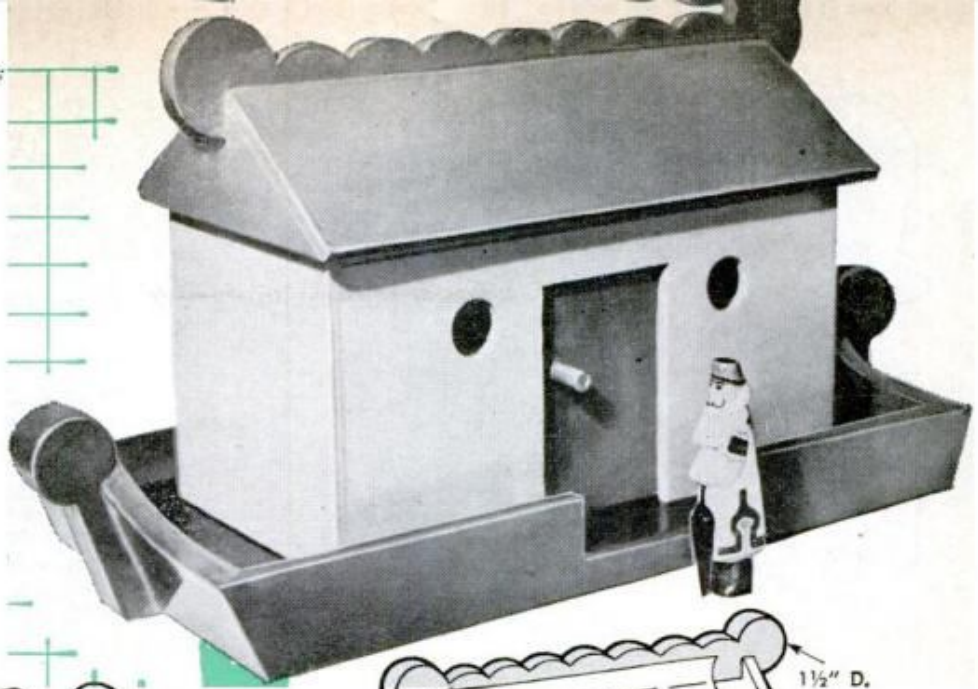
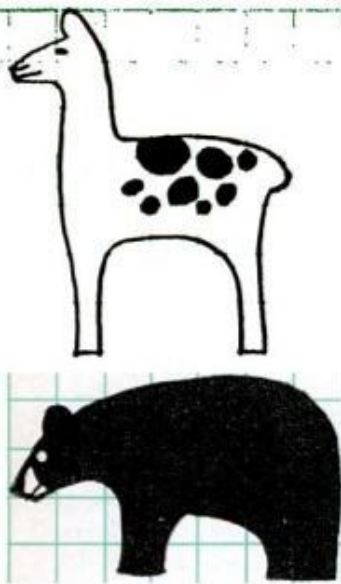

Noah's Ark

Dad couldn't make a more fun-packed toy for little tykes than this old favorite—Noah's ark. Most of it can be made from scrap plywood and pine. The cabin has a sliding door and the roof lifts off for chucking in the many animals. The pull-apart drawing shows how the ark is made in three sections, the cabin being glued to the hull. Cleats attached to the floor of the hull and across the top of the door opening on the inside provide a track for the sliding door. The lift-off roof rests in notches, and a piece of dowel is used as a door handle. Patterns for the animals are given on $\frac{1}{2}$ -in. squares, two animals are carved from each pattern

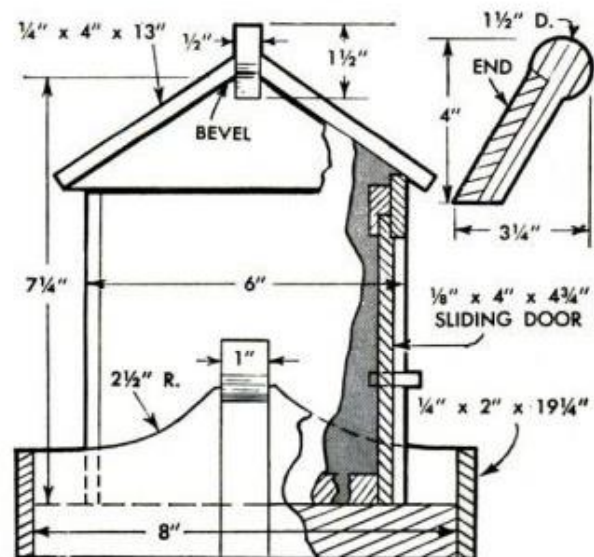

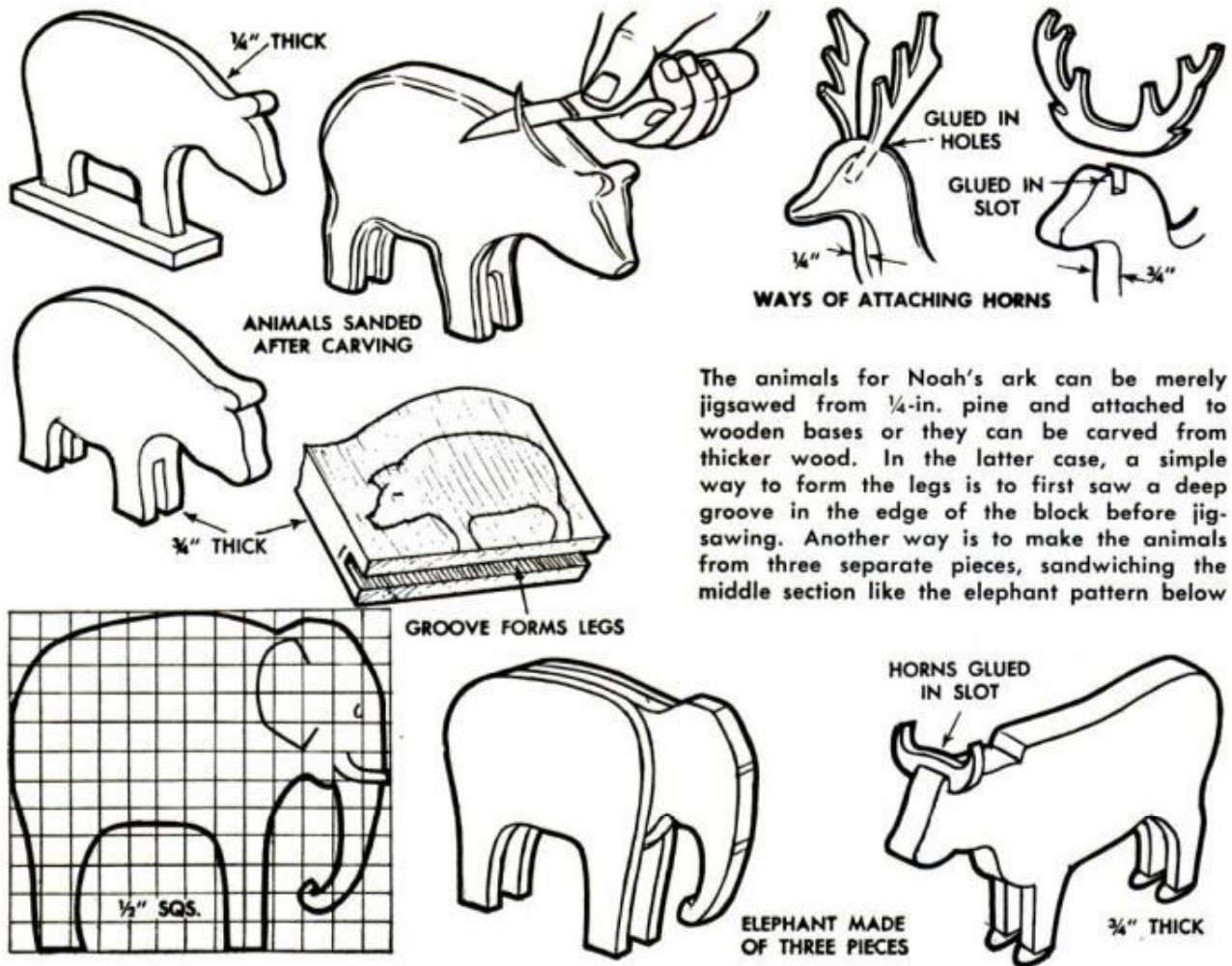

The animals for Noah's ark can be merely jigsawed from 1/4-in. pine and attached to wooden bases or they can be carved from thicker wood. In the latter case, a simple way to form the legs is to first saw a deep groove in the edge of the block before jigsawing. Another way is to make the animals from three separate pieces, sandwiching the middle section like the elephant pattern below

★ MAKE A GIFT FOR CHRISTMAS ★ MAKE A

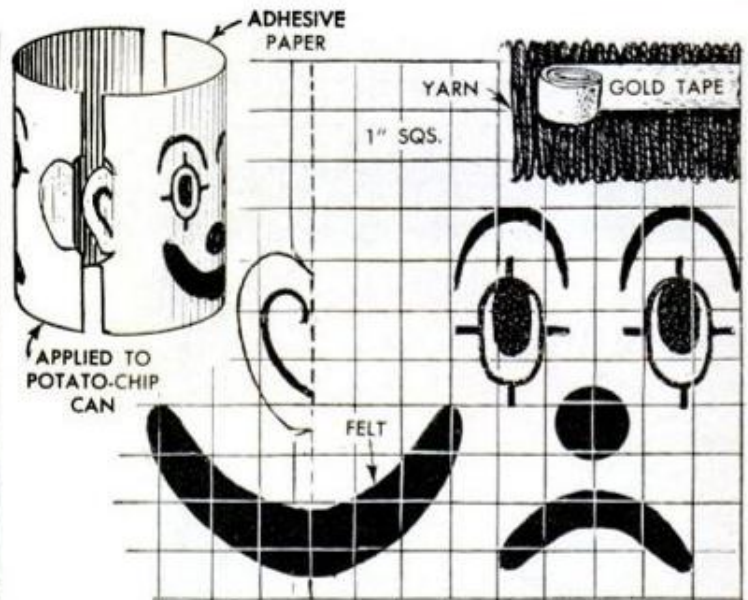

Clown Waste Basket

Happy on one side, sad on the other, this novel waste-basket is a potato-chip can covered with two pieces of self-adhering white paper cut to form ears when stuck together. Red yarn hair is added at the top, features are cut from black, blue and red felt, glued to front and back

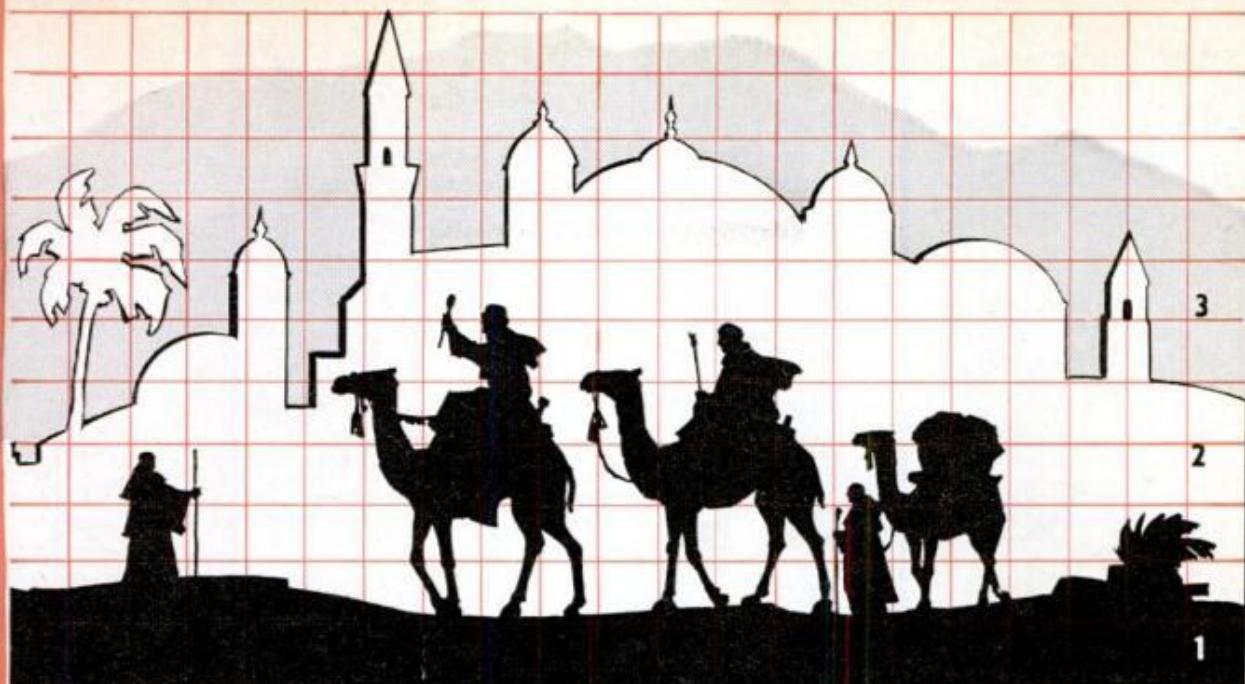

Christmas Window Silhouettes

Stood parallel in a grooved wooden base, three jigsawed cutouts make an eye-catching silhouetted Christmas display for a window when lighted from below. Cut from hardboard to which the enlarged patterns are pasted for sawing, the front cutout is painted black, the middle one light blue and the rear one dark blue. White bulbs placed in the channels provided create a third dimension in making the cutouts stand out in stark relief against the background

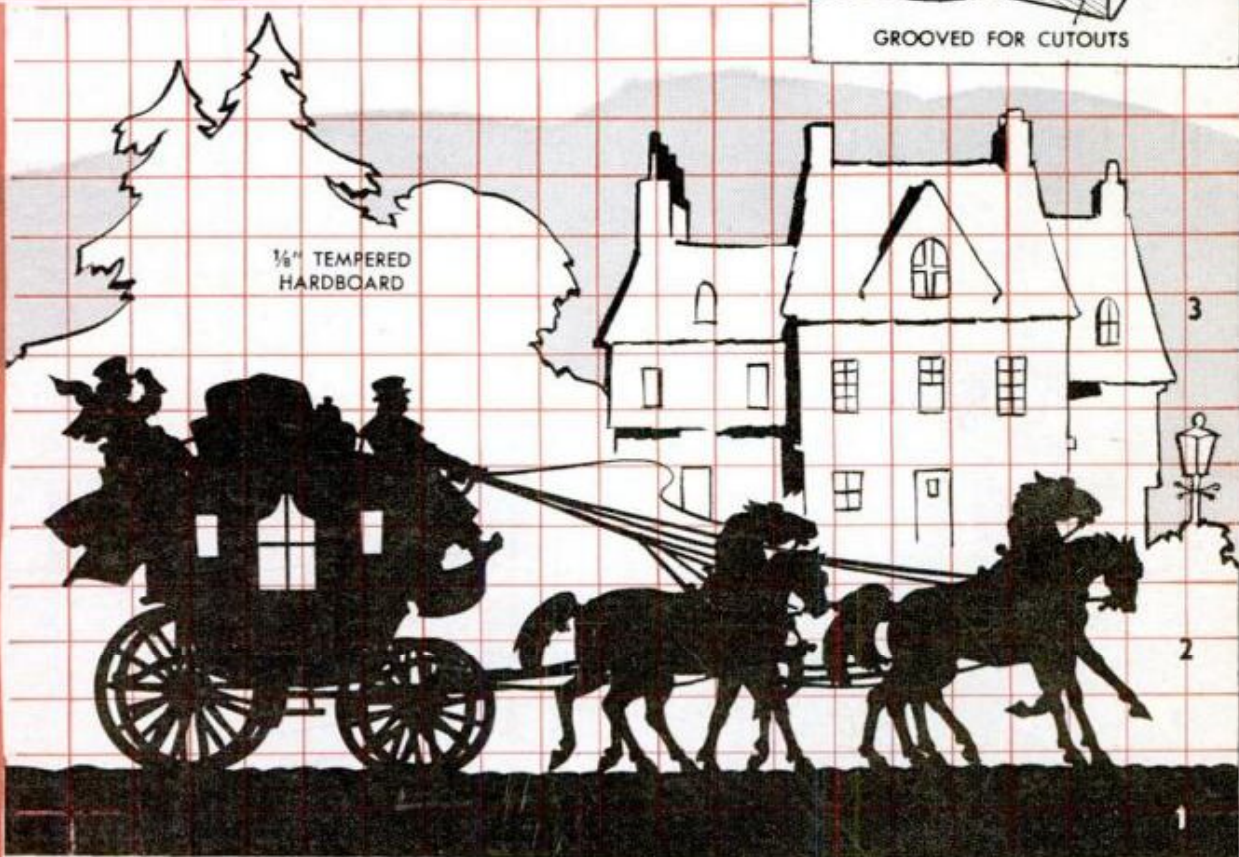
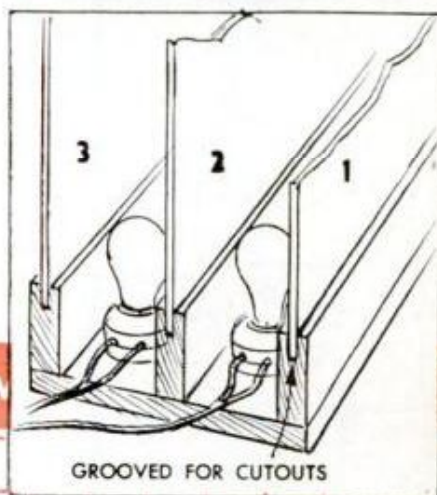

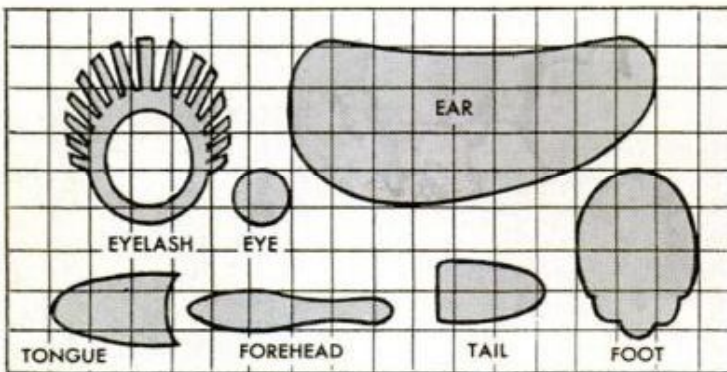
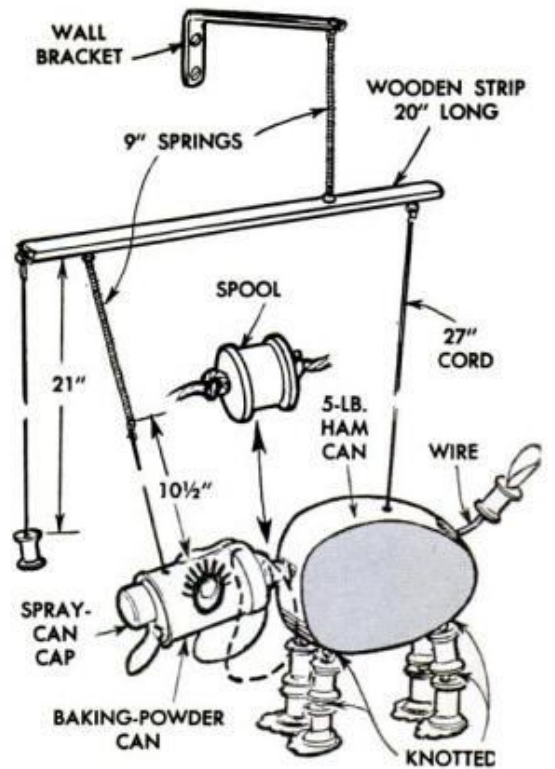
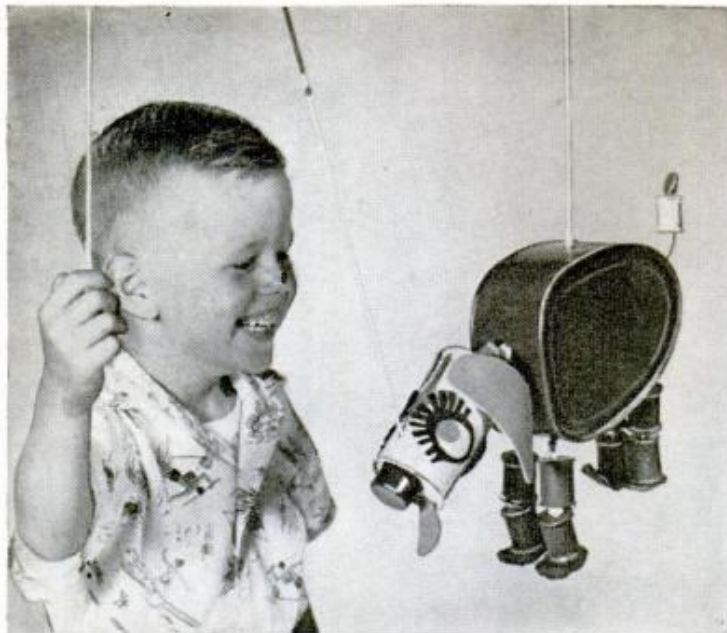

Gangling Pooch

A tug on the cord causes this tin-can hound to flop and gangle about like the lazy dog he is. Hung in reach of the crib in a nursery it provides a novel infant's toy that is made from odds and ends



Christmas Favorites

Sambo is not apt to brush you off since he makes it his job to keep your toothbrush handy. It takes a head start to make him as his body requires many plastic toothpaste-tube caps which are threaded on wire. Choo-choo pull toy is a toddler's favorite and is easily made from scraps in the wood box

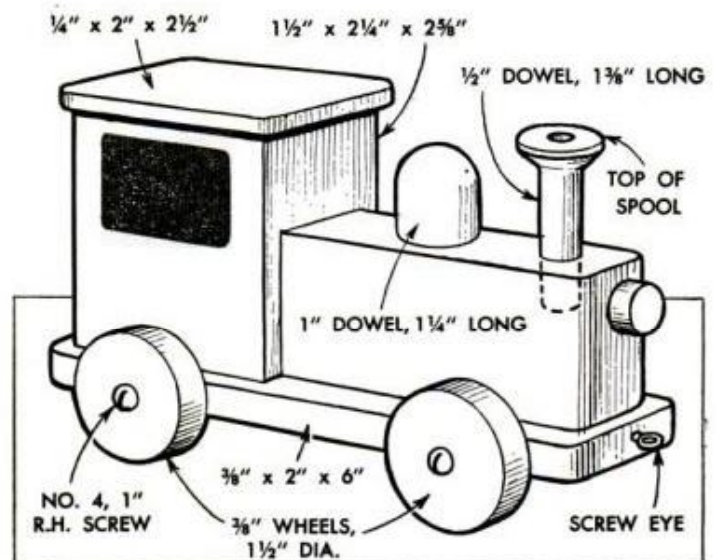

Rainy-Day Swing

Designed to hang from three clothesline hooks screwed to the basement joists, this indoor swing will while away many hours for cooped-up youngsters. It's made from 1 x 3 lumber, 1-in. dowels and hung with strong hemp rope

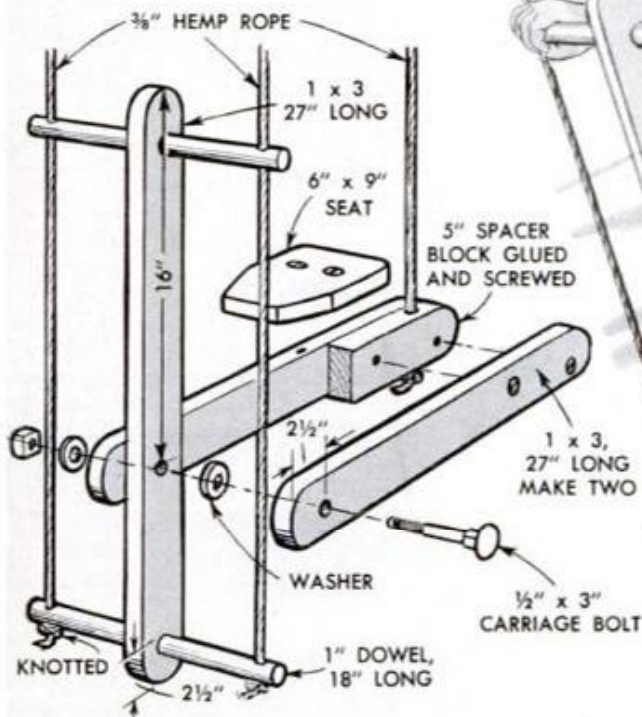

Balancing Herkimer

An amusing toy, "Herk" seemingly defies the law of gravity when he hangs precariously by his heels. Counterbalanced newspaper is the secret

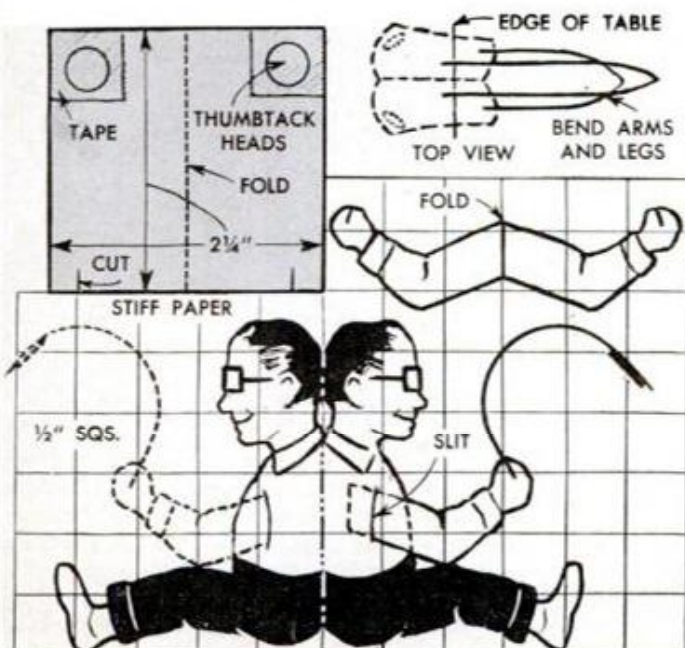

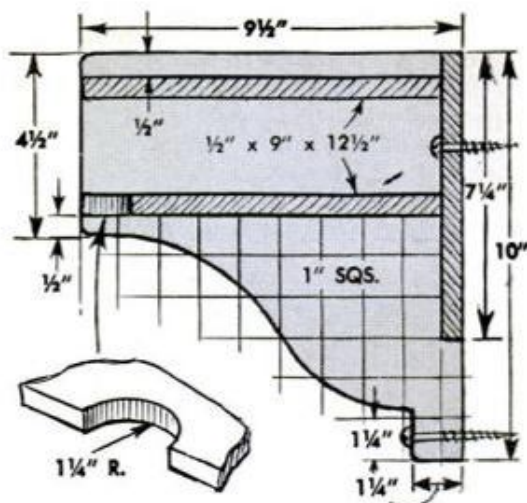

Hold the Phone

Handiest thing ever can be a "pin-up" telephone shelf. Large enough to accommodate a cradle phone with room to jot a note, there's a second shelf to hold a directory. Screws fasten it to the wall

★ MAKE A GIFT FOR CHRISTMAS ★ MAKE A

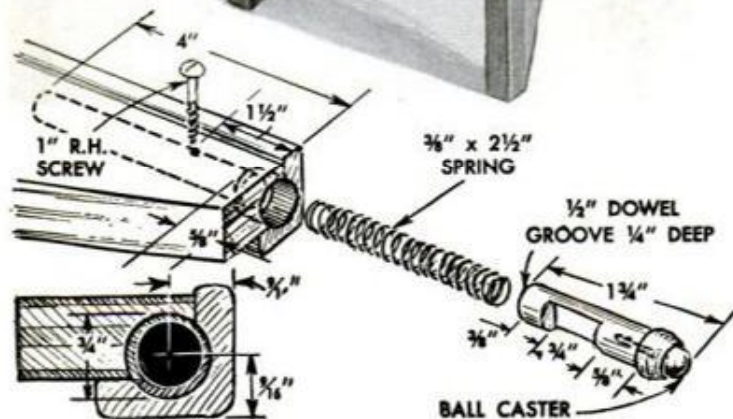
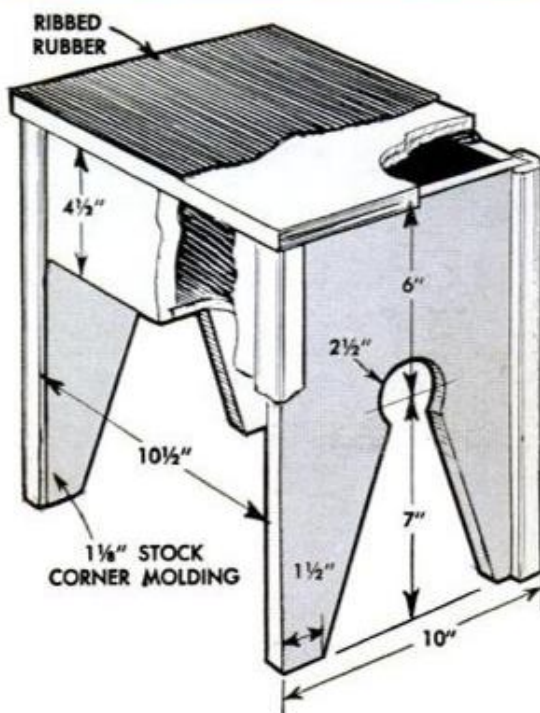
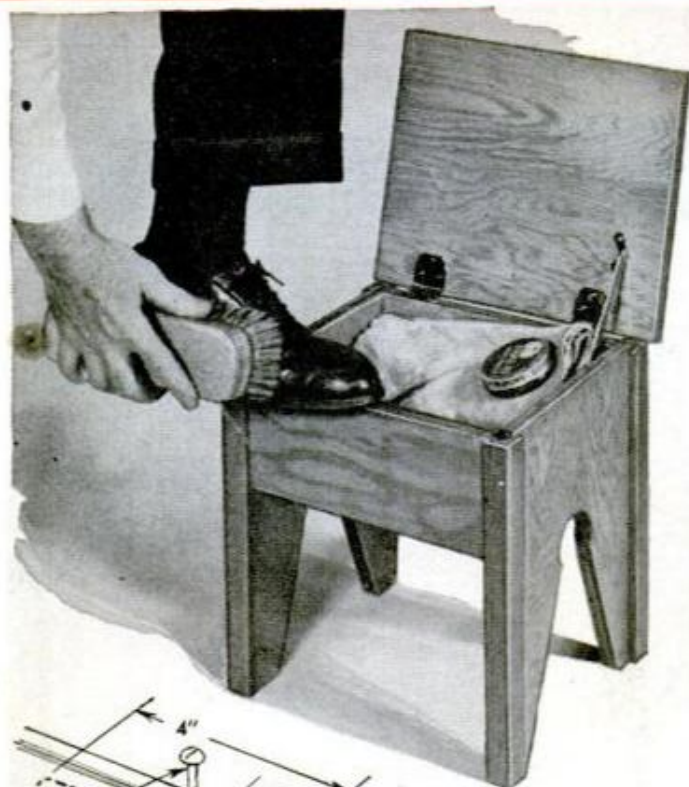

It Rolls With a Kick

This kitchen step-stool rolls across the floor but not when you stand on it. Pop-out casters in legs retract under weight. Handy for reaching cupboards, also for chucking shoe-shine kit. An easy project to make, it uses strips of ready-made corner molding to trim the legs and hide the joints. Rubber surfaced lid affords safe footing



Display Your Salon Photos On a Folding Screen

Where's the best place to display your prize photos when it is not permissible or feasible to mount them on a wall? One apartment photographer found that a folding screen offered the best place. Besides providing a portable wall that could be moved about and used as a striking room divider, the two sides of the screen permitted as many as 24 mounted prints to be displayed. Such three-section screens can be purchased or one can be made, using panels of wallboard. Map tacks are used to hold the mounted prints to the screen.

—Charles Scott

Crossarm on Light Stand Increases Usefulness

Not only will a wooden crossarm on a folding light stand permit one or more photo reflectors to be clamped to it, but it will serve to store the reflector cord as well as an extra extension cord. Blind holes 1-in. deep are drilled in each end and one edge of a length of 1 x 2 so it will fit over the light stand either in a horizontal or vertical position. The cords store in $\frac{3}{4}$ -in. holes.

—Bil Toman

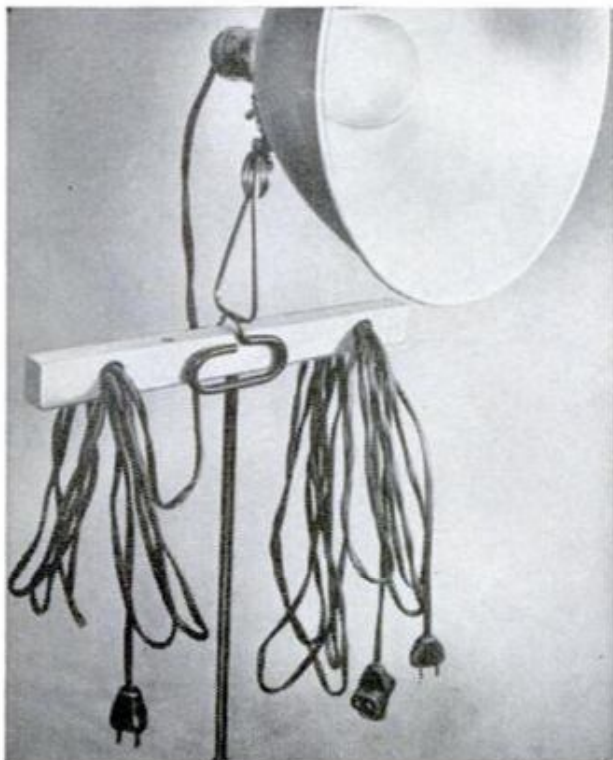

Keeping photo developer at the proper temperature during hot weather is less of a problem for the amateur darkroom finisher if he makes use of a can or two of liquid coolant. The coolant has the cooling effect of dry ice and the sealed cans are "recharged" each time by simply placing them in the freezer compartment of a refrigerator. In use, the cold can is placed in a plastic bag and set directly in the photo solution.

Clamp-On Reflector Has Own Cord Reel

One good place to store the cord of a clamp-on photo light is around the reflector. You can do this by adding three loose-leaf ledger binding posts to the reflector. Each post consists of a threaded tube and a short threaded bolt and is available in several lengths, either in aluminum or brass, at most stationery stores. Drill three $\frac{1}{8}$ -in. holes in each reflector, spacing them as indicated in the photograph below. After inserting the bolt from the inside, screw the tube on from the outside. The cord is stored by wrapping it around the reflector and against the binding posts.

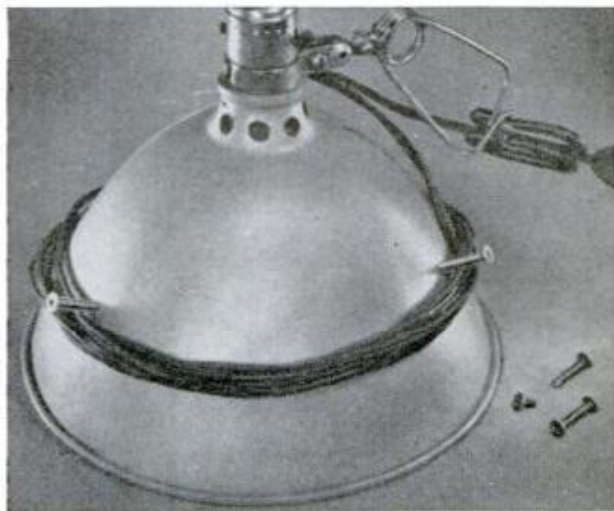

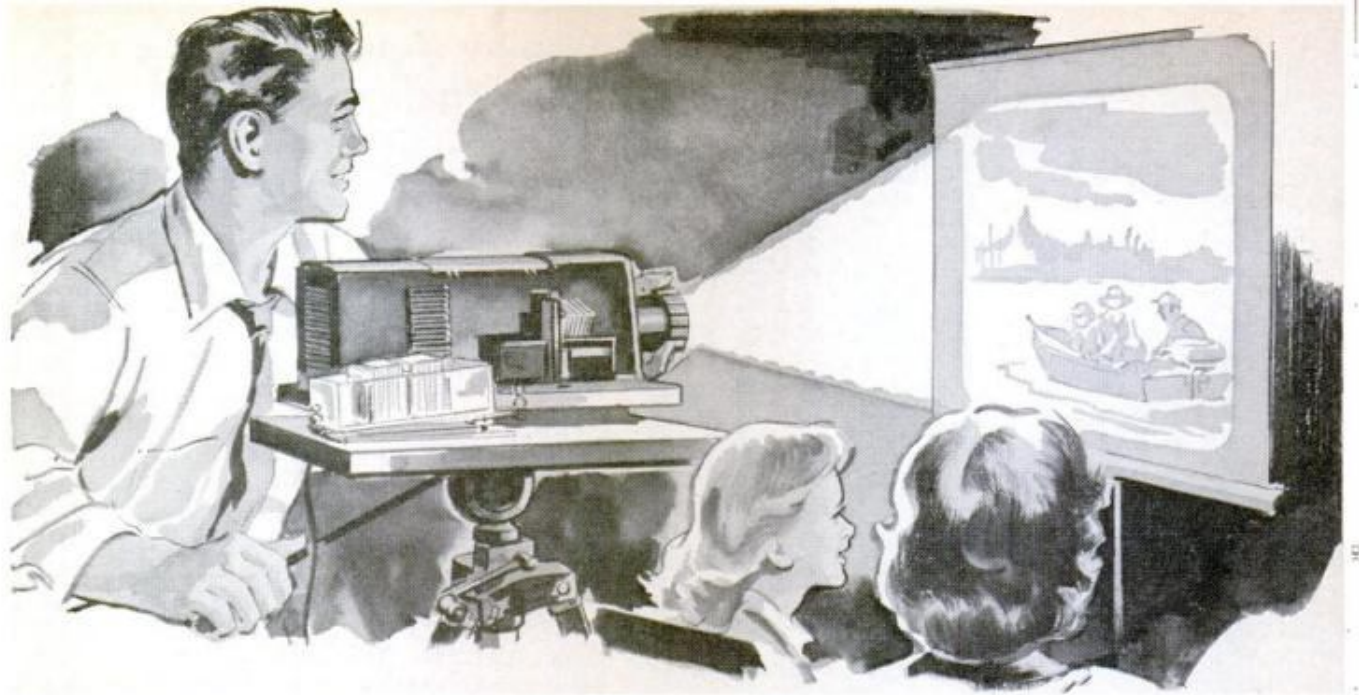

TRIPOD PROJECTOR

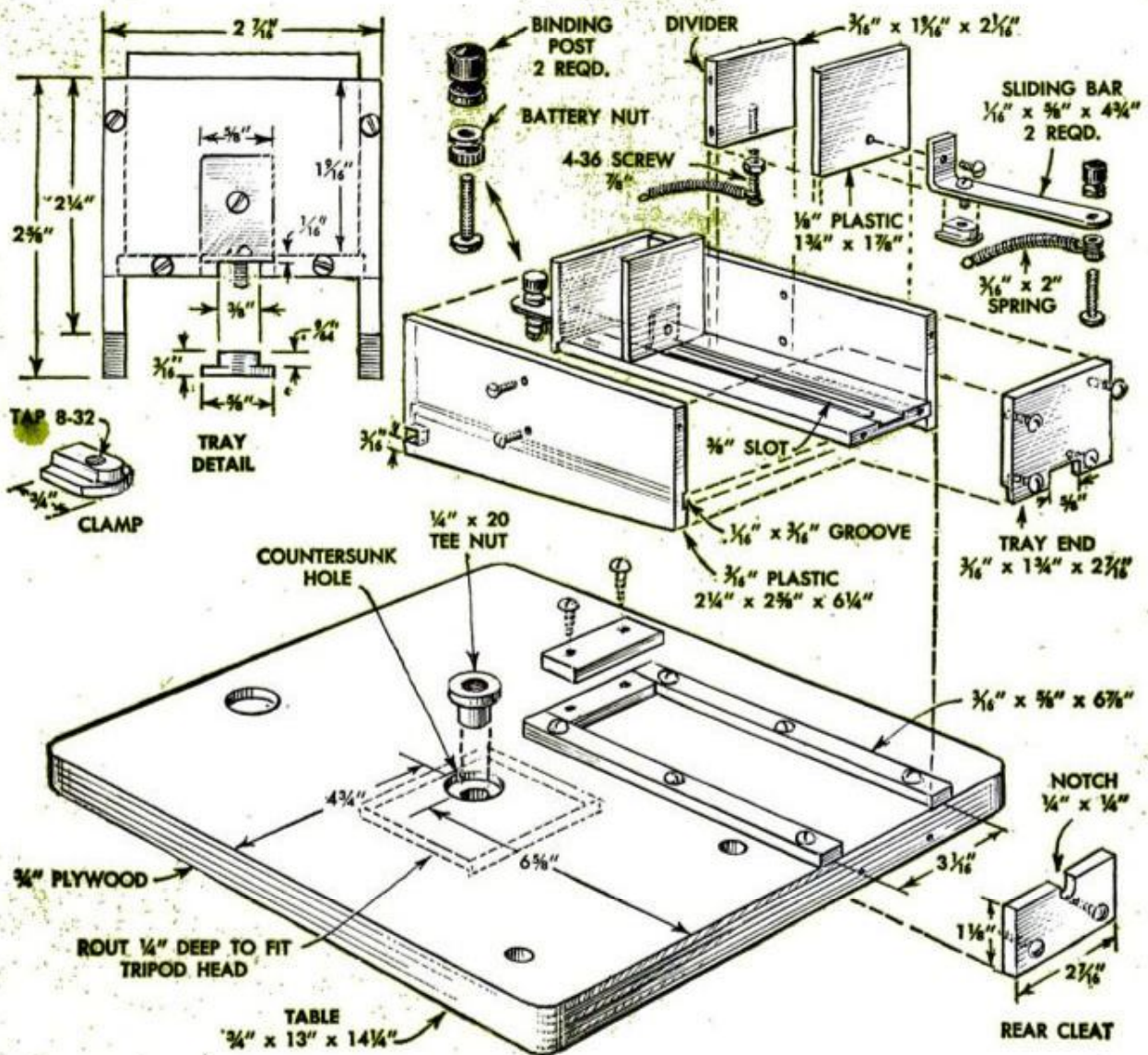

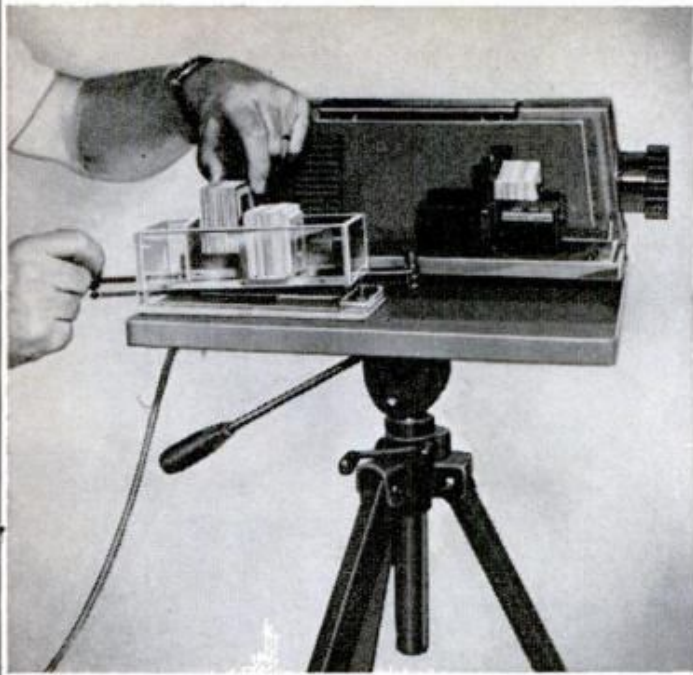

TABLE

YOUR TRIPOD need not stand idly by when you get ready to show your vacation color slides. In fact, if it's husky enough it's the perfect answer to the problem of finding a suitable table for the projector. Since most occasional tables are so low that the projector must be tilted, the image is usually distorted on the screen, particularly when the projector has a short focus lens. But by being adjustable, your tripod lets you elevate the projector to just the right height, and its pan head makes it easy to swing the image to center it on the screen.

All you need to adapt your tripod to the purpose is this simple table top which is attached by merely screwing it onto the tripod mounting screw, or stud. The plastic slide tray is optional although it is particularly handy when the projector accepts up to 36 slides. Between the changer and tray, a total of 108 slides can be handled. The over-all size of the table is determined by the particular projector. Mark the spacing of the projector feet and drill shallow holes for them in the table top. The flanged nut (a standard $\frac{1}{4}$ -20 Tee nut) that receives the tripod screw is located at the center of balance. The balancing point is easily determined by placing the projector and tray on the tripod table and resting all three on the edge of a hand saw. The underside of the table is recessed $\frac{1}{4}$ in. deep to seat the tripod head snugly. This can be routed or chiseled out as the case may be. The optional slide tray is assembled from $\frac{3}{16}$ -in.-thick rigid plastic following the details. Finish the table to match the color of the projector.—Howard R. Clark

DECEMBER 1960

Eraser Polishes Convex Forms in Drill Press

Final polishing of small convex surfaces can be done in your drill press, using a rubber ink eraser. First, spot, or "dimple," the eraser with a twist drill to provide a recess for the work. Then chuck the workpiece and center the eraser under it. Shift the belt on the cone pulleys to give the spindle a speed of 3000 to 5000 r.p.m. Use very light pressure on the work to avoid heating the eraser, possibly burning the rubber and distorting the recess in its surface. When one recess becomes worn, spot another and proceed.—H. J. Gerber

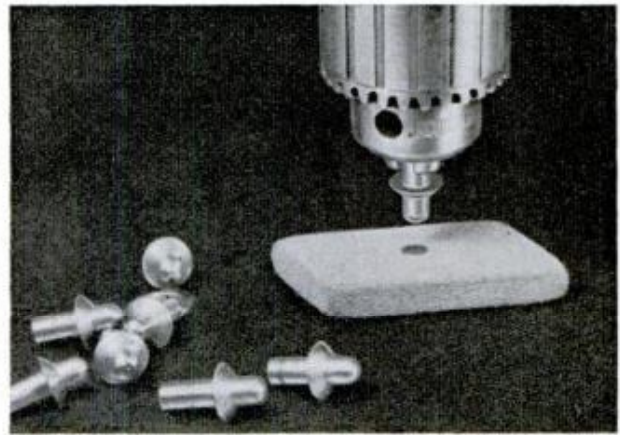

Lathe Attachment Is Aid In Turning Half Sphere

To turn a true spherical surface, or half sphere, on the end of a rod the point of the cutting tool must be set on the axis of the work. Also provision must be made to manually rotate the tool outside the center of rotation of the compound rest. These are the requirements and on some small lathes it is necessary to make an attachment that permits mounting the tool in this position. The attachment consists of a saddle made from flat-steel parts and mounted by means of four capscrews turned into tapped holes in the compound.—H. L. Campbell

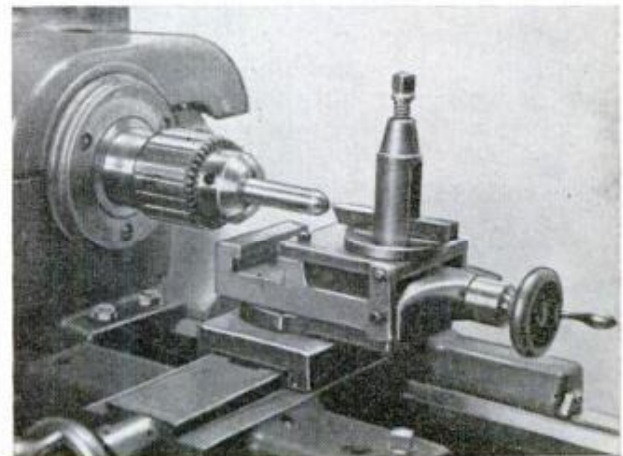

179

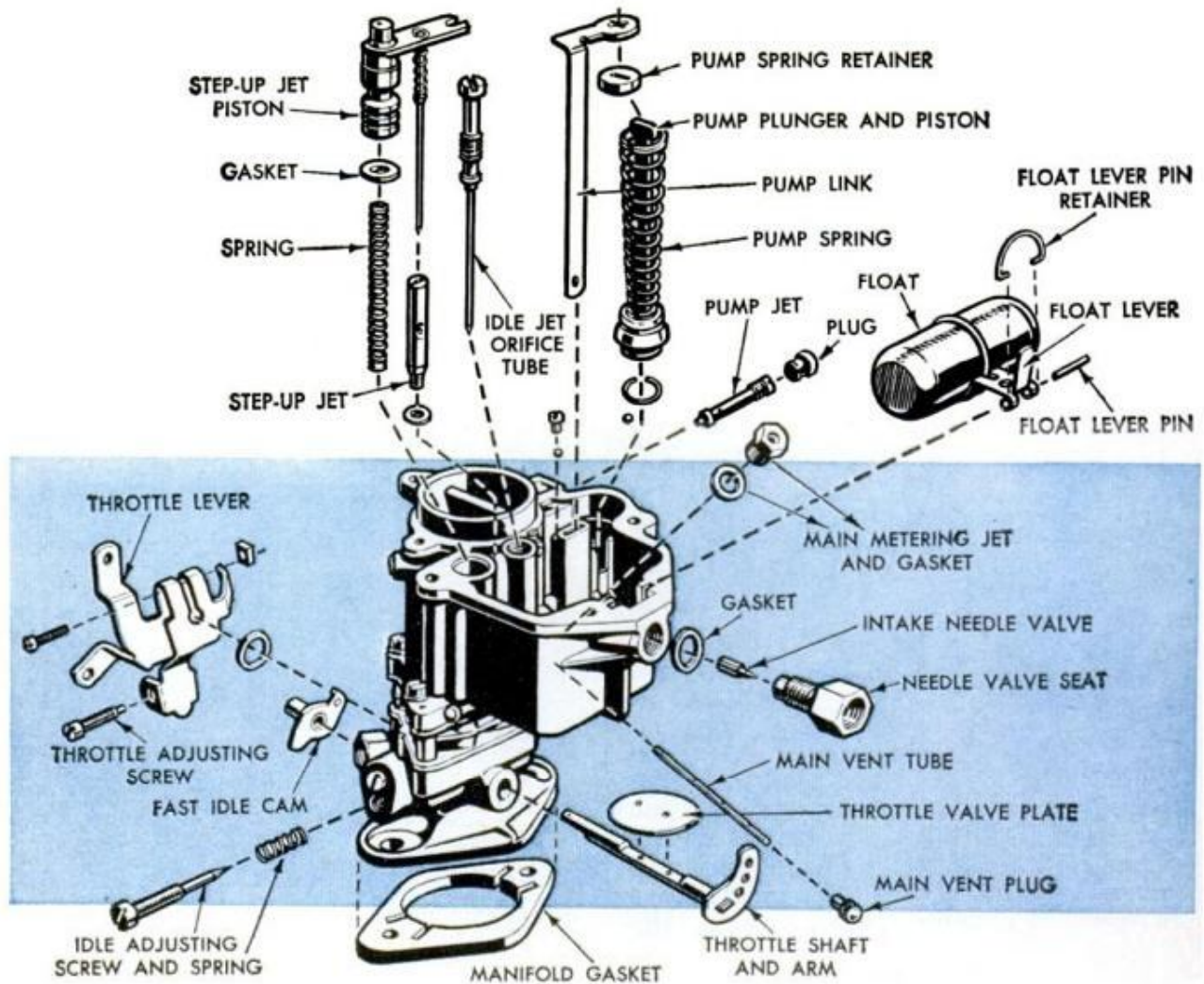

THOUGH NO TWO makes are exactly alike in every respect, the carburetor shown in exploded view above may be considered a typical example of the single-throat downdraft type used on many automobiles today

YOU CAN OVERHAUL YOUR CARBURETOR

By Guerrino Amati

THERE IS a certain satisfaction to be had in changing your own spark plugs, installing new points and in generally keeping your car humming. But, to many a do-it-yourself mechanic, that strange looking thing sitting on the engine—the carburetor—is too much to tangle with. Actually, though it is fairly complicated, many of its parts, shown above, are accessible enough to be removed with ordinary tools so that a quick, general overhaul requires little more than a fundamental understanding of the carburetor's operation and a bit of common sense application. Essentially a carburetor is a tube through which air and fuel are drawn, mixed, converted to a vapor and conducted to the engine's cylinders. Its principal parts are thus best understood in relation to their functions in creating and

conducting this vapor to the cylinders.

The Float Bowl and most of the other parts and components of the carburetor are immediately accessible upon removal of the air horn. Beginning with the float bowl assembly, pull out the lever pin retainer first. The float, lever pin and lever will then lift out easily and the intake needle valve and its seat are removed with a small wrench. This assembly is designed to maintain an optimum level of fuel in the carburetor on which the engine feeds. Fuel from the pump forces its way past the intake needle valve and into the bowl. As the fuel level in the bowl rises, the float also rises and pivoting on its lever pin presses its lever back against the valve to shut off the flow of fuel. As the fuel is used up, the level drops, the float releases the valve

CARBURETION depends on a steady fuel supply from the float bowl. Here, float rise is being determined by means of a gauge

and the action is repeated. In your overhaul replace a leaky float and bent pins and levers which can't be straightened out. Bent pins and levers may cause the float to bind against the sides of the bowl. Worn, pitted intake valves must also be replaced. Once everything is in order, use a simple gauge, included in most repair kits, to determine whether or not the float will rise to the proper level. Consult your car manual for the correct float level.

An engine running from idle to a speed of 20 m.p.h. is operating on its low-speed circuit. Fuel flows from float bowl through the idle orifice tube and combines with air drawn down the air horn through one of the carburetor's internal passages. A twist of the screwdriver and the tube will pop up under the released tension of the step-up piston spring. In cleaning the parts of this circuit, blow out all openings and internal passages with compressed air. The idle-adjusting screw and its spring may be cleaned with solvent and a stiff brush. The throttle valve plate should move freely under light pressure. Do not insert a wire or any other object

SIMPLEST of the various assemblies, the float and its parts lift out upon removal of the retainer pin

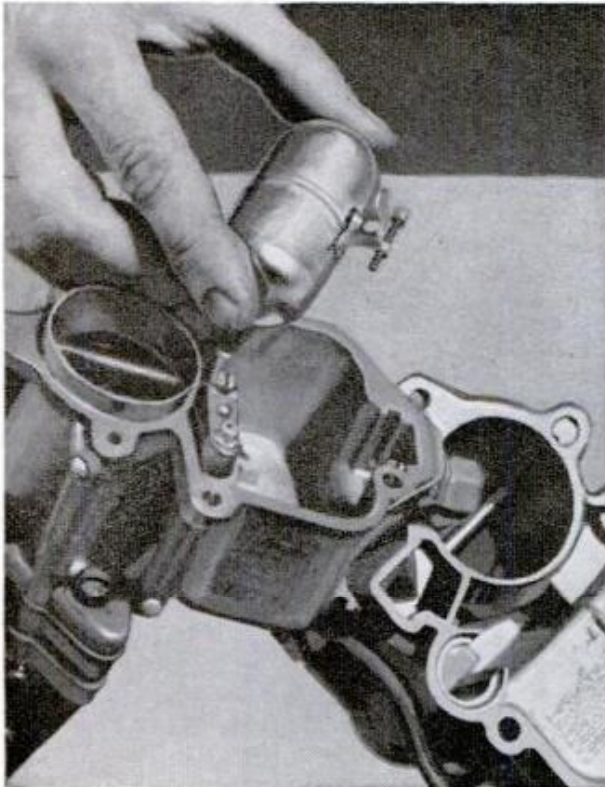

DECEMBER 1960



into the opening of the idle orifice tube as this is likely to increase the size beyond its critical tolerance.

The High-Speed Circuit, part of which you have removed with the idle orifice
(Continued to page 234)

CARBURETOR "changes stride" from low-speed circuit to step-up assembly, shown being removed as a unit

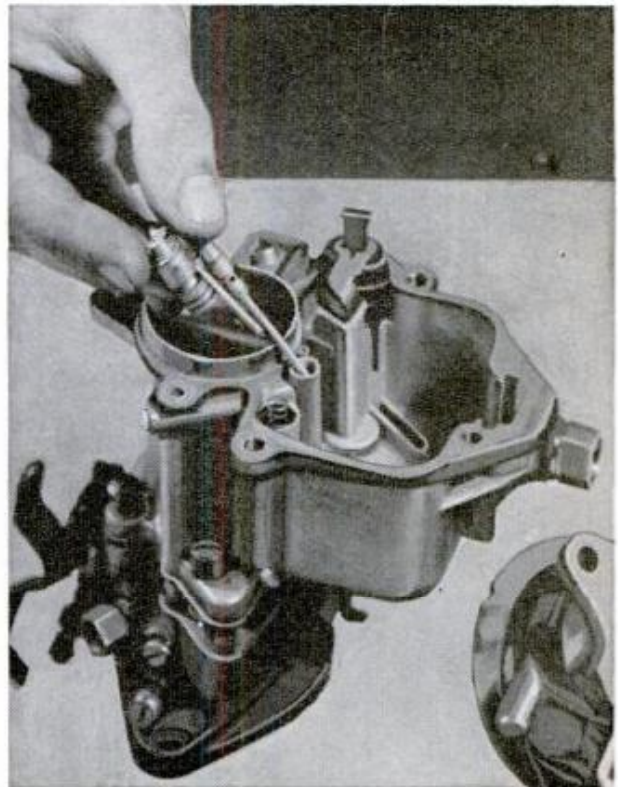

181

STRONG PLUG SPARKS

*Boating
Annual, 1961*

MEAN TOP R.P.M.'S

By Earl F. Wobeck

OUT ON "Lake Anywhere," there is an outboard boat homeward bound after a successful day of fishing. The skipper notes that his twin 35's are acting more sluggish than usual, shrugs his shoulders and mutters to himself, "Must have tanked up on some poor gas again." A series of coughs are heard, followed by two or three sputters—then, a deep, deep silence.

The tale of this outboarder, like so many others who fail to give their motors proper servicing at regular intervals, could have a sad ending. In a real situation, the outcome would depend upon the weather, sea conditions and how well the skipper is prepared for such emergencies. But the objective of this story is to help boaters avoid engine failure, giving inside information direct from spark-plug manufacturers on how you can avoid excessive plug fouling and get better outboard performance.

The king-size spark plug pictured at left, shows a cross-section of all the parts that make up a plug of modern design. A careful study of their interrelation

A GOOD PLUG should give a strong spark when held $\frac{1}{8}$ in. away from motor

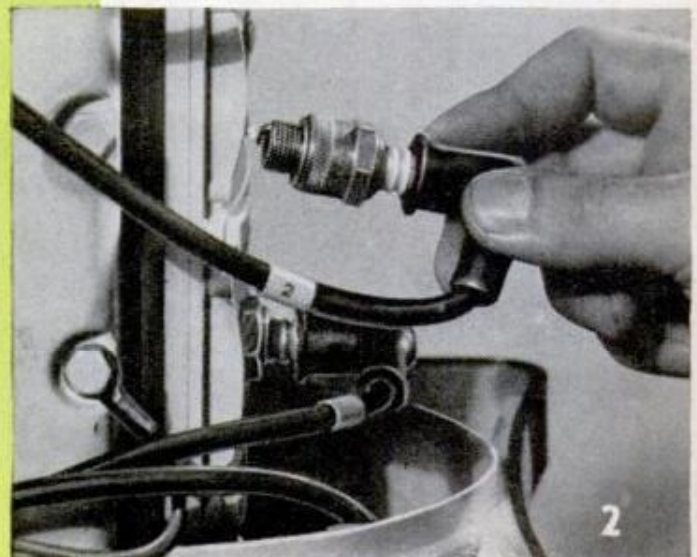
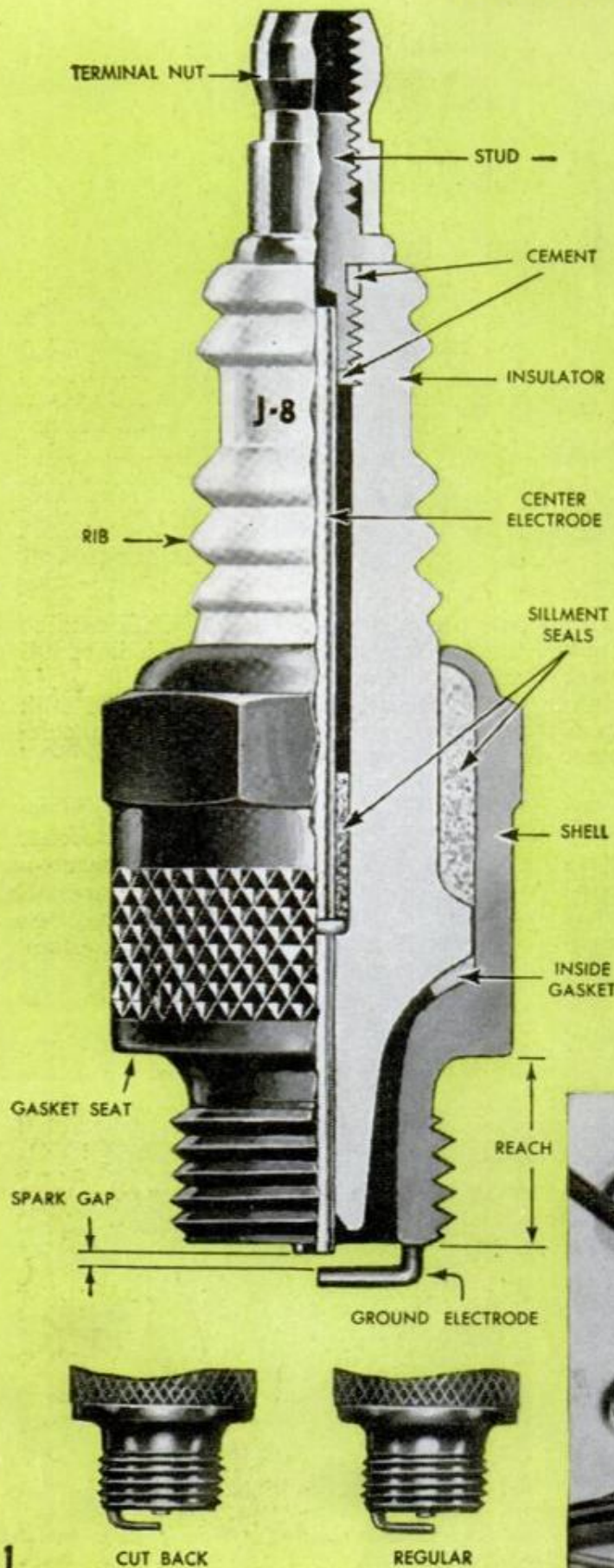

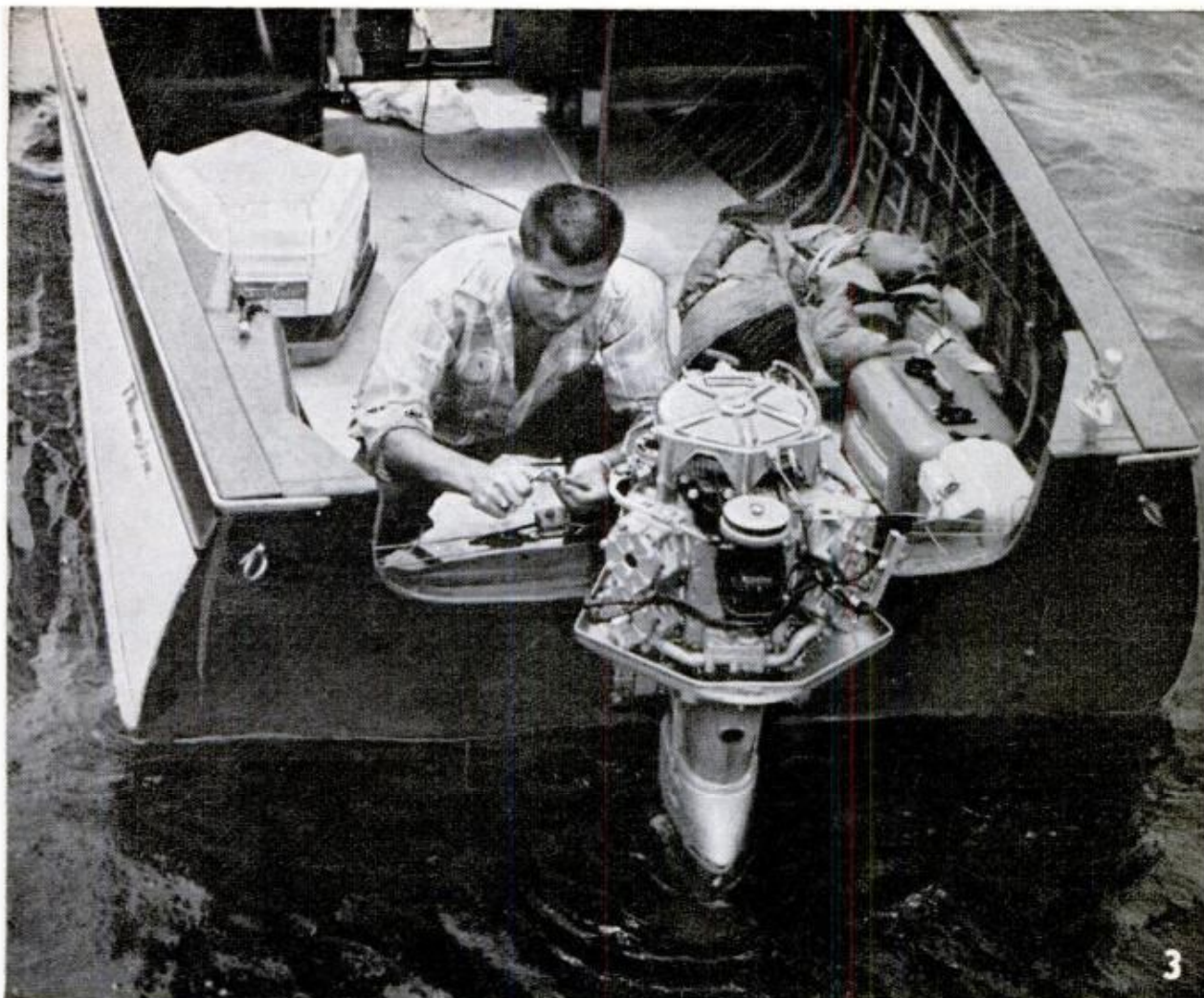

3

will help to give you some insight into the fouling problems to be explained and illustrated in the story. This plug is of a type that could have been taken from any gasoline engine, except for one feature—the cut-back electrode, which means it is designed for use in an outboard motor. Why the cut back electrode instead of a regular, overlapping one as used in car engines? An offset ground electrode simply provides greater spark exposure, encouraging easier starting and smoother idle in 2-cycle engines, which use a somewhat slower burning

MELTED SHELL shown below left, is startling example of what happens when plug is not seated properly. Below right, wire feeler gauge is best for checking gap spacing

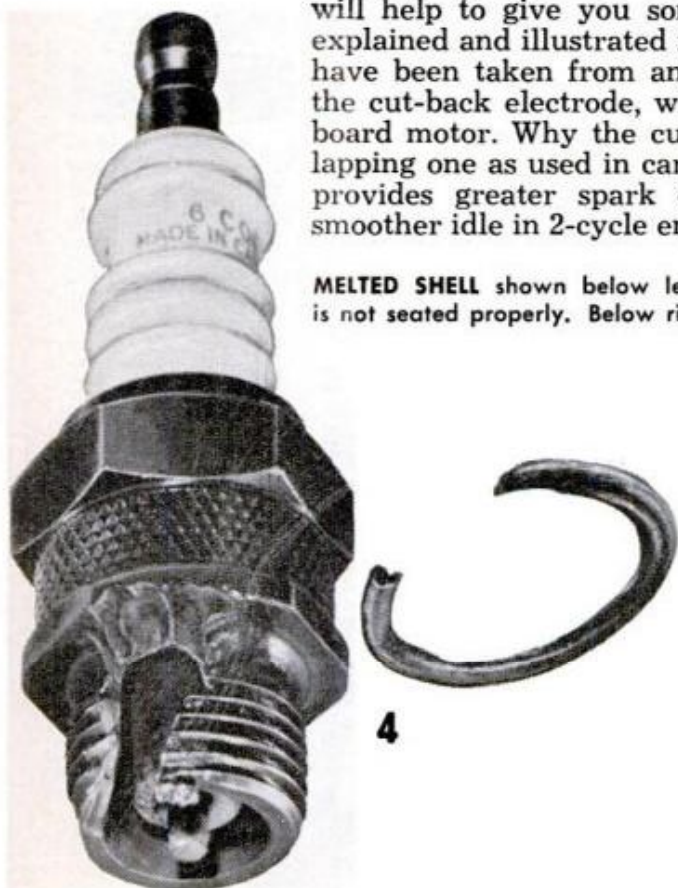

4

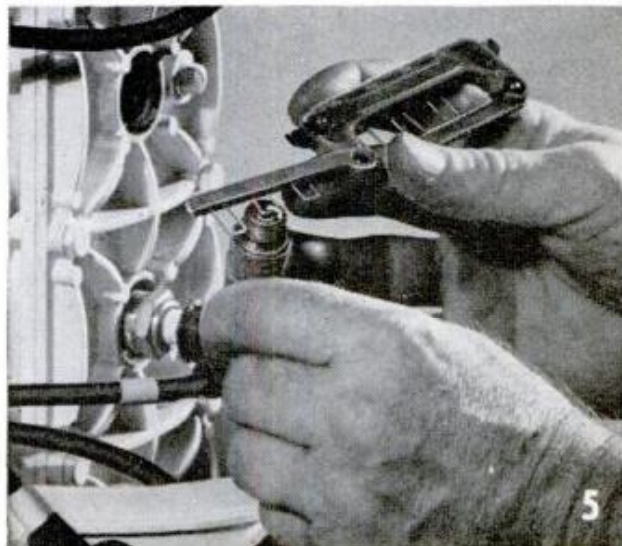

5

gasoline-oil fuel mixture. When factory assembled, most plugs are intended never to be taken apart for reconditioning. Any cleaning that is to be done, must be accomplished with all parts intact.

Spark plug improvements of recent years, include multiple ribs on the insulator, preventing buildup of a continuous layer of moisture-laden dirt. On the old smooth insulators, the latter frequently caused shorting or electrical "flashover" extending from the terminal to the steel shell and resulting in misfire and hard starting. The insulator itself now is made of a tough ceramic that is highly resistant to cracking and heat. The old porcelain insulators were quite brittle and more conductive of electricity. The center electrode is welded together from two lengths of wire, the upper one of which is steel, the lower one, a special alloy that resists corrosion and deposit of combustion byproducts. Sillment seals and special cements that are impervious to moisture, prevent plug components from vibrating loose. A thin, non-corrosive metal plating on the shell, is one of the most recent innovations that not only helps to merchandise them but prevents formation of unsightly rust. A big advance in spark-plug design is the manufacture of plugs in a wide range of

heat ranges. To avoid excessive fouling at low speeds, and pre-ignition (firing of compression stroke ahead of time) at high speeds, the spark plug insulator nose temperature must remain between definite limits. About 1700-deg. F. is the upper limit, while 700 deg. approximates the lower limit. The temperature of the insulator nose and electrodes is controlled primarily by the length of the tapered portion of the insulator exposed to the combustion chamber. A long taper makes the heat travel a longer route before being dissipated in the coolant, a short one simply allows the heat to be dissipated more rapidly, keeping the plug cooler as indicated by the blue arrows in Fig. 10. Since temperature conditions vary according to work load, outboard use and size of engine, it is important to match these requirements with a plug that will not overheat, at high speed, yet minimize fouling at low speeds. When buying plugs, look for the "heat" type in the plug type number usually found imprinted on the upper body of the insulator. Cold plugs have low numbers, hot plugs the higher numbers. When replacing plugs that have given satisfactory service, be sure the new ones you buy are of the same heat range.

If your outboard motor (or motors in the case of a twin installation) begins to



CONDITION OF USED SPARK PLUGS often provides clues leading to source of motor malfunctioning. Wave patterns in blue dots indicate engine performance as observed on screen of ACilloscope, spark-plug analyzer

FIGS. 7 AND 8, torque wrench should be used to install plugs so that seat gaskets are compressed correctly. Gaskets prevent leakage from combustion chamber, transfer heat from plug to head, to cooling system

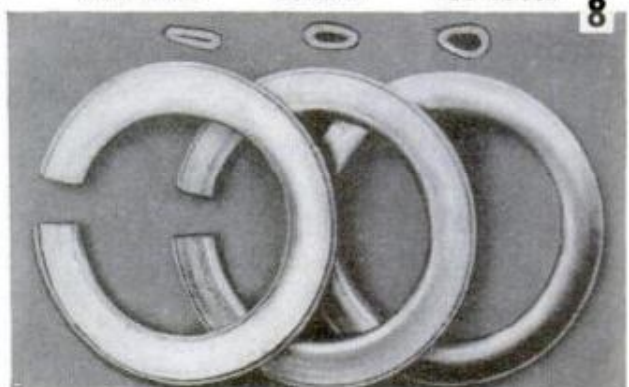
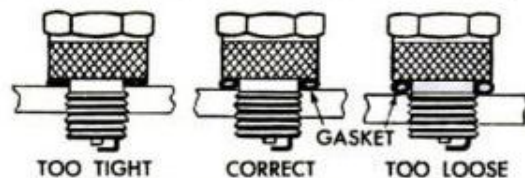
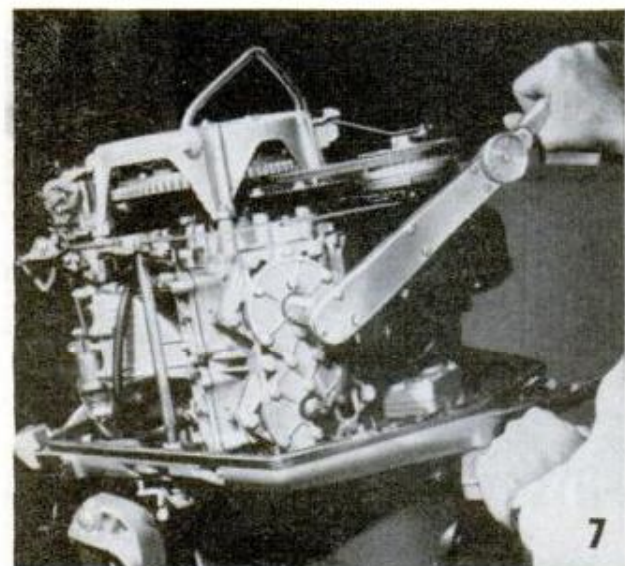

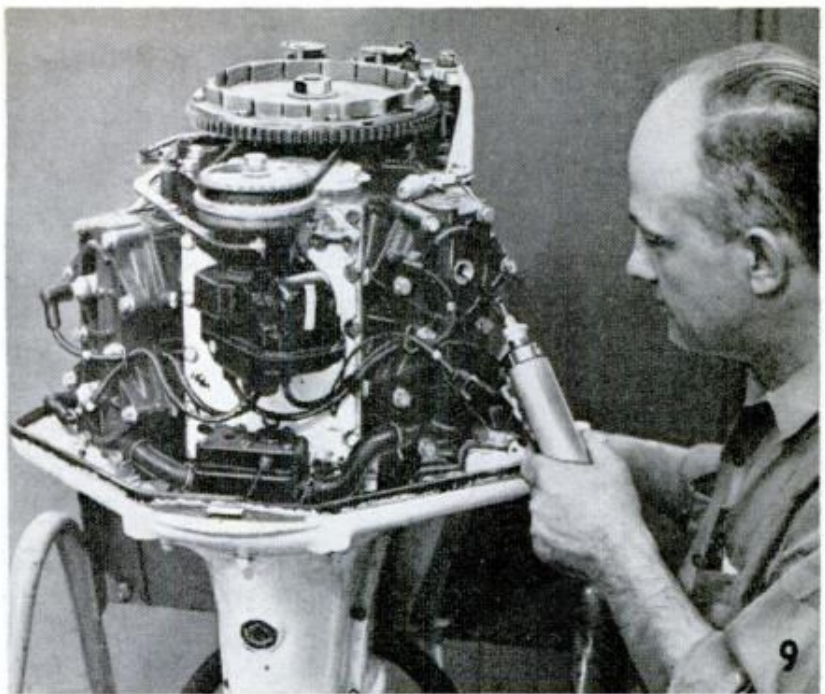

Champion Spark Plug Co. photo

ABOVE, MEDICAL PROBE LIGHT is handy for looking into combustion chamber through spark-plug openings for evidence of carbon deposits

start hard, or misfires, check out the more obvious sources of trouble before getting into fouling problems and determination of whether spark plugs of the correct heat range are being used. First, determine if adequate voltage is reaching the plugs by holding the ignition terminal a short distance from the plug terminal as in Fig. 2. Voltage should be sufficient to jump a 1/4-in. air gap. No plug can fire properly if voltage available from the ignition system is inadequate. If spark plug covers or boots are installed, check them for cracks or brittleness. Dirt

(Continued to page 244)

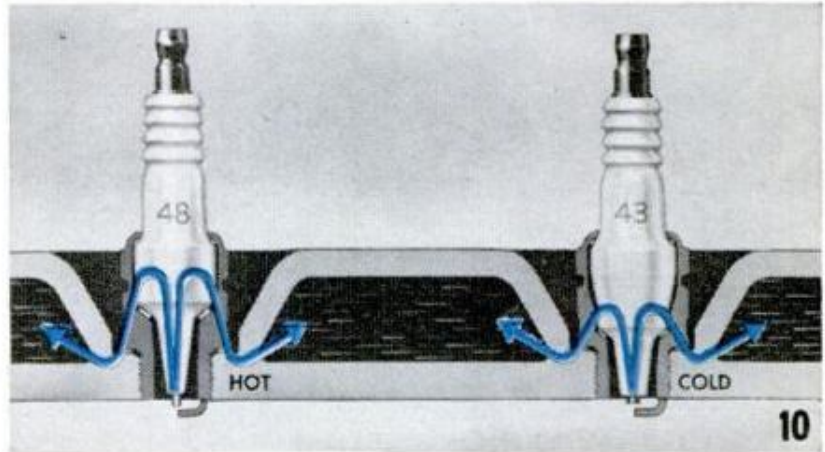

ABOVE, BLUE ARROWS indicate long and short routes heat must travel through hot and cold plugs respectively, before being dissipated

PROPER TIMING of ignition system, Figs. 11 and 12, not only results in smooth-running engine but ups power and the fuel economy as well

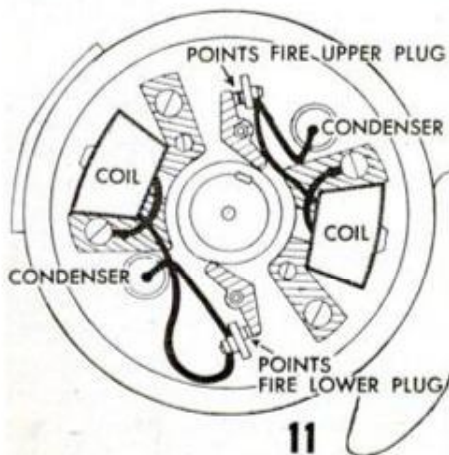

11

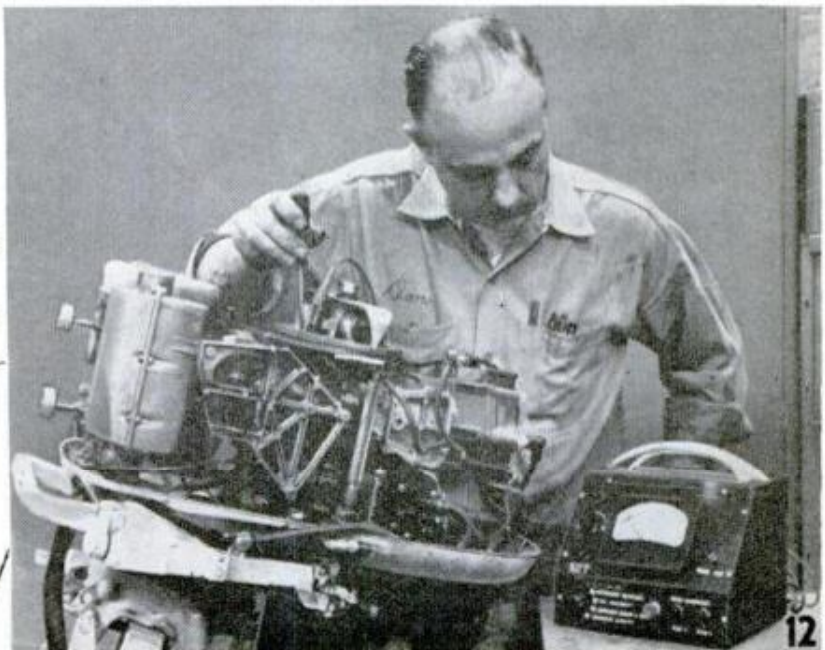

12

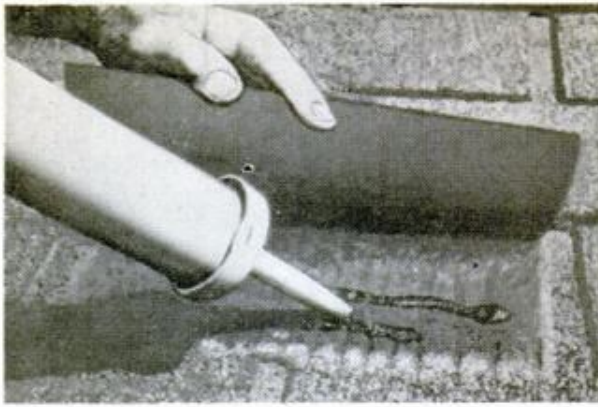

Cement Anchors Shingle Tabs

After a severe windstorm had flipped up many of the shingle tabs on one side of the gable roof of his home, one owner cemented all the tabs down securely with roofing cement applied with a caulking gun. Of course, this remedy would not apply to later types of composition shingles having self-sealing tabs, but it is effective on older composition shingles. The work should be done on a warm day so that turned up tabs can be pressed down without breaking.

Go Easy on Masking Tape

Generally it is possible to save a lot of masking tape on any painting job where you have to mask out large areas for spraying or brushing to the edge of another color. Simply cut spaced notches along one edge of the masking paper and then stick it in place with short pieces of tape rather than a continuous strip. Substantial savings are made in this way.—L. Shepanik

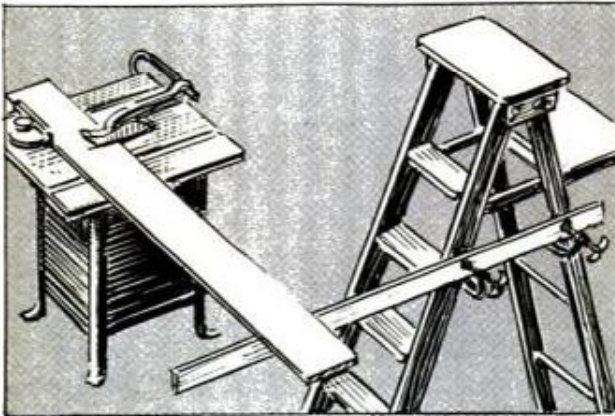
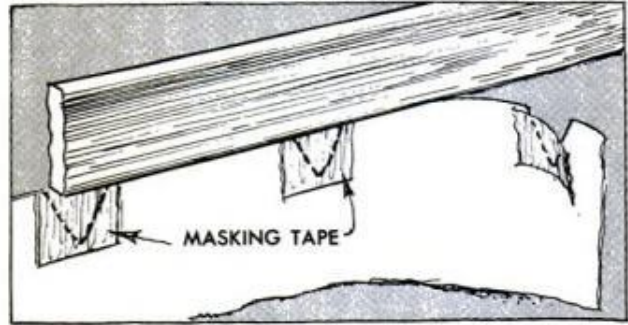

Ladder Serves as Work Support

Easy and safe crosscutting of long boards on a circular saw calls for a support for the outer end of the board. Lacking a conventional outboard support for this job you can quickly improvise one by using a step ladder as the stand and then clamping a 1 x 4 strip to two legs of the ladder to form a slide for the end of the board. Be sure the 1 x 4 is located at the same height as the saw table and that it is level.

—Robert L. Sargisson

Knife Switch for Electric Toys

Three brass paper fasteners and a piece of 1/8-in. plastic make a simple knife switch for battery-operated toys. Two fasteners, inserted through slits in the plastic base, form terminals, a fixed contact and a pivot for the blade, which is made from one leg of the third fastener. The blade has a handle cut from rubber tubing. The other leg forms a collar for the fixed contact.

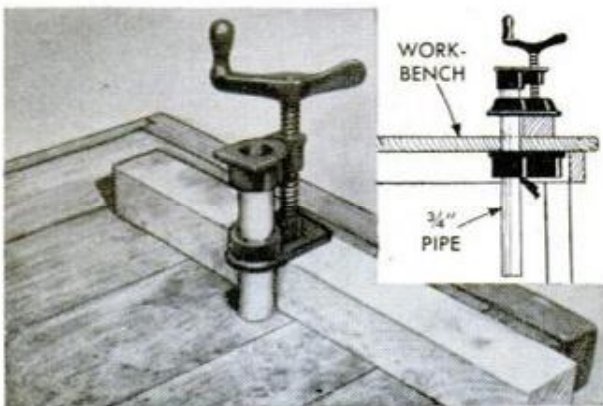
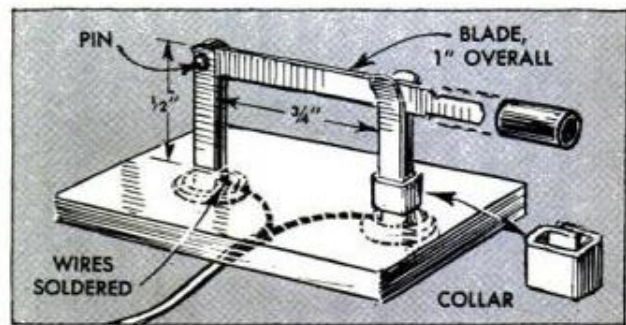

Pipe Clamp Is Bench Top Aid

Workpieces of fairly large size can be held rigidly on top of the work bench by installing a pipe-bar clamp in the bench top so that the clamp can be operated in the vertical position. All you do is drill a hole through the bench top, unscrew the cap on the end of the pipe bar, and slide off the moveable clamp jaw. Then drop the pipe bar through the hole in the bench top and reassemble with the moveable jaw underneath as in the detail.—H. Hanscom

Spring-Back Binders Protect Clippings

Popular Mechanics readers who cannot save the complete magazine because of a lack of space may find this hint useful for saving their favorite articles for reference. Just clip the desired pages and insert them in a spring-back binder like the one pictured. The pages need not be punched and are easy to insert or remove. Simply spring the covers open, insert the clippings and release.—M. C. Anderson

To keep a diamond sparkling, clean it daily in detergent. Rinse in clear water and dry with blotting paper. Also, have the mounting checked periodically by your jeweler.

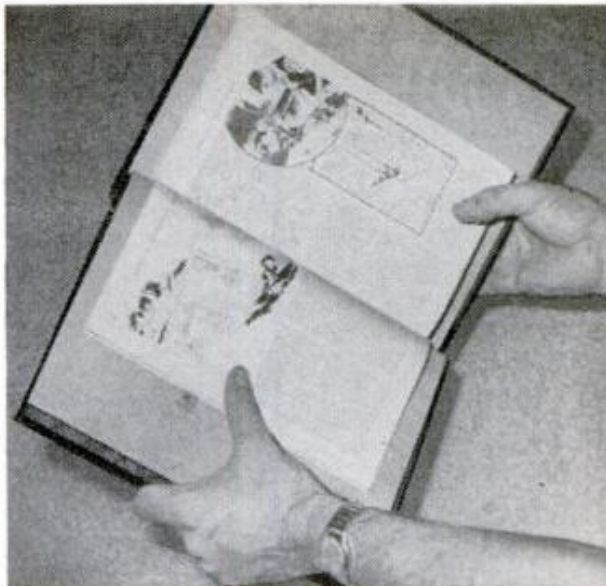

Save Bottle-Cap Inserts

Before you toss out bottle caps take time to pry out the cork inserts. These have many practical household uses as you will readily discover for yourself. The photo suggests one or two applications. There are, of course, others. For example, cement an insert to the bathroom doorknob to prevent it from banging against the plastered wall. Or, cement four inserts to the base of the electric mixer for more quiet operation. They make dandy bumpers for hinged lids.—Bil Toman

When you hang the weekly wash in the basement to dry during stormy winter weather, drying can be speeded up by placing an electric fan so that the air blast is directed parallel to the clothesline.



COMING UP NEXT...

Driving In Snow. S-n-o-w! Makes you think of skid chains, shovels, sand, sleet inside your coat collar and maybe a late dinner, doesn't it? But learn how to avoid this sort of thing by reading the timely driving tips in the January issue

Shoji Screens. A shoji screen is more than a conversation piece. It's functional Oriental design at its best. It goes anywhere, with most furnishings. The article coming up tells you how to build not just one, but several of glass fiber

How To Install Docking Lights. Only the skipper who has docked his packet in the dark can tell you what docking lights will do for a boatman in the tight places. That's why we picked an experienced skipper to tell you about them

All About Twist Drills. No matter whether you sharpen one twist drill a year or a hundred a day, this article is a must for the shop man. Tells how to sharpen the many kinds of drills and also how to use them on various types of work.

HERE ARE THE FINE POINTS OF

X314

By C. W. Woodson

MAKING A CLEAN, sharp score to a uniform width and depth throughout the length of the cut is the trick—the whole trick—in cutting glass. Fill this single requirement and you'll get a perfect break every time. That clean, sharp score is the result of several preparatory steps. These are simple to carry out but each calls for close attention to detail.

First, there's the method of holding the wheel-type glass cutter, Fig. 1. This cutter is the type most commonly used. Note in Fig. 1 that the handle of the cutter is held between the first and middle fingers and that the handle is shaped to make this the most comfortable grip. If you hold the cutter between the thumb and first finger, you tend to lose control when making the cutting, or scoring, stroke. In actual practice glaziers usually incline the cutter slightly when making the scoring cut, as in Fig. 4. The slight inclination gives some-

what better control of the cutter when working against a straightedge.

Before cutting, the sheet of glass must be cleaned thoroughly. This is important for if there is a coating of dust or a grimy film on the surface you cannot get a clean score. Fine dust usually can be wiped off with a damp cloth as in Fig. 2, and then the surface should be wiped dry. But if the glass has been stored for some time, the surface is likely to be coated with a cloudy film of grime that will not ordinarily wipe off easily. The film must be removed by scrubbing vigorously with an artificial sponge and a medium washing-powder solution as in Fig. 5. After scrubbing, rinse the surface of the glass with clean water and wipe dry. If you are cutting old window glass that may have been cleaned with a wax-type cleaner, wipe the surface with a solvent after scrubbing to make sure that all the wax coating has been removed.

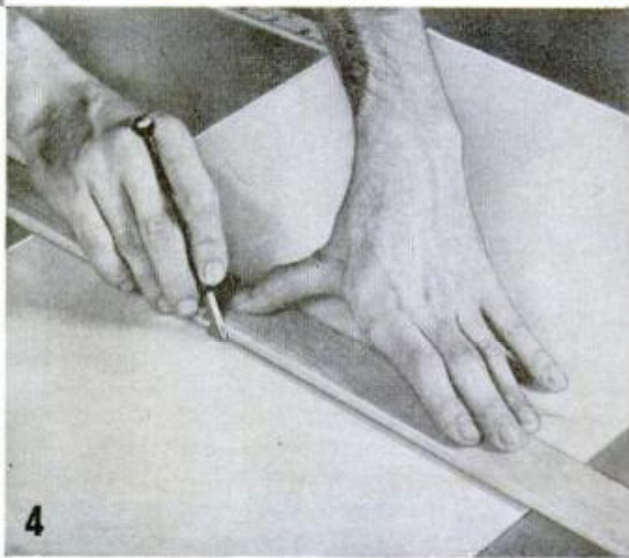
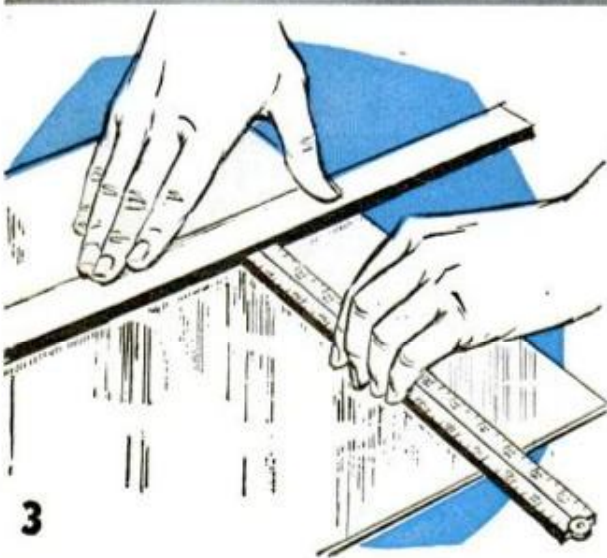
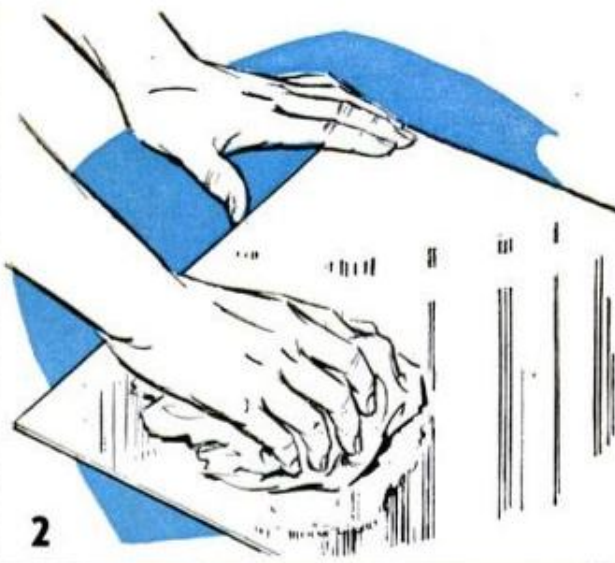
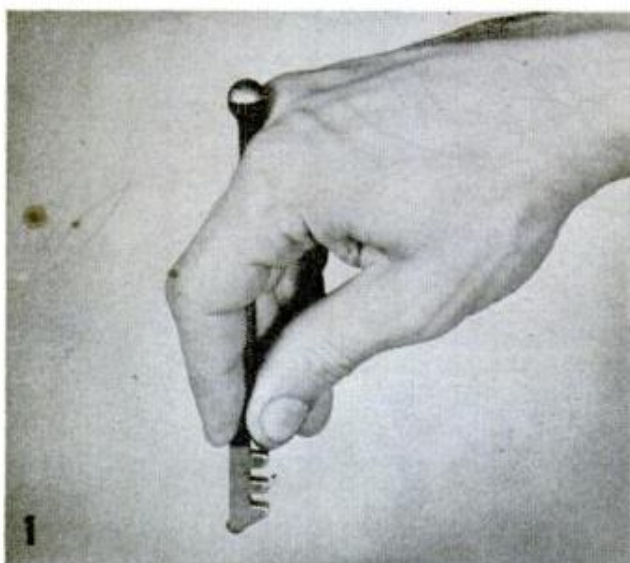

CUTTING GLASS

The next step in the procedure is to locate the straightedge accurately. A yardstick will serve as a straightedge as it is about the right width and thickness. In ordinary work, positioning the straightedge can be done as in Fig. 3. Place several layers of newspaper or a desk blotter on a level surface such as a bench top or table top and lay the glass on top. Then measure from one edge with a rule, near one end as indicated. Do the same at the opposite end of the piece to be cut. When taking these measurements don't forget to allow for the offset of the glass-cutter wheel in its frame, or yoke. Usually this is about $\frac{1}{16}$ in. but may vary with different types of cutters. Check to make sure. Also, if there is any doubt about the squareness of the piece of glass you are to cut, check the corners with a square.

With the straightedge in place you're ready for scoring, or cutting, as it is generally called. Place the wheel of the cutter at the edge of the glass farthest from you,

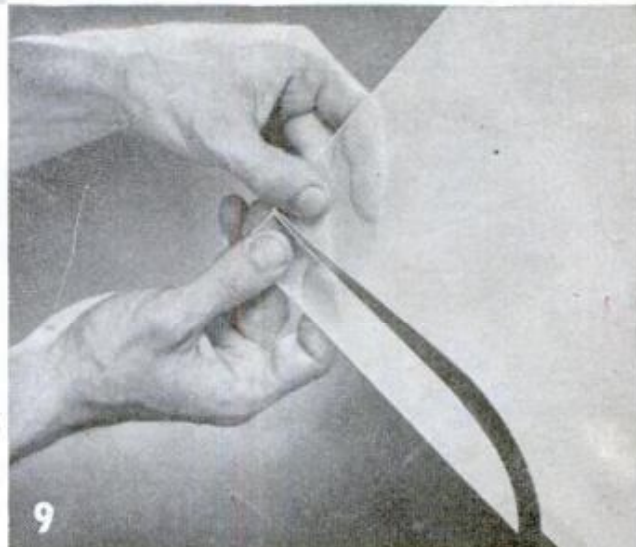
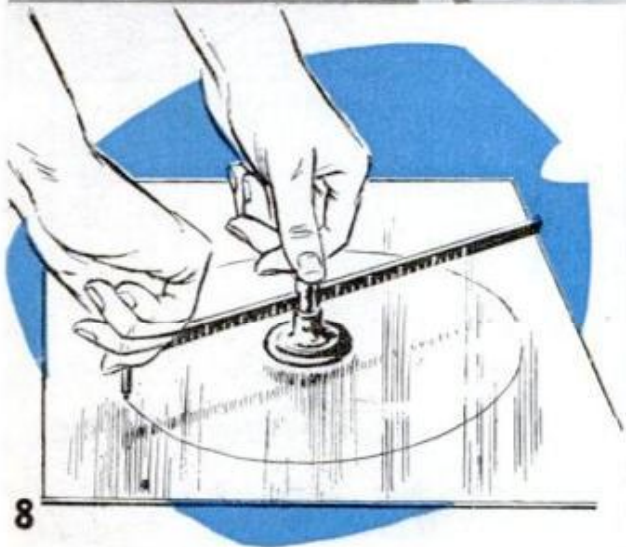
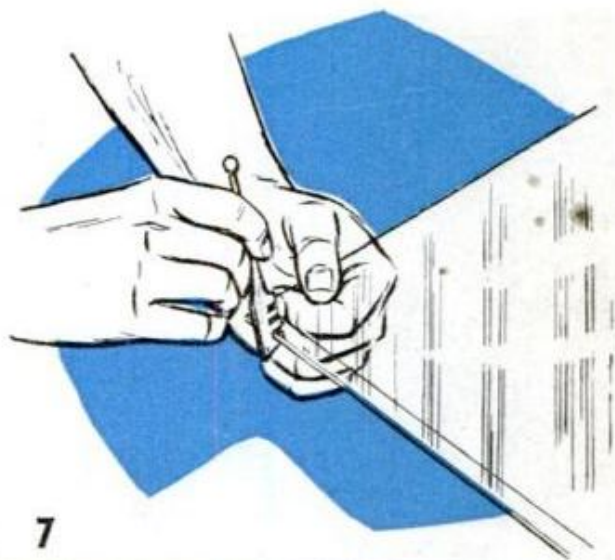
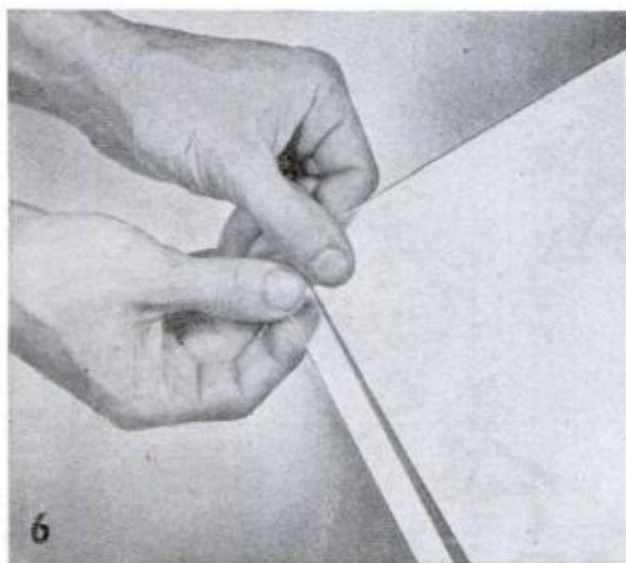

hold the cutter as in Figs. 1 and 4, and make the cut along the straightedge in one sweeping stroke, keeping light and uniform pressure on the cutter and holding the straightedge firmly in place. Now, before the cut gets "cold", pick up the sheet by a corner and grasp the edge with both hands, a thumb and forefinger on each side of the score as in Fig. 6. Exert a light breaking pressure to snap the sheet into two pieces along the score, or cut. If the score is continuous, the sheet will break true along the cut. But if you hesitate or skip at any point, it will break short as in Fig. 9.

After the first cut you measure again as in Fig. 3 and make the second cut to get the piece of a width and length you want from the sheet. Don't attempt to cut a small square or rectangular piece from the corner of a larger sheet. Glass will not break two ways simultaneously even though the cuts are perfect. You can cut close to an edge and still get a perfect break as in Fig. 6, but if the distance from the cut to the edge is less than $\frac{1}{2}$ in., then it is better to make the break with the glass cutter as in Fig. 7,

or use glass pliers, Fig. 19. When cutting to measured sizes, as in cutting panes for window sashes, allow at least $\frac{1}{16}$ in. for expansion of the glass and for bedding in putty.

Round, square and rectangular openings can be cut in glass sheets and circular panes are easily cut with a circular glass cutter as in Fig. 8. After the circular cut has been made, straight cuts are made from the four edges of the sheet as in the left-hand detail, Fig. 13. Then fractures are started by tapping lightly with the ball end of the glass-cutter handle on the underside of the sheet and directly under each straight cut. Once the cracks are started, the pieces can be broken away, leaving the circular pane. A square opening in a sheet, relatively large or small, also can be cut as in the right-hand view of Fig. 13 and the left-hand detail in Fig. 14. First you cut the outlines of the opening but note that the cuts are not completed to the corners. Next, tap the underside of the glass sheet with the ball end of the cutter handle at the center of each cut. The purpose of this step is to

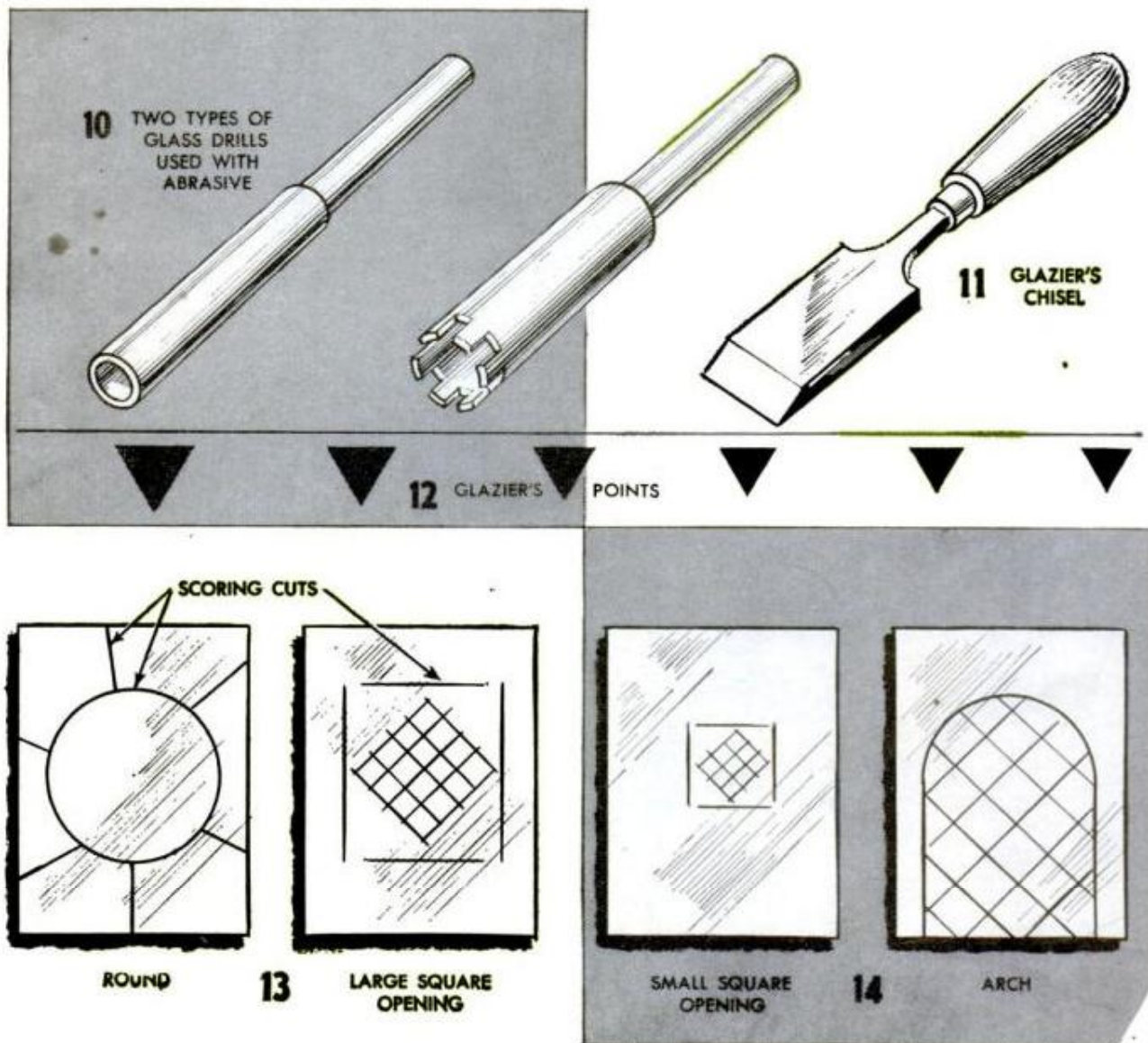

start a crack at each of the four points. Then you make the diagonal cuts in two directions and equally spaced as indicated. Tap these cuts from the underside to start cracks, or fractures, in both directions. Then simply knock out the center square. If the cuts are complete and the breaks well started, it will drop out when tapped lightly with a mallet. Then you can break away the triangular corners that remain. Finish the rough edges with an oilstone. By a similar procedure you can form an arch in a sheet of glass by first completing the semi-circular and straight cuts to one edge as in the right hand detail, Fig. 14. Then cross-hatch the waste with spaced cuts and start fractures by tapping as before. This must be done very carefully as otherwise the sheet may shatter. By starting fractures on all the diagonals and working from the edge of the waste, it is possible to remove the waste one piece at a time until you reach the top of the arch. Breaks along curved cuts are not always as smooth as along a straight cut. It usually is necessary to fin-

(Continued to page 240)



DRILLING HOLES through glass is done in a drill press, using suitable drill and mixture of abrasive and oil. Use slowest speed, lift drill frequently

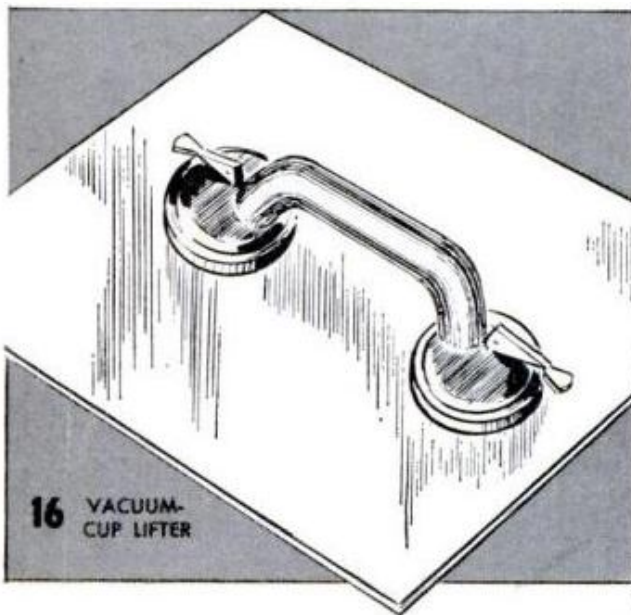

16 VACUUM-CUP LIFTER

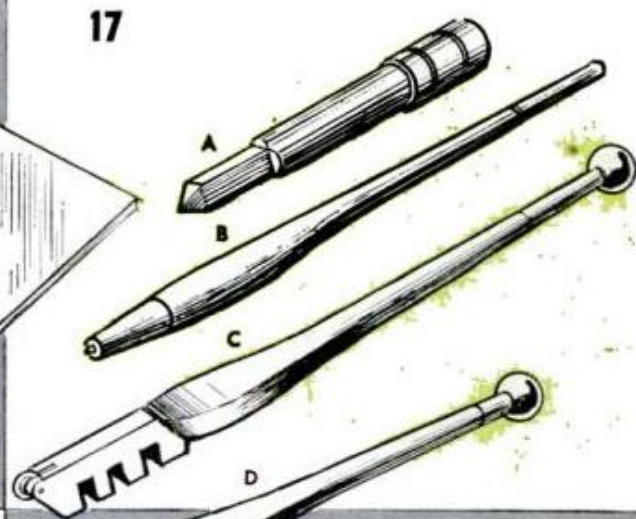

17

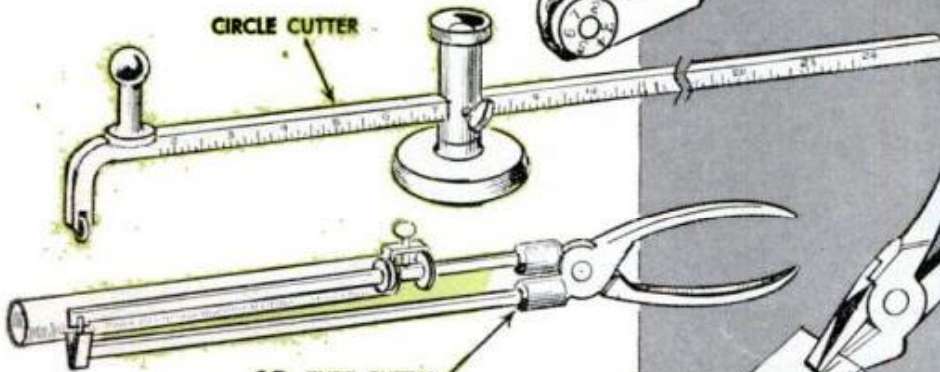

18 TUBE CUTTER

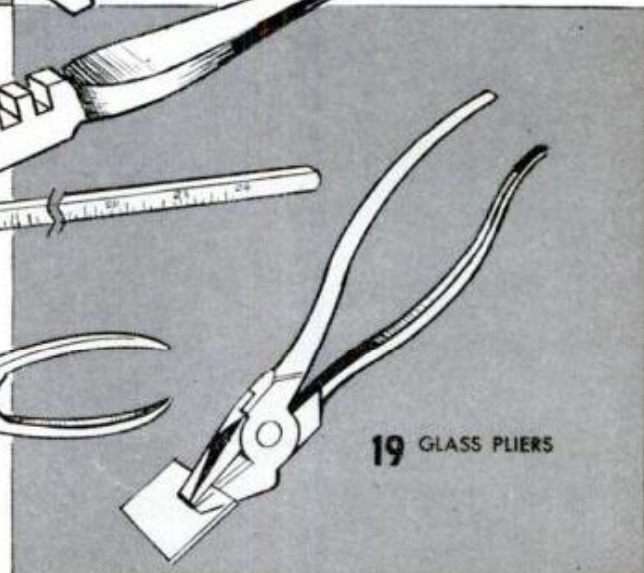

19 GLASS PLIERS

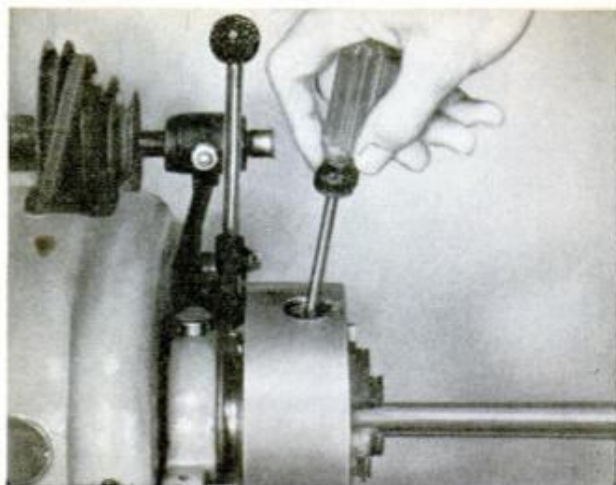

Chuck Adjusted With Screwdriver

When the job requires movement of chuck jaws through a wide range, either when centering work or in chucking parts of various sizes, you'll find a screwdriver much faster than the regular chuck wrench for running the jaws in and out. Be sure to select a screwdriver with a blade of just the right width to fit diagonally into the square socket of the adjusting screw. You don't use the driver for tightening the screw, but merely to run it in or back it off fast. If you're careful, you won't damage the chuck screw in any way and you'll save a lot of time.—R. Hanscom

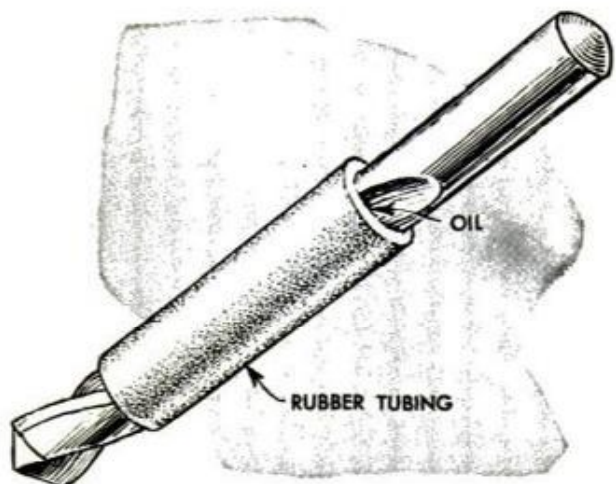

Lubricant Fed to Drill Bit

Where you have only an occasional job of metal drilling the main problem is that of getting lubricant to the point of the drill continuously and in a uniform amount. Applying a few drops with an oil can occasionally won't do. The oil will be thrown off the rotating bit before it reaches the point. A better way is to slip a length of rubber tubing over the drill and then pump several drops of lubricant into the flutes before starting the machine. The rubber tube will conduct the lubricant down the flutes to the point without loss.—Daniel Bousha

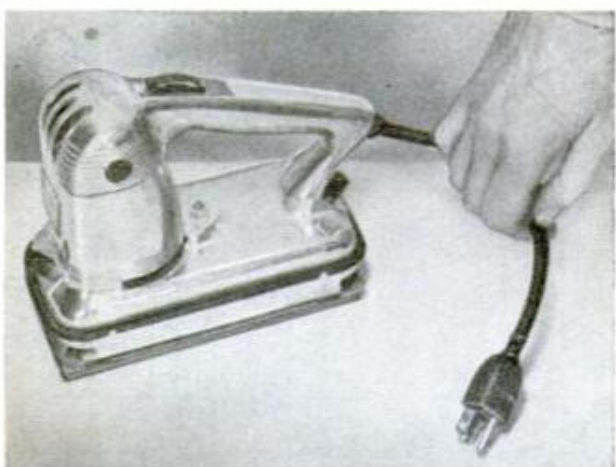

Short Power Cords for Convenience

Shortening the power cord of portable electric tools such as sanders, drills, and saws to about 12 in. and then fitting a grounding plug makes these tools much more convenient to handle and store, especially where the tools are kept in individual carrying cases. Each tool is then operated by plugging it into one end of a long heavy-duty cord which leads from a nearby outlet. This preferably should be a three-wire cord so that the tool is always grounded when connected to the power source. Long, three-wire power cords are readily available.

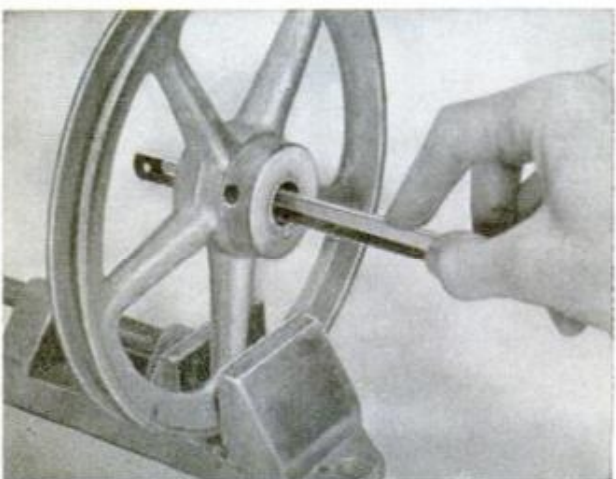

Backing Stiffens Hacksaw Blade

Although it's not an orthodox procedure one sometimes finds it convenient or necessary to use a hacksaw blade without the frame. The average hacksaw blade is not stiff enough for accurate work, especially if you have to use considerable pressure. If you take the time to cut a strip from sheet metal, bend it lengthwise to a tight U-shape and then force it over the back of the blade, you will find that the strip stiffens the blade so that you can make a very accurate cut with it. Cutting a key way as pictured is an example of what can be done with a blade backed in this manner.

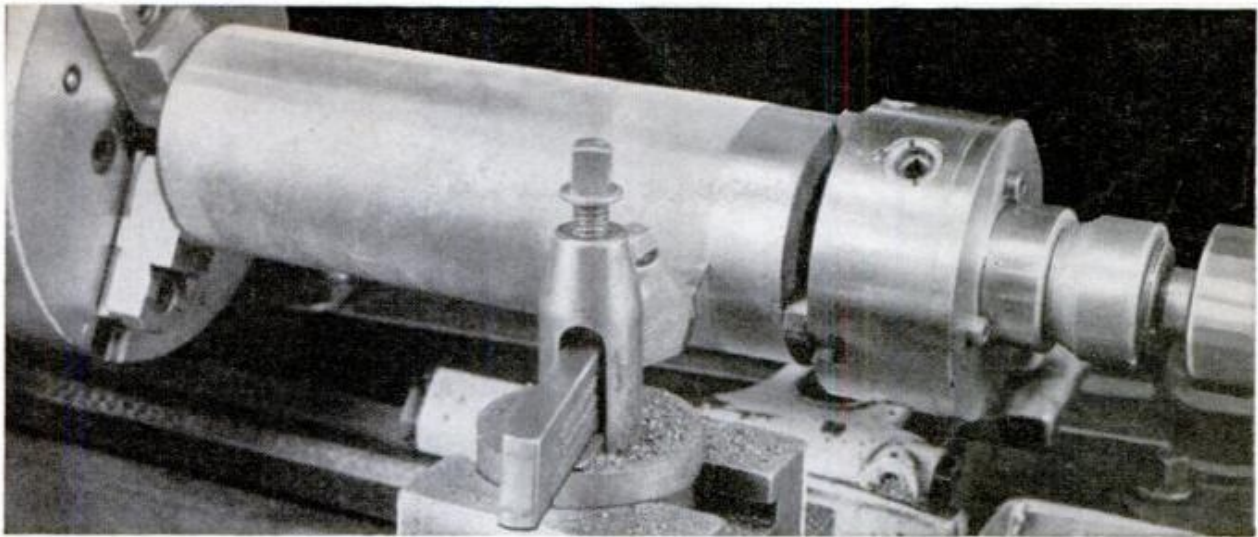

Chuck Supports Tubular Work on Tail Center

When the inside diameter of tubular work is too large to permit the outboard end of the tube to be supported on a pipe center, a small three-jaw chuck will fill in nicely. First the hub of the chuck backplate is lightly chamfered internally to provide a seat for accurate bearing on a small pipe center. Be sure to run the chamfer at

the correct angle. Then, using the internal jaws in the chuck, stand the work on end, place the chuck and tighten the jaws. If the tubing has been saw-cut to length, deburr the end before mounting the chuck. Then make the setup between centers as pictured, with the smaller chuck supporting the work at the tailstock end.

Flexible Battery Carrier Serves as Motor Lifter

Motor repair shops and home workshop owners who use one motor for driving machines at different locations will find an ordinary flexible battery carrier handy for lifting and carrying small motors with double shafts. The holes in the lugs of the battery carrier will fit over both $\frac{1}{2}$ and $\frac{5}{8}$ -in. diameter shafts easily and permit the motor to be carried safely in an upright position with one hand. Small diameter pulleys need not be removed from the motor when using the carrier.

—H. Hanscom

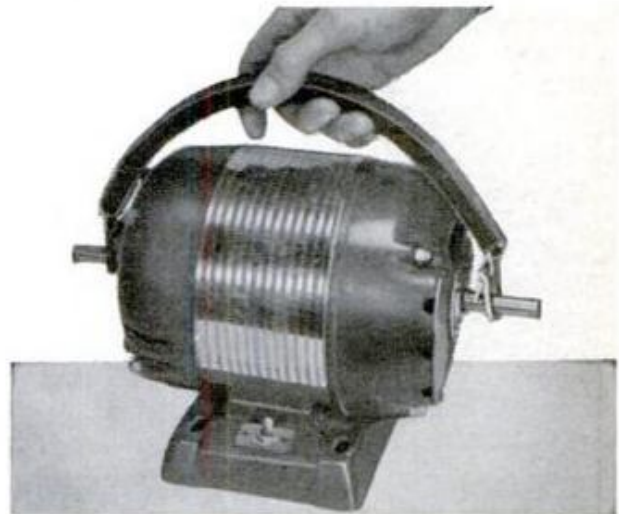

Lathe Toolpost Grinder Handles Bench Work

Due to the variable speeds and the various types and grades of grinding wheels which can be used, a lathe toolpost grinder mounted on the edge of the workbench gives you a versatile high-speed unit for handling those delicate freehand grinding jobs. To mount the grinder simply drill a hole through the bench top near the outer edge, or at the end of the bench top if you prefer, and fasten the grinder in place with a single bolt. Although it is pictured at approximately a 45-degree angle with the edge of the bench top, the grinder also can be located at right angles and shimmed higher if desired.

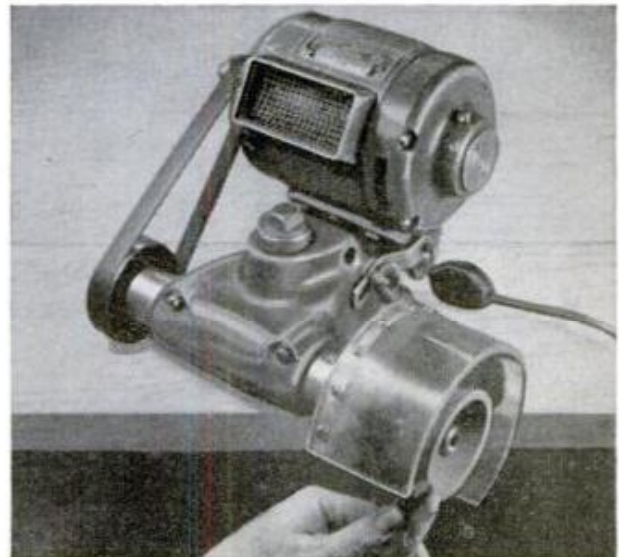

Eight Handy Tips

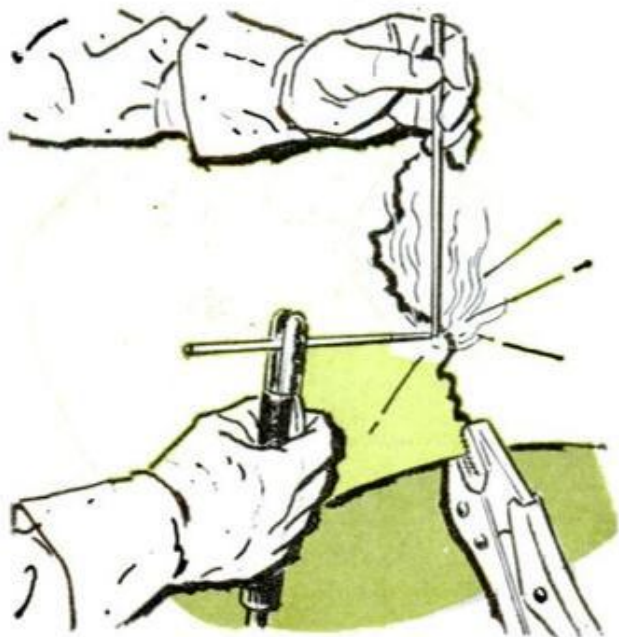

When welding light sheet metal with the arc there is a tendency for the metal to burn away rather than join. To prevent this the sheets are sometimes overlapped, but as a rule a better way is to use two welding rods. Hold one rod on the surface being welded and start the arc against the rod and about $\frac{1}{4}$ in. above the tip.

To join ends of a broken bandsaw blade, file a bevel $\frac{1}{2}$ in. long on each end of the broken blade. Then clamp the ends to a flat-steel bar with the beveled ends overlapping the exact length of the bevels. Apply a suitable flux and a small square of silver solder. Then play the torch flame along the bottom of the clamping bar.

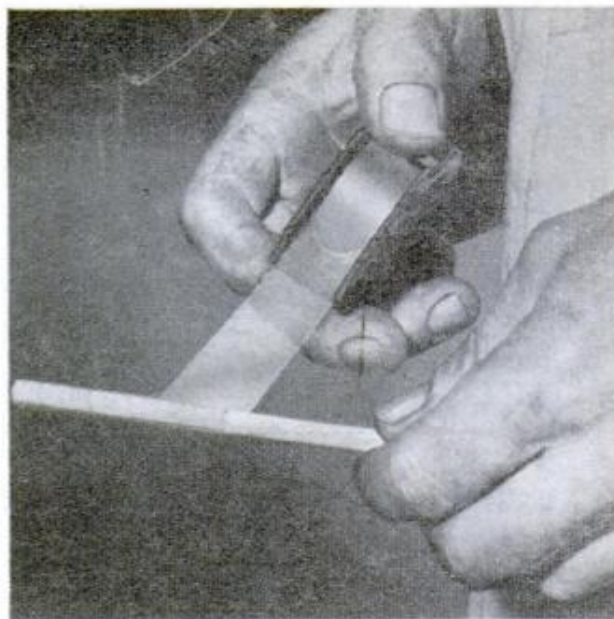
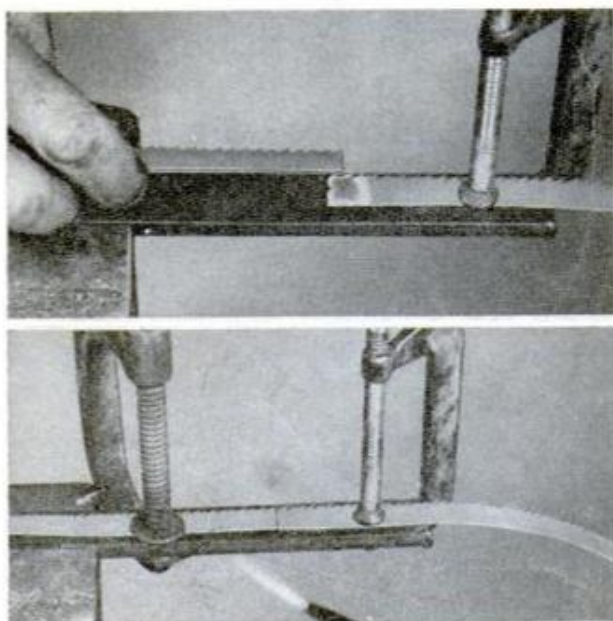

When emergency repairs are needed where there is a lot of moisture, you're less likely to have trouble making a weld under these conditions if you keep the rod dry by wrapping it with cellophane tape. If the repair is a long, wide crack, then it's usually best to lay an extra rod in the crack to serve as a filler strip.

When necessary to use the arc welder for cutting light sheet metal one fairly good method of eliminating slag and making a clean cut through the metal is to dip the rod in water before striking the arc. Repeat the dip if the cut is long. Of course, steady holding of the rod also contributes something to the smoothness of the cut.



For Welding Shops



On occasion it may be necessary to cut metal where it is difficult or impossible to work with a hacksaw. In such hard-to-get-at places the arc often can be used to solve the problem. When making any cut under difficult conditions with an arc, always keep the fire hazards in mind. Clear away flammable material before attempting cut.

Threaded end of a broken bolt is easily removed from a tapped hole simply by welding a short length of metal rod to the broken section to serve as a "wrench." Hold the length of rod on the broken end of the bolt and strike an arc about $\frac{1}{4}$ in. up from the end. Work down to the end. This will prevent slag from filling exposed threads.



DECEMBER 1960

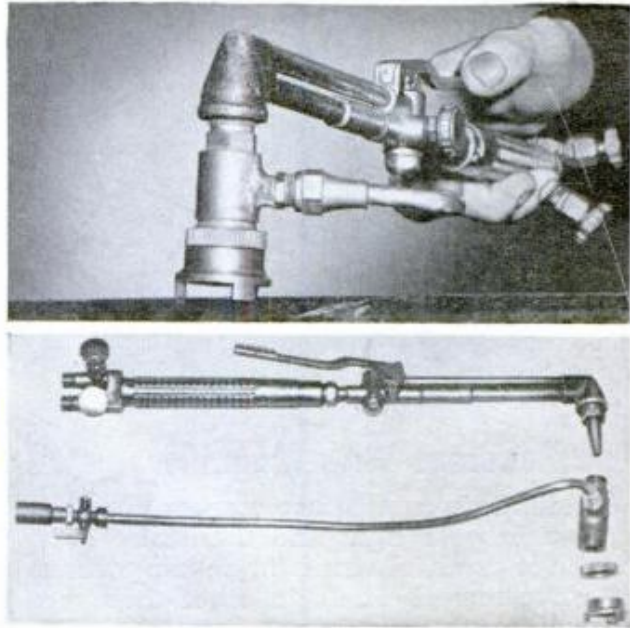

To cut under water the tip of a burning torch must be protected. The two photos above picture one way of making a suitable protective sleeve, or shroud. The sleeve is made from pipe fittings and tubing, the latter conducting compressed air to the tip. The sleeve is fitted with a depth gauge having three prongs which allow air to escape.

Before welding aluminum the work must always be preheated. One way to determine the proper temperature is to smoke the surface with raw acetylene flame until it is blackened. Then adjust the torch to welding flame and heat until soot is burned away and the metal returns to its normal color. It is then preheated for welding.



195



True Readings With Magnifier

Graduations on a micrometer are difficult to read in poor light and there also is a chance of error in taking the reading when the mike must be held in other than the normal position. One way to minimize the chance of error is to attach a small magnifier to the mike with a rubber band. A magnifier of the type having a plastic bezel is just the thing as it is of ample size and is not easily broken. The rubber band holds the magnifier securely, yet permits it to be held at the proper distance for accurate reading of the graduations.

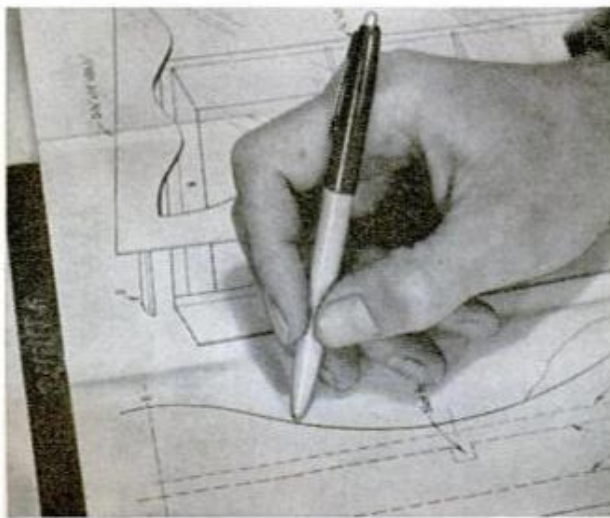

Ball-Point Pen Serves as Stylus

When all the ink in the cartridge of a ball-point pen has been used, the pen itself makes an excellent stylus for making clear tracings with carbon paper or on a mimeograph stencil. The ball point of the pen rolls smoothly on any tracing surface without wrinkling or cutting through under considerable pressure. The rolling point makes it easy to trace some drawing free-hand, without using a ruler or draftsman's curve. Should the ball stick in its socket and refuse to roll, dip in lacquer reducer.

PIPE BAR CLAMPS Get Bigger Bite

FACING THE JAWS of bar clamps with large wooden pads gives the clamps greater capacity in work thickness and also a soft, smooth jaw face that won't mar, indent, or crush the work. Large wooden pads can be made for any type of bar clamp, those with wooden bars, pipe bars and also steel-bar clamps having I-shaped, T-shaped, or rectangular steel bars. The pad detailed on the opposite page is made for the pipe-bar clamp and can be made with a round hole through which the pipe bar is passed, or it can be made with a U-shaped opening which allows the auxiliary wooden pad to be removed and replaced without having to unscrew the end cap on the pipe bar and slide off the moveable jaw in order to remove the pads.

Often, when you're all set to edge-clamp a large panel consisting of several pieces which are to be glued together, you discover that the moveable, or sliding, jaw of a pipe clamp is not in line with the fixed jaw. That's a time when you may wish you had an extra pair of hands to get things lined up before the glue begins to set. To avoid this, file a narrow flat along the length of the pipe bar, then paint a thin stripe in contrasting color on the flat and over both jaws as in the photo below.

When you fit pipe-clamp fixtures to pipe bars it's a good idea to provide three lengths of pipe as in the center photo, opposite page. Then you have three bar lengths for each clamp.

Then there's the problem of storing pipe-bar clamps. One simple way is pictured in the upper photo, opposite page. Cut a metal disk to fit inside the end cap, or stop, center-drill it, then form an eye from heavy wire. Insert the end of the wire in the hole and bend over. Then screw the whole thing back in place and you have a hanger.

—R. Hanscom

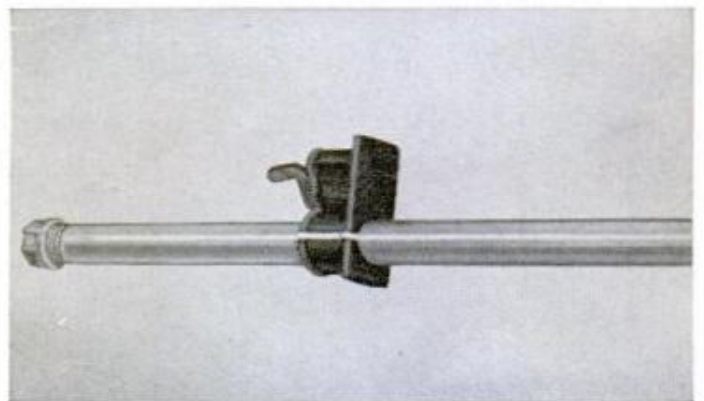

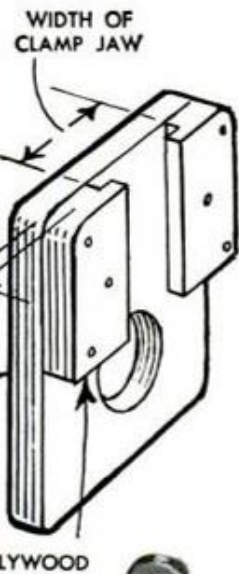
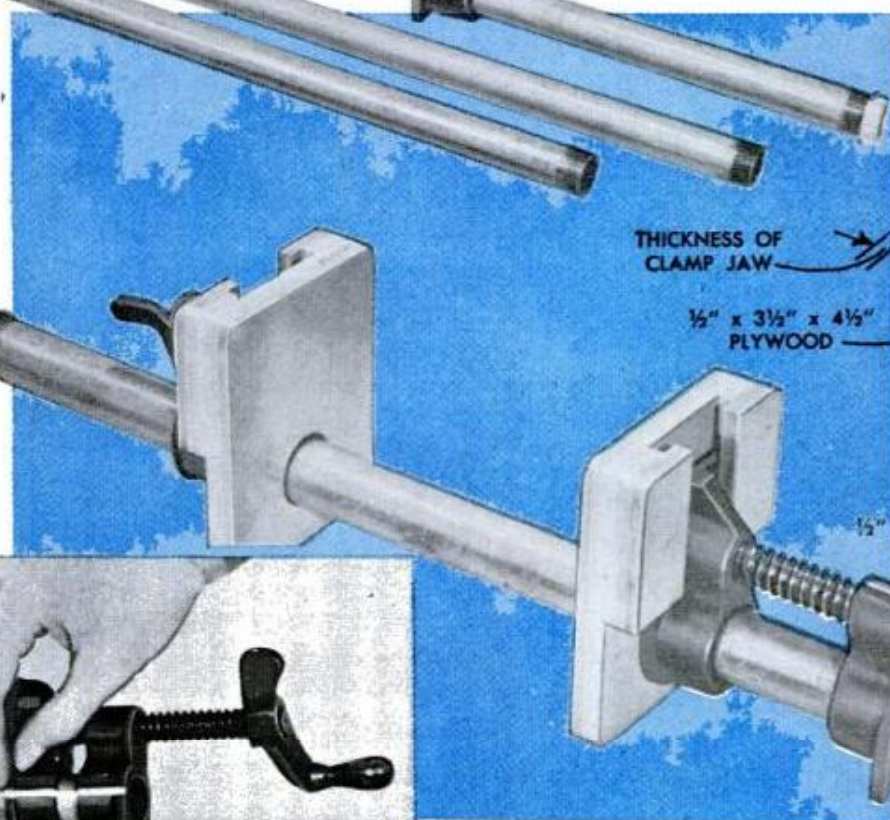
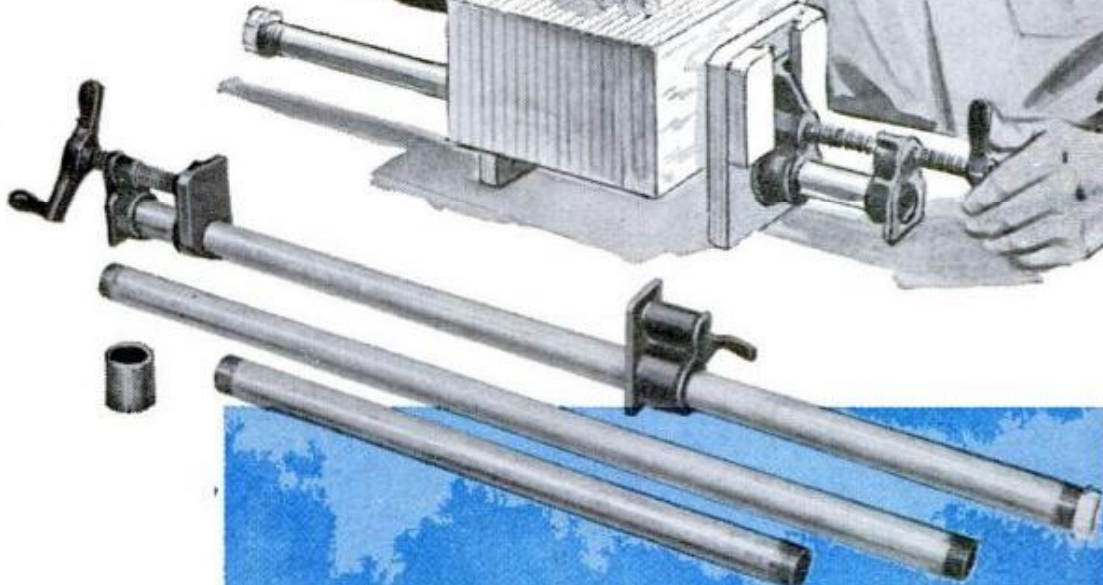
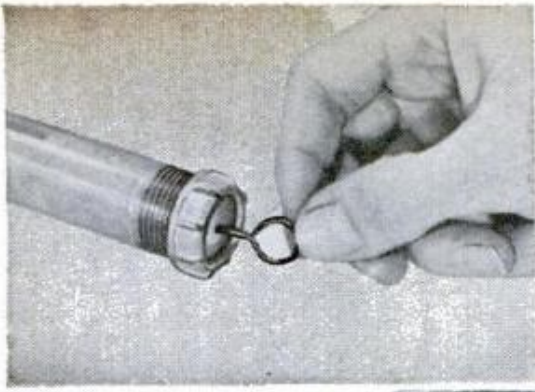

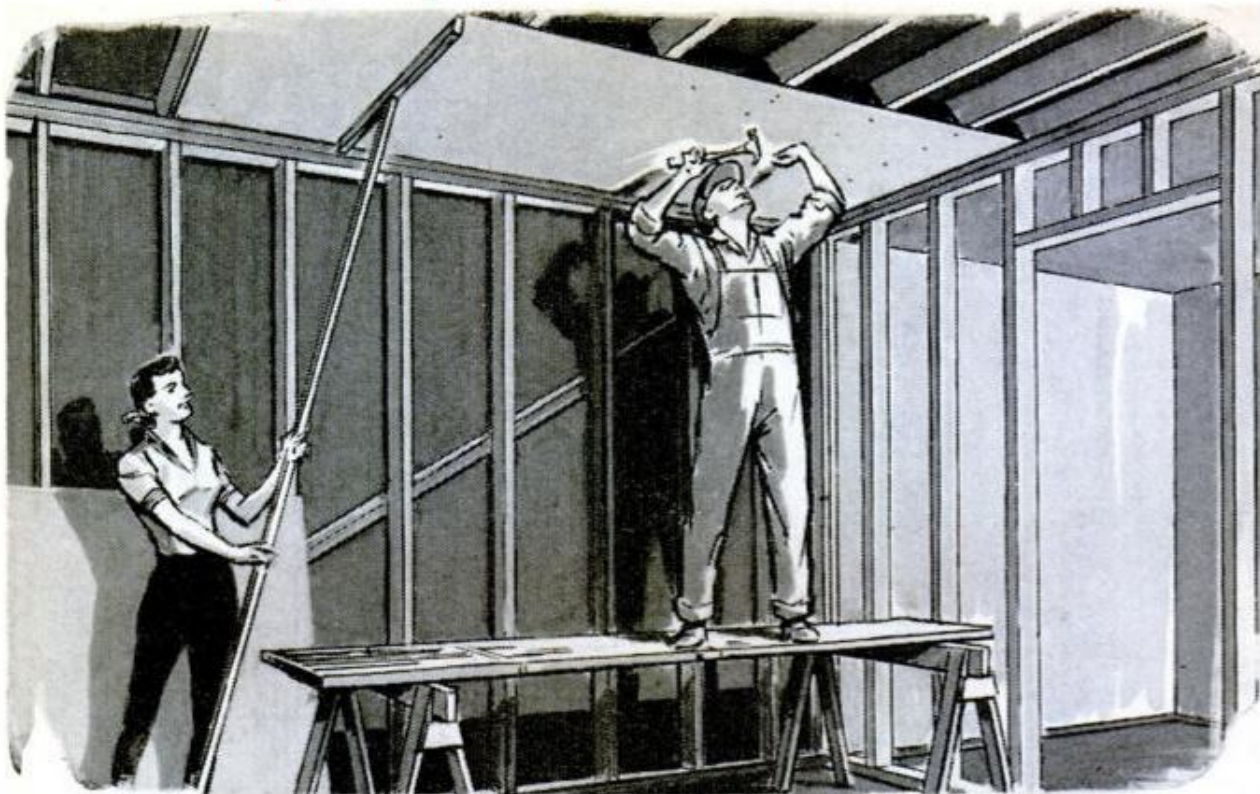

HOW TO CUT, NAIL AND

YOU CAN ARGUE the merits of dry-wall versus plaster but from the standpoint of do-it-yourself application, there's little room for question—plastering, generally speaking, is off limits for the inexperienced homeowner. It's just beyond the ability of the average do-it-yourselfer. But drywall is something most any handyman can tackle with professional results. It's all in knowing how to cut the board, nail it and tape it.

Selection of the type and thickness of the wallboard depends, of course, on the nature of the job at hand and on the thermal and insulating qualities demanded.

Thus, for installation over an existing wall or ceiling which is badly cracked, $\frac{1}{4}$ -in. board is usually preferred. The $\frac{3}{8}$ -in. and $\frac{1}{2}$ -in. boards are mainly used in new construction. A $\frac{5}{8}$ -in. thickness also is available for single-layer construction. If desired, insulating qualities also are provided by a special aluminum foil lamination on the back surface for use on the interior faces of exterior walls. This reduces heat loss in winter and heat gain in summer. Remember, the thicker the wallboard used, the stronger the wall will be, the less sound will be transmitted through it and the greater its fire resistance.

WALLBOARD PANELS are easily cut by placing them on a flat surface, scoring the face paper with a sharp knife and bending them downwards to break the core. Finish cutting by slicing through the back paper



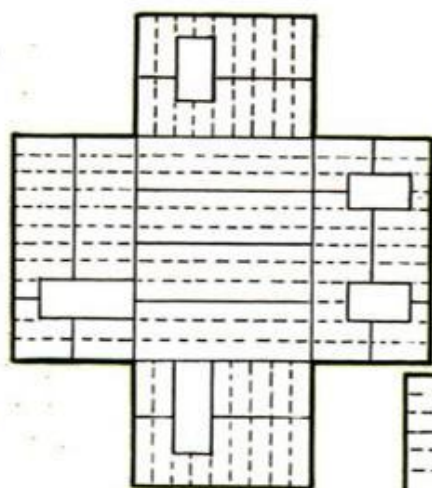

HORIZONTAL

NO GUESSWORK involved when the room is measured and the layout of the wallboard panels is carefully planned and plotted in a sketch like the one above

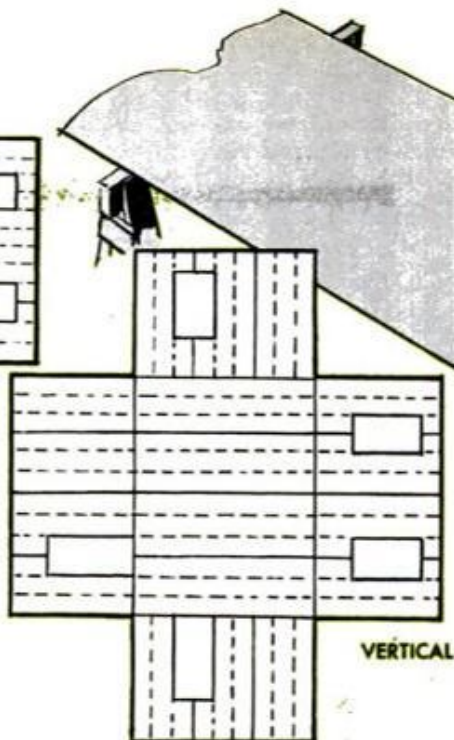

VERTICAL

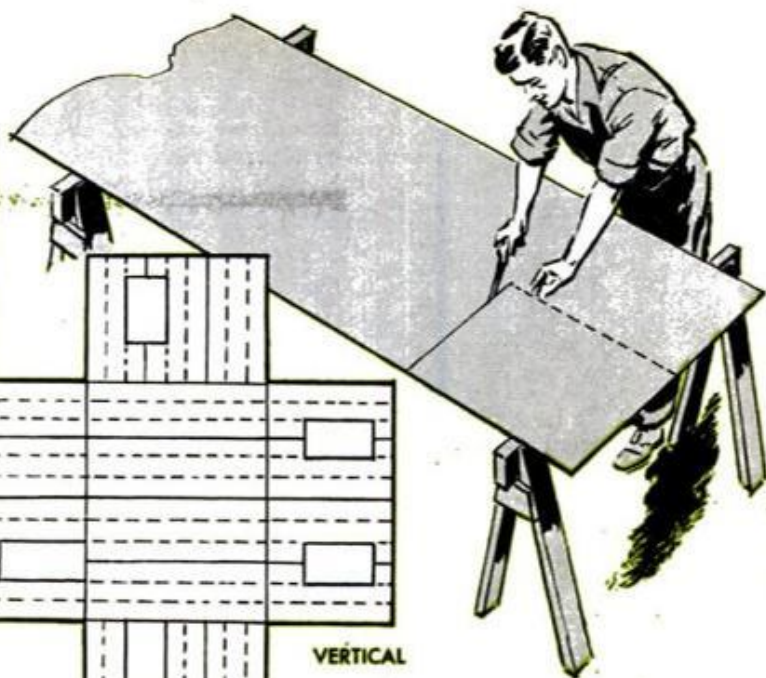

TAPE PLASTERBOARD

A little planning goes a long, long way and in putting up wallboard, this is bound to result in a much better looking job. To begin with, see that the framing is plumb and level. Existing framing particularly. Sagging or deteriorating members may cause difficulties in the application of the wallboard. Double up studs at all corners for edge or end nailing and be sure that all headers supporting fixtures, such as sinks, cabinets etc., are in place. Inside corners also should be checked for nailing supports and all bridging should be securely nailed. Now, once you have all doors and window frames in place and set for the proper thickness of the wallboard and trim to be used, the preliminaries are over and you are ready for the next step.

For the relatively inexperienced do-it-yourselfer, it is usually a good idea to work from a placement sketch like the one shown above. The walls and ceiling of the room are drawn in a flat plan scaled $\frac{1}{4}$ in. to the foot. The doors and windows are drawn in and the layout of the panels is determined. If the ceiling height is 8 ft. 3 in. or less, a horizontal application of the wallboard panels will result in fewer joints, easier handling and less cutting. For greater

heights, or if the wall is 4 ft. wide or less, vertical application is more practical. Wallboard in 12-ft. lengths often is used as it results in fewer butt-end joints that must later be concealed. In many cases, panels of this length will entirely span a wall or ceiling, eliminating butt joints entirely. However, in determining whether to use 8, 10 or 12-ft. lengths, take into consideration the area in which you are working, and, of course, whether or not you will have someone to give you a hand. The longer lengths will require at least two men, whereas one man can easily handle the 8-ft. panels alone.

The only tools needed to apply wallboard are a sharp knife, a hammer, a straight-

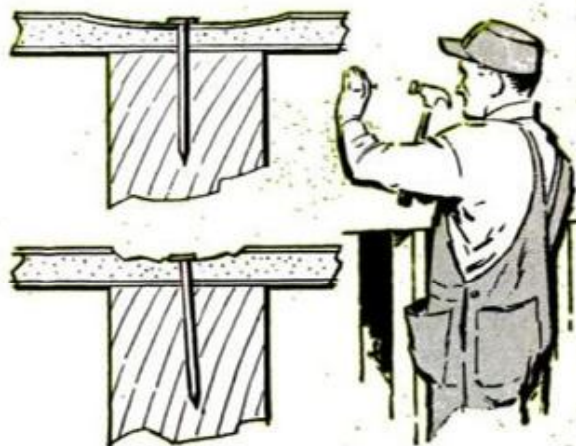

PROPER NAILING procedure is vital to final appearance and durability of the finished wall. At the right, a well-driven nail set in a dimple formed by the head of the hammer. Below, poorly driven nail leaves paper broken and torn exposing gypsum core



TAPE is cut to the length of the joint, centered and pressed into place with the knife. Though excess cement is removed, be sure to leave enough cement under the tape to insure a permanent bond

CHANNEL formed by the tapered edges of the wallboard is filled fully and evenly. On the care taken in joint finishing depends the entire appearance of finished job



AS SOON as the tape has been embedded a thin covering of cement is applied over it, completely concealing it. While this is drying, panels may be checked for looseness and for protruding nails



WHEN the base coat of cement has dried, a second and third coat are added. The edge of each coat is feathered beyond the edge of the previous and each is then sanded



SUCCEEDING COATS of topping cement are feathered two or three inches beyond edges of previous coat

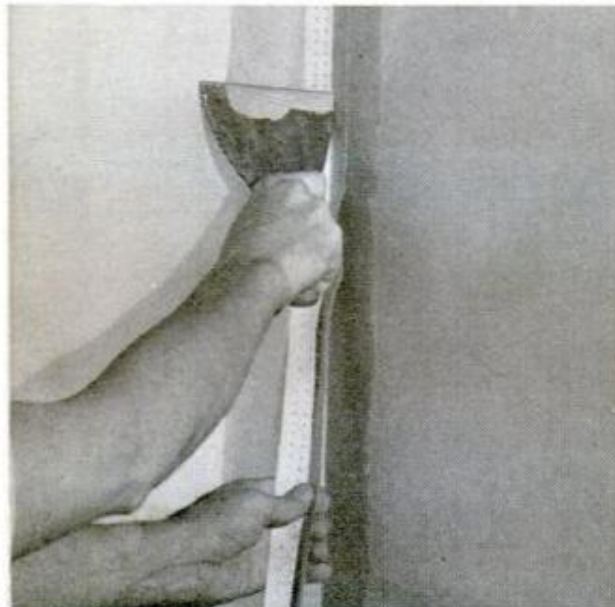

edge, a joint-finishing knife with a broad, flexible blade (like a large putty knife) and a keyhole saw.

Of course, the final appearance of the wall and the service it will give will depend on a good nailing job. This in turn depends on a proper selection of nails for the particular job. Below is a list of the proper nails to use, depending on the thickness of the wallboard selected.

$\frac{5}{8}$ -in. wallboard	6d wallboard nail (not a broadhead nail used for lath) or 1 $\frac{3}{8}$ -in. annular ring nail
$\frac{1}{2}$ -in. wallboard	5d wallboard nail or 1 $\frac{1}{4}$ -in. annular ring nail
$\frac{3}{8}$ -in. wallboard	4d wallboard nail, or 1 $\frac{1}{4}$ -in. annular ring nail

For the best results, nails should be driven straight into the wallboard and into the supporting member. The nailhead is set slightly below the surface of the board in a dimple created by the head of the hammer. **Above all, the head should not break the surface of the paper.** This is important. Before settling down to work, try driving a few practice nails through a piece of scrap and into a piece of 2 x 4. This will give you the feel of the hammer and of the resistance offered by the wallboard. Proper placement of the nails also is important. For example, never drive a nail less than $\frac{3}{8}$ in. in from the edge of the panel. On ceiling applications, spacing should be 7 in. o.c. On walls, the nails should be 8-in. apart. Always start nailing in the center of a panel

TAPE EMBEDDED into initial coat of cement must be pulled straight and even to be completely concealed



and work toward the edges, and hold the board firmly against the studs and joists with the free hand while nailing. The double-nailing system, illustrated at the right, provides an ideal means of avoiding loose panels. This system consists of driving the nails in pairs 2 in. apart with each pair 12 in. o.c. This same nail pattern may be used on ceilings as well as walls.

As a rule, it is a good idea to begin applying the ceiling first. Although two men usually work on a ceiling together, one man alone can easily install the wallboard by nailing a 1 x 2 wooden cleat to the wall just below ceiling level. This provides a support for one end of the panel while a long T-support is used to raise and hold the other end against the joists. To cut the panels to size, lay them flat on sawhorses or on a table and score the face paper with a sharp knife. Then break the gypsum core by snapping or bending downwards and cut through the back paper. (Remember, whenever possible the panels should be applied horizontally in lengths great enough to span walls and ceiling without end joints.) Once the ceiling is up, top wall panels are nailed in place and butted against the ceiling. In wall areas, butt joints should be centered above and below windows and doors and whenever a butt joint is made in the field of the wall, it must be made over a stud. Of course, where horizontal application is impossible or impractical, a vertical plan is followed.

Wallboard panels can be formed to almost any curved surface by placing a stop at one end of the curve and then gently and gradually pushing the other end of the board, forcing the center against the framing until the curve is complete. For sharp

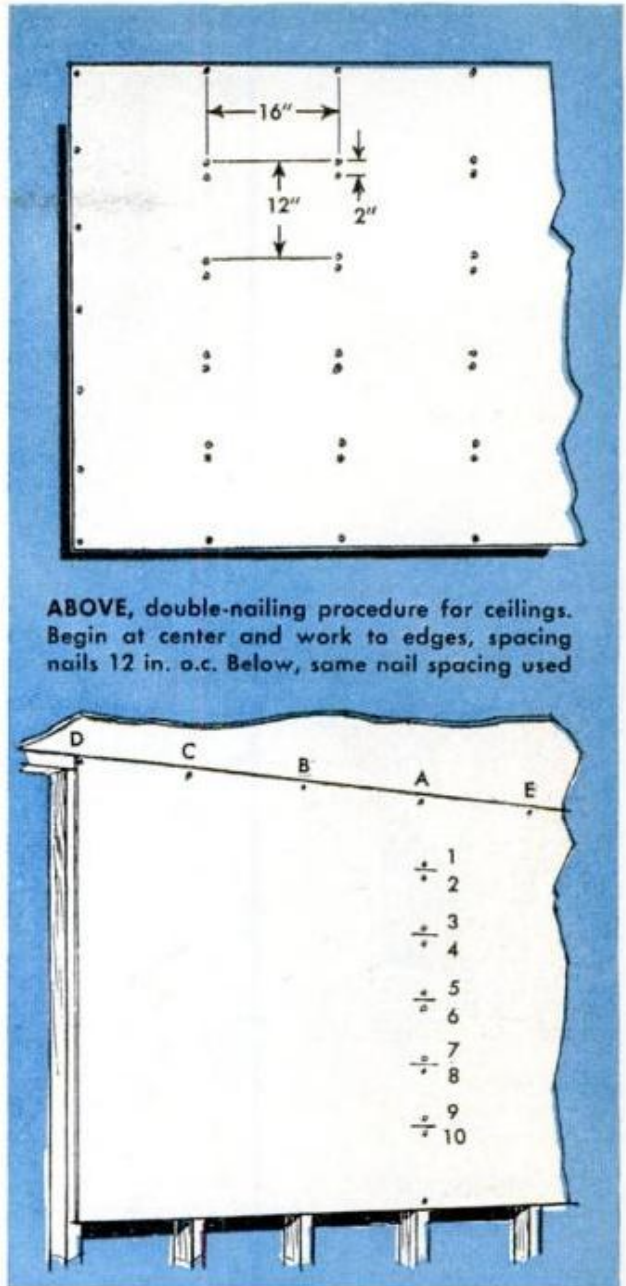

ABOVE, double-nailing procedure for ceilings. Begin at center and work to edges, spacing nails 12 in. o.c. Below, same nail spacing used

OUTSIDE CORNERS are concealed with three additional coats of cement feathered to a smooth finish

MADE ESPECIALLY for drywall construction, metal corner bead insures a strong, rigid outside corner



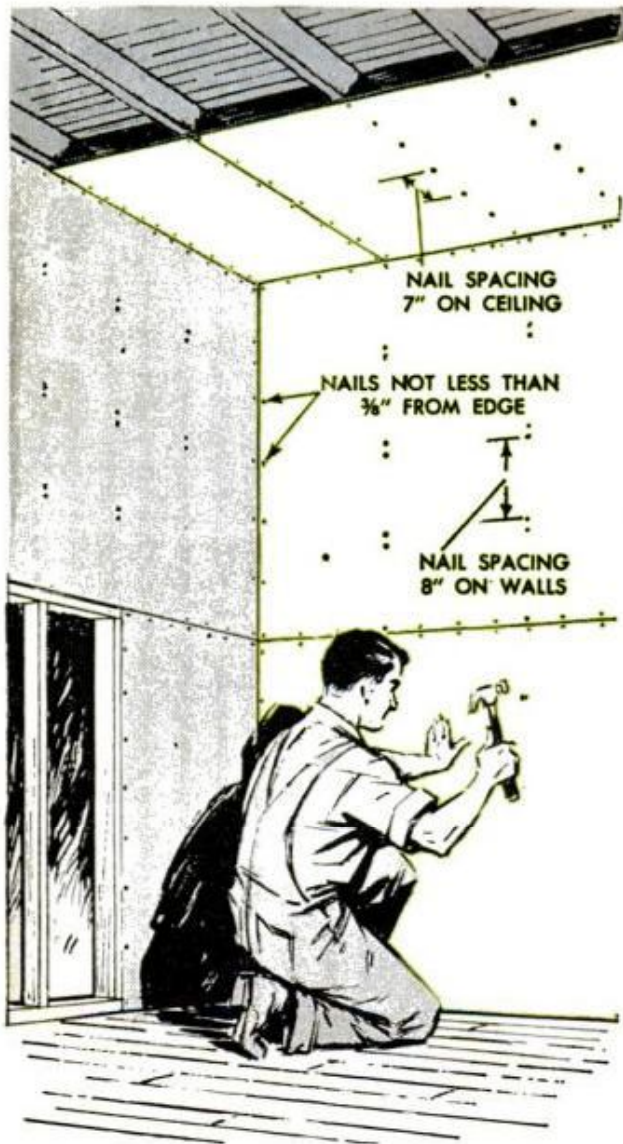

curves moisten the surface and the back of the panel thoroughly and allow the water to soak well into the gypsum core. This will allow it to be bent to a shorter radius. When dry, it will regain its original hardness. For arches, measure the total width of the arch, cut a strip of wallboard to this measure and score the back at 1-in. intervals. Break the core at the scorings and nail the panel to the framing at alternating segments. To locate the exact position of electric switches and outlets, hold the panel in place and, using a wooden block to protect the face paper, tap around the approximate location of the outlet with a hammer. This will leave a mark on the back of the panel to serve as a guide in sawing the opening.

A new method of applying wallboard uses a special mastic which is applied directly to the framing members. The advantage of this method lies in the fact that only half as many nails are required, and since the panels are bonded to the framing, the risk of loose boards is greatly reduced. It is particularly good when 1/2-in. or 5/8-in. panels are used over a fairly large area. Although it produces a superior single-layer drywall construction, the average homeowner finishing only a room or two will find it more expensive because of the added cost of the mastic, gun and pump.

As with any project, the beauty of the finished work is the prime objective, and in this case the joint finishing will either make or mar the job. In mixing the cement, pay attention to the instructions on the package pertaining to the amount of water

NAILS SHOULD NEVER be less than 3/8 in. from board edges and spaced 7 in. apart on ceilings, 8 in. on walls. Be sure to hold boards firmly against frame members during nailing to insure against looseness

LARGER OPERATIONS may adopt the method of using a special mastic. This is applied directly to the frame members with a gun not unlike a caulking gun. Below, the gun is filled and a bead of mastic applied to studs



FOR ARCHES of considerable depth, wallboard is bent by scoring the back surface and breaking the core along the kerfs. For shallower arches, as above, panels of wallboard are mounted, one on each side of the arch frame and cut to shape. Tape edges are cut at intervals to permit it to follow the curve of the arch and the segments are later cut away

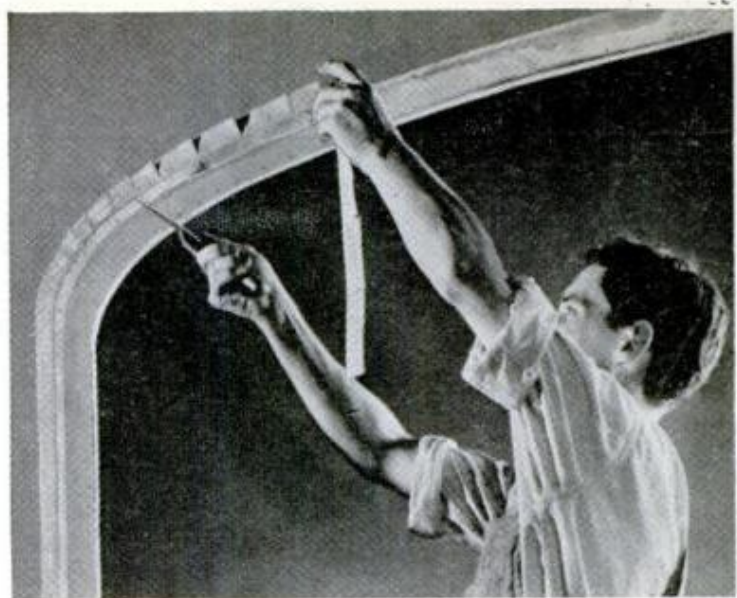

needed. When properly mixed, the cement will be somewhat dry and mealy and not as smooth as might be expected. Allow it to "set" for the length of time specified—usually about 30 minutes. It may then be stirred vigorously to break up any lumps and, if necessary, thinned with a bit more water. The best consistency is a little thinner than putty. Now inspect the walls for protruding nail heads and loose panels, rest these and begin to tape. Using a broad-bladed joint-finishing knife, butter the cement into the joints, filling them fully and evenly. Cut a piece of special joint tape to

the proper length and press it into the cement with the knife, removing the excess cement at the same time. Now cover the tape with another layer and while this is drying cover all the nail heads and fill the dimples into which the nails are set. After a period of 24 to 48 hours, a thin second coat of special topping cement may be applied to all joints and nail heads, feathering it beyond the edges of the first. Sand this second coat and apply a third, feathering ever further. A final sanding and you are ready for application of sealer and paint.

★ ★ ★

Number of Square Feet of Wallboard Required for Walls and Ceilings for 8-Foot Rooms
(no allowance made for openings)

		LENGTH IN FEET →															
		8	9	10	11	12	13	14	15	16	17	18	19	20	21	22	23
WIDTH IN FEET ↓	4	224	244	264	284	304	324	344	364	384	404	424	444	464	484	504	524
	5	248	269	290	311	332	353	374	395	416	437	458	479	500	521	542	563
	6	272	294	316	338	360	382	404	426	448	470	492	514	536	558	580	602
	7	296	319	342	365	388	411	434	457	480	503	526	549	572	595	618	641
	8	320	344	368	392	416	440	464	488	512	536	560	584	608	632	656	680
	9	344	369	394	419	444	469	494	519	544	569	594	619	644	669	694	719
	10	368	394	420	446	472	498	524	550	576	602	628	654	680	706	732	758
	11	392	419	446	473	500	527	554	581	608	635	662	689	716	743	770	797
	12	416	444	472	500	528	556	584	612	640	668	696	724	752	780	808	836
	13	440	469	498	527	556	585	614	643	672	701	730	759	788	817	846	875
	14	464	494	524	554	584	614	644	674	704	734	764	794	824	854	884	914
	15	488	519	550	581	612	643	674	705	736	767	798	829	860	891	922	953
	16	512	544	576	608	640	672	704	736	768	800	832	864	896	928	960	992
	17	536	569	602	635	668	701	734	767	800	833	866	899	932	965	998	1031
	18	560	594	628	662	696	730	764	798	832	866	900	934	968	1002	1036	1070
	19	584	619	654	689	724	759	794	829	864	899	934	969	1004	1039	1074	1109
	20	608	644	680	716	752	788	824	860	896	932	968	1004	1040	1076	1112	1148
	21	632	669	706	743	780	817	854	891	928	965	1002	1039	1076	1113	1150	1187
	22	656	694	732	770	808	846	884	922	960	998	1036	1074	1112	1150	1188	1226
	23	680	719	758	797	836	875	914	953	992	1031	1070	1109	1148	1187	1226	1265

New Kits for Christmas

By Byron G. Wels

FOR NEW AND DIFFERENT Christmas gifts that will continue to "give" for years, why not consider electronic kits for your shopping list? This year you'll find a wide range of new kits designed for everyone from Junior to Grandpa, for the lowliest beginner and the highest hi-fi addict.

Here are test results from just a few of the new kits:

The Heathkit AJ-10 FM-AM tuner went together quickly and easily. Even with the AFC switch in the off position, there was no drift, even after a full hour of playing time.

Another attractive gift from Heath is an intercom unit. The novelty in this circuit stems from its flexibility. While the use of

multiple remote stations is not unique in itself, this unit permits the remotes to institute calls to the master. This is accomplished by a relay circuit, energized by a battery in the remote. The panel switching set-up allows private conversations between remote and master or between remote stations.

Lafayette has also brought out a unique and useful transistorized telephone amplifier. The compact box contains a five-transistor amplifier, driven by an inductive pick-up coil. Both sides of a telephone conversation are amplified via a loudspeaker. The unit is adaptable to other applications. For example, it has been used in the laboratory to amplify the signal from a portable

Stereophonic music system can relax the tensions that an executive faces every day. Music must be unobtrusive, and the system must require no attention. FM tuner (on bookshelf) is pretuned to a station broadcasting soft music with no commercials. Preamplifier (under tuner) is set for low volume. Music comes through matching loudspeakers all day, does not interfere with usual office routine





Busy office gets help from the new electronic kits. As telephone conversation is carried on, both sides are picked up and amplified. Secretary can hear and record the entire conversation. Intercom unit (rear) permits up to five remote stations to be used. Remotes can institute call

tape recorder. Secretaries can transcribe with the Lafayette amplifier instead of an earphone.

Stereo equipment has frightened away many would-be audiophiles because of the high prices. Lafayette has removed this objection with the KT-126 kit which provides four watts of stereo output and costs less than \$20.00. Not intended to compete with the higher power, more expensive amplifiers, this kit is adequate for a beginner in stereo, or for converting monophonic equipment to stereo.

New transistor radio kits are available from Knight and Eico. Both feature printed circuit boards. The Knight unit is housed in a plastic and metal case, the Eico in leather. Both units were tested in the PM electronics laboratory. The Eico unit has a larger speaker, additional transistor stage and larger antenna, making it somewhat more selective and sensitive, and improv-

Transistor radios are popular for beach or pool-side. Upper kit has a plastic case, lower unit is covered with leather. Both utilize printed circuitry





Component installation uses stereo preamplifier atop FM-AM tuner. Combination rests on one of the two matched loudspeaker systems. Tuner can be purchased as a kit, semikit, or fully wired and tested



ing the audio quality. But it is also somewhat more expensive. The advantage of the Knight unit is that it can be slipped into an ordinary purse. The Eico is about the size of a purse.

Acrosound has produced a preamplifier in kit form with some novel features. The two-tone panel separates left and right control functions, and the function switch provides equalization for all popular recording characteristics. The mode switch is operated in conjunction with nine lamps. As you switch positions, the lights indicate the channels and speaker combinations in use. Enough input jacks are available on the rear apron to cover any equipment you have or intend to own. Internally, the preamplifier boasts two prewired printed circuit boards. These not only facilitate assembly, but reduce the possibility of errors.

The Acrosound preamp was

Basic stereo amplifier has prewired printed circuit board to make assembly easier



Clock radio kit can be preset to shut off radio after user falls asleep to music, start radio in morning. After 10 minutes of radio, an alarm buzzer sounds. Rear outlet can turn on electric coffee percolator

tested by using it to drive a Dynaco Stereo 70 basic amplifier. Basic amplifiers in general, are designed for out-of-sight installation. However, the chromium plated chassis and the brown perforated cover make this unit attractive enough for full-view display. The audio output transformers are conservatively rated, with the result that they operate well inside the point of possible distortion. It seems that the Dynaco engineers have underrated the unit to be sure that it performs as well as the specifications. According to our tests, it out-performs them.

Paco has produced an FM-AM tuner kit. FM tuners have been a sore spot for the manufacturers, as the critical front end is always a source of trouble. Most firms today get around this problem by wiring and sealing the front end, leaving it to be assembled into the balance of the kit which the

Low-cost stereo amplifier can be built in one weekend, using basic electronic tools

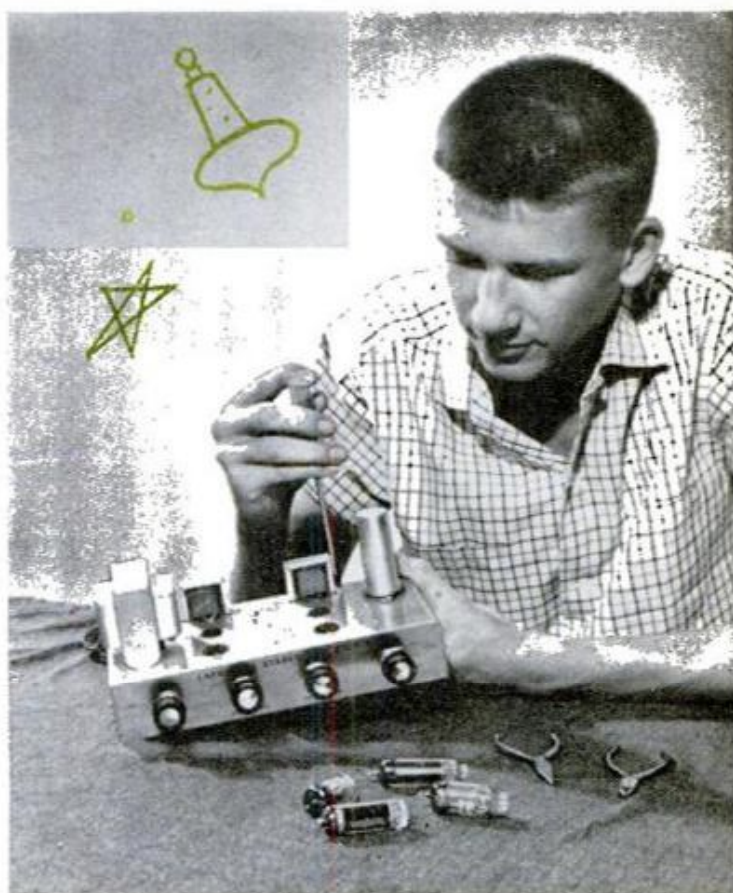



Complete kit of parts for this stereophonic preamplifier includes a matched pair of pre-wired printed circuit boards. Finished unit works with basic amplifier, provides all control and selector functions needed



Swiss craftsmanship and precision are available in this turntable kit. All parts demanding precision workmanship are prefabricated. Builder assembles these into high quality addition to hi-fi installation



Educational kit is designed to teach electronic fundamentals. In building, use of electronic tools is learned. Instruction book outlines series of experiments designed to prove many of the basic electronic laws

(Continued to page 220)

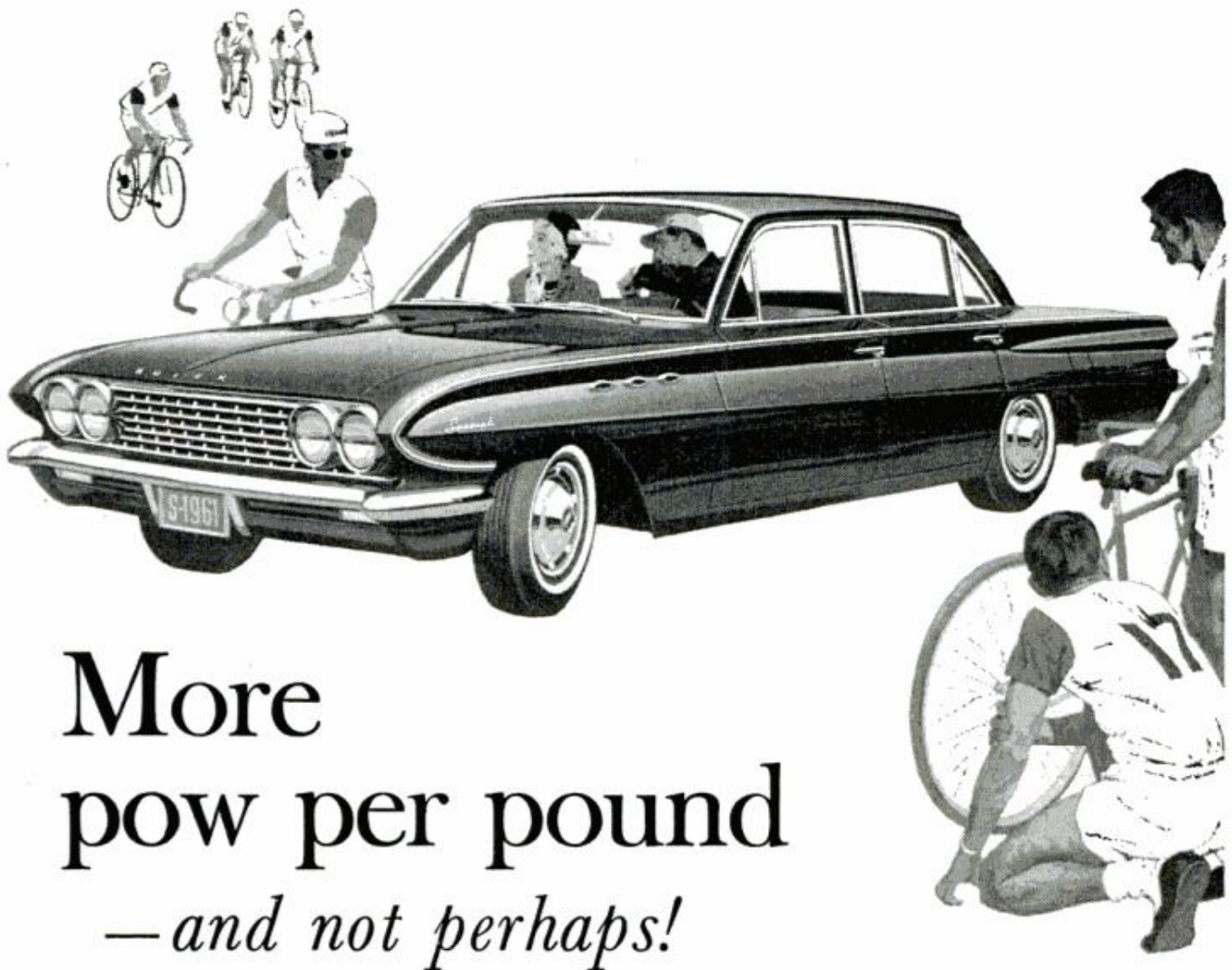

More pow per pound — and not perhaps!

WHY IS THE BIGGEST NEWS in '61's new-size cars Buick's snappy Special? Styling for one. It's got the full-size Buick's Clean Look of action — and Buick room and ride. This on a 112" wheelbase—that nips in and out of tight spots like a scooter.

But the really big news in this beauty is its *oomph!* The Special has *twice* the pow per pound of most compacts . . . actually more than many full-size sixes and V-8's! The miracle explained?

BUICK'S REVOLUTIONARY ALUMINUM V-8. This hot 155 HP Fireball V-8 weighs just 318 pounds for a .487 horsepower to weight ratio — *highest in the industry!* Yet for gas savings, it's right up there with the

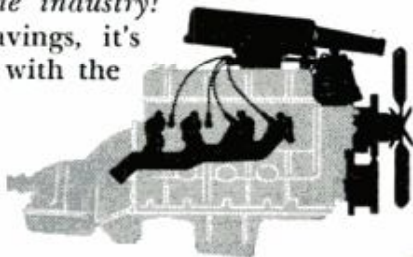

compacts. Sports Cars Illustrated magazine has already predicted it will be "the most widely copied engine in the next 10 years."

BUT THERE'S EVEN MORE to the Special's zip. It's Buick's new Aluminum Dual-Path Turbine Drive* (weight: just 100 pounds)! Made just for a new-size car, it's the liveliest, simplest, most compact automatic made. Its "dual path" principle is like having two transmissions continuously working as a team—one a turbine drive for smoothness, the other a direct mechanical connection for more go and gas savings.

IN A NUTSHELL, the Special gives you small car pleasure without small car penalty. Why not take a Special spin today and prove it for yourself? Buick Motor Division—General Motors Corporation. **Optional at extra cost.*

BUICK SPECIAL

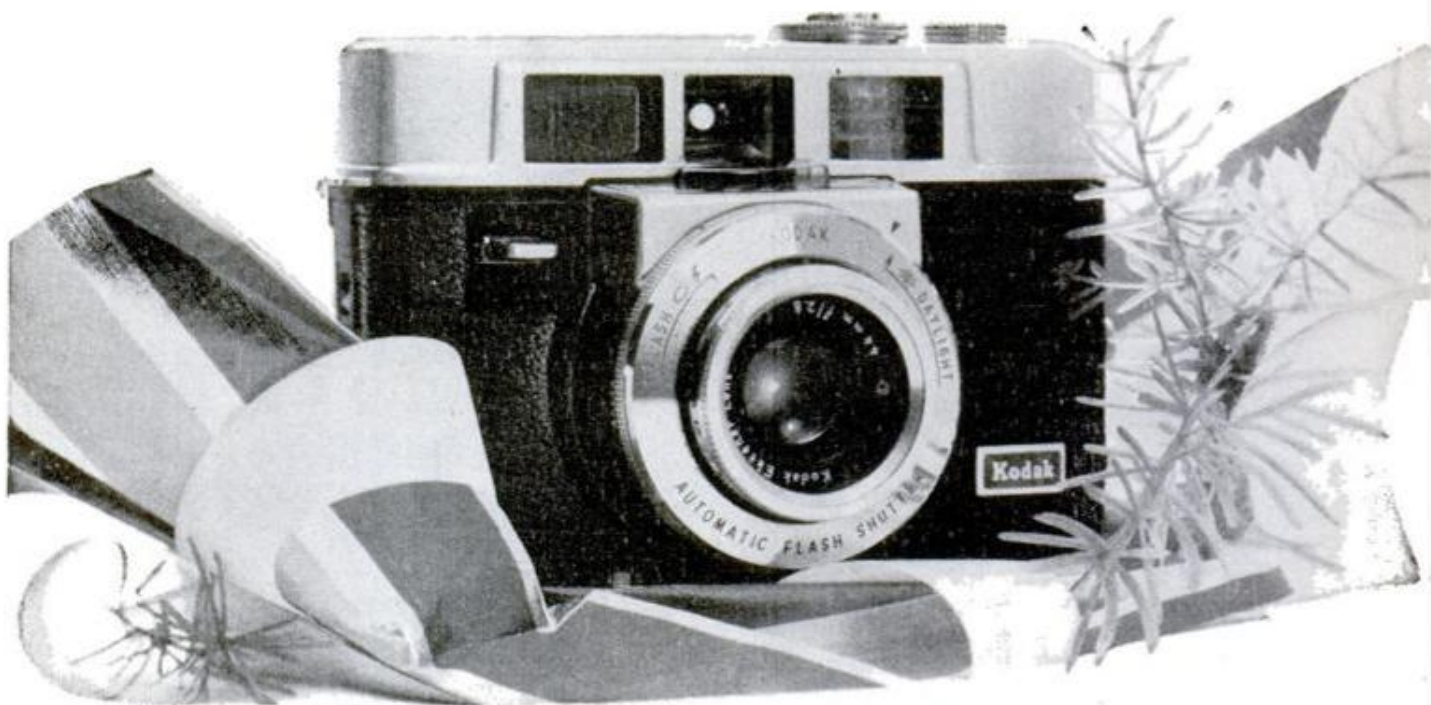

Winds the film for you! New Kodak Motormatic 35 Camera advances film automatically—sets exposure automatically, too . . . less than \$110. Kodak Automatic 35 Camera . . . less than \$90.

Kodak gifts say *Open me first!* because

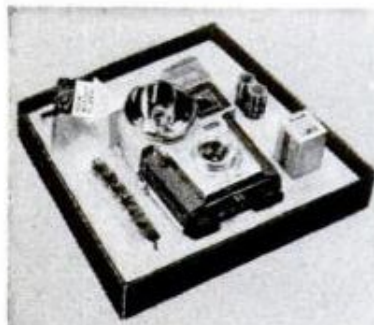

◀ ***Smallest Brownie flash camera!*** Brownie Starmite Camera with built-in flash gets sparkling pictures *any time*. Complete outfit . . . less than \$12.

▶ ***35mm precision—new ease!*** Kodak Retina Automatic III Camera gives you fully automatic exposure control and precision-coupled rangefinder . . . less than \$130.

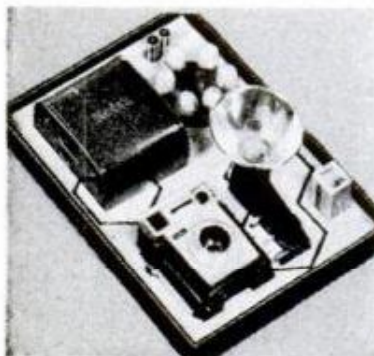

◀ ***Sets its own lens!*** Brownie Starmatic Camera has built-in electric eye for automatic exposure settings. Complete outfit . . . less than \$40.

▶ ***For big, bright slide shows.*** Handsome new Kodak 500 Projector, Model B. Self-cased, only 11 pounds . . . from less than \$68. Kodak Cavalcade Projector, Model 520, with zoom lens . . . less than \$137.

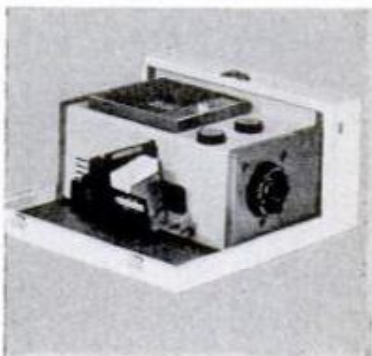

See your dealer for exact retail prices



Zoom your movies with one finger! New 8mm Kodak Zoom 8 Reflex Camera lets you zoom up close with push-button ease. You view the zoom effect through the lens. Automatic exposure . . . less than \$190.

you can picture all the fun of Christmas right from the very first moment!



◀ *Three 8mm cameras in one.* Brownie Movie Camera, Turret $f/1.9$, takes wide-angle, regular, and telephoto shots . . . less than \$60.



◀ *8mm movies—automatically!* Brownie Automatic Movie Camera, $f/2.3$, has built-in electric eye that automatically sets lens . . . less than \$78

▶ *Add quality sound to your 8mm movies!* New Kodak Sound 8 Projector lets you add voices, music, sound effects . . . less than \$350.



▶ *Fully automatic 8mm projector.* Kodak Cine Showtime Projector, A20 . . . less than \$125. Variable-speed model with Presstape Movie Splicer . . . less than \$150.

Prices subject to change without notice.

EASTMAN KODAK COMPANY, Rochester 4, N. Y.

See Kodak's "Ed Sullivan Show" and "Adventures of Ozzie and Harriet"

Kodak
TRADEMARK

THE EASIEST WAY IN THE WORLD TO DRIVE AND REMOVE SCREWS

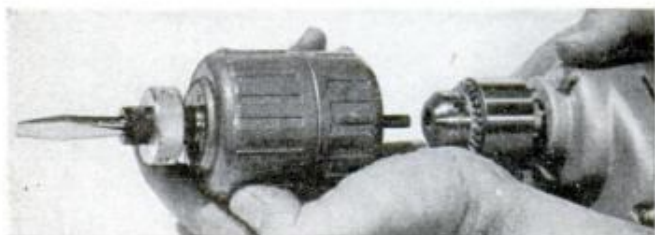

1. After drilling pilot holes simply attach a Versamatic to electric drill. Fits any make.

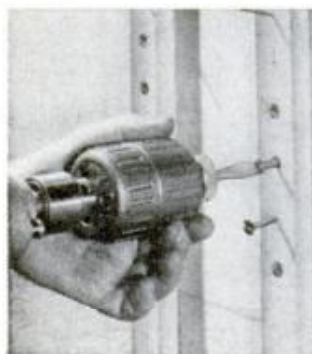

2. Place screw in hole; drive it easily with slight forward pressure . . . hold housing in fingertips.

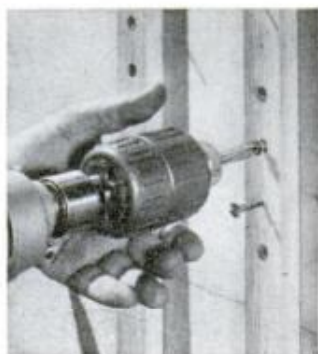

3. Your fingers act as a clutch . . . starting, stopping action instantly. Simple and safe . . . no blisters.

Versamatic puts your power drill into low gear . . .

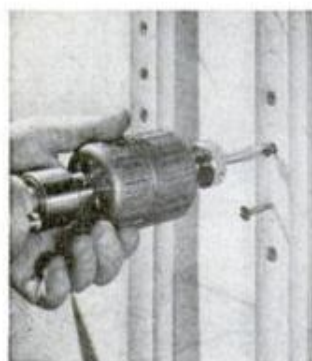

4. Versamatic runs in reverse for removing screws. You won't believe how easy it is until you try it.

by means of 7 to 1 speed reduction. Gives your drill 7 times more power.

Supreme Versamatic

MADE BY THE MAKERS OF SUPREME BRAND CHUCKS

SUPREME PRODUCTS CORPORATION

2222 S. CALUMET, CHICAGO

Sold by leading tool dealers...\$14.95 list

PRECISION  PRODUCTS

Clinic for Homemakers

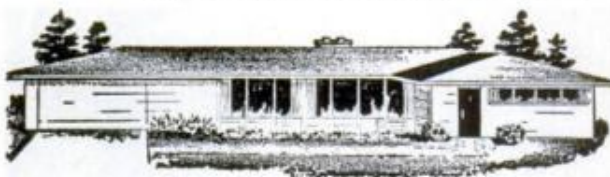

As a service to our readers in solving the hundreds of problems pertaining to a home—inside or out—the editors of *Popular Mechanics* invite you to present your problems to The Clinic Editor for help and advice. Address your questions to The Clinic Editor, *Popular Mechanics Magazine*, 200 East Ontario Street, Chicago 11, Ill.

Oil-Finishing Walnut

Q—I have a solid walnut dining table and four chairs, from which I have removed the original finish. I would like to refinish all pieces in oil. But to my questions as to how to go about this I get conflicting answers. Some say never to attempt an oil finish; others direct me to apply linseed oil, wipe off the excess and I have an oil finish. Is this correct?—O.P., Wis.



A—No. You have oil on the wood, of course, but not an oil finish. We always hesitate to recommend an oil finish on old work as so much time, labor and other factors are involved. Yet many crafters seem to feel that an oil finish is the ultimate in a quality finish on wood. In some respects, it is the quality finish, on a surface that is as nearly perfect as you can make it. That means sanding, more sanding and still more sanding until all the minute imperfections are eliminated. Then you're ready to think about oil finishing. Early cabinetmakers who used oil as a finishing material—not all of them did use oil—employed several methods of application, also varying combinations of materials. Some used pure boiled linseed oil alone. Others used a mixture of pure linseed oil and turpentine. Still others mixed pure linseed oil with an equal amount of copal

(Continued to page 214)



Again, Choice of the Newest!

Spark plugs are selected for new-car installation only after exhaustive tests covering hundreds of thousands of hours. Tests range from heat conductivity of the insulator design to fouling and pre-ignition. Because AC Fire-Rings were best in these laboratory and road tests, they were selected for original equipment on the 1961 Buick Special, Oldsmobile F-85, Pontiac Tempest and Chevrolet Corvair. That's why ACs are on more new cars than any other brand. Best for replacement, too.

They must be the best!

AC Fire-Ring
Spark Plugs



AC SPARK PLUG 
THE ELECTRONICS DIVISION
OF GENERAL MOTORS

Now—Use the Finishing Secret of
World-Famous Furniture Manufacturers

WATCO DANISH OIL FINISH

NEVER BEFORE AVAILABLE TO YOU



PROVED BY
PROFESSIONALS
—YET SO EASY
FOR YOU TO
APPLY ON
FURNITURE,
PANELING,
CABINETS
AND DOORS

For the first time available to you is the original time-proved WATCO Danish Oil Finish used by international names in luxury furniture. WATCO is used to produce the same beautiful, natural wood finish you see in the finest furniture and paneling—yet, it's so easy to use...in one simple application you can seal, prime and finish new wood.

Secret is in the polymerizing oils in WATCO that give you the toughest and richest oil finish of any in existence. Use it clear to bring out gorgeous color and natural grain, or use with stains. Save wasted hours spent sealing and sanding...save money, because you need only WATCO!

Get envied, superior results...the remarkable natural wood finish that resists stains and mars.

American Walnut Manufacturers Association recommends WATCO... may be used on all woods... specifically walnut, oak, birch, cherry, teak, mahogany, knotty pine and cedar.



**1 Easy
Application**

**PRIMES!
SEALS!
FINISHES!**

Sold in 16 oz. aerosols, pints,
quarts, gallons and 5 gallon tins

**WATCO®
DANISH
OIL
FINISH**

Now available through
leading retail lumber
dealers, paint and
hardware dealers and
unfinished furniture
dealers.

or write
WATCO-DENNIS CORP.

1756 22nd Street, Santa Monica, California; U. S. Manufacturers of Watco Products for Wood and Masonry.

varnish, thinned the mixture with pure turpentine and added a small amount of drier. This latter combination of materials produces perhaps the finest type of oil finish, but is somewhat more difficult to apply. Use of oil alone requires long drying periods between applications, as much as two or three weeks, depending on conditions. But the oil, copal, turpentine and drier mixture is much faster and, properly applied, "builds" more rapidly and fills the grain of the wood in a manner similar to French polishing. In applying this latter type of mixture use a saturated pad and lay on the material with a circular motion. Some finishers prefer to use a pad of fine steel wool rather than fabric. After covering the surface once over with all the oil it will take, wipe off the excess lightly and allow to dry. Then repeat the process several times until the surface shows the quality and luster desired. No filler or stain is used in this finishing process, even on open-grain woods such as walnut. There are, of course, specially prepared oil-finishing materials now available which you may find even more satisfactory than compounding the ingredients separately.

Cold Chimney

Q—My two-flue chimney is on the outside north wall and in extremely cold weather fumes from the oil-burning furnace seem to come back into the basement. My serviceman says he believes this is due to what he called a "cold" chimney and he has recommended a change in the burner cycle in order to maintain a somewhat higher flue temperature, or, in other words, release more heat to the chimney. He may be right, but it seems to me that this will be a rather expensive remedy. Do you know of any other?—T.W., Pa.



A—Your serviceman is undoubtedly right when he refers to a cold chimney as a cause of the trouble and the change he has recommended would be our recommendation, assuming, of course, that the flue is not partially clogged with soot, a bird's nest, or other partial obstruction, and that there are no other contributing factors peculiar to the installation. One thing is certain: You should make every effort to remedy the condition immediately, as there

(Continued to page 218)



To everyone from 8 to 80

THREE TIMES MORE SHOOTING FUN!

To Gramps it means fun plinking around his home—to Dad, target shooting in the basement—to young Bill, his first lessons in safe gun handling. To the whole family—including Mother and Sis—a Crosman CO₂ gas-powered pellgun means unlimited shooting pleasure.

Controlled range and power lets you shoot more often, in more places, all year 'round. These safer, quieter, cleaner guns cost less than a penny a shot to use—so accurate that shooting champs use them to keep fit between matches.

Choose from today's most complete gas-powered line: Crosman Pellgun Rifles and Pistols, and Hahn western-style Super BB Rifles and Revolvers... a right gun for everyone. Priced from \$14.95.



WRITE for free literature. Crosman Arms Co., Inc., Dept. PM-0712, Fairport, New York.

See them at your Crosman Select Dealer Sales Center!



Crosman CO₂ GAS **HAHN**
PELLGUNS BB GUNS



WORLD'S LARGEST MANUFACTURERS OF CO₂ GAS-POWERED RIFLES AND PISTOLS

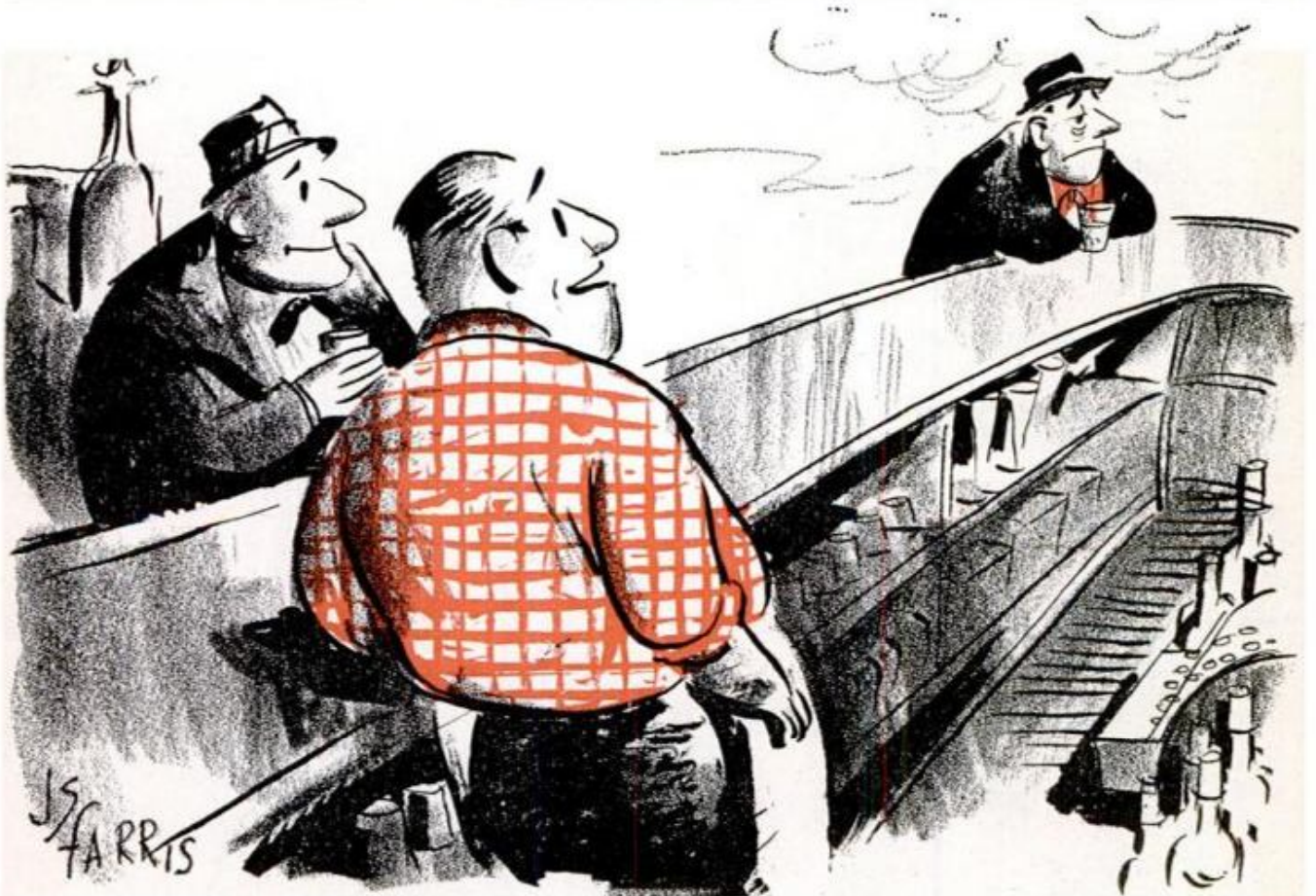

"Poor guy—he offered his brain to science and it was rejected."

SHOCKPROOF!



AN
INDUSTRY
FIRST

NEW MILLERS FALLS NYLON SAFE-T-DRILL

an important SAFETY-FIRST in power tools

NEW NYLON HOUSING. Provides extra insulation against electric shock. Extra strength, too. Made of a specially rugged Nylon—Du Pont Zytel 31%.



INSULATED SPINDLE. Unique polycarbonate insert forms hub of spindle gear—fully insulates spindle, chuck, and thus all attachments used with drill.

INSULATED TRIGGER SWITCH and Locking Button round out the exterior sheath of insulation. Operator is completely protected against electric shock.



SPECIALLY DESIGNED MOTOR. Nylon insulated wire and Mylar® armature slot insulation give extra measure of internal protection.



SURGE TESTED. Powerful surges of high voltage current reveal an "X-Ray" of each drill's electrical condition on an oscilloscope. Internal insulation must be flawless to pass this rugged safety test.



DELTRIN® NOSEPIECE. This remarkable material has exceptional toughness and scuff-resistance. Withstands wear under heaviest use—assures precision fit and alignment of attachments for years.

QUICK-CHANGE ATTACHMENTS. A full line—many with new Millers Falls, on-and-off-in-seconds feature—convert the Safe-T-Drill to a power workshop of 14 basic tools and many accessories.

2.7 AMP. MOTOR. Plenty of power to drive power-hungry attachments like 5½" portable circular saw, finish sander, hedge trimmer, sabre saw.

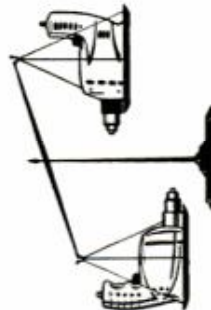

LIGHTWEIGHT. Nylon housing cuts weight drastically—produces drill 20% lighter than comparable aluminum models.



COMFORTABLE GRIP. Even after sitting in a sizzling summer sun—or lying in sub-zero winter snow—the new Millers Falls Safe-T-Drill won't burn or freeze your hand. It's always pleasant to touch and hold.

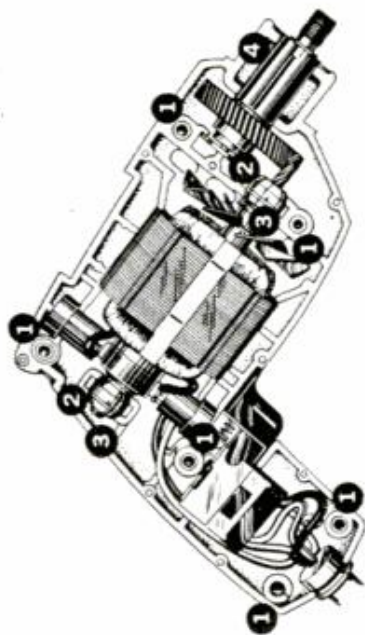

1. Self-locking metal inserts provide never-comes-loose grip for screws . . . assure tight drill housing.
2. Spring-loaded, self-aligning armature bearings keep motor shaft true and free running—even under stress of heavy load.
3. Oversize oil reservoirs insure ample lubrication.
4. Porous iron spindle bearing withstands heavy abuse.
5. Induction hardened gears maintain high efficiency of teeth.



If you like the latest and best in fine tools, you'll like the No. 1144 Safe-T-Drill. Ask your dealer to let you see and try it soon. Write also for free descriptive folder: Millers Falls Co., Dept. PM-35, Greenfield, Mass.

A JOINT DEVELOPMENT OF MILLERS FALLS COMPANY AND E. I. DU PONT DE NEMOURS & COMPANY (INC.)

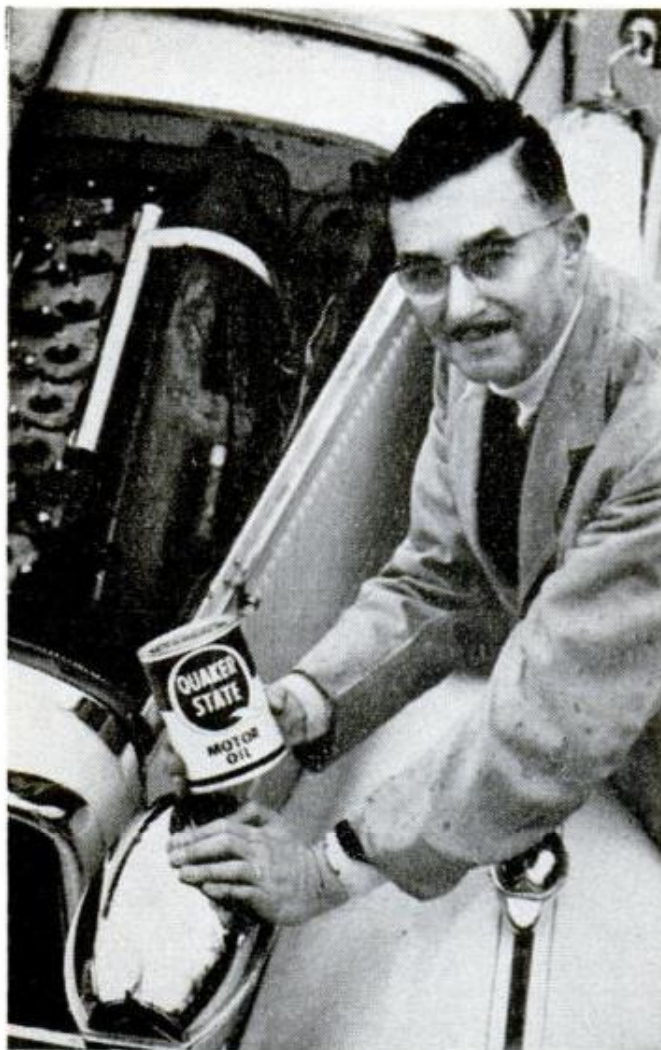

J. LeRoy Forsythe, of Millhelm, Pa., services the engine of his rare front-wheel-drive 1929 Ruxton.

"Quaker State protects the engine of my classic Ruxton, and my new car, too!" one of the earliest front-wheel-drive cars, this handsome Ruxton Series 1003 has a special body by Budd. After 30 years and 75,000 miles, its straight 8 engine is in superb condition, thanks to expert care. Car experts everywhere depend on Quaker State for long-lasting lubrication and complete protection for cars old and new. Super-refined from 100% pure Pennsylvania Grade Crude Oil, it is the finest motor oil your money can buy.

Available most everywhere . . . always ask for Quaker State by name.

For the name of your nearest dealer, call Western Union by number and ask for Operator 25.



QUAKER STATE OIL REFINING CORP., OIL CITY, PA.
Member Pennsylvania Grade Crude Oil Association

(Continued from page 214)

is always the possibility of a dangerously high concentration of carbon monoxide gas. Even though this possibility may be remote, it should never be minimized or overlooked. We would check closely the condition of the flue. If the chimney is an older type and is unlined, the inside of the flues may have been plastered. If this is so, then there is the possibility that a piece of plaster may have loosened, broken away and partially clogged the flue. If a large tree overhangs the top of the chimney, this could be a partial cause of the trouble. Also, your basement may be air-locked, that is, closed so tightly that the natural draft in the chimney is affected. We would investigate all these possible causes and again we would caution you to take immediate steps to correct the defect.

Cleaning Old Brass

Q—How does one clean brass and prevent it from tarnishing? I have several old pieces and one late piece which seem to have tarnished badly. Also my front door lock is of brass and although I have attempted to clean it several times, it still discolors rapidly and appears dull and dingy.—H.S., Del.



A—You do not describe the pieces other than the door lock, or say whether they are large or small. This makes it rather difficult for us to outline suitable procedures. Brass that is merely tarnished and is not badly corroded or otherwise discolored is quite easily cleaned and polished either by hand methods or by means of a power-driven buffer. First it usually is best to wash the pieces in a mild, soapy solution and when dry polish with a suitable prepared polish—there are a number of good polishing compounds available—or polish with a power-driven cloth buffing wheel mounted in a wood lathe on an adapter, or mounted on a bench polishing head. The wheel should be charged with a fine polishing rouge, which is an abrasive in cake form. If you polish by hand methods with a polishing compound it is important to clean the work thoroughly after polishing to remove all the polishing compound. Then wipe all surfaces again with a clean, dry cloth and apply a coat of clear metal lacquer according to instructions on the can.

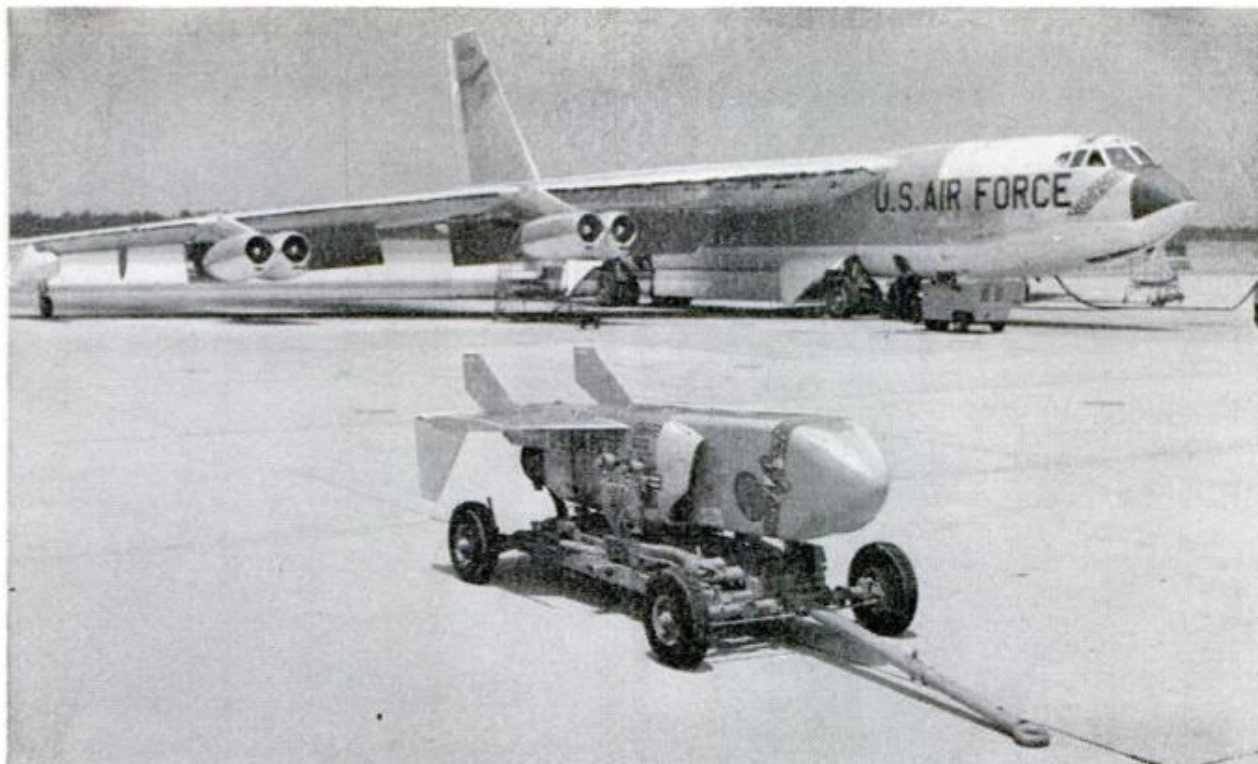

McDonnell Aircraft Corp. photo

Decoy Missile Fools Enemy Air Defenses

Carried aloft in the bomb bay of a B-52 and dropped when approaching an enemy air-defense zone, the Quail diversionary missile will confuse enemy defenses. Powered by a jet engine, it flies a similar flight

path and at the same speed as the bomber, thus presenting an extra blip on the enemy radar screen. When used in large numbers, these decoys puzzle the enemy and force him to waste ammunition.



The EXTRA WEIGHT in this Atlas 10" Saw Means GREATER ACCURACY in the Work You Do

Because it has more beef—because it's heavier and huskier throughout—the Atlas gives you far greater accuracy in every job you do. Compare these Atlas features with those of any other 10" saw:

- Massive grey-iron cradle, saw arm, and trunnions. Atlas has the heaviest, most rigid mechanism of any 10" saw. Saw alone weighs 165 lbs!
- Precision-ground, solid steel arbor— $\frac{3}{4}$ " diameter at the big, lubricated-for-life ball bearings.
- Double locking lift-off fence—cast aluminum for lasting accuracy.
- Big cast aluminum mitre gauge—keyed to table for greater cut-off capacity.
- 6" diameter cast iron handwheels.
- Dual V-belt drive—for full power transmission.
- Big table capacity—20" x 27 $\frac{1}{2}$ ", or 59 $\frac{1}{2}$ " x 27 $\frac{1}{2}$ " with two extensions.
- Removable motor mount for easy portability.

Why settle for less? You can own an Atlas for only \$139.75! Write for details today.



354

Write for new catalog

ATLAS PRESS CO.

12-24 N. Pitcher St.

KALAMAZOO, MICHIGAN

REPLACE OR REPAIR YOUR HOLLEY CARBURETOR AT NEW LOW COST!

**BRAND NEW
HOLLEY PEP
CARBURETORS
AT PRICES
COMPETITIVE
WITH REBUILTS**



You can give your car new power and pep at low cost with a *genuine* Holley PEP Carburetor. These inexpensive PEP Carburetors are brand-new, factory built to the exacting *original equipment* specifications. They are simple to install. . . complete, easy-to-follow instructions are furnished. PEP Carburetors are available for all Ford-built cars and the most popular American Motors models.

**GENUINE
PEP KITS FOR
NEW-CAR
PERFORMANCE
IN OLDER
CARBURETORS**



These low-cost PEP Kits contain everything you need to restore new *power, economy and performance* to a mileage-worn carburetor. PEP Kits are available for all Holley and Ford-designed carburetors. Each includes genuine Holley parts: needle and seat assemblies, gasket kits, power valves and accelerating pump diaphragms or pump plungers, along with complete instructions. See your Holley Distributor or Dealer today.

★ ★ ★

When you make your own carburetor or ignition repairs and parts are required, be sure to use genuine Holley parts. Your Authorized Holley Distributor or Dealer, listed in the Yellow Pages, has a complete stock of Holley carburetor minor overhaul kits, tune-up kits, ignition parts, and brand-new replacement carburetors priced competitively with rebuilds. All are engineered and built to exacting *original equipment* standards. It will pay you to buy or specify Holley Parts.

HOLLEY
Carburetor Co.

THE
COMPLETE LINE
OF CARBURETION
and
IGNITION EQUIPMENT

C-2

11955 E. Nine Mile Rd. • Warren, Michigan
ORIGINAL EQUIPMENT MANUFACTURERS FOR OVER 55 YEARS

New Kits for Christmas

(Continued from page 208)



Three new kits teach youngsters rudimentary electronic experiments. Other new kits allow children to build intercoms, wireless broadcasters, various radios. All safely built and used as no soldering is required. Completed kits operate on batteries. Cartoons make instruction manuals easier to follow

builder wires. Paco packages this kit in three ways. The experienced builder who has the necessary equipment and know-how to build and align FM front ends can build the entire unit. A less skilled kit builder buys the kit with the critical work completed, aligned and tested. A novice, afraid of the wiring, can buy the unit completely wired and tested by the factory.

The Knight clock radio has a preconstructed clock-work assembly. The radio section (five-tube superhet) is built on printed circuit boards.

Thorens has a turntable kit that offers Swiss precision to the do-it-yourselfer. Thorens provides the construction parts, but the components are Swiss-made.

Electro-Voice has produced a small bookshelf speaker system. Called the Esquire, the unit boasts an eight and a twelve-inch speaker and is finished in natural woods.

If someone on your shopping list has no knowledge of electronics, Heath solves the problem with a new educational kit. Building the kit teaches the use of fundamental tools and techniques. The finished unit then is used to illustrate the principles of electronics, such as Ohm's Law, power problems and many others.

The new kits for Christmas are designed to be more than symbolic presents. They provide hours of relaxation during construction, and when completed continue to give fine service for many years. ★★★



...there's a world
of **FUN**

in every
ERECTOR
set! [®]



The finest toy ever invented — and world-famous for over 50 years! Erector sets contain all-steel parts to make, literally, up to **thousands** of different models, many with exciting electric motor action. Builds latest missiles and jet aircraft, plus bridges, hoists, merry-go-rounds, ferris wheels and giant robots that walk step-by-step. Makes models 5 feet high! Teaches youngsters engineering principles and methods. Fun and instructive! See your Gilbert dealer today!



Send **TODAY** for **FREE** Gilbert Science Set Catalog
Fully illustrated — over 50 different sets

The Finest Name
in Career-Building Science Toys
THE A. C. GILBERT COMPANY
Erector Square, New Haven, Connecticut

The A. C. Gilbert Company
Dept. PM, New Haven 6, Conn.

Please send new 1960-61 Gilbert
Science Set catalog.

NAME _____

STREET _____

CITY _____ ZONE _____ STATE _____

CRESCENT OPEN END AND BOX WRENCHES



Crescent Open End and Box Wrenches are drop-forged from special analysis alloy steel, precision machined to insure accurate opening sizes, and handsomely finished in chromium plate. These fine wrenches provide world famous Crescent quality at popular prices. Open End Wrenches are available in 13 sizes from $1/4''-5/16''$ to $1-1/8''-1-1/4''$; Combination Wrenches in 14 sizes from $3/8''$ to $1-1/4''$; and Double Offset Box Wrenches in 9 sizes from $3/8''-7/16''$ to $7/8''-1-1/16''$.

Sold singly or in sets by Hardware Dealers everywhere.



Crescent is our trade-mark, registered in the United States and abroad, for wrenches and other tools. Sold by leading distributors and retailers everywhere and made only by
CRESCENT TOOL COMPANY, JAMESTOWN, N. Y.

The Metric System—PRO

(Continued from page 138)

metric system in the United States, with gradual conversion to its use in all household, business, scientific, industrial, sporting, engineering, and even artistic affairs, would result in better economy, efficiency, and mutual understanding in all our activities, either with ourselves or with people in other parts of the world. This is a scientific era, and the metric system is at the very basis of scientific advance because of its convenience, simplicity, and uniformity.

Slowly and surely the metric system will become accepted throughout the world, and may become a major factor in promoting mutual understanding and effective communication between people everywhere. The English-speaking peoples are causing themselves unnecessary inconvenience, lowered efficiency, and reduced economy in clinging to an ancient system of measurement derived in old Egypt from human body references, which regardless of what standards are agreed upon, must be standardized if there is to be honest trade or if scientific advance is to occur. This standardization is essentially a matter of voluntary agreement. If it is made on the basis of the metric system, it will have the advantages of being in accord with world usage, scientific usage, and of being simple, easy to use, systematic, and precise. Let's get at it, in our schools, and in our businesses, and gradually it will be in use, helpfully for all.

★ ★ ★

Weather Warning System Charts Lightning Static

Weathermen, detecting gleams in the sky, are learning where tornadoes come from. They are operating, experimentally, an automatic warning system that pinpoints the discharge of lightning as far as 2000 miles away and relays the information to headquarters in Kansas City, Mo. Six detector stations in neighboring states are equipped with radio receivers that pick up static generated by lightning. Simultaneously, the stations record the time and compass direction and relay the information within one-tenth of a second to the headquarters operated by the Air Weather Service. An electronic device displays the information on a map of North America where an observer can follow increasing electrical activity that may indicate developing thunderstorms or tornadoes. When more stations are operating, it is thought the warning system will be valuable in tracking electrical disturbances over oceans.



Jet fighter-bomber, capable of 1500 miles per hour and pinpoint bombing from sea level to 75,000 feet, would take off straight up. Once airborne, special valves would divert engine thrust backward for propulsion

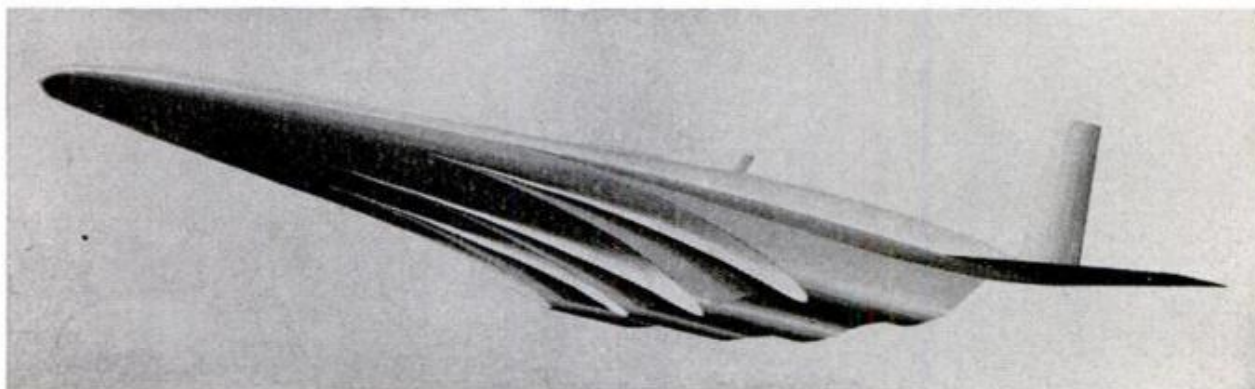

Called "ultimate" design, dream bomber would orbit earth at 200,000 feet and 17,000 miles per hour. Powered by eight engines, four of them burning nitrogen, it would carry fighter plane, piggy-back fashion

Designer Describes "New Generation" of Planes

Alexander Kartveli, aircraft designer for Republic Aviation Corporation (he designed the World War II P-47 Thunderbolt, among others), claims the potential of aircraft design has not been fully exploited.

Unpredictability of tomorrow's air needs demands that the search for tomorrow's aircraft continue, he says. He offers four weird-looking types, based on Republic studies, as members of "new generation."



Weirdest design is almost all engine. Nuclear-ramjet aircraft, with 8500-mile range, could be based in U.S., strike anywhere



Flying wedge, powered by two ramjet and two turbojet engines, would be used for stratospheric reconnaissance at 120,000 feet

STANLEY

PSST . . . Any gal
can take a hint. "Hide"
this ad in an
obvious place—get
the Stanley Christmas
Special you want!

(Special offer ends Dec. 31, 1960.)



**Heavy-duty sabre saw—only \$46.95
PLUS 7 assorted blades worth \$4.90—FREE!**

Fastest selling heavy-duty sabre saw on
the market! Cuts scrolls, curves, wood,
metal. Special blades cut flush up to a
wall and to $\frac{5}{8}$ of an inch along a wall.



MODEL H75



MODEL H131

\$5.00 off on 3-amp 1/4-inch drill!

Christmas Special: only \$19.95

Regularly priced at \$24.95, here's the most power-
ful $\frac{1}{4}$ " drill for the price on the market. Features
rugged, balanced construction, non-slip pistol grip,
3-jawed geared chuck, 3-wire cord.

Electric tools built for the professional.

Christmas Specials



MODEL H37

NEW! Finishing sander... only \$34.95 PLUS—2 packs of sanding sheets... FREE! Sands and fine-finishes table tops, cabinets, bookcases and many other kinds of furniture. Ideal for small work areas.

Heavy-duty builders saw—now \$54.95 PLUS—\$2.65 combination rip/crosscut blade... FREE! This 6½" saw lets you tackle any cutting job... a breezeway, porch, playroom, fence! Features rear controls; exclusive "free-start" blade guard that never jams.



MODEL H268

NEW! Bench grinder... only \$46.95 special introductory price! Reg. \$49.95. You save \$3.00 and get two grinding wheels and two special tool rests, too! ¼ hp, general purpose grinder. Perfect for sharpening tools, skates, removing rust—a "must" in your workshop!

Stanley Electric Tools, Div. of The Stanley Works, New Britain, Conn.

Prices slightly higher in Canada. Subject to change without notice. Canadian Plant: Hamilton, Ont.



MODEL H634

priced for everyone

STANLEY

®

The Engine That Was Born Again

(Continued from page 148)

from Seal Rock, because ships couldn't get close enough to put down a gangplank or use a crane. Many washouts of the road and severe damage to the wharf on several occasions forced discontinuance of this operation in 1914, when the little locomotive had her last fire put out until her recent rescue from ruin by rust.

A shed had once sheltered the engine, but it had rotted away. Floods in 1942 and 1943 had piled rock and mud around the relic, leaving it buried so deep that it was first thought there was nothing there but boiler and stack. Pick and shovel work disclosed that she was complete, however, and sitting on tracks!

Fifteen different pick and shovel expeditions were required to uncover the little locomotive entirely. Each trip in and out required a crossing of the river, and at first a rented boat was used. Later, Henry built an eight-foot flat-bottomed boat that made a very efficient ferry for men and equipment.

June 9, six months after the job began, Henry brought his flatbed truck to the site, fording the Mattole. That day, using the access road they had built, he and his crew hauled out the saddle tank and any other parts they could remove from the engine.

Ten days later the engine was hauled out and, as it weighed six tons, this was no laughing matter. With no lifting equipment available, a sloping pit was dug in front of the locomotive, deep enough to accommodate the truck. Then the flat-bed was backed into position, and the locomotive was winched slowly onto the truck. To do this, Henry and Gus, with a crew of helpers, built a windlass, using the principles of a post puller, and multiplied their strength with three sets of blocks.

The truck was flooded out in the river, as was a helping tractor, and they only got out when another truck was added to the combination.

They weren't through at the site even then, for what good is a train without tracks? More back-straining pick and shovel work uncovered some of the rails that were under three feet of dirt, but an even tougher job was encountered in picking up the rails that went "around the horn" along the river and ocean. These rails were the "light" variety, weighing 25 lb. to the yard, and a standard 30-foot long, which is a clumsy bundle to handle any way you look at it. Most of this section of rail—the longest section of the road

—was within a few feet of water, so a raft was built on a group of eight empty oil drums. An outboard motor and hand-poles powered the craft, which was kept as close to the shore as possible. As rails were dislodged on shore, they were shifted to the raft, which was tricky, for in the rough water the raft was as frisky as a cake of soap in a washing machine.

Later, when everything had been trucked to his ranch at McKinleyville just north of Arcata, Henry made a careful examination of his engine and found that it needed much more than just a face-lifting. It was rough on the outside, but the insides had, so to speak, gone up the flue.

The owners of Bay Tank and Boiler Works in Eureka offered their facilities to Henry with the proviso that he do all the work, and he gratefully accepted. For the next 13 months he cut, welded, cleaned and fitted until he could do no more, and the locomotive was removed once again to the ranch.

Meanwhile, Henry had enrolled in a night class in woodworking so he would be better equipped to build a new engine cab. It was well that he did, for he was suddenly given a caboos by a sympathetic lumber company. This caboos, about 60 years old, had originally been a passenger coach, but somewhere along the line a cupola had been mounted on top and the inside fitted for caboos duty. Henry and Gus have already started to reconvert this car into a coach again.

Sunday, May 22 of this year, Henry pulled the throttle on his little locomotive and moved it out of its shed. This was the first time it had moved under its own power since 1914. It only had a 300-foot run because that's all the rail that had been salvaged in usable condition.

Train fanciers for hundreds of miles around come to see old No. 1 in her new finery, and find it hard to believe that a few years ago an alder tree grew in her cab and the boiler was a home for pack rats.

Henry and Gus are now on the alert for more rail and spare parts. Especially rail, for it pains them to think of the engine all fired up and no place to go. So if you have a few old lengths of light rail lying around in the attic, get in touch with Henry. His ambition now is to run his slim-gauge pike all the way around the pasture. ★ ★ ★

☛ Solar energy is helping to dry corn in experiments conducted by the U.S. Department of Agriculture; sun-heated air circulated through a silo, dries the grain faster and at less expense, compared to unheated-air systems.

16-page
gluing
guide

FREE



16 illustrated pages give hints and tips on how to glue what to what—and the right glue to use for every job indoors and out. Send a stamped, self-addressed envelope for your free copy. The Borden Company, Dept. PM-120, 350 Madison Ave., New York 17, New York.

NO MUSS... NO FUSS!
KRYLON SPRAY
PAINT

DRY IN MINUTES!
IF YOU PRIZE IT... KRYLON-IZE IT!

SERVICE
FOR YOUR B&D
TOOLS



Check the Yellow Pages under "Tools-Electric" for the location of the nearest Black & Decker factory service branch or authorized service station.

Free tool inspection when requested • Genuine B&D parts used • Factory-trained technicians • Standard B&D Guarantee at completion of recommended repairs • Fast service, reasonable cost, always.

Or write for address of nearest of the more than 50 branches and service stations to: THE BLACK & DECKER MFG. CO., Dept. 8012-S, Towson 4, Md.



Black & Decker



Quality Tool Service

TURNPIKES MURDER "SISSY" ENGINE BEARINGS

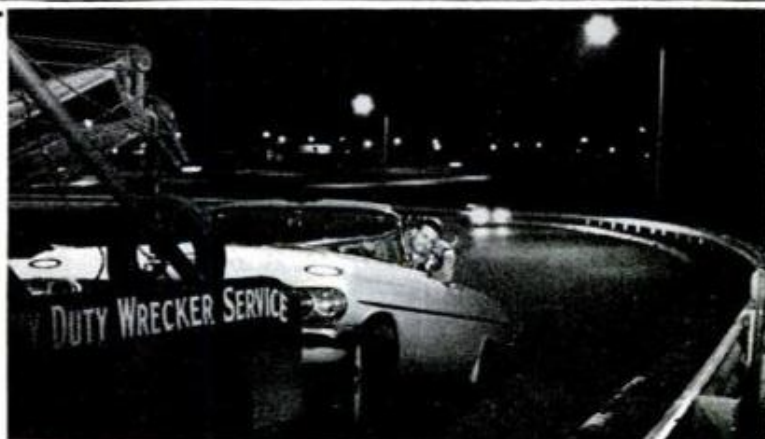

Long, hard turnpike driving proves there is a big difference in engine bearings. "Sissy" brands burn out, but Michigan Bearings stay on the job. They're "Turnpike Tough." All materials are specially chosen to assure maximum fatigue strength, high thermal conductivity, corrosion and oxidation resistance, superior embeddability and surface action. Michigan Engine Bearings are machined to tolerances as close as .000125 plus or minus—fit perfectly at every point.

Michigan Bearings are made to rigid standards of perfection by Detroit Aluminum and Brass, for over 35 years a principal supplier of original equipment bearings for leading cars, trucks, buses, marine, aircraft and industrial engines, farm and off-the-road equipment. Insist on "Turnpike Tough" Michigan Bearings... the bearings preferred by men who know the difference.



made by

Michigan
ENGINE BEARINGS
Detroit Aluminum and Brass Corporation, Detroit 11, Michigan

BUILD THE BEST ELECTRONIC EQUIPMENT



it's fun to build
years-ahead money-saving

knight-kits®

A PRODUCT OF ALLIED RADIO

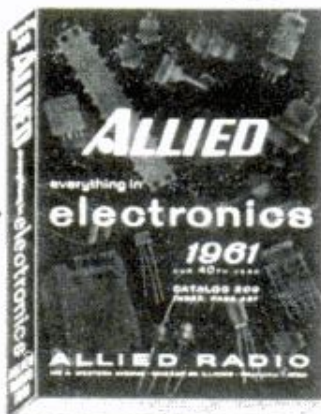

featured in the

ALLIED

Big 444-Page 1961

ELECTRONICS CATALOG

free

build-your-own..
it's easy..it's fun

BIG SAVINGS



KITS FOR ANY NEED

Hi-Fi
Hobby
Instrument
Amateur

See the exciting 1961 line of KNIGHT-KITS—available only from ALLIED. They're lowest in cost, convenience-engineered for easiest assembly, outstanding for performance—the only kits offered with Free Inspection Privilege. Send today for the 1961 ALLIED Catalog—select your KNIGHT-KITS—and...

SAVE ON EVERYTHING IN ELECTRONICS



Get more for your money in: Stereo hi-fi systems and components • Recorders and tape • Amateur station equipment • Citizen's 2-way radio • TV tubes, antennas, accessories & test instruments • Electronic parts, tubes, transistors, tools • Send today for your FREE 444-page 1961 ALLIED Catalog!

only \$2 down
on orders up to \$50

FREE catalog



ALLIED RADIO

ALLIED RADIO, Dept. 24-M
100 N. Western Ave., Chicago 80, Ill.

Rush FREE 1961 ALLIED Catalog.

Name _____

Address _____

City _____ Zone _____ State _____

The Metric System—CON

(Continued from page 139)

"thought" for a long time. This would simply put America out of business for a long time. Surely, books could be written on why this should not be done.

Now, I ask, who are these people so interested in changing our system of measurements?

Surely, the general public is not asking for a change. What difference does it make to them how the ounce, pound, ton, inch, yard, mile, pint, quart, gallon and so on came about or their relationship to each other or to the metric system? If the thought is to remove fractions from our measuring system, the metric system will not do it. I just can't imagine a housewife who normally requires a pound of pork chops asking for 453.5924 grams or asking for 5 hectograms. She would probably ask for a "little light of ½ kilo"—and if it were sandwich bologna, she would probably ask for ½ kilo. I am also sure that our people do not want their present machines and equipment made obsolete by the unavailability of parts with present dimensions. I can't visualize our housewife agreeing to this philosophy.

Certainly industry is not asking for this change. It would be ridiculous to say our measuring system has been a handicap in our industrial development and growth. What metric system country has done better? The use of decimals instead of fractions within the one-inch measurement gives us the same mathematical simplification as does the metric system. When working to a tenth, hundredth, or thousandth, no one is too interested in an inch or any of its fractions—nor what its relationship is to the meter. We must agree that adopting the metric system will not improve quality nor reduce cost by increasing quantity. This takes machines and personnel.

If we were an exporting nation, then the adoption of the metric system might make sense. But I am afraid there is a big question as to whether we are or will be. But even if we were, domestic versus export demand must be considered. At least up to now, as far as I know, export demand appeal has never influenced the design of our automobiles, refrigerators, washing machines and such products. This is probably true also for our airplanes, diesel locomotives, buses and trucks. Conversely speaking, this is not true for imports. Frequently foreign manufacturers have designed for the American market.

Although none of our people would benefit by a change to the metric system, the

(Continued to page 230)

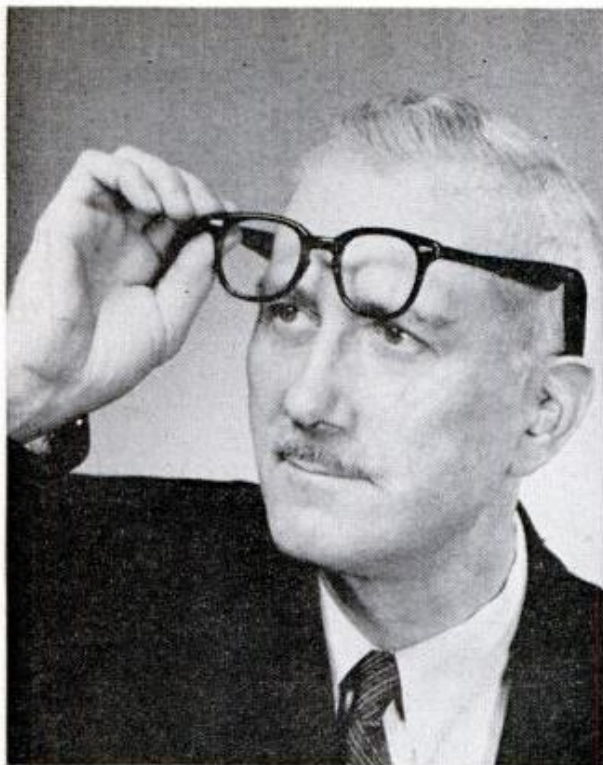

Telex, Inc., 1633 Eustis Ave., St. Paul, Minn.

Radio Built Into Glasses Serves as Hearing Aid

Built into a pair of eyeglasses, a new hearing aid actually is a radio station. A transmitter in the temple bows converts sound waves to electrical energy and transmits it to the receiver earpiece. The earpiece amplifies the energy, converts it back to sound waves and delivers them to the ear canal. There is no connection between receiver and ear button. The aid uses six transistors and is powered by two subminiature energy cells.



One-Ton Room Divider

Ordinary production-grade steel chains, burnished and brass-plated, form an unusual screen and room divider at Doro's Restaurant in San Francisco, Calif. The 256 strands each 10 feet long, hang from a supported rod.

DECEMBER 1960

2 NEW RIGGID® CHAIN WRENCHES



give real Action-Grip
in Tightest Places

No. C-14 for up to 2" Pipe and Fittings
No. C-18 for up to 2½" Pipe and Fittings

Work on Round, Square or Irregular Shapes Other Wrenches Can't Reach!

In extra close quarters there's nothing that'll beat these new RIGGID Chain Wrenches for getting the job done. Fast, ratchet-like action in either direction . . . from either side. Give tight grip without crushing. Large, easy-to-grab end ring for fast chain adjustment. Tempered steel chain locks securely . . . releases quickly. Rugged, comfort-grip, I-beam handle, guaranteed not to break or warp . . . handy hang-up hole.

Light and easy to use, these new RIGGID Chain Wrenches do everything a regular wrench can do . . . and much more. Stop at your Hardware or Building Supply Dealer's and get one today!

RIGGID®

The Ridge Tool Company • Elyria, Ohio, U.S.A.

The Christmas Gift
that does what
warning lights will
never do!

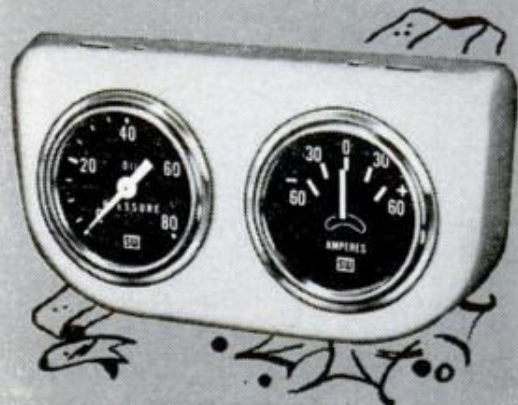

Stewart-Warner
DELUXE

"twin-gauge" panel

Warning lights never tell you the full story of your car's electrical system. With only warning lights you never know *how much* oil pressure you have. Stewart-Warner's "Twin Gauge" Panel is the answer to both of these problems!

The ammeter tells actual rate of current flow. Indicates when current flow exceeds generator output, or when there is danger of burning out the generator or battery due to overcharging. The oil pressure gauge tells exact oil pressure, helps assure safe engine operation.

Instruments have Black and White and Twin-Blue face dials. Panels are available in choice of black enameled steel, chrome plated steel, or deluxe panel of Colonial White grain finish Royalite.

Ask your nearby service station, garage, or automotive parts store for a Stewart-Warner "Twin Gauge" Panel!



Dept. AM-120, 1840 Diversey Pkwy., Chgo. 14, Ill.

foreign manufacturer could benefit. With lower labor costs, he could ship his products (which are produced to the metric system) to fill orders, large or small, for customers in the United States. This could be catastrophic to the United States unless some way could be found to compete with these countries without lowering our high standard of living.

In conclusion, I should like to point out that in medical science as well as in religion, Latin is used as a common language due to its international usage. But I haven't as yet heard of any movement to change our language to Latin. Surely, it would not be any more out of order, nor less confusing and costly, to change our system of measurements. Today, the metric system is doing an excellent job in this country's laboratories—let's keep it there! ★ ★ ★

Leaf Wall Decor

(Continued from page 152)

Caution: In working with muriatic acid avoid contact with the hands and clothing and do not inhale the fumes.

Stems are formed from 3-in. lengths of $\frac{1}{16}$ and $\frac{3}{32}$ -in. brass welding rod, spot-soldered to the backs of the leaves. Use as little solder as possible here for appearance sake. The branch itself is formed from half hard seamless brass tubing of telescoping diameters, $\frac{1}{8}$ to $\frac{1}{16}$ in. You'll need about 18 in. of each size. The tubing is cut into 4-in. lengths and made into tapering branches by inserting one section into another and soldering.

Offshoots of the main branch are formed in the same manner, after which they are joined to the main branch by sawing the large ends at an angle, filing concave and soldering. Four offshoots of the main branch should be made. Holes are made in the branches 2 in. apart for attaching the leaves. Insert the stems and use a spot of solder to hold them. Finally, three angle brackets are soldered to the branches for hanging. After all the stems have been soldered in place they are bent to give a natural effect. Dark-oak stain applied to the branches will tone them just enough to make them look like the real thing, after which the entire decoration is sprayed with clear plastic to keep it bright. ★ ★ ★

QUOTE:

"A full-scale nuclear war might fill the atmosphere with deadly radiation, but tests, past or future, involve only one danger—ulcers for people who worry about them."

—DR. EDWARD TELLER
"Father of the H-Bomb"

ADJUSTABLE MITER BOX & CORNER CLAMP



No. 44—COMBINATION MITER BOX AND CORNER CLAMP
 Holds the wood and holds your saw. Uses any handsaw for accurate cuts from 0° to 180°. Full 3" capacity. Sides of joints exposed for nailing, gluing.
\$2.75 PPD.
 No. 33 Works the same as No. 44, but without saw guide attachment.
\$1.75 ppd.

SAW SHARPENING IS EASY

Super Filer No. 11 joints and sharpens hand and circular saws 6" to 10" with all teeth correct in height, depth, pitch, bevel. When file hits steel roller, teeth are finished. Saw runs true with no side pull. Includes 8" file.
\$9.95 PPD.



FREE LITERATURE



"TRU-CIRCLE" saw set automatically sets teeth at 10° or more.
\$2.95 PPD.

MONEY BACK GUARANTEE

A. D. McBURNEY, 5908 Hollywood Blvd., Hollywood 28, Cal., Dept. A-120



GENUINE ALNICO MAGNETS

AMAZING, PERMANENT, NON-ELECTRIC, HIGHLY PRACTICAL. Conduct interesting experiments. Hundreds of uses. Retrieve valuable steel items such as guns, tackle from fresh or salt water; tools from tanks & drains. **GUARANTEED.** Try any magnet one week. Money back if you are not well-pleased.

No. M-710 (Wt. 53 oz.) Has pull of 225 lbs. on steel block...	\$18.00
No. M-625 (Wt. 70 oz.) Has pull of 125 lbs. on steel block...	\$10.00
No. M-575 (Wt. 18 oz.) Has pull of 75 lbs. on steel block...	\$7.00
No. M-500 (Wt. 13 oz.) Has pull of 50 lbs. on steel block...	\$5.00
No. M-90 (Wt. 5 oz.) Has pull of 15 lbs. on steel block...	\$3.50
No. M-47 Hot Pad Magnets, 10 for \$1.00...	\$1.00
No. M-35 Hobbyist assortment of 8 magnets...	\$2.00

Send M.O. or check. We pay postage. Sorry no C.O.D.'s.

MIAMI MAGNET COMPANY, 3240 N.W. 27th Ave., Miami 42, Fla.



Heavy Duty Type ALLEN PUNCH PRESSES

Model BT-5
 5 ton
\$19950
 fob
 less motor

Hundreds of Different model combinations
 1 to 25 ton capacities
 Moderate in price
 Fully guaranteed
 See your supply dealer or write for Free catalog giving complete information and prices on our Heavy Duty Punch Presses.

ALVA ALLEN INDUSTRIES, Dept. PM, Clinton, Mo.



GEARS

In Stock — Immediate Delivery
 Gears, speed reducers, sprockets, thrust bearings, flexible couplings, pulleys, etc. A complete line is carried in our Chicago stock. Can also quote on special gears of any kind. Send in your blueprints and inquiries.

Send for Complete Catalog No. 10
CHICAGO GEAR WORKS
 440-50 N. Oakley Blvd., CHICAGO 12, ILL.

LOCK-EASE® Graphited LOCK FLUID

For house—car—garage — office locks. LOCK-EASE makes all locks work easier. Flushes out dirt, seals out moisture. Protects against freezing. Frees stuck locks. Prevents sticking, stops rust. American Grease Stick Co. Mushegon, Michigan
 1-205-5



Famous The World Over For The Finest

PRECISION TOOLS



Send For This Big, FREE Illustrated Catalog

Preferred the world over for superior quality, unfailing accuracy and complete dependability, STARRETT TOOLS are the first choice of skilled craftsmen and experienced industrial buyers — men who know and want the best. Choose from the world's most complete line — more than 3,500 fine mechanic's hand measuring tools and precision instruments, dial indicators, steel tapes, and hacksaws, band saws, hole saws and precision ground flat stock.

SEND FOR FREE CATALOG NO. 27

THE L. S. STARRETT COMPANY, Dept. PM
 Athol, Massachusetts, U. S. A.

Please send my free copy of the big 462-page Starrett Catalog No. 27.

Name.....
 Occupation.....
 Address.....
 City.....Zone.....State.....

STARRETT TOOLS are carried by leading Industrial Supply Distributors and Hardware Tool Stores.

...all the thrills of
AMERICAN FLYER



Duplicate the excitement and action of a real stock car race — right in your own home! With remote control racing throttle in your hand, you "drive" your car around the twisting figure 8 track, rocketing along the straightaways, slowing down for the bends. Has all the action of a real race — spin-outs, crashes, sideswipes, skids and flipovers. Motorized cars carry authentic AUTOLITE insignia and race on realistic roadway. No deep grooves or channels to spoil realism.

**Game is complete and ready-to-run; nothing more to buy.
Sets up in minutes.**

Outfit is complete with Transformer, two control throttles, 12 roadway sections, 2 motorized racing cars, ramp set and fence sections.



With extra roadway, you build raceways this size or larger!

a real speedway!

STOCK CAR RACE

Each car has precision electric motor and travels on realistic roadway.

1



2

Push on throttle and car streaks ahead; ease up and racer slows down.

Like real racers, cars go into spins and skids . . .

3



4

. . . and sometimes even pile up! It's all part of the fun and these rugged cars can really take it!



SEND FOR
FREE CATALOG!

Dept. 18
A. C. Gilbert Co.
New Haven 6, Conn.

NAME _____
(please print)

STREET _____

CITY _____ ZONE _____ STATE _____

Dr. Grabow Pre-Smoked PIPES

Only Dr. Grabow pipes are mechanically pre-smoked with fine tobacco. Need no breaking-in. Sweet and cool from the first puff.



Viscount
\$5.

Others to \$10.
Imported Briar

For Free Booklet Write:
Dr. Grabow Pre-Smoked
Pipes • Greensboro, N.C.

IDEAL CHRISTMAS GIFT FOR ANY MAN

WELD **BRAZE**
SOLDER **CUT**



4WAY

ONLY
\$14.75
f.o.b. factory

WELDER

Complete with
Twin Carbon Arc
Torch and ac-
cessories... to
handle all metal-
craft work.

Accclaimed by thousands of Homeowners, Mechanics and Hobbyists as the welder of 1001 uses. Easily operated from properly wired 110 volt AC or DC line. The ideal gift with a life-long use. Order today on 10 day money back guarantee. Send only \$3.00 today. Pay postman balance C.O.D. plus charges. Literature on larger equipment on request.
FOUR-WAY WELDER CO., Dept. F2-N
1810 S. Federal St. Chicago 16, Ill.



Heavy Duty, All Steel
TOOL CHEST
\$28⁵⁰

WHERE ELSE

can you get 4 drawers with built-in locking system, sliding on compound glides - at this price! Baked blue-gray enamel. 26" x 12 1/2" x 12 1/4". Your money back if not satisfied! Write for bulletin describing this and 12 other models.

HUOT MANUFACTURING CO.
555 No. Wheeler St., St. Paul 4, Minn.



Overhaul Your Carburetor

(Continued from page 181)

tube, consists of the step-up piston assembly, main metering jet and the main vent tube, with a diffuser hole and air passage which are an integral part of the carburetor body. At about 20 m.p.h. partial vacuum in the carburetor begins forcing fuel through the main metering jet, through the main vent tube and out the diffuser hole into the throat of the carburetor. At 30 m.p.h. this circuit has completely taken over leaving the low-speed circuit inoperative. The richer fuel mixture needed at high speeds is provided by the step-up piston assembly. With an increased throttle opening vacuum pull in the carburetor drops and is not enough to hold the step-up piston down in resistance to its spring. It is forced up, raising the step-up rod with it and allowing fuel to flow through the step-up jet in addition to that flowing through the main metering jet, thus enriching the mixture for more power. Be extremely careful in removing the jet assembly not to bend the idle orifice tube or the step-up rod. Remove all gum deposits with solvent and then blow all passages out with compressed air. Now, this may all sound a bit complicated but you'll find that the general overhaul involves nothing that can't be mastered with a bit of application and practice. Just bear in mind that most of these parts are made of soft brass and are easily damaged by improper handling.

The Accelerator-Pump Assembly is the last of the fairly complicated parts you'll have to deal with. This circuit acts as an intermediary between the low and high-speed circuits. It consists of a small cylinder which is part of the carburetor body, into which is fitted a spring mounted plunger (or rod) and piston. The piston itself is an inverted leather cup made of a special leather. A small amount of air is trapped between the surface of the fuel in the cylinder and the cup and when the accelerator linkage is activated, it forces the plunger and cup down, compressing the air which in turn forces fuel through the pump's outlet valve, into the pump jet and out into the carburetor throat. With its several parts the pump assembly is open to a number of malfunctions. For example, a worn cup will allow trapped air to escape, the amount of fuel will be lessened, the engine will be slow in turning over and the high-speed assembly will be unable to take hold. The engine will most likely "flat out" and be unable to exceed a certain low speed. In this case both the cup and the plunger spring should be replaced. If either intake

or outlet valve leaks or cannot be made to work properly, it must also be replaced. The hand choke on older cars requires no more than that the valve plate move freely in response to a pull on the linkage and that its breather valve be clear. Automatic chokes are mainly subject to leaky gaskets and tubing and accumulations of dirt impeding the flow of warm air from the exhaust manifold to the thermostatic coil. With all parts clean and the carburetor re-assembled, you're ready to remount it on the engine and tune it up. Even though you don't have precision equipment, it isn't difficult to learn to set the carburetor "by ear." Remember, set the idle adjustment screw for mixture and **then** set the speed until the engine purrs with a minimum of "rock" and vibration. ★ ★ ★

Hydrogen Gun Bombards Material Being Tested for Spaceship Use

Scientists developing skins for future spaceships are building a hydrogen gun that will fire plastic projectiles at various materials to test how they would stand up under a meteoroid bombardment in outer space. Analysis of the impacts is expected to lead to better design and material choice, says Dr. Robert Perry, chief of the Re-entry Simulation Laboratory of Republic Aviation Corp., at Farmingdale, L.I. In addition, sequence cameras will photograph free flight of the projectiles to provide information on flight phenomena. The gun works in this manner: Hydrogen, heated by an electrical spark discharge to 15,000 degrees F. in a chamber, ruptures a metal diaphragm and forces the projectile down a shotgun-like barrel. It shoots out at 26,000 miles an hour and travels 25 feet before bombarding the test material.

Treated Corn Needs Less Water

University of Illinois scientists introduced a chemical to the roots of corn plants and have grown corn with a third less water than was used by untreated plants. W. J. Roberts, Illinois State Water Survey engineer who originated the project, suggests the technique may eventually increase the usefulness of available water in areas where the supply is limited. He and university botanists used a fatty alcohol that forms a film a molecule thick on water surfaces. (This chemical had been used to reduce evaporation from water-supply reservoirs.) They believe the chemical forms a protective film at the opening in the plant from which water evaporates and plan to use fatty alcohol tagged with radioactive tracers to test this theory.

BELSAW
MULTI-DUTY
POWER TOOL

SAWS
PLANES
MOLDS

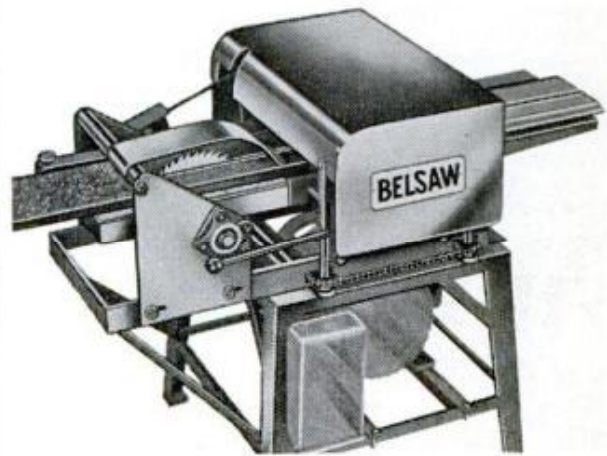

Now you can use this **ONE power feed shop** to turn rough lumber into high-value moldings, trim, flooring, furniture... **ALL popular patterns.**

RIP... PLANE... MOLD... separately or all at once by power feed... with a one horse-power motor. Use 3 to 5 HP for high speed commercial output.

LOW COST... You can own this **MONEY MAKING POWER TOOL** for only... **\$30⁰⁰** down payment

Send coupon today

BELSAW POWER TOOLS

901 Field Bldg., Kansas City 11, Missouri

Send me complete facts on the **MULTI-DUTY Power Tool.** No obligation.

Name _____
Address _____
City _____
State _____

**Bore 35 standard holes
with just one tool**

**New IRWIN
Expansive Bit**

lets you dial your size

Just turn the dial and you're set to go with this new Irwin Expansive bit. No hunting for the size you need. Fits all hand bit braces. Clean, fast, accurate boring action from $\frac{7}{8}$ " to 3"—35 standard hole sizes in all!

And what a really fine precision tool to own. It's drop-forged from special bit steel, heat treated full length, machined for accuracy and sharpness, highly polished, too. Two cutters supplied with each bit. Model No. 21 with $\frac{5}{8}$ " to $1\frac{3}{4}$ " boring range also available. Ideal for home handyman, professional woodworker, or farm. See your independent hardware dealer soon.



IRWIN

Wilmington, Ohio

the original solid
center auger bit

screw drivers
screw driver bits

**NEVER BEFORE SO MANY
FEATURES . . . SO MANY "EXTRAS"!**

sensational **NEW**
Evans **WOOD
FOLDING RULES**

Evans "GOLD TIP"
6 ft. EXTENSION RULE

1. **FREE!** Rule holster with belt clip.
2. **EASY TO READ!** Marked in inches, plus feet-and-inches. Stud marks every 16". "Flags" every foot.
3. **BUILT-IN GRADUATED BRASS TIPS** at both ends.
4. **BRASS EXTENSION**, graduated for inside measurement. (Models X40 and X40F only).
5. **MANUFACTURER'S REPLACEMENT AND REPAIR SERVICE!**

Also available: **STANDARD "SILVER TIP" Rule, \$1.79**



BRASS NAMEPLATE plus set of "A to Z" metalized initials with all rules.

Evans RULE CO.

Factories at: Elizabeth, N. J.
& Montreal, Quebec

Train Your Own Horse

(Continued from page 136)

body and neck in line. Make sure he learns to stop readily when given the command "Whoa" and to back up from this position.

Another method to teach reining before the colt is ridden is by standing at his left side with the right rein in the right hand and the left rein in the left hand. He can be taught to rein in either direction by pulling and giving slack on the direct rein—one on the side he is to turn—and giving slack at the same time on the indirect rein. This teaches the colt to neck rein.

Mounting the horse: A gentle horse can be mounted for the first time with little trouble. By holding the rein next to you quite short in comparison to the other rein, it will cause the animal to move in a short circle if he is going to move at all. It will also keep him from trying to run away and give you an opportunity to get settled in the saddle. Most gentle horses won't buck at all if handled properly; others will only jump a little. By holding his head up and the left rein short, you can restrict their bucking and make them move in a short circle until they settle down.

Your additional weight will be new to the horse and you should give him an opportunity to become accustomed to it. Sometimes it is good to mount and dismount several times before you try to ride.

Don't overwork your horse at the beginning. An hour, the first few times, is sufficient and don't push him too hard during the hour. It is much better to work him a short time regularly than to work him hard and long at irregular intervals. It is a good practice to exercise the colt a few minutes each time before you attempt to mount.

Doing figure eights is a good way to start teaching a horse to rein, but don't always turn him the same way, and vary the size of the figures so he will be learning to rein rather than learning a particular pattern.

The use of your legs is a valuable asset in getting the horse to do what you want. For example, press both legs to start forward, and when turning, press against his body with the leg opposite the direction you want him to turn. Shift your weight in the same direction. Some horses are trained to turn so well in this manner that reins are not needed.

Turning along a fence will teach him to turn short and on his back feet. After he has learned to rein at a walk, you can advance him to a trot and then to a slow lope.

Training your own horse can be very satisfying, and it isn't too difficult as long as you use plenty of patience. ★ ★ ★

PEEL PAINT OFF



Furniture



Floors



Boats



Woodwork



KLEAN-STRIP PAINT REMOVER

Fast • Clean • Non-inflammable

THE KLEAN-STRIP CO., INC.
2340 S. Lauderdale, Memphis 6, Tenn.

THE ORIGINAL PACKAGED

KITS

• World's Largest Line—New Fiberglass Hulls. Over 200 styles Boats—Kits, Formed-Hulls, Semi & Custom finished. All types: Prams, Cruisers, Racers, Inboards, Outboards. Easy to build. Professional results. Dealers - Agents Inquire.

Send 35¢ for Colored Catalog 52 pg. Kit Catalog plus 20 pg. Hardware and 8 pg. Armor Glass books. (SPECIAL OFFER!)

Colored CATALOG plus "Boating Handbook"... all for \$1.

CUSTOM • CRAFT



CREDIT TERMS

BOAT PLANS PATTERNS FRAME PACS

• Over 400 Plans—Patterns, Frame Pak Kits, Frames, Kayaks, Racers, Runabouts, Catamarans, Cruisers, In-Outboards (6' to 40') Wood, Plywood and Steel. **Send 35¢ for 120 pg. Plan Catalog.** Catalog plus "Boat Building Handbook"... Send \$1.00.

Buffalo 7, N. Y.

NEW 24" TURBO TINES

AND POWER REVERSE
MAKE GARDENING
FUN . . . EASY

with
Ariens
new **SUPER JET**



- Fingertip operating controls
- Tine Reverse Drive at no extra cost
- Choice of 4 engines — 3 h.p. to 4½ h.p.

Power to spare for any tilling job when you own an Ariens Super JET! With all-steel TURBO TINES that till 24" wide . . . fingertip controls . . . power reverse . . . free swinging depth bar, gardening has never been easier — nor more fun! Lawn aerator, edger, furrower attachments. Write for free literature today!

ARIENS COMPANY, 161 Calumet St., Brillion, Wisconsin
Please send SUPER JET tiller details advertised in Popular Mechanics.

Name _____
Address _____
City _____ Zone _____
County _____ State _____



Richard ©

"... and in case the penicillin doesn't work ..."

What's New for Dinner

(Continued from page 126)

substances so that bread that is a number of days old would still retain its freshly-baked appeal.

Somewhat similar studies are being made at the food technology department of the Davis campus of the University of California. Here the problem is to impart a fresh, yeasty essence to "instant" bread that has been developed by the Army's Quartermaster Corps. The new bread uses a chemical leavening system instead of yeast and so requires no lengthy rising time. In fact, no more than 40 minutes elapse from the time the dry mix is stirred with water until the fresh loaves are removed from the oven. The only trouble with the bread is that it doesn't smell like bread. That's what the U.C. people are trying to remedy.

Aseptic canning is something else that is being studied at Davis. In the ordinary canning process, food gets a final cooking in the can so as to kill any micro-organisms that might otherwise cause deterioration. In aseptic canning, food that has been pre-cooked is given a final cooking at 220 degrees F. for 15 seconds while it travels through a heat exchanger. Then it is cooled immediately and is sealed in cans that have been sterilized in superheated steam. One advantage of the process is that foods retain more of their original nutritive values. Another is that their flavors are more like those of the fresh product.

Other canning studies at Davis include the use of a nitrogen atmosphere during the cooking and canning processes. The nitrogen blanket keeps atmospheric oxygen away from the food and so prevents the discolorations often caused by oxidation. Davis also is studying essence recovery—the trapping of vapors that are lost during the cooking process. It may be that these can be condensed and returned to the food just before it is canned, restoring lost flavor and, possibly, any vitamins that escaped.

Still another way of preserving foods, already in limited commercial use, is a combination of both the dehydration and quick-freezing processes. The food is first dried to about half its original moisture content and is then frozen in the ordinary way. The process retains many of the advantages of each method and avoids most of the disadvantages. The dehydrofrozen product weighs less and takes up much less space than a frozen product, yet has a better flavor, texture, appearance and color than a completely dehydrated food. Apples, cherries, peas, carrots, lima beans and celery have been preserved this way.

No other process, it has been said, offers

preserved food of comparable quality at such a low cost, but the relatively low cost applies only to such bulk users as restaurants and military installations. Unfortunately for the retail purchaser, packaging costs do not diminish proportionally with size. The average housewife is apt to want no more than five ounces of dehydrofrozen apples, knowing that they will swell to a 10-ounce amount when she soaks them in water. In any event, dehydrofrozen foods are not yet available at retail.

Sonics, or the use of sound waves, appears to have a big future in the food industry. In one application, sound waves are being used to homogenize whole milk which is then frozen and stored until needed. Fresh milk can thus be available at any time to the crews of submarines or ships on lengthy voyages. The sonic treatment overcomes the previous objection to frozen fresh milk, in which the butterfat separated out and coagulated.

Sonics, too, is helping tenderize meat. An enzyme preparation that does this has been on the market for years but its tenderizing effect is mostly confined to the meat surfaces. Recently a patent was granted for a technique that uses sound waves to drive the enzymes all the way through the meat, achieving a uniform tenderizing effect.

Sound waves have been used experimentally at Stanford Research Institute to speed up and improve the washing processes by which vegetables and fruits are cleaned before processing or marketing. The sonic treatment removes many of the traces of pesticides that are found on fresh produce, and helps to remove the detergents used in the washing processes.

For years the Army Quartermaster Corps has been looking for better ways of preserving meats, and as of now it is still hunting. Dehydrated meats have not been too successful. For a time it appeared that irradiation (exposing steaks and roasts to beta or gamma rays) might be the answer. The irradiated foods could be stored without refrigeration and looked good and tasted good. But recently it was found that experimental animals that were fed a diet of irradiated foods developed all the symptoms of severe vitamin deficiency. Irradiation doesn't seem to be the answer at present. The final solution may still be some improved form of dehydration, possibly with vitamins and flavor enzymes provided in an encapsulated form.

All in all, food technicians have a host of new ideas on which they are working; today it seems that you'll be buying the products of some of these ideas at the grocery store and judging them for yourselves in the next few years. ★ ★ ★

If your spirit is wheeling...



RIDE A '61

HARLEY-DAVIDSON DUO-GLIDE

Hitch your wagon to a new Duo-Glide and get that wheeling feeling. Like riding a cloud — the way its deep-chested OHV engine flattens out hills . . . digs out for passing . . . smooths out the straightaway. Three-point suspension takes the spring out of rough roads . . . even cushions the smoothest roads.

Put yourself on your own personal "cloud" at your Harley-Davidson dealer. New *Astro-Flite*-styled Duo-Glides come in standard FL and super-powered FLH models. Or mail coupon for this colorful folder.

HARLEY-DAVIDSON MOTOR CO.
Dept. P, Milwaukee 1, Wis.

Please send me more facts on
the distinctive Duo-Glide and the
other exciting Harley-Davidsons for '61.



Name..... Age.....

Address.....



BUY GREAT NECK HAND TOOLS
... for long-lasting performance



GREAT NECK SAW MFRS., Inc.
MINEOLA, N. Y. — SEE YOUR LOCAL STORE

EMERSON ELECTRIC

PORTABLE WELDER High Capacity ... Low Price

Ideal for farm, home workshop. Cuts, brazes, solders, welds. One man can carry ... only 68 lbs. 6 welding heats up to 180 amps ... $\frac{3}{32}$ " to $\frac{3}{16}$ " rod sizes. Write today for prices and receive **FREE WELDING SELECTOR GUIDE** ... gives working data you need in seconds!



DEPT. W-556

EMERSON ELECTRIC of St. Louis
8100 Florissant • St. Louis 36, Mo.

DECEMBER 1960

239

Christmas Treat
for
THE-MAN-OF-THE-HOUSE

CUSHION GRIP
SCREWDRIVERS by
Bridgeport

Gift Set

A pleasure to give or receive ... and a pleasure to use! Four most-needed CUSHION GRIP Screwdrivers in handsome red and gold gift package. Only \$5.50 retail at Hardware stores. Tested and Approved by Mechanics.

- 50% greater Turning Power.
- Blisterproof, resilient nitrile handle.
- Super Comfortable.
- Chrome plated alloy tool steel blades.
- Fully guaranteed.

THE BRIDGEPORT HARDWARE MFG. CORP., BRIDGEPORT 5, CONN., U.S.A.
Subsidiary of PUROLATOR PRODUCTS, INC.

you can always
BE SURE OF A JOB

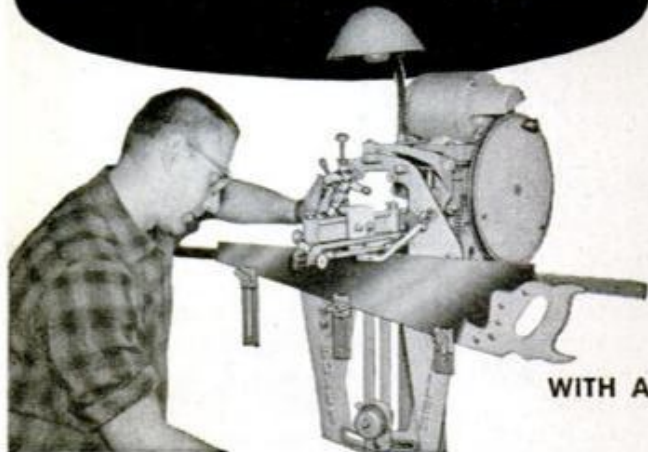

WITH A

FOLEY SAW FILER

Have you been laid off—or afraid you may be? If you want security, plus a bigger income too—don't look for a job—start your own spare time business. In his first 2 months J. P. Robitaille earned \$300 with his Foley Saw Filer. From his starting day R. T. Hart made \$600 in 4 months. Frank P. Layne wrote—"In our town of 2,800 instead of 200 to 300 saws I did over 1,500 the first year, averaging about \$1.50 each.

FREE booklet "MONEY MAKING FACTS" shows you how to get business. The new Foley "200" sharpens hand, band and both "combination" and crosscut circular saws. Use our Time Payment Plan—pay for the machine out of your CASH profits. Send coupon today—no obligation, and no salesman will call.

FOLEY MFG. CO., 1243-O Foley Bldg., Minneapolis 18, Minn.
Send Free Booklet and Time Payment Plan on Foley Saw Filer.

Name _____
Address _____
City _____ State _____



New KING MIDGET FOR 1961

WORLD'S MOST EXCITING LOWEST PRICED CAR

Rider Agents Wanted. Send 25c for 32 page picture book, full details, dealer price. Or send \$1 (refunded first order) for this plus Service and Repair Manual and 16 5x7 photos of car and factory.

MIDGET MOTORS CORPORATION, Athens 1, Ohio

READY CUT HOMES

\$2295 AND UP DIRECT FROM MILL

YOU SAVE the items which help make today's building cost expensive: high labor cost, contractor's profit and overhead, insurance, architect's fees. Cut-to-Fit eliminates usual lumber and material waste, also costly mistakes. Anyone can assemble. Simple, easy-to-follow plans furnished and each part numbered. Complete with all lumber, roofing, nails, glass, hardware, paint, doors, windows. Freight paid. Low-cost building plans sold separately if desired. 57 Homes and Floor Plans.

5 EASY PAY PLANS
COLOR CATALOG

Send **25c**

INTERNATIONAL MILL & TIMBER CO.
Dept. PM 120 Bay City, Mich.

Fine Points of Cutting Glass

(Continued from page 191)

ish the edges by hand-grinding with an oil-stone or with a power-driven grinder. If you use the power grinder, be careful not to heat the glass or it may shatter. Use very light pressure and remove the glass from the wheel at short intervals, to permit heat of grinding to dissipate.

The methods described apply not only to common glass, or window glass, in standard size sheets and in single(ss) and double strength(ds), but also to plate glass in sheet sizes that are easily handled and cut by hand methods. If you have occasion to cut glass which comes with one side textured or embossed or otherwise patterned, the cut should always be made on the smooth side.

Special Tools

Professional glaziers use the special tools shown in Figs. 10, 11 and 12 and also in Figs. 17 through 19. The glazier's chisel, Fig. 11, and the points, Fig. 12 are used only when glazing wooden window sashes. The chisel is used for removing hardened putty. The points are driven into the rails, stiles and muntins of wooden sashes to hold the glass panes in place. Drills of the type shown in Fig. 10 are used in a drill press as in Fig. 15. In practice, a dam of putty is built up around the point where the hole is to be drilled to hold a mixture of abrasive and oil. Then the work is set up as in Fig. 15, using either one of the drill types shown in Fig. 10. The drill is raised at short intervals to permit the point to pick up a new charge of abrasive. Another type of glass drill, used without abrasive and only in professional work, is shown in detail A, Fig. 17. Details B, C, and D show different types of glass cutters. The diamond cutter, detail B, is quite widely used in professional work. The cutter is a genuine industrial diamond. Cutter C is the common wheel type most widely used. Some cutters of this type are now available with carbide wheels. Cutter D is simply a variation of cutter C with a rotating, or turret, head in which are fitted several cutting wheels. The circle and tube cutters are special tools for professional work. The vacuum lifter, Fig. 16, is handy where it is necessary to lift and place fairly large sheets of double-strength or plate glass.

★ ★ ★

Science has come to the aid of migrating birds, many of which have flown into the light of a lighthouse off the coast of Dungeness, England, in past years. The new light will be tinted blue, a color that does not attract birds.

Christmas Greetings
1960

Christmas Greetings
1960

**FIGHT
TB
WITH
CHRISTMAS
SEALS**

ANSWER YOUR CHRISTMAS
SEAL LETTER TODAY

Christmas Greetings
1960

SPARE-TIME MONEymaking OPPORTUNITIES
READ OUR CLASSIFIED ADS
HUNDREDS OF BARGAINS AMAZING OFFERS

HIGH SPEED DRILLS
 17 pc. set from 1/2" to 1" (in 4th, 8th, 16th, 32nd sizes) All With 1/2" Straight Shank
 For Industrial and Home Workshop. In sturdy container case which serves as wall rack with Decimal Equivalent Chart. Used, factory reconditioned, finest quality. We guarantee your satisfaction within 10 days with our money back guarantee. Prepaid if payment accompanies order. 50% on COD's, shipped postage collect. If purchased individually a value of more than \$100. Order today.
\$39.50
COMPLETE
GRAFF MACHINE TOOL COMPANY
 820 W. Lake St., Dept. PM-120, Chicago 7, Illinois

Start a profitable business of your own

easy-to-own!

NEW SHOP TYPE WELDER—The 180 amp. "Hustler" welds, cuts, burns holes, hard-surfaces, and heats metal for bending and forming. It's a complete welding package—including accessories, and meets REA requirements.

Get complete information...no obligation! →



...there's **BIG MONEY** in arc welding

NEW COMBINATION WELDER—The 200 amp. "Power/Weld" furnishes DC current for welding and simultaneously provides 110/220 v. AC power for running tools, pumps, lights, sprays, etc. Can also be used as an emergency power source.

for outside or shop use.

HOBART BROS. CO., Box M-120, TROY, OHIO, Ph. FE 2-1223



This is one of Southern Screw's popular EZ to C color-coded labels. It's your assurance of unexcelled quality!

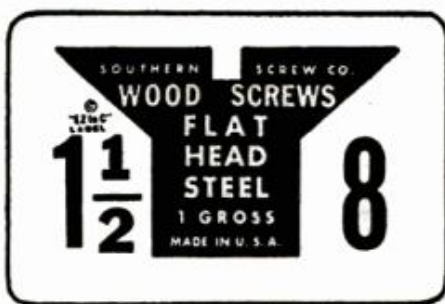

For **QUALITY RESULTS IN EVERY PROJECT**

there is no substitute for Slotted or Phillips
Southern Screws
 Made in USA with USA materials by Southern—leading fastener specialists

Buy 'em by the box and SAVE!
 Sold Through Leading Hardware and Building Supply Dealers

- Wood Screws
- Stove Bolts
- Tapping Screws
- Machine Screws
- Machine Nuts
- Carriage Bolts
- Drive Screws



ONLY A SCREW HOLDS LIKE A SCREW
 Specify Southern . . . Most Craftsmen Do!

SATISFACTION  For 54 years, sold under guarantee of satisfaction. FREE catalog to toolmakers.
GERSTNER TOOL CHESTS
 460 Columbia St., Dayton 7, Ohio

ALL NEW! **1961 Edition of Constantine's WOODWORKING CATALOG & MANUAL**

Get the biggest Constantine Catalog & Manual—2000 items! World's largest source since 1812 for rare imported and domestic woods in veneers, lumber, plywoods, bandings, inlays, mouldings, carvings . . . hard-to-find hardware, new solid brass hardware, wood finishing and upholstery supplies, patterns, tools, wood-working materials—at bargain prices! Also exclusive Inlaid-Wood-Picture Kits. . . . Identification Chart of 60 rare woods in color . . . inspiring projects, plans, etc. For all-new 1961 Catalog & Manual, send 25c (refunded on first order). Write today!

ALBERT CONSTANTINE AND SON, INC.
 2050 Eastchester Rd., Dept. T-5
 New York 61, N. Y.

FREE—Year's subscription to "Chips & Chats" . . . brings news of exciting woodworking ideas and latest offerings . . . Free with Catalog!



Real Man's Gift!



Put a Whole Tool Kit in His Christmas Stocking!



Boy! I can sure use this!

WISE-GRIP®

He'll use Vise-Grip as a pliers, wrench, hand vise, clamp, wire-cutter. Locks to work with ton grip. Releases with flick of finger. Give Vise-Grip. Does more jobs than any other hand tool. Quality-made—yet budget-priced at only \$2.15 to \$2.95 at your hardware store.

PETERSEN MFG. CO., DeWITT, NEBR.
DEPT. PM-12



STOP WATER DAMAGE...



Wood
Plywood
Shingles
Asbestos siding
Concrete blocks
Concrete
Mortar
Stucco
Plaster
Brick
Paint
Wallboard
Tile
Canvas
Leather
Linoleum
Fabrics

Prevents warping, swelling, mildew, mold, water stains, seepage, dampness, rot.

Keeps moisture out 5 years and longer.

Use on all woodworking jobs, boats, patio furniture, planter boxes, shutters, screen doors, window sash, shingle roofs. Stops seepage in basement walls, concrete silos, foundations. Waterproofs canvas, tarps, tents, awnings, leather boots, shoes, outdoor clothing. Won't harden or crack leather or fabrics. Perfect underseal for oil base or alkyd paints. Deep penetrating, colorless. Apply by brush, spray or roller. At paint or hardware stores or order direct. 16 oz. spray can \$1.89, Qt. \$1.75, Gal. \$5.35, 5 Gal. \$25.25, ppd., tax incl. Send check or money order to E. A. Thompson Co., 13 1/2 Market St., San Francisco 3, Calif. No COD's please. (Since 1929.) Dealer and jobber inquiries invited.

Bonneville's Magnificent Trials —and Errors

(Continued from page 106)

speed car across country, and a small fleet of auxiliary vehicles was brought along as tenders. One Land Rover served as an emergency repair shop for small jobs; another carried various chemicals for fighting different kinds of fire.

Land Rovers Service "Bluebird"

Two Land Rovers were rebuilt to service *Bluebird* at each end of the course, each carrying electric batteries for starting the jet engine, air compressors for renewing its compressed-air supplies and the fans for cooling its disk brakes. One truck carried fuel, another the radio telemetry equipment, still another the tires that would be used for one run.

Bonneville Speedway is on the salt flats along the Utah-Nevada border and is an immense flat wasteland having a hard crust of white salt. It is considered the world's best course for high-speed automobiles. The salt is cool and provides ideal traction.

For speed record attempts, a 120-foot-wide path is dragged, scraped and swept with power machines to bring the salt to utmost smoothness, and a black line is painted down the centerline. This year the course was 11½ miles long, with the measured mile and the measured kilometer being located in the middle of the distance. The length of the course varies from year to year, depending on the firmness of the salt at each end. In a good year, with heavy rains during the preceding winter, a firm course as long as 13 or 14 miles can be laid out.

Attempts for new records are timed by the U. S. Auto Club, the American representative of the Federation Internationale de L'Automobile. Timing is by the light beam-photo cell method.

Must Make Two Runs to Qualify

To qualify for an international record, a driver must make a second run, in the opposite direction, within an hour of his first run. His official speed is the average speed of the two runs.

Campbell plans to be back at Bonneville next fall with a reworked *Bluebird*. Mickey Thompson will be there too, either in *Challenger I* or *Challenger II*, a jet-engined car that he is beginning to put down on paper. Neither driver will be shooting for 500 miles per hour this year, but that's the speed that each of them has in the back of his mind. Ultimately someone is going to drive a car that fast. ★ ★ ★

R. Coil Arc Stabilizer... \$10.95
 G-1 160-250 amp New \$19.50 good C \$14.95
 R-1 300 amp. G.E. recond. \$24.50 good 16.95

Accessories Kit For Arc Welder for above generators has helmet, gloves, elect. holder, volt reg. rheostat, RC relay, voltmeter, Gr. Clamp, including switch plus 1G-1 gen. 160-250 amp. \$26.00
New Welder Throttle Solenoid \$7.50

Multi-Weld D.C. Arc Welding Kit Complete with G.E. R-1, 300-350 amp gen. incl. accessory kit, reactor coil w/solenoid control \$47.95

AC-DC WELDER KIT—511 G.E. Generator. Makes 1250 Watts AC light plant and 200 amp. DC welder and battery charger. Includes all items listed in accessories kit. AC-DC generator & instr. \$38.50

HYDRAULIC SNOW FLOW LIFT KIT Consists of 1 Stratopower hyd pump .450 cu. in. 1400PSI drive from engine or power take off, 1 DA cyl. 2 3/4 x 9 1/4" control valve tank, filter hose & fittings... \$49.95

SAVE ON SURPLUS MOTORS
H.P. 24-12VDC Shaft
 Delco 1/2 6.5 amp 7/32"x2" \$5.95
 Bendix 1/4 8 amp 5/16"x1" \$6.50
 Delco 1/4 8.4 amp 5/16"x1" \$6.75
 Pesco 3/4 2.50 amp 1/2"x2" \$9.95
 Gear Red. Mtr. 54-1, 1/20 P. \$5.95

NEW HYDRAULIC CYLINDERS

Bore	Stroke	Shaft C.	Length	D.A.	2000 PSI
1 1/2"	4 1/2"	1 1/8"	10"	3 1/2"	lbs. \$ 3.75
1 5/8"	2 3/4"	1"	38"	11 lbs.	\$12.95
1 1/2"	8 1/2"	3/4"	13"	8 lbs.	\$ 7.50
2 3/8"	18"	1 5/8"	26"	11 lbs.	\$17.95
2 1/4"	9"	1 1/2"	24"	12 lbs.	\$14.95
3"	9"	1 1/8"	18"	10 lbs.	\$15.50
2 1/2"	3 1/4"	3/4"	11"	L.C.	\$ 9.95
3 3/4"	10"	1 1/4"	27"	21 lbs.	\$24.50
3 1/2"	8 5/8"	1 1/4"	20 1/2"	12 1/2 lbs.	\$17.95
3 3/4"	2 1/8"	1 3/4"	31"	15 lbs.	\$24.50
4 7/8"	8"	2"	22"	35 lbs.	\$29.75

Dual Power battery motors kit Excellent for golf cart, winch, etc., fully reversible, runs on 24-12VDC kit, includes 2 motors. Each 3/4 HP, 250 amp. 2300 RPM, 2 relays, switch, 2 flex couplings with speed reducers 10:1 & all connecting cable. Value \$79.10—save \$46.15. Kit price \$32.95

WATER PUMP WITH MOTOR 1/2 H.P. VDC adj. press 400 G.P.H. \$12.95 with 700 G.P.H. pump... \$14.95

HYDRAULIC PUMP BARGAINS 1500 P.S.I.
 Type RPM *Reversible
 *Pesco Gear 4500 270 \$ 9.95
 *Vickers -410 3750 375 \$21.50
 *Stratopower PD 4500 375 \$15.95

BUILD YOUR OWN HYDRAULIC PRESS
 Complete kit consists of New Heavy Duty D.A. cylinder 3" bore x 10 1/4" stroke 3000 PSI, heavy duty Weaver hand pump, control valve, gauge reservoir, hose, fittings and 1 gal. oil. Rated output 9 tons. Instructions incl. \$125.00 value, save \$67.50. Only \$57.50

NEW HYDRAULIC PUMP-MOTOR SYSTEM KIT
 Consists of 2 new Vickers p.d.s. pumps ea. .410 cu. in. rev. 3750 RPM 1000 PSI 375 GPH where one pump is belt driven as motor, 1 four way c. valve with variable speed control, reservoir, filter, gauge, hose & fittings. Value \$98.10. \$49.95

NEW HYDRAULIC SYSTEM KIT
 #400 K heavy duty Power driven rated 16000 lbs lift. Consists of 2 D.A. hyd cylinders 3 1/2" bore x 2 1/8" stroke ea. rated 8000 lbs with 1000 P.S.I 1 four way hyd control valve with built in relief #821 1 Vickers hyd pump 375GPH 410 Cu. In. 3750 RPM filter, gauge, 2000 PSI hose & fittings. Value \$169.95 save \$90.00 \$79.95 Same kit with Two D.A. Cylinders 3 bore x 10 1/4" stroke \$69.95

GENERAL SALVAGE CO Check or M. O.
 2922 E. 27 St., Dept. 126, Kansas City 27, Mo.



Works in seconds!

Loosens Rusted Bolts nuts, screws, "frozen" parts!

LIQUID WRENCH
 SUPER-PENETRANT

The super-penetrating rust solvent that quickly loosens rust and corrosion.

AT ALL HARDWARE AND AUTO STORES

RADIATOR SPECIALTY COMPANY
 CHARLOTTE, N. C.

Don't Miss The

BIG ANNUAL AUTO SECTION

IN JANUARY

—with eight pages of classic cars in

FULL COLOR

New Self-locking perforated board fixtures

DOUBLE YOUR STORAGE SPACE

without remodeling!

Just insert Easy Hang fixtures into perforated board. They automatically lock into position. Ideal way to double your storage space in closets, playroom, kitchen, workshop. Fast! Low cost!

Dozens of styles and sizes.

Free, new idea folder tells all!

Turnbuckles, Inc.

Turnbuckles Inc., Dept. PM, Box 333, Michigan City, Ind.
 Rush free folder showing how to double my storage space.

Name _____
 Address _____
 City _____ State _____

Strong Plug Sparks Mean Top R.P.M.'s

(Continued from page 185)

and grease inside the boot may cause a direct short over the surface of the insulator. Next, check the gap spacing of the electrodes to be sure the correct gap is being used. A round-wire feeler gauge like the one shown in Fig. 5, is best for this purpose because there is little chance of committing an error. For example, to set a gap of .037-in., use the .040-in. wire as a "no go" and the .035-in. wire as a "go" gauge. If the gap is too large, tap the ground electrode gently with any blunt lightweight metal object, or force it down with the wire gauge. If the gap is too small, open it with the gauge. Never attempt to bend the center electrode, and do not use a pair of pliers on the side electrode because the jaws will leave sharp ridges on it.

Plugs that are not seated properly, also may be a source of trouble. If they are too loose, or have particles of dirt between the gasket and seats on the engine, compression loss and a certain amount of "blow-by" may result. The latter is particularly bad since it causes overheating of the plug, which in extreme cases can melt a hole in the plug shell as shown in Fig. 4. To be sure that a plug is tightened properly, it is best to use a torque-indicating wrench and apply the recommended foot pounds of pressure. If a torque wrench is unavailable, screw in the plug by hand until it is finger-tight, being sure the plug is seated on its gasket snugly against the engine block. Then, with a plug wrench tighten it one-half turn, if the plug is of 14 m.m. size; one-half to three-fourths turns if it is an 18 m.m. Check the manufacturers' recommendations for other sizes. When a plug is tightened correctly, the gasket should flatten to about one-half its original thickness as indicated in Fig. 8.

Ignition timing also affects engine performance, although checking this is a job for your dealer service man. A recently improved way of doing this is by means of a Stevens contact tester, and a timing fixture that looks much like a juice-can opener as shown in Fig. 12. Removal of the flywheel and spark plugs is necessary to expose the breaker points and armature plate, Fig. 11, so that the timing fixture and tester leads can be attached. This method of timing the ignition is more accurate than the old one of using a feeler gauge to check and adjust breaker-point gap.

The condition of used spark plugs often provides clues that lead to the source or sources of engine trouble, Fig. 6. The wave

pattern in the blue dot next to each of the plug conditions illustrated, indicates the respective engine performance as observed on the screen of an ACilloscope spark-plug analyzer. A plug that appears normal has a light powdery covering on the electrodes and inner walls of the shell ranging in color from brown to greyish tan. There are no globular combustion deposits and almost no evidence of electrode burning. Such a plug could be cleaned and reinstalled, if it does not have too many hours on it. Otherwise, a set of such plugs can be kept on the boat as spares, so that you don't have to clean plugs out on the water the next time they foul out, as the hapless lad shown in Fig. 3 is doing.

Lead fouling can be recognized by the formation of various shades of brown or grey as a normal plug, except that there are large concentrations of deposit, sometimes nearly filling the cavity between insulator tip and shell hole. Lead fouling usually is troublesome only at higher speeds or heavy-load operation when plug temperatures become high. The engine will start normally and run without trouble at low speeds but will miss when full power is applied. Gradual, steady opening of the throttle when such missing occurs, sometimes burns off light lead deposits and clears the plug, but frequently the deposits become glazed and the plug must be replaced. Lead fouling usually is caused by use of highly leaded or premium fuels, which should not be used in an outboard. The best fuel is marine white gasoline, not the camp stove variety. A good brand of regular gasoline having low lead content is second best.

Another type of fouling is oil or carbon fouling, with traces sometimes of other oxides. This can be broken down into two subclasses of dry and oily carbon fouling. The dry type is recognizable as a fluffy dry coating of black deposit on the insulator tip and electrodes. Usually, it is caused by overly rich fuel mixtures, but long periods of trolling, or idling also can be the culprits. Low engine speeds result in inefficient combustion due to low crankcase and combustion chamber turbulence as well as low combustion chamber temperature. Overly rich layers of atomized fuel resulting from low turbulence fail to burn completely, leaving an excess of carbon to coat the combustion chamber and the parts of the plug exposed to it. The plug insulator tip temperature, being too low to burn off the carbon, allows the latter to build up on the insulator tip until it forms a conductive path from the center electrode

(Continued to page 246)



FROM SANTA'S

WORKSHOP AT DISSTON

Gifts on every Dad's "want" list ... at Special Christmas Prices

Even a Junior-sized Santa can shop "Disston" for Dad this year. Disston's 1960 Christmas list of fine tools range in specially reduced prices from \$1.10 to \$49.95. And that lucky Dad . . . homeowner, hobbyist or handyman . . . will appreciate any gift bearing this famous name, even if he buys it for himself. *There are no better tools made!*

Better Hardware, Building Supply, Garden Supply and Department stores *everywhere* handle Disston Tools. You can rely on their expert advice. Make this a special Christmas for Dad . . . *make it a Disston Christmas!* Disston Division, H. K. Porter Company, Inc., Philadelphia 35, Pa.

(A) DISSTON "DISCUS" 6½" Portable Electric Circular Saw—Built for a lifetime of convenience. 10' lifesaver cord detaches at saw handle. Fool-proof slip-clutch eliminates kickbacks and burnouts. Smooth acting blade guard rides on nylon bearing. Precision helical gears. Lever-lock for depth of cut. Cuts 2" stock at 45°. 115 Volt AC-DC motor. 6700 r.p.m. cuts 6300 surface feet per minute. Regular Price—\$54.50
Suggested Christmas Special at **\$49.95**

(B) DISSTON D-23 HAND SAW—America's most popular quality hand saw . . . yet costs less than ten dollars. Hardened and tempered saw steel. Weather-proofed, natural finished handle. Specially gift boxed in bright colors for holiday

giving. 26" length, 8 and 10 points to inch, cross cut. Regular Price—\$9.75
Suggested Christmas Special at **\$8.95**

(C) DISSTON "DAGGER" Electric Sabre Saw—Home improvements are finished faster with this all-purpose, power tool. Cuts wood, metal and plastic. Cuts straight and curved lines. Cuts full 45° in 2" lumber. Exclusive, high speed "Orbite" cutting action. Exclusive, plug-in cord detaches at saw handle. Regular price—\$54.50
Suggested Christmas Special at **\$49.50**

(D) DISSTON "accu-rule"—8 Foot Length—An economy rule with all Disston quality features. Durable, light-

weight and strong die cast cases, chrome plated. Double side reminder for inside measurements. Tip withstands 100 lbs. pull. Permanent "clear sight" rules. Easy-to-read, accurate markings, clear 16" stud markings. Regular Price—\$1.20
Suggested Christmas Special at **\$1.10**

(E) DISSTON-CARLSON "WHITE CHIEF" RULE—8 Foot Length—Most popular of all Disston rules. Exclusive swing tip. Permanent stay-white blade. Crack-proof, rust-proof blade surface. Rigid blade for good "reach," replaceable with 10 second change-over. Sturdy zinc die cast case; chrome plated. Two assembly screws for shock-proof durability. Regular Price—\$2.10
Suggested Christmas Special at **\$1.89**

DISSTON DIVISION

PORTER

H. K. PORTER COMPANY, INC.

to the shell. At this time missing occurs and finally, complete shorting out of the plug. If the engine can be accelerated before shorting occurs, spark plug temperature will rise and the carbon most likely will burn off the insulator tip and clear the plug.

The oily type of carbon fouling is recognizable by a greasy black coating covering the entire firing end of the plug. This may result from an oil-rich fuel mixture, extended periods of idling or trolling, or simply because of the fact that the plug is of a heat range which is too cold for the engine. In the latter case, the insulator tip never reaches a temperature high enough to prevent carbon accumulation. Late model outboard motors that are equipped with thermostatically controlled cooling systems, have overcome this type of fouling to a great extent.

In bad cases of fouling, where the carbon and lead deposits are so extensive that they form a bridge from the insulator tip to the shell, a "dirty engine" is indicated. By dirty engine it is meant that pistons, valve ports and other parts within the combustion chamber are covered with carbon deposits. This diagnosis can be confirmed by peering into the combustion chamber through the spark-plug holes, using a medical probe light (or pen light) as shown in Fig. 9. Details A and B show the appearance of a clean piston crown as compared to one that is deposit laden. By rotating the prop to place the pistons at bottom dead center, you can look right into the valve ports. According to Champion engineers, exhaust ports are sometimes found to be blocked by as much as 50 per cent due to carbon deposits. The carbon deposits shown in Detail B, fly off the piston crown in big chunks when the engine is running and are blown or thrown against the plug since the latter usually is located directly over the intake or vertical side of the piston baffle (raised portion of the crown). The plug location, though quite vulnerable to this type of failure, is considered necessary because it is directly in the path of the compression charge, providing the best ignitability for good idling. It also is centrally located to provide the fastest burn at full throttle. If an engine builds up combustion chamber deposits again shortly after cleaning, it is time to look for a new brand of oil, according to AC Spark Plug engineers. In this connection, it is very important that you use oils which are intended for outboard motors or other two-cycle engines. It may be necessary to try more than one brand before satisfactory results are obtained.

Electrode wear simply means loss of metal from the center and ground elec-

trodes, resulting in excessively widened gap spacing and smaller, less effective surfaces for producing a spark to ignite the combustion charge. Electrode wear is the direct result of overheating, which can be detected by a dead white or light gray coloring on the insulator. Sometimes combustion oxides will be fused onto the insulator surface itself. Use of a colder type plug usually will relieve electrode burning, especially if it is apparent under continuous heavy duty operation. If electrodes tend to burn in light duty use, the engine should be checked for proper coolant circulation. A carburetor that is set extremely lean, or improper spark timing can cause excessive electrode wear. Improperly installed plugs and low engine r.p.m. at full throttle due to the use of the wrong propeller size for the boat application, also may be the cause of overheating and consequent electrode wear. Other than these basic difficulties, most of which can be remedied easily, rapid electrode wear simply means that the plugs are too hot and should be replaced with colder ones.

The service life of spark plugs usually can be extended with proper periodic cleaning and regapping. Recommended procedures are outlined as follows:

1. Remove oily deposits by brushing with a suitable petroleum solvent.
2. Dry the plug thoroughly.
3. To remove remaining oxides, have the plug cleaned in an air-abrasive blast cleaning unit at a service station. Abrasive should be applied only about 2 to 3 seconds, being sure to wobble the plug in the rubber adapter during cleaning so abrasive can reach all areas of the firing end.
4. Reset gap to manufacturer's specifications, bending only the side electrode.
5. Check the sparking efficiency of the cleaned plug as in Fig. 2.
6. If the latter check is satisfactory, re-install the plug with a new gasket. ★ ★ ★

QUOTE:

"It took around 133 gallons of agricultural water to produce the breakfast you ate this morning. Your glass of orange juice took 18 gallons of water. If you had some peaches on your cereal, that item took 24 gallons; your bacon took 7 gallons, and your two eggs 28 gallons. Your glass of milk took 53 gallons. And your wife could add 6 to 9 gallons to all this for washing the dishes."

—ROBERT M. HAGAN
Chairman, Irrigation Department
University of California

A FINE CHRISTMAS GIFT FOR YEAR 'ROUND ENJOYMENT



**WELD FOR PLEASURE OR PROFIT
TRINDL INDUSTRIAL ARC WELDER**

Own a Trindl 125 Amp Industrial Welder at less than smaller machines. Welds metals to 1/2" thick. Operates off properly wired 110 or 220 volt line. 16 heat stages from 20 to 125 amps. Make, repair anything of metal in the home, garage, farm or shop. No experience or training needed. Full "do-it-yourself" instructions. Guaranteed 12 months in continuous operation. Complete only \$98.50 FOB or write for details on 125A and other Heavy Duty Trindl Welders. Dealer Inquiries Invited.



FREE
Write for
Details and
Easy Pay Plan

Trindl Products, Ltd., Dept. T2-N, 1807 S. Clark St., Chicago 16, Ill.

EASY TERMS
\$98.50 FOB



39" SHEARS

- Mfrd. by PEXTO
- 1/4" Cap. • 9" Shear Blade
- Shipping Weight—25 lbs.

\$14.50

F.O.B. Montebello

Send check or M.O.

30% Dep. with C.O.D.

HEAVY DUTY SHEAR

- Mfrd. by BARTH
- 1/4" Cap. • 5" Shear Blade
- Complete with Handle
- Shipping Weight—240 lbs.

\$69.50

F.O.B. Montebello

ROSEN'S ELECT. P.O. Box 189, Montebello, Calif.

AUTOMATIC

MAKES NEW
PROFITS

RETOOTHER

for HAND SAWS

Cuts new teeth in 50 seconds—any size 4 to 16 points. Old teeth fall off as chips. Easy to operate. A perfect job.

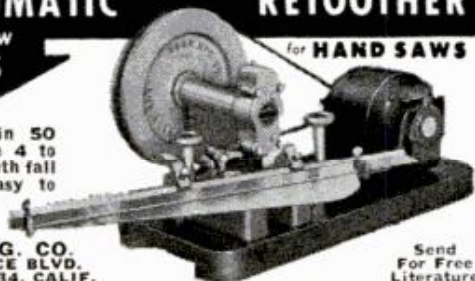

BURR MFG. CO.
8933-D VENICE BLVD.
LOS ANGELES 34, CALIF.

Send
For Free
Literature

SUBSCRIBE TO

**POPULAR
MECHANICS
MAGAZINE**

SAVE UP TO \$2.40!

Don't miss a single one of the great issues to come. *Subscribe and be sure!*

MAIL THIS COUPON NOW!

POPULAR MECHANICS, Dept. PM-1260
200 East Ontario St., Chicago 11, Illinois

Please enter my subscription to **POPULAR MECHANICS Magazine** for:

- ONE YEAR \$3.50** (Saving me 70c*)
- TWO YEARS \$6.00** (Saving me \$2.40*)

Please enclose remittance in full.

Name _____ Please Print

Address _____

City _____ Zone _____ State _____

*All savings based on single-copy price

TOOLS WHOLESALE

**\$100
PUTS YOU IN
BUSINESS**

Start your own business, sell tools to your friends and neighbors, or buy tools for your own use and **SAVE MONEY \$\$\$**

A MILLION DOLLAR INVENTORY AT YOUR FINGERTIPS. NO STOCK TO CARRY. ORDER AS YOU NEED IT.

BUY AT WHOLESALE PRICES. Extra \$25.00 profit on your accumulated purchases. \$1.00 refund on first purchase or refunded if you are not 100% satisfied.

THOUSANDS!! of Nationally Advertised items of Hand Tools, Power Tools, Machinist Tools, Tool Chests, Paint Sprayers, Light Fixtures, Appliances, Guns, Gifts, Toys and other items too numerous to mention.

WE SHIP COAST TO COAST

Whlse. Disc. up to 50% off

Dept. **SILVO HARDWARE CO., PM-12 107 Walnut St., Phila. 6, Pa.**

DRAINS cellars, cisterns, wash tubs; **\$7.95**
IRRIGATES - CIRCULATES - SPRAYS



1,001 uses. Stainless shaft. Won't rust or clog! Use 1/8 HP motor or larger. 3/4 HP for up to 2,400 GPH; 450 GPH 80' high; or 1800 GPH from 25' well. 1" inlet; 3/4" outlet. Coupling included free. **\$7.95.**
HEAVY DUTY BALL-BEARING PUMP. Up to 5,200 GPH; or 3,000 GPH from 25' well. 1 1/4" inlet; 1" outlet. **\$12.95**
Postpaid if cash with order. **MONEY BACK GUARANTEE**
Centrifugal and Gear Pumps in All Sizes
LABAWCO PUMPS, Belle Mead 7, New Jersey

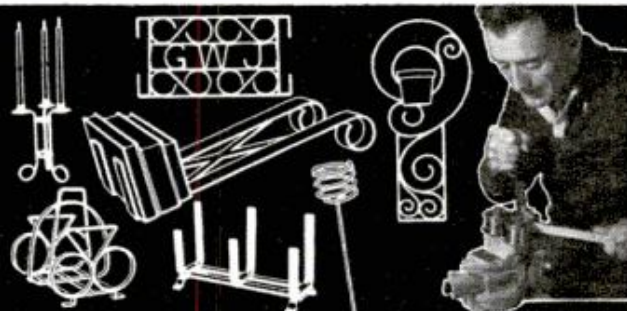

Make Wrought-Metal
Decorator Articles
with the

\$29.95

PREPAID

(34.95 west of Denver)

METL-FORMER

ROLLS • FORMS • BENDS

Save money . . . earn money in your home workshop with the Metl-Former. Make screen door guards, wall plaques, hollywood bed headboards, plant shelves, room dividers—anything you want in light wrought metal and with a truly professional appearance.

This tool rolls, forms, bends and serves as a vise. You can produce many useful and decorative articles of your own design or from the **FREE** project folder. It's easy! It's fun!

Write for complete information or order your Metl-Former now and receive a special assortment of **FREE** material to work with. (We can supply additional material at minimum cost.)

SWAYNE, ROBINSON & CO.

226 E. MAIN ST., RICHMOND, INDIANA

FOR PANELING... BUILT-INS... CABINETS... FURNITURE

The Complete Interior

WOOD FINISH

in One Can

READY TO USE

A finer clear, semi-gloss for natural wood beauty. Non-darkening. ANYONE can use Deft... it's so easy.

Wherever paints are sold, or write Dept. SSPM
Deft, 1526 W. 228th St., Torrance, Calif.



Free Shop Chart on Wood Finishing,

Write Dept. SSPM.



Automatic Saw Set...

MAKE EXTRA PROFITS!

Set 400 teeth per minute on hand or band saws, 4 to 16 point, with the BeMaCo Automatic Saw Set. Fast, accurate, true hammer-anvil action sets teeth uniformly, eliminates tooth breakage. Used profitably by saw shops and manufacturers everywhere. Every machine positively guaranteed! Write for details—today!

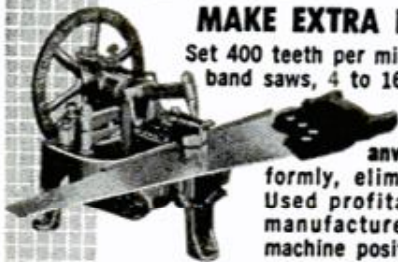

BEAVER MFG. CO., P.O. BOX 434, 800 So. Isis Ave.
SAW DIV. 3K Inglewood, Calif.

SMALL! POWERFUL!

ECONOMY TRACTOR

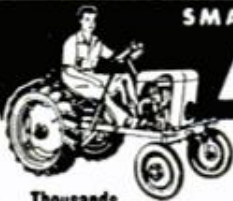

Thousands in Use

Write for complete details.

Engineering Products Co.
1005-K-12 Anoka Ave.
Waukesha, Wis.

Unequaled value! Low price! America's finest tractor. Ruggedly built. Easy to operate. 790 lbs. Borg-Warner clutch, trans. and diff 140 to 1 reduction. 40% more drawbar pull than ordinary tractors 8-1/4 H.P. engine. 20 quick change implements. HOOD, FENDERS.

use the solder that most home owners use!



KESTER SOLDER

For your electrical work, radio-TV, do-it-yourself projects... always use the best... KESTER SOLDER. Send for FREE 16-page book that tells you how!

KESTER SOLDER COMPANY

4251 Wrightwood Avenue • Chicago 39, Illinois

OVER 60 YEARS' EXPERIENCE IN SOLDER AND FLUX MANUFACTURING

Greatest Atom Gun Blasts Off

(Continued from page 96)

the proton bullets like beads on a string. Radio frequency booster stations along the way speed them up to one-third the velocity of light, and they are swept into the "third stage"—the huge circular tunnel—with an energy of 50-million electron-volts.

Once in the half-mile raceway, the proton "bunches" are smoothed out. The beam is guided into orbit by a string of 240 strong-focusing magnets. These monsters, each about seven feet long, C-shaped in cross section and weighing more than 16 tons including copper coils, are the real core of the Synchrotron. The vacuum pipe carrying the proton beam is only 7 inches wide by 2 3/4 inches high. It rests like a stretched-out doughnut inside the jaws of the magnet.

"The strong-focusing principle is relatively new," explains Julius Spiro, one of Brookhaven's top engineers. "It enables us to reach 30 BEV with magnets a fraction the size of those used by the Russians in their gigantic machine, which has yet to reach its advertised 10 BEV as far as we know." Half the magnets have jaws bowed outward for vertical focusing; the rest bow inward to keep the beam tight and true horizontally. Each magnet section bends the proton beam 1.5 degrees.

While the magnet ring keeps the bullets on course as they *zing* around the big circle, 12 radio-frequency stations along the way give them an 8000-volt kick every time they pass—for a total 100,000 electron-volts per circuit. By the end of the one-second acceleration period, and some 300,000 revolutions, the flying protons have achieved 30 BEV of energy and are moving at approximately 186,000 miles per second (the speed of light)!

Once the AGS has produced its high-energy beam, the idea is to do something with it. This is accomplished in two ways. At various places around the ring, "flags" of material—copper grids, quartz plates, and so on—containing atoms that scientists want to study, can be flipped into the path of the proton beam inside the vacuum pipe. In the ensuing collision, atomic debris flies off and is painstakingly examined.

More interesting and productive is the "ejection" system that is expected to go into operation soon. Using powerful magnetic force, the beam will be bent out of the circle and shot into a 250 by 100-foot "target building" piled high with concrete blocks to contain radiation from the atomic collisions. The particles will be directed against targets and the explosions analyzed.

(Continued to page 250)

SURPLUS SALE

GOVT SURPLUS
EXCESS INVENTORY
BANKRUPT STOCK

GOVT. GEARED BATTERY MOTOR

• ITEM #573. Powerful geared-down motor. Runs on 6 or 12-v. Use for golf cart, boat, farm winch, etc. Reversible. Speed 25-85 rpm. Wt. 35 lbs. Govt. cost \$250. **\$18.95 FOB**



• Many other values—get catalog.

115-V AC WATER PUMP



• ITEM #246. Genuine Surplus. Rupp electric pump. Use for draining, circulating, empty tubs, fluid transfer. Rustproof housing. Cap. 500 gph. 1" outlet and inlet. 7" x 4" x 4". Wt. 5 lbs. SALE Ppd. **\$8.95**

HYDRAULIC EQUIPMENT BARGAINS



Savings to 80%. Build loaders, diggers, presses, etc. All brand new.

- Control Valve, 1 or 2 way . . . \$18.00 Ppd.
 - Tractor Pump 1000 psi 45.50 Ppd.
 - 12-v Motor & Pump 1000 psi. 16.95 FOB
 - 2-way cyl, 2 1/2" bore, 9" str. 12.91 FOB
 - Hyd. Press-gauge 1500 lb. . . . 3.49 Ppd.
- Many other types, sizes, items.

STANDARD DIAL PHONE



• ITEM #716. Genuine W.E. modern, hi-efficiency dial phone. Use for extension to main line on private system. Use several for complete private system. Work on any system. Shipping weight 8 lbs. Cost **\$9.25 FOB** gov't. \$29.50. SALE

Shipping weight 8 lbs. Cost **\$9.25 FOB** gov't. \$29.50. SALE

TRUCK-BOAT WINCH



• ITEM #311. Powerful ball-bearing winch. Reversing switch mounted on winch. For cars, trucks, docks. Use on 6 or 12-v battery. 1000-2000 lb. pulling capacity. Will hold up to 40' cable. Wt. 54 lbs. Govt. cost \$280. **\$46.75 FOB** SALE

lb. pulling capacity. Will hold up to 40' cable. Wt. 54 lbs. Govt. cost \$280. **\$46.75 FOB** SALE

POWER PLANTS

• Amazing buys in DeLuxe Govt. 115-v. 60-c plants. Large selection.



- | | |
|-----------|----------|
| • 1000 W | ALL FOB |
| • 1500 W | \$159.95 |
| • 3000 W | 179.95 |
| • 5000 W | 249.50 |
| • 10000 W | 449.50 |
| • 3000 W | 595.00 |
| DC | 169.50 |

CHRISTMAS GIFT SPECIAL! EXPERIMENTAL GENERATOR



• ITEM #670 . . . Wonderful gift for the young experimenter. Perform many fascinating, educational experiments. Helps teach AC theory. Use for fun at parties, etc.

• Has Super-Alnico magnets. Produces 110-V AC. Creates powerful electrical field. Use also as fish worm shocker, clear private ponds of coarse fish. Instructions furnished. Gov't cost over \$12.00 Sale **\$3.89 Ppd.**

EXAMPLE BARGAINS IN NEW CATALOG

- \$ 6.00 V-R 4 digit counter. . \$ 1.69 FOB
- \$504.00 FM Radio Transmitter. \$13.95 FOB
- \$ 16.50 Immersion Htr. 115-V \$ 3.95 FOB
- \$230.00 Gear Reducer 140 to 1. \$29.75 FOB
- \$ 65.50 Self Prime Pp. 40 gpm. \$22.90 FOB
- \$175.00 Electric Hyd. Pump. . \$16.95 FOB
- \$ 27.95 Battery Charger 6-12-v. \$16.95 FOB
- \$ 47.00 AC, DC 10,000 rpm mtr. \$ 4.95 FOB
- \$ 67.50 2 Cyl. Air Compressor. \$54.75 FOB
- \$ 52.00 Cathode Ray Tube (905) \$ 4.91 Ppd.
- \$300.00 Welding Gen. Pl. . . . \$16.95 FOB
- \$ 30.00 Hand Winch
1500 lb. cap. \$15.95 FOB

Save to 70% on 1000's of Surplus and New Equip't. Bargains.

**MONEY BACK
GUARANTEE
ON ALL ITEMS**

Write for
FREE
BIG 1960
CATALOG

SURPLUS CENTER
LINCOLN, NEBR DEPT 814

INCREASE HOME VALUE-MAKE NEEDED IMPROVEMENTS NOW

NEW TRUE LAPSTRAKE KIT FREE CATALOG

MASS PRODUCTION PRICE

Only **\$205** Freight Incl.

TAFT MARINE WOODCRAFT

World's largest kit builder—cruisers, runabouts, fishing boats.

Dept. PM-1260 636-39th Ave. N.E., Minneapolis, Minn.

BREAKS THE GRIP OF RUST

KROIL, the amazing chemical lubricant, creeps into millionth inch spaces and loosens frozen metal parts when all others fail. Used by 25,000 leading industrial shops.

8 oz. spout can **65c** at your dealer.

KANO LABS Nashville 11, Tenn.

MAGNETS

TSX-15 Magnet Assembly (150 lb. pull) Each . . . \$9.50

TS-1 Magnet Assembly (50 lb. pull) Each 2.95

TSX-15 TS-2 Alnico 5 Pot Holder Magnets 50 for \$3.50, 20 for 1.50

TS-4 Pencil Magnet with clip, 29c each, 4 for 1.00

TS-5A Rectangular U's (4 lb. pull) 10 Magnets. 3.25

TS-6 Sample Magnets & Catalog (over 200 sizes listed) 25c

Money Back Guarantee—Send check or money order, sorry, no C.O.D.'s

TERRY SALES CORP., 1043 Silver Beach Rd., Riviera Beach, Fla.

Parker Line No. 10

WOOD BORING DRILL SET

EXTRA WIDE RANGE 1/4" TO 1 1/4"

For your 1/2" POWER DRILL (3/8" Shank)

8 different bits to bore holes: 1/4", 3/8", 1/2", 5/8", 3/4", 7/8", 1", 1 1/4" and 1 1/2".

12 pieces set in the sturdy plastic case and wrench.

Power, cleaner boring in all woods, panel board, plaster, compositions, plaster, gypsum, masonry or dry wall. ANGLE, pre-ford, fine and grain.

PARKER MANUFACTURING CO. Worcester, Mass. U.S.A.

Now!

A Wood Boring Drill Set

with an extra wide range from 1/4" to 1 1/4"

Yours for only \$2.75

New 10 piece set fits all 1/4" electric drills and drill presses. Bore faster, cleaner, truer holes in wood, plastics, panelboard, plaster, compositions. New plastic case gives you permanent, moisture resistant container for your bits. Hardened tool steel — rugged construction. Sold at leading hardware stores.

Set includes universal shank and wrench.

Buy the **Parker Line**

PARKER MANUFACTURING CO.
WORCESTER 1, MASS., U. S. A.

**LEAKY
TUB
JOINTS?**



Seal 'em with DAP®



DAP Kwik-Seal® puts a smooth, white, water-proof seal around tub, sink and lavatory joints in minutes. Good for pointing tile joints, too. Easy-to-use tube has handy dispenser nozzle. Get DAP Kwik-Seal® and other nationally advertised DAP products at hardware, paint and building supply dealers everywhere. Write for free do-it-yourself folder.

DAP

CAULKING COMPOUNDS
GLAZING COMPOUNDS
TUB AND TILE SEALER
SPACKLING COMPOUND

DAP inc., General Offices: Dayton 31, Ohio

GUNK® degreases

At better automotive supply and hardware retailers everywhere.



Cleans engines, garage floors, power mowers, greasy walls economically and safely.
In aerosol or pour spout cans.



GUNK CHICAGO CO., River Forest, Illinois
serving the Midwest and Southwest
RADIATOR SPECIALTY CO., Charlotte, No. Carolina
serving the East, Southeast and far West

When proton bullets hit target nuclei, subatomic particles fly off in all directions—some of them striking and smashing other particles in secondary collisions. Since many of these tiny bits of matter are born, shoot away at the speed of light, and “decay” into other particles or spent energy all within a fraction-of-a-millionth of a second, it takes some tricky equipment to watch them go. In the Brookhaven target building, scientists will use a variety of devices:

Colliding particles will zip through stacks of photographic plates, etching their routes and collisions in three dimensions through the layers of emulsion. Scintillation counters will produce tiny splashes of light as particles pass through their crystals or liquid solutions. Each flash, picked up by photoelectric cells, will be recorded for later study—revealing important data on the decay times of various particles. Another device is the “bubble chamber.” In one 80-inch bubble chamber, the tank will contain liquid hydrogen under pressure at —414 degrees F. When a target is hit by the beam, and pieces of atomic nuclei penetrate the liquid in the tank of the chamber, the flying bits make the frigid hydrogen “boil” along their routes, due to the “heat” they generate. These bubbly tracks are photographed by special cameras located behind a glass wall of the chamber.

Out of it all will come more knowledge about the amazing structure of our universe. An advisory panel on high energy accelerator physics put it neatly in a note to President Eisenhower: “. . . We are peeling an onion layer by layer, each layer uncovering in a sense another universe; unexpected, complicated and—as we understand more—strangely beautiful.” ★ ★ ★

Do You Know This Old-Timer?

(Answer to quiz, page 33)



Pope-Toledo circa 1901-02

WAR SURPLUS 40 COINS BARGAINS **SAVE UP TO 90%**

REVERSIBLE RATCHET WRENCH Use for oil rigs, bridge bldg., combines and heavy equipment. Hi torque, delivers tremendous leverage. 4" handle with reversible ratchet. 4 hexagon nut sockets — 2 3/8", 2 — 9/16" and 3 — 1/4". Mfd. by Lowell. Approx. GOVT. COST \$215 per set. Wt. 50 lbs. NEW. Only **\$9.95** per set.

R3 GENERATOR Terrific for making arc welder, 3000 RPM. 30 V, 300 AMP output. Approx. GOVT. COST \$750. Like NEW. **\$29.95.**

BUILD YOUR OWN ARC WELDER, LIGHT PLANT OR BATTERY CHARGER \$37.50
Kit incl. 1 Navy NEA-5 Gen. combination AC-DC type. AC 115 V. DC 24 V.. 200-300 Amps. 2 complete generators in 1, yet no larger than reg. gen. Ideal for home, shop and farm lighting plants. Delivers 1200 Watts AC, DC side for charging batteries, welding and operating war surplus motors. Also in kit: 2 Voltage Regs., AC & DC, Reverse Current Relay, 30' New Welding Cable, 1 Ammeter, Rheostat, Electrode Holder, Toggle Switch, Welder's Shield, Wiring Diagram for kit. Wt. under 100 lbs. Approx. GOVT. COST \$650. Kit—**\$37.50.** Navy NEA-5 Gen. as above, purchased separately, **\$23.50.**

"DELUXE 11" ARC WELDING KIT
Consists of 200 AMP. Gen., voltage reg., ammeter, shunt, adjustable helmet, electrode holder, pr. welder's gloves, 30' welding cable, reactor coil, toggle switch, rheostat. Approx. GOVT. COST \$650. Units guaranteed pre-tested. **\$34.95** complete.

AIRBORNE ALL-PURPOSE ELECTRIC WINCH
Fully bearded 3 HP motor with a reduction of 240 to 1. Will operate on 6, 8, 12, 24 or 32 V. Will lift up to 2 tons. Safety clutch set at 3 tons. Fully reversible. Adjustable hand brake and lock. Drum will handle over 500' of 1/4" steel cable or 5/8" rope. A terrific, compact power takeoff for beaching boats, etc. Will work off any battery within the range from 6 to 32 V. Cost of this unit is less than an installation for a competitive brand. Shpg. Wt. 150 lbs. Complete, ready to run (less cable). Dim.: 8" W x 34" L x 18" H. NEW, **\$99.50.**

HEAVY-DUTY CABLE Size No. 0. Four layers insulation. Fiberglass jacket. Use as positive & negative electrode cables for arc welder. High amperage, late govt. spec. Anorox. GOVT. COST \$40. 50' lengths only—**\$14.50.**

WESTERN TOWN MOVIE SET — A great gift for youngsters. Realistic full color scale models (in 3rd dim.) of typical western street scene incl. ranch house, corral, barn, sheriff's office, wagon with wheels that roll, cowboys and horses in action (bldg. 5"x10" hi). Already cut and formed, quick and easy to assemble. Sturdily constructed, weighs 5 lbs. All 93 pieces, only **\$3.45** pld.

BENDIX GEROTOR PUMP & MOTOR — NEW!

Use wherever fluid pumping required. Excellent for hydraulic installations and as crankcase drain pump for marine engines. Has 3/4" pipe connections, built-in relief valve adjustable up to 1500 lbs. Max. cap. 6 GPM. 1 1/2 H.P., 24 V. motor. Use on 12 to 32 V. Approx. GOVT COST \$350. **\$10.95.**



SPECIAL ON \$4770 NAVY AIR-COOLED POWER UNITS

Tremendous power package. Can be used as a portable or stationary unit. Makes terrific welder. Great engine for 1/4 midget racers. 30D-1A Lawrence. 24V. 2 Cylinder opposed 4 cycle 10 1/2 H.P. Complete with various generators. Net wt. 180 lbs. Gross wt. 250 lbs. Like NEW. With 24 to 32 V. D.C. Gen., 160 to 200 amps, 2500 RPM **\$149.50.** With 24 to 32 V. D.C. Gen., 175 to 250 amps, 2500 RPM **\$155.75.** With 24 to 32 V. D.C. Gen., 200 to 300 amps, 2500 RPM **\$162.75.** With NEA-5 AC-DC Gen., 24-32 V. D.C. 175 to 220 amps, 110 V. A.C. 10.5 amps, 800 cycle, 1250 watts **\$167.50.** Engine only **\$137.50.**

ELECTRIC PUMP WITH CONTROL UNIT

Runs on 12 or 24 V. Centrifugal type. Draws 5.2 AMPS. Has built-in removable filtering screen. Great for bilge, circulating or sump pump... bait tanks, etc. Pumps 500 GPH. Complete with on and off switch rheostat, 2 speeds (hi & lo). Mfd. by Ingersoll-Rand. Shpg. Wt. 7 lbs. Approx. GOVT. COST \$195. NEW **\$8.95.**



BATTERY OPERATED CAPSTAN — Terrific

power for pennies. Use for rope rigging of any type as anchor windlass on boats. Can be bumper mounted for pulling power, lifting or dragging on jeeps, tractors, trailers, trucks and campers. Fully enclosed weather-proof case. 5 1/2" dia. spool. Capacity 2500 lbs. plus shpg. wt. 66 lbs. 18" L. (incl. spool) x 8" hi x 12" wide. 3 HP motor with tremendous reduction. NEW. Another Airborne exclusive—**\$89.95.**

140-1 REDUCTION GEAR For beaching boats,

winch, hoists. Ideal motor in golf or boy's electric car. DC motor & clutch. Easily reversible wiring diagram furnished. Hi torque, 105 RPM. Runs on 6-12 or 24-32 V. 65 lbs. gross, Approx. GOVT. COST \$300. **\$12.00.** Matched splined gear — **\$3.00** ea. **c225-1 Reduction Gear — \$13.50.**



AIR FORCE & NAVY BUBBLE SEXTANT

(AN 5851) The finest navigational aid on land, sea or air. Adjustable bubble and nite lite, built-in averaging device. Both artificial and natural horizon. Comes complete with filters, astigmatizer, batteries, carrying case & instruction book. Approx. GOVT. COST \$586. Like NEW. **\$16.50.**

NEW 1961 CATALOG!

Tremendous catalog—our biggest ever—fully illustrated—1000s of bargains in war surplus & other items. Send 25c in coin for your copy today or free copy with order. Where pd. indicated applies to US only. Other prices FOB Culver City, Cal. Send cash, check, money order. 50% dep. COD.



AIRBORNE SALES CO., INC. DEPT. PM 1260

8501 Stellar Drive, Culver City, Calif



Lucky Tractor Driver Pilots 10 Italian Girls

Italy, which overflows with beautiful women, has the happy problem of finding room for all of them. A tractor has been

equipped to seat 10 rice workers. The women, who formerly walked, now leisurely plant crops from their perches.



Fish Thermometer Also Measures Depth

Surest way to locate fish, especially when they're down deep, is to find the level where the water is at their favorite temperature. A new depth and temperature indicator works like the usual sounding lead, but the weight carries an electronic thermocouple and the line is a light, flexible wire. You read the depth on the marked wire, and read the temperature at that depth on a dial. The outfit comes with a chart of favorite temperatures.



Motor Up Front On Three-Wheeler

Mounted on the front wheel, the engine of a three-wheel truck eliminates the drive-shaft assembly and allows the vehicle to perform a variety of farm or industrial chores. The simple rear end is adaptable to a number of different truck bodies; the short turning radius makes it highly maneuverable; and the simplified controls allow one man to operate the vehicle from the cab or even from the ground. It has four speeds forward, from 2 to 15 miles per hour, and one reverse.



Helping "Hand" Lifts Many Eggs

Egg "factory" workers can pick up as many as 48 eggs at a time with a new vacuum egg lifter, and hold them gently but securely while transferring them from box or conveyor to cases or crates. The rubber vacuum cups, connected to an exhaust pump, suck the eggs up firmly, and automatically space them to fit the crate, then release them when the operator opens a valve.

EPOXY-ADHESIVE WORKS LIKE PUTTY SETS HARD LIKE METAL

Repairs
FENDERS • MUFFLERS
RADIATORS • BOATS
MACHINERY

IT'S EASY TO USE!
THRIFTY KIT .98c ppd.



#1100
WILHOLD GLUES, INC. • CHICAGO 12 • LOS ANGELES 31

Send 10¢ for a complete illustrated catalog to:



2202 Santa Fe Avenue, Los Angeles 54, California

NOW! EVERYTHING YOU NEED TO BUILD Authentic Scale Model Trains in "O" Gauge

Scale Locomotives—Steam & Diesel, Scale Freight & Passenger Cars, Scale track supplies, Parts, Structures, Materials, etc. Everything you need to the smallest screw.

GET OUR BIG ILLUSTRATED CATALOG NOW!
See The Wonders of True "O" Gauge Model Railroad.

Send \$1.00 TODAY (refundable on orders) to . . .
ALL-NATION HOBBY SHOP
Dept. C. 182 N. La Salle Street, Chicago 1, Illinois

"WE DISCOVER
A
PHANTOM
COAST"—

in the January issue the deputy commander of a U.S. Navy expedition tells the adventure-packed story of a voyage of discovery into a hitherto unknown region of Antarctica



(Item 24) 700 Watt, push button start, 115 v. 60 cyc. AC. 2.2 HP, easy starting Briggs eng. No wiring necessary: just plug in and operate. Plenty of current for any oil burner, freezer, brooder, emergency lights, etc. which require up to 700 watts. Ideal for television and radios. Complete with voltmeter and built-in winding to charge auto batteries. (Item 24) Wt. 75 lbs. Easily fits in car trunk. Be prepared if storm knocks out power lines. Reg. \$275. . . . \$149.50

1500 Watt Plant (Item 45) same as Item 24 but larger generator and engine with 50% greater output. . . . \$199.50
ELECTRONIC BRAIN Now Available On All Our Plants—Write



Use as portable or shop welder. Up to 300 amps, Senior model. Made for years of trouble-free, continuous service. Will handle light or heavy jobs. Easily welds up to 3/4" plate using 3/4" rods. Built-in air cooling system. Arc is easy to strike and hold, because of specially designed arc stabilizer. Hi-lo switch and dial control gives wide range of welding heats. Run welder at 2600 rpm. with tractor, jeep or 15 hp. gas engine, and triple V belt or flat pulley. You can pay more, but you can't buy a better welder. Wt. 110 lbs. \$400.00 value. . . . \$119.50

WELDING KIT. Two 10 ft. leads, welding helmet, electrode holder, ground clamp. Sold only with welder at. . . . \$10.50

STANDARD DIAL PHONES
Western Electric dial phones same as used by all telephone companies. Ideal as extensions on any system. Phones are converted to work without central station for use as private communication systems. Merely dial to ring other party. Rings loud and clear. Several may be connected on same line. Fine for long distances. Standard 110 v. current used one end. Needs 4 cond. wire for private line.
Item 855 Wt. 8 lbs. each. . . . \$8.95
Wire—4 cond. 22 gauge, 250 ft. coil. . . . \$4.95
Wire—4 cond. 19 gauge (for distances over 500 ft.) 250 ft. coil \$7.95

HEATING AND VENTILATING FAN
(Item 10) Easily installed in furnace pipes. Forces even heat to all rooms. Over range removes kitchen smoke and odors. Powerful, continuous duty motor, 110-120 v. AC. Mount in wall or ceiling to ventilate any area. Quiet, super-efficient fan moves huge volume of air. (400 to 600 CFM).
8" Pipe, wt. 5 lb. . . . \$6.85
10" Pipe, wt. 6 lb. . . . \$7.85
12" Pipe, wt. 7 lb. . . . \$8.85
14" Pipe, wt. 8 lb. . . . \$9.85

HEAVY DUTY FAN. Semi-enclosed motor, suitable for spray booths, restaurant exhausts, poultry houses, etc.
10" Fan, wt. 8 lbs. (Item 10E) . . . \$11.95
12" Fan, wt. 10 lbs. (Item 10D) . . . \$12.95
HIGH SPEED BARN FAN similar to above, but larger, high speed motor moves huge volume of air.
12" Fan (Item 10F) . . . \$14.95
14" Fan (Item 10G) . . . \$17.95

Heats instantly anything from a cup of water to a washtub full . . . much faster than any stove or costly heater. Indispensable for laundry, dishes, baths, etc. Terrific for coffee, tea, soups. Made of unbreakable shock proof "Nyalite." Simple and cheap to operate . . . just plug it in. 1200 watts. 115 v. A.C. Money back guarantee. Item 856. Shipped prepaid. . . . \$3.95
Send 10¢ for 100 page Catalog—FREE with order. Prices f.o.b. factory—Send check or M.O.

ZIP INSTANT WATER HEATER



MASTER MECHANIC MFG. CO., Dept. A-126, Burlington, Wis.
Southern Customers Order from Dept. A-126, Box 65, Sarasota, Fla.

Shop PM Ads for Exciting
Direct-Mail Offers

CRAFTSMEN—GET NEW 132 PAGE CATALOG



WOOD

and Workshop Supplies, Equipment
World's Largest Selection, Rare, Fancy & Imported Woods, Mosaic Tile, Lamp and Upholstery Supplies, Tools & Hardware! ALL AT MONEY SAVING PRICES! . . .
Send for this complete new wood buying guide and project book. Craftsman is your best, most complete source of finest kiln-dried domestic and rare imported woods, beautiful wood inlays, colorful bandings, matched plywoods, embossed moldings, carved ornaments, newest woodworking tools, "hard to find" cabinet hardware and fittings . . . more than 1,500 items! Packed with new patterns, project ideas and money making plans. Enclose 25¢ (refunded with first order) to help pay mailing and handling cost. Write: **CRAFTSMAN WOOD SERVICE CO., Dept. A-12 2729 South Mary St., Chicago 8, Ill.**

NOW—Stanley Power Tools at Discount Prices!

Материал, защищенный авторским правом



there's **MAN SIZE SPORT**
when you're at the control of a

Thimble-Drome

INTERNATIONALLY RECOGNIZED AS
THE VERY FINEST IN POWERED MODELS

king
size

Comanche



Largest Plastic
Model Plane on
the Market!

Fully Assembled,
Powerful Sportsman .15 Engine,
T-D Control Handle and
Lines included.

An exciting challenge to fly—with more than 3 times the power of any previous ready-to-fly plane... yet completely controllable by anyone experienced in model flying! Almost yardstick broad, the 32" wingspan **COMANCHE** looms **BIG** on any flying field. Color striping and details are completely authentic from VHF antenna to landing gear covers! Even a king couldn't buy finer beauty, performance and dependability than this king-size aristocrat from Thimble-Drome craftsmen!

\$25.00

Sup. Ret.

PT-19 Flight Trainer

ALL NEW from Thimble-Drome!
The finest flying plane in the
.049 Ready-to-Fly class
—bar none!



Wingspan 22"

Fully Formed
Fuselage. Instant-
Starting Babe Bee
.049 engine. T-D Control
Handle and Lines included.

For the seasoned flyers, here's flight performance they've never gotten before out of an .049... yet for the beginner it takes the roughest student landings without costly crack-ups! With T-D's **slip-together** rubber band assembly, its almost indestructible parts merely separate... reassemble in seconds to fly again! Unique engine-thrust adjustment gives you **time to think** about controls, brings instant flying confidence. Adjusts with experience right up through primary maneuvers. Get the Thimble-Drome PT-19 and join in the greatest sport of all—POWERED MODEL FLYING!



THIMBLE-DROME
FUELS

Bring out the best
performance from
any engine.

\$9.00 Sup. Ret.
Pint 95¢ (slightly higher in Canada)
½ Pint 50¢

Illustrated Catalog PM12
on request.

At all hobby shops—most toy and dept. stores
L. M. COX MANUFACTURING CO., INC.

World's Largest Manufacturer of Ready-to-Fly Planes and Engines
P. O. BOX 476A • SANTA ANA, CALIF.

The Magic Box That Reads Russian

(Continued from page 112)

trusting machines. Even geniuses have found it impossible to express some ideas with high fidelity in a different language from that in which they were first put. Undetected errors in translations could do more harm than no translations. More rather than fewer bilingual persons will continue to be needed.

M.I.T.'s great mathematician, Prof. Norbert Wiener, thinks "the boundaries of words in different languages are too vague and the emotional and international connotations too extensive" for machines to handle well. But M.I.T.'s famous pioneer in computing machinery, Dr. Vannevar Bush, believes that machines may be made to exercise as good judgment about words as some people do, "particularly when they get to translating in a subject which they do not understand."

Although machine translations can be produced more cheaply—and faster than anyone can read them—no one yet knows how to make a machine produce as smooth and accurate a translation as a bilingual person can.

The obstacles, in fact, are so numerous that one of the most widely known pioneers in machine translation, Professor Dostert of Georgetown, has suggested that a National Institute of Language Science, similar to the national institutes of health, is needed to direct the attack on them.

Theoretically, according to Prof. Richard P. Feynman of the California Institute of Technology, all of the information in all of the books in the world could be so compressed that it could be carried around in your hand. Hence, it would be ridiculous to conclude that translating machines cannot be made smaller than those now used.

An interpreting telephone—such as that described in *Popular Mechanics* 50 years ago—would not have to read, but would have to understand speech. IBM is working on a Stenewriter now with which it hopes to produce printed English versions of Russian speeches as they are received by radio. In principle, too, a reading machine called the Perceptron, developed at the Cornell Aeronautical Laboratory, could be made to hear. The interpreting telephone also would have to speak.

Mountains of both basic and applied research remain to be done. As this magazine's editor wrote when the interpreting telephone first was envisioned, however: "Every great invention has appeared impossible to the many and difficult to most before its arrival, and very simple afterwards." ★ ★ ★

STANLEY

Christmas Specials so nice to give . . . so nice to get!

ATTRACTIVELY GIFT-PACKAGED! These fine Stanley tools have been especially selected for holiday gift-giving. And if you like to get as well as give, take this tip: Leave this page where it will do the most good! Simply write on it, "Here are the Stanley tools I want for Christmas."



FREE!

"WORKBENCH" magazine subscription for 6 months with any one of these Stanley tools in gift package.



STEELMASTER HAMMER only \$5.25

The finest hammer made. All-steel, perfectly balanced, non-slip grip.



NEW! KEYHOLE SAW—3 BLADES only \$3.50

Interchangeable blades can be faced in 8 positions. Use for wood, metal, even pruning bushes, trees!



STEELMASTER CAMP AXE— with leather sheath only \$7.70

The "most wanted" gift for the teen-age Scout or camper in your house. An all-steel beauty!



"YANKEE-HANDYMAN"[®] SPIRAL SCREWDRIVER only \$4.98

Quick return spring permits one-hand use. Extra bit, 3 drill points in handle. The complete tool.



STANLEY WOODWORKER'S VISE

only \$7.50

Clamps on bench, table top or saw horse. Pressed wood face plate protects the work.

STANLEY SMOOTH PLANE

only \$11.00

Preferred by 8 out of 10 woodworkers. Adjustable 2" blade.



SEE THEM AT YOUR NEARBY DEALER!

Stanley Tools
The Tool Box of the World
A Division of The Stanley Works,
New Britain, Conn.

STANLEY

®

Special "Workbench" Magazine offer ends Jan. 15, 1961 • Prices slightly higher in Canada.

SAVE 82% **SPECIAL HYDRAULIC CYLINDER SALE**

HVY. DUTY-2000PSI

Engineered for earth moving equip., tail gates, presses, agricultural equip., lift assemblies, industrial machines, etc. Ideal for backhoes and front loaders.

No. H-70A - Has 2-1/2" bore, 8-3/8" stroke, 1-1/2" shaft, 18-3/4" lgh. **988**

No. H-70E - Has 2-1/2" bore, 30" stroke, 1 1/2" shaft, 40-1/2" length . . . **2488**

No. H-70L - Has 3-1/2" bore, 43-1/2" stroke, 1-3/4" shaft, 55-1/8" lgh. **4488**

NOTE: Write for complete list of cylinders & info on Backhoes and Frontloaders.

21 to 1 SPEED REDUCER

Gives approx. 90 RPM with a direct drive, 1750 RPM motor. Can be belt driven with 1/2 HP motor. Ball bearings throughout. Precision built for Gun Control. **1188**

SAVE HYD. HAND PUMP 675

No. H-P3USU

Operates at 1500 PSI. Displaces .19 GPM at 30 cycles per minute. Has capacity of 1.5 cu. in. per a stroke cycle. Has built-in check valve. Regularly \$17.50

4-WAY HYD. VALVE

No. H-V7A-1 **395**

A spring loaded, poppet type valve. Pressure balanced. Off in neutral. Has 1/4" tube ports. Cost Gov't approx. \$30

SPECIAL AIR TANKS

G-1 TANKS - Stainless steel. Tested to 400 PSI. 12 1/2" x 24". 1/4" ports. Used - **1195**

NEW G-1 Tanks **15.95**

F-1 Stainless Steel TANKS - 500 cu. in. capacity. Size: 10" x 18" . . . **10.95**

D-2 Carbon Steel AIR TANKS - Tested to 400 PSI. Capacity 500 cu. in. Size: 6 1/2" x 24". D2-C - NEW . . . **595**

HYDRAULIC CYLINDERS

1500 PSI Double Action CYLINDER - Bore 1-1/2", Shaft 9/16", Stroke is adjustable 1-3/16" to 4-3/8", length 14-1/2". No. H-84 . . . **395**

1500 PSI - Double Action CYLINDER Bore 2-3/8", Stroke adjustable from 7-3/8" to 9-5/8", Shaft 7/8", eye-to-eye length is 20". No. H-17USU - Used . . . **788**

No. H-17NSU - New **\$14.88**

1500 PSI Hydraulic Cylinder with 11" long, 19 tooth rack. Double action type. Bore 1 1/2", Stroke 7 1/2", Shaft 1 1/16" Length with rack 23". Catalog No. H-98 . . . **775**

1/2 HP MOBILE AIR COMPRESSOR

Only **9950**

Specially designed to deliver 90 PSI. Can be adjusted up to 125 PSI. Displaces 2 1/2 cubic feet per minute. Complete with an automatic pressure switch, relief valve, pressure regulator, gauges, 15 feet of hose and a bio-gun. Compressor unit mounted on a 10-gallon stainless steel G1 tank and has rubber tired wheels and handle. Ideal for all types of paint spraying . . . **SAVE** at our special low price!

NEW HYDRAULIC "HI-LO" PRESSURE PUMPING UNITS

Will deliver total combined volume of both pumps of 21 GPM, at pressures up to 500 PSI, then delivers output of high pressure pump (4 GPM) at up to 3000 PSI. Both the pumps face mounted to 7-1/2 HP, double-end, 220/440, 3-phase, 60 cycle AC motor. Entire pumping unit mounted on 33 gallon reservoir (available without reservoir). Overall size: 35" long x 18 1/2" wide x 18 1/2" high. Other HI-Lo units available from 1500 PSI to 3000 PSI. Write for details.

No. DPR-21-3000 **785.00**

SAVE ON NEW PALLEY IMPORTS

NEW 100 TO 750 POWER MICROSCOPE

WITH TRANSFORMER and SUB-STAGE LIGHT

Has 100, 150, 300, 450, 500 and 750 power magnification with an illuminated sub-stage mirror and triple turret. Lenses are precision ground and polished. Turret has 10X, 30X & 50X lenses. Interchangeable eyepieces are 10X and 50X. Has plano sub-stage mirror plus sub-stage light which operates on either batteries or AC current from household outlet. No need for an external light. Complete with a fitted wood case.

IDEAL GIFT! **ONLY 14.88**

25 POWER 30MM TELESCOPE AND TRIPOD

688

CARRYING CASE \$2.00 extra

A gift for Sportsmen, Star Gazer, etc. 1 Of lightweight aluminum and chrome plated brass. Has sturdy swivel tripod. Field of view: 62 ft. at 1000 yds. With 1-3/16" objective lens. \$25.00 value.

from INDIA CARVING ENSEMBLE

\$3.88

Walnut and brass combine for eternal elegance. Case is hand carved by the native craftsmen with brass trim and legs. Walnut handled carving knife is 13" - companion fork is 11".

palley's

2263 E VERNON AVE., DEPT. PM-120
LOS ANGELES 58, CALIFORNIA

TO ORDER - Send check or M.O. 1/2 deposit with C.O.D.s. All prices are F.O.B. Los Angeles Warehouse. All items sent postage or freight collect.

Modelmakers in a Tizzy

(Continued from page 86)

proved under the National Defense Education Act and is being widely used in American schools.

Nowadays, Junior gets to play with model kits because Dad has his own. They provide "a legitimate source of pride, satisfaction and serenity," explains Dr. William Menninger, the mental health authority, commenting on the fact that modeling is becoming a prescription for relaxation.

It's not only father or son, but father and son when modelers get into railroading and powered aircraft models. Modelmaking is one of the few really big father-son sports, and this is particularly true of flying models. A real "first" in this field is a realistic flying model of the 1911 Curtiss Pusher, turned out by the L. M. Cox Manufacturing Company. Even the old bamboo braces and taut fabric are simulated in plastic. Another Cox model is a break-apart trainer. When it crashes, the sections fly apart to prevent damage. You merely reassemble them with rubber bands.

Today, adults are every bit as involved as their kids. As a matter of fact, people over 21 put together more than 40 percent of all models in this country! ★ ★ ★



Owl Aboard

Two wide-eyed, two-faced plastic owls have joined the crew of a "Texas Tower" built off San Diego, Calif., for Navy oceanographic studies. The high steel tower became a favorite gathering and roosting place for seagulls, who in turn became a noisy and unsanitary nuisance. After all the usual gull-shooing methods failed, the owls, which are made as decoys for crow hunters, were obtained and installed at the top of the tower. The gulls left in a huff and haven't returned.

See what you can do...easily, quickly ...with a SWINGLINE STAPLE GUN!

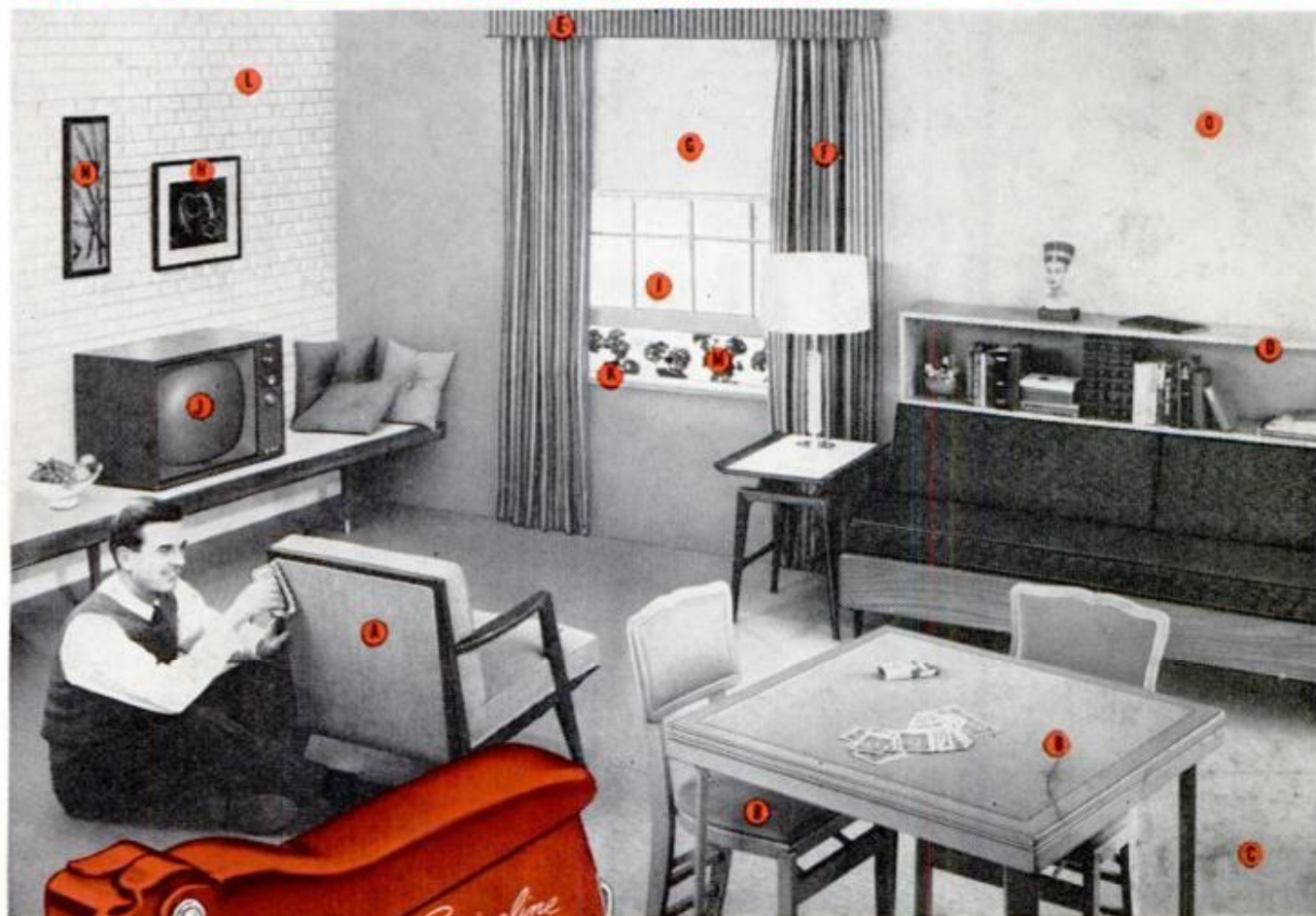

ONLY \$ **4.95** with
PUSH-BUTTON
LOADING

A SWINGLINE staple gun makes *immediately possible*—and *easy*—all those time consuming, hard-to-do chores both inside

and outside your home. This is a lightweight, maneuverable, *precision* tool that's so easy to operate even a housewife can use it. Drives those staple-nails flush and holds 'em tight!

The price? A hard-to-believe \$4.95—that's all! Your choice of Gray, Red or Green. Insist on a SWINGLINE staple gun—with push-button loading—at better hardware, department, stationery stores!

- Built-in • extractor
- Handle lock •
- Push-button • loading
- Rugged, heavy-duty • steel construction
- Load indicator •
- Open channel • takes 2 staple sizes: 1/4" and 5/16"

CHECK THIS LIST

- A—upholstering furniture
 - B—recovering card table and chairs
 - C—installing carpeting
 - D—shelf trimming
 - E—valances
 - F—hanging drapes
 - G—window shades
 - H—matting pictures
 - I—window screens
 - J—attaching TV antenna
 - K—weather stripping
 - L—installing plastic wall brick
 - M—making window boxes
 - N—wall decorations
 - O—insulating
- And hundreds of other uses.

FREE! Send

for Booklet "Tips for Tacking"

How to do many stapling jobs.



Swingline® INC. Long Island City 1, New York
World's Largest Manufacturer of Staplers For Home and Office!

Whether you give 'em
or get 'em this Christmas

...there's real
gift
excitement in

Weller® POWER TOOLS

It's a wise choice to give work-saving power tools at Christmas because any man will appreciate them. And it's a wiser choice to give Weller Tools because their fine quality and advanced features mean dependable performance.



**DUAL HEAT
SOLDERING GUN KIT**

Heat and spotlight come on instantly when you pull the trigger of this Weller Gun, and 2 trigger positions give 2 soldering temperatures. Switch instantly to the heat best suited for the job—90 or 125 watts. Superior tip has long reach, long life. Shockproof plastic housing. Kit includes soldering aid, cleaning brush and solder.

MODEL 8200K **\$795**

Single Heat Soldering Gun
MODEL 8100B—\$6.44



HOMECRAFTER KIT

Features the same heavy duty 250-watt soldering gun that's used by professional service technicians the world over. Instant heat. Twin spotlights. Long reach, long life tip. Perfect balance. Kit also includes metal storage case with handle, cutting tip, smoothing tip, tip interchange wrench, supply of solder and instruction booklet.

MODEL 8250AK **\$1495**

Heavy Duty Soldering Gun
MODEL 8250A—\$12.95



POWER SANDER

Big 25 sq. in. sanding surface and 14,400 strokes a minute make sanding fast and easy. Straight-line action—never bucks, twists or scars wood. Goes all the way into corners. Low design—gets under low places. Easy sandpaper replacement. Fingertip "on-off" control. Assorted sandpaper and polishing cloth included.

MODEL 700 **\$1348**

All Weller Tools are
guaranteed for 1 year

AT YOUR HARDWARE OR HOBBY DEALER • Weller Electric Corp. Easton, Pa.