

POPULAR MECHANICS

WRITTEN SO YOU CAN UNDERSTAND IT

*Hunter's "Centipede"
—page 113*



Huckleberry Hound - TV HIT FROM A CARTOON FACTORY
WE'RE LISTENING FOR OTHER WORLDS
How Do Owners Like the THUNDERBIRD?

Remember how great cigarettes used to taste?
LUCKIES STILL DO



CHANGE TO LUCKIES

and get some taste for a change!

TOBACCO AND TASTE
TOO FINE TO FILTER

© A. T. Co.

Product of *The American Tobacco Company* — "Tobacco is our middle name"

There's a Weldwood Adhesive for just about every gluing job

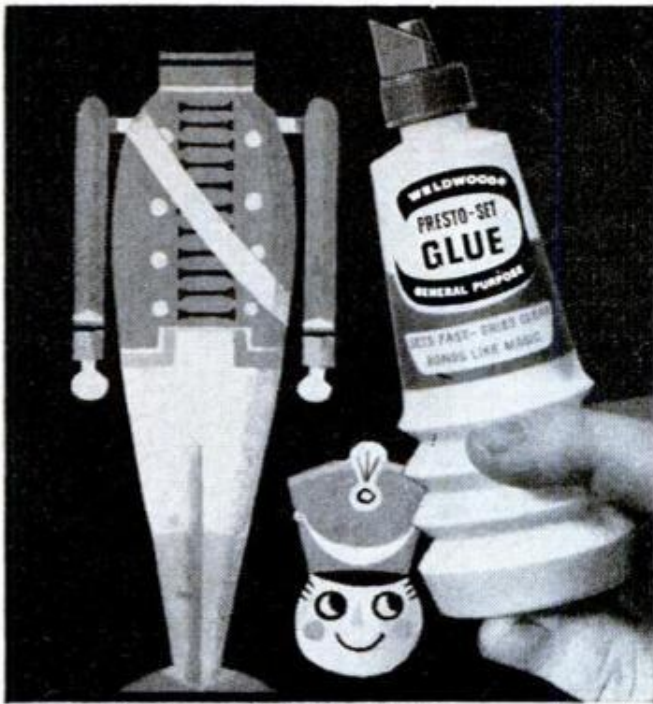

QUICK, CLEAN Presto-Set® Glue, the all-purpose glue, bonds paper, wood, cloth, china. Dries fast, won't stain. Handy new bellows-action squeeze bottles with spreader tops. From 39¢.



EASY-TO-USE Weldwood Contact Cement bonds leather, wood, plastic instantly, permanently, on contact. Needs no clamping; water-resistant, stays flexible when set. From 29¢.



STRONGEST of them all is Weldwood Plastic Resin Glue. Nothing like it for heavy-duty jobs. Makes joints even stronger than the wood itself. Mixes instantly, is water-resistant. From 40¢.



WATERPROOF and best for lawn furniture, boats, Weldwood Waterproof Resorcinol Glue makes a powerful bond on most porous materials. Resists rot, fungus, heat, cold. From \$1.15.

Each Weldwood® Adhesive has an important place in every home. In your kitchen, workshop, garage, family activities room, wherever repairs or projects go on in your house, one or more of these Weldwood work savers belong—there when you need it. Your hardware, lumber, and paint dealers stock all four—pick up your supply soon.

SEPTEMBER 1960

WELDWOOD
ADHESIVES

This One



ASL3-GXB-4UQG

Материал, защищенный авторским правом

POPULAR MECHANICS®

Address communications to: 200 E. Ontario St., Chicago 11, Illinois. **SUBSCRIPTION SERVICE:** Mail all subscription orders, changes of address, correspondence concerning subscriptions, and Postmaster notices of undeliverable copies to Popular Mechanics, 250 West 55th St., New York 19, N. Y.

Editor

RODERICK M. GRANT

Executive Vice-President

RICHARD E. DEEMS

Publisher

G. HARRY CHAMBERLAINE

Managing Editor

CLIFFORD B. HICKS

Shop Notes and Crafts Editor

WAYNE C. LECKEY

Associate Editor, General Features

JOHN A. LINKLETTER

Associate Editor, Automotive

JAMES R. WHIPPLE

Associate Editors, Shop Notes and Crafts

W. CLYDE LAMMEY, EARL WOBECK

Radio-Television, Electronics Editor

BYRON G. WELS

Assistant Editors, General Features

**JAMES BIERY, KEVIN V. BROWN
R. B. KIRKPATRICK**

Assistant Editors, Shop Notes and Crafts

GUERRINO F. AMATI, ROBERT L. HERING

Assistant Editors, Makeup

WALLACE MYERS, JEAN KAVANAUGH

Art Staff

FRANK BEATTY, Director

HENRY NEHRBASS, Assistant Director

RICHARD A. POTTS, Art Editor

Eastern Editor

RICHARD F. DEMPEWOLFF

959 Eighth Ave., New York 19, N. Y.

Western Editor

THOMAS E. STIMSON, JR.

Suite 1003, 3460 Wilshire Blvd.
Los Angeles 5, Calif.

Advertising Manager

JOSEPH R. BUELL, JR.

Director, Bureau of Information

ALLAN CARPENTER

Advertising Offices

Chicago: 200 E. Ontario St., Whitehall 4-0100;
New York: 959 Eighth Ave., Columbus 5-7300;
Detroit: General Motors Bldg., TRinity 5-8711;
Cleveland: Hanna Bldg., 1422 Euclid Ave.,
PRospect 1-0456; Los Angeles: 3460 Wilshire,
DUnkirk 2-8458; San Francisco: Russ Bldg.,
235 Montgomery St., YUKon 2-0823.

Published monthly by Popular Mechanics Company, 200 E. Ontario St., Chicago 11, Ill. Richard E. Berlin, President; Richard E. Deems, Executive Vice-President; Fred Lewis, Vice-President and General Manager; Robert F. MacLeod, Vice-President; John R. Miller, Vice-President; G. Harry Chamberlaine, Vice-President; G. O. Markuson, Treasurer; R. P. McCauley, Secretary. Single copy in the United States and Canada, 35 cents; subscription rates in the United States and possessions and Canada, 1 year \$3.50; 2 years, \$6.00; 3 years, \$8.00. In countries of the Pan-American Postal Union, 1 year \$4.50; 2 years \$8.00; 3 years \$11.00. In all other countries 1 year \$5.50; 2 years \$10.00; 3 years \$14.00. If you plan to move, notify us at least 30 days in advance so you will not miss an issue. Give both your old and new addresses. Second-class postage paid at Chicago, Illinois, and at additional mailing offices. Entered as Second Class Matter at Post Office Dept., Canada. Registered as Second Class Matter at the Post Office at Mexico, D.F., Mexico, June 29, 1950. © 1966 by Popular Mechanics Company. All rights reserved. Printed in the United States of America.

INTERNATIONAL EDITIONS

SPANISH: Mexico-Caribbean, Southern Hemisphere
FRENCH, DANISH, SWEDISH, GERMAN, PORTUGUESE, DUTCH

Volume 114

SEPTEMBER 1960

Number 3

In This Issue...

We're Listening for Other Worlds - - -	81
Movable-Wing Plane - - -	90
This Business of Spying - - -	94
Owners Report on the Thunderbird - -	102
We Need Safer Taillights - - -	109
TV Hit From a Cartoon Factory - - -	120
Eskimos Carve Soapstone - - -	134
Rehearse for the Hunt - - -	142

For the Craftsman...

Portable Saber Saw - - -	150
Make All-Metal Screens and Storm Sashes	162
Stretchy Tie-Downs - - -	165
Lumberyard Picture Frames - - -	168
Better Photos Are a Snap - - -	174
Chisel Tips - - -	188
In-and-Out Circles - - -	194
Radio, TV and Electronics - - -	205

Regular Departments...

GUIDE TO THIS ISSUE - - - 6

Know This Old-Timer! - - -	18	Spotlight: DKW 750 - - -	72
Pentagon Sidelights - - -	20	An Eye on Space - - -	88
Pioneer in Science - - -	22	Detroit Listening Post - - -	92
Tune In on the Inventors - - -	24	What's New for Your Home -	130
Keeping Up With the Atom - - -	26	Solving Home Problems - - -	158
Items From All Outdoors - - -	32	On the Market - - -	184
What's Up in the Air - - -	34	Shopping for Tools - - -	198
Science Bulletins - - -	37	Clinic for Homemakers - - -	212

Turn to detailed index on page 6. Sources of additional information on items in this issue are shown on the Where-to-Find-It List, available without charge by writing the Bureau of Information, Popular Mechanics, 200 E. Ontario St., Chicago 11, Ill.

Next Month...

DON'T MISS the most exciting annual home section ever—featuring full color plans and photographs of the PM House of Built-Ins. Designed especially for Popular Mechanics readers, the contemporary home has been duplicated in major population areas all over the country, and a complete list of sites will be printed. Also, in October, see pictures and specifications of 16 of the 1961 automobiles

POPULAR MECHANICS

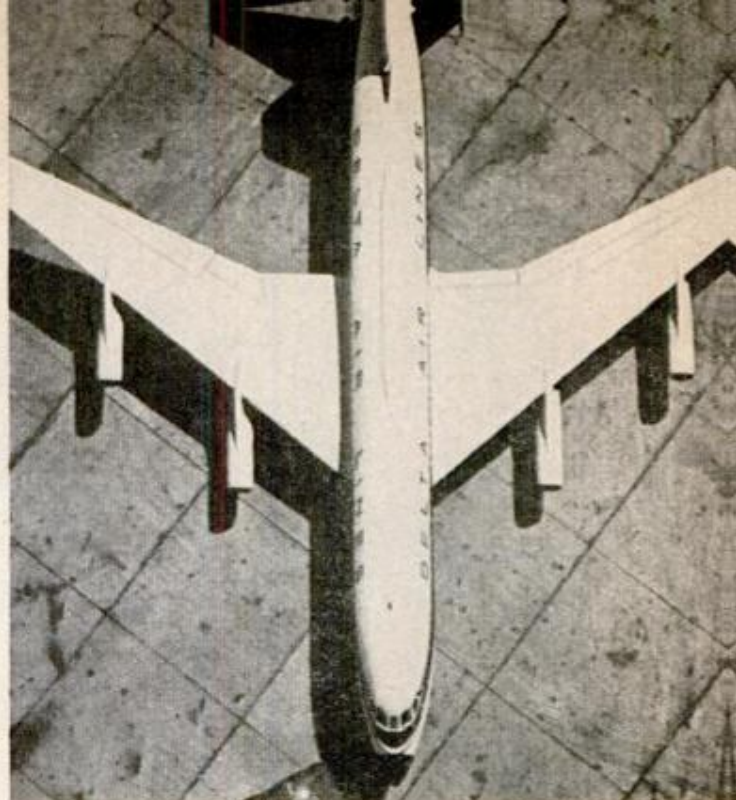
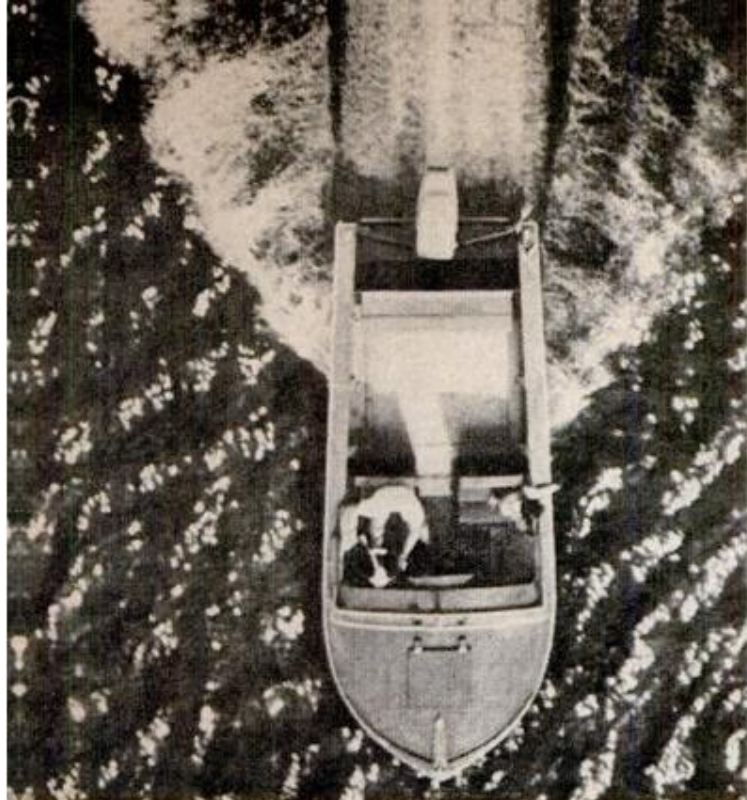

Every major U. S. outboard maker uses Champions

All U. S. jet engine manufacturers use Champions

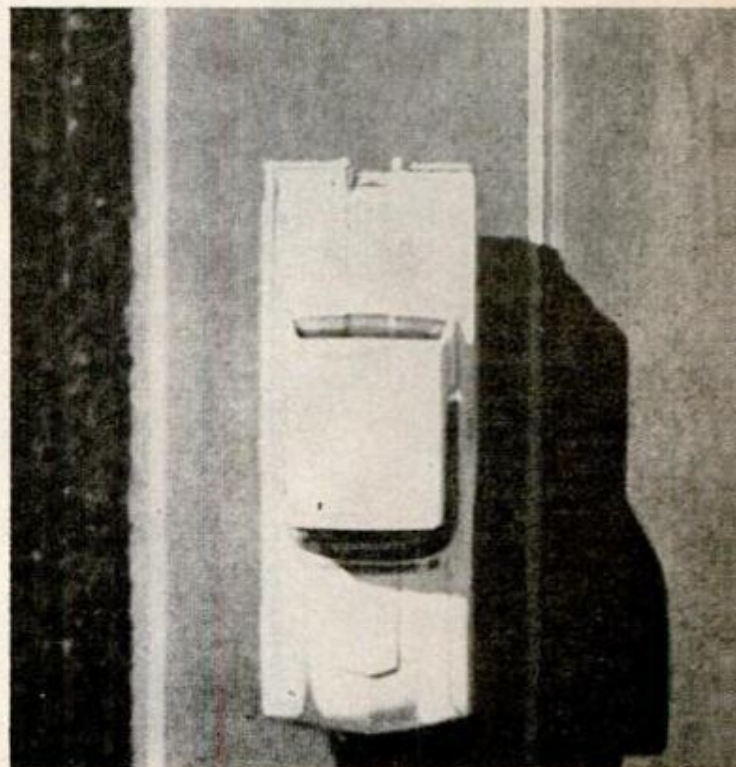
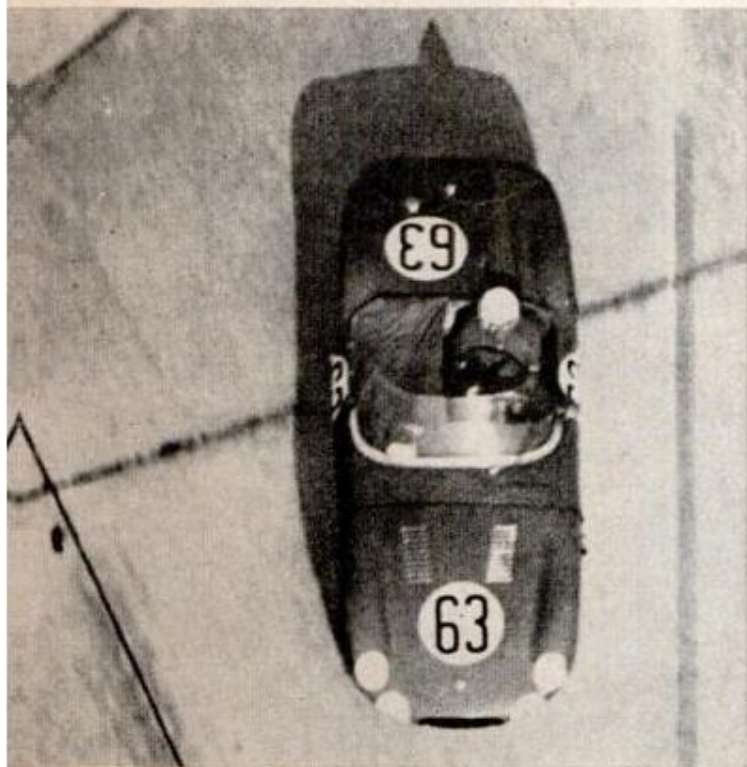

6 out of 10 winners at Sebring used Champions

Twice as many car manufacturers use Champions

Q. Why do the experts, in field after field, where performance is vital, choose Champion spark plugs?

A. Because they know they can depend on Champions to deliver every bit of performance from every drop of gas. Your car will perform better, too (and save money on gasoline) with new Champions. Put in a set every 10,000 miles!

*Worn spark plugs waste lots of gas—
so check your plugs every 5,000 miles!*



Manufactured in the U.S.A. by Champion Spark Plug Company



GRAVEL HAULER: Russ Crowell, Osceola, Arkansas. "You bet I'm on Firestones. Ordinary truck tires can't begin to take the beating I'll give them and still give me the wear Firestones will!"

HIGH-PERFORMANCE TIRES HUSTLE 18-TON LOADS OVER RUTTED ROADS

Firestone

proved where profit depends on performance

In this road-maintenance operation in Mississippi County, Arkansas, trucks spend their day hustling 18-ton loads of gravel over rutted roads to the work site. It takes tough, high-performance Firestone truck tires to survive such brutal daily battering! It takes Firestone Shock-Fortified cord and Firestone Rubber-X, the longest-wearing rubber ever used in Firestone tires. And it takes Firestone's 425-million-mile program of torture-testing to keep producing the industry's toughest tires every year. That's why, where profit depends on performance, truckers depend on Firestones. Get them at your Firestone Dealer or Store.

Copyright 1960, The Firestone Tire & Rubber Company



Transport*

Super Mileage Lug*

Super All Traction*

Rib Excavator*

Rock Grip Excavator*

All Traction*

*Firestone T.M.

*Here's owner proof of
Firestone truck tire
performance!*



SOD HAULER: Duane Wilson, Des Moines, Iowa. "I'd have real problems if I had tire troubles delivering a load of moist sod. That's why I buy Firestones 100%."



GRAIN HAULER: Richard Racette, Wichita, Kansas. "Hauling in and out of farm yards and out on the highway takes truck tires that can stand most anything. One thing sure . . . Firestones can take it!"



REFRIGERATION SPECIALIST: Bob Rich, Omaha, Nebraska. "Until I bought Firestones I couldn't keep tires on trucks . . . especially on rear wheels. I won't buy anything else but Firestones now!"

If it takes more
ACCURACY
 it's a job for a
**SOUTH
 BEND**
 10" lathe



- Accuracy that's a match for any job.
- Superfinished spindles with sleeve type bearings that hold tolerances for years.
- Hardened and ground bed ways optional for extreme conditions.
- Smooth, vibration-free operation for fine finishes.
- More usable power.
- 1-1/16" collet capacity—70 threading, longitudinal and cross-feeds.
- 14 engine and toolroom models.

PRICES START AT \$1454 F.O.B. FACTORY

WRITE for complete catalog of South Bend 9" to 16-24" lathes, turret lathes, milling machines, shapers, drill presses, pedestal grinders and attachments.



Up to 36
 months to pay.

SOUTH BEND LATHE
SOUTH BEND 22, INDIANA

Building Better Tools Since 1906

GUIDE TO THIS ISSUE

With Sources of New Products

Automotive

Do-it-yourself car kit (Lotus Engineering Co., Ltd., 7 Tottenham Lane, Hornsey, London N. 8).....	89
Drive-in vacuum cleaner (Vacmobile Mfg. Co., Old Oak Common Lane, Willesden Junction, London, NW 10, Eng.)...	101
Hunter's mountain car outperforms pack horse.....	113
Flying laboratory, (Bristol Aircraft, Filter House, Bristol, England).....	119
Light utility car for work or play (Saviano Vehicles, 14333 E. Ten Mile Road, Warren, Mich.).....	127
Two-story camper (Capt. Paul J. Woli, USAF, 433 Lewis Drive, Fairborn, Ohio).....	127
Volvo unveils sports coupe at international auto show (Volvo Import Inc., 357 Wilson Ave., Newark 5, N.J.).....	132
Jumbo truck tire replaces duals (The Firestone Tire and Rubber Co., 1200 Firestone Parkway, Akron 17, Ohio)...	141
Colored concrete for safer superhighways (Minnesota Mining & Mfg. Co., St. Paul 6, Minn.).....	145

Aviation

"Peaceful Torpedo" produces emergency power for navy jets (The Garrett Corp., Air Research Mfg. Div., Phoenix, Ariz.).....	93
Gyroplane "jumps" 200 feet at takeoff (Avian Industries Ltd., Georgetown, Ontario).....	114
Drifting parachute snatched by copter.....	118

Construction

Church of arches.....	115
French monorail train rolls quietly on pneumatic tires.....	148
"Stained-glass" window with blocks (Pittsburgh Corning Corp., One Gateway Center, Pittsburgh 22, Pa.).....	149

Miscellaneous

Collapsible fire escape folds up inside window (Marryatt, Lane & Co., Inc., George Washington Bridge Plaza, Fort Lee, N. Y.).....	93
"Wheel" digger gobbles big bites.....	101
Prerecorded tape cartridge player.....	107
Tractor engine powers ferry.....	107
Mobile missile system (United Steel Corp., 525 William Penn Pl., Pittsburgh, Pa.).....	108
Old cargo plane becomes mobile home.....	114
High-speed color movie film (Eastman Kodak Co., 343 State St., Rochester 4, N. Y.).....	115
Pirogue race.....	116
Quick-release lock collapses 'chute.....	118
Mechanical depth finder for fishermen (Brion Depth Finder, The Brion Co., Box 6363, Minneapolis 23, Minn.).....	128
"Sausage" barge carries 35-ton cargo, then rolls up for trip home (Dracone Operations Ltd., 52 Bishopsgate, London, E.C.2, England).....	129
Skirt boosts lure's allure (Ad-a-Lure, Gombor Enterprises, 12591 Glenfield, Detroit 13, Mich.).....	129
Canadian conservationists work to save grizzly bears.....	132
New infantry weapon in production (Colt's Patent Fire Arms Mfg. Co., Inc., Hartford 15, Conn.).....	133
Whimsical aluminum chairs look like people (Aluminum Co. of America, 1501 Alcoa Bldg., Pittsburgh 19, Pa.).....	137
Dike watcher.....	138
Army has movable missile tower.....	140
Portable Electric smoke house (Ewing Products, 1014 Burbank Blvd., Burbank, Cal.).....	140
Portable Refrigerator (Selectra Industries Ltd., 22 Dorchester Ave., Toronto 18, Canada).....	140
Mechanical hand picks up brush (Larry Redmond, Phoenix Garbage Service Co., Phoenix, Ariz.).....	141
How about a breath of oxygen for an after-work pick-me-up.....	146
Mirror magic.....	146

(Continued to page 8)

Are You "STANDING STILL" on your job?

**SAME OLD
JOB . . .
SAME LOW
PAY . . . ?**

You can justify a real pay raise and a better position—by making one simple move—the move that opens the way to more earnings and promotions—*practical training*.

If YOU are "standing still" on your job—no promotions—only token increases in pay—then you had better do something about it. You know that if you are untrained, your chances of getting ahead are slim. **NOW IS THE TIME TO PREPARE.**

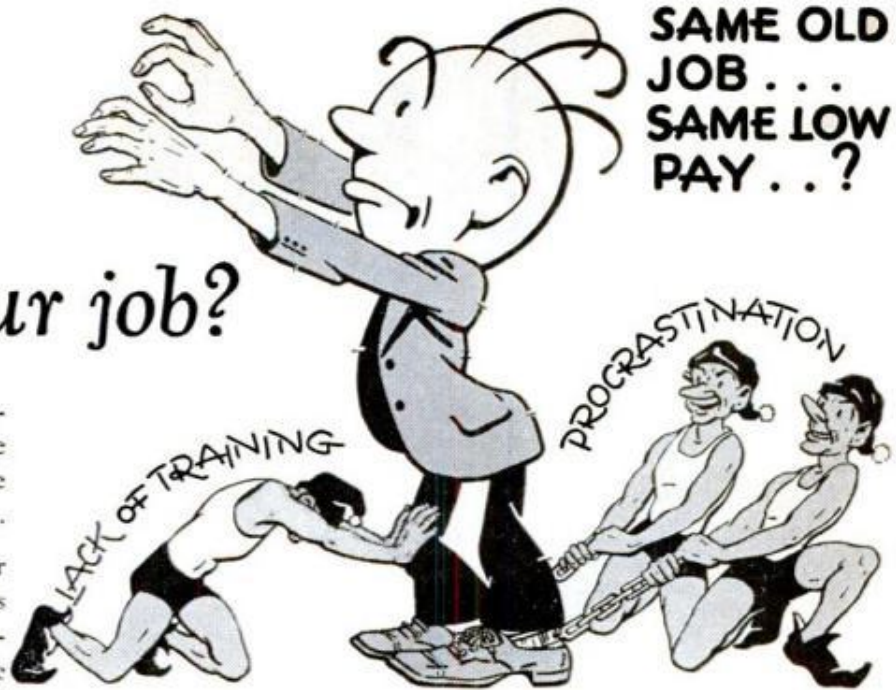

WILL RECOGNITION COME?

The only answer, as you know, is that success *does* come to the man or woman who is really *trained*. LaSalle has provided the "key to success" for many thousands of ambitious people who have sought our training for more than fifty years.

Get all the facts. Investigate the opportunities in your chosen field. It costs you nothing to learn about LaSalle's proven and tested accredited correspondence courses in the major fields of business. You can train right in the privacy of your own home, progressing at your own rate.

You lose no time from work, and your instructors guide you every step along the way through our famous Practical Problem Method. Low cost—easy terms.

Don't let promotions pass you by—do something **TODAY** about your future.

LaSalle

EXTENSION UNIVERSITY
A CORRESPONDENCE INSTITUTION

417 So. Dearborn St. Dept. 964X Chicago 5, Ill.

The coupon below is for your convenience. Simply mark the program in which you are most interested, and mail at once. We'll send you, without obligation, free booklets describing that field together with the opportunities and what you must know to be a success.

ACCREDITED MEMBER, NATIONAL HOME STUDY COUNCIL

LA SALLE EXTENSION UNIVERSITY, A Correspondence Institution
417 South Dearborn Street, Dept. 964X, Chicago 5, Illinois

Please send me your booklet describing the program I have checked below:

ACCOUNTING

- Modern Bookkeeping
- Basic Accounting
- Practical Accounting
- Principles of Acctg.
- Cost Accounting
- Federal Income Tax
- Accounting Systems
- Business Law
- Auditing Procedure
- Controllership
- CPA Training
- Complete Accounting

TRAFFIC & TRANSPORTATION

- Organization & Mgt.
- Classification, Rates & Tariffs
- Transportation Agcy. & Services
- Transportation Law & Regulation
- Rate Making & Rate Cases
- Complete Traffic & Transportation

LAW

- Law of Contracts
- Insurance Law
- Claim Adjusting Law
- Law for Trust Officers
- Business Law I
- Business Law II
- General Law
- First Year Law
- American Law and Procedure (LL.B. Degree)

FOREMANSHIP & PRODUCTION METHODS

- Foremanship Training

STENOTYPE

(machine shorthand)

- Secretarial

SALESMANSHIP

- LaSalle Sales Training

BUSINESS MANAGEMENT

- Principles of Management
- Psychology in Business
- Selling & Sales Management
- Advertising and Marketing
- Production Problems
- Business Financing
- Credits and Collections
- Office Management
- Managing Men
- Accounting & Statistical Control
- Business Correspondence
- Organization & Reorganization
- Legal Problems
- Complete Business Management

MANAGEMENT COURSES

- Basic Management
- Production Management
- Sales Management
- Advertising & Sales Promotion
- Financial Management
- Personnel Management
- Sales & Executive Training

Name..... Age.....

Address.....

City, Zone, State.....

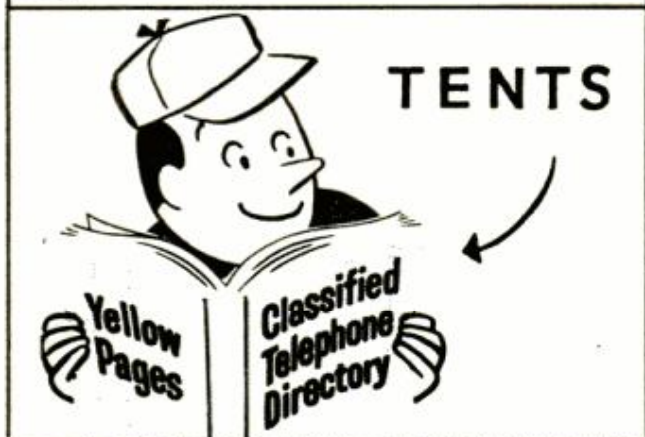

TENTS

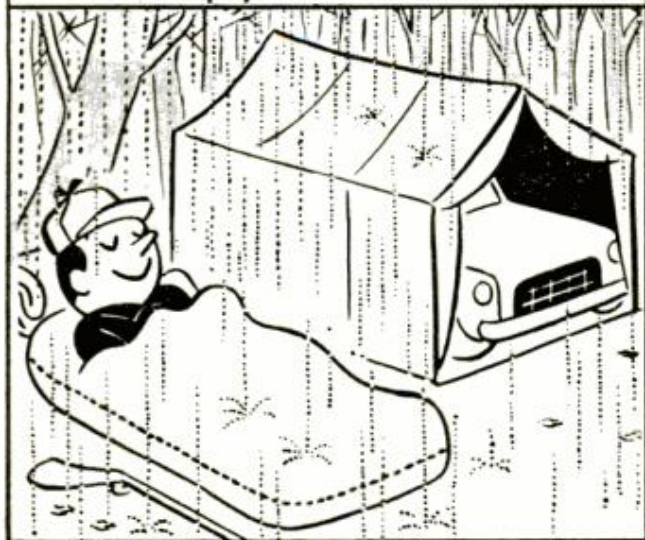

garages, furnaces, watch repair,
garden equipment, taxicabs, bridal wear

whatever you need—



Advertisers displaying this emblem
make your shopping easy.

Science

Doctors study skaters.....	108
Ground-controlled approach radar swings on turntable.....	115
Asphalt blanket boosts crops (Esso Research & Engr. Co., 15 W. 51st St., New York 19, N. Y.).....	118
Portable electronic lung (W. Watson and Sons, Cambridge, England).....	119
Skindiver's sonar (Stromberg-Carlson Div. General Dynamics Corp., San Diego, Cal.).....	127
Mobile telephone center provides service to public and press.....	128
Tilttable tower tests radomes.....	137
Bean harvester does three jobs.....	141
Twigs grow after deep, deep freeze.....	145
Eclipse televised through binoculars.....	149
Magnetic quenching forms "supermetals".....	238

What's New for Your Home

Electric grill.....	130
Dairy reminder.....	130
Peg pole.....	130
Adjustable rake.....	131
Electric range.....	131
Condiment shelf.....	131
Battery-powered manicure.....	131

Radio, TV, Electronics

Stereo goes back on tape.....	206
-------------------------------	-----

Craftsman and Shopnotes Index

Automotive

Two-engine power carts kick up dust.....	178
Trouble shooting the tough ones.....	180
Chevy dashboard noises.....	180
Loose shifting in Volkswagen.....	180
Galaxie weather seal hinders door opening.....	181
Aging V-8 Chevy develops heat-valve rattle.....	181

Farm

Hot wire divides feed bunk.....	201
V-gate built into wire fence.....	201
False guard bars fool cattle.....	201
Pipe posts for feedlot fence.....	201

Hints to Remember

Rubber handle for scrub pail.....	154
Markers for leftover paint.....	154
Broomstick screwdriver.....	154
Rubber-stamp holder.....	154
Keeping hinges and screws together.....	154
Plastic vegetable bag protects seedlings.....	155
Trowel measures depth for seeds.....	155
Push stick finds its niche.....	155
Hacksaw stores own blades.....	155
Under-window "defroster".....	156
Shovel makes useful trowel.....	160

Miscellaneous

View finder sheds new light.....	156
Eye dropper bulb steadies reels.....	156
Sunshades for binoculars.....	160
Whirligig toy.....	161
Strap support for bicycle.....	161
Corrugated tray holds instruments on tilted draining board.....	182
Can slides down fishing line to free snagged hooks.....	182
Venetian-blind slat on board protects tracing-paper edge.....	186
Electric circuit puzzler stumps the experts.....	186
Rake converts to grade leveler.....	186

(Continued to page 10)

IF YOU'RE WILLING TO BACK YOUR DREAMS OF SUCCESS WITH SPARE-TIME STUDY I.C.S. WILL SEND YOU FREE THIS FAMOUS CAREER KIT!

Here's an opportunity to see for yourself how I.C.S. has helped thousands of ambitious men and women earn more pay, find new opportunity and real job security. All you have to do is mark and mail the coupon below and you'll receive absolutely FREE the famous I.C.S. Career Kit with these three valuable booklets:

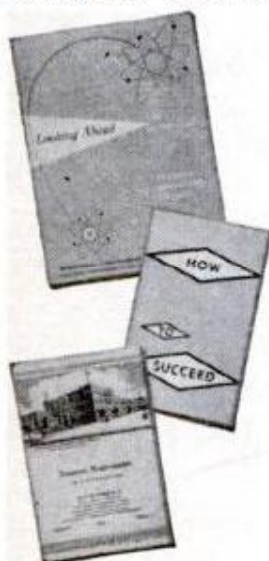

- 1 HOW TO SUCCEED** is a gold mine of tips on how your personality, your outlook on life can affect your future. Helps you discover hidden talents within yourself, shows how to plan your career, how to deal with your boss, plus dozens of other ideas on how you can succeed.
- 2 OPPORTUNITY CATALOG** is a complete directory that outlines opportunities in the particular job fields in which you are most interested. Gives you down-to-earth facts on just what you can expect and how you can start now toward success in the field of your choice.
- 3 SAMPLE I.C.S. LESSON** (math) demonstrates the famous method by which so many people have achieved amazing success. Literally thousands of men and women of all ages have won promotions, better pay, real job security through I.C.S. training.

MARK AND MAIL THE COUPON TODAY FOR YOUR FREE CAREER KIT

For Real Job Security—Get an I. C. S. Diploma! I. C. S., Scranton 15, Penna.

Accredited Member,
National Home Study Council

INTERNATIONAL CORRESPONDENCE SCHOOLS



BOX 33953J, SCRANTON 15, PENNA.

(In Hawaii, reply P.O. Box 418, Honolulu)

(Partial list of courses)

Without cost or obligation, send me "HOW TO SUCCEED" and the opportunity booklet about the field BEFORE which I have marked X (plus sample lesson):

ARCHITECTURE and BUILDING CONSTRUCTION

- Air Conditioning
- Architecture
- Arch. Drawing and Designing
- Building Contractor
- Building Estimator
- Carpenter Builder
- Carpentry and Millwork
- Heating
- Painting Contractor
- Plumbing
- Reading Arch. Blueprints

ART

- Commercial Art
- Magazine Illus.
- Sign Painting and Design's
- Sketching and Painting

AUTOMOTIVE

- Automobile
- Auto Body Rebuilding and Refinishing
- Auto Engine Tuneup
- Auto Electrical Technician
- Diesel Engines

AVIATION

- Aero-Engineering Technology
- Aviation Engine Mech.
- Reading Aircraft Blueprints

BUSINESS

- Accounting
- Advertising
- Bookkeeping and Cost Accounting
- Business Administration
- Business Management
- Clerk Typist
- Creative Salesmanship
- Managing a Small Business
- Professional Secretary
- Public Accounting
- Purchasing Agent
- Real Estate Salesmanship
- Salesmanship
- Salesmanship and Management
- Traffic Management

CHEMICAL

- Analytical Chemistry
- Chemical Engineering
- Chem. Lab. Technician
- General Chemistry

- Oil Field Technology
- Pulp and Paper Making

CIVIL ENGINEERING

- Civil Engineering
- Construction Engineering
- Highway Engineering
- Professional Engineer (Civil)
- Reading Struc. Blueprints
- Sanitary Engineer
- Sewage Plant Operator
- Structural Engineering
- Surveying and Mapping
- Water Works Operator

DRAFTING

- Aircraft Drafting
- Architectural Drafting
- Drafting & Machine Design
- Electrical Drafting
- Electrical Engineer Drafting
- Industrial Piping Drafting
- Mechanical Drafting
- Sheet Metal Drafting

ELECTRICAL

- Electrical Appliance Servicing
- Electrical Engineering

- Electric Motor Repairman
- Elec. Engr. Technician
- Elec. Light and Power
- Practical Electrician
- Practical Lineman
- Professional Engineer

HIGH SCHOOL

- Good English
- High School Diploma
- High School General
- H. S. College Prep. (Eng'g & Science)
- High School Math
- High School Science
- Short Story Writing

LEADERSHIP

- Industrial Foremanship
- Industrial Supervision
- Personnel-Labor Relations
- Supervision

MECHANICAL and SHOP

- Diesel Engines
- Gas-Elec. Welding
- Heating and Air Conditioning
- Industrial Engineering
- Industrial Instrumentation

- Industrial Safety
- Machine Shop Practice
- Mechanical Engineering
- Plumbing and Heating
- Professional Engineer
- Quality Control
- Reading Shop Blueprints
- Refrigeration and Air Conditioning
- Tool Design
- Tool Making

RADIO, TELEVISION

- General Electronics Tech.
- Industrial Electronics
- Practical Radio-TV Eng'g
- Radio-TV Servicing
- TV Technician

RAILROAD

- General Railroad

STEAM and DIESEL POWER

- Combustion Engineering
- Power Plant Engineer
- Stationary Diesel Engr.
- Stationary Steam Engines

TEXTILE

- General

Name _____ Age _____ Home Address _____

City _____ Zone _____ State _____ Working Hours _____ A.M. to P.M. _____

Occupation _____ Canadian residents send coupon to International Correspondence Schools, Canadian, Ltd., Montreal, Canada. . . . Special low monthly tuition rates to members of the U. S. Armed Forces.

AUDELS GUIDES

FOR

MECHANICS & ENGINEERS

EARN MORE...LEARN MORE

No. 1	AUTOMOBILE MECHANICS GUIDE. 1696 Pages.....	\$ 6.00
No. 2	HOME APPLIANCE SERVICE GUIDE. 864 Pages.....	6.00
No. 3	TV & RADIO SERVICE LIBRARY. 2 Book Set.....	8.00
No. 4	HANDY BOOK OF ELECTRICITY. 1520 Pages.....	5.00
No. 5	TRUCK & TRACTOR GUIDE. 1376 Pages.....	5.00
No. 6	PLUMBERS & STEAMFITTERS GUIDES. 4 Book Set.....	8.00
No. 7	PAINTING & DECORATING MANUAL. 464 Pages.....	3.00
No. 8	CARPENTERS & BUILDERS GUIDES. 4 Book Set.....	8.00
No. 9	DIESEL ENGINE MANUAL. 640 Pages.....	3.00
No. 10	WELDERS GUIDE. 608 Pages.....	3.00
No. 11	MATHEMATICS MADE EASY. 752 Pages.....	3.00
No. 12	MACHINISTS & TOOLMAKERS HANDBOOK. 1728 Pages..	6.00
No. 13	WIRING DIAGRAMS. 304 Pages.....	2.00
No. 14	REFRIGERATION & AIR CONDITIONING. 1360 Pages.....	6.00
No. 15	ELECTRIC LIBRARY. 10 Volume Set.....	20.00
No. 25	BLUE PRINT READING. 448 Pages.....	3.00
No. 26	MASONS & BUILDERS GUIDES. 4 Book Set.....	8.00
No. 27	ELECTRIC MOTOR GUIDE. 1056 Pages.....	5.00
No. 28	OIL BURNER GUIDE. 416 Pages.....	2.00
No. 29	SHEET METAL PATTERN LAYOUTS. 1152 Pages.....	7.50
No. 30	SHEET METAL WORKERS HANDY BOOK. 448 Pages.....	2.00
No. 31	MECHANICAL DRAWING GUIDE. 192 Pages.....	2.00
No. 32	MECHANICAL DRAWING & DESIGN. 480 Pages.....	3.00
No. 33	ELECTRONIC DEVICES. 304 Pages.....	3.00
No. 34	ELECTRICIANS EXAMINATIONS. 272 Pages.....	2.00
No. 35	ELECTRIC POWER CALCULATIONS. 480 Pages.....	3.00
No. 36	ELECTRIC DICTIONARY. 9000 Terms.....	3.00
No. 37	POWER PLANT ENGINEERS GUIDE. 1568 Pages.....	5.00
No. 38	ENGINEERS AND FIREMANS EXAMS. 544 Pages.....	2.00
No. 40	PUMPS, HYDRAULICS & AIR COMPRESSORS. 1760 Pages	6.00
No. 41	HOUSE HEATING GUIDE. 1008 Pages.....	5.00
No. 42	MILLWRIGHTS & MECHANICS GUIDE. 1248 Pages.....	5.00
No. 43	DO-IT-YOURSELF ENCYCLOPEDIA. 2 Book Set.....	8.95
No. 44	NEW MECHANICAL DICTIONARY. 712 Pages.....	6.95

7-DAY FREE EXAMINATION

SEND NO MONEY — Pay the postman nothing! We'll send you any of the Audel Guides for FREE examination in your home. If you decide to keep the books you may pay for them under our easy-pay plan of only \$2 a month.

HERE IS ALL YOU DO

IT'S EASY TO ORDER — In the No-Risk Mail Order Coupon below you need only draw a circle around the number of Audel Guides you want. We will send them to you at once. If you are not completely satisfied, return the books to us.

MAIL THIS COUPON TODAY!

THEO. AUDEL & CO. — Self Improvement Publishers Since 1879
49 W. 23rd Street, New York 10, N. Y.

P 9

Please mail me for 7 days' FREE EXAMINATION the books I have circled. I agree to mail \$2 in 7 days on each book or set ordered, and to further mail \$2 a month on each book or set ordered until I have paid the purchase price, plus shipping costs. If I am not completely satisfied with my Audel Guides I may return them.

NAME _____

ADDRESS _____

OCCUPATION _____

EMPLOYED BY _____

1 2 3 4 5 6 7 8 9 10 11 12 13 14 15 25 26 27
28 29 30 31 32 33 34 35 36 37 38 40 41 42 43 44

SAVE SHIPPING COSTS! Check here if you enclose complete payment with order. We pay postage charges. You have some return privilege.

On the Market

Shelf kit	184
Self-adhering nylon tape	184
Complete finishing kit	184
Novel decorative material	184
Additive cleans fuel-oil tanks.....	184
Prefinished plywood paneling	185
Paint edger	185
Rust preventive	185
Chemical plasticizer	185

Shopping for Tools

Foam-producing unit	198
New buffing wheels	198
Electrically driven seam roller.....	198
Air cylinder	198
Screw extractor	199
Magnetic tire shields	199
Nylon drill sleeve	199
Slotted steel angle	199
Non-clogging file	199
Rip-fence extensions	200
Steel-bonded carbides	200
Step ladder, stair ladder	200
Finger- p wrench	200

Solving Home Problems

Display prized figurines.....	158
Stand for holding copy.....	158
Indelible stains	158
Loose drawer easily tightened.....	158
Small fry clothes rod.....	158
Pencil kept handy for phone messages.....	158
Permanent paste brush holder.....	159
Picnic salt container kept handy.....	159
Storage space in a basement.....	159
Broken safety straps on highchair replaced.....	159
Paint brushes kept in solvent or oil.....	159

Workshop Hints

Lacquer clears holes in plastic.....	156
Substitute marking gauge	160
C-clamp used as wood vise.....	160
Improvised glue applicator	161
Shelf brackets from scraps.....	161
"Third hand" on paper cutter catches cutoffs and trimmings.....	182
Slit section of plastic hose makes self-locking sander.....	182
Tool I.Q.	183
Cutting kerfs the easy way.....	186
Large hex nuts make V-blocks for rough work.....	187
Demagnetize tools in seconds.....	187
Full face-off without burring.....	192
Simple guide aligns hand reamer.....	192
Spray-oiling rustproofs tools	192
Strap clamp adjusts for height.....	192
Drill chuck on straight shank permits power feeding.....	193
Detachable C-clamp pads save work surfaces.....	197
U-shaped cutoff stop fits on rip fence.....	197
Seven shopmade wedge clamps.....	202
Thread spreads glue evenly	204
Drill bit lifted with pliers.....	204
Saw kerfs release warp stress.....	204
Grooved block holds steel wool	204

NOTICE—It is the intention of this magazine to provide its readers with information regarding the latest developments in the mechanical arts. Except where otherwise indicated, this magazine has no information as to any unexpired patents in respect of the developments reported herein. In the event that commercial use is to be made of any of the developments reported herein, it is suggested that legal counsel be consulted to avoid liability for patent infringement. It is not the purpose of this magazine to encourage patent infringement but, as indicated, it is the intention of this magazine to report on the latest developments in the mechanical arts.

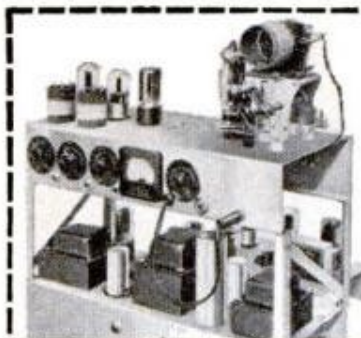

YOU BUILD Broadcasting Transmitter

As part of N.R.I. Communications Course you build this low power Transmitter; use it to learn methods required of commercial broadcasting operators, train for FCC license.

YOU BUILD Signal Generator

N.R.I. sends kits of parts to build this Signal Generator. You get practical experience, conduct tests to compensate Radio frequency amplifiers, practice aligning a typical I.F. video amplifier in TV circuit, many other experiments.

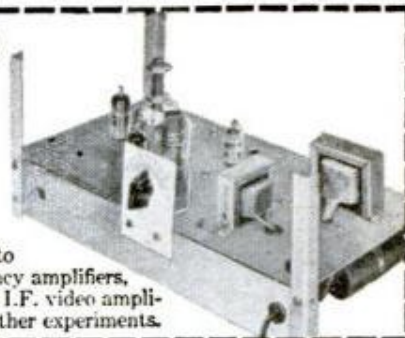

YOU BUILD Vacuum Tube Voltmeter

Use it to get practical experience, earn extra cash fixing neighbors' sets in spare time, gain knowledge to help you work in Radio, Television, Color TV. With N.R.I. training you work on circuits common to both Radio and TV. Equipment you build "brings to life" things you learn in N.R.I.'s easy-to-understand lessons. 64 page Catalog FREE, shows all equipment you get.



YOU BUILD AC-DC Superhet Receiver

N.R.I. servicing training supplies all parts, everything is yours to keep. Nothing takes the place of practical experience. You get actual servicing experience by practicing with this modern receiver; you learn-by-doing.



Learn RADIO TELEVISION ELECTRONICS

by Practicing at Home

WHAT GRADUATES DO AND SAY

Chief Engineer

"I am Chief Engineer of Station KGCU in Mandan, N. D. I also have my own spare time business servicing high frequency two-way communications systems." R. BARNETT, Bismarek, North Dakota.



Paid for Instruments

"I am doing very well in spare time TV and Radio. Sometimes have three TV jobs waiting and also fix car Radios for garages. I paid for instruments out of earnings." G. F. SEAMAN, New York, N. Y.



Has Own TV Business

"We have an appliance store with our Radio and TV servicing, and get TV repairs. During my Army service, NRI training helped get me a top rated job." W. M. WEIDNER, Fairfax, South Dakota.



NEED FOR TECHNICIANS INCREASING

Fast Growing Field Offers Good Pay, Bright Future

Today's OPPORTUNITY field is Radio-Television. Over 125 million home Radios plus 30 million sets in cars and 40,000,000 Television sets mean big money for trained Radio-TV Technicians. More than 4,000 Radio and TV Broadcasting stations offer interesting and important positions for technicians, operators. Color television, portable TV sets, Hi-Fi, other developments assure future growth.

It's the trained man who gets ahead. The fellow who uses his spare time to develop knowledge and skill gets the better job, drives a better car, lives in a better home, is respected for what he knows

and can do. So plan now to get into Radio-TV.

Keep your job while training with N.R.I. You learn at home in your spare time. N.R.I. is oldest and largest home study Radio-TV School. Our methods have proved successful for more than 40 years, provide practical experience.

Soon after enrolling, many N.R.I. students start to earn \$10, \$15 a week extra in spare time fixing sets. Many open their own full time Radio-TV shops after getting N.R.I. Diploma. Find out more. Mail Coupon. Cost is low, terms easy; includes all equipment. Address: National Radio Institute, Dept. OJA, Washington 16, D. C.

Send for
LESSON
and **CATALOG**
FREE

VETERANS
Available under
G.I. Bills



MAIL COUPON NOW

NATIONAL RADIO INSTITUTE
Dept. OJA, Washington 16, D. C.
Mail me Sample Lesson and 64-Page Catalog,
FREE. (No Salesman will call. Please write plainly.)

Name _____ Age _____

Address _____

City _____ Zone _____ State _____

ACCREDITED MEMBER, NATIONAL HOME STUDY COUNCIL

ALL-AMERICAN HALFBACK DISCOVERS OIL!

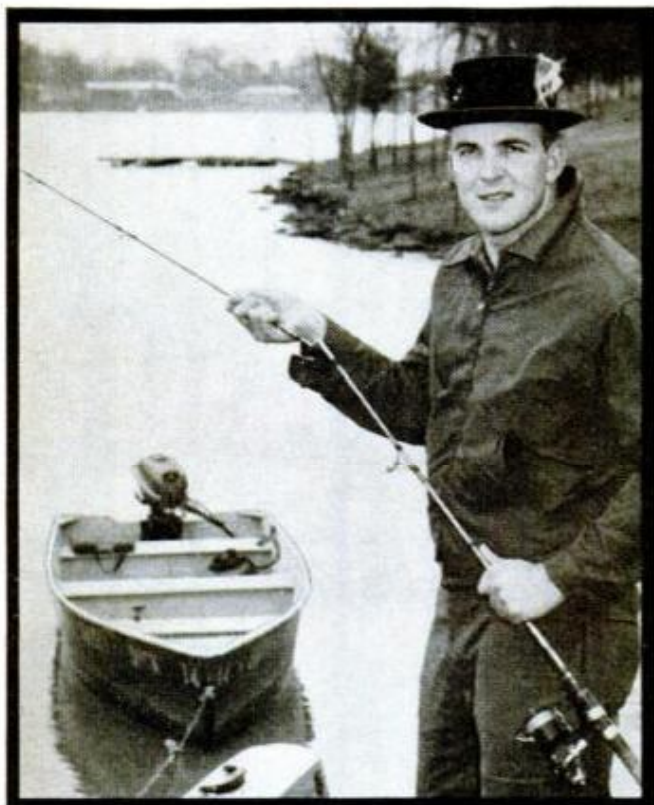

Tom Moore, ex-all-American, now of the Green Bay Packers, has discovered the richest, most complete motor oil in the world—Pennzoil Z-7!

"I drive 25,000 long, hard miles every year," says Tom. "A lot of it in hard-on-engines, stop-and-go city traffic. A tough workout for any car. But with Pennzoil Z-7, my car goes whenever I need it—and keeps going!"

This amazing oil is so rich it gives double the protection demanded. So complete you never need extra additives. Refined from 100% pure Pennsylvania crude, Pennzoil contains special power ingredient Z-7 that keeps engine parts so clean the oil can give peak lubrication protection *full time*.

Ask for Pennzoil by name—at your favorite car dealer, service station or garage. Sound the "Z" that makes Penn Oil—PennZoil.

Member Penn. Grade Crude Oil Assn.
Permit No. 2, Oil City, Pa.



Over the Editor's Desk



THE FIRST BOOK published by *Popular Mechanics* was the 1904 edition of *Shop Notes*. Thus, it seems fitting that the first book to appear under our new annuals program should be the 1961 *PM Workshop Annual*, incorporating *Shop Notes* and another old favorite, *What to Make*. The *Workshop Annual* is at your newsstand now, and we think you'll like it.

Incidentally, future annuals will cover Electronics (October), Hot Rods (November), Science (January), Cars (February), Boating (March) and Homeowners (April). All will have cover designs resembling that of *Popular Mechanics*, so you shouldn't have any trouble finding them on the newsstand.

☆☆☆

Credit Is Due:

Through an oversight the source of the information contained in the article "Sunglasses for Your Windows" (May 1960) was not mentioned. Anyone interested in tinting the windows of their home should write to Transparent Glass Coating Co., 533 North La Cienega Blvd., Los Angeles 48, Calif.

☆☆☆

To the Editor:

There is only one such conveyance in all the world. It is 17 years old, built in 1943. The originator and designer was the late Mr. Edward C. Hammond of Auburndale, Mass. He built the Weep during his retirement and it afforded him much pleasure to build and drive it.

The Weep is an ingenious vehicle with an assemblage of parts from 16 different automobiles, a mowing machine, a tractor and an auto trailer. Many of the parts have been in existence for over 30 years and come from cars which were manufactured from 1927 to 1939. It is a rugged worker and thrives on a minimum of gasoline. The Weep is registered as a 1943 Hammond #1 Weep—Open Runabout Scootmobile.

This little car is equipped with 4.00 x 8.00 tires on four tractor wheels; 1939 Plymouth, two-wheel service brakes and a 1929 Ford hand brake. It sports two very large headlights from a 1927 Cadillac and a tail-light from a 1929 Model-A Ford.

A 1939 Willys-Jeep four-cylinder engine is the power plant, with electricity supplied by a large Buick battery. A clever master

(Continued to page 14)

How to 'take charge' of a highly-paid job

in

AIR CONDITIONING & REFRIGERATION

Are you interested in a better job, big money and a secure future? Do you prefer work that is interesting, a challenge to your imagination, and loaded with opportunities to go in business for yourself? Then why not consider a career as mechanic or technician in the Air Conditioning and Refrigeration industry!

You see, Air Conditioning is now America's finest opportunity field. The government reports that during the past 12 years, production increased 400%. *No other industry did better!* The fact is, 8,200,000 domestic and industrial units are produced annually. Already 150,000,000 are in use. Experts say that 20,000 technicians must be trained each year to match industry growth! You can qualify for a top-pay job. How? *Train at home in spare time.* The CTI method is easy, practical and resultful. Quick, too. For full information, mail coupon below.

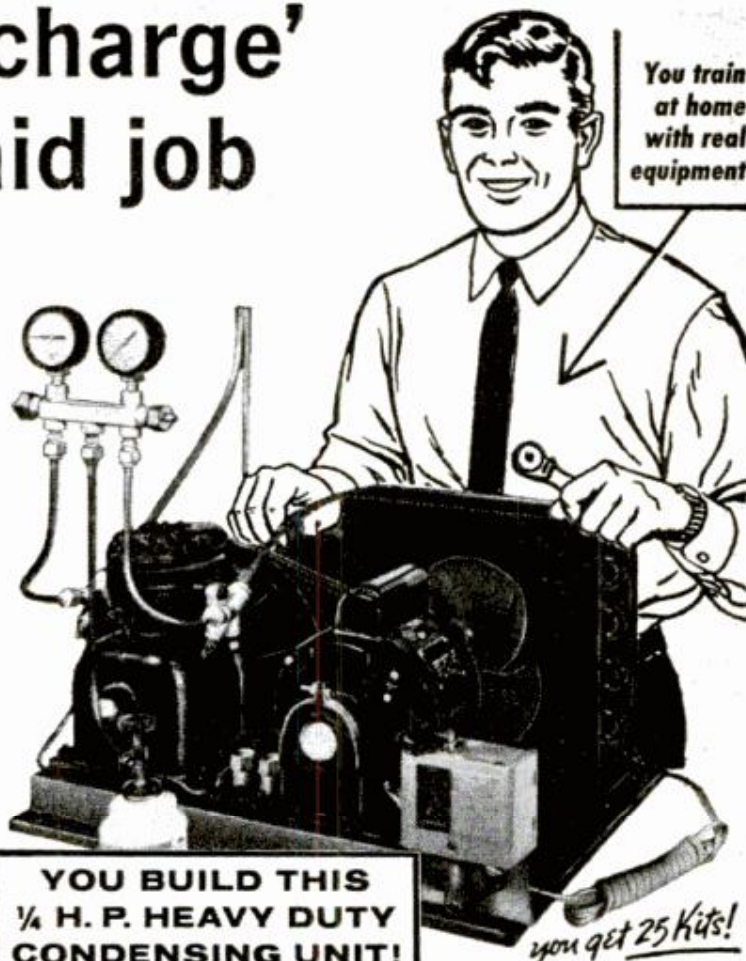

Many CTI graduates go in business



It is relatively easy to start a repair business in the Air Conditioning and Refrigeration field. Armed with up-to-date knowledge, seasoned with skill acquired through practice on kits, and equipped with tools and gauges, many graduates start out on their own. Some expand into retail stores. Others have contracts to service taverns, restaurants, food stores and commercial buildings. The more resourceful become contractors. Conditions for success are excellent.

Many students earn cash as they train

The average CTI student is eager to put his skill to profitable work, on a part-time basis. Though most students prefer to tie up with local dealers and repair establishments, a surprising number are independents. The extra cash helps meet training cost. Often there's enough to bank, or invest in more equipment.



Letters prove efficiency of training



"I have a business of my own servicing domestic and commercial refrigerators."—*Paul Humphrey, Colo.* "I made \$1,000 while training, and am now a refrigeration man for a dairy."—*Giles Minton, N. C.* "I opened a little shop and am swamped with work."—*Charles Corley, Kan.* "Doing service work on a part-time basis the past 10 months, I earned \$2,400. Have a nice business."—*Renos Johnson, Ind.* "My firm advanced me to field superintendent."—*Milburn Dougan, Ark.* You can do as well as these graduates!

An exclusive feature of CTI training is that you get parts to build a 1/4 h.p. commercial-type condensing unit (above). You also receive mechanic's tools and gauges (right). After unit is assembled, you can build an air conditioner, freezer, refrigerator or milk cooler. Only CTI sends *working kits.*



Learn by practicing—Get valuable experience

The modern way to train is to gain skill and experience *with* knowledge—not *after* you graduate. From CTI's simple picture-lessons, you master elemental theory. From experiments and building with kits, you develop skill. In other words, you learn by practicing, pick up solid experience much like on the job. That's the interesting, relaxing way to train after a day's work on your present job. CTI training is exciting!

Send for fact-filled booklets—Mail coupon now

Exactly what are your opportunities in Air Conditioning and Refrigeration? How does CTI train men for success? Get detailed, accurate answers to these and many more questions by filling out and mailing the coupon below. No obligation. —Commercial Trades Institute, Chicago 26, Ill.

COMMERCIAL TRADES INSTITUTE
1400 GREENLEAF AVENUE DEPT. R-767
CHICAGO 26, ILLINOIS

Please rush me your opportunity booklet, *Success in Air Conditioning and Refrigeration*; and *Lesson Samples*. Both free.

NAME _____ AGE _____

ADDRESS _____

CITY _____ ZONE _____ STATE _____

A Non-Profit Organization • Accredited by National Home Study Council



UNUSUAL BARGAINS

See the Stars, Moon, Planets Close Up!

3" ASTRONOMICAL REFLECTING TELESCOPE

60 to 180 Power — Famous Mt. Palomar Type! An Unusual Buy!



Assembled—Ready to use! You'll see the Rings of Saturn, the fascinating planet Mars, huge craters on the Moon, Star Clusters, Moons of Jupiter in detail. Galaxies! Equatorial mount with lock on both axes. Aluminized and overcoated 3" diameter high-speed f/10 mirror. Telescope comes equipped with a 60X eyepiece and a mounted Barlow Lens, giving you 60 to 180 power. Low-cost accessory eyepiece available for higher powers. An Optical Finder Telescope, always so essential, is also included. Sturdy, hardwood, portable tripod. **FREE**

with Scope—Valuable **STAR CHART** plus 272 page "**HANDBOOK OF HEAVENS**" plus "**HOW TO USE YOUR TELESCOPE**" BOOK.

Stock No. 85,050-H.....\$29.95 postpaid

KNOW THE TRUTH ABOUT POWER. Telescope experts will confirm that an Astronomical Telescope will only give you practical powers to about 50 or 60 times per inch of objective diameter—powers above this only produce empty magnification—make viewing dim, difficult and unsatisfactory.

4 1/4" ASTRONOMICAL TELESCOPE! UP TO 255 POWER!

New Vibration-Free Metal Pedestal Mount

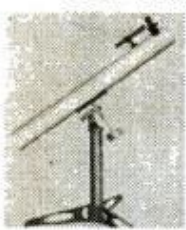

With this scope you can see everything as above but with greater power plus will split finer stars. Rack and pinion focusing, real equatorial mounting—only one adjustment follows stars! Aluminum tube 6 power finder telescope. 2 standard size eyepieces and mounted Barlow lens give you powers of 40X, 90X, 120X, and 255X. Low-cost accessory eyepiece available for higher powers. **FREE** with Scope—Valuable **STAR CHART** plus 272 page "**HANDBOOK OF HEAVENS**" plus "**HOW TO USE YOUR TELESCOPE**" BOOK. Shipping wt. 25 lbs.

Stock No. 85,105-H.....\$79.50 f.o.b.

War Surplus American-Made 7x50 Binoculars,

Big savings! Brand new! Crystal clear viewing—7 power. Every optical element is coated. An excellent night glass—the size recommended for satellite viewing. Individual eye focus. Exit pupil 7mm. Approx. field at 1,000 yds. is 376 ft. Carrying case included. American 7 x 50's normally cost \$195. Our war surplus price saves you real money.

Stock No. 1533-H.....only \$55.00 postpd. (Tax included)



Terrific Buy! American Made! OPAQUE PROJECTOR

Projects illustrations up to 3" x 3 1/2" and enlarges them. No film or negatives needed. Projects charts, diagrams, pictures, photos, lettering in full color or black-and-white. Operates on 115 volt, A.C. current. 6-ft. extension cord and plug included, operates on 60 watt bulb, not included. Size 12" x 8" x 4 1/2" wide. Plastic case with built-in handle.

Stock No. 70,199-H.....\$7.95 Postpaid



NEW! CIRCULAR SLIDE RULE!

Pocket Size—Fast—Easy to Use!

Multiplies, divides, figures fractions, percentages, squares, cubes, roots, proportions, circumferences, areas, retail prices, fuel consumption. Faster, easier to learn and use. Directions included.

Stock No. 30,336-H.....\$4.95 postpaid



BUILD A SOLAR ENERGY FURNACE

A fascinating new field. Build your own Solar Furnace for experimentation—many practical uses. Easy! Inexpensive! Use scrapwood! We furnish instructions. This sun powered furnace will generate terrific heat—2000° to 3000°. Fuses enamel to metal. Sets paper aflame in seconds. Use our Fresnel Lens—14" diameter...f.l. 14".

Stock No. 70,130-H.....Fresnel Lens.....\$6.00 Postpd.

Order by Stock No.—Send Check or M.O.—Money-Back Guarantee

EASY PAYMENT PLAN AVAILABLE! DETAILS WITH CATALOG!

EDMUND SCIENTIFIC CO., Barrington, New Jersey

MAIL COUPON FOR FREE CATALOG "H"

128 Pages! Over 1000 Bargains!

EDMUND SCIENTIFIC CO., Barrington, N. J.

Please rush Free Giant Catalog-H.

Name.....

Address.....

City.....Zone.....State.....



switch prevents an amateur tampering with the various accessories or even stealing the car.

From an old sail was sewn a sturdy canvas top which is stretched over a framework, reminiscent of the Covered Wagon.

Next to the 1930 LaSalle instrument panel, which houses the speedometer, a clock, ammeter, water temperature and gasoline gauges, are three tachometers. These register the speed of the rear wheels, transmission and engine.

The Weep has an electric siren and bell, three trumpet horns, a Bermuda wicker basket, a flag holder and a compass.

The steering wheel is a real antique. A Boston piano manufacturer made it in the days when "horseless carriages" were still being steered by a rod, such as a sailboat tiller.

Its springs are from a Model-A Ford and the rear end and front axle are out of a Model-T Ford.

The windshield is from a Model-T, 1920 Ford truck and an efficient wiper is from a 1934 Hudson.

The muffler and exhaust pipe are from a 1928 four-cylinder Chevrolet—to which is attached an exhaust whistle!

A single cylinder air compressor from a 1927 Pierce-Arrow and driven by the engine, is under the 1935 Oldsmobile hood.

The Weep has 1936 Chevrolet fenders and the seats, reupholstered in red leather, came from an Essex. The radiator is graced by a Whippet ornament. The directional signals, installed before such were standard equipment, are now twenty years old.

The hand-forged snow plow is a winter attachment. The plow frame is U-shaped and was created from the front axle of a Model-T Ford.

The Weep attains a speed of thirty-five miles an hour, and boasts of fifty miles to the gallon.

Mrs. Carmela E. Toscano
Auburndale, Mass.

(Continued to page 16)



Now! Work Over
300 PRACTICAL
PROJECTS with these
PARTS AT HOME!



to help You learn

ELECTRONICS

RADIO - TELEVISION - RADAR

NOW . . . at home in your spare time you can get the very kind of training and subsequent Employment Service you need to get started toward real earnings in one of today's brightest opportunity fields—TELEVISION-RADIO-ELECTRONICS. Now that Electronics is entering so many new fields, here is a chance of a lifetime to prepare to cash in on its remarkable growth.

DeVry Tech's amazingly practical home method enables you to set up your own HOME LABORATORY. You spend minimum time to get maximum knowledge from over 300 practical projects, using the same type of basic equipment used in our modern Chicago and Toronto Training Centers!

DeVry Tech Provides EVERYTHING YOU NEED . . .

—to help you master TV-ELECTRONICS. In addition to the home laboratory and easy-to-read lessons, you even use HOME MOVIES—an exclusive DeVry Tech advantage. You watch hidden actions . . . see electrons on the march. Movies help you to learn faster . . . easier . . . better.

LABORATORY TRAINING

Full time day and evening training programs in our modern Chicago and Toronto Laboratories are also available. MAIL COUPON TODAY for facts.

EARN WHILE YOU LEARN

DeVry Tech's practical training helps you toward spare time income servicing Radio and Television sets.

BUILD and KEEP Valuable TEST EQUIPMENT

As part of your training, you build and keep a fine Jewel-Bearing Vacuum Tube VOLTMETER and a 5-inch COLOR OSCILLOSCOPE—both high quality, needed test instruments.

EFFECTIVE EMPLOYMENT SERVICE

Get the same Employment Service that has helped so many DeVry Tech graduates get started in this fast-growing field.

"One of North America's Foremost Electronics Training Centers"

Accredited Member
of National Home
Study Council



DeVRY TECHNICAL INSTITUTE

CHICAGO 41, ILLINOIS

VACUUM TUBE VOLTMETER



5-INCH COLOR OSCILLOSCOPE



Build and keep this BIG DeVry Engineered TV set—easily converted to U.H.F. (DeVry offers another home training, but without the TV set.)

✉ CHECK These Exciting Job Opportunities:

- TV-Radio Broadcast Technician
- Color Television Specialist
- Radar Operator
- Laboratory Technician
- Airline Radio Man
- Computer Specialist
- Quality Control Manager
- Your Own Sales & Service Shop
- . . . PLUS MANY OTHERS

MAIL COUPON TODAY!

DeVRY TECHNICAL INSTITUTE
4141 Belmont Ave., Chicago 41, Ill., Dept. PM-9-Q

Please give me your FREE booklet, "Electronics in Space Travel," and tell me how I may prepare to enter one or more branches of Electronics.

Name _____ Age _____
Street _____ Apt. _____
City _____ Zone _____ State _____

2045 Canadian residents address DeVry Tech of Canada, Ltd., 970 Lawrence Ave., West, Toronto, Que.

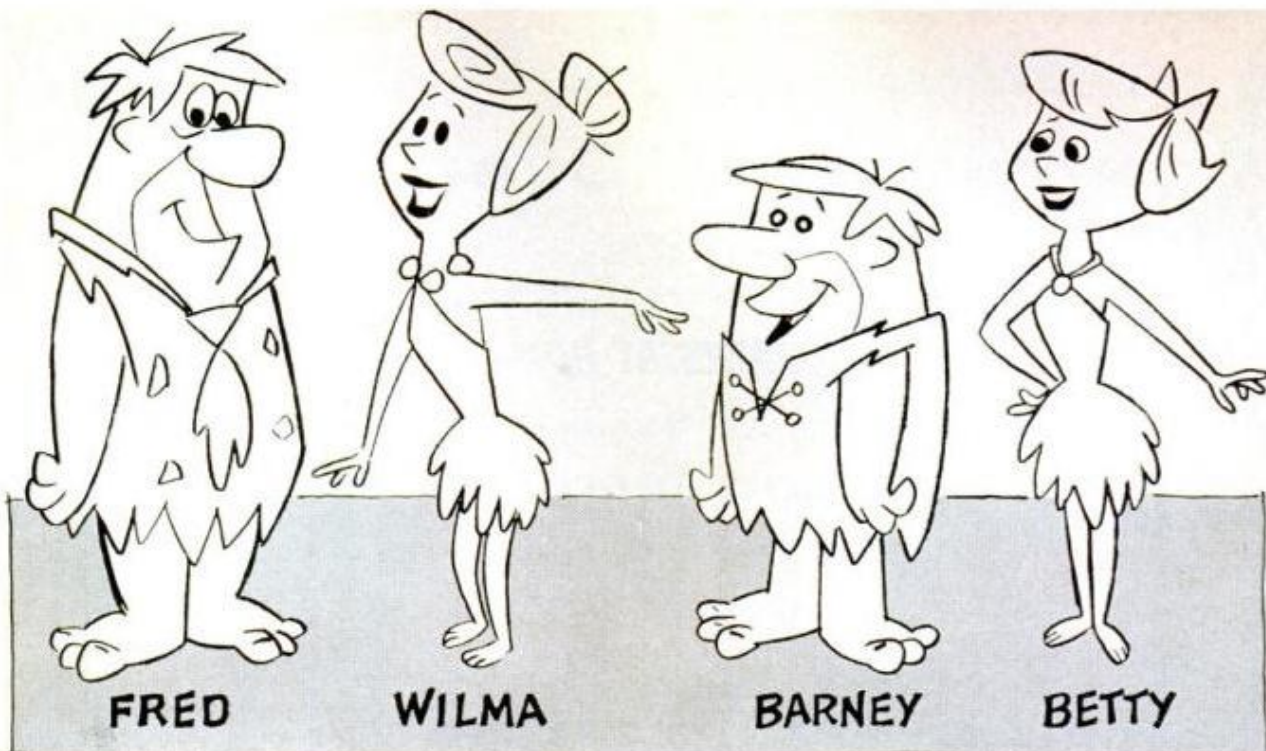

INTRODUCING THE FLINTSTONES

A family of cave dwellers with modern problems and anxieties will make its first television appearance late in September. Fred, Wilma, Barney and Betty Flintstone are creations of Joe Hanna and Bill Barbera—who also brought into existence

©1960 Hanna-Barbera Productions
 such other famous folks as Huckleberry Hound, Yogi Bear and Quick Draw McGraw. (See page 120 for the story of how the Emmy-award-winning producers turn out as many as six animated films a week.) The Flintstones will appear for a half hour beginning at 8:30 every Friday night.

HEAD-QUARTERS FOR ALL SPORT CAR TIRE SIZES

ALL FAMOUS BRANDS!

TIRES!

FARM TRUCK AUTO

AT LESS THAN WHOLESALE

SAVINGS NEVER LESS THAN 50% up to 70% OFF REG. PRICE!

FREE - SEND FOR YOUR FREE CATALOG - FREE!

RELIABLE TIRE DIST., 730 Morgan Blvd., Camden 4, N. J.

earn as TAX EXPERT

\$15 HOUR

Our students earn as much as \$3,000 in 3 short months preparing income tax returns in spare time. Also operate lucrative year-round Business Tax Service Dignified home-office business. Experience unnecessary. We train you; help you start. State approved home training program. Write today for free prospectus.

UNION INSTITUTE, Lakewood 20Q, N. J.

INVESTIGATE ACCIDENTS

Train quickly in your own home for repeat income in the exciting, secure Claim Investigation and Claim Adjusting field. Our students and graduates are already earning \$4, \$5, \$6 an hour extra SPARE TIME — and up to \$10,000 a year Full Time. You need NO prior experience or higher education. Your age does NOT matter.

HERE IS YOUR CHANCE FOR ACTION AND REAL JOB SECURITY

As a trained Claim Investigator you will (1) INVESTIGATE FACTS and (2) DISTRIBUTE MONEY as the representative of wealthy organizations.

No other business offers you greater opportunities for success and security. Here's why: The huge, rapidly expanding Claim Investigation and Adjusting Profession right now distributes more money than any other service industry. And it's growing fast. Over 200 MILLION ACCIDENTS must be investigated this year for Insurance Companies, Airlines, Railroads, Steamship Lines, and Government Offices.

MAIL NOW for FREE BOOK ➔

SEND TODAY for Big, FREE, Illustrated Catalog. Learn the exciting facts about Universal Schools' low cost training. No obligation. No salesman will call. GI APPROVED.



UNIVERSAL SCHOOLS
 6801 Hillcrest Ave.
 Dept. PM-9, Dallas 5, Texas

Please rush me your FREE book on Claim Investigation. This does not obligate me and no salesman will call.

Name _____ Age _____

Address _____

City _____ Zone _____ State _____

Approved by Government for Korean Veterans

**Courses in Radio and
Electronic Fundamentals—
TV Servicing—Color TV—
Electronics for
Automation—
Transistors**



RCA Institutes, one of the leading technical institutes in the United States devoted exclusively to electronics, offers the finest training-at-home. The very name "RCA" means dependability, integrity, and scientific advance. Practical work with your very first lesson. Pay as you learn. *No monthly installment payments.* You pay for your next study group only when you order it. Remember, in electronics, the more you know the higher you go! Licensed by the New York State Education Dept.

SEND FOR THIS FREE 64-PAGE BOOK TODAY!

RCA INSTITUTES, INC., Home Study School Dept. PM-90
350 West Fourth Street, New York 14, N. Y.

Please rush me your FREE illustrated 64-page book describing your electronic training programs. No obligation. No salesman will call.

Name _____ Age _____
(please print)

Address _____

City _____ Zone _____ State _____

Korean Vets: Enter discharge date _____

Canadians—Take advantage of these same RCA Institutes courses at no additional cost. No postage, no customs, no delay. Send coupon to: RCA Victor Company, Ltd., 5581 Royalmount Ave., Montreal 9, Quebec



RCA INSTITUTES, INC.,
A Service of Radio Corporation of America
350 West Fourth Street, New York 14, N. Y.

**The Most Trusted Name
in Electronics**

Resident School Courses in Los Angeles and New York City offer comprehensive training in Television and Electronics. Day and Evening classes. Free Placement Service. Catalog free on request.

DO YOU KNOW THIS OLD-TIMER?

If you think the imported car craze is new, you're wrong. Here's an import that back near the turn of the century was selling to wealthy Americans. Beautifully finished inside and out (the term "inside" is not quite accurate in a car as fresh-airish as a bicycle), the highly-refined machine featured oval-shaped acetylene headlights and, we believe, the most easy-to-get-at distributor ever built—that's it at the base of the radiator, to the right of the crank handle. Those women, happy as they may look, are actually nervously waiting for some gentleman to come along and spin the crank so they can drive away. For the answer see page 226.

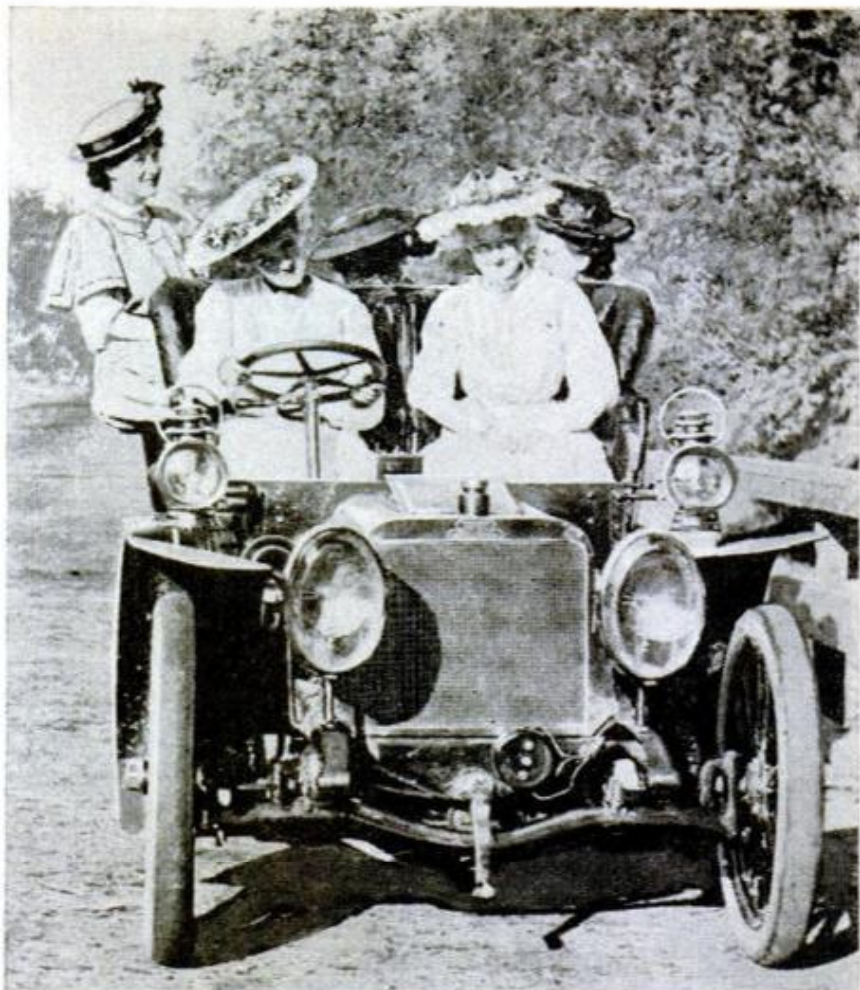

"Snow removal jobs go three times faster with MONARCH POWER HYDRAULIC CONTROLS"

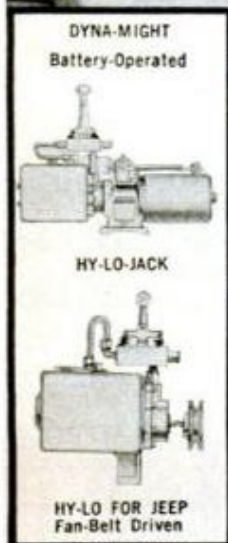

says
E. H. UECKER
Madison Square Garage,
Grand Rapids, Mich.

Mr. Uecker has found what everyone finds—that Monarch Power Hydraulic Controls make snow removal jobs easier, faster, and more economical! One man controls the plow from the cab . . . instant up-and-down action with the flick of a wrist. Battery-operated or fan-belt driven units. See your dealer. Free folder upon request.

MONARCH ROAD MACHINERY COMPANY

1331 Michigan St., N.E.

Grand Rapids 3, Michigan

TRAVEL LUXURIOUSLY WITH HOME CONVENIENCE



At automobile speed in self-sustained, power controlled, air conditioned motorized trailer, light plant, bath, refrigeration, radio, TV, rear end engine, coil springs, short turning, well balanced good maneuverability. No truck, bus or trailer restrictions in any states. Licensed as five passenger vehicle. 20, 28 and 35 foot units. Write: **FRANK MOTOR HOMES**, Brown City, Michigan.

FAST ANSWER FOR DIRECTION MIX-UPS



HULL AUTO COMPASS

When direction mix-ups happen, hundreds of thousands of HULL owners have the fast, easy answer to trouble and delay. At your dealer's or write for literature.

Beaconlite \$6.95
\$7.50 Streamline \$5.95
\$6.50

See Hull Boat Compasses, Too



HULL MFG. CO., Box 246-D-9, Warren, Ohio

RUPTURED

BE FREE FROM TRUSS SLAVERY

Surely you want to **THROW AWAY TRUSSES FOREVER**, be rid of Rupture Worries. Then Why Do you put up with wearing a gripping, chafing and unsanitary truss the balance of your life? If you do, it will **NOT** be through necessity but through choice on your part.

Now there is a new modern **Non-Surgical** treatment that is designed to permanently correct rupture. These **Non-Surgical** treatments are so certain, that a Lifetime Certificate of Assurance is given. Write today for our New **FREE** Book that gives facts that may save you painful, expensive surgery. Tells how **non-surgically** you may again work, live, play, love and enjoy life in the manner you desire. There is no obligation.

Excelsior Medical Clinic, Dept. H6124, Excelsior Springs, Mo.

WHAT HAPPENS WHEN A MAN DECIDES TO DO SOMETHING! ABOUT HIS FUTURE!

The proven rule of "learn more to earn more" took M.E.F. (name on request) from a position of truck driver to that of an accounting executive in sixteen months. Listen to what M.E.F. says:

"I was driving a truck—working long hours and not making much money. I had a burning desire to better myself in life, and decided to enroll with LaSalle. I went along driving my truck days and studying nights and got my first break after completing 35 assignments. I took a cost accounting position. Within one month after starting full-time, I received my first raise, thereafter followed more. One of the greatest thrills of my life came just nineteen months after I started with LaSalle. When our firm opened up a branch office, I was assigned to take charge of the Accounting Department and my salary has doubled."

M.E.F. took a proved road to success—and his letter is typical of the thousands we have in our files from men and women in all walks of life.

YOU DESERVE SUCCESS

There is no reason why you can't win success through LaSalle's Accounting Training. Today the demand for good accountants far exceeds the supply. This spells real opportunity to the man who is prepared.

You need no special talents to become a success in Accounting. You do not even need a preliminary knowledge of bookkeeping. All you need is the will to work—to achieve success perhaps years sooner.

Under the LaSalle Problem Method you can acquire a thorough knowledge of Accounting—you can master its fundamental principles—become expert in the practical application of those principles. You learn by doing—without losing any time from your present work. You train directly under the supervision of a competent staff of Certified Public Accountants and accounting experts.



TWO FREE BOOKS

We offer you a FREE SAMPLE LESSON so that you can *prove to yourself* that you can master Accounting—quickly, thoroughly—in spare time at home. You'll see exactly how LaSalle's famous "problem method" works . . . how you are led step-by-step through actual accounting work—learning by doing and not by study of theory alone. Along with the sample lesson you will receive FREE the valuable book, "Opportunities in Accounting." It explains how we train you from the ground up—or from where you are now—according to your individual needs.

Send the coupon RIGHT NOW. Don't lay it aside and say you'll do it later. It can be the means of your SUCCESS—perhaps larger success than you have ever dreamed. At least it's worth considering.

ACCREDITED MEMBER, NATIONAL HOME STUDY COUNCIL

LEU

SEND FOR FREE BOOK



LaSalle Extension University

— A Correspondence Institution —

Dept. 964 H, 417 S. Dearborn St., Chicago 5, Ill.

Please send me, free of all cost or obligation, a sample lesson in Accounting . . . also, your latest illustrated book, "Opportunities in Accounting."

Name Age

Address

City, Zone, State



Sidelights from the PENTAGON

By William R. Kreh

"AT FIRST IT isn't too bad, then hot ashes hit your eyes and ground glass goes to work on your throat."

A soldier was describing "CS," the Army's new riot-control gas. He and a few other GIs recently helped test it at Fort Richardson, Alaska. Wearing field clothes and protective masks, they entered the gas chamber, doffed the masks, and got a good whiff.

"At first you just blink," one of them said. "Your eyes begin to water, then burn. Then the hot ashes hit, and at the same time you feel a weird sensation in your throat, an odd metallic taste. Seconds later it turns to molten copper, then to hot ground glass."

"A riot wouldn't last long with this stuff around. It really tears you up."

The Army reports the gas is not toxic, not permanently harmful. After a few minutes in fresh air, the victims lose the worst effects, but are in no mood to riot.

Air Force scavengers have picked the bones of "Lady Be Good," the B-24 bomber lost during World War II and found 17 years later in the Libyan Desert. Their purpose was to salvage as many parts as possible to study their state of preservation. Among other things, they found hydraulic fluid still in the liquid state despite the fact that in the parched desert no rain falls for as long as nine years.

Did you know that the life-expectancy of Navy submarines is only about 13 to 15 years because of their constant exposure to salt water? Destroyers and cruisers, by comparison, last about 20 years, and carriers about 25 years.

When an Atlas ICBM showed a malfunction during recent preflight tests at Cape Canaveral, Fla., the Air Force called the hospital for emergency assistance. The problem had been

traced to a faulty elbow in the liquid oxygen line. Afraid to make repairs without a detailed diagnosis of the trouble, engineers called on S/Sgt. Donald P. Johnson, an X-ray technician. After several hours of shooting, Johnson's pictures revealed a flaw in an elbow joint. It was replaced and the Atlas hit its target.

The submarine *Pomfret* carried an unusual cargo recently. When they ran out of pennies at the Naval base at Sasebo, Japan, an urgent call was made to the Yokosuka Naval Supply Depot for more. So 50,000 one-cent pieces were loaded into the *Pomfret's* forward torpedo tube and sent to the rescue.

And if you think the Navy is having all the fun in Japan check this. At Yokota Air Force Base, the Air Force is operating a popsicle plant. Run by five Japanese employees, it turns out about 2500 popsicles a day, in six flavors, to help quench the thirst of parched airmen during hot weather.

The possibility of using seaplanes on aircraft carriers is being eyed by the Navy. The problem is how to land and take off from carrier decks. One suggestion is to cover the deck with a sheet of rubber and spray water over it as a lubricant. When landing, the seaplane can hook an arresting gear, the same as other carrier-based aircraft, and skid to a stop on its skis. When taking off, the area near the catapult can be sprayed. The water spray will still leave the deck usable for conventional wheeled planes.

A new record was set recently when the USS *Neptune*, a Navy cable layer, anchored in 3490 fathoms—nearly four miles—of water in the Atlantic. Using a special 5000-lb. anchor, it stayed at the spot nearly four days. When it finally made ready to go, it took four hours and 10 minutes to weigh anchor. The exact location was not released, but nautical charts will show there aren't many spots in the Atlantic that deep.

Doctors at the new Naval hospital at Great Lakes, Ill., are being equipped with pocket radio receivers, each tuned to a different frequency. The idea is to be able to reach each doctor instantly, and directly, without paging him or disturbing others.

The Coast Guard is experimenting with 40-foot glass-fiber boats as replacements for conventional steel-hulled boats. Plastic neither rusts nor rots.

The Navy reclaimed silver from obsolete tableware and sold it to the U.S. Mint for a cool \$139,595. ★ ★ ★

BREAK THROUGH TO HIGHER PAY

in ELECTRONICS

TV-RADIO

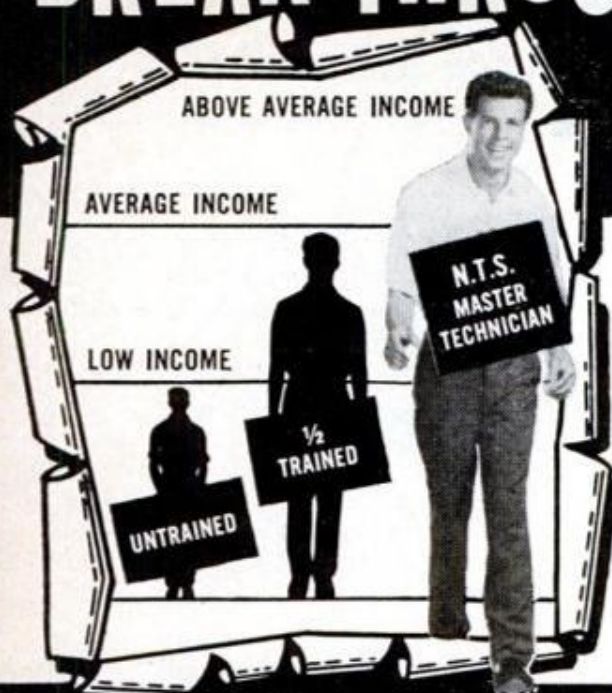

START NOW! Break through the Earning Barrier that stops half-trained men. N.T.S. "All-Phase" training prepares you — at home in spare time — for a high-paying CAREER in Electronics — TV — Radio as a **MASTER TECHNICIAN**. One Master Course at One Low Tuition trains you for unlimited opportunities in All Phases: *Servicing, Communications, Preparation F.C.C. License, Broadcasting, Manufacturing, Automation, Radar and Micro-Waves, Missile and Rocket Projects.*

A more rewarding job... a secure future... a richer, fuller life can be yours! As an **N. T. S. MASTER TECHNICIAN** you can go straight to the top in industry... or in your own profitable business.

You work on actual job projects

SUCCEED IN MANY HIGH-PAYING JOBS LIKE THESE...

- TV-Radio Sales, Service and Repair
- Profitable Business of Your Own
- Communications Technician — F.C.C. License
- Hi-Fi, Stereo & Sound Recording Specialist
- TV-Radio Broadcasting Operator
- Technician in Computers & Missiles
- Electronics Field Engineer
- Specialist in Microwaves & Servomechanisms
- Expert Trouble Shooter
- All-Phase Master Technician

19 BIG KITS YOURS TO KEEP

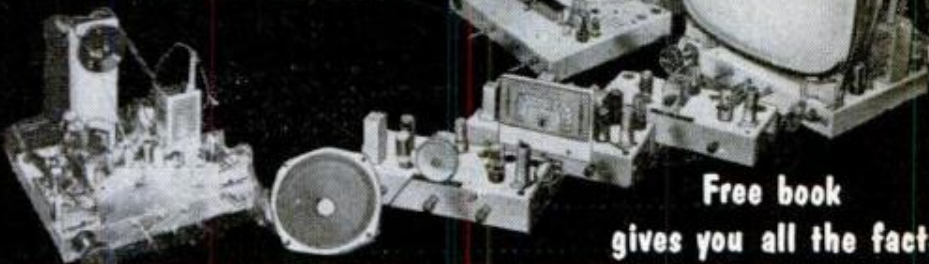

Free book gives you all the facts

NATIONAL TECHNICAL SCHOOLS

WORLD-WIDE TRAINING SINCE 1905

4000 SO. FIGUEROA ST., LOS ANGELES 37, CALIF., U.S.A.

Write Dept. RB-90



RESIDENT TRAINING AT LOS ANGELES
If you wish to take your training in our Resident School at Los Angeles, start NOW in our big, modern Shops and Labs. Work with the latest Auto and Diesel engines — all types — fuel injection, automatic transmissions, all power equipment — most complete facilities offered by any school. Expert, friendly instructors. Graduate Employment Service. Help in finding home near school — and part time job while you learn.
WRITE FOR SPECIAL RESIDENT SCHOOL CATALOG AND INFORMATION



ACCREDITED MEMBER
... the only nationally recognized accrediting agency for private home study schools.

N.T.S. Shop-Tested HOME TRAINING is **Better, More Complete, Lower Cost**... and it is your key to the most fascinating, opportunity-filled industry today!

YOU LEARN QUICKLY AND EASILY THE N.T.S. SHOP-TESTED WAY

You get lessons, manuals, job projects, unlimited consultation, graduate advisory service.

You build a Short Wave-Long Wave Superhet Receiver, plus a large-screen TV set from the ground up, with parts we send you at no addi-

tional cost. You also get a Professional Multitester for your practical job projects.

EARN AS YOU LEARN... WE SHOW YOU HOW!

Many students pay for entire tuition — and earn much more — with spare time work they perform while training. You can do the same... we show you how.

SEND FOR INFORMATION NOW... TODAY! IT COSTS YOU NOTHING TO INVESTIGATE.

N.T.S. HOME TRAINING is

- Classroom Developed
- Lab-Studio Planned
- Shop-Tested
- Industry-Approved
- Specifically Designed for Home Study



MAIL COUPON NOW for FREE BOOK and ACTUAL LESSON



NO OBLIGATION! NO SALESMAN WILL CALL

NATIONAL TECHNICAL SCHOOLS

WORLD-WIDE TRAINING SINCE 1905

Mail Now To
National Technical Schools, Dept. RB-90
4000 S. Figueroa St., Los Angeles 37, Calif.
Please rush **FREE** Electronics-TV-Radio "Opportunity" Book and Actual Lesson. No Salesman will call.

Name _____ Age _____

Address _____

City _____ Zone _____ State _____

Check here if interested **ONLY** in Resident Training at Los Angeles.

VETERANS: Give date of discharge.

FREE!

TRIAL LESSON

Trial lesson in DRAFTING

LEARN AT HOME IN SPARE TIME

Check the want ads in any newspaper — SEE the big-pay opportunities open to you as a draftsman. What's more, you can learn this well-paid, prestige profession at home — quickly, easily! No special talent needed! Get complete, step-by-step Chicago Tech lessons in the mail, spend a few pleasant hours studying each week. In a short time you'll be a well-trained draftsman, ready to take your pick of many good jobs. Act now!

FREE INFORMATION—MAIL COUPON TODAY!

Get FREE TRIAL LESSON plus information about C.T.C. practical training. Learn what successful Chicago Tech graduates say about high pay and opportunities in drafting. No charge, or obligation.

Accredited National Home Study Council

CHICAGO TECHNICAL COLLEGE

M-218 Tech Bldg., 2000 So. Michigan Ave.
Chicago 16, Illinois

Mail me FREE lesson with information about big opportunities in DRAFTING.

Name..... Age.....
Address.....
City..... Zone..... State.....

Great Pioneer in Science
Do You Know Him?

By James S. Thistle

AFTER THE WAR BETWEEN THE STATES railroad travel was a risk because there was no way of stopping a train quickly. There were many wrecks and many deaths. Our scientist came to the rescue with the invention of the compressed-air brake which was to be a boon to all humanity.

A railway "frog" making it possible for trains to pass from one track to another, electric railway signals and an apparatus that absorbed shocks between railroad cars were additional safety inventions. During his lifetime he patented almost 400 inventions.

In 1886 our Pioneer organized a corporation that bears his name today. It is one of the world's largest producers of electric power machines. This was the company that built the atomic reactor and propulsion equipment for the nation's first atomic-powered submarine and the first jet engine of American design. For his service to humanity, the governments of Belgium, France and Italy bestowed on him their highest honors.

These letters, unscrambled, spell the name of this month's Great Pioneer in Science:

OSWEGORINGGUESTHEE

(First and Last Names)

Write the correct name here:

Now turn to page 236 for the answer.

KEEP YOUR... EYE ON

BENJAMIN

Largest Selection in the World—Single Shot & Repeaters for Every Shooter's Needs! • 25 MODELS

You Can DEPEND on BENJAMIN . . . for Safety—Power—Accuracy—Convenience—Economy

FREE Catalog All Models Benjamin Single Shot & Repeaters—Cal. BB or 177 or 22. Also, Special Hunting & Fishing Knife Offer.

BENJAMIN AIR RIFLE CO., 896 MARION ST., ST. LOUIS 4, MO.

HI-COMP AIR GUNS AND POWERFUL CO₂ GUNS

No. 2600 BENJAMIN Super 35-Shot BB Gas Pistol. Safe—No Pumping—Uniform Hi-Power. For Target & Small Game. \$18.95

No. 2620 BENJAMIN 20-Shot Cal. 22 Gas Pistol. Economical. \$20.95

No. 1300 50-Shot BB Air Pistol \$23.50

No. 1320 BENJAMIN 35-Shot Cal. 22 Air Pistol \$25.50

No. 3600 BENJAMIN Super 100 Shot BB Gas Rifle. Non-Toxic—Safe—Convenient—Uniform Hi-Velocity Power. \$19.95

No. 3620 BENJAMIN Super 85 Shot Cal. 22 Gas Rifle . . . \$21.95

No. 3100 Super 100 Shot BB Air Rifle. Adj. Shooting Force \$24.95

No. 3120 BENJAMIN Super 85 Shot Cal. 22 Air Rifle . . . \$26.95

Here's The Offer No Other Radio-TV School

DARES MAKE!

LEARN AT HOME in Spare Time!

YOU DO MANY PRACTICAL JOBS with the kits we send you. That's right, you PRACTICE what we TEACH! You build a Signal Generator, AC-DC Power Pack, and AC-DC Superheterodyne Radio Receiver and top quality 21 inch TV Set. EARN AS YOU LEARN with the famous RTS 30 Day Income Plan. Full instructions provided. NO HIGH SCHOOL DIPLOMA NECESSARY. This is a COMPLETE course which starts with basic subjects and gradually advances to Radio-TV. . . . ALL FOR A PRICE YOU CAN AFFORD!

***THE ONLY VERTICAL MULTI-CHASSIS 21" TV KIT OFFERED BY ANY RADIO-TV SCHOOL**

RTS Will Train You at a Price You Can Afford and When You Are a Qualified Graduate Will Help You Open a Service Shop of Your Own and Supply You With Every Bit of Equipment You Need to Get Started - Plus an Inventory of Parts and Necessary Supplies.

ALL FINANCED WITHOUT INTEREST OR CARRYING CHARGES!!

You Also Receive . . . Advertising Help and Material, Shop Plans, Business Systems, Letterheads, Calling Cards and Much More!

Here's What Two of Many Business Plan Shop Owners Have to Say!

This business takes in between \$1500 and \$2000 a month. I've had to hire help to keep up with it.

CULLEN W IRBY
Corpus Christi, Texas

The school lives up to its promises 100%. RTS does not lose interest in its students once they graduate.

HAROLD R. STANLAKE
Perry, Michigan

DON'T LOSE OUT — FIND OUT!

RADIO TELEVISION TRAINING SCHOOL, Dept. PM-90
815 EAST ROSECRANS AVE LOS ANGELES 59 CALIF
Rush me full information by return mail. (Please Print)

NAME _____ AGE _____

STREET _____

CITY _____ ZONE _____ STATE _____

NO SALESMAN WILL CALL ON YOU!



YOU BUILD THESE AND OTHER UNITS!

COMPLETE COLOR TV INSTRUCTION INCLUDED!

Each student is entitled to unlimited consultation service. All questions are answered promptly and completely by highly specialized instructors.

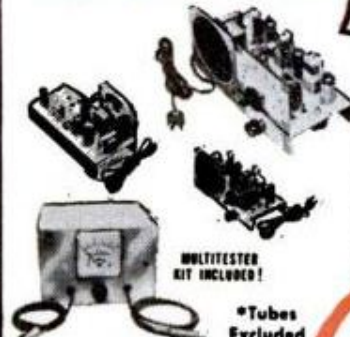

MULTIMETER KIT INCLUDED!

*Tubes Excluded

RTS' Membership in The Association of Home Study Schools is your assurance of Reliability, Integrity and Quality of Training.

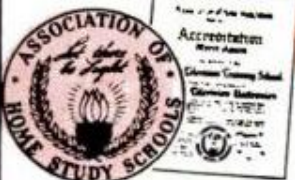

RADIO-TELEVISION TRAINING SCHOOL
815 EAST ROSECRANS AVENUE
LOS ANGELES 59 CALIFORNIA

Est. 1922



Rush Coupon for FREE FACTS!

"MADE \$1200 ON ONE JOB"

Some make more, some less...

We help you start Your Own All-Year Business

Make BIG Money! With our easily operated, highly efficient wall washer, G. H. Jones made \$1200 on one school job. E. L. Goss took in more than \$10,000 in one year.

E. C. Taber wrote, "I made \$400 gross in two weeks." And no wonder... this machine washes walls 6 times faster and better than by hand—with no mess... no drop cloths.

Your Money-Making Opportunity • We want more men to go into this profitable business for themselves and enjoy independence—freedom from layoffs and bosses. Customers everywhere—homes, offices, schools, churches, hotels, etc. How much you earn depends largely on you. What you take in is mostly profit. No need to rent shop or office; operate from home. Start spare time until full time is justified.

Lose No Time — Send Coupon Today for All the Facts



FREE BOOK! MAIL COUPON TODAY!

VON SCHRADER MFG. CO.

910 "W" Pl., Racine, Wisconsin

Send at once (no obligation) your **FREE** booklet containing information about your **WALL WASHING MACHINE** and how I can start my own permanent, profitable business.

Name _____

Address _____

City _____ Zone _____ State _____

MAKE EXTRA CASH

SHARPENING LAWN MOWERS THE MODERN WAY



As Low As
\$250.00

Start your own shop! Full or spare time. Earn many dollars in a short time... average \$5.00 per hour. Many mowers need sharpening. With **MODERN'S Extra Heavy Duty LAWN MOWER SHARPENER AND BED KNIFE GRINDER** you have 6 machines in one. All operations are done quickly and easily. You make money from the start. Write for free details.

MODERN MFG. CO.

160 N. Fair Oaks Ave. Dept.
Pasadena, California 10-6



TUNE IN ON THE INVENTORS

By John Linkletter

THE DAY MAY COME when a close call at home plate brings forth a deluge of pop bottles and catcalls aimed—not at the umpire—but at television cameras. Lloyd F. Knight of Levittown, N. Y., has come up with an "automatic baseball umpire or the like" which is really a system of television cameras that watch action on the diamond and store the images on tape. A disputed strike can be replayed over and over until everyone is satisfied it really was a strike. Knight's patent, No. 2,943,141, was assigned to Servo Corporation.

Designed as a replacement for complex and expensive proximity fuses, a "relatively simple" thermal fuse sets off a missile when heat generated by air friction reaches a certain temperature. Inventors James Meek of Silver Spring, Md., and Raymond Warren of McLean, Va., assigned their patent, No. 2,937,596, to the Army.

Air travelers will benefit from two new patents. One, the idea of Robert Bell of Palm Beach, Fla., is a glass-bottomed sight-seeing lounge for airplanes. Passengers would sit around the floor window to view scenes that can be seen in their entirety only from the air. Another air scheme comes from Paul Dostie of Quebec, Canada, who devised an accordion-pleated tube which connects the tail of one plane to the nose of another. Passengers could walk the tube while the planes are in flight. Bell has patent No. 2,942,811, and Dostie has No. 2,942,816.

A simple key ring that holds keys in place so that they can be removed only by someone who knows the secret of the device won patent No. 2,938,375 for Frederick Wehrli of the Bronx, N. Y. The ring also functions as a simple lock.

An underwater marine scaffold—a horizontally and vertically telescoping unit—fits all types and sizes of vessels for repairs at sea or in harbor. It may also be lowered to great depths for salvage or deep-sea operations. The inventor, Capt. Semon Kronhaus of Los Angeles, Calif., was awarded patent No. 2,919,763. ★ ★ ★

*Is There an
Invisible Influence
Upon Our Lives?*

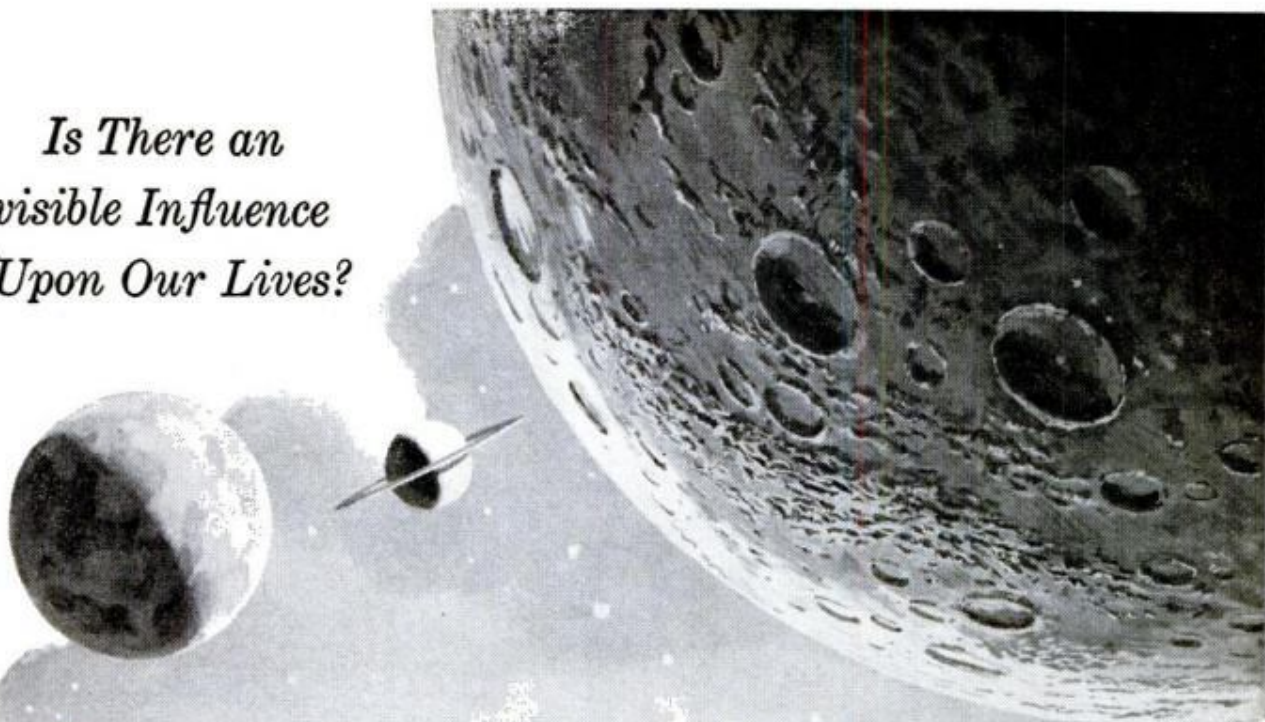

Somewhere Out There Are Other Minds!

Does man stand alone in the tideless ocean of space? Is earth the only habitat of intelligent beings? Certainly the phenomenon of life is not a chance one. Somewhere in the countless shining orbs are minds... how puny by comparison in mental and psychic stature we may be! Those strange, inexplicable feelings we have at times... are they a tugging from the recesses of space upon our senses? Are they the effort of Cosmic beings to reach out—to find a bond of communication with earth?

This FREE BOOK Explains

There are two ever exciting, unsolved mysteries—the nature of self and our Cosmic connections. Let the Rosicrucians, a centuries-old organization of learning (not a religion), send you a fascinating *free* book, *THE MASTERY OF LIFE*. It casts amazing light upon these things. Find new pleasure and *achievement* in this unique knowledge. Use the coupon for your *free* copy or write Scribe T.Q.N.



Scribe T.Q.N.
Rosicrucian Order, (AMORC)
Rosicrucian Park, San Jose, California, U.S.A.
Gentlemen:

*Kindly send me a free copy of THE MASTERY OF LIFE.
I am sincerely interested in the mysteries of self and
of the Cosmic.*

NAME _____
ADDRESS _____
CITY _____ STATE _____

The ROSICRUCIANS (AMORC) • SAN JOSE, CALIFORNIA

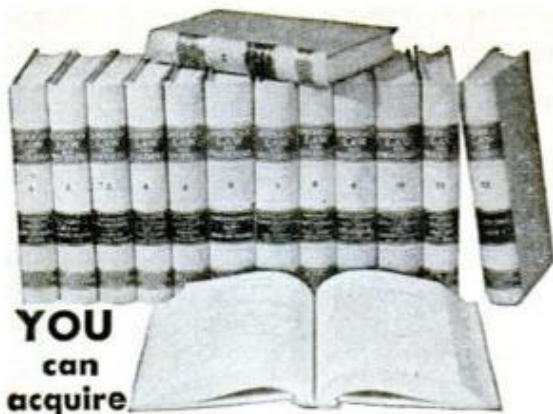

**YOU
can
acquire**

**LAW AT HOME!
EARN LL. B. DEGREE**

LaSalle's famous Law Library—used as reference in many Law libraries and Law offices—has enabled thousands to master Law surprisingly fast, in spare hours at home, for business and professional advancement.

These 14 remarkable volumes, compiled by leading professors and lawyers, cover the whole basic field of Law in condensed, orderly, simplified manner.

You advance rapidly with this great library, plus special lectures furnished. We guide you step-by-step with personalized Problem Method of instruction... you *learn by doing*—handling legal problems—not by memorizing rules.

Send for two FREE booklets, "Law Training for Leadership," and "Evidence," answering questions about Law and its value to you. Mail coupon below. No obligation.

Accredited member, National Home Study Council

**LA SALLE EXTENSION UNIVERSITY
A Correspondence Institution**

417 S. Dearborn St. Dept. 964 L Chicago 5, Ill.

Send me your two FREE booklets described above, without obligation.

Name Age

Street

City, Zone & State

BIG EARNINGS WAITING



**FREE
Professional Tools,
Typewriter Supplied**



**Be a
TYPEWRITER
REPAIRMAN**

Earn while you train at home. Take your place in this booming multi-million dollar field. Skilled men are in demand—thousands more needed. Quickly step into a big-pay job or business of your own. Learn easily under expert guidance with clearly illustrated lessons. Work on a real typewriter, with professional tools.

SEND FOR FREE BOOK—Get vital government facts about urgent need for trained typewriter repair men. Free Book describes the vast opportunities waiting for you. Lic. by N. J. Dept. of Education



MAIL COUPON TODAY!

Typewriter Repair School, 4-10, 150 Park Ave., E. Rutherford, N. J.
Send FREE Book, "Opportunities Unlimited", at no obligation.

Name

Address

City Zone State

**Keeping up
with the
ATOM**

By James Biery

A PILOT PLANT for removing radioactive strontium from commercial quantities of milk has been established in St. Louis, Mo., which leads other areas in the U.S. in having such contamination. Strontium 90 is produced by nuclear explosions, and its radioactivity, thought by some scientists to cause leukemia and bone cancer, lasts for years. Dr. H. T. Blumenthal, one of the scientists engaged in the project at the Pevely Dairy Company milk-processing plant, found a resin of the sulfonic acid type capable of taking up to 93 percent of the strontium from milk samples while making no appreciable change in the mineral balance of the milk or the taste.

Argonne National Laboratory, in Illinois, is building a \$29,000,000 atom smasher that is expected to produce large quantities of subnuclear particles that previously have been available to high-energy physicists only in small amounts. One such particle is the neutrino, which has no electrical charge and can be detected only by making it react with another particle. The particle was detected in 1956 and it is so elusive it can pass through the Earth and the entire solar system without being deflected. Argonne's atom smasher will be the first to make enough neutrinos to allow experiments with these bits of matter.

A \$12,000,000 electron accelerator will go into operation at Cambridge, Mass., next year to provide scientists at Harvard and the Massachusetts Institute of Technology with the smallest known particles of matter for study. Located in a circular subway 236 feet in diameter, the accelerator is expected to spurt out—60 times a second—a pulse of 100 billion electrons moving at 99.9999996 percent of the speed of light. Four dozen magnets, each 12 feet long and weighing eight tons, will hold the electrons in place while they are being accelerated through an oval tube. Energy will be imparted to the electrons by a radio-frequency system comparable to that of the largest search radar systems. They will dissect stable particles to produce unstable particles such as negative protons. ★ ★ ★

DON'T BE HALF-TRAINED! Be A Master Technician

NOW... ONE
modern master
home training course
IN ALL 3 PHASES



AIR CONDITIONING - REFRIGERATION ELECTRICAL APPLIANCES

**ALL AT ONE
LOW TUITION**
only
National Technical Schools
gives you this complete
training at no extra cost

YOU GET AND KEEP ALL THESE TOOLS AND INSTRUMENTS



Incomplete training limits your earning power, even disqualifies you for top-pay jobs. The big service companies require complete, all-phase training. If you open your own shop, you'll be called upon to service and repair all types of refrigerators, air conditioners and appliances. With complete training—as only National Technical Schools can give you—you can accept every job, make big profits all year round.

FUTURE BRIGHT FOR TRAINED MASTER TECHNICIANS

Over 30,000 new technicians must be trained annually. You are needed to help service and repair the 50 million air conditioners, refrigerators and electrical appliances that will need fixing this year alone. No wonder the Master Technician has steady work, at high pay, year after year. He can go places in his own business or with a manufacturer, dealer, distributor or department store. Armed with all-phase training, his earning power is unlimited.

THE MOST FOR LESS

We give you illustrated Shop-Tested Lessons and Manuals...many other training aids...privilege of CONSULTATION with our instructors and engineers. Every lesson, every manual has been SHOP tested and approved.

JOB TRAINING AT HOME

You get Professional Tools, Precision Instruments, PLUS a Factory-Made APPLIANCE TESTER! A shop-full of PRACTICAL, professional equipment. Use them to conduct over 100 experiments...also in Spare Time Work and ON THE JOB. It is all yours to keep...no EXTRA MONEY DEPOSITS...no EXTRA COST on your equipment kits.

EARN AS YOU LEARN

We show you how. Many of our students pay for their entire course—and more—in Spare Time while learning. So can you. Graduate Advisory Service, too.

GET THE BENEFIT OF OUR OVER 50 YEARS EXPERIENCE

N.T.S. also offers training in
TV — RADIO — ELECTRONICS
and AUTO MECHANICS — DIESEL



MEMBER



NATIONAL TECHNICAL SCHOOLS

WORLD-WIDE TRAINING SINCE 1905

4000 SO. FIGUEROA ST., LOS ANGELES 37, CALIF., U. S. A.

RESIDENT TRAINING AT LOS ANGELES

If you wish to take your training in our Resident School at Los Angeles, start NOW in our big modern Shops and Labs. Here you work with latest equipment...professionally installed...finest, most complete facilities offered by any school. Expert, friendly instructors. Personal attention. Graduate Advisory Service. Help in finding home near school...and part time job while you learn. Check box in coupon for full information.



**SEND FOR
FREE
BOOK AND
ACTUAL
LESSON NOW!**

We'll rush you our big, illustrated OPPORTUNITY BOOK and ACTUAL LESSON, show you how easily you can learn. NO OBLIGATION; no salesman will call. Do it NOW! It costs nothing to find out.

NATIONAL TECHNICAL SCHOOLS

WORLD-WIDE TRAINING SINCE 1905

MAIL NOW TO
National Technical Schools, Dept. CB-90
4000 S. Figueroa St., Los Angeles 37, Calif.
Rush FREE "Opportunity" Book and Actual
Lesson. No Salesman will call.

NAME _____ AGE _____

ADDRESS _____

CITY _____ ZONE _____ STATE _____

Check here if interested ONLY in Resident Training at Los Angeles.



NOW!

How to Fix ANY

QUICKLY, EASILY and

BRAKES

FUEL PUMPS

Transmissions

Starter Switches

Carburetors

Fuel Pumps

Generators

Ignition

Engines

Brakes

Overdrives

AXLES

HYDRA-MATIC

STARTING MOTORS

VALVES

IGNITION SYSTEMS



Fig. 10. Adjusting breaker and contact points in distributor cap.

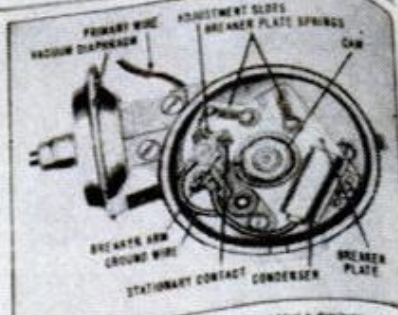

Fig. 11. Breaker plate details of Ford 6 and 8 and 1961 6 cylinders.



Fig. 9. Exploded view of typical distributor from Buick Wildcat and Ford Falcon and Mercury.

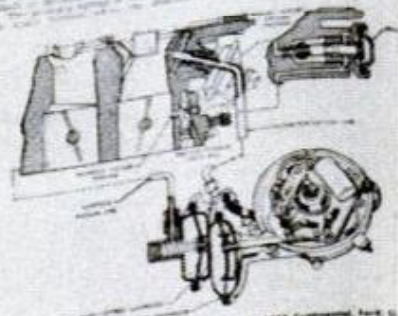

Fig. 12. Distributor repair kit used on 1958 Continental, Ford 6 and Mercury with top-bar breaker assembly from the Buick version shown which is used for basic control of breaker plate advance circuit.

THIS GIANT PICTURE BOOK SHOWS REPAIR PRACTICALLY EVERY CAR

Whether You're a Beginner or an Expert Mechanic
—This Manual Can Help You "Breeze Through"
the Toughest Auto Repair Job

Don't waste time, money, energy by trying to guess how to fix a car! Do what the experts do. Whether it's a simple carburetor adjustment or a complete overhaul—simply look up the job in the index of MOTOR'S New AUTO REPAIR MANUAL. Turn to page covering job. Follow clear, illustrated, step-by-step instructions. See for yourself how easy it is!

No guesswork! MOTOR'S Manual takes nothing for granted. Tells you where to start. What tools to use. Then it leads you easily and quickly through the entire operation!

Over 2,800 Pictures! So Complete,
So Simple, You CAN'T Go Wrong

BRAND NEW EDITION covers everything you need to know to repair over 1,960 car models. Over 1,000 giant pages, 2,850 "This-Is-How" pictures, 195 "Quick-Check" charts, 30,000 essential specifications. Over

Same FREE 7-Day Trial on TRUCK REPAIR MANUAL

Covers every job on every popular make truck from 1952 thru 1960, including GM, Mack and Cummins Diesels. Engines, fuel systems, ignition systems, starters, generators, transmissions, axles, brakes, steering, etc., etc. For FREE TRIAL, check box in coupon.



SEE FOR YOURSELF

Part of ANY Car!

RIGHT on the very first try

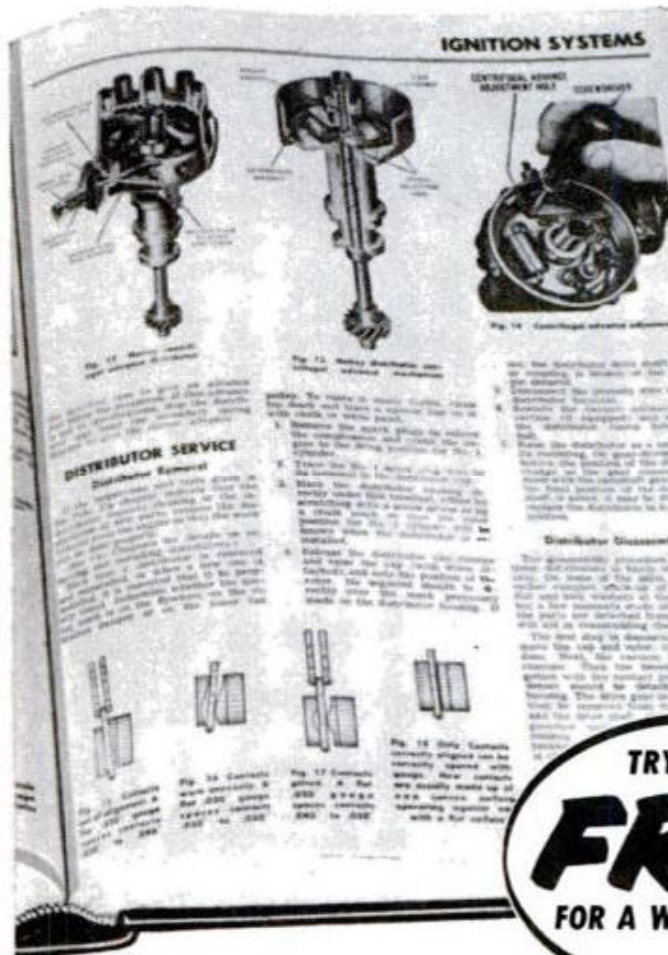

- Power Steering
- Steering Gears
- Dash Gauges
- Power Brakes
- Water Pumps
- Starters
- Front Ends
- Oil Pumps
- Rear Ends

TRY BOOK
FREE
FOR A WHOLE WEEK!

THOUSANDS NOW DO CAR REPAIRS THEY NEVER KNEW THEY COULD HANDLE

Has Paid for Itself Time and Again "It doesn't take schooling to read it. Has pictures of every part. Paid for itself time and again."
—Paul R. Pemper, Wisc.

Paid for Itself on First 2 Jobs "MOTOR'S Manual paid for itself on the first 2 jobs and saved me valuable time by eliminating guess-work."
—W. Schrop, Ohio

No Trouble Learning "Instructions so clear I have had no trouble learning anything about any car. Now working as mechanic in big plant."
—Sam Ordonez, Calif.

Gets Better Job ... Thanks to Manual "I have become foreman of my garage—thanks to help of your Manual."
—E. Hensler, Wisc.

Amazed Self and Friends "I amazed myself and my friends, too. Now do auto repair jobs that stumped me before."
—Michael Baliczky, Newark, N. J.

YOU STEP-BY-STEP HOW TO BUILT FROM 1953 THRU 1960

225,000 service and repair facts. Instructions and pictures are so crystal-clear you just can't go wrong!

Meat of 176 Official Shop Manuals

Engineers from every automobile plant in America worked out these time-saving procedures for their own motor car line. Now this wealth of "Know-How" from 176 Official Shop Manuals has been "boiled down" into crystal-clear terms in one handy indexed book!

No wonder this guide is used by the U.S. Armed Forces and hundreds of thousands of repair men. It's *guaranteed* to help even a beginner mechanic do a good job. And top-notch mechanics are amazed by the time-saving methods it brings them.

SEND NO MONEY
Try Book for a Week FREE

Just mail coupon. (Attach it to postcard for faster action.) Test book in your own garage or shop. It's **GUARANTEED** to pay for itself in 7 days. If it doesn't, return it, and owe nothing. Rush coupon now. MOTOR Book Dept., Desk 019, 250 W. 55th St., New York 19, N. Y. (SCHOOLS, BOOKSTORES: Write for discounts.)

OVER 3 MILLION COPIES SOLD
USED BY U. S. ARMED FORCES

- COVERS ALL THESE MAKES 1953 Thru 1960**
- | | | |
|-------------|----------------|--------------|
| Buick | Edsel | Nash—'55-'57 |
| Cadillac | Falcon | Oldsmobile |
| Chevrolet | Ford | Plymouth |
| Chrysler | Hudson—'55-'57 | Pontiac |
| Continental | Imperial | Rambler |
| Corvair | Jeep | Studebaker |
| Dart | Lincoln | Thunderbird |
| De Soto | Mercury | Valiant |
| Dodge | | |

MAIL COUPON NOW FOR 7-DAY FREE TRIAL
(Attach to postcard for faster action)

MOTOR BOOK DEPT.
Desk 019, 250 W. 55th St., New York 19, N. Y.

Rush to me at once (check box opposite book you want):

MOTOR'S New AUTO REPAIR MANUAL. If O.K., I will remit \$2 in 7 days, \$2 monthly for 2 months and a final payment of \$1.95 (plus 45c delivery charges) one month after that. Otherwise I will return the book postpaid in 7 days. (Foreign price, remit \$10 cash with order.)

MOTOR'S New TRUCK REPAIR MANUAL. If O.K., I will remit \$3 in 7 days and \$2 monthly for 3 months, plus 45c delivery charges with final payment. Otherwise I will return book postpaid in 7 days. (Foreign price, remit \$11 cash with order.)

Print Name..... Age.....

Address

City..... Zone..... State.....

Check box and save 45c shipping charge by enclosing WITH coupon in envelope entire payment of \$7.95 for Auto Repair Manual (or \$9 for Truck Repair Manual) plus sales tax. Same 7-day return refund privilege applies.

MAKE YOUR MARK IN THIS HIGH-PAY FIELD

A better job with more pay will mean better living for you—fine home, new car and nice vacations. To afford the good life, get training in Auto Mechanics. Experts say that "America is short 100,000 mechanics and 25,000 repair shops." Opportunities to make good are everywhere. Pay is tops, work is steady!



Train AT HOME for a GOOD JOB in

AUTO MECHANICS

CTI lessons are fully illustrated and clearly written. You learn in months. Previous experience is unnecessary. No need to give up present job. Many students earn as they learn. Many go in business. Diesel Mechanics or Body-Fender Rebuilding instruction is also included at no extra cost.



CTI sends you professional Mechanic's Tools and valuable instruments, including a Compression Tester, Vacuum Gauge & Fuel Pump Tester, Ignition Timing Light; and a handy portable steel case.



MAIL COUPON TODAY

COMMERCIAL TRADES INSTITUTE Dept. A-35
1400 Greenleaf Avenue • Chicago 26, Illinois
Send booklet, Make Big Money in Auto Mechanics

Name _____ Age _____

Address _____

City _____ Zone _____ State _____

Accredited by National Home Study Council



... TURN CONCRETE INTO GOLD!

MAKE UP TO \$75 A DAY IN YOUR OWN BUSINESS

If you want to have your own business — to start a business on your own — here's your big opportunity! New high speed, low cost General block machine produces up to 1,000 concrete blocks a day. Sell all you make to builders, supply houses, and others for homes, factories, buildings, garages. Cash in on the building boom! You can make profits of 100% to 150% — up to \$75 a day! General block machine equipped with 1/2 h.p. electric motor — or can be supplied with gasoline engine — works anywhere, in little space, indoors or out. Operates from ordinary house light socket. Simple, foolproof 3 step operation — so easy a child can do it. Makes superior 3 core blocks any size from 4" to 12" Also makes chimney, sash, corner and other types. Blocks meet any building code anywhere in the country. Materials — sand, water, cement, available anywhere. Simple illustrated operating instructions and mixing formulae for cement and cinder blocks supplied with each machine. Write for FREE folder with full information.

R. L. T. of New York City reports: "MY GENERAL BLOCK MACHINE PAID FOR ITSELF IN FIRST 2 WEEKS!" Hundreds now in use the world over! Write for FREE details today!

EXTRA

Amazing illustrated

book gives floor plans for 6 sensational concrete block bungalows. Tells how to lay blocks, lay out building lines, mix concrete, build steps, porch and concrete floors all at great savings. Written by experts. Can save many times the cost of the machine! Get it now! No strings attached. Send \$1.

BOOK SENT FREE IF YOU BUY MACHINE.
\$1 REFUNDED IF YOU BUY LATER.

GENERAL ENGINES CO.

DEPT. M-90, ROUTE 130, THOROFARE, N. J.



QUOTE:

"The engineers dreaming about the supersonic transport aircraft are more or less in agreement that it would be necessary to go to at least Mach 2.5 (two and a half times the speed of sound), and probably to Mach 3, to produce a machine that would make sense economically. These speeds can only be achieved at altitudes of 50,000 to 60,000 feet. Altitudes as high as 70,000 feet are being discussed. At such heights, a sudden loss of pressure in the passenger cabin would result in disaster for all persons aboard even though they wore oxygen masks and were breathing pure oxygen. Sudden depressurization would cause almost immediate unconsciousness, followed by loss of life itself. The only protection against this, the individual pressure suits which military fliers use for high-altitude work, is obviously impracticable for commercial airline operation.

"Another unfavorable environment problem is the high temperatures encountered cruising at high Mach numbers. At Mach 3, the skin temperature on an aircraft would be in the area of 570 degrees F., which in turn requires a reliable refrigeration system to protect passengers from this intense heat and maintain a comfortable cabin temperature.

"There are numerous other difficult problems involved in supersonic flight. For example, these airplanes will be extremely noisy on takeoff and will have to be held well below supersonic speed during climb to prevent a series of disturbing and even destructive sonic booms along the path of flight. Even at high altitude, sonic booms are disturbing to people on the ground, although possibly tolerable when the planes are flying at altitudes above 50,000 feet.

"Admittedly, the view that there will be no supersonic airliner within the next decade is conservative. However, it is based on known engineering principles of 1960, presented in the light of realistic airline operating experience. What I have said should in no way be interpreted to mean supersonic airliners are an engineer's unrealistic dream. They will be built and flown but will not be seen in scheduled operation for at least 10 or 12 years."

—J. A. HERLIHY,
Senior Vice-President,
United Air Lines

☐ In flight tests, the U.S. Navy's twin-turbine, submarine-hunting helicopter, the HSS-2, hovered continuously over one spot for more than three hours—a far more demanding feat than normal forward flight.

LOOKING FOR LONG WEAR IN SERVICE SHOES?

TRY **ORTHO-VENT** SHOES

WITH **NEOPRENE SOLES!**



Neoprene soles give long wear... resist oil, grease, chemicals and cold weather cracking. Neoprene soles are resilient... cushion each step... help make standing jobs less tiring.

Ask for neoprene soles the next time you buy service shoes.



BETTER THINGS FOR BETTER LIVING...THROUGH CHEMISTRY

If You're Looking for More Money... **WE'LL SET YOU UP FOR LIFE** with America's Most Sensational Shoe Line for the Whole Family

It is no trick at all to make big money daily—full or spare time—when you are able to offer the biggest line of shoes in the entire industry, featuring everything from baby shoes to work, dress and sport shoes for every member of every family.



SHOES GIVEN PRODUCERS AS AN EXTRA BONUS

NO SHOE EXPERIENCE—NO INVESTMENT NEEDED

The shoes shown here are only a few examples to be found in Ortho-Vent's New line for Fall and Winter 1960-61, now ready for those who want to make more money NOW. Over 220 styles to choose from in every imaginable size and width including 10 styles of water-proof boots and shoes. Family Discount Plan helps build permanent ever-more-prosperous shoe business of your own. Amazing 1 second demonstrators show exclusive "Spring Step" cushion construction that proves Ortho-Vent shoes the most comfortable, most flexible shoes in all the world. Repeat orders are sure and steady. One try and a customer is sold for life.

Can you use up to \$32.00 a day—up to \$150.00 a week—up to \$600.00 a month and more? Starting at once? Then get in on the shoe line that has revolutionized the entire industry, backed by an amazing selling plan that has no equal. Fill out the coupon below or send a postcard for the most valued selling outfit you ever saw. Mail it TODAY.

ORTHO-VENT SHOE CO. Inc.
1109 Brand Road, Salem, Va.

ORTHO-VENT SHOE CO.
1109 Brand Rd., Salem, Va.

I want to sell Ortho-Vent Shoes and make big money. Rush me the complete Ortho-Vent Line and Special Salesman's Proposition.

Name Age

Address

City State

Would YOU Like to Make \$1,000 A MONTH?

That's what Stanley Hyman made selling the amazing new PRESTO Fire Extinguisher!



Amazing new kind of fire extinguisher. Tiny "Presto" does job of bulky extinguishers that cost 4 times as much, are 8 times as heavy. Ends fires fast as 2 seconds. Fits in palm of hand. Never corrodes. Guaranteed for 20 years! Sells for only \$4.95! Over Two Million Sold!



STANLEY HYMAN

Show it to civil defense workers, owners of homes, cars, boats, farms, etc. and to stores for resale—make good income. H. J. Kerr reported \$20 a day. C. Kama, \$1,000 a month. Write for FREE Sales Kit. No obligation.

MERLITE INDUSTRIES, Presto Div., Dept. P-15T

114 East 32nd Street, New York 16, New York

IN CANADA: Mopa Co., Ltd., 371 Dowd Street, Montreal 1, P.Q.

LEARN TO MOUNT BIRDS



ANIMALS, FISH, PETS

Be a Taxidermist. Save your hunting TROPHIES. Have a fine home-museum. Hunters, save and MOUNT your beautiful DUCKS, QUAIL, DEER, TAN skins and FURS. Great Fun. Spare-time PROFITS. **FREE BOOK** Tells ALL about it. 100 fine wild-game pictures. 48 pages. Send TODAY, don't delay. Get this WONDERFUL FREE BOOK, MEN AND BOYS. Learn Taxidermy. Double your hunting pleasure. Rush letter or POSTAL today. STATE AGE. N.W. SCHOOL OF TAXIDERMISTRY, Dept. 2509 Omaha, Neb

Learn PACKAGING!

MAKE TO 2500% PROFITS AT HOME
YOU PACKAGE WE DO YOUR SELLING!

HERE'S PROOF
that Packaging means
Big Profits for You!

Item	Bulk Cost	Sells For
Per Doz.		
Safety Pins	2 1/2¢	15¢
Balloons	3 1/2¢	19¢
Fish Hooks	2¢	50¢

Make profits like these on over 100,000 other products you can package right in your own home. We show you how!

Package products at home for nationwide sales force. You package bulk items in your own home. We do your selling coast-to-coast. FREE 'No Selling Plan' reveals thousands full, spare time big profit opportunities for beginners in self-service packaging, contract packaging, gift wrapping. We guide you step by step. Everything furnished. Write today for FREE "10-STEP PACKAGING PROFIT PLAN", and full details. No salesman will call.



HOME PACKAGING CO., Dept. C259
2212 E. Jesse St., Los Angeles 23, Calif.

ITEMS FROM ALL OUTDOORS

By Dick Kirkpatrick

NEXT TIME you meet someone who thinks he's got an easy job, tell him to go see William Schmidt, of Annapolis, Md., a retired boilermaker who has been hired by the Magothy River Association to fish (yes, fish) four hours a day, five days a week. At \$1.70 an hour, whether he catches anything or not. The Association and a local sports group, working with the Maryland Department of Research and Education, is testing the theory that fishing is better around oyster bars. Schmidt fishes half his time around an area where 700 bushels of shells have been dumped; the other half in other areas. He keeps a record of his catch and reports on the success of other fishermen in the area. But other than that, all he has to do is fish. How's that?

Lt. Charles Meyer, of New York City's river-front squad, has offered this check list to help cut down thefts and vandalism around boats:

1. Store detachable equipment in lockers.
2. Don't leave valuable property in an unattended boat.
3. Keep unauthorized persons away from docks; note descriptions of loiterers.
4. Note descriptions of strangers trying to sell equipment; it may be stolen.
5. Put a secret mark on your property for later identification if it's stolen.
6. Record serial numbers of property.
7. Secure motors with lock and chain.
8. Report vandalism or theft to police.
9. In clubs, appoint a security officer.
10. Get to know your waterfront police.

Remember the unusual sailing "Kolumaran" that graced the cover of this year's March Boating Issue? The designer, Dean Kennedy of San Diego, Calif., reports that inquiries from readers of PM and our seven international editions are still coming in at the rate of about two a day, and that the response from overseas has been remarkable. He reports letters from England, France and South Africa (3 each); Denmark, West Germany, Australia, New Zealand and the Philippines (2 each); and singles from Argentina, Mexico, Honduras, Ecuador and Okinawa. ★ ★ ★

engineering degree in 27 months

Share rewards awaiting college men . . . higher income . . . advancement. Important firms visit Tri-State campus to interview seniors. *Bachelor of Science Degree in 27 Months* in Electrical Engineering (Electronics or Power major), Mechanical, Civil, Aeronautical, Chemical Engineering. In 36 Months a B.S. in Business Administration (General Business, Accounting, Motor Transport Management majors). For earnest, capable students. Small classes. More professional class hours. Well-equipped, new and modernized, buildings, labs, dorms. Modest costs. Year-round operation. Enter January, March, July, Sept. Founded 1884. Write J. E. McCarthy, Director of Admissions, for Catalog and "Your Career in Engineering and Commerce" Book.



TRI-STATE COLLEGE

490 College Avenue Angola, Indiana

MAKE BIG MONEY

MAKING COSTUME JEWELRY AT HOME!

Thrilling spare-time, MONEY-MAKING hobby! Make newest, beautiful jeweled earrings, necklaces bracelets, pins, pendants, cuff links, tie clips! Quick, easy to make—easier to sell to friends, neighbors, stores, at big profit! Details FREE!

DON-BAR CO., Dept. K-19
3511 W. Armitage Ave., Chicago 47, Ill.



Learn YOGA Secrets

Have better health, reserve vitality, and a sharp, keen mind . . . from YOGA, the science of body and mind control.

New POWER for Success! Spend a few minutes a day on this fascinating study to gain new energy, will power, confidence . . . whatever your age. Test this great life-science yourself . . . FREE Trial Lesson 1, no obligation! ACT NOW! Send 25¢ to cover mailing cost.

INSIGHT SCHOOL Dept. A290, 845 Chicago Ave., Evanston, Ill.

LAW FREE BOOK THE LAW TRAINED MAN

Write today for a FREE copy of illustrated law book, "THE LAW TRAINED MAN," which shows how to earn the professional Bachelor of Laws (LL.B.) degree through home study of the famous Blackstone Law Course. All necessary books and lessons provided. Moderate cost; convenient monthly terms. Write for FREE law training book today.

Blackstone School of Law, 307 N. Michigan Ave.
Founded 1890 Dept. 56, Chicago 1, Illinois

JEEP OWNERS

RE-POWER NOW WITH A V-8 OR 6 CYL. ENGINE — USE FORD—CHEV—MERCURY—GMC—PONT—STUDE—DODGE OR PLYMOUTH in Jeeps, Jeepsters, Sta-Wgn, trucks, Kaiser & H. J. cars. Conversion Kits \$45.35 to \$56.90. Want fast action? Give us full information, send \$15.00 Dep. and we will ship correct kit. Bal. COD. Send full amount for prepaid shipment. Wire, phone or write today. Details FREE

HOOSIER MACHINE PRODUCTS CO.
312 S. E. 6th St. Phone CR 6-3442 Pendleton, Oregon

BEST SPORTS CAR YOU CAN OWN!

A 4-WHEEL DRIVE WITH WARN HUBS

Hi-ball on the highway in free-wheeling 2 w.d. with Warn Hubs on your 4 w.d.—no front end drag or whine, better gas mileage, easier steering. Save money, save road time. Switch in seconds into 4 w.d. when the going gets rough! Change to 2 or 4 w.d. automatically with Warn Lock-O-Matics, manually with Warn Locking Hubs. Guaranteed. Models for all makes 4 w.d.s. to 1 1/2 tons. At your dealer's or write:

WARN MFG. CO., Riverton Bx 6064-A, Seattle 88, Wash.



Learn at Home

in your spare time

to Fix Electric Appliances



Better Pay—More Opportunities

Get into a field where there is important work and opportunity for the trained man. Millions of electric appliances are sold every year. Every wired home now has an average of 8. Many of them need service and repair. Owners pay well to have them fixed quickly, properly. This is your opportunity for a better job, your own part time or full time business. NRI can give you the training you need, at home, in your spare time.

Spare Time Earnings Start Soon

Soon after starting you will be able to earn extra cash fixing toasters, clocks, fans, vacuum cleaners, etc., for neighbors and friends. Keep your job while learning and earning. Put spare time to work for you. Work in your basement, garage, spare room. You'll be amazed how easily, quickly you, too, can start earning many extra dollars. NRI shows you how. Even before you finish training your spare time earnings may pay for the course and equipment.

NRI Sends Tester to Learn and Earn

You need proper equipment to service today's automatic appliances. With this course you get parts to build professional type, multi-use Appliance Tester. You learn to use it. Takes guess work out of servicing. Mail coupon for FREE book and Sample Lesson. See how easy it is to learn. Find out about NRI—a school that for more than 40 years has been training men, through home study, for success, good pay jobs. Our reputation, record, experience back up this course. Address: NATIONAL RADIO INSTITUTE, Dept. AJ0, Washington 16, D.C.



FREE Lesson and Book
Mail this NOW!

NATIONAL RADIO INSTITUTE

Dept. AJ0 Washington 16, D. C.
Send me Lesson and Book Free. No Salesman will call.

Name.....Age.....

Address.....

City.....Zone.....State.....

ACCREDITED MEMBER NATIONAL HOME STUDY COUNCIL



YOU TOO, CAN BEAT THE GASOLINE HABIT!

More people ride HONDA Super Cubs than any lightweight motorcycle or scooter in the world... Amazing in performance, the new Super Cub, CA-100 gives you over 200 m.p.g., features a 3 speed trans and automatic clutch.

\$245 P.O.E.



Electric Starter \$30 additional

Its famous 50cc OVER-HEAD VALVE engine develops 5 H.P. at 9500 r.p.m. and rates as one of the finest 4 stroke engines ever engineered. Dependable, rugged and economical it's real easy to ride...AND IT'S FUN!

* 8 models available (50cc thru 305cc) *
* Electric starters *



AMERICAN HONDA MOTOR CO., INC.
4077 WEST PICO BLVD. LOS ANGELES 19, CALIF.

Learn LANDSCAPE GARDENING

AND GROWING OF PLANTS. Latest information on propagation, soil-testing, plant growth regulators, garden design. Start a profitable business or wonderful hobby. Unique and modern home study course - accredited. Earn your certificate at home. May I send FREE, and without obligation, my Informative Booklet? **NORM MORRIS NATIONAL LANDSCAPE INSTITUTE** DEPT. M-90 11826 SAN VICENTE BLVD., LOS ANGELES 49, CALIF.



C-10

Beauty by Colorcrete Can Earn High Incomes



Beautifying buildings by Colorcrete is a business opportunity awaiting men of modest capital everywhere. Owners of homes, stores, motels, schools - almost any type of construction - are looking for means to give lifetime eye-appeal to drab or dirty concrete, stucco and similar masonry surfaces. Colorcretors can do such jobs, in little time and at little cost, and pocket generous profits. Colorcrete is a cementitious material, applied by air pressure. Tough, tenacious, enduring; 30 colors. Investigate this low-investment enterprise by writing for the Opportunity Book.

COLORCRETE INDUSTRIES, INC.
570 Ottawa Ave., Holland, Mich.



WHAT'S UP IN THE AIR



By Kevin V. Brown

SPACE STATIONS may have trouble attracting tenants, and for an ironic reason. After the initial excitement of pioneering space travel wears off, the spaceman, an extraordinary sort of individual, may succumb to a rather ordinary human failing—boredom. Recent Air Force tests, in which two crews spent 15 days in earth-bound "space cabins," brought this into sharp focus. The airmen's chief reactions: "We were bored, tired and sleepy." They had trouble getting to sleep, trouble getting awake and, "after our work was done, there just wasn't anything to do." North American Aviation Co. is working on the problem of providing a more interesting environment in cramped quarters for men on space duty, fearing that, if it isn't solved, recruits may be as hard to get as lighthouse keepers. Ping-pong and television perhaps?

An airplane ticket for three cents? It happened in Spain, land of the bullfight, where tradition and protocol are paramount. An agent for Iberia, Spain's national airline, checking a cargo of 100 chickens for transport from Barcelona to Tortosa, felt it his duty to issue a ticket for each chick. Price: 1½ pesetas each (three cents).

Photography is receiving increasingly ingenious attention in space research. The Navy plans a reconnaissance satelloid that will be aimed to pass over a preselected point on earth, take pictures, and then be recovered after one orbit. RCA is working on an electric camera for satellites that will do what no space camera has done before—take pictures of the satellite itself. Flashed back to earth, the photos would give visual reports on the satellite's performance.

In the wake of the summit fiasco at Paris comes a report that the U-2 was not the only American airplane that upset Nikita Khrushchev. After one night at the suburban home of the Russian ambassador, Nikita moved back to the USSR Embassy in town. The noise of the American jetliners, taking off and landing from nearby Orly Airport, had kept him awake most of the night. ★ ★ ★

New Table Top Invention Puts You In...
**PROFITABLE RUBBER
 STAMP BUSINESS**

Home Operators now make
\$9.20 AN HOUR in business
 once monopolized by
 a few big companies

Special rubber stamps bring high prices—cost only pennies to make on new, low-cost table top machine. Take 27 cents worth of material, make perfect stamps, the kind businesses and offices now buy by the dozen at \$1.80 each. Make up to \$9.20 an hour. Start in spare time in your own home. Run machine on kitchen table using ordinary electrical outlet. Make any kind of stamp. We'll send you free information without obligation about this established, highly profitable business, now open to individuals for the first time. For free information send name today on a post card to
Rubber Stamp Div., 1512 Jarvis, Dept. R-2-K, Chicago 26, Ill.

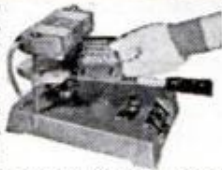

**GOVERNMENT OIL LEASES
 LOW AS \$1 PER ACRE**

You do no drilling, pay no taxes, may realize a king-size profit without ever leaving home. Write for free map and literature.

**AMERICAN OIL SCOUTS, Dept. PM
 8350 Santa Monica Blvd. Los Angeles 46, Calif.**

make your own Gems 36⁵⁰
 The Gem Maker comes complete with all necessary equipment, including a super-charged diamond blade for sawing, and all the wheels for grinding, shaping and polishing; also complete instructions. The complete equipment as shown, less motor and belt for only \$36.50, f.o.b., Burlington, Wisconsin. Write today for information and literature.
B&I MANUFACTURING CO., Dept. P Burlington, Wis.

MONEY in WORMS

Sell 20,000 fishworms per week @ \$4 per 1000 from a bed 3 feet wide and 8 feet long. We teach you how to raise and where to sell fishworms and crickets. Write for free literature.
CARTER WORM RANCH, PLAINS, GEORGIA
 Read our success story in LIFE MAGAZINE, December 23, 1959 Issue

**WANT MORE MONEY?
 GET INTO PHOTOGRAPHY**

Coast to coast, high-paying jobs in photography are waiting for people with the "know-how" to fill them. You can quickly, easily qualify at home with the world-famous NYI Learn-by-Doing Method. Write today for free catalog. Also resident training in N. Y. Our 51st Year. Approved for Veterans.
**NEW YORK INSTITUTE OF PHOTOGRAPHY
 Dept. 49 10 West 33 St. New York 1, N. Y.**

MEN PAST 40

**Afflicted With Bladder Trouble,
 Pains in Back, Hips, Legs,
 Nervousness, Tiredness.**

If you have these troubles, particularly bladder trouble, then your condition may be traced to Glandular Inflammation . . . a constitutional disease. Neglect of this condition often leads to premature old age and sometimes incurable malignancy.

The Excelsior Medical Clinic has a New Free Book that tells how thousands of men have been successfully treated here at Excelsior Springs for Glandular Inflammation by NON-SURGICAL Methods. They found soothing relief and a new outlook in the future of life.

This Free Book may prove of utmost importance in your life. Write Today. There is no obligation.

Excelsior Medical Clinic, Dept. B6129, Excelsior Spgs., Mo.

**FREE
 CAREER
 BOOKLET**



To guide you to a
 successful future in
**ELECTRONICS
 RADIO-TV
 COMPUTERS
 ELECTRICAL
 ENGINEERING**

This interesting pictorial booklet tells you how you can prepare for a dynamic career as an Electrical Engineer or Engineering Technician in many exciting, growing fields:

- MISSILES • AVIONICS • AUTOMATION**
- SALES • DEVELOPMENT**
- ELECTRICAL POWER • ROCKETRY**
- RADAR • RESEARCH**

Get all the facts about job opportunities, length of study, courses offered, degrees you can earn, scholarships, part-time work — as well as pictures of the Milwaukee School of Engineering's educational and recreational facilities. No obligation — it's yours free.

**MILWAUKEE
 SCHOOL OF ENGINEERING**

MAIL COUPON TODAY!

Milwaukee School of Engineering
 Dept. PM-960, 1025 N. Milwaukee St., Milwaukee, Wis.

Please send FREE "Your Career" booklet
 I'm interested in

- Electronics Radio-TV Computers
- Electrical Engineering Mechanical Engineering

Name _____ Age _____
 PLEASE PRINT

Address _____

City _____ Zone _____ State _____

- I'm eligible for veterans education benefits.

Discharge date _____

LEARN MEAT CUTTING AT NATIONAL

Pay After Graduation

National School of Meat Cutting, Inc., Dept. 50-J, Toledo 4, Ohio

Send me your FREE school catalog on National Training at Toledo in Meat Cutting, Meat Merchandising and Self-Service Meats. No obligation. No salesman will call.

Name _____ Age _____

Address _____

State _____ City _____
Approved for Veterans

The steady dependable trade of Meat Cutting taught easily in 8 short weeks. YOU LEARN BY DOING under actual meat market conditions in big modern school at Toledo.

For beginners or men with experience. Get a profitable store of your own. Remember, PEOPLE MUST EAT! Big pay jobs. Free employment help. Thousands of successful graduates.

Buying, cutting, percentage, pricing, advertising, selling, etc. A complete retail meat education. National School established 37 years. Get National training NOW. Pay your tuition in easy monthly payments after you graduate. Send coupon for FREE 40 page school catalog—TODAY. G.I. approved.

High School at Home

MANY FINISH IN 2 YEARS

No classes. No time wasted going to and from school. Progress as fast as your time and abilities permit. Standard H.S. texts supplied. Thousands enroll each year in this 63-year-old school. Send for FREE descriptive booklet.

AMERICAN SCHOOL, Dept. H645
Drexel at 58th St., Chicago 37, Ill.

Without obligation, please send FREE descriptive booklet.

Name _____

Address _____
Accredited Member National Home Study Council



BARBELLS

140-Pound, CHROME DELUXE Barbell-Dumbbell set only \$19.80.
This is our feature set and is the finest ever manufactured.

100 POUND SET \$12.80

Training with adjustable weight is the BEST way to keep fit; the ONLY way to develop great strength and a perfect body. As the oldest and best equipped barbell company, BUR gives value and prices no one can equal.

SEND FOR FREE CATALOG
BUR BARBELL CO.
Lyndhurst 9, New Jersey

Extra Plates Only 12c Pound

"YOU ARE UNDER ARREST!"

Help Bring Crooks to Justice Through Scientific **CRIME DETECTION!**



We have taught thousands this exciting, profitable, pleasant profession. Let us teach you in your own home. Learn Finger Printing, Firearms Identification, Police Photography, Secret Service Methods thoroughly, quickly, at small cost. Over 800 of all American Bureaus of Identification employ I.A.S. students or graduates. Write for FREE "Blue Book of Crime."
(A Correspondence School Since 1916)

Institute of Applied Science, 1920 Sunnyside Ave., Dept. 1356, Chicago 40, Ill.

TELEPHONES



MODERN CRADLE STYLE

\$3.00

2 for \$5.00

Genuine telephone company phones, reconditioned. Ideal for Inter-House, House-to-Barn, Office to Shipping Room, etc. Battery operated. Guaranteed. Also, Magneto Telephones for Farms, Camps and Mines. Telephone Materials and Supplies of all kinds.

TELEPHONE DEPT. PM-130, 1760 Lunt Avenue, Chicago 26
"America's Largest Independent Telephone Repair Shop"

ALL AROUND ELECTRIC TESTER

Shipped on Approval



Tests all Electrical Appliances, TV tubes, Automobile Circuits, etc. Measures A.C. and D.C. Voltages, Amperes, Resistance and Leakage. Price complete including 64 page book only \$15.85.

Shipped on approval!
NO MONEY WITH ORDER—NO C.O.D.

Order Model 70 "on approval." If satisfactory you pay \$15.85 (plus p.p.) in 4 monthly payments. Otherwise return after 10 days free trial. Moss Electronic, Inc., Dept. D-808, 3849 Tenth Ave., N. Y. 34, N. Y.



MOVING WITH THE JOB?

Opportunity seekers find success the convenient, comfortable way in their Travel Trailers. Fully and smartly furnished, including showers, cooking facilities, your home on wheels adapts to any climate or site. Weatherized life-time construction, with conditioned air, gives you every home comfort, with ample storage space. Learn how to do it in TRAILER TOPICS the magazine of successful trailer living.



SPECIAL OFFER \$1.00
4-Month subscription only

TRAILER TOPICS magazine

Suite 1574, 28 E. Jackson Blvd., Chicago 4, Ill.

BULLETINS *from the world of* SCIENCE

By James Biery

THE FLIGHT of an unusual man-made satellite, shock waves and sound waves are providing proofs that our wrinkled old Earth not only is pear-shaped, it's sometimes shaped like a football. And, once-upon-a-time, it may even have been squeezed oddly out of shape by a heavy-fingered glacier.

When the U.S. fired two satellites into orbit from a single rocket this summer, the instrumented spheres were kicked apart by a spring arrangement. One, a 42-pound ball sent to measure types of solar radiation, made the 500-mile trip piggyback atop the 233-pound Transit II-A, which will provide a navigation check-point for ships, planes and submarines. Its orbit will be studied to confirm the U.S. Navy's conclusion (reached by observing effects of gravity on satellite orbits) that Earth is slightly pear-shaped.

Earth appears to have quivered like a plucked guitar string during four or five days of this summer's Chilean earthquakes. As a result, it frequently, but slightly, assumed the shape of a football. "Free vibrations" caused by the quakes resulted when long shock waves passed around the Earth and came back to the same spot, after shorter waves had died out. When the distance from wave crest to wave crest is half the Earth's circumference, the wave has a "football mode," and power to distort Earth's shape. Such vibrations pass an observatory about once an hour. At least one vibration produced by the Chilean quakes passed every 25 minutes. These vibrations were observed by Dr. Jack Oliver, a seismologist at Lamont Geological Observatory, Palisades, N.Y., one of the first men to observe such an occurrence.

Ice soundings made by U.S. and U.S.S.R. tractor parties in Antarctica, coupled with gravity readings, suggest the continent is in isostatic equilibrium—its rocky surface has subsided to compensate for the heavy load of ice it bears. If the ice melts, mountains would gradually rise about 2500 feet, according to the Soviets' postulate. They say the main body of Antarctica was one of the highest continents in days when it was green with forests but its height and polar location encouraged growth of glaciers that bore down with such weight the continent sank. ★★ ★

FOR YOU BETTER PAY and a BRIGHTER FUTURE IN AUTO MECHANICS AND DIESEL



HE IS NOW SHOP FOREMAN



HE OWNS HIS OWN REPAIR SHOP

Your spare time pays off BIG with our world-famous **SHOP TESTED Home Training**

MAKE YOUR FUTURE AS BRIGHT AS THEIRS

In a matter of months, you can quit your no-future job for a big-pay, big-future career as an Auto-Diesel Mechanic. Free Illustrated Book gives you the facts. Send coupon below. No Obligation. No Salesman will call.

All Phase Training

N. T. S. students become skilled, all-around mechanics. Crystal-clear lessons, Shop-Tested manuals, real professional equipment, make it easy to learn. Big equipment kits, yours to keep. Earn as you learn...we show you how. Graduate Advisory Service.

N.T.S. Training is Better, More Complete, Lower Cost **BETTER...**

Because training is SHOP-TESTED in Resident School Shops & Labs. **MORE COMPLETE...** You learn all phases of Auto Mechanics & Diesel. **LOWER COST...** One low tuition covers entire cost of course and all equipment.

Unlimited Opportunities

Trained mechanics make top money...are in demand at dealer shops, garages, large bus and truck lines, construction projects, government labs, factories, and many others.

YOU GET AND KEEP ALL THIS PROFESSIONAL EQUIPMENT



NATIONAL TECHNICAL SCHOOLS

WORLD-WIDE TRAINING SINCE 1905
4000 S. FIGUEROA ST. LOS ANGELES 37, CALIF., U. S. A.



FREE!

Illustrated Fact Book & Actual Lesson
Mail coupon now.

Complete TV-Radio Electronics training also available.

RESIDENT TRAINING at Los Angeles!

If you wish to take Resident Training at Los Angeles, in our Big, Modern Shops & Labs, check special box in coupon for full information.

NATIONAL TECHNICAL SCHOOLS

WORLD-WIDE TRAINING SINCE 1905

MAIL NOW TO
NATIONAL TECHNICAL SCHOOLS, Dept. DB-90
4000 S. FIGUEROA ST., LOS ANGELES 37, CALIF.
Send for FREE Auto-Diesel Opportunity Book and actual Lesson.

NAME _____ AGE _____

ADDRESS _____

CITY _____ ZONE _____ STATE _____

Check if interested ONLY in Resident School training at Los Angeles.

VETERANS: Give date of Discharge _____



Member



ENGINEERING

HOME
STUDY
COURSES

Courses written by world authorities in all branches of engineering and science. Step-by-step instructions using methods proved successful by thousands of our graduates. One hour each day in your spare time will start you off to higher pay, security and prestige. Fill in the coupon to-day and indicate the course of interest. We will send you a complete outline of the course with a booklet describing the Institute and our advanced teaching methods.

CIVIL ENG.
SURVEYING
ARCHITECTURE
FORESTRY
STRUCTURAL
MECHANICAL ENG.
INDUSTRIAL ENG.
REFRIGERATION
DRAFTING
ELECTRICAL ENG.
RADIO
ELECTRONICS
TELEVISION
AERONAUTICAL ENG.
HIGH SCHOOL
CHEMICAL
MATHEMATICS
ACCOUNTING

MAIL THE COUPON TODAY

Canadian Institute of Science & Technology Ltd.,
753 Century Bldg., 412, 5th St. N.W., Wash., D.C.

NAME.....

ADDRESS.....

CITY.....STATE.....

COURSE OF INTEREST.....

Canadians: Send to C.I.S.T., 753 Garden Bldg.,
263 Adelaide St. W., Toronto, Ont.



C. I. S. T.



Modern Scarecrow Operates on Gas

Successor to the scarecrow, this mechanical noisemaker was designed to frighten hungry birds away from farm fields in New Delhi, India. The noisemaker is operated by adding calcium carbide to water inside the base. When the lid is in place, acetylene gas forms and produces loud explosions at short intervals; the sound has been compared to the firing of a howitzer. It will protect a five-acre field for around five cents a day, and also frightens elephants, snails, jackals and "flying fox" bats. The ingenious machine was invented by V. K. Murthy, an Indian agricultural engineer.



You can make money in

WATCH REPAIR

Learn at home the low cost Sweazey Way

Watch repairing pays up to \$6 an hour, part time watch makers report on survey. Unique and modern Sweazey home study System starts you making repairs right away on Swiss and American watches. Professionally prepared training. No previous experience needed. Special tools provided for practice. Tuition only \$5 a month. Diploma Awarded. Free sample lesson and opportunity book give all facts. Write today. No obligation.

CHICAGO SCHOOL OF WATCHMAKING
2330 N. Milwaukee Avenue, Dept. 190, Chicago 47, Illinois

Draw CARTOONS



...for a wonderful pastime or excellent earnings. Master cartooning at home in a few short weeks without waste of time or effort through the Famous System of Manual Training. Send for Big, Illustrated FREE Catalog!

CONTINENTAL SCHOOLS, INC., Dept. A-9
4201 South Broadway, Los Angeles 37, California

FIRES WINCHESTER.303 AMMO

BRITISH MADE
Custom Sporters!

CLEARANCE! Take advantage of our special purchase of these fine British rifles at a low clearance price! Sporter conversion done by famous Birmingham, England, gunsmiths from select Lee-Enfield late Mark 4 bolt action 10-shot repeater. Semi-pistolgrip contoured sporter stock. Action bedded, headspaced, testfired, guaranteed accuracy, mechanically perfect. **AMMUNITION:** Fires standard .303 Cal. ammo made in U.S. by Winchester, Remington, Peters, available at all sporting goods stores. Add \$5 for select grade.

SURPLUS SCOPE OFFER: A fabulous purchase of surplus, 4 power color corrected rifle scopes, adjustable for windage and elevation allows us to make this combination offer: We will mount and boresight scope to rifle at no additional cost with purchase of rifle and scope at \$24.95! **ORDER:** Enclose \$10 deposit for C.O.D. Shipped F.O.B. Culver City, Calif. resid. add 4% state tax. 10-day money back guarantee!

WEAPONS, INC. 11029 Washington Blvd. Culver City 78, Calif.



\$19.95

with original peep sights!

\$24.95

with 4x scope mounted and boresighted complete!

AMMO & NEW ACCESSORY SPECIALS

(sold only with rifle)
100 rds. Mil. target \$7.50
40 rds. Softnose hunting, \$5.90
Leather sling, \$2.00. Cleaning rod, \$1.00.
Gun Case (heavy duty duck), \$2. Cleaning
Kit (patches, bore cleaner & gun oil), 75c

FREE OUTFIT STARTS YOU IN BIG MONEY SHOE BUSINESS!



Run your own profitable 'shoe store' business from home! Represent fast growing million dollar firm in spare or full time. We give you—**FREE**—complete Starting Outfit that makes you **\$217.00 EXTRA** each month for just 2 easy orders a day. You feature 195 fast-selling dress, sport, work shoe styles for men and women. Air-cushion shoes, many other special features! Sizes 2½-15—widths AAAA to EEEE. Draw on 200,000 pair stock. Also horsehide jackets. Start now selling to friends, folks where you work. Rush postcard for **FREE** Outfit!

MASON SHOE, Dept. G-302, CHIPPEWA FALLS, WIS.

Hotels Call for Trained Men

Record-breaking travel means nation-wide opportunities and a sound substantial future for trained men in the hotel, motel and hospitality field. Fascinating work; fine living; quick advancement. You can qualify at home or through resident classes in Washington. Previous experience proved unnecessary. Placement Service **FREE**. Write for **FREE** Book, "Your Golden Opportunity." Accredited by N.H.S.C.

Course Approved for ALL Veteran Training. 44th Year. LEWIS HOTEL TRAINING SCHOOL, Room FO-312, Wash. 7, D.C.

REAL ESTATE BE A BROKER

PAYS BIG! SEND FOR FREE, BIG, ILLUSTRATED CATALOG NOW! Graduates report making substantial incomes. Start and run your own business quickly. Men, women of all ages, learn easily. Course covers Sales, Property Management, Appraising, Loans, Mortgages, and related subjects. **STUDY AT HOME** or in classrooms in leading cities. Diploma awarded. Write **TODAY** for free booklet! No obligation. Approved for World War II and Korean Veterans.



WEAVER SCHOOL OF REAL ESTATE (Est. 1936)
2020R Grand Avenue Kansas City, Mo.

LEARN PLASTICS



COMPLETE LOW COST SHOP METHOD HOME TRAINING NOW AVAILABLE

Get in on Big Money opportunities in Plastic molding, casting, forming, carving, etc. Earn as you learn with Interstate's professionally prepared course. All plastic materials furnished.

WRITE FOR FREE BOOKLET

INTERSTATE TRAINING SERVICE
DEPT. C-3, PORTLAND 12, OREGON

High School at Home

No classes...interesting spare-time home study; standard texts; credit for previous schooling; diploma awarded. Equivalent to resident school work. If you've completed 8th grade and are over 17, write for free catalog and Sample Assignment in English Review.

Accredited Member, National Home Study Council
Wayne School of La Salle Extension University
A Correspondence Institution
419 So. Dearborn St., Dept. 959 W, Chicago 5, Ill.



Unlock the answers to hundreds of Do-It-Yourself problems with this tremendous Service File list of Popular Mechanics' booklets, books, full-size patterns, and blueprints. Send self-addressed stamped envelope to

SERVICE BUREAU, Popular Mechanics
Room 520D, 200 E. Ontario, Chicago 11, Illinois

Some make more, some less:

F.E. DORAN reports:

\$1050
gross in single
MONTH
in my own business



Start your own business!

Here's YOUR chance to start a money-making, year 'round business of your own and make the success you've dreamed about.

G. R. Adcock took in \$102 in one day. O. W. Hare landed a \$750 hotel job. J. S. Corbit grossed \$279.50 his first month. Homes, hotels, offices, clubs, offer you big profit possibilities. Auto upholstery also.

NO SHOP OR OFFICE NECESSARY - You clean furniture on customers' premises. No hauling, no high rents. Supplies inexpensive; you operate from your own home. What you take in is mostly profit.

If you want to be your own boss—free from lay-offs and strikes, we will help you to start and succeed.

This is not a lease proposition. You own the machine, you work when and where you please and all the money you take in is your own.



VON SCHRADER MFG. CO.
910 "D" Pl., Racine, Wisconsin
Without obligation rush your **FREE** booklet about how I can start my own permanent, profitable electric Upholstery Cleaning business.

Name _____
Address _____
City _____ Zone _____ State _____

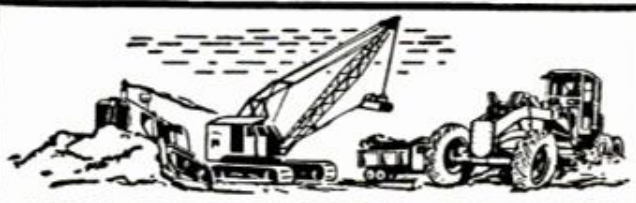

HIGH WAGES!

High wages can be yours as an Operating Engineer of heavy construction equipment! Learn NOW to operate our diesel engined bulldozers, draglines, cranes, back hoes, rubber-tired scrapers and motor graders! Machines of major manufacturers are used in our training program. Contractors are on our advisory staff. Full courses of 220 hours for bulldozers, scrapers, motor graders; 440 hours for cranes. National is the ORIGINAL construction equipment operators training school. COMPARE our training with any other school, anywhere!

We are NOT a correspondence school, but a fully equipped educational institution in the beautiful Piedmont area of North Carolina where you will live while you learn. Budget plan available. **VETERANS:** Ask about G. I. Benefits. Booking NOW for October, November and December classes.

Write **TODAY** for **FREE** School Catalog, no obligation, to

NATIONAL SCHOOL of HEAVY EQUIPMENT OPERATION
Dept. D-9 P. O. Drawer 8415, Charlotte, N. C.
Western Office: 730 S. Western Ave., Los Angeles 5, Cal.



PAY 2 or 3¢ on the DOLLAR for 1000's of Useful Items of U.S. GOV'T SURPLUS

LOOK
AT THE AMAZING PRICES

PAID AT GOV'T SURPLUS SALES

Autos.....\$78 Tractors.....\$68
Trucks.....\$212 Motors.....99¢
Boats.....\$5.90 Typewriters..\$6.80
Compressors..\$9.69 Generators..\$8.78

You BUY DIRECT from U. S. Government at TREMENDOUS savings. Eliminate middlemen—Save BIG MONEY! Pay as LOW as 2¢ on the dollar. Our DIRECTORY Gov't Surplus Sales lists 100's Army, Navy, Air Force Surplus Depots all over the world. BUY JEEPS, sports equipment, hunting, fishing and photographic equipment and supplies, radio, electronic and electrical equipment, trucks, boats, airplanes, Plumbing, hardware, office equipment & supplies. Tools, machinery, furniture. This 1960 book tells how to buy Gov't Surplus DIRECT. No dealer profits to pay. Get on the gravy train NOW! Send \$1 TODAY for "Gov't Surplus DIRECTORY" to AVIATION SURPLUS, Dept. PM-9, Box 789, York, Pa.

YOU CAN BE A REAL HE-MAN!



DON'T let anybody tell you that you're just "naturally" skinny... flabby... soft. I'll show how you can have the handsome muscle-mighty HE-MAN BODY that Nature meant you to have! In just 15 minutes a day I can make you a NEW MAN! I'll build smooth, powerful layers of muscle wherever you want 'em—arms, chest, stomach, back, legs, etc.—send wonderful new pep and energy surging through your whole body! WRITE FOR FREE BOOK. Tells about famous "Dynamic Tension," the NATURAL way I built my own famous body. How I've built up other fellows. What I can do for YOU. Address:

Send for
FREE
BOOK



CHARLES ATLAS, Dept. 89,
115 E. 23rd St., New York 10, N. Y.
In England: Chitty St., London, W1

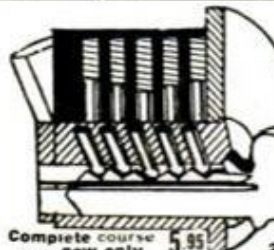

Locksmithing AND KEY MAKING

Now Made Easy! Practical up-to-date course

teaches you how to pick locks, de-code, make master keys, repair, install, service, etc. New self-instruction lessons for every handyman, homeowner, carpenter mechanic, service station operator, fix-it shop, hardware dealer, gunsmith. 53 easy illustrated lessons. Full price only \$5.95 postpaid; or C.O.D. plus postage. Satisfaction or refund guaranteed.

Complete course 5.95

NELSON-HALL CO., DEPT. JP-2
210 S. Clinton Chicago 6, Ill.

INVENTORS NEEDED AT ONCE

If you have an invention you wish to sell outright or license on royalty, write us at once. We are seeking inventions of household items, games, toys, sports items, tools, and mechanical and technical devices. Patented or unpatented. For further information and free brochure outlining manufacturers' requirements, royalty rates, send your name and address (no drawings, please) to us by letter or on postcard at once.

KESSLER CORPORATION, Dept. D-59, Fremont, Ohio

Make Big Money LIGHTING MATCHES!



**Fastest, Most Dramatic
Demonstration Pulls in
Fantastic Profits!**

Imagine getting paid as much as \$1000 and more a week, just for lighting matches! It's entirely possible when you use matches to demonstrate sensational new MERLITE Fire Alarm. Takes only 5 seconds!

Owners of homes, stores, offices buy at once!

Just light a match, hold it below Merlite Fire Alarm. Almost at once heat from tiny flame automatically sets off Alarm's tremendous "HOWL"—audible 1/5 mile or more. Proves Merlite's so super-sensitive that in a fire, the "HOWL" will wake soundest sleeper, save lives. Entirely self-contained; needs no installation; hangs on wall like picture; "on duty" 24 hours a day. When folks see dramatic demonstration, hear astonishing low price (only \$4.95), they order 3 to 7 at a time and you make up to \$2.70 profit on each one. FREE—complete illustrated Sales Kit, with everything you need to start making fantastic profits right from start. Rush coupon with name, address TODAY!

MERLITE INDUSTRIES, INC.

Dept. F-15T (Alarm Div.) 114 E. 32nd St., New York 16, N.Y.

MERLITE INDUSTRIES, INC., Dept. F-15T (Alarm Div.)
114 E. 32nd St., New York 16, N. Y.

Rush big Sales Outfit showing how I can make big money with 5-second "lighted-match" demonstration of amazing Merlite Fire Alarm—everything FREE, no obligation.

Name _____

Address _____

City _____ Zone _____ State _____

IN CANADA: Mopa Co., Ltd., 371 Dowd St., Montreal 1, P.Q.

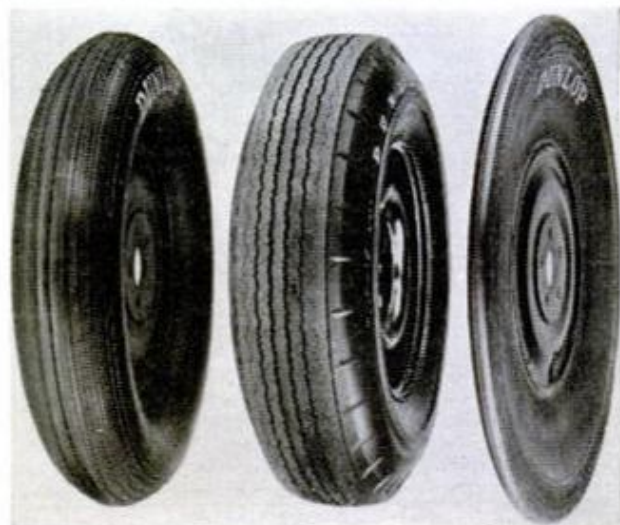

Dunlop Tire & Rubber Corp., P. O. Box 2011, Buffalo 5, N.Y.

Standby Tire Eliminates Spare

With modern punctureproof tires, fast punctures are becoming uncommon, but very few drivers are willing to bet with the odds and drive without a spare. At the same time, they grudge the trunk space that a spare occupies. One answer is the "standby" tire, a steel disk drilled to fit the wheel studs and carrying a narrow tubeless tire. When needed, it's inflated with a CO₂ bottle supplied with the unit. Compare sizes, left to right, inflated "standby," standard tire, deflated "standby."

BVI FAMOUS ELECTRIC PAINT SPRAYER

Easiest way to paint, varnish, enamel, spray plants, moth-proof fabrics. Completely automatic—just plug in and pull trigger. Adjustable for heavy or light spray. Easy to clean. Built-in motor, jeweled nozzle, 24-oz. jar. No extras to buy. Product of Burgess Vibrocrafters, Inc., Grayslake, Ill. At paint, hardware and department stores.



only \$12.95

costs less than a good brush

Switzerland



HOME-IMPORT BUSINESS

Men, women. Make big profits buying low cost imports abroad (see examples at left) and selling to friends, stores or by mail order. Famous world trader guides you—shows you how to find thousands of exotic imports for full or spare time business, how to pocket profits in advance on foreign drop shipment plan. Full details FREE! Airmail reaches us overnight. Write Today! **MELLINGER CO., 1717 Westwood Dept. C259, LOS ANGELES 24, CALIFORNIA**

Finish HIGH SCHOOL AT HOME IN YOUR SPARE TIME

DIPLOMA AWARDED

Learn more! Earn more! Enter professional or technical schools. Advance socially. Live a happier, fuller life. Individual Courses or complete schedule. Write for School Bulletin.

ACADEMY FOR ADULTS
30 W. Washington, Dept. PM-960, Chicago, Ill.

ADDING MACHINE \$1.97 or 2 \$3.49 ea. for

+ — × ÷
ADD — SUBTR. — MULT. — DIVIDE

Does all 4 operations. Handles 9 columns of numbers. Settle for no less. Leatherette case. Lowest price adder made in America. Beware of cheapened foreign imitations. Money back guarantee. Agents wanted. \$1.97 add 4% tax in Pa.



TOM THUMB P. O. Box 5066, Dept. S-10 Philadelphia 11, Pa.

PELLET FIRING LUGER AUTOMATIC

- MAGAZINE LOADING CLIP
- OVER 15 MOVING PARTS
- FULLY AUTOMATIC

Automatic full size model of a Luger Automatic pistol—contains over 15 moving parts. Loads 8 complete rounds which snap into the hard butt simulating a Luger. Fires 8 bullet shaped pellets. Has automatic slide action.

ONLY \$1.98

MOST AUTHENTIC MODEL GUN WE'VE EVER SEEN

Comes to you with working parts disassembled with cleverly engineered springs, full instructions, supply of pellets and specially designed belt holster. Full Money Back Guarantee. Simply send \$1.98 plus 27¢ shipping charge or order C.O.D. From: **HONOR HOUSE PROD. CORP., Dept. LL-47, Lynbrook, N. Y.**



TRAIN AT HOME

in Your Spare Time or in the Great Allied School

1338-42 South Michigan Ave. Chicago 5, Ill.

DRAFTING—All Branches
• Mech. • Structural • Aeronautical

ENGINEERING
• Industrial Engineering
• Tool Engin. & Designing

ELECTRONICS

AUTO MECHANICS

AIR CONDITIONING
Refrigeration — Heating & Cooling

TOOL & DIE MAKING
Machinist Trade

Now you can attend Allied under the Education Fund Plan. Get Details.

PREPARE for the best jobs in your spare time at home. With ALLIED'S practical home study program you can progress so rapidly that big new opportunities will soon be open to you. Students planning a career in engineering can begin their training in short courses at Home or at Allied Institute and continue progressively toward an Engineering Degree in 31 months. Enjoy benefits of Allied's Education Fund Plan and Industrial Coop Plan. Pay almost all your tuitions from earnings. Allied is approved by Industry, National Home Study Council, Department of Education, Office of Public Instruction, State of Illinois, U. S. Department of Justice.

ALLIED INSTITUTE OF TECHNOLOGY,
1338-42 South Michigan Ave., Dept. PM-90, Chicago 5, Ill.

- Send me without obligation information on your courses:
- | | |
|---|--|
| <input type="checkbox"/> MECHANICAL DRAFTING | <input type="checkbox"/> AUTO MECHANICS |
| <input type="checkbox"/> STRUCTURAL DRAFTING | <input type="checkbox"/> ELECTRONICS |
| <input type="checkbox"/> ELECTRONIC DRAFTING | <input type="checkbox"/> AIR CONDITIONING |
| <input type="checkbox"/> AERONAUTICAL DRAFTING | <input type="checkbox"/> REFRIGERATION |
| <input type="checkbox"/> INDUSTRIAL ENGINEERING | <input type="checkbox"/> TOOL & DIE MAKING |
| <input type="checkbox"/> TOOL & DIE DESIGNING | |
| <input type="checkbox"/> HOME STUDY | <input type="checkbox"/> RESIDENT |
| | <input type="checkbox"/> EDUCATION FUND |
| | <input type="checkbox"/> VETERAN |

NAME AGE.....

ADDRESS

CITY..... COUNTY..... STATE.....



Be Your Own Art Teacher

IT'S EASIER THAN YOU THINK!

YOU don't have to be a "genius" to break into the high-paying art field. Now, through our famous simplified course, you can learn commercial art, painting, cartooning, fashion, TV, etc. . . . right at home, in your spare time. And all for only 20c a day!

No previous Art training needed. You start with simple fundamentals — progress rapidly through personalized, step-by-step instruction. Soon be your own boss. Or earn good money as staff artist for advertising agency, newspaper, magazine, etc. Even earn while you learn. **TWO 22-piece art outfits given AT NO EXTRA COST.**

FREE BOOK tells about the opportunities in Art as a profession or hobby; describes famous low-cost WSA Course in detail; also tells of success of our students. Send for it **TODAY**. No cost or obligation. No salesman will call upon you. Just send this ad with name and address filled in below to **Washington School of Art, Studio 149, Port Washington, N. Y.** (Estab. 1914 — Licensed by N. Y. State Education Dept.)



Name.....Age.....

Address.....

City.....Zone.....State.....

Learn **BAKING** At Home

Baking is one of America's high industries in wages. Nearly depression-proof. Thorough basic home course lays sound foundation. If you have aptitude, write for **FREE BOOKLET, "Opportunities in Commercial Baking."** National Baking School, 835 Diversey Pkwy., Dept. 1356 Chicago 14, Illinois



LEARN TO EARN

HIGH WAGES

AS A HEAVY EQUIPMENT OPERATOR!



Secure a high paying future in the exciting construction industry today! Learn to operate bulldozers, draglines, cranes, back hoes, scrapers and motor graders on our actual construction projects!

- ONLY CONTRACTOR OWNED AND OPERATED SCHOOL IN WORLD
- ASSOCIATE MEMBER ASSOCIATED GENERAL CONTRACTORS
- MODERN EQUIPMENT
- V. A. APPROVED FOR G. I. TRAINING
- BUDGET PAY PLAN AVAILABLE

WESTERN NATIONAL
SCHOOL
OF HEAVY EQUIPMENT
OPERATION

WRITE TODAY
FOR FREE
SCHOOL
CATALOG

DEPT. B-B BOX 510
WEISER, IDAHO PHONE 910



Dr. William Feinbloom, 130 E. 74th St., New York City

Telescopic Contact Lenses For Partially Blind

Called the world's smallest telescope, the quarter-inch "Miniscope" is tiny enough to be built into a contact lens and worn directly over the eye. Its inventor, Dr. William Feinbloom of New York City, says the Miniscope will increase vision of the partially blind by 200 percent and provide a field of vision 80 percent of normal. Based on the telescopic principle, each Miniscope consists of two lenses cemented together with an air space between. The front and rear elements are in focus, producing a telescopic effect. Dr. Feinbloom says the same optical arrangement can be used for spectacles for people who can't wear contacts.

Study Fishes' Swimming Secrets

Fish should not be able to swim so fast, according to all the natural laws governing velocity for energy output, and the Naval Ordnance Testing Station at China Lake, Calif., has assigned a team of scientists from the University of Washington to find out the reason. By studying live fish swimming in a controlled current, the scientists confirmed that they swim further and faster on a given amount of energy than a wooden model of the same fish can be moved with the same amount of force. Motion pictures are being made of the test fish in the clear plastic current flume to study their motion and the flow of water around their bodies. The water turbulence behind the fish may, it is believed, hold clues to their efficiency. The information will be of value in designing both surface and underwater craft.

TURN YOUR HANDS, FEET, FINGERS INTO SUPER WEAPONS

Learn KARATE Quicker, Better than Judo! Amazing Deadly Defense.

Fully illustrated book shows many defense and attack methods. How to temporarily paralyze your opponent, how to subdue an enemy who may come unexpectedly out of the dark. **FEAR NO MAN!** Profusely illustrated with actual combat photos. Learn quickly by yourself, at home, in weeks. Learn just where the KARATE striking points and nerve centers are. Send \$2.98. Cash, Check or M. O. to Best Values Co., Dept. W-58, 403 Market St., Newark, N. J.



"\$10,784 IN ONE YEAR

SERVICING RADIATORS!

— Sidney Radiator Shop, Sidney, Mont. Make good money servicing auto-truck-tractor radiators with new Inland 1-Piece Radiator Shop. Easy to test, clean and repair radiators. Inland, world's largest radiator equip. mgr., trains you free. Small down payment starts you. "Pays-for-itself!" Purchase Plan. Profitable dept. for garage or service station. Write for free information!



INLAND MFG. CO.
Dept. PM-9
1108 Jackson St.
Omaha 2, Nebr.

GET INTO ELECTRONICS

V.T.I. training leads to success as technicians, field engineers, specialists in communications, guided missiles, computers, radar, automation. Basic & advanced courses in theory & laboratory. Assoc. degree in 29 mos. B.S. obtainable. ECPD accredited, G.I. approved. Graduates with major companies. Start Sept., Feb. Dorms, campus. H. S. graduate or equivalent. Catalog.

VALPARAISO TECHNICAL INSTITUTE
DEPT. D VALPARAISO, INDIANA

EARN \$125 A WEEK AND UP

BE AN AUTO DIESEL EXPERT — LEARN A TRADE YOU LIKE

You learn fast in our shops because you learn with tools on real equipment. Students short of money may earn most of their expenses by doing part-time work. Experienced instructors explain WHY and show you HOW, then you DO IT YOURSELF. Many of our graduates earn \$125 a week and up. Approved for veterans. Day and evening classes. Free bulletin-write today.

MAIL THIS COUPON TODAY!

NASHVILLE AUTO-DIESEL COLLEGE
226 7th Ave., No., Dept. 86, Nashville, Tenn.
Please send without obligation free catalog.

NAME _____
(please print or write plainly)

ADDRESS _____

CITY _____ STATE _____

SAVE UP TO 1/2 ON FINE ITALIAN

CHORD ORGANS

Buy Direct-From-Importer... GET BIG DISCOUNTS

PLAY ON SIGHT! NO LESSONS NEEDED!

Here's the new musical instrument sensation that's suddenly captured the entire country! You and the children can play old and new songs in just a matter of minutes! ... thanks to the famous DA-MAR System, included FREE! Makes music fun right from the start. Brings the whole family closer together as everyone joins in playing everything from hit tunes to lovely hymns. Best of all ... you actually save 1/2 off mfr's list prices ... buying direct from the importer. Pay only a small amount down ... the rest just pennies a day!

HAND CRAFTED IN ITALIAN TRADITION OF QUALITY

Many domestic-made Electric Chord Organs use inferior plastic reeds ... but every Philharmonic reed is made of finest, carefully treated Swedish Stainless Steel for superbly richer tonal quality and volume. Your Philharmonic Electric Chord Organ is largely hand crafted, just as any outstanding instrument should be! A giant in performance—yet it's light in weight, fully portable. Choose from a wide selection of models, including Piano-Keyboard model for those with piano background. **DOUBLE GUARANTEED.** Get new FREE Color Catalog and lowest Direct Importer-to-You Discount Prices. Rush Coupon . . .

PIANO-KEYBOARD MODELS ALSO AVAILABLE

FREE BONUS GIFTS

- Big Solo Kit...with special easy-play arrangements of favorite songs.
- Plastic Protective Cover
- Expandable Music Portfolio
- Chemically Treated Polishing Cloth
- **DOUBLE GUARANTEE**...gives you 100% certified protection.

Rush coupon for details

5 DAY FREE HOME TRIAL

Try it—play it—enjoy it in your own home on 5-FULL DAYS' FREE TRIAL. Only then can you appreciate how much fun the Philharmonic can bring into your home. Details free.

PHILHARMONIC ORGAN CORPORATION
Dept. R-90, 2003 West Chicago Avenue, Chicago 22, Illinois



EASY TERMS
SMALL DOWN PAYMENT
BALANCE only
PENNIES A DAY

24 MODELS

FREE! GET COLOR CATALOGS AND DIRECT IMPORTER-TO-YOU DISCOUNT PRICES

Philharmonic Organ Corporation—Dept. R-90
2003 W. Chicago Avenue, Chicago 22, Ill.
Rush Color Catalogs and Lowest Discount Prices

NAME _____

ADDRESS _____

CITY _____ ZONE _____ STATE _____

WANTED!

**Mechanically Inclined
Men to Qualify for
BIG PAY JOBS
AND SPECIAL FACTORY
TRAINING IN DIESEL**



"We need qualified repairmen, operators, mechanics NOW!" say Diesel Manufacturers, Highway Builders, Truck Line Operators in every corner of America. Can you qualify for these High Pay Jobs? We can help you! Interstate's General Course and Cummins-approved Diesel home-training courses are internationally recognized. Advisory placement service for trainees. Don't wait. Men are needed NOW!

Get the Facts Today!

WRITE INTERSTATE TRAINING SERVICE

Dept. A-3, Portland 12, Oregon

Rush information on I.T.S. Diesel Courses, Special Factory Training and Diesel Job Opportunities.

Name _____
Address _____
City _____ Zone _____ State _____

95% PROFITS YEAR 'ROUND

Be your own boss, Operate a SIMPLEX lawn-mower sharpening service in your community. One compact machine grinds all mowers, sharpens cutlery. Low investment, 95% profit. Pays for itself in average month.



SIMPLEX

—4 Machines in One!

Reel Grinder—sharpens any mower reel in or out of mower.
Bed Knife Grinder—grinds with either round or cup wheel.

Rotary Blade Grinder—hollow grinds any rotary mower blade.
Cutlery Knife Grinder—sharpens cutlery, tools, scissors.

Send for free, money-making details!

The FATE-ROOT-HEATH Company • Dept. PM-9, Plymouth, Ohio

Exclusive Double-Bearing HEAVY-DUTY PUMPS

IRRIGATE • DRAIN • CIRCULATE • SPRAY
Use 1/4 HP motor or larger . . . 1 HP for up to 5,200
GPH: 1,000 GPH 60" high; or 3,000 GPH from 25" well.
1 1/4" inlet; 1" outlet. Stainless shaft.

TYPE X—2 oil-less bronze bearings. Won't rust. . . . \$10.95

TYPE XB—Ball bearing model. . . . \$12.95

Postpaid if cash with order. Rush your order today

MONEY BACK GUARANTEE

Centrifugal and Gear Pumps in All Sizes

LABAWCO PUMPS, Belle Mead 2, N. J.



cabana marrone



PLAN YOUR FUTURE NOW...
have a business of your own

Luxurious, high-fashion fur now being ranch-raised in U.S.A. and Canada. All select, pedigreed, registered stock. Easy and economical to raise in any climate. One pair should produce 10 to 15 young per year. Warranty assures life and production. You may qualify for membership in CNBA (Cabana Nutria Breeders Association), the largest and strongest Nutria association. Free ranch training program. Cabana Marrone Nutria garments nationally advertised.

Cabana Marrone available only through authorized distributors. Write for complete information. Distributor inquiries invited.



CABANA NUTRIA INC.
Dept. 71 636 West Lemon Arcadia, Calif.

Navy Ship Sends Message Both Ways Around World

Radio antennas sprout from the deck of the USS *Northampton*, the command ship of the Second Fleet, like TV antennas from a housing development. The *Northampton* below decks houses miles of wires and circuits that aid it in keeping in touch with any part of the world. Although the number of channels this sea-going super-communications center controls is a closely guarded secret, the speed at which it can relay information has recently been disclosed. In an experiment, naval communications stations around the world were alerted to relay a message from the *Northampton*. The message was sent east and it was sent west. Both messages whipped around the world from the ship and were received back aboard in less than two seconds. They were ungarbled, too.



General Electric Co., Schenectady, N. Y.

Portable Fuel-Cell Plant Powers Combat Radar

One soldier can carry a fuel-cell power plant designed to operate combat radar sets of the Army and Marine Corps. The plant, about the size of a suitcase, weighs 30 pounds. Inside are 30 fuel cells which produce 200 watts of direct current at 24 volts. (Model above is cut away to show cell arrangement.) It converts chemical energy to electricity: Each cell works on oxygen from the air and hydrogen gas produced as the cells' fuel, a metal hydride, decomposes.

Magic Mail Plan—Make up to \$5 an Hour!



THIS MAN...

... is taking out of the machine a Plastic Sealing Job—ordered by mail—only 11¢ in material cost brings back \$2.58 in cash by mail. Capacity of machine: \$25.00 profit per hour of operation.

Get **ORDERS** and **CASH** from your mailman—do work in **SPARE TIME** at home—or expand into **FULL TIME** business.

Send coupon for Free facts about the newest and most fascinating of all home operated businesses. For the first time a simplified machine brings the fabulous profits of **Plastic Sealing and Plastic Laminating** within the reach of the small operator. Anyone can learn to operate the machine with a few minutes practice—then with our **Magic Mail Plan** can get mail orders pouring in daily with cash in every envelope. **No canvassing—no selling.** We even

Get into **PLASTIC LAMINATING** at home

supply the circulars you mail to bring back cash and orders. Don't waste a minute. Rush your name. We'll send you **FREE** and postpaid, pictures, prices, details, and all the facts you need to start. Mail coupon or send name on postcard. No charge. Warner Electric Co., 1512 Jarvis Av., Dept. L-2-K, Chicago 26, Ill.

Make Thousands of Beautiful Art Creations

COSTUME JEWELRY • CIGARETTE BOXES TRAYS • CANDLESTICKS • COASTERS LAMP BASES • BOOK ENDS...ALL IN SPARKLING COLORED PLASTIC



WARNER ELECTRIC CO., 1512 Jarvis Av. Dept. L-2-K, Chicago 26, Ill.

At no cost to me, please rush complete details postage prepaid. I am under no obligation.

Name _____
Address _____
City _____ Zone _____ State _____

HEAVY EQUIPMENT MECHANICS WANTED:

Men to train for excellent pay, exciting work, wide-open future! Learn how to maintain, trouble shoot heavy duty construction and earthmoving equipment. Work for major contractors or your own business! Train on latest model diesel bulldozers, trucks, cranes, scrapers, etc.! Experienced instructors. 13½ week intensive course. Write today for **FREE** Catalog, Complete details.

GREER TECHNICAL INSTITUTE—Earthmoving School
Attn.: P. K. HUTCH, Box 368, Braidwood, Illinois

TRAINED AND SKILLED MEN IN CLOCK AND WATCH REPAIR

Are Needed in Watchmaking, Electronics, Defense, Aviation, and other technical and precision instrument fields. **NOW IS THE TIME TO LEARN THIS VALUABLE TRADE.** But, **KANSAS CITY SCHOOL OF WATCHMAKING** 1226 Admiral Blvd. Kansas City 6, Missouri Before You Enroll in Any **HOME STUDY** Course in Watchmaking, Write for Your Copy of "LEARN THE FACTS."

*After the city,
Before the state
The ZONE keeps your mail
From being late*



The Post Office has divided 106 cities into postal delivery zones to speed mail delivery. Be sure to include zone number when writing to these cities; be sure to include *your* zone number in *your* return address — after the city, before the state.

FORTUNES IN DIVING Train at Home in Spare Time Write Today for Amazing Free Booklet



Here is one of the greatest opportunities of our time. Make big money fast in Skin and Lung Diving. Trained divers needed in hundreds of industries and by government. Build a successful business of your own. Hourly rates among highest paid in any field. Training program by E. R. Cross, world famous master diver. Get the facts now. Mail coupon for **FREE BOOKLET TODAY!**

DIVEMASTER, Dept. PM-90
5637 W. 63rd Place, Chicago 38, Ill.

Send me free information about Diving.

Name _____ Age _____
Address _____
City _____ State _____

ACT NOW... YOU, TOO, CAN BE A CHAMPION **JUDO** *KARATE *STRONGMAN STUNTS *MUSCLES *BOXING *STRENGTH *HANDBALANCING *YOGA ETC!

YOU GET ALL THESE COURSES! *20 Smashing KARATE lessons. *Secret NERVE CENTER and PRESSURE POINT charts. *20 lethal JUDO lessons. *Terrific STRONGMAN STUNTS. *Complete MUSCLE course. *Ancient YOGA secrets. *HANDBALANCING stunts. *10 prize-ring K.O. PUNCHES. *Secrets of PHYSICAL ENDURANCE. All picture packed. Charts, Diagrams, etc. **OXFORD STUDIO, 44-A Bromfield St., Boston, Mass.**

FOR ONLY **35¢**

Name _____ Address _____ City _____ State _____ you get the lol! MOST FABULOUS OFFER EVER!

ELECTRONICS

Train in the new shop-labs of the world famous **COYNE ELECTRICAL SCHOOL** on a quarter of a million dollars worth of equipment or learn at home in your spare time with Coyne's modern television training.

Use this coupon to get our free book "GUIDE TO CAREERS"

COYNE ELECTRICAL SCHOOL
1501 W. Congress Pkwy. Chicago 7, Ill., Dept. of Electronics II-B
NAME _____ ADDRESS _____ CITY _____ STATE _____
 training at Coyne training at home

Unlike most other schools, we do not employ salesmen.

FREE
EICO

CATALOG

Build Your Own
Hi-Fi, Radios,

Ham Gear, Test Inst., — Save 50%

Get started in ELECTRONICS the easy EICO way. No technical knowledge needed to build EICO kits. Simple, step-by-step "Beginner-Tested" pictorial instructions guide you all the way. LIFETIME service & calibration guarantee. Mail coupon now!



EICO, 33-00 Northern Blvd., L. I. C. 1, N. Y.
Please send FREE catalog & name of local dealer.

Dept. PM-9

Name

Address

City Zone State

Millions
have
done it
so
can
YOU!



Also
FREE Photo Book
of Strong Men

Jowett Institute, Dept. PM-09, 220 Fifth Avenue, N. Y. 1, N. Y.

Stop being **SKINNY** like I was
Quickly **GAIN 25 LBS.** of

HANDSOME, POWER-PACKED MUSCLES like I did

Send for these 5 AMAZING PICTURE COURSES

All 5 FREE before \$1 price goes back

1. How to GAIN MIGHTY ARMS
2. How to GAIN A BIG CHEST
3. How to GAIN A MIGHTY BACK
4. How to GAIN POWERFUL LEGS
5. How to GAIN A GRIP OF STEEL

Send 10c for postage for all 6 items



Before

SCIENCE ENGINEERING

Bachelor's degree in 27 or 36 months
Accelerated year-round program: Aero., Chem., Civil, Elec.,
Mech., Metal.; Math., Chemistry, Physics. Modest rate. Earn
board. New classes start Sept., Jan., March, June. Catalog.
1690 East Washington Blvd., Fort Wayne 2, Indiana

INDIANA TECHNICAL COLLEGE

TV SERVICE

Save 50%, or More

Service calls cost money—so do mistakes made by the do-it-yourselfer. You can avoid these unnecessary and costly expenses with *THIS IS YOUR TV*, a new book that:

- Includes a special "Quick Check Chart" for error-free troubleshooting using 42 repair operations plus full information on all adjustments. Covers 85% of all TV troubles.
- Tells you, in easy-to-understand terms, how your TV set works and what to do when it doesn't. You'll know exactly the faulty tube and its exact location in your set.

Only \$2.00 Postpaid—Send check or MO TODAY

SONOVISION 2743 E. 79th Street
Dept. PM, Chicago 49, Ill.

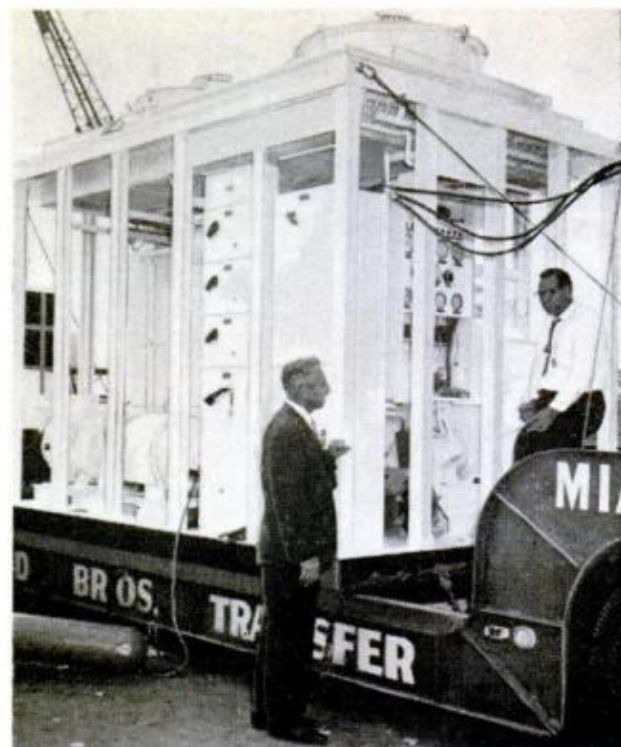

Air Conditioner for Missiles

When temperatures inside the Atlas missiles rose above 100 degrees, causing improper functioning of some of the delicate mechanisms, Convair Astronautics designed a portable air conditioner which forces chilled air into the missile and maintains an average temperature of 35 degrees throughout. The unique unit, which is self-sustaining and can be moved about on a flat-bed trailer, is set about 200 yards from the launching pad. It produces 2280 cubic feet of air per minute, which is forced into the missile through flexible piping at 600 miles per hour.

Alloy for Electrical Industry

General Electric scientists have alloyed iron, nickel and cobalt to make a material, Fernico-5, that can be joined with aluminum oxide—a ceramic that has excellent insulating properties but one that has been difficult to use in the electrical industry because of its low thermal expansion. The thermal expansion of the new alloy closely matches that of alumina, or aluminum oxide, and will allow greater use of alumina in situations that require ceramic-to-metal seals.

"With the advent of Fernico-5," says Dr. Guy Suits, General Electric's director of research, "we now have an inexpensive and easily fabricated alloy that will enable us to use alumina in such products as electron tubes, capacitors, switchgears and high-temperature circuits—all of which require such seals."

Biggest

HOME ISSUE

ever —

That's what's coming to you in

POPULAR MECHANICS

FOR OCTOBER

You Can Play



... even if you don't know a single note of music now!

IMAGINE! Even if you never dreamed you could play, you can soon surprise your friends with your musical ability. No special talent needed. Only a few minutes a day—a few cents per lesson. Teach yourself piano, guitar, accordion. ANY instrument. Play top hits, hymns, classics, country music—by note, quickly. Over 1,000,000 students including Lawrence Welk. (Est. 1898.)



Win popularity! New friends. Gay parties. money. Satisfy creative urge. Gain self confidence.

Career. Extra

Mail This Ad For Free Book

Send this ad with your name and address filled in below to: U. S. School of Music, Studio 309, Port Washington, N. Y. (No obligation. No salesman will call.) Licensed by N. Y. State Educ. Dept.



Name

Address

City Zone..... State.....

FREE DETAILS Reveal New Franchise Opportunity...
start your own **HOME-IMPORT**
MAIL ORDER BUSINESS Overnight!

Make profits up to five times the original cost on hundreds of exotic "below wholesale" imports! No experience necessary. No investment in merchandise. No face-to-face selling. Exclusive franchise if you act now! Complete details by return mail.

Write: **MAIL ORDER DISTRIBUTORS, DEPT. B-59,**
15201 SO. BROADWAY, LOS ANGELES 54, CALIF.

BECOME AN EXPERT IN TRAFFIC

Men trained in Traffic Management earn top pay. Thousands of firms need experts on rates, tariffs, regulations. We train you thoroughly in spare time for executive traffic jobs. Personal training under traffic authorities. Placement counsel and help. Write for free book "Traffic & Transportation."

LASALLE Extension University, 417 So. Dearborn Street
A Correspondence Institution Dept. 964T Chicago 5, Ill.

BUILD, FLY YOUR OWN COPTER!

Easy to build, inexpensive, simple to fly. Order 3-view drawings, specs, photo of Glider \$1 or motor powered Gyro-Copter \$2. Factory kits available.

BENSEN AIRCRAFT CORP., Dept. PM-90
Raleigh-Durham Airport, Raleigh, N. C.

NAME _____
ADDRESS _____

LEARN UPHOLSTERY

in your spare time
run your own
business
AT HOME

FREE BOOK
with sample lessons

BE YOUR OWN BOSS
Earn more from the start! Set up your own profitable business, in your own home, enjoy steady income, independence for life. You're in demand in the booming field of Custom Furniture Upholstery.

Right off you start upholstering with the tools, complete frames, fabrics and materials, included **FREE** with N.Y. State-approved UTS Home Study course. You learn skilled professional custom upholstery, reupholstery, furniture finishing, repairs, how to make beautiful slip covers, cushions and draperies. **EARN WHILE YOU LEARN**, in your spare time **AT HOME**... the UTS easy way.

FREE ILLUSTRATED BOOK—FREE SAMPLE LESSON
Get ready for well-paid job and big profits, from steady work, as your own boss, running your own business. Mail coupon NOW for **FREE BOOK!** Training in N. Y. Schools also available. **VET APPV'D, ACCREDITED BY N.H.S.C.**

UPHOLSTERY TRADES SCHOOL
Dept. HO-310, 721 B'way, N. Y. 3, N. Y.
Please send me **FREE** book, "Your New Way to a Successful Career," and **FREE** sample lesson. No obligation—no salesman will call.

Home Study Training in N. Y. School

Name _____
Please Print Plainly
Address _____
City _____ Zone _____ State _____
 Check if Korean Veteran

SLIPPER CHAIR
CLUB CHAIR
OTTOMAN
PLUS
SLIP COVERS
Yours to Keep
or Sell

94.6% OF BAILEY GRADUATES ARE EMPLOYED AT TOP PAY IN THE FIELDS WHICH THEY WERE TRAINED!



DIESEL-AUTO MECHANICS DESPERATELY NEEDED!

We have a far greater demand for our students than we can fill! We can show you an actual waiting list of leading companies throughout the world who have tried Bailey graduates — found them outstanding, and are coming back for more! Bailey Graduates are Successful . . . RECEIVE BIG PAY — HAVE SECURE FUTURE!

The Famous Bailey Course prepares you for BOTH Diesel and Gasoline Mechanics.

This is a must—due to the advent of using Diesel principles, such as 'Fuel Injection' on passenger cars . . . use of gasoline engines for starting Diesel engines, etc. You learn all this at Bailey in the amount of time ordinarily required to learn just one of these subjects, ALL FOR THE PRICE OF ONE.

Don't be satisfied with a 'futureless', one-type job — learn how you can make big money now! Write today for Free Booklet that takes you on a step-by-step camera tour through our spacious, modern shops — See Bailey students in action as they Learn-by-doing with the Famous Bailey Method of training!

We provide you with housing and part time jobs while in school, plus nation-wide placement service for graduates.

BAILEY Technical SCHOOLS

1634 S. GRAND ST. LOUIS 4, MO.

MAIL TODAY!

Please mail immediately this free booklet without obligation.

FREE BOOKLET



Name.....

Address.....

City..... State.....

APPROVED FOR VETERAN... NON-VETERAN

MY SPARE TIME HOBBY MAKES ME

\$5⁰⁰ an hour CASH PROFIT

—Grover Squires



START YOUR OWN SPARE TIME BUSINESS

You can turn your spare time into Big Cash Profits with your own COMPLETE SHARPENING SHOP... Grind saws, knives, scissors, skates, lawn mower blades... all cutting edges. Your Own Cash Business with no inventory right at home... no experience needed. FREE BOOK tells how you can start your own spare time business while you are still working at your regular job. Low Cost—time payments only \$15.00 a month. Send postcard today.

BELSAW SHARP-ALL CO, 711 Field Bldg., Kansas City 11, Mo.

27 YEARS IN BUSINESS AT THE SAME ADDRESS.

Beat the high cost of new tires. EXTRA MILEAGE TOP GRADE Tires, ANNIVERSARY SPECIAL. SEND AD WHY PAY MORE? UP TO 15,000 MI.



Our entire stock of good used tires. ALL SIZES IN STOCK. White Walls \$1.00 extra

600-16	\$4.72	670-15	\$4.72	700-15(6)	\$10.92	750-20(8)	\$12.22
600-16(6)	7.92	710-15	4.72	750-16(8)	11.02	825-20	19.92
650-16(6)	8.82	760-15	4.72	700-17	10.72	900-20	18.92
750-14	4.72	800-15	4.72	750-17	10.92	1000-20	19.92
800-14	4.72	820-15	4.72	850-14	4.72	1100-20	19.92
750-16(6)	10.02	700-16(6)	10.02	700-20	10.92	1000-20	20.92

"EXTRA SPECIAL" TOP QUALITY all size 4-ply pass. FREE TIRE with 2 or more of these.—W.W. \$1.00 Extra. \$7.92 Orders rushed. GIANT TIRE SALE. EA.

Thousands of tires shipped all over the U.S.A. All tires shipped F.O.B. Phila. Send Check or M.O. with this ad. Dept. 2 No C.O.D.

STANDARD 834 N. Broad St., Philadelphia 30, Pa.

\$3.25 OR 2 FOR \$6.00!

With 40 ft. of wire. Additional wire 3c ft. TESTED AND GUARANTEED. Write for free list of all types of telephones. Shipments FOB Simpson, Pa. TELEPHONE ENGINEERING CO., Dept. 980, Simpson, Pa.

SIGN PAINTING

Home-Study Course — Only \$5.95

Teaches you commercial sign painting and sign building as it is being done TODAY in leading shops all over the country. Complete practical course for self-instruction. Shows latest methods of truck lettering, office doors, wood letters, reflecting signs, plastics, sprayed signs, gold leaf, silk screen process, up-to-date alphabets, money-making business information, etc.



SATISFACTION GUARANTEED OR REFUND! Contains all the instruction of a high-priced correspondence course. Full price, only \$5.95, postpaid. Or C.O.D. plus postage. No risk—order today. Satisfaction or money back! Order "Sign Painting Course." NELSON-HALL CO., 210 S. Clinton St., Dept. 2JP-2, Chicago 6, Ill.

Shrinks Hemorrhoids New Way Without Surgery Stops Itch—Relieves Pain

For the first time science has found a new healing substance with the astonishing ability to shrink hemorrhoids and to relieve pain — without surgery.

In case after case, while gently relieving pain, actual reduction (shrinkage) took place.

Most amazing of all — results were so thorough that sufferers made astonishing statements like "Piles have ceased to be a problem!"

The secret is a new healing substance (Bio-Dyne*) — discovery of a world-famous research institute.

This substance is now available in suppository or ointment form under the name Preparation H.* Ask for it at all drug counters—money back guarantee. *Reg. U.S. Pat. Off

**WORLD'S
BEST
WANT-AD
MEDIUM**

CLASSIFIED ADVERTISEMENTS



Advertisements in this section \$1.30 per word, each insertion, minimum 10 words, payable in advance.

To be inserted under proper classification, copy must be in our office the

18th of the second month preceding date of issue

F. W. Johnson, Manager, Classified Advertising

Popular Mechanics, 200 East Ontario Street, Chicago 11, Illinois

YOU'LL PROFIT

By reading and answering the classified ads in this section. Hundreds of opportunities for you to make and save money

AUTOMOBILES, MIDGET CARS

BRITISH Kart engines, Villiers—all classes, British Anzani twin-Class C. Send 25¢ for complete information and literature. Taylor Accessories, Box 63, Revere, Penna.

NON-PROFIT Organization offers automobile literature—old, modern, foreign; dealer books, service manuals, glossy photographs; free motor magazines. Write immediately, get on free mailing list. Auto Maniacs A, Box 451, Mt. Clemens, Mich.

HISTORICAL Record of 1960 U.S. and foreign cars, fully illustrated. Detailed specifications on all models. 160-page "Car Facts Book, 1960." \$1.00. Service Bureau, Room 517C, Popular Mechanics, 200 E. Ontario, Chicago 11, Ill.

HOT Rod racing book reports 1959 races, trials, drags. Expert advice on hopping up engines, tuning the stock Corvette, supercharger selection. Send 75¢ (85¢ in Canada) to Service Bureau, Room 517D, Popular Mechanics, 200 E. Ontario, Chicago 11, Ill.

GO-KART Parts and supplies. Complete information 25¢ to cover postage. Rocky, Galveston, Indiana.

FREE Engine chemical information. Ore-Lube, 11 Front Street, New York City.

BODIES By La Dawri. Fiberglass sports car kits enable you to own a luxurious sports car at a do-it-yourself price. Send \$1.00 for 20 page color brochure. La Dawri Coachcraft, 1540 Canal St., Long Beach 13, Calif.

HOTTSPARK Starting, mileage, pep. 1955 Kaiser, varitypers, multiliths, mimeos, IBM's. EG, Elmsford, New York.

AUTO SUPPLIES AND EQUIPMENT

CRANKSHAFT Grinder. Hand operated. Makes bearings fit without taking engine apart. \$4.00. Literature, L. D. McGee, 719 Cascade St., Wenatchee, Wash.

NEW And used parts at savings. Complete guaranteed parts service for all models cars and trucks, 1924 and later. Largest in the West. Jeep and army parts specialists. Newest type shifting hubs for all jeep and all military and latest production front end drive vehicles. \$27.50 and up. Also, foreign car parts. Write, Pioneer Auto and Truck Parts Co., 734 W. 13th Avenue, Denver 17, Colo.

FREE! New catalog. Speed, power, mileage increasing equipment. Discounts! Almquist Engineering, Milford PM5, Penna.

JEEP Parts! For military and civilian. At great savings. Largest inventory. Catalog for owners and dealers. Inquiries invited. American Auto Parts Co., 1830-PM Locust, Kansas City, Mo.

PARTS Model "A". List 25¢. Matco, Box 135, San Pedro, Calif.

RING-Valve job while driving. \$6.00 postpaid. Guaranteed! Nothing like it! Lasts 100,000 miles! Motaloy, Grantham, Penna.

JUST Out! New 388-page, illustrated catalog offering savings up to 50% on over 100,000 auto parts and accessories, many hard to get. All makes (1920 to 1960 models), trucks, foreign and sports cars. Also Hollywood accessories, custom styling, hi-speed equipment. Send 25¢ for postage, packing—refundable on first order. Whitney, 1919 PM9 Archer, Chicago 16, Ill.

AUTO Shop welding repair training in world's largest non-profit welding school. Low tuition. Free booklet. Hobart Welders, Box M-901, Troy, Ohio.

GREATEST Auto parts catalog. Thousands racing and restyling accessories for all cars. Only 25¢ (refundable). Newhouse Automotive Industries, 5805-PM9, Beverly, Los Angeles 22, Calif.

SILENCE Hydraulic valves \$3.00 postpaid. Free literature. Micro-Moly Products, Garrison 1, Kentucky.

1909-1934 FORD Parts. Illustrated catalogue 75¢. Mark Auto, Layton, N. J.

JEEP Owners — V8 conversions. Read Jeep Owners ad, page 33.

NEW Magnetized warning signal reflector. Warns and slows down all traffic making it safe for you in any emergency when stopping on any dark highway. No bulbs or batteries needed. As shown Page 81, May 1960, Popular Mechanics. Only \$2.50 postpaid. A. Scarpello, Box 1031, Secaucus, New Jersey.

AUTO TRAILERS

HOUSE Trailer frames, new, less axle. 45' x 8', only \$200.00. Order from Altergott, 3842 E. Wisconsin Road, Appleton, Wis.

CAMPING Travel trailer blueprints. Booklet 25¢. Kamcraft, Box 1153, Milwaukee 1, Wisconsin.

PICKUP Coach blueprints. Kits. Literature 10¢. Comstock Trailers, Parsons, Kansas.

BUILD Expanding eight foot trailer. Accommodates five. Literature 10¢. Fra-Mar Company, Wilmington, Mass.

MOTORCYCLES, BICYCLES, MOTORSCOOTERS AND SUPPLIES

WHIZZER Motorbike \$15, Childs gasoline car \$15. Go cart \$35, Cushman \$35, Villiers engine \$5, Outboard motor \$6. Mailorder only. Send 25¢ (35¢ for first class mailing) for 32-page Directory-Catalogue Number 96 listing these and hundreds of other bargains in midget cars, motorscooters, homebuilders parts, plans, etc. Midget Motors Directory, Athens, Ohio.

MOTORCYCLE Parts. New, used. List 25¢. Ballak, 811 N. 9th, St. Louis 1, Mo.

RECONDITIONED Motorcycle motors. Chrome accessories. Complete stock Indian parts. Expert rebuilding. Fast service. Indian Motorcycle Sales, Kansas City 27, Missouri.

HARLEY-Davidsons — Used bargains. New, used parts, accessories, all models. Bulletin 25¢. Knuth's (Factory Dealer), 1753 Muskego, Milwaukee, Wis.

NEW Motorscooter frames for vertical lawnmower engines \$18.00. West Sales, 850 Mansfield Ave., Columbus 19, Ohio.

AVIATION

HELICOPTER — Completely engineered, assembly drawings and parts available. Send \$2.00 for photo, 3 view drawings, specifications and design information. Send additional \$2.00 for book "Basic Helicopter Aerodynamics" uses our helicopter as example problem for performance calculations. Helicopter Research Co., Box 121, La Mirada, Calif.

BUY Govt. surplus: Aircrafts; helicopters; boats; jeeps; tractors; misc. Individuals can buy direct now from govt. Send for "U.S. Depot Directory & Procedures." \$1.25. Brody Surplus, Box 425-PM, Nanuet, New York.

AIRLINE Careers. Adventure! Prestige! Promotion! Four-week course. Free placement service with 35 airlines. G. I. approved. Free catalog B. McConnell Airline School, 1030 Nicollet, Minneapolis, Minnesota.

PROPELLERS. Plans, supplies for airboats and snowplanes. Latest designs, prompt delivery. Catalog 25¢. Banks-Maxwell, Box 3301E, Ft. Worth 5, Texas.

ELECTRICAL SUPPLIES

LAMP—Appliance parts wholesale. Catalogue 25¢. Seco, 26 South 20th Street, Birmingham 3, Alabama.

OUR Early warning thermostat will give you time to escape or extinguish a fire. It operates on a battery or a transformer. It is easy to install. Free folder. Signal Specialties, South Acton, Massachusetts.

PROVEN, Guaranteed, job-assisting guides. Free list. Pal-Notes, Underwood, N. D.

ELECTROLUMINESCENCE: Revolutionary new area light source by Westinghouse. Wafer-thin, requires no bulbs, wires or filaments. Ideal as night, safety or dark room light. Burns night and day for less than penny a year. Sensational! Send \$1.50 for each lamp. Money-back guarantee. Approved Products, 666 Third St., Newark, N. J.

LAMP, Electrical parts, wholesale. Thousands of items for repairing, converting. Catalog 25¢. Brown Lamp, Box 305, Clayton 5, Mo.

A.C. Anywhere! 110 or 200 volt light plants. Save! Write for free details. A.C. Generators, Kasota, Minn.

WELDING, SOLDERING, PLATING

ACETYLENE Welding outfits—arcwelders. Dealership open. Eagle Welding, Dept. PM, 5085 Broadway, Chicago 40, Ill.

FREE Catalog, welders, welder kits. Build 350-ampere welder using aircraft generator, plans 25¢. Dunbar Manufacturing, Minneapolis 8, Minnesota.

WELDERS, 110/220, \$39.50. Morris, 1070 Inner Drive, Schenectady 3, New York.

PLATING Equipment, supplies. Complete line of anodes, solutions. Home workshops, industrial sizes. Hollywood Bronze Supply, Dept. C, 1624 East First, Los Angeles 33, California.

MACHINERY, TOOLS, SUPPLIES

WOODWORKERS—Free homeshop notes and time saving tool catalog. Lee Tools, Box 8122M, Rochester 17, N. Y.

ACCURATE Low cost milling machine. Rough or semi-finished castings supplied. Free literature. McKin Manufacturing, 4223 Lincoln, Venice, California.

TWO Pounds assorted metal screws, small machine screws, cap screws, bolts, stamped nut fasteners. Over 200 items. \$2.00 postpaid U.S. Specialsales, Box 788, Dayton, Ohio.

NEW 6" Four jaw independent chuck 1½-8 thrd. \$35.00; 5" Universal 1½-8 thrd. \$49.50; ½ ton bench Arbor Press 4" capacity \$16.50. Check or money order. Wardell Products, Box 11, Parchment, Kalamazoo, Michigan.

FREE New catalog showing only complete line of work holding tools available anywhere. Drill press vises, angle and swivel machine vises, rotary tables, production and heavy duty angle vises. 68 different models, fully described with prices. Palmgren Products Co., 8365 South Chicago Ave., Chicago 17, Illinois.

SHEET Metal brakes: 36", \$45.00. Also 49", 61". Bench shears. Free catalog. Vyke Co., P4158 Jason, Denver 11, Colo.

SURVEYING INSTRUMENTS

NEW And guaranteed factory rebuilt transits and levels, sale or rent, with purchase option. We will repair, trade or buy old instruments. Write for list M-90. Warren-Knight Co. (Manufacturers of Surveying Instruments), 136 N. 12th St., Philadelphia 7, Penna.

ENGINES, MOTORS, DYNAMOS

REWIND Motors yourself. Complete instructions, \$1.00. Lewis Manufacturing, Howell, Michigan.

DIESEL Injector parts and fuel pumps wanted. GM51-53-71-110. Bares, 7120 Carnegie, Cleveland 3, Ohio.

WINDING Data, 275 motors, single and three phase \$1.10. Data Company, 512 Kensington, Kansas City 24, Mo.

AMAZING New motor rewinding charts and parts catalog \$1.00. Modern, Box 8715, Kansas City 14, Mo.

SEWING Machine motors \$5.95. Foot controls \$2.95. Millies, Box 56, Lemay Branch, Lemay, Mo.

BOATS, OUTBOARD MOTORS

MARINE Conversions, Ford, Chevrolet, Jeep engines. Catalog 25¢. Lehman Manufacturing Company, 800 Elizabeth Avenue, Linden 4, N. J.

NEW, Used, rebuilt marine motors. Marine conversions, fittings. Free catalog. Stokes Marine Supply, Dept. 24, Coldwater, Michigan.

PROPELLERS, Plans, supplies for airboats, snowplanes. Catalog 25¢. Banks-Maxwell, Box 3301P, Ft. Worth 5, Texas.

FULL Size, cut-to-shape boat patterns, blueprints, 7½-38 feet. Big new 88 pg. illustrated "Build a Boat" catalog of naval architect-designed Catamarans, cruisers, runabouts, skiffs, outboard boats, sailing, racing, houseboats, 50¢. "How to Build a Boat" booklet \$2.50. Cleveland Boat Blueprint Co., Dept. A-66, Box 1651, Cleveland, Ohio.

MARINE Conversions, Willys to Cadillac, kits and parts. Catalog and conversion hints free. Barr Marine, 2706A Castor Avenue, Philadelphia 34, Penna.

CLEARANCE Small outboard motors. 260 boat plans, patterns, catalogs \$1.00. Marinecraft, Box 161-M, Brighton, Mass.

FRAME Kits, plans or full-size patterns for 35 inboards and outboards. Prepared for amateur builders. New 80 page illustrative catalog, 50¢. Glen Designs, 9152-S Rosecrans, Bellflower, Calif. See display ad page 237.

I Want to send you proof of the wonderful pulling power of Popular Mechanics classified pages. What's your proposition? Write me today. Include literature if possible. F. W. Johnson Manager Classified Advertising, Popular Mechanics Magazine, 200 E. Ontario St., Chicago 11, Ill.

ATHLETIC EQUIPMENT, BODY BUILDING COURSES

4 MUSCLE Courses 25¢. 12 large courses \$2.00. Big deal \$3.00 (guaranteed). Agents wanted. Sid's System, PMC4, 8421-C Evergreen, Southgate, California.

SWEAT Suit conditioning. Free details. Jerry's, Box 2344, Providence 6, R. I.

DEADLIEST "Fighting Arts Orient." Elemental Karate, Kung-Fu manual. 336 illustrations. Break planks bare-handed using breath, sand, straw, \$3.98. Positively no minors. Oriental Book Sales, P.O. Box 1183, Oakland 4, Calif.

BARBELLS, Dumbbells. Courses. Booklet 10¢. Good Barbell Co., Siloam Springs, Arkansas.

TRIM Your waistline in one minute a day! New, scientific 1-minute Waistliner Method. Tested, guaranteed results. Equipment with instructions \$2.00 ppd. Write for brochure. Pacific Mart, 1953-(104) Camden Ave., Los Angeles 25.

OUTSTANDING Physical development! Any age. New guaranteed discovery uses only a rope! Strength, health, muscles. Gain—reduce. Free booklet. Roperceise, 4834 Art, San Diego 15, California.

"BIG Muscles. The Quick Way." Dr. Young's revolutionary discovery. Free information. Gaucho, Box 9309-S7, Chicago 90.

FREE Muscle building information. Body-Tone, Box 638B, North Miami, Florida.

MUSCLES From Africa. Write for your free brochure on the latest body-building methods to: Milo Institute, Dept. PM, P. O. Box 1060, Johannesburg, South Africa.

JUDO Course. 40 illustrated lessons \$1.00. Scientific holds, Karate chops, nerve pressure points. Powerful fighting secrets. Sanson Institute, 44 Bromfield, Boston, Mass.

SPORTING GOODS, GUNS, FISHING, SKIN DIVING, ARCHERY

MOLDS For fisherman's sinkers, jigs, squids, casting and spinning lures. Free catalog. Sweet's Molds, Tonawanda 1, New York.

MOLDS—For casting your own fishing sinkers. Free illustrated booklet. Reading Instrument Co., Box PM78, Reading, Penna.

BIG Money raising crickets and 12 inch African fishworms. Free literature. Carter Ranch, Plains, Georgia.

FREE—Wholesale catalog. Beads, Spinners. Lure parts. Sinker molds. Jigs. Reels. Finnyports (ME), Toledo 6, Ohio.

AMAZING Wholesale sporting catalog. Save 70%. Tremendous selections. Econ-O-Mart, Whippany 2, New Jersey.

KILL Submersed water weeds which foul up motor propellers, tangle fishing gear, with R-H Weed Rhap-20, Granular 2,4-D. Inexpensive, easy to use, sure results. For free information write Reasor-Hill Corporation, Box 36PM, Jacksonville, Arkansas.

JAP Rifle altering to 30-06, \$6.00. Japshells, \$3.95. Catalog 10¢. T. P. Shop, West Branch 11, Mich.

CONVERT Fishing boat to Jet! Nothing below hull! Tried, tested, operating perfectly in waters impossible with any other type propulsion. Go Jet! Complete plans, layout, instructions, photos, etc. for the do-it-yourself guy. Free details. Fisherman's Jet Boat, Inc., 704 Inland Bldg., Indianapolis, Ind.

10,000 GUNS. Antiques, moderns, swords, armour. Every description. Giant catalog \$1.00. Agramonte's, Yonkers 2 G, N. Y.

100 ORIGINAL 2" Nose up "swimmer" lures. Complete not assembled. \$100.00 value \$14.00. Quaker Mfg., 3514-24 N. Lawrence, Philadelphia 40, Penna.

SPINNING Reel, all DuPont Delrin \$1.00. Set 3 stainless guides, 30¢. Abop Company, 5204 S. Lorel, Dept. 20, Chicago 38, Ill.

CAMPING EQUIPMENT AND TENTS

STATION Wagon owners. Build portable dressing room attached to your wagon. Easy, illustrated plans \$1.00. Ada-Cabana, 1397 Hedding, San Jose 26, California.

CAMPING Equipment, tents, world's largest selection. Send 25c for new 160 page catalogue-handbook-camp site directory. (Print name, address). Morsan Tents, 10-21R 50th Ave., Long Island City 1, New York.

EARTHWORMS, CRICKETS, FROGS

YOUNG Frogs and jumbo breeders for stocking lakes and ponds. Nu-Tex Frog Farm, 4014 Mueller, Corpus Christi, Texas.

12,000 YEARLY Raising rabbits, crickets and worms. Free information. Hudson's Bait Ranch, R.F.D. 4, Sanford, North Carolina.

FAT Red worms 1000—\$3. 2000—\$5. 5000—\$11. Postpaid with raising instructions. Live delivery guaranteed. Worm Gardens, 324 David Drive, Waco, Texas.

AFRICAN Nightcrawlers, 100—\$2.00. 500—\$7.00 (Dealers quoted). Ozark Worm Farm-J, Willow Springs, Missouri.

BIG Money raising fishworms and crickets. We teach you how to raise and where to sell. Free literature. Medium redworms, 3000, \$5.95; 10,000, \$16.95. Carter Redworms, Plains, Georgia.

FREE Picture folder, "How to Make \$3,000 Yearly, Sparetime, Backyard, Raising Earthworms!" Oakhaven-56, Cedar Hill, Texas.

RAISE Fishworms and rabbits on \$500 month plan. Free details. White's Rabbitry, Mt. Vernon, Ohio.

MUSIC & MUSICAL INSTRUMENTS

SONGPOEMS And lyrics wanted. Mail to: TinPan Alley, Inc., 1650 Broadway, New York 19, N. Y.

POEMS Wanted for musical setting and recording. Send poems. Free examination. Crown Music Company, 49-C West 32 Street, New York 1.

POEMS Needed immediately for new songs and records. Free examination and appraisal. Send poems: Songcrafters, Acklen Station, Nashville, Tenn.

GUITAR Making books, plans, imported woods, tools. List 10¢. Satinwood, 510 East 11th Street, New York 9, N. Y.

ELECTRIC Guitars, amplifiers, wholesale. Free catalog. Carvin, PMM, Covina, Calif.

SONGWRITERS! Money waiting for your poems! Information free! Successful Songs, Box 608, Danbury, Conn.

LEARN Musical instrument of your choice—easy! New home study tape course. Write for free brochure. Carver School, Box 366-P, Palos Heights, Ill.

VIOLINMAKERS. Repairers. Fine tone wood, and all violin supplies. Send for free wholesale new price list. International Sales, 414-MPM E. Baltimore St., Baltimore 2, Maryland.

ACCORDIONS! Direct from importer—savings to 50%. Free home trial. Trades accepted. Easiest terms. Famous makes. Free 1961 catalog. Accordion Corporation, Dept. R, 2003 Chicago, Chicago 22.

WRITE Songs! Words and music! New easy way! No musical training needed! Whole wonderful exciting story free! Write Composograph, Dept. C-7809, Darien, Conn.

SWISS Musical movements. Mechanical; electrical. Spielman, 131 West 42nd, New York 36.

POEMS Wanted! Best songs recorded free with 7-piece orchestra. Melodies written. Send poems, free examination. Songmakers, 1472-M Broadway, New York 36.

BUY Accordions-organs direct from importer. Big savings. 5-day trial. Free color catalog. Dept. PM9. Accordion Import Center, 7120 Galli Drive, San Jose, Calif.

SONGWRITERS. With publisher contacts, want song ideas. Share royalties. No fees. Send poems: Songwriters' Associates, 1650 Broadway, New York City 19-G.

RADIO, TELEVISION AND ELECTRONICS

FREE 444-Page 1961 Allied Electronics Catalog! World's biggest, including products and values available only from Allied. Everything in Stereo hi-fi systems and components; latest money-saving build-your-own Knight-Kits; tape recorders; TV accessories; Public Address systems; world's largest stocks of parts, tubes, transistors, test instruments, tools, books. Only \$2 down on orders up to \$50. Write for value-packed FREE catalog! Allied Radio, 100 N. Western Ave., Dept. 96, Chicago 80, Ill.

HI-FI Components—tape recorders. All brands in stock at "We Will Not Be Undersold Prices." Quotations, free wholesale catalog return mail. Hi-Fidelity Center, 1797M 1st Ave., New York 28, N. Y.

FREE! Giant wholesale catalog on electronics, hi-fi, transistor, scientific, hobby, optics, photographic, housewares, jewelry, tools, novelties, toys. Write: Lektron, 131M Everett Ave., Chelsea 50, Mass.

FREE Antenna with instructions. Experiment with nature's electronics. Stillwater, Box 317-J, Morris Plains, New Jersey.

AUTO Radio. Distributor selling, servicing Blaupunkt Becker, FM-AM, other European American sets for all cars. Save 30%+. Square Electronics, 150-60 Northern Blvd., Flushing, N. Y. HI 5-2715—Dept. P.M.

GOVERNMENT Surplus radios, parts. Picture catalog 10¢. Meshna, Malden 48, Mass.

TAPE Recorders. Hi-Fi components, sleep learning equipment, tapes. Unusual values. Free catalog. Dressner, 69-02M, 174 St., Flushing 65, N. Y.

LEARN While asleep with amazing "Electronic Educator" endless tape recorder. Details free. Research Association, Box 24-N, Olympia, Washington.

ELECTRIC Guitars, amplifiers, wholesale. Free catalog. Carvin, PMR, Covina, Calif.

RADIO And TV tubes at manufacturer's prices! 100% guaranteed! Brand new! No re-brands or pulls! United Radio, Box 1000-M, Newark, N. J.

CASH For used short-wave ham receivers, transmitters and accessories. Treger, W9IVJ, 2023D N. Harlem Ave., Chicago 35. TUxedo 9-6429.

HI-FI Components, recorders. Free wholesale catalogue. Carston, 125-Y East 88, N. Y. C. 28.

NEW Tubes, 50% off. Top brands. Top performance. List free. Lukacs, Dept. A, Box 353, Jersey City, N. J.

RENT Stereo tapes, 1500 different. Free brochure. Stereo-Parti, 811-X Centinela, Inglewood, California.

BUSINESS OPPORTUNITIES

MAIL Order franchise. No experience needed. Spencer Gifts, a well-established and successful mail order firm, starts you in business. Supplies catalogs with your own name imprinted. No investment in stock. No shipping merchandise. Catalog items pre-tested for salability. Initial investment of less than \$50 can get you started. Write for free information kit. Spencer Gifts, EZ-50 Spencer Building, Atlantic City, N. J.

MAKE Extra money—Big cash commissions plus premiums for you and your customers. Sell advertising book matches. Sensational new tenorama, glamour girls, hillbillies; dozens others. All sizes. Quick daily sales; big repeat business. Free master kit makes selling easy. No experience necessary. Superior Match, Dept. MX-960, 7530 Greenwood, Chicago 19.

START Your own business on credit (U.S. and Canada). Your own boss. 1396 dealers sold \$5,000 to \$25,500 in 1959. We supply stocks, equipment on credit. 200 home necessities. Sales experience unnecessary. Pleasant profitable business backed by world-wide industry. Write Rawleigh's, Dept. I-U-PPM, Freeport, Ill.

FRANCHISES Make profits! Operate your own exclusive franchised business. Write today for free interesting details. National Franchise Reports, W-528, 333 North Michigan, Chicago 1.

\$250.00 WEEK Spare time profit possible. Earn at home with new fascinating printing method. \$5 starts you—send no money now. Free confidential facts and valuable sample. Screen-Print, SR, Los Angeles 61.

BUSINESS Kit free! Postcard puts you in business! Complete line 230 shoe styles, jackets! New discoveries pay big commissions. No investment. Send for free kit. Mason, Chippewa Falls KB-324, Wisconsin.

WILL You test new items in your home? Surprisingly big pay. Latest conveniences for home, car. Send no money. Just your name. Kristee 101, Akron, Ohio.

INVISIBLE Reweaving; \$5-\$10 per job possible reweaving burns, tears, moth-holes. Spare-full time. Free details. Skill-Weave, Dept. WC-169, 335 W. Madison, Chicago 6, Illinois.

LEARN Landscaping and the growing of plants. Start a profitable business part or full time. Free information without obligation. National Landscape Institute, Dept. MC-90, 11826 San Vicente Blvd., Los Angeles 19, Calif.

START Profitable home business of your own. Write for details. Constant, 5417 West End, Chicago 44, Ill.

BUSINESS! Mail Order! Imports! Anything—worldwide. Details free. M. Kolezar, 611 Naysmith, McKeesport, Penna.

\$1.00 BRINGS You \$18.00 spare-full time home business opportunity! Amazing new velvet-spray transforms old cheap lamps, TV-radios, figurines, furniture, anything, into valuable products! Free samples, 50 business opportunities booklet. Send no money. Flok-Kraft SR, Los Angeles 61.

FREE! Name brands catalog! Your own high profit business. Sell name brands, full or part time. No inventory, no investment. More than 2,000 name brand items; lowest wholesale prices. Watches, jewelry, cameras, hi-fi, stereo radios-phonos, appliances, housewares, hardware, power tools, luggage, musical instruments, garden equipment, sporting goods, toys, many others. 8 floors of name brands. Million dollar inventory. Orders shipped complete in 24 hours! Send for free, beautifully illustrated catalog now! Separate wholesale price list. H. B. Davis Corp., Dept. 11, 145 W. 15 St., New York 11, N. Y.

FREE! Beautiful Mexican curios! Rush 30¢ stamps mailing. Sylviako, Apartado 9036, Mexico City.

DISTRIBUTE Lowest priced wholesale catalog. Felix, 160-04-16th, Whitestone 57, N. Y.

NEW Home-import mail order profitability! Your mailbox stuffed with money! No selling. No experience. No investment. We supply everything. Free details. Mail Order Distributors (Import Division), 15201 South Broadway, Los Angeles B59C, California.

INCREDIBLE New "table-top" machine manufactures over 15,000 salable products. Also laminates, encases, moulds and plates in bronze, chrome, or copper. 20¢ materials produce \$10.00 products. Free confidential details and home-business plan. Plasti-Form, Dept. PM-9, Gardena, Calif.

WANT To make big money at home? \$10.00 profit in an hour possible with invisible mending. Make tears, holes disappear from clothing, fabrics. Steady year-round demand from cleaners, laundries, homes. Details free. Fabricon, 6234 Broadway, Chicago 40, Ill.

MARKETS Everywhere. Make artistic concrete birdbaths, pottery. Best coloring. Home workshop. Hundred varieties. Hollywood Cementcraft, 8527-S Wonderland, Hollywood 46, California.

LEARN Sewing machine repairing. To \$125 weekly. Sparetime. Supplies. Add to present business. Write today! Taylor Service, Box 2126, San Bernardino, Calif.

IMMEDIATE Profits with no capital or experience. Take orders for all magazine subscriptions. Friends and neighbors are your prospects. Write now for complete, free kit. McGregor Magazine Agency, Dept. 6B, Mount Morris, Illinois.

FREE Picture folder, "How to Make \$3,000 Yearly, Sparetime, Backyard, Raising Earthworms!" Oakhaven-38, Cedar Hill, Texas.

VENDING Machines. No selling. Operate a route of coin machines and earn amazing profits. 32-page catalogue free. Parkway Machine Corporation, Dept. #27, 715 Ensor Street, Baltimore 2, Maryland.

BIG Money raising fishworms and crickets. Free literature. Carter Farms, Plains, Georgia.

BUSINESSES. Resorts, motels, investment property, ranches. Our special service dept. at your disposal. No obligation. World's largest. 58 years' service. Strout Realty, 7-MB S. Dearborn, Chicago 3, Ill.

TO \$100.00 Weekly. Sparetime, home operated mailorder business. Successful beginner's plan. Everything supplied. Lynn, 10420-M National, Los Angeles 34.

PIANO Tuning learned quickly at home. Tremendous field! Musical knowledge unnecessary. Information free. Empire School of Piano Tuning, Champaign, Ill. (Founded 1935).

I want to send you proof of the wonderful pulling power of Popular Mechanics classified pages. What's your proposition? Write me today. Include literature if possible. F. W. Johnson, Manager Classified Advertising, Popular Mechanics Magazine, 200 E. Ontario St., Chicago 11, Ill.

COPUBLISH Mail Sale Advertiser, leading mail order paper. Details, latest copy, dime. Vanroy Shirk, Lebanon, Penna.

11,000 NEW Prospects daily. Baby record books, shoes, albums. Sell mailorder. Use our literature. Write: No-Co-Ro, Capitola, California

BRONZE Baby shoes: Instructions, equipment and mountings for genuine electroplating process. Largest supplier of all plating equipment, supplies. Free catalogue. Hollywood Bronze Supply, Dept. B-3, 1624 East First, Los Angeles 33, Calif.

MAKE \$46 From square foot plywood; jigsaw necessary. Free details. Woodart, Bridgewater, Mass.

OPERATE Profitable mail order business. Write Walter Service, 4159A East 112th, Cleveland 5, Ohio.

EARN Good money sharpening chain saws, scissors, cutters, knives. Free manual. Treyco, North Tonawanda, N. Y.

BAKE New greaseless doughnuts in kitchen. Sell stores. Free recipes. Montgomery, 3665 South 15th, Minneapolis 7, Minnesota.

If You like motorcycles and money then send for Harley-Davidson dealership book on how to become a dealer of motorcycles and a new line of motorscooters. Here's a chance to own your own business with a very modest investment. The youth market is beginning to explode and the next few years promise a chance to cash in on it. Write for free illustrated dealership book today. Harley-Davidson Motor Company, Dept. P, Milwaukee 1, Wisconsin.

\$3.00 HOUR—Home, sparetime, assembling pump lamps. Easy. Free details. Ougor, Caldwell, Arkansas.

RAISE Rabbits on \$500 month plan. Free details. White's Rabbitry, Mt. Vernon, Ohio.

\$400.00 MONTHLY Raising giant worms. Odorless soilless method. Charlie Morgan, Bushnell, Florida.

BOSS Your own home business. Profits 1200% to 3000%! Make, distribute stunning Shellcraft jewelry. Sells itself wherever displayed. Big repeat demand. Details free; Shellcraft, Dept. A, Box 804, Panama City, Florida.

LIQUID Molding rubber, free sample. Shellcraft supplies. Chaney's, 1907-A East Road, Jacksonville 11, Fla.

VENING Machine catalog. Rakes, 609P Spring Garden, Philadelphia 23, Penna.

LEARN Appliance service and repair. Motors, washers, refrigeration, cleaners, everything. Free booklet. Appliance, 3570 W. First St., Los Angeles 4.

PLATE Baby shoes, jewelry, gifts, bronze and colored pearl. We finance. Free booklet. Platex, 11029 South Vermont, Los Angeles 44.

MAKE Fabulous weekly profits clipping newspaper items for publishers. Some clippings worth \$5.00 each. Particulars free. National, 81-PM, Knickerbocker Station, New York City.

COLORGLAZED Concrete pottery made without molds. Patented method. Cemetery products, novelties, tiles. Basement leak-sealing. Money-making projects. Booklet, details free. Men only. National Potteries Company, Grand Rapids, Minnesota.

RECAST Junk batteries into new. Latest achievements. Battery Laboratories, Bayou LaBatre, Alabama.

\$34.70 TWO Hours. Manufacturing concrete products. No selling. Castings #3, 2907 Dundee, Rapid City, South Dakota.

GET Dollars in the mail. Details free! American Distributors, Box 409-P, Niles, Michigan.

PRACTICAL Mailorder. Start small. Moneymaker 860, 722 East Silver Spring, Milwaukee 17, Wisconsin.

PACKAGE At home for profit! We supply everything. No selling, ready market. Free details. HPC, 2212B Jesse Street, Los Angeles 23.

LATEST Mail order trade leads sources in Mail Gazette. Copy 25¢. Mail Trade Contacts, Montrose 20, N. Y.

CANDIED Popcorn and potato chip equipment. Eakins, Box 933-AO, Springfield, Ohio.

MAILORDER Moneymaking imprints. Samples 4¢. Ballard's, 1834 Edgeland, Louisville 4, Ky.

BUY Direct from factories. Appliances, cameras, watches! Free details! Cam, 116 Malden Street, Worcester, Mass.

FREE Details! Make money at home. Respectable field. Experience unnecessary. No public contact. Free help. Columbia, 45-09-PM Broadway, Long Island City 3, New York.

REPAIR Hydraulic jacks. Easy and profitable. Details free. Hydraulics, Box 4104, El Paso, Texas.

BUY Direct from factories. Appliances, cameras, watches! Free details! Cam Co., 6810PM-20th Ave., Brooklyn 4, N. Y.

BIG Money—Operate own fix-it shop. Service household appliances, motors, mowers, saws, skates, etc. Free book. Christy Trades School, A-9403, 3214 Lawrence, Chicago 25.

MOTEL—Resort management. Qualify for hundreds fascinating, leisurely, well-paid executive openings. Learn at home. Free booklet. Motel Managers Training School, PM-4, 612 S. Serrano, Los Angeles 5.

PROSPER By selling "The World's Most Usable Bible." Sales quick, easy and highly profitable. To start earning a better living, write today. International Book Company, Department M., Box 118, Wichita 1, Kansas.

NATURAL Molding rubber, extra thick. Free samples. W. Wooley, 2801-A Latrobe, Peoria, Illinois.

LEARN Professional TV servicing in one week! Fabulous new simplified system. No big expense. No studying. No tools or equipment. Spare, full time. Own your own big profit business! Save! Amazing but true! Free! Write, TV Systems, Dept. DC-179, 1038 So. LaBrea, Los Angeles 19, Calif.

LEARN Tailoring, alterations, repairs. Be self-employed! Poulin Tailors, Penacook, N. Hampshire.

MAIL Order, home workers, dealers, hobbyists opportunities. Part time or full. Earn extra income. Details. Sterling, Box 626-PM, Dania, Florida.

FORTUNES In Formulas! 900-page book of magical opportunities! 10,000 money-making ideas, home, farm, workshop. Endorsed by universities, scientists, others. Full satisfaction guaranteed. \$3.00, postpaid. Traphagen's, 1850-P W. Cermak, Chicago 8.

TOOL Steel. Make hunting knives, parallels, V-blocks, sinebars, jigs, fixtures. 16 page sketch book \$1.00. Alcon Production Tool Co., 579 Baird Street, Akron 11, Ohio.

MAILORDER Beginners no cost plan. Armstrong's, 154 Darrington S.W., Washington 24, D. C.

MAKE Fast selling children's item from scrap plywood. Details free. Clifford Richards, Castalia, Ohio.

MAILORDER To motels, churches, institutions. Complete individual set-up, not just instructions. Hermes Advertising, 152 West 42, New York City 36.

INTERNATIONAL Mailorder business made easy. Individual setup service. Not just instructions. Hermes, 152 West 42, New York City 36.

PROFIT With Popular Mechanics' subscription plan. No investment, no experience needed. Earnings begin immediately when you obtain subscriptions for Popular Mechanics, Good Housekeeping and others. High commissions, bonus. No experience needed. Deal directly with the publisher. Write Popular Mechanics, Room 9B, 250 West 55th St., New York 19, N. Y.

FREE Book "990 Successful, Little-Known Businesses." Work home! Plymouth-72J, Brooklyn 4, New York.

RAISE Night crawlers, redworms. Easy odorless, soilless method. Three Oaks Ranch, Dresden, Tennessee.

EARN \$200.00 Monthly. With table or jigsaw. Sparetime. Mac-Dan, Box 457, Stanton, Calif.

WANTED: Home producers, to be subcontractors. Cast plastic products for manufacturers in our clearing house service. Thousands of easily made items required. Cash in at home, without previous experience. Plastic Service Associates, Dept. 9-PM, East Boston 28, Massachusetts.

PLASTERCRAFT Molds, liquid rubber, plasters, flocks, candle supplies. Catalog and manual free. Blue Rapids Supply, Blue Rapids, Kansas.

STATUES, Plaques, figurines, molds, liquid rubber, plastercraft supplies. Free sample and details. Lavin Novelties, Box 296D, Flora Rd., Leavittsburg, Ohio.

SELL Books by mail. 400% profit. Royal, Box 368-X, Cleveland 27, Ohio.

225 JAPAN Exporters; wholesale price lists, transistors, opticals, sewing machines, etc. \$1.00. Globe-Wide, Box 56, Lemay Branch, Lemay, Mo.

IMPORT-Export opportunity, profitable, world-wide, mail-order business from home, without capital; or travel abroad. Established world trader ships instructions for no-risk examination. Experience unnecessary. Free details. Mellinger, C709, Los Angeles 24.

BECOME Refrigerator serviceman. Complete instructions \$3.00. Information free. Lincoln, P. O. Box 52R, Hempstead, N. Y.

TRAVEL The world! At 75% discount or more. Opportunity. Profitable. Be a travel agent. Experience unnecessary. Free details. United States Travel Research Associates, 708 Lucerne Ave., Lake Worth, Florida.

STRIKE It rich with home repairs at set prices. My \$160,000 yearly business makes fantastic profits. Free details. House Clinic National, Dept. P-9, P.O. Box 4804, Dallas 6, Texas.

NEW Profitable home business opportunities. Write K&K Distributors, Box 801, Dubuque, Iowa.

NOW Answer ads without effort. "Jiffy" postcards printed your name-address-message. You just address. Sample free. Rafter, North Boston 9, N. Y.

EARN \$10,000 Yearly raising Angora rabbit wool for us. Information 25¢ coin. American Angora Company, Malta 77, Montana.

PRACTICAL Mailorder. Start small. Moneymaker 960, 722 East Silver Spring, Milwaukee 17, Wisconsin.

\$70 WEEKLY—Home, spare time. Simplified mail bookkeeping. Immediate income—easy! Auditax, 34757A, Los Angeles 34.

COLLECT Names for us, \$1.00 each. Instructions 25¢. Wilson's Specialties, Box 61-M, Mt. Pleasant, Michigan.

HOME Business Digest. Teaches how to make money; by mail; part-time; hobbies; at home. Give sources of supply for new products. Rush 50 cents for sample, \$3.00 year, prepaid. Institute Press, Box 1902, Cleveland 6, Ohio.

NOW Available! "Import-Confidential" reveals where-to-get-what in Europe. Sample selection \$1.00. Boisclair Buyer's Service, Gildenplatz 8, Essen, West Germany.

MAILORDER Techniques, rules, laws, regulations, do's, don'ts. Complete "how-to" mailorder manual, \$1.00. Dean Products, Box 40-PM, Eiberton, Georgia.

HOMEWORKERS. What can you make? We sell all type craft products through nationwide markets. Produce and ship to our customers. We pay you. Crafters Marketing Service, P.O. Box 1534, Birmingham 4, Alabama.

EVERYBODY Likes candy and popcorn specialties. Learn to make professionally home. (Our 50th year.) Ragsdale Candies, B-107, East Orange, New Jersey.

PROFITS. Radios, guns, novelties, catalogue U.S. \$1.00. Napro, Box 49, Tainan, Formosa.

\$1,670.00 PROFITS In 90 days. New home mailorder opportunity. Everything furnished. New 45 r.p.m. record shows you how to make \$1,670.00 in 90 days. "Ferguson received 52 orders in one day." Details. Record mailed postpaid. Send \$2.00 (refundable) to Jesco Gifts, Wholesale Division, P.O. Box 411-M, 401 Cravens Building, Oklahoma City 1, Oklahoma.

MONEYMAKING OPPORTUNITIES

If You sell Christmas cards, make most extra cash with lines of all leading companies from one firm. World's biggest line. Over 150 Christmas, everyday box assortments, 600 big money-makers. Make up to 50% profit plus big cash bonus. Free giant color catalog of all lines; samples on approval. Arrow Greeting, 513 Fourth Ave., S. Dept. 83-N, Minneapolis, Minn.

AMAZING Successes through franchises! Become exclusive franchise holder your territory. Information rushed. National Franchise Reports, MP-528, 333 North Michigan, Chicago 1.

BUSINESS Kit free! Postcard puts you in business! Complete line 230 shoe styles, jackets! New discoveries pay big commissions. No investment. Send for free kit. Mason, Chippewa Falls KM-324, Wis.

IT'S Easy to make money writing articles and stories for young people's magazines. Complete guidebook \$2. Alicia Press, 1521 Princeton Northeast, Albuquerque, New Mexico.

HOW To run into an unsuspecting fortune. Make your own products. \$3.95 investment will bring you Fortunes in Formulas. All you need in one book. Ingills Laboratories, P.O. Box 1602, Chicago 90, Ill.

WIN Contest money. General Contest Bulletin gives hundreds of tips. Lists current contests, rules. Sample magazine 25c. General Contests, 1609 1/2 East 5th, Duluth 12, Minnesota.

BUSHELS Of mail! Free offers, samples, opportunities! Get "Listed for Life"—25c. Hamilton's, Hatch 10, New Mexico.

TEAR Out this ad. and mail with name, address for big box of home needs and cosmetics for free trial, to test in your home. Tell your friends, make money. Rush name. Blair, Dept. 31DS, Lynchburg, Va.

PLASTIC Vacuum-forming machine. Hobby. Easy. Profitable. Burr Plastic, 330 East Center, Kalamazoo, Michigan.

LEARN Sign painting, cartooning. Strahley, 410 So. Western, Springfield, Ohio.

MAKE Money in your spare time, or even go into business for yourself. Write today for free details. Address all correspondence to: Zephyr Enterprises, Box 1484-D, Hartford 1, Connecticut.

IN 1952 I was unemployed, broke. Today own \$18,000 home, drive Cadillac, have bank account. Anyone can do this. Write Norris Cole, 217 West 49th, Bradenton, Florida.

\$200.00 MONTHLY. Spare time. With tablesaw, bandsaw or jigsaw. Write. Holiday House, 7228 4th Plain, Vancouver, Washington.

FORMULAS For 10,000 products \$4.95. Ervin Sales, Box 366, Roseburg, Ore.

FREE Details! Make money at home. Respectable field. Experience unnecessary. No public contact. Free help. Columbia, 45-09-M Broadway, Long Island City 3, New York.

MAKE \$200.00 Monthly spare time with jigsaw. Free details. Elkman, 346 N. Summit, Sioux Falls, So. Dak.

SELL By mail. Mail order specialist shows how to start on low capital. Modern merchandising methods, not crackpot schemes. Free details. Weimann, 148 West Fifth Avenue, Vancouver 10, British Columbia, Canada.

MEN—Women! Start money-making plastic laminating business at home in spare time. Material that costs 11c brings back \$2.58. No canvassing or selling but mail orders bring in \$20 a day. Write for full particulars free. Rush name on postcard to Warner, Room CL-2-H, 1512 Jarvis, Chicago 26, Ill.

MAKE Fabulous weekly profits clipping newspaper items for publishers. Some clippings worth \$5.00 each. Particulars free. National, 81-PM, Knickerbocker Station, New York City.

EASY To start rubber stamp business at home in spare time. Make up to \$9.80 an hour without experience. Facts free. Write Roberts, 1512 Jarvis, Room CR-2-H, Chicago 26.

GET Listed for life! Receive hundreds free magazines, samples, special offers. Rush 25c, stamped, addressed envelope. Columbia, 45-09-MH Broadway, Long Island City, New York.

EASY To earn extra money! Free 100 page catalog. Tandy Leather Company, Box 791-T37, Fort Worth, Texas.

100% PROFIT. No investment. Stamp brings samples, details. Miller, Box 584, Brooklyn 1, New York.

START Big-pay business at home in spare time. No experience needed to operate little table-top machine for bronzing baby shoes. Make \$5.46 profit on every pair. Full particulars free. Send postcard to Mason, 1512 Jarvis, Room CM-2-H, Chicago 26, Ill.

LEARN Appliance service and repair. Motors, washers, refrigeration, cleaners, everything. Free booklet. Appliance, 3570 W. First St., Los Angeles 4.

MINK Raising information free. Complete. Lake Superior Mink Farm, Superior, EE1, Wisconsin.

VENDING Machines. No selling. Operate a route of coin machines and earn amazing profits. 32-page catalogue free. Parkway Machine Corporation, Dept. #26, 715 Ensor Street, Baltimore 2, Maryland.

GROW Mushrooms. Cellar, shed and outdoors. Spare, full time, year round. We pay \$4.50 lb dried. We have 29,000 customers. Free book. Mushrooms Dept.: 173, 2954 Admiral Way, Seattle, Wash.

CIGARETTES: Make 20 plain or filter-tips for 9c. Facts free. Moberly, Box 821, Owensboro, Kentucky.

EARN Money evenings copying and duplicating comic cartoons for advertisers. Adservice, Argyle 1, Wisconsin.

YOUR Own, easy-to-start, home mail-order business, sparetime. Fascinating; profitable! Information free. Alfano, 19-PM Pine, Closter, N. J.

BIG Money raising fishworms and crickets. Free literature. Carter Hatchery, Plains, Georgia.

READ "Progressive Mailtrade," the magazine that tells how to make money by mail. Quarter brings sample and special offer. Progressive Mailtrade, Box 357, Sheboygan, Wisconsin.

WANTED Men, women bait raisers. Guaranteed market. Down-East, PM-3, Box 149, Bangor, Maine.

START A profitable subscription business in spare time! We need men and women (young and old) as representatives for all leading national magazines. Liberal commissions on all subscriptions. Supplies free. No experience needed. Send this ad with your name and address to: Popular Mechanics, Room 9-O, 250 W. 55th St., New York 10, N. Y.

BUILD Backyard greenhouses. Cost low as \$29.95. Sell for \$59.50 up. Plans \$1.00. Refunded first material order. Every homeowner a prospect. The Jefferson Co., Box 416, Jefferson, Oklahoma.

BIG Profits possible in library research! Easy! Pleasant! Full—sparetime! Write: Trotta (PMIJ), 2036-66th, Brooklyn 4, New York.

TERRIFIC Profits. Easy. Assemble and sell waitress name plates, all businesses. Sample parts, instructions, \$1.00. Ace Novelty, Box 182P, Maywood, Calif.

MAKE Big money with fast-selling line self-help manuscripts, many titles! Imprints available; drop shipments if desired! Complete details to established mailorder dealers only! Economy, Box 2580-PM, Greensboro, North Carolina.

MONEYMAKING Home-business. No selling. Typewriter helpful. Refundable samples 50c. Interstate, 37 Besch, Albany 9, N. Y.

TEN Patio-garden accessories, easily built, no equipment, local materials. Business, hobby. Plans \$2.00. Hetrick, 11290 Wilson Road, Riviera Beach, Florida.

12 SURE-FIRE Mail order business plans plus 30 fast-selling products to manufacture in your basement. Complete \$1.00. Lekoa Enterprises, 2968B Wilson, Campbell, Ohio.

MAILORDER Below wholesale sources 750,000 items. Free lists. Dean's, Box 40-PM, Elberton, Georgia.

10,000 DOLLAR—Making formulas! Arkin, 1448 Crotona Park East, New York 60.

SELL Cars! Self training manual by expert. Approved by 7 auto editors. Free details. Dept. PMX, Westminster Automotive Sales Consultants, Box 130, Scarborough, Ontario, Canada.

BIG Profit selling Ferto (manure) pots and other house plant fertilizers. Novel, different. No competition. Send 25c for instructions and samples. Fertopot, Pitts-town, N. J.

MAKE Beautiful concrete products for profit. Useful lawn and home items. Small investment in our fiberglass forms puts you in business. Zeidler, Clear Lake, Iowa.

EXPORT — IMPORT

JAPAN: Direct mail-order. 26 page catalogue, kimonos, dolls, novelties, gifts, business information, manufacturers' names, addresses. Send \$1.00. Clarence Yamagata, 814 Toginbiru, Marunouchi, Tokyo.

IMPORTED Expressive Israel character dolls, \$3.98. The Azure Co., Spencer, W. Va.

IMPORT And gift catalog free. Sharon, Box 5114, Kansas City 32, Missouri.

SCIENCE & CHEMISTRY

CHEMICALS, Apparatus, glassware. Illustrated catalog 25c. Bio Chemical Products, Somerset, Belmont 78, Massachusetts.

CHEMICALS And apparatus for industrial, analytical, and private laboratories. Catalog 25c. Dept. M-50, Biological Supply Co., 1176 Mt. Hope Ave., Rochester 2c, N. Y.

ILLUSTRATED Catalog: Chemistry, mineralogy, biology 25c. Tracey Laboratories, Evanston, Illinois.

ROCKET Supplies for amateur rocketry. Catalog 25c. Mervin Hill Company, R.D. #1, Seward, Penna.

POPULAR Mechanics book, "Science Year," illustrated survey of last year's developments in science. Covers rockets, medicine, astronomy, electronics, etc. Send \$1 to Service Bureau, Room 517E, Popular Mechanics, 200 E. Ontario, Chicago 11, Illinois.

UNUSUAL Chemistry books, courses, kits! Rare chemicals, cheap! Catalog 25c. NSC, Box 11133, Palo Alto, Calif.

EXPERIMENTERS: New! Bigger catalog and "Experiments Booklet." Only 25c. Hagenow Laboratories, Manitowoc, Wis.

AMAZING New book of science experiments, formulas, and catalogue of laboratory supplies. Only 35c. National Scientific Co., 13 S. Park Avenue, Dept. PM-9, Lombard, Illinois.

ROCKETEERS: Illustrated catalog, plans, formulas, 25c. Central Rocket Company, Waupaca, Wis.

BOOKLET, "Scientific Oddities," 10c. Franks, 3121 South Racine Avenue, Chicago 8.

CHEMISTRY Catalog 25c. Textbook bargains! Laboratory Sales, Box 161A, Brighton, Mass.

ILLUSTRATED Catalog 25c. Chemicals glassware, biologicals. Winn Chemicals, 174 1/2 West 23 Street, New York 11, New York.

ROCKET Chemicals, apparatus. Keefe Scientific, 159-10A Hillside Avenue, Jamaica, New York.

FORMULAS, PLANS, ETC.

MAKE Waterproof cement paint 5c lb.! Details free. Courtney, Ancaster, Ontario.

FORMULAS—All kinds. Latest. Best. Literature, stamp. Kemixal, Park Ridge, Ill.

FORMULAS For latest money-making discoveries. New! Good! Valuable literature free! Miller, Chemist, 1517-D, Tampa, Florida.

RESILVER Mirrors—make one-way mirrors. Both \$1.00. Kem-Mir, Park Ridge, Illinois.

LATE, Modern manufacturing formulas. List free. Moon Chemical, Martville, New York.

PLASTICS

PLASTIC And supplies for laminating Colambo, 12 Center, New Haven, Conn

BOXES, Plastic, 200 sizes. Free list. Athor, 170 Bay 23 Street, Brooklyn, N. Y.

NEW Liquid casting plastic, clear, colors. Embed real flowers, butterflies, photos, coins. Send 25¢ for two handbooks "How to Cast Liquid Plastics" and "How to Make Extra Money at Home." Castolite, Dept. K-101, Woodstock, Illinois.

VINYLITE, Plastic, laminating supplies, machines. Solomson, 4 Beacham, Everett 49, Mass.

MAKE Sell signs. Plastic letters. Samples 25¢ refundable. Dixie Plastics, Lakeland, Fla.

AGENTS WANTED

PRINTING, Advertising salesmen—Excellent moneymaking sideline selling decalcomania name plates, small quantities Automobile initials, sign letters. Free samples. Ralco, XL, Boston 19, Mass.

SELL Champion, AC, Autolite spark plugs. Reconditioned, electroplated, guaranteed 10,000 miles. 100% profit. Free sample. Lee Plugs, 1608-E Roberts, Houston 3, Texas.

YOUR Own business—Used suits \$1.50; overcoats 65¢; mackinaws 35¢; shoes 12½¢; ladies' coats 30¢; dresses 15¢. Enormous profits. Catalog free. National Mail Order, 211-AA Roosevelt Road, Chicago 8, Ill.

DOUBLE Spare-time earnings with 65¢ profit on exclusive, new \$1.25 Christmas card assortment. Imprints, 40 for \$1.50. Over 400 assortments, gifts retail \$1 up. Get samples on approval, \$1.25 assortment. \$1 gift on free offers. Cardinal, 1400 State, Dept. 36-A, Cincinnati 14.

SELL Famous Swami car and furniture polishing cloths, treated with General Electric Silicone Oil. Over one million sold. Write Swami Cloth, Box 155, Great Neck, N. Y.

BIG Profits. Stamp social security plates, key protectors. Sample 50¢. Catalog free. General Products, 11 No. Pearl St., Albany 7, N. Y.

START Making money now. Earn top commissions taking orders for all magazine subscriptions. Friends and neighbors are your prospects. No experience needed. Write for free money-making kit. McGreggor Magazine Agency, Dept. 5A, Mount Morris, Illinois.

MAKE Up to \$50.00 a day soliciting delinquent accounts. Terrific commissions. Write today. National Credit, 304Y Pickwick Bldg., Kansas City 6, Mo.

RUN A spare-time greeting card and gift shop at home. Show friends samples of our new 1960 Christmas and all-occasion greeting cards and gifts. Take their orders and earn to 100% profit. No experience necessary. Costs nothing to try. Write today for samples on approval. Regal Greetings, Dept. 79, Ferndale, Mich.

FARM 200 Acres or less? You can make \$20 or more daily spare time. Supply customers McNess farm-home necessities. Write McNess, Freeport 24H, Ill.

MAKE \$10-\$100 A day! Sell new 5 year light bulbs. Guaranteed. Send for sample 6 pak \$1.98. Sells for \$4.69. Free details. Sunmaster, 366 Fifth Ave., Dept. 09PMC, New York City.

BUSINESS Kit free! Postcard puts you in business! Complete line 230 shoe styles, jackets! New discoveries pay big commissions. No investment. Send for free kit. Mason, Chippewa Falls KA-324, Wisconsin.

MAKE \$25-\$500. Sell Christmas, all occasion greeting card assortments; gifts, wrappings, stationery. Experience unnecessary. Big profits. Name imprinted Christmas cards. Salable samples on approval. Write Hedenkamp, 361 Broadway, Dept. PM-64, New York.

NEW Bathroom deodorizer Hangs on wall. Banishes odors bathroom, kitchen. Lightning seller. Samples sent on trial. Kristee 73, Akron, Ohio.

CHRISTMAS Cards—with customer's name imprinted. Personal and business designs—all in one album. These deluxe cards pay deluxe commissions. Earn \$300 to \$500 (plus bonuses) easily this season, even in spare time. Sales experience unnecessary. Free sales kit includes sample album and easy-to-follow selling instructions. Send for kit now; pocket profits next week! Write: Process Corp. (reliable for 39 years), Dept. PM-3, 1954 S. Troy, Chicago 23, Ill.

MEN-Women sell penny shoe shine and famous nationally advertised Turtle Wax products. Earn big money fast! Penny shine pre-sold by Bing Crosby coast to coast. Other big promotions. 122% profit possible. Send for free information. Plastone Sales, Dept. 60E, 1800 N. Clybourn Ave., Chicago 14, Ill.

UP To \$300 extra money. Show friends fabulous self-selling Evans Christmas card, gift line. Profits to 100%. Send no money—write for sample boxes to be paid for or returned, plus big free album personalized cards, 2 catalogs 300 items. New England Art Publishers, North Abington 940-C, Mass.

MAKE Money selling ties. Free catalog. Write to Philip's Neckwear, 24 West 22nd, New York City.

FREE! Beautiful Mexican curios! Rush 30¢ stamps mailing. Sylviak, Apartado 9036, Mexico City.

DAMASCENE Earrings Exotic orientalism. Huge profit. OHGA, PM-204, Sigakenkusatu, Japan.

MAKE Profitable men's-women's wear. Sample free. Sunmade, Brockton 64, Massachusetts.

TREMENDOUS Margin! Religious Medalion line starts buying rush. Multiple profit plan. Sell stores, individuals. Details free. Romaine Products, Dept. PM36, Oaklyn 6, New Jersey.

MEN! Women! 60% profit on cosmetics. Famous nationally advertised Hollywood cosmetics pay 60%. Make \$25 day up. Hire others. For free samples, details, write Studio Girl, Glendale, California, Dept. 1209J.

FUNNY Cards—50 samples 25¢. New wholesale gag, novelty catalog free. Dohn-MM-Marks, Broadview, Illinois.

SPARE Time can mean extra cash for you. With no experience, no big investment, you can earn fantastic profits! Take orders with big, colorfully illustrated catalog of toys, jewelry, gifts, collector's items, household gadgets. Work your own hours. Write for free catalog. North Star, Dept. 6-605, 251 East Fifth Street, St. Paul 1, Minnesota.

MAKE Money 50% faster! Keep 75¢, not 50¢, on \$1.25 Christmas card assortment; \$75.00 on hundred. 199 exciting assortments, gifts, \$1 up. Free samples 53 personalized cards. Gift bonuses. Approval samples. Free gift offer. Creative, 4401 Cermak, Dept. 506-P, Chicago 23.

PHOTO Murals. Large full color. Every bare wall prospect. Free color brochure. Details. Sanders, Dept. PM-9, 1359½ Poplar, San Bernardino, Calif.

MAKE \$1,000 Extra this year! Over 800 best-selling items. Gifts for men, women, children, the home Distinctive greeting cards, stationery, jewelry, cosmetics, mechanical gadgets, novelties, household helps, toys, games. No minimum order. Samples on approval. Make up to 92% profit! Write for free catalog. Greetings Unlimited, 6-207 Park Square, St. Paul 1, Minn.

CAPITALIZE On bowling's popularity. Sell "My Bowling Scores"; new, different. Bowlers go for it. Over 100% profit. Sample copy 25¢. Deductible when you order. Pope Enterprises, 1907 Cuyler Avenue, Chicago 13, Illinois.

BIG Profit. Stock market game. Buy, sell, collect dividends. Fascinating family fun. Game, details \$3.00 postpaid. Satisfaction guaranteed. Schmid Game Co., 767 Van Buren, St. Paul 4, Minn.

MAKE Profitable men's-women's wear. Sample free. Sunmade, Brockton 64, Mass.

\$300.00 WEEKLY! Part time. Chemical supercharger. Increases RPM, upgrades gasoline, eliminates knocks and pings. Guaranteed. Dept. PM, Box 530, Freeport 30, New York.

BE The Popular Mechanics representative in your neighborhood and earn big profits in your spare time. Write Popular Mechanics, Room 9-A, 250 West 55th St., New York 19, N. Y.

BIG Profits! Terrific repeats, selling new packaged chamois skins. Wholesale, retail, direct. Salable sample \$1.00 postpaid. Details free. Samuel Glenn-MP90, Box 507, Jacksonville, North Carolina.

SELL Amazing glow-in-dark pictures. Big profits. Samples free. Madison Mills, 303 Fourth Ave., New York 10, N. Y.

60,000,000 PROSPECTS. Amazing new product. P.O. Box 42-608, Miami 42, Florida.

SPARETIME Profit. New household item. Every housewife a customer. 10¢ information. B. Schuelter, 1600 Decarie, St. Laurent, Queb., Canada.

NEW Sleeping comfort means generous profits with Electro-Warmth. Beats electric blankets 10 ways, costs less. Adds no top covering you sleep on it. Best season starting. Patented Products Corp., Dept. PM-960, Danville, Ohio.

COSMETIC Representatives. Need all 50 states your city town. Latest cosmetics sensation sweeping nation. Hire others. Earn fabulous commissions. Write Nu-Living, Inc., 7485 Wallings Road, North Royalton 33, Ohio.

TOILET Soap and shampoo in tubes. Imported. Details. Johnson's Supply Company, New Rochelle, N. Y.

SHOES—Men's, women's, children's. Low as \$1.10. Free brochures. Jules, 273-A West 40th Street, New York City.

MEN, Women. Make money spare time and earn new car as bonus for encouragement. Amazing hosiery guaranteed to wear without holes, snags, and runs, or replaced free. For example, lovely 60 gauge nylons guaranteed for as long as 1½ years, or replaced free. Write: Wilkmit, 1709 Washington, Greenfield, Ohio.

YOUR Ad in this space will get some good agents for you. Yes, I'll prove it. Write for Folder "A" right now. F. W. Johnson, Classified Advertising Manager, Popular Mechanics Magazine, 200 E. Ontario St., Chicago 11, Ill.

BUY IT WHOLESALE

HANDMADE Western boots. Big free catalog. Ysleta Boots, Box 815M, Ysleta Station, El Paso, Texas.

NEW Deluxe wholesale catalog, automobile catalog, and others. Housewares, appliances, refrigerators, freezers, washers, dryers, television, radios, furniture, clothing, luggage, binoculars, phonographs, recorders, cameras, projectors, typewriters, power tools, toys, sporting goods, watches, jewelry. Name brands. Huge discounts. Postcard (any card): Selbyco, Decatur 160, Illinois.

JOIN Now and save 20% to 50% on nationally advertised appliances, furniture, carpeting, photo equipment and other famous brand merchandise. Limited exclusive membership. Write for free brochure to Mutual Buyers Club, Inc., Dept. PM-1, 1000 W. Roosevelt Road, Chicago 8, Ill.

WORLD'S Largest wholesale supply. Buy from 679 American, European, Japanese wholesalers. Tailormade suits from Hongkong. 123 dropship catalogs. Rockbottom prices. Free details. International Buyers, 216-M Jackson, Chicago 6, Illinois.

VITAMINS: High potency. 1½¢ daily. Free details. Barclay Supplements, North Scituate, R. I.

TYPEWRITERS, Cameras, watches. New, latest. All makes. Simms, Warwick, N. Y.

WHOLESALE Catalog. You profit. Free details. Loeber, 224-D Wyatt, Lincoln, Ill.

2,000 PAGES Wholesale catalogs! Write: Mosser, Box 47-B, Newark, Ohio.

BUY At factory prices. Typewriters, housewares, jewelry, watches, musical instruments, appliances, hardware, television, sporting goods, cameras. Thousands other nationally advertised products. New factory buying plan saves you up to 40% below wholesale. Details free. Factory Supply Company, Box 1857B, Paterson, New Jersey.

PHOTOGRAPHIC Equipment. Free wholesale catalog. RNG Sales, PM, Wildomar, California.

BULOVA, Benrus watches like new \$5.95 up. Illustrated catalog with hundreds of bargains. free. Cosmos, New York 35, N. Y. Dept. 615.

ELECTRIC Guitars, amplifiers, wholesale. Free catalog. Carvin, PMW, Covina, Calif.

WHOLESALE: 850,000 Items. Supply source directory 25¢. Idealer, Park Ridge, Illinois.

LARGEST Wholesale supply source in U.S.! Furniture, clothing, appliances, housewares, automobiles and accessories, tools, sporting goods, hobby supplies, farm equipment, imports, new products, bargain merchandise. Free details. Associated Wholesalers, Box 2068-DD, Sioux City 4, Iowa.

USED And new watches \$2 up. Free list. Southern Watches, 5-PM So. Wabash, Chicago 3.

BELOW Wholesale most merchandise. Write: Factory Buyer, 446, Jacksonville, Illinois.

BUY Wholesale! Big catalog! Postcard: Spartan Industries, 1236-F Winona, Chicago 40.

SALESMEN—DISTRIBUTORS

PROFITABLE Lifetime oil business. Franchises still available for automotive Molybdenum. Small investment. Pacific Lubricants, 5807-PM9 Beverly, Los Angeles 22, Calif.

MAKE Extra money—Big cash commissions plus premiums for you and your customers. Sell advertising book matches. Sensational new tenorama, glamour girls, hillbillies; dozens others. All sizes. Quick daily sales; big repeat business. Free master kit makes selling easy. No experience necessary. Superior Match, Dept. M960, 7530 Greenwood, Chicago 19.

ANYONE Can sell famous Hoover uniforms for beauty shops, waitresses, nurses, doctors, others. Miracle fabrics—nylon, dacron, wash 'n wear cottons. Exclusive styles, top quality. Big income, real future. Equipment free. Hoover, Dept. L-100, New York 11, N. Y.

CALENDARS. Advertising novelties, matches. All styles, including religious, varnished, 12 sheet, girls. Hundreds of advertising novelties, book matches, etc. Fleming Calendar Co., Sales Division, 6539 Cottage Grove, Chicago 37, Ill.

MONEY-Making opportunity! Take big profit orders for world famous patented varieties fruit trees. Also flowering shrubs, roses, vines. Big sales outfit free. Stark Bro's, Desk 30191, Louisiana, Missouri.

BUSINESS Kit free! Postcard puts you in business! Complete line 230 shoe styles, jackets! New discoveries pay big commissions. No investment. Send for free kit. Mason, Chippewa Falls KS-324, Wisconsin.

SHINE Shoes without polish. New invention. Lightning seller. Shoes gleam like mirror. Samples sent on trial. Kristee, 42, Akron, Ohio.

MAKE Extra money selling advertising matchbooks. Free catalog and sales outfit. Matchcorp, Dept. PM-90, Chicago 32.

\$1,000.00 A Month for making dramatic 3-second demonstration of amazing lightweight Presto Fire Extinguisher. New chemical used by airforce snuffs out fires instantly. Only \$4.95. Terrific commissions. Millions want it. Free kit. Merlite, 114 E. 32nd, Dept. P-66T, New York 16.

WILL You wear new suits and topcoats without one penny cost and agree to show them to friends? You can make up to \$30.00 in a day even in spare time, without canvassing. J. C. Field & Son, Inc., Dept. K-1826, Harrison & Throop Sts., Chicago 7, Ill.

LAFF Lighters. America's hottest selling new novelty. Make \$25.00 to \$60.00 daily, easy, fast. Details free. Send \$1.00 for "sell on sight" sample demonstrator. Clever creations, Dept. P, Terminal Sales Building, Seattle 1, Washington.

YOUR Own spare time home-operated business. Take over your area as our service distributor keeping retail stores supplied. Nationally advertised 30-year-old line pays up to \$20.00 hour. Under \$100.00 for merchandise gets you started. For samples, highly successful plan, write Novo, 3855 Lincoln, Desk W-85, Chicago 13.

GET New shirt outfit free! \$90 weekly on 5 average orders a day. Famous quality made-to-measure dress and sport shirts at \$3.95 up, sell fast to all men. No experience needed. Full or part time. Write: Packard Shirt Co., Dept. 222, Terre Haute, Ind.

FULL. Part time. Babies' patented jumper-exerciser. Booming market. Nationally known. Big profits. Free testimonials, literature. Shurtliff Manufacturing, 225 Southeast Tenth, Pocatello, Idaho.

MAKE Up to \$50.00 a day soliciting delinquent accounts. Terrific commissions. Write today. General Finance, 304V Pickwick Bldg., Kansas City 6, Mo.

IF You're interested in making money in selling, see the hundreds of exceptional opportunities in Salesmen's Opportunity Magazine. Send name for your copy, absolutely free. Tell us what you're selling now. Opportunity, 848 N. Dearborn, Dept. 17, Chicago 10, Illinois.

MONEYMAKING Opportunity in fast growing market selling attractive outdoor advertising pennants. Write: Radder Products, Box 31, Colvin Station, Syracuse 5, New York.

YOU'LL Make big money selling famous Swami polishing cloths, treated with General Electric Silicone oil. Over one million sold. Write Swami Cloth, Box 155, Great Neck, N. Y.

SELL Dickey's complete line of auto cleaners. 10 products. Established 30 years. Dickey-Becker Mfg. Co., 2624 North Adams, Peoria, Ill.

EMPLOYMENT INFORMATION

CHALLENGING Jobs are available in Southern California. Current directory of missile and electronic engineering companies employing engineers, draftsmen, technicians, etc. \$1.00. Dick's Service, Box 413, Montebello, California.

U.S.A. Foreign jobs, up to \$1600.00 monthly. Construction, clerical, supervisory, etc. Skilled, unskilled. Free transportation. Unusual opportunities. Complete information plus worldwide project listings. Only \$2.00 (\$2.25 airmail). Satisfaction guaranteed. International Reports, Dept. M, 109 W. 42, New York 36, N. Y., or Box 621, San Jose 6, Calif.

CHICAGO! Jobs galore! All types; high wages. Men, women. Big Sunday classifieds. Terrific business opportunities included free! \$1.00. Airmail, \$2.00. Traphagen, 1850-A W. Cermak, Chicago 8.

JOBS: High pay. Foreign countries, U.S.A. All trades. Write Dept. 55C, National Employment Information, 1020 Broad, Newark, N. J.

AMERICAN—Overseas jobs. Higher pay. Transportation, benefits. Men-women. All occupations. Details. Write: Employment Headquarters, 79 Wall Street, Dept. B-12, New York 5.

LATEST Foreign jobs! Highest wages. Unlimited opportunities. Laborers, clerical, construction, electronics, oil fields, civil service. \$2.00 (c.o.d.'s accepted). America's leading overseas employment researcher. Plus newest South American, Alaskan, Venezuelan listings. Universal Research, Box 4912, Baltimore 20, Md.

CONSTRUCTION Job lists: Alaska, Hawaii. Latin-American information. Each \$2. 216-MB Jackson, Chicago 6.

GOOD Salaries—Petroleum, construction, manufacturing, teaching, etc. Technical, professional personnel. Travel paid, living allowances, bonuses. U.S. tax exempt. Information \$2.25 air mailed. Colombian Opportunities, Apartado Aereo 14448, Bogotá, Colombia.

JOBS On ships and yachts traveling foreign countries. Davenport's, 1354-K, G.P.O. New York 1, N. Y.

MERCHANT Marine jobs! Top wages, men and women. Travel! Details 10¢. Captain, Box 501-P, Reading, Mass.

HIGH Pay overseas, domestic jobs. Men, women. Generous benefits. Companies pay transportation. For information write: World Wide, Dept. B3, 149 N. Franklin St., Hempstead, N. Y.

160s GOVERNMENT Jobs. Civil Service security. Overseas, in States. West Point-Annapolis entrance. Learn how to come out high in exams. \$1 starts you. Tole House, Box 2521M, Hollywood 28, Calif.

HIGH Paying jobs. Travel, adventures, world wide, Alaska, Japan, South America, Far East, Europe. All ages, skilled and unskilled. Thousands of positions open, and jobs on ships. Write for free information today to: International Employment Information Center, P.O. 115, Boston 27, Mass.

FOREIGN Employment information. Work overseas. Travel, adventure. Europe, Africa, Asia, Canada, Alaska. Earn as much as \$1,600 monthly. Construction men, truck drivers, clerks, teachers, professionals, etc. Fabulous opportunities. Most complete information, application blanks, etc. Sent by return mail same day received. Send \$2.00 to Dept. PM, Foreign Bureau, P.O. Box 512, New Orleans, Louisiana.

FREE Information—U.S.A., overseas jobs. High pay, transportation. Futures, Dept. M, 215 West 34th Street, New York City 1.

JOBS On ships. \$100 weekly, beginners. Travel, adventure. Write: Seaman's Service, Box 17-M, Brooklyn 8, N. Y.

FOREIGN Jobs—Latin America, Alaska, Canada up to \$1500 monthly. Up-to-date 1960 foreign service directory gives complete information; hot list of firms hiring for military and civilian construction, aircraft, oil, exporters-importers, mining. How-when-where to apply. 12th successful year. \$1.00. Global Reports, Box 8873-S, Los Angeles 8, Calif.

SPECIAL SERVICES

IRISH Coats of Arms booklet of officially recorded family names. Guaranteed accurate and authentic. \$1.00. Pioneer Arms, 65 Tenafly Drive, New Hyde Park, N. Y.

YOUR Wallet photos, cards, sealed in plastic \$1.00. Sample, circular 25¢. Lifetime, B363, Auburn 1, New York.

INFORMATION On anything. Ferguson Research Specialists, 116-14 141 St., South Ozone Park 36, N. Y.

EDUCATIONAL AND INSTRUCTION

LEARN Another language at home, easily, quickly, naturally with Linguaphone, the World's Standard Conversational Method. You learn to speak French, Spanish, German, Russian, Modern Greek, any of 34 modern languages available on lifelike conversational recordings. It's like living in another country. Complete language course available on free trial. Send for free book and details of free trial. No obligation. Linguaphone Institute, T-83-090 Radio City, New York City 20.

DRAFTING Pays big money, leads to top positions in automotive, aeronautical, construction, mechanical fields. Learn at home in spare time. All equipment supplied. Pay later plan. Free book. Christy Trades School, CD-4703, 3214 Lawrence, Chicago 25.

"HOW To Train Horses"—A book everyone who likes horses or ponies should have. Free. No obligation. Simply address Beery School, Dept. 1109, Pleasant Hill, Ohio.

COMPLETE Your high school at home in spare time with 63-year-old school. Texts furnished. No classes. Diploma. Information booklet free. American School, Dept. X645, Drexel at 58th, Chicago 37, Illinois.

GOOD Paying jobs open! Operate, repair heavy earth moving equipment! Learn "on the job" operating latest cranes, bulldozers, earth carriers! V.A. approved. Free catalog. Write: T. I. Hutch, Greer Technical Institute, Braidwood, Illinois.

BE A locksmith! Earn while you learn. Big opportunities await you in this fascinating, profitable trade. Earn quickly—step into a wellpaid job or start a business of your own, full or part time. Learn easily at home, all materials and special tools supplied. Write for free book today! Locksmithing Institute, Dept. 6709, 150 Park Avenue, East Rutherford, New Jersey.

NEW Self-teaching course in memory helps you achieve greater success in business and social world. Free booklet. Memory Studies, 835 Diversey Parkway, Dept. 3436, Chicago 14.

CERAMICS Terrific hobby. Home study course \$2.00 postpaid. John's Ceramics-P, Box 878, Omaha 1, Nebraska.

FINGERPRINTING Course \$12.00. Diploma awarded. Details free. Alabama School of Fingerprinting, Box 185-A, Fairfield, Alabama.

LEARN Expert cake decorating, candy making. Free details to housewives! Candy & Cake, Dept. 737, Fallbrook, Calif.

OIL Coloring photographs—A fascinating hobby or profitable sideline for those with artistic talent. Learn at home. Easy simplified method. Free booklet. National Photo Coloring School, 835 Diversey Parkway, Dept. 3436, Chicago 14.

GAME Warden, government hunter, forestry, park and wildlife service announce job openings regularly. Enjoy outdoor work, good pay real security. Complete information free! Write North American School of Conservation, Dept. 179B, 810 Midsworth, Covina, Calif.

CIVIL Service. Learn about this field of work and how you can prepare yourself by home study for a high entrance mark. Private organization. Free booklet. No obligation. Franklin Institute, Dept. W20, Rochester 4, N. Y.

STUDY At home for personal advancement and spiritual unfoldment. Systematic study of Metaphysics or Metaphysical Psychology may help solve mental worries. Correspondence only. Free booklet. College of Universal Truth, 23 East Jackson, Dept. 3, Chicago 4, Ill.

MASTER Watchmaking at home. Free sample lesson. Chicago School, 2328-YJ Milwaukee, Chicago 47.

OPERATE Restaurant or diner. Free booklet reveals plan. Write School of Restaurant Business, Dept. KC-359, 335 W. Madison, Chicago 6, Illinois.

ENGINEERING And art degrees earned through home study. Electronics, electrical, mechanical, civil, physics, liberal arts. When writing, specify course desired. Pacific International College of Arts & Sciences, primarily a correspondence school. Resident classes also carried. 5719-B Santa Monica Boulevard, Hollywood 38, Calif.

DENTAL Technician's manual. Send only \$2.98 for "The Know How of Artificial Denture Construction." Ten complete chapters, easy to understand. Authentic, illustrated information direct from a dental laboratory. Grant Dental Laboratory, Haas Bldg., Los Angeles 14, Calif.

PIANO Tuning learned at home! Profitable, uncrowded profession. Write **TUNECRAFT**, Box 5074-M, St. Paul, Minnesota.

MATHEMATICS, Science, business home study courses. Free catalog. Technical Training Service, Department 146MF, Brooklyn 14, New York.

USED Correspondence courses, books. Satisfaction guaranteed. Catalog 10¢ refundable. Courses bought. Bayles, 78-B Courtright, Wilkes Barre, Penna.

POPULARITY Through music! Make new friends. Earn extra money. Learn accordion, guitar. Easy lessons. Instrument furnished. Satisfaction guaranteed. Free information. National Conservatory of Music, P.O. Box 1938, New Haven, Connecticut.

SLEEP And learn. School subjects, personality improvement, foreign languages, financial security. Simple. Inexpensive. Free details. Mass Distributors, Box 26A, Cambridge 41, Massachusetts.

CHA Cha! Foxtrot! Jitterbug! Free lesson proves you can! Castle, 507 Fifth Ave., New York 17.

EARN College degree or diploma. Educational Bureau, P.O. Box 281, Essex Sta., Boston, Mass.

BILLION Dollar technical industry needs qualified men! Our unique combination home training assures high earnings. Free placements. Vital information furnished. Northeast Schools, New Haven 9, Conn.

DIVERS—Training in advanced methods of construction, salvage and general commercial diving. Send for free brochure. Commercial School of Deep Sea Diving, Inc., 2301 E. Anaheim, Wilmington, Calif.

BE A memory machine! Earn to \$3,700 yearly extra! Research Center, 520 W. Fewel, El Paso 8, Texas.

INVESTIGATOR Training—Free booklet covering approved home-study plan. Write National Detective Academy, Dept. E, 722 West Chapman Avenue, Orange, Calif.

BE A Real Estate Broker. Insure security for yourself and your family. Study at home. Prepare for state examination. GI approved. Write for free book today. Weaver School of Real Estate, 2018 P Grand, Kansas City, Missouri.

LEARN Auctioneering. Free catalog. Missouri Auction School, Box 9252X3, Kansas City, Missouri.

LEARN Appliance service and repair. Motors, washers, refrigeration, cleaners, everything. Free booklet. Appliance, 3570 W. First St., Los Angeles 4.

LEARN World interlanguage approved by UNESCO. Textbook 25¢. Esperanto. Middleton, Wis.

LEARN Asleep or awake. Self-help books, tapes, recordings. Free catalog. Drawer PM-697, Ruidoso, New Mexico.

HIGH School diploma at home. Licensed teachers. Approved materials. Southern States Academy, Station E-16, Atlanta, Ga.

WANT A diesel job? Higher pay? Advancement? We can help you qualify! Complete diesel, tractor and heavy equipment and Cummins Diesel Engine Shop-method home-training courses available. Write today. Interstate Training Service, Dept. B-3, Portland 12, Ore.

DEVELOP Mind power, personality while asleep. Use your phonograph, recorder. Amazing psychological tapes, records now available. Details free. Sleep-Learning Association, Box 24-N, Olympia, Washington.

EARN While you learn. Auto and diesel mechanics master this top paying trade. Many graduates earn \$100 a week and up. Approved for Korean veterans. For free information write Dept. No. 256, Nashville Auto-Diesel College, Nashville 3, Tenn.

PHYSICAL Therapy and massage. Home training. Practice privately or work with doctors and hospitals. Free catalogue. National Institute, Desk 4, 159 E. Ontario, Chicago, Ill.

BOOKS, Free general catalog, 100 pages. Text, vocational, educational, instructional subjects. Millions of volumes, new and used. Bargain prices. Books bought. Est. 1902. Long's College Book Co., Dept. PM, Columbus 1, Ohio.

STRENGTHEN Your voice—for more success in business, social life! Free booklet. (Give age.) PV Institute, Studio EP-2, 210 South Clinton, Chicago 6.

PIANO Tuning pays. Big money in spare time. Learn at home in 30 days. No musical knowledge necessary. Phonograph, records, tools and instructions furnished. Personal instructions available. Free catalog. Capital Piano Tuning School, 3160 S.W. 16th Court, Fort Lauderdale, Fla.

INVESTIGATOR Training—Robert B. Phillips Sr., Founder, former U.S. Government Special Agent. Write to 1917-K North Kenneth, Chicago 39, Ill.

USED Correspondence courses and books sold and rented. Money back guarantee. Catalog free. (Courses bought.) Lee Mountain, Pisgah, Alabama.

BOOKKEEPERS. Operate your own "Dollar-A-Week" system. Ellis, Box 200, Cedar Grove, North Carolina.

ANALYZE Handwriting for profit, pleasure. Free sample lesson, catalog reveals plan. Write IGAS, Inc., Dept. 2, Springfield 4, Missouri.

OWN Collection agency. Little "gold mine." Franklin Credit, Roanoke, Va.

PIANO Tuning pays. Learned easily at home. GI approved. 59th year. Free booklet. Niles Bryant School, Dept. P, 3731 Stockton, Sacramento 20, Calif.

ANALYZE Handwriting. Big earnings. 12 lessons \$12. \$1 monthly. L. Earnshaw, 430 Thompson, Glendale, Calif.

BOY Scouts. Morse code memorized in one hour. New method. Guaranteed. Used in Armed Services, ham radio, scouting. "Ketchum's One Hour Code Course" \$1.00, postpaid. O. H. Ketchum, Box 325, Bellflower, California.

BLUEPRINT Reading. Learn to read blueprints with confidence in 10 easy lessons. Write: Belton, 1059B North Lawn-dale, Chicago 51.

SWEDISH Massage. Home study. Diploma. Illinois Licensed School, 3809 Alta Vista, Chicago 13.

PROFESSIONAL Investigators. Home study. Lapel pin, certificate, future. Box 41197-F, Los Angeles 41, California.

PLAYS. STORIES. MANUSCRIPTS

ATTENTION All writers! Authorship means prestige! Your short stories, articles, books, plays, will receive our prompt sales handling! Write immediately for free literature! Literary Agent Mead, 915 Broadway, New York City 10.

WANT Your book published? Learn how we publish, advertise, promote, distribute. Many successes. Free booklet PM. Vantage, 120 West 31, New York City. Or 6253 Hollywood Blvd., Hollywood 28, Calif.

ADVERTISING AGENCIES. LETTER WRITERS. FOR ADVERTISERS

FREE! Red-hot book, "More Profit From Your Advertising." Lists—best mail order magazine, newspapers. Adservice, 516 Cornelia, Chicago 13.

"AMAZING New Book"—"Profits From Classified Advertising." Tells how and what to advertise. Be sure to read this book before you invest one cent in advertising. Write for your copy now. Just send 10¢ for postage and handling. W. Johnson, Classified Advertising Manager, 202 East Ontario Street, Chicago 11, Illinois.

MAILING Lists most any classification \$5.00 1000. Your circulars mailed with ours \$4.00 1000. Write for our literature. Dixie Mailers, King, N. C.

CREATIVE Advertising. Magnetic copy. Dramatic layouts. Moran Agency. Shoemakersville, Pennsylvania.

ADVERTISING Ratebook leading newspapers, magazines, free. Chicago Advertising Agency, 28-E Jackson, Chicago 4.

SAVE! Circulars, brochures, folders, catalogs designed and printed. Samples! Flair, 8 West 45th, New York City 36.

NOW Ready: New, amazing Classified Advertising Record Book—prepared especially for classified advertisers. Here is a book that tells you instantly whether or not your advertising in any publication is paying you real results. You can tell immediately how many inquiries each publication produced—how much cash received from every ad. Spaces are provided for the name and address of the publication, date of issue, space used, rate, cost of ad, key number, etc. You have a complete record of each publication right before your eyes. Plenty of space to keep accurate record of 28 separate publications. You can have a copy by sending only 10¢ to cover postage and handling. Send for your copy now. W. P. Johnson, Classified Adv. Mgr., Popular Mechanics Magazine, 204 E. Ontario Street, Chicago 11, Illinois.

CARTOONING, COMMERCIAL ART, SHOWCARD & SIGN PAINTING, TATTOOING

LEARN Sign painting at home. Free talent test. Ben Kerns, Box 812-PM, Greenville, S.C.

LEARN Profitable, fascinating tattooing. Illustrated information \$1. Zeis, 728-O Leslie, Rockford, Illinois.

LEARN Sign painting with fascinating system. Straley, 410 S. Western, Springfield, Ohio.

CARTOON Your way to success! Internationally known instructor, Raye Burns, will personally teach you to create original, salable cartoons at home. Cost of course is very low. Write for free details. Raye Burns School, Box 3583-P, Cleveland 18, Ohio.

"HOW To Make Money With Simple Cartoons"—A book everyone who likes to draw should have. It is free! No obligation. Simply address Cartoonists' Exchange, Dept. 99, Pleasant Hill, Ohio.

CARTOONERAMA Teaches you cartooning in a new, low-priced 24 lesson course. Free brochure, CFA, Box 263A1, Branford, Connecticut.

PAINT Signs! Use patterns! Trial alphabet \$1.00. Harwell, PM-960, Byrdstown, Tennessee.

BOOKS Plus optional inexpensive assistance. De-Signs, Box 2024F, Davenport, Iowa.

TYPEWRITERS, DUPLICATORS, OFFICE DEVICES

RECONDITIONED Typewriters, duplicating, printing devices. \$25.00 up. Supplies. Appliances. DixieGraph, King, N. C.

PRINTING, MULTIGRAPHING, MIMEOGRAPHING, GUMMED LABELS

PROFESSIONAL Quality printing. Free samples, pricelist. Jones, Box 343-PM, Mineola, N. Y.

OFFSET Printing, 1000 8 $\frac{1}{2}$ x11, \$5.50. Alpine, Box 676-EA, Cupertino, Calif.

LETTERHEADS: 500—\$4.50. Free sample. Carlayne, 1803 Fremont, Rapid City, South Dakota.

MIMEOGRAPHING—Letters, pricelists, formulas, instructions. Lowest prices. Lem's Letter Shop, 5710 Stanton, Detroit 8.

ADS Running under this heading sell printing. Ask me for proof. I'll gladly send you amazing facts. Ask for Folder "P." F. W. Johnson, 200 E. Ontario St., Chicago 11, Ill.

FREE Catalogs postpaid printing. Rubber stamps. DM Press, Sebastopol, Calif.

1,000 BUSINESS Cards. Raised printing. \$3.75. Agents wanted. Elco, 5909 Highlandview, Sylvania, Ohio.

PRINTING Office supplies wholesale 10,000 items. Save 50%. Literature free. Stiefel, 32 Lehigh Place, Irvington 11, New Jersey.

MIMEOGRAPHING Service U.S.A. Swanson, 834 (X) Harvey Road, Toms River, New Jersey.

1,000 BUSINESS Cards. Raised letters \$3.95. Samples. Pioneer, PM-9, Island Park, N. Y.

FREE Catalog, samples, 1000 2-color address labels \$1.75. Youngers Printing, Princeton, Iowa.

250 8 $\frac{1}{2}$ x11 HAMMERMILL Letterheads \$2.95. 250 Envelopes \$2.95. Samples! Davis, 7609 Spruce Road, Baltimore 22, Maryland.

COLORED Or white 8 $\frac{1}{2}$ x11 offset. \$6.50—1,000; \$18—5,000. Fast! Flair, 10 West 45th, New York City 36.

LOW Priced printing, mimeographing. Postpaid. Free samples. Burnfin, Weaubleau, Missouri.

TWO Color letterheads. Free samples. Sanderson, Box 1489, Boston 4, Mass.

FINE Printing, reasonable prices. Free catalog. Forslund Printers, 109 East Stewart, Puyallup, Washington.

MIMEOGRAPHING—Black, colors. Samples, prices free. Stadler, 1733 North Ohio, Roswell, New Mexico.

MIMEOGRAPHING. Printing, office supplies. Lowest prices. Business Service Co., 1555P St. Marks Ave., Brooklyn 33, N. Y.

1,000 NAME And address labels—\$1.00. 3 line rubber stamp \$1.00 postpaid. Lynette's, Box 1-M, Noroton, Connecticut.

1000 RAISED Business cards \$3.49. Free card case. L-D, 534 State, Hammond, Indiana.

BUSINESS Cards two colors process embossed 1,000 only \$5. One color \$3.75. Write for brochure. Alert Advertising, 4419 Second Blvd., A-7, Detroit 1, Mich.

PRINTING OUTFITS AND SUPPLIES

TYPE For printers and rubber stamp makers. Send 25¢ for big new 96 page catalog. Largest selection in U. S. Acme Type, 633 Plymouth Court, Chicago 5, Ill.

HARD Type for rubber stamp making and printing. Special introductory offer. 10 or 12pt. 20th Cent. medium or Stymie medium. Cap ft. \$2.00. L.C. ft. \$2.00. Free catalog. Barco Type Founders, 64 Wagner, Northlake, Ill.

RUBBER Stamp presses, hydraulic operated, electrically heated. Sizes 5"x8", 8"x12", 10"x15". Starting outfits, supplies. Printing presses. Custom Manufacturing, 507-P N. Jefferson, Springfield, Missouri.

PRINTING Presses, type, supplies. Lists 4¢. Turnbaugh Service, Mechanicsburg, Penna.

RUBBER Stamp presses, supplies. Kiewit, 2025 Barney Road, Kalamazoo, Mich.

MAKE Your own self-molding rubber stamps and printing cuts. Plexirubber, Argyle 1, Wisconsin.

DO Your own printing. Save money. Simple rules. We supply everything. Print for others; good profit. Raised printing like engraving too. Have home shop. Details free. Kelsey Presses, V-11, Meriden, Connecticut.

RUBBER STAMPS AND OFFICE SUPPLIES

INDEXED, Cushioned 3 line stamp \$1.00. Each additional line 25¢. Stock stamps, novelty stamps, stamp pads. Rubber Stamp Service, 109 North Hyatt St., Tipp City, Ohio.

THREE Lines 60¢, pocket or handled. Johnson Stamp Works, Newburg, Mo.

BARGAIN Rubber stamps! Literature free! Arthur Johnson, 400 North Cicero, Chicago 44.

POSTCARD Printer. Nationally advertised, \$10.95. Addressing machine, for all type mailings. \$30.97. Free literature. Tozer Sales, 13932 Mayfield, Detroit 5, Mich.

FREE—Rubber stamp catalog. Martin, 1425 Major Drive, Jefferson City, Missouri.

3 LINES \$1.00. 4 or 5 lines \$1.50. Free literature. Younger Stamp Shop, Princeton 1, Iowa.

3 LINE Rubber stamp 50¢. Repco, P.O. 956, Evanston, Illinois.

POCKET, 3 Lines \$1.00. Guaranteed. W. J. Specialty, 8464 Manhattan, Detroit 11, Michigan.

FOR INVENTORS

PATENT Drawings your invention made by our experts. Reasonable cost. Patent Service Associates, Haverhill, New Hampshire.

INVENTIONS Needed immediately for manufacturers. For additional information write Kessler Corporation, C-59-FI, Fremont, Ohio.

YOU Can easily apply for patents. Save with complete professional kit, featuring "Exclusive Demonstrator Method" and fill-in forms. Free registration certificate. Patent Associates, 1214 Commonwealth Building, Philadelphia 7, Pennsylvania.

HOW To Become Wealthy Through Inventing! Complete book containing new and practical ideas which could be developed. Suggested methods are provided. Procedures to be followed. Pitfalls to avoid. Other aids. Valuable must for all beginning and experienced inventors—\$1.00. Lehigh Laboratories, 2047 Somerset, Philadelphia 32, Penna.

SAVE! New Inventor's Patent Kit makes it easy to apply for patents yourself. Free "Registration Form." Miss Suzan Bla'ne, 306 Carry Building, Washington 5, D. C.

PROFESSIONAL Searches of the Patent Office records. Dependable. Reliable. \$6.00. For free protection forms write: Inventions on Demand, 412 Albee Building, Washington 5, D. C.

DON'T Pay high fees! Obtain U.S. patent yourself. It's easy with Professional Kit with fill-in forms. Free "Registration Form." Patent Protection Institute, 2000 P Street, N.W., Washington 5, D. C.

INVENTORS' Complete service. Cash-royalties sales. Inventions researched. Patent development engineering. Free invention certificate. George Spector, Licensed Invention Engineer, 3615 Woolworth Building, New York.

INVENTIONS Wanted now by my manufacturer clients. Patented. Unpatented. Write Gilbert Adams, Patent Broker, 80 Wall St., Financial District, New York City.

PATENT Searches, including copies of nearest patents, \$6.00. Reports airmailed within 48 hours. More than 200 registered patent attorneys have used my service. For free invention protection forms, write Miss Ann Hastings, P. O. Box 176, Washington 4, D. C.

WE Have the markets if you have the ideas. Harvey Engineers, Cambridge 1, Maryland.

INVENTORS: Test the commercial value of your patented or unpatented inventions, quickly and inexpensively. Write for free information. Institute of American Inventors, Dept. 40-B, 635-F St., N.W., Washington 4, D. C.

COMPREHENSIVE Search through patent office records \$10. "Protection" forms unnecessary. Complete inventor's service. Sales, market evaluation. Johns-Hanson Associates, 421 Washington Building, Washington 5, D. C.

PATENT Searches, including complete copies of nearest patents, \$6.00. Inventors, attorneys, manufacturers use my original world-wide airmail service. "Proof of Invention" protection form and "Information Every Inventor Needs" sent free. Miss Jean Hayward, 1029 Vermont Avenue, NW, Washington 5, D. C.

INVENTORS! Determine patentability of your invention. Searches of the Patent Office Records administered professionally—\$6.00. For free invention protection forms, dependable service write Washington Patent Office Search Bureau, 1426 G Street, N. W., Washington 5, D. C.

HIGHEST Cash royalties. Ideas developed into products, drawings, patent search, reliable protection, promotion, manufacturers lists. Inventors Creative Service, 354 South Spring, Los Angeles 13, California.

QUALITY Patent searches, \$6.00. Copies of closest patents forwarded. Free "Protection Certificate." American Patent Search Co., 422 Washington Bldg., Washington, D. C.

SEARCHERS. Commercial studies. Development assistance. Marketing. Postcard brings details free. Or send 25¢ coin for valuable booklet of important protection information. Satisfaction guaranteed. Inventors Guidance Service, Calimesa, Calif.

PATENTS Skillfully prepared for maximum commercial value, with useful product development. High record of success in proving and claiming patentability. Valuable market service. Patent prepared for a fee as low as \$200.00. Send for self-protecting record of invention forms free. Patent search with valuable engineering report \$15.00. Foreign patents filed at low cost. Thirty years established. Joseph O'Brien, Patent and Development Engineer, 132 Nassau St., New York 38, N. Y.

INVENTORS! Outright cash sale or royalties for your inventions. Patented. Unpatented. Constant demand from our client manufacturers. Write: United States Invention Brokerage, 78 Wall Street, New York 5, N. Y.

PATENT Searches, \$5.00. Reliable reports. Same accurate search as conducted for attorneys. Complete patent and trademark services. Satisfied customers for 15 years. Patent Service Institute, 945-A Pennsylvania Avenue, Washington 4, D. C.

BASIC Patent information \$1.00. Brooks, 1436 19th Terrace, Lawrence 4, Kansas.

INVENTIONS Protected and sold. Industrial Inventions, 53 West Jackson, Chicago 4, Illinois.

INVENTIONS WANTED

INVENTIONS Needed immediately for manufacturers. For additional information write Kessler Corporation, C-59-IW, Fremont, Ohio.

INVENTIONS. Ideas wanted for manufacturers immediately. Ketchum's Advertising, Springfield, Illinois.

INVENTORS Needing help with any problem, financial, development, securing manufacturer, obtaining patent. Write the organization that delivers action and results—not promises. Pioneer Inventions, 150 Broadway, New York 38, New York.

INVENTIONS Wanted for immediate promotion—patented, unpatented! Outright cash or royalties. Casco, Dept. G, Medical Science Building, Washington 5, D. C.

INVENTORS! Outright cash sale or royalties for your inventions. Patented. Unpatented. Constant demand from our client manufacturers. Write: United States Invention Brokerage, 78 Wall Street, New York 5, N. Y.

INVENTORS—Get the best offer first! Patented or unpatented. Write Carl Sommer, Director, Industrial Invention Sales, 3136-A Sylvania Ave., Toledo 13, Ohio.

INVENTORS' Complete service. Cash-royalties sales. Inventions researched. Patent development engineering. Free invention certificate. George Spector, Licensed Invention Engineer, 3615 Woolworth Building, New York.

INVENTIONS Wanted: patented, patent pending. 29 years experience promoting inventions. National Service Bureau, 3120 Meramec, St. Louis 18, Mo.

INVENTIONS Wanted now by my manufacturer clients. Patented. Unpatented. Write Gilbert Adams, Patent Broker, 80 Wall St., Financial District, New York City.

INVENTORS: Hundreds of manufacturers have requested our assistance in locating marketable new products. Complete information free. Institute of American Inventors, Dept. 40-D, 635-F St. N.W., Washington 4, D. C.

INVENTIONS Wanted. Patented; unpatented. Tremendous manufacturers lists. Global Marketing Service, 2420 77th, Oakland 5, California.

INVENTORS! Consider our offer first before selling or licensing your invention on a cash or royalty basis. Patented. Unpatented. Inventions on Demand, 79 Wall Street, New York 5, N. Y.

ARE You interested in offers from reliable manufacturers for your invention? Patented. unpatented. Harvey Engineers, Cambridge, Maryland.

INVENTORS! Don't sell your invention, patented or unpatented, until you receive our offer. Write Universal Inventions, Box 298, Marion, Ohio.

INVENTIONS Wanted for manufacturers. Free details. Write Allen, Dept. C., 712 Davis Bldg., Big D., Dallas, Texas.

PATENT Pending inventions wanted. Write today for free description of the ways we can help you market your invention. Our clients are manufacturers looking for new ideas. Product Research Institute, Department C, 1400 Guadalupe, Austin 1, Texas.

PATENTS FOR SALE

SIMPLE Versatile ellipses enlarging compass. Ed Rouch, 5707 Sadler, Dallas 35, Texas.

MANUFACTURING

MODELS—Small lot manufacturing. Metals, plastics, etc. Milburn, Burlington, Kentucky.

WE Want production work for our shop. Welding, cutting, pipe bending, electroplating, chrome, cadmium, nickel, copper. We will quote on samples. Ocala Mark Inc., Ocala, Florida.

MODELS, MODEL SUPPLIES

FREE 22 DeLuxe metal fittings with your purchase of the 29" model United States Coast Guard utility boat kit. Die-cut wood parts. Adapts to radio control. \$12.50 postpaid. Dumas Products, Box 6096, Tucson, Arizona.

SCALE Model materials for building model homes and architectural buildings of any type. $\frac{1}{4}$ " and $\frac{1}{8}$ " scale. Send 50¢ for catalog. A & B Model Builders, 454-H Donovan Road, Kansas City, Kansas.

SHIP Models. Most complete line in New England, kits, fittings, plans, books, tools, engines, motors. Illustrated catalog 35¢. James Bliss & Co., Inc., Dept. SM, 342 Atlantic Ave., Boston 10, Mass.

ROCKET Supplies—Nozzles, cones, tubes, Specials also made. Catalog 10¢. Sky Mfg., Mineral Point, Penna.

SHIP And yacht model fittings; blueprints. Send 40¢ for illustrated catalog listing hundreds of items. A. J. Fisher, Inc., 1002-1 Etowah Ave., Royal Oak, Mich.

SHIP Model kits and fittings: clippers, frigates, etc. Catalog, paint-tool list, book list, 25¢. Model Shipways, Box 85, Bogota, N. J.

"POWER Drives Handbook"—36 pages illustrating many types motor drives for model autos, boats, displays, turntables, etc. Mail 25 cents cash, returnable first order \$3.00 or more. Wilson's of Cleveland, Dept. PM, P.O. Box 8995, Ft. Lauderdale, Fla.

ROCKET. Liquid fuel, 2 stages. Complete plans and specifications, \$1.95. Missile Research, Station 1, Provo, Utah.

POWER Models. Unusual steam, gasoline and traction engines, fittings, metals. New comprehensive, 100-page catalog \$1.00. Hot off press! Chas. Cole, Ventura, Calif.

ROCKETS! Seven complete blueprints. Officially built by United States Altitude Champion. Plus fuels, instrumentation, electrical ignition, parachute system, 2-stage. \$1.00. Rocketry, Box 4122, Washington 15, D. C.

HOME CRAFTSMEN

SHELL Lamps. Interested send for free How To Make Them bulletin. Shellcraft, Dept. LB, 514 N. W. 79th St., Miami 50, Fla.

VALUES In leathercraft. Latest ideas. Catalog, 10¢. Larson, Dept. 1027, 820 S. Tripp, Chicago 24.

FREE Leathercraft catalog. Quality kits, leather, tools. Handicrafters, Montrose, Calif.

101 PATTERNS Of smart Gifts, Novelties, Shelves, Action windmills plus "Make Money Jig Sawing." \$1.00. Mastercraft, 95M, 7041 Olcott, Chicago 31.

GRANDFATHER Clock movements, case plans, kits. Wholesale catalog 25¢. Mason-Sullivan, Noroton 7, Conn.

FOUNDRYETTE, 2400° F. $1\frac{1}{2}$ to 48 lb. capacity. Free circular. Kansas City Specialties Co., Dept. P-9, Marysville, Kan.

FREE, New catalog. 2447 plans, patterns. World's greatest selection things to do, make. Fun. Profit. Craftplans, 1322-A Wabash, Chicago 5.

SKIL-CRAFTS—World's finest and largest selection of leathercraft, hobby craft, art & craft supplies. Free billfold or leathercraft kit with first purchase. Send 25¢ latest catalog. Skil-Crafts, Box 167-P-Joplin, Missouri.

NON-CORROSIVE Wood screws. More than 50 assorted screws in reusable plastic box. Flat head. Aluminum \$1.25. Stainless steel \$1.75. Postpaid. Joart Specialty, Box 3007, Elmira, N. Y.

BRASS Hardware. Many beautiful unusual antique reproductions. Surplus and odd lots at reduced prices. Send 10¢ for illustrated catalog. Bazaar, Dept. 99, P.O. Box 506, Sheboygan, Wisconsin.

INTERESTING! Useful! Fun! "101 Home Workshop Projects for Wood Raps and Files." How to use them, things to make for house and hobby. 65 pages. Plenty of photos, diagrams, drawings, how-to info and details. For beginners or advanced craftsmen. Send 25¢ to Nicholson File Co., Dept. X, Providence 1, R. I.

WOODWORKING Catalog and manual. Brand new 1961 edition! World's largest selection of domestic, imported woods—materials, tools, supplies, do-it-yourself plans, projects. 130 pages, many full color. Send 25¢ (refunded first order). Year's subscription to "Chips and Chats" included free. Constantine, 2050 Eastchester Road, Dept. M-101, New York 61, N. Y.

LEATHERCRAFT. Send 10¢ for catalog. Saxcrafts, Inc., 1101 N. 3rd, Milwaukee, Wisconsin.

FREE! Leathercraft catalog. Hundreds of new items. Write MacPherson Bros. Leather Company, Dept. E, 730 Mission St., San Francisco 3, Calif.

LEARN Jewelry making at home. Inexpensive art metalcraft course teaches how to make all types cuff links, earrings, tableware, etc. of silver, gold, copper. Send postcard for free booklet. Interstate Training Service, Dept. L-3, Portland 12, Oregon.

WALNUT, Cherry, silver maple, kiln dried lumber, squares, blocks and picture frame moulding. Midland Lumber Company, Box 262, Savannah, Mo.

FREE "Do-It-Yourself" leathercraft catalog. Tandy Leather Company, Box 791-Q36, Fort Worth, Texas.

WOODWORKERS: Build beautiful contemporary, Danish modern furniture using our plans. Illustrated brochure 25¢. Monroe Associates, Box 441, La Habra, Calif.

DO IT YOURSELF

MODERN Plant stand designed by American craftsman. Directions 25¢. Miss M. Room 206, 485 Madison Ave., New York City 22.

MAKE Your own will. Legal in all states. \$2.00. Will-O-Matic, 552 Lakeshore, Dept. 19, Nice, Calif.

10' FERRIS Wheel kit—\$149.95. \$50.00 cash. Bal. F.O.B. Specialty Welding, 64 West 22nd Street, Hialeah, Florida.

FREE Check-list covering more than 500 classifications of projects, plans, instructions, service and repair information detailed in Popular Mechanics famous series of instructional booklets, books, patterns, and blueprints. List covers an extremely wide variety of do-it-yourself data on home remodeling, repair and improvement, hobbies, crafts, boating, games, lawn and garden, and hundreds of others. For your free copy of this helpful list, write: Service Bureau, Popular Mechanics, Room 520, 200 East Ontario, Chicago 11, Ill.

WATCHES, OLD GOLD, JEWELRY

FREE Illustrated catalog. Jewelry parts, supplies, rhinestones. Reasonable prices. Unique merchandise. Fast service. Folsom's, Box 52, Medford 55, Massachusetts.

HIGHEST Cash for old gold, jewelry, gold teeth, watches, diamonds, silverware, spectacles, platinum, mercury. Free information. Rose Refiners, Heyworth Building, Chicago 2.

TIMEX—Westclock watches repaired \$2.00. Workmanship guaranteed. Send cash, save c.o.d. Anderson Jewelry, Box 3722, Wichita 8, Kansas.

HIGHEST Cash paid for old gold, jewelry, gold teeth, diamonds, watches, silver. Mail articles today. Information free. Chicago Gold & Precious Metals, 6 E. Monroe, Dept. 2358, Chicago 3.

GOLD, Silver, platinum, discarded jewelry, watches, spectacles, gold teeth, gold coins. Highest prices paid immediately. Information free. Wilmot's, 1067PM Bridge, Grand Rapids 4, Mich.

WATCH And clock repairing books. Free catalog. North American, 2320-AW Milwaukee, Chicago 47, Illinois.

You Can Make a BIG LINE of Concrete Products on a SMALL INVESTMENT

Brick . . . patio stones . . . screen block . . . flag-stones, slump brick and many other items can be made on the low-cost, easy-to-operate Gardencrete Machine. \$1.00 worth of material can be turned into \$5.00 to \$8.00 worth of products to build patios, planters, walks, barbecues, walls, terraces, etc. A cash-and-carry business with large, waiting market. Every home can use Gardencrete.

As Little as \$810.10 Cash

Can procure you a Gardencrete Machine, with up to three years to pay the balance. Easy to set up in shed or garage. Gives opportunity to turn idle hours into profit and build a spare-time activity into a full time enterprise. Full information in 4-color brochure — free. Write today.

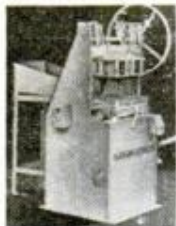

COLORCRETE INDUSTRIES, INC.
704 Ottawa • Holland, Mich.

GARDENCRETE



G-6

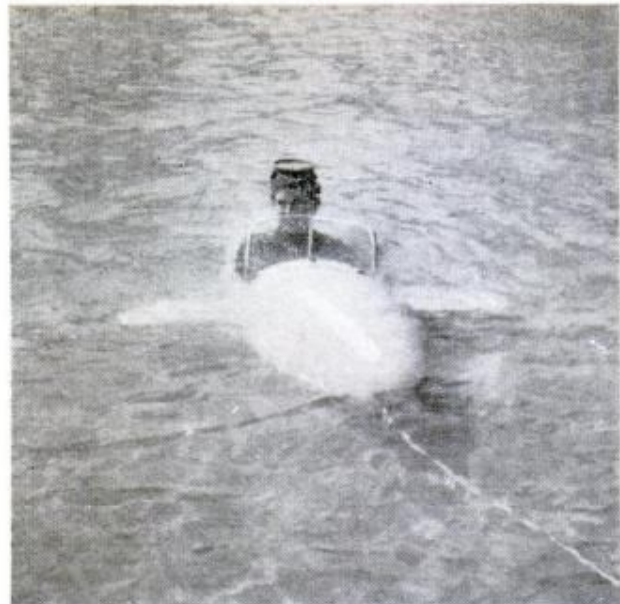

"Tow-Sub," John G. Green, 774 West 34th St., Hialeah, Fla.

Towed "Sub" Gives Underwater Ride

Like a one-man submarine, a new plastic sled dives, cruises and even does underwater acrobatics when towed behind a boat. The rider can wear SCUBA gear and stay down as long as he likes, or can duck quickly in and out with only a face mask, taking pictures, hunting for fish or treasure, or just sightseeing. The diver has full control of the running depth, but surfaces automatically if the towboat stops.



Hydraulic "Hand" Helps Paralytics

Paralyzed hands can regain enough manual dexterity for eating, writing, shaving and other tasks with an ingenious new "hand" developed by Dr. A. J. Heather, above left, working on a grant from Easter Seal funds. Using hydraulic pressure to replace lost strength, the device moves and holds three fingers in a chucklike grip when the master cylinder is activated by some other part of the body. The six-ounce system uses ordinary tap water for fluid; nylon parts make it light and durable.

Become A --- BUILDING CONTRACTOR! MAIL COUPON for FREE BROCHURE

Simplified home study training program. Learn every phase of building, estimating, contracting. Fortunes are made in this line of work every year. Use spare hours—no interference with present work. Diploma awarded. Low tuition rates.

AMERICAN TECHNICAL SOCIETY
Dept. BH-90, 850 E. 58th Street, Chicago 37, Ill.

Please send me your FREE Brochure and full details of your building, estimating and contracting training program.

Name _____ Age _____
Address _____
City _____ State _____



Be a LOCKSMITH

Want BIG PAY—Your Own Business?



You can quickly step into a well-paid job or start a big-profit business of your own. Shortage of locksmiths means opportunities everywhere, spare-time or full-time.

EARN EXTRA MONEY FROM THE START!
All Special Tools, Supplies Furnished Free

Age, education, minor physical handicaps don't matter in this growing, steady-income trade. You learn fast at home—gain practical experience through well-illustrated lessons. You do real jobs under the personal guidance of experts.

ILLUSTRATED BOOK—FREE
For a future as your own boss, or in a big pay job, send for FREE illustrated book. Mail coupon today. No salesman will call. Only school of its kind. Lic. State of N. J.; Accredited Nat'l Home Study Council. Approved for Veterans.
LOCKSMITHING INSTITUTE, Dept. 109,
150 Park Avenue, E. Rutherford, N. J.



MAIL COUPON NOW

Locksmith Inst., Dept. 109, 150 Park Avenue, E. Rutherford, N. J.
Please send FREE and without obligation Illustrated Book.

Name _____
Address _____
City _____ Zone _____ State _____

**He built a \$200 investment
into a mail order business
now doing \$3,000,000 yearly**

*(he now shares his
formula to success with you)*

You, too, may improve your financial security and independence in the fascinating mail order business. 12 years ago Max Adler started his business with \$200. Today his firm, Spencer Gifts, is known throughout the U.S.A. His volume is now over \$3,000,000 a year.



Mr. Adler now invites a limited number of qualified people to join his group of Independent Franchise Dealers. Through the Spencer Gifts Franchise Plan you can operate your own mail order business under your own name, from your home, spare time or full time! You will be supplied with mail order catalogs with your own name printed on them. You make no investment in stock. You don't pay for merchandise until your customers pay you. Spencer Gifts serves as your supplier, shipping department, warehouse. An initial investment of less than \$50 can get you started.

SEND NO MONEY! Write for complete information. We'll send you by return mail full details, sample catalog, application for franchise.

Write **TODAY**. Spencer Gifts, Wholesale Division, EZ-52, Spencer Building, Atlantic City, N. J.

**PREHEATED FRESH AIR IN
YOUR HOME ALL WINTER**

The new **DIBERT** Pressurizer (for hot air systems) does just that - also eliminates odors - cold spots - saves on fuel. Inexpensive - easily installed.

RYMCO, INC.

P. O. BOX 175A * GROSSE ILE, MICHIGAN

WRITE FOR CATALOG

**FIX LEAKS
YOURSELF!**



**Why pay a
\$10 repair bill?
39¢ gets you**

NEW HERCULES TAPE DOPE!

Stop leaks fast in shower heads, sink traps, radiators, valves, water lines, hose connections - any threaded joint - with cleaner, faster Hercules all-purpose Tape Dope, the modern pipe joint compound in easy to use tape form. Made of DuPont Teflon,® Hercules Tape Dope eliminates old-fashioned messy pastes, gloppy brushes, soiled hands; it never runs or drips. Tape Dope permits easy assembly and disassembly and does a permanent leakproof job on all household plumbing connections. Only 39¢ for the 30" roll (seals 20-½" joints) at your hardware store or wherever plumbing supplies are sold. For free literature write to:

Hercules Chemical Co., Inc., 416 Broadway, New York 13

Rush Coupon for Your

FREE full year's subscription to
**Radio Shack's Famous
Electronics Catalogs**

Receive giant Electronics Buying Guide and all new issues for a year! See newest and best in electronics at money-saving prices! Over 100,000 items for "pro" or amateur.



SAVE UP TO 50% ON TYPICAL VALUES LIKE THESE

**Scores
MORE VALUES!**

- Hi-Fi
- Test Equipment
- Kits & Parts
- Ham Radio
- Tapes
- Sports Goods



**Realistic 2-speed
TAPE
RECORDER**

-compare
at \$99.95

**only
\$49.50**



CODE PRACTICE SET
complete with key,
buzzer **only \$1.79**

Realistic fully wired
**STEREO
AMPLIFIER**

only
\$9.95



MAIL COUPON TODAY!

RADIO SHACK CORP. Dept. 60J3
730 Commonwealth Ave., Boston 17, Massachusetts

Without obligation, please send me **FREE** and **POSTPAID**, your latest giant Electronics Catalog plus every new issue for one full year.

Name _____
Address _____
Post Office _____
or City _____ Zone _____ State _____

If coupon is clipped, write

RADIO SHACK CORP.

730 Commonwealth Ave., Dept. 60J3
Boston 17, Massachusetts

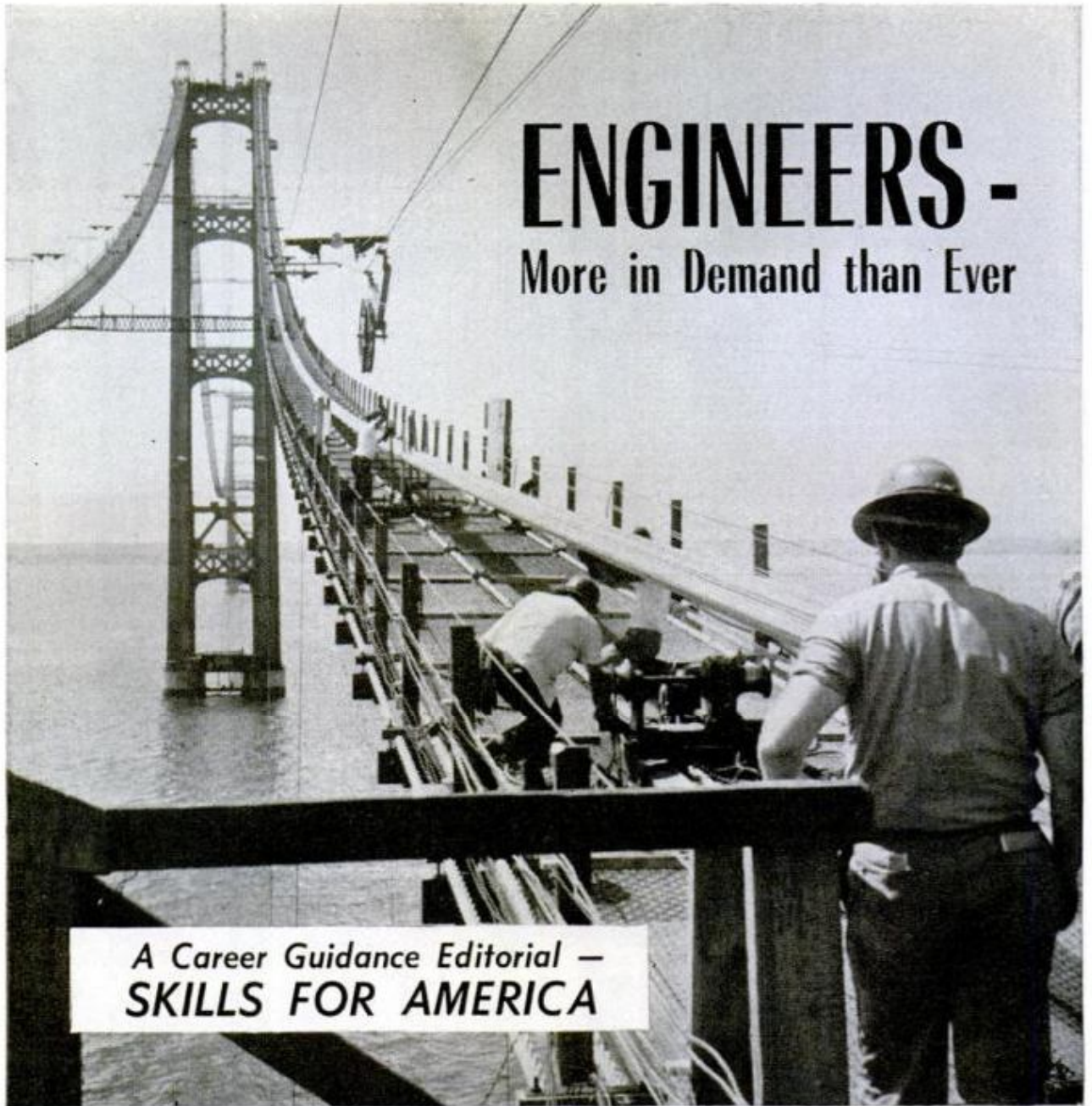

ENGINEERS - More in Demand than Ever

A Career Guidance Editorial —
SKILLS FOR AMERICA

He can select his own type of work. His services are needed throughout the world. He is the architect of civilization.

Today there are approximately 850,000 engineers at work in this country. Estimates show that we will need 1,550,000 engineers 10 years from now.

Our activity in the race for space, our program of national defense, our multi-billion-dollar highway construction program, our growing population—these are some of the factors that have brought about this tremendous increase in demand for trained engineers.

Engineering has been one of our fastest-growing occupations for the past 50 years and today it is the largest profession for men in the country.

Engineering has been called the art of making pure science useful. Throughout history, man has built all his works upon the foundation laid by the engineer. He is truly the “architect of civilization.”

Engineers are important to our national economy

(Continued on Page 68)



ADVERTISED IN LIFE

make \$10 an hour -
\$300 a week

HELP US
SUPPLY THE OVERWHELMING DEMAND
FOR OUR NEW, REVOLUTIONARY

sunmaster "Multi Million-Prism"

5 YEAR BULBS

Wonderfully soft, flattering, eye-comfort light unconditionally guaranteed for 5 years. (Outlasts 13 ordinary bulbs). Unlimited earning possibilities! **ONE-TIME-ONLY OFFER** — Send \$1.98 for six sample bulbs worth \$4.69. Sell them or return for full refund.

Silicate-treated to assure positive overall light for 5 years

Write for free Dynamic Sales Kit.
SUNMASTER ELECTRIC PRODUCTS, INC.
Dept. PM90, 366 Fifth Ave., New York 1, N. Y.
In Canada: Dept PM90, 539 King Street West, Toronto, Ont.

Catalog of 2900 Novelties 10c

Send 10c for amazing catalog of novelties, live animals, scientific supplies, hobbies, funmakers, planes & boats, magic tricks, joke articles, unusual seeds, gadget timesavers, cameras, optical goods, projectors, movies, lucky jewelry, religious novelties, disguises, musical instruments, stamps, coins, puzzles, fortune tellers, radios, auto & bike accessories, telescopes, magnifiers, compasses, banks, smokers' gadgets, artists' supplies, printing sets, engines, motors, shockers, knives, billfolds, guns, rifles, sports, books, games, plants, etc. Send 10c.

JOHNSON SMITH COMPANY Dept. 478 Detroit 7, Michigan

"MINIATURE MACHINE SHOP
No Bigger Than A Typewriter, Outperforms Machines Many Times its Size!"

That's what a popular publication says about UNIMAT in their 3 page feature story in the May issue. If you want a reprint of this story plus complete information about this amazing 10 in 1 combination precision tool write to:

AMERICAN EDELSTAAL, Inc.
UNIMAT DIV., DEPT. GI, 350 BROADWAY, NEW YORK 13



Shop PM Ads for Exciting Direct-Mail Offers

FREE GUIDE Reveals 200 Ways to Make Extra Money

YOU can turn your spare hours into cash (\$25 to \$100 a week)! Ask for Free Subscription to *Opportunity Magazine*, nationwide guide to extra cash for millions of men and women. Contains hints, plans, hundreds of offers. No matter what your age, experience, or occupation—write TODAY for next 5 issues FREE. Send no money—just your name.

OPPORTUNITY, 850 N. Dearborn, Dept. 169, Chicago 10, ILL.

RUPTURED? Write for New Relief **FACTS FREE!**

ENTIRELY DIFFERENT

ENJOY NEW FREEDOM of action, peace of mind and comfort at work or play. Proven, patented MILLER holds your rupture back Day and Night—will bring you lasting relief when worn as directed.

For FREE facts in plain wrapper—Send Name and Address to
Dept. 1-N, **FRED B. MILLER**
Manufacturer, HAGERSTOWN, MARYLAND



YOU BUY DIRECT FROM FACTORY AT SURPRISING LOW PRICE

THE SAW THAT CAUSED A REVOLUTION!

THIS 8" TILT ARBOR SAW PUT POWER TO WORK IN HALF A MILLION HOMES!

AT THE PRICE OF A HAND SAW

POWER does it faster, better, accurately! Half a million wood workers use this famous saw to save money, cut time, and make home repairs, building, and hobby work a joy! Our mass production techniques bring you big savings. We offer, at only \$9.95, a machine tool that sold for over \$20 as far back as 1949! Yet this saw actually has more features than our costlier older models. Heavy duty, all cast iron and steel construction. Price includes massive cast mitre gauge, **PRECISION GROUND CAST IRON TABLE**, patented motor drive fits any motor! We guarantee this saw will do same jobs as ACCURATELY and as WELL as others costing up to \$100. **WE GUARANTEE IT**—and almost half a million enthusiastic owners agree!

LOOK AT ALL THESE SPECIAL FEATURES
Blade adjusts to any angle up to 50°. Single Hand Wheel Control. Blade raises and lowers; cuts from 0" to 2 1/4". Precision ground cast iron table. Patented Motor Mount transmits full power. Takes standard 8" blades. Saw insert removable for dado heads and other accessories. Shipping weight 25 lbs.

Send check or M.O. \$2 deposit on C.O.D.'s. All tools sent express collect.

AMERICAN MACHINE & TOOL CO.
ROYERSFORD 43, PA.

SHIPPED COMPLETE AS SHOWN LESS BLADE

NOW \$9.95

SAVES WORK • CUTS TIME FOR ANY HOMEOWNER
Home Repairs Are Enjoyable When Work Is Easy—Cuts Are Straight. Makes Boat, Hobby Repair, Woodwork Fun to Do...
• RIPS • BEVELS • MITRES • DADOES • CUTS COMPOUND ANGLES

FAMOUS IRONCLAD AMERICAN GUARANTEE
Try this famous saw 10 days. If you are not satisfied that it does the work of any tilt arbor saw, regardless of price, return for immediate money back refund.

OUR 30th YEAR

OWN a BUSINESS!

We'll Train and Establish You

Start part-time if employed. You'll be trained by a nearby dealer and at 5-day training school. As carpet-upholstery cleaning expert, you provide 6 services to multiply profits and customer satisfaction. No shop needed. Just 2 average jobs a day nets \$8,760 first year. We help build your business with 27 continuous services: counseling, nat'l advertising (McCall's, Parents, House Beautiful, others), newspaper ads mats, etc. Send for FREE booklets.

DURACLEAN CO., 0-169, Duraclean Bldg., DEERFIELD, ILLINOIS

ENGINEERING

AMERICAN INDUSTRY NEEDS TRAINED ENGINEERS NOW

BACHELOR OF SCIENCE DEGREE, 30 MONTHS

SAVE 2 YEAR'S TIME

B.S. Degree Courses:

- Electronic Engineering
- Electrical Engineering
- Mechanical Engineering
- Civil Engineering
- Architecture

Diploma Courses:

- Radio-Television Plus Color
- Electronic Technician
- Architectural Drafting
- Mechanical Drafting
- Structural Drafting

APPROVED FOR VETERANS

Send for **FREE Information**

HEALD Engineering College
Van Ness at Post, Dept. PM San Francisco, California

NAME _____
STREET _____
CITY _____ STATE _____

U.S. AIR FORCE Photo. Missile headed for outer space. Courtesy of Space Technology Laboratories, Inc.

ENROLL NOW FOR NEW TERM
Heald College Ranks **FIRST** West of the Mississippi in "Who's Who in America!"

**ENGINEERING
SCIENCE
MATH** **DEGREE IN
27 or 36 MOS.**



ACCELERATED YEAR-ROUND PROGRAM prepares for early employment in fields of SCIENCE AND ENGINEERING. Regular 4-year program for B.S. Degree completed in 36 months, special engineering degree program in 27. Classes start quarterly — September, January, March, June. QUALITY EDUCATION. Graduates employed from coast to coast. Government approved for veteran training. Students from 50 states, 10 countries. 20 buildings: dorms, gym. Campus. SAVE TIME AND MONEY. EARN BOARD while studying. Write for catalog and complete information.

INDIANA TECHNICAL COLLEGE

590 East Washington Boulevard, Fort Wayne 2, Indiana

Please send me free information on Bachelor's Degree Programs in Engineering and Science as checked below:

- | | |
|---|--|
| <input type="checkbox"/> Aeronautical Engineering | <input type="checkbox"/> Mechanical Engineering |
| <input type="checkbox"/> Chemical Engineering | <input type="checkbox"/> Metallurgical Engineering |
| <input type="checkbox"/> Civil Engineering | <input type="checkbox"/> Physics |
| <input type="checkbox"/> Electrical Engineering | <input type="checkbox"/> Chemistry |
| <input type="checkbox"/> Electronic Engineering | <input type="checkbox"/> Mathematics |

Name _____

Address _____

FREE! 1961 LAFAYETTE CATALOG
324 GIANT-SIZED PAGES

Complete "Shopping Center" for
Electronics and Hi-Fi Equipment

- ★ The newest and finest in stereo Equipment, Hi-Fi Systems, Tape Recorders, P.A., Electronic, Radio and TV Parts, Tubes, Antennas, Transistor Kits and Miniature Components, Tools, Books, Telescopes, Microscopes and Amateur Gear — ALL AT BIGGEST SAVINGS EVER!
- ★ A "must" for the economy-minded hi-fi lover, experimenter, hobbyist, engineer, serviceman and dealer.

Send FREE Lafayette 1961 Catalog No. 610



Name _____
Address _____
City _____ Zone _____ State _____

LAFAYETTE RADIO DEPT. LI-6
P.O. Box 190 • Jamaica 31, N.Y.



**Exciting Jobs — Big Pay... Operating
EARTH MOVING EQUIPMENT**

Men needed now for good paying jobs in booming road and construction work. Learn how to operate heavy road machinery, cranes, bulldozers, earth carriers, etc. Actual "on the job" training. 5 to 13 1/2 week courses. Classes start every Monday. Reserve your space now. Complete catalog and reservation facts FREE. Approved for veterans. Write

Greer TECHNICAL INSTITUTE
Attn.: P. I. Hutch, Box 368, Braidwood, Ill.

TOOLS WHOLESALE

Start your own business, sell tools to your friends and neighbors, or buy tools for your own use and SAVE MONEY \$\$\$

A MILLION DOLLAR INVENTORY AT YOUR FINGERTIPS. NO STOCK TO CARRY. ORDER AS YOU NEED IT.

BUY AT WHOLESALE PRICES. Extra \$25.00 profit on your accumulated purchases. \$1.00 refund on first purchase or refunded if you are not 100% satisfied.

**\$100
PUTS YOU IN
BUSINESS**

THOUSANDS! of Nationally Advertised items of Hand Tools, Power Tools, Machinist Tools, Tool Chests, Paint Sprayers, Light Fixtures, Appliances, Guns, Gifts, Toys and other items too numerous to mention.

WE SHIP COAST TO COAST
Wholesale Disc. up to 50% off

SILVO HARDWARE CO., PM-9 107 Walnut St., Phila. 6, Pa.

because it is their job to transform natural resources as efficiently and economically as possible into useful products for the benefit of all of us.

For example, it is the engineer's job to determine the best method for extracting oil at a low enough cost so that it can be marketed successfully. If a chemist discovers a new chemical compound, it is the engineer who develops the method for manufacturing the compound in quantity.

It is the engineer who calculates the weight a wall of a building will have to support, and decides what construction material will best be used with minimum cost and maximum durability.

The engineer's calculations and experience play a part in virtually all of the diverse products of our nation's industry. It is for this reason that the engineer has so many challenging job opportunities at the present time.

Engineering is so important in many of our major industries that hundreds of engineers are taking part in company administration and management. In fact, many of the presidents of some of the biggest firms in the country have an engineering background.

For this reason, the earning power of an engineer is all but unlimited. Not only do experienced engineering specialists get top salaries, but their earning power is increased even further when they enter into company management.

Even beginning engineers, just having completed their education, ordinarily can expect a higher starting salary than those of other occupations. It isn't unusual for a young engineer with only five years of experience to earn over \$8,000 a year. In 1958 the median yearly income for engineers with 10 years of service was \$9,000.

In general, an engineer's earning power increases with his experience, and, from the standpoint of income alone, it is a highly rewarding occupation.

Although the rewards are great, it does take time and diligent study to become an engineer. In recent years employers have stressed the need for engineers with a comprehensive background in mathematics and the basic sciences. Therefore, if you are considering engineering as a career, it is important that you take all the mathematics courses you possibly can in high school, and you should have a natural ability with mathematics.

Many fine institutions offer resident training in engineering. Most of these institutions help students find part-time work to defray the cost of their education, and these schools and colleges help find living accommodations for students.

(Continued on Page 70)

**BUY
DIRECT
Importer-
to-You**



ACCORDIONS! SAVE UP TO 1/2

SAVE UP TO 50% OFF RETAIL PRICES of comparable accordions! Buy **Direct** from World's Largest Dealer! **5-Day Free Trial!** Low Importer-to-You Prices! Over 30 models—finest Italian makes. New easier terms! Bonus gifts FREE. Rush coupon for **Free Color Catalogs** and **Direct Importer-to-You prices!** Write today!

ACCORDION CORPORATION OF AMERICA, Dept. R-90, 2003 W. Chicago Ave., Chicago 22, Ill. Rush Free catalog and Importer-to-You prices.

**FREE
Color
Catalog**

Name.....
Address.....
City..... State.....

FREE GERMAN STEEL HUNTING KNIFE



4-INCH BLADE

We give you handiest hunting and fishing knife you've ever had! Has 4-INCH LONG highly tempered steel blade—VERY SHARP! Attractive handle. We send knife FREE to acquaint you with our below-wholesale bargains. Please send 25c for handling. NO LIMIT—but send 25c handling for each knife. Order TODAY! HUNTING KNIFE, Dept. K-506, Box 881, St. Louis, Mo.

CONCRETE BLOCK HOME PLANS

\$1600 RANCH HOME

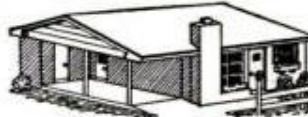

Build your own 24'x40' Ranch Home complete for \$1600. Liv. Room, Kit., two bedrooms, bath, fireplace, slab or basement, carport or garage. Blueprints, instructions, and material list \$3.00 ppd. Money back guarantee. Other plans—\$1000 Cottage, \$1150 Garage Apt., \$1900 Duplex, \$2500 Ranch Home, \$3500 Cape Cod, \$3800 3 bedroom 2 bath family room Ranch Home. Illustrated Folder, "How To Build Your Own Block Home," plus Plan Folder 10c.

QUALITY PLANS SINCE 1953
BAILEY BUILDERS, 201-F Cherokee, Little Rock, Arkansas

MEN - WOMEN LEARN REWEAVING MAKE MONEY AT HOME

Repair burns, tears, moth holes in Suits, Dresses... Like New. All instructions sent on no risk trial. Skil-Weave's invisible patch method of repair is quickly learned at home—a short cut to earnings. Spare or Full Time. Send name and address on postcard today for FREE details.

SKIL-WEAVE CO., 335 W. Madison St., Dept. R-169, Chicago 6, Ill.

Learn MECHANICAL DENTISTRY

To make Crowns, Plates, Bridgework, etc., for Dentists. Easy practical way to learn mechanical dentistry at home in spare time. FULL EQUIPMENT OF TOOLS AND MATERIALS INCLUDED WITH COURSE. Low tuition. Easy terms. Write for FREE BOOK about this money making profession that is not affected by machine age.

McCARRIE SCHOOL OF MECHANICAL DENTISTRY
207 N. Broad St., Dept. 104, Philadelphia 7, Pa.

MAKE MONEY! REPAIR HYDRAULIC JACKS



Earn While You Learn At Home
Make up to \$5 an hour, full or part-time, in the competition-free field of Hydraulic Jack Repair. Millions of jacks in auto service stations, truckers, body shops, riggers, farms, need servicing. We show you HOW. Easy step-by-step directions.

Get Folder PM 9 & free bonus offer

Institute of Hydraulic Jack Repair

P.O. BOX 50 • BLOOMFIELD, N. J.
A Correspondence School Licensed by N.J. Bd. of Ed.

FREE MUSCLE BUILDING INFORMATION

Sensational New Methods
Less Time—Less Effort—Better results
BODY-TONE, Box 638, North Miami 61, Fla.

1000 SURPRISES

FUN! TRICKS! JOKES! MAGIC! PUZZLES!

Be the Life of the Party! Amaze—astonish—mystify! Great Fun! Get Big Catalog of over 1000 Tricks! (160 Pages). Rush name, address and only **25c**
FREE CARD TRICK GIVEN!
HOUSE OF 1000 MYSTERIES Dept. PM9
202-48 Pinewood, Trumbull, Conn.



SHORTHAND IN

Famous **SPEEDWRITING** shorthand. 120 words per minute. No symbols: no machines: uses ABC's. Learn at home or through classroom instruction. Low cost. 500,000 graduates. For business and Civil Service. Typing available. 37th Year. Schools in over 400 cities. Write for FREE booklet.

Speedwriting
Dept. 1509
55 W. 42 St., N.Y. 36, N.Y.

**6
WEEKS**

AVIATION CAREER

SPECIALIZED EDUCATION / PROFESSIONAL TRAINING... only 16 months to 2 years

Top-pay prestige positions, bright future in aviation. Job opportunities waiting for you as soon as you're ready. Airframe and Powerplant Technician, Aeronautical Engineering Technologist, Business or Executive Pilot. Classes in Miami.

SEND FOR FREE 80-PAGE BOOK

Embry-Riddle Aeronautical Institute
Dept. B Miami, Florida (Founded 1926)

Name.....
Address.....
City..... Zone..... State.....



"Take it to the jeweler a block west."

BROWNING

9mm HI-POWER AUTOMATIC



\$74⁵⁰

with fitted case
U. S. or CANADA

**GREATER
FIRE-POWER**
for the outdoorsman
or law enforcement

OFFICIAL PISTOL OF MANY NATO NATIONS
GREATER FIRE-POWER! — 14 cartridge capacity. 133% greater than any center-fire revolver and 55% greater than any other center-fire pistol.

8 SAFETY FEATURES — Perfectly safe to carry loaded. Accidental blow on hammer cannot discharge gun.

REMARKABLE ACCURACY stems from extra rigid barrel mounting, full grip and fine balance. Penetrates ten $\frac{3}{8}$ inch boards at 15 feet.

SPECIFICATIONS—Length: 7 $\frac{3}{4}$ ". Barrel: 4 $\frac{3}{8}$ ". Weight: 2 lbs. 9mm Parabellum or Luger Ammunition.

ENGRAVED MODEL — Nickel Plated, Pearl Grips, Gold Trigger **\$200**

Prices subject to change without notice

WRITE FOR CATALOG SEE YOUR BROWNING DEALER
Browning Arms, Dept. 195, St. Louis 3, Mo.
— in CANADA, Dept. 195, Box 991, Montreal 9, P. Q.



**NEW WORLD
OF OPPORTUNITY**
it's yours



IF YOU KNEW that professional homecare maintenance was the fastest-growing field for service and for products... *with*

ServiceMASTER[®]
WORLD FAMOUS AUTHORITY ON HOMECARE

FIND OUT how much an investment you need to obtain such a franchise (surprisingly low, surprisingly easy arrangements)

write ServiceMASTER

c/o Marion Wade, Dept. 122

2117 North Wayne Ave., Chicago 14, Illinois

Almost all of the institutions specializing in engineering have job placement departments set up specifically to aid graduates in finding employment.

It is also possible for you to start your training in engineering by means of correspondence courses. Many fine detailed courses are available, and they provide an excellent means of attaining a background in this field.

If you find that you are unable to set aside the time required for a four or five-year course in engineering, a very important branch of engineering is still open to you. Special two-year courses have been set up by some top engineering colleges to train students as engineering technicians.

At the present time there is an unprecedented need for highly skilled technicians both in industry and in the government's defense program. It has been estimated that three to five technicians will be needed for every engineer, and so it is obvious that the present demand will be multiplied in coming years.

In general, engineering technicians are less concerned with theory and more concerned with the practical application of an engineer's work. Technicians have a combination of basic scientific and mathematical knowledge and manual skill so that they can participate in research work and in designing, producing and maintaining the machines and materials of our technological society.

Engineers have a wider range of employment opportunities today than has been the case in the past. Many companies with highly technical products are finding engineers of great value in their sales programs. Engineers have the technical background and knowledge that is so essential in selling the complex products of many of our industries.

The majority of engineers, however, is employed in private industry and particularly in electronics, aeronautics and machinery industries in which engineering plays a major role in product and manufacturing programs.

Since the days of World War II engineers have played an increasingly important part in our national economy; and today, with industry's need for skilled technicians to assist engineers in the practical application of their work, this field offers a marvelous opportunity for men not only because of the substantial salaries that are offered, but because engineers and technicians are so important to America.

For Popular Mechanics' free booklet giving details on the nation's leading correspondence and resident-training institutions, write Popular Mechanics, Dept. SFA, 200 E. Ontario Street, Chicago 11, Ill.

POPULAR MECHANICS

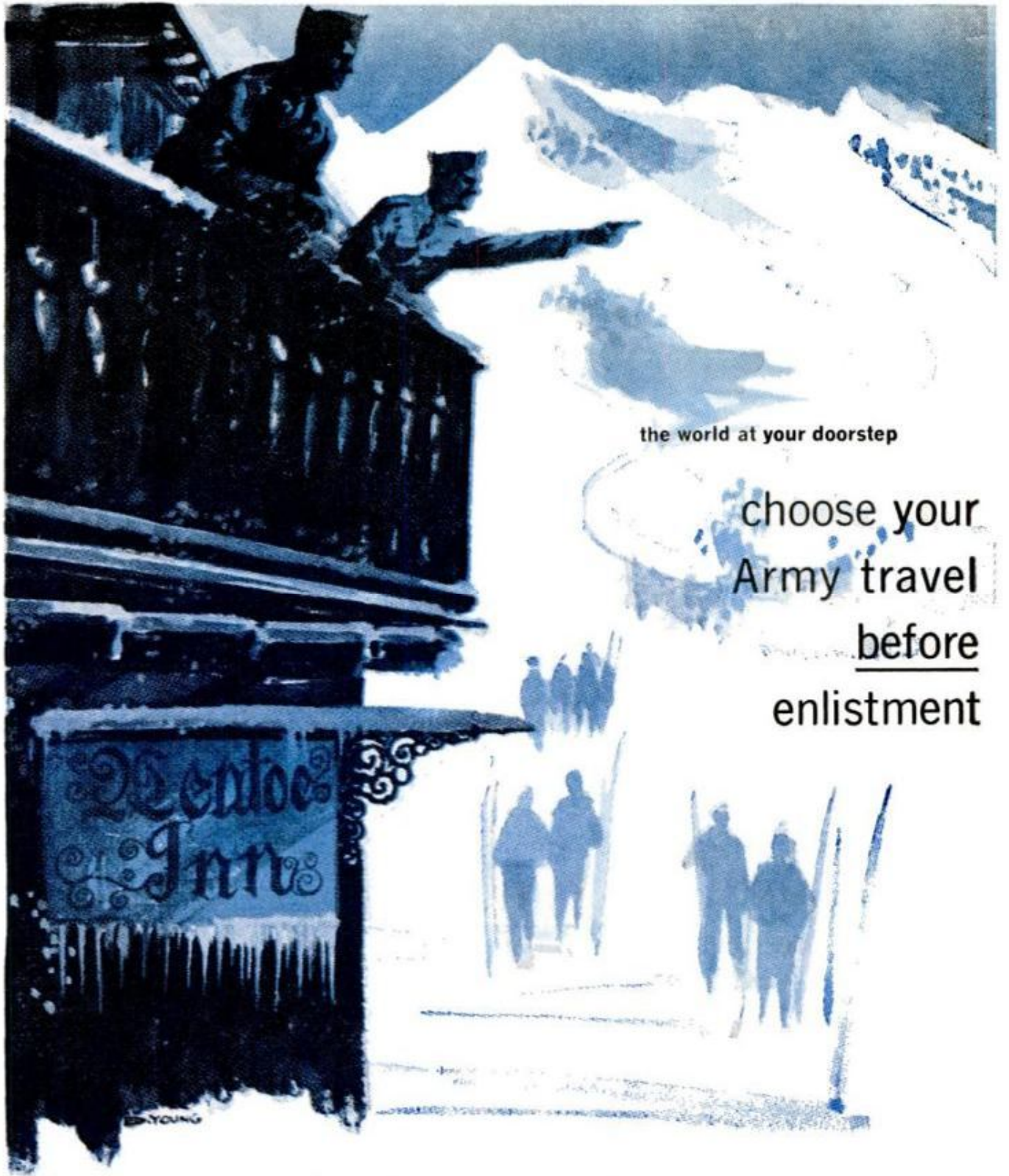

the world at your doorstep

choose your
Army travel
before
enlistment

Like skiing? How about the Bavarian Alps? Swimming? Try the beautiful blue Mediterranean. Mountain climbing? Tackle the heights of Mt. Fujiyama in Japan. Today's Army lets you **choose** the overseas area where you'll be stationed—Europe or Far East. On duty and on leave, you'll be able to travel widely while you're there. Ask

anyone who's traveled. Nothing beats the excitement of new and fascinating places. And now the Army puts them at your doorstep. So don't just dream of faraway places you'd like to see. Make your travel arrangements with your Army recruiter this week. See him—and choose your travel before you enlist!

CHOICE, NOT CHANCE



US ARMY

NOW! MORE POWER, LONGER
with revolutionary
DOUBLE PLATE
MARATHON
7 YEAR BATTERY



Completely ends battery replacement for the average car, boat and truck owner. One of America's long-established manufacturers* presents a new type battery so superior in power and performance it is guaranteed for seven full years. The MARATHON BATTERY uses an entirely new and original principle of construction not available on any other battery!

EXCLUSIVE DOUBLE-PLATE DESIGN



Marathon

Other

A leading automotive magazine says: "In all cases the larger the metal surfaces, the more current you get... that's why plate surface is such a key factor in battery design."

MARATHON BATTERIES have double the normal number of plates, or up to 100% more plate area than other nationally-known batteries. More plate area greatly increases the MARATHON BATTERY's power capacity over single-plate design... gives it far greater recuperative power... enables it to deliver power long after other batteries fail!

WRITTEN 7 YEAR GUARANTEE... Your money refunded, if necessary to replace your MARATHON BATTERY, refund based on unexpired guaranteed service pro-rated over 84-month (7 year) guarantee period; or your battery replaced or repaired free.

PROVED BY LABORATORY AND FIELD TEST...

- Tremendous recuperative power.
- No loss of power in extreme heat or cold.
- Vibration-proof... spill-proof... corrosion-proof.
- High reserve power even when stored over long periods.
- Long, trouble-free life with minimum attention.

OPPORTUNITY for DISTRIBUTORS

Sales territories available, protected in writing. Complete references gladly furnished through Torrance, Calif., Chamber of Commerce. We welcome inquiries.

AS LOW AS
\$36.95

*IMPORTANT! Do not confuse this with any other previously advertised, so-called "long life" batteries.

Available for all cars, trucks, tractors, electric cars, industrial, marine, aircraft and bus use. Get all the facts, or order direct using coupon below. We pay shipping costs.

MARATHON SALES CO.

Affiliated with Commercial Battery Co. of Los Angeles, manufacturers of electric storage batteries and components since 1944.

P. O. BOX 474, 25916 WESTERN AVENUE, HARBOR CITY, CALIF., CABLE ADDRESS: MARATHON

Please ship MARATHON BATTERY with 7 Year Guarantee:

- 6 volt auto battery (\$36.95 inc. tax.) 12 volt auto battery (\$39.95 inc. tax.)

for _____
Make, Model, Year of Car

Cash, check or money order enclosed. MARATHON pays all shipping costs to your door.

NAME _____

ADDRESS _____

CITY _____ ZONE _____ STATE _____

Spotlight on the

DKW 750

By Art Railton

STYLED WITH an American touch, the DKW 750 is, under its sheet metal, as different from the American idiom as a car can be. Looking at it, however, you couldn't guess it.

Complete with tailfins and diagonal front fenders that give it the Yankee "lunge," the small car has its trunk in back where a trunk belongs, according to the nearest bellhop.

But once you pull into a gas station, you realize something's different. Printed on the gas cap are detailed instructions as to fueling procedures. Being a two-stroke with three cylinders, the engine requires that oil be added to the gasoline as in an outboard (or some lawnmowers). No mixing is required, however. You dump in a pint of oil for each five gallons of gasoline and the mixing is accomplished automatically.

Since pints of oil of the right type are not always easy to come by, 'tis best to stow in the trunk a carton of DKW's special two-cycle oil (it comes in pint cans).

The two-cycle design is simplicity itself, as you probably know. It has no valves, no camshaft, no rocker arms, no push rods, no valve springs, no timing gear, no valve lifters. There are only seven moving parts in the basic engine: Three pistons, three connecting rods, one crankshaft.

The fuel-air-oil mix is drawn into the combustion chamber through slots in the cylinder walls. When the piston is up, all openings are covered; when it is down the exhaust and inlet ports are open. Unlike a four-stroke engine (in which combustion

(Continued to page 74)



If you take

Color Pix

8mm - 16mm - 35mm 127 • 120 • 620

You must get our MONEY SAVING

Free Catalog

Listing all popular KODAK and ANSCO Film Type and Sizes . . . WRITE TODAY!

SOLAR CINE PRODUCTS, Inc.

"Direct-by-Mail" Film and Processing Specialists for almost a quarter century" Dept. ME
4247 S. Kedzie Chicago 32,

PROFIT IN YOUR SPARE TIME

FIX SMALL GASOLINE ENGINES
Outboard • Powermower • Chain Saw • Tractor
MAKE EXTRA MONEY—or, repair your engines and SAVE. Illustrated, easy-to-understand, Home Study Course. FREE information. Write TODAY!



LINCOLN TECHNICAL INSTITUTE
Suite 9-E, 472 Market Street, Newark 5, New Jersey

Finish HIGH SCHOOL ^{AT HOME} IN YOUR SPARE TIME

DIPLOMA AWARDED

Learn more! Earn more! Enter professional or technical schools. Advance socially. Live a happier, fuller life. Individual Courses or complete schedule. Write for School Bulletin.

ACADEMY FOR ADULTS

30 W. Washington, Dept. PM-967, Chicago, Ill.



119 JIG SAW PATTERNS

FULL-SIZE . . . trace on wood and saw out. Clever, ORIGINAL designs, things you can make to SELL. Wall shelves, lawn signs, planters, book ends, others. **postpaid**

BURGESS VIBROCRAFTERS, INC.

Rush \$1 today. DEPT. C-168, Grayslake, Illinois

CONCRETE BIRD BATHS AND OVER 250 OTHER MONEY MAKING ITEMS



You've seen them all over the country . . . concrete bird baths, garden seats, flower boxes, appealing statuary, and many other items that add charm around the house and lawn. They're made by enterprising people, just like you, from our COPYRIGHTED ALUMINUM MOLDS. It's easy. It's fun. It's profitable.

Send \$2.00 today for this 82-page "How to" book, 20 pages of clear instructions. Valuable trade secrets. Over 250 items beautifully pictured (with description, dimensions, and prices of molds). Rushed to you by first class mail.

CONCRETE MACHINERY CO., INC.
HICKORY 2, NORTH CAROLINA

Name _____

Address _____

**HOW TO
TURN
CONCRETE
INTO
GOLD**

WORLD!

ALLIED MONEY-SAVING 1961 ELECTRONICS CATALOG

**444-PAGES
WORLD'S
BIGGEST**

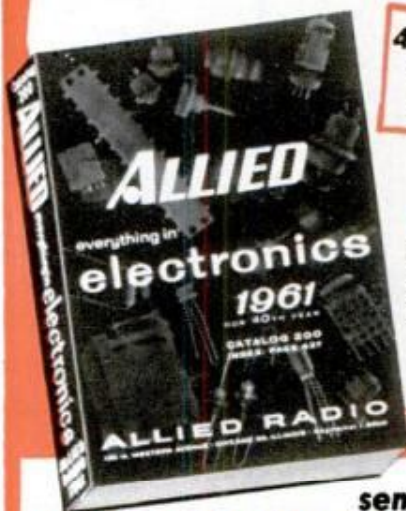

ONLY \$2 DOWN
on orders up to \$50; only \$5 down up to \$200; \$10 down over \$200

send for it today!

Largest Selection—Lowest Prices

Send for the leading buying guide to everything in Electronics, including products available only from ALLIED. Builders, experimenters, hi-fi fans, Amateurs, servicemen, engineers—save most on:

- KNIGHT-KITS®—Best in Build-Your-Own
- Everything in Stereo High-Fidelity
- KNIGHT® Super-Value Stereo Hi-Fi
- Tape Recorders & Phono Equipment
- TV Tubes, Antennas, Accessories
- Parts, Tubes, Transistors
- Everything in Tools & Technical Books
- Amateur Station Equipment
- Citizen's Band 2-Way Radio
- Public Address & Paging Systems
- Latest Test & Lab Instruments



SAVE on everything in Electronics at ALLIED. Get every buying advantage: fastest shipment, expert personal help, easiest-pay terms, satisfaction guaranteed or your money back. Send today for your value-packed, FREE 1961 ALLIED Catalog.

YOU CAN DEPEND ON THE WORLD'S **40th**
LARGEST ELECTRONIC SUPPLY HOUSE year

ALLIED RADIO

ALLIED RADIO, Dept. 5-J
100 N. Western Ave., Chicago 80, Ill.

Rush FREE 1961 ALLIED Catalog

Name _____

Address _____

City _____ Zone _____ State _____

**SEND FOR
FREE
CATALOG**

I did it with my Wen "All Saw"

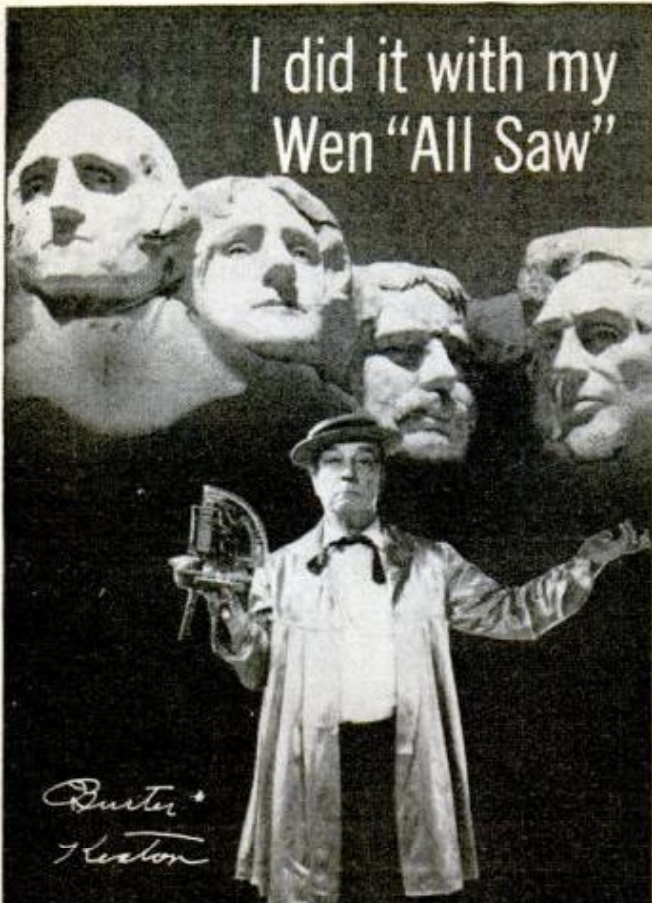

*Buster
Heston*

The Wen "All-Saw" does everything a pattern saw will do . . . more than a circular saw . . . many things normally done by a hand saw or nibbler—and many things that, until now, only a chain saw could do. In fact, the Wen "All Saw" will cut anything from a 6" log to intricate pattern work in wood, all metals, including steel thin gauge to 1/2", pipe and thin wall up to 2" in diameter. It cuts curves, circles, straight cuts or patterns in Masonite, Bakelite, tiles, formica, wallboard, Plexiglass, plaster-board, asbestos. Knife blade cuts anything normally cut with a knife. It's perfect for home workshops—yet it's UL "Industrially Rated." You get 7 blades, a rip guide and a circle cutter at no extra cost. **\$44.95**

YOU CAN ALWAYS DEPEND ON NEWER AND FINER PRODUCTS FROM

WEN

FINE FINISH SANDER—Light, handy and quiet. Powerful motor delivers 14,400 straight-line-action strokes per minute. Perfect for fine finishing and polishing. Strong black plastic case. Comes complete with 6 assorted abrasive sheets and 2 polishing pads. **\$13.95**



MULTI-PURPOSE SOLDER GUN KIT—Feather-light slim gun with 100 watts power. Heats in 2 1/2 seconds. Built-in spotlight focused on work. The kit includes the gun, extra tips for hot-cutting, smoothing, and rosin core solder . . . all in a strong metal box for neat compact storage. **\$7.95**



3/8" 2-Speed Power Drill **\$29.95**
Lightweight Sabre Saw **\$26.95**

WEN PRODUCTS, INC., 5810 Northwest Hwy., Chicago 31, Ill.

occurs on every other down stroke), a two-stroker fires on each down stroke. Thus the expression "three equals six," meaning the three cylinders fire as many times per engine revolution as a six-cylinder engine.

Engine lubrication comes from the oil in the fuel mix. There is no crankcase sump and no oil level to check or oil to change. You simply add oil each time you buy gas.

First shown in prototype at the Frankfort Show in 1957, the DKW 750 is just now becoming available for sale over here. Its engine is exactly square with a bore and stroke of 2.68 inches. Displacement is 45 cubic inches, horsepower is 34.

Mounted ahead of the front axle, the engine drives the front wheels. The floor, front and rear, is flat, there being no need for a tunnel. Front brakes are mounted in-board and have finned drums. Front suspension is by longitudinal torsion bars (similar to Chrysler's). The rear axle is a solid bar and rear springing is by a transverse torsion bar tied to the wheels by trailing arms.

Unlike most small cars (wheelbase is only 85.5 inches, over-all length 13 feet 1 inch), the 750 has a separate frame consisting of two box-section side rails that belly outward amidships like a Ford's. The body panels bolt together for easy replacement and the assembly bolts to the frame in conventional Detroit fashion. It comes only as a two-door sedan (sun roof optional).

Steering, by rack and pinion, is precise. The DKW goes where you aim it and, if you keep your foot on the gas pedal, it will go around corners at about any speed you are brave enough to try. The front wheels pull it around in a most confident manner.

So far so good, you say. Is everything perfect? Of course not. Most obvious deficiency is a steering-column shift so clumsy to use you find yourself wishing for an automatic transmission. Perhaps the test car was an exception (it was brand new), but the linkage was about as uncooperative as it could be. Getting through the gears is not the crisp pleasure it should be in a car that otherwise handles as well as this one. Reverse is especially stubborn. Not only are the gears hard to find (the whole pattern is located too high, being atop the column rather than beside it), but the physical effort is too much for fast gear changes. There's no two-finger shift here, no flipping, no boy-is-this-fun feeling at all. However, all four gears are synchromesh and you can drop into first gear (if you can find it) while rolling, an excellent advantage in any small-engined car.

Economy is good, not outstanding. In a

(Continued to page 76)

FIBERGLASS or PLYWOOD

\$41.95 Up: EASY TERMS

FREE CATALOG

50 Models 8-22 ft.

Cruisers, houseboats, runabouts, convertibles, fishing, sailing. Pre-assembled, pre-formed units anyone easily assembles. Equal factory-built. Save 1/2 to 3/5. Free catalog has all details, color photos, paint, accessories, Fiberglass supplies, trailers. WRITE TODAY.

LUGER BOAT KITS

Dept. B-9, 9200 Access Road, Minneapolis 20, Minn.



FREE CATALOG!

TREMENDOUS SAVINGS ON HUNDREDS OF SURPLUS AND NEWLY MANUFACTURED ITEMS!

New 1960 edition contains over 50 pages of tools and equipment for farm, home, workshop, factory. Hydraulic equipment, pumps, motors, construction and diesel equipment and parts! Write for your **FREE CATALOG** Today.

GROBAN SUPPLY COMPANY

1139 South Wabash Ave., Dept. G-9 Chicago 5, Ill., WEbster 9-3793

First truly new lunch bucket in 40 Years!

SAFE-T-PAK

AND VACUUM BOTTLE

Can't come open when carried. Slide out tray for cleaning. All Steel—You can sit on it! Bottle and weight on bottom.



\$4.95

ALLCO INDUSTRIES - BOX 212, PROVO, UTAH



Porter-Cable Machine Company, Syracuse, N.Y.

Yard Worker Rides in Style

Free-flowing design characterizes a riding mower that has a chassis made of aluminum and an engine housing formed of glass fiber. In addition to its grass-cutting duties, the mower also tows accessories for such other yard chores as rolling, seeding, spreading, aerating, sweeping and carting.

SEPTEMBER 1960

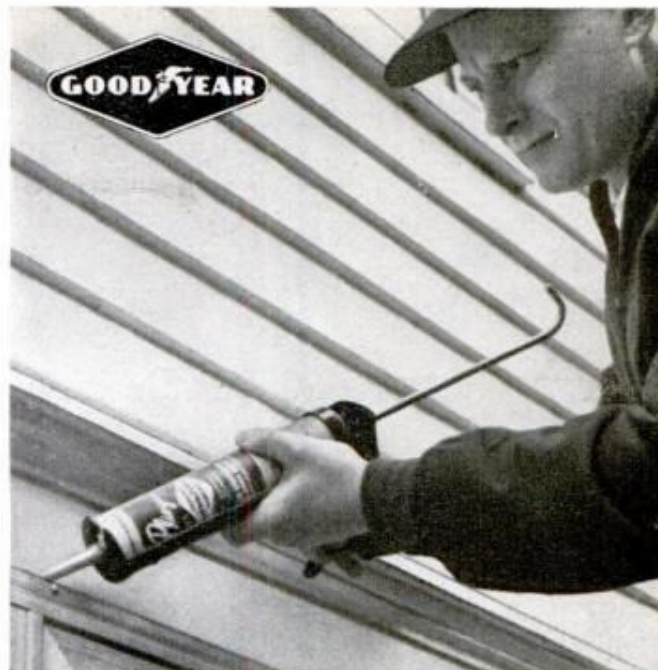

Seal it! Coat it! Caulk it! Then forget it!

WITH 3 NEW PLOGRIP PRODUCTS FOR HOME PROJECTS

Outstanding weatherability, exceptional adhesion, unusual durability, strength and flexibility. They're all yours with PLOGRIP, the completely new family of synthetic rubber compounds by Goodyear.

PLOGRIP 12-1—Ideal consistency for sealing seams on gutters, downspouts, flashing, window and door frames. Applies easily from handy tube. Resists seam corrosion, deterioration. Skins-over immediately. Won't lose adhesion with age.

PLOGRIP 12-2—Outstanding protective coating for gutters, flashing, corrugated galvanized surfaces. Easily applied with brush. Offers exceptional crack- and abrasion-resistance. Withstands weather, greases, oils, chemicals.

PLOGRIP 12-3—Top caulking compound for storm doors, window frames, other trouble spots. Handy cartridge simplifies application. Adheres well to wood, metal, brick, stucco and other masonry surfaces.

PLUS PLIOBOND

The one adhesive that does the work of many! Needs no mixing, no involved surface preparation. Available in tube or brush-top can. Dries to touch in minutes. Resists heat, cold, water, most chemicals, oil.

PLOGRIP and PLIOBOND are available at hardware, chain or lumber supply stores everywhere. Or write Goodyear, Chemical Division, Dept. U-9459, Akron 16, Ohio.

Lots of good things come from

GOODYEAR
CHEMICAL DIVISION

Pliogrip, Pliobond — T.M.'s The Goodyear Tire & Rubber Company, Akron, Ohio

75

MOSSBERG

MODEL
K

SHOTGUNS

bring
home
the
game

195K
12 gauge
3-shot
repeater



Here's why:

RIGHT PATTERN—instantly, with Mossberg's factory-installed C-LECT-CHOKE. Settings are positive and clearly visible.

ON TARGET BETTER and FASTER—because of correct balance—and safety is behind the barrel at your right thumb. No hand shifting, no fumbling.

COMFORTABLE SHOOTING—cushion rubber recoil pads. Barrel vents behind choke where they're most effective.

SURE OPERATION—Mossbergs are factory guaranteed. Yet less than 1 in 1,000 comes back for repair.

195K (12 ga.)	185K (20 ga.)
\$43.95	\$39.95
190K (16 ga.)	183K* (410 ga.)
\$42.95	\$37.95

*No recoil pad. No barrel vents.

Ask your dealer to show you Mossberg's K Model shotguns. They bring home the game.

FREE: For Mossberg's new, fully illustrated catalog, tear off the bottom of this ad, write your name, street address and town in the margin, and mail to

O. F. MOSSBERG & SONS, INC.
9709 St. John St., New Haven 5, Conn.

Mossberg
for accuracy

fast, hard-driving country test (with gusty winds and temperatures about 50), the DKW 750 averaged 26.3 miles per gallon. Much of the test was at full throttle with numerous hard accelerations. In a city-driving test with four stops per mile and an over-all average of 16 miles per hour, the car did better, getting 27.6 miles per gallon.

Top speed is about 67 miles per hour, true, although the day was so windy with unpredictable gusts that this figure should not be taken precisely. From 0 to 30, the average was 5.5 seconds; from 0 to 60 it was 31.6 seconds. The car moves away fast enough for normal American traffic.

At high speed it is quiet and stable with little or no wander even under gusty conditions.

Poorest part of the car is its bodywork with door and window operation being stiff and laborious. All seats are well shaped and comfortable, but the front seats tilt backward too much for this driver. Fore-and-aft adjustment is also an effort. The passenger's front seat has a catch to hold it to the floor in case of sudden stops. To pivot the seat forward for access to the rear seat, you release a floor knob. The catch seems too flimsy to hold it in any serious accident.

Some small items:

Turn signals (control is to right of steering column rather than left) don't cancel themselves. Wipers are fast, but noisy. The ignition lock is located close to the steering column at a spot virtually impossible to see without craning your neck. The wheel is elliptical on one side.

To the left of the wheel is a headlight dip switch. It allows you to depress your headlamps without kicking around at the floor for the button. The switch also has a spring-loaded position so you can flash the lights on and off during the day as a signal when overtaking or to warn a car that you're coming through fast and furious.

Heater is adequate, but that's all. The trunk is more than adequate by European economy-car standards.

Riding quality is good on the boulevard, rather hard and stiff on rough stuff.

Altogether here is a car that will take you around in comfort and security on all types of road conditions. It is especially good on ice and snow thanks to its front-wheel drive. It does have some disadvantages (biggest, perhaps, being the two-stroke fuel problem). However, you soon learn to take this in stride. Except for hard-to-use doors, windows and shift lever, it is a car that will be easy to live with and will provide excellent short-haul usage as well as highway usage economically and with considerable comfort. Price is \$1723 at the port of entry. ★ ★ ★

Here's why **AC** Spark Plugs **ARE THE BEST**

for your car!

Shown here are four exclusive AC Fire-Ring Spark Plug features not found in any other spark plugs . . . four points of proof why ACs are the best . . . four reasons why ACs will give you the finest spark plug performance you can buy for your car.



- 1** **Buttress Top design** lengthens the flash-over path to provide sure firing under conditions of high humidity and extreme dirt deposits.
- 2** **Copper-Glass sealing** of inner structure prevents alteration of spark plug heat range and consequent spark plug and engine damage—assures smoother engine performance.
- 3** **Hot Tip Insulator**, long and thin, with deeply recessed tip, heats faster, cools faster to stay clean longer.
- 4** **Isovolt Alloy electrodes**, massive and thick, decrease electrode wear and resultant misfiring, for longer peak performance.

If your car has gone 10,000 miles or more since you last changed spark plugs, ask your dealer to install a set of new . . .

AC **FIRE-RING**
SPARK PLUGS

THEY MUST BE THE BEST!

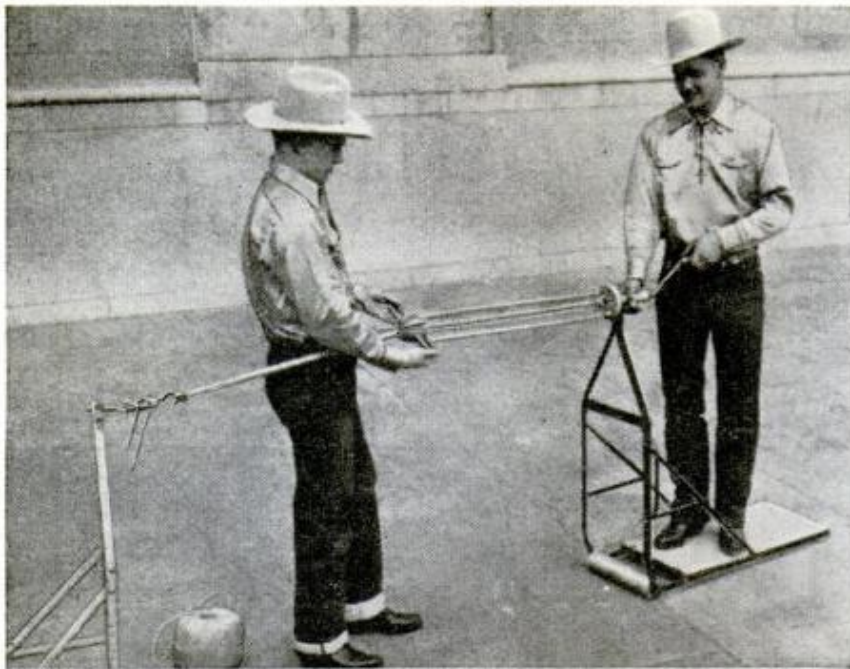

Rolling Rope Shop Preserves Old Art

One of the last men to practice the ancient art of rope making, J. M. Cattoor, of Prosser, Wash., travels the West in his rolling rope shop, making custom ropes for cowboys, stockmen, farmers—even water skiers. Using a simple hand machine developed from the Plains Indians' principle of twisting horsehair rope, he twists four strands of any fiber into rope by hand. With an electrically-powered model he can produce 100 feet of one-inch rope in 10 minutes. The old Indian system works with any fiber—horsehair, wool, cotton, jute, hemp, linen, silk, nylon—even such unlikely fibers as grass roots. Hay-baling twine twists into a fine, strong rope. Using fancy fibers, often dyed and twisted into distinctive patterns, he makes lassos and ropes for cowboys and riding clubs as well as working ropes. Those and the ski ropes are waterproofed by running them through beeswax; then polished.

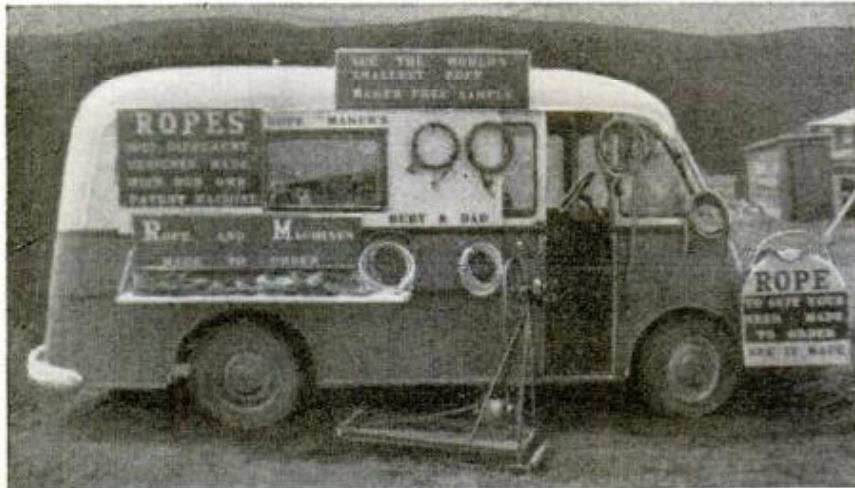

75 POWER TELESCOPE \$398

NEW 3 in one telescopes, 3 variable 25X-45X-75X magnification. Brass bound, 25 power for ultra bright images 45 & 75 power for long range. Guaranteed to bring distant stars, moons, objects, sports 75 times closer.

Most powerful scope sold anywhere near this amazing low price. American made, 5 sections. Opens 36", closes 1 ft.; contains 4 ground & polished lenses. Can also be used as powerful compound microscope. Mass production enables us to offer telescope complete at \$3.98 postpaid. Money back guarantee.

CRITERION CO., Dept. PMB-85, 331 Church St., Hartford, Conn.

KILLS MOSQUITOS / MOTHS / MILLERS / FLIES / GNATS / FISH FLIES / ETC.

USES NO CHEMICALS, GASES, ETC.
No insect recovery. Harmless. Guaranteed. Built to last 25 years. Beautiful outdoor lighting. Plug into any 110 volt socket. Very reasonably priced...

NO AREA CONTAMINATION
Uses up to 200 watt bulb. Grid costs 10¢ per month. Complete with fly attractor. Dead insect catcher. Write to **SING SING BUG CHAIR, INC. BOX P. 3708 / OAK PARK 37, MICH.**

OVER ACRES

BOX SIZE 15x15x19
WEIGHT 12 LBS.

DEALER
FRANCHISES
in some territories
STILL AVAILABLE

New, Colored Aluminum Roof Coating and Resurfacer



Johnston Foil-Gard

Write Dept. 31, The R. F. Johnston Paint Co., Cincinnati 12, Ohio



Arthur Behn brushes on a new pebble white roof with Foil-Gard Aluminum Paint, a product of the R. F. Johnston Paint Co., Cincinnati, Ohio.

What's new at 6700 Bantry?

JOHNSTON FOIL-GARD COLORED ALUMINUM PAINT RESTORES 12-YEAR-OLD ROOF

The Arthur E. Behn residence, 6700 Bantry Ave., Cincinnati, needed a new roof. Appearance was dingy—leaks had developed. Mr. Behn found the economical solution: He simply brushed on a new roof. He used Foil-Gard, a colored, fibrated aluminum coating made with ALCOA® Pigments. We talked recently with Mr. Behn, who had this to say:

"Foil-Gard went on very easily—even covered the dark exposed edges of the shingles. I chose *Pebble White* Foil-Gard and my new roof just looks fine. In fact, the neighbors were all out to see my latest do-it-yourself project. The shingles are at least 12 years old, maybe 15. Now I expect another 8 to 10 years of life from this old roof."

A safe prediction, Mr. Behn. Here's why. Aluminum coatings like Foil-Gard protect in any climate . . . stay firm on top, soft and pliant underneath . . . will not run or crack. One coat seals any surface, bridges small cracks and nail holes, keeps shingles in place.

There's a choice of harmonizing, fadeproof

colors that stay new-looking for years. In fact, weathering actually intensifies the colors. And reflective aluminum pigment turns back much of the sun's heat, helps keep interiors cooler in summer.

Ideal for composition, metal, slate, tile, tar paper roofs . . . brick, masonry, concrete or metal siding. Apply with brush, squeegee or heavy-duty spray equipment. Ask your dealer for Foil-Gard or one of the other fine brands made with ALCOA Pigments.

Alcoa does not make roof coatings, but we will be happy to refer you to reputable manufacturers who do. Send coupon for our booklets.



For exciting drama watch "Alcoa Presents" every Tuesday, ABC-TV, and "Alcoa Theatre" alternate Mondays, NBC-TV

Aluminum Company of America
1748-J Alcoa Building, Pittsburgh 19, Pa.

Please send your free booklets:

- Painting With Aluminum in Color*
 Aluminum Roof Coatings Make Time Stand Still

Name _____

Company _____

Address _____

City _____ Zone _____ State _____

GUESS THE YEAR

A PATENT QUIZ

By Rick Krepela

Try this quiz to see how well you can pinpoint the dates these common items were **FIRST** patented. Some are older than you think—others fairly recent. All were granted patents here in America. See how close—give or take a few years—you can come to guessing the year.

1. A mechanical refrigerator for the "artificial production of ice."
2. A self-winding clock: a forerunner of the self-winding watch.
3. A method to adjust the angle of the slats on Venetian blinds.
4. That American tradition—the soda fountain.
5. The familiar fountain pen.
6. The photographic flash bulb.
7. A "compound for culinary use" called oleomargarine.
8. The "pour lip" on the everyday screw-cap bottle.
9. A "device to bake waffles"—the first waffle iron.
10. Canning—a process to "preserve . . . in tin."
11. The first machine to show animated pictures or movies.
12. A machine to make threaded metal screws for use in woodworking.

Now look below to see how well you did.

ANSWERS TO "GUESS THE YEAR" QUIZ

1. Refrigerator—Patent No. 8080 granted to Dr. John Gorrie in 1851.
2. Self-winding clock—An exclusive 14-year patent right from Connecticut granted Benjamin Hanks in 1783. According to the application the clock "winds itself up by the help of air."
3. Venetian blinds—U.S. Patent No. 2223 granted John Hampson in 1841.
4. Soda fountain—Jacob Ebert and George Dulty obtained the patent in 1833.
5. Fountain pen—1830 is the date here; to a Mr. D. Hyde of Pennsylvania.
6. Flash bulb for photography—Not until 1930 on this one when Johannes Ostermeier took out patent No. 1,776,637.
7. Oleomargarine—Henry Bradley was issued patent No. 110,626 in 1871.
8. Pour lip for bottles—Patent No. 2,039,345 granted Edward Ravenscroft in 1936.
9. Waffle iron—1869 is the date here; to Cornelius Swarthout of Troy, N.Y.
10. Canning in "tins"—Ezra Dragget got an earlier start than you would think. The patent was granted him in 1825.
11. Animated "movies"—A device called the "wheel of life," showing "moving drawings" through a slit was patented by William Lincoln in 1867.
12. Screw machine—David Wilkinson took out his patent on his crude but workable machine in 1798.

100% FRESH STARTS



There's just no substitute for a fast start when the occasion calls for it. (Ask any car owner!) And you *get* fast starts from a Delco Dry Charge battery—because a Delco DC is 100% FRESH. It's not activated until you buy it—so you get all the power you pay for. Better yet, you can count on a long life of dependable starts from this battery because it's specifically designed to handle the increased electrical needs of today's high compression engines.

Don't take a chance—ask your regular serviceman for a Delco DC-12, the battery built by Delco-Remy, world-famous manufacturer of a complete line of automotive electrical equipment.

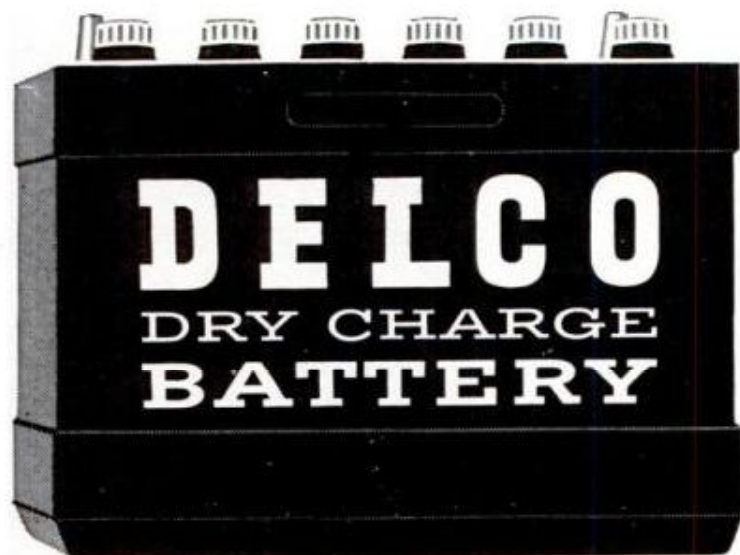

DELCO BATTERIES ARE
ANOTHER RELIABLE
GENERAL MOTORS PRODUCT
... DISTRIBUTED NATIONALLY
THROUGH



BE ON TV...
ask your **DELCO** dealer about the
exciting Hollywood TV contest

Get satisfying flavor...so friendly to your taste!

NO FLAT "FILTERED-OUT" FLAVOR!

NO DRY "SMOKED-OUT" TASTE!



Never too strong.
Never too weak.
Always just right!

You can light either end!

See how Pall Mall's famous length of fine, rich-tasting tobacco travels and gentles the smoke—makes it mild—but does not filter out that satisfying flavor!

HERE'S WHY SMOKE "TRAVELED" THROUGH FINE TOBACCO TASTES BEST



1 You get Pall Mall's famous length of the finest tobaccos money can buy.



2 Pall Mall's famous length travels and gentles the smoke naturally . . .



3 Travels it over, under, around and through Pall Mall's fine tobaccos . . . and makes it mild!

OUTSTANDING...and they are MILD!

© A. T. Co. Product of *The American Tobacco Company*—"Tobacco is our middle name"

POPULAR SEPTEMBER 1960 MECHANICS

WRITTEN SO YOU CAN UNDERSTAND IT
VOL. 114 NO. 3

We're Listening for Other Worlds

By
Clifford B. Hicks

ONE DAY early in April a prematurely-gray young man handed his assistant a list of figures. The assistant fed the information into the controls of a huge radiotelescope which swung around until it was aimed at a point low in the southern skies.

Thus began one of the most fascinating experiments—and perhaps the most significant—in the history of man.

The young scientist was Dr. Frank Drake. At that moment, as every science-minded newspaper reader now knows, he began listening for signals from intelligent beings elsewhere in the universe. Many of our foremost scientists endorse the experiment, and have faith in its ultimate success.



Dr. Frank Drake, in charge of the program, is aiming the 85-foot radio "ear" at two nearby stars

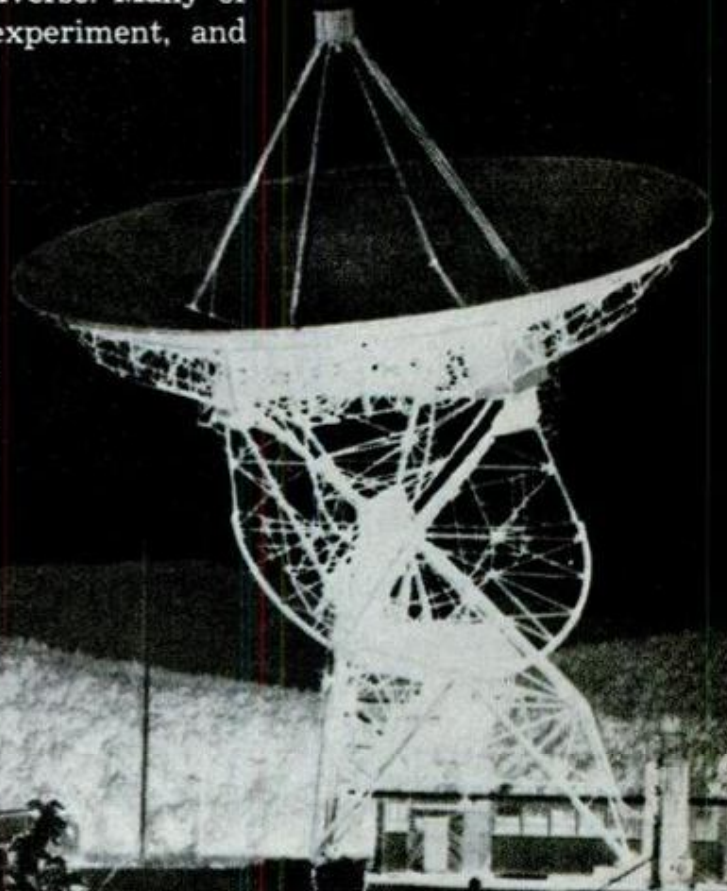



Exploding stars (an example is the Crab Nebula at left) splash incredible clouds of luminous gases into space. Gases form clouds of matter, right, which may condense into new stars with all the elements necessary for life

The experiment sounds like cockeyed science fiction, but there is not the slightest doubt in Drake's mind that eventually it will succeed. When a signal is received, it will touch off a revolution in thought. No longer will man be alone in his universe. And no longer can he consider himself the most advanced of all creatures.

"When that message comes in," says Dr. Drake, "we won't know what kind of a creature transmitted it. Could even be a porpoise at the bottom of some other-world ocean. But we *will* know one thing. *The signal itself will prove that it came from a more intelligent being.*"

We then will be faced with the indisputable fact that there are other beings, superior to us in intelligence and scientific achievement, living in their own civilization on their own planet spinning around their own sun.

Why is Frank Drake so sure that he (or someone following in his footsteps) will receive a signal from another intelligent creature? The answer is found in a scientific revolution, a revolution that has passed right over the heads of most of us who are too busy contemplating the crabgrass in the lawn or the changes in the TV schedule to lift our eyes to the stars.

Actually it is a two-front revolution. One involves the great strides made in *cosmology*, the study of the universe and its origin. The other involves new work in *biochemistry*, the study of the origin and development of life.

Cosmologists have developed new theories, based on strong scientific evidence, as to the origin and evolution of the universe. Naturally there is some difference of opinion among the scientists themselves.

According to one theory, the universe billions of years ago consisted of a cloud of hydrogen atoms, a cloud so incredibly thin that we would consider it an absolute vacuum. Over a period of billions of years, a few of the atoms, quite by accident in their random wanderings, drifted together, forming an invisible wisp in the thin cloud. Once formed, it began pulling in more and more particles. The growth accelerated.

Clots and eddies started spinning through the cloud, apparently at random but governed by natural laws. An arm thrust out here, a whirling ball there. The clots themselves united into larger forms. The whole cloud shrank as the incredible gravitation increased. And as it shrank, the temperature and pressure built up.

Shaking with convulsions, unstable, wracked by great currents of energy, the cloud in effect exploded over an incomprehensible period of time. Great gobs of matter splashed out into the wastelands of space. Each spinning gob was an embryo galaxy, an island universe.

One of these gobs measured 300,000 to 500,000 light-years in diameter (a light-year is six trillion miles). As it spun, it contracted, making it spin all the faster. The subcloud took on the form of a disk with spiral arms. At last it reached a steady state, spinning off into space. Thus was born the Milky Way, our home galaxy.

Within the range of our telescopes are at least half a billion such galaxies, all rushing away from us at incredible speeds. Some, in the far reaches of space, pass "over the horizon" of the universe. We'll never see them again no matter how we refine and improve our telescopes. Their light simply can never catch up with us.

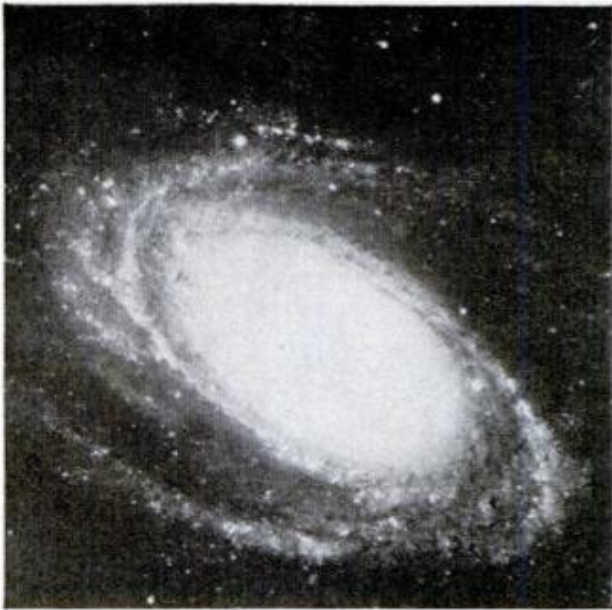

Our Sun is quite an ordinary star far out toward the fringes of a spiral galaxy somewhat similar to this

Indeed, these disappearing galaxies are a key part of another theory. According to this belief, the universe is a self-regulating system. As fast as old galaxies disappear, new ones are born. Although the rate of "birth" is extremely slow, it requires the creation of enough matter *every second* to make 50,000 suns. This is the "steady state" theory, and it describes a universe which continually sheds matter and simultaneously gives birth to the same amount.

Right now, the Navy is using radiotelescopes to test this steady-state theory. The huge instruments pick up the "music of the cosmos"—noises that sound like gravel on a tin roof. If the scopes discover that some of the noise is caused by a particular type of X ray, it will be strong evidence that galaxies are going through their birth pangs right now, and we are listening to the whisper of creation.

Far out on the edge of our galaxy when it was born, an insignificant event occurred. Some of the gas swirled into a tiny eddy. Gradually the eddy shrank, and the smaller it became the higher went the temperature, until the high temperature touched off a process of nuclear fusion deep in the interior. The ball of gas began to throb. Eventually it settled down to a steady glow. Thus was born our Sun.

Our Sun is a "second generation" star, though, and we must look first to its forebears. Astronomers have known for some time that stars have a definite life; a typical star may live for 10 to 12 billion years.

Power of radiotelescope is shown at right. Top photo was made with an optical telescope. When radiotelescope revealed intense activity, as shown on graph, optical astronomers concentrated on specific area and made bottom photo of two galaxies in collision

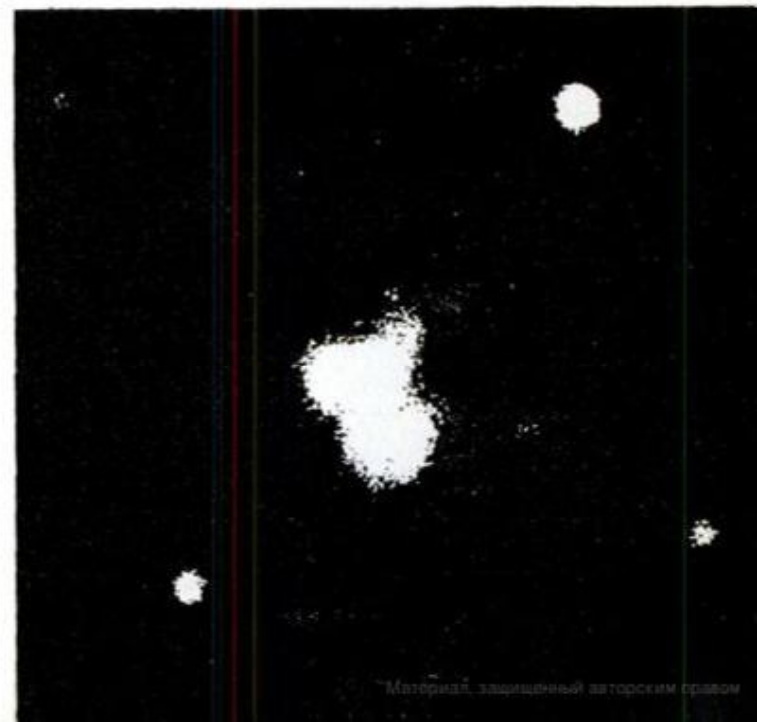
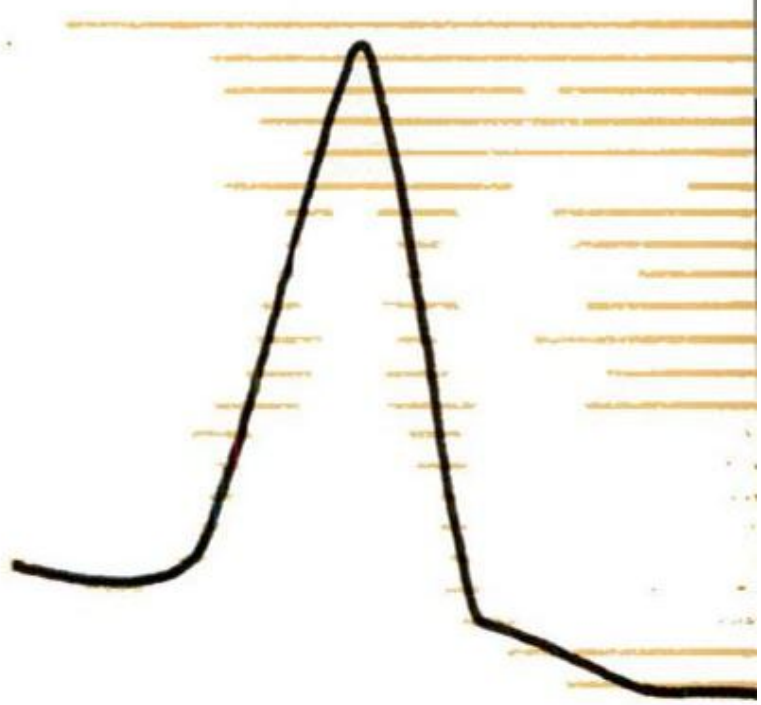
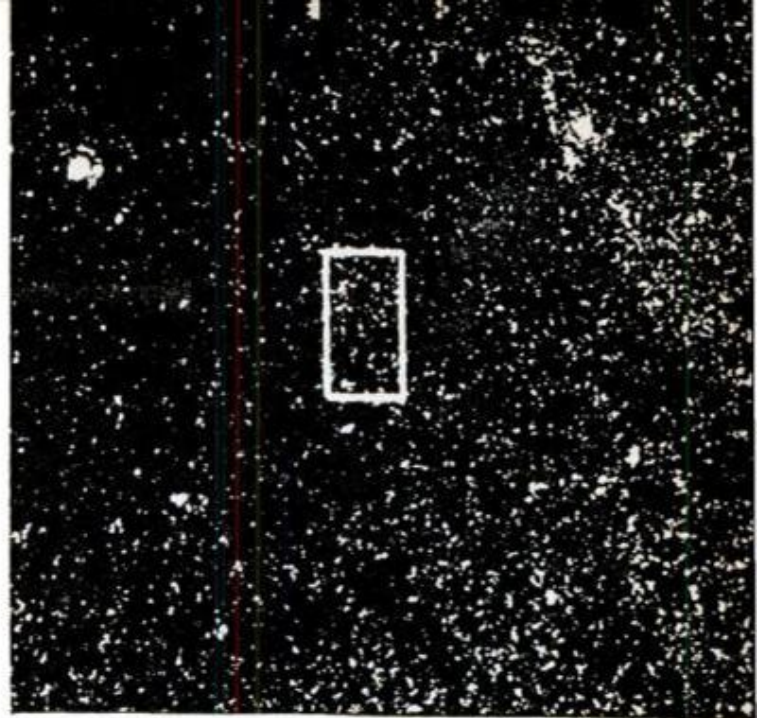

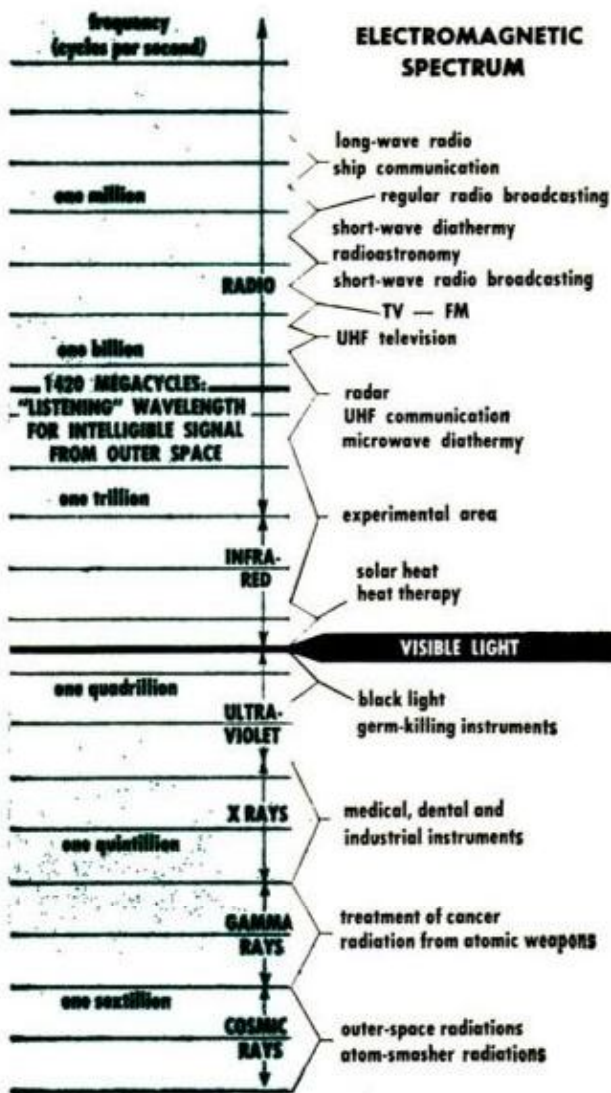
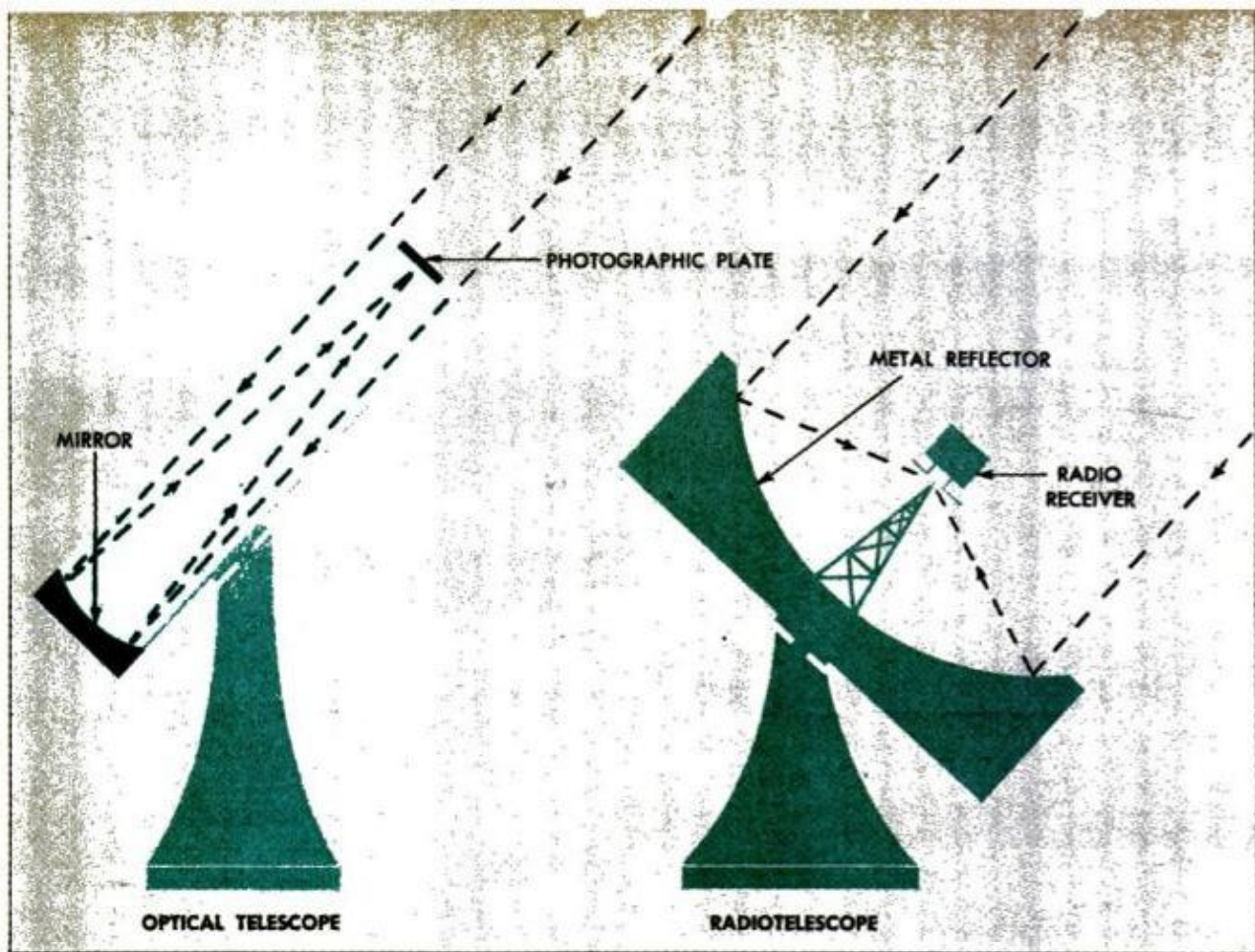

Optical telescope and radiotelescope are similar except that optical telescope gathers only light waves, while a radiotelescope gathers and focuses all radio waves, thus giving us a bigger window to the universe

←Here's the complete electromagnetic spectrum. Note what a very small part of it we actually can see. Dr. Drake is "listening" at 1420 megacycles as shown, considered the "universal wavelength" because it is radio-emission line of hydrogen, the parent element

Below, our neighborhood, astronomically speaking, shows Sun and two stars which will be checked first
From model by Sarah Lee Lippincott, Sproul Observatory, Swarthmore College





Meteor darts through sky over Hollywood. Large organic molecules, similar to those that are believed to have evolved into life on Earth, have been found in meteorites. Can this be way life spreads through universe?

As death approaches, it begins to expand, eventually exploding and then shrinking into a dead star perhaps half its former mass. But what happened to the other half of its material? This was ejected back into the vast dust clouds of the galaxy.

But now there is a difference. Originally the material was hydrogen gas. When the hydrogen was "burned" in the parent star, some of the atoms were altered. Atomic particles were lost and captured. The new cosmic dust, ejected from the exploding star, contains helium, nitrogen, iron, uranium and all the other known elements.

When a "second generation" star, such as our Sun, is born of this dust, it contains these heavier elements—which are vital to life processes.

As this cloud of dust condenses into a star, swirls and eddies are "left behind." These continue to circle the new-born star, contracting and condensing into a swarm of planets. Thus was born the Earth.

Not long ago, astronomers believed the Sun was an accident of the universe, that no other suns had planets. Today most astronomers are convinced that an incredible number of stars have swarms of planets. Instead of being unique in the universe, our Sun and its planets are just plain common. The Earth is no accident; it probably is duplicated countless times in our own galaxy.

The resulting picture of the universe may be difficult for man, the egotist, to accept. We live on a minor planet whirling around a commonplace star that exists near the edge of a galaxy of 100 billion stars. Harlow Shapley, one of the greatest of all astronomers, estimates that within reach of our present telescopes there are more than one hundred thousand million billion stars (if you write this in figures, it is 10 followed by 19 zeros).

How many of these stars have planets suitable for life—at least the form of life that we know?

This brings up the second scientific revolution—the new theories of biochemistry. What is life? What are its essential ingredients? How did it start?

Most biochemists now believe that life started from complicated molecules—amino acids—that were formed in the early cooling-off period of our planet. Such molecules have an inherent ability to grow and, in a sense, to reproduce.

At the University of Chicago, Stanley Miller made studies which indicate that these complex molecules *could* have been formed in tremendous quantities as the Earth condensed. Dissolved in the oceans, they formed a vast "organic soup." Eventually, through a combination of random "accidents" which may have included an

(Continued to page 220)

Dr. Wernher von Braun, one of the scientists responsible for developing the German V-2 rocket during World War II, is now a U.S. citizen. He directed development of the Jupiter C ballistic missile and launching of Explorer I Earth satellite



My Most Exciting Moment

By Dr. Wernher von Braun

ON THE NIGHT of the historic launching of the U.S. Army's scientific earth-satellite, EXPLORER I, I sat in the Communications Center of the Pentagon watching the teleprinters as they clacked out the progress of the countdown underway at Cape Canaveral, Fla.

As the teleprinters raced to keep pace with the countdown, large screens reflected their messages. This one read:

HUNTSVILLE, ABMA-19, X-27 AND COUNTING AT 2221 EST. THE CAMERAMEN HAVE UNTIL X-21 TO FINISH THEIR JOB AND GET OFF THE PAD. EYEWITNESSES SAY THAT THE MISSILE IS A BEAUTIFUL SIGHT WITH THE SEARCHLIGHTS PLAYING ON IT. SERVICE STRUCTURE IS MOVING BACK INTO FIRING POSITION.

During the actual firing of EXPLORER I, Dr. William Pickering of the Jet Propulsion Laboratory, Dr. James A. Van Allen of Iowa State University and I were in Washington—to meet the press. We had been told in so many polite words that we had to sweat it out in the Communications Center of the Pentagon. In this way, if everything worked successfully, we would be readily available to go over to the National Science Academy to meet the press, newsreel, and television people. That's why I put on a dark suit. But, just in case things didn't come off so well, I had a pair of dark glasses with me and was determined to sneak away to a still darker movie theater.

At Cape Canaveral's Missile Firing Laboratory, Maj. Gen. John Bruce Medaris, who had decided to go ahead with the launching despite the high winds of the past two days, was now sweating out the countdown in a squat, unpretentious concrete blockhouse.

The teleprinter moved again:

HUNTSVILLE, ABMA-20—THE CLUSTER (the high-speed unit designed to impart a bullet-like spin to the satellite) IS BEING REVVED UP. 370 RPM NOW . . . 440 RPM . . . 470 RPM . . . EVERYTHING IS GOING FINE. THE BLOCKHOUSE IS BUTTONED UP, THE COUNT IS X-7 AT 2241 EST . . . X-6 AT 2242 . . . EVERYTHING IS OPERATIONAL.

In the blockhouse Robert Moser pressed his earphones more tightly to his head, glanced at his countdown schedule, and directed the sequence recorders be turned on. He checked the control console.

X-2 MINUTES . . .

In Moser's earphones the voice was jarring: "We have a jet-vane deflection!"

With 100 seconds to go, Moser spoke through his mike to Dr. Kurt Debus, Missile Firing Lab Chief. "What do you want to do?" he asked.

Debus's eyes bored through the window. "Forget it," he said.

"Rudder drive on!" Moser continued his countdown.

X-1 MINUTE . . . FINAL WEIGHT MEASUREMENT BEING TAKEN.
SPINNER STILL RUNNING SMOOTHLY.

The teleprinter raced to keep pace with the event.

At X-30, Moser began to call out the final seconds whipping by: "X-30, 20, 10, 9, 8, 7, 6, 5, 4, 3, 2, 1—Firing Command!"

A burst of flame roared out of the rocket. They say the rocket rose ponderously with awful majesty from the pad; picking up speed as it screamed skyward. The time was 10:48 p.m., Eastern Standard Time.

In the hot, crowded telecon room the teleprinter kept ticking out the good news that the big first stage was performing perfectly, that the rocket was slowly arcing out toward the Atlantic. At 155 seconds the first-stage power cut off—right on schedule. A few seconds later the nose section separated from the booster, just as planned. Ninety more seconds passed slowly before the teleprinter reported that the second stage ignition was "OK." Then for a whole minute there was silence.

I hurriedly penciled a message which flashed on the outgoing screen:

WASHINGTON DA-5, OFFICIAL FOR ABMA FROM PROF. VON BRAUN
DID THE 3D AND 4TH STAGES FIRE? (If the high-speed stages had not fired,
there would be no orbit.)

HUNTSVILLE, ABMA-21, REF DA-5—DO NOT KNOW YET. WILL LET YOU
KNOW SOON AS POSSIBLE. GEN. MEDARIS SAYS HAVE A CUP OF COF-
FEE, SMOKE A CIGARETTE, AND SWEAT IT OUT WITH US.

Presently we had word from Antigua Microlock that both EX-
PLORER transmitters had been clearly heard passing that point. The
island of Antigua is about 1300 nautical miles downrange from Cape
Canaveral, and the time elapsed between the firing of the second stage
and the passing of Antigua was a pretty good indication of whether
or not the final speed of the fourth stage was at least in the right order
of magnitude for orbital flight.

As a result of the measured travel time between firing of the second
stage and the passing of Antigua, the data-evaluation group at Canav-
eral concluded the EXPLORER I had reached sufficient speed and must
have settled in a 106-minute orbit. But the evidence was still too ten-
uous to cheer.

It only gave us an indication in our Pentagon communications room
as to when to expect the first reports from California that the top stage
had really gone around the world!

Well, after the predicted 106 minutes were over, nothing happened,
and I can assure you those eight more minutes until something did
happen were the most exciting eight minutes in my life.

As the minutes dragged on without a signal reported from California,
our spirits sagged. At the end we were frankly desperate and yet we
couldn't show it because there was so much brass around. We had to
keep up appearances, and had to smile and convince everybody that
things were in perfect shape.

Bill Pickering had the West Coast on long distance—his four receiver
stations in California—and still none of the four had heard a thing.
That went on for what appeared to be hours. I heard Bill shouting
into the telephone, "Why the hell don't you hear anything?"

Then, suddenly, within 30 seconds all four stations came in and said
they had a clear signal! At this moment we knew that we were in the
satellite and space business.



see ~~at~~ Nov 60, 10

AN EYE ON SPACE

By Dr. Dan Q. Posin

PROFESSOR OF PHYSICS, DE PAUL UNIVERSITY
SCIENTIFIC CONSULTANT AND ADVISOR, COLUMBIA BROADCASTING SYSTEM

A FRIEND OF MINE was saying the other night, "I don't see how the scientists can know the distance to the Moon—or to the Sun. And, when they talk about galaxies, how can anyone know how far they are? Have the scientists measured that far—with a tape?"

I don't blame him for being skeptical, but the fact of the matter is that it's not always necessary to measure distances in the way that you would measure the length of a table. There are other ways, some just as good, others better.

First, the distance to the Moon can be measured by aiming radio waves at it, and timing how long they take to bounce back.



In one such trial, the total time for the roundtrip was 2.4 seconds. This means, of course, that the radio waves took 1.2 seconds to go one way. They travel at the rate of 186,000 miles in one second, so the Moon was $186,000 \times 1.2$ or 223,200 miles away. Not many people would want to buy a tape that long and unreel it as they space-travel toward our satellite.

The distance to the planet Venus has been measured in the same way. And also the distance to the Sun. In this case, you might think that since the Sun is a gaseous body, the radio waves would not bounce back. But they do. Radio waves can be reflected by flames, cyclones, electrified regions, gases.

This radio method—or radar, if you like—does not work very well for our more distant planets. We do not have, as yet, enough radar power to send a radar beam strong enough to carry successfully, say, to the planet Pluto. So we measure the dis-

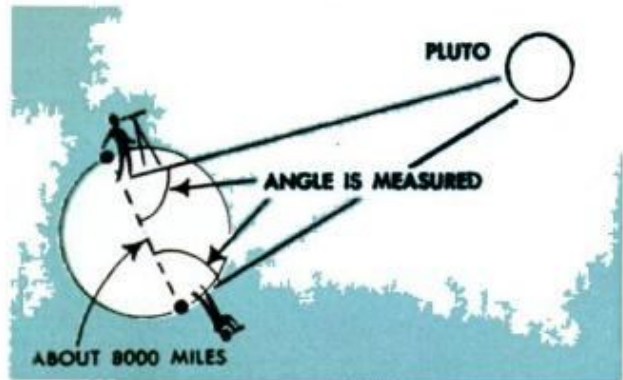

tance to Pluto this way: two men on Earth, widely separated, point their telescopes at Pluto and note their angle of tilt.

That's all there is to it. They have a triangle with one side, say 8000 miles and two known angles. It's simple to calculate the lengths of the other two sides. The distance to Pluto in this way comes out 3,600,000,000 miles.

When it comes to measuring the distance to the stars, our biggest base line (that 8,000 miles, the diameter of Earth) is not big enough. You can see what happens, of course, if you try to use this method to measure relatively great distances employing a relatively small base line. Your angles come out almost 90 degrees, and a slight error in the angles will give you an entirely different measurement on the two long sides of the triangle.

The remedy for this difficulty is to use a larger base line. Do we have one which is bigger than the diameter of Earth?

Of course we do. It is the diameter of the Earth's orbit around the sun. So, an astronomer sights on a star tonight; then,

(Continued to page 240)

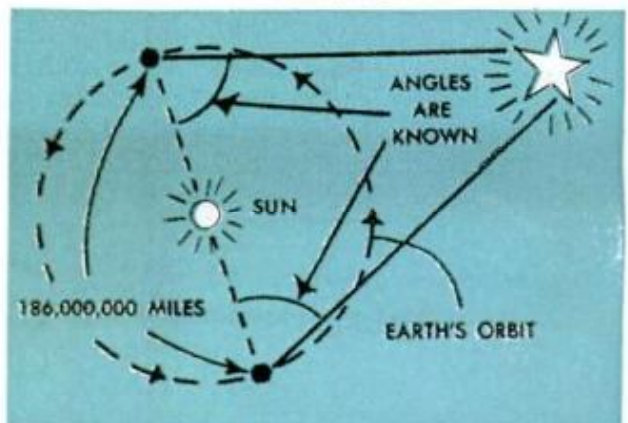
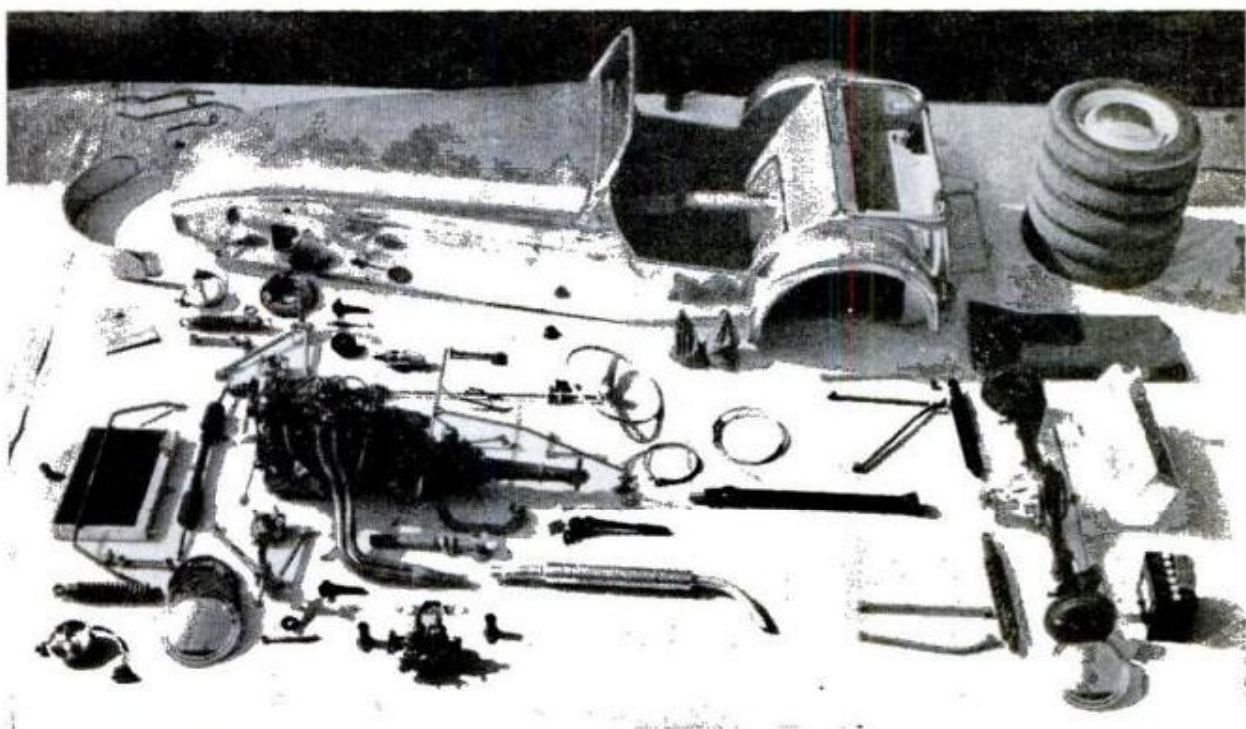
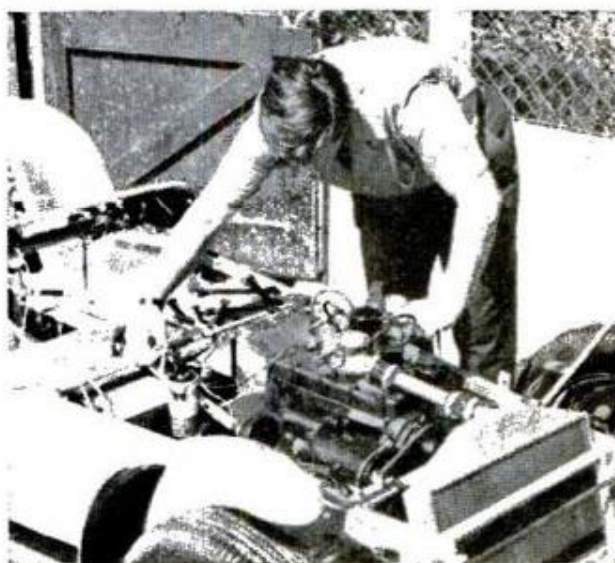



Photo Universal

Do-It-Yourself Car Kit

ALL THE COMPONENTS of this speedy little Lotus Seven sports car are included in a do-it-yourself kit. They can be assembled with a set of hand tools and a drill. While the completed car is sold in the U.S., the do-it-yourself kit is available only in England. For a nonmechanic, the job of assembling the car takes about 60 hours. The 825-pound Lotus has a wheelbase of 88 inches and is 123 inches long, 53 inches wide and 27½ inches high. Ground clearance is 5 inches. The kit model has a choice of a Ford 100E or Coventry Climax engine; a higher-compression Ford engine is offered the U.S. buyer. The Lotus can be fitted with a top that folds flush into the rear compartment. This fall, the import models will have a lefthand steering wheel.



TO SECURE EARLY DATA, A SERIES OF EXPERIMENTS WERE CARRIED OUT WITH A LARGE PILOTLESS MODEL LAUNCHED FROM A ROCKET-PROPELLED TROLLEY. THE AIRCRAFT HAD A WINGSPAN OF 30 FEET AND WAS POWERED BY TWO ROCKET MOTORS AND RADIO CONTROLLED. THESE TESTS PROVED THE PRACTICABILITY OF THE REAR WING POSITION AND THAT THE AIRPLANE COULD BE MANEUVERED WITHOUT THE USE OF TAILPLANE OR AILERONS BY A SIMPLE MOVEMENT OF THE WINGS

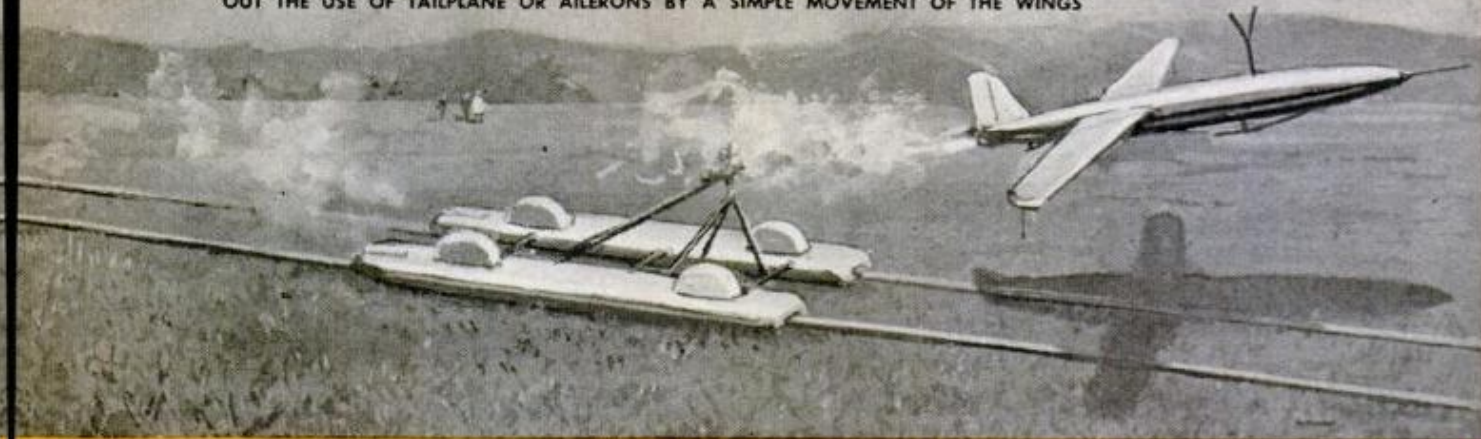

WHEN THE FUSELAGE IS LONG OR WINGS STEEPLY SWEEPED, AS THEY HAVE TO BE FOR SUPERSONIC FLIGHT, A PROBLEM IS CREATED AT TAKEOFF AND LANDING: THE UNDERCARRIAGE LEGS WOULD HAVE TO BE IMPOSSIBLY LONG TO GIVE THE NECESSARY GROUND CLEARANCE



DR. WALLIS' "SWALLOW" CONCEPT WITH THE WINGS IN POSITION FOR TAKEOFF OR LANDING

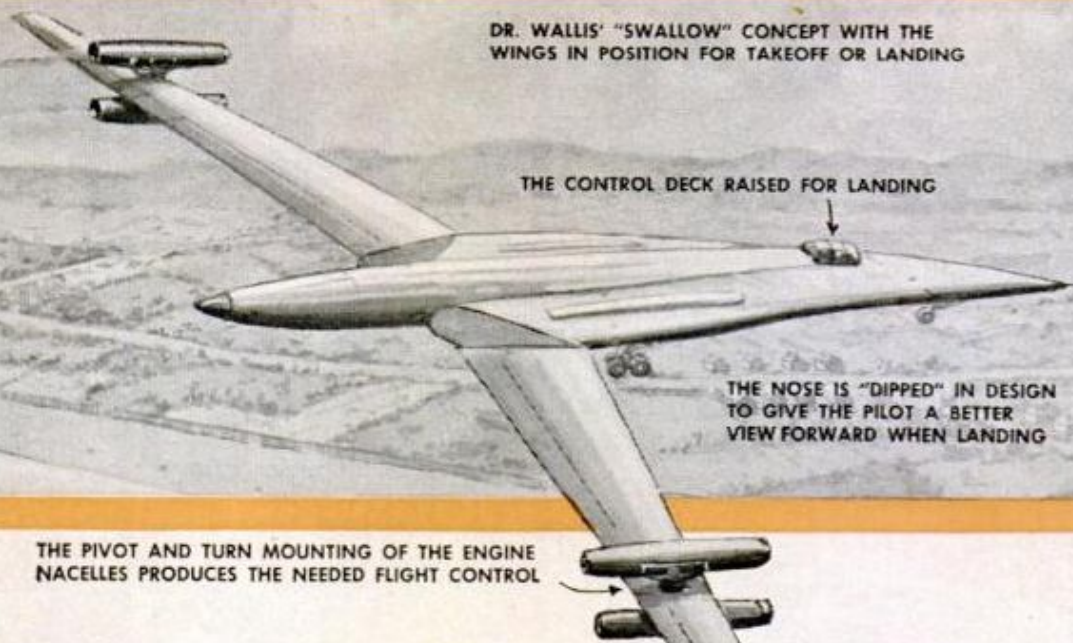

THE CONTROL DECK RAISED FOR LANDING

THE NOSE IS "DIPPED" IN DESIGN TO GIVE THE PILOT A BETTER VIEW FORWARD WHEN LANDING

THE PIVOT AND TURN MOUNTING OF THE ENGINE NACELLES PRODUCES THE NEEDED FLIGHT CONTROL

Movable-Wing Plane

MAN'S ATTEMPTS TO FLY like birds—by flapping his arms or some winglike contrivance—usually end in disaster. A variation on that ancient approach, however, may solve some problems involved in supersonic flight and help man to swoosh through the air at a feather-singeing speed of 1800 miles an hour.

Dr. Barnes Wallis, English airship in-

ventor and chief development scientist at Vickers-Armstrong, has designed a movable-wing plane—appropriately called the "Swallow"—that is thought capable of such speeds. Wings move forward and backward, rather than up and down, to give it high performance capabilities at both supersonic and landing-takeoff speeds.

(Continued to page 251)

IT IS KNOWN THAT WITH DELTA-WING AIRCRAFT, THE HIGH LIFT IS PRODUCED NEAR THE FORWARD EDGES OF THE WINGS. THE CENTER PORTION, HOWEVER, HAS POOR LIFT AND PRODUCES CONSIDERABLE DRAG

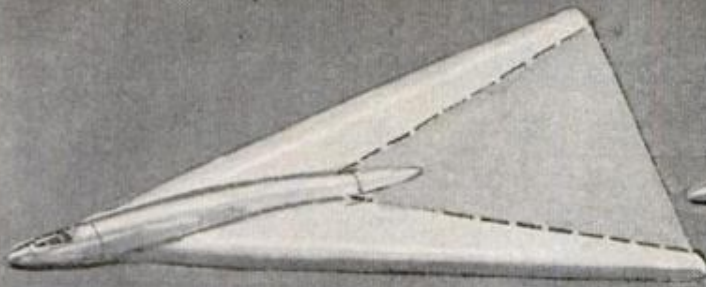

CENTER PORTION HAVING POOR LIFT AND CONSIDERABLE DRAG

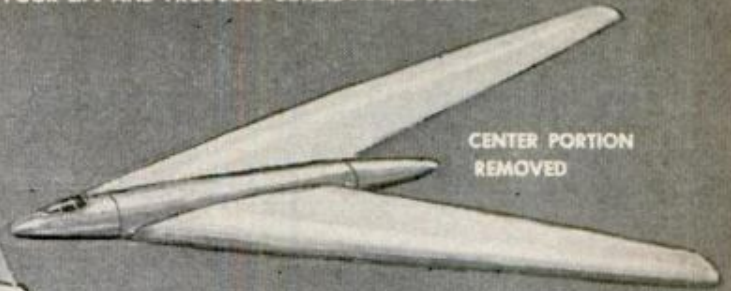

CENTER PORTION REMOVED

EXPERIMENTS PROVED THAT THIS TYPE OF WING CONFIGURATION HAD AN EXCELLENT LIFT/DRAG RATIO FOR SUPERSONIC SPEEDS

AN EARLY DESIGN BY DR. BARNES WALLIS OF A MOVING-WING, VARIABLE-GEOMETRY AIRCRAFT



PLAN OF WINGS IN POSITION FOR TAKEOFF AND LANDING

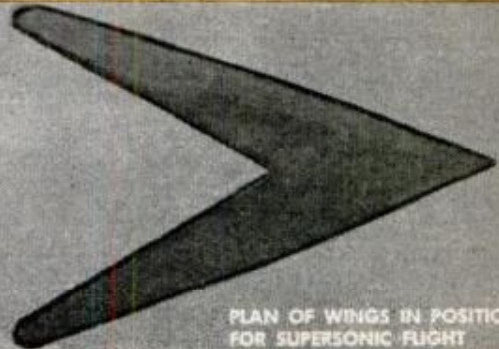

PLAN OF WINGS IN POSITION FOR SUPERSONIC FLIGHT

THE WINGS IN POSITION FOR SUPERSONIC FLIGHT

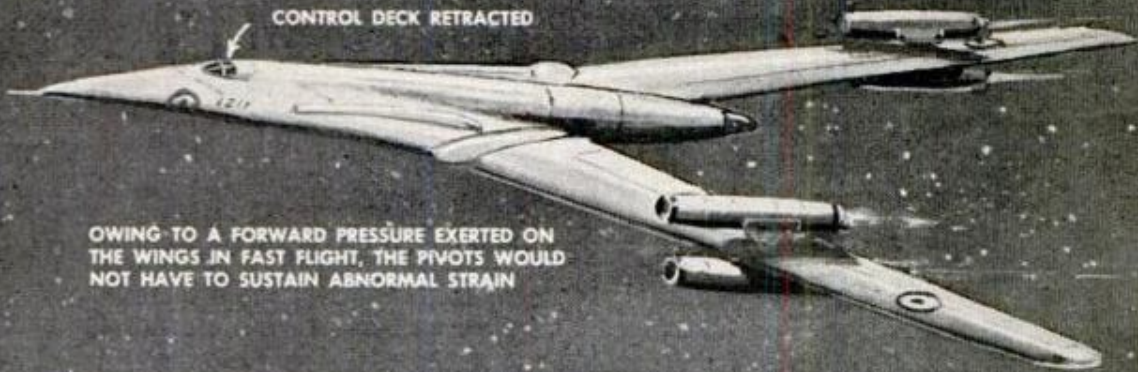

CONTROL DECK RETRACTED

OWING TO A FORWARD PRESSURE EXERTED ON THE WINGS IN FAST FLIGHT, THE PIVOTS WOULD NOT HAVE TO SUSTAIN ABNORMAL STRAIN

PLAN OF SUGGESTED SUPERSONIC LINER WITH A TOTAL WEIGHT OF 100,000 POUNDS

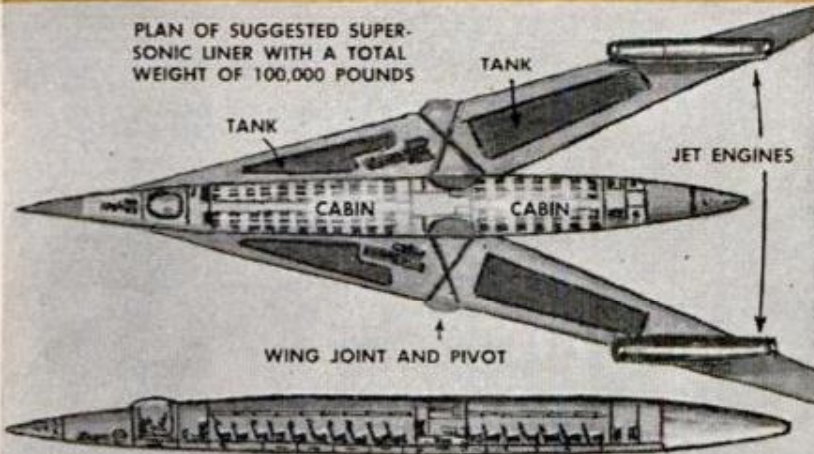

JET ENGINES

WING JOINT AND PIVOT

SIDE VIEW OF SUGGESTED LINER ON THE "SWALLOW" PLAN FOR SOME 60 REAR-FACING PASSENGERS

THIS IS A PHOTOGRAPH OF A MODEL OF THE "SWALLOW" SHOWING THE WINGS IN VARIOUS POSITIONS DURING ALTERING ASPECTS FOR TAKEOFF AND LANDING, AND SUPERSONIC FLIGHT





By Jim Whipple



Every-other-year lubrication? Lifetime mufflers?

LIKE PEAS in a pod. That's what the word was in the world of half truths, rumors and educated guesses concerning the **Buick, Olds** and **Pontiac** compacts. But how wrong can we prognosticators get? The **B.O.P.** compacts share pods all right—nearly identical unit bodies by **GM's** Fisher Division—but inside these sleek shells divisional engineering staffs have gone their separate ways with a vengeance.

OLDS F-85 and **Buick Special** share suspensions, drivelines and manual transmissions. Their V-8 engines are considerably different, although based on a common aluminum block. Automatic transmissions follow different paths entirely.

Pontiac's Tempest—a name well-chosen—is the only one of the three with independent rear suspension "transaxle," contrary to a false lead published in this column last month. **Buick Special** and **Olds F-85** have conventional, "solid" rear axles.

AN ILLUSTRATION of how such stories start; some sources held that the **Tempest** would have torsion-bar suspension a la **Chrysler**. This assumption was based on fact too, **Pontiac** was ordering torsion bars in pairs from a supplier. **Pontiac** engineers are enjoying a laugh on this one however—the bars are used as driveshafts!

The **Tempest** does have the startling, 45° slant four-cylinder engine however, the first four to appear on a **GM** car since 1928.

For those who want it, the syrupy smooth, more powerful aluminum V-8 will also be available in the **Tempest**.

THESE THREE new compacts should make a profound impression on the 1961 market. They represent the second phase of the compact car revolution—that of the designed-for-the-job, medium-priced compacts. (The third and final phase will be Detroit's invasion of the small economy market with a \$1600, four-passenger car.)

The **F-85, Tempest** and **Special** provide all the traditional virtues of the typical medium-priced big car; smoothness, excellent ride, low noise level, powerful performance and good workmanship. What's more they're practical, six-passenger cars with center-of-seat comfort.

HOWEVER, these new **B.O.P.** cars are expected to throw a wicked curve at the harassed ranks of the "low-priced-three," (**Chevy, Plymouth, Ford**, and newcomer **Dodge Dart**). Some of these are already bleeding from wounds inflicted by the "economy five" (**Falcon, Rambler, Corvair, Valiant** and **Lark**) in the 1960 sales battle.

Just how rough things will get for some of the old timers in the low and medium-price fields remains to be seen. A lot depends on the **B.O.P.** compacts' prices too. Most educated guesses peg them at \$2400 to \$2700 with the four-cylinder version of the **Pontiac Tempest** base-priced at close to \$2000.

IF THIS LAST price holds true it will be the result of a shrewd marketing move by **Pontiac** boss S. E. Knudsen to put his new **Tempest**, with its larger (112-inch wheelbase) body, into competition with smaller compacts such as **Falcon, Rambler** and **Corvair**. The expectation of lower price for the **Tempest** would be a natural result of engine economies. The cast-iron **Pontiac** four is machined right on the big-engine line—it is actually the "starboard" bank of the 389-cubic-inch V-8, and so is considerably cheaper to tool and produce than the all-new aluminum V-8.

PERHAPS equally interesting as the '61 cars themselves are some of their features designed to keep owners happy long after that new-car thrill has gone.

For example, all **Rambler**s will be coming off the line with ceramic coated exhaust systems. This is the lifetime muffler for real—'61 **American Motors** tail pipes and mufflers will be as rustproof as a china cup. This should become an industry-wide trend and put the million-dollar muffler replacement business in the same class as miniature golf courses.

AN END to incessant—for those who follow the book—and inconvenient grease jobs will be the result of a lubrication breakthrough at **Ford Motor Company**. Owners of '61 **Fords, Mercurys** and **Lincoln Continentals** will probably need take their car in for a lube job once *every other year* unless they drive more than the 10,000-mile-a-year national average. ★ ★ ★



Collapsible Fire Escape Folds Up Inside Window

So compact it fits into a small metal box that extends just six inches from the wall, and so easy to use that an 11-year-old boy can operate it, a collapsible fire ladder is strong enough to allow a teacher and 30 pupils to evacuate a room in three minutes. Bolted under the window sill, the platform is swung over the sill, allowing the chain ladder, folded up inside, to drop freely to the ground where it is anchored.



"Peaceful Torpedo" Produces Emergency Power for Navy Jets

Resembling a torpedo, but containing a power package instead of explosives, a 26-foot-long pod provides emergency ground support for Navy jets. Driven by a gas-turbine engine, the power unit produces electricity for ground instrument check-out, refrigeration for cooling both the aircraft electronic compartments and the pilot's suit, and air for engine starting. The advantage of placing this equipment inside

a compact torpedo-shaped pod is that the pod can be strapped to the jet, just like a torpedo, and flown to advance bases where similar equipment is unavailable. Ordinarily such equipment is brought in by cargo ship or truck. Inside the compact pod it can be flown from base to base at will. Since such equipment is necessary only prior to takeoff, none of it is built into the jets, leaving them as light-weight as possible.

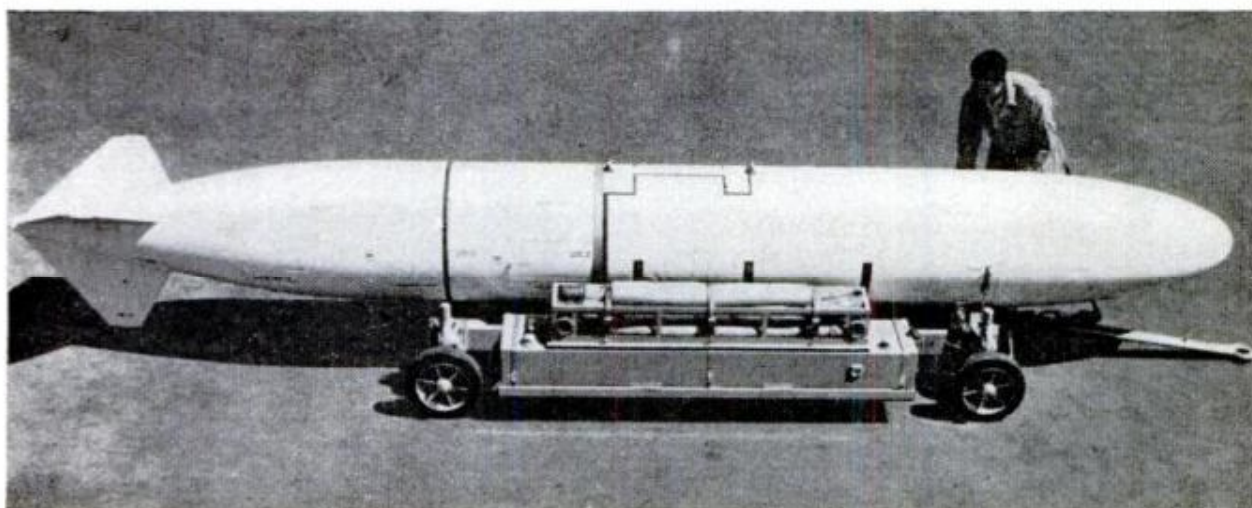

THIS BUSINESS

A former OSS agent and foreign-affairs expert tells how both kinds of intelligence—open and secret—are collected, evaluated and put to use

Kindly innkeeper and his frau gave a last glass of beer on the house to outward-bound German sub crews, waved them on their way and scuttled to a radioman who flashed word to the British Admiralty

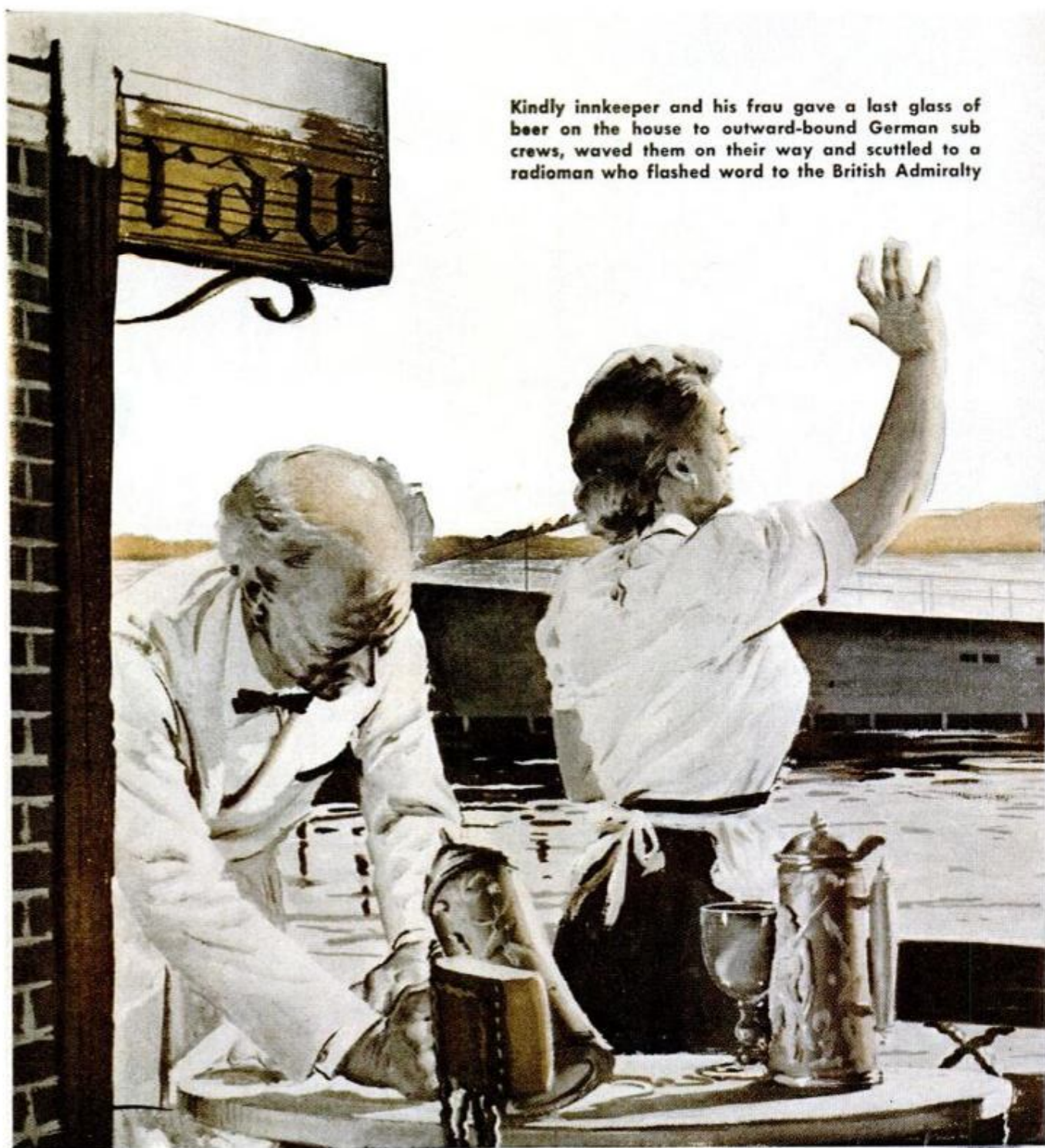

OF SPYING

By
Richard
Dunlop

LATELY it has almost seemed that Alfred Hitchcock has taken to writing newspaper stories. Relentless Israeli agents climax a 15-year search for a hated Gestapo official, Adolf Eichmann, by kidnaping him from his Argentine hiding place. A high-flying United States U-2 weather plane is downed in the Soviet Union, and its pilot admits he is an American spy taking reconnaissance pictures with a secret high-altitude camera. The American representative to the United Nations reveals that the handsome great seal of the United States, a gift from the Reds which had hung over the desk of the American ambassador to Russia at the embassy in Moscow, had a listening device and antenna concealed in it. President Eisenhower sets out on a good-will trip to the Orient, but professional agitators in the pay of the Communists stir up such violent anti-American riots in Tokio that Japan's government has to tell him not to come for fear it cannot protect his life.

In an easy-going world of suburban back-yard barbecues and Sunday after-

noon ball games it all sounds incredible. One day a neighbor said to me, "You were in OSS. Is all of this agent stuff for real?" I regretfully had to assure him it most certainly was for real and that, in fact, the United States is the world's fattest target for foreign spies and agents.

When an intense ideological and political conflict reaches a stalemate as has the cold war, then the cloak and dagger war of subversion takes on greater activity and meaning. In all countries, winning diplomacy and national strategy must depend upon how effectively intelligence concerning other nations' capabilities and intentions is collected. This means that today shadow armies of secret agents are contending for the future of mankind.

The late Maj. Gen. William J. Donovan, director of the Office of Strategic Services (OSS), America's first effective intelligence organization, told me once that in a democracy the public must support an intelligence effort if it is to be successful. He pointed out that the FBI, which is responsible for counter-intelligence in the United

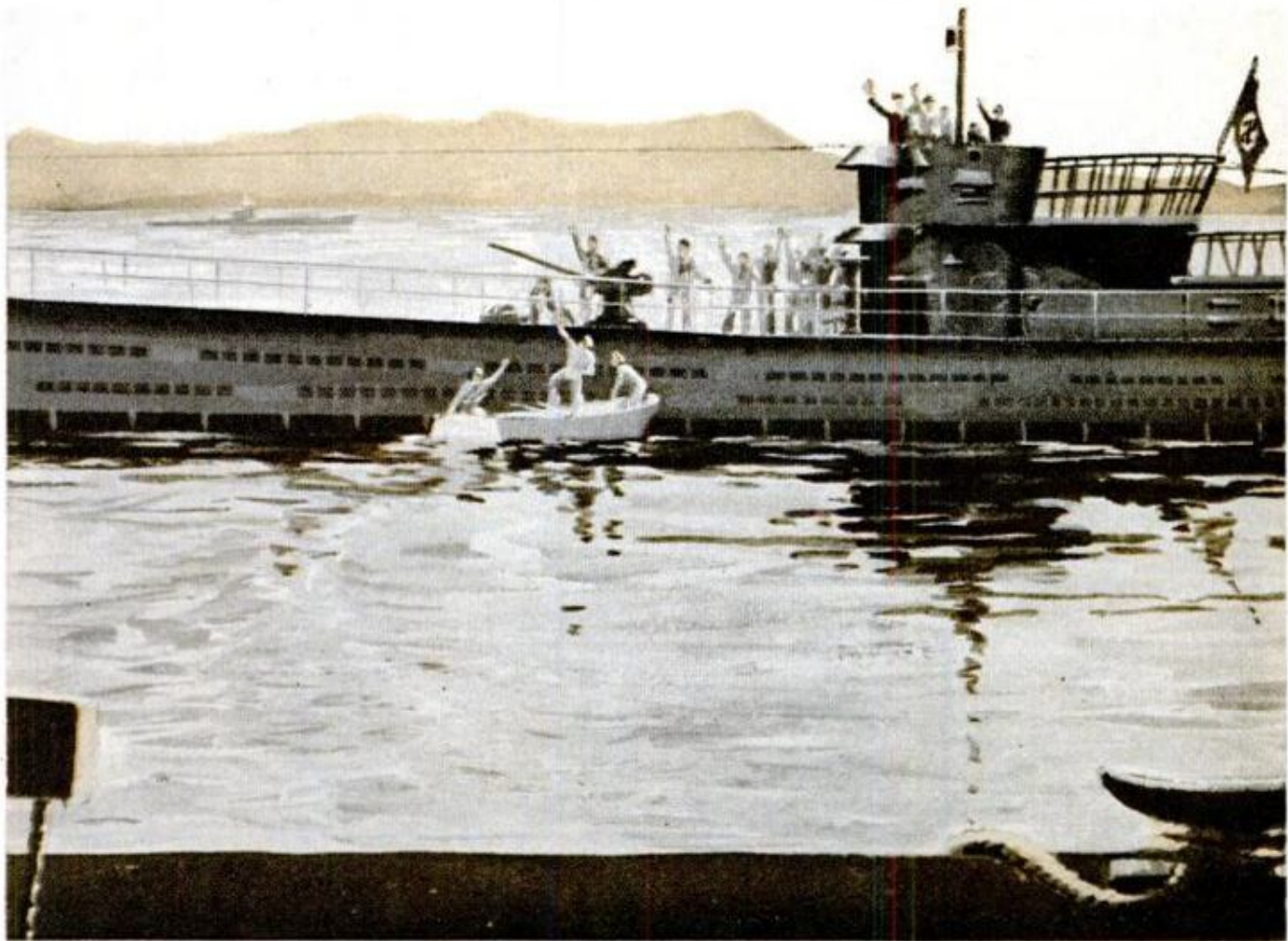



Richard Dunlop, foreign affairs expert and prize-winning author, served as an agent with the Office of Strategic Services in Burma and China during World War II. Guerrilla warfare and intelligence experience in the crack OSS Detachment 101 in Burma and assignments in China gave him inside knowledge into Asiatic affairs, which led to a post-war career in foreign trade as president of Richard B. Dunlop, Inc. He was chairman of the American-Kachin War Memorial Committee which was formed by the late Maj. Gen. William J. Donovan, director of OSS, to repay America's debt of gratitude to the Kachin people of Burma's hills who had aided the Allied cause. Dunlop later withdrew his firm from Asia because of Red turmoil. He has since acted as a foreign affairs consultant while at the same time becoming a nationally known writer of stories and articles. He has made contributions to leading magazines, including *POPULAR MECHANICS*, and is author of "Burma," "St. Louis" and "The Young David." He shared the Spur Award for the best western nonfiction of 1958 for "Saddlebag Docs" in the collection, "This Is the West."

States, has long understood the value of public support, but that the OSS's successor, the Central Intelligence Agency, balks at taking the public into its confidence even when security would permit it.

I have never been a spy nor do I have any intention of being one. But my work in OSS and a continuing private interest in foreign problems since World War II have made me familiar with the way in which an intelligence apparatus works. I think that the public should be told as much as possible about the vital business upon which so much depends.

First thing to keep in mind is that at least 90 percent of intelligence is gathered in an above-board manner. Even the Bible can be a source of intelligence. In February, 1918, a British force was moving on Jericho which was in the hands of the Turks. It was first necessary to take Michmash village, which governed the approaches. Since the point was on a high hill and heavily fortified, there seemed nothing to do but storm it. But the name, Michmash, sounded familiar to a young officer. That night he thumbed through his Bible until he came to I Samuel, Chapters 13 and 14.

There he read how the Israelites had surprised the Philistines at Michmash, making use of a hidden pass. The Bible went on to describe just how to find the pass. The officer, using this ages-old intelligence report, led his unit through the pass and, striking the Turks by surprise, defeated them.

This was an exceptional case. For the most part, open intelligence is gathered by specialists who sit at desks in Washington, London or Moscow and study newspapers, books, scientific journals, official publications, yearbooks and corporation annual reports. This copy of *Popular Mechanics* will be read in every major intelligence bureau in the world. When travelers return from abroad, many countries "debrief" them of any information which they may have learned. The United States rarely does this, but Communist countries almost always do. Experts also monitor radio and television broadcasts.

Most of the information gathered in this unsensational way is of economic, social, political, technical and scientific or cultural nature. Rarely are military plans leaked in the public press. Still, amazing things can be learned from open sources. Experts at

Opposite page: Swiss waiter helps German agent carry "drunken" friend from restaurant to waiting car. His helpless victim at his side, the agent drove through border guards to the waiting Gestapo in Berlin

Henry Cabot Lodge (below), U.S. representative to the U.N., displays the great seal of the U.S. which hung over the desk of the American ambassador to Russia. In it the Reds had hidden a transmitter and antenna





SEPTEMBER 1960

97

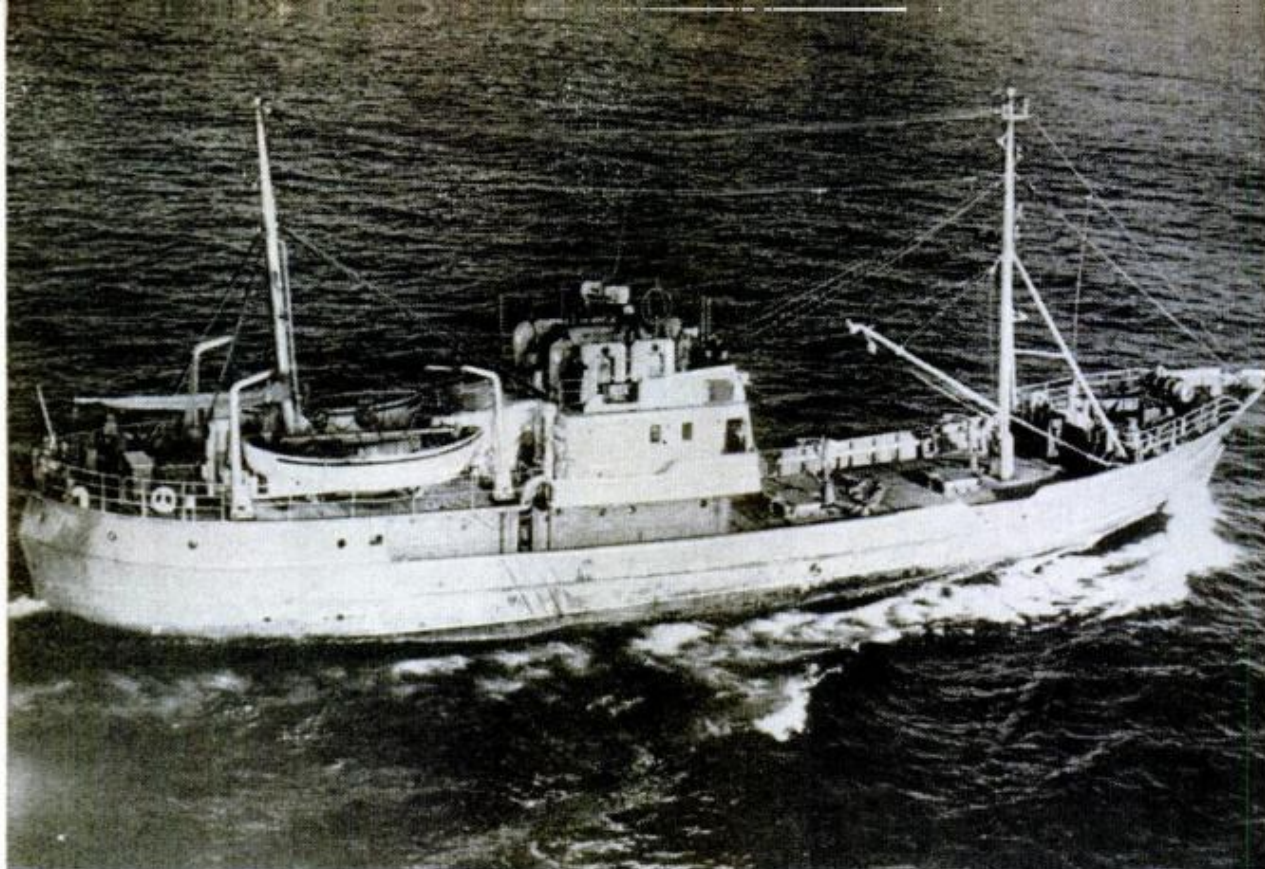

Soviet trawler Vega loaded with radar, was caught red-handed spying on Polaris missile tests off Long Island, and photographed by a Navy airship. The Reds are often caught "fishing in troubled waters"

reading between the lines get a lot more out of an ordinary newspaper report than does the commuter on a home-bound train. This was brought home to Adolph Hitler one day in 1935 in a way which caused him to bite his knuckles with rage.

Berthold Jacob was a German journalist who fled the Reich when the Nazis seized power. He edited an anti-Nazi newspaper in Strasbourg, France, and taunted the Führer. One day he published a book giving the complete organization of Hitler's illegal new army. That is when Hitler exploded. He demanded that his spymaster, Col. Walther Nicolai, find out who was responsible for such damaging leak of top-

secret information. Nicolai in turn assigned the case to agent Hans Wesemann.

Wesemann found a favorite Red or Fascist solution to the problem. He lured Jacob to Basel, Switzerland, by posing as a literary agent. The two men dined in a fancy restaurant in the heart of the city as the seeming literary agent promised great things to the aspiring newspaperman. When Jacob excused himself to go to the men's room, Wesemann slipped knockout drops in his drink. Jacob sipped his glass and slumped into helplessness.

"I apologize for my friend," Wesemann said to the Swiss waiter. He persuaded the man to help carry the apparently drunken

Spies have trouble hiding their monitoring schedules. Russian agent Abel hid his in this hollow pencil

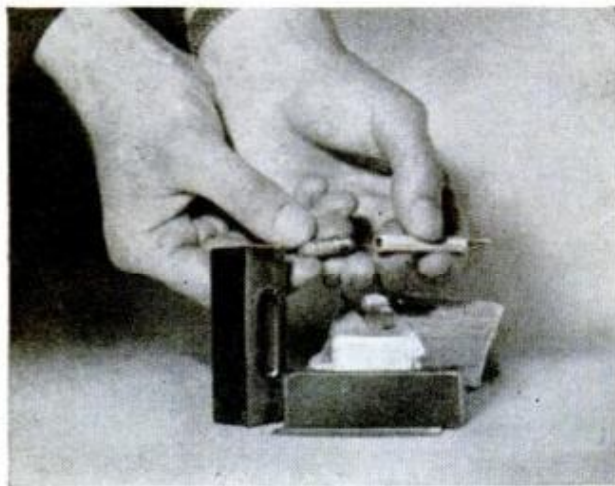

British major won a battle in the Middle East with the aid of intelligence learned from the Holy Bible

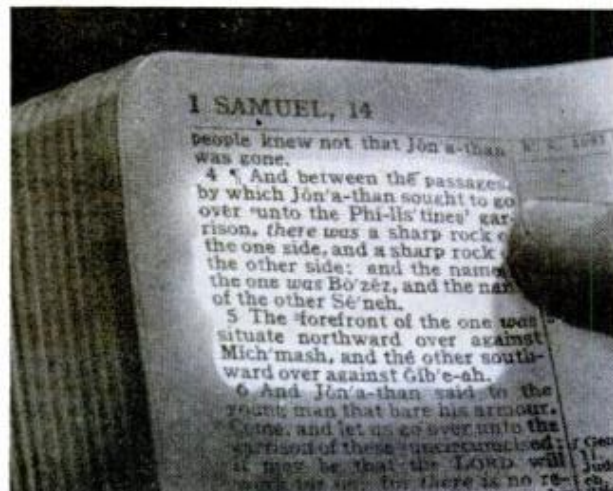



Jacob to a waiting car. Then he drove furiously through the Swiss border guards into Germany.

Jacob regained consciousness to find the cold eyes of Walther Nicolai looking into his own. He was at Gestapo headquarters in Berlin. How had he discovered the German Army's secrets? It was not hard. Jacob talked freely. He had read accounts of funerals and weddings which appeared in newspapers throughout the Reich. Whenever an army officer present had been identified by name, rank and unit, he had jotted the information down. In this way, he had been able to piece together the composition of the entire German army. An amateur had beaten the sharpest intelligence officers at their own game of assembling scraps of information to arrive at the complete picture. Nicolai could not help but admire Jacob's skill and graciously returned him

Zionist spies bugged this book with a transmitter and listened in on the Egyptians by remote control

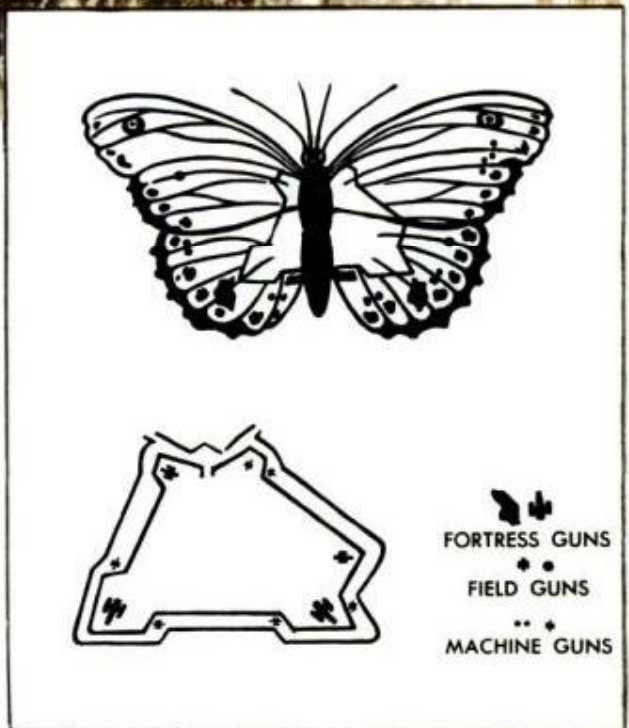
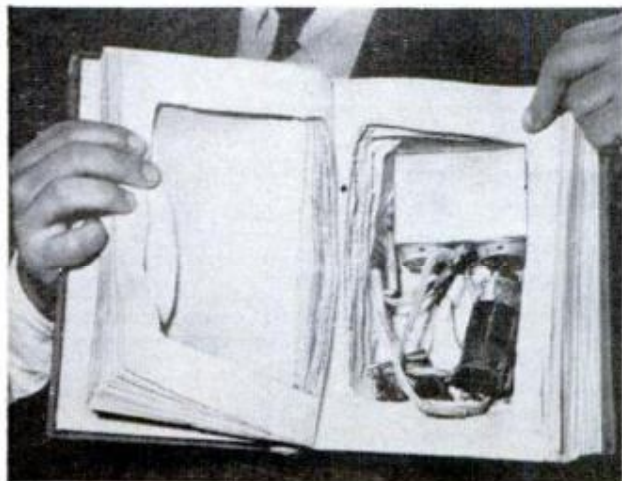

Posing as an entomologist, Baden-Powell drew vital details of an Austrian fort in a butterfly sketch

FBI cryptanalyst shows how alphabet strips are slid in an effort to decode a spy's secret message





Newsboy James Bozart holds up a nickel which split in half and betrayed Soviet spy Rudolph Abel. The boy received the nickel from two women customers. When it broke apart in his hands and revealed some microfilm, he gave it to a policeman who turned it over to the FBI. The clue led to the spy's arrest

safely to Switzerland, creating an international furor when Switzerland and France learned how he had been abducted in violation of their sovereignty.

In a real way Berthold Jacob had acted as a one-man intelligence apparatus. As do all intelligence organizations, he had collected information, appraised it, pieced it together and disseminated it to those who needed it, in this case, the people of western Europe whom he wished to alert against the Nazi menace.

It is probable that the Russian intelligence numbers at least 15,000 men and that our own CIA has perhaps 12,000 employees. Only a small fraction of these people are intelligence officers and fewer still are spies, but together they have as their primary task the same sort of job as Jacob set for himself.

To take the mystery out of this process

let's reconstruct the way in which Red agents reported the atomic bomb to the Kremlin. Of course, while Jacob was dealing in open intelligence, the Reds were trafficking in secret intelligence. In other words, they were spying.

On March 28, 1945, a Soviet agent in Ottawa, Ont., lunched with a young scientist named Durnford Smith, who had long been informing on American, British and Canadian research. The agent, who had been instructed to learn all he could about radar development, kept pressing Smith for more information. Smith heatedly told him that radar just was not important anymore. The main thing now was that the three allies were making a frightful bomb using atomic energy. The agent reported this information to Colonel Zabutin, the top Soviet spy in Canada. Zabutin graded

(Continued to page 230)

Typical agency has three divisions for collecting information, evaluating it, and managing the business

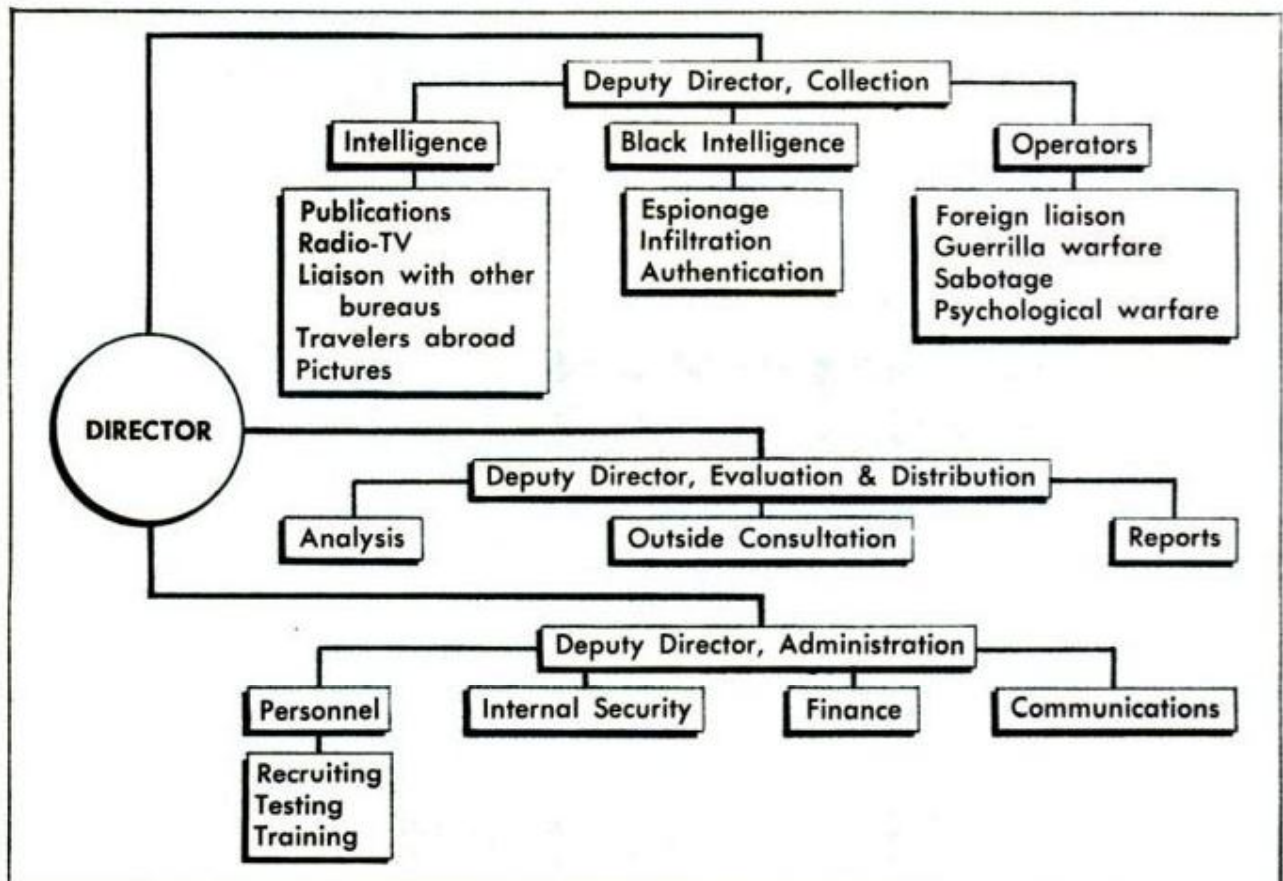



NOW IT'S THE drive-in vacuum cleaner! Resembling a gas pump, a coin-operated British machine is installed at service stations to allow motorists to clean car interiors, seats and ashtrays when they stop for gas. The outdoor vacuum cleaner operates for three minutes for sixpence (about seven cents), with the expired time registering on a large dial. The upper part of the unit contains the electric suction equipment, plus the coin slot and timing mechanisms. Refuse container is located at bottom of machine

"Wheel" Digger Gobbles Big Bites

Digging, screening and delivering 14 million tons of earth fill for Abiquiu Dam in New Mexico seemed like a heroic task for at least four big five-yard power shovels until contractor Bill Mittry and engineer Carl Wilms designed a huge wheel excavator. It wades into the ground with six 1½-yard buckets turning at 10 revolutions per minute on a 21-foot wheel, with the wheel turning in a 180-degree arc at the same time. Gobbling up 3500 tons of earth per hour, the wheel throws it over its shoulder onto a four-foot continuous belt which carries the earth 54 feet to a 30-yard mobile storage bin following behind. From there the fill is trucked to a 4300-foot overland belt system.

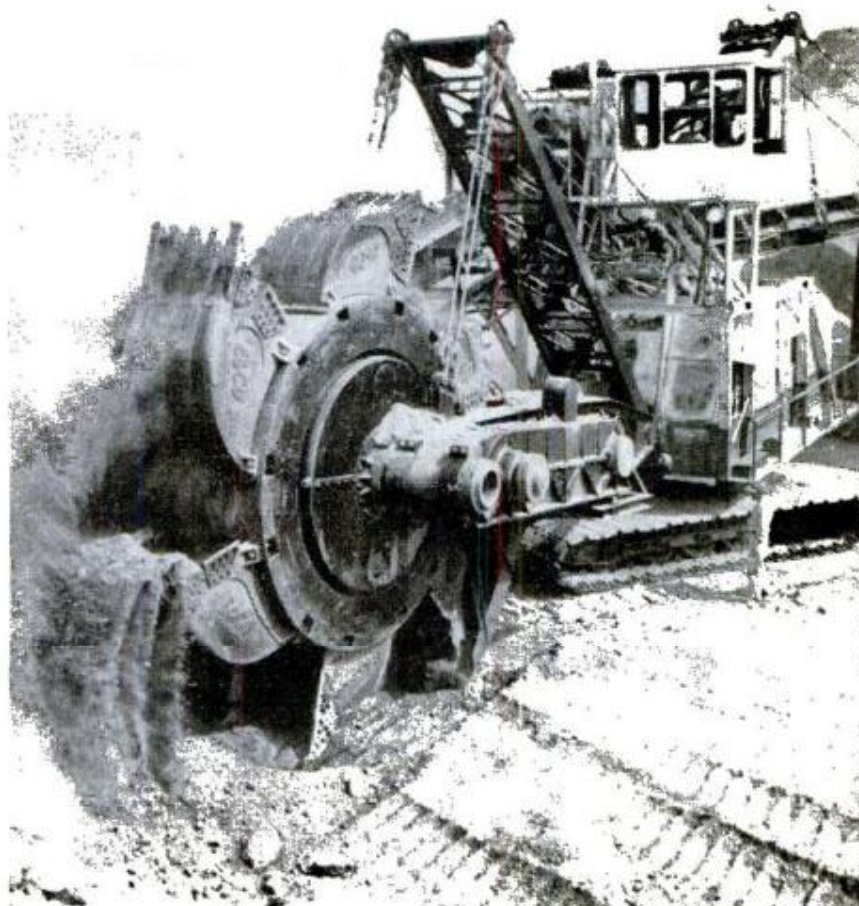

U.S. Rubber Co. photo

OWNERS
REPORT

A NATIONWIDE SURVEY

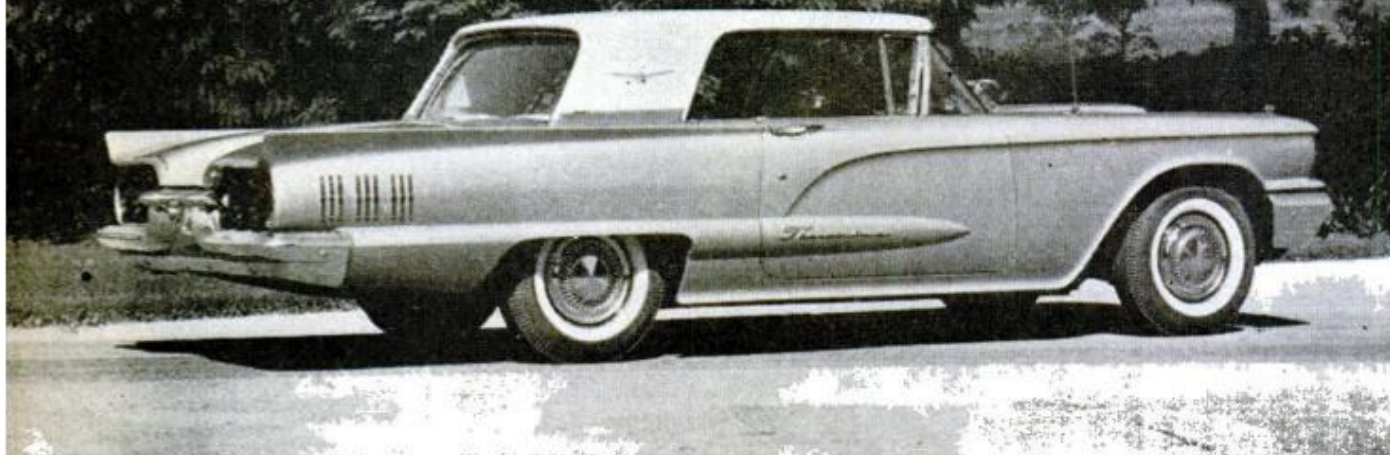
BASED ON 2,494,808
OWNER-DRIVEN MILES

LOVE THE LOOKS, RIDE AND

MARGINAL COMMENTS
BY JIM WHIPPLE
PM's AUTO EDITOR

This job was the original "bachelor's bomb," an ideal vehicle for luring → delicious damsels off the sorority house front porch.

The 'Bird represented the return of something like the Cord, Packard → boat-tail speedster or Stutz Bearcat, cars that these people had coveted in their youth, but could not afford.

IT'S HARD to remember a single car that's made the impact on public imagination that Ford's Thunderbird has in the past two-and-a-half years. The big 'Bird stormed the rarefied atmosphere of the luxury field like Marilyn Monroe crashing a society tea.

It all started rather quietly when Ford brought out the first two-passenger T-Bird back in 1955. It was billed as a "personal car" intended as a hedge against the encroachment of imported sports cars.

To the surprise of most of the auto industry's crystal gazers—the world's most fallible prophets—the '55 and '56 T-Birds appealed to more than just the young sports looking for a sort of Corvette with creature comforts.

Highly proper, middle-aged doctors and bankers—and their wives—began to appear on the highways happily crouched in Thunderbirds. Along with this new and somewhat unexpected buyer group came a strong groundswell at the dealer level in the shape of demand for a T-Bird with greater passenger and luggage capacity. Ford heeded the call and the rest is history. The current four-passenger, bucket-seat 'Bird, introduced in the fall of 1957, has been a virtual sellout everywhere ever since.

Now, let's take a look at a wide sampling of 1960 T-Bird owners who answered PM's questionnaire, find the reasons

HOW GOOD IS THE THUNDERBIRD?

Owners like:

Styling55.4%
Handling ease49.2%
Riding comfort36.1%

Power, performance31.4%
Roadability, cornering16.9%
Comfortable seats12.6%

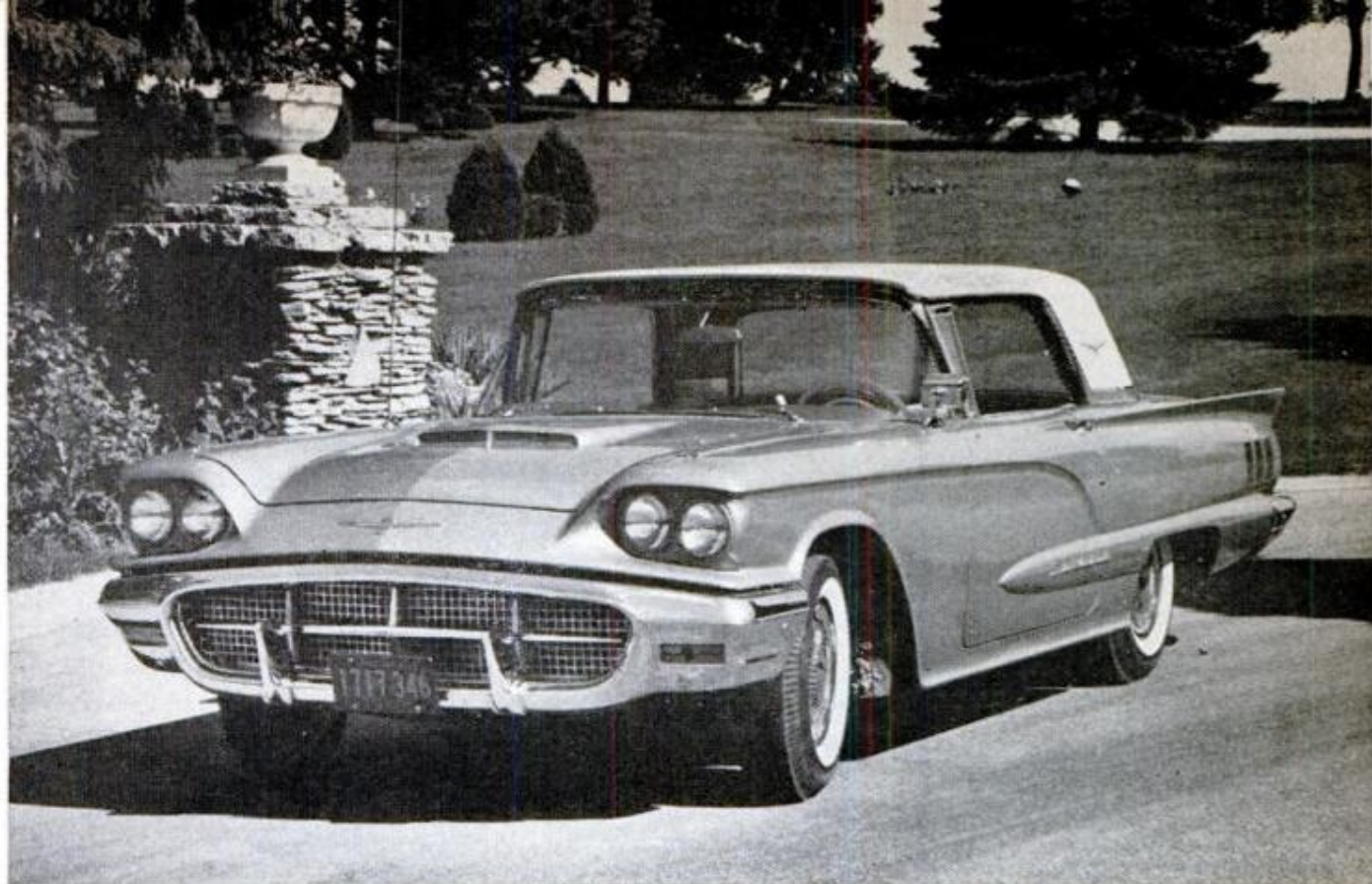

POWER, SAY THUNDERBIRD OWNERS

why they bought the car, what they like about it and how well they are satisfied with their choice.

A healthy 76.5% of owners reporting consider their Thunderbirds Excellent. A minority of 18% say that their joy of ownership has been marred by minor flaws and repair problems. At the bottom of the pile, and really unhappy are 5.3% who rate their cars poor.

Styling is really the big attraction with 55.4% mentioning it as a "best-liked feature." Next comes handling ease with 49.2% of owners reporting, and riding comfort follows with a 36.1% mention.

Here's what the owners actually said in their reports. The following quotations describe the five best-liked features in order of frequency of mention.

"Acquiring my Thunderbird—the best-looking car on the market—gave me as big a thrill as when I bought my first car back in 1933."—Missouri librarian.

"This is the best-looking car on the road."—Texas store owner.

"Styling, and not changing that styling is the principal reason that I bought a T-Bird. If they change that styling, they lose me!"—Minnesota art director.

"I've always liked the T-Bird's looks since it first came out, a real beauty of a car."—Illinois typist.

Part of the magic too, is that the T-Bird is so different in appearance. Its styling represents a welcome change of pace from long cars with high fins.

Owners like this man are on to a good thing—a car that grows old gracefully rather than rapidly obsolete. A well-kept '58 T-Bird looks just as "new" as a '60; a state of affairs too good to last.

WHAT'S WRONG WITH IT?

Owners dislike:

Hard to get in and out....28.9%
 Engine trouble11.2%
 Poor gas mileage..... 8.5%

Bad workmanship 7.4%
 Brakes 4.9%
 Transmission troubles..... 4.6%



Rear seats are fairly roomy, quite comfortable once you get in. Three might squeeze in except for tunnel



Here's T-Bird owners' biggest gripe, the difficulty in getting in or out. Seat's all the way back



Space to waste up under hood—a full eight inches lies between rear of engine and the firewall—who needs it?



The rear-seat passengers, that's who! If firewall moved up, rear legroom could be doubled

Graph shows that most 'Bird owners get 10 to 12 miles per gallon in city, 15-16 in cross-country driving

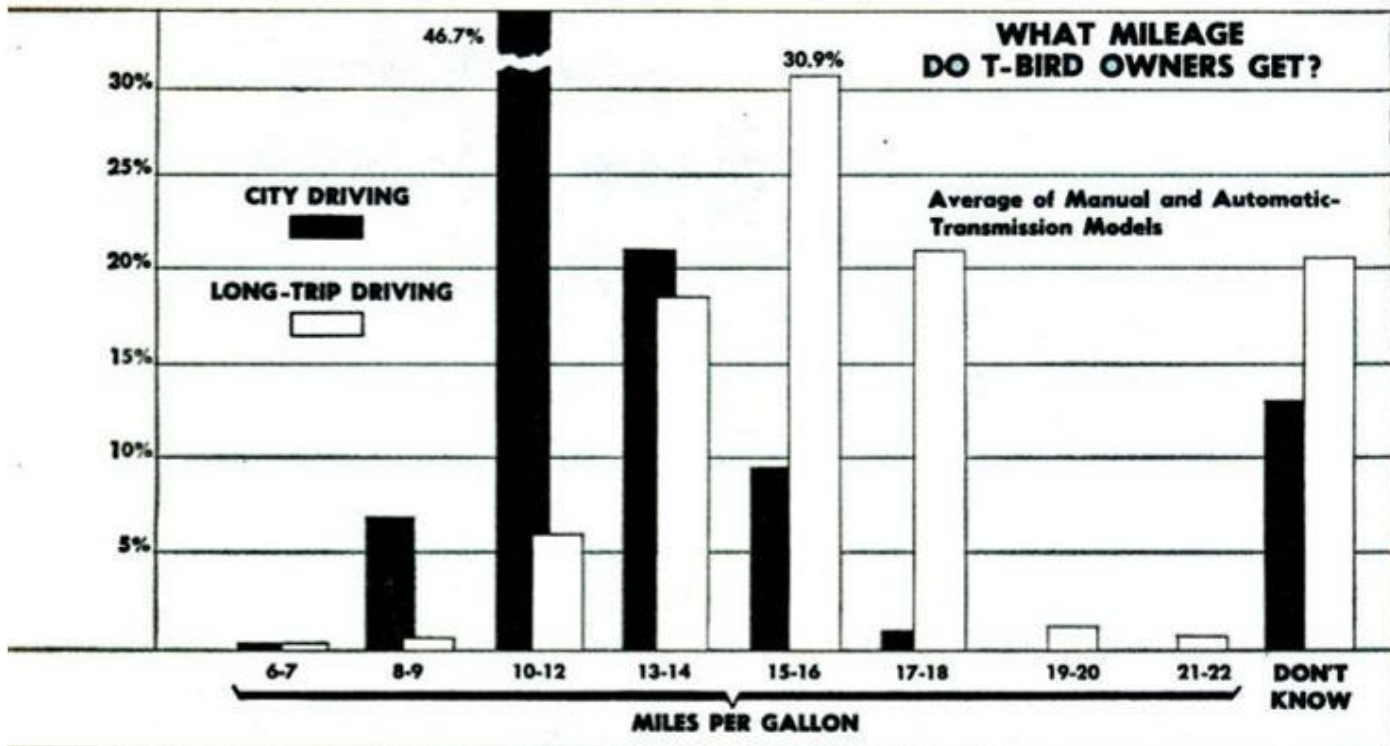



Tunnel dividing front compartment is a source of annoyance when you must cross through car



Trunk is shallow but makes good use of space provided. It's easy to load, and adequate for small family

"It's conservative, genuine leather upholstery is striking."
—Montana merchant.

"Tell Ford not to change the styling or size. This one is too good to be true."—New York lawyer.

"It has big-car ride and comfort, but handles like a compact car in traffic."—Tennessee cement plant manager.

"This is the finest and most-fun car I've ever owned—a joy to drive."—Indiana housewife.

"I like the way the car handles, but so does my wife, therefore I seldom get a chance to drive it!"—Utah refinery superintendent.

"Driving this car is tireless."—Michigan architectural consultant.

"Effortless town and road driving, fun to drive."—Virginia traveling salesman.

"It is so easy to handle it almost seems to drive itself."—Michigan clerk.

"Excellent ride and handling, I drive around 60,000 miles a year."—California salesman.

"It is the easiest car to drive on a trip or in town that I've ever driven."—Florida carpenter.

"I drove 700 miles without stopping except for gas and food and was in good shape at the end of the trip."—Indiana baker.

"Rides like heavier cars that I've had in the past yet handles easier."—Pennsylvania broker.

"Bucket seat is wonderfully comfortable, the car itself handles well and I've covered over 1200 miles in 24 hours without being exhausted."—Oklahoma jet pilot.

"Bird has the needed reserve power for safety in passing."—Wisconsin financier.

"The T-Bird just sits down and goes without burning any rubber off the tires."—Michigan instrument man.

"Quick pickup, can walk away from anything without being obvious about it."—Connecticut housewife.

"Has the speed and power when you need it."—Massachusetts sales manager.

"Riding and handling perfect, a really good 'old people's sports car.'"—Massachusetts housewife.

"Holds the road very well; when necessary to run off onto shoulder the car stays under control."—Missouri sales agent.

"Handles like a big car, remarkable on turns at high speed."—Nevada truck driver.

The comfortable, semi-bucket driver's seat, shorter wheelbase and power steering are the prime ingredients in T-Bird's recipe for success in this area.

At close to 4000 lb., the Thunderbird is probably the heaviest car ever built on a modest 113-inch wheelbase.

With the big, 430-cubic-inch engine rated at 350 horsepower, there is a good deal of genuine thunder in the 'Bird. You can reach 60 m.p.h. in less than nine seconds.

Very true. The T-Bird has a nimble, close-to-the-road quality that gives the impression of a sports car without the violent movement and harsh ride of the real thing.



Birds of a feather! Comet, right, shows strong styling kinship to T-Bird, a point to which some owners object

It's next to impossible to make a car as low as T-Bird is with engine in front and conventional rear axle drive. →

On long trips the comfort outweighs the inconvenience, but on short hops around town, entry-exit problems are a valid complaint. →

"High winds do not seem to affect it."—California treasurer.

And Here Are Some Complaints

The following quotations describe in the order of their frequency the five leading complaints.

"When driver must exit from right because of parallel parking it makes for a very awkward situation climbing over center tunnel, especially for a woman."—California auditor.

"Difficulty in getting into car on account of 'knee-knocker' windshield corner."—Florida engineer.

"Ingress and egress most awkward, but car is most comfortable once you're inside."—California druggist.

"Children bump their heads getting into it."—Montana housewife.

"Impossible to get in and out comfortably, I'm 5'10" tall and weigh 160—so it's not me that's at fault."—New York surgeon.

(Continued to page 242)

SUMMARY OF OWNERS REPORT: T-BIRD

Excellent 76.5%

Poor
Average 18.2% 5.3%



Thunderbird is only car in family?	
Yes, it is.....	37.4%
No, it is not.....	62.6%
Make of other cars	
Thunderbird	2.1%
Ford	18.9%
Other Ford makes.....	8.2%
Cadillac	6.8%
Chevrolet	6.8%
Other GM makes.....	14.0%
Chrysler Corp. make.....	7.1%
Other U.S.	2.5%
Foreign cars	5.7%
Unspecified	1.1%
Satisfied gasoline economy?	
Yes, satisfied	69.6%
No, not satisfied.....	30.4%
Best-liked features	
Styling	55.4%
Handling ease	49.2%
Riding comfort	36.1%
Power, performance	31.4%
Roadability, cornering	16.9%
Comfortable seats	12.6%
Compact size	12.3%
Most-frequent complaints	
None at all	28.9%
Hard to get in and out.....	11.2%
Engine trouble	10.9%
Poor gas consumption.....	8.5%
Bad workmanship	7.4%
Brakes	4.9%
Transmission troubles	4.6%

Had engine trouble?	
No trouble	67.2%
Some trouble	26.8%
Considerable trouble	6.0%
What was trouble?	
Carburetor	7.4%
Wiring, ignition trouble.....	6.0%
Poor idling, missing.....	3.3%
Hard starting	3.3%
Best-liked interior features	
Seats	46.4%
Instrument panel	10.9%
Upholstery	10.4%
Least-liked interior features	
Transmission hump	12.6%
Divided seats	5.5%
Difficult entry or exit.....	4.1%
Did you consider a foreign car?	
Yes	12.8%
No, did not.....	87.2%
What make?	
Mercedes	21%
Jaguar	11%
Triumph	3%
Did you consider another U.S. car?	
Did	38.8%
Did not	58.5%
No answer	2.7%
What make?	
Ford	5.5%
Other Ford products.....	5.5%

Cadillac	7.4%
Corvette	2.1%
Chevrolet	1.9%
Other GM make.....	13.7%
Chrysler Corp.	3.0%
Foreign car ownership	
Never owned a foreign car.....	78.4%
Previously owned one.....	10.7%
Now own one.....	4.4%
No answer	6.5%
Best-liked exterior features	
Low distinctive lines.....	33.6%
Minimum of chrome trim.....	4.9%
Roof line	4.6%
Least-liked exterior features	
Taillights	5.7%
Grille	5.2%
Rear fender trim.....	3.0%
How is dealer service?	
Excellent	45.6%
Average	39.7%
Poor	14.7%
Would you buy from him again?	
Yes, would buy again.....	57.3%
No, would not.....	13.7%
No answer, don't know.....	29.0%
Next car will be	
Another Thunderbird	56.0%
Other Ford make.....	2.2%
General Motors make.....	2.7%
Chrysler Corp. make.....	1.1%
Foreign car	2.7%
Undecided	35.3%



Tractor Engine Powers Ferry

Eighteen hours a day, seven days a week, a ferry powered by a tractor engine "furrows" its way across the Wabash River transporting passengers and automobiles between docks in Indiana and St. Francisville, Ill.

The ferry has been operated by a family named Caldwell since 1920, but it was not until 1941 that Ike Caldwell hit upon the idea of using a farm tractor as the rugged power source his almost continuous operation called for. A tractor, devoid of wheels, was moved into the boathouse. Plates were welded to axle ends and bolted to shafts carrying the eight-foot paddle wheels.

"We grind the valves and replace the rings each 18,000 hours of service," Caldwell says. "It costs about \$7.00 a day to run. That's why we can ferry cars for 35 cents a trip and still show a profit."

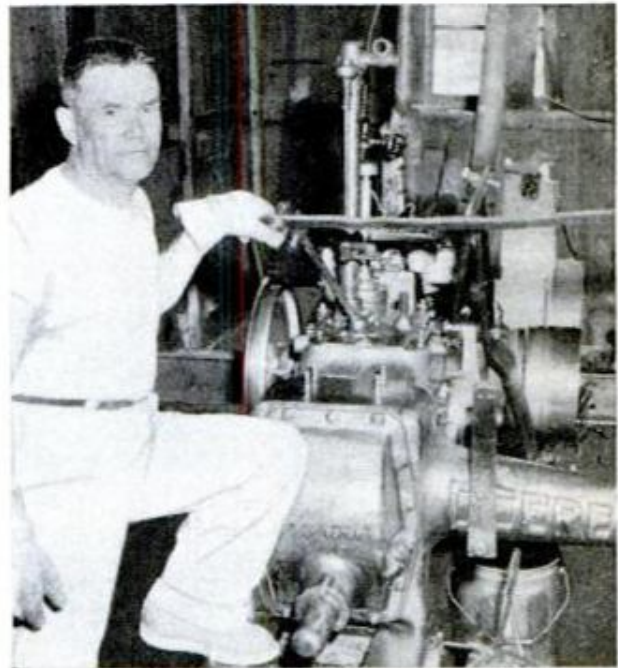

Prerecorded Tape Cartridge Player

Prerecorded tape cartridges are played automatically on a new cartridge-playing mechanism. A wide variety of prerecorded tapes are available, and the small size makes easy storage possible. After choosing any of the selections available, the desired recordings are simply stacked on the playing mechanism and the unit turned on. The tapes are played one at a time, in sequence. There is no problem involving the threading of tape, as encountered in the reel-type tape recording devices. The tape moves at $1\frac{7}{8}$ inches per second; each cartridge providing one hour of listening.

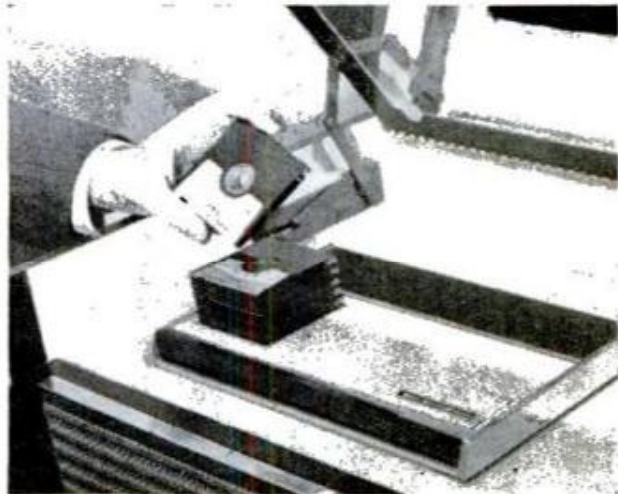



Mobile Missile System

Transportable by airplane, the U.S. Army's Sergeant missile system makes wide use of a new steel alloy which pares pounds from its launching and trailer rigs. The supporting vehicle that assembles, erects and launches the surface-to-surface missile weighs only 16,000 pounds, some 7000 pounds less than if it had been built with standard-strength steel. U.S. Steel Corporation developed the new alloy for the Army Rocket and Guided Missile Agency which is directing work on the new system.

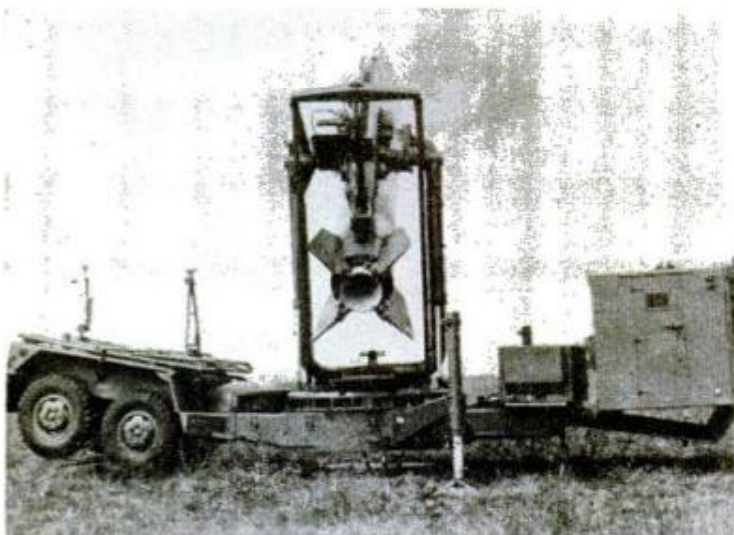

Doctors Study Skaters

Two University of Michigan doctors are studying spinning ice skaters to learn how they control dizziness when whirling. The results—which so far indicate that skaters somehow suppress impulses rising to the brain from the balancing center in the ear—could offer new avenues of help for people who suffer from motion sickness and certain ear disorders. The experimenters, Drs. Brian F. McCabe and Merle Lawrence, believe their findings may be of help to future astronauts who will encounter, in weightlessness, the disorientation expected in space flight. They photographed skater Ronnie Robertson making 400 r.p.m. without getting dizzy.

We Need Safer Taillights

By Charles Marsh

Associate Professor of Electrical Engineering
Pennsylvania State University

**Stylists have confused
decoration with function;
all that glitters is not good.**

IN THE SPEED and confusion of the homeward bound rush, a driver signals with his turn indicator for his turnoff, then touches his brake pedal a few times as he slows down. But the sun shining on his rear spread of chrome dazzles the driver behind him, who doesn't see the feebly flashing signals.

As the first car brakes for the turn, the following car crashes into it. The first car had signaled his intentions clearly, or so he thought, but the severe "whiplash" injury to his neck, as his head was thrown back by the impact, may have paralyzed him for life.

Such rear-end collisions, with their accompanying neck injuries, are occurring more frequently as more and more cars travel on the highways. Not much can be done about the number of cars on the road, but improvements to the stop signals as well as the front and rear turn indicators would help drivers to signal more clearly and thus avoid many accidents.

So that the signal can be seen clearly, the signal lamp should be bright enough for every condition, yet not so bright that it blinds other drivers. It should be located where it can be seen in congested traffic. It should be placed so that mud will not coat it. And it should be separated from dazzling and confusing masses of chromium.

But, most important, the meaning of the signal should be absolutely clear to even the sleepest and most bewildered driver who must make split-second decisions with only half his mind in operation.



The hood or shroud may delight the stylists, but it not only narrows the angle through which the light is seen but causes eddies of air to deposit muddy spray onto the lens much more rapidly (1959 Olds)

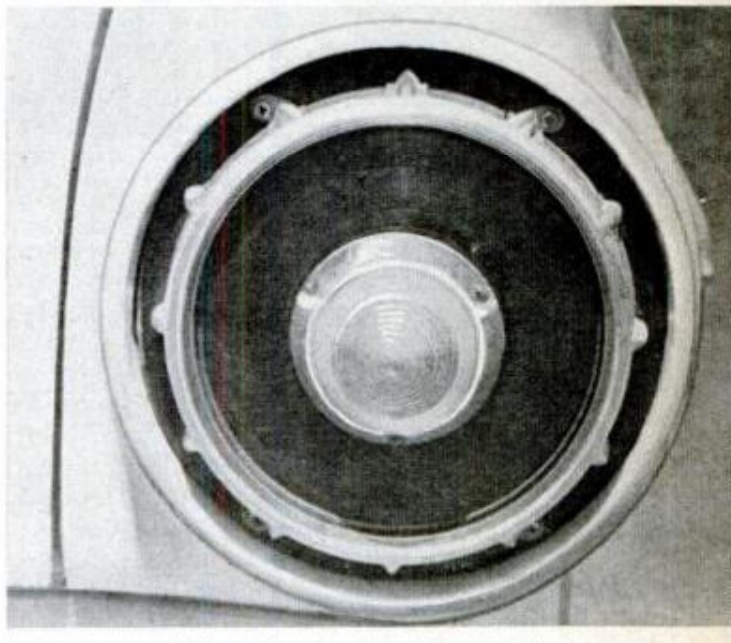

Addition of a high reflectance outer ring and backup light at center greatly reduces the daytime effectiveness of this large, low-brightness lamp (1957 Ford)

Here is an example of good lamp placement. The blade-like lense on fin tip can be seen equally well on curves and straights. Air currents flow smoothly around it keeping it free from dirt (1956 Cadillac)

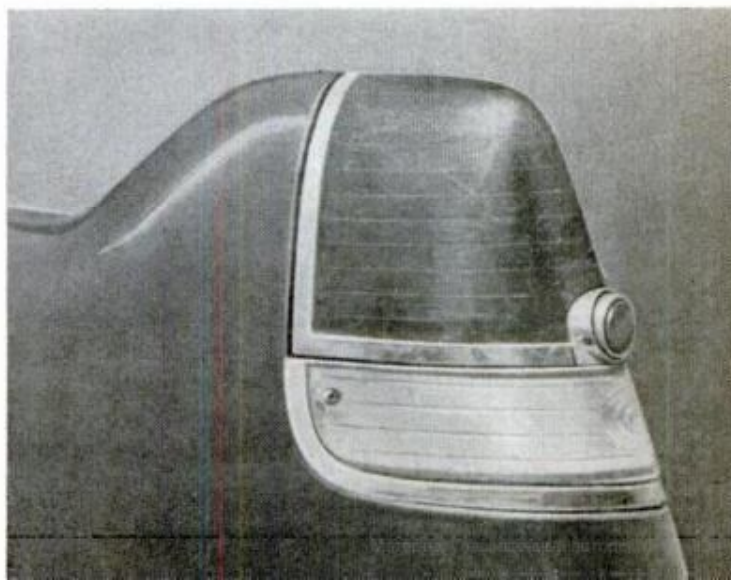

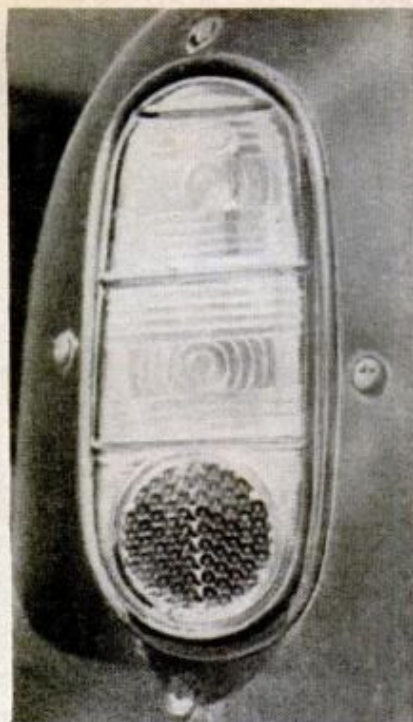
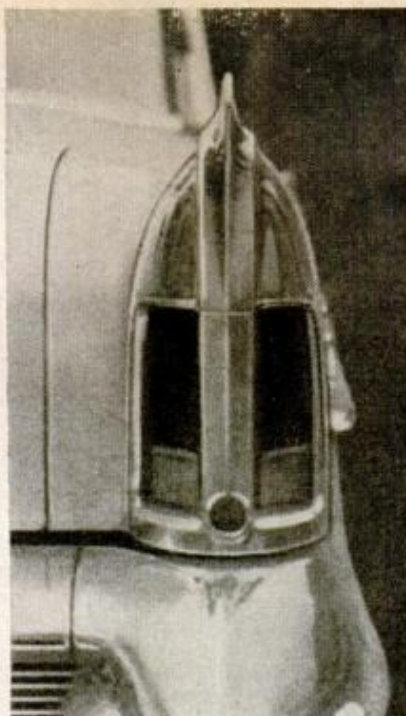
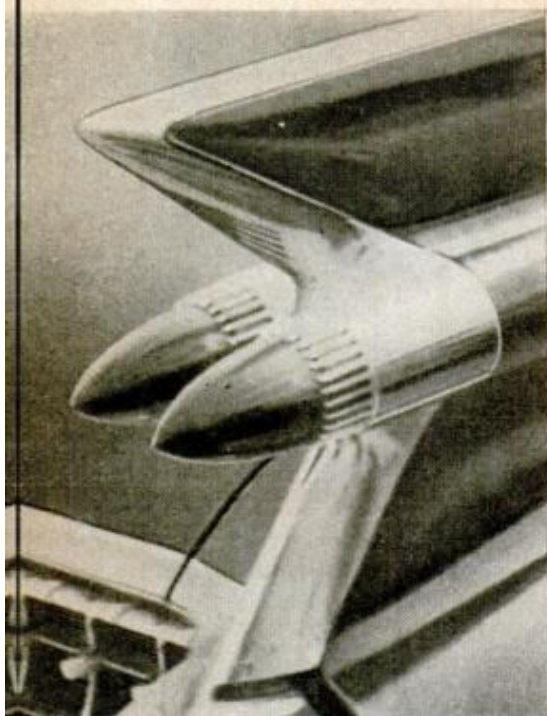

Fin-mounted lights, left, on 1959 Cadillac, look like something from space-age toy, but are effective because they're swept clean by airflow and are visible from all angles. Shrouded, smothered in glaring chrome, taillights on this '58 Buick, center, are very poor. English Ford, right, has clear simple unit combining tail, stop and turn indicator in upper two sections with adequate reflector located separately below

And a drowsy driver can make some pretty strange split-second decisions. For instance, one night the driver of a car carrier found his headlight had failed, so he climbed up and switched on the lights of the front car in his load. Coming over the next hill he met an exhausted, all-night driver who, figuring "If it's that high, it must be that wide," panicked into the ditch.

With the cars on the road today, when a driver sees a red light, assuming he sees it at all, he must ask, "Is it a tail or brake light? Is it bright or not so bright?" If he assumes it is the bright taillight of a new

car, he may find as he jams on his brakes that it is really the dim and dirty taillight of someone stopping on the highway.

If the red light is flashing, his dilemma increases. Is it a turn signal? Or has one brakelight burned out and the driver is pumping his brakes?

If there are two red lights flashing at different rates, what can this mean? One light signals a turn, while the other is the brake light, flashing as the driver slows down. But which way will he turn?

Who would have confidence in marine navigation lights which used bright red

Separate lamps for different functions on this late model Lincoln, below left, are a step in the right direction but horizontal spread in dazzling chrome is poor. Lamps on 1949 Packard, below right, had good separation but were poor because of low intensity lens and confusing integral reflectors

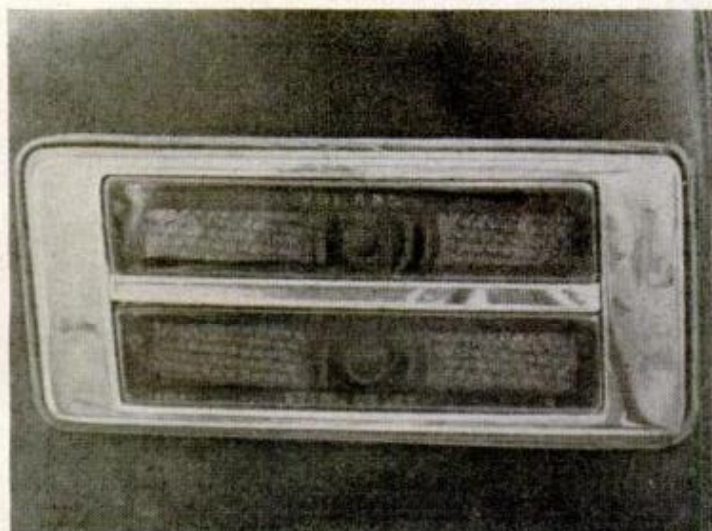
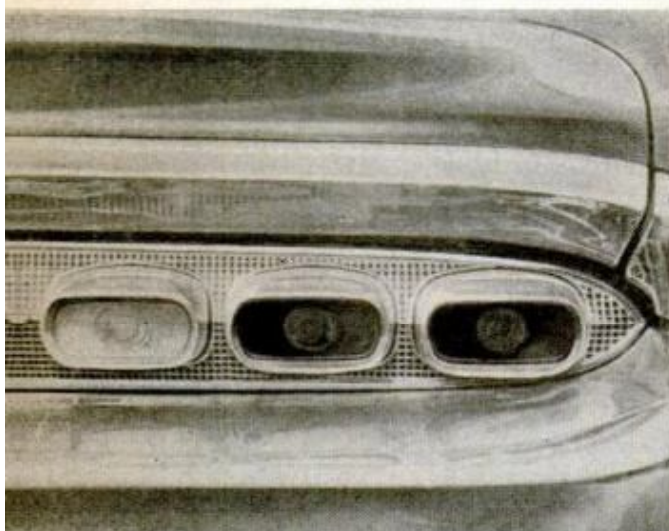

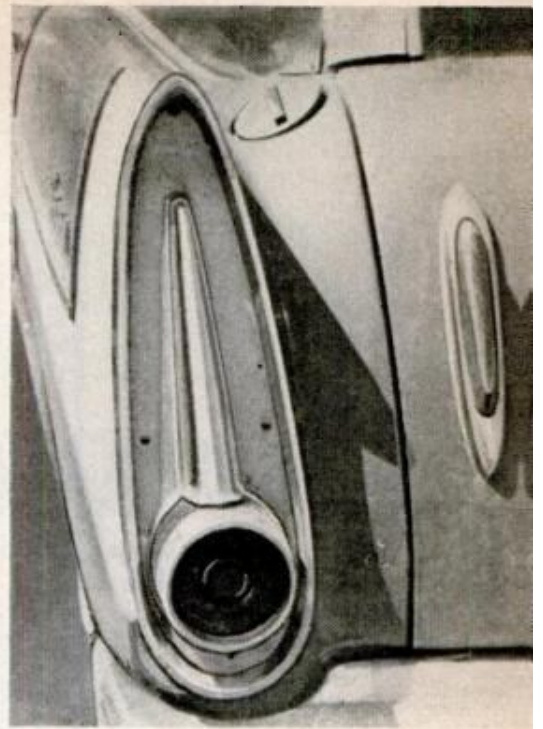
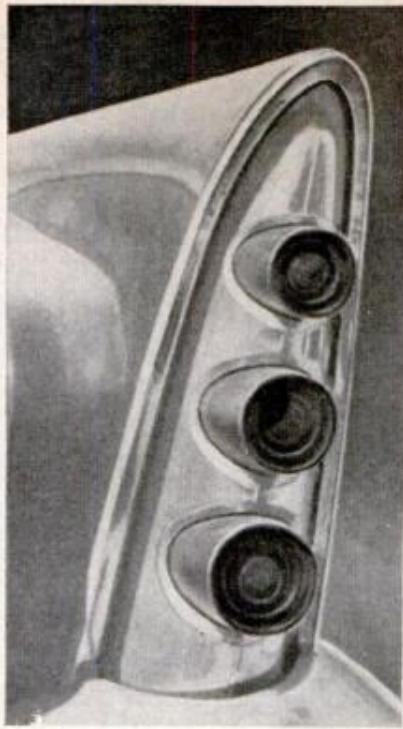
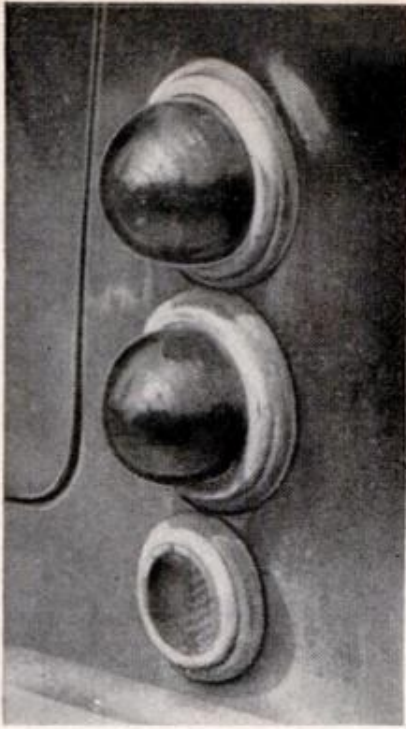

Twin lamps, one for tail and one for stop on this English Triumph, left, with separate reflector are excellent. The triple lights in vertical stack like railroad signals on this 1957 DeSoto above are an ideal arrangement but are surrounded with annoying chrome. Here's a poor setup, right, on '58 Plymouth where a minimum lamp is made worse for daytime driving by surrounding it with bright aluminum trim

lights for port and dimmer red lights for starboard?

So, one fairly obvious improvement would be to use different color lamps for different messages, instead of using only red lamps in the rear. Many European cars use red for their taillights and amber for stop and turn. This is an improvement, but it is really backward. Red should mean stop, and only stop, while amber should mean proceed with caution.

One such system would require an upper red and a lower amber light on each side. Both would be on dim as taillights for night

driving. At a distance, the red and yellow lights would merge to orange, giving some measurement of spacing.

For signaling, both lights would flash, the red light flashing for stopping only, and the amber light for turns. The same flasher would serve both turn and stop lights, so that if the car were both turning and braking at once, while the turn indicator flashed brightly, the brake on the opposite side would drop back to dim. The rate of flashing of a brakelight might even indicate the rate of braking.

The turn signals in front also need im-

The tail lamp lens on Jeep, below left, is going to get much dirtier from eddy currents of spray than the outboard turn signal. Turn signal grouped with headlamp on this 1957 Plymouth, below right, is very difficult to see clearly when headlamp is on and can be dangerously confusing under certain conditions

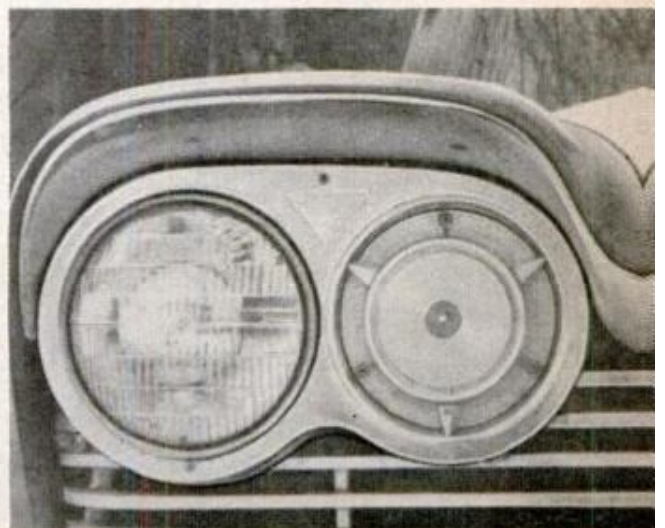



A poorly placed turn signal placement on this '57 Mercury. It is so far inboard that it can easily be hidden by a preceding car. It is also too small and viewers are distracted by much glittering chrome

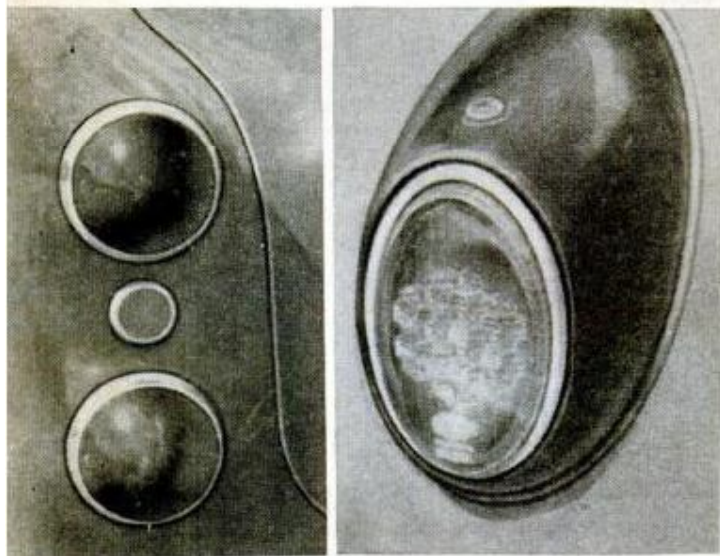

One of the best systems seen in recent years, above left, on '54 Buick. Both are lit for tail lamp, one brightens when brake is applied, other blinks for turn, while reflector is separated. A fine prismatic reflector in exactly the wrong place, above right, on Volkswagen; reflections look like stoplight flashes

Here, on '57 Buick, below, is a nearly ideal signal lamp. It is small to give high brightness, away from chromed surfaces and near outer limit of body

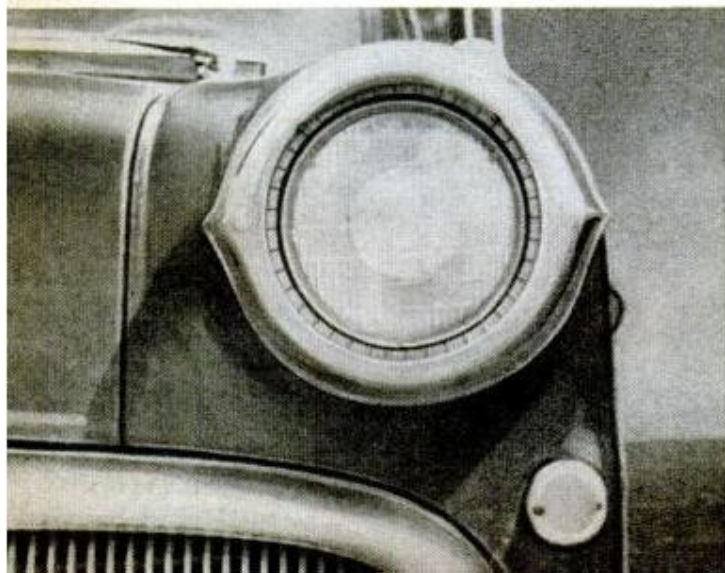

provement. For instance, amber lamps are more noticeable, but most cars still have white turn indicators unless truck fixtures have been installed.

Some turn indicators are so embedded in the grille decorations that they are all but invisible when the sun shines on the chromium. Lights bright enough to outshine all that glitter are too bright for night driving.

If a bright signal is desired in the daytime and a dimmer one at night to avoid glare, it would be a simple matter to connect a switch between the signal and the headlight system.

But, for driving in fog, bright signal and headlights are needed at the same time. In daytime fog the high-beam headlights and the brightest signals are needed to be seen at all.

At night, low-beam headlights are easier to see over in fog, but the brightest signals are still needed, so a special light switch for fog could be used.

In winter especially, road grime can all but obscure rear signal lamps. In some positions turbulence seems to spray dirt onto the lenses, while lamps in other positions are swept relatively clean by the airstream.

Lamps that are mounted high can both keep themselves cleaner and be seen more readily, either in crowded traffic or on topping a hill in the country. Once upon a time, the tailfins served to hold high-mounted lamps up where they could be seen, but now by some evolutionary process, the lights have slipped down and nestle beneath the fins which create turbulence and suck dirt onto the lenses.

Another design trick to watch for is signal lamps which have reflectors built into their lenses. When lit up by a following car or low sun, these lenses are so bright that the signal may be invisible.

These simple changes, such as using amber turn indicators fore and aft, using red light for stop only, and mounting the lights where they can be seen easily, would give a large margin of safety at very little cost other than intelligent planning.

Yet, even such changes are not easily made, for the massive auto industry and the public to which it sells must be convinced, and in addition the codes of every state must be modified, and this can take several years.

However, changes are under way. Lighting and traffic engineers are studying possible signal systems. Many states are streamlining their equipment-approval procedure. And with today's heavy traffic superior signal systems are essential. Before too long we will find them on our new cars. ★ ★ ★

The Cover Story



HUNTER'S MOUNTAIN CAR OUTPERFORMS PACK HORSE

INJURED in an accident that prevented him from climbing or riding horseback into the mountains, an ardent Montana sportsman built a mountain car that covers rough country quicker and carries a bigger load than a horse. Ted Duke's "Centipede" works on the same principle as a tractor. Five wheels are mounted on each side of the machine, the front two coming into play only when the Centipede noses into a large obstruction. The eight rear wheels provide

the pulling power, each operating independently. A bicycle chain drives each one from a sprocket, and independent suspension allows the vehicle to cover rough obstructions smoothly. Steering is accomplished by disengaging the clutch for either side of the machine. The Centipede can easily haul two days' camping supplies, any size game, and two men over steep trails. Its five-horsepower motor uses about a gallon of gasoline per half-day's drive.

Ted Duke (right) and his brother Harold load up for camping trip. Ten-inch wheels carry over any terrain





Gyroplane "Jumps" 200 Feet at Takeoff

No runway is needed for taking off or landing a Canadian autogyro, the Avian 2/180 Gyroplane. A rotor, normally free-wheeling, serves as a wing; forward motion is given by a ducted fan-shaped propeller at the tail. The Gyroplane cruises at 150 miles per hour, approaches at 20 miles per

hour, and lands vertically. While a normal takeoff run is 100 feet, the plane also can "jump" into the air. The rotor is accelerated on the ground by means of a jet air nozzle at each blade tip. Compressed air is forced through the nozzles, lifting the Gyroplane 200 feet straight up.

Old Cargo Plane Becomes Mobile Home

Australian ingenuity and the fuselage of a Douglas DC-3 cargo plane paid off in a self-propelled mobile home for author Jeff Carter, who combines the front half of the aircraft body with a truck chassis, using the old cockpit as a cab. Carter's family

has accompanied him around the Australian continent for five years in the "land yacht" while he gathers material from sheep and cattle drovers, kangaroo and wild-dog hunters and fishermen, in country where temporary quarters are scarce.



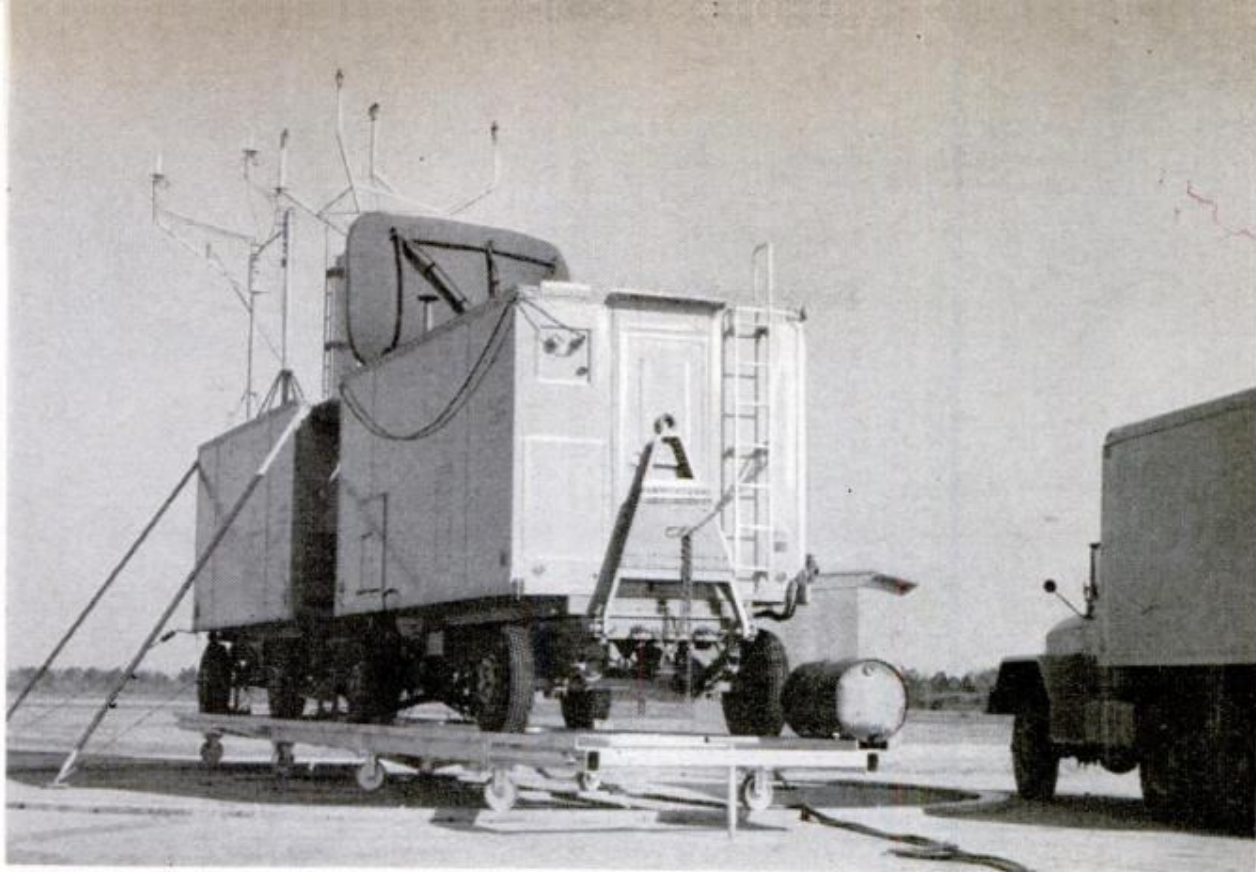

Ground-Controlled Approach Radar Swings on Turntable

Naval ground-controlled approach equipment is being placed on turntables to reduce the time planes must wait to land. Before this technique was devised, every major change in the wind required that the radar-housing unit be laboriously hauled into a new position for alignment with the runway dictated by the new wind direction. Aligning the unit with the runway required 30 to 40 minutes. The turntable al-

lows the radar housing to be positioned within three to ten minutes. It is hand-operated and can be moved by one man. Its use also adds to the life of the equipment by permitting it to be realigned before it cools. Cooling and reheating shortens the life of tubes. First installations have already been made at the Marine Corps Air Station, Beaufort, S.C., and at the Naval Air Station, Dallas, Tex.

Church of Arches

Soaring skyward in a spectacular series of graceful arches, the newly completed Our Lady of Grace Church dominates the landscape at Higüey, Dominican Republic. The topmost arch towers 246 feet above the ground. The church was built at the cost of \$5,000,000. It is a shrine, and millions of pilgrims are expected to use it for worship.

High-Speed Color Movie Film

With a normal exposure index of 160, a high-speed color motion-picture film enables photographers to record poorly lighted scenes and technical subjects for which accurate color and high film speed are essential. The film, Ektachrome ER, daylight type, has been exposed at indexes as high as 500 while recording missile data. Its tungsten-balanced counterpart, type B, has a normal exposure index of 125. The manufacturer describes the film as of "adequate sharpness, moderate grain pattern and excellent color reproduction." It is available in 16-mm. and 35-mm. sizes.

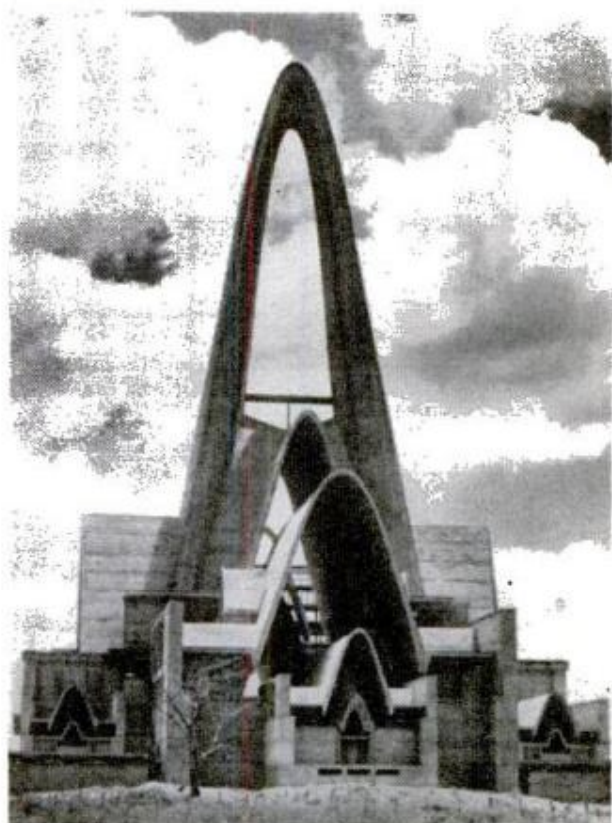



Two most popular types of pirogue—left, hollowed-out cypress log, right, plywood

Racing pirogueman, ready for takeoff. He kneels to get better leverage, and the plastic cover keeps out water during race



Pirogue Race

By Dev Klapp

WHEN 6000 LOYAL French Acadians were exiled from British Nova Scotia in 1755, they were shipped to English Colonies all over the East Coast to disperse them among loyal British colonists. Many of the Acadians, in an attempt to escape British rule, wandered westward to the former French colonies in what is now Louisiana. Their descendants, their name mispronounced "Cajuns," form a large part of Louisiana's population. In those difficult early days, the Cajuns hunted and trapped for a living in the bayous and swamps of the lower Mississippi. They soon found the Central American natives' dugout canoes, called piraguas, to be the best craft for threading between cypresses and live oaks in shallow backwaters, and the "pirogue" became their standard means of transportation. Even today the pirogue is the back-country standby, and the dream of Acadian

parish youngsters is to be a good pirogue-man first and a baseball hero second. Each year, at Bayou Baratavia in the heart of the Acadian country, they hold the annual pirogue races, and Cajun experts race lightweight racing pirogues over a four-mile course "to see who's the best man on the bayou." A field of 62 competed when these photographs were made, and the winner, 19-year-old Gerald Evans LeBlanc made the run in 36 minutes to win a cash prize, a trophy, and the acclamation of the marshland people. But the times are catching up with the traditional sport—the standard pirogue is hollowed out from a solid cypress log or built up of paper-thin plywood or planking, roughly 20 feet long and light as a dry leaf to skim lightly over the shallow bayous. But LeBlanc's championship pirogue was lovingly fashioned from modern glass-fiber reinforced plastic.

Jockeying for positions just before the starting gun. Anything goes, short of upsetting a rival's boat
Photos: Louisiana Dept. of Commerce and Industry





Drifting Parachute Snatched by Copter

Parachutes carrying missile nose cones or data capsules may, in the future, be plucked from the air by helicopters before their cargo has the chance to be lost at sea or destroyed by impact with the ground. The aerial recovery technique was recently tried and termed promising by service officers. A Sikorsky S-55 helicopter equipped with a 20-foot boom and a hook attachment made five in-the-air pick-ups. Parachutes were released at an altitude of about 8000 feet; recoveries were made at 1000 to 6000 feet.

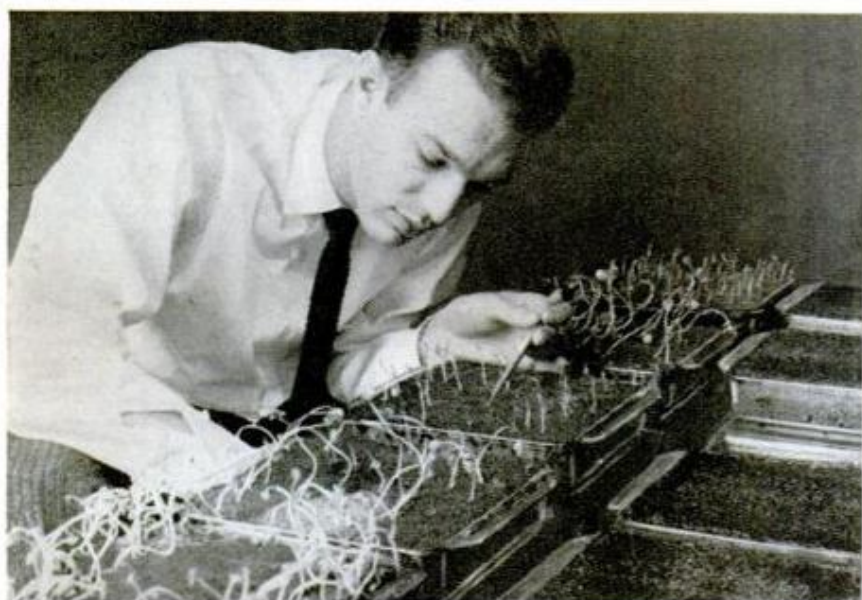

Asphalt Blanket Boosts Crops

Excessive loss of moisture through the ground surface, a contributing factor in dust-bowl conditions, might be prevented by a thin layer of asphalt film. Experiments show that special blends, when sprayed over seeded soil, are sufficient to hold moisture in the ground when young plants need it most, but thin enough to allow delicate shoots to pierce it easily. Experimental sprouts are shown.



Quick-Release Lock Collapses 'Chute

Many paratroopers have been killed or injured when dragged by their chutes after landing. A new quick-release lock, that can't be opened accidentally in mid-air, may end all that. Three quick actions unlock it. A protective canvas flap is lifted up, a metal cover is pulled down, and two metal buttons are pressed together. Releasing one of two locks will collapse it.



Portable Electronic Lung

Weighing only 56 pounds, an electronic lung developed in England allows patients with respiratory problems greater mobility than has been possible with iron lungs. The machine, called the Barnes Ventilator, is connected to the patient by two plastic tubes and is, itself, portable. It has built-in batteries from which its transistorized circuit will run for up to 20 hours without recharging. Thus, a polio patient, for example, can be moved from one hospital to another, or between continents by air, with relative ease.



Flying Laboratory

Sometime this year the Bristol 188, an English-built research plane made of stainless steel, is scheduled to take off from a runway and fly at speeds exceeding 1500 miles per hour. The single-seat jet, built at a cost of more than \$14 million, is powered by two de Havilland engines. Observers say it will be used as a flying laboratory which will lead to the design of a supersonic airliner. Since the 188 will take off as a conventional aircraft under its own power, the manufacturer, Bristol Aircraft, claims the plane has a range of speed "probably greater than any aircraft now flying."





Bill Hanna, left and Joe Barbera look over the story board for a television cartoon. Having already established the Huckleberry Hound characters, they're introducing a new feature this fall, the Flintstones

TV HIT FROM A

As Yogi Bear would say, Huckleberry Hound is better than the average cartoon. More than 30 million Americans, from college professors to kindergarten tots, would agree. The television industry agreed—and gave Huck an Emmy award in June as the best children's program. Here's how Huck—and all his strange companions—are reborn each week.

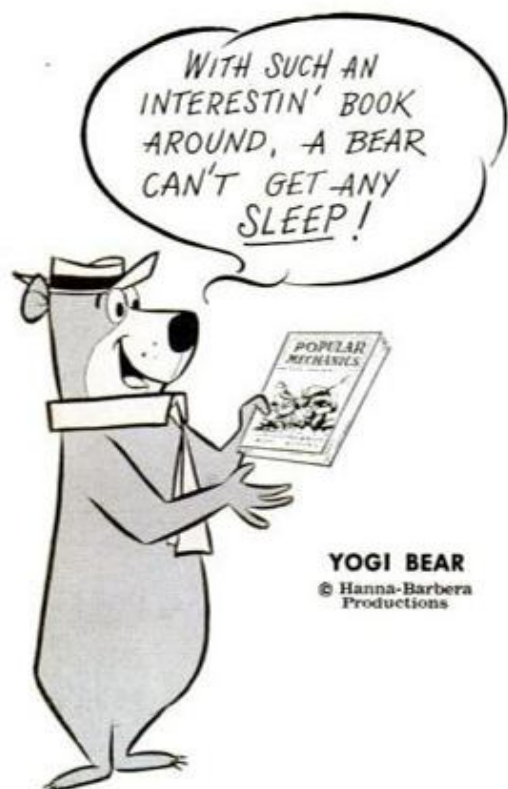

YOGI BEAR
© Hanna-Barbera
Productions

A GROUP OF LITTLE CHARACTERS, whose real selves are scarcely more imposing than the place mats on your table, each week manages to capture the attention of some 33 million U.S. television viewers.

And, remarkable as is the widespread appeal of the animated cartoon featuring Huckleberry Hound (the program is among television's top 10), even more remarkable is the fact that new cartoons appear each week. By ordinary standards, Huck should be just too expensive to produce.

In the past, a six-minute cartoon for theater showing cost \$40,000 or more—enough, anyway, to keep an audience in popcorn indefinitely. On this basis, a half-hour television show—less time for commercials—would cost close to \$200,000.

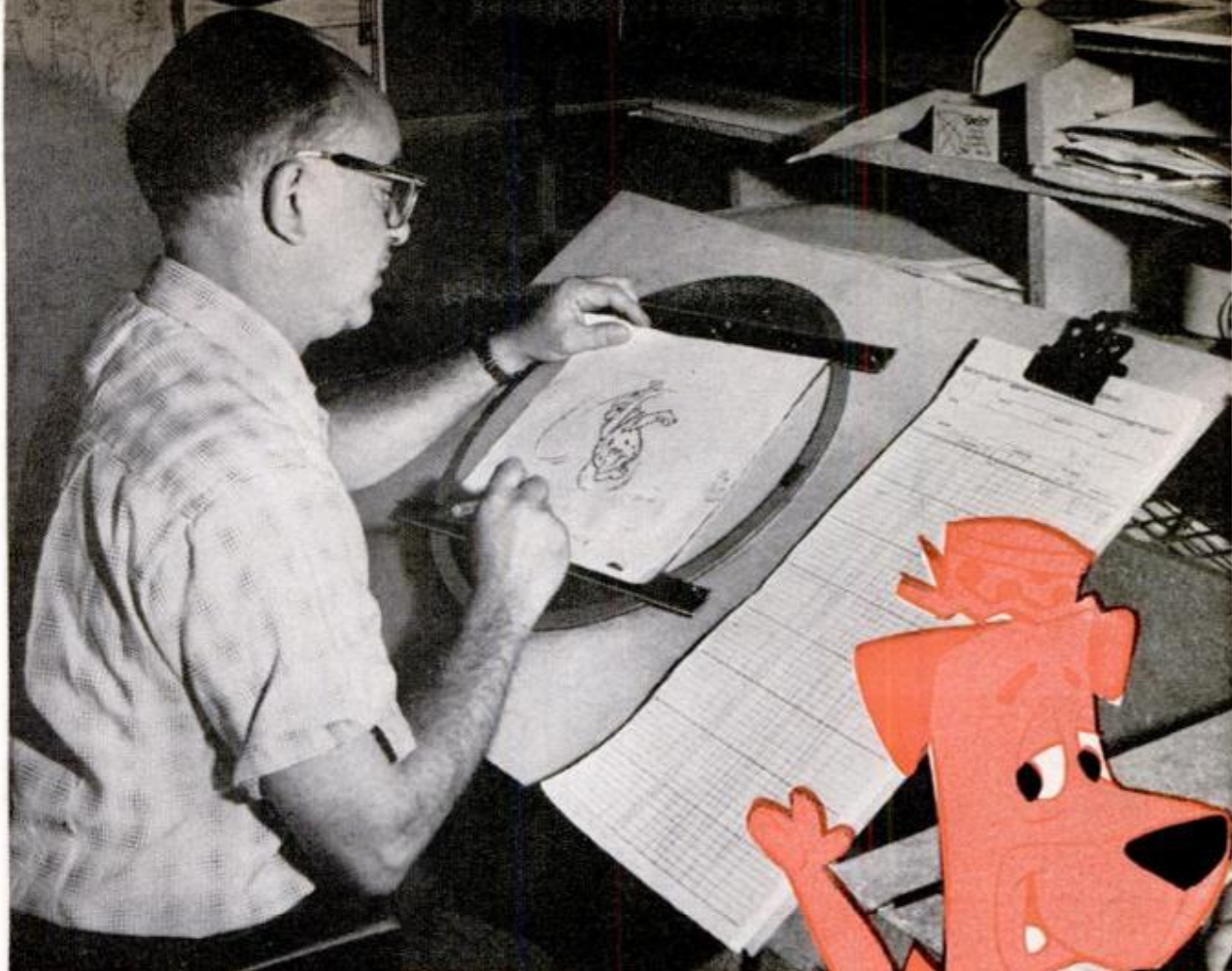

Animator draws character on easel that's illuminated from below. Notched drawing paper enables him to locate sequences accurately

CARTOON FACTORY

By **Thomas E. Stimson, Jr.**

PM photos by the author

Advertisers do not readily part with that kind of money on a weekly basis.

So when Bill Hanna and Joe Barbera, two of Hollywood's top cartoon producers, decided three years ago to break into television, they had some sharp-pencil-and-adding-machine type figuring to do. Twenty years of producing MGM's Tom & Jerry cartoons had given them plenty of experience in animation techniques.

They invented shortcuts, new ways of achieving effects and new methods of treating action. They called the results *planned animation*. Planned animation is much less expensive than the typical cartoons of only a few years back—and they've made the films even more entertaining.

Basically, they use the same animation process by which cartoons have always been made.

"First of all, we have to come up with a new story idea," Bill Hanna explains. "Joe Barbera and I contribute some ideas, the writers and other people on the staff contribute others. Next we reduce the story to pictures by drawing a series of rough sketches that outline the action of the plot. These pictures are called the story board, since they originated on the drawing board. A story board for a six-minute cartoon may contain 140 drawings and as many as 600 for a half-hour show."

Once the story is approved, a layout story board is put together—this time with



Long background scene will be shifted during filming to give illusion that animated character is moving

all the technical directions for the different departments written on each drawing.

Surprisingly, the voices of Huckleberry Hound and friends plus all sound effects are recorded before any of the actual animation begins. In the recording studio, the commentator speaks his lines and the characters deliver their dialogue while still in a disembodied state. Daws Butler, an ex-

perienced voice man with a repertoire of more than 25 voices and accents, handles many of the parts.

"These recordings are turned over to sound-track editors who listen to them and mark each syllable of speech on what are called animation sheets," Hanna continues. "These sheets will guide the animator so he can allow the proper number of frames for mouth action.

"The animators then make the actual drawings. Each bit of motion calls for several sequence drawings, possibly as many as six drawings to show a character taking a step. The drawings then go to the inking department where a girl lays a transparent sheet of acetate (known as a *cel* because celluloid sheets were used in the old days) over the drawing and traces in the outlines with a broad pen. From here the cels go to the painting department where they are filled in with color, using quick-drying vinyl house paints. The cels are all painted in color because of the possibility of color television reruns in the future."

Actually, Huck and his friends exist in a rather fragmented way (for which there



Quick Draw McGraw
and Baba Looney
© Hanna-Barbera
Productions

FADE IN (C)



KID: (G.S.) (AD LIB HUMMING)... ..DUM-DE-DUM-DUM * ... DI, DI, PA-DUH PA - DUM - DE-DUM-DUM!..

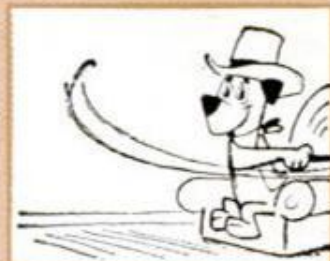

DUM, DUM-DOO DAN DUM ~~~~~ ... OOK!

FX: ZIP!



FX: FLIP ~~~~!

HUCK: ... WHERE YA GOING, SON?

KID: I'M GONNA WATCH 'TRUE STORIES OF THE WILD WEST,' ON TEE-VEE GREAT-GREAT-GRANDPAPPY HUCK!

Sequence of rough drawing on story board is first step in reducing a story to pictures for animated cartoon

is probably some psychiatric or medical term). The inkers and painters make very few complete drawings. Huck's body may be painted on one cel, his head on a second, his legs and feet on a third. Stacked in register atop one another, the cels produce the full figure. This technique allows Huck to talk or walk merely by going through a sequence of heads or legs and continuing to use the cels that make up the rest of the body.

Backgrounds are drawn on sheets of heavy paper and form the base under the stack of cels. If a character is to move to the left or right during a scene, a long background is used that shows a series of clouds or trees. The action then is created by moving the background one notch at a time in the proper direction. The animated character merely moves his legs and remains in the center of the scene.

The aim of all this work, of course, is to get the action on film. So each set of cels is photographed with a sequence motion picture camera that exposes one frame of film at a time. The cameraman places the background drawing on the flat easel under

the camera, matches up the various cels on top of it (so that legs, arms, bodies and other miscellany fit together), presses a button to make the exposure and then consults his direction sheet to learn which cels should be replaced for the next exposure. Run at standard speed in a movie projector, the series of still drawings becomes a motion picture.

Animation is no pastime for a man who likes to let somebody else handle the details. It's tedious and time consuming work. At the rate of 24 frames per second, a six-minute cartoon requires 8640 exposures. That's probably more shutter snapping than you'll do in a lifetime with your Baby Brownie . . . and you might miss the whole 8640-exposure sequence if you leave your TV set to put the cat out. That same six-minute cartoon may also require as many as 14,000 cels. A half-hour TV show consumes more than 43,000 exposures in all.

Until TV cartooning came along, a cartoon often was more expensive to create than a live action movie of the same length. A single six-minute short took all of six weeks to produce.

AND - A - HOUND - DOG'S

1 2 3 2 1 1 4 5 6 7 6 6 6 5 6 7



Here's how Huckleberry Hound's mouth moves to form the words "and a hound dog's howdy to you." Each of the cells is a transparent acetate sheet on which the features are drawn. By laying each of the numbered acetate sheets over the close-up of Huck (in which his mouth is missing) and photographing them one at a time in this sequence, his mouth positions are made to correspond with his bucolic canine greeting

Inker uses broad pen to trace outline of original drawing onto cel; next step is to paint the characters



— HOWDY - TO - YOUUU

7 2 1 5 7 2 2 7 5 5 6 5 8 9 9



Today, with about the same size crew, Hanna and Barbera are producing as many as six shorts a week in the Hanna Barbera Productions studio.

"One thing we do is take advantage of the small size of the home television screen," Joe Barbera says. "The small screen calls for close-ups instead of theater-wide scenes with babbling brooks and falling leaves in the background. We even like close-ups of a character's head instead of showing his full body, just to avoid the necessity of making more drawings.

"We've reduced the animation of speech to nine standard mouth positions, and a character has a full vocabulary with these nine expressions. More than that, you'll notice that we often finish a speech with a still picture of the character who is listening. Nothing is lost by this, and we can use the same drawing of the listener for many, many frames.

"Another thing, all the characters move either to the left or right, rarely away from you or toward you. This eliminates the need for tricky three-dimensional effects that require numerous separate drawings."

Other savings were achieved by eliminating entire departments, such as the test camera department formerly used to photograph each drawing before inking and painting. Too, the music sheet department in which cartoons were once timed to music is no longer used.

The biggest saving of all was obtained by eliminating the work of the *in-betweener*. Previously a chief animator would make most of the important drawings, and his assistant would fill in with some of the others. Additional sequence drawings, to be placed between the others, would be drawn by the *in-betweener*, actually a sec-

ond assistant animator. His drawings accounted for half the cels.

By eliminating the in-between drawings, the number of cels is reduced by half. To make up for this, each cel is shot twice by the camera, on two frames of film. Thus each drawing is seen for $\frac{1}{2}$ of a second when the film is projected instead of $\frac{1}{24}$ of a second. Action is speeded up, yet not to the point where it is jerky or displeasing. The cartoon effect is enhanced.

All this tells the story of how cartoons can be produced cheaply enough for television but it doesn't explain the universal appeal of the Hanna and Barbera animations. College professors as well as school children, engineers and kindergarten tots all delight in Huckleberry Hound.

"Part of the reason is that we have returned to the basic idea of a cartoon," Joe Barbera says. "In the old days of theater cartooning the animators tried to imitate people and animals as closely as possible in actions and voice. Cartoon effect was lost and results were not always funny.

"Today we exaggerate a character's appearance and actions on purpose. We hunt for plausible story situations and we use satire and absurdity and slapstick. In a sense it's a return to the old Punch & Judy shows. We use simple drawings without too much detail. The result is fairly good comedy, good cartooning.

"The fact is that we used to make good cartoons in the old days and then throw them away. As soon as we had a story we'd make a 'rough' preview reel to see how the story looked. The action was fast, everything was exaggerated and the effects were pretty hilarious. After looking over this rough we'd go ahead and produce the slower-paced animation. Today's cartoons to a great extent are the roughs of the past."

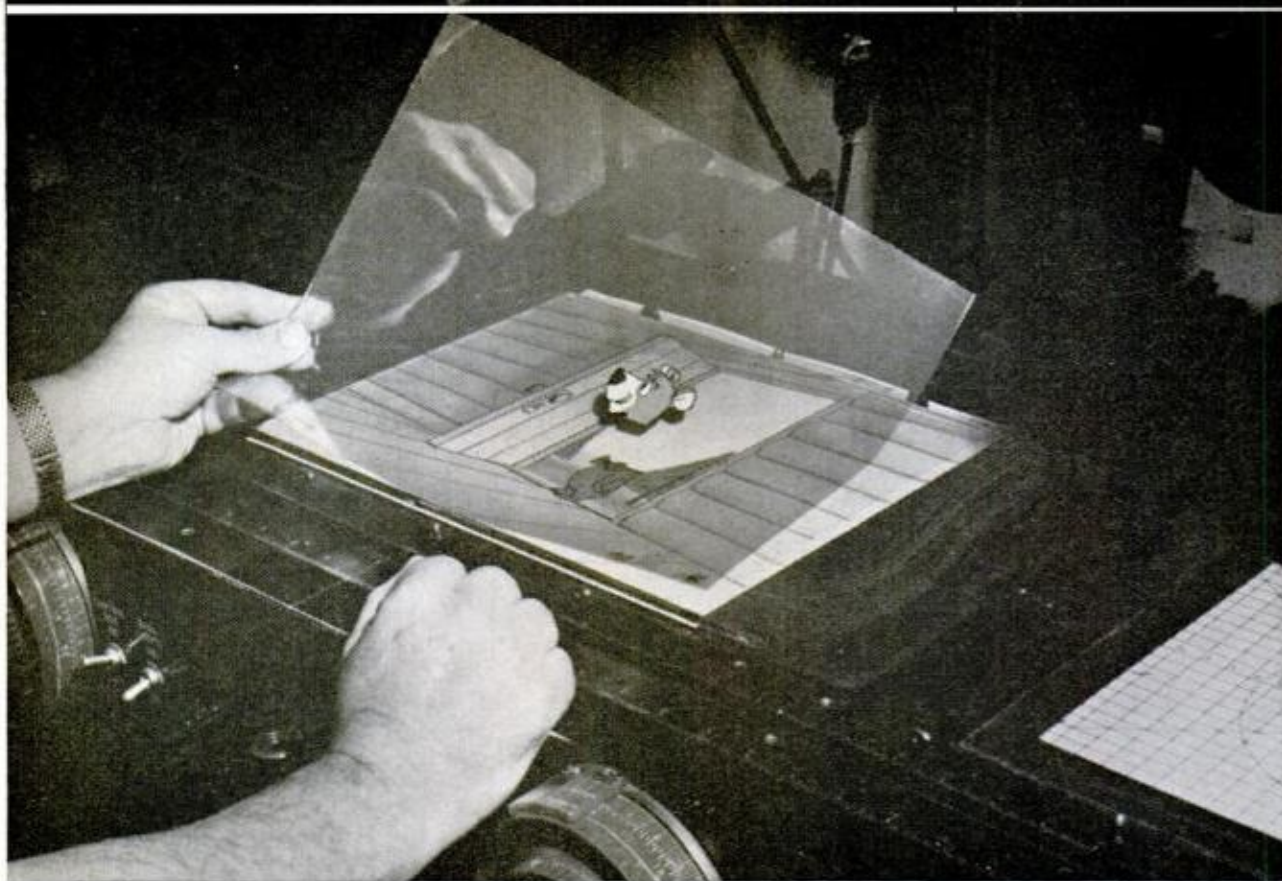

Two cels (background and character's body) are already in place on easel as cameraman places third cel (showing head) over them. After taking picture, he'll substitute slightly different head action for next frame

The results have scored with viewers and with the industry. Not only is the Huckleberry Hound show distributed via 192 outlets in the U.S. and Canada, it has gone world wide as well. Much of Europe, most of Latin America, and Japan and other parts of Asia watch the Huck show every week. As if this weren't enough to keep the producers' cup running over, they were given the Emmy award for the best program in the children's field at the 12th annual TV award ceremony in June.

Cartooning is so popular, in fact, that about a year ago Hanna and Barbera introduced Quick Draw McGraw, a separate TV show that satirizes the gunmen of the old wild west. And more recently a third show known as Ruff and Reddy was put on the air, telling the story of a cat and dog that work as a team.

Television has to have commercials, of course, and in the Huck show the principal characters also appear in the commercials. Audiences don't find this objectionable at all, mainly because the characters retain their identities and continue to entertain.

Just like the rest of Hollywood, the animators are finding that they have fan mail and "star" problems. Yogi Bear, one of the main characters in the Huck presentation, has become so popular that he is being considered for a star part in his own show. And sometimes a character that is used once or twice and then dropped has to be returned. Fan mail demands it.

With their new techniques Hanna and

Barbera have also made a return to theater cartooning. Now being distributed by Columbia is their Loopy de Loop series that is designed for theater audiences.

Also new this fall is the Flintstones, the continuing story of the trials and tribulations of a prehistoric family. The Flintstones live in a cave and carry clubs, but it turns out that they have all the problems and anxieties of modern civilized life. Starting in late September the Flintstones will be on the air for half an hour beginning at 8:30 every Friday evening. This is prime time on television, time for which a cartoon never before was even considered.

"It's a show intended for grownups," muses Bill Hanna, "but I suppose the kids will be pushing their parents away from in front of the screen so that they can watch it too!"

★ ★ ★

Pixie and Dixie
and Mr. Jinks

© Hanna-Barbera
Productions



POPULAR MECHANICS

Light Utility Car For Work or Play

Compact economy entered the field of utility cars with the introduction of the Saviano Scat, by Saviano Vehicles of Warren, Mich. The two-door, four-passenger convertible has an 80-inch wheelbase and weighs only 1700 pounds; the 25-horsepower air-cooled engine delivers 25 to 30 miles per gallon, and the Scat has a top speed of 50 miles per hour with a three-speed straight transmission. Developed both for industrial and sporting use, the Scat also is available for indoor industrial use with propane for fuel. The body can be opened up for big carrying capacity.



Two-Story Camper

Most of the problems of vacationing with seven children were solved by a truck camping body designed and built by Capt. and Mrs. Paul J. Wolf of Fairborn, Ohio. The special body fits onto the chassis of a half-ton pickup truck. The double-decked camper sleeps all nine Wolfs and provides riding and play space on the road for the children.

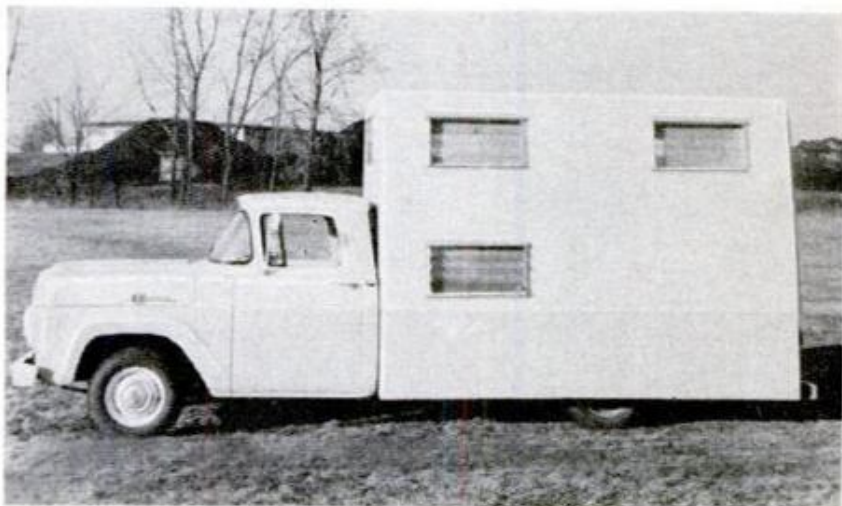

Skindiver's Sonar

Navy frogmen working in the dark or in murky water can locate underwater objects electronically with a new portable sonar system. The 20-pound, basketball-sized outfit is powered by standard flashlight batteries; the diver-operator uses underwater earphones to get audio information on any object detected by the sonar beam. Sealed into an aluminum casing, the unit is self-contained, and has negative buoyancy for easy handling under water.

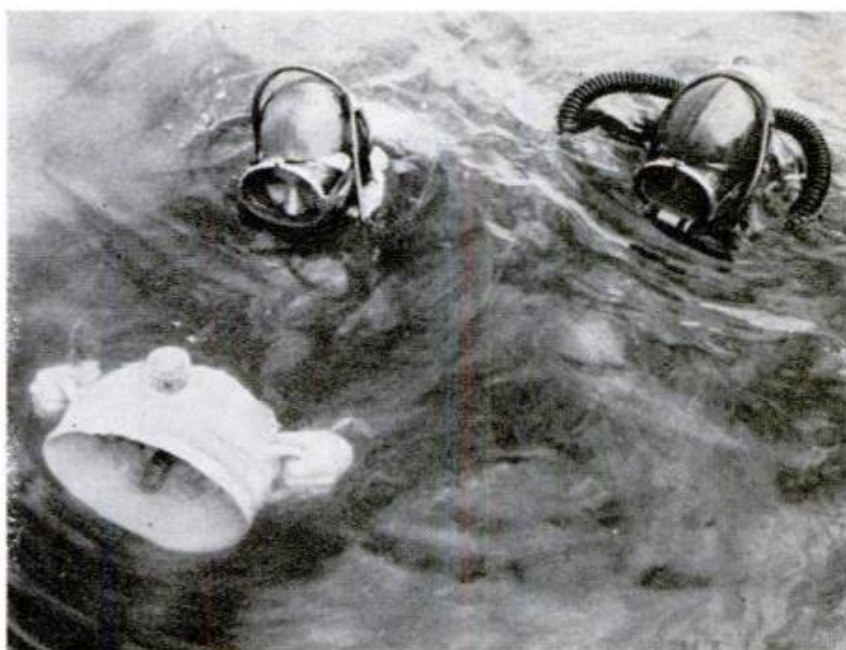

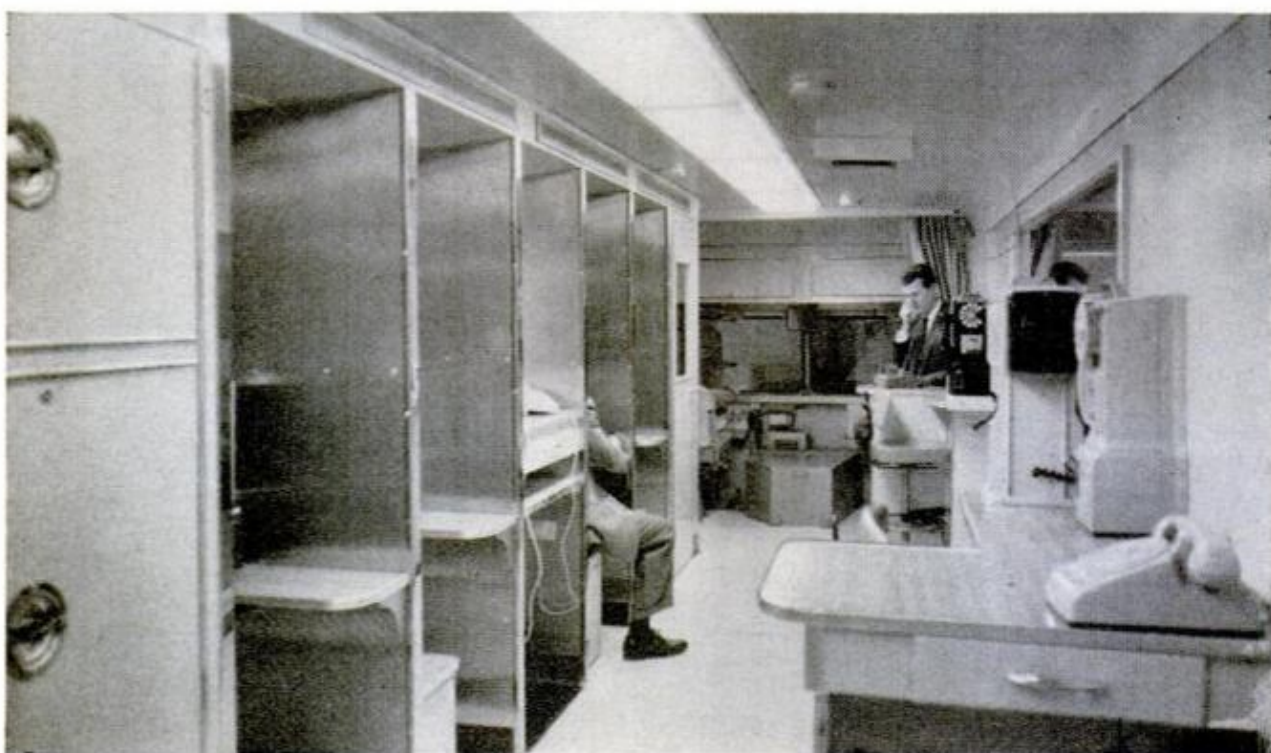

Mobile Telephone Center Provides Service to Public and Press

Ready to roll to the site of major news events is a new, 32-foot-long mobile telephone center operated by the Illinois Bell Telephone Company. It carries 15 telephones, including two mounted outside the bus body. Ten mobile radio-telephone channels provide communications anywhere; it has a public-address system as well as two power units.



Mechanical Depth Finder for Fishermen

Smart fishermen study their geography under water, because the one who knows the reefs and bars and deep holes often has the best chance of catching fish. But mapping the bottom of a lake or even finding the depth at one spot can be quite a job. A new mechanical depth finder does the job easily by releasing a weighted line and registering the amount paid out on a graduated dial. The release lever is also the retrieving crank. It's available in 50-foot or 100-foot models.

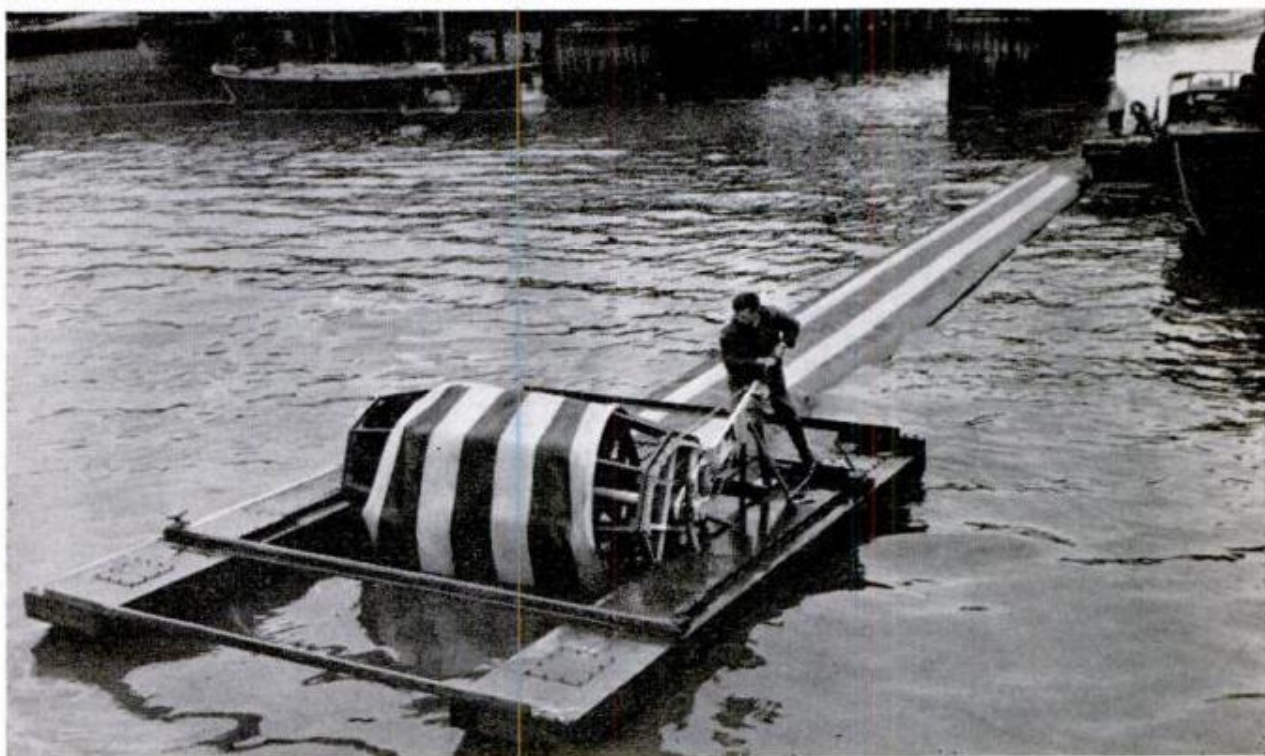
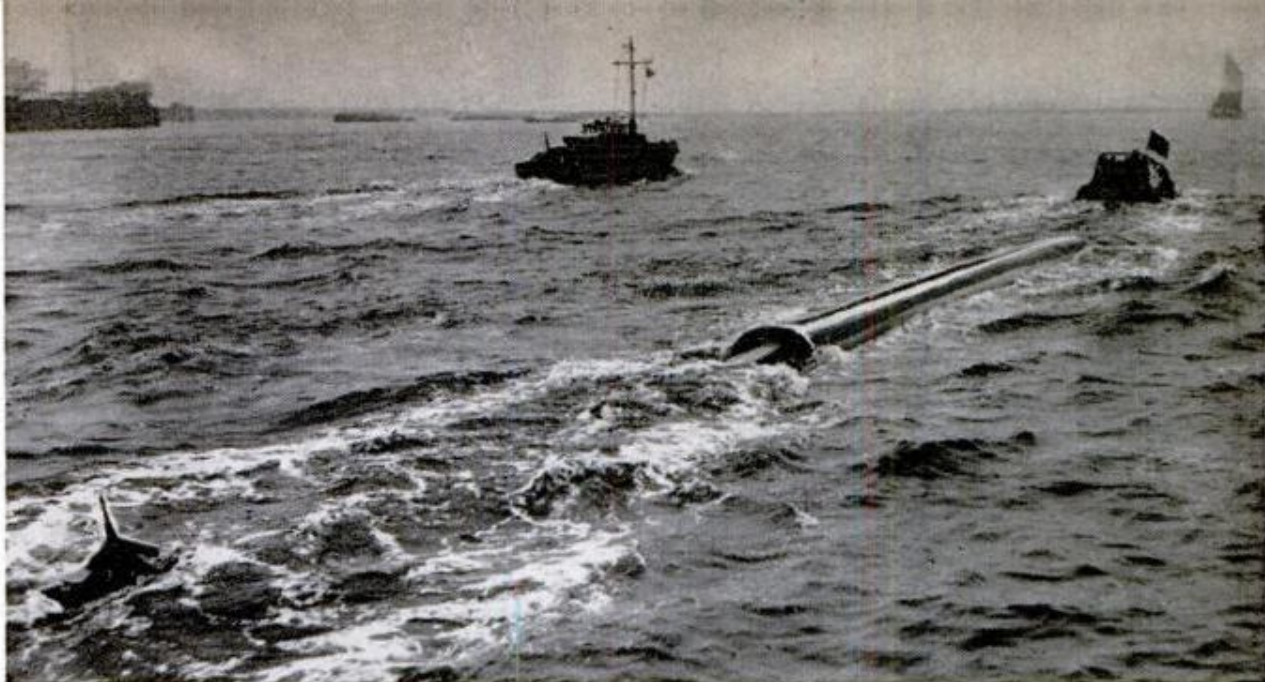

"Sausage" Barge Carries 35-Ton Cargo, Then Rolls Up for Trip Home

Going up the Solent toward Southampton, England, a new "flexible oil barge" carries 10,000 gallons of oil or 35 tons of other cargo—liquid or solid—behind a small motor launch. This 100-foot-long, five-foot-diameter model is undergoing commercial trials. Much larger containers

are being planned. Called a Dracone, the rubber-impregnated nylon bag tows easily to its destination, then can be rolled into a compact bundle and shipped back to the cargo source for another load. It is especially useful on inland waterways in West Africa and the Far East.

Skirt Boosts Lure's Allure

By increasing the light reflectance of any fishing lure, a new self-sticking plastic skirt makes it as much as three times easier to see, and more attractive to fish, especially in cloudy water. Six of the $\frac{5}{8}$ -inch skirts come on a card; each has five "tails" and a waterproof adhesive base that sticks to anything. They are available in gold, silver, and six colors; $1\frac{1}{2}$ or 3-inch sizes; either pinked (as shown) or straight.



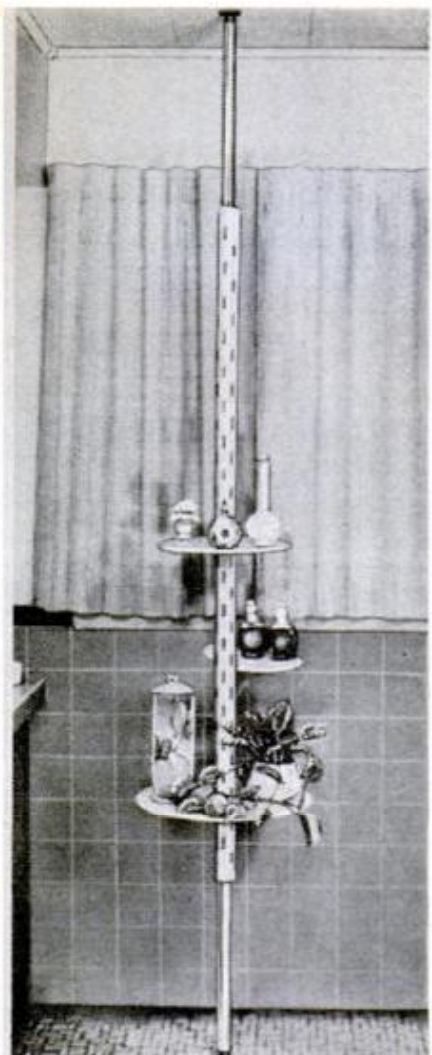

WHAT'S NEW FOR Your Home

ELECTRIC GRILL for outdoor use has a spate of push-button controls. Located on one side is a console with off-on buttons for a built-in fire starter (which ignites charcoal), starter warning light, rotisserie motor, night light; it also has an automatic timer with bell alarm and an outlet for electrical appliances. The grid may be arranged to grill, simultaneously, meats rare, medium and well-done

Union Steel Products Co., Albion, Mich.

DAIRY REMINDER allows a housewife to leave an order or make changes in one without interrupting other activities in order to deliver it personally to the route man. The 4 by 8-inch "reminder" is made of white weather-resistant plastic and permits ordering by peg-board selection. There is a tilted slot on the back for coins and milk tickets

Anga Specialties, P. O. Box 128, Avoca, Peun.

↑ **PEG POLE** utilizes normally wasted space for holding such things as towels, shelves of condiments. Two combine to form a room divider. Accessories slip into its many slots

House of Fiske,
1237 West 47th St., Chicago 9, Ill.



POPULAR MECHANICS



ADJUSTABLE RAKE sweeps leaves, loosens soil, rakes dead grass and spreads seed. It is set to perform any of these tasks by loosening a wing nut and moving the handle up or down, or sideways, to vary the tension on the tines and the position of the handle
Braun Manufacturing Co., Inc., 1635 N. Kostner Ave., Chicago 39



ELECTRIC RANGE with overhead ovens features some space-saving innovations. The oven doors, for example, glide up out of the way rather than pull down. The cooking surface pulls out, like a drawer, at a 32-inch work height. The range is free-standing
Frigidaire Div., General Motors Corp., Dayton 1, Ohio

CONDIMENT SHELF built in three steps provides large storing capacity for a small area. The 8 by 10-inch shelf is made of formed wire. It has a chrome finish, and rubber tips on the feet protect the counter or table surface. Labels of canisters are always in view
Stanley Products Co., 1026 Milwaukee Ave., Chicago 22



SEPTEMBER 1960

BATTERY-POWERED MANICURE tapers cuticles; shapes, files and trims nails of both hands within minutes. It is powered by flashlight batteries and has a silicon-carbide shaping disk and a buffing attachment. It may also be used for removing dry skin
Thompson Designs Inc., 3550 Martens St., Franklin Park, Ill.



131



Ten-foot length of steel culvert provides grizzly trap body; door drops over opening when trigger is touched

Canadian Conservationists Work to Save Grizzly Bears

Last stronghold of the great grizzly bears that once hunted bison across the northern plains, the Swan Hills area on the shore of Lesser Slave Lake in northern Alberta has been declared a bear

Volvo Unveils Sports Coupe at International Auto Show

Companion to the popular Volvo sedans, the new Volvo P-1800 sports coupe was introduced at the International Automobile Show at New York Coliseum in April. Based on standard units already in-

cluded in the other Volvo cars, the P-1800 is powered by a 1780 c.c. (108.5 cubic inch) four-cylinder engine producing 100 hp. for "a very high top speed." It has a four-speed transmission; optional overdrive.





Air holes plugged, ether is sprayed into the trap

sanctuary. Albert A. Oeming, Edmonton, Alberta, wrestling promoter and a top zoologist, led the drive to locate the bears' range and establish the preserve, and developed the grizzly trap above which al-



Out but unharmed, bear is tagged and trucked away

lows live capture and tagging. Oeming's method of capturing the bears and re-locating them on the sanctuary is believed by conservationists to have saved the species from almost certain extinction.



New Infantry Weapon in Production

Called "the best in 20 years," the new Colt combat rifle, now in production, is unique in its versatility. It will fire semiautomatically with sniper-rifle accuracy, or will fire 720 rounds a minute as a machine gun. It weighs only 5 pounds, 11 ounces fully loaded with 20 rounds.



Left, polishing a carving of walrus cow and calf; right, a favorite subject, an Eskimo mother and child

Eskimos Carve Soapstone

By **Richard Harrington**
Photos by the author

ESKIMOS of the tribes around the upper shores of Hudson Bay have carved soapstone for many centuries. Sensitive, creative, and imaginative, the natives of that frozen land are thought to have begun the practice for occult purposes, carving images of their many spirits, talismans for hunting, or charms for witchcraft, passing

the time in their often-snowbound igloos by shaping chunks of relatively soft steatite, or soapstone. Strangely once a carving was finished, the artist lost interest, discarded it and began another.

Twelve years ago, James Houston, a young Canadian artist, penetrated to the east coast of Hudson Bay on a painting ex-



At the Povungnetuk quarry, members of the Sculptors' Society chop out pieces of soapstone. They pry it out with axes and ice chisels, cut it to shape with handsaws and hatchets, strange tools for such fine work



Left, lucky trapper carries one fox, picks up another; right, Charlie Sheeguapik, Sculptors' Society president

pedition and encountered some of the carvings, which were then being handled by the local trading posts as novelties without much success. Greatly impressed by the primitive artistry in the figures, Houston carried several pieces back to Montreal to the Canadian Handicrafts Guild. The rest is history—collectors snapped those few pieces up, the Eskimo sculpture caught on and was publicized, and pieces are now being shipped all over the world and sought as collectors' items by art fanciers, decorators, museums and housewives alike. In-

deed, the reputation of the Eskimo work grew until it received the highest accolade—imitation. Japanese craftsmen began turning out "Eskimo art," and sold quantities of it in British Columbia. Now, however, all genuine pieces are signed by the Eskimo artist and carry his government serial number.

(As if in retaliation for this imitation, the Eskimos, again aided by Houston, learned the Japanese techniques of printmaking from incised soapstone carvings, and are now profiting from this new art form.)



Quarrying the soapstone is the start of the carving process; they never make sketches, but take inspiration from the shape of the rough stone. Charlie Sheeguapik loads a sled and plans his work at the same time

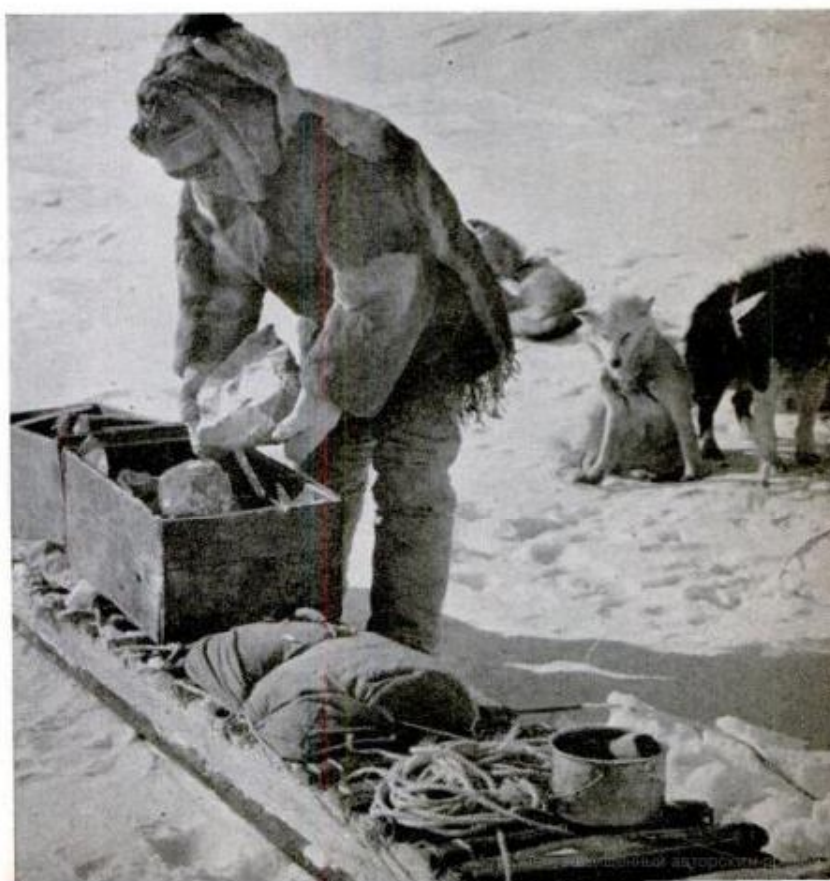



Sheeguapik carves an incident in stone—a hunter, aided by a sled dog, cutting the throat of a young caribou. From top to bottom, the finishing process, first a rough file for final shaping, then sandpaper for details, then buffing with a soft cloth wrapped over the file to bring out the stone's lustre



One of the centers of the new business is Povungnetuk, on the northeast coast of Hudson Bay, where soapstone is readily available in a primitive "quarry," eight miles outside the settlement.

The Povungnetuk carvers make a group excursion out of their quarrying, gathering several co-workers and taking several sleds at once to their "quarry," which is actually an outcropping of pyrites which contain pockets of the softer steatite. They chop and hack out chunks of the soft stone and haul it to their homes for carving. A trained sculptor would scorn their tools—ice chisel, mallet, ax and saw for the cutting, and files or sandpaper for finishing. The carver sits contentedly in his igloo, legs stretched out in front on his snowbench, usually working barehanded in near-freezing temperatures and often barely able to see his work through the smoke of his seal-oil lamp, a dim light at best. One of the reasons for the smooth simplicity of Eskimo sculpture is that a great deal of it is done almost by touch in the dim igloos.

Subjects are usually from the artist's surroundings, but vary otherwise from artist to artist. Some prefer to work with small pieces, carving birds or walrus or seals; others undertake larger subjects, even groups of figures. Some show more imagination than others, and a few less-skilled carvers are inclined to copy an idea or shape—though not the actual carving—that has proved successful and sold well.

When the work is completed, the members of the Sculptors' Society of Povungnetuk gather in the Eskimo Room of the Roman Catholic Mission to decide on its worth. They estimate a price on a ballot (you can always tell which estimate is the artist's—it's the highest) and usually decide on a value around the middle of the price spread. The Society then deducts the cost of air shipment and credits the balance to the sculptor's account at the trading post. Prices range from five to one hundred dollars, rarely more, and air freight costs 50 cents a pound.

James Houston is now settled at Cape Dorset, working as civil administrator for the Canadian government and handling the output of carvers in that area; they gross over \$150,000 a year, earning half of Cape Dorset's income. And the 400 Eskimos at Povungnetuk are happy, well-fed, and warmly clothed, thanks to his efforts and their hobby. ★ ★ ★



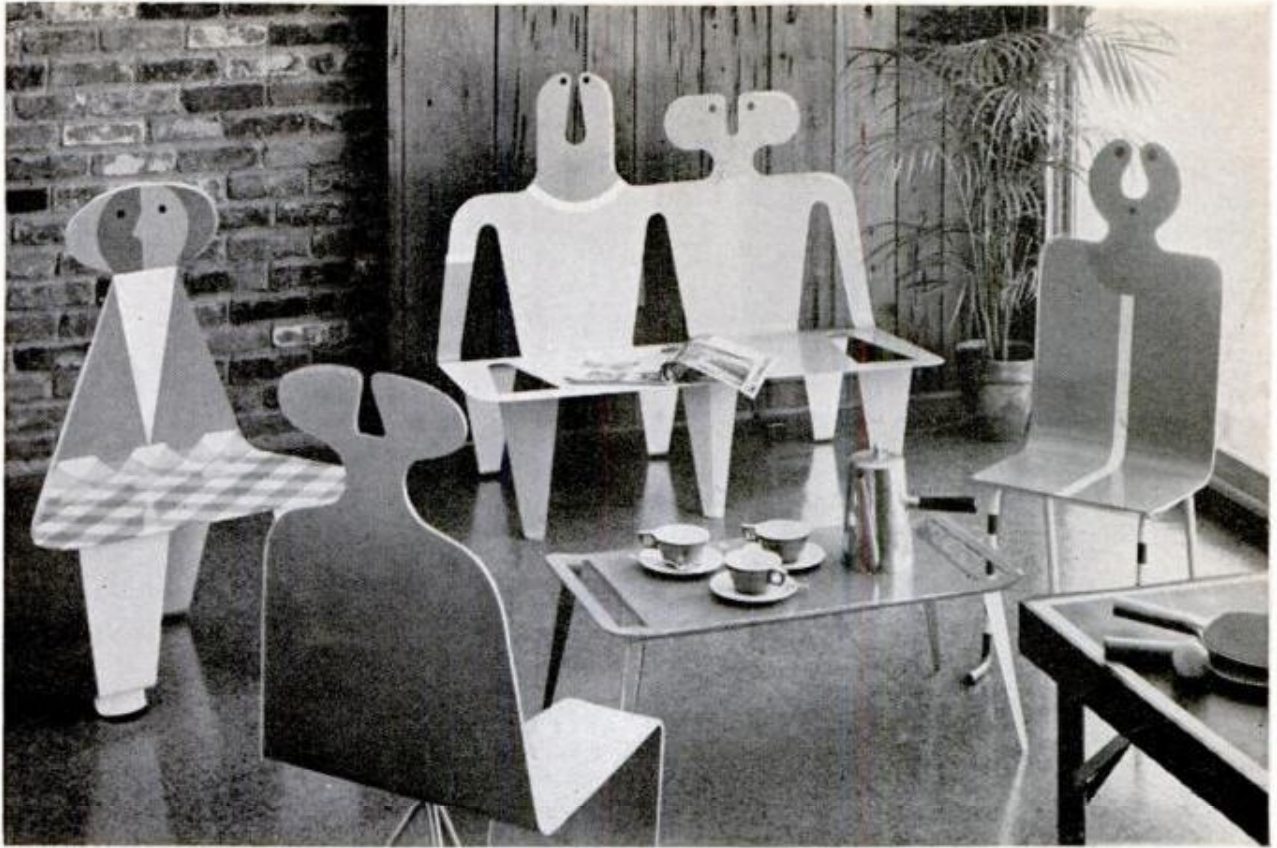

Whimsical Aluminum Chairs Look Like People

It's a cinch you'd never feel lonely in a setting like this. These "People Chairs" were done by designer Jay Doblin for the Aluminum Company of America's program of designs for the future in aluminum. The

whimsical seating pieces reveal a new approach to the manufacture of furniture, that of folding items from a single piece of aluminum. People chairs are experimental and are not currently being sold.

Tiltable Tower Tests Radomes

How much does a radome deflect the radar signal being picked up by the antenna it houses? General Electric scientists have built a huge tower to answer that question. Despite its great bulk and weight—120,000 pounds—the tower is a precision testing instrument. It consists of a tiltable platform coupled to a stationary steel framework; the platform can be moved through 41 degrees, on only one axis, with such accuracy that the angle of tilt is achieved within $1\frac{1}{2}$ minutes of arc. The tower is installed at the company's antenna development facility near Cazenovia, N. Y. Radomes of various designs can be mounted on the tower's framework to find out how much they deflect the radar signal.

☐ Swiss cheese and charcoal will filter 90 percent of the tars emitted by common cigarette brands, according to a University of Wisconsin professor.

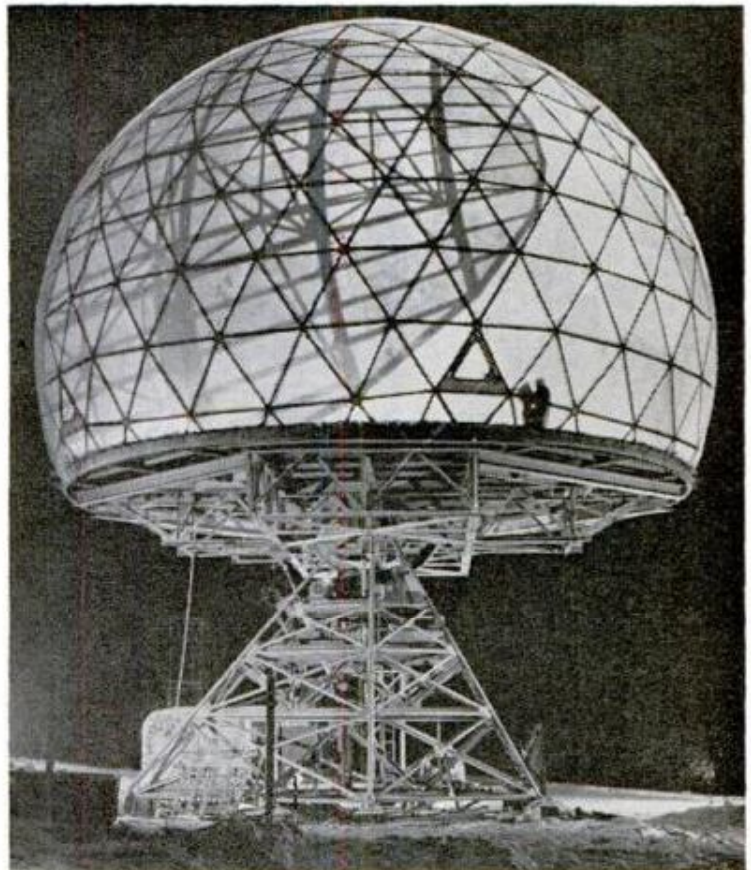

DIKE WATCHER

NIGHT AFTER NIGHT, day after day, the North Sea licks greedily at The Netherlands' coast. Earth is washed away, a boulder tumbled, water trickles from a stone and a dirt wall. Each destructive sign is noticed by the men and women who protect the dikes and battle the sea. Their land is vulnerable to attack for much of the country is below sea level. So the watchers, as organized as an army, patrol day and night. They look for gaps in the walls, for erosion, for storm signs, for changes in the water level. Typical of the watchers is a grizzled farmer named Jan. Sometimes his patrol ends with a skirmish; sometimes it begins that way. One stormy night, the sea lashed its thundering water again and again across his land. These pictures show Jan's mission that night.



Howling winds of a North Sea storm whistle about his home as Jan goes on a dawn patrol of a coastal area



His son helps pitch out sandbags for shoring-up the storm-weakened earth and stone walls of the dike



Jan calls the headquarters for dike protection at The Hague, the capital, to relay damage information



Water is splashing around the wall when Jan closes the gates which shut off the road leading to the harbor on top of the dike. Since the sea has already weakened the dike walls, Jan and son jam sandbags into the gap, right. Dike watchers employ telephones and trucks for quick operations throughout maintenance system

Ebb tide reveals the extent of the sea-wrecked damage and the watchmen start repairing the dike, one of many that keeps the water from flooding over their reclaimed farmland. First they build a "coffer dike" from basalt blocks at right angle to the dike so that at high tide the sea near the work area will be calm



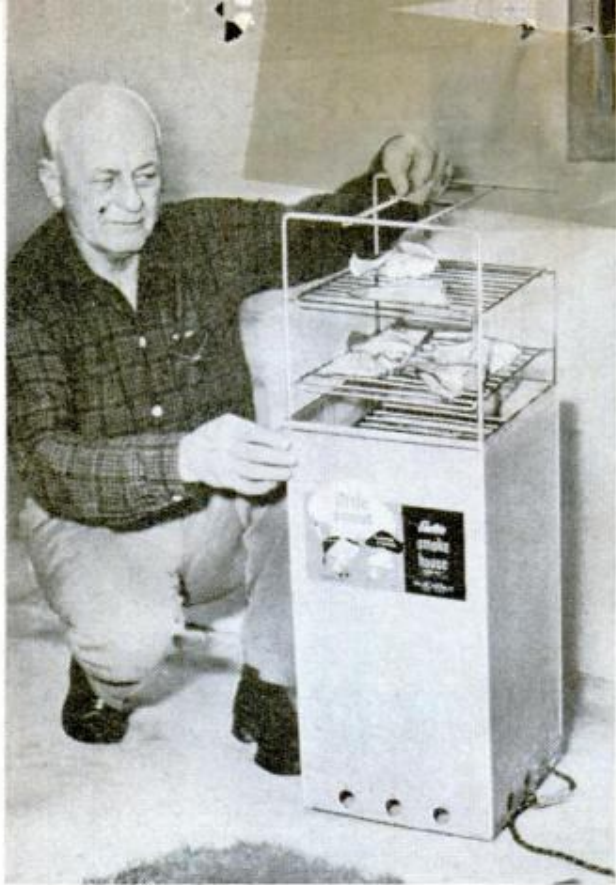

Portable, Electric Smoke House

Up to 10 pounds of meat or fish may be smoked in a new, portable smoke house. The unit contains an electric coil at the bottom over which hickory chips are laid to provide smoke, and removable racks on which the material to be smoked is placed.



Portable Refrigerator

Operating on either a car battery or on a small can of LP gas, a 25-pound portable refrigerator works on the absorption principle with no moving parts and thrives on movement in a car or boat. It will hold 25 pounds at 45 degrees on a 95-degree day.



Army Has Movable Missile Tower

Although it's 151 feet tall and weighs 350,000 pounds, a new servicing tower for such missiles as Redstone and Jupiter moves on pneumatic tires. It is mounted on two base trailers of six wheels each and contains platforms for servicing-specialists as well as elevators and fueling equipment. Previous towers were either fixed or rail-mounted.

Number, Please!

Whenever you write us to

- Renew your subscription
- Change your address
- Order your own or a gift subscription

. . . In fact, whenever you write us,

PLEASE INCLUDE YOUR CITY POSTAL ZONE NUMBER IN YOUR ADDRESS

*This insures better delivery.
It helps you and it helps the postman.*

Jumbo Truck Tire Replaces Duals

Twice as wide as a conventional truck tire, the new Firestone 18x19.5 experimental truck tire is intended to eliminate the need for dual wheels on trucks. Besides convenience, its advantages are lighter weight, softer ride, fewer parts, smaller space requirements, greater off-road performance, and never any damage from rocks or other objects wedged between tires.

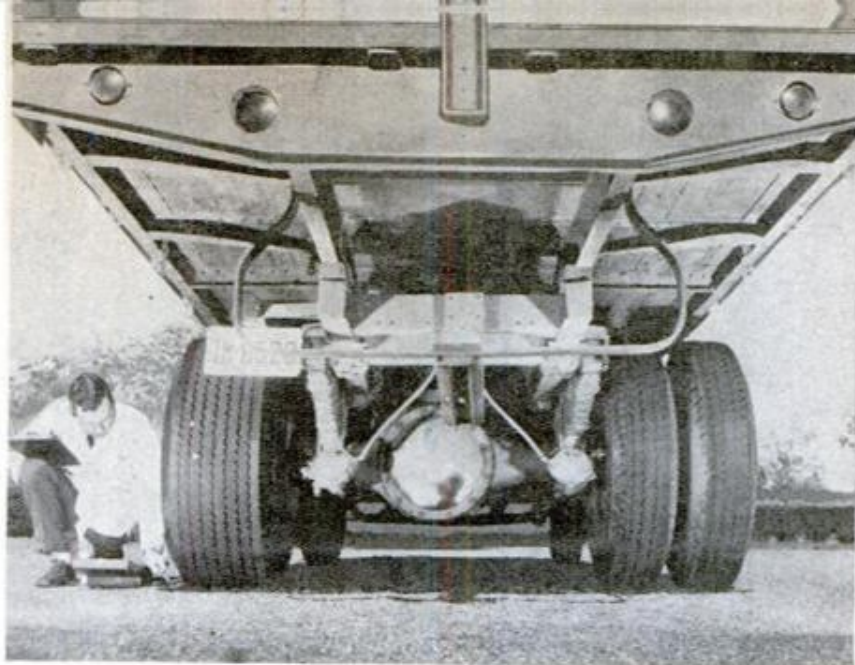

Mechanical Hand Picks up Brush

Thorny rose cuttings, palm branches and other spiny stems left by Phoenix, Ariz. residents for trash pickup are easily handled by a clamshell bucket developed by a member of Phoenix Garbage Service Company. The clamshell "hand," which can rotate 360 degrees, operates at the end of a jointed arm. Recently the rig picked up in 15 minutes a load of palm branches that would previously have taken a loading crew over five hours to handle. The hydraulic device was developed by Larry Redmond.



Bean Harvester Does Three Jobs

Experiments at Cornell University indicate a new bean harvester can perform in one simple operation the three-step task of pulling, raking and gathering beans. The machine fits a standard combine. It thrusts short rubber fingers among bean plants, lifting them so a moving blade can cut the stem below the bean pods. Its inventor, Professor Wesley Gunkel, says the device has performed successfully on bean plants of several sizes. Further experiments are under way.

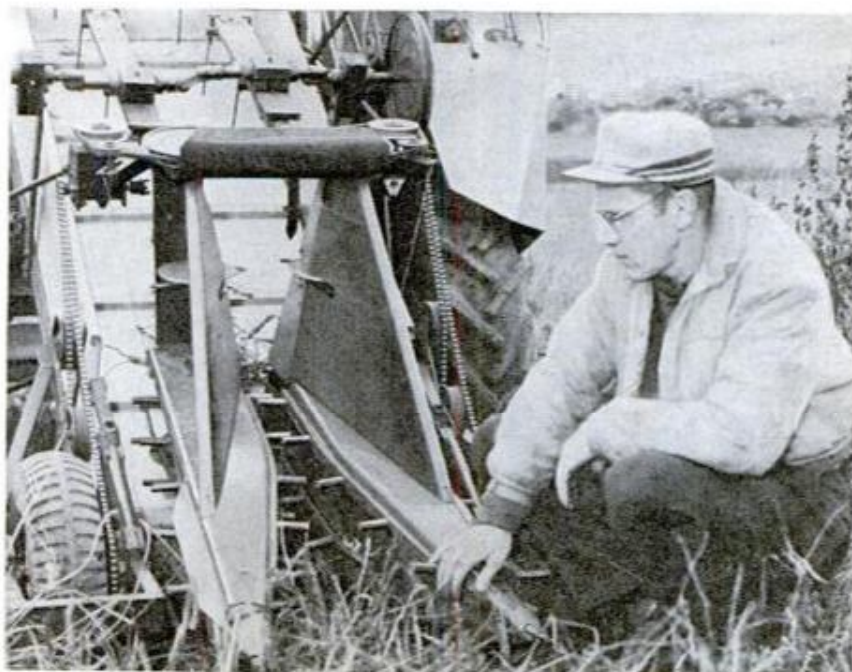



Target! But is it man or game? You'd better be sure, but if it's a deer, you'd better be fast, too

First, a mechanical checkup, to make sure the action is working properly, the safety is operating, and the barrel is clear. Right, target inside a bouncing, rolling tire is as tough a target as any game animal





Two men and an inexpensive hand trap can produce some fine practice for upland game-bird shooting

Rehearse for the Hunt

By Russell Tinsley

IF YOUR BOSS suddenly announced that you were to take a job-efficiency test, you wouldn't think of tackling it "cold." You'd brush up on the more important aspects of your livelihood so that you'd be reasonably sure of passing. This seems like the logical approach to any similar situation; yet an estimated 65 percent of our nation's hunters take their weapons from storage each fall, whip off a year's accumulation of dust, and go afield without ever firing a practice shot.

This approach is really hard to understand, because with some basic practice a hunter would be increasing his chances of bagging game considerably, and he might even be sharpening his visual perception and reflexes to prevent a crippling or fatal mishap in the woods.

Either of those reasons should be sufficient to prompt you to get out your pet

hunting piece and condition your shooting eye and reflexes for the forthcoming hunting seasons.

Practice needn't be dull, though. In fact, it can be fun. Simply banging away at an inanimate paper target can get boring, and isn't the best practice, either. In the field there are no so-called pattern shots like those encountered on a target range. Each chance is different and must be dealt with individually. The successful hunter is one who can size up a situation in a split-second and adapt himself to that particular situation.

That's why I like to make a challenging and interesting game out of preseason practice. It not only makes otherwise dull routine more enjoyable, but also it improves my hunting technique and field-shooting ability—and even makes me more safety conscious.



Above, another difficult target—and one that doesn't require a partner—target inside a swinging tire

Right, how could anyone confuse a deer with a man? From the number of accidents yearly, it must be easy

Below, loose balloons bouncing along the ground (in front of a backstop) imitate running game

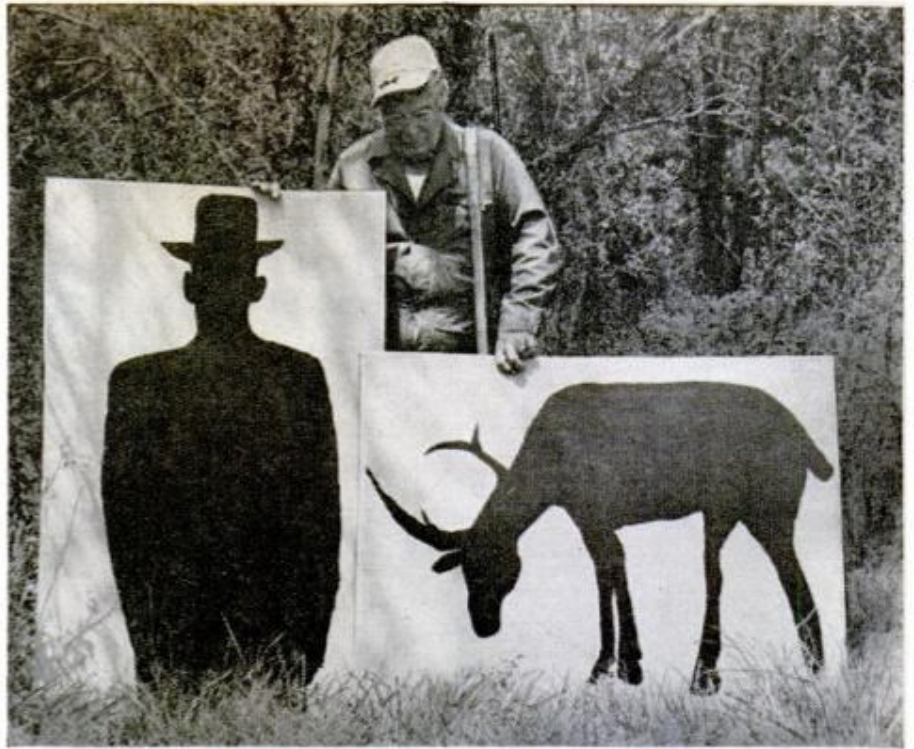

My companions and I always practice in the very woods where we'll be hunting later on in the year. There are two reasons for this. One, we'll be simulating the actual conditions which we will encounter when after live game and second, we are far away from "civilization" and won't be endangering others. Our two cardinal rules are to make sure of our target before we squeeze the trigger and to know the area where we are shooting.

Our favorite preseason practice is called "the silhouette game." We improvise life-size silhouettes of both the game we are hunting and of a human form. Ours are crude black paintings on ordinary cardboard (the cartons that mattresses come in are fine for this). But to be more realistic you might paint the game animal—a deer, for instance—in its true colors and put the human in a red or yellow jacket.

We make a half dozen of each silhouette figure, then one of our party hides the cardboard squares along a marked trail. The idea is for the hunter to still-hunt along that trail, searching for the silhouettes hidden in the underbrush. When he spots one he must first determine whether it is game or human. If it is game, he has five seconds to get off his shot. This way he'll be taking spontaneous shots much like the ones he'll be called on to duplicate in actual hunting.

Our score sheet reads like this: Ten points for a hit in a vital area of the animal (head, neck or heart-lung area); two points for just a hit; a minus five points for a complete miss; minus ten points if the hunter points his weapon at the silhouette and it turns out to be a human shape (we stress the positive identification angle above all others); minus two points if he fails to see one of the hidden silhouettes; and complete disqualification and disgrace if he shoots at a human silhouette. The one who scores the highest number of points wins, naturally. The one with the least ends up buying lunch for everyone else.

A different twist to this game is to station the silhouettes across a draw or canyon with the hunter walking down one side and looking for the cardboard squares on

(Continued to page 234)

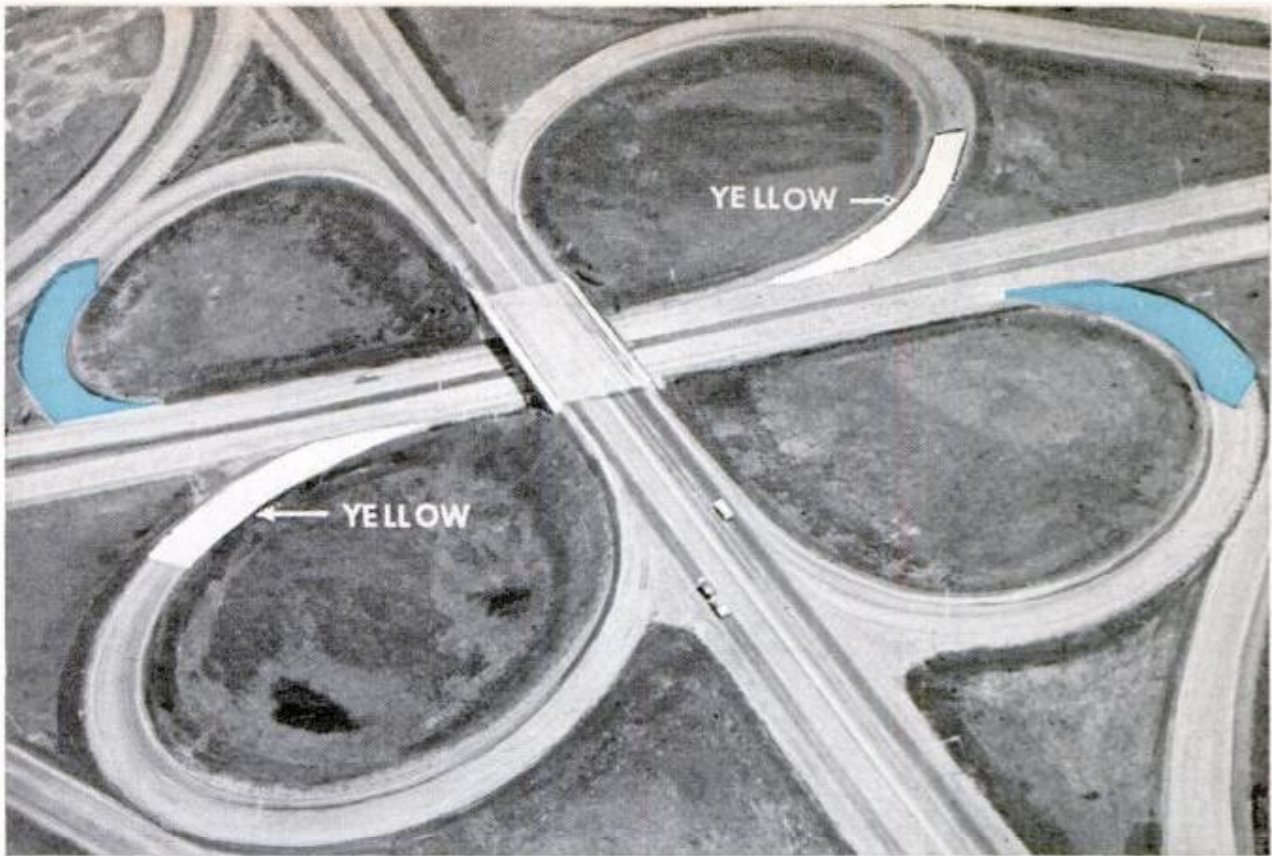

Colored Concrete for Safer Superhighways

Greater safety for motorists entering and leaving multilane superhighways may result from an experiment in color coding of entry and exit ramps at interchange of U.S. Highway 61 and Minnesota 36. Por-

tions of entry ramps are painted with yellow reflective paint to caution drivers of coming merger into high-speed lanes. In contrast, lanes to exit ramps are blue to warn of slowdown for the curve ahead.

How About a Breath of Oxygen For an After-Work Pick-Me-Up?

Parisians who have been cooped up in a stuffy office all day can now step inside a drugstore on the Champs Elysees and get a breath of pick-me-up. Just inside the door is a cabinet vending machine that supplies pure oxygen with a perfumed scent for people in need of quick energy. For one franc (about 20 cents), customers get a chance to inhale 20 liters of pure oxygen.

Twigs Grow After Deep, Deep Freeze

Working to develop a method of "training" trees to withstand cold, Russian scientist I. I. Tumanov has succeeded in freezing birch and black-currant twigs to 423 degrees below zero F., then making them grow after thawing. The freshly-cut twigs were first "hardened" by being gradually chilled to 76 below, then immersed in liquid nitrogen. The twigs grew buds and roots normally after the freezing, but other twigs of similar stock, which were frozen without the hardening process, died at 40 below. Botanists believe that the work may prove helpful in developing hardier fruit trees.



MIRROR MAGIC

SPECIAL - EFFECTS MEN have dazzled movie and television audiences for years with lights, shadows, and super-imposed animated figures to create an effect, attract attention, or to photograph an unphotographable idea like Tinker Bell in Peter Pan. Probably the most startling and effective of all these are the dancing and floating figures thrown onto your television screen by a process called Mobilux. You've seen it on the Ed Sullivan and Ernie Kovacs programs, and in many fanciful forms in commercials. You'll be seeing it in your home and schools in do-it-yourself kits and on a complete network program soon.

Like a lot of good things, the Mobilux system is the simplest, yet most ingenious, method imaginable. Here's how the inventors, John and Dotte Hoppe, produce their seeming magic . . .



John and Dotte Hoppe with two elephantine "friends"—the figures were cut from aluminum-coated, flexible plastic, with details painted in and backgrounds painted out as shown on the sample figure below

Strong light source from behind a screen is reflected from the polished aluminum onto the screen like sunlight from a signal mirror. When the flexible mirror is manipulated by hand, its reflection seems to move across the screen. The image is picked up from the screen and used alone or superimposed on another

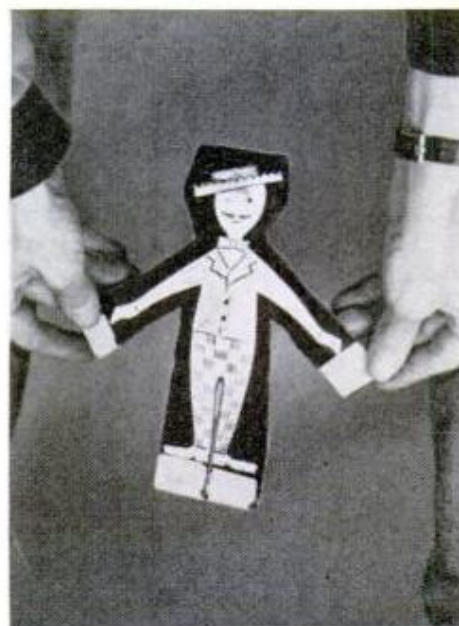

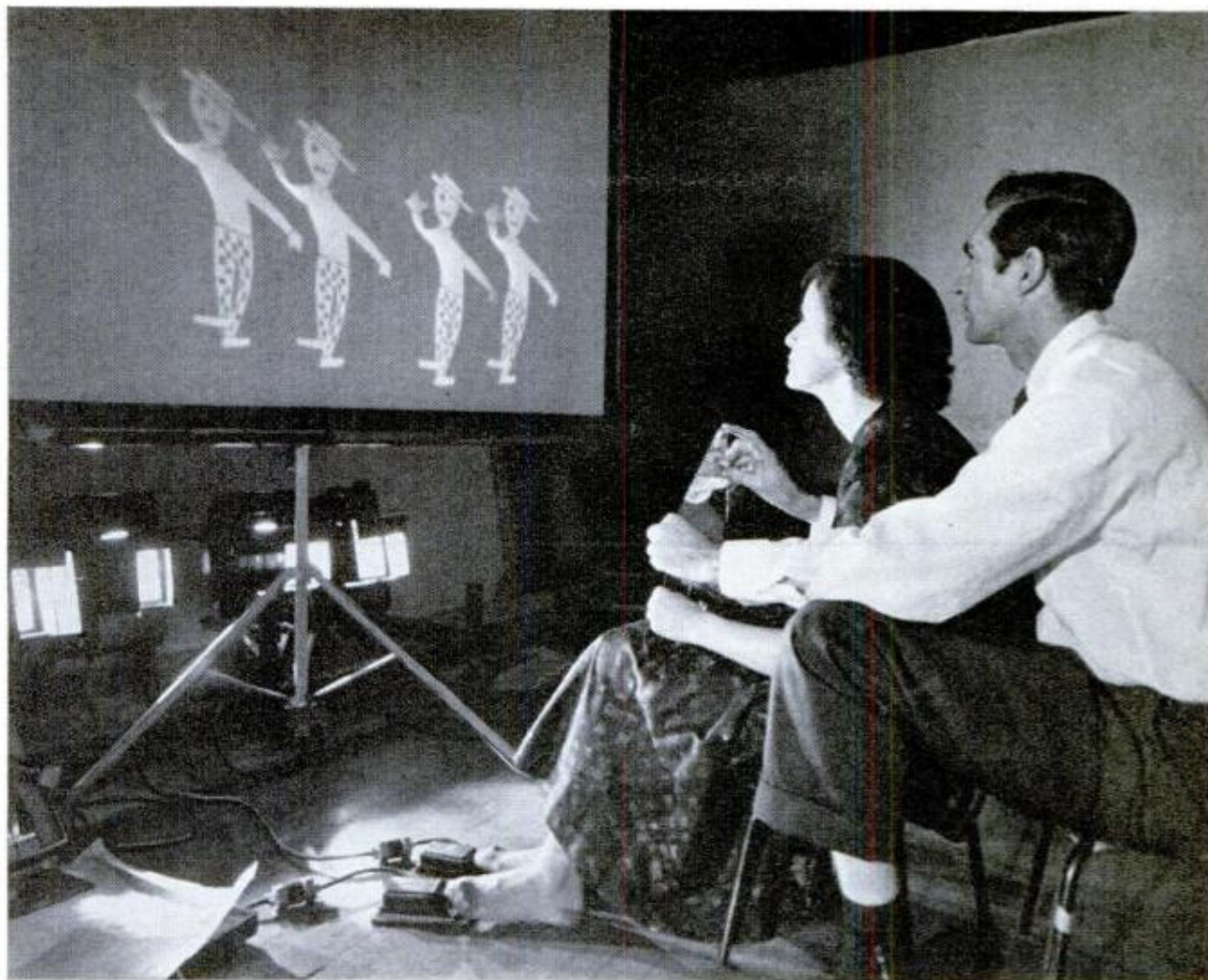

For more figures, simply add more light sources, and one cutout can become a whole chorus line. Here the Hoppes cooperate, John on the head and arms and Dotte on the feet, and the result is a very realistically animated image, without the time and expense of animation, but with infinite flexibility of action

Demonstrating the versatility of the Mobilux system, John Hoppe produces two very different triple light patterns from one floral figure and three spotlights. In practice, he and Dotte, with as many as two assistants project onto the same screen, working lights with their feet while the camera aims over their heads



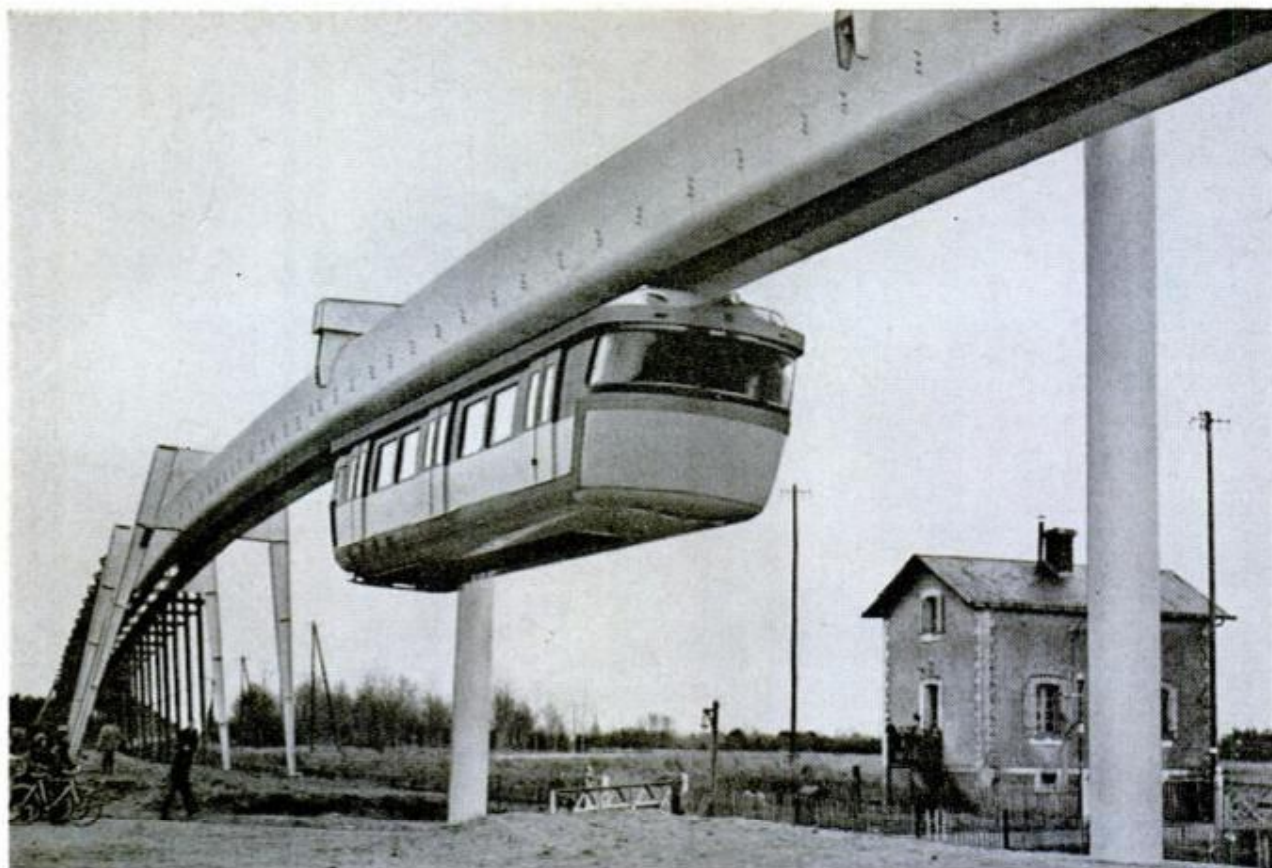

French Monorail Train Rolls Quietly on Pneumatic Tires

Fast, quiet and relatively inexpensive to build, a French monorail system of urban transportation may help solve the problem of mass transit. Built by Renault as a test program, the monorail operates on a demonstration track just over a half-mile long

near Orleans, France. Operating speed of the electric-powered car is about 60 miles per hour. Eight pneumatic-tired wheels carry the weight of the car, rolling quietly inside a box girder. Eight smaller wheels are mounted horizontally to position the trucks inside the "rail." Cost of building such a system is about one-seventh the cost of a conventional subway system. The cars hold 32 persons seated, 91 standing.

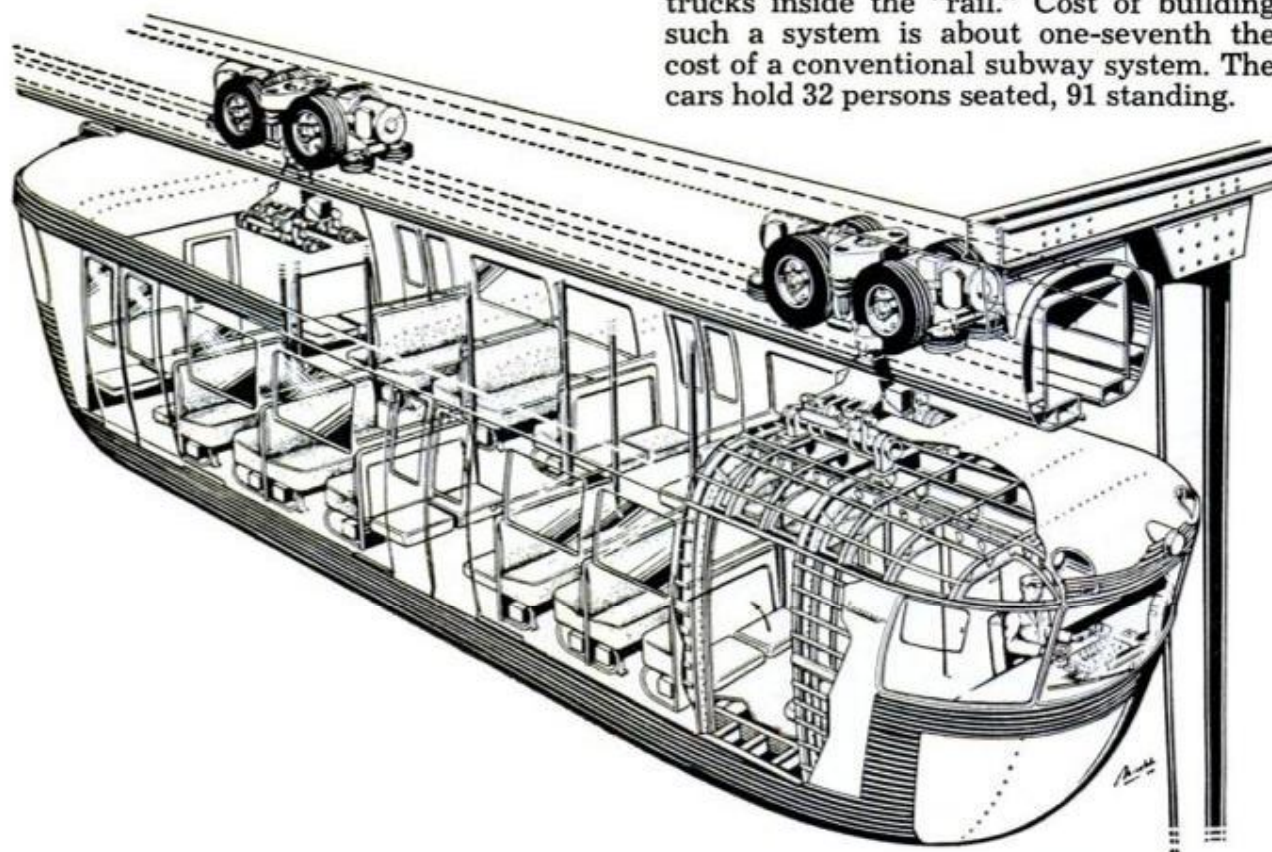



Eclipse Televised Through Binoculars

Enterprising cameraman Ed Cushman, of television station WFRV in Green Bay, Wis., trained his camera on the moon and televised the phases of an eclipse. He shot through a pair of 20 by 50 binoculars. The eclipse occurred during Saturday night and Sunday morning, March 12 and 13, and the telecast covered the major part of the 1½-hour display. This is thought to be the first live telecast of a moon eclipse.

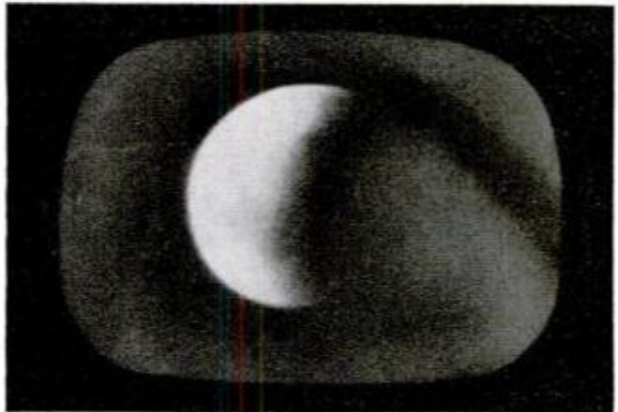

"Stained-Glass" Window With Blocks

Architect Richard Hapke gave a stained-glass effect to Grace Evangelical Lutheran Church, in Peoria, Ill., but at a much lower cost than the real material. He employed a new construction material called Color Glass Blocks which also gives the translucent areas of the church the insulation qualities of an eight-inch masonry wall. The new material has a translucent, fired-on ceramic finish that resists scratches and abrasions. Its manufacturer, Pittsburgh Corning Corp., says the finish resists industrial atmospheres and that long exposure to sunlight causes no significant fading. Hapke employed some 4000 red, blue, yellow, green, black and white blocks on back and front walls of the church. The blocks continue down to grade level.

☐ Repairs to California highways are being made with epoxy resins so strong they hold even when the concrete itself breaks.



SHOP NOTES AND CRAFTS

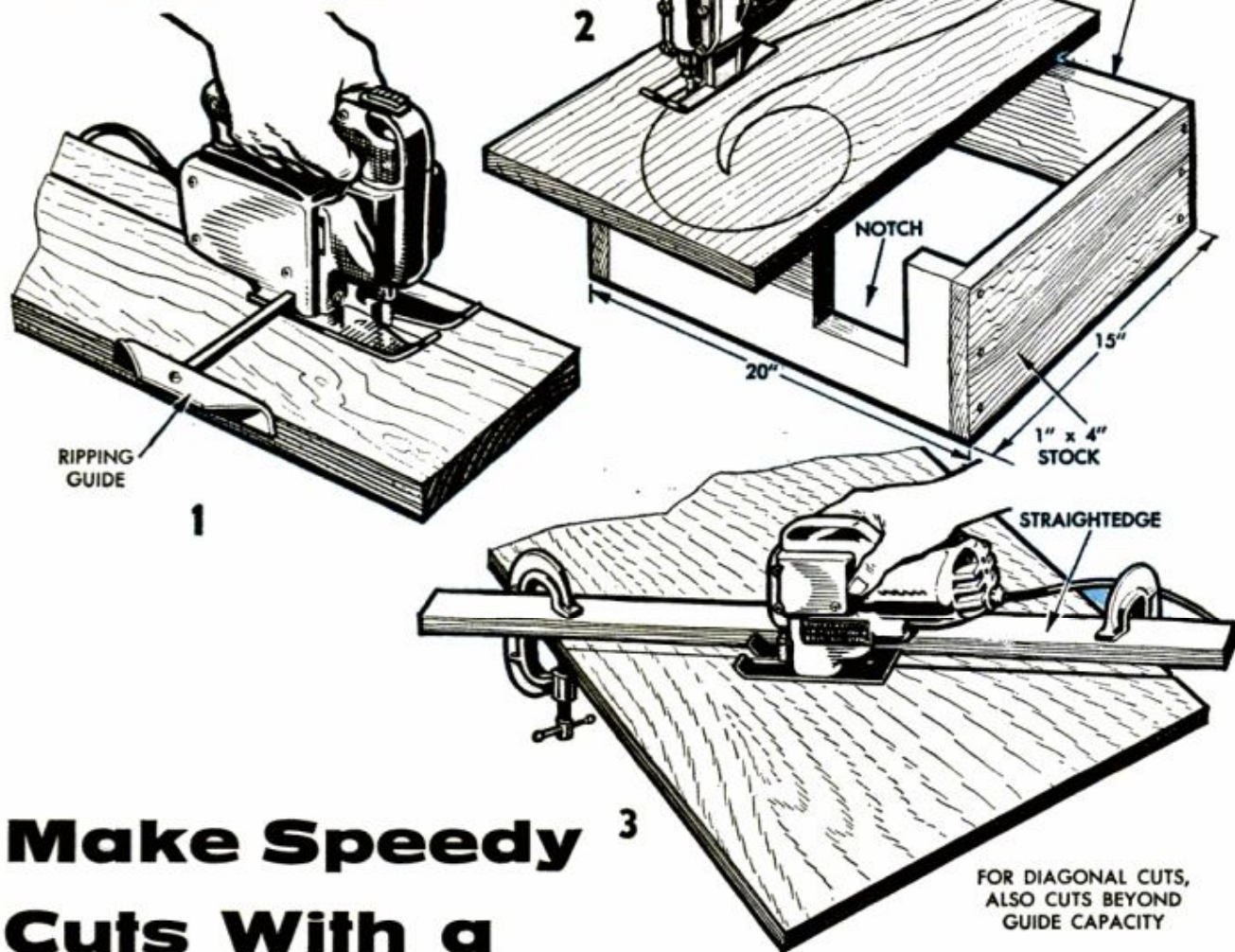

Make Speedy ³ Cuts With a PORTABLE SABER SAW

By E. R. Haan

LIGHTWEIGHT and easy to handle, a portable saber saw is an efficient hand-ful of power having many applications in the home and shop. It will make straight and curved cuts in wood, hardboard, plastic and metals. It can do almost any job for which a stationary jigsaw or small band-saw ordinarily is used. Also it can take on some jobs these power tools can't handle such as plunge cuts and inside and outside cuts on large panels which cannot be worked on conventional jigsaws or band-saws because of the limited throat clearance of these machines. No other electrical tools combine the convenience and ability of the saber saw for cutting small openings of almost any shape in walls, floors and cabinet tops for the installation of outlet boxes, conduit and plumbing.

On some saber saws the shoe, or sole, plate is pivoted as shown in Fig. 5, which permits cutting at various angles, usually up to 45 deg. in two directions. While portability is one of their outstanding features, saber saws also can be mounted in an inverted, fixed position on an accessory stand which usually is provided with a miter gauge and a ripping fence. Such a stand is useful when work requires fine accuracy.

Due to the projection of the blade below the sole plate of the saber saw, adequate clearance must be provided under the stock being cut. Small work can be mounted vertically in a vise or it can be held horizontally on an improvised supporting frame which provides clearance above a workbench or table, Fig. 2. Plywood panels usually can be adequately supported on sawhorses.

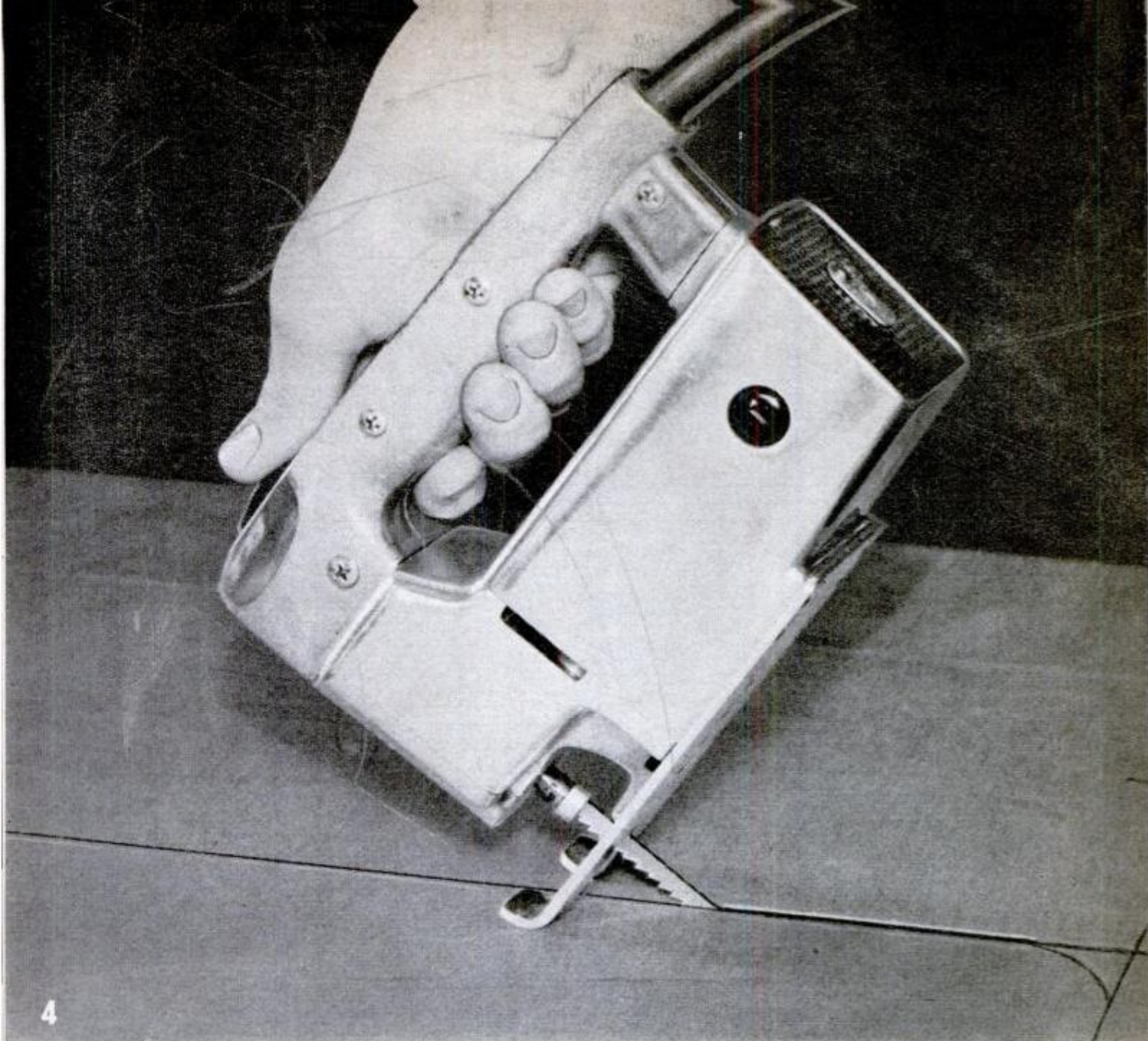

4

PLUNGE CUTTING, which is making an inside cut without a starting hole, can be done with portable saber saw

Many saber saws are provided with an adjustable ripping guide, or fence, which aids in making cuts parallel to the edges of stock, Fig. 1. When a straight cut is made beyond the limits of the ripping guide, or the cut is not parallel to an edge, the saw is run along a straightedge clamped to the work as in Fig. 3.

Letting the blade cut into wood, plaster or other soft material to make an internal cut is referred to as plunge cutting. To do this you rest the front edge of the sole plate on the work surface as in Fig. 4 so that the moving blade comes directly over the cutting line, or in the waste as the work requires. Then, using the sole plate as a fulcrum, you gradually lower the blade into the work. It will cut through $\frac{3}{4}$ -in. wood in a few seconds. As soon as the saw has been lowered to its normal operating position you proceed with cutting.

A circle-cutting attachment usually is

available for saber saws as an accessory. The pivot point of the circle-cutting jig must be in alignment with the cutting edge of the blade so that the teeth are located at the intersection of a radial line and the circumference of the circle. On some saws the accessory ripping guide can be used, Fig. 10. The pivot point is located for a blade of certain width, or gauge. A blade of different width will not be in perfect alignment and will tend to lead in or out of a true circular path. Make sure that the pivot point is correctly located before cutting stock.

For small-radius work, pivot holes may be drilled in the sole plate in line with the cutting edge as in Fig. 6. Pivot pins, usually brads, should fit these holes exactly since any play may cause waviness in the circular cut. In producing decorative edges with arcs and half circles, as for example scalloped window valances, a saber saw can be pivoted as shown in Figs. 7 and 8.

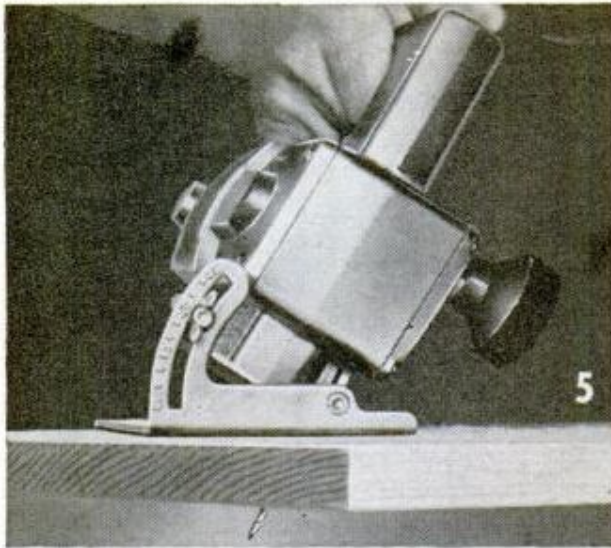

MANY SABER SAWS can be tilted from 0 to 45 deg. for making cuts at an angle. Note graduated quadrant

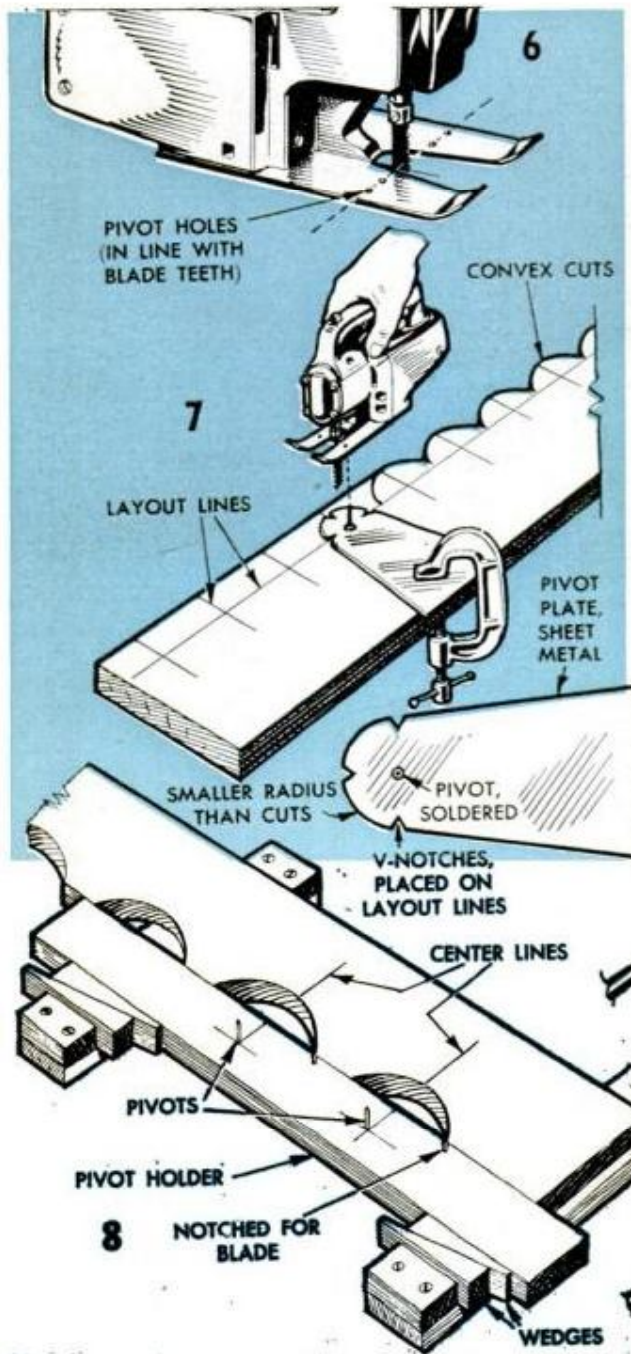

Movable pivot holders can be clamped on the surface of the work as in Fig. 7 where it is not desired to mar the work with holes made with brads. In this case a sheet-metal plate to which a brad is soldered is clamped onto the work, Fig. 7, so that the three notches coincide with right-angle layout lines. This automatically centers the pivot brad. The radius at the end of the plate should be smaller than that of the semi-circle to be cut. Fig. 8 shows a pivot-pin holder that can be adjusted to any position along the edge of the work in which concave cuts are to be made. After lining up the pivot pins with previously marked center lines on the work, the holder is clamped in position with wedges.

In nearly all types of work saber saws are held in the hand while in operation and for this reason they should always be grounded to prevent accidental shocks to the operator. For this purpose saber saws generally are provided with 3-wire cords, the third wire being a ground wire. Connection is made either to a matching 3-wire outlet box, Fig. 9, detail A, which is already grounded to the electrical system, or to a 3-wire adaptor that fits into a 2-wire outlet as shown in detail B. The wire extending from the adaptor is fastened to the metal screw that holds the plate or cover.

Always use metal-cutting blades, preferably with wave-set teeth, for sheet metal and thin-wall tubing. Clamp light sheet metal firmly so that cutting takes place as closely as possible to the points of support. Make turns slowly to prevent blades from bending or breaking. To avoid objectionable burring and possibly tearing along edges of thin sheet metal, clamp it firmly between two flat pieces of hardboard or

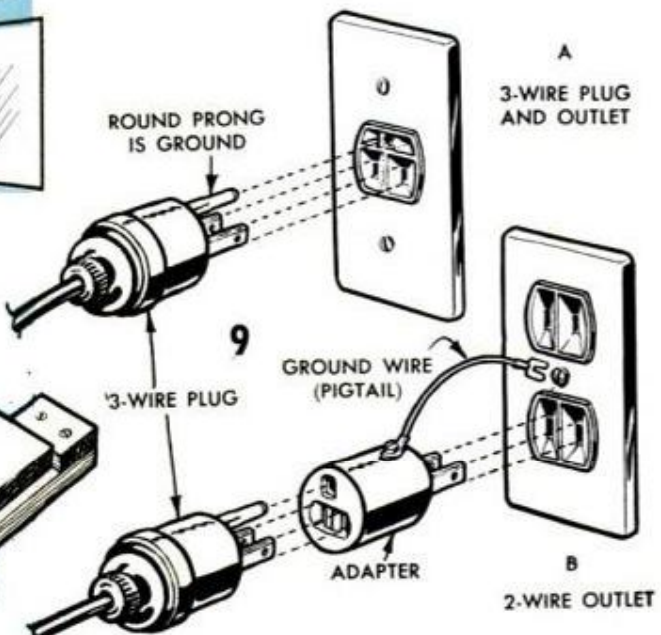

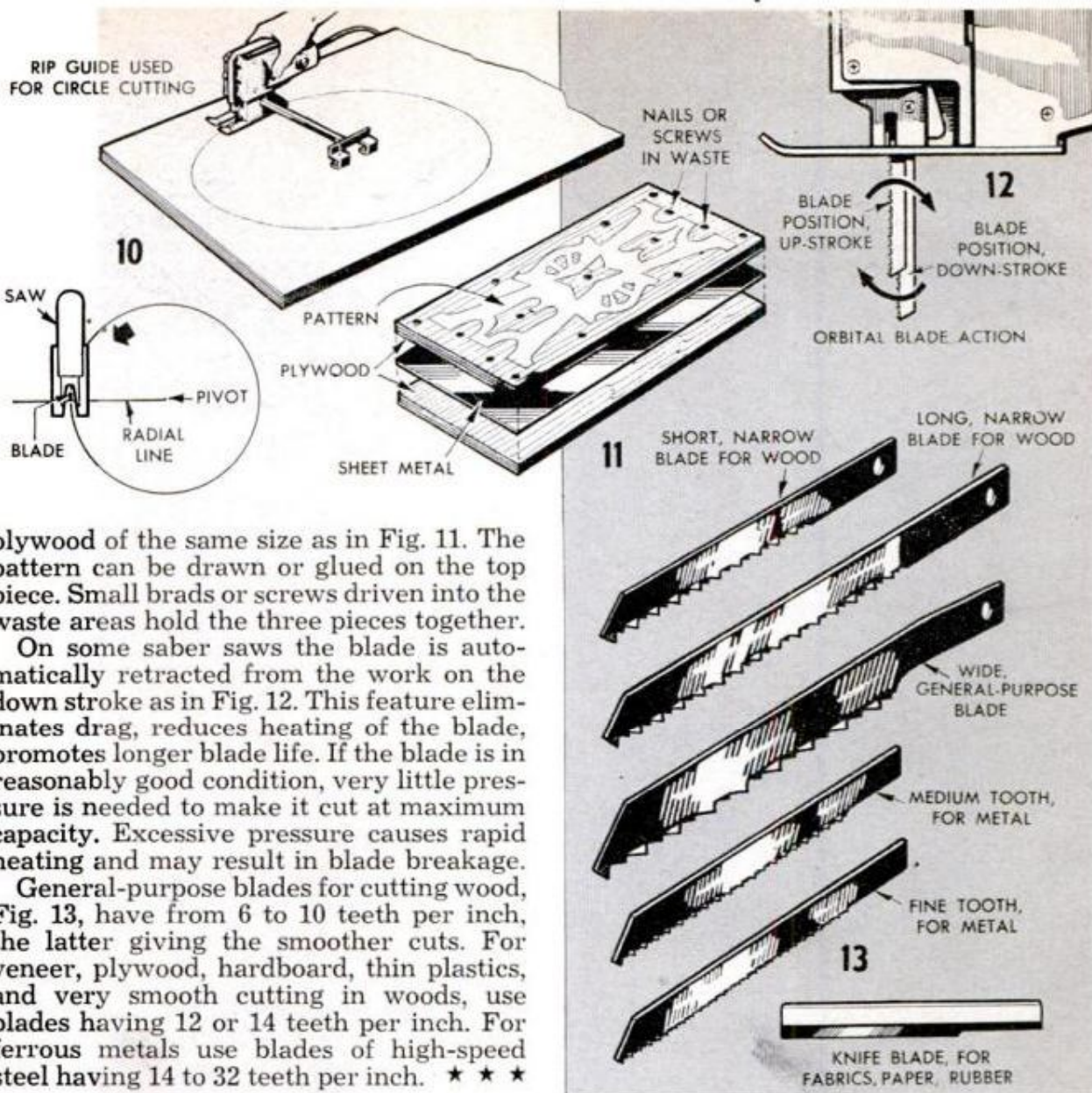

plywood of the same size as in Fig. 11. The pattern can be drawn or glued on the top piece. Small brads or screws driven into the waste areas hold the three pieces together.

On some saber saws the blade is automatically retracted from the work on the down stroke as in Fig. 12. This feature eliminates drag, reduces heating of the blade, promotes longer blade life. If the blade is in reasonably good condition, very little pressure is needed to make it cut at maximum capacity. Excessive pressure causes rapid heating and may result in blade breakage.

General-purpose blades for cutting wood, Fig. 13, have from 6 to 10 teeth per inch, the latter giving the smoother cuts. For veneer, plywood, hardboard, thin plastics, and very smooth cutting in woods, use blades having 12 or 14 teeth per inch. For ferrous metals use blades of high-speed steel having 14 to 32 teeth per inch. ★ ★ ★

GENERAL SPECIFICATIONS OF PORTABLE SABER SAWS (all dimensions in inches)

TRADE NAME, MAKER & CAT. NO.	CUTTING CAPACITY	STROKE LENGTH	STROKES PER. MIN.	WEIGHT (lbs.)	OVERALL DIMENSIONS			BEARINGS	ADJUSTABLE FOOT
					LENGTH	WIDTH	HEIGHT		
Black & Decker Mfg. Co. U-10	1½ Softwd. 1 Hdw.	½	3750	3½	8				
"Craftsman" 2798 Sears Roebuck & Co.	2½ Wood	1	2700	6½	8	2¾	8¾	Ball bearings in motor and needle bearings in gear case	
"Disston" D-23 H. K. Porter Co. Inc.	2½ Wd., ½ Alum. ¼ Steel		3800	5¼				3 ball and 9 needle bearings	
Cummins Portable Power Tool Co. Div. John Oster Mfg. Co. 466	2	½	3500	5	6¼			Ball and Sintered Bronze	
"Dyna-Mite" 480 Millers Falls Co.	1¾ Wd. ½ Metal	½	3000	3½	7½		6		
Porter-Cable Machine Co. 152	1¾ Wd., ¼ Alum. ¼ Steel		4700	5	7	4½	7	Self-lubricating bronze	Accessory foot
"Powr-Kraft" 8930 Montgomery-Ward Co.	2 Wd.	¾	2650	4					
Skill Corp. 514	2 Softwd. 1½ Hardwd.		4000	3¾	9			Ball thrust and cushion- mounted sleeve bearings	
Stanley Electric Tools H-75	2 Wd.	¾	3300	4¾					
Sunbeam Corp. 76	1¾ Wd.	¾	1780	3¾	7	2½	3½	Ball and needle	
Thor Power Tool Co. 440	1¾ Wd. ¼ Steel	½	3400	4	6¾		7	Oilite	
Weller Electric Corp. 800	1 Wd.								
Wen Products, Inc. 505	1¾ Wd. ½ Steel	¾	2650	3½	6¾		5		
Portable Electric Tools, Inc., "Shopmate"	2	¾	3050	4	7½		5	Needle and Bronze	

Hints To



1



2

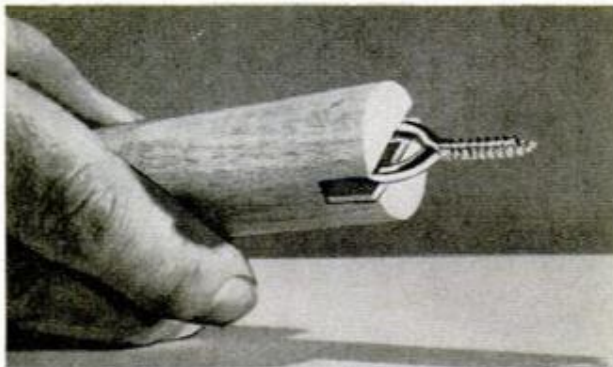

3

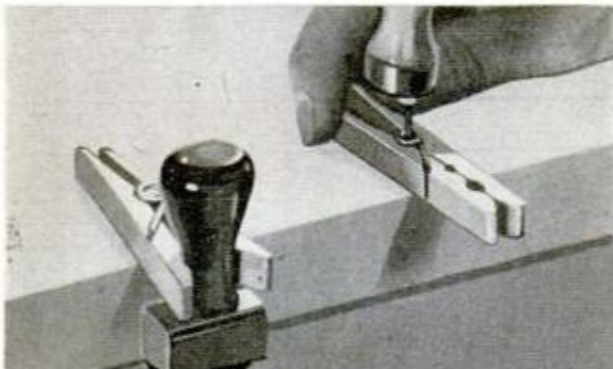

4

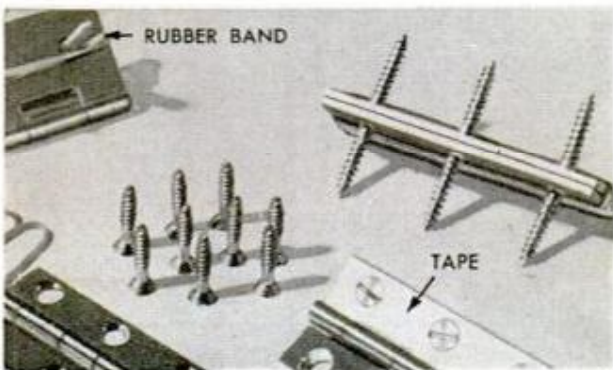

5

1. Household chores can be mighty hard on a lady's hands, especially those involving the use of a bucket with a wire handle. However, a length of rubber hose slipped over the handle offers good protection and provides an excellent grip at the same time.

2. No need to guess how much paint there is left in those cans when it is so easy to keep track. After using the can, place a rubber band around it at the level of the remaining paint and you'll know at a glance.

3. Inserting a number of screw eyes is no problem if you make things easy for yourself with this simple driver. It involves no more than cutting a slot in the end of a piece of broomstick just wide enough to receive the head of the screw eye. A small piece of wood may be wedged in the slot to accommodate screw eyes of smaller size.

4. Why let rubber stamps get tossed around in a drawer when you know such treatment will eventually ruin them? If you have spring-type clothespins around the house, tack several of these along the edge of the desk or worktable. They will keep the stamps clean and readily available for use and if desired, may be painted to suit.

5. Got a handful of hinges and no screws? Next time find a way to keep them together before you store them. Quickest and easiest way is to insert the screws in the holes, close the hinge, and wrap it with tape or with a large rubber band until needed.

Remember

6. Garden enthusiasts—don't throw away those plastic vegetable bags. They are the ideal thing for protecting sprouts and seedlings through the fall and early spring chills and also are much easier to store than glass jars kept for the same purpose.



7. Here's another one for you backyard farmers. A series of notches filed along one edge of your trowel will help to quickly determine when you have reached the proper depth in inches at which to plant seeds.

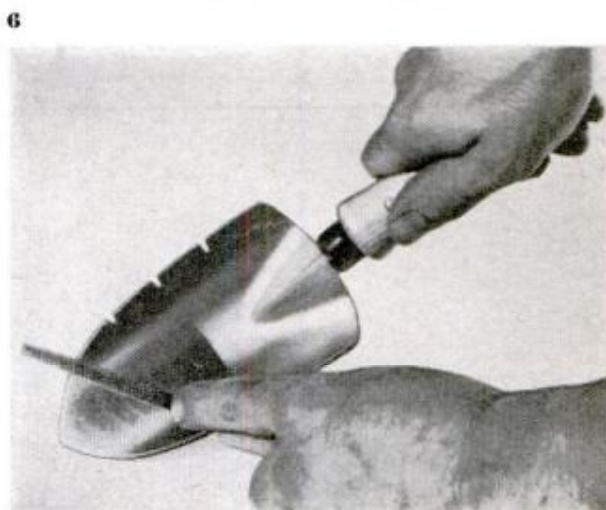

8. Wondering where to put that push stick you use on the circular saw? It is bound to get lost if left lying around, so place a small permanent magnet near the top of the stick. Now you can put the push stick anywhere along the sides of the saw cabinet or table and know that you can find it whenever needed to safeguard the fingers.

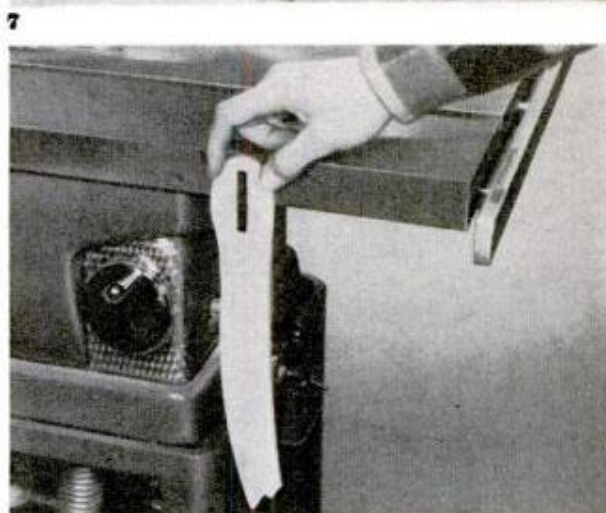

9. One of the best places to store those extra hacksaw blades you always need and can't find is right on the saw itself. Then if you can find the saw you have the blades. Tape several blades of different sizes to the top member of the saw frame as pictured. They won't interfere with use of the tool.

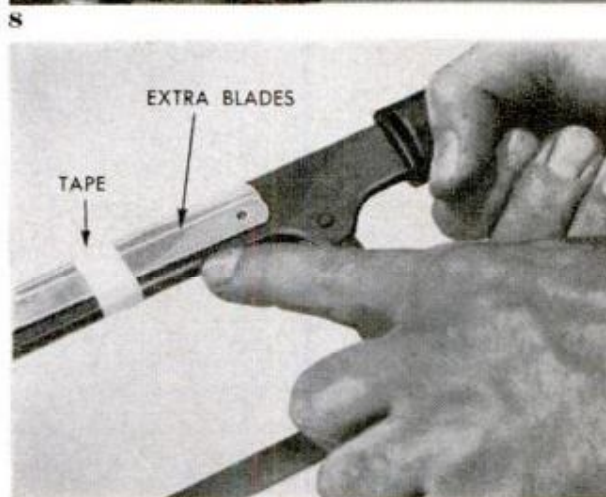

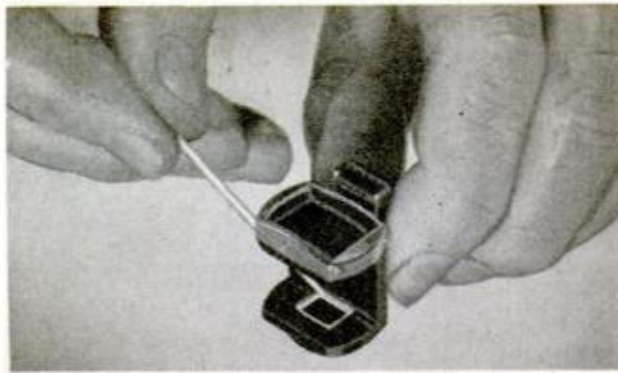

View Finder Sheds New Light

If the reflected white frame of a photographic view finder is hard to see in dim light, the situation can be remedied by coating the frame with phosphorescent paint. The paint can then be charged by holding the view finder near a lighted lamp.

—W. E. Burton



Eye-Dropper Bulb Steadies Reels

Cure your tape-recorder reels of wobble and backlash by slipping the rubber suction bulb of a discarded eye dropper over each spindle. All play, record and rewind operations will run smoothly even with the recorder in a vertical position.

—W. A. Crane

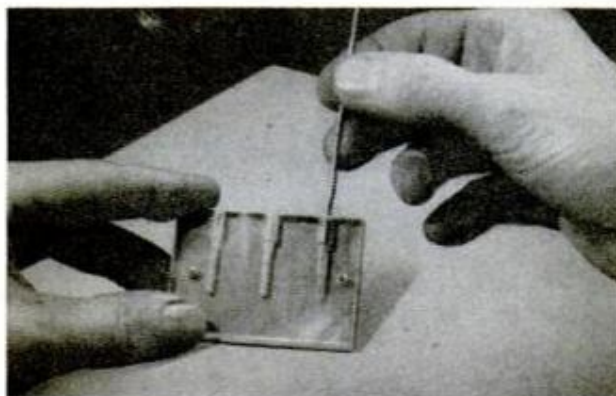

Lacquer Clears Holes In Plastic

Holes drilled in transparent plastic usually have a frosty appearance which, for one reason or another, you may find objectionable. In this case, most of the frosty appearance can be eliminated by coating the holes with clear lacquer.

UNDER-WINDOW

By John Jefchak

OUTSIDE IT'S ZERO. Inside it's warm as toast but stuffy. You raise the window and open the storm sash. What happens? You get relief with the fresh air but the windows start to sweat and frost over. The cold air causes condensation to form on the glass. By morning you will be mopping water and chipping ice off the window stool. Come spring you'll be repairing checked paint and refinishing watersoaked wood. You're apt to feel you just can't win.

But you can by installing through-the-wall window defrosters. These neat little air inlets, which are located under windows, solve the window-sweat and fresh-air problem once and for all. When you want some fresh air in the room you simply open the defroster instead of the storm window. And since driving snow or rain cannot enter, the units can be used the year round. Each defroster is made of sheet aluminum and a length of 3-in. drain pipe. The room end of the pipe is capped with a 1/8-in. hardboard collar 5 3/4-in. square which has a 3-in. hole centered 2 1/4 in. down from the top. The hardboard is faced with sheet aluminum which is cut according to the pattern given below. Note that the hole is made smaller than the hole in the hardboard, and that the lower edge of the metal is bent upward to form a drip trough to catch the small amount of condensation that forms on the metal. A little cleansing tissue placed in the trough will absorb what little moisture collects. The aluminum facing is peened down over

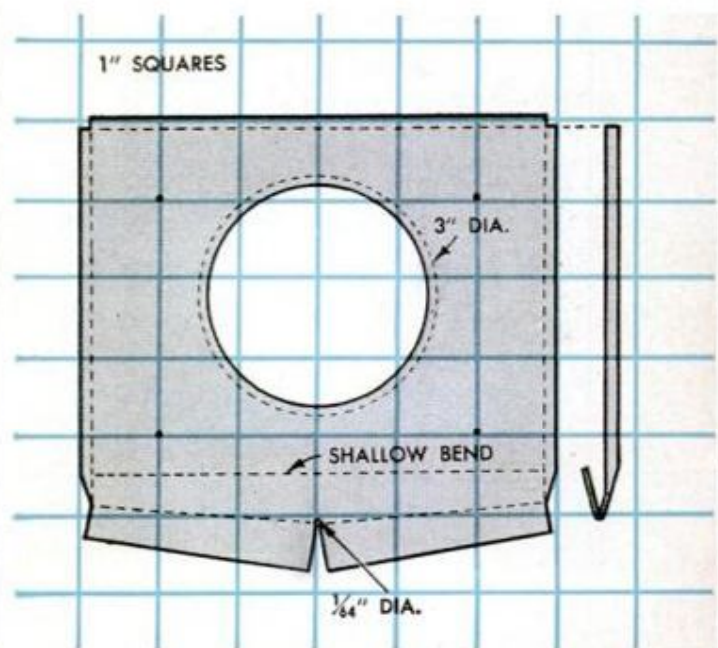

"DEFROSTER"

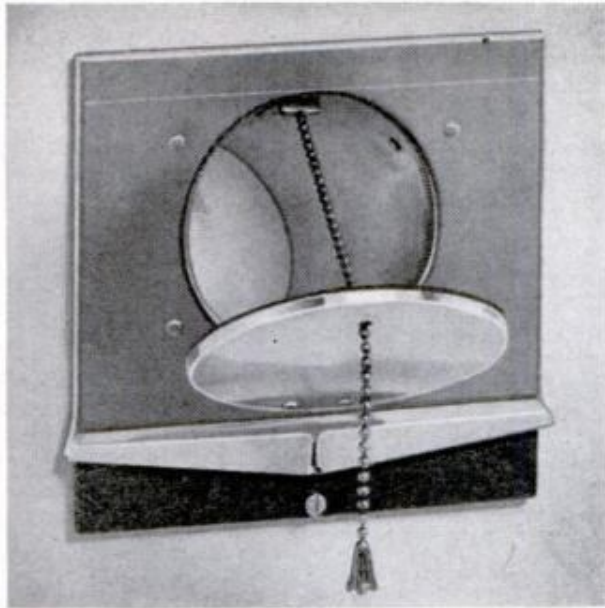

three edges of the hardboard, including the hole. Peening around the hole is done with the angle-cut drain pipe in place and then four small angle brackets are added to join the hardboard collar to the drain pipe. Holes for these are made in both the collar and pipe for short aluminum rivets. The circular cover, or door, for the defroster is a 3½-in. disk of hardboard covered with sheet aluminum and is hinged with a small brass hinge. A beaded chain taken from a pull-chain socket provides adjustment for controlling the amount of air entering the room. The chain is attached to the pipe on the inside.

Cut the hole through the lath and plaster
(Continued to page 228)

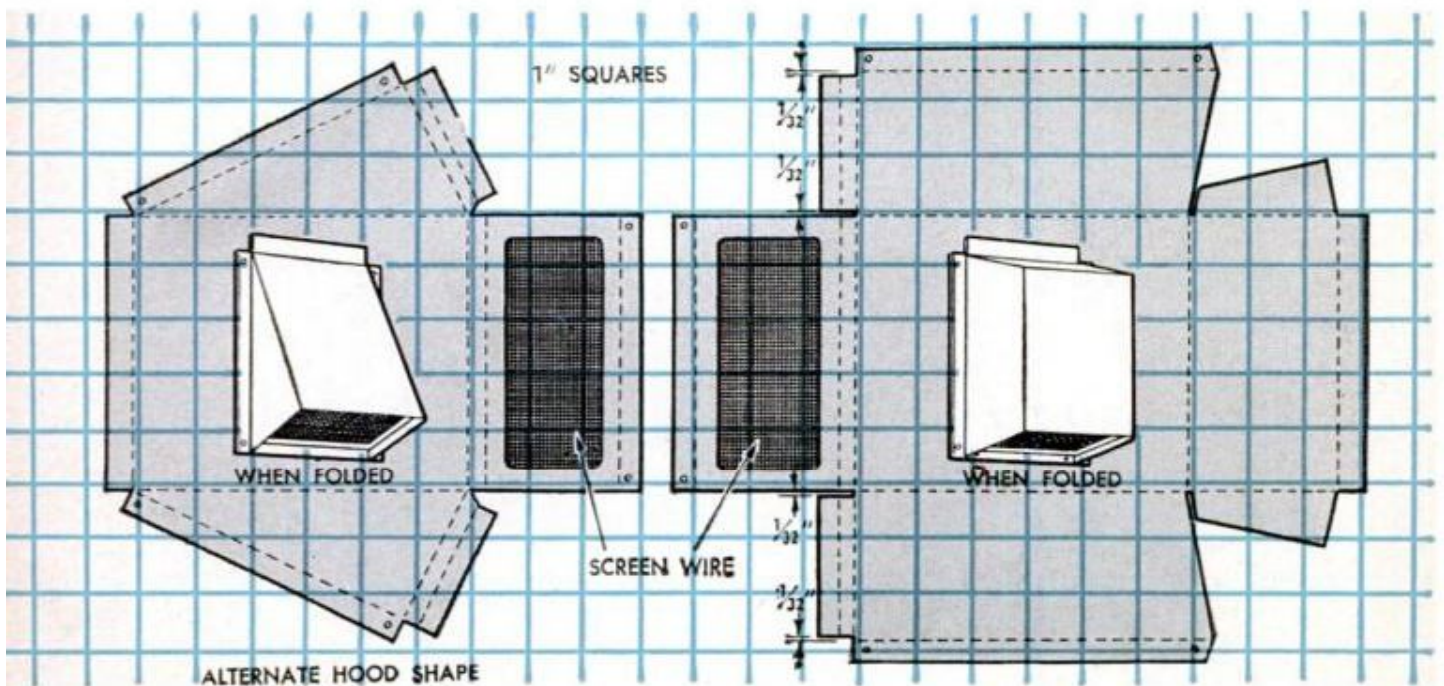
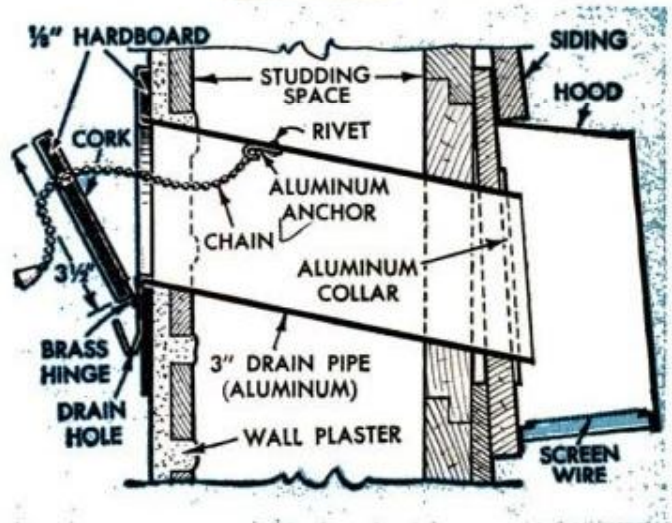

SOLVING HOME PROBLEMS



STAND FOR HOLDING typing copy, instructions, recipes and the like is made from a coat hanger and spring-type paper clamp. Remove hook from top of the hanger and bend hanger ends forward, as shown

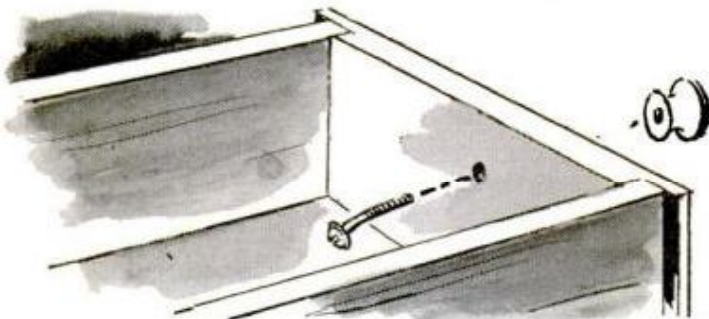

WHY BOTHER with a drawer knob that keeps coming loose when there's an easy way to tighten it permanently. Remove the screw and bend it slightly as in the detail. The bend prevents the knob from turning

SMALL FRY TAKE GREAT PRIDE in hanging their own clothes if the clothes rod is brought down to their size. A length of pipe is suspended from the regular rod by two hardwood hangers and ends are capped

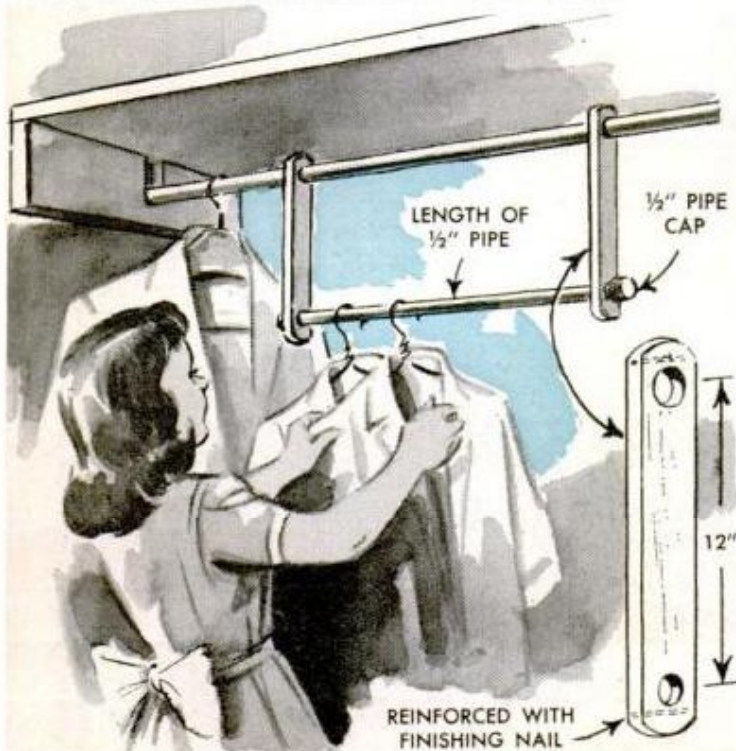

PRIZED FIGURINES and small art objects are given their own individual display cases by placing them in clear-plastic gift boxes. Decorate the paper base of the box, adding suitable background cut from magazine illustration if desired. Place the figurine in the center and top it with the plastic cover

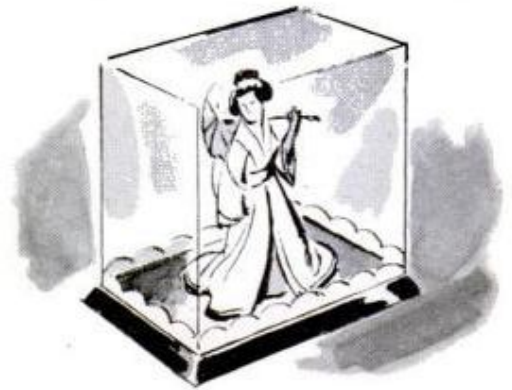

INDELIBLE STAINS on clothing may be set so thoroughly by ordinary laundering methods that you cannot remove them. Before laundering, wet stains with lighter fluid and then blot repeatedly until all of the pigment is removed



YOU'RE TAKING A PHONE MESSAGE and there's no pencil handy—that's the usual story. It won't happen if you wrap a rubber band around the receiver and slip a pencil under it





LOST YOUR PASTE BRUSH? What you need is a permanent holder. Bend one end of a paper clip outward, as shown, and tape the clip to the side of the jar. The projecting end makes an ideal holder over which to slip the hollow brush handle

PICNIC MEALS call for salt and finding a container is no problem if you hang onto an empty spice box. The kind with the sliding metal top is ideal since it is lightweight, leakproof and unbreakable



MR. HANDYMAN, if you're saving a can for keeping paint brushes in solvent or oil, don't cut the top entirely out. Leave a half inch or so to serve as a hinge, lift and bend the top, and snip a slot in it to hold the brush handle so bristles clear bottom of can

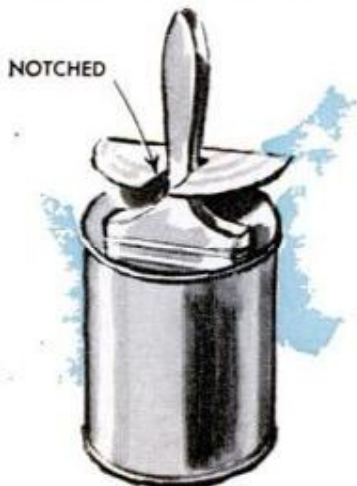

SEPTEMBER 1960



CRAFTSMEN lacking sufficient storage space in a basement can make good use of the floor joists. Center a wide board on the edge of each joist, fasten with screws and you have a pair of shelves for storing those small parts and miscellaneous items

BROKEN SAFETY STRAPS on the highchair can be replaced using an old garter. Cut the hard-rubber disk from one end of the garter and nail it to the bottom of the chair. Slip the metal buckle over this and nail the other end of the belt to the tray

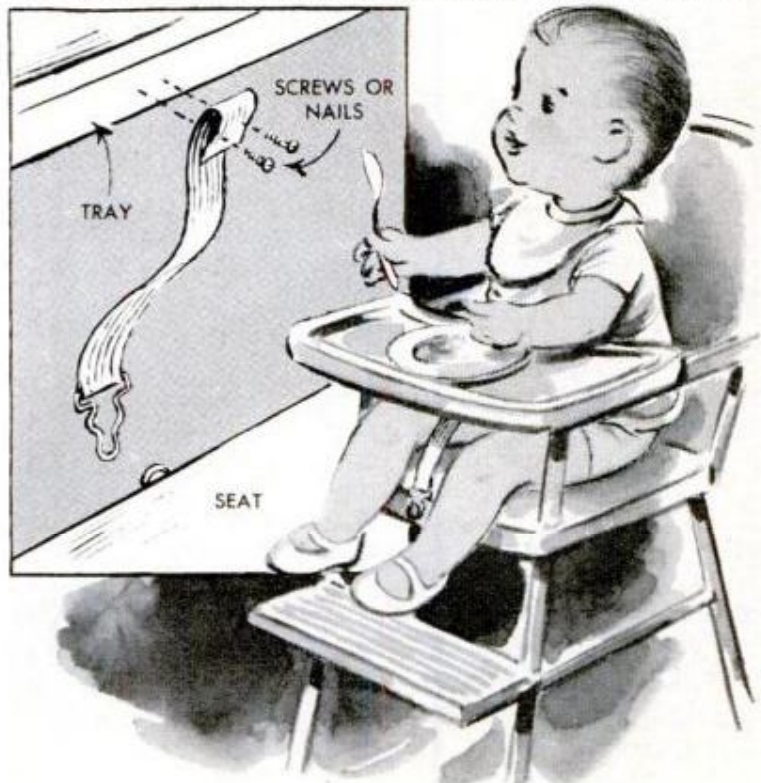

159



Shovel Makes Useful Trowel

Need a convenient trowel for those small patching jobs in concrete walks and foundation walls? A fire shovel makes a good substitute. The shovel also is handy for placing small amounts of concrete directly in holes. Afterwards shovel can be easily cleaned under a faucet.

—G. E. Hendrickson

When boring a deep hole in hardwood or soft metal, be sure to clean out the hole at frequent intervals to clear the bit.

Substitute Marking Gauge

This improvised marking gauge is made by fitting a pulley to a piece of metal rod. A thumbscrew is substituted for the pulley setscrew so that adjustments can be made quickly. A $\frac{1}{16}$ -in. hole drilled through the end of the rod receives the marking pin. The pin is held in place with a short screw in a tapped hole at the end of the shaft. Both ends of the marking pin are pointed so that the pin can be used either way.

—H. Hanscom

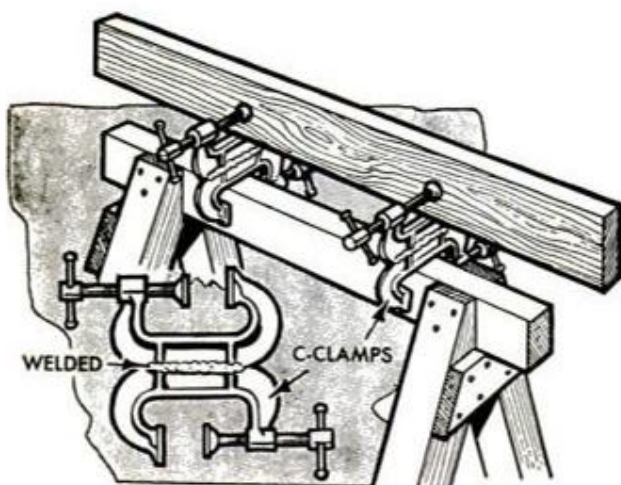
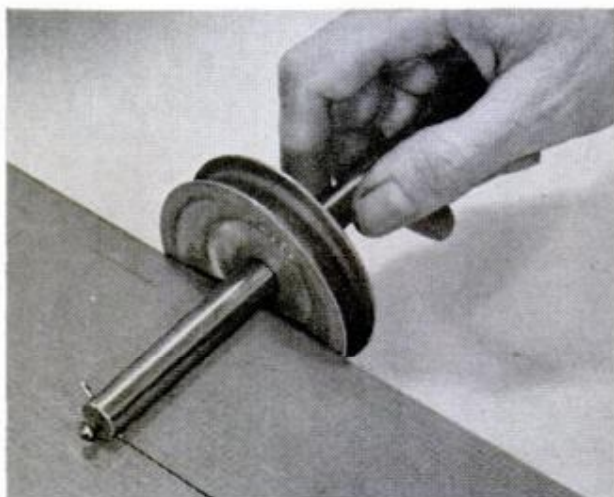

C-Clamps Used as Wood Vise

When away from the workshop, boards to be planed can be held in a vise made from 4 or 5-in. C-clamps mounted on sawhorses. Weld the C-clamps together in pairs, back-to-back, and arrange the screws on opposite sides to avoid interference with each other while turning them. Clamp a pair on each end of the sawhorse. To use, place a board in the vise and clamp in upright position. The clamps can be kept handy, yet out of the way when not in use, by attaching them to the underside of the sawhorse rail.—William B. Eagan

Sunshades for Binoculars

Direct sunlight can be shielded from the lenses of binoculars with a set of shades made from an old inner tube. Cut out a cardboard pattern the size and shape desired, and make the pattern about $\frac{1}{4}$ " shorter than the circumference of the barrel. Then, when the ends are joined, the shade will fit snugly. Cement is used to fasten the pieces together. If the joints are lapped, allow extra length for the overlaps.

To save rubber gloves, turn them inside out and apply pieces of adhesive tape over each finger tip. The tape helps protect the gloves from sharp fingernails.

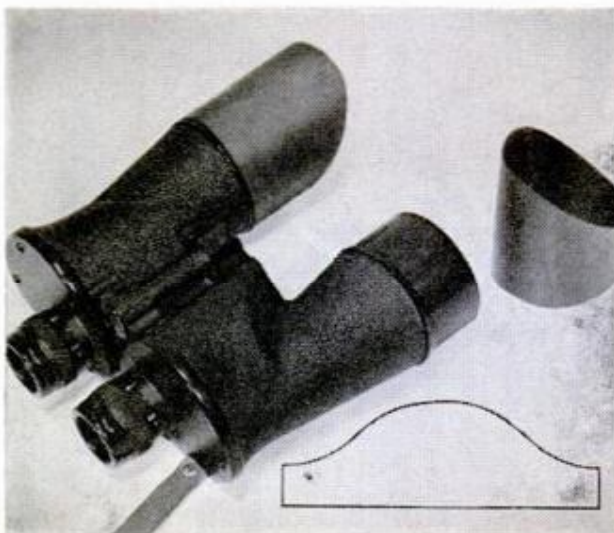

Fun Galore With a Whirligig

An amusing toy that children are sure to go for can be made from two forks, a cork and a nail. Thrust the forks into the cork at an angle that brings the center of gravity below the point of the nail. The cork and nail will be held in a vertical position at all times, regardless of whether the toy is spinning or motionless. By applying a twisting motion to the cork the toy is set spinning. This rotating motion will continue for a long time because there is almost a complete absence of friction.

—Bertram Brownold

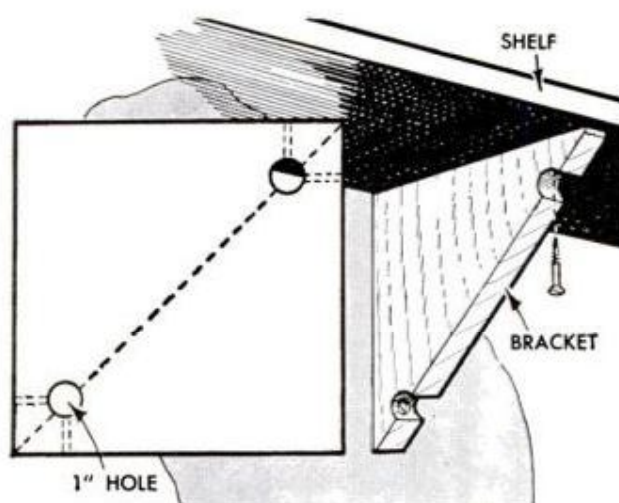

Shelf Brackets From Scraps

Sturdy shelf brackets can be made from squares of scrap lumber. Just be sure to square the pieces before drawing the diagonal line across each board. Bore 1-in. holes 2 in. from each corner to permit placement of screws as pictured. Saw each square on the diagonal line to make a pair of brackets. Screw holes are drilled in the edges of the brackets. The shelves are attached to the wall with screws through the predrilled holes. The brackets are made to extend almost the full width of the shelf.

—Joseph Federico

Improvised Glue Applicator

Don't discard those broken hacksaw blades. You can always find uses for them, such as spreading glue on a flat surface. Use a large spring paper clamp as a handle to hold a piece of hacksaw blade. The teeth of the blade allow glue to be applied in a smooth, uniform layer.—Bil Toman

Your glass-topped coffee table or other furniture will become real conversation pieces if you slip some of those prized snapshots under the glass.

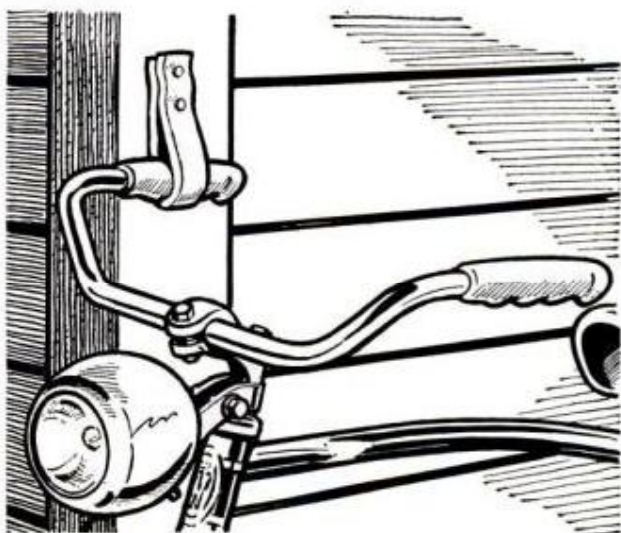

Strap Support for Bicycle

Bicycles have a habit of getting in the way around the garage or driveway. But if you nail a looped strap to the corner of the garage, inside or out, it insures a safe, upright location for parking a bicycle in an out-of-the-way spot. Place strap at a suitable height so that one of the handles can be inserted.

Waterproof capsules can be made for matches taken along on a fishing or camping trip by sealing the matches between two strips of cellophane tape. Using sulphur matches, seal one in each capsule.

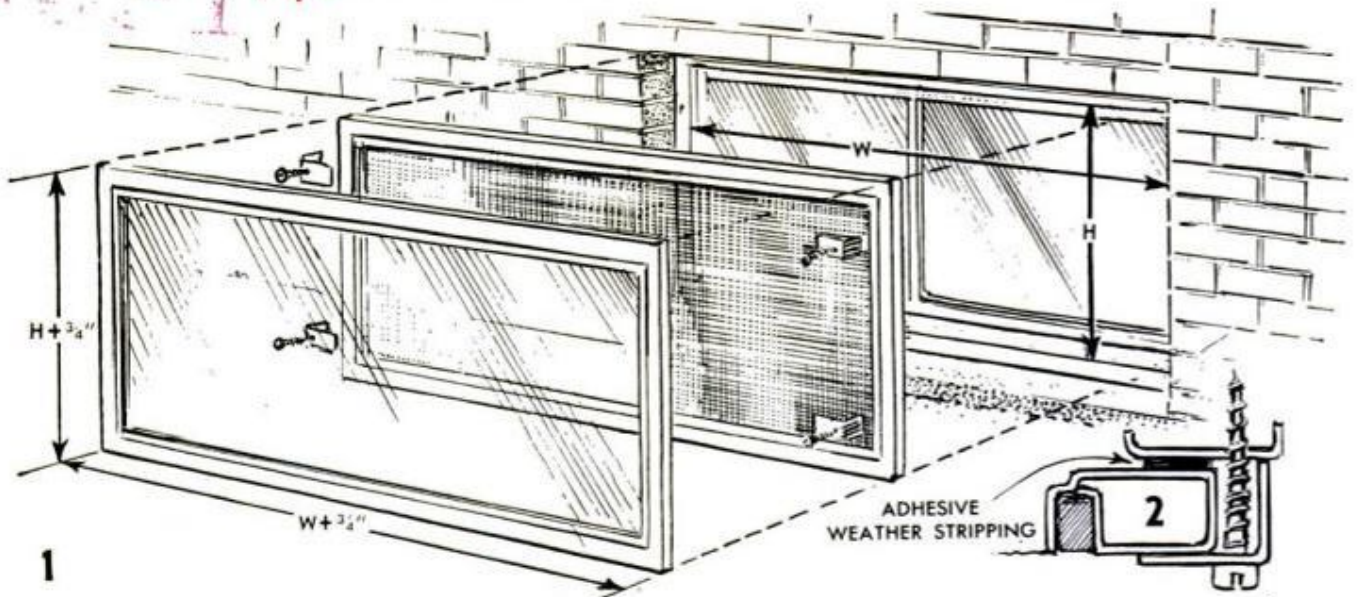

Make All-Metal Screens and Storm Sashes

for basement windows. Frames are easily made with household tools from stock metal shapes available almost anywhere

By Dave Swartwout

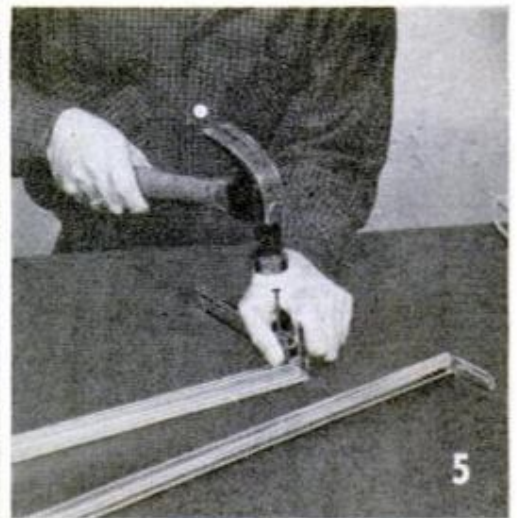

FRAMING PIECES can be sawed with woodworking tools such as fine-toothed hand saw or table saw. Corner locks are pushed into side pieces and tapped firmly in place with mallet. Then locks are "staked" to sides

STORM-WINDOW GLASS is sealed around edges by rubber glazing strip. And the corner locks are pushed into the metal channels so the glazing strip fits snugly between the glass and the metal channel of the frame

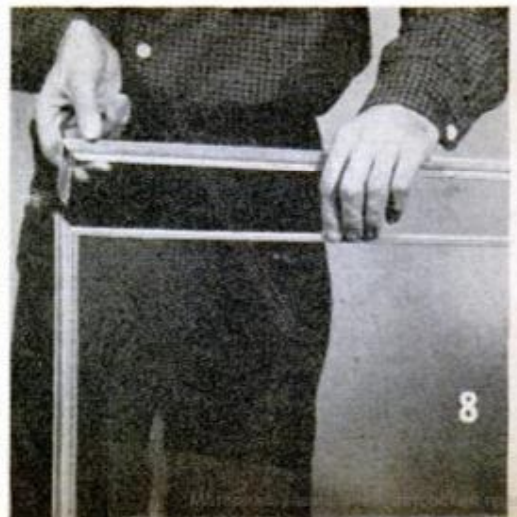

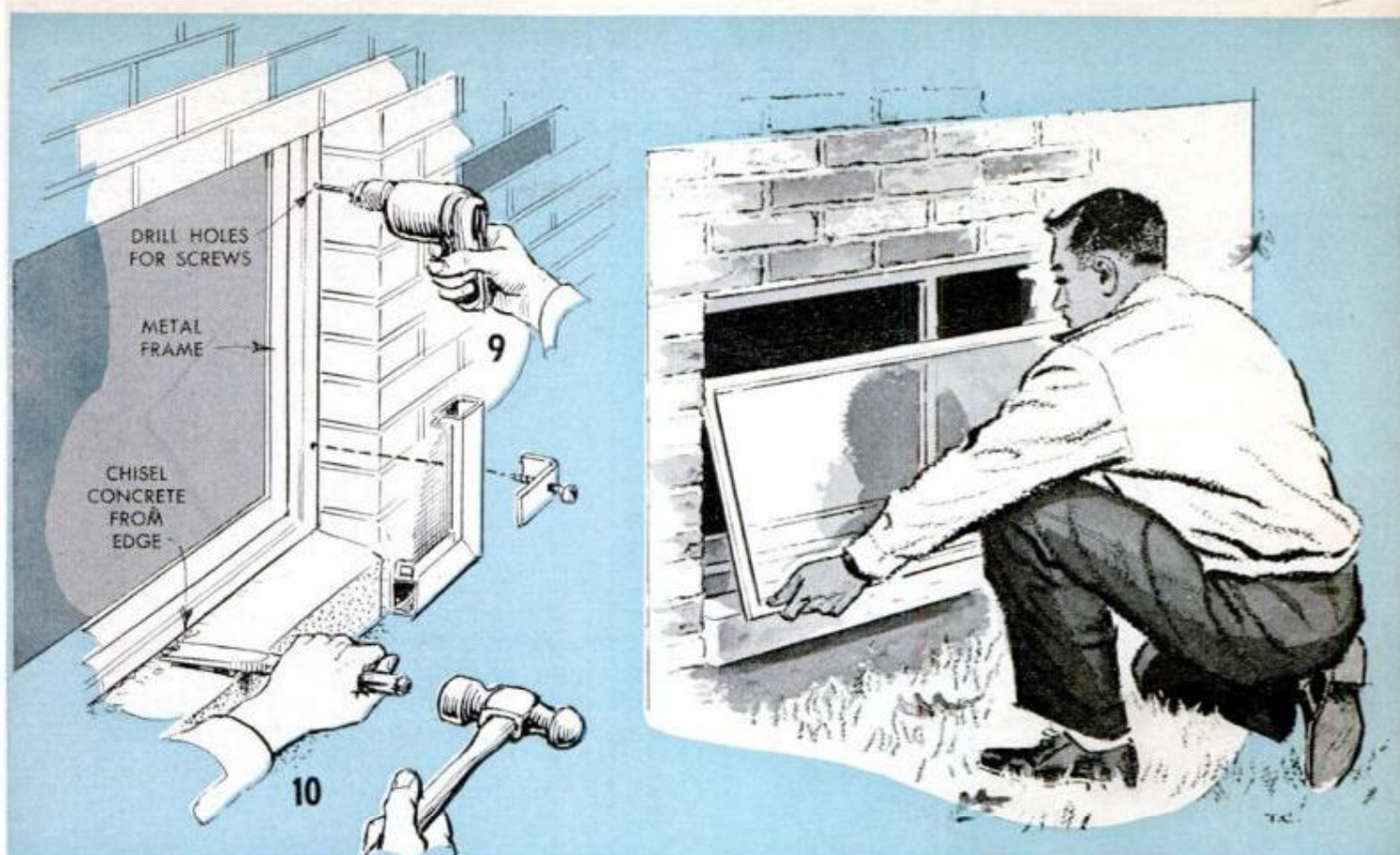

USING easy-to-work aluminum, it's a snap to make lasting screens and storm-sash frames for basement windows. Aluminum is easily worked with ordinary hand tools. The metal frames do not require painting and never need repair or other seasonal maintenance if carefully handled.

Window openings must first be measured accurately as shown in Fig. 1, and to these measurements add $\frac{3}{4}$ in. to the length of each piece, which allows an overlap of $\frac{3}{8}$ in. on all sides. You may find it necessary to change the overlap dimensions slightly.

Framing members can be cut with a power saw, Fig. 3, or in a homemade miter box, Fig. 11, using a fine-toothed hacksaw or backsaw. When sawing a framing member to length, make sure the piece is held securely so that there is no chance for "creeping." File the cut ends with a mill file or smooth with garnet paper.

Making the Screens

After framing members have been cut to length, assemble them as shown in Figs. 12 and 13, using the proper corner locks. Push the corner locks into ends of framing members—a gentle tapping with a hammer seats them firmly. Check the corners of the frame with a carpenter's square before lining up the screen wire and cutting it to size.

Cut aluminum screening to the outside dimensions of the frame and align it with the outer edge of the groove, Fig. 16. If plastic screening is used, the job of cut-

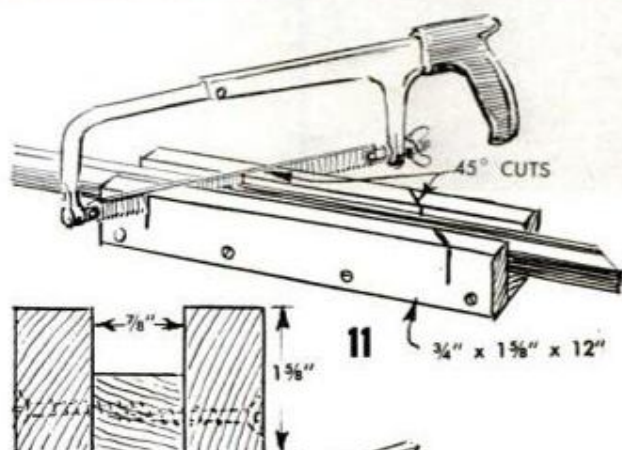

END VIEW

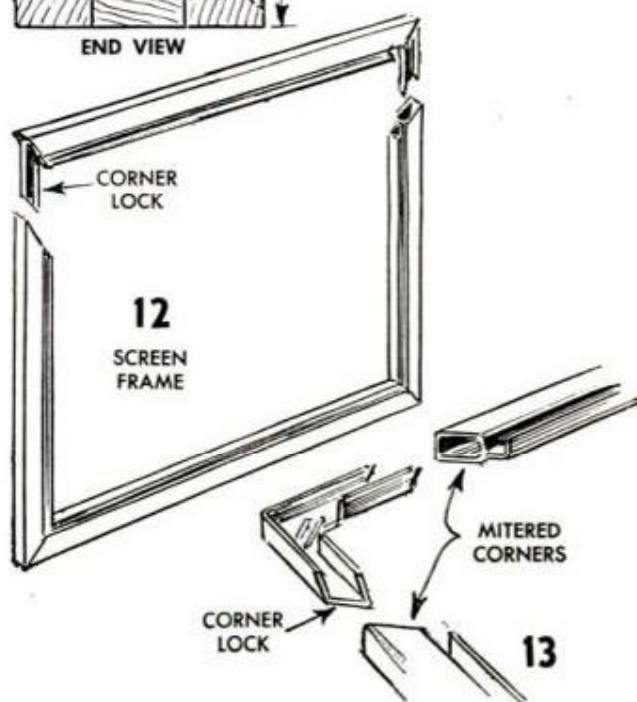

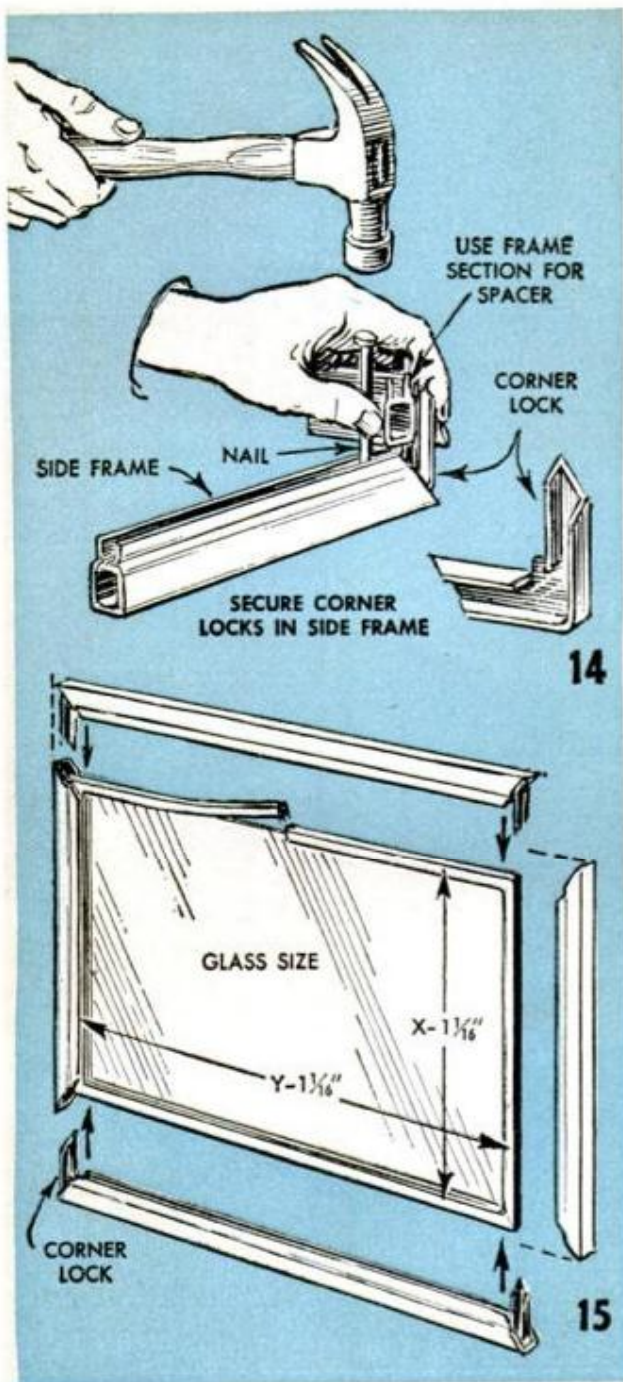

ting and assembling is simplified. An ordinary pair of scissors is satisfactory for cutting plastic screening. Trim away the excess material so screening lines up with the outside edges of the spline slots. Then bend the screening into the grooves with a putty knife and a block of wood. Then using a hammer and a suitable block of wood, tap the spline firmly into the groove along one of the long sides. Work around the frame forcing the screening into each groove and inserting the spline. Plastic screening can be tapped into grooves with a small strip of hardboard. Splines fit together at the corners with butt joints.

Making the Storms

The storm sashes are made the same size as the screen frames. Glass size is obtained by deducting $1\frac{1}{16}$ in. from the length and width of the frame, Fig. 15.

To assemble storm sash, insert corner locks into the long side pieces, Fig. 4. The small projection in the corner lock is staked to the side frame with a nail and hammer as shown in Figs. 5 and 14, locking the two pieces together. Glazing strips fit around edges of glass, Fig. 6. For ease in assembling, use short pieces of cellulose tape for holding strips to the glass. Cut triangular pieces from the corners of glazing channels to make neatly mitered corners. Now assemble the frame and glass as shown in Figs. 7 and 8. Adhesive weather stripping or a strip of rubber is cemented around the edges of the storm sash, between the sash and a metal casement, insuring a tight weather seal and avoiding metal to metal contact. For attaching frame to the window casing, use aluminum angles and screws, and fasten the angles to the casing as in Fig. 2, also Figs. 9 and 10, the latter showing the method of installing in a window opening in masonry. ★ ★ ★

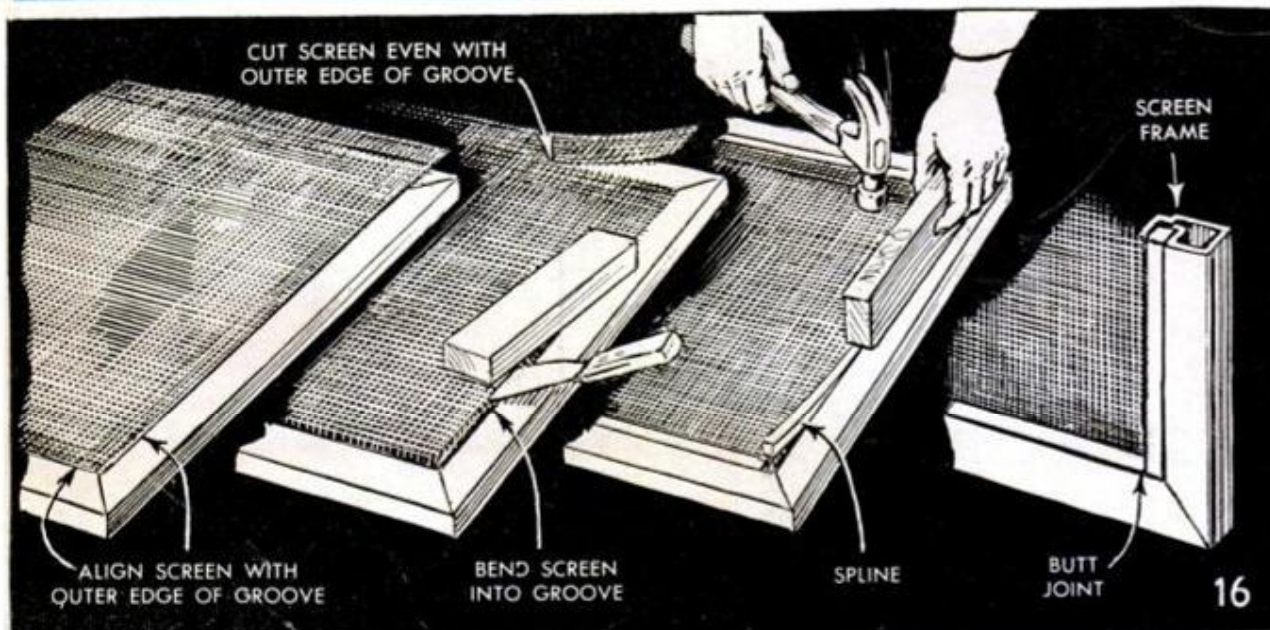

S-T-R-E-T-C-H-Y TIE-DOWNS

By V. Lee Oertle

KEEPING boating gear snugged down, without constant attention to lines, is a simple matter when shock cord is used for this purpose as illustrated in this story. Made up of a bundle of small rubber strands sheathed in a woven cotton or nylon casing, this highly elastic cord may be stretched to nearly twice its normal length. Unlike manila or cotton rope, shock cord resumes its original length at the instant strain is removed. This characteristic is what makes it ideal for tie-downs.

Sold at marine-supply stores by the foot, shock cord comes in sizes ranging from $\frac{1}{8}$ to $\frac{3}{4}$ in. in diameter. Breaking strengths range from 30 to 1000 lbs. A frequently-used size, $\frac{1}{4}$ in., sells for about 20 cents per ft. While you can make any splice needed by using the materials and methods outlined in this story, patented fittings for making tie-downs also are available.

Since the work a tie-down must perform determines what size of cord should be used, selection of cord size is important. If your dealer cannot advise you on this, the manufacturer's table of rated breaking strengths (less about 40% allowance for safety) serves as a good guide. Match the weight of the object to be secured or restrained with the size-strength of cord, corrected for safety.

The value of shock cord is in the tension or pull it can apply when stretched. Therefore, the tie-down must be made shorter than the distance to be spanned. For normal tension requirements, one-fifth short of this distance is about right. When cutting cord to the length required for a job, allow sufficient length for the doubled portion of loops and eye splices. The latter are made fast with hog rings installed as shown in the photos. The addition of a tape binding, thimbles, steel rings and snap hooks strengthens the tie-downs and makes it easy to fasten and remove them quickly.

SEPTEMBER 1960

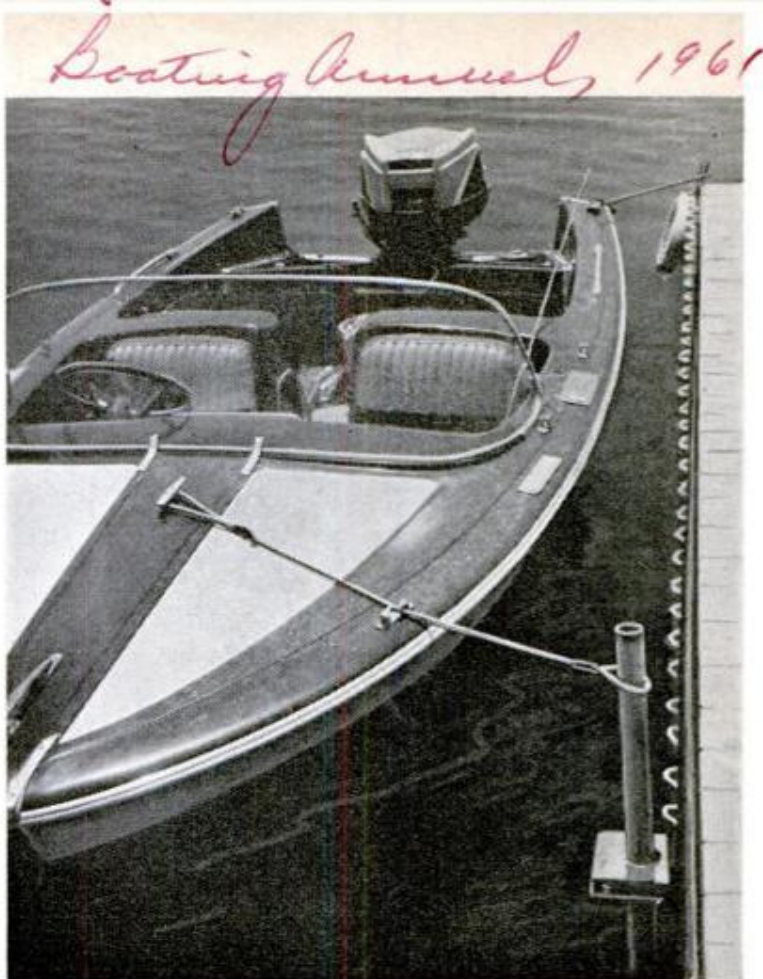

SHOCK CORD DOCK LINES with loops spliced on ends permit quick tie-ups for temporary stopovers. The cord won't chafe the boat's finish, saves tying knots, coiling and storing long, wet lines. By having a large loop at one end and smaller one at other end, ends may be reversed to suit the size of cleat, piling or other object on dock used as mooring bitt

TRAILING YOUR BOAT on a long trip? Shock cord can be used to snub boat to trailer at port and starb'd sides of stern, also at bow eye. Chain tie-downs are necessary for safety, of course, but the elastic cord provides sufficient tension to prevent the boat from rubbing or rocking on its support points



165

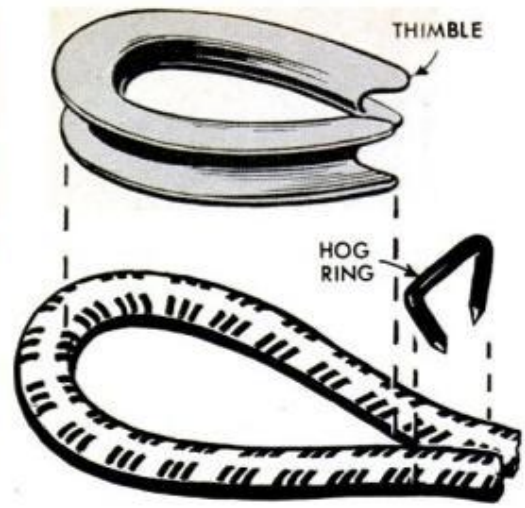
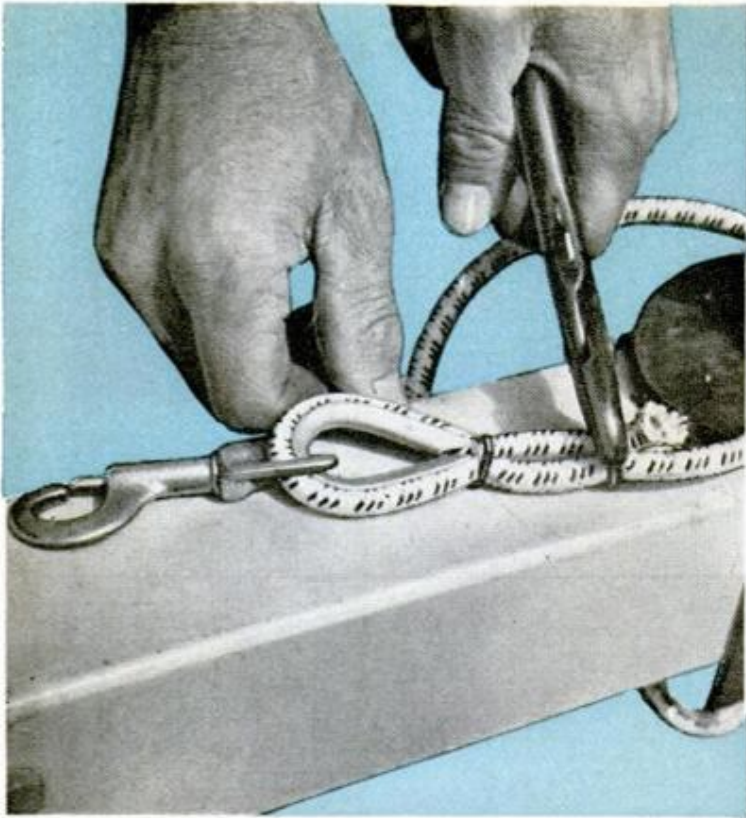

SPLICING EYES OR LOOPS on ends of shock cord is easy. One end of cord is folded back on itself to form loop of required size and fastened with two hog rings. Eye splices (small loops) that see hard use should be fitted with galvanized or stainless-steel thimbles as in the drawing above

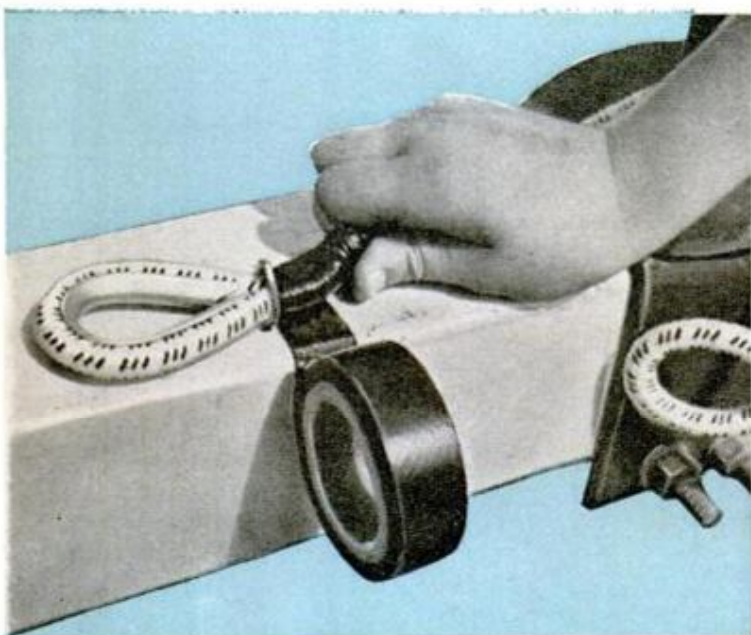
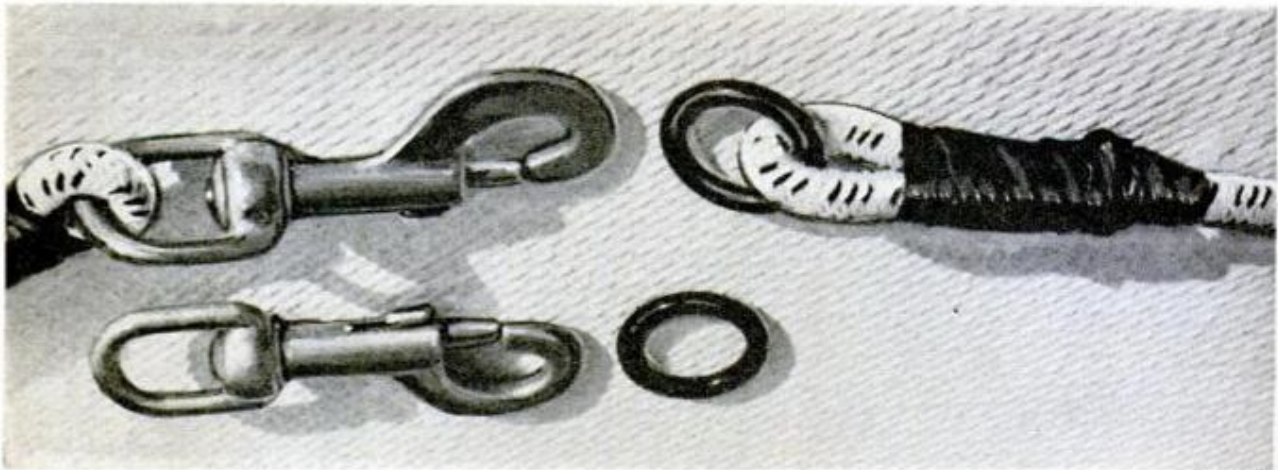

SWIVEL-EYE SNAP HOOK is spliced on one end of cord, galvanized-steel ring on other end to make endless cord when snapped together. Used for special tie-down jobs, cord is cut to exact length needed to produce desired tension when outstretched and secured (make cord one-fifth shorter than distance spanned by unstretched cord)

PLASTIC TAPE wrapped tightly around rope parts of splice covers metal hog rings and cut end of cord, making stronger, neater splice that won't slip or become undone when subjected to heavy strain



ENDLESS TYPE of tie-down is used here to secure anchor, paddle and other gear to motor-well bulkhead. Tension on cord keeps these items snugly in place even when water is rough, yet it can be removed very quickly simply by unhooking the snap

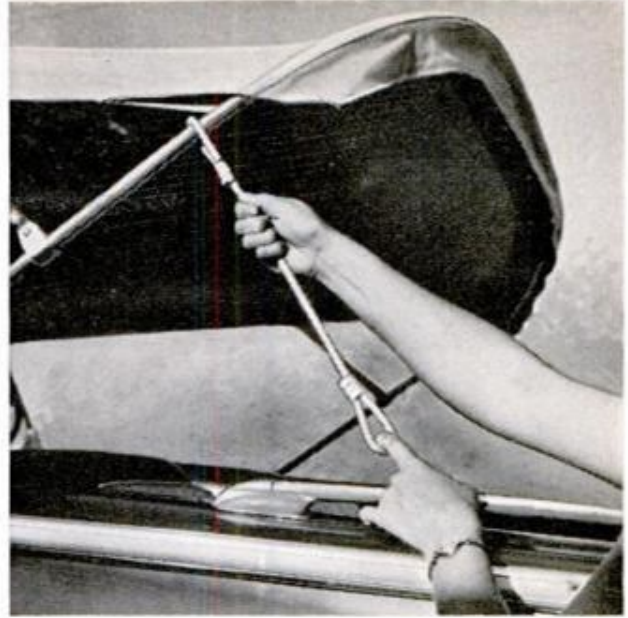

CONVERTIBLE BOAT TOP is held firmly in extended position by shock cord ties attached permanently to each side of the U-frame member. Loops on ends of tie-down slip on small cleats fastened to structural members port and starb'd on inside of hull

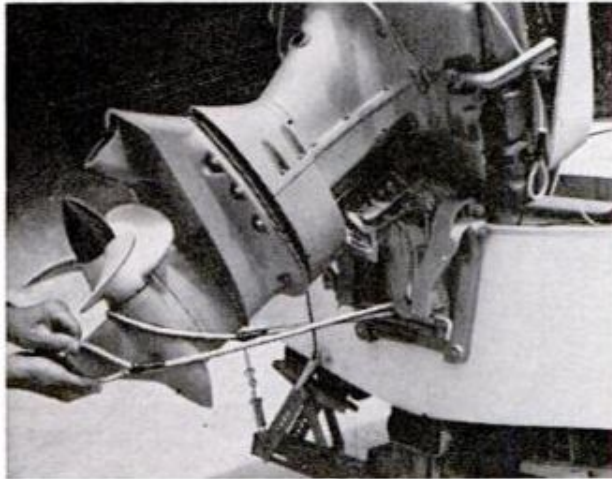

HEAVY MOTOR trailed in full-tilt position as shown above, is prevented from rocking on tilt pin by snubbing the lower unit tight with tie having loop spliced on each end. Loops are made large enough to be slipped over skeg and gearcase housing. Center of tie is looped over tilt pin. Another such tie looped over the motor steering bracket and made fast to stern cleat on each side of boat, holds motor straight, keeping its weight centered on transom

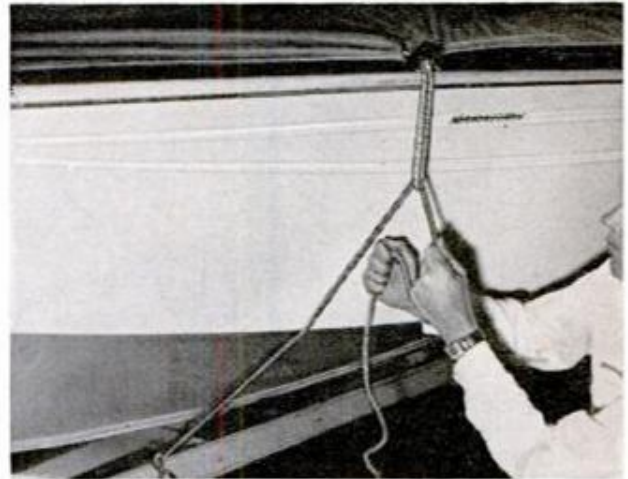

TENSION TRANSFERRED to boat cover by shock cord tie-down, prevents it from flapping, minimizing chafe on the boat's finish and wear on the cover. This is especially important if the boat is trailed with a cover on. Fiber-rope tie-downs lengthen under strain, leaving the cover loose to thrash about in the wind

PORTABLE FUEL TANK located where conventional tank holders can't be used, is held in place by shock cord having ring on one end and snap on other end. Two such hold-downs are used, each looped through the tank handle and secured to a part of the boat easily accessible in the manner shown in the photo

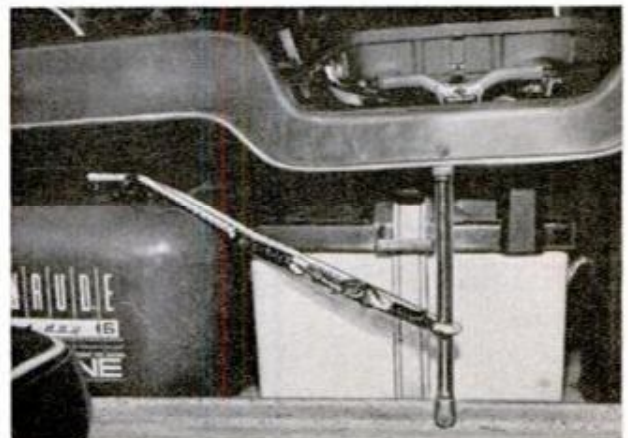



1



STOCK 1" LUMBER

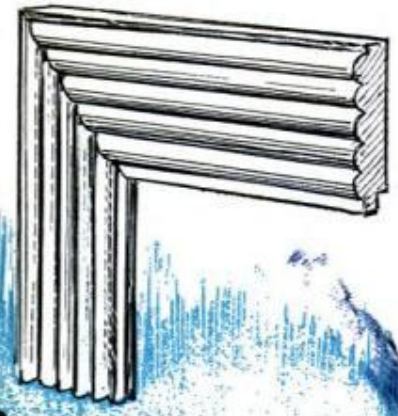

2



FLUTED CASING

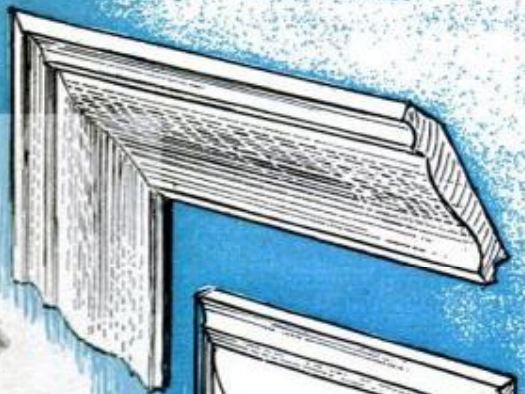

3



CROWN MOLDING

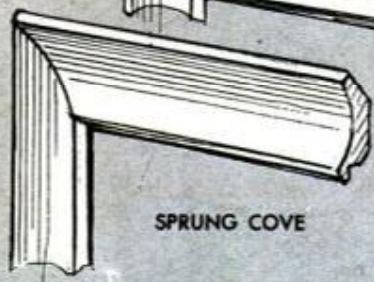
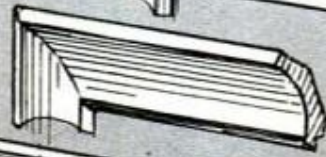
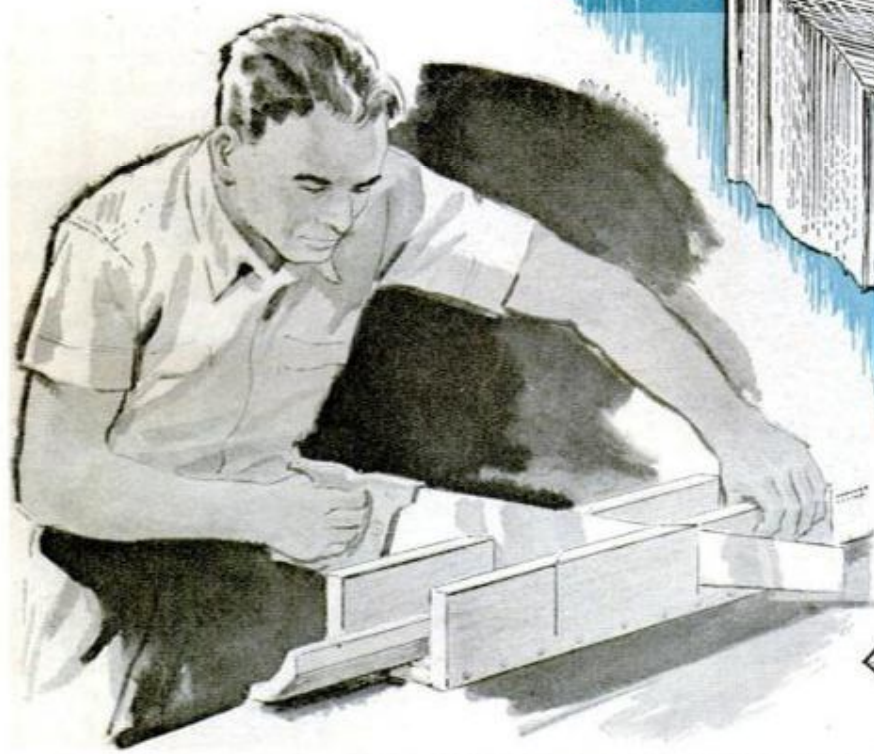

4

SPRUNG COVE

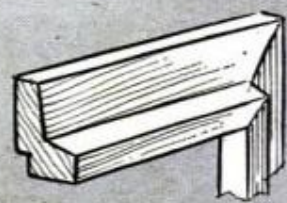

5

DRIP CAP

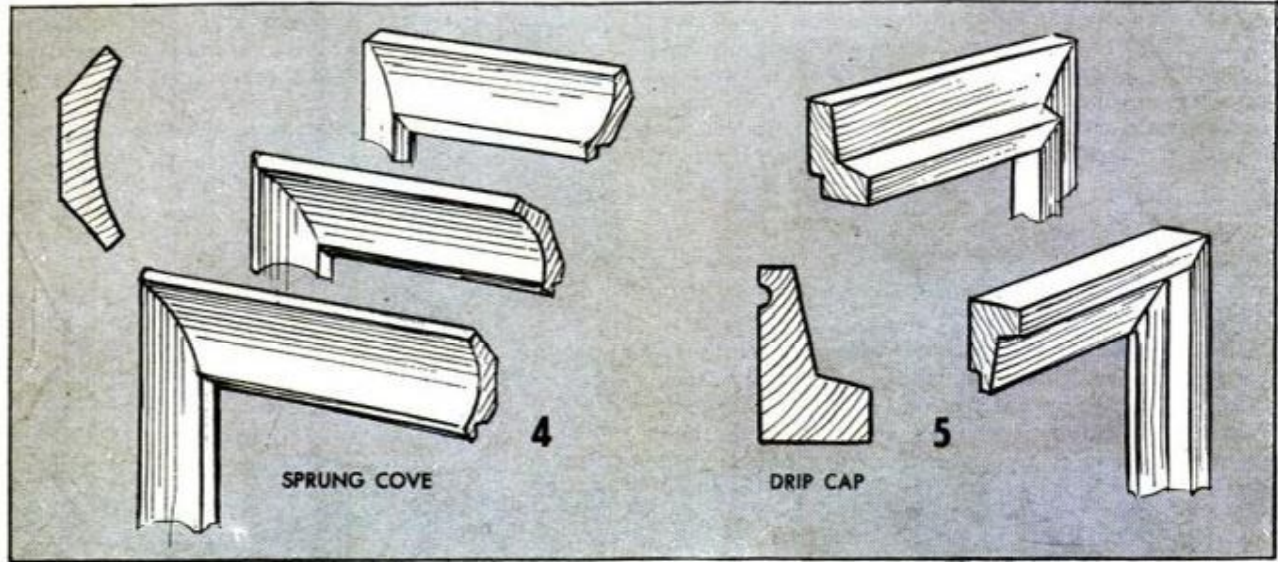
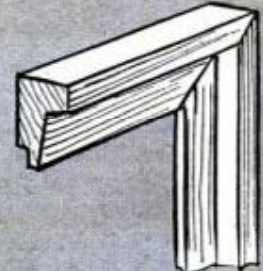

LUMBERYARD PICTURE FRAMES

There are picture frames galore waiting for you at your lumberyard at a fraction of the price you would pay at a store. Stock builders' moldings offer a wide selection of shapes at pennies per foot

By E. R. Haan

WHO WOULD THINK of going to a lumberyard for picture-frame molding! But there you'll find an array of standard molding shapes that will frame your pictures for a song. Priced by the foot, the molding is nicely shaped from choice grades of pine and other woods and needs only to be mitered to length, Figs. 1 through 5. Some moldings are already rabbeted, on others the rabbet is formed with a second molding, Fig. 8. All have one thing in common, they're comparatively inexpensive.

Figuring Molding Lengths

To determine molding length required for a desired glass size, add the height and width of the glass and multiply by two. To this add the width of the frame multiplied by eight. For example, in case of an 11x14-in. glass-size, twice the height and width is 50 in. For a frame 2 in. wide, add 16 in. to 50, totaling 66 in. or 5½ ft. to allow for waste.

Unfinished molding to be given a transparent coating should receive a coat of sealer to avoid stains from glue. Many

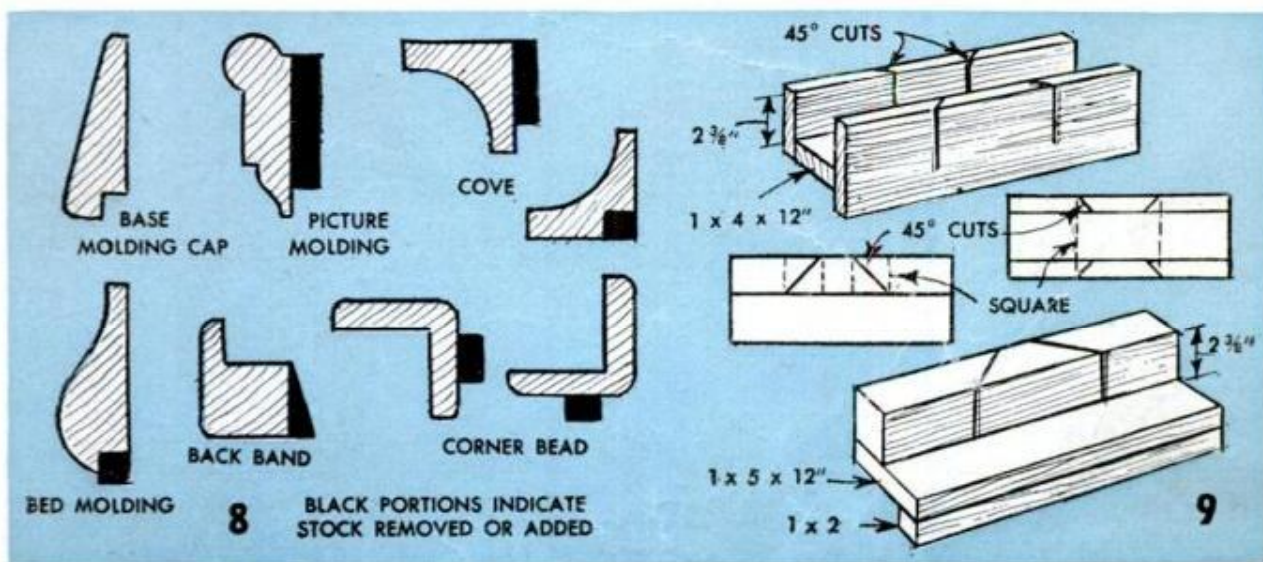
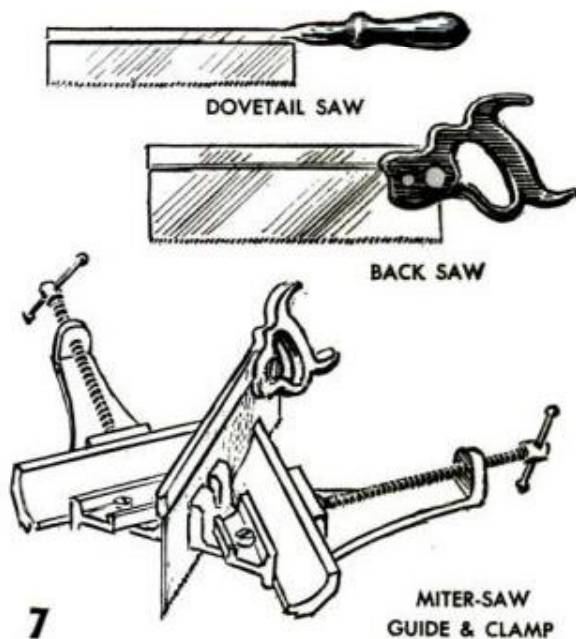

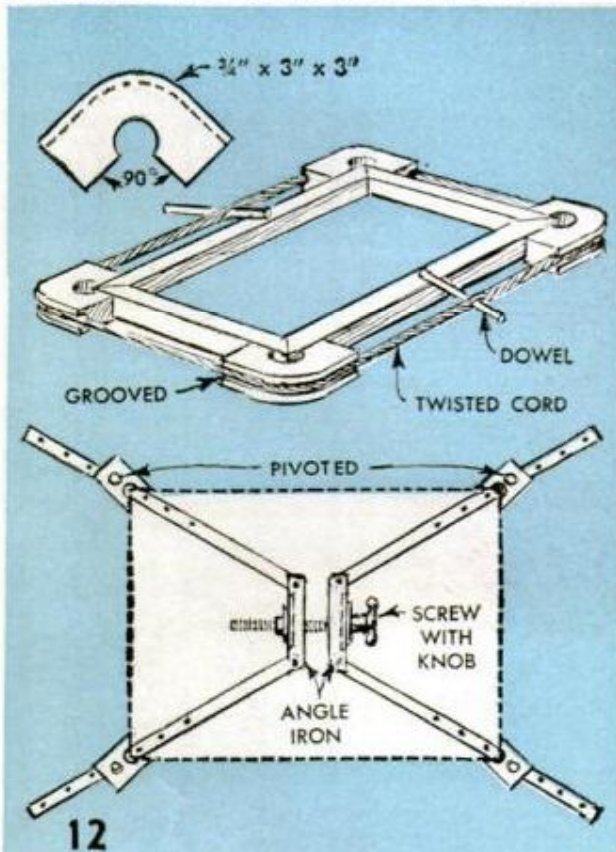
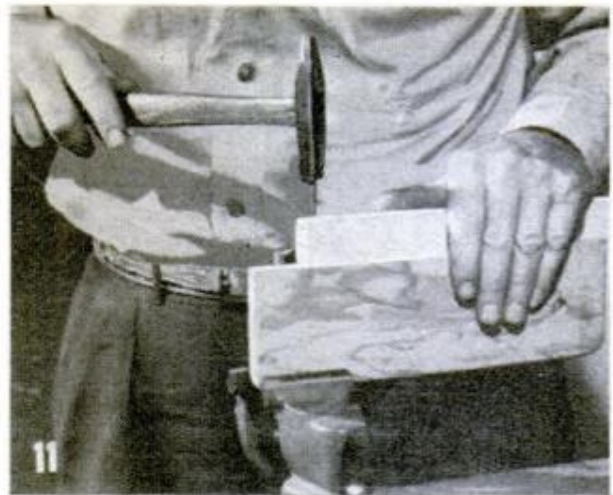

pleasing effects are obtained by making the grain of the wood contrast with a colored, semitransparent toner. Molding also can be covered with self-adhering sheet plastic having an imitation-wood finish.

Guides for Miter Sawing

If you haven't a circular saw to cut miters accurately, use a fine-toothed hand-saw such as a dovetail or back saw, Fig. 7, plus a suitable miter-sawing guide. Fig. 7 also shows an inexpensive combination miter-sawing guide and clamp.

A homemade miter guide and miter box are shown in Fig. 9. The dimensions given are intended for a back saw having a cutting depth of $2\frac{1}{2}$ in. To mark a block or box for cutting the 45-deg. saw kerfs, use a sharp pencil to make perfect diagonal gauge lines as in Fig. 9. Also draw vertical lines on the sides for checking the cut while sawing. The 45-deg. kerfs in the guide should be made by the saw to be used in them or one of identical thickness and set. One edge of the kerf should be right on the fine diagonal lines.

BLOCK LAID ON BED OF MITER BOX FOR CUTTING COMPOUND MITERS

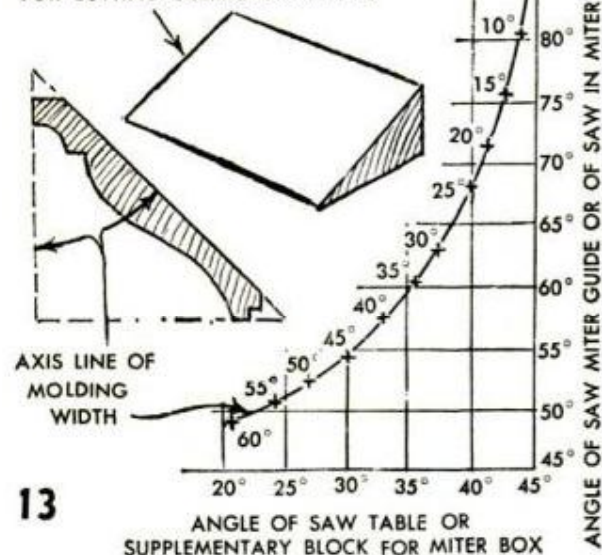

13

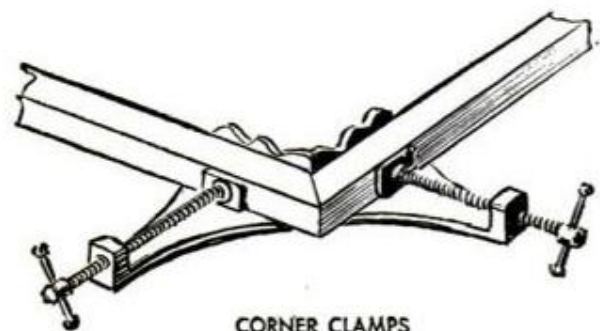

CORNER CLAMPS

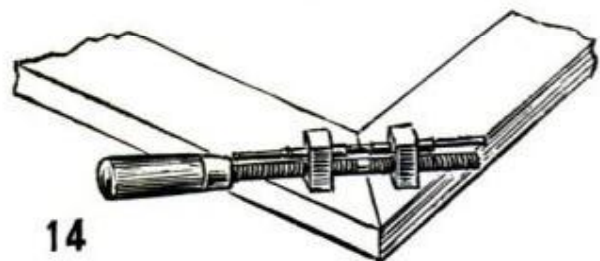

14

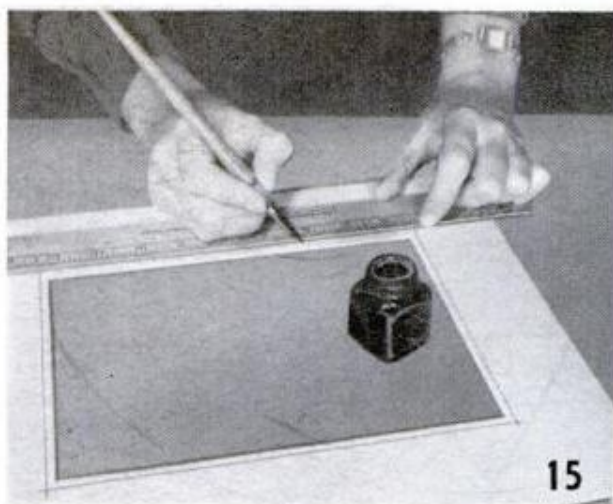

15

Using Miter-Saw Guides

Place the molding in the miter-saw guide or box so its back rests on the bottom and one edge comes snugly against one side. The molding must be held immovable—preferably clamped—in this position while sawing. Start the cut by drawing the saw backwards to prevent chipping the molding. To avoid a ragged back edge, place the molding on a strip of hardboard. If this is not done, the ragged edge must be removed carefully with fine sandpaper. Smoothly cut miters do not require sanding or planing, which sometimes changes the bevel or causes other damage.

Laying Out Frame for Cutting

For aligning the molding visibly, with the saw at the point where it is to cut, mark the outside edge of the molding. After cutting off one end at 45 deg., locate the mark for the next miter cut as follows: Measure the width of the molding from the outer edge to the bottom of the rabbet but not to the inner edge of the molding. Add twice this distance to the length of one edge of the glass, plus $\frac{1}{16}$ in. for clearance. This gives the exact length of the molding along the outer edge from the corner already cut.

Compound Miters

Hopper-type frames require compound miter cuts. Lacking a circular saw with its accurate miter gauge and tilting arbor you can use a sloping block in a miter box, Fig. 13. When cutting compound miters, use a miter box that is adjustable. Extreme accuracy is highly important for sawing compound miters. For frames having sides that slope 45 deg., the miter-gauge or miter-saw angle is $54\frac{3}{4}$ deg., while the table tilt or the angle of the supplementary block in a miter box is 30 deg. You can find this in graph, Fig. 13, which covers various slopes of picture frames.

SEPTEMBER 1960

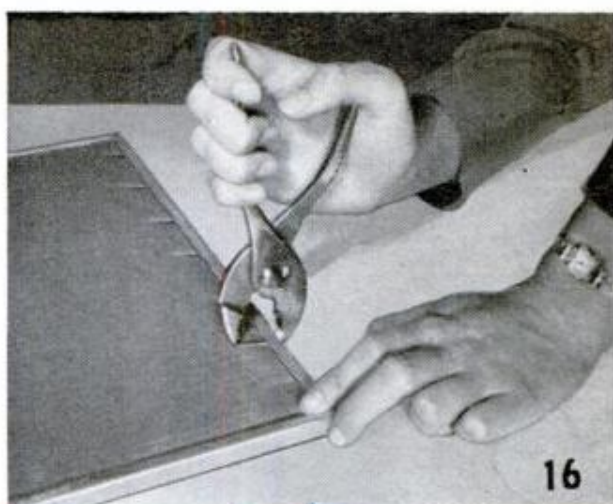

16

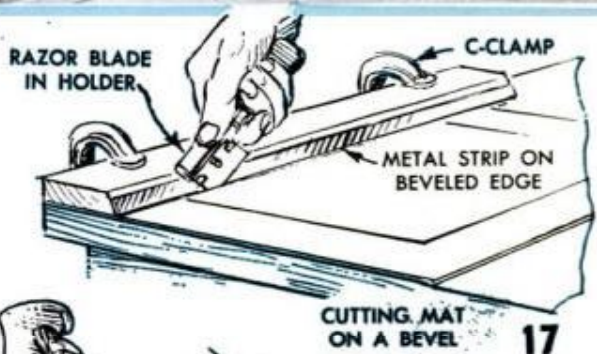

17



18

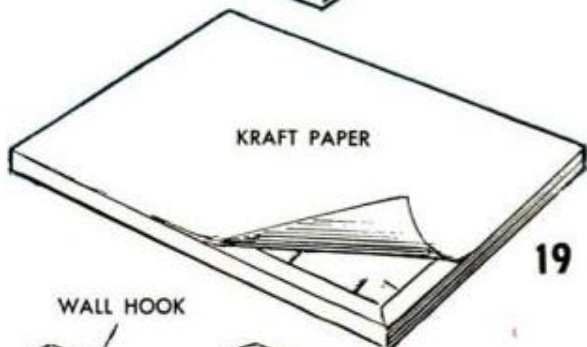

19

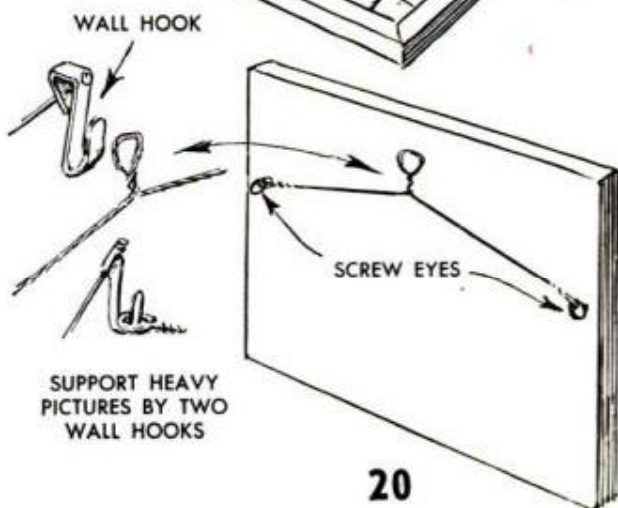

20

171

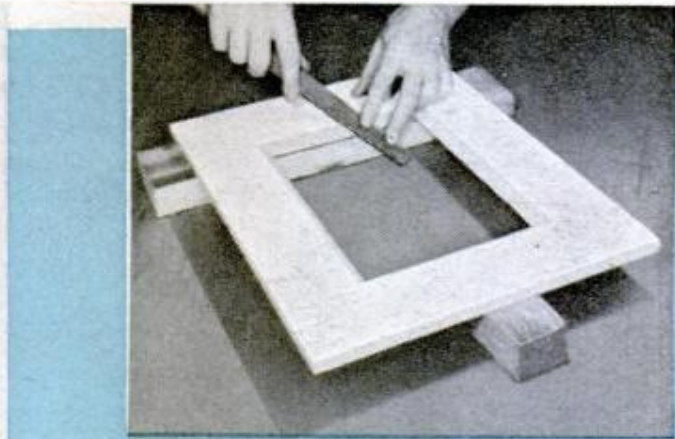

21

Assembling Frames

Check the four lengths of molding for accuracy. Assembling the pieces with glue and brads or finishing nails of suitable size is next. Often, small nails can be driven into soft molding without splitting it, even though no pilot holes are provided. But to forestall the risk of splitting, pilot holes are available, especially in hardwood. Generally a pilot hole needs to extend only from the outer edge of the molding to the miter cut—not into the joining molding.

After both pieces are glue-coated, place them together in a corner clamp, Figs. 10 and 14. Leave the molding in the clamps until the glue has dried.

Miter clamps that draw up the four corners of a mitered frame are shown in Fig. 12. However, when using these you glue the corners first but do the nailing after the glue has dried and the frame is removed from the clamp. For nailing, hold each side of the frame in a vise, using smooth, protective strips of hardboard on the finish side.

You can also glue and nail all corners of a frame freehand. To join corners freehand, chuck one member in a vise, using a protective pad against the molded surface and a backing piece such as plywood, Fig. 11. When joining molding, wipe off all excess glue with a damp cloth.

Mounting the Picture

Most pictures look best when offset by mats. Almost any thick paper of dull finish, preferably textured, will do. Thin paper is apt to buckle from moisture absorption. Best material to use is regular mat board. Interesting wood-grain and marble-

ized effects on mats are possible by covering cardboard with self-adhering sheet plastic. Another attractive effect is obtained by using $\frac{1}{8}$ -in. perforated hardboard against a colored background.

The picture should overlap the mat no less than $\frac{3}{8}$ in. Cut openings in matboard with a sharp razor blade held in a substantial holder; run the blade along a metal straightedge. For an angle cut, use a beveled straightedge as in Fig. 17. Mats often can be improved by black or colored ink lines drawn close to the edges as in Fig. 15. The picture is fastened to the mat with glue or removable tape.

The backing may be cardboard or corrugated board to bring the surface a trifle below the edge of the frame to permit the backing to be fastened with brads. On small frames you can push brads in gently with pliers, Fig. 16. For large frames, use a light hammer and punch, Fig. 18. After the brads are in place, seal the back of the picture with heavy paper to keep out dust, Fig. 19.

Screweyes used for hanging pictures generally are located from a third to a fourth of the picture height from the top edge as in Fig. 20. A loop formed at the center of picture wire as in Fig. 20 keeps a picture hanging straight, Fig. 6. Heavy pictures should be supported by two hooks.

Novelty Frames of Softboard

Attractive picture frames without glass, Fig. 21, can be made of soft wallboard. The outside edges are cut on a circular saw and then smoothed with sandpaper. The beveled cut is made as follows: Mark the position of the innermost edge on both

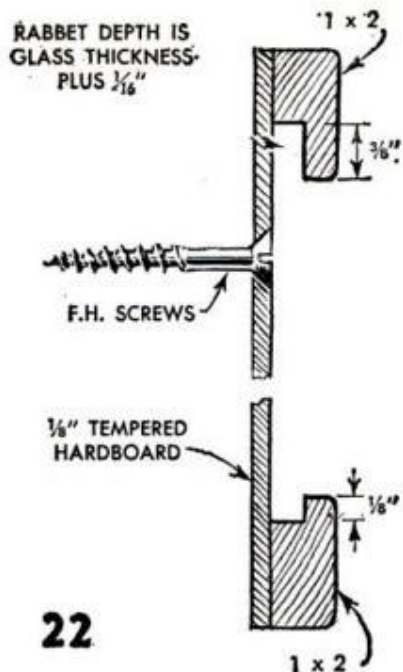

sides and cut halfway through the board from each side. Place the frame on blocks as in Fig. 21. With the finish side up, a medium-coarse file is used to dress off the beveled edges. Such frames are hung by gummed eyelet tabs as shown in Fig. 24.

Gang Frames

The frame in Fig. 22 holds several pictures of equal size and permits them to be exchanged quickly. Each picture is set behind a glass pane of the same size. Both are inserted into the upper rabbet and dropped into the shallow rabbet in the lower molding.

Imitation Frames of Sheet Plastic

Imitation wood frames can be made from strips of gummed sheet plastic. A

backing of softboard gives the desired thickness, Fig. 23. Place the glass carefully on the two strips. Hold the glass, mat, and backing together firmly while turning the assembly over. Next, apply the two other strips to the glass. Before fastening these to the back, make a miter cut at each corner with a sharp razor blade to eliminate overlap, Fig. 25. To minimize opening mitered joints, avoid stretching the tape lengthwise when applying it. Pictures so assembled are provided with gummed eyelet tabs for hanging.

Besides the imitation wood tapes, many other colorful plastic tapes are available. When a decorating change is wanted, simply add a new tape to the frame. ★ ★ ★

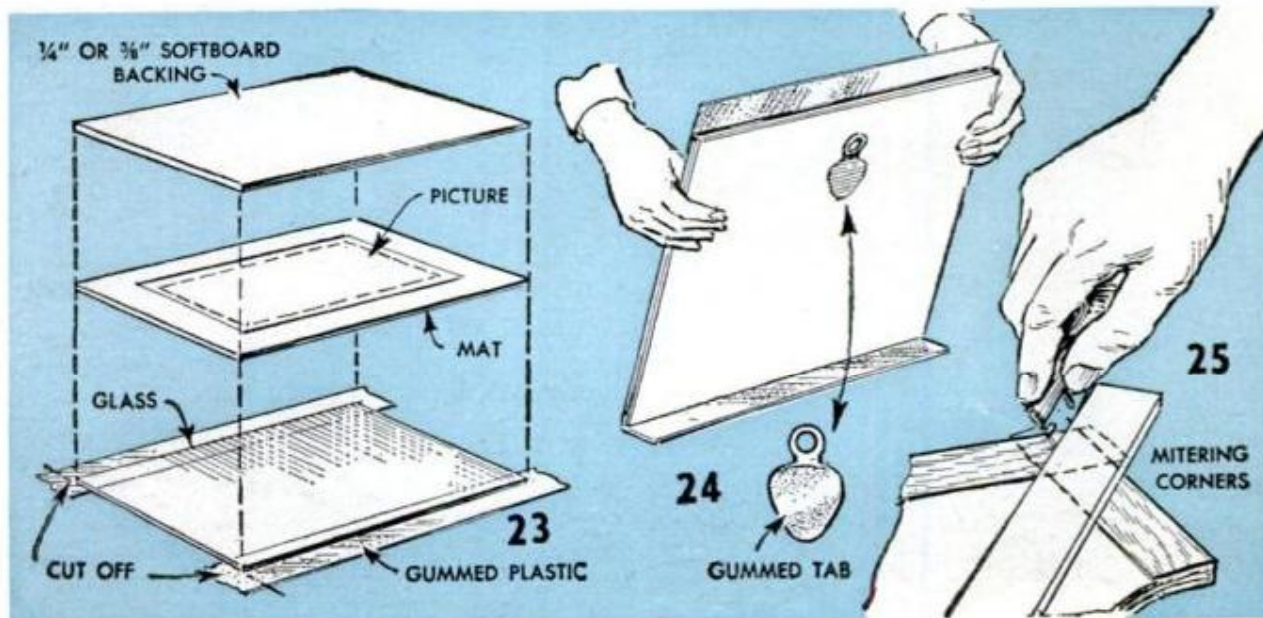

BETTER

By George Laycock



WHEN PHOTOGRAPHING action, be sure to show the subject moving into the picture and not out of frame as seen in print above

FOREGROUND FIGURES add interest and depth to your travel photographs. Show person looking into scene

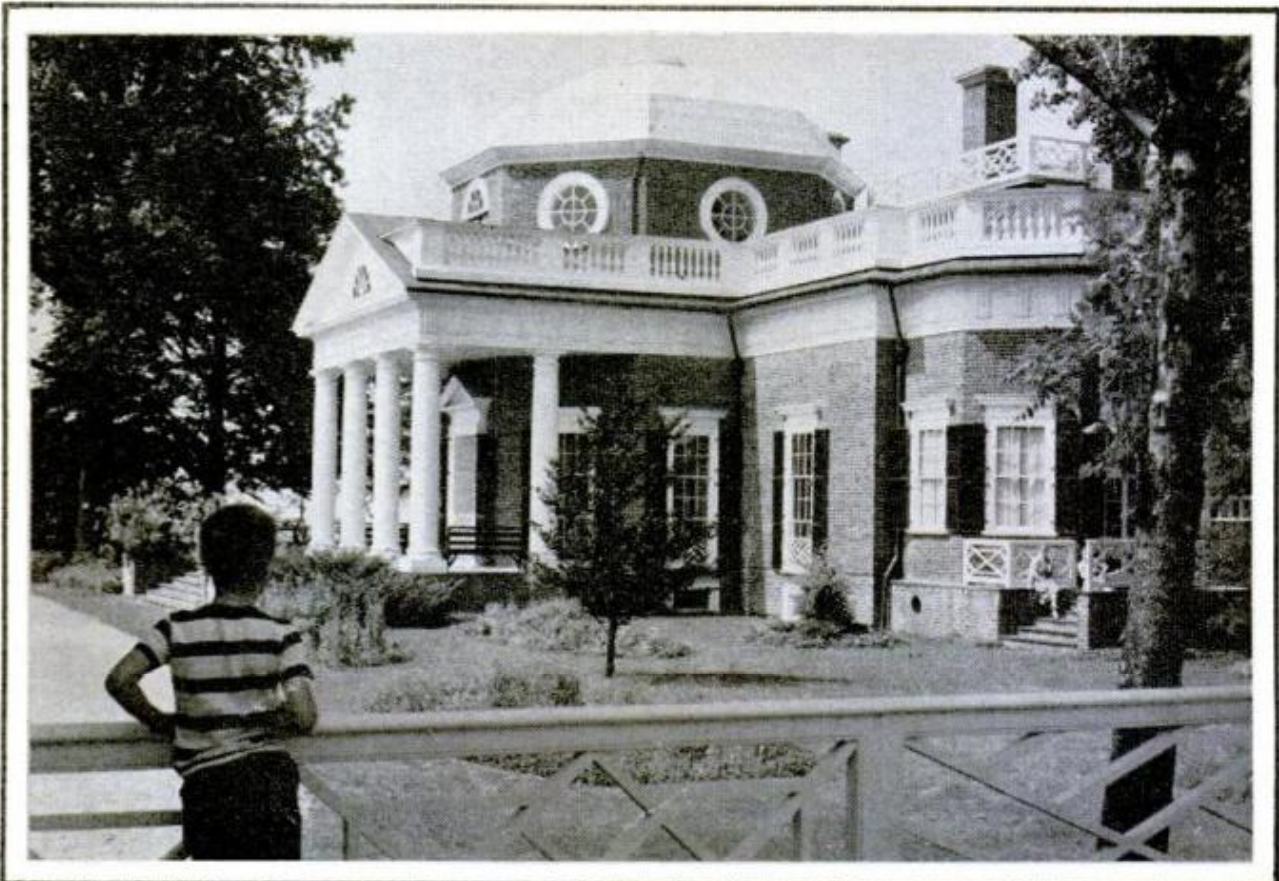

AMATEUR photographers shoot more than two billion snapshots a year. That's a lot of pictures, but the sad side of the story is that a large number of them are ruined in the making. Film manufacturers, in fact, estimate that of the 2.2 billion snapshots made last year about a third of them were spoiled by making improper exposures.

But usually the faults can be easily corrected by the person who holds the camera. There are a few basic rules for making good photographs, and once you understand and observe these rules your pictures are sure to be more satisfying and interesting.

Exposure

The most common error in taking pictures is improper exposure. Yet this problem is quickly solved by following the instructions given on the data sheet which comes with each package of

film. Determine the basic exposure that works best with your film in direct sunlight. Then vary the exposure only as the lighting conditions change. The film data sheet lists these varying conditions. When you've once found the right combination, stick with it except when experimenting.

An exposure meter makes an excellent tool for calculating exposures, but don't expect the meter to think for you. It's necessary to learn the correct handling of a meter before it will serve you properly.

Fuzziness

Fuzzy photographs are the result of camera or subject movement, or of an out-of-focus lens. Camera movement alone ruins hundreds of thousands of photographs every year. To avoid this, practice until all the camera operations become habit. Brace the elbows and press the shutter gradually. Be careful not to jerk the release. By establishing a routine method of operation, good camera work soon becomes a habit.

To stop subject movement, use a shutter speed fast enough to stop all motion. Action moving approximately at right angles to the camera requires a much faster shutter speed than action moving towards or away

from the camera. In many activities there are short periods of arrested action, such as at the end of a ball player's swing.

Out-of-focus pictures result if the lens is used with the wrong setting or if focusing is neglected. When the lens opening is set at $f/4.5$ to $f/2$, the depth of field may be so shallow that sections of the picture will be fuzzy. You can correct this by stopping down the lens diaphragm.

Composing the Picture

When looking into the viewfinder, keep in mind that the finder itself is not capable of selecting one subject as more interesting than another. It sees them all, including the garbage cans and the children's toys. This is where you come in. You should select your subject so that it shows only one point of interest. Then emphasize that point and subordinate or eliminate all the rest. If a view is cluttered up with too many competing points of interest, the whole composition falls apart.

Most photographers back away too far from their subjects. You should move in close enough to eliminate the confusing backgrounds and objects that only compete for attention with the main subject.

GET SOMETHING into your travel pictures besides a general landscape. This scene lacks a point of interest



If people are included in the picture, have them doing something, or at least have them looking at something other than the camera. If you photograph a man holding a fish or a couple of rabbits, show him looking at the game, not the camera. This draws attention to the main interest.

By photographing your subjects against simple backgrounds, you eliminate confusion and emphasize the subject. Pictures, for instance, of people in front of automobiles are usually uninteresting. If you want a car in the picture, why not photograph your subject driving the car or loading fishing gear into it? This helps tell a story and adds interest to the picture. And it moves the car out of the background, making it part of the subject.

Watch for such background distractions as electrical wires, telephone poles and unsightly signs. One of the simplest and best backgrounds is the sky.

Once you learn these few basic rules about making good pictures, try experimenting with camera angles. Instead of making all your photographs from shoulder height, try shooting from a few inches above the ground. Or, bring out a ladder for some high-angle shots. You will find, by using various angles, you can emphasize or minimize different parts of the subject. The news photographer's "cheesecake" shots



MOVE CLOSE enough to eliminate distracting details are invariably made from a low angle. So vary your camera angles to add drama and interest to your photographs.

The mood of a picture can be created with lighting. Outdoors you can't swing the sun to just the desired location, but you can select the best time of day.

UNDEREXPOSED NEGATIVES lack detail in the shadow areas. And when such negatives are printed, the photographs usually appear muddy, with the dark areas blending together. Prints lack good snappy tones

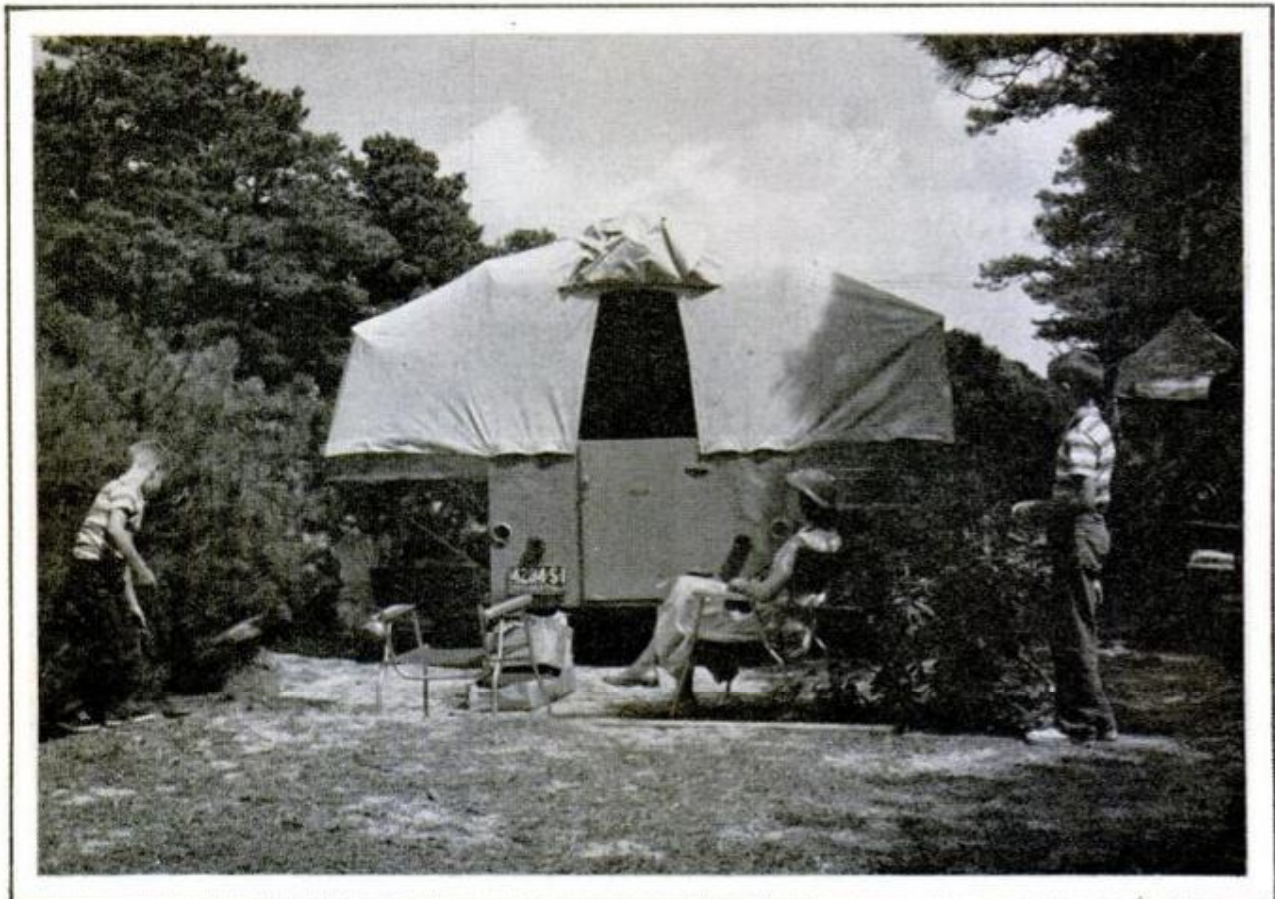



COMMON MISTAKE is getting too far from subject

When you photograph people in bright sunlight, with the sun directly in their eyes, it will make them squint. By turning the subject around you can add snap to the picture with backlighting and put an end to the squinting. With backlighting subjects increase the exposure or fill in the shad-



WATCH BACKGROUNDS to avoid a grotesque effect

ows with flash or reflector to reduce lighting contrast. Also, make sure the lens is protected from direct sunlight.

Spend a little time studying the shifting play of light and shadow. You'll find an endless variation of tones and moods created by the changing patterns. ★ ★ ★

OVEREXPOSED NEGATIVES usually print up without good detail in the highlights. The prints lack the sparkling tones and the crisp lines which are seen in photographs made from normally exposed negatives

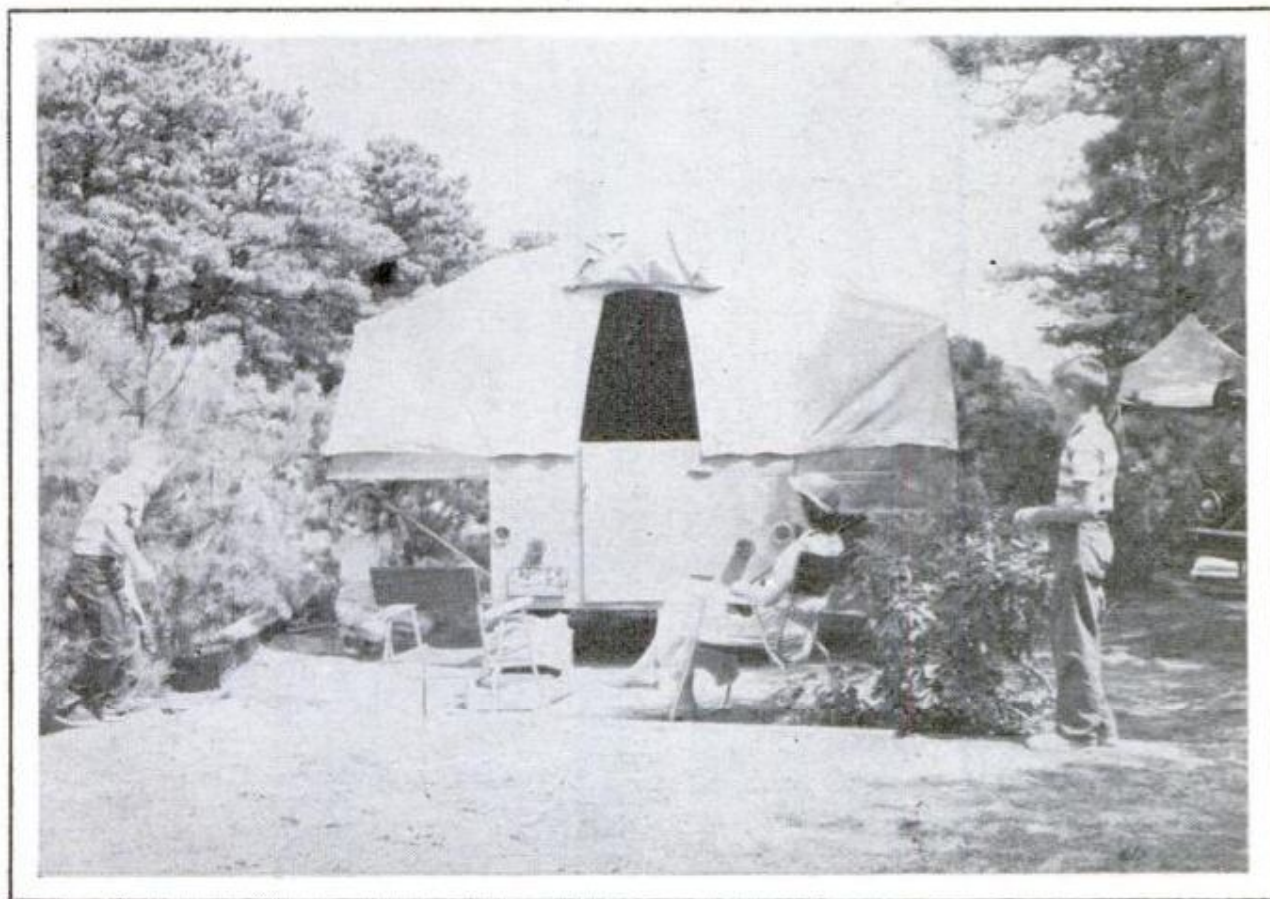



From Boston to California, Indianapolis champs of tomorrow are cutting their racing teeth on dirt tracks, behind the wheels of speedy, thrill-a-minute midgets. Here's the lowdown on the latest development in the power-cart picture—power for one or both wheels

TWO-ENGINE



INSTALLATION of the engines is quite simple, requiring only hand tools and a bit of patience. The clutch, for example, is adjusted with no more than a socket-head type wrench as is illustrated in the photograph above left

FELLOW AT LEFT has mounted one engine and is setting the other in place. To drive both wheels in the same direction, engines rotate in opposite directions and are mounted accordingly

FOR MAXIMUM delivery of power, chains must properly engage sprocket teeth, below, and must be given the right amount of play. For minor adjustments, engines are moved in mounting holes before final tightening of bolts

YOUNG FOLKS the country over are becoming aware of the sound of tiny engines, the screech of brakes—all the excitement of driving a power cart. What's more, these are not luxury items, but within the reach of any young racer eager to get into the roaring din of the track. For those hardened young track veterans, there's more news. A set of new engines, built especially for power carts, makes it possible to assemble a two-engine racer with full 5 hp., qualifying it for class B competition.

Installation of the engines is quite simple. The clutch is first locked on the drive shaft by means of a socket setscrew mounted on the clutch assembly, as shown in the photograph at the top of the page. Then matching engines are set on the mounting brackets with the clockwise rotating en-

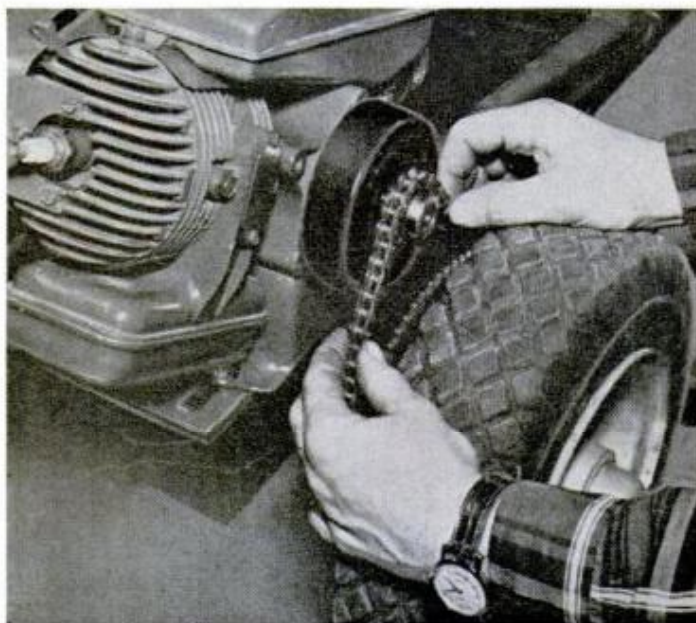



POWER CARTS KICK UP DUST

gine on the right and the counter-clockwise on the left, illustrated below.

The reversed rotation of one unit is necessary so that both wheels may be driven in the same direction. Each engine is loosely bolted to the brackets, after which the inside of the wheel sprocket is aligned with the inside of the sprocket on the clutch. Minor adjustments may be made by shifting the engine on its mounting plate. Both the mounting plate and engine base can be marked so that the alignment can be kept when the engine is moved forward for chain adjustment. Make sure that the

TOUGH LOOKING little customer below is the business-end of a power cart fully assembled and equipped with matching single-cylinder, air-cooled engines

chains engage properly, as shown on the opposite page, to avoid any chance of drop or mesh in the chain to the sprockets. The engine is moved forward to a point where there is from $\frac{1}{2}$ to $\frac{3}{4}$ in. of play in the chain and the mounting bolts are tightened.

The two most popular throttle control hook-ups are one which uses a speed-control lever, and one which connects the accelerator pedal linkage directly to the carburetor, without the use of a governor. The linkage connects a speed-control lever which governs the speed of the engine up to 3800 r.p.m. ★★★

LINKAGE CONNECTS accelerator pedal with a speed control lever, or governor, which serves to hold the speed of the engine to a maximum of 3800 r.p.m.

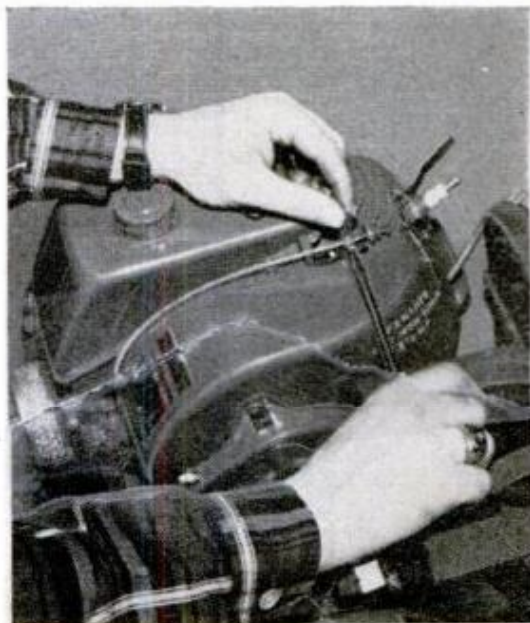
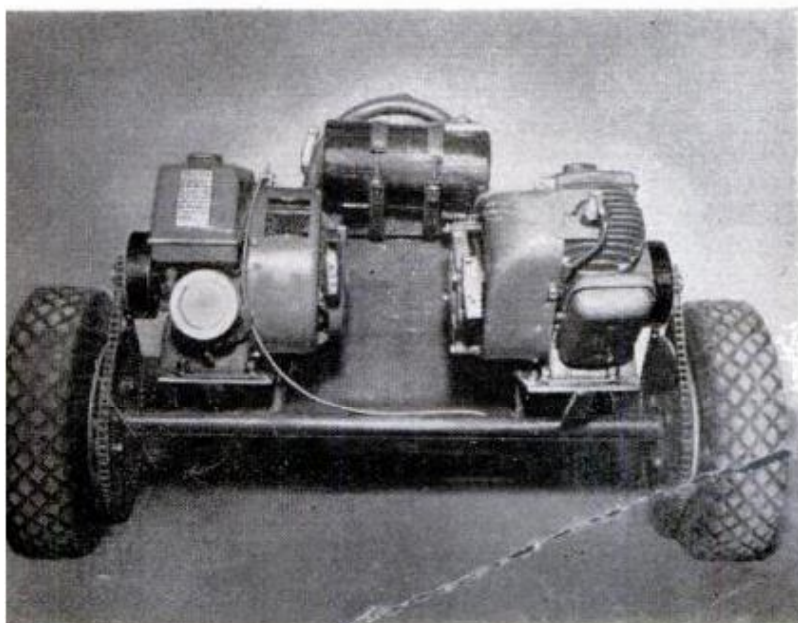

Trouble Shooting THE TOUGH ONES

By Ben L. Davis

ONE DAY during a breather Bill and I sat in the shop kicking around some of the really puzzling jobs we'd had, and he came up with real poser. Seems a fellow came in with a '51 Chevy he'd bought off the lot. Only 8000 miles on it and the buggy looked to be in pretty fair shape. New plugs, wiring, carburetor—an all around clean and well-cared-for job. But, the first time he took the car out on the road, up pops trouble. Seems he hit a stretch of rough pavement some 10 miles out and the engine up and died. But not a minute later, it kicks right over again. Bill gave it the once over next day. Timing, compression, ignition, fuel feed and carburetion—all were good. Now, Bill's a shrewd one and figured the best way to find the trouble was to put the car through the same paces that brought on this unusual performance.

Over the highway he goes and over another rough stretch—and sure enough the engine expires. But just before it died Bill

noted a brief period of misfire. Quick as a flash he's out and under the hood. But, the spark's good, fuel perfect and again the engine kicks right over. Scratching his head, Bill heads back to the shop. A thorough check shows the water level in the radiator to be pretty low, and this he figured might be a clue. Removing the plugs and cranking the engine showed no moisture coming from the cylinders—so, no water jacket to cylinder leak. Under a radiator pressure test there it is—a drip from the heater hose next to the distributor. Shaking the hose opened the fine crack and hot water squirted over the distributor cap and up into Bill's face. Bumps shook the hose just enough to cause water to squirt out, causing a short in the high-tension current at the plug wires. Of course, engine compartment heat dried this up before anybody could spot it and the engine would always start as though nothing at all had happened.

Unusual Locations Where Trouble May Occur

Chevy Dashboard Noises

Owners of the '59 Chevy may hear noises and rattles coming from under the dashboard. Two possibilities are the speedometer-cable housing rubbing against a dash member and a low whistle from the air-vent housing. Silence the speedometer noise by enclosing the housing in a length of slit rubber tubing. Put the quietus on the whistling by sealing the air-vent housing.



Loose Volkswagen Shifting

Don't let the loose and troublesome shifting on a high-mileage, well used Volkswagen give you undue cold sweat. Chances are you don't need an expensive transmission overhaul but only replacement of the shift plate. The plate is under the base of the shift lever and is secured by the same two bolts, making replacement a relatively quick and inexpensive repair.

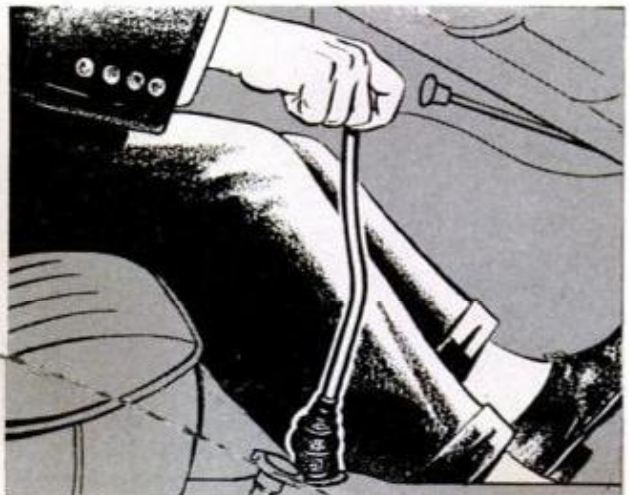



Galaxie Weather Seal Can Hinder Door Opening

Effective door sealing can cause other problems. For example, on the '60 Ford Galaxie 4-door hardtop, opening a rear door with the glass up takes a bit of muscle since the window frame presses against a firm weather seal for the first few inches. Try applying a bit of chassis grease or a special lubricant along the seals. This should relieve the tendency to stick.



SEPTEMBER 1960

Aging V-8 Chevy May Develop Heat-Valve Rattle

Like a man approaching middle age, cars can develop creaky joints, rattles and wheezes. A V-8 Chevy for instance, may develop an annoying rattle under the hood. Should this noise pop up when the engine is accelerated, take a look at the manifold heat valve. Best cure is to replace the valve assembly—a simple task. It is bolted between the manifold and the exhaust pipe.



181



"Third Hand" on Paper Cutter Catches Cutoffs and Trimmings

One of the disadvantages of using a paper cutter at the end of a table is that there is nothing to catch the cutoffs. When left-overs amount to more than mere trimmings, it becomes a bit of a juggling act to hold the work and keep it from dropping to the floor. A simple solution is to place a sheet of hardboard or cardboard under the cutter and let it extend over the edge of the table to form an outboard shelf. The weight of the cutter will hold it level and when the shelf is not needed, it can be pushed back under the cutter.

Printers in a hurry can take proofs without having to ink up the press. Lock the form and chase in the press and back the proof paper on the platen with several sheets of newspaper. Place a sheet of carbon paper over the proof sheet and close the press for a clean, readable proof.

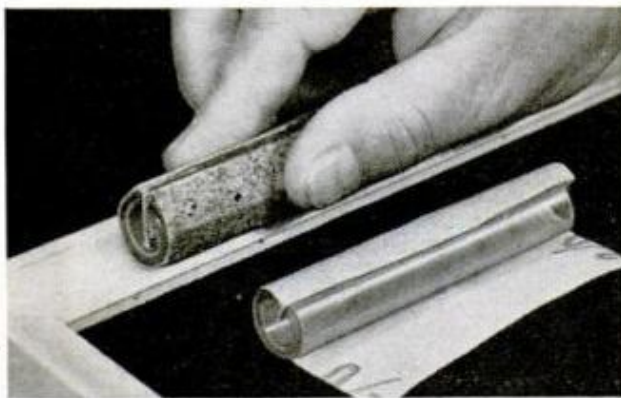

Slit Section of Plastic Hose Makes Self-Locking Sander

When smoothing concave surfaces, a section of dowel is all right as a sanding block, but here is something better. Slit a 3-in. section of plastic garden hose and insert one edge of the sandpaper into the slit. Then wrap the paper around the hose and insert the other edge. The paper will be securely clamped as soon as hand pressure is applied.—Bil Toman

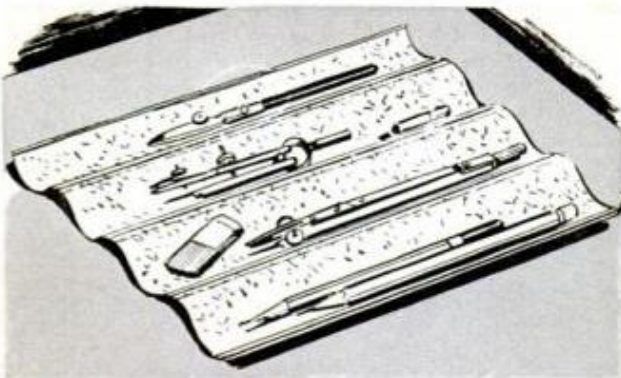

Corrugated Tray Holds Instruments On Tilted Drawing Board

How can you prevent drafting instruments from sliding off a tilted drawing board? Use a piece of corrugated aluminum roofing as a tray. The corrugations provide a series of handy individual troughs that not only keep your instruments separated but easy to pick up. Tabs of masking tape can be used to keep the tray stuck securely to the tilted board.



Can Slides Down Fishing Line To Free Snagged Hooks

When he snagged his hook on submerged tree roots and lost his fishing lure for the third time, one fisherman decided to do something about it and came up with the following idea: He removed the ends from a coffee can and slid the can down the line to the snagged hook. A little manipulation and in most cases the hook was freed.

TOOL IQ



1. EARLY WOODTURNERS kept this tool handy to check on progress of work. It usually was made by the village blacksmith, or ironsmith, as he was sometimes called. Note variation in radii of the fixed legs



2. SURE YOU KNOW what it is? Study it closely before you come up with an answer. Great grandfathers used this tool to cut round-end mortises in fence posts to take ends of rails. The cutting edge is curved



3. OF COURSE, YOU'VE ALREADY GUESSED what this is—or have you? It was made from a tree limb with a natural bend, or crook. No doubt it took some searching to locate one suited to the craftsman's purpose



4. WHEN ONE VIEWS the skilfully wrought work turned out by early cabinet and coachmakers it's difficult to believe that this was one of the tools they used to cut fine woods to the sizes and shapes required

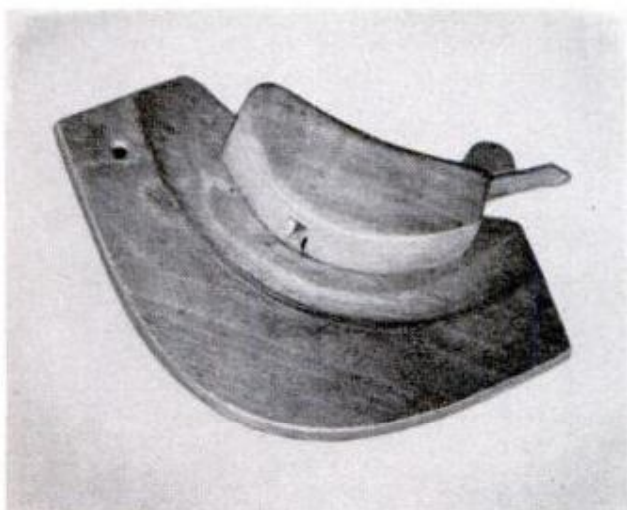

5. TAKE YOUR TIME on this one. You're right. It was used by coopers (the fellows who made barrels) to cut the chamfer on the staves at top and bottom of barrel. But they had a name for it. What was it called?



Turn to
page 218
for answers.

6. THIS VENERABLE TOOL is thought to have been made by colonists about the year 1600, possibly earlier. We don't know precisely when, but we know it was one of the first edged tools used by early craftsmen



On the
MARKET
for Do-It-Yourselfers

SELF-ADHERING NYLON TAPE, above, makes any drawer slide easily without use of any other friction-reducing device or material such as wax or other lubricants. To apply, remove paper backing and press into contact on the drawer slide, or underside of the drawer sides. Adheres to wood, metal, plastic
Hardware Designers, Inc., P. O. Box 4, S. Hackensack, N. J.

COMPLETE FINISHING KIT, below, is made up especially for those who need only small quantities of finishing materials for a given job. Kit consists of 5 containers of finishing material, brush and 3 sheets of 5-0 and 7-0 sandpaper. Available in natural, mahogany, fruitwood, maple, cherry, ebony, blond, golden oak
Homewood Industries, Inc., 26 Court St., Brooklyn, N. Y.

SHELF KIT, above, center, consists of four 10-in. hardwood spacers, four 14-in. spacers, four end caps, and four 4-in. legs with brass ferrules. This kit provides spacers and legs for three shelves. All individual parts are available separately, making it possible to build up any convenient number of shelves
Stanley-Judd, Div. of Stanley Wks., Wallingford, Conn.

GLITTER in tubes, above right, is a novel decorative material. Each tube contains a mixture of adhesive and glitter particles. The tubes have special tips which serve as applicators, or pens, which make glittering a simple matter of applying the material over pattern lines or freehand as you choose
O. E. Linck Co., Inc., Junction Routes 3 and 46, Clifton, N. J.

ADDITIVE cleans fuel-oil tanks of oil-fired home heating systems, prevents clogged burner nozzles and strainers and inhibits soot formation. Ordinary usage calls for adding about 4 oz. of the solvent to each 250 gallons of oil but this may be varied somewhat to suit special conditions. Follow instructions in all details
Document House, Chemical Div., P. O. Box 242, Greenwich, Conn.





PREFINISHED PLYWOOD PANELING and matching flush doors are factory-coated with a grained plastic film which resists scuffing, fading and satining. Comes in five grained finishes, pecan, sandalwood, temple, walnut and cherry. Also redwood, hemlock and golden larch. Available in 1/4-in. thickness, 4 x 8 and 4 x 10-ft. panels
Simpson Logging Co., 1032 White Bldg., Seattle 1, Wash.

RUST PREVENTIVE in a spray can, below, left, takes care of household corrosion problems on tools, appliances, lawn mowers, fishing tackle—anything of metal which is subject to rusting. Keeps door locks working freely, prevents corrosion of car battery and battery mounting. Forms protective film on any surface
Rocket Chemical Co., Inc., 4674 Alvarado Canyon Rd., San Diego 20, Calif.

PAINT EDGER, below, center, enables do-it-yourself painters to produce clean, sharp ceiling lines, cut around window and door trim, baseboards, and moldings without overlaps when working with two colors. Consists of pad attached to aluminum frame fitted with two plastic wheels which serve as guides
Emerson House, P. O. Box 370, Downers Grove, Ill.

CHEMICAL PLASTICIZER prevents hardening of brushes used in any oil-base paints, varnishes or enamels. Just dip the brush full bristle length in the plasticizer and lay on a square of aluminum foil or any other non-absorbent material. Plasticizer is nonflammable and nontoxic and does not irritate the skin
Winfield Brooks Co., Inc., Woburn, Mass.

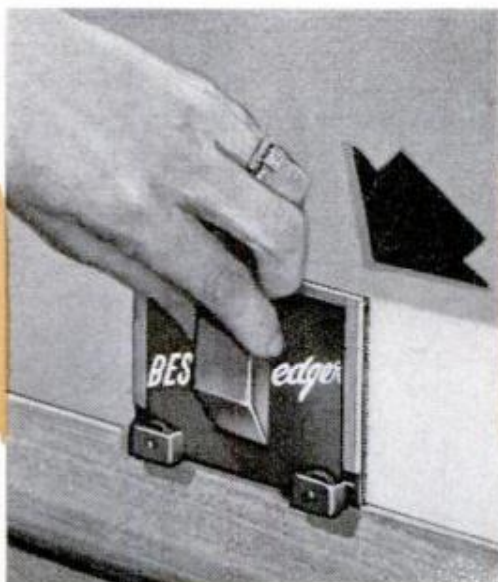



Venetian-Blind Slat on Board Protects Tracing-Paper Edge

Draftsmen and hobbyists — here's a tip for you. That complicated tracing job may require quite a bit of burning of the midnight oil and in time, your constant leaning over the drawing board will rough up the bottom edge of the tracing paper, making it appear ragged and unsightly. To get around this, tack a venetian-blind slat along the bottom edge of the board as shown. It will protect the paper and has enough snap to enable it to hold the sheet firmly.—Warren L. Hockert

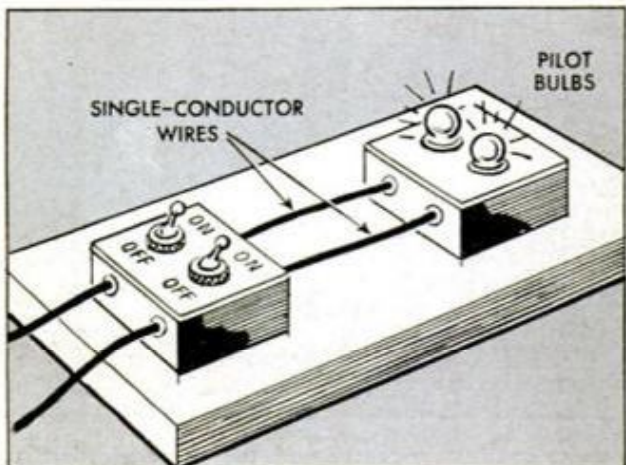

Electric-Circuit Puzzler Stumps the Experts

Here's a little device which can keep even a professional electrician guessing. At first glance there's nothing to it. Two pilot bulbs in one box are controlled independently by two switches in another box. Either bulb can be turned on or off by its own switch, or both may be turned off or on at the same time. But—and here's the hitch—only single conductor wires connect the switches to the bulbs. How is it done? For the answer turn to page 228.

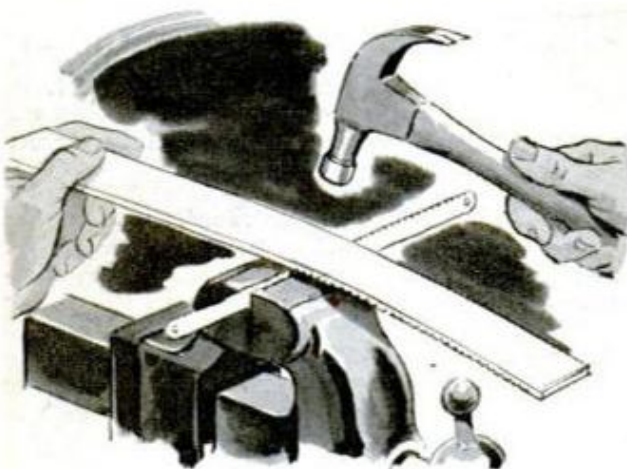

Cutting Kerfs the Easy Way

There's an easy way to do almost everything including kerfing a strip of balsa wood preparatory to bending it. Clamp a hacksaw blade in the bench vise to the required depth of the kerfs. Hold the wood strip over the saw teeth and tap it with a hammer. The resulting series of kerfs will be uniform in depth.—G. E. Hendrickson

For a neat, organized workshop, suspend tools from hangers inserted in perforated hardboard. A white line traced around each tool indicates its proper place.

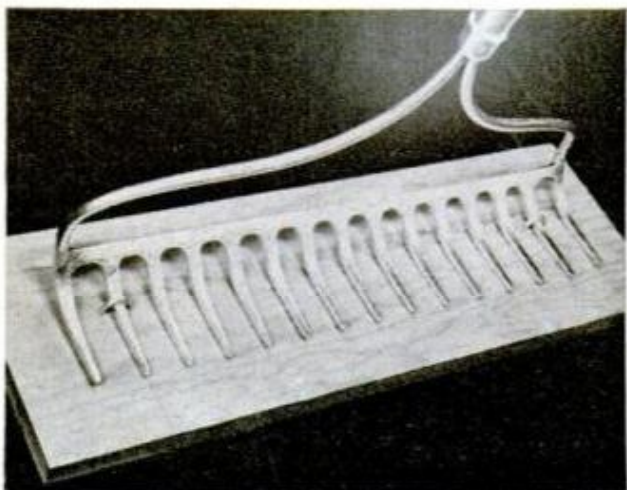

Rake Converts to Grade-Leveler

Say there, Mr. Handyman, if you need something with which to level off grading in preparation for seeding a lawn, your rake can be adapted to serve as a leveler and will do an excellent job. Just staple a piece of scrap lumber to the teeth of the rake, as shown, and go to work.

—Bil Toman

When stacking lumber for storage, lay the boards flat and place small wooden strips between them to allow the air to circulate. This will help prevent warping and checking, which otherwise would occur.

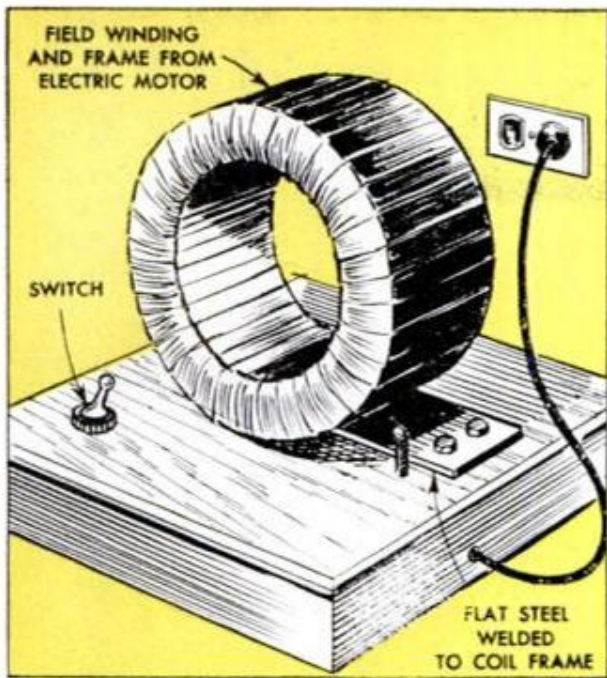

DEMAGNETIZE TOOLS IN SECONDS

The field and frame of a small, single-phase motor are used to make this combination demagnetizer and magnetizer. Remove the end shields, pull out the armature, cut the wires leading to the centrifugal switch and isolate the leads to the running coil. Cut all other leads short and tape the ends. Cover windings with friction tape. Provide a momentary contact switch of 10-amp. capacity. Wire the switch and coil in series to a heavy cord. To use as a demagnetizer, close and hold the switch and pass the object through the coil, in and then out, about one second in each direction. To magnetize, close switch and hold object stationary inside the coil.—Norman A. Kath

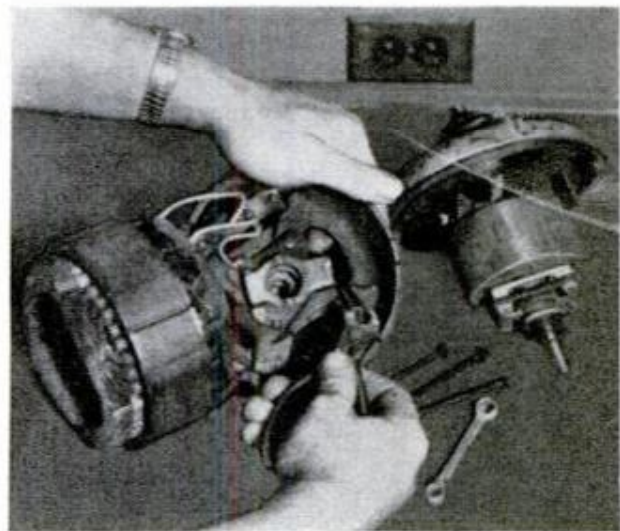

FIRST STEP in converting motor to demagnetizer is to remove end shields and cut leads to starting switch

Large Hex Nuts Make V-Blocks for Rough Work

When drilling transverse holes through round stock where the accuracy requirements permit, it is possible to make suitable V-blocks from large hex nuts. Holes are centered on the flats to take small bolts long enough to pass through two nuts. The holes should be slightly oversize so that when the bolts are tightened the meeting flats will be drawn tightly together. V-blocks made in this manner are suitable for use only in pairs.

To overcome any tendency of light-gauge metal to curl or buckle when welding, first tack-weld on a wide spacing. Then allow the parts to cool and tack-weld at points equidistant from the first tacks. Where several parts are to be welded the welds often can be made in rotation so that one part is cooling while other welds are made.

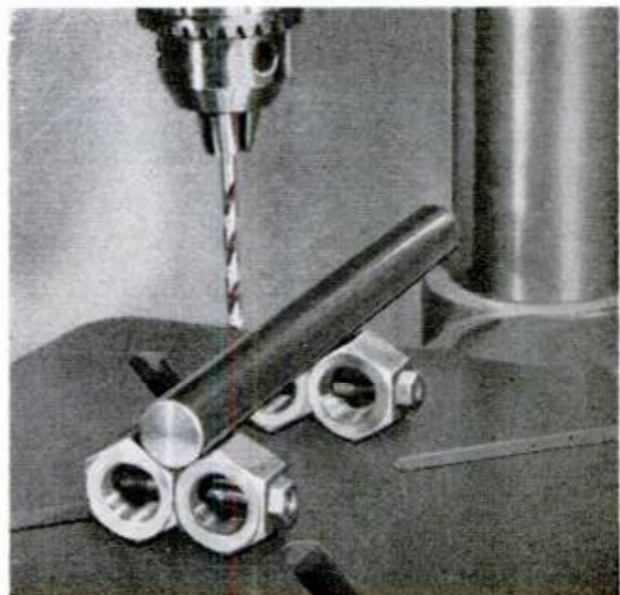

Shop Projects 1961

CHISEL TIPS

By C. W. Woodson

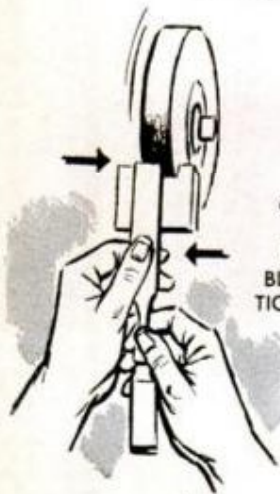
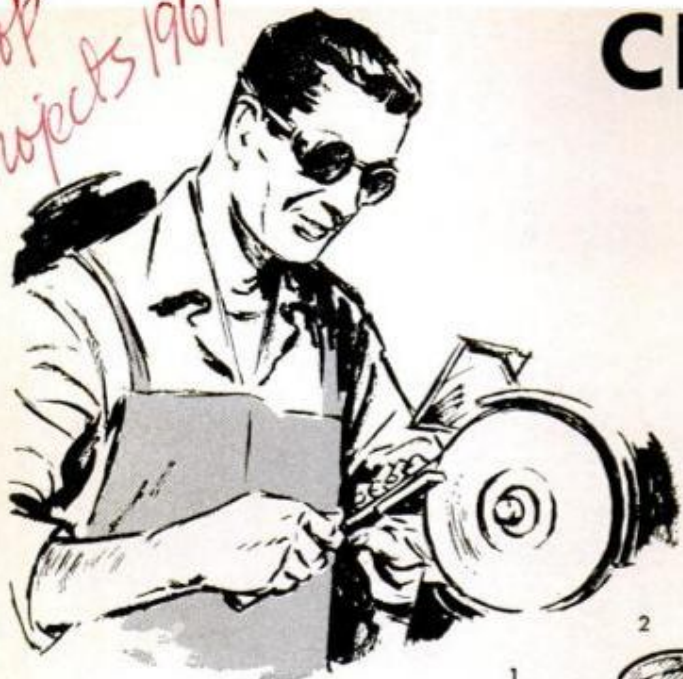

1
GRIND CHISEL TO RESTORE BEVEL. MOVE BLADE IN DIRECTION OF ARROWS



2
WHET CHISEL ON OILSTONE WITH BACK EDGE OF BEVEL RAISED SLIGHTLY



3
REMOVE FEATHER EDGE BY STROKING ON OILSTONE WITH FLAT SIDE OF BLADE DOWN



- 1 BUTT CHISEL
- 2 PARTING CHISEL
- 3 SOCKET FIRMER CHISEL
- 4 SOCKET MORTISING CHISEL
- 5 OUTSIDE-BEVEL GOUGE
- 6 INSIDE-BEVEL GOUGE (BENT TANG)

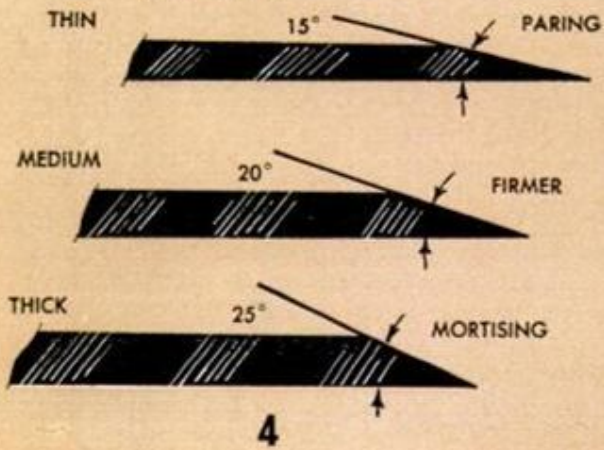

For Craftsmen Who Work With Hand Tools

WHEN REPRODUCING old pieces and also in many types of custom work, skilled craftsmen still use wood chisels and gouges of various types to make cuts found in common cabinet joinery. In order to take full advantage of the versatility of these hand tools one must know the types and uses of chisels and gouges, how to handle them in hand work and how to sharpen each one to attain the keenest cutting edge.

In Fig. 4, illustrations 1 through 6 show types of wood chisels and gouges in common use. Chisel No. 2 also is referred to as a paring chisel; the others are usually referred to by the names given. The gouges, Nos. 5 and 6, Fig. 4, are of the types used for paring cuts. These tools are made in styles other than those shown. Sizes of all the chisel types vary in blade widths and lengths according to work requirements,

Fig. 11. Blade widths of chisels run from $\frac{1}{8}$ to 2 in. Note the difference in the edge bevels indicated in the lower details in Fig. 4. The paring chisel has a very long bevel at a 15-degree angle and is intended to be driven entirely by hand on light, accurate work. The firmer chisel edge is formed at a 20-degree bevel and serves as a general-purpose cutting edge to be driven by hand pressure alone and also by mallet blows. The mortising chisel is a sturdy, heavy-duty hand tool with a short beveled edge designed to withstand heavy mallet blows and moderate prying as must be done when making mortises.

Figs. 1, 2 and 3 outline the basic steps in sharpening a chisel. Note also in this connection the details in Figs. 5, 6 and 7. In sharpening on a high-speed grinder use a vitreous wheel and, if available, a sliding tool rest. In whetting the edge on the fine

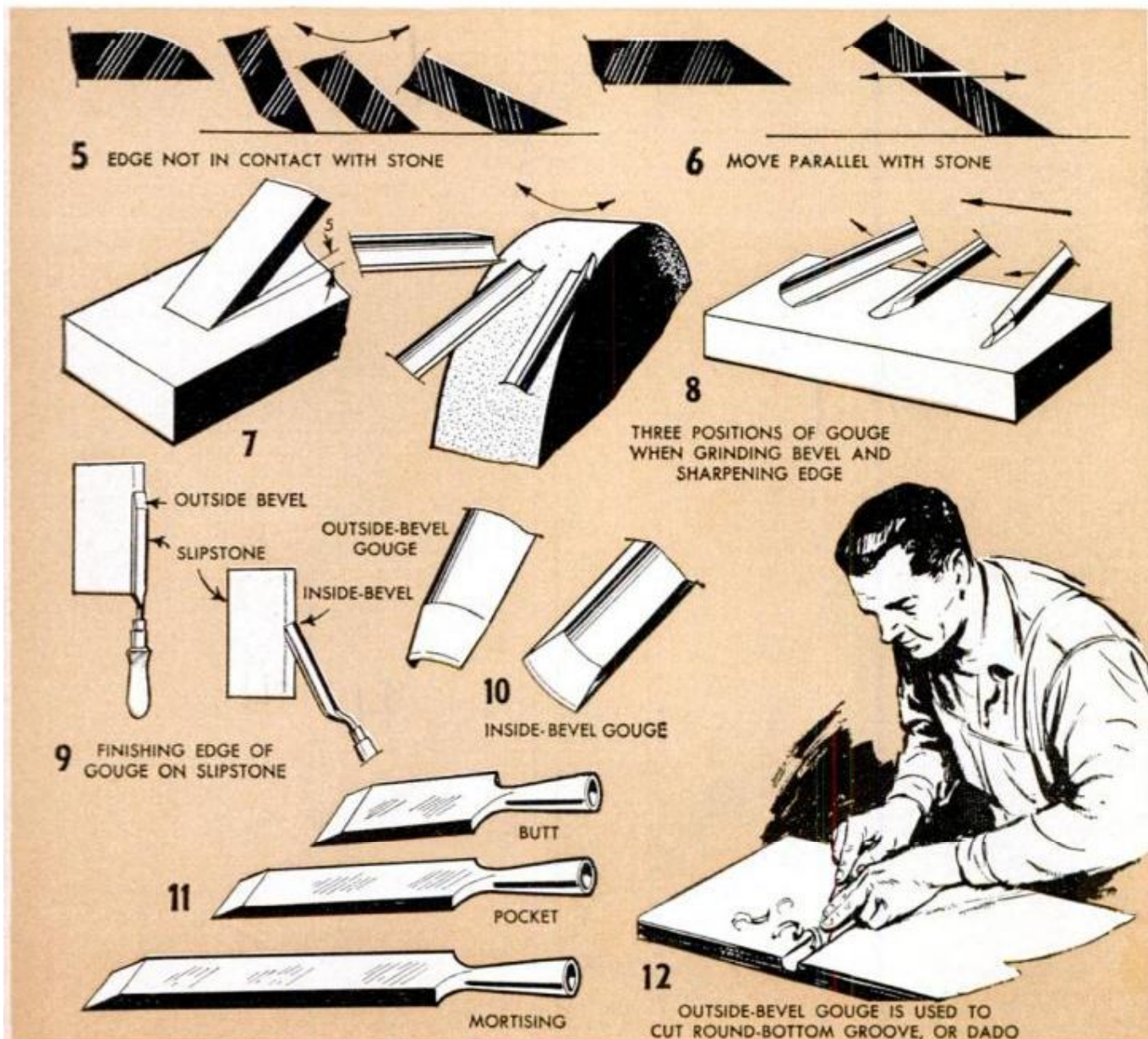

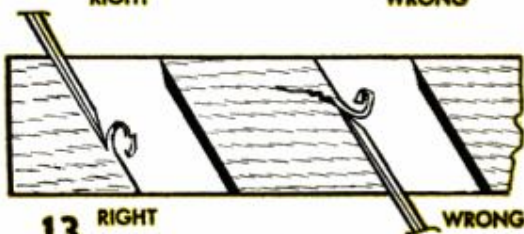
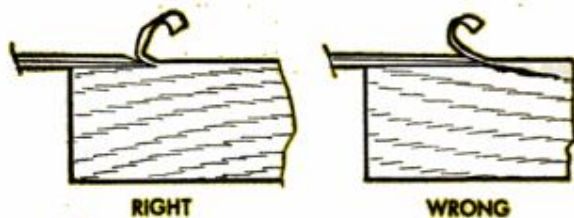

13 RIGHT
WRONG
CUTS SHOULD ALWAYS BE MADE WITH GRAIN TO SEVER FIBERS AND LEAVE SURFACE SMOOTH. WORKING AGAINST GRAIN MAY CAUSE SPLINTERING

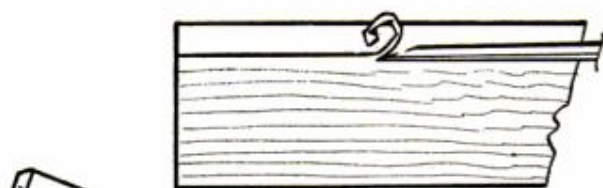

14 WHEN CUTTING DADO OR RABBET, CHISEL IS HELD WITH BEVEL UP



15 WHEN RABBET IS LONG, CHISEL IS HELD WITH BEVEL DOWN



16
LAYING OUT TENON WITH MARKING GAUGE

LAYOUT LINES SCORED DEEPLY

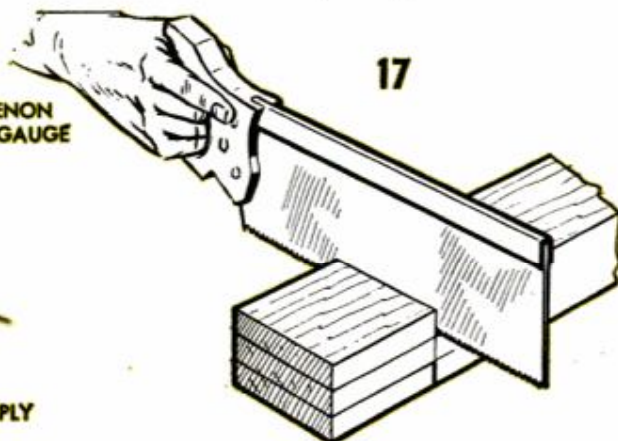

17

side of the oilstone, hold paring and firmer chisels with the back edge of the bevel raised about 5 degrees as in Fig. 7. When whetting a short beveled edge, such as that on the mortising chisel, it's a common practice to hold the bevel flat on the stone as in Fig. 6. Avoid rocking the blade as the whetting strokes are made, as otherwise the effect will be to form several bevels as in Fig. 5. Gouges with inside and outside bevels, Fig. 10, are sharpened and whetted as in Figs. 8 and 9. Inside-bevel gouges cannot, of course, be sharpened on a flat-faced grinding wheel; use only on a round-faced wheel or a taper oilstone. Both types are finished on a slipstone, Fig. 9. As a rule, grinding is needed only when it is necessary to form or reform the bevel or when the cutting edge is nicked.

Although many craftsmen skilled in handling chisels and gouges have developed methods which suit their own requirements, the techniques outlined in Figs. 13 through 26 are in common usage. Several rules apply to nearly all chisel and gouge operations: Always work with the grain. Always score gauge lines deeply when laying out tenons and matching mortises and when making round-bottom grooves or dados as in Fig. 12, also when rabbeting with a chisel as in Figs. 14 and 15. Scoring prevents the wood from breaking beyond the gauge line when cutting out the waste.

To get a neat job of rounding a corner, make the light chip-raising cuts A in Fig. 23. Note also the chip-raising, or chip-breaking cuts being made in Fig. 21. These chip-breaker cuts prevent splitting of the stock and make it easier to remove waste. When forming a tenon of any size or type make scorings as in Fig. 16 and shoulder cuts, Fig. 17, first. Then, if the wood is straight grained, you usually can lift the waste in one cut from each side as in detail A, Fig. 26. But if the wood is even slightly cross grained, proceed to lift the waste in stages as in details B and C, Fig. 26. Always work from both edges of the stock. Finish with the paring chisel. ★★★

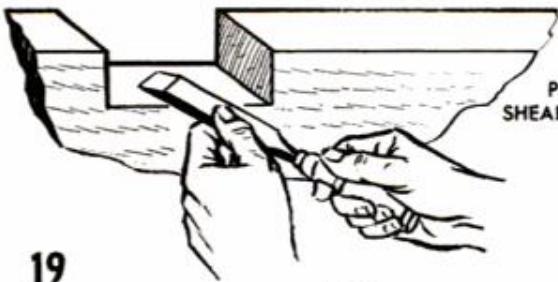

18

PARING CHISEL MAKES SHEARING CUT WHEN WORKED IN RECESS

19

WHEN FINISHING TO LINE, HOLD CHISEL AT ANGLE AND MAKE SHEARING CUT IN DIRECTION INDICATED

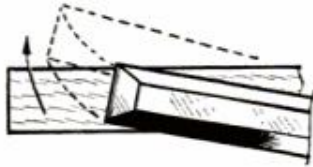

22

OR, BORE ROW OF CLOSELY SPACED HOLES TO REMOVE WASTE.

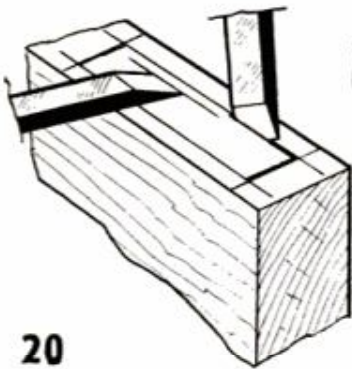

20

WHEN MORTISING, MAKE SCORING CUTS ON GAUGE LINES FIRST

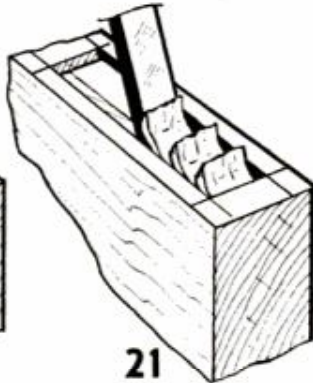

21

MAKE DEEP, CLOSELY SPACED CUTS TO REMOVE WASTE



23

FOLLOW SWEEP OF CURVE WHEN ROUNDING CORNER OF STOCK



24

WHEN PARING ACROSS GRAIN MAKE SHEARING CUT

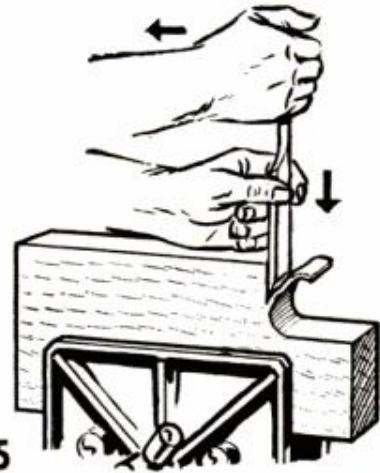

25

CONCAVE CUT CAN BE MADE BY PRESSING DOWN AND PULLING BACK SIMULTANEOUSLY ON CHISEL HANDLE

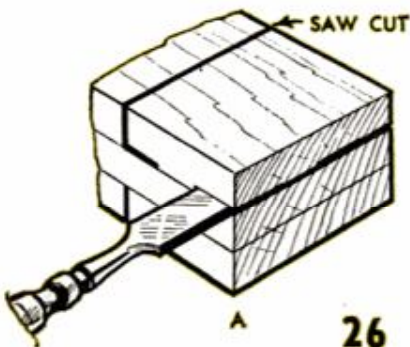

A

26

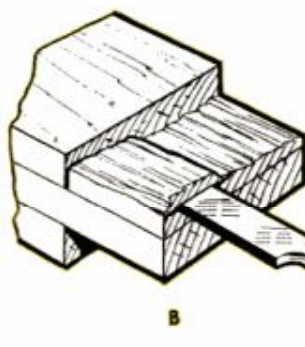

B

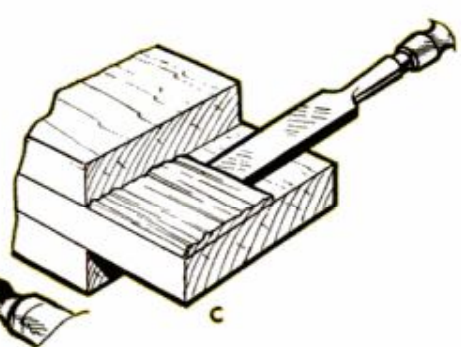

C

THREE STEPS IN REMOVING WASTE FROM TENON

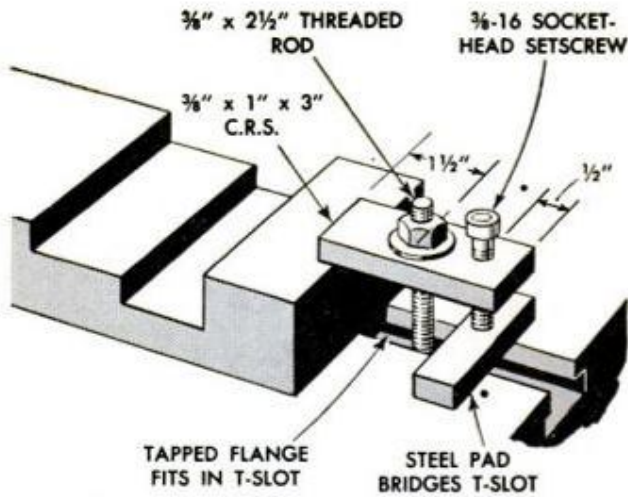

Strap Clamp Adjusts for Height

When setting up work on a milling machine or drill press it's nearly always handy to have at least one strap clamp that can be adjusted quickly to the desired height. This one fills the requirement. You make it yourself to suit the work. All you need are a jaw of C.R. steel, a threaded rod, a socket-head screw, a flange to fit the T-slot and a small steel pad on which the end of the socket-head screw can be surfaced. Assemble these parts and you have a strap clamp that can be adjusted through a wide range and one that holds positively when tightened.—William Siry

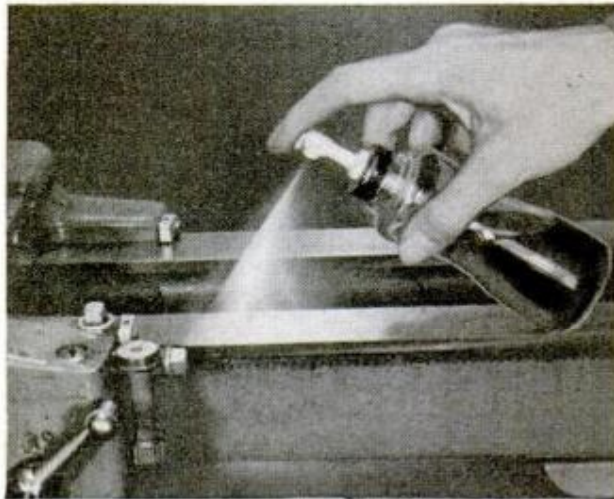

Spray-Oiling Rustproofs Tools

Few machine owners and operators like to spread a protective oil coating on bright machine parts with finger tips, an oily pad or a brush. It's a messy job and rarely do any of these methods get the oil on all the bright parts. Some are never reached with the protective film. One way to make the job much easier and far more thorough is to use a sprayer and container of the type supplied with window-cleaning solutions. This unit will handle light lubricating oils nicely and the spray will reach every part of the surface being coated.—H. Hanscom

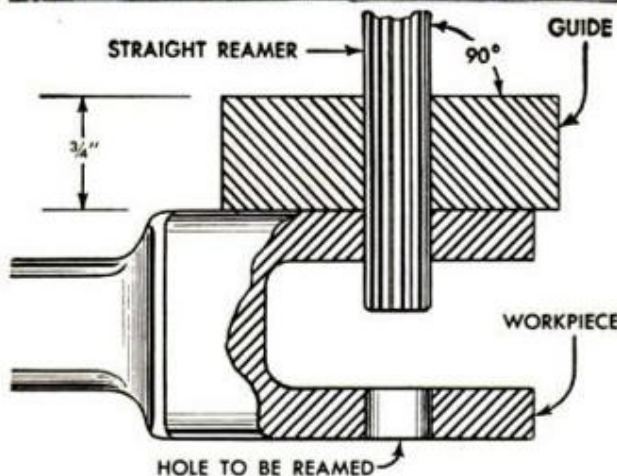

Simple Guide Aligns Hand Reamer

In hand reaming holes in the two machined arms of a small yoke one job shop had trouble holding the finish ream within the specifications. A check of the hole alignment after reaming classified too many of the yokes as rejects. After much experimentation it was found that a block of steel machined all over, then drilled and reamed and hand-held on the machined outer surface of the arm did the trick, enabling the operator to start the reamer true. After that the holes came well within the specifications.—Frank LaSaracina

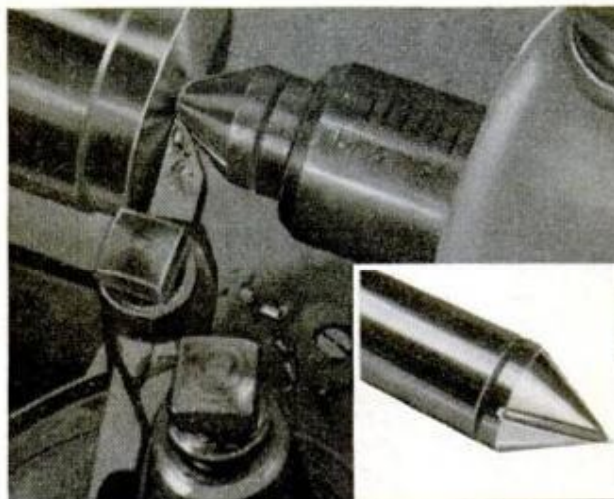

Full Face-Off Without Burring

It's difficult to fully face off the end of work mounted between centers in a lathe without forming a burr at the edge of the center hole. If you force the tool, you may shift it axially into the work and form a cavity, or concave. A full facing cut can be made easily if you grind a shallow V-groove on the bevel of the tail center, using the corner of a dressed grinding wheel. After grinding de-burr the edges of the vee. As you see in the illustration, the groove allows the tool point to be fed past the edge of the bearing surface in the center hole.—H. J. Gerber



Drill Chuck on Straight Shank Permits Power Feeding

BY MOUNTING a drill chuck on a straight shank you can set it up in a block-type tool holder for accurate, power-fed drilling and reaming in the lathe. The method saves time on repetitive work, minimizes breakage and, due to the use of power feed, gives greater wall uniformity in both drilled and reamed holes. The use of power feed also is especially helpful when drilling and reaming tough metals. When using the tool post as a holder it is necessary to locate the holes in the post on the center line, or axis, of the lathe. To do this, a center-drilled round is locked in the chuck and the chuck

and shank are mounted between centers, the tool-post bolt being left slack so that the parts won't be under tension. Shim the tool post if necessary. Or, if the tool post is too high, determine how much must be turned off the lower end. This will not affect its use for holding boring bars and other round-shank tools and once centered it is easy to relocate it. A drill chuck fitted with a straight shank and mounted in a block-type tool post in this manner also is useful in certain special lathe operations involving use of very small boring and internal threading tools.—H. J. Gerber

ACCURATE DRILLING of large and small-diameter holes is possible with chuck mounted on straight shank

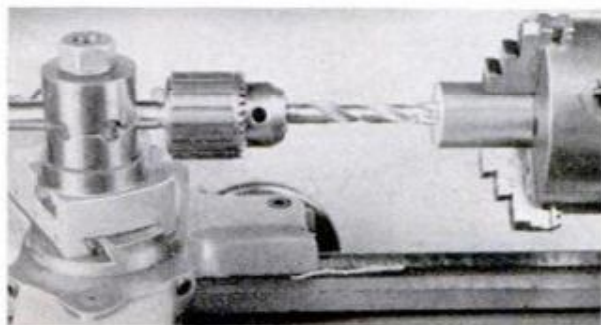

CHUCK MOUNTED on straight shank permits use of carriage power feed for true reaming of drilled holes

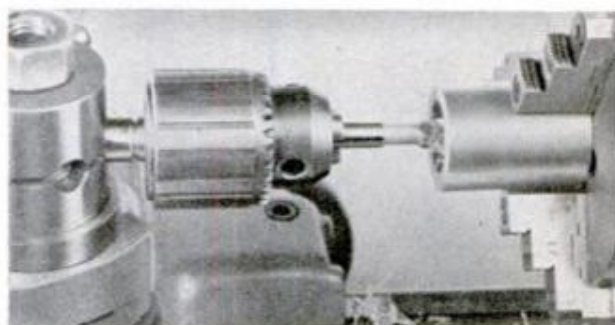

IN-AND-OUT CIRCLES

are easy to cut accurately with both hand and power tools by using these methods

By Walter E. Burton

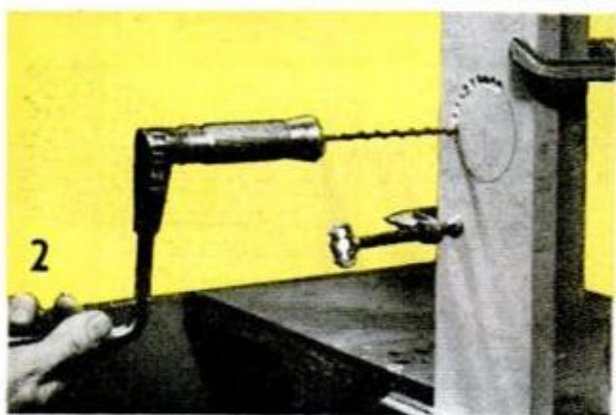

WITH NO OTHER, FASTER MEANS at hand you can form disks or circular openings by the method above. After drilling holes, finish edges with rasp. Below, circular cut is made with keyhole saw and pivoted arm

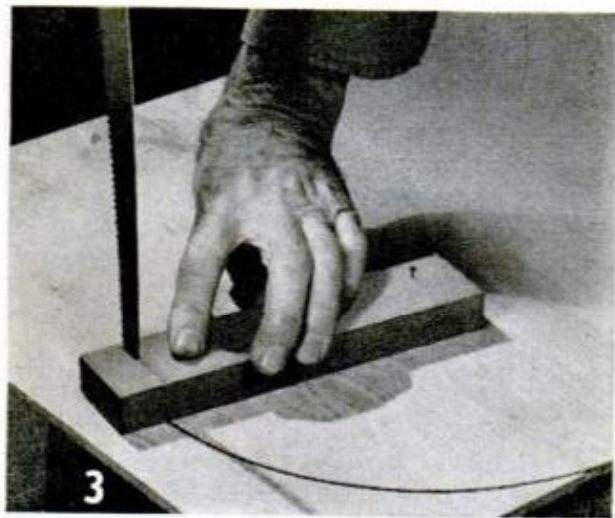

WHEN YOU need a disk or a round opening cut more accurately than you can do freehand, the problem is how to do the job simply and quickly with whatever tools are available. You wouldn't use the method shown in Fig. 2 except in an emergency or when no other means were available for cutting an inside or outside circle. However, you can produce a very accurate disk or inside opening by smoothing the surfaces to a gauge line with



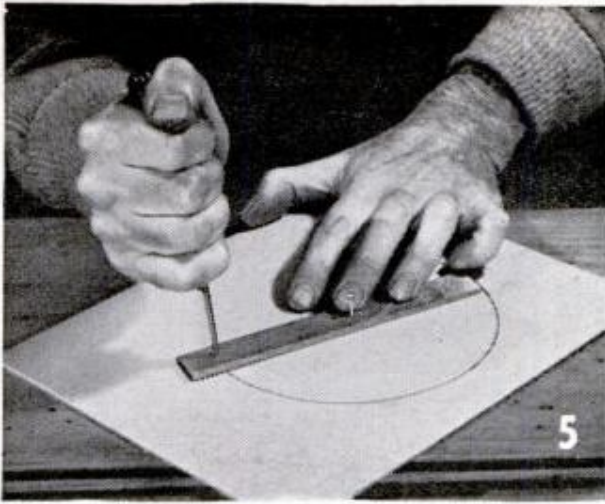

USING A PIVOTED ARM, or sweep, similar to that pictured in Fig. 3, you can make accurate circular cuts in many soft materials with ordinary pocket knife

a rasp after the hole drilling has been completed around the circumference. By using a pivoted arm, or sweep, as in Fig. 3 you can cut a very accurate circle, inside or outside, with an ordinary compass saw or keyhole saw. The arm is detailed in Fig. 13. Working in much the same manner and with the same type of arm, you can cut a true circle as in Fig. 5, using an ordinary pocket knife. It is, of course, difficult to make circular cuts in wood, even very thin wood, with the pocket knife, but cardboard, heavy paper, linoleum and similar soft materials can be cut accurately. The knife blade must be ground thin and the edge formed with a long bevel for this work.

If you have a portable jigsaw, you can easily make a circle-cutting jig, or sweep, to work as in Fig. 4. A sweep suitable for most jigsaws is detailed in Fig. 13. Many portable jigsaws can be fitted with an accessory jig made especially for the purpose. Accessory circle cutters also are supplied for stationary jigsaws, an example of this type of circle-cutting jig being shown in use in Fig. 7. Making circular cuts with power tools and accessory jigs is, of course, fast and more accurate than any hand method, as the problem of keeping the edges of the cut square is automatically taken care of by the right-angle position of the power-driven blade.

Circle cutters made for use in the drill press as in Fig. 6 will do accurate circle cutting in harder materials such as fiber, plastic and sheet metals. Measurements must be made carefully and the setting of the cutter checked closely to assure accurate work. Care must be taken also to adjust the rate of feed to the type of materials being cut, as otherwise tearing and chipping of the edges may result.

Often a gasket cutter of the type pictured in Fig. 8 comes in handy for cutting



CIRCLE CUTTER on drill press will cut circles in hard-board, fiber, plastic, soft metals. Below, accessory circle jig in use on stationary jigsaw. Cuts true circle

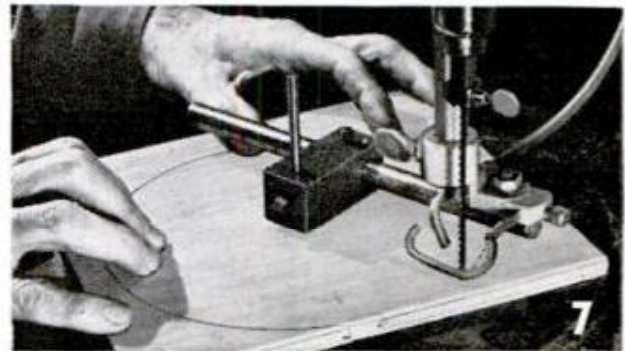

GASKET CUTTER does good work on materials such as leather, artificial leather, cardboard. Below, for true circles, perfect round openings, use lathe

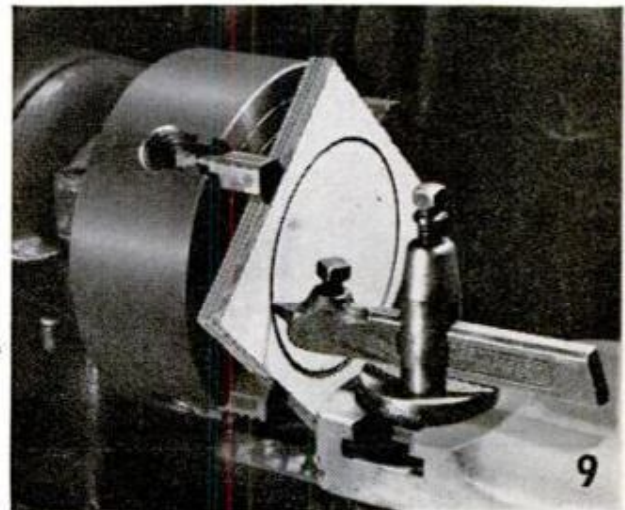

small-diameter circles in soft materials such as thin cardboard, tooling leather, also artificial leathers, thin plastic and similar materials. You also can use a sewing machine to "cut" many of these materials as in Fig. 11. The closely spaced holes made by the needle in thin materials make a very neat, accurate tear line. A simple turning jig can be made from cardboard and a brad.

Tools not normally used for circular cuts in wood can often be made to serve this purpose. An example is use of the hole saw, Fig. 10. Here it is used to cut a round opening in plastic-faced plywood. Ordinarily, this tool is driven by a portable electric drill, but it works equally well, although slower, when driven by a bit brace.

A router bit mounted in the drill press does an acceptable job of cutting a circular opening in wood. You'll need a pivot, of course, on which to turn the workpiece. This can be improvised from a piece of hardboard or plywood large enough to support the workpiece as it is turned about the pivot. The latter can be a small nail inserted in a clearance hole center-drilled through the workpiece. Tap the nail into the supporting piece and clamp to the drill table. The cut should be made successively, running only about $\frac{1}{8}$ in. deep at each pass.

If you must have a disk or opening as near perfectly round as is possible in wood, then chuck the work in a lathe as in Fig. 9. Or, you can do very nearly as accurate a job with a simple setup on a circular saw as in Fig. 1. Rough-cut the disk just outside the pattern line, then center it on a pivot and finish the job with the saw. Use a blade with wide set and make the final cut slowly.

★ ★ ★



HOLE SAW cuts round openings in harder materials such as plastic-faced plywood, hardboard, metals

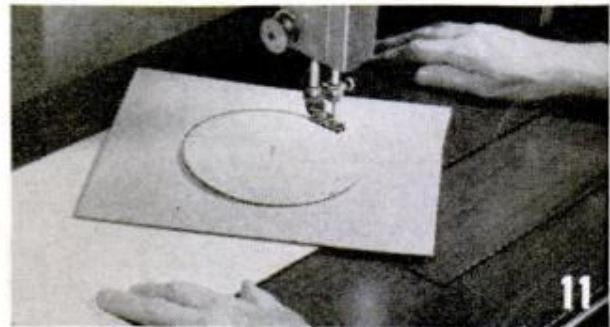

USE SEWING MACHINE to perforate a tear line in soft materials. Quite accurate work is possible. Below, router bit being used to cut round opening

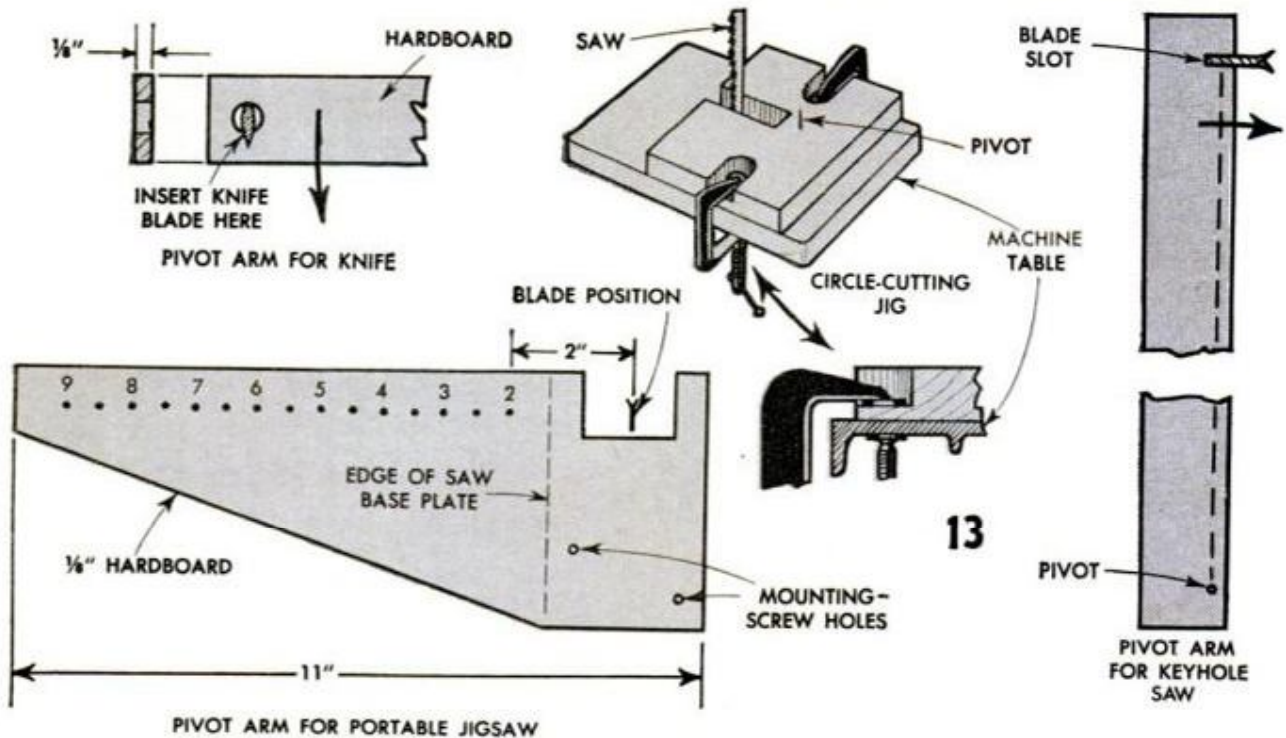
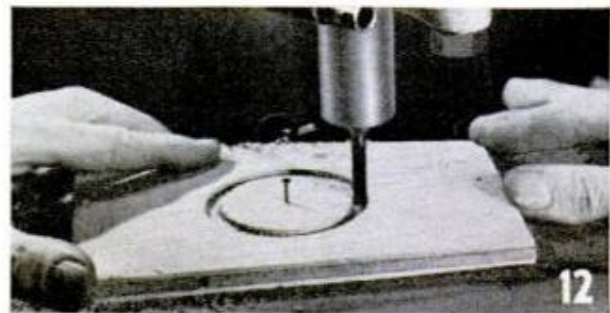

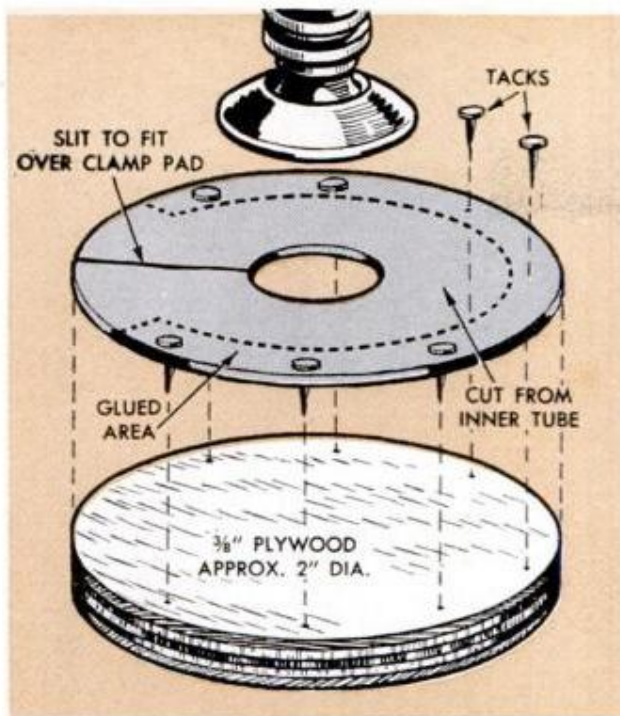

Detachable C-Clamp Pads Save Work Surfaces

Not only do these clamp pads prevent damage to work surfaces, they also save the time and trouble of holding the pads in place while tightening the clamps. A pair of the pads is made for each clamp when you are preparing to assemble parts that must not be marred or dented. Each pad is made from a disk of plywood to which is attached a disk cut from an innertube. The latter is slit from one edge to a center hole so that when tacked to the plywood disk the assembly slips over the clamp pads. Tension of the rubber disk will hold the pad

in place while the clamp is tightened or loosened. Although the diameter of each pad is given as 2 in. they can be made any convenient size, and for the larger C-clamps the plywood disks should be cut from $\frac{1}{2}$ or $\frac{5}{8}$ -in. material. For maximum protection against damaging the surface of the work, glue or cement a disk of rubber to the face of the plywood disk. Although the pads are detailed as disks, they also can be made square in larger or smaller size as the job requires. A square pad is often an advantage.—H. Hanscom

U-Shaped Cutoff Stop Fits on Rip Fence

When cutting duplicate workpieces to length on a circular saw the usual practice is to clamp a stop block to the rip fence at a point far enough ahead of the blade to permit the stock to clear the block before being cut off by the blade. This U-shaped "block" serves the same purpose and does away with the necessity of assembling the usual C-clamp and block each time cutoff work is to be done. It can be made from plywood as indicated, or from solid stock if you prefer, and should be dimensioned to fit the fence snugly. You'll have to determine the overall dimensions yourself, working from the ripping fence on your saw. Normally the block should be about 3 in. long.



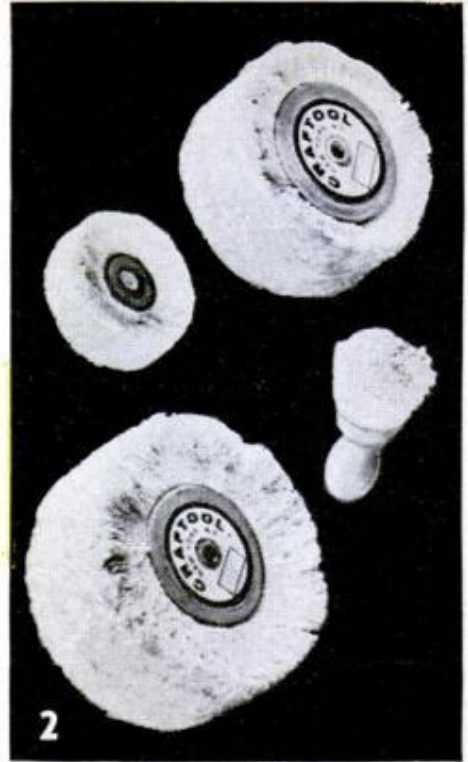
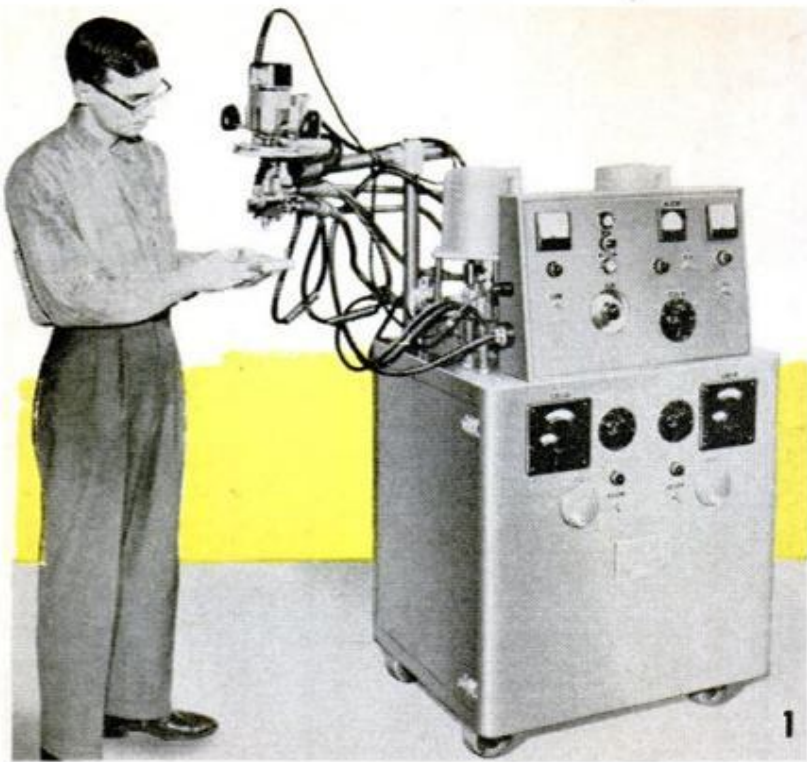

SHOPPING FOR TOOLS

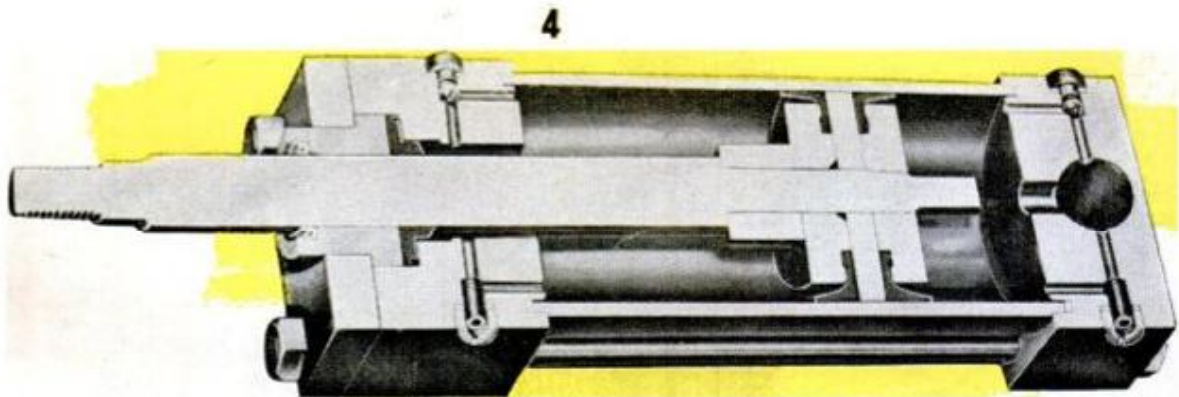
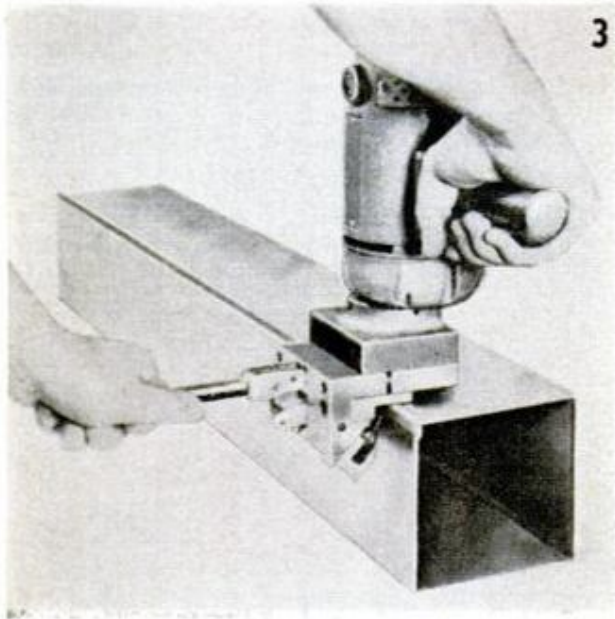

3

1. FOAM PRODUCING UNIT is self-contained and is capable of pumping, metering and mixing formulations for rigid, semirigid, flexible foams. Meets requirements of research, foam-development laboratories
 Martin Sweets Co., 114 S. First St., Louisville 2, Ky.

2. NEW BUFFING WHEELS, or mops, are designed for jewelers, silversmiths, craftsmen in metals, and for school shops. Dense cotton-tufted wheels give maximum efficiency and wear and produce fine finishes
 Crafttools, Inc., 306 Broadway, New York 13, N. Y.

3. ELECTRICALLY DRIVEN SEAM ROLLER for tinsmiths rolls a perfect lock seam at rate of 18 to 30 ft. per min., speed depending on gauge of metal. With accessory equipment handles metal from 18 to 28 ga.
 Millers Falls Co., 57 Wells St., Greenfield, Mass.

4. AIR CYLINDER combines a simple, rugged mounting with new operational features. Designed with one flange plate extending, extension fitting into groove milled in machine pad. No pins or dowels required
 Miller Fluid Power Div., Flick-Reedy Corp., York and Thorndale Bldg., Bensenville, Ill.

4

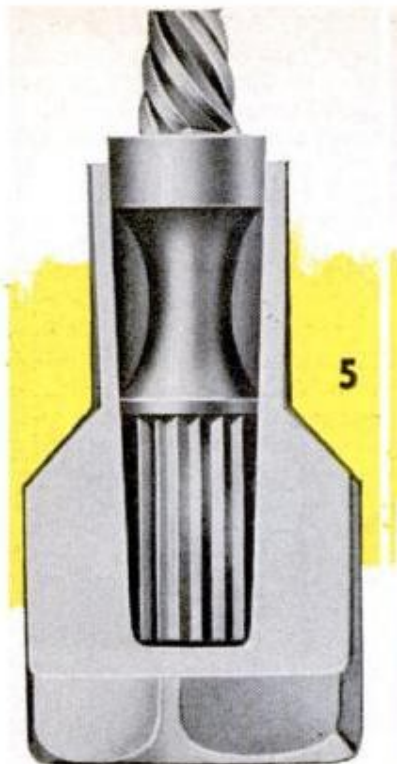

5



6



5. SCREW EXTRACTOR is so designed that, should it break in use, it will break at a point above shoulder shown in cutaway view. Thus a portion of extractor remains above surface so that it is easily removed
 Roddick Tool Co., 1023 Pauline St., Anaheim, Calif.

6. MAGNETIC TIRE SHIELDS simplify the ticklish job of spray-painting auto and truck wheels. Shields, or masks, snap into place and are held by permanent magnets. Made of galv. sheet metal. Are easily cleaned
 Temple Tool Co., 3516 Imperial Highway, Lynwood, Calif.

7. NYLON DRILL SLEEVE puts drill bits with broken tangs back into service. No turning down or other preparation necessary. Sleeve slips right over damaged tang, or shank, fits into tapered drill spindle
 Rick, Inc., 2630 West 12th St., Erie, Pa.

8. SLOTTED STEEL ANGLE is available with accessories for building storage racks, partitions, special stands. Comes regularly in 14-ga. and in heavy-duty 12-ga. steel. It's available in 6, 7 and 8-ft. lengths
 Lyon Metal Products, Inc., 22 Plant Ave., Aurora, Ill.

9. NON-CLOGGING FILE for auto-body work and filing soft and hard metals such as aluminum, copper, steel and cast iron; can also be used as rasp on hard and soft woods. Handle is adjustable to two positions
 Gordon Associates, Inc., Derby, Conn.



7

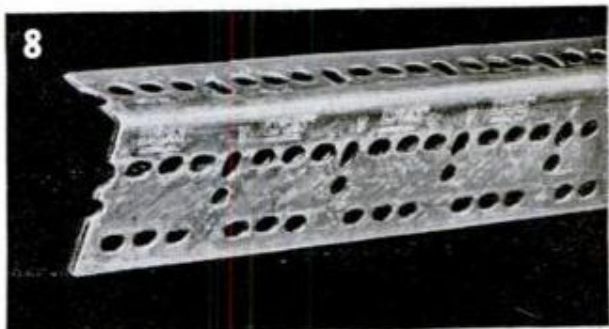

8



9



LEFT-HAND



RIGHT-HAND

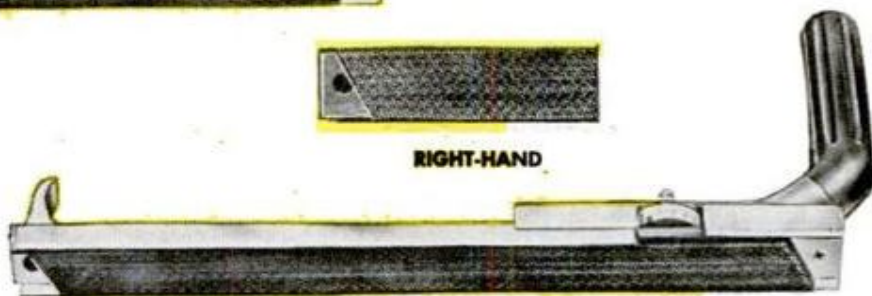

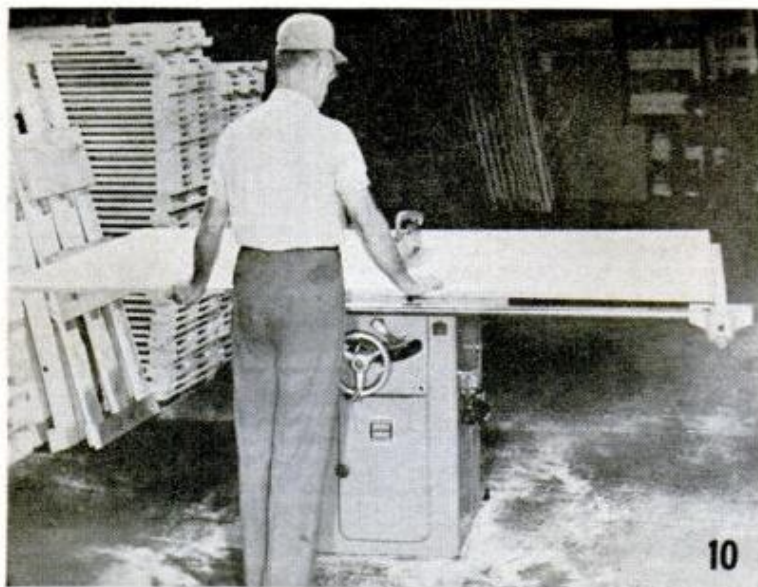

10

10. RIP-FENCE EXTENSIONS give this table saw a fence-to-blade capacity of 49 in. Fence extensions ordinarily are used without table extensions on large panels but for supporting long boards table extensions, or wings, also are available. Saw takes blades up to 10 in. in dia. and can be supplied with motors up to 3 hp.

Boice-Crane Co.,
943 W. Central Ave., Toledo 6, Ohio

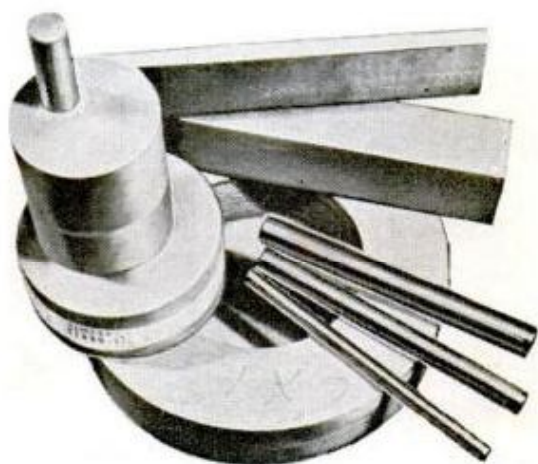

11

11. STEEL-BONDED CARBIDES can be machined with conventional tools, thus giving designers and engineers a versatile, machinable carbide in the stock forms of rounds, squares, disks and other shapes. From these tools and other items may be fashioned for use where high heat, wear and corrosion resistance are essential

Sintercast Div., Chromalloy Corp.,
132 Woodward Ave., Yonkers 2, N. Y.

12. STEPLADDER, STAIR LADDER and extension ladder—it's all three in one light unit. Six-foot ladder extends to 10 ft., or, when used as stepladder, it can be adjusted easily for use on stair steps as in the smaller views. Comes in 6 to 10-ft. stepladder sizes. Of all-magnesium construction it is corrosionproof

White Metal Rolling & Stamping Corp.,
443 4th Ave., New York 16, N. Y.



12

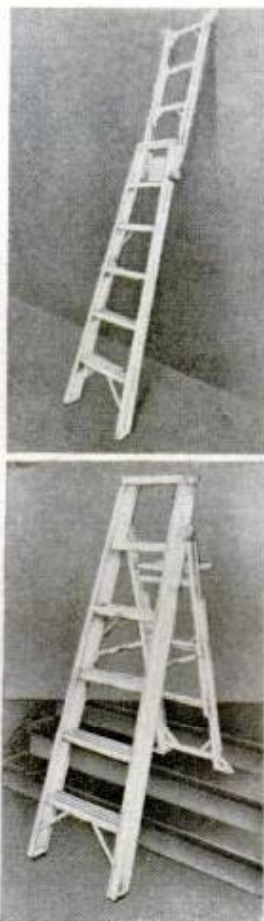

13. FINGER-TIP WRENCH enables user to reach a bolt head or nut in any space into which a finger can be inserted safely. It's made from stainless steel so that it will not rust and comes in individual sizes or as a complete set with a range of $\frac{1}{4}$ to $\frac{3}{8}$ in. The thimble, or cot, is adjustable to fit comfortably

Beaver Tool Co.,
P. O. Box 256, Huntington Station, N. Y.

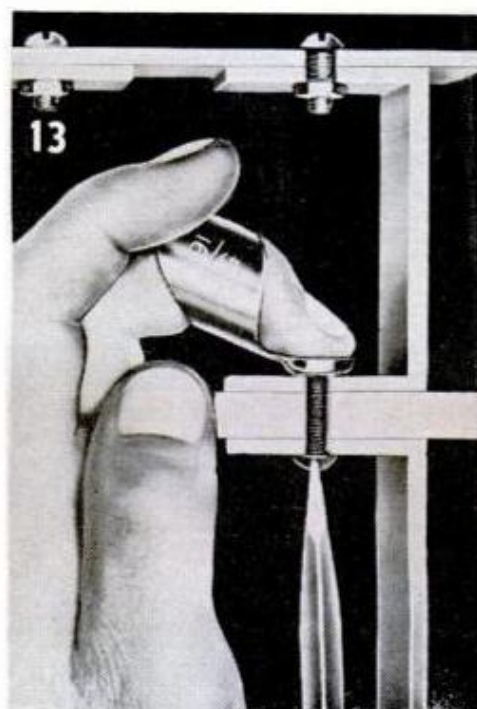

13

Hot Wire Divides Feed Bunk

Cattle won't compete for feed across the width of this bunk which, in effect, is separated into halves by a hot wire energized by an electric fence controller. The arrangement assures that each animal gets its fair share of silage or other feeds which have been uniformly distributed by the unloader. Stronger and more energetic animals are effectively restrained from reaching beyond the center of the bunk. The wire is carried on standard electric fence posts cut to required length and anchored in the bottom of the bunk.



V-Gate Built Into Wire Fence

V-gates, or walk-throughs, are a convenience in any wire fence where free passage from one fenced area to another is frequently necessary. The gate is made by arranging the posts as in the inset detail, the space between being made sufficiently wide to permit a person to pass through easily. Anchor posts should be braced as in the photo to prevent sagging of the wires along the length of the fence. Note that the angle of the three posts which form the Vee is about 90 deg. or slightly less to assure that cattle and horses cannot pass through the gate.—V. and G. Russel

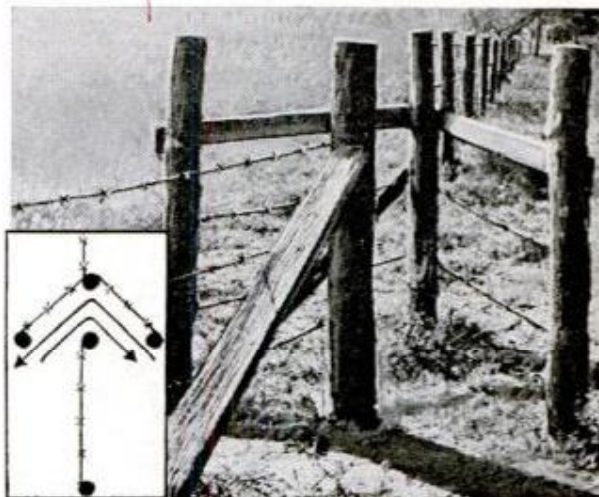

False Guard Bars Fool Cattle

The four-bar cattle guard pictured soon proved inadequate as the more venture-some animals, tempted by lush grazing on the opposite side, found they could jump over the existing guard quite easily. Rather than install a swinging gate, the owner painted stripes of uniform width on the surface of the blacktopped lane, spacing the stripes the same distance apart as the guard bars. Thereafter cattle would not attempt to cross the guard as long as the stripes were kept painted so that they were well defined.—Wayne Floyd

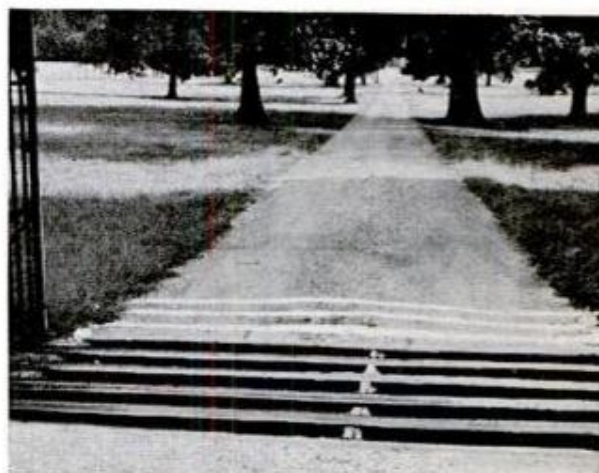

Pipe Posts for Feedlot Fence

Lengths of heavy 2½-in. pipe set in concrete support this feedlot fence. The pipe posts also are filled with concrete to prevent them from filling with rainwater. The board fence is built up by nailing 1 x 8s to 2 x 8 cleats, the latter spaced on 6-ft. centers to match the spacing of the posts. After the fence sections have been assembled in the horizontal position and painted, they are raised to the vertical position and are attached to the posts with ¾-in. U-bolts, one bolt being placed at the top and bottom of each post as indicated.—A. M. Wettach

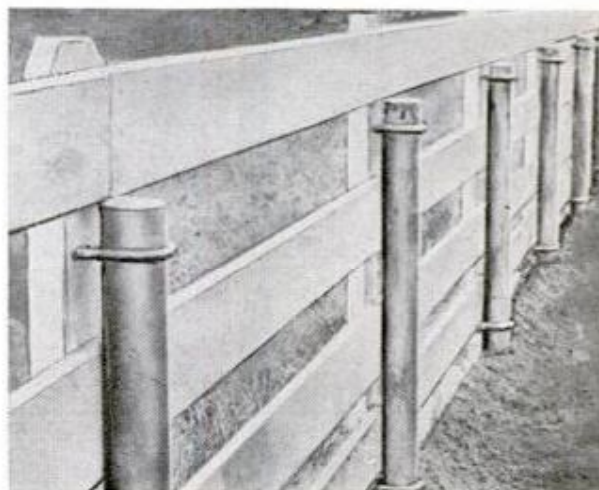

SEVEN SHOPMADE WEDGE CLAMPS

bring pressure to bear on heavy gluing jobs

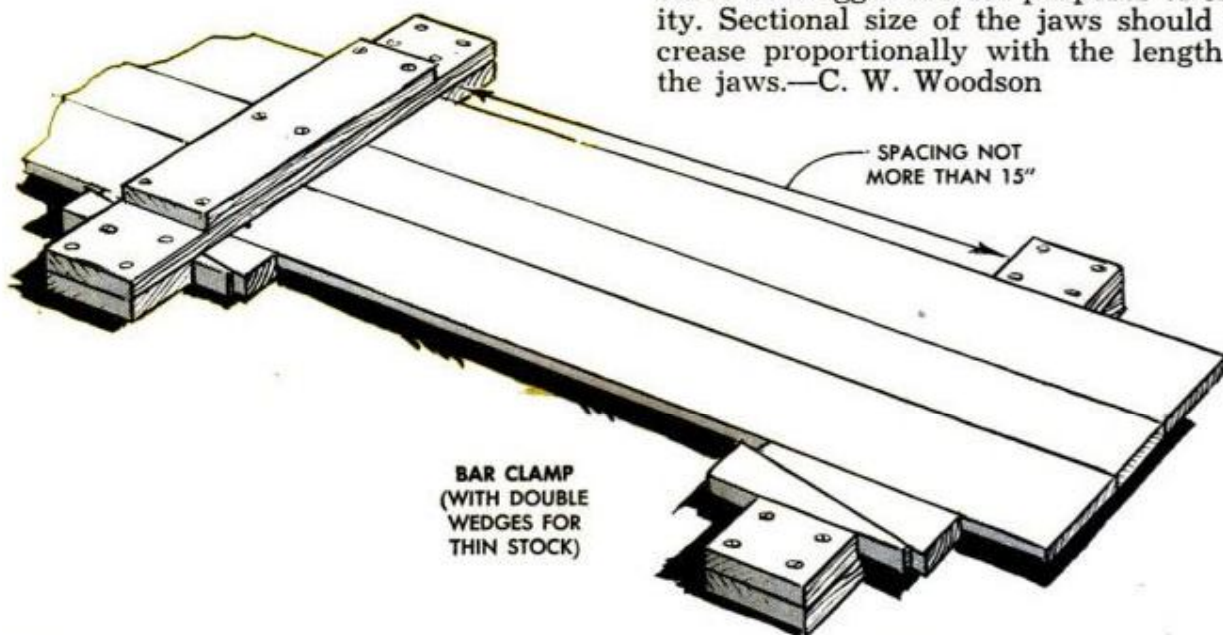
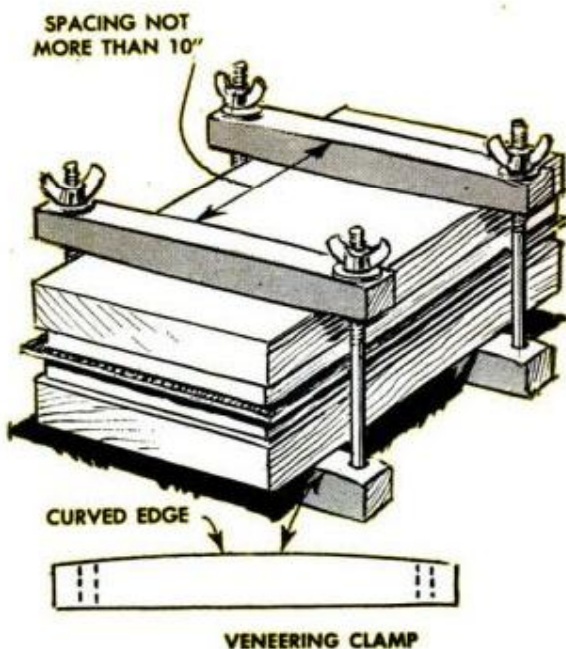
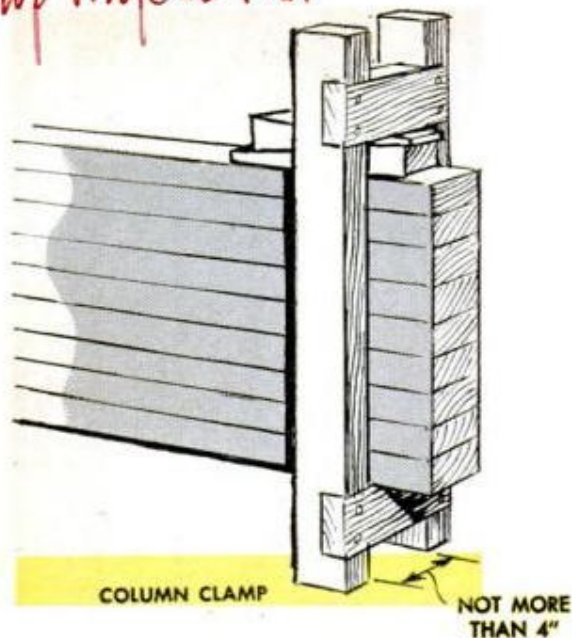

THESE CLAMPS have the advantage of being made to order for the job. They're inexpensive, too, as nearly all the types shown can be made from sound, rough stock and the wedges cut from a hardwood, such as oak. As detailed, the wedges are an average size. You can make them larger or smaller as the job requires. Fixed jaws of the bar clamps are wide and do not indent edges of the stock being clamped. This makes extra padding blocks or strips unnecessary on average work. The heavier bar-clamp unit with a single wedge, detailed on the opposite page, is especially effective when gluing up heavy stock, such as 2 x 4s for a bench top. Any of the bar clamps shown can be used for clamping narrower widths simply by inserting filler blocks between the wedges and the edge of the stock being clamped.

One does not often have use for a box clamp or a column clamp, but when needed they can be assembled quickly and in any number of duplicate units required by the job. Units will be stronger if you assemble the parts with screws and glue.

Note that one edge of each jaw of the veneer clamp is curved. Purpose of this is to cause each jaw, or bar, to exert uniform pressure across the full width when the wingnuts are tightened. The face of the jaw can be curved sufficiently by planing lightly from each end. In the detail, the curve is exaggerated for purposes of clarity. Sectional size of the jaws should increase proportionally with the length of the jaws.—C. W. Woodson

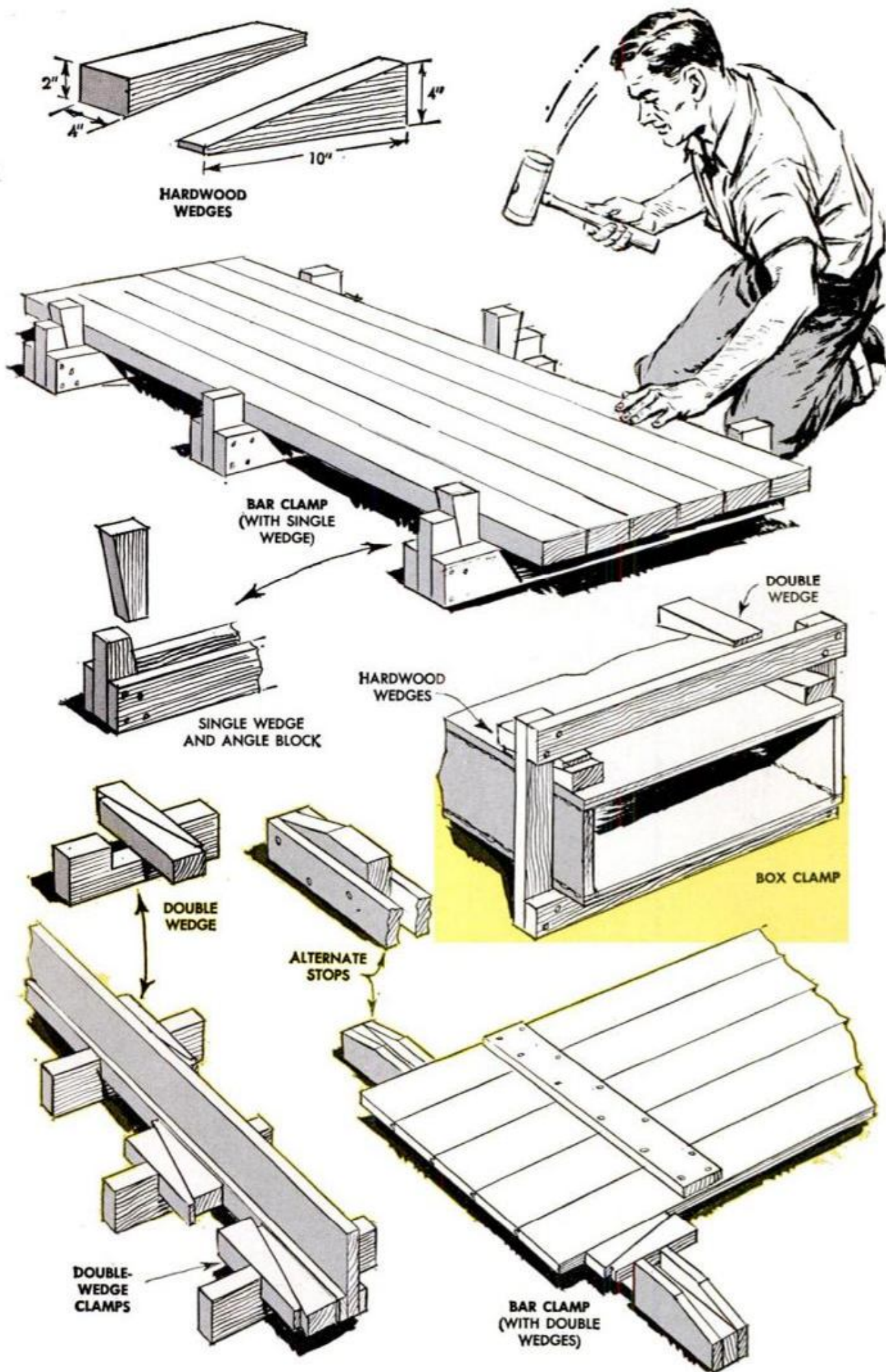

HARDWOOD WEDGES

BAR CLAMP (WITH SINGLE WEDGE)

SINGLE WEDGE AND ANGLE BLOCK

HARDWOOD WEDGES

DOUBLE WEDGE

BOX CLAMP

DOUBLE WEDGE

ALTERNATE STOPS

DOUBLE-WEDGE CLAMPS

BAR CLAMP (WITH DOUBLE WEDGES)

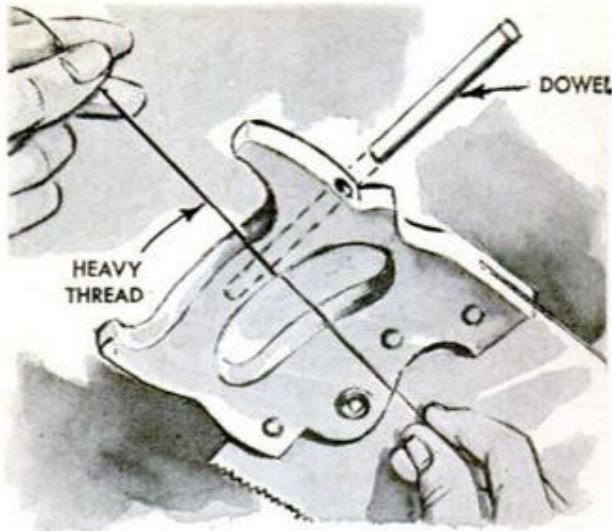

Thread Spreads Glue Evenly

Working glue into a crack or split when making a repair can become a baffling problem unless you know the trick of using a length of thread or cord to spread it uniformly on the meeting surfaces. There's no need to open the crack or split wider unless it's less than thread width. Just lay a thin line of glue over the opening, then, holding both ends of the thread, work it into the crack with a back-and-forth motion. It takes the glue right along with it. You may have to make a second application of glue and repeat the performance to cover the surfaces completely. Clamp the work until dry.—Robt. L. Sargisson

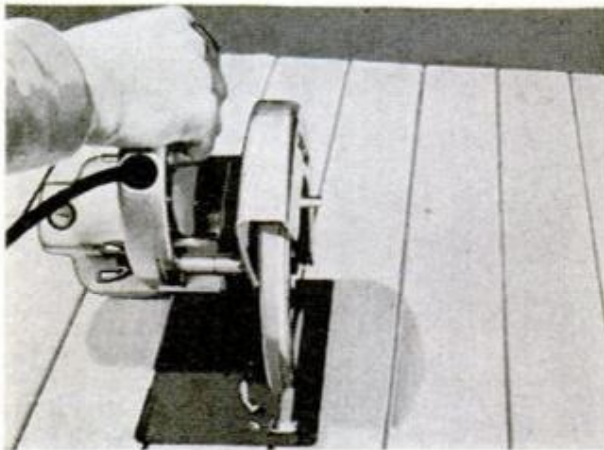

Saw Kerfs Release Warp Stress

One effective way to prevent or correct warping of a wide panel is to run spaced saw kerfs across one face, the depth equal to about half the thickness of the stock. This has the effect of relieving stresses set up across the width of the panel by expansion of the wood fibers. In the case illustrated, warping of a sliding tailgate on a farm truck made raising and lowering very difficult. Here the saw kerfs were run along the tongue-and-groove joints of the boards to relieve stress.—Ken Hadenfeldt

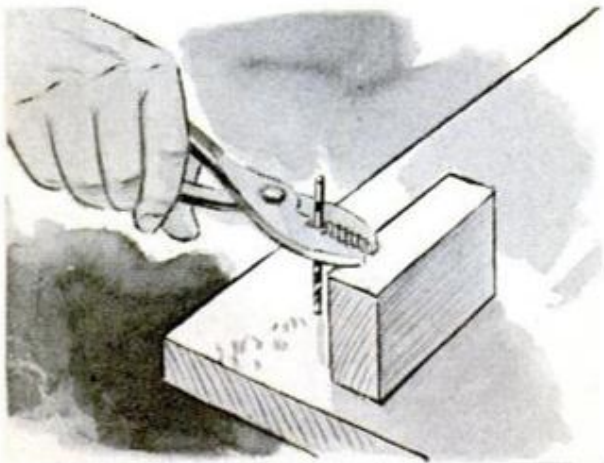

Drill Bit Lifted With Pliers

When drilling hardwood with a small twist drill the bit sometimes fills with fine chips and binds tightly in the hole. Simultaneously the chuck on your hand drill lets go. Getting the drill bit out of the hole without breaking or bending it can become quite a project, unless, of course, you remember this simple method. Locate a suitable block of wood, place it close to the bit and then grip the shank of the bit with pliers resting on the block. Ease the bit out of the hole with a series of short lifts with the pliers.

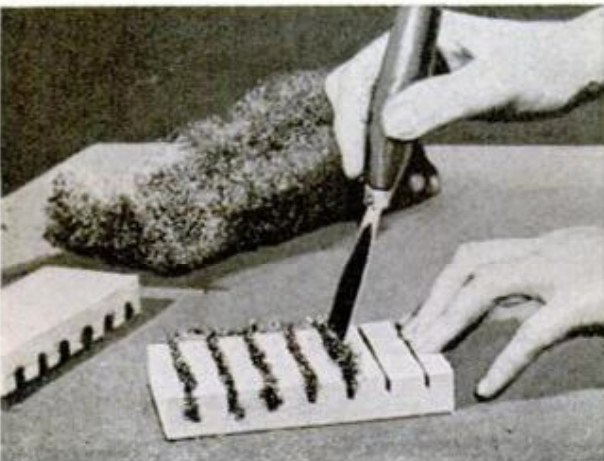

Grooved Block Holds Steel Wool

One of the discomforts that seems to go along with working with steel wool is the tiny steel slivers that work their way into the fingers and palms of the hands. They can be quite painful. I tried a number of ways of overcoming this problem but none has worked out as well as the kerfed wooden block pictured. Use a rectangular block of a handy size. Run saw kerfs crosswise and to a depth equal to about half the thickness of the block. Then press the steel wool into the kerfs as pictured.—Benson E. Hall

Stereo Goes Back on Tape



By Art Zuckerman

THOUGH THE AVERAGE phonograph owner probably doesn't know it, stereophonic sound didn't begin with the stereo record. This wonderful disk put stereo on the map, but tape had put it on the road much earlier.

It all began when some bright recording engineer observed that home recorders use two tracks, recording on one side and then on the other after the reel is flipped. Instead of using the tracks one at a time for that same old monophonic sound, this genius reasoned, why not add an extra tape head to the recorder? That way you could use two microphones spaced apart and put their pickups on each track at the same time. Thus you would create the full-dimensional effect the world today knows as stereo.

This innovation coincided with a dramatic improvement in tape heads, an improvement that made possible the captur-

ing of the entire audible range of sound on tape running at the home recorder's top speed of $7\frac{1}{2}$ i.p.s. Up to then, only a 15-i.p.s. speed could record clean up to 15,000 cycles.

The combination of top-quality recording at home-economy speed, plus the two-channel recording technique made stereo the tape industry's new byword. It was almost impossible to buy a recorder that wouldn't play commercially recorded stereo tapes.

If this earlier stereo tape was so great, why didn't it revolutionize the recorded-music business the way two-channel platters did later on? First, because tape recorders are a pretty stiff investment for the average customer. Second, because the commercially prepared stereo tapes were themselves expensive.

A standard seven-inch reel with 1200 feet of tape plays monophonically for an



Left, RCA home tape machine plays RCA 3 3/4 i.p.s. tape cartridges. Below, Tandberg system boasts outrigger recording amplifier. This Norwegian unit has dual playback amplifiers and one built-in speaker which can be applied to either channel 1 or channel 2. The microphone for channel 2 record is plugged into the external recording amplifier



hour at 7 1/2 i.p.s., half an hour on each side. Use the second side, or track, for the extra stereo channel, and you've cut playing time in half. So half-track stereo tapes generally cost two to three times as much as monophonic phonograph records.

When the stereo disc finally arrived with its one hour of playing time, the half-track stereo tape really took a beating. Only the confirmed audiophile was willing to stick to his stereo-tape guns. He knew tape sounded better than the stereo records, with greater tonal range, smoother response, and freedom from pops and clicks. But price talks, and though half-track tape still offers the finest stereo listening available, the commercial-tape producers saw the disc grooves on the wall, as it were.

It took the recent development of four-track tape to save the day for them. While it's done nothing to reduce the price of the recorder itself, it has given stereo tape twice its old playing time, so it can now compete pretty closely with the minute-for-minute cost of stereo discs. Best of all, quarter-track tape at 7 1/2 i.p.s. is almost as good in quality as half-track tape. So it is better sounding than today's stereo records.

As a matter of fact, in one important respect quarter-track tape at 7 1/2 i.p.s. is even better than half-track. Quarter-track is less susceptible to cross-talk problems. In half-track, the heads are stacked one above the other and, since together they

take up the entire tape width, they're immediately adjacent. As a result, there's some slight tendency for part of the channel 1 material to seep into channel 2 and vice versa, especially during recording. This is known as cross talk.

Quarter-track heads together take up only half the tape width. Therefore they can be and are spaced an entire quarter track apart, in this way virtually eliminating cross-talk.

Quarter-track stereo tape has one advantage records will never be able to match. You can make your own stereo recordings on it with many of the machines now available. This means you can borrow a friend's stereo disc and copy it on tape, or you can record an AM-FM stereocast from radio. Since the price of virgin tape is much lower than that of a phonograph record, this provides you with music at a substantial saving. And it's completely legal so long as you don't sell the copies you make.

Of course, with a machine that records quarter-track stereo, you can also make your own live stereo recordings. Furthermore, if you elect to use a quarter-track recorded monophonically, you can put two full hours of the highest quality music reproduction on a mere 1200 feet of tape!

Quarter-track stereo recording is a feature of many tape recorders offered by such companies as Ampex, Bell, Ferrograph, Norelco, Pentron, Roberts, Sony, Tandberg, Telectro, Uher, V-M and Web-

Unique stereophonic microphone manufactured by Norelco is actually two microphones in one. The top markings indicate the mid-point between the channels and the louvered openings along the sides of the microphone provide sound entry to the operating elements. To make monophonic recordings, turn the unit so that the side marked "left" faces the source

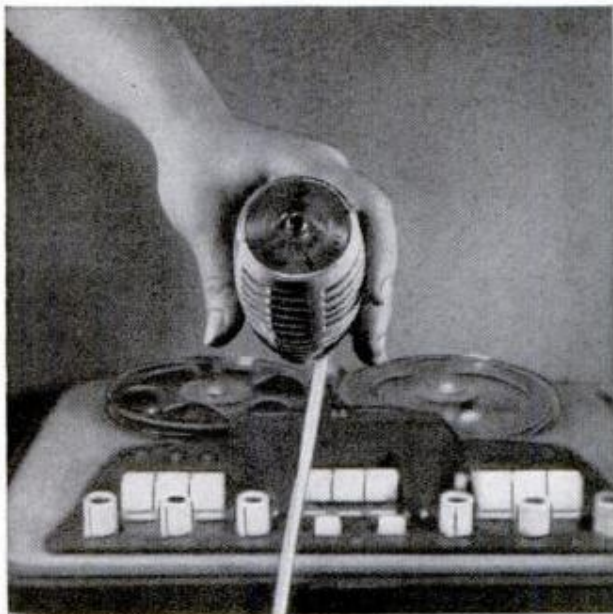

Uher Stereo III boasts push-button controls for the selection of either stereophonic or monophonic channel 1 and channel 2 recording. A similar arrangement located on the opposite side of the tape deck selects playback modes in the same fashion. A utility speed of $1\frac{7}{8}$ i.p.s. is also provided where tape economy possibly may be an important factor

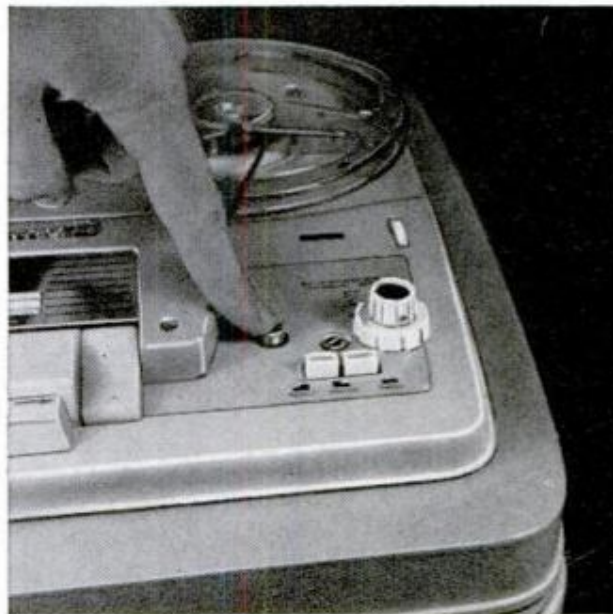

cor. Other machines permit half-track stereo recording plus quarter-track playback. American Concertone is one that works that way.

On some of the new quarter-track machines, only quarter-track recordings can be made. This is true of the Norelco and Tandberg, for instance. Others, such as the Ampex, Roberts and Sony, have head-shift switches that make half-track recording possible, too. But any quarter-track machine can play half-track tapes.

Playback arrangements vary widely. Most of the machines on the market allow the playing of both channels through an external stereo amplifier and speaker system. In fact, some units like the basic Ampex model can't be used any other way. They have no playback amplifiers or speakers of their own.

If you insist on high-fidelity reproduction, this is the only way to do it anyway. The self-contained playback amplifiers and speakers found in even the best tape recorders don't usually produce particularly good sound.

If you want to take your recorder "on location" and monitor your tapes easily, you'll prefer machines like the Roberts that have a playback amplifier and speaker built in for at least one channel. These generally need an auxiliary amplifier and speaker for the second channel.

The Roberts requires an auxiliary amplifier-speaker unit for stereo recording as well as second-channel playback.

Recorders like the Tandberg need only an extra speaker to give stereo playback because they're equipped with two playback amplifiers. Some recorders, such as Norelco's Continental 400, certain Pentron and Telectro models and the latest Ampex, are completely self contained, with amplifiers and speakers for each channel included in the basic unit.

There are also some tape recorders on the market that follow the original stereo-tape pattern. They play stereo but record monophonically only.

Without question, $7\frac{1}{2}$ i.p.s. is the speed that gives the truest reproduction of music. But virtually every stereo recorder on the market today also operates at $3\frac{3}{4}$ i.p.s. Some, like Norelco, Tandberg, Telectro and Uher even provide a $1\frac{7}{8}$ i.p.s. tape speed for utility purposes where tape economy must be considered.

Let's take a close look at that $3\frac{3}{4}$ i.p.s. tape speed for a minute. Several years ago it was merely a utility speed itself, suitable mainly for voice recording. But with today's improved tape heads, $3\frac{3}{4}$ i.p.s. can deliver an easy 8000 to 10,000 cycles, and even better in some cases. This equals yesterday's top performance at $7\frac{1}{2}$ i.p.s.!

The combination of better quality at lower tape speed and quarter-track recording has led to the development of the practical tape cartridge by Radio Corporation of America. Consisting of two small reels completely enclosed in a plastic case,

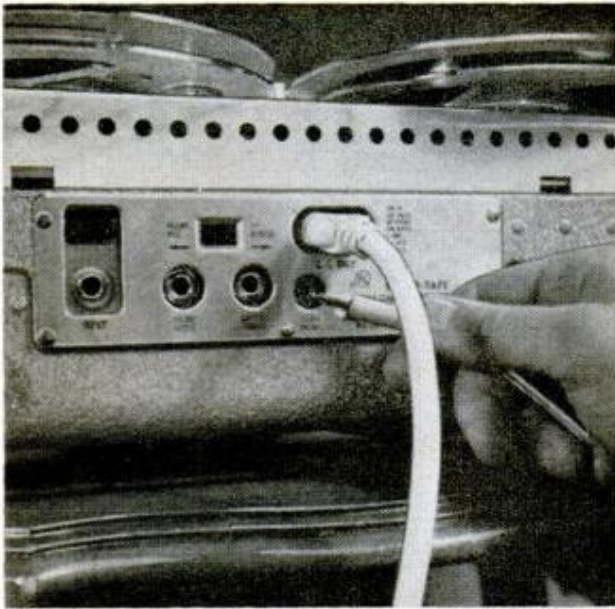

Wollensak model 1616 shown here requires an external amplifier and speaker for second channel



Many tape recorders have shift levers to select either half-track or quarter-track arrangement



Fixed position heads such as on the Tandberg produce only half-track tapes and play them as well

the cartridge can be used only with a special machine.

RCA has marketed such a unit, designed to record and play its own cartridges. Bell has gone RCA one better and produced a whole string of cartridge machines. The top of the line is a complete recorder, like RCA's. Then there are models that must be used with external amplifier and speaker system. One Bell offering even requires a separate preamplifier to get the music from the tape, since its only electronic part is the tape head.

Chief among the cartridge's attractions is the handling ease it offers. It's even easier to play than a record. All you have to do is put it on the machine and push a button. When the first side is through, the cartridge stops automatically. Then you pick it up, flip it over, and start all over again.

(Continued to page 216)

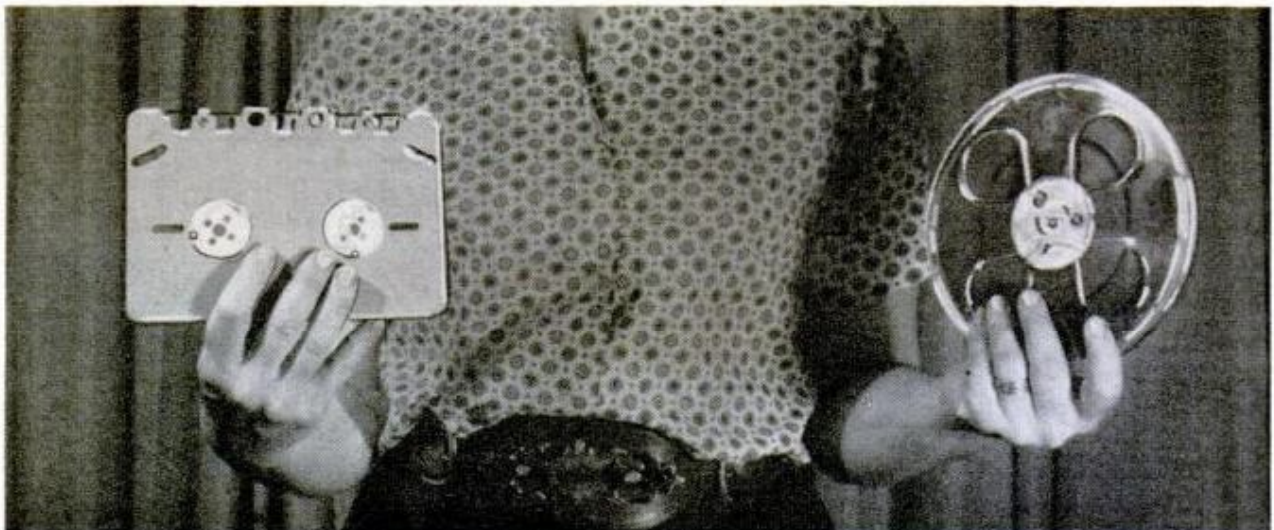

Blank tape cartridge by Audio Devices contains 560 feet of tape. The standard tape reel contains 1200 feet





ARMSTRONG TIRES' PATENTED TREAD FEATURES CAN SAVE YOUR LIFE!

*Read these 3 ways
Armstrong Tires add the grip
that stops deadly skids
as no other tires can!*

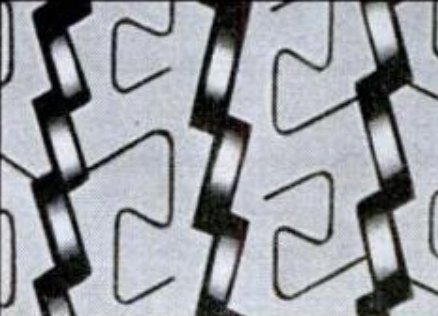
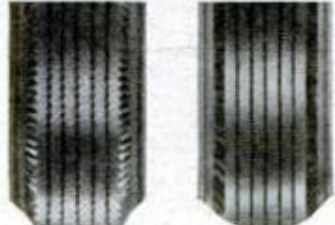
 <p>ARMSTRONG TIRES</p>	 <p>ORDINARY TIRES</p>		 <p>ARMSTRONG TIRES ORDINARY TIRES</p>
<p>Famous "Ounce of Prevention" PATENTED SAFETY DISCS KEEP TIRE'S GRIPPING EDGES OPEN</p> <p>Just as Safety Discs in fist (above left) keep fingers apart, so over 1000 Safety Discs in each Armstrong Tire keep tread's gripping edges apart, always ready to grip — no matter how hard you brake!</p> <p>But fingers of fist <i>without</i> discs (above right) can squeeze shut. That's why ordinary tires, lacking Safety Discs, can squeeze smooth and slippery under braking pressure — <i>and you skid.</i></p>	<p>Grip in all directions! PATENTED INTERLOCKING SIPES ADD OVER 2600 GRIPPING EDGES!</p> <p>Sipes are slots put in tires to add gripping edges. Only Armstrong tires have S-shaped, <i>interlocking</i> sipes. They add over 2600 gripping edges, provide "bite" in ALL directions, sharply improve protection against forward and side skids.</p> <p>In winter, interlocking sipes' "wiper" action keeps you safer on wet roads, gives you snow tire "go" on packed ice and snow.</p>	<p>Grip where it counts! UNI-CUSHION CONTOUR LAYS MORE LIVE RUBBER ON ROAD</p> <p>Armstrong Tires, when inflated and rolling, put more tread — more gripping edges — on pavement. Greater stability at high speeds! Faster, surer stops when you brake!</p> <p>Another extra: Armstrong's anti-vibration tread literally cancels noise! No hum, no whine, no drone: you ride on a whisper. Talk to your local Armstrong dealer — he's listed in the Yellow Pages.</p>	

Get this extra safety at no extra cost!

ARMSTRONG TIRES

grip the road to stop deadly skids as no other tires can!

Armstrong Rubber Company, Home Office, West Haven, Conn.

New Ideas in Photography



Kodak Sound 8 Projector comes complete in built-in case with $f/1.6$ lens, speaker, microphone, and phono

Now you can add quality sound

Magnetic head of "Alfenol" alloy is almost wearproof, assures realism

Now you can get top-quality 8mm magnetic sound at half the cost of fine 16mm magnetic sound, thanks to a major advance in metallurgy.

The Navy has developed a new alloy called Alfenol: *Al* for aluminum, *fe* for iron, *nol* for Naval Ordnance Laboratory. Used in the new Kodak Sound 8 Projector, it provides fidelity rarely surpassed even in 16mm sound movies.

Gives long service

Alfenol is amazingly durable. While other recording heads need to be replaced after a few hours, the Alfenol head records for thousands of hours without any loss in sound quality.

The Kodak Sound 8 Projector makes it easy

to add commentary, music, and sound effects to all your 8mm movies—old or new. Just ask your photo dealer to have Kodak Sonotrack Coating added to the edge of your edited film.

Comes with microphone

Then project your striped film at 16 or 24 frames, and record your commentary by speaking into the microphone that comes with the projector.

To add music or sound effects, connect your record player or tape recorder, using the phono connector cord. You can record, play back, and re-record until you are satisfied—as you would with a tape recorder.

When you hear the final playback, you'll be delighted with the clear, balanced tones produced by the built-in 10" x 2" oval speaker.

Judge the sound and picture quality of the

from Kodak

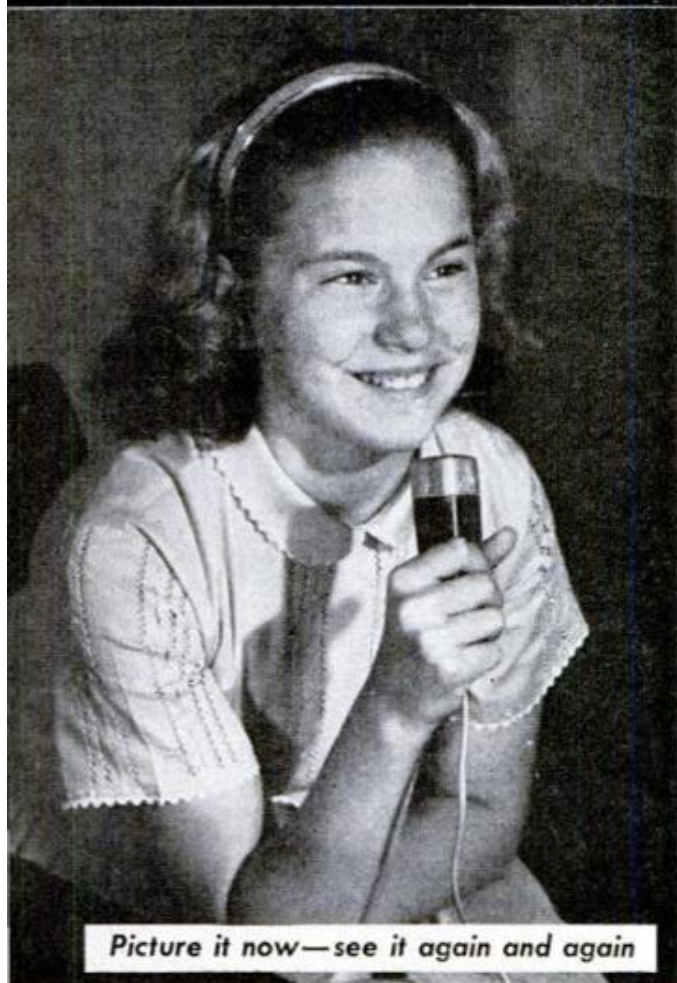

Picture it now—see it again and again

connector cord. \$345.

to 8mm movies!

Kodak Sound 8 Projector for yourself. \$345 list, or as little as \$34.50 down.

Budget Movie Projector Automatically Threads Film Right Onto Take-up Reel



Easiest low-cost way to show movies. Just feed the film into a slot and the show is on! Brownie 8 Movie Projector (Model A15) shows bright, sharp 8mm movies up to 4 feet wide. 200-foot reel capacity. \$54.50.

EASTMAN KODAK COMPANY, Rochester 4, N. Y.

See Kodak's "Ed Sullivan Show" and "Adventures of the Nelson Family"

SEPTEMBER 1960

Automatic Cameras' Tiny Power Plants Made of Selenium, Cadmium, Gold

Imagine subminiature power plants that use light as fuel! They are the keys to picture-perfect results with Kodak's new electric-eye cameras.

The power plants are photocells. Each is composed of a thin steel plate coated with layers of selenium, cadmium, and gold or platinum. The last layer is about one molecule thin, and is covered with lacquer to seal out moisture.

Light falling on the cell is converted directly into an electric current. The current is so small, it is measured in millionths of an ampere. Yet it



1



2



3



4

1) Brownie Starmatic Camera, \$29.95; 2) Kodak Automatic 35 Camera, \$89.50; 3) Brownie Automatic Movie Camera, *f*/2.3, \$77.50; 4) Kodak Cine Automatic Turret Camera, *f*/1.9, \$124.50.

can move the carefully balanced meter mechanism of any Kodak automatic camera (above).

The position of this mechanism determines your lens opening. In still cameras, the lens "squints" in sun, opens in shade when you press the shutter release. In movie cameras, the lens opening adjusts continuously.

These ultra-modern automatic cameras by Kodak make picture-taking easier and surer than ever before. See them at your dealer's.

Prices are list, include Federal Tax, and are subject to change without notice.

Kodak
TRADEMARK

211

Cut it with WISS

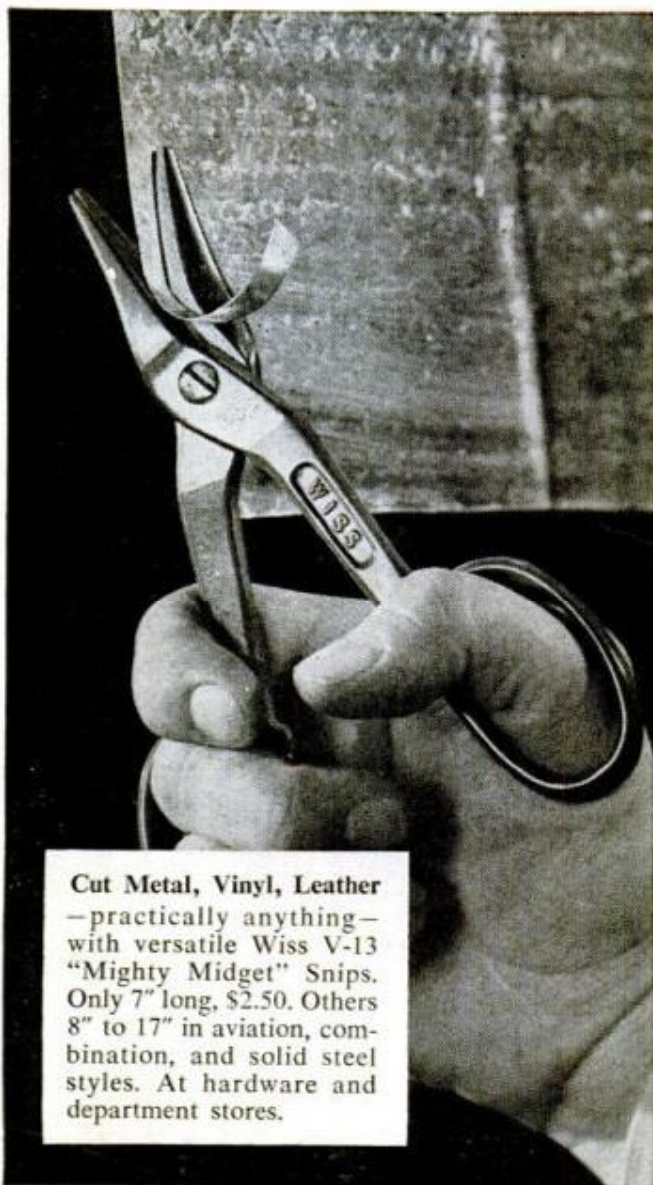

Cut Metal, Vinyl, Leather—practically anything—with versatile Wiss V-13 "Mighty Midget" Snips. Only 7" long, \$2.50. Others 8" to 17" in aviation, combination, and solid steel styles. At hardware and department stores.

OTHER FINE WISS CUTTING TOOLS

GRASS SHEARS

No. 701
\$2.75



Easiest cutting, fastest cutting grass shears you've ever used, with molded vinyl handle grips and special closing latch. Others from \$1.39 to \$4.95.

PRUNERS

No. 907-G
\$3.25



Wiss Hy-Power Pruners, with new vinyl grips, cut toughest limbs, protect your hands. 7-inch pocket size. \$3.25 wherever garden tools are sold.

J. WISS & SONS CO., NEWARK 7, N. J.

World's Largest Manufacturer of Shears, Scissors, Pinking Shears, Skalloping Shears, Metal Cutting Snips and Garden Shears

Clinic for Homemakers

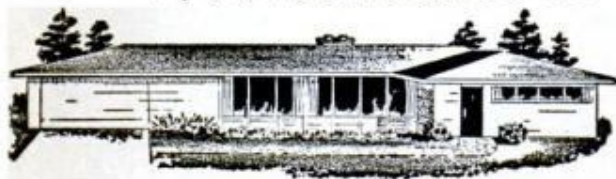

As a service to our readers in solving the hundreds of problems pertaining to a home—inside or out—the editors of *Popular Mechanics* invite you to present your problems to The Clinic Editor for help and advice. Address your questions to The Clinic Editor, *Popular Mechanics Magazine*, 200 East Ontario Street, Chicago 11, Ill.

Now Is the Time To Seed and Feed Lawn



Q—I have two lawn problems. First, I live on a corner lot and the curbs are wide, that is, the distance from the street to the walks is about 15 ft. I have not been able to get grass to grow under the red maples along the curb because of the thick foliage. Second, although my lawn is not large it is old and in rather poor condition, seems to be thinning from year to year. What's the solution to these two problems?—N. R., Va.

A—We'll say at the outset that the solutions are going to require some time and labor. Take the first problem. Both the trees and the grass are competing directly for the nutrients available with the trees having the edge on the grass which must struggle for existence in day-long shade. Feeding roots of the trees (you did not say how old the trees are) draw nutrients from the top soil as well as from the subsoil. Some gardeners cut away a portion of the tree roots closest to the surface in order to give the seeding a better chance to become established. This practice may be open to some question, but in many instances it does achieve the desired result. Much depends on seasonal conditions, topography, moisture available and other local factors. In some instances the trees can be trimmed in such a way as to permit some sunlight to reach the ground underneath. Work the soil under the trees to a depth of 2 to 3 in., apply a complete fertilizer and rake into the soil so that it is well distributed. Use a shady mixture of seed, apply a moderately heavy seeding, rake lightly to cover the seed, and, if the curb slopes, cover with burlap to prevent the soil from washing away during a heavy rain. Apply a second feeding after the blades of the seedlings are 2 or 3 in. high. This job can be done in the fall or in the early spring, success at either time of sowing depending to considerable extent on the season. Usually an old lawn such as yours—we are judging from your description—needs spiking, top dressing and reseeding. A regular schedule of feeding also should be established. Spiking is done with any one of several tools made especially for the purpose. It takes time to do a thorough job, but as a rule the effort is well repaid. This done, old lawns usually are benefited greatly by top dressing with black soil to a depth of an inch or two. This should be raked and leveled to a uniform depth. Follow this with new seeding and with at least two applications of fertilizer before the coming of cold weather halts growth.

(Continued on page 214)

Have an autumn-full of fun with **Coleman**



Off to a vacation? Headed for a camping trip? Or just living it up in your own backyard? Whatever's ahead in outdoor fun, you'll have more fun with Coleman.

See the Coleman coolers and picnic jugs that keep food and drinks cold or hot lots longer than any

others. The camp and picnic stoves that give you "gas-range" cooking anywhere. And the lanterns that brighten every after-dark activity.

They're all at your hardware or sporting goods store. Stop in!

The Coleman Company, Inc., Wichita 1, Kans.



Snowlite
Cooler



Snowlite
Jug



Folding
Camp Stove



Floodlight
Lantern

Can't Gouge Chrome Fittings ...

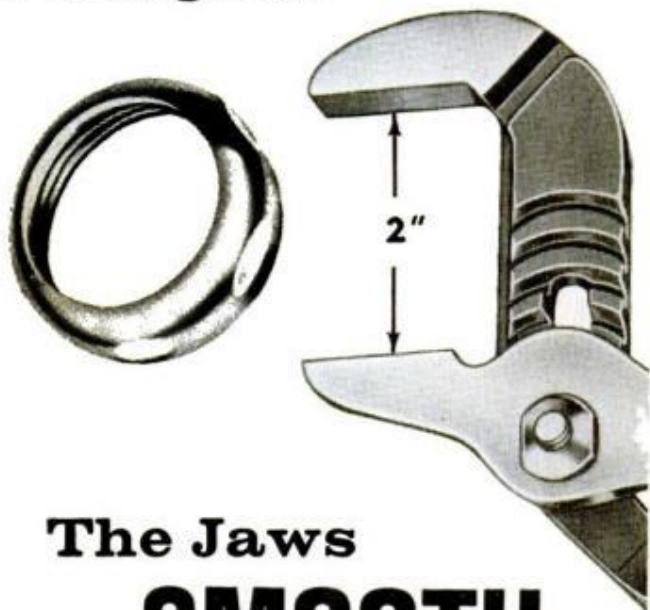

The Jaws
are **SMOOTH**

CHANNEL LOCK[®]

No. 415 Smoothjaw Plier

Now you can change faucet washers—easily, quickly—without gouging your chrome fittings . . . thanks to the CHANNEL-LOCK Smoothjaw Plier. The "toothless" jaws are adjustable for any size fitting to a full 2". The machined, undercut channels are smooth working . . . can't slip under any load. Equip yourself with this handy plier. You'll be glad you did next time you have a dripping faucet. If your tool supplier is out of them, ask him to order a genuine CHANNELLOCK Smoothjaw Plier for you.

Write for Catalog of Complete Line of Pliers

CHAMPION DEARMENT TOOL COMPANY

MEADVILLE 1, PENNSYLVANIA

What Causes Condensation

Q—When the temperature falls below freezing the windows in my new home sweat and water runs down on the sills and sometimes onto the floor. This happened last winter during the colder months, even though the weather was clear. We have gas heat. Could this be the cause? If not, then what is the cause and where does the water come from?—H. J., Ala.



A—Did you ever notice the beads of moisture that quickly form on the outside of a glass tumblerful of cold water on a warm summer day? And did you ever wonder why? The reason is quite simple. The surface of the glass is cooled rapidly by the cold water to a temperature much lower than the air which contacts the outer surface of the glass. The moisture in the air is cooled to the dewpoint and condenses on the outer surface of the tumbler, forming the beads of moisture you see. Look at the inner surface of a window pane in your home which is covered with condensate and you are looking at precisely the same thing, and for the same basic reasons. The pane is cooled by the cold outside air. The warm, moisture-laden air from inside the room contacts the inner surface and the moisture (water vapor) it contains is rapidly cooled below the dewpoint. The result is the condensation, or "sweating," that is causing your trouble. The gas-fired furnace or heater (you did not say what type of heating equipment you have) is not a cause if it is properly vented. An unvented oil or gas-fired heater is a principal contributing cause of condensation troubles as one of the products of the combustion of concentrated fuels is water vapor.

Drainage Problem

Q—My neighbor's lot is graded higher than mine and when we have heavy rains water runs off the high lot and collects along my basement wall, from where it seeps into the basement and under the basement floor. Although this drainage water does not cause any damage, I would like to find some way to keep it away from the basement wall. The high lot is terraced along the lot line and my lot is quite level from the bottom of the terrace. What do you suggest?—R. C., N.Y.



A—You do not say but we'll assume that the area involved is grassed over and is level each way. If these assumptions are correct then the problem is to intercept the water before it reaches the wall and drain it in one or the other or both directions from a midpoint along the wall. If there is sufficient fall, or slope, at the front or back of the lot to carry away the water once it reaches either point, then it usually is possible to use a wide and shallow waterway, or swale, to intercept the surface water that runs down the terrace slope and drain it away fast enough to prevent it from seeping below the surface and working toward the foundation wall. To do this you will have to remove the sod and then remove enough soil to form a shallow swale about 3 to 4 ft. wide and about 3 in. deep. Use a level to make sure that there is a slight slope, say about 1/4 in. to the ft., each way from the midpoint of the wall. As soon as the swale has been established, replace the sod and water thoroughly so that growth can continue.

Pittsburgh perfects a sensational new **Latex** house paint!

*Easier to apply...even paints over damp surfaces...
dries in 30 minutes...resists blistering...lasts longer*



- **Leadership in research** pays off! After years of laboratory work and field tests in all parts of the country, Pittsburgh perfects an amazing new house paint — Pittsburgh Latex!

- **This new paint** is the greatest advance in paint development in years... gives you advantages in ease of application and durability never before thought possible!

- **New Pittsburgh Latex House Paint** is made from the same miracle resins that keep many of today's cars and appliances new-looking year after year! It can be used on wood, masonry, stucco, asbestos or metal surfaces.

- **Read below** about the remarkable results you can expect from new, *perfected* Pittsburgh Latex House Paint!

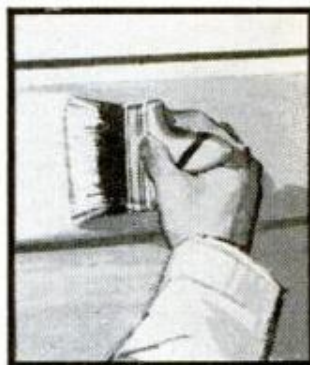
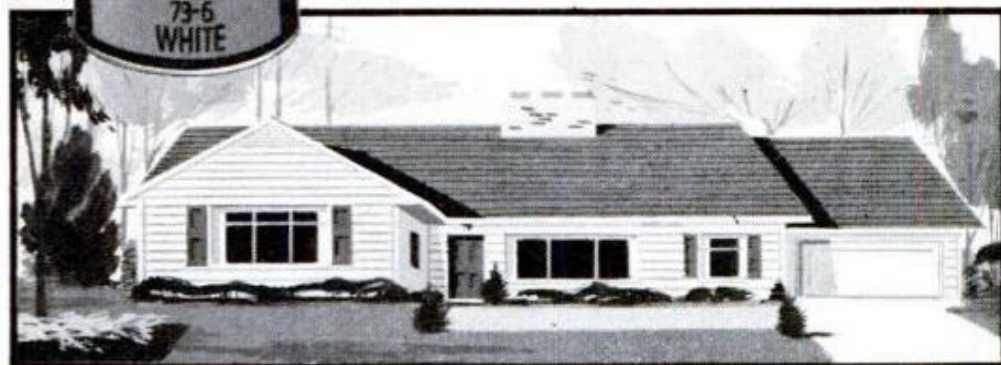

- **Sensational new Pittsburgh Latex House Paint** can keep your house looking "just-painted" years longer. The colors are fade-resistant...white stays white, colors retain their

crisp, clean beauty... and the new miracle resins are so durable they fight the effects of time and weather far longer! The result? A money-saving bonus of extra years between paint jobs!

- **You'll save hours** because Latex goes on so fast and smooth! No brush drag, no lap marks. Use brush, roller or spray.



- **Paint over damp surfaces!** With Latex you can paint over surfaces damp with dew or rain... or paint between showers.



- **Dries in 30 minutes!** Forget about rain, dust and insects messing up your paint job! Latex dries in only 30 minutes.

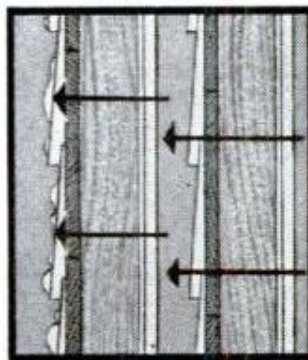

- **Resists blistering!** Correctly applied, Latex resists blistering. It lets trapped moisture out, yet will not let moisture in!



- **Clean up with water!** Cleanup and brush care is a snap! Just wash brushes, roller or spray gun in plain soapy water!



PITTSBURGH PAINTS

PAINTS • GLASS • CHEMICALS • BRUSHES • PLASTICS • FIBER GLASS

PITTSBURGH PLATE GLASS COMPANY

IN CANADA: CANADIAN PITTSBURGH INDUSTRIES LIMITED



- For America's finest oil-base house paint, ask for Sun-Proof—famous for highest quality for 100 years.

screens, upholstery, carpets...

hundreds of other uses.

You name 'em!*



Swingline 101 Staple Gun

Staples practically anything. Exclusive push-button loading and built-in staple extractor. At your stationery, department or hardware store.

only **4⁹⁵**

*Win \$5 per Idea!

Swingline pays \$5 for each practical new idea on how to use the SWINGLINE STAPLE GUN... to be published in "Tips for Tacking." Send your ideas today!

Send for FREE 12-page booklet "Tips for Tacking."



Swingline INC.

138-00 Skillman Ave., Long Island City 1, New York

STOP WATER DAMAGE...



Wood
Plywood
Shingles
Asbestos siding
Concrete blocks
Concrete
Mortar
Stucco
Plaster
Brick
Paint
Wallboard
Tile
Canvas
Leather
Linoleum
Fabrics

Prevents warping, swelling, mildew, mold, water stains, seepage, dampness, rot.

Keeps moisture out 5 years and longer.

Use on all woodworking jobs, boats, patio furniture, planter boxes, shutters, screen doors, window sash, shingle roofs. Stops seepage in basement walls, concrete silos, foundations. Waterproofs canvas, tarps, tents, awnings, leather boots, shoes, outdoor clothing. Won't harden or crack leather or fabrics. Perfect underseal for oil base or alkyd paints. Deep penetrating, colorless. Apply by brush, spray or roller. At paint or hardware stores or order direct. 16 oz. spray can \$1.89, Qt. \$1.75, Gal. \$5.35, 5 Gal. \$25.25, ppd., tax incl. Send check or money order to **E. A. Thompson Co.** 1355 Market St., San Francisco 3, Calif. No COD's please. (Since 1929.)

Stereo Goes Back on Tape

(Continued from page 208)

Of course, should you want to play only the second selection, you've got to rapid wind the first side before flipping the cartridge, just as you must with tape reels.

Another claimed advantage of the cartridge is economy. Since it operates at 3 $\frac{3}{4}$ i.p.s., it uses only half the tape required for quarter-track reels at 7 $\frac{1}{2}$ i.p.s. But the cost of the cartridge housing and mechanism largely offsets this tape saving in actual practice. In fact, a cartridge containing an hour of prerecorded stereo music can cost up to \$9.95, while you can get tape on reels with the same amount of music prerecorded at 7 $\frac{1}{2}$ i.p.s. for only \$8.95!

For the man who likes to make his own recordings, the ease of cartridge handling can prove a costly luxury. A standard blank cartridge with 560 feet of tape lists at about \$4.50. For \$3.50 you can get 1200 feet of tape on a reel. Since just about every home tape recorder has a second tape speed of 3 $\frac{3}{4}$ i.p.s., you can see that the cartridge actually costs more than twice as much as the reel for the same level of home recording quality.

People Skeptical

Many people are inclined to question the great improvement in handling ease you get from a cartridge, too. Just how hard is it, they ask, to thread a tape past the heads of a standard recorder and onto a takeup reel? One leading tape manufacturer, who also sells cartridges, observes that home movie makers greatly prefer roll-film cameras to cartridge types because of their economy, and roll-film cameras are a lot harder to load than the most complicated tape recorder.

As for cartridge features like the automatic end-of-tape stop, you also can get this in a number of reel-to-reel machines. Ampex, Norelco, Revere, Tandberg, Uher and many others have either tension devices that stop the transport when the tape runs out or special electric contacts that turn the machine off when shorted by a metallic leader near the end of the tape.

How about the most important consideration, sound quality?

Full-range reproduction is claimed for the new cartridges. But while all the frequencies may be there, they just don't come out as smoothly at 3 $\frac{3}{4}$ i.p.s. as they do at 7 $\frac{1}{2}$ i.p.s. The low tape speed also aggravates the problem of signal-to-noise ratio, a stickler created by the reduced width of the quarter-track.

(Continued to page 218)

POPULAR MECHANICS

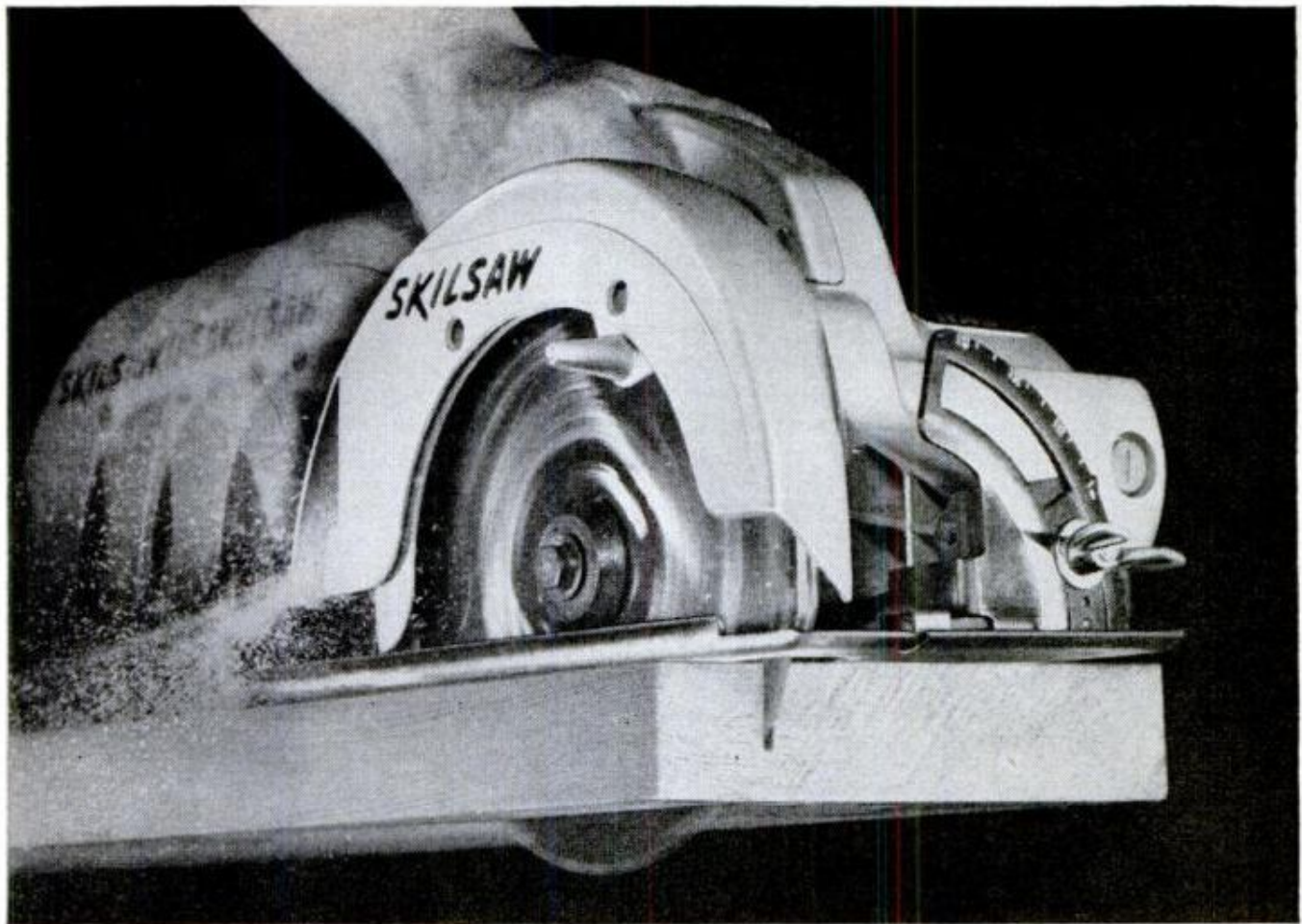

New 7 $\frac{1}{4}$ " Saw... more cutting depth!

Only \$59.95 for New Skilsaw 7 $\frac{1}{4}$ " Model with over 1 $\frac{1}{2}$ hp motor for heavier duty jobs and toughest rip cuts

No other saw compares in cutting performance and value with this genuine Skilsaw Power Saw. Its full 7 $\frac{1}{4}$ " blade cuts 2" lumber at 45°—even after repeated blade sharpenings. And with a big motor—over 1 $\frac{1}{2}$ hp—it handles even the toughest cutting jobs with ease.

Here are other professional-quality Skil features you get with this new saw: • Heavy-duty quadrant and ribbed shoe for extra rigidity and accuracy at any cutting angle or depth • Ball and anti-friction bearings throughout • Ejector system directs sawdust away from operator • Heavy-duty 1 $\frac{5}{8}$ " safety clamp blade washer • Vari-Torque safety clutch disengages blade if it binds in cut • Bind-free lower blade guard can't jam even on compound miter cuts.

See the new Skilsaw 7 $\frac{1}{4}$ " Model 537 at your hardware or lumber dealer . . . compare it feature for feature . . . see why it's your best buy!

SKILSAW \$49⁹⁵
6 $\frac{1}{2}$ " model



World's largest selling saw! Over 1 hp motor, cuts 2" lumber at 45° bevel.



...and SKILSAW POWER TOOLS

Skil Corp., Chicago 30, Ill. Prices higher in Canada

In any recording there is some undesirable noise. The trick is to make the program signal so strong that a gap is created between music and noise levels. This permits you to drop out the noise without losing part of the music. The lower the signal-to-noise ratio, the harder this is to do. And signal-to-noise ratio is inherently lower with smaller track width.

For 7½ i.p.s. operation, this track-width problem is licked by special head design. But even this can't completely eliminate the problem at 3¾ i.p.s. The slower speed also creates special distortion difficulties where extreme high frequencies are involved.

All in all, tape recorded at 3¾ i.p.s. at the present state of the art suffers enough from distortion and from limited frequency and volume range to make it a second runner to stereo discs in the quality sweepstakes. Since discs have problems of their own, including their classic snaps, crackles and pops, 7½ i.p.s. tape remains the quality king of them all.

Most experts see the cartridge as strictly a mass-market product, not really suited to the true high-fidelity market. Could be. But a stereo cartridge recorder costs about \$299.50. Compare that with the price of a package stereo phonograph. Besides, for about the same price you can

get a good reel-to-reel tape recorder, one that gives you a choice of either top audio quality or cartridge quality with twice the playing time for the tape dollar.

Even the cheapest cartridge player costs over \$100. Since such a player must be used with an external preamp-amplifier combination, its price has to be compared with that of a stereo record changer. That means you pay \$30 to \$40 more for the privilege of using tape cartridges instead of the better sounding discs.

When all is said and done—barring startling new developments—it's probably a safe bet that cartridges will never seriously challenge stereo discs for the mass music-lovers market. It's an equally safe bet that the new quarter-track, reel-to-reel recorders are going to make a lot of new friends for stereo tape. ★ ★ ★

Answers to TOOL IQ, Page 183

- 1.—Double Caliper.
- 2.—Fence Builder's Adze.
- 3.—Bit Stock.
- 4.—Coachmaker's Saw.
- 5.—Cooper's Howel.
- 6.—Gouge.



STOP RAKING... START LIVING

ROTO SWEEP

Parker

LAWN SWEEPERS



Fall leaves disappear as you stroll. Saves back-breaking hand raking. Sweeps grass clippings, twigs and stones for total cleaning of lawn, patio, and drives. See your dealer for a demonstration.

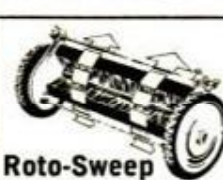

Roto-Sweep



Traillette



Electro-Sweep



Springfield



Homemaster



Parkerette 20" and 28"



THE PARKER SWEEPER CO., SPRINGFIELD, OHIO

POPULAR MECHANICS

The easy way to remove paint



If you think paint removing is a tough job, try Wonder-Paste. With this deep-penetrating remover, the toughest coats of paint, enamel or varnish come off clean in one easy stroke of your putty knife. Great for woodwork, trim and furniture because it does not drip off upright surfaces. Harmless to hands. At paint and hardware stores. Send 25c for illustrated Refinishing Manual or write for free Wonder-Paste folder.

Wilson-Imperial Co., 118 Chestnut St., Newark 5, N.J.

WONDER-PASTE Over 6 million cans sold

ADJUSTABLE MITER BOX & CORNER CLAMP



No. 44
COMBINATION
MITER BOX AND
CORNER CLAMP

Holds the wood and holds your saw. Uses any hand saw for accurate cuts from 0° to 180°. Full 3" capacity. Sides of joints exposed for nailing.

\$2.75 ppd.

No. 33 Works the same as No. 44, but without saw guide adjustment.

\$1.75 ppd.

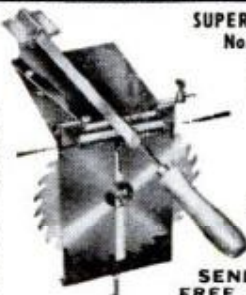

SUPER FILER
No. 11

For both hand and circular saws. Steel rollers give all teeth correct bevel, pitch and cut.

\$9.95 ppd.

SEND FOR FREE Catalog.

A. D. McBurney, 5908 Hollywood Blvd., Hollywood 28, Calif. Dept.: A-90

The PM

HOUSE OF BUILT-INS

highlights a big

ANNUAL HOME ISSUE



NEXT MONTH

SEPTEMBER 1960

Soldering's a cinch...



with a *Weller*® Dual Heat SOLDERING GUN KIT

Only Weller has Dual Heat! 2 trigger positions give low 90-watt and high 125-watt heat as your job requires. Tip heats instantly, has superior heat transfer and long reach. Spotlight eliminates shadows. Result... soldering is simple, sure and fast. Kit includes cleaning brush, soldering aid and solder.

Model 8200K **\$795**

You'll have many uses for this Weller Gun



APPLIANCE REPAIRS



HI-FI KIT ASSEMBLY



MENDING METAL



HOBBIES AND CRAFTS

Weller Dual and Single Heat Soldering Guns from 100 to 275 watts are available at your Hardware or Hobby Dealer.

WELLER ELECTRIC CORP., EASTON, PA.

219

We're Listening for Other Worlds

(Continued from page 85)

electrical discharge (lightning), a reproducing molecule was changed into a reproducing cell. And from this humble beginning evolved 10 million species, including man, who now is able to speculate the odds that a similar process occurred elsewhere in the universe.

According to this view, the same process not only is possible, but inevitable, on other planets with similar environments.

"Life is probably the inevitable consequence of chemical evolution wherever physics, chemistry and climatology are right," says Harlow Shapley.

Such conditions can be right only on certain planets. The planet must circle at least a second-generation star (to provide the heavier elements necessary to life). It must have water. It must have a steady temperature over a long period of time to permit a molecule to evolve into a brain. The temperature must not only be steady, but within a narrow range.

(The Earth's extreme annual variation in temperature is about 250 degrees F. The hottest temperature ever recorded is 136 degrees, and the coldest minus 124. At any given point on the land area of the Earth, though, the difference between the highest and lowest temperatures of the year averages about 100 degrees).

Spores Might Spread Life

Can life spread through the universe, without originating on each suitable planet? Research proves that spores can live for long periods in an environment similar to space. Melvin Calvin of the University of California has studied meteorites and found no evidence of life. But he has found large organic molecules similar to those that may well have evolved into life on Earth.

A more fascinating theory is expressed by Prof. Thomas Gold, director of the Cornell University Center for Radiophysics and Space Research. He feels that life may well be hitchhiking from planet to planet. Perhaps in 50 or 100 years, he points out, we may be able to visit planets of other suns. On those distant worlds we will inevitably leave behind viruses which, in a suitable environment, may evolve someday into intelligent life. Perhaps in a billion years the descendants of "our" viruses will be intelligent creatures able to spread life to still other planets. The startling implication of this "contamination" theory is that we are descended from viruses left behind by space travelers of the past!

Both the "contamination" theory and the "inevitability" theory presuppose a planet with a suitable environment. What evidence do we have that there are such planets—in effect, twins of the Earth?

Most of the evidence involves mathematical probability. Of our own galaxy's 100 billion stars, for example, astronomers say that 10 percent are twins of our sun, essentially identical in size, luminosity and chemistry.

They also rotate slowly. Dr. Otto Struve, Director of the National Radio Astronomy Observatory (and Drake's boss), originated the now-accepted theory that a slowly rotating star is strong evidence that the star has a covey of planets. According to the theory, the planets sap much of the star's original rotational energy.

If you assume that each "twin" of our sun has only five planets (our sun has nine) you come up with a figure of 50 billion planets in our galaxy alone.

How Many Suitable Planets?

Now carry this numbers game a little further. How many of these planets are the "right" distance from their suns, and are able to support life? Dr. Harold Urey of the University of California estimates that life exists on at least 100,000 of these planets. Other scientists consider this a conservative figure, and their estimates range up to a million planets upon which life exists *right now*.

Drake states that within 100 light-years of our sun (our "near neighborhood" by astronomical standards), it is highly probable there is intelligent life. "Within the galaxy, it's virtually certain," he says.

Stars have various ages. Therefore, various levels of life must exist on their planets. Thus we can expect degrees of intelligence both superior and inferior to our own.

It is from the superior beings that Dr. Drake expects his signal. Such creatures, according to P. Morrison and G. Cocconi of Cornell (who have done much of the preliminary study in this field), must look upon our Sun as a likely candidate for a scientific community. They are anticipating some signal from us. Indeed, they may already be aware of our presence.

"Certainly," says Dr. Struve, "at the present time man-made production of powerful beams of radio-radiations has produced a change in the physical properties of the Earth that could be detected from a distance of 10 or 20 light-years."

Such beings, say Morrison and Cocconi, will already have set up a channel of com-

(Continued to page 222)

*Aluminum Paint
now in colors!*



Paint an aluminum roof onto your home

Here's a tough, weatherproof, metallic shield you brush, spray, or roll on: paints and roof coatings made with Reynolds Aluminum Pigment, now offered in colors.

The aluminum flakes in these paints and coatings form a continuous protective shield over the surface—weatherproofing, protecting, beautifying.

They'll help prevent rust, corrosion and decay on metal, masonry or wood surfaces. And they'll reflect the sun's radiant heat for better insulation.

Write today for names of leading brands: *Reynolds Metals Company, P.O. Box 2346PB, Richmond 18, Va.*

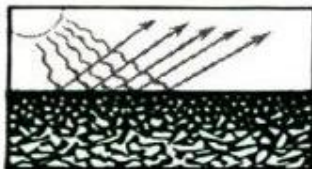

Aluminum flakes form protective shield on coated surface.

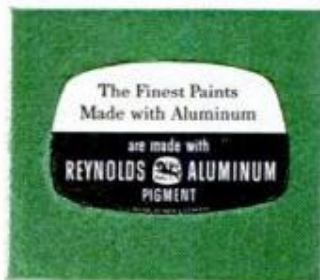

REYNOLDS ALUMINUM

Watch Reynolds new TV show "Harrigan & Son", Fridays, starting October 7; also, "All Star Golf", Saturdays, resuming October 15—ABC-TV. And on Sunday, October 16, be sure to see the exclusive showing of America's new 1961 cars on The National Automobile Show, direct from Detroit over CBS-TV, 6 to 7 P.M. EDST.

BUILD THE BEST ELECTRONIC EQUIPMENT



it's fun to build
years-ahead money-saving

knight-kits®

A PRODUCT OF ALLIED RADIO

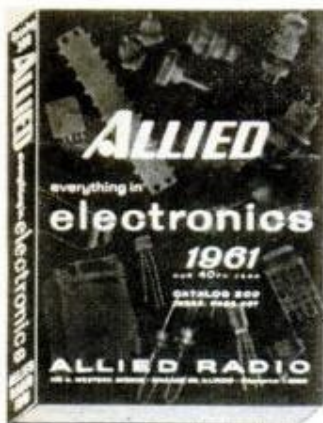

featured in the

ALLIED

Big 444-Page 1961

ELECTRONICS
CATALOG

free

build-your-own..
it's easy..it's fun



KITS FOR
ANY NEED

Hi-Fi
Hobby
Instrument
Amateur

SAVE UP TO 50%

See the exciting 1961 line of KNIGHT-KITS—available only from ALLIED. They're lowest in cost, convenience-engineered for easiest assembly, outstanding for performance—the only kits offered with Free Inspection Privilege. Send today for the 1961 ALLIED Catalog—select your KNIGHT-KITS—and...

SAVE ON EVERYTHING IN ELECTRONICS



Get more for your money in: Stereo hi-fi systems and components • Recorders and tape • Amateur station equipment • Citizen's 2-way radio • TV tubes, antennas, accessories & test instruments • Electronic parts, tubes, transistors, tools • Send today for your FREE 444-page 1961 ALLIED Catalog!

only \$2 down
on orders up to \$50

FREE
catalog



ALLIED RADIO

ALLIED RADIO, Dept. 24-J
100 N. Western Ave., Chicago 80, Ill.

Rush FREE 1961 ALLIED Catalog.

WORLD'S
BIGGEST!

Name _____

Address _____

City _____ Zone _____ State _____

munication. The only known way to transmit a signal through space is by electromagnetic radiation. The complete spectrum of such radiation covers everything from very short cosmic rays through visible light to very long radio waves. Only radio waves, so far as we know, can be "manmade" and transmitted for great distances. Thus we should start listening for a radio signal from our intelligent other-world neighbors.

At what wavelength? Ask any astronomer or physicist to specify a "universal" wavelength and he will immediately suggest 1420 megacycles. This is the radio-emission line of hydrogen—the "parent" element of the universe.

Scientists have developed a relatively new and extremely sensitive instrument for "listening" to radio signals. It is the radiotelescope, which can focus on the radiation emitted by stars and clouds of interstellar dust.

Radiotelescopes Unbelievably Sensitive

The sensitivity of the radiotelescope is difficult to believe. Here's an example cited by Dr. Drake: To us, the strongest radio source in the heavens, with the exception of our own Sun, is a star called Cassiopeia A. This "strong" star sends the total surface of the Earth about 50 watts of radiation—just enough to light a standard bulb. The amount of this energy falling on the dish of a radiotelescope is infinitesimal, yet the scope can focus on the power source and come up with a meaningful analysis of the radiation.

Indeed so sensitive are today's radiotelescopes that they can record what actually occurred 10 billion years ago.

In your imagination, transport one of our existing radar transmitters 100 light-years out into space. Now turn the radar until its signal is beamed toward your old home planet. A hundred years later the signal will be detected by a 600-foot radiotelescope, similar to the one the Navy now is building at Sugar Grove, W. Va.

Within 100 light-years of Earth are more than 10,000 stars, and at least 10 percent of them are twins of our Sun. The odds are high that some of these planets support rational beings. Still playing the odds, half of these civilizations are more advanced than our own. Our most powerful transmitter on Earth today is about one megawatt. Therefore we can assume that half the other-world beings will have a transmitter at least this powerful. All they have to do is ring us up on the radiotelescope.

The 85-foot scope which Dr. Drake is using at Green Bank can detect signals

(Continued to page 224)

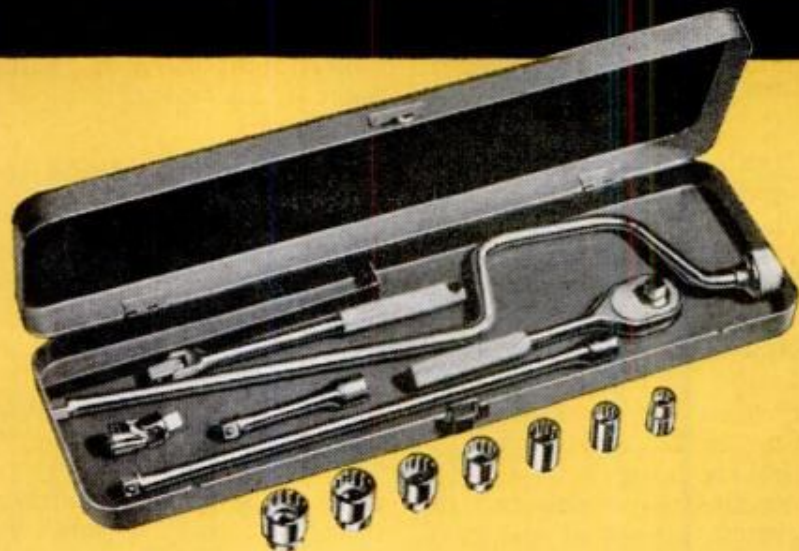

PROTO 3/8" DRIVE SOCKET SET NO. 5200AB— A beautiful basic socket set for the amateur or professional mechanic, with the most needed sockets, handles and attachments. All forged or hot formed in Protoloy® alloy steel for professional performance; heavy chrome plate; all guaranteed. Contents: Seven 12-point Sockets—3/8" thru 3/4" opening. 7" Ratchet. 3 1/2" and 12" Extension. 7 3/8" Hinge Handle. U-Joint. 16 7/8" Speed Handle. In Red Steel Box with extra space for other tools.

Get yours at your local Proto Hardware or Auto Parts Dealer

PROTO TOOLS
PROFESSIONAL QUALITY TOOLS

Division of Pendleton Tool Industries, Inc.

2202 Santa Fe Avenue, Los Angeles 54, California • 502 Allen Street, Jamestown, New York • 1702 Oxford East, London, Ontario, Canada



Treatment Plant on Truck Converts Helium Into Liquid

Mounted on a truck, the U.S. Navy's new helium liquefier rolls around Lakehurst Naval Air Station, N.J., where the helium is used in a variety of experiments. The mobile liquefier can convert 45,000 standard cubic feet of helium into its liquid state each day. The liquid has a temperature of -452 degrees F. Among other things it is

used as a pressuring and purging agent in many liquid-fueled missiles because it does not combine with other elements. Since there are increasingly more uses for the super-cold liquid, the Navy is studying the economics of transporting helium in this state. The liquefier is the prototype of a larger unit which may be built.

from a one-megawatt transmitter up to about 30 light-years away. Within this close neighborhood are two stars that seem likely candidates. They are Tau Ceti and Epsilon Eridani.

In April, Dr. Drake began pointing the 85-foot scope alternately at these stars. Specifically what he looked for was a pattern of bumps on a pen-traced graph. If a signal is received, there's not the slightest doubt that it will be recognized. All other cosmic noise is random, formless, without pattern.

No elaborate schedule has been laid out. When the project began, Dr. Drake tried to pick up a signal for six hours a day for a month or so. Then the scope was put to other use, but will be aimed at the two stars again later. Drake is convinced that the search will go on, by fits and starts, at Green Bank or elsewhere, until a signal is picked up.

Other scopes may join the search. The 600-foot Navy receiver, for example, could pick up one-megawatt messages from at least 60 light-years away, and the 1000-foot bowl planned for the Puerto Rican hills could hear a message across more than 100 light-years. Within this region there are about 10,000 stars.

What will happen when an intelligible signal is detected? What a field day for

headline writers—the greatest news story of all time. It's a safe guess that the highest government officials and scientists will meet in hasty conferences to decide what to do.

Should We Answer?

The question has even been raised: Should we answer at all? Cal Tech's Albert Hibbs has said that the risks of reply are "just terrible." In the eyes of such out-of-this-world creatures, he points out, "we may be the finest beef animals ever."

But Dr. Drake feels that we can't help but answer. "In any case, remaining silent will not protect us," he says. "We already radiate signals sufficiently strong to be detected by another intelligent community. If we wanted to remain hidden, it's too late now—already we have broadcast our presence."

The most powerful transmitter on Earth, very likely, will be focused on the invisible citizens of the distant world. A two-way conversation will start. It won't be neighborly gossip, though. Any question we ask of a citizen of Tau Ceti will take 11 years to reach his ears (if he *has* any ears!) and another 11 years for the reply to arrive.

According to Dr. Drake, the language barrier won't be insurmountable. "What

(Continued to page 226)



New from Wolverine!

WORLD'S LIGHTEST SERVICE SHOES

Most comfortable ever! Weigh a pound less than ordinary work shoes. Their exceptional lightness is so easy on the feet. Uppers are flexible elk-tanned leather . . . soles are springy, oil-resistant, neoprene cushion crepe, nearly three-quarters of an inch thick. Steel shanks, of course. And smart sports styling plus handsome Burgundy color add good looks to the comfort.

WOLVERINE
ROCKFORD, MICHIGAN

Service Oxfords
Boots

Work Shoes
Safety Shoes



Wood Carvers!

"HERE'S THE
NEWEST
IN THE
CARVING FIELD!
\$10.95 PER SET!
OVERALL LENGTH OF
EACH TOOL 6 1/2".
PLASTIC HANDLES



6 PIECE CARVING SET

Most Complete Line of Chisels and Gouges

CATALOG
AVAILABLE!"

BUCK BROS. INC.
RIVERLIN WORKS MILLBURY, MASS.

Use Appliance Motors in the Workshop!



Now you can take end-mounted motors (major appliance type) and use them with your power tools. It's economical and easy with a sturdy LEWACO Motor Holder. Adjustable up to 1/3 H. P. **\$175** ppd. ONLY.....

Order PM-104 from:

LEWACO, Box 237, Mound, Minn.

FREE POWER TOOL CATALOG

Get the right tool for the job! Write:

World's largest
maker of
electric tools

Black & Decker®
Dept. D-090 Towson 4, Maryland

Nature-Made Radio Pipeline May Spur Intercontinental TV

Intercontinental television could become a reality with discovery of a nature-made pipeline. An experimental program by the United States Navy and Air Force shows that there is a sort of radio pipeline about 5000 feet above the South Atlantic Ocean. About 500 feet thick, it is described as an atmosphere duct capable of trapping and transmitting radio waves at a low loss. The Air Force research center said it might be possible to send radio voice or television-type signals from England or Europe to Spain and from there to French West Africa for transoceanic transmission. The United States would be linked by oceanic duct with Puerto Rico.

Vinyl-Based Solid Rocket Fuel

Fire-resistant vinyl plastic is now being used in a compound to provide a solid fuel for rockets. In the propellant, polyvinyl chloride reacts with ammonium perchlorate with a powerful release of energy. At present, the manufacturer is casting the solid fuel propellant, using molds to shape the mix to the design required for a particular rocket.

SEPTEMBER 1960

THE EASIEST WAY IN THE WORLD TO DRIVE AND REMOVE SCREWS

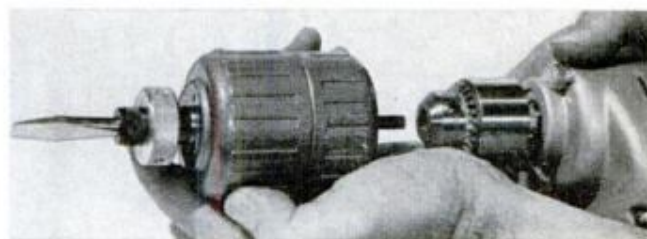

1. After drilling pilot holes simply attach a Versamatic to electric drill. Fits any make.

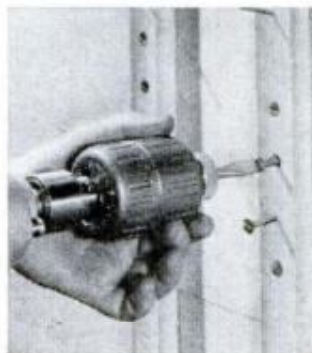

2. Place screw in hole; drive it easily with slight forward pressure . . . hold housing in fingertips.

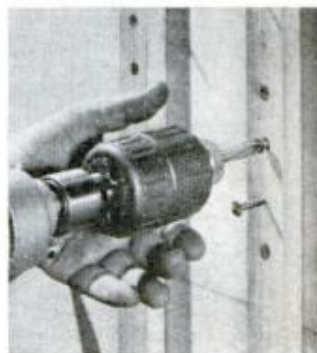

3. Your fingers act as a clutch . . . starting, stopping action instantly. Simple and safe . . . no blisters.

Versamatic puts your power drill into low gear . . .

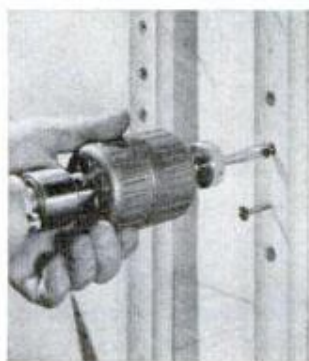

4. Versamatic runs in reverse for removing screws. You won't believe how easy it is until you try it.

by means of 7 to 1
speed reduction.
Gives your drill 7
times more power.

Supreme Versamatic

MADE BY THE MAKERS OF
SUPREME BRAND CHUCKS

**SUPREME PRODUCTS
CORPORATION**

2222 S. CALUMET, CHICAGO

Sold by leading tool dealers...\$14.95 list

PRECISION  PRODUCTS

225

Any man will enjoy new

AIROGRATE

YELLO-BOLE

1. Smokes sweeter!

Imported briar bowl lined with *real honey*. Starts caking the instant you light up. Hence, no break-in.



2. Smokes drier and healthier!

Metal grate condenses moisture, tars, nicotine. No wet heel.

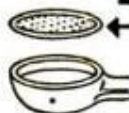

3. Smokes cooler!

Air-vented chamber draws in fresh air. Aluminum fins and shank throw off heat, cool the smoke.

Famous honey-lining!

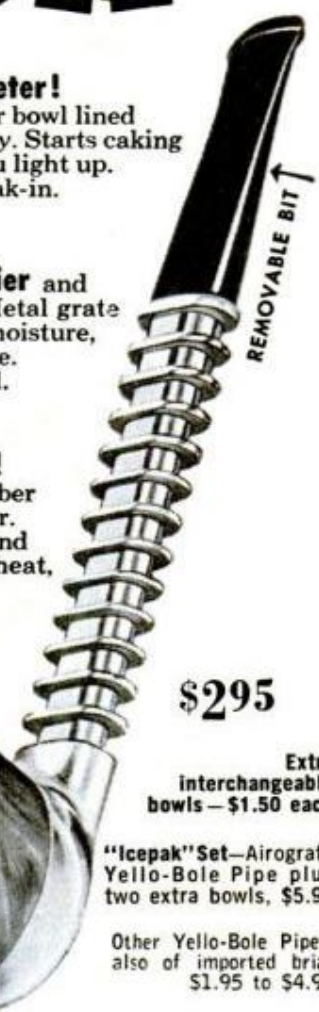
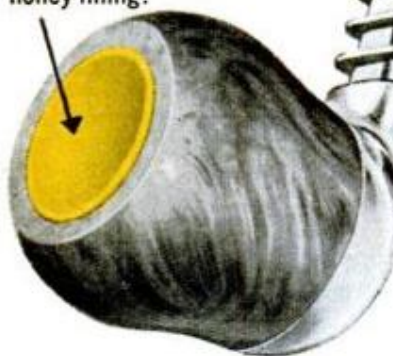

\$295

Extra interchangeable bowls — \$1.50 each

"Icepak" Set—Airograte Yello-Bole Pipe plus two extra bowls, \$5.95

Other Yello-Bole Pipes, also of imported briar \$1.95 to \$4.95

Send for FREE FOLDER, YELLO-BOLE PIPES, Inc., Dept. Y92 N. Y. 22

EMERSON ELECTRIC

NEW POWER For Your Tools...

There's an Emerson Electric Motor for every tool... sanders, saws, joiners, pumps, lathes, drills, buffers, etc... Home workshop or commercial. Operate in any position... exclusive dust-proof contact points. One year guarantee.



multi duty MOTORS

Write today for prices and FREE MOTOR SELECTOR GUIDE... tells you the exact motors you need for your tools.

EMERSON ELECTRIC of St. Louis
8100 Florissant • St. Louis 36, Mo.

we need," he says, "is a cosmic Rosetta Stone—something that, so far as we know, would be universal, and could be decoded by a scientific mind anywhere. It could be a sequence of prime numbers, or a coded version of the periodic table of elements, or the laws of physics. Once such a message is interpreted, a common language could be built upon this base."

Eventually he feels the best transmission would be television pictures. The transmission would be quickly recognized as a pattern, and analyzed. It would be simple today for Earth scientists to solve such a pattern and build a receiver suitable to convert the signal into a picture. Presumably the advanced minds at the other end of our messages could do the same.

Dr. Drake sees tremendous advantages in such an "interview." Have these other-world beings harnessed fusion energy? Do they have cancer? How have they solved their own social problems?

Perched on his mountaintop, Dr. Drake is seeking a "hello" from a kindred mind in outer space. The work may go on spasmodically for generations.

But even in his secluded laboratory, Dr. Drake cannot escape the problems of his own world. As you enter his office, you notice a small sign on the door.

It asks: "Is there intelligent life on Earth?" ★ ★ ★

Do You Know This Old-Timer?

(Answer to quiz, page 18)



1904 Darracq
(FRENCH)

FREE! FREE! FREE!



714 RIFLES AND SHOTGUNS

Now you can be the proud owner of a new gun from H&R, renowned for quality firearms since 1871! With superb handling qualities, these light weight guns are designed by the manufacturer of the world famous M-1 and M-14 military combat rifles. The first 357 winners receive a model 402 pump action .410 shotgun. The next 357 winners get a "Plainsman" .22 caliber bolt action repeating rifle complete with five shot magazine. Both are perfect companions for the outdoorsman, and one of them can be yours absolutely free!

For your free H&R catalog, mail the coupon below.

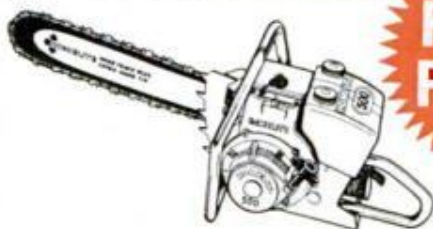

HOMELITE CHAIN SAW OF YOUR CHOICE

Set your sights on the quality line of Homelite chain saws . . . one of them can be yours free! There's the new light weight Homelite 500 direct drive, for general cutting around your farm or camp . . . or perhaps you'd prefer the new gear-drive Homelite 900-G with all the power you need for felling trees up to 10 feet in diameter. There are eight models to choose from, one for every woodcutting job. Take your pick!

For complete information about the new full line of Homelite chain saws, mail the coupon below.

FIRST PRIZE



\$4,000 MOHAWK VACATION LODGE

Here's the answer to your vacation dreams! Designed especially for Homelite by Henry Bickford, President of the Mohawk Log Cabin Company, it includes a living room, bedroom, kitchen, bath and front porch . . . truly a vacation-built-for-four. It is completely insulated, has a knotty pine finish and includes a fireplace-stove.

For more information about Mohawk Log Cabins, mail the coupon.

WIN

- * \$4,000 Mohawk Vacation Lodge
- * Homelite Chain Saw of your choice
- * 714 H & R Rifles and Shotguns

SHOOT THE WORKS WITH HOMELITE

Ever dreamed of living it up? Here's your chance! Now you can win this vacation lodge for four plus your choice of a famous Homelite chain saw in Homelite's exciting new "Shoot the Works" contest. 714 other prizes consisting of Harrington and Richardson rifles and shotguns.

IT'S EASY! IT'S FUN! IT'S FREE!

Here's all you do to obtain your free copy of the "Shoot the Works" contest rules and entry blank — stop in at your nearby Homelite dealer's or write to: Homelite, "Shoot the

Works Contest," Port Chester, N. Y. Then, fill in the entry blank, stamp and drop it in the mail.

That's all there is to it! Nothing to buy, no obligation. Don't wait, get your entry blank today. You'll find your Homelite dealer in the Yellow Pages under "Chain Saws."

HOMELITE

A DIVISION OF TEXTRON INC.
609 Riverdale Avenue, Port Chester, New York

Harrington and Richardson, Inc.

383 Park Ave.
Worcester 10, Mass.

Please send me your new catalog of H&R rifles, shotguns and revolvers.

Name.....
Address.....
City.....State.....

HOMELITE

A DIVISION OF TEXTRON INC.
1-9 Riverdale Avenue
Port Chester, New York

- Please send information about the new full line of Homelite chain saws.
 Please send me the name of my nearest Homelite dealer.

Name.....
Address.....
City.....County.....State.....

MOHAWK Log Cabin Co.

136 West 42nd Street
New York, N. Y. Dept. 383

- Please send me more information about the "Shoot the Works" Vacation Lodge.
 Please send me full information about a cabin for people.

Name.....
Address.....
City.....State.....

NEW "100" SERIES ELECTRIC TACH!

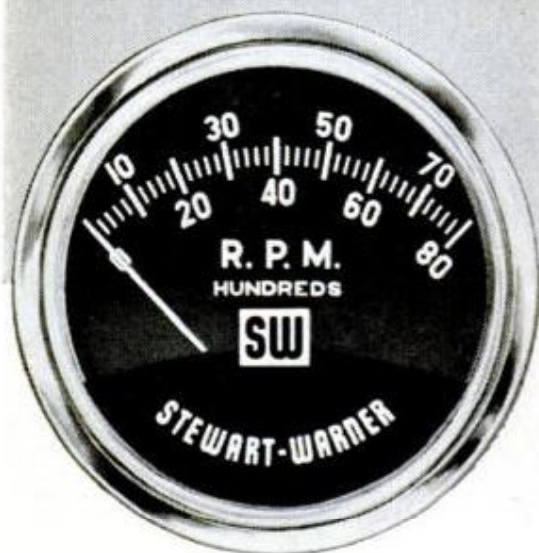

New precise readings through highest engine speeds! Easy-to-read dial with black face, white numerals and pointer pin-points engine performance . . . for "speed" shifting . . . peak operating efficiency and economy.

New standards for dependability . . . accuracy. New design eliminates pointer waver. There's no chance of over-run or pointer lag. You get precise readings that help prevent engine lugging. The result: lower maintenance costs and less power loss!

New, fast, do-it-yourself installation with deluxe top-of-dash, steering post or panel mounted models for 4, 6 and 8-cylinder engines; 6 and 12-volt battery ignition systems; 0-5000, 0-6000 and 0-8000 dial scales. Case size is 3 $\frac{1}{2}$ inches in diameter. Simple wiring connections mean quick, reliable do-it-yourself installation.

For details see your
Stewart-Warner Dealer or write:

Symbol of
SW
Excellence
INSTRUMENT DIVISION
STEWART-WARNER
CORPORATION
Dept. AM-90, 1840 Diversey Pkwy., Chicago, Ill.

Under-Window "Defroster"

(Continued from page 157)

as neatly as you can, avoiding studs by checking beforehand. The hardboard collar will cover any raggedness of the hole. You can spot the approximate location of the opening in the outside wall by drilling a pilot hole through from the inside. A key-hole saw is used to cut through the siding and sheathing. Before installing the defroster in the wall it is a good idea to paint the pipe with asphalt paint. Then smear some spackling compound on the back side of the hardboard collar and press it in place against the wall. An aluminum collar is pressed over the end of the pipe on the outside wall and caulked. A choice of patterns is given for the hood which is cut from sheet aluminum and riveted together as shown. The top edge of the hood is forced up under the siding, centering it over the inlet pipe and then nailed to the siding with four aluminum nails. ★ ★ ★

QUOTE:

"In science, particularly, the tendency more and more has been to penetrate farther and farther into chosen subjects until specialists dig themselves deep out of sight, out of hearing, out of understanding of what other scientists are doing in their own and neighboring fields. And, if this state of affairs is alarming, even more alarming is the growing cleavage between science and scientists as a whole and the great mass of humanity in other callings."

—T. KEITH GLENNAN
Administrator, NASA

Answer to Electric-Circuit Puzzler

(Page 186)

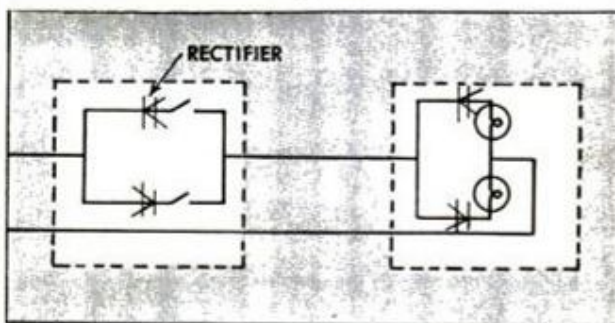

How is it done? It's simple. The single 110-volt circuit actually is converted to three separate circuits by employing four selenium rectifiers, one in series with each bulb and one in series with each switch, as shown in the diagram above. The seven-watt pilot bulbs allow the use of small rectifiers.

An Idea for Taillights

Dr. Howard D. Garber of Los Angeles, an optometrist, proposes something new in taillights to avoid rear-end and chain auto collisions.

"The vastly increased area of auto windshields enables one to view one car through another, several cars ahead, depending on road conditions. If the taillights of all cars were at higher positions (as illustrated)

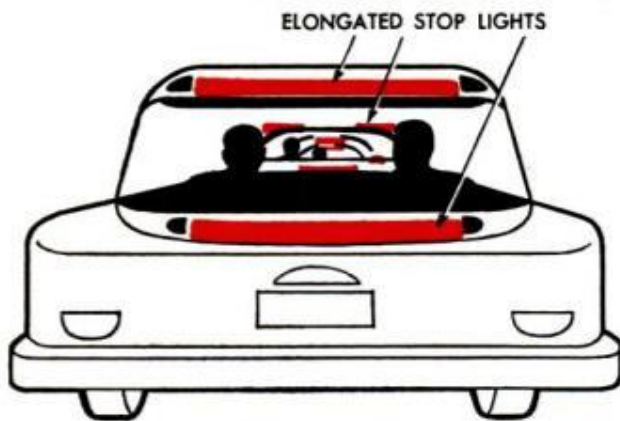

one could observe not only the tail signal lights of the car immediately ahead, but signal lights further ahead, particularly at night. This would reduce our dependency on the reaction time of the driver immediately ahead in applying his brakes, since warning of halting traffic would come from taillights visible further ahead."

GUNK® degreases

At better automotive supply and hardware retailers everywhere.



Cleans engines, garage floors, power mowers, greasy walls economically and safely. In aerosol or pour spout cans.



GUNK CHICAGO CO., River Forest, Illinois
serving the Midwest and Southwest
RADIATOR SPECIALTY CO., Charlotte, No. Carolina
serving the East, Southeast and far West

PROTECT YOUR CAR WITH

Latest and best automotive products —you'll find them advertised in PM.

IF YOU WANT TO WORK IT YOU HAVE TO HOLD IT

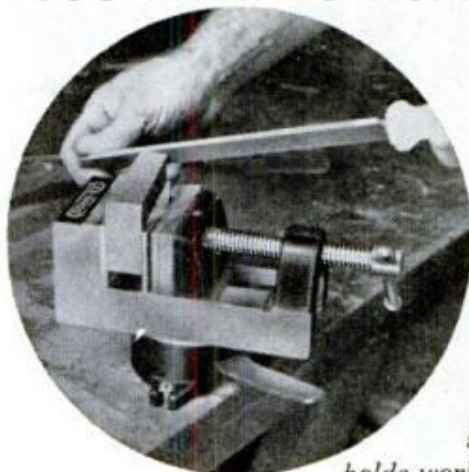

Stanley-Yankee swivel vise holds work on bench

This Stanley-Yankee vise is adjustable all along length of base with simultaneous swivel feature. Removes easily from swivel base for machine work. Available in two sizes—2¼ and 3" jaws.

Other Stanley-Yankee vises are angle vise, swivel-tilt vise and vise as above without base. Several jaw sizes and prices from \$5.50 up. Ask for Stanley-Yankee vises wherever good tools are sold.

STANLEY

Stanley Tools
Division of The Stanley Works
New Britain, Connecticut

DRAINS cellars, cisterns, wash tubs; **\$7.95**
IRRIGATES - CIRCULATES - SPRAYS

1,001 uses. Stainless shaft. Won't rust or clog! Use 1/8 HP motor or larger . . . 3/4 HP for up to 2,400 GPH; 450 GPH 80" high; or 1800 GPH from 25' well. 1" inlet; 3/4" outlet. Coupling included free. **\$7.95.**

HEAVY DUTY BALL-BEARING PUMP. Up to 5,200 GPH; or 3,000 GPH from 25' well. 1 1/2" inlet; 1" outlet. **\$12.95** Postpaid if cash with order. **MONEY BACK GUARANTEE**

Centrifugal and Gear Pumps in All Sizes
LABAWCO PUMPS, Belle Mead 7, New Jersey

If it's worth painting it's worth sanding . . . with sandpaper by



CARBORUNDUM®



WELD FOR PLEASURE OR PROFIT TRINDL INDUSTRIAL ARC WELDER

Own a Trindl 125 Amp Industrial Welder at less than smaller machines. Welds metals to 1/2" thick. Operates off properly wired 110 or 220 volt line. 16 heat stages from 20 to 125 amps. Make, repair anything of metal in the home, garage, farm or shop. No experience or training needed. Full "do-it-yourself" instructions. Guaranteed 12 months in continuous operation. Complete only \$98.50 FOB or write for details on 125A and other Heavy Duty Trindl Welders. Dealer Inquiries Invited.

Trindl Products, Ltd., Dept. T2-J, 1807 S. Clark St., Chicago 16, Ill.



EASY TERMS
\$98.50 FOB

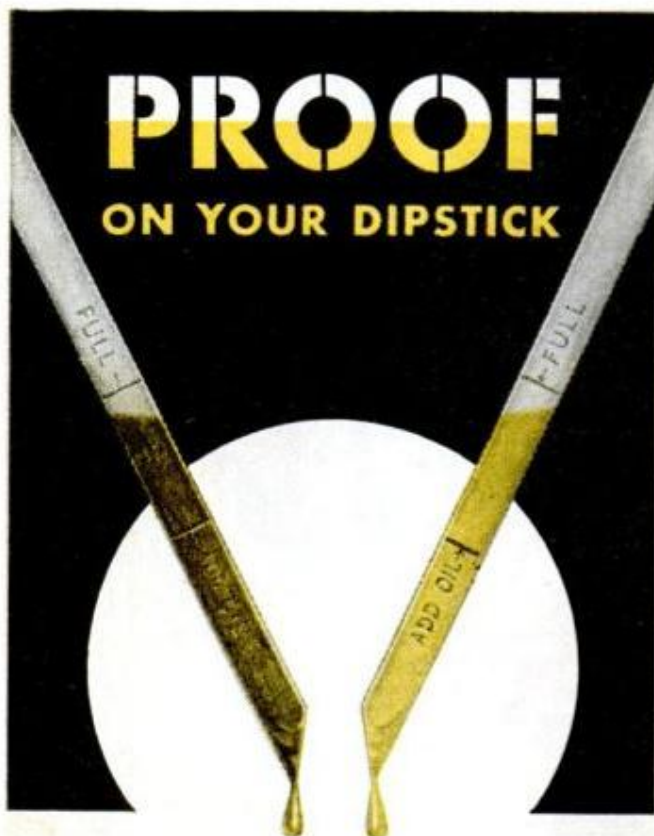

Hastings keeps oil clean

Oil shows dirty? Dirt is abrasive and dirty oil causes wear. Get full-time protection—ask for Hastings Oil Filter Cartridges, and have *clean oil* from filter change to filter change.*

The Hastings DENSITE filtering material traps and holds all the dirt, even the most microscopic size particles. And, *only* Hastings has Densite.

Hastings Cartridges assure clean oil—less engine wear and less subsequent repair bills—as no other filter can. See for yourself . . . on your dipstick!

*When replaced as normally recommended



U. S. Patent
Nos. 2797811, 2584711

HASTINGS
OIL FILTER CARTRIDGES

HASTINGS MANUFACTURING COMPANY
HASTINGS, MICHIGAN

Oil Filters, Piston Rings, Casite Additives,
Spark Plugs

This Business of Spying

(Continued from page 100)

the information as to its probability and reliability of the source and flashed it back to General Kuznetsov in Moscow through embassy communications channels. Kuznetsov checked the report against other sources, which confirmed the startling fact of the bomb. He once again graded the information and then brought it to the man who needed it, Joseph Stalin.

The inordinately suspicious mind of Stalin often caused him to doubt well-authenticated intelligence reports, but in this case he took the information at face value and directed that an all-out effort be made to steal the secret. How Red spy nets in the English-speaking nations went to work made intelligence history. Within three months they learned all the needed scientific details, even down to the trigger mechanism and blue prints. Our vaunted security measures proved tragically ineffective. We would never even have learned for sure that the Reds had stolen our secret except that years later, Igor Gouzenko, a cipher clerk at the Ottawa embassy, deserted to our side and told all he knew. Even then we were only able to capture part of the atomic spy ring. The rest are probably still at work systematically gaining information, appraising it and passing it back to Moscow.

Since the early 1930's the accomplishments of Russian spies have been so outstanding that they have earned the begrudging admiration of intelligence students in the free world as well. That the Reds time and again have been able to knife into the free world's inner sanctums is no accident. It is a triumph of careful organization and painstaking preparation. Even under the Czars the Russians, with an annual budget of approximately \$5 million were noted for their concentration on intelligence. Now with a yearly budget estimated as high as \$500 million Russian intelligence is probably the best-heeled, best-muscled and best-nerfed shadow army in the world. The Russians are also fortunate in being able to manipulate the minds and loyalties of millions of native Communists in the free world to obtain the services of dedicated amateurs when the occasion demands.

Whether we are talking about the Red intelligence organization, our CIA, the Secret Intelligence Service of the British, the resurgent intelligence of West Germany, or that of France, Japan, Cuba or any other major or minor power, there are certain things that they all must do.

To begin with there is the matter of selecting potential agents. It takes a peculiar breed of a man to be a spy. As a CIA recruiter put it to an old OSS friend of mine, "Have you met any well-adjusted psychotics lately?" Normal people like to be open about their actions and words. A spy cannot afford to be. He cannot, on the other hand, be deranged or odd, or he will soon betray himself, or at least be incapable of accurately gathering and rating information. He must be capable of withstanding intense loneliness and the unnerving threat of hidden dangers.

A spy must remain cool in a crisis as did a World War II OSS agent who was returning to Bordeaux from Paris. Carrying his suitcase which contained a telltale radio transmitter, he went to the railroad station and found the platform deserted. Prayerfully he got onto a train and took a seat in a compartment. In a moment there was a heel-clicking flourish of protocol and Field Marshall Rommel appeared. Followed by his adjutant, Rommel entered the astounded agent's compartment and sat down. The agent was apologetic. He did not wish to intrude. He was bound for Bordeaux and had climbed aboard the wrong train. He begged the Field Marshal's permission to leave.

"Not at all," replied Rommel graciously. True, the train was for German staff officers, but the army owed it to civilians to share accommodations where possible. He leaned forward and confided that he was making a tour of southern defenses and lengthily discussed his views on Allied bombings. Then, his aide at his heels, he left for another compartment. Soon the adjutant came back. The agent quailed inwardly.

"The Field Marshal would like to know if you would care to join him for tea," the adjutant said. The OSS man calmly sipped his tea with Rommel. When the train reached Bordeaux, he hefted his suitcase and went off on his mission.

As might be expected the coolest agents of all are British. One night a British spy in neutral Sweden bribed the guard and entered the office of the German embassy air attache in Stockholm. He set right to work in a businesslike way copying top secret documents. Then the door opened and to his shock, a Luftwaffe captain walked in. The agent fought down an impulse to plunge through the window and flee. He went right on copying. He sighed wearily over the long hours a man must work. The captain gave him a bored look,

(Continued to page 232)

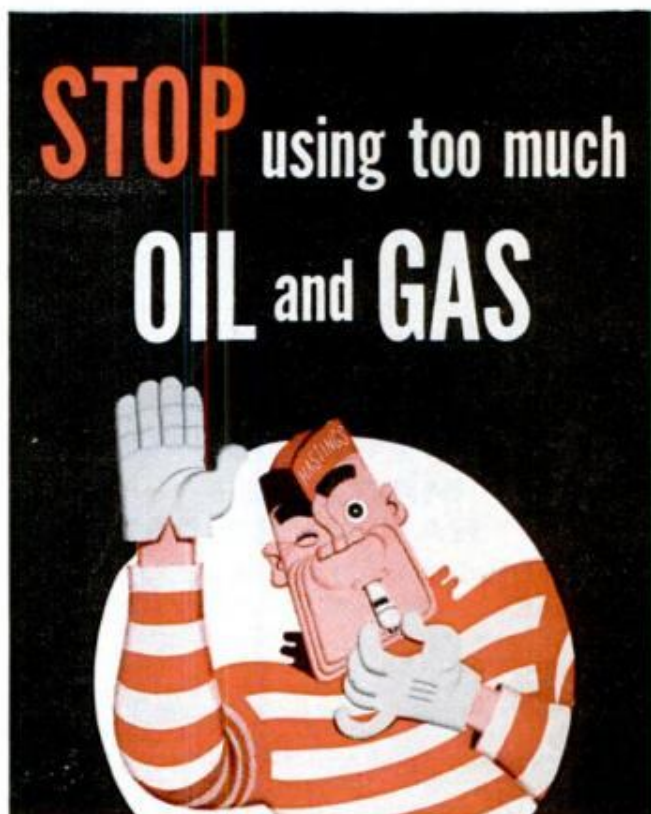

worn out piston rings mean waste oil and gas...power drop-off...costly repairs to come

You can prevent excessive oil and gas consumption . . . restore your engine's lost pep and power . . . with a Hastings re-ring job.

The sooner you act, the less it will cost. See your motor specialist the minute oil-pumping warns you there's trouble ahead. When he says you need new piston rings be sure you get Hastings. They're engineered exclusively for replacement service . . . to provide the additional lubrication worn engines need . . . to stop oil pumping, save gasoline, restore lost performance.

Get new car power and performance from your present car—with Hastings. Truly your best investment for many thousands of extra miles of trouble-free driving pleasure.

TOUGH
on oil pumping
GENTLE
on cylinder walls



HASTINGS
PISTON RINGS

HASTINGS MANUFACTURING COMPANY
HASTINGS, MICHIGAN

Oil Filters, Piston Rings, Casite Additives,
Spark Plugs



NEW MARLITE RANDOM PLANK

*beautiful wood-grain paneling
you can install yourself!*

Add extra luxury to any room with new Marlite Random Plank. The 16"-wide planks are 1/4" thick, tongued and grooved for easy installation. Six exclusive new Trendwood finishes capture the beauty of fine woods in a random-width paneling effect. And Marlite's baked plastic finish resists stains and mars, requires no painting or further protection. See your building materials dealer or write for free decorating book. Marlite Division of Masonite Corp., Dept. 942, Dover, O.

5942

Marlite plastic-finished paneling

ANOTHER QUALITY PRODUCT OF MASONITE® RESEARCH

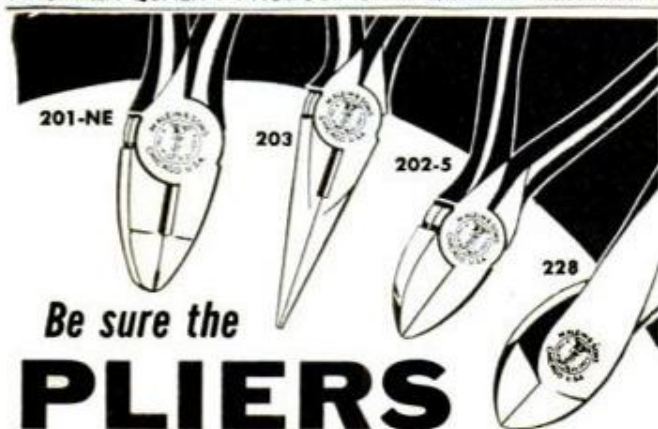

Be sure the
PLIERS
you use are
KLEINS

"Since 1857" the name Klein has stood for the finest in tools. Linemen, electricians and good workmen everywhere prefer Kleins because of the high standard of quality that is back of every pair. Now Klein Pliers are available in a wider selection of styles and sizes than ever before.

Ask your supplier for genuine Klein Pliers or write for a new Klein Plier Catalog.
FREE Klein Plier Catalog. On request.

Mathias KLEIN & Sons
Established 1857 Chicago, Ill., U.S.A.
7200 McCORMICK ROAD • CHICAGO 45, ILLINOIS



went to a wall safe, took out a bottle of Scotch, and left.

A valuable spy might look and act like a congenial businessman intent on nothing more consequential than a deal, but he must be an egghead with courage and determination. Contrary to popular notions, he draws relatively little pay and therefore whether he is a CIA agent or a Red spy he must be motivated above all by his cause or patriotism. No particular profession helps a man qualify as a spy. Lawyers or doctors, for example, may be accustomed to keeping professional secrets, but they do not necessarily make good agents. Journalists are very good at gathering information, but we have the unfortunate instinct to tell everything we know to as many people as we can.

Just how miscellaneous a group a spy net may be was demonstrated when Hitler took over Austria. With the bloodless conquest, an assistant foreman in a print shop emerged from cover as number one Nazi spy. When he called together his apparatus at the chancellery, his 1000 agents were found to include policemen, mailmen, bank clerks, telephone repairmen, businessmen, teachers and government officials. Most were Austrians who favored the Nazi cause.

Some of the most surprising people have been agents. Jumping Joe Savoldi, Detroit Tigers pitcher Tommy Bridges, movie actor Douglas Fairbanks, Jr., explorer and lecturer Nicol Smith and the expatriate White Russian, Prince Serge Obolensky, all served in OSS. Novelist Somerset Maugham was in British intelligence. There is a pretty young matron in the suburbs of a large American city who was once the most dangerous OSS agent in the Middle East. Now she contents herself with innocent intrigues in the local PTA.

Agents must undergo exhaustive testing and training. In OSS we were particularly proud of our psychological testing of agents, and I understand CIA is equally proud of its methods. But it was the Germans who pioneered in this field. They had an impressive testing program as early as World War I. Elsbeth Schragmuller was a German schoolmarm, but her school was not devoted to the three R's. She taught black intelligence and also sabotage which frequently is a spy's sideline.

When a neophyte was brought to her, she locked him in a well-furnished room upstairs. He had a desk he could use for writing, books to read, a comfortable bed, all the amenities of home. But for days on end no one interrupted his loneliness ex-

(Continued to page 248)

POPULAR MECHANICS

Scientists Study Kelp Shortage

Scientists at the Scripps Institute of Oceanography are working to solve the "mystery of the disappearing kelp." The valuable sea algae has declined 75 percent in the water off Southern California in the past few years, and a two-million-dollar industry is threatened. Dr. Wheeler North, biologist in charge of the kelp studies at the Institute, reports that several factors are contributing to its decline. Unseasonably warm coastal waters have caused much kelp to die; it begins to disintegrate when the temperature reaches 65 degrees, and at 70 it dies. Locustlike hordes of sea urchins

are eating whole kelp beds, and scallops are killing even more than the urchins. The scallop larvae attach themselves to the kelp fronds while they are very small, but as they grow bigger, their weight forces the fronds to the bottom, and the plant dies for lack of sunlight. Other factors found in the study were storms, dirty water, and black rot disease. The industry most threatened by the shortage of kelp is the manufacture of industrial chemicals, particularly that of algin, a chemical with many uses in food processing, sizing and dyeing fabrics, and as a thickener for plastics.



The proof is in the puffing

and P. A. has the flavor most favored in the U.S.A.

BILLY GRAMMER
OF "GRAND OLE OPRY"



R. J. Reynolds
Tobacco Co.,
Winston-Salem,
N. C.

- always tastes fresh
- mild, mellow flavor
- cool 'n' steady burning

PRINCE ALBERT

America's Largest-Selling Smoking Tobacco!

SEPTEMBER 1960

233



If your wife is nagging
you about shabby
WOOD FLOORS
Refinish them yourself in
just ONE DAY with



FABULON

the fabulous FLOOR FINISH

Give your floors the armor-like protection of FABULON, the original "bowling-lane" finish for home use. Applies easily with brush or roller. Your wife will love her FABULON-ed floors. ..NO MORE WAXING OR SCRUBBING. At paint, hardware and lumber stores everywhere. For comprehensive manuals on all phases of wood finishing, send 25c in coin to . . .



PIERCE & STEVENS CHEMICAL CORP.
710 OHIO STREET • BUFFALO 3, N. Y.
Available in Canada—Le Page's, Toronto 18, Ont.

shaw

shoes are designed for men whose feet
are part of their job!

Here's a sturdy work oxford, with all the styling, fit and comfort of a dress oxford! Shaw's high value features include full cushion insole heel to toe with metatarsal pad and cushion side arch support . . . oil resistant Neoprene sole . . . steel arch . . . Nylon stitched . . . plus the finest leathers and craftsmanship, in black or Cordovan color. AT STORES EVERYWHERE, or write us for details.



IDEAL FOR
mechanics, filling station men, mailmen, factory workers—anyone who wants comfort and style in a work oxford! Also available as high shoe.



ARCH

Today's
top values,
\$10.95 to \$14.95

M. T. SHAW, INC.
Coldwater, Michigan

"37 Years of Quality Shoemaking"



Rehearse for the Hunt

(Continued from page 144)

the opposite. It teaches him to make positive identification at long distances (the silhouettes are placed at varied ranges from 100 to 300 yards away), and also aids him in learning to judge distances accurately. This is all-important, especially in Western states where the targets are likely to be way out yonder.

We've got other games to sharpen our shooting eyes and reflexes, like firing at balloons bouncing erratically across the ground in a brisk breeze (always in front of some backstop to block ricocheting bullets), or firing at an old casing with a cardboard insert bouncing down a hillside (this is a fine system for learning to lead moving targets correctly), or shooting at a target swinging by a rope from the limb of a tree.

Skeet Range Good Practice

If you are a bird-shooting enthusiast, some first-rate practice is only as far as the nearest trap and skeet range. A so-called "round" of either is 25 targets. A trap layout has five different shooting positions adjacent to one another in a crescent-shaped formation: the shooter moves to the right one position every time he completes five shots. The trap is hidden in a low concrete building in front of the shooter and targets are tossed out at varied angles unknown to the shooter.

A skeet field is laid out in a half circle. There are eight shooting positions, with two single targets being shot from all eight positions and "doubles" from four positions. There are two target houses—a "high house" where targets are thrown high, and the "low house." All targets are thrown in the same pattern of flight, but the angle of the shot is different as the shooter changes positions. The twenty-fifth shot is optional since it is a repeat of the first miss, or optional from any position if the shooter has broken twenty-four consecutive targets.

In many towns, however, there are no trap or skeet facilities. Two people can accomplish the same objective with a hand trap and a supply of targets, or clay pigeons. Hand traps are available at most sporting goods stores. There are two types—one throws only a single target; the other either a single or double.

Get in an open area where there is plenty of elbow room for shooting and take turns, one person shooting while the other throws the targets. With some practice the thrower can learn to simulate practically any upland bird situation, from low hedge-hop-

(Continued to page 236)

Everything for the Craftsman!



WRITE FOR NEW 132 PAGE

WOOD
AND HOME
WORKSHOP **CATALOG**

**Finest Domestic and Imported Woods
... Mouldings, Hardware, Tools ...
ALL AT LOW MONEY-SAVING PRICES!**

Your complete wood buying guide and project book. Craftsman is your best, most complete source of finest kiln-dried domestic and rare imported woods, beautiful wood inlays, colorful bandings, matched plywoods, embossed mouldings, carved ornaments, newest woodworking tools, "hard to find" cabinet hardware and fittings... more than 1500 items! Packed with newest scroll saw patterns, project ideas and money making plans. Enclose 25c (refunded with first order) to help pay mailing, handling cost. Write:

NEW!!

- Mosaic Tile Kits
- Period Clock Kits
- New Line of Metal Legs
- Over 1,500 Items!

**CRAFTSMAN WOOD SERVICE COMPANY, Dept. A-9
2729 SOUTH MARY STREET - CHICAGO 8, ILLINOIS**

Works
in
seconds!



**Loosens Rusted Bolts
nuts, screws, "frozen" parts!**

**LIQUID
WRENCH**
SUPER-PENETRANT

The super-penetrating rust solvent that quickly loosens rust and corrosion.

**AT ALL HARDWARE
AND AUTO STORES**

RADIATOR SPECIALTY COMPANY
CHARLOTTE, N. C.



**FIRST OF THE
1961
CARS**



See them next month in
**POPULAR
MECHANICS**

SEPTEMBER 1960



SCREWDRIVERS

*made to withstand a
lifetime of hard use...*

You'll recognize the lasting quality of a P&C Screwdriver when you first pick it up. The craftsmanship is obvious. Each P&C screwdriver blade is forged of alloy steel, heat treated and oil tempered. Bits are highly polished, resist rust and are torque tested to withstand twisting. Tough, hardened, precision ground tip will not chip... stays sharp. There is a P&C screwdriver for every type of screw—slotted, phillips and clutch. UL approved.

You'll find P&C screwdrivers on the colorful P&C Merchandiser in your favorite hardware store.

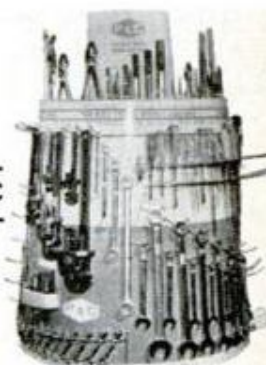

TOOL COMPANY

Portland 22, Oregon
Chicago Warehouse
Box 87, Schiller Park, Illinois
In Canada, Box 366, London, Ontario



235

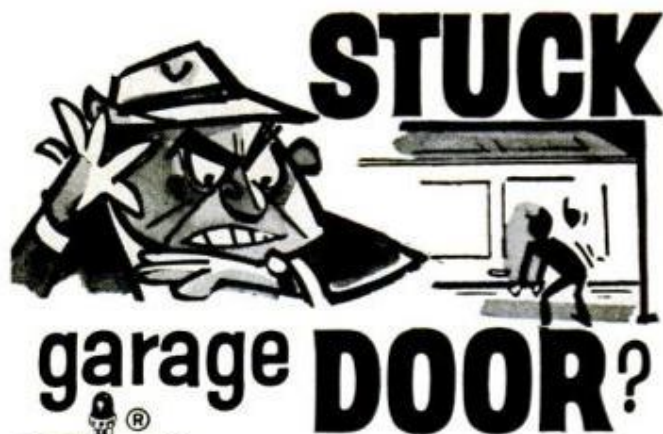

garage **DOOR?**



QUICK! Get it moving and keep it running smoothly with dependable 3-IN-ONE. Lubricates, cleans, prevents rust. On sale everywhere.

3-IN-ONE OIL

REGULAR · OIL SPRAY · ELECTRIC MOTOR

It's Sharp . . . keep it that way with the right sharpening stone by



CARBORUNDUM®

DOG, PET OWNERS, SPORT & FISHERMEN

ATTENTION

FIELD TESTED & PROVEN
AUTO TRUNK "VENT" & "LOCK"

CONVERTS TRUNK TO TRAVEL-SAFE ROOM!

GUARANTEED &

Precision Built to Fit most
cars 1950-1961 . . . from \$3.65

INSTALLED IN
MINUTES

WRITE FOR
LITERATURE

VENT-LOK SALES COMPANY

Dept. P.M., 9224 VAN DYKE, DETROIT 13, MICHIGAN

Turner Torch

90th Anniversary Special!



The famous Turner Torch . . . for soldering, light brazing, thawing frozen pipes, burning weeds, removing paint, laying tile and hundreds of uses . . . now on sale with the green tank that contains 10% more fuel than any other disposable tank.

SAVE \$1.00. Buy the regular Turner Torch now with two tanks for only **\$7.89** complete

Available wherever hardware is sold or write

Turner Corporation

839 Park Avenue, Sycamore, Illinois

ping birds to those which climb almost straight up, with the simple hand trap. This practice is particularly helpful since it teaches the shooter to swing smoothly, and the secret of scoring consistently in bird hunting is a properly grooved swing.

Another, perhaps even better type of practice for any kind of shooter is varmint hunting, which can usually be done at any time of the year. Crows, woodchucks, coyotes, or any other undesirable wildlife can make fine early-season sport and will serve the conservation effort as well. But check first with your state's game laws to learn what, where, and when to shoot. A varmint in one state can be a protected species across the border in a neighboring state.

Look over the accompanying illustrations and learn how you can enjoy practicing for the upcoming hunting seasons. Everything is there except real live game—and perhaps this tune-up even will help you bring *that* home later this year. ★ ★ ★

Studies by the National Aeronautics and Space Administration of the orbital flight of the Vanguard I satellite have shown that sea level in the north polar region is 50 feet higher—and in the south polar region is 50 feet lower—than had been thought.

This Month's "Great Pioneer in Science"

(Page 22)



George Westinghouse (1846-1914)

"GLEN L" BOAT PLANS PATTERNS & FRAME KITS

LARGE SCALE BOAT PLANS, FRAME KITS AND FULL-SIZE PATTERNS SPECIALLY PREPARED FOR AMATEUR BUILDERS

Send for our new 80-page catalog illustrating over 35 modern build-it-yourself power boats, including outboard and inboard runabouts, cruisers, catamarans, dragsters and many others.

SEND FOR YOUR CATALOG TODAY—ONLY 50¢

"GLEN L"—9152T Rosecrans, Bellflower, Calif.



NEW WORKSHOP IDEAS!

Every issue of THE DELTAGRAM—popular bi-monthly home workshop magazine—brings you 28 colorful pages packed with ideas. Projects for extra fun and profit are fully illustrated, include plans, "how to" instructions, and bills of materials. Get 1 year subscription for \$1.75 (or 3 years for only \$4.00!) Send check or money order to: THE DELTAGRAM, Rockwell Manufacturing Co., 502J N. Lexington Ave., Pittsburgh 8, Pa.

World's THRIFTIEST Light Plants



700 Watt, push button start, 115 v. 60 cyc. AC. 2.2 HP, easy starting Briggs eng. No wiring necessary; just plug in and operate. Plenty of current for any oil burner, freezer, brooder, emergency lights, etc. which require up to 700 watts. Ideal for television and radios. Complete with voltmeter and built-in winding to charge auto batteries. (Item 24) Wt. 75 lbs. Easily fits in car trunk. Be prepared if storm knocks out power lines. Reg. \$275... **\$143.50**
1200 Watt Plant (Item 45) same as Item 24 but larger generator and engine with 50% greater output... **\$199.50**
ELECTRONIC BRAIN Now Available On All Our Plants—Write

MASTER MECHANIC MFG. CO., Dept. A-96, Burlington, Wis.
Southern Customers Order from Dept. A-96, Box 65, Sarasota, Florida

GET THE HABIT OF READING OUR CLASSIFIED ADS.
Wonderful Opportunities Amazing Bargains



GENUINE ALNICO MAGNETS

AMAZING, PERMANENT, NON-ELECTRIC, HIGHLY PRACTICAL. Conduct interesting experiments. Hundreds of uses. Retrieve valuable steel items such as guns, tackle from fresh or salt water; tools from tanks & drains. **GUARANTEED.** Try any magnet one week. Money back if you are not well-pleased.
No. M-710 (Wt. 53 oz.) Has pull of 225 lbs. on steel block... \$18.00
No. M-625 (Wt. 70 oz.) Has pull of 125 lbs. on steel block... \$10.00
No. M-575 (Wt. 18 oz.) Has pull of 75 lbs. on steel block... \$ 7.00
No. M-500 (Wt. 13 oz.) Has pull of 50 lbs. on steel block... \$ 5.00
No. M-90 (Wt. 5 oz.) Has pull of 15 lbs. on steel block... \$ 3.50
No. M-44 Rod Magnets for Electric Guitars, 1/4" Dia. x 1 1/4" 12 for \$4
No. M-47 Hot Pad Magnets, 10 for \$1.00... 50 for \$ 4.87
No. M-35 Hobbyist assortment of 8 magnets... \$ 2.00
Send M.O. or check. We pay postage. Sorry no C.O.D.'s.

MIAMI MAGNET COMPANY, 3240 N.W. 27th Ave., Miami 42, Fla.



The Modern PLASTIC for lasting Home Repairs

PERMANENTLY mends cracks or holes in wood, tile, stone or plaster. Sticks and stays put—Does not chip, shrink or fall out. Easy to use. Economical. Mold it, chisel it, polish or paint it. The big 4-lb. can is obtainable from your lumber, paint or hardware dealer at \$1.40; or will be shipped direct postpaid (in U. S.) for \$1.75. Complete satisfaction guaranteed or your money refunded.

DONALD DURHAM CO.
Box 805-T Des Moines, Iowa

Professional Mechanics' TOOL CHEST FOR YOUR HOME WORKSHOP



This may be the lowest cost full-sized chest in America! 4 sliding drawers in blue-gray rugged steel cabinet. 26" x 12 1/2" x 12 1/2". Keep your valuable tools safe, clean and always at your fingertips.

\$28.50

FREE BULLETIN describes this and 15 other models!

HUOT MFG. CO.
555 No. Wheeler St., St. Paul 4, Minn.



Speedy Sprayer

sprays paint

7 times faster than hand brushing!

And what a finish... smooth, flawless, no brush strokes. So easy—just pull the trigger. Speedy Sprayer is a real professional tool. Paints anything, toy to a house. A must for every workshop. Operates with any 1/4 or 1/2 hp motor. 890 OUTFIT, less motor, **\$42.50**

Mobile Wheel Kit, \$7.50 extra

W. R. BROWN CORP.

Specialists in Portable Sprayers for 38 Years
2635 N. Normandy Ave. • Chicago 35, Ill.

Wheel it to the job!



FREE! "How to Spray" booklet and catalog. Write!

The new **SHAPE** of a new **SOUND!**



A glass packed muffler that looks like original equipment—of popular flat oval shape—with a tone that's mellow without bellow—distinctive, but lullaby-low!

NEW SHAPE—Redesigned with compact flat oval, just 3 in. thick. Fits all cars snugly, with more road clearance.

NEW SOUND—No flat harsh blare to invite a ticket—intermediate shell and tone chamber provide muted purr.

NEW PERFORMANCE—Engineered to give you all the power-and-go from highest compression engines. Long service, low back pressure. Everything about it says "Go"!

... plus these advantages!

- Two types of fiber glass for best tone
- Double-wrapped outer shell
- Heavy-gauge steel in shell and heads
- Takes little time and work to install
- Handsome gold enamel finish

And be sure to see the famous Goerlich—original equipment type mufflers—the economical Standard or deluxe Master. Either is the biggest buy for your dollars.

GOERLICH'S, Inc.

MUFFLERS AND PIPES

Dept. 2J, 619 Smith St., Toledo 1, Ohio

Magnetic Quenching Forms "Supermetals"

Conventional steel and titanium alloys are being turned into "supermetals"—with strengths in some cases more than 100,000 pounds per square inch above normal—by a new process that borrows from an old and well-known physics experiment. In the experiment, iron filings are scattered at random on a piece of paper; a magnet placed under the paper causes the filings to become uniformly arranged.

"Our process resembles standard heat-treating procedure," says William I. Basset III, who developed the process for Research Development Corporation of America, Gardena, Calif. "However, we use an electromagnetic field to improve the basic nuclear structures of metals. It's a well-known fact that many fabricated metals can be strengthened if they are properly heated, then quenched. But it hasn't been practical to bring out the greatest possible strength in most alloys, since the heat required would cause them to become excessively brittle."

Heat alone created a chaotic condition in the metals. Consequently when they were suddenly quenched in some medium such as water or oil, their nuclear components were frozen in odd patterns which produced many weak spots in their structure.

"We move hot metals from a furnace into a strong magnetic field," Basset says. "Due to the semifluid condition of the materials, the field is able to orient, or align, their nuclear constituents—much in the same manner as in the experiment with iron filings. Because the metals remain in the field until they are cool and stabilized, the uniform alignment is retained and the metals have high strength as well as excellent ductility."

Basset says high-strength steel parts treated by the process can be bent 180 degrees without breaking. In addition, the parts have none of the warpage or variation in dimension that is sometimes found in conventionally heat-treated parts and their ability to resist corrosion is improved.

QUOTE:

"The solution of almost every problem we have in maintaining our leadership in science and engineering must begin with better education. Particularly is it important at this juncture to strengthen and extend graduate education."

—JAMES R. KILLIAN, JR.,
Chairman of the Board,
Mass. Inst. of Technology

PEEL PAINT OFF



Furniture



Floors



Boats



Woodwork



KLEAN-STRIP PAINT REMOVER

Fast • Clean • Non-inflammable

THE KLEAN-STRIP CO., INC.
2340 S. Lauderdale, Memphis 6, Tenn.

FREE
THE HISTORY OF
THE COMPASS
SEND FOR YOUR COPY

New DINSMORE *Celebrity* COMPASSES

in Beautiful GOLD or SILVER

A jeweled, precision instrument—designed for modern cars. Full, indirect illumination. Sharp, clear letters. Silver or gold Celebrity models \$7.45, standard models \$5.95. Illuminated \$6.95

APPROVED BY AUTO MAKERS
Fine Quality Compasses for over 31 Years

DINSMORE INSTRUMENT CO.
1802 Keiso St., Flint 1, Michigan



Write
for Folder

YOUR FIRST
PIPEFUL TELLS
YOU—YOU'LL
GET ALONG
FINE WITH
AMPHORA



Make your next pipeful AMPHORA; the even-burning, longer lasting, gentle blend from The Netherlands, at tobacco counters everywhere.



AMPHORA

U.S. Importer: Romick's International Tobacco Co., 11607 Vanowen St., North Hollywood, Calif.

HERE'S A MONEYMAKER FOR YOU!

make from \$3 to \$6 an hour
with the FOLEY SAW FILER

Ask yourself these three questions: 1. Do I really want to get ahead *faster*? 2. How can I do it? 3. Am I willing to *use* my spare time? If you answer "Yes" to questions 1 and 3—then we have a positive answer for you on No. 2. Men make from \$3 to \$6 an hour sharpening hand, band and circular saws with Foley Saw Filers. No experience needed, to turn out sharp, smooth-cutting saws with this automatic machine. Start in spare time—no canvassing.

HERE'S THE WAY TO START

Read "Money Making Facts"—shows you how others have added hundreds or thousands of dollars to their incomes in this steady, repeat, CASH business. Start your *own* business in your basement or garage, no overhead, small investment. With *Time Payment Plan* the Foley can more than pay for itself out of profits. Send for "Money Making Facts"—mail coupon now. No salesman will call.

HERE'S PROOF

"When Mr. Patrick got his Foley Saw Filer in March 1946 he made a good and wonderful investment. He has done so well that we bought a house and paid for it; bought a new car, built an addition to our house. Nicest of all, it's all paid for." Mrs. Leslie Patrick.

"I made \$765 last year filing saws, and it sure comes in handy. I do this work in my spare time."
—James B. Williams

"Last year's profit amounted to \$3,000. Not so bad for a one-man outfit."
—Charles C. Hough.

"I have done 4 or 5 thousand saws in my spare time in the 4½ years since I got the outfit, and they are all coming back with repeat orders."
—Len Crego.

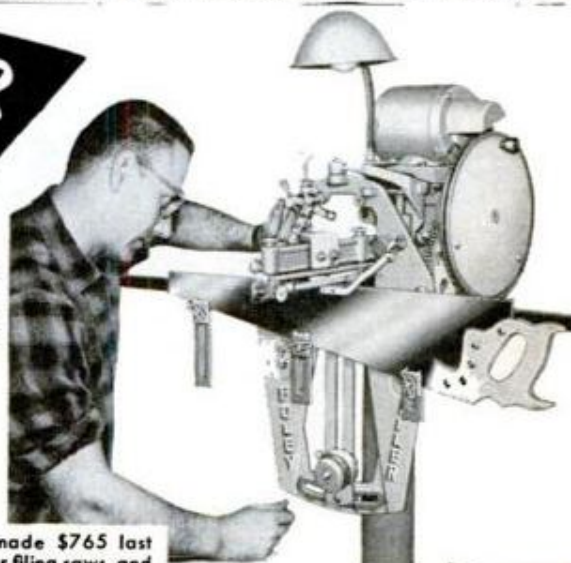

FOLEY MFG. CO., 916-0 Foley Bldg., Minneapolis 18, Minn.
Send me free book "MONEY MAKING FACTS" and Time Payment Plan.

NAME _____

ADDRESS _____

New
FORMICA[®]
 Laminated Plastic
sink top?

It's easy: use Formica Safe-Bond, the new non-toxic, non-flammable adhesive that "tells" you when to contact. And surprise "the missus" with Formica laminates in the smart new Raymond Loewy designs. Get Formica Safe-Bond and sheet stock at your local lumber dealer. Formica Corp. Cincinnati, Ohio.

a product of **CYANAMID**

THE KING MIDGET

World's Most Exciting Lowest Priced Car. Rider Agents Wanted. Send 25c for 32 page picture book, full details, dealer price. Or send \$1 (refunded first order) for this plus Service and Repair Manual and 16 5x7 photos of car and factory.



MIDGET MOTORS CORPORATION, Athens 1, Ohio

WELD **BRAZE**
SOLDER **CUT**

4WAY
 ONLY **\$14.75**
 f.o.b. factory

WELDER

Acclaimed by thousands of Homeowners, Mechanics and Hobbyists as the welder of 1001 uses. Easily operated from properly wired 110 volt AC or DC line. The ideal gift with a life-long use. Order today on 10 day money back guarantee. Send only \$3.00 today. Pay postman balance C.O.D. plus charges. Literature on larger equipment on request.

FOUR-WAY WELDER CO., Dept. F2-J
 1810 S. Federal St. • Chicago 16, Ill.

Complete with Twin Carbon Arc Torch and accessories... to handle all metal-craft work.

NEW BELSAW MULTI-DUTY POWER TOOL
SAWS - PLANES - MOLDS



Now you can use this ONE power-feed shop to turn rough lumber into moldings, trim, flooring, furniture... ALL popular patterns. RIP... PLANE... MOLD... separately or all at once with a one HP motor. Use 3 to 5 HP for high speed output. Low Cost... You can own this power tool for only **\$30.00** down payment.

Send postcard today for complete facts.
BELSAW POWER TOOLS, 901 Field Bldg., Kansas City 11, Missouri

An Eye on Space

(Continued from page 88)

six months later he sights again—and he has his two angles! And the base line is 2 x 93 million miles, or 186,000,000 miles.

Measuring by this method, the nearest star comes out to be about 24 trillion miles away (24 followed by 12 zeros). Incidentally, when light travels for one full year—at 186,000 miles per second—it covers a distance of about 6 trillion miles. So we can say that the nearest star is about four "light-years" away.

But even this method with our orbital baseline is good only up to distances of about 100 light-years. Again, we begin to get angles of nearly 90 degrees for larger distances, and again our triangle becomes unreliable.

So what to do?

There is a way of beating the rap again. Next month we'll discuss the problem of measuring the really BIG distances. Do you know what the greatest distance measured is? A couple of colliding galaxies have been spotted at a distance of 6 billion light-years. That is, a distance of 6,000,000,000 x 6,000,000,000,000 miles; or at a distance of 36,000,000,000,000,000,000 miles.

Anyone for a tape?

★★★



Ultra-High-Speed Russian Camera

Reportedly 1000 times faster than an ordinary electronic flash, Russians claim a new camera can take 2.5 million pictures a second. The lens focuses on a rotating mirror that reflects the image onto a semi-circular strip of film. Metal gratings break down the streak into separate pictures.

NOW ON SALE!

SPECIAL SECTION ON WOODS
POPULAR MECHANICS
WORKSHOP
ANNUAL \$1.00



1961

INCLUDING...

SHOP NOTES *Easy short cuts and how-to tips for the handyman*

WHAT TO MAKE *New build-it-yourself projects for the home craftsman*

THE FIRST NEW POPULAR MECHANICS ANNUAL!
BIG WHAT TO MAKE AND SHOP NOTES SECTIONS
PACKED WITH PROJECTS AND HOW-TO IDEAS FOR
THE HOME CRAFTSMAN. AT YOUR NEWSSTAND

PROFESSIONAL DEVICE AVAILABLE

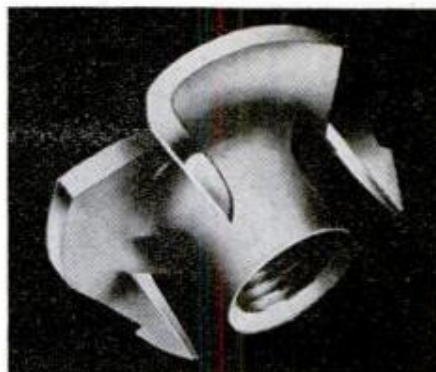

DOT TEENUTS

Use this flush mounted, "can't slip" nut that needs no washer!
... get the strength of steel threads in wood. Fast, easy, sure.
The professional fastener!



Now specified in
EASI-BILD PATTERNS

Get them both at Hardware, Variety
and Lumber Stores:

Ask for TEENUTS!

COLUMBIA FASTENER COMPANY
Chicago 8, Illinois

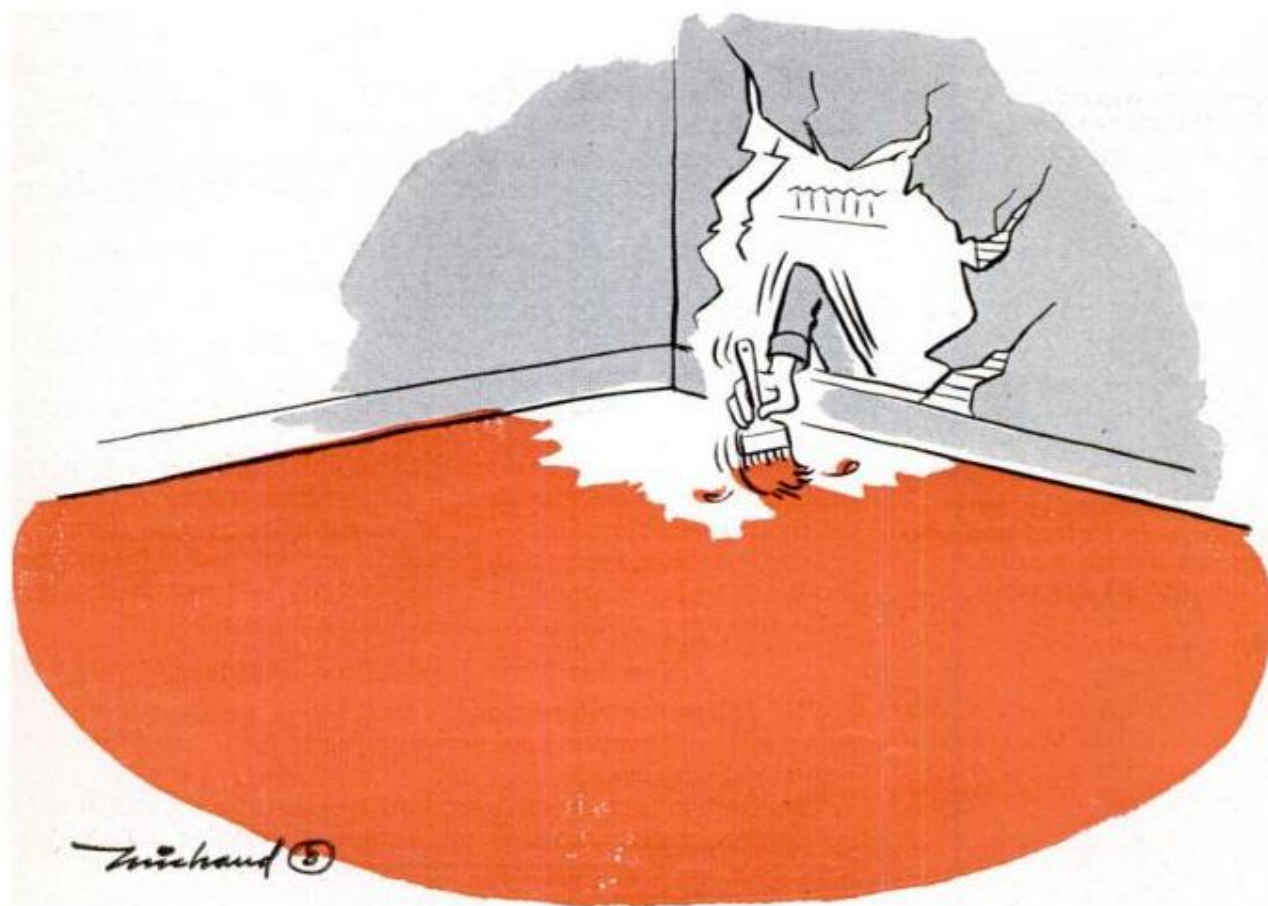

Richard ©

Owners Report on the Thunderbird

(Continued from page 106)

"Doors too heavy, thus require effort when getting out of car."—California accountant.

"Reverse angle of windshield increases difficulty in getting in and out of the front seat."—Indiana doctor.

"I'm getting tired of difficulty getting in and out of car in close quarters at parking lots."—

"Hole in top of piston at 12,000 miles."—Missouri TV director.

"The cooling system is wholly inadequate, car overheats easily, carburetor constant source of trouble, car will not idle properly."—New York freight sales manager.

"Automatic choke trouble, gasoline filters defective, I had to install two."—Illinois pharmacist.

"Have had endless trouble starting the car, and engine stopping while driving."—Wisconsin executive secretary.

"Costly to maintain, have had nothing but trouble with the engine, major tune-up every 2400 miles."—Missouri drive-in operator.

"The first two months that I had T-Bird, it was in garage more than on the road—new rings, bearings, valves ground at 6000 miles."—North Carolina doctor.

"This is the second engine in my car, first one blew up at 6200 miles."—Illinois tree surgeon.

"Great difficulty starting, have had numerous carburetor adjustments."—New Jersey salesman.

"No one can say that he is really satisfied with mileage, however considering size and power and my mode of driving, I think that 12 miles per gallon is all one can expect."—Rhode Island postal employee.

"My lady friend luxuriates in it, but she doesn't buy the gas!—eight miles per gallon!"—New Jersey magazine editor.

"I believe that the engine could be designed to get somewhat better mileage (12-14 reported) and yet preserve the power and pep."—Louisiana geologist.

"Very poor gas mileage."—Pennsylvania pattern maker.

"The craftsmanship isn't what it should be in a prestige car in this price class."—Illinois salesman.

"More care on production line so that it doesn't become necessary to return to dealer to fix nuisances."—New Jersey doctor.

"Too many defective items; spark plug wires, manifold gasket, differential gearing, top control switch, gearshift lever collar."—California engineer.

"T-Bird is kin to the Ford and therefore not well-made."—Texas saleswoman.

"Windshield cracked at 4000 miles."—Ohio chief metallurgist.

"Expensive brake trouble within 5500 miles—master cylinder had to be overhauled."—Ohio office manager.

"Brakes inadequate."—Pennsylvania insurance man.

"Brakes fade very badly, need frequent adjustment, are inadequate for car of T-Bird's weight."—Iowa instructor.

"It has very poor brakes."—California contractor.

Now for More Best-Liked Features

The following quotations describe other best-liked features of the Thunderbird ranging from sixth to eleventh in order of frequency.

"Seating is terrific on long hauls."—Illinois salesman.

"Bucket seats provide much comfort for the driver on a long ride."—Massachusetts restaurant manager.

(Continued to page 244)

Most of these complaints on cooling failure come from owners of air-conditioned cars. →

Here is the rarest of all men, a realist who is not looking for "something for nothing." →

In respect to some items like glove box, heater controls, wipers, he's right; they are Ford parts at Lincoln prices. →

If car is driven as hard as its power plant and chassis permit it will "outrun" its brakes. →



SATISFACTION GUARANTEED!

EXPERT ENGINE SERVICE

*How the Sun Program equips
car dealers, repair shops, service stations
to render top quality engine repair service*

Your repair job is no better... than the skill of the man who does it... and the precision of the test equipment used... and the training of the technician who makes the tests. That is why the Sun Service System assures all three. This 3 point Sun Program makes it possible for shops using Sun Test Equipment to give you a **GUARANTEED SATISFACTION** engine repair job. Why not drop in and get your car serviced by the repairman who uses Sun Engine Testing Equipment and who displays the "SATISFACTION GUARANTEED" SIGN.



SUN SCHOOLS... Sun is famous for its leadership in establishing technical training courses for mechanics to make them masters in the techniques of expert engine testing.

Look for this Sun Sign
on the road... in
your neighborhood.



SUN TECHNICIANS... nearly 300 Sun Men throughout the United States, in clinics and on the job, are daily counseling with mechanics... assisting in the solution of difficult engine repair problems.



SUN TECHNICAL SERVICE... newest service consists of Sun Flash Cards which tell the mechanic, at a glance, how your engine compares with the car factory specifications for your exact model engine.



This message is sponsored by
Sun Electric Corporation, Chicago, Illinois, on behalf of over
75,000 Car Dealers, Service Shops, Service Stations
who use the

Sun SERVICE SYSTEM

© 1960 Sun Electric Corp.

917

**He's right only if you →
limit search to high-price
cars; there are plenty of
sensible-size cars in
low-price field with
more to come.**

Amen. →

**Here we go again, another
guy who wants his cake
and eats it too. If the
T-Bird were a six-passenger
sedan this man wouldn't
have bought it! →**

**Yes, indeed. They are hard
for driver to get at, but
an easy reach for in- →
quisitive fingers of
children riding in the
back seat.**

**Quite so, T-Bird manages
to give the impression →
of first-class travel
without the ostentation
of great bulk.**

"Ease of handling, and, it fits in my garage."—New Jersey salesman.

"Cars have been getting too large, T-Bird offers the only escape unless you can tolerate a two-passenger car.—Ohio assistant to president.

"Has the advantages of a compact car yet is heavier with better maneuverability and holds the road better."—Ohio bank president.

"Interior perfect, everything fits in place and upholstery is beautiful."—California mechanic.

"It's a pleasure to drive a car that doesn't take two spaces to park."—Kansas sales manager.

"Nary a squeak or rattle."—New York salesman.

"Sturdy, solid body."—Arizona farmer.

"The feeling of structural solidity."—Maryland salesman.

And Now Some Additional Complaints

Sixth on the list of complaints from T-Bird owners is transmission trouble. Here in the order of frequency are this and other complaints.

"Handshift is hard to operate and clutch seems to be slow to engage."—Virginia clerk.

"Automatic transmission doesn't shift smoothly."—Georgia bottler.

"Rattles under dash, both doors and front seats are loose."—Illinois sausage maker.

"Too many body rattles for a car of this category."—New York dentist.

"The back seat should not have the hump so that three can sit in the back."—California machinist.

"Seats are comfortable, but could stand more length for better leg support."—Michigan mechanic.

"Exterior paint job could be better."—California rancher.

"Paint is so thin in spots that undercoat shows through."—New York architect.

"Small, unlighted glove compartment."—Wisconsin advertising man.

"No trunk, underhood or glove compartment light."—Massachusetts dentist.

"Poor location of power-window control switches."—Indiana owner.

"Blind spot created by wide panel between side and rear window is annoying."—Georgia doctor.

Here Are Some Best-Liked Features

In order of frequency here are quotations from reports describing best-liked items from 13th to 17th.

"Built low with plenty of visibility."—Michigan plastics manufacturer.

"Is very sporty looking, a prestige car."—New York housewife.

"It is styled right, everyone you pass looks at the car; it gives you a pride of ownership."—Arizona motel manager.

"Performance and the elegant appearance—you feel like a queen. Definitely a prestige car."—Michigan budget analyst.

"I like its low lines."—California director.

"I was promised a new T-Bird each year on trade for about \$500, if this works out cost of ownership will be low and I'll keep on buying 'Birds.'"—New Jersey doctor.

(Continued to page 246)

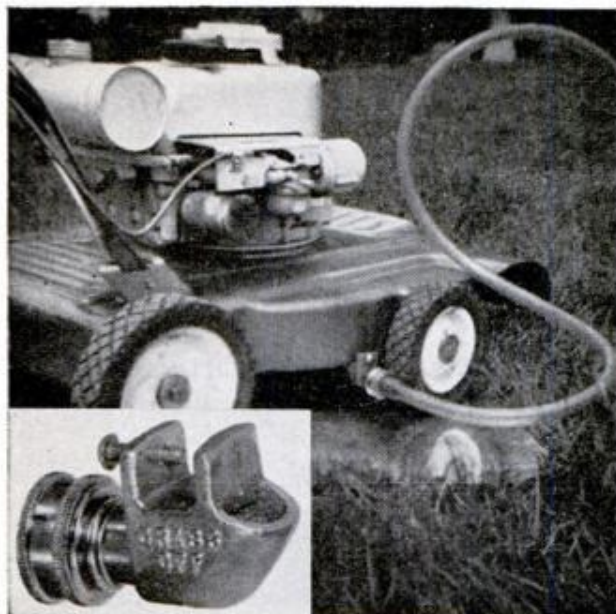

Garbark Engineering, Box 114, Broadview, Ill.

Water Jet Cleans Rotary Mower

Grass that sticks to the underside of a rotary power mower is quickly cleaned off by a combination of a jet of water and the turbulence created by the turning blade. Water, supplied by a garden hose, is shot into the housing of the mower through an aluminum fixture that is coupled to the hose and then clamped with a screwdriver to the edge of the housing.

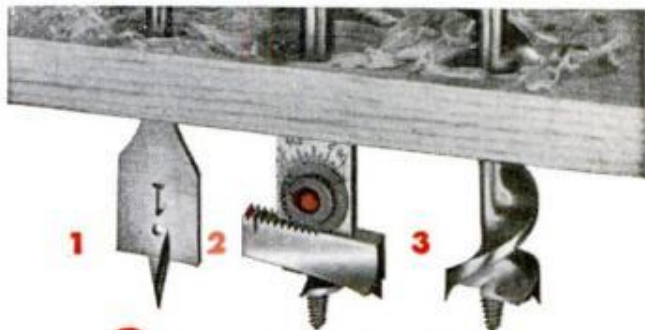

3 easy ways to bore holes faster

- 1. Irwin Speedbor "88"** for all electric drills. Bores up to 5 times faster in any wood, at any angle. Sizes 1/4" to 1", \$.75 each. Sizes 1 1/8" to 1 1/2", \$1.25 each.
- 2. Irwin No. 22 Micro-Dial** expansive bit. Fits all hand braces. Just dial your size. Bores 35 standard holes, 7/8" to 3". Only \$4.00 No. 21 small size bores 19 standard holes, 5/8" to 1 3/4". Only \$3.60
- 3. Irwin 62T Solid Center** hand brace type. Only 16 turns to bore 1" holes through 1" wood. Double-cutter boring action. Sizes 1/4" to 1 1/2". As low as \$1.05 each.

Made to last for years. Every Irwin wood bit is made of high analysis steel, machine-sharpened, and heat-tempered full length for longest life. Highly polished, too. Irwin is the wood bit independent hardware dealers recommend for faster, cleaner boring action. Write Irwin, Dept. 90PM, Wilmington, Ohio, today for free booklet on how to select, use, and care for wood auger bits.

IRWIN every bit as good as the name
at Wilmington, Ohio, since 1885



New **Self-locking** perforated board fixtures **DOUBLE YOUR STORAGE SPACE** without remodeling!

Just insert Easy Hang fixtures into perforated board. They automatically lock into position. Ideal way to double your storage space in closets, playroom, kitchen, workshop. Fast! Low cost!

Dozens of styles and sizes.

Free, new idea folder tells all!

Turnbuckles, Inc.

Turnbuckles Inc., Dept. PM, Box 333, Michigan City, Ind.
Rush free folder showing how to double my storage space.

Name _____
Address _____
City _____ State _____

Send for your **FREE** **HEATHKIT** **1960 CATALOG**

HI-FI, HAM RADIO MARINE... TEST

Over 150 do-it-yourself electronic kits are illustrated and described in this complete Heathkit Catalog.



DO-IT-YOURSELF... IT'S FUN
IT'S EASY & YOU SAVE UP TO 1/2

HEATH COMPANY/Benton Harbor 17, Mich.

a subsidiary of **DAYSTROM, INCORPORATED**

Please send the **FREE** Heathkit Catalog.

NAME _____
ADDRESS _____
CITY _____ ZONE _____ STATE _____

"The main thing is that appearance doesn't change much each year hence the good trade-in value."—Texas oil producer.

"Car is extremely quiet at all times."—Minnesota airline mechanic.

And Now Some Final Complaints

Here is a roundup of minor complaints represented by quotations from typical owner reports in order of frequency.

"Wipers are very poor in winter with snow or ice, defroster little use."—New Jersey owner.

"Vacuum wipers unheard of in car of this class."—Illinois electric lineman.

"Shallow trunk space."—New York construction superintendent.

"Not enough trunk space."—Wisconsin salesman.

"Any honest owner of a T-Bird convertible ('60) will admit that luggage space is ridiculous."—Indiana owner.

"Mirror hinders your vision of oncoming vehicles."—Illinois mason.

"Breakdown of carbon core ignition wires."—Texas dairy owner.

"Ignition wiring had to be replaced."—Ohio realtor.

"Engine seems sluggish, doesn't have the pep that I think it should."—Indiana inspector.

"Engine-transmission combination seems sluggish; you really have to hit the throttle to get going."—Missouri housewife.

This wraps up the report on the 1960 Thunderbird as told by owners and based on 2,494,808 miles of driving experience. For a complete summary of the percentages turn back to page 106. ★★★

It's hard to see why this problem wasn't nipped before it was put into production. →

WIL-BOND

No washing • No sandpapering
FINER RESULTS
in PAINTING

Now you can eliminate the messy arm-tiring job of scrubbing and sandpapering woodwork before repainting. WIL-BOND, applied with a rag, removes dirt and grease. And unlike sandpaper, it dulls enameled or varnished surfaces without scratching. The new finish goes on smoothly, bonds tightly, looks its best! At paint and hardware stores.

• Send 25c for illustrated Refinishing Manual or write for free Wil-Bond folder.
Wilson-Imperial Co., 118 Chestnut St., Newark 5, N. J.

NO JOB WORRIES

PLASTEX INDUSTRY needs manufacturers on small scale for big production of Lamps, Clock Stands, Art Goods, Novelties in Plastic Marble imitation. No Experience necessary. Large material makes regular 10¢ store sellers. Moulds furnished for fast production. Small investment brings good profit. Big wholesale orders now being placed. Ambitious men have chance for real prosperity and job security. Our NEW FREE booklet will interest and benefit you.

PLASTEX INDUSTRIES, Dept. A
3400 Third Ave. New York 56, N.Y.

FIRST
CHOICE



Among men who use fine tools, it's Gerstner Chests. Free catalog to toolmakers and machinists.

GERSTNER TOOL CHESTS
460 Columbia St., Dayton 7, Ohio

GIVE
AMERICAN
CANCER
SOCIETY

NEW shop type
ac arc welder



Here's how YOU can get those "Big Profit" Welding Jobs

② Start a
Big Paying
Business
of Your
Own!

Every day, men like yourself depend on Hobart welders like these to help produce big profits doing construction, repairs, metal fabrication, etc. You'll like Hobart's rugged strength and built-in features that assure long, trouble-free life—professional results, every time.

① The 180 amp. "HUSTLER" is a complete welding package (including accessories). It welds, cuts, burns holes,

hard surfaces and heats metal for bending and forming. Meets REA requirements... it's an all around shop welder.

② The 200 amp. "POWER/WELD" furnishes DC current for welding and simultaneously supplies 110/220 volt power for running lights, tools, motors, pumps, sprays, etc. It can also be used as an emergency power source to run brooders, milking machines, etc.

Write today

...HOBART BROS. CO.,

BOX M-90, TROY, OHIO, Ph. FE 2-1223

How to Turn a \$5⁰⁰ Raise into a \$1,000 Bonus



WHAT SHOULD HE DO WITH AN EXTRA \$5 A WEEK? He can spend it, of course. But, if he buys a \$25.00 U. S. Savings Bond each month for 40 months with his \$5 a week raise, he is going to have Bonds worth \$1,000.

Wishing won't turn a \$5 a week raise into a \$1,000 bonus, but it's easy to do. If you take that \$5 raise and put it into U. S. Savings Bonds you can buy a \$25.00 Bond a month (cost \$18.75) and have money left over. If you keep buying one of these Bonds a month for 40 months you'll have your big bonus—Bonds worth \$1,000 at maturity.

Why U. S. Savings Bonds are such a good way to save

- You can save automatically with the Payroll Savings Plan.
- You now earn $3\frac{3}{4}\%$ interest to maturity.
- You invest without risk under U. S. Government guarantee.
- Your money can't be lost or stolen.
- You can get your money, with interest, anytime you want it.
- You save more than money; you help your Government pay for peace.
- You can buy Bonds where you work or bank.

Every Savings Bond you own—old or new—earns $\frac{1}{2}\%$ more than ever before when held to maturity.

You save more than money with U. S. Savings Bonds

The U. S. Government does not pay for this advertising. The Treasury Department thanks The Advertising Council and this magazine for their patriotic donation.



cept silently to slip meals to him. Frau Schragmuller and her staff kept him under constant surveillance through a wall mirror which was in reality a screen. By the time they set the candidate free there was little that they did not know about him.

Agents go to schools which have more hard knocks in the curriculum than any other schools on earth. They are toughened and conditioned, mentally as well as physically, and taught all sorts of things, from how to operate a fountain-pen gun or incapacitate an auto's engine by putting sugar in the gas tank to how to organize a report. They become chemists versed in secret inks and the composition of exotic explosives.

How to tap a phone, rifle mail, break into a house or blackmail a statesman are all in the curriculum. Agents learn such little tricks as carrying an extra necktie. A man can switch neckties in a hurry and appear to be a different person. Hats also change a man's appearance, but an agent is told that sunglasses favored by writers of spy thrillers merely make a man conspicuous. One thing is cruelly certain. He must learn his lessons well for any gaps in his training increase his chances of failure, not arithmetically but geometrically, as he gets farther and farther into his assignment.

Naturally an agent must have a valid cover. He cannot accomplish much if he gets found out as easily as did a clumsy OSS agent in a neutral country during World War II. Every time he entered his favorite restaurant the orchestra struck up a catchy number called, "Boo! Boo! I'm a Spy." Some jobs naturally make better covers than others. The representative of a Soviet trading corporation or a Red airline employee, for example, are more likely to be spies than a visiting Soviet journalist. A seaman on a Polish ship might be a high-ranking intelligence officer. Whatever his cover, the agent is so comfortable in it that it is not his second nature but his first. Any spy who thinks of himself as a spy is insufficiently prepared for his task. Any spy who thinks himself mysterious and romantic is temperamentally unsuited for his job.

A resilient Britisher, Sir Robert Baden-Powell, who is better known as the founder of the Boy Scouts, was actually one of the great professional spies of this century. Baden-Powell was a master of cover. On one occasion he was assigned the task of getting the caliber of guns in an Austrian fortress on the Dalmatian coast. Instead of hot-footing it to the Adriatic he went back to college to study entomology. He specialized in butterflies. Then one summer he set

out for the Dalmatian coast with carefully prepared notes in his field book together with sketches of the colorful insects which he had learned to do in exquisite detail. He even carried his butterfly net in exactly the way as did his professor. On the Dalmatian coast he was so obviously a British entomologist that authorities paid no attention as he captured butterflies and sketched them in his little book. He happily showed his beautiful drawings to everybody who asked to see them and to many who did not. But into the wings of his butterflies he carefully drew the outlines of the fortress he was sent to map. He went back to London with every scrap of information he had been assigned to get.

An equally patriotic American colonel was less successful. He set out shortly before World War II on a mission similar to Baden-Powell's. The Japs had fortified Jaluit Island in the Pacific, and the colonel, pretending to be interested in flora and fauna, intended to find out how. He fooled nobody. The colonel died a mysterious death and was cremated by the Japanese, who with polite smiles presented the American ambassador in Tokyo with a handsome vase containing his ashes.

Sometimes a whole intelligence apparatus working in a foreign country masquerades behind a cover organization. Recently a former CIA agent bitterly complained to me that a well-known newspaper columnist had blown the cover which he and his friends had been using in Formosa. He was particularly incensed because the columnist himself had served in OSS.

"I should think he would have known better," he grimly observed.

Fortunately for the CIA agents, they were in the good graces of the friendly nation from which they carried on their anti-communist intrigues, and they were able to re-establish their activities under another cover. Such was not the case with a prewar cover firm in Japan, Max Klausen Shokai. Max Klausen was an associate of the notorious Richard Sorge, who was the top Red spy in the Far East. He set up a business in Japan to make printing presses for the production of blue prints. The company made a perfect cover for Communist spies. Moreover, it gave Sorge and Klausen ironic pleasure when their agents stole blue prints from the Japanese army and navy, which had been printed on the equipment their cover firm had sold to them. Max Klausen Shokai was blown as a cover when Sorge was captured and executed. Scores of Red agents were fingered.

Most successful spy nets depend upon

(Continued to page 250)

WAR SURPLUS AND OTHER **BARGAINS** **SAVE UP TO 90%**



CORNELIUS AIR COMPRESSOR Ideal for filling underwater diving tanks, air horn tanks, etc. Three stage USAF air compressor. Has built-in 1/3 HP, 27 V. DC electric motor. Develops 1500 PSI or may be reset to 2000 PSI. Delivers .04 CPM. Approx. GOVT. COST \$375. Like NEW. \$29.95.



PILOT'S MAGNETIC COMPASS Used by A. F. in Jet fighters. Fully jewelled. Dual compensators. Accurate to 1° for readings at every point. Will operate in all temp. from -55° to +70°C. Graduated in 5° increments. Ideal for panel mounting. Electrically lighted. 2 1/4" W. x 2 3/8" H. Approx. GOVT. COST \$100. Like NEW. \$12.95 (lim. quantity).



BUILD YOUR OWN ARC WELDER, LIGHT PLANT OR BATTERY CHARGER \$37.50
Kit incl. 1 Navy NEA-5 Gen. combination AC-DC type. AC 115 V. DC 24 V., 200-300 Amps. 2 complete generators in 1, yet no larger than reg. gen. Ideal for home, shop and farm lighting plants. Delivers 1200 Watts AC, DC side for charging batteries, welding and operating war surplus motors. Also in kit: 2 Voltage Regs., AC & DC, Reverse Current Relay, 30' New Welding Cable, 1 Ammeter, Rheostat, Electrode Holder, Toggle Switch, Welder's Shield, Wiring Diagram for kit. Wt. under 100 lbs. Approx. GOVT. COST \$650. Kit—\$37.50. Navy NEA-5 Gen. as above, purchased separately, \$23.50.

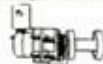

ELECTRIC STORAGE BATTERY WINCH
Powerful reduction gear, fully reversible, ball bearing, safety locking device. Handles from a 1000 to more than 2000 lbs. pull. Use on 6, 8, 12, 24, 32 V. battery. Holds 50' of 1/4" cable. For tractors, boats, tow trucks, etc. Complete with bracket for mounting in any position. Heavy-duty equipment. Approx. GOVT. COST \$400. NEW, \$49.50.

ELECTRIC PUMP WITH CONTROL UNIT

Runs on 12 or 24 V. Centrifugal type. Draws 5.2 AMPS. Has built-in removable filtering screen. Great for bilge, circulating or sump pump... bait tanks, etc. Pumps 500 GPH. Complete with on and off switch rheostat, explosion-proof motor, 2 speeds (hi & lo). Mfd. by Ingersoll-Rand. Shpg. Wt. 7 lbs. Approx. GOVT. COST \$195. NEW—\$8.95.



BENDIX GEROTOR PUMP & MOTOR—NEW!

Use wherever fluid pumping required. Excellent for hydraulic installations and as crankcase drain pump for marine engines. Has 3/4" pipe connections, built-in relief valve adjustable up to 1500 lbs. Max. cap. 6 GPM. 1 1/2 H.P., 24 V. motor. Use on 12 to 32 V. Approx. GOVT COST \$350. \$10.95.



NEW 1961 CATALOG!

Tremendous catalog—our biggest ever—fully illustrated—1000s of bargains in war surplus & other items. Send 25c in coin for your copy today or free copy with order. Where ppd. indicated applies to US only. Other prices FOB Culver City, Cal. Send cash, check, money order, 50% dep. COD.



AIRBORNE SALES CO., INC. DEPT. PM 960

8501 Stellar Drive, Culver City, Calif.

The second most important tool...
for every
woodworking shop

A VERSATILE

**W&H
MOLDER-PLANER**

is second only
to a saw... it
molds, planes and rabbets.
"Your savings pile up as your
shavings pile up."

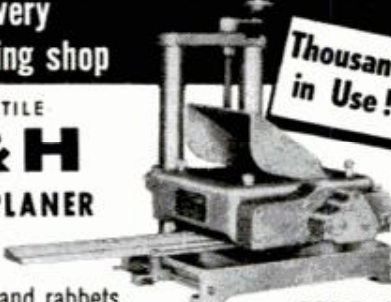

Thousands
in Use!

SEND FOR
FREE BROCHURE

WILLIAMS & HUSSEY MACHINE CORP.
CLINTON ST., MILFORD, NEW HAMPSHIRE



National Multiple Sclerosis Society



great glue for
every job you do

For Free copy of "Elmer's Guide to Good Gluing," send stamped, self-addressed envelope to The Borden Company, Dept. PM-90, 350 Madison Avenue, New York 17, N. Y.

BORDEN'S PRODUCTS FOR THE HOME HANDYMAN

NEW TRUE LAPSTRAKE KIT **FREE CATALOG**

MASS PRODUCTION PRICE Only **\$189** Freight Incl.

EASY TERMS World's largest kit builder—cruisers, runabouts, fishing boats.

TAFT MARINE WOODCRAFT
Dept. PM-960. 636-39th Ave. N.E., Minneapolis, Minn.



LICKITY LOG SPLITTER

Ends Wood
Splitting Drudgery

Hydraulic power splits profits from waste wood
• 7 HP trailer model • two speed • auto shift
• auto stroke. Power "squats" to receive large diameter logs without "dead" lift—eighteen ton smooth hydraulic force cuts right through knots, 26" stroke handles up to 30" length, any diameter. Your name on a postal card will bring literature.

THE WACO AIRCRAFT CO., Dept. D, Troy, Ohio
Dealer Inquiries Invited

disloyal citizens of a country for part-time help. The CIA sometimes employs foreign nationals although it also makes good use of naturalized Americans who can readily pass in their native lands. Because of their distinctive appearance, the Japanese in particular have had to rely upon foreigners to spy for them. This is especially true of their activities in white countries. Such a Japanese spy was the White Russian dancer, Katherine Melikov. She was trained by the unscrupulous Japanese spymaster Kenji Doihara and sent into Siberia to make as good a marriage as she could among the young Communist engineers working for the Soviet Far Eastern Railroad.

Katherine lived up to her mentor's hopes and married a section superintendent. Her husband proved brilliant and was in time transferred to Moscow where he held sway over all Russian railroads. Katherine had fallen deeply in love with her fanatic Red husband, but this did not keep her from continuing to serve Doihara. She hated the Communists far too much to let conjugal love interfere.

Russian security required her husband to leave her behind in Siberia until her antecedents could be properly checked. He lovingly promised to send for her as soon as he could. But Katherine did not wait for the security police to call on her. She left for Japan where Doihara had facial surgeons change her looks. She dyed her blonde hair brunette. With proper proletarian cover in detail, she made her way to Moscow where she got a job in a lamp factory. She worked hard and climbed through Red circles until one day during a party at the home of an engineer her husband entered the room. She calmly chatted a moment with a companion and left without appearing to recognize him.

Germany and Japan were then colleagues in turmoil, and she called upon Nicolai Petrovich, a German agent, to ask his advice. What should she do about her husband? He solved the problem by arranging a train wreck which killed her mate. Now there would be no danger of her being caught. She continued to rise and became secretary of personnel in a Red army bureau. She gave the Reds a dose of their own medicine by placing her subversive friends in important posts. Then one day the secret police arrested her together with Nicolai Petrovich and some 94 other German and Japanese agents. Her husband had indeed recognized her at the party. Since she had not looked him up when she came to Moscow, he realized that she could be up to no good. He reported

her. The police had delayed arrest until they could net as many spies as possible.

Canny agents look far ahead and sometimes plan decades in advance. One such British agent met a kindly old German couple. When he learned that they were staunchly anti-Nazi, he proposed that they set up an inn at the North Sea end of the Kiel Canal. It became the custom for outward-bound German submarines to put in at the inn for a last glass of beer in the fatherland. Following the agent's advice, the couple passed out foaming beer on the house. The agent also had suggested an agreeable custom for officers and men to sign a guest book. Both customs continued on into World War II. As soon as the submarine had put out from the inn, the innkeeper seized the guest book, went to his cellar, and hurried through an underground passage to a nearby house where a British radio operator waited to send details to the Admiralty.

Communications are always a problem for an agent in the field. Much intelligence moves by diplomatic pouch which is normally immune from search. Some is enciphered and sent by radio. Fortunately for a spy, the agent with a transmitter in his suitcase is a thing of the past. Thanks to transistors, he is now able to slip his equipment into his pocket. But radio is still a dangerous means of communication, for counter-espionage has little trouble in locating an unauthorized transmitter through triangulation.

Sometimes information is microphotographed. The tiny film as small as the head of a pin is stuck to a letter or postcard and mailed to a neutral country, from which, in due course, it finds its way to headquarters. During Hitler's day German steamship lines were known as the "bridge of spies" because of the flow of information they carried back to Germany. In this air age, airliners have taken over the job of ferrying secret couriers across the oceans with their contraband information.

Finally, both the open and secret intelligence from the field reaches the map room or the situation room as it is sometimes called. There the analysts study it and compare it with information from other sources. There it is compiled into reports and brought to the attention of the nation's leaders. After all the drudgery and danger of gathering intelligence, it galls an intelligence organization, from the spy in the foreign capital to the director at home, when their most urgent and accurate reports are ignored. Russian intelligence must have felt particularly frus-

trated when in 1941 Stalin would not believe conclusive evidence that Germany was about to attack Russia. He refused to take precautionary defense measures and as a result his armies were hurled back all along the frontier.

On the other hand, British agents had cause for satisfaction when they turned in reports gleaned in Greece by infiltrating the Greek communist party. They learned that the Russians were going to strike at both Greece and Turkey. In March, 1947, British leaders alerted Washington to the imminent invasion and admitted that British strength was not sufficient to prevent it. President Truman announced the Truman Doctrine and frightened the Reds off. Both British and American leaders acted swiftly and decisively on intelligence reports. Peace was preserved.

This underlines the fact that intelligence need not serve the cause of war. It serves only to inform policy-making national leaders of the plans and potentials of other nations. Wise leaders will make wise use of intelligence to keep the peace. ★ ★ ★

Movable-Wing Plane

(Continued from Page 90)

Artist G. H. Davis recently visited Dr. Wallis and sketched development steps and projected concepts of the unusual plane, which has backing by the British and U.S. governments; those sketches appear in these pages.

One problem posed in planning a large supersonic plane—Dr. Barnes is making a design study for a 50-ton airliner—is that a long fuselage and swept-back wings would demand landing gear too long to be functional. Dr. Barnes therefore fashioned a variable-geometry plane with a wing comparable to the delta wing except its center portion is missing. The wing can be pivoted forward for takeoff and landing—giving it a wingspread of some 130 feet, or a spread as wide as the plane is long—and tucked back, like tail feathers, to give the configuration necessary for faster-than-sound flight.

The plane should be able to takeoff after a run of 200 or 300 yards at 100 miles an hour ground speed. The four engines, placed in pairs above and under each wing, can swivel from side to side; they also can pitch up or down. So they are to be the elevators and rudders of this remarkable plane which may be the first to have movable wings that will be of real help to man in achieving his age-old desire to soar into the sky. ★ ★ ★

GIGANTIC SURPLUS SALE!

BATTERY HYDRAULIC PUMP



• Item #920. New electric hydraulic pump. Use on lift trucks, loaders, etc. Operates from 12-v truck battery DC, 1000 p.s.i., 1 to 3 rpm. Inlet and outlet ports, 3/8". Size 15" x 7 7/8" x 6", 35 lbs. New, perfect. Use for plow lifts, wagon lifts, etc. Cost Govt. \$175. **\$16.95 SALE** FOR

TRUCK-BOAT WINCH



• ITEM #311. Powerful ball-bearing winch. Reversing switch mounted on winch. For cars, trucks, docks. Use on 6 or 12-v battery, 1000-2000 lb. pulling capacity. Will hold up to 40' cable. Wt. 54 lbs. Govt. cost \$280. **\$46.75 FOR SALE**

GOVT. GEARED BATTERY MOTOR

• ITEM #573. Powerful geared-down motor. Runs on 6 or 12-v. Use for golf cart, boat, farm winch, etc. Reversible. Speed 32-70 rpm. Wt. 3 1/2 lbs. Govt. cost \$250. **\$18.95 FOR SALE**



• Many other values—get catalog.

Write for FREE BIG 1960 CATALOG

Save to 70% on 1000's of Surplus and New Equip. Bargains. MONEY BACK GUARANTEE ON ALL ITEMS

EXAMPLE BARGAINS IN NEW CATALOG
 \$24.50 German Stop Watch* \$14.96
 12.50 S. Warner Tachometer 0-3500 5.25
 65.50 Self Prime Pump, 40 g.p.m. 22.90
 40.00 St. Steel Air Tank 400 p.s.i. 14.95
 4.25 Battery Booster Cables, pr. 2.75
 30.00 Abney Type Sighting Level* 13.50
 250.00 Hyd. Cylinder 1-way, 72" str. 69.50
 65.00 Automatic Sump Pump 39.95
 47.50 Gear Reducer, 20 to 1 8.95
 30.00 Hand Winch, 1500 lb. cap. 15.95
 195.00 Generator, 3000 w., 115 VDC \$4.75
 (All F.O.B. except those marked with *)

SURPLUS CENTER
 LINCOLN, NEBR. DEPT. 811

KIT BOATS

Boat Plans
 Patterns
 Frame Kits

• KIT CATALOGS—Over 50 Models—Pre-assembled, Runabouts, Cruisers, Fishing (8' to 19'). Anyone can assemble. Complete Marine Accessories, Fiberglass plastics, Trailers, Paint, etc. Also Catalog on 50 Modern Plans and Patterns. Prefab Frame Kits—SEND 10c FOR 2-COLORED CATALOGS

FREE FREIGHT—SAVE 2/3
CRAIG-CRAFT, Tonawanda 1L, N. Y.

WISE-GRIP®



DOES MORE JOBS EASIER THAN ANY OTHER TOOL

AT YOUR DEALER

only \$2.15 to \$2.95

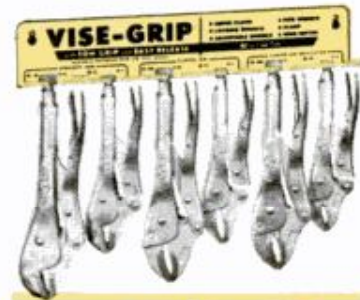

PETERSEN MFG. CO.
 DE WITT, NEBRASKA
 Dept. No. PM-9

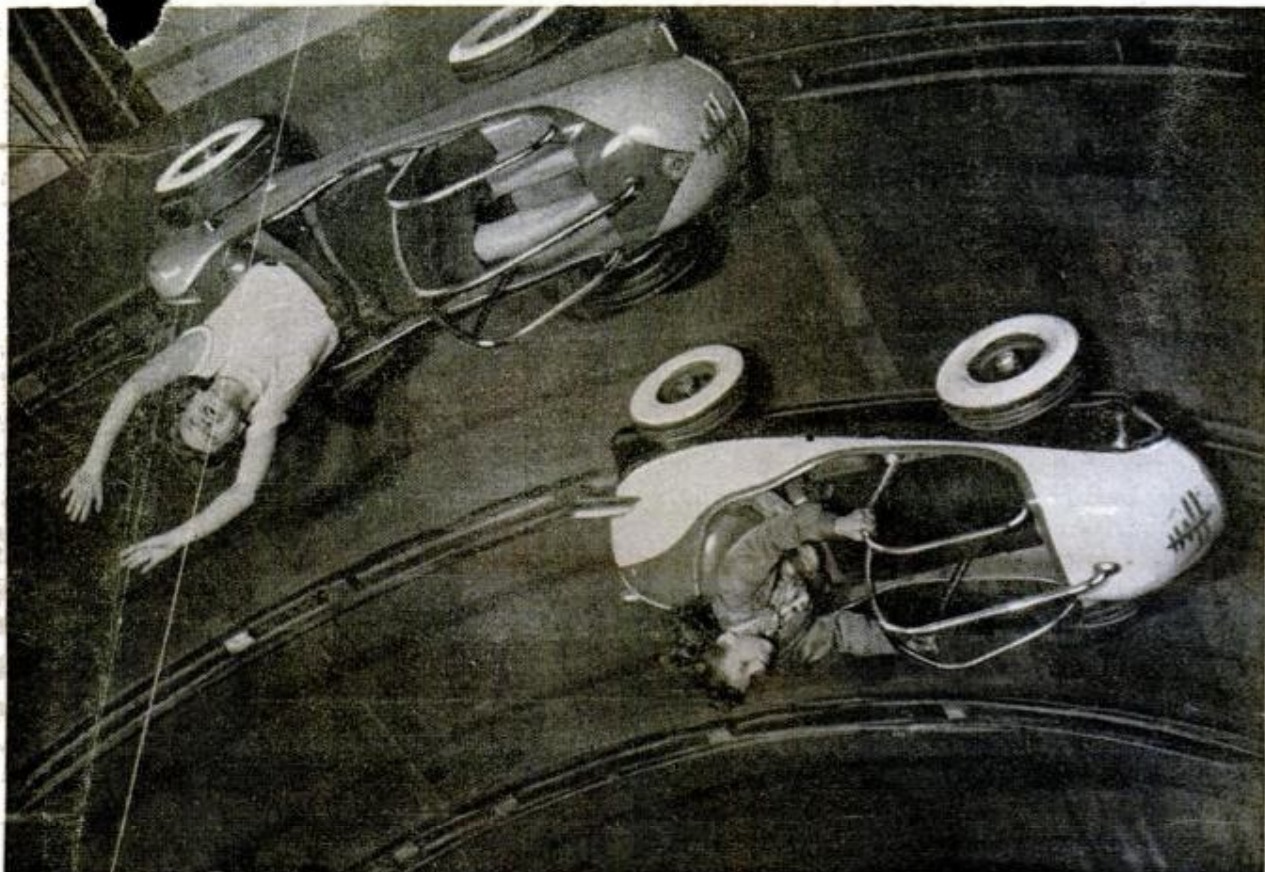

DIZZY WHIRL

By Robert A. Kelly

AMUSEMENT PARKS, like everything else, are changing with the times. There are still enough of the old favorites—the roller coasters, octopi, looping planes and snap-the-whips—to go around, but the park managers and their ride manufacturers are always looking for new ways to scare you as badly as possible without actually placing you in danger of bodily harm.

Armed with their favorite tools—centrifugal force, big (but safe) bumps, and seemingly-precarious heights—they're spinning and bumping and hoisting their customers faster and harder and higher than ever before.

The first rule of successful ride design (and amusement park management) is to scare you at first, but convince you as quickly as possible that there's really no danger. They know you'll come back again and again, whether it's to relive the thrill of the ride, to take someone else through it, or just to prove that it doesn't *really* scare you, even if it does.

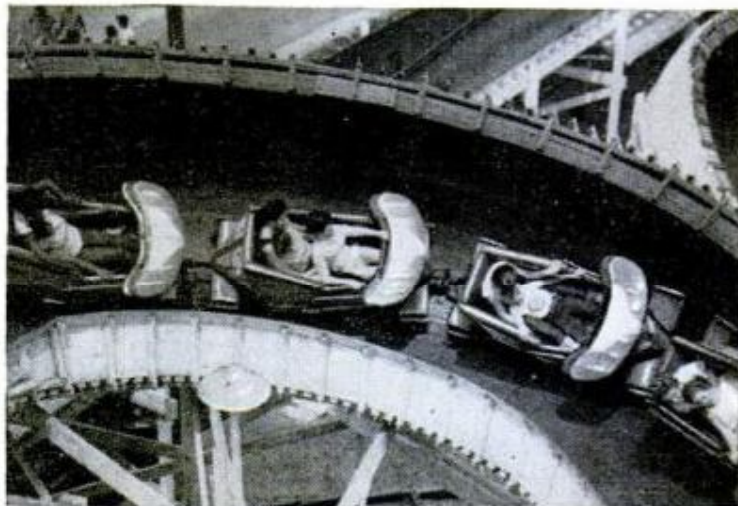

◆ At Chicago's Riverview Park, the Flying Cars spin inside a rotating cylinder on steel tracks. By operating a footbrake, the driver can go up and over inside the cylinder at any speed

Latest variation on the Ferris wheel is the Space Wheel built by Allen Herschel Co. for Pacific Ocean Park in Los Angeles, Calif. Entire structure rotates while the small wheels turn separately

◆ Principle of the big bump goes aquatic at Riverview with their Water Bug. Two passengers ride inside a huge rubber tube boat which is free-running and self-propelled. Note padded cockpits

Perhaps the dizziest whirl is ◆ on the Round-Up built by Frank Hrubetz Co. The wheel turns at high speed, then rises as shown. Riders on top seem to hang suspended, held by centrifugal force

◆ Flying Turns ride at Riverview combines a bobsled run with a roller coaster, with trains of cars racing on a shaped track. This park's rides are designed and built by their own staff

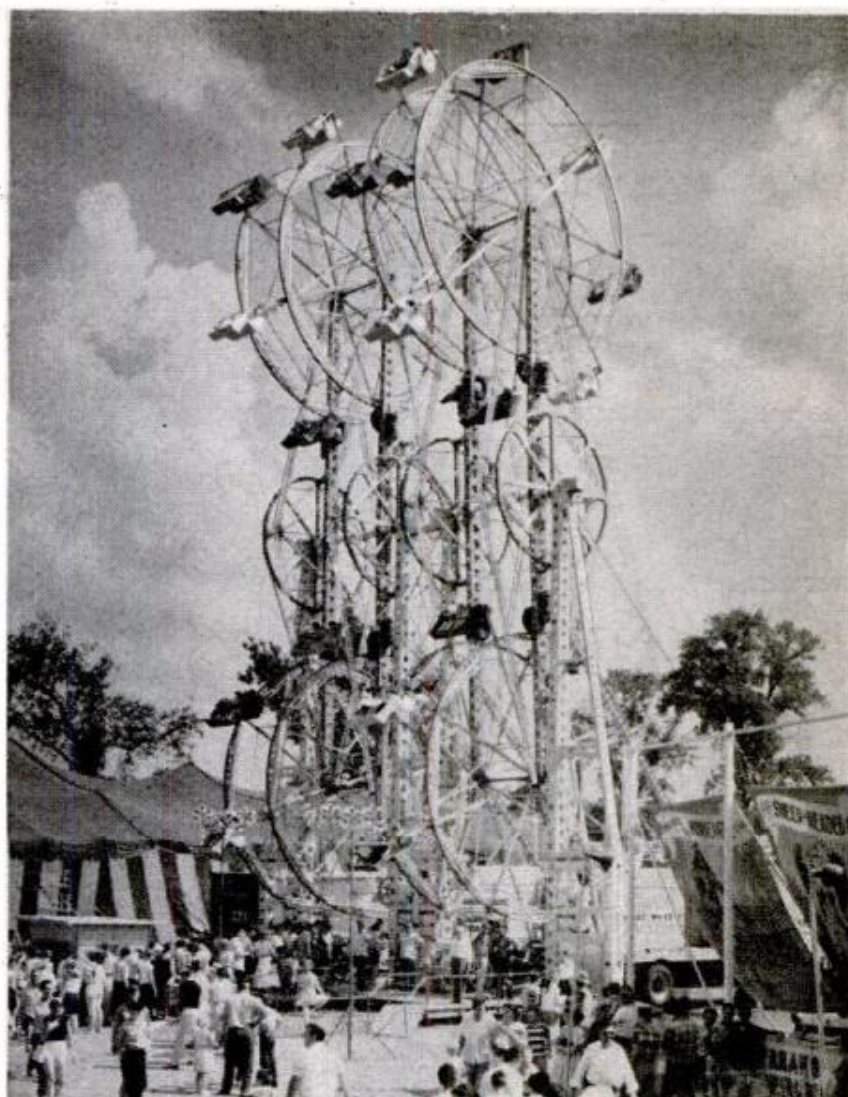



Hand-rubbed finish
without rubbing

McCLOSKEY HEIRLOOM®

The specially developed finish for antiques,
furniture, wall cabinets and paneling

Flows on silken smooth, leaves no brush marks,
never a sheen variation. Heirloom is extremely
pale, nonyellowing, nonstaining—sets up dust-
free in 1 to 2 hours, hardens overnight.

Send for free booklet, "How
to Finish Furniture, Wall Cab-
inets and Paneling with HEIR-
LOOM Varnishes."

McCLOSKEY VARNISH CO.

Dept. 213, 7600 State Rd.
Philadelphia 36, Pa.



put **SKILL** in your hands Dremel **MOTO-TOOL**

In your workshop, on your job
—it's the handiest tool you'll
ever own! Moto-Tool is ideal for
precision grinding, polishing,
carving, drilling, engraving,
deburring, sharpening — does fine
detail work with pin-point
accuracy. It eliminates
time-consuming hand work,
gives the finished job a
professional look. Moto-Tool
weighs only 13 oz. — fits
your hand like it belongs
there. Fastest, most powerful
tool of its kind — develops
27,000 rpm! Widely used by tool
and die makers, model builders,
craftsmen, lab technicians, re-
pairmen, gunsmiths, schools.



Moto-Tool Kit No. 2
with steel case \$27.50

No. 2 Moto-Tool
only\$19.95

See your dealer or write
for free catalog.

DREMEL MFG. CO., Dept. 110-J, Racine, Wis.
Quality Power Tools Since 1934

132



C. van der Lely N. V., Weverskade 10, Maasland, Holland

Rotary Lawn Rake

Fitted with four spoked wheels that
brush loose grass, twigs and leaves to one
side, a lawn rake can sweep a lawn clean
in one continuous operation. Similar to a
side-delivery rake used for raking hay, the
lawn rake has four wheels that are set, one
in front of another, on a diagonal crossbar.
When the rake is pushed forward, the
wheels, which are in contact with the
ground, begin to rotate. For storage, they
can be lifted free of the ground and locked
in place.

Rats Substitute for Man In Spaceship Experiment

Fifty-nine white rats sat in for one man
in an experiment to determine whether
human beings can live comfortably in
space. This many rats consume the same
amount of oxygen as one man and give off
approximately the same amount of carbon
dioxide and moisture. In the experiment,
according to Aerospace Industries Asso-
ciation, the rats were placed in a 100-cubic-
foot chamber resembling a deep-sea diving
bell. An altitude of 15,000 feet was simu-
lated to test a new cabin-conditioning sys-
tem for space vehicles on trips of fairly
short duration. The system relies on a
mixture of liquid oxygen and liquid nitro-
gen held in a single container. If further
tests are successful the 59 rats will have
demonstrated that space crews may work
without pressure suits.

HOW TO SUPERCHARGE YOUR CAR FOR ONLY A DOLLAR



ONE BOTTLE OF **PLUS** CONDITIONS

EIGHTY GALLONS OF GASOLINE

Cleans carburetor and complete fuel system of gums and varnishes... prevents fuel line clogging for faster starting and better gas mileage. Frees sticky valves and removes carbon... restoring power and pick-up and improving compression. Reduces engine rumble and excessive gas knock.

One bottle treats 80 gallons of gasoline

Now A.S.T.M. tests prove Power-Pal products disperse and remove more gums in fuels than other leading brands tested.

At your local dealer or send one dollar today to:

**Motive Specialties Division
NUTMEG CHEMICAL COMPANY**

Dept. PM, 130 Haven St., New Haven, Connecticut

ALSO MANUFACTURERS OF POWER-PAL FOR DIESEL ENGINES



Print Your Own

Cards, stationery, circulars, etc. Save money. Print for Others, Good Profit; easy rules sent. Raised Printing like engraving, too. Junior press \$15; Senior \$29 up. Sold direct from factory only. We furnish everything. Write for free details.

KELSEY PRESSES, Y-37 Meriden, Connecticut



Jiffy SAWHORSE BRACKETS

NO NAILS NO SCREWS NO BOLTS

Now a sawhorse in a jiffy! Just use Jiffy Brackets and 2x4s. Sold by hdw. and bldg. supply stores everywhere, or order direct. \$1.95 A pair. *Higher W. Coast*

GRAND HAVEN STAMPED PRODUCTS CO.

Grand Haven, Mich.

OUR MOON PROGRAM STARTS NOW

Watch for this
exciting feature in
the October issue
of **PM**

**JUST PURCHASED
THE MOST
FANTABULOUS
BUY IN OUR
HISTORY!
10,000
DOUBLE ACTION
HYDRAULIC
CYLINDERS...**

2000
PSI

**SAVE
82%**

HEAVY
DUTY



All sizes, bores and strokes. This purchase made possible by a contract termination on mobile equipment. NOW offered to you at "once-in-a-lifetime", **LOW - LOW Palley PRICES**. Compare - Buy NOW for future needs and insure against breakdowns. Engineered for Earth Moving Equipment, Presses, Tail Gates, Agriculture Equipment, Industrial Machines, Lift Assemblies, Oil, Fields, and hundreds of other uses requiring unusual strength and durability.

ATTENTION PURCHASING AGENTS for Mfrs., City, County, State and Government Agencies. All inquiries promptly handled. Send for special Hydraulics Brochure on other hard-to-find Hydraulic Equipment.

Part No.	Bore	Stroke	Eye-to-Eye Length	Shaft Dia.	PRICE
H-70A	2-1/2"	8-3/8"	18-3/4"	1-1/2"	9.88
H-70B	2-1/2"	10"	21-1/4"	1-1/2"	10.88
H-70C	2-1/2"	15"	26-1/8"	1-1/2"	12.88
H-70D	2-1/2"	23-3/4"	35-1/2"	1-1/2"	18.88
H-70E	2-1/2"	30"	40-1/2"	1-1/2"	24.88
H-70F	2-1/2"	48-1/2"	64-3/8"	2"	29.88
H-70G	3-1/2"	8"	19"	2"	17.88
H-70H	3-1/2"	10-1/4"	21-1/4"	2"	19.88
H-70I	3-1/2"	15-1/8"	26-1/8"	1-3/4"	23.88
H-70J	3-1/2"	22-15/16"	34-1/4"	2"	29.88
H-70K	3-1/2"	30"	41"	1-3/4"	34.88
H-70L	3-1/2"	43-1/2"	55-1/8"	1-3/4"	44.88
H-70M	3-1/2"	47"	64-1/2"	2"	49.88
H-70N	4"	22-1/4"	34-3/8"	2"	36.88

**2,500-lb. LIFT
WINCH HOIST
NOW
37.50**

Has 24 to 1 gear drive with a bronze worm gear. Has 3-speed crank, free-spool clutch & 18ft. of 3/16" cable. **MOUNTING FRAME extra - \$5.00**

**TELEPHONE
REPEATER
AMPLIFIER
4.88**

**COST GOV'T
Approx. \$200**

Made to amplify signals & maintain load balance in phone circuits. Can be used to fire dynamite. Loaded w/tubes, switches, rheostats, etc.

**2,500 PSI
CORNELIUS
AIR
COMPRESSOR**

Has 1/3 HP, 27 V. DC motor. Delivers .04CFM at 2500 PSI. Use where high pressure air is needed. Comes in metal carrying case. **32.50**
Cost Gov't approx. \$629

**1/2 HP
MOBILE AIR
COMPRESSOR
99.50**

Delivers 90 PSI. Adjusts up to 125 PSI. Displaces 2-3/4 cu. in. per minute. With automatic pressure switch, relief valve, gauge, pressure regulator, hose and blun. Has 10 gal. tank and wheels.

Stainless Steel J-1 AIR TANKS - Size: 24"x45". Capacity 18000 cu. in. \$95.00 **Stainless Steel G-1 AIR TANKS - Size: 12 1/2"x24". 400PSI test. . . \$11.95**

**MECHANICS
COVERALLS
3.88**

Cost \$22.00
herringbone twill. Four large pockets. Size: Small and Large.

**ASTRO
COMPASS
ONLY 9.50**

Gives true heading, determines bearing and compass errors. Orig. cost \$87.50

**B-16
MAGNETIC
COMPASS
9.75**

Precision inst. w/floating card. Adjustable cover. For car or plane.

**8 POWER
ELBOW SCOPE
ONLY 9.88**

Field 325 ft. or 1000 yards. 2" objective lens and Kellner eyepiece.

**Gear Head
MOTOR
3.88**

Use to turn antenna, open or close doors, etc. It turns at 1 R.P.M. Set to 90° turn, can reset to a 360° turn.

**2 1/2 TO 1
SPEED REDUCER
14.75**

Gear ratio gives approx. 90 RPM w/direct drive 1750 RPM motor. Operates timing devices, etc.

1500 PSI GEAR PUMP & MOTOR
1 1/2 HP, 24V DC motor. Del. 3 1/2 GPM. \$8.88

1500 PSI 4-WAY HYD. VALVE - Sliding piston type. 7.88
Reg. \$12.75 -

palley's
2263 E. VERNON AVE., Dept. PM-90
LOS ANGELES 58, CALIF.

TO ORDER: Send Check or Money Order. 1/2 dep. with C.O.D.'s. All items shipped postage or freight collect.

NEW DEWALT for only \$199!

Economy 925-E Power Shop,
quality-built as always



YOU SAVE \$50

This 925-E DEWALT gives you features not found in other makes costing 25% more. It's cut-tested for accuracy, power-packed, versatile, safe. See it at your dealer's now. Send coupon for free catalog.

DEWALT, INC., Dept. PM-609, Lancaster, Pa.
Please send me free, 20-page catalog on
DEWALT.

Name _____

Address _____

City _____ State _____

HE JUST DOESN'T HAVE IT!



I OVERHEARD THE BOSS TALKING ABOUT ME—FRANK SMITH! THE WORDS HURT. BUT DEEP DOWN I KNEW THEY WERE TRUE.

I'D WATCHED OTHER YOUNGER MEN MOVING AHEAD, GETTING RAISES...THE GOOD JOBS. WHY WAS I BEING LEFT BEHIND?

GEE—ANOTHER PROMOTION, JIM? CONGRATULATIONS!



THANKS, FRANK. SORRY YOU'RE NOT COMING ALONG, TOO.

THAT NIGHT I FELT DESPERATE. THEN MY WIFE SAID SOMETHING THAT CHANGED MY WHOLE LIFE!



REMEMBER THAT INTERNATIONAL CORRESPONDENCE SCHOOL'S ADVERTISEMENT YOU SAW THE OTHER DAY? I SAVED IT FOR YOU.

SAY! THAT'S AN IDEA—MAYBE I.C.S. CAN GIVE ME THE JOB TRAINING I NEED TO GET AHEAD!

I MAILED THE I.C.S. COUPON. THE FREE CAREER KIT I.C.S. SENT ME BY RETURN MAIL PROVED TO ME WHAT I.C.S. COULD DO.

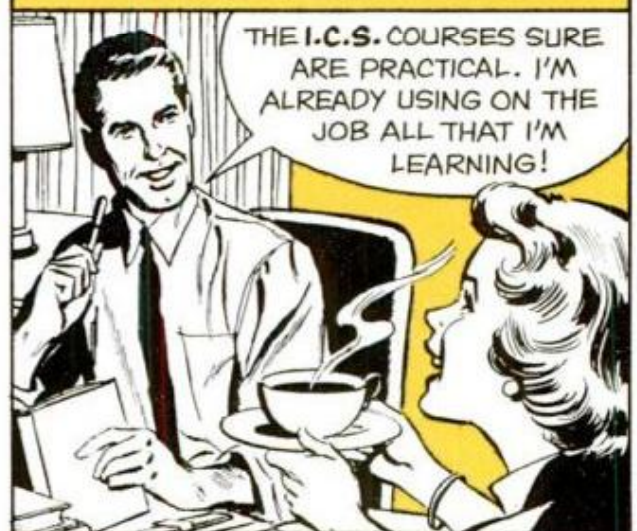

THE I.C.S. COURSES SURE ARE PRACTICAL. I'M ALREADY USING ON THE JOB ALL THAT I'M LEARNING!

THE BOSS HEARD ABOUT MY I.C.S. COURSE. AFTER THREE MONTHS I GOT A GOOD RAISE—AND A LITTLE LATER...



I GUESS I WAS WRONG, FRANK. YOU'VE GOT WHAT IT TAKES. WE'RE GIVING YOU A PROMOTION. YOU EARNED IT, AND THE WAY YOU'RE GOING THERE'LL BE ANOTHER RAISE SOON!

I COULDN'T WAIT TO TELL THE FAMILY THE GOOD NEWS.



I GOT THE PROMOTION! AND ALL BECAUSE YOU SAVED THAT I.C.S. ADVERTISEMENT! MAILING THE COUPON WAS THE BEST MOVE I EVER MADE!



The big difference is **FILTER-BLEND**

...and only Winston has it!



R. J. REYNOLDS TOB. CO., WINSTON-SALEM, N. C.

Remember, Winston was the cigarette that put flavor into filter smoking by developing exclusive **FILTER-BLEND** — rich, golden tobaccos specially selected and specially processed for filter smoking.

Try Winston! It's America's best-selling filter cigarette.



Also available in crush-proof box.

Winston tastes good—like a cigarette should!