

ANNUAL OUTDOOR LIVING SECTION

POPULAR MECHANICS

WRITTEN SO YOU CAN UNDERSTAND IT

APRIL, 1960

35 CENTS



*Outdoor
Living Wall*

**SHELTERED PATIOS...
BARBECUE EQUIPMENT...
PLANTERS...SWIMMING POOLS**

**What Owners Think of the FALCON
SOLVING CRIMES BY HYPNOSIS**



Any cure for spring fever ?

SYMPTOM: Daydreams like this—

You feel a new warmth in the spring sun. A soft wind ruffles the water. The gentle hum of your Evinrude is punctuated by the whir of your reel.

Somewhere below, the "granddaddy" of this lake moves with a lazy rhythm.

Then it happens! The water erupts! You strike, reel in . . . every nerve geared to the taut line and the fighting demon on the other end!

That's spring fever. But, why try to cure it? Relax and enjoy it! Best way to do that is a trip to your Evinrude dealer.

Look at those gleaming new Evinrudes—from 3 to 75 hp! Ask about features that make them the finest fishing motors ever built . . . like thermostat-controlled cooling for longer engine life, smoother trolling . . . sound-sealed cushioned power . . . automatic choke for instant starts . . . full gearshift control . . . slip-clutch propellers Cruis-Throttle fuel economy. These are dream motors. But why dream? For a few dollars down you can make it a happy reality. Ask for colorful 1960 catalog. If you suddenly feel too lazy to go to your dealer—write EVINRUDE MOTORS, 4206 N. 27th Street, Milwaukee 16, Wis.

*A Division of Outboard Marine Corporation
In Canada: Mfd. by Evinrude Motors, Peterborough*

EVINRUDE

**FIRST
IN
OUTBOARDS**

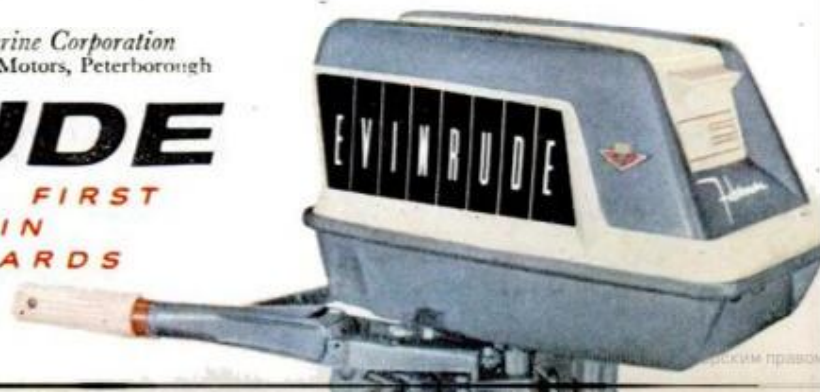



Junction of the Greater New Orleans Expressway and the Greater New Orleans Bridge over the Mississippi.

The World's First Turnpike-Proved Tires

Now precision-built with electronic controls... to give you the three great new tire advances of 1960...

1. Up to 25% more safe mileage—anywhere. Now, the mixing of Goodyear's super-tough tread compound is controlled by electronics. And the other major reason for Turnpike-Proved mileage—triple-tempered 3-T Cord (Rayon or Nylon)—is produced and built into tires with the precision control of electronic eyes.

2. New whisper-quiet, cushion-soft ride. New chemicals permit us to soften tread rubber *without sacrificing mileage*. In fact, because we've been able to produce a rubber that's softer, yet tougher, Goodyear tires now give you up to 25% more mileage than before.

3. New 3-way sureness on the road. Quicker starts—safer stops—better car control on turns. Again, this 3-way Goodyear advance comes not only

from design factors, but from the precision we get from *electronic controls*.

Without question, these are the finest tires we've ever built. You can get them now at your nearby Goodyear dealer—and they won't cost you one cent more. Goodyear, Akron 16, Ohio.

GOODYEAR

MORE PEOPLE RIDE ON GOODYEAR TIRES THAN ON ANY OTHER KIND

Watch the award-winning "Goodyear Theater" on TV every other Monday evening.

Precision-Built
TURNPIKE-PROVED

This One



FXK5-AC5-PGZC

Материал энциклопедий авторским

POPULAR MECHANICS®

Address communications to: 200 E. Ontario St., Chicago 11, Illinois. **SUBSCRIPTION SERVICE:** Mail all subscription orders, changes of address, correspondence concerning subscriptions, and Postmaster notices of undeliverable copies to Popular Mechanics, 250 West 55th St., New York 19, N. Y.

Editor
RODERICK M. GRANT

Executive Vice-President
RICHARD E. DEEMS

Publisher
G. HARRY CHAMBERLAINE

Managing Editor
CLIFFORD B. HICKS

Shop Notes and Crafts Editor
WAYNE C. LECKEY

Associate Editors, General Features
ARTHUR R. RAILTON, Automotive
JOHN A. LINKLETTER

Associate Editor, Shop Notes and Crafts
W. CLYDE LAMMEY

Radio-Television, Electronics Editor
LOTHAR STERN

Assistant Editors, General Features
JAMES BIERY, ROBERT L. HULL, JR.
R. B. KIRKPATRICK

Assistant Editors, Shop Notes and Crafts
EARL WOBECK, GUERRINO F. AMATI

Assistant Editors, Makeup
WALLACE MYERS, JEAN KAVANAUGH

Art Staff
FRANK BEATTY, Director
HENRY NEHRBASS, Assistant Director
RICHARD A. POTTS, Art Editor

Eastern Editor
RICHARD F. DEMPEWOLFF
Room 4102, Empire State Bldg.,
New York City 1

Western Editor
THOMAS E. STIMSON, JR.
Suite 1003, 3460 Wilshire Blvd.,
Los Angeles 5, Calif.

Advertising Manager
JOSEPH R. BUELL, JR.

Director, Bureau of Information
ALLAN CARPENTER

Advertising Offices
Chicago: 200 E. Ontario St., Whitehall 4-0100;
New York: Empire State Bldg., 350 Fifth Ave.,
LONGacre 5-7580; Detroit: General Motors
Bldg., TRinity 5-8711; Cleveland: Hanna
Bldg., 1422 Euclid Ave., PRospect 1-0456; Los
Angeles: 3460 Wilshire, DUnkirk 2-8458; San
Francisco: Russ Bldg., 235 Montgomery St.,
Yukon 2-0823.

Published monthly by Popular Mechanics Company,
200 E. Ontario St., Chicago 11, Ill. Richard E.
Berlin, President; Richard E. Deems, Executive
Vice-President; Fred Lewis, Vice-President and
General Manager; John R. Miller, Vice-President;
G. Harry Chamberlaine, Vice-President; G. O. Mar-
kuson, Treasurer; R. F. McCauley, Secretary. Single
copy in the United States and Canada, 35 cents;
subscription rates in the United States and pos-
sessions and Canada, 1 year \$3.50; 2 years,
\$6.00; 3 years, \$8.00. In countries of the Pan-
American Postal Union, 1 year \$4.50; 2 years,
\$8.00; 3 years \$11.00. In all other countries 1
year \$5.50; 2 years \$10.00; 3 years \$14.00.
If you plan to move, notify us at least 30 days in
advance so you will not miss an issue. Give both
your old and new addresses. Second-class postage
paid at Chicago, Illinois, and at additional mail-
ing offices. Entered as Second Class Matter at
Post Office Dept., Canada. Registered as Second
Class Matter at the Post Office at Mexico, D.F.,
Mexico, June 20, 1950. © 1960 by Popular
Mechanics Company. All rights reserved. Printed
in the United States of America.

INTERNATIONAL EDITIONS

SPANISH: Mexico-Caribbean, Southern Hemisphere
FRENCH, DANISH, SWEDISH, GERMAN, PORTUGUESE, DUTCH

Volume 113

APRIL 1960

Number 4

In This Issue...

The Army's Electronic Magic Shop	- - -	81
Jackie Gleason's Round House	- - -	88
Policing Iceberg Alley	- - -	90
Revolutionary Engine	- - -	96
Owners Report on the Falcon	- - -	98
Solving Crimes by Hypnosis	- - -	106
Nose Count, 1960	- - -	113
In Search of Plants That Cure	- - -	121
Sneak up on the Bass	- - -	134

For the Craftsman...

OUTDOOR LIVING—

Patios, Storage Wall, Barbecue Equipment, Planters	144
Swimming Pools—Part I	160
The PM Houseboat—Conclusion	170
Decorative Block Walls	174
Variety in Room Dividers	190
Faceplate Turning	200
Radio, TV and Electronics	213

Regular Departments...

WHERE-TO-BUY-IT INDEX - - - 6

Know This Old-Timer	12	Detroit Listening Post	95
Pentagon Sidelights	20	Solving Home Problems	178
Pioneer of Science	22	On the Market	206
Spotlight: Ford Anglia	70	Shopping for Tools	210
An Eye on Space	87	Clinic for Homemakers	224

Turn to detailed index on page 6. Sources of additional information on items in this issue are shown on the Where-to-Find-It List, available without charge by writing the Bureau of Information, Popular Mechanics, 200 E. Ontario St., Chicago 11, Ill.

Next Month...

WONDERING what to do about your vacation this year? A special 17-page section of the May issue is devoted to holidays galore—from 10 unusual vacations (we'll bet you've never heard of most of them) to "Tips on Tenting," vacation cabins, and what you can expect to find in driving the nation's toll roads. . . . Also in May, Valiant owners answer the question: How good can a compact be?

ATTENTION OWNERS OF 2-HEADLAMP CARS

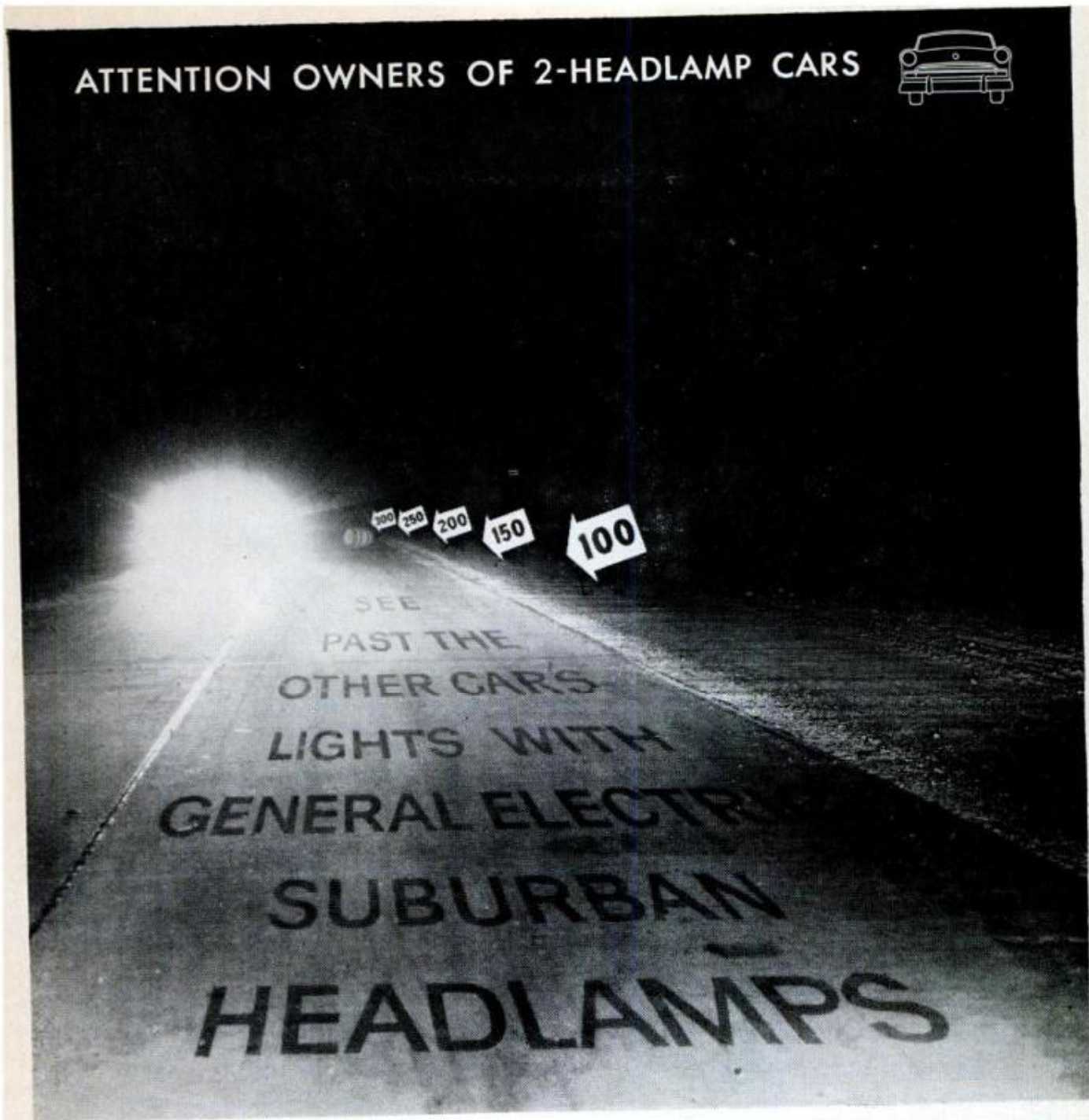

This picture was taken with new G-E SUBURBAN Headlamps *on the low beam*. See the barrel in the road beyond the lights of that oncoming car? With the low beam of ordinary headlamps, you'd be lucky if you saw it in time.

With new G-E SUBURBAN Headlamps you can see better in spite of the other car's lights—even when drivers fail to "dim" for you. Only General Electric puts the low beam

filament *on-focus* to provide a "spotlight" effect that gives you *twice as much light as previous two-headlamp systems*—down the right side of the road where you need it.

Get a pair of G-E SUBURBAN Headlamps for *your* 2-headlamp car—and be sure you have them aimed properly. Enjoy safer night driving from now on! General Electric Co., Miniature Lamp Dept. M-05, Nela Park, Cleveland 12, Ohio.



Have a pair of G-E SUBURBAN Headlamps installed and aimed today. Look for the big G-E monogram (bigger than a quarter).

Progress Is Our Most Important Product

GENERAL  ELECTRIC

APRIL 1960



Photographed at Florida's Silver Springs

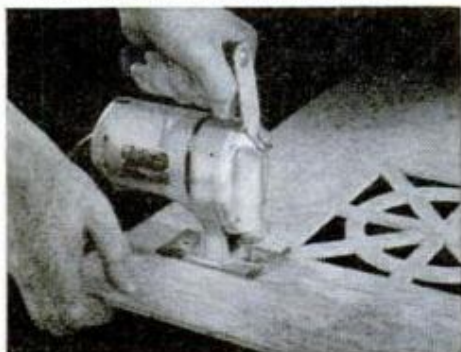

B&D's IMPROVED JIG SAW gives 25% faster cutting, better control. Cuts straight, curved or intricate designs. Two extra blades free. Only \$29.95.

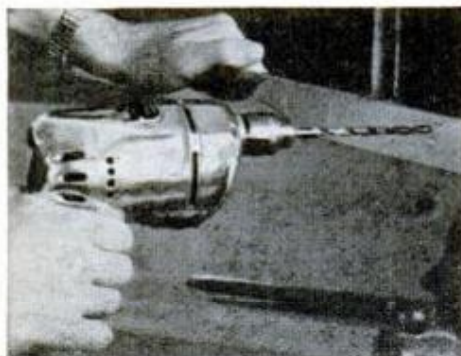

B&D's 1/4" DELUXE UTILITY DRILL packs a reserve of power to drive major attachments. B&D Drills from \$16.95. Attachments from \$9.95.

Less time for trimming— More time for living!

Give you ideas? Want to take the backache out of trimming? Have time for *living*? Well, why wait? Here's a truly professional Black & Decker Lawn Trimmer 'n' Edger at a homeowner price! Say "Goodbye!" to *all* hand work around trees, along walls and walks, on slopes. Take a look at B&D's Hedge Trimmers, too. Famous B&D power, *handling ease and durability*, of course.

50th YEAR

For free power tool catalog, write: The Black & Decker Mfg. Co., Dept. D-040, Towson 4, Md.

See 'Tools-Electric' -YellowPages- for Service & Sales

Black & Decker®

WORLD'S LARGEST MAKER OF PORTABLE ELECTRIC TOOLS

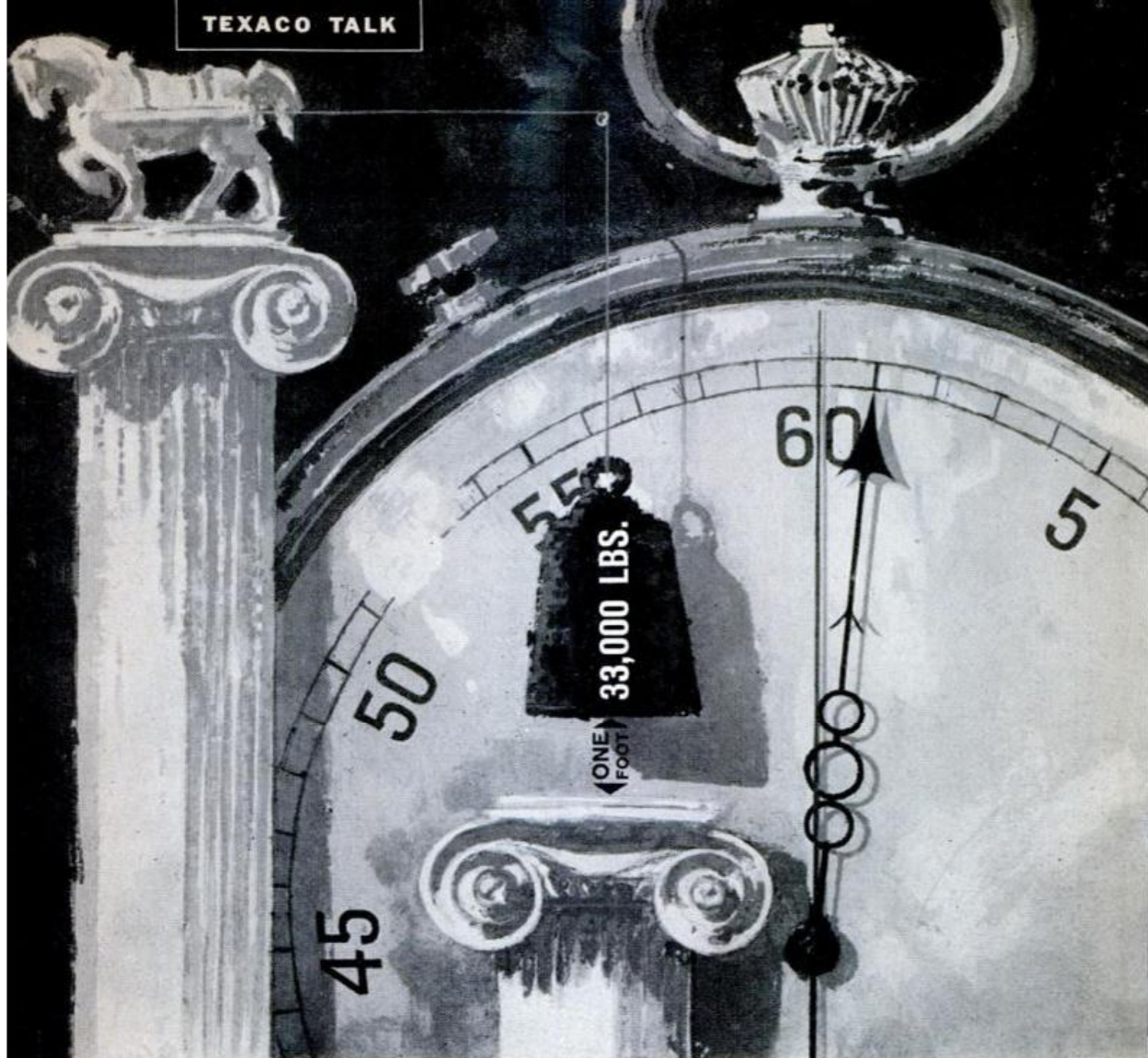

What horsepower really means

James Watt, the inventor of the steam engine, determined that a husky horse could lift a weight of 33,000 pounds one foot in one minute. He called this horsepower.

Automobile manufacturers later adopted what they call *brake* horsepower—so named because they used a brake on the flywheel of the engine to measure horsepower. The method of measuring brake horsepower has undergone changes over the years, but the term is the one in everyday use.

Brake horsepower simply means the developed power that's actually delivered at

the engine's flywheel and therefore available to drive the car's wheels. The average American compact car engine has about 90 "horses," while the most powerful American car engine has about 350.

Be sure to get all the power your engine can develop. Your Texaco Dealer has two great gasolines for your driving needs: top octane Sky Chief Supreme, with Petrox... or famous *regular-price* Fire Chief. You drive with more pleasure and save for good measure, at Texaco's Tower of Power.

Buy the best... buy TEXACO

TUNE IN: TEXACO HUNTLEY-BRINKLEY REPORT/MONDAY THROUGH FRIDAY/NBC-TV



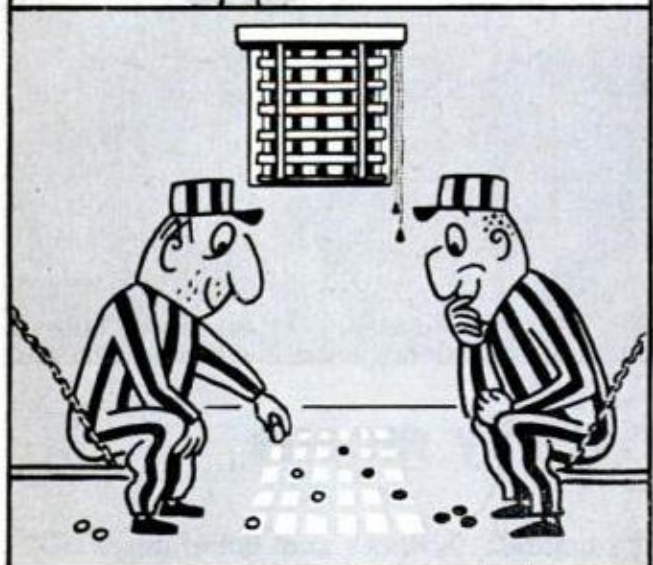
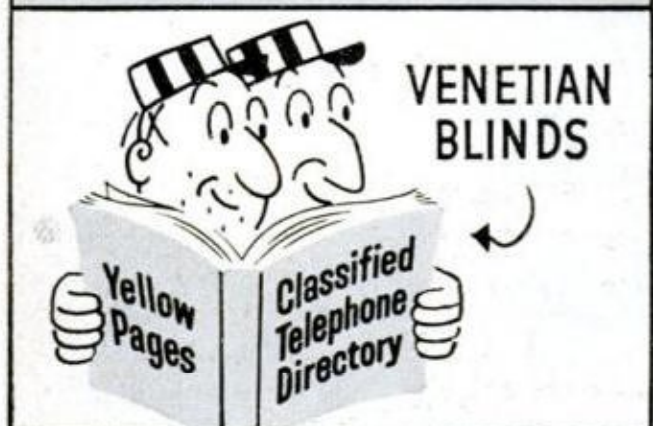
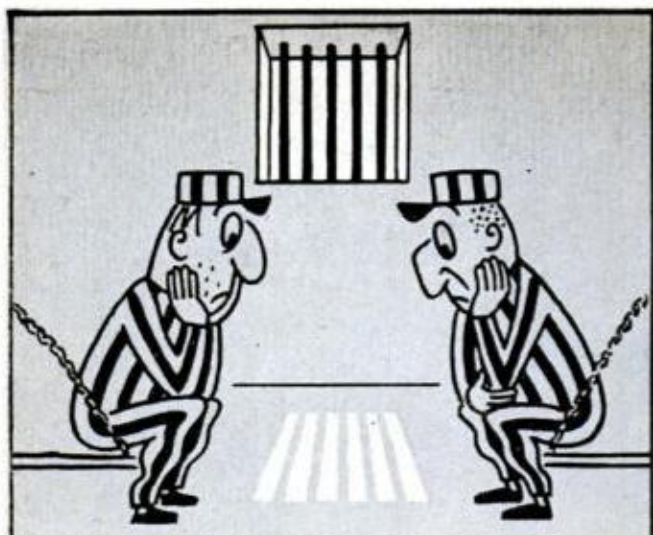

games, furniture, hardware,
jewelers, plumbers, shoe repair
whatever you need—



Advertisers displaying this emblem
make your shopping easy.

GUIDE TO THIS ISSUE

With Sources of New Products

Automotive

- Kit puts shift on floor (California Equipment Co., Mfr. Div., P. O. Box 8036, Northgate Station, Seattle 55, Wash.)104
- Self-expanding trailer becomes camp home (Holite, Inc., Grantsburg, Wis.)110
- Extended-shell spark plug (A. C. Spark Plug Div., General Motors Corp., Flint 2, Mich.)120
- Replacement carbs for imports (Carter Carburetor Div., ACF Industries Inc., 2840 Spring Ave., St. Louis, Mo.)...143

Aviation

- Here's a peek at tomorrow's huge planes 86
- 500-foot high jump111
- Pill detects water in jet fuel (Esso Research and Engineering Co., 15 W. 51 St., New York 19)118
- It might fly if it had wings—or an engine (Ghia Auto Body Shop, Turin, Italy)119
- Double feature! (Transports Aeriens Intercontinentaux, 23 Rue de la Paix, Paris 20, France)125
- Vertiplane really puts flaps down128
- Aircraft jet engine pumps natural gas (The Cooper-Bessemer Corp., Mount Vernon, Ohio)230

Construction

- Giant pipes support bridge to Swedish mainland128
- Rome being built in our day129
- The church that's built of straw (Father Francis Dales, Sexsmith, Alberta, Canada)130
- Farmer builds bridge of gas pipe (Lawrence W. Crouse, Rogersville, Pa.)139
- Inflated plastic domes shelter winter builders143

House and Home

- Jackie Gleason's round house 88
- Amsterdam's narrow house103
- Geodesic canopy can be assembled by home owner (Pease Woodwork Co., 900 Forest Ave., Hamilton, Ohio)118
- One-man house (Building Center, P. O. Box 299, Rotterdam, Holland)141

Miscellaneous

- Revolutionary engine (Curtiss-Wright Corp., Wood-Ridge, New Jersey) 96
- Clean way to clean type (Minnesota Mining and Mfg. Co., 900 Fauquier St., St. Paul, Minn.)103
- Bed for traveling dog (Porta Company, Inc., 32 Neponset St., Canton, Mass.)104
- Portable handwagon hauled like trailer (Wenger Music Equipment Co., P. O. Box 300, Owatonna, Minn.)105
- Armon electric trap grabs burglar's leg (Sweigert Protection Co., Inc., Wilmington, Del.)112
- Merry-go-round house for Japanese hens112
- Balancing mount stabilizes camera (Howard Dearborn Inc., 678 Front St., Berea, Ohio)118
- Bridge for gymnasts arches across pool (Williams Form Engineering Corp., 1501 Madison Ave. S.E., Grand Rapids, Mich.)129
- Ships dock in huge mass of "soap bubbles"132
- Wind-up plug for bass (H. L. Whitmer, Giftsearches, P. O. Box 11603, Mt. Lebanon 28, Pa.)132

(Continued to page 8)

5 reasons why ACCOUNTING

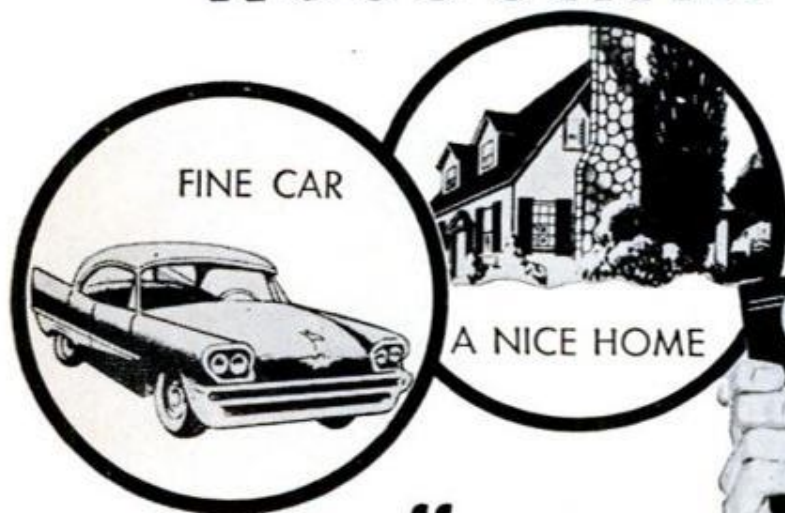

offers you

MORE MONEY and SUCCESS



**SEND FOR FREE
SAMPLE LESSON**

REASON #1. If you were an expert accountant right now, chances are you would find yourself in one of the best paid fields of business.

REASON #2. The demand for accountants is great—everywhere. All businesses must have trained accountants to cope with ever-growing requirements. It's a field offering wide opportunity—always—to the man who knows.

REASON #3. You can fit into any business, anywhere in the country—because accounting principles are universal. Think what this means in terms of security and independence!

REASON #4. Accounting is open to all. Any man or woman of good intelligence, who enjoys figure work and is willing to follow LaSalle's systematic "problem method" plan, can rapidly qualify for a highly profitable, enjoyable lifetime career . . . and he doesn't have to finish his training before beginning to "cash in."

LASALLE
417 S. Dearborn St.,
CHICAGO 5, ILL.

REASON #5. Without losing a day from your present work, you can prepare in spare hours at home, at low cost, under LaSalle's step-by-step "Problem Method" of "learning by doing." This famous plan accounts for LaSalle's remarkable record of having trained one out of every 13 of all Certified Public Accountants in the U. S. . . . and of having put many thousands of others into high-paying careers.

Send today for Free Sample Lesson and "Opportunities in Accounting." Learn about the several great fields of opportunity . . . and LaSalle's time-tested plan for helping men and women to rapid advancement, higher income and greater prestige. The coupon below will bring this information to you—without cost or obligation.

Accredited Member, National Home Study Council

SEND FOR FREE BOOK

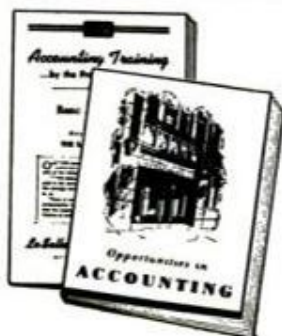

LaSalle Extension University
— A Correspondence Institution —

Dept. 464H 417 S. Dearborn St., Chicago 5, Ill.
Please send me, free of all cost or obligation, free sample lesson and your latest book, "Opportunities in Accounting."

Name.....Age.....

Address.....

City, Zone, State.....

Skilled Machinists

Prefer South Bend

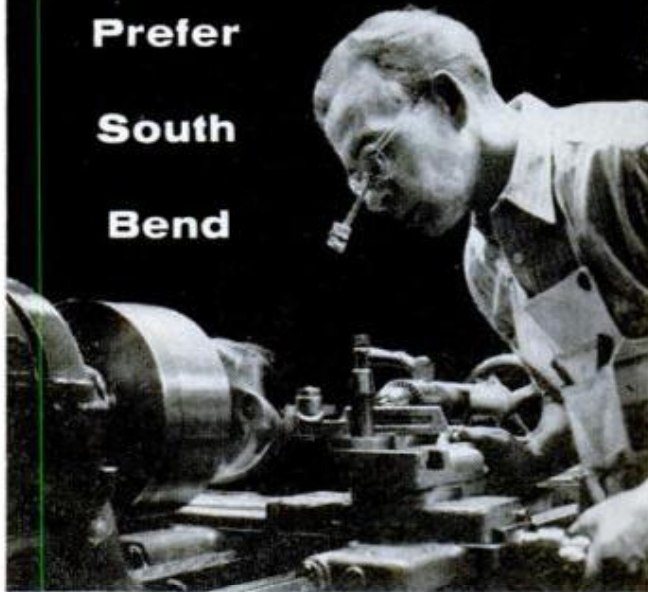

Photo from Learcal Division, Lear, Inc., Los Angeles

The day of the precise craftsman is not past. You should see how some of the nations finest workmen go about doing their jobs with painstaking accuracy.

Such accuracy is absolutely vital in the manufacture of many of the precision components that make this "Space Age" possible.

To get the accuracy and fine finish so necessary on precision parts, skilled machinists choose South Bend 16" Lathes.

- Dependable—Trouble-Free
- Spindle bearings designed specifically for precision work.
- Quiet running—No Vibration—No Gear Marks—Delivers parts with extremely fine finish.

Prices of South Bend 16" Lathes start at \$2468 f.o.b. factory

Write for catalog of South Bend Lathes, Milling Machines, Shapers, Drill Presses and Pedestal Grinders

SOUTH BEND



LATHE

SOUTH BEND 22, INDIANA

BUILDING BETTER TOOLS
SINCE 1906

Up to 36
months to pay.

Hey! look at the blonde!.....	133
Suction cup holds a dog.....	140
Dali's ovocipede.....	140
Wrist life preserver (Sgt. Daniel O. Davis, 2227 Camellia Drive, Wilmington, N. C.).....	140
Bow turns flame thrower for oilman.....	142
Inboard-outboard runabout (Joseph Bryan, 1616 Pine St., St. Joseph, Mo.).....	142
Rush-hour reading glasses.....	142
Truck cab serves as bus stop (Mr. Grover Brinkman, Okawville, Ill.).....	143

Science

Tester finds right metals (General Electric Co., Schenectady, N. Y.).....	103
Plastic "igloo" shelter (Atlantic Research Corp., 321 Montgomery St., Alexandria, Va.).....	104
"Live water" aeration cuts swimming pool algae (Polk Pool Products Inc., 6388 S. Dixie Highway, So. Miami 38, Fla.).....	112
Look—No mom! (K&K Mfg. Inc., 1001 Washington Ave. South, Minneapolis 15, Minn.).....	120
These men "operate" rivers.....	133
Rocker applies traction (Edward Munz and Co., 6 Friedestr, Wuerzburg, W. Germany).....	258

Radio, TV and Electronics

Personalized stereo fidelity.....	213
-----------------------------------	-----

Craftsman and Shopnotes Index

Boats

Upholster your boat.....	169
Temporary dry rot repair.....	180
Pipe cap locks tire on dock post.....	196

Fishing

Durable surf-fishing spike made from angle and pipe.....	180
Holder carries fishhooks safely.....	180
Pocket-size tackle box.....	184

Garden and Yard

Bench set on iron supports.....	180
Mobile patio screen.....	184
Leak in garden sprayer repaired with screw and faucet washer.....	188
Lawn sprinkler caddy.....	189

House and Home

Hanging wall desk.....	165
Dog-dish anchor.....	168
Decorative block walls.....	174
How to care for marble.....	177
Wall light hides film screen.....	177
Tips to keep sash in top shape.....	182
Doorbell system does double duty as basement-flooding alarm.....	188
Decorative concrete-block screen.....	196
Painted "on" face of switch serves as "pilot light".....	196

Miscellaneous

Filter on sanding board cleans draftsman's pencil.....	167
Matchbox scratching surface subs for sanding board.....	167
Newspaper torch.....	168
Pipe-cleaner ties.....	168
Seedling sunshades.....	168
Dual tractor wheels double traction on soft ground.....	181

(Continued to page 10)

How to pass a genius



All of us can't be geniuses. But any ordinarily talented mortal can be a success—and that's more than some geniuses are.

Now, as in Æsop's time, the race doesn't always go to the one who potentially is the swiftest. The *trained* man has no trouble in passing the genius who hasn't improved his talents.

In good times and bad times, in every technical and business field, the *trained* man is worth a dozen untrained ones, no matter how gifted.

The International Correspondence Schools can't make you into a genius. For more than 67 years, however, I. C. S. has been helping its students to become *trained, successful leaders*—and it can do the same for you.

Mark your special interest on the coupon. Don't be like the unsuccessful genius who wastes his life in dreaming of what he intends to do. Act now!

For Real Job Security—Get an I. C. S. Diploma! I. C. S., Scranton 15, Penna.

Accredited Member, National Home Study Council

INTERNATIONAL CORRESPONDENCE SCHOOLS



BOX 59953X, SCRANTON 15, PENNA.

(Partial list of 258 courses)

Without cost or obligation, send me "HOW to SUCCEED" and the opportunity booklet about the field BEFORE which I have marked X (plus sample lesson):

ARCHITECTURE and BUILDING CONSTRUCTION

- Air Conditioning
- Architecture
- Arch. Drawing and Designing
- Building Contractor
- Building Estimator
- Carpenter Builder
- Carpenter and Millwork
- Carpenter Foreman
- Heating
- Painting Contractor
- Plumbing
- Reading Arch. Blueprints

ART

- Commercial Art
- Magazine Illus.
- Show Card and Sign Lettering
- Sketching and Painting

AUTOMOTIVE

- Automobile
- Auto Body Rebuilding and Refinishing
- Auto Engine Tuneup
- Auto Technician

AVIATION

- Aero-Engineering Technology
- Aircraft & Engine Mechanic

BUSINESS

- Accounting
- Advertising
- Business Administration
- Business Management
- Cost Accounting
- Creative Salesmanship
- Managing a Small Business
- Professional Secretary
- Public Accounting
- Purchasing Agent
- Salesmanship
- Salesmanship and Management
- Traffic Management

CHEMICAL

- Analytical Chemistry
- Chemical Engineering
- Chem. Lab. Technician
- Elements of Nuclear Energy
- General Chemistry
- Natural Gas Prod. and Trans.
- Petroleum Prod. and Engr.
- Professional Engineer (Chem)
- Pulp and Paper Making

CIVIL ENGINEERING

- Civil Engineering
- Construction Engineering
- Highway Engineering
- Professional Engineer (Civil)
- Reading Struc. Blueprints
- Sanitary Engineer
- Structural Engineering
- Surveying and Mapping

DRAFTING

- Aircraft Drafting
- Architectural Drafting
- Drafting & Machine Design
- Electrical Drafting
- Mechanical Drafting
- Sheet Metal Drafting
- Structural Drafting

ELECTRICAL

- Electrical Engineering
- Elec. Engr. Technician
- Elec. Light and Power
- Practical Electrician
- Practical Lineman
- Professional Engineer (Elec)

HIGH SCHOOL

- High School Diploma

- Good English
- High School Mathematics
- High School Science
- Short Story Writing

LEADERSHIP

- Industrial Foremanship
- Industrial Supervision
- Personnel-Labor Relations
- Supervision

MECHANICAL and SHOP

- Diesel Engines
- Gas-Elec. Welding
- Industrial Engineering
- Industrial Instrumentation
- Industrial Metallurgy
- Industrial Safety
- Machine Shop Practice
- Mechanical Engineering
- Professional Engineer (Mech)
- Quality Control
- Reading Shop Blueprints
- Refrigeration and Air Conditioning
- Tool Design
- Tool Making

RADIO, TELEVISION

- General Electronics Tech.

- Industrial Electronics
- Practical Radio-TV Eng'g
- Practical Telephony
- Radio-TV Servicing

RAILROAD

- Car Inspector and Air Brake
- Diesel Electrician
- Diesel Engr. and Fireman
- Diesel Locomotive

STEAM and DIESEL POWER

- Combustion Engineering
- Power Plant Engineer
- Stationary Diesel Engr.
- Stationary Fireman

TEXTILE

- Carding and Spinning
- Cotton Manufacture
- Cotton Warping and Weaving
- Loom Fixing Technician
- Textile Designing
- Textile Finishing & Dyeing
- Throwing
- Warping and Weaving
- Worsted Manufacturing

Name _____ Age _____ Home Address _____
 City _____ Zone _____ State _____ Working Hours _____ A.M. to P.M. _____
 Occupation _____

Canadian residents send coupon to International Correspondence Schools, Canadian, Ltd., Montreal, Canada. . . . Special low monthly tuition rates to members of the U. S. Armed Forces.

IDEAL!



for farmers

... for hunters

.. everyone who finds the weather wet and the going tough!



No. 1188

1. Soft, tan Syl-Mer treated upper leather breathes ... lets heat and perspiration out... won't let water in.
2. Uppers stay soft for the life of the shoe.
3. Leather laces.
4. Caulk welt.
5. Uppers Vulcanized to brown corker sole and heel.

RANGER

HEAVY DUTY SHOES

"THE GREATEST NAME
IN WORK SHOES"

For name of your dealer write:

ENDICOTT  JOHNSON

Endicott 1, N. Y.

Cattle guards—permanent and portable.....	181
Pencil flashlight aids in scale reading.....	184
Here is the way to a better wax job.....	185
Earthbound play spaceship made from aircraft drop tank...	188
Homemade hand truck eases moving chores.....	197
Dual-purpose ski rope.....	198

On the Market

Sealer protects concrete.....	206
Redwood finish.....	206
Fiber pipe elbow.....	207
Aluminum in a tube.....	207
Sash lock.....	207
Wipe-on liquid.....	207
Surface-mounted electrical outlets.....	207
Wedge-shaped cork strips.....	207

Photography

Curtain rod used as mall stick.....	167
Darkroom graduate.....	168
Equipping a home darkroom.....	176
Convenient place for carrying filters.....	176
Finding the right filter in darkroom.....	176
Skylight filter.....	176
Storing tripods.....	176

Solving Home Problems

Keep garments from sliding together on clothesline.....	178
Soap easily found when in the shower.....	178
Removing broken lamp bulb.....	178
Easy to retrieve fallen cloths when washing windows.....	178
Palm wrench can be made from rubber ball.....	178
Clogged kitchen or bathroom drain easily cleaned.....	178
Caster wheels kept from making streaks on floors.....	179
Window air conditioners can be kept clean.....	179
Easy way to start a syphon.....	179
Remove hard, dry putty.....	179

Shopping for Tools

Clamp and finger guide.....	210
Blind fastener.....	210
Hand-operated sharpener.....	210
Wood screw drills.....	210
Paintbrush comb.....	211
Gap gauge.....	211
Plastic nozzle.....	211
Modular drilling unit.....	211
Subminiature speed reducer.....	211
Ultrasonic resonance gauge.....	211
Drill stand.....	212
Balancer for rotary power mower.....	212
Rotary pump.....	212
Abrasive band.....	212

Workshop Hints

Bolts used as masonry anchors.....	167
Dispenser for wire solder made from tape holder.....	167
Pantograph lubricant.....	168
Squares used as calipers.....	184
Heavy-duty support jack.....	196
Socket-head wrench and rod make efficient speed wrench...	204
Tape indicates setting of lathe gear train.....	204
Fixture holds drill bushing securely on grinder.....	204
Coating of rubber cement keeps tools rust-free.....	205
Socket ratchet converted to offset screwdriver.....	205
Cardboard on drill bit clears away shavings.....	205
Socket-head wrenches stored in metal bench-top holder.....	205
Jig cuts gaskets to order.....	208
Nut used as tap-drill gauge.....	208
Plane gauges work surface.....	208
Rust erased from tools.....	208
Setting swivel-base machine vise.....	209

NOTICE—It is the intention of this magazine to provide its readers with information regarding the latest developments in the mechanical arts. Except where otherwise indicated, this magazine has no information as to any unexpired patents in respect of the developments reported herein. In the event that commercial use is to be made of any of the developments reported herein, it is suggested that legal counsel be consulted to avoid liability for patent infringement. It is not the purpose of this magazine to encourage patent infringement but, as indicated, it is the intention of this magazine to report on the latest developments in the mechanical arts.

For a Successful Career in Radio-Television Electronics

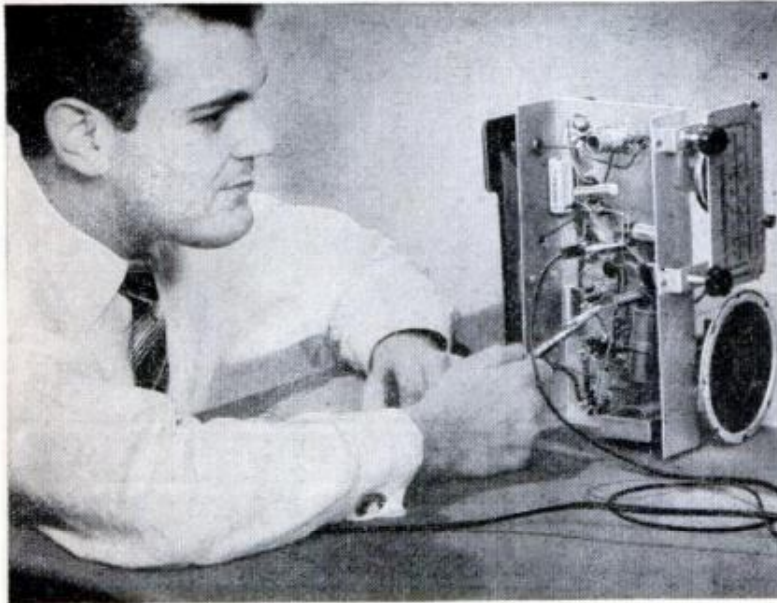

Train at Home
in Spare Time
with N. R. I.
**OLDEST and
LARGEST**
Home Study Radio-Television School

N.R.I. Trained These Men

ENGINEER STATION WHPE
"Thanks to NRI, I operated a successful Radio repair shop. Now I am an engineer for WHPE."
VAN W. WORKMAN, HIGH POINT, NORTH CAROLINA



QUICK SPARE TIME CASH
"Knew nothing about Radio-TV when I enrolled. After 15 lessons started repairing sets. My future looks bright."
DONALD B. ACKERMAN, MINNEAPOLIS, MINNESOTA

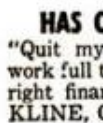

HAS OWN TV BUSINESS
"Quit my job to do Television work full time. I love it and do all right financially."
WILLIAM F. KLINE, CINCINNATI, OHIO



Prosperous Fast Growing Industry Offers You GOOD PAY-BRIGHT FUTURE-SUCCESS

It's the trained man who gets ahead—gets the better job, drives a better car, lives in a better home, is respected for what he knows and can do. For a job with a future—find out how you can train at home for Radio-Television.

TODAY'S OPPORTUNITY FIELD

Training PLUS OPPORTUNITY is the ideal combination for success. And today's OPPORTUNITY field is Radio-Television. Over 125 million home Radios plus 30 million sets in cars, plus 40 million TV sets mean big money for trained Technicians. More than 4,000 Radio and TV broadcasting stations offer interesting and important positions. Color television, portable TV sets, Hi-Fi, assure future growth. Find out about NRI. Since 1914—for more than 40 years—NRI has been training ambitious men

at home in spare time for Radio-TV. With NRI 50-50 method, you study basic principles AND learn by practicing with actual equipment NRI furnishes. You learn with your hands and your head. You get dependable training, backed up by the reputation of the oldest and largest home study Radio-TV school.

ADD TO YOUR INCOME SOON \$10-\$15 A WEEK IN SPARE TIME

Soon after enrolling many start earning extra money fixing sets. Many open their own full time Radio-TV shops after getting NRI Diploma. MAIL COUPON. Get FREE Sample Lesson and 64-page Catalog showing equipment supplied, outlines of courses, opportunities in Radio-TV. Price is low—terms easy. Address: **NATIONAL RADIO INSTITUTE, Dept. ODA, Washington 16, D. C.**

You Learn Servicing—Broadcasting at Home—By Practicing with Kits N.R.I. Sends

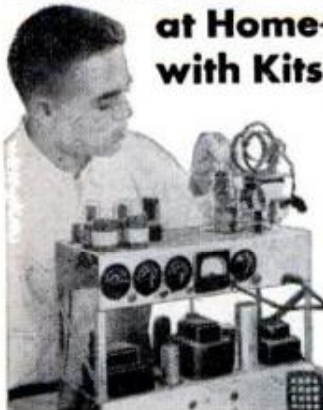

Nothing takes the place of practical experience. That's why NRI training is Learning-by-Doing. With Servicing Course you build Radio shown at top and other equipment. With Communications Course you build Transmitters at left and other equipment. Catalog shows all equipment you get.

Available To
VETERANS
Under G.I. Bills



SAMPLE LESSON AND CATALOG FREE

MAIL COUPON TODAY

National Radio Institute
Dept. ODA, Washington 16, D. C.

Mail me Sample Lesson and 64-Page Catalog FREE. (No salesman will call. Please write plainly.)

Name _____ Age _____

Address _____

City _____ Zone _____ State _____

ACCREDITED MEMBER, NATIONAL HOME STUDY COUNCIL

Do You Know This Old-Timer?

"In this car we have embodied every up-to-date improvement known to the art." That's how the manufacturer described this model when it was introduced shortly after the turn of the century. This ancient ancestor is a far cry in size from its present entry. It had a 76-inch wheelbase and was 112 inches long. It was 64 inches high. Note the flywheel between the two fenders, through which it was probably quite easy to put your foot. The car sold for \$950. If you can't name it, turn to page 74.



DRAINS cellars, cisterns, wash tubs; **\$7.95**
IRRIGATES - CIRCULATES - SPRAYS

1,001 uses. Stainless shaft. Won't rust or clog! Use 1/6 HP motor or larger... 3/4 HP for up to 3000 GPH; 450 GPH 80' high; or 1800 GPH from 25' well. 1" inlet; 3/4" outlet. Coupling included free. **\$7.95.**
HEAVY DUTY BALL-BEARING PUMP. Up to 7,500 GPH; or 3,000 GPH from 25' well. 1 1/4" inlet; 1" outlet. **\$12.95**
 Postpaid if cash with order. **MONEY BACK GUARANTEE**
 Centrifugal and Gear Pumps in All Sizes
LABAWCO PUMPS, Belle Mead 7, New Jersey

Learn **MECHANICAL DENTISTRY**

A profession offering unlimited opportunities. Most modern and complete course embracing every branch from Plate to Porcelain Work, which prepares you to work for Dentists or start your own business. Individual instruction - practical training in day or night school. No books - no classes. Catalog upon request.

McCARRIE SCHOOL OF MECHANICAL DENTISTRY
 207 N. Broad Street Dept. 99 Philadelphia 7, Penna.

**STOP RAKING...
 START LIVING**

ROTO  SWEEP

Parker
LAWN SWEEPERS



Sweep away lawn cares... have a lawn and patio free of winter's accumulated debris, grass clippings, twigs and small stones... in one-tenth the time of hand-raking! Amazing "Roto-Sweep Action" gives total cleaning. See your dealer for **FREE DEMONSTRATION.**

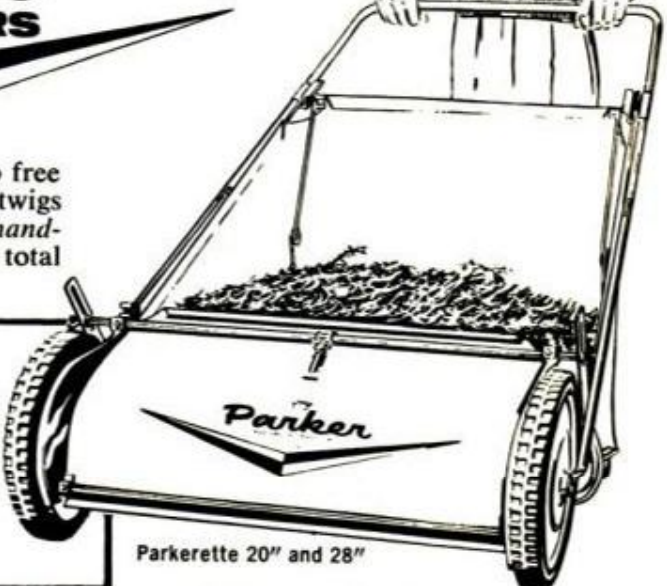
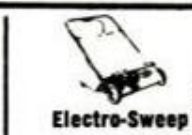
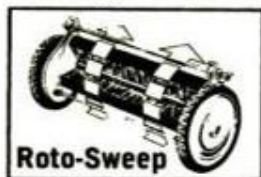

THE PARKER SWEEPER CO., SPRINGFIELD, OHIO

MAKE A FRESH START!

Get ahead faster in Air Conditioning and Refrigeration

IF YOU HAVE A low-pay job with little security and no future, it's time you gave yourself a fresh start. It's never too late to launch a new career in a huge, booming industry such as Air Conditioning and Refrigeration. The government reports that during the past 12 years, production of air conditioners increased 400%. No other industry did better! Thanks to this fabulous growth, over 20,000 newly-trained technicians and mechanics are needed each year to fill a wealth of steady, good-pay jobs. Get set for success: Train at home in spare time. It's easy and it's practical. For full information, fill out and mail handy coupon.

How CTI Home Training starts you in a business of your own or a good job

CTI offers you a short-cut to success. You learn by practicing with real operating equipment! CTI sends you 25 big kits of parts and tools to build a 1/4 h.p. commercial-type, heavy-duty condensing unit (illustrated at right.) You perform experiments, complete many projects, and get experience much like in the field. This is the practical way to learn and only CTI has it. Only CTI combines practice with easy-to-understand theory.



Many students earn spare time cash during their training

Because CTI training is so practical, many students earn extra money by installing and servicing air conditioning and refrigerating equipment. Some work evenings and Saturdays for local dealers; others set up service routes which include restaurants, motels, supermarkets, taverns, etc. You can earn money in spare time as you learn!

These men are making good—You can, too

"I'm in the refrigeration business for myself now. I earn nearly double what I used to. During my training, I made enough to pay my tuition."—*Alfred Helm, Ky.* ... "I've started a business and it's a success."—*Otto Degner, Canada* ... "I am in business for myself. I am building a nice trade doing service work."—*Paulie Waters, Tex.* ... "I applied for a job to install air conditioners in autos and got it."—*Richard Vinet, La.* ... "Your refrigeration training helped me get repair jobs after only twelve of your lessons."—*Frank Green, W. Va.*



TRAINING WITH A BIG DIFFERENCE

CTI trains you to be a master craftsman in air conditioning and refrigeration—not a jack-of-all-trades in minor fields. Only CTI sends 25 big kits of valuable parts and tools so you can learn by practicing.

COMMERCIAL TRADES INSTITUTE • CHICAGO 26, ILLINOIS
A Non-Profit Organization—Accredited by National Home Study Council

YOU BUILD THIS
1/4 H.P. HEAVY DUTY
CONDENSING UNIT!



YOU PRACTICE WITH
25 BIG KITS



When you finish assembling condenser (above), you may then build an air conditioner, freezer, refrigerator or milk cooler. CTI also sends mechanic's tools (left.) You keep all tools and equipment.

Be a specialist in well-paid Auto Air Conditioning field

Hottest new opportunity field is auto air conditioning! Over 500,000 units installed yearly—and growing fast. There's a severe shortage of technicians. Strong need for sales and repair shops, too. Start a business!



FIRST GET THE FACTS—THEN DECIDE

Invest a postage stamp in your future. Fill out and mail coupon. Get complete information on job opportunities and how to train. No cost. No obligation. Be sure to act today!

MAIL TODAY
FREE
BOOKLETS

COMMERCIAL TRADES INSTITUTE

1400 GREENLEAF AVENUE
CHICAGO 26, ILLINOIS

DEPT. R-702

Rush me your catalog, Success in Air Conditioning & Refrigeration, and Lesson Samples. Both FREE.

Name _____ Age _____

Address _____

City _____ Zone _____ State _____



when your mower
won't go...

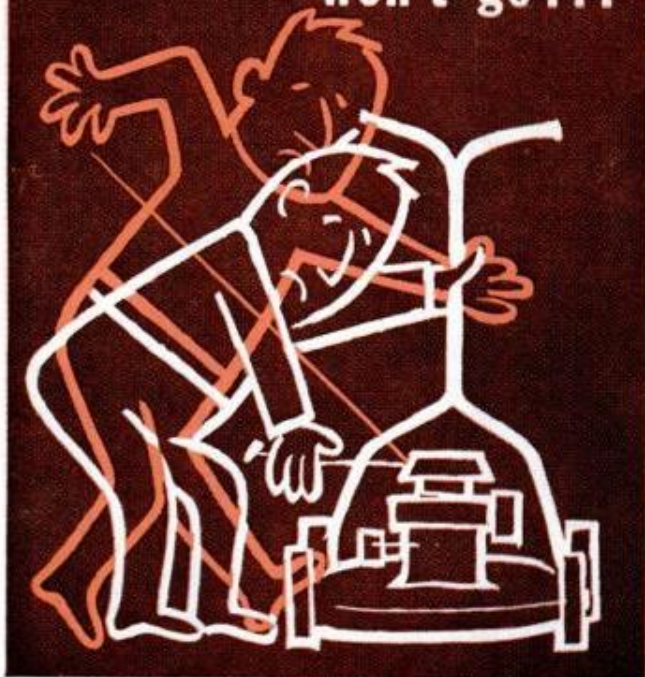

HOW LONG SINCE YOU CLEANED THE CARBURETOR?

When your power mower stands idle for days or weeks at a time, gum and varnish build up in the carburetor and fuel system. It's hard to start and can't deliver full power.



CLEAN THE CARBURETOR WITH GUMOUT

It's easy. Simply add GUMOUT to the gas tank. It dissolves and removes gum and varnish, cleans the carburetor and fuel system quickly, completely. You'll enjoy easier starts and lots more power. Get GUMOUT now. There's nothing like it.

Sold at most hardware and
garden supply stores.

GUMOUT • CLEVELAND 4 • OHIO

Over the Editor's Desk



To the Editor:

Just thought you people would be interested in knowing that I built your original "Ranch-Type House." I first saw your house in *Popular Mechanics* in 1951. After looking and planning for some time we decided your build-it-yourself ranch-type house best suited us in every way.

About mid-1954 we got started. Just my wife and I, and what charitable help we got from friends. It was hard work all the way but I must admit I enjoyed every bit of it.



I am a machinist and toolmaker, my wife worked at the Naval Ordnance plant here in Macon. Late in 1956 she lost her job due to the recession and we moved into the uncompleted house about the same time. . . . We both love the house and have a lot of admirers of it here.

We made very few changes in the basic plans. For example, we brick-veneered the outside rather than using weather board. We just love the fireplace as originally planned.

George E. Mellinger,
2624 Reynolds Drive,
Macon, Ga.

☆ ☆ ☆

To the Editor:

Your article in the January issue on U. S. cars is great. In all this hullabaloo however I am wondering why "Willys" sleeps on. Their economy car was wonderful—it just came out prematurely—a 1960 model would go over big.

I drove to Toledo and picked mine up from the factory in December (the 1952 model). It cost me \$18.00 for gas to return home to Logan, Utah, a distance of 1800 miles. It rode like a Cadillac at speeds up to 90, consistently gave me 31 miles per gallon—was outstanding in every respect. Many of these '52 models are still around—

(Continued to page 16)

NOW!
at a price
you can afford!

MAKE MORE MONEY in TELEVISION RADIO-ELECTRONICS

**BETTER...MORE COMPLETE...LOWER COST...
WITH NATIONAL SCHOOLS SHOP-METHOD
HOME TRAINING!**

BETTER... Training that is proved and tested in Resident School shops and laboratories, by a School that is the **OLDEST** and **LARGEST** of its kind in the world.

MORE COMPLETE... You learn **ALL PHASES** of *Television-Radio-Electronics*.

LOWER COST... Other schools make several courses out of the material in our **ONE MASTER COURSE . . .** and you pay more for less training than you get in our course at **ONE LOW TUITION!**

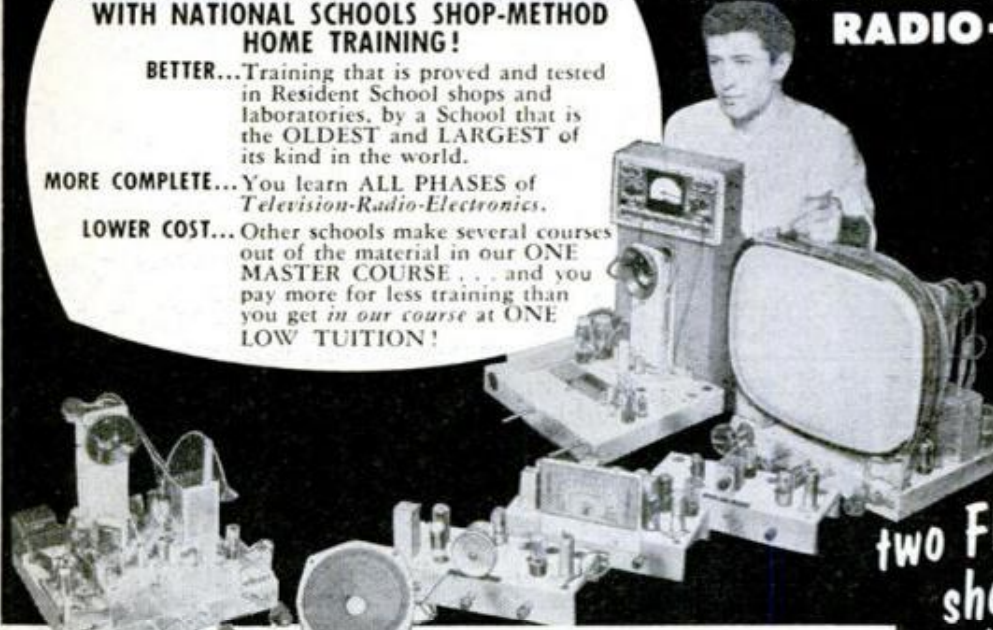

These **two FREE** books will show you how!

You get all information by mail . . . You make your own decision . . . at home! **NO SALESMAN WILL CALL**

TOP PAY... UNLIMITED OPPORTUNITIES LIFETIME SECURITY CAN BE YOURS!

You are needed in the Television, Radio, and Electronics industry! Trained technicians are in growing demand at excellent pay—in **ALL PHASES**, including Servicing, Manufacturing, Broadcasting and Communications, Automation, Radar, Government Missile Projects.

NATIONAL SCHOOLS SHOP-METHOD HOME TRAINING, with newly added lessons and equipment, trains you in your spare time at home, for these unlimited opportunities, including many technical jobs leading to supervisory positions.

YOU LEARN BY BUILDING EQUIPMENT WITH KITS AND PARTS WE SEND YOU. Your National Schools course includes thorough *Practical training—YOU LEARN BY DOING!* We send you complete standard equipment of professional quality for building various experimental and test units. You advance step by step, perform more than 100 experiments, and you build a complete TV set from the ground up, that is yours to keep! A big, new TV picture tube is included at no extra charge.

EARN AS YOU LEARN. We'll show you how to earn extra money right from the start. Many of our students pay for their course—and more—while studying. So can you!

RESIDENT TRAINING AT LOS ANGELES

If you wish to take your training in our Resident School at Los Angeles, the world's TV capital, start **NOW** in our big, modern Shops, Labs and Radio-TV Studios. Here you work with latest Electronic equipment - - professionally installed - - finest, most complete facilities offered by any school. Expert, friendly instructors. Personal attention. Graduate Employment Service. Help in finding home near school - - and part time job while you learn. Check box in coupon for full information.

LESSONS AND INSTRUCTION MATERIAL ARE UP-TO-DATE, PRACTICAL, INTERESTING. Every National Schools Shop-Method lesson is made easy to understand by numerous illustrations and diagrams. All instruction material has been developed and tested in our own Resident School Shops, Laboratories and Studios.

SEND FOR INFORMATION TODAY . . . it can mean the difference between **SUCCESS** and failure for you! Send for your **FREE BOOK** "Your Future in Television-Radio-Electronics" and **FREE Sample Lesson.** Do it **TODAY**, while you are thinking about your future. It doesn't cost you anything to investigate!

GET THE BENEFITS OF OUR OVER 50 YEARS EXPERIENCE

Approved for
GI Training



NATIONAL SCHOOLS
Los Angeles 37, Calif.

YOU GET...

- 19 Big Kits—**YOURS TO KEEP!**
- Friendly Instruction and Guidance
- Job Placement Service
- Unlimited Consultation
- Diploma—Recognized by Industry
- **EVERYTHING YOU NEED FOR SUCCESS!**

SHOP-METHOD HOME TRAINING COVERS ALL PHASES OF INDUSTRY

1. Television, including Color TV
2. Radio AM & FM
3. Electronics for Guided Missiles
4. Sound Recording and Hi-Fidelity
5. FCC License
6. Automation and Computers
7. Radar & Micro-Waves
8. Broadcasting and Communications

NATIONAL TECHNICAL SCHOOLS

WORLD-WIDE TRAINING SINCE 1905

MAIL NOW TO

National Technical Schools, Dept. RB-40
4000 S. FIGUEROA ST., LOS ANGELES 37, CALIF.
Rush free TV-Radio "Opportunity" Book and sample lesson. No salesman will call.

NAME _____ AGE _____
ADDRESS _____
CITY _____ ZONE _____ STATE _____

Check if interested **ONLY** in Resident School training at Los Angeles.
VETERANS: Give date of Discharge _____

UNUSUAL BARGAINS

See the Stars, Moon, Planets Close Up! 3" ASTRONOMICAL REFLECTING TELESCOPE



60 to 180 Power — Famous Mt. Palomar Type! An Unusual Buy! Assembled—Ready to use! You'll see the Rings of Saturn, the fascinating planet Mars, huge craters on the Moon, Star Clusters, Moons of Jupiter in detail. Galaxies! Equatorial mount with lock on both axes. Aluminized and overcoated 3" diameter high-speed f/10 mirror. Telescope comes equipped with a GOX eyepiece and a mounted Barlow Lens, giving you 60 to 180 power. Low-cost accessory eyepiece available for higher powers. An Optical Finder Telescope, always so essential, is also included. Sturdy, hardwood, portable tripod. FREE BOOK.

with Scope:—Valuable STAR CHART plus 272 page "HAND-BOOK OF HEAVENS" plus "HOW TO USE YOUR TELESCOPE" BOOK.
Stock No. 85,050-H \$29.95 postpaid

KNOW THE TRUTH ABOUT POWER. Telescope experts will confirm that an Astronomical Telescope will only give you practical powers to about 50 or 60 times per inch of objective diameter—powers above this only produce empty magnification — make viewing dim, difficult and unsatisfactory.

War Surplus American-Made 7x50 Binoculars

Big savings! Brand new! Crystal clear viewing 7 power. Every optical element is coated. An excellent night glass — the size recommended for satellite viewing. Individual eye focus. Exit pupil 7mm. Approx. field at 1,000 yds. is 176 ft. Carrying case included. American 7 x 50's normally cost \$195. Our war surplus price saves you real money.
Stock No. 1533-H only \$55.00 postpd. (Tax included)



Terrific Buy! American Made! OPAQUE PROJECTOR

Projects illustrations up to 3" x 3 1/2" and enlarges them. No film or negatives needed. Projects charts, diagrams, pictures, photos, lettering in full color or black-and-white. Operates on 115 volt, A.C. current. 6-ft. extension cord and plug included, operates on 60 watt bulb, not included. Size 12" x 8" x 4 1/2" wide. Plastic case with built-in handle.
Weight 1 lb., 2 oz.
Stock No. 70,199-H \$7.95 Postpaid



CLOSE OUT! MECHANICAL DRAWING SET

Regular Price \$18.00
Our Price Only \$8.00 Postpd.
American mfr. couldn't compete with foreign imports—thus you get a terrific bargain, even far below import prices. 10 handsome pieces in velvet-lined case. Nickel plated brass—precision American-made. We guarantee you'll be satisfied or money refunded.
Stock No. 50,200-H \$8.00 Postpaid

NOTICE: Edmund is now headquarters for Math Learning and Teaching Aids! See dozens of offerings in our FREE Catalog "H".



NEW! CIRCULAR SLIDE RULE!

Pocket Size—Fast—Easy to Use!
Multiplies, divides, figures fractions, percentages, squares, cubes, roots, proportions, circumferences, areas, retail prices, fuel consumption. Faster, easier to learn and use. Directions included.
Stock No. 30,336-H \$4.95 postpaid

BUILD A SOLAR ENERGY FURNACE

A fascinating new field. Build your own Solar Furnace for experimentation—many practical uses. Easy! Inexpensive! Use scrapwood! We furnish instructions. This sun powered furnace will generate terrific heat—2000° to 3000°. Fuses enamel to metal. Sets paper aflame in seconds. Use our Fresnel Lens—14" diameter . . . f.l. 14".
Stock No. 70,130-H . . . Fresnel Lens . . . \$ 6.00 Postpd.

Order by Stock No.—Send Check or M.O.—Money-Back Guarantee
EASY PAYMENT PLAN AVAILABLE! DETAILS WITH CATALOG!
EDMUND SCIENTIFIC CO., Barrington, New Jersey

MAIL COUPON for FREE CATALOG "H"

128 Pages! Over 1000 Bargains!
EDMUND SCIENTIFIC CO., Barrington, N. J.
Please rush Free Giant Catalog-H.

Name
Address
City Zone State



still going great—and are right in style with all this "small car" fad. I traded my sedan in on a truck but during the 68,000 miles I had it, it gave me nothing but sheer pleasure to own.

I wish I had one now—my wife loved it too and we could use a second car now that we have five kids.

Reid A. Bench,
Provo, Utah

☆☆☆

Correction

The statement made in the article "Sprung Doors" (January 1960) that the doors of convertibles and hardtops will be sprung when such cars are placed on a frame-contact hydraulic lift has been brought to our attention as being incorrect. The process of lifting a car does not create any permanent condition which would affect the alignment or operation of doors. While exceedingly minor deflections do occur at the door gaps of convertibles and hardtops when raised on frame-engaging-type hoists, these deflections are canceled, immediately and permanently, as soon as the car is lowered. It has been further pointed out that all automobiles are built to withstand deflections and bending movements, and that ordinary driving conditions and the use of bumper jacks often impose stresses and strains even greater than those which result when the vehicle is raised on a hoist.

☆☆☆

Twin-Pontoon Rescue Boat

From Lt. R. N. Ireland of the 3001st Radio and Rescue Detachment, Texas State Guard Reserve, comes this report of a rescue boat built from two jet-fuel tanks by men who had never before built a boat. The six men accomplished their job without plans, at a cost of \$60, using only hand tools and drills and an acetylene torch.

Carrying five men, the craft has a draft of about six inches; without its crew, only four inches. With a 25-horsepower motor, its speed on a Texas river approximates 20



(Continued to page 18)



Now! Work Over 300 PRACTICAL PROJECTS with these PARTS AT HOME!



to help You learn

ELECTRONICS

RADIO - TELEVISION - RADAR

NOW . . . at home in your spare time you can get the very kind of training and subsequent Employment Service you need to get started toward real earnings in one of today's brightest opportunity fields—TELEVISION-RADIO-ELECTRONICS. Now that Electronics is entering so many new fields, here is a chance of a lifetime to prepare to cash in on its remarkable growth.

DeVry Tech's amazingly practical home method enables you to set up your own HOME LABORATORY. You spend minimum time to get maximum knowledge from over 300 practical projects, using the same type of basic equipment used in our modern Chicago and Toronto Training Centers!

DeVry Tech Provides EVERYTHING YOU NEED . . .

—to help you master TV-ELECTRONICS. In addition to the home laboratory and easy-to-read lessons, you even use HOME MOVIES—an exclusive DeVry Tech advantage. You watch hidden actions . . . see electrons on the march. Movies help you to learn faster . . . easier . . . better.

LABORATORY TRAINING

Full time day and evening training programs in our modern Chicago and Toronto Laboratories are also available. MAIL COUPON TODAY for facts.

BUILD and KEEP Valuable TEST EQUIPMENT

As part of your training, you build and keep a fine Jewel-Bearing Vacuum Tube VOLTMETER and a 5-inch COLOR OSCILLOSCOPE—both high quality, needed test instruments.

EFFECTIVE EMPLOYMENT SERVICE

Get the same Employment Service that has helped so many DeVry Tech graduates get started in this fast-growing field.

EARN WHILE YOU LEARN

DeVry Tech's practical training helps you toward spare time income servicing Radio and Television sets.



"One of North America's Foremost Electronics Training Centers"

Accredited Member
of National Home
Study Council



DeVRY TECHNICAL INSTITUTE

CHICAGO 41, ILLINOIS



VACUUM TUBE VOLTMETER



5-INCH COLOR OSCILLOSCOPE



21 INCH

Build and keep this BIG DeVry Engineered TV set—easily converted to U.H.F. (DeVry offers another home training, but without the TV set.)

✉ CHECK These Exciting Job Opportunities:

- TV-Radio Broadcast Technician
- Color Television Specialist
- Radar Operator
- Laboratory Technician
- Airline Radio Man
- Computer Specialist
- Quality Control Manager
- Your Own Sales & Service Shop
- . . . PLUS MANY OTHERS

MAIL COUPON TODAY!

DeVRY TECHNICAL INSTITUTE
4141 Belmont Ave., Chicago 41, Ill., Dept. PM-4-Q

Please give me your FREE booklet, "Electronics in Space Travel," and tell me how I may prepare to enter one or more branches of Electronics.

Name _____ Age _____
PLEASE PRINT
Street _____ Apt. _____
City _____ Zone _____ State _____
2045 Canadian residents address DeVry Tech of Canada, Ltd.
626 Roselawn Ave., Toronto 12, Ontario

miles per hour, or 15 mph with five men aboard. This in windy, choppy water. Lieutenant Ireland writes that the catamaran can change direction in its own length at full speed and open throttle.

Using two 450-gallon jet-fuel tanks, the two cockpits were cut out in each tank and an aluminum "I" beam removed from the inside of each was used to connect the two pontoons together. Connector plates of 1/2 x 4 x 12-in. steel were heated with a torch and hand hammered to fit the contours, bolted through the pontoon body at positions where each was clamped through the "skin" of the tank and through the heavy inner baffle-plate edges. Three connectors were used, each double-coated with rust-preventive paint and bolted on the wet second coat over a latex rubber gasketing. Bolts through the hulls are the original aircraft bolts.

Separated by a deck 4 1/2 feet wide and 10 1/2 feet long, ample space is allowed for working area. The underside of the I-beam cross members has been fitted with a plywood bottom that curves from the front cross-member (2 by 4 oak) back under the beams and is fastened to the transom. Edges were hand fitted and rubber gasketing seals the edge at hull side.

Transom is 2 by 8-inch oak on a welded bracket.

Removable front deck section allows storage of lines and some tackle essential to normal operation but which must be placed out of the way during assigned operations. Cockpits allow operator to maneuver the craft without interference from crew. Other openings allow storage of rope, drags, portable light plants of 6 and 24 volts, floodlights, extra gear necessary to emergency work and comfortable ride to and from the work area for the crew. "Scuba" equipment also rides inside the hulls.

Says Lieutenant Ireland:

"Built strictly for rescue and recovery work of water accidents, tests on Falcon Lake in high wind and waves prove it a stable and well-mannered boat with sufficient room for working crew and operator. It handles well, carries more than enough gear that is out of the way at all times when not in use and is far safer for such work than ordinary single-hulled boats usually so employed."

☆☆☆

JAMES R. WARD, Shop Notes and Crafts Editor of *Popular Mechanics*, died recently. Over a span of 15 years in this position, Jim earned a notable reputation, and his work will be missed, not only by his friends here, but by contributors and readers everywhere.

Learn To MOUNT BIRDS

Here's Best Hobby for Fun & Profit

TAN SKINS, MAKE UP FURS
 Be a Taxidermist. We teach you at Home. Mount Birds, Animals, Pets, common specimens. Save your hunting trophies, decorate home and den. Make genuine KROME LEATHER, tan and make up furs for sparetime profit. **INVESTIGATE TODAY** FREE BOOK 48 pages-tells all about it. Hunters, get your copy. It's Now Free. Send post card. State your AGE. IN. W. SCHOOL OF TAXIDERMISTRY, DEPT. 2504, Omaha, Nebr.



PLANT CHRISTMAS TREES for PROFIT
 Write for free catalog to . . .

Pikes Peak Nurseries

Quality Nursery Stock For More Than 35 Years

801 WATER STREET INDIANA 11, PA.



INVESTIGATE ACCIDENTS

Train quickly in your own home for repeat income in the exciting, secure Claim Investigation and Claim Adjusting field. Our students and graduates are already earning \$4, \$5, \$6 an hour extra SPARE TIME — and up to \$10,000 a year Full Time. You need NO prior experience or higher education. Your age does NOT matter.

HERE IS YOUR CHANCE FOR ACTION AND REAL JOB SECURITY

As a trained Claim Investigator you will (1) INVESTIGATE FACTS and (2) DISTRIBUTE MONEY as the representative of wealthy organizations.

No other business offers you greater opportunities for success and security. Here's why: The huge, rapidly expanding Claim Investigation and Adjusting Profession right now distributes more money than any other service industry. And it's growing fast. Over 200 MILLION ACCIDENTS must be investigated this year for Insurance Companies, Airlines, Railroads, Steamship Lines, and Government Offices.

MAIL NOW for FREE BOOK →

SEND TODAY for Big, FREE, Illustrated Catalog. Learn the exciting facts about Universal Schools' low cost training. No obligation. No salesman will call. GI APPROVED.



UNIVERSAL SCHOOLS
 6801 Hillcrest Ave.
 Dept. PM-4, Dallas 5, Texas

Please rush me your FREE book on Claim Investigation. This does not obligate me and no salesman will call.

Name _____ Age _____

Address _____

City _____ Zone _____ State _____

Approved by Government for Korean Veterans



LET RCA TRAIN YOU IN ELECTRONICS

RCA Institutes, one of the world's leading electronic technical schools, offers a Home Study Course in . . .

ELECTRONICS FOR AUTOMATION

. . . Now you have *four* comprehensive courses for your electronic training . . . from basic electronic theory to the more advanced principles of color TV and Automation.

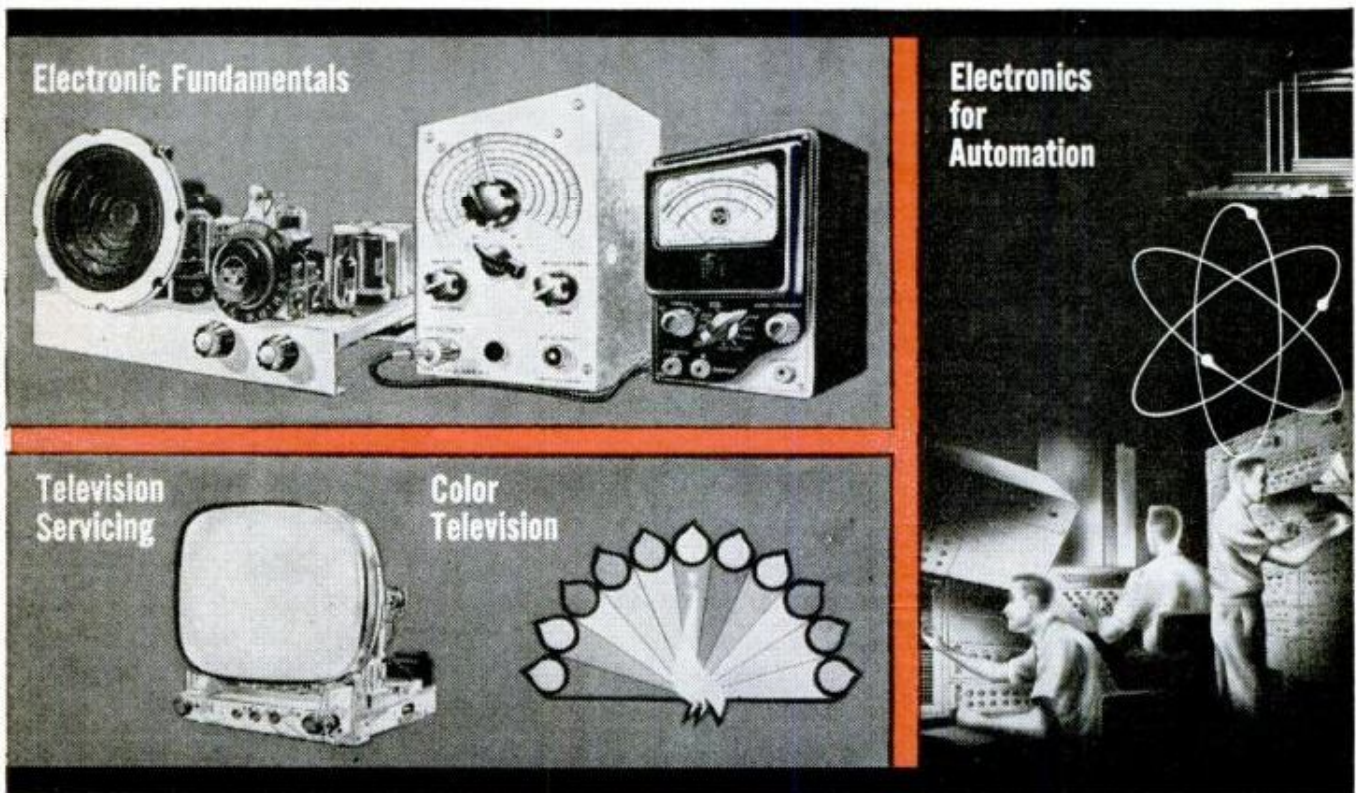

Send for our
64 page Home
Study Catalog

FREE!

RESIDENT SCHOOLS in New York City and Los Angeles offer Technical Institute and Vocational School Courses in Electronics. Day and Evening classes start 4 times each year. Resident School Catalog sent free on request.

ANOTHER WAY RCA SERVES EDUCATION THROUGH ELECTRONICS



Practical work with the very first lesson. Pay-as-you-learn. You need pay for only one study group at a time.

RCA INSTITUTES, Inc. Home Study School, Dept. PM-40
A Service of Radio Corporation of America
350 West Fourth Street, New York 14, N. Y.

Please rush me your FREE illustrated 64-page book "Your Career in Electronics," describing your home training programs. No obligation. No salesman will call.

Name Age

Address
Please print

City Zone State

Veterans: Enter discharge date

CANADIANS— Take advantage of these same RCA courses at no additional cost. No postage, no customs, no delay. Send coupon to:
RCA Victor Company, Ltd., 5001 Cote de Liesse Rd., Montreal 9, Quebec
To save time, paste coupon on postcard.

DRAFTSMEN



CASH BIG PAY CHECKS!

Train Now for more success, greater security

LEARN AT HOME IN SPARE TIME (or at college in Chicago)

Check the want ads in any newspaper—SEE the big-pay opportunities open to you as a draftsman. What's more, you can learn this well-paid, prestige profession at home — quickly, easily! No special talent needed. Get complete, step-by-step Chicago Tech lessons in the mail, spend a few pleasant hours studying each week. In a short time you'll be a well-trained draftsman, ready to take your pick of many good jobs. Act now!



Free Information—Mail Coupon Today!

Get FREE TRIAL LESSON plus information about C.T.C. practical training. Learn what successful Chicago Tech graduates say about high pay and opportunities in drafting. No charge, or obligation.

CHICAGO TECHNICAL COLLEGE

D-218 Tech Bldg., 2000 So. Michigan Ave.
Chicago 16, Illinois

Mail me FREE lesson with facts about big opportunities in DRAFTING.

Name _____ Age _____

Address _____

City _____ Zone _____ State _____

FIND GOLD, SILVER BURIED TREASURE VALUABLE RELICS



Thousands of dollars worth of valuables have been found with DETECTRON instruments. Gold and Silver Ores and Nuggets, Other Precious Metals, Indian Artefacts, Battlefield Relics, Pirate Coins, Caches of Money buried or hidden in adobe walls.

Six Models available including transistors. Have many features not found elsewhere. Light weight. Guaranteed to out perform Geiger Counters for Uranium. Ultra-Violet lamps for tungsten and oil.

FREE INFORMATION.

Write Dept. 7

Detectron SYLMAR, CALIFORNIA



Sidelights from the PENTAGON

By William R. Kreh

WILLIE AND JOE, the famous GIs whom cartoonist Bill Mauldin created during World War II, had to struggle mightily to keep even a pair of socks dry. They, and other GIs, would appreciate a new substance developed by the Army. It's a water-repellent finish for combat clothing that can withstand a continuous one-inch-per-hour rainfall for seven straight days without being penetrated.

Four representatives of another World War II institution—the huge Mars flying boats—have been saved from the junkpile and are being outfitted to fight forest fires in Canada. Lumber firms are rigging them to scoop up 35 tons of water at a gulp while skimming over the surface of British Columbia lakes. It is proposed that the planes will then fly above forest fires and dump their cargo of water in a matter of seconds. Water tanks, to be installed in the main cargo section of the planes, between the 200-foot wings, will have hydraulic doors controlled by the pilot, who'll be able to select the amount of water he wants to drop.

A 67-year-old English woman, Mrs. Edith Hurry, who had been confined to a hospital bed because of low blood pressure, is walking again—thanks to a jet pilot's "G-suit" which was donated by the U.S. Air Force's 20th Tactical Fighter Wing. Dr. William Stanford, a flight surgeon, zippered Mrs. Hurry into the green, tight-fitting outfit and she was able to stand—for the first time in six months—without losing consciousness. The suit applied pressure on her abdomen, thighs and calves, maintaining blood pressure and circulation, and keeping blood from leaving her head when she stood. The "G-suit," incidentally, had withstood the brunt of as much as 7-Gs while being worn by American jet pilots.

Are You "STANDING STILL" on your job?

You can justify a real pay raise and a better position—by making one simple move—the move that opens the way to more earnings and promotions—*practical training*.

If YOU are "standing still" on your job—no promotions—only token increases in pay—then you had better do something about it. You know that if you are untrained, your chances of getting ahead are slim. **NOW IS THE TIME TO PREPARE.**

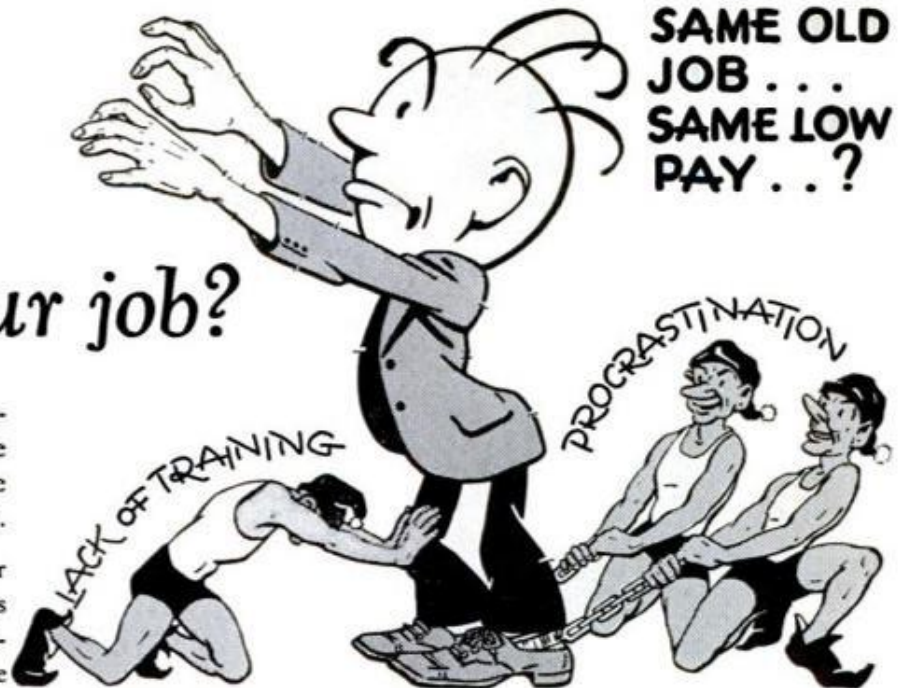

WILL RECOGNITION COME?

The only answer, as you know, is that success *does* come to the man or woman who is really *trained*. LaSalle has provided the "key to success" for many thousands of ambitious people who have sought our training for more than fifty years.

Get all the facts. Investigate the opportunities in your chosen field. It costs you nothing to learn about LaSalle's proven and tested accredited correspondence courses in the major fields of business. You can train right in the privacy of your own home, progressing at your own rate.

You lose no time from work, and your instructors guide you every step along the way through our famous Practical Problem Method. Low cost—easy terms.

Don't let promotions pass you by—do something **TODAY** about your future.

LaSalle

EXTENSION UNIVERSITY
A CORRESPONDENCE INSTITUTION

417 So. Dearborn St. Dept. 464X Chicago 5, Ill.

The coupon below is for your convenience. Simply mark the program in which you are most interested, and mail at once. We'll send you, without obligation, free booklets describing that field together with the opportunities and what you must know to be a success.

ACCREDITED MEMBER, NATIONAL HOME STUDY COUNCIL

LA SALLE EXTENSION UNIVERSITY, A Correspondence Institution
417 South Dearborn Street, Dept. 464X, Chicago 5, Illinois

Please send me your booklet describing the program I have checked below:

ACCOUNTING

- Modern Bookkeeping
- Basic Accounting
- Practical Accounting
- Principles of Acctg.
- Cost Accounting
- Federal Income Tax
- Accounting Systems
- Business Law
- Auditing Procedure
- Controllorship
- CPA Training
- Complete Accounting

TRAFFIC & TRANSPORTATION

- Organization & Mgt.
- Classification, Rates & Tariffs
- Transportation Agcy. & Services
- Transportation Law & Regulation
- Rate Making & Rate Cases
- Complete Traffic & Transportation

LAW

- Law of Contracts
- Insurance Law
- Claim Adjusting Law
- Law for Trust Officers
- Business Law I
- Business Law II
- General Law
- First Year Law
- American Law and Procedure (LL.B. Degree)

FOREMANSHIP & PRODUCTION METHODS

- Foremanship Training

STENOTYPE

- (machine shorthand)
- Secretarial

SALESMANSHIP

- LaSalle Sales Training

BUSINESS MANAGEMENT

- Principles of Management
- Psychology in Business
- Selling & Sales Management
- Advertising and Marketing
- Production Problems
- Business Financing
- Credits and Collections
- Office Management
- Managing Men
- Accounting & Statistical Control
- Business Correspondence
- Organization & Reorganization
- Legal Problems
- Complete Business Management

MANAGEMENT COURSES

- Basic Management
- Production Management
- Sales Management
- Advertising & Sales Promotion
- Financial Management
- Personnel Management
- Sales & Executive Training

Name.....Age.....

Address.....

City, Zone, State.....

"MADE \$1200 ON ONE JOB"

Some make more, some less...

We help you start Your Own All-Year Business

Make BIG Money! With our easily operated, highly efficient wall washer, G. H. Jones made \$1200 on one school job. E. L. Goss took in more than \$10,000 in one year. E. C. Taber wrote, "I made \$400 gross in two weeks." And no wonder...this machine washes walls 6 times faster and better than by hand—with no mess...no drop cloths.



Your Money-Making Opportunity • We want more men to go into this profitable business for themselves and enjoy independence—freedom from layoffs and bosses. Customers everywhere—homes, offices, schools, churches, hotels, etc. How much you earn depends largely on you. What you take in is mostly profit. No need to rent shop or office; operate from home. Start spare time until full time is justified.

Lose No Time — Send Coupon Today for All the Facts

FREE BOOK! MAIL COUPON TODAY!

VON SCHRADER MFG. CO.

410 "W" Pl., Racine, Wisconsin

Send at once (no obligation) your **FREE** booklet containing information about your **WALL WASHING MACHINE** and how I can start my own permanent, profitable business.

Name _____

Address _____

City _____ Zone _____ State _____

Beauty...

backed by
**SCIENTIFIC
MARINE
ENGINEERING**



Every Penn Yan is built to scientific principles of marine design. As a result, Penn Yans are superbly maneuverable,

fast, durable and safe. They are built—as they have been for nearly 40 years—to give greater satisfaction longer.



FREE catalog describes complete new line. Write Penn Yan Boats, Inc., 34th St., Penn Yan, N. Y.

Penn Yan Boats

Great Pioneers in Science Do You Know Them?

By James S. Thistle

"MR. WATSON, COME HERE; I WANT YOU," were the first words ever uttered over an electric wire. The person who gave this message to his assistant on March 10, 1876, is our Pioneer in Science, the inventor of the telephone. Having been a teacher of the deaf, his knowledge that sound waves cause the eardrums to vibrate gave him the idea that the same principle might be used to send sound over a wire.

On his 29th birthday, he was granted the first historic telephone patent. No. 174465. He fought an uphill battle to protect his rights. Finally, after the most prolonged litigation in the history of American patent law, the U.S. Supreme Court upheld all of his claims. At the International Centennial Exhibition at Philadelphia, June 25, 1876, he was given an opportunity to explain his invention. The following year the first telephone company bearing his name was organized.

*These letters, unscrambled,
spell the name of this
month's Great Pioneer
in Science:*

REXALLBANDLEE

(First and Last Names)

Write the correct name here:

Now turn to page 290 for the answer.

POPULAR MECHANICS



ARE YOU GIVING YOUR CHILDREN MORE THAN YOU HAD?

A THOUGHTFUL DISCUSSION by Dr. D. Alan Walter

"When you look around your home with its comforts and conveniences, you will undoubtedly answer an unhesitating 'yes . . . my children have much more than I had.' But a moment's reflection may lead you to wonder —'am I giving my children more of the *important* things?"

"There is a distinction to be made between a *standard of living* and a *standard of life*. It is natural to want to give one's children more of the material things. But no material standard of living is adequate preparation for the years to come. Your children must have a standard of life—to guide their conduct, to direct their thinking, to give them strength and wisdom.

"The first step in developing a high standard of life is knowledge. That is why the Encyclopaedia Britannica is an essential possession. Children who develop the habit of 'looking it up in Britannica' develop a habit that will help to sustain them throughout life."

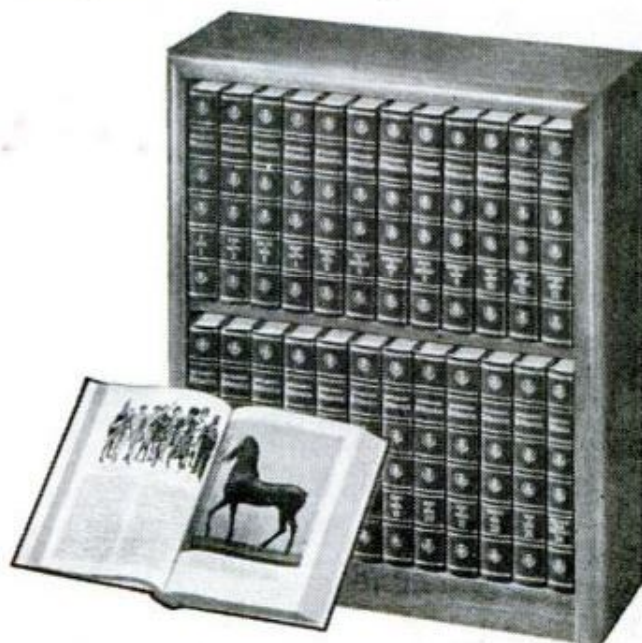

Brand new edition

ENCYCLOPAEDIA BRITANNICA

now available direct from the publisher on

Book a Month Payment Plan

you get all 24 volumes now—pay later!

The latest edition of Britannica—the most respected treasure of knowledge ever published—is the biggest and greatest in our almost 200-year publishing history. An enormous printing materially reduces our costs and under an unusual direct-from-the-publisher plan, we pass these savings on to you. All 24 handsome volumes will be delivered to your home NOW *direct from the publisher*. You pay later at a cost so low it is as easy as buying a book a month!

Equivalent to a library of 1,000 books

The Encyclopaedia Britannica is the most valuable gift you can give yourself and your family—the priceless gift of knowledge. Contained in its pages is information on every subject significant to mankind. It is equivalent to a library of 1,000 books, bringing you the knowledge and authority of world-recognized leaders in every field.

The new Britannica almost "televises" information to you, with 25,042 magnificent photographs,

maps and drawings. In every respect, Britannica is the most complete reference set published in America, containing 27,357 pages, and over 38,000,000 words.

Symbol of a good home

Benjamin Franklin said: "An investment in knowledge pays the best interest," and Britannica gives you the accumulated knowledge of the world in clear, easy-to-read language and superb illustrations. It is essential in every home where edu-

cation is valued and respected.

Preview Booklet Offered FREE

Simply fill in and mail the coupon today, and we will send you . . . without cost or obligation . . . a copy of our new booklet which contains an exciting preview of the latest edition of Encyclopaedia Britannica. Send no money—not even for postage. It's yours, absolutely free! However, since this offer is necessarily limited, please mail the coupon today before it slips your mind.

Mail Coupon Now for
FREE BOOKLET



ENCYCLOPAEDIA BRITANNICA, DEPT. 60-J
425 N. Michigan Avenue, Chicago 11, Illinois

Please send me, *free and without obligation*, your colorful Preview Booklet which pictures and describes the latest edition of ENCYCLOPAEDIA BRITANNICA. Also include complete information on how I may obtain this magnificent set, *direct from the publisher*, on the Book a Month Payment Plan.

Name _____ *Please Print*

Address _____

City _____ Zone _____ State _____

In Canada, write E. B. Ltd., Terminal Bld., Toronto, Ont.



**YOU
can
acquire**

**LAW AT HOME!
EARN LL. B. DEGREE**

LaSalle's famous Law Library—used as reference in many Law libraries and Law offices—has enabled thousands to master Law surprisingly fast, in spare hours at home, for business and professional advancement.

These 14 remarkable volumes, compiled by leading professors and lawyers, cover the whole basic field of Law in condensed, orderly, simplified manner.

You advance rapidly with this great library, plus special lectures furnished. We guide you step-by-step with personalized Problem Method of instruction...you learn by doing—handling legal problems—not by memorizing rules.

Send for two FREE booklets, "Law Training for Leadership," and "Evidence," answering questions about Law and its value to you. Mail coupon below. No obligation.

Accredited member, National Home Study Council

**LA SALLE EXTENSION UNIVERSITY
A Correspondence Institution**

417 S. Dearborn St., Dept. 464L, Chicago 5, Ill.

Send me your two FREE booklets described above, without obligation.

Name Age

Street

City, Zone & State



**NEW WORLD
OF OPPORTUNITY**
it's yours



IF YOU KNEW that professional homecare maintenance was the fastest-growing field for service and for products... *with*

ServiceMASTER®
WORLD FAMOUS AUTHORITY ON HOMECARE



FIND OUT how much an investment you need to obtain such a franchise (surprisingly low, surprisingly easy arrangements)

write ServiceMASTER

c/o Marion Wade, Dept. 106

2117 North Wayne Ave., Chicago 14, Illinois

**95% PROFITS
YEAR 'ROUND**

Be your own boss, Operate a **SIMPLEX** lawnmower sharpening service in your community. One compact machine grinds all mowers, sharpens cutlery. Low investment, 95% profit. Pays for itself in average month.

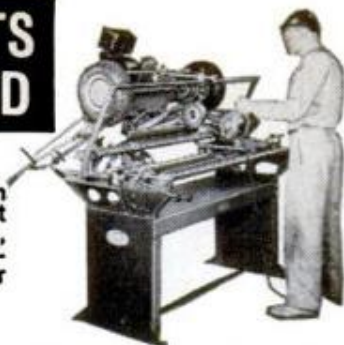

SIMPLEX

—4 Machines in One!

Reel Grinder—sharpens any mower reel in or out of mower.
Bed Knife Grinder—grinds with either round or cup wheel.

Rotary Blade Grinder—hollow grinds any rotary mower blade.
Cutlery Knife Grinder—sharpens cutlery, tools, scissors.

Send for free, money-making details!

The **FATE-ROOT-HEATH** Company • Dept. PM-4, Plymouth, Ohio



119 JIG SAW PATTERNS

FULL-SIZE . . . trace on wood and saw out. Clever, ORIGINAL designs, things you can make to **SELL**. Wall shelves, lawn signs, planters, book ends, others. **\$1** postpaid

BURGESS VIBROCRRAFTERS, INC.

Rush \$1 today. DEPT. C-140, Grayslake, Illinois

**Secrets of VENTRILOQUISM
Now Revealed!**



Easy to learn in 60 to 90 days with our Home Study Course. **RESULTS GUARANTEED.** Make Money! Be Popular! Have Fun! Big Opportunity! Radio, Television, Stage Appearances! For FREE Information regarding price and terms **WRITE**. You must state your age. Dummy Catalog 25c.
MAKER HOME COURSE OF VENTRILOQUISM
Box 36, Studio PM-4, Kensington Station
Detroit 24, Michigan

**REAL ESTATE
BE A BROKER**

PAYS BIG! SEND FOR FREE, BIG, ILLUSTRATED CATALOG NOW! Graduates report making substantial incomes. Start and run your own business quickly. Men, women of all ages, learn easily. Course covers Sales, Property Management, Appraising, Loans, Mortgages, and related subjects. **STUDY AT HOME** or in classrooms in leading cities. Diploma awarded. Write **TODAY** for free book! No obligation.
Approved for World War II and Korean Veterans
WEAVER SCHOOL OF REAL ESTATE (Est. 1936)
2020R Grand Avenue Kansas City, Mo.



FREE GERMAN HUNTING KNIFE



4-INCH BLADE

We give you handiest hunting and fishing knife you've ever had! Has 4-INCH LONG highly tempered steel blade—VERY SHARP! Attractive handle. We send knife **FREE** to acquaint you with our below-wholesale bargains. Please send 25c for handling. **NO LIMIT**—but send 25c handling for each knife. Order **TODAY!**
HUNTING KNIFE, Dept. K-484, Box 881, St. Louis, Mo.

EXTRA CASH Own Your Own **SHOE BUSINESS!**

We will set you up in a Shoe Business of your own! Full-time or part-time. No investment or experience needed. Cushioned comfort feature sells fast. Advance earnings to \$5.00 a pair plus bonus. Satisfaction guaranteed. Samples supplied Free. Write for **FREE CATALOG** and details **TODAY!** No obligation!



3 BIG LINES IN ONE!

COLT SHOE Co., Dept. 207, 657 Atlantic Ave., Boston, Mass.

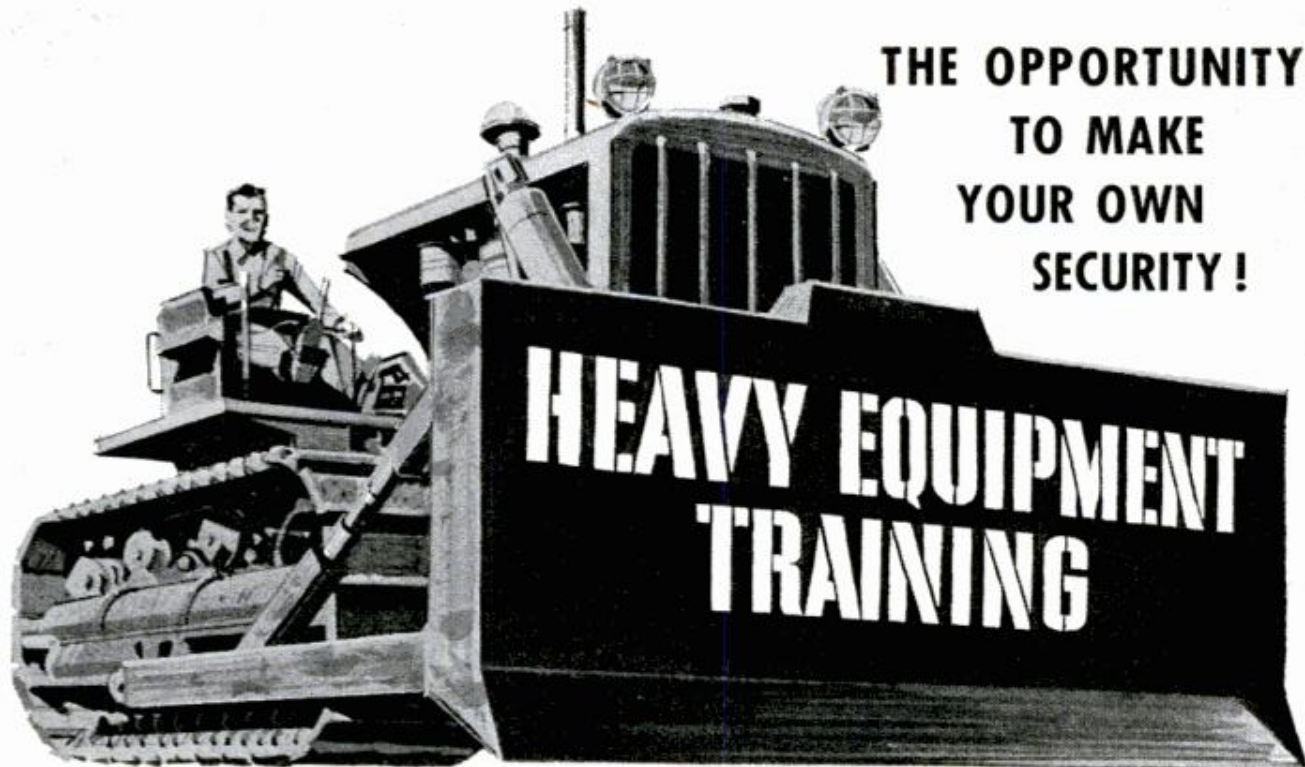

**THE OPPORTUNITY
TO MAKE
YOUR OWN
SECURITY!**

HEAVY EQUIPMENT TRAINING



With the increasing number of construction projects under way throughout the country—highways, dams, airports, bridges, factories; the need for trained men is also increasing and will continue to increase as newly planned projects get underway.

YOU CAN SHARE IN THE OPPORTUNITIES

TRAIN NOW to fill the demand for qualified heavy equipment operators... specialize in the construction field.

LEARN to operate the heavies: tractors, scrapers, graders, carry-alls, bulldozers. Learn field maintenance on modern equipment.

EQUIP YOURSELF as a specialist in the booming construction industry, with the proper training and background.

BROADEN your prospects to a better position, advancement, higher compensation, and security, by preparing today.

COMPLETE AND THOROUGH TRAINING PROGRAM INCLUDES COVERAGE OF:

- Blueprint Reading — Grade and Grade Stakes
- Operating Controls — Engineering Fundamentals
- Field Maintenance — Actual Work on Modern Equipment



START YOUR TRAINING IMMEDIATELY

You can learn without interference with present job or schooling. Placement assistance upon completion.

**IF AGE 17 TO 45
MAIL COUPON NOW**

HEAVY EQUIPMENT TRAINING, Northwest Schools, Inc. (Dept. M-7)
1221 N.W. 21st Avenue, Portland 9, Oregon

Rush information without delay

Name _____

Address _____

City _____ State _____

Phone _____ Age _____

Education _____ Hours Worked _____

START at the TOP

Learn Auto Mechanics at Home in Spare Time

"America is short 100,000 auto mechanics," a famous magazine reports. "America needs 25,000 more auto repair shops," a noted motor executive says. Pay is tops. Work is steady everywhere. Two-thirds of all cars are in heavy-repair class! *Mail coupon for free new catalog and sample lesson.*



Tools & Tune-Up Kit Sent

CTI sends you professional Mechanic's Tools and valuable instruments, including a Compression Tester, Vacuum Gauge & Fuel Pump Tester, Ignition Timing Light; and a handy portable steel case.

MANY STUDENTS EARN CASH as they train. They fix cars on their own, or work in local shops. All facts free. *Mail coupon now for Catalog and Sample Lessons.*

COMMERCIAL TRADES INSTITUTE Dept. A1248
1400 Greenleaf Avenue • Chicago 26, Illinois
Send booklet, *Make Big Money in Auto Mechanics*



Name _____ Age _____
Address _____
City _____ Zone _____ State _____
Accredited by National Home Study Council

OWN a BUSINESS

Be a Specialist in a Booming Industry



Get in on the ground floor of a booming \$750 million a year industry. Fill the need in your area for safe, effective "on location" cleaning of carpets and upholstery. Every home houses a customer! We'll train and establish you in your OWN lifetime business. Start part-time if employed. You'll be trained by a nearby dealer and at 50-hour school. You provide 6 services to multiply profits. You get exclusive use of process which cleans without harmful scrubbing, soaking, shrinkage. It's acclaimed by housewives, manufacturers and backed by famous McCalls and Parents Seals. No shop needed. Just 2 jobs a day nets \$8,750.00 first year.

WE HELP YOU GROW Our whole program is cooperative; thus, your training is only the beginning of a continuous assistance program designed to build your business. You receive continuous counseling from specialists at Hdqtrs. You're backed by *National Advertising* in Parents', House & Gardens, McCalls, others; ads in national trade magazines target retailers in your town to refer customers to you. Others among 25 regular services you receive are conventions, regional conferences, product development, sales letters, advertising kits, monthly magazines. Free booklets explain everything. No obligation. No salesman will call. So write for *Free Booklets* today!

DURACLEAN CO., 0-164 Duraclean Bldg., Deerfield, Ill.

"OWN A BUSINESS" COUPON

DURACLEAN CO., 0-164 Duraclean Bldg., Deerfield, Illinois
Without obligation, rush me FREE 16-page booklets giving full details on a dealership in my town.

Name _____
Address _____
City _____ State _____

cabana marrone



PLAN YOUR FUTURE NOW... have a business of your own

Luxurious, high-fashion fur now being ranch-raised in U.S.A. and Canada. All select, pedigreed, registered stock. Easy and economical to raise in any climate. One pair should produce 10 to 15 young per year. Warranty assures life and production. You may qualify for membership in CNBA (Cabana Nutria Breeders Association), the largest and strongest Nutria association. Free ranch training program. Cabana Marrone Nutria garments nationally advertised.



Cabana Marrone available only through authorized distributors. Write for complete information. Distributor inquiries invited.

CABANA NUTRIA INC.
Dept. 71 636 West Lemon Arcadia, Calif.

make your own Gems 3650

The Gem Maker comes complete with all necessary equipment, including a super-charged diamond blade for sawing, and all the wheels for grinding, shaping and polishing; also complete instructions. The complete equipment as shown, less motor and belt for only \$36.50, f.o.b., Burlington, Wisconsin. Write today for information and literature.

B&I MANUFACTURING CO.
Dept. P, Burlington, Wis.



High School Course at Home Many Finish in 2 Years

Go as rapidly as your time and abilities permit. Course equivalent to resident school work—prepares for college entrance exams. Standard H. S. texts supplied. Diploma. Credit for H. S. subjects already completed. Single subjects if desired. High school education is very important for advancement in business and industry and socially. Don't be handicapped all your life. Be a High School graduate. Start your training now. Free Bulletin on request. No obligation.

American School, Dept. H445, Drexel at 58th, Chicago 37

Print Your Own

Cards, stationery, circulars, etc. Save money. Print for Others, Good Profit; easy rules sent. Raised Printing like engraving, 10¢. Junior press \$15; Senior \$25 up. Sold direct from factory only. Write for free details.

KELSEY PRESSES, Y-37 Meriden, Connecticut

KILLS • • NO CHEMICALS, GASES, ETC.

- MOSQUITOES • MOTHS, MILLERS
- FLIES, GNATS • FISH FLIES, ETC.

OVER 1/2 ACRE HANG IT ANYWHERE

No insect recovery. Harmless. Guaranteed. Built to last 25 years. Beautiful outdoor lighting. Plug into any 110 volt socket.

NO AREA CONTAMINATION

Uses up to 200 watt bulb. Grid cost 10¢ per month. Complete with fly attractor. Dead insect catcher. Cord. Directions, Etc.

Very reasonable price - Write to -
SING SING BUG CHAIR, INC.
Box P 3708, Oak Park 37, Mich.



BOX SIZE - WT. 15 1/2 X 11 X 11 - 9 LBS.

RUPTURED

BE FREE FROM TRUSS SLAVERY

Surely you want to THROW AWAY TRUSSES FOREVER, be rid of Rupture Worries. Then Why Do you put up with wearing a griping, chafing and unsanitary truss the balance of your life? If you do, it will NOT be through necessity but through choice on your part.

Now there is a new modern Non-Surgical treatment that is designed to permanently correct rupture. These Non-Surgical treatments are so certain, that a Lifetime Certificate of Assurance is given. Write today for our New FREE Book that gives facts that may save you painful, expensive surgery. Tells how non-surgically you may again work, live, play, love and enjoy life in the manner you desire. There is no obligation.

Excelsior Medical Clinic, Dept. H6124, Excelsior Springs, Mo.

POPULAR MECHANICS

Start him toward success
with the authoritative,
easy-to-understand
**BOOK OF POPULAR
SCIENCE®**

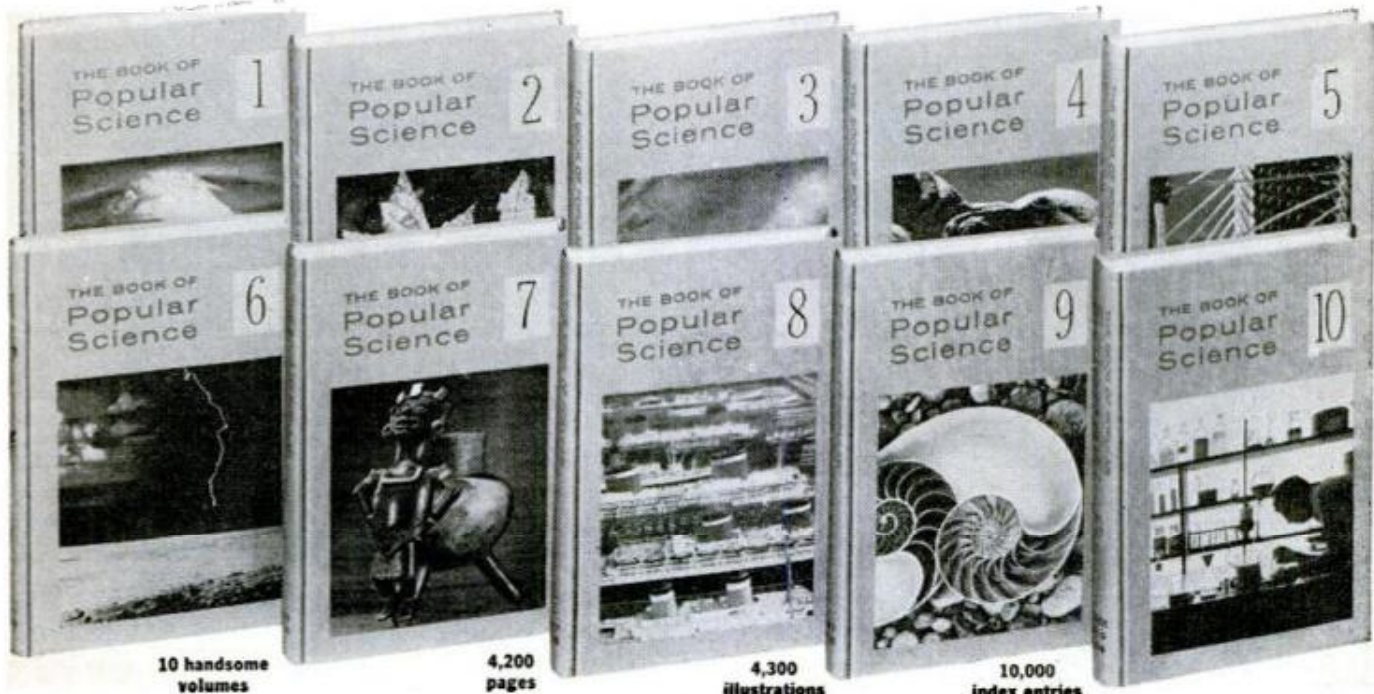

10 handsome
volumes

4,200
pages

4,300
illustrations

10,000
index entries

This could be one of the most important investments you will ever make for your child. It will give him a basic foundation in the sciences. It may even spur him on to a brilliant scientific career.

Only science library of its kind. The Book of Popular Science is much more than an encyclopedia. Like a good teacher, The Book of Popular Science makes "complicated" subjects crystal clear and exciting. It is up-to-date and remarkably complete.

Takes your child through 15 major areas of science. 33 chapters on The Universe cover ASTRONOMY and ASTROPHYSICS. 37 chapters on The Earth cover GEOLOGY, MINERALOGY and METEOROLOGY. 18 chapters on Life cover BIOLOGY. 31 chapters on Plant Life cover BOTANY. 55 chapters on Animal, Marine, Bird and Insect Life cover ZOOLOGY. 21 chapters on Man cover AN-

THROPOLOGY, GENETICS, PSYCHOLOGY and PHYSIOLOGY. 42 chapters on Matter and Energy cover PHYSICS and CHEMISTRY. 45 chapters on Industry cover METALLURGY and many branches of ENGINEERING.

Plus: Transportation (AERONAUTICS, ASTRONAUTICS, and AUTOMOTIVE ENGINEERING); Communication (ELECTRONICS, PHOTOGRAPHY, etc.); Health (HYGIENE and MEDICINE); Science Through the Ages; Society (ARCHAEOLOGY and SOCIOLOGY); Science In the Home. Also, 21 chapters of exciting Projects and Experiments to give your child the satisfaction of "doing it himself."

Contributors include 99 eminent scientists and educators, such as: WILLY LEY, America's foremost writer on rockets and space travel. SAMUEL L. BOOTHROYD, Professor of Astronomy, Emeritus, Cornell University. DR. KARL M. BOWMAN, Prof. of Psychiatry, Univ. of Cali-

fornia School of Medicine. DR. LEE DE FOREST, pioneer electronics inventor. DR. THEODOSIUS DOBZHANSKY, Prof. of Zoology, Columbia Univ. DR. BENTLEY GLASS, Assoc. Prof. of Biology, John Hopkins Univ. DR. EARLE H. KENNARD, Prof. of Physics, Cornell Univ.

It is like having 99 distinguished scientists and educators in your home, to teach your child science!

FREE Booklet of Experiments!

The LITTLE Book of Popular Science describes 12 scientific experiments that your child can do himself; teaches him about atmospheric pressure, molecules in motion, refraction of light, etc. Shows him how much fun it can be to learn about science.

For free copy, mail coupon right now.



Read this excerpt from a review in
"SCHOOL SCIENCE & MATHEMATICS"

(Journal of the Central Assoc. of
Science & Math Teachers, Inc.)

"The reviewer put The Book of Popular Science into use for more than two months. It was eminently clear that the publication was excellent... The contributors... read like a 'Who's Who of the Scientific World'... without question up-to-date... adequate coverage of the newest scientific innovations... an indispensable item..."

(from the January, 1958 issue).

**THE GROLIER SOCIETY INC. • FOUNDED 1895
PUBLISHERS OF THE BOOK OF KNOWLEDGE®**

The Grolier Society Inc. (Science Division)
Putnam Valley, New York

I would like a free copy of "The LITTLE Book of Popular Science," without obligation.

There are _____ children in my family, ages _____

MY NAME _____

ADDRESS _____

CITY _____ ZONE _____

COUNTY _____ STATE _____

© The Grolier Society Inc., 1968

Popular Mechanics 4/60

**MY SPARE TIME HOBBY
MAKES ME
\$5⁰⁰ an hour
CASH PROFIT**

—Grover Squires

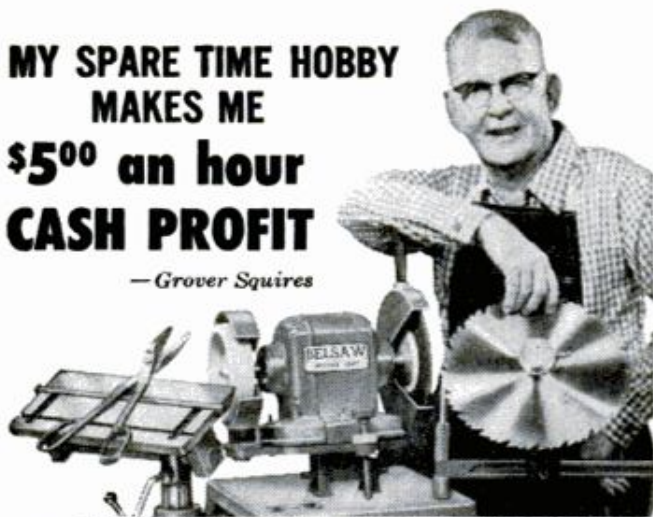

START YOUR OWN SPARE TIME BUSINESS

You can turn your spare time into Big Cash Profits with your own COMPLETE SHARPENING SHOP . . . Grind saws, knives, scissors, skates, lawn mower blades . . . all cutting edges. Your Own Cash Business with no inventory . . . right at home . . . no experience needed.

FREE BOOK tells how you can start your own spare time business while you are still working at your regular job. Low Cost — time payments only \$15.00 a month. Send coupon today.



BELSAW SHARP-ALL CO, 710 Field Bldg., Kansas City 11, Mo.

Send Free Book "LIFETIME SECURITY". No obligation.

Name _____

Address _____

City _____ State _____

**EARN \$125
A WEEK AND UP**

**BE AN AUTO DIESEL
EXPERT — LEARN
A TRADE YOU LIKE**

You learn fast in our shops because you learn with tools on real equipment. Students short of money may earn most of their expenses by doing part-time work. Experienced instructors explain WHY and show you HOW, then you DO IT YOURSELF. Many of our graduates earn \$125 a week and up. Approved for veterans. Day and evening classes. Free bulletin-write today.

MAIL THIS COUPON TODAY!

NASHVILLE AUTO-DIESEL COLLEGE

226 7th Ave., No., Dept. 86, Nashville, Tenn.

Please send without obligation free catalog.

NAME _____
(please print or write plainly)

ADDRESS _____

CITY _____ STATE _____

engineering degree in 27 months

Share rewards awaiting college men . . . higher income . . . advancement. Important firms visit Tri-State campus to interview seniors. *Bachelor of Science Degree in 27 Months* in Electrical Engineering (Electronics or Power major), Mechanical, Civil, Aeronautical, Chemical Engineering. In 36 Months a B.S. in Business Administration (General Business, Accounting, Motor Transport Management majors). For earnest, capable students. Small classes. More professional class hours. Well-equipped, new and modernized, buildings, labs, dorms. Modest costs. Year-round operation. Enter July, Sept., January, March. Founded 1884. Write J. E. McCarthy, Director of Admissions, for Catalog and "Your Career in Engineering and Commerce" Book.



TRI-STATE COLLEGE

440 College Avenue Angola, Indiana

Hotels Call for Trained Men

Record-breaking travel means nation-wide opportunities and a sound substantial future for trained men in the hotel, motel and hospitality field. Fascinating work; fine living; quick advancement. You can qualify at home or through resident classes in Washington. Previous experience proved unnecessary. Placement Service FREE. Write for FREE Book, "Your Golden Opportunity." Accredited by N.H.S.C.

Course Approved for ALL Veteran Training. 44th Year. LEWIS HOTEL TRAINING SCHOOL, Room FD-312, Wash. 7, D.C.

BRONZE FOUNDRY

Since 1935

Schools • Home Workshops • Inventors

Make your own castings of aluminum, copper, bronze, silver. Foundry sets are available in six sizes, capacity 1 1/2 lb. to 48 lb. of red brass. 2400 Deg. F. blast furnace included with each. Write for Free Circular.

KANSAS CITY SPECIALTIES CO. DEPT. P-4, P.O. BOX 6022, MARYSVILLE, KANSAS

JEEP OWNERS

RE-POWER NOW WITH A V-8 OR 6 CYL. ENGINE — USE FORD—CHEV—MERCURY—GMC—PONT—STUDE—DODGE OR PLYMOUTH

In Jeeps, Jeepsters, Sta-Wgn, trucks, Kaiser & H. J. cars. Conversion Kits \$45.35 to \$56.90. Want fast action? Give us full information, send \$15.00 Dep. and we will ship correct kit. Bal. COD. Send full amount for prepaid shipment. Wire, phone or write today. Details FREE

HOOSIER MACHINE PRODUCTS CO.

312 S. E. 6th St. Phone CR 6-3442 Pendleton, Oregon

SINCE 1854 YOUR BEST BUY



Selsi
FINE OPTICAL GOODS

AT BUDGET PRICES
SEE YOUR DEALER

WRITE DEPT. 44 FOR ILLUSTRATED LITERATURE
SELSI CO., Inc., 29 East 22nd St., New York 10, N. Y.

BINOCULARS
BAROMETERS
TELESCOPES
MICROSCOPES

26 YEARS IN BUSINESS AT THE SAME ADDRESS.

Our entire stock of very slightly used EXTRA MILEAGE TOP GRADE Tires, (Written Insurance Guarantee), SEND AD

WHY PAY MORE? FREE PASS. TUBE
EVERYBODY 10% off ON EVERY TIRE
MAY DEDUCT 10% off ON EVERY TIRE

12 MOS. Written Guarantee. White Walls \$1.00 extra	600-16 \$6.92	670-15 \$6.82	700-15(6) \$9.72	750-20(8) \$12.42
	600-16(6) 8.62	710-15 6.92	750-16(8) 10.82	825-20 18.92
	650-16(6) 9.32	760-15 6.92	700-17 10.42	900-20 18.92
	750-14 7.72	800-15 6.92	750-17 12.22	1000-20 19.92
	800-14 7.72	820-15 6.92	650-20 10.02	1100-20 19.92
	750-16(6) 9.82	700-16(6) 9.92	700-20 11.82	1000-22 20.92

Thousands of tires shipped all over the U.S.A. All tires shipped F.O.B. Phila. Send Check or M.O. with this ad. Dept. 2. No C.O.D.

STANDARD 834 N. Broad St., Philadelphia 30, Pa.

Here's the "STRAIGHT DOPE" on HOW TO FIX ANY PART OF ANY CAR from the Men Who Build 'Em!

Engineers from every American car factory put their know-how at your fingertips in this giant 1,100-page, picture book!
COVERS ALL THESE MAKES, OVER 1,967 MODELS—1953 thru 1960!



BRAND-NEW EDITION!

MOTOR'S
AUTO
REPAIR
MANUAL

TRY BOOK
FREE
FOR A WHOLE WEEK!

Now — the "meat" of 176 shop manuals makes practically any car repair or service job child's play for beginner or expert mechanic!

Now you can "breeze thru" the toughest car repair jobs — in DOUBLE-QUICK time. If you're a beginner mechanic you can tackle jobs you never dreamed you could handle. And if you're already an expert, you'll save yourself hours of back-breaking work... and save money, to boot!

It's easy with the big brand-new Edition of famous MOTOR'S Manual. You get the expert help of 176 Official Factory Shop Manuals — the time and work-saving methods developed by factory engineers in every auto plant in America for their own motor car lines—boiled down in one handy indexed book.

Factory Experts Practically Guide Your Hands

NO guesswork! NO false starts! MOTOR'S Manual starts you from

"scratch" — expert "know-how" guides your hands through every step of practically every job. With clear illustrations and 1-2-3 instructions, these experts show you how to "polish off" any repair on any car listed—1953 thru 1960!

NEW, REVISED Edition gives you everything you need to know to repair 1,967 models. Over 1100 giant-size pages, 2850 "this-is-how" pictures and diagrams, 195 "Quick-Check" Charts, 30,000 essential repair specifications, 225,000 Service and Repair FACTS. Instructions and pictures so clear you CAN'T go wrong!

Here's everything you need to know to make fast, expert repairs on Automatic Transmissions, Engines, Ignitions, Carburetors, Steering Gears, Generators, Distributors, Power Steering and Brakes, Starter Motors, Starter Switches, and much, much more. No wonder THREE MILLION copies have been sold. No wonder it's used by the U.S. Armed Forces.

Try It FREE 7 Days

SEND NO MONEY! Just mail coupon. (Paste it to a postcard for fast action.) Use the Manual for a week, free. If you don't agree that it is the greatest time-saver and work-saver you've ever seen—return book in 7 days, pay nothing. Mail coupon today! MOTOR Book Dept., Desk 014, 250 West 55th St., New York 19, N. Y. (Schools, Bookstores: Write for discounts.)

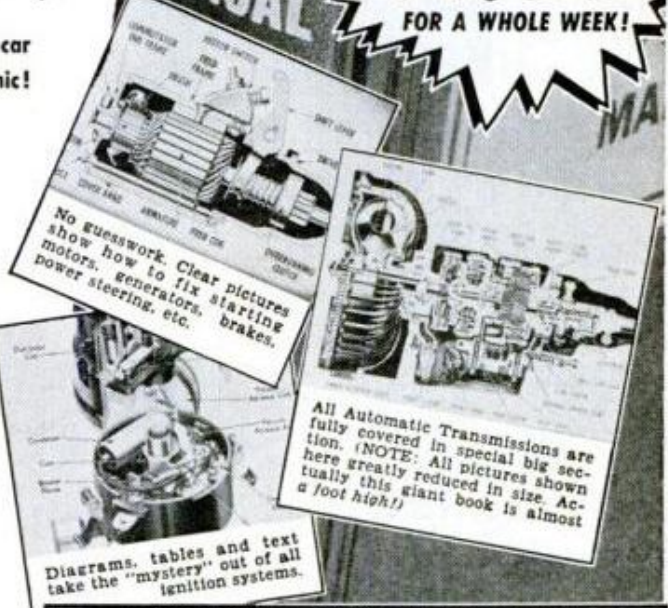

No guesswork. Clear pictures show how to fix starting motors, generators, brakes, power steering, etc.

All Automatic Transmissions are fully covered in special big section. (NOTE: All pictures shown here greatly reduced in size. Actually this giant book is almost a foot high!)

Diagrams, tables and text take the "mystery" out of all ignition systems.

MAIL COUPON NOW FOR 7-DAY FREE TRIAL (Attach to postcard if more convenient)

MOTOR BOOK DEPT.
Desk 014, 250 W. 55th St., New York 19, N. Y.

- Rush to me at once (check box opposite book you want):
- MOTOR'S New AUTO REPAIR MANUAL. If O.K., I will remit \$2 in 7 days, \$2 monthly for 2 months and a final payment of \$1.95 (plus 45¢ delivery charges) one month after that. Otherwise I will return the book postpaid in 7 days. (Foreign price, remit \$10 cash with order.)
 - MOTOR'S New TRUCK REPAIR MANUAL. If O.K., I will remit \$3 in 7 days and \$2 monthly for 2 months, plus 45¢ delivery charges, with final payment. Otherwise I will return book postpaid in 7 days. (Foreign price, remit \$11 cash with order.)

Print Name.....Age.....

Address.....

City.....Zone.....State.....

Check box and save 45¢ shipping charge by enclosing WITH coupon in envelope entire payment of \$1.95 for Auto Repair Manual (or \$9 for Truck Repair Manual.) Same 7-day return refund privilege applies.



"This wonderful book has paid for itself time and time again."
—P. Pemper, Wis.



"Have been a mechanic for 25 years. MOTOR'S Manual still takes me out of the tight spots."
—V. Lauria, Nev.



"So complete, easy to understand—have done jobs with Manual I would not have attempted without it."
—C. L. Vanerstrom, Mich.



Same FREE 7-Day Trial on TRUCK REPAIR MANUAL

Covers every job on every popular make truck made since 1952 including GM, Mack, Cummins Diesels. Engines, fuel systems, ignition systems, starters, generators, transmissions, axles, brakes, steering, etc., etc. For FREE TRIAL, check box in coupon.

Make way for power
with
a new thrill!

DREAM



Model, HONDA DREAM
(CE-71)
Engine: O.H.C. Twin cylinder, 4-stroke
Cylinder capacity: 247 c.c.
Max. HP: 22HP/8,500 r.p.m.
Tire size: Front (3.25-18),
Rear (3.50-18)
Max. speed: 82 m.p.h.
Fuel consumption: 106
m.p.g. with electric
starter.



AMERICAN HONDA MOTOR CO., INC.
4077 W. Pico Blvd., Los Angeles 19, Calif.
PHONES: REpublic-12596, 12597

IT'S EASY TO ROLL OUT THIN LINES with

Master[®] PAINT STRIPER

You can do professional striping on furniture, boats, autos, bikes, plywood, etc. Master Striper rolls out uniform lines on wood, glass, plastic, ceramics, almost any surface with paint, temperas, glue, textile-paint or underglaze; also used in industry.

- TYPE M Tool with 1/16" roller tip. **\$1.50**
 - Other size Tools (1/64", 1/32", 3/64", 5/64", 3/32", 1/8")..... **2.00**
 - Extra Roller Tips, Sizes above, ea..... **1.00**
 - Extra Roller Tips, 1/4" ea..... **1.25**
 - Special complete set with 7 tips, only **5.50**
 - DOUBLE STRIPE KIT—5 combinations **3.50**
- (COD's. Postage Collect)



**MAKES
CLEAN,
STRAIGHT OR
CURVED LINES;
VARIOUS WIDTHS
AVAILABLE.**

WENDELL MFG. CO., 4234 LINCOLN AVE. DEPT. 44
CHICAGO 18, ILL.

NEW FIBERGLASS LAPSTRAKE & PLYWOOD BOAT KITS

Most complete line. 8' to 23'. Prams, row-boats, outboards, cruisers.

MAIL 50c (coin)
REFUNDABLE
for BIG COLOR
CATALOGS



U-MAK-IT, DeLAND, FLORIDA • DEPT. 12

**Take Up Slack Time — Make Extra Money
FIX SMALL AIR COOLED ENGINES**

New 4th Edition available—Contains 387 Makes & Models



Complete information on maintenance, servicing and repairing gas engines used on Chain Saws, Lawn Mowers and Go Karts. Edited by engineers and professional mechanics. Information on 24 major manufacturers engines. 2 New sections added—American Mare and Homelite. 387 Makes and Models in all including Lauson, Power Products, Briggs & Stratton, Clinton, Cushman etc. 121 New engine models added with total of 387 models listed. 529 mameoto and 947 carburetor models listed. 320 pages of practical down-to-earth information on 2 and 4 cycle engines, 1, 2 and 4 cylinder models. Central parts distributors listed. Authoritative section on gas engine fundamentals. Trouble shooting and servicing of ignition and carburetor equipment. Section on trouble shooting for beginners. \$4.95 postpaid. Satisfaction guaranteed or your money back. Send check or money order. Order now. Clip this ad.

**Small Engines Service Manual. Dept. 360,
1014 Wyandotte, Kansas City 5, Missouri**

DAN LURIE
America's
Champion
Muscle Builder



Send
10c
For
Catalog

**BUILD YOUR MUSCLES FAST
WITH DAN LURIE BARBELLS**

Get results as no other method can. See your arms, chest, legs grow like magic. no other method compares. Get \$10.00 BODY MOLD COURSE FREE with order. Results guaranteed. Buy direct and save.

50 lb. set \$ 9.48 • 100 lb. set \$15.98
150 lb. set \$23.48 • 200 lb. set \$29.98

Semi-steel sets approx. 10% higher. Extra wts. 15c per lb. Send 50% cash, balance COD.. F.O.B. Plant. Order today.

DAN LURIE BARBELL CO., 52-M4 Bristol St., Dept. 59D, Bklyn. 12, N.Y.

Finish HIGH SCHOOL AT HOME

Complete 4 Yrs. in 12 Months

Learn More! Earn More! Enter professional or technical schools. Advance Socially. Live a Happier, Fuller Life. Individual Courses or complete schedule. **WRITE FOR SCHOOL BULLETIN.**

ACADEMY FOR ADULTS

30 W. Washington, Dept. PM-460 Chicago, Ill.

"YOU ARE UNDER ARREST!"

Help Bring Crooks to Justice Through Scientific **CRIME DETECTION!**



We have taught thousands this exciting, profitable, pleasant profession. Let us teach you in your own home. Learn Fingerprinting, Firearms Identification, Police Photography, Secret Service Methods thoroughly, quickly, at small cost. Over 800 of all American Bureaus of Identification employ I.A.S. students or graduates. Write for FREE "Blue Book of Crime." (A Correspondence School Since 1916)

Institute of Applied Science, 1920 Sunnyside Ave., Dept. 1354, Chicago 40, Ill.



SEND FOR THIS **FREE!**

Make money. Know how to break and train horses or ponies. Write today for this book **FREE**, together with special offer of a course in Animal Breeding. If you are interested in Gaiting and Riding the saddle horse, check here (). Do it today—now.

**BEERY SCHOOL OF HORSEMANSHIP
Dept. 1104 Pleasant Hill, Ohio**

NO JOB WORRIES

PLASTEX INDUSTRY needs manufacturers on small scale for big production of Lamps, Clock Stands, Art Goods, Novelties in Plastic Marble imitation. No Experience necessary. 1 1/2 material makes regular 10c store sellers. Moulds furnished for fast production. Small investment brings good profit. Big wholesale orders now being placed. Ambitious men have chance for real prosperity and job security. Our NEW FREE booklet will interest and benefit you.

**PLASTEX INDUSTRIES, Dept. A
3400 Third Ave. New York 56, N.Y.**



Shrinks Hemorrhoids New Way Without Surgery Stops Itch—Relieves Pain

For the first time science has found a new healing substance with the astonishing ability to shrink hemorrhoids and to relieve pain — without surgery.

In case after case, while gently relieving pain, actual reduction (shrinkage) took place.

Most amazing of all — results were so thorough that sufferers made astonishing statements like "Piles have ceased to be a problem!"

The secret is a new healing substance (Bio-Dyne*) — discovery of a world-famous research institute.

This substance is now available in suppository or ointment form under the name Preparation H.* Ask for it at all drug counters—money back guarantee. *Reg. U.S. Pat. Off

GET INTO ELECTRONICS

V.T.I. training leads to success as technicians, field engineers, specialists in communications, guided missiles, computers, radar, automation, basic & advanced courses in theory & laboratory. Assoc. degree in 29 mos. B.S. obtainable, ECPD accredited, G.I. approved. Graduates with major companies. Start Sept., Feb. Dorms, campus, H. S. graduate or equivalent. Catalog.

DEPT. D VALPARAISO TECHNICAL INSTITUTE VALPARAISO, INDIANA

Learn LANDSCAPE GARDENING

AND GROWING OF PLANTS. Latest information on propagation, soil-testing, plant growth regulators, garden design. Start a profitable business or wonderful hobby. Unique and modern home study course—accredited. Earn your certificate at home. May I send FREE, and without obligation, my Informative Booklet?

NORM MORRIS NATIONAL LANDSCAPE INSTITUTE
DEPT. M-40 11826 SAN VICENTE BLVD., LOS ANGELES 49, CALIF.

A POSTCARD

CAN PUT YOU IN A FINE BUSINESS!

Rush Card TODAY for FREE OUTFIT!

Get into highly profitable, repeat-order shoe business! Sell new line of Air-Cushion comfort shoes to friends, neighbors, folks at work! Over 210 dress, sport, work, safety shoe styles for men, women. Never sold by stores. Just 2 easy orders a day—in spare time—bring you \$217 extra income a month! No investment. Rush name and address TODAY for FREE SELLING OUTFIT! MASON SHOE. Dept. G-17, Chippewa Falls, Wisc.



MAKE MONEY!

REPAIR HYDRAULIC JACKS



Earn While You Learn At Home
Make up to \$5 an hour, full or part-time, in the competition-free field of Hydraulic Jack Repair. Millions of jacks in auto service stations, truckers, body shops, riggers, farms, need servicing. We show you HOW. Easy step-by-step directions.

Get Folder PM-4 & free bonus offer

Institute of Hydraulic Jack Repair

P.O. BOX 50 • BLOOMFIELD, N. J.

A Correspondence School Licensed by N.J. Bd. of Ed.

HELPFUL HINTS FOR MECHANICS

Want the answer to poor gas mileage complaints? A good tune-up usually will solve the problem — IF the job includes a MILEAGE MINDER. Only with MILEAGE MINDER can you safely set carburetor float at lowest recommended point. Result? Spillage from float bowl is stopped; flooding and stalling are ended; your customer saves gas; and you look good. See your distributor, or write:

MILEAGE MINDER

537 TURK ST. SAN FRANCISCO 2, CALIF.

FREE

it's value-packed...
SEND FOR IT!

ALLIED'S MONEY-SAVING 1960 ELECTRONIC SUPPLY CATALOG

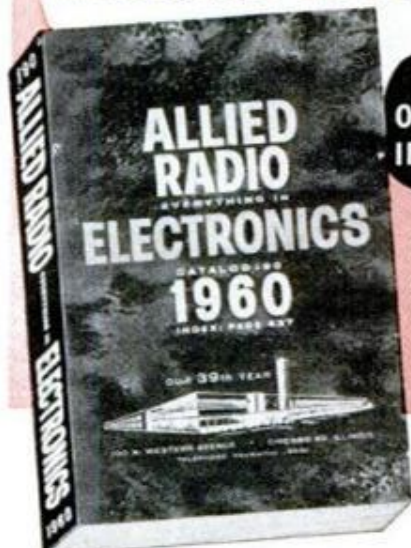

SAVE ON EVERYTHING IN ELECTRONICS

ONLY \$2 DOWN on orders up to \$50; only \$5 down on orders up to \$200; \$10 down over \$200.

Largest Selection—Lowest Prices

Send for the most widely used buying guide to everything in Electronics for Builders, Experimenters, Hi-Fi fans, Amateurs, Servicemen and Engineers. Save on:

- KNIGHT-KITS®—Best in Build-Your-Own
- Everything in Stereo Hi-Fi
- Hi-Fi Music Systems and Components
- Tape Recorders & Phono Equipment
- TV Tubes, Antennas, Accessories
- Parts, Tubes, Transistors
- Everything in Tools & Technical Books
- Amateur Station Equipment
- Public Address & Paging Systems
- Latest Test & Lab Instruments



SEND FOR FREE CATALOG

SAVE on everything in Electronics at ALLIED — get fastest service, expert personal help, guaranteed satisfaction. Send today for your FREE 1960 ALLIED Catalog.

our 39th year

ALLIED RADIO

ALLIED RADIO CORP., Dept. 5-D
100 N. Western Ave., Chicago 80, Ill.

Rush FREE 1960 ALLIED Catalog.

Name _____

Address _____

City _____ Zone _____ State _____

FREE! AIRMAILS!



Fabulous collection of all-different genuine Airmail Stamps from remote corners of the world — Africa, Europe, Exotic Orient, everywhere! World's Largest Airmail, Flying Doctor, Bomber, \$2.00 Helicopter, many others. PLUS Collection of thrilling Space-Age stamps . . . Sputniks, Jets, fantastic Moon Rocket stamps. Both of these remarkable collections — containing stamps worth up to 25c each! — for only 10c to cover mailing costs. Extra: Other sensational stamps for your free examination, plus Big Bargain Catalog. Rush 10c today to:

Jamestown Stamp Co. Dept. F40PM, Jamestown, New York

RUSH my Free Airmail Collection and other offers. I enclose 10c for mailing costs. PLEASE PRINT

Name

Address

City & State

TECHNICAL DATA

FOR ENGINEERS • TEACHERS
STUDENTS • TECH. WORKERS
Loose Leaf Pocket Size \$1.25

Each book contains about 140 pages of essential technical data. A digest of many books and other sources condensed into one thin pocket size volume. Printed on 6-hole 6 3/4" x 3 3/4" bond paper, in loose leaf binder.

Architecture	Survey Tables	Machinist's Data	Radio
Home Heating	Highway Eng'g.	Mech. of Materials	Television & FM
Illumination	General Math.	Pwr. Trans. Mach.	Electricity, AC
Electric Data	Math Tables	Thermo. Tbls.	Electricity, DC
Builder's Data	Physics	& Charts	AC Motors &
Lumber Data	Trig-Log Tables	Phys. & Thermo-	Generators
Air-Conditioning	Gen'l. Chemistry	dynamic Data	Conversion Tabl.
Building Constr.	Chemical Tables	Metallurgy	Steel Forms
Reinf. Concrete	Analytic Chem.	Hydraulics	Welding Data
Piping Data	Mech'l. Drawing	Metals	Transformers
Survey Data	Machine Design		Relays & Meters

Write for FREE Catalog (2000 listings). See how helpful Lefax can be to you. Send \$1.25 book, or \$6. for any 5 books to:

LEFAX PUBLISHERS Dept. PM-460 PHILADELPHIA 7, PA.

WANT MORE MONEY? GET INTO PHOTOGRAPHY

Coast to coast, high-paying jobs in photography are waiting for people with the "know-how" to fill them. You can quickly, easily qualify at home with the world-famous NYI Learn-by-Doing Method. Write today for free catalog. Also resident training in N. Y. Our 50th Year. Approved for Veterans.

NEW YORK INSTITUTE OF PHOTOGRAPHY
Dept. 49 10 West 33 St. New York 1, N. Y.

Catalog of 2900 Novelties 10c

New Send 10c for amazing catalog of novelties, live animals, scientific supplies, hobbies, funmakers, planes & boats, looms, magic tricks, joke articles, unusual seeds, gadget timesavers, cameras, optical goods, projectors, movies, lucky jewelry, religious novelties, disguises, musical instruments, stamps, coins, puzzles, fortune tellers, radios, auto & bike accessories, telescopes, magnifiers, compasses, banks, smokers' gadgets, artists' supplies, printing sets, engines, motors, shockers, knives, billfolds, guns, rifles, sports, books, games, plants, etc. Send 10c.

JOHNSON SMITH COMPANY Dept. 472 Detroit 7, Michigan

DOLLS!

Learn to make, repair and sell dolls and accessories at home. Excellent money making opportunities. May we send FREE informative booklet? No obligation!

NORM & SUE'S DOLL HOSPITAL SCHOOL, Studio M-48
11826 San Vicente Blvd., Los Angeles 49, Calif.

PROFIT IN YOUR SPARE TIME

FIX SMALL GASOLINE ENGINES
Outboard • Powermower • Chain Saw • Tractor
MAKE EXTRA MONEY— or, repair your engines and SAVE. Illustrated, easy-to-understand, Home Study Course. FREE information. Write TODAY!

LINCOLN TECHNICAL INSTITUTE
Suite 4-E, 472 Market Street, Newark 5, New Jersey

\$ POPULAR MECHANICS MEANS MORE MONEY IN YOUR POCKETS

YOU CAN EARN \$10, \$25, \$50 NOW!
Handling orders for POPULAR MECHANICS and other magazines your friends read! Commissions—Bonus—DETAILS FREE!

POPULAR MECHANICS Dept. 460-C
250 W 55th St. N.Y. 19, N.Y.

Name

Address

City State Zone

POPULAR MECHANICS

... TURN CONCRETE INTO GOLD!



MAKE UP TO \$75 A DAY
IN YOUR OWN BUSINESS

If you want to have your own business — to start a business on your own — here's your big opportunity! New high speed, low cost General block machine produces up to 1,000 concrete blocks a day. Sell all you make to builders, supply houses, and others for homes, factories, buildings, garages. Cash in on the building boom! You can make profits of 100% to 150% — up to \$75. a day! General block machine equipped with 1/2 h.p. electric motor — or can be supplied with gasoline engine — works anywhere, in little space, indoors or out. Operates from ordinary house light socket. Simple, foolproof 3 step operation — so easy a child can do it. Makes superior 3 core blocks any size from 4" to 12" Also makes chimney, sash, corner and other types. Blocks meet any building code anywhere in the country. Materials — sand, water, cement, available anywhere. Simple illustrated operating instructions and mixing formulae for cement and cinder blocks supplied with each machine. Write for FREE folder with full information.

MOTOR DRIVEN

R. L. T. of New York City reports: "MY GENERAL BLOCK MACHINE PAID FOR ITSELF IN FIRST 2 WEEKS!"
Hundreds now in use the world over!
Write for FREE details today!

EXTRA Amazing illustrated book gives floor plans for 6 sensational concrete block bungalows. Tells how to lay blocks, lay out building lines, mix concrete, build steps, porch and concrete floors all of great savings. Written by experts. Can save many times the cost of the machine! Get it now! No strings attached. Send \$1.

BOOK SENT FREE IF YOU BUY MACHINE.
\$1 REFUNDED IF YOU BUY LATER.

GENERAL ENGINES CO.

DEPT. M-40, ROUTE 130, THOROFARE, N.J.





YOU CAN PLAY!

Piano, Guitar, ANY Instrument

PLAY real tunes on ANY instrument right from the start even if you don't know a single note now! Amazing course lets you teach yourself at home, in spare time. No boring exercises. You play real notes. Make rapid progress. Easy as A-B-C. Low cost. Over 1,000,000 students.



FREE BOOK describes this famous course in full. See how easy learning music can be. No obligation. Write TODAY to: U. S. SCHOOL OF MUSIC, Studio 304, Port Washington, N.Y. (Largest in the world—62nd successful year.) Tear this out as reminder.

SHORTHAND in

6 WEEKS

Famous SPEEDWRITING shorthand. 120 words per minute. No symbols; no machines; uses ABC's. Learn at home or through classroom instruction. Lowest cost. For business and Civil Service. 500,000 graduates. Typing available. 37th year. Write for FREE booklet.

© 1959

Speedwriting

Dept. 1504, 55 W. 42 St., New York 36

Switzerland

147



HOME-IMPORT BUSINESS

Men, women. Make big profits buying low cost imports abroad (see examples at left) and selling to friends, stores or by mail order. Famous world trader guides you—shows you how to find thousands of exotic imports for full or spare time business, how to pocket profits in advance on foreign drop shipment plan. Full details FREE! Airmail reaches us overnight. Write Today!

MELLINGER CO., 1717 Westwood
Dept. C254, LOS ANGELES 24, CALIFORNIA

LAW FREE BOOK THE LAW TRAINED MAN

Write today for a FREE copy of illustrated law book, "THE LAW TRAINED MAN," which shows how to earn the professional Bachelor of Laws (LL.B.) degree through home study of the famous Blackstone Law Course. All necessary books and lessons provided. Moderate cost; convenient monthly terms. Write for FREE law training book today.

Blackstone School of Law, 307 N. Michigan Ave.
Founded 1890 Dept. 54, Chicago 1, Illinois

MAKE EXTRA CASH

SHARPENING LAWN MOWERS THE MODERN WAY



\$275.00
F.O.B. Pasadena

Start your own shop! Full or spare time. Earn many dollars in a short time . . . average \$5.00 per hour. Many mowers need sharpening. With MODERN'S Extra Heavy Duty LAWN MOWER SHARPENER AND BED KNIFE GRINDER you have 6 machines in one. All operations are done quickly and easily. You make money from the start. Write for free details.

MODERN MFG. CO.
160 N. Fair Oaks Ave. Dept.
Pasadena, California 10-4

94.6% OF BAILEY GRADUATES ARE EMPLOYED AT TOP PAY IN THE FIELDS WHICH THEY WERE TRAINED!



DIESEL-AUTO MECHANICS DESPERATELY NEEDED!

We have a far greater demand for our students than we can fill!

We can show you an actual waiting list of leading companies throughout the world who have tried Bailey graduates — found them outstanding, and are coming back for more!

Bailey Graduates are Successful . . . RECEIVE BIG PAY — HAVE SECURE FUTURE!

The Famous Bailey Course prepares you for BOTH Diesel and Gasoline Mechanics.

This is a must—due to the advent of using Diesel principles, such as 'Fuel Injection' on passenger cars . . . use of gasoline engines for starting Diesel engines, etc. You learn all this at Bailey in the amount of time ordinarily required to learn just one of these subjects, ALL FOR THE PRICE OF ONE.

Don't be satisfied with a 'futureless', one-type job — learn how you can make big money now! Write today for Free Booklet that takes you on a step-by-step camera tour through our spacious, modern shops — See Bailey students in action as they Learn-by-doing with the Famous Bailey Method of training!

We provide you with housing and part time jobs while in school, plus nation-wide placement service for graduates.

BAILEY Technical SCHOOLS

1634 S. GRAND

ST. LOUIS 4, MO.

MAIL TODAY!

Please mail immediately this free booklet without obligation.

FREE BOOKLET



Name.....

Address.....

City..... State.....

APPROVED FOR VETERAN . . . NON-VETERAN

Not everyone does as well, but T. N. CODY, who started a business of his own, reports...

For 12 months I've averaged

\$800

per month income

— most of it clear profit for me!

Many men have discovered how to be independent, to be free of layoffs and bosses. C. G. Naples grossed more than \$200 his first week. A father-son combination grossed \$44,000 their second year. H. Lemon says, "I netted \$133 in one 8-hour day."

How much you make depends largely on you. You need no special skill, no large investment. Start part time if you wish.

NO SHOP NECESSARY • Our Electric Deterger shampoos rugs, carpets right on floor—removes dirt and grime and helps to show their natural color and beauty. So efficient and safe it is used by largest railroads and hotels.

This is not a lease proposition. You own the machine, you work when and where you please and all the money you take in is your own. No risk. Machines fully guaranteed.

Mail
Coupon
Today
for
FREE
Book

VON SCHRADER MFG. CO.,
410 "R" Pl., Racine, Wis.

Without obligation send me FREE booklet about your RUG DETERGER and tell me how I can start my own permanent, profitable business.

Name _____
Address _____
City _____ Zone _____ State _____

\$3.25 OR 2 FOR \$6.00!

With 40 ft. of wire. Additional wire 3c ft. **TESTED AND GUARANTEED.** Write for free list of all types of telephones. Shipments FOB Simpson, Pa.

TELEPHONE ENGINEERING CO., Dept. 4 B0, Simpson, Pa.

KEEP YOUR... ON

BENJAMIN

Largest Selection in the World
Single Shot & Repeaters
for Every Shooter's Needs! • 25 MODELS

You Can **DEPEND** ON BENJAMIN . . . for
Safety — Power — Accuracy — Convenience — Economy

No. 2600 BENJAMIN Super 35-Shot BB Gas Pistol. Safe—No Pumping—Uniform Hi-Power. For Target & Small Game. \$18.95
No. 2620 BENJAMIN 20-Shot Cal. 22 Gas Pistol. Economical. \$20.95
No. 1300 50-Shot BB Air Pistol \$23.50
No. 1320 BENJAMIN 35-Shot Cal. 22 Air Pistol \$25.50

No. 3600 BENJAMIN Super 100 Shot BB Gas Rifle. Non-Toxic—Safe—Convenient—Uniform Hi-Velocity Power. \$19.95
No. 3620 BENJAMIN Super 85 Shot Cal. 22 Gas Rifle . . . \$21.95
No. 3100 Super 100 Shot BB Air Rifle. Adj. Shooting Force \$24.95
No. 3120 BENJAMIN Super 85 Shot Cal. 22 Air Rifle . . . \$28.95

FREE Catalog All Models Benjamin Single Shot & Repeaters—Cal. BB or 177 or 22. Also, Special Hunting & Fishing Knife Offer.

BENJAMIN AIR RIFLE CO., 896 MARION ST., ST. LOUIS 4, MO.

YOUR OWN 2-WAY RADIO!

Messenger

FROM **\$129.75**

Anyone can operate—license issued by the FCC on request! The very finest Citizens' Transceiver available! Excellent selectivity and sensitivity for maximum range. Maximum legal power. Dozens of features!

WRITE TODAY FOR FULLY ILLUSTRATED BROCHURE
E. F. JOHNSON COMPANY
162 SECOND AVE. S. W. • WASECA, MINNESOTA

'How to Make Money with Simple Cartoons'

A book everyone who likes to draw should have. It is free; no obligation. Simply address **FREE BOOK**

CARTOONISTS' EXCHANGE
Dept. 94-D Pleasant Hill, Ohio

MONEY in WORMS

Sell 20,000 fishworms per week @ \$4 per 1000 from a bed 3 feet wide and 8 feet long. We teach you how to raise and where to sell fishworms and crickets. Write for free literature.
CARTER WORM RANCH, PLAINS, GEORGIA
Read our success story in LIFE MAGAZINE, December 25, 1959 Issue

SUPER JU JITSU

Now get tough double quick! A course of instruction in the art of practicing and using this method of applying LIGHTNING-QUICK Super Ju Jitsu. Be Dangerous! These amazing lessons show you how it's done . . . in a big illustrated home-study course. The weapons are just your BARE HANDS—they can be used effectively if you know how and practice the art. Easy to learn; quick. Full 76-lesson course only \$5.95 postpaid—or COD, plus postage. Satisfaction or your money back guaranteed! Order "super Ju Jitsu Course."

NELSON-HALL CO., 210 S. Clinton St., Dept. 8DP-2, Chicago 6, ILL.

GOVERNMENT OIL LEASES LOW AS \$1 PER ACRE

You do no drilling, pay no taxes, may realize a king-size profit without ever leaving home. Write for free map and literature.

AMERICAN OIL SCOUTS, Dept. PM
8350 Santa Monica Blvd. Los Angeles 46, Calif.

BATTEN DOWN THAT JUG, BAIT CAN OR GAS CONTAINER WITH A

Thingama JUG

Holds any size or shape container securely, safely in place without danger of rolling or sliding yet permits removal without unstrapping.

Sturdy triple-chrome plated steel. Mounts anywhere—boat, car, or campsite.

\$2.95 ORDER NOW! Sent postage paid with check or money order. Ohio residents please add 3% sales tax.

CARLSON PRODUCTS Dealer Inquiries Invited
Box 141, Cincinnati 11, Ohio

"I'M MAKING MORE THAN \$1000 a Month



C. KAMA

Haven't Touched Bottom Yet!



—reports Chas. Kama, Texas, one of many who are "cleaning up" with orders for PRESTO. Science's New Midget Miracle Fire Extinguisher. So can you! Amazing new kind of fire extinguisher. Tiny "Presto" does job of bulky extinguishers that cost 4 times as much, and are 8 times as heavy. Ends fires fast as 2 seconds. Never corrodes. **GUARANTEED for 20 years! Over 3 million sold! Sells for only \$4.95.**

Show it to civil defense workers, owners of homes, cars, boats, farms, etc. and to stores for re-sale—make good income. H. J. Kerr reports \$20 a day. Wm. Wydallis, \$15.20 an hour. Write for FREE Sales Kit. No obligation. **MERLITE INDUSTRIES, Dept. P-15M Presto Div., 114 East 32nd Street, New York 16, New York** IN CANADA: Mopa Co., Ltd., 371 Dowd Street, Montreal 1, P. Q.

WANTED! New Products

We urge manufacturers with products requiring sales representation in the automotive or service-station field to write to us. Inventors, if you have patented items applying to the same sales field, let us know and we'll work out manufacturing and distribution problems for you. We have salesmen in every state.

JACK P. HENNESSY COMPANY, INC.

12 Depot Square • Englewood, New Jersey

Learn ACCOUNTING Business Administration

Bookkeeping, secretarial and allied subjects at home in your spare time or attend nationally approved resident school. Write for FREE Success Book giving complete details on courses, plans, rates and employment opportunities. G.I. approved. Write Dept. A



Hills BUSINESS UNIVERSITY AND EXTENSION SCHOOL
629 W. MAIN ST. OKLAHOMA CITY 2, OKLAHOMA

DO FALSE TEETH Rock, Slide or Slip?

FASTEETH, an improved powder to be sprinkled on upper or lower plates, holds false teeth more firmly in place. Do not slide, slip or rock. No gummy, gooey, pasty taste or feeling. FASTEETH is alkaline (non-acid). Does not sour. Checks "plate odor" (denture breath). Get FASTEETH at any drug counter.

Painting is Easy! BVI Electric PAINT SPRAYER

only **\$12.95** complete

with built-in motor

Fully Guaranteed



Just plug in, pull trigger and spray paint, varnish, enamel, garden sprays and insecticides. 3 to 7 times faster than painting with a brush! Features sapphire nozzle, instant adjustment for heavy or light spray. Foolproof and trouble-free! Available now at dealers everywhere!

Burgess Vibrocrafters Inc.
Grayslake, Illinois

prepare for your career in ELECTRONICS ELECTRICAL ENGINEERING RADIO-TV COMPUTERS

At MSOE, you can equip yourself for a career in many exciting, growing fields: **MISSILES • RADAR • AVIONICS AUTOMATION • RESEARCH DEVELOPMENT • ELECTRICAL POWER • ROCKETRY**

When you graduate from the Milwaukee School of Engineering, you are prepared for a dynamic career as an Electrical Engineer or Engineering Technician. Under a faculty of specialists, you gain a sound technical education in modern, completely equipped laboratories and classrooms. As a result, MSOE graduates are in great demand and highly accepted by industries nationally.

At MSOE, you will meet men from all walks of life and all parts of the country — some fresh out of high school or prep school, others in their twenties — veterans and non-veterans.

You can start school in any one of four quarters and begin specializing immediately. Engineering technicians graduate in 2 years with an Associate in Applied Science degree. For a Bachelor of Science degree in Engineering, you attend 4 years. A 3-month preparatory course also is available.



FREE CAREER BOOKLET!

If you're interested in any phase of electronics, radio or television, be sure to look into the programs of study offered by the Milwaukee School of Engineering. Just mail the coupon.

MILWAUKEE SCHOOL OF ENGINEERING

Dept. PM-460, 1025 N. Milwaukee St. Milwaukee, Wisconsin

Please send FREE Career Booklet. I'm interested in

Electronics Electrical Power Television

Mechanical Engineering Radio Computers

Electrical Engineering Industrial Electronics

PLEASE PRINT

Name _____ Age _____

Address _____

City _____ Zone _____ State _____

I'm eligible for veterans education benefits

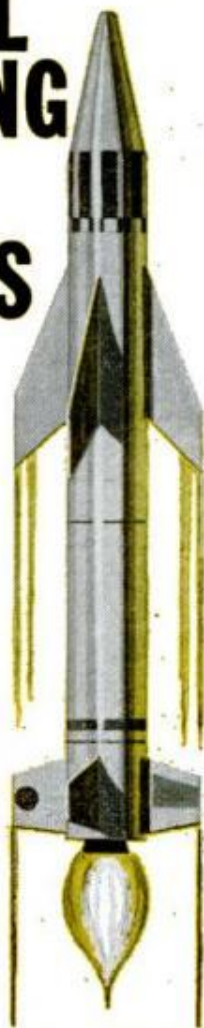

Check the Kind of Body You Want

Charles Atlas

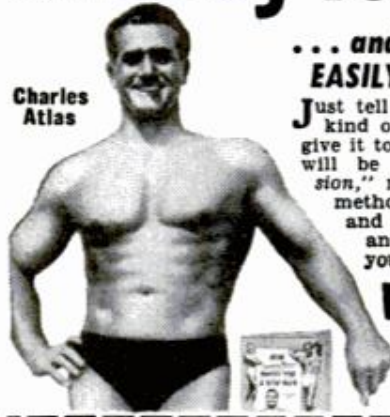

... and I'll Show You How EASILY You Can Have it!

Just tell me, in coupon below, the kind of body you want—and I'll give it to you SO FAST your friends will be amazed! "Dynamic Tension," my easy, 15-minutes-a-day method, will make your chest and shoulders bulge . . . arms and legs surge with power . . . your whole body feel "alive!"

FREE BOOK Learn how I became "World's Most Perfectly Developed Man" — Mail coupon! CHARLES ATLAS, Dept. 84, 115 East 23 Street, New York City 10, N. Y.

CHARLES ATLAS, Dept. 84, 115 East 23rd St., New York 10, N. Y.
In England write: 10 Chitty Street, London, W.1.

Dear Charles Atlas: Here's the Kind of Body I want:
(Check as many as you like)

- | | |
|---|--|
| <input type="checkbox"/> More Weight—Solid—in | <input type="checkbox"/> Powerful Arms, Legs, Grip |
| <input type="checkbox"/> The Right Places | <input type="checkbox"/> Slimmer Waist, Hips |
| <input type="checkbox"/> Broader Chest, Shoulders | <input type="checkbox"/> Better Sleep, More Energy |

Send me absolutely FREE a copy of your famous book showing how "Dynamic Tension" can make me a new man—32 pages, crammed with photographs, answers to vital questions, and valuable advice. No obligation.

NAME _____ AGE _____
(please print or write plainly)
ADDRESS _____
CITY _____ ZONE _____ STATE _____

Make \$20 to \$30 a Week EXTRA MONEY!

With the high prices of food, clothing and everything else, just think what you could do with extra money every week! Turn your spare time into CASH—sharpening saws with a Foley Automatic Saw Filer pays from \$3 to \$6 an hour.

Start in your basement or garage—no experience necessary. "The first saw I sharpened with my Foley Filer came out 100%"—writes Clarence E. Parsons. No canvassing—"I advertised in our local paper and got in 93 saws"—says M. L. Thompson. With a new model 200 Foley you can file all hand saws, also band and both combination and crosscut circular saws.

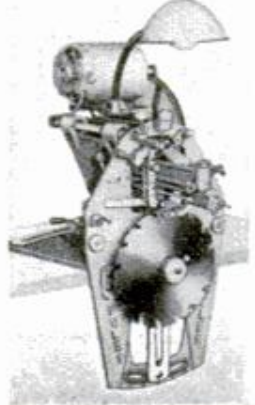

FREE BOOK Shows How to Start

It explains how you can get business from home owners, farmers, carpenters, schools, factories, etc. "I get work from 20 and 30 miles away"—says Charles H. Smith. Free Book, "Money Making Facts," tells how to start. Time Payment Plan. Send coupon today—no salesman will call.

Send Coupon for **FREE BOOK**

FOLEY MFG. CO.
443-O Foley Bldg., Minneapolis 18, Minn.
Send FREE BOOK—"Money Making Facts," and Time Payment Plan.

Name _____
Address _____



\$1 BRINGS YOU \$18

Discover Flok-Kraft and Earn \$\$\$\$\$ AT HOME

Earn up to \$15.00 per hour spare time. Amazing new Velvet-fiber spray instantly makes any object (Lamps, Radio & TV Cabinets, Figurines, Signs, Auto dash boards, toys, furniture, draperies—anything) worth expensive \$\$\$\$\$ Prices . . . like magic, you can spray anything with this beautiful new suede-like finish that feels like rich Velvet.

EARN UP TO \$300.00 PER WEEK SPARE TIME

Imagine, materials cost only 3c per square foot. (Average TV or radio cabinet can be beautifully sprayed with this startling new 3-dimensional Velvet finish in 15 minutes at a cost of only 34c in materials. Your charge for this job is at least \$10.00.)

REPRESENTATIVES IN YOUR AREA URGENTLY NEEDED

Own your own business. Work at home in your spare time. Help fill the huge growing demand for this amazing new Velvet-fiber finish. Orders come from stores, offices, homes, architects, auto dealers,—everywhere. Possible \$20,000,000.00 worth of jobs to be done. Investigate today—be first in your area! Actual samples in 16 Radiant Colors. Booklet of 50 Home Business Opportunities and Confidential Details all sent free! Send No Money. Write: Coast Industries, Los Angeles 61, Calif., Dept. B-4.

WONDER RAT GLUE BOARDS

A SURE WAY TO GET RID OF RATS and MICE

Catch Rats and Mice Like Flies on Fly Paper. No Springs — No Poisons.

\$18 PER DOZEN SAMPLE BOARDS \$2 EACH

STAR EXTERMINATING CO., 2958 Nostrand Ave., Brooklyn 29, N.Y.



BIG EARNINGS WAITING for TYPEWRITER REPAIRMEN

Skilled men are in demand in the new, uncrowded field of typewriter repair. You'll quickly step into a big-pay job or business of your own, full or part time. EARN while learning easily at home under expert guidance. Materials, tools, typewriter supplied. Write TODAY for FREE book.

TYPEWRITER REPAIR SCHOOL, INC.
Dept. D-10, 150 Park Ave., E. Rutherford, N. J.
Lic. by New Jersey Dept. of Educ.

GET THE HABIT OF READING OUR CLASSIFIED ADS.

Wonderful Opportunities Amazing Bargains

Locksmithing AND KEY MAKING

Now Made Easy! Practical up-to-date course teaches you how to pick locks, de-code, make master keys, repair, install, service, etc. New self-instruction lessons for every handyman, homeowner, carpenter, mechanic, service station operator, fix-it shop, hardware dealer, gunsmith. 53 easy illustrated lessons. Full price only \$5.95 postpaid; or C.O.D. plus postage. Satisfaction or refund guaranteed.

Complete course \$5.95 . . . now only \$3.95
NELSON-HALL CO., DEPT. DP-2
210 S. Clinton Chicago 6, Ill.

Everything YOU WANT TO KNOW ABOUT INDOOR & OUTDOOR Fireplaces AND BARBECUES

76 PAGES — 220 ILLUSTRATIONS

A complete handbook of designs, layouts, plans, equipment . . . everything in indoor and outdoor fireplaces and barbecues. Only \$1 ppd. Send for yours now!

The **Majestic Co., Inc.**
540 Erie St., Huntington, Indiana



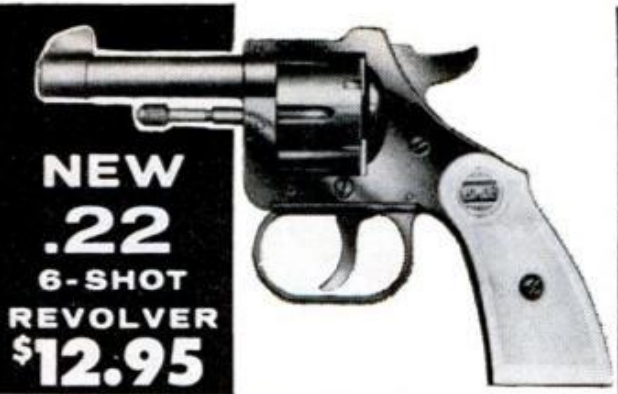

**NEW
.22
6-SHOT
REVOLVER
\$12.95**

Fires both .22 short & long ammo. This sensational NEW 6-shot Rosco Vest Pocket .22 revolver is a tremendous value at 3 times its price. Made in W. Germany, it is a tight, well-made, exceedingly accurate handgun. Fires easy-to-get Win., Rem. Western & Peters .22 Long & Short ammo. Features side gate loading, trigger adjustment, screw-in ejector rod. Has STEEL RIFLED BARREL with blade front sights. Easy and fun to shoot. Terrific for target shooting, varmint hunting or as a home defense weapon. Only \$12.95. Leather holster \$2.25. 100 rds. of .22 Long ammo \$1.30. Shipped F.O.B. Los Angeles express charges collect. Send cash, check or M.O. COD's require \$7.50 deposit. Satisfaction guaranteed. Purchasers must be 18 yrs. old. Res. of L.A. & vicinity, please purchase at our store.

SEAPORT TRADERS, INC., Dept. PM-4
1221 S. Grand Ave. Los Angeles 15, Calif.

ADDING MACHINE \$197 or 2 \$349
lea. for

+ — × ÷
ADD — SUBTR. — MULT. — DIVIDE

Does all 4 operations. Handles 9 columns of numbers. Settle for no less. Leatherette case. Lowest price adder made in America. Beware of cheapened foreign imitations. Money back guarantee. Agents wanted. \$1.97 add 4% tax in Pa.



TOM THUMB P.O. Box 5066, Dept. A-10, Philadelphia 11, Pa.

LEARN REAL ESTATE

Men and women, regardless of education or experience you CAN GET OUT OF THE RUT! Learn this high-paying profession easily by listening to records. We train and start you, full or part time, your own boss. First lecture free. Lee Institute, Brookline, Mass.

**ADD THIS RUGGED MASSAGE UNIT
TO YOUR FAVORITE CHAIR!**

Same unit now being used in highest priced vibrating chairs, sofa beds, etc. Easy to install — all parts, mounting bolts and instructions included. Sold on 10-day money back offer. Full 3 year guarantee. Only

L & O MFG. CO.
1636 Rapids Dr. • Racine, Wis.

995

POST PAID



**3
SPEED
SWITCH**

**MONEY
ADVENTURE**
can be yours NOW...

With Buried Treasures. Have the thrill of locating coins, gold and silver. New Transistorized Instruments for greater locating depth... operate on flashlight batteries... low as \$79.50. FREE literature... WRITE Today.

Authentic
Treasure Books & Maps
Now Available



GOLDAK COMPANY
1551-4 W. Glenoaks Blvd.
Glendale 1, California

DON'T BE HALF-TRAINED! Be A Master Technician



AIR CONDITIONING-REFRIGERATION ELECTRICAL APPLIANCES

**NOW ONE Modern Master
Home Training Course
IN ALL 3 PHASES
ALL AT ONE
LOW TUITION**

Only National Technical
Schools gives you this
complete training
at no extra cost!

YOU GET AND KEEP ALL THIS EQUIPMENT



Incomplete training limits your earning power, even disqualifies you for top-pay jobs. The big service companies require complete, all-phase training. If you open your own shop, you'll be called upon to service and repair all types of refrigerators, air conditioners and appliances. With complete training — as only N.T.S. gives you — you can accept every job, make big profits all year round.

Future Bright For Trained Master Technicians

Over 30,000 new technicians must be trained annually. You are needed to help service and repair the 50 million air conditioners, refrigerators and electrical appliances that will need fixing this year alone. No wonder the Master Technician has steady work, at high pay, year after year. He can go places in his own business or with a manufacturer, dealer, distributor or department store. Armed with all-phase training, his earning power is unlimited.

The Most For Less

We give you illustrated Shop-Tested Lessons and Manuals... many other training aids... privilege of CONSULTATION with our instructors and engineers. Every lesson, every manual has been SHOP tested and approved.

Job Training At Home

You get Professional Tools, Precision Instruments, PLUS a Factory-Made APPLIANCE TESTER! A shop-full of PRACTICAL, professional equipment. Use them to conduct over 100 experiments... also in Spare Time Work and ON THE JOB. It is all yours to keep... no EXTRA MONEY DEPOSITS... no EXTRA COST on your equipment kits.

Earn As You Learn

We show you how. Many of our students pay for their entire course — and more — in Spare Time while learning. So can you. Graduate Advisory Service, too.

FREE!



ILLUSTRATED
FACT BOOK
and
ACTUAL
LESSON
Clip Coupon now

NATIONAL TECHNICAL SCHOOLS

WORLD-WIDE TRAINING SINCE 1905
4000 S. FIGUEROA ST., LOS ANGELES 37, CALIF., U.S.A.

N.T.S. also offers training in
TV - RADIO - ELECTRONICS
and AUTO MECHANICS - DIESEL

NATIONAL TECHNICAL SCHOOLS
WORLD-WIDE TRAINING SINCE 1905

MAIL NOW TO

National Technical Schools, Dept. CB-40
4000 S. Figueroa St., Los Angeles 37, Calif.

Rush FREE "Opportunity" Book and Actual Lesson. No Salesman will call.

NAME _____ AGE _____

ADDRESS _____

CITY _____ ZONE _____ STATE _____

Check here if interested ONLY in Resident Training at Los Angeles.



MEMBER

EARN MORE - LEARN AUTO DIESEL MECHANICS

OR TRAIN WITH OTHER GREER DIPLOMA COURSES

- | | |
|--|---|
| <input type="checkbox"/> AUTO MECHANICS | <input type="checkbox"/> REFRIGERATION |
| <input type="checkbox"/> DIESEL MECHANICS | <input type="checkbox"/> AIR CONDITIONING |
| <input type="checkbox"/> BODY & FENDER REPAIR | <input type="checkbox"/> MACHINIST TRADE |
| <input type="checkbox"/> GAS-ARC WELDING | <input type="checkbox"/> ADVANCED MACHINIST |
| <input type="checkbox"/> CONSTRUCTION EQUIPMENT OPERATORS TRAINING | |
| <input type="checkbox"/> CONSTRUCTION EQUIPMENT MECHANICS TRAINING | |

Skilled men are needed in every part of the country. Earn top pay in established shops or start your own business. Greer's expert instruction and actual shop training teaches you how. You learn by doing—quick, easy courses using the latest tools and equipment. Day, evening and part time instructions available.

Job placement and convenient living accommodations are yours while training. Contact GREER'S FREE JOB PLACEMENT ASSISTANCE when you enroll if you wish part time or full time employment.

All Courses Approved Civ. or G. I.

Please rush me free literature on the trade indicated.

NAME _____ AGE _____

STREET _____

TOWN _____ ZONE _____ STATE _____

GREER SHOP TRAINING
Box D, 2236 S. Michigan Ave.
Chicago 16, Illinois



You can make money in

WATCH REPAIR

Learn at home the low cost Sweazey Way

Watch repairing pays up to \$6 an hour, part time watch makers report on survey. Unique and modern Sweazey home study System starts you making repairs right away on Swiss and American watches. Professionally prepared training. No previous experience needed. Special tools provided for practice. Tuition only \$5 a month. Diploma Awarded. Free sample lesson and opportunity book give all facts. Write today. No obligation.

CHICAGO SCHOOL OF WATCHMAKING
2330 N. Milwaukee Avenue, Dept. 140, Chicago 47, Illinois

FREE BOOK and SAMPLE LESSON

CHICAGO SCHOOL OF WATCHMAKING
2330 N. Milwaukee Ave., Dept. 140, Chicago 47, Illinois
Please rush **FREE BOOK** and Sample Home Study Lesson.

Name _____ Age _____

Address _____

City _____ Zone _____ State _____

GIANT ITALIAN HUNTING KNIFE!

CLOSES WITH LIGHTNING SPEED! Imported direct from Italy. This is the same knife that is world famous for its effectiveness in life or death hunting or fishing emergencies. Blade is of durable high test carbon steel, guaranteed to stay razor sharp. Has genuine bone handle. Unlike a switch blade knife, there are no buttons to fool with, no springs to break.

MERCHANTS, INC., Dept. PM-4, 1221 S. Grand Ave., Los Angeles 15, California

LOCKS IN OPEN POSITION FASTER THAN THE EYE CAN SEE. Easy to handle, easy to carry. 4 sizes: 13 1/2" \$7.95, 11" \$7.50, 9" \$6.95, 5 1/2" \$4.50. **SENT POSTPAID IMMEDIATELY.** Send cash, check or M.O. 10-day money back guarantee. Calif. res. add 4% state tax.



ENTERTAIN AND AMAZE FRIENDS WITH 1000 MAGIC TRICKS

YOU CAN DO THEM ALL!



Baffling Magic! Amazing Pocket Tricks! Astonishing Mysteries! Self-working Miracles! Mystifying Secrets! Wonderful Illusions! Terrific Mindreading Stunts! Hypnotism! Tricks with Cards, Coins, Balls, Silks, Ropes, Apparatus! Puzzles! Joke Novelties! Party Pranks! Gimmicks! Books! Judo! Combination Offers! Low Prices!

Rush **25¢** today for
GIANT SURPRISE CATALOG

160 Pages... 800 Illustrations... 1000 Mysteries
Most amazing catalog ever published
Famous Coast to Coast

FREE TRICK GIVEN WITH EACH CATALOG

HOUSE OF 1000 MYSTERIES • 202-PM4 PINWOOD • TRUMBULL, CONN.



TOOLS WHOLESALE

Start your own business, sell tools to your friends and neighbors, or buy tools for your own use and **SAVE MONEY \$\$\$**

\$1.00 PUTS YOU IN BUSINESS

A MILLION DOLLAR INVENTORY AT YOUR FINGERTIPS. NO STOCK TO CARRY. ORDER AS YOU NEED IT.

BUY AT WHOLESALE PRICES. Extra \$25.00 profit on your accumulated purchases. \$1.00 refund on first purchase or refunded if you are not 100% satisfied.

THOUSANDS! of Nationally Advertised items of Hand Tools, Power Tools, Machinist Tools, Tool Chests, Paint Sprayers, Light Fixtures, Appliances, Guns, Gifts, Toys and other items too numerous to mention.

WE SHIP COAST TO COAST

Wholesale. Disc. up to 50% off

Dept. PM-4 107 Walnut St., Phila. 6, Pa.

Shop PM Ads for Exciting
Direct-Mail Offers



FREE

MUSCLE BUILDING INFORMATION

Sensational New Methods

Less Time—Less Effort—Better results

BODY-TONE, Box 638, North Miami 61, Fla.

FIBERGLASS or PLYWOOD

\$41.95 Up: EASY TERMS
FREE CATALOG

Write Now

50 Models 8-22 ft.

Cruisers, houseboats, runabouts, convertibles, fishing, sailing. Pre-assembled, pre-formed units anyone easily assembles. Equal factory-built. Save 1/2 to 2/3. Free catalog has all details, color photos, paint, accessories, Fiberglass supplies, trailers. **WRITE TODAY.**

LUGER BOAT KITS

Dept. B-4, 9200 Access Road, Minneapolis 20, Minn.



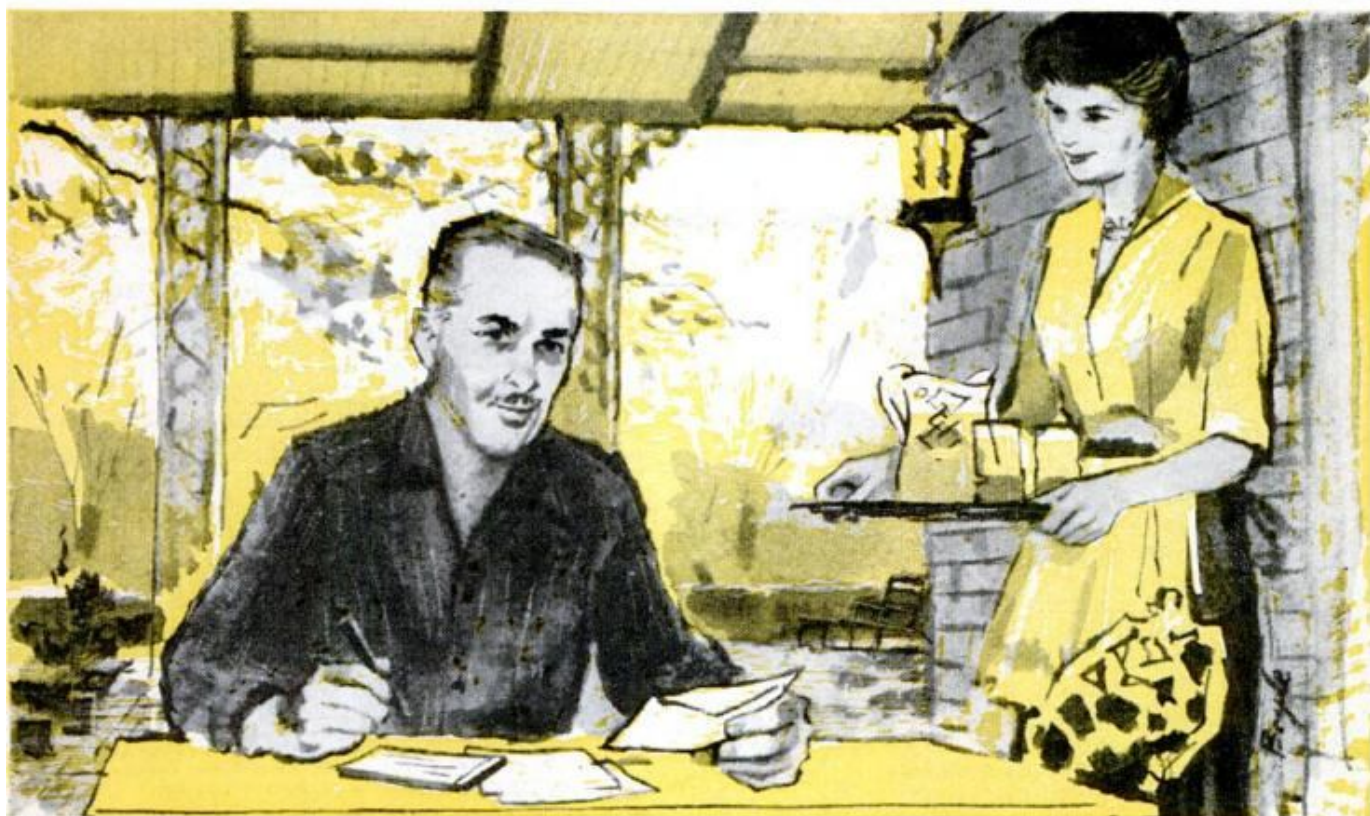

Now Earn **5½%** On Your Savings ... By Mail

Picture yourself in this profitable scene. You can now save-by-mail from the comfort of your home and earn a full 5½% a year paid quarterly on your hard earned funds. Simply transfer your savings—by mail—to First Western Savings, Nevada's largest Savings and Loan Association. First Western has always paid more to savers, and *this* higher interest rate follows fourteen consecutive interest payments to First Western Savers of 5% per annum or more, paid quarterly! Quarterly payments allow you to easily withdraw funds without losing interest, or you can let the interest remain in the account for compound earnings, every three months.

Few savings institutions can offer such an attractive rate. First Western can do it because it is located in the fastest growing area in the country, where dollars are needed to finance expansion. The officers and directors of this \$33,000,000.00 institution are all community and state leaders of long standing. And, First

Western proudly boasts a long history of dependable performance and above-average earnings. Another important point; withdrawals-by-mail have always been paid instantly.

Saving by mail is the easiest and most profitable way to save—no traffic, no waiting in line, no wasted time. Join the more than 16,000 First Western Savers from all 50 states and 51 foreign countries who save more and earn more by transacting their savings business... by-mail... with First Western Savings, Nevada's largest Savings and Loan Association.

You can open a Save-By-Mail account with as little as \$1.00. Transfer your savings today, and earn: 5½% a year on accounts of \$5,000 or more, 5¼% a year on all others. Interest paid quarterly on all accounts. Funds received by the 15th of any month earn from the 1st.

Write or mail funds to:

**FIRST WESTERN SAVINGS
AND LOAN ASSOCIATION, DEPT. T.,**

118 Las Vegas Blvd., South • Las Vegas, Nevada • A. G. Neumeier, Pres.



HOW TO MAKE THINGS OF PLASTICS

Complete
Low-Cost
Home Training
Course NOW
Available

There's exciting opportunities for you in Plastics Fabrication. Fun and relaxation as a hobby! Big money as a spare or full-time business! Course teaches fibreglassing, model building and how to make molded, cast, internally carved colored plastic jewelry, toys, furniture, novelties, signs. Professionally prepared. Used by Industrial Arts Teachers. All materials furnished. For men and women.

Accredited Member National Home Study Council
SEND FOR FREE BOOKLET



INTERSTATE TRAINING SERVICE
Dept. C-3, Portland 12, Oregon
Send Free Booklet on Plastics Home Training Course.

Name _____
Address _____
City _____ Zone _____ State _____

Superior's New Model 70 UTILITY TESTER® FOR REPAIRING ALL ELECTRICAL APPLIANCES MOTORS • AUTOMOBILES • TV TUBES

As an electrical trouble shooter the Model 70:



- Will test Toasters, Irons, Broilers, Heating Pads, Clocks, Fans, Vacuum Cleaners, Refrigerators, Lamps, Fluorescents, Switches, Thermostats, etc.
- Will test all TV tubes for open filaments, interelement shorts, burned out tubes, etc.
- Measures A.C. and D.C. Voltages, A.C. and D.C. Current, Resistances, Leakage, etc.
- Will measure current consumption while the appliance under test is in operation.
- Incorporates a sensitive direct-reading resistance range which will measure all resistances commonly used in electrical appliances, motors, etc.
- Leakage detecting circuit will indicate continuity from zero ohms to 5 megohms (5,000,000 ohms).

As an Automotive Tester the Model 70 will test:

- Both 6 Volt and 12 Volt Storage Batteries • Generators • Starters • Distributors • Ignition Coils • Regulators • Relays • Circuit Breakers • Cigarette Lighters • Stop Lights • Condensers • Directional Signal Systems • All Lamps and Bulbs • Fuses • Heating Systems • Horns • Also will locate poor grounds, breaks in wiring, poor connections, etc.

Model 70 comes complete including 64 page book, only... **\$15.85**

**SHIPPED ON APPROVAL
NO MONEY WITH ORDER - NO C.O.D.**

Try it for 10 days before you buy. If completely satisfied then send \$3.85 and pay balance at rate of \$4.00 per month for 3 months — No Interest or Finance Charges Added! If not completely satisfied, return to us, no explanation necessary.

MOSS ELECTRONIC, INC., Dept. D-734
3849 Tenth Ave., New York 34, N.Y.

Please rush Model 70. If satisfactory, I will pay on terms specified. Otherwise I will return tester.

Name _____
Address _____
City _____ Zone _____ State _____
All prices net, F.O.B. N. Y. C.

New Table Top Invention Puts You In... PROFITABLE RUBBER STAMP BUSINESS

Home Operators now make
\$9.40 AN HOUR in business once monopolized by a few big companies

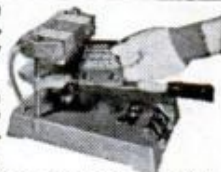

Special rubber stamps bring high prices—cost only pennies to make on new, low-cost table top machine. Take 27 cents worth of material, make perfect stamps, the kind businesses and offices now buy by the dozen at \$1.80 each. Make up to \$9.40 an hour. Start in spare time in your own home. Run machine on kitchen table using ordinary electrical outlet. Make any kind of stamp. We'll send you free information without obligation about this established, highly profitable business, now open to individuals for the first time. For free information send name today on a post card to
Rubber Stamp Div., 1512 Jarvis, Dept. R-2-D, Chicago 26, Ill.



"\$7,108.50 FIRST YEAR SERVICING RADIATORS!"

— Hank Konter, Newcastle, Wyo.

Make good money servicing auto-truck-tractor radiators. Easy to learn. Inland, world's largest radiator equipment mfr., offers complete package — equipment, merchandising, "pays-for-itself" financing, free training. Small down payment on equipment starts you. Profitable dept. for garage or service station. Write

INLAND MFG. CO., Dept. PM-4, 1108 Jackson St., Omaha 2, Nebr.

— OWN CALIFORNIA LAND —

STATE GOV'T LANDS. 500,000 Acres as low as \$2. per acre — min. offer 40 to 640 Acres. Ranch and Farm Tracts. Southern and Northern California Locations.

NO HOMESTEADING! NO IMPROVEMENTS! NO SALES TO ATTEND! You select, apply and **BUY DIRECT** through the mail. Lists & maps now available. **WRITE RESEARCH DIV.**

PIONEER RANCHES 8228 Sunset Blvd., Dept. 9
Hollywood 46, Calif.
LARGEST LAND CORPORATION OF ITS KIND IN THE WORLD

Next Month

What to Look for in SCHOOLS



For the facts
on correspondence
and resident schools
see the

MAY ISSUE

I'll Set You Up For Life In Your Own BIG PAY SHOE BUSINESS

With The ONE Shoe Line That Serves Everyone
From Baby to "Pop" and "Mom"



Only 8 orders a day can make you up to \$32.00 a day, \$180.00 a week, \$600.00 a month. It's no trick at all to make big money full or Spare Time with America's most comfortable shoes. Amazing new "Spring-Step" cushion design proves it by actual demonstration. Over 200 styles for men, women, boys, girls and infants! Profits are BIG—repeat orders sure and easy. No experience needed. No investment. Everything furnished free, including finest sales outfit and actual demonstrators; Send today for Free Outfit.



Amazing 2-Minute
Demonstration
Does Your Selling
Job for You FAST!
I Give producers
Their Own Shoes
AS A BONUS!

ORTHO-VENT SHOE CO.

1104 BRAND ROAD
SALEM, VIRGINIA

TELEPHONE



HANDSETS

Use as inter-house phone, talk house to garage, as loud speaker system, etc. You receive transmitter, receiver, 3 conductor cord and simplified, illustrated installation diagrams. Handsets are guaranteed to be the same as used in our great National Telephone System. Price delivered \$2.95. Two for \$5.00!

TELEPHONE REPAIR AND SUPPLY CO.
Dept. PM-125 1760 Lunt Ave., Chicago 26

SCIENCE ENGINEERING

Bachelor's degree in 27 or 36 months
Accelerated year-round program: Aero., Chem., Civil, Elec., Mech., Metal.; Math., Chemistry, Physics. Modest rate. Earn board. New classes start June, Sept., Jan., March. Catalog. 1640 E. Washington Blvd., Fort Wayne 2, Indiana

INDIANA TECHNICAL COLLEGE

SIGN PAINTING

Home-Study Course — Only \$5.95

Teaches you commercial sign painting and sign building as it is being done TODAY in leading shops all over the country. Complete practical course for self-instruction. Shows latest methods of truck lettering, office doors, wood letters, reflecting signs, plastics, sprayed signs, gold leaf, silk screen process, up-to-date alphabets, money-making business information, etc.



SATISFACTION GUARANTEED OR REFUND!
Contains all the instruction of a high-priced correspondence course. Full price, only \$5.95, postpaid. Or C.O.D. plus postage. No Risk—order today. Satisfaction or money back! Order "Sign Painting Course." NELSON-HALL CO., 210 S. Clinton St., Dept. 2DP-2, Chicago 6, Ill.

PRICES SMASHED on MEN'S NEW ELECTRIC SHAVERS

Lowest prices in U. S. of wonderful, brand new, factory fresh, latest models Men's Nationally Advertised Electric Shavers. (Prices smashed on Women's Shavers, too. Write for prices). In unopened factory cartons. COMPLETE! Nothing left out—all attachments included. We GUARANTEE you will be delighted, or purchase price refunded. We have over 1,000,000,000 satisfied customers. We'll please you, too! Order at these low prices.

	Others Charge	Our Price
Ronson—C. F. L.	\$20.00	\$11.80
Norelco—Speedshaver	\$24.95	\$13.75
Sunbeam Rollmaster	\$24.95	\$16.30
Remington Roll-A-Matic	\$29.95	\$17.70
Remington Auto & Home	\$31.95	\$19.85

We mail orders within 10 hours, or less, except in unusual circumstances. EXTRA! FREE! If you send this ad with order, we'll send you a knife that looks like a key! Send money and we pay all postage charges, or send 25¢ deposit and we'll mail C.O.D.

L & M CO., Dept. ES-10, Box 881, St. Louis, Mo.

MEN PAST 40

Afflicted With Bladder Trouble,
Pains in Back, Hips, Legs,
Nervousness, Tiredness.

If you are a victim of these symptoms, your trouble may be due to Glandular Inflammation. A constitutional Disease that requires special types of medical treatment. Neglect of such inflammation causes men to grow old prematurely and before their time.

Most men, if treatment is taken in time, can be successfully NON-SURGICALLY treated for Glandular Inflammation. If the condition is aggravated by lack of treatment, surgery may be the only chance.

NON-SURGICAL TREATMENTS

The NON-SURGICAL New Type treatments used at the Excelsior Medical Clinic are the result of discoveries in recent years of new techniques and drugs, plus over 20 years research by scientific technologists and doctors.

Men from all walks of life and from over 1,000 communities have been successfully treated here at Excelsior Springs. They found soothing and comforting relief and new health in life.

EXAMINATION AT LOW COST

When you arrive, our Doctors, who are experienced specialists, make a complete examination. You then decide if you will take the treatments needed, which are so mild, hospitalization is not needed—a considerable saving in expense.

RECTAL-COLON

Are often associated with Glandular Inflammation. These disorders, we can successfully treat for you, at the same time we treat Glandular Inflammation.

REDUCIBLE HERNIA

Is also amenable to a painless Non-Surgical treatment that we have developed. Full details of this treatment given in our Free Book.

Write For FREE BOOK

The Excelsior Medical Clinic has published a New FREE Book that deals with diseases peculiar to men. It could prove of utmost importance to your future life. Write today. No obligation.



EXCELSIOR
MEDICAL CLINIC
Dept. B6150
Excelsior Springs, Mo.

Gentlemen: Kindly send me at once, your
New FREE Book. I am interested in full
information. (Please Check Box)

- Glandular Inflammation Hernia
 Rectal-Colon

Name _____

Address _____

City _____ State _____

AUDELS GUIDES

No. 1	AUTOMOBILE MECHANICS GUIDE. 1132 Pages.	\$ 6.00
No. 2	HOME APPLIANCE SERVICE GUIDE. 864 Pages.	6.00
No. 3	TV & RADIO SERVICE LIBRARY. 2 Book Set.	8.00
No. 4	HANDY BOOK OF ELECTRICITY. 1052 Pages.	5.00
No. 6	PLUMBERS & STEAMFITTERS GUIDES. 4 Book Set.	8.00
No. 8	CARPENTERS & BUILDERS GUIDES. 4 Book Set.	8.00
No. 9	DIESEL ENGINE MANUAL. 640 Pages.	3.00
No. 10	WELDERS GUIDE. 608 Pages.	3.00
No. 11	MATHEMATICS MADE EASY. 672 Pages.	3.00
No. 12	MACHINISTS & TOOLMAKERS HANDBOOK. 1250 Pgs.	6.00
No. 13	WIRING DIAGRAMS. 304 Pages.	2.00
No. 14	REFRIGERATION & AIR CONDITIONING. 1360 Pages.	6.00
No. 15	ELECTRIC LIBRARY. 10 Volume Set.	20.00
No. 25	BLUE PRINT READING. 448 Pages.	3.00
No. 26	MASONS & BUILDERS GUIDES. 4 Book Set.	8.00
No. 27	ELECTRIC MOTOR GUIDE. 1056 Pages.	5.00
No. 28	OIL BURNER GUIDE. 416 Pages.	2.00
No. 29	SHEET METAL PATTERN LAYOUTS. 1152 Pages.	7.50
No. 30	SHEET METAL WORKERS HANDY BOOK. 448 Pages.	2.00
No. 43	DO-IT-YOURSELF ENCYCLOPEDIA. 2 Book Set.	8.95
No. 44	NEW MECHANICAL DICTIONARY. 712 Pages.	6.95

7-DAY FREE EXAMINATION

SEND NO MONEY—Pay the postman nothing! We'll send you any of the Audel Guides for FREE examination in your home. If you decide to keep the books you may pay for them under our easy-pay plan of only \$2 a month.

HERE IS ALL YOU DO

IT'S EASY TO ORDER: In the No-Risk Mail Order Coupon below you need only draw a circle around the number of Audel Guides you want. We will send them to you at once. If you are not completely satisfied, return the books to us.

MAIL THIS COUPON TODAY!

THEO. AUDEL & CO. — Self Improvement Publishers Since 1879
49 W. 23rd Street, New York 10, N.Y. P4

Please mail me for 7 days' FREE EXAMINATION the books I have circled. I agree to mail \$2 in 7 days on each book or set ordered, and to further mail \$2 a month on each book or set ordered until I have paid the purchase price, plus shipping costs. If I am not completely satisfied with my Audel Guides I may return them.

NAME _____

ADDRESS _____

OCCUPATION _____

EMPLOYED BY _____

1 2 3 4 6 8 9 10 11 12 Check Here for Free
13 14 15 25 26 27 28 29 30 43 44 Complete Catalog

SAVE SHIPPING COSTS! Check here if you enclose complete payment with order. We pay postage charges. You have same return privilege.

WOULD YOU DO THIS IF ATTACKED?

80 MODERN INDIVIDUAL LESSONS ON LETHAL JUDO



Defend or attack with scientific "know how". Lessons packed with pictures, charts, etc. Armed & unarmed attack & defense. Nerve center pressure points, unbreakable holds. 80 lesson professional course by return mail. **ONLY \$3**
(MONEY BACK GUARANTEE)

MUSCLE-BUILDING COURSE

100 ILLUSTRATED LESSONS pack on inches of rock-like muscles. Build a power-charged body & sinews of strength. Be a mighty man **\$5** FAST! All the tricks of the champs . . . charts diagrams etc. Complete only . . .
OXFORD STUDIO 44 Bromfield St., Boston, Mass.



For Rotary Mower Servicing . . .

MAGNA-MATIC BALANCER

FAST, ACCURATE, CONVENIENT . . . The Magna-Matic balancer is a precision tool for checking Track and Balance on Rotary Cutter Blades and Disks.

- Permanently assembled—Wall Mounted.
- No set up time—No loose pieces.
- Magnetic Holding Collar—Fast on and off.
- Spindle adjusts to hole sizes up to 1 1/2 inches.
- Automatic Adjustable Track Checker.

Send for Free Literature
MAGNA-MATIC DIVISION
A. J. KARRELS CO., Port Washington, Wisconsin



FREE AMAZING NEW BOOK

"HOW TO ANSWER ADS"



Never before have you seen anything like this. Tells you in simple language the correct way to answer ads. Gets you quicker replies—better results, and greater satisfaction. Will save you time and money and it's **ABSOLUTELY FREE**. No obligation whatever. Every reader of advertising should have this booklet. Send a postcard for your copy **NOW. F. W. JOHNSON, Popular Mechanics Magazine, Room 600-A, 204 East Ontario Street, Chicago 11, Ill.**

**After the city,
Before the state
The ZONE keeps your mail
From being late**

★ ★ ★

The Post Office has divided 106 cities into postal delivery zones to speed mail delivery. Be sure to include zone number when writing to these cities; be sure to include *your* zone number in *your* return address — after the city, before the state.



TRAILER HITCH RETRACTS!



AVOIDS THIS

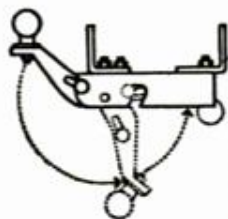

Swings out of sight in seconds. Lets you park or be pushed safely. Prevents hidden license numbers, and bruised shins. Fits most cars. Write for folder and name of nearest dealer!

BIG BOY PRODUCTS DIVISION
The Dalton Foundries, Inc., Warsaw 11, Ind.

MAKE BIG MONEY with your own low cost **ARC WELDER**



SHOP TYPE AC TRANSFORMER WELDER COMPLETE

Model TLF-182



WELDER PLUS EMERGENCY AC POWER FOR RUNNING TOOLS—LIGHTS

Model GO-2245-S

These two profitable EASY TO OWN Arc Welders let you start making **BIG MONEY** right away. Cut, burn holes, weld and hardsurface. Welding is in big demand. No special training needed. Build and repair anything.

Save on costly replacement parts and avoid teardown delays. Special built-in features make adjustments easy . . . simplify welding on all types of work. Cash in on the constantly growing need for emergency repair work and construction jobs.

Write for complete details—no obligation
HOBART BROTHERS CO., Box M-40, TROY, OHIO, Phone FE 2-1223

1960 ELECTRIC SHOPPER

- All Electric
- 2 passengers
- 30 miles on single battery charge
- Operates for 1c per day
- Dependable for more than 25 years

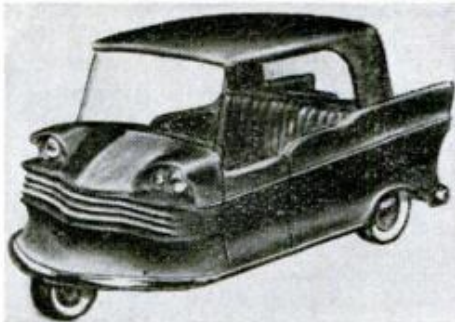

Write for specifications and prices

ELECTRIC CAR CO. OF CALIFORNIA, INC.
495 Alamitos Ave. Long Beach, Calif.

Everything For The BOAT

Outboard — Inboard — Sail — Game Room, Gear—Equipment
Hardware — Supplies — Jewelry — Instruments — Controls —
Refrigeration, Scores of Money-Saving Boat Supplies.

NEW Inboard Gasoline Diesel Engines
WE TAKE YOUR OLD ENGINE IN TRADE—By Mail

Send for 125 Page, Big Illustrated part color, catalog. Only \$1.00 (rebated, with first order). FREE—Floating Key Ring accompanies each catalog.

BOAT EQUIPMENT UNLIMITED, Oceanport 2, N. J.

You Can Have a HE-MAN VOICE

Send today for FREE booklet "Voice Power and Personal Power" by Eugene Feuchtinger. Just send your name, address and age. Mailed in plain sealed envelope. No obligation.

PREFECT VOICE INSTITUTE
210 S. Clinton, Studio DP-2, Chicago 6, Ill.



Taking a holiday?

Don't miss

TEN UNUSUAL VACATIONS

in the

MAY

POPULAR MECHANICS

APRIL 1960

RADIO SHACK FLASH!

Send Coupon for Latest
FREE
ELECTRONICS CATALOG
plus every new issue for 1960



For the newest and best in electronics equipment—stereo, hi-fi, ham radio, tapes—mail coupon today for Radio Shack's latest FREE 312 page catalog. Also get every new edition for next 12 months, Free. Satisfaction guaranteed or your money back. Mail coupon now.

Radio Shack Corp., 730 Commonwealth Ave.,
Boston 17, Mass. Dept. 60D3

Send FREE Electronics Catalog—Also every new issue for 12 months, a full year's subscription Free.

Name _____
Address _____
Postoffice _____
or City _____ Zone _____ State _____

ENGINEERING



Photo of Heald Students in Electrical Laboratory

Enroll Now for New Term
Heald College Ranks **FIRST**
West of the Mississippi
in "Who's Who in America"

Send for FREE Information

Heald Engineering College

Est. 1863

Van Ness at Post, Dept. P.M.
San Francisco, California

American Industry
Steps Up Its Demand
for Trained Engineers.
Train Now at Healds

**BACHELOR OF
SCIENCE DEGREE,
30 MONTHS**

SAVE 2 YEARS' TIME

Degree Courses:

- Electronic Engineering
- Electrical Engineering
- Highway Engineering
- Mechanical Engineering
- Structural Engineering
- Civil Engineering
- Architecture

Diploma Courses:

- TELEVISION Color TV
- Electronic Technician
- Industrial Electronic Tech.
- Tool & Die Design
- Architectural Drafting
- Mechanical Drafting
- Structural Drafting

Approved for Veterans

NAME _____
STREET _____
CITY _____
STATE _____

IDEAS THAT BECAME BIG BUSINESS

By Clinton Woods

This tremendously inspiring new book—the only one of its kind in the world—contains the fascinating stories of how 206 great American concerns started; some in kitchens, barns, garages, a back yard.

Intimate details of the bitter human and financial struggles with heart-breaking problems for years; finally huge success! Thrilling examples of vision, tenacity and fortitude. Excellent reference work. One of the most exciting, gripping books of all time!

Prominent Americans write: "The book is terrific and challenging. Congratulations on a fine piece of work."—"A terrific idea to begin with, put together most effectively. Am enjoying it tremendously."—"Really magnificent. Much success with this wonderful book."—"Most impressive, both in appearance and content. You did a great job."

Hard board, cloth bound covers; hot-die gold stamped; 430 pages 6" x 9"; 3-color dust jacket. Impressive gift. Price \$5.75. Send check or money order now. Delivered postpaid. Or write for folder. Money back if not satisfied.

FOUNDERS, Inc.

Dept. PM1

Garrett Bldg., Baltimore 2, Md.

**Want BIG PAY—
Your Own Business?**

**Be a
LOCKSMITH**



You can quickly step into a well-paid job or start a big-profit business of your own. Shortage of locksmiths means opportunities everywhere, spare-time or full-time.

EARN EXTRA MONEY FROM THE START!
All Special Tools, Supplies Furnished Free

Age, education, minor physical handicaps don't matter in this growing, steady-income trade. You learn fast at home—gain practical experience through well-illustrated lessons. You do real jobs under the personal guidance of experts. For a future as your own boss, or in a big pay job, send for FREE illustrated book. Mail coupon at once. No salesman will call. Only school of its kind. Licensed by State of N. J.; Accredited by Nat'l Home Study Council. Approved for Veterans.

**LOCKSMITHING INSTITUTE, Dept. 104,
150 Park Ave., E. Rutherford, N. J.**

**LOCKSMITHING INSTITUTE, Dept. 104,
(Div. of Technical Home Study Schools, Inc.)
150 Park Ave., E. Rutherford, N. J.**

Please send Illustrated Book FREE and without obligation.

Name _____
Address _____
City _____ Zone _____ State _____

MAKE GARDENCRETE G-4

A Spare-Time Activity Can Lead to a Full-Time Business

On one compact, low price, easy-to-operate machine you can make 24 different kinds or sizes of Gardencrete for patios, walks, planters, barbecues, terraces, etc. Easily set up in shed or garage. With small investment, you can turn idle hours into profit and build into a full-time operation. Gardencrete enables you to cash in on large, growing demand for garden masonry in color.



Patio Stones
Flag Stones
Solid Brick
Hollow Brick
Roman Brick
Slump Brick
Cap Stones
Curb Stone
etc., etc.

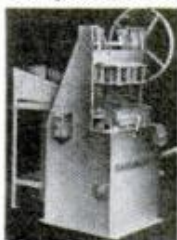

\$1.00 worth of materials can be turned into \$5.00 to \$8.00 worth of Gardencrete. A cash-and-carry business. We supply full instructions. Complete information in full-color brochure. Write today.

COLORCRETE INDUSTRIES, INC.
704 Ottawa Ave., Holland, Mich.

75 POWER TELESCOPE \$3.98

NEW 3 in one telescopes, 3 variable 25X 45X-75X magnification. Brass bound, 25 power for ultra bright images 45 & 75 power for long range. Guaranteed to bring distant stars, moons, objects, sports 75 times closer.

Most powerful scope sold anywhere near this amazing low price. American made, 5 sections. Opens 36", closes 1 ft.; contains 4 ground & polished lenses. Can also be used as powerful 6-pound microscope. Mass production enables us to offer telescope complete at \$3.98 postpaid. Money back guarantee.

CRITERION CO., Dept. PMB-80, 331 Church St., Hartford, Conn.



It's FUN to do

MAGIC TRICKS

Amaze—mystify—entertain! 500 TRICKS, 1960 Edition now ready. Contains latest, best magic for pocket, club, stage. Only 10c.

DOUGLAS MAGICLAND, Dept. E, DALLAS TEXAS

MAKE \$5.00 AN HOUR IN SPARE TIME BIG, EASY "AT HOME" PROFITS—METALIZING

It's so easy to earn Big Money right at home in fascinating new spare time business. Little easy-to-run table-top machine returns Cash Dollars for a few cents cost. We furnish everything to put you in business for yourself, "eternalizing" baby shoes, and other keepsakes. Write TODAY for full facts FREE. No salesman will call on you. No obligation.

WARNER ELECTRIC, 1512 Jarvis, Dept. M-2-D, Chicago 26, Ill.

FORTUNES IN DIVING

Train at Home in Spare Time

Write Today for Amazing Free Booklet

Here is one of the greatest opportunities of our time. Make big money fast in Skin and Lung Diving. Trained divers needed in hundreds of industries and by government. Build a successful business of your own. Hourly rates among highest paid in any field. Training program by E. R. Cross, world famous master diver. Get the facts now. Mail coupon for FREE BOOKLET TODAY!

**DIVEMASTER, Dept. PM-40
5637 W. 63rd Place, Chicago 38, Ill.**

Send me free information about Diving.

Name _____ Age _____
Address _____
City _____ State _____

Need Better Experimentation In Quest of Weather Control

If we are ever to tame the "ocean at every man's door" through weather modification, we must first change our methods of experimenting with the atmosphere. This is the substance of a report issued by the National Academy of Sciences — National Research Council.

In stressing the need for fundamental understanding of atmospheric processes, the report distinguishes between experiments designed to produce basic data and experiments designed to produce rainfall. Acknowledging that cloud-seeding efforts during the past decade have contributed to our knowledge of weather phenomena, the report points out that they have also led to many "false starts" and that "the economic value of obtaining even a small degree of control over rainfall has created undesirable pressures which have tended to dilute the scientific quality of some weather-modification experiments."

The value of rain-making experiments of a scientific nature is recognized in the report. Here, perhaps, lies the key to unlock the entire mystery of energy balance in weather systems—providing man with the ability to control not only rain and snow, but also hail, lightning and violent storms. Therefore, the report asserts, financial support of weather modification experiments should be channeled into investigations of relevant basic atmospheric processes and modification techniques, using scientific methodology and modern principles of experimental design. Other points made in the report are these:

1. Laboratory and field studies should be carried out by an individual or small group. Although such projects will be largely exploratory, any promising results can be given large-scale experimentation.

2. Statisticians must work with meteorologists to provide sound statistical methods.

3. Where effective cooperation exists between meteorologists and statisticians in universities and research institutions, it should be strengthened.

4. Few U.S. experiments have been carried out long enough. Most field experiments must go on for several years.

5. Experiments must be repeated in space as well as in time, and improvements must be made in measurements, instrumentation and in standardizing terminology.

6. Basic research programs in atmospheric physics, chemistry and electricity should be considerably augmented. Laboratory studies should include solid-state physics, crystallography, surface chemistry and electron microscopy.

FOR YOU BETTER PAY and a BRIGHTER FUTURE IN AUTO MECHANICS AND DIESEL



Your spare time pays off BIG with our world-famous **SHOP TESTED Home Training**



MAKE YOUR FUTURE AS BRIGHT AS THEIRS

In a matter of months, you can quit your no-future job for a big-pay, big-future career as an Auto-Diesel Mechanic. Free Illustrated Book gives you the facts. Send coupon below. No Obligation. No Salesman will call.

All Phase Training

N. T. S. students become skilled, all-around mechanics. Crystal-clear lessons, Shop-Tested manuals, real professional equipment, make it easy to learn. Big equipment kits, yours to keep. Earn as you learn...we show you how. Graduate Advisory Service.

N.T.S. Training is Better, More Complete, Lower Cost **BETTER...**

Because training is SHOP-TESTED in Resident School Shops & Labs. **MORE COMPLETE...** You learn all phases of Auto Mechanics & Diesel. **LOWER COST...** One low tuition covers entire cost of course and all equipment.

Unlimited Opportunities

Trained mechanics make top money...are in demand at dealer shops, garages, large bus and truck lines, construction projects, government labs, factories, and many others.

YOU GET AND KEEP ALL THIS PROFESSIONAL EQUIPMENT



NATIONAL TECHNICAL SCHOOLS

WORLD-WIDE TRAINING SINCE 1905
4000 SO. FIGUEROA ST. LOS ANGELES 37, CALIF., U.S.A.



FREE!
Illustrated Fact Book & Actual Lesson
Mail coupon now.

RESIDENT TRAINING
at Los Angeles!
If you wish to take Resident Training at Los Angeles, in our Big, Modern Shops & Labs, check special box in coupon for full information.

Complete TV-Radio Electronics training also available.

NATIONAL TECHNICAL SCHOOLS

WORLD-WIDE TRAINING SINCE 1905

MAIL NOW TO
NATIONAL TECHNICAL SCHOOLS, Dept. DB-40
4000 S. FIGUEROA ST., LOS ANGELES 37, CALIF.
Send for FREE Auto-Diesel Opportunity Book and Actual Lesson.

NAME _____ AGE _____

ADDRESS _____

CITY _____ ZONE _____ STATE _____

Check if interested ONLY in Resident School training at Los Angeles.

VETERANS: Give date of Discharge _____



Member



make it with 60c worth of sand & cement!

SELL IT FOR \$2000

every home a prospect for these "LIFETIME"

CONCRETE INCINERATORS

Make big profits manufacturing rust proof, fire proof, almost indestructible concrete incinerators in your own backyard or garage... full or part time. Sell to home-owners, hardware, department and garden supply stores. Phila. manufacturer doing big volume with Sears, Roebuck; large department stores. Easy to follow instructions and all needed equipment supplied. Exclusive protected franchise—No competition! Territories going fast. Write immediately for full details.



Dept. PM-460-A, T. C. TOR
318 Rancocas Ave., Delanco, N.J.

Gentlemen:
Rush full information about your concrete incinerator protected franchise offer.

Name _____
Street No. or R.D. _____
City _____ Zone _____ State _____

AVIATION CAREER

SPECIALIZED EDUCATION / PROFESSIONAL TRAINING... only 16 months to 2 years

Top-pay prestige positions, bright future in aviation. Job opportunities waiting for you as soon as you're ready. Airframe and Powerplant Technician, Aeronautical Engineering Technologist, Business or Executive Pilot. Classes in Miami.

SEND FOR FREE 80-PAGE BOOK

Embry-Riddle Aeronautical Institute
Dept. B Miami, Florida (Founded 1926)

Name.....
Address.....
City.....Zone....State.....

Build a low cost

PONTOON BOAT

with a

"Perma-D" KIT



You can now have all the fun—and economy—of building your own pontoon boat. Pontoons are made with standard 55-gal. steel drums fastened to platform frames with "Perma-D" Pontoon Brackets. The "Perma-D" Pontoon Boat Kit includes two nose cones, outboard motor mount, brackets and tie rods for pontoons, with complete instructions for building frame, pontoons, deck. **Dealer inquiries invited.**

Write for circular on "Perma-D" pontoon boat kit, deck and float brackets, boat mooring bars, springboard, boat canopy, etc.

"Perma-D" DIVISION, Central Machine Works Co.
1235 Central Ave. Minneapolis 13, Minnesota



An Easy Way to Earn

EXTRA MONEY

For Your

NEW CAR!

POPULAR MECHANICS—the magazine that helps you to *save money* on hundreds of projects—now offers you an opportunity to earn *extra money* as a spare-time or full-time subscription representative for POPULAR MECHANICS and *all other* leading national magazines.

Thousands of men, and women too, are earning substantial sums daily through this pleasant, convenient and profitable work. What *they* are doing, you can do too, just as easily and successfully. The rapidly growing interest of men in all kinds of practical crafts has created millions of potential subscribers for POPULAR MECHANICS — one of the easiest of all magazines to sell.

MAIL THE COUPON NOW!

Few ways of earning extra money at home are so convenient to engage in, so easy to start, so certain to add worthwhile amounts to your personal or family income. Let us send you complete details of our plan, free supplies—everything you need to start earning extra money at once.

POPULAR MECHANICS, Dept. 460
250 West 55th St., New York 19, N. Y.

Please send me, without obligation, complete details of your subscription plan.

NAME _____

ADDRESS _____

CITY & ZONE _____

STATE _____

Magic Mail Plan—Make up to \$5 an Hour!



THIS MAN ... is taking out of the machine a Plastic Sealing Job—ordered by mail—only 11c in material cost brings back \$2.58 in cash by mail. Capacity of machine: \$25.00 profit per hour of operation.

Get **ORDERS** and **CASH** from your mailman—do work in **SPARE TIME** at home—or expand into **FULL TIME** business.

Send coupon for Free facts about the newest and most fascinating of all home operated businesses. For the first time a simplified machine brings the fabulous profits of **Plastic Sealing** and **Plastic Laminating** within the reach of the small operator. Anyone can learn to operate the machine with a few minutes practice—then with our **Magic Mail Plan** can get mail orders pouring in daily with cash in every envelope. **No canvassing—no selling.** We even

Get into PLASTIC LAMINATING at home

supply the circulars you mail to bring back cash and orders. Don't waste a minute. Rush your name. We'll send you **FREE** and postpaid, pictures, prices, details, and all the facts you need to start. Mail coupon or send name on postcard. No charge. Warner Electric Co., 1512 Jarvis Av., Dept. L-2-D, Chicago 26, Ill.

Make Thousands of Beautiful Art Creations

COSTUME JEWELRY • CIGARETTE BOXES TRAYS • CANDLESTICKS • COASTERS LAMP BASES • BOOK ENDS...ALL IN SPARKLING COLORED PLASTIC



WARNER ELECTRIC CO., 1512 Jarvis Av. Dept. L-2-D, Chicago 26, Ill.

At no cost to me, please rush complete details postage prepaid. I am under no obligation.

Name _____
Address _____
City _____ Zone _____ State _____



get into operating or repairing EARTH MOVING EQUIPMENT

Men needed now for good paying jobs in booming road and construction work. Learn operating or repair-rebuilding of heavy road machinery, cranes, bulldozers, earth carriers, etc. Actual "on the job" training. 5 to 13 1/2 week courses. Classes start every Monday. Reserve your space now. Complete catalog and reservation facts **FREE.** Approved for veterans. Write

Greer TECHNICAL INSTITUTE
Attn: P. D. Hutch, Box 368, Braidwood, Ill.



BARBELLS

140-Pound, **CHROME DELUXE** Barbell-Dumbbell set only **\$19.80.**
This is our feature set and is the finest ever manufactured.

Training with adjustable weight is the **BEST** way to keep fit: the **ONLY** way to develop great strength and a perfect body. As the oldest and best equipped barbell company, **BUR** gives value and prices no one can equal.

SEND FOR FREE CATALOG
BUR BARBELL CO.
Lyndhurst 9, New Jersey

100 POUND SET \$12.80

Extra Plates Only 12c Pound

A MICHIGAN PROPELLER

MATCHED TO YOUR OUTBOARD MOTOR, BOAT AND LOAD

GIVES BETTER PERFORMANCE FOR SKIING, SPEED, CRUISING or GENERAL OPERATION

SEND postcard for 1960 catalog (**FREE**). Contains much helpful boating data and carefully engineered propeller recommendations; also fine line of skis, boat accessories. **MICHIGAN WHEEL CO.,** Grand Rapids 2, Mich., Dept PM



BOAT TRAILER KIT Only \$69.50

Assemble and Own This High Quality Trailer—Save 1/3! Handles Boats to 16'. Other Models for Larger Craft. All parts furnished to assemble to a few pieces locally purchased pipe. Cuts freight costs. Trailer completely engineered—no special skills or tools required—assemble & tighten U-Bolts. **CAMPING AND UTILITY KITS ALSO AVAILABLE—ONLY \$52.50.**



Write today for illustrated catalog. Enclose 10c for postage and handling.

Reference—First National Bank, Kingsport, Tenn.

TRAILER PRODUCTS COMPANY, INC.
Dept. PM-4, P.O. Box 176, Kingsport, Tenn.

MAGNALOK—NEW MAGIC SECRET LOCK

Lock your wooden cabinets, drawers, or doors with **MAGNALOK.** No key-hole! Only you know where the lock is.

Just a few minutes to install. Then remove your Alnico magnet key from your pocket. It comes with gold key chain and simulated leather holder. Wave the key over the lock—doors, cabinets, drawers open as if by magic! Your magnetic key also serves as a stud finder and retriever of pins, tacks, etc.

Already thousands of cabinet makers and carpenters swear by **MAGNALOK**—only invisible, foolproof and rustproof lock! Money-back guarantee. \$2.00 postpaid. 3 for \$5.00. In Calif. add 4% sales tax.

Kellart Co., 166 Geary, San Francisco 8, Calif.

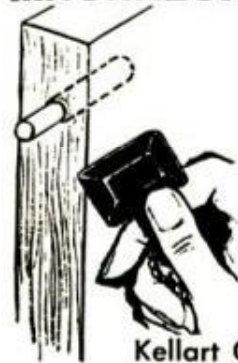

Get Into One Of Today's TOP OPPORTUNITY FIELDS

ELECTRICITY —ELECTRONICS TELEVISION RADIO • ELECTRONICS

Train in the New Shop-Labs of Oldest, Best Equipped School of Its Kind in U.S. Founded 1899

in Chicago—Electrical and Electronic Center. Prepare for a better job and a successful future. Train on real equipment—no advanced education or previous experience needed. Lifetime employment service to graduates. Part time employment help to students. Finance Plan—enroll now, pay most of tuition later.

FREE BOOK—Mail Coupon or write to address below for Big Free Illustrated Book—"Guide to Careers."

Information comes by mail. No obligation and **NO SALESMAN WILL CALL.**

COYNE ELECTRICAL SCHOOL

Chartered as an Educational Institution Not for Profit
1501 W. Congress Pkwy., Chicago 7, Ill., Dept. 40-3C

COYNE ELECTRICAL SCHOOL, Dept. 40-3C
1501 W. Congress Pkwy., Chicago 7, Ill.

Send **FREE** Book, "Guide to Careers" and details of all training you offer. I am especially interested in

Electricity Television Both Fields

Name _____

Address _____

City _____ State _____

(I understand no salesman will call)

LEARN MEAT CUTTING AT NATIONAL

Pay After Graduation

National School of Meat Cutting, Inc., Dept. 50-D, Toledo 4, Ohio

Send me your FREE school catalog on National Training at Toledo in Meat Cutting, Meat Merchandising and Self-Service Meats. No obligation. No salesman will call.

Name _____ Age _____

Address _____

State _____ City _____

Approved for Veterans

The steady dependable trade of Meat Cutting taught easily in 8 short weeks. YOU LEARN BY DOING under actual meat market conditions in big modern school at Toledo.

For beginners or men with experience. Get a profitable store of your own. Remember, PEOPLE MUST EAT! Big pay jobs. Free employment help. Thousands of successful graduates.

Buying, cutting, percentage, pricing, advertising, selling, etc. A complete retail meat education. National School established 37 years. Get National training NOW. Pay your tuition in easy monthly payments after you graduate. Send coupon for FREE 40 page school catalog—TODAY. G.I. approved.

Draw CARTOONS



...for a wonderful pastime or excellent earnings. Master cartooning at home in a few short weeks without waste of time or effort through the Famous System of Manual Training.

Exciting Kit Included... Start earning money at once. FREE CATALOG. Send coupon below.

Continental Schools, Inc.
4201 S. BROADWAY, LOS ANGELES 37, CALIF. DEPT. A-4

Continental Schools, Inc., Dept. A-4
4201 S. Broadway, Los Angeles 37, Calif.
Please rush me your Free Catalog and other information by return mail. No charge or obligation, no salesman will call.

NAME _____
ADDRESS _____
CITY _____ ZONE _____ STATE _____



FREE BOOK
Send Coupon!

on any object ELECTROPLATE

ANY OBJECT IN HOME SHOP GARAGE. NOW with our NEW ELECTROCHEMICAL Outfit. You can easily do your own plating with same LUSTER and DURABILITY as by more expensive equip. Outfit comes completely ready to start plating immediately. With instructions on plating metal & non-metal objects as Tools, Auto Parts, Silverware, Jewelry, Baby Shoes, 1001 other articles with COPPER, CHROME, NICKEL, GOLD, etc. SEND NO MONEY. Everything sent C.O.D. for low price of ONLY \$5.95 or send \$5.95 now and receive it postpaid. Money back in 7 days if not satisfied. M.Z. Sales Co., Dept. G-33, 113 W. 42nd St., N. Y. 36, N. Y.

INVENTORS

Before you do ANYTHING, send for information on WHAT you should do. Write for FREE copy of "The Inventor's Guide" and learn how to protect, evaluate, and market your ideas. No obligation, of course.

INVENTORS GUIDANCE SERVICE
Calimesa, California

MODEL CHANGEOVER SALE! 1959 MODEL—BELOW COST!

8" TILT ARBOR SAW

BLADE TILTS—TABLE REMAINS LEVEL

Heavy duty all cast iron and steel construction. Precision ground cast iron table. Price includes massive cast iron mitre gauge and patented motor drive that fits any motor. Cross cuts, rips, bevels, mitres, dadoes, cuts compound angles — everything expected of saws costing four times as much. Depth of cut adjustable; 0" to 2 1/4" — table always level. Send check or M.O. \$2.00 deposits on C.O.D.'s.

SPECIAL BARGAIN — This saw is our 1959 model. Each saw is brand new — sent to you in factory sealed cartons. Sold and guaranteed direct from the factory to you at a fantastic bargain.

FREE 10 DAY TRIAL — MONEY BACK GUARANTEE

Try this famous saw 10 days. If you are not satisfied that it does the work of any tilt arbor saw, regardless of price, return for immediate money back refund.

Sent Express Collect.

We reserve right to refund money if stock is exhausted

AMERICAN MACHINE & TOOL CO.
ROYERSFORD 16, PA.



MODEL 590

NOW \$9.95
Was \$24.95

Shipped Complete as shown Less Blade

MEN NEEDED NOW—BIG PAY OPPORTUNITIES FOR JET ENGINE MECHANICS AND TECHNICIANS

Learn at Home in Spare Time or in Atlantic Jet Training's Own Modern Airport Shop—Work on Jet Engines. Practical training covers all phases for top paying jobs including Flight Line Maintenance, Shop Overhaul Maintenance, Inspectors With Airlines, Air Bases, Manufacturers and Government Missile Projects. FAA Licensed Instructor. Employment Service. WRITE TODAY FOR FREE BOOKLET.

ATLANTIC JET TRAINING, INC., Dept. PM-40
Municipal Airport Jet Engine Training Shop, Zephyrhills, Florida

LEARN TO EARN

HIGH WAGES

AS A HEAVY EQUIPMENT OPERATOR!



Secure a high paying future in the exciting construction industry today! Learn to operate bulldozers, draglines, cranes, back hoes, scrapers and motor graders on our actual construction projects!

- ONLY CONTRACTOR OWNED AND OPERATED SCHOOL IN WORLD
- ASSOCIATE MEMBER ASSOCIATED GENERAL CONTRACTORS
- MODERN EQUIPMENT
- V. A. APPROVED FOR G. I. TRAINING
- BUDGET PAY PLAN AVAILABLE

WRITE TODAY FOR FREE SCHOOL CATALOG

WESTERN NATIONAL
SCHOOL OF HEAVY EQUIPMENT OPERATION

DEPT. B-3 BOX 510
WEISER, IDAHO PHONE 910





CLASSIFIED ADVERTISEMENTS



Advertisements in this section \$1.30 per word, each insertion, minimum 10 words, payable in advance. To be inserted under proper classification, copy must be in our office the 18th of the second month preceding date of issue
 F. W. Johnson, Manager, Classified Advertising
 Popular Mechanics Magazine, 200 East Ontario Street, Chicago 11, Illinois

YOU'LL PROFIT

By reading and answering the classified ads in this section. Hundreds of opportunities for you to make and save money

AUTOMOBILES, MIDGET CARS

SAVE—When buying new car. We show you how. Literature free. Price Research Bureau, Box 15, Tonawanda, N. Y.

CATALOG On parts kits for golf buggy or Jr. sports car. 25¢. Indus Corporation, 1815 Madison, Indianapolis.

MIDGET Kart racers. New. Unassembled. Less engines. \$29.95 prepaid. Benzick, 421 Sixth Street S.E., Minneapolis, Minn.

TR²/₃ OWNERS Illustrated Tune Up manual shows how. \$2.00. SCM, Box 215, Springfield, Va.

ELECTRIC Car plans. \$1.00. Magnuson Co., Box 15003, San Diego 15, Calif.

HOTTSPARK. Starting, pep, mileage. Varytaper, multilith, mimeograph. \$1.95. EG, Elmsford, N. Y.

JEEP Headquarters. New and used Jeeps, parts, snow plows, Winches. Every type of special equipment. Franklin Weber Pontiac, 6101 N. Clark St., Chicago 26, Ill.

NON-PROFIT Organization offers automobile literature—old, modern and foreign; dealer books, service manuals, glossy photographs; free motor magazines. Write immediately. Get on free mailing list. Auto Maniacs, Stockbridge, Mich.

BUILD Your own Go-Kart from our parts lists 25¢. Receive Go-Kart formula and track plan free. 1/4-Midget plans and material list \$2.00. Rocky, Galveston, Indiana.

GIANT Illustrated catalog. Kart and Midget information and parts. \$1.00. Steen's, 19 E. Valley, Alhambra 28, Calif.

AUTO SUPPLIES AND EQUIPMENT

JEEP Parts! For military and civilian. At great savings. Largest inventory. Catalog for owners and dealers. Inquiries invited. American Auto Parts Co., 1830-PM Locust, Kansas City, Mo.

CUSTOMIZE! Bubble fender skirts give your car that expensive long, low look. Free literature. Skirts, 5401 W. Warren, Detroit 10, Michigan.

NEW And used parts at savings. Complete guaranteed parts service for all models cars and trucks, 1924 and later. Largest in the West. Jeep and army parts specialists. Newest type shifting hubs for all jeep and all military and latest production front end drive vehicles. \$27.50 and up. Also, foreign car parts. Write, Pioneer Auto and Truck Parts Co., 734 W. 13th Avenue, Denver 17, Colo.

PARTS. Model "A." List 25¢ (refundable). Matco, Box 135, San Pedro, Calif.

RING—Valve job while driving. \$6.00 postpaid. (9th successful year.) Guaranteed! Yellow Cab test-proven. Motaloy, Grantham, Penna.

1909-1934 FORD Parts. Illustrated catalogue 50¢. Mark Auto, Layton, New Jersey.

FREE! New catalog. Speed, power, mileage increasing equipment. Discounts! Almqvist Engineering, Milford PM5, Penna.

CRANKSHAFT Grinder. Hand operated. Makes bearings fit without taking engine apart. \$4.00. Literature. L. D. McGee, 719 Cascade St., Wenatchee, Wash.

1960 EDITION. IT'S NEW! It's different! Get world's largest auto accessories and parts catalog, save up to 50%. 356 pages, over 10,000 items, earliest to 1960 models including Hollywood accessories, custom styling and Hi-Speed Equipment. All parts and sports cars. We have that hard to get part. Jam packed with bargains. Completely illustrated. Send 25¢ (refundable). J. C. Whitney, 1919 PM-4 Archer, Chicago 16, Illinois.

BUY The best. British made. Easily installed. Desmo-Kigass windshield washer. \$6.00. Air Industrial Developments (Canada) Ltd., P. O. Box 73, Willowdale, Ontario.

STEERING Wheels, Midgets, etc., \$3.95 up. Literature 10¢. Steerite Products, Dept. PM-4, Box 221, Long Branch, N. J.

GIANT Auto parts catalog. Thousands special accessories, speed, power, performance. Mileage, custom equipment. Send 25¢ (refundable). Newhouse Automotive Industries, 5805-PM4 Beverly, Los Angeles 22, Calif.

AMMETER Oil gauge kit. Protect your car with these gauges left out by factory. Two inch ammeter, two inch oil pressure gauge mounted in illuminated, durable chrome panel. All installation parts included with complete instructions. Only \$13.95, postpaid. Details free. Cold Spring Products Company, Cold Spring 8, New York.

HYDRAULIC Jack repair kits. Free catalog. Hydraulic Parts Supply, Box 4104, El Paso, Texas.

AUTO Shop welding repair training in world's largest non-profit welding school. Low tuition. Free booklet. Hobart Welders, Box M-401, Troy, Ohio.

JEEP Owners — V8 conversions. Read Jeep Owners ad, page 28.

NOW You may see the fuel you save with remarkable "Injecta-Flo" fuel pressure (regulator) controls. Eliminates vapor-lock, etc., \$7.95 with fittings. Dynarex Corporation, Maryland Heights, Mo.

GUARANTEED. Racing car power. Foreign car economy. Information 10¢. George Nemitz, Cedarburg, Wisconsin.

NONCORROSIVE Battery post shims. Perfect contact. Faster starts. Pair 50¢. Acme, 6625 Raiston, Raytown, Missouri.

TRAILER Hitches. Custom made. 1960 Ford, Mercury. 4000 lbs. capacity. Guaranteed. Bolts on in 3 places. \$15.00 other 59-60 models. Inquiry prices. Custom, 6221-N Astor, Spokane 23, Wash.

200 MODEL "A" parts. Free list. Box 423, Bensenville, Illinois.

SPARK Plug tester, neon, pocket pencil type, accurate. \$1.00 postpaid. P.O. Box 5972, Detroit 10, Michigan.

BRAKE Adjusting tool universal for cars & trucks. Drop forged chrome alloy steel. Triple chrome plated. \$1.00 postpaid. P.O. Box 5972, Detroit 10, Michigan.

Make your four door sedan safe for children, foolproof, simple, information \$1.00. Sedan, Box 1098, New Orleans 4, Louisiana.

3-D HEADLITES. Installed 15 minutes. Amazing illumination. Complete \$3.95 postpaid. Motorlax, Box 681, Waterloo, Iowa.

SILENCE Hydraulic valves. More power, speed, gas & oil mileage. Guaranteed. \$3.00 postpaid. Literature. Micro-Molly Products, Garrison 1, Kentucky.

AUTO TRAILERS

LEVELALL — The only adjustable level that fits all travel trailers. Guaranteed to make your trailer more livable. \$3.95 postpaid. Levelall Co., 64 Hawthorn, Eugene, Ore.

PICKUP Coach blueprints. Kits. Literature 10¢. Comstock Trailers, Parsons, Kansas.

TRAVEL Trailer large floor plans. Includes booklet illustrating 5 models. \$1.00. Kamcraft, Box 1153, Milwaukee 1, Wisc.

TRAVEL Trailers, camping trailers. Also plans, tent top, running gear, etc. Tents (galore!), camping equipment, boats (painted-unpainted). Finest selection. Lowest prices! 25¢ for 1960 catalog: Easy Camping, Inc., 128-Z Chicago, Evanston, Illinois.

COMMERCIAL Style pickup coach. Plans \$1.00. Save 75%. Burns, Box 624, Moscow, Idaho.

BUILD Expanding eight foot trailer. Accommodates five. Literature 10¢. Fra-Mar Company, Wilmington, Mass.

MOTORCYCLES, BICYCLES, MOTORSCOOTERS AND SUPPLIES

Ride a unicycle. Send \$2.00 for booklet on how to build and ride a unicycle. Unicycles, 1233 N. Union, Kennewick, Wash.

BEST Deals on wheels. Leopard motorbikes. \$199.50. Motorscooters, \$285.00. Motorcycles, \$375.00. Illustrated catalog 25¢. Motorcycle Import Corporation, P.O.B. 1950-A, New York City 17.

1000 MOTORCYCLE. Motorbike, bicycle bargains. Parts, accessories. Bargain catalog 35¢. Bunico, 146PM, Covington, Virginia.

BICYCLES — Buying, reconditioning, selling. Make money at home. Illustrations, instructions, \$1.00. Boldt, 616 N. Walth, Sioux Falls, S. Dak.

VINCENT Motorcycles, parts. "world famous classic" SAE. Aucott, 6204 Wisahickon Ave, Philadelphia 44, Penna.

BMW Motorcycles, shaftdrive. U.S. distributor. Butler & Smith, Inc., 160 West 83 St., New York 24, N. Y.

MOTORCYCLE Parts. New, used. List 25¢. Ballak, 811 N. 9th, St. Louis 1, Mo.

RECONDITIONED Motorcycle motors. Chrome accessories. Complete stock Indian parts. Expert rebuilding. Fast service. Indian Motorcycle Sales, Kansas City 27, Missouri.

WHIZZER Motorbike \$20, Travis bike motor \$7, Go cart with engine \$45, engines \$3 up. (Mailorder only). Send 25¢ (35¢ for First Class Mailing) for new Directory-Catalogue Number 94 listing these and hundreds of other bargains in midget cars, motorscooters, homebuilders parts, plans, etc. Midget Motors Directory, Athens, Ohio.

HARLEY-Davidsons — Used bargains. New, used parts, accessories, all models. Bulletin 25¢. Knuth's (Factory Dealer), 1753 Muskego, Milwaukee, Wis.

AVIATION

DUCTED Fan design. Used in air sleds and flying platforms. Specifications and six pages of drawings. \$2.00. Tyna-Turbine, Box 373, Chandler, Arizona.

BUY Gov't surplus: Aircrafts; engines; helicopters; boats; Jeeps; misc. Buy direct now from gov't. Send for "Depot Directory & Procedure" \$1.00. Gov't Surplus Sales, Box 425-PM, Nanuet, New York.

PROPELLERS. Plans, supplies for airboats and snowplanes. Latest designs, prompt delivery. Catalog 25¢. Banks-Maxwell, Box 3301E, Ft. Worth 5, Texas.

MISSILE. Automation books. Discounts. Free literature. Mathematics, Box 52, Woodlyn, Penna.

SPORTPLANE Building manual \$1.50. Circulars illustrated lightplanes, etc., \$5.00. Kamcraft, Box 1153, Milwaukee 1, Wis.

HELICOPTER — Completely engineered. You build from our drawings. Parts available. Send \$2.00 for photo, 3 view drawing, specifications and design information. Helicopter Research Co., Box 121, La Mirada, California.

HELICOPTERS Are our business, not our sideline. A-W, originators of home built helicopters (not autogiros), sells more kits, plans than all others combined! Learn why—photos, specifications, complete prices; 25¢. Adams-Wilson Helicopters, Inc., Lakewood 1, California.

ELECTRICAL SUPPLIES

ELECTRO-Scribe! Engraves all metals, \$2.00. Beyer Mfg., 10511-H Springfield, Chicago 43.

LAMP. Electrical parts, wholesale. Thousands of items for repairing, converting. Catalog 25¢. Brown Lamp, Box 305, Clayton 5, Mo.

LAMPS. 25¢ Brings parts catalog. Refunded first order. Gyro, 5208P N.W. 35th Ave., Miami 42, Florida.

FREE Bargain catalog. Fluorescent fixture kits, circlines, parts. Shoplite, 650-M Franklin, Nutley 10, New Jersey.

WHOLESALE Appliance parts catalogue 25¢. Seco, 26 South 20th Street, Birmingham 3, Alabama.

BOOK 200 Electrical stunts \$1.00. Kuttingson, 875 Arastradero, Palo Alto, Calif.

SPECIAL Workshop light, other fluorescent lighting. Amazing bargains. Free catalogue, free gift. Morton Company, 2733 West Lunt, Chicago.

WELDING, SOLDERING, PLATING

PLATING Equipment, supplies. Complete line of anodes, solutions. Home workshops, industrial sizes. Hollywood Bronze Supply, Dept. C, 1624 East First, Los Angeles 33, California.

FREE Catalog, welders, welder kits. Build 350-ampere welder using aircraft generator, plans 25¢. Dunbar Manufacturing, Minneapolis 8, Minnesota.

WELDERS. 110/220, \$39.50. Morris, 1070 Inner Drive, Schenectady 3, New York.

"BUILD 350 AMPERE welder. Guaranteed plans 25¢, includes welder kit catalog. LeJay Manufacturing, Minneapolis, Minnesota."

MACHINERY, TOOLS, SUPPLIES

TOOL Life increased 2500% with inexpensive coolant formula. \$2.00. Ronrick, Box 6001, East Side Station, Flint 6, Michigan.

POWER Tool repairs. Tool armatures rewound. All makes—all models. Guaranteed. You save one half with Wholesale Power Tool, Bath, Maine.

SHEET Metal bending machines. 36", \$37.00; 61", \$80.00. Also made to order. Vyke Mfg. Co., P4158 Jason, Denver 11, Colo.

SCREWDRIVERS, 24". Many other advanced features. Free illustrated literature. Robert G. Vaughn, 357 Church St., Greensboro, N. C.

POWER Tools wholesale. Free catalog. Roberson, 14A Brooks Drive, Austell, Ga.

PRECISION Milling machine, plans \$1. McKin Manufacturing, 4223 Lincoln, Venice, California.

ENGINES, MOTORS, DYNAMOS

ALTERNATING Current generators 750 watt \$42.50, twincylinder compressors with 1/2 horse \$22.00, motors 1 horse \$38.50. Butler, 1885 Milwaukee, Chicago.

GEAR Motor: 1.2 rpm., 110V., 250# pull. Excellent for driving rotisseries, toys, mechanical devices. 134#, \$5.50. Benhams, 973 Forest, Muskegon, Mich.

DIESEL Injector parts and fuel pumps wanted. GM51-53-71-110. Bares, 7120 Carnegie, Cleveland 3, Ohio.

WINDING Data. 275 motors, single and three phase \$1.10. Data Company, 512 Kensington, Kansas City 24, Mo.

REWIND Motors yourself. Complete instructions, \$1.00. Catalog. Lewis Manufacturing, Howell, Michigan.

REPAIR Your own lawn mower. Our instruction brochure shows you how to eliminate 85% of all engine troubles with minor adjustments. Also complete instruction on blade balancing. Brochure, only \$1.00. Buy your new lawn mower direct from the manufacturer. 3 H.P. Clinton 24" only \$36.95. Seven models available. Lawn Care Mfg. Co., 140 E. Cerro Gordo, Decatur, Illinois.

BOATS, OUTBOARD MOTORS

FULL Size, cut-to-shape boat patterns, blueprints, 7 1/2-38 feet. Big new 88 pg. illustrated "Build a Boat" catalog of naval architect-designed Catamarans, cruisers, runabouts, skiffs, outboard boats, sailing, racing, houseboats, 50¢. "How to Build a Boat" booklet \$2.50. Equipment catalog \$2.00. Cleveland Boat Blueprint Co., Dept. A-66, Box 1651, Cleveland, Ohio.

MARINE Conversions. Ford, Chevrolet, Jeep engines. Catalog 25¢. Lehman Manufacturing Company, 800 Elizabeth Avenue, Linden 4, N. J.

NEW, Used, rebuilt marine motors. Marine conversions, fittings. Free catalog. Stokes Marine Supply, Dept. 24, Coldwater, Michigan.

SAVE Money. New, used outboard motor parts. Send wants. Stamp appreciated. Outboard Motor Mart, 229-M State, Boston 9, Mass.

FRAME Kits, plans or full-size patterns for 35 inboards and outboards. Prepared for amateur builders. New 80 page illustrative catalog, 50¢. Glen Designs, 9152 Rosecrans, Bellflower, Calif.

FIBERGLAS Permanent boat waterproofing. Special 25% discount. Complete kits, \$9.45 up. Guaranteed materials. Easy application. Full instructions. Free literature. Mail post card. Ajax Plastics, P. O. Box 1323, Fort Worth, Texas.

PROPELLERS. Plans, supplies for airboats, snowplanes. Catalog 25¢. Banks-Maxwell, Box 3301F, Ft. Worth 5, Texas.

FORDS And Jeeps 100% marine engines with famous Convo-Kits. Deluxe catalogue 25¢ coin. Oscomotors, 3627B Lawrence, Philadelphia 40, Penna.

FACTORY Propeller repair. Inboard & outboard. Prompt and quality workmanship. Cochell Marine Company, 9135 Hall, Detroit 13, Michigan.

WHOLESALE: Buy direct from the factory. Fiberglass and coreglass runabouts, fishing boats, pontoon boats and houseboats. Free estimates on complete boat, motor and trailer packages. Also boats, pontoon boats and houseboats available in kits. Free catalog. Osage Mfg. Co., Box 117-M, Osage, Minnesota.

CANOE Kits, double ender and square stern. Free literature. Schneider Boats, Dept. 41, 3133 W. Lisbon, Milwaukee 8, Wisconsin.

BOATS? Painted! Unpainted! See Easy Camping Inc.'s ad under "Auto Trailers."

HOW To build twenty boats \$2.50; Skindiver's handbook \$2.50. Satisfaction guaranteed. Bayer Publications, 938H Betty Avenue, Neenah, Wisconsin.

FISHERMEN, Build pontoon raft. Unique design, low cost. Particulars free. Carroll Haigler, Route #2, Box 366, Lenoir, N. C.

MAKES Water logged docks new again, also eliminate anchors with a dock lifter. Pamphlets. Knott Dock Co., Newport, Wash.

I Want to send you proof of the wonderful pulling power of Popular Mechanics classified pages. What's your proposition? Write me today. Include literature if possible. F. W. Johnson, Manager Classified Advertising, Popular Mechanics Magazine, 200 E. Ontario St., Chicago 11, Ill.

ATHLETIC EQUIPMENT, BODY BUILDING COURSES

LEARN Secret to powerful arms. Increase measurements. No weights necessary. \$1.00. T. Keller, P.O. Box 903, Patterson, Calif.

DEADLY Karate, Kung-Fu fighting. Break planks bare-handed. Training with breath, sand, straw, pebbles. Illustrated manual \$3.98. Oriental Book Sales, P.O. Box 1183, Oakland 7, Calif.

"BIG Muscles. The Quick Way." Dr. Young's revolutionary discovery. Free information. Gaucho, Box 9309-S7, Chicago 90.

BARBELLS, Dumbbells. Courses. Booklet 10¢. Good Barbell Co., Siloam Springs, Arkansas.

BACKACHE Sufferers. Many helped. Free literature. Lou Stein, 311 Delsea Dr., Woodbury, N. J.

FREE Muscle building information. Body-Tone, Box 638B, North Miami, Florida.

JUDO — Complete course, only \$1.00. 1112 Tipton St., High Point, N. C.

SPORTING GOODS, GUNS, FISHING TACKLE, ARCHERY, TRAPPING

ARMY Tent stoves, 19"x20", weighs 60#. Portable for hatcheries, hot houses, dairies, farmers, outdoorsmen. Only \$9.95. National Surplus, 1800 Charlotte, Kansas City, Mo.

SPIN Flash the trolling lure for light or heavy equipment. Ideal for spinning rods. Free literature. Terlese Specialty Co., Dept. 96-A, Capitola 1, California.

154 PAGE Catalog—A real dream book for fishermen! It's free! Netcraft Company, Dept. B-4, Toledo 13, Ohio.

SEND Me your name and I'll tell you about a method that lets you take giant bass out of waters that other folks say are "fished out." Facts free. Write Eric B. Fare, Highland Park 40, Illinois.

SPIN-Cast reel. Push-button type. Metal construction, gray and anodized silver finish. Positive drag control. Filled with 80 yards 8 pound test monofilament nylon line. Rubber practice plug. Can not backlash. Send \$4.95. Stanbud Sporting Goods Company, Box 8361, Denver 10, Colorado.

HOOK Threader makes fly changing easy. For OX-6X leaders, 12-20 hooks. \$2.00 postpaid. Snel-A-Fly, Chester Springs, Penna.

GUNS Reblued \$3.00 each. Any size. Work guaranteed. Robert Merryman, Formosa, Ark.

BIZIBUG For spinning. New action! More bass! Free literature and introductory offer. Shaw Tackle Company, R. 2, Montevallo, Alabama.

ANTIQUE Guns, decorators to Patersons. Large photo illustrated catalog \$1.00. Jackson Arms, Box 8065-PM, Dallas 5, Texas.

MOLDS For fisherman's sinkers, jigs, squids, casting and spinning lures. Free catalog. Sweet's Molds, Tonawanda 1, New York.

10,000 **GUNS**. Antiques, moderns, swords, armour. Every description. Giant catalog \$1.00. Agramonte's, Yonkers 2 G. N. Y.

MOLDS—For casting your own fishing sinkers. Free illustrated booklet. Reading Instrument Co., Box PM78, Reading, Penna.

CROSSBOWS! Hunting—Bows! Factory prices! Jayco, Box 1355, Wichita, Kansas.

BIG Money raising crickets and 12 inch African fishworms. Free literature. Carter Ranch, Plains, Georgia.

FREE—Wholesale catalog. Beads. Spinners. Lure parts. Sinker molds. Jigs. Reels. Finnyports (ME), Toledo 6, Ohio.

AMAZING Wholesale sporting catalog. Save 70%. Tremendous selections. Econ-O-Mart, Whippany 2, New Jersey.

KILL Submersed water weeds which foul up motor propellers, tangle fishing gear, with R-H Weed Rhap-20, Granular 2,4-D. Inexpensive, easy to use, sure results. For free information write Reasor-Hill Corporation, Box 36PM, Jacksonville, Arkansas.

MINNOW Graders. Free circular. Crescent Mfg., Box 3303, Ft. Worth, Texas.

5000 **GUNS**, Swords, war relics. Catalog 50¢. Smith Firearms, Runnemed, N. J.

HOW To catch fish with smell. Secret formulas, new recipes. \$1.00. Johnson's, 312-M Lake Avenue, Ithaca, New York.

GUARANTEED Weedless lures. Write for catalog. Weedless Bait Company, Aitkin, Minnesota.

JAP Rifle altering to 30-06, \$6.00. Japshells, \$3.95. Catalog 10¢. T. P. Shop, West Branch 11, Mich.

KLEIN'S 100 Page bargain all-sports catalog—"Nobody undersells Klein's" is sent for 25¢ (refunded with first order). Kleins-PM, Chicago 24.

FREE—Information on Coe bows. Coe Archery, Otter Lake, Mich.

POCKET Size cooking stove. Compact, foolproof, guaranteed to work properly. Burns any gasoline 1½ hours on a few ounces. \$12.95. Morrow's, 648 Main, Groveport, Ohio.

TENTS? Trailers? See Easy Camping Inc.'s ad under "Auto Trailers."

THROWING Knife. Instructions, targets, games. \$2.00. Four for \$5. Trader Jim, 6715-D East 25th, Tulsa, Oklahoma.

FREE Wholesale tackle catalog. Tremendous discounts. Haakonsen, 479 Senator, Brooklyn 20, N. Y.

FISHERMAN Catch up to 1,000 night-crawlers in the daytime. Guaranteed. No digging. No electricity. Harmless, fast, easy. And lots of fun to see them come out. Super "Wormout" kit \$5.00 ppd. Bishop's, 29 Main Street, Bangor, Maine.

FREE Catalog, army surplus clothing, camping equipment. Princeton, 300V Northern Blvd., Great Neck, N. Y.

CAMPING EQUIPMENT AND TENTS

CAMPING Equipment, tents, world's largest selection. Send 25¢ for new 160 page catalogue-handbook-camp site directory. (Print name, address). Morsan Tents, 10-21R 50th Ave., Long Island City 1, New York.

CAMPING Maps, U.S.A. and Canada. Set of three authoritative books listing camp sites, public and private facilities, charges, nearest highways, and other information. \$3.95 postpaid. Ro-S-Co Sales, P.O. Box 12, South Haven, Michigan.

FREE Full-color brochure on compact new fold-out camping trailer, "cartop" camper, camp kitchen. Nation's pioneer manufacturer, Heilite Trailers, 1415 South Sacramento, Lodi, California.

EARTHWORMS, CRICKETS, FROGS

EARTHWORMS—Red hybrid. Breeding bait, culture. Packed breeders. \$5.00—1,000. Instructions. Prepaid. George Pape, Jacob, Illinois.

WANTED, Men, women worm raisers. Sherwood, Dept. A-2A, Monmouth, Maine.

WIGGLERS—2 Cents. Minimum order one dollar. Hillaire, Northville, Mich.

BIG Profits raising fishworms. Select breeders available. Free information. Lone Star Acres, Box 104, Richardson, Tex.

FANTASTIC Profits raising redworms. Free instructions. Georgia Farms, Richard, Georgia.

WORMS Galore. Just pick them up! Professional secrets \$2.00. Grutter, Box 92, River Grove, Ill.

OUR Famous Rocky Mountain hybrid worms. Mixed sizes. 10,000—\$19.95 postpaid. Dewey's Worm Ranch, Henderson, Colo.

RAISE Fishworms and rabbits on \$500 month plan. Free details. White's Rabbitry, Mt. Vernon, Ohio.

\$1,000 **MONTHLY** Possible. raising earthworms, African giants! Backyard, garage, basement. Complete illustrated booklet, explains raising, feeding, packing, marketing. Send 25¢! Ozark Worm Farm-J, Willow Springs, Missouri.

BIG Money raising fishworms and crickets. We teach you how to raise and where to sell. Free literature. Medium redworms, 3000, \$5.95; 10,000, \$16.95. Carter Redworms, Plains, Georgia.

FREE Picture folder, "How to Make \$3,000 Yearly, Sparetime, Backyard, Raising Earthworms!" Oakhaven-56, Cedar Hill, Texas.

MAKE Money raising worms. Free literature. Maxwell, Rt. 2, Irving, Texas.

LABORATORY Controlled worm bedding \$2.49. James W. Steward, 601 Union S.E., Grand Rapids 6, Mich.

BINOCULARS, TELESCOPES, MICROSCOPES, MAGNIFIERS

BINOCULARS, Telescopes, microscopes: Terrific values \$3.98 up! Request free money-saving catalogue. Criterion, Dept. P-89, Hartford, Conn.

TELESCOPES, Binoculars, microscopes—all sizes. Complete telescope makers supplies. Free catalog. Suffolk Science, Mattituck, New York.

DYNASCOPE—Amazing world-famous reflector telescope. Request free brochure. Criterion, Dept. DP-66, Hartford, Conn.

BARGAINS, Binoculars, telescopes, microscopes. Free brochure. Adventure Sales, Box 2133, San Diego 12, California.

REFLECTOR Telescope kits direct from factory. From \$7.75. Other optical do-it-yourself kits. Free booklet. Esco-Hampton, P.O. Box 772, Sparta, N. J.

BUILD Your own reflector telescopes. Complete kits: Mirrors, eyepieces, tripods, all other accessories. Request free illustrated literature. Criterion Manufacturing, Dept. DPM-63, Hartford, Conn.

FINEST Telescopes, binoculars. Write to join mailing list. Vernonscope & Co., Candor, New York.

REFLECTING Telescope, 60X, completely assembled. Guaranteed observatory clearness. Free information. Skyscope, P.O. Box 55, Brooklyn 28, N. Y.

TELESCOPES, Mirrors, binoculars, microscopes, accessories. Free catalog. National Optical Company, 505 New York Avenue, Union City, New Jersey.

AMAZING Prices precision binoculars. "Binocular Selecting," catalog free. Prentiss Importers, Mercury Bldg., West Los Angeles 25, Calif.

WAR Surplus bargains: Millions of lenses, instruments, telescopes, binoculars, components and complete line of astronomical telescope items. World's greatest optical market-place! Send only \$1.00 for beginner's 10-lens kit and big instruction booklet Stock 2-CH. Write for Catalog CH free! Edmund Scientific Co., Barrington, New Jersey.

PLANTS, SEEDS, BULBS, NURSERY AND GARDEN SUPPLIES

GROW Dwarf trees! Instructions and seeds 35¢. Mail Order Specialties, 1439-PM-F Sabraton Ave., Morgantown, W. Va.

UNUSUAL Package of seeds from world famous Yakima Valley. Limited quantity. Rush \$1.00 to Proven Seeds, 22 South Second Street, Yakima, Washington.

GINSENG Bringing \$12 pound. Have seeds, plants. Goldenseal. Full information. K. Collins, Viola, Iowa.

PETS—DOGS, BIRDS, RABBITS, HAMSTERS, ETC.

FREE Rabbit facts folder. Rabbit magazine, markets, dime. Associated Rabbitries 3, Hickman Mills 34, Mo.

EARN \$10,000 Yearly raising Angora rabbit wool for us. Information 25¢ coin. American Angora Company, Malta 12, Montana.

YOU Can master the ancient sport of falconry. Capture and train your own wild hawks for unforgettable hunting adventures. Illustrated trapping and training instructions, only \$2.00. Gabe Smith, Box 4012, Shreveport, Louisiana.

BOA Constrictors \$2. Monkeys \$5. Alligators 25¢. Falcons, ocelots, chimpanzees, many others. Shipped direct to you from Africa, India, South America. Complete details, price lists, addresses, only \$2.00. Gabe Smith, Box 4012, Shreveport, La.

GOLDEN Hamsters—Pedigreed breeders \$3.85 pair. Albinos Whitebands. Literature. Moore's Hamster Ranch, Shepherdstown 25, West Virginia.

MAKE Money raising chinchillas, mink, rabbits, cavies for us. Free catalog. Keeney Brothers, New Freedom 2, Penna.

RAISE Rabbits on \$500 month plan. Free details. White's Rabbitry, Mt. Vernon, Ohio.

HAMSTERS—Ideal pets, \$2.95 pair. Free booklet. Jer-fre's Hamstery, 1447 Apple, Muskegon 13, Michigan.

SKUNKS, Reptiles, hawks, raccoons. Illustrated catalogue, 25¢. Trails End Co., St. Stephen, S. C.

RAISE Rabbits successfully by knowing facts. 48 page illustrated book describing 25 breeds. Housing, feeding, breeding, marketing, etc. Plus bulletin. 25 cents. American Rabbit Association, 36 Arba Building, Pittsburgh, Penna.

PETS Postpaid—Alligator \$3.00. Iguana \$4.00. Box turtle \$1.50. Pair chameleons \$1.00. Small snake \$1.50. Medium rat-snake \$3.00. Large kingsnake \$5.00. Catalog 10¢. Ray Singleton, Rattlesnake Station, Tampa, Fla.

FARMS, FARM LANDS, REAL ESTATE

CENTRAL Florida developments. Trailer homesites; also lakefront and highway lots; acreage. No interest. From \$295.00. Terms. Victor Roepke, DeLand, Fla.

MR. Property Owner—Want a map of your property? Write Deed-Ettes, Mt. Pocono, Penna.

FREE Strout catalog! Farms, homes, businesses, resorts, retirement properties. Over 3000 values in 36 states. 58 years' service. World's largest! Write Strout Realty, 7-MP S. Dearborn, Chicago 3, Ill.

FLORIDA. Nice homesites. \$345 at \$10 monthly. Folder free. Howard Vernor, DeLand, Florida.

OZARKS! America's best place. Ten lovely timbered acres \$195. \$5.00 monthly. descriptions mailed free. Write: Armstrongs, Shook, Missouri.

CANADIAN Tax sale lands, average price five dollars an acre. Small monthly payments. Farms, timber, hunting and fishing camps, minerals. Limited number of properties. Write at once for free catalogue. Tax Sale Service, Room 105, 120 Bloor Street, West, Toronto 5, Canada.

FLORIDA—Silver Springs area. ¼ acre waterfront homesites. \$795.00, \$10.00 month. Free color photos. Write: Smith Lake Estates, Box 5681, Belleview, Florida.

OPPORTUNITIES! Government land, U. S., Alaska, Canada. Sledge Surveys, Macon, Mississippi.

GOVERNMENT Land available in booming California. Box 1106, Richmond, Calif.

FLORIDA Homesites \$395. No money down! Lovely 1/4 acre sites in Central Florida hills, lake, grove area \$395, no money down, \$10 a month. Suburb of Ocala, near Silver Springs. Streets, utilities, 22 mi. to Gulf Beaches. Fish, hunt. Invest or retire. Free color folder. Write Dept. 618-I Rainbow Park, Box 521, Ocala, Florida.

FLORIDA Lot bargain! Only \$149 full price! (for limited time.) No money down—\$5.00 per month. On U.S.#441-27 between Ocala and Orlando. High and dry. Hard surface streets, electricity, phones, schools, churches. 3000 fishing lakes closeby. Write for free photos. Dept. 214A, Orange Blossom Hills, Box 1222, Leesburg, Florida.

CANADIAN Vacation lands: \$285.00 full price, 40 acres, \$10.00 month. Suitable cottage sites, hunting, fishing, investment. Free information. Land Corporation, 130C Shaftesbury, Downsview, Ontario, Canada.

FLORIDA Security homesites, \$120, \$5.00 monthly. Warranty deeds. Thompson, Lecanto, Fla.

PICTURE BOOK rancho! Scenic Western Colorado, 80 acres, nestled close to the foot of majestic snow-capped mountains. See picture in catalog! 30 tillable acres, 30 irrigated, pasture will handle 25 cows, barb and woven fence. Located in the cool atmosphere of the Western Colorado Mesas, 2 1/2 mile town. Good 4-room electric lighted house, running water, phone. Good milk barn, hay barn, bunk house, cow shed, garage, granary, other buildings. Includes several shares in 2 different water companies. All for only \$8,450.00, half down! Free 160 page Spring catalog, 950 photos, bargains coast to coast. United Farm Agency, 2825-PM Main Street, Kansas City 41, Mo.

FLORIDA'S Sunnyland Village. Introductory sale. \$10.00 down-month. Water mains, paved streets. Under const. R.E.A. electricity. Write: Box 768, Dept. 4, Brooksville, Fla., AD 59075-1.

FARM MACHINERY AND SUPPLIES

CHAIN Saws. Popular brand. Discount prices. Taplin Co., 472 Bridge St., Springfield, Mass.

ELECTRIC Welders. New, heavy-duty, 180 amp. Free trial. Dealerships open. 20 year warranty. 8159 South Pleasant Department A1, Minneapolis 20, Minn.

GARDEN Tractor—Nationally known—now sold at discount. Eliminates all hand hoeing, also tills. Nothing like it. Patent 2742840. Discount catalogue free. Autohoe, DePere 68, Wis.

PROFITABLE OCCUPATIONS

INVESTIGATE Accidents—Earn \$125 week to start. Claim investigators are urgently needed to investigate more than 490,000 accidents daily. Work full time for insurance company, railroad, steamship line, or government office. Or step into your own profitable spare time business. No experience needed. Free book. Now! Universal Schools, CPM-4, Box 8227, Dallas 5, Texas.

EXTRAORDINARY Profits. Fabulous Aerosols. Sample, instructions. Two dollars. Janscott, Box 1291, Ashland, Kentucky.

WHOLESALE Magazine subscriptions. Highest commissions. Bonus. Qualified Agencies, 451KA Kingston, Brooklyn 25, N. Y.

APPLY Push-pull door decals. Prospects unlimited. Send \$1.00 for two samples and brochure. \$4.00 profit. Cordry, Nineveh, Indiana.

FREE Book "990" Successful, Little-Known Businesses." Work home! Plymouth-7X, Brooklyn 4, New York.

EARN Easy money! Home mail order! Write today! H. R., Box #72, Bath Street Station, Brooklyn, N. Y.

START A magazine subscription business. Earn generous commissions on Popular Mechanics, Good Housekeeping and all others. Best commissions, bonus, all materials sent free. No experience needed. Write Popular Mechanics, Room 4-P, 250 West 55th St., New York 19, N. Y.

MAKE Money making new greaseless doughnuts in kitchen. Sell stores. Free recipes. Michael, 3605 South 15th, Minneapolis 7, Minnesota.

BECOME Independent with your own franchise business. Thousands earning handsome incomes. Request interesting facts today. National Franchise Reports, PM-528, 333 North Michigan, Chicago 1.

BIG Money raising fishworms and crickets. Free literature. Carter Wormery, Plains, Georgia.

\$200 WEEKLY Extra introducing buyers to sellers, weekends. Men, women enjoy learning real estate by listening to records. First lecture free. Lee Institute, Brookline, Mass.

AUCTIONEERING—Home study course. Diploma granted. Auction School, Ft. Smith, Ark.

RAISE Pheasants on \$100 week plan. Little capital and space can make you independent. Free details. Great Central System, Columbus 1, Kansas.

VENDING Machines. No selling. Operate a route of coin machines and earn amazing profits. 32-page catalogue free. Parkway Machine Corporation, Dept. #25, 715 Ensor Street, Baltimore 2, Maryland.

GROW Mushrooms. Cellar, shed and outdoors. Spare, full time, year round. We pay \$4.50 lb. dried. We have 29,000 customers. Free book. Mushrooms, Dept. 99, 2954 Admiral Way, Seattle, Wash.

EARN \$240.00 A month at home, spare time doing only two \$5.00 invisible mending jobs a day. Big money paid for service that makes cuts, tears disappear from fabrics. Steady demand. Details free. Fabricon, 6236 Broadway, Chicago 40, Ill.

MAKE Flexible molds. Cast plaques, figurines. Free sample. Tooker, 1045-M Fairview, Hamilton, Ohio.

"FORMULA For Success" pamphlet \$1. Jayson, Box 41, Watertown, S. D.

FUR BEARING ANIMALS

NUTRIA, Lacosta, Brunett, fur samples dollar each. Hawkeye Nutria Farm, Kalona, Iowa.

MINK Raising information free. Complete. Lake Superior Mink Farm, Superior, EE1, Wisconsin.

BOOKS, PERIODICALS, PICTURES, POSTCARDS

BOOKS. If it is a book you want, write to us. You name it—we'll get it for you. Prices reasonable. Wallace Hill Books, Box 97, Malvern, Ark.

7000 GOOD Books 50% to 90% off! List free. Werewolf Bookshop, Verona 13, Penna.

SPACE Map 20x42 (colors) 10¢. Marino, 415 W. 44th, New York City 36.

WORLD Famed educational paperbacks. Lists free. Bookseller, 3121 South Racine, Chicago 8.

"HOW To" books. Many other fascinating subjects. Details free. Doran, 12-A Daffodil Lane, Wantagh, New York.

LOCATE Any book. No obligation. Aardvarks Search Service, Santee, Calif.

BOOKFINDING Our specialty. Try us. Babcock, 412 Lulu, Wichita 11, Kansas.

OUT-Of-print books at lowest prices! You name it, we find it! Fast service. No obligation. International Bookfinders, Box 3003-PM, Beverly Hills, Calif.

BRITISH Book bargains—Any subject. Catalogues free. Transatbooks, Wantagh, N. Y.

FREE Catalog. Self-help books. Write: Wilshire, 8721 Sunset, Los Angeles 46P.

BOOKFINDERS! All subjects. Send wants! Jaher Book Service, 183 Hazelwood Drive, Westbury, N. Y.

"SCIENCE Milestones." Records march of science starting 400 years before Christ, right up to date. Amazing facts revealed. 312 pages packed with startling information that will thrill you. A real history of science. \$5.00. Literature free. Popular Mechanics Press, 200-SM East Ontario St., Chicago 11, Ill.

NATIONAL Geographic magazines, 1888-1960, any issue. Periodical Service, Box 465-PM, Wilmington, Delaware.

GOOD Books. Huge stock. K. Gaisser, 1242 Broadway, Toledo 9, Ohio.

SPARETIME Repeat profits taking magazine subscriptions. Special offers. Cassell Agency, Boynton Beach, Florida.

CAMPING Maps, U. S. A." New guide book lists thousands of campsites, facilities in all 48 states. Authentic, 1960 edition. \$2.00. Books, Box 106, Highlands, N. C.

GAMES, TOYS, NOVELTIES

10¢ GRAB Bag toys ideal for P.T.A. or churches. 100 toys postpaid \$5.00. Free bazaar game instructions. Refundable. Monarch, 1331 14th St. N.W., Washington 5, D. C.

NEW! Play baseball with standard deck of 52 playing cards. Instructions 25¢. Flick, 814 Ross, Pittsburgh 21, Penna.

MAGIC TRICKS, PUZZLES, JOKER NOVELTIES

HOUSE Of 1000 mysteries! Professional magic! Pocket tricks! Jokers novelties! Two big catalogs combined into one giant dollar deluxe edition! 160 pages! 800 illustrations! 1000 surprises! Vick Lawston, 202(PM4C) Pinewood, Trumbull, Conn.

500 TRICKS, 1960 Edition Douglas 120-page catalog now available. Complete catalog—magic tricks and equipment. Just 10¢. World's fastest service. Douglas Magicland, Dept. A, Dallas, Texas.

MAGIC Trick, with catalog 25¢; catalog only 10¢. Lohmers, 825 Lima P-46, Burbank, Calif.

EXCLUSIVE Tricks! \$2.50 precision made vanishing coin for \$1.00 plus "Top Hat Topics" booklets. Lou Tannen, 120 West 42nd Street, New York 36, N. Y.

BE A magician! Large professional catalog of latest tricks, 35¢. Ireland, C-109 North Dearborn, Chicago 2, Illinois.

3100 NOVELTIES, Jokes, tricks, gadgets, funmakers, hobbies. Big catalog 10¢. Johnson-Smith, D-498, Detroit 7.

WORLD'S Finest professional magic. Joker novelties. Giant illustrated catalog 10¢. Top Hat, Evanston 12, Illinois.

PROFESSIONAL Catalog, 175 pages, 25¢. Williams, 900 Plymouth, Ellwood City, Penna.

CATALOG, Free trick, 25¢. (1,500,399 tricks, jokes). Magico, Box 4373-P, San Antonio 7, Texas.

3000 TRICKS, Pocket, parlor, stage. World's finest magic catalog (408 pages), \$2.50. Kanter's, M-1311 Walnut, Philadelphia 7.

COINS, TOKENS, CURRENCY

12 DIFFERENT Mexico \$1.25 postpaid. Dedmon, 1002 W. St. Charles, Brownsville, Texas.

WOW! Indian cent, foreign coin, bargain lists. 10¢. Hutchinson's, Box 4747, Philadelphia 34, Penna.

FOR Sale 1913S, 1924S, 1931P, 1932D, 1938S, 1939D cents. All six for \$2. Gasser, Box 34615, Los Angeles 34, California.

BRILLIANT Uncirculated United States five dollar gold pieces, \$15.00. Twenty dollar, fine, \$45.00. Rare Coin Company, 31 North Clark St., Chicago 2, Ill.

EIGHT Different Indian cents \$1.00. Collector's Bargains, New Hope, Penna.

FREE List! U. S. coins. Lowest prices! Hugh's Coins, Hickory, N. C.

NEW 1960 Giant U. S. coin catalogue 25¢. Ace, 107 N. Dearborn, Chicago 2.

COIN News Magazine, 35¢, subscription \$3.00 year. Dept. P, 231 North 18th, E. Orange, N. J.

NUMISMATICS Largest newspaper. Semi-monthly. Sample 25¢. \$2.00 yearly. Numismatic News, Box 452, Iola, Wis.

FREE Bonus offer! U. S. bargain list, 10¢ (refundable). Economy Sales Company, Mansfield, Massachusetts.

\$9,000.00 for 1913 Liberty Head nickel. We paid \$6,500.00 for one silver dollar, \$2,300.00 for one cent. Thousands of others we paid \$20.00 to \$1,400.00 each. Wanted certain dates: Cents before 1932—\$2,000.00; Nickels before 1940—\$275.00; Dimes before 1943—\$4,000.00. Canadian coins—1921 Nickel \$200.00, 1889 Dime \$250.00, 1875 Quarter \$75.00, 1921—50¢—\$1,000.00. Hundreds of others listed in our catalogue worth \$100.00 to \$25,000.00 each. For complete alloin information, before sending coins, purchase our large illustrated guaranteed Buying-Selling Catalogue \$1.00. Catalogue dollar refundable. Thousands of persons have sold us coins. Incorporated 1938. Worthycoin Corporation (K-488-C), Boston 8, Massachusetts.

SIXTEEN Page 1960 retail price list of USA and Canadian coins for 10¢. Our selling prices on thousands of coins and coin collectors' supplies. Bryson Incorporated, 612A White, Toledo 5, Ohio.

U.S. Coin list 10¢. Contains over 100 illustrations; 5,000 delightful bargains. Stoney, 260 Washington, Boston 8, Mass.

SPECIAL Old Morgan dime, quarter, half dollar, 28 page coin catalogue, \$2.00. Hobby Sales, Box 4054, St. Paul 16, Minn.

RAREST CC mint dollar, 1885 uncirculated \$10.00. Coin catalogue 50¢. Shultz, Salt Lake 10, Utah.

LARGEST Coin magazine. 200 pages, 50¢. Scrapbook, 7320-J Milwaukee, Chicago 31.

FOREIGN Coin, banknote and large illustrated coin list for 4¢ postage. Bargains: Indian head cent, 10¢; Wooden nickel, 10¢; Chinese dollar, 53¢. Approvals included with every order. Tatham Coin Company, Springfield 30, Massachusetts.

MEXICAN Silver pesos—11 for \$3.00. Douglas Stutes, Box 16-F, Killeen, Texas.

LINCOLNS 1909VDE, 1932, 1932D, 1933, 1939D, 25¢; 1911D, 1913D, 1933D, 45¢; 1910S, 1912D, 1913S, 1915S, 1922D, 1926S, 1931D, \$1.10. All \$9.00. United, 101 Cranston, Providence, R. I.

LINCOLNS, 40 Different 1909-1939, \$1.95. Harris, 1457 Moreno, Oceanside, Calif.

COINS From Formosa, Vatican, etc., plus foreign banknote, 10¢ with coin approvals. Littleton Coin Company, Littleton 51, New Hampshire.

I'M Buying coins! New higher prices! My confidential buying guide only \$1.00! Hubers, National Building, Minneapolis, Minnesota.

COIN Catalog, 72 pages, \$1.00. Listing, pricing, picturing, Canadian, Newfoundland, U.S. coins we buy. Philacoim, Regina 3, Canada.

GENUINE United States two dollar bills \$3.00. Jim Carter, Box 25, Buckley, Wash.

STARTER Collections. 15 Indian cents, \$2.50. 12 Liberty nickels \$2.50, 23 Mercury dimes, \$5.00, 15 Barbours quarters \$8.00, 15 Barbours halves, \$15.00. In folders. All different postpaid. Prager, 470 27th Avenue, San Francisco, Calif.

LINCOLN Cents: 1916-S-D, 1917-S-D, 1918-S-D, 1919-S-D, 1920-S-D, 1921-S, 1925-S-D, 1927-S-D, 1928-S-D, 1929-S-D, 1930-S, 1955-S. Only \$2.50. Berry, Box 306, Westminster, Calif.

RARE Unc. 1899-P silver dollar, each \$5.00. Butts, Box 889, Torrington, Wyo.

COIN Oddity. Lord's Prayer embossed on a penny, 2 for 35¢. Box 124, Mendota, Illinois.

BRILLIANT Proof sets—1957 \$3.95; 1958 \$8.95; 1959 \$4.50; 1960 \$2.95; Ghana \$10.50; Guernsey \$9.50; So. Africa \$6.95; Queen Elizabeth Coronation \$12.50. World coin book \$4.15; Guidebook \$1.75. World's greatest bargain catalogue \$1.00. (Deductible first \$10.00 order.) Bebee's, 4514 North 30th, Omaha 11, Nebraska.

FREE Uncirculated Mexican silver dollar with order three line rubber stamp and pad \$1.00. Barbara Baker, 3359 Cromart, Fort Worth 15, Texas.

JOHNSON Buys, sells large cents. 644 E. Valerio, Santa Barbara 3, Calif.

WANTED—All U. S. coins. Free list. Harlan Gates, 400 James, Syracuse, N. Y.

\$40-\$500 PAID For 59 circulating Lincoln pennies. Album, information \$1.25. SanRan Enterprises, Box 118, Colvin Station, Syracuse, New York.

HIGHEST Prices paid for all old or rare coins, banknotes. Complete buying catalogue \$1.00 (refunded with \$15.00 sale). International Coinbroker, Sackville, N.B., Canada.

STAMP COLLECTING

300 DIFFERENT Given free with approvals. Particulars. Windsor Stamps, 8834 Cornell Avenue, Chicago 17.

DAMAGED Old U.S. 1/2 catalog, on approval. K. Swartz, Malden Bridge, N. Y.

200 DIFFERENT Worldwide—50¢. Sam Ruggeri, 901-46th, Brooklyn 19, N. Y.

ALBUM! Hundreds of spaces! Only 10¢. Postpaid! Stampart, Hartford 1, Conn.

200 WORLDWIDE Different stamps 15¢. Approvals. A. H. Fehnel, 26 Easy Street, Colorado Springs, Colo.

300 DIFFERENT Given free with approvals. Particulars. Windsor Stamps, 8834 Cornell Avenue, Chicago 17.

100 DIFFERENT U.S.A.—50¢. Approvals. Utecht, 1143D North Keeler, Chicago 51.

105 DIFFERENT U.S. stamps 25¢. Approvals included. Shelron, Box 907-K, New York 8, N. Y.

FREE 400 Genuine postage stamps! Worth \$10.00 at catalogue prices. Africa, Europe, Asia, British Emp. A fascinating, valuable mixture from foreign convents, banks, etc. Who knows what you will find. Also, free helpful collectors handbooks. Adults only. Fine approvals enclosed. Frasek Co., PM, White Plains, N. Y.

SURPRISE Collection exotic mint British Colonial stamps absolutely free with approvals. Viking, Great Neck 8, N. Y.

U. S. Stamps. List free. Bredin, Turley Station, Tulsa 9, Okla.

YEMEN Flag stamps with Saudi Arabia and Iraq flags. Also Hospital stamp. Big multi-colored, unused, scarce stamps. Catalog \$1.80, 10¢ with approvals. Ozark Stamps, Spring Lake 2A, Michigan.

LARGE U.S. commemoratives, 115 different \$1.00, 200 different \$2.25. McCarley, 3315 E. Davison, Detroit 12, Michigan.

EUROPEAN Commemoratives, 10¢ with approvals. Schaefer, Californiastrasse 16, Wiesbaden, Germany.

FREE Hinges, Penny approval selection 1000 mounted 25¢. Page, Dept. M, Box 1129, Lumberton, N. C.

FROM Iceland, ten different pictorial sets, \$2.00. Brynjolfsson, Box 734, Reykjavik, Iceland.

100 FOREIGN, 20 U.S. commemoratives, 10¢. Approvals. Weckerling, 806G Orange, Weslaco, Texas.

SPECIAL Offer: 24 British Colonies stamps for 10¢ to approval applicants. Stamp Department, Valley Cover Service, Box 28, Harrisonburg, Virginia.

APPROVALS, Special: \$3.00 value—25¢ with request. Lakeside Stamps, Route 3 (235), Newburgh, N. Y.

500 MIXED U.S. 10¢. Wesley Rood, Box 285, Cedar Rapids, Iowa.

BREAKING Up, 45 year collection. Approvals. Terrific prices. Postage paid. Silvergate Stamps, Box 4003, San Diego 4, Calif.

WOW! 100 All different Germany 10¢. Zeppelins, semi-postals, airmails, high values, etc. Giant catalog, bargain lists included with beautiful approvals. Jamestown Stamp, Dept. A40PM, Jamestown, New York.

FREE! 25 Egypt, 5¢ handling. Approvals. Bellett, Mapledale, Hazel Park, Mich.

21,000 ALL Different stamps, yours for only pennies a day on our systematic payment plan. Details free. Sjoquist, 1435 Cherrydale, San Jose 25, California.

GIANT-Size issues collection: Laos elephant set, Brussels Fair, Olympic. Jet aircraft, Boy Scout, Small animals complete. Romania flags. Togo set, diamond popes. UN set, etc., plus big stamp dictionary and approvals. Everything 10¢! Stampex, Box 47-KM, White Plains, N. Y.

FREE. 250 Peelable hinges and 20 different Brazil with approvals. Jaydee, 218 Dickinson S.W., Grand Rapids 7, Mich.

FREE! \$1.00 Worth, your choice, from first selection. No strings! Adults only. Rush request now. Philatelics, Dept. RF, New Paltz, N. Y.

U.S. \$1, \$2, \$5. Special—10¢, with approvals. Stevens, Box 24, Bay Station, Brooklyn 35, New York.

PARTICULARY? Want unusual stamps on approval. Try Bayou Stamps, Box 4126, Pensacola, Florida.

150 DIFFERENT United States stamps, fabulous value only \$1.00. Free United States price list. Universal, Box 6, Kenosha 5-C, Wisconsin.

ENJOY Stamp collecting! Write for "Penny-provals." Penny-approval Service, New York Building, Saint Paul 1, Minn.

INTRODUCING Our better United States approvals we offer 15 United States stamps including Columbian, Bi-Centennials, famous American, airs, others; only 10¢. Ocean Stamps, Box 64-PM, Brooklyn 29, New York.

FREE Packet! Five different foreign countries. Request fascinating approvals. Coral, Box 7095 (Ludiam), Miami 55, Fla.

10 BEAUTIFUL Mint British Colonies 10¢ with approvals. Bennett, Candor 3, N. Y.

PENNY Approvals. Thousands. Bargains for pennies. Gifts with purchases. Penny Stamps, Orange, California.

UNITED Nations. Five different 10¢. Approvals. Anderson, 1112 Harrison, San Francisco 3, Calif.

TERRIFIC Value. Eight complete mint sets 10¢ with approvals. Beatties, 58 Glenagar, Islington, Ontario, Canada.

25 DIFFERENT Commemoratives 1893 up 10¢. U. S. approvals. K&B, Box 70, Brooklyn 23, N. Y.

FREE Sample! Interesting, informative, illustrated. National Stamp News, Anderson, South Carolina.

FREE 50 Worldwide, mailed with inexpensive approvals. University Stamps, P.O. Box 95, Tamiami Station, Miami 44, Florida.

TRADE Your duplicates toward our approvals! (Foreign only.) Complete information, 10¢. Variety Stamps, Box 98-P, Newton Highlands 61, Mass.

307 WORLDWIDE Different stamps only 25¢. Approvals. Niagastamp, St. Catharines 671, Ontario.

MINT U.S. at face! Older commemoratives only. Send 25¢ for all different packet with first selection mint U.S. approvals. Western, Box 1689P, Salinas, California.

1000 DIFFERENT Worldwide stamps \$1.00. Valued over \$20.00. Universal, Box 6, Kenosha 5, Wisconsin.

60 DIFFERENT U. S. (30 commemoratives) 25¢. No approvals. Seidenberg, Appleton, Wisconsin.

GIANT Approvals, thousands different, 1¢ and 2¢ each. Wahl's Stamp Exchange, 7008P Farragut, Chicago 31, Ill.

UNITED States commemorative collection containing 33 different—10¢. Approvals. White, 516-A Avenue L, Brooklyn 30, New York.

SELL Your surplus good grade stamps. Write, describing fully what you have. Vanroy Shirk, Lebanon, Pennsylvania.

AMAZING OFFER! 200 United States stamps— including commemoratives, airmails, high denominations to \$1.00. Only 10¢ to approval applicants! Illustrated bargain lists free. Mystic Stamp Co., Dept. 80, Camden, New York.

100 STAMPS, 10¢ With approvals. Smith, 508A Brooks, College Station, Texas.

OLD Scarce U.S. seconds on approvals. Slight imperfections, lowest prices. Hernefeld, Clintonhill Sta., Newark 8, N. J.

100 OLD United States between 1861 and 1935, \$1.00. Roush Stamps, 51 Chestnut, Mansfield, Ohio.

225 STAMPS For only 10¢! This mammoth value includes airmails, pictorials; stamps from strange countries cataloging up to 25¢ each! Also approvals. Mystic Stamp Company, Camden 80, New York.

UNITED States price list, 116 pages, price 25¢. Mark Hanna, 335 Fifth Ave., Pittsburgh 22, Penna.

SELL Stamps to our readers. Your ad in this space will be read by thousands of stamp buyers. I'll prove that to you. Write now for Folder "S." F. W. Johnson, Classified Advertising Manager, Popular Mechanics, 200 E. Ontario St., Chicago 11, Ill.

14,000 DIFFERENT! Amazing new plan builds your collection systematically, country by country. Only 50¢ weekly. Free details. L. G. Ware, Stepney 75, Conn.

U. S. Mint flag set, complete, \$1.00. Free list. Brooks, 2323 Avenue X, Brooklyn 35, New York.

103 DIVERSIFIED British colony stamps only 10¢. Approvals. Niagastamp, St. Catharines 671-A, Ontario.

102 DIVERSIFIED Worldwide stamps 10¢. Approvals. Linstamp, St. Catharines 618, Ontario.

PENNY Approvals! Regardless catalogue! Kloster, 4164-52nd St., San Diego 5, Calif.

25 DIFFERENT Large American commemoratives 10¢. With approvals. Linstamp, St. Catharines 618-A, Ontario.

INTERESTING Worldwide animal stamp collection 10¢. With approvals. Niagastamp, St. Catharines 671-B, Ontario.

ECONOMICAL 1/2¢-3¢ Approvals, 33,000 varieties. Dresel, Box 128-N, West Englewood, New Jersey.

105 BRITISH Colony stamps, all different 10¢. Approvals. Crown Stamp Company, 901, Virgil, Ontario.

50 DIFFERENT Stamps free! Approvals. Marford, Box 48, Queens Village 29, New York.

FREE! Liberia airmail triangle, diamond, midget, mammoth to approval buyers. Plymouth, Dept. A-8, Bell, California.

STAMP Collecting outfit. Includes packet worldwide stamps, package hinges, watermark detector, millimeter gauge. Everything 10¢ with approvals. Loraine Brown, Marion, Michigan.

SUPERIOR Worldwide mission mixture. Amazing variety! Six ounces \$1.65. Pound \$3.95. Bay Nielsen, 4545B Harvard, Montreal 28, Canada.

100 DIFFERENT Belgium free. UPU. Brussels Fair, railroad stamps free. Approval applicants only. Trylon, Box 31-P, Brooklyn 30, N. Y.

U.S. Illustrated list free. Big irresistible discounts. National, Box 60, Boston 1, Mass.

LOOK! Six Queen Elizabeth mint sets from Singapore, Tristan, Malacca, Malta, Antigua, Caymans! 21 brilliant pictorials, 25¢. Attractive approvals. Gannon Stamps, Box 931, Canton 1, Ohio.

MOONE Rocket including 111 different stamps, 10¢ with approvals. Finney, Box 89, El Monte, Calif.

FINE U.S. stamps, \$5.00 Coolidge of the 1938 Presidential series, and the \$5.00 Hamilton of the 1954 series. Both for only \$1.00. Fine U.S. approvals included. Willett Co., P.O. Box 338, Dept. 45, Yorktown Heights, N. Y.

BIG U.S. price list free! Bailey, 45-G Bromfield, Boston, Mass.

FREE! Over 100 different, \$2.50 value, including space satellite, Israel, British, U.S., first U.N., Siberia. Approvals. Send 25¢ for mailing. Horace Gatewood, Winston-Salem, N. C.

508 DIFFERENT World-wide from Formosa, Morocco, Indonesia, etc., cataloging over \$15.00, only 35¢. Offer to adults only. Approvals. Littleton Stamp Company, Littleton Q1, New Hampshire.

FREE! Set of seven Nigerian stamps with approvals. Fire Island Stamp Company, Box 37A, West Islip, New York.

FREE! 50 Different. Approvals. Ehrlich's, 426 Jefferson St. N. E., Washington 11, D. C.

FREE Any volume Scott's International albums, Scott's 1960 catalogues, even master Global Albums free, when you buy our sensational foreign approvals. Bargain Stamps, Redlands 2, California.

FREE Monaco nudes. Hurry. Stamp Ranch, 902 Addison, Chicago 13, Ill.

1002 DIFFERENT Worldwide for approval buyers only. Jacobsen, Crompond, N. Y.

50 CHINA 10¢. Approvals, gifts. Coast, P.O. 2187A, Santa Ana, California.

BONANZA! 100 Different pictorials, mostly large, 20¢. Approvals. Curran Stamps, 16 Curran, Whitesboro, N. Y.

F. D. C. Collectors! Subscribe to our foreign mailed direct service. Watch your collection grow. Brumsey, 2418 First, Ft. Myers, Fla.

MAKE Money with stamps! Outstanding profits possible! Free Information! Adults Only! Columbia 9268-MT Piney Branch Road, Silver Spring, Maryland.

ADULTS! Like stamps? Then start your own mail-order business. Our free Guidance Program shows you exactly what to do, makes it easy, profitable for you. Details free! Columbia, 9268-MP Piney Branch Road, Silver Spring, Maryland.

FREE! Giant bargain catalog. New edition listing thousands of bargains including U.S. and B.N.A. stamps, packets, mixtures, albums, accessories and supplies; sent with beautiful approvals. Jamestown Stamp, Dept. E40PM, Jamestown, New York.

U.S. Stamps. Giant discount catalog—20¢. Raymax, 37-VZ Maiden Lane, NYC 38.

VATICAN Coronation souvenir — Pope John XXIII card and 10 attractive stamps in protective plastic folder. Story of Vatican and coronation on reverse. A beautiful addition to any collection. 25¢ with approvals. Capital Stamp Co., Ferrysburg 2B, Mich.

GIGANTIC Collection free. Includes triangles, early United States, animals, commemoratives, British Colonies, high value pictorials, etc. Complete collection plus big illustrated magazine all free. Send 5¢ for postage. Gray Stamp Company, Dept. PM, Toronto, Canada.

CANADA Commemoratives. Fifty all different. One dollar. Interesting old cover free if approvals requested. Suburban Stamps, Box 481, Thistleton, Ont.

100 WORLD 10¢. Approvals accompany. Robert Arthur, 920 Third, Seattle 4, Wash.

AIRMAIL Collection: Many countries complete sets. Approvals. Rush dime. Each different. Boger, Box 152, North Wales, Penna.

ONE Pound mixture 50 countries. \$3.50 postpaid. No approvals. Phillippi, Box 551, Bloomington, Indiana.

FREE! Triangles, pictorials, others. 55 different, colorful, unusual approvals. Baird-Stamps, Box 8113, Portland 7, Ore.

LOOK It's different. Packet worldwide pictorials identified ready for album. One dollar. Langfords, 53 Durham Road, San Anselmo, Calif.

1 TO 3 Cent approvals in envelopes. Schnoeblen, Columbiana, Ohio.

50 FREE. Approvals, Adults, Patton's Stamps, 660 Cal., Boulder City, Nev.

WASHINGTON Bicentennial complete, 25¢ with approvals. Superior Stamps, Dept. 44, Box 53, Cathedral Station, New York 25, N. Y.

DIAMOND, Timor, topicals, others, 44 different 10¢, approvals. Carpenter, P.O. Box 310, Claremont, Calif.

MACAO! 20 Exotic beauties 10¢. Bargain approvals. Cork, Box 4934, Midland, Tex.

UNITED Nations. 12 different stationery. \$2. Rare 2¢. Postcard free. Approvals. Teddie, Crystal Beach, Florida.

SPRING Offer. 1100 worldwide stamps \$1.00. Guaranteed. Harrison's Stamps, 1435-First Ave., Oakland 6, Calif.

CANADIANA Stamp club. \$2.00 membership. Bulletin, gifts, exchange. Box 551, Lethbridge, Alberta, Canada.

STAMPS Wanted. Buying lists 20¢. Ormonde Doyle, Box 5, Independence, Mo.

25 AUSTRALIAN Commemoratives 10¢. Approvals. Binkowski, 944 Park, Schenectady, New York.

FREE Surprise mystery packet. Premiums. Approvals. Dancer, 75-P9, Mansfield, Ohio.

INDIA 50 Different 10¢. Complete Somali animal set free with approvals. Penn, P.O. Box 303, Philadelphia 5, Penna.

90,000 STAMPS Sale: Terrific bargain lots hundreds of stamps \$1. Giant assortment better stamps \$5. High value packet \$3. Persile, 436 N. Y. Ave., Brooklyn 25, N. Y.

115 UNUSUAL Including \$1 U.S., jets, \$2 helicopter, Pope diamond, sputnik, Ghana, Israel, U.A.R., Vatican. 10¢ with approvals. Rosen, 238M-8th Ave., Paterson 4, N. J.

COUNTRY Collection 10¢ handling. Sherman, 6728 N. Talman, Chicago 45, Ill.

FREE! Monaco wedding set. (Grace Kelly) 4¢ postage. Approvals. Universal, Box 6, Kenosha 5-F, Wisconsin.

STUNNING: Three unusual foreign sets, only 10¢ handling. Beautiful foreign approvals accompany. Craghead, 4817H Mac-cot Avenue, Sacramento 20, California.

NO Approvals. 115 different colorful stamps 25¢. Continental, Box 1553, Washington 13, D. C.

CHOICE U.S.A.! 50 different commemoratives, 25¢. Approvals. Carrling's, Howard City, Michigan.

SWEDEN—100 Different, 25¢! Inexpensive approvals. Carling, Howard City 4, Michigan.

109 SURPRISING, Asia, Africa, Americas 20¢. Approvals. Bristol's, Canton Center, Conn.

FREE! Five different packets. Adult approval applicants. Norge, Ho-Ho-Kus, N. J.

SPACE Age collection, etc., 100 different 10¢. Approvals. Stanley McCall, 12316 E. San Bernardino Rd., El Monte, Calif.

FREE! Afghanistan, Bahawalpur, Negri-semblan, Tanganyika, Thailand. Inexpensive approvals accompany. Nade's, 6316 Crescentville, Philadelphia 20, Penna.

UNITED States approvals. Select copies, used—mint. Kingsbury, Groton 1, Vt.

TIPEX, S.P.A., Cipep, Fipep. Complete set of four fine mint U.S. sheets. \$1.50. Knowlton, 49 Aborn, Wakefield, Mass.

STAMP Grabs 50¢. Three for \$1.00. Lore Company, Dedham, Mass.

SWISS Set free with popular approvals. Meredith Atkins, Sumner, Illinois.

AMAZING Pricelist. Cheapest packets on market! 10¢. Niekerk, Tottenham, Ontario.

FREE Sets \$1.00 value, discounted approvals. Bonus. Francis Lemle, Box 5646, Norfolk 16, Va.

CANADA—50 Different. To serious approval applicants 25¢. Fundy Stamps, Box 431, Saint John, N.B.

PACKETS—Collections. Large list free. Allcom Co., 667 Madison, New York City.

40,000 FOREIGN Stamps! 2¢ each! Request thrilling approvals! ABC, Box 849-AM, San Francisco 1, California.

ZOWIE. 100 Different US—25¢, with U.S. approvals. Price lists. Stamps, Kennebunk, Maine.

YEMEN UPU set free with approvals. W-B Stamps, Wilkes-Barre, Penna.

1010 DIFFERENT World wide, stamps from over 40 countries, only \$1.00. CK Stamp Co., 6912 Sheridan Road, Kenosha, Wisconsin.

ANTIQUES, RELICS, INDIAN GOODS, CURIOS

ANCIENT Grooved stone tomahawk \$3.00. Indian relic list free. Lear's, Glenwood, Arkansas.

4 ARROWHEADS \$1.00. List. Smith, 841 N. Tacoma, Indianapolis 1, Indiana.

10 ANCIENT Stone arrowheads, \$2.00. Stan's, 1054 Lilley, Columbus 6, Ohio.

SCALPING Knife, spearhead, thunderbird \$4.00. Catalog free. Arrowhead, Glenwood, Arkansas.

PRECIOUS STONES, MINERALS

INDIA Importer has crystal and gem specimens for rock collectors; uncut; this material not perfect enough for gems, but will greatly enhance your collection. India star rubies from 75¢ to \$1.25. Moonstones 65¢ to \$1.00. E. D. Skinner, Box 4252, Station K, Milwaukee 10, Wis.

"TREASURE Map of Mojave Desert," gems, minerals, recreation. 21"x33" \$1.00 postpaid. Gemac, 808A, Mentone, Calif.

FREE Bargain gem list. Lapidary and silversmith catalog. 56 pages, 25¢. O'Brien's, 1116M Wilcox, Hollywood 38, Calif.

"GEMS & Minerals Magazine," largest rock hobby monthly. Field trips, "how" articles, pictures, ads. \$3.00 year. Sample 25¢. Box 687A, Mentone, California.

SEMI-Precious uncut gems. Ten different for \$1.00. Request list 26. Prospectors Shop, 201 San Francisco, Santa Fe, New Mexico.

EARTH Science, the rockhounds national magazine. Subscription \$2.00. Sample 35¢. Box 1357-PM, Chicago 90, Ill.

ROCKHOUNDS, Gem cutters, jewelry makers. New free catalog, just off the press! Biggest suppliers to hobbyists and craftsmen offers you tools, materials, equipment, introductory bargains and know-how. Free catalog. Write Grieger's, Dept. C-12, 1633 E. Walnut, Pasadena, California.

WESTERN Minerals carefully labeled, mounted: 24, \$1.50; 50, \$3.00; 100, \$6.00. Scott's Mineral Box Industries, Box 767, Custer, So. Dak.

PROSPECTORS! Learn from experienced geologists how to locate and identify rocks and minerals. A comprehensive home study course designed for anyone interested in exploring for valuable ore deposits. Write now for free literature. Pacific School of Mines, Dept. B4, Box 2538, Palm Springs, Calif.

ROCKHOUNDS, Adventurous vacationers. Dig diamonds, gold, rubies. Mines open to public. Booklet tells where. 25¢. Diggins, 1848 Oakland, Ft. Worth, Texas.

HOBBIES AND COLLECTIONS

SHELLS 100 Assorted for beginners \$1.00 postpaid. Varble, Harlingen, Texas.

NOVEL Pecos diamond \$1.00. Indian artifacts. Petrified wood. Details 10¢ refunded with order. Glenn Carson, Ft. Sumner, N. M.

ARMOR, Swords, daggers, illustrated list 10¢. Cavalier, Box 57, Middle Village 79, N. Y.

COLLECT Military medals: Medal of Honor, \$1.50; Silver Star, 50¢; Air Medal, 50¢; Bronze Star, 50¢. American and Foreign Catalog, 25¢ each. Hobbies, Box 71-M, Rockaway 94, N. Y.

FREE Purple Heart when ordering 40 new U.S. military shoulder patches, ribbons. Postpaid \$1.00. N. Kimmel, 10436 Cheviot Dr., Los Angeles 64, California.

MINIATURE Tools—They actually work. Less than 1 1/4 inch long. Excellent craftsmanship; metal; well designed; gilt plated. Pocket knife; shears; nutcracker; pliers; tin snips; also, screwdriver. 30 tools \$1.100 tools \$2.75, postpaid. Hansens, Inc., 2721 East 11th Street, Oakland 1, Calif.

COLLECTORS Matchbook covers. 100 different unused. \$1.00. Catalog 25¢. Album \$3.00. Charles Edelman, 1311-C East 84, Cleveland 3, Ohio.

PHOTOGRAPHY, CAMERAS, PHOTO SUPPLIES

164 PAGE Photographic bargain catalog, listing thousands of photographic bargains. Send 25¢ for your copy, credited on first order. Dept. 1-C4, Central Camera Company, 230 So. Wabash Ave., Chicago 4, Illinois.

KODAK 8mm Electric-eye zoom \$93.50 (regularly \$139.50). Discount prices, name brands. Free catalog. Mailers Mart, Box 135-PM, Pelham, New York.

EARN \$3.00 Per hour with a Polaroid camera. Proved method. Details \$1.00. Roy Vaughn, Anton, Colo.

PHOTO FINISHING

SAVE On photo service. Kodacolor 8 exposure roll—\$2.50. 12 exposure—\$3.50. Reprints 25¢. Black and white 8—50¢. 12—70¢. Reprints—5¢. Fast Kodachrome, Ektachrome and Anscochrome processing. Free mailers and price list. Save on: Photo Service, Box 50, Watertown, Wis.

INTRODUCTORY Special. Processing Kodachrome 8mm movie or 35mm 20 exp. \$1.00. Kodacolor 8 exp. complete \$2.00; 12 exp. \$3.00. Black and white 8 jumbos 40¢. Jumbo reprints 5¢. Quality guaranteed. Prompt service. Write for free mailers. Fast-X-Photo, Dept. PM, Box 7A, Jersey City, N. J.

BEAUTIFULLY Colored 8x10 enlargements \$1.00. Send negative or any photo. Dick's Photo, Louisville 12, Ky.

ENLARGEMENTS! 4x5 10¢; 5x7 30¢. Elba Photo, Box 387F, Jackson Heights 72, N. Y.

ENLARGEMENTS! One 8x10, two 5x7, four 4x5 from one negative, \$1.00. Daniel Hillard, Frankfort, Ky.

FREE Film kodacolor, kodachrome, black-white. Details. Write: Mail Film, Box 338, Bradley Beach, New Jersey.

50 WALLET Size pictures, 2 1/2 x 3 1/2. Name on each, \$2.00. Send snapshot. No C.O.D. Carolina, 719 Mangum, Durham, N. C.

SUPERIOR Enlarged prints with this ad. 8 ex. roll 30¢. 12 ex. roll 50¢. Post-L-Pix, Box 1, Worcester, Massachusetts.

FILMS—Developed and printed 50¢—127, 620, 120 film. Color film developed and printed, save 25 to 33 1/3 discount on all color work. World's finest quality. Send for mailers—price list. Apex Photo, Box 511, Paoli, Penna.

FREE! Kodak film for life. New Kodak film for every roll you send to develop. Jumbo size. Black and white: 8 exp. 80¢; 12 exp. \$1.05. Kodacolor: 8 exp. \$3.50, 12 exp. \$4.50. Send for price catalog for more savings. Satisfaction guaranteed. Yankee Photo Service, Box 1820-PM, Bridgeport 1, Conn.

A Triple value. Quality, price, service. Color or black and white, 12 exp. (black and white) 59¢. 20 gift photos \$1.00. Holiday Photos, Dept. 16, Box 666, Denver, Colo.

A 3-In-1 value. Price, quality, service. 20 gift photos, \$1.00. 12 exposure rolls (black and white), 59¢. Color or black and white. Interstate Photos, Dept. 11, Box 15, Aurora, Ill.

KODACHROME Processing by Kodak. 8mm. roll or 35mm., 20 exp., \$1.40. Prompt service. Write for mailers and prices. Color Pix, Dept. P, CPO Box 30, Kingston, N. Y.

TWELVE Exposure rolls 49¢. Wallets 20 for \$1.00. Lincoln Studios, Dept. K, Box 13, Lincoln, Nebr.

ENLARGEMENTS, Heavyweight, six 5x7's or three 8x10's \$1.00. Jack Koons, Huntington Mills, Penna.

MOTION PICTURES AND SOUND EQUIPMENT

FREE Every month. Blackhawk's newspaper-size catalog 8mm., 16mm. movies, 2"x2" color slides. Biggest selection in USA. Bargains in used 16mm. sound films, projectors. Blackhawk Films, Davenport 14, Iowa.

ROSE Parade, 1960, color movies, 8mm 50' \$4.95. Complete parade 200' \$17.50. 12 35mm color slides \$2.75. Send check or M.O.: Rose Parade Movies, Box 10-A, Van Nuys, Calif.

EARN Money daily with 8mm-16mm projectors! Copyrighted plan! \$1.25 postpaid! B. Metcalf, 10806 Glenroy, Chicago 43.

8MM Movies, 50', comedies, cartoons, travel, airplanes, hunting, fishing. Limited offer. Send \$1.00 each. MovieLand, Box 10-M, Van Nuys, Calif.

CARTOON Title movies add fun to your films. Large list 8mm, 16mm covers every situation. Free. Cartoon Movies, 105 Washington St., Boston 8, Mass.

5,000 8-16MM. Movie films. Free catalogues. International, Greenvale, N. Y.

MOVIE Camera film: 8mm. roll \$1.50. 16mm. 100' \$3.00. Free processing. Better Films, 742 New Lots, Brooklyn, N. Y.

16MM. Sound shorts. Tremendous assortment features. \$16.50 up. Used 16 mm. sound projectors, \$79.50 up. Catalog. Abbe Films, 417 West 44th Street, New York City 36.

16MM. Sound films. Bargain bulletin. Duquette, 97-T Snow, Fitchburg, Mass.

MOVIE Film! Free catalog! ESO-R, 47th Holly, Kansas City 12, Missouri.

16MM. Sound, projectors, films. Sale, rental, exchange. Visit store or write for catalog. National Cinema, 71 Dey St., New York City.

10¢ BRINGS Big new cine manual for the 8mm-16mm. movie maker. Save money on film and color movie film, all camera equipment. Superior, 448

SPECIAL Entertainment—8 mm. b&w. 50 feet \$12.00. 16 mm., b&w, 100 feet \$20.00. Tex, Box 368, Terminal A, Toronto, Canada.

ADD Sound to 8mm. movies. Write: Phototronic, Fort Atkinson, Wis.

16 MM. Sound—8mm. Sale, rental. Entertainment Films, 2021 Broadway, New York City.

BARGAINS 16MM sound features shorts. Bedner, 5300 So. Talman, Chicago.

KODACHROME 8MM. Featurettes, gag stockshots, pictorial titles. Projection sampler \$1.00. Specify interest: cartoons, glamour, foreign varieties, travel. Rose Parade closeout, 50' \$4.95. Dixie Enterprises, P.O. Box 42177, Los Angeles 42, Calif.

COLOR SLIDES

700 TITLE Slide selections. Sample title plus illustrated list 25¢. Title-Color, Dept. T4, 3618 Marsh Lane Place, Dallas 20, Texas.

MISS America slides. Twenty 2x2 color slides \$5.00. Free brochure. Box 117, Atlantic City, N. J.

LINCOLN Story, complete in 500 color slides. Catalogue and sample, 35¢. Willems, Box 1515-A, Chicago 90.

TRANSPARENCIES Wanted. Up to \$500.00 each. For information write: American Color, Box 38391, Hollywood 38, California.

COLOR Slides of American beauties. Listings. Slides, Box 384, Chicago 90, Ill.

MUSIC & MUSICAL INSTRUMENTS

VIOLIN Makers supplies. Free catalog. 309 W. Fourth, Los Angeles 13.

ACCORDIONS—1960 Models. Lowest discount prices. Save up to 50%. Free home trial. Trades accepted. Big color catalog free. Accordion Manufacturers, Dept. 40-R, 2003 Chicago, Chicago 22.

PORTABLE Chord organs from distributor. Save. Sixty chords only. Free information. Libro Music Center, 591-593 Chapel St., New Haven, Conn.

SONG Poems wanted. Free examination. Send poems. McNeil, Master of Music, 1112 PM Wilshire, Santa Monica, Calif.

PROFESSIONAL Services for amateur songwriters. Colonna Enterprises, Box 888, Burbank 1, Calif.

SONGS Recorded! Four musicians-vocalist. \$19.95 postpaid. William Lash, Box 5024, North Hollywood, California.

ELECTRIC Guitars, amplifiers, wholesale. Free catalog. Carvin, PMM, Covina, Calif.

SONGWRITERS, With publisher contacts, want song ideas. Share royalties. No fees. Send poems: Songwriters' Associates, 1650 Broadway, New York City 19-G.

SONGPOEMS And lyrics wanted. Mail to: TinPan Alley, Inc., 1650 Broadway, New York 19, N. Y.

POEMS Wanted for musical setting and recording. Send poems. Free examination. Crown Music Company, 49-C West 32 Street, New York 1.

SONGS Into dollars. Share \$33 million dollars yearly for new songwriters, song poets. Any subject, songs composed, published, promoted by largest firm. Information, appraisal free. Send Nordyke Music Publishers, 6000 Sunset, Hollywood 28 PM, California.

POEMS Wanted for musical setting and recording by America's largest song studio. Send poems. Free examination. Five Star Music Masters, 630 Beacon Building, Boston.

POEMS Needed immediately for new songs and records. Free examination and appraisal. Send poems: Songcrafters, Acklen Station, Nashville, Tenn.

POEMS Wanted! Best songs recorded free with 7-piece orchestra. Melodies written. Send poems, free examination. Songmakers, 1472-M Broadway, New York 36.

GUITAR Making books, plans, imported woods, tools. List 10¢. Satinwood, 510 East 11th Street, New York 9, N. Y.

SWISS Musical movements. \$1.90. Helax, 218 W. 72nd St., New York City 23.

RADIO, TELEVISION AND ELECTRONICS

RADIO Power increased. No electrical connections. Booster \$4.95 prepaid. Build crystal sets that bring amazing results. Design manual \$1.00. Meeker, 5251 Stockwell, Lincoln 6, Nebraska.

WANTED, Small manufacturers: Aggressive industrial development corporation in Iowa community, prepared to assist small manufacturer anxious to grow. Contact: W. E. Petersen, President, Building Corporation, Harlan, Iowa.

DUST May affect television performance. Clean vital parts quickly, safely. New device attaches to your vacuum cleaner. \$1.95. MacLaughlan, 345 Sip, Jersey City 6, N. J.

AMPEX Tape recorders. Components. Boynton Studio, 10-PM Pennsylvania, Tuckahoe, N. Y.

TUBES — TV, radio, transmitting, special purpose types. Bought, sold, exchanged. Unused only. Send details to Barry Electronics Corp., 512 Broadway, Dept. PM, New York 12, N. Y.

CASH For used short-wave ham receivers, transmitters and accessories. Treger, W91VJ, 2023 N. Harlem Ave., Chicago 33, Texedo 9-6429.

FREE! Giant wholesale catalog on electronics, hi-fi, transistor, scientific, hobby, optics, photographic, housewares, jewelry, tools, novelties, toys. Write: Lektron, 131M Everett Ave., Chelsea 50, Mass.

TAPE Recorders, Hi-Fi components, sleep learning equipment, tapes. Unusual values. Free catalog. Dressner, 69-02M, 174 St., Flushing 65, N. Y.

LEARN While asleep with amazing "Electronic Educator" endless tape recorder. Details free. Research Association, Box 24-N, Olympia, Washington.

GOVERNMENT Surplus radios, parts. Picture catalog 10¢. Meshna, Malden 48, Mass.

ELECTRIC Guitars, amplifiers, wholesale. Free catalog. Carvin, PMR, Covina, Calif.

RADIO And TV tubes at manufacturers' prices! 100% guaranteed! Brand new! No re-brands or pulls! United Radio, Box 1000, Newark, N. J.

RECORDERS, Hi-Fi. Free wholesale catalogue. Carston, 125-PM E. 88, New York City 28.

SOUNDLESS Television commercials with my ingenious device. \$3.25. Picture stays on. Moneyback guarantee. Voice Control, 234 Monroe St., Passaic, New Jersey. Patent Pending.

CRYSTAL Radio kit \$1.00; preassembled \$1.25; phone \$1.75; catalogue. Clearco Crystal Co., 2966 N. 4th, Milwaukee 12, Wisconsin.

BUSINESS OPPORTUNITIES

MAILORDER Beginners no cost plan. Details for stamp. Armstrong's, 154A Darrington S.W., Washington 24, D. C.

OPERATE Home mail-order business. Vosacek Printing, 4444A1 Ute, San Diego 17, Calif.

MARKETS Everywhere. Make artistic concrete birdbaths, pottery. Best coloring. Home workshop. Hundred varieties. Hollywood Cementcraft, 8527-S Wonderland, Hollywood 46, California.

CAN You qualify? Selected men. We help establish floor refinishing business. Complete program. Tool Rental, 3602 California, St Louis 18, Missouri.

CO-PUBLISH "Home Business Digest." Free details! GPO, Box 972-po, New York 1.

12 SPINNING Lures. None better. \$11.00 value. All different. Send \$3.00. Quaker, 438 Sedgley, Philadelphia 40, Penna.

INTERNATIONAL Mailorder business made easy. Individual setup service. Not just instructions. Hermes, 152 West 42, New York City 36.

LEARN Sewing machine repairing. To \$125 weekly. Sparetime. Supplies. Add to present business. Write today! Taylor Service, Box 2126, San Bernardino, Calif.

EARN \$10,000 Yearly raising Angora rabbit wool for us. Information 25¢ coin. American Angora Company, Malta 77, Montana.

MAIL Trade magazine has moneymaking opportunities galore. Sample 25¢. Donovan, 79-PM Greenbelt, Levittown, New York.

FRANCHISES Make profits! Operate your own independent franchised business as distributor, dealer or agency owner. Nationwide opportunities. National Franchise Reports is the recognized source for information regarding the booming franchise field. Write today for interesting free details of this helpful service. National Franchise Reports, W-528, 333 North Michigan, Chicago 1.

FREE Picture folder, "How to Make \$3,000 Yearly, Sparetime, Backyard, Raising Earthworms!" Oakhaven-38, Cedar Hill, Texas.

VENDING Machines. No selling. Operate a route of coin machines and earn amazing profits. 32-page catalogue free. Parkway Machine Corporation, Dept. #27, 715 Ensor Street, Baltimore 2, Maryland.

SELL Books by mail. 400% profit. Royal, Box 368-X, Cleveland 27, Ohio.

PLASTERCRAFT Molds, liquid rubber, plasters, flocks, candle supplies. Catalog and manual free. Blue Rapids Supply, Blue Rapids, Kansas.

BIG Money raising fishworms and crickets. Free literature. Carter Farms, Plains, Georgia.

OPERATE Mailorder folio business. Free details. Ballard's, 1834 Edgeland, Louisville 4, Ky.

FREE! Name brands catalog! Your own high profit business. Sell name brands, full or part time. No inventory, no investment. More than 2,000 name brand items; lowest wholesale prices. Watches, jewelry, cameras, hi-fi, stereo radios-phonos, appliances, housewares, hardware, power tools, luggage, musical instruments, garden equipment, sporting goods, toys, many others. 8 floors of name brands. Million dollar inventory. Orders shipped complete in 24 hours! Send for free, beautifully illustrated catalog now! Separate wholesale price list. H. B. Davis Corp., Dept. 11, 145 W. 15 St., New York 11, N. Y.

IF You like motorcycles and money then send for Harley-Davidson dealership book on how to become a franchised dealer of motorcycles and a new line of motor-scooters. Here's a chance to own your own business with a very modest investment. The youth market is beginning to explode and the next few years promise a chance to cash in on it. Write for free illustrated dealership book today. Harley-Davidson Motor Company, Dept. P, Milwaukee 1, Wisconsin.

BUSINESSES, Resorts, motels, investment property, ranches. Our special service dept. at your disposal. No obligation. World's largest, 58 years' service. Strout Realty, 7-MB S. Dearborn, Chicago 3, Ill.

TO \$100.00 Weekly. Sparetime, home operated mailorder business. Successful beginner's plan. Everything supplied. Lynn, 10420-M National, Los Angeles 34.

PIANO Tuning learned quickly at home. Tremendous field! Musical knowledge unnecessary. Information free. Empire School of Piano Tuning, Champaign, Ill. (Founded 1935).

WANT To make big money at home? \$10.00 profit in an hour possible with invisible mending. Make tears, holes, disappear from clothing, fabrics. Steady year-round demand from cleaners, laundries, homes. Details free. Fabricon, 6234 Broadway, Chicago 40, Illinois.

\$70 WEEKLY—Home, spare time. Simplified mail bookkeeping. Immediate income—easy! Auditax, 34757A, Los Angeles 34.

I want to send you proof of the wonderful pulling power of Popular Mechanics classified pages. What's your proposition? Write me today. Include literature if possible. P. W. Johnson, Manager Classified Advertising, Popular Mechanics Magazine, 200 E. Ontario St., Chicago 11, Ill.

COPUBLISH Mail Sale Advertiser, leading mail order paper. Details, latest copy, dime. Vanroy Shirk, Lebanon, Penna.

11,000 NEW Prospects daily. Baby record books, shoes, albums. Sell mailorder. Use our literature. Write: No-Co-Ro, Capitola, California.

BRONZE Baby shoes: Instructions, equipment and mountings for genuine electroplating process. Largest supplier of all plating equipment, supplies. Free catalog. Hollywood Bronze Supply, Dept. B-3, 1624 East First, Los Angeles 33, Calif.

MAKE \$46 From square foot plywood; jigaws necessary. Free details. Woodart, Bridgewater, Mass.

FIX Typewriters. Free repair course. Home operated. Remit 25¢ for book explaining free course and agency appointment. Athey, Tarentum, Penna.

OPERATE Profitable mail order business. Write Walter Service, 4159A East 112th, Cleveland 5, Ohio.

EARN Good money sharpening chain saws, scissors, cutters, knives. Free manual. Treyco, North Tonawanda, N. Y.

RE-Cast junk batteries into new. Latest achievements. Battery Laboratories, Bayou LaBatre, Alabama.

BAKE New greaseless doughnuts in kitchen. Sell stores. Free recipes. Montgomery, 3605 South 15th, Minneapolis 7, Minnesota.

\$3.00 HOUR—Home, sparetime, assembling pump lamps. Easy. Free details. Ougor, Caldwell, Arkansas.

PLAQUES—Figurines-molds. Free details. Russo, 1196 Brooklyn, Bklyn 3, N. Y.

BE A notary. Information: Stationers, 515 East 33rd, Kansas City 9, Missouri.

QUICK Profits, with no capital! Take orders for magazines your neighbors like, want. Make cash on the spot! We show how with free kit. Get yours now. Write Mount Morris Magazine Agency, Dept. 312, Mount Morris, Ill.

"MAILORDER And the Law." Know about required licenses, federal and state regulations, taxes, etc. Only \$1.00. Included free: "Starting a Mailorder Business." Dorf, 186-M Covington Lane, Woodbury, New Jersey.

MAKE Flexible molds. Cast plaques, figurines. Free sample. Tooker, 1045-R Fairview, Hamilton, Ohio.

ENJOY A profitable business of your own selling the "World's Most Useable Bible." Profit from our 26 years experience. International Book Company, Dept. M., Box 118, Wichita 1, Kansas.

CANDIED Popcorn and potato chip equipment. Eakins, Box 933-AO, Springfield, Ohio.

RAISE Rabbits on \$500 month plan. Free details. White's Rabbitry, Mt. Vernon, Ohio.

PROFITABLE Home mail order business! Particulars free. Progressive, Box 422-B, Raymond, N. H.

OPERATE Your own home mail order business. It's profitable. Write: Webb Imports, Pico Rivera, Calif.

"MAIL Order World of Opportunities." Free subscription, details. GPO, Box 972-P, New York 1.

\$400.00 MONTHLY Raising giant worms. Odorless soilless method. Charlie Morgan, Bushnell, Florida.

BOSS Your own home business. Profits 1200% to 3000%! Make, distribute stunning Shellcraft jewelry. Sells itself wherever displayed. Big repeat demand. Details free: Shellcraft, Dept. A, Box 804, Panama City, Florida.

LIQUID Molding rubber, free sample. Shellcraft supplies. Chaney's, 1907-A East Road, Jacksonville 11, Fla.

LEARN "Mailorder Do's and Don'ts", other selections. 50¢. Carruthers, Box 626-A, Dania, Florida.

AMAZING Moneymaking opportunity! Work home, sparetime. Typewriter helpful. Samples, instructions 50¢, refundable. Interstate, 37 Besch, Albany 9, N. Y.

OPERATE Profitable low cost mailorder business! Liberty, 210-PMM6 Fifth Avenue, New York 10, N. Y.

BIG Profits selling ball point pens. Bonomp, 54 Jefferson, Brooklyn 6, N. Y.

MONEY Making mail-order opportunities galore! Free! American Distributors, Box 409-P, Niles, Michigan.

517 FREE Catalogs, sales kits, products samples, 1,000,000 items at wholesale. The greatest bargain of all time. 10 huge directories just off the press, \$2.00 (refundable). Orders shipped prepaid day received. Preskile Enterprises, P.O. Box 7142, Rochester 16, N. Y. Notice: We reserve the right to withdraw offer without notice when present supply is exhausted.

START Your own business trimming windows. Full instructions on trimming, how to get work, etc., only \$1.00. Jem, Box 144, Cranford, N. J.

\$200.00 MONTHLY. Spare time. With tablesaw. Write. Holiday House, 7228 4th Plain, Vancouver, Washington.

SELL By mail. High income! Everything furnished. Irvin, Box 1052, Oklahoma City 1, Oklahoma.

FIBERGLASS Awnings—No investment. Part, full time. Fiberlux, 29 Elm Avenue, Mt. Vernon, N. Y.

\$34.70 TWO Hours. Manufacturing concrete products. No selling. Castings #3, 1803 Fremont, Rapid City, South Dakota.

EARN \$100.00 Weekly part time from your arm-chair and in one year you'll receive a free trip to Europe for two. No selling. No mailorder. Pan Pacific, MAP, Box 595, Laguna Beach, Calif.

WORLD'S Easiest mailorder business. (Designed especially for beginners). Details free. Tasker, Box 3131, Alexandria, Virginia.

MONEY-MAKING Machines for sale; proven performance in thousands of shops. Acme saw and lawnmower sharpeners. Free literature. Max Manufacturing Company, 138 Stockton Avenue, San Jose 26, Calif.

COLORGLAZED Concrete pottery made without molds. Patented method. Cemetery products, novelties, tiles. Basement leak-sealing. Money-making projects. Booklet, details free. Men only. National Potteries Company, Grand Rapids, Minnesota.

VENDING Machine catalog. Rakes, 609P Spring Garden, Philadelphia 23, Penna.

FREE! Free! 10 large money-making magazines! Enclose 10¢ for postage. Harry Phillips, Bonavista-PS, Newfoundland.

\$250.00 WEEK Profit possible. Earn at home spare time with fascinating printing method. \$5 start you. Send no money now. Free confidential facts and valuable samples. Screen-Print AL, Los Angeles 61.

MAKE Extra money—Big cash commissions plus premiums for you and your customers. Sell advertising book matches. Sensational new tenor, glamour girls, hillbillies; dozens others. All sizes. Quick daily sales; big repeat business. Free master kit makes selling easy. No experience necessary. Superior Match, Dept. MX-360, 7530 Greenwood, Chicago 19.

OPERATE Profitable employment agency. Home, office. Personnel Associates, Box 592-M, Huntsville, Ala.

JAPAN Directory. 145 Japanese manufacturing exporters, Japan and Hong Kong trade journal information. Asia opportunities. \$1.00 today. Nippen Annai, Box 6266, Spokane 28, Washington.

MONEY-MAKING Opportunity in your own fishing equipment business. Free details. Postal Sales Div. FB4, 11139 McCormick, North Hollywood, Calif.

HAIR Coloring Pomade. Successful mail order item 8 years. Drop shipments. Marion Labs., Sunnyside, L.I.C. 4, N. Y.

WANTED. Men, women. Raise bait for us at home. Full, spare time. Doesn't take-up space. We furnish everything. Sherwood, Dept. A-2, Monmouth, Maine.

BUY Direct from factories. Appliances, cameras, watches! Free details! Cam Co., 6810PM-20th Ave., Brooklyn 4, N. Y.

START Your own business on credit (U.S. and Canada). Your own boss. 1396 dealers sold \$5,000 to \$25,500 in 1959. We supply stocks, equipment on credit. 200 home necessities. Sales experience unnecessary. Pleasant profitable business backed by world-wide industry. Write Rawleigh's, Dept. D-U-PPM, Freeport, Ill.

GROW Living miniature forest (only inches high) or orchard that bears tasty tiny fruit. Learn amazing dwarfing secrets! Fascinating hobby! Profitable home-business opportunity! Free seeds and plan. (State your age.) Miniature Nurseries, Dept. AL, Gardena, California.

BIG Money—Operate own fix-it shop. Service household appliances, motors, mowers, saws, skates, etc. Free book. Christy Trades School, A-9003, 3214 Lawrence, Chicago 25.

"50 NEW Home-Business Ideas" booklet, sample free. Spray exotic Velvet-Suede on anything. Flokcraft-AL, Los Angeles 61.

DOLLS! Dolls! Dolls! We teach you to repair, make, sell all kinds of dolls and accessories including clothing. Study at home. Earn while you learn. Free catalog. Doll Hospital School, Studio MC-40, 11826 San Vicente Blvd., Los Angeles 49, Calif.

IMPORT-Export opportunity, profitable, world-wide, mail-order business from home, without capital; or travel abroad. Established world trader ships instructions for no-risk examination. Experience unnecessary. Free details. Mellinger, C704, Los Angeles 24.

PROFIT With Popular Mechanics' subscription plan. No investment, no experience needed. Earnings begin immediately when you obtain subscriptions for Popular Mechanics, Good Housekeeping and others. High commissions, bonus. No experience needed. Deal directly with the publisher. Write Popular Mechanics, Room 4B, 250 West 55th St., New York 19, N. Y.

LEARN Landscaping and the growing of plants. Start a profitable business part or full time. Free information without obligation. National Landscape Institute, Dept. MC-40, 11826 San Vicente Blvd., Los Angeles 19, Calif.

NEW Home-import mail order profitability! Your mailbox stuffed with money! No selling. No experience. No investment. We supply everything. Free details. Mail Order Distributors (Import Division), 15201 South Broadway, Los Angeles B54C, Calif.

LIQUID Rubber, \$10.00 gallon, prepaid. Free details. Steece Bros., Box 177-AM, Sioux Falls, So. Dak.

MAILORDER To motels, churches, restaurants, institutions. Complete individual set-up, not just instructions. Hermes Advertising, 152 West 42, New York City 36.

STOP Searching! This is it! Get fresh facts! Triton lists new business enterprises, services, agencies, franchises, ideas, promotions. Many others. All areas. Free interesting information rushed airmail. Triton, C102, 760 Market, San Francisco 2.

HIGH School students. Sell inexpensive, repeat items. Sample free. Civil Service Bulletin, Haypath Road, Plainview 52, New York.

MAILORDER Literature for beginners. Write: Enterprises, Box 1592, Beverly Hills, California.

CASH From sawdust, tin-cans, newspapers. Over 200 methods. Instructions \$1.00. Charles Company, 42-GPV, Norwood, Ohio.

PYRAMID Income. Operate garden golf. Sell equipment. Brockway, Box 3924, Portland 8, Oregon.

TINTING Alum statuettes, profitable. 6 samples, instructions, \$3.00. We manufacture, supply any amount. Marble Castings, P.O. Box 451, Kingsport, Tennessee.

EASY Repeat business selling public service advertising booklets to local businesses. Free sales kit. Wedgewood, Box 446, Roslyn Heights, N. Y.

PENNY, Nickel, and dime counter and packager, accurate fast. Free details. Sample \$1.00. Sterling, P. O. Box 626, Dania, Florida.

FREE Report for unique invention suggestion. Howard, 2026 Ave. E, Scottsbluff, Nebraska.

MADE \$10,000 Typing at home. Guaranteed proof. Amazing information 15¢. Lenore Felgen, 30 Washington, Oak Park, Ill. Dept. PM.

IMPORT Anything from anywhere. International 1960 copyright trade directory. Contact 50 countries. William Benko, Box 188-A, New York 21.

BECOME Independent. Own your own rug and upholstery cleaning business. \$229.00 full price includes everything. Write: Alladin, Shawano, Wisconsin.

START Your own International Shopping Service. Offer unique foreign imports at amazing discounts. Capital unnecessary. Free details. Bennett, 956-C, 52nd, Brooklyn 19, N. Y.

IMPORT, Mail-order is booming. Tremendous money-making opportunity offered. Free information. Rosegard, Box 4123, Panorama City, California.

TERRIFIC Mailorder deal. Free details. Young's, Box 324, Metairie, Louisiana.

\$100.00 WEEKLY Dealing in old jewelry. Complete instructions. No investment. No selling. D'Amico, 24-F North Wabash Ave., Chicago 2.

LEARN Bookkeeping quickly \$1.98. A quick, complete course, made easy. Includes important chapter "Bookkeeping and Budgeting" for housewives. Literature free. Aned, 1933 Lakewood Circle South, Jacksonville 7, Florida.

INCREASE Your income. Free information. Excello, Box 500, Shreveport, La.

OPERATE Ready-made mailorder business. Ketchun's Advertising, 1058-P, Springfield, Illinois.

SELL Labels by mail. Wagler, Box 66P, Wyandotte, Michigan.

FANTASTIC Profits raising redworms. Free instructions. Georgia Wormeries, Richland, Georgia.

STRIKE It rich with home repairs at set prices! My \$160,000 yearly business makes fantastic profits! Get free details. House Clinic National, Dept. P-4, Meadows Bldg., Dallas 6, Texas.

MAKE Money at home—mailing literature to mothers. Big earnings. Everything furnished. Write: Schaefer, 31 Nagle, New York 40.

MAILORDER Or home profits! Vikari, 468-P1 Third Avenue, Salt Lake City 3, Utah.

WANTED: Home producers, to be subcontractors. Cast plastic products for manufacturers in our clearing house service. Thousands of easily made items required. Cash in at home, without previous experience. Plastic Service Associates, Dept. 4-PM East Boston 28, Massachusetts.

BE A specialty manufacturer. 94 fast-selling products. Complete manufacturing instructions, formulas, \$1.00. Sax, Milan, Ohio.

BIG Money in formulas! Concentrates! Products! Small investments! Free details. Blomberg, Burt Lake, Michigan.

NEED Cash-capital? For methods and sources to raise money; Write: Capital, 101 Bank Bldg., Cole Camp, Mo.

"**23 WAYS** To Build a Home Mail Business," with lifetime repeat income. Rush \$1.00 for amazing manual. Guaranteed. Glenn Publications, Dept. MP40, Box 507, Jacksonville, North Carolina.

MONEYMAKING OPPORTUNITIES

A Natural for sporting goods, boat, hardware, auto dealers, service stations, ambitious individuals. Become dealer for nation's number one camping trailer. Sets up into complete camp in just one minute! Dealer details by return airmail. Heilite Trailers, 1525 South Sacramento, Lodi, California.

HUSBANDS & Housewives wanted! Big money. Spare or full time cake decorating and candy making. Turn your kitchen into a gold mine. No age, education limits. Complete instruction, learn and earn at home. Write for free facts: Candy And Cake, Dept. 661, Fallbrook, California.

UNIQUE Homework offer. Ralph Wall Products, 1071 Linden, Zanesville, Ohio.

MEN — Women! Start money-making plastic laminating business at home in spare time. Material that costs 11¢ brings back \$2.50. No canvassing or selling but mail orders bring in \$20 a day. Write for full particulars free. Rush name on postcard to Warner, Room CL-2-D, 1512 Jarvis, Chicago 26, Ill.

We Establish you in your own business on our capital. No investments. No experience necessary to start. Part time or full time. Small cities and towns best. Winona Monument Co., Winona, Minn.

INVISIBLE Reweaving: \$5 in one hour possible reweaving burns, tears, moth-holes. Spare-full time. Free details. Skill-weave, Dept. WC-164, 335 W. Madison, Chicago 6.

WEAVE Rugs. Make good profits! No experience necessary! Free catalog, sample card, and low prices on carpet warp, rug filler, looms, parts, inexpensive beam counter. If you have loom—advise make, weaving width please. Or. Rug Company, Dept. 4053, Lima, Ohio.

MAKE Big easy profits making costume jewelry at home in spare time! Quick, easy to make, easier to sell! Details free! Don-Bar, 3511 W. Armitage, Dept. D-192, Chicago 47, Illinois.

50¢ EQUALS \$5.00. How? Profits are fantastic in imports. Obtain "Selected Foreign Trade Lists" for top dollar profits. Only \$2.00. Free "Import-Export Glossary" with introductory offer. Interama Mart, Box 4234M, Miami Beach, Fla.

START A profitable subscription business in spare time! We need men and women (young or old) as representatives for all leading national magazines. Liberal commissions on all subscriptions. Supplies free. No experience needed. Send this ad with your name and address to: Popular Mechanics, Room 4-O, 250 W. 55th St., New York 10, N. Y.

MAKE \$5,000 Yearly sparetime raising mink, chinchillas, nutria, etc. Free booklet reveals proved plans. Write: Furs, 588 Mt. Pleasant Road, Toronto 1, Canada.

MONEY-Making formulas, trade secrets; giant book over 900 pages. Free literature. Write: Joseph Arkin, 1448 Crotona Park East, New York 60, New York.

STOP Searching! This is it! Get fresh facts! Triton lists new business enterprises, services, agencies, franchises, ideas, promotions. Many others. All areas. Free interesting information rushed airmail. Triton, C103, 760 Market, San Francisco 2.

\$100,000 WORTH Of unused government surplus for \$500. Resell at a 1000% profit. \$1 will bring details on how to buy direct from government and where to sell. Jamco, Box 693, Rome, N. Y.

REFLECTIVE Decals. Samples for stamp. E-Z-On Sign Letters, Pell Lake, Wisconsin.

EARN Money using any camera. Proved method. Experience not necessary. Work at home, anywhere—make money! Write today. CPC, Box 1066, Richmond, Calif.

OPPORTUNITY Mail free. H. Edlund, 752 South Main, Los Angeles 14, Calif.

RAISE Nightcrawlers, redworms. Easy new soilless method. Three Oaks Ranch, Dresden, Tenn.

GET Money for newspaper clippings. Free details. Write: Whitted-40A, 2815 Nicholson, Dallas 24, Texas.

START Big-pay business at home in spare time. No experience needed to operate little table-top machine for bronzing baby shoes. Make \$5.46 profit on every pair. Full particulars free. Send postcard to Mason, 1512 Jarvis, Room CM-2-D, Chicago 26, Ill.

EASY To start rubber stamp business at home in spare time. Make up to \$9.80 an hour without experience. Facts free. Write to Roberts, 1512 Jarvis, Room CR-2-D, Chicago 26.

YOUR Name on our giant mailing list, brings you moneymaking and other mail offers galore! Send 25¢ today! Direct Mail Service, Dept. GM, Box 581, Bakersfield 7, California.

GLAMORIZE For camera profits. Free details. Glamourize, Box 467E, Warren, Ohio.

WHOLESALE Catalog free. Good selling jewelry. Jacobi, 1715 E. Mercer, Seattle 2, Washington.

\$3,000,000.00 FUTURE; 6% Royalty paid from three inventions sales every 90 days for each \$200.00; 3% for \$100.00; 1% for \$50.00. Wall Street Inventions, Investments, 210 5th Ave., Suite B-106, New York 10, N. Y.

MONEY? Big money! 900% profit. Fabulous Moneymaking Secret. Mailorder. Guaranteed Details 25¢. Opportunities, 940 East Broadway, Phoenix, Arizona.

OPERATE Home mail-order business. Vosacek Printing, 4444A Ute, San Diego 17, Calif.

MINK Raising information free. Complete. Lake Superior Mink Farm, Superior, EEl, Wisconsin.

VENDING Machines. No selling. Operate a route of coin machines and earn amazing profits. 32-page catalogue free. Parkway Machine Corporation, Dept. #26, 715 Ensor Street, Baltimore 2, Maryland.

GROW Mushrooms. Cellar, shed and outdoors. Spare, full time, year round. We pay \$4.50 lb. dried. We have 29,000 customers. Free book. Mushrooms Dept.: 173. 2954 Admiral Way, Seattle, Wash.

CIGARETTES: Make 20 plain or filter-tips for 9¢. Facts free. Moberly, Box 821, Owensboro, Kentucky.

EARN Money evenings copying and duplicating comic cartoons for advertisers. Adservice. Argyle 1, Wisconsin.

YOUR Own, easy-to-start, home mail-order business, sparetime. Fascinating; profitable! Information free. Alfano, 19-PM Pine, Closter, N. J.

BIG Money raising fishworms and crickets. Free literature. Carter Hatchery, Plains, Georgia.

READ "Progressive Mailtrade," the magazine that tells how to make money by mail. Quarter brings sample and special offer. Progressive Mailtrade, Box 357, Sheboygan, Wisconsin.

WIN Contest money. General Contest Bulletin gives hundreds of tips. Lists current contests, rules. Sample magazine 25¢. General Contests, 1609½ East 5th, Duluth 12, Minnesota.

AMAZING Successes through franchises! Become exclusive franchise holder your territory. Information rushed. National Franchise Reports, MP-528, 333 North Michigan, Chicago 1.

IN 1952 I was unemployed, broke. Today own \$18,000 home, drive Cadillac, have bank account. Anyone can do this. Write Norris Cole, 217 West 49th, Bradenton, Florida.

\$340.00 MONTHLY With jigsaw. Details. Elkman, 346F North Summit, Sioux Falls, So. Dak.

\$50,000 YEARLY Possible. Distribute sales literature your territory. Write Afja, Box 33-D, Southfield, Michigan.

BUILD Dutch windmill and wishing well dog houses. Two plans \$1.00. Craft Shop, Peotone, Illinois.

MONEY In chemicals. Make own products. Pocket all profits. Others work for you. Details free. Ranslow, 51 W. 32 St., Hialeah, Florida.

\$200 WEEKLY Buying gold. D'Amico, 24 North Wabash-A Ave., Chicago 2.

BIG Money opportunities—Jobs, businesses, investments. Retirement opportunities. Free details. Shoreland, 20 W. Jackson, Suite 1412-K, Chicago 4.

MAKE Money typing. Details 17 proven plans. Crafts, Mulino, Oregon.

MAKE Big money operating your own home mailorder business! Full, sparetime. Specialist's complete instructions show how you can make easy start! Further particulars free. Griffin, 322 West State, Ithaca, N. Y.

EXPORT — IMPORT

100 ADDRESSES Of foreign exporters \$2.00. B. Twyford, 343 Harding Court, Pitman, N. J.

FREE—"World Shopper" subscription. Imports, discounts. Send ad, 25¢. Ric-Atate, 29 Orleans, Valley Stream, N. Y.

JAPAN: Direct call order. 26 page catalogue, kimonoes, dolls, novelties, gifts, business information, manufacturers' names, addresses. Send \$1.00. Clarence Yamagata, 814 Toginbiru, Marunouchi, Tokyo.

FREE Complimentary copy import bulletin. How to Import for Profit. Write: Boisclair Buyers Service, P.O. Box 276, Napa, California.

TERRIFIC Import, gift bargains, catalogue 25¢ (refundable). Carle Distributors, 2 Empire Street, Buffalo 12, New York.

SCIENCE & CHEMISTRY

SCIENCE Educational kits for home, group, school study—chemistry, biology, physics, nuclear, electronic, etc. Catalog 25¢. Refundable. Science Edu. Games, 793GR Hy. N., Sebastopol, Calif.

EXPERIMENTERS: — "Terrific Bargains" scientific catalog, 25¢. Hagenow Laboratories, Manitowoc, Wisconsin.

SPECTROSCOPE For quick analysis \$3.00. Kuttingson, 875 Arastradero, Palo Alto, Calif.

STROBOSCOPE—"Stop" motion with strob. Kit, \$7.50. Mechanics, experimenters, science teachers send for free brochures. Morris Lee, 294 Elm St., Buffalo 3, N. Y.

CHEMICALS, Paint, plastic coatings. Monroe Chemical Company, Hilton, New York.

AMAZING New book of science experiments, formulas, and catalogue of laboratory supplies. Only 35¢. National Scientific Co., 13 S. Park Avenue, Dept. PM-4, Lombard, Illinois.

CHEMICALS In small quantities, apparatus, glassware. Catalog 25¢. Winn Chemicals, 124M West 23 Street, New York 11.

ROCKETEERS: Folio listing 50 different solid propellants: \$1. Box 1655, Marysville, California.

FREE—Six 4 inch Pyrex test tubes with every \$4.00 order. Catalog 25¢. Bio Chemical Products, 30 Somerset, Belmont 78, Massachusetts.

232 PAGE Catalog \$2.00. Laboratory Materials, 7319 Vincennes, Chicago, Ill.

RADIOACTIVE Isotope experiments—New. 16 for 60¢. Atomic Researchlab, 10717 Venice, Los Angeles 34, Calif.

ROCKET Supplies for amateur rocketry. Catalog 25¢. Mervin Hill Company, Bolts Pennsylvania.

CHEMICALS And apparatus for industrial, analytical, and private laboratories. Catalog 25¢. Dept. M-50, Biological Supply Co., 1176 Mt. Hope Ave., Rochester 20, N. Y.

ILLUSTRATED Catalog: Chemistry, mineralogy, biology 25¢. Tracey Laboratories, Evanston, Illinois.

FORMULAS, PLANS, ETC.

OPPORTUNITIES. Unlimited! World's finest formulas. Product development. Analysis. Monthly product report. Exciting details. free. Alpha-Midwest, LaPorte, Indiana.

10,000 FORMULAS. Trade secrets. 900 pages. \$3.95 refundable. Circular free. Marjen, 1109-P, Balmoral, Chicago 40, Illinois.

FORMULAS For latest money-making discoveries. New! Good! Valuable literature free! Miller, Chemist, 1517-D, Tampa, Florida.

FORMULAS; All kinds, latest, best. Literature free. Kemixal, Park Ridge, Ill.

LATE. Modern manufacturing formulas. List free. Moon Chemical, Martville, New York.

RESILVER Mirrors—make one-way mirrors. Both \$1.00. Kem-Mir, Park Ridge, Illinois.

PLASTICS

VINYLLITE. All colors, all gauges, for laminating, printing, vacuum forming, silk screening, etc. Free price list. Solomon, 4 Beacham, Everett 49, Mass.

NEW Liquid casting plastic, clear, colors. Embed real flowers, butterflies, photos, coins. Send 25¢ for two handbooks "How to Cast Liquid Plastics" and "How to Make Extra Money at Home." Castolite, Dept. D-101, Woodstock, Illinois.

REPAIR False teeth yourself. Special, new professional plastic. \$2.00 postpaid. Guaranteed. Grant Dental Laboratory, 219 W. 7th St., Los Angeles, Calif.

PLEXIGLAS—1/8" \$1.25; 1/4" \$1.73 sq. ft. Sheets, rods, tubings, fabricating. Catalog 15¢. Plastic Shop, 2025 Nevada, Butte, Montana.

SIMPLIFIED Plastic molding, repairing, trial unit \$2.00. Hallmark Dental Co., Box 1924, Detroit 31, Mich.

MONEY-MAKING Opportunity. Learn plastics. New fast streamlined method. Free information. Trialpha, Dept. F4, 7950 Mammoth, Van Nuys, Calif.

CELLULOID Scrap. Sheets, state thickness, colors. Box 333, Kearny, N. J.

SOFT Plastic, fishing lures, tool grips, novelties. Uncured sample, instructions; 50¢. Electronic Service, 318 Dorwil Dr., Akron 19, Ohio.

FIBERGLAS Repair kits. For: gunstock inletting, boats, athletic equipment, home, farm repairs. Literature. Baer Plastics, 215 Ellen, State College, Penna.

MIRACLE Weld by manufacturing chemists over thirty years. Amazing plastic iron will weld any material, repair machine tools and household items. Order today \$2.00 postpaid. Wherry Engineering Co., 3617 Washington, Houston 7, Texas.

ELECTRIC Laminating kit. Easy. Fun. Profitable. Details. Burr, 330 East Center, Kalamazoo, Mich.

LEARN Plastics fabrication for spare time income. Low cost home training now available. Write for free booklet. Interstate Training Service, Dept. D-3, Portland 12, Oregon.

BOXES, Plastic. Free list. Althor, 170 Bay 23 Street, Brooklyn, N. Y.

PLASTIC And supplies for laminating. Colambo, 12 Center, New Haven, Conn.

PLASTICS—Plexiglas, polyester, fiberglass, acetate, vinylite, supplies. Manufacturers' distributor, sheets, rods, tubes, liquids, coatings, films, boat plastics. Large, small quantities. Complete instructional catalog. 25¢. Gem-O-Lite, 5529-A Cahuenga Blvd., North Hollywood, Calif.

AGENTS WANTED

ENJOY Camping: Make big profits while you play, with Hellite Camping Trailer dealer franchise. Sets up into complete camp in just one minute; attracts crowds wherever shown! Write for dealer program. Hellite Trailers, 1524 South Sacramento, Lodi, California.

MAKE Your spare time profit time! Over 800 money-makers! Gifts for men, women, children, the home! Distinctive greeting cards, stationery, toys, novelties, jewelry, cosmetics, gadgets at prices for every pocketbook. No minimum order. Make up to 92% profit! Write today for exciting details, colorful catalog. Greetings Unlimited, 6-147 Park Square, St. Paul 1, Minn.

MEN! Women! 60% profit on cosmetics. Famous Nationally advertised Hollywood cosmetics pay 60%. Make \$25 day up. Hire others. For free samples, details, write Studio Girl, Glendale, California, Dept. 1204J.

CLEANS Automobiles without water. New invention. Lightning seller. Automobiles gleam. Samples sent on trial. Kristee 37, Akron, Ohio.

REFLECTIVE Signs-letters, numbers 1"-12". Amazing profits. Wallman Co., P.O. Box 8508, Minneapolis 10, Minnesota.

BE The Popular Mechanics representative in your neighborhood and earn big profits in your spare time. Write Popular Mechanics, Room 4-A, 250 West 55th St., New York 19, N. Y.

MEN—Women agents: Sensational new moneymakers — Beautifully hand-painted, plastic personalized photo enlargements, compacts, rings, bracelets, lockets, etc. Simply take orders, pocket 40% commission. We deliver and collect. Sales outfit free. Novelco, 3343 North Ave., Chicago 47.

AGENTS—300% Profit selling genuine gold window letters; stores and offices. Free samples. Metallic Sign Letter Co., 1217-D West Newport, Chicago.

EVERY Man a prospect. Request refundable sales kit offer showing line of belt buckles, tie clasps, money clips, cuff links, lapels, individualized with customer's name and emblems. Cap badges for trucking, bus, taxi, police, firemen also heavy construction emblems. Choice 3000 emblems. Hook-Fast, Box 1425PM, Providence, R. I.

BIG Profits. Sell proven family medication. Low wholesale prices. Free sample. Porter's, Box P-907, Piqua, Ohio.

BIG Earnings selling amazing floor treatments, business firms, factories, institutions. Exclusive territory. Free sales kit offer. Sheridan Chemicals, 1417 Sheridan Street, Camden 4, N. J.

GOLD Or silver letters, numbers. Windows, doors, trucks. 1" to 6". 500% profit. Free samples. Atlas, Box 543-T, Oak Lawn, Ill.

RUN A spare-time greeting card and gift shop at home. Show friends samples of our wonderful new 1960 all-occasion greeting cards and gifts. Take their orders and earn up to 100% profit. No experience necessary. Costs nothing to try. Write today for samples on approval. Regal Greetings, Dept. 58, Ferndale, Mich.

BIG Profits. Stamp social security plates, key protectors. Sample 50¢. Catalog free. General Products, 188-PM State, Albany 10, N. Y.

MEXICAN Art goods! Free sample! Send 14¢ stamps mailing. Sylviak, Apartado 9036, Mexico City.

PRINTING, Advertising salesmen—Excellent moneymaking sideline selling decalcomania name plates, small quantities. Automobile initials, sign letters. Free samples. Ralco, XL, Boston 19, Mass.

YOUR Ad in this space will get some good agents for you. Yes, I'll prove it. Write for Folder "A" right now, F. W. Johnson, Classified Advertising Manager, Popular Mechanics Magazine, 200 E. Ontario St., Chicago 11, Ill.

SELL Champion, AC, Autolite spark plugs. Reconditioned, electroplated, guaranteed 10,000 miles. 100% profit. Free sample. Lee Plugs, 1608-E Roberts, Houston 3, Texas.

YOUR Own business—Used suits \$1.50; overcoats 65¢; mackinaws 35¢; shoes 12½¢; ladies' coats 30¢; dresses 15¢. Enormous profits. Catalog free. National Mail Order, 2111-AA Roosevelt Road, Chicago 8, Ill.

DON'T Miss our ad under "Salesmen Wanted" in this magazine. National Press.

SAMPLE 50¢. Sells \$1.00. "Check Smart" Manual. 617 SW 31, Oklahoma City 9, Oklahoma.

400% SELLING Dramatic, humorous imaginative tour poems America, Europe, Australia. Dramatist Ponto, Box 57036, Los Angeles 57.

HAVE Personal purchasing representative in Singapore. Specify items you wish to import. We'll furnish prices. Wholesale quantities only. P. Boone's, 6647 Michigan, Chicago 37.

NATION'S Best bed warmers. Agents wanted. Get literature. Send 10¢. Wentworths, P.O. Box 143, Muskegon, Mich.

400% PROFIT—Men, women, teenagers. Free sample. Stamped self-addressed envelope. Moneymaker, Box 88, Berwyn, Illinois.

VARI-TYPERS, Office machines, equipment. Free list. Sachs, 119 W. 23, New York.

DAMASCENE Earrings; Exotic orientalism. Huge profit. Ohga, PM-183, Sigenkusatu, Japan.

GET Back \$99.00. Send \$1.00 refundable. San-Fran Studio, Madisonville, Ky.

SELL Oil portraits. Free details. Schrage, 1060 Sherman Avenue, New York 56, N. Y.

HERE Is 1960# A-1 opportunity for you. HI-KID all adjustable rubber tipped hickory wood stilts. It's bigger than hula-hoops. Hurry. Mfrs. protected franchises. Sample pair \$2.00 postpaid. C. C. Brawley Mfg. Company, 266 Dean, Brooklyn 17, New York, U.S.A.

BUY IT WHOLESALE

HANDMADE Western boots. Free catalog. Ysleta Boots, Box 815M, Ysleta Station, El Paso, Texas.

BULOVA, Benrus watches like new—\$5.95 up. 32 page illustrated catalog free. Cosmos, New York 35, Dept. 560.

WHOLESALE Catalog. Lowest prices anywhere. Guaranteed. \$1. Refundable first order. Loeber, 224-C Wyatt, Lincoln, Illinois.

FREE, Big three color wholesale catalog. Appliances, housewares, toys, everyday needs. Carolina, 719 Mangum, Durham, N. C.

NEW Electric shavers. Norelco \$16.00. Schick 3 speed \$21.00. Remington Rollmatic \$19.00. Remington Letriconic (cordless) \$25.00. Ronson CFL \$13.50. American Shaver Center, 17 N. State, Chicago, Ill.

NEW Multicolor wholesale catalog, automobile catalog, and others. Housewares, appliances, refrigerators, freezers, washers, dryers, television, radios, furniture, clothing, luggage, binoculars, photographs, recorders, cameras, projectors, typewriters, sewing machines, power tools, toys, sporting goods, watches, jewelry. Name brands. Huge discounts. Postcard: Selbyco, Decatur, 155, Illinois.

BOOTS, Handsome western styles. Free catalog. Austin Boot Co., Box 5303J, El Paso, Tex.

FREE Double-edge razor blade. Fine quality. Precision made. Gryder, Box 187, Barberton, Ohio.

WHOLESALE: 850,000 Items. Supply source directory 25¢. Idealer, Park Ridge, Illinois.

ELECTRIC Guitars, amplifiers, wholesale. Free catalog. Carvin, PMW, Covina, Calif.

USED And new watches \$2 up. Free list. Southern Watches, 5-PM So. Wabash, Chicago 3.

BUY Wholesale; 100,000 nationally advertised products. Appliances, cameras, sporting goods, housewares, watches, typewriters, tools, clothing, etc. Discounts to 60%. Buy-Rite, Box 258, Hawthorne 2, New Jersey.

LARGEST Wholesale supply source in U.S.! Furniture, clothing, appliances, housewares, automobiles and accessories, tools, sporting goods, hobby supplies, farm equipment, imports, new products, bargain merchandise. Free details. Associated Wholesalers, Box 2068-DD, Sioux City 4, Iowa.

BUY Nationally advertised products at discounts to 60%. Appliances, watches, cameras, clothing, housewares, jewelry, toys, typewriters, tools, etc. Stephens Distributing Co., Box 1434, Atlanta 1, Ga.

2,000 PAGES Wholesale catalogs. Write: Mopam, Box 47, Newark, Ohio.

MONOFILAMENT Fishing reel. Guaranteed tangle-free. Springtime, Box 3911, Seattle 24, Washington.

SAVE 80%. New illustrated wholesale catalog 25¢. Cam, Barrett Hill, Lake Carmel 3, New York.

FREE Catalog offer! Tools, appliances, clothing, toys, etc.! United Wholesalers, 1263-M Broadway, New York 1, N. Y.

WHOLESALE: Appliances, watches, tools. Catalog 25¢ refundable. French's, 1804 So. 23rd St., Louisville 10, Kentucky.

WHOLESALE! World's largest supply. Buy from 257 American, European, Japanese wholesalers. Tailormade suits from Hongkong. Free details. International Buyers, 216-M Jackson, Chicago 6, Ill.

HUMOROUS Contemporary greeting cards, western, etc. 15 assorted \$1.00. Retail value \$3.75. Representatives wanted. McLean Studios, 2703 E. Third, Denver 6, Colorado.

FREE! Free! Wholesale catalog appliances, housewares. H.R., Box 72, Bath Street Station, Brooklyn, N. Y.

FREE Dollar certificate. Buy power tools, torches, telescopes, etc., direct from manufacturers' representative. Send \$1.00 for 128 page catalogue. NB Manufacturers, 216 Eldridge Street, New York 2, N. Y.

JEWELRY. Fantastic bargains! Free literature. Royal, Box 1224-A, Clarksburg, W. Va.

LAWN Mowers direct from the manufacturer. 3 H.P. Clinton 24". Only \$36.95. With windup starter \$49.95. Seven models available at similar savings. Lawn Care Mfg. Co., 140 E. Cerro Gordo, Decatur, Illinois.

JUST Off the press. New wholesale tool and equipment catalog. But at the same prices as the big industrial plants. Send 50¢ for your copy, refunded with first order. General Industrial Supply, Inc., Dept. PM, 822 Sixth Street, Racine, Wis.

SALESMEN—DISTRIBUTORS

MAKE Up to \$50.00 a day soliciting delinquent accounts. Terrific commissions. Write today. General Finance, 304V Pickwick Bldg., Kansas City 6, Mo.

MAKE Up to \$50.00 a day soliciting delinquent accounts. Terrific commissions. Write today. National Credit, 304V Pickwick Bldg., Kansas City 6, Mo.

SALESMEN. Big money showing nationally advertised Down-Spout-O-Matic sensation wherever shown. Attaches to all down spouts, uncoils when it rains, recoils after it rains. Once in a lifetime item. Dry basements guaranteed. Commissions advanced. Special sample offer. Campbell Co., Rochelle 63, Illinois.

SERVICE Your area. Agents, dealers, farmers make \$125 up weekly distributing nationally advertised Campbell's Gro-Green Liquid and 100% soluble crystal fertilizer concentrates. No investment. Demonstration kit furnished. Campbell Co., (Est. 1928), Rochelle 5, Ill.

EARN Big commission full or part time. Build profitable business of your own selling America's largest line low priced business printing. 360 page catalog, samples, hundreds of items used daily by business people. Imprinted ball pens low as \$8.95 for 100. Calendars low as \$5.95 for 100. Free sales kit. National Press, Dept. 8, North Chicago, Illinois.

IF You're interested in making money in selling, see the hundreds of exceptional opportunities in Salesmen's Opportunity Magazine. Send name for your copy, absolutely free. Tell us what you're selling now. Opportunity, 848 N. Dearborn, Dept. 17, Chicago 10, Illinois.

AMERICA'S Hottest item! 50 Star Flag. Sell homes, dealers, institutions, industry, banks, etc. Sample \$5.00. Free particulars. Atlas Flag Corp., Inc., Benton, Ill., or Hahnco, 418 St. Paul St., Rochester 5, N. Y.

ATTENTION Busy mothers. The world's only garment made infant seat for safe propping and feeding. It's a Prop A Tot designed by mother. Approved by doctors. Price \$2.49. Dealers commission 37 to 43 percent. Jones Export-Import, 215 N.W. 79 St., Miami 50, Florida.

MAKE Extra money—Big cash commission plus premiums for you and your customers. Sell advertising book matches. Sensational new tenorana, glamour girls, hillbillies; dozens others. All sizes. Quick daily sales; big repeat business. Free master kit makes selling easy. No experience necessary. Superior Match, Dept. M-460, 7530 Greenwood, Chicago 19.

ANYONE Can sell famous Hoover uniforms for beauty shops, waitresses, nurses, doctors, others. Miracle fabric—Nylon, Dacron, Wash 'N Wear cottons. Exclusive styles, top quality. Big income, real future. Equipment free. Hoover, Dept. D-100, New York 11, N. Y.

WILL You wear new suits and topcoats without one penny cost and agree to show them to friends? You can make up to \$30.00 in a day even in spare time, without canvassing. J. C. Field & Son, Inc., Dept. D-1826, Harrison & Throop Sts., Chicago 7, Ill.

MAKE Extra money selling advertising matchbooks. Free catalog and sales outfit. Matchcorp, Dept. PM-40, Chicago 32.

GET New shirt outfit free; make \$90.00 weekly on 5 average orders a day. Famous quality made-to-measure dress and sport shirts at \$3.95 up sell fast to all men. No experience needed. Full or part time. Write: Packard Shirt Co., Dept. 130, Terre Haute, Ind.

EPOXY Coatings and other advanced building materials pay top commissions. Paramount, Box 1956, Cleveland 6, Ohio.

MONEYMAKING Opportunity in fast growing market selling attractive outdoor advertising pennants. Write: Radder Products, Box 31, Colvin Station, Syracuse 5, New York.

GENUINE Leather hand-laced billfolds. Sample \$2.75. Satisfaction guaranteed. Leathercrafters, Midway Island, Va.

SELL Wholesale, inflatable beach and swimming pool toys. Season is here. Send one dollar for two samples, or five dollars for nine samples. The Boden Company, Box 10908, St. Petersburg, Fla.

TRUCKS Need vinyl signs. Sell at good commission. Gordon's Diversified Distributors Co., 6915 Michigan Ave., Dept. C-29-1, Detroit 10, Michigan.

LONG Established firm needs salesmen for non-competitive, untapped field. High repeat potential. Commissions up to \$1,000 monthly being earned selling long-needed improvement of essential automotive and marine electrical systems product. Free sample. Full details. Write: Camco, Dept. PM, Littleton, Colorado.

VITAMINS! Private labels! Exclusive sales! We supply product, plan, printing; you furnish management, sell wholesale, employ salesmen. Terrific profits! Lifetime repeats! Sample and details free. VimVite, 2908-E Beverly Boulevard, Los Angeles 57.

EXCELLENT Profits. Guaranteed signature rubber stamps. Yours \$2.00. Boardman Engraving, Houghton, New York.

EMPLOYMENT INFORMATION

CHICAGO Jobs. Classifieds. \$1.00. Harvey Bailey, 3950 Lakeshore Drive, Chicago 13.

"GO Foreign!"—U.S. companies operating in South America offer extraordinary opportunities of employment and life-time careers. Supervisory, technical, clerical, sales, trades. Fabulous salaries, benefits. Factual information tips—only \$2.00 (Airmailed). Checks, money orders OK! Included free: "Living Overseas" report. Globetrotter, Casilla 5439, Guayaquil 7, Ecuador.

HAWAII Current job information. \$2.00. Hawaii Research Associates, Dept. M., 21 Nuuanu Sq. Bldg., Honolulu.

AMERICAN—Overseas jobs. Higher pay. Transportation paid. Men-women. Act now! Free information. Employment Headquarters, 79 Wall Street, Dept. B-7, New York 5.

EMPLOYMENT in Florida. Details 25¢ (refundable). Fairbrothers, 710 Dora, Jacksonville 4, Florida.

ATLANTA Booming! Complete classified job listings, rentals, opportunities, \$1.00. Paragon, Box 11714, Atlanta 5, Ga.

NEVADA Job information on Nevada fabulous clubs and casinos. No experience necessary. Pay is the best. \$2.00. Nevada Information Service, P.O. Box 2833, Reno, Nevada.

TERRIFIC Jobs—business opportunities galore in Southern California. Big Los Angeles Sunday classifieds, \$1.00. Airmail \$2.00. Waite, Box 2096A, Inglewood, Calif.

U.S.A. Foreign jobs, up to \$1600.00 monthly. Construction, clerical, supervisory, etc. Skilled, unskilled. Free transportation. Unusual opportunities. Complete information plus worldwide project listings. Only \$2.00 (\$2.25 airmail). Satisfaction guaranteed. International Reports, Dept. K, 109 W. 42, New York 36, N. Y.

JUST Out: Exclusive 1960 USA-worldwide job directory. Only \$2.00. Elsinger, Box 12, Detroit 13, Mich.

MERCHANT Marine jobs. Men and women. Top wages. Travel. Details 10¢. Captain, Box 501-P, Reading, Mass.

LATEST Foreign jobs. Highest wages. Unlimited opportunities. Laborers, clerical, construction electronics, oilfields, Civil Service. \$2.00. (C.O.D.'s accepted). America's leading overseas employment researcher. Plus: newest South American, Alaskan, Venezuelan listings. Universal Research, Box 4912, Baltimore 20, Md.

BOOMING Latin America! Prosperous Brazil, Venezuela. Only hours from the States. New data regarding jobs, opportunities, conditions. American companies employing, etc. All skills required. Salaries to \$1,650.00 monthly: U.S. tax exempt. Bonuses, living allowances, travel expenses, exciting vacations, and more! First-hand information direct: \$2.00 (\$2.35 airmail) checks or money orders. Latin American Opportunities, Sabana Grande, Apartado 10212, Caracas, Venezuela.

JOBS On ships. \$100 weekly, beginners. Travel, adventure. Write: Seamans Service, Box 17-M, Brooklyn 8, N. Y.

FOREIGN Jobs—Latin America, Alaska, Canada, up to \$1500 monthly. Up-to-date 1960 foreign service directory gives complete information; hot list of firms hiring for military and civilian construction, aircraft, oil, exporters-importers, mining. How-when-where to apply. 12th successful year. \$1.00. Global Reports, Box 8873-S, Los Angeles 8, Calif.

JOBS On ships and yachts traveling foreign countries. Davenport's, 1354-K, G.P.O. New York 1, N. Y.

COPYRIGHTED Reports. Best paying companies, travel, adventure, promotions. Construction, aviation, shipping, oil fields, laborers, clerical, trades, supervisory, factory, unusual opportunities. Skilled, unskilled. Foreign, stateside. Only \$2.00 (\$2.25 airmail) (COD'S accepted). Satisfaction guaranteed. Included free: Special reports on Alaska, Venezuela, South America. Research Services, Meramec Building, St. Louis 5-PM, Missouri.

FREE Information—U.S.A., overseas jobs. High pay, transportation. Futures, Dept. M., 215 West 34th Street, New York City 1.

JOBS: High pay. Foreign countries, U.S.A. All trades. Write Dept. 55C, National Employment Information, 1020 Broad, Newark, N. J.

SPECIAL SERVICES

HAVE Your cards, photos, etc., sealed in plastic. Lifetime protection. Burr Laminating, 330 East Center, Kalamazoo, Mich.

INFORMATION On anything. Ferguson Research Specialists, 116-14 141 St., South Ozone Park 36, N. Y.

EDUCATIONAL AND INSTRUCTION

PROFITABLE Welding training available Hobart Welding School, Box M-402, Troy, Ohio. GI approved. Finest equipment in U.S.A. Reasonable prices. Request catalog.

INSTRUCTION Courses, manuals, folios: \$1.00 to \$9.95. Free catalog. Spaulding Co., Fond Du Lac, Wis.

PIANO Tuning learned at home! Profitable, uncrowded profession. Write Tune-craft, Box 5074-M, St. Paul, Minnesota.

WORLDWIDE Register, adult education. Most comprehensive correspondence school directory! Details free. Aureas, Central Valley, New York.

ANYONE. Learn speedy scientific method for manipulating screwdriver, 50¢. Veejay, Box 69, Old Saybrook, Conn.

STUDY High school and college subjects at home. Free catalog. Technical Training Service, Dept. 146MB, Brooklyn 14, New York.

BECOME A genius. Amazing methods \$2.00 complete. Theodore Reilly, 305 Maney Drive, Newport News, Virginia.

DENTAL Technicians' practice kit. Artificial teeth, instruments, plastic, etc. Instruction manual free with kit purchase. Grant Laboratory, Haas Bldg., Los Angeles 14, Calif.

U. S. Civil Service tests! Men-women, 18-52. Start high as \$95.00 week. Preparatory training until appointed. Thousands of jobs open. Experience usually unnecessary. Free information on jobs, salaries, requirements. Write today! Lincoln Service, Pekin 64, Illinois.

LEARN By ear with Dormiphone. While you slumber, the amazing new scientific Dormiphonic tools give you a shortcut to learning languages, correct speech; memorizing facts, figures; relaxation, habit training. Saves you time, effort. So simple to use, children benefit. Used by educators, psychologists. Write today for fascinating free book. No obligation. Modernophone, Inc., 320-040 Radio City, New York 20.

LEARN World interlanguage approved by UNESCO. Textbook 25¢. Esperanto, Middleton, Wis.

BECOME Tax consultant. Graduates earn \$1,000-\$3,000 every tax season preparing returns evenings. State approved. Union Institute, Lakewood 2K, N. J.

CIVIL Service. Training for U. S. tests. Get full information about this field: home study preparation for high rating. Free booklet. Private organization. No obligation. Franklin Institute, Dept. V-60, Rochester 4, N. Y.

TIMESTUDY—Ladder to careers in scientific management. Associated Techniques, Box 426, Cedar Rapids, Iowa.

GET Advancement thru inexpensive Engineering Blueprint Reading Manual. Be expert. No education required. Holtzinger, Industrial Consultant, Buttonball, Orange, Connecticut.

LEARN Civil and criminal investigation at home. Earn steady, good pay. Institute Applied Science, 1920 Sunnyside, Dept. 164, Chicago 40, Illinois.

LEARN Another language at home, easily, quickly, naturally with Linguaphone, the World's Standard Conversational Method. You learn to speak French, Spanish, German, Russian, Modern Greek, any of 34 modern languages available on lifelike conversational recordings. It's like living in another country. Complete language course available on free trial. Send for free book and details of free trial. No obligation. Linguaphone Institute, T-83-040 Radio City, New York City 20.

MASTER Watchmaking at home. Free sample lesson. Chicago School, 2328-YD Milwaukee, Chicago 47.

COMPLETE Your high school at home in spare time with 63-year-old school. Texts furnished. No classes. Diploma. Information booklet free. American School, Dept. X445, Drexel at 58th, Chicago 37, Illinois.

PEACE Of mind. Lucrative profession. Study psychology, mental science, nutrition, philosophy, related sciences. Earn degrees. Free brochure. Psychonomic Research Center, 1213 N. Highland Ave., Suite 205-PM, Los Angeles 38.

FREE Booklet. Seven Steps to Success. End money worries. Develop prestige. Amazing results. Counselors, 7912 Curragh, Burnaby 1, British Columbia, Canada.

ENGINEERING—Home study. Midwest Engineering School, 10923 Hillcrest, Hickman Mills, Missouri.

10,000 **FREE** College scholarships from unions, companies, foundations, where and how to apply, send \$1. Scholarship Research, Box 5001, Miami 1, Fla.

BLUEPRINT Reading. Learn to read blueprints with confidence in 10 easy lessons. Write: Belton, 1059A North Lawn-dale, Chicago 51.

LEARN Cha-cha right at home. John Paxton's method. Send \$1.00. Box 532, New Bedford, Mass.

PROFESSION—Correspondence course—physical therapy, massage. Diploma. Personal assistance. Northwestern Institute, Box 368, Rock Falls, Illinois.

METAPHYSICS, Religious, faith therapy correspondence courses. Diploma. Mishal, 1601 Ninth St. S.E., Roanoke, Virginia.

ENJOY Life! Be well! Solve personal problems by self-mastery. Free information. Leavitt Science, Clinton, Illinois.

AUTOSUGGESTION. Home study courses with phonograph recordings. Free brochure. Write Clark R. Bellows, 200 West 57th St., New York 19A, N. Y.

LEARN Asleep or awake. Self-help books, tapes, recordings. Free catalog. Drawer PM-697, Ruidoso, New Mexico.

SECRET Investigations. Experience unnecessary. Investigators particulars free. George Wagner, M125 West 86th, New York City 24.

PROFESSIONAL Investigators. Home study. Badge, certificate, future. Box 41197-F, Los Angeles 41, California.

HIGH School diploma at home. Licensed teachers. Approved materials. Southern States Academy, Station E-16, Atlanta, Ga.

BE A real estate broker. Study at home. Write for free book today. GI approved. Weaver School of Real Estate, 2018P Grand, Kansas City, Missouri.

WANT A diesel job? Higher pay? Advancement? We can help you qualify! Complete diesel, tractor and heavy equipment and Cummins Diesel Engine Shop-method home-training courses available. Write today. Interstate Training Service, Dept. B-3, Portland 12, Ore.

DEVELOP Mind power, personality while asleep. Use your phonograph, recorder. Amazing psychological tapes, records now available. Details free. Sleep-Learning Association, Box 24-N, Olympia, Washington.

SING, Speak with power. Self-training records. Amazing! Canfield, 2018-A Fifth Avenue South, Minneapolis 4, Minnesota.

EARN While you learn. Auto and diesel mechanics master this top paying trade. Many graduates earn \$100 a week and up. Approved for Korean veterans. For free information write Dept. No. 256, Nashville Auto-Diesel College, Nashville 3, Tenn.

PHYSICAL Therapy and massage. Home training. Practice privately or work with doctors and hospitals. Free catalogue. National Institute, Desk 4, 159 E. Ontario, Chicago, Ill.

BOOKS, Free general catalog, 100 pages. Text, vocational, educational, instructional subjects. Millions of volumes, new and used. Bargain prices. Books bought. Est. 1902. Long's College Book Co., Dept. PM, Columbus 1, Ohio.

PIANO Tuning pays. Big money in spare time. Learn at home in 30 days. No musical knowledge necessary. Phonograph, records, tools and instructions furnished. Personal instructions available. Free catalog. Capital Piano Tuning School, 3160 S.W. 16th Court, Fort Lauderdale, Fla.

INVESTIGATOR Training — Robert B. Phillips Sr., Founder, former U.S. Government Special Agent. Write to 1917-K North Kenneth, Chicago 39, Ill.

USED Correspondence courses and books sold and rented. Money back guarantee. Catalog free. (Courses bought.) Lee Mountain, Pisgah, Alabama.

BOOKKEEPERS. Operate your own "Dollar-A-Week" system. Ellis, Box 200, Cedar Grove, North Carolina.

LEARN Real estate business fast. Unlimited opportunities. Economical home-study course. Particulars free. Gordon-Howard Institute, 320 Glover Building, Kansas City 5, Missouri.

DISK Jockeys in demand. Radio station eager for men and women trained to do and sell own programs. Big money in salary, fees and commissions plus personal appearances. Successful N. Y. disk jockey has trained thousands, will show you how. Free information. No salesman will call. Darwin, Studio B, 1639 Broadway, New York 19, N. Y.

PIANO Tuning pays. Learned easily at home. GI approved. 59th year. Free booklet. Niles Bryant School, Dept. P, 3731 Stockton, Sacramento 20, Calif.

ANALYZE Handwriting for profit, pleasure. Free sample lesson, catalog reveals plan. Write IGAS, Inc., Dept. 2, Springfield 4, Missouri.

OWN Collection agency. Little "gold mine." Franklin Credit, Roanoke, Va.

INVESTIGATORS Trained, men-women. Fascinating, profitable profession, spare time study. Big pay. Details to open own agency any state. Free booklet. Investigator, Box 490, Times Square Station, New York 36, New York.

SWEDISH Massage. Home study. Diploma. Illinois Licensed School, 3809 Alta Vista, Chicago 13.

PLAYS, STORIES, MANUSCRIPTS

WANT Your book published? Learn how we publish, advertise, promote, distribute. Many successes. Free booklet PM. Vantage, 120 West 31, New York City. Midwest office: 220 S. Michigan Ave., Chicago, Ill.

PUBLISH Your book! Join our successful authors. Publicity, advertising, promotion, handsome books. All subjects invited. Send for free manuscript report and our detailed booklet. Comet Press Books, Dept. MP 4, 200 Varick Street, New York City 14.

AUTHORS! Publisher seeks manuscripts. Free details. Pan Press, Tahlequah, Okla.

ADVERTISING AGENCIES, LETTER WRITERS, FOR ADVERTISERS

BEFORE Advertising — Get instructive Ad-Guide and newspaper-magazine rate-book, free. Chicago Advertising Agency, Chicago 4.

DISSATISFIED Advertisers. If ads don't pull write: Kelley, 84 Longview, White Plains 6, N. Y.

FREE! Red-hot book, "More Profit From Your Advertising." Lists—best mail order magazines, newspapers. Adservice, 516 Cornelia, Chicago 13.

ADVERTISE: 24 Words, 100 Canadian newspapers, \$5.50. Lists free Advertising Bureau, 10511-C Springfield, Chicago 43.

NEW Mothers. \$7.50 thousand. Sample \$1.00 hundred. Lorraine, 506 Bevan, Joliet, Illinois.

"AMAZING New Book"—"Profits From Classified Advertising." Tells how and what to advertise. Be sure to read this book before you invest one cent in advertising. Write for your copy now. Just send 10¢ for postage and handling. W. Johnson, Classified Advertising Manager, 202 East Ontario Street, Chicago 11, Illinois.

NOW Ready: New, amazing Classified Advertising Record Book — prepared especially for classified advertisers. Here is a book that tells you instantly whether or not your advertising in any publication is paying you real results. You can tell immediately how many inquiries each publication produced—how much cash received from every ad. Spaces are provided for the name and address of the publication, date of issue, space used, rate, cost of ad, key number, etc. You have a complete record of each publication right before your eyes. Plenty of space to keep accurate record of 28 separate publications. You can have a copy by sending only 10¢ to cover postage and handling. Send for your copy now. W. F. Johnson, Classified Adv. Mgr., Popular Mechanics Magazine, 204 E. Ontario Street, Chicago 11, Illinois.

MAILING Lists most any classification \$5.00 1000. Your circulars mailed with ours \$4.00 1000. Write for our literature. Dixie Mailers, King, N. C.

CREATIVE Advertising. Magnetic copy. Dramatic layouts. Moran Agency, Shoemakersville, Pennsylvania.

ADVERTISING. Result-getting ads prepared, placed newspapers, magazines, radio, anywhere! Lowest rates. Catalogue free. Baker Advertising Agency, 189 W. Madison, Chicago 2.

CARTOONING, COMMERCIAL ART, SHOWCARD & SIGN PAINTING, TATTOOING

YOU Can entertain with chalk talks. Catalog 10¢. Balda The Cartoonist, Oshkosh, Wis.

ART—Learn at home. Earn big money. Learn illustrating, cartooning, painting, figure, fashion drawing, TV art, at home in spare time. All for 20¢ a day. Send for free book. No obligation. Washington School of Art, Studio 144, Port Washington, N. Y.

CARTOON Your way to success! Internationally known instructor, Raye Burns, will personally teach you to create original, salable cartoons at home. Cost of course is very low. Write for free details. Raye Burns School, Box 3583-P, Cleveland 18, Ohio.

LEARN Sign painting at home. Free talent test. Ben Kerns, Box 812-PM, Greenville, S. C.

LEARN Profitable, fascinating tattooing. Illustrated information \$1. Zeis, 728-C Leslie, Rockford, Illinois.

LEARN Sign painting with fascinating system. Straley, 410 S. Western, Springfield, Ohio.

PAINT Signs! Use patterns! Alphabet \$1.00. Harwell, PM-460, Byrdstown, Tenn.

"HOW To Make Money With Simple Cartoons." A book everyone who likes to draw should have. It is free; no obligation. Simply address Cartoonists' Exchange, Dept. 94-C, Pleasant Hill, Ohio.

MAKE Signs, stencils. Use Anderson's lettering patterns. Alphabets, numerals to 6" \$1.00 postpaid. Anderson Studio, 1034 East Colfax, Denver 18, Colorado.

RUBBER STAMPS AND OFFICE SUPPLIES

FINEST Commercial quality rubber stamps, 3 lines, \$1.00. Fast! The Evero Co., Box 5377, Phoenix, Arizona.

POCKET, 3 Lines \$1.00. Guaranteed W. J. Specialty, 8464 Manhattan, Detroit 11.

RUBBER Stamp, three lines, \$1.00. Free literature. Grimsley's, Box 5314, North Charleston, S. C.

PERSONALIZED Rubber stamp printer 50¢. Falco, 1122 Prospect, Lansing 12, Mich.

CATALOG! Free from rubber stamp manufacturer. Campfield, Box 798; Springfield 1, Massachusetts.

RUBBER Stamps, labels sign letter stencils, inks. Illustrated style folder free. Warner, Box 482B, Aberdeen, Maryland.

INDEXED. Cushioned, 3 lines \$1.00, 4 or 5 lines, \$1.50. Signature stamps, \$3.50. (Script, print, or old English.) Free stock stamp literature. Youngers Stamp Shop, Princeton 4, Iowa.

FREE—Rubber stamp catalog. Martin, 1425 Major Drive, Jefferson City, Missouri.

4-LINE Pocket stamp, \$1.00. Self-inking case. Two (different), \$1.50. Retter, 223-PM, Tipp City, Ohio.

TYPEWRITERS, DUPLICATORS, OFFICE DEVICES

RECONDITIONED Typewriters, duplicating, printing devices. \$25.00 up. Supplies. Appliances. DixieGraph, King, N. C.

**PRINTING. MULTIGRAPHING.
MIMEOGRAPHING.
GUMMED LABELS**

BEST Quality printing. Reasonable prices. Samples. Estimates. Fitz. Inc., 347 Worthington St., Springfield, Mass.

50 DECALS: Name, address, \$1. Eddy, 7 Greenacres, West Hartford 7, Conn.

OFFSET Printing, 1000 8 $\frac{1}{2}$ x11 \$4.95. Alpine, Box 676-E, Cupertino, California.

FREE Business printing catalog. Samples. Howprint, 723-C Eunice, Webster Groves 19, Missouri.

MIMEOGRAPHING—Letters, pricelists, formulas, instructions. Lowest prices. Lem's Letter Shop, 5710 Stanton, Detroit 8.

1000 EMBOSSED Business cards, \$4.00—Name and address rubber stamp, \$1.00. Illustrated folder free! Price Brothers, 406-PM, South Main, Los Angeles 13, California.

PRINTING—All kinds. Best quality, stock, workmanship. Reasonable. Free samples. Hilltop, Box 2253, Oakland 21, California.

BUSINESS Cards (raised letters) 500—\$2.50, C.O.D. Samples free. Picha, 27600M Joy, Livonia, Michigan.

1000 BUSINESS Cards, raised letters, \$3.95 postpaid. Samples. John H. Taylor, R.D.2, Box 215, West Middlesex, Penna.

FREE Catalog, samples, quality work. Willis Printing, Box 661, Albany, Georgia.

FREE Catalogs postpaid printing. Rubber stamps. DM Press, Sebastopol, Calif.

OFFSET. Highest quality. Free pricelist, samples. Napco Press, 1744 Bath Avenue, Brooklyn 14.

ADS Running under this heading sell printing. Ask me for proof. I'll gladly send you amazing facts. Ask for Folder "P." F. W. Johnson, 200 E. Ontario St., Chicago 11, Ill.

1000 BUSINESS Cards "raised letters" \$3.50 postpaid. Samples. Elco, 5909 Highlandview, Sylvania, Ohio.

250 8 $\frac{1}{2}$ x11 HAMMERMILL Letterheads \$2.95. 250 envelopes \$2.95. Guaranteed. Samples! Davis, 7609 Spruce Road, Baltimore 22, Maryland.

100 6 $\frac{3}{4}$ ENVELOPES. 100 5 $\frac{1}{2}$ x8 $\frac{1}{2}$ letterheads printed, \$2.35. M. Fortney, Route 3, Dillsburg, Penna.

750 NAME Address labels 35¢. Catalog 10¢. Scheetz's, Sellersville, Penna.

1,000 BUSINESS Cards. Raised letters, \$3.95. Samples. Pioneer, PM-4 Island Park, N. Y.

QUALITY Printing, reasonable. Cerny, 9700 West 56th Street, La Grange, Illinois.

1,000 CARDS \$2.75. Business printing. Low postpaid prices. Samples. Lane, Box 2038, Niles, California.

1000 NAME And address labels \$1.00. H&T Supply, 510S. Clinton, Dallas, Texas.

BOND: 100 5 $\frac{1}{2}$ x8 $\frac{1}{2}$ Letterheads, 100 6 $\frac{3}{4}$ envelopes, \$2.25. Guaranteed! Greg McCulloch, 1375 Josephine, Denver 6, Colo.

PERSONALIZED Items: iron-on cloth labels, stationery, informals, envelopes, shipping labels, etc. Free circular. A. Golfieri, 103 Revere St., Revere 51, Mass.

OFFSET—Professional layout, graphic art, copy, rewriting. Grosch, Fox River Grove, Illinois.

BUSINESS Cards, letterheads, envelopes, post cards, labels, rubber stamps, offset printing. Free samples. Youngers Printing, Princeton, Iowa.

1000 PRINTED Envelopes 6 $\frac{3}{4}$, \$5.95; #10, \$7.95; statements, \$5.95. Postpaid. C. Barnes, Box 823, Pulaski, Tenn.

100 EACH 8 $\frac{1}{2}$ x11 Letterheads, 6 $\frac{3}{4}$ envelopes, carefully printed \$2.35 postpaid. Race Printers, Hudson, New York.

OFFSET Circulars 8 $\frac{1}{2}$ x11 one color two sides 10M \$61.00. Two colors one side \$66.00. Craftsmen, 130 Bergen Blvd., Fairview, N. J.

BUSINESS Cards two colors \$4.85. Black \$3.35. Free list. Peerless, 266 Dean, Brooklyn 17, New York.

HIGHEST Quality. Lowest prices. Printing, offset, photo-engraving. Color. Own plant. Herrion, 119 Lafayette, New York 13.

PRINTING OUTFITS AND SUPPLIES

PRINTING Presses, type, supplies. Lists 4¢. Turnbaugh Service, Mechanicsburg, Penna.

RUBBER Stamp presses, supplies. Kiewit, 2025 Barney Road, Kalamazoo, Mich.

RUBBER Stamp presses, hydraulic operated, electrically heated. Sizes 5"x8", 8"x12", 10"x15". Starting outfits, supplies. Printing presses, supplies. Custom Manufacturing, 507-P N. Jefferson, Springfield, Missouri.

TYPE For rubber stamp making and printing made from hard foundry metal. Send for free 20% discount catalog. Barco Type Founders, 64 Wagner Dr., Northlake, Ill.

TYPE And cuts for printers and rubber stamp makers. Largest selection in U. S. Catalog free. Acme Type, 633 Plymouth Court, Chicago 5.

MAKE Your own self-molding rubber stamps and printing cuts. Plexirubber, Argyle 1, Wisconsin.

DO Your own printing. Save money. Simple rules. We supply everything. Print for others; good profit. Raised printing like engraving too. Have home shop. Details free. Kelsey Presses, V-11, Meriden, Connecticut.

FOR INVENTORS

INVENTIONS Needed immediately for manufacturers. For additional information write Kessler Corporation, C-54-FI, Fremont, Ohio.

SEARCH Details free. Patent Searching Service, 437 Washington Building, Washington 5, D. C.

MAKE Money from ideas. Information free. Grayland, 5312 Grace, Chicago 41.

QUALITY Patent searches \$6.00. Copies of closest patents forwarded. Free "Protection Certificate." American Patent Search Co., 422 Washington Bldg., Washington 5, D. C.

PATENT Searches \$6.00. 48-hour service. Formerly with U. S. Patent Office. Free invention protection forms. Write Raymond L. Smith, Patent Searcher, 620 Sheraton Building, Washington 5, D. C.

INVENTORS! Our Patent Search Department administers searches expertly. \$6.00. For dependable service, free invention protection forms write: United States Inventions Brokerage, 78-S Wall Street, New York 5, N. Y.

FREE Registration protection certificate, plus facts on new low cost professional patenting kit. Washington Patent Pending Service, Box 4955, Dept. 164-D, Washington, D. C.

PROFESSIONAL Searches of the Patent Office records. Dependable. Reliable. \$6.00. For free protection forms write: Inventions on Demand, 412 Albee Building, Washington 5, D. C.

DON'T Pay high fees! Obtain U.S. patent yourself. It's easy with Professional Kit with fill-in forms. Free "Registration Form." Patent Protection Institute, 2000 P Street, N.W., Washington 5, D. C.

FREE! A valuable booklet full of information every inventor needs. Tells how to protect, evaluate, and market your invention. Can save you time and money. Write for free copy of "The Inventor's Guide." No obligation. Inventors Guidance Service, Calimesa, Calif.

PATENT Searches \$6.00. 48-hour airmail service. Invention protection forms free. Write Patent Engineering Service, 711 14th Street, N.W., Washington 5, D. C.

INVENTORS—Get the best offer first! Patented or unpatented. Write Carl Sommer, Director, Industrial Invention Sales, 3136-A Sylvania Ave., Toledo 13, Ohio.

INVENTORS—Save high fees! Apply for your patent yourself. New do-it-yourself patent kit now makes it easy. Free "Registration Form." Miss Claire Arden, 806 Wm. Penn Annex, Philadelphia 5, Penna.

YOU Can easily apply for patents. Save with complete professional kit. Free registration certificate. Patent Associates, 1214 Commonwealth Bldg., Philadelphia 7, Penna.

PATENTS Skillfully prepared and filed for total service charge of \$200.00 for U. S. and Canada for simple invention, with valuable development and market service. Accurate receipt for any data sent me. Patent search and valuable report \$15.00. 30 years' experience as patent and development engineer. Foreign patents obtained. Joseph O'Brien, 132 Nassau St., New York, N. Y.

INVENTORS! Determine patentability of your invention. Searches of the Patent Office Records administered professionally—\$6.00. For free invention protection forms, dependable service write Washington Patent Office Search Bureau, 1426 G Street, N. W., Washington 5, D. C.

INVENTORS' Complete service. Cash-royalties sales. Inventions researched. Patent development engineering. Free invention certificate. George Spector, Licensed Invention Engineer, 3615 Woolworth Building, New York.

INVENTIONS Wanted now by my manufacturer clients. Patented. Unpatented. Write Gilbert Adams, Patent Broker, 80 Wall St., Financial District, New York City.

PATENT Searches, including copies of nearest patents, \$6.00. Reports airmailed within 48 hours. More than 200 registered patent attorneys have used my service. For free invention protection forms, write Miss Ann Hastings, P. O. Box 176, Washington 4, D. C.

WE Have the markets if you have the ideas. Harvey Engineers, Cambridge 1, Maryland.

INVENTORS: Test the commercial value of your patented or unpatented inventions, quickly and inexpensively. Write for free information. Institute of American Inventors, Dept. 40-B, 635-F St., N.W., Washington 4, D. C.

HIGHEST Cash, royalties. Inventors having good ideas that need developing, drawing, patent search, marketing. Write Inventors Creative Service, 354 South Spring, Los Angeles 13, California.

INVENTORS! Why be broke? Turn your invention into cash. If saleable, we can sell it. Write Universal Inventions, Box 298, Marion, Ohio.

INVENTIONS WANTED

SUPERIOR Promotions. Patented; unpatented inventions. Information booklet, free. Superior, 338-344 North Rodeo, Beverly Hills, Calif.

INVENTIONS Wanted. Cash, royalty, world wide. Free "Protection Certificate." Inventions International, Box 172, New York 8, N. Y.

INVENTORS! Outright cash sale or royalties for your inventions. Patented. Unpatented. Constant demand from our client manufacturers. Write: United States Invention Brokerage, 78 Wall Street, New York 5, N. Y.

FREE List needed inventions. Protection form. Inventors Sales and Engineering Bureau, Box 4973, Dept. 164-D, Washington, D. C.

INVENTIONS Needed immediately for manufacturers. For additional information write Kessler Corporation, C-54-IW, Fremont, Ohio.

INVENTIONS Wanted for immediate promotion! Free Protection Form. Casco, Dept. F, 1424 "K" Street N.W., Washington 5, D. C.

INVENTORS—Get the best offer first! Patented or unpatented. Write Carl Sommer, Director, Industrial Invention Sales, 3136-A Sylvania Ave., Toledo 13, Ohio.

INVENTIONS Wanted: patented, patent pending. 29 years experience promoting inventions. National Service Bureau, 3120 Meramec, St. Louis 18, Mo.

INVENTORS' Complete service. Cash-royalties sales. Inventions researched. Patent development engineering. Free invention certificate. George Spector, Licensed Invention Engineer, 3615 Woolworth Building, New York.

INVENTIONS Wanted now by my manufacturer clients. Patented. Unpatented. Write Gilbert Adams, Patent Broker, 80 Wall St., Financial District, New York City.

INVENTORS: Hundreds of manufacturers have requested our assistance in locating marketable new products. Complete information free. Institute of American Inventors, Dept. 40-D, 635-F St. N.W., Washington 4, D. C.

INVENTIONS Wanted. Patented; unpatented. Tremendous manufacturers lists. Global Marketing Service, 2420 77th, Oakland 5, California.

INVENTORS! Consider our offer first before selling or licensing your invention on a cash or royalty basis. Patented. Unpatented. Inventions on Demand, 79 Wall Street, New York 5, N. Y.

ARE You interested in offers from reliable manufacturers for your invention? Patented, unpatented. Harvey Engineers, Cambridge, Maryland.

CASH, Royalty, obtainable for good ideas, inventions. Ketchum's Advertising, B-1058A, Springfield, Illinois.

INVENTORS! Don't sell your invention, patented or unpatented, until you receive our offer. Write Universal Inventions, Box 298, Marion, Ohio.

MANUFACTURING

MODELS — Small lot manufacturing. Metals, plastics, etc. Milburn, Burlington, Kentucky.

MODELS, MODEL SUPPLIES

ROCK-A-CHUTE Missile kits, parts, motors. New illustrated catalog 25¢. Central Rocket Company, Waupaca, Wis.

LIONEL Trains. Big discounts. Catalog 25¢. Mack Bros., 2043-P Chicago Ave., Chicago 22.

SHIP Models. Most complete line in New England, kits, fittings, plans, books, tools, engines, motors. Illustrated catalog 35¢. James Bliss & Co., Inc., Dept. SM, 342 Atlantic Ave., Boston 10, Mass.

ROCKET Supplies—Nozzles, cones, tubes. Specials also made. Catalog 10¢. Sky Mfg., Mineral Point, Penna.

SHIP And yacht model fittings: blueprints. Send 40¢ for illustrated catalog listing hundreds of items. A. J. Fisher, Inc., 1002-1 Etowah Ave., Royal Oak, Mich.

SHIP Model kits and fittings: clippers, frigates, etc. Catalog, paint-tool list, book list, 25¢. Model Shipways, Box 85, Bogota, N. J.

MODEL Cars, electrified roadways. Electromat Company, Box 13742, Dallas, Texas.

SHIP Models and yacht supplies complete. Large 68 page catalogue 50¢. Bill Wild's, 510 East 11 St., New York City 9.

"POWER Drives Handbook"—36 pages illustrating many types motor drives for model autos, boats, displays, turntables, etc. Mail 25 cents cash, returnable first order \$3.00 or more. Wilson's of Cleveland, Dept. PM, P.O. Box 8995, Ft. Lauderdale, Fla.

HOME CRAFTSMEN

KILN Dried walnut, cherry, etc., hardwoods, blocks, and squares. Midland Lumber Company, P.O. Box 262, Savannah, Missouri.

FREE. New plans catalog. Make 2400 things. Fun. Profit. Craftplans, 1322-A Wabash, Chicago 5.

KNOCKDOWN Cedar chests, also over fifty kits. Catalog 25¢. Giles Kendall Co., Huntsville 2, Alabama.

WOODWORKING And cabinetmaking course for beginning and advanced home craftsmen. Only complete low-cost home training program available. Write for free booklet. Interstate Training Service, Dept. G-3, Portland 13, Ore.

KNOCKDOWN Cedar chests and lumber. Free price list. Bedford Lumber Company, Shelbyville, Tennessee.

LEATHERCRAFT. Send 10¢ for catalog. Saxcrafts, Inc., 1101 N. 3rd, Milwaukee, Wisconsin.

FREE Do-it-yourself leathercraft catalog. Tandy Leather Company, Box 791-K34, Fort Worth, Texas.

GRANDFATHER Clock movements, kits, case plans. Wholesale catalog 25¢. Mason-Sullivan, Noroton 7, Conn.

WRITE For free catalogue of craft supplies. New lower than discount prices. Apache Leather Co., 2804 East Washington St., Phoenix, Arizona.

FREE! Leathercraft catalog. Hundreds of new items. Write MacPherson Bros. Leather Company, Dept. E, 730 Mission St., San Francisco 3, Calif.

TAKE Shrink and swell out of wood with polyethylene glycol. New treatment developed U. S. Forest Products Laboratory published October and December issues Forest Products Journal. Chemical now available. Crane Creek Company, Box 268, Waseca, Minnesota.

LEARN Art metalcraft and jewelry making. Complete, inexpensive, home training course now available. Metals and materials furnished. Send postcard for free booklet. Interstate Training Service, Dept. L3, Portland 12, Oregon.

"RUG Braiding Simplified" by Kay Flemer. Color photographs, patterns, material requirements and complete instructions. Send \$1.00 to: Kay Flemer, Box 65E, Chatham, N. J.

BUY Picture frame moldings at wholesale, actually less than cost of raw lumber. All styles and widths. Free delivery. Write for free list. Chesapeake Picture Frame Co., 511 N. Charles St., Baltimore 1, Maryland.

NEW Big illustrated catalog. Supplies for leathercraft, metalcraft and numerous small inexpensive crafts. Prompt shipments. Top values. Latest ideas. Send 10¢ today to J. C. Larson Co., Dept. 9727, 820 S. Tripp, Chicago 24.

FREE Leathercraft catalog—quality kits, leather, tools. Handicrafters, Dept. P, Box 427, Montrose, Calif.

CRAFT Catalog free. Mosaics, leathercraft, enameling, plastic casting, metal tooling, floralcraft, shellcraft. Many more. Kit Kraft, 204, Studio City, Calif.

VIOLIN Making supplies. Free catalog. Fred Artindale, Box 71992, Los Angeles 1, Calif.

BEGINNERS Make fine furniture in 25 lesson projects. Free details. Old Craftsman, Box 2220, Dearborn, Mich.

BELT Sander—easily made from plans. Also, low cost kits. Free literature. Gripple, 121-A School, Buffalo 13, N. Y.

PROFITS To 3,000% making Shellcraft jewelry. We show you how to cash in! Details, illustrated booklet, wholesale catalog 25¢. Shellcraft, Dept. AA, Box 804, Panama City, Florida.

101 PATTERNS Of smart gifts, novelties, shelves, action windmills plus "Make Money Jig Sawing" \$1.00. Mastercraft, 45M, 7041 Olcott, Chicago 31.

SAVE Money on your vacation! Use thoroughly tested, cheap to construct, car top sleeper for entire family. Beds stay clean, ready for use. Protection from snakes and insects. A natural for the home craftsman. Plans \$2.35. Bondercraft Engineering, 5165 East 30th Street, Tulsa, Oklahoma.

MAKE Attractive walnut serving tray for under \$6.00. Excellent for gifts or sale. For complete easy instructions send \$1 to A. Schloss, 490 Bleeker Avenue, Mamaroneck, New York.

IT'S New, different, adapter attaches tool to motor shaft, converts motor into grinder, buffer, saw, etc. Inexpensive; manufacturer to user. Write: Estess Enterprises, Parker, Indiana.

AMAZING Book reveals exactly what to pay for minor home repairs! Each price proven! Rush \$1.00. Satisfaction guaranteed. Home Repair Books, Dept. P-4, 267 Meadows Building, Dallas 6, Texas.

DO IT YOURSELF

SPARROW Or pigeon trouble? Build your own trap and catch hundreds. Easy to make plans \$2.00. Johnson's, Waverly, Kentucky.

WATER Softeners, filters. Assemble yourself. Save on tanks Solo Valves, zeolite, etc. Free instructions, price list. McCarthy Company, 7136 W. State Street, Milwaukee 13, Wis.

MAKE A garage or workshop stove that burns used crankcase oil. Safe, clean, and economical. Send \$1.00 for complete details and detailed drawing. Write: Box 167, Paradise, Mont.

SWIMMING Pool. Read how I built a 12' x 27' excavated pool and filter for around \$300.00. Illustrated booklet \$3.00. Bob Garmater, Box 16, Woodburn, Ind.

FURNITURE Refinished "antique old ivory" over any finish, without moving from room. \$1.00 to: Antiquing Method, 403 No. Ridgeland, Oak Park, Ill.

EVERLASTING Welder from junk. Fain Electric, R. 13, Fort Worth 3, Texas.

FREE Do-it-yourself leathercraft catalog. Tandy Leather Company, Box 791-K34, Fort Worth, Texas.

HOW To harden steel. \$1.00. PSI, 1342-A East 58th Street, Kansas City 10, Mo.

FREE Check-list covering more than 500 classifications of projects, plans, instructions, service and repair information detailed in Popular Mechanics famous series of instructional booklets, books, patterns, and blueprints. List covers an extremely wide variety of do-it-yourself data on home remodeling, repair and improvement, hobbies, crafts, boating, games, lawn and garden, and hundreds of others. For your free copy of this helpful list, write: Service Bureau, Popular Mechanics, Room 520, 200 East Ontario, Chicago 11, Ill.

WATCHES, OLD GOLD, JEWELRY

WATCH And clock repairing books. Free catalog. North American, 2320-AR Milwaukee, Chicago 47, Illinois.

GENUINE Brazilian citrin topaz cut stones. \$1.50 per ct. Satisfaction or money back. M.H.T. Imports, 828 Treat, San Francisco, Calif.

HIGHEST Cash paid for old gold, jewelry gold teeth, diamonds, watches, silver. Mail articles today. Information free. Chicago Gold Refining Co., 6 E. Monroe, Dept. 2158, Chicago 3.

EASY To make costume jewelry. Catalog 10¢. Introductory kit including catalog \$1.00. J & M Novelties, Dept. CD-3, Box 173, Broadview, Ill.

WE Make your old watches and jewelry like new. Ask for estimate. Cosmo, New York 35.

WANTED—Old gold jewelry, spectacles, watches, teeth, silverware, mercury for cash. Electro Company, 1042 Highland Ave., Buffalo 23, N. Y.

BULOVA Watches etc. Out of pawn. \$2.95 up. Cosmos, New York 35.

COSTUME Jewelry supplies, settings, rhinestones, etc. 88 page illustrated catalog. 30¢. Milady, Box 1328, G.P.O., New York City.

FREE Catalog. Costume jewelry parts. Supplies. Reasonable prices. Fast service. Guaranteed quality. Unique merchandise. Folsom's, Box 52, Medford 55, Mass.

HIGHEST Cash for old gold, jewelry, gold teeth, watches, diamonds, silverware, spectacles, platinum, mercury. Free information. Rose Refiners, Heyworth Building, Chicago 2.

WATCHMAKERS' Tools, materials, supplies, watches. Catalog. Gales, Box 1000, Chicago 90, Illinois.

WATCHMAKERS Journal contains watch repairing instructions. Sample copy 25¢. Box 3218-M, Daytona Beach, Fla.

RAZORS, BLADES, SHARPENING

RAZOR Blades \$9.00 thousand. Double edge. Ford, Box 26, St. Albans 12, N. Y.

FOR THE HOME

AUTOMATIC Potato peeler. No potato waste. \$6.95 postpaid. Cook Enterprises, 54C Holland, Asheville, North Carolina.

OF INTEREST TO WOMEN

MAKE Money weaving rugs at home for neighbors on \$89.50 Union Loom. Thousands doing it. Booklet free. Union Loom Works, Dept. 3, Boonville, N. Y.

HOUSEWIVES, Teachers, students, office workers, if you need extra cash each week but household or other duties prevent you from taking a part-time job, learn how you can earn by accepting orders to Popular Mechanics, Good Housekeeping and all other magazines. No experience needed. Write Popular Mechanics, Room 4W, 250 West 55th St., New York 19, N. Y.

FREE Import catalog. Get free gifts. We explain how. No selling. Send 25¢. Wentworths, P.O. Box 143, Muskegon, Michigan.

TREMENDOUS Savings. Practically everything, cars, housewares; details free. Snyder, 7945 Tippecanoe, San Bernardino, Calif.

FREE Wholesale pricelist. Full line popular cosmetics. Profitable full or part time business. Velvet Touch, 2301 N. Oak Park, Chicago, Ill.

SELL Fine fabrics. Get yours wholesale. Box 863, Norwalk, Conn.

DRESSES 24¢; Shoes, 39¢; men's suits, \$4.95; trousers, \$1.20. Better used clothing. Free catalog. Transworld, 164-G Christopher, Brooklyn 12, N. Y.

PERSONAL

BIBLE Questions answered. Stamped envelope. Bylon, 17167 Bentler, Detroit 19, Michigan.

BORROW By mail. \$100-\$600. Anywhere. Air mail service. Postal Finance, 200 Keele Building, Dept. 17-E, Omaha 2, Neb.

LOANS By mail. \$50 to \$600 for any purpose. Employed men and women eligible. Confidential, 2 years to repay. Write for free loan application. American Loan Plan, City National Bldg., Dept. PM-3240, Omaha 2, Nebraska.

BORROW \$100 To \$600 by mail. Quick, easy, private. No co-signers. Repay in 24 small monthly payments. For the amount you want write today to Dial Finance Co., 410 Kilpatrick Bldg., Dept. D-1, Omaha 2, Nebraska.

LEARN Much about yourself. Handwriting analysis \$1.00. Burrows, P.O. Box 12594, St. Petersburg 33, Fla.

WE Remail! Post card brings our confidential system. R. Lawrence, 116-33-142 Street, Jamaica 36, New York.

REMAILING SERVICE

SOUTH America remails 3 for \$1.00. Includes postage. Larios, Brownorte 382, Santiago, Chile.

NORTH Pole, Alaska remails \$1.00. H. Daniel, P.O. Box 1412, Fairbanks, Alaska.

CONFIDENTIAL Worldwide remail-forwarding service. Smith, 1306 South Darlington, Tulsa 12, Oklahoma.

RENT Confidential postal re-mailing, receiving-forwarding address. Agents since 1950. William McLaughlin, 800 Stewart, Columbus 6, Ohio.

REMAILS 25¢. Monthly \$3.00. P.O. Box 195, Fort Lauderdale, Florida.

PRIVATE, Secret mail address. Details free. Box FG-44, Salt Lake City 16, Utah.

SECRET Letter, package receiving, forwarding. \$3.00 per month from Texas or Box 347, New Castle, Indiana.

LETTERS Mailed 25¢; forwarded 30¢. Henri Labrie, Room 7, 380 Elgin St., Ottawa, Ont., Canada.

REMAILS 25¢. Secret receiving forwarding. Details free. Lillian's, Box VC 3011A, No. Hollywood, Calif.

CHEYENNE Remails, 25¢. Monthly \$3.00. Ray, Box 2434, Cheyenne, Wyoming.

MAILING Lists. Remail service. Details. Fred's, 3910 University Avenue, Madison 5, Wisconsin.

LETTERS Remaild 25¢. Free details on receiving-forwarding service. John Green, Box 2353, Colorado Springs, Colorado.

CONFIDENTIAL New York City mailing. Receiving, forwarding, address, \$3.00 month. Remails 25¢. Birnman, 109 W. 42 St., New York 36, N. Y.

BOSTON Remailing 5¢-20¢. Details free. Selby Service, Box 12-N, Chestnut Hill 67, Boston, Mass.

GUAM Remail. Letters 50¢. Milpat, Box 536, Agana, Guam, M. T.

FOREIGN Remail 50¢. Monthly \$3.00. Arbin Ignatigr. 4, Stockholm G, Sweden.

SECRET Mail receiving-forwarding system. Hedgpath, Box 830, Alhambra 23, California.

REMAILS — 25¢. \$3.00 month info. Kenny, 8420 Laddie Rd., Minneapolis 21, Minn.

SAN Francisco remails and forwarding. \$4.00 month. Souveniers, Box 783, San Francisco 1, Calif.

HAWAII — Secret mail address. \$3.00 month. Details free! Write today: Fobel, 617-P, Kuaiaina, Kailua, Hawaii.

REMAILS 25¢. Monthly rates. Campbell, 130 E. Dorothy Lane, Dayton 19, Ohio.

CONFIDENTIAL, Prompt remailing 25¢. Monthly \$3.00. Ked Riding, 1038 Palm St., Las Vegas, Nevada.

JAPAN 2 Reairmails \$1. 3 seemail \$1. Ross, 911 Nishihara-cho, Shibuya-ku, Tokyo.

TREASURE FINDERS

445 TREASURES, United States map 2x3 feet, plus catalogue. \$1.00. Foul Anchor, Rye 2, N. Y.

TREASURE Locators, "Screen." Special model. Batteries V. last 1000 hrs. \$185.00. Literature in English and Spanish. Free catalog. Adolfo Vicente, 659, Escobar St., Havana, Cuba.

METAL Locator kits and assembled models from \$39.90. Transistorized and underwater models available. Free catalog. Electronic Applications, Dept. M, Box 8, Arlington 10, Virginia.

DISCOVER Buried loot, sunken treasure, gold, silver, coins; battlefield and ghost town relics, with powerful transistorized locators pioneered and perfected by Goldak. Low as \$79.50. Free, exciting information; literature on maps. The Goldak Co., 1541 West Glenoaks Boulevard, Glendale 1, California.

GOLD-Silver detectors. Geiger counters. Violites for tungsten, etc. Best available. Guaranteed. Information free. Detectron, Dept. 8, Sylmar, California.

TRANSISTORIZED M-Scope unexcelled detecting treasures, gold, silver, etc. Lightweight, supersensitive, dependable. From \$59.50. Easy terms. Free catalog. Fisher Research, Dept. C-1, Palo Alto, Calif.

TREASURE! Handbook, map, 25¢. Locators. Howe, 811 Kansas, Atchison, Kansas.

FOR SALE—MISCELLANEOUS

HEARING Aid batteries, wholesale. Free list. Habs, Box 51, York, Penna.

HEARING Aid batteries, save! Free list. Habs, Box 51, York, Penna.

MAGNETS. Plastic. (12), \$1.00. Cosmic Enterprises, 4526 Miller, Gary, Indiana.

WANTED—MISCELLANEOUS

QUICKSILVER, Platinum, silver, gold. Ores analyzed. Wholesale Terminal, Norwood, Mass.

MISCELLANEOUS

FREE Listings. Buy or sell through Southwestern, 1306 South Darlington, Tulsa 12, Oklahoma.

BOOKS On antiques and their prices. Free circular! P. Warman Publishers, Uniontown, Penna.

GET Samples, opportunities, magazines, catalogs, offers galore! Your name in 5000 big mail directories, 25¢. Results guaranteed. King's, Moorestown, Ontario, Can.

ORNAMENTAL Iron designs. Book of 1600 beautiful, practical designs for railings, columns, etc. Free literature. Cunningham, 3881 South 3200 West, Salt Lake City 4, Utah.

YOUR Name wanted. We'll send 1000 publishers, mailers, wholesalers your name, on our list one year 25¢. Dixie Mailers, King, N. C.

CIGARETTES: Make 20 plain or filter-tips for 9¢. Facts free. Moberly, Box 915, Owensboro, Kentucky.

100,000 PRODUCTS Wholesale — Free catalog! Send postcard: Econ-O-Mart, Whippany 15, New Jersey.

SUPER Memory overnight! Success guaranteed! Bijou, Box 1727-M, Hollywood 28, California.

HOW To improve your golf score. \$1.00. Satisfaction. Albetco, Box 843, Union, N. J.

IMPRESS Your friends. Receive from South America one beautiful senorita's picture with lovely inscription your name, \$1.00. Three different \$2.00. Larios, Brownorte 382, Santiago, Chile.

TINSEL Signs, dime. 15 assortment, \$1.00. Cool cob cigarette holder with each sign. Wayne's, Box 3, Jefferson, Iowa.

TRADESMAN, Handyman, homeowner. Lay your own brick, rock, stone work. Excel the professionals. No special training needed. Use our new revolutionary guard guide tools. You'll be amazed and satisfied. 10 day money-back guarantee. Order today Kit #4. Only \$3.95 postpaid. Quist Mfg. Co., Box 307, Dept. P4, Puyallup, Washington.

DECAL Transfers. Identify tools, guns, sports equipment. Name-address only, 50—\$1.00. Unique Enterprises, 214 10th, Toledo 2, Ohio.

UNUSUAL Purchases. Imports, wholesales, etc. Catalogs \$1.00, deductible from first order. House of Brown, P.O. Box 8741, Washington 11, D. C.

LET Us tell you how to turn the reading habits of your friends into profit for you. \$10.00, \$25.00 or \$50.00 can easily and quickly be made under our Popular Mechanics subscription plan. No experience needed. Write Popular Mechanics, Room 4M, 250 West 55th St., New York 19, N. Y.

FOR Sale. Books, novelties, household items. Write for information. H. A. Wernly, 514E, Allegheny Ave., Philadelphia 34, Penna.

SEND Us wool for blankets. Free literature. West Texas Woolen Mills, 421 Main, Eldorado, Texas.

RECEIVE Samples! Bargains! Offers! Mail from everywhere, 25¢. Lee Wiersma, Orange City, Iowa.

RECEIVE—Magazine samples, mail offers, bargains from everywhere. Get listed 25¢. Rorick, Cincinnati 26, Ohio.

LEARN To dance the cha-cha-cha, waltz, foxtrot, and other popular steps. Book only \$4.50. Reynec, 31 University, Buffalo 14, N. Y.

BEADED Necklace or bracelet made by Chippewas \$2 each; both \$3.75. A Schloss, 3134 No. Victoria, St. Paul, Minn.

BRAND New concrete molds for beautiful leg pedestal, supports sun dial, gazing ball, bird bath, etc. It's hot. Staples Foundry, Mt. Vernon 7, Indiana.

SOIL Concrete—Make your own sidewalk, driveway for \$2 yard, have \$14 a yard. For information send \$1 to Box 168, East Palestine, Ohio.

GENUINE Marble & granite tombstones \$12.50 up, including lettering and footstone. Freight paid. Free catalog. Allstates Monument Co., Station F-26, Atlanta 6, Georgia.



NEW! DO-IT-YOURSELF FIBREGLAS BOAT KIT

Your Own Boat at a Fantastic Saving!
 Foolproof easy-to-follow instructions make it a cinch to complete. No tools necessary! Exclusive 2-way mold comes with beautifully finished exterior.
8 ft. Dingy \$59. 10 ft. Cartop \$99. 15 ft. Runabout \$169.

Write for descriptive literature and full details.
T. C. TOR Delanco, N. J. Dept. PM 460



7 OUTBOARD PROPS IN 1

YOU VARY THE PITCH with "MULTI-PITCH"

With a flick of your wrist, change to any of SEVEN pitches, without tools. Select BEST pitches for your cruising, racing, skiing. Special "trolling pitch" cuts trolling speed IN HALF!
 from \$27.75- Models for almost all 25-45 hp outboard motors. Ask your dealer or write manufacturer.
GUARANTEED • OVER 10,000 IN USE

LESNOR-MAEHR MARINE CO., INC. • FLORAL PARK, L. I., N. Y.



You too, can chirp if you've remembered: through **EASTER SEALS** you help the crippled

National Society for Crippled Children and Adults
 2023 W. Ogden Ave.
 Chicago 12, Ill.

CONCRETE BIRD BATHS AND OVER 250 OTHER MONEY MAKING ITEMS

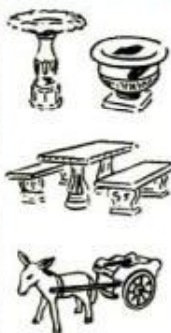

You've seen them all over the country . . . concrete bird baths, garden seats, flower boxes, appealing statuary, and many other items that add charm around the house and lawn. They're made by enterprising people, just like you, from our COPYRIGHTED ALUMINUM MOLDS. It's easy. It's fun. It's profitable.

Send \$2.00 today for this 82-page "How to" book, 20 pages of clear instructions. Valuable trade secrets. Over 250 items beautifully pictured (with description, dimensions, and prices of molds). Rushed to you by first class mail.

CONCRETE MACHINERY CO., INC.
 HICKORY 2, NORTH CAROLINA

Name _____
 Address _____

HOW TO TURN CONCRETE INTO GOLD

PREPARE FOR BETTER JOB, BIGGER PAY IN SPARE TIME AT HOME

Today, choose the job you want—and prepare for it in time you might otherwise waste. Or if you are already in the work you like best, start training now for quicker promotion and increased pay. During the past 63 years AMERICAN SCHOOL has helped ambitious people to reach higher goals. Check subject that interests you and mail coupon for full information.

AMERICAN SCHOOL, Dept. G445, Drexel at 58th, Chicago 37, Ill.

Without obligation, please send FREE and postpaid, full particulars about the subject checked below.

- | | | |
|--|---|---|
| <input type="checkbox"/> Accounting | <input type="checkbox"/> Diesel Technician | <input type="checkbox"/> Machinists |
| <input type="checkbox"/> Apprenticeship Courses | <input type="checkbox"/> Drafting—Building | <input type="checkbox"/> Mechanical Engineering |
| <input type="checkbox"/> Architecture & Building | <input type="checkbox"/> Drafting—Machine | <input type="checkbox"/> Mechanical Technology |
| <input type="checkbox"/> Automotive Technician | <input type="checkbox"/> Electrical Engineering | <input type="checkbox"/> Metalworking Courses |
| <input type="checkbox"/> Better Foremanship | <input type="checkbox"/> Electricity—Practical | <input type="checkbox"/> Plumbing—Practical |
| <input type="checkbox"/> Bookkeeping | <input type="checkbox"/> Electronics—Industrial | <input type="checkbox"/> Private Secretary |
| <input type="checkbox"/> Business Management | <input type="checkbox"/> HIGH SCHOOL COURSES | <input type="checkbox"/> Retail Merchandising |
| <input type="checkbox"/> Civil Engineering | <input type="checkbox"/> Human Relations | <input type="checkbox"/> Sheet Metal Work |
| <input type="checkbox"/> Contracting | <input type="checkbox"/> Instrumentations | <input type="checkbox"/> Tool Making |

NAME _____ OCCUPATION _____ AGE _____
 HOME ADDRESS _____ STATE _____
 CITY _____ ACCREDITED MEMBER NATIONAL HOME STUDY COUNCIL

MAIL COUPON NOW



LEARN UPHOLSTERY

in your spare time
 run your own business AT HOME

BE YOUR OWN BOSS
EARN RIGHT OFF!
 Earn more from the start while learning AT HOME. Set up your own profitable business at home, enjoy steady income, independence. You're in demand in the booming field of Custom Furniture Upholstery.

EARN WHILE YOU EARN . . . the easy UTS way. Right off, you start with tools, complete frames, fabrics, materials, included FREE with your N. Y. State approved UTS course. You earn as you learn skilled professional custom upholstery, reupholstery, furniture finishing, repairs; to make slip covers, window cornices, cushions, draperies in your spare time at home.

Send for FREE Illustrated Book, Sample Lesson. Get ready for well-paid job, steady work and big profits as your own boss. Also Training in N.Y. School. Accredited by N.H.S.C. APPROVED FOR VETERANS.

MAIL COUPON TODAY. No obligation.

UPHOLSTERY TRADES SCHOOL, Dept. MD-310
 721 Broadway, New York 3, New York

Please send me FREE book with FREE Sample Lesson. No obligation—no salesman will call.

Home Study Training In N.Y. School

Name _____
 (Please print plainly)

Address _____
 City _____ Zone _____ State _____
 Check if Korean Veteran

TRAVEL LUXURIOUSLY

WITH HOME CONVENIENCE

At automobile speed in self-sustained, power controlled, air conditioned motorized trailer, light plant, bath, refrigeration, radio, TV, rear end engine, coil springs, short turning, well balanced good maneuverability, 28 or 35 foot units. Write, **FRANK MOTOR HOMES** Brown City Michigan or **FRANK INDUSTRIES**, 5880 Hollywood Blvd., Hollywood, Calif.

Материал, защищенный авторским правом

NEW FROM V-M



THE IDEAL AMPLIFIER FOR YOUR CUSTOM
INSTALLATION!

\$89.95* List

THE VOICE OF MUSIC DELUXE STEREO AMPLIFIER

Precision-built, this AC type amplifier has a built-in pre-amplifier and integral controls. Output sockets. Dual-channel, push-pull output of 28 watts (peak); 14 watts (peak) each channel. Jack panel with stereo inputs for phono, tape, tuner and a monophonic input for TV. Outputs to drive a stereo or monophonic tape recorder.

ASK YOUR DEALER ABOUT THE COMPLETE LINE OF EXCLUSIVE V-M 'STERE-O-MATIC'® 4-SPEED RECORD CHANGERS —THE WORLD'S FINEST! From \$50.00 List*

*Slightly higher West

the Voice  of Music®

V-M CORPORATION, BENTON HARBOR, MICHIGAN, WORLD FAMOUS FOR THE FINEST IN RECORD CHANGERS, PHONOGRAPHS AND TAPE RECORDERS

PREPARE FOR THE BEST JOBS

TRAIN AT HOME
in Your Spare Time
or at Allied Institute
in Chicago

Also
for FREE
SAMPLE LESSON

SEND FOR
FREE
BOOKS

- DRAFTING
- TOOL DIE-DESIGNING
- TOOL-DIE MAKING
- IND. ENGINEERING
- IND. ELECTRONICS
- AIR CONDITIONING
- REFRIGERATION
- AUTO MECHANICS

ALLIED INSTITUTE OF TECHNOLOGY

1338-42 So. Michigan Ave., Dept. PM-40, Chicago 5, Ill.



America is a Better
America —
thanks to Advertising!

ESCAPE THE
GRAVITATIONAL
PULL OF
EVERYDAY CARES





DR. DAN Q. POSIN

Discover the mysteries of Space Science and Electronic Magic in a new fascinating way. Authentic information so cleverly and simply written that you will be amazed at the knowledge you will absorb effortlessly. For a delightful experience in "painless" education, read "OUT OF THIS WORLD."

AVAILABLE AT YOUR FAVORITE BOOKSTORE OR WRITE DIRECT — \$3.95
POPULAR MECHANICS PRESS—200 EAST ONTARIO ST. CHICAGO 11, ILL.

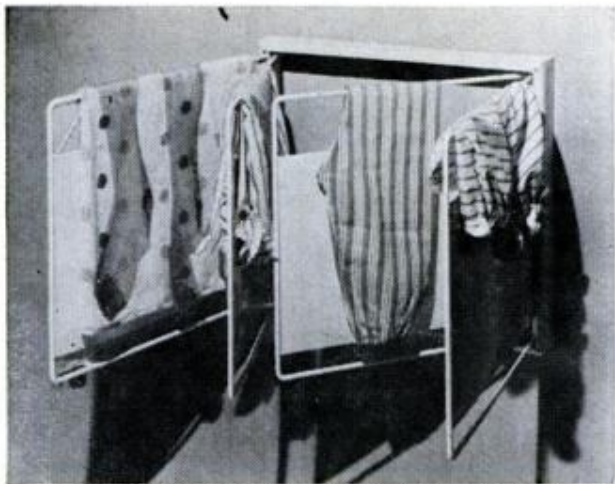

Inferation Ltd., 12-13 Copthall Court, London, E.C.2, England

Clothes Drier Doubles as Heater

Mounted on a wall, an English-built, electronic clothes drier saves space and doubles as a convection room heater. It projects only two and one-half inches when folded shut. The four hinged panels are heated by internal elements consisting of a carbon-impregnated glass-fiber material which is sealed by plastic insulation, making the elements water and shockproof. The total electrical load of 600 watts is spread evenly throughout the panels. The thin sheets on which clothes are hung swing out like the pages of a book when a release button is pressed.

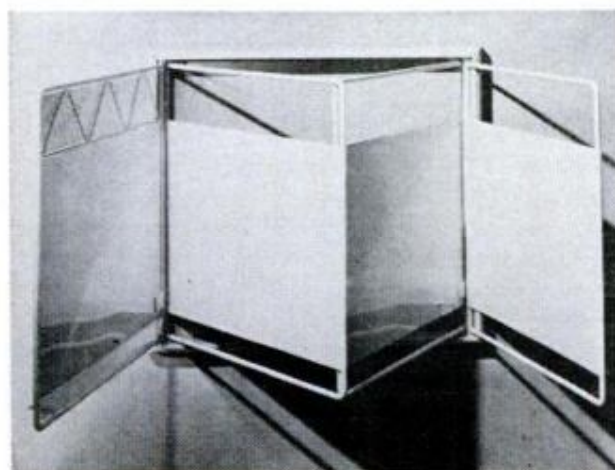
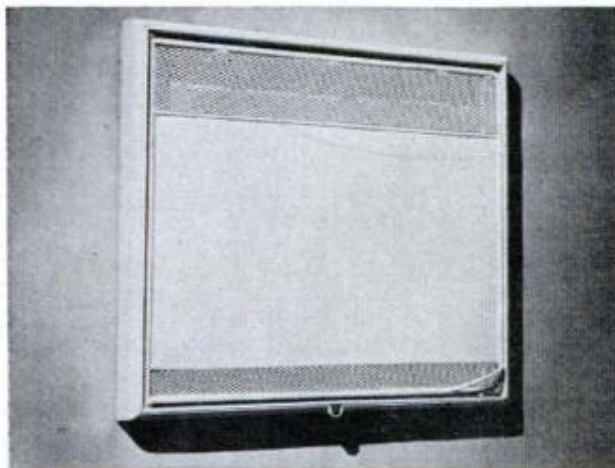

APRIL 1960

For peak performance . . .

TRIUMPH



**BACKED BY
COAST-TO-COAST
DEALER SERVICE**

Take a new lease on life! Ride the hottest motorcycles ever built — the "sizzling '60" Triumphs. Whatever you want in a 'cycle, you'll find in a Triumph — speed, power, peak performance and operating economy.

There isn't a 'cycle *anywhere* to keep pace with the exciting 1960 Triumphs.

FREE OFFER

DEPT. P

Mail this coupon today for FREE 1960 full-color catalog showing the complete Triumph line and the name and address of your nearest Triumph dealer. Send coupon to nearest address:

In the West:
Johnson Motors, Inc.
267 W. Colorado Street
Pasadena 1, Calif.

In the East:
The Triumph Corporation
Towson, Baltimore 4
Maryland

PLEASE PRINT

Name

Street

City or Town State

Telephone Number Age

MANUFACTURE THIS BEAUTIFUL CONCRETE OUTDOOR FIREPLACE

Right In Your
Own Backyard

**\$4.00 Worth of
Sand & Cement
produces this
Attractive
Fireplace.**

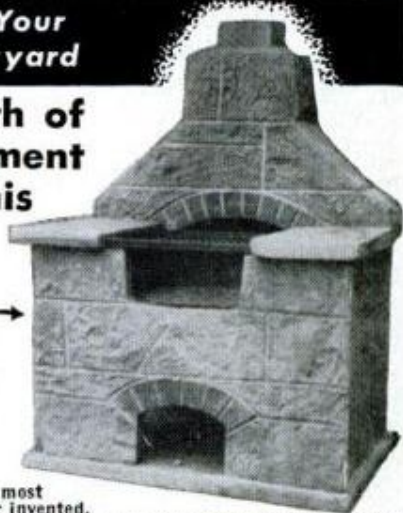

**Sells on Sight
from \$60. to \$80.
Easy to start your
own Profitable
Business.**

The General Fireplace Molds and Process are the most amazing and foolproof ever invented. Simple to operate. Two men can produce five fireplaces a day.

BIG DEMAND!!

Sell all you produce to Department Stores, Homeowners, Parks, Nurseries and Picnic Groves. Fireplaces sell on sight. No experience necessary. We supply full operating instructions and equipment plus the know-how that spells **BIG PROFITS**. This is an outstanding opportunity for men of vision and small capital to get into a busy rich paying field. Don't delay, be the only exclusive manufacturer in your own home town. Mail coupon at once for full details as to how you can reserve your territory. **Molds sold only on exclusive franchise.**

**GENERAL ENGINES CO., Inc., Dept. MF-40
ROUTE 130, THOROFARE, N. J.**

Mr. Tor of Philadelphia writes:
Sold 250 in first 4 months. Selling to Sears Roebuck, John Wanamaker, and Gimbel Bros. in Philadelphia area.

Name

Address

City Zone

State

67



Tom McCahill Reports on: *Heavier, More Durable Muffler Construction*

You hear a lot of bellowing from car owners about how often mufflers have to be replaced on modern cars, and they have some grounds for beefing, for the typical muffler only lasts 6 to 18 months. Mufflers are pretty perishable items today, due to stepped-up compression ratios, higher horsepower, and high-octane fuels.

The thing to look for in buying is thicker, heavier coated steel. Even this will wear out, but it takes longer than the thin-skins. You don't have to have a sheepskin from M.I.T. to figure out that thicker steel will take longer to rust through. This is only one indication of muffler quality, but an important one. Oddly enough, cars run only occasionally for short distances use up mufflers twice as fast as police cars and trucks under constant use, because the harder-working mufflers dry out the corrosive condensate that continually eats away the shell. All mufflers rust from the inside—not the outside.

Next time you need a replacement, look up your AP dealer. AP mufflers have much thicker shells and heads than other brands. Heft them, and you'll feel the difference. AP mufflers weigh several pounds more than would-be rivals. Tie this up with rust-resistant coatings and with their exclusive "Dri-Flow" design, which keeps AP sound-busters drier inside, and your muffler problems will be over for a long time—and they don't cost a dime more than ordinary thin-skinned jobs.

It's easy to find the nearest AP dealer. As the largest manufacturer of replacement mufflers in the world, AP has more than 100,000 dealers from coast to coast. Just look for the red and white AP "Free Muffler Check" sign.



THE AP PARTS CORPORATION

14-Q AP-BUILDING, TOLEDO 1, OHIO

Advertisement

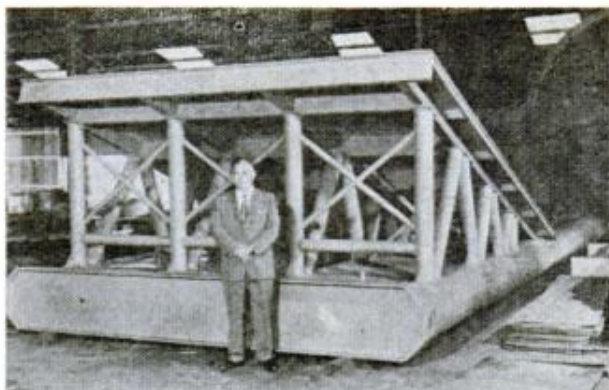

Designer A. L. Smith with a section of his breakwater



Breakwater model in surf shows wave-deflecting action

Ramp on Raft Breaks up Waves

Offshore oilmen, dredgers, dockmen and shore construction men may soon be using a portable, self-anchoring breakwater to control wave action without building an entire breakwater around their operations. Designed and developed by A. L. Smith of the Petroleum Instrument Co., of Houston, the "Sea Raft" is 38 feet long, 15 feet wide and 9 feet high, but can be used to break seven-foot waves in 15 feet of water. In use, the buoyant rafts are towed into position and sunk, usually in long rows, at right angles to the current or wave direction. The incoming water mass climbs the inclined surface to a height where gravity offsets its forward motion, and at the same time its weight presses the structure downward with a force greater than the wave's horizontal impact. The "raft" is held in place by the waves that it stops. After use, the structure can be refloated by applying air pressure to fill the base tubes and can be towed to a new location or, since it will float in as little as 24 to 30 inches of water, it can be beached for storage or repair. The big value of the "raft," of course, is its ability to protect construction or military operations from wave action which can make work difficult or impossible if the waves become higher than four feet.

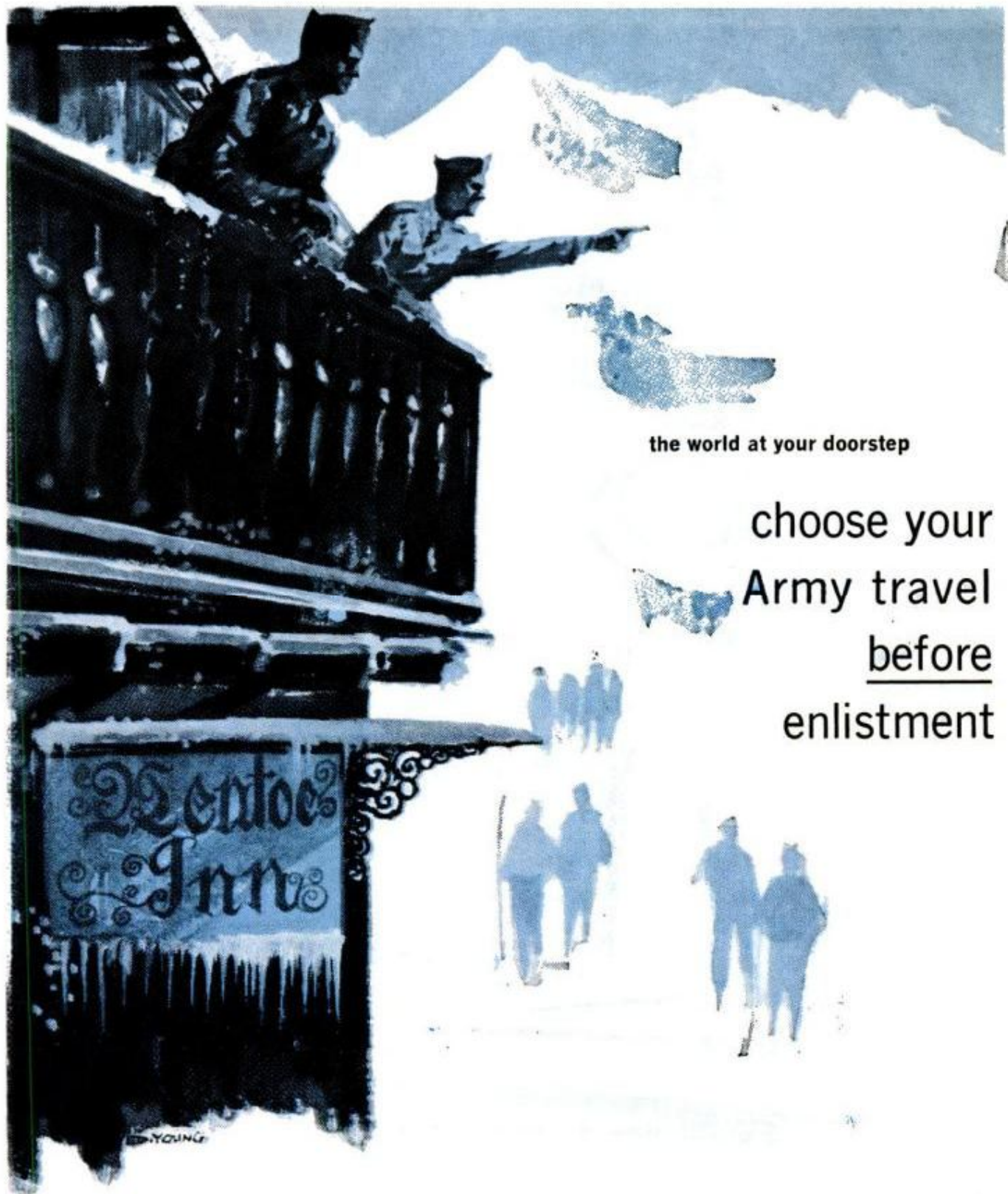

the world at your doorstep

choose your
Army travel
before
enlistment

Like skiing? How about the Bavarian Alps? Swimming? Try the beautiful blue Mediterranean. Mountain climbing? Tackle the heights of Mt. Fujiyama in Japan. Today's Army lets you **choose** the oversea area where you'll be stationed—Europe or Far East. On duty and on leave, you'll be able to travel widely while you're there. Ask

anyone who's traveled. Nothing beats the excitement of new and fascinating places. And now the Army puts them at your doorstep. So don't just dream of faraway places you'd like to see. Make your travel arrangements with your Army recruiter this week. See him—and choose your travel before you enlist!

CHOICE, NOT CHANGE



US ARMY



END SEWER-LINE ROOT MESS, SAVE ON COSTLY REPAIRS!

Roots are just naturally thirsty. They force their way through joints in your sewer line, eventually clog it. Toilets and sinks "back up", soon overflow. Now you can avoid costly digging or mechanical cleaning this easy, permanent way.



Pour one box of revolutionary Hercules R-D into toilet bowl. R-D kills and decomposes roots permanently, often overnight. To keep sewer lines root free, apply R-D twice a year. Safe to handle. Safe in septic tanks. Don't wait for trouble. Get R-D now from your plumbing or hardware dealer. It works, or your money back. Only \$3.95 for 2 lb. box. Send for literature.



HERCULES CHEMICAL CO., INC.
416 Broadway, New York 13, N.Y.



YOU NEED THIS

FREE GIANT 1960 B-A CATALOG

A Complete Buying Guide for Everything in

**RADIO 1960
TV
ELECTRONICS**

ANNUAL
CATALOG
601

BA
SINCE 1937

Guarantee

204
KING-SIZED
PAGES

EVERYTHING
IN RADIO
TV AND
ELECTRONICS

100'S OF
NEW ITEMS
LISTED HERE
FOR 1st TIME

21 PAGES
OF BARGAINS
NOT IN ANY
OTHER CATALOG

BURSTEIN-APPLEBEE CO.

Dept. PM, 1012 McGee St., Kansas City 6, Mo.

Send Free 1960 B-A Catalog No. 601.

Name.....

Address.....

City.....

State.....

**SEND
FOR IT
TODAY**

Spotlight on the

English Ford Anglia

By Art Railton

GONE IS the stiff, proper look. Relaxed a bit is the Episcopalian posture. The all-new Ford Anglia is stylish enough that women call it "cute," something they never did before.

Viewed in profile, its reverse-slanted rear window gives a pertness, a tailored, tweedy look that combines novelty with neatness.

The reverse-slant window has several practical advantages as well. It doesn't collect ice and snow. It allows a larger trunk opening. It keeps the sun off the shoulders of rear-seat riders. And it increases headroom in the back seat. Its only disadvantage seems to be the elimination of the shelf behind the rear seat (a disadvantage that is a benefit in terms of safety).

But Anglia's changes are not only in looks. Mechanically, it's new as well.

The new overhead-valve engine has a stroke so short that piston travel per mile is under 1200 feet, making it less than Volkswagen's (always considered lowest in this department). Low piston travel per mile means less wear, longer engine life. Even when wide open (slightly over 70 miles per hour), this short-stroke engine won't be overworked.

Behind the new engine (which looks so small tucked as it is deep in the hood cavity that you wonder if there isn't more somewhere) is an equally new four-speed transmission. Previous Anglias have had a three-speed gearbox. The added ratio is a blessing. Third gear gives a valuable pass-

Both in looks and performance, the Anglia is all new



(Continued to page 72)

POPULAR MECHANICS

Материал, защищенный авторским правом

Patented, UL Approved, Made in U. S. A. Precision

MAGNAJECTOR

Projects Pictures in Full Color up to
FOUR FEET WIDE

No films or negatives required! Adjustable Twin Lens enlarges ANYTHING—illustrated or printed—Photos—Clippings—Fine Print—Coins—Stamps—Maps—even tiny insects and butterflies—against any flat white screen or surface!

Operates on regular 115 Volt A. C. with ordinary electric bulb. MAGNAJECTOR is precision made to last a lifetime. Measures 12" x 8" x 4½" and comes with 6' extension cord and insulated plug, complete and compact in a handy luggage type carrying case **ONLY \$7.95** postpaid



NEW 50 STAR FLAGS EMBROIDERED STARS SEWED STRIPES

All weather proofed—color fast—heavy duty cotton—quality exceeds government specifications—complete with canvas heading and brass grommets. 3 ft. x 5 ft. Flag..... **\$5.95** ppd.

3 ft. x 5 ft. Flag with 2pc 6' hardwood pole, brass screw joint and ball top, halyard and window bracket **\$7.50** ppd.



EXECUTIVE DESK FLAG SET 8" x 12"

Printed on lustrous rayon with rich, waterfast colors, gold fringed, 12" solid brass staff topped with 2" solid brass eagle and 3" solid brass base. Gold tassel, red tie ribbon. Gift boxed **\$7.50** ppd.



Send Check or M.O. If C.O.D. Fees Extra
MONEY BACK GUARANTEE

SCOTT-MITCHELL HOUSE, INC.

Dept. HC30 415 S. Broadway Yonkers, N.Y.



CAMPING IS FUN WITH

HEILITE



Heilite camping trailers make up into a complete camp for a family of 5—in just one minute. Clean, comfortable fully-floored tent, ready-made double bed, ample storage space for gear. Now in single and two-wheel (compact car) models.

FREE COLOR FOLDER, write—

HEILITE TRAILERS, INC.

1307 SO. SACRAMENTO ST. • LODI, CALIF.

APRIL 1960

**ENGINEERING
SCIENCE
MATH**

**DEGREE IN
27 or 36 MOS.**



Accelerated year-round program prepares for early employment in fields of Science and Engineering. Regular 4-year program for B.S. Degree completed in 36 months, special engineering degree program in 27. Classes start quarterly—June, September, January, March. Quality education. Graduates employed from coast to coast. Government approved for veteran training. Students from 50 states, 40 countries, 20 buildings; dorms, gym. Campus. Save time and money. Earn board while studying. Write for catalog and complete information.

INDIANA TECHNICAL COLLEGE

540 E. Washington Boulevard, Fort Wayne 2, Indiana

Please send me free information on Bachelor's Degree Programs in Engineering and Science as checked below:

- | | |
|---|--|
| <input type="checkbox"/> Aeronautical Engineering | <input type="checkbox"/> Mechanical Engineering |
| <input type="checkbox"/> Chemical Engineering | <input type="checkbox"/> Metallurgical Engineering |
| <input type="checkbox"/> Civil Engineering | <input type="checkbox"/> Physics |
| <input type="checkbox"/> Electrical Engineering | <input type="checkbox"/> Chemistry |
| <input type="checkbox"/> Electronic Engineering | <input type="checkbox"/> Mathematics |

Name.....

Address.....

NEW WESTERN HAIG
.12 CALIBER
SPECIAL FACTORY
OFFER!



\$3.00
post-paid

USES POWDER CHARGE

This small bore gun shoots .12 cal. lead bullets fired by small 4.4 mg. powder charge. Not a CO₂ gun! You'll like the handsome lines, grip, and balance. Western in style, but patented ball and cap action allows this low price. 9¼" steel barrel cased in knurled styrene stock, overall 13½". Develop pistol form, accuracy at a fraction of cost of large caliber pistols. Comes with 50 lead bullets. Satisfaction guaranteed. Send \$3 to: HAIG MFG. CO., Box T-4, Alhambra, Calif.

NOW! ACCORDIONS

UP TO **1/2 OFF** retail prices you'd expect to pay ...



IMPORTER TO YOU!

Buy DIRECT from World's Largest Dealer. Compare our low Importer-to-You prices... see how much you save! All famous Italian makes... over 30 models... latest features, new colors! Little as \$9.95 down—amazingly E-Z terms. 5-day FREE Playing Trial. Unconditional money back guarantee.

Free Bonus Gifts for promptness. Trade-ins welcomed—free appraisal. Rush coupon for new color catalogs. No obligation. Write

ACCORDION MANUFACTURERS AND WHOLESALE OUTLET, Dept. R-40, 2003 W. Chicago Ave., Chicago 22, Ill.

**5 DAY
FREE TRIAL**

Accordion Manufacturers & Wholesalers Outlet
Dept. R-40, 2003 W. Chicago Avenue, Chicago 22, Illinois
Rush Color Catalogs and "Importer-to-You" prices on famous-make accordions... FREE.

NAME.....

ADDRESS.....

CITY..... Zone..... STATE.....

125 Home Repairs (& More) Made Easy with Famous

DURO PLASTIC ALUMINUM

SAVE MONEY ○ FIX IT YOURSELF

DURO The Original
PLASTIC ALUMINUM

HUNDREDS OF USES FOR THIS AMAZING METAL IN PUTTY FORM

\$1.00 LARGE 5 1/2 OZ. TUBE

Guaranteed by Good Housekeeping

SAFETY: NEVER USE ON HOT SURFACES

LIFE

DURO-PLASTIC ALUMINUM squeezes right from the tube to repair gutters, downspouts, auto bodies, pots 'n' pans, plumbing leaks . . . just about anything in your home, auto, boat or shop.

\$1 The Original Big 5 1/2 oz. Tube

\$1.29 in Canada

PLUS AN EXTRA ADDED ATTRACTION

free 25c Do-It Yourself Booklet By Popular Mechanics

Sent to you free when you mail us the special coupon on the back of each DURO-PLASTIC ALUMINUM pack.



DURO

also makes Plastic Rubber, Porcelain Repair, Liquid Steel, Plastic Mender, Rust Remover, Windshield Sealer and other famous fix-it products for your home, auto, boat and shop.

Available at hardware, auto accessory, paint and variety stores everywhere, or write

THE WOODHILL CHEMICAL CO.

"Originators and World's Largest Mfrs. of Plastic Metals"

1390 East 34th Street Cleveland 14, Ohio

In Canada: 840 Montee de Liesse, Montreal, Quebec



Fins, reverse-slant rear glass, all for only \$1583

ing kicker which is desirable with this engine size. You can run up to 60 miles per hour in third for quicker passing. Using third, it accelerates from 40 to 60 in 20.6 seconds, a noteworthy performance for its 61 cubic inches. Surprisingly quick at the stop light, the car gives the alert and eager driver enough pep to keep up with normal traffic situations.

From 0 to 60, the Anglia ticks off 29.1 seconds. From 0 to 40, the average is 10.6 seconds. Both are satisfactory times for an economy car.

Okay, then, what about economy? Here is a true economy car. You don't have to feather-foot it to get 30 miles per gallon. Even the most abusive, kick-it-in-the-pants driver will do better than 25 miles per gallon. In one winter test, with temperatures ranging from 5 to 15 above zero, the Anglia averaged 28.0 miles per gallon in a series of short "hacking" trips, similar to those a housewife would take in a normal day. Included were many cold starts with choke operation. Even so, economy was good, as the 28 miles per gallon indicate.

Country-road fast driving resulted in 31.5 miles per gallon. Included were long stretches at 65 miles per hour. Careful, more temperate driving would boost economy to 35 miles per gallon (even more in warm weather).

Handling is excellent with steering being light, fast and precise. The floor-mounted shift lever is close at hand and a pleasure to use. Action is direct and accurate with no concern about where you might end up. There is no tricky stickum to master, no temperamental quirks to humor.

One minor problem is the odd-ball reverse-gear location (you lift up and pull back). It may make things a bit complicated for unfamiliar (if such exist) park-

(Continued to page 286)

HERB SCORE, Cleveland
Indians pitcher, says:

**“The best friend in
my home shop is a
tube of 
PLASTIC ALUMINUM”**



“Of all the fix-it products I’ve tried, Duro Plastic Aluminum wins my vote . . . it saves me time and money,” says Herb Score, front-line pitcher and strike-out specialist for the Cleveland Indians.

Off-hours, family man Score likes to relax in his well-equipped home shop. Equipment always includes a tube of Duro Plastic Aluminum. Metal in putty form, Duro Plastic Aluminum fills, seals, solders, repairs—adheres to virtually any surface.

Made with ALCOA® Aluminum Powders by Woodhill Chemical Co., Cleveland, Ohio, Duro Plastic Aluminum is applied like paste, dries metal-hard in three hours. Users say it fixes anything.

ALCOA does not make aluminum putties, but ALCOA Aluminum Powders are used in all the best brands. Cold solders are easy to use, require no tools, heat or flame. They adhere to metal, wood, plastic, glass or concrete . . . are not affected by water, oil or gasoline . . . can be burnished to a high luster or even painted. Write today for more information. Use the coupon.

SAVE MONEY... FIX IT YOURSELF

DURO The Original
PLASTIC ALUMINUM

HUNDREDS OF USES FOR THIS AMAZING METAL IN PUTTY FORM!

\$1.00 LARGE 5 1/2 OZ. TUBE

“The Family Handyman”

Applied Cold, Hardens into Metal

SEALS - SOLDERS - REPAIRS
Not a Cement—Not a Glue
ANYONE CAN USE IT!



Adheres to metal, Wood, Concrete, Glass and Most Plastics

SATISFACTION GUARANTEED

DURO PLASTIC ALUMINUM

HUNDREDS OF USES For the Home, Auto, Boat and Shop.

REPAIR Holes and Leaks in Laundry Equipment

SEAL Plumbing Leaks

REPAIR Holes and Dents in Auto Bodies

SEAL and SOLDER Leaky Gaskets and Drainspouts

REPAIR Holes and Leaks in Pails, Pans, and Pots

REPAIR Holes and Leaks in Wood and Metal Boats

Look for this label . . . it's your guide to the best in aluminum value



For exciting drama watch "Alcoa Presents" every Tuesday, ABC-TV, and the Emmy Award winning "Alcoa Theatre" alternate Mondays, NBC-TV

Aluminum Company of America
1748-D Alcoa Building, Pittsburgh 19, Pa.

Please send more information on cold solders made with Alcoa Aluminum Powders.

Name _____

Address _____

City _____ Zone _____ State _____

YOU BELONG IN THIS PICTURE



**EARNING \$9,000 TO \$13,000
FOR 8 MONTHS' WORK!**

Here is a ground-floor opportunity to come in with Mister Softee, leader in the booming mobile soft ice cream field and one of America's most successful enterprises! An initial investment of \$4,000 puts you in the driver's seat, with the balance on a pay-as-you-profit basis. And profit you will . . . for we give you advertising and promotional support, and work with you until success is assured. Write today!

Fleet Operators Invited!

Multi-unit operations can be supervised with hired management, and a working capital of \$20,000 should earn \$25,000 to \$30,000 the first year!

Mister Softee[®]
INC.

Dept. PM-1
Runnemede, N. J.

Do You Know This Old-Timer?

(answer to quiz, page 12)



1905 Cadillac

French Inventor Wins Patent Suit Against United States Government

Raymond Saulnier, French inventor of the cockpit canopy ejector for airplanes, is entitled to collect damages because the U. S. government infringed his patent, according to the United States Court of Claims. Saulnier filed his suit against the government five years ago, estimating he was owed at least \$5 million.

The Court recently ruled that his patent was infringed every time a Thunderbolt, Thunderjet, Mustang, Scorpion, Fury or Sky Raider was built, between Dec. 9, 1948 and Dec. 9, 1954. The device may have been used on other planes; if so, Saulnier is entitled to collect for those uses as well, said the Court.

The government's defense was that Saulnier did not invent anything, that the elements he put together were old and the result was obvious to anyone skilled in working with them. But the Court said inventors had been seeking such a canopy for years. It needed two mechanisms: one for sliding the roof back and forth, the other for detaching it completely in emergencies. The court said that Saulnier had produced "something no one else had been able to do."

In making the decision, one judge pointed out that the British government has bought a license from Saulnier to use his invention, and that the French government—under an international agreement to pay a citizen's claims against another country—had paid him for 31,000 canopies used on American planes in World War II.

Helicopter With Depth Finder Scouts for Fishing Fleet

Trailing the microphone of a depth-sounding instrument in the water 50 feet below, a helicopter is leading the boats of Russian fishing fleets all over the world with deadly accuracy and at speeds up to 10 miles an hour. The same instrument and methods are used as with shipboard installations, but the whirlybird covers much more area, doesn't scare the fish, and can operate over rougher water than any boat and still give accurate readings. The sound projector, or microphone, is towed at a depth of about 20 feet under a streamlined float. A wire from the float leads to the instrument panel inside the helicopter. The operator communicates with the fishing fleet by radio. The instrument reports the size and shape of the schools of fish, their depth, and even the species of fish found. The boats can set their trawls or seines accordingly.

More time for fishing...with



ALUMA

Craft

● Nine specially designed fishing boats. Light, strong, comfortable, and seaworthy. Always dry. Always ready. Ride smooth for trolling... sit steady for casting. Cover open water fast for more actual fishing hours. Priced as low as \$225.00.

**SEND FOR FREE
ALUMA CRAFT
BOAT SELECTOR**



ALUMA CRAFT BOAT CO.
1519 N. E. Central Ave., Minneapolis, Minn.

Please send new 1960 *Boat Selector* catalog including specially designed fishing fleet.

Name _____
Address _____
City _____ State _____

Take Correspondence Courses
For a Better Education

TINY CRYSTAL SET RADIO PLAYS FOR 10 YEARS!

NO TUBES — TRANSISTORS — BATTERIES OR "PLUG-INS" NEEDED



Smaller than a pack of cigarettes, 1960 model never runs down or burns out. Guaranteed to receive local radio stations most anytime, anywhere — without EXTRA ANTENNA WIRES. Easy thumb station tuner. Chrome black plastic case. BUILT IN SPEAKERPHONE — NO SEPARATE DANGLING EARPHONE. American made and service guaranteed.

SEND ONLY \$2.00 (cash, ch., mo) and pay postman \$4.99 C.O.D. on arrival or send \$6.99 for postpaid delivery. Sent complete — Ready to listen. No extras to buy. Free long distance antenna enclosed if you order at once.
Midway Co., Dept. TPM-4, Kearney, Nebr.

INCREASE HOME VALUE—MAKE NEEDED IMPROVEMENTS NOW

BRONSON

America's Lowest Priced Spin Casting Reel!

DART 905—America's fastest selling reel with no line twist and factory pre-set drag . . . yet it's adjustable. All metal gears. Anti-reverse crank. In black and gold. Comes with 10 lb. test monofilament line. 7 oz.
Only one of 25 Bronson quality reels. Sold everywhere. . . . **\$5.95**

Write for FREE
"FISHING HANDBOOK"

BRONSON REEL COMPANY
BRONSON, MICHIGAN
Division of Higbie Mfg. Co.





PAPERWOOD HAULER: James O. Clark, Butler, Ala. "Only Firestones can take the severe abuse of pulpwood hauling!"

TOUGH TIRES KEEP BIG LOADS MOVING ALONG "STUMP AVENUE"

Firestone

proved where profit depends on performance

From tire-walloping haul roads to high-speed turn-pikes, Firestones prove their superiority best where trucking is toughest. And 425 million grueling tire test-miles every year are behind such Firestone "extras" as Shock-Fortified cords and Firestone Rubber-X, the longest-wearing rubber ever used in Firestone tires. That's why, when your profits depend on truck tire performance, it pays to depend on Firestones for proved low cost per mile and on-time deliveries. Get all the facts about Firestone truck tires from your Firestone Dealer or Store.

Copyright 1960, The Firestone Tire & Rubber Co.



Transport*

Super Mileage Lug*

Super All Traction*

Rib Excavator*

Rock Grip Excavator*

All Traction*

*Firestone T.M.

*Here's owner proof of
Firestone truck tire
performance!*



MILK HAULER: Dale Heckber, Ossian, Indiana. "Milk won't wait on truck tire troubles. That's why I depend on Firestones. I've been buying them for 25 years!"



STEEL HAULER: Peter Hartman, Lorain, Ohio. "For 'pike runners, or on any road for that matter, I can't beat Firestone truck tires for wear. I run on them 100%!"



FOOD PROCESSOR: John Carroll, Milwaukee, Wisconsin. "We count on Firestones 100% to stop costly truck tire downtime and keep our food moving expenses in line!"

WHAT SECRET POWER DID THIS MAN POSSESS?

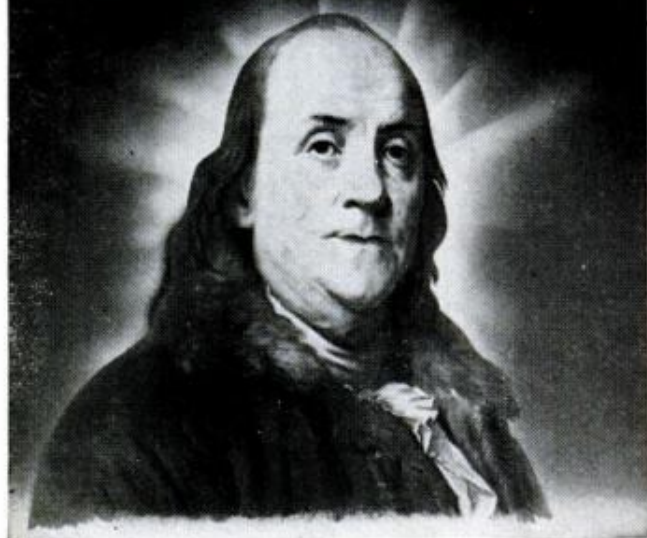

BENJAMIN FRANKLIN
(A Rosicrucian)

WHY was this man great? How does anyone—man or woman—achieve greatness? Is it not by mastery of the powers within ourselves?

Know the mysterious world within you! Attune yourself to the wisdom of the ages! Grasp the inner power of your mind! Learn the secrets of a full and peaceful life!

Benjamin Franklin—like many other learned and great men and women—was a Rosicrucian. The Rosicrucians (NOT a religious organization) first came to America in 1694. Today, headquarters of the Rosicrucians send over seven million pieces of mail annually to all parts of the world. Write for YOUR FREE COPY of "The Mastery of Life"—TODAY. No obligation. No salesmen. A non-profit organization. Address: Scribe N.B.X.

THIS BOOK FREE!

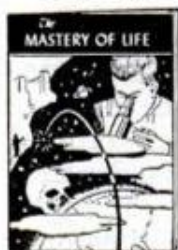

The ROSICRUCIANS

SAN JOSE • (AMORC) • CALIFORNIA

—SEND THIS COUPON—

Scribe N.B.X.
The ROSICRUCIANS (AMORC)
San Jose, California
Please send me the free book, *The Mastery of Life*, which explains how I may learn to use my faculties and powers of mind.

Name _____

Address _____

City _____

Tunnels Permit Tiny Eels To Swim up Rhine

Engineers building 17 huge sluices that will pour 60 percent of the waters of the Rhine River into the North Sea near Hellevoetsluis, Netherlands, are making sure that millions of eels—about one-third of an inch long—can pass, easily, from the sea and go upriver to their feeding grounds.

Instead of opening the massive sluice gates, each weighing some 425 tons, which would allow torrents of water to pour inland, the engineers are building small tunnels through the sluice piers which can be opened and closed at either end to permit passage of the tiny glass eels with a minimum of water.

This extra work is necessary because the eels, one of the Netherlands' most succulent delicacies, provide a livelihood for several hundred fishermen. Born in the Sargasso Sea off the U. S. coast, the eels make their way to Europe, where they grow to full size before returning to the Sargasso seven years later to breed and die.

The sluice engineers took this cycle into account because, in 1932, a group of dam engineers did not. Then, another huge project, the closing of the Zuider Zee against the North Sea by a 20-mile dam was completed. It was soon discovered that each spring the water in front of the dam literally shimmered with millions of baby eels, and that eel fishermen were having poor catches.



"Whatcha doin', building a boat?"

"I 'built' my Chevy to take a hint—automatically!"

"You'd be surprised what two big brothers can teach a girl about cars—especially when they're automobile engineers. So when I went down to buy my new car, I knew what I wanted: an absolutely automatic car, one that would do everything for me short of driving itself.

"Thanks to Chevy's list of options (longest in the business, my brothers say), I've got that dream car parked in front of my apartment house.

"Naturally, it's an Impala Sport Coupe. (I happen to be a fashion model, so style is extra important to me.)

I wanted V8 smoothness with the economy of a 6—and Chevy's economy V8 is just the thing. And I let Turboglide* do my shifting for me. Power steering* and power brakes*, of course, and then Chevy's six-way power seat*. Power windows* are a touch of luxury I wouldn't miss for the world. Why, I've even pampered myself with a power radio antenna* and a power ashtray!* (Those Chevrolet people think of *everything*.)

"Cars just don't come much more automatic than mine. And even though my brothers are mad about

sports cars, I notice they get a real charge out of driving my four-wheeled robot."

This is just one kind of Chevrolet. There are as many other kinds as there are people: heavy-duty work-horse wagons, outright thrift cars, cars that move in utter splendor. The point is this—you can virtually custom-build your Chevrolet to suit yourself. We'd suggest a trip to your nearby Chevrolet dealer's soon. . . . Chevrolet Division of General Motors, Detroit 2, Michigan.

*Optional at extra cost.

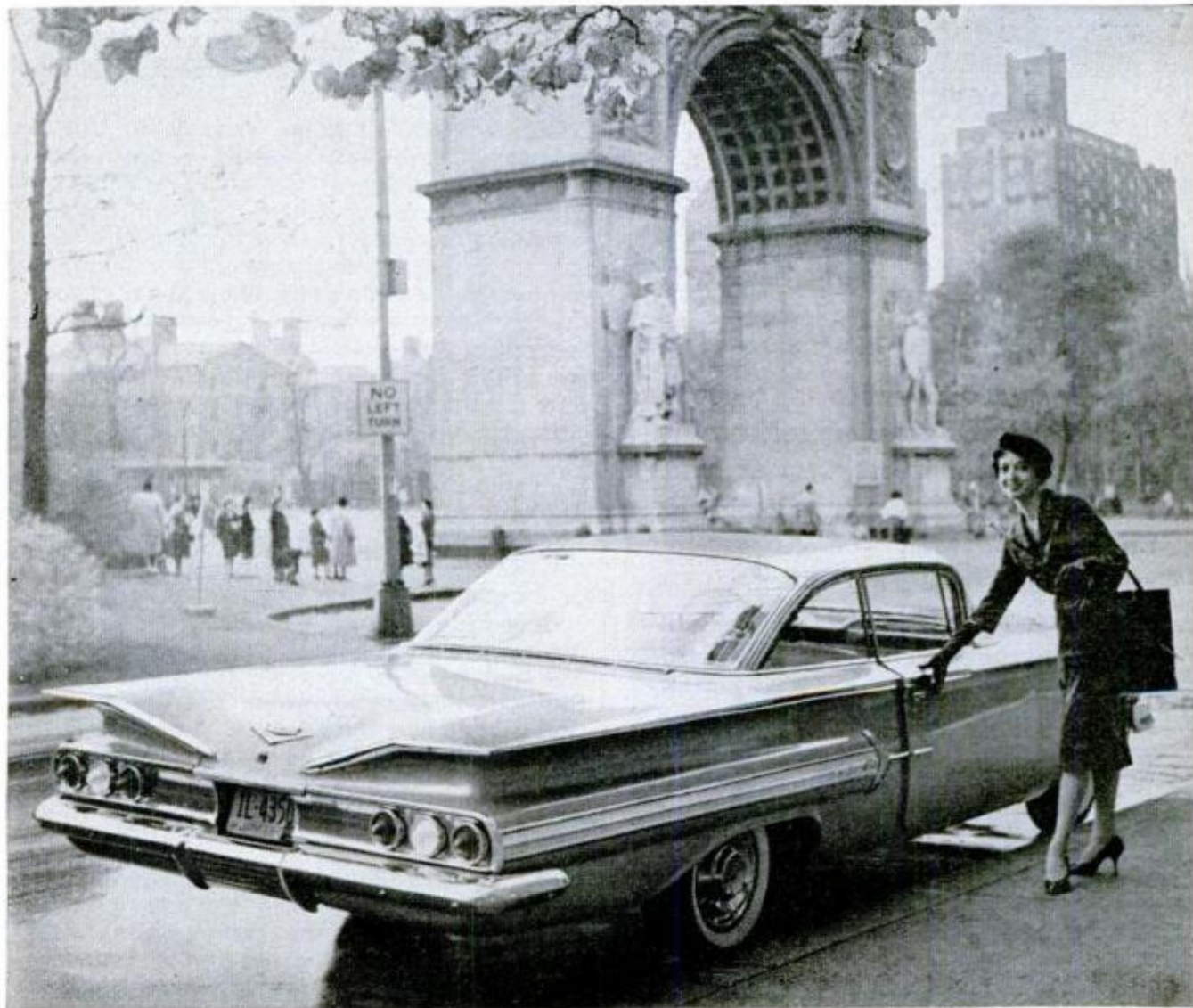

Got a good idea of what you're after in a car? Chevy lets you choose from seven engines, five transmissions, regular or Positraction rear axles, special cams, solid or hydraulic valve lifters . . . the widest choice of options in the industry. And that means you can "build" your personal car to fit you like a glove.

BEAR
BRAND
sandpaper



lasts longer
gives best results

whether you're using



SHEETS or BELTS



DISCS or ROLLS

The BEAR Brand trademark tells you right away you're using top quality. ADALOX® sandpaper, for example. Faster-cutting grits firmly rooted to the backing . . . you get a better sanding job, and more work out of each sheet. Look for BEAR Brand ADALOX sandpaper at your local hardware, paint dealer, lumberyard or marine supply store.

BEAR
BRAND

Sandpapers



BEHR-MANNING CO.
TROY, NEW YORK

A DIVISION OF NORTON COMPANY 

BEHR-MANNING PRODUCTS: Coated Abrasives • Sharpening Stones • Pressure Sensitive Tapes • Floor Maintenance Products
NORTON PRODUCTS: Abrasives • Grinding Wheels • Machine Tools • Refractories • Electro-Chemicals
In Canada: Behr-Manning (Canada) Ltd., Bramford. • For Export: Norton International Inc., Troy, New York, U.S.A.

Rhine Suspension Bridge Hangs From Single Tower

When the city fathers of Cologne, Germany, decided five years ago that a new bridge across the Rhine was needed to divert some of the traffic from the five bridges already within the city's limits, they also gave their director of construction, Karl Schuessler, definite instructions on how *not* to build it. The bridge, they said, should not obstruct the view of the city's celebrated Gothic cathedral, nor should it tower above the cathedral's spires. As a result, the bridge, which opened for traffic last November, is perhaps the longest single-tower suspension bridge ever built. Schuessler decided its single, 255-foot, A-shaped pylon should rise on the right bank of the river (the cathedral is on the opposite bank), from where it supports the 996-foot main center span with six light steel cables fastened at intervals along the structure. Named after St. Severinus, the bridge is as austere in its modern conception as the twin spires of the still-plain-to-see cathedral are ornate.

Construction director Schuessler thus maintained the Gothic beauty of the river town founded by Julius Caesar, but he posed problems for Chief Engineer Gottfried Vogel. In order to lay the steel, Vogel first sank a concrete caisson 20 feet below the bed of the Rhine and 400 feet out from the right bank. On this he erected the steel A-frame. Successive temporary caissons were built in the middle of the river to support the bridge until the supporting cables were woven and attached. The length of the bridge, from pier to pier, is 1488 feet. It stretches 2280 feet overall, from midtown Cologne to the industrial suburb of Deutz. The bridge itself weighs 8244 tons, with the cables—the heaviest of which is 16 inches in diameter—counting for 600 tons. It is 98 feet wide. A double streetcar track runs down the center. On either side are double automobile lines, a bicycle track and a 10-foot-wide pedestrian walk. The St. Severinus bridge cost the equivalent of \$14,000,000 to build. It will be operated toll-free.

QUOTE:

"What non-scientists do not realize is that science is fun, that there are few, if any, emotional experiences so profound, so satisfying, so beautiful, as seeing a pattern where there was none before, as finding an answer to a question asked long ago, as finding a new question to ask."

—DR. ANNE ROE,
Harvard Researcher

POPULAR MECHANICS

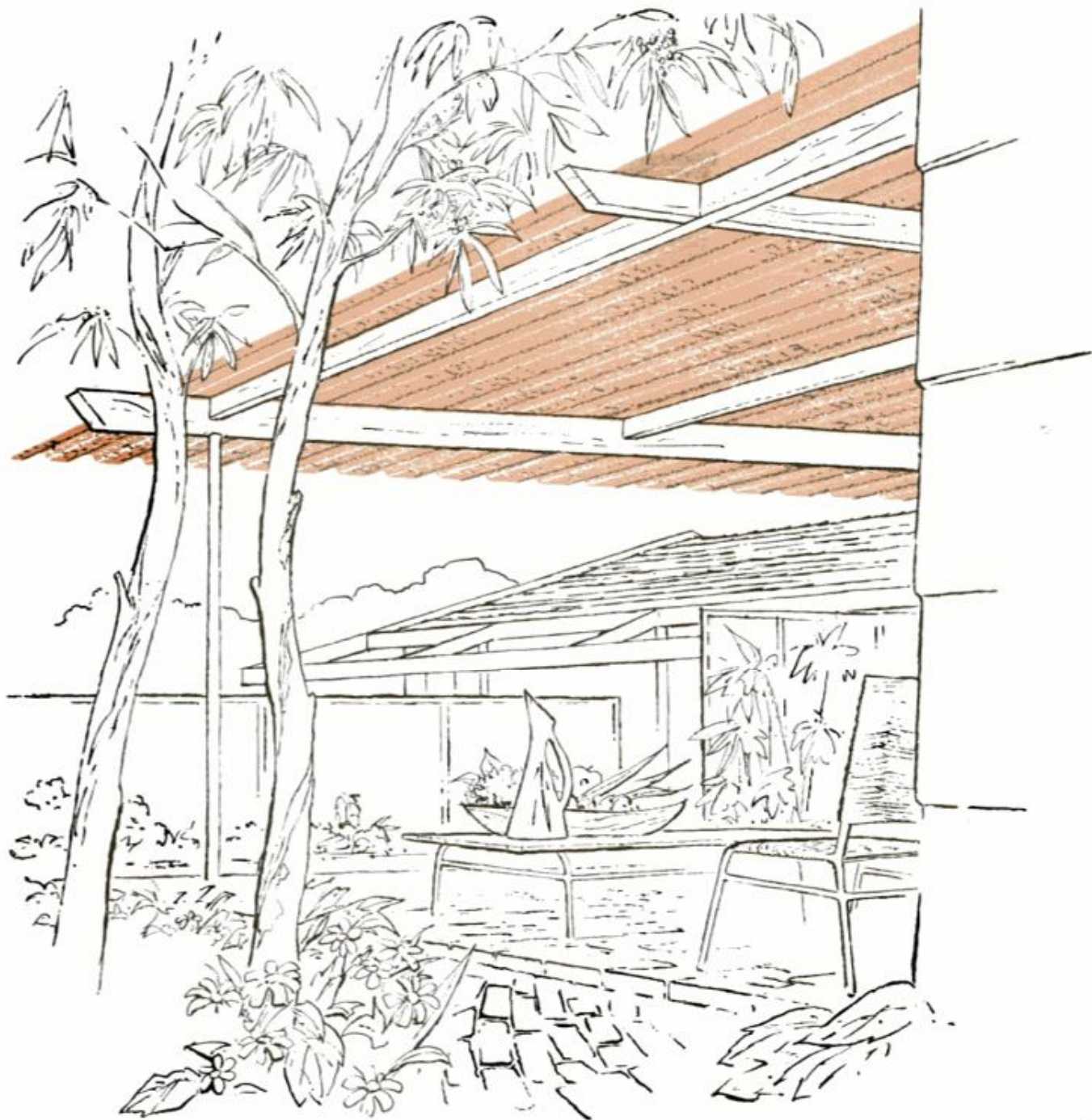

HOW EASY TO BUILD YOUR OWN PATIO!

Saw, drill, nail and install translucent Alsynite panels with ordinary workshop tools. No painting, no care needed with shatterproof Alsynite. Just enjoy it! Alsynite's exclusive heat-block, Filtron 25, cuts up to 90% of the sun's heat. And Superglazed Alsynite is guaranteed in writing to maintain color, texture and strength for 10 years. Now available in exciting new Ridgeway line as well as corrugated and flat. Write Alsynite Company of America, Dept. PM-40, San Diego 9, Calif. for free detail sheets. Or look under "Plastic Products" in the Yellow Pages.



Regional Offices: Albany; Atlanta; Chicago; Columbus; Denver; Houston; Kansas City; Paterson, N.J.; St. Petersburg; San Diego; Seattle

MERCURY is the world's

No. 1 outboard in

Power!

Of all outboards on the market, *only* a Mercury has enough thrust to lift five times its own weight! That's why Mercury's 70 hp Merc 700 is outperforming 75 hp competitors. Mercury gives you the widest useful operating range and the greatest reserve power above normal requirements.

The reason is Mercury's modern *in-line* engine design, with smaller, lighter, tougher reciprocating parts and much lower piston speeds than long-stroke "big-bore" engines. Mercury's small-bore, short-stroke design not only develops usable power throughout a wider speed range but reduces inertia forces — the main cause of engine wear — to only about one-third those of competitive outboards operating at the same RPM! The result is bonus power and performance with longer engine life. See your Mercury dealer for a demonstration of power no other outboards can touch — 6 to 80 hp, in twins, fours and sixes.

Write for free booklet, "An Introduction to Outboarding".

© KIEKHAEFER CORPORATION, FOND DU LAC, WISCONSIN

Below — Static thrust testing proves that a Mercury can lift five times its own weight!

80 hp
Merc 800—
World's Most
Powerful
Family
Outboard!

No. 1 in PERFORMANCE... RELIABILITY... ENGINEERING
... FUEL ECONOMY... STYLING... FEATURES... SAFETY

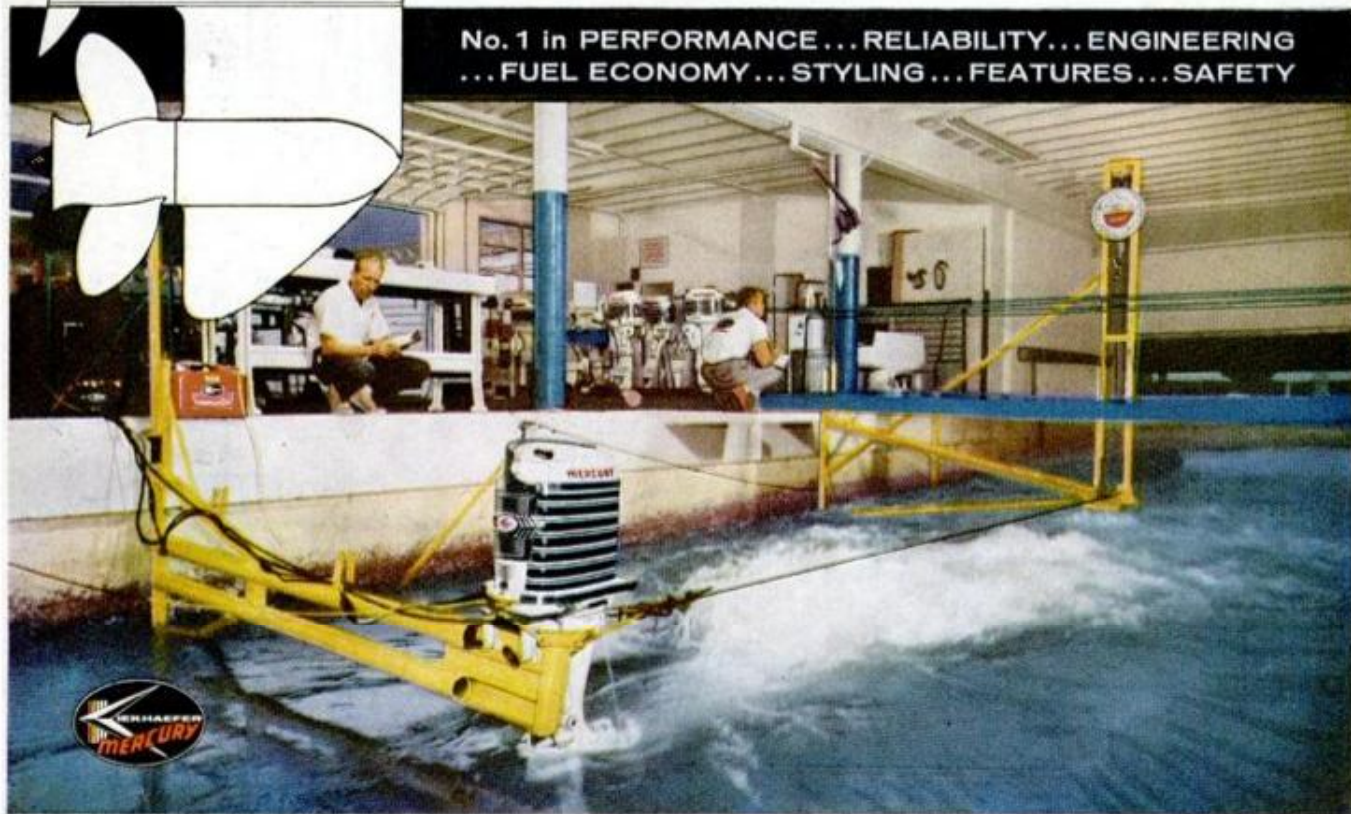

TWENTY MILES from Tombstone, Ariz., at an old cavalry post named Fort Huachuca, the United States Army is testing the electronic weapons it will use in the future.

Eighty years ago the troopers at the fort flashed news of Apache raids by heliograph; today the technicians at the huge 160-square-mile Electronic Proving Ground are using single sideband circuits, infrared and even radio reflections from the ionized trails of meteors for communication between units or around the world.

The remote location in southern Arizona was chosen partly for secrecy, partly because the region is one of the best "electronic vacuums" that the Army could find. There are no powerful commercial transmitters in the surrounding desert, no big TV stations that might interfere with the accuracy of the tests.

The 7500 military and civilian technicians under the command of Maj. Gen. Francis F. Uhrhane are not only testing improvements on present equipment—they are also working on strange new electronic and infrared weapons that may not go into service in the field for another five or ten years.

POPULAR MECHANICS

APRIL 1940

WRITTEN SO YOU CAN UNDERSTAND IT
VOL. 113 NO. 4

The ARMY'S Electronic Magic Shop

By Thomas E. Stimson, Jr.

From a jeep in the Arizona desert, this sergeant can talk around the world by radiotelephone network

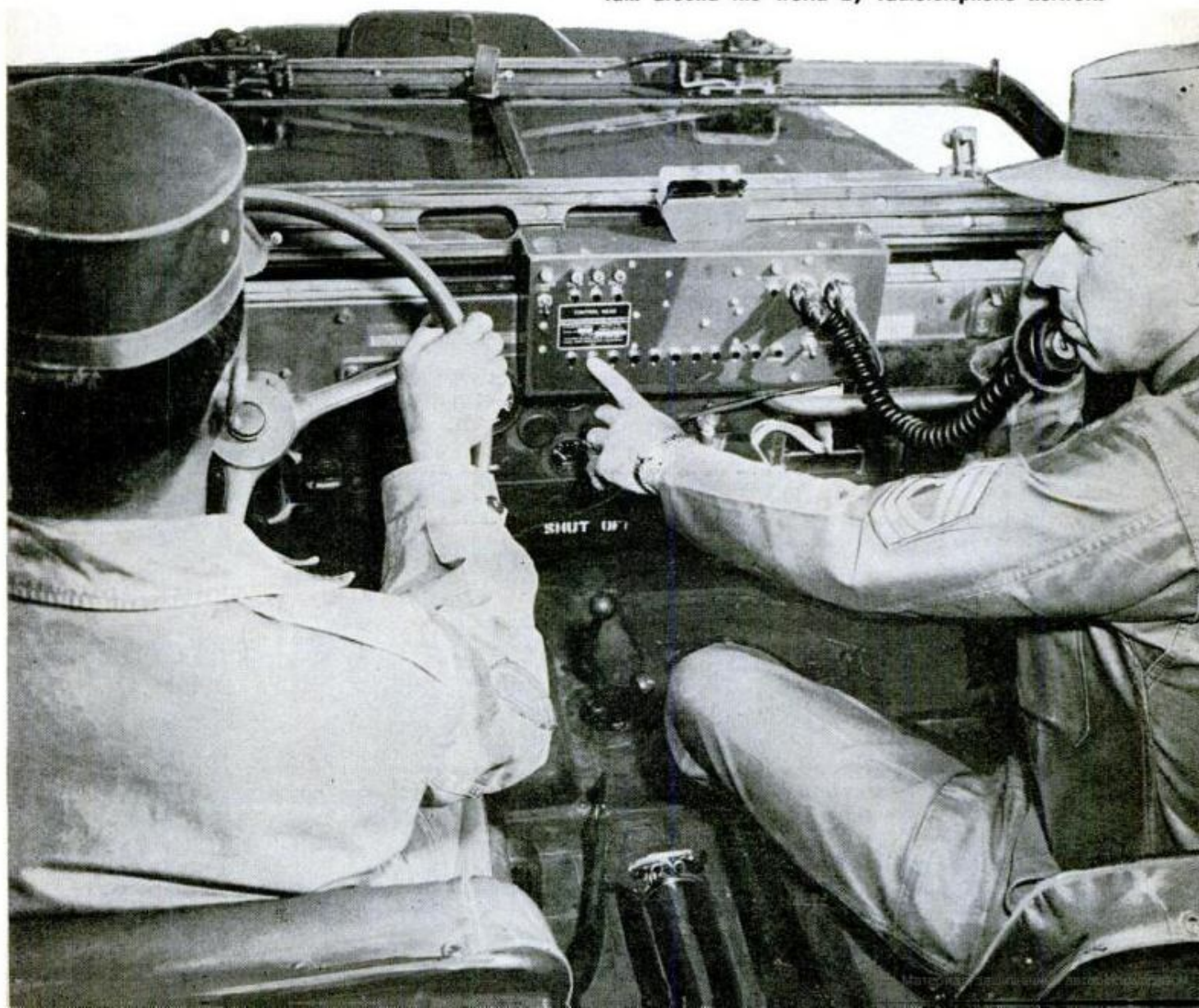



Army technician readies a subsonic drone aircraft—a type now augmented by new long-range jets that fly at Mach 11

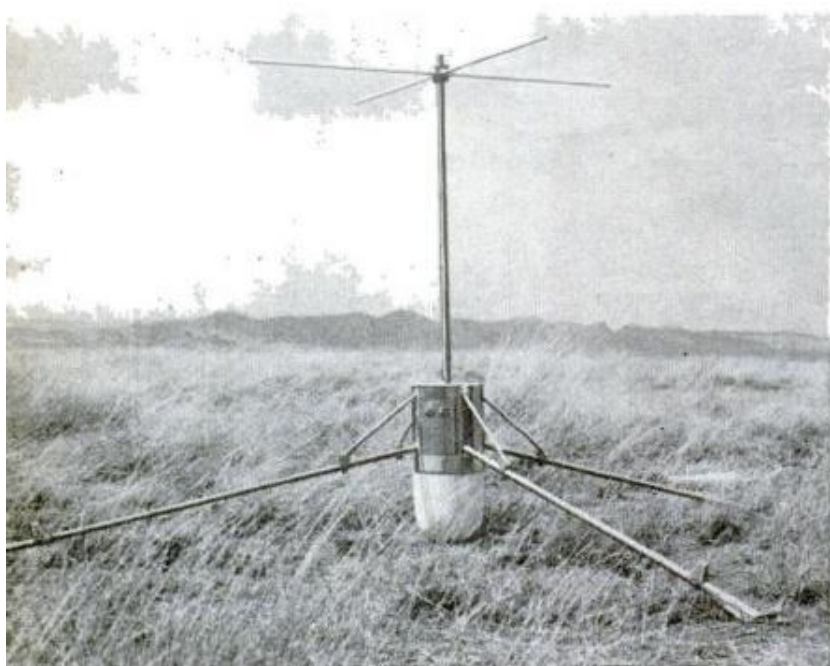

Expendable radio jammer is airdropped into enemy territory, sets itself up after landing to upset radio communications

When I visited Fort Huachuca recently I was told I'd be shown no secret devices and yet I was amazed at some of the things I was permitted to see. Not far from the crumbling ruins of the old Indian scout quarters I watched a new kind of radio station being erected. Technically it's called "mobile multichannel tropospheric scatter." A crew pulled a pair of large rubber bags from inside a couple of trucks, then minutes later the bags were installed on top of pedestals and were being inflated into shape.

"These 15-foot rubber dishes are our antennas," a tech sergeant explained. "The rear surface of each bag is metalized and serves as a parabolic reflector. The inflated bags take the place of the huge antennas the size of outdoor movie screens that are used in the troposcatter network in Alaska.

"We can erect our antennas in a matter of minutes and then we're in business. We beam high-frequency energy into the sky in the direction we want, and some of the energy scatters downward from the troposphere. We don't bother about line-of-sight communication—we can park the trucks in one valley and reach into other valleys as far as 150 miles away. We don't need relay points and it's almost impossible to jam us with any equipment."

Down in the basement of Greely Hall, the post's new fortresslike command headquarters, I watched a technician operate a computer that can tell amazing things to a battlefield commander. The commander feeds into the machine all the information about his own

1. Miniaturized "flying platform" radar scanner will be so small it can be carried and hand-launched by one man

2. Planned automatic long-distance switchboard will provide 200 lines, electronically switched in microseconds, but will fit in a 2½-ton truck and needs only one operator. A conventional dial system of comparable capacity would require a building many times the size of the truck. Insert—portable handset for use with the truck's system

3. Television drones will cover tomorrow's battlefields, providing the field commander with instantaneous reports on conditions in the battle area. USAEPG artists showed this one the size of the proverbial breadbox

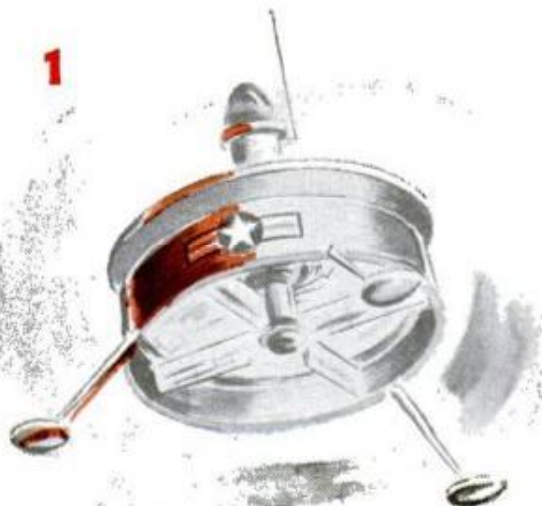

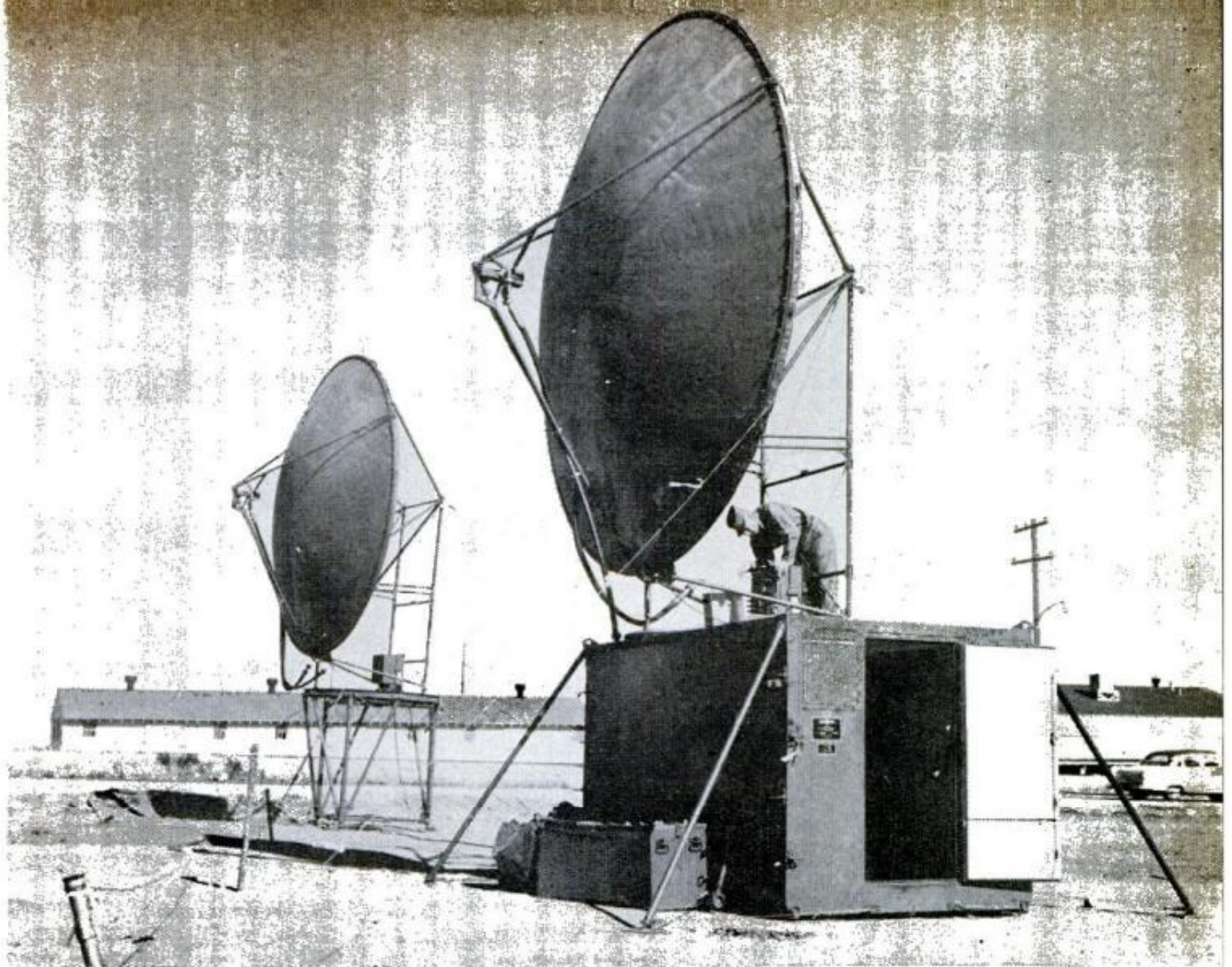

Air-inflated rubber antenna uses the metalized inner rear surface as a parabolic reflector for tropospheric scatter radio communication. It can be unpacked, inflated and set up in the field in a few minutes

forces and all the known information about an enemy, plus other data including terrain and weather. The computer analyzes this information and tells the commander the possible courses of action that he might take, and gives the probable results of each. One thing was emphasized to me. The decision and responsibility for what he does are still the commander's. The machine gives no orders.

At nearby Libby Field I watched a plane

take off with a long boxlike structure suspended below its fuselage. This was SLAR, the Army's "side-looking airborne radar" that allows a pilot to fly in safety on our side of the lines and observe deep into enemy territory. SLAR can see farther than a human observer and through darkness and clouds. It spots anything that moves, from a squad of men to a vehicle or moving train.

SLAR is one member of a new radar



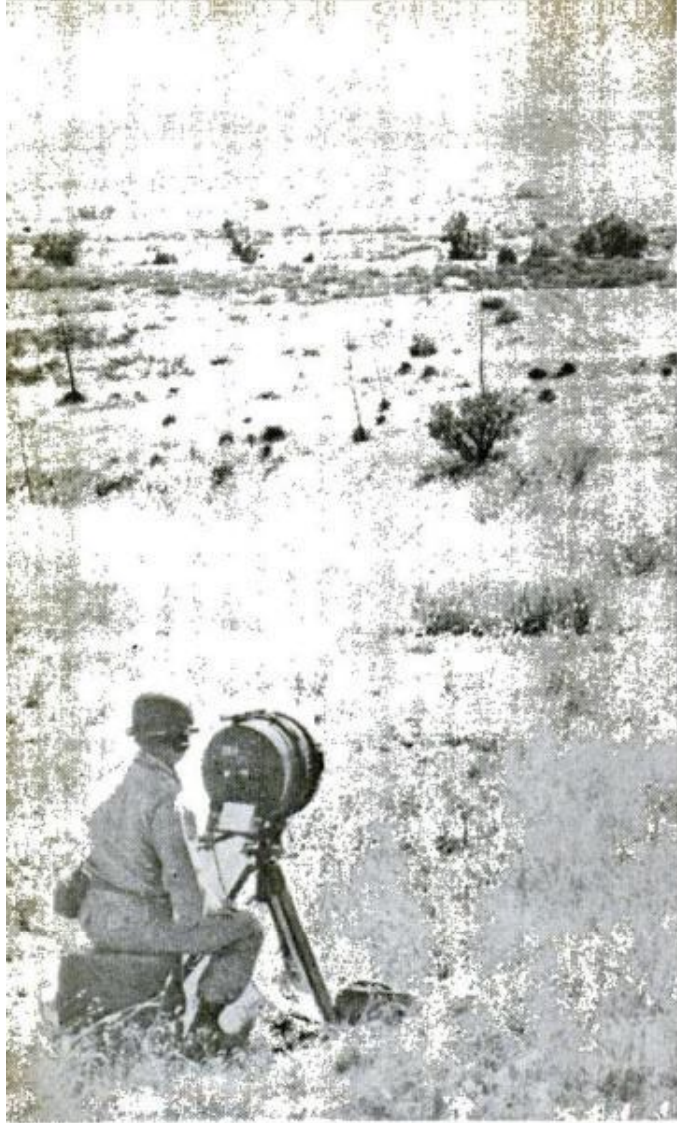

Backpacked "silent sentry" can spot a moving man a mile away in the dark or in any weather



Huachuca's original concern—Geronimo (right) and friends

family that pinpoints moving objects. In its simplest form this kind of equipment produces an audible or visible signal when it detects a moving object, and shows the distance to the object and its direction on a pair of meter dials. The smallest of these radars can be carried by two men and is called the "silent sentry." It can stand guard 24 hours a day and reports a moving man a mile away.

One of the most close-mouthed organizations at the Proving Ground is the Electronic Warfare Department. Its chief, Col. Walter E. Lotz, Jr., wouldn't go into details about his department's job, which has the responsibility of testing countermeasures against the fuze systems of artillery shells and rockets, and countermeasures against infrared and electronic devices.

"Colonel," I said, "I've heard a rumor that we can detonate an enemy's rocket or artillery shell while it is still far from its target, and that we have a way of preventing an enemy from exploding one of our own proximity-fuzed weapons. How about it?" Colonel Lotz wouldn't answer but I think I saw a twinkle in his eye.

This spring the Proving Ground is putting a new installation into use, an "electromagnetic environmental area." The area is 60 miles long and 60 miles wide, centered on Gila Bend. Inside the area the entire electronic array of an Army corps in the field can be simulated, including all its navigational aids, field TV, ground and airborne radar, radio and radar jammers and all sorts of communication circuits.

Jeep-and-trailer station gets maximum range from folding antenna



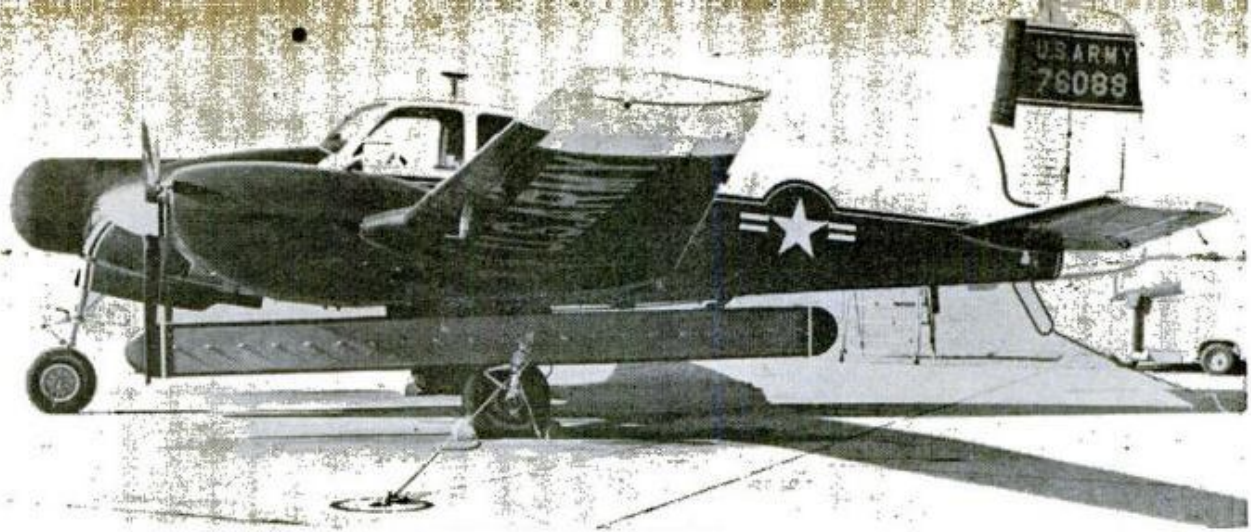

SLAR, side-looking airborne radar, flies outside enemy territory but spots moving objects miles inside lines

A modern corps carries more than 20,000 electronic emitters and in addition there are the communication and electronic devices of adjacent units, the Air Force and Navy, and the enemy. The whole electromagnetic spectrum is badly overcrowded.

No one knows what would happen if even a good percentage of a corp's emitters should be operated at the same time. But it doesn't take an expert to guess. Cross modulation, harmonics and spurious radiations would occur. Communication would become an unintelligible Babel. Our own proximity-fuzed shells might explode over our own troops. Our rockets might fly in the wrong direction and explode among friendly forces. By upsetting the standard radio aids to navigation the electronic mishmash might cause our pilots to fly into mountainsides after dark.

To avoid such possibilities the Proving

Ground is operating individual pieces of equipment against a simulated electromagnetic background in the new area. The idea is to learn whether the background interferes with the device and whether the device in turn interferes with other equipment. The goal is to make all the systems operate in harmony. Otherwise it may be necessary to establish frequency priorities, allowing some devices to operate only when others are shut down.

The Proving Ground is also setting up a corridor 50 miles wide and extending from Fort Huachuca to Yuma on the California border 250 miles away. Here the Army's new supersonic surveillance drone aircraft are to be tested.

"Are you interested in drones?" I was asked by Lloyd E. Snapp of Combat Surveillance and Avionics. I told him I'd seen plenty of small pilotless aircraft—I

(Continued to page 280)

Medium-range field radar set detects moving objects, then tells its operator their distance and direction



APRIL 1960

Temperature gradient tower tells micrometeorologists variations in temperature just above ground level



85

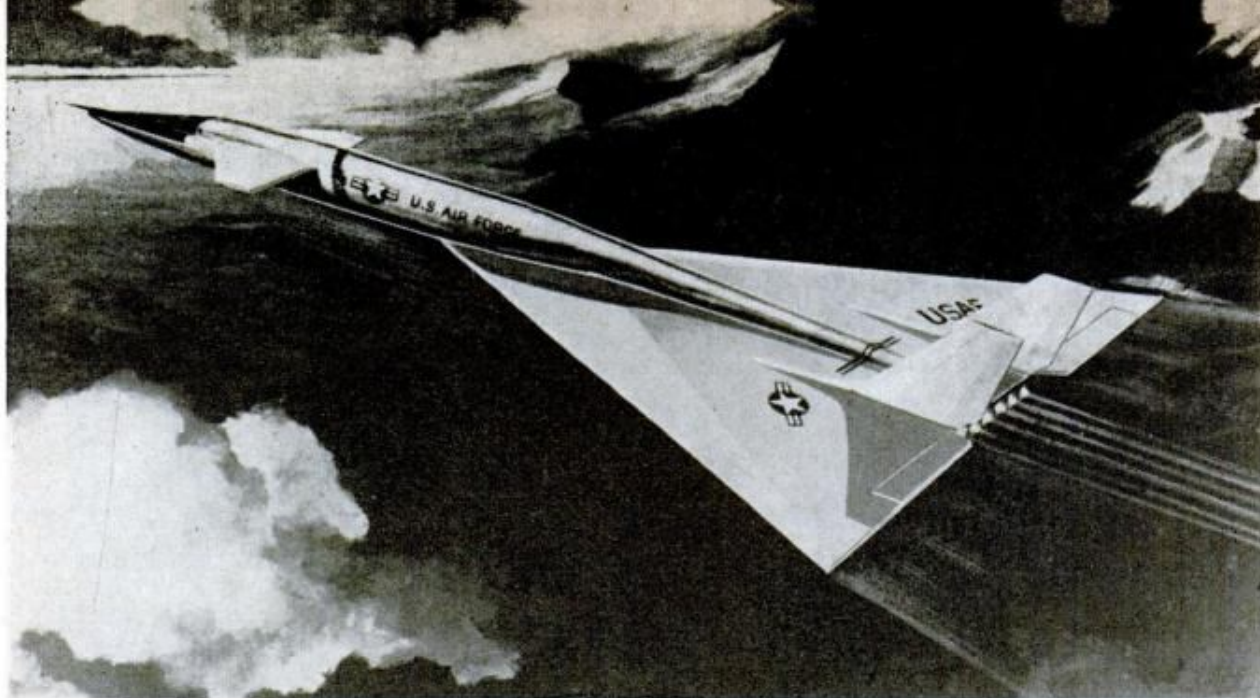

Here's a Peek at Tomorrow's Huge Planes

TWO aircraft companies are taking first steps to introduce faster-than-sound, large-sized commercial and military airplanes within the coming decade. North American Aviation, Inc., is building a prototype of the B-70 intercontinental bomber (above). Lockheed Aircraft Corp. is advocating a 2000-mile-per-hour transport adaptable for use as a military tanker, and has suggested a possible design (below) as well as an estimate of production costs.

The B-70 will feature a supersonic survival seat for each of the four crew members. Constructed like a capsule, it is sealed so there is no need for the men to wear oxygen masks or pressurized flying suits. In an emergency, at near-vacuum heights above 70,000 feet, for example, the

seat will rocket from the plane and be lowered by a 34-foot parachute. It will function as a boat should it land in water, and will carry 45 pounds of survival gear, giving protection against cold and heat.

Lockheed officials, arguing there is now no technical, operational or economic reason why a supersonic transport could not be developed in the U. S., suggest that its shape could be needle-pointed fore and aft, and that it have a swept-back stabilizer near the front of the fuselage. Passengers would sit forward of the delta wing. Such a 250,000-pound steel airliner would cost some \$160,000,000 to develop, according to Vice-President Burt C. Monesmith. He estimates that in quantities of 200 the planes could be built for \$9,240,000 each.

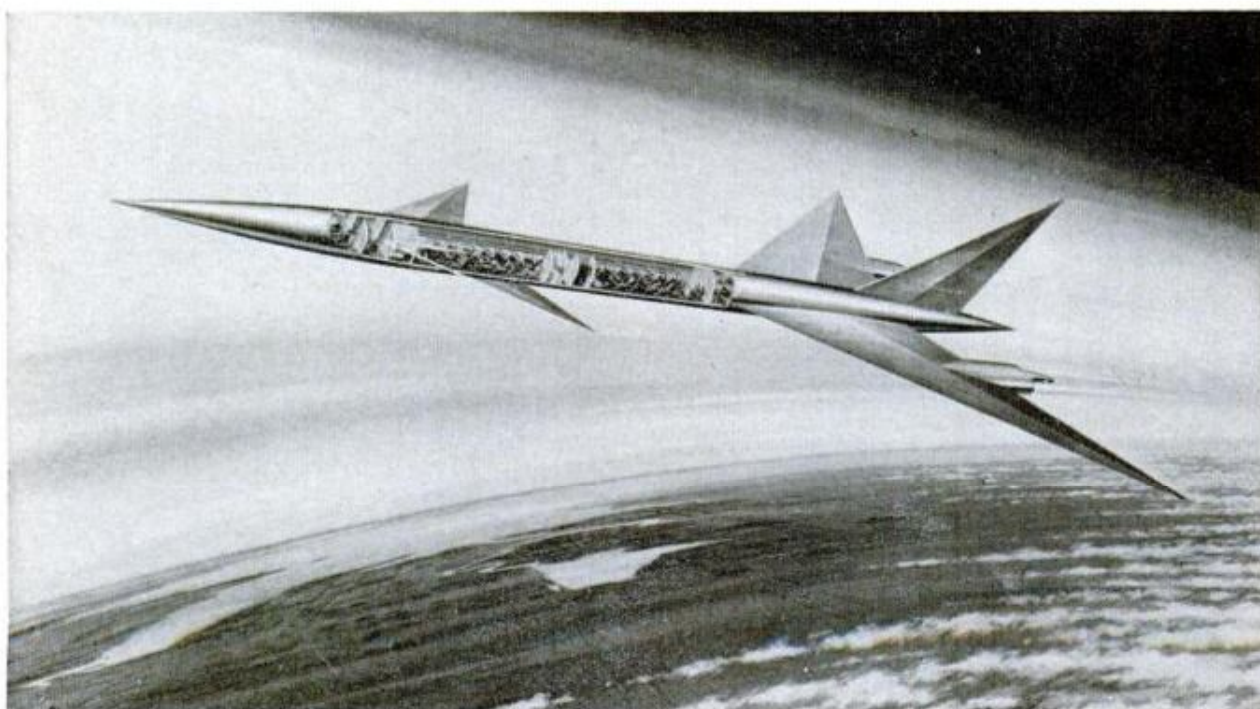

AN EYE ON SPACE



By *Dr. Dan Q. Posin*

PROFESSOR OF PHYSICS, DE PAUL UNIVERSITY
SCIENTIFIC CONSULTANT AND ADVISOR, COLUMBIA BROADCASTING SYSTEM

EARTHLINGS ARE PREPARING many kinds of fuels to propel themselves out of this world.

1. **Gasoline** is inexpensive, and its flow is easy to control. It is, however, hard to store and manipulate. It is not too reliable, as the rocket using it has to be intricate and there are many chances for breakdown. Thrust is moderate to low, amounting to about 270 pounds from one pound of fuel burning per second. Kerosene's kick also is fairly low.

2. **Exotic fuels.** Some are common substances difficult to use. Hydrogen could be a powerful fuel if burned, but it is hard to maintain in liquid form. One might liquefy hydrogen by allowing it to combine with an element such as boron, which has a high heat of combustion (25,000 B.T.U.s). So a good exotic fuel is diborane (B_2H_6), its heat of combustion being 31,000 B.T.U.s per pound. But boron hydrides are poisonous and may explode.

3. **Solid fuels** are handy, since they can be built into the rocket. Fuel material could be something as simple as rubber burning with the oxygen of some solid compound. But solid-fuel rockets tend to burn unevenly.

4. **Nuclear fission engines** are under development and, of course, they give high thrust and last a long time. But their radioactive exhaust would contaminate the launching site. The engine may be used after takeoff with safer fuel.

5. **Nuclear fusion** is something for the future, since controlled fusion has not yet been achieved.

6. **Atomic bursts**—small atomic blasts will some day be used to propel rockets or spaceships.

7. **The ion rocket** is one in which charged particles such as cesium ions are accelerated by an electric field and hurled out the nozzle. A cesium atom can easily be made to lose an electron (i.e., become ionized), and then the electric field can act on it. A thrust of more than 20,000 pounds can be obtained for every pound of cesium used up each second, but it is not easy to ionize pounds and pounds of cesium.

8. **The plasma-jet rocket** operates like this: Some fuel mixture is injected as a vapor, and an electric spark ignites it. The combustion heats up the constituents, and the expanding gases go sizzling out the nozzle.

9. **Solar propulsion** is of several types. Concave mirrors (or other devices) could absorb sunlight and produce heat to heat some gas, thereby driving it out of the engine. Or, solar heat may spin a turbine which produces electricity to expel ions. Or, sunlight may be used as mere pressure. In regions of vacuum far from restraining gravitational fields, acceleration due to sunlight pressure on a large surface eventually gives the spaceship an enormous velocity.

10. **Other energy from space**, such as plasma or ion energy belts like the Van Allen belts around Earth, may be used in the future. By ingenious navigation from one belt to another, it may be possible to "sail" almost forever on this fuel just waiting to be tapped.

Some of these may be plucked out of the so-called emptiness of space, for use in helping Earthlings on their way to the stars.

Jackie Gleason's Round House



Built of circular units connected by sweeping curved stairways, the "Studio," as Gleason calls it, sits lightly on its hilltop for all its bulk. Window walls open the view to the woods on all sides

Circular studio room is equipped with connections for broadcasting and recording equipment. Gleason plans to originate some TV programs from the house



Massive triple fireplace in the living room faces three living zones. It is built into a marble chimney that is 40 feet tall and weighs 240 tons



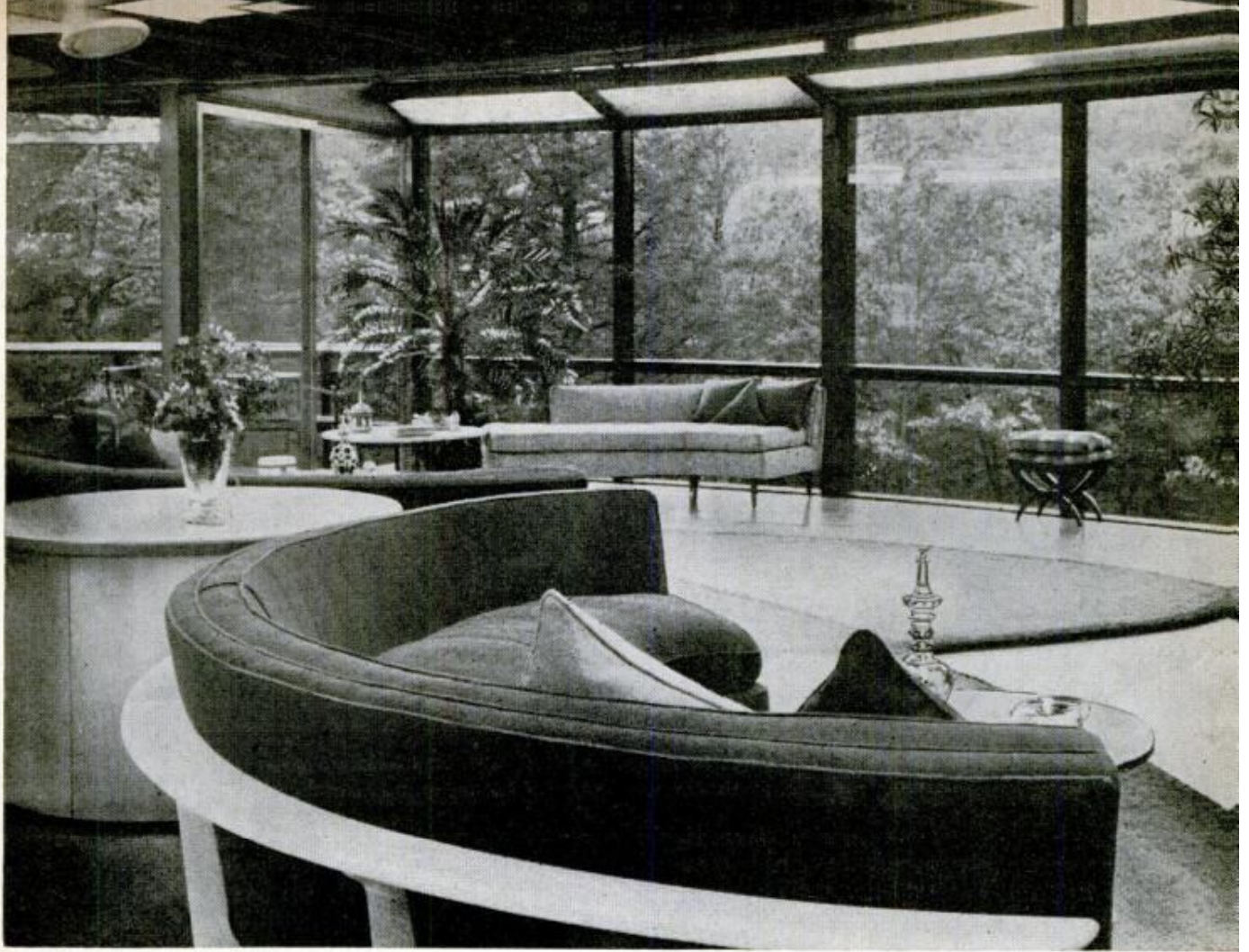

In the living room, all the furnishings, even to rounded rugs and accessories, carry out the circular design theme. Walls radiate inward from the perimeter and open in the center to connect the rooms without doors

THE MANY TALENTS and accomplishments of Jackie Gleason would put him out of the ordinary class of home builders. And Round Rock Hill, his new home on the outskirts of Peekskill, N. Y., is just that—out of the ordinary. Built on top of a hill in the center of nine acres of dense woodland, the house provides the comedian-composer-actor with “a pattern for living and working” — it contains his office and a broadcasting studio as well as his home.

Everything about the home is round. There's an eight-foot round bed with a built-in television set in the ceiling above it; a round shower room in glass and tile; round and semicircular rugs and furniture. Even the stairways curve to match the curve of the outside walls. In the center of the round living room is a huge triple fireplace. The studio room focuses on a grand piano.

The house is built on three levels across the 175-foot front elevation. Glass walls everywhere look out over the wooded hills. ★ ★ ★

Even the storage building on the grounds is round, almost top-shaped. The only other building visible from the main house is the eight-room stone guest house not seen here





Greenland's east coast during the "calving" season. This is at Cape Brewster, on the 70th parallel

Policing Iceberg Alley

By John C. Devlin

U.S. Coast Guard Photos

THE U. S. COAST GUARD Cutter *Androscoggin*, assigned to the International Ice Patrol, rolled and pitched in the foggy seas on the Grand Banks off Newfoundland. In the dark wheelhouse there was only the sound of the cold, wet wind humming and moaning in the rigging. Then over the intercom system came a brisk voice: "Surface contact by radar. Bearing 100 degrees. Range 38,000 yards."

The officer of the deck stepped quickly into the small Combat Information Center jammed with electronic devices and a big plotting table. "How's it look?" he asked.

The man crouched over the radarscope peered down on the dark face of the round televisionlike tube where a pencil-thin beam of white light fanned back and forth over the target area. With each scan it

brought a pulsing greenish-white blip at the same spot on the tube. "I think it's an iceberg, sir," the radar operator said.

At 20 minutes past four in the morning, the *Androscoggin* had groped its way to within a mile of the contact and hove to. Shortly after dawn, through thinning fog, the somber, ugly-looming mass of the huge iceberg became visible. One of its pinnacles rose 180 feet above the sea, roughly equivalent to a 15-story building. It was 300 feet across, the length of a football field. And it was grounded on the comparatively shallow Grand Banks where the ocean is 60 fathoms, or 360 feet, deep. The berg's weight was estimated at one million tons—almost as heavy as 15 *Queen Marys*. The cutter immediately issued a radio warning to all ships.

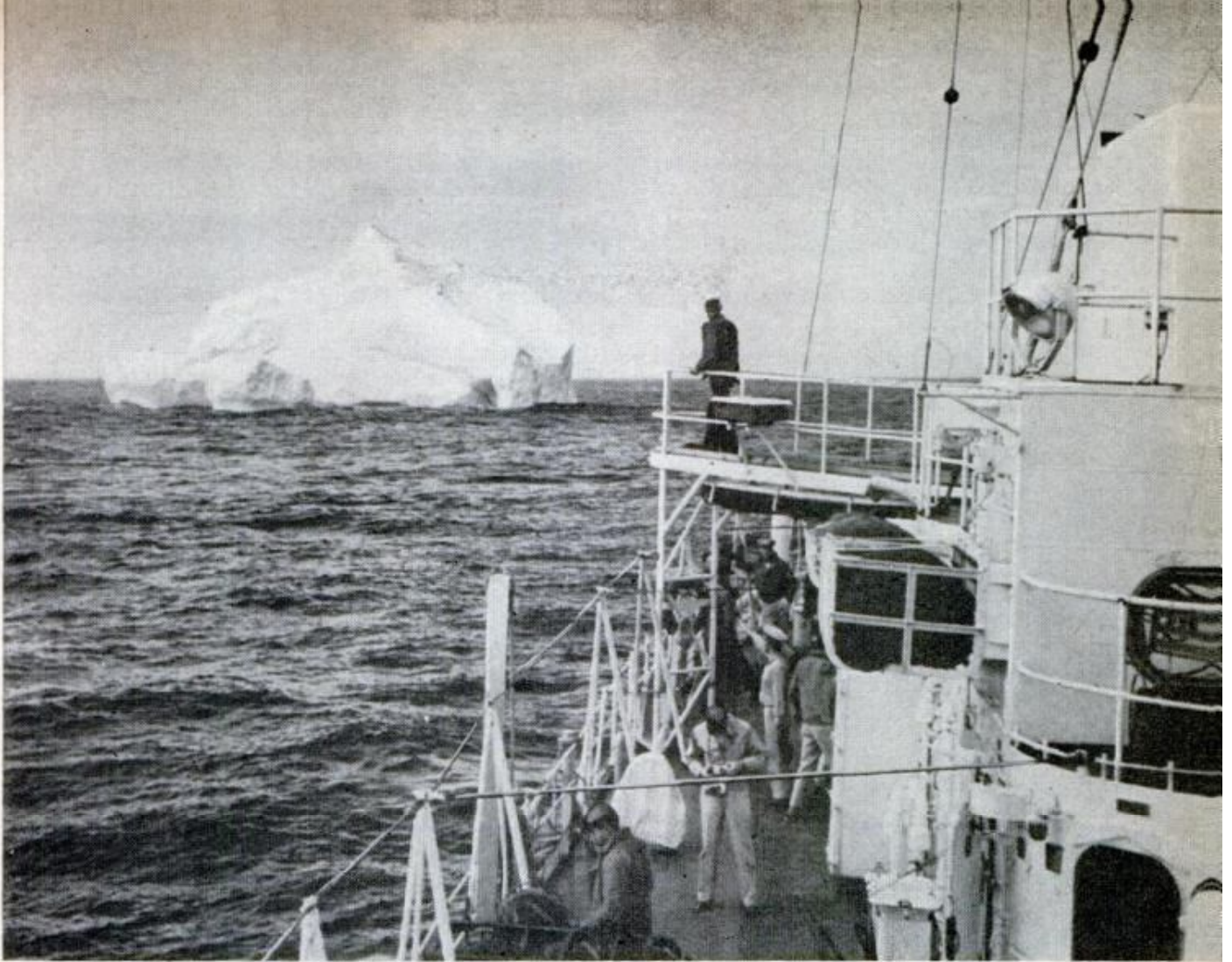

Coast Guard Cutter *Androscoggin* tracks an iceberg off Newfoundland, dangerously near shipping tracks

This massive booby trap lying in wait for the unwary was one of approximately 16,000 icebergs "calved," as seamen say, each year, mostly on the eastern and north-western shores of Greenland, by glaciers of unmelting snows that fell as long as 50,000 years ago. An iceberg may be as small as an average house or as large as a city block; and on rare occasions in the upper North Atlantic some have been reported to be a fifth of a mile long or longer. In spite of the help of radar, mariners who sail the North Atlantic route between America and Europe—the world's most congested seaway — call this great white silent ghost-fleet the worst menace they have to face in thick of fog, storm or night.

The best ally of mariners and steamship passengers against this deadly enemy is the International Ice Observation and Ice Patrol Service. For the Patrol, playing a deadly game of hide-and-seek with icebergs, warns transatlantic vessels of the position of these great mountains of ice in the shipping lanes.

Icebergs calve in warm weather, and the danger season extends from March to July and sometimes through August. Ice Patrol aerial reconnaissance begins in January or

Same iceberg seen from *Androscoggin* lifeboat. Its size was estimated at 500 feet long, 200 high, 400 under water



February, depending on reports from ships and aircraft that icebergs have been seen approaching the critical area of the North-Atlantic.

At Ice Patrol headquarters in Argentia, a windswept outpost 90 miles from St. John's, Newfoundland, each berg's position is marked on a big wall chart as the report comes in by radio from air and sea patrols. This shows the officer how many bergs are near the shipping lanes. Every four hours ships in the ice area report their position, speed, ice conditions, air and water temperatures, visibility, wind direction and velocity. From the "ice-house," as Argentia headquarters is called, an ice bulletin is broadcast twice each day by Morse code to all ships at sea.

The Patrol was founded after the White Star liner *Titanic* collided with an iceberg and sank on the night of April 14, 1912, taking with her 1502 of the 2224 persons who had boarded her in England for her maiden voyage. She was the world's big-

gest and newest—an "unsinkable" ship. Her loss was a nightmarish disaster that shocked the world. In November, 1913, an International Conference on the Safety of Life at Sea met in London and provided for countries using the hazardous area to support an international ice observation and patrol service. The United States was asked to undertake its management, and the convention went into effect on July 1, 1915. The second International Conference on Safety of Life at Sea was convened in London April 16, 1929, the third in 1948, and the fourth will be convened this year, also in London.

The cost of the patrol—ranging between \$300,000 and \$500,000 a year—is borne on a "pay-as-you-benefit" basis, according to the amount of shipping tonnage each participating country has passing through the area patrolled. These countries include Belgium, Canada, Denmark, France, Italy, Greece, The Netherlands, Norway, Sweden, the United Kingdom and Northern Ire-

Chart shows iceberg drift areas and responsible currents. Dotted grid indicates area dangerous to shipping

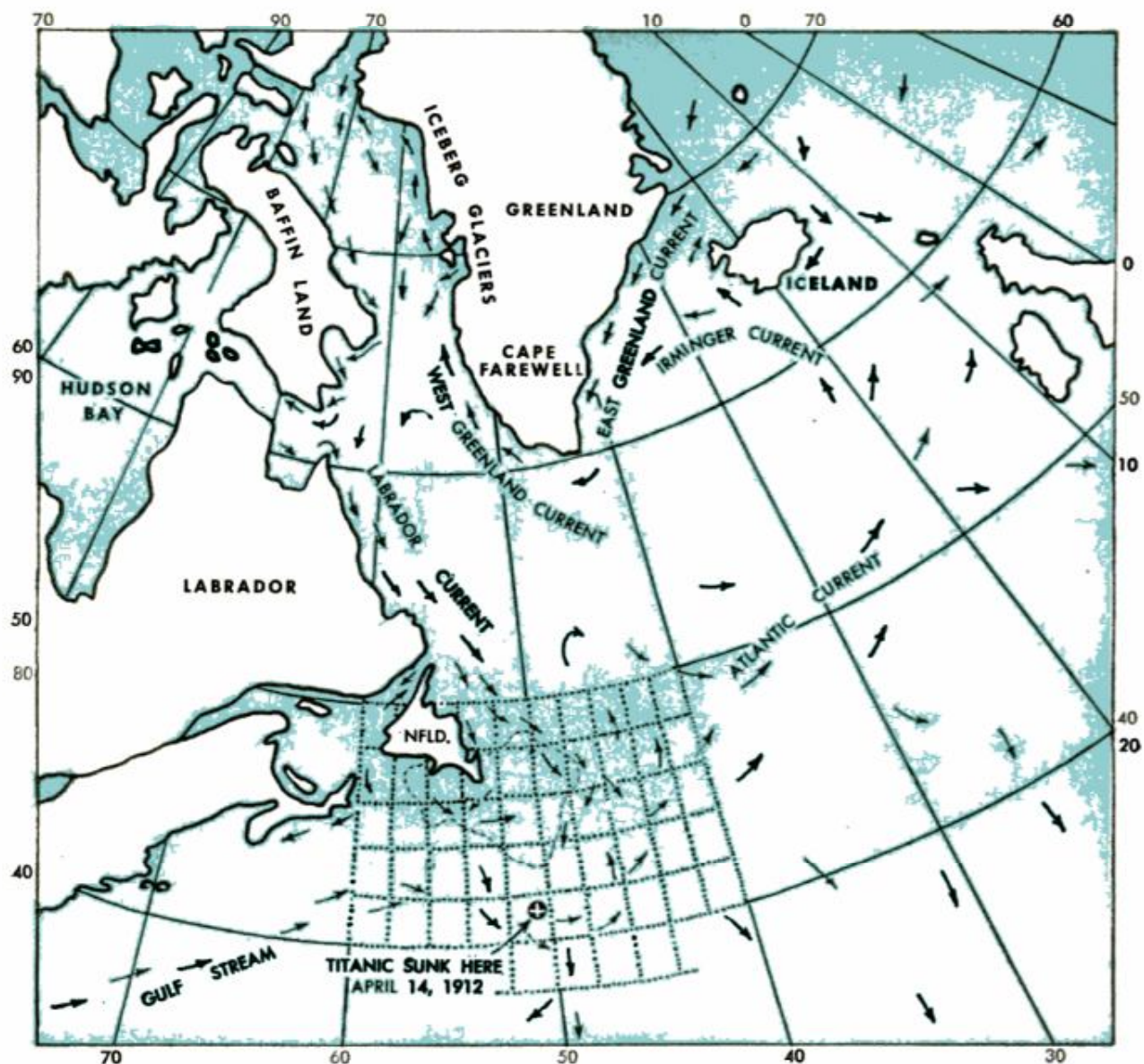

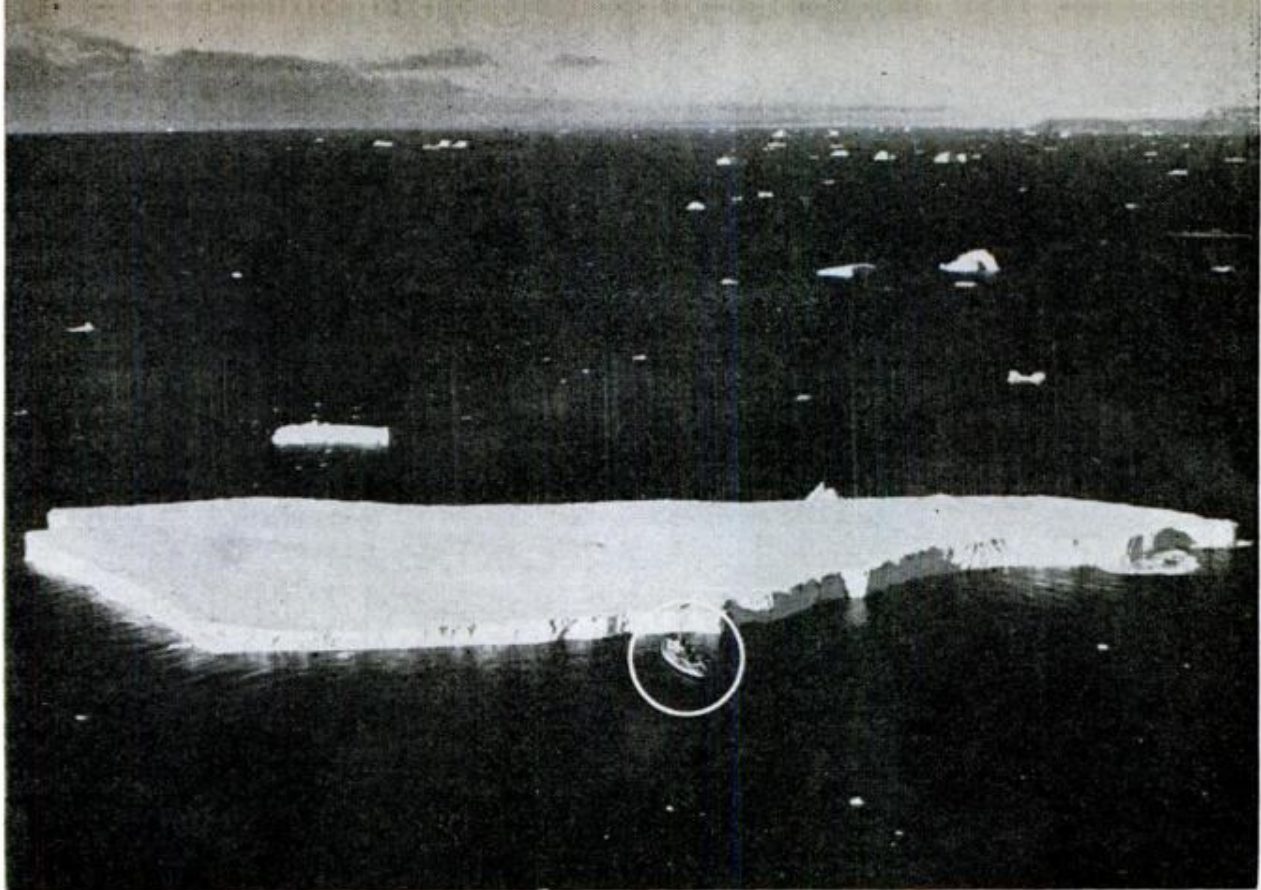

Androscoggin (circle) is dwarfed by a big "table-top" iceberg, very unusual in the North Atlantic area

land, and the United States. Negotiations were conducted in 1958-59 for the inclusion of Spain, West Germany, Liberia and Panama. The U.S.S.R., which had joined in 1929, dropped out in 1948.

It is the proud boast of the Ice Patrol that since the service began, no lives have been lost in the Pennsylvania-size area it patrols. During World War II several lives were lost when several ships in a convoy collided with a berg. But the war had caused discontinuation of the patrol service.

The latest ship sunk after a collision with an iceberg was the Danish vessel *Hans Hedtoft*, brand new and especially designed to cope with the thick icefields at Greenland. Like the *Titanic*, she was supposed to be "unsinkable," yet she struck a berg off the southern tip of Greenland last January and was lost with all hands. She was in local coastal waters, however, *not* in the area covered by the International Ice Patrol, which devotes itself only to transatlantic steamship lanes.

Icebergs are awesome whether you come across them in sunshine, fog, a driving gale laced with blinding snow or, incredibly, glittering in moonlight like some fairylike ice castle. Generally the

Planes take off to bomb iceberg. Below, aerial radar operator

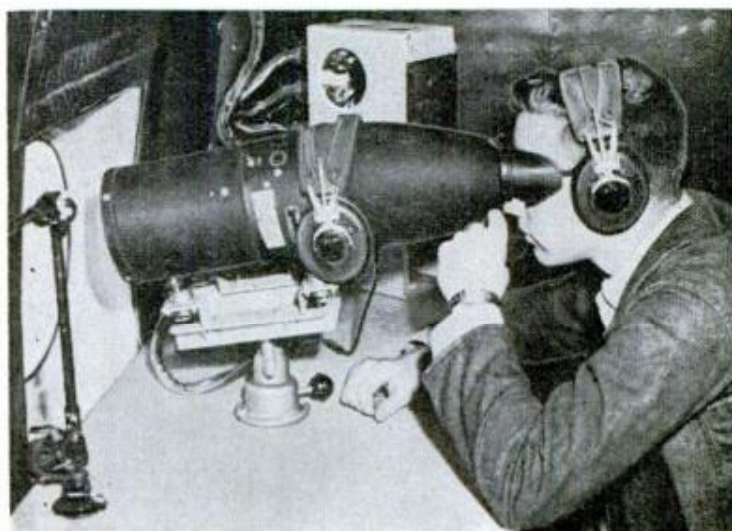



Experimental incendiary "bomblet" burns a pocket into an iceberg. Bombs apparently have little effect on bergs

North Atlantic bergs have a pronounced opaque whiteness — with thick "cracks" which are actually lines of green or blue where the berg has frozen-in plankton or streaks of brown dirt picked up as the original glacier scraped over bare earth. The surface may look like polished marble or fused glass, or it may be honeycombed. They resemble a luminous white monster if the sun is shining—otherwise a dark and somber mass.

Sometimes, while still unseen, a berg's presence will be heralded by "brash," slushy bits of junk ice up to the size of a piano, that have broken away. The berg itself may be shaped like a big ice cake, with a flat top and sheer clifflike sides; or, if weathered, it may be irregular in shape—pinnacled or steepled, U-shaped, arched or tunneled. Dome-shaped bergs are a particular curse because their rounded noggins send a ship's radar signals bouncing off erratically in all directions instead

of straight back in a clear, sharp reflection.

On rare occasions a polar bear will be found riding along on a flat-surface berg as if he were its captain. There are almost always flocks of sea birds perched on the icy crags. There was a theory for a time that seamen might be able to detect icebergs by the seabirds serving as harbingers. Still another theory was that the presence of an iceberg could be detected by blowing a ship's whistle and listening for an echo. None of these theories, however, have proven reliable. Even with the wonders of our nuclear age, the Coast Guard says the "only sure sign of an iceberg is to see it."

Icebergs are calved by breaking off from glaciers in one of two fashions. The sheer weight of the glaciers, always increasing, forces them downward out of Greenland's mountains and into the sea, sometimes at speeds up to 70 feet a day. When the shore

(Continued to page 232)



Two Greenland glaciers join on their slow path to the North Atlantic. At the edge of the water they will give birth to big bergs

TALK ABOUT rigged TV shows! What about the so-called stock-car events at Daytona Beach? The results weren't rigged, but the conditions and the machines were.

The results have backfired somewhat. So high were the speeds, so great was the economy that the companies hesitate to quote results without explanations that say, in effect, these figures are unrealistic.

Who believes, for example, that truly stock family sedans can average over 150 miles per hour for miles? Or that truly stock compact cars can go over 125 miles per hour? Or that a stock six-cylinder car can average 51 miles per gallon?

The promoter claims that these Daytona cars are stock and can be bought by anybody (doctored only with special parts, usually described as for "safety" reasons).

The facts seem quite different. Valiant's power package includes non-standard carburetor, cylinder head, exhaust system, valves, camshaft, bearings, valve springs, crankcase (including an added oil cooler). When asked how much it would cost to get these parts on a Valiant, a factory spokesman said no price was available and that none would be available (because, apparently, no kits are available except for Daytona).

Take Falcon's modifications. The factory says it knows nothing about them except what it reads in the papers. Ford doesn't make them or sell them. The so-called "stock" Falcons in the races were equipped with three carburetors plus a fast cam and other changes based on a modification kit built by a North Carolina speed shop, not by Ford at all. How sticky can a stock-car race get?

Corvair's 95-horsepower pack was announced in mid-January but six weeks later no price nor any kit was available for the public.

What about the economy test? Here there was no AMA anti-racing resolution to bother and the factories were in it with both feet. They hired skilled economy drivers, factory mechanics reworked the cars, using extra-lean jets.

The event is sponsored by a gasoline company which, naturally, was anxious to get plenty of miles per gallon—that sells gas.

The winner Rambler American had overdrive (the three new compacts don't have overdrive) and used it. It has the Rambler overhead-valve six that puts out 125 horsepower, allowing a very high rear-axle ratio (a new heated intake manifold, which uses hot water from the heater hose not much different from the way it is used in the Ford Falcon, helps economy on the low end).



DETROIT LISTENING POST

By Art Railton

So it racked up an unbelievable 51 miles per gallon! And the industry wonders why the guy who buys a compact car and gets the usual 20 miles per gallon thinks he's been robbed! When you read about 51 miles per gallon, surely you have a right to expect 25 over-all!

It's too early to be certain of the exact details, but it looks as though the down-the-road-a-piece Big Three entries in the really-small-car field will shape up like this: General Motors will offer a rear-engined, air-cooled car; Ford will have a front-engined, front-wheel-drive, water-cooled car; Chrysler will have a rear-engined, water-cooled car. All will be four-cylinder, short-stroke OHV engines of about 100-inch displacement. All will have full-independent suspension, under 100-inch wheelbases.

Look for something important at Lincoln this fall. It is expected to begin the big switch to a smaller, more personal car, a four-door Thunderbird concept. The switchover to the new size will take more than one model change, but the start will be made this year. In a couple of years, the big-as-a-house Lincoln will be only a memory. The days of the leviathan auto are numbered (except for funeral entourages). Even Cadillac will start getting smaller next year.

Remember the dream truck that GM had at the 1955 Motorama? It was a low-slung, front-wheel-drive buslike vehicle with its floor only a few inches off the ground. Its styling will reappear with chassis modifications (rear engine, rear-wheel drive) as the Corvair station wagon and truck line.

The BOP car will have, as you all know by this time, an aluminum V8 with cast-iron liners. It will be front mounted. More powerful, more stylish than the Corvair, it will be fast enough to run circles around all the present compacts including, rumors have it, the Valiant. All three divisions (Buick, Oldsmobile and Pontiac) will sell the car.

Goodbye, Opel and Vauxhall. It was nice having you visit! ★ ★ ★

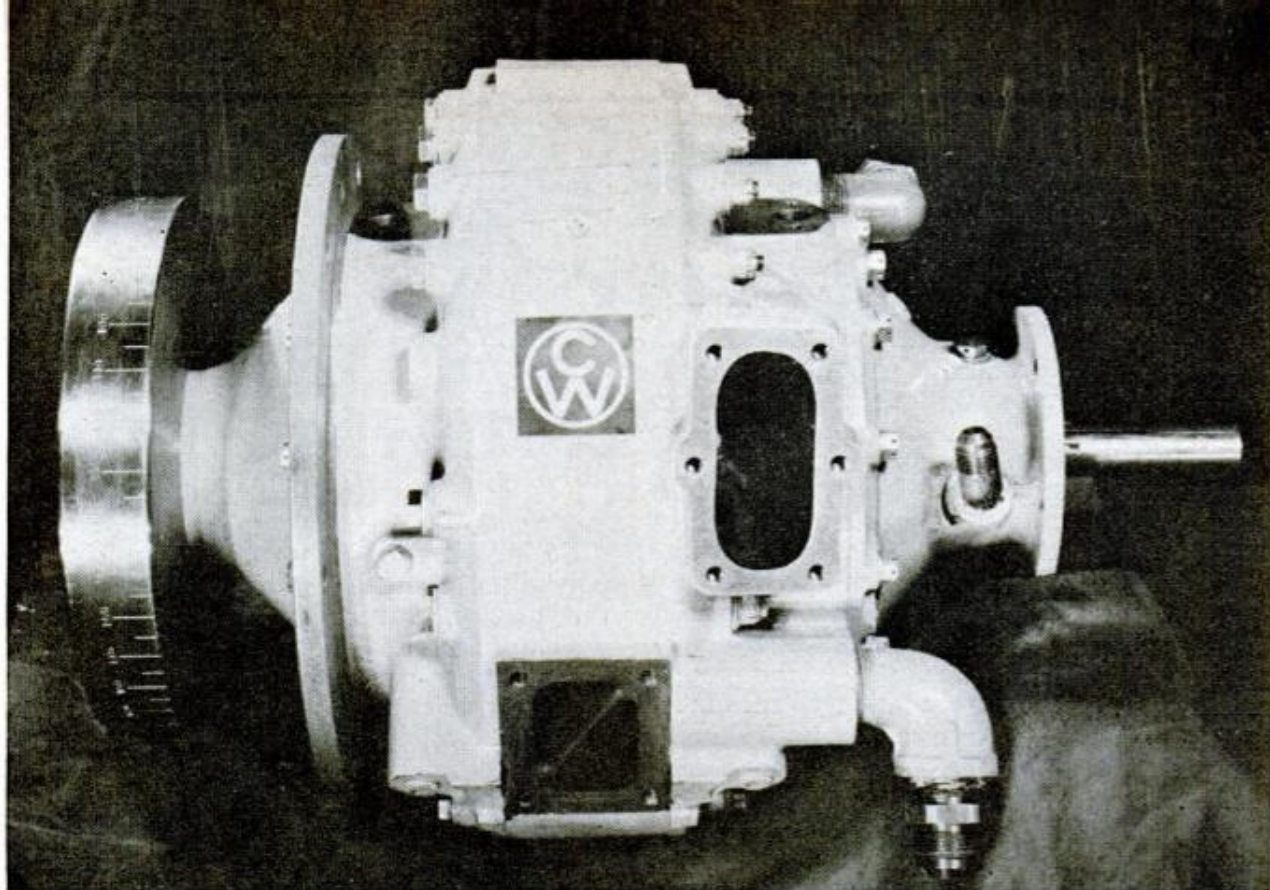

Curtiss-Wright Corporation photos

Rotating combustion engine has only two moving parts and is compact, lightweight and free from vibration

REVOLUTIONARY ENGINE

ABOUT 30 YEARS AGO, Felix Wankel, a German industrial designer, concluded that the stop-and-start action of a stroke-piston internal-combustion engine was not the most efficient way to make wheels revolve. A far more logical method, he felt, was through a smooth, rotating action—like that of a water wheel.

As a result of experiments that Wankel carried on during the ensuing years, and

of further development in recent years by a German and an American industrial firm, that smooth, rotating source of power—the rotating combustion engine—is now close to becoming a production-line product.

The American firm, Curtiss-Wright Corporation, plans to begin producing the engine this year. NSU Werke, a motor company in West Germany with which inventor Wankel is associated, will concen-

The intake, compression, ignition, expansion and exhaust sequence in the rotating combustion engine is practically continuous because it is rotating with the rotor. As shown in Figure 1, the gasoline-air mixture enters the chamber through a port. As the rotor turns further, mixture is compressed (Figures 2 and 3)

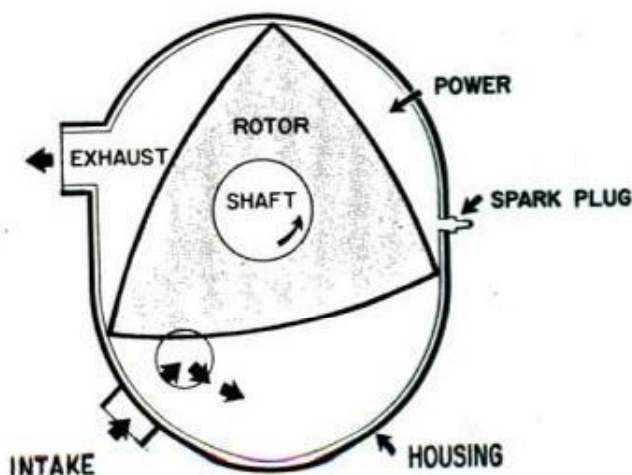

FIGURE 1

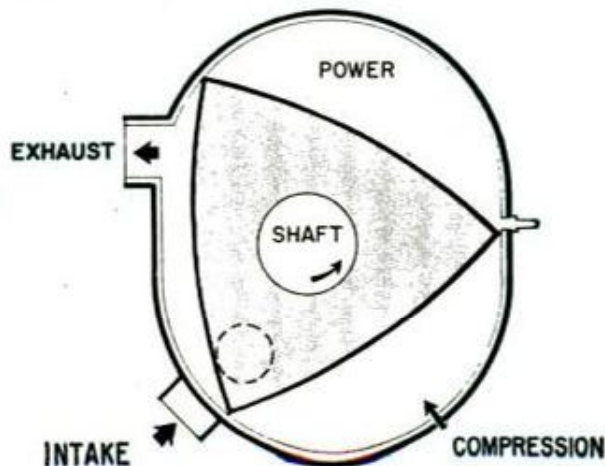
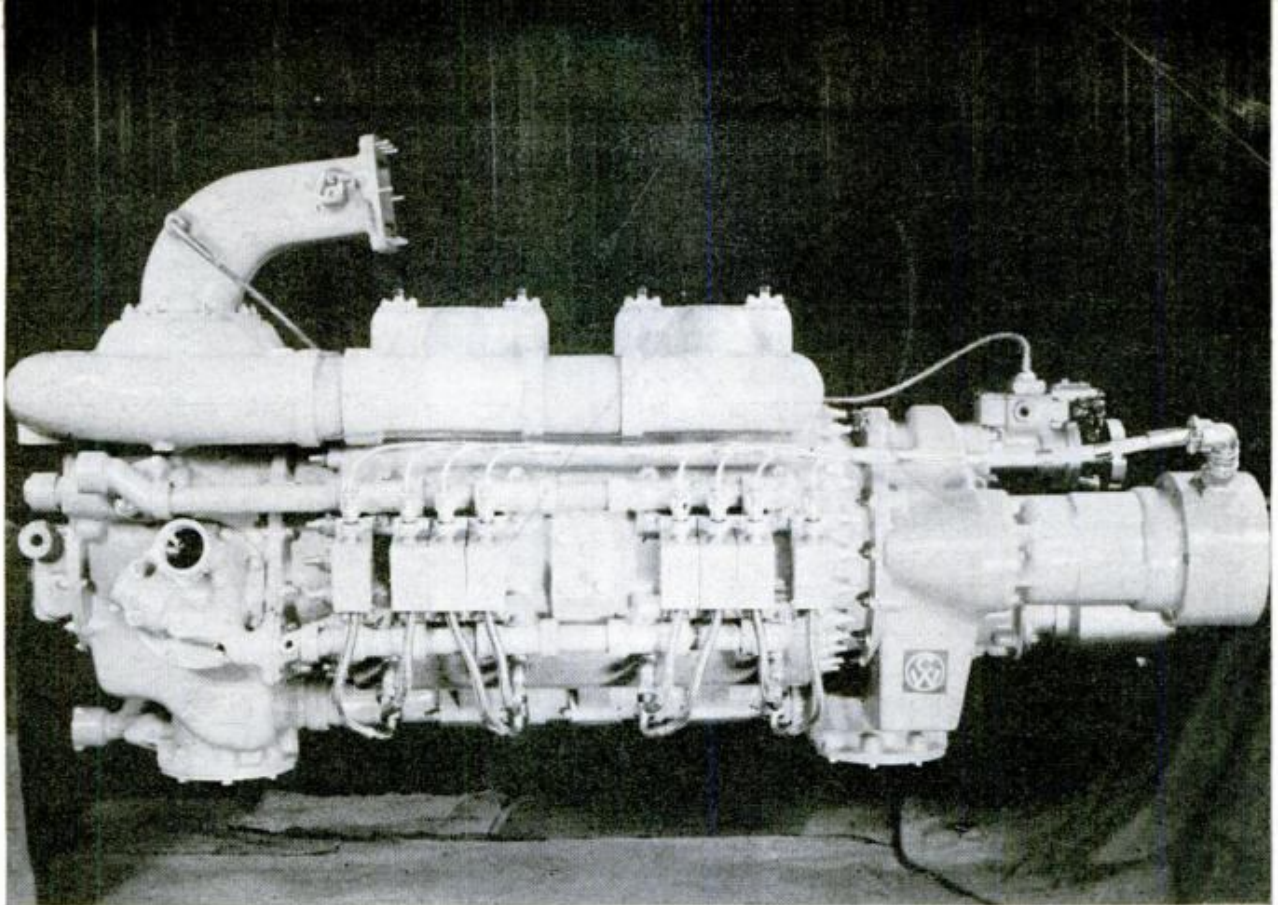

FIGURE 2



Developed for aircraft, this YRC 600 supercharged engine operates on the rotating combustion principle

trate on low-horsepower engines while Curtiss-Wright will develop those in high-horsepower classes, including types for aircraft.

Compact and lightweight, the rotating combustion engine requires no valves, springs, camshafts, pistons or connecting rods. Rather than cylinders and pistons, the engine has a single combustion chamber shaped somewhat like a jelly bean. Revolving inside the chamber is one of the engine's two moving parts, a rotor that is shaped like an equilateral triangle with its

sides bowed outward. (The other moving part is the crankshaft.)

The rotor makes an eccentric orbit inside the chamber so that its three corners are in contact with the chamber sides at all times. An inset metal strip at each corner of the rotor acts as a piston ring, sealing each of the three cavities formed between the rotor's sides and the walls of the chamber.

An automotive carburetor supplies a mixture of gasoline and air into the engine
(Continued to page 258)

The compressed mixture is fired by a spark plug (Figure 4). The expanding gases during combustion deliver the power through the rotor to the crankshaft. The chamber then exhausts through a port. Since all events occur almost simultaneously, the rotating combustion engine is smooth operating and highly efficient

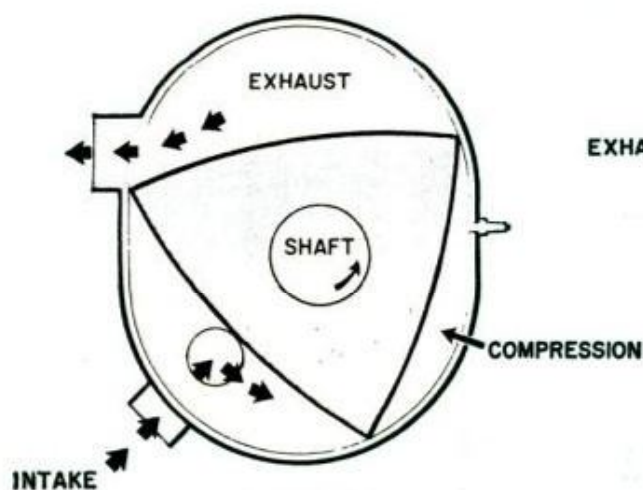

FIGURE 3

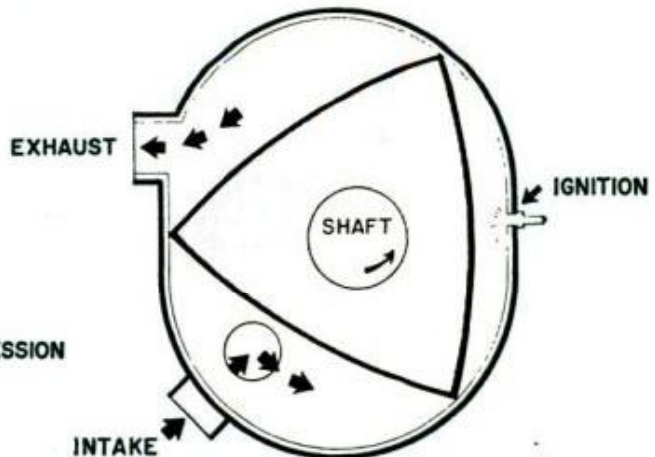

FIGURE 4

HOW GOOD IS THE FALCON?

Owners like:

Handling ease	61.3%
Gas economy	49.9%
Riding comfort	24.9%

Why did they pick Falcon?

Economy of operation	68.8%
Over-all size	48.0%
Exterior styling	41.5%

WHAT'S WRONG WITH IT?

Owners dislike:

Not enough power	18.2%
Body rattles	7.0%
Poor gas mileage	5.8%

What should be changed?

Step-down floor	4.7%
Tire size	3.4%
Increase horsepower	3.4%

WILL THE FALCON CUT INTO IMPORTED-CAR SALES?



YES say 90.6%

NO say 9.4%

Falcon has:

More room
Better service
U.S. label

Imports have:

More economy
Better quality
Lower price

FALCON OWNERS LOVE IT,

Falcon owners like the ease of making sharp turns like this, but some find fault with its grille design





BASED ON 1,406,369
OWNER-DRIVEN MILES

Well liked is Falcon's simple styling, but owners say windshield is so high driver is bothered by the glare

BUT WOULD LIKE MORE PEP

THEY LOVE IT—that's how owners feel about the Falcon. This new Ford compact racked up the best record of owner approval in the history of PM's Owners Reports. Less than one percent rates it Poor.

These owners are happy. They like the car. They like its simplicity. They like its economy. They like its conventionality. There's little they don't like.

What about the inevitable new-car bugs? Apparently, there are very few. This well-thought-out machine may not be exciting to the engineer, but it sure is satisfying to the owner.

PM asked 1000 Falcon owners from coast to coast about their cars. These owners have driven their cars under all kinds of weather, over all kinds of terrain, in all kinds of traffic. Result: Wholesale approval.

Here are some general comments about the car, before we get into the particulars:

"Just between me and you, people don't think you are stuck up and they are not jealous when you buy a small car even if new. That was what happened on our street. Everyone was going above their pocketbook, buying a larger car with more power, high price, high-octane gas, too much money on their car for such a small house as they lived in. The people don't need a bigger car. It's just right."—North Carolina truck driver.

MARGINAL COMMENTS
BY ART RAILTON
PM's AUTO EDITOR

*What kind of car is it?
Certainly not frisky.
You'll get no tittup here.
← But it's sensible, so
much so that you feel
confident just looking at
it. Surely, you feel,
nothing could go wrong
with such a simple ma-
chine. You won't rave
about it, but neither
will you rant.*

*Detroit used to shrug off
talk like this. But now,
people are putting their
money where their mouths
are—and money is the
← loudest noise Detroit
hears.*



Owners like the way it drives on a winding road. Dashboard is orderly

Left, women say the stepdown floor makes it awkward getting in and out

Carburetor icing is prevented by piping hot water around intake manifold

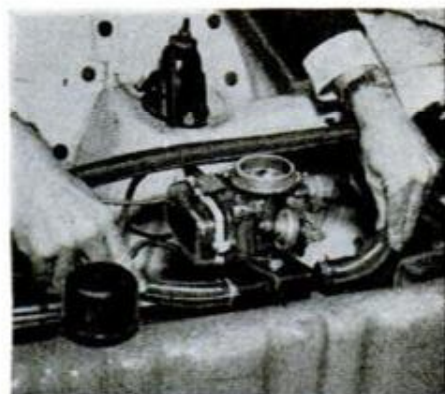

Five years? More likely only two. Certainly no more than three. →

"This car represents the initial stage of a movement, demanded by the average family, toward more economical and practical transportation. These compact cars will dominate the automobile industry within as short a period as five years."—Maryland salesman.

With missionaries like him out spreading the gospel, how can the small-car fail? →

"I'm tired of all the fancy trim and humps on the modern car. First-cost and upkeep are way out of reason. Now I have a car again that is satisfactory, just as easy to drive, good heater and economical."—South Dakota cafe owner.

There's something about returning to fundamentals that is satisfying—like a good steak after your wife's been on a let's-try-some-new-recipes binge! →

Let's be specific about the Falcon. Most of all, the owners like its handling ease, with 61.3 percent listing it as the best-liked feature. They have discovered that small cars have more virtues than economy, that they are easier to live with, easier to navigate.

"The more I drive the better I feel about buying this Falcon. I have not given up comfort because the car is small. I enjoy driving a car more now than I ever enjoyed it before. On long trips I'm not as tired as I used to be in my old car which was much larger."—Utah aircraft worker.

"I enjoy it more than any car I've ever owned and my wife does too. Giving up power steering, brakes and an automatic transmission took a lot of doing, but we were so sick of buying gas every time we drove that we were eager to try something new. If more people would try it they would soon learn to enjoy a smaller car."—Ohio foreman.

Second on the best-liked list is gasoline economy with 49.9 percent mentioning it.



Hood is not counterbalanced. You must prop it open with this rod (arrow)

Right, the top complaint is a lack of power, especially on steep hills

Trunk is roomy. Gas tank neck (center) tends to spill gas when topped

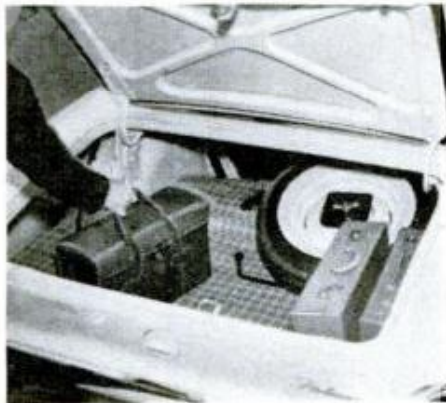

Most Falcon drivers with handshift transmissions say they are getting between 23 and 30 miles per gallon

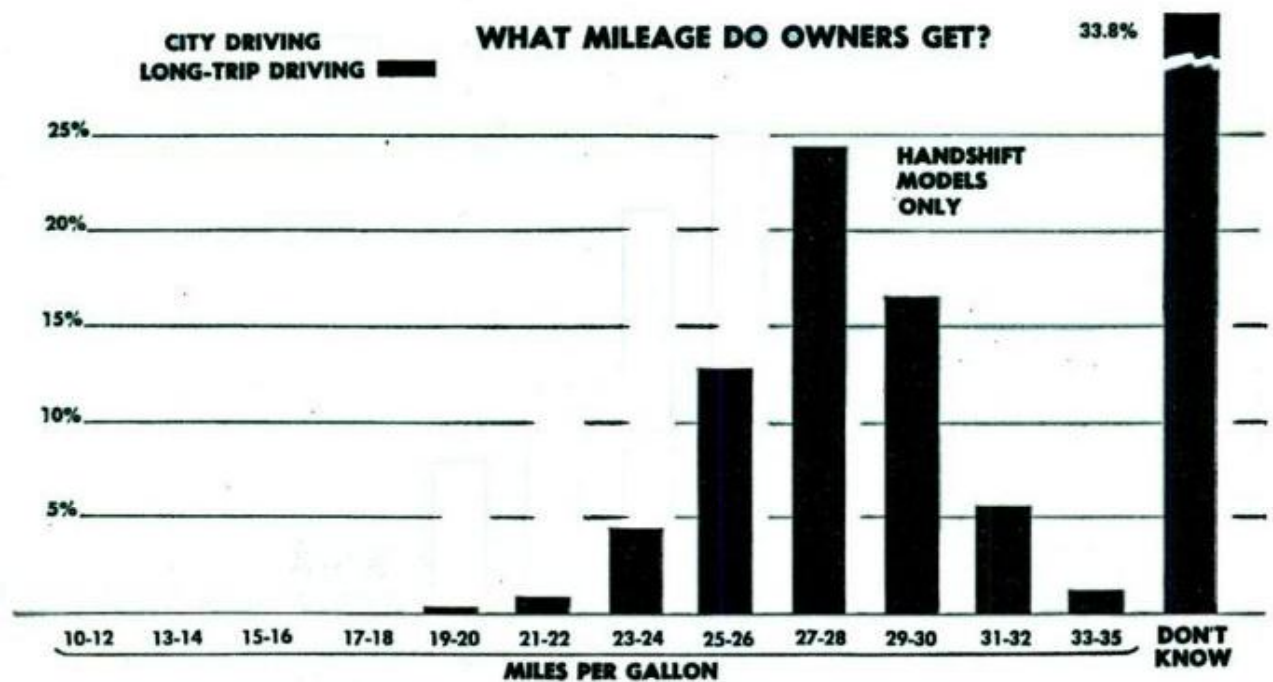



Neat is the rear-end styling with simple metal sculpturing. Huge back window gives excellent visibility

See page 270 for PM's test on gas economy →

Not just an in-town car, Falcon is well mannered on the highway



"I am a rural mail carrier with a 47.35-mile route, including 6 miles of dirt road. I average 22.9 miles per gallon. My route consists of 45 stops. I'm well pleased. I have a hand-shift transmission."—South Dakota mail carrier.

"I spend \$3 a week for gas. My 1958 Edsel cost me between \$10 and \$12 a week."—Rhode Island conservation officer.

"Under 60 miles per hour you can get 28 miles to the gallon, but if you drive 70 you will get about 22."—Nebraska farmer.

Third on the list of praiseworthy features is riding comfort with 24.9 percent mentioning it.

"We took a fast 8300-mile trip in 33 days, covering Ohio, Pennsylvania, West Virginia, Virginia, North and South Carolina, Georgia, Florida, Alabama, Mississippi, Louisiana, Texas, New Mexico, Arizona, California, Nevada, Oklahoma, Missouri, Illinois, Indiana and back to Ohio. We enjoyed this long vacation because we had a very comfortable riding car."—Ohio electrician.

(Continued to page 270)

SUMMARY OF OWNERS REPORT:

FALCON



What about gas mileage (handshift)?	Tire, wheel size 3.4%	What make was traded?
Satisfied with it 89.0%	Increase horsepower 3.4%	Ford 43.5%
Not satisfied 8.7%	Why did they pick Falcon?	Other Ford Motor make 5.0%
No answer 2.3%	Expected gas economy 68.8%	General Motors make 25.0%
What about mileage (automatics)?	Over-all size 48.0%	Chrysler Corp. make 7.3%
Satisfied with it 81.3%	Exterior appearance 41.5%	Other U.S. make 3.9%
Not satisfied 18.7%	Initial price 38.7%	Foreign make 7.3%
Best-liked features	Engineering 20.4%	No trade, no answer 8.0%
Handling ease 61.3%	What like best in styling?	What make will buy next?
Gas economy 49.9%	Simplicity, lack of chrome 35.2%	Another Falcon 36.6%
Riding comfort 24.9%	Large glass area 10.1%	Other Ford make 15.4%
Exterior styling 22.7%	Sloping hood 8.1%	General Motors make 1.8%
Interior room 22.5%	What like least in styling?	Other U.S. make 1.6%
Ease of parking 21.2%	Front-end design 8.6%	Foreign make 0.8%
Most-frequent complaints	Single headlights 2.2%	"Small car" 2.2%
None at all 30.3%	Small wheels 2.2%	No answer, undecided 41.7%
Not enough power 18.2%	What like best inside?	Large enough for "family" car?
Body rattles 7.0%	Expensive upholstery 26.3%	Yes, it is 86.0%
Poor gas economy 5.8%	Roominess 19.0%	No, it is not 14.0%
Poor workmanship 4.3%	Seating comfort 13.1%	Is it only car in family?
Step-down floor 4.0%	What like least inside?	Yes, it is 62.6%
Had engine trouble?	Step-down floor 8.1%	No, own another car 36.8%
No trouble at all 83.1%	Hump in the floor 4.2%	No answer 0.6%
Some trouble 15.1%	Glove compartment 3.8%	What is other car?
Considerable trouble 1.8%	How is dealer service?	Big Ford 31.0%
What was trouble?	Excellent 55.4%	Another Ford make 8.4%
Engine skips, misses 3.2%	Average 36.1%	General Motors make 36.5%
Carburetor trouble 2.4%	Poor 8.5%	Chrysler make 13.6%
Ignition, timing 2.4%	Would buy from him again?	Foreign make 5.7%
What one thing should be changed?	Yes, would 59.3%	Other U.S. make 4.7%
Nothing or no answer 50.0%	No, would not 10.1%	
Step-down floor 4.7%	Don't know, no answer 30.6%	



Amsterdam's Narrow House

Facing a canal in Amsterdam, The Netherlands, is a two-story house so narrow that two people have difficulty passing each other in its tiny rooms. The front door opens onto a staircase which leads directly to the living room of its occupants, a retired seaman and his wife, who've made the house their home for 21 years.



Clean Way to Clean Type

Typewriter keys now can be cleaned merely by running a letter-size sheet of special paper through the feed roller and typing on it. The paper, a soft fibrous material that looks like pink "flocked" paper, has a mild adhesive that causes dirt on the type to stick to the surface as the type face strikes the paper. It automatically cleans the feed roller, too, without depositing any liquid on the typewriter mechanism. The paper is perforated every 1½ inches so portions may be torn off.



Tester Finds Right Metals

Choosing correctly between metals that look alike but have different properties is the job of a "metal sorter" being used at the Knolls Atomic Power Laboratory in Schenectady, N.Y. Metals, such as inconel and stainless steel that are used in nuclear reactors, look alike but cannot be used interchangeably in a reactor. Metals are attached to a clamp-on lead on the tester, and a carbon-steel file is rubbed against them, generating current. Current causes a dial to indicate the type of metal tested.

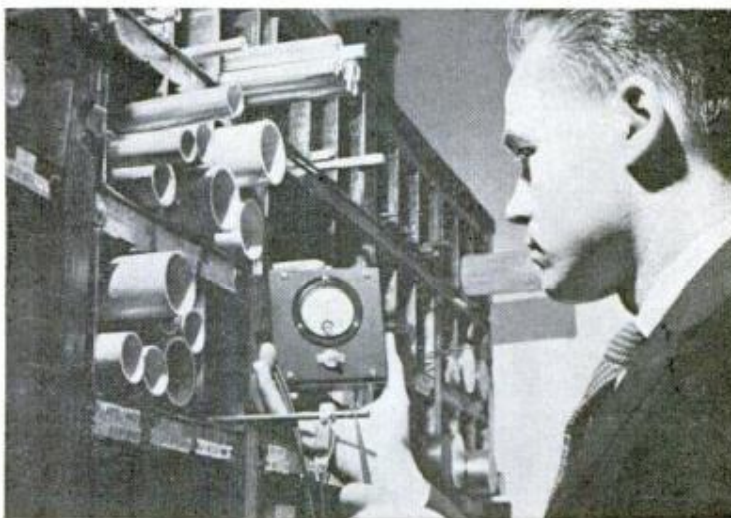

Plastic "Igloo" Shelter

Old soldiers may soon mark the passing of another familiar Army institution—the olive-drab canvas tent. The Atlantic Research Corp., working with the Quartermaster Corps, has developed a plastic-foam shelter that is low in cost, lightweight and weatherproof. One man can carry a kit which will form a shelter big enough for 10 soldiers. In use, a canvas dome "form" is inflated on the site, then sprayed with a self-rising foaming plastic which hardens in an hour. The form is deflated and removed for reuse, leaving a plastic shell 6 feet high, 12 feet wide, and weighing less than 200 pounds. The foaming plastic can be mixed quickly in the field, and color additives used to make the "igloo" match its surroundings perfectly. The door is simply cut out with a bayonet.



Bed for Traveling Dogs

One of the problems of traveling with a dog is providing a familiar, comfortable bed so he'll sleep well in strange places. A new traveling dog bed provides a good-sized suspended-canvas "pad" for all but the biggest breeds. The bed is 26 by 36 inches, and 6 inches high, but folds into a one-inch by eight-inch package 36 inches long which can be packed easily in the car. Made of canvas and aluminum tubing, it weighs only three pounds.

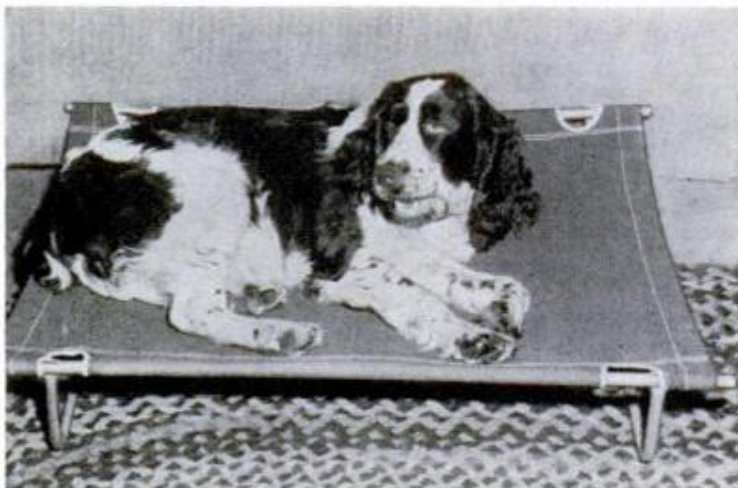

Kit Puts Shift on Floor

Chopping valuable racing seconds from stick-shift driving, a column-shift conversion unit eliminates completely the zigzag motion of conventional "H" patterns. Installed on the floors of both competition and family cars, the unit has a straight-line shift. For low, you push down and forward, for second pull straight back, for third push straight forward, and for reverse push down and pull back. It is impossible to miss a shift, according to the manufacturer. The unit converts column handshifts of all cars except Fords between 1932 and 1948.

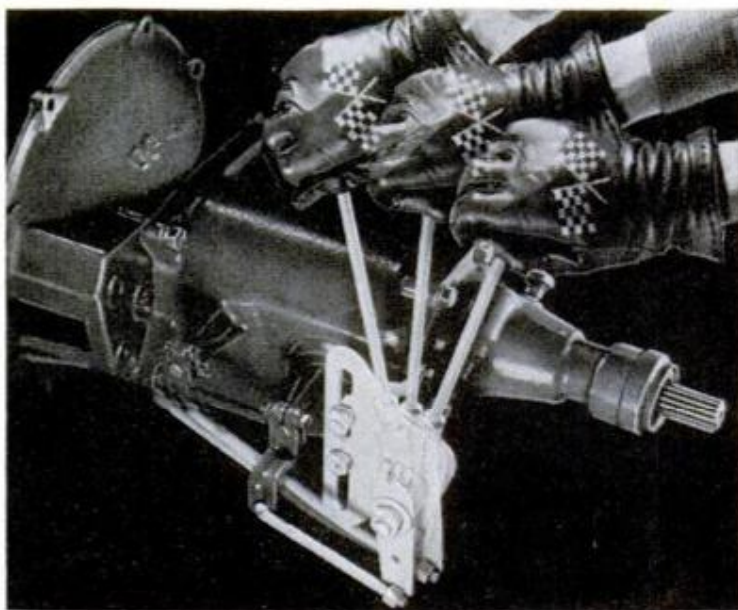



Portable Bandwagon Hauled Like Trailer

Transported like a house trailer, an all-purpose bandwagon can be set up quickly as a music shell, a stage or a show wagon. When time comes to travel, the portable wagon folds into a trailer eight feet wide. Varying in length from 24 feet to 32 feet depending upon the model, the unit's stage consists of risers that can be left flat to form a stage eight feet deep, pulled straight out, or unfolded as steps or risers in sections four feet wide. When all steps are unfolded (photo at right), the bandwagon accommodates a band of 60 pieces. A stage 16 feet deep can be set up when the risers are pulled straight out flat.

☐ Nuclear bombs have produced radioactive carbon-14 in the earth's atmosphere 15 times faster than nature during the past four years.

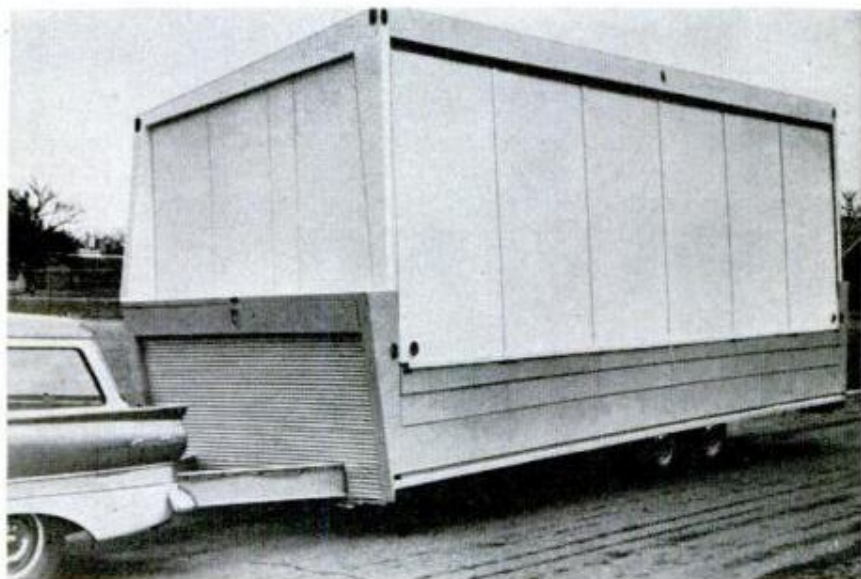



Dr. Dezso Levendula hypnotizes five policemen who witnessed a staged "murder" at the Cleveland, Ohio, Law-Medicine Center. The experiment demonstrated hypnosis can help eye-witnesses recall details of a crime

Solving Crimes By Hypnosis

By George J. Barmann

*Cleveland Plain Dealer
1301 Superior Ave.
Cleveland 14, Ohio*

TWENTY YOUNG POLICEMEN were sitting in the bright, comfortable classroom of the County Coroner's Building, on the campus of Western Reserve University in Cleveland, Ohio, listening to a lecture on methods of questioning witnesses to a crime.

A psychotherapist, Dr. Dezso Levendula, was conducting the lesson in scientific law enforcement, one of the regular courses given by the university's noted Law-Medicine Center. He was speaking that morning about the difficulty of getting witnesses to recall accurately what they have seen.

Behind him, on a sofa facing the class, were two stenographers, busily taking notes on the lecture. The audience of patrolmen and several guests was attentive, but relaxed. Only the occasional hum

of an automobile outside the windows cut into the professor's talk.

At a desk near the stenographers sat Dr. Samuel R. Gerber, the county coroner. Now and then Dr. Gerber glanced around the room and scribbled on an envelope.

Suddenly, there was a commotion, and Dr. Levendula turned to see what was happening.

The stenographers were arguing and getting up from the sofa. In a second, they were grabbing at each other's hair and tussling over a handbag.

"Stay out of my purse!" the blonde shouted. "You're stealing my money!"

"No, I'm not. I'm only after your cigarette lighter," the brunette snapped. "You keep your hands off me!"

The women struggled. Something red



Two stenographers who normally took notes during lectures participated in the experiment. They unexpectedly threw down their notebooks and began quarreling over a purse. Then one woman "stabbed" the other

flashed in the hand of the dark-haired one. She swung at her opponent, who screamed, clutched her left side and doubled up on the sofa.

"Oh, my God, what have I done?" the brunette cried, and ran out of the door.

Quickly, before the stunned audience could move, Dr. Gerber rapped his desk for attention.

"All right, class," he said, "let's all take it easy. What you just saw was only an act. This was a fake murder. We staged it, we're doing an experiment. Now, if you'll sit back, we'll have something new in our lesson."

After everyone had calmed down, Dr. Gerber, who is a physician, attorney and co-director of the Law-Medicine Center, which counsels in legal, medical and police problems, told the lecturer to go on. Dr. Levendula resumed his talk where he had left off—the questioning of witnesses with the help of hypnosis.

Dr. Levendula explained that the "crime" followed a carefully rehearsed script. He wondered how many details of this "murder" the class could recall. The psychotherapist, who is president of the Cleveland Society of Clinical Hypnosis and an authority on the medical uses of hypnotism, suggested that hypnosis might sharpen their memories.

Five of the patrolmen volunteered for a unique test which may add significantly to the science of criminal investigation.

First, the policemen were asked to write down all they had seen, just as they would for any routine police report. After this, they were hypnotized by Dr. Levendula; then, upon awakening, they made their observations orally to a tape recorder. They were hypnotized a second time, and now gave oral statements while under hypnosis. Finally, they were brought out of this trance and requested to write new reports.

As the patrolmen moved along in the four-stage test, their ability to recall events improved surprisingly. Dr. Gerber and Dr. Levendula compared the two written reports so there would be no chance of a mix-up, the one before hypnosis had been written on white paper, the other, after hypnosis, on blue paper. The doctors found that the results were remarkable.

The first reports were all matter-of-fact, somewhat sketchy. But in the last reports, even some of the fine details of the classroom incident were vividly described. And, as law enforcement authorities know, those little details often break a baffling case wide open.

The violent scene—the two stenographers arguing on the couch, one rifling



After the "murder," the men recalled few details, but they gave fuller accounts after being hypnotized. While in a second trance, they were able to remember even more details

the other's purse and removing the lighter and a \$5 bill, the fight ending in the stabbing with the phony ice pick—took only ten seconds.

In the reports, the patrolmen reveal how hypnosis helped them to recall this event.

Before he was hypnotized, Patrolman Foster Lockhart wrote that the weapon "looked like a screwdriver." But after hypnosis, he remembered that the instrument

had a red handle—which was correct. He also was able to recall another important fact that he hadn't before — there was a faint scar on the blonde's upper lip. He now remembered, too, that when she collapsed, "she put her head on the arm of the sofa." That was right.

Patrolman Anthony R. Lutz, in his first try, said the crime was committed with an "unknown instrument." However, when

On awakening from the second trance, the men were asked to write detailed reports. They described, among other things, the "killer's" weapon, her hair style and toeless shoes





Dr. Levendula, standing, and Dr. Samuel R. Gerber, co-director of the Center, question one of the men while he is still in a trance. They believe that hypnosis will come to be a recognized weapon against crime

he awoke from hypnosis, he wrote: "The dark-haired girl pulled from her purse an object that looked like it was rounded on the end and circular throughout, because the cap which fits over the end of the wooden handle appeared to be round. I did not see the blade, but I caught a reflection of light, which leads me to believe that it was either highly polished, or plated. This object looked like it was about seven inches in overall length." A pretty good description.

The patrolman also said that the pencils the stenographers used were yellow and had erasers—details he had missed before. And, most important, he wrote, "This fight lasted about ten seconds." He hit the time right on the nose.

In first discussing the women, Patrolman Joseph Pokrandt gave what Coroner Gerber calls an "adequate" description. Later, the policeman listed camera-eye details—the blonde had "long hair touching the shoulders;" the brunette's hair was up-swept, "with loose ends about the region of the upper ear."

Another patrolman, Lloyd J. McKenna, Jr., was able to reproduce some of the fastest dialogue just before the stabbing occurred, almost as if he had been the author of the script. And the fifth patrolman, James Painter, in his final statement, added a footnote about the killer's shoes. He said, rightly, that they were toeless.

"The results of our work offer a strong argument for the use of hypnosis in police investigations," says Dr. Gerber, who has lectured on criminology to physicians and

Scotland Yard men, in London. "Everybody knows that one of the big problems in checking a crime, or just a simple traffic accident, is in getting full and accurate information. You get skimpy and conflicting accounts of what happened from eyewitnesses. Even from the honest and most intelligent ones.

"Many times, people would really like to recall events to help the authorities, but they can't. The power of human beings to remember precisely is, at best, rather faulty. In fact, after witnessing violent and tragic happenings, a person usually tries to forget, because it pains him to remember. Actually, the subconscious mind suppresses such pictures; it tries to bury and hide them. We all choose to recall nice, pleasant things in this world; that's why we like to think about the 'good old days.'"

Dr. Gerber believes, therefore, that hypnosis could be used to unlock many secrets for police and detectives.

Dr. Levendula, who uses hypnosis successfully in his own private medical practice, says that many persons who themselves have been victims of a crime often are poor witnesses. They are shocked psychologically, for example, by fear, excitement, horror, grief. "In such cases," he remarks, "hypnosis could be very helpful, permitting the person to relax and remember."

The doctor explains that men and women may be entirely innocent of any wrongdoing, yet they are hostile to inquiring police "merely because authority to them

(Continued to page 234)

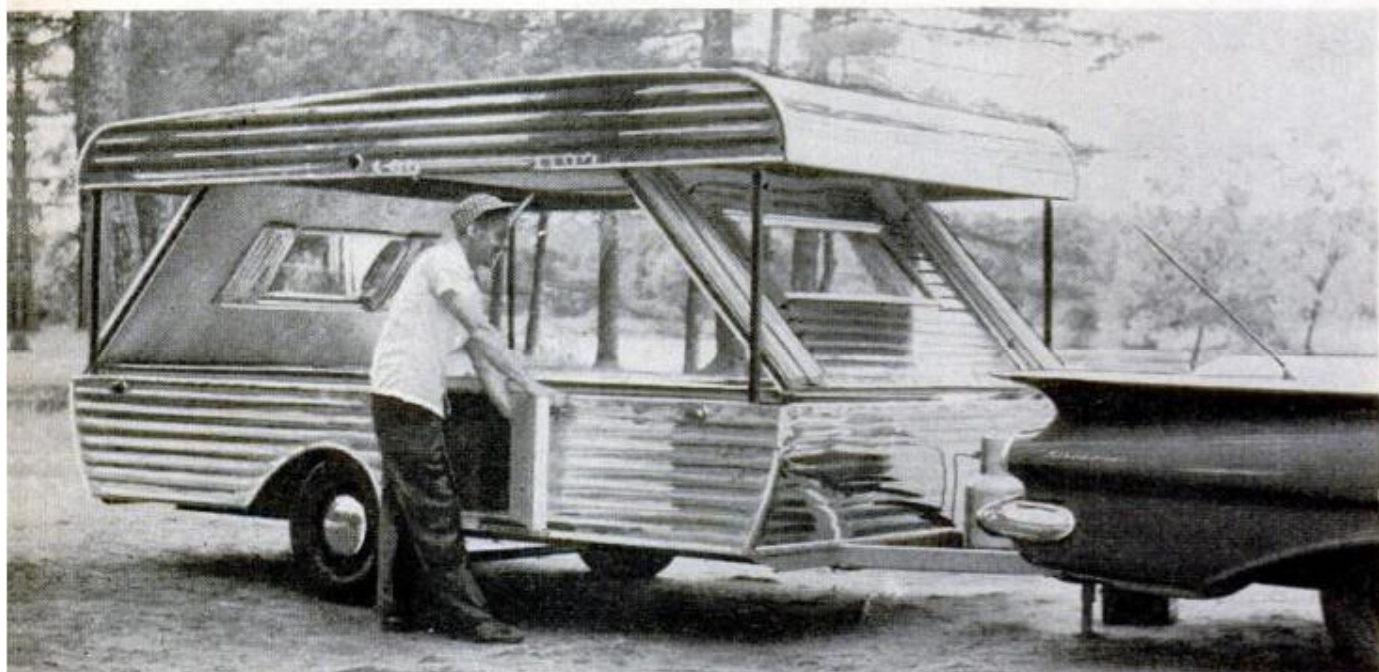
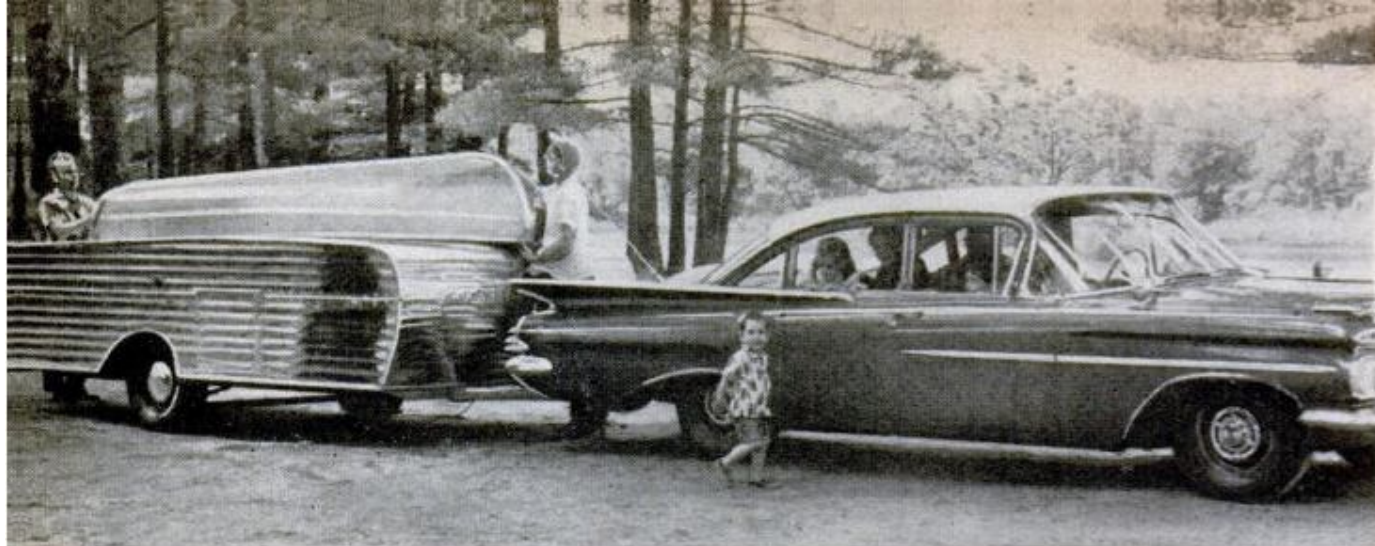

Self-Expanding Trailer Becomes Camp Home

EVERY YEAR the nation's camping-trailer manufacturers go a bit further in their contest to see which can cram the most possible living and sleeping space into the smallest folded package. A new trailer expands electrically from the neat, low-slung package in the top photo to the full size 15-foot trailer at left below. In the minute that it takes to expand itself, the inside sprouts a gas floor furnace, gas stove, sink, closet, dining area, two beds and a couch, all of which fold up or down out of the walls as the roof is raised. An interesting new feature is full glass-fiber insulation. The inventor, Leo Hagenson, won a grand championship ribbon at the Minnesota Inventor's Congress for his work on the trailer.



P2V Neptune patrol bomber grabs the pickup line at 500 feet and 125 knots. Pickup yoke is on its nose

500-Foot High Jump

MARINE Gunnery Sgt. Levi W. Woods, at right, is experiencing the first pickup of a man by a high-performance aircraft — and winning himself the Navy and Marine Corps Medal for volunteering for the job. With the new system, the rescue plane drops a kit containing 500 feet of nylon line with a balloon on one end and a lift harness on the other. The rescuee inflates the balloon from a helium cartridge, then straps himself into the harness. The plane intercepts the line with a pickup yoke, then hoists the man aboard. The nylon line cushions the shock.



Sgt. Woods, none the worse for his trip, is carefully lifted into the rescue plane through a belly hatch





"Live Water" Aeration Cuts Swimming Pool Algae

Built into the filtering and circulation systems in a swimming pool, a new aerating system retards algae growth by depriving the algae of their chief growth-producing element, free carbon dioxide in the water. Since algae consume chlorine, the result is that the pool's chlorine residual is maintained much longer. The system picks up air through an intake tube, mixes it with the filtered water and releases the aerated water through outlets in the floor. It is not practical for addition to existing pools.

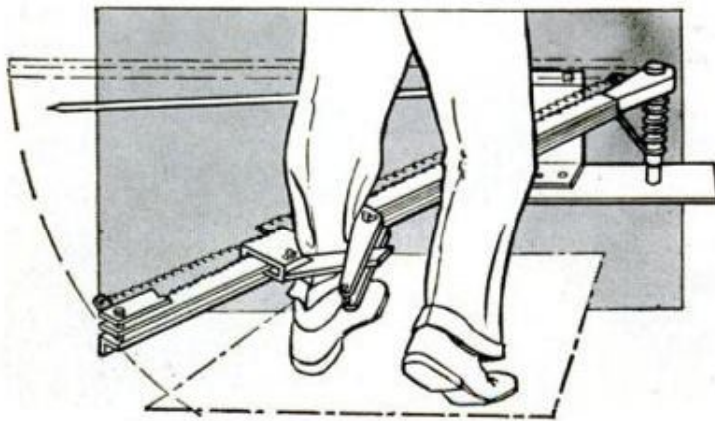

Arm on Electric Trap Grabs Burglar's Leg

Burglars and prowlers get a sudden and disconcerting surprise with a trap recently invented and patented by David Sweigart, of Wilmington, Del. When an intruder steps on a signal mat, it closes an electric circuit and a metal bar, concealed within a wall or under a safe or counter, suddenly is released. As the bar strikes the leg of the person who has sprung the trap, clawlike arms grab his leg.

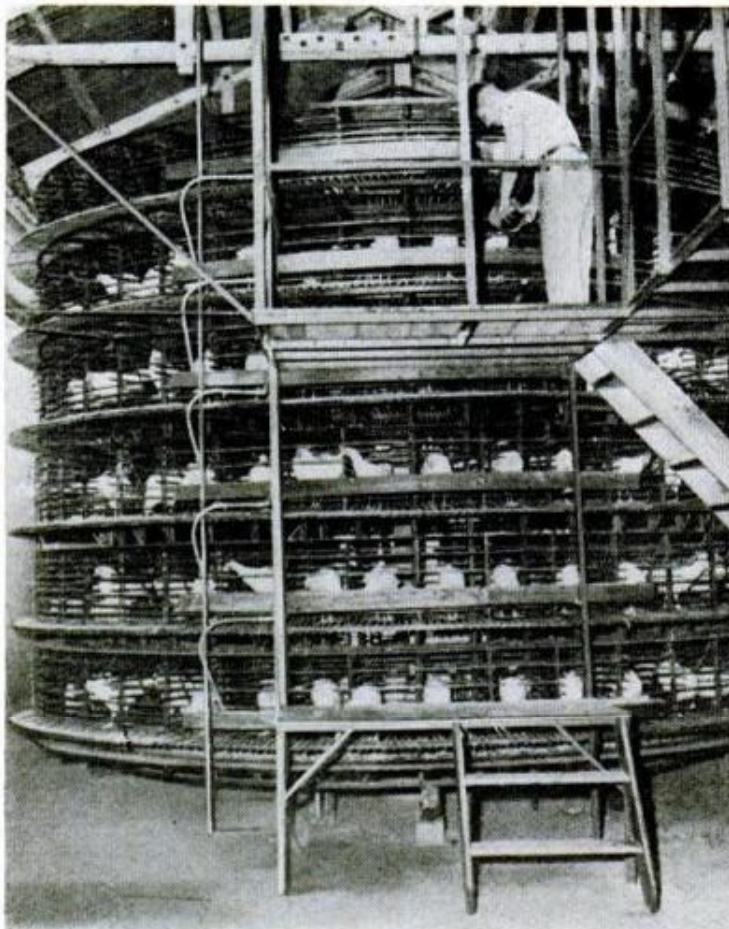

Merry-Go-Round House For Japanese Hens

Even the chickens are profiting from an automation boom in Japan! In operation at Okayama, a seven-story "apartment house" for chickens does everything but lay the eggs for the hens. An electric motor rotates the house, causing it to make a complete circuit every 38 minutes, stopping five minutes on each revolution to allow the birds to feed and drink from three food boxes on each story. The attendant remains in one spot to fill the boxes. Instead of keeping 420 separate boxes filled, he has only 21 feed boxes to look after for the entire 420 chickens in the house. The machine is so geared that three cages on each floor stop for five minutes every 38 minutes, feeding 21 hens each turn. In appreciation for such deluxe service, the chickens readily lay eggs which roll forward on a small ramp to be collected.



Census-taker's visit will be short this year. Mainly he (or she) will check the mailed do-it-yourself form

NOSE COUNT, 1960

By Richard F. Dempewolff

THIS IS THE YEAR we count off again, take a look at ourselves to see how we've grown, where we're heading and how we're doing. Ever since 1790, when the Constitution authorized a "decennial enumeration of the population," the Bureau of Census has had to brace itself each year ending with zero, and charge into the monumental task of inventorying American noses, one by one.

As such nose counts go, the first one was easy. A handful of census takers knocked at the doors of log cabins, tepees and prairie dugouts to smoke out a total of 3,929,214 people. Questions determined little more than their sex, age and whether they were



Burgess, Director of Census Bureau, warns citizens not to admit any "census taker" unless he shows this identification to you
Hemington Rand photo



1. CENSUS TAKER calls at each home, checks the answers on the previously mailed do-it-yourself form, and transfers the information in the form of circled dots onto a special sheet he carries

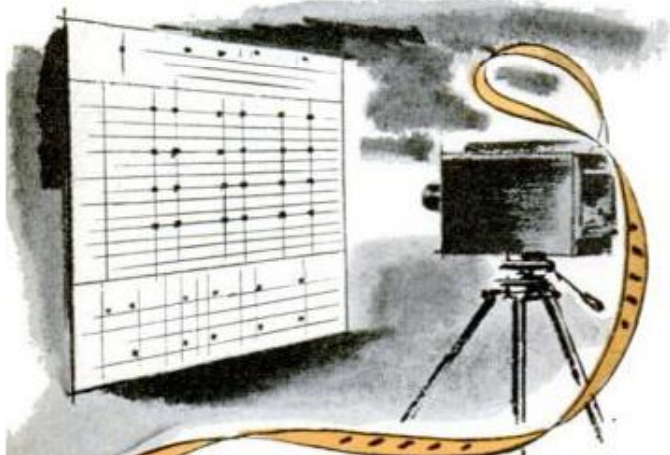

2. ENUMERATOR'S completed forms are rushed to census office in Indiana, where a battery of 30 cameras records them on microfilm. Two census sheets click through the cameras each second

3. REELS of microfilm are shipped to headquarters in Maryland, where they are fed through FOSDIC, the new electronic wizard. FOSDIC converts data from each form into pulses on a magnetic tape

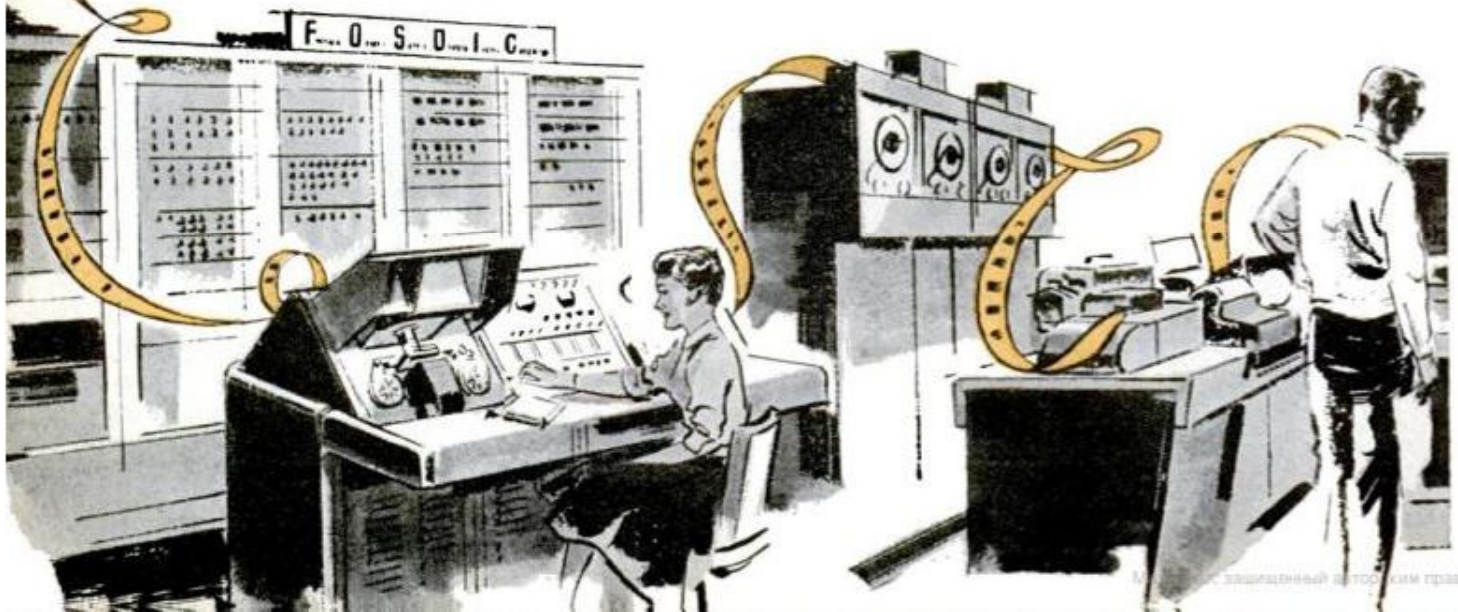

freedmen or slaves. But the population soared with each succeeding census. More and more agencies added questions to the census taker's list to prod, poke and explore Mr. and Mrs. Average American, and see what made them tick.

For its 1960 population and housing census, the Bureau, now the granddaddy of all U.S. polling agencies, will face what probably will be the most staggering house-to-house canvass in history. Not only must it rap on more than 60 million doors to tally an estimated 180 million Americans (an increase of 30 million over 1950), but it must collect answers to some 60 questions designed to reveal trends in our living standards, social structure, family relationships, occupations and myriad other things.

To do the job, census experts have been busy building a complex array of brand new devices and systems. This year, for the first time, take-your-own-census forms will be mailed to every home in the country. In the sprawling corridors of the Department of Commerce Census Building in Suitland, Md., just outside the nation's capital, rows of new electronic computers are warming up to gobble the billions of figures that soon will be pouring into them. Newest phenomenon is a complicated group of electronic cabinets and consoles reminiscent of the gear in a Cape Canaveral blockhouse. It is known as "FOSDIC" (Film Optical Sensing Device for Input to Computer). This monster will transfer all the data collected from you and me to magnetic tape—performing in an instant a job once tediously handled by 2000 punch-card operators.

Gigantic UNIVAC 1105's will swallow the tape as fast as it is produced, digesting its magnetic pulses and spewing out masses of coded census figures on request. Fed through new high-speed electronic printers, UNIVAC's taped "summary" codes

4. TAPE from FOSDIC then is run through the big UNIVAC. This electronic brain can be instructed to pick out and summarize any specific information. It tallies the particular results on a summary tape

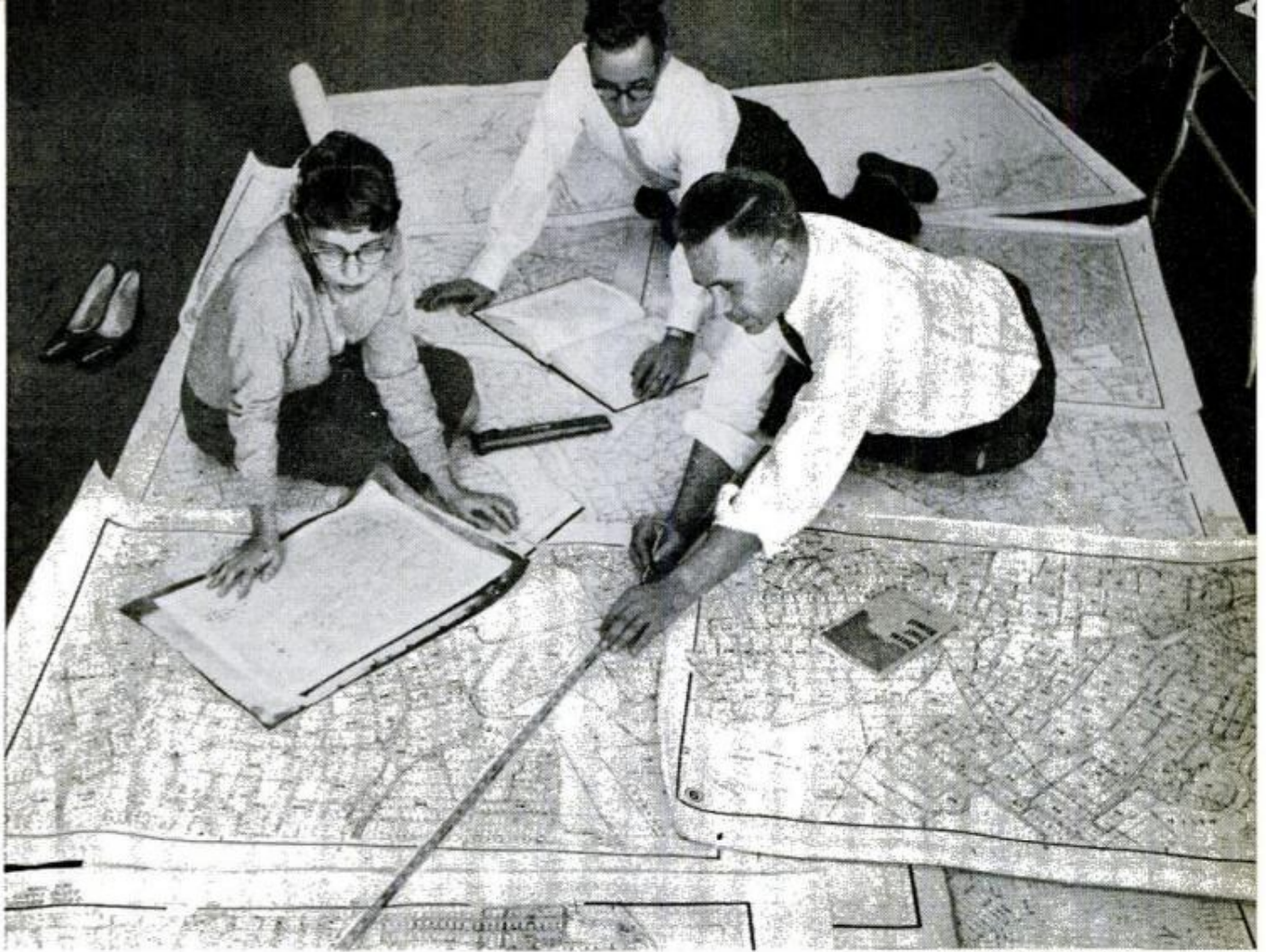

Remington Rand photo

Three years before the census, Bureau cartographers were working over huge maps to split country into districts

will be magically transformed into readable statistical tables ready for the printer.

As a result of all this high-speed wizardry, population totals for counties will begin to make their appearance no more than two weeks after the census is completed in mid-April. By fall, official figures for all areas will be announced. And by December 1, 1960, final census figures will be presented to the President by the Secretary of Commerce. In spite of the in-

crease in population, publication time for various phases of the new decennial census will be speeded up by six months to a year-and-a-half! The entire incredible report will fill 100,000 printed pages in a stack of volumes more than 10 feet high.

Regardless of all the new "gee whiz" census wonders, the good old census taker, or "enumerator," must still make his rounds to check the do-it-yourself forms and code your answers on sheets for microfilming.

IN THIS WAY the Census Bureau can quickly learn any particular fact or facts about an estimated 180 million Americans. Also, UNIVAC will come up with trends and ratios, which have not been spotted in past

5. SUMMARY TAPES from UNIVAC will move through electronically controlled high-speed printers which will read the magnetic impulses and turn out statistical tables at the dizzy rate of 600 lines per minute



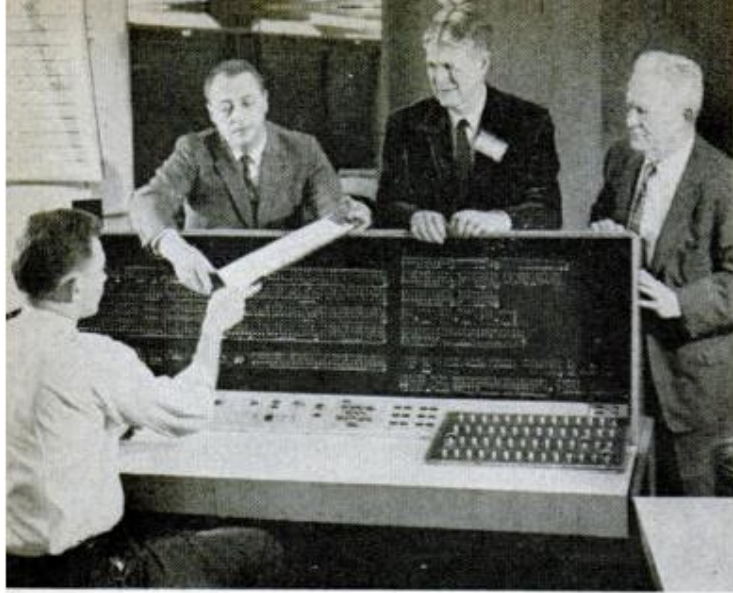

At control console of UNIVAC, operator sets up circuits to produce any desired set of figures

Remington Rand photo



Electronic eye of FOSDIC scans each frame of microfilm. Below, operators prepare reel of the film

Remington Rand photo

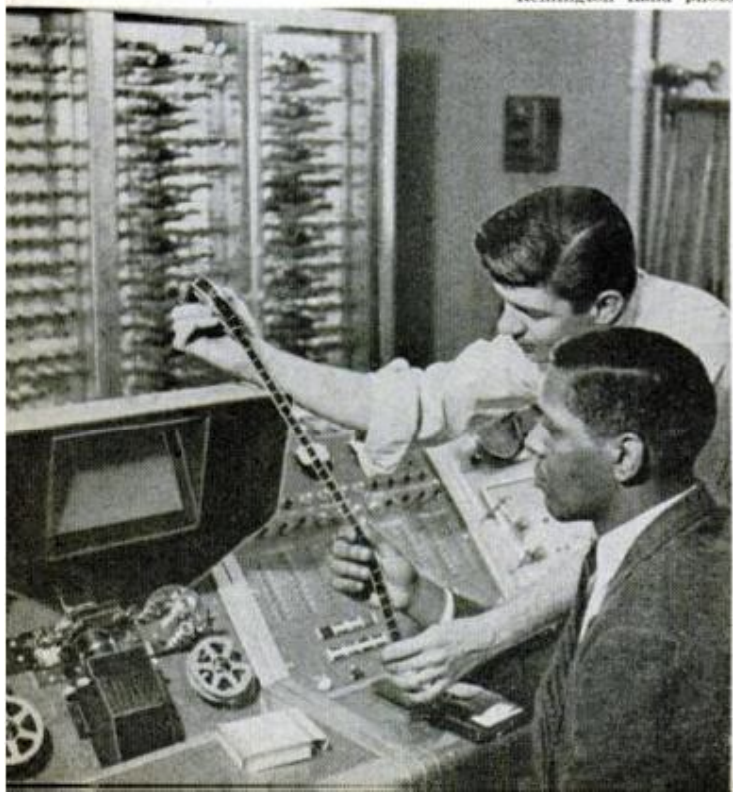

On April first, 160,000 of these politically appointed door-to-door canvassers—largely housewives, widows or part-time workers—will set out armed with 1,080,000 pencils, 260,000 pocket-type sharpeners, 2,850,000 scratch pads, infinite patience and considerable ingenuity. For two weeks they will explore every nook and cranny of the United States—including the new states of Alaska and Hawaii, as well as Guam, American Samoa, the Virgin Islands, Puerto Rico and the Panama Canal Zone.

To make the job easier, the Bureau has divided the nation into 250,000 enumeration districts, so that each census taker will list facts about 1200 people, covering 350 to 400 dwellings. Months ago, in the Suitland map department, you could have watched cartographers sprawled in stocking feet on rug-size maps spread across the floors. They worked from an avalanche of up-to-the-minute city, town, county, highway, topographic, soil and aerial maps constantly pouring in from all over. Every change since the last census, no matter how small, went on the master charts—new homes, new streets and highways, old streets blocked off, old buildings condemned for demolition, changes in boundaries of towns and cities due to shifting rivers, new dams and exploding populations. When he sets out from one of 400 district offices operated by some 10,000 supervisors, each canvasser will carry with him a set of yard-square maps detailing every latest innovation in his territory.

But map or no map, there's no blueprint for what the enumerators will find. They will knock politely for admittance to cardboard huts in hobo jungles, glittering penthouse apartments, mansions and row houses. They'll call at homes converted from chicken shacks, old railroad cars, caverns, mine tunnels and barn lofts. They'll visit traveling circuses, nudist camps and remote lighthouses.

To ferret out every possible citizen, these determined scouts will travel some 28 million miles, bouncing over lumber trails in jeeps, hiking up mountains and scaling cliffs to lonely fire towers. Some will skim across snow-covered Arctic tundra on dog sleds and snowmobiles to enumerate back-country Indians and trappers. They'll row boats through dismal Florida swamps to tally the shy Seminoles. Some will be bitten by dogs, chased by bears, scratched by cats, or attacked—as one was last time—by a flock of turkey gobblers.

If history is any criterion, they'll meet with a wild assortment of adventures.

During the last census, some enumerators found themselves rushing sick and injured children to the hospital, breaking up family quarrels, and—as happened in one



Every 10 years, some enumerators in Alaska set out by dog sled to smoke out every settler, trapper and Indian

case—notifying authorities of a freshly committed murder. One nose-counter arrived just in time to join a bucket brigade for a burning house he had come to enumerate. Another was refused admission to a nudist camp because he wouldn't remove his clothes, and had to appoint a member nudist to do the job for him. More than one census taker has turned midwife when a new addition to a family arrived simultaneously with him.

For the most part, people are inclined to cooperate, but an interviewer never knows what he's going to be up against. In the last national countdown, a lady compiler had to tight-rope-walk a wobbly log crossing a mountain stream to reach some cabins when the occupants wouldn't come out. She fell in twice—once going and once coming. Even less hospitable was the grumpy prospector who invited a lady census taker to sit on a mound of earth nearby while asking questions. Things got pretty lively after about the second question when the ants swarmed out.

Many people will not stop what they're doing to oblige the interviewer, but have no objection to answering questions on the run—such as the painter who bellowed his personal affairs to the whole neighborhood from the top of the ladder he wouldn't descend. At another stop, an enumerator had to help a busy mother hang out the week's wash during the questioning.

Actually, refusal to answer census ques-

tions can result in a \$100 fine, or two months in jail. But once the enumerator explains that everything is confidential by law, and that even the Internal Revenue Department can't check the family-income figures, few objectors hold out. There are some favorite "wrong answers" the enumerator must watch for, however.

"Wives like to upgrade their husbands," explains one census official. "The mate of a trolley conductor or a locomotive driver may list him as an 'engineer,' for instance. And many women tend to round off their

(Continued to page 260)

Here's the final result of the 1950 census—four tall stacks of books that took two years to publish





Pill Detects Water in Jet Fuel

Detecting small amounts of dispersed water in jet-airplane fuel has been greatly simplified by the development of a "pill" treatment by Esso Research and Engineering Company. A capsule, dissolved in a small fuel sample, changes color at any sign of water within one minute.

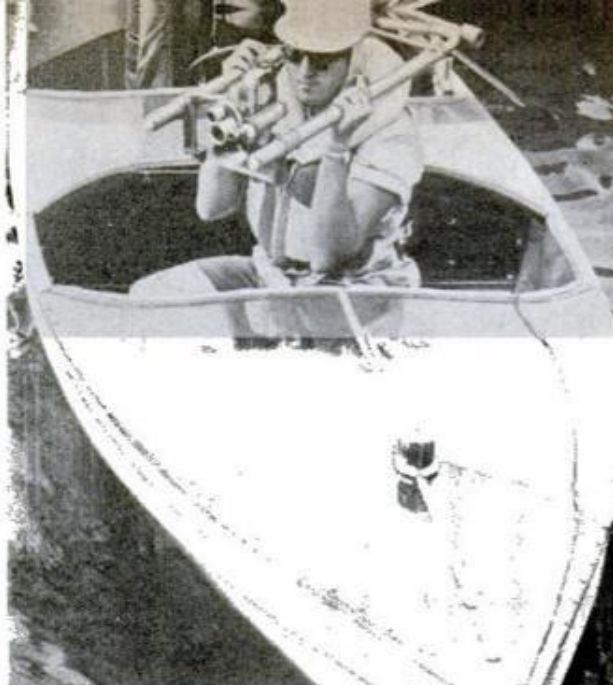

Balancing Mount Stabilizes Camera

Jumpy movies caused by camera motion can be avoided with a simple, seven-pound aluminum camera mount fitted with compensating weights. Held at its balance point, it gives the camera near-gyroscopic stability even in a boat or a moving car; helps with regular movie making, too.

Geodesic Canopy Can be Assembled by Homeowner

Readily assembled from fabricated parts, a geodesic canopy provides a 23-foot circle of protection from sun and rain. No special foundation is required other than anchors

for the V-columns. The canopy may be erected over a patio, in a back yard, beside a pool or at a campsite. A hard surface, such as concrete may be placed under it.



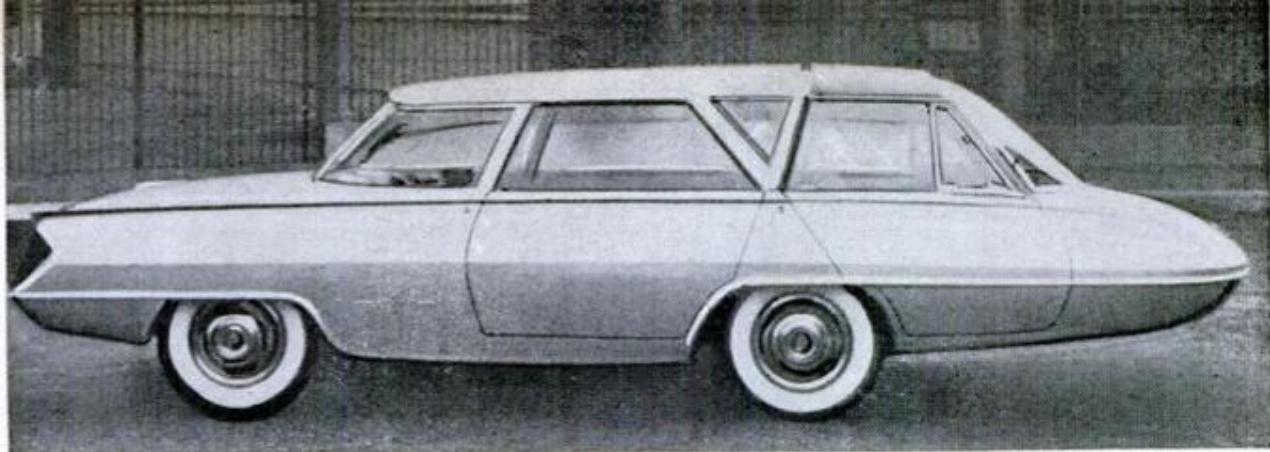

Which way is it going? It takes a close examination to tell, but Selene's front end is at the right

It Might Fly If It Had Wings — or an Engine

AIRCRAFT-TYPE styling gem by the famed Ghia car body manufacturers, the Selene was created by the Italian company as a show car. The auto has no engine. Its purpose is to show what might be expected in car styling of the future. Two back seats, facing each other, give the back compartment a lounge-room effect, complete with bar (right). Sliding airplane-type steering wheel and double sets of instruments would allow the car to be driven from either side.

Dream car deluxe, Selene has a steering wheel that pivots to either side (below). Rear (right) resembles airplane lounge

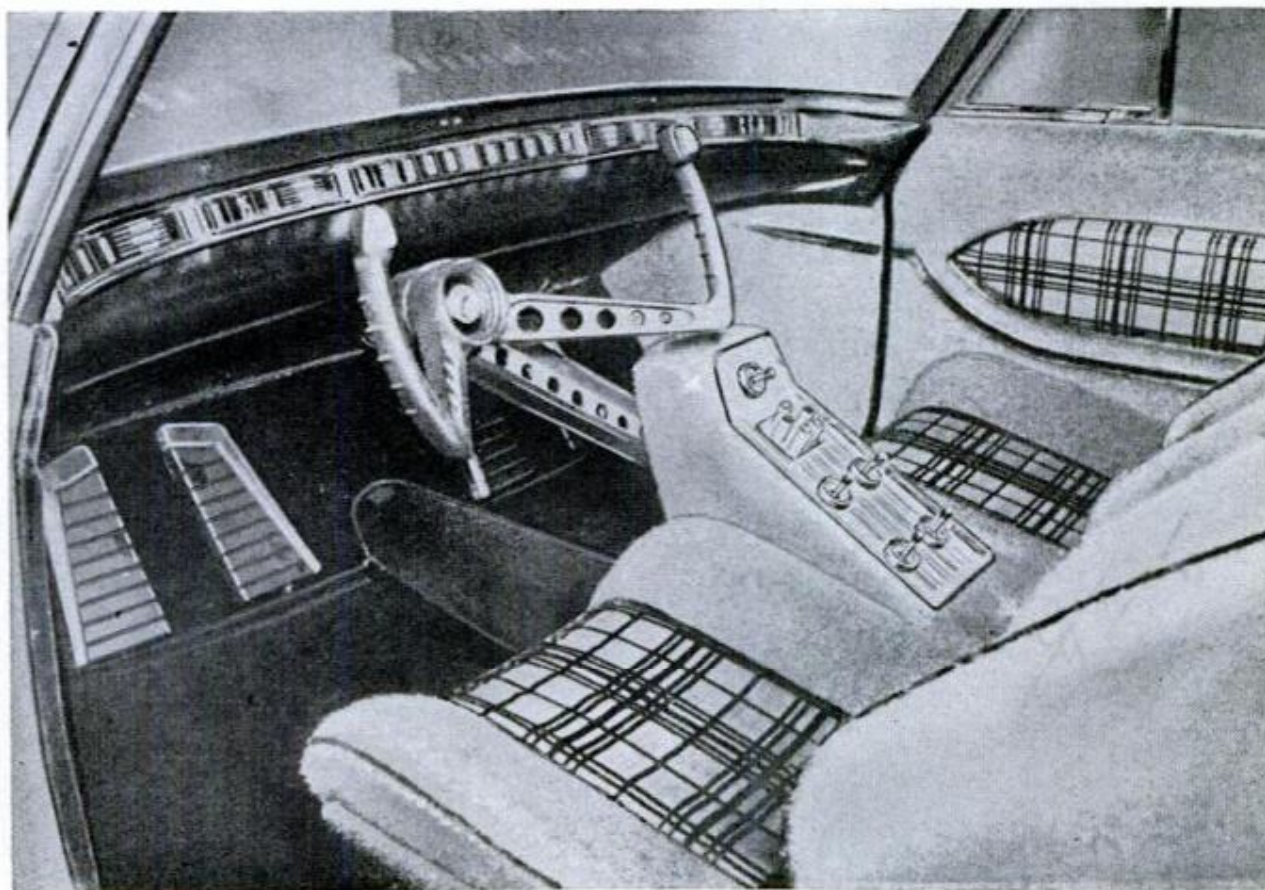
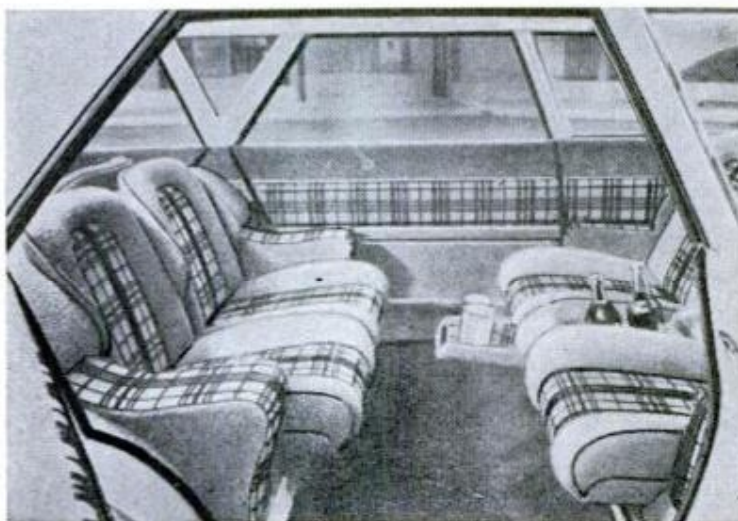

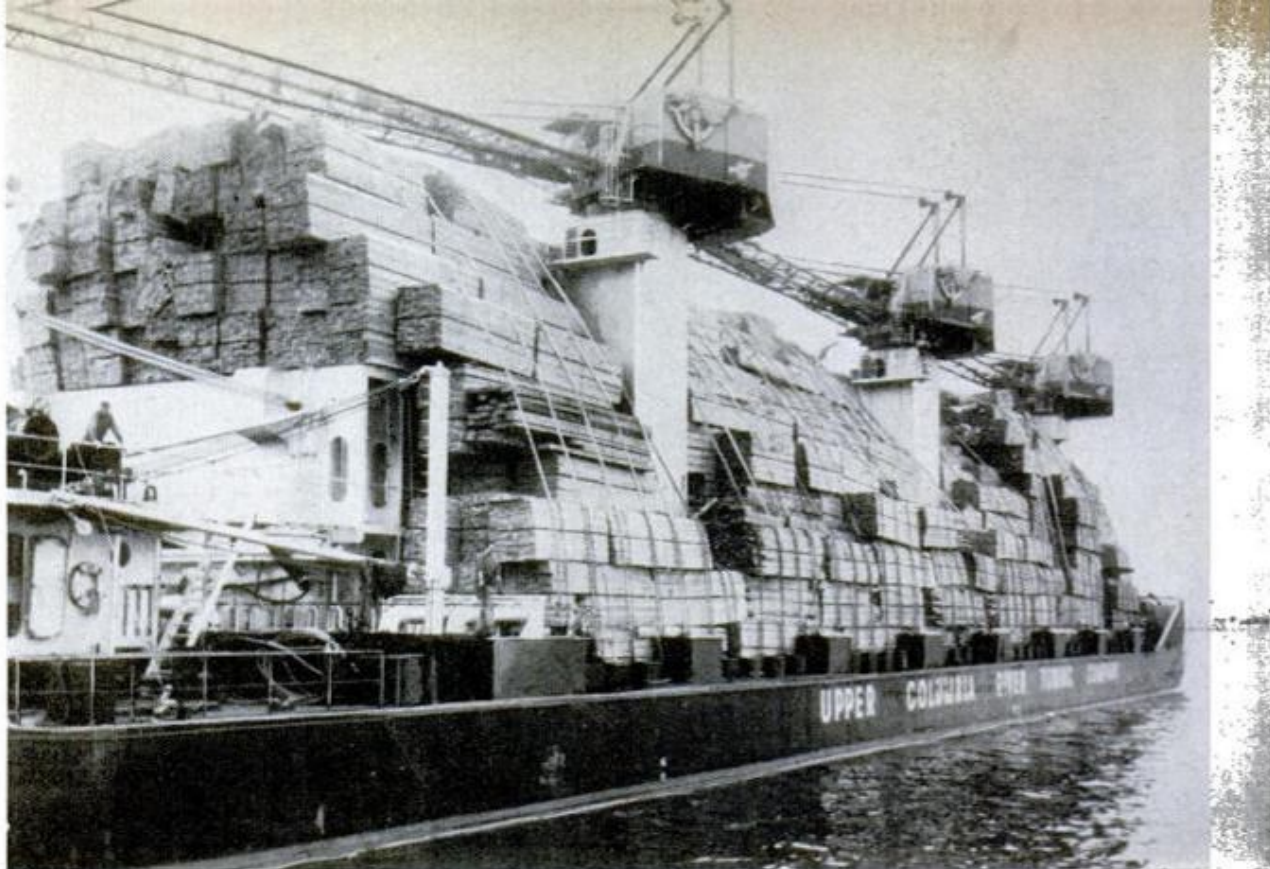

Like the girl on the barbershop calendar, this barge is really stacked. It is stacked high with 4,600,000 board feet of lumber. It hauled this huge load along the Pacific Coast from Washington to California

Look—No Mom!

Electronics has freed bovine mothers from dinnertime chores. An electronic calf feeder, in which water and calf-food powder are stored, mixes and warms the solution as needed — and dispenses it on demand.

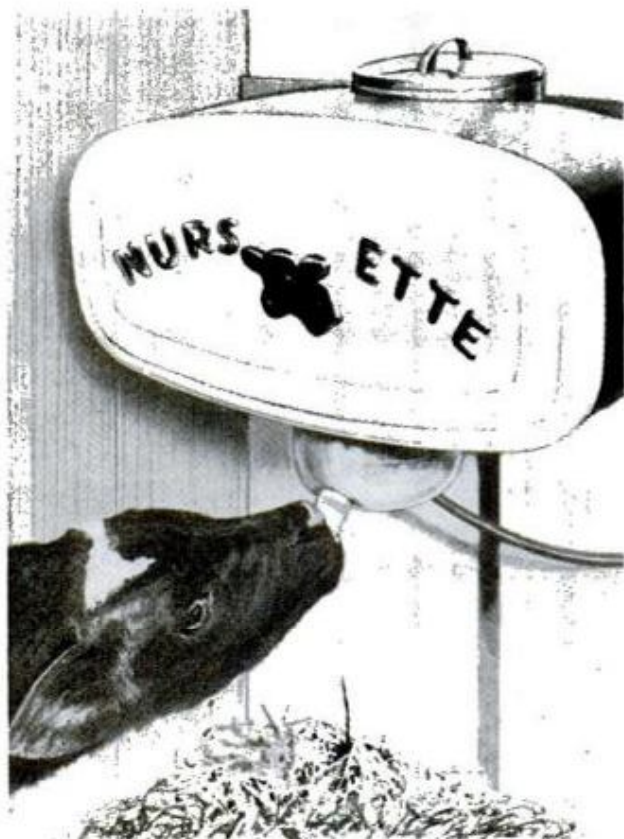

120

Extended-Shell Spark Plug

Longer electrode life is claimed for a new spark plug that has an extended shell, rather than merely an extended tip. This keeps the gap deep inside the combustion chamber, but shortens the side electrode, thus reducing damage from erosion.



POPULAR MECHANICS

In Search of Plants That Cure

By James Joseph

AN ARMY OF MEDICAL EXPERTS, outfitted with walkie-talkies, aqua-lungs and mobile labs, is pushing into the four corners of the globe—and into every American back yard—in search of plants that cure.

Often a search is started by a rumor like this: From the milk-white sap of a jungle herb, a witch doctor has been extracting a potion that cures insanity.

Soon, deep into equatorial Africa plunge the botanical sleuth and his party. The assignment: Find the witch doctor and his "magic" herb.

The sleuth, his interpreter and two porters are outfitted with some modern magic—a solar-powered phonograph, Polaroid camera and VHF radio transmitter. A day's march down the trail from their jungle location is tethered a dugout, rigged with a 60-horsepower outboard motor. Down-river still further stand a four-wheel-drive Land Rover and air-conditioned trailer. In the trailer are a diesel-powered shortwave radio and lab.

Now, squatting before the red-robed witch doctor, the medical expert conjures magic . . . from the phonograph. And more magic yet, as he hands the old man his Polaroid-snapped picture.

Suddenly the African grins, rummages in his bag of tricks and offers a withered plant.

Instantly, the plant sleuth recognizes its familiar leaves and flowers. It's a weed common to every back yard in America, yet a plant that no medical researcher has as yet thought to investigate!

Moments later, in the garbled code which only he and his employer—a pharmaceutical company—savvy, the jungle explorer is flashing the word Stateside, via a dozen radio relays.

"Investigate plant L57-67 . . . as possible cure for insanity."

He's fired the starting gun in a race extraordinary. It's a race to extract from the plant its secret cure which, should it prove medically valuable, could mean solace for many among the U.S.'s nine million mentally afflicted . . . and a king's ransom, upwards of \$100 million, for the drug



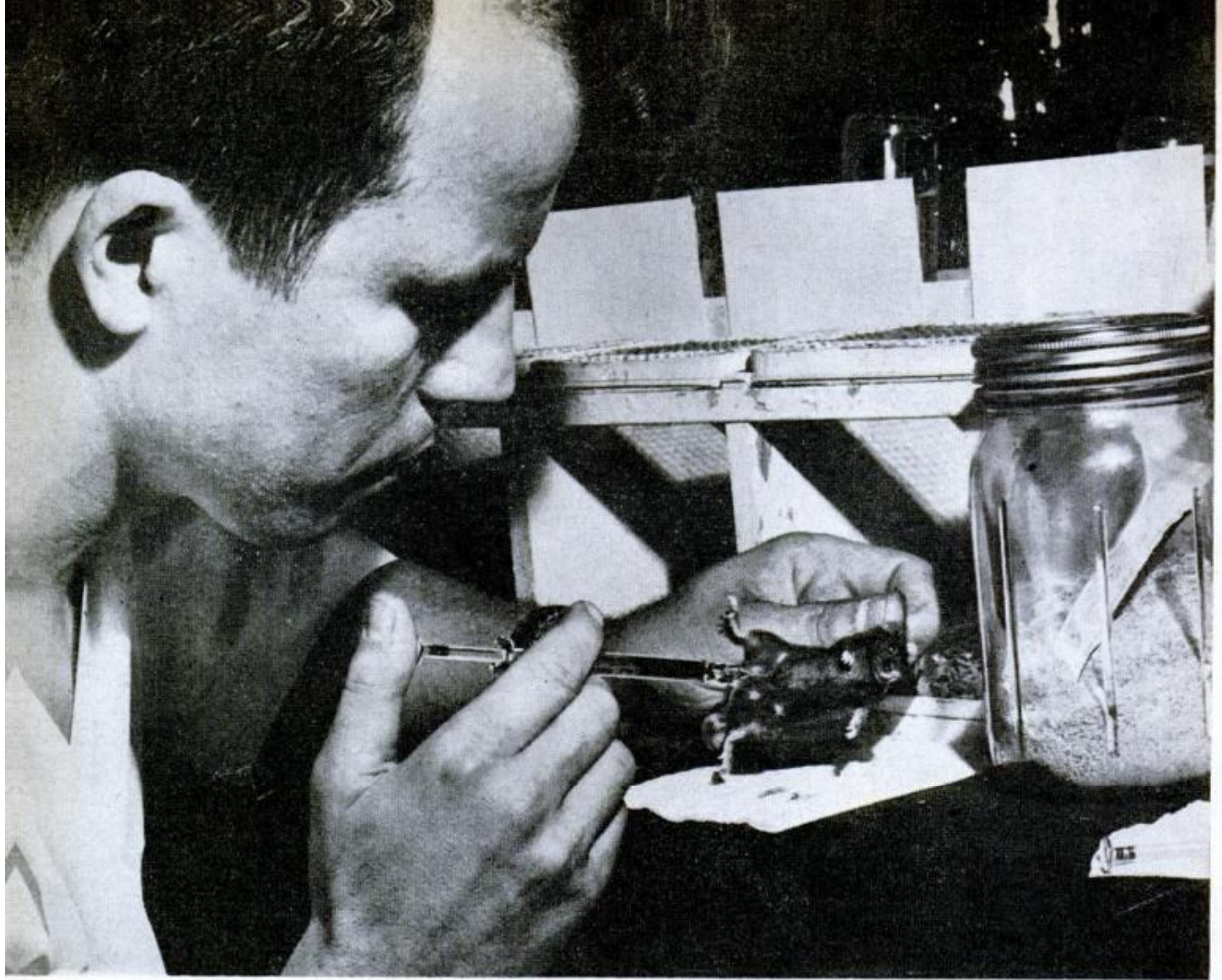

Possible cancer inhibitor, taken from a still-secret African plant, is injected into a cancerous mouse

Equipped with an aqualung, Dr. E. Yale Dawson collects algae plants on a coral reef in the tropical Pacific

Don Ollis photo

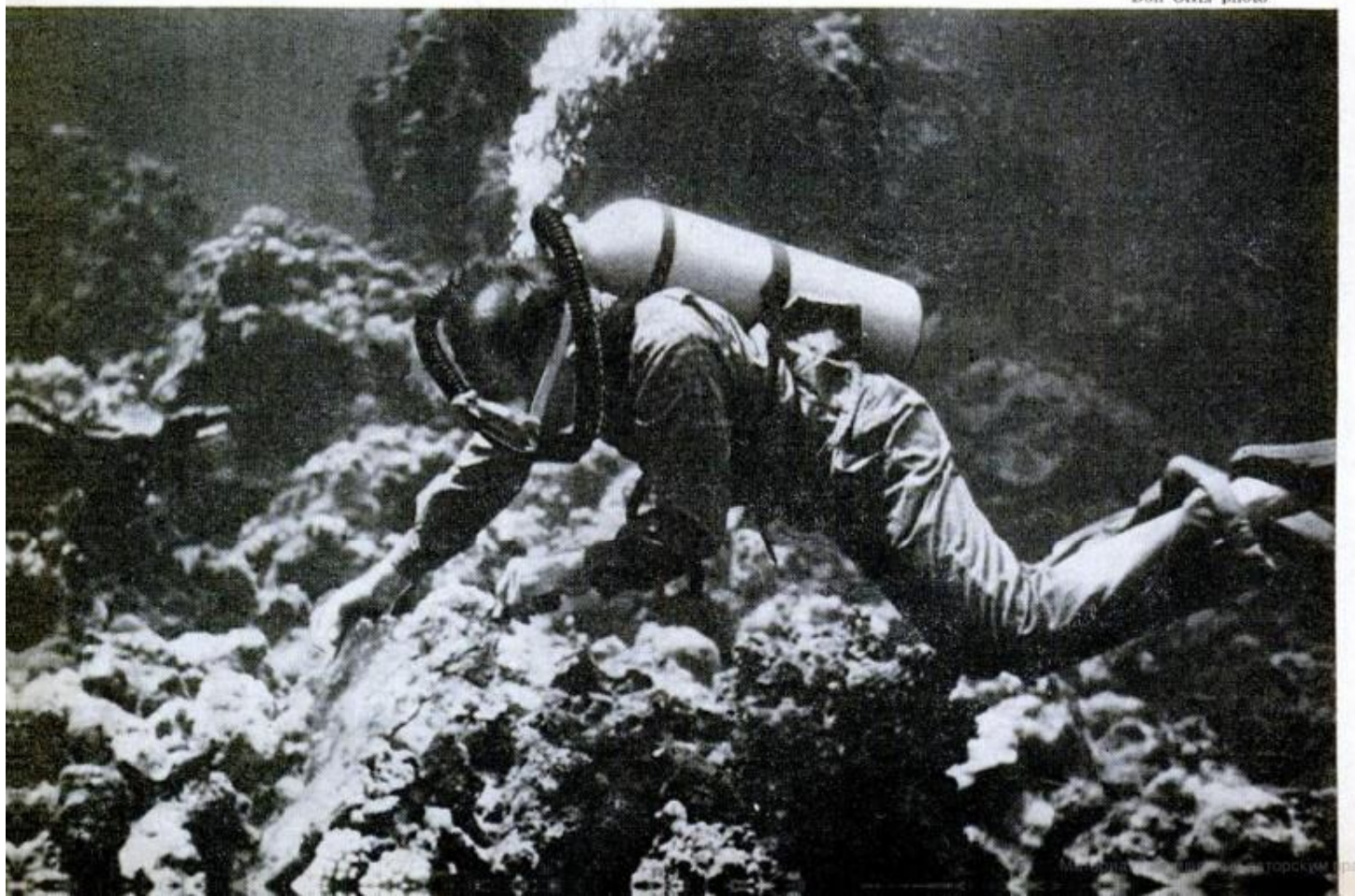

company that is first to place it on the market.

L57-67? Though its identity is shrouded in secrecy (for plant sleuthing is a high-stakes, tight-lipped profession), it is a plant common to your yard and mine. A weed which perhaps only recently you disdainfully plucked from between your petunias.

"As yet, though," admits Egyptian-born Dr. Saleem A. Farag, who bosses a world-roaming team of plant detectives from his headquarters at the College of Medical Evangelists, Loma Linda, Calif., "we haven't succeeded in isolating L57-67's active—and perhaps curative—ingredients. But the plant looks promising."

L57-67 and thousands of plants just as medically promising are objects of a global search unparalleled in history. Combing five continents and the seas are more than 1000 plant detectives—men like botanist John Wurdack of the New York Botanical Gardens. Backed by Yale University and Eli Lilly & Co., a leading drug maker, Wurdack is beating through the jungles of Venezuela in search of plants that cure.

"Certainly Mr. Wurdack will seek out witch doctors and even headhunters if they deal in tribal medicine," says an associate.

Startling though that admission is, it underscores a medical paradox: Some of the world's top medical experts are paying a kind of belated homage to primitive healers. And with reason. For, though the test tube has synthesized some remarkable cures, it has failed to find answers to many of man's most dreaded diseases—including cancer.

U.S. drug companies this year alone are gambling \$5 million to outfit plant safaris both here and abroad in the belief that there may be more fact than fiction in witch-doctor remedies, medical folklore and tribal cure-alls.

Backed by a four-year, \$240,000 grant from big Sterling Drug Co., Dr. Donald Brown, a medical botanist, recently headed for Tanganyika, East Africa, where he'll coordinate plant gathering among the Seventh-Day Adventists' 197 world-flung hospitals, many of them set deep in primitive wilds. Before Dr. Brown enplaned for



African studies his picture—quick-photo "magic" used by some plant hunters to wring from primitive healers their plant secrets

The magic works, and the witch doctor plucks a familiar plant—a common weed in America which no one had yet investigated



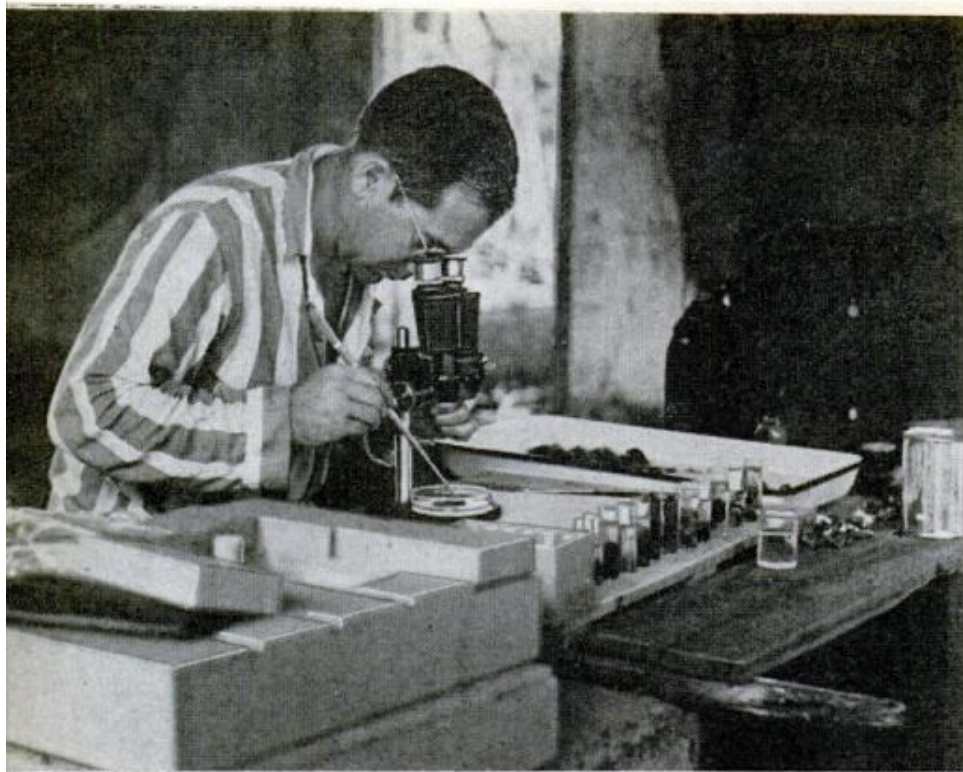

Don Ollis photo

In an improvised jungle laboratory, Dr. Dawson studies his collection of plant specimens. This laboratory is located on Jaluit Island in the Marshalls

Nairobi, he shipped ahead a mechanized lab: A spanking new $\frac{3}{4}$ -ton, four-wheel-drive Ford pickup truck, rigged with a sportster camping body and pulling a field lab compacted into a two-wheel, eight-foot-long aluminum trailer.

Charles Pfizer & Co., Inc., another major drug house, has organized throughout South America a vast net of plant suppliers who use outboard-motored dugouts, diesel launches, seaplanes and even helicopters to harvest rare and hard-to-reach plants. CIBA Pharmaceutical Products, Inc., which air freights Indian root plants fresh from Asian jungles to its U.S. labs, is right now bolstering its global army of plant sleuths.

Dried and bottled, a plant that shows promise as a cancer inhibitor is inspected by Dr. George Nelson

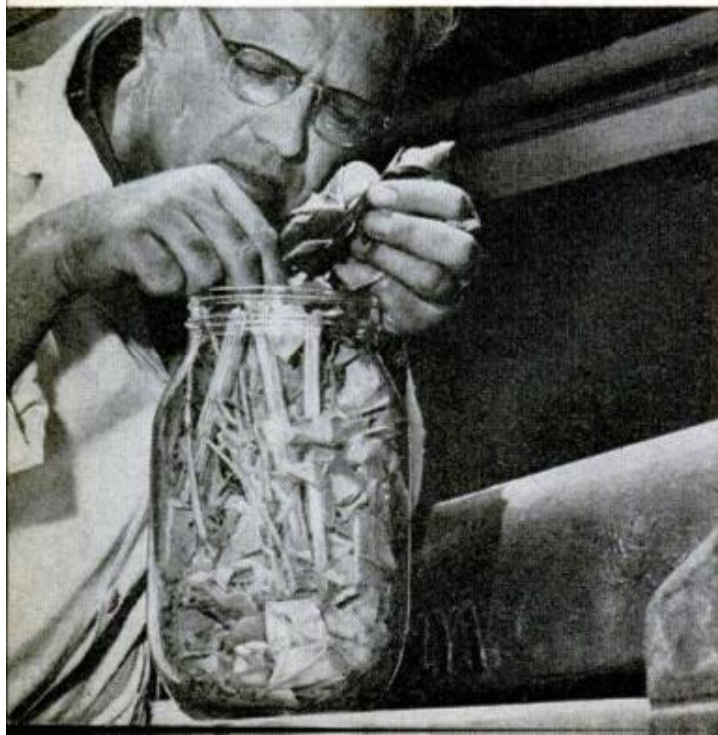

North Chicago's Big Abbott Laboratories, though fielding no full-time plant gatherers, looks to its world-wide corps of drug salesmen to send back plants and soil samples (the latter for antibiotic research). Only in 1957, Abbott announced discovery of a drug which combats atherosclerosis (the artery-hardening disease which annually kills 200,000 Americans). Basis for the new drug: Oil pressed from the seeds of the East Indian safflower, a thistlelike herb whose American relative is the common garden aster.

The gamble, a calculated one, is based upon what some medical researchers call "documented medical magic" . . . performed by tribal medicos or recorded in the annals of folklore, including American.

"We're literally leaving no plant unturned," confirms Dr. Farag who not long ago brought back 80 plants regularly used as "medicine" by East Africa's primitive Ha tribe.

"Our search," he continues, "is reaching into every American back yard. There's just no telling about a plant until it's been squeezed dry of its secrets."

- The cinchona tree of South America held such a secret—quinine (a secret well known to Andean primitives long before Spanish conquest). Quinine, though now grown in Java and rivaled by man-made atabrine, is a staple antimalarial drug.

- As typical is curare, the plant-derived poison which turns lethal many an Amazon arrow. "Discovered" by modern medicos only in 1938, though long known to jungle savages, curare is a "miracle" drug—a top-

(Continued to page 239)



Double Feature!

TO ENTERTAIN passengers on their long nonstop international flights, TIA, a French airline, tried to install movies, but could not make them visible simultaneously on both sides of the partition that separates the tourist class from the first-class cabins. To solve this problem, Pathé engineers in Paris designed a double lens-prism projector which throws one picture on the screen mounted forward in the tourist cabin, and diverts another image to one side toward a smaller screen in the rear cabin. The regular public-address system carries the sound track. The "Pullman berth" folding projector saves space but also provides a shock and vibration-free mount for the projector.

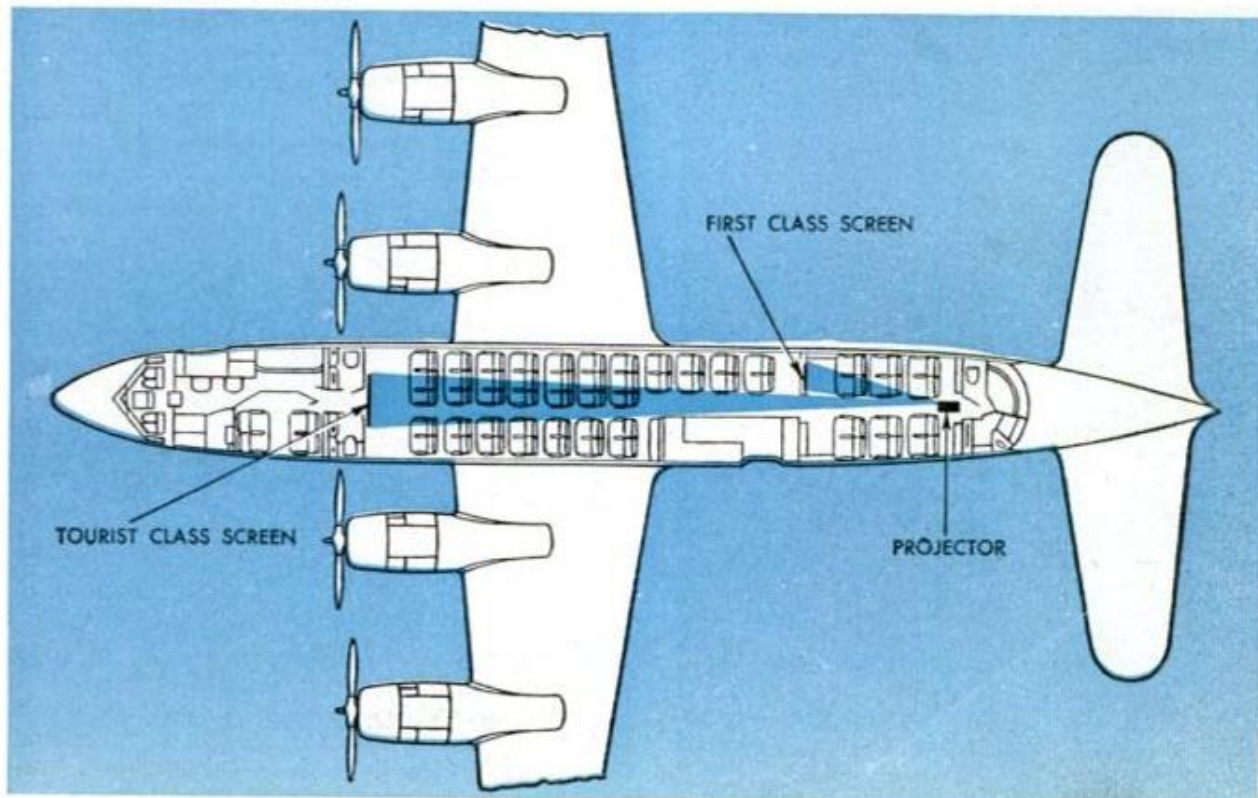

The Moons Shine Down on Austin



By Dev Klapp

A STRANGER SELDOM FORGETS his first glimpse of Austin, Tex., if he approaches the city by night. For he sees strung before him clusters of pale blue will-o'-the-wisps hovering without apparent support high above the city. The sight is indescribably weird and leaves a deep impression on anyone who doesn't know about Austin's famous tower lights—



the only ones of their kind in the world.

They are a sort of lamp-in-the-window to homecoming natives, a romantic setting for amorous couples and a strong tie to the past for older folk.

Built in 1894, these unusual lights were once the city's only source of illumination, though they now supplement a more expansive lighting system. When they were erected, they met rigid specifications: Each light had to illuminate a circle 3000 feet in diameter brightly enough to make readable the numerals on the dial of an ordinary watch. Total cost was \$154,000.

The lights were turned on in 1895. And since that day these manmade moons have shed their soft blue radiance over the city every night through all sorts of weather.

The frail-looking metal towers were well constructed, for now, after 65 years, all but four of them are still standing and in use every night.

Of the four lost, two met violent ends. A hurricane destroyed the first, and in 1946 a city bus swerved from the street and crashed into the base of the other. There was a terrific impact. Guy wires snapped, curling about the silvery framework as the tower buckled and fell. The tower settled its full length along busy Guadalupe Street, without scratching a car, marring a building or injuring a person.

There has been tragedy connected with these lights because of the allure of their height. Climbers have challenged the towers despite the difficulties placed in their way by engineers who set the framework of each tower atop a 15-foot smooth pipe.

Such a barrier, though, doesn't discourage small boys. More than once the fire companies have been called to bring down some youngster clinging in terror to the metalwork. In 1929 a boy climbed to the top of the Ninth Street tower. As he

Base of each tower is a smooth steel pole which discourages most would-be climbers — but not all

reached the final rung in the ladder, he lost his grip. Luck was with him that day, however, for he fell the entire length of the structure, bouncing from side to side, and landed on the iron catwalk 150 feet below—without breaking a bone or suffering serious injury. The escape was so unusual that the incident and boy were featured in Ripley's *Believe It or Not*.

Not so fortunate was another venturesome youth who, a few years ago, climbed the same tower. He was seized with vertigo, lost his hold and fell to his death.

These are the only two recorded accidents. But there are many stories told about the Austin lights that have a lot of humor in them. One of the best is about the early days when Austin had its share of come-to-town-shoot-'em-up cowboys. According to this tale, which is claimed to be true, a ranch hand, accompanied by his buddies, rode into town one Saturday night and began shooting it up. After emptying his sixshooter several times at the new-fangled lights without result, this cowpoke sought out the sheriff and raised a rumpus about the ---- things being strung too high for good shooting.

Now and then some parsimonious councilman introduces a motion to do away with the tower lights as needless expense, but he is always voted down at once. The gravest threat to the tower lights came during the war years when it was suggested that they might be hazardous to aircraft. But the idea of destroying them was finally abandoned, and seemingly in justification there has never been a collision, though two airfields are located near the city.

Austin's tower lights are not crumbling relics. They are kept in top shape and are an integral part of the city's lighting system. The original carbon lamps were later replaced by incandescent lamps which were used until changed to the new vapor lamps. There is one headache, however, in keeping them operating efficiently—and that is maintenance. Being the only lights of their kind in the world, they have no ready supply of spare parts. So the four towers that fell have been carefully husbanded and their skeletons used to keep the remaining 28 in repair.

Even though modernized, Austin's unusual lights retain their original charm, for no basic change has ever been made in their structure. And though romance probably didn't enter into the calculations of the city fathers when these lights were erected, the fact remains that no other city can deliver moonlight to its boys and girls 365 nights a year simply by throwing a switch. ★ ★ ★

Yearly coat of aluminum paint is typical of the care that has kept the towers in good shape since 1894

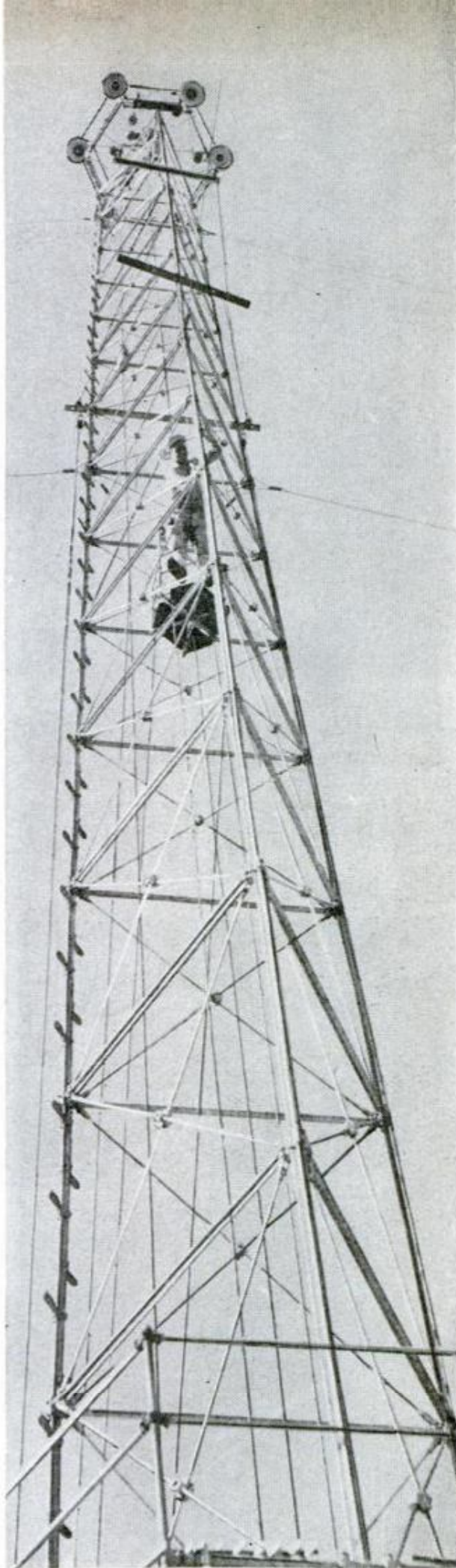



Giant Pipes Support Bridge to Swedish Mainland

Crossing the 918-foot gap between Tjorn Island and the Swedish mainland is an unusual bridge that will be completed this summer. Supporting it are two parallel pipes arching from shore to shore. Pipe sections, over 12 feet in diameter, were carried

to the site by boat, hoisted in place and riveted together. Pylons and suspension cables were removed after serving to aid in erection. Engineers chose pipe construction after testing models in a wind tunnel. The bridge is said to be largest of its type.

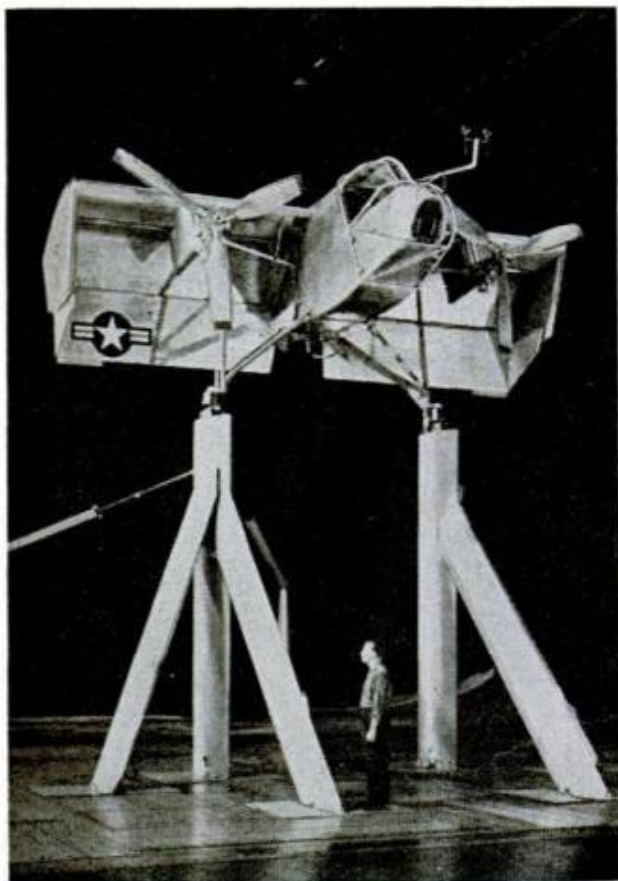

Vertiplane Really Puts Flaps Down!

Already flyable, the Ryan Vertiplane—it has large, retractable wind flaps to deflect the slipstream of propellers for vertical takeoff—is undergoing further wind-tunnel tests at the National Aeronautics and Space Administration center, Moffett Field, Calif. One gas turbine powers both propellers.

Number, Please!

Whenever you write us to

- Renew your subscription
- Change your address
- Order your own or a gift subscription

... In fact, whenever you write us,

PLEASE INCLUDE YOUR CITY POSTAL ZONE NUMBER IN YOUR ADDRESS

This insures better delivery.

It helps you and it helps the postman.



Bridge for Gymnasts Arches Across Pool

Swimmers who like to invent new ways to enter and leave the water should find a new swimming-pool bridge a source of entertainment. Slightly arched and resilient,

the bridge is available in various lengths. It is made from two one-foot-wide aluminum sections topped with $\frac{3}{8}$ -inch plywood, is strong enough to hold 12 gymnasts.

Rome Being Built in Our Day

Pausing to view the famed Colosseum, this cardboard figure of a tourist is a forerunner of tourists of tomorrow who will be able to wander through the streets of ancient Rome, viewing the city as it looked at the height of its power. A model of Rome is being built in the present-day city to permit future visitors to see it as it was in the time of Caesar. Models of the Colosseum and surrounding buildings are part of a small plastic representation of the famed city that has been constructed as a pilot model for the permanent display which will be built on a larger scale.

☐ Soon to be built in Puerto Rico, a huge radar antenna will be used by Cornell University scientists to probe the surface of the planet Jupiter.

☐ Radio signals, reflected from ionized air left in the path of meteors, have been used to transmit messages 40 times as fast as teletype machines.



The Church That's

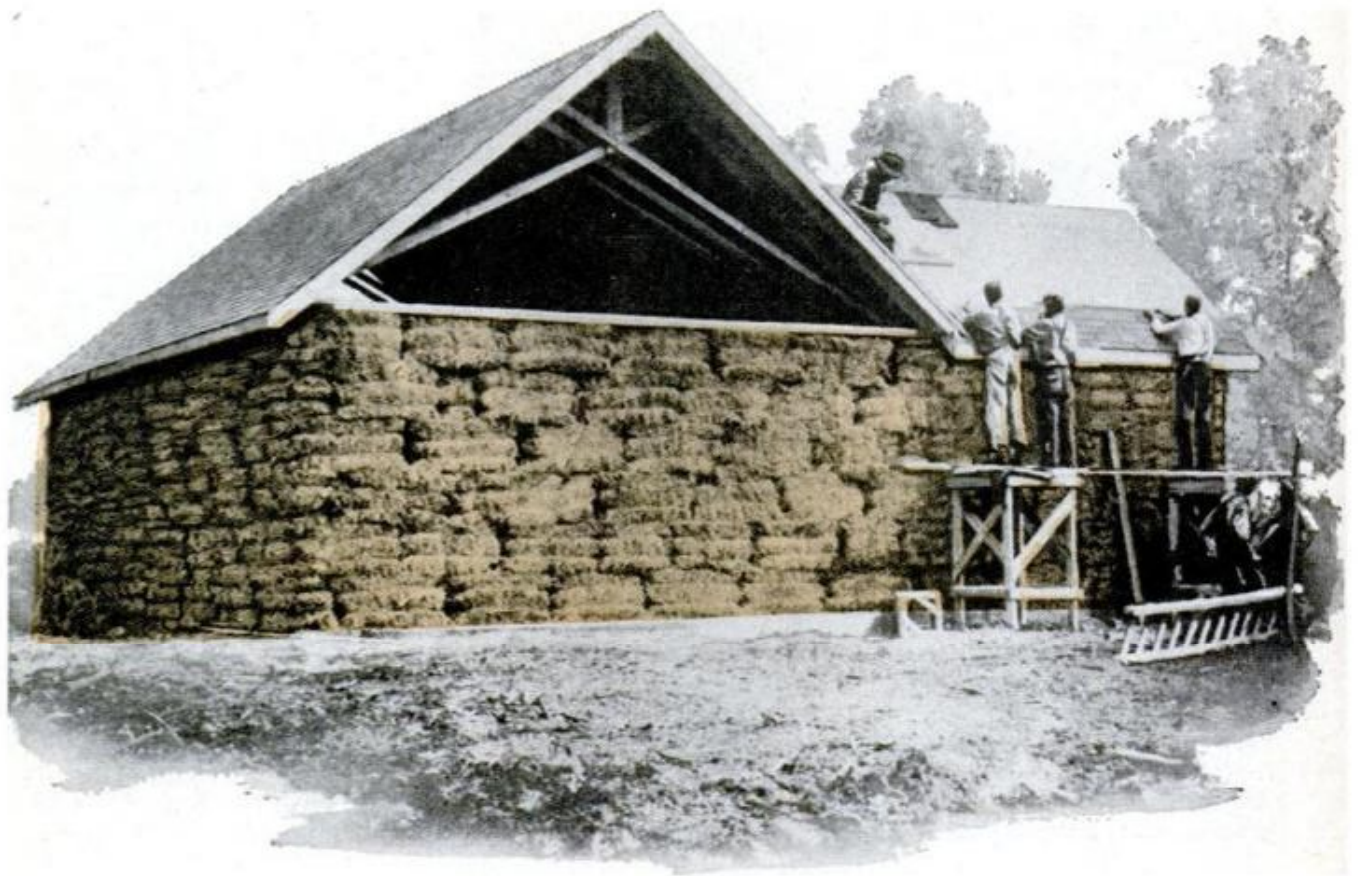

From a perch on the roof, Father Francis Dales supervises the shingling job during construction of the straw chapel in Sexsmith, Alta., Canada. The straw walls have not yet been covered over with stucco



Father Dales, an adept carpenter, not only did the design work himself but helped build the church

DESPITE THE NURSERY TALE, huffs and puffs won't necessarily blow down a straw building. The proof is a chapel of straw which stands in the Peace River region of Alberta, Canada, where winter winds and 40-degree-below-zero temperatures are standard fare.

The chapel is the fond effort of Father Francis Dales who, since coming to Alberta in 1950, has helped build community halls, churches, homes, and schools.

The straw construction was the idea of Father Dales' late brother, an Ontario contractor. But the priest designed the structure himself. It seats 50 persons.

Bales of straw were piled on a concrete foundation to form walls. Pipes bolted together between rows of bales compress the straw and hold it in place. Wire and stucco cover the exterior.

To help raise the \$605 that it cost, Father Dales designed six private homes and a \$70,000 church (which he also helped build). The community's Protestants and Catholics alike pitched in to build the straw chapel. ★ ★ ★

Built of Straw



Bales of straw—plentiful around Sexsmith which claims to be grain capital of the British Empire—placed on concrete form the walls. Below, with steeple in place and the walls stuccoed, the chapel is almost finished



APRIL 1960

131



Ships Dock in Huge Mass of "Soap Bubbles"

Detergents from nearby factories make a foamy bed for ships at a lock in the River Neckar at Stuttgart, Germany. Factories

deposit the detergents in already dirty water, making the river unfit for swimming. Fish cannot live in the water either.

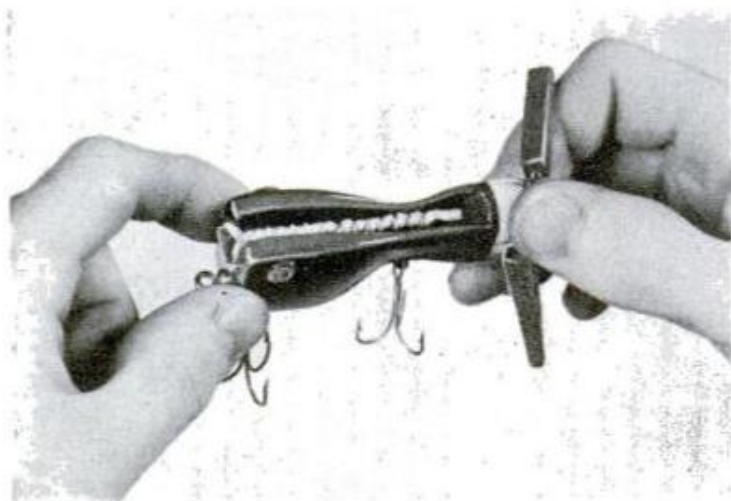

Wind-up Plug for Bass

One of the most important tricks of successful bass fishermen is the ability to keep a surface lure moving, however slightly, without retrieving it from the productive water along shorelines or weedbeds. For many years lure designers have worked to develop a lure that would move without being pulled through the water. This lure is designed to move like a drowning animal; its back "legs" are powered by a rubber band which is wound up by the angler. A plastic-and-wax compression disk between the body and the legs retards the unwinding action so the plug operates for at least a couple of minutes after landing. (Two spare disks are supplied with the lure, though one disk should last through a season of ordinary use.) In the water, the legs rotate, kicking up a fuss without moving the plug. The angler keeps a tight line and waits for the strike.

☐ At any given moment, the U.S. Air Force has 1000 aircraft airborne somewhere in the world; these planes fly an average of 4800 miles every 60 seconds.



Measuring the flow of water in a river means half a day's work for members of Northern Rhodesia's hydrological section. Below, evaporation of water is calculated to learn the true capacity of a dam

These Men "Operate" Rivers

Members of the hydrological section of Northern Rhodesia's Irrigation Department spend countless hours tediously measuring rainfall, the flow of rivers and the depth of water in dams. Their job is to end flooding and provide electricity in rural areas. They must decide where dams should be placed, where irrigation and hydroelectric plants should be built. Their dream is to stop in the future such damage as the flooding of the powerhouse at Livingstone and the cofferdam at Kariba.



Hey! Look at the Blonde!

Motorists approaching a cafe near Atascadero, Calif., often find their attention caught by what, at first glance, seems to be a comely waitress. Their second glance, of course, takes in the cafe sign—as the manager had planned. The attractive blonde waitress is a costumed window display dummy.



☐ Lithium, lightest of all metallic elements, has been alloyed with aluminum to form the skin of the U.S. Navy's supersonic attack-bomber, the A3J Vigilante; the new alloy gives a three percent weight saving over conventional aluminum compositions used on present aircraft.



SNEAK UP ON THE BASS

At right, here's how, with a trolling motor mounted offcenter beside the regular motor. At left, here's why — four "braggin' size" Texas largemouths

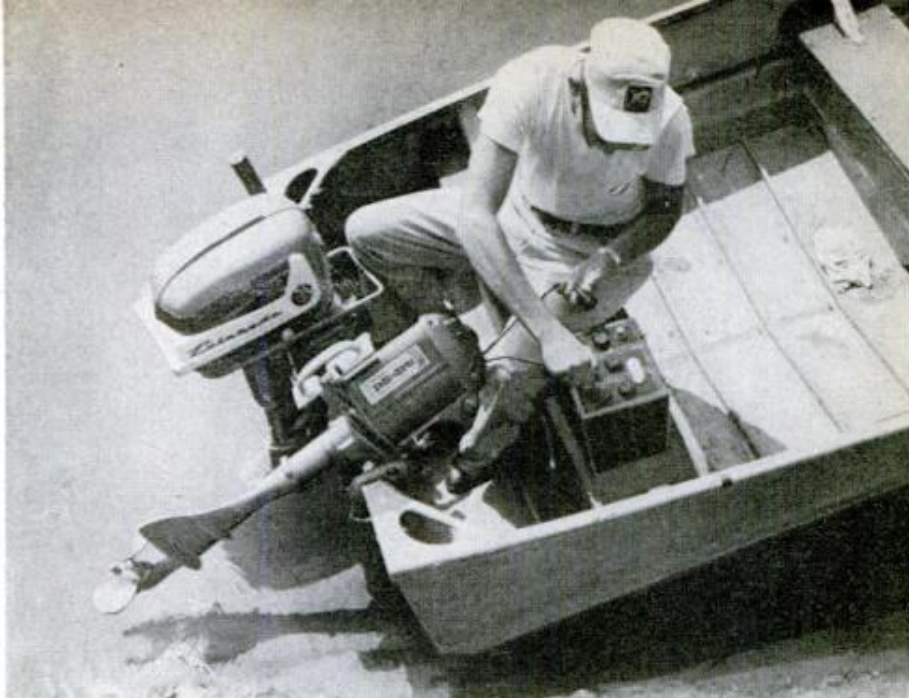

Increasing popularity of small electric trolling motors brings an electrical age to fishing

By Russell Tinsley

ANYONE WHO has ever fished for bass will sympathize with my predicament. It was a typical late-March Texas afternoon, hot and windy, and the gusty northeast breeze whipped the waters of Granite Shoals Lake into a rough chop which tossed my boat around like a fisherman's cork bobber. I was working off a rocky point jutting into the lake, trying to maneuver into position so that I could cast along the slope where the shallow waters faded into deeper depths. Each time I drifted past and prepared to cast, the wind promptly blew me out of strategic position.

I was fishing a jig, a weighted bucktail lure which requires an ultra-slow retrieve along the bottom for best results. There was no percentage in a snap cast and a hasty recovery. The sensible thing for me to have done, naturally, was anchor and fish that stretch of water properly. But I was in a hurry to fish down the shoreline and didn't figure the spot was worth the time or effort required to lower and raise the anchor.

I was cussing the wind and struggling with a paddle to keep from being washed ashore when my friend Kenneth Gumm motored up. "Have you fished that point yet?" he shouted. I shook my head. Switching off his outboard, he cut on the small electric troll-motor to his left on the transom. Gradually he crept into position, flipped his bait at a tangent to the rocky point and brought it back slowly. Suddenly he was fighting a half-moon rod and beyond the point a pugnacious bass shattered

the water surface as it catapulted skyward. Shortly Ken had the fish flouncing helplessly in his landing net and held it up for me to see. "About five pounds," he announced proudly.

That was my introduction to the electric troll-motor in bass fishing; similar incidents since have sold me on their merits. I've reached the conclusion that such a motor is the wisest investment a dedicated bass angler can make. It takes much of the labor and guesswork out of fishing, and it definitely pays off with better catches.

As any seasoned fisherman will tell you one of the foremost requirements for successful bass angling is proper presentation of the bait. Haphazard fishing won't fill the stringer; to succeed with bass, the fisherman must pinpoint his casts into likely spots and fish the bait correctly. Most anglers work their lures too fast. In most cases, the slower the retrieve, the better your chances for a bragging-size fish.

Proper approach is also all-important. Bass are often spooked by unnatural vibrations in the water and a big bass may not strike a bait if it is forewarned by a hint of strange noise.

At one time the bass angler had four choices for handling his boat while fishing. The favorite was — and probably still is — to drift with the prevailing wind. That was fine when nature cooperated, but all too often there was no wind or it was from the wrong direction. The angler was at the mercy of the weather with no control over his fishing pattern.

GO OUT FAST . . . FLICK THE SWITCH . . .

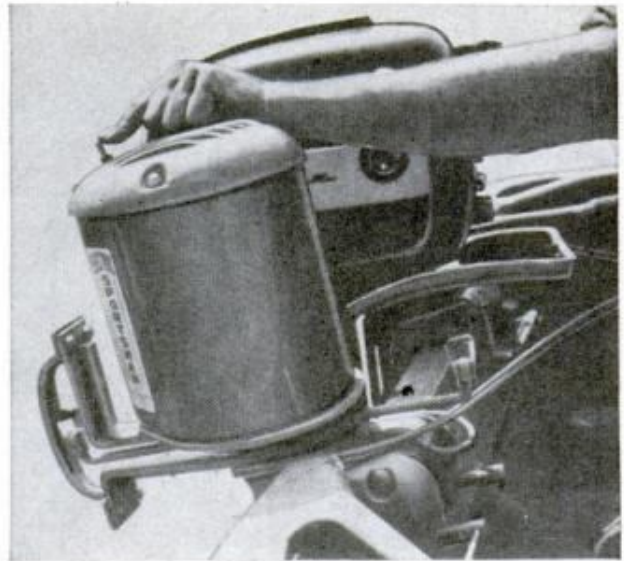

Author Tinsley, in his favorite fishing rig, runs out across Granite Shoals Lake in Texas with his aluminum boat and a 12-horsepower motor. When he's reached his spot, it's a simple matter to kill the big motor, drop in the troller, and ease quietly along the shoreline, casting with one hand and operating the small motor with the other when necessary. The motor in these photos is an Electric Sportsman; shown at far right are three other available motors. Another, not shown here, is the Minn-Kota Electric Troller

Second, two anglers could fish from the same boat—one fished while the other paddled slowly. This worked wonderfully, except that each angler could fish only half the time. Also it is difficult to maneuver a boat steadily with a paddle without making some unnatural noises.

Third, the fisherman could run his outboard at its slowest speed and fish on the move. But outboards don't idle along slow enough to allow the deliberate fishing required for this drift-and-cast method.

Fourth, he could drop anchor at each respective spot and fish it thoroughly. This was foolish. Not only was there a lot of work involved, but the angler could cover much less water. You can't catch fish unless you find them first. Fishing a variety of waters is often the key to angling success, especially in strange water.

Today the angler has a fifth choice, the troll-motor. It eliminates most of the problems; the only drudgery is keeping an ordinary automobile battery charged and ready as a source of power.

The tiny electrical motor pushes a boat along slowly and quietly; the slight motion is the only hint that the motor is running at all. It operates at a convenient speed for bass fishing, and by sensible operation of the troll-motor, the angler can have com-

plete control of his fishing. When you approach a likely-looking spot you can switch off the motor and fish there as long as you like. Or you can reverse the motor (most have full-pivot shafts) and move back and forth, plugging every foot of available water. You can even fish into a stiff breeze and still control the boat, and a wind, unless it is of gale proportions, is no problem. The possibilities are unlimited.

Most of the troll-motors on the market at present—such as The Electric Sportsman, the Minn-Kota Electric Troller and the LeJay Elec-Troll—have power units modeled after conventional outboard motors. The motor is on top with a drive shaft down to the prop. The lone exception is the Silvertrol with the power unit submerged in a waterproof housing and connected directly to the prop to eliminate the extra weight of a drive shaft.

An electrical troll-motor serves a myriad of purposes in fishing. Some fishermen use them as power units for small one-man prams, others troll with them. Troll-motors are allowed on many lakes where gasoline-combustion engines are prohibited. But its biggest splurge in popularity has come as an auxiliary motor for bass fishing. It is especially popular on the large artificial impoundments of the South and Southwest.

FISH AT A SNAIL'S PACE

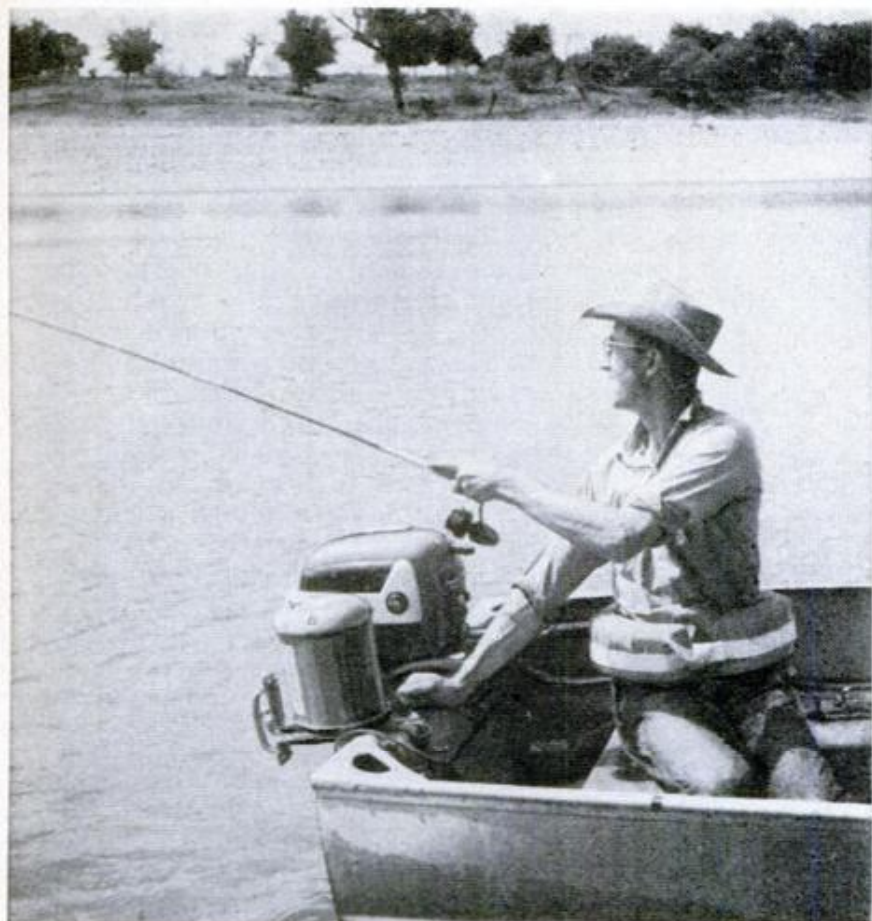

A veteran bass angler on the sprawling artificial reservoirs of my home state of Texas is usually equipped with a powerful outboard unit to take him to faraway fishing grounds and a small troll-motor to put into use once he starts fishing. The troll-motor isn't built to compete with the larger gasoline-powered outboards; its battery-operated motor has limited power. At its best, it is only another tool in the highly specialized bass fishing we know today.

Most electric troll-motors operate with ordinary twelve-volt or six-volt automotive batteries, and a fully-charged battery is good for a hard day of fishing. When the angler comes in at night, he merely plugs a quick-charger into an electrical outlet, attaches wire clips to both posts of the battery and by the following morning he'll be in business again. Since many of the larger outboards now have electric starting units, the troll-motor can be operated off the same battery.

Many of the motors have two or more forward speeds. A complete outfit (motor, charger and battery) can be bought for between \$100 and \$175, depending on individual components. Troll motors are compact and lightweight; a woman can carry one easily. They range in weight from about twenty pounds to thirty-five pounds.

A troll-motor is very economical. Under normal use the automobile battery will have long life, and the electricity needed to recharge a battery is negligible.



LE-JAY ELEC-TROLL

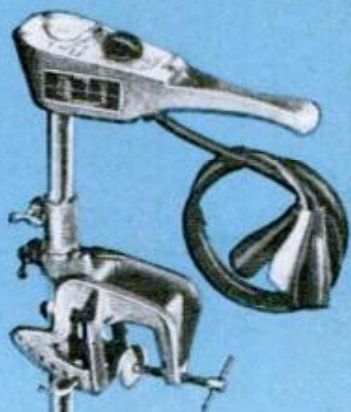

SILVERTROL MODEL 5-62

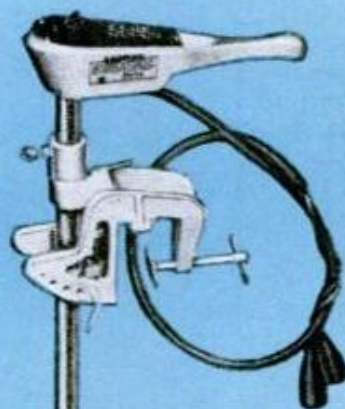

SILVERTROL MODEL 5-60





Two tricks with electric motors—above, sit on the motor and steer with one foot. Below, mount the motor on the bow (note footrests). But don't try either without a good, stable boat



The secret of using the troll-motor successfully in bass fishing is being able to maneuver the boat, yet still have freedom for everyone aboard to fish. The Silvertrol has a wide, flat steering control, and many fishermen manipulate their crafts by simply steering the motor with one foot. The others have easily operated hand controls or optional remote steering.

Standing upright in a rocking boat with one foot on a motor is an awkward and precarious position. To steady himself, the angler can lean against the larger outboard, giving him a three-point stance. But even at that, he won't be as steady nor as confident as he would with both feet on the boat floor. Best wear a life preserver since the slightest jar can topple the angler overboard. I've seen it happen numerous times when the boat would strike a submerged limb or rock.

With other motors, the angler can steer by situating himself where he can readily reach the steering control with his left hand (or right hand if he is a southpaw). By merely touching the control between casts he will have complete control.

Most troll motors are mounted on the transom alongside the outboard, but some anglers bracket them on the bows of their boats. Others even place the motors amidships. I saw one fishing boat equipped with troll-motors both at the stern and bow, and two operators could move the craft slowly along with it at right angles to the shore. Thus both anglers could fish forward in the best waters rather than one having to cast his bait behind the boat in areas where his companion's lure already had run.

Last year, when I visited Bull Shoals and Norfolk lakes, man-made reservoirs on the Arkansas-Missouri border, I was amazed at the number of boats equipped with small troll-motors. All the professional fishing guides use them. A guide, always before occupied with fighting a paddle to keep the boat in position, now has the time to offer other services to his clients. One told me that the troll-motor was the greatest single advance in bass fishing since the artificial lure was invented. I think so, too. ★ ★ ★



Farmer Builds Bridge of Gas Pipe

FOR YEARS, Lawrence W. Crouse of Greene County, Pa., carried 10-gallon milk cans across a swinging footbridge between his farm and the highway. And each year, during high-water periods, he had to ford the creek to reach the road. Now he has a

brand new bridge, built to his own design, although he has had no engineering training. He built the 140-foot trestle from eight-inch and three-inch natural-gas transmission pipe. The roadway is a wooden deck bolted to the pipe.

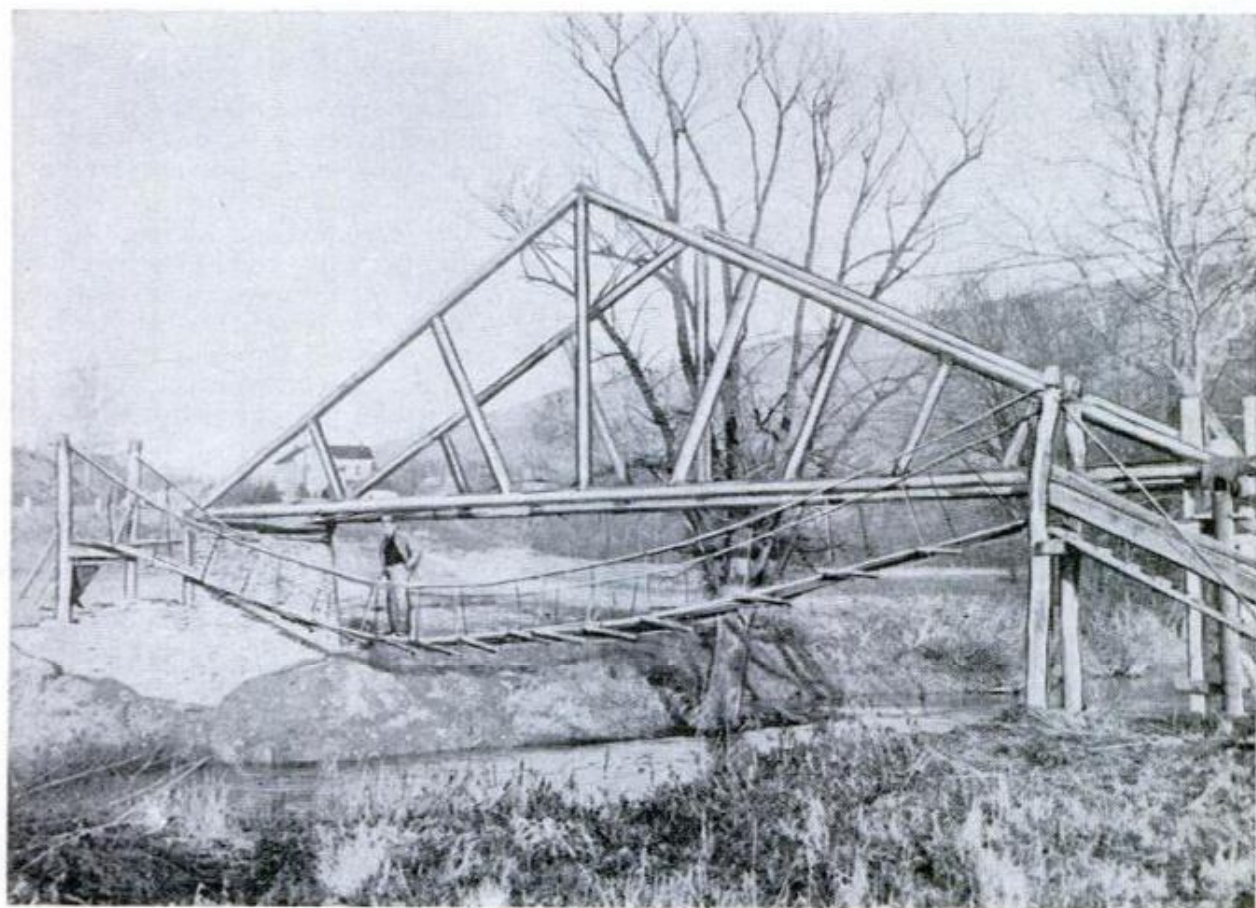



Wrist Life Preserver

Necessity is billed as the mother of invention, but a nightmare was the inspiration for this one. Marine Gunnery Sgt. Daniel O. Davis, of Camp Lejeune, N. C., dreamed he was drowning but was saved by a floating wrist watch. He decided later that a wrist-worn life preserver was a good idea, and is planning manufacture of the small cartridge-filled model shown here. A small button actuates the cartridge; the preserver is reusable.



Dali's Ovocipede

Looking like something dreamed up by Salvador Dali (it was), the ovocipede is a transparent plastic sphere that is propelled by the occupant, who runs along on the inside track like a squirrel in an old-fashioned squirrel wheel. The famous painter claims that the "vehicle" can be rolled over land, water, ice, or snow—the operator stands and holds the two hand bars on the axis, or can sit on the seat to coast. Steering is managed by shifting the weight along the axis in the direction of the turn. The driver turns around to reverse.



Suction Cup Holds Dog

For those who like to shop while taking their dog for a walk, a London girl had an idea. She fixed a rubber suction cup to the end of the dog's lead that can be attached quickly to any plate glass window. To leave the dog safely tied outside a shop, she merely pushes the suction cup on the shop window. The cup has been found to hold firmly in spite of persistent tugging over periods of an hour or more. Yet it can be removed easily by lifting the edge with a fingernail.

Similar rock samples found in Antarctica and Tasmania by a New Zealand research team indicate that Australia and Antarctica were once joined.

First of its kind in Europe, a new pulp mill in Corbehem, France, makes possible the use of hardwoods to produce newsprint.

ONE-MAN HOUSE

COMBINING the compact convenience of an apartment with the privacy of a free-standing house, this neat 16 by 26-foot "bachelor" townhouse was designed by the architects in Holland's Rotterdam Stichting Bouwcentrum (Building Center) to meet the demand for comfortable quarters for tenants who want to live alone but don't like the towering downtown apartment buildings.

Packing all the components of an independent home into 400 square feet can't have been easy, but the designer did it by eliminating the bedroom (as such) and using built-ins to keep furniture at a minimum. There's outdoor living, too—with a broad veranda outside the utility-entry section and a balcony opening off the living-dining-sleeping room at the other end. Two glass doors open onto the balcony, and one forms a wind-screen against the open side. The other side is screened by an extended wall.

Inside, wardrobe storage is built into the entry wall; kitchen storage is in built-in cabinets; more storage is at the foot of the bed and along the storage wall in the living room, which also doubles as a desk.

Cleaning equipment, utility meters, and pass-through delivery port adjoin entry

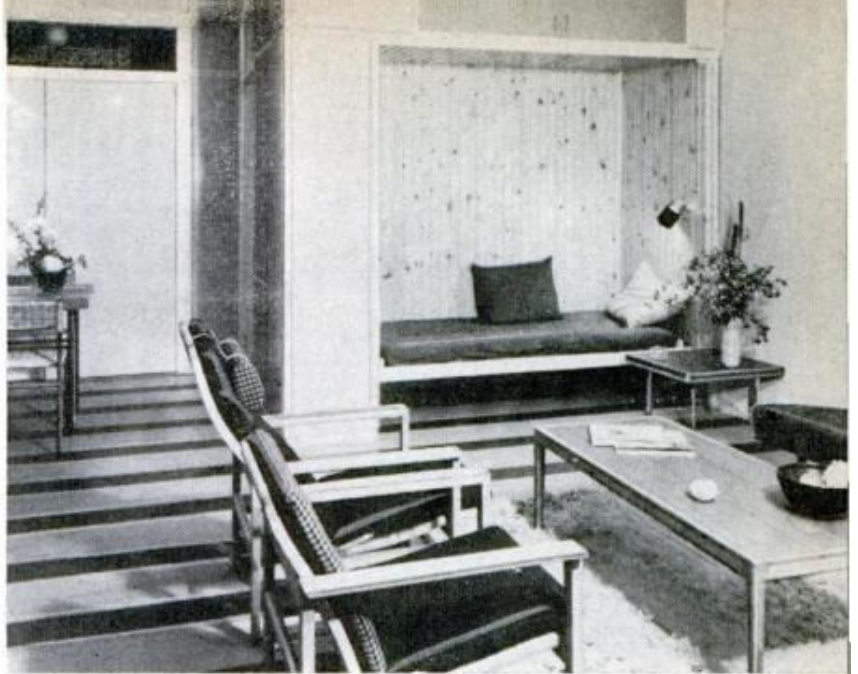

Traditional Dutch enclosed bed, at right rear, doubles as an extra couch in daytime or can be closed off with draperies

Adjustable living-room storage wall is also an office and an entertainment center with portable TV and rollout phonograph

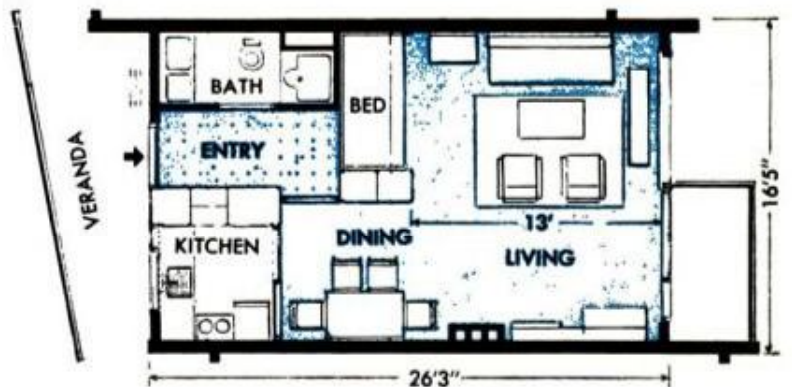
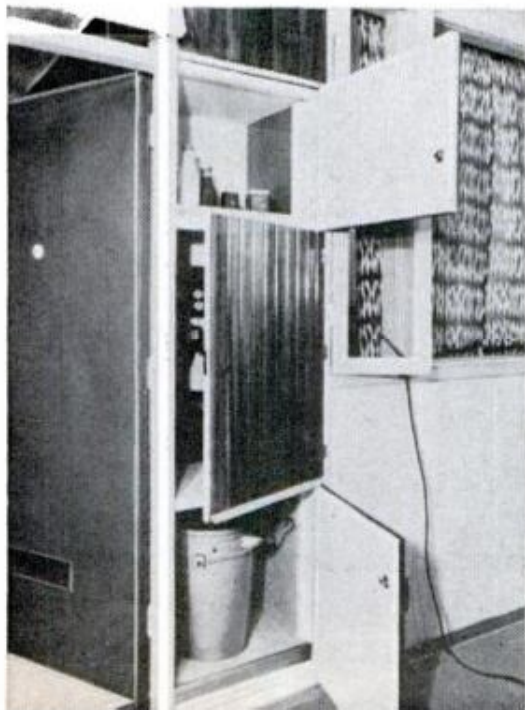
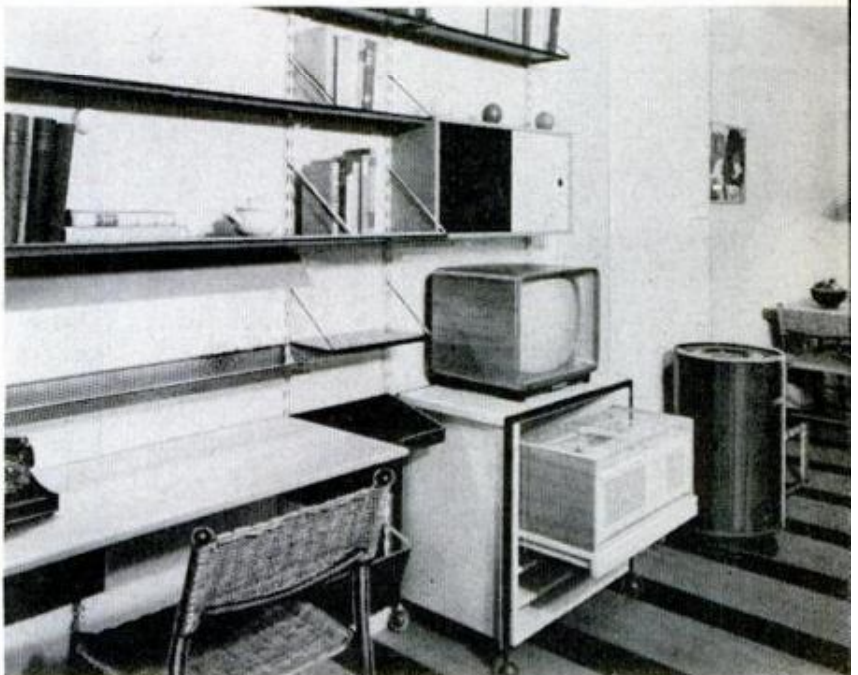



Inboard-Outboard Runabout

Dissatisfied with commercial outboard motorboats, Joseph Bryan of St. Joseph, Mo., worked for two and a half years to design and build his own runabout, and finished last summer with this trim 18-footer which boasts several features new to outboards. Most apparent is the enclosed outboard motor, which is readily accessible through the cutout, but baffled until it's almost silent. Other features are auto-type lights; full convertible top, seats that shift fore and aft, and a radically different trailer on which the boat can be turned around and launched bow first. The engine hood also covers fuel, battery, and flotation.

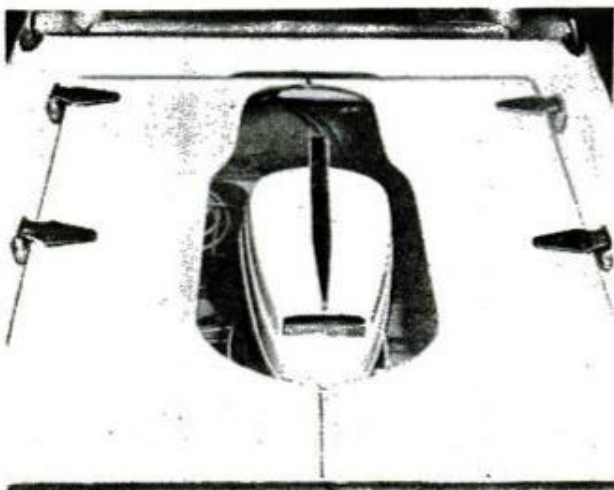

Bow Turns Flame Thrower for Oilmen

Waste gas fumes burning off from this flare tower at Nevis, Alberta, sometimes blow out, and the mechanical relighting device doesn't always work. The oilmen keep a bow and a fire arrow handy and relight the flare by shooting a flame through the fumes. It doesn't require any skill at archery—note this oiler's unusual form.



Rush-Hour Reading Glasses

Rush-hour crowds packed John Holding into the London subway too tightly to read his paper. In desperation, he bought a pair of right-angle-vision glasses, the type used for reading in bed by invalids who can't sit up, and reversed the prisms so the glasses viewed straight upwards. Now he rides and reads in the densest crowds.



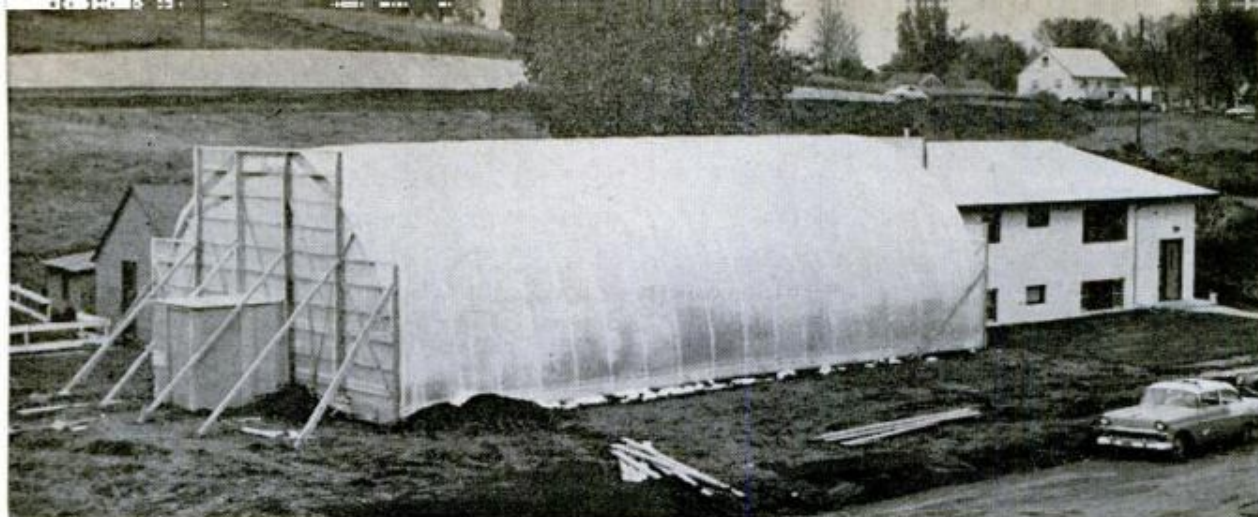

Inflated Plastic Domes Shelter Winter Builders

Three Minneapolis home-building crews work during winter months under sun-warmed domes of air-supported, transparent polyester plastic. When the sun doesn't shine, the 40 by 70-foot domes are heated with auxiliary units. The builder expects the technique to allow him to erect 60 more homes than the Minnesota winter conditions normally would allow.

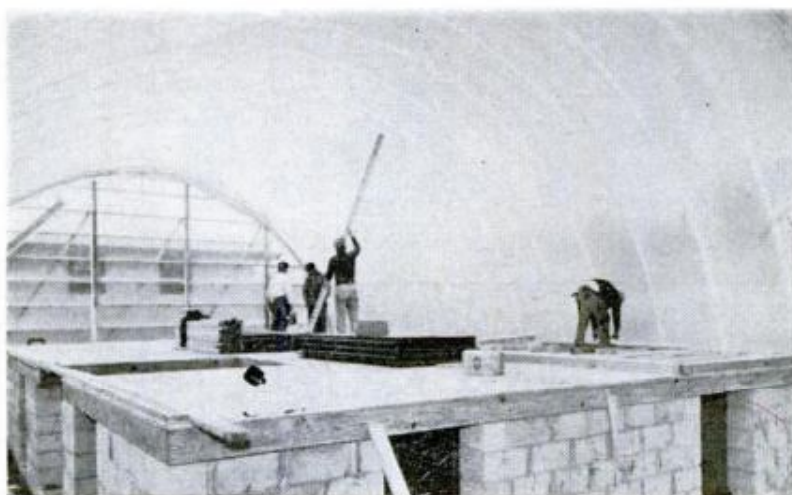

Truck Cab Serves as Bus Stop

Rural youngsters at Okawville, Ill., won't have to wait for the school bus in the cold any more. An old discarded truck cab, put on skids and placed near the highway, makes waiting fun. The seat accommodates four, and with good glass in the cab, the most blustery wait is no problem.



APRIL 1960

Replacement Carbs for Imports

Carburetors on four foreign cars now can be replaced easily if necessary with a special carburetor package. Replacement is made by a "take-off, put-on" procedure. The carbs, designed by Carter Carburetor, fit Volkswagens, Hillmans and the Anglia and Prefect models of English Ford.

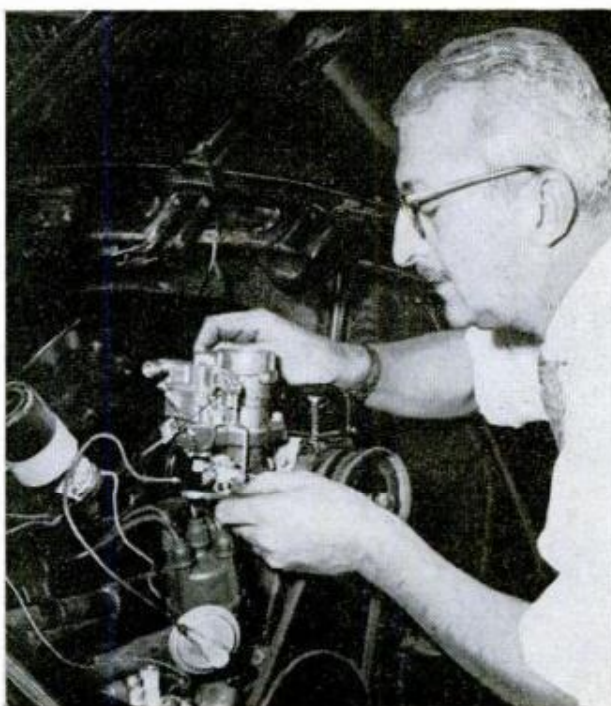

143



FOR THE MILLIONS who soon will be permeating the air with the odor of sizzling steaks cooked over open charcoal fires, *POPULAR MECHANICS* presents its 5th annual outdoor living section — 21 pages packed with unusual suggestions to help you better enjoy living outdoors

Permanent Additions to Improve Outdoor Living

OUTDOOR LIVING has outgrown its swaddling clothes and is no longer a way of American life to be satisfied by improvisation, makeshifts or portability. Most home owners are seeking permanency in the equipment and structures used in outdoor living, and prospective home buyers are influenced favorably by the means provided for this type of living. Therefore, careful thought should be given to design and permanency of equipment.

SHELTERED PATIOS

FOR THE COST, a patio attached to your home will add more to the value and do more toward your enjoyment of living outdoors than anything. It will provide a comfortable spot on hot days, protection against showers, and can be screened against insects, or glazed for cool days.

While actual construction of a roofed patio is relatively simple, it is not a matter of building a porch onto your home. It must be designed and located to blend with the architecture of the home. On this and the following two pages several designs of patios are shown. Notice how they blend with the architecture of the houses to which they are attached. Therefore, when planning your patio be sure its design is suitable for your particular home. Step back a couple of hundred feet from the house and try to visualize the appearance of the patio you plan. Will it complement your home, or will it detract from the appearance? A poorly integrated addition can actually decrease the value, whereas a suitable addition often will add much more than its cost to the value of a home.

Notice in the sketches on these pages how the architect has made the patios compliment the buildings and become part of them. In the sketch of the Cape Cod house above, running the patio roof around the end of the house does the trick. Had the roof stopped at the eaves, the appearance would not have been so effective.

Simple shed-roof patios such as shown at the left, will be enhanced by adding an arch fascia and matching the siding to that of the existing house. The details show how to frame the roof into the side of the house for either brick or frame construction.

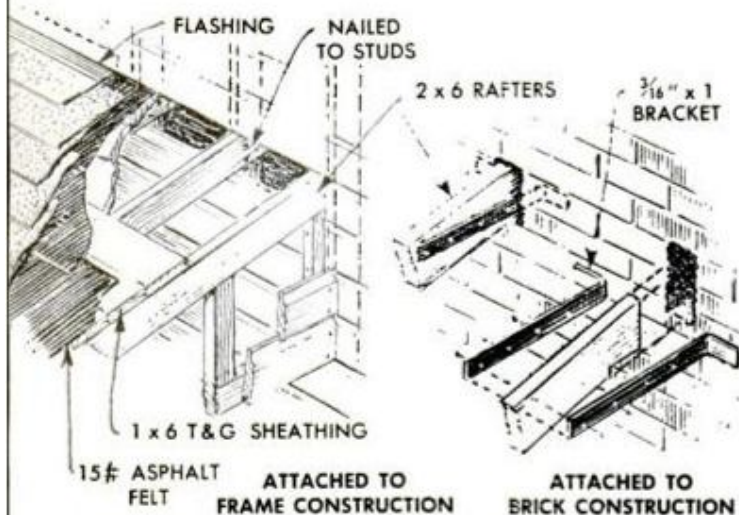



A gable patio roof with open end and exposed rafters, such as the one above, will blend with almost any house having a gable roof. Such a patio will give a decidedly modern flair to your home. Use large brick columns for a brick home, and large framed columns covered with siding

for a home of frame construction. Details below left show roof construction.

In the lower right sketch notice how the lines of the gable-end patio roof are carried across the end of the house. This treatment avoids the appearance of a lean-to type of addition and helps blend the patio roof into

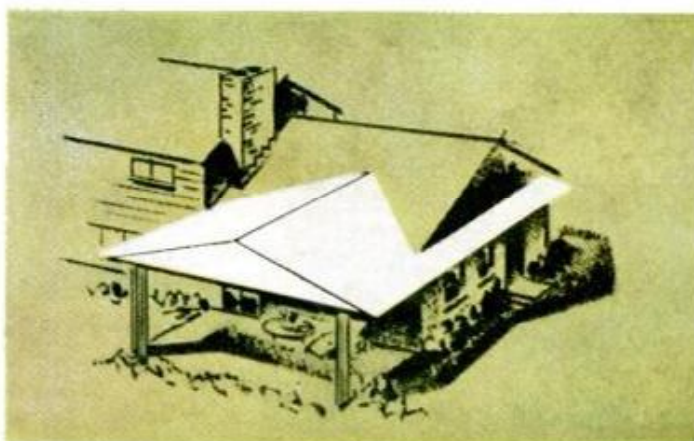
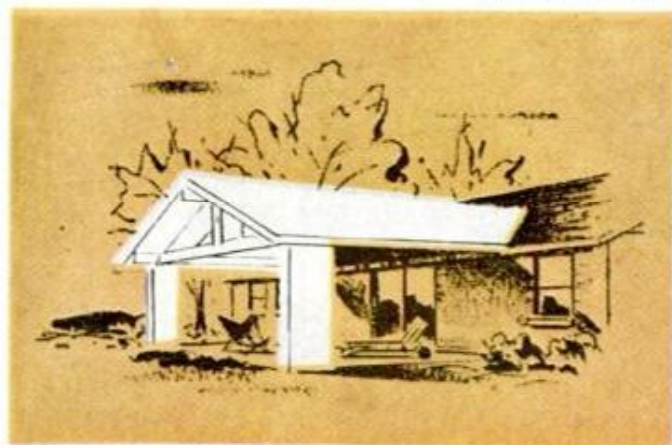
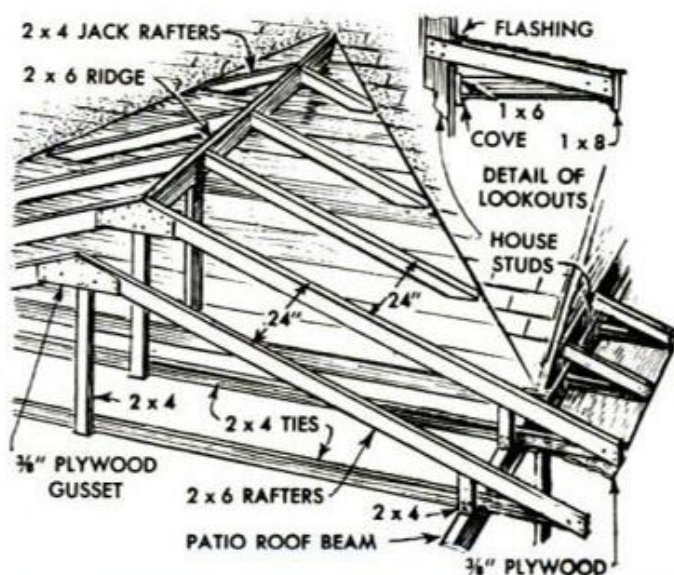
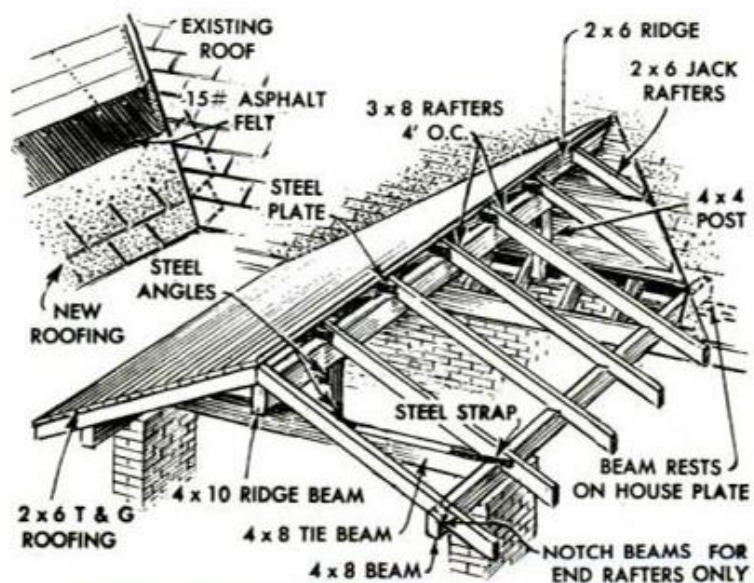

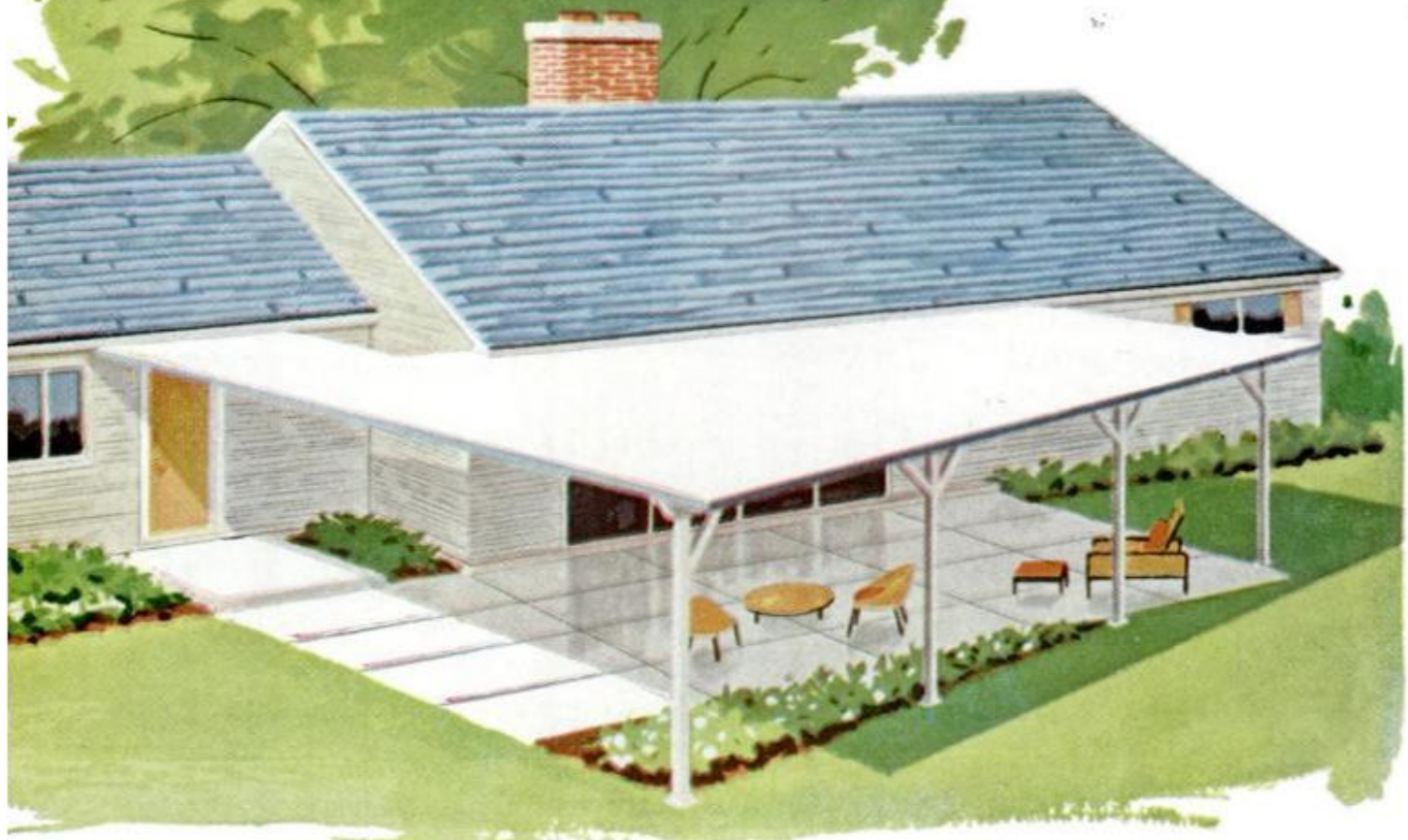

a house of this shape. Notice in the details how lookouts are constructed to support the roof along the end of the building.

For a ranch-house patio where a matching roof is not practical, build a flat roof that compliments the building by performing some extra functional task, such as cov-

ering a walk as shown above and the lower left-hand detail. A Georgian home with its formal appearance suggests two solutions; stately columns with a roof matching that of the house, below right, or a flat roof. If a flat roof is used, add a roof-top railing to complete the picture.

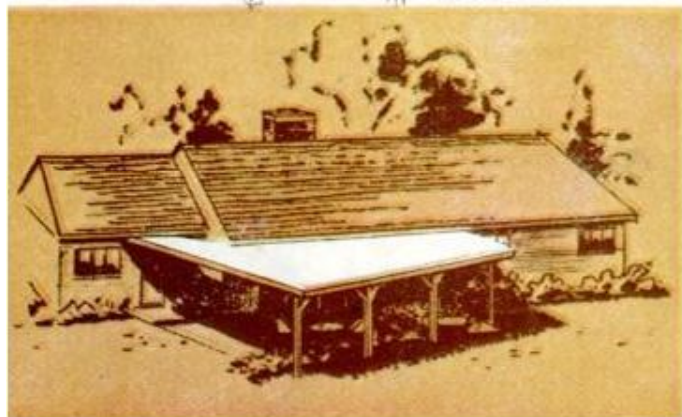
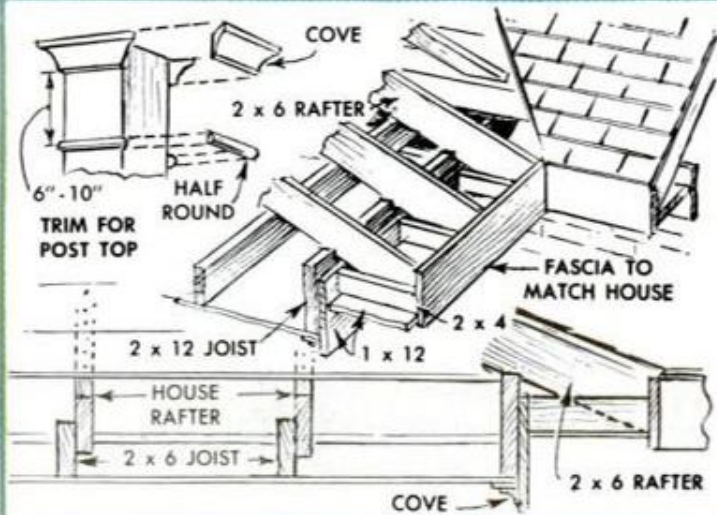
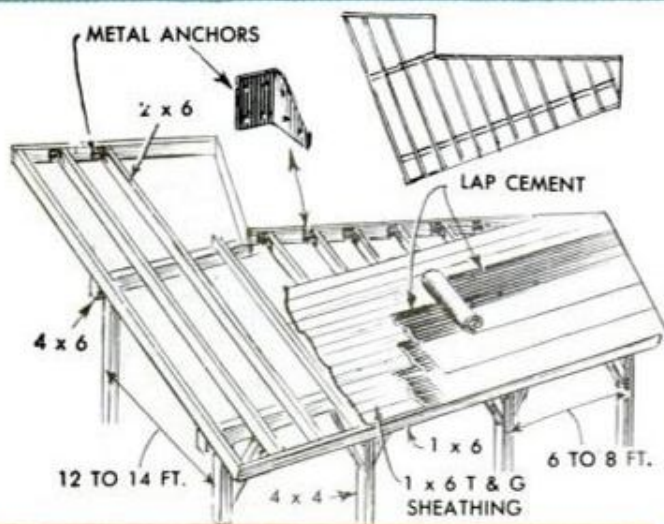



OUTDOOR STORAGE WALL

WHERE A HOUSE or yard doesn't lend itself too well to an attached patio, a free-standing one in the form of a "living wall" may be the answer to your outdoor way of life. A veritable oasis in your back yard, this outdoor storage wall contains everything—including the kitchen sink.

For your cookouts, it provides an attractive and sheltered barbecue center, complete with cooking and dishwashing facilities. As an entertainment center, it houses a portable TV and hi-fi unit for your loafing pleasure. It has a place to keep

outdoor game equipment, all within easy reach. It contains ample storage for your garden truck, everything from potting supplies to the power mower. And the beauty about the whole thing is that when you are through entertaining or loafing family-style, the mess can be chucked away right on the spot with little or no effort. There is even a cubby-hole for a folding table and chair set to save carting it inside.

Whatever the shape of your yard, this adaptable wall will fit in because it is composed of three separate sections, A, B and C, which can be arranged and nested to-

A



B

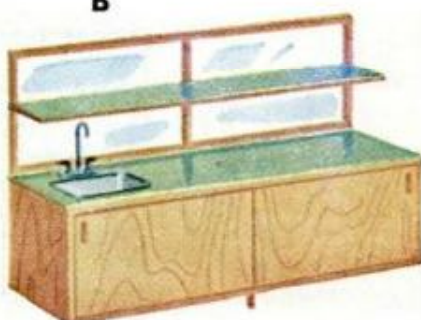

C





gether as desired. For a limited budget this year, one section could be built now, the others later. All three, with one or two of the 8-ft. screen sections shown, will give you a luxurious outdoor room.

Section A is the entertainment center. Its six sliding doors on the front side open into deep cabinets for games, the TV, etc. Its 8-ft. width allows good acoustics for the two speakers of a portable stereo set kept inside the cabinet. In back, two large hinged doors open to other shelves—generous storage for garden and lawn supplies, paints, etc. Section B is basically a kitchen-

sink cabinet designed for outdoor usage. You can store a large folding barbecue table and its chairs inside this open cabinet. Its back is a screen matching the other screen sections. Section C gives a dish cabinet above and another below on the front side for storing a movable charcoal grill. On the rear side it stores your bulky garden tools—lawnmower, rakes, shovels, etc. There, at the middle, it also has a compact work counter and shelves for small garden tools.

All three sections are roofed with flat asbestos-cement board, a simple and per-



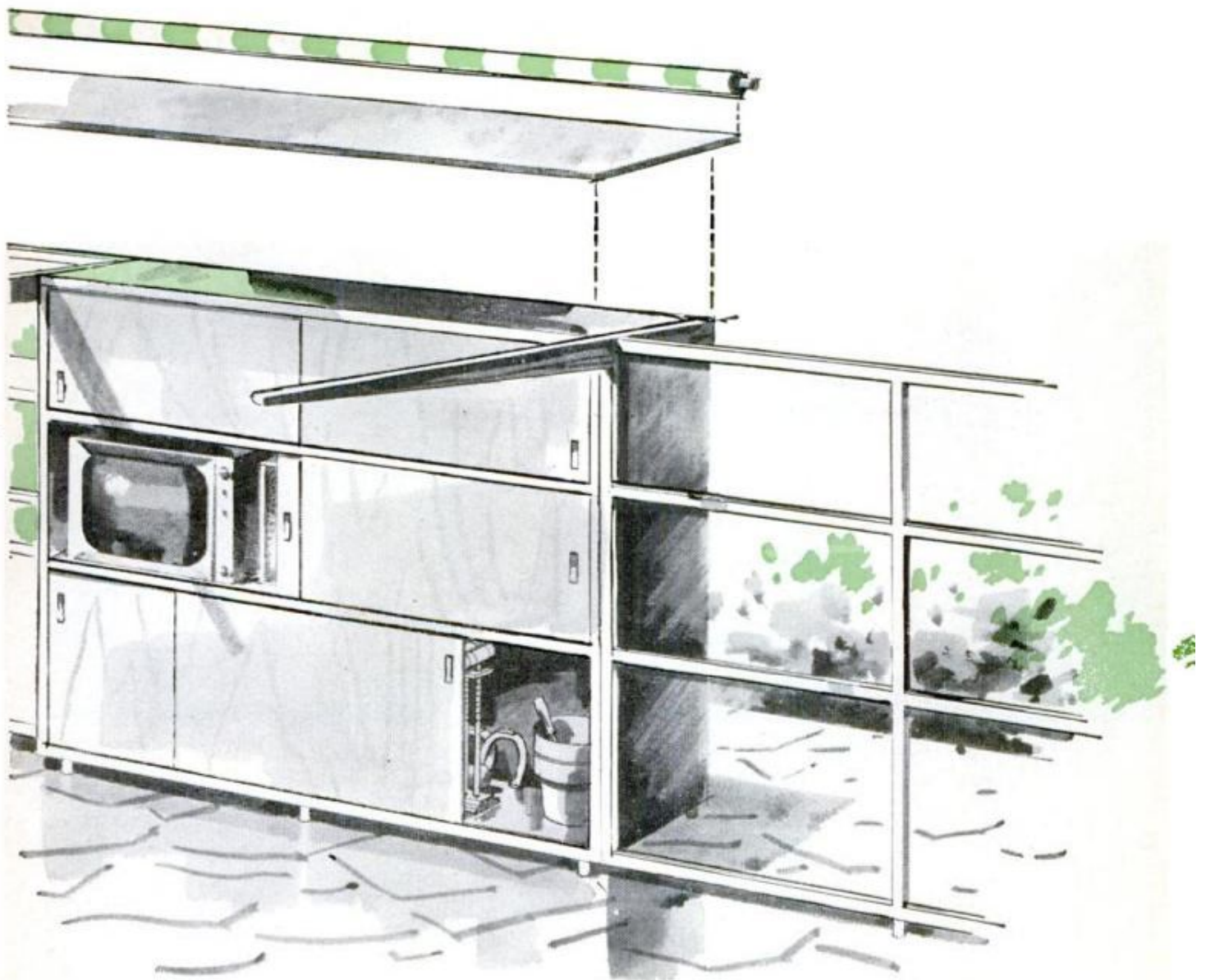

manent roofing for the design. To shelter the dining-entertainment area from sun or rain, any lightweight patio roofing material can be laid over the tapered roof beams—canvas, glass-fiber panels, lath, reed fencing or the like. A roll-up canvas canopy is another possibility. It gives you adjustable shade overhead and can roll back on the roofs of A and B sections when not needed. If you are using glass fiber, the roofs of the three sections can be of the same

material. The three sections, and any matching screen sections, rest on short pipe legs to be above wet and snow. Thus, they also can be placed over anything from bare earth to a concrete slab. The 5-in. height is enough to allow using a hose or push broom underneath.

Cabinets as shown are built of $\frac{3}{4}$ -in. fir exterior plywood — the floor, sides, partitions, shelves, hinged doors. This gives the easiest construction as no framing is re-

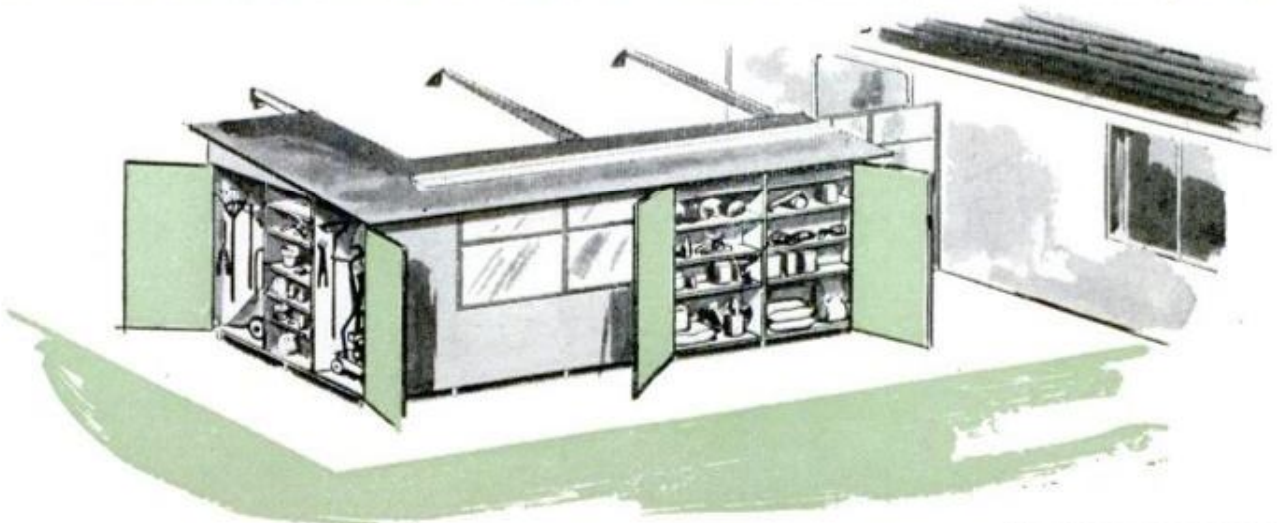

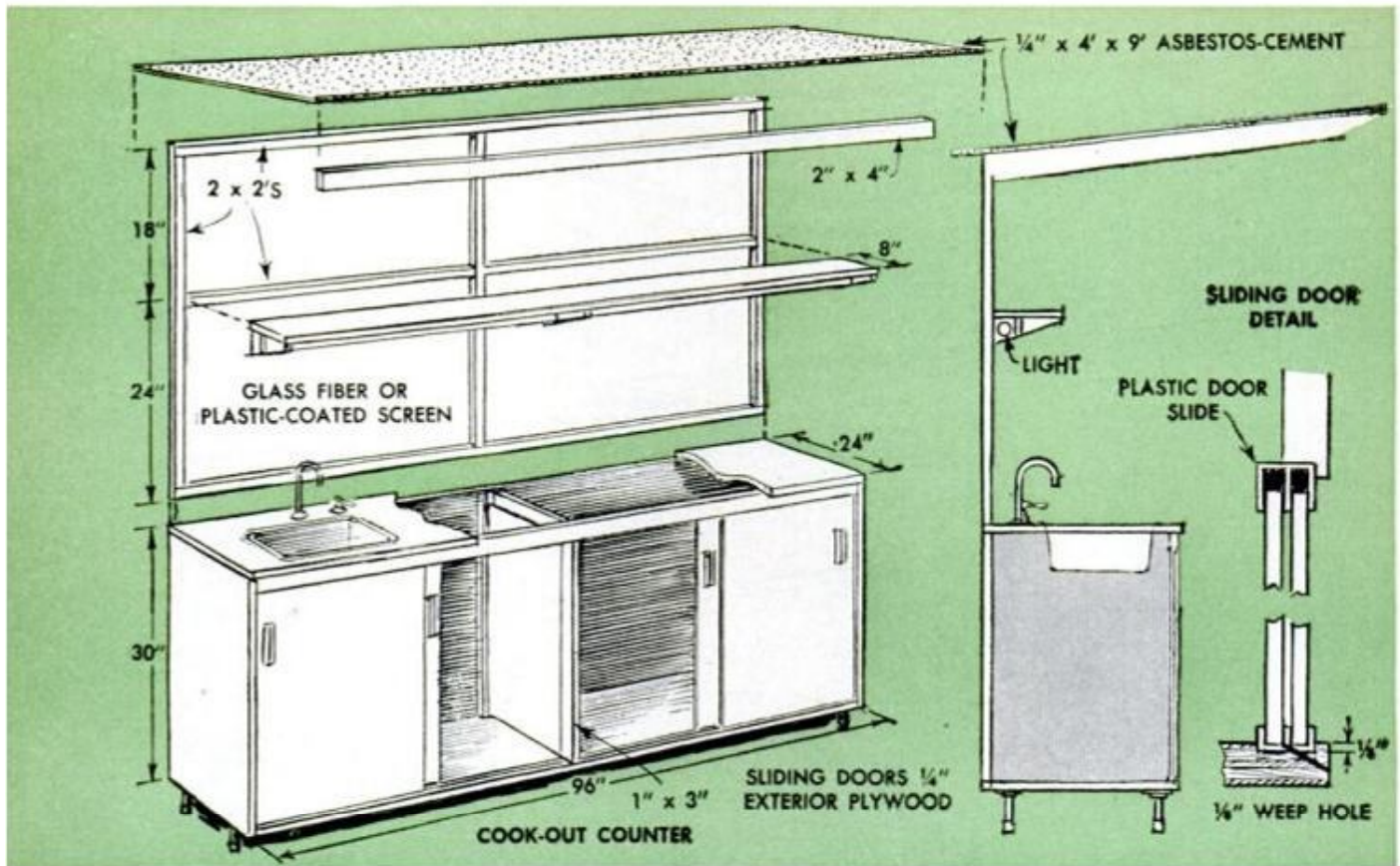

quired but, if desired, you can frame with 2 x 2s and use a board siding to exactly match that of your house. First, attach the plywood floor to the pipe legs, then attach sides and partitions, using a waterproof glue and galvanized nails. Note that the floor of section C is cut out at the grill cabinet so a wheeled barbecue grill can simply roll inside. Dimensions given will store the average 24-in. round charcoal grill complete with hood. You can vary the size

of this cabinet to accommodate other grills. All three sections can be completed up to the roof and then be moved and nested together. Or A and C can be built in place and B then built to fit between. Note that the pipe legs shown have pipe couplings at the bottom. On a fairly smooth concrete patio you can simply set the cabinet sections on the concrete floor, then level them over small irregularities by screwing the couplings up or down on the pipe with a

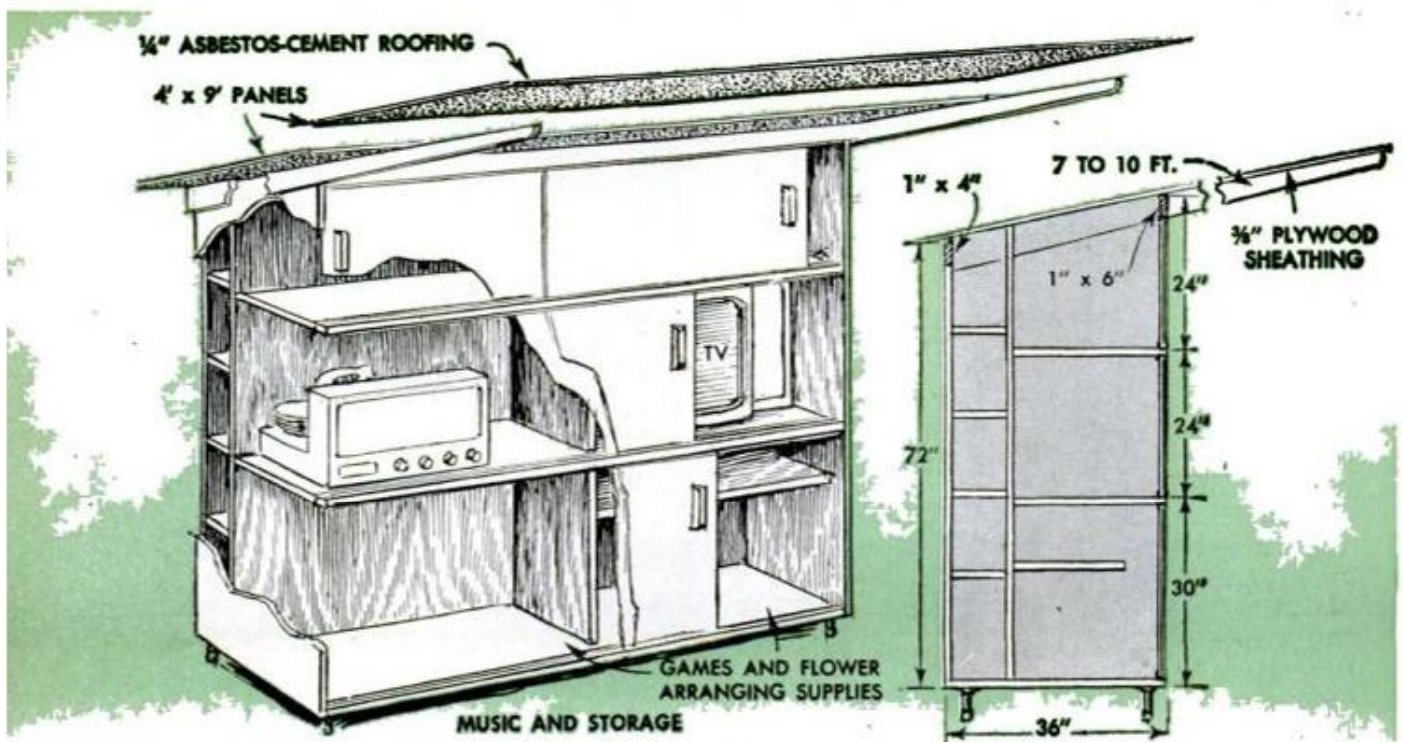

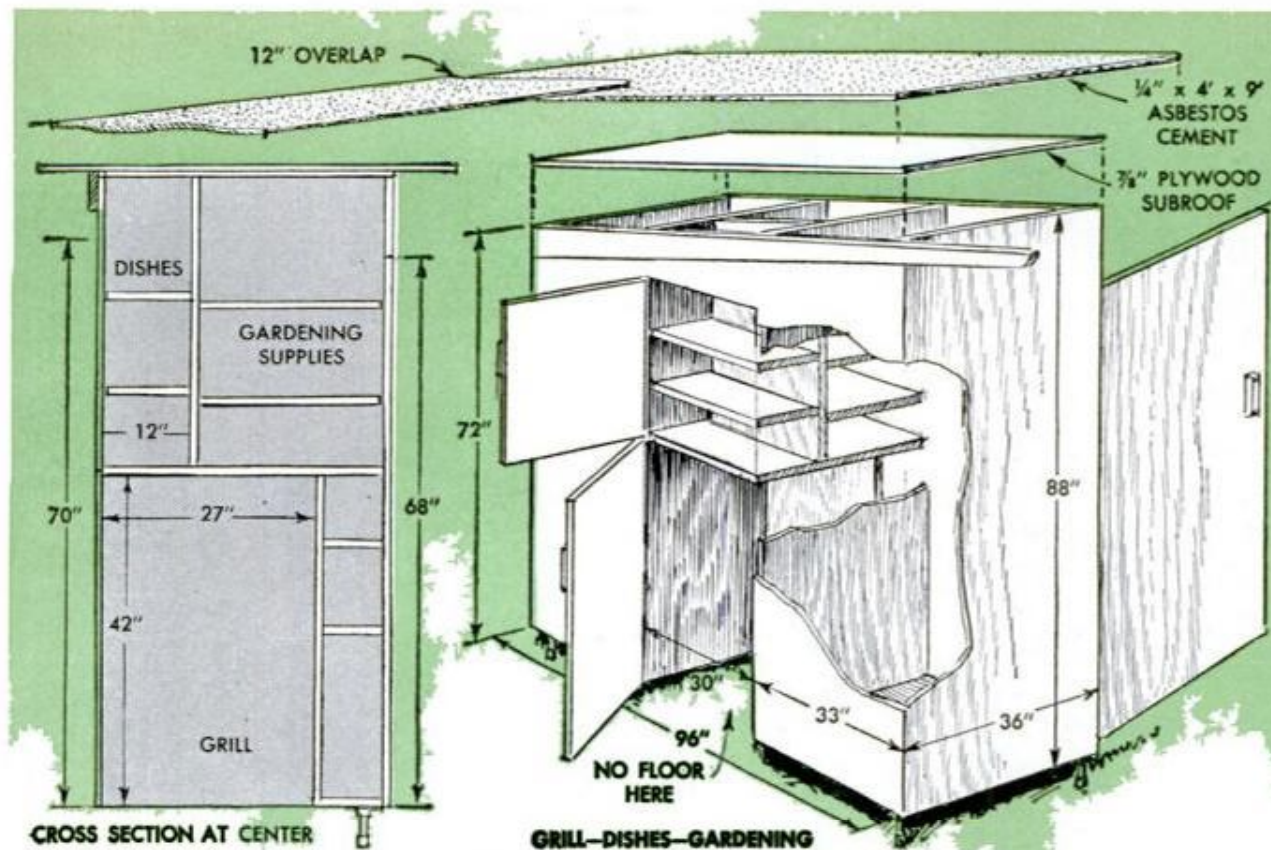

wrench. On rougher or softer floors, set longer pipes in concrete in the ground with their tops leveled. Section B needs only two legs at the middle, since it is supported at its ends by screws into A and C.

The details show a simple way to weatherproof the sliding doors of A and B. Set the lower plastic slide in mastic and, after installing the trim, drill an $\frac{1}{8}$ -in. weep hole every 12-in. along its length to drain off rainwater. The doors can be $\frac{1}{4}$ -in. plywood or hardboard; a pair should lap each other at least 4 in. Hinged doors of $\frac{3}{4}$ -in. plywood are used elsewhere. Those on the rear side of the wall can be 3 to $3\frac{1}{2}$ -ft. wide; at least three hinges should support each. Paint all doors, hinged and sliding, on both sides to prevent warping.

Sections A and C have $\frac{3}{8}$ -in. plywood sub-rafts or roof sheathing. When the cabinets are permanently in place, a 4x9-ft. panel of asbestos-cement board is laid over each section, giving a one-piece roof with a 6-in. overhang on all sides. A third 4x9-ft. panel of the asbestos-cement board is laid over section B. Supported lengthwise by the screen frame and the 2x4 front beam, it overlaps the other roofs 12 in. at each end. Use seam compound where the panels lap. Secure the asbestos-cement board with large-head roofing nails using only about eight through each panel, and placing a spot of seam compound under each nail when driving it down. When all three cabinets are to be placed in a straight row, build the roof of C the same as that of A.

A roasting pan (or large round mixing bowl) of stainless steel will inexpensively give you a durable bar-type sink for section B. Choose a pan with fairly wide rim and place mastic underneath when screwing it down to the countertop. Finish the countertop first with laminated plastic or vinyl linoleum. Only a cold-water faucet is shown. Running a hot-water supply from the house is optional but usually more of a complication than an asset. The high-

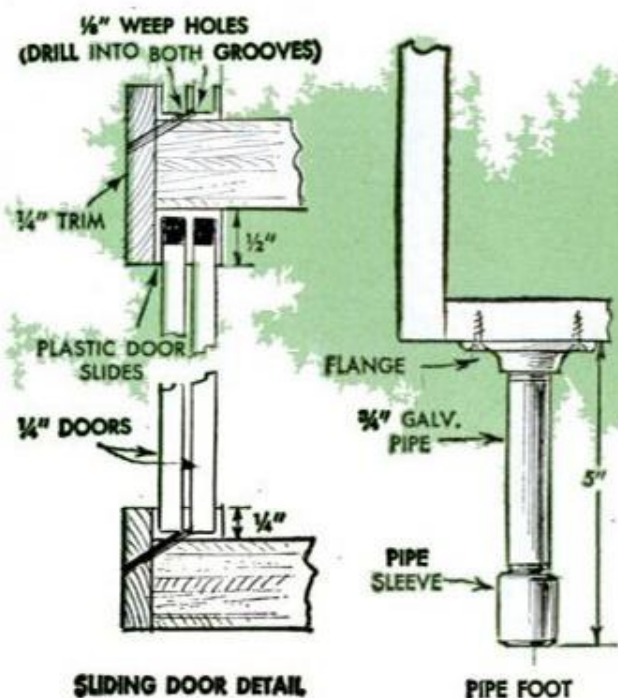

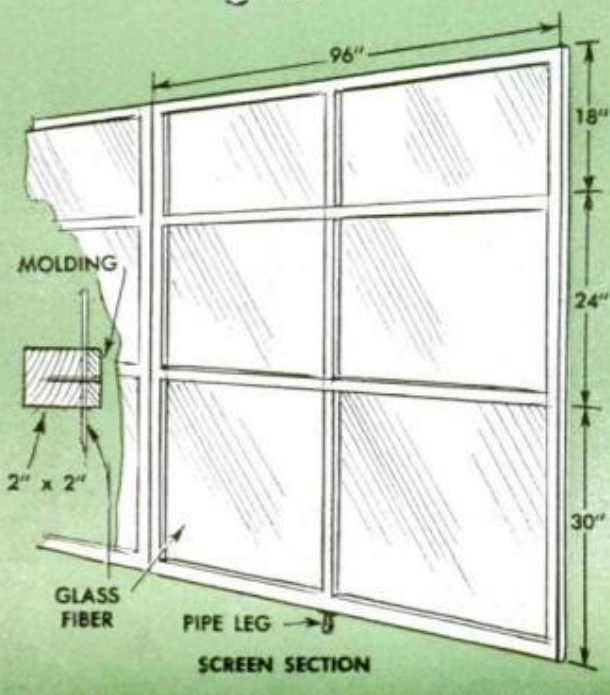
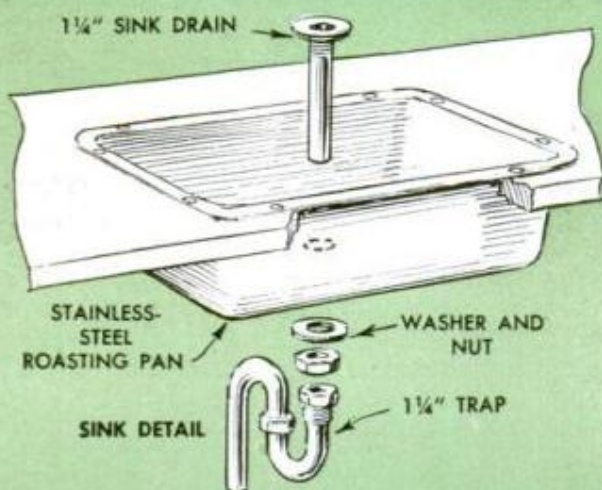
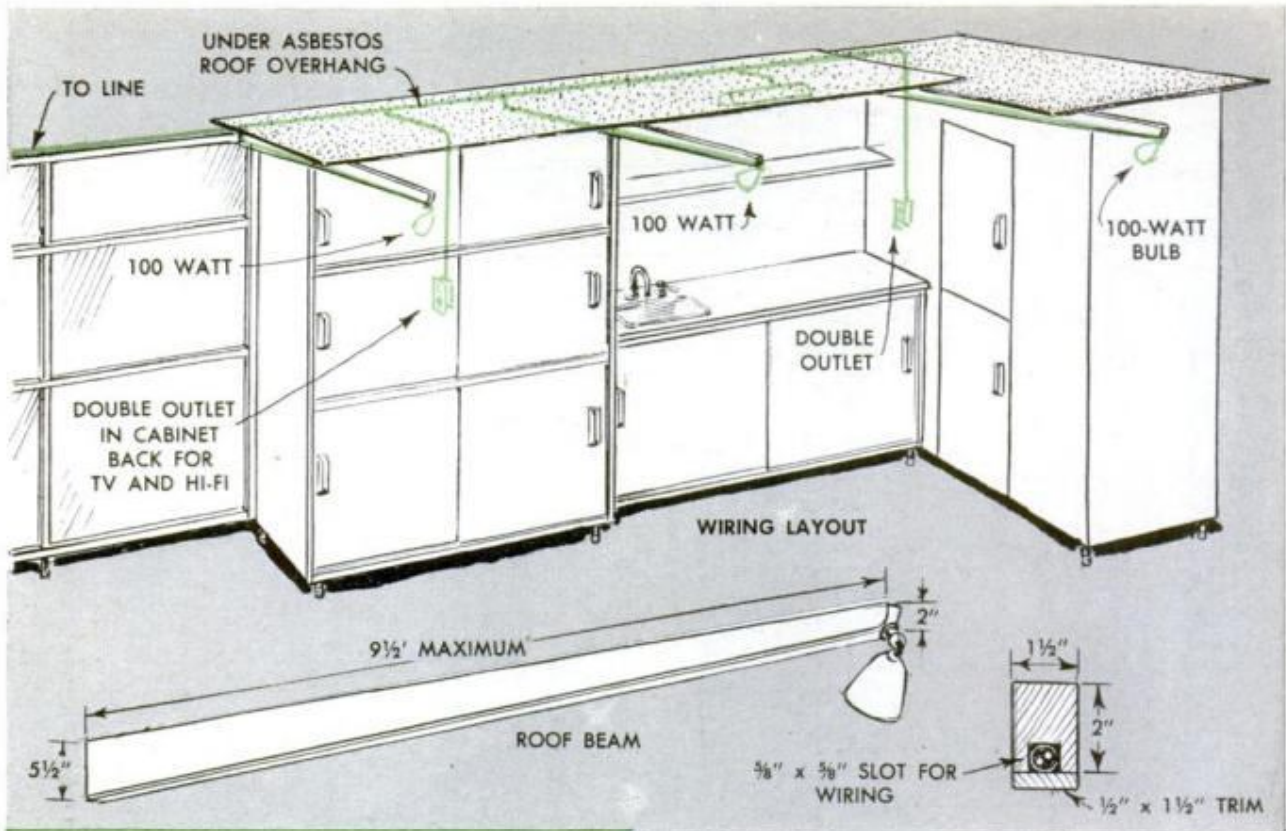

necked faucet shown makes the sink handy for watering potted plants.

You can tap the cold-water supply from any convenient outdoor faucet, using pipe, plastic pipe or heavy hose, as your individual layout demands. Provide for draining the line in freezing weather. The waste line will also vary individually — from a hose leading to a rock-filled sump to a 1½-in. soil pipe leading to the sewage line. Definitely include the sink trap if connected to the house sewer.

Your electrical wiring also varies. First, check your building code for local requirements. A layout similar to the one shown in the drawings will give good lighting overall and also outlets at the counter and for the TV and hi-fi. The three bullet lights can be switched separately or be all on one switch. This is a grounded 20-amp. circuit from the house, using No. 12 wire. It can be two wires in conduit or two, plus a grounding wire, in plastic cable, depending on code. Note how wiring to the bullet lights can be hidden in the tapered roof beams. However, when you arrange the living-wall sections, tend to run all wiring from above, the plumbing from underneath.

The screened section to extend the living wall out from the house is easily framed of 2x2s as shown in the drawings. Clear or colored flat glass fiber gives it permanent translucent panels. Plastic-coated fly screen gives a budget-wise substitute which will last two to four years. ★ ★ ★

PATIO AND BARBECUE EQUIPMENT



DESIGNED FOR your cookout dining pleasure, here is an attractive combination barbecue and outdoor fireplace, a unique table that "serves you," and other furniture pieces and equipment that are inexpensive and easy to make. Construction of each piece is shown in the drawings on the next two pages. The combination fireplace is laid up of bricks on a concrete foundation to the dimensions given in Fig. 7. The grill has no smoke opening into the fireplace flue since most barbecuing is done over charcoal.

An overgrown lazy susan, the table detailed in Fig. 2, is ideal for self-service barbecue dining. The rotating top permits guests to select food from any dish desired without having to file around the table.

This arrangement is especially convenient when all guests can be seated within reach of the table. Built of $\frac{1}{2}$ -in. exterior plywood, the table has a 48-in.-dia. top that rotates on a 36-in.-dia. sub top mounted on hairpin legs. The rotating feature is provided by a stud that serves as a shaft and four ball-type glides or casters installed as detailed in Fig. 2. The plywood disk that takes the smooth end of the stud (cut from a $\frac{1}{2}$ -in. bolt), is glued and screwed to the underside of the table top; the other disk is fastened to the underside of the sub top in the same manner. Both disks are 3 in. in diameter. The threaded end of the stud is turned into an undersize hole drilled through the sub top and disk as shown in the sectional detail. Note that a brass bush-

ing in the top takes the end of the stud. The ball glides roll on the sub top when the top is rotated, providing an easy, stable motion, even when the table is heavily loaded.

A companion bench for the table is detailed in Fig. 8. After the leg-and-back support assemblies are welded from $\frac{1}{2}$ -in.-steel rod and $\frac{1}{8}$ x $1\frac{1}{4}$ -in. flat steel, the seat and back are cut to size from pine or fir lumber and bolted to the supports as shown.

For those whose outdoor living consists of only an occasional cook-out, the grill shown in Fig. 1 is about the least expensive you can make to serve the purpose. It consists of a large cultivator disk having a steel rim welded around the edge, and a piece of hardware cloth welded to it over a hole in the center. A portable grill that is somewhat similar and about as inexpensive, is shown in Fig. 4. This one utilizes a large disk but has a steel-plate grill supported above the fire by removable brackets. The legs are not welded to the disk. Instead, they are merely driven into the ground so as to support the disk tripod fashion. This type of assembly permits the entire unit to be dismantled and stored in a small space. Where efficiency and low cost are more important than appearance, it is hard to beat the oil-drum barbecue detailed in Fig. 3.

Highly functional and easy to move about on rough surfaces, the service cart detailed in Fig. 5, will be one of the most popular items of your patio accessories. It can be used as a beverage-and-food dispenser, as well as for carting food and dishes from house to patio and return, saving many steps for host and hostess. The top, bottom and glassware shelf are $\frac{1}{2}$ -in. exterior plywood cut 16 x 24 in. for the top and 14 x 22 in. for bottom and shelf. All glassware holes are the same size, except for the row at the back of the shelf, which are cut large enough to take 1-qt. beverage bottles. The hole in the top may be cut to take a plastic ice bucket or a serving dish, as desired. All wooden and metal parts of the furniture and equipment should be given protective coatings of paint or varnish. Liquid preservative should be applied to the wood parts first. ★ ★ ★

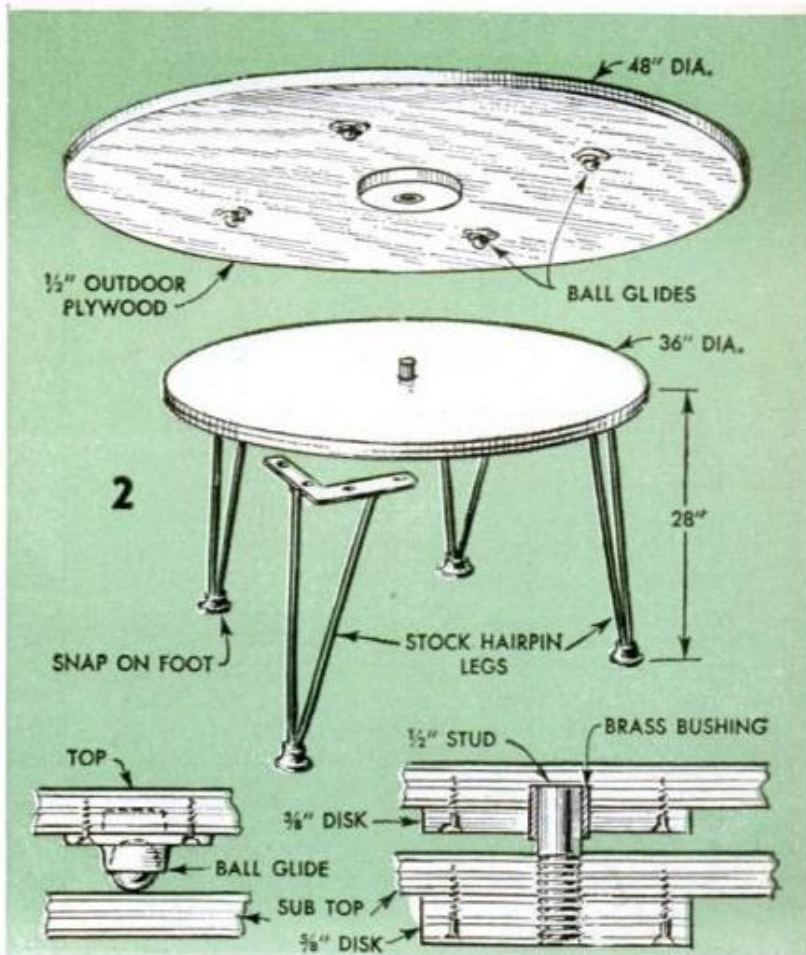
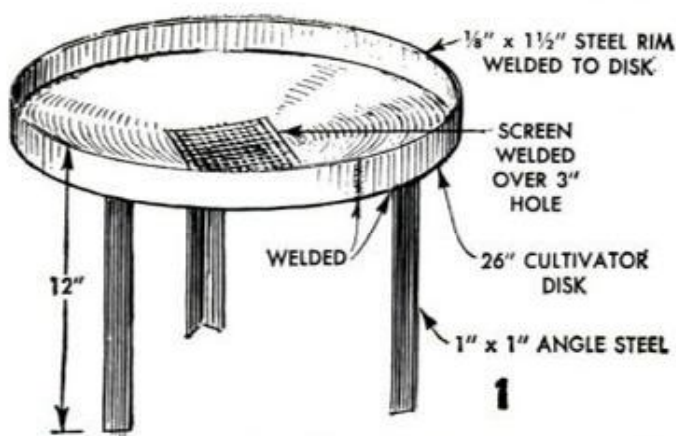

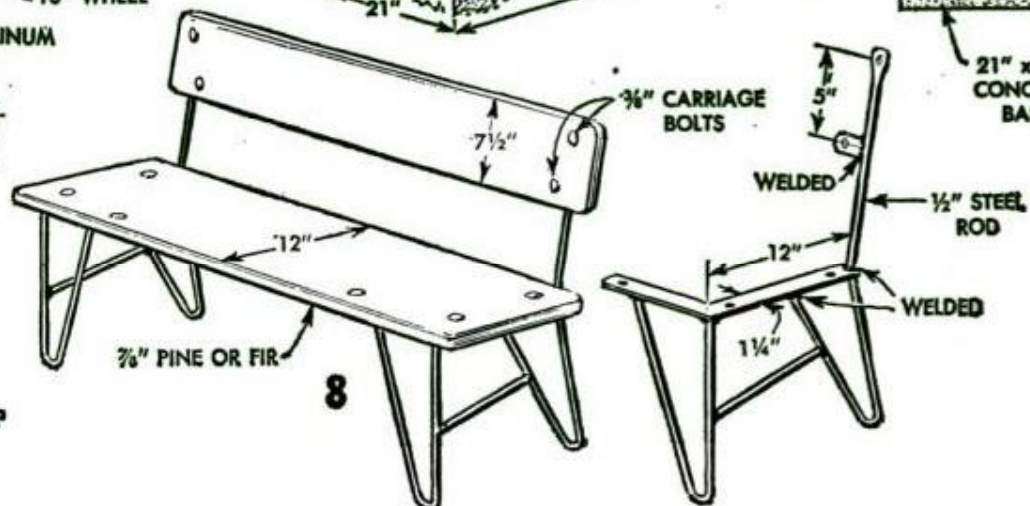
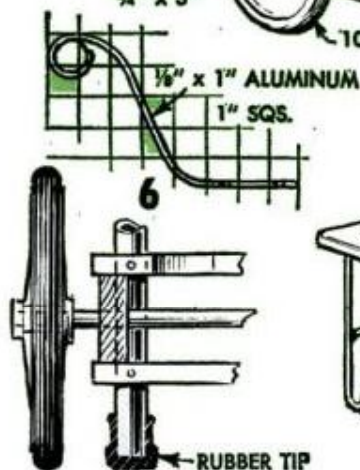
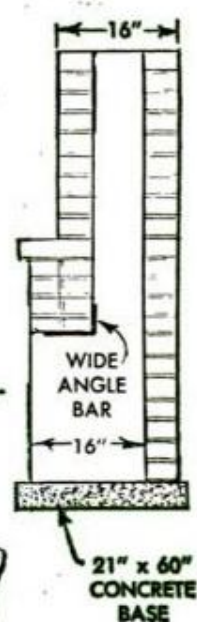
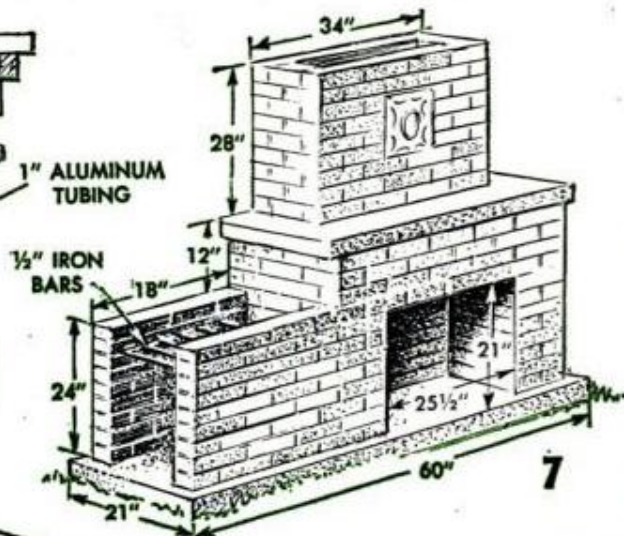
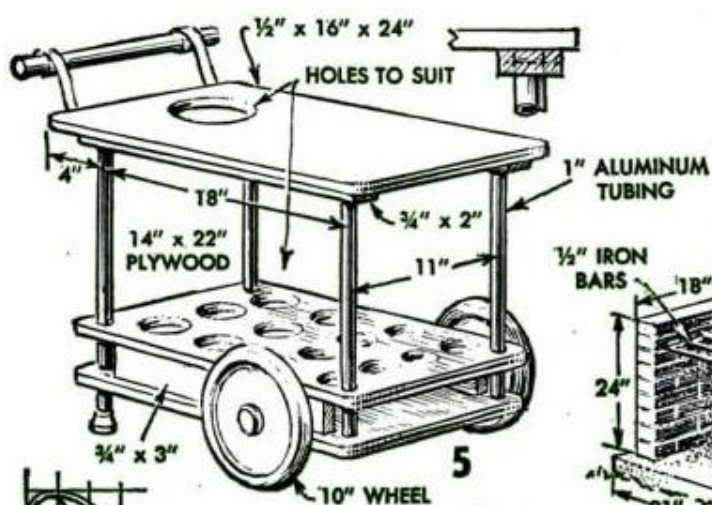
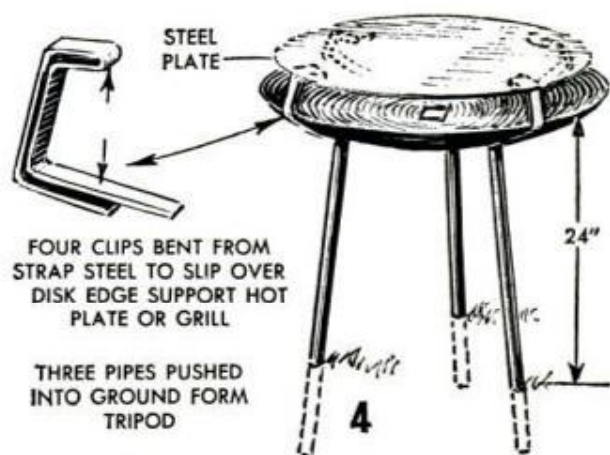
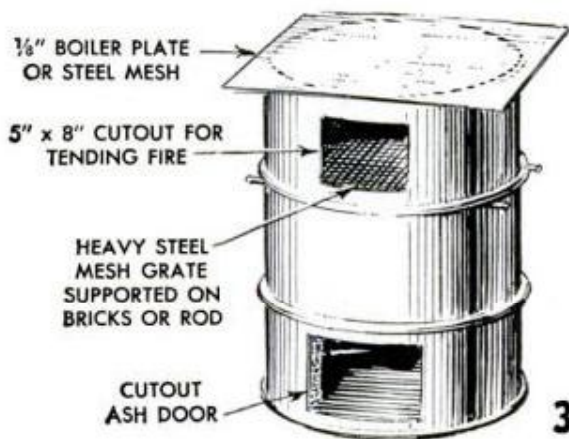

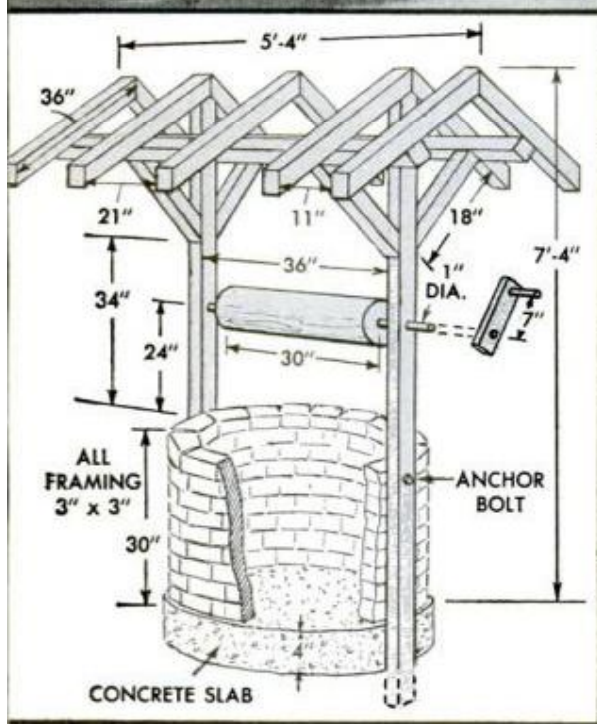
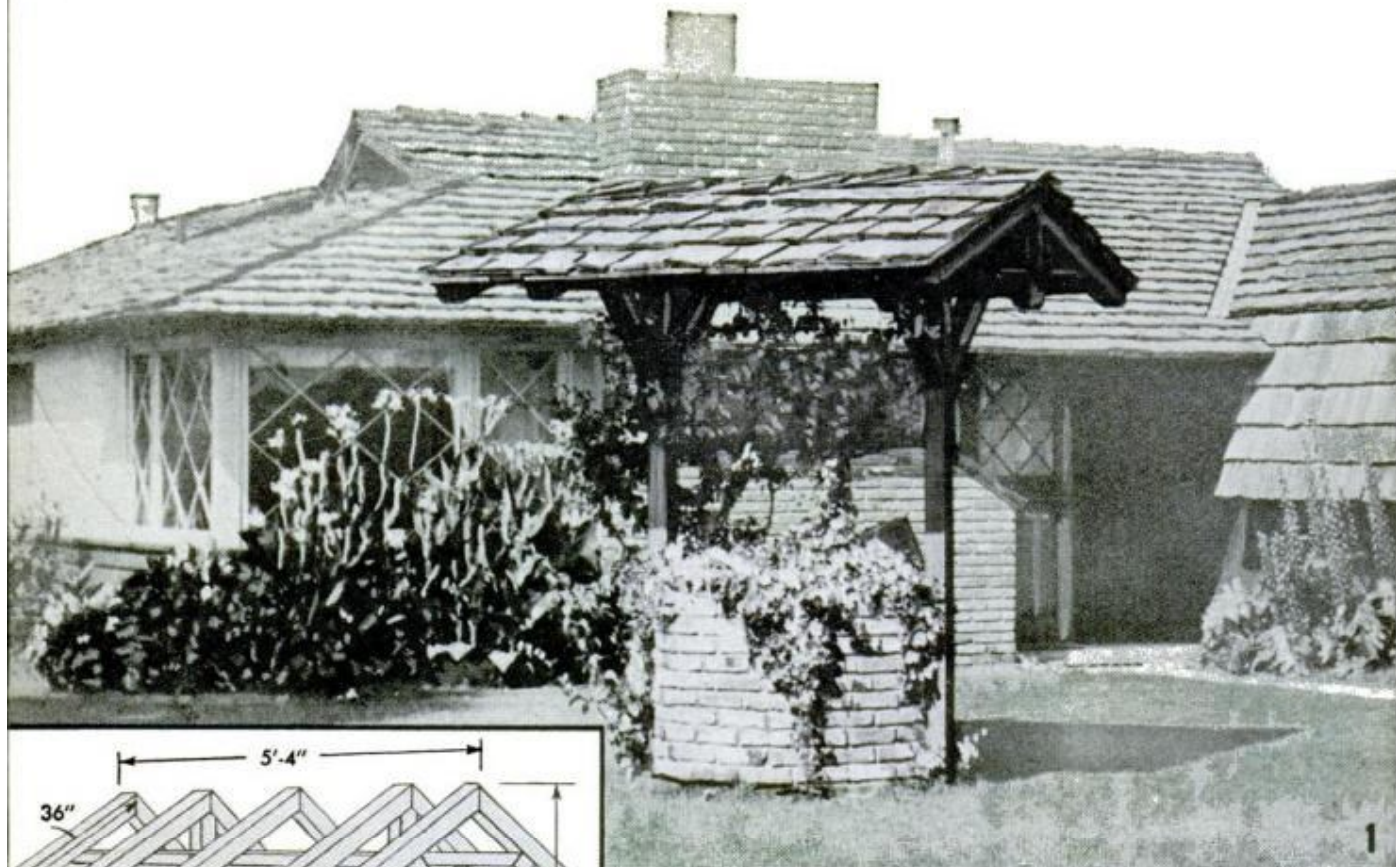

PLANTERS SET THE SCENE

ONE CAN USE outdoor planters to key the planning of nearly all outdoor-living areas. As an example, note how the replica above, Fig 1, not only is a decorative planter in itself, but also is, architecturally, a part of the house. Materials and finish have been selected to achieve this end. The covered well is made of used brick and is covered by a shale roof. Framing is of 3 x 3-in.

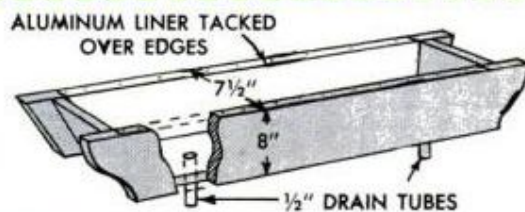
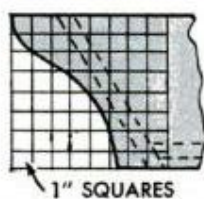

2. The planter shown at the right is a simple red-wood box lined with sheet aluminum and has a 1/2-in. tube near each end for drainage. It may be supported by shelf brackets or screwed to a window sill

4. A simple shelf like this one may be decorated with a valance. The cedar "buckets" are cut, assembled with glue and then bound with aluminum bands

5. This planter is made of cypress which properly finished will well stand dampness and inclement weather. If made of pine, planters such as this should be lined with sheet metal or with tar





Flanking the entrance walk, planters such as this one add color and atmosphere to the house and grounds

redwood uprights secured with bolts and set below grade to a depth of about 1 ft. For strength, the unit is erected on a 4-in. concrete slab with the brickwork laid in after the uprights are installed.

The number of designs used to make outdoor planters is limited only by the imagination and resources available to the de-

signer. The size and shape of the lawn or garden area will, of course, largely determine the limits of what can be done. But once the practical possibilities have been assessed, imagination may be given free rein. If planters are used to divide an area, for example, the beginning of a geometrical motif is set, and a judicious use of smaller

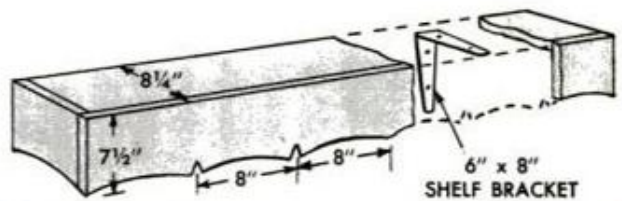
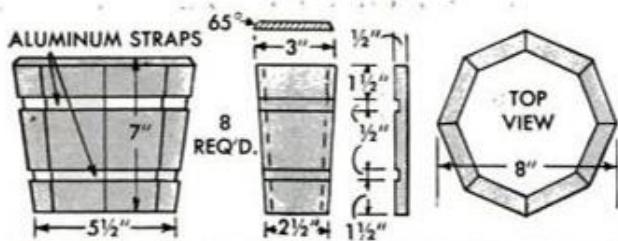

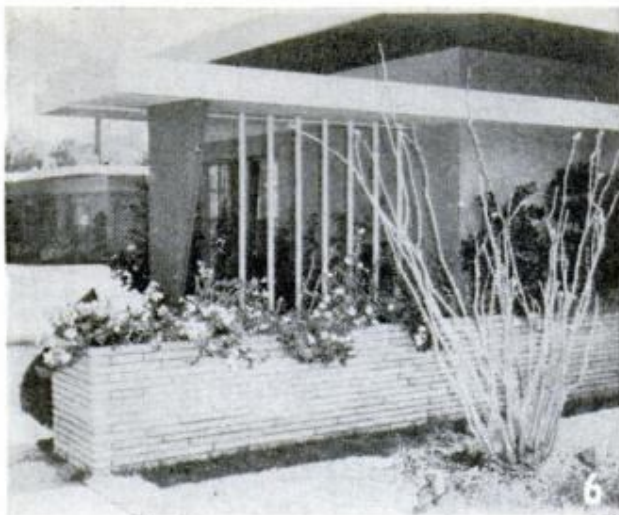

Cut flagstone has the advantage of being both pleasing to the eye and easy to manage in construction. This planter is made of layers of flagstone and has a grillwork of iron pipes supporting a wooden roof

planters, flower beds and shrubbery, Figs. 7 and 9, may be used to further develop it. The use of wood and stone in a rather large planter may set the accent which the rest of the ground design repeats and develops. The use of plants also offers many possibilities. For instance, climbing vines and flowers in a central planter which has a trellis may be set midway between the house and the fence or walk. This may then be repeated in shallow planters bordering the area and by ivy climbing the house itself. Stone planters extending perpendicularly from the house midway into the lawn

Wagon wheels add a picturesque quality to any lawn. This one was set in a shallow planter and is backed by a pedestal topped by a lamp. The planter is open at the bottom for drainage of the lush English ivy



Here, blocks of limestone were used to enclose a flower bed near the entrance of the house. Level with the surface of the porch, the planter becomes, in effect, an extension of the house itself

area, as in Fig. 3. match the masonry construction of the house walls, which may again be repeated in stone-bordered flower beds flanking the house on two sides and along the front. The planter shown above is a good example of the rugged beauty of stone and of the use to which it can be put. It is made of cliff stones of various sizes and the spreading rock plants will eventually cover it. The contrast of leaf and stone will only serve to enhance its beauty. If desired, such planters may be made to extend the entire width of a lawn and thus serve as rustic stone fences. The

Almost austere in its formality, this stone planter is set with a sword palm near the entrance of the house. Several of these placed on a concrete patio or veranda add an air of dignity to their surroundings





10

Homeowners in the dry Southwest will appreciate the decorative grace of these sand-filled cactus planters. They are made of cultivator disks welded to pipe flanges and set on pipes driven into the ground

planter in the photograph has a lamp and a bench running along one side.

Various objects, such as wagon wheels, or hand pumps, Figs. 8 and 11, serve to add a certain flavor to a garden's semiformal arrangement. This motif may be extended to replicas of the old oaken bucket set on window shelves, Figs. 2, 4 and 5, or to an open-"well" planter. For more sophisticated decoration, a patio may be decorated with individual "gardens," Fig. 10, or divided from the rest of the garden by brick planters with uprights extending to the patio roof as shown in Fig. 6. ★ ★ ★

Novel arrangement combines a means of watering plants and illuminating the lawn. A 1/2-in. pipe through the masonry has shutoff valve connected to the pump handle. Lamp is switched on from the house

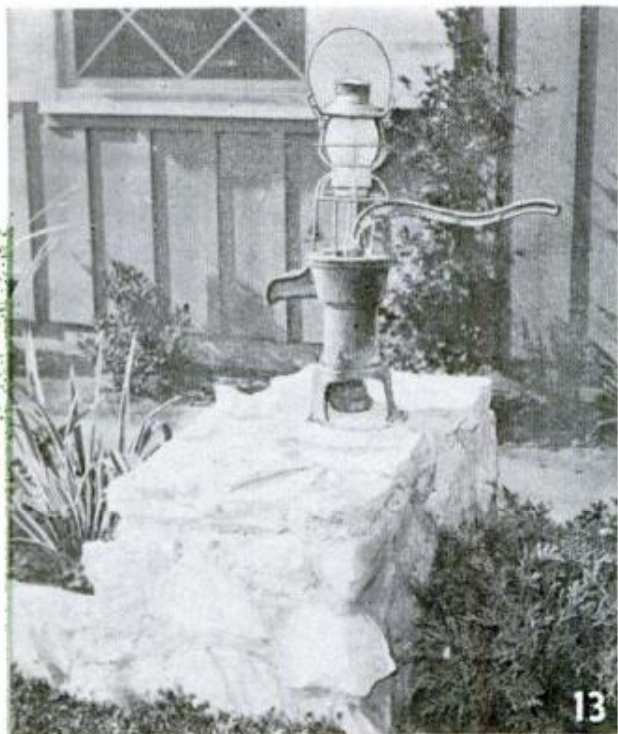

13

APRIL 1960

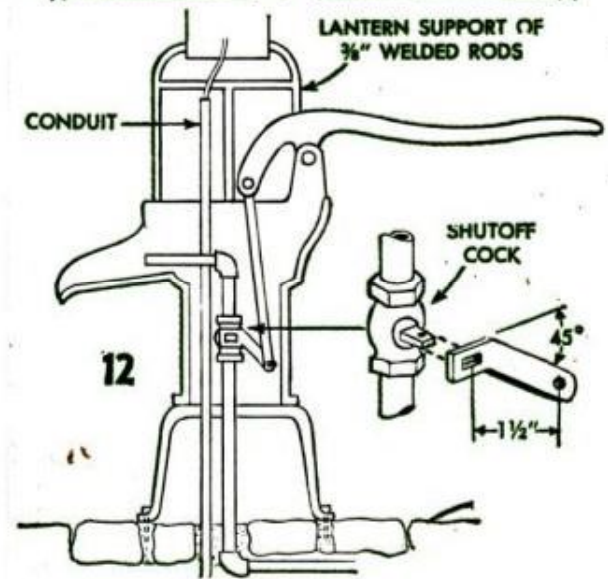
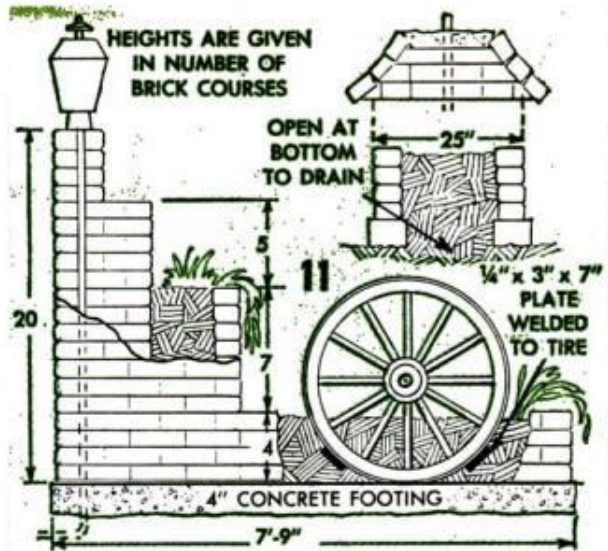

A combination of concrete and colored pebbles forms the dish top of this striking patio planter



14

159

SWIMMING POOLS —

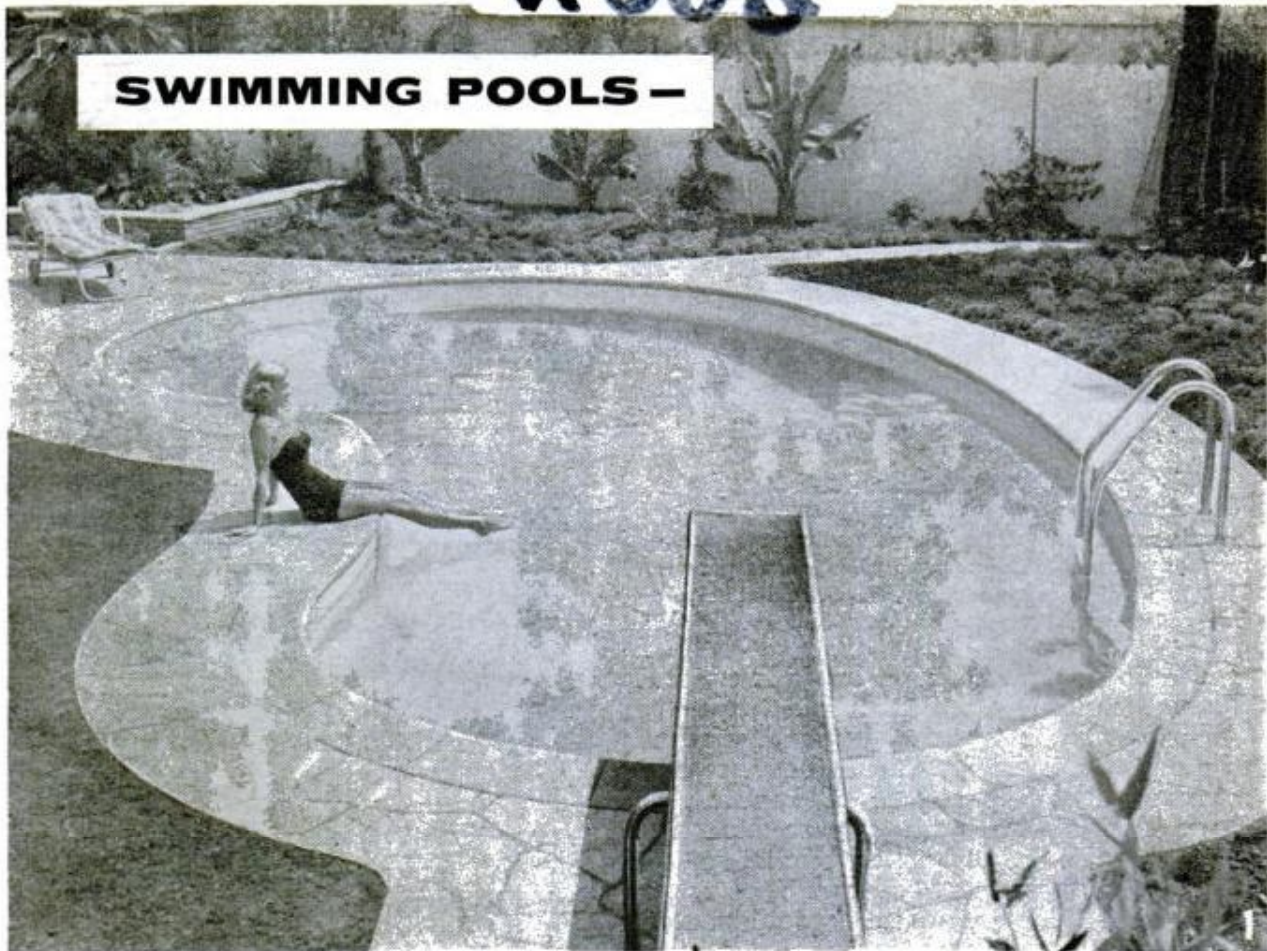

Luxury free-form pool measures about 16 x 34 ft. Gunited, it costs about \$3500 in the Los Angeles area

PART I

ADDING THE FINAL TOUCH of luxury, a swimming pool, undoubtedly, will be the one facet of modern outdoor living most appreciated by all members of the family. And, while it likely will carry the largest initial cost, it will be the least expensive in the long run as it will increase property value more than its original cost.

Built to various shapes and sizes, swimming pools generally are constructed by one of four methods—Gunited concrete, poured concrete, built up of concrete blocks, and plastic-lined over sand and concrete. In operation they are either the fill-and-draw type or the recirculating type which is pictured in Fig. 6.



Larger Gunited pool in free form but expensive, cabana and all. Pool is made shallow at end in foreground to provide children play area

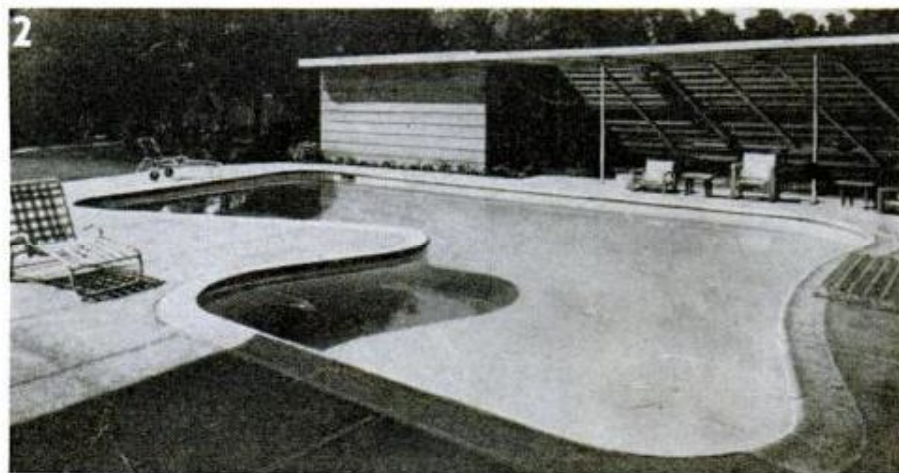

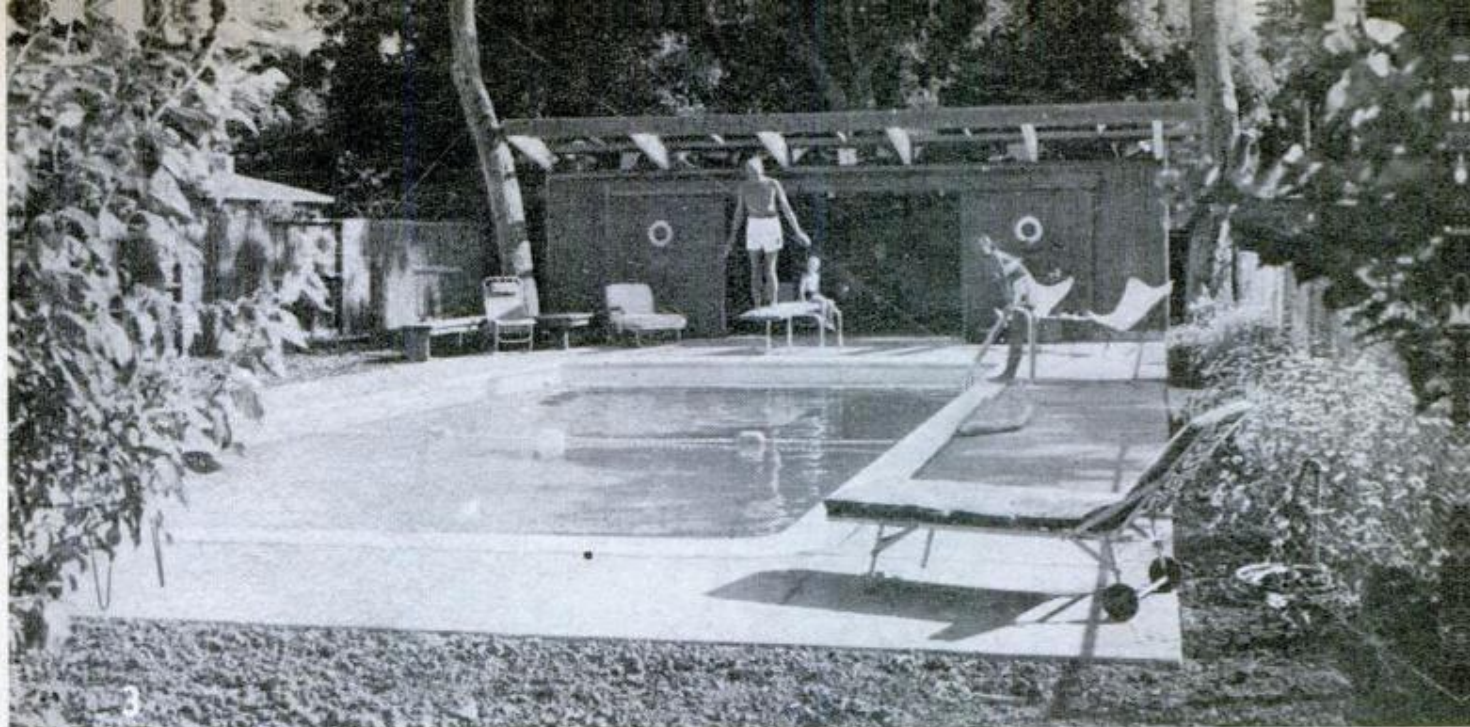

Above, this 20 x 42-ft. pool has everything — filter, heater, cabana with dressing rooms, even intercom and hi-fi. Left, flagstone coping, rock wall and plantings give this rustic pool a cool mountain-lake look

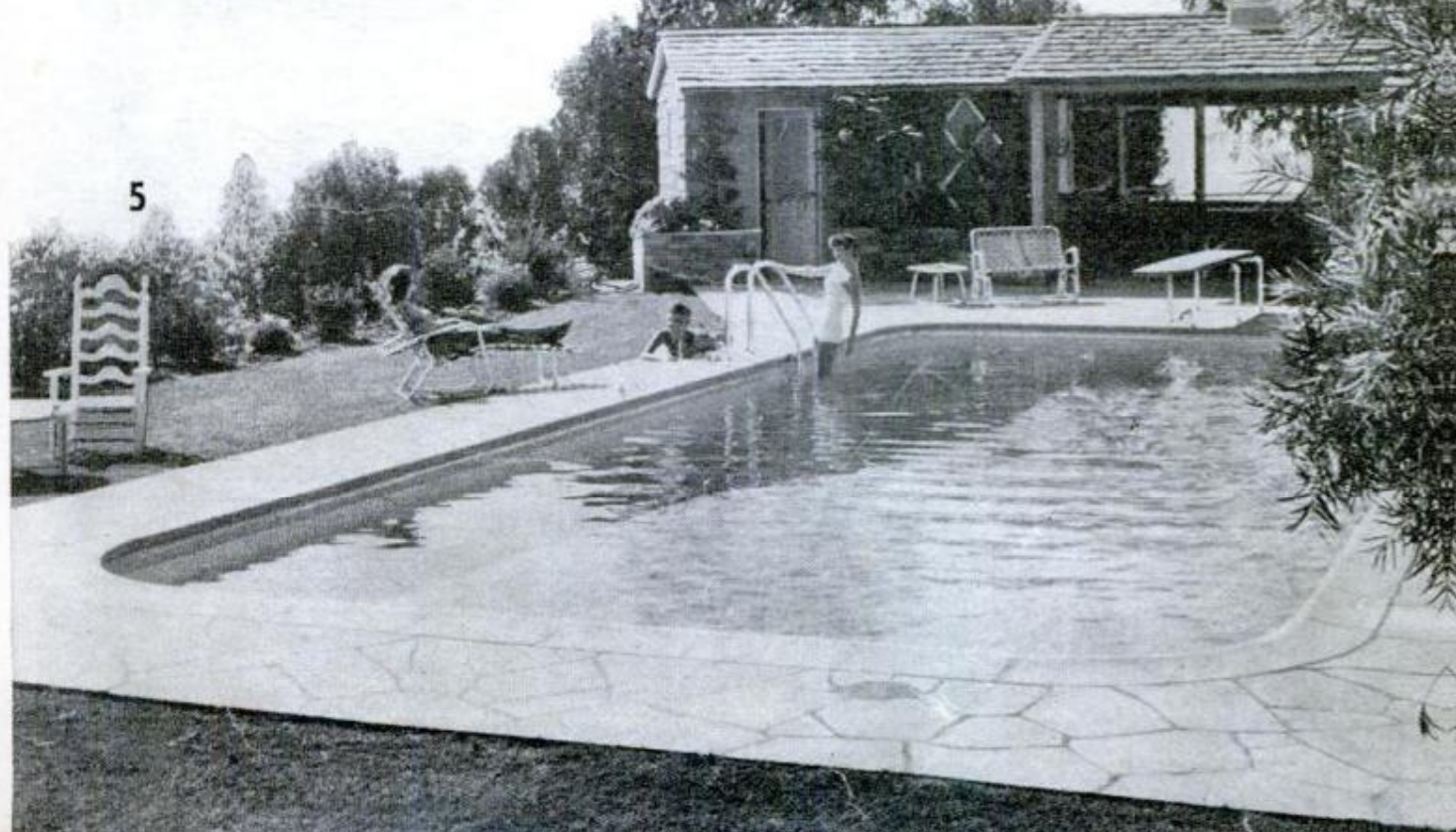

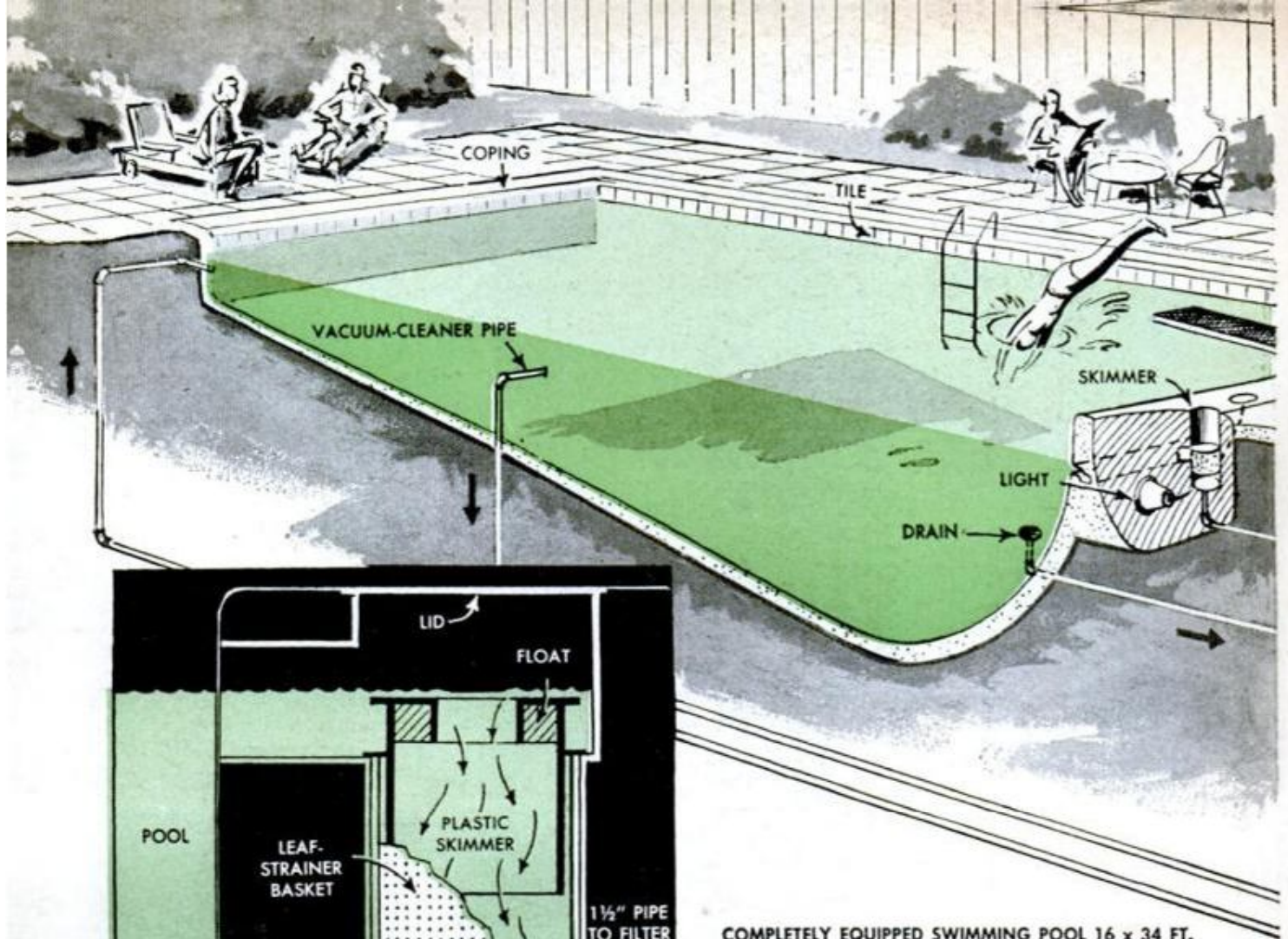

COMPLETELY EQUIPPED SWIMMING POOL 16 x 34 FT.

6

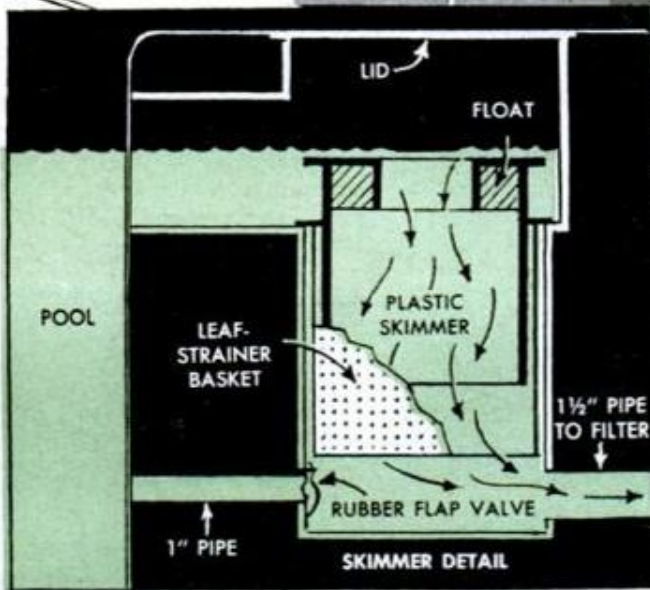

One of the most important things is the location of the pool. The location must comply with local codes on street setbacks and the like, and the site should be where power equipment and trucks can get to it. Any hand digging or wheel barrowing of materials in and earth out will balloon both time and costs. If your landscaping is already in, try to locate the pool where heavy trucks will do a minimum of damage. Avoid filled ground and hard rock, which will increase construction costs considerably.

For swimming, sunbathing, play—for full

future usage—place the pool where it will receive maximum sunlight. A sunny pool is always more enjoyable, and the free energy heats the water considerably thus reducing heating bills. Equally important is to place the pool where the house or high fencing and a cabana will protect it from the prevailing winds. A cool breeze reduces the months you can use it and also brings in dust and leaves to increase cleaning time.

Most trees should be avoided. Any close-by tree which will shed leaves gives a continual pool maintenance problem. The

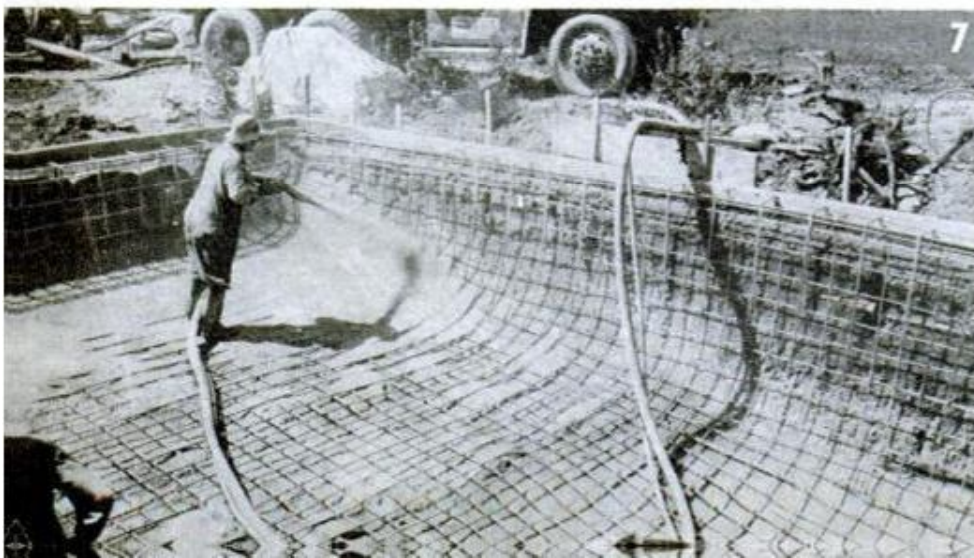

GUNITED POOL

Here the concrete is sprayed rather than poured. Two hoses feed dry-concrete mix and water under pressure to a single nozzle from which mixture is sprayed over framework of reinforcing-rods, wired together and blocked out 2 in. from the earth wall

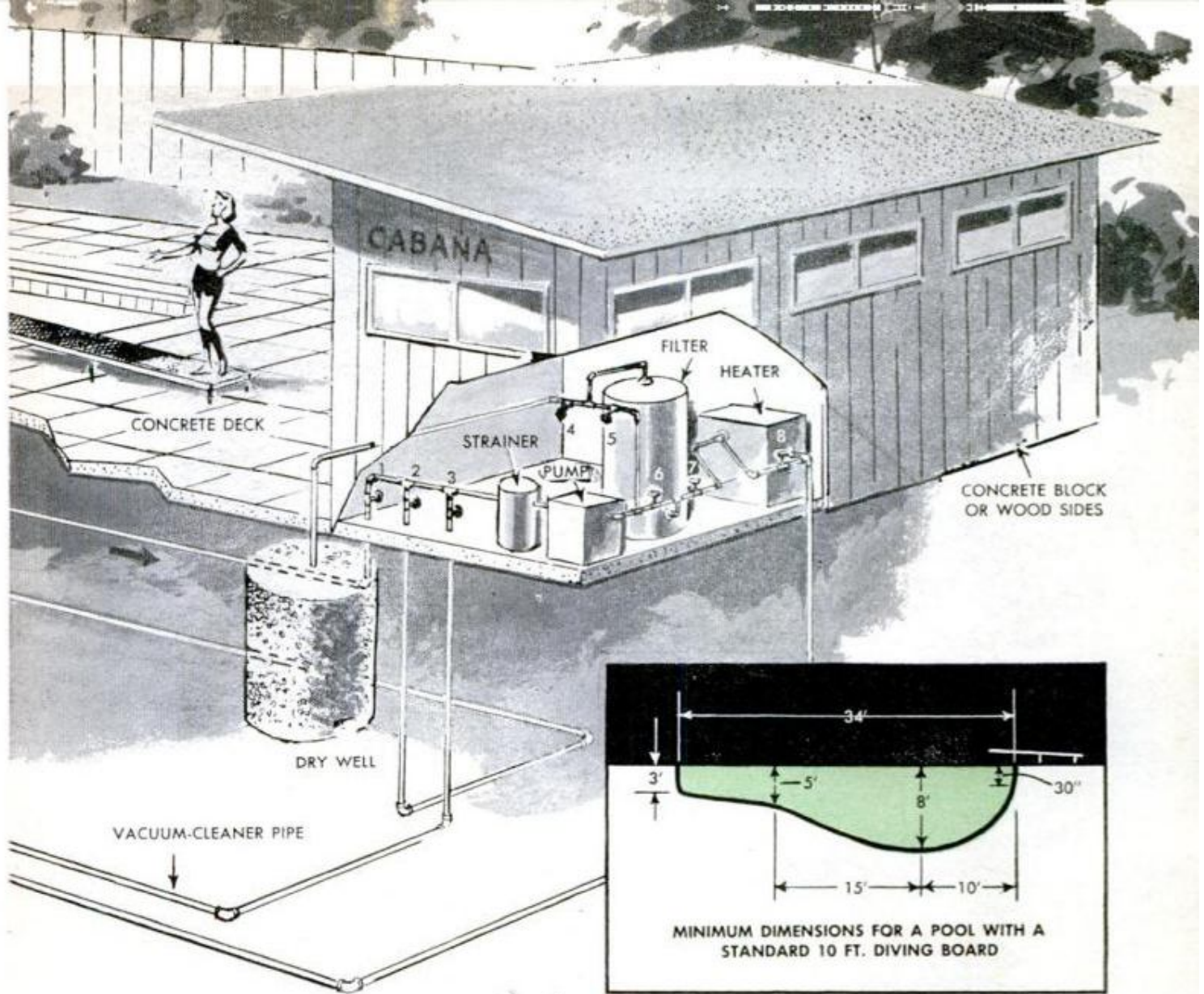

leaves clog skimmers and strainers, and stain plastered pools if left on the bottom any length of time.

Your pool's size is mostly a matter of the budget and the space available, but not all. Figs. 1 through 5 and 9 and 10, show pools of many sizes and shapes. A large pool (20 x 40 ft. or more) will continue to be expensive, can require double the usual monthly costs for chlorination and heating, and considerable more time for cleaning. One 16 x 34 ft. seems most ideal; 75 percent of contractor-built pools today are about this size.

Smaller pools without diving boards have proved fully satisfactory.

The minimum pool for a standard 10-ft. diving board placed about 18 in. above the water is the 16 x 34-ft. size, dimensioned as shown in the right-hand detail of Fig. 6. Less depth or length of the deep area can be dangerous. A 1-meter board (one meter above the water) requires at least a 9-ft. depth. A 3-meter board needs a much larger pool with a 10-ft. minimum depth at 15 ft. distance from the deep end and the 5-ft. break 35 ft. from the deep end.

DRY-PACKED POOL

Here pool shell is "plastered" with stiff concrete mix which is packed in place over reinforcing wire with shovel. Note how wood braces keep the stiff mix from sagging on walls. Shell can be rounded as in guniting but must be made extra thick

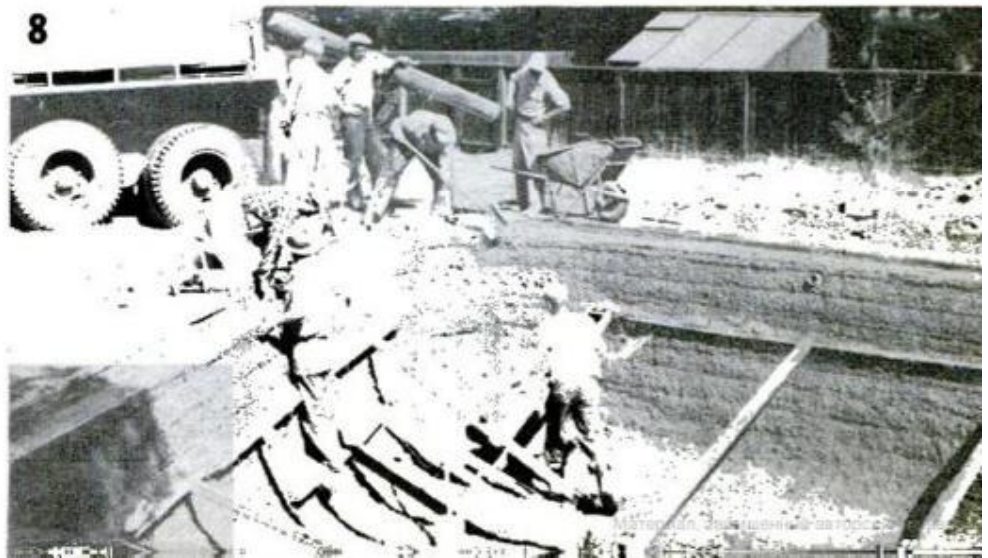



Without diving board or ladder, this 30-ft. glass-fiber pool costs about \$3000 installed in areas close to manufacturer

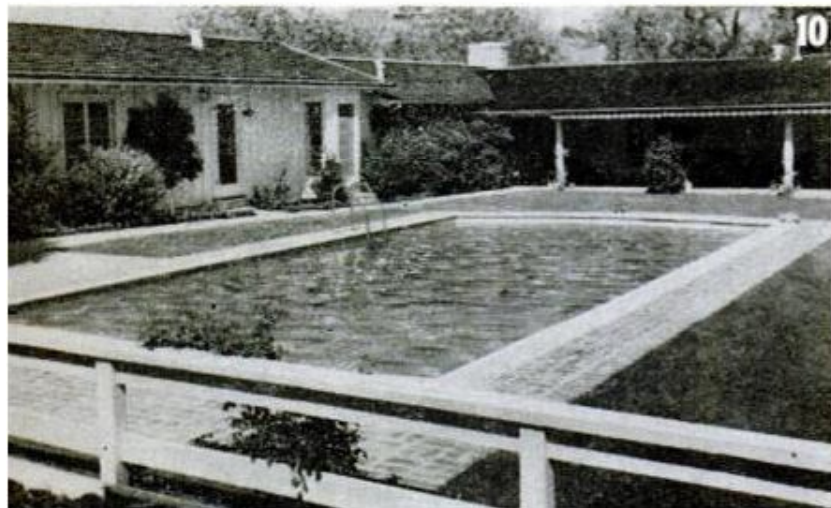

Being well enclosed, this 20 x 40-ft. pool is easy to maintain. Features precast coping and a non-skid brick decking



Portable plastic pools afford limited swimming but lots of water play at low cost. This 18-ft. Doughboy retails about \$250

If your family is not particularly interested in diving, a pool with 5½ to 6-ft. depth is fully ample for active swimming and for diving from the pool's edge. A contractor will build the shallower pool for \$500 to \$1000 less, depending on its size, and it is much easier to build yourself. The depth also makes a considerable difference in the heating the water will receive from the sun. In many fairly cool regions, the shallow pool will be warm with no heating unit at all.

However, for adults and even small children, a shallow end with less than 3-ft. depth usually is unsatisfactory for swimming and play. For young toddlers, rather than reduce the shallow end to a 2-ft. depth or less, give them a separate plastic wading pool, or plan to keep the water in your pool a foot below normal level for awhile, or build an oversize playpen with a raised plywood floor to sink in the shallow end until the children learn to swim. The sides of a pool should be vertical for about 30 in. down to allow active swimming close to the edges.

Most pools today are built of Gunited concrete. A builder's tab for a large fully-equipped 20 x 40-ft. Gunited pool placed in your yard will likely be over \$5000, over \$3500 for a 16 x 34-ft. pool. A Gunited pool has the advantage of being available in any shape desired and very easy to clean. Applied under pressure, the Gunited concrete is stronger than poured concrete, usually needs to be only 4 in. thick, and as its sides are curved there are no weak corners to give cracks. The Gunited concrete is reinforced with steel as shown in Fig. 7.

An equally strong pool can be built of poured, reinforced concrete, practically the same as building a basement. However, the squared corners at the bottom of a poured pool are somewhat difficult to clean, add nothing to swimming

(Continued to page 250)

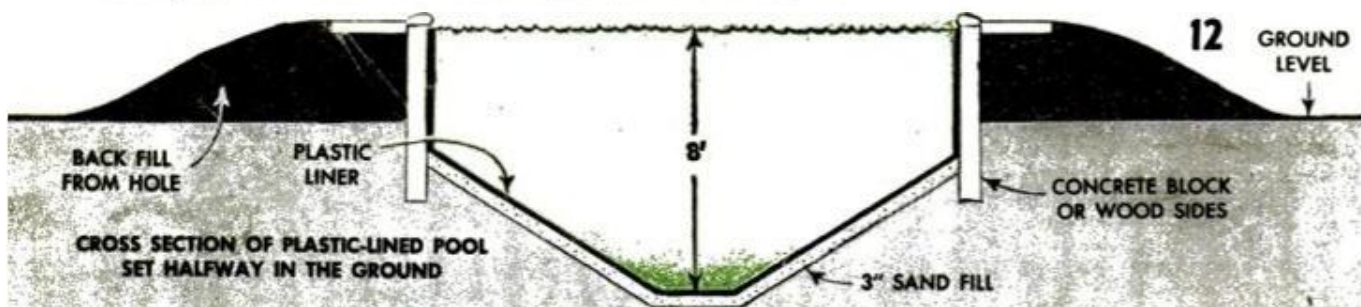

12 GROUND LEVEL

BACK FILL FROM HOLE

PLASTIC LINER

CONCRETE BLOCK OR WOOD SIDES

CROSS SECTION OF PLASTIC-LINED POOL SET HALFWAY IN THE GROUND

3" SAND FILL

X217



Placed in a corner of the living area or study, this desk is an attractive addition to any home. Its swing-away feature makes the most of limited space



Photos courtesy The Masonite Corp.

HANGING WALL DESK

SLEEK AND MODERN in appearance, this hanging wall desk is compact and space saving, yet provides an ample work surface plus storage and drawer space. The desk consists of a wall-hung cabinet and a pivoting work table which may be swung against the wall when not in use. The cabinet is a frame of $\frac{3}{4}$ x $1\frac{5}{8}$ -in. stock covered with $\frac{3}{16}$ -in. hardboard. It is divided by a center panel so that one half accommodates drawers while the other half becomes a storage area. The cabinet frame is best secured with corrugated fasteners, and all joints should be set flush and square. When the frame has been assembled, cover the ends, back and top with hardboard, as well as the bottom portion of the storage area. Drawer guides should be tacked in temporarily until the drawers have been assembled and adjustments made for an easy, sliding fit. The sliding doors for the storage area are two pieces of hardboard measuring $11\frac{3}{4}$ x 14 in. which move in aluminum tracks screwed to the inside top and bottom of the frame. Screwed to the under side of the drawer section is a 2 x 4 x 4-in. wooden block through which runs a $\frac{1}{2}$ x 4-in. carriage bolt. This device, when bolted through one end of the worktable surface, will allow the pivoting action whereby it

will be possible to move the table out and away from the wall as it is needed. When assembled, the cabinet is attached to the wall with wood screws driven through the top frame members and into the wall studs.

The drawer sides are made by laminating two layers of hardboard, allowing for grooves for assembly and to engage guides, as shown in the drawer detail in the diagram on the following page. The drawer bottoms are hardboard while the front and back are of wood, cut to the size and in the manner shown in the diagram.

The work table itself is a simple 24 x 48-in. frame covered with $\frac{1}{4}$ -in. tempered hardboard. One end is pivoted to the bolt-

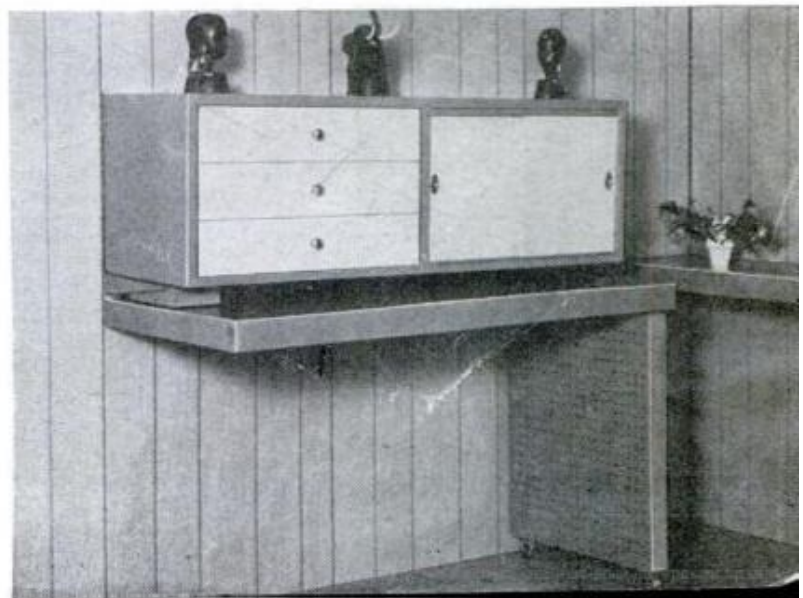

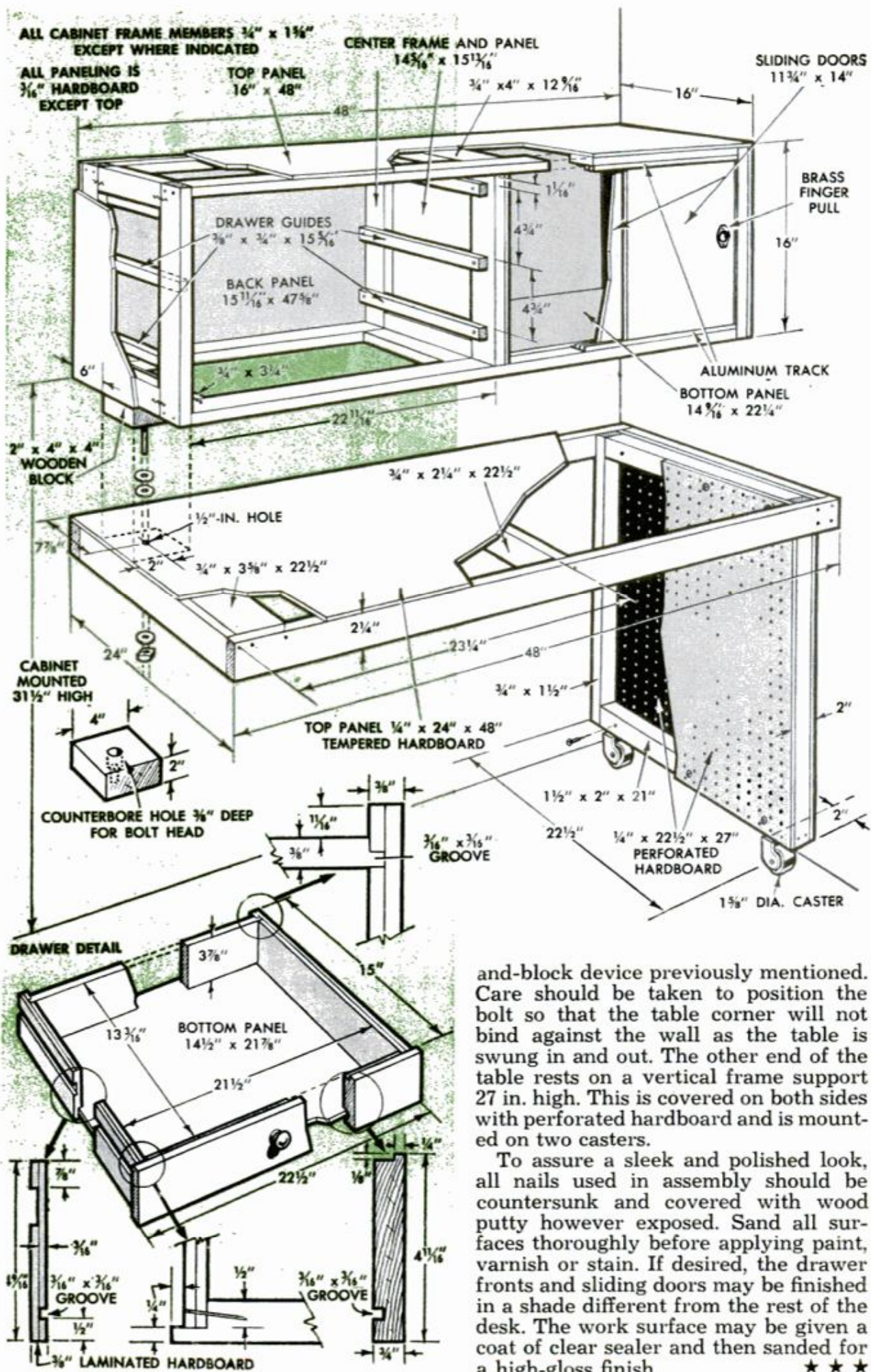

and-block device previously mentioned. Care should be taken to position the bolt so that the table corner will not bind against the wall as the table is swung in and out. The other end of the table rests on a vertical frame support 27 in. high. This is covered on both sides with perforated hardboard and is mounted on two casters.

To assure a sleek and polished look, all nails used in assembly should be countersunk and covered with wood putty however exposed. Sand all surfaces thoroughly before applying paint, varnish or stain. If desired, the drawer fronts and sliding doors may be finished in a shade different from the rest of the desk. The work surface may be given a coat of clear sealer and then sanded for a high-gloss finish. ★ ★ ★

Dispenser for Wire Solder Made From Tape Holder

Wire solder will not become twisted and mixed with the contents of a tool box if it is placed in its own dispenser. A dispenser may be made from a plastic holder of the kind used for cellophane tape. Wind the solder around the empty tape spool, place it in the holder and feed it through a hole in front of the holder as it is needed.

Hugh Lineback, Stillwater, Okla.

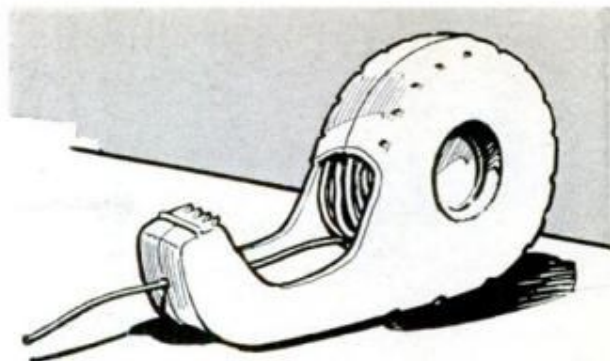

Curtain Rod Used as Mall Stick

When coloring or spotting large photographs, it is often difficult to keep from smearing the colors with your hand. To prevent this, use a discarded curtain rod as a mall stick. Rest one end of the rod on the edge of the board and support the other end with your free hand. This will give you steady support for fine critical areas.

Wayne Floyd, Fayetteville, Tenn.

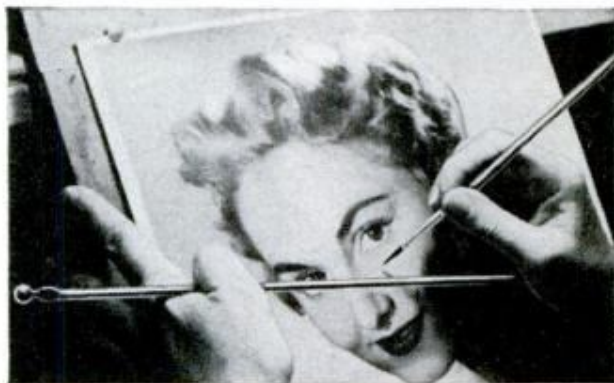

Filter on Sanding Board Cleans Draftsman's Pencil

Here's an odd twist whereby a draftsman can make use of a cigarette filter. Wrap the filter in masking tape and staple it to a regular sanding board as shown in the illustration at the right. In this manner, the filter can be used to remove powdered lead from the tip of a freshly pointed pencil.

A. Champion, Toronto, Ont.

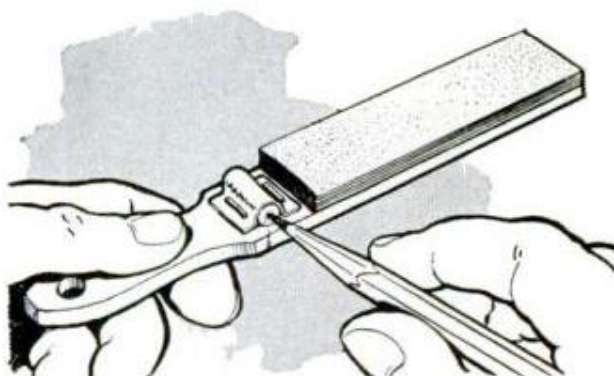

Matchbox Scratching Surface Subs for Sanding Board

If a draftsman's sanding board is not available, a good substitute is the scratching surface of a safety-matchbox. Once a pencil has been initially sharpened, the scratching surface is of a fine enough grain to give it an extra fine point, or to sharpen a stick of lead in a lead holder. The box may also be used to store extra pieces of lead, as well as penpoints.



Bolts Used as Masonry Anchors

Shelves and other fixtures can be fastened to a concrete-block wall even if toggle bolts or masonry anchors are not available. Drill a $\frac{3}{4}$ -in. hole into the block, through to the hollow core. Bend the head end of a $\frac{1}{4}$ -in. stove bolt to a right angle, place it in the hole, and cement the bolt in place. A nut run up the protruding threaded end will secure any object to the wall.—J. D. Campbell, East Alton, Ill.

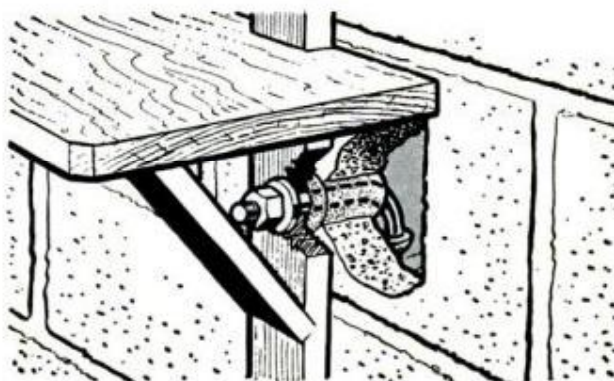



Dog-Dish Anchor

An over-eager puppy can't push his food dish around the floor if it is cemented to a disk of linoleum as shown. The disk also catches stray food particles, helping to keep the floor clean.

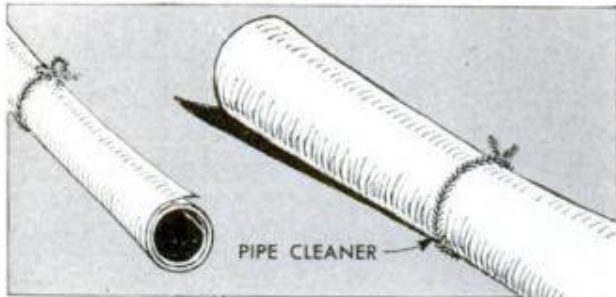

Pipe-Cleaner Ties

Pipe cleaners make excellent ties for rolled blueprints and wrapping paper. A twist of the ends fastens or releases them quickly.—G. E. Hendrickson, Argyle, Wis.

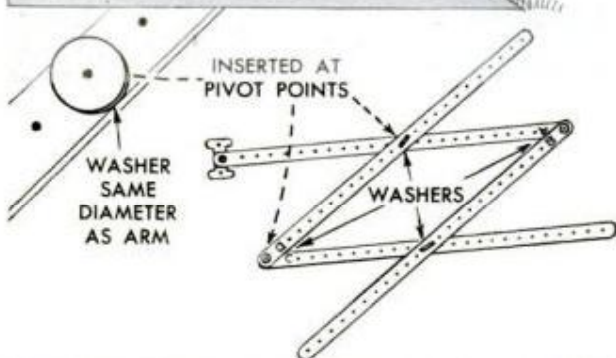

Pantograph Lubricant

Washers cut from waxed paper permit smooth operation of pantograph arms when they are inserted at the pivot points as indicated at left.

W. C. Wilhite, Carlinville, Ill.

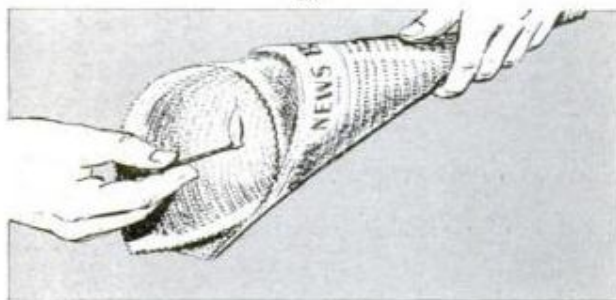

Newspaper Torch

For quick lighting of an incinerator or campfire, form a cone from a newspaper to shield the match from the wind as shown. Then light the paper on the inside and use it as a torch.

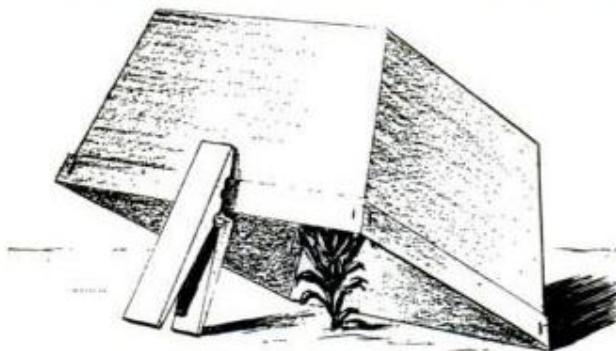

Seedling Sunshades

Seedlings are protected from the sun during the first few critical days after transplanting, when berry boxes are propped up over them as shown. Ample light and ventilation are admitted for plant growth.

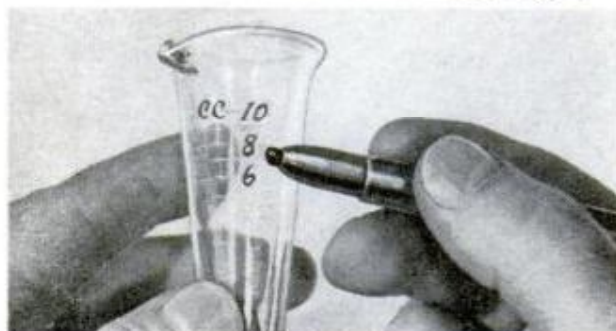

Darkroom Graduate

To make etched graduations and numbers on a graduate more legible for use in a darkroom, coat them with a black marking crayon. Wipe the surplus from the glass, leaving the crayon only in the etched lines.



UPHOLSTER YOUR BOAT

By James Lockhart

IF YOUR runabout needs new seat upholstery, here is an economical way of doing a smart-looking job. Simply remove the old upholstery, including the panels to which it is fastened, and install cushions made up as shown in the drawing below. Cushions like these also can be installed in a boat without upholstery, using metal brackets or clips to fasten them in place.

Plywood panels for seat backs and bottoms are cut to leave enough clearance at the edges to fit flush when upholstered as shown in the photos. When fastening the cover material to the plywood, first drive a few screen staples at each end and side, pulling the material roughly into position as you go. Then pull out the wrinkles and refasten it permanently.

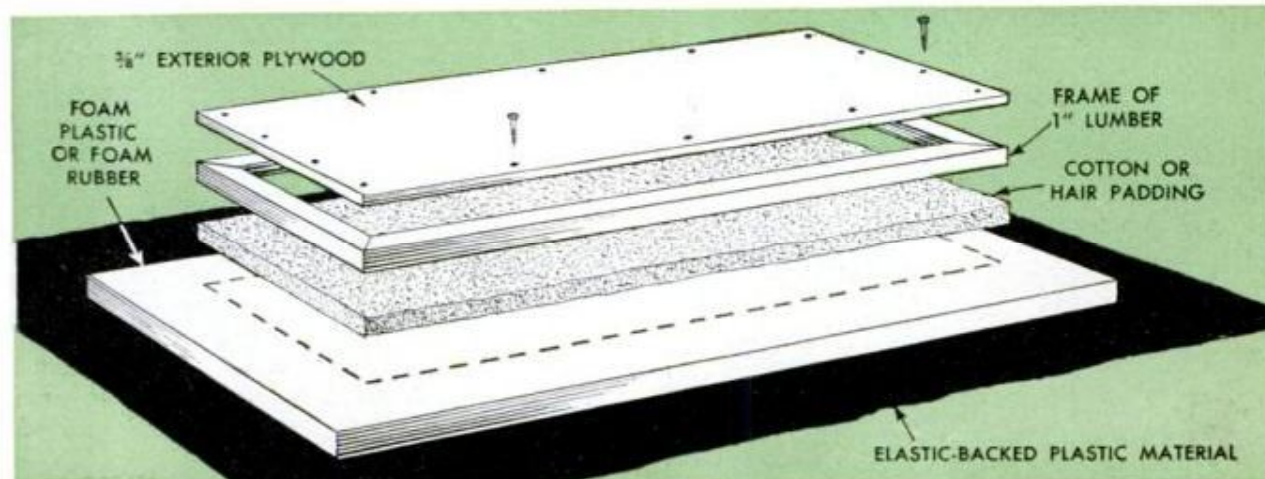
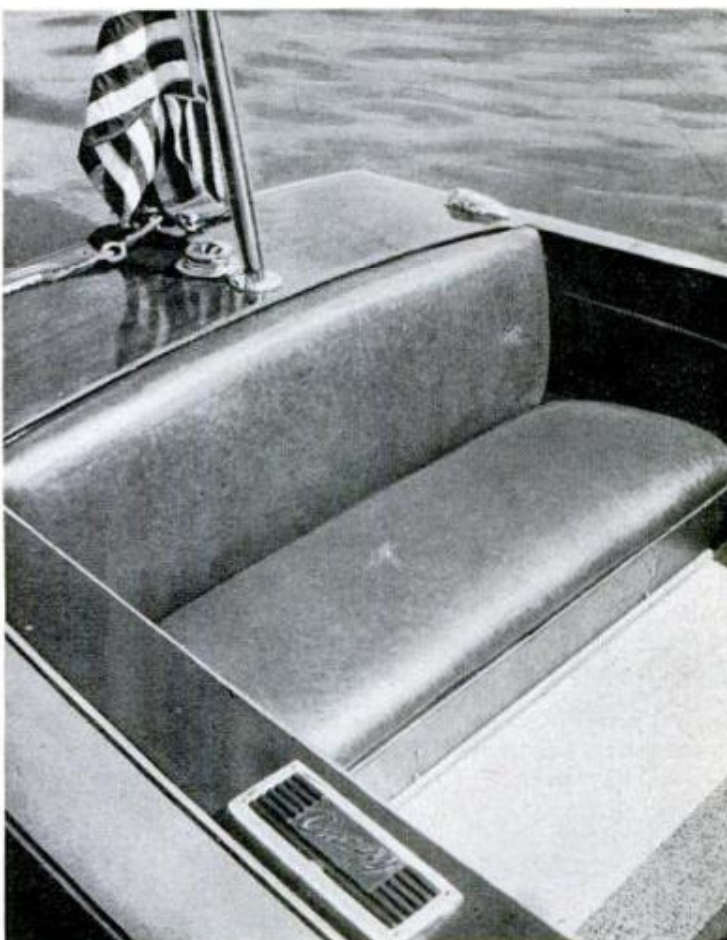

BUILDING THE 24-FT. PM HOUSEBOAT

Conclusion

WITH THE cabin interior completed insofar as the cabinet work is concerned, the happy day of christening and launching your houseboat is near at hand. After painting, there will be drapes to add to the windows, book and magazine racks to make and lighting fixtures to install. Exteriorwise, the remaining work includes bolting motor-mounting brackets to the stern, adding the cabin-roof ladder and installing the chrome railing across the stern and around the cabin roof. Outside painting, of course, precedes the final step of adding the deck fittings and hooking up the motors.

Multicolored texture paint makes a most attractive finish for the cabin interior. Used a lot in cruiser and runabout interiors, it covers fir plywood perfectly and produces a durable, washable finish. It's a spray paint which contains two or more paint particles held in suspension. When applied, these particles produce a pleasing spatter effect to the background color. You have a choice of several colors, all of which can be sprayed perfectly with the spray attachment of an ordinary vacuum sweeper. The interior of the PM houseboat was done in a white salt-and-pepper finish, this being applied to all the plywood surfaces, as well as the cabin roof beams. As with most paints, a prime coat of the basic background color is recommended. This is a

plain, flat-drying finish which is applied with a brush. Before the multicolored paint can be sprayed, surfaces not to be painted must be masked. This includes the fixed windows, countertops and mahogany trim. Drawers and cabinet doors should be removed. Spraying technique differs from ordinary application only in that occasional short bursts have been found to give the best spatter. Being considerably thicker than ordinary paint, you will get a somewhat heavy application. This, however, tends to flatten out upon drying, concealing all grain and surface defects beautifully. If you find the consistency too thick for proper spraying, the paint can be thinned sparingly with water. All the counter tops should be covered with plastic laminate, and the mahogany trim finished natural with a couple of coats of sealer. Vinyl makes the best covering for the floor and the raised platform of the dining nook.

While one 35-h.p. outboard motor will move your houseboat along at about the same speed (8 to 10 m.p.h.) as two 18-h.p. motors, two outboards will give you better maneuverability. In either case, motor-mounting brackets are required to support

Special metal brackets bolted to oak plank provide transom board for mounting twin outboard motors to stern. Set consists of three cast-aluminum brackets

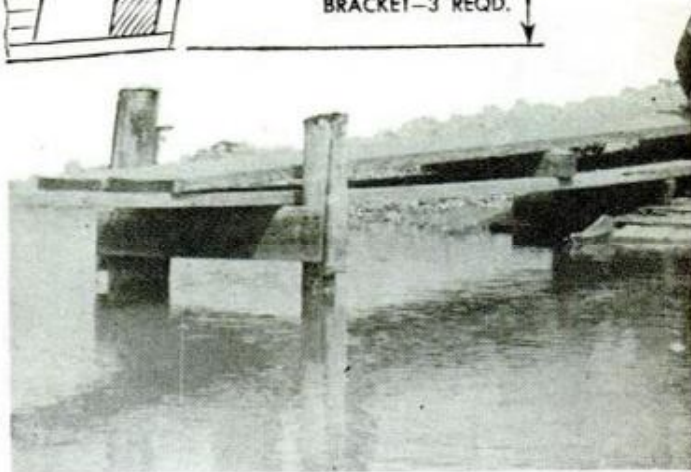
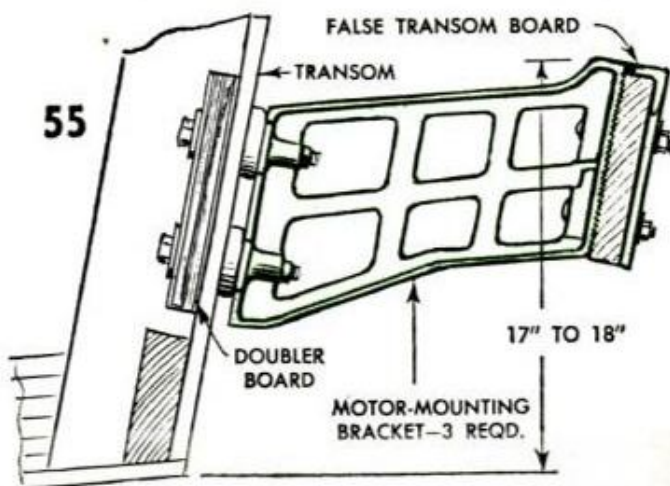
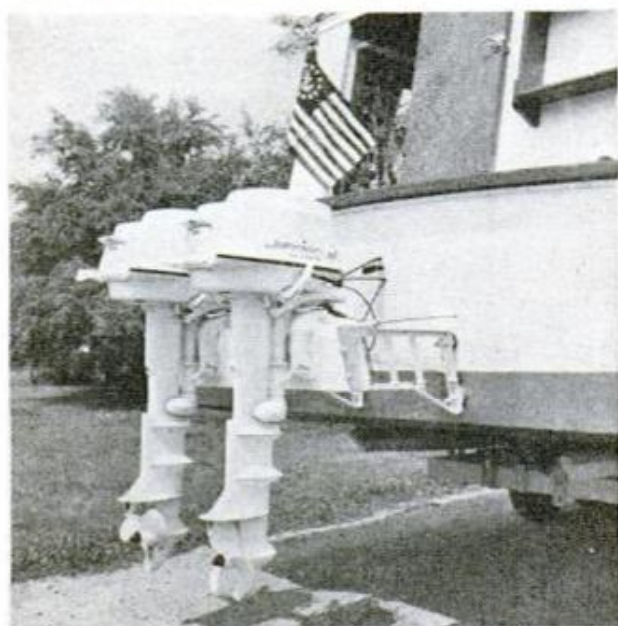

a false transom board for the power units. Three brackets are needed and Fig. 55 shows how they are held with bolts passing through the doubler board backing up the transom planking. The transom board itself is a 1½-in. oak plank bolted to the outboard ends of the cast-aluminum brackets. Note that the brackets should be mounted to bring the top of the plank about 18 in. above the bottom of the hull. The brackets, incidentally, are special fittings which must be ordered direct from the manufacturer.

The fancy chrome-finish railing is assembled from standard deck-railing fittings and tubing. Fig. 56 shows how the deck plates (flanged sockets) are canted inward 5 deg. by screwing them to beveled strips attached along the edges of the roof, port and starboard. Note how the railing continues down the cabin-roof ladder to form hand rails. A less expensive railing can be

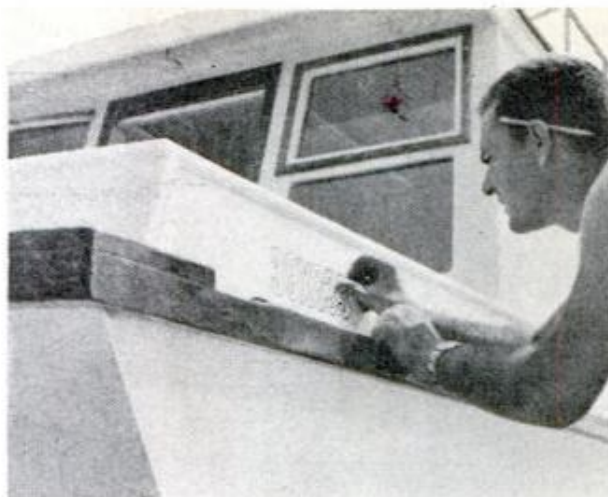

Decal numerals of the assigned registration number are applied at the bow, both starboard and portside



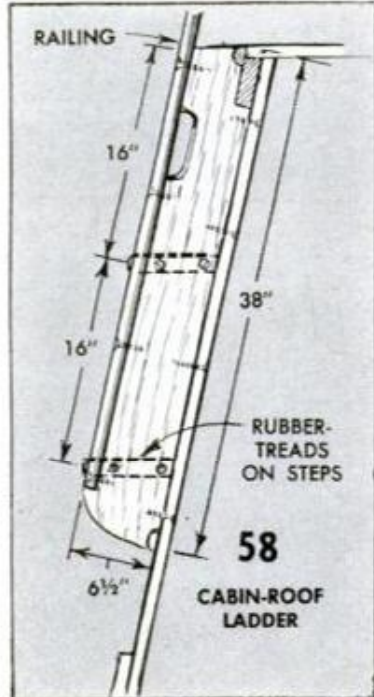
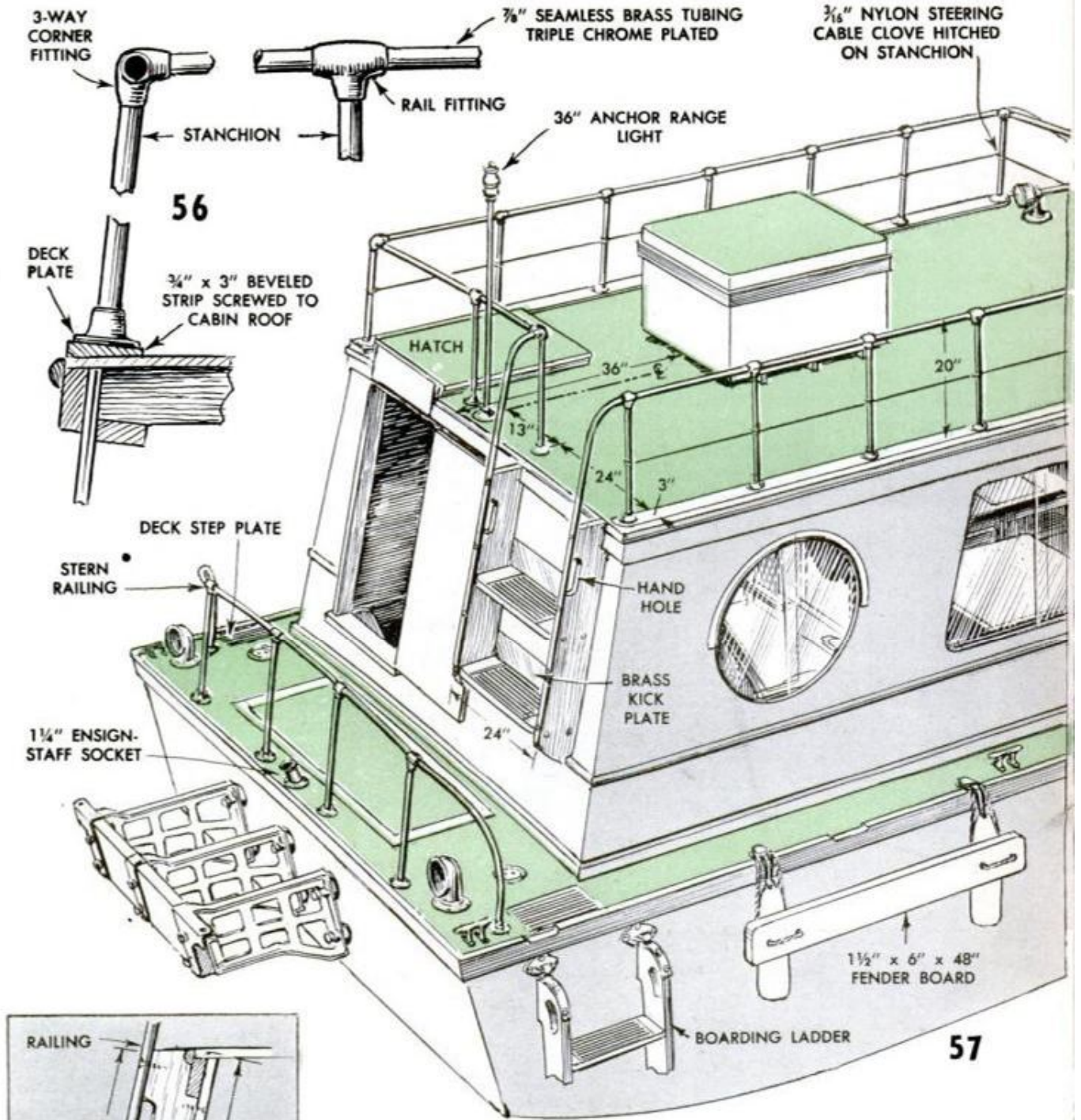

made from common pipe and pipe fittings and painted. Here it will be necessary to weld 90-deg. elbows to the ends of the five corner posts to improvise three-way corner fittings. Other than this, regular tees and flanges will do nicely. If necessary to cut costs, the railing can be omitted altogether, although it does add a classy look to the overall design, as well as provide a necessary guard rail when the roof is used by the family as a sun deck. Actually, the railing, as well as the ladder, would not be permanently installed until after final painting. Fig. 58 details the ladder. The treads are covered with regular rubber step plates, and brass kick plates are screwed to the cabin wall to protect it from toe marks. The wood parts of the ladder are mahogany.

The interior view of the hold below the hatch cover in the after deck, Fig. 59, shows the location of the two 18-gal. fuel tanks and how they are lashed down to wooden saddles with hold-down straps. Fill pipes for the tanks are fitted

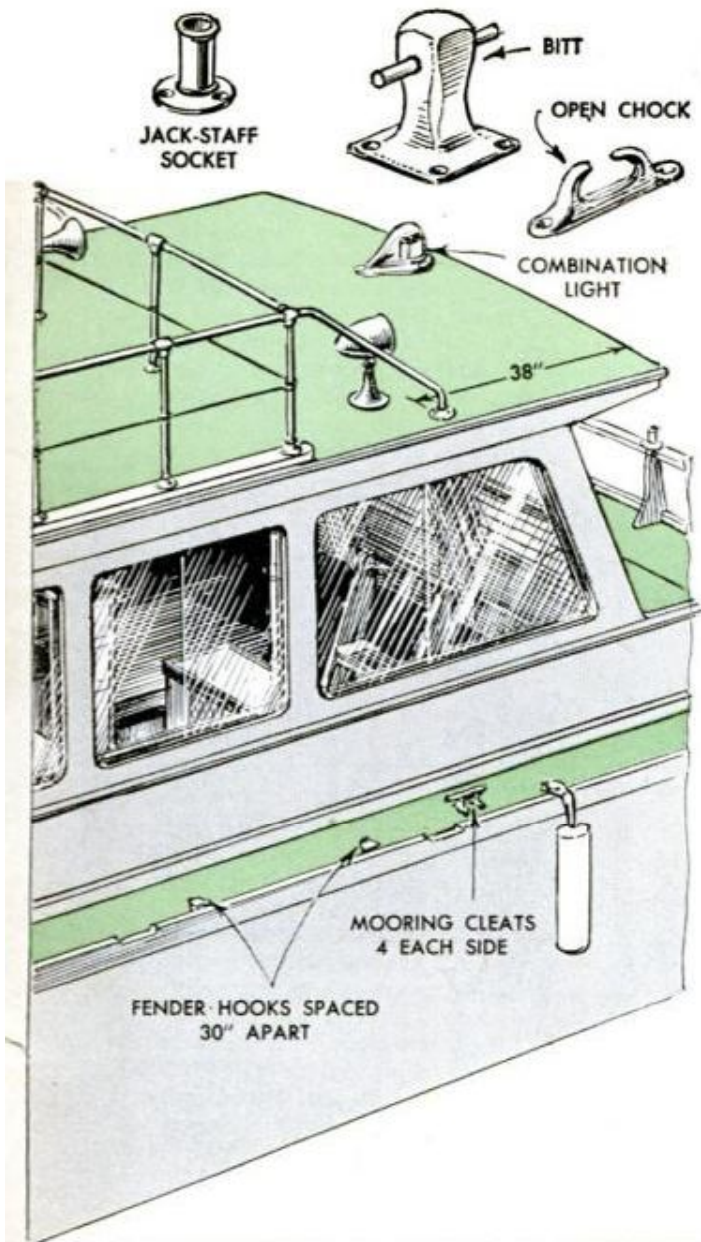

with deck plates, and fuel lines are brought out through holes at the top of the transom. Each tank is vented with a Neoprene hose which is connected to a through-the-hull fitting in the side planking. Notice that each tank also is grounded to a copper plate bolted to the bottom of the hull. The hold itself is vented through two louvered transom vents and two bilge downspouts fitted with hoods. The 12-volt storage battery needed to power the cabin and navigation lights is kept in the fuel-tank compartment. Three lighting fixtures are installed in the cabin; an overhead dome light amidships, a bullet-type bulkhead light in the enclosed head and a bullet fixture on the dining-nook bulkhead. Both cabin and navigation lights are on a single parallel circuit with individual switches at the fixtures.

The overall view in Fig. 57 shows what you will need in the way of deck fittings. The bitt is securely bolted to the king plank at a point forward of the fore-deck coaming. The open chock is centered and screwed to the bow toe rail. The jack-staff socket is centered on the knee which braces the bow coaming. Four mooring cleats are spaced along the covering boards, port and starboard, while fender hooks are spaced about 30 in. apart. An anchor range light

(Continued to page 230)

HOUSEBOAT BLUEPRINTS

If you prefer to work from plans larger than magazine-size, blueprints can be purchased at \$10.00 per set of eight sheets by writing to Popular Mechanics, Blueprint Dept., 200 East Ontario St., Chicago 11, Ill.

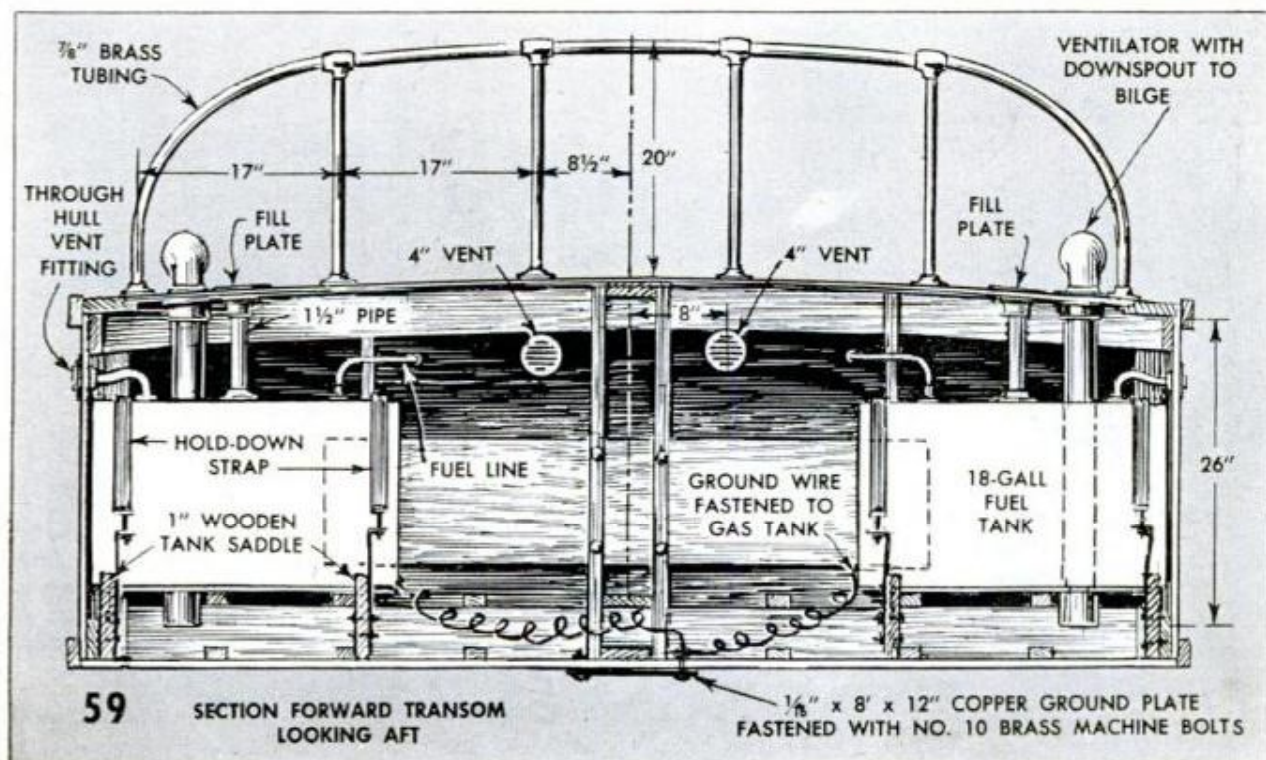

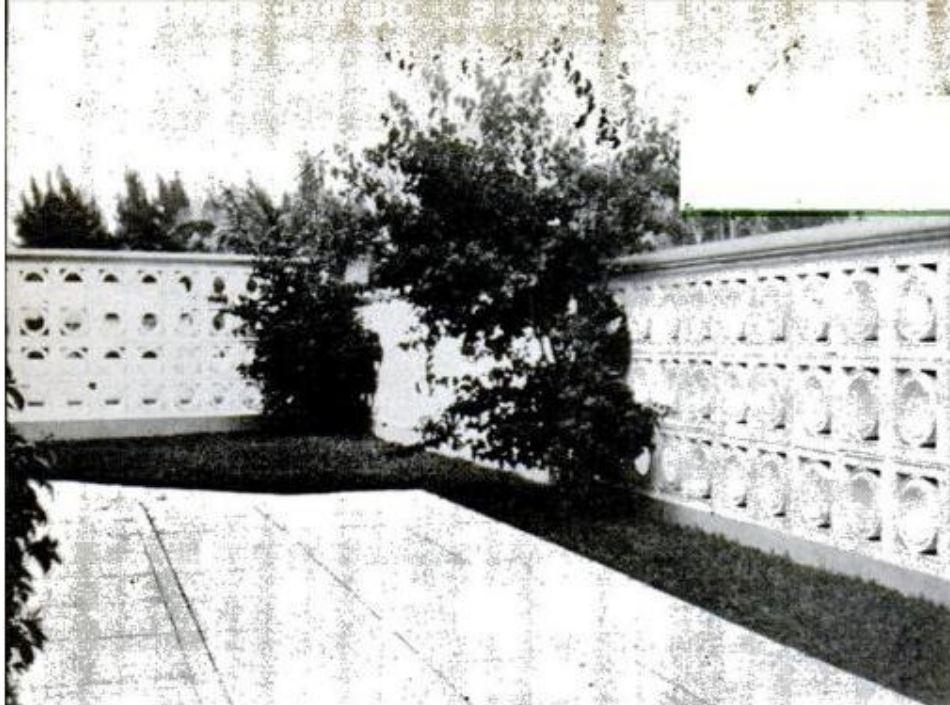

EVER THINK of using standard concrete blocks to build a decorative garden wall? A fine example is shown at the left. Here 8 x 16 x 16-in. chimney-flue blocks, placed on edge, are mortared side by side in rows. Units can be laid brick-fashion or aligned vertically. Wall is built on concrete footing and ends are finished with 4 x 8-in. blocks

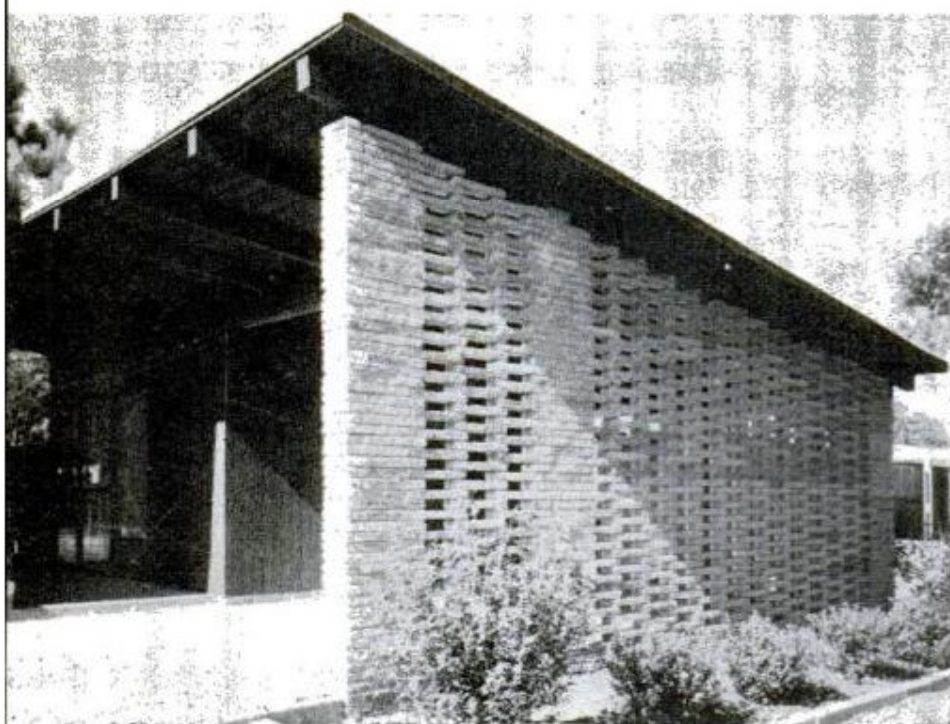
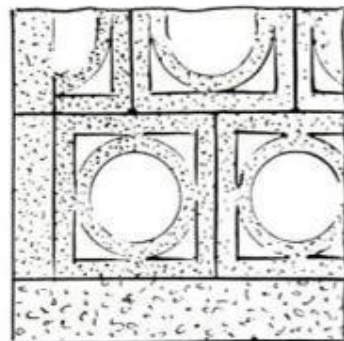

OPEN SECTIONS of attractive carport wall at left are formed by lapping ends of narrow 16-in. unpressed concrete blocks. The resulting filigree, or pierced design, makes the wall blend with the surrounding lawn and shrubs. Spaced piers of brick add strength to finished wall. Concrete bricks used here measure 1 3/8 in. thick, 4 in. wide, 16 in. long

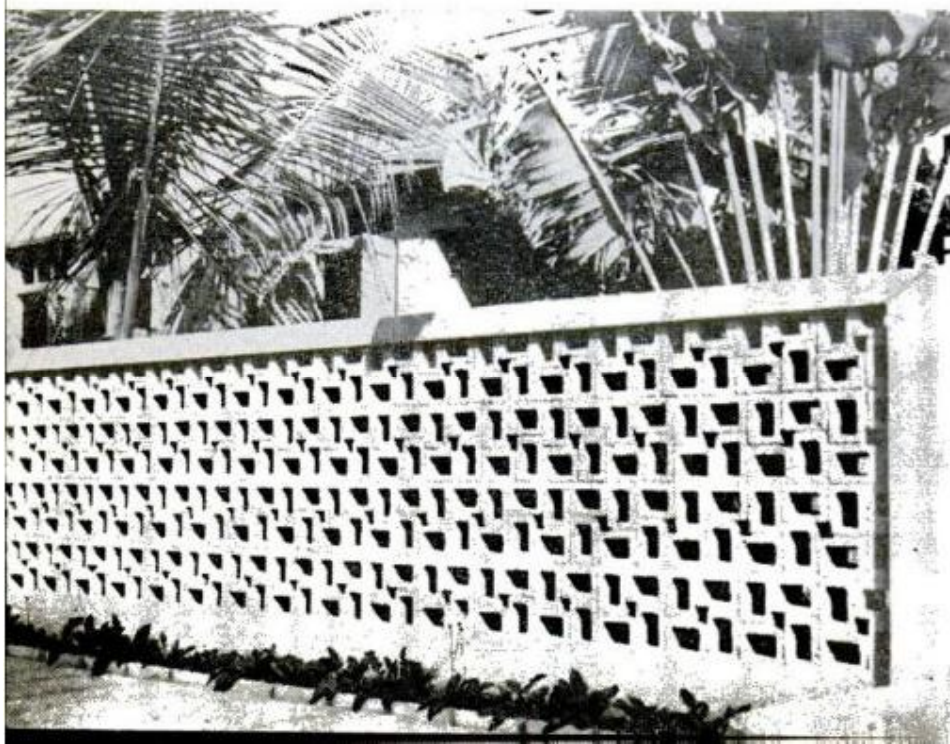
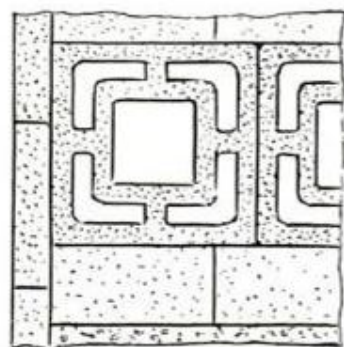

MODULAR CONCRETE core blocks are used in this attractive patio wall. Interesting geometric pattern is formed by alternating position of blocks in each course, placing one on its side, the other on end, etc. Blocks of second course are laid in a reverse position, third course reverts back to position of the beginning or starter row of core blocks

POPULAR MECHANICS

WALLS

EVEN COMMON concrete blocks laid as a solid wall make a most durable and practical patio windbreak and screen. In the photo at the right, two adjacent walls form corner for outdoor fireplace. Open "egg-crate" roof ties walls at top and serves as sun diffuser. Upper rows of blocks are laid "open" to form decorative pierced effect to relieve plainness

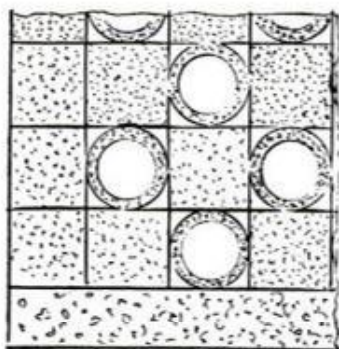

LOW WALLS around patio floor perform double duty when made to serve as planters. Two rows of narrow unpressed concrete blocks are laid around perimeter of patio slab and filled with dirt. Such walls reduce out-in-the-open feeling while high plantings afford partial privacy as can be seen in the photo at the right. Blocks are laid 24 in. high

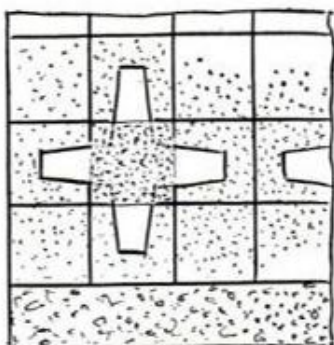
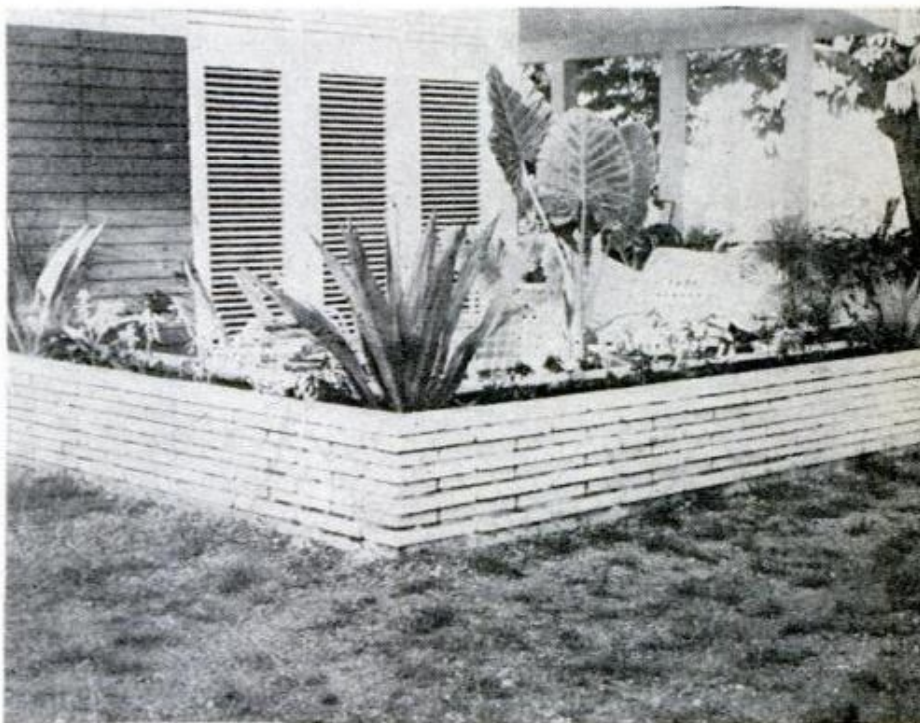

FILIGREE INSERTS of ornamental concrete add a distinctive touch to the garden wall shown at the right. Inserts are concrete castings which are mortared in openings left in the upper courses of the wall. Note that mortar joints are aligned vertically so that piers, two blocks wide, can be formed to create openings. Mortar joints are struck or raked

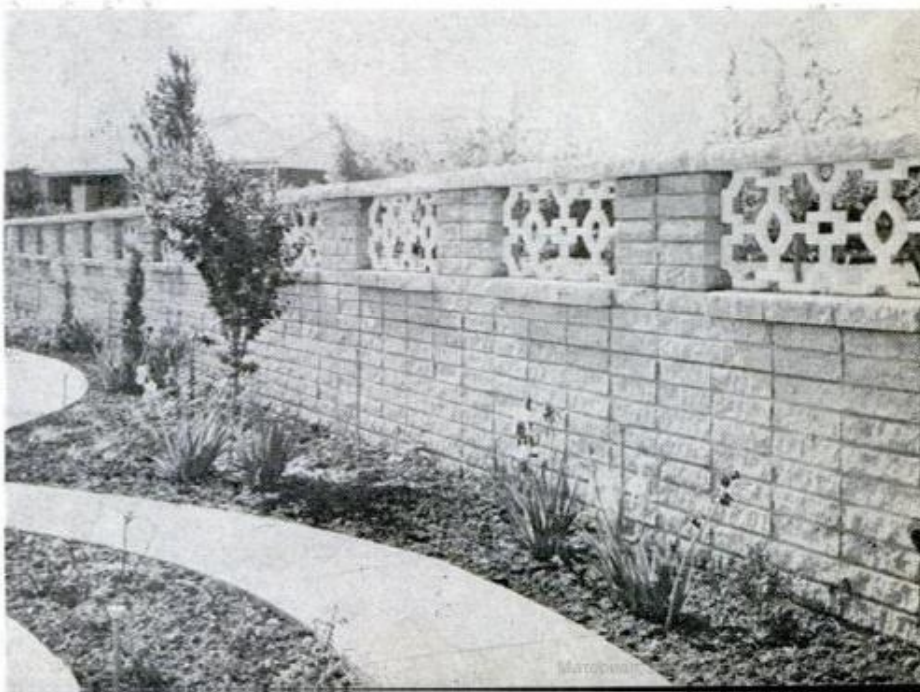

PHOTOKINKS

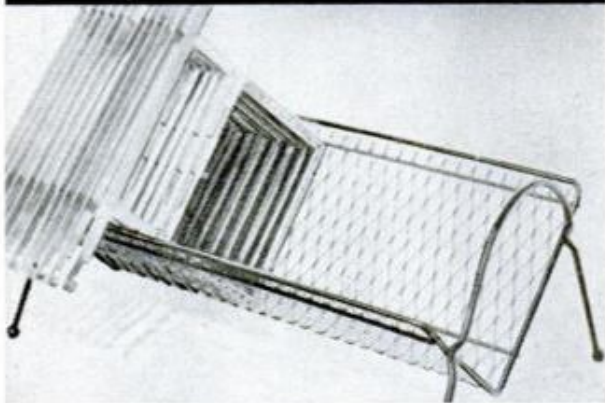

WHEN EQUIPPING a home darkroom, the beginner will often make use of discarded items. Such is the case here where a wire-type book trough was found to serve perfectly as a draining and storage rack for cut-film hangers. It can be put to good use, too, for holding cut-film holders, as well as boxes of sheet film. When used as a draining rack, a coat of clear shellac or lacquer will prevent the wire from rusting



PERHAPS THE MOST convenient place of all for carrying your filters is on the camera itself. Here they are at finger tips whenever needed without having to search through a cluttered tote bag. Cemented to the top of a press-type camera, for example, the screw-top filter box will not interfere in any way with the normal operation of the camera and yet be right at hand for quick use when needed on the spot



TIRED OF TEARING the darkroom apart looking for the right filter? Place a piece of adhesive tape down the side of the filter case and label it at the level of each filter box. To avoid storing a filter in the wrong place order, it is a good idea to label the individual filter boxes as well to coincide with outside markings

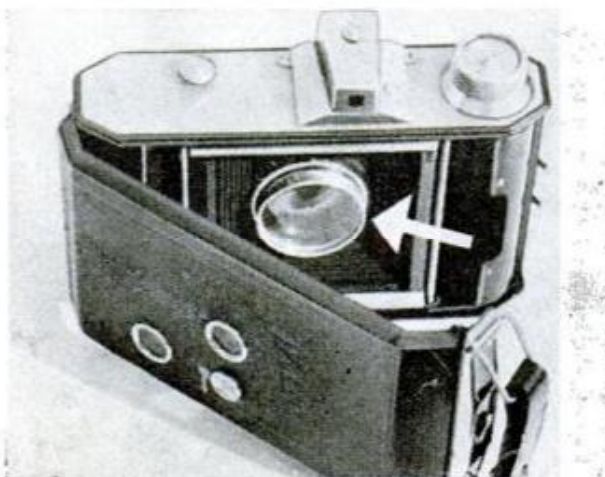

WHEN A SKYLIGHT (haze) filter is used on the lens of a folding-type camera, it must be removed each time or the camera won't close. There is a way you can avoid this when the camera is used at the time solely for outdoor color. Simply mount the filter semipermanently over the rear lens inside the camera bellows. Here it will not interfere with the closing of the camera whatsoever. A strip of adhesive tape, wrapped around the rims of the lenses, will hold the two together and permit easy removal of filter

HAVING TROUBLE storing tripods? Leaned against the wall they are sure to fall or be kicked over. Why not clip them to a wall or inside a door with clips normally used to hold paintbrushes and hand tools

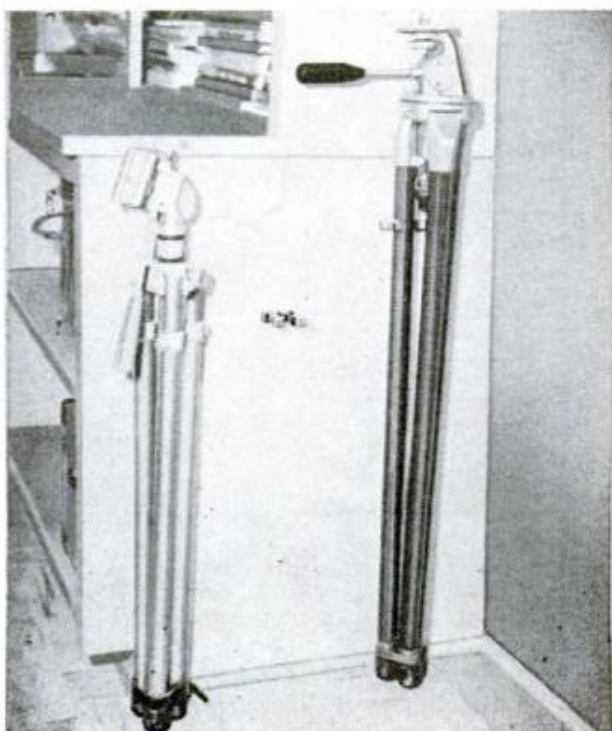

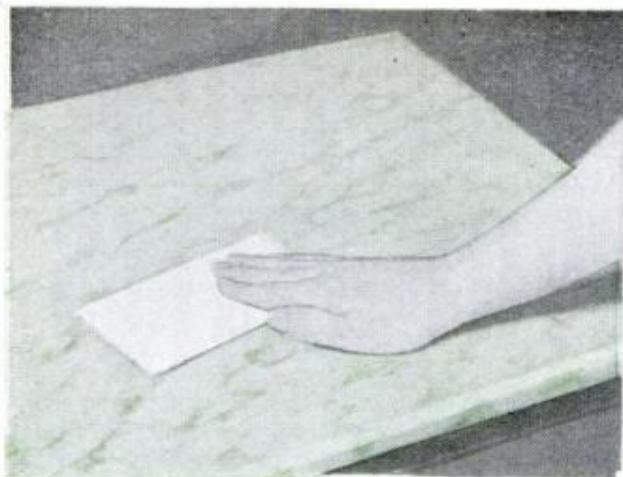

How To Care for Marble

Beauty and durability of marble are again making it a favorite in the American home. Keeping its sleek surface in good condition, however, takes a bit of know-how. For example, soap will work its way into the marble's somewhat porous surface and eventually cause it to yellow. For superficial stains, use a bit of detergent instead. Normally, clear water is enough to keep the surface clean. Grease stains are best removed with an equal mixture of acetone and amyl acetate, available in most drugstores. Saturate a cloth with the mixture and weight it down over the stain. Remove the cloth only when it is dry. Remember, the mixture is inflammable and should be handled with care. Coffee stains come away with a mixture of water, 4 parts and glycerine, 1 part applied in the same manner. In all cases, after application of the cleansing agent, rinse the surface with clear water and apply a coat of wax.

M. C. Anderson, Arlington, Va.



Wall Light Hides Film Screen

With this mounting, a screen for home movies or slide projection can be placed permanently in the living room and remain unnoticed except as an attractive boxed-in "wall light." It is made of two pieces of $\frac{1}{2}$ x 4-in. white pine long enough to accommodate your screen, a piece of flat molding of the same length, two window-shade brackets, and enough hardboard to cover the ends. Screw the pine sections together as shown in the illustration and close the ends with the hardboard. Screw the molding onto the front and mount the screen on the window-shade brackets. If desired, space can be allowed for a fluorescent lamp to be placed inside the mounting, making the device in fact, a wall light. Used to illuminate a wall picture, the mounting will thus serve two purposes.

Mrs. F. W. Davids, State College, Pa.

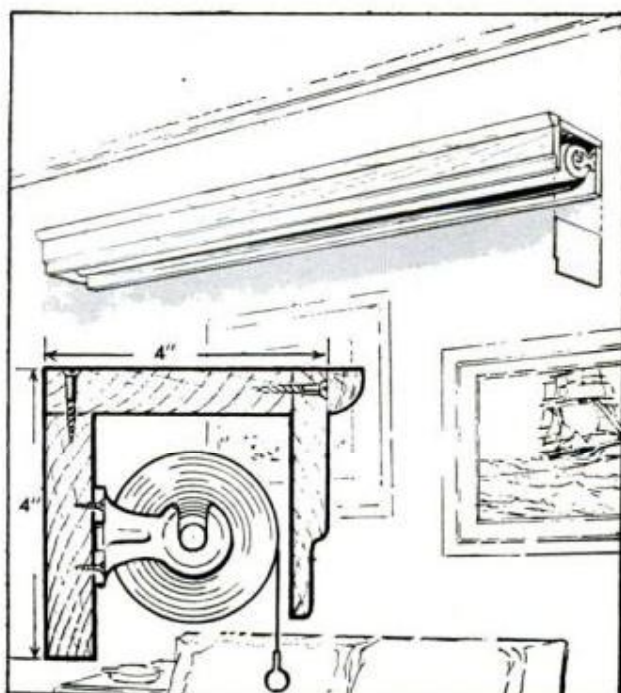

Solving HOME PROBLEMS



1. If you have had the wind slide garments together when placed on a clothesline on hangers, splice a short chain into the line at one end. Then slip the hanger hooks into the links of the chain and the hangers will stay put. Use a medium size chain of sufficient length to suit your particular needs



2. You won't have to stoop and hunt for the soap in the shower if you sew a soap pocket to one of the curtains. A plastic tobacco pouch is ideal for this purpose. Be sure to locate it at a height suitable for members of the family—even the little tots

3. Many suggestions have been made for removing a broken lamp bulb, but one of the most practical is to use the cork from a vacuum bottle. Even when using the cork, it is a good idea to wear gloves for added protection against cuts from broken glass

4. Getting off a ladder while washing windows to retrieve cloths that have been dropped or blown off will be unnecessary if they are slipped under a spring around the top step of the ladder. A screen door spring, or one used as a curtain rod, is best for this purpose. Tie the spring ends together

5. If you can snatch one of Junior's hollow rubber balls, you have the makings of an ideal "palm wrench" for loosening lids on fruit jars. Cut the ball in half and then slit one piece around the edge so that it will better conform to the shape of the lid

6. When a kitchen or bathroom drain becomes clogged and there is no tool at hand to clean it, try a spring-type curtain rod. Open the coils by stretching, leaving about 3 in. at one end just slightly opened. Straighten the end of the end coil as indicated. Insert this end into the drain, using a cranking motion. Repeat until the drain is opened

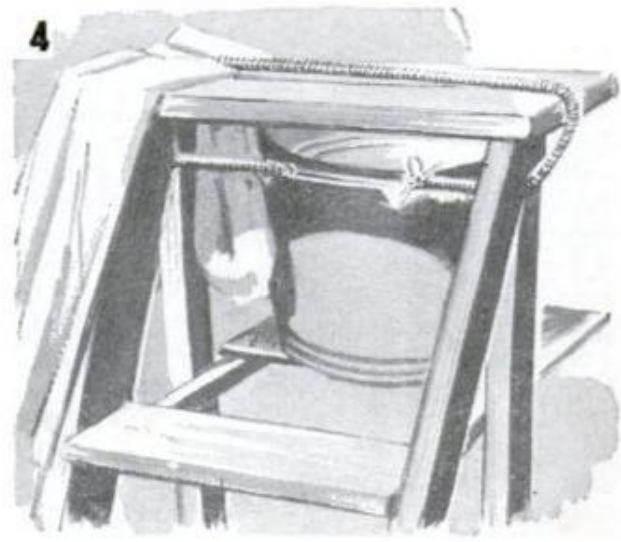
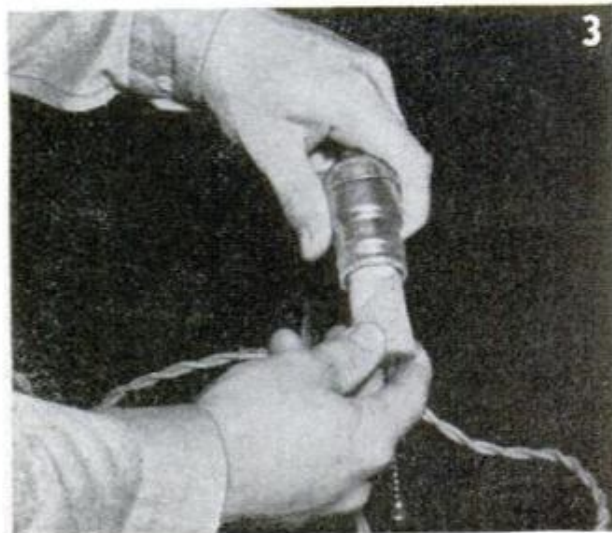

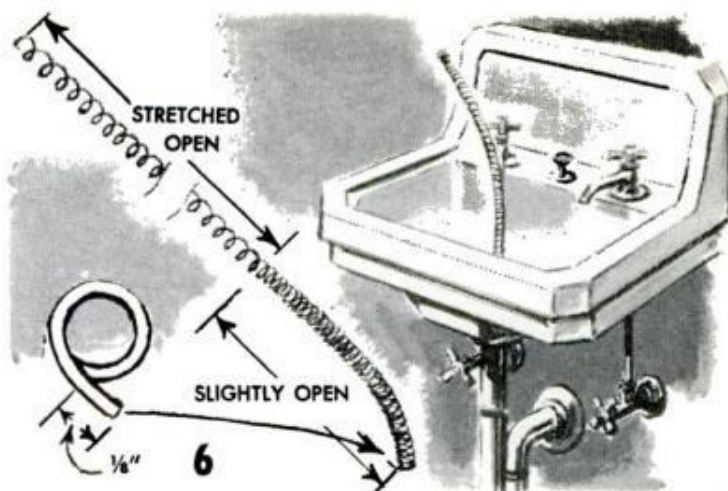
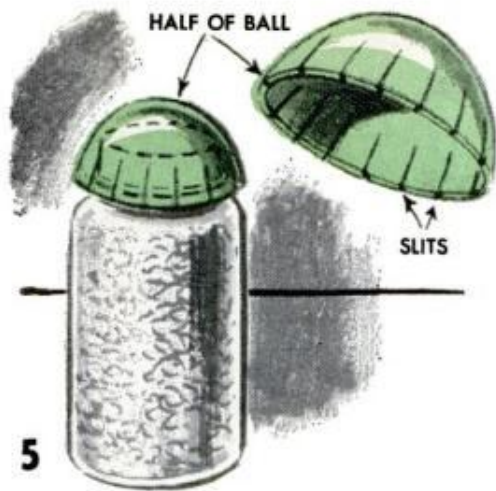

7. To keep caster wheels from making streaks on hardwood floors, apply a thin layer of cellophane tape to the casters on furniture. Be sure the wheels are clean otherwise the tape will not adhere, and do not let it overhang the edges of the wheels. If it does, it may be torn off when the wheel rotates



8. Most window air conditioners have finishes similar to those on cars and should be cared for in the same manner. Wash and wax the finish at regular intervals so it does not become drab looking or deteriorate and permit the metal underneath to rust

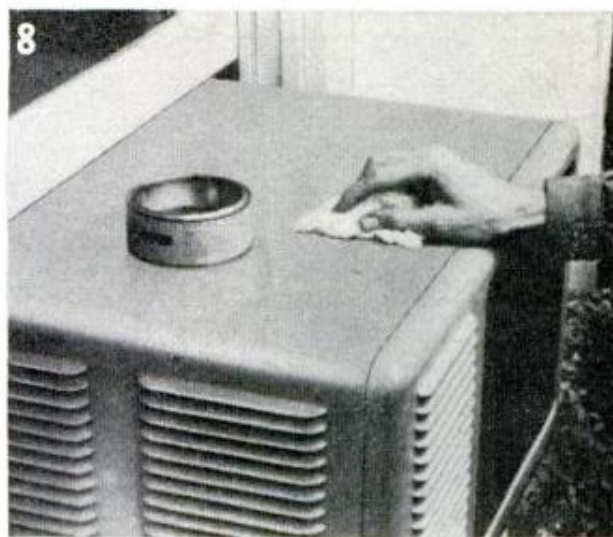

9. An easy way to start a siphon is to roll the hose tightly, leaving only enough at one end to insert into the container. After inserting the hose, let it unroll quickly. The vacuum resulting from forcing the air from the hose by rolling and then unrolling it will start the siphoning action quickly

10. Hard, dry putty that seems almost impossible to remove will come off easily if it is first coated with lacquer thinner. Use a small brush and apply enough to soak the putty. Then wait a few minutes for the lacquer to penetrate. The putty then should lift off easily with a sharp chisel or a putty knife





Durable Surf-Fishing Spike Made From Angle and Pipe

Here is an idea which will enable the surf-fishing enthusiast to make his own surf spikes. Make the tube of the spike from a piece of pipe with an inside diameter of $1\frac{1}{2}$ in. It should measure at least $11\frac{1}{2}$ in. long. The spike itself is a 1×1 -in. steel angle, 15 in. long. Aluminum or brass tubing and angles may be substituted if preferred, and the length of the spike may be varied to suit individual needs. The angle is attached to the tube by means of a $\frac{1}{4}$ -20 brass roundhead machine screw and a wing nut and washer. The screw is inserted into one of several holes drilled through the pipe and the spike. The holes make it possible to adjust the spike to suit the various conditions which may be encountered on a fishing trip. A stout cord tied to the spike and to the fishing rod will further insure against the possibility of lost tackle should the rod by some means be pulled from the tube.

Leon Reissman, Brooklyn, N. Y.

Bench Set on Iron Supports

This simple outdoor bench will greatly add to the comfort of warm evenings spent in the yard or garden. To make the bench, screw three short lengths of $1\frac{1}{2}$ -in. wrought-iron pipe into a tee fitting. Two of these pipe and tee combinations are then set in concrete a few feet apart as shown in the illustration. When the concrete has set, bolt six lengths of 2x4s to the pipe assemblies to form the seat and the back as indicated.

Glen F. Stillwell, Manhattan Beach, Cal.



Holder Carries Fishhooks Safely

To prevent loose fishhooks from becoming mixed with the contents of the tackle box, make knife cuts in the ends of a short length of garden hose and insert the hooks in these cuts. Lures and flies may also be stored in this manner, and a similar piece of hose may be placed above the grip of the pole to hold extra hooks and flies for the trout and bass fisherman.

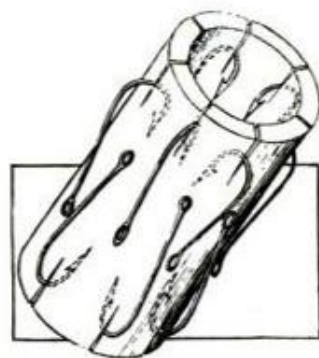

G. E. Hendrickson, Argyle, Wis.

Temporary Dry Rot Repair

If your boat shows signs of dry rot, here is a way to keep the rot from spreading until permanent repairs can be made. Begin by sanding all paint from the rotted area. Then soak the area with resorcinol-resin glue, allowing the glue to soak in thoroughly. Once it has set, the glue will form a hard, waterproof substance and hold the rot in check. Remember, this is not recommended as a permanent repair, but only as a handy stopgap measure.

Ken Murray, Colon, Mich.

Cattle Guards - Permanent and Portable

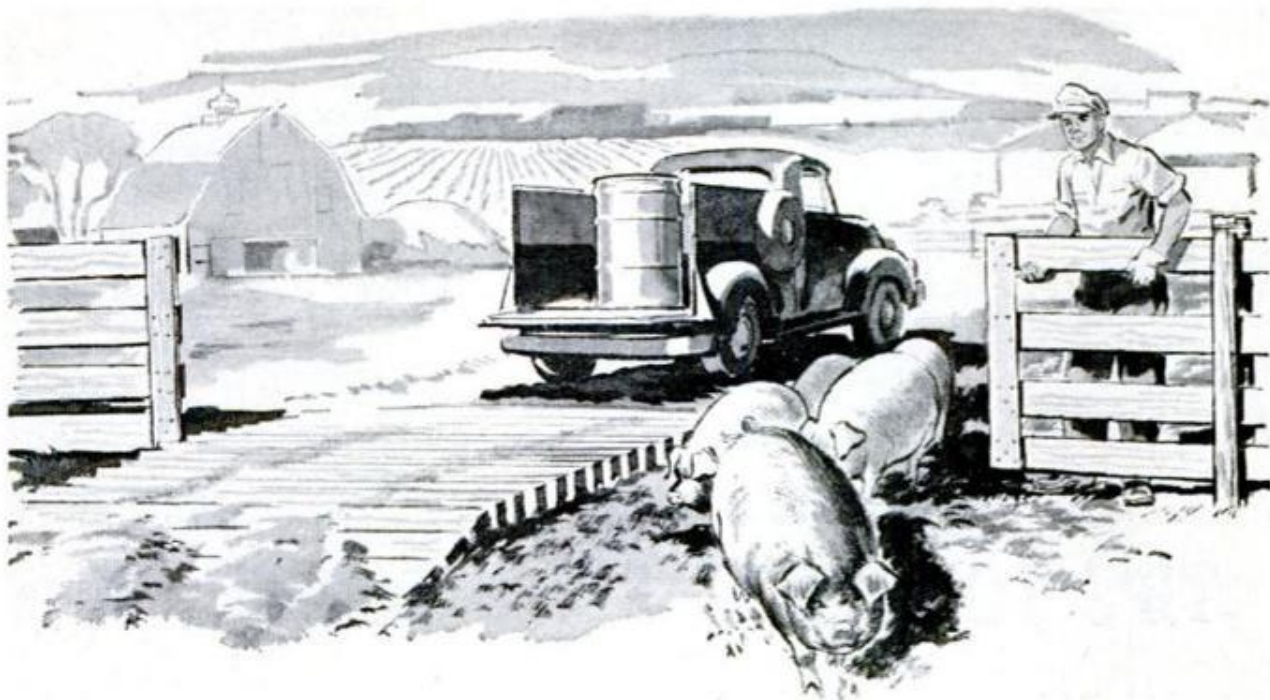

To provide himself with the benefits of a cattle guard when hauling feed and water to livestock on temporary pasture, one farmer uses the portable guard shown above. It can be moved to different fences or gateways as needed. It cannot be crossed by the livestock, yet is wide enough to let trucks and tractors pass over it. To allow livestock to pass, the gate is simply swung aside. As a permanent installation, the cattle guard at the right is hard to beat. It is made of flat iron sections welded across a row of I-beams set in concrete. A shallow spillway runs below. A strip of road between the guard and a fence is closed by a gate through which the cattle may be allowed to pass.



Dual Tractor Wheels Double Traction on Soft Ground

Driving a tractor through soft, wet or sandy soil often requires the use of tire chains. Rather than lose time mounting and removing the chains, one farmer equipped his tractor with dual wheels. The added traction allows him to drive the tractor over almost any soil with ease.

In an emergency, a radiator-hose clamp for your tractor can be fashioned quickly from a short length of wire and a bolt and nut. Join the two ends of the wire to form an elongated loop, and twist each end again to form two smaller loops. Wrap the wire around the hose and pass the bolt through the smaller loops. When the nut is threaded on the bolt, the wire will draw tightly around the hose.



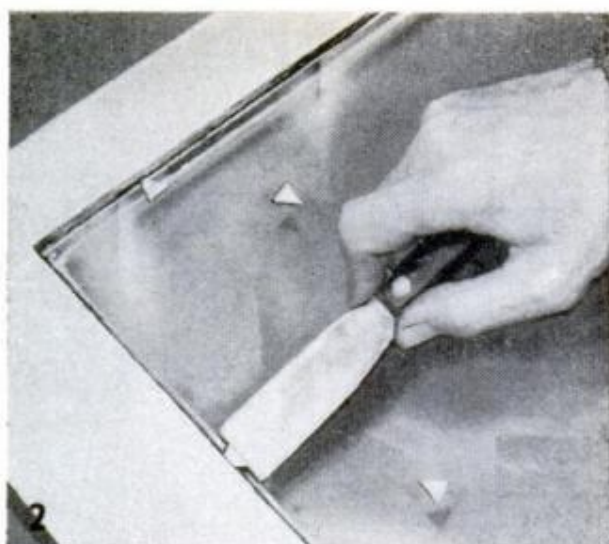
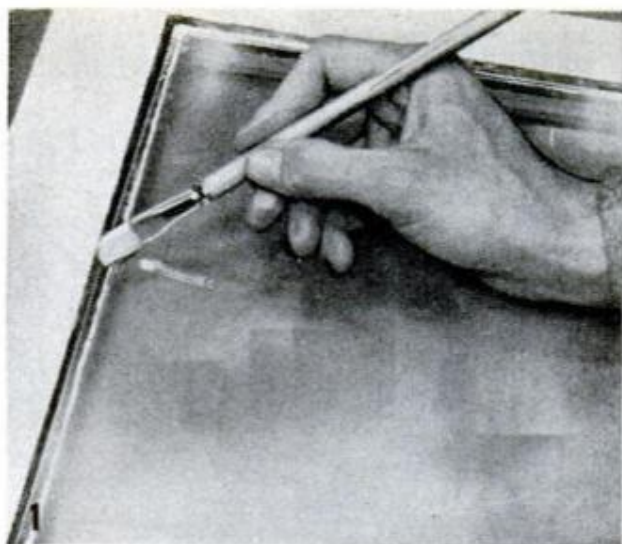

After old, cracked putty is removed from window, linseed oil is brushed on exposed edge of wood and glazier's points are pressed into place against the glass to hold it in place until freshly applied putty hardens

TIPS TO KEEP SASH IN TOP SHAPE

By R. Hanscom

AN OUNCE of prevention . . .," certainly applies to the job of keeping window sash in good repair. Unless outside surfaces are maintained in a watertight condition, moisture will enter the wood and rot it. Loose sections of putty are the main source of trouble. Putty in this condition retains water for a long time, creating conditions that are ideal for dry rot when the weather is hot and humid.

The first step in preserving the putty bond is to paint it correctly. The paint line should overlap the glass slightly so that water cannot soak into the relatively porous putty. If the putty line is crooked, this offers an opportunity to make it appear straight. If you have trouble painting a straight line, use masking tape. Loose or cracked putty should be removed to the

bare wood and linseed oil brushed on as in Fig. 1. The latter is an important step, as uncoated wood will absorb much of the oil from fresh putty, leaving it dry and crumbly. Next, glazier's points are pressed into the wood, Fig. 2, after which the new putty is applied.

A window that has been neglected to the point that the mortise-and-tenon joint is partly rotted out, usually can be repaired as shown in Figs. 3, 4, 5 and 6. Begin the repair by sawing off the bad wood as in the drawing next to Fig. 5. To reinforce and help to hold the joint together rigidly, drill a hole through the stile and into the rail to take a dowel as in Figs. 3 and 4. If there is space, drill two such holes, coat the dowels with glue and drive them in place. When the glue has set, saw the dowels flush

Dowel glued in hole drilled in sash corner joint being repaired, reinforces and helps to hold joint together

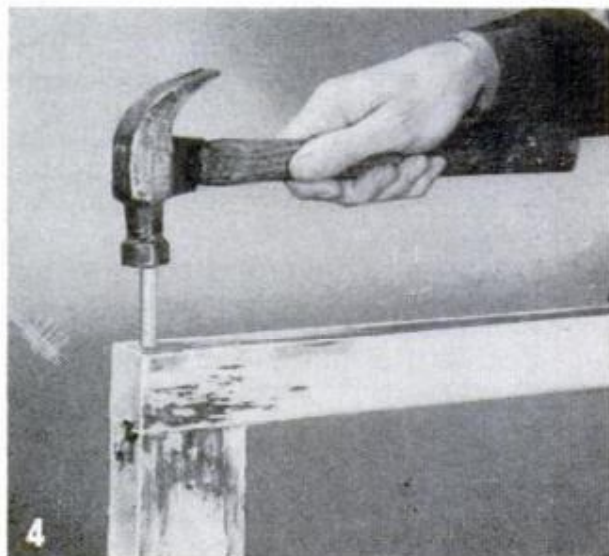
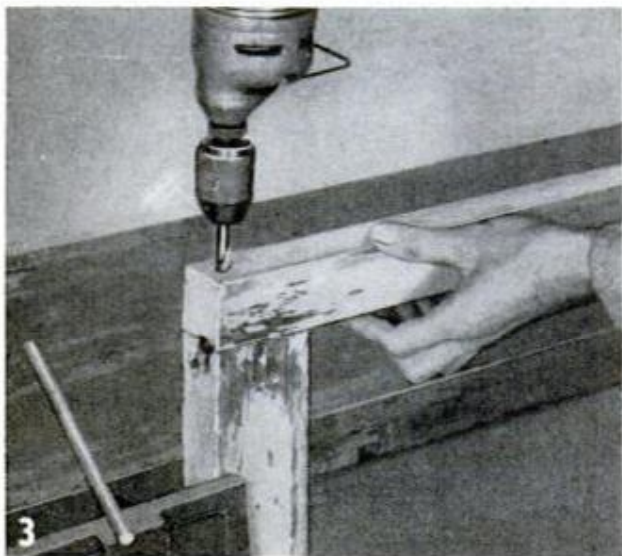

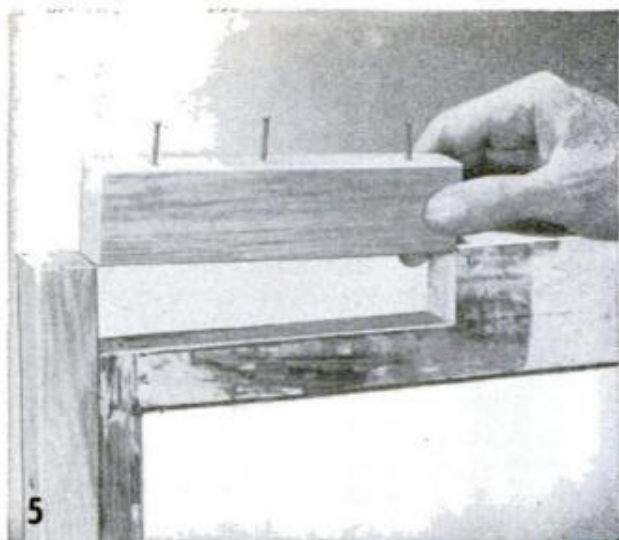

Rotted wood cut from sash is replaced by new wood cut to fit

with the stile and cut two pieces of wood to replace the wood that was removed as in Fig. 5. These are then glued and nailed to the sash. Drill pilot holes for the nails and countersink them, being careful not to drive the points through the sash. After the glue sets, the repair area is sanded flush with the old wood. When primed and painted, it will be difficult to detect the repair even from close observation.

On a porch, garage or attic window, where inside appearance is not important, a rotted or broken sash corner joint can be repaired as shown in the drawing next to Fig. 6. Since this type of repair takes only minutes to make, it is ideal as a temporary repair for sash in any location, until



a permanent repair can be made. All that need be done is cut a 1/4-in. plywood gusset and screw it into place as shown, being careful not to position the gusset so as to prevent the window from being closed properly. Double-hung sash that is repaired in this manner should be closed when fastening the gusset. Paint the plywood gusset only if it is to serve as a permanent repair. ★ ★ ★

When sanded flush with old wood of sash, repair area in photo below will be unnoticeable, after painting

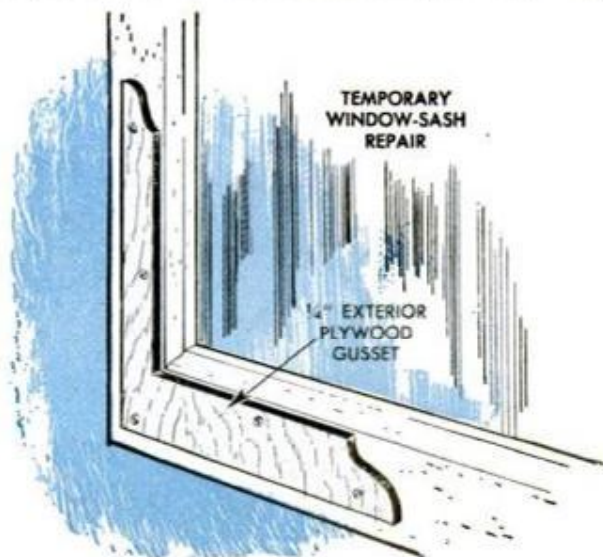

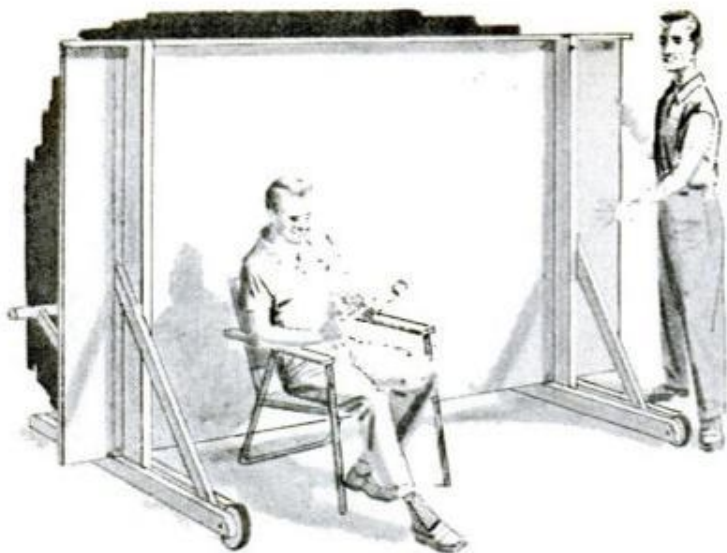

Mobile Patio Screen

No garden or patio is complete without this movable wind and sunscreen. The screen consists of a plywood panel mounted on a frame of 2 x 4s. The base, to which wheels are attached, is made by nailing two additional 2 x 4s to the bottom of each of the frame members as shown in the illustration at left. Diagonal supports extend from the frame and fit between the base members. These serve as spreaders and allow space for the wheels. By means of a handle the back is easily lifted and the screen may be wheeled into any desired position.

W. A. Leak, Cupertino, Calif.

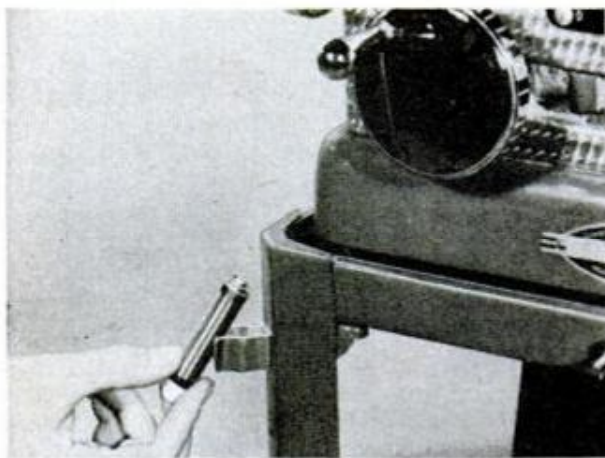

Pencil Flashlight Aids In Scale Reading

The figures on machine scales and dials are often difficult to read even in a well-lighted shop. For easier reading and to make settings with greater assurance, provide yourself with extra light. Fasten a small pocket flashlight to a convenient portion of the machine stand or frame. The clip to hold the flashlight can be made by bending a strip of light-gauge metal, and may be fastened with a small nut and bolt, or with a self-tapping screw.

H. Hanscom, Elmhurst, Ill.

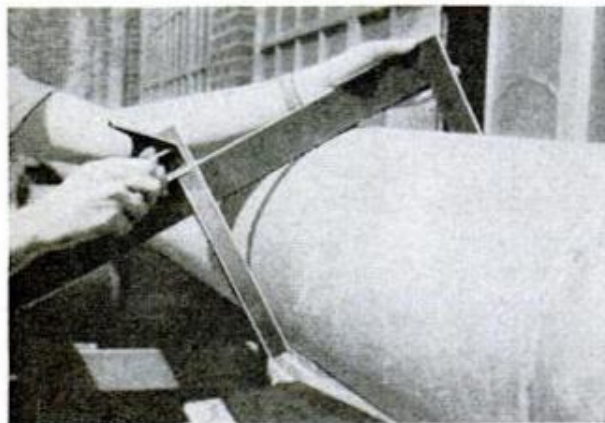

Squares Used as Calipers

To measure the diameter of large pipes and ducts, use two squares in the manner shown in the photograph at the left. One square is placed over the pipe and another is aligned along its blade. The diameter of the pipe is read where the two blades intersect. To check for uniformity, the same procedure is repeated several times along the length of the pipe or duct.

Hugh Lineback, Stillwater, Okla.



Pocket-Size Tackle Box

Smooth the way to fishing enjoyment by keeping your fishing lines from getting knotted and tangled with the rest of the tackle. This can be done by using an empty tobacco tin as a pocket-size fishing kit. Insert fishhooks in holes punched along one side of the can and wind the attached lines around it. Spare hooks, lures and sinkers kept inside the can will be available when needed.

G. E. Hendrickson, Argyle, Wis.

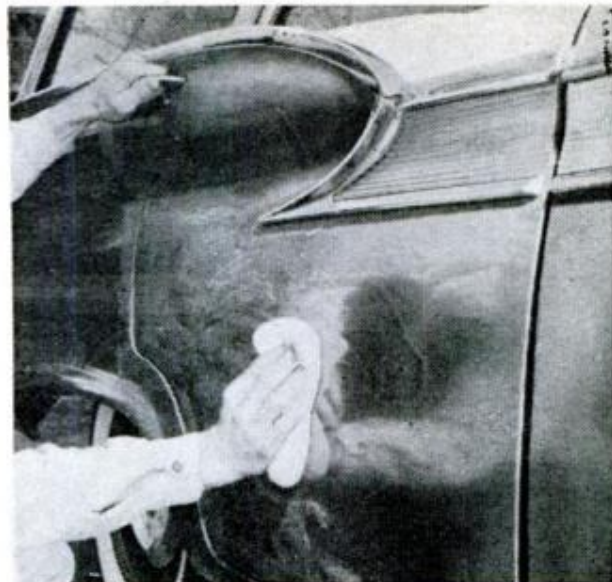
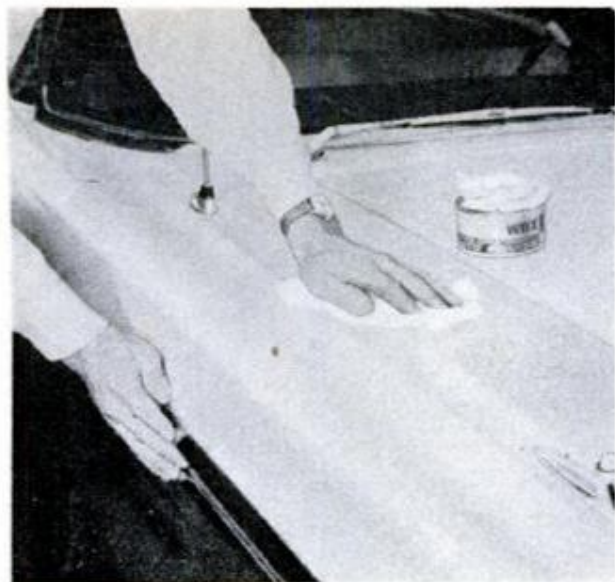

Here Is the Way to a Better Wax Job

BEFORE YOU BEGIN to wax a car, there are several things which should be kept in mind. Otherwise, through no amount of effort will you be able to avoid blemishes, streaks, and greasy areas. To begin with, first be sure that the car is clean. If clear water alone will not remove stubborn road film, try a mixture of water and vinegar. Water and washing soda is even more effective and is best for removing accumulations of summer insects from grillwork and windshields. Less abrasive than commercial rubbing compounds, soda is less likely to scratch the paint finish. Remember, allow the car to dry thoroughly before applying wax.

Do not apply wax to a car which has been sitting in the hot sun. Auto waxes are air-drying compounds containing materials which evaporate rapidly. A hot metal surface will greatly accelerate this evapora-

tion and reduce the polishing qualities of the wax. Also be careful in your selection of a wax. The rapid deterioration of a cheap product will make frequent applications necessary and in the long run you will be wasting time and money.

Once the car surface is clean and dry, it is ready to be waxed. A more smooth and even job will be obtained if one small area is polished while the wax on another area is drying. Apply the wax with a damp, clean cloth and in a consistent pattern—either back and forth or with a circular motion. The important thing is to overlap the strokes. In polishing, rub the area vigorously, shaking out the cloth frequently, until a high luster is obtained. Take special care with areas adjacent to door handles and hood ornaments as the total appearance of the finished job will depend largely on little touches such as these.

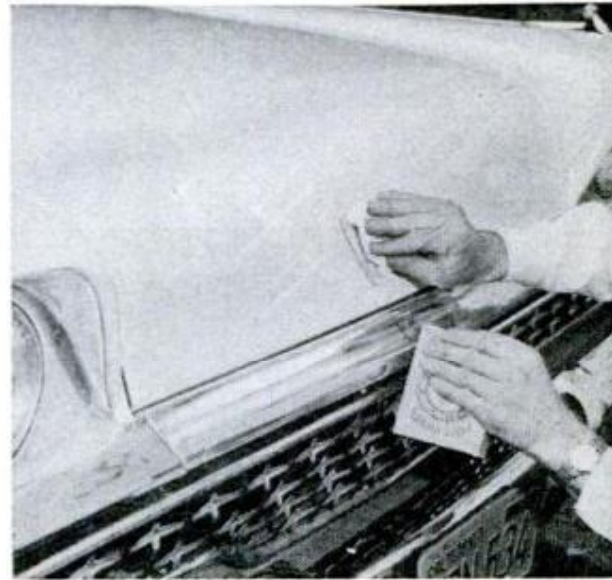
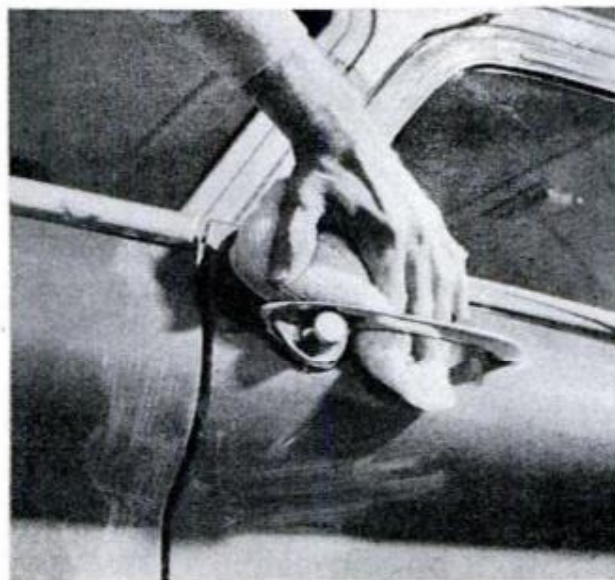



PACK RACK FOR SMALL CARS

By J. M. Rosenthal and R. Edwards



Above, conduit bender makes easy job of forming 90-deg. bend on carrier rail. Below, rail end is flattened and bent to required angle in vise, after which it is drilled to take 1/4-in. mounting bolt

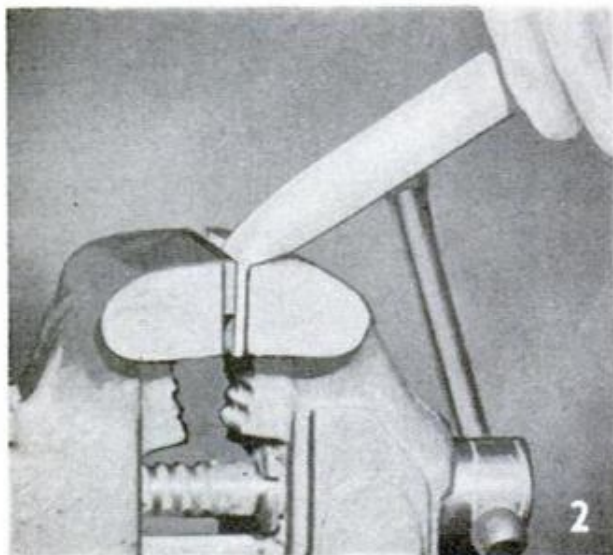

TAKING A family vacation trip in one of the small-small cars is likely to produce a larger dose of "togetherness" than most people will tolerate, unless most of the luggage is carried on a cartop rack like the one shown. Made of lightweight materials, the attractively designed carrier can accommodate several suitcases and some sports equipment. When covered with a waterproof tarpaulin, the luggage is given the same protection from dust and moisture as it would receive in the trunk.

The carrier will fit most foreign and domestic small cars when made according to the dimensions given in Fig. 6. For cars having roofs with high crowns or other unusual roof forms, the dimensions may be changed to suit. Exterior plywood 1/2 in. thick is used for the platform, 1/2-in. thin-wall conduit for the rails and longitudinal supports that go at the sides underneath. Suction cups attached to the flattened ends of the rails hold the carrier in place on the cartop, although a hold-down strap is secured to the gutter on each side as a safety measure.

Side rails are formed from 44-in. lengths of conduit; end rails, from 50-in. lengths. The 90-deg. bends are formed with a con-

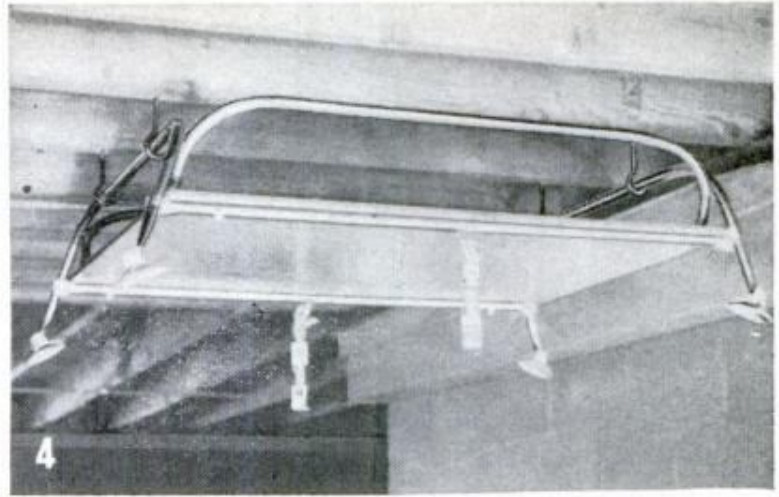
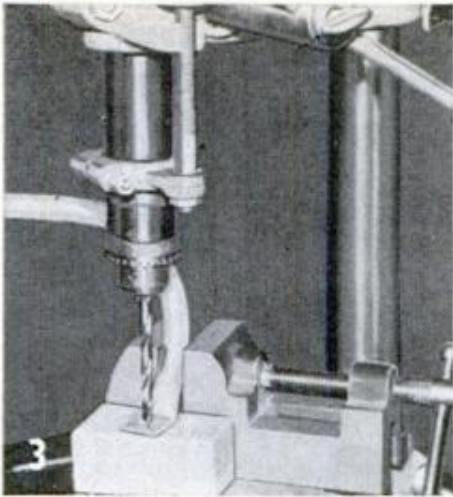

Above left, jig eases job of drilling rail end. Above, carrier stores easily on screw hooks on garage joists

duit bender as in Fig. 1, after which the ends are flattened in a vise, Fig. 2. Be sure the ends are flattened correctly in relation to their mounting position. Unless the curves are shaped by an expert, it's a good idea to cut rail pieces 2 in. longer than needed and then trim the vertical leg portions exactly to the required lengths, after bending them.

After the conduit parts are shaped, bolt holes for the fastenings are drilled. If a jig is used as in Fig. 3, this is an easy job. Holes for bolting the rails together at the corners are drilled after the rails are fastened to the carrier, Fig. 5.

Although the carrier may be painted when it is completely assembled, a better job can be done when it is apart. When not in use, the carrier can be stored out of the way on screw hooks as in Fig. 4, the latter being driven into ceiling joists. ★ ★ ★

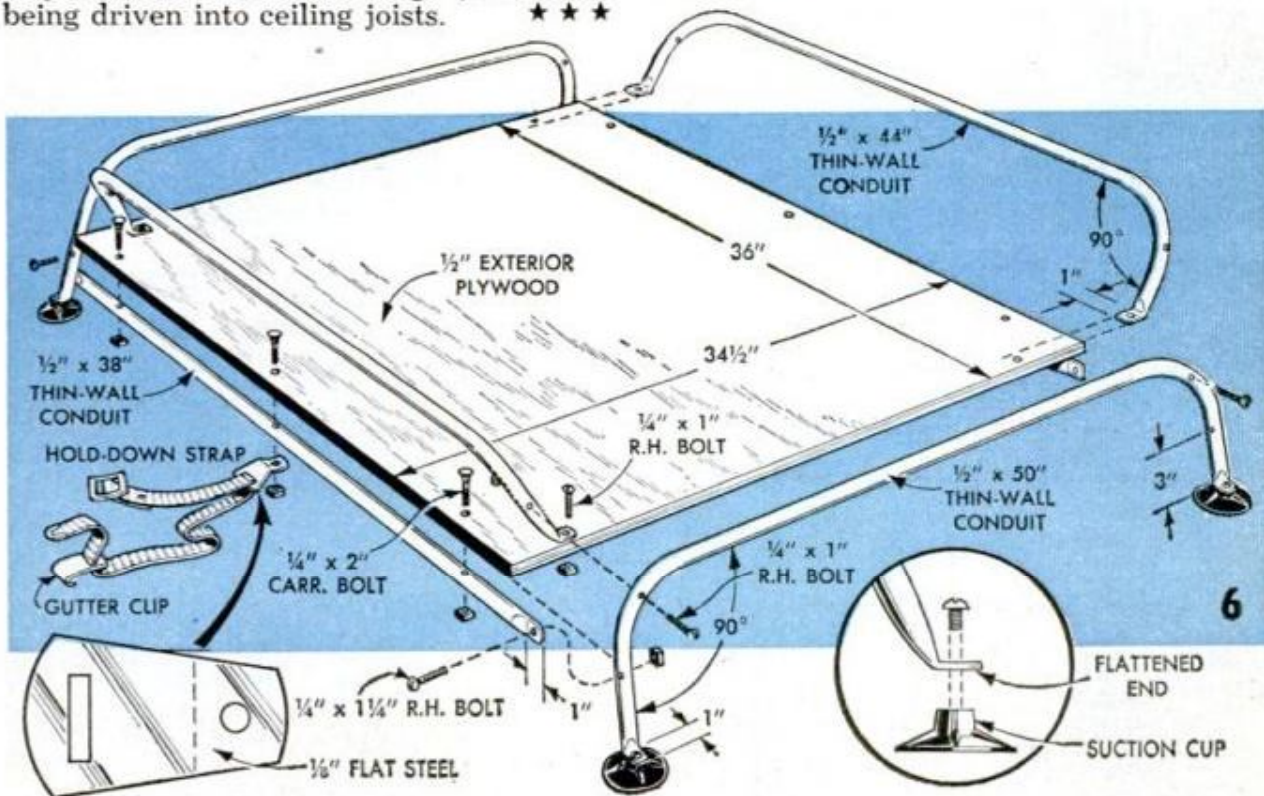
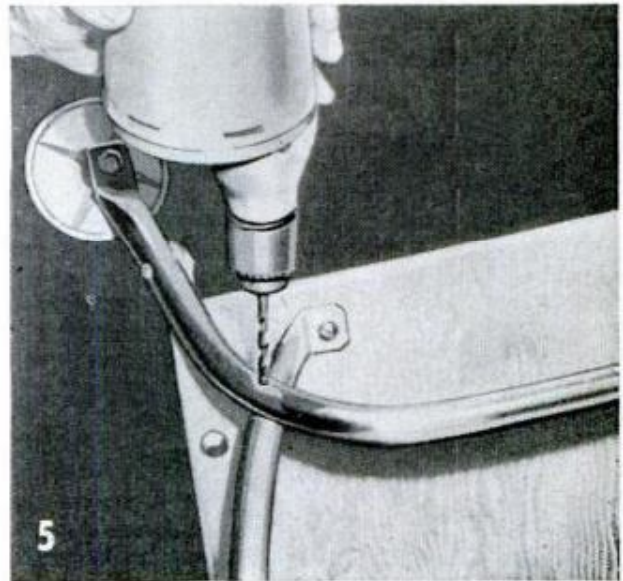

—see Aug 60, 144

Doorbell System Does Double Duty As Basement-Flooding Alarm

Living in an area where seasonal flooding occurs, here is what one homeowner did to alert the household to the threat of a flooded basement. The device consists of a spring-type clothespin, to each jaw of which a brass bolt and a lead to the doorbell is attached as shown. An aspirin tablet holds the lead contacts apart, except when flooding occurs. Then the wetted tablet dissolves, the jaws close and the circuit to the bell is completed. The device is placed next to the floor drain so that the earliest possible warning can be sounded.

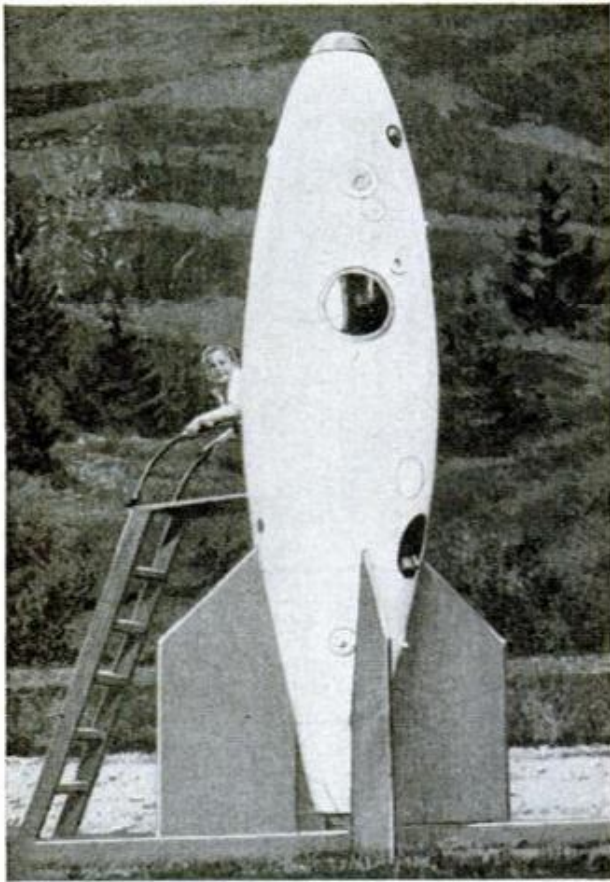
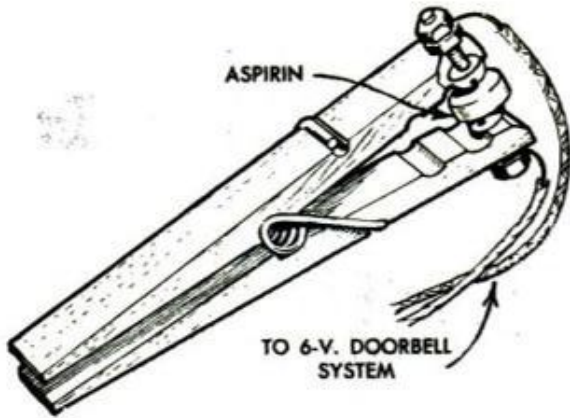

Earthbound Play Spaceship Made From Aircraft Drop Tank

This earthbound rocket for outer-space-minded youngsters was made from a surplus aircraft fuel tank of the drop type, plywood, and miscellaneous switches and instruments of no value, for fake controls. The "ship" is supported in a vertical position, ready for takeoff, by pieces of $\frac{3}{4}$ -in. exterior plywood cut to the shape of flight-control vanes and bolted to the tank sides in the positions shown by means of metal brackets. Inside are two platforms reached by climbing an outside ladder made of 2 x 4s and fitted with handrails which are bent from electrical conduit. Cleats of 2 x 4s nailed to the vanes and bottom of the ladder hold it in place. A short ladder inside connects the two platforms. An impressive-looking panel of controls and instruments is mounted in the "pilot's" compartment. Mounted in the lower end of the tank is an old vacuum sweeper that may be turned on by a toggle switch on the instrument panel. The whine of the vacuum provides an atmosphere of authenticity to impress backyard "space cadets."

Leak in Garden Sprayer Repaired With Screw and Faucet Washer

To stop a small leak in a compression-type garden sprayer, slip a rubber faucet washer on a sheet-metal screw and drive the latter into the hole so that the washer is forced tight against the tank as indicated in the drawing. For best results, drill the leak hole to the diameter of the screw body, and be careful not to drive the screw so tight as to break the grip of the thread in the hole. If the leak persists, wait until the tank will not be used for a few days and coat the hole area with an all-purpose household cement, refastening the screw and washer as before.

S. N. Stresnic, Ft. Lauderdale, Fla.

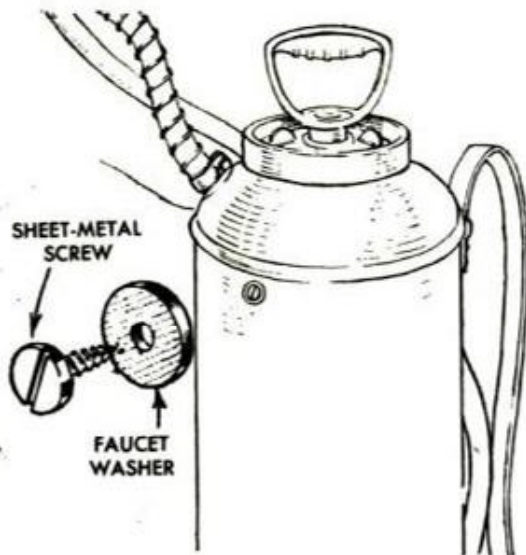

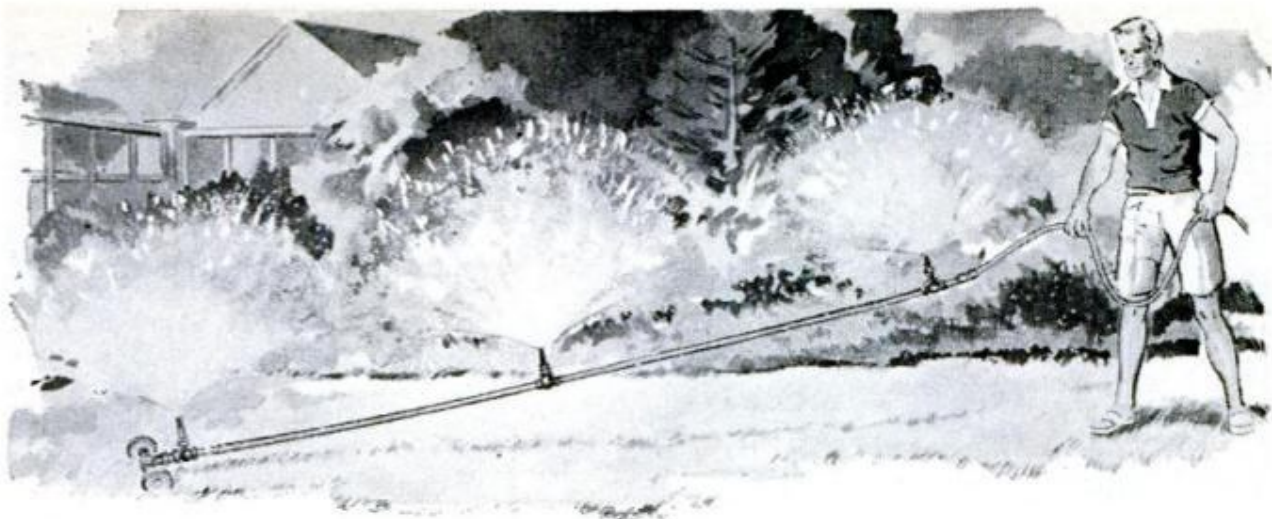

LAWN SPRINKLER CADDY

By Fred Haitz

KEEPING A large lawn watered properly during a "dry spell" is much less of a chore when you have a lawn sprinkler caddy like the one shown. It waters a large section at one time, is easy to move and is made of $\frac{3}{4}$ -in. steel pipe and fittings to which hose nozzles are attached as indicated in the photo, below left. The nozzles permit complete adjustment of spray—from large volume, coarse droplets for quick saturation, to a fine mist that is ideal for watering seedlings and slow soaking.

Each of the caddy wheels is mounted on a bolt through an assembly consisting of a pipe cap, nipple and tee fitting installed at one end as in the photo, below right, and the drawing. If two wheels and a shaft are available from a discarded tricycle or coaster wagon, the shaft may be installed in the above assembly instead of welding a bolt to each of the pipe caps as suggested. This will save a welding job. Wheel bearings should be well-greased to prevent corrosion.

When not in use during the watering season, the caddy stores inconspicuously next to a fence or along the edge of a flower bed. For compact winter storage, it may be disassembled into easy-to-handle sections.

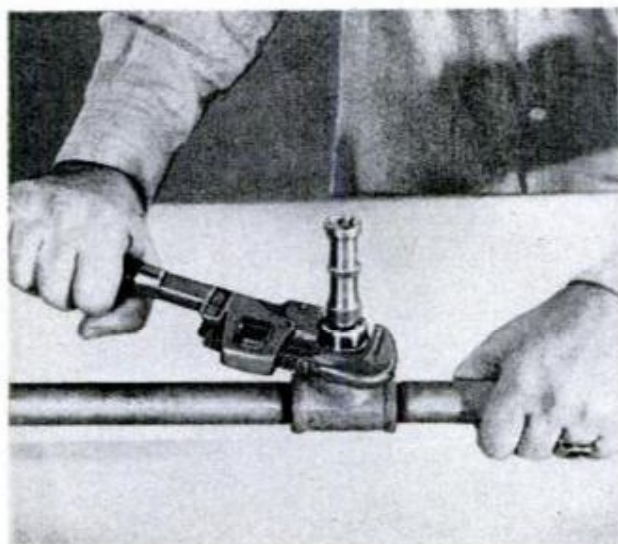
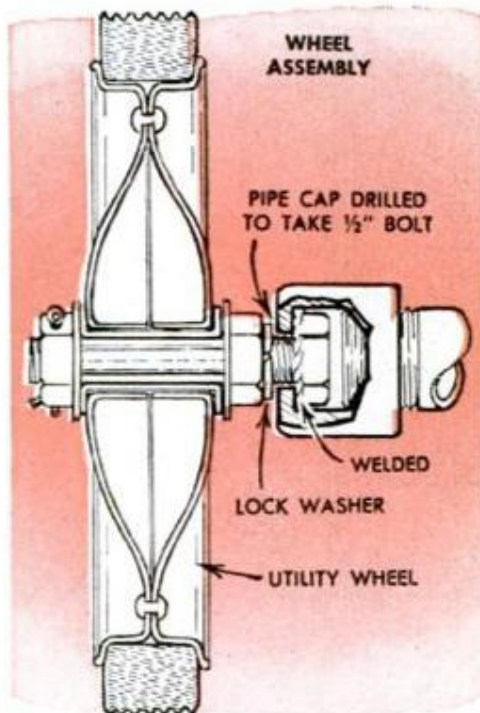

Variety in Room

By Enno R. Haan

AS AN important part of modern decor, the room or space divider adds a distinctive touch to any home. In today's quest for gracious living, room dividers have become as various in design and function and in their use of materials as decorative ingenuity can make them. The oriental influence of room dividers is evident in the filigree screen shown at the far left and in those shown below. The floor-to-ceiling type consists of panels of lightweight Philippine mahogany veneer attached to metal poles.

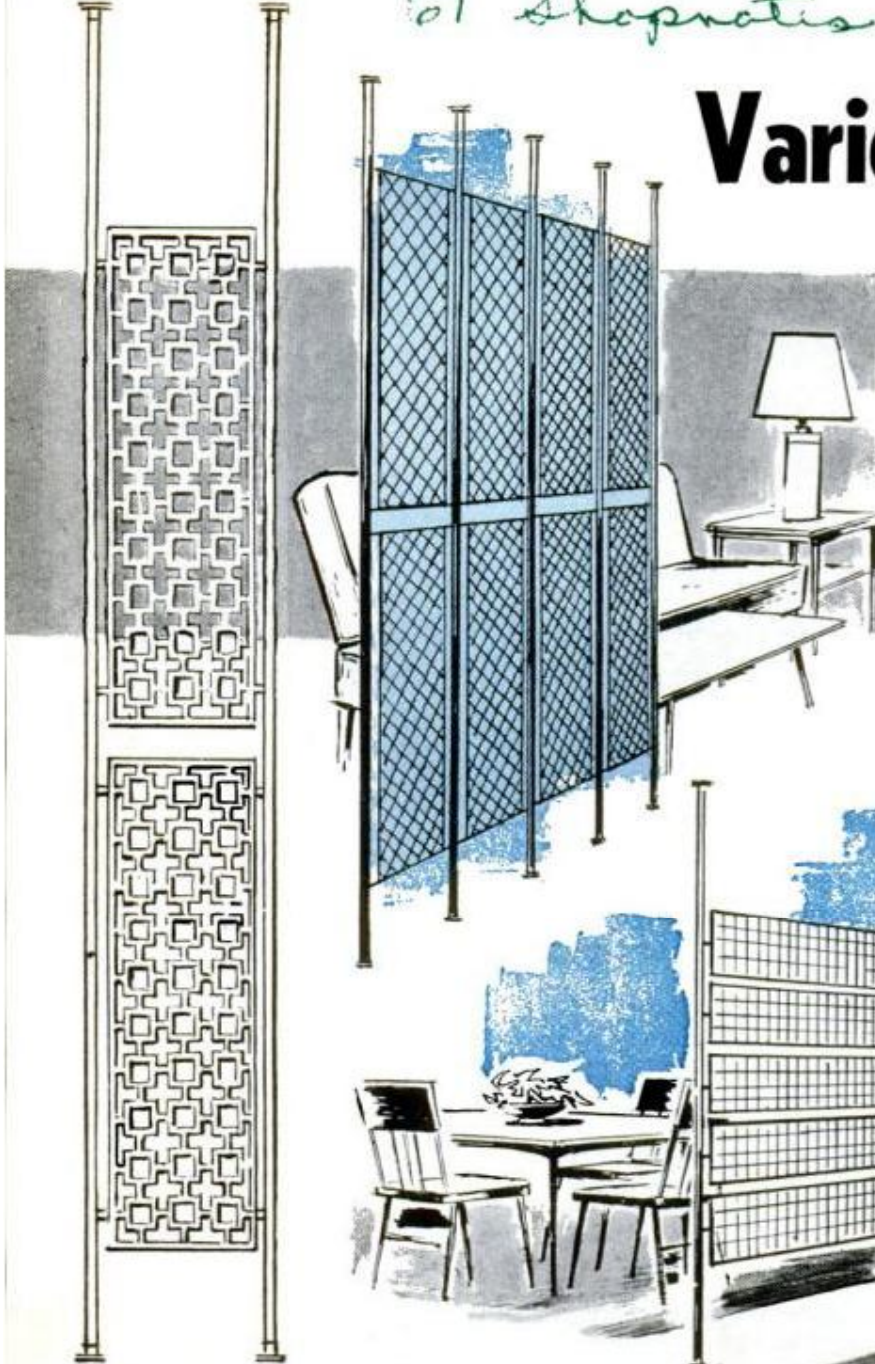

Dividers consisting of poles only, below left, do not obstruct light or vision and may be fitted with plants. Below, a permanent divider in a basement playroom. Metal tubes extend from the base planter to a ceiling canopy fitted with semiconcealed fluorescent lamps

Insulite Div., Minnesota & Ontario Paper Co. photo

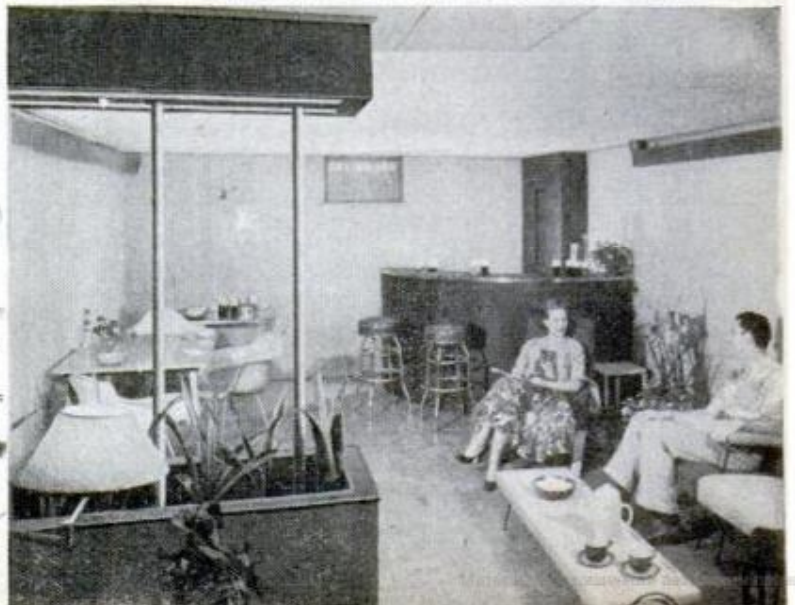
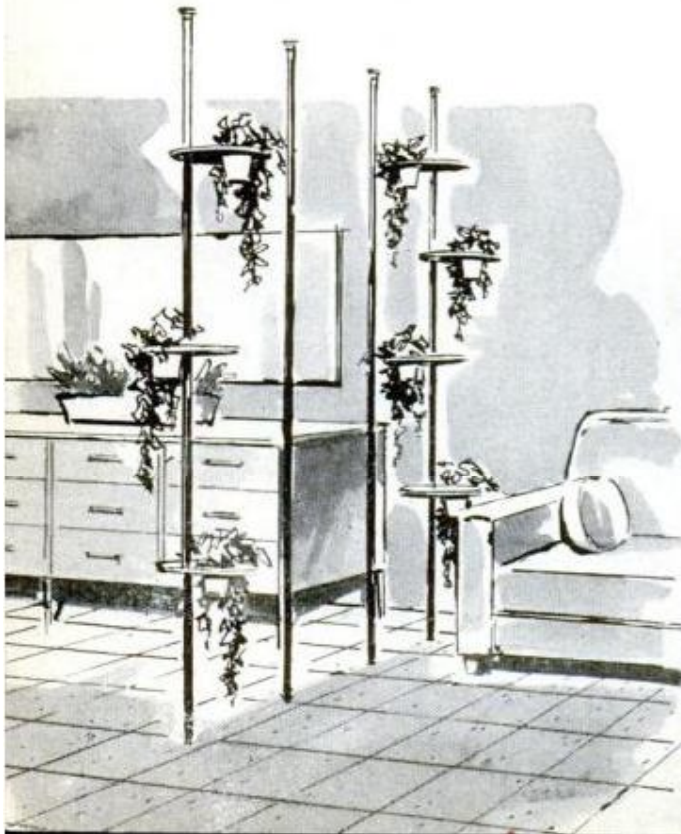

Dividers

Another design, pleasing in its simplicity, is the open type divider, right. Easily constructed from 1 x 3-in. wood stock, it may be painted to complement the dominant room color and is particularly effective when only four uprights are used to form three vertical sections of which the center one is the widest. This divider is well suited for doorways and for displaying whatnots and small potted vines. The detail below shows how it is made, 1 x 2s being used for the uprights which are nailed to ten cross members equally spaced.

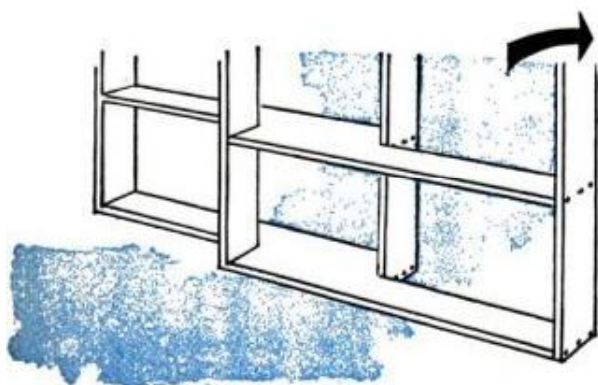

Similar in pattern to the oriental panels shown on the opposite page, the 14 x 64-in. panel, at the right, may be purchased ready made. Set in a redwood frame, it may be finished to suit individual taste. Several may be joined together with hinges to form a portable divider as shown below. The panels may also be mounted on floor-to-ceiling supports, or hung from the ceiling track, below right. If hung from the ceiling as screens, they may be folded out of the way or extended for use as needed.

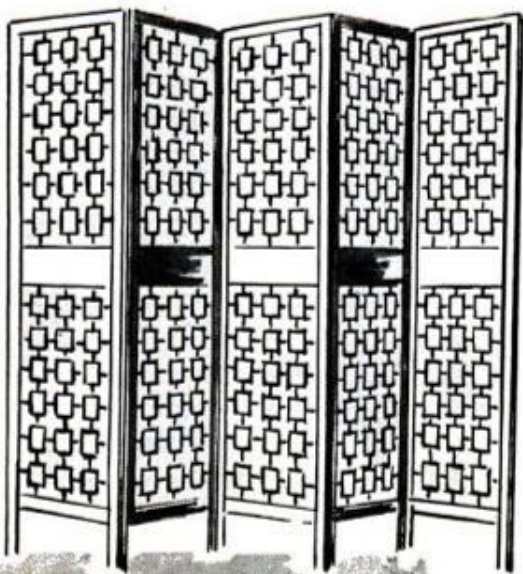

St. Charles Mfg. Co. photo

The screens shown below are of the same design as louver-type shutters and are hung from a ceiling track for easy movement. They are joined with folding-screen hinges



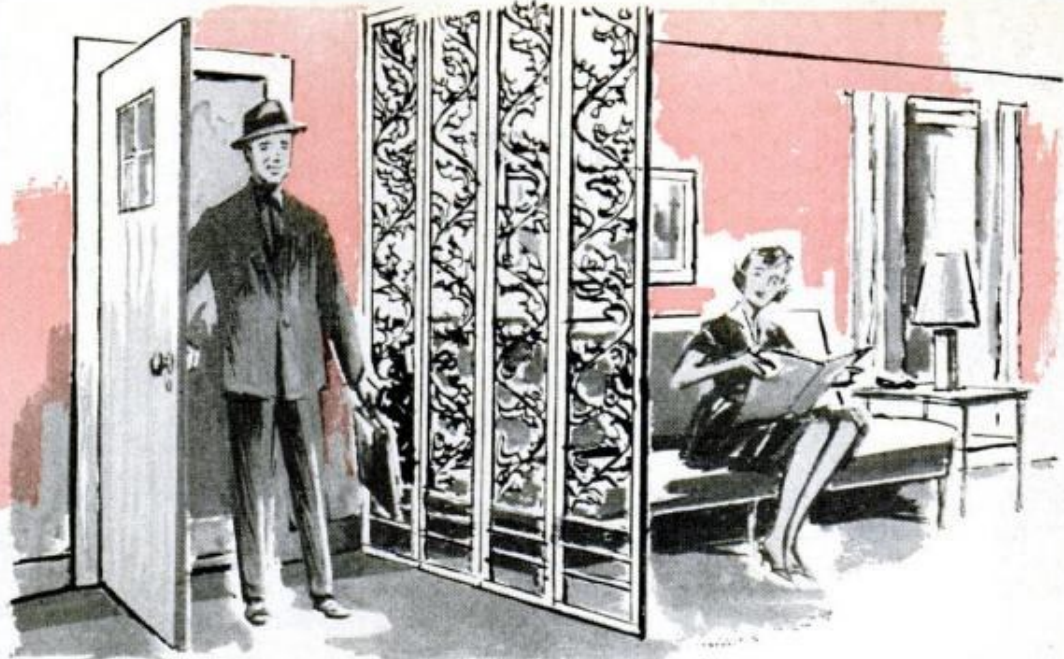

Graceful scrollwork panels of cast iron or aluminum are popular for use on patios and porches and offer distinctive possibilities for use as floor-to-ceiling dividers. The cast panels are mounted between square tubular posts. Each unit measures about 13 in. wide and 8 ft. high but may be cut to room dimensions

Many different materials are available for use in room dividers. Corrugated glass fiber, for instance, is particularly striking and is ideal for dividing the cooking area from the dining area. These panels are held by matching wood strips. Spring-loaded supports, right, wedge the panels between the floor and ceiling and permit the panels to be turned to increase or cut down on the amount of air circulation

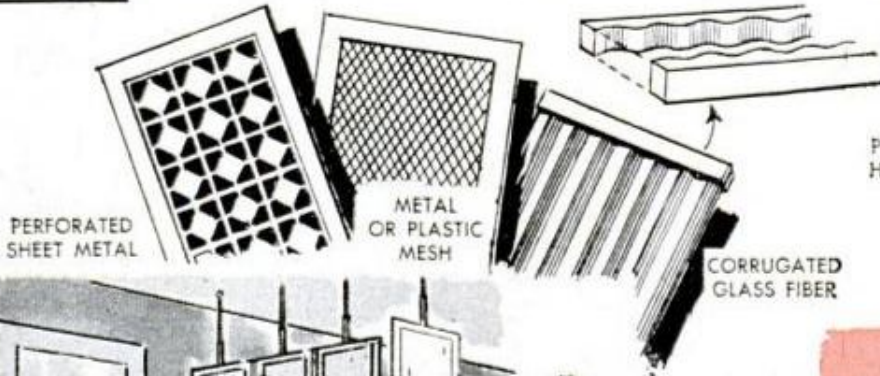

PERFORATED SHEET METAL

METAL OR PLASTIC MESH

CORRUGATED GLASS FIBER

HARDBOARD

PERFORATED HARDBOARD



SUCTION CUP
TWO TELESCOPING TUBES

HARDBOARD

PERFORATED HARDBOARD

SPRING

SLOT

SCREW

RUBBER TIP

TIGHT FIT

THREE TELESCOPING TUBES PERMIT TURNING AND UP-AND-DOWN MOVEMENT

Room divider panels, right, can be held in angle-iron frames whose ends are bent to allow attachment. Detail below shows the joint between vertical and horizontal members and the grooved wood strips which hold the panels. Strong and durable, dividers of this kind are best used as permanent fixtures and are especially useful in connection with rumpus rooms where less hardy dividers might suffer damage

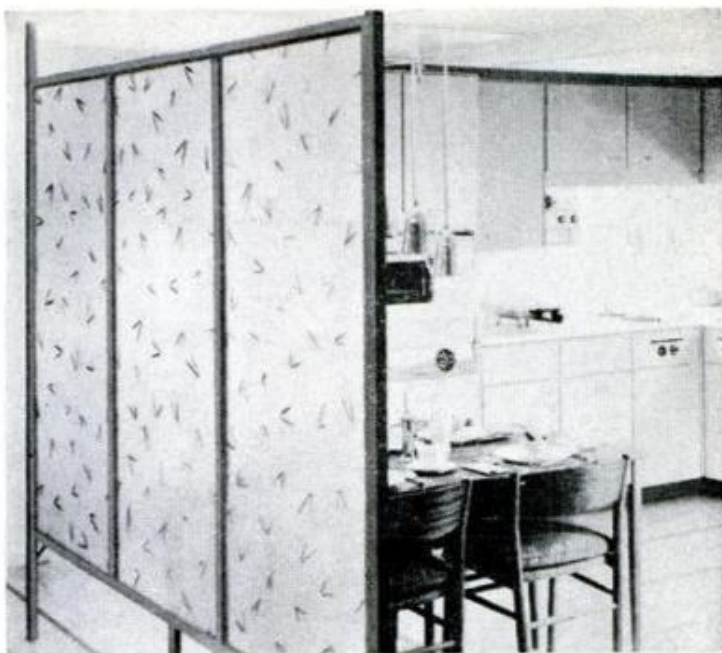
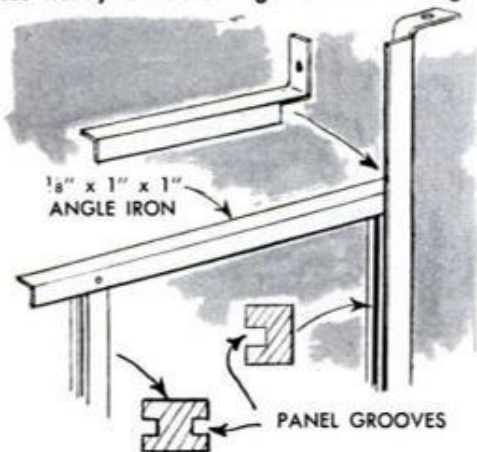

Westinghouse Electric Corp. photo

Common everyday materials offer the imaginative decorator an opportunity to give his home an artistic touch at little cost. Sheets of translucent plastic, above right, not only divide one area from another but diffuse the lights from adjoining rooms

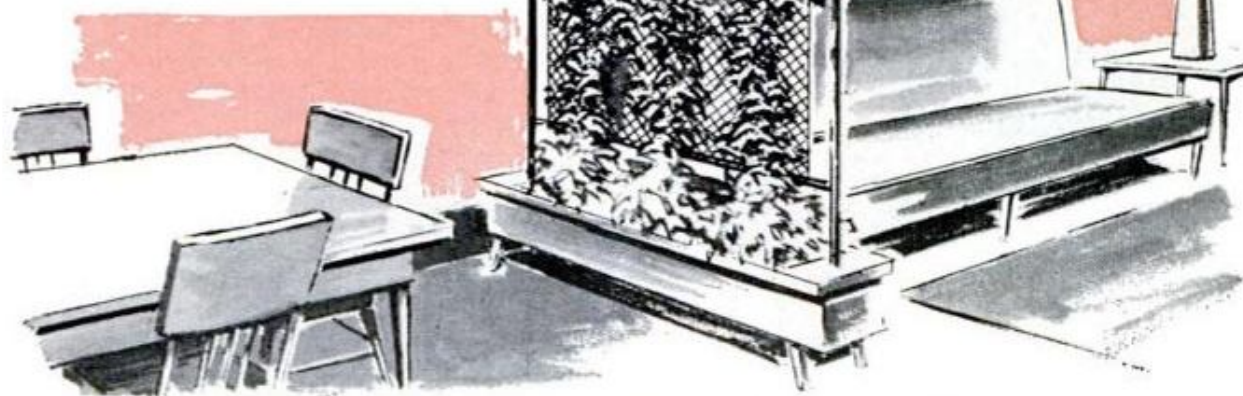

Chicken-wire netting also may be used, as at the right. In this case, the netting was pulled over the top of the aluminum tubing frame and attached to a crosspiece near the bottom. The bottom ends of the frame fit into holes in the planter base. Climbing flowers or ivy planted in the base planter will in a short time create a screen of flowers or green leaves

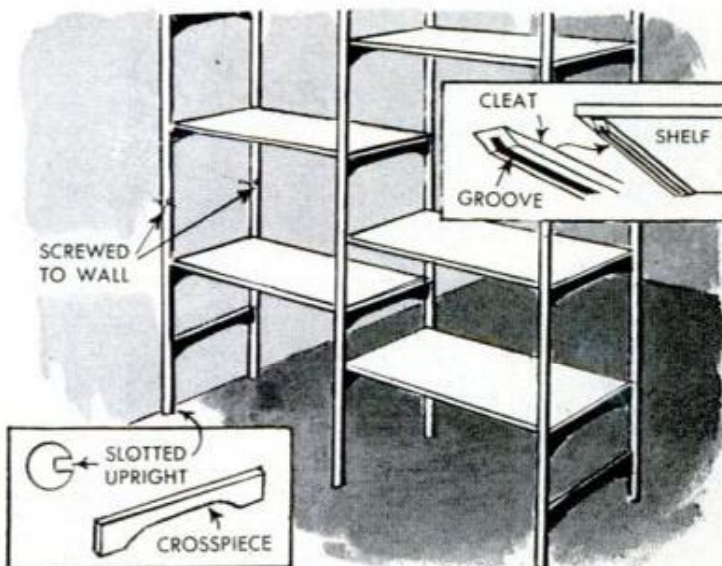

Delicate display shelf units like those illustrated at the right serve as shelves and also double as room dividers. Details show how such a unit can be changed in size and appearance through the use of its slotted cleats and crosspieces. The cleats slip snugly over the crosspieces of the "ladders" and hold the assembly together as a unit. One set of uprights must be screwed to the wall for rigidity

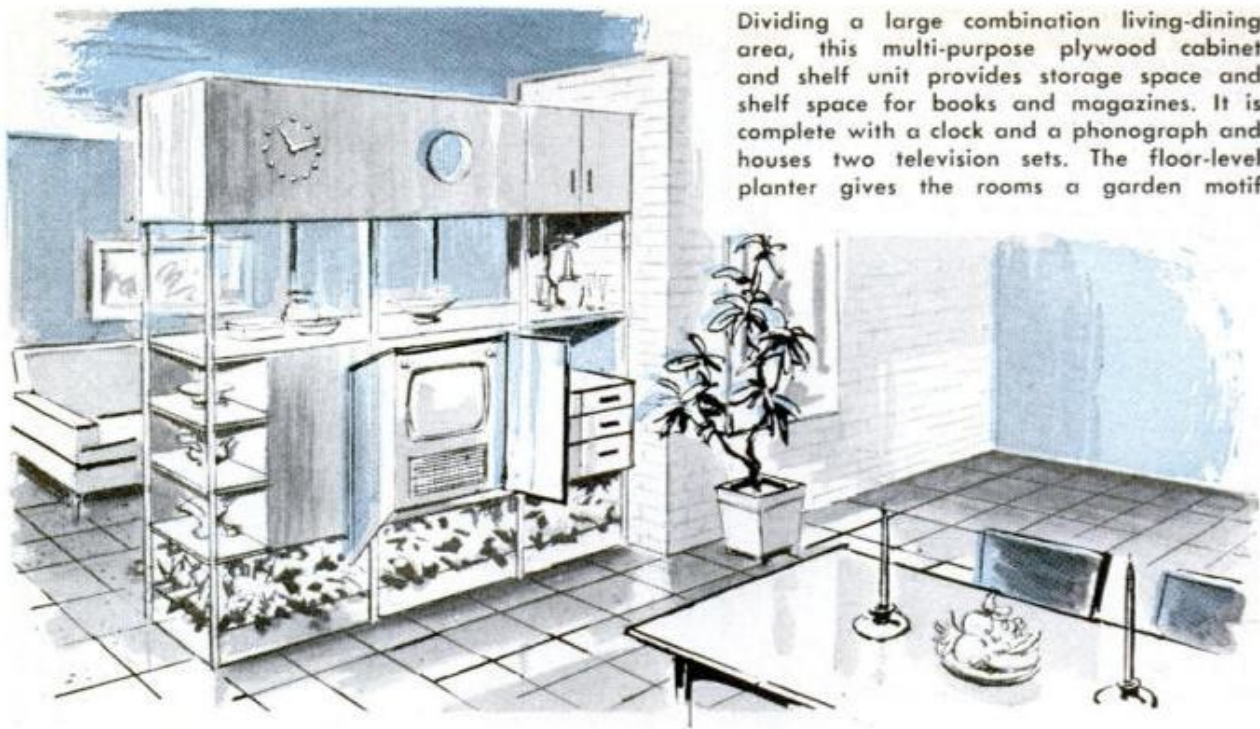

Dividing a large combination living-dining area, this multi-purpose plywood cabinet and shelf unit provides storage space and shelf space for books and magazines. It is complete with a clock and a phonograph and houses two television sets. The floor-level planter gives the rooms a garden motif

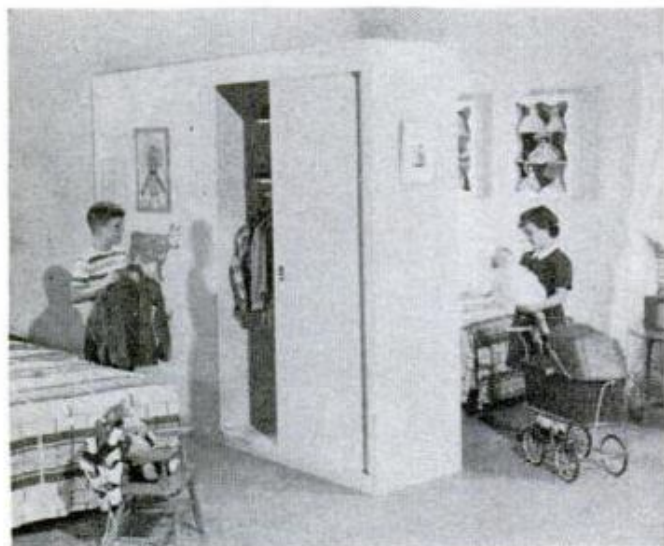

Cabinet-type room dividers, like the one shown on the left, transform a single large bedroom into two smaller sleeping quarters, providing extra privacy for growing children. The divider may be made to cross the room entirely if each area has a separate exit to the hall. This design is particularly valuable where extra storage space is needed

Below is another design in room dividers intended primarily for use by teen-agers. The closets, not less than 2 ft. deep and 3 ft. wide, are accessible from opposite sides. One side of the center portion may be fitted with a vanity mirror, table, drawers and extra shelves. The other side may be arranged in the same way or in any other fashion suiting the taste of the occupant of the room

Masonite Corp. photo

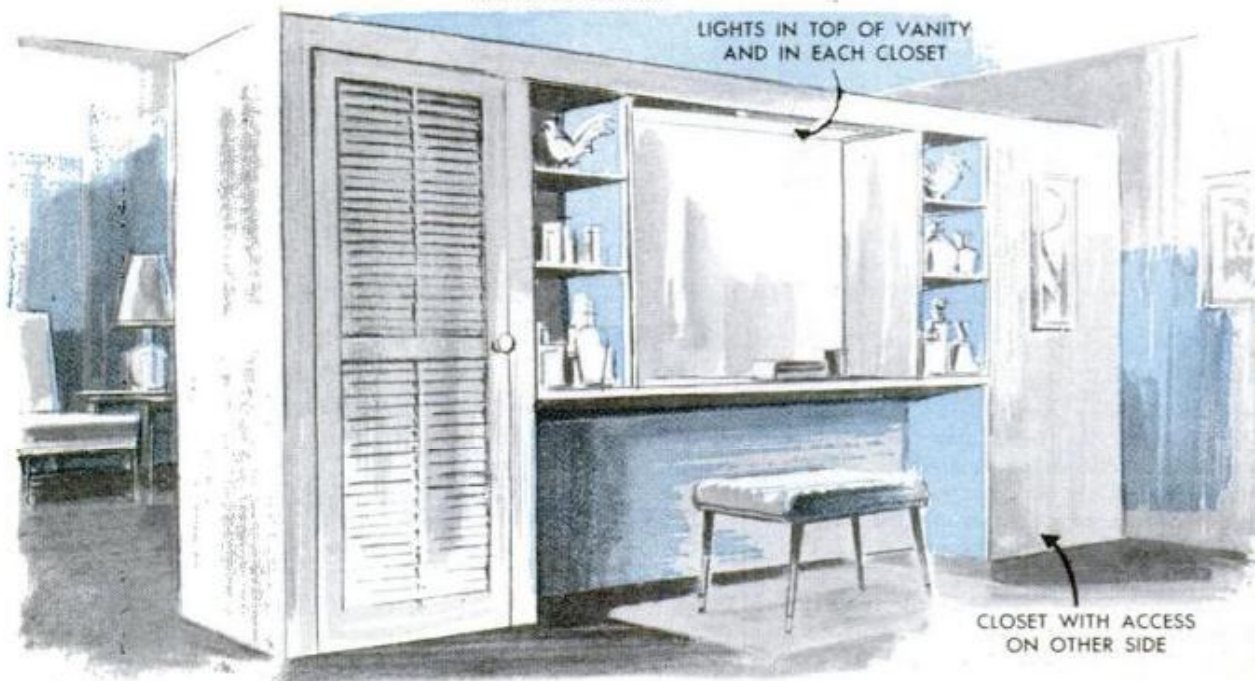

LIGHTS IN TOP OF VANITY AND IN EACH CLOSET

CLOSET WITH ACCESS ON OTHER SIDE

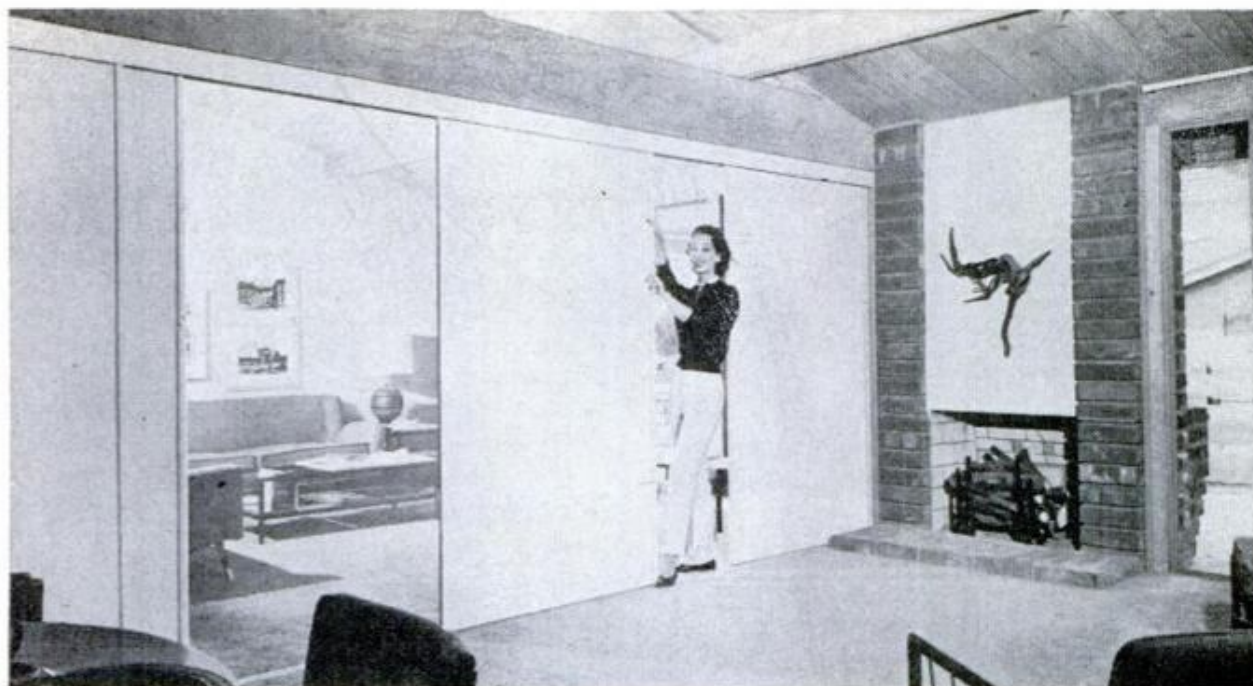

Woodall Industries, Inc. photo

Sliding walls, such as that shown above, may be made of glass or wood to permit a more positive separation than is possible with open grillwork or with cabinets that divide only part of the room. Sliding doors open up the home to large numbers of guests, or close to afford maximum privacy to individuals. Since doors of this kind are made of single panels, there is little to do in the way of construction. Steel or aluminum tracks are screwed to the floor and ceiling and guides are screwed to the panels. Once mounted, the panel may be finished with each side complementing the color of the room it faces

Another example of a sliding wall is shown at the right below. The frames of this divider are made of sturdy oak and the panels are translucent frosted glass. The entire assembly slides easily on a track fitted into the bottom of a special framework suspended from the ceiling. The opening between the ceiling and the divider assures a continuous circulation of air; is best for areas around swimming pools

Dividers of the folding, or accordion type, shown below, have a sturdy metal frame covered with a strong and durable fabric. They require very little space when open and may even be fitted into wall recesses and be completely concealed from view. The overhead track on which they run is easy to install in any existing home. This type is especially useful in smaller homes where portions of rooms, such as a bedroom doubling as a nursery, must be closed off during certain times of the day from other rooms

New Castle Products, Inc. photo

Libbey-Owens-Ford Glass Co. photo

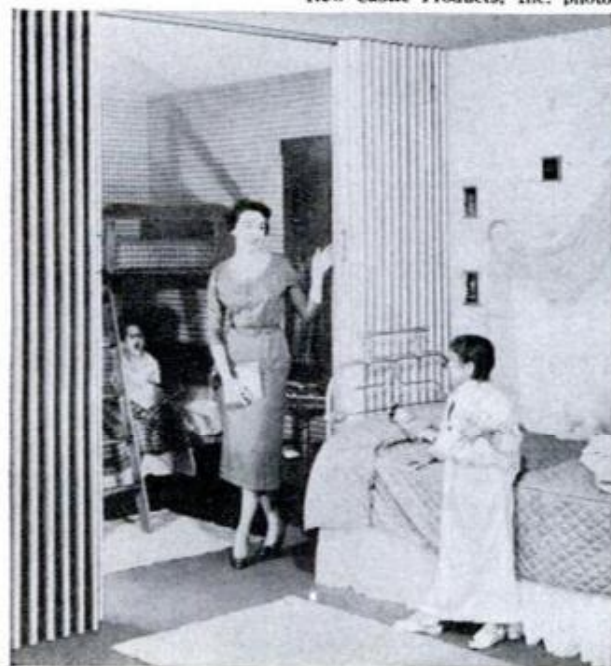

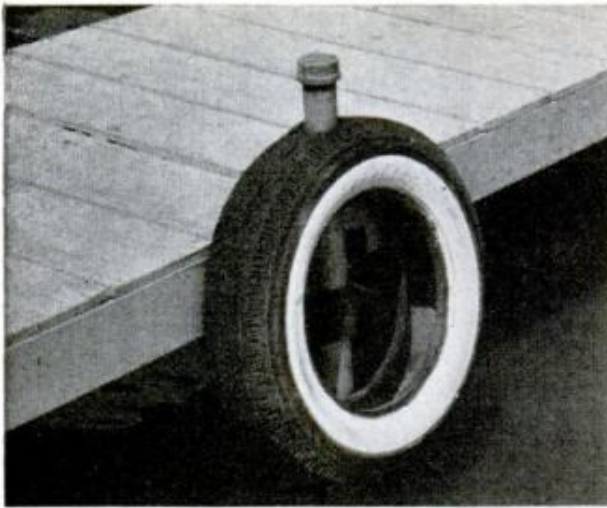

Pipe Cap Locks Tire on Dock Post

To protect the topsides of my new boat and dock as well, I collected enough discarded whitewall tires for the steel-pipe posts on the dock and installed them as shown. A slightly undersize hole was cut in the tread of each tire to take the post, making it difficult for trespassers to remove them without unscrewing the pipe cap. The tight fit also helps to keep the tires in place. Most metal and glass fiber boats do not become marked from contact with the tires, which remain serviceable for many seasons.—R. Amati, Chicago

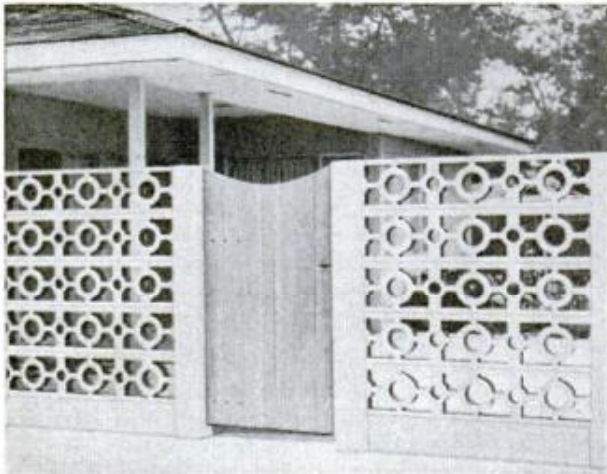

Decorative Concrete-Block Screen

This attractive concrete-block screen wall provides semiprivacy without stopping summer breezes. Available in other designs that are equally open, many patterns can be worked out in such a wall by combining the decorative blocks with solid ones. For a strong vertical accent, space columns of solid blocks fairly close together. A row of solid blocks at the bottom and top of a wall will give it a horizontal accent. Other basic patterns, such as squares, diagonals and checkerboard are easy to make. Use standard concrete-block mortar for all joints.

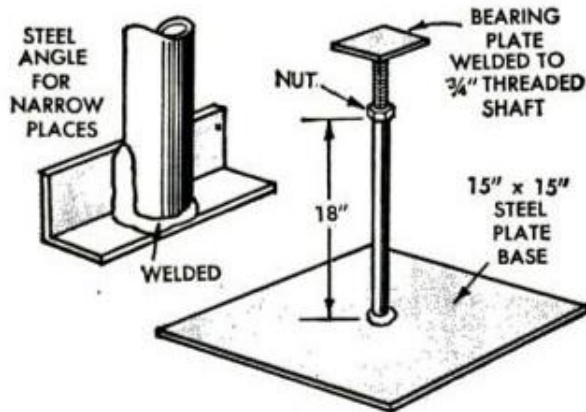

Heavy-Duty Support Jack

Make your own heavy-duty jack when one is needed for raising a sagging corner of a garage, or for a permanent support that should be fully adjustable. The drawing at left shows you how to make such a jack at a fraction of the cost of manufactured ones. Lifting action is obtained by turning a nut on a threaded shaft, the former of which bears against the upper end of a pipe length welded to a base. A broad steel base is best for use on soft ground; a steel-angle base when a jack is to be used in a narrow place.

J. A. Lockhart, Bryan, Ohio

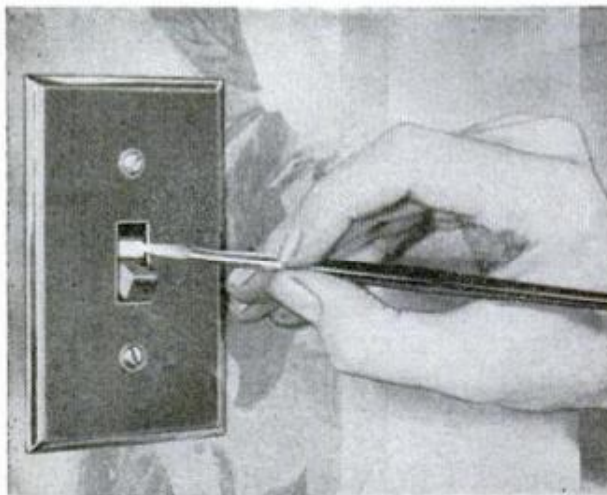

Painted "On" Face of Switch Serves as "Pilot Light"

When a switch is located where it is difficult to observe whether the light it operates is "on" or "off," such as a basement or attic light, here is a way of telling at a glance. Simply enamel the "on" face of the toggle in white or some other color that will give maximum contrast with the color of the switch plate as indicated in the photo at left. Use reflective tape, if the switch is located in a service area that is quite dark most of the time.

Henry Hanscom, Elmhurst, Ill.

Homemade Hand Truck Eases Moving Chores

KNOWING THE proper way to lift heavy objects is not sure proof against a strained back. Younger men are more likely to attempt heavy jobs and fall victim to kinks and strains as often as their older friends. This useful hand truck eliminates such mishaps. It is useful in man-sized jobs, such as moving trash cans and sacks of cement, and can be used by the little woman in the garden and the house. The frame and wheels are cut from a piece of 2 x 8 x 52-in. fir, 36 in. of which are used for the frame. The wood is ripped along a diagonal line as shown in the illustration. Drill a series of blind holes in each piece and mount and glue the frame sections on 1-in. dowels or sections of broom handle. Cut the wheels from the remaining 16-in. of fir. An 18-in. dowel run through a hole bored in the frame and in the center of each wheel serves as an axle. The platform is cut from 1/2-in. plywood in the shape illustrated, and is fastened to the frame with screws, glue and 3-in. corner braces.

Paul Corey, Sonoma, Calif.



Though light in weight, the truck handles an amazing variety of heavy jobs. Its small size not only makes it convenient to store, but allows it to be used by women and children in home and garden chores, and for hauling heavy stock and scrap in the shop. For bulky objects, such as potted shrubs and plants, a screw eye and rope combination across the front secures the load and eliminates danger of tipping

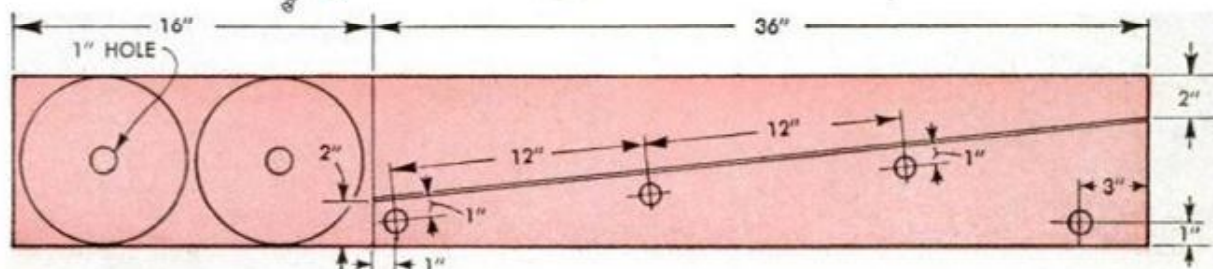
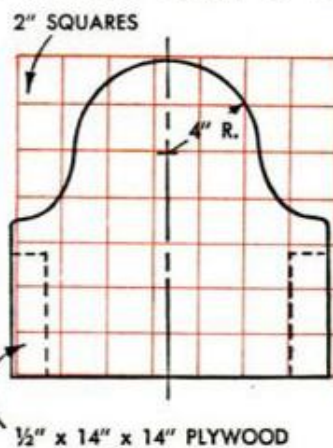
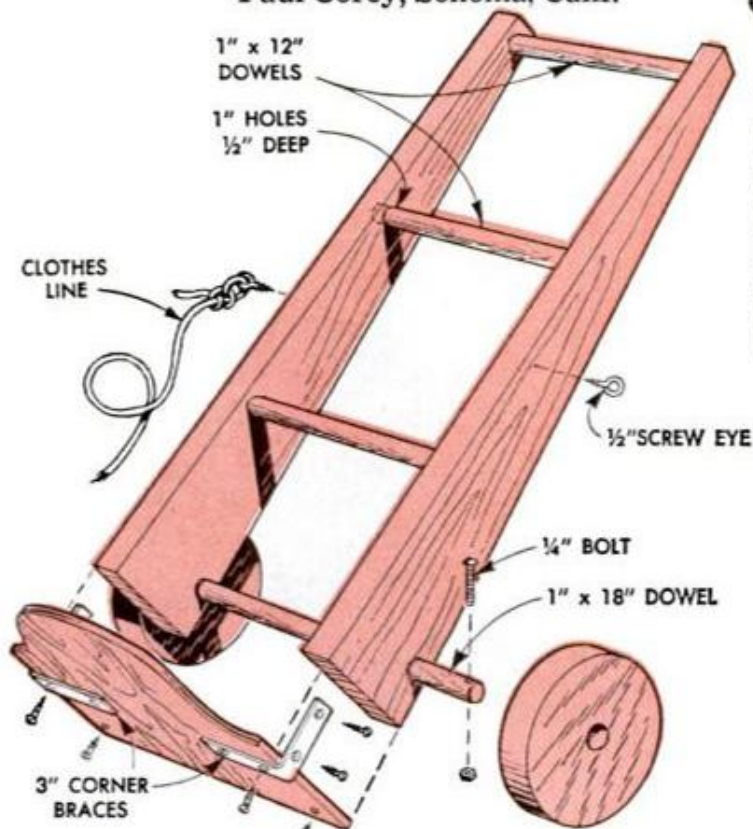

DUAL-PURPOSE SKI ROPE



FOR THE WATER SKIER who likes to do slalom skiing as well as the regular variety, here is a ski rope that has quick-change single and double handles, eliminating the need for two complete ropes. You can make the rope in less than an hour. Cost, about five dollars, if you make the handles yourself instead of using patented aluminum ones popular now.

The quick-change feature is provided by a new type of patented hook that is used in pairs as in Fig. 9. One is attached to the outboard end of the main part of the ski rope and another is attached to each of the handle ropes (single and slalom). The handle desired then may be connected to

the rope in a second by engaging the eye of one hook with the other as in Fig. 5.

The materials needed for the rope are available at most marine-supply stores, except for the 1-in. ash dowel stock from which the handles are cut and drilled, Fig. 8. A 100-ft. length of braided $\frac{1}{4}$ -in. plastic ski rope is required, from which the following lengths are cut (finished lengths of each section are given in parenthesis). Main section, 76 ft. (75 ft.); single handle rope, 2½ ft. (11 in.); center, connecting section for slalom rig, 17 ft. (8 ft.); rope for slalom handles, 2 ft. each (9 in.). The above includes an allowance of 6 in. for eye splices where required. A small plastic

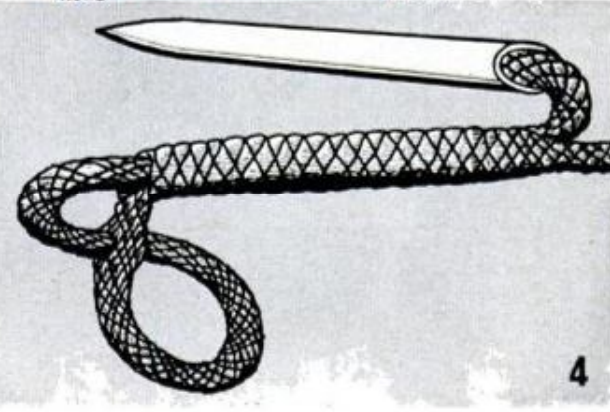
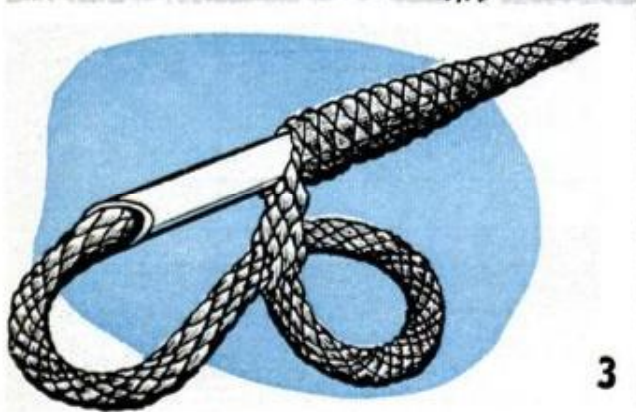
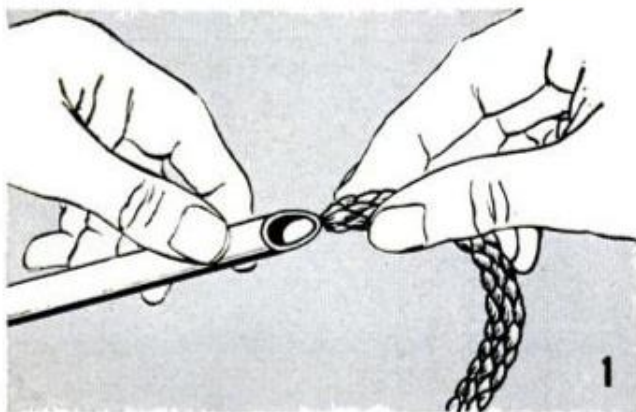



float attached as shown, provides flotation for the metal hooks.

Forming the eye splices at both ends of the main part of the rope and at the ends of the center slalom section is an easy job as shown in the drawings. The hollow fid used for passing the rope end between the strands and through the hollow core can be made by shaping a short length of copper tubing to a point. The flame of a match is touched to the rope end of a completed eye splice to fuse the strands, after which it is pressed into the rope with cardboard, Figs. 6 and 7. The hook is held in place on the center slalom section by whipping the doubled rope as in Figs. 5 and 9. ★ ★ ★



5

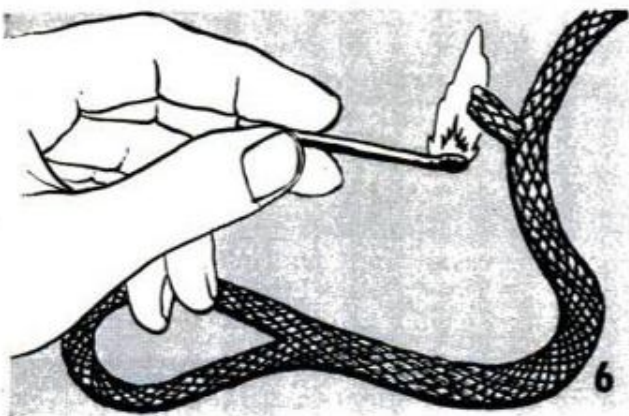

6

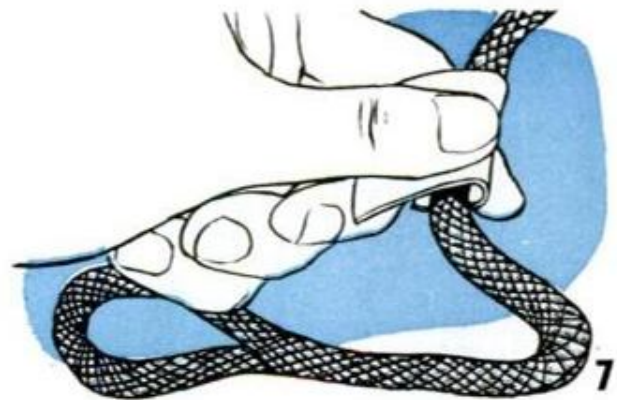

7



8

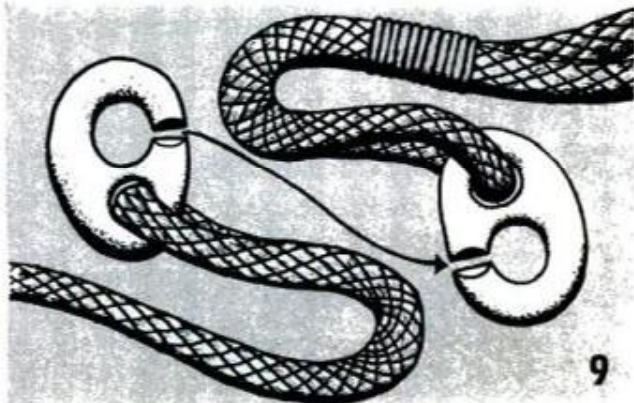

9

SHOP NOTES

FACEPLATE TURNING

By Sam Brown

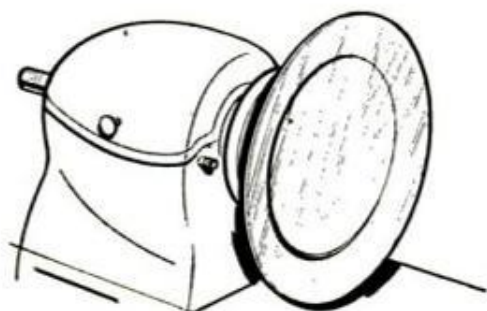

NO FORM OF wood turning gives as much enjoyment and satisfaction as the turning of a cylindrical box, bowl or platter in select cabinet woods. Projects of this kind take two to four hours to complete from start to finish, and require little skill — only a little muscle and patience. Hard, white maple is the recommended first choice in readily-obtainable woods, and a single plate or platter about 11 in. in diameter is a good first project. Preferably the wood should be one piece, but stock with a single waterproof glue joint is satisfactory.

Work is mounted as shown in Fig. 1. The backing block is screw-fastened to the lathe faceplate and is turned on the outer face to form a true flat surface. The work stock is glued to the backing with

X264

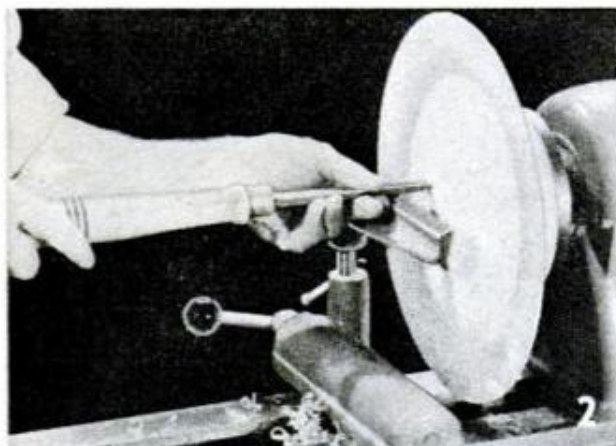
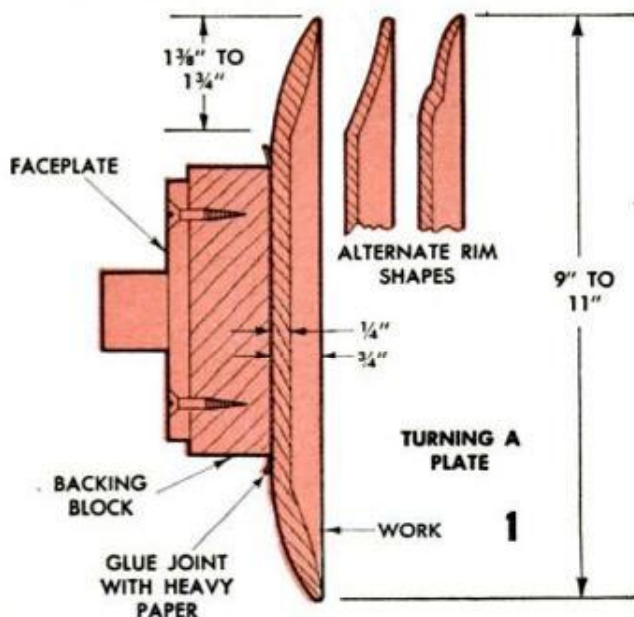

a disk of glazed paper at the joint. The slick paper used for magazine covers is excellent. Coat both sides of the paper disk with glue and then clamp the assembly with C-clamps. It also is practical to use the lathe itself for clamping by bringing up the tailstock to press against the wood.

Turning is just a matter of scraping, using any chisel that fits the shape of the wood surface. The most important point is to keep chisels sharp—light honing every 10 or 15 min. is required for

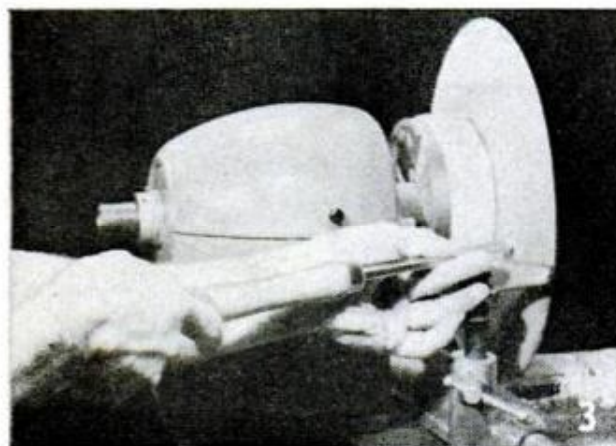

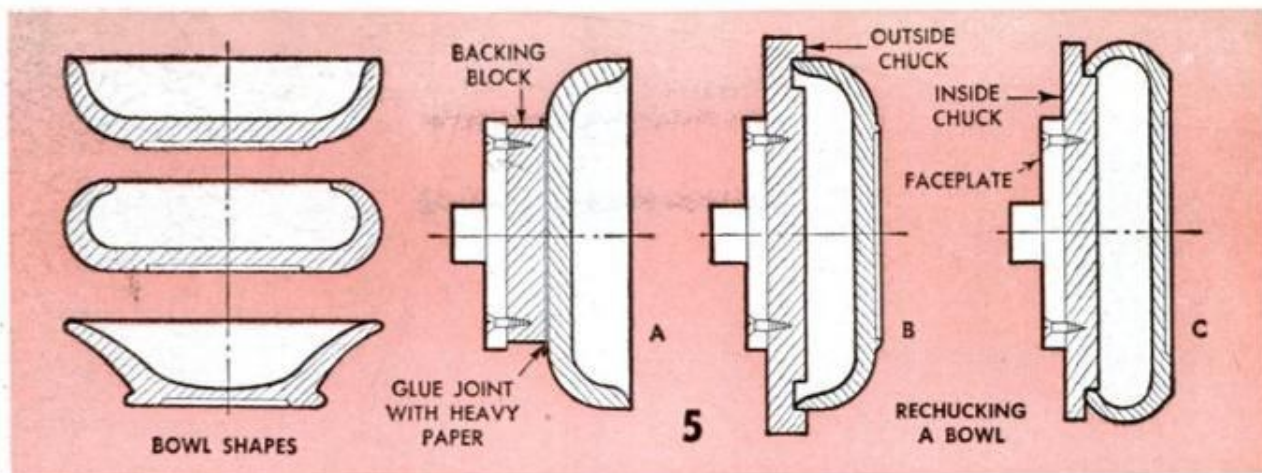

clean, fast cutting. A large gouge usually is used for roughing cuts, while lighter finishing cuts can be taken with a round-nose chisel. The main secret of chisel technique is to pick up a "bite" and hold it, moving the chisel slowly across the work. Very light cuts with flat or round-nose chisels are needed, Fig. 2, and at least $\frac{1}{16}$ in. of wood must be removed in this manner to obtain smoothness in the two cross-grained areas present in every turning. Final sanding with 3/0 garnet abrasive will remove minor humps and hollows. The lathe should run at slowest speed, or about 600 r.p.m. for roughing, while second speed (about 1200 r.p.m.) can be used for finishing cuts and sanding, but only if you feel comfortable with the work turning at this higher

speed. For a flat-bottom plate, all of the turning can be completed in one chucking. Fig. 3 shows the back being turned. After turning is completed, you can remove the plate from the back block by driving a sharp wood chisel into the papered glue joint. The glue itself will hold tightly to the wood—but the paper will split, as can be seen in Fig. 4. The flat bottom is finished by hand-scraping and sanding.

Sometimes you may wish to turn the bottom of a plate or bowl. In this case, the work must be rechucked. This is done by turning a disk of wood to form a recessed chuck into which the half-finished work can be press-fitted as indicated in Fig. 5. Details A, B and C show chucks for bowls of the three most common

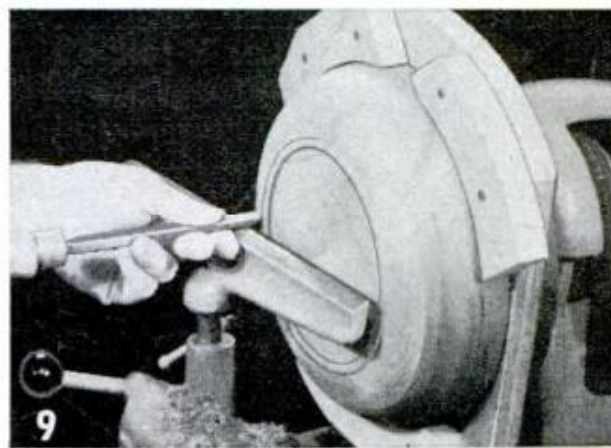
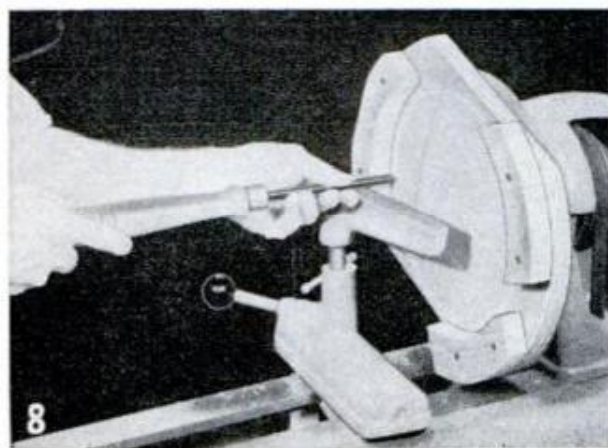
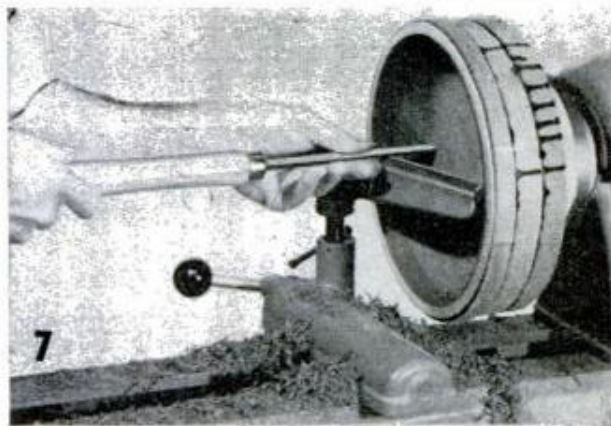
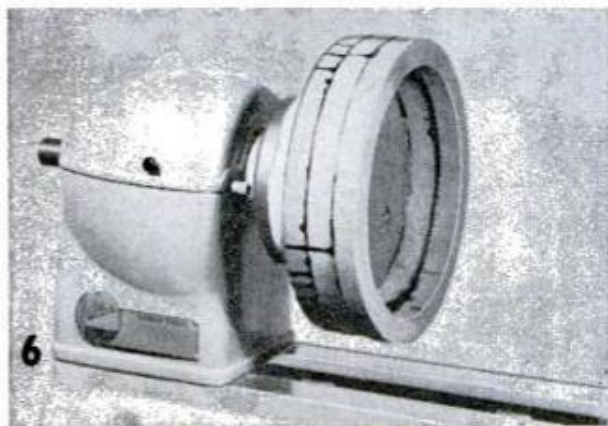

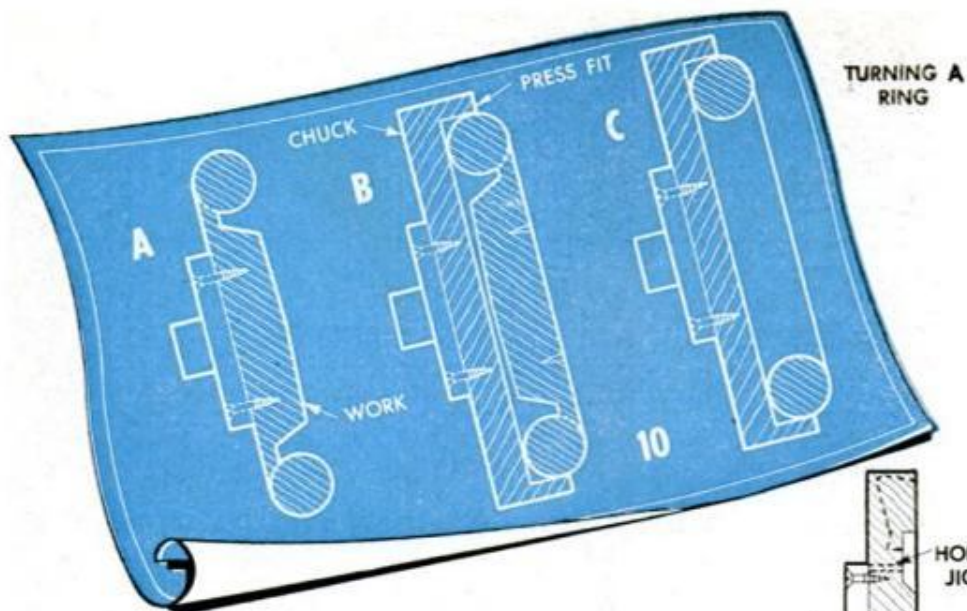

TURNING A RING

shapes. Wooden "jaws" nailed to a flat piece of plywood often are used, Fig. 8, instead of a one-piece solid chuck. Fig. 9 shows the bottom of the bowl being turned. Bowls always require thick wood. The needed thickness often is built up from thinner wood, always with an uneven number of layers, and usually with the grain running the same way in all pieces, Figs. 6 and 7. Rough stock for glue jointing need be surfaced only around the rim, a job which can be done by turning or with a planer head in the drill press.

Similar work operations are used in turning a ring or making a round, rabbeted frame, Figs. 10 to 14. Fig. 10 shows the steps in turning a ring. The first operation is done on a faceplate, detail A,

11 RABBETED FRAME

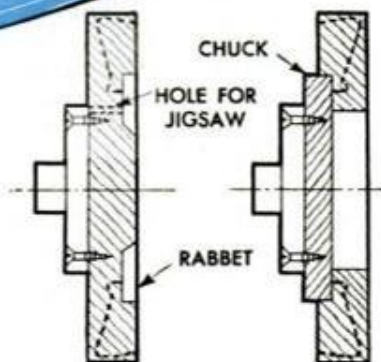

after which the partly completed work is held in a wooden chuck, detail B, to complete removal of the waste stock, detail C. Steps in turning a rabbeted frame are given in Fig. 11, starting with a faceplate and finishing the frame on a special wooden chuck.

Often in plate and platter turning, the work will be too large to swing over the lathe bed and must then be worked on the outboard end of the headstock

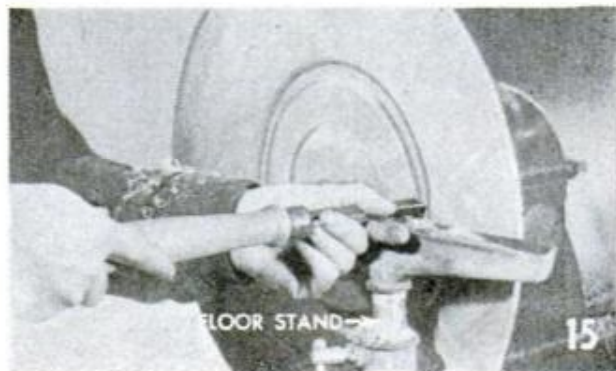
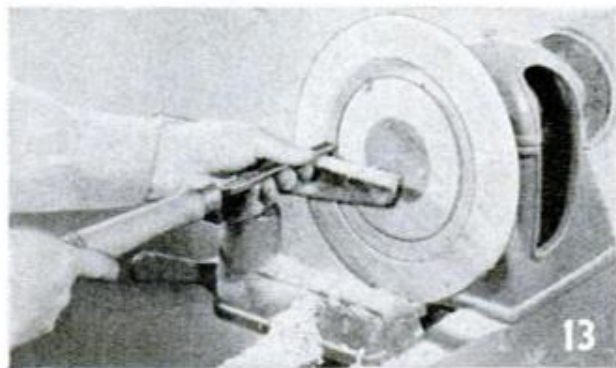
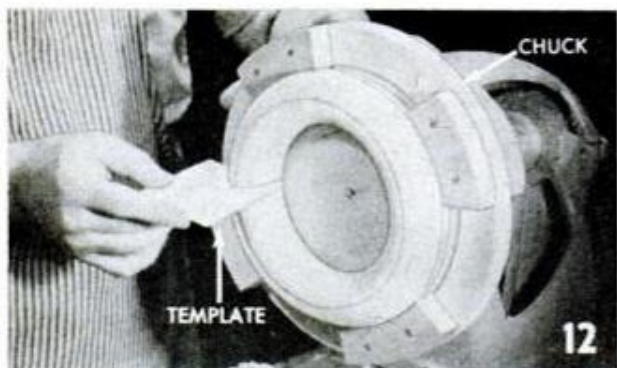

spindle with the aid of a floorstand tool rest, Fig. 15. If you don't have a floor stand, use a tool rest, or a wood or metal support, clamped to the table of a floor-model drill press as in Fig. 16.

When turning a cylinder-shaped box, the work itself provides a chuck for re-chucking the lid. Figs. 17 through 20 give the details. The lid often is worked on the same length of stock, but may be worked up from a separate length of wood if desired. A hollow cylinder is turned very much like a box but, if over 3 in. long, is usually rechucked to permit turning from the opposite end as shown in Figs. 18 and 19.

The fastest, easiest finish for faceplate projects is done with two coats of penetrating floor finish. This material is "in" the wood rather than on the surface. The finish is applied by brush or cloth, Fig. 21, and wiped clean in 15 to 20 min., no longer, and a second coat is similarly applied in about 8 hours, each coat being sanded down lightly and the final coat dulled by rubbing compound. For the more conventional "on the surface" finish, nothing beats three or four coats of water-white lacquer applied by spray. ★ ★ ★

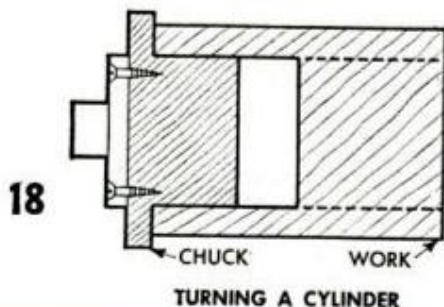
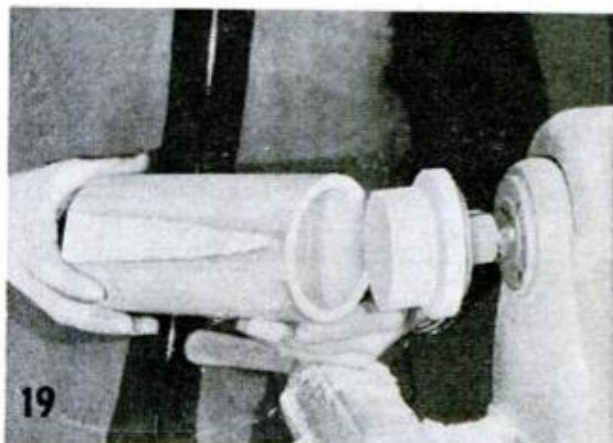
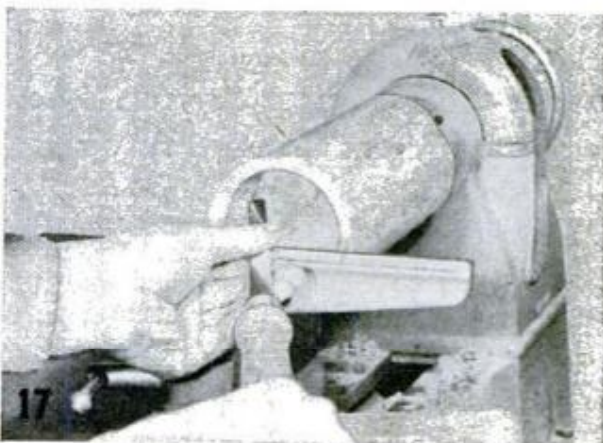
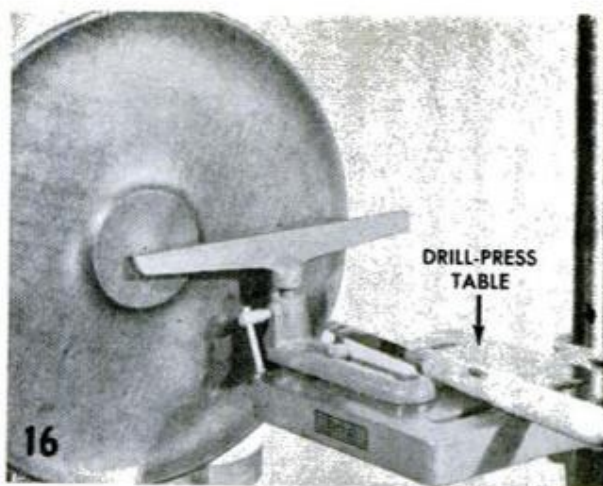

TURNING A CYLINDER

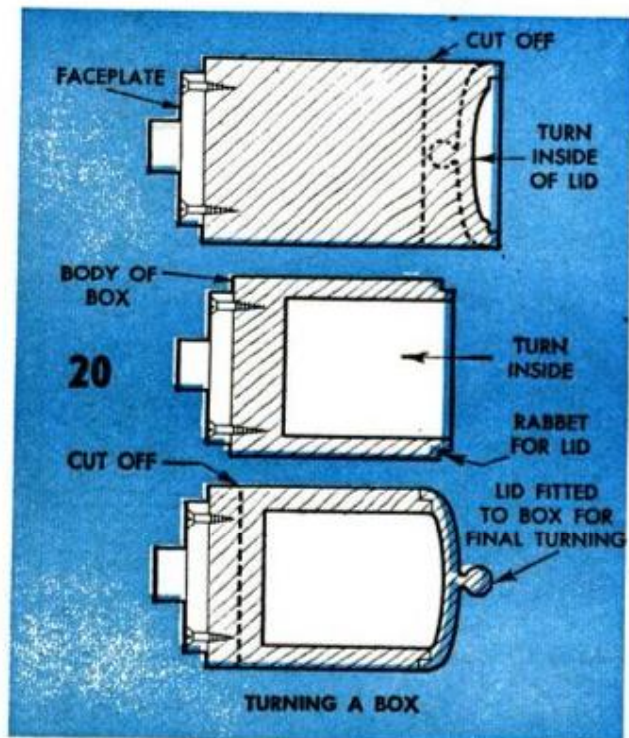

TURNING A BOX

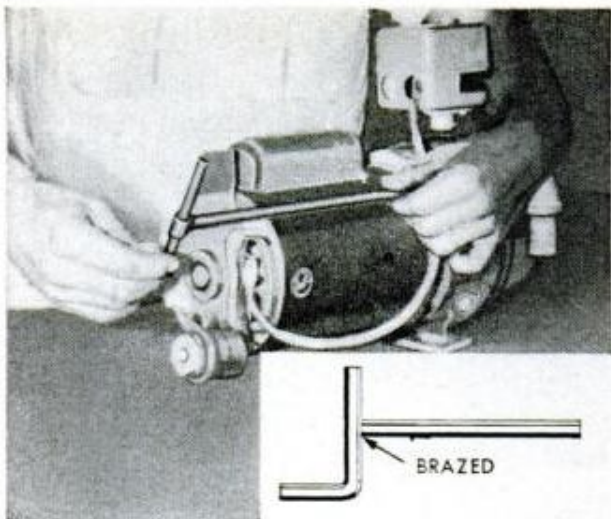

Socket-Head Wrench and Rod Make Efficient Speed Wrench

Caught without a speed wrench? A good substitute can be worked up with little time and effort by brazing a regular socket-head wrench to a suitable length of hex rod. This makes a T-handled speed wrench which will enable you to reach those otherwise inaccessible screws.

Harry J. Miller, Sarasota, Fla.

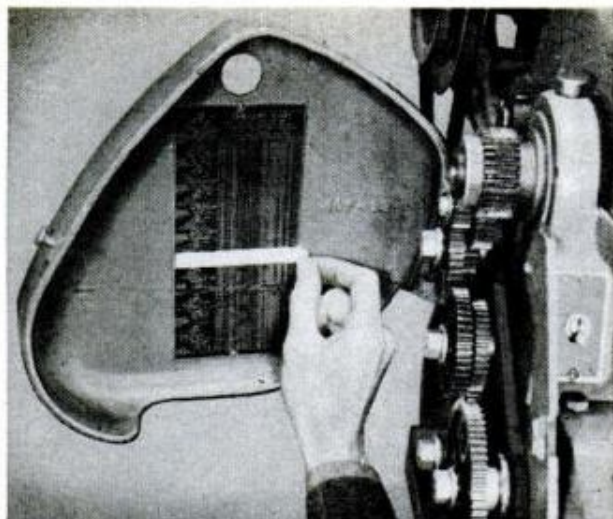

Tape Indicates Setting Of Lathe Gear Train

When setting up the gear train on a lathe, it may prove convenient to place a piece of adhesive tape under the appropriate setting listed on the threading chart. In this manner, persons who do not know what the current setting is can find out at a glance, and changes in the setting can be indicated by moving the tape.

Fixture Holds Drill Bushing Securely on Grinder

Although most drill bushings come in standard lengths, a toolmaker may find it convenient to grind from .010 to .015 in. from the bushing's total length so that it will fit a jig plate. To do this without having the bushing tip or slip on the surface grinder, a simple fixture can be made which will hold bushings of various sizes. First select a piece of steel and machine a clearance to accommodate the head of

the bushing, as shown in illustration B, below. Then make two cuts in the steel at 45-deg. angles. This will produce a notch with a total angle of 90 deg. To use the fixture, set it on the magnetic chuck with the shank of the bushing bearing against the notch. As the grinder moves over the top of the bushing, the fixture will hold it and keep it from tipping.

Frank La Saracina, New York, N. Y.

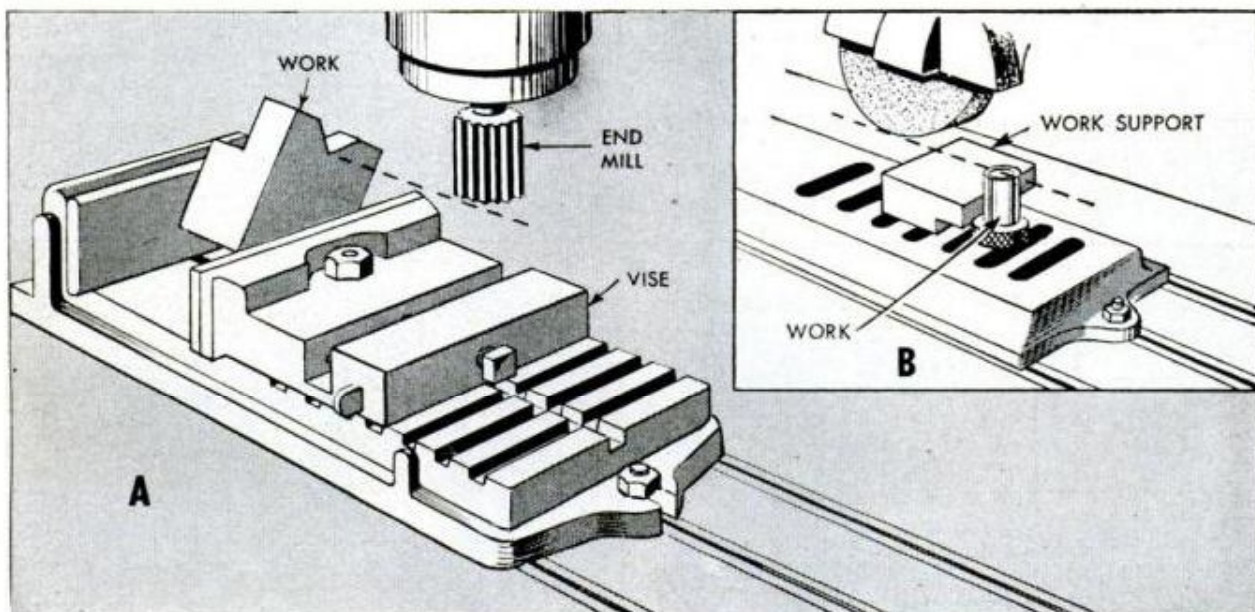

Socket Ratchet Converted To Offset Screwdriver

To make an offset screwdriver, fit a flat steel blade into the socket of a ratchet wrench and fit the socket into its handle, as shown in the photograph at the right. The blade must be wide enough to press fit into the socket head so that it remains firmly in position even under considerable pressure. A blade of almost any length may be chosen, depending on the nature of the job to be done, though for close work a short blade may be preferred.

R. Hanscom, Elmhurst, Ill.



Socket-Head Wrenches Stored In Metal Bench-Top Holder

With a brass block drilled and tapped to accommodate several different sizes of socket-head screws, fumbling and searching for the right size wrench is made a thing of the past. Each screw serves as a holder for a wrench of a particular size as shown in the illustration at right. Thus, the wrenches are sorted and ready to be selected as needed. By drilling additional holes, spare screws are also sorted and available for use.

S. Clark, East Bradenton, Fla.

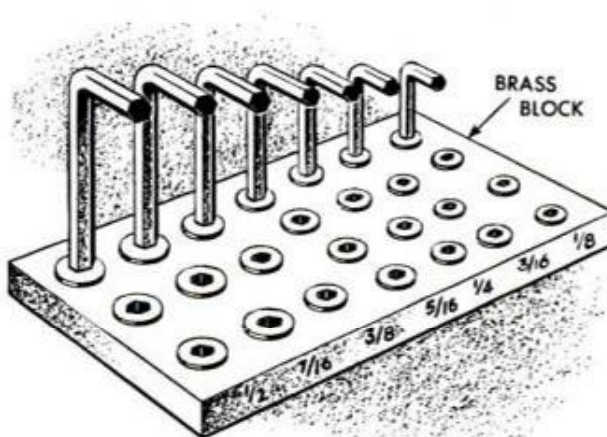

Coating of Rubber Cement Keeps Tools Rust-Free

Metal tools which are to be stored for a good length of time can be protected from rust by coating them with rubber cement. The cement dries in a few minutes and affords a moistureproof seal. An added advantage is that the tools can be stored almost immediately without the need for special wrapping, as is the case where oil is used as a preservative. When the equipment is again needed the cement can be rubbed off quickly, leaving a clean, rust-free surface.

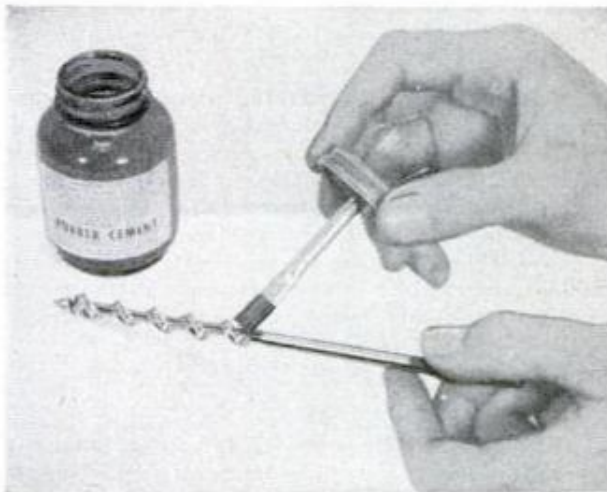

Cardboard on Drill Bit Clears Away Shavings

It is not hard to keep a workpiece and drillpress table free of shavings if a piece of cardboard is cut and slipped over the drill bit as shown in the photograph at the right. This method is effective and quite safe. Should your hand touch it, the cardboard will merely stop spinning.

Wayne Judy, International Falls, Minn.

When painting a window sash, be careful not to get paint on the weather stripping or on the track. If you do, the sash will be hard to move. Clean the track with fine steel wool and give it a coat of paraffin or boiled linseed oil.

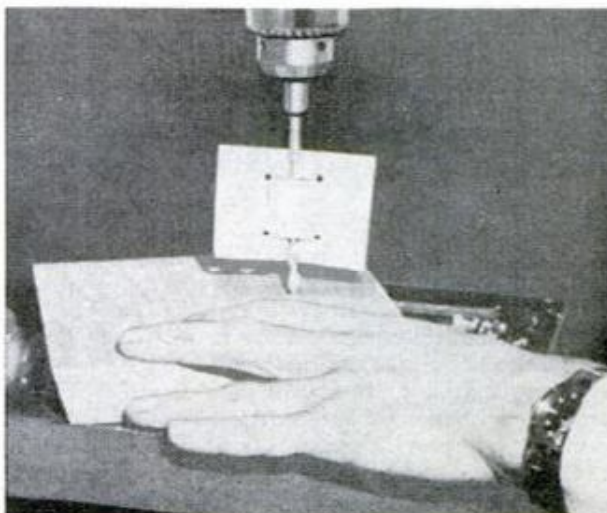

On the
MARKET
for Do-It-Yourselfers



1



2

1. SEALER PROTECTS CONCRETE floors and driveways against damage by the calcium chloride and salt residues which are carried onto the driveways and floors by cars during the winter months. This sealer is designed to guard against the pitting and dusting of the concrete surface caused by the salty slush. It's in liquid form and can be applied with a brush, squeegee, roller or sprayer. Two coats give maximum protection against salt residues and the dirt and dusts that seem to work their way right into unprotected concrete

Archer-Daniels-Midland, 700 Investors Bldg., Minneapolis 2, Minn.

2. REDWOOD FINISH is clear, like varnish, does not contain pigments. Gets its durability and resistance to breakdown from ultraviolet and mildew inhibitors incorporated in finish itself. Thus, by providing a protective shield against harmful effects of sunlight and discolorations caused by mildew, this new finish offers protection to redwood exteriors not heretofore achieved. Material spreads easily and uniformly with a brush, levels and dries without sags or runs. In applying, be sure to follow instructions on the container in detail

Linseed Oil Products Corp., 1603 Talbert Ave., Santa Ana 50, Calif.

3. FIBER PIPE ELBOW to connect downspouts to underground dry wells or other types of underground drainage systems, has been made available. Elbow is supplied in a 100-deg. angle which automatically provides the correct slope for the underground drainage lines. Both elbows and pipe are easily cut to required lengths and tapping the tapered joints together forms a tight, permanent seal against leakage. Pipe resists crushing, perpetual dampness and frost damage, yet has greater flexibility than either metal or clay drainpipes and tile

Bermico Pipe Div. of Brown Co., Boston 14, Mass.

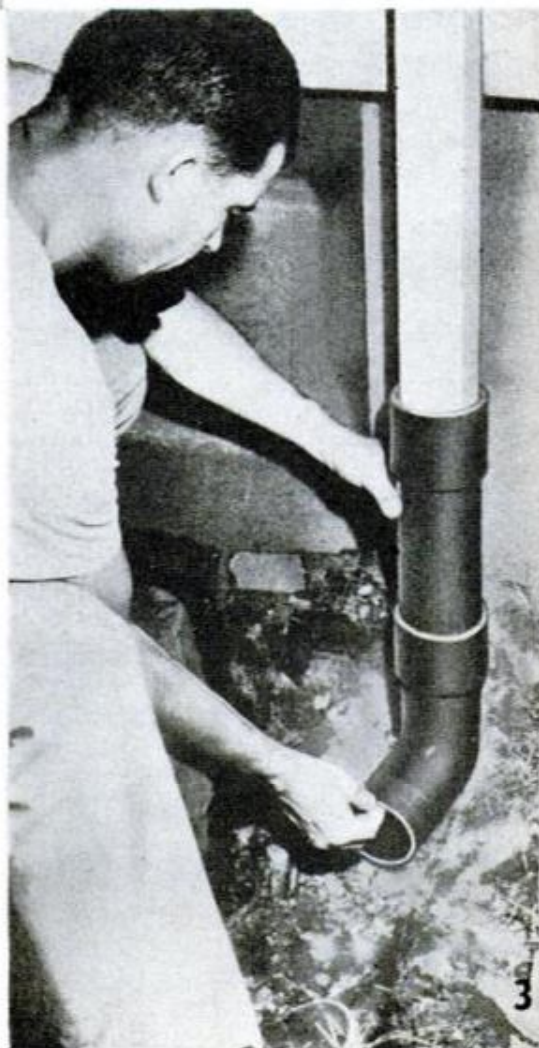

3

4. ALUMINUM IN A TUBE joins almost any material in a lasting repair. It applies like putty but dries as hard as metal. Use it to join parts of wood, porcelain, plastic, glass, leather, and also common metals. Stops leaks in plumbing, repairs car mufflers, fenders, broken parts of metal toys. Unusual features of the product are the applicator which is a part of the screw cap, also the projection inside cap which prevents the material from hardening in neck of tube

Amee Corp., 111 John St., New York 38, N. Y.



5. SASH LOCK holds sash securely at any point desired. Partly open sash cannot be pried up. Pressure up or down causes lock to grip tighter. Also holds sash closed as effectively as any conventional sash lock. Attaches to stile, either in the position pictured or lower, by means of two screws. Lock is released simply by pressing projecting levers together, levers being provided with finger pads for this purpose. Available in attractive brass or nicked finish

Two-Way Lock Co., 220 Insurance Exchange Bldg., Des Moines, Iowa

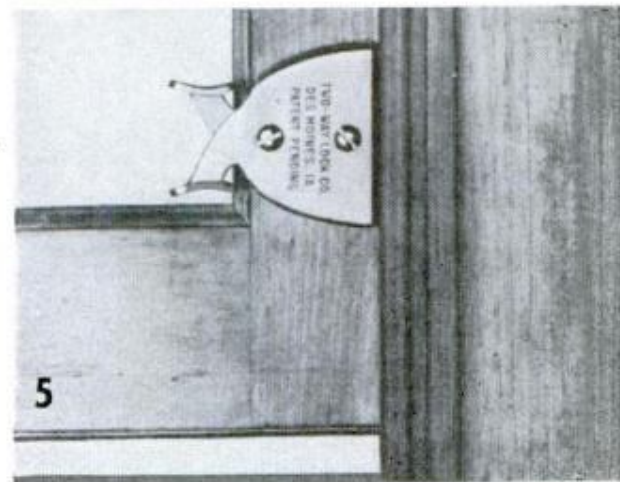

6. WIPE-ON LIQUID preparation smoothes old painted and varnished surfaces in preparation for new finish. Cleans off dirt and grime and eliminates fine checks. Won't injure hands or damage surface on which it is used. Leaves no finish-softening residue; new finish can be applied over old without any further preparation. Also removes the gloss of the old finish and prepares a surface to which new finish will bond solidly. Helps to prevent peeling of new finish

Savogran Co., 25 Huntington Ave., Boston 16, Mass.

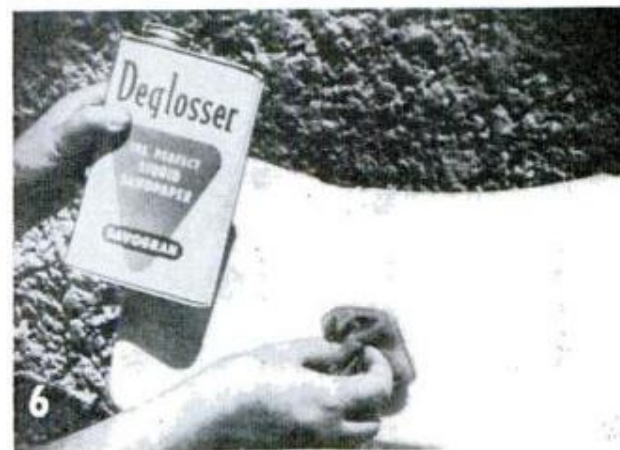

7. SURFACE-MOUNTED ELECTRICAL OUTLETS wherever you want them are provided by this interlocking wall strip. One of its features is a special cap which, when plugged into the feeder outlet, makes possible either horizontal or vertical installation of the strip. Four different units are available to make up an interlocking raceway: a straight link for extension purposes, an outlet link with three receptacles, a flexible link and the cap which plugs into feeder outlet

Cable Electric Products, Inc., Providence 7, R.I.

8. WEDGE-SHAPED CORK STRIPS combined with ribbed aluminum building sheets make this attractive wall covering. Both products are now available for use in this combination. The colored cork strips are made wedge-shaped to fit tightly in the valleys between the aluminum ribs of the base sheets, leaving the top of each rib showing between the strips. In addition to its decorative value, the combination also affords a measurable degree of soundproofing

Kaiser Aluminum & Chemical Sales, Inc., 919 N. Michigan Ave., Chicago 11, Ill.

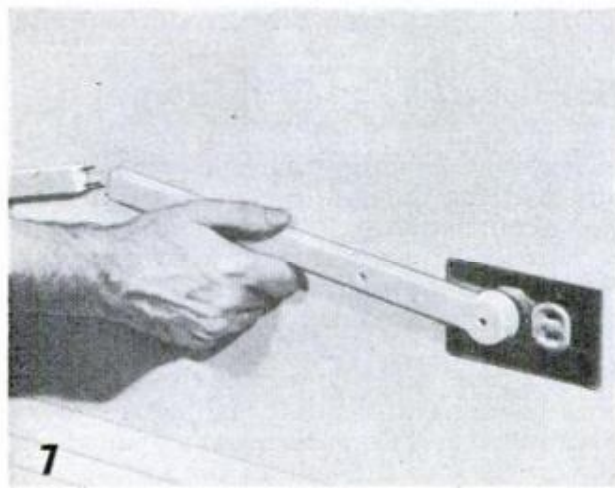

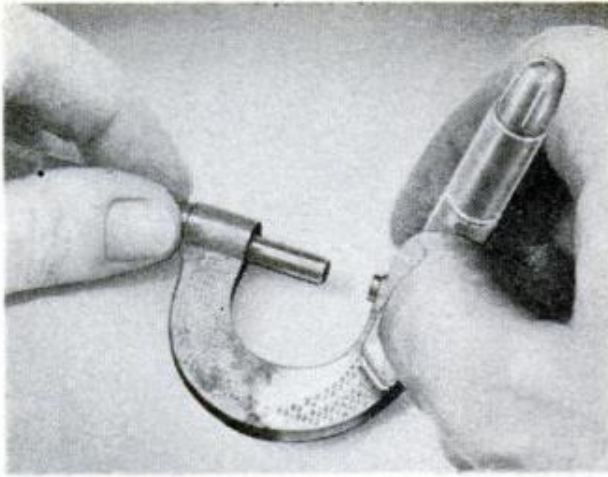

Rust Erased From Tools

Rust on small tools and precision instruments is easily removed with a glass-fiber eraser of the kind used to make corrections on duplicator stencils. Obtainable at any stationery-supply store, these erasers are made up of fine glass-fiber bristles held in a plastic holder. Unlike abrasive cloth or chemical compounds, they will not attack the metal itself but only rust and other foreign matter adhering to the surface. The bristles are able to penetrate into crevices which are almost impossible to clean by other methods.

H. J. Gerber, Stillwater, Okla.

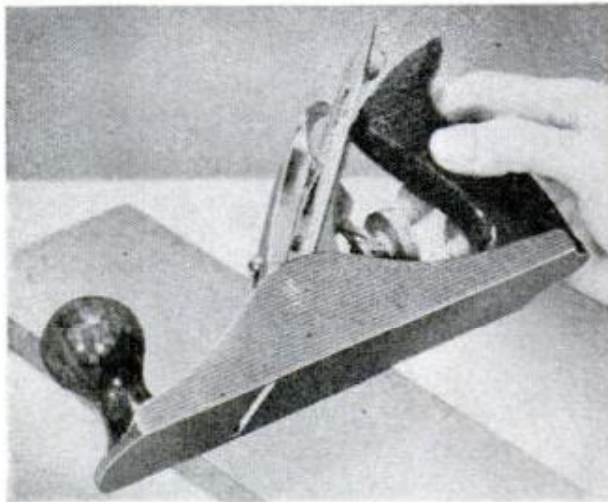

Plane Gauges Work Surface

If while planing the flat surface of a piece of wood you find that a carpenter's square is not at hand, make a rough estimate as to the uniformity of the surface by using the edge of the plane in place of the carpenter's square.

R. Hanscom, Elmhurst, Ill.

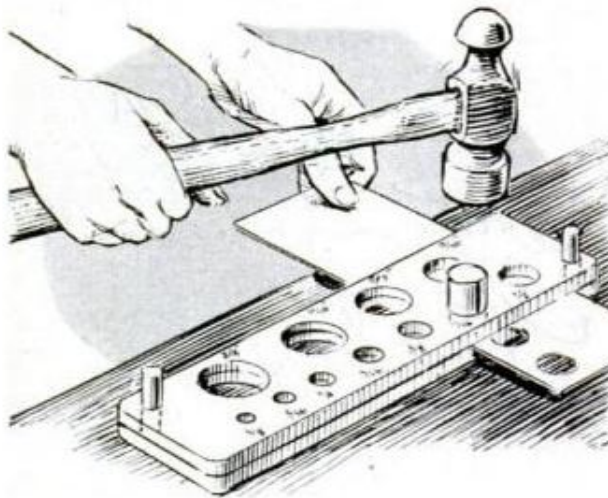

Jig Cuts Gaskets to Order

This fast-cutting gasket jig is made of two $\frac{1}{4}$ -in. steel plates measuring $2 \times 7\frac{1}{2}$ in. Drill two $\frac{3}{16}$ -in. holes in diagonally opposite corners, as shown. Dowels placed in these holes should fit tightly in the bottom plate and slip-fit the top. Drill a series of holes through both plates ranging from $\frac{1}{8}$ in. to $\frac{3}{4}$ in. or whatever sizes you prefer. Punches are cut from round stock and should be about 3 in. long. To use the jig, place gasket material between the two plates and strike it with a punch and hammer for a perfect cut.

S. Clark, East Bradenton, Fla.



Nut Used as Tap-Drill Gauge

If a tap-drill chart is not available, it is possible to determine the proper size tap drill for the job by using a nut. Select a nut which will screw onto the tap to be used. Then select a drill which will just fail to pass through the nut. With this slightly oversized drill, the hole will be tapped a little less than the full depth of the thread and allow freer threading action. Though full-depth threading is seldom required, if it is desired, select a drill which fits snugly into the hole in the nut.

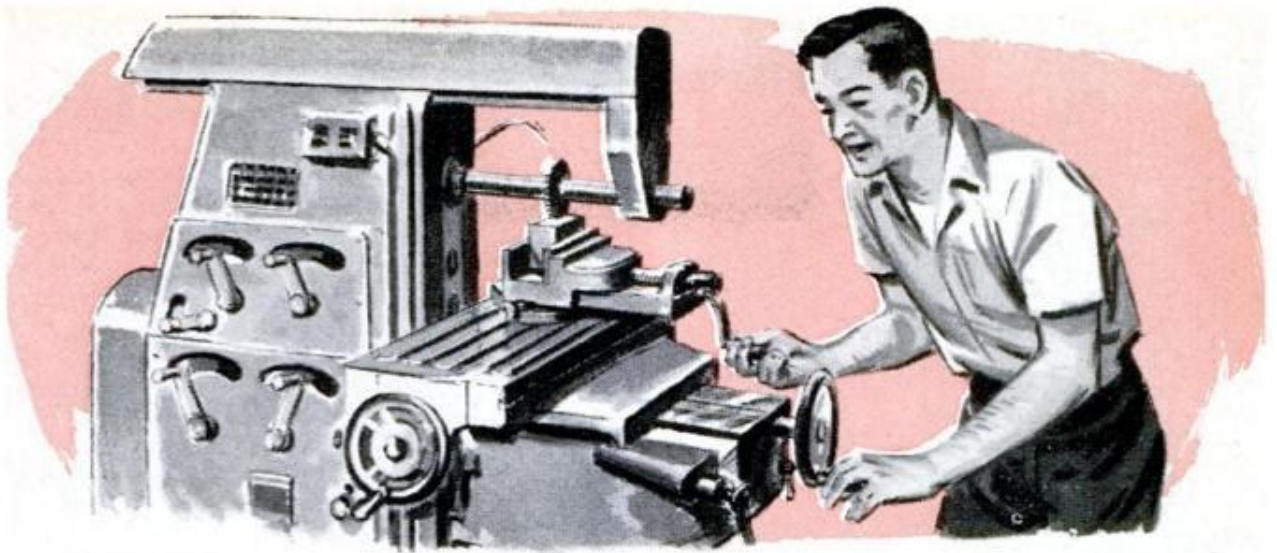

SETTING SWIVEL-BASE MACHINE VISE

By H. J. Gerber

GRADUATIONS on a swivel-base machine vise give accurate settings if read correctly. That's the trick, reading the setting "within the index mark," especially if the light isn't too good. If you don't trust your eye to achieve a precise setting, here are suggestions for setting a vise with paper feelers.

As an example, take the first method pictured in the top photo at the right, that of setting the vise jaws parallel to the milling-machine spindle. Bring the jaw up to the spindle with tissue-paper feelers in place as indicated. Have a soft hammer handy to tap the vise lightly. The accuracy of the setting is dependent on one's ability to determine by feel the uniformity of tension on each of the two feelers, but if you're careful you can come very, very close to a precisely true setting.

Using a machinist's square the vise can be swiveled and set perpendicular to the spindle by using the method pictured in the center photo. Note how the paper feelers are placed.

Another method often used is shown in the lower photo. Here the square bears against the vertical ways of the machine pedestal, the paper feelers being placed between the blade of the square and the surfaces of the ways. Always be sure that the machine is clean. Make sure that there are no metal chips, waste or even heavy oil or grease on any of the surfaces used in making the settings.

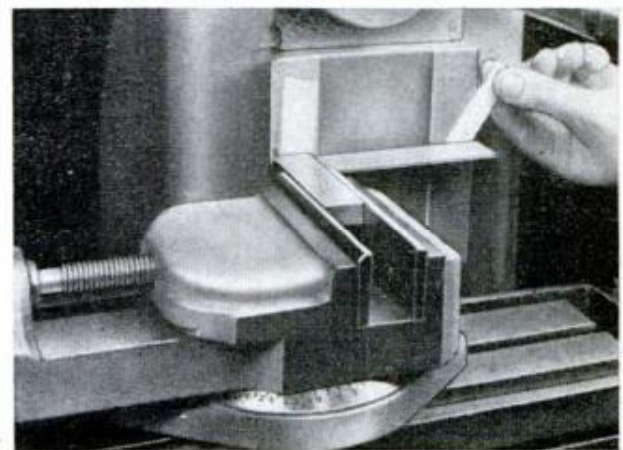
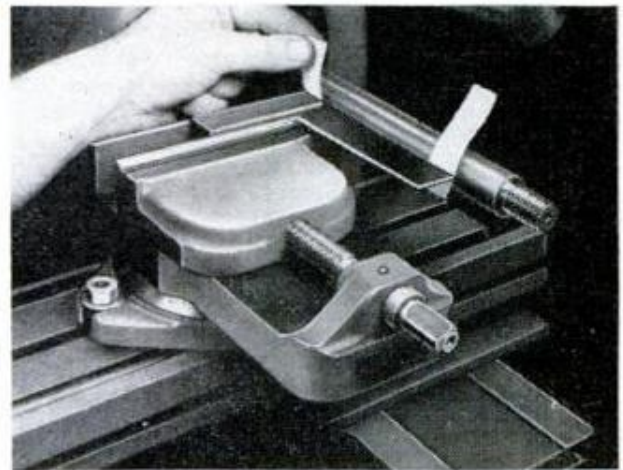
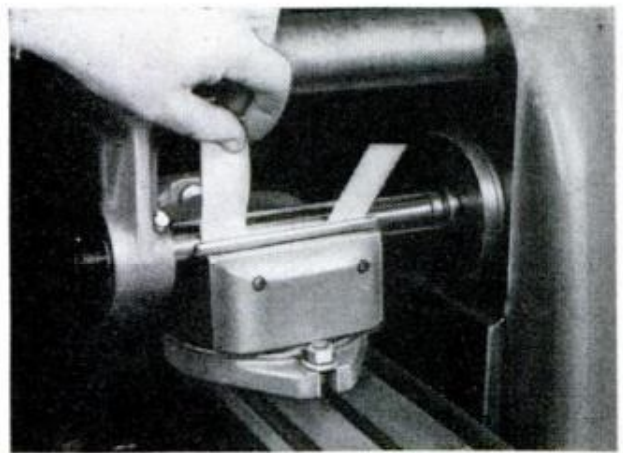

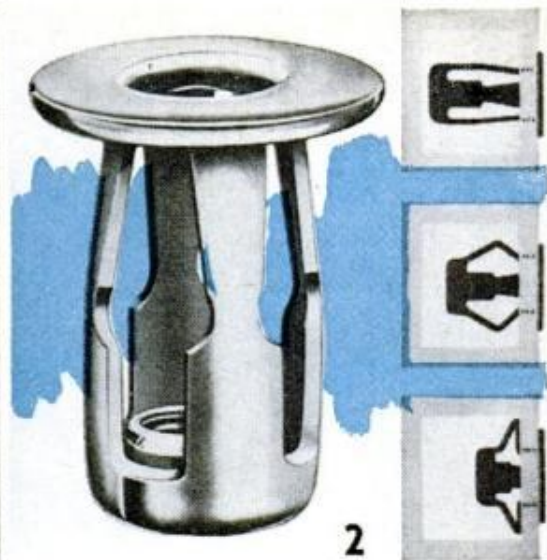
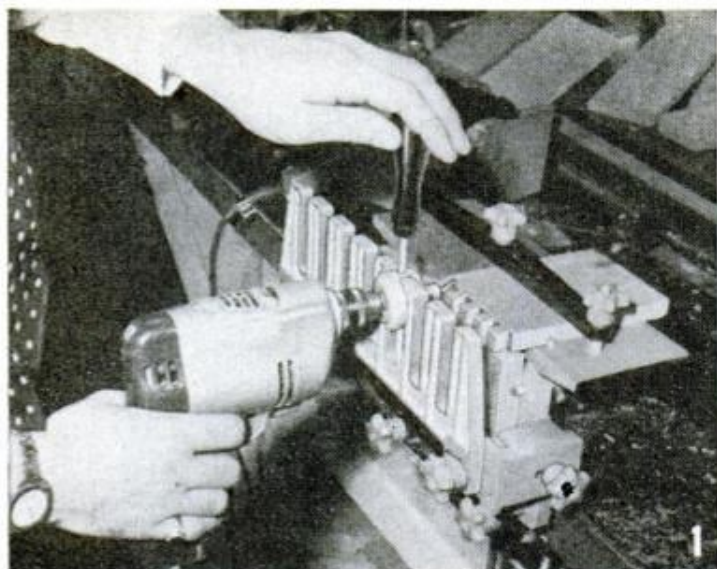

SHOPPING FOR TOOLS

1. CLAMP AND FINGER GUIDE utilize the speed and power of a $\frac{1}{4}$ -in. portable drill to cut dovetails with machine precision. Drill drives the dovetail cutter which is carried in a grooved collar, the latter fitting in the slots of the finger guide. Cuts the pins and sockets in one pass of the cutter. You finish with a complete dovetailed corner joint ready to assemble

A. Robinson & Co., Ltd., Knowsley Rd.,
Boothle 20, Lancs, England

2. BLIND FASTENER has been designed to hold fixtures in hollow construction with extraordinarily narrow expansion areas. As an example, these fasteners can be used in hollow-core doors and in plywood or wallboard installed over furring strips. Units are self-adjusting to grip any material that will withstand pressure. Come in two lengths, 0 to $\frac{3}{16}$ and 0 to $\frac{3}{8}$ in.

Molly Corporation, Reading, Pa.

3. HAND-OPERATED SHARPENER puts a keen edge on rotary lawnmower blades with a few light strokes. No adjustments are necessary; no need to remove blade from spindle, except on some older type mowers having no grass-clipping chute. The sharpener automatically gives the correct bevel on any blade from $\frac{1}{8}$ to $\frac{3}{16}$ in. thick. Remove nicks with file

Main Mfg. Co., 3639 E. Main St., Richmond, Ind.

4. WOOD SCREW drills its own hole in hard or soft wood. Body of screw is notched as pictured, forming cutters which remove wood as screw is driven. Screws are heat treated; won't twist off under extreme driving tension and slots will hold driver blades without breaking out at corners or edges. Screws are available in all head types and in sizes commonly used

Shakeproof Div., Illinois Tool Wks., St. Charles Rd., Elgin, Ill.

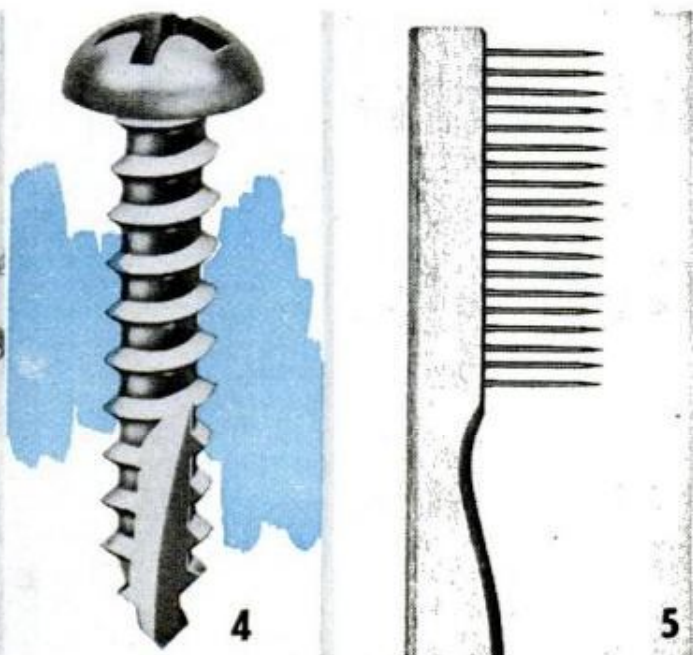
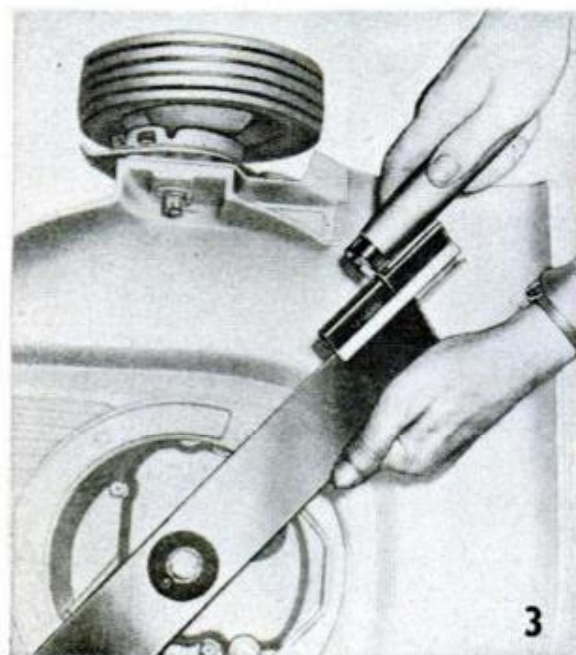

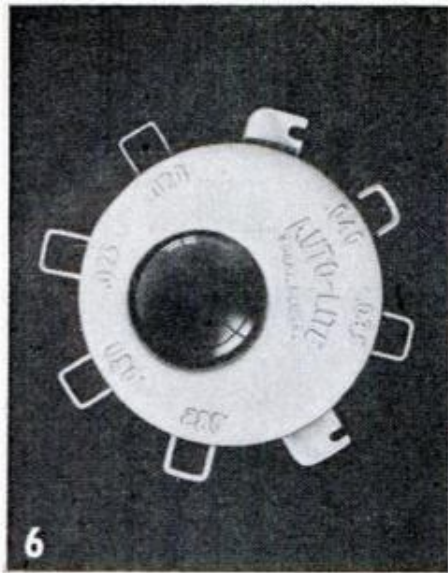

6



7

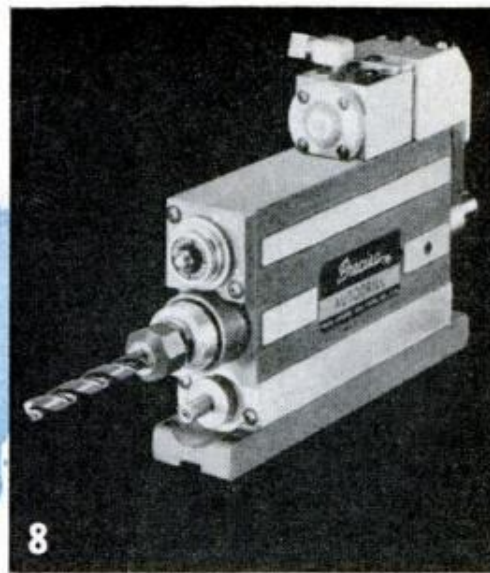

8

5. PAINTBRUSH COMB will be appreciated by those who need to do a thorough job of cleaning brushes. This comb does two things: it straightens bristles of brush throughout the length and at the same time spreads them, permitting solvent to penetrate and wash accumulated paint out of center of bristle clusters

Robert A. Main & Sons, Inc., 257 Pasack Rd., Paramus, N.J.

7. PLASTIC NOZZLE is corrosionproof, long wearing and is intended for use where any or all of these operating conditions must be met. The unusual spiral design of the nozzle beyond the orifice breaks up and distributes material uniformly throughout the spray pattern. Available in seven different flow rates

Bete Fog Nozzle, Inc., 309 Wells St., Greenfield, Mass.

9. SUBMINIATURE SPEED REDUCER is available in 34 different ratios and will handle 16 oz.-in. of torque at the output shaft. Can be operated at speeds up to 3600 r.p.m. Input and output shafts are located offcenter in the gear case so that they can be mounted at $\frac{1}{4}$ or $\frac{1}{2}$ in. height. Weighs only $2\frac{1}{4}$ oz.

Metron Instrument Co., 432 Lincoln St., Denver 3, Colo.

6. GAP GAUGE combines a wrench, or bender, for moving spark-plug electrodes to the desired clearance, 6 feelers ranging in size from .020 to .040 in. dia. for checking the electrode gap, and a magnifying lens for detailed examination of small parts. All this in a plastic housing slightly larger than a half dollar

Watertown Mfg. Co., Watertown, Conn.

8. MODULAR DRILLING UNIT can be used singly or in multiples for simultaneous drilling of a number of holes of the same size or of various sizes. Pneumatic control of advance and retraction of drill and precise control of depth of hole are special features of the unit. Can be mounted in any position

Precise Autodrill Corp., Blue River Rd., Racine, Wis.

10. ULTRASONIC RESONANCE GAUGE can be used for thickness measurement of nearly all metals, glass, ceramics and plastics, measurement being taken from one side of material. Unit weighs less than 5 lb., including batteries, probe, harness, cable and ear-phones, making it ideal for all common field tests

Branson Instruments, Inc., 40 Brown House Rd., Stamford, Conn.

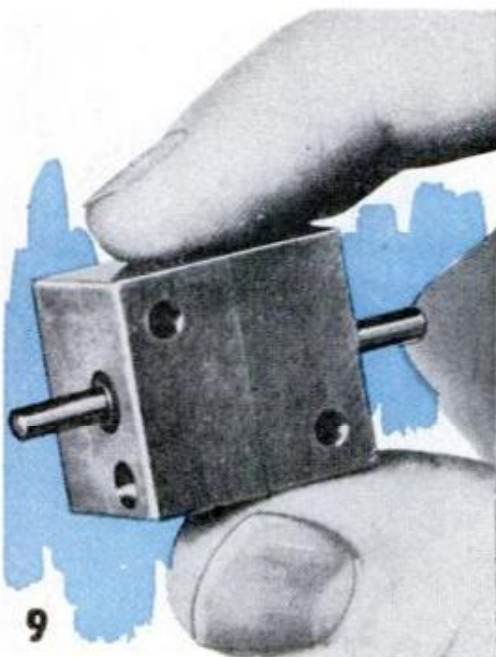

9



10

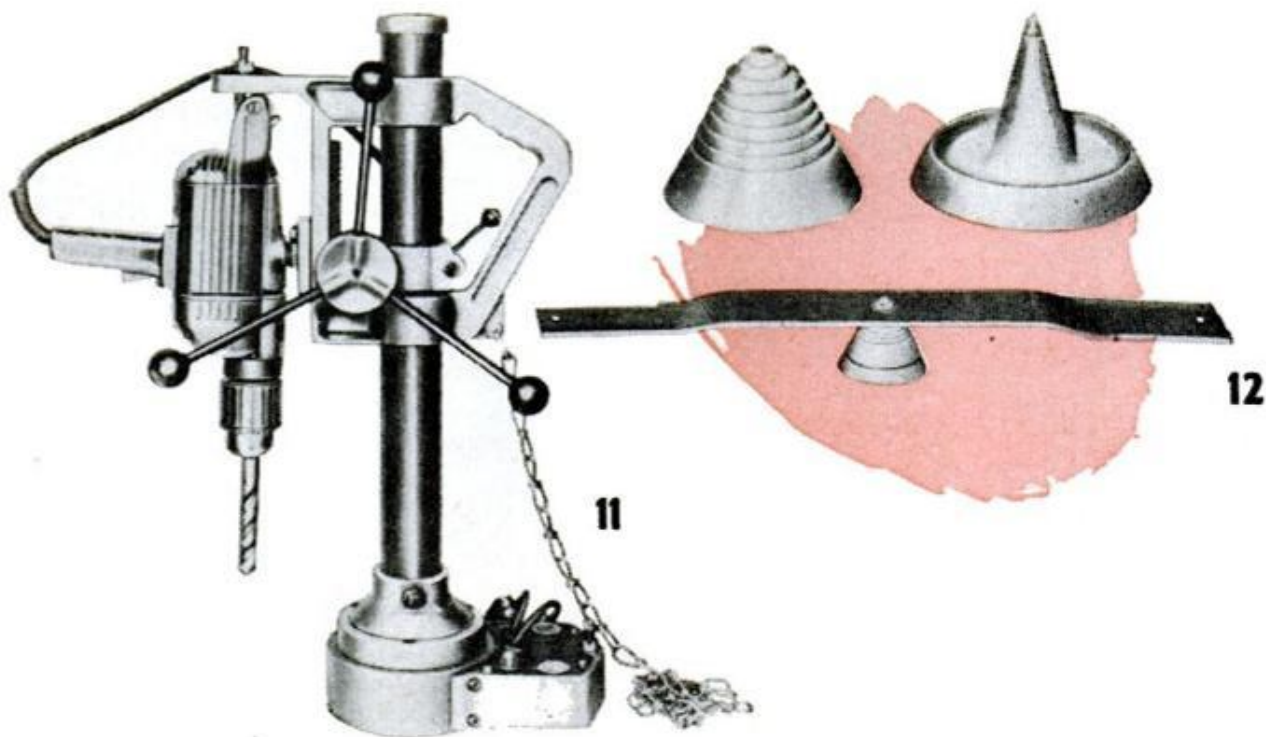

11. DRILL STAND comes equipped with a magnetic base so that it can be set up on any ferrous-metal surface for drilling operations. Frame of stand is designed to take nearly all types of portable electric drills. Three sizes of stands are available for medium and large sizes of electric drills and also pneumatic drills up to 2-in. capacity. Unit works in any position, vertical, horizontal, or suspended above the workbench
 Thor Power Tool Co., La Grange Park, Ill.

12. BALANCER for rotary power mower blades consists of a light, durable plastic stand 2 in. high and 2½ in. in diameter, and a cone designed to balance on stand and to accommodate any shaft hole from ½ to 1½ in. Blade is removed from shaft and placed on balancer as pictured. If test shows blade out of balance, metal is removed from heavy end until test shows perfect balance. Test only after grinding
 Akay Corp., Div. of Hauser Products, Inc.,
 4034 N. Kolmar Ave., Chicago 41, Ill.

13. ROTARY PUMP is designed to handle corrosive liquids and also liquids carrying abrasives. Supplied in two sizes having capacities of 54 and 185 gal. per hour, and is available in both sizes with or without motor, speed controls and explosionproof fittings. Unusual design of pump makes it possible to install it without altering existing tubing or piping systems and without exposing liquids to air or contaminant
 The Randolph Co., 1018 Rosine St., Houston 19, Tex.

14. ABRASIVE BAND is crowned at the center so that when placed on an inflated finishing wheel it can work a concave surface having a radius as small as 2 in. When inflated the wheel carrying the crowned band has a major diameter of 6 in. at the crown. This diameter permits work in small, round-bottom recesses which are difficult to reach into with any other type of abrasive wheels. Band is 2½ in. wide
 Nu-Matic Grinders, Inc., 8224 Carnegie Ave., Cleveland 3, Ohio



RADIO TV HI-FI

ELECTRONICS



- RADIO TUNERS
- TURNTABLES
- RECORD CHANGERS
- CARTRIDGES

Personalized STEREO FIDELITY

PART IV

By
Lothar Stern

SELECTING YOUR SOUND SOURCE

MAYBE WE'RE overdoing things a bit in this modern generation. Back in the days of Mozart and Beethoven when you wanted music you either attended a concert or you learned to play some musical instrument. Now, all you do is flick a switch and you can hear practically any worthwhile piece of music that's ever been composed, played by the world's top orchestras, right in your own living room. What's more, you can get your music from radio, from a phonograph or from a tape recorder. And when you start trading dollars for sound, one of the first decisions you'll make is—which one will it be?

Music systems, whether radio, phono or tape; whether hi-fi or lo-fi; whether stereo-

phonic or monophonic; all follow the same general pattern. All consist of a sound source, an amplifier and a loudspeaker. For stereo, of course, you'll need a dual amplifier and two speakers, but whatever amplifier and speaker system you buy, it can be used with any or all sound sources. That's where the advantage of a components-assembled hi-fi system really shows up. You can start with a single sound source, perhaps a record player or a radio tuner, or a tape transport mechanism, and expand the system as additional funds become available. And if you build the components yourself, from commercial kits, the money you save will permit you to complete your system that much quicker.

**FM AND AM BROADCASTING
HERE'S HOW THEY DIFFER**

IN THE TRANSMITTER

FM AM



THE AUDIO SIGNAL FROM THE MICROPHONE IS THE SAME IN BOTH CASES BUT THIS CANNOT BE TRANSMITTED DIRECTLY

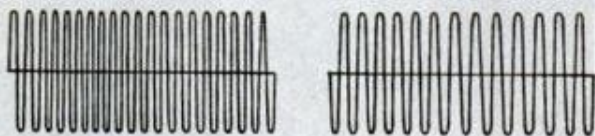

THE HIGH-FREQUENCY CARRIER WHICH TRANSPORTS THE AUDIO FROM TRANSMITTER TO RECEIVER. HIGHER CARRIER FREQUENCY FOR FM LIMITS RANGE TO LINE-OF-SIGHT DISTANCES

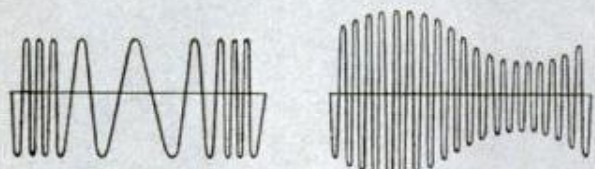

THE TRANSMITTED SIGNAL. IN FM, THE AUDIO VARIES THE FREQUENCY OF THE CARRIER; IN AM THE CARRIER AMPLITUDE IS VARIED

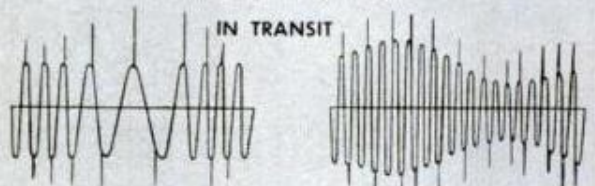

NOISE PULSES DUE TO STATIC VARY THE AMPLITUDE OF BOTH FM AND AM SIGNALS

IN THE RECEIVER



HUM AND NOISE IN INITIAL RECEIVER STAGES FURTHER CHANGE THE AMPLITUDE OF BOTH SIGNALS

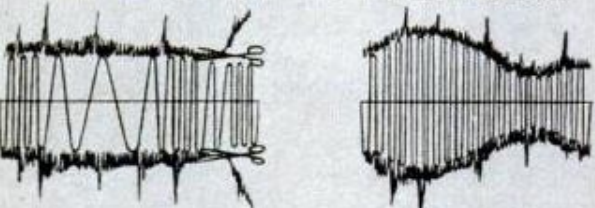

SIGNAL AFTER AMPLIFICATION IN RECEIVERS

CLIPPER STAGES IN FM CUT OFF AMPLITUDE VARIATIONS WITHOUT AFFECTING THE AUDIO INFORMATION. AMPLITUDE IN AM SIGNAL CANNOT BE CUT WITHOUT ALSO AFFECTING THE AUDIO



AFTER DETECTION, FM SIGNAL CLOSELY RESEMBLES ORIGINAL AUDIO. IN AM, THE DETECTED SIGNAL CONTAINS STATIC AND NOISE PULSES

Which One First?

It used to be that a basic hi-fi system was a phono system, but times are changing. Today, almost as many people start with radio as with phono. The reason—FM.

Considered all but a dead issue after World War II, FM radio has made a strong comeback in recent years. Spurred by the ever-increasing interest in good music, more and more FM stations are going on the air each year. Their broadcasts are not limited by the restricted frequency range of most AM stations and the natural immunity of good FM receivers to all forms of static and man-made interference makes them ideal for high-fidelity listening. With FM radio you may not get the exact recording you want when you want it but, if you live within range of several stations, you're almost sure to find something of interest at all hours of the day.

Stereo Transmission. There's every indication that stereophonic sound, via FM radio, will soon be available. By a process called multiplexing, FM stations can transmit the two different signals required for stereo within the confines of their assigned channels. To receive stereo you need only an FM tuner plus an inexpensive adapter.

Several methods of FM multiplexing have been perfected. Some of these are already "on the air" with limited, experimental broadcasts. The only thing holding up widespread FM stereo transmission is an FCC decision as to which method will be employed. This decision, it is hoped, will be forthcoming in the near future.

In the meantime, there's been an upsurge in the number of FM and AM stations which are broadcasting stereo on a cooperative basis. To receive these you need both an FM and an AM tuner or an FM-AM *stereo* tuner. While the quality of AM is not comparable with that of FM, such stereo broadcasts do sound amazingly realistic. For anyone interested in the greatest variety of music without additional cost, a radio tuner is probably the biggest bargain.

But there's no getting around it—a hi-fi system just isn't complete without a record player. Sooner or later you'll add one to your system, and if you're not within range of a number of FM stations, the record player is your best initial choice. Some public libraries now have record collections which can be obtained on a rental basis at a small cost. This reduces the need for a large investment in records right off the bat, while still giving you the type of music you want whenever you want it.

Tape is the latest medium to capture the interest of hi-fi fans. Like disc records, prerecorded tapes are available with a wide selection of recorded material. And,

say the tape enthusiasts, prerecorded tapes are inherently better than their disc counterparts. Certainly they do not lose their inherent quality with repeated playings as discs are apt to do.

But the inherent quality of tapes can be realized only with expensive professional playback equipment. Tapes played on competitively priced machines are not likely to sound better than a good disc record. What's more, the tapes are more expensive. In my opinion, a tape mechanism, or deck, is a worthwhile investment—though primarily for its recording function.

At the present time, the tape portion of the hi-fi industry is in a state of confusion—and so is the prospective buyer of tape equipment. You can buy prerecorded stereo tapes of the 2-track, 7½ i.p.s. variety or of the 4-track, 7½ i.p.s. type. What's more, there's an ever-increasing number of stereo-tape *cartridges*—recorded on 4 tracks at a speed of 3¾ i.p.s. In view of these differences, the selection of a tape deck, and the necessary auxiliary equipment, involves so many considerations that this will be covered in a separate article in a later issue. Here we will concern ourselves chiefly with radio tuners and record-playing equipment.

Selecting a Radio Tuner

Whether you buy a kit or a factory-assembled unit you can get a tuner in one of three ways. At a minimum initial cost you can buy an FM tuner and supplement it later, if desired, with a matching AM tuner. Somewhat higher in price are the FM-AM tuners which combine both functions on a single chassis. Usually these are less expensive than the total cost of two separate units because the same tubes and much of the same circuitry are employed for both FM and AM reception. A front-panel switch permits selection of either the FM or the AM function.

At the top of the ladder are the FM-AM *stereo* tuners which combine the best features of both the other methods. By having both sections built on the same chassis, such units take up little more space than a single-function tuner. But, because each



Heath Stereo Tuner . . . as sensitive as the best



EICO FM Tuner . . . performance without frills

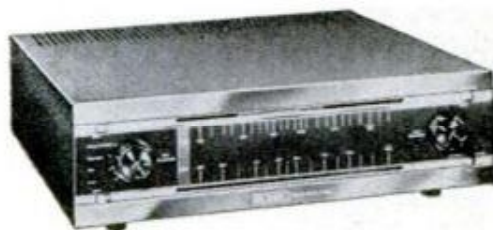

Knight-Kit Stereo Tuner . . . something added

of the tuner sections uses separate tubes and circuitry, they may be operated individually or simultaneously—a vital qualification for receiving FM-AM stereo.

At this stage of the game the ordinary FM-AM tuner has little to recommend it. If you're interested principally in FM, or if you already have a good-quality AM radio (not the \$19.95 table-model variety), an FM tuner is perfectly adequate. If the AM function is desired as well, the versatility of an FM-AM *stereo* tuner makes it well worth the extra investment.

Building a Tuner Kit. Until recently, the construction of a high fidelity FM tuner was considered beyond the scope of the hobbyist or home builder. Adjustment of the various circuits was deemed so critical that only a skilled technician with special

TABLE I. Results of tests for three kit-built tuners indicate close adherence to published specifications

	EICO HFT90-K	HEATH PT1	KNIGHT 83YX731
SENSITIVITY			
For 20 db quieting	4.5 uv.	less than 1 uv.	1.5 uv.
For 30 db quieting	8.5 uv.	4.5 uv.	4.5 uv.
HUM AND NOISE (Referred to 30% modulation)	-47 db	-41 db	-46 db
FREQUENCY RESPONSE	All tuners were flat within ± 1 db from 20 to 20,000		
HARMONIC DISTORTION* (At 1000 cycles—30% modulation)	1.7%	1.25%	1.6%

* These distortion figures should be used for comparative purposes only since they have not been modified to compensate for distortion inherent in the test instruments themselves.

test equipment could obtain the desired results. To test this theory, we built and tested three tuner kits of different manufacturers. The tests were run after making only those adjustments outlined in the instruction manuals—without the use of test instruments. The results given in Table I left little doubt that tuners can be built at home, and that the performance can be expected to approach the published specifications.

Quieting Sensitivity. Tune an FM receiver to a spot between stations and you will hear a great deal of background noise. The instant a station is tuned in, however, the noise almost magically disappears. That is—it disappears if the signal is strong enough to activate the receiver's clipping circuits. The weakest signal that reduces the noise to a certain level below that of the resulting audio determines the sensitivity of the set.

In FM tuners, sensitivity is expressed as the number of microvolts of signal needed to reduce the noise power to one-hundredth (20 db) or one-thousandth (30 db) of the strength of the audio. With a 20 db signal-to-noise ratio, the quality of the sound is judged "listenable"; with 30 db, the noise is almost inaudible.

The signal-to-noise ratio increases according to the strength of the station's carrier—up to a point. Beyond that, no further noise reduction is noted as the carrier strength is increased. This final noise level is the residual *hum and noise*. It, too, is specified as so many db below the strength of the audio.

Some manufacturers specify sensitivity and hum noise with respect to the strength of the *average* audio signal (30% modulation), others make the comparison with the loudest audio signal (100% modulation) that would ever be encountered. Obviously, the noise level would be lower with respect to the loudest tones than in relation to the average loudness. The reference level, therefore, must be taken into consideration when comparing the specifications given for competitive tuners.

Frequency Response and Distortion. In common with all other electronic devices, a tuner should not discriminate against high and low audio frequencies, nor should it change the character of the signal to a noticeable degree. These considerations were described in last month's amplifier article and, in general, the same information applies also to radio tuners.

Drift. One of the most annoying habits of many FM sets is their tendency to drift off frequency, especially during the warm-up period. You turn the receiver on and tune in a station, and just about the time

you get settled in your easy chair you have to get up again to retune the set. During an evening this may happen several times and, in severe cases, it almost takes the pleasure out of FM listening.

In hi-fi tuners, drift is usually eliminated with special circuitry called AFC (automatic frequency control). With AFC, a station will remain tuned in, but it may be difficult to tune in weak stations—particularly if these are located near some strong stations on the radio dial. AFC tends to pull in the strong stations to the exclusion of the weaker ones.

To overcome this detriment, most of the better tuners incorporate a switch which disables the AFC circuit when you want to tune in a weak station.

Other Considerations. While every FM tuner is subject to the characteristics discussed above, units of different manufacturers have various special features which may make one or the other particularly desirable. This will become increasingly obvious as we discuss some of the features of the three tested units. Before a final selection is made, the literature of several manufacturers should be studied.

Heath PT1 Stereo Tuner Kit (\$89.95)

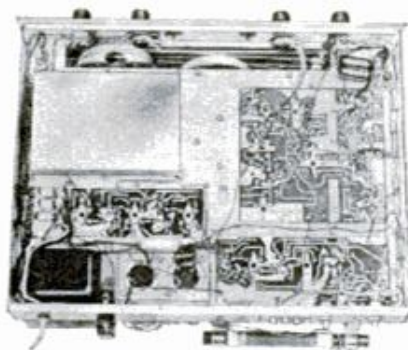

As indicated in the table, this tuner is the most sensitive of the three, as well it should be. Its 10-tube FM section is by far the most elaborate, though construction is simplified by three printed circuit boards and a preassembled tuning unit.

If you've had just a little experience you'll have no trouble with this tuner. Its 72-page instruction manual guides you through every step of the way with careful descriptions and detailed illustrations. It's a time-consuming project, but the results are worth the effort.

The extreme sensitivity of this tuner permits its use in many areas without the benefit of an external antenna. A built-in line-antenna provides all the signal strength you need unless you live in a fringe area.

As might be expected, there's no drift, due to AFC action, though the AFC cir-

cuit can be switched off for reception of weak stations. A built-in meter permits on-the-nose tuning—a vital factor for high-fidelity reception. A separate output jack permits later addition of a multiplex adapter when this becomes available.

On AM, a two-position "broad-narrow" switch permits changing the frequency response of the AM tuner to meet specific conditions. In the "broad" position, maximum high-frequency response is obtained. In the "narrow" position, the response is limited and the gain is increased. This position would be used for reception of weak signals or in noisy locations. A total of 16 tubes, as compared with the normal 10 or 12 used in other high-quality stereo tuners, makes this one of the best fringe-area tuners you can buy.

Knight 83 YX 731 Stereo Tuner Kit (\$87.50)

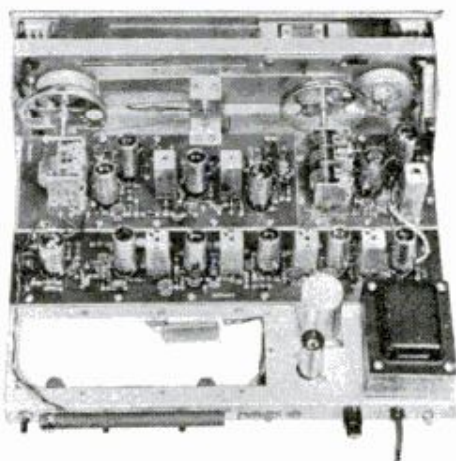

Though less sensitive than the Heath tuner, this latest addition to the Knight-Kit line offers several unusual features.

You can buy it in two ways—as a complete stereo tuner or as an FM tuner with provisions for adding the AM section later on the same chassis. And there's room enough for the subsequent addition of a multiplex adapter which Knight plans to make available as soon as the FCC approves this type of transmission.

In addition to the normal features of a high-quality tuner (AFC, tuning indicator, etc.) this unit incorporates a unique circuit for reducing distortion caused by overmodulation at the FM station. Knight calls it "dynamic sideband regulation," and it really works. Overmodulated signals which otherwise would cause considerable distortion, sound perfectly normal and the effectiveness of the circuit is demonstrable with a front-panel switch which can be used to disable the DSR.

The Knight tuner is somewhat easier to build than its Heath counterpart—at least for the less experienced builder.

Both use printed circuits and carefully prealigned parts, but the Knight-Kit includes precut color-coded wires and carded, easily identified resistors which can save a lot of assembly time.

EICO HFT90-K FM Tuner Kit (\$39.95)

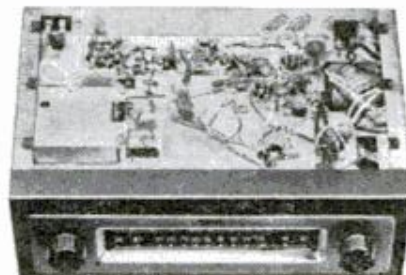

Of the three tuners tested, the Eico is the only one that does not include an AM section. It is also one of the few tuner kits which does not employ printed circuits and has no AFC action. The tests on the EICO unit, therefore, were of particular interest.

Despite the fact that every wire in this tuner must be inserted by hand, construction is not difficult. The simplicity of the circuit, coupled with a prewired tuning unit and thoroughly detailed instructions reduces construction time to about 15 hours. The only special care used in the assembly was in the parts placement to make sure that every part and wire was placed, as much as possible, in the position shown in the illustrations. And the results were gratifying indeed.

Station drift? There isn't any! Despite the lack of AFC, there was no need to re-adjust the dial once a station was tuned in. In fact, the set can be shut off at night, after several hours' use, and the next morning the same station comes in right on the nose without any retuning at all. This is amazing performance—even for much higher priced FM tuners.

In all other respects, too, the EICO tuner acquitted itself admirably. Though the 6-tube circuit is not as sensitive as that of the 8-tube Knight or the 10-tube Heath (considering only the FM portions of these sets) it is more than adequate for most applications.

With all FM tuners, an antenna is a vital part of the receiving system. For nearby stations a hank of wire will sometimes suffice, but for distance an outdoor antenna is often the determining factor between good and bad reception. A TV antenna can give satisfactory results and a single antenna can be made to do double duty (TV and FM) through the use of a two-set coupler.



Kit-built turntables and record changer. The differences are measurable but audible variations are slight

CHOOSING YOUR RECORD PLAYER

Record changer or manual player? On the surface this seems to be a simple question to answer, but if you dig a little deeper you'll find plenty to think about before making up your mind.

Automatic record changers are by far the most popular of the record-playing machines. They're used in virtually all commercially assembled hi-fi systems and in a majority of custom installations. But their popularity is no indication of absolute quality. Many confirmed audiophiles wouldn't use a changer on a bet. Their reasons—changers are harmful to records and don't provide true high fidelity. Here are some of the arguments, both pro and con, to help you decide for yourself.

Modern changers, say their advocates, combine turntable performance with changer convenience. With them, you get up to four hours of virtually uninterrupted music and the automatic set-down of the pickup arm eliminates the danger to stylus and record grooves accompanying manual fumbling. The audiophile's answer to this is that modern LP records provide in excess of 20-minutes playing time per side, which reduces the need for a changer. And if you're a bit shaky, you can buy an inexpensive accessory to a turntable which handles the pickup arm semi-automatically.

On the other hand, what about the wear and tear on the record's center hole when they are stacked on the spindle of a chang-

er or rotating about the fixed spindle? What about possible warpage of records due to insufficient support over prolonged periods of time? And it certainly doesn't help records to be dropped one on top of the other—particularly if the bottom record is rotating. If there's any danger to records, they contend, it's from record changers.

There are rebuttals even to these arguments. The raised edges of modern records prevent damage to stacked record surfaces. Polished spindles present little friction, and good changers handle records almost as gently as you could yourself. Certainly, if changers were particularly harmful, they never could have reached their present peak in popularity. In my opinion, the differences in performance between the two types of record players are of greater significance.

The object of high fidelity is to approach perfection as closely as possible. The design of a changer, because of its very function, involves a number of compromises. For example: Perfect reproduction requires a very precise turntable speed. With a changer the speed can vary considerably, depending on the number of records on the turntable. The same holds true for stylus angle which should be vertical with respect to the record groove. This angle varies slightly between the first and last record of the stack. Stylus pressure, another critical factor, changes

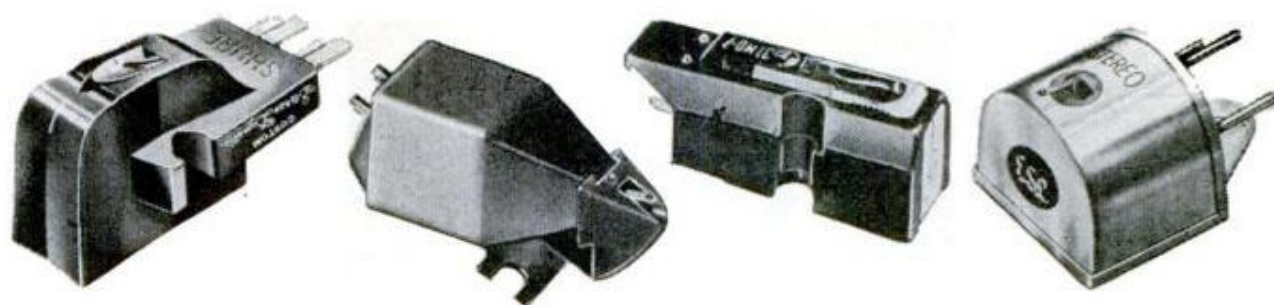

Hi-fi cartridges. Units shown are Shure, Pickering, Electro-Voice and ESL. Just a few of many

a bit as the stack rises and, at best, the tracking force needed for a changer is greater than for a manual player because some extra force is always required to initiate the change cycle. Finally, few if any changers, because of their inherent complexity, have the very low wow, flutter and rumble content of a professional turntable.

This deterioration is measurable with sensitive instruments, but whether it is audible is a matter only your own ears can determine. A number of current changers claim to meet minimum standards set up for professional broadcast equipment. This is undoubtedly true, but many turntables exceed this standard by a comfortable margin.

Building Your Own. For the do-it-yourselfer, there are four turntables and one changer currently available in kit form. There is a considerable price difference between the turntable kits and equivalent assembled models. The difference between the changer kit and a similar assembled model, however, is relatively small. Possibly the main advantage of building your own changer is that this procedure, though simple, acquaints you with its operation and permits you to make your own adjustments and eventual repairs.

Any of the five units illustrated can be

built in an evening. Some of the turntables, in fact, require less than an hour to build, but you'll have to add the installation and/or assembly time of a separate pickup arm.

The results of tests made on the assembled kits are given in Table II. All turntable tests were made under identical conditions and can be used as a basis for comparison. Tests on the changer were made with the built-in pickup arm and Shure M7D cartridge. Since the specified results indicate the performance of the complete unit, rather than that of the turntable alone, they are practical and realistic.

Can You Hear the Difference? Listening tests on the four turntables revealed no audible noise or distortion, even under the most critical practical conditions. With the changer, rumble and wow are audible—but only under conditions deliberately set up to accentuate these flaws. Rumble—the low-frequency noise caused by vibrations transmitted from the mechanism to the cartridge—was audible only at high volume settings, when the bass control was advanced to increase amplifier response to this form of noise. A slight amount of wow was noticed on single-frequency tones from a test record. When listening to music, these pitch variations due to minor chan-

TABLE II. COMPARATIVE TESTS MADE ON KIT-BUILT RECORD PLAYERS

	Type of Motor	Absolute Speed (RPM)			Wow & Flutter % at		Rumble and Noise
		110V	115V	120V	1 Gram	7 Grams	
GRAY HSK-33 (\$49.50)	Hysteresis	33 $\frac{2}{3}$	34 $\frac{1}{2}$	34 $\frac{3}{4}$.31	.32	-59 db
REK-O-KUT K-33H (\$49.95)	Hysteresis	32	32 $\frac{1}{3}$	33	.21	.23	-59 db
THORENS TDK 101 (\$47.50)	4-pole (Vernier speed adjustment)	Adjustable to			.17	.25	-41 db
		33 $\frac{1}{3}$	33 $\frac{2}{3}$	33 $\frac{3}{4}$			
WEATHERS KL-1 (\$34.50)	Hysteresis	32 $\frac{1}{3}$	33 $\frac{2}{3}$	34 $\frac{1}{2}$.28	.34	-46 db

ALL OF THE ABOVE TURNTABLES ARE OF THE SINGLE-SPEED (33 $\frac{1}{3}$ RPM) TYPE

	Motor	Turntable Speed			Wow & Flutter			Rumble
		1 record	5 records	10 records	1 record	5 records	10 records	
HEATH RP-3X CHANGER	4-pole	35 $\frac{1}{3}$	34	31 $\frac{1}{3}$.68%	.92%	2%	-36 db

ALL MEASUREMENTS WERE MADE AT THE 33 $\frac{1}{3}$ RPM SPEED OF THIS 4-SPEED CHANGER

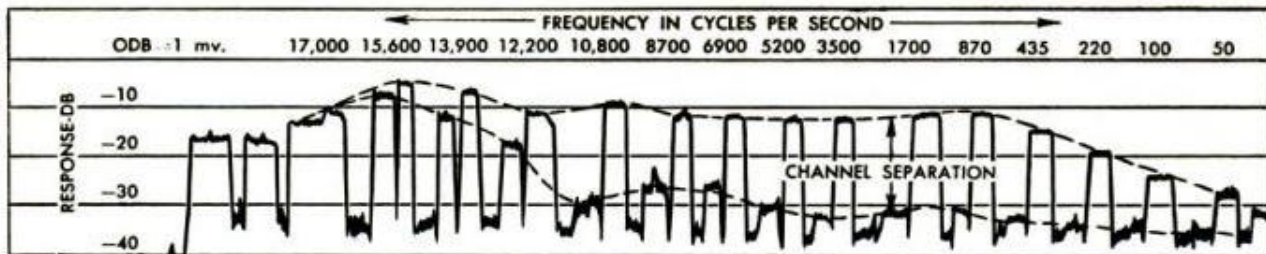

FREQUENCY RESPONSE AND CHANNEL SEPARATION OF ESL C-100 ELECTRODYNAMIC STEREO CARTRIDGE WITH OR 3004 TEST RECORD

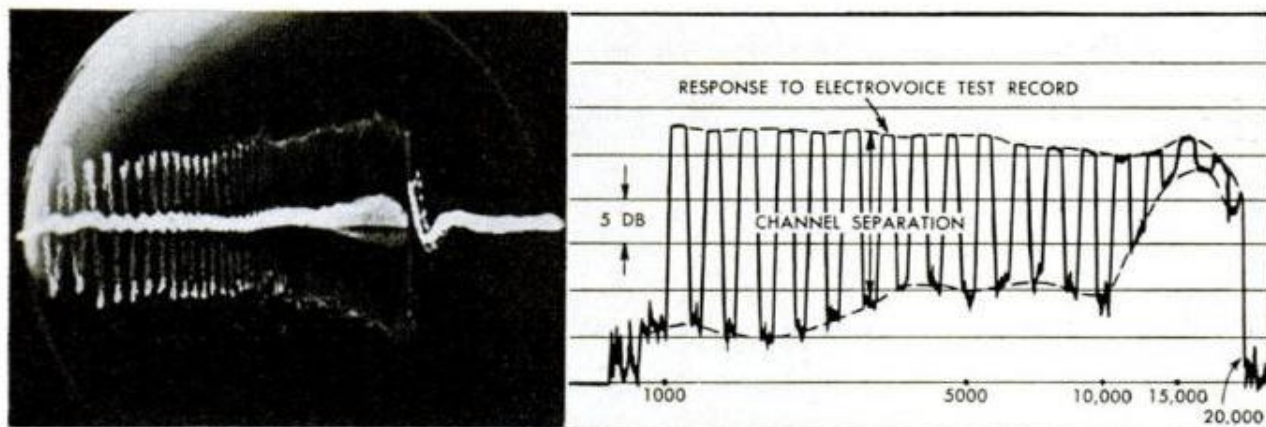

FREQUENCY RESPONSE OF EV 31 MD-7 CERAMIC STEREO CARTRIDGE
OSCILLOSCOPE TRACE SHOWS OVER-ALL RESPONSE TRACE OF RESPONSE TO TONE BURSTS FROM 1000 to 20,000 CPS.

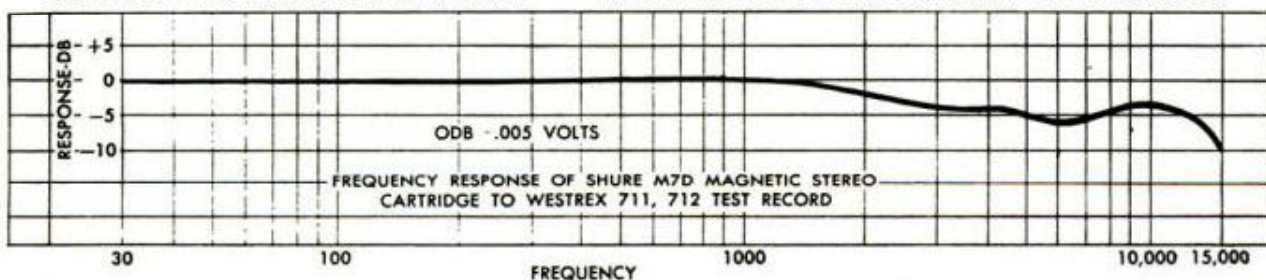

FREQUENCY RESPONSE OF SHURE M7D MAGNETIC STEREO CARTRIDGE TO WESTREX 711, 712 TEST RECORD

Specifications for both magnetic and ceramic cartridges are excellent. Your ears can decide what's best

ges in turntable speed were completely unobtrusive.

While a poor turntable can introduce noise and variations in pitch, the ultimate tonal quality depends primarily on the pickup cartridge. And, whether you buy a changer or a manual system, you're generally given your choice as to which cartridge you wish to use. That's because cartridges, like loudspeakers, tend to add their own characteristics to the resulting

sound. Two equally good cartridges, from a standpoint of electrical specifications, can sound quite different, and only your ears can tell which one you like best.

Basically there are two types of cartridges; those which convert stylus motion into electrical signals by magnetic means, and those which accomplish the same thing by causing the stylus to flex a crystal or ceramic element.

(Continued to page 268)

Not all pickup arms are alike. Try before you buy—or build—is a good motto. It's worth the effort

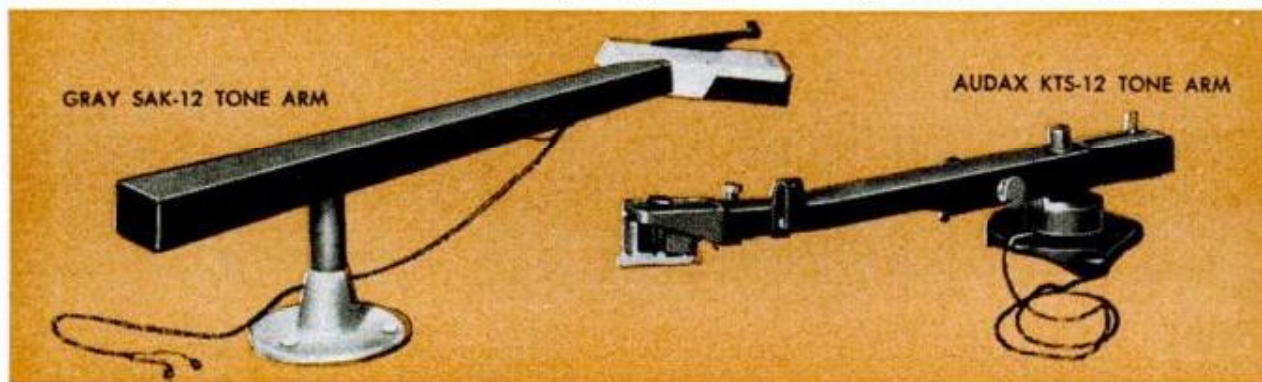

Too much flexing wears out people... and tires!

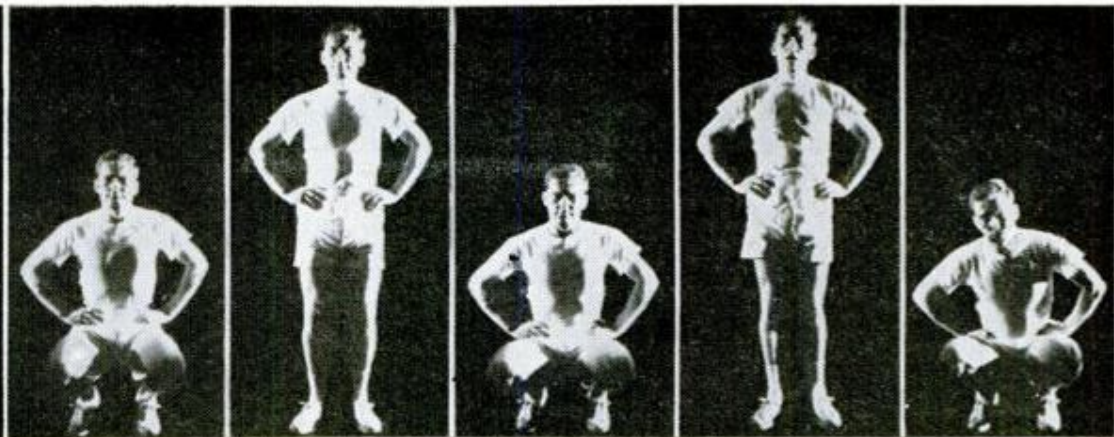

New "Low Profile" tire shape flexes less, reduces heat build-up, increases mileage!

NOW! THE TIRE THAT DOESN'T GET TIRED

Takes regular air pressure...yet it's lower and wider to keep you safe at top speeds!

Do a few quick knee bends—and what happens? You heat up fast, soon feel real strain.

Ordinary tires do 700 "knee bends" per mile as they roll along under your car. This excessive flexing builds up torturous heat, weakens rubber and fabric, increases blowout danger.

Now U. S. Royal reduces danger of tire failure with a revolutionary new tire. Even though air pressure is the same as in ordinary tires, U. S. Royal "Low Profile" tires are lower and wider to flex less, run cooler, wear better.

"Low Profile" tires cost no more than ordinary tires. See the complete line now in 5 popular price ranges for every make and model car—at your U. S. Royal Dealer.

Same air pressure...but look at the difference!

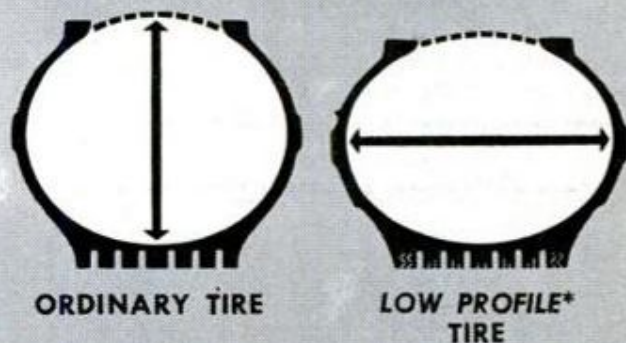

STOPS QUICKER, RIDES SMOOTHER. A lower, wider shape gives U. S. Royal "Low Profile" tires more tread to grip the highway. "Low Profile" tires are made of U. S. Royal's exclusive no-shock rubber for the "Red Carpet Ride"!



STEERS BETTER, SAVES GAS. Pre-shaped to actual rolling proportions, U. S. Royal "Low Profile" tires are much more stable on curves, respond quicker in emergencies. And less flexing means 6 to 12 extra miles per tankful of gas!

ORDINARY TIRE SHAPE flexes excessively building up intense heat that murders tires, burns 'em out fast. But the "LOW PROFILE" TIRE SHAPE reduces flex, keeps temperature well below destructive danger zone. Running for hours on end at top highway speeds, U. S. Royal "Low Profile" tires stay cooler, keep you far safer.



PIONEERED BY U. S. RUBBER AS THE ANSWER TO GREATER TIRE SAFETY



U.S. ROYAL LOW PROFILE* TIRES

US United States Rubber

Rockefeller Center, New York 20, N. Y.

*"Low Profile" is U. S. Rubber Company's trademark for its lower, wider shape tire.

New Ideas in Photography

Drama for 8mm Movies! New Kodak Movie Camera Zooms Scenes In or Away

Now you can give your home movies the same dramatic zoom effects you see in theater movies or on your TV screen. Catch your subject in motion—then zoom in for a close-up without interrupting the action or changing your position!

The remarkable new Kodak Zoom 8 Camera (Automatic $f/1.9$) features a variable focal length lens. As you slide the lens barrel forward or back, it seems to "shrink" or "stretch" the distance to your subject.

In shooting sports scenes, for example, you can get an over-all view of the action, then zoom in on one player. When you project the scene, the player comes closer and closer, growing bigger on your screen.

You can also use the Zoom 8 lens to get the same wide-angle, regular, or telephoto effects that used to require a 3-lens turret camera. Each field is outlined in the telescopic viewfinder.

Another great feature: built-in electric eye adjusts the fast $f/1.9$ lens automatically for correct exposure. And the viewfinder eyepiece adjusts for your own eye.

Enjoy a new kind of action-packed movies with the Kodak Zoom 8. An unusual value at only \$139.50, or as little as \$14 down. Many dealers will take your old camera in trade.

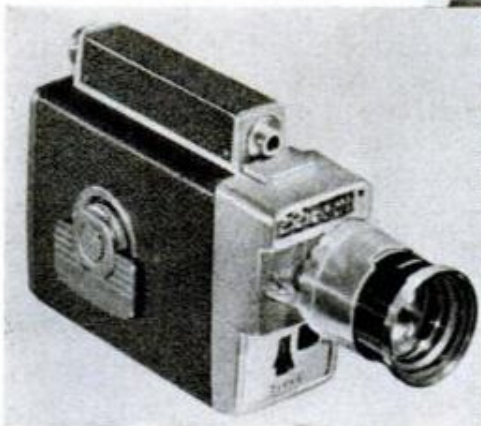

Kodak Zoom 8 Camera brings faraway subjects up close without stopping the action.



Enormously magnified crystal of silver bromide (left) in 10,000-volt-per-centimeter field. It is just starting to develop; note tiny metallic silver specks along bottom. At right, fully developed silver network. Photos are of electron-microscope images.



Film Now Investigates Film, World's Most Sensitive "Amplifier"

Scientists are now using photography itself—and the electron microscope—to learn more about the inner behavior of photographic film.

They have found that when photons, the "energy bullets" of light, strike the silver halides in film, electrons are liberated. These electrons, in turn, trigger a development reaction a billion times as great as the photons' original power!

Such advanced research into the physics of film emulsions gives Kodak new knowledge to create faster, finer grained films for amateur and professional use.

from Kodak

Screen Arrow Adds Showmanship to Automatic Slide Shows

Now when you show slides to guests you can point out details on your screen without leaving your chair for even a moment.

Lift a finger-tip control on your automatic Kodak Cavalcade Projector—and a shadow arrow appears on the screen. Up, down, right, left—the arrow moves as you choose, to point out details you want to discuss.

And all the time, your Cavalcade is changing slides automatically at the pace you chose—as many as 40 slides in sequence. Instant change between slides, too—no long drag or dark screen!

Controls let you hold, repeat, or skip any slide—or lift out any slide with a finger-tip ejector. And each slide is held in its own steel protector, for smooth showing, no jamming.

Take some slides along when you ask your dealer to demonstrate this wonderful projector. With $f/3.5$ lens, only \$124.50, or \$12.50 down.



Arrow points out details as you talk about them.

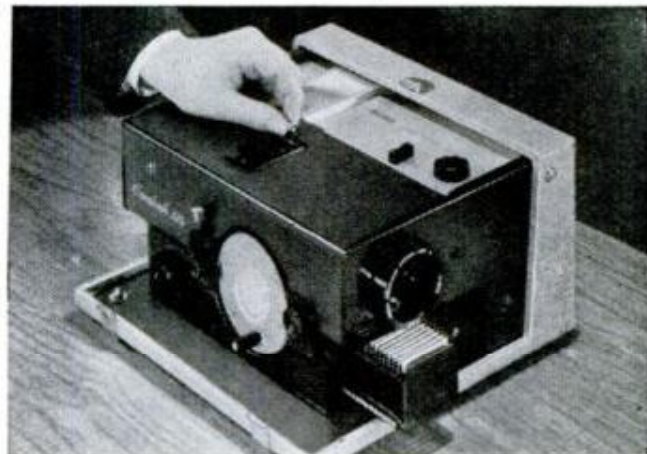

Control for arrow is easy to reach, easy to use.

Ingenious Film Loading System Does Away With Take-up Spool

Here's the quickest, simplest 35mm film loading ever devised. No threading or hooking on a take-up spool. *There isn't any spool.*

With the Kodak Signet 80 Camera, you just drop the film in, start the tip into a slot, and close the camera back. As you advance the film, it feeds smoothly into an expansion chamber.

Such ease of operation is typical of the Signet 80. Exposure control is easy—the built-in light meter ends guesswork. Focusing is easy, rangefinder couples to all lenses. Film advance is easy—two thumb-flicks!

This is truly the camera with the skill built in. See for yourself. With 50mm $f/2.8$ lens, only \$129.50, or as little as \$13 down.

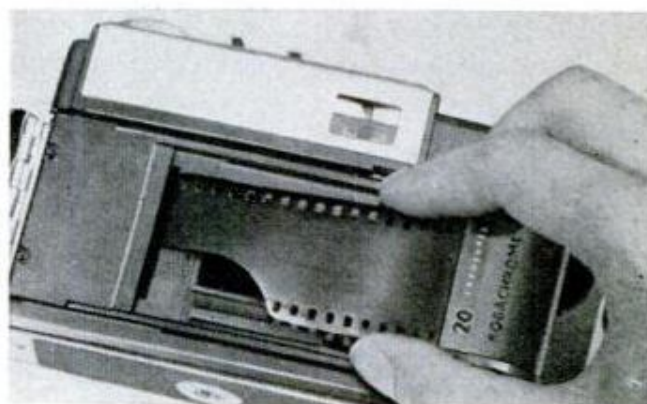

Loading so easy you can do it blindfolded!

35mm wide-angle lens for Signet 80, \$57.50; 90mm telephoto lens, \$69.50; multi-frame finder, \$17.50. Other aids available for ultra close-ups, sports, even photomicrography.



Prices are list, include Federal Tax, and are subject to change without notice.

EASTMAN KODAK COMPANY, Rochester 4, N. Y.

SEE KODAK'S "THE ED SULLIVAN SHOW" AND "OZZIE AND HARRIET."

Kodak
TRADEMARK

Clinic for Homemakers

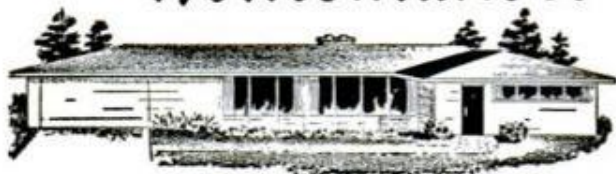

As a service to our readers in solving the hundreds of problems pertaining to a home—inside or out—the editors of *Popular Mechanics* invite you to present your problems to The Clinic Editor for help and advice. Address your questions to The Clinic Editor, *Popular Mechanics Magazine*, 200 East Ontario Street, Chicago 11, Ill.



Brown Tinted Lawn
Q—Last year after mowing my lawn I noticed each time that the grass turned a brownish color over most of the area. I examined the blades of the grass closely and noted that the tip of each blade was discolored for a distance of $\frac{1}{4}$ in. or so just below the point where it had been cut. What is wrong?
A—No, it is not likely that disease is present, nor is there anything especially wrong except that your mower is dull. That brownish patina you see on many lawns a day or so after mowing is due to the blades being torn at the point of

cutting rather than severed cleanly. In dry weather this mower defect does considerable damage. Sharpen your mower and keep it sharp. This is just as true of the rotary mower as it is of the reel-type mower. And be sure that the mower is set to cut the grass at the proper height, $1\frac{1}{2}$ in. on the average lawn in spring and about 2 in. or more in summer.



"Mums" Grow Tall

Q—My chrysanthemums grow so very tall each year that long before blooming the plants fall over and become entangled. Half the blooms are ruined or are invisible. I've been told that the thing to do is cut them off in early summer to a height of about 12 in. I've never tried this. What would happen?
A—Don't cut the plants as you have been advised. From

your description we would judge that your plants are growing in beds and that they need thinning to permit more normal growth of those remaining. A common procedure is to keep the plants pinched back, forcing them to develop numerous stems and more larger blooms. Many successful gardeners begin pinching back the tips early in the growing season, but unless you are concerned mainly with extra large blooms, it is perhaps well to allow the plants to attain a height of 12 to 15 in. or more before tipping in the manner described. Plants that grow in open beds or in plantings along walls and at the edges of beds often need to be permitted to grow to a somewhat greater height and be supported in a manner similar to a tomato plant by means of a circular wire rack.

(Continued to page 226)

LOOKING FOR LONGER WEAR IN SAFETY SHOES?

TRY Lehigh SAFETY SHOES

with NEOPRENE SOLES!

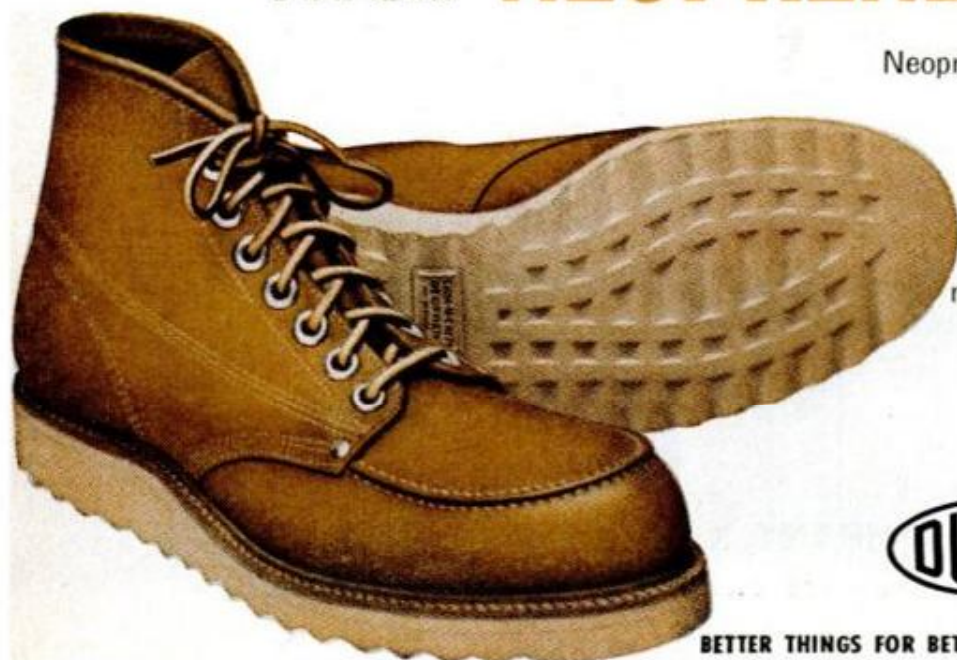

Neoprene soles give longer wear...
 resist oil, grease, chemicals
 and cold weather cracking.
 Neoprene soles are resilient
 ... cushion each step... help
 make standing jobs less tiring.

Ask for neoprene soles
 the next time
 you buy safety shoes.



BETTER THINGS FOR BETTER LIVING... THROUGH CHEMISTRY
 POPULAR MECHANICS



Light plane record holder uses Champions! Max Conrad set a new endurance record for single-engine, light planes last June . . . 7,668 miles non-stop! His Lycoming-powered Piper Comanche was sparked by Champions.



Outboard record holder uses Champions! Hugh Entrop holds the world's outboard motor record with a dazzling 107.8 miles per hour. His stock Mercury outboard was powered by Champion spark plugs.

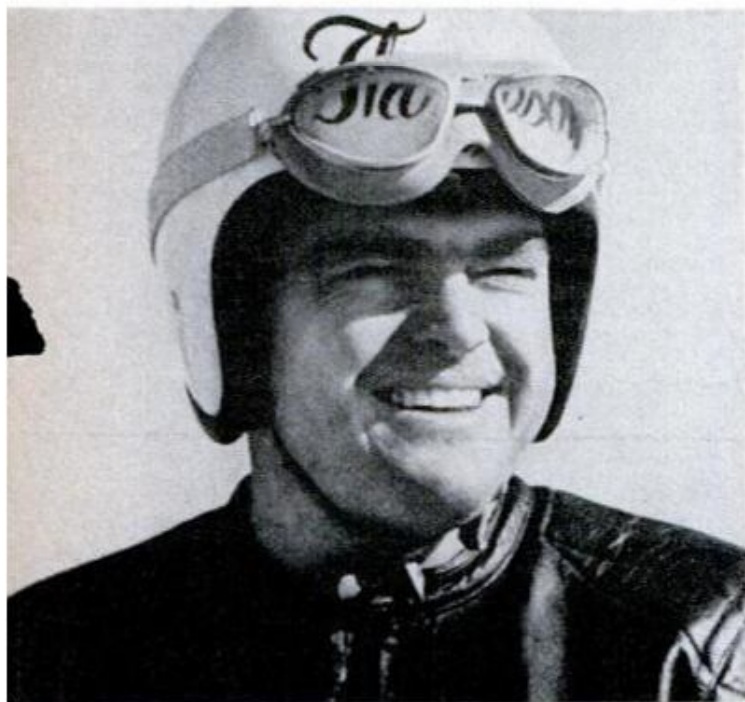

Land speed record holder uses Champions! Mickey Thompson set a new American speed record of 363 m.p.h. at Bonneville Salt Flats last October. His car's four Pontiac engines were all sparked by Champions.



Indianapolis record holder uses Champions! Rodger Ward set a new record at Indianapolis last year at 135.8 miles per hour. Rodger, like 9 out of 10 race car winners, uses Champion spark plugs!

Q. Why do the record breakers, in field after field, use Champion spark plugs?

A. Because they know they can depend on Champions to wring every bit of performance out of every drop of gas. Your car will perform better, too (and save money on gasoline) with new Champions. Put in a set every 10,000 miles!

*Worn spark plugs waste lots of gas—
so check your plugs every 5,000 miles!*



Материал, защищенный авторским правом

Watchmaker's Precision

plus a

BULL-DOG GRIP



Specially
Designed

CHANNEL LOCK[®]

No. 718 Long-reach

Flat-Nose Plier

Looking for a precision plier that really takes hold in hard-to-reach places? Here's your answer . . . this specially designed CHANNELLOCK Flat-Nose Plier. Just the ticket for electrical, radio, TV, Hi-Fi and other electronics work. Micro-matched, scored, long, flat jaws. Comfortable, blue-plastic grips. Top quality, polished forged steel. Ask your tool supplier for a CHANNELLOCK No. 718 Flat-Nose Plier.

If he's out of them, ask him to order one for you.



Write for Catalog of
Complete Line of Pliers

CHAMPION DEPARTMENT TOOL COMPANY

Meadville 1, Pennsylvania

Driveway Repair



Q — My concrete driveway is poured along the house foundation for a distance of about 20 ft. Now after 5 years or so, the driveway slab has cracked at the center and the half next to the house foundation has tilted toward the wall. When it rains hard I get trickles of water in the basement.

What to do is my problem. Should I remove the defective part of the driveway and pour new concrete, or is there some way to repair the old? —E.P., Mich.

A—It's rather hard to decide just what is best to do. No doubt the original driveway slab was poured over freshly graded earth which had not been properly tamped or perhaps not even allowed to settle normally. Such a condition alone would leave the slab without adequate support on that half which is laid over the area originally excavated for the foundation wall. Perhaps in the long run it would be best to plan on replacing at least the defective half of the slab. It might be advisable to consider replacing that portion of the entire slab which is poured along the wall. The latter procedure would permit the preparation of an adequate bed for a wire reinforced slab. First, lay a tamped gravel fill at least 4 in., and better 5-6 in. thick, pour and spread a grout coat, lay the wire reinforcement and finish by pouring a slab at least 4 in. thick. There should be an expansion joint along the foundation wall and the slab should be tilted away from the wall at least 1 in. across its width to permit water to drain away from the wall. Of course, it also is necessary to check the new portion of the driveway for slope, or fall, along the length to carry water away so that it does not stand at any point.

Growing Gladiolus

Q—I'd like some general information on growing gladiolus, where and how to plant the bulbs, how deep to plant, what kind of soil is best, how and when to use plant foods, and so on.—L.A., Wis.

A—Gladiolus require very little attention during the growing season. Of the summer blooming bulbs they are among those easiest to grow. The plants do require an enriched, friable soil that has been deeply spaded or otherwise worked, preferably in the late fall. They need exposure to full sunlight and they should never be planted where they must compete for available plant food with trees or shrubs. Good natural drainage also is essential. Glads will not thrive in heavy wet soils or in an area that is flooded after a heavy rain. Planting can begin in the spring as soon as the soil is dry and loose. The larger corms are placed in a trench, at a depth of about 6 in. in a sandy soil and from 4 to 5 in. in a heavier clay soil. The smaller corms are never set so deeply; a fair rule of thumb to follow is planting them at a depth roughly 4 times the diameter. Ordinarily corms of large and small sizes are placed about 6 in. apart in the trench. Some gardeners prefer a spacing of 8 in. Cover the corms with loose, fine soil but do not fill the trench entirely. After planting keep the soil stirred by hoeing or cultivating to a depth of 1 in. or so to develop a self-mulch, or dust mulch, to conserve moisture. Water sparingly during the period after planting and before the first blades, or leaves, show above ground. Always stir the top soil after watering or after a rain. Do this as soon as the soil is sufficiently dry on top to make it workable. After the plants reach a height of 6 in. or so, dig a trench on each side of the row and about 4 in. from it. Each trench should be 5 to 6 in. deep. Place a complete fertilizer in the bottom of the trench in the proportion of about 2 lb. to 50 ft. Fill the trench with loose soil, water lightly and again stir the top soil as soon as it is sufficiently dry to work. After the blooms have been cut the plants should again be side dressed with a complete fertilizer in this same manner. The second side dressing will develop stronger corms for next year's planting.

See what you can do...easily; quickly ...with a SWINGLINE STAPLE GUN!

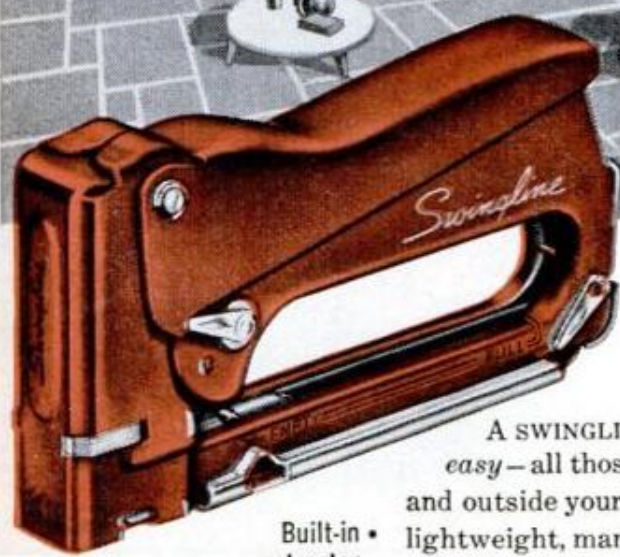
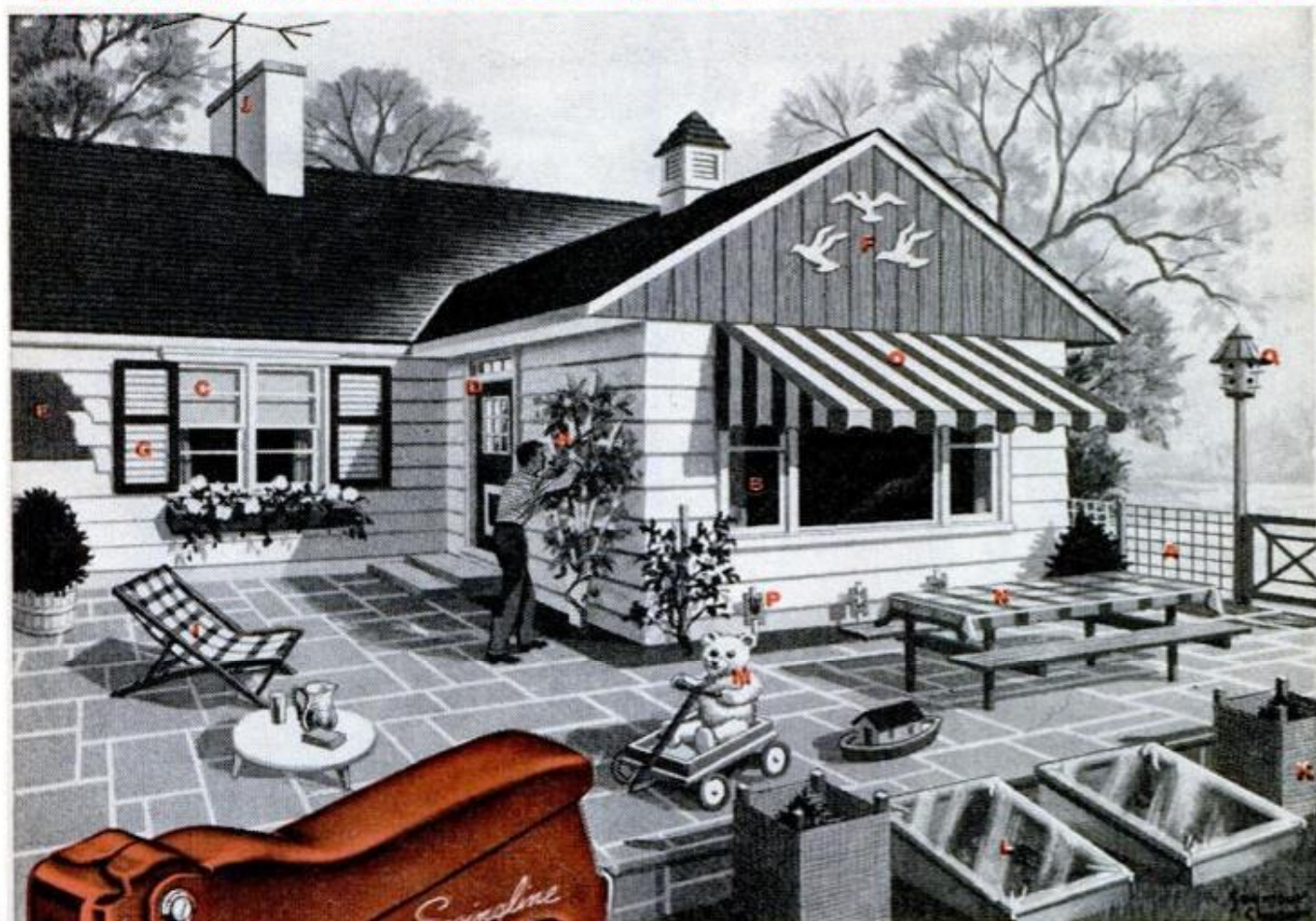

ONLY \$ **4⁹⁵** with
PUSH-BUTTON
LOADING

A SWINGLINE staple gun makes *immediately possible*—and *easy*—all those time consuming, hard-to-do chores both inside and outside your home. This

- Built-in extractor
 - Handle lock
 - Push-button loading
 - Rugged, heavy-duty steel construction
 - Load indicator
 - Open channel takes 2 staple sizes: 1/4" and 5/16"
- The price? A hard-to-believe \$4.95—that's all! Your choice of Gray, Red or Green. Insist on a SWINGLINE staple gun—with push-button loading—at better hardware, department, stationery stores!

CHECK THIS LIST

- A—wire fencing
 - B—screening
 - C—window shades
 - D—weatherstripping
 - E—tar papering
 - F—outdoor decorations
 - G—repairing shutter slats
 - H—fastening vines to trellis
 - I—recovering furniture
 - J—television antenna wire
 - K—burlap covers on shrubs
 - L—cold frames, with plastic sheeting
 - M—repairing toys
 - N—picnic table covering
 - O—awnings
 - P—markers for seeding
 - Q—bird houses
- And hundreds of other uses.

FREE! Send for Booklet "Tips for Tacking" How to do many stapling jobs.



Swingline INC.

World's Largest Manufacturer of Staplers For Home and Office!

32-00 Skillman Avenue
Long Island City 1, New York

You can do more with

DELTA



Angular drilling for the splayed legs on a coffee table is no problem with this tool because the angle of right or left tilt can be set by a calibrated scale and locked into position. Resetting head to vertical position is simplified by setting of the automatic stop into a milled groove.



Inlay routing in the center of a 30" x 40" project is possible because there is 16 $\frac{3}{8}$ " capacity between the column and the router bit. Use of the fastest of the four speeds available makes this a smooth operation. Controls are conveniently grouped "up front" for safe, positive action.



Spindle drilling on an extra long hand rail *does not* require a special fixture or jig because the head tilts. Big $\frac{3}{4}$ " x 23 $\frac{3}{4}$ " x 15 $\frac{7}{8}$ " table gives adequate support while remaining parallel to the base. Laminated wood work surface is mounted to a fully machined 8 $\frac{1}{2}$ " x 9" cast iron table.

DELTA DRILL PRESS, REGISTERED TRADEMARK OF DELTA TOOL WORKS, INC.

New radial drill press



makes
"impossible" drilling
easy

DELTA 32" RADIAL DRILL—basic machine complete with $\frac{1}{2}$ " capacity geared chuck, belt and motor pulley.

Weight 85 lbs—only **\$89.50** (slightly higher in the West).

Here's just what you'd expect from Delta—a brand new radial drill—specifically designed to handle drilling jobs you *can't* do on a conventional drill press. There is almost no limit to the flexibility this tool puts at your fingertips—and you'll really appreciate the big capacity. The head swivels 360° around the column, tilts more than 90° left and right, travels almost a foot forward and back—yet the work always remains parallel with the base. You can drill to the center of a 32" circle, rout, sand, mortise, do dozens of operations at your choice of four speeds (700,1250,2400,4700 r.p.m.) on a wide variety of materials.

You can count on this tool to extend your skill, broaden your range of projects. And because you know tools, you know you can count on the precision, ruggedness and safety that Delta's 31 years of experience build into tools used throughout industry and in home workshops.

Consider the many ways you can do more jobs better, quicker and easier with the *newest* Delta tool—you'll want to see the Radial Drill in action! Visit your Delta Dealer (he's listed under "TOOLS" in the Yellow Pages) or your leading Department, Hardware or Building Supply Store. Do it soon!

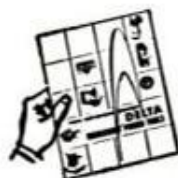

See the world's most complete line of home workshop power tools and accessories—pictured and described in this colorful, FREE Homecraft catalog. Write to: Rockwell Manufacturing Company, Delta Power Tool Division, 502D N. Lexington Ave., Pittsburgh 8, Pa. In Canada: Rockwell Manufacturing Company of Canada, Ltd., Guelph, Ontario.

DELTA POWER TOOLS

another fine product by

ROCKWELL



Cut it with WISS

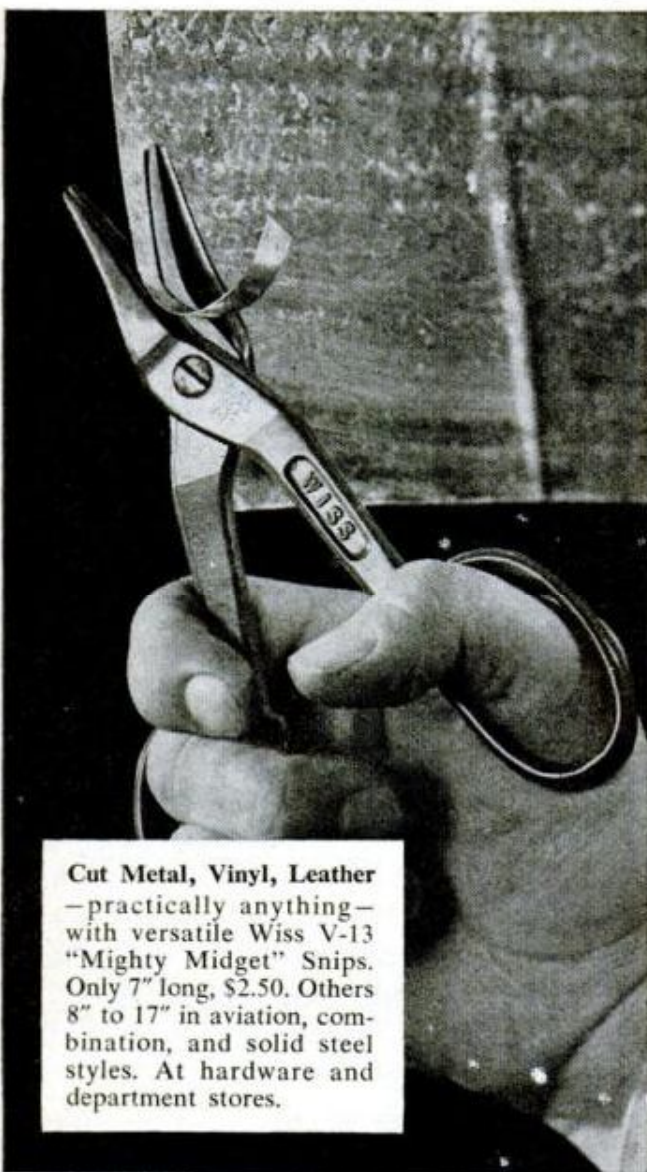

Cut Metal, Vinyl, Leather—practically anything—with versatile WISS V-13 "Mighty Midget" Snips. Only 7" long, \$2.50. Others 8" to 17" in aviation, combination, and solid steel styles. At hardware and department stores.

OTHER FINE WISS CUTTING TOOLS

GRASS SHEARS

No. 701
\$2.75



Easiest cutting, fastest cutting grass shears you've ever used, with molded vinyl handle grips and special closing latch. Others from \$1.39 to \$4.95.

PRUNERS

No. 907-G
\$3.25

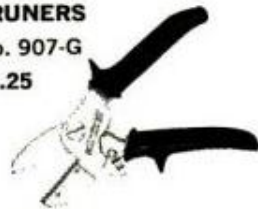

Wiss Hy-Power Pruners, with new vinyl grips, cut toughest limbs, protect your hands. 7-inch pocket size. \$3.25 wherever garden tools are sold.

J. WISS & SONS CO., NEWARK 7, N. J.

World's Largest Manufacturer of Shears, Scissors, Pinking Shears, Skalloping Shears, Metal Cutting Snips and Garden Shears

The PM Houseboat

(Continued from page 173)

is positioned at the aft end of the cabin roof, and a socket for an ensign staff is mounted to the after deck at the transom. The spotlight and horn are optional fittings, as is the boarding ladder.

If you have been building your houseboat outdoors, painting the outside is something you would have done as soon as the exterior carpentry work was completed. At least the wood would have been protected with a priming coat. Of course, the time to apply the copper bottom paint to the hull was when the latter was upside down. The bottom paint is stopped at the water line. If you have been able to carry on construction under cover, you may be ready to paint the exterior now. An A-1 job of finishing the outside would consist of going over the entire hull, decks and cabin, and filling any ill-fitting joints with non-hardening calking. It is best to seal all exposed plywood edge grain with glass-fiber tape. Such edges will be found exposed in the hull planking and around the window openings. The bare wood should be given a priming coat, followed by two finish coats of high-grade marine paint. The glass-fibered decks and cabin roof were painted dark green in the prototype to offset an all white exterior. The rub rails, as well as the toe rail at the bow, were stained dark and finished with two coats of marine spar varnish. All outside mahogany trim was treated likewise.

Instructions for coupling two outboard motors is given by the manufacturer. Tiller cables that have been previously threaded through the bushed holes in the side frame members are brought out through holes in the transom and attached to the tiller connections on the motors. ★ ★ ★

Aircraft Jet Engine Pumps Natural Gas

The same engine that provides the thrust for military and commercial aircraft has been harnessed to a new job with its feet securely on the ground. The Cooper-Bessemer Corporation of Mount Vernon, Ohio, has developed a turbine that runs on the jet exhaust of a Pratt & Whitney J-57 engine. The turbine will run a centrifugal compressor pump in a natural-gas pipeline system. The engine is conveniently modified to operate on the same gas in the lines, which eliminates the biggest problem of jet-engine operation, their heavy fuel consumption. The first turbine, rated at 10,500 horsepower, will be installed early in 1960.



**PERFECT CIRCLE
PISTON RINGS ARE BUILT
TO TAKE IT**



**25 BLOWS
EVERY SECOND***

*IN ANY 4-CYCLE ENGINE AT 3000 RPM

You can't see the hammer-like blows piston rings receive, but costly results are soon evident when inferior material is used.

Correct metallurgy is one of the most important features of every Perfect Circle piston ring. Over six different metals are used at Perfect Circle...each material the highest strength compatible with the specific application...each material selected for utmost protection against breakage.

Correct, proven metallurgy is another reason why Perfect Circles are preferred and installed with confidence by leading engine manufacturers and mechanics everywhere.



PERFECT  CIRCLE

**PISTON RINGS • PRECISION CASTINGS
POWER SERVICE PRODUCTS • SPEEDOSTAT
HAGERSTOWN, INDIANA • DON MILLS, ONTARIO, CANADA**

©1974 Perfect Circle, Inc. All rights reserved. Material protected by copyright.



Denis Drysdale, of Lafayette, Indiana, checks the engine of his classic Auburn cabriolet.

"Quaker State keeps the engine of my classic 1936 Auburn trouble-free, and my new car too!" This Series 852 beauty boasts a 150 hp. straight 8 engine, big for its day, and dual rear axle ratios. Performance is still superb, thanks to the loving care it has always received. Important item in that care: Quaker State Motor Oil. Its long-lasting protection and complete lubrication guard any car best, new or old! Super-refined from 100% pure Pennsylvania crude oil. It's the finest motor oil your money can buy.

Available most everywhere . . . always ask for Quaker State by name.

For the name of your nearest dealer, call Western Union by number and ask for Operator 25.



QUAKER STATE OIL REFINING CORP., OIL CITY, PA.
Member Pennsylvania Grade Crude Oil Association

Policing Iceberg Alley

(Continued from page 94)

slopes away gradually, the ribbon of glacial ice presses out and down into the sea until the buoyancy of the ice breaks off the lip, and away it floats as a separate entity. When the sea floor drops away from the shore, wave action erodes the underpinning. Finally the weight of the overhanging lip cracks and with a great, roaring splash the ice ship floats free.

Bergs from the eastern coast of Greenland are caught by a current that carries them around the southern tip of the island and then north toward the Arctic Circle. En route, they are joined by the bergs that are calved each year by the 20 principal glaciers on the northwestern coast of Greenland. For an average of three years the bergs drift northward and westward and then, in the embrace of the Labrador Current, southward toward Newfoundland, the Grand Banks and the steamship lanes.

Happily, most of the bergs are stopped along the way. They run aground or are trapped in coves and slowly rot away in the summer sun. Others, however, continue to drift southward at a speed of about two knots, or more than 50 miles a day, until they pass the 48th parallel at northern Newfoundland. There they become the concern of the Ice Patrol.

The main tongue of the Labrador Current is funneled through a deep-ocean channel formed by the eastern slopes of the Grand Banks and a comparatively small midocean shoal called Flemish Cap. The Ice Patrol calls this the "Slot" or "Main Street." Through it the surviving icebergs stream toward the congested shipping lanes. There the icebergs suddenly are shunted aside by the northward-flowing Gulf Stream, known in these latitudes as the North Atlantic Current. Its temperature runs as high as 68 degrees, compared with the Labrador Current's frosty 28 to 32 degrees.

Now the bergs change abruptly. Within fewer than 40 miles, less than a day's travel for an iceberg, rivulets of water from melting ice begin cascading over a berg's sides into the sea. Mammoth chunks of ice split off and drift away. In a few days—or at most two or three weeks—the bergs are destroyed, or remnants are deflected toward northern European waters by the sweep of the North Atlantic Current.

Iceberg experts can never be sure, however, that the northern fringes of the Gulf Stream will do their job as expected, says Lt. Comdr. Robertson P. Dinsmore, Executive Officer in Charge of the Ice Patrol. In

(Continued to page 248)

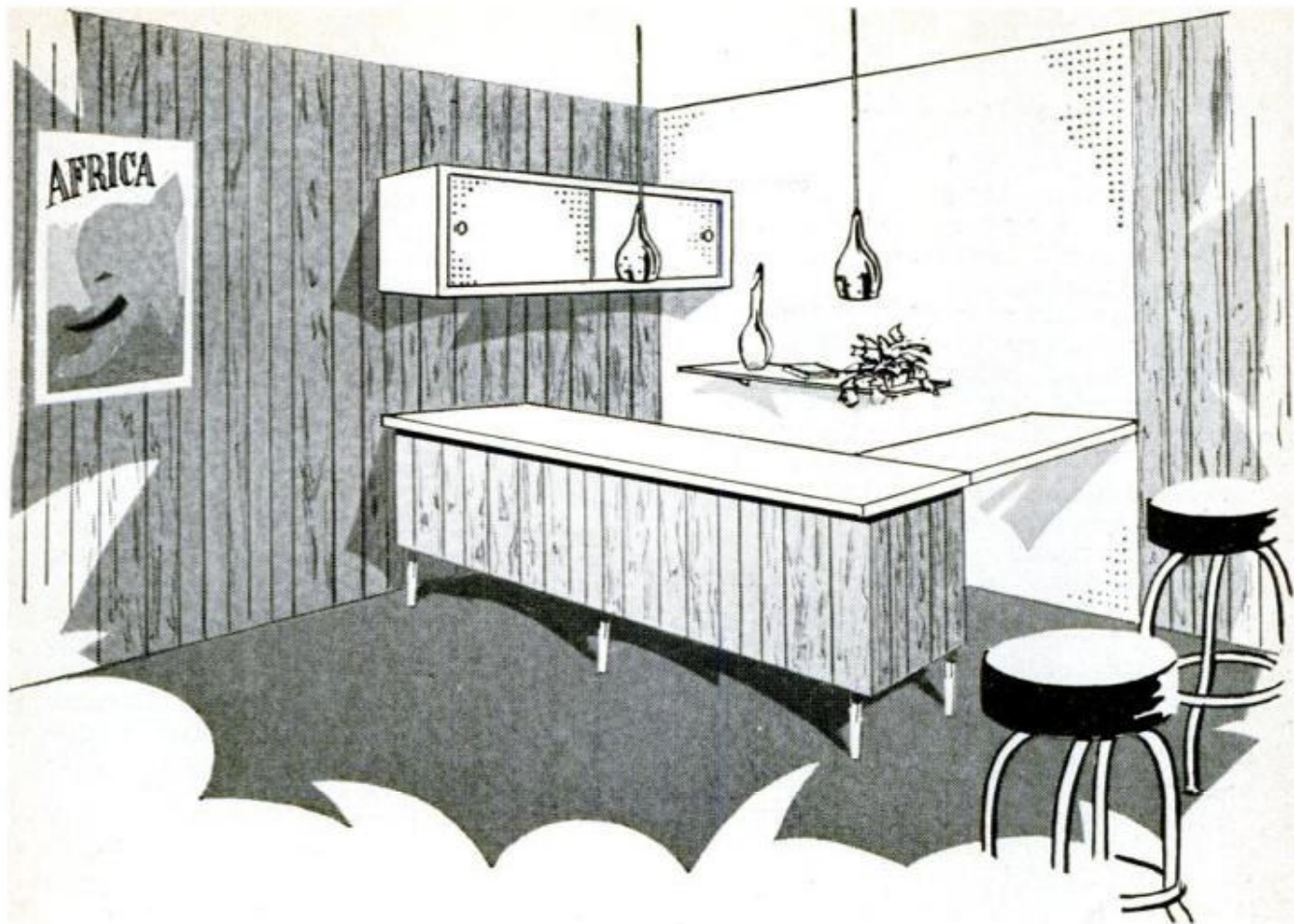

Have Fun! Build This "Sip 'n Snack" Project

SEND FOR FREE PLAN

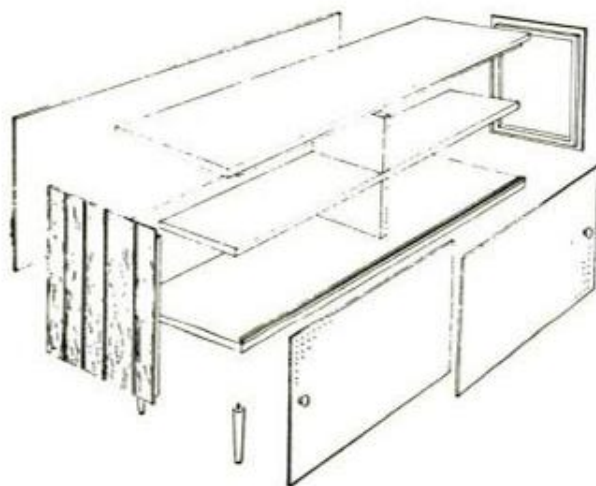

... which shows how to build a smart, efficient "sip 'n snack" center for a family or activities room. You will find it enjoyable and easy to work with these complete plans in doing the walls and snack bar with Masonite's new cherry and walnut wood-grained panels in seven delightful color tones.

Expensive? Not at all. Masonite® Royal-cote® panels, for a 12' x 8' wall, cost as little as \$22.12. The materials call for only a modest expenditure compared to the pride and joy this project will bring you.

But see for yourself. Fill in and mail the coupon for free information on Masonite's "sip 'n snack" center and new wood-grained panels, available at your lumber dealer's.

MASONITE 
CORPORATION

©Masonite Corporation—manufacturer of quality panel products for building and industry.

Masonite Corporation
Dept. PM-4, Box 777, Chicago 90, Ill.
In Canada: Masonite Corporation, Gatineau, Quebec
Send FREE plan on your new "sip 'n snack" center—
no obligation.

Name.....
Address.....
City..... Zone.....
State..... County.....

Solving Crimes by Hypnosis

(Continued from page 109)

means force." He thinks that hypnosis could help to unburden this kind of witness, also.

"There's no doubt in my mind," he says, "that hypnosis, by stepping up the brain's ability to recall, could be most valuable in solving crimes."

Dr. Levendula says that hypnosis today is still surrounded by "mysticism, misconceptions and misunderstandings." It is not an unconscious state. It simply releases the subconscious mind, the storehouse of memory. The hypnotist puts you "under" by concentrating on some repetitive stimulus—"You are so sleepy, so sleepy, so sleepy"—and then makes you act by suggestion. Hypnosis, in itself, is harmless. And almost anyone can be hypnotized.

"By its very nature, hypnosis is a logical tool for the criminologist," says William Mayers of Washington, D. C., a consultant to the Department of Defense in World War II. "It amazes me that more has not been done in the field."

In the quarterly magazine, "Hypnosis," the official journal of the Association to Advance Ethical Hypnosis, he tells of instructing Army Intelligence investigators on how to use hypnosis in questioning Japanese prisoners and recommends it, not only for witnesses, in police work, but also for crime suspects, if the law allows.

"Possibly one reason why hypnosis has not been more widely used by detectives and other investigators," he writes, "is the belief that a suspect can resist being hypnotized. While this is generally true, there are methods for hypnotizing people without their knowing it. This still does not mean they can be hypnotized against their will. It simply means the trance can be induced in an indirect or disguised manner."

This "intense inter-personal relationship between two people" is brought about most readily when the subject is willing. But a person can be put into a trance before he realizes what is happening.

The experts say, too, that a suspect might try to fake a trance. He could pretend he was hypnotized and go right on lying. But he would not often fool a skillful hypnotist.

In Cleveland, Dr. Gerber feels that the time is coming when police will rely on hypnosis as frequently as they now lean on the lie detector. He thinks, however, that it will be used exclusively on witnesses to develop cases, to uncover "leads." The courts may never approve it for suspects. "If you hypnotize someone suspected of a crime, get a confession, then take it into court," he says, "you'd be stopped

right there. They'd say you were taking unfair advantage of him, that you got your evidence illegally from him when he had a constitutional right to say nothing."

A confession, obtained under hypnosis, was knocked out of the recent "Lady in Red" murder case in Miami, Fla. In the county jail, the 20-year-old suspect, Rudolph Valentino Herring, had written a note to detectives: "Help me to remember." At their instruction, he had been put in a trance by a Miami teacher of hypnosis, Julian A. Arroyo, Jr. He admitted the crime.

This unusual procedure was immediately attacked, and defended, by Florida authorities.

The prosecuting attorney, Richard Gerstein, denounced the method of obtaining the confession as "most irregular," and went on to say: "Any statement extracted under hypnosis is unorthodox and might be viewed with suspicion by a jury." Dr. Bruce Alspach, president of the Greater Miami Society of Psychiatry and Neurology, cautioned that such stories told during hypnosis may be completely false.

On the other hand, Dr. Ben J. Sheppard, who has been Dade county's medical-legal adviser, and Sheriff Thomas J. Kelly both asserted that the confession was valid. Dr. Sheppard, who had been present when the prisoner was hypnotized, said he believed that Herring had amnesia and that hypnosis "opened the door" to his memory.

The youth was indicted by the grand jury, but before his case, and the hypnosis controversy, could be tried, he was sent to a mental hospital. Anyway, the homicide squad obtained a murder warrant for him if he is released.

The question of whether a person can be hypnotized and forced to commit a crime also has been before the courts. Some authorities say that it can be done; others insist that it can't.

Perhaps the most dramatic case of this kind occurred in Copenhagen, Denmark, a few years ago. An ex-convict robbed a bank and killed two employees. He was caught, and pleaded guilty. But he testified that his former cellmate had hypnotized him and told him to commit the deeds. He was sentenced to a home for psychopaths. Then the cellmate was tried, found guilty of inciting the crime, through hypnosis, and sent back to prison for life. The legal-medical battle lasted more than six years.

You don't need to know medicine or psychiatry to hypnotize; neither do you have to be Mandrake the Magician. Hypnotists, of one kind or another, are teaching the art these days to Americans of

(Continued to page 236)



Carefree Boating Starts with Delco DC Marine Batteries!

It's fitting-out time . . . and getting things shipshape begins with installing a dependable Delco DC Marine Battery! All the features that make Delco famous in the automotive field are found in these 100% fresh marine models . . . plus special features for those who want the best for their boats. Delco DC is dry charge . . . stays bone dry until you buy it, then delivers 100% fresh power for dependable starts in all kinds of weather plus plenty in reserve for emergencies. 12-volt models for outboards, 8-volt for inboard use. Get all the power you pay for with Delco DC . . . product of Delco-Remy, manufacturer of a complete line of fine ignition parts.

Your battery dollar buys more with Delco!

YACHT ROPE HANDLES with polyethylene sleeves, bonded into case; flexible, non-conductive, resist acid and salt.

STAINLESS STEEL TERMINAL CONNECTIONS resist corrosion. Wing nuts spin on and off quickly, easily, make secure connections.

SPLASH-PROOF VENT CAPS with special traps let gas escape but keep battery fluid in.

ALL HARD RUBBER CASE resists shock, stands up under extreme heat or cold.

RUBBER SEPARATORS provide uniform fluid action on plate surfaces, prevent active material transfer between positive and negative plates.

SPECIAL ALLOY GRIDS for long life, even current distribution, resistance to over-charge damage.

HIGH-PURITY ACTIVE MATERIALS improve low temperature power, minimize self-discharge.



*Delco is another General Motors reliable product available through
See your marine supply dealer.*



CRESTOLOY MINIATURE PLIERS



Forged from CRESTOLOY Steel, these fine pliers have precision-fitted box joints that assure perfect jaw alignment and smooth operation under long, hard usage. Excellent balance, combined with broader handles reduces worker fatigue. All are electronically hardened. Cutting pliers have tested edges. Finished with polished heads and gun metal handles.

Sold by hardware dealers everywhere



Crescent is our trade-mark, registered in the United States and abroad, for wrenches and other tools. Sold by leading distributors and retailers everywhere and made only by
CRESCENT TOOL COMPANY, JAMESTOWN, N. Y.

many occupations. The American Society of Clinical Hypnosis, and the organizations in the field, are constantly warning against any misuse of hypnosis. Several communities have been considering regulatory laws.

Dr. Gerber, who is one of the few coroners with both medical and legal degrees, says that police departments will want to use only the best men, properly trained medical people, either those on the staff or on call, as hypnotists. To be truly effective, they must know a great deal about law and the problems of evidence, as well as about medicine and human behavior. "I would wish to see only those of the highest ethics and competence in this work," he says.

An instance of a hypnotist's skillful work is related by Harry Arons of Irvington, N. J., executive secretary of the Association to Advance Ethical Hypnosis.

A man whose mind was blanked out by amnesia walked into the sheriff's office in Orlando, Fla., and asked for help in finding out who he was. Deputies summoned a hypnotist, who put the man into a deep trance. He then revealed his name and age and said he had come from Hattiesburg, Miss. He had lost his memory when he was struck by a small foreign car. Under hypnosis, he not only identified himself but went on to recall minute events several years back. He returned to his family.

Valuable as Aid to Recall

Hypnotism creates, as one of its characteristics, what doctors call "hypermnnesia," which is the power to recollect seemingly forgotten incidents and details. Apparently the deeper the trance, authorities say, the better the recall.

In the experiment at Western Reserve University, the five policemen were put into a shallow trance, since the event they were trying to remember had happened only moments before. Dr. Gerber believes that they could have gone into greater detail about the "murder" if the trance had been deeper. When these patrolmen were hypnotized, they were simply told that, upon awakening, they would recall more about the case.

Dr. Gerber is not ready to say that any quick way has been found to help solve crimes. Much more research is ahead.

"I am certain, though, that our studies, and those of—200—others, are going to contribute importantly to hypnosis and criminology," he says. "I can see the time when the science of hypnosis will become just as valuable in our fight against crime as fingerprinting is today." ★ ★ ★

Around the world in 41 miles

The story of the Chrysler Engineering Proving Grounds

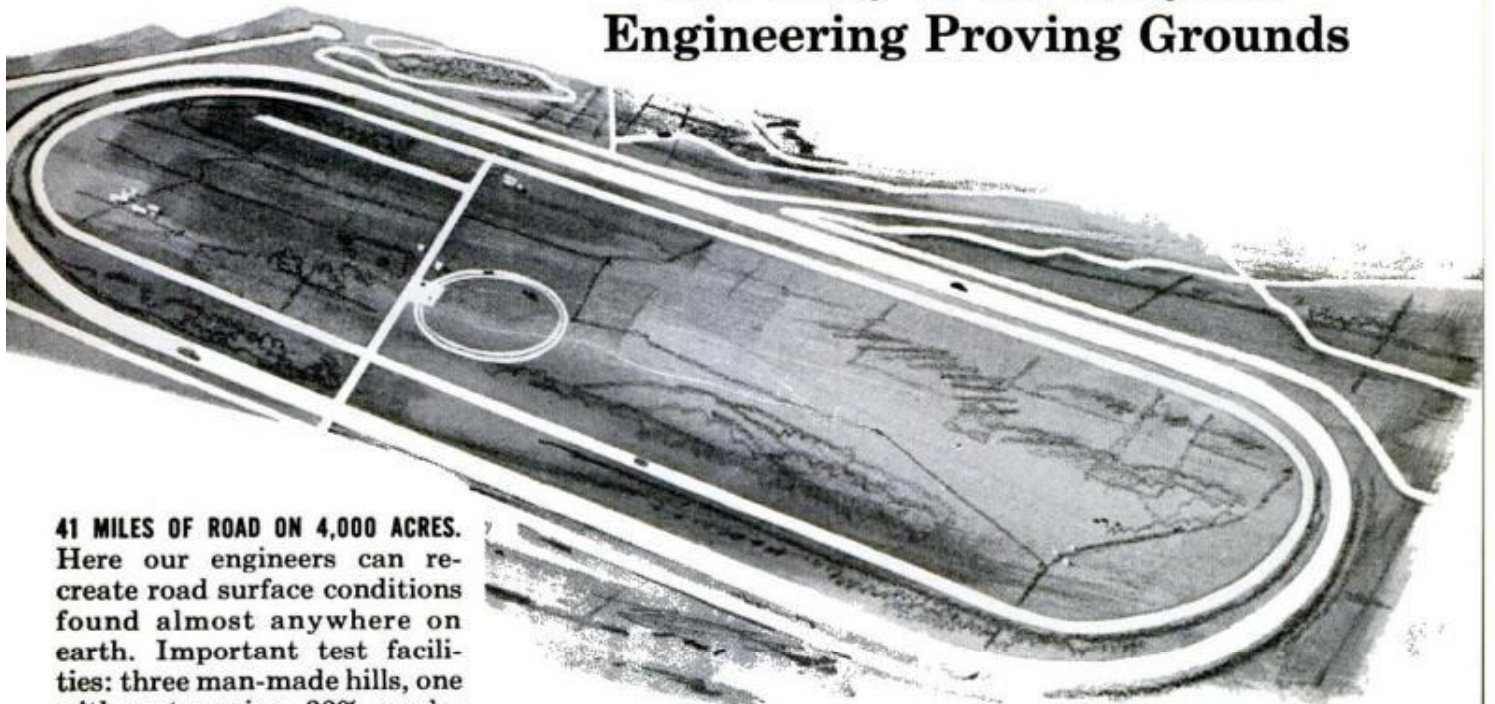

41 MILES OF ROAD ON 4,000 ACRES. Here our engineers can recreate road surface conditions found almost anywhere on earth. Important test facilities: three man-made hills, one with a towering 32% grade; a water trough 340 feet long; the High-Speed Oval, probably the most precisely engineered road of its kind; and the 8-mile Endurance Road.



WORLD'S WORST PLACE TO DRIVE. The Endurance Road (left), is laced with teeth-jarring stretches of washboard asphalt, crushed rock, and Michigan gravel. Round the clock punishment on this torture track proved our new Unibody Construction has twice the torsional strength, 40% more beam strength than previous models. *Slam-bang dunking* in the 340-foot water trough helped develop famed splash-proof ignition system, safer brakes, and engines that keep going in the worst kind of weather.

ENGINEERING WORKSHOP, TWO BLOCKS LONG. Here four hundred car experts—graduate engineers, mechanics, old-time car-builders and analysts—put our cars through the wringer. They equip, study, and tear them apart, again and again. Results for 1960: Pure Automobile—The Quick, the Strong, and the Quiet.

A drive will bring out the difference great engineering makes.

The Quick, the Strong, and the Quiet from **CHRYSLER CORPORATION**

VALIANT • PLYMOUTH • DODGE DART • DODGE • DE SOTO • CHRYSLER • IMPERIAL

Материал, защищенный авторским правом



CREATED FOR THE PARTICULAR CRAFTSMAN
Porter-Cable 7/8 HP ROUTER

From the manufacturer of the world's finest professional routers comes this extremely accurate Model 100 with many exclusive Porter-Cable features. Its high-speed, powerful motor assures chip-free cutting of difficult laminates. Plus features include twin molded plastic knobs, sealed ball bearings, precision micrometer-ring depth adjustment, non-marking base, lightweight for easy handling. Wide variety of bits, cutters and templets makes it the most versatile and useful production tool in any shop. Motor can be used interchangeably with Plane or Shaper Table attachments. *See this router demonstrated at your Porter-Cable Dealer.*

PORTER-CABLE MACHINE COMPANY
 6143 Marcellus Street, Syracuse 4, New York

FREE! YOUR CHOICE OF ROUTER CARRYING CASE or 5-PIECE ACCESSORY KIT

Up to \$15
in free accessories
with your purchase
of a Porter-Cable
Model 100 Router!



ROUTER CARRYING CASE—carries everything you need to the job—router, templets, cords, etc. Special built-in shelf for bits, cutters, templet guides. "Fold-away" front puts everything in easy reach.



ACCESSORY KIT—basic assortment of bits for grooving, dadoing, decorative edging, rabbeting . . . plus a router edge guide for precision parallel routing.

* * *

See this **BIG Money-Saving Special** at your Porter-Cable dealer **NOW**—this limited offer expires July 9, 1960.

Porter-Cable

Quality Power Products

FREE GUIDE . . . send for complete Porter-Cable POWER TOOL Guide.

Porter-Cable Machine Co.
6143 Marcellus Street, Syracuse 4, N. Y.
Please send me **FREE** copy of your illustrated Power Tool Guide.

NAME _____

ADDRESS _____

CITY _____ ZONE _____ STATE _____

In Search of Plants That Cure

(Continued from page 124)

rate anesthetic (particularly in abdominal surgery), a muscle relaxer and a "standard" for treating some victims of mental disorders, including manic-depressives.

- Digitalis, extracted from the leaves of the foxglove plant (and a centuries-old European folk remedy for dropsy), is among our most effective heart stimulants.
- By contrast, the root of the aconite plant, a much-used poison in ancient Rome, today quiets hearts and lowers blood pressures (and comes bottled and branded under half a dozen household-common names).
- Seaweed-derived iodine, an old Polynesian antiseptic, is a staple in your medicine cabinet and mine.
- Cortisone, some of it extracted from the African strophanthus plant (but now produced from home-grown sweet potatoes), is a miracle drug used to relieve rheumatoid arthritis.

All were "discovered," often by accident, when skeptical researchers decided to test the truth of an ancient remedy.

Witch Doctor Relieves Toothache

Recently, for example, the brother of an African foreman was agonized by a toothache. A U.S. dentist examined the tooth, declared it'd have to be pulled. The patient refused and straightway consulted a witch doctor. No heebie-jeebie quack (as some witch doctors), the herb healer—an authentic practitioner of plant medicine—worked a cure within minutes.

Amazed, the dentist jeeped three days over primitive trails to the witch doctor's hut. Cajoling the healer out of his "medicine," the dentist beelined for civilization where, in a report rushed Stateside, he described the plant—coded F57-11—and how it had accomplished its cure:

"The native doctor," reported the incredulous dentist, "filled half a gourd with water, and covered it with the other half whose top he'd drilled with a hole. Over the hole he placed three small sticks dipped in animal fat and rolled in the seeds taken from plant F57-11. He ignited the sticks and allowed them—and the seeds—to burn slowly. The medicating smoke was directed to the offending tooth through a straw. Complete relief was obtained."

Magic? Not really, say researchers. A better term might be "medical mistake."

"The native medico is the world's worst—and most ruthless—'researcher,'" says a world-roaming botanist. "He often kills dozens of patients while experimenting with a new plant."

"Eventually, though," he continues, "the

(Continued to page 240)



from
4" to 24"

"There is
nothing finer
than a
DIAMALLOY"

DIAMALLOY

From the accurate, smooth working little 4-inch size, to the rugged 24-incher, there is built-in reserve strength in every Diamalloy Wrench . . . jaws that stay square and true . . . knurls that always operate smoothly . . . satisfaction that grows with use.

Diamond and Diamalloy Wrenches, long known as the finest quality tools by discerning home workmen and skilled mechanics, are made in the U.S.A., and only by

DIAMOND TOOL
and Horseshoe Co.

DULUTH, MINNESOTA  TORONTO, ONTARIO

For free tool booklet, write your name and address on margin below, clip ad and mail to manufacturer.

witch doctor or itinerant healer may happen upon the right dosage. He has no inkling why his potion works. Nor does he care. Regardless, he may have stumbled upon one of those not-so-rare flukes . . . a positive, even startling, medical discovery."

Mission doctors in East Africa, for example, concede that a native remedy for tapeworm compounded from the ekyinyaraba plant "is as good as anything we have—and maybe a bit better."

Recently, plant hunter Don Overton, of the College of Medical Evangelists, returned from Colombia with a home remedy brewed by the Guahibo Indians. The Guahibos regularly sniff the stuff—a compound of dried yopo berries and pulverized snail shells (calcium)—claiming it improves vision, immunizes against jungle fever and cloaks its user in a protective trance.

Lab dissected, the Guahibos' unsavory potion has already yielded five new organic substances. At least one is being tested as a "truth serum."

Rauwolfia Is Typical "Discovery"

As typical, perhaps, was the case of the Indian plant rauwolfia—the common snakeroot—which even Gandhi is said to have dunked in his tea to calm his nerves. Chewed, the plant's snakelike roots had for 30 centuries quelled fits of nervous depression among natives of India and Africa. No less than one million Indians regularly used the herb.

Yet, not until 1931 did Western researchers take serious notice of the pink-flowered shrub. When they did, they discovered (only in 1952) the source of its "magic"—a chemical called reserpine, contained mostly in the root. Result: Tranquilizers, perhaps the decade's most sensational new family of mental drugs. Marketed under such trade names as "Serpasil" and "Reserpoïd," \$30 million worth of reserpine-based drugs—generally used to treat diagnosed psychotics—are annually administered to the bothered and bewildered.

Says a drug company executive somewhat lamely, "We finally figured that one million Indians couldn't be wrong."

Concedes a top researcher, "We've come full circle. Back in the 1800s, fully 80 percent of all medicines were plant derived. Gradually, researchers turned more and more to chemicals, both organic and inorganic. Today, half the curatives in the average family's medicine cabinet are products of somebody's test tube. And only 30 percent are plant based."

"Now?" he shrugs, "Now, almost out of desperation, we're going back to nature . . . back to plants. For good as the test tube is, it hasn't cured man's greatest cripples

(Continued to page 242)

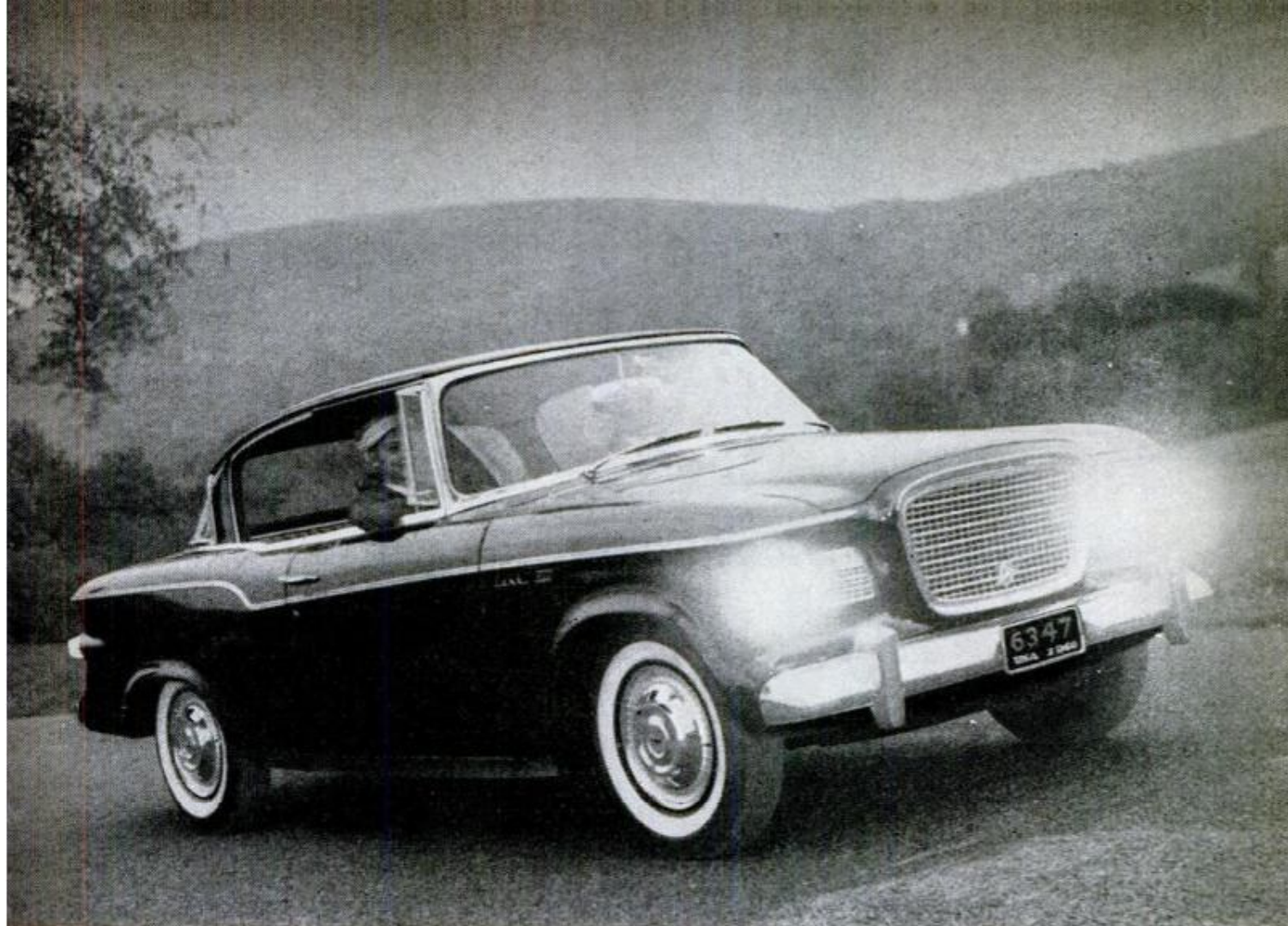

WINNING COMBINATION

... PERFORMANCE... SIZE... COMFORT... AGILITY

No compact car anywhere in the world combines so much in one car, at so low a price. ➤ **LARK PERFORMANCE** puts it way out front ahead of any of the others. And, it does it with economy. The Lark V-8 stretches gas consumption like a rubber band. It's big car performance in a compact car. ➤ **LARK SIZE** is ideal. It's three to fifteen inches shorter than any other U.S.A.-made compact. ➤ **LARK COMFORT** is delightful. Though Lark overall length is shortest, its interior dimensions combine larger-car head-shoulder-hip-leg room. The Lark seats six adults in real comfort. ➤ **LARK AGILITY** is terrific. Scoot, slip, scurry through traffic with verve and ease. The Lark's short bumper-to-bumper size and firm suspension make driving delightful, effortless fun. ➤ **DRIVE THE LARK** and see for yourself. Visit your Studebaker Dealer for a demonstration, today!

LOVE THAT **LARK**  **BY STUDEBAKER**

Материал, защищенный авторским правом

PROTECTS YOUR MOTOR
WHETHER RUNNING

HOT OR **COLD**



Short trip city driving creates "cold engine" sludge deposits that cause corrosion and excessive wear. Long trip highway driving produces "hot engine" varnish deposits on critical engine parts. Power goes down. Wear increases. Solve *both* deposit problems with regular price KENDALL Dual Action MOTOR OIL—a product of the richest Pennsylvania Crude Oil.

Ask your favorite
dealer for it!

KENDALL REFINING COMPANY
BRADFORD, PENNA.

—arthritis, heart trouble, insanity, asthma and cancer."

Sometimes a plant will point the way to the development of a synthetic that has a medical application. For example, it has been known for some years that native Mexicans eat certain mushrooms because they produce visions or hallucinations. Researchers have now developed a synthetic substance, Psibocybine, which duplicates some of the beneficial effects of the mushrooms and which they hope will be useful in the treatment of schizophrenia and other mental illnesses.

"Plant hunting isn't for sissies," says lean, muscular Dr. Farag, remembering a skin-drenching, fever-ridden trek he made deep into Tanganyika—a trek which ended in a tantalizing dead-end.

Schizophrenic Apparently Cured

"A mission doctor," recalls Dr. Farag, "diagnosed a tribesman's illness as schizophrenia, a mental disorder that afflicts millions the world over. Modern medicine has no sure cure. But to the doctor's amazement, a native healer not only treated the man but returned him within a short time to apparent sanity."

Dr. Farag set out with a guide. They found the witch doctor drunk, a gourd of home-brewed banana beer in one hand and violence in his eyes. Point-blank, he refused to part with his secret. A week later, Dr. Farag tried again. But again the witch doctor ranted violently—and refused, for any amount of money or even for a cow, his usual curative fee, to divulge his secret.

"The thing haunts me," confesses Dr. Farag. "We know that one patient was cured by whatever it was the fellow used. And, though we always take with a proverbial grain of salt even the most locally renowned of native cures, you never know—until you've put a plant through the research wringer."

Another thing that haunts plant sleuths: A promising plant which, though once located, can't be found again.

"The fault," explains a researcher, "lies usually in identification. With a rare, often unclassified plant, a sleuth may fail properly to tag it with its family, genus and species. Or, worse, fail to pinpoint exactly where—within an acre—he found it."

Even as plant detectives push into equatorial Africa, through the wilds of South and Central America and across the Middle East, other botanical sleuths are literally rooting through your garden and mine.

At the University of Arizona, botanists are putting to the medical test every plant that inhabits desert America. Their quest: A cure for cancer.

(Continued to page 244)

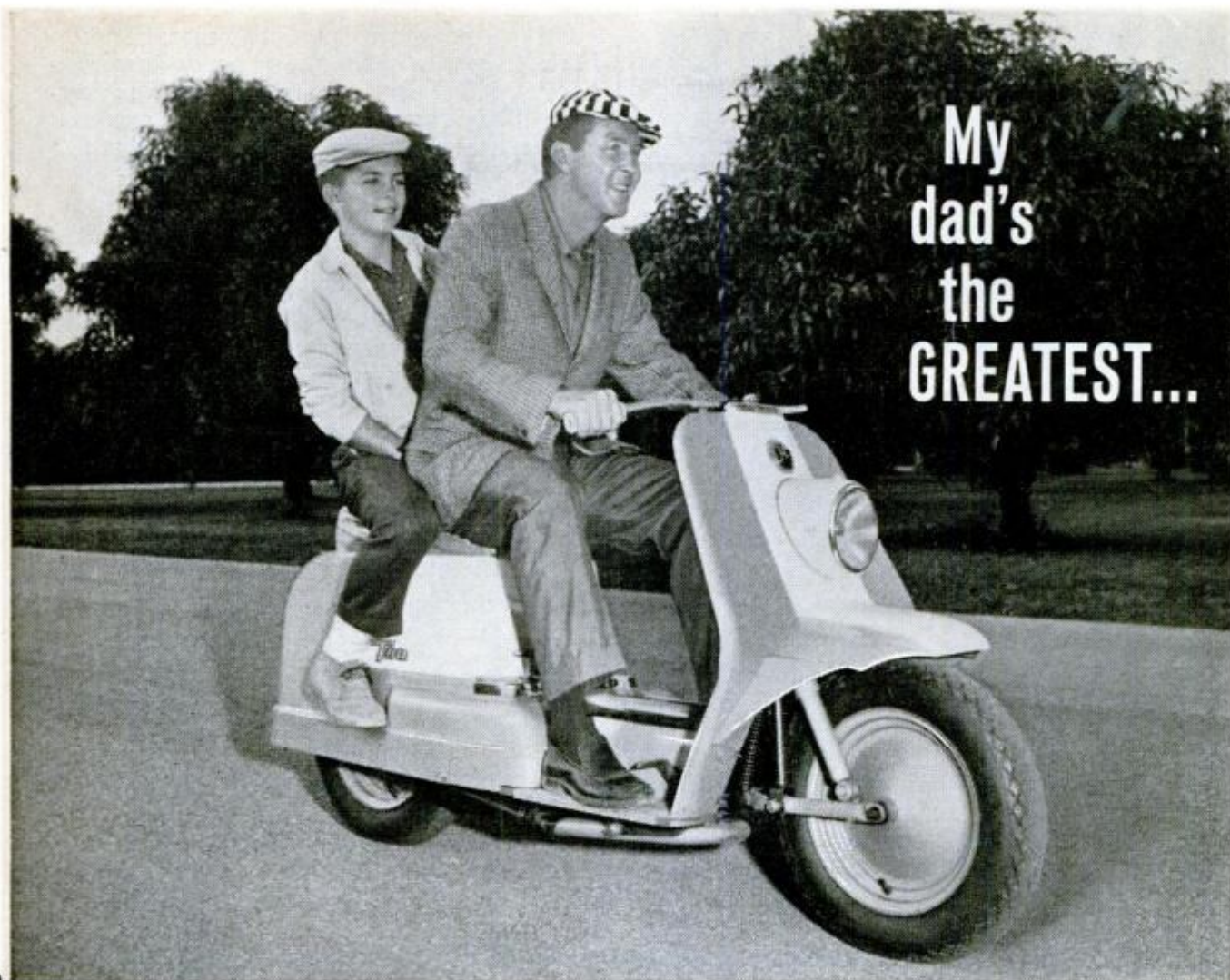

My
dad's
the
GREATEST...

and so is my new HARLEY-DAVIDSON **TOPPER**

Like father, like son... happy with the new Topper.

What a ride — gentle as a billowy summer cloud... with dual suspension and large foam rubber saddle. Dependability — plenty of get-up-and-go. Automatic *Scot-away* transmission—no shifting or clutching needed.

Dad is sold on safety features like the large diameter wheels and sure-stop front and rear drum brakes. Tells everyone about Topper economy — up to 100 miles to the gallon.

Mom's a Topper fan, too! She likes its good looks: sharp, clean

lines molded in tough beautiful fiberglass... two-tone color styling... chrome-plated instrument panel.

See your Harley-Davidson dealer. He will arrange a fun-filled demonstration ride. Or send in the coupon for literature.

HARLEY-DAVIDSON MOTOR CO.
Dept. P, Milwaukee 1, Wisconsin

Send me more information on
the Harley-Davidson Topper

Name.....Age.....

Address.....

.....

SERVICE

FOR YOUR B&D TOOLS



Check the Yellow Pages under "Tools-Electric" for the location of the nearest Black & Decker factory service branch or authorized service station.

Free tool inspection when requested • Genuine B&D parts used • Factory-trained technicians • Standard B&D Guarantee at completion of recommended repairs • Fast service, reasonable cost, always.

Or write for address of nearest of the more than 50 branches and service stations to: THE BLACK & DECKER MFG. CO., Dept. 8004-S Towson 4, Md.



Quality Tool Service

RAIN BIRD Precision-JET*

the greatest lawn sprinkler yet!

Model No. 25PJ-DA on Sled Base

*Pat. Pend.

NO BACK OR SIDE SPLASH!

Here is the greatest advance in lawn sprinklers since Rain Bird introduced the part circle sprinkler. New, exclusive Rain Bird arm enables the Precision Jet to confine water to desired areas while walks, driveways and patios stay beautifully dry. There's no puddling, no water waste with Precision Jet . . . There's just the even precipitation of water *where it's needed!*

A Complete Line of the Finest Sprinklers Made!

Precision Jet can be used alone or in combination with other fine Rain Bird sprinklers. See your local dealer, or write for PJ literature.



National Rain Bird Sales & Engineering Corp.
627 N. San Gabriel Ave. • Azusa, California

On the same trail, too, is a research team headed by Dr. Alfred Taylor of the University of Texas. Reports cautious Dr. Taylor, "We've never had as much success with chemicals invented by man as we're having with plant extracts."

Backed by a grant from the U.S. Public Health Service, Dr. Mervin Hardinge, at California's College of Medical Evangelists, is tackling the near impossible: Dissecting for their medical secrets *every* plant that grows in California. During the past three years, Dr. Hardinge and his staff have managed literally to take apart more than 1500 California plants—and with some startling results. A half dozen at least show "high activity" and definite effects upon cancer in laboratory animals.

Oregon Plant Shows Promise

The "most promising" cancer plant yet to come under Dr. Hardinge's scrutiny—a plant he won't name just yet—is a native of Oregon.

"One of our faculty members was vacationing in Oregon," explains the scientist, "and brought this plant back . . . partly on a hunch, partly because local folks had for years used it as a medicine. Tests show it to be highly active. In fact, it shows real signs of inhibiting the growth of some cancer cells. It'll take years, perhaps, to prove its worth—and safety—for human patients. But right now we're putting the plant to the medical test with better than anticipated results."

Natural plant cures for cancer, long scoffed at by researchers, are being seriously investigated by the National Cancer Institute. The Institute's Dr. Jonathan Hartwell is right now deep in a monumental perusal of ancient literature—including translations of Egyptian medical scrolls which date back 3500 years. He's already turned up two cancer-promising plants: The juniper tree and American mandrake, both of which appear to destroy cancer cells in test animals.

Even a tiny fungus—one that's small enough to grow on the bodies of dead insects—seems to have promise as a weapon against cancer. Nicholas Kredich, a junior at the University of Michigan medical school, is currently working with a product of the fungus, a chemical called cordycepin. Part of his research involves the injection of cordycepin and other compounds into mice with cancer to see if the combination can halt growth of cancer cells.

The fact is that almost every plant in your garden has, one time or another, been used—and prescribed—as a local remedy, if only to treat sunburn. What's more, it's

(Continued to page 246)

before you buy a power mower **LOOK** at

LAWN-BOY

Note to value-wise buyers: look at LAWN-BOY, world's most imitated power mower! The first glance tells you, from blade tip to handle grip, this one is designed for years of trouble-free, dependable performance!

You'll see the famous Balanced Power engine, made only by LAWN-BOY for LAWN-BOY mowers. More powerful, starts easier, runs smoother, cuts better at any angle. Always completely and properly lubricated. These are the lightest, easiest-handling, sweetest-

running power mowers ever built! Quieter, too, with less vibration. The biggest mufflers in mowing, along with the exhaust, are tucked under the housing. Noise and fumes go down into the grass!

No wonder people who know prefer LAWN-BOY mowers. This year the selection is wider than ever before. New models, new features, new lower prices. So be sure you get your money's worth. Before you buy a power mower, look at LAWN-BOY.

See the biggest values in power mowers priced from \$59.95!

AT LAST!

Complete automatic lawn care in one modern mower! New LAWN-BOY Grass Catcher rakes and sweeps as it mows!

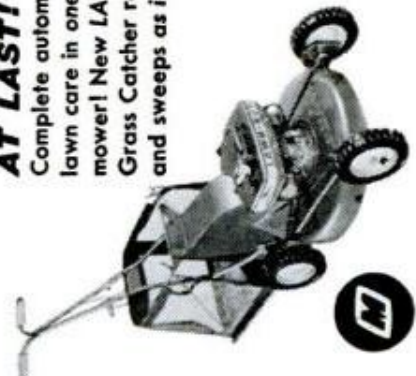

Ask your LAWN-BOY dealer for a free demonstration on your own lawn. Look him up in the "Yellow Pages" under Lawn Mowers, or write LAWN-BOY for name and colorful free booklet.

LAWN-BOY, Lamar, Missouri. Division Outboard Marine Corporation • In Canada: LAWN-BOY, Peterborough, Ontario. Manufacturers of LAWN-BOY power mowers, rotary trimmers, edger-trimmers, snow removal equipment.

a safe bet that growing within a dozen miles of your home, city dweller though you may be, is a plant which, incredible as it may seem, has escaped the botanists.

Explains one plant hunter, "Back in the 1850s, only a mere 6000 of the 350,000 plants we know to exist today had been examined and classified. Even today, some 4000 'new species'—new to botanists, at least—are yearly added to the list."

Skeptical? Well, only last spring—in nearby Baja California—a staffer from Scripps Institution of Oceanography eyewitnessed the curative powers of a startling "new" plant.

The scientist's guide, a native of Mexico's desert domain, severely cut himself. As blood flowed, he ambled almost nonchalantly to a nearby—and yet unidentified—shrub, plucked a few of its leaves and laid them over the wound. Almost immediately the bleeding stopped. No drug known today comes close to duplicating this feat.

But you don't have to discover a new plant. Medical researchers want *any* plant with a local record for curing.

Suppose some local folks are fond of chewing on the stem of plant X. And while maybe neither you nor the others can prove it, plant X seems, at least, to settle that too-full feeling after Sunday supper.

The fact that plant X is a generally accepted home remedy puts it on the plant hunter's "most wanted" list. What researchers want is a brief note, describing the plant and telling locally what it cures.

Your library, for example, can help tag the plant with its all-important scientific name. "Local" names merely confuse researchers because some plants have dozens of nicknames. If a librarian can't help, maybe a high school botany teacher can. Or, your town may have a botanical garden, whose staffers know their plants.

What we need to know, at least, is a plant's *genus* and *species*," explains a plant detective. "Black mustard, a common plant, goes under the scientific name of *Brassica*, its genus, and *nigra*, its species. Discuss this plant as a local curative and you'd begin by saying, 'the black mustard plant, *Brassica nigra*'."

Letter Triggers Research

Not so simple, however, is the research your letter triggers, once it arrives in the plant detective's mail. The botanist neatly pigeonholes your plant in its proper niche—both botanically and medically.

Then the bibliographer—a kind of botanical librarian—sets to work. His job: To search through medical history, to see what other claims have been made for your plant. He may discover that the Egyptians used the plant for upset stomachs, too. Or,

that Maya legend attributed other cures to the same plant. Gradually the file builds.

If the botanist hasn't a specimen of your plant, you may be asked to ship a few samples. Generally, you're expected to dig the plant up, being careful not to injure roots, stem, leaves, flowers or seeds. Uprooted, the plant's put out in the sun and allowed to dry. When all but brittle, it's carefully sandwiched between blotters and shipped to the botanist. Sometimes, once dried, the plant is dissected. You literally take it apart, putting in separate bottles or containers its various parts: Leaves, stem, flowers, roots, seeds, etc. And you label each bottle. Example: "Stem, black mustard, *Brassica nigra*."

At the lab, scientists set to work armed with a phalanx of research tools: *Grinders*, which reduce the plant's parts to the consistency of milled wheat; *chemicals*, including acids, which dissolve out or separate the raw plant extract, which may contain upwards of 200 substances, known and unknown; *electrostatic machines*, designed to isolate substances electrically; a *counter-current distributor* whose complex net of glass tubes separates compounds which are soluble; and finally, an *infrared spectrophotometer* which, when a plant's vital and pure ingredients are found, double-checks them for purity.

It's a little like panning for gold—for a golden, perhaps revolutionary, medical discovery. The plant's raw substances, like raw pay dirt, are chemically dissolved until every *known* substance is washed away. Finally, there remains only the pure extract, perhaps a chemical or crystal never before put to the medical test.

Injected into cancerous test animals, for example, it may have no effect whatever. But in one case out of 100, it may prove "active"—may slow up or inhibit, although slightly, the growth of cancer in the animal.

A cure for cancer? No, merely a promising inhibitor. For hundreds of equally promising substances have proven, when finally tested on humans, to have dangerous or even deadly side effects. So, again, the search starts literally from scratch . . . to find an extract which, slowing the growth of cancer cells in animals, proves both effective and harmless to man.

Will plant hunters and their research teammates find curative plants which fight cancer, arthritis, or heart trouble?

Medical researchers are hopeful. Once, they remember, there was no drug called digitalis, nor a tranquilizer named reserpine nor a hundred others like them which today are lifesavers. Meantime, the secret search for miracles goes on relentlessly—across five continents, the seven seas . . . and even in your own back yard. ★ ★ ★

TIRE FACTS THAT CAN SAVE YOUR LIFE



ONLY ARMSTRONG TIRES HAVE PATENTED INTERLOCKING SIPES

"SIPES" are the slots put in a tire's tread to give more gripping edges, to stop skidding. Armstrong's interlocking, S-shape siping (see magnified view at left) provides grip in ALL directions, gives you sharply improved protection against both forward and side skids.

AND UNLIKE tires which have siping just cut into the tread, Armstrong siping is *molded* in, deeply. Long after the mileage that wears away the shallow siping of ordinary tires, Armstrong siping continues to give you full protection. Safeguard your car against deadly skids . . . compare, and see how Armstrong gives you far more siping than other leading tires.

ONLY ARMSTRONG TIRES HAVE PATENTED SAFETY DISCS

*—Grip the road to
stop deadly skids
as no other
tires can!*

ARMSTRONG TIRES



TREAD STAYS OPEN

Like fist above with discs between fingers, tread CAN'T squeeze shut. Hundreds of Armstrong Safety Discs hold tread's gripping edges open, always ready to "bite."

ORDINARY TIRES



TREAD CAN CLOSE

Without discs, tread CAN squeeze shut, like fist above. Tire's gripping edges are pushed together, lose their grip. Even brand new tires can go smooth like this . . . and you skid!

ARMSTRONG RUBBER COMPANY
Home Office, West Haven, Connecticut

ALIVE
in your
hand—

\$5⁴⁹

True Temper's
ROCKET hammer
seems to have a
vitality all its own.
Grip it: it's as secure
in your hand as if it
were gripping back.
Heft it: the balance is
perfect. Swing it: you'll
feel its comfortable,
shock-absorbing action
while it delivers a power-
centered blow. See this
superb hammer at your
hardware store today.
True Temper, 1623 Euclid
Ave., Cleveland 15, Ohio.

See the popular JET
ROCKET sportsman's
axe, too—the head
just can't fly off. \$5.25.
With leather sheath, \$6.25.

TRUE TEMPER
THE RIGHT TOOL FOR THE RIGHT JOB

1926, for instance, a British steamer came upon the remnants of an iceberg 170 nautical miles south of Bermuda. The ice chunk had been reduced to 30 feet by 15 feet and rose only three feet above the ocean surface, but it was still big enough to slice open the side of a ship.

The number of icebergs found in North Atlantic shipping lanes averages 425 a year, but varies surprisingly. In 1912, when the *Titanic* was lost, there were 1019. In 1924 there were only 11. But 1957 was a bad year—nearly 1200 icebergs were spotted, though none, for some reason, reached the main shipping lanes. In 1958, by paradox, only one berg was sighted below the northerly 48th parallel; there was not even an ice patrol that year.

Last year proved to be a potential troublemaker. In April the number of bergs suddenly jumped to 266—almost three times that month's annual average of 95. May became critical because the ice not only penetrated the northern steamship Track C (Charlie Track); it also went into the more southerly route, Track B (Bravo), always considered safe after April 11. It was in this track that the *Titanic* was sunk. The ice congestion caused transatlantic traffic to be rerouted south to Track A, where ships were last assigned in 1946.

Then in May a big berg turned up even in the "safe" emergency route. Somehow, in thick fog that had grounded Coast Guard aircraft at Argentia and in spite of the probing radar of Ice Patrol cutters, the berg had sneaked through. How many ships had swept past it in dark of night or in fog or blinding storm probably never will be known.

The report of the presence of the iceberg had the same effect on shipping as would a disclosure that an armed killer was loose in your own home. In a bad ice area skippers sometimes heave to and drift when darkness falls or thick fog closes in. However, a majority of ship captains, including the late skipper of the *Titanic*, decide to plow along regardless of fog, darkness and ice. The Ice Patrol has no jurisdiction over the decisions of these captains if they choose to jeopardize their ships to maintain a transoceanic schedule demanded by their steamship lines.

In at least two cases, at night, an Ice Patrol cutter has had to send visual "Iceberg Dead Ahead" signals with blinkers to vessels whose wireless operators apparently were off duty. In another case the cutter *Androscoggin* had to turn its searchlight on an iceberg before an oncoming ship would change its course.

These vessels were freighters, but at
(Continued to page 278)

POPULAR MECHANICS



...extends Spark Plug **"PRIME OF LIFE"**



Comparison Proves Special Duty Advantages

The usual extended tip spark plug (left) has a long ground electrode that can burn or wear away under severe operating conditions.



The new AC Fire-Ring Extended Shell Spark Plug has the short, sturdy ground electrode design that reduces vibration, burning and breaking off, assures superior performance.

Every AC Fire-Ring Spark Plug features the exclusive Hot Tip that heats faster, cools faster to stay clean longer.

***They must be
the best!***

AC FIRE-RING SPARK PLUGS



Here's the newest of the new for car owners requiring extended tip spark plugs — an *extended tip* spark plug with an *extended shell*.

This revolutionary new shell design offers all the advantages of the extended tip design, plus greater efficiency during the spark plug's peak power period — or "Prime of Life." It permits a shorter ground electrode that reduces power-robbing misfire and electrode wear. It fully protects the insulator tip to shield it during starts and prevent "drowning," after false starts.

You get faster, surer starts and cleaner burning full power performance throughout the entire life of the spark plug.

If your car calls for extended tip spark plugs, ask for this newest development — new AC Fire-Rings with *extended shell*.

AC SPARK PLUG  THE ELECTRONICS DIVISION OF GENERAL MOTORS

AC PRESENTS THE ART CARNEY SHOW,
NBC-TV, April 8

APRIL 1960

249

Give your son's
GO-CART
 the sleek aluminum look



made easy with Reynolds
DO-IT-YOURSELF ALUMINUM

Aluminum hood, grill and fittings make the slickest Go-Cart on wheels. For either push or powered car, Reynolds rust-free Do-It-Yourself Aluminum lasts ages without painting. Finish easily in an afternoon using common woodworking tools and free plans (see coupon).

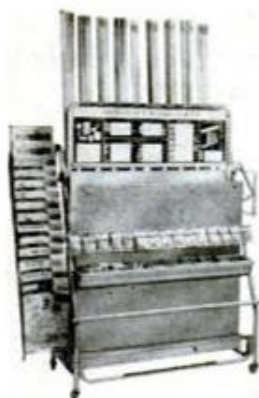

Look for this rack at most hardware and building supply stores. Over 73 items—
 sheets, tubing
 tubing fittings
 window and screen frame sections
 fasteners, rod, bar
 angle

Reynolds Metals Co. • Richmond 18, Va.
 Please send your Do-It-Yourself Aluminum How-To booklet with free Go-Cart plans.

Name _____

Address _____

City _____ Zone _____ State _____

Dept. PM

Swimming Pools

(Continued from page 164)

and give more water to treat and heat. In areas close to the manufacturer, precast concrete pools give another practical method. The precast walls are joined to a poured concrete bottom, giving a good solid pool.

Some companies and many self-builders have eliminated the wood forms of poured concrete pools by "dry-packing," Fig. 8, using a fairly stiff concrete mix which is shoveled and packed in place by hand, almost like plaster. Such a pool shell can be rounded the same as a Gunited pool; has more strength that way. The shell needs to be extra thick because the dry-packed concrete has low density and strength. Most Gunited, poured and dry-packed pools are finished off with a white calcareous-base plaster coat (contains marble dust instead of sand) which gives a lifetime finish to a pool kept clean and filled year-round. Applying this special finish is tricky and requires an experienced pool plasterer. Ordinary plasters containing lime will disintegrate under water and should never be used.

Concrete-block construction has been used satisfactorily for pools. At a glance, the construction seems easier to do yourself than poured or dry-pack concrete but it actually is more difficult because the blocks must be very carefully laid and reinforced to prevent cracks. Concrete blocks give a weaker pool shell than concrete and should not be used on filled ground or elsewhere where subject to any disturbance. For the same reason, most block pools are finished with a heavy vinyl liner rather than a plaster finish. The cost, contracted, of a fully-equipped pool is about 10 to 15 percent less than for a gunited pool.

A vinyl-lined pool with a sand bottom and shallow sides reinforced with poured concrete, concrete block or wood gives you a "real" pool at the lowest cost. One builder of custom-made Gunited pools has do-it-yourself vinyl-lined kits available. A kit for a 20 x 40 ft. pool costs \$1320; \$870 for a 16 x 32 ft. pool, and \$700 for a 12 x 27 ft. pool. The kit includes a double-thickness vinyl liner made to size, a complete sand or diatomaceous-earth filter, the pump required, and all pipe and fittings needed. You supply the hole and lay the plumbing and liner. Such heavy vinyl linings have a life expectancy of at least 10 years and can be replaced. While the lining can be pierced by a sharp object, to patch any but a small break does require emptying the pool. Fig. 12 shows a half-sunk construction that is easiest for a vinyl-lined pool.

(Continued to page 254)



handiest glue around the house

Speedy squeeze bottle. No muss, no fuss. Dries fast, clear and strong! From furniture to scrap-books, best all-purpose glue you can buy. Send stamped, self-addressed envelope for Free copy of "Elmer's Guide to Good Gluing". Write The Borden Company, 350 Madison Avenue, New York 17, N. Y.

BORDEN'S PRODUCTS FOR THE HOME HANDYMAN

**CUT ANY SIZE — ANY SHAPE
WITH Spearhead Cutter**

Handy pocket size — cuts leather, asbestos, rubber, cork, etc. — round 1/4" to 6" — any size straight and odd shapes.

Send Check or
Money Order!

935
POSTPAID

ZIMMERMAN PACKING — NORWOOD 12, OHIO

Pound for
pound the
finest hammer
ever made



STANLEY "STEELMASTER"...\$5²⁵

You feel it the moment you lift it. The grip, the balance, the all-steel power instantly tell you, "This is it!" Buy one. It will serve you well. Here's why: *tempered rim* minimizes chipping; *locked-on head* will never come loose; *chrome alloy handle* has built-in flex, absorbs vibration, won't rust; *contoured grip* is cushioned for comfort, won't slip or mar.



Stanley Tools • Division of The Stanley Works,
New Britain, Connecticut

STANLEY®

for **fun** and more...

GO CUSHMAN



A distinctively styled Cushman scooter, with its dynamic performance and safe roadability puts a new lift in your life. And there's more: A Cushman scooter provides today's most economical transportation—takes you anywhere for less than a penny per mile.

- Dependable Husky 4-cycle engine
 - Up to 100 miles per gallon
 - New brake action for sure stops
- Sold and serviced nationally**

Ask your dealer for
FREE demonstration
or write for colorful booklet

**NEW! LOW COST
SCOOTER
INSURANCE**

Write: Mack & Coons
The Stuart Bldg.
Lincoln, Nebr.

The smart
1960
ROAD
KING

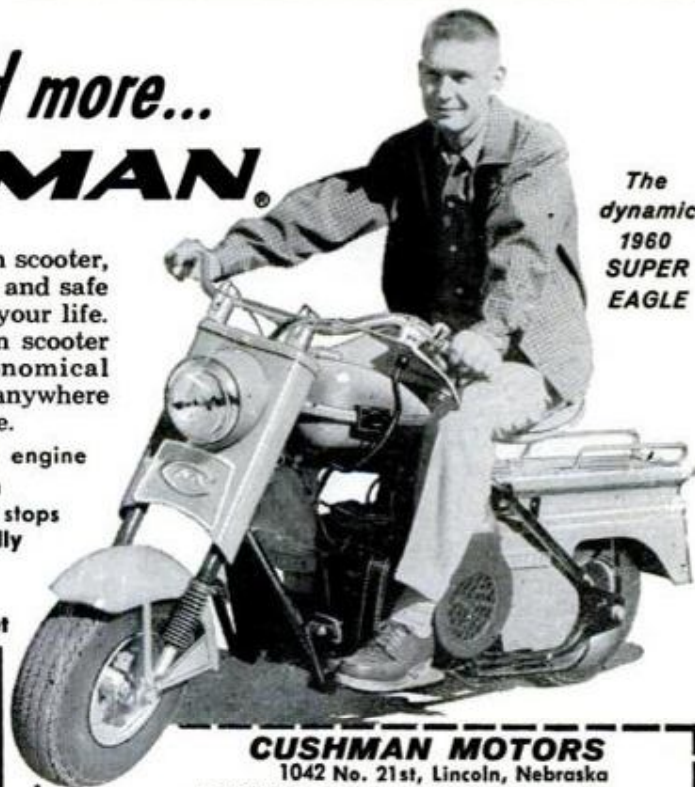

The
dynamic
1960
SUPER
EAGLE

CUSHMAN MOTORS

1042 No. 21st, Lincoln, Nebraska

A subsidiary of Outboard Marine Corporation,
maker of Johnson and Evinrude outboard motors

Please send Scooter booklet.

Name _____
Address _____
City _____ State _____

NEW PAINT PROVIDES POSITIVE

PROOF!

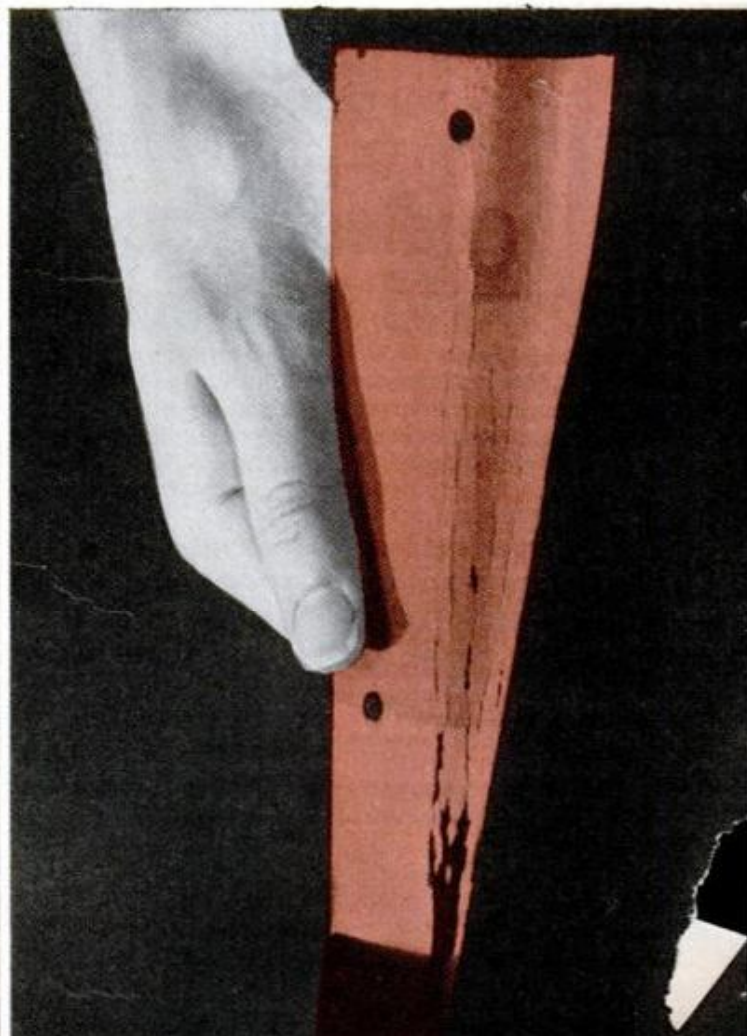
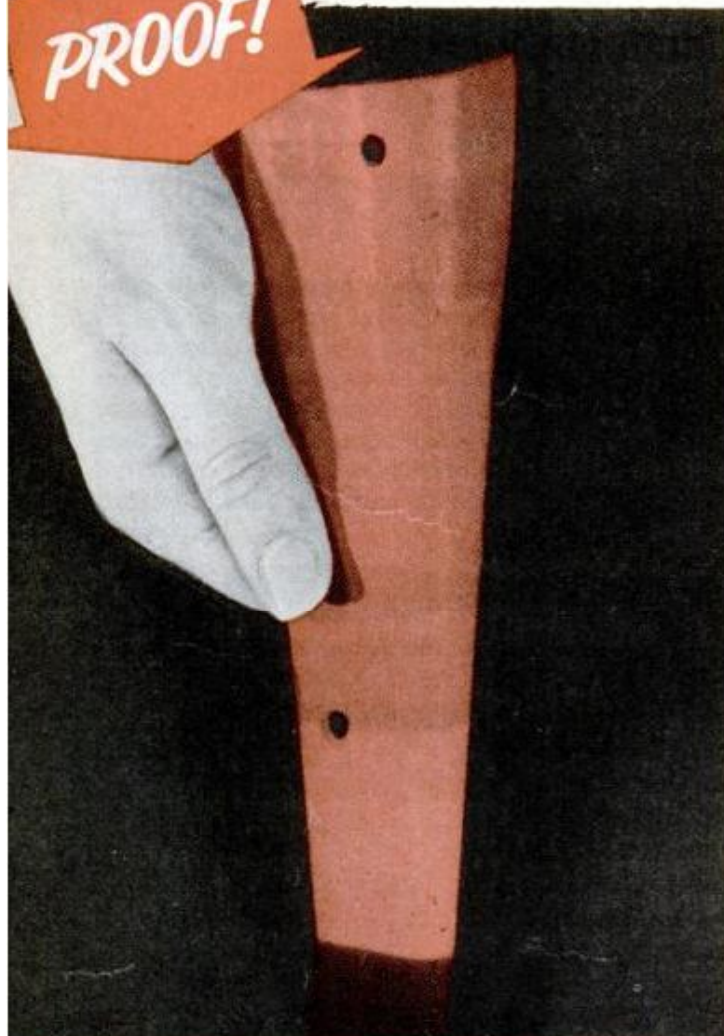

RUSTMASTER PRIMER

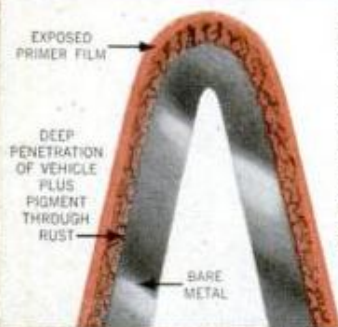

Deep-down RUSTMASTER penetration produced flexible film which bonded directly to bare metal. Film remained intact despite rupturing of rust layers by bending.

ORDINARY PRIMER

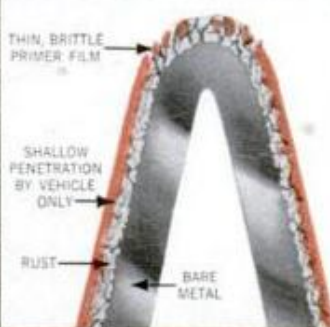

Thin, brittle film cracked and broke away from the surface as panel was bent. Poor penetration performance resulted in improper protection of rusted metal.

Here's why industry prefers RUSTMASTER

Rusted metal panels were coated with primers and finish coats and exposed to weathering test at 95 degrees and 95 per cent humidity for 300 hours (equivalent to approximately one year of exterior exposure). Both panels were then subjected to severe bending. Conventional paint cracked and broke away from the surface. RUSTMASTER showed little sign of stress, revealing far greater penetration, endurance, flexibility and adhesion.

PROTECTION AGAINST RUST!

RUSTMASTER penetrates deep down into metal pores; forces out corrosive moisture and air
THE INDUSTRY-PROVED PAINT FOR HOME USE

RUSTMASTER, the paint developed to combat the \$6 billion annual corrosion losses of industry, can now beautify and lengthen the life of metal surfaces in and around your home.

PAINT RIGHT THROUGH RUST! **RUSTMASTER** can be brushed on right over rusted surfaces—provides positive protection.

Secret to the remarkable protective action is a special surface wetting additive. Operating on a principle similar to modern detergents, **RUSTMASTER** is able to penetrate right through rust layers to the metal beneath. Hidden pockets of corrosive moisture and air are forced out.

RUSTMASTER PRIMER is easy to apply by brush or with the convenient spray can. It dries overnight, ready for finish coat.

Insist on the finest in metal protection. Ask your paint dealer for **RUSTMASTER**, the paint proved in industry. Primer and nine attractive colors are available plus **RUSTMASTER GALVANIZED PRIMER** for aluminum and galvanized metal.

EASY TWO-STEP RUSTMASTER SYSTEM

1. Apply **RUSTMASTER PRIMER** to wirebrushed rusted surface or clean metal. Let dry overnight.
2. Apply **RUSTMASTER FINISH COAT** in color of your choice.



PACEMAKER IN PAINTS

The Glidden Company • Cleveland 14, Ohio
West Coast: The Glidden Co. • General Paint Co.,
10C - 16th Street, San Francisco 7, California
In Canada: The Glidden Co., Ltd., Toronto, Ontario
RUSTMASTER also sold by dealers for CLIMATIC
HEATH & MILLIGAN • ROYAL • MOUND CITY

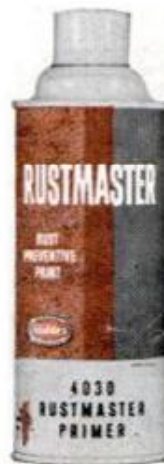

Just
time
for a
TREND,
friend—



TREND

MILD LITTLE CIGARS

...with new Trend-Air conditioning

No time for a big cigar—but you'll always have time for a Trend . . . long enough for complete satisfaction, short enough to enjoy *anytime*. New Trend-Air conditioning "breathes" just the right amount of cool, fresh air into the smoke stream for maximum mildness. 100% cigar tobaccos clear through. Enjoy rich, mild cigar taste *plus* cigarette size and convenience—try Trend, today.



And you need
not inhale
to enjoy them!

Humidor pack of 20 **35c**

Coming soon . . . **TREND PANATELA**
... with new Trend-Air conditioning!

STEPHANO BROTHERS (Cigar Division) Phila. 7, Pa.

PIONEERS IN MODERN CIGARS

You place the retaining walls only about halfway down in the ground and use the excavated earth as a fill to secure the sides.

The larger portable "splashing" pools of about 3-ft. depth allow some swimming, and are available today at a cost as low as \$200 to \$300 complete. They are simple to erect, are filled and emptied with a hose and can be stored away in winter. Some more permanent types are sunk halfway into the ground, like a plastic-lined pool. Similar pools have been built by simply digging a rounded hole and lining it with heavy asphalted roofing paper. As on a roof, the laps of the paper are sealed with asphalt and all is finished with a roofing paint, preferably one with an aluminum base. Such a sunken pool will hold water and is very inexpensive if you build it yourself. However, it is easily damaged and the most difficult of all to keep clean.

Your swimming pool can operate either as a fill-and-draw or recirculating type. A fill-and-draw pool works like a bathtub. It is filled with water and then drained, scrubbed and refilled whenever necessary. Because algae can form in as little as three days time in summer, this refilling and cleaning can be quite a chore, requires a large source of water and usually is practical only in rural areas where water is cheap and can be used afterwards for irrigation. Some owners chlorinate their fill-and-draw pools and thus the water will stay clear for weeks, but getting rid of the chlorinated water is a problem in most yards because it kills vegetation. Running a small stream of fresh water continually through the pool seldom is successful because it usually is not enough to keep the pool clear, gives a cold pool and does not allow any chlorination. Some good fill-and-draw pools along seacoasts use salt water pumped from the ocean. For such, a good idea is to expose the piping and paint it black so the sun will warm the water before it enters the pool.

Almost all permanent pools built today are recirculating and the larger portable plastic pools, which are fill-and-draw, usually are made recirculating sooner or later by adding a portable pump and filter unit. In any recirculating pool, the water is pumped through a filter system and then a heater, if included, and back into the pool. Surprising to many people is that the same water is used for years—a closed circuit—adding only the little lost to evaporation and backwashing of the filter, and that amount will never show on your water bill. After filtering, the water is much clearer than when it comes from city mains. Its purity is easily maintained and the filtered pool does a good part of its cleaning automatically.

(Continued to page 256)

Dodge Dart Is Sound-tight, Weather-tight, Built To Stay Tight!

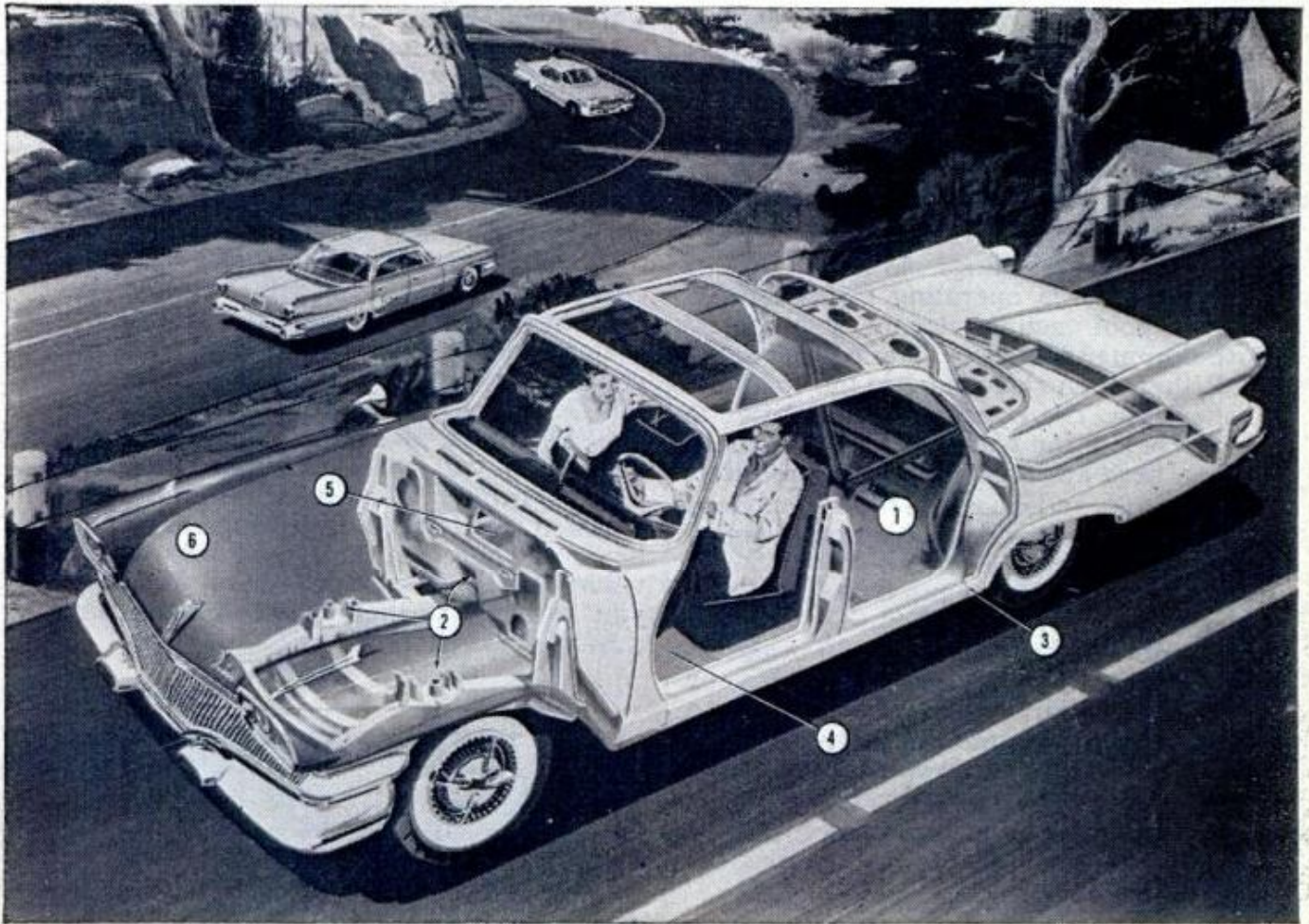

There are many reasons why Dart rides and feels like it costs hundreds of dollars more than it really does. To build this new kind of low-priced car, Dodge engineers used a striking series of important advances never before available in the low-price field.

1. UNIBODY CONSTRUCTION—Dart eliminates conventional two-piece body-frame construction. It's welded into a single unit with stressed-strength. One-piece construction eliminates body squeaks and rattles. It's far stronger to begin with—and it stays that way.

2. FREE-FLIGHT POWER—New three-point suspension cradles engine in space—actually floats it on supple steel coils and rubber blocks. Sound and vibration are completely isolated from passengers.

3. SPECIAL WEATHER SEALING—All body seams and joints are shiplapped to prevent leakage. Seams are further sealed with a special

gun-applied mastic that stays pliable—won't dry out or crack with age.

4. NEW SOUND-DEADENING TECHNIQUES—Under hood, roof, and floor mats, heavy layers of special felt and rubber acoustical materials soak up road and wind noise. These sound deadeners are eight times as effective as the best of conventional sprayed-on materials.

5. SPECIAL SEALING FOR WIRES AND CONTROLS—Instead of punching separate holes in the firewall for entrance of control cables and wires, Dodge engineers routed major units through an ingenious self-sealing keyhole. There, special die-cut rubber blocks simultaneously position the wires and seal out drafts and noise.

6. COMPLETE RUSTPROOFING INSIDE AND OUT—Every Dart Unibody is deep-dipped seven times in tenacious rust preventives. This deep-dipping completely seals every crack and seam, inside and out. Final finish is then added—two coats of special primer, two coats of lustrous, long-lasting Lustre-Bond baked enamel.

AMERICA'S FIRST FINE ECONOMY CAR

DODGE DART



NOW DODGE BUILDS TWO GREAT CARS: DODGE DART • '60 DODGE

Fig. 6 shows a completely equipped recirculating pool using a sand-and-gravel filter. The pump draws half its water from the lowest point in the pool, half from the surface skimmer. Thus it constantly "drains" sediment from the bottom and skims leaves and pollen from the surface. Leaves are caught by the skimmer, smaller particles by the pump strainer and dissolved dirt, etc., by the filter. The water then passes through the heater, if included, and back to the pool through one or more openings, preferably at the shallow end so that the flow will sweep most of the bottom.

Note the number of valves. They let the system do several things. As shown in Fig. 6, the system is operating normally. To power a pool vacuum cleaner, you simply close skimmer valve No. 1 and bottom drain No. 2, then open valve No. 3 in the vacuum-cleaner line. The opening for the latter is located below the water line so air cannot enter. There are four valves for the filter. To backwash and clean the filter, you close valves No. 5 and 6 which are normally open, and open valves No. 4 and 7 which are normally closed. The pump then forces water in at the bottom and flushes the collected debris out the top of the filter and on to waste in a dry well or sewer line. If your pool gathers a large amount of dirt from a storm, you can bypass the filter and vacuum the dirt directly to waste by opening valves 4 and 5 and closing valves 6 and 7. Some new filters have a single four-way valve which accomplishes the same as the four valves shown.

The latest versions of diatomaceous-earth skim-filters are as efficient as the sand-and-gravel type and of special interest to anyone building his own pool, because they include built-in skimmers and eliminate much of the plumbing ordinarily required. These compact filters are installed directly alongside the pool shell as is a separate skimmer. Some include the back-flushing and vacuum-cleaner features of a sand-and-gravel filter and require for maintenance only a handful of diatomaceous earth added each week. Some others use replaceable filter cartridges. This type of filter, or the separate skimmer of a sand-and-gravel filter, should be located on the side or corner of the pool where the prevailing wind most often deposits floating debris.

The left-hand detail in Fig. 6 shows the action of a modern skimmer. It is a large plastic tube with a ring-shaped float in the top so the tube will just barely float and will be sucked down about $\frac{1}{2}$ in. below the water level whenever the filter pump is operating. Thus, water is drawn off the

surface only, along with any floating material, regardless of daily changes in the pool level. The skimmer moves up and down inside a perforated metal basket, which catches the leaves, etc. The 1-in. pipe with rubber flap valve is included to prevent the pump from drawing air if the water level should fall below the skimmer's inlet and to let it draw a full flow if the skimmer basket is clogged with leaves.

In the past, a pool heater was considered a definite luxury but today three out of four permanent pools have heaters. One will raise the water's temperature to well over 80 deg., and, more important, will do so in early spring and late fall. In most climates a heater doubles the months you will use your pool. A modern pool heater is not cheap, costs from \$400 to \$600, depending on your pool's size, and from \$10 to \$25 for fuel each month of full operation. House water heaters cannot be used because they will not heat water constantly passing through. The flow of the filter pump needs to pass fairly slow through most pool heaters. Therefore, a bypass line with a valve usually is included there, Fig. 1, so you can adjust the amount of the flow through the heater.

(Continued next month)

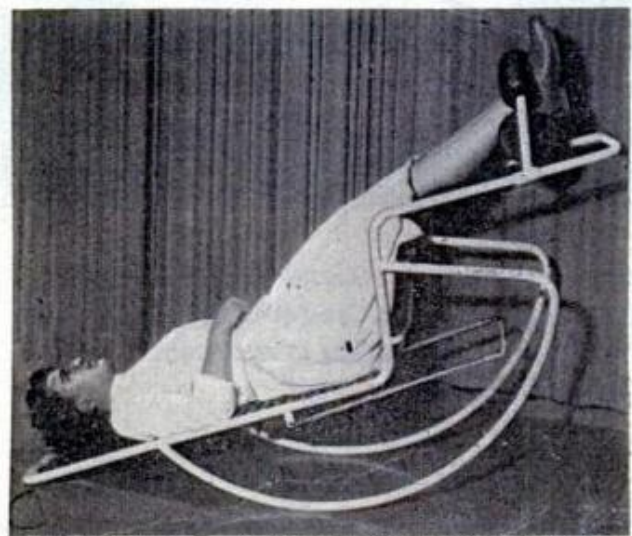

Eduard Munz & Co., 6 Friedenstr., Wuerzburg, West Germany

Rocker Applies Traction

Lying on a row of rollers, the patient on a West German spinal-therapy apparatus undergoes traction on his body simply because of his own weight. The device, which resembles a rocking chair, tips backward until the patient is inclined, head downward, to a maximum of 20 degrees. The patient's feet are secured. Thus, as his weight causes his body to slide along the rollers, the desired traction is applied over the entire spinal column. The patient can roll the device upright by himself.

BUY **GRAVELY** FOR

MORE PERFORMANCE

MORE POWER

MORE FOR YOUR MONEY

Why tolerate equipment you have to push, pull and pamper? The Gravelly and its Rotary Mower attachment solves your toughest mowing problems!

Whether you cut and mulch heavy, tough weeds over the roughest ground, or mow the finest lawn, Gravelly does the job *better!* Because Gravelly, with its ~~extra~~ power (now 6.6 HP) and versatility, does more tough jobs other tractors can't!



30 Tools



PERFECT SEEDBED WITH ROTARY PLOW



POWER CULTIVATE GARDENS



MOW FINE LAWNS



HAUL HALF-TON LOADS

SINCE 1922

UNMATCHED PERFORMANCE!

Choose the tools that fit your jobs from 30 year-round attachments. All powered by one Gravelly tractor!

Do the job *better* because power attachments are driven direct from the engine by splined steel shafts and gears. No belts or chains to slip, wear or break. More power *at the working tool!*

A FREE demonstration by your local sales and service representative will show you, beyond doubt, that the Gravelly and its attachments will do your jobs *better, faster, easier.* Compare. You will see that you get *more power, more performance, more for your money!* . . . Available on installment plan.

WRITE FOR FREE 24-PAGE BOOKLET!

Big, 24-page illustrated booklet, "Power vs Drudgery", shows how the Gravelly solves your lawn and garden problems . . . Write for it today!



FREE! MAIL NOW

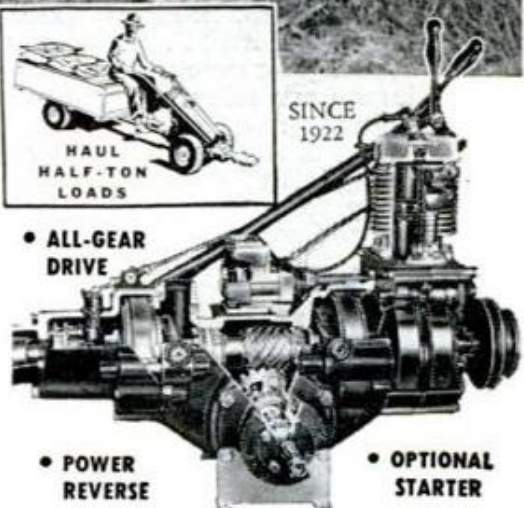

• ALL-GEAR DRIVE

• POWER REVERSE

• OPTIONAL STARTER

Power attachments *securely* mounted by only four bolts. Balance, easy handling, simple controls. Cutaway view shows Gravelly's clean, compact, power-engineered design — the reason for its remarkable performance. Make the wise choice — choose Gravelly!

GRAVELY TRACTORS, INC.

P.O. BOX 601-D DUNBAR, W. VA.

Please send "Power vs Drudgery" Booklet and dealer's name to:

Name _____

Address _____

Town _____ State _____

2
New

RIGID Tubing Cutters

Give you Grooved Rollers for close flare cut-offs . . . no waste! Also, Enclosed Feed Mechanism • Spare Cutter Wheel in Handle •



RIGID No. 205 Tubing Cutter

Time-Saving, Slide-to-Size $\frac{1}{8}$ " to $2\frac{3}{8}$ " O. D. Capacity

Made of lightweight, high-strength cast aluminum alloy, you'll find these new RIGID Tubing Cutters extra handy. Slight push on handle of large-size-range RIGID No. 205 snugs cutter wheel against tubing . . . locks it in position until released. Feed screw fully protected and enclosed . . . always feeds into tube with easy handle turn . . . can't jam with chips or dirt. Wheel gives quick, clean cuts of copper, brass, aluminum tubing and thin-wall conduit . . . no burr. Grooved rollers give easy flare cut-offs without tubing waste. Tubing always turns freely on 2 of 4 Rollers. Rollers smooth tubing ready for soldering. Fold-in reamer always handy. Spare Cutter wheel in handle. Wheel for plastic and aluminum pipe available for No. 205 only.

Conform to Fed. Spec. GGG-C-771b Type II—
Class I—enclosed feed mechanism

RIGID No. 105 Tubing Cutter



Protected Feed
Screw Always
Easy-Turning
 $\frac{1}{8}$ " to $1\frac{1}{8}$ " O. D.
Capacity

Save time on home maintenance and workshop projects; get a RIGID Tubing Cutter from your Dealer today!

RIGID

The Ridge Tool Company • Elyria, Ohio, U.S.A.

Revolutionary Engine

(Continued from page 97)

chamber through a side-wall port. As the engine's rotor turns, the mixture is compressed and fired by a single spark plug. The exploding gases deliver the power to the crankshaft through the rotor. Exhaust fumes escape through another port in the chamber wall.

There are three power sequences per revolution to the crankshaft, maintaining an almost continuous intake, compression, ignition, expansion and exhaust cycle.

Made of iron and steel, the engine can deliver one horsepower for each pound of its own weight; made of lighter metals, the ratio may reach one horsepower for each half pound of weight. Engineers predict rotating combustion engines of up to 10,000 horsepower.

Liquid or Air Cooled

Other advantages that are claimed for the revolutionary new engine include the fact that it can be liquid cooled or air cooled; it has no compression ratio limitation due to hot spots; acceleration is extremely rapid; no torque is developed by offset parts; an ice-cold engine can be opened to full throttle in two minutes; and at maximum revolutions per minute there is no power loss or high progressive fuel consumption as in reciprocating engines. The fact that there are few moving parts, too, leads to a longer life for the engine.

Felix Wankel was by no means the first inventor to attempt to build an engine with a revolving piston. As he points out, James Watt, inventor of the steam engine, tried some 200 years ago to drive a sort of revolving piston engine with steam. Wankel investigated the many engines that were attempted by inventors seeking to perfect the revolving piston principle and gradually filled the "gaps" until he arrived at the present configuration with the unique triangular rotor.

One of his greatest problems was that of sealing the individual chambers formed by the sides of the rotor and the chamber walls. The inset metal strips at the tips of the triangle finally were developed as a solution to the problem.

Simplicity of the rotating combustion engine and the absence of "exotic materials" will be factors that will keep the engine low in cost, say its developers. They are directing developmental efforts into all fields of transportation, including automotive, marine, commercial aircraft and vertical-take-off aircraft, and into such industrial applications as compressors, generators, pumps, farm implements and large-volume earth-moving equipment. ★ ★ ★

LOT OWNERS!

DON'T WAIT FOR HIGHER INTEREST RATES OR EVEN "TIGHTER" MONEY!!!



Each PARAGON HOME is CUSTOM-CUT to your order!

You can build this lovely home on your land NOW and save up to 40% using our proven sub-contractor system—more if you do part of the work yourself.

Available in FOUR different sizes and floor plans; two with double baths. Beautiful interiors, large closets, center halls, separate dining rooms, picture windows, fireplace, 24" overhangs. All interior trim, wallboard, oak floors, choice of roof shingle colors, etc. down to the last nail.

Paragon Pre-Cut Homes feature douglas fir framing exclusively. No prefabricated panels. Paragon guarantees all materials to complete the job as specified. Because Paragon Homes are pre-cut they can meet all building and zoning specifications.

PARAGON WILL FINANCE YOUR HOME AT ONCE!

No red tape
No closing or inspection fees
Eight finance plans, from \$50 per month
Carpentry money available
"No Down Payment" and "Trade-In" Plans
Plumbing, heating, electric, tile, kitchen cabinets and most other improvements available and financed by Paragon.

°Brick as shown optional at extra cost.

THE KIRKLIN \$4122*
6 Rooms
3 Bedroom Ranch



First Prize Winner at the 1960 Paragon Homes Show

Delivered FREE to your property via our own trucks, from our N. Y. and Ind. mills.

Visit your nearest Paragon Model Home. Representatives in major cities in: N. Y., N. J., Pa., Del., Md., Va., Wash. D.C., N.C., Ala., Ky., Mass., R.I., Conn., Vt., N.H., Me., Ohio, Ill., Ind., Mich., Ia., Minn., Wis. Consult your local telephone directory or write to us regarding our 110 models of ranch, split level and colonial homes for year round or summer occupancy.

Send Today for PARAGON'S FREE Leaflet 60 P

**PRE-CUT
HOMES
PARAGON**

499 Jericho Turnpike, Mineola, N. Y.
Pioneer 2-8200 • Fieldstone 3-3900



This point lets you bore holes up to 1 1/2" with small electric drill

It's hollow ground to bore cleaner, faster at any angle

NOW YOU CAN increase the boring range of your small electric drill or drill press. New Irwin Speedbor "88" bits bore faster, cleaner holes up to 1 1/2" in any wood. 1/4" shank chucks perfectly. No wobble, no run-out. Sharp cutting edges on Irwin exclusive hollow ground point start holes faster, permit spade-type cutters to bore up to 5 times faster. All Irwin Speedbor "88" wood bits are forged from single bar of special bit steel, tempered full length and machine-sharpened for extra accuracy, longest life. 17 sizes, 1/4" to 1 1/2". Buy individually or in sets from your Irwin hardware or building supply dealer.

Only 75c each, sizes 1/4" to 1"
Only \$1.25 each, sizes 1 1/8" to 1 1/2"

IRWIN SPEEDBOR "88" WOOD BITS
 at Wilmington, Ohio, since 1885

BUILD 'EM YOURSELF



with **DOT**
TEENUTS®
 and **EASI-BILD® PATTERNS!**

TEENUTS . . . the flush-mounting, "can't-slip" nut that needs no washer . . . is now specified in 10 popular Easi-Bild patterns! Get them both at Hardware, Variety and Lumber stores!
 *T. M. Reg. U. S. Pat. Off.

Columbia Fastener Company Chicago 8, Illinois

Nose Count, 1960

(Continued from page 117)

ages to the nearest zero below the truth." For the coy one who says she is "over 21," the census taker has a stock trick. "Very well," he says, eyeing her, "I'll put you in the 55-60 group." That usually gets the accurate age in a hurry.

Most people recognize the importance of accurate reporting once the enumerator explains that representation in Congress, old-age benefits, government planning for roads, schools and hospitals, business planning for new outlets, industrial production and many other vital national functions depend on the integrity of individual reporting. It's not unusual for a housewife to walk miles to a district office in order to correct her age, which she has falsified "because my husband was home when the census taker asked me, and I didn't want him to know I am older than he is." Or for a man to correct his income "because my wife doesn't know about the other \$2000."

When the enumerator stops at your house in April, he will pick up the form you received in the mail and check the answers with you. These will be blocked out on a FOSDIC form in a special code arrangement of black squares. At every fourth home, he will leave another form with 45 questions. This is a "sampling" survey of housing, which recipients will fill in themselves and mail to the Bureau, detailing such things as education, occupation and marital status of every member of the household, the number of television sets, cars and so on. Averages struck from this spot check will provide census officials with an accurate picture of the standard of living and the direction it is taking.

Most enumerators will wind up their rugged tour in 10 days, making one special "T-night" roundup of wanderers in trailer camps, motels, lodging houses—and an "M-night" survey scouring the skid-row missions, flophouses and hobo jungles. In spite of it all, they expect to miss an estimated 2,000,000 people, as they did last time.

When the enumerators are finished, the real job begins. From some 400 temporary field offices, 2150 tons of paper—enough to fill 100 boxcars and to print an average Sunday edition of *The New York Times*—will pour into census headquarters as they always have. But there, similarity with the past ends.

Keeping one jump ahead of its ever-burgeoning job has been a specialty of the Census Bureau ever since 1880 when it took seven years to complete a 22-volume report on a mere 50,000,000 Americans, using

(Continued to page 262)

New Du Pont LUCITE® House Paint adds years of beauty... saves real money



“Lucite” makes the difference...and only Du Pont makes “Lucite”

Outstanding durability, superior blister-resistance, easy application make Du Pont “Lucite” the greatest house paint discovery in 30 years.

OUTLASTS ORDINARY PAINTS. Du Pont research chemists tested new “Lucite” Acrylic House Paint for years in all kinds of weather, in all parts of the country. Result: proof that “Lucite”, applied according to directions over Du Pont Blister-Resistant Primer, can actually last 50% longer than conventional house paints.

COMBATS BLISTER PROBLEM. Moisture blistering, once the homeowner's most serious problem, has been solved. Tests show that “Lucite” over Du Pont Blister-Resistant Primer, on new wood or old surfaces from which the paint has been removed, effectively resists blistering.

GOES ON EASILY, DRIES FAST. Never before has an exterior house paint been so easy to apply. New “Lucite” flows on without effort. Dries quickly. Ideal for wood and masonry surfaces.

Send for new 12-page booklet, “How to Get Extra Years of Beauty from Your Next House Paint Job.” Write Du Pont Finishes Div., Dept. PM-64, Wilmington 98, Delaware. Or ask your Du Pont Dealer. He's in the Yellow Pages of your telephone directory.

*Buy the paint that's worth
the work...the beauty lasts*

DU PONT
REG. U. S. PAT. OFF.

Better Things for Better Living
...through Chemistry



ADD BEAUTY ON with **FILON**®

TRANSLUCENT FIBERGLASS BUILDING PANELS



COLORFUL BUILDING IDEAS

Guaranteed FILON, the do-it-yourself dream material! Add low-cost comfort plus the beauty of color-softened light. For patio roofs, carports, fences, glowing ceilings, room dividers.

Now! Exclusive THERMOBLOK Colors for maximum comfort under the sun.

When Filon goes up — upkeep goes down

FILON is shatterproof, weatherproof. Needs no painting. Only minimum maintenance. Available at lumber, building material and glass dealers.



Insist on the FILON label with the EXCLUSIVE FILON GUARANTEE

F FILON PLASTICS CORP.

Los Angeles • New York • Chicago • Atlanta
Denver • Dallas • Indianapolis • Miami
Philadelphia • Pittsburgh • San Francisco • Seattle

FILON Plastics Corporation
Consumer Service Department
333 N. Van Ness Ave., Hawthorne 29, Calif.
RUSH free booklet, complete guide to building with FILON fiberglass panels. Complete with ideas, patio plans, decorator color chart.

FREE
IDEAS
AND
PLANS

Name _____

Address _____

City _____ Zone _____ State _____

tedious hand methods. By then the 1890 census was already in the making. The first innovation, invented by one of the Bureau's own men—Dr. Herman Hollerith—involved transferring information from the census-taker's sheets to paper cards, in the form of punched codes.

But for the 1960 decennial census, even punch cards were too cumbersome and time consuming. The result is FOSDIC—an electronic wizard that was under development even before the last card was filed in the 1950 countdown.

Here's how the new system will work: Before FOSDIC can digest the masses of information on each of the enumerators' 60 million work sheets, they must be micro-filmed. So, first stop for these bales of paper will be the census offices at Jeffersonville, Ind., where a battery of 30 cameras will reduce each tabloid-size sheet to a crystal-sharp picture half the size of a four-cent stamp. By the time these cameras have finished their continuous grind, 950 miles of 16-mm. film will have clicked through their shutter gates.

As fast as it is processed, the film will speed to Suitland, and be fed into the electronic maws of five humming FOSDICs. Basically, FOSDIC is an electronic scanner, similar to a television camera. An electron beam in its single cathode-tube "eye" scans two work sheets simultaneously, sweeping across them in a series of lines. But instead of transmitting what it sees in light and shadow signals, like the lines on your TV screen, the enumerator's black circles that the "eye" picks out on the work forms are converted into magnetic pulses on a magnetic tape.

Since FOSDIC's eye can be instructed to examine only certain sections of a form—such as the "male" squares, or the "single family dwelling" circles written in by the enumerators—you can begin to understand the significance of these devices.

As fast as the magnetized tape spews from the FOSDICs, it is fed through one of a battery of four giant UNIVAC (Universal Automatic Computer) brains. UNIVAC is really the core of the census miracle. This is the nerve center that, once instructed, digests the magnetic information from FOSDIC, analyzes it, and produces requested answers in orderly fashion on a new magnetic tape. If, for instance, UNIVAC is told to tabulate the number of male household heads from the FOSDIC tapes, the big brain will sample the magnetic pulses, decide on a "yes" or "no" basis which ones qualify, and store in its memory only those that do. The incredible brain makes each decision in 17-millionths of a

(Continued to page 264)

LIFT 3 TONS 9" IN 30 SECONDS! Complete HYDRAULIC LIFT KIT

- For Lift Trucks • Fine for Snow Plows, Disc Harrows, etc. • To Tip Farm Wagons
- Hydraulic Presses

KIT CONTAINS:

- 1) **HYDRAULIC PUMP** with 24" handle, 2 qt. oil reservoir, adjustable release valve, filler plug, 3/8" P.T. port, Universal mounting holes — Pump rated 1500 P.S.I., .80 cu. in. per stroke.
No. G-1500P . . . Shpg. wt. 15 lbs.
F.O.B. Chgo. \$29.50
- 2) **HYDRAULIC HOSE ASSEMBLY** — 8 ft. long, wire braid constructed. Rubber jacket, smooth neoprene core. 3/8" P.T. male fittings.
No. G-HX83 . . . F.O.B. Chgo. \$3.50
- 3) **HYDRAULIC CYLINDER** — 2 1/4" bore, 9" stroke, 1 1/2" piston rod stainless steel. Clevis mount, both ends.
No. G-C562 . . . Shpg. wt. 15 lbs.
F.O.B. Chgo. \$17.95
- 4) **HYDRAULIC FLUID**, 2 qts.
No. G-B11 . . . F.O.B. Chgo. \$1.00

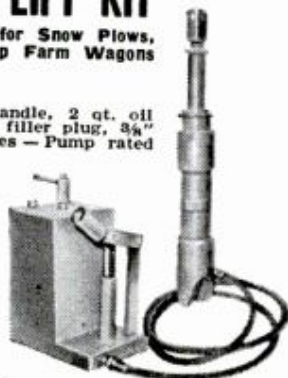

Included in it are fittings, and instructions — just pour in oil, connect hoses, and go to work! It's easy!

SAVE MONEY—ORDER COMPLETE KIT! Items can be ordered separately if desired.

COMPLETE KIT:
No. G-K116A Shpg. wt. 38 lbs. F.O.B. Chgo. \$51.40

FREE CATALOG . . . Tremendous Savings on Hydraulic Equipment, Diesel Parts, Electric Generator Sets, Electric Motors, Welding Equipment, Hand Tools, etc. Write for your **FREE COPY** Today!



GROBAN SUPPLY COMPANY

1139 South Wabash Ave., Dept. G Chicago 5, Ill., WEbster 9-3793

Constantine's Catalog & Manual for WOODWORKERS

ALL-NEW! 1960 Edition. More than a catalog—a manual, too! 130 pages—exciting new items! Since 1812, world's most complete source for rare imported & domestic woods at rock-bottom prices. Inlays, bandings, carvings, hard-to-find hardware, inlaid wood picture kits, new brass hardware, etc. Plus tools, plans, projects. Enclose 25c (refunded on 1st order). Get **FREE** year's subscription to "Chips & Chats" too. Write NOW!

ALBERT CONSTANTINE and SON, INC.
2050 Eastchester Rd., Dept. E-5, New York 61, N. Y.



OUTWORKS THEM ALL

Prepares the toughest soils in one operation. All-purpose tiller-tractor tills to 12" deep — 12" to 40" wide. 3 models; 7 rotor styles including mulchers. 40 attachments include all tractor tools, mowers, snow plow. Tough chain-gear drive. Send for details.

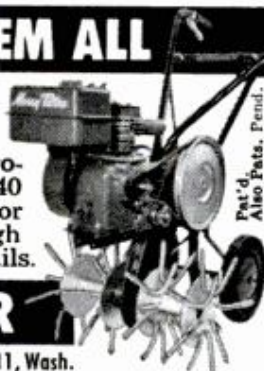

MERRY TILLER

Northern Life Building, Box 1829, Seattle 11, Wash.

AMERICAN DRIPLESS OIL

Runs in—won't run out! Penetrates where ordinary oils can't reach. Lubricates from —20° to +200°F. Rustproofs—Best for tools, appliances, guns, etc. At hardware and auto stores, super markets. American Grease Stick Co., Muskegon, Michigan



APRIL 1960

CHOOSE SILENTONE Master or Standard

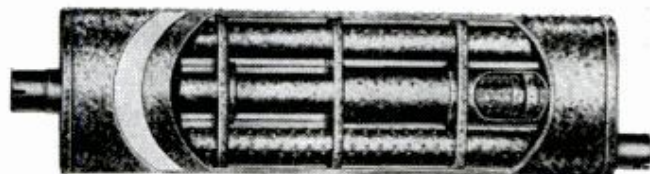

SILENTONE Master

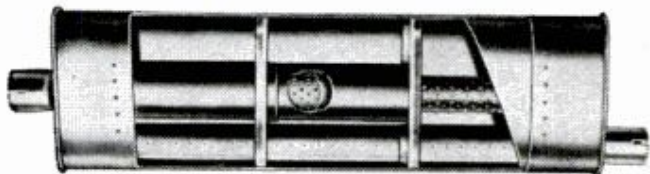

SILENTONE Standard

Either one gives you more service

Master The finest muffler your money can buy anywhere. Up to 41% more steel than ordinary mufflers. Rust-resisting design. Double shells. Zinc-coated steel. Asbestos liners. Heavier end caps. If quality is your first consideration, ask to see a Master. It costs no more than ordinary mufflers!

Standard A proud new economy version of Silentone. Though priced for the thrifty, this is no tinny makeshift. It is a heavy, durable muffler, the equal of most higher priced mufflers on the market. That's why we call it Standard.

For a fine glass-packed muffler with a unique quiet power tone, ask about Dynatone—now custom engineered for your car.

Sold only by America's leading automotive chain stores

SILENTONE MUFFLERS

Dept. 2D



Toledo 1, Ohio

BE SURE YOU'RE SAFE

Protect Toes as Workers in Industry Do... with HY-TEST Safety Shoes

Accidents happen! Do-it-yourself chores, such as operating power mowers and other equipment take their toll! Be safe, not sorry, by wearing comfortable, casual SAFETY SHOES designed by HY-TEST especially for wear around the house. They feature the famous Anchor Flange® Steel Box Toe... the same inconspicuous "Arch of Steel" that protects the toes of many workers. They call it...



"THE OUNCE THAT COUNTS"



H535

Smoked buc upper treated with Scotchgard (water and soil repellent) leather protector; oil resistant Cellular Grit Anti-Slip sole. Also in grey buc (H546).



H946

Popular feather light brown glove leather Chukka shoe; oil resistant Cellular Grit Anti-Slip sole.

New women's smoked gore pump; Nitro-Crepe Saf-Tred cemented sole; light, flexible, high-style.



H853

These are only a few of more than 100 HY-TEST styles available. Always specify HY-TEST or write for the name of dealer in your city. HY-TEST SAFETY SHOES, Division International Shoe Company, 1509 Washington Ave., St. Louis 66, Mo.

You Can't Tell Them from Regular Shoes
... Until They Save Your Toes

HY-TEST

SAFETY SHOES FOR EVERY NEED



second, and reads some 20,000 impulses per second. More than 1000 census forms are read, analyzed and broken down into required bulk statistics by UNIVAC in about five minutes.

Although UNIVAC can't think, it can spot errors and mistakes with unerring accuracy. If, for instance, it stumbles onto a string of illogical facts, such as 55 male heads of households under 10 years of age, it will automatically reject these from its final totals. If a circuit fails, or a series of pulses are missing due to a tape failure, it will make a note of this on its own tape, and the message will be conveyed to the operators of the high-speed printers moments later. To cover all of the wide variety of census statistics, the FOSDIC master tapes will spin through the system over and over again.

Summary tapes from the UNIVACs move on to the electronically controlled high-speed printers, which read their magnetic pulses and instantly turn them into a sort of teletype form that anyone can read. This little whiz can turn out statistical tables at the dizzy rate of 600 lines per minute.

Besides speeding publication of the census reports, the use of these electronic wizards will enable the Bureau of Census to compute many more averages and statistical breakdowns than ever before. Complicated ratios and trend figures, formerly left uncalculated because of the tremendous manpower and time involved, will be duck soup for the UNIVAC 1105.

What's more, plucking a given set of facts from the stored memory films at any time in the future will be simple compared to the handling of endless punch-card files. Microfilm for the entire 1960 population and housing census will be stashed in an area no bigger than your bedroom. Cards from the 1950 decennial census fill an area nearly 200 times greater.

Storage and easy access gets to be a major headache when you realize that the decennial census is only one more job for the Bureau, albeit a big one. Actually, census-taking never stops at Suitland. Month after month all manner of special surveys are conducted by mail as well as by armies of interviewers. Many are published in various summaries such as the annual *Statistical Abstract*, in which you can find such tidbits of miscellaneous intelligence as the total number of lady locomotive engineers in 1957, or how many childless male "laundresses" there are today.

There isn't much information about Americans and their business or social enterprises that can't be found stored away in some Bureau survey. Not all of it has

(Continued to page 266)



Weight-saving, welded construction helps the Falcon go up to 30 miles on a gallon of gas.

Why does the Falcon have a welded single-unit body and bolted-on front fenders?

Welded, single-unit construction gives more usable space, great strength, an unusually quiet ride. That means the Falcon can be compact outside and yet carry six big people in comfort. And this *lightweight* method is one big reason why the Falcon goes up to 30 miles a gallon.

Bolted-on front fenders cost less to replace. In fact, just about half what welded-on fenders cost. They speed repair jobs, too, to save you time *and* money! That makes them *right* for an economy car.

It's the same with Falcon's single carburetor that costs half what a dual system costs to replace. And it's much easier to adjust since it does not require synchronizing with a twin.

But a *true* economy car must have fine-car quality to keep resale value high. And that's where the Falcon shines brightest!

Try these simple quality tests. *Push* your hand against the Falcon's "ceiling." You'll find a deep layer of sound-conditioning material. *Feel* the texture of that beautiful upholstery. *Inspect* the workmanship of each bright metal detail. That's quality you can see and feel.

Economy where it *pays*... quality where it *counts*! That's the Falcon...easiest car in the world to own.

THE
1960
FORD

Falcon
FORD DIVISION, Ford Motor Company.

WISE-GRIP



**DOES
MORE JOBS
EASIER THAN
ANY OTHER TOOL**

**AT YOUR
DEALER**

only
\$2.15
to
\$2.95



PETERSEN MFG. CO.
DE WITT, NEBRASKA
Dept. No. PM-4

LOOK at its economy —
LISTEN to its "whis-purr" —

QUIET-TONE
HI-EFFICIENCY fiberglass-packed
MUFFLER

GET GASOLINE ECONOMY . . .
and **FULL HORSEPOWER!** Quiet-tone's straight-thru construction for unobstructed flow of gases gives you *both!* Plus the deep "acceptable" tone you admire, thanks to exclusive Turbo-Jet Diffuser. And, because Thermo-Dynamic Heat Flow produces faster evaporation of corrosive exhaust acids, **QUIET-TONE mufflers last longer!**

FIT ALL CARS — EASY TO INSTALL

See the complete line at your favorite dealer's today!
. . . and **ASK** about the complete lines of Dual Exhaust Systems, too.

GRAND AUTOMOTIVE PRODUCTS
2055 N. Ruby St.
Melrose Park, Illinois
World's Largest Producer of Dual Exhaust Systems

been broken down into published statistical tables. But if you or your company had to know, let's say, how many transistors were produced by how many American factories in 1948—and how this compared with Japanese production—the Bureau will run its stored data through the mill for you at a nonprofit fee, provided the job can be squeezed into its busy schedule. On occasion, when the survey concerns something of national interest that they are free to publish themselves, they will even take a private census for anyone willing to pay the cost of labor and equipment time. Many special nose-counts are conducted for cities and towns.

Although individual forms are strictly confidential, any person with a legitimate reason can call on the Bureau to dig out information about himself and his immediate family. Since it started business, the Bureau's Personal Census Service has helped 3,500,000 people to prove birth dates or citizenship for purposes of clearing their right to old-age benefits and legacies.

Usually searchers have only the skimpiest facts to go on. "I was born in Wisconsin during the big smoke;" or "It was the year that big ship sank." So, starting with the date of the big Peshtigo forest fires, or the Titanic disaster, the hunt begins and is often successful. To avoid the hazard of misspelled names, the Bureau has a "Soundex" file in Kansas, coding nearly a quarter of a billion names by the way they sound. An ordinary uncomplicated name, such as John Q. Doe, can be turned up here in a matter of seconds.

All this constitutes day-to-day operations for the Bureau of the Census. The big countdown each zero year is the icing on the cake. The one coming up next month was three years in planning.

Out of it all, in just a month or two, you and I will know a lot more about us. Some of the facts that the new census will reveal have already been projected by the Bureau. They know, for instance, that it's going to show American families growing bigger; that marriageable women are going to outnumber marriageable men by about 2,000,000 in every place but Alaska, where the ratio is five-to-one in the other direction; that Americans are growing younger as well as older, due to rapid strides in medical care and war against disease; that the center of our population will move almost 20 miles further west from its last focal point near Olney, Ill., due to the addition of two new states.

But when UNIVAC has finished gobbling up the actual data, there are bound to be some surprises. ★ ★ ★

For a home of
ANY SIZE



For a home of
ANY TYPE



Now—P-B Components build extra quality into your new home— **at lower cost**

Finer materials and precision workmanship add quality to your new home. They mean weathertight construction, freedom from drafts, mildew and bathroom noises, friendly walls and ceilings that give you quiet, comfortable rooms.

Today the floors, walls, partitions, ceilings, gables and roof for your home are *custom-built to fit your plan*—by a nearby building materials distributor. They come to your site and are assembled with engineering precision in one day. You occupy your new home in three to four weeks.

To build this way, you buy (or have your builder buy) P-B Components from your local lumber dealer. Your walls and partitions are not of some limited, arbitrary length or width, but *room-size*—with either exterior finish

or sheathing applied and with the interior finish applied. Floor components are built mainly in 8-foot widths and of the length needed; the underflooring is insulated and the factory-finished flooring already in place. Roof and gable components have the sheathing already in place. You have a wide choice of both exterior and interior finishes.

Write for 8-page brochure. It tells the whole story in full detail, plus the facts about our 24 years' experience with this method of building quality homes with low maintenance costs and high re-sale value. For your *free* copy, address Dept. D-3.

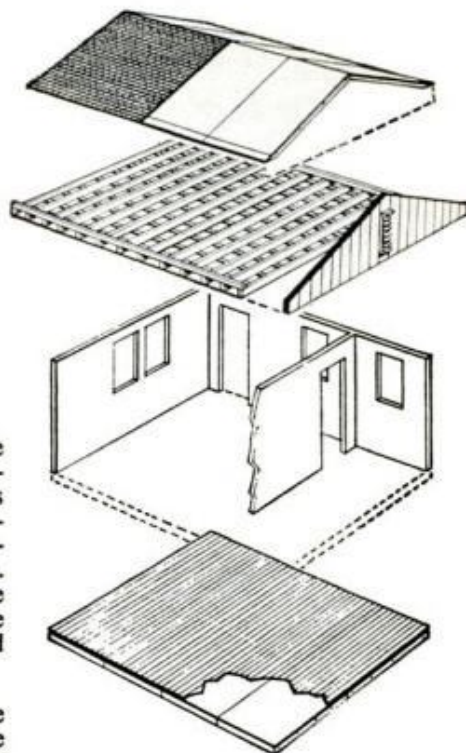

HOMASOTE

COMPANY
Trenton 3, New Jersey

Homasote of Canada, Ltd., 224 Merton Street
Toronto 7, Ontario



HANDY, BIG PLASTIC BOX

24 compartments,
13 1/8 x 9 x 2 1/4.

Beautiful,
crystal clear,
rigid plastic.
Ideal for fish

lures, nuts, bolts, washers,
buttons, jewelry, office supplies.
Sturdy cover and hinges. At hardware,
automotive, sports goods stores.

The **Vichek** Tool Co. Dep't. P
Cleveland 4, Ohio

EMERSON ELECTRIC

PORTARC 180c PORTABLE WELDER High Capacity... Low Price

Ideal for farm, home workshop. Cuts, brazes, solders, welds. One man can carry... only 68 lbs. 6 welding heats up to 180 amps... 3/32" to 3/16" rod sizes. Write today for prices and receive **FREE WELDING SELECTOR GUIDE**... gives working data you need in seconds!



EMERSON ELECTRIC of St. Louis
8100 Florissant • St. Louis 36, Mo.

"finest mower made!"

BIG WHEEL YAZOO



Here's the power mower that's built to take it! Glides easily over rough terrain, weeded area... and clips the finest lawn to smooth perfection! These unbeatable features of Big Wheel Master Mowers make Yazoo tops for every cutting need:

- Big Wheels glide smoothly, mean easy handling!
- Stays in top condition... with minimum upkeep!
- Covers ground faster... stands-up under wear!
- Gives years of efficient, trouble-free service!

See the Yazoo Complete Line at your dealer!

YAZOO SALES COMPANY, INC.

3607 Livingston Rd.
Jackson, Miss.

114 N. Central St.
Gilman, Ill.

Route 59
Monsey, N.Y.

Selecting Your Sound Source

(Continued from page 220)

For many years, only magnetic cartridges were used in the highest-quality systems. Their performance was so far superior to that of the other types that the difference was clearly audible. This is no longer true. With present-day stereo units, the audible differences between a good magnetic unit and an equivalent ceramic one are no more pronounced than the variations between high-fidelity cartridges of the same classification.

The frequency-response curves of three highly rated cartridges, see p. 220, indicate a measure of performance which leaves little to be desired. Yet, they do not sound as much alike as the curves would indicate. Only a listening test can tell you which one you will like best.

There's one thing you should take into consideration, however. Magnetic cartridges are not nearly as efficient as ceramic ones. They require greater amplification and that means a greater hum and noise level in the amplifier. Unless you have a truly high-quality amplifier, a ceramic cartridge would be your best bet.

The Stylus. If you were to ask my opinion as to the most critical part of a modern hi-fi phono system, I'd have to answer

—the stylus. Today's speakers and amplifiers do a creditable job. If they distort the signal, it's generally only at very high volume levels, and if they don't reproduce all of the musical tones, their discrimination is principally against the very high and very low frequencies which constitute only a small portion of the sound. But a worn or chipped stylus affects the total sound. It distorts *all* frequencies at *all* volume levels, and even a single playing with a bad stylus can damage a hi-fi record.

Most of the better stereo cartridges today are sold exclusively with diamond stylus. But there are plenty of others which give you your choice as to diamond or sapphire—and the price difference is appreciable. Now there's nothing wrong with a sapphire stylus if it's in good condition. The trouble is that a sapphire begins to show signs of wear after about 10 or 20 hours of use. It's likely to have passed the danger point before you realize that it's time for a change.

A diamond, on the other hand, gives well over 100 hours of playing time and it more than pays for itself in the long run. An investment in anything but a diamond stylus is truly false economy.

Unless a listening test convinces you that a particular cartridge is clearly

Only Eclipse Mowers



RIDING MODELS

Make lawn mowing almost fun! The Eclipse Deluxe "Ranger" mows up to 5½ acres a day. It's ruggedly built with auto-type tubular steel frame. Has two forward speeds and reverse. Big canvas "Sun-Brella" is an optional accessory... fits on to tow-bar pin at rear of mower. Try it soon at your Eclipse dealer.



REEL-TYPE

Preferred by many who take special pride in their lawns... Eclipse precision reel-type mowers—18" to 25" models—give a smooth shearing action that's ideal for Bermuda, Zoysia, and St. Augustine, as well as blue grasses.

**SEE THE BIG "E" LINE
AT YOUR DEALERS SOON...**

superior to all others, try to select one with a user-replaceable stylus. Though this won't save you any money, it eliminates the necessity for returning the unit to the factory and the subsequent delay in putting it back into operation.

The Pickup Arm. If you buy a changer or a complete, factory-assembled manual player, you won't have to worry about the pickup arm. If you plan to use a professional turntable, however, this is another component you'll have to select with care.

The function of the arm is a purely passive one. It should do nothing more than to hold the cartridge in the correct position as the latter travels across the record. It should be light enough to follow the eccentric variation of the slightly warped records, yet stable enough to resist vibrations which otherwise would cause the stylus to skip grooves. At the same time, its resonance should be low enough so that it does not impose its own characteristics on the reproduced sound.

Properly adjusted and installed, both of the kit-built arms shown on page 220 should perform satisfactorily. There is, however, a considerable difference between the two. While the resonant frequency of both is well below the audio range, the Gray arm required only 1.7 grams of stylus pressure for proper track-

ing. With the same cartridge, minimum pressure for the Audax was 3.5 grams.

Moreover, while it is always a good idea to level the turntable, this is absolutely essential for the Audax arm, while the Gray is somewhat more tolerant. The Audax is also more susceptible to vibrations. Even at tracking pressure as high as 4.5 grams, it still had a tendency to jump out of the groove when vibrations were deliberately introduced. Of the two units, the Gray arm is definitely superior, though it is considerably higher in price, and far more involved in construction.

If proper facilities are available, it would be a good idea to compare the performance of a number of pickup arms before making a final selection. At least, send for manufacturers' literature and compare the specifications and features.

Final Notes. The equipment cabinet described in our January 1960 issue will house all record changers and most commercially assembled manual players. The record-player compartment is too small, however, for the separate professional turntables and arms. If this type of installation is intended, be sure to check the minimum space requirements of the turntable and arm you plan to use. During the initial construction, the dimensions of the cabinet can easily be changed. ★ ★ ★

give you MOW-ABILITY*

ROTARIES

You get power to spare with 4-cycle Briggs & Stratton engines on all Eclipse mowers. Your Eclipse dealer will be glad to show you all the new features that make an Eclipse mower your best buy in the long run. New wind-up starter is furnished on W-20 and W-22 Duo-Masters.

GRASS CATCHER

(Optional extra)

Collects clippings as they leave discharge chute. Easily attached. Fits all Eclipse walking rotary models.

EASY CUTTING HEIGHT ADJUSTMENT



It's brand new and exclusively Eclipse! A simple twist of one control adjusts all four wheels simultaneously. Select any cutting height between 1 1/8" and 3 1/8" —even while mower is operating.



13 MODELS PRICED FROM \$69.95

APRIL 1960

- *DESIGN AND CONSTRUCTION TO OUTPERFORM
- ALL ORDINARY MOWERS YEAR AFTER YEAR—
- FOR THE LOWEST ANNUAL OPERATING COST

RUGGED AS A RHINO

Inside and out—from stem to stern —Eclipse mowers are built to "take it." Many Eclipse mowers 20, 30, or even 50 years old are still on the job and cutting efficiently.



DURABLE AS A CAT

Eclipse mowers seem to have "9 lives"—just don't die easily. To assure long life, repair parts are available for many years after the expected life of the average mower.



POWERFUL AS A BULL

Equipped with job-matched 4-cycle engines, Eclipse gives you a bonus of reserve power. You can operate your mower at safer, quieter and more economical half speed.



THE ECLIPSE LAWN MOWER CO.

Div. of Buffalo-Eclipse Corporation
4014 Railroad St., Prophetstown, Illinois

ECLIPSE

Owners Report on the Falcon

(Continued from page 102)

If you live in a hilly area, you should buy the automatic transmission. → You'll use about eight cents more gas a day, but who wants to shift gears all day for eight cents?

Here's a pleasant week-end recreation. Cheap, too. →

The Falcon does well → in city driving. The heated manifold helps. PM's test car (with automatic transmission) averaged 19.2 miles per gallon in city, 19.9 in high-speed rural-road driving. Temperature was 35 degrees, driver was alone in the car.

In winter (when this survey was made) 20 miles per gallon is good for → any except the very smallest cars. V8s get about eight miles per gallon then.

Falcon owners are not → foreign-car types. Few had imported-car experience. As a group they are more conservative, less inclined to the "off beat" than the usual foreign-car owner. This may have influenced their judgment.

"It rides just like a big car. You hardly feel the bumps."
—Wyoming clerk.

Do they have any complaints? Of course they do. Leading the list is the lack of power, the sluggishness that results when a small engine is coupled with a 3.10 rear axle.

"Not enough power. Second gear isn't enough for many hills in town driving and first gear isn't synchromeshed for downshifting."—Tennessee graduate student.

"It should have more power in high. You have to put it in second when you pull into a drive or turn a corner."—North Carolina truck driver.

"Doesn't have pickup in high. You have to stay in low and second longer and go into second quicker on hills."—District of Columbia geologist.

Second on the complaint list is body noise. The Falcon apparently develops rattles despite its unit body.

"The dash panel had many rattles, most of which I eliminated myself with pliers and a screwdriver."—Virginia aircraft mechanic.

"Glove compartment rattles, including what's in it."—Ohio artist.

"Unpleasant body noise at low speed in high gear. Lack of tightness in door windows. Have had one removed for tightening."—Nebraska credit man.

Third among complaints is that the Falcon uses too much gasoline with 5.8 percent of the owners mentioning it.

"I am disappointed in the mileage per gallon. I have never come close to the advertised 30 miles per gallon. I get 22."—New Mexico college student.

"Am a little dissatisfied with gas mileage. I had a 1949 Ford V8 with overdrive that gave the same gas mileage that my Falcon gets. And it ran more smoothly. I get 21.5 miles per gallon over-all."—Tennessee apprentice printer.

"My Falcon has automatic transmission and I average 15.7 miles per gallon."—Ohio maintenance superintendent.

"I was hoping for at least 25 miles per gallon. I get about 20."—Vermont music supervisor.

What About the Imports?

Will the new compact American cars cut into sales of foreign cars? *PM* asked the Falcon owners what they thought. The answer was overwhelmingly that they would, with only 9.4 percent saying the imports would not be hurt by this new breed of automobile.

Here are some typical comments:

"Most anyone would prefer to buy anything made in U.S.A. even if it costs a little more."—Tennessee fire fighter.

"I buy a car for transportation, not prestige or show. I do not go for snob appeal associated with owning things labeled 'imported.'"—Virginia personnel officer.

"I have had trouble getting service on foreign cars. Most mechanics don't care to work on them. Tuneups were available at the dealer only and often quick service was impossible due to the rush of business."—New Hampshire appraiser.

"I have driven several foreign makes and to me none of them looked like an automobile."—Nebraska insurance man.

"I do not like foreign cars but I am grateful to them because they have educated Detroit into building practical automobiles."—Maryland sailor.

And here's the view of the minority:

(Continued to page 272)

“Zero-five-seven...you are fifty feet above glide path... increase your rate of descent... you are now on course, on glide path...over touchdown point...take over visually for landing and contact tower.”

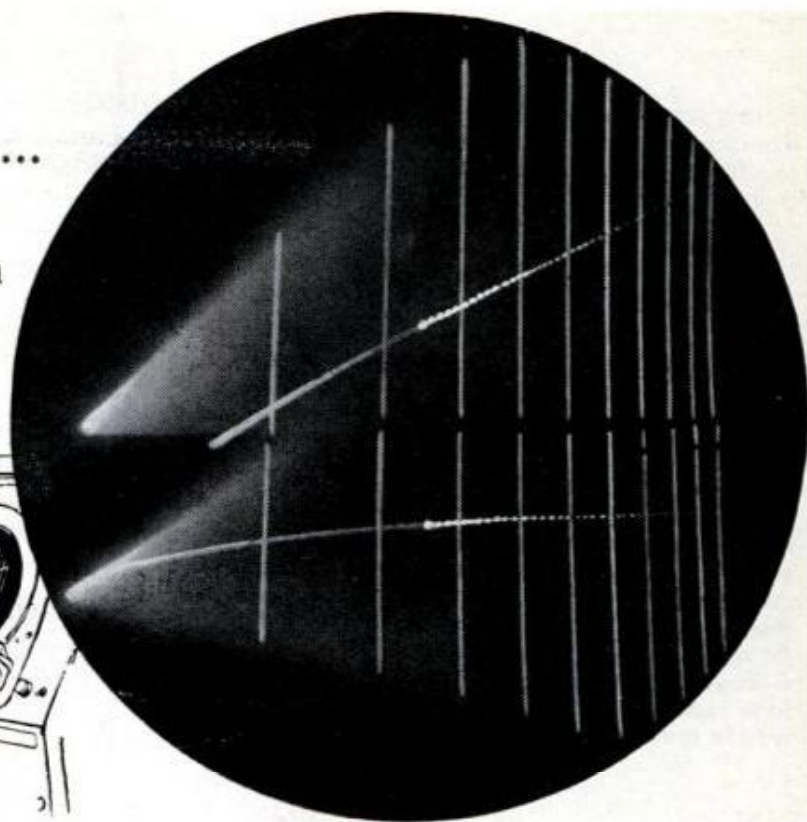

YOU MAY HANDLE A SITUATION LIKE THIS...

If you measure up to the Aerospace Team

The man in command of this situation is an Air Force Ground Control Approach Radar Technician. And those “blips” on the glide paths of his radar screen represent an aircraft coming down blind through bad weather. This is the kind of man whose dependable skill and calm judgement make him a key member of the Aerospace Team...he is the kind of man who can meet the qualifications of the U. S. Air Force.

Are you that man? As a trained and ex-

perienced Air Force technician, you will have an opportunity to build a career for yourself in the Aerospace Age—the age of air and space travel. Such a career offers you valuable training and education, steady advancement and an assured future.

If you are the kind of young man who could learn to handle situations of increasing responsibilities, we of the Air Force would like to talk to you. If you are interested, just clip and mail this coupon.

U.S. AIR FORCE

There's a place for tomorrow's leaders on the Aerospace Team

PASTE COUPON ON POSTCARD AND MAIL TO:

Airman Information, Dept. MM04, Box 7608, Washington 4, D. C.

Please send me more information on my opportunities in the U.S. Air Force. I am between the ages of 17-34 and reside in U.S.A. or possessions.

Name _____

Address _____

City _____ Zone _____ County _____ State _____

Here's why the Big Three plans smaller cars for the future. The demand is inevitable. →

Workmanship can be a fetish. I like it. You like it. But its value is mainly psychological. A car runs just as well even though trim doesn't fit right. But somehow if it doesn't fit right, you lose confidence in the whole machine. →

The wheel turns easily, but lots of winding is required. It has the slowest steering ratio of all compacts. That's why it's not frisky in any sense of the word. →

A company has a choice: Put money in engineering innovation or put it in fancy interiors. Ford put it where it shows. →

If you know how to use it, a hand choke is great, but let a woman wrestle with it and the car may never start! →

"My first American car in five years. I had hoped that in this time Ford had caught up with Europe. In 5000 miles this Falcon needed new transmission, valves, crankshaft. I am not a hot rodder either, but do considerable road travel. It does not hold a candle to VW or Renault and they are \$400 cheaper."—Florida general contractor.

"Compacts won't affect foreign-car sales because so many women desire small, easy-to-handle-in-shopping-center cars. Also men must drive 15 to 30 miles to work each way."—Virginia technologist.

"I believe that the American car builders should study some of the foreign cars and compare them with their own. Maybe then we could get a good small car built in this country."—Ohio tool and die maker.

"My husband is planning to trade in his car soon and will buy either another Falcon or a VW. We like our Falcon but do not think any American small cars have the workmanship that some foreign-made cars possess." — North Carolina physician's wife.

More Best-Liked Features

The following quotations describe additional best-liked features, in order of frequency of mention by the owners:

"I like the styling without all that chrome cluttering it up."—Vermont clerk.

"Styling incorporates the very best features from two higher priced models. Falcon has the Thunderbird's cowl and hood and Lincoln's sculptured sides."—Ohio railroad telegrapher.

"I am six foot eight inches tall with my hat and shoes on. This is the only car I ever owned with ample head and leg-room."—Nebraska auctioneer.

"Parks very easy, pulling into a meter or pulling out from one."—North Carolina meat cutter.

"I like the advantage of seeing directly down in front of the car. Visibility all around."—Colorado rancher.

"Very nice size. Not too much overhang and so very easy to maneuver."—Rhode Island railroad clerk.

"It weighs only 2260 pounds but holds the road at high speeds better than all others. Takes short curves at greater speeds."—Maryland building inspector.

"Upholstery is as good as in our 1959 Galaxie."—Tennessee real estate man.

"Large luggage space for a small car."—Idaho airman.

"Ease and accessibility of all parts to be repaired or replaced."—Ohio service station.

"I'm a big man and getting in and out many times each day can be done with ease."—Colorado insurance man.

"I am 73 years old. It is so easy to get in and out."—Wisconsin retired owner.

"I think the balance between power and economy is best where it is. I like the 3.10 rear axle. I use second gear in passing. Acceleration in this gear is excellent up to 55 miles per hour."—Virginia realtor.

"After much shopping (I talked with eight different dealers) I bought the Falcon \$300 cheaper than any competitive make with same equipment."—Ohio life insurance underwriter.

"Best body Ford ever made on a low-price car."—Ohio aircraft flight engineer.

"We like the hand choke on these cold 25 below mornings."—Maine postal carrier.

"It's built so high you don't scrape bottom on bad roads."—Ohio construction superintendent.

(Continued to page 274)

The cool way to go!



Coleman SNOWLITE Coolers and Jugs



These handsome new refreshment holders are record holders, too!

Coleman SnowLite Coolers hold cold **45% longer**. Most efficient coolers under the sun! Leakproof white Royalite liner won't pick up odors, can't rust. Easy to clean. Plastic bead foam insulation all around. Rugged baked enamel casing. Rust-proof, scuff-proof Royalite base. 3 models. 7 and 14-gallon capacities. Pink, green or charcoal.

Coleman SnowLite Jugs hold heat or cold up to **115% longer!** Why? Because they're the only jugs that are 100% insulated from neck to base. Tough Royalite base won't scuff or rust. Exclusive "pitcher-pour" (1 gal.) or nylon-faucet models (1 and 2 gal.). Patio pink or green.

At hardware, sporting goods and department stores.



FREE BOOK!

"Happier Vacations" by motor-travel experts George and Iris Wells. Useful information for hunters and fishermen. Ask your dealer or write for Catalog 081-PM

Other Coleman Outing Products

Floodlight Lanterns Folding Camp Stove
LP-Gas Picnic Stove Sportmaster Stove
Folding Camp Stool

The Coleman Company, Inc., Wichita 1, Kansas

And the Other Complaints

Here, also in order of frequency of mention, are the additional complaints of Falcon owners:

"Very poor alignment of doors. Paint seems to be very thin. Not as well constructed as higher price cars."—Nevada teacher.

"Exterior welding particularly around taillights and trunk is not finished well. Even after two touchups of paint, rust is forming rapidly. Many rust spots."—Florida housewife.

"Don't like the stepping down to get into it and the stepping up to get out."—Vermont construction worker.

"Engine takes too long to heat sufficiently at city speeds to get full usage from heater."—Tennessee business machine serviceman.

"Not enough power on hills. Needs higher rear-axle ratio for this area."—West Virginia clerk.

"Will not drive under 25 miles per hour unless in second gear. I work on a military reservation where there are speed zones of 15 miles per hour. My car heats up in this gear when driven slowly for long distances."—North Carolina ward attendant.

"Wheels are too small and the car tends to bottom on dirt roads."—Ohio tool dresser.

"A lot of sunshine in the face. Windshield should not be so high. Have to use sun visor 90 percent of the time in daylight."—Ohio office manager.

"Don't like slowing down of wipers during acceleration."—North Carolina physician.

"At 25 miles per hour it bucks in high and at 10 miles per hour it bucks in second. I haven't been able to shift to low without a complete stop."—Nevada plumber.

"Steering wheel should be higher for more knee room in getting in and out."—Florida chiropractor.

"Dealer service department is exceedingly poor. Mechanics are parts replacers and lack real diagnostic ability. I make this statement as one who has been in the service field for over 25 years."—Colorado realtor.

"Serious leaks during rainstorms."—Florida engineer.

"I damaged the rear-end gear. The dealer claims to have ordered new gears to replace the damaged ones. Two months have gone by and he has not been able to get them yet. Could it be that the Ford Motor Company made a new car and forgot to make any spare parts or did I select the wrong dealer?"—Rhode Island railroad employee.

"Engineers goofed when they fixed the instrument panel so the light reflects directly against the windshield at night. I have to turn off the instrument lights."—Idaho service station operator.

"Glove compartment too small."—Maryland lecturer.

"Has a tendency to yaw in a stiff quartering wind."—Arkansas Air Force pilot.

"On icy roads it is almost impossible to drive. About like a pup on a new linoleum."—Nebraska manager.

"Front end should be more stable. Brakes squeak and pop when you stop and back up."—North Carolina salesman.

"Gas intake pipe is so low that the gas backs up quite a few times when you stop for gas."—District of Columbia auditor.

"Please build this car a little more sporty so people can get more pleasure out of it."—Florida pantry man.

"Considerable noise from wind at speeds of 55 miles per hour and up."—South Carolina engineer.

"Front wheels do not seem to hold balancing well. Have had wheels balanced twice in 6500 miles."—Ohio salesman.

(Continued to page 276)

Seems to be a styling fault. Falcon looks like a pregnant roller skate with wheels too small for the body. Other compacts have same size wheels and don't give this impression at all. →

There's really no excuse for wipers that stall on acceleration. That is when you need them most. →

Amazing how faults like this get through. The reflections on the inside of the windshield are annoying and dangerous at night. →

In a year, the back end of the Falcon will carry an ugly stain from spilled gas. →



PROTO UNIVERSAL IGNITION SET—NO. 3200C—everything you need for fast, professional-grade work on any ignition system. Includes eight 15° x 60° offset Midget Open End Wrenches, Gap Gauge Set, Midget Plier, Tungsten Point File, Aviation Type Screw Starter, and Screwdriver. In roll-up/hang-up vinyl-treated kit. Separate pockets keep tools organized. At your Proto Hardware and Auto Parts Dealers.



2202 Santa Fe Avenue, Los Angeles 54, California • 502 Allen Street, Jamestown, New York • 1702 Oxford East, London, Ontario, Canada

Comforting Facts about **WOLVERINE WORK SHOES**

WOLVERINE SHELL HORSEHIDES
ARE THE LONGEST WEARING ...
EASIEST WEARING WORK
SHOES YOU CAN STEP INTO



WOLVERINE'S 50 YEAR OLD SECRET
TRIPLE TANNING PROCESS KEEPS
THESE TOUGH SHELL HORSEHIDE
LOGGER BOOTS SOFT



THEY CAN TAKE RUGGED WEAR, TOO,
AND GIVE YOUR FOOT PLENTY
OF MUCH NEEDED PROTECTION



EVEN IF YOU SPEND DAY AFTER
DAY IN THE MUD, WOLVERINE WORK
SHOES WILL NOT HARDEN OR CRACK
...BUT WILL DRY SOFT & FLEXIBLE

**PLUS THESE COMFORT
FEATURES—**



Sweat Proof Leather Insoles
• Triple Ribbed Steel Shank • Tapered
Backstay • Outside Counter Pocket,

WOLVERINE

ROCKFORD, MICHIGAN

SERVICE OXFORDS
WORK SHOES • BOOTS
SAFETY SHOES

Miscellaneous: *If you're the type who likes the conservative, the tested, this car is for you. It's ideal for the guy who wants dependable, easy-to-service transportation. And it rides well on good roads (not so good on rough ones), is quiet at normal speeds (wind noise is bad at high speeds). Acceleration is poor. Economy in city is good. At high speeds, not so good. Visibility unexcelled. Dash instruments are simple, easy to read, but markings on the gas and temperature gauges are ridiculous, make no sense at all. A great family car for America's workingmen, it's the car the Ford would have become if somebody hadn't convinced the industry that the automobile was a way of life.*

"Rides nicely on rough roads, but a long ride on concrete with many cracks and ups and downs does make one weary."
—Wisconsin priest.

Finally, here are some quotations that, while they do not represent an important percentage of owners, are of such interest that they are worth repeating:

"If Detroit took more pains in finishing an auto, there would be no foreign competition."—Virginia soldier.

"Have found that 24 pounds of air in the tires lowers gas mileage, but gives a better ride."—Florida radar technician.

"Most women can change the small tires easily and my kids can see a drive-in movie from the back seat without sitting on their knees."—New Mexico electrician.

"Since purchasing my Falcon I've driven 6200 miles during which time I have had no desire to drive my 1959 Star Chief Pontiac."—Ohio salesman.

"Service department is highly disorganized. Appointments mean nothing. But I would buy from dealer again because of favorable deal I got. I can have normal maintenance performed conveniently by reliable service station."—Wisconsin claims adjuster.

"Fuses are hard to get at to replace." — Idaho salesman.

"Harder to see around cars in traffic in a low car."—Vermont housewife.

"Not loaded with chrome and other costly items. It is 100 percent small car with 100 percent big-car comfort."—Florida airline pilot.

There you have it—the good and the bad. Here's a car that is satisfying a higher percentage of its owners than any American-built car surveyed in this series. Only the German Volkswagen did better. Obviously, if you are interested in a compact, you should investigate Falcon. ★ ★ ★

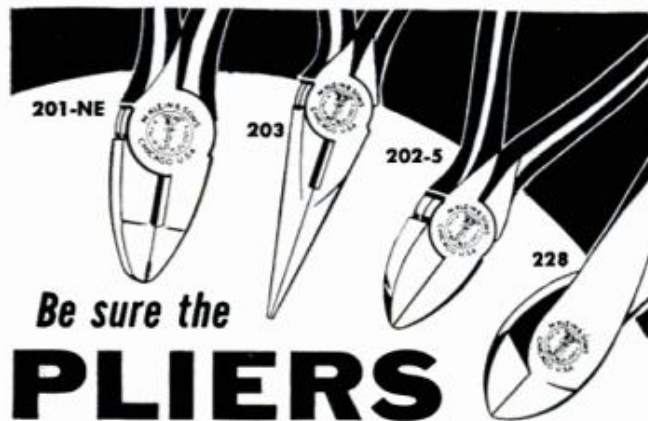

Be sure the
PLIERS
you use are
KLEINS

"Since 1857" the name Klein has stood for the finest in tools. Linemen, electricians and good workmen everywhere prefer Kleins because of the high standard of quality that is back of every pair. Now Klein Pliers are available in a wider selection of styles and sizes than ever before.

Ask your supplier for genuine Klein Pliers or write for a new Klein Plier Catalog.
FREE Klein Plier Catalog. On request.

Mathias **KLEIN** & Sons
Established 1857 Chicago, Ill., U.S.A.
7200 McCORMICK ROAD • CHICAGO 45, ILLINOIS

Everything for the Craftsman!

WRITE FOR NEW 132 PAGE
WOOD
AND HOME WORKSHOP CATALOG

Finest Domestic and Imported Woods . . . Mouldings, Hardware, Tools . . . ALL AT LOW MONEY-SAVING PRICES!

Your complete wood buying guide and project book. Craftsman is your best, most complete source of finest kiln-dried domestic and rare imported woods, beautiful wood inlays, colorful bandings, matched plywoods, embossed mouldings, carved ornaments, newest woodworking tools, "hard to find" cabinet hardware and fittings . . . more than 1500 items! Packed with newest scroll saw patterns, project ideas and money making plans. Enclose 25c (refunded with first order) to help pay mailing, handling cost. Write:

NEW!!

- Mosaic Tile Kits
- Period Clock Kits
- New Line of Metal Legs
- Over 1,500 Items!

**CRAFTSMAN WOOD SERVICE COMPANY, Dept. A-4
2729 SOUTH MARY STREET - CHICAGO 8, ILLINOIS**

Tractor with the "Most"

SPEEDEX



9 h.p. B. & S. powered model S-23 shown is today's "MOST" Tractor. Compare with anything on the market at its \$475 price. Two other riding models (4 h.p. & 5 3/4 h.p.) and 3 h.p. walking model

also use complete line of "unit-design" tools. Full year guarantee; sold on 10 day money-back guarantee. Color FOLDER gives complete information and dealer's name. Send 10c for it today.

**SPEEDEX TRACTOR 367 No. Freedom St.
COMPANY, RAVENNA, OHIO**

POPULAR MECHANICS

Great for
outdoor gluing
on sea
and land!

Elmer's Waterproof Glue. Forms a bond stronger than the wood itself! The glue of glues for boats, furniture, sports equipment, window boxes—and every other outdoor job. Send stamped, self-addressed envelope for free copy of "Elmer's Guide To Good Gluing". The Borden Company, 350 Madison Ave., New York 17, New York.



GENUINE ALNICO MAGNETS

AMAZING, PERMANENT, NON-ELECTRIC, HIGHLY PRACTICAL. Conduct interesting experiments. Hundreds of uses. Retrieve valuable steel items such as guns, tackle from fresh or salt water; tools from tanks & drains. **GUARANTEED.** Try any magnet one week. Money back if you are not well-pleased.

No. M-710 (Wt. 53 oz.) Has pull of 225 lbs. on steel block... \$18.00
No. M-625 (Wt. 70 oz.) Has pull of 125 lbs. on steel block... \$10.00
No. M-575 (Wt. 18 oz.) Has pull of 75 lbs. on steel block... \$ 7.00
No. M-500 (Wt. 13 oz.) Has pull of 50 lbs. on steel block... \$ 5.00
No. M-90 (Wt. 5 oz.) Has pull of 15 lbs. on steel block... \$ 3.50
No. M-300 Kit of Flat Bars 5 pairs (10 Magnets)... \$ 3.00
No. M-47 Hot Pad Magnets, 10 for \$1.00... 50 for \$ 4.87
No. M-35 Hobbyist assortment of 8 magnets... \$ 2.00
Send M.O. or check. We pay postage. Sorry no C.O.D.'s.

MIAMI MAGNET COMPANY, 3240 N.W. 27th Ave., Miami 42, Fla.



— TIPS & TECHNIQUES — MACHINE TOOL RECONDITIONING & THE ART OF HAND SCRAPING (4th printing)

SEND FOR FREE FOLDER DESCRIBING
ILLUSTRATED MANUAL FOR MACHINISTS

Machine Tool Publications, 382 Holly Ave., St. Paul 2, Minn.



(Item 24)

World's THRIFTIEST Light Plants

700 Watt, push button start, 115 v. 60 cyc. AC. 2.2 HP, easy starting Briggs eng. No wiring necessary; just plug in and operate. Plenty of current for any oil burner, freezer, brooder, emergency lights, etc. which require up to 700 watts. Ideal for television and radios. Complete with voltmeter and built-in winding to charge 6 v. auto batteries. (Item 24) Wt. 75 lbs. Easily fits in car trunk. Be prepared if storm

kicks out power lines. Reg. \$275... \$143.50
1200 Watt Plant (Item 45) same as Item 24 but larger generator and engine with 50% greater output... \$199.50

ELECTRONIC BRAIN Now Available On All Our Plants—Write



MASTER AIR COMPRESSOR

COMPARE! This is the only compressor built with a NO RUST stainless steel tank. Safe up to 500 lbs. (Item 209) High pressure type (4 c.f.m.) Large volume of air for heavy duty spraying, inflating truck & auto tires, greasing, sand blasting, etc. Piston type 2" bore compressor with built-in air filter. Master built with high strength alloys and precision bearings. Tank, 12"x24", 2100 cu. in. cap. Equipped with automatic switch that starts and stops motor to maintain desired pressure (up to 150 lbs.) and check valve, safety valve, gauge, shut-off valve, 20 ft. air hose and tire chuck.

1/2 HP. heavy duty model, Industrial motor and unloader switch. (Item 209a)... \$129.50
wheels and rubber tires. Don't take chances with used or surplus equipment. Our compressors are factory new and are guaranteed SAFE. Low factory prices. 1/2 HP. Model Regularly \$175. (Item 209)... \$109.50

MASTER MECHANIC MFG. CO., Dept. A-46 Burlington, Wis.

Southern Customers Order form Dept. A-46, Box 65, Sarasota, Florida

Fishin' Favorite!



14' Aluminum River Fisherman (FD-14R)

Stable... rugged... roomy! All fitting words for Arkansas Traveler's River Fisherman, the finest development in "Johnboat" design. Ideal for fishing, hunting and float trips. Unit constructed of heavy gauge aluminum... camouflage green finish... ample safety flotation... takes up to 7.5 hp motor. A real boating buy!

Free: Write for full-color catalog on the exciting 1960 models—both aluminum and fiberglass.

Arkansas Traveler Boats, 2006 E. 14th St., Little Rock, Ark.

You Get MORE with
Arkansas TRAVELER



REPLACE YOUR
WORN-OUT
WOODEN
HATCHWAY...

with an
all-steel
BILCO
basement
door



... and your basement entrance will be weathertight, good-looking — for a lifetime. A spring-balanced Bilco door floats open at a touch... locks securely... costs so little. And you can install it yourself — in just a few hours!

Bilco

The Bilco Co., Dept. R-94
New Haven 5, Conn.

Please send me your free illustrated folder and name of local dealer.

NAME _____

ADDRESS _____

CITY _____ ZONE _____ STATE _____

AMERICA'S FINEST
BASEMENT DOOR

UNIMAT

complete machine shop-in-miniature

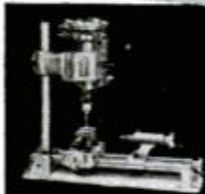
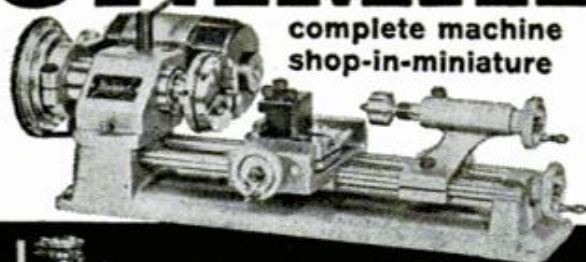

Converts from lathe to drill press, tool and surface grinding machine, vertical milling machine, or polisher/grinder—in seconds! \$12950

THIS is that jewel of a machine tool you've been looking for—if you're the kind of craftsman, hobbyist, model builder or inventor who demands all-out precision. It's hard to believe that such versatility, such high-level performance could be built into a rugged instrument that measures only 16" from headstock to tail wheel! The basic UNIMAT includes a powerful 3500 RPM motor and everything you need for fundamental machining operations. Advanced workers, of course, will want many of the accessories that make UNIMAT the most practical, all-purpose tool available anywhere in the world! Whether you're a perfectionist or putterer, you'll really enjoy working with UNIMAT. Available at better hardware stores and hobby shops, or WRITE FOR FREE CATALOG AND BUDGET PLAN INFORMATION.

AMERICAN EDELSTAAL, INC. DEPT. GD
350 BROADWAY ■ NEW YORK 13, N. Y.



Speedy Sprayer

sprays paint

7 times faster than hand brushing!

And what a finish . . . smooth, flawless, no brush strokes. So easy—just pull the trigger. Speedy Sprayer is a real professional tool. Paints anything, toy to a house. A must for every workshop. Operates with any ¼ or ½ hp motor. 890 OUTFIT, less motor, \$42.50

Mobile Wheel Kit, \$7.50 extra

W. R. BROWN CORP.

Specialists in Portable Sprayers for 38 Years
2635 N. Normandy Ave. • Chicago 35, Ill.

Wheel it to the job!

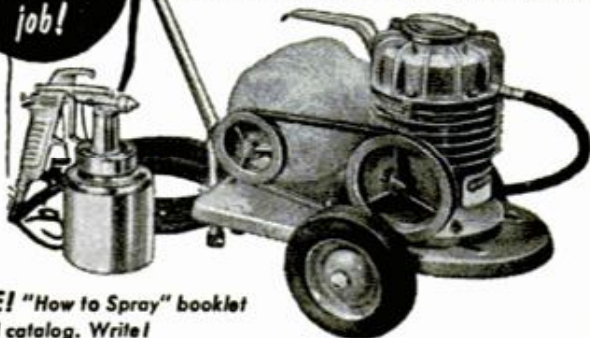

FREE! "How to Spray" booklet and catalog. Write!

least two big ocean liners have been tracked by radar and seen, rushing at night or in fog across the iceberg-cluttered Grand Banks area to Montreal at top speeds up to 25 knots. One slashed between the cutter and an iceberg. One drove at full speed through the fog without sounding her foghorn. Another liner sounded her fog whistle and reduced her speed from 18 to 11 knots, but only after an urgent warning of "ice ahead" by the Coast Guard cutter.

So far the Coast Guard has found no way to do away with its tough icy enemy. Destroyers and cutters have fired torpedoes at bergs, flung five-inch shells at them and slung demolition mines on long lines underwater against their icy faces. In each case the result was the same; there has been a big bang, and the berg has remained as imperturbable as the Sphinx.

Last June the Coast Guard conducted demolition tests with thermite incendiary bombs dropped from aircraft. Two hundred feet above the berg, a proximity fuse blasted the bomb open, and 22 thermite fire bombs spewed down against the icy cliff of the berg. There was a splatter of explosions that shrouded the berg in smoky steam. Sea birds on the icy pinnacles flew off in alarm—then came back. The plane dropped more bombs. But the iceberg remained intact. Nature had won again.

There is a commonly held theory that the presence of an iceberg can be detected by an unusual chill in the air; another theory is that the ocean water near a berg is colder and less salty than normal. Neither theory stands up. Icebergs have no significant effect on air and water temperature or on the degree of salinity of the water around them. The simple fact is that man, with all his ingenuity and resourcefulness, cannot control, regulate or entirely avoid the iceberg menace.

Tests last year by the Ice Patrol show that as a radar reflector an iceberg is only one sixtieth as efficient as a ship of comparable size and that even sea water is a better reflector than ice. This means that the clutter which ordinary waves reflect on a radar screen may so obscure a berg that the danger cannot be observed at all.

So the awesome tragedy of the *Titanic* still hangs over the area swept by the International Ice Patrol. And every year on April 14 the Patrol's bulletin to all ships in the North Atlantic concludes with this message: "RMS (Royal Mail Ship) *Titanic* 41 46N, 50 14W (her position at time of disaster), 14 April 1912. RIP (Rest in Peace)." ★ ★ ★

PEEL PAINT OFF



Furniture



Floors



Boats



Woodwork



KLEEN-STRIP PAINT REMOVER

Fast • Clean • Non-inflammable

THE KLEEN-STRIP CO., INC.
2340 S. Lauderdale, Memphis 6, Tenn.

ADJUSTABLE MITER BOX & CORNER CLAMP



No. 44
COMBINATION
MITER BOX AND
CORNER CLAMP

Holds the wood and holds your saw. Uses any hand saw for accurate cuts from 0° to 180°. Full 3" capacity. Sides of joints exposed for nailing, gluing.

\$2.75 ppd.

No. 33 Works the same as No. 44, but without saw guide adjustment.

\$1.75 ppd.



SUPER FILER
No. 11

For both hand and circular saws. Steel rollers give all teeth correct height, pitch and bevel.

\$9.95 ppd.

SEND FOR FREE CATALOG.

A. D. McBurney, 5908 Hollywood Blvd., Hollywood 28, Calif. Dept.: A-40

EPOXY WELD

World's 4 Strongest Menders
Developed for Missiles and Jets

- TRANSPARENT ● PORCELAIN
- ALUMINUM ● STEEL

Forms permanent molecular bond

At F. W. Woolworth and all Hardware Stores



G E A R S

In Stock — Immediate Delivery

Gears, speed reducers, sprockets, thrust bearings, flexible couplings, pulleys, etc. A complete line is carried in our Chicago stock. Can also quote on special gears of any kind. Send in your blueprints and inquiries.

Send for Complete Catalog No. 10
CHICAGO GEAR WORKS
440-50 N. Oakley Blvd., CHICAGO 12, ILL.

HIGH QUALITY — LOW PRICE!

NEW HAHN POW-R-BOY "66" ROTARY TILLER

pulverizes even
hard-packed soil!

So light and well-balanced, women and children operate it easily. Instantly adjustable depth bar. Instantly detachable wheels. Five models, 2½ to 3½ h.p. Pulverizes to 6" depth, 16" swath — 24" with extension tines. New optional reverse drive. ONE-YEAR GUARANTEE. As low as \$124.95 in most areas.



WRITE TODAY
FOR FREE FOLDER

HAHN, INC. Dept. PM-40
EVANSVILLE 7, INDIANA

MISSILE MECHANIC or



MODEL RAILROADER



You'll work better with

Starrett TOOLS

Big job or small, pay job or fun, there are tools in the big Starrett catalog that will help you do it better, faster, easier. Among the 3,000 items shown, you'll find tools made expressly for your job or hobby. Send for your free copy today. Use the coupon.

STARRETT TOOLS are carried by leading Industrial Supply Distributors and Hardware Tool Stores.



THE L. S. STARRETT COMPANY
Dept. AP, Athol, Massachusetts

Please send my free copy of Catalog 27 describing over 3,000 Starrett Tools for professional and amateur craftsmen.

Name.....
Occupation.....
Address.....
City.....Zone.....State.....

NEW Z-BRICK®

(NON-CERAMIC)

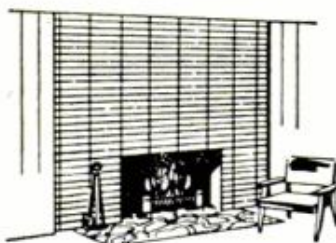

unequaled for
BEAUTY!
ELEGANCE!
QUALITY!

Wherever Z-Brick is used it adds new elegance, charm and warmth to today's home. Z-Brick eliminates 90% of the weight of conventional brick or stone. Excellent for exterior use.

- **FIREPROOF** — excellent for kitchens.
- **LIGHTWEIGHT** — apply to existing wall.
- **SOUNDPROOFS** — softens room noise.
- **3 COLORS** — won't fade, easy to clean.

EASILY APPLIED WITH ADHESIVE . . .
NO FOUNDATION, NO MORTAR, NO MESS

SEND FOR FREE BOOKLET TODAY

Vermiculite Manufacturing Co., Dept. A-1
2107 North 34th St., Seattle 3, Wash.
Please send me Free Booklet and information about
New Z-Brick. No obligation.

Name.....
Address.....
City..... State.....

HANDLE

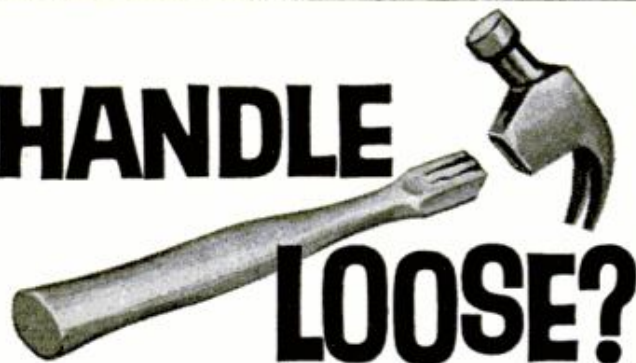

LOOSE?

FIX IT QUICK!

Reset it solidly with Plastic Wood
for a permanent job! Sticks
to metal, wood, stone.

For surest results always use **GENUINE**



PLASTIC WOOD

Handles like putty—hardens into wood!

The Army's Electronic Magic Shop

(Continued from page 85)

knew they could be controlled by radio in line-of-sight distances and that they could take pictures and bring the films back for processing.

"You're behind the times now," Snapp answered. "The drones we're working with can fly long-range missions. After they leave local radio control they fly a preprogrammed flight, changing altitude and direction according to preset instructions, eventually returning to local control.

"Meanwhile, they take pictures. The camera on the drone adjusts its diaphragm according to the amount of light, changes focus automatically depending on the distance to the ground, uses image motion compensation to offset the drone's speed and also uses powerful flash cartridges for after-dark work—all automatically.

"The drone develops its own pictures in the air and uses an optical transducer to convert the images into electrical impulses that are radioed back to base. Here a receiving camera converts the impulses into finished prints and at the same time produces a transparency that can be looked at in a viewer.

"This all happens in the space of three minutes while the drone may be several hundred miles away and traveling at twice the speed of sound at extremely high altitude!"

He went on to say that another new development is a TV system that doesn't blur at high speed and so can be mounted in a drone, radioing its pictures back to a viewing tube on the ground. The "side-looking" radar also can be mounted on a drone, as can infrared surveillance devices.

The Army still likes wire telephone circuits for some critical uses, but today is laying wire by helicopter at 70 miles an hour and also by short-range rockets. But for ordinary communication it is turning more and more to radio.

One of the newest innovations is a truck-mounted radio central that serves as many as 18 "subscribers" in a 10-mile radius. The system replaces the usual small wire telephone net and yet provides telephone service. In turn, it ties in with radio trunk circuits to other areas and even to land wires. It serves both fixed and mobile stations.

Recently an official who was touring the Proving Ground picked up the handset in his jeep, punched a series of buttons (that replace the usual dial) and asked radio central to connect him with an officer in Washington, D.C. The call went

(Continued to page 282)

New ignition wire 5mm. 200 ft. . . . \$8.95
 G-1 150-250 Amp New \$17.50 good C \$12.95
 R-1 300 amp G.E. record \$24.50 good \$15.50

Accessories Kit For Arc Welder for above generators has helmet, gloves, elect. holder, volt reg. rheostat, RC relay voltmeter, Gr. Clamp, including switch & 30' cable. . . . \$19.95
 With G-1 160-250 am gen. . . . \$26.00

Multi-Weld (R), D.C. Arc Welding Kit Complete with G.E. R-1, 300-350 amp gen. incl. all items in accessories kit & reactor coil with solenoid control all pretested \$56.50

AC-DC WELDER KIT #511 G.E. Generator. Makes 1250 Watts AC light plant and 200 amp. DC welder and battery charger. Includes all items listed in accessories kit. AC-DC generator & instr. \$38.50

New Reactor Coil Arc Stabilizer for R-1, P-1, G-1 & ACDC. \$10.95. Incl. engine throttle solenoid control \$14.95

V Belt Pulley Kit fits R-1, P-1 & A.C.-D.C. gen., has 2 ball bearings blocks, high speed bearings, triple V-pulley, shaft 3/4" & flex coupling \$17.50

New Throttle Solenoid & Idling device for all welder engine control 1" travel 6"L Wt. 4 lbs. \$7.50



New Water Pressure System.
 #AM400 Complete automatic has new pump 400GPH, relief, & adj. press. connected to motor 1 1/2 H.P. 7 amp 24VDC runs on 12V.DC adj. press switch set for 8# on and 20# off, gauge check valve, filter, overload switch, tank & R' cord value \$89.95 save \$47.45 price \$42.50 #AM401 same model less motor incl. ball bearing pump mount with Vbelt pulley \$47.50 incl. 1/2 H.P. A.C. motor \$55.50

HYDRAULIC SNOW PLOW LIFT KIT. Consists of Stratopower hyd. pump rates .450 cu. in. 1400 PSI drive pump from engine or power take off, 1 for way control valve #821 tank, filter, hose and fittings \$49.95

NEW HYDRAULIC PUMP-MOTOR SYSTEM KIT
 Offers fluid drive of varying power, consist of 2 new Vickers p.d.s. pumps ea. .410 cu. in. rev. 3750 RPM 1000 PSI 375 GPH where one pump is belt driven as motor, 1 four way c. valve with variable speed control, reservoir, filter, gauge, hose & fittings. Value \$98.10. \$49.95

New open center 4 way control valve #10060 with adj relief for 1 to 4 D.A. cyl. 3/4" ports \$12.95 #3w57 for 1 cyl 3/4" P \$8.95

Spectacular Bargain Electric pump 400GPH complete with screen, 24-12VDC 5.2 Amp. motor off-on switch rheostat \$7.95

NEW HYDRAULIC CYLINDERS

Air or Oil	Bore	Stroke	Shaft	D.A.	2000 PSI
#607	1 1/2"	4 1/2"	1 1/8"		\$4.95 2/\$7.90
#300	2 3/8"	9 1/4"	1 1/4"		7 lbs. \$10.95
#511	3 1/2"	2 1/8"	1 1/4"	15 lbs.	\$24.50

NEW HYDRAULIC SYSTEM KIT
 #400 K heavy duty Power driven rated 16000 lbs lift. Consists of 2 D.A. hyd cylinders 3 1/2" bore x 2 1/8" stroke ea. rated 8000 lbs with 1000 P.S.I. 1 four way hyd control valve with built in relief #821 1 Vickers hyd pump 400GPH 1000-2000 PSI filter, gauge, hose & fittings. Value \$169.95 save \$90.00 \$79.95 Same kit with two No. 300 cylinders \$59.95

HYDRAULIC PUMP BARGAINS 1500 P.S.I.

Type	RPM	GPH	Reversible
Vickers PF	3750	375	\$17.50
*Pesco gear	3750	198	\$9.95
*Pesco gear	4500	270	\$12.95

* Bendix, Vacuum, Air or fluid P. Disp. pump 15 C.F.M. 1500-4500RPM 10" HG suction 24" HG Press Reversible 3/4" ports new \$22.50 used \$12.95 (Add 15¢ for P.post)

GENERAL SALVAGE CO Check or Cash
 2922 E. 27 St., Dept. 146, Kansas City 27, Mo.

CHANGE SPARK PLUGS REGULARLY



Stimulating, adventure-packed reading for young boys and girls

A perfect blending of scientific information and exciting adventure. Each book \$2.95. At your bookstore, or order direct from Popular Mechanics, 200 E. Ontario Street, Chicago 11, Illinois.

NEW Taft "CAT KIT" 14 FT. CATAMARAN BOAT KIT



EASY TERMS
 18 ft. roominess, seaworthiness, at Taft's low, low mass production price. Other models from \$42. Freight Paid

\$279

FREE COLOR CATALOG **Taft MARINE WOODCRAFT**
 Dept. PM-460
 636 39th Ave. N.E.
 Minneapolis, Minn.

EXTRA VALUE Real value built into every style and size. Free catalog to toolmakers and machinists.
GERSTNER TOOL CHESTS
 460 Columbia St., Dayton 7, Ohio

BSA MOTORCYCLES

The most popular motorcycle in the world

Ride the hottest competition two-wheelers sold in this country. In races, scrambles, and "drags", BSA motorcycles consistently out-race, out-scramble, and out-drag competitive entrants. You'll find BSA's victory engineered machines loaded with all the hot performance champion riders demand. Get the details today!



BSA 40 cu. in. SUPER ROCKET

Send this coupon for free catalog showing complete new line of great models for racing or road touring.

Western: HAP ALZINA
 Dept. PM 4, 3074 Broadway
 Oakland, Calif.

Eastern: BSA INCORPORATED
 Dept. PM 4, 639 Passaic Ave
 Nutley, N. J.

Name _____
 Address _____
 City _____
 State _____ Age _____

STAR
BLADES
MAY 1951
L. B. BAZZ
MAY 1951
L. B. BAZZ

STAR

Hack Saw Blades and Frames

... used throughout
industry

STAR
Moly
MAY 1951
L. B. BAZZ
MAY 1951
L. B. BAZZ

★ For better, faster metal cutting in your home work-shop or on the job, use the ★
 ★ Hack Saw Blades preferred by people ★
 ★ who know — Star. "Handy-Pak" convenience, with card holding one or two ★
 ★ blades, makes storing and handling easier and safer. Cards give valuable and ★
 ★ helpful tips on metal cutting. © 1483 ★

Star "Lever-Lock" Hack Saw Frames

★  automatically position and tension blade.

★  perfectly balanced to make cutting easier.

★  At all leading hardware stores — be sure and ask for STAR

★  Send 10¢ in coin for information-filled booklet on metal cutting.

★  high-strength tempered steel back.

★

★

★

★

★

★

CLEMSON BROS., INC. Middletown N.Y., U.S.A.

ANYONE CAN FIX ANYTHING

WITH



New Magic RUBBER

Repair All Rubber and Fabrics with a Squeeze of the tube.

Tough, elastic rubber in paste form. Seals windshield leaks, repairs convertible tops, awnings, tarps, boots, raincoats, swimming pools, hoses. Dries quickly — permanent, waterproof.

AND Magic

PLASTIC ALUMINUM

The Amazing Metal Mender with 1001 Uses

Solders, seals, repairs all metal. No heat or tools needed. It's real metal in paste form that can be drilled, filed, tapped, threaded when dry. Waterproof, gasolineproof, heatproof to 600°. For Home, Auto, Boat, Plumbing.

NEW APPLICATOR CAP MAKES SPREADING A SNAP

In 59¢ and \$1.00 sizes at all Hardware, Paint, Department and Auto Supply stores — or send \$1.00 direct to:





magic

IRON CEMENT CO., INC

5400 Bower Avenue, Cleveland 27, Ohio

through as if it were a routine operation, which it actually is.

The next step in improved communication in the field will be automatic electronic switching for either wire or radio nets. Ordinary automatic switching is too bulky and delicate to use in the field, so the Signal Corps is assembling automatic switching equipment that uses printed circuits and transistors. One 2½-ton truck will carry a complete central automatic station that provides instant switching for 200 lines. The equivalent commercial equipment would fill a building many times the size of the truck.

In an atomic war a field commander needs to have exact information about any atomic explosion, whether it is ours or an enemy's. The nuclear surveillance people at Fort Huachuca have worked out a method that detects an atomic blast at once and pinpoints its location within two miles of ground zero from up to 300 miles away. The method gives an indication of the yield of the blast. Fallout, rainout and the movement of any radioactive cloud can be calculated. Information like this is useful in correcting aim, assessing damage and determining contaminated areas which troops must avoid.

The Army figures that there are more than 74 complicated and time-consuming jobs that can be performed by automation far faster and more accurately than by humans. The tasks range from logistics and the making up of march tables to fire control and target analysis. Interrogation of prisoners—even language translation—quite possibly can be done by machines.

To study these possibilities the Army has installed one of the world's largest computer centers at Fort Huachuca. This Automatic Data Processing Department is using an enormous IBM 709 digital computer to help design small mobile systems that can move with the troops. Three sizes are envisioned—a large MOBIDIC (mobile digital computer) for major headquarters use, a medium-sized computer that could be transported by truck, and a smaller 87-pound package that fits in the back of a jeep for local jobs.

"Aiming a battery of guns might be one typical problem for the small computer," Lt. Col. Luther W. Murphy explains. "You feed in meteorology, the barrel life of the guns, obstacles in front of the guns, number of rounds available, location of our own forces, and other data. Within seconds the machine will tell you which guns should fire how many rounds of what type of shells, giving you the elevation and azimuth settings for each gun.

(Continued to page 284)

Material, защищенный авторским правом

Welders • Mechanics • Plumbers • Hobbyists

MANUFACTURER'S SPECIAL
of Nationally Famous, Professional

WELDING & SOLDERING Outfit

Incl. 2 Regulators,
Torch Handle, 2
Welding Tips, Sol-
dering Tip, 2
Welding Hoses,
Goggles, Lighter.

REG. \$74.95
Bargain
Priced at only
\$54.95
Ppd.



ORDER NOW before the supply is gone. Money Back if not completely satisfied.

Additional Welding-Soldering Tips & Cutting Attachments available. Send 25c for complete catalog.

ARC WELDING SUPPLY CO.

DEPT. PM-4, 467 BRUCKNER BLVD., BRONX 55, NEW YORK

MAKE HOME IMPROVEMENTS NOW



Minneapolis-Honeywell Regulator Co., 2954 4th Avenue,
Minneapolis 8, Minn.

Electronic Lifeguard Tends Swimming Pool

So sensitive it can detect a hand splashing water, an electronic alarm sounds a warning horn should someone enter an unattended swimming pool. The system, which can be installed in new or existing pools for less than \$200, includes a sensing element submerged approximately a foot below the surface of the water, and a remote alarm panel. Whenever an object or person enters the pool, the sensing element detects the sound vibrations, then relays the signal to the alarm panel, where the horn sounds.

APRIL 1960

for just easy tilling

ARIENS JET

ROTARY TILLER



... with NEW,
Optional
REVERSE
DRIVE

Enjoy a bigger, better, more productive garden—save hours of work—tilling with an easy-to-use 3 h.p. Ariens JET! All-steel tines till 8" to 20" wide. Free-swinging steel depth bar. Optional tine reverse drive. Fingertip controls. Engineered for long, dependable service—Just Easy Tilling.

Ariens / Another Gard-N-Yard tool sold and serviced only by selected independent dealers

Mail Coupon today to:

Ariens Co. 161 Calumet St., Brillion, Wis.

Send free Gard-N-Yard literature.

Name _____

Address _____

City _____

State _____



FREE
BOOK
TELLS
HOW

CLOGGED SEWERS CLEANED INSTANTLY BY IMPACT SAVES PLUMBING BILLS—TIME

Anyone can trigger new Flush Gun shooting air & water impact on stubborn stoppages in Toilets, Sinks, Urinals, Bathtubs, & Sewers 200 ft in pipe 1/2" to 8"; Rags, Grease, and Roots melt away INSTANTLY when struck by hammer blow. Amazingly effective! Worth many times its cost in Plumbing Bills or start your own Business. Tear out Ad now & write address beside it for FREE BOOKLET or phone Kildare 5-1702, Miller Sewer Rod, Dept. PM-4, 4642 N. Central Ave., Chicago 30, Ill.

AUTOMATIC

MAKES NEW
PROFITS

RETOOTHER

for HAND SAWS

Cuts new teeth in 50 seconds—any size 4 to 16 points. Old teeth fall off as chips. Easy to operate. A perfect job.

BURR MFG. CO.
8933-A VENICE BLVD.
LOS ANGELES 34, CALIF.

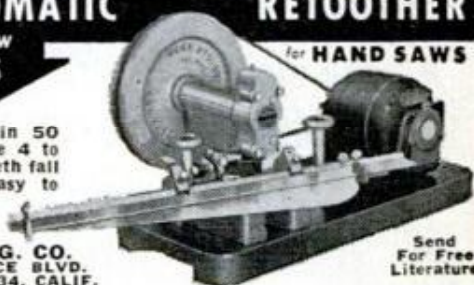

Send
For Free
Literature

283

new FORMICA® counter top?

Laminated Plastic



It's easy when you use (1) Formica Safe-Bond, the new non-toxic, non-flammable adhesive that "tells" you when to contact . . . and (2) Formica laminated plastics in the smart new Raymond Loewy designs. Get Formica Safe-Bond and sheet stock at your local lumber dealer. Formica Corp., a subsidiary of American Cyanamid, Cincinnati.

a product of

CYANAMID

It's Sharp . . . keep it that way with the right sharpening stone by



CARBORUNDUM®

Exclusive Double-Bearing HEAVY-DUTY PUMPS

IRRIGATE • DRAIN • CIRCULATE • SPRAY

Use 1/4 HP motor or larger . . . 1 HP for up to 7,500

GPH; 1,000 GPH 60' high; or 3,000 GPH from 25' well.

1 1/4" inlet; 1" outlet. Stainless shaft.

TYPE X-2 oil-less bronze bearings. Won't rust. . . . \$10.95

TYPE XB—Ball bearing model. . . . \$12.95

Postpaid if cash with order. Rush your order today

MONEY BACK GUARANTEE

Centrifugal and Gear Pumps in All Sizes

LABAWCO PUMPS, Belle Mead 2, N. J.



The second most important tool... for every woodworking shop

A VERSATILE

W&H

MOLDER-PLANER

is second only to a saw . . . it molds, planes and rabbets.

"Your savings pile up as your shavings pile up."

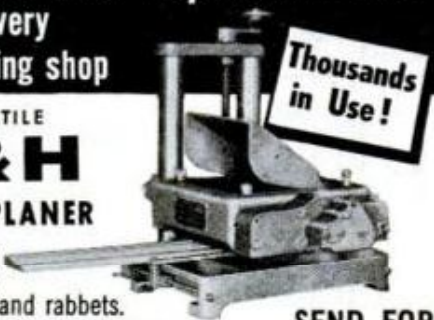

Thousands in Use!

SEND FOR FREE BROCHURE

WILLIAMS & HUSSEY MACHINE CORP.
CLINTON ST., MILFORD, NEW HAMPSHIRE

Weather always has been a complicating factor in tactical operations and it's more important now than ever. Knowledge of local winds is important when flying a drone; information about winds aloft is necessary when launching a missile. So the Meteorology Department at the Proving Grounds is conducting basic research in micrometeorology, the small-scale weather variations that occur in small areas. Soil and vegetation, lakes and mountains and valleys all have local effects. Being able to predict the details of local weather is almost as important as large-scale forecasting.

In still another kind of weather support, a dozen teams from Fort Huachuca are stationed in various parts of the Western Hemisphere from the Greenland ice cap to Puerto Rico to study the effects of extremes in climate on the behavior of munitions, on stored materials and on types of clothing. Lt. Col. Lawrence R. Klar, meteorology chief, never knows what new kind of assignment will be handed his group. Recently they provided information that helped solve the puzzle of why a pilot's ejection apparatus sometimes doesn't work when the pilot needs to leave his plane.

It was suspected that the explosive cartridge that operates the ejection apparatus sometimes deteriorates because of the heat that builds up in a plane in hot weather. They found that inside temperatures on a hot day can climb as high as 250 degrees, hotter than boiling water. The answer was pretty obvious—an explosive is bound to deteriorate under a condition like this, and won't fire when needed. The solution is to replace the ejection cartridges at regular intervals.

Dozens of other projects are under way at Fort Huachuca. Some of the technicians are studying a special kind of night television that provides a good picture under moonlight alone. They are developing inertial navigation systems for drone aircraft, and terrain indicators to prevent a drone from flying into a mountainside if it gets off course. Air-droppable and backpack radio and radar jammers are being tested, too. The list is constantly changing.

In these days of intercontinental missiles and space craft a lot of people have forgotten all about the foot soldier. They don't realize that in the long run it is the troops on the ground that fight the battles and move in and occupy an enemy's territory. But the Army hasn't forgotten. That's why it is developing "futuristic" weapons for possible practical use in the future. ★ ★ ★



AIR Corp., Oakland, Calif., Municipal Airport

Oxygen-Supply Kit For High Fliers

Quickly installed in most unpressurized airplanes, a new kit will automatically provide correct amounts of oxygen needed for breathing at altitudes up to 30,000 feet. It consists of an oxygen regulator, oxygen console, fittings, brackets and an oxygen cylinder, which is usually placed in the baggage compartment. The console can be installed in cabin walls or on the instrument panel. Minus the cylinder, the kit weighs four and one-half pounds. To use, pilots and passengers don lightweight face masks and plug plastic-tubing inserts into the console. Systems with up to 15 outlets are available.

POPULAR MECHANICS
MAGAZINE

now complete on
MICROFILM

VOLUMES ONE THROUGH NINETY-SIX

Early volumes of POPULAR MECHANICS have been eagerly sought as collector's items. Now the monumental new microfilm collection makes this wealth of reference material available to all libraries

Begun in 1902 as a weekly, POPULAR MECHANICS was one of the first "picture" magazines. It also pioneered the do-it-yourself idea, and its files contain plans for almost any project desired

Ninety-six volumes - \$750.00 for the set.

UNIVERSITY MICROFILMS, Inc.

313 North First Street

Ann Arbor, Mich.

APRIL 1960



CLEAN IT FAST

with **IMPERIAL BRUSH CLEANER**

Brushes that are caked hard with paint or other finishes can be made like new with Imperial Brush Cleaner. Leaves bristles springy and glossy—never flabby.

At paint and hardware stores.

● Send 25c for illustrated Refinishing Manual or write for free folder "Care of Paint Brushes." Wilson-Imperial Co., 118 Chestnut St., Newark 5, N.J.

WELD

SOLDER

BRAZE

CUT

4WAY

ONLY
\$14.75
f.o.b. factory

WELDER

Complete with
Twin Carbon Arc
Torch and accessories... to
handle all metal-craft work.

Acclaimed by thousands of Homeowners, Mechanics and Hobbyists as the welder of 1001 uses. Easily operated from properly wired 110 volt AC or DC line. The ideal gift with a life-long use. Order today on 10 day money back guarantee. Send only \$3.00 to-day pay postman balance C.O.D. plus charges. Literature on larger equipment on request.

FOUR-WAY WELDER CO., Dept. F2-D
1810 S. Federal St. • Chicago 16, Ill.

Stop Drips Quick

with **P & C**

PIPE WRENCHES!



You do it fast and easily with tough, special analysis steel P&C Pipe Wrenches. Deeply milled, oil tempered teeth give you real gripping power, prevent slipping, knuckle busting. Shop from colorful P&C Merchandisers, in 12,000 stores. Send 10c for catalog.

P & C **TOOL COMPANY**

Box 5926, Portland 22, Oregon
Warehouse: Schiller Park, Ill.

Subsidiary of Pendleton Tool Industries, Inc

285

My answer
to the
high cost
of home
improvement

is
SPRAYIT[®]

Do a week's worth of painting in a week-end, and do it better, with one of these professional-quality compressor paint sprayers! Made by the world's largest manufacturer of portable spray painting equipment.



SPRAYIT 400 — \$39.95

- 1/4 h.p. motor-compressor
- adjustable nozzle
- 8 ft. hose
- unbreakable nylon gun
- sprays any type paint



Tough-hearted compressor keeps a steady 18 lbs. pressure in the spray gun. Sprays exterior and interior oil, latex paint, water-soluble, multi-color, stains, lacquers, enamels, varnishes, insecticides, etc. Precision made, guaranteed for a full year.

SPRAYIT HOME-PAK — \$39.95

- extra-powerful compressor
- uses any 1/4 or 1/3 h.p. electric motor
- pulleys and belt included
- professional type spray gun
- 15 ft. hose



Best dollar-for-dollar buy in spray painting equipment! Powerful enough to spray your house. Compressor delivers 2.5 c.f.m. at 30 lbs. pressure—for faster spraying than outfits costing much more. Sprays any exterior or interior paint.



SEND for new "HOW TO SPRAY" book 10c brings you picture book of tips and techniques for professional-looking results every time. Shows how to paint a house in a week-end. Dozens of ideas.



THOMAS INDUSTRIES INC. Dept. PM2
207 E. Broadway, Louisville, Ky.

Write your name and address in margin, and mail with 10c.

ing-lot service attendants and doormen. Seats are high and comfortable for four persons. The center tunnel will make any rear-seat middleman long for a saddle. Wheel housings intrude into the ends of the rear-seat back. Front seats are separate and are limited to two riders. Altogether, it is a four-adult machine.

Driver's seat back reclines too much for this driver. A small, nimble car like this encourages alert driving, but the seat back (British call it squab) is designed for relaxed repose.

Left-door armrest is in the way of the driver's elbow during fast maneuvers. Other demerits include a rear-view mirror that is so small it is virtually useless in today's phrenetic multi-lane expressway traffic.

On the boulevard, the Anglia rides well. But on a rough stretch, things are different. The high seat and the firm suspension combine to give you a feeling of sitting on top of the car rather than in it. This is particularly true on washboard and chuckholes. On such surfaces, the rear wheels tend to break loose and crab if speed is more than a fast trot.

On ice the rear end is light and if extreme care is not used in throttle application, the rear may swing about with a lump-in-the-throat suddenness.

Under normal conditions and with normal driving, the Anglia behaves quite properly. It will go where you aim it, without fuss.

The tiny engine has an amazing amount of lugging ability in fourth gear. It ambles away from 15 miles per hour in high, if you have the heart to insist. It may protest slightly and it may ping a bit (it has an 8.9-to-1 compression), but it will pull away without undue fuss and make you ashamed you were so demanding.

Inside the body, details are well thought out with a few minor exceptions. Upholstery is luxurious, no austerity shows.

One glaring exception is the bright metal trim used on the steering-wheel spokes. This applique is quilted sheet metal tacked (actually tacked) to the spokes in a most uncraftsmanlike manner. Its sharp edges are exposed and could catch on a glove or a ring. The reflection of this brightwork in the windshield is annoying when driving into the sun.

Inadequate at near-zero temperatures, the hot-water heater does fine in normal winter weather. Controls are not marked at all and it takes considerable experimentation to determine how to operate it properly. The one-speed blower is noisy, especially on defrost. Identical with the heater

(Continued to page 288)

the "CLASS" of '60

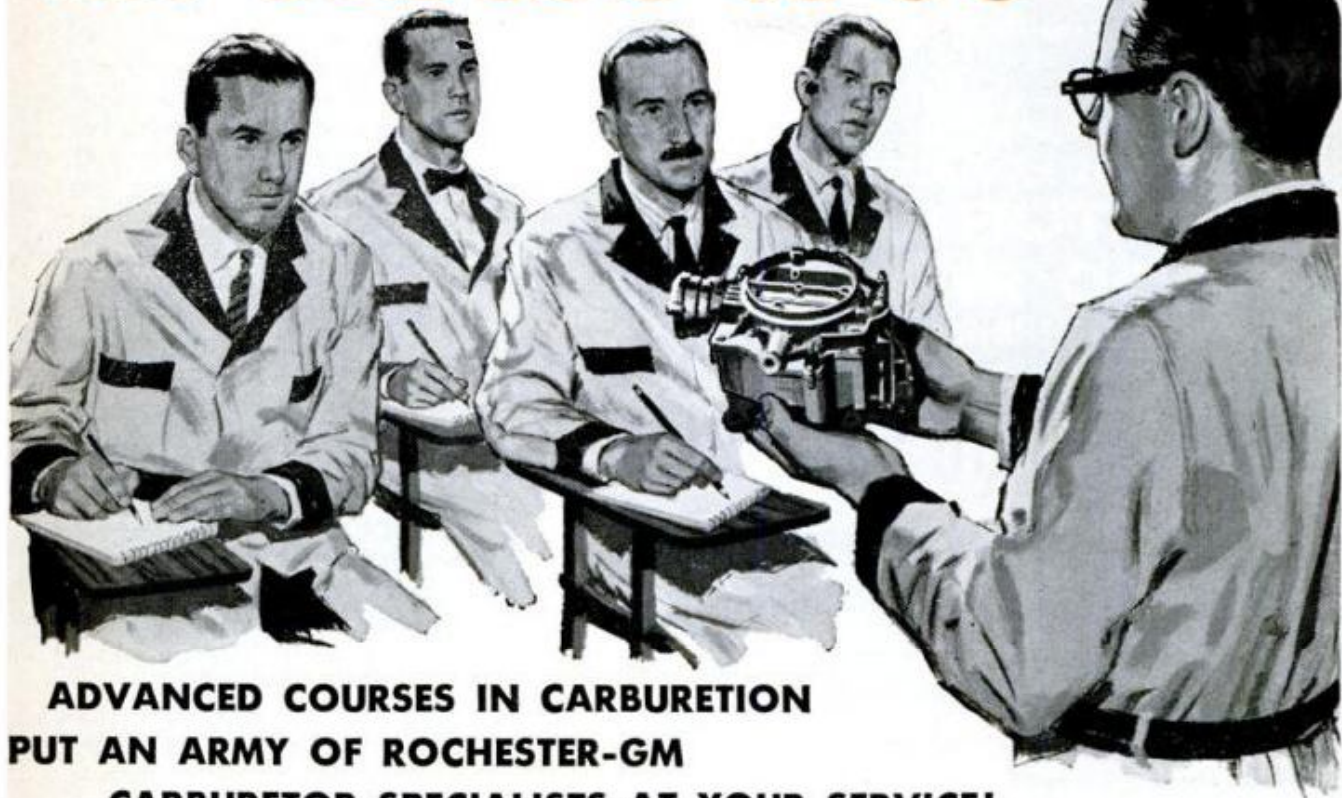

ADVANCED COURSES IN CARBURETION PUT AN ARMY OF ROCHESTER-GM CARBURETOR SPECIALISTS AT YOUR SERVICE!

When a young man graduates from a General Motors Training Center or a Rochester-GM Carburetor Field School where he has specialized in carburetion, he's a man who is expert in helping you get new-car performance regardless of the

age of your car. These men learn the time-tested methods of carburetor cleaning, adjusting and servicing that make the big difference in performance. Look up one of these experts for the right service. By the way, if service is your business, and you'd like to learn the professional way to service the world's number one original equipment carburetor, write: *Rochester Products Division of General Motors, Rochester, New York.*



Talk it over with a man who knows, a Rochester-GM Carburetor specialist. You'll be glad you did.



America's
number one
original equipment
carburetors

ROCHESTER CARBURETORS



CABINETS

FURNITURE

WOOD PANELLING

NOW!
LUXURIOUS HAND-RUBBED
NATURAL WOOD FINISH
WITHOUT THE RUBBING

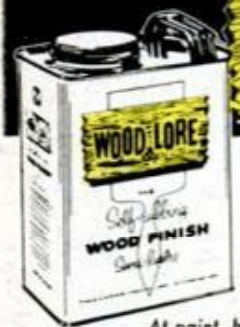

Needs no primer; applies so easy anyone can use it with excellent results.
Use over any wood interior—new or old—natural or painted—for luxurious "hand-rubbed" effect.

At paint, hardware and lumber dealers coast-to-coast



PIERCE & STEVENS CHEMICAL CORP.
710 OHIO STREET, BUFFALO 3, N. Y.
Makers of FABULON the fabulous floor finish

quality projects call for Southern fasteners

The Craftsman's Standard of QUALITY



SPECIFY SOUTHERN in this tough soil-proof box.
ONLY A SCREW HOLDS LIKE A SCREW!
Buy 'em by the box and save!

- Wood Screws
- Stove Bolts
- Hanger Bolts
- Dowel Screws
- Tapping Screws
- Machine Screws
- Carriage Bolts
- Drive Screws



SOLD THROUGH LEADING HARDWARE AND BUILDING SUPPLY DEALERS

controls in appearance and also unlabeled is the hood release. It is located in the center of the dash where it can be pulled by a child or an unsuspecting stranger. Fortunately the hood is front-hinged so an unintentional release will not flip it through the windshield.

The odometer was optimistic by 1.1 percent, not bad as odometers go. For 101 miles on the reading, you travel only 100. The speedometer was not so accurate. At an indicated 70 miles per hour, true speed was 64.6, at 60 it was 55.4, at 50 it was 47.

Around town on smooth roads, it is most pleasant, offering just enough "foreignness" to be interesting, not enough to be strange. The horn button, for example, is diabolically concealed in the turn-signal lever. You push it in and the horn peeps—it doesn't blow, it peeps. The sound is so "peepy" as to be embarrassing (one way to cut down on pestiferous horn blowers)

Many amenities are provided at no extra cost. The rear side windows are hinged and push outward at the trailing edge to provide ventilation without stirring up a windstorm inside. There is a tenth-of-mile scale on the odometer. A wide and convenient package shelf runs the full width of the dash (incidentally, a safe, secure place to carry home that expensive bottle). The glove compartment is elbow deep and has a lockable door. There are two ashtrays in back, one in front. Rubber mats cover the entire floor and have thick felt underlayers for sound control. The trunk is surprisingly roomy for a car only 153.5 inches long.

Backing and parking are easy. Nobody need be frightened of tight parking in this car. Windows are large and the neat, unpretentious tailfins act as handy guides. The driver can see the pavement within a few feet of the car, forward and backward, making it almost tragedy-proof in suburban, child-infested neighborhoods

Foot pedals are smallish and require some getting used to, but after a day or so, the strangeness disappears.

Getting in and out of the front seat is easy. There is no stepdown nor wrap-around to battle. Climbing into the back seat (it comes only as a two-door) is not so easy, although both front seats pivot upward and forward as units (the seat back does not pivot separately) allowing plenty of foot room for entry to the rear. However, this arthritic seat design means that the front-seat rider must disembark to permit the rear passenger to enter.

Altogether, here's a car that is cute to look at, gentle to control and cheap to support—who can argue with that in either a wife or a car? ★★★

NEW BELSAW MULTI-DUTY POWER TOOL
SAWS—PLANES—MOLDS

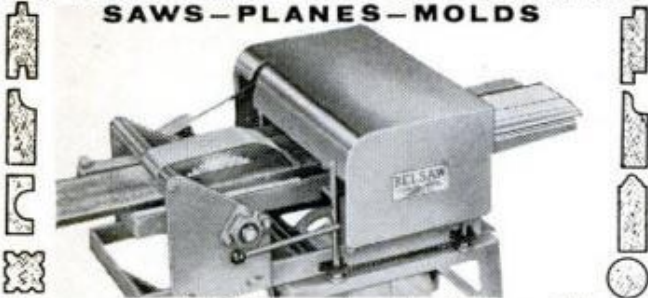

Now you can use this ONE power-feed shop to turn rough lumber into moldings, trim, flooring, furniture... ALL popular patterns. RIP... PLANE... MOLD... separately or all at once with a one HP motor. Use 3 to 5 HP for high speed output. Low Cost... You can own this power tool for only \$30.00 down payment.

Send postcard today for complete facts.

BELSAW POWER TOOLS, 900 Field Bldg., Kansas City 11, Missouri

Works in seconds!



Loosens Rusted Bolts
nuts, screws, "frozen" parts!

LIQUID WRENCH
SUPER-PENETRANT

The super-penetrating rust solvent that quickly loosens rust and corrosion.

AT ALL HARDWARE
AND AUTO STORES

RADIATOR SPECIALTY COMPANY
CHARLOTTE, N. C.



HOME IMPROVEMENT

POPULAR
SERVICE
BUREAU
MECHANICS

LIBRARY
12 AUTHORITATIVE MANUALS
FOR ONLY \$2.00

★ Now sold together in a service packet for the first time—a complete library of Popular Mechanics' home service, repair and improvement booklets—all 12 offered at one low group price. Listed below are only a few of the many topics covered:

★ Additions and Remodeling—How to modernize kitchens; how to work with concrete around the home; how to lay linoleum and tile; how to refinish floors and woodwork; how to remodel basements and attics; how to modernize walls and ceilings.

★ Basic Service and Repairs—House wiring and electrical repairs; plumbing repairs made simple; how to paint inside and out; how to cure your leaky basement; how to winterize your home; how to insulate your home.

★ The home owner who owns the HOME IMPROVEMENT LIBRARY will be prepared. Send your order in at once!

ONLY \$2.00

SERVICE BUREAU POPULAR MECHANICS, Room 517
200 E. Ontario, Chicago 11, Ill.

Enclosed find remittance in the amount of \$2.00. Please rush the complete HOME IMPROVEMENT LIBRARY (12 booklets).

Name.....

Address.....

City..... State.....

**PATCHING
PROBLEMS?**



Solve 'em with DAP



New DAP Spackling Compound lets you patch cracks, holes and breaks in plaster with professional skill and ease. Good for wood, too, and for sealing dry wall panel joints. Ready-mixed. Creamy smooth. Get DAP Spackling and other nationally advertised DAP products at paint, hardware and building supply dealers. Write for free do-it-yourself folder.

DAP

CAULKING COMPOUNDS
GLAZING COMPOUNDS
TUB AND TILE SEALER
SPACKLING COMPOUND

DICKS-ARMSTRONG-PONTIUS, inc. • Dayton, Ohio.

KIT BOATS Boat Plans
Patterns
Frame Kits



FREE FREIGHT

SAVE
2/3

Tonawanda 11, N.Y.

SEND 10¢ FOR 2-COLORED CATALOGS—NOW

Craig's Craft

Name..... City.....

Address..... State.....

KIT CATALOGS—Over 50 Models—Pre-assembled. Runabouts, Cruisers, Fishing (8' to 19'). Anyone can assemble. Complete Marine Accessories, Fiberglass plastics, trailers, paint, etc. Also CATALOG on 50 Modern Plans and Patterns. Prefab Frame Kits—All types best for the amateur builder.

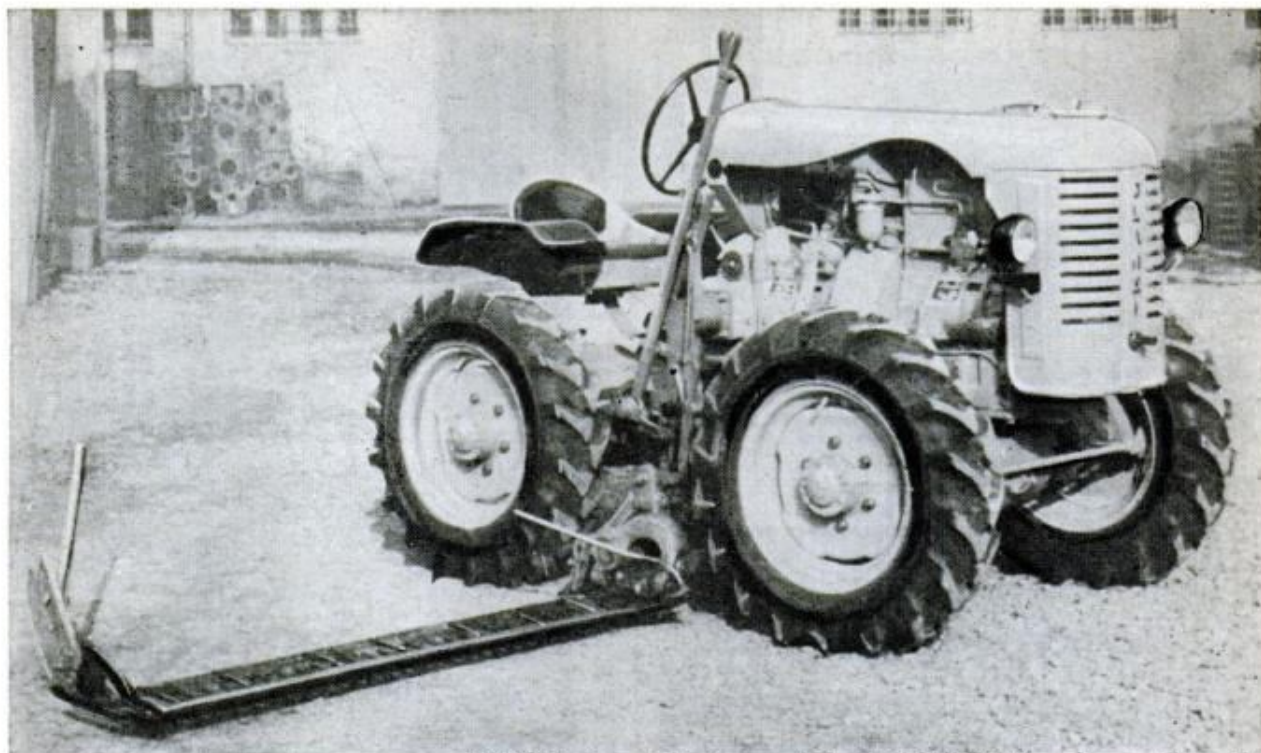

SLANZI Tractor and Engine Imports, Inc., 5912-14 W. Chicago Avenue, Chicago, Ill.

Italian-Built Tractor Has Four-Wheel Drive

Axle flexibility and four-wheel drive enable an Italian-built tractor to operate on very rough terrain. Front and rear axles are jointed to allow more than a foot of flexibility, so all wheels can exert drive

on uneven ground. The tractor weighs 3000 pounds and is 86 inches long, 54 inches high and 51 inches wide. Its 17-horsepower engine is a two-cylinder, four-cycle direct-injection diesel power plant.

GUNK degreases

At better automotive supply and hardware retailers everywhere.



Cleans engines, garage floors, power mowers, greasy walls economically and safely. In aerosol or pour spout cans.



GUNK CHICAGO CO., River Forest, Illinois
serving the Midwest and Southwest
RADIATOR SPECIALTY CO., Charlotte, No. Carolina
serving the East, Southeast and Far West

This Month's "Great Pioneer in Science"

(Page 22)



Alexander Bell (1847-1922)

Room with Romer

Sleeps 5, has ALL the features. Fits any pickup, goes anywhere. Write today for free illustrated brochure of all ROMER COACHES and name of nearest dealer.

Dealers and Distributors please write.



Write to nearest factory.

Romer

HONORBUILT TRAILER MFG. CO.
756 Hansen Ave., Lakeview, Calif.
DIVISION, SIEGMUND WERNER, INC.
225 Belleville Ave., Bloomfield, N. J.

I'm walking on air...



Just had my annual medical check-up. (Smart move.) I'm making out a check to the American Cancer Society, right now—that's a smart move, too.



Guard your family!
Fight cancer with
a checkup and a check!

AMERICAN CANCER SOCIETY

\$1,000.00 MONTHLY FROM SMALL CLASSIFIED AD

THINK OF IT! A classified advertiser in Popular Mechanics takes a thousand dollars monthly from his mail box. You should read this amazing letter. I'll send it to you free. Write: F. W. Johnson, Class Adv. Mgr., Popular Mechanics Magazine, Room 603, 200 E. Ontario, Chicago 11, Illinois.

Bridgeport CUSHION GRIP NUT DRIVERS

New! Patented INTER-LOCKED HANDLE cannot slip or come off!

Patent No. 2871899

For use in repairing radio, T.V., cars and home appliances. 9 sizes, $\frac{1}{8}$ " to $\frac{3}{8}$ " \$1.00 to \$1.50 ea. Top quality nickel plated forged steel blades. Look for the handy 7 piece set No. 497 ($\frac{3}{8}$ ", $\frac{1}{4}$ ", $\frac{5}{16}$ ", $\frac{1}{2}$ ", $\frac{3}{8}$ ", $\frac{7}{8}$ ", $\frac{1}{2}$ ") at hardware stores.



**50%
GREATER
TURNING
POWER**

- Blisterproof
- Non Slip Grip
- Unbreakable Handle
- Super Comfortable
- Fully Guaranteed

Resilient Nitrile CUSHION GRIP lets you turn nuts tighter with less work - and you don't hurt your hands! Tested & approved by Mechanics.

The Bridgeport Hardware Mfg. Corp., Bridgeport 5, Conn.
Subsidiary of PUR OLATOR PRODUCTS, INC.

READY CUT HOMES

\$2250 AND UP DIRECT FROM MILL

YOU SAVE the items which help make today's building cost expensive: high labor cost, contractor's profit and overhead, insurance, architect's fees. Cut-to-Fit eliminates usual lumber and material waste, also costly mistakes. Anyone can assemble. Simple, easy-to-follow plans furnished and each part numbered. Complete with all lumber, roofing, nails, glass, hardware, paint, doors, windows. Freight paid. Low-cost building plans sold separately if desired. 57 Homes and Floor Plans.



**5 EASY PAY PLANS
COLOR CATALOG**



INTERNATIONAL MILL & TIMBER CO.
Dept. PM40 Bay City, Mich.



WELD FOR PLEASURE OR PROFIT TRINDL INDUSTRIAL ARC WELDER

Own a Trindl 125 Amp Industrial Welder at less than smaller machines. Welds metals to $\frac{1}{2}$ " thick. Operates off properly wired 110 or 220 volt line. 16 heat stages from 20 to 125 amps. Make, repair anything of metal in the home, garage, farm or shop. No experience or training needed. Full "do it yourself" instructions. Guaranteed 12 months in continuous operation. Complete only \$98.50 FOB or write for details on 125A and other Heavy Duty Trindl Welders. Dealer Inquiries Invited.

Trindl Products, Ltd., Dept. T2-D, 1807 S. Clark St., Chicago 16, Ill.



**EASY TERMS
\$98.50 FOB**

FREE
Write for
Details and
Easy Pay Plan

MAC'S

NO. 13

**STOPS RUST AND SCALE
IN YOUR RADIATOR**

**SAVES COSTLY
REPAIRS**

**At Service
Stations
Everywhere**

Unlucky for rust!

DREMEL MOTO-TOOL
THE "POCKET SIZE MACHINE SHOP"

Handiest tool you'll ever own. Its high speed is ideal for precision grinding, polishing, carving, drilling, engraving, de-burring, sharpening, and hundreds of other household and workshop uses. Eliminates time-consuming hand work — gives the finished job a professional look. Weighs only 13 oz.—handles easily as a pencil. Does fine detail work with pin point accuracy. Fastest, most powerful tool of its kind — develops 27,000 RPM. Widely used by tool and die makers, model builders, craftsmen, lab technicians, repair men, gun smiths, schools, etc.

SEE YOUR DEALER or write for FREE catalog on the complete Dremel line of power tools.

MOTO-TOOL KIT No. 2 (as shown) Incl. Model No. 2 Moto-Tool, 23 accessories (high-speed steel cutters, grinding wheels, etc.) in a sturdy storage case.....\$27.50

MODEL No. 1.....\$14.85
MOTO-TOOL MODEL No. 2.....\$19.95
MOTO-TOOL KIT No. 1.....\$23.50

QUALITY POWER TOOLS SINCE 1934

DREMEL MFG. CO. Dept. 110D, RACINE, WIS.



Sam Martin, 281 Reid Avenue, Brooklyn 33, N. Y.

Timer on Key Chain Prevents Parking Ticket

Overtime parking becomes no problem with a pocket-size timer that records up to 60 minutes. An audible alarm lets you know when your time is up. The timer, which is attached to a key chain, finds many other uses, too. It can be used to time speaking engagements, cooking, baking, baby's formula, telephone calls or short naps. Built like a watch, the timer consists of more than 35 different parts assembled by Swiss watchmakers, according to the manufacturer.

HOW GOOD
Can a Compact Be?

Read what owners of the

VALIANT

have to say in the

MAY

**POPULAR
MECHANICS**

POPULAR MECHANICS

SURPLUS SALE

GOVT. SURPLUS
EXCESS INVENTORY
BANKRUPT STOCK

6 or 12-V STORAGE BATTERY WINCH

• Item #311. Powerful fully reversible ball-bearing gear reduction winch, 1000-2000 lb. pull. Use on 6 or 12-v battery. Holds 40' of 1/4" cable. For trucks, docks, boats. Shipping wt. 55 lbs. Govt. cost \$280. Sale **\$46.71 FOB**



ELECTRIC CAR MOTOR

• Item #576. Powerful, compact battery gear motor. Tremendous torque. Wonderful unit for building boy's car, golf cart, winch, elevators, door closers, ice augers, etc. Runs on 6 or 12-volt battery. Fully reversible. Gear ratio 33 to 1. 100-150 r.p.m. Ball bearings throughout. Shaft 5/8" diam. Size 1 1/2" x 5 1/4". Wt. 30 lbs. Govt. cost \$15.79. SALE **\$15.79 FOB**



FISH-WORM AC SHOCKER

• Item #670. Harvest worms, clear private ponds of coarse fish. Powerful 110-v AC hand geared generator creates powerful electric field in ground or water. Amazing results. • Also fascinating for experimental—use for fun at parties. Has Super-Alnico magnets. Govt. cost over \$12. SALE. **\$3.89 Ppd.**



Standard DIAL PHONE



• Item #716. Genuine W.E. modern, hi-efficiency dial phone. Use for extension to main line on private system. Use several for complete private system. Work on any system. Cost **\$9.25 FOB**

Shipping weight 8 lbs. gov't. \$29.50. SALE

AIR COMPRESSOR BARGAINS

• Compressor 1 cyl. \$21.50. Air tank, \$11.95. Regulator, \$3.95. Pop-Off \$1.95. Press. Gauge \$1.89. Finest paint run, \$11.50. Auto Switch, \$4.75.



HYDRAULIC EQUIPMENT BARGAINS

Savings to 80%. Build loaders, diggers, presses, etc. All brand new.
• Control Valve, 1 or 2 way... **\$18.00 Ppd.**
• Tractor Pump 1000 psi... **45.50 Ppd.**
• 12-v Motor & Pump 1000 psi. **16.95 FOB**
• 2-Way cyl. 2 1/2" bore, 9" str. **12.75 FOB**
• Hand Hydraulic Pump... **10.95 FOB**
Many other types, sizes, items.



SPECIAL OF THE MONTH!

HIGH VOLUME BLOWER



• Item #1602. Finest General Electric ball bearing squirrel cage blowers. Use for ventilating, cooling, exhausting fumes in trucks, trailers, boats, etc.
• High (up to 600 c.f.m.) output. Operates on 12 to 24 volts DC or AC. Size 12" x 9" x 8". Shipping weight 12 lbs. Govt. cost \$48.50. SALE **\$13.95 FOB**

SEND FOR FREE 1960 CATALOG

1000's of New Equip. and Surplus Bargains
EXAMPLE BARGAINS IN OUR NEW CATALOG

\$150 Airport Prismatic Light **\$16.95**
\$100 Bronze Centrifugal Pump..... **49.50**
\$1248 Power Plant 3000-w, AC .. **345.00**
\$100 Remote Control Switch..... **16.95**
\$ 66 Gear Reducer, 80 to 1..... **8.98**
\$300 Welding Generator P 1..... **14.95**

• Order direct from ad. Send check or money order. 25% deposit on C.O.D. orders.

MONEY BACK GUARANTEE

SURPLUS CENTER
LINCOLN, NEBR. DEPT. 806

8 PARKER HACK SAWS



The Parker model you want from 89c to \$2.99, saws easier, holds blades more rigidly, and fits your pocketbook. Unconditionally Guaranteed.

PARKER MANUFACTURING CO.
WORCESTER 1, MASS., U. S. A.

Now KING MIDGET

World's Lowest Priced Car. Rider Agents Wanted. Send 25c for 32 page picture book, full details, dealer price. Or send \$1 (refunded first order) for this plus Service and Repair Manual and 16 5x7 photos of car and factory.



MIDGET MOTORS CORPORATION, Athens 1, Ohio

you can always
BE SURE OF A JOB

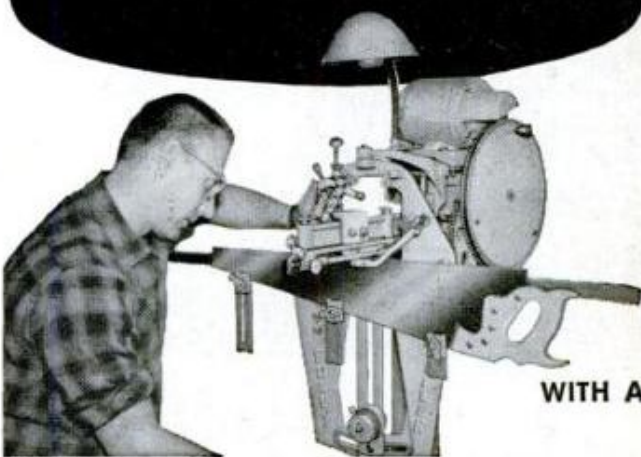

FOLEY SAW FILER

Have you been laid off—or afraid you may be? If you want security, plus a bigger income too—don't look for a job—start your own spare time business. In his first 2 months J. P. Robitaille earned \$300 with his Foley Saw Filer. From his starting day R. T. Hart made \$600 in 4 months. Frank P. Layne wrote—"In our town of 2,800 instead of 200 to 300 saws I did over 1,500 the first year, averaging about \$1.50 each.

FREE booklet "MONEY MAKING FACTS" shows you how to get business. The new Foley "200" sharpens hand, band and both "combination" and crosscut circular saws. Use our Time Payment Plan—pay for the machine out of your CASH profits. Send coupon today—no obligation, and no salesman will call.

FOLEY MFG. CO., 416-0 Foley Bldg., Minneapolis 18, Minn.
Send Free Booklet and Time Payment Plan on Foley Saw Filer.

Name _____
Address _____
City _____ State _____



SMALL! POWERFUL! ECONOMY TRACTOR



Thousands In Use Write for complete details.

Engineering Products Co.
1005-K-4 Anoka Ave.
Waukesha, Wis.

Unequaled value! Low price!
America's finest tractor. Ruggedly built. Easy to operate. 790 lbs. Borg-Warner clutch, trans. and diff 140 to 1 reduction. 40% more drawbar pull than ordinary tractors 8-1/4 H. P. engine. 20 quick change implements. HOOD, FENDERS.

use the solder
that most
home owners
use!



KESTER SOLDER

For your electrical work, radio-TV, do-it-yourself projects... always use the best... **KESTER SOLDER.** Send for FREE 16-page book that tells you how!

KESTER SOLDER COMPANY
4251 Wrightwood Avenue • Chicago 39, Illinois
OVER 60 YEARS' EXPERIENCE IN SOLDER AND FLUX MANUFACTURING

NOW-

Series E Bonds

*turn \$18⁷⁵ into \$25⁰⁰
fourteen months quicker
than ever before*



Here are three new reasons why today's Savings Bonds are the best ones in history:

1. Every Bond bought since June 1, 1959, earns $3\frac{3}{4}\%$ interest when held the full term. Series E Bonds now mature in 7 years, 9 months—fourteen months faster than ever before.
2. Your older Bonds now earn more—an extra $\frac{1}{2}\%$ from June 1 on, until maturity.
3. All Series E Bonds, old and new, carry an automatic extension privilege now. This means they'll automatically keep earning liberal interest for 10 years beyond maturity.

You get these new advantages, plus complete safety, guaranteed return, and protection against loss or theft. And, you can buy Bonds automatically through the Payroll Savings Plan at work. Plan to start saving with U.S. Savings Bonds now.

**YOUR MONEY GROWS $3\frac{3}{4}\%$ IN JUST 7 YEARS
AND 9 MONTHS WITH NEW SERIES E BONDS**

**YOU SAVE MORE THAN MONEY
with U.S. Savings Bonds**

The U.S. Government does not pay for this advertising. The Treasury Department thanks The Advertising Council and this magazine for their patriotic donation.



WAR SURPLUS AND OTHER BARGAINS SAVE UP TO 90%



VICKERS HYDRAULIC TRANSMISSION

Self-contained, 2 HP, constant torque at all speeds with variable volume reversible, piston pump (controlled by outside lever) supplying piston hydraulic motor. Automatic pressure dash pot for smooth control. Power output RPM—0 to 1/3 input RPM in both directions. Input RPM 1800 continuous 4000 intermittent. Dash pot can be removed for greater RPM. Ideal for Lathes, Duplicate Setup on Mills, Conveyors, Small Cars, Drives, Gearing, etc. Wt. 21 lbs. Approx. GOVT. COST \$675. Like NEW, \$57.50.



THERMOSTATIC ACTUATOR

White-Rodgers Elec. Co. 24 volts D.C., .4 amps, 1.3 RPM, 7.5 inch lbs. torque. Has thermostatic control head operating range 350 to 570 deg. F. with sensing element. Use for oil tank, furnace temperature control anywhere heat & electrical actuation required. Reversible. Wiring diagram incl. in cover of unit. 5 3/4" H x 4" W x 5 1/2" D. This unit provides the experimenter with limitless possibilities, a small winch, door opener or raiser, display table drive, coil winder, rotisserie motor, TV antenna rotator, etc. Shpg. Wt. 6 lbs. Approx. GOVT. COST \$300. Like NEW, \$7.95.



AIRBORNE ALL-PURPOSE ELECTRIC WINCH

Fully bearded 3 HP motor with a reduction of 240 to 1. Will operate on 6, 8, 12, 24 or 32 V. Will lift up to 2 tons. Safety clutch set at 3 tons. Fully reversible. Adjustable hand brake and lock. Drum will handle over 500' of 1/4" steel cable or 5/8" rope. A terrific, compact power takeoff for beaching boats, etc. Will work off any battery within the range from 6 to 32 V. Cost of this unit is less than an installation for a competitive brand. Shpg. Wt. 150 lbs. Complete, ready to run (less cable). NEW, \$99.50.

"SUPER 9" 200 AMP WELDING KIT

With Deluxe accessories consisting of one 200 AMP. Gen., adjustable helmet, electrode holder, 30' welding cable, rheostat, giant toggle switch, voltmeter, voltage reg., 1 pr. heavy-duty welder's gloves. All units guaranteed pre-tested. Approx. GOVT. COST — \$500. Most items new — all perfect. \$26.00.



"DELUXE 11" ARC WELDING KIT

Consists of 160-250 AMP. Gen., voltage reg., ammeter, shunt, adjustable helmet, electrode holder, pr. welder's gloves, 30' welding cable, reactor coil, giant toggle switch, rheostat. Approx. GOVT. COST \$650. All units guaranteed pre-tested, \$34.95 complete.



225-1 REDUCTION GEAR For beaching boats, winches, hoists. Ideal for motor in golf or boy's electric car. DC motor & clutch. Easily reversible wiring diagram furnished. Hi torque, 105 RPM. Runs on 6-12 or 24-32 V. Wt. 65 lbs. gross. Approx. GOVT. COST \$300. Like NEW, \$13.50. Matched splined gear—\$3.00 ea.



DOUBLE-V SPLINE 3" PULLEY For P-1, R-1, GE Gen. shown above. Heavy-duty machine-broached steel. Heavily constructed, will handle any job. Spline receptacle will fit most types of aircraft generators. Set screw locked. Shpg. Wt. 3 lbs. NEW, \$5.95. Triple-V Spline 3" Pulley—NEW—\$6.95.

ELECTRIC PUMP WITH CONTROL UNIT

Runs on 12 or 24 V. Centrifugal type. Draws 5.2 AMPS. Has built-in removable filtering screen. Great for bilge, circulating or sump pump... bait tanks, etc. Pumps 500 GPH. Complete with on and off switch rheostat, explosion-proof motor, 2 speeds (hi & lo). Mfd. by Ingersoll-Rand. Shpg. Wt. 7 lbs. Approx. GOVT. COST \$195. NEW—\$8.95.



\$2940 NAVY AIR-COOLED POWER UNIT

Most compact engine ever assembled. Portable, net wt. 150 lbs. 200 Amp. Gen. self-starter capable of delivery of double overload or continuous service at 200 Amps. Mfd. by Ranger aircraft. 2 cylinder, 4 cycle, 10 HP, 3200 RPM. Fully governed for varying loads. This unit makes one of the finest arc welders obtainable. Also makes excellent boat engine. Shipped complete with rheostat & voltage reg. All units checked & pre-tested in our shop. Complete \$185. Engine same as above with deluxe welding accessories as follows: rheostat, voltage reg., dry charged 24 V. battery, 50' heavy duty welding cable, 1 electrode holder, 1 hood, pr. of gloves, voltmeter. All this only \$225.



SENSITIVE ALTIMETER in 20 ft. increments. 0 to 35,000 ft. (inches of Mercury). Famous Pioneer. Tested & inspected in our own instrument lab. Guaranteed perfect. Approx. GOVT. COST \$150. Wt. 2 lbs. \$13.95



200 AMP D.C. WELDER 24-32 volts D.C., 200 amp gen. Extra heavy duty. Internal fan cooling. Brand new 9 H.P., ball bearing, Briggs & Stratton engine. 200 amp generator (direct coupling to engine). Portable wheeled frame mount. Voltage reg. Rheostat. Reactor coil. Welds 1/8" rod to SAE standard, any thickness metal. Complete. Wt. 200 lbs. NEW. A \$750 value. \$199.50.

NEW 1960 CATALOG!

Tremendous catalog—our biggest ever—fully illustrated—1000s of bargains in war surplus & other items. Send 25c in coin for your copy today or free copy with order. Where ppd. indicated applies to US only. Other prices FOB Culver City, Cal. Send cash, check, money order. 50% dep. COD.



AIRBORNE SALES CO., INC. DEPT. PM 460
8501 Stellar Drive, Culver City, Calif.

PAGE FOR TILLING PLOWING MOWING

A FULL LINE — 2 to 9 HP with complete gear drive and reverse
FREE CATALOG—LOW PRICES—EASY TERMS
Over 40 years experience
OVER 60 ATTACHMENTS AVAILABLE!

PAGE 1904 S. 81 St.
Milw., Wisc.



RETAIL PRICE \$125.00 FACTORY TO YOU \$79.95

SUPERSHOP includes precision-built 8" tilting table saw, vertical and horizontal drill press, 30" lathe, sander, grinder. 100% BALL BEARING. Write for FREE catalog, full details, trial plan.
UNITED INDUSTRIES, INC.
Power Tools Division
130 YATES AVENUE
BELOIT, WISCONSIN

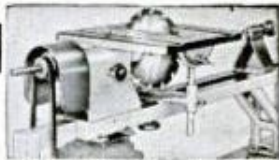

Solid, Man! MFG



Built to take it . . . rough waters, heavy loads, high speeds! Hull is fiber glass, all-over-lapstrake, and tough . . . molded in matched metal dies . . . wide, deep, stable, safe. A beautiful, practical, maintenance-free boat. Five sizes, 12 models. Write for literature.
MOLDED FIBER GLASS BOAT COMPANY 71 Fourth Ave.
Union City, Pa.

If it's worth painting
it's worth sanding . . .
with sandpaper by



CARBORUNDUM®

LICKITY LOG SPLITTER



Ends Wood
Splitting Drudgery

Hydraulic power splits profits from waste wood
• 7 HP trailer model • two speed • auto shift
• auto stroke. Power "squats" to receive large diameter logs without "dead" lift—eighteen ton smooth hydraulic force cuts right through knots, 26" stroke handles up to 30" length, any diameter. Your name on a postal card will bring literature.

THE WACO AIRCRAFT CO., Dept. D, Troy, Ohio
Dealer Inquiries Invited



\$50,000 HULL

Want high flying thrills? Command a Glass Magic! High styled beauty . . . dependable, rugged construction . . . plus the sensational performance of the famous \$50,000 hull. Glass Magic, Inc. Fort Worth, Tex. Elkhart, Ind. MAIL COUPON FOR FREE 1960 CATALOG



GLASS MAGIC, INC.
2730 Ludelle Fort Worth, Texas
Rush free 1960 Glass Magic Catalog

Name _____
Address _____
City _____ State _____

NEW PISTON RINGS CUT OIL WASTE

ELECTRIC WELD - BRAZE & CUT

REPAIR MOST EVERYTHING MADE OF METAL.

Home Appliances, Auto parts, Farm-garden equipment,

toys. Make and repair playground equipment,

lawn chairs, tables, ornamental iron work, gates,

wagons, etc. Solder, heat,

bend, and straighten, with

terrific heat from arc torch.



Cut and weld up to 1/4"

steel plate. A million uses

for Home, auto, farm,

inventors, factories, etc.

Works from any home 110

volt plug-in. Complete with dark welder's mask, arc torch, supply of

carbon welding and brazing rods and complete Welding Instruction

Book. Efficient—durable—1 year guarantee. Wt. only 4 lbs.

SEND ONLY \$3 (cash, ck. mo) and pay postman \$9.95 plus COD

postage on arrival or send \$12.95 and we will send

postpaid. Ideal gift for mechanically minded home owners, relatives,

friends. Order now for early delivery. Available only from:

MIDWAY WELDER Dept. DPM-4 Kearney, Nebraska

Automatic Sunglasses

For Spacemen

Sunglasses that automatically adjust to the amount of light will reduce eye damage to our first spacemen. Once in space, man will see either total blackness or white-light brightness, according to Dr. Hubertus Strughold, Air Force research advisor. There will be no shades of gray, says Dr. Strughold, because there are no particles to diffuse light in space. This sudden change from darkness to extreme light will cause the light to hit and scar the retina of the eye, producing a blind spot. The special glasses, now under development, also may be made available for civilian use, automatically adjusting to the light in a room or outdoors.

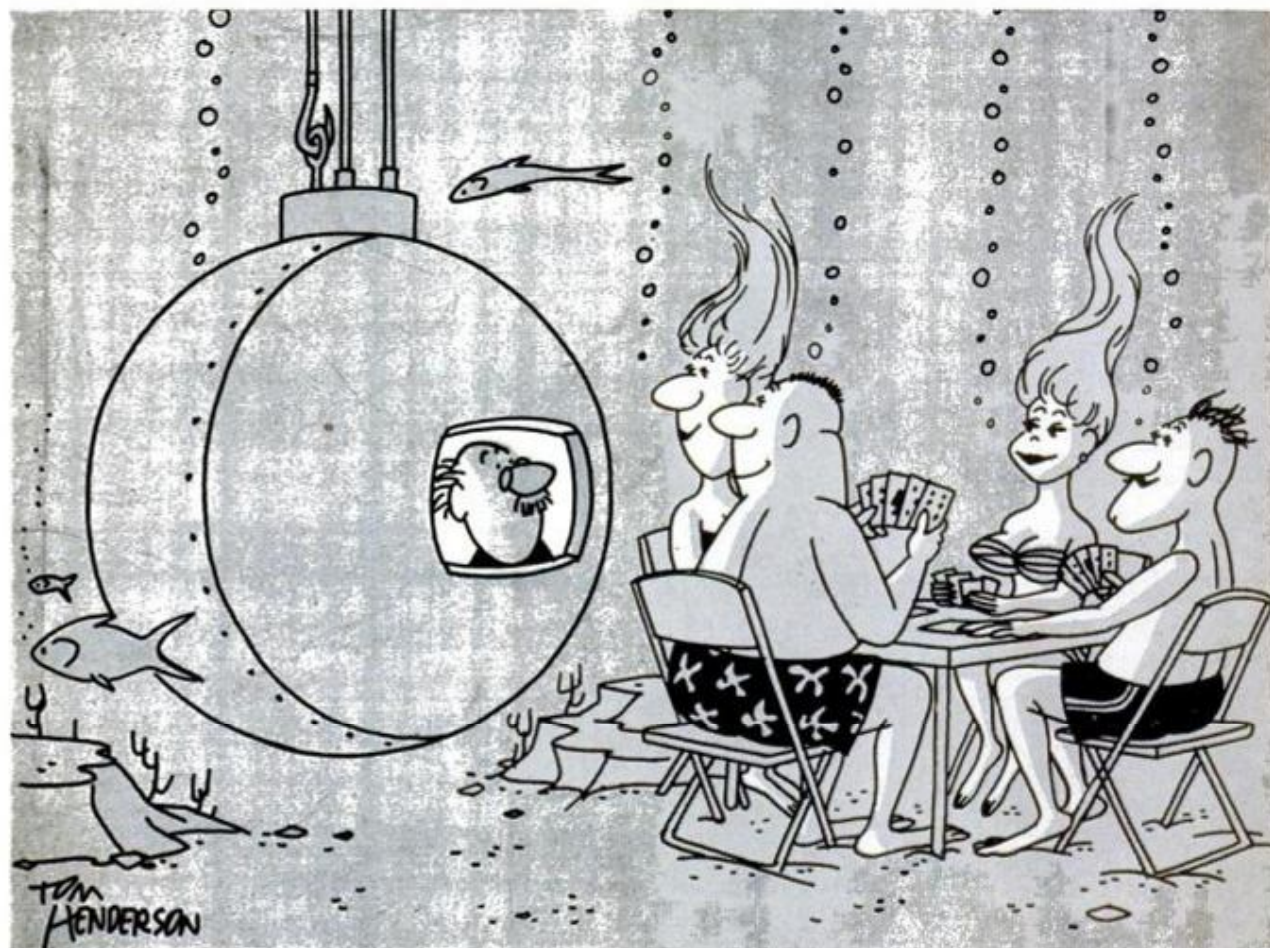

SAVE almost \$1⁰⁰



on this **VACO**[®]
Hardware Week Special
 No. 1902C
 Famous #1902 Bolt Cutting & Crimping Tool plus free 69¢ Pak of assorted solderless terminals.
A \$4.64 Value . . . \$3.69 Only
 At Better Stores Everywhere
VACO PRODUCTS CO.
 323 E. Ontario Street
 Chicago 11, Illinois

BUY GREAT NECK HAND TOOLS
 . . . for long-lasting performance

Precision Balanced NAIL HAMMER

One-piece, forged steel, rubber-cushioned, no-slip grip

GREAT NECK SAW MFRS., Inc.
 MINEOLA, N. Y. — SEE YOUR LOCAL STORE

• FOR HANDS • FOR FLOORS • FOR WALLS

QUICKEE[®]

SPECIALIZED CLEANERS

Send for FREE HAND CLEANER SAMPLE. Dept. PM
 At Stores Everywhere / Quickee Products, Inc., Yonkers, N. Y.

5 GAL. PORTABLE MIXER
 Model \$64.95

Not a toy—built for long hard use. Mixes cement plaster, paints, chemicals, plastic, feed, fertilizer. One man operation can mix 15 cubic feet per hour. Comes complete with 5 gal. removable pail, agitator, electric motor, switch and cord ready to plug in and go to work. Gasoline powered model with 10" wheels. \$89.95 FOB Pasadena.
 Modern Mfg. Co. 160 N. Fair Oaks, Pasadena, Calif.

Automatic Saw Set..

MAKE EXTRA PROFITS!

Set 400 teeth per minute on hand or band saws, 4 to 16 point, with the BeMaCo Automatic Saw Set. Fast, accurate, true hammer-anvil action sets teeth uniformly, eliminates tooth breakage. Used profitably by saw shops and manufacturers everywhere. Every machine positively guaranteed!
 Write for details—today!

BEAVER MFG. CO.
 PO Box 434
 800 ISIS AVENUE • INGLEWOOD, CALIF.

UNUSED SURPLUS 1-1/2 HP - 4 CYCLE - 2000 CFM
 Briggs & Stratton GASOLINE
PORTABLE MOTOR AND BLOWER

An unusual Surplus Value. An engine driven blower for ventilating manholes, sewer, cellar, mine, tanks, etc. Powerful 2000 CFM centrifugal blower has 4" ID inlet and outlet. Simply connect flex pipe below and ventilate, circulate or use for drying. Comes with tools, 3 gallon Safety Gas Can, Oil Can, Oiler & tool case. **59.98**
 4" Steel FLEX TUBING for use with above blower - **900 EA. & BLOWER**
 21 ft. length ONLY . . .

HYDRAULIC CYLINDERS

1500 PSI Double Action CYLINDER - Bore 1-1/2", Shaft 9/16", Stroke is adjustable 1-3/16" to 4-3/8", length 14-1/2". No. H-84. . . **395**

1500 PSI, long stroke cylinder - Has Stroke of 15-5/8", Bore 1-3/8", Shaft 1", Length 22". No. H-14
 Cost Gov't approx. \$120.00
 Palley Catalog Price \$11.75 **795**

NEW 12 VOLT SEALED BEAM LAMP
Only 4.29

Pistol grip type with removable stand and 4-hole foot mount. Has sealed beam, 5" lamp and aiming sight. Uses 12V. battery. With amber, green & red clip-on lenses. Easily adapts as Blinking red emergency light. Ideal for spot or signal light on boat, truck, car, farm, etc.

New 1500 PSI Dbl. Action Cylinder.
 Ideal for clutch or throttle control when used as a master & slave. Has 5/8" bore, 4-1/8" stroke, 7/16" shaft, 9-5/8" closed length. Parts are 1/4" tube (7/16-20 thread). No. H-60 **375**

2500 lb. LIFT HOIST

Ideal for garages, shops, on boats, jeeps, trucks, etc. Has 24 to 1 ratio through a worm gear drive. Has free-spool, pull-out clutch and a three-speed crank. Comes with 18 ft. of 3/16" high tensile strength steel cable. Lifts up to 2500 pounds. **375**
 MOUNT for HOIST \$5.00

1500 PSI Dbl. Action HYD. CYLINDER
 Has 2-3/8" bore, 19" stroke, 1-1/4" shaft, 30 1/2" lgh. Gov't cost approx. \$75.
NEW LOW PRICES No. H-53AU - USED . . . **1275**
 No. H-53AN - NEW . . . **1975**

100 TO 1 HEAVY DUTY REVERSIBLE GEAR HEAD MOTOR

A real "workhorse" in a compact, rugged gear head motor. Gear ratio is 100 to 1—gives the 24V. DC motor tremendous take-off power. Has clutch set at 375 ft. lbs. Take-off shaft is 1-1/16" dia. **2450**

1500 PSI Double Action Cylinder - Bore is 1-7/8", Shaft 7/8", Length 12", Stroke adjustable from 3-3/4" to 6-1/2".
 Cat. No. H-10U - USED . . . **675**
 Cat. No. H-10N - NEW . . . **1075**

1500 PSI Long Stroke CYLINDER - Has 1-1/2" Bore, 1" Shaft, Stroke is 26-3/8", eye-to-eye lgh. 32-3/4".
 Catalog No. H-355U . . . **1475**

1000 PSI VICKERS PUMP

A piston type, positive displacement Hydraulic Pump. Displaces .507 cu. in. per revolution. Capacity: 6 GPM at 3000 RPM with 1000 PSI or 3 GPM at 1500 RPM. Cat. No. H-P4USU . . . **2250**
PUMP MOUNT for above. No. H-PM-1. Adapts pump to 1/2" key slot drive. Has ball bearings. **1195**

NEW 3-3/4 HP ELECT. MOTOR

An ideal motor to operate a portable winch such as tow truck or utility boat. Series wound for continuous duty. Rated 3.75HP at 2300 RPM. Draws 240 Amps on 24 volt DC. Has 5/8" diameter drive shaft **895**
USED
NEW - ONLY 1295

SAVE HYD. HAND PUMP **675**
 No. H-P3USU

Operates at 1500 PSI. Displaces .19 GPM at 30 cycles per minute. Has capacity of 1.5 cu. in. per a stroke cycle. Has built-in check valve. Regularly \$17.50

VANE TYPE VACUUM PUMP
 No. H-PV-3 USU

Positive displacement type. Built to withstand extreme range of operation. Has capacity of 15 cu. ft. of free air at 1500 to 4500 RPM. Provides 4 to 10 inches of mercury SUCTION and 16 to 20 inches of mercury PRESSURE with pressure differential of 24 in. mercury max. Normal oil consumption is 150cc per hour. Has 3/4" pipe ports. Used by Xint. **2575**
PUMP MOUNT No. H-PM-2 - Has ball bearings and foot mount . . . **1695**

FOUR WAY HYDRAULIC VALVE
 No. V-13USU

Sliding piston type with built-in relief valve to limit stroke. Pressure balanced in neutral position. Has 5/8" AC tube ports. **788**
 Reg. Catalog price \$12.75

85 to 1 RATIO GEAR DRIVE

For use where tremendous power at a low take-off speed is desired. Drives through a train of 6 gears that rotate on self-lubricating high speed roller bearings. The take-off shafts are 1-1/4" and 3/8" in diameter. Has 180° offset drive. Overall size: 6"x4"x2-1/2". NEW... **995**

4-WAY HYD. VALVE
 No. H-V7A-1 **395**

A spring loaded, poppet type valve. Pressure balanced. Off in neutral. Has 3/4" tube ports. Cost Gov't approx. \$30

TO ORDER - Send check or M.O. 1/2 deposit with C.O.D.s. All prices are F.O.B. Los Angeles Warehouse. All items sent postage or freight collect.

palley's
 2263 E VERNON AVE., DEPT. PM-40
 LOS ANGELES 58, CALIFORNIA

DOUBLE HANDLE 1000 lb. HOIST
1988

Portable. Has 21 to 1 gear ratio. A double handle for speed and power. Has automatic brake. With 20 ft of 1/4" steel cable.

HAYES... THE ONE SPRAYER THAT GUARANTEES YOU PROPER APPLICATION OF GARDEN CHEMICALS

If you are not getting effective results with garden or lawn sprays, don't blame the chemicals... blame the sprayer!



The money you spend on garden and lawn chemicals can be completely wasted if they are applied with an inferior sprayer.

But NEVER—when you use a Hayes garden hose sprayer!

The Hayes enables garden and lawn chemicals to positively do the job they were designed for. Because—it has patented, built-in *balanced, metering jets* that are precision-made and control-tested. These jets produce a thoroughly mixed, accurately proportioned spray—the correct mixture as specified by the chemical manufacturer.

This is important because tests by independent research laboratories show that many garden hose sprayers are woefully inaccurate in proportioning the water and chemical. These sprayers deliver a mixture that is either *far too weak* to do any good—or *so strong* it can burn the plants.

Along with its exceptional accuracy, the Hayes is so easy to use...lightweight, compact—automatic in operation. It has been tested and approved by leading manufacturers of garden chemicals for use with their products...the only sprayer ever to be awarded this remarkable endorsement.

Hayes garden sprayers are available in models priced from \$3.25. At nursery and hardware dealers everywhere. Write for *free* booklet on garden and lawn care.

NOTE THESE EXCLUSIVE FEATURES:



Patented internal metering jets for thorough mixing and accurate proportioning.

Adjustable nozzle deflector. Sprays up, down, sideways and to tall foliage.

Positive on-and-off control valve for instant shut-off at any stage of spray application.

Patented back-flow valve—for safety. Positively prevents back siphoning of chemical into water line.

SINCE 1934—Hayes spray guns have been tested and proved by 26 years' usage... millions are in operation today.



Hayes Spray Gun Company

World's largest manufacturer of garden hose sprayers
98 No. San Gabriel Blvd., Dept. M, Pasadena, California

Producer of Hayes and Ortho spray guns • Look for the name Hayes on the sprayer you buy



Gaslight Motors Corporation, Box 1902, Lathrup Village, Mich.

1902 Version of Rambler Enters Compact-Car Field

Latest entry into the compact-car field is a full-scale replica of the original Rambler car produced in 1902. Featuring such advancements as an air-cooled engine in the center of the car, an automatic clutch, unit body construction and tiller steering, the car is being sold by Gaslight Motors Corporation, organized by three American Motors employes. Production goal is to exceed the 1500 units originally built by the Thomas B. Jeffery Co. The two-passenger runabout is built on a 77-inch wheelbase, is 112 inches long and 80 inches high. It weighs 640 pounds. Powered by a one-cylinder four-horsepower engine, the car has a top speed of 30 miles an hour and delivers 60 to 70 miles per gallon on regular gas. List price is \$1495.

Moth Imported to Control Weed

Larvae of the cinnabar moth have been introduced to the West Coast in an attempt to control the spread of tansy ragwort, a poisonous weed that has been spreading among range grasses used to feed horses and cattle.

The United States Department of Agriculture imported the larvae from Europe and Great Britain, hoping that moths will emerge in the spring when the weed starts to form flower buds. The female moth lays its eggs on the underside of the weed's leaves and the larvae feed on the foliage and young buds. The experiment is underway in California, Oregon and Washington.

Tests conducted by the Department showed the cinnabar moth has no liking for any useful plants. The moth larvae also will not feed on safflower, a relative of tansy ragwort that is grown as a commercial oilseed crop.

TAIL DRAGGING?



scraping on driveways?

Load-Levelers* put an end to this common annoyance by increasing road clearance of even heavily loaded cars.



swaying on curves?

Without Load-Levelers*, loaded car sways and swings as it rounds curves; passengers are thrown from side to side. Stability is impaired. Tires wear faster.



"bottoming" on bumps?

Without Load-Levelers*, car scrapes bottom on impact of hitting bumps and ruts, with frightening noise and possible damage.

Keep your car on the level with Load-Levelers*—Monroe stabilizing units with built-in ride control for a level ride under all road and load conditions. With Load-Levelers*, your car will always ride on an even keel . . . without "tail drag" or side sway. You'll like the way your car will take rough bumps and steep driveways without "bottoming" on its axles. You'll appreciate the extra stability on tight curves. And you'll like the improved steering and longer tire life you'll get with Load-Levelers.*

Have Load-Levelers* installed today in less than 30 minutes at your car dealer's, repair shop or service station. You'll be amazed at the really big difference they make!

only
\$39.90

a set
for most cars



Listen to
BILL STERN'S "MONROE SPORTSREEL"
every morning, Monday through Friday, on the Mutual radio network. Check your local radio listings for time and station.

*Trademark

MONROE AUTO EQUIPMENT COMPANY • MONROE, MICHIGAN
In Canada, MONROE-ACME LTD., Toronto, Ontario • In Mexico, MEX-PAR, Box 21865, Mexico City
WORLD'S LARGEST MAKER OF RIDE CONTROL PRODUCTS, INCLUDING MONRO-MATIC® SHOCK ABSORBERS

PICK YOUR OWN SUCCESS STORY FROM THIS PAGE

These are the true stories of people who seemed trapped in routine, low-pay shaky jobs. Handicapped by lack of proper training, they couldn't get the things they wanted out of life—more money, a job they liked, security and happiness.

They are a small sample of the thousands of men and women—young and old—who turn to I. C. S. for help. Their will-to-learn plus I. C. S. training have changed the course of their lives.

Are you discouraged with your job and pay and feel you can't improve yourself because of lack of specialized education? Well, these men and women were in the same boat. With I. C. S. training, one of these success stories could be about you.

I. C. S. is the oldest and largest correspondence school. 258 courses. Business, industrial, engineering, academic, high school. One for you. Direct, job-related. Bedrock facts and theory plus practical application. Complete lesson and answer service. No skimping. Diploma to graduates.



Wins \$3000 contest—"After my I. C. S. courses I secured a new position," says Mr. Cecil Rhodes. "My income has more than doubled and I recently won a \$3000 sales contest."



From clerk to Assistant Estimator, thanks to I.C.S. "Any way you look at it," writes Mrs. Edna James, "the time and money one spends for I. C. S. Courses will be repaid a thousandfold."



"As a college graduate, I found I.C.S. very valuable." Robert Lee took the I. C. S. Course in Advertising, is now Promotion Manager for a large corporation. "I. C. S. got me started on the way up," he says.



From \$152 to \$395 a month—"I.C.S. made my engineering work more interesting," Frank Bachtik tells us. "I was a Jr. Draftsman making \$152 a month. My present income is \$395.25 a month."

3 FREE BOOKS—a 36-page pocket-size guide to advancement, a gold mine of tips on "How to Succeed." Also a big catalog outlining opportunities in your field of interest and a sample I.C.S. lesson (Math.).

For Real Job Security—Get an I. C. S. Diploma! I. C. S., Scranton 15, Penna.

Accredited Member,
National Home Study Council

INTERNATIONAL CORRESPONDENCE SCHOOLS



BOX 92953D, SCRANTON 15, PENNA.

Without cost or obligation, send me "HOW TO SUCCEED" and the opportunity booklet about the field BEFORE which I have marked X (plus sample lesson):

- ARCHITECTURE and BUILDING CONSTRUCTION**
- Air Conditioning
 - Architecture
 - Arch. Drawing and Designing
 - Building Contractor
 - Building Estimator
 - Carpenter Builder
 - Carpentry and Millwork
 - Carpenter Foreman
 - Heating
 - Painting Contractor
 - Plumbing
 - Reading Arch. Blueprints
- ART**
- Commercial Art
 - Magazine Illus.
 - Show Card and Sign Lettering
 - Sketching and Painting
- AUTOMOTIVE**
- Automobile
 - Auto Body Rebuilding and Refinishing
 - Auto Engine Tuneup
 - Auto Technician

- AVIATION**
- Aero-Engineering Technology
 - Aircraft & Engine Mechanic
- BUSINESS**
- Accounting
 - Advertising
 - Business Administration
 - Business Management
 - Cost Accounting
 - Creative Salesmanship
 - Managing a Small Business
 - Professional Secretary
 - Public Accounting
 - Purchasing Agent
 - Salesmanship
 - Salesmanship and Management
 - Traffic Management
- CHEMICAL**
- Analytical Chemistry
 - Chemical Engineering
 - Chem. Lab. Technician
 - Elements of Nuclear Energy
 - General Chemistry
 - Natural Gas Prod. and Trans.
 - Petroleum Prod. and Engr.
 - Professional Engineer (Chem)
 - Pulp and Paper Making

- CIVIL ENGINEERING**
- Civil Engineering
 - Construction Engineering
 - Highway Engineering
 - Professional Engineer (Civil)
 - Reading Struc. Blueprints
 - Sanitary Engineer
 - Structural Engineering
 - Surveying and Mapping
- DRAFTING**
- Aircraft Drafting
 - Architectural Drafting
 - Drafting & Machine Design
 - Electrical Drafting
 - Mechanical Drafting
 - Sheet Metal Drafting
 - Structural Drafting
- ELECTRICAL**
- Electrical Engineering
 - Elec. Engr. Technician
 - Elec. Light and Power
 - Practical Electrician
 - Practical Lineman
 - Professional Engineer (Elec)
- HIGH SCHOOL**
- High School Diploma

- Good English
 - High School Mathematics
 - High School Science
 - Short Story Writing
- LEADERSHIP**
- Industrial Foremanship
 - Industrial Supervision
 - Personnel-Labor Relations
 - Supervision
- MECHANICAL and SHOP**
- Diesel Engines
 - Gas-Elec. Welding
 - Industrial Engineering
 - Industrial Instrumentation
 - Industrial Metallurgy
 - Industrial Safety
 - Machine Shop Practice
 - Mechanical Engineering
 - Professional Engineer (Mech)
 - Quality Control
 - Reading Shop Blueprints
 - Refrigeration and Air Conditioning
 - Tool Design Tool Making
- RADIO, TELEVISION**
- General Electronics Tech.

- Industrial Electronics
 - Practical Radio-TV Engr'g
 - Practical Telephony
 - Radio-TV Servicing
- RAILROAD**
- Car Inspector and Air Brake
 - Diesel Electrician
 - Diesel Engr. and Fireman
 - Diesel Locomotive
- STEAM and DIESEL POWER**
- Combustion Engineering
 - Power Plant Engineer
 - Stationary Diesel Engr.
 - Stationary Fireman
- TEXTILE**
- Carding and Spinning
 - Cotton Manufacture
 - Cotton Warping and Weaving
 - Loom Fixing Technician
 - Textile Designing
 - Textile Finishing & Dyeing
 - Throwing
 - Warping and Weaving
 - Worsted Manufacturing

Name _____ Age _____ Home Address _____
 City _____ Zone _____ State _____ Working Hours _____ A.M. to P.M. _____
 Occupation _____

Canadian residents send coupon to International Correspondence Schools, Canadian, Ltd., Montreal, Canada. . . . Special low monthly tuition rates to members of the U. S. Armed Forces.

SHOPMATE®

**NOW
AT**

TWIST-LOCK® POWER TOOLS

A. SUPER POWER 2.9 AMP. 1/4" MIRROR FINISH DRILL powers all Twist-Lock attachments! (Model SD-2500)

\$1998

(All Shopmate 740-CG drills accept Twist-Lock attachments except older models with serial numbers 95A, B, C, D, E or F.)

TWIST—IT'S ON..



EASY AS 1-2-3!

* Patent Applied for

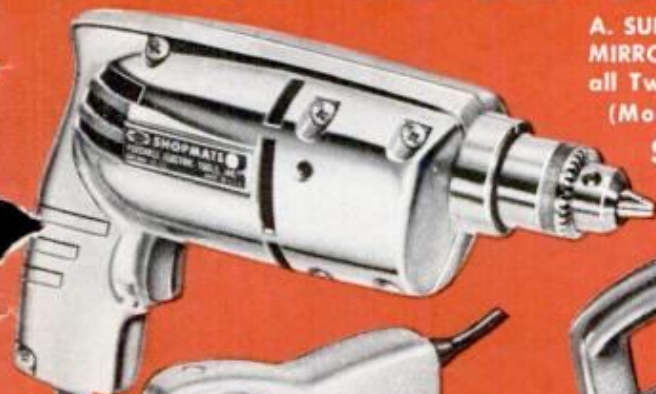

C. OSCILLATING SANDER. Sands, finishes, polishes any material satin smooth. (Model TLS-18)

\$1095



B. 5 1/2" CIRCULAR SAW with full 2x4 cutting capacity. (Model TLC-500)

\$1095

A. POWERFUL 2.9 AMP. 1/4" DRILL . . . geared chuck, lifetime mirror finish, multi-ball thrust bearing. Model SD-2500 . . . \$19.98

2.6 AMP. 1/4" DRILL . . . also powers Twist-Lock attachments. (Illustrated with attachments.) Model 740-CG . . . \$18.98

B. 5 1/2" CIRCULAR SAW . . . cuts 2 x 4's, bevels to 45°. Model TLC-500 . . . \$10.95

C. OSCILLATING SANDER . . . 25 square inches of sanding surface, patented knurled locking rollers. Model TLS-18 . . . \$10.95

D. JIG SAW . . . 7 saws in 1: scroll, rip, band, jig, coping, crosscut, hack saw. Bevels to 45°, cuts 2 x 4's. Complete with 3 blades. Model TLJ-58 . . . \$10.95

E. VERTICAL DRILL STAND . . . one of the finest ever made. Model TLV-27 . . . \$12.95

F. HORIZONTAL DRILL STAND . . . fastens securely to workbench for fine bench grinding. Model TLH-26 . . . \$2.00

G. POWER TRIMMER . . . 13" Swedish Blue Steel Cutter Bar, precision ground to stay sharp. Model TLT-13 . . . \$12.95

E. VERTICAL DRILL STAND precision drill press. (Model TLV-27)

\$1295



D. JIG SAW bevels to 45°, easily cuts 2 x 4's. (Model TLJ-58)

\$1095



F. HORIZONTAL DRILL STAND for bench grinding, sharpening, buffing, etc. (Model TLH-26)

\$200



\$1295

G. POWER TRIMMER for precision trimming hedges, bushes, trees, etc. (Model TLT-13)

ADAPTOR INCLUDED FREE WITH EACH TWIST-LOCK ATTACHMENT



Winston's **FILTER-BLEND**
up front is packed for pleasure!



IT'S WHAT'S
UP FRONT
THAT
COUNTS!

Sure, most filter cigarettes *look* alike. But there the resemblance ends. Winston is different. Winston has *both* a modern filter and *Filter-Blend* — choice, golden tobaccos specially selected and specially processed for filter smoking. That's why, more folks find it fun to smoke Winston than any other filter cigarette. How about you? Next time you buy cigarettes, ask for Winston.

WINSTON TASTES GOOD like a cigarette should!