

ANNUAL BOATING SECTION

POPULAR MECHANICS

WRITTEN SO YOU CAN UNDERSTAND IT

MARCH, 1960

35 CENTS

28 PAGES ON BOATING

Offshore Cruising by Outboard

JET BOATS . . .

YOUR BOAT AND THE LAW . . .

Boat Loading . . . Trailering

★ ★ ★

We're Going to Work Miracles

By Dr. Edward Teller

KOLUMARAN!

Page 166



FOLLOW THE LEADER.



new **75hp STARFLITE II** with Jetstream drive TODAYS TOP-PERFORMANCE OUTBOARD MOTOR



SLALOM POWER!
Starflite II never falters... whips slalom skiers through the course at competition speeds.



SKI BAREFOOT!
No skis necessary as far as Starflite's tremendous torque and sizzling speed are concerned.

Skiers never had it so good! The new Starflite II is the most versatile ski motor ever built. It's second to none in speed, load handling power, ruggedness, fuel economy and safety.

Under its trim hood, you'll find a compact, perfectly balanced V-4 engine that pours out a whopping 75 hp! *Jetstream Drive* delivers its high thrust with high speed efficiency... *without sacrificing control!* Its fin-slim gearcase houses full gearshift transmission for safer skiing and easier dockside handling. Idles smoothly in neutral, shifts easily for instant take-off starts.

Here is controlled power to pop a gang of skiers out of water with ease... the stamina to streak full throttle with thrill-happy skiers in tow for more hours, days and seasons of trouble-free service than you'd expect from any other motor.

New 1960 Catalog *Free!* Write EVINRUDE MOTORS, 4209 N. 27th St., Milwaukee 16, Wis.

A Division of Outboard Marine Corporation
In Canada: Mfd. by Evinrude Motors, Peterborough



EVINRUDE

FIRST
IN
OUTBOARDS



*9 out of 10 race car winners use
Champion spark plugs . . .*



*9 out of 10 powerboat winners use
Champions . . .*



*More aircraft use Champions
than any other spark plug . . .*



*Over twice as many car makers
specify Champion spark plugs.*

Q. Why do the experts in field after field where power is vital choose Champion spark plugs?

A. Because they know they can depend on Champions to deliver every bit of performance from every drop of gas. Your car will perform better, too (and save money on gasoline) with new Champions. Put in a set every 10,000 miles!

*Worn spark plugs waste lots of gas—
so check your plugs every 5,000 miles!*



NOW! THE FACTS YOU'VE BEEN WAITING FOR!

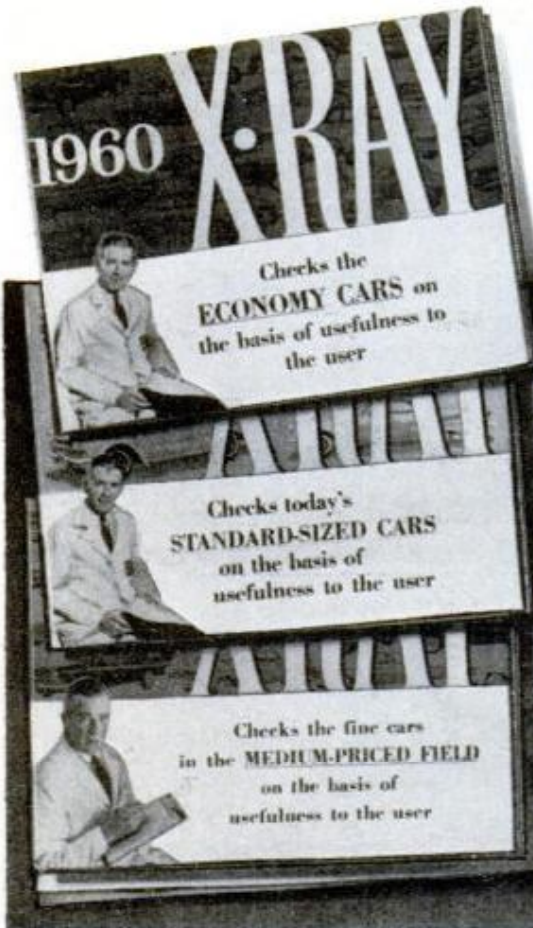

- ☆ About the new 1960 economy cars
- ☆ About the 1960 standard-size cars
- ☆ About the 1960 medium-priced cars

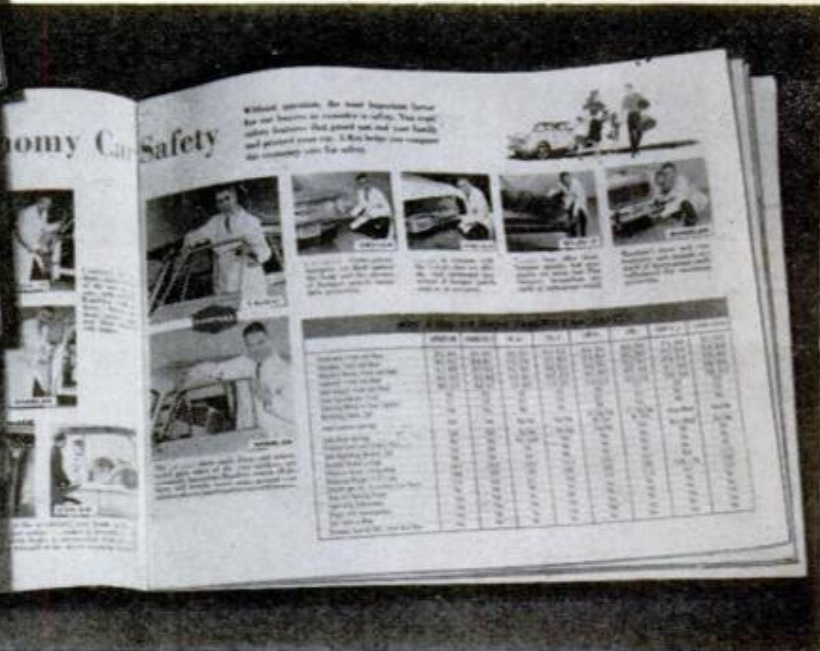

NEW FREE AUTOMOTIVE X-RAYS

Compare All Popular 1960 Cars

Here, for the first time, are the straight authentic facts you want to know about the 1960 cars.

- Which cars actually offer six-passenger room?
- How do 1960 engines and mechanical features stack up?
- Economy claims—which are proved and official?
- Which car is really low-priced in each category? Which has official highest resale value?
- Three complete books—one for each field.
- Don't buy any 1960 car until you see these invaluable new comparisons. You'll get the honest, straight answers to these and hundreds of other questions in the new, just-off-the-press 1960 Automotive X-Rays. Just a few minutes spent reading this information can save you hundreds of dollars when you buy your new car.

AMERICA'S LOWEST PRICE

\$1795

Suggested delivered price of the 1960 Rambler American 2-Door Deluxe Sedan at the factory, Kenosha, Wisconsin, including federal taxes. State and local taxes, if any, optional equipment, extra.

**GET YOUR FREE 1960 AUTOMOTIVE X-RAY
AT YOUR RAMBLER DEALER'S TODAY**

POPULAR MECHANICS®

Address communications to: 200 E. Ontario St., Chicago 11, Illinois. **SUBSCRIPTION SERVICE:** Mail all subscription orders, changes of address, correspondence concerning subscriptions, and Postmaster notices of undeliverable copies to Popular Mechanics, 250 West 55th St., New York 19, N. Y.

Editor

RODERICK M. GRANT

Executive Vice-President

RICHARD E. DEEMS

Publisher

G. HARRY CHAMBERLAINE

Managing Editor

CLIFFORD B. HICKS

Shop Notes and Crafts Editor

JAMES R. WARD

Associate Editors, General Features

ARTHUR R. RAILTON, Automotive

JOHN A. LINKLETTER

Associate Editors, Shop Notes and Crafts

WAYNE C. LECKEY **W. CLYDE LAMMEY**

Radio-Television, Electronics Editor

LOTHAR STERN

Assistant Editors, General Features

JAMES BIERY, ROBERT L. HULL, JR.

R. B. KIRKPATRICK

Assistant Editors, Shop Notes and Crafts

EARL WOBECK, GUERRINO F. AMATI

Assistant Editors, Makeup

WALLACE MYERS, JEAN KAVANAUGH

Art Staff

FRANK BEATTY, Director

HENRY NEHRBASS, Assistant Director

RICHARD A. POTTS, Art Editor

Eastern Editor

RICHARD F. DEMPEWOLFF

Room 4102, Empire State Bldg.,
New York City 1

Western Editor

THOMAS E. STIMSON, JR.

Suite 1003, 3460 Wilshire Blvd.
Los Angeles 5, Calif.

Advertising Manager

JOSEPH R. BUELL, JR.

Director, Bureau of Information

ALLAN CARPENTER

Advertising Offices

Chicago: 200 E. Ontario St., Whitehall 4-0100;
New York: Empire State Bldg., 350 Fifth Ave.,
LONgacre 5-7580; Detroit: General Motors
Bldg., TRinity 5-8711; Cleveland: Hanna
Bldg., 1422 Euclid Ave., PROspect 1-0456; Los
Angeles: 3460 Wilshire, DUmkirk 2-8458; San
Francisco: Russ Bldg., 235 Montgomery St.,
YUKon 2-0823.

Published monthly by Popular Mechanics Company,
200 E. Ontario St., Chicago 11, Ill. Richard E.
Berlin, President; Richard E. Deems, Executive
Vice-President; Fred Lewis, Vice-President and
General Manager; John H. Miller, Vice-President;
G. Harry Chamberlaine, Vice-President; G. O. Mar-
kuson, Treasurer; R. F. McCauley, Secretary. Sin-
gle copy in the United States and Canada, 35 cents;
subscription rates in the United States and pos-
sessions and Canada, 1 year \$3.50; 2 years,
\$6.00; 3 years, \$8.00. In countries of the Pan-
American Postal Union, 1 year \$4.50; 2 years
\$8.00; 3 years \$11.00. In all other countries 1
year \$5.50; 2 years \$10.00; 3 years \$14.00.
If you plan to move, notify us at least 30 days in
advance so you will not miss an issue. Give both
your old and new addresses. Second-class postage
paid at Chicago, Illinois, and at additional mail-
ing offices. Entered as Second Class Matter at
Post Office Dept., Canada. Registered as Second
Class Matter at the Post Office at Mexico, D.F.,
Mexico, June 20, 1950. © 1960 by Popular
Mechanics Company. All rights reserved. Printed
in the United States of America.

INTERNATIONAL EDITIONS

SPANISH: Mexico-Caribbean, Southern Hemisphere

FRENCH, DANISH, SWEDISH, GERMAN, PORTUGUESE, DUTCH

Volume 113

MARCH 1960

Number 3

In This Issue...

We're Going to Work Miracles	97
First of the Big Small Cars—The Comet	103
Should We Let Nature Take Its Course?	106
X-Ray Detectives	116
Owners Report on the Corvair	124
Olympic Horsemen Go to School	130
This Company Loves Tough Problems	137
Physical Fitness Factory	150

ANNUAL BOATING SECTION

Offshore Cruising by Outboard	160
Kolumaran!	166
Three New Boats for 1960	168
For Better Boating . . . Trim Ship!	169
Boatman's Burden	173
New for Your Boat	176
PM Reports on the Jet Boat	177
Sink-Proof Your Boat	180
Trail It Right!	184

For the Craftsman...

Make Your Own Water Skis	192
The PM Houseboat—Part IV	198
Make Your Own Glass-Fiber Awnings	206
TV Snack-Tray Set	208
How to Cut Mortise-and-Tenon Joints	218
Radio, TV and Electronics	232

Regular Departments...

WHERE-TO-BUY-IT INDEX - - - 6

Clinic for Homemakers	92	Solving Home Problems	194
An Eye on Space	102	Car Trouble Shooting	214
Detroit Listening Post	112	On the Market	226
What's New for Your Home	146	Shopping for Tools	229

Turn to detailed index on page 6. Sources of additional information on items in this issue are shown on the Where-to-Find-It List, available without charge by writing the Bureau of Information, Popular Mechanics, 200 E. Ontario St., Chicago 11, Ill.

Next Month...

THE GREATEST—and shortest—mass migration of all time soon will take place. Millions of persons will move from inside their homes to lawns, patios and swimming pools. In April we present our annual Outdoor Living Section. You'll find plans for an outdoor living wall (complete with sink, built-in storage and even TV), information on covered patios and swimming pools. . . . Also in April, the owners drive the Falcon 1,400,000 miles—and give their report

Plain talk about
power mowers

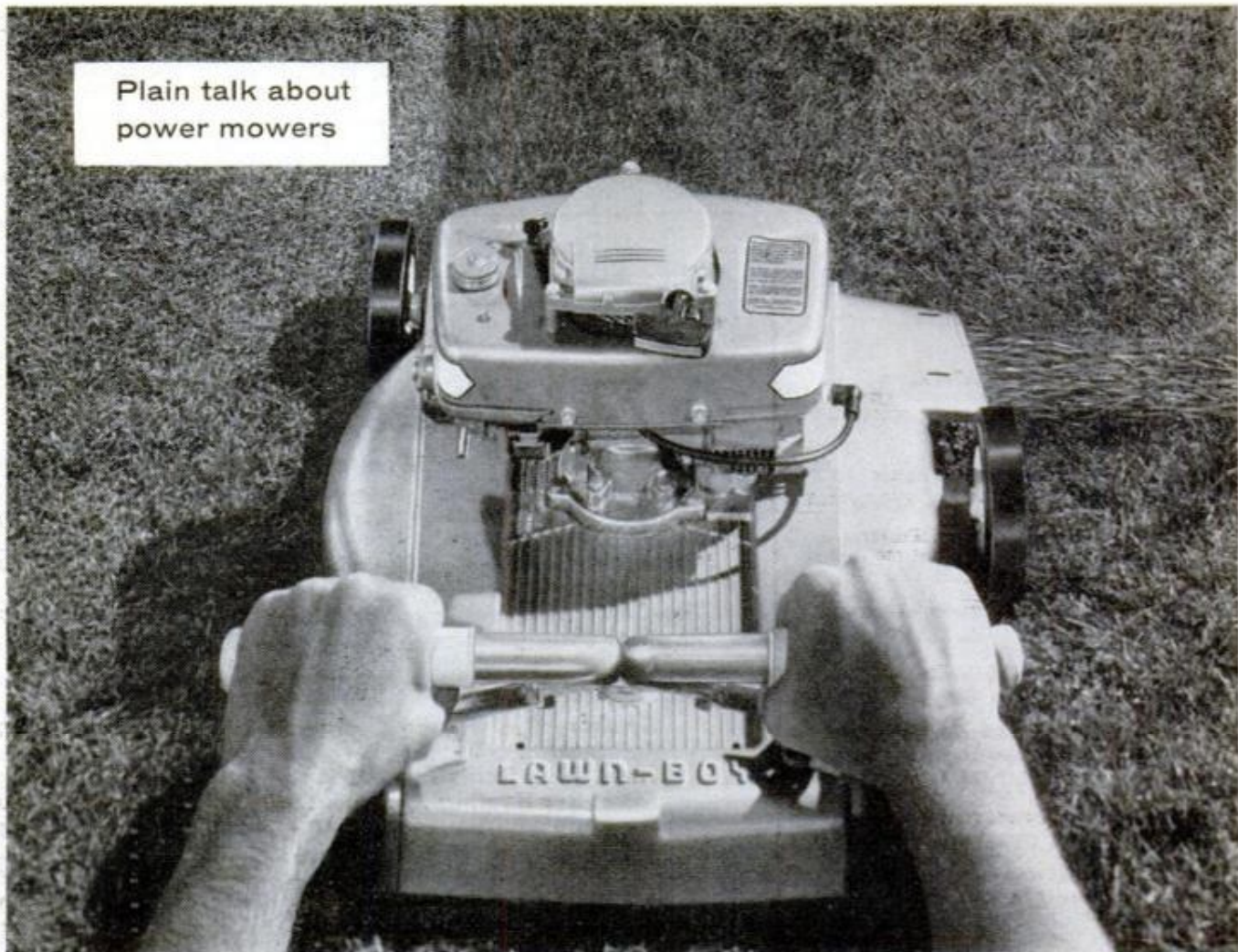

How to pick a power mower

There is a big difference in power mowers that goes past the price tag, beyond the pretty paint. Certainly price is important. That's why some mowers are *made* to sell for less. But where *value* is concerned, even high price is no guarantee. How do you know you're getting your money's worth? Don't settle for sales talks. Find out for yourself fast, with the six-step test for power mower buyers.

Walk up to any mower, regardless of price or reputation. Look it over. Lift it. Start it. Listen to it. Then look at LAWN-BOY. Measured by any yardstick, this is the mower built for value! The nationally known, nationally serviced brand. The one that sets a standard others would like to live up to. This time, get more mower for your money! Go LAWN-BOY! Wide selection for every kind of lawn, starting at \$59.95.

SIX-STEP TEST OF A MODERN POWER MOWER

Standard to judge any power mower by—before you buy!

1. **TILT** the mower, as you would to clean it or to mow along a hillside. Oil should not leak out or spill. A drip-free LAWN-BOY mower keeps oil in the engine for full-time lubrication.
2. **FLEX** the blade. It should be pre-stressed, under tension. A long, whippy blade cuts unevenly, can cause crankshaft damage. LAWN-BOY uses a short, hard shaft, with bronze main bearings.
3. **TAP** blade housing. It should be solid as a rock . . . yet lightweight. Thin steel stamped housings will vibrate, can spring out of shape. LAWN-BOY light, strong, durable aluminum housings never do.
4. **LIFT** the mower. It should be light, easy to push or turn. Not too big, not too heavy. LAWN-BOY is aluminum-

light, nimble and comfortable to use. Even the handle is designed to fit you better.

5. **START** the engine. Several times. Starting should be easy, fast, sure. LAWN-BOY is famous for fast starting. Hottest ignition spark on any mower delivers years of easy one-pull starting.

6. **LISTEN** to it. Does it roar? Or spit fumes a step ahead of you? It shouldn't. LAWN-BOY has the biggest mufflers of any power mower. And exhaust is under the mower, away from you.

AT LAST! Complete automatic lawn care in one modern mower! New LAWN-BOY Grass Catcher rakes and sweeps as it mows!



LAMAR, Missouri,
Division Outboard Marine Corporation
In Canada: LAWN-BOY, Peterborough, Ont.
Manufacturers of LAWN-BOY
power mowers, rotary tillers,
edger-trimmers, snow removal equipment.

Ask for a free demonstration on your own lawn. Look in the "Yellow Pages" under Lawn Mowers for your nearest LAWN-BOY Dealer, or write LAWN-BOY direct.

LAWN-BOY

*Spring Special!
Limited time
Only!*

SAVE
\$3²⁰



Get a 1 year subscription to both of these magazines
with purchase of any one of these

Weller **POWER TOOLS**



Popular Homecraft and Home Craftsman are the leading magazines in the do-it-yourself field. Both are full of ideas for fixing and making things. They feature home workshop projects with photographs, plans and blueprints—and a host of money-saving tips on home improvement. Regular subscription price, \$3.20 a year. Subscription cards included in tool cartons. Special offer expires June 15, 1960.

PROFESSIONAL SOLDERING GUN—The same heavy duty, 250-watt gun used by electronic servicemen the world over. Just pull the trigger—tip heats instantly and twin spotlights flick on to illuminate your work. Tip has long reach and can be bent to get into difficult places. MODEL 8250A **\$12⁹⁵**
Both magazine subscriptions included

POWER SANDER—Big 25 sq. in. sanding surface and 14,400 strokes a minute get jobs done fast and easy. Straight-line action never bucks, twists or scars the surface. Goes all the way into corners and under low places. Assorted sandpaper and polishing cloth included. MODEL 700 **\$16⁹⁵**
Both magazine subscriptions included

SABRE SAW—A portable saw that makes every kind of cut through plywood, composition board, plastics, aluminum, etc. Even makes its own starting hole for inside cuts—no need to drill. Exclusive strain-relief feature prevents breakage. 3 different blades included. MODEL 800 **\$19⁹⁵**
Both magazine subscriptions included

AT YOUR HARDWARE OR HOBBY DEALER

Weller Electric Corp.,
Easton, Pa.

South Bend

10" LATHES

with new
welded steel
floor legs

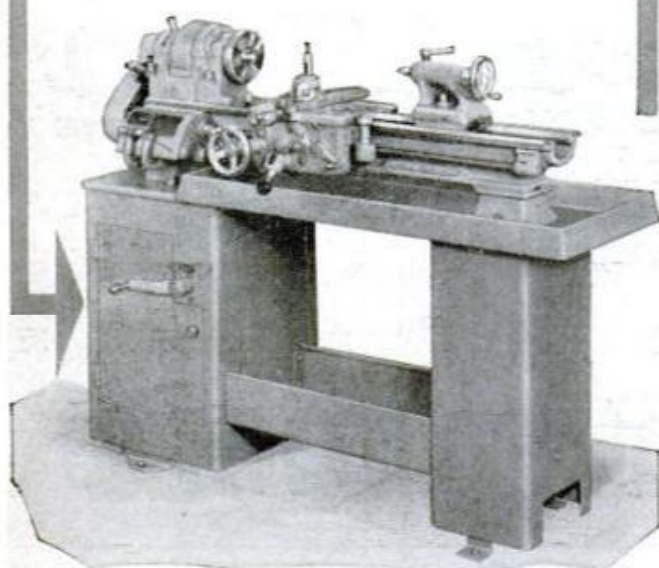

- New, trim floor legs . . . reinforced construction of welded, heavy gauge steel . . . maximum rigidity with minimum weight . . . no increase in price!
- Famous South Bend dependability.
- Superfinished spindles and bearings for uniform accuracy and fine finishes.
- 70 screw threads (4 to 480 per in.) . . . 70 longitudinal feeds . . . 70 cross feeds.
- Tool room and Engine Lathe models . . . prices start at \$1282 f.o.b. factory.

WRITE FOR CATALOG

of South Bend Lathes, Milling Machines,
Shapers, Drill Presses and Pedestal Grinders

SOUTH BEND LATHE, INC.

South Bend 22, Indiana

Building Better Tools Since 1906

Only 3¼% interest per year
on unpaid balance
up to 36 months to pay



GUIDE TO THIS ISSUE

With Sources of New Products

Aviation

Army's helicopter fires surface missiles	113
Jet plane gets roller skate	123
Huge "TV screen" plots aircraft thousands of miles away	154

Boats and Boating

First diesel outboard motor (American Marc. Inc., Maine Div., 1601 W. Florence Ave., Inglewood, Calif.)	129
Tall boat	136
All-aluminum catamaran uses crescent-shaped hull (Mitchell Boat Co., Elkhart, Ind.)	144
Trim elevators for boat (Sea-Trim Corp., 1317 Western Ave., Plymouth, Ind.)	144
"Pontoon" tires float marsh buggy (Goodyear Tire and Rubber Co., Akron, Ohio)	145
Long lever swings boat onto dock (G. A. Murphree, Box 34, Santa Margarita Lake, San Luis Obispo County, Calif.)	153
Small electric boat sneaks angler into good fishing holes (Fishing Dude Co., 4721 Holiday Lane West, Fort Worth, Texas)	155
Kolumaran	167
Boat's wheels retract in water (Amphibious Boats, Inc., Dallas, Texas)	168
Cruiser buttons up, sleeps four (A.I.D. Ltd., 181 Maynard St., Halifax, Nova Scotia)	168
Two-for-one boat uses sail or motor (Bock Boats, Inc., 3600 Summit St., Toledo, Ohio)	168
Cockpit seat cushions (Charles Ulmer, Inc., 175 City Island Ave., City Island, New York)	176
Overboard fuel tank (Tranex Tanks, Mark Mfg. Co., RFD 2, Tacoma 22, Washington)	176
Water-ski towlines (K.D. Engineering, 2310 S. 7th, Lincoln, Nebr.)	176
Motorless bilge pump (Newbeck Bilge Pump, Riverside Machine Shop, 37 S. Main St., Homer, New York)	176

Fishing

Fish dispenser (Fred R. Edwards, Turon, Kansas)	136
Look, firemen—no hands (Brace-Corbett, Inc., Box 7713, Prairie Village, Kansas)	144
Fishing lunks get diesel power	148

Miscellaneous

No redcaps need apply	115
Blast of horn changes slides (E. Leitz, Inc., 468 Park Ave., New York 16, N. Y.)	115
Bicycle built for family	123
Loader separates operator from shovel (Caterpillar Tractor Co., Peoria, Ill.)	123
Army howitzer weighs eight tons less	129
Safety switch cuts off car's power (A. L. Rogers Development Corp., 2560 Ocean Ave., Seaford, Long Island, N. Y.)	129
Buoy unloads oil	136
Women in giant "sewing bee" prepare fabric for blimps (Goodyear Aircraft Corp., Akron 15, Ohio)	141
Amsterdam's Saturday mountain climbers	142
Clockwatchers' paradise	149
Custom auto body finished in mosaic	153
Tape holds photo lamp (Lowel-Light Photo Engr., 421 W. 54th St., New York 19, N. Y.)	154
Giant "footballs" protect freight (Firestone Industrial Products Co., Noblesville, Ind.)	155

(Continued to page 8)

5 reasons why ACCOUNTING



offers you

MORE MONEY and SUCCESS

**SEND FOR FREE
SAMPLE LESSON**

REASON #1. If you were an expert accountant right now, chances are you would find yourself in one of the best paid fields of business.

REASON #2. The demand for accountants is great—everywhere. All businesses must have trained accountants to cope with ever-growing requirements. It's a field offering wide opportunity—always—to the man who knows.

REASON #3. You can fit into any business, anywhere in the country—because accounting principles are universal. Think what this means in terms of security and independence!

REASON #4. Accounting is open to all. Any man or woman of good intelligence, who enjoys figure work and is willing to follow LaSalle's systematic "problem method" plan, can rapidly qualify for a highly profitable, enjoyable lifetime career . . . and he doesn't have to finish his training before beginning to "cash in."

LASALLE
417 S. Dearborn St.,
CHICAGO 5, ILL.

REASON #5. Without losing a day from your present work, you can prepare in spare hours at home, at low cost, under LaSalle's step-by-step "Problem Method" of "learning by doing." This famous plan accounts for LaSalle's remarkable record of having trained one out of every 13 of all Certified Public Accountants in the U. S. . . . and of having put many thousands of others into high-paying careers.

Send today for Free Sample Lesson and "Opportunities in Accounting." Learn about the several great fields of opportunity . . . and LaSalle's time-tested plan for helping men and women to rapid advancement, higher income and greater prestige. The coupon below will bring this information to you—without cost or obligation.

Accredited Member, National Home Study Council

SEND FOR FREE BOOK



LaSalle Extension University
A Correspondence Institution

Dept. 364H 417 S. Dearborn St., Chicago 5, Ill.
Please send me, free of all cost or obligation, free sample lesson and your latest book, "Opportunities in Accounting."

Name.....Age.....

Address.....

This One



89QP-SWL-BHF2

Материал, защищенный авторским правом



SPORTING GOODS



fishing tackle, wallpaper, batteries,
fences, washing machines, draperies
whatever you need—



Advertisers displaying this emblem
make your shopping easy.

(Continued from page 6)

Cactus to order (Chester Moorten, 1735 S. Palm Canyon Dr.,
Palm Springs, Calif.).....156

Science

Gravity meter detects hidden cavities, pits beneath streets
(The Franklin Institute, Philadelphia 3, Pa.).....113
Rubber-clad submarine ahead (U. S. Rubber, Ave. of the
Americas, New York 20, New York).....122
Chemical spray "prunes" trees.....141
Largest mail sorter zips through letters (International Div.,
Burroughs Corp., Detroit 32, Mich.).....145
Beware! Your ears may give you away.....153
Salt water made fresh by energy from sun (Hoffman Elec-
tronics Corp., 3761 Hill St., Los Angeles 7, Calif.).....158
Helicopter kite.....158
Morse-code sender has typewriter keyboard.....158
High-pressure oxygen aids in radiotherapy.....159

What's New for Your Home

New beds created from old ones.....146
Drying tray for drip-dry clothing.....146
Lemon peeler.....146
Tilting picture window.....147
Portable step.....147
Cord caddy.....147
Storage chest.....147

Craftsman and Shop Notes Index

Automotive

Auto ash tray lined with foil.....196
Turn-signal lights switch to trailer.....197
Cylinder pinging.....214
Bumper guards.....215
Cooling fan.....215
Rusted parking light.....215
Loose handbrake lever.....215

Farm Shop Ideas

Tire chains on gate serve as poultry guard.....190
Permanent barn window support swings away when not in
use.....216
Livestock watering ideas.....217

House and Home

Garden tool shed combined with play fort.....188
Broken panel in garage door replaced the easy way.....204
Garden gate gives privacy.....205
Solid-unit form for pouring concrete steps.....213
Pad protects wooden floors and aids removal of nails.....224

Miscellaneous

Rubber band helps self-timer snap reflex-camera shutter.....190
Feathered pets travel in a portable bird cage.....191
Gambrel for skinning small game.....196
Raincoat used as storage bag.....196
Shelf mounted between studs.....106
Light warns drill operator when bit contacts buried pipe...204
Merry-go-round improvised from wagon wheel and axle....204
Pincushion glued to caster cup used as dress-pattern hold-
down.....211
Reflective tape on flashlight makes it easy to find in dark...211
Oil spreading on water drives model boat.....212

(Continued to page 10)

Learn Radio-Television Electronics

by Practicing at Home in Your Spare Time

WITHOUT EXTRA CHARGE YOU GET special NRI kits developed to give you actual practice with Radio-TV receiver or broadcasting circuits and equipment. All equipment is yours to keep.

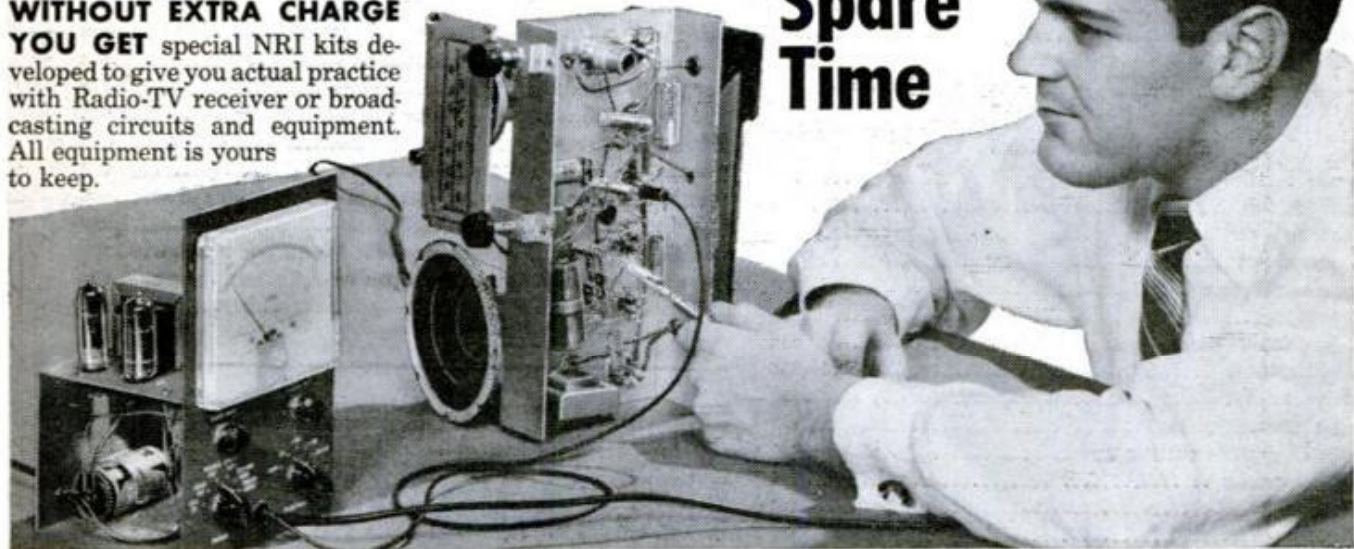

RADIO-TV BROADCASTING (see above) offers important positions as Operators and Technicians. **RADIO-TV SERVICING Technicians** (see below) needed in every community. Their services are respected, their skill appreciated.



Fast Growing Field Offers You Good Pay, Success, Bright Future



J. E. SMITH
Founder

Bigger than ever and still growing fast. That's why Radio-TV has special appeal to ambitious men not satisfied with their job and earnings. More than 4,000 Radio and TV stations. More than 150 million home and auto Radios, 40 million TV sets. Color TV promises added opportunities. For the trained man, there are good jobs, bright futures in Radio-TV Servicing or Broadcasting. Training PLUS opportunity is the ideal combination for success. So plan now to get into Radio-TV. The technical man is looked up to. He does important work, gets good pay for it. Radio-Television offers that kind of work. NRI can supply training quickly, without expense of going away to school. Keep your job while training. You learn at home in your spare time. NRI is the **OLDEST** and **LARGEST** home study Radio-TV school. Its methods have proved successful for more than 40 years.

Added Income Soon - \$10, \$15 a Week in Spare Time

Soon after enrolling, many NRI students start to earn \$10, \$15 a week in spare time fixing sets. Some pay for their training and enjoy extra luxuries this way. Some make enough to start their own Radio-TV shops. NRI training is *practical*—gets quick results. Easy to understand, well illustrated lessons teach you basic principles. And you **LEARN-BY-DOING** by practicing with kits of equipment which "bring to life" things you study.

Find Out What NRI Offers

NRI has trained thousands for successful careers in Radio-TV. Study fast or slow—as you like. Diploma when you graduate. Mail coupon now. Paste it on a postcard or mail in envelope. **ACTUAL LESSON FREE.** Also 64 page catalog that shows opportunities, shows equipment you get. Cost of NRI courses low. Easy terms. **NATIONAL RADIO INSTITUTE, Dept. OCA, Washington 16, D. C.**

N.R.I. TRAINED THESE MEN FOR SUCCESS



"I was repairing Radios by 10th lesson. Now have good TV job." **M. R. LINDEMUTH,** Fort Wayne, Ind.



"Doing spare time repairs on Radio and TV. Soon servicing full time." **CLYDE HIGGINS,** Waltham, Mass.

"I had a successful Radio repair shop. Now I'm Engineer for WHPE." **V.W. WORKMAN,** High Point, N.C.



"There are a number of NRI graduates here. I can thank NRI for this job." **JACK WAGNER,** Lexington, N. C.



VETERANS Approved Under G. I. Bills

SEND FOR BOTH FREE

National Radio Institute
Dept. OCA, Washington 16, D. C.

Mail me Sample Lesson and 64-Page Catalog FREE. (No salesman will call. Please write plainly.)

Name _____ Age _____

Address _____

City _____ Zone _____ State _____

Accredited Member National Home Study Council



(Continued from page 8)

Adhesive tape is guide in using stapler.....	216
Easy way to accuracy on a paper cutter.....	216
Precut tape placed on glass simplifies wrapping problems....	222
Suggestions for care and use of the versatile flashlight.....	224

On the Market

Remodeler's hardwood flooring.....	226
Paintbrush cleaner.....	226
Precut wood pictures.....	226
Ready-mixed wallpaper adhesive.....	226
Liquid gold-plating solution.....	227
Corrugated metal roofing.....	227
Plastic tape.....	227
Multicolor paint.....	227

Shopping for Tools

Metric taps.....	229
Air-operated marking tool.....	229
Quick-change tool holder.....	229
Tilting arbor saw.....	229
Universal turret vise.....	230
Flaring tool.....	230
Thread-measuring wire carriers.....	230
High-speed spinner.....	230
Micrometer head.....	230
Automatic electric stapler.....	231
Nippers with carbide cutting tips.....	231
Metal disintegrator.....	231
Paint roller.....	231
Portable tool kit.....	231

Solving Home Problems

Desk blotters cut to lie flat.....	194
Vacuum cleaner on wheels.....	194
Weatherproof name tags for garden flowers.....	194
Hat and coat rack easily made.....	194
Chain and spring combination for doors that jolt.....	195
Keep small framed pictures from tilting.....	195
Applying clean varnish to floor.....	195
Applying wallpaper patches.....	195

Workshop Hints

Screening protects bristles of soaking paintbrush.....	190
Edges on transparent plastic polished on leather "stone".....	204
Electrical junction box holds spare fuses.....	212
Tool handles wrapped in foil remain free of paint and tar.....	212
Knob on carpenter's square makes handling easier.....	213
Simple aids and hints for cutting glass.....	216
Tape and sandpaper are aids for the busy draftsman.....	216
Dividers become calipers for small precision work.....	222
Dowels hold miter box firmly on workbench.....	222
Workbench and odd corners make storage nooks for saws.....	222
Radius turning tool.....	223
Suspending brush in solvent prevents bending of bristles.....	223
Tape attached to micrometer records measurement figures.....	224
Tubing cutoff tool.....	225

NOTICE—It is the intention of this magazine to provide its readers with information regarding the latest developments in the mechanical arts. Except where otherwise indicated, this magazine has no information as to any unexpired patents in respect of the developments reported herein. In the event that commercial use is to be made of any of the developments reported herein, it is suggested that legal counsel be consulted to avoid liability for patent infringement. It is not the purpose of this magazine to encourage patent infringement but, as indicated, it is the intention of this magazine to report on the latest developments in the mechanical arts.

DON'T DECIDE YOUR FUTURE UNTIL YOU HAVE READ



How To Make Big Money Fast in the Accident Investigation & Adjusting Field

A. J. Allen earned over \$2,000 in ten weeks. Gary Williams doubled his former salary. Jessie Hill says "Had I not learned of Universal Schools' Accident Investigator Course I would still be just another time card puncher; but today I have a wonderful position, and I receive \$3.00 an hour plus an expense allowance."

RIGHT NOW the Accident Investigation and Adjusting Field offers you a tremendous future. Here's why: *This vital business distributes more money than any other service industry.* Last year alone over 200 MILLION ACCIDENTS had to be investigated for Insurance Companies, Airlines, Railroads, Steamship Lines, and Government Offices — and the need for trained men is booming!

You can investigate full time for one company — or earn \$3 to \$10 an hour in *your own business*. No prior experience or higher education needed. And age is no barrier. Here is a field wide open to men 18 to 60.

NOW! FREE Book Gives You All the Facts

Send TODAY for new, illustrated Book mailed FREE. Learn how you can prepare at home in just a few weeks for excellent full time or spare time income. See for yourself how others have doubled and even tripled their earnings. Let us show you how Universal Schools has trained hundreds of men in their own homes spare time — and then helped them add thousands of dollars to their incomes. Absolutely no obligation on your part. No salesman will call. Write at once to me, M. O. Wilson, Universal Schools, 6801 Hillcrest Ave., Dallas 5, Texas.

Mr. M. O. Wilson, Dept. PM-3
 Universal Schools, 6801 Hillcrest Ave.,
 Dallas 5, Texas
 Send me free book on Big Money in Accident
 Investigating & Adjusting Field. No salesman will call.

Name..... Age.....
 Address.....
 City..... Zone..... State.....



How to build a big-pay future in the Air Conditioning and Refrigeration industry with CTI Home Training Kits

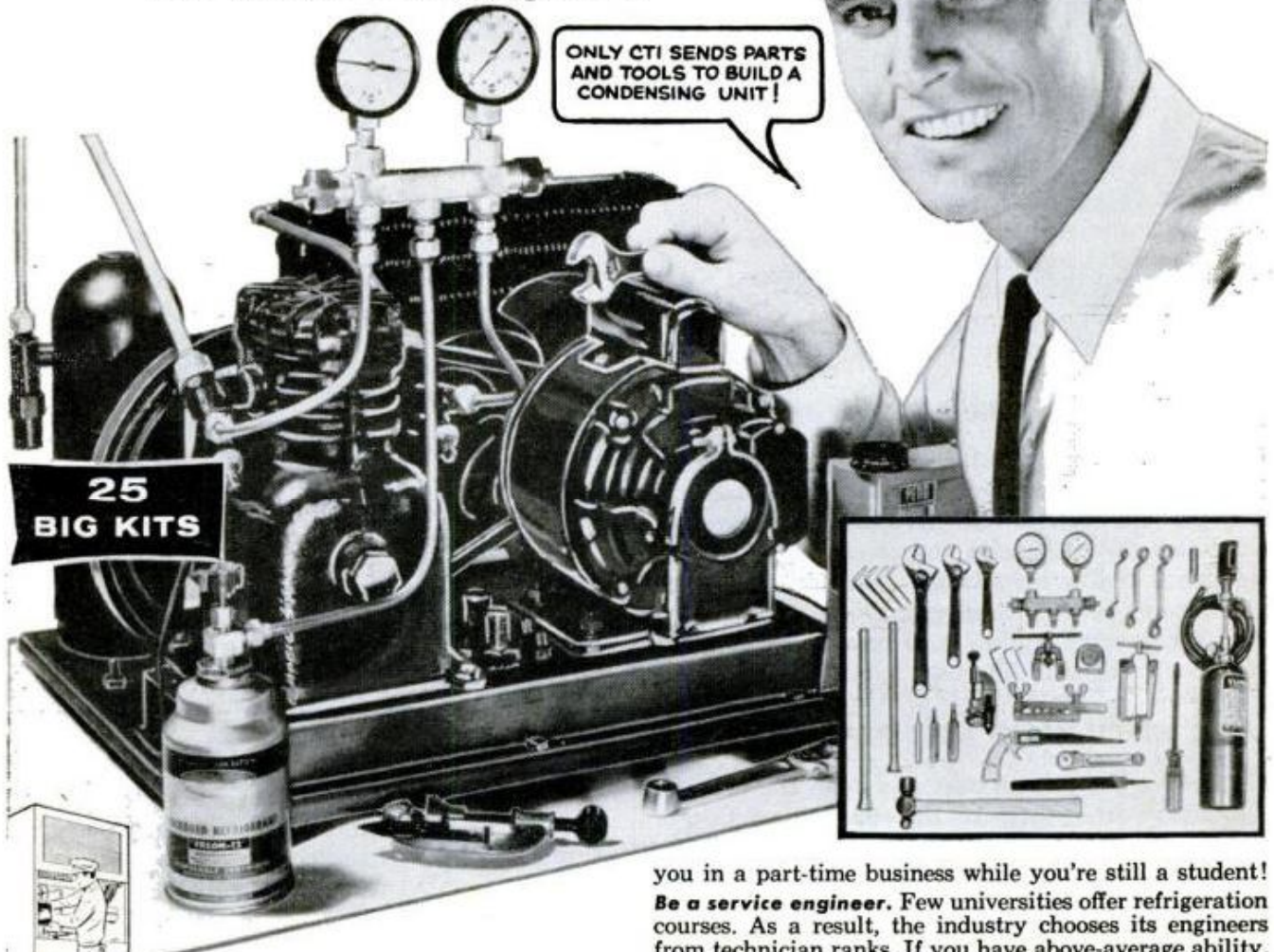

A better job or your own business

The news is spreading fast: America's finest opportunity field is now Air Conditioning and Refrigeration! Today there are over 150 million domestic and industrial units in use. Over 6 million new freezers, refrigerators and air conditioners are manufactured annually. So quickly is the industry expanding that 20,000 service technicians must be trained each year. Yes, air conditioning is a big, uncrowded field where the opportunities are as large as the paychecks!

Learn at home by practicing. It's easy to master this craft. CTI sends you 25 kits of parts and tools to build a heavy-duty, commercial-type, 1/4 h.p. condensing unit (illustrated above). You complete 23 work projects—do 10 trouble-shooting jobs. Then you build an air conditioner, freezer, refrigerator or milk cooler.

Make money as you train. So practical is CTI training that many students earn extra cash fixing and installing. Some make calls on their own; others work for local appliance dealers. CTI training pays its way—actually puts

you in a part-time business while you're still a student! **Be a service engineer.** Few universities offer refrigeration courses. As a result, the industry chooses its engineers from technician ranks. If you have above-average ability, you too may get into planning and estimating—the engineering phase of a great business.

Go in business. This is one of the easiest of all fields in which to start small and grow big. You make friends as you make calls, and build a list of potential customers. You also can sign service contracts with food stores, taverns, motels, restaurants, etc. CTI has special information on how to get started.

Write for new catalog. Your opportunities in the air conditioning and refrigeration industry are thoroughly covered in our big new booklet. *Mail coupon for your free copy.* We'll also send a lesson sample so you can see for yourself how easy it is to learn this top-pay, secure craft. Be sure to mail coupon today.—Commercial Trades Institute, Chicago 26, Illinois.

FIRST GET THE FACTS—THEN DECIDE
Mail Coupon Today for 2 Free Booklets

COMMERCIAL TRADES INSTITUTE

1400 GREENLEAF AVENUE
CHICAGO 26, ILLINOIS

DEPT. R-696

Send catalog, *Success in Air Conditioning & Refrigeration*, and Lesson Sample. Both FREE.

Name _____ Age _____

Address _____

City _____ Zone _____ State _____



HOW A FEW LOW-COST PARTS CAN GIVE YOUR CAR THOUSANDS OF EXTRA MILES!

Which parts to replace is as important as when to replace

Nobody wants to put out good money for an engine overhaul if there's no real need for one. But when key parts such as bearings are too far gone, your car engine can no longer operate efficiently.



WHEN TO GET AN OVERHAUL

Know the signs, and you'll know the time. You'll probably notice that your engine has lost much of its original pep. Gas mileage drops off, oil consumption begins to get out of hand . . . and your engine may knock or misfire. Your car isn't ready to be retired yet. Do as fleet owners do. Treat your engine to a *complete* overhaul. Your car will purr like new again.

WHICH PARTS NEED REPLACING

Get a first class mechanic, and *don't compromise on parts*. Parts represent the smallest portion of the cost. You'll probably need new main, connecting rod, and camshaft bearings. These bearings control the amount of oil that lubricates vital parts in your motor. And for bearings to give proper oil clearances, they must be manufactured to tolerances as small as .00025".

FEDERAL-MOGUL MEANS LONG SERVICE

Your car engine is a precision mechanism, and bearings—main, connecting rod and camshaft—are the very heart of it. Yet it costs no more to use the best—Federal-Mogul. Ask any mechanic. *There's a Federal-Mogul engine bearing to fit every domestic and leading imported make of car.*



FEDERAL-MOGUL SERVICE



Division of Federal-Mogul-Bower Bearings, Inc. • Detroit 13, Michigan

Sidelights from the PENTAGON

By William R. Kreh

When men of the Navy's Experimental Air Squadron 6 return from this year's expedition in the Antarctic, they may seem a little buggy.

But don't blame it all on the six months of isolated duty at the South Pole.

They've been contributing to the advancement of scientific knowledge—by collecting bugs, no less.

The icy insects were needed by entomologists on Operation Deepfreeze 60 who wanted to see just what kind of bugs would live in the icy wastes. It's believed that the insects aren't there by their own choices; that they're blown there on winds from South America.

So it's reported that everywhere you look around the Navy camp at McMurdo base are brightly colored butterfly-like nets. And the Navy men devised two net sleeves on a specially constructed hoist that swings them out of the doors of one of their single-engine planes. At least three times a week, the flight schedule lists a three-hour "bug run."

The Army's trying to come up with a dual-purpose carton for combat-type meals.

The idea is to find a carton that can be used as a package and later converted to a stove. One example would be a box which, when emptied, would make a stove with legs. Water could be added to the bottom of the box, a fuel table set underneath, food on top, and presto—one short order coming up.

The Air Force is testing a remotely controlled "decontamination sweeper" designed to keep bases operating in case of a radioactive fallout.

Weighing 10 tons, the giant vacuum cleaner can be used either as a remotely controlled sweeper in case of atomic attack, or as a manually operated cleaner for routine sweeping of ramps, runways and hangars.

Equipped with a radio guidance system and three TV cameras, it can be operated from as far as five miles away.

NOW!
at a price
you can afford!

MAKE MORE MONEY in TELEVISION RADIO-ELECTRONICS

**BETTER...MORE COMPLETE...LOWER COST...
WITH NATIONAL SCHOOLS SHOP-METHOD
HOME TRAINING!**

BETTER... Training that is proved and tested in Resident School shops and laboratories, by a School that is the **OLDEST** and **LARGEST** of its kind in the world.

MORE COMPLETE... You learn **ALL PHASES** of *Television-Radio-Electronics*.

LOWER COST... Other schools make several courses out of the material in our **ONE MASTER COURSE . . .** and you pay more for less training than you get in our course at **ONE LOW TUITION!**



These **FREE** books will show you how!

You get all information by mail . . . You make your own decision . . . at home! **NO SALESMAN WILL CALL**

TOP PAY... UNLIMITED OPPORTUNITIES LIFETIME SECURITY CAN BE YOURS!

You are needed in the Television, Radio, and Electronics industry! Trained technicians are in growing demand at excellent pay—in **ALL PHASES**, including Servicing, Manufacturing, Broadcasting and Communications, Automation, Radar, Government Missile Projects.

NATIONAL SCHOOLS SHOP-METHOD HOME TRAINING, with newly added lessons and equipment, trains you in your spare time at home, for these unlimited opportunities, including many technical jobs leading to supervisory positions.

YOU LEARN BY BUILDING EQUIPMENT WITH KITS AND PARTS WE SEND YOU. Your National Schools course includes thorough *Practical training—YOU LEARN BY DOING!* We send you complete standard equipment of professional quality for building various experimental and test units. You advance step by step, perform more than 100 experiments, and you build a complete TV set from the ground up, that is yours to keep! A big, new TV picture tube is included at no extra charge.

EARN AS YOU LEARN. We'll show you how to earn extra money right from the start. Many of our students pay for their course—and more—while studying. So can you!

RESIDENT TRAINING AT LOS ANGELES

If you wish to take your training in our Resident School at Los Angeles, the world's TV capital, start **NOW** in our big, modern Shops, Labs and Radio-TV Studios. Here you work with latest Electronic equipment - - professionally installed - - finest, most complete facilities offered by any school. Expert, friendly instructors. Personal attention. Graduate Employment Service. Help in finding home near school - - and part time job while you learn. Check box in coupon for full information.

LESSONS AND INSTRUCTION MATERIAL ARE UP-TO-DATE, PRACTICAL, INTERESTING. Every National Schools Shop-Method lesson is made easy to understand by numerous illustrations and diagrams. All instruction material has been developed and tested in our own Resident School Shops, Laboratories and Studios.

SEND FOR INFORMATION TODAY . . . it can mean the difference between **SUCCESS** and failure for you! Send for your **FREE BOOK** "Your Future in Television-Radio-Electronics" and **FREE Sample Lesson.** Do it **TODAY**, while you are thinking about your future. It doesn't cost you anything to investigate!

GET THE BENEFITS OF OUR OVER 50 YEARS EXPERIENCE

Approved for
GI Training



NATIONAL SCHOOLS

Los Angeles 37, Calif.

YOU GET.

- 19 Big Kits—**YOURS TO KEEP!**
- Friendly, Instruction and Guidance
- Job Placement Service
- Unlimited Consultation
- Diploma—Recognized by Industry
- **EVERYTHING YOU NEED FOR SUCCESS!**

SHOP-METHOD HOME TRAINING COVERS ALL PHASES OF INDUSTRY

1. Television, including Color TV
2. Radio AM & FM
3. Electronics for Guided Missiles
4. Sound Recording and Hi-Fidelity
5. FCC License
6. Automation and Computers
7. Radar & Micro-Waves
8. Broadcasting and Communications

NATIONAL TECHNICAL SCHOOLS

WORLD-WIDE TRAINING SINCE 1905

MAIL NOW TO

National Technical Schools, Dept. RB-30
4000 S. FIGUEROA ST., LOS ANGELES 37, CALIF.

Rush free TV-Radio "Opportunity" Book and sample lesson. No salesman will call.

NAME _____ AGE _____

ADDRESS _____

CITY _____ ZONE _____ STATE _____

Check if interested **ONLY** in Resident School training at Los Angeles.

VETERANS: Give date of Discharge _____

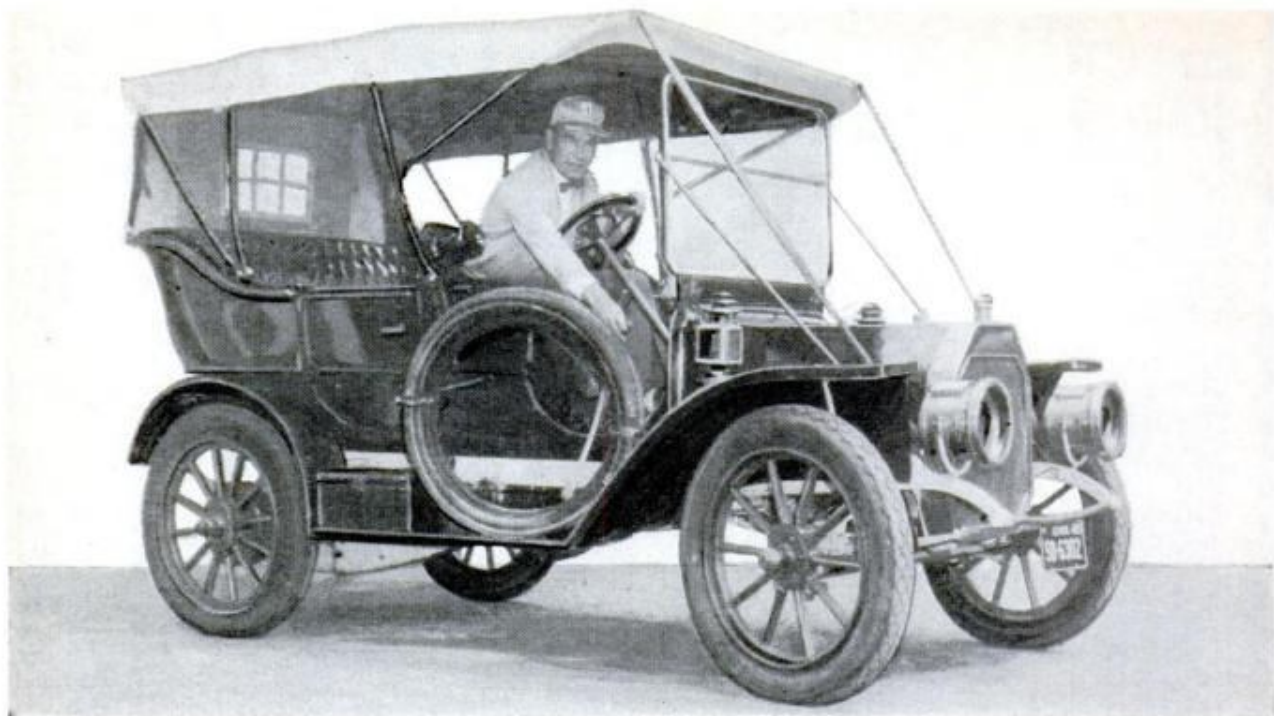

Do You Know This Old-Timer?

One of few still around, this two-cylinder touring car at one time was manufactured by the founder of a famous washing machine company bearing his name. A

product of the Midwest, the car was built at Waterloo, Iowa, for just a few years shortly after the turn of the century. If you have trouble naming it, turn to page 71.

Big Volume and Big Profits are yours...with versatile
“Two-Way” Grinding Option on the
NEW IDEAL 900
LAWN MOWER
SHARPENER

New heavy-duty IDEAL MODEL 900 sharpener precision grinds either by “hook” or “straight-line” method for EXTRA VOLUME and EXTRA PROFIT. Unit sharpens all kinds of reel-type mowers from the smallest edger to the largest fairway or power machine.

Outstanding Features Include:

- Gravity Feed • Screw-type Adjustments
- 1/2 h.p. Motor • 6-inch Grinding Wheel
- Includes Bed-knife Grinding Bar, Reconditioner and Tool Tray

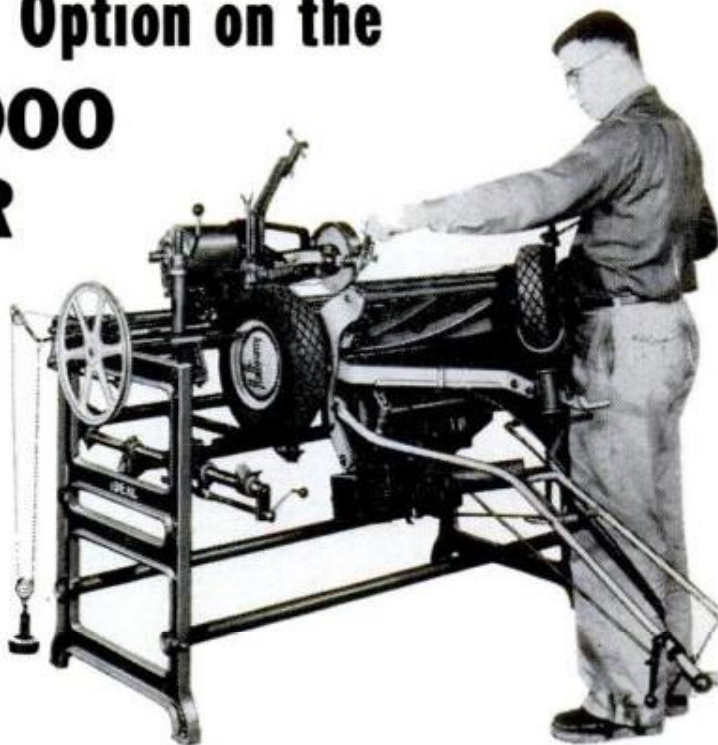

THE FATE-ROOT-HEATH COMPANY
 Dept. PM-3, Plymouth, Ohio

Write Today For Full Details On The
NEW IDEAL MODEL 900



Now! Work Over 300 PRACTICAL PROJECTS with these PARTS AT HOME!



to help You learn ELECTRONICS RADIO-TELEVISION-RADAR

NOW . . . at home in your spare time you can get the very kind of training and subsequent Employment Service you need to get started toward real earnings in one of today's brightest opportunity fields—TELEVISION-RADIO-ELECTRONICS. Now that Electronics is entering so many new fields, here is a chance of a lifetime to prepare to cash in on its remarkable growth.

DeVry Tech's amazingly practical home method enables you to set up your own HOME LABORATORY. You spend minimum time to get maximum knowledge from over 302 practical projects, using the same type of basic equipment used in our modern Chicago and Toronto Training Centers!

DeVry Tech Provides EVERYTHING YOU NEED . . .

—to help you master TV-ELECTRONICS. In addition to the home laboratory and easy-to-read lessons, you even use HOME MOVIES—an exclusive DeVry Tech advantage. You watch hidden actions . . . see electrons on the march. Movies help you to learn faster . . . easier . . . better.

LABORATORY TRAINING

Full time day and evening training programs in our modern Chicago and Toronto Laboratories are also available. MAIL COUPON TODAY for facts.

EARN WHILE YOU LEARN

DeVry Tech's practical training helps you toward spare time income servicing Radio and Television sets.

BUILD and KEEP Valuable TEST EQUIPMENT

As part of your training, you build and keep a fine Jewel-Bearing Vacuum Tube VOLT METER and a 5-inch COLOR OSCILLOSCOPE—both high quality, needed test instruments.

EFFECTIVE EMPLOYMENT SERVICE

Get the same Employment Service that has helped so many DeVry Tech graduates get started in this fast-growing field.



"One of North America's Foremost Electronics Training Centers"

Accredited Member of National Home Study Council



DeVRY TECHNICAL INSTITUTE
CHICAGO 41, ILLINOIS

VACUUM TUBE VOLTMETER



5-INCH COLOR OSCILLOSCOPE



21 INCH
Build and keep this BIG DeVry Engineered TV set—easily converted to U.H.F. (DeVry offers another home training, but without the TV set.)

✓ CHECK These Exciting Job Opportunities:

- TV-Radio Broadcast Technician
- Color Television Specialist
- Radar Operator
- Laboratory Technician
- Airline Radio Man
- Computer Specialist
- Quality Control Manager
- Your Own Sales & Service Shop
- . . . PLUS MANY OTHERS

MAIL COUPON TODAY!

DeVRY TECHNICAL INSTITUTE
4141 Belmont Ave., Chicago 41, Ill., Dept. PM-3-Q

Please give me your FREE booklet, "Electronics in Space Travel," and tell me how I may prepare to enter one or more branches of Electronics.

Name _____ Age _____
PLEASE PRINT
Street _____ Apt. _____
City _____ Zone _____ State _____
2045 Canadian residents address DeVry Tech of Canada, Ltd.
626 Roselawn Ave., Toronto 12, Ontario

My name is Charles Atlas. I can't promise you'll win the title of "World's Most Perfectly Developed Man" as I did. But I do believe I can make a powerful He-Man out of you-- in a very short time. In fact, you can prove it to yourself-- at my risk. During the last 30 years I've turned thousands of weaklings into human dynamos of strength and endurance. My big free book tells how my secret of "Dynamic Tension" may be able to do such a job for you. No cost or obligation. Where shall I send your copy?

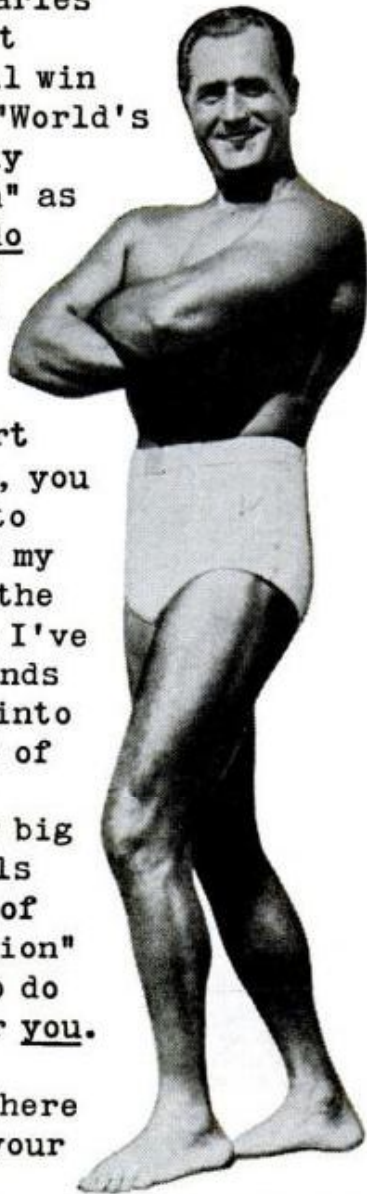

FREE BOOK

Mail coupon now for FREE 32-page book. Tells how I can give you "Stand-Out" muscles—how "Dynamic Tension" can make you a new man—confident, popular, successful. See actual photos of men who became "Atlas Champions." Read answers to vital questions about your health,

your personality, your future. Rush coupon to me personally: **CHARLES ATLAS, Dept. 83, 115 E. 23 St., N.Y. 10, N.Y.**



**CHARLES ATLAS, Dept. 83,
115 East 23rd St., N. Y. 10, N. Y.**

Dear Charles Atlas—Here's the Kind of Body I Want:
(Check as many as you like)

- | | |
|---|---|
| <input type="checkbox"/> Slimmer Waist, Hips | <input type="checkbox"/> More Powerful Arms, Grip |
| <input type="checkbox"/> Broader Chest, Shoulders | <input type="checkbox"/> More Powerful Legs |
| <input type="checkbox"/> More Weight, Solid | <input type="checkbox"/> Better Energy, Sleep |

Send me, absolutely FREE, a copy of your famous book showing how "Dynamic Tension" can make me a new man. 32 pages, crammed with photographs, answers to vital questions, and valuable advice. No obligation.

Name..... Age.....
(Please Print or Write Plainly)

Address

City..... Zone.... State.....

Great Pioneers in Science Do You Know Them?

—By James S. Thistle—

ABOUT 100 YEARS AGO a distillery owner found that his beet-pulp vats were souring instead of fermenting to produce alcohol. He called in our scientist who discovered in the beet-pulp small rodlike forms called bacteria which caused it to sour.

By heating the beet-pulp mixture somewhat below the boiling point (about 150 degrees Fahrenheit) for 15 to 20 minutes, he discovered that most of the bacteria were destroyed. The same process is used today in milk-bottling plants to the benefit of all mankind. As a result of this discovery he is known as the "Father of Bacteriology."

Further investigations by our scientist revealed that certain infectious diseases are caused by specific micro-organisms. This he called the germ theory of disease. Experimenting in this field, he discovered vaccines to prevent rabies in humans and anthrax in animals. His work also laid the foundation for study and control of cholera, tuberculosis, tetanus and diphtheria.

*These letters, unscrambled,
spell the name of this
month's Great Pioneer
in Science:*

USAROULETSP I

(First and Last Names)

Write the correct name here:

Now turn to page 85 for the answer.

WHAT ALL AUTO MECHANICS WANT TO KNOW

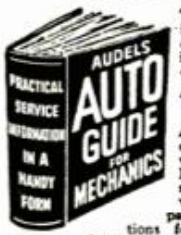

This Big Practical Book gives full information, with working diagrams, covering the principles, construction, ignition, service and repair of modern cars, trucks and buses.

Air Conditioners, Hydramatic & Fluid Drives Fully Explained.

A complete guide of 1132 Pages, with over 1000 Illustrations showing inside views of working parts, with instructions for service jobs. Completely up-to-the-minute! Priced at only \$6.
CIRCLE No. 1 IN COUPON

HOW TO FIX HOME APPLIANCES

REFRIGERATORS WASHERS TOASTERS DRYERS IRONERS RANGES VACUUMS FREEZERS

Many other GAS AND ELECTRIC APPLIANCES



Handy Reference for Electric & Gas Servicemen, Mechanics, Dealers and Homeowners. Explains clearly and simply how to locate troubles, how to test, reassemble and connect. Wiring diagrams. 1000 Facts. Easy to read. Answers ALL your questions. 864 Pages. Illustrated. Only \$6.
CIRCLE No. 2 IN COUPON



TV TELLS HOW TO ANSWER RADIO AND TELEVISION REPAIRMEN, SERVICEMEN AND STUDENTS

HERE IS LATE INFORMATION IN A HANDY FORM FOR RADIO AND TELEVISION REPAIRMEN, SERVICEMEN AND STUDENTS

TWO COMPLETE VOLUMES—1568 Pages—1085 Illustrations and Diagrams. 1001 Important Facts and Figures on Modern T.V., Radio, Electronic Devices. INCLUDES TRANSISTORS & Transistor Circuits, Rectifiers, Record Changers, P.A. Systems, Phonograph Pick-ups, F.M., Auto Radio, Short Wave.

Basic principles, Construction, Installation, Operation, Troubleshooting, How to Sharpen, Clear T.V. Pictures. Install Aerials. How to Test. Explains COLOR SYSTEMS, Methods of Conversion, Terms, etc. Includes Ultra High Frequency. Quick ready reference or use as a home study course. Only \$8 for BOTH volumes.
CIRCLE No. 3 IN COUPON

OIL BURNERS

New, complete, explaining in detail both domestic and industrial oil burners. Includes electrical hook-ups and wiring diagrams. Fully covering the theory, construction, installation, operation, testing, servicing and repair of all equipment. Indexed for ready reference. Over 416 Pages. 320 Illustrations and Diagrams. Only \$2.
CIRCLE No. 28 IN COUPON

ALL TYPES OF BLUEPRINT READING

How to read scales, the standard symbols, detail and assembly prints, working drawings, short cuts, helps, hints and suggestions. THE MAN WHO CAN READ BLUEPRINTS IS IN LINE FOR A BETTER JOB. This book gives you the secret language, step by step in easy stages. 448 Pages. Very Fully Illustrated. Priced at \$3.
CIRCLE No. 25 IN COUPON

PLUMBERS AND STEAMFITTERS' GUIDES

Practical Trade Assistant & Reference Set. Explains in plain language and by clear illustrations, diagrams, charts, graphs and pictures the principles of modern plumbing practice including Pipe Fitting and Air Conditioning. 4 Vols.—2624 Pages—3642 Diagrams & Illustrations. Only \$8 for the complete set of 4 vols.
CIRCLE No. 6 IN COUPON

7-DAY FREE EXAMINATION

SEND NO MONEY—Pay the postman nothing! We are glad to send you any of the Audel Guides for absolutely FREE examination in your own home. We take all the risks and leave all the decisions up to YOU. There is no obligation! If you decide to keep the books of your choice you may pay for them under our astounding easy-pay plan of only \$2 a month.

HERE IS ALL YOU DO

IT'S EASY TO ORDER: In the No-Risk Mail Order Coupon at the right just draw a circle around the number of Audel Guides you want us to send you for FREE EXAMINATION. We will send them to you at once to help you build a brighter future by increasing your SKILL. If for any reason at all you are not COMPLETELY satisfied, return the books to us, and that will end the matter! NO STRINGS OR CATCHES TO THIS OFFER.

THEO. AUDEL & CO.
49 West 23rd Street, New York 10, N.Y.

MARCH 1960

CARPENTERS AND BUILDERS GUIDES



PRACTICAL STOREHOUSE OF MODERN CONSTRUCTION INFORMATION (4 vol. set) for carpenters and all woodworkers. Explains in easy language and by profuse illustration principles, advances, short cuts, trade secrets, all based on the NEWEST information. Vol. 1—Tools, steel square, saw filing, joinery, furniture, etc.; Vol. 2—Builders' mathematics, drawing plans, specifications, estimates, etc.; Vol. 3—House and roof framing, laying out, foundations, etc.; Vol. 4—Doors, windows, stair building, millwork, painting, etc. 4 vols. 1904 pages. 3700 Illustrations. Whole set only \$8. **CIRCLE No. 8 IN COUPON**

PRACTICAL ELECTRICITY

A COMPLETE HANDBOOK—Quick, simplified, ready reference. Complete instruction and practical information on the rules and laws of electricity—Maintenance of Machinery—A.C. and D.C. Motors—Armatures—Wiring Diagrams—House Lighting—Power Wiring—Meters—Batteries—Transformers—etc. Simple to understand. 1052 Pages. 2600 Illustrations. Priced at \$5. **CIRCLE No. 4 IN COUPON**

DIESEL

ALL THERE IS TO KNOW ABOUT MODERN DIESEL ENGINES—Basic principles, starting valves, timing, fuel pumps, fuel injection compressor, air compressor, pistons, cylinder, lubrication, cooling systems, etc. Answers on operation, calculations. 640 Pages. Fully Illustrated. Priced \$3.
CIRCLE No. 9 IN COUPON

MASONS & BUILDERS GUIDES

A PRACTICAL ILLUSTRATED 4 VOL. SET—Explaining in clear, simple language and profuse illustration, principles, advances, short cuts, trade secrets, based on modern practice—including how to figure and calculate various jobs. Vol. 1—Brick work, bricklaying, bonding, design. Vol. 2—Brick foundations, arches, tile setting, estimating. Vol. 3—Concrete mixing, placing forms, reinforced stucco. Vol. 4—Plastering, stone masonry, steel construction, blueprints. 4 Vols. 1440 Pages. 2067 Illustrations. Complete Set only \$8.
CIRCLE No. 26 IN COUPON

MATHEMATICS MADE EASY

A COMPLETE HOME STUDY COURSE—Starting with the first principles of arithmetic, advancing step by step through the various stages of mathematics, including the rules and calculations for mechanical and electrical problems. New EASY correct methods. Includes plane and solid geometry, trigonometry, algebra, calculus, etc. Practical tests, reference tables and data. How to use slide rule. 672 Pages. 550 Illustrations. Priced at only \$3.
CIRCLE No. 11 IN COUPON

NEW MACHINISTS AND TOOLMAKERS HANDBOOK

MODERN MACHINE SHOP PRACTICE—For every Machinist, Toolmaker, Draftsman of Student. Tells how to set up and operate lathe, screw and milling machines, shapers, drill presses and all other machine tools. A COMPLETE INSTRUCTOR AND REFERENCE BOOK. 1250 Pages. Fully Illustrated. Priced at only \$6.
CIRCLE No. 12 IN COUPON

ELECTRIC MOTORS

THIS GUIDE covers the construction, hook-up, control, maintenance and trouble shooting of all types of motors. Includes armature winding. Explains entire subject in great detail in simple language. Over 1056 Pages of information. 617 Diagrams. All types of motors fully illustrated and indexed for ready reference. Priced at only \$5.
CIRCLE No. 27 IN COUPON

REFRIGERATION & AIR CONDITIONING

FOUR BOOKS IN ONE—basic principles, servicing, operation, repair of: 1. Household Refrigeration. 2. Special Refrigeration Units. 3. Commercial & Industrial Refrigeration. 4. Air Conditioning Systems. A GOLD MINE of essential information. Completely up-to-date. 1360 Pages. Fully Illustrated and Indexed. Priced at only \$6. **CIRCLE No. 14 IN COUPON**

New MECHANICAL DICTIONARY

THE AUTHORITATIVE WORD BOOK FOR MECHANICS TECHNICIANS AND STUDENTS

With the revolutionary progress being made today in all mechanical fields, new words and phrases come into use. Any mechanic who wants to be up to date must know this new trade language.

Audels New Mechanical Dictionary gives you all these new words and also the old. Every mechanic will find his job made easier if he knows the exact meaning and use of technical words that come up every day at work. It is an engineer's shop companion and a student's guide.

TABLES, FORMULAS, PROCESSES AND PRACTICAL SUGGESTIONS

Constant use of Audels New Mechanical Dictionary will increase your knowledge and skill in a matter of days without any conscious effort on your part. The right word at the right time is like the right tool — be sure you have it and use it! Defines 17,000 words — terms phrases — rules and formulas, 712 pages only \$6.95.
CIRCLE No. 44 IN COUPON

THE NEW ELECTRIC LIBRARY

A COMPLETE ENCYCLOPEDIA explaining in the simplest terms the fundamental principles, rules and applications of applied electricity.

A COMPLETE COLLEGE EDUCATION! Fully illustrated with diagrams and sketches, calculations and tables for ready reference. Questions and answers. Trial tests for practice study and review. All based on the most modern theory.

- Vol. 1—Principles and rules of electricity, magnetism, armatures, repairs. No. 15
- Vol. 2—Dynamos, DC Motors, construction, installation, maintenance, etc. No. 16
- Vol. 3—Testing instruments and tests, storage battery constr. and repairs. No. 17
- Vol. 4—Alternating current, power factor, alternators, transformers. No. 18
- Vol. 5—A.C. Motors, windings, maintenance, converters, switches, fuses, etc. No. 19
- Vol. 6—Relays, condensers, regulators, rectifiers, meters, switchboards, etc. No. 20
- Vol. 7—Wiring, house light and power, circuits, high tension, plants, code, etc. No. 21
- Vol. 8—Railways, signals, elevators, ignition, etc. No. 22
- Vol. 9—Radio, telephone, telegraph, television, motion pictures. No. 23
- Vol. 10—Refrigeration, illumination, welding, x-ray, electrical appliances, Index. No. 24

6,000 fully illustrated pages. Priced at only \$20 for the ENTIRE SET. Also sold individually for \$2 each.



WELDERS GUIDE

Covers Electric, Oxy-acetylene, Thermit, Unionmelt welding for sheet metal, spot and pipe welds, pressure vessels and aluminum, copper, brass, bronze and other metals. Airplane work, surface hardening, hard facing, cutting, brazing, etc. 608 Pages. Fully Illustrated. Only \$3.
CIRCLE No. 10 IN COUPON

ADDITIONAL IMPORTANT TITLES

The following Audel Guides are all the best in their fields, written in clear simple fashion, all lavishly illustrated. Circle the numbers wanted in the MAIL ORDER COUPON below. All books are sent for FREE EXAMINATION.

- No. 5 TRUCK & TRACTOR GUIDE. 1376 Pages \$5.00
- No. 7 PAINTING & DECORATING MANUAL. 417 Pages 3.00
- No. 13 WIRING DIAGRAMS (Light & Power). 304 Pages 2.00
- No. 29 SHEET METAL PATTERN LAYOUTS. 1152 Pages 7.50
- No. 30 SHEET METAL WORKERS HANDY BOOK. 448 pages 2.00
- No. 31 MECHANICAL DRAWING GUIDE. 192 Pages 2.00
- No. 32 MECHANICAL DRAWING AND DESIGN. 410 Pages 3.00
- No. 33 ELECTRONIC DEVICES. 304 Pages 2.00
- No. 34 ELECTRICIANS EXAMINATIONS. 272 Pages 3.00
- No. 35 ELECTRIC POWER CALCULATIONS. Page 480 3.00
- No. 36 ELECTRIC DICTIONARY. 9000 Terms 3.00
- No. 37 POWER PLANT ENGINEERS GUIDE. 1568 Pages 5.00
- No. 38 ENGINEERS AND FIREMANS EXAMS. 544 Pages 2.00
- No. 39 OPERATING ENGINEERS LIBRARY. 3 Book Set 12.00
- No. 40 PUMPS, HYDRAULICS AND AIR COMPRESSORS. 1760 Pages 6.00
- No. 41 HOUSE HEATING GUIDE. 966 Pages 5.00
- No. 42 MILLWRIGHTS & MECHANICS GUIDE. 1248 Pages 5.00
- No. 43 DO-IT-YOURSELF ENCYCLOPEDIA. 2 Book Set 8.95

MAIL THIS NO-RISK COUPON TODAY!

THEO. AUDEL & CO.—Self Improvement Publishers Since 1879— P 3 1 2 3 4 5 6
49 W. 23rd Street, New York 10, N. Y.

Please mail me for 7 days' FREE EXAMINATION the books I have circled at right. I agree to mail \$2 in 7 days on each book or set ordered, and to further mail \$2 a month on each book or set ordered until I have paid the purchase price, plus shipping costs. If I am not completely satisfied with my Audel Guides I may return them.

NAME _____ 7 8 9 10 11
ADDRESS _____ 12 13 14 15 16
OCCUPATION _____ 17 18 19 20 21
EMPLOYED BY _____ 22 23 24 25 26
27 28 29 30 31
32 33 34 35 36
 SAVE SHIPPING COSTS! Check here if you enclose complete payment with order. We pay postage charges. You have same return privilege. 37 38 39 40 41
42 43 44



PLAY RIGHT AWAY! ANY INSTRUMENT

... even if you don't know
a single note of music now!

IMAGINE! Even if you never dreamed you could play . . . you can soon surprise your friends with your musical ability.

No special talent or previous training needed. Clear, simple directions tell you exactly what to do, so you can't go wrong! Spend a few minutes a day—and only a few cents per lesson. Teach yourself piano, guitar, accordion, organ, any instrument. Play popular music, country music, hymns, classical, any other music—by note, quickly. Over ONE MILLION students have taken up music this famous way, including TV Star Lawrence Welk.



Stop Cheating Yourself of These Joys!

Popularity! New friends. Gay parties. Good times. Career. Extra Money . . . understand, appreciate, converse about music. Learn lives and compositions of modern and great masters . . . Relax! Banish worries and frustrations. Satisfy self-expression, creative urge. Gain self-confidence.

MAIL COUPON FOR FREE BOOK

See for yourself why our method has been successful for 62 years! Read the whole fascinating story of this wonderful method in 36-page illustrated book. For FREE copy, mail coupon. No obligation. No salesman will call.



U. S. School of Music,
Studio 303, Port Wash-
ington, N. Y.
Licensed by N. Y. State
Education Dept.



U. S. SCHOOL OF MUSIC
Studio 303, Port Washington, N. Y.

Please send me your 36-page illustrated Free Book. I'm interested in playing (name instrument) _____

I do I do NOT—have instrument now.

Name _____ Age _____
(please print)

Address _____

City _____ Zone _____ State _____

Over the Editor's Desk



IN ROHNER PARK at Fortuna, Calif., stands this monument to a beetle.

The hero of this unusual honor is the Klamath Weed Beetle, acclaimed for its part in ridding California of the Klamath weed (*Hypericum perforatum*), sometimes known as goatweed. An immigrant from

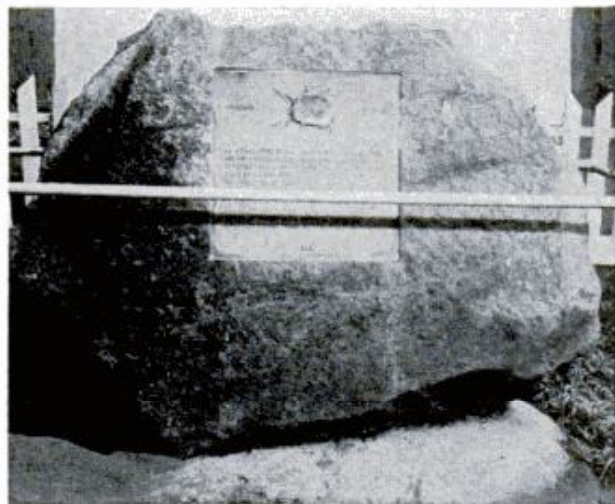

Europe, the weed by 1940 had overrun 250,000 acres of 27 California counties, depreciating land values and irritating cattle and sheep grazing on it. The beetle was imported from Australia in 1945-46 and went to work against the weed.

For the story of this and other battles of man and nature, turn to the article "Should We Let Nature Take Its Course," beginning on page 106.

☆☆☆

To the Editor:

I certainly enjoyed your automotive section in the January issue of PM.

Several of our library people were wondering if it would be possible to get a copy of the pull-out insert which starts on Page 145. They feel it is a good graphic history of the auto industry. Three copies would fill our needs if extras are available.

Fred A. Chapman,
Automobile Manufacturers Association,
Detroit, Mich.

☆☆☆

Ready-to-Frame Reprints Available

We still have a supply of the full-color pictorial history of "The American Automobile" which was originally published in our January auto issue. These colorful and informative reprints are 31 inches long, 10 inches high and printed on one side only. They will be mailed to you unfolded and ready for framing upon receipt of 25 cents

(Continued to page 20)



RCA INSTITUTES



OFFERS YOU THE FINEST OF HOME STUDY TRAINING

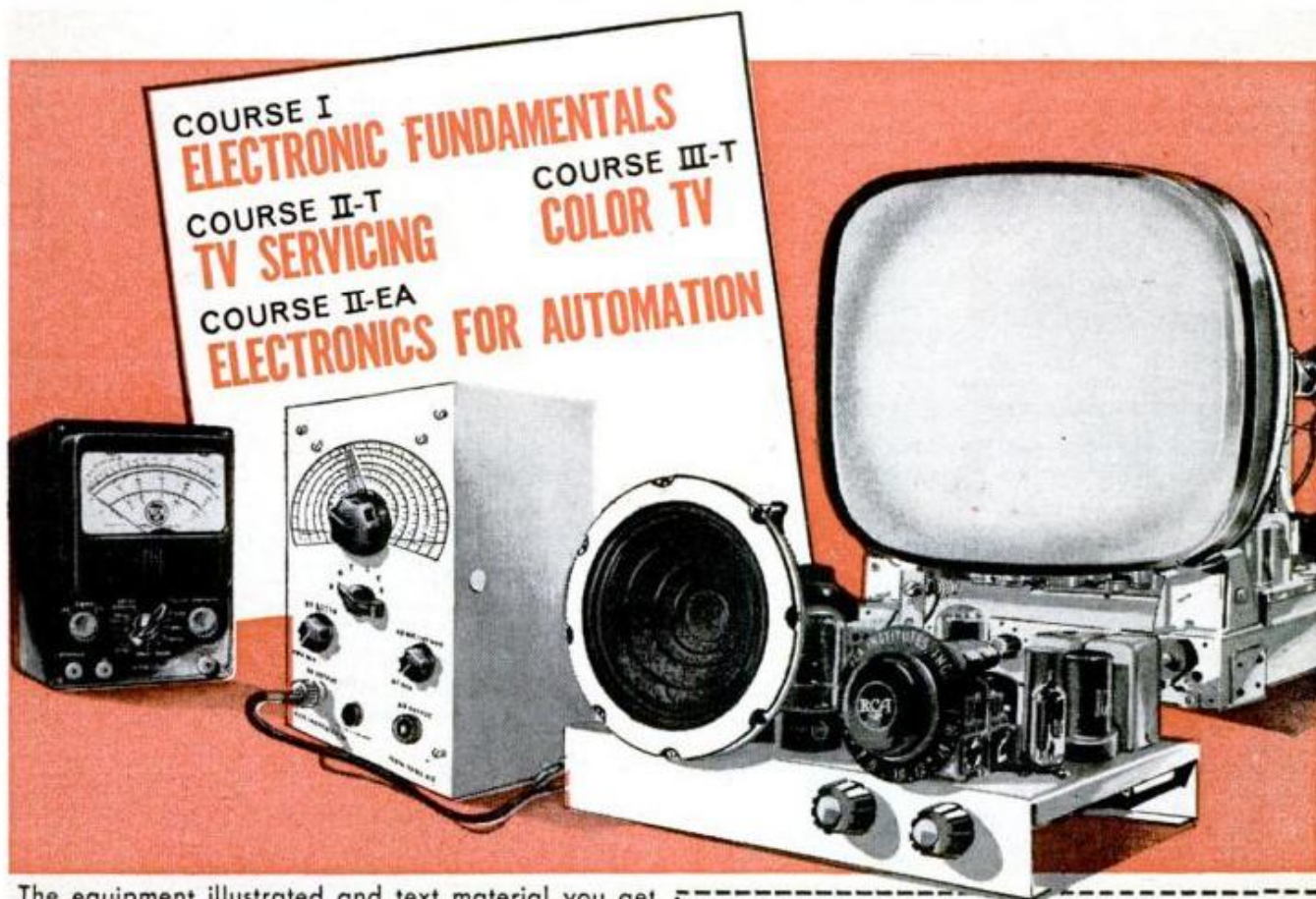

**COURSE I
ELECTRONIC FUNDAMENTALS**

**COURSE II-T
TV SERVICING**

**COURSE II-EA
ELECTRONICS FOR AUTOMATION**

**COURSE III-T
COLOR TV**

The equipment illustrated and text material you get with each course is yours to keep. Practical work with very first lesson. Courses for the beginner and the advanced student. Pay-as-you-learn. You need pay for only one study group at a time.

RCA INSTITUTES, Inc. Home Study School PM-30
A Service of Radio Corporation of America
350 West Fourth Street, New York 14, N. Y.
Without obligation, send me **FREE 64-page CATALOG**
on Home Study Courses. No salesman will call.



**SEND FOR THIS
FREE BOOK NOW**

Resident School courses in New York City and Los Angeles offer comprehensive training in Television and Electronics. Day and evening classes start four times each year. Detailed information on request.

Another way RCA serves education through electronics

Name Age

Please print

Address

City Zone State

Korean Vets! Enter discharge date

CANADIANS—Take advantage of these same RCA courses at no additional cost. No postage, no customs, no delay. Send coupon to:

RCA VICTOR COMPANY, LTD.
5001 Cote de Liesse Rd., Montreal 9, Que.

To save time, paste coupon on postcard

DRAFTSMEN



**CASH BIG
PAY CHECKS!**

**Train Now for
more success,
greater security**

**LEARN AT HOME IN SPARE TIME
(or at college in Chicago)**

Check the want ads in any newspaper—SEE the big-pay opportunities open to you as a draftsman. What's more, you can learn this well-paid, prestige profession at home — quickly, easily! No special talent needed. Get complete, step-by-step Chicago Tech lessons in the mail, spend a few pleasant hours studying each week. In a short time you'll be a well-trained draftsman, ready to take your pick of many good jobs. Act now!



Free Information—Mail Coupon Today!

Get FREE TRIAL LESSON plus information about C.T.C. practical training. Learn what successful Chicago Tech graduates say about high pay and opportunities in drafting. No charge, or obligation.

CHICAGO TECHNICAL COLLEGE

C-218 Tech Bldg., 2000 So. Michigan Ave.
Chicago 16, Illinois

Mail me FREE lesson with facts about big opportunities in DRAFTING.

Name _____ Age _____

Address _____

City _____ Zone _____ State _____

LEARN TO EARN

HIGH WAGES

AS A HEAVY EQUIPMENT OPERATOR!



Secure a high paying future in the exciting construction industry today! Learn to operate bulldozers, draglines, cranes, back hoes, scrapers and motor graders on our actual construction projects!

● ONLY CONTRACTOR OWNED AND OPERATED SCHOOL IN WORLD ● ASSOCIATE MEMBER ASSOCIATED GENERAL CONTRACTORS ● MODERN EQUIPMENT ● V. A. APPROVED FOR G. I. TRAINING ● BUDGET PAY PLAN AVAILABLE

WESTERN NATIONAL
SCHOOL
OF HEAVY EQUIPMENT
OPERATION

DEPT. B-2 BOX 310
WEISER, IDAHO PHONE 910



WRITE TODAY
FOR FREE
SCHOOL
CATALOG

in coin. Send your request to Bureau of Information, Dept. A-H, Popular Mechanics Magazine, 200 East Ontario St., Chicago 11.

☆☆☆

World's Highest Tower

Henry Whiting of Auburn, Me., takes issue with our description of Tokyo's new television tower as the "world's highest tower." The report appeared on page 128 of the January issue. The folks in Maine, he says, claim as the world's highest the television tower of station WGAN, on Brown Hill 25 miles from Portland—1619 feet high, compared with Tokyo tower's 1092 feet.

☆☆☆

Another World's Highest

You state that the Tokyo TV tower is the highest TV tower in the world. Please check your measurements again and you will find that the Tokyo Tower including the TV antenna is 518 feet shorter than KSWB TV in Roswell, N. Mex., which is 1610 feet above the ground plus 3600 feet above sea level so I guess we beat them pretty good.

Everett Griffin
Roswell, N.Mex.

☆☆☆

Homemade Golf Cart

There is an old saying that when a man gets too old to fish he starts playing golf. But what does a man do when he gets too old to walk around the golf course?

Most men would be content to settle down in the old rockin' chair, but not Adolph Birr. Adolph, who likes to make things almost as much as he likes to play golf, decided to make his own power golf cart. Adolph, 64, plans to retire in March. He is a powerhouse operator in the Niagara, Wis., mill of Kimberly-Clark Corporation, which manufactures paper products.

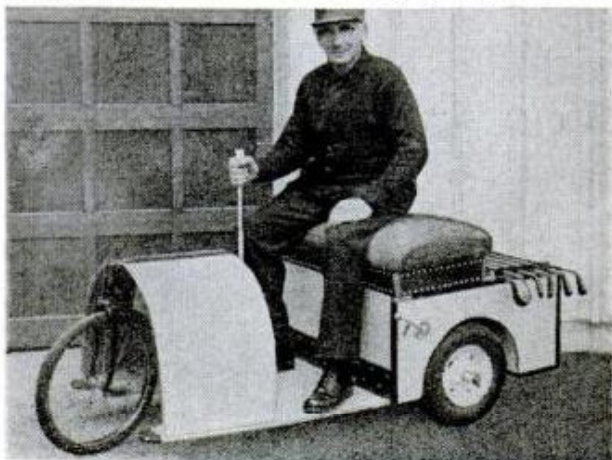

He started with a sheet of 1/2-inch plywood, reinforced it at strategic places, added two 16-inch wheelbarrow wheels and tires on the rear and a 20-inch bicycle wheel in front. It was necessary that the front

(Continued to page 22)

The STUDY of LAW

A "Must" for the ambitious man seeking Business Success!

... Can YOU answer these legal problems?

CASE #1 Jones wrote Smith making an offer. Smith wrote his acceptance and mailed it. Then he decided to call it off and telegraphed Jones to that effect. Jones got the telegram before he did the letter. May he hold Smith to the contract?

ANSWER: Yes. Both Smith and Jones became bound when the letter containing the acceptance was mailed.

CASE #2 Doe said to Crane, "I will sell you 100 shares of XY stock at \$50." Crane said, "I'll give you \$45." Doe, knowing the market was unsettled, said nothing, but an hour later tendered 100 shares and a bill for \$4,500. May he hold Crane?

ANSWER: No. Crane's counter-offer was a rejection of Doe's offer.

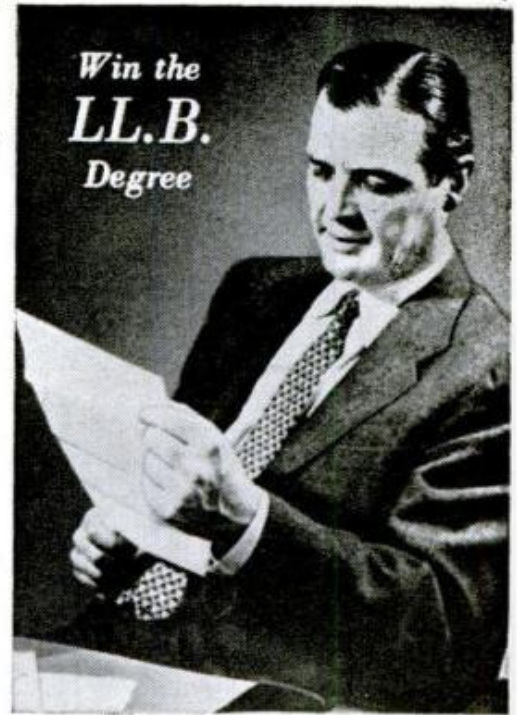

Law... A FASCINATING STUDY AND A LIBERAL EDUCATION

Law today is involved in practically everything we do—regardless of what our position or status in life may be. That's why thousands of ambitious men and women who never intend to practice are studying Law with LaSalle in spare time—not for a legal career but as an aid to business advancement.

Whether your work is related to banking, insurance, advertising, credit or collections, transportation, accounting, claim adjusting, merchandising, store proprietorship, partnership, brokerage, manufacturing—ANY FIELD—you need to understand and know Law.

The study of Law is a great help to men in every walk of life. Many physicians, clergymen, and other professional men are now studying Law with LaSalle as a matter of recreation, mental training, culture, as a necessary part of a liberal education.

Aside from the actual knowledge that you acquire, the reading of Law is conceded to be a superior developer of reasoning power. For all types of work, Law training develops keen, clear, quick, correct and decisive thinking. Reading a Law text is much more interesting to most people than a fiction story—you'll be learning the underlying principles of man's relation to society, his rights, privileges, and restrictions toward himself and his fellow man.

STUDY AT HOME—IN SPARE TIME

You can study American Law and Procedure right in your own home—advancing at your own pace. For over 50 years we have helped more than 1,400,000 ambitious men and women to greater success in the business world. You too can benefit, as have so many before you. Low cost—easy terms.

The training includes the 14-volume LaSalle Law Library—American Law and Procedure. This library has been compiled by leaders in the field of Law. It covers the whole basic field of Law in an orderly and easily understood manner that can be quickly learned. Collateral reading and printed lectures on legal problems supplement the text. Law instructors who are licensed attorneys personally supervise your program from the first assignment to the LL.B. Degree or Diploma.

SEND FOR TWO FREE BOOKS, "LAW TRAINING FOR LEADERSHIP" and "EVIDENCE"

If you are determined to enjoy the advantages of Law training—to prepare for greater future possibilities—send the coupon and get all the facts. The interesting and informative booklets, "Law Training for Leadership" and "Evidence" will be sent promptly, and without obligation. MAIL THE COUPON TODAY!

Accredited Member, National Home Study Council



A MOST UNUSUAL LAW LIBRARY

SEND FOR FREE BOOKS

OTHER LASALLE OPPORTUNITIES

- Accounting
- Traffic and Transportation
- Business Management
- Stenotype (Machine Shorthand)
- Modern Bookkeeping
- CPA Training
- Salesmanship

LaSalle Extension University

— A Correspondence Institution —

Dept. 364LR 417 S. Dearborn St., Chicago 5, Ill.

Please send me, free of all cost or obligation, your latest illustrated booklets "Law Training for Leadership" and "Evidence."

Name.....Age.....

Address.....

City, Zone, State.....

REVOLUTIONARY NEW
DESIGN SAVES YOU \$20 TO \$40

4 1/8" JOINTER PLANER

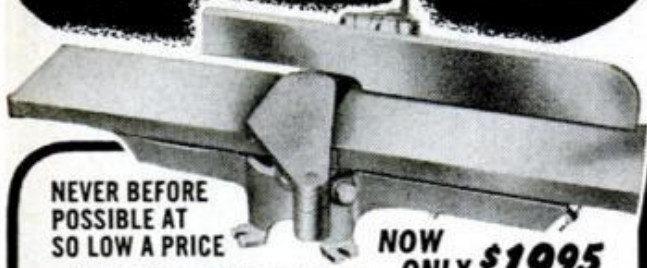

NEVER BEFORE
POSSIBLE AT
SO LOW A PRICE

NOW
ONLY \$19.95

(shipped complete as shown)

SOLD DIRECT FROM FACTORY

Patents pending on revolutionary new engineering developments make this bargain possible. This is a power plane with all the features of machine tools costing 3 times OUR PRICE. It planes, rabbets, bevels, aids beveling and glueing joints; is so rugged and durable we guarantee it unconditionally for ten years.

SEE THESE QUALITY FEATURES

All cast iron and steel construction • Balanced steel cutter head • Hardened and ground knives • Precision ground cast iron tables • Rugged cast iron base • Table depth adjustable 0" to 3/8" • Cast fence with single action cam lock • Pat. lift-off aluminum guard • Big, full size—22" long • Shp. wt. 25 lbs. Order By Mail — Sold Direct From Factory to You

OUR 30TH YEAR SEND \$19.95 CHECK OR M.O.
SENT C.O.D. WITH \$3.00 DEPOSIT

(If not completely satisfied after ten days return for full refund.) Shipped express collect.

AMERICAN MACHINE & TOOL CO., INC.
ROYERSFORD 34, PENNSYLVANIA



**MEN! Make up to
\$1,000 IN A
MONTH!**

without "SELLING"

Sensational Demand for Low-Priced Fire Alarm PLUS Sure-Fire "No-Selling" Plan Offers Ambitious Men Huge Profit Opportunities



Even beginners cleaning up unbelievable profits with first practical, effective, low priced Fire Alarm. Needed in homes, factories, offices, stores, on farms, etc. Merlite Fire Alarm hangs on wall like a picture . . . no wiring, no installation. It's always on guard, "smells" fire before danger point. When temperature rises, Fire Alarm goes off automatically, howls loud warning that can be heard 1/5 mile, wakes up soundest sleeper, gives precious time to put out fire, call fire department, or escape. Sells for only \$4.95, with profit up to \$2.70 on each one.

Nearest Thing to Automation Selling

With our field-tested plan customers sell themselves. No cold canvassing; no hard selling. It's the nearest thing to "Automation Selling." Even a child can use plan successfully with powerful sales tools we give you (which you leave with prospects). This plan makes money for you even while you sleep! No room here to give you full details, but write for amazing facts.

FREE SALES KIT

Send no money. Just rush your name and address for all the exciting money-making facts, complete Illustrated Sales Kit, everything you need to make money first day. Learn how selling only 20 Fire Alarms a day brings you \$1,080.00 a month. No competition. Rush your name and address today.

**Dramatic
LIGHTED-MATCH
DEMONSTRATION**
Sensitive!
Lighted match
triggers Alarm
in 3 seconds!

MERLITE INDUSTRIES, INC. (Alarm Div.)

114 E. 32nd St., Dept. F-15L

New York 16, N. Y.

IN CANADA: Mopa Co., Ltd., 371 Dowd St., Montreal 1, P.Q.

wheel and accompanying fork be very substantial so Adolph looked around a long time before he found a wheel with heavy-duty spokes and a solid steel fork.

He purchased a new Briggs and Stratton three-horsepower gasoline engine and installed it with the necessary drive mechanism. Then he enclosed everything with 1/8-inch Masonite board. He trimmed the edges with chrome strips and painted the cart yellow with black trim. He made the seat cushion from upholstery springs and foam rubber and covered it with an exotic scarlet material.

While he was building the cart, Adolph kept in mind many important details. For example, the cart had to fit into his station wagon and be easily loaded and unloaded. It had to have a compartment for beer and ice, a hitch and chain for pulling stumps and trees which created unplayable lies and an umbrella to protect him from the rain.

For loading the cart, Adolph built a grooved ramp and a device to lock the front wheel of the cart in position so it can be rolled into the wagon easily.

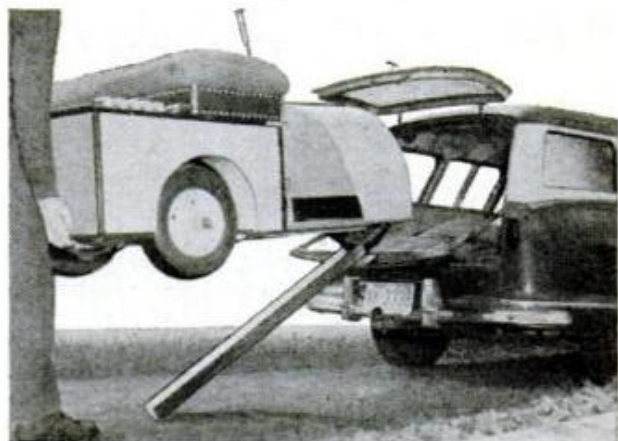

The controls are extremely simple. There is a starter, accelerator, brake lever and shut-off switch. The engine drives the rear wheels through a centrifugal clutch so there are no gears to shift. Adolph used some unusual parts for his cart, but the most unique application of all is the hinge on the steering rod. It is a knee joint from a steel leg brace similar to those worn by polio victims.

Not forgetting safety, Adolph has a fire extinguisher mounted in the cart and a lightning rod with a ground wire and rod for the umbrella. He dislikes noise and distraction when playing golf, so the engine has a special muffler and all of his clubs are held in spring-loaded, rattle-free solid rubber brackets.

Much of last summer was spent building the cart, but Adolph is convinced that it will enable him to play golf for many more summers to come.

Walter Yurk,
Neenah, Wis.

DON'T BE HALF-TRAINED! Be A Master Technician

NOW... ONE
modern master
home training course
IN ALL 3 PHASES



AIR CONDITIONING - REFRIGERATION ELECTRICAL APPLIANCES

**ALL AT ONE
LOW TUITION**
only
National Technical Schools
gives you this complete
training at no extra cost

YOU GET AND KEEP ALL THESE TOOLS AND INSTRUMENTS

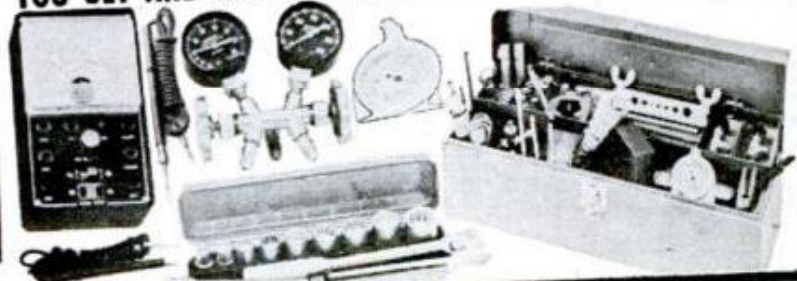

Incomplete training limits your earning power, even disqualifies you for top-pay jobs. The big service companies require *complete*, all-phase training. If you open your own shop, you'll be called upon to service and repair *all types* of refrigerators, air conditioners and appliances. With *complete* training—as only National Technical Schools can give you—you can accept every job, make *big profits* all year round.

FUTURE BRIGHT FOR TRAINED MASTER TECHNICIANS

Over 30,000 new technicians must be trained annually. You are needed to help service and repair the 50 million air conditioners, refrigerators and electrical appliances that will need fixing this year alone. No wonder the Master Technician has steady work, at high pay, year after year. He can go places in his own business or with a manufacturer, dealer, distributor or department store. Armed with all-phase training, his earning power is unlimited.

THE MOST FOR LESS

We give you illustrated Shop-Tested Lessons and Manuals...many other training aids...privilege of **CONSULTATION** with our instructors and engineers. Every lesson, every manual has been **SHOP** tested and approved.

JOB TRAINING AT HOME

You get Professional Tools, Precision Instruments, PLUS a Factory-Made **APPLIANCE TESTER!** A shop-full of **PRACTICAL**, professional equipment. Use them to conduct over 100 experiments...also in Spare Time Work and **ON THE JOB.** It is all yours to keep...no **EXTRA MONEY DEPOSITS**...no **EXTRA COST** on your equipment kits.

EARN AS YOU LEARN

We show you how. Many of our students pay for their entire course—and more—in Spare Time while learning. So can you. Graduate Advisory Service, too.

**GET THE BENEFIT OF OUR OVER
50 YEARS EXPERIENCE**

N.T.S. also offers training in
**TV - RADIO - ELECTRONICS
and AUTO MECHANICS - DIESEL**



NATIONAL TECHNICAL SCHOOLS

WORLD-WIDE TRAINING SINCE 1905

4000 SO. FIGUEROA ST., LOS ANGELES 37, CALIF., U. S. A.

RESIDENT TRAINING AT LOS ANGELES

If you wish to take your training in our Resident School at Los Angeles, start **NOW** in our big modern Shops and Labs. Here you work with latest equipment...professionally installed...finest, most complete facilities offered by any school. Expert, friendly instructors. Personal attention. Graduate Advisory Service. Help in finding home near school...and part time job while you learn. Check box in coupon for full information.

ACTUAL LESSON



**SEND FOR
FREE
BOOK AND
ACTUAL
LESSON NOW!**

We'll rush you our big, illustrated **OPPORTUNITY BOOK** and **ACTUAL LESSON**, show you how easily you can learn. **NO OBLIGATION**; no salesman will call. **Do it NOW!** It costs nothing to find out.

NATIONAL TECHNICAL SCHOOLS

WORLD-WIDE TRAINING SINCE 1905

MAIL NOW TO
National Technical Schools, Dept. CB-30
4000 S. Figueroa St., Los Angeles 37, Calif.
Rush **FREE** "Opportunity" Book and Actual Lesson. No Salesman will call.

NAME _____ AGE _____

ADDRESS _____

CITY _____ ZONE _____ STATE _____

Check here if interested **ONLY** in Resident Training at Los Angeles.

Sworn statement from CHAS. LEMMING reads:

"After starting my own business



I've averaged \$100 A DAY
—most of it clear profit!"

• If you want to be independent—free from layoffs, bosses—start profitable, year 'round business of your own. Ours is NOT a lease proposition. You own the machine, you work when and where you please, and all the money you take in is your own. FREE book tells you how.

MAIL COUPON TODAY FOR FREE BOOK

VON SCHRADER MFG. CO.

310 "D" Pl., Racine, Wisconsin

Without obligation rush your FREE booklet about how I can start my own permanent, profitable electric Upholstery Cleaning business.

Name _____

Address _____

City _____ Zone _____ State _____

Not everyone does as well...

Mr. Lemming owns two machines

In city of less than 50,000, Mr. Lemming started his own business after filling in coupon like one below. He averaged \$100 a day during first year, some days \$200. F. E. Doran grossed \$1050 in single month. Geo. Held grossed \$300 in one week.

How much you earn depends largely on you. No special skill, no large investment required for our electric upholstery cleaning machine. Start spare time until full time justified. Hire helpers as needed.

NO SHOP NECESSARY • You clean upholstered furniture on customers' premises—homes, hotels, motels, etc. Auto upholstering, too. No hauling; operate from your home. Watch business grow as satisfied customers tell friends. Supplies cost little, profits high.

Millions have done it so can YOU!



Stop being **SKINNY** like I was. Quickly **GAIN 25 LBS.** of HANDSOME, POWER-PACKED MUSCLES like I did. Send for these 5 AMAZING PICTURE COURSES

All 5 FREE before \$1 price goes back

1. How to GAIN MIGHTY ARMS
2. How to GAIN A BIG CHEST
3. How to GAIN A MIGHTY BACK
4. How to GAIN POWERFUL LEGS
5. How to GAIN A GRIP OF STEEL

Send 10¢ for postage for all 6 items

Also FREE Photo Book of Strong Men

Jowett Institute, Dept. PM-03, 220 Fifth Avenue, N.Y. 1, N.Y.



Before

GOVERNMENT OIL LEASES LOW AS \$1 PER ACRE

You do no drilling, pay no taxes, may realize a king-size profit without ever leaving home. Write for free map and literature.

AMERICAN OIL SCOUTS, Dept. PM
 8350 Santa Monica Blvd. Los Angeles 46, Calif.

STUDY TO BE A DOCTOR of Psychology or Metaphysics

Obtain a Ps.D., Ms.D., or Ph.D. Be a Teacher, Lecturer or Accredited Practitioner. Teach others how to achieve Health, Happiness and Contentment. Overcome problems. Correspondence Course only. Write for FREE book telling how.

THE NEOTARIAN FELLOWSHIP
 Desk 8, Pickwick Building Kansas City 6, Missouri



TIRED OF HIGH RENT?

Learn how luxurious suburban **MOBILEHOMES** can save money and expensive moving. Comes fully and smartly furnished, including many major appliances. Modern mobilehomes have every home comfort. Conditioned air provides comfort in any climate. Multiple bedroom units have convenient spacious storage areas. Mobilehomes give you mobility, easy care, minimum maintenance. Learn how in **TRAILER TOPICS**—the magazine of luxury low cost living.

SPECIAL OFFER 4 month subscription **Only \$1.00**



TRAILER TOPICS magazine

Suite 1571, 28 E. Jackson Blvd., Chicago 4, Ill.

engineering degree in only 27 months

Realize your dream of becoming a graduate engineer. Then promotion will not pass you by. Share rewards awaiting college men . . . higher income . . . rapid advancement. Important firms visit Tri-State campus to interview seniors. Founded 1884. Bachelor of Science Degree in 27 months in Electrical Engineering (Electronics or Power major), Mechanical, Civil, Aeronautical, Chemical Engineering. In 36 Months a B.S. in Business Administration (General Business, Accounting, Motor Transport Management majors). For earnest, capable students. Small classes. More professional class hours. Well-equipped, new and modernized buildings, labs, dorms. Modest costs. Year-round operation. Enter July, Sept., Jan., Mar.

Write J. E. McCarthy, Director of Admissions, for Catalog and Career Book.



TRI-STATE COLLEGE

430 College Avenue • Angola, Indiana

JUST OUT!

3 Great Rinehart training books to help You get ahead . . .

← LEARN OIL BURNER REPAIR!

Solve oil heat problems of all kinds!



Save real money by repairing, adjusting or even redesigning your own oil burner installation. Earn good pay by doing this work for others!

This new, 400-page manual, DOMESTIC OIL BURNERS AND OIL HEAT with its more than 300 pictures and diagrams trains you for fast, accurate service on all types in common use

—even without a lot of previous experience. Teaches you all about puzzling oil burner controls. Shows how to make heat loss surveys and design economical heating systems accordingly. Includes full details on firing rates; chimneys & drafts; piping, wiring and dozens of other subjects. Duo-Spiral binding puts BOTH pictures and related text side by side for easy use on the job. Price \$6.95 —or see money-saving offer in coupon.

← REPAIR ELECTRIC MOTORS!

It pays to train for something different



The electric motor is the "heart" of all electrified appliances and machinery—and this famous ELECTRIC MOTOR REPAIR manual is a complete training guide to help you cash in on this fast-growing repair field. Shows step by step how to handle all repair jobs (including complete rewinding) on practically any AC or DC motor or

generator, small or large. Includes motor controls. 560 pages and over 900 how-to-do-it pictures. Handy duo-spiral binding. When a specific motor comes in for repairs just look it up. Pictures and text tell what to do—exactly how to do it. Price \$6.95 —or see money-saving offer in coupon.

← REPAIR ELECTRIC APPLIANCES!

Save on repair bills..earn in spare time!



DO IT YOURSELF!

This 370-page Rinehart ELECTRICAL APPLIANCE REPAIR MANUAL shows you how to do the toughest repair jobs as well as the easy ones—even if you've never fixed an appliance before! Gives clear how-to-do-it instructions on every modern appliance — irons, toasters, ranges, cleaners, mixers, washers, ironers, clocks, razors and

all the rest. Handy charts help you locate troubles fast. Simple home-made test tools are described. Gives you the "know how" you need to fix your own appliances—or to build a profitable full or part time repair business. Price only \$5.00 separately. See money-saving offer in coupon.

TEAR OUT AND MAIL FOR 10 DAY FREE EXAMINATION

SAVE \$1.90

... get all three books ...

A COMPLETE, 1330-PAGE HOW-TO-DO-IT LIBRARY!

CHECK HERE to order all three books at special price of only \$17.00 plus postage. (Regular price \$18.90—you save \$1.90!)

Payable at rate of \$5.00 after 10 days if you decide to keep books and \$4.00 per month for 3 months. Save even more! Send cash with order and we pay postage. 10-day money-back guarantee if books are returned.

OUTSIDE U.S.A.—Cash only. Add 50c to price of each book. All 3 books \$18.50. 10-day money-back guarantee.

**Dept. PM-30, RINEHART & CO., Inc
232 Madison Ave., New York 16, N. Y.**

Send books checked for no-risk examination. In 10 days, I will send price indicated plus postage or return books and owe you nothing. (Send cash with order and we pay postage—same 10-day return privilege.)

- DOMESTIC OIL BURNERS & OIL HEAT.....\$6.95
- ELECTRIC MOTOR REPAIR.....\$6.95
- ELECTRICAL APPLIANCE SERVICE MANUAL.....\$5.00

Name

Address

City, Zone, State

YOU'LL NEVER REGRET MONEY INVESTED IN TRAINING YOURSELF FOR A BETTER JOB!

Lift the Hood to a Bright Future

Be a Top Pay Auto Mechanic—Learn at Home in Spare Time

Tie this for opportunity: America needs 100,000 newly-trained mechanics—and 25,000 more repair shops! Skilled men earn up to \$3 an hour and more. Learn this well-paid, interesting, secure trade at home. CTI shop-method is easy, fast, sure. Diesel Mechanics or Body & Fender Rebuilding included at no extra cost. *Mail coupon.*

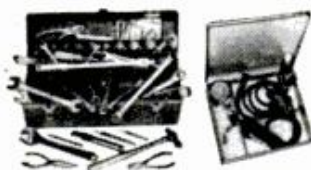

Tools & Tune-Up Kit Sent

CTI sends you professional Mechanic's Tools and valuable instruments, including a Compression Tester, Vacuum Gauge & Fuel Pump Tester, Ignition Timing Light; and a handy portable steel case.

MANY STUDENTS EARN CASH as they train. They fix cars on their own, or work in local shops. All facts free. *Mail coupon now for Catalog and Sample Lessons.*

COMMERCIAL TRADES INSTITUTE Dept. A1238
1400 Greenleaf Avenue • Chicago 26, Illinois
Send booklet, *Make Big Money in Auto Mechanics*

Name _____ Age _____
Address _____
City _____ Zone _____ State _____
Accredited by National Home Study Council



FINANCIAL HELP TO START YOUR OWN HOME BUSINESS!



Tired of being squeezed between rising prices and a *stationary salary*? Could you use a nice little home-business to bring in *extra income* from your spare time, evenings and week-ends? I can show you *how*—will even *help finance you*, if you're short of cash. Sound unreasonable? Wondering how I can afford to do it? Well, it's simple. The business I'm talking about uses supplies. I *make and distribute* those supplies. So do other firms—but I'm willing to gamble that when your business gets rolling you'll rather do business with a *friend* than with strangers who did not show up until you were in the money. I've gambled the same way with hundreds of others, and it has paid off by helping me build the *biggest business of its kind in the world!* The Golden Rule of "do unto others..." *always works* for those who give it a fair trial.

What is this business? It's *printing without a press*, an amazing process I call "Screen Print." With it, you can turn out printing in *gorgeous coloring* that many big shops cannot duplicate, even with presses costing *thousands of dollars!* Yet my equipment (supplied to you with my instructions) *weighs only a few pounds*, can be set up on a *small table* in the corner of your garage, basement, attic, or even a bedroom. You can earn in a *few hours* to print on paper, metal, glass, plastic, leather, cloth, and about anything you can name—even on curved or round surfaces that ordinary printing presses cannot handle at all! And I show you how to get *big-profit orders* from stores, factories, theatres, schools, and practically every type of business or organization for miles around—even by *MAIL ORDER* coast to coast.



JUST SEND ME YOUR NAME & ADDRESS—NO MONEY
Remember, I'll help finance you, so *don't worry about the money*—whether you are employed or not. I'm *sure* I can help you get set in a home business that may settle your money problems forever. Just send name and address for **FREE** information, without obligation. **TODAY SURE.**
Mr. C. J. Nowak, President, Screen Print Co., Dept. 23, 15127 S. Broadway, Los Angeles 61, California

Would YOU Like to Make \$1 000 A MONTH?



That's What Stanley Hyman Made Selling **PRESTO**

Amazing Midget Fire Extinguisher

Sensational! Presto does job of bulky extinguishers costing 4 times as much. Ends fires fast as 2 seconds; fits palm of hand. Never corrodes; guaranteed 20 years! Sells for only \$4.95. Show it to owners of homes, cars, boats, farms, etc., and to stores for re-sale—make good income. Write for **FREE** Sales Kit.



Stanley Hyman

MERLITE INDUSTRIES, Presto Div.
114 East 32nd St. Dept. P-15L New York 16, N. Y.
In Canada: Mopa Co., Ltd., 371 Dowd St., Montreal 1, P. Q.

PLANT CHRISTMAS TREES for PROFIT

Write for free catalog to



Pikes Peak Nurseries

Quality Nursery Stock For More Than 35 Years

801 WATER STREET INDIANA 11, PA.

LAW FREE BOOK THE LAW TRAINED MAN

Write today for a **FREE** copy of illustrated law book, "THE LAW-TRAINED MAN," which shows how to earn the professional Bachelor of Laws (LL.B.) degree through home study of the famous Blackstone Law Course. All necessary books and lessons provided. Moderate cost; convenient monthly terms. Write for **FREE** law training book today. **Blackstone School of Law, 307 N. Michigan Ave. Dept. 53 Chicago 1, Illinois**
Founded 1890

GET INTO ELECTRONICS

V.T.I. training leads to success as technicians, field engineers, specialists in communications, guided missiles, computers, radar, automation. Basic & advanced courses in theory & laboratory. Assoc. degree in 29 mos. B.S. obtainable. ECPD accredited. G.I. approved. Graduates with major companies. Start Feb., Sept. Dorms, campus. H. S. graduate or equivalent. Catalog. **DEPT. D VALPARAISO TECHNICAL INSTITUTE VALPARAISO, INDIANA**

JEEP OWNERS

RE-POWER NOW WITH A V-8 OR 6 CYL. ENGINE — USE FORD—CHEV—MERCURY—GMC—PONT—STUDE—DODGE OR PLYMOUTH
In Jeeps, Jeepsters, Sta-Wgn, trucks, Kaiser & H. J. cars. Conversion Kits \$45.35 to \$56.90. Want fast action? Give us full information, send \$15.00 Dep. and we will ship correct kit. Bal. COD. Send full amount for prepaid shipment. Wire, phone or write today. Details **FREE**
HOOSIER MACHINE PRODUCTS CO.
312 S. E. 6th St. Phone CR 6-3442 Pendleton, Oregon

STOP FRONT DRIVE DRAG ON YOUR Jeep



PROVEN IN OVER A BILLION MILES OF SERVICE!
Warn Hubs on your 4 w.d. give double-duty value — economical, *free-wheeling* 2 w.d. (with added pep!), normal 4 w.d. — *automatically* with Lock-O-Matics, manually with Warn Locking Hubs. See your 4 w.d. dealer!

WARN HUBS

WARN MFG. CO., Inc.
Riverton Box 6064-A
Seattle 88, Wash.

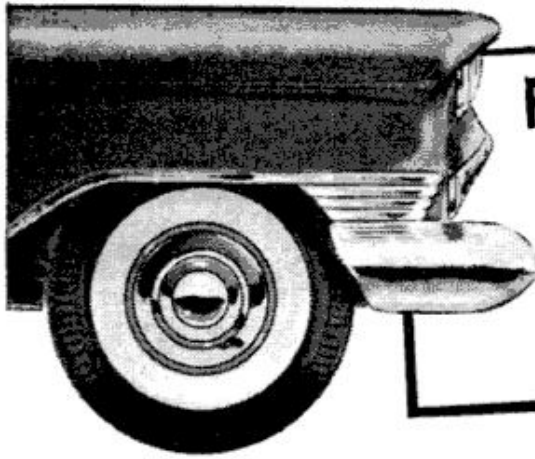

Fix ANY Part of ANY of These Cars
—ALL MODELS, 1953 thru 1960:

Buick
 Cadillac
 Chevrolet
 Chrysler
 Continental

Corvair
 Dart
 De Soto
 Dodge
 Edsel

Falcon
 Ford
 Hudson
 Imperial
 Jeep

Lincoln
 Mercury
 Nash
 Oldsmobile
 Plymouth

Pontiac
 Rambler
 Studebaker
 Thunderbird
 Valiant

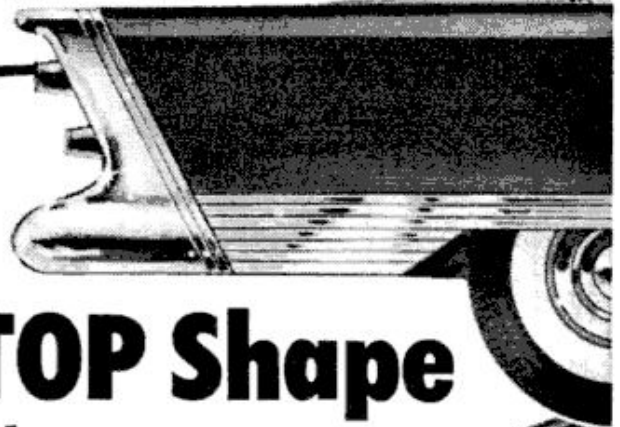

How to Keep ANY Car in TIP-TOP Shape

—from bumper to bumper

Here's How Even A Beginner Can "Lick" ANY Car Repair
 —and How Expert Mechanics Can SAVE Time, Work,
 and Money on ALL Repairs, Maintenance Jobs, Tune-Ups!

3,000,000
 COPIES SOLD!

YOU name it — ANY car repair, maintenance, tune-up — and this brand-new Edition of famous **MOTOR'S AUTO REPAIR MANUAL** will make it easy for you to breeze right through the job. Right off the bat, you know exactly **WHERE** to look for the trouble . . . **HOW** to start . . . **WHAT** tools to use . . . **HOW** to do the job *quickly, easily, right!*

Automatic transmission trouble? A carburetor adjustment? A brake or valve job? Or a complete overhaul? No matter what the trouble, **MOTOR'S MANUAL** starts you from "scratch", leads you every step of the way through the entire job. You **CAN'T GO WRONG** because your hands are guided by the men who actually build the cars—the "blue prints" developed by factory experts to save time, work, and money on every job.

The "Meat" of 176 Official Shop Manuals

The editors of **MOTOR'S** Manual have gathered the "meat" from 176

Official Shop Manuals—the work and time-saving methods used by the manufacturers themselves. And to make things as easy as possible for you, this goldmine of fix-it "know how" has been "boiled down" into clear A-B-C directions, pictures, and diagrams—all crammed into **ONE** handy indexed book!

HIG, NEW, REVISED edition! Over 1,100 giant pages, 2,850 "This-Is-How" pictures — clear drawings, diagrams, cut-away photos — make every step **EASY**. 195 "Quick Check" charts — 30,000 essential repair specifications. 225,000 service and repair facts. Instructions and pictures so complete, so clear even a green beginner can do a good job. And top mechanics will be amazed at the time-saving procedures.

Everything You Need to Know
 —Right At Your Fingertips

Includes **ALL** Automatic Transmissions, Carburetors, Engines, Fuel Pumps, 12-Volt Ignition Systems, Starting Motors, Generators, Distributors, Voltage Regulators, Brakes, Power Steering, etc. **PLUS** Trouble-Shooter section that enables you to spot any car trouble in a jiffy—and much more!

Used by hundreds of thousands of auto service men! 3,000,000 copies sold!

SEND NO MONEY

Try Book for a Week **FREE**

Just mail coupon. (Attach it to postcard for fast action.) Test book in your own garage or shop. **GUARANTEED** to pay for itself in 7 days. If it doesn't, return book and owe nothing. **MOTOR** Book Dept., Desk 013, 250 West 55th St., New York 19, N.Y. (Schools, Bookstores: Write for Discounts).

Same FREE 7-Day Offer on MOTOR'S Brand-New TRUCK REPAIR MANUAL

Covers **EVERY** job on **EVERY** popular-make gasoline — powered truck made since 1952. Includes GM, Mack and Cummins Diesels. Over 2,000 illustrations. Over 300,000 facts. Check proper box in coupon for free 7-day trial.



SEND NO MONEY!
TRY BOOK FREE!
FOR A WEEK FREE!

Newest Up-to-the-Minute Edition Used by U. S. Armed Forces

- Over 1,100 Giant Pages
- 2,850 "This-Is-How" Pictures, Diagrams, Cut-Away Photos
- 195 Valuable "Quick Check" Charts
- 30,000 Essential Repair Specifications
- 225,000 Service and Repair Facts
- Complete Trouble Shooter
- Almost a Foot High. Shipping Weight Almost 5 pounds

Just 2 of the Many Letters of Praise

Does Every Job. "My **MOTOR** Manual is a wonderful help. It has put me in a position to do every job."
 —S. L. Sharpless, Los Angeles, Calif.

Amazed Self and Friends. "I amazed myself and my friends, too. Now do jobs that stumped me before."
 —Michael Baliczsky, Newark, New Jersey.

MAIL COUPON NOW FOR 7-DAY FREE TRIAL
 (Attach to Postcard if More Convenient)

MOTOR Book Dept., Desk 013,
 250 West 55th Street, New York 19, N. Y.

Rush to me at once: (Check box opposite book you want).

MOTOR'S New **AUTO REPAIR MANUAL**. If okay, I'll remit just \$2.00 in seven days, then \$2.00 monthly for two months and a final payment of \$1.95 (plus 45¢ delivery charge) one month after that. Otherwise, I'll return the book postpaid in seven days. (Foreign price: Remit \$10 cash with order.)

MOTOR'S New **TRUCK REPAIR MANUAL**. (Described at left.) If okay I will remit \$3.00 in seven days, and \$2.00 monthly for three months, plus 45¢ delivery charge with final payment. Otherwise I will return book promptly. (Foreign price: Remit \$11.00 cash with order.)

Print Name.....Age.....

Print Address.....

City & Zone No.....State.....

SAVE 45¢ delivery charge by enclosing **WITH COUPON** in envelope full payment of \$7.95 for Auto Repair Manual (or \$9.00 for Truck Manual). Same 7-day return-for-refund privilege applies.

LEARN WOODWORKING AT HOME

Complete Home Training Course in Woodworking and Cabinetmaking Now Available

Today—it's easy to acquire the skills and craftsmanship of fine woodworking and cabinetmaking with Interstate's complete "shop method" course. Prepared by expert instructors, the course consists of 22 profusely illustrated training manuals containing more than 1100 pages of instruction. Covers all phases of woodworking, including selection of woods, planning and laying out projects, correct use and care of all hand and power tools, joint making, cutting, assembling, finishing, simple upholstery, etc. Over 75 learn-by-doing instruction projects give work bench training and experience in actual construction. Course is approved for beginners and professionals alike.



SEND FOR FREE BOOKLET TODAY

INTERSTATE TRAINING SERVICE

Dept. F-3, Portland 12, Oregon

Please send free booklet and information on your complete course in Woodworking and Cabinetmaking.

Name _____
 Address _____
 City _____ Zone _____ State _____

Make way for power
 with
 a new thrill!

DREAM



Model: HONDA DREAM (CZ-7)
 Engine: OHC, Twin-cylinder, 4-stroke
 Cylinder Capacity: 247 cc.
 Max. HP: 22 HP @ 5,200 r.p.m.
 Top speed: 85 m.p.h.
 Fuel consumption: 100 m.p.g.
 with electric starter.

H
AMERICAN HONDA MOTOR CO., INC.
 4077 W. Pico Blvd., Los Angeles 19, Calif.
 PHONES: REpublic-12590, 12597



HOW TO WIN SUCCESS WITH YOUR VOICE

Special NEW experts' course!

Put new strength, magnetism into your voice. Exclusive course originally created for actors, announcers, etc. NOW AVAILABLE TO PUBLIC FOR FIRST TIME! Takes only minutes a day in privacy of your own room—no other course like it! Includes 2 big LP training records, special microphone for self-testing, 10 illustrated, easy-to-follow lessons, plus tape-recorded "final exam." Money-back guarantee.

FREE BOOKLET—Just send name, address, age today and open a fascinating new world of business, social and financial success! No cost, no obligation. No salesman will call.

HOLLYWOOD

VOICE-SPEECH INSTITUTE

Studio B-30, 5504 Hollywood Blvd., Hollywood 28, Calif.



FIND BURIED TREASURE

GOLD, silver, coins, jewelry, strong-boxes, battle relics! M-SCOPE transistorized electronic Treasure-Metal Locators detect them all. Used world-wide. Exciting! Rewarding! Guaranteed. Lightweight, super-sensitive. Indestructible fiberglass cases. From \$59.50. Easy Terms. FREE catalog.

FISHER RESEARCH LAB., INC.
 Dept. PM-3, Palo Alto, Calif.

TIMESTUDY



Cash in now on the fast growing demand for Timestudy Men. Thousands needed in modern automated companies. Quick route to promotions and better jobs. Be ready for an important job in just one year! Good starting pay. Save big money for your Co. with simple Methods improvements. Production Control, Plant Layout. BEGIN ANY TIME. Free Job Placement. Request 40 page Bulletin and THE PAY INCREASE YOU WANT.

Address INDUSTRIAL ENGINEERING COLLEGE
 3307 Washington Blvd., Chicago 24, Illinois

Every Mason Wants



Masonic books for Blue Lodge Chapter, Commandery, Scottish Rite and Shrine. Our Rituals Are Used the World Over

Send for free catalog for Masons, Odd Fellows, Knights of Pythias, Knights of Columbus, etc.

EZRA A. COOK PUBLICATIONS, INC.

P. O. Box 796 Dept. A52 Chicago 90, Ill.

YOUR OWN BUSINESS with BIG EARNINGS in..

ELECTRIC APPLIANCE REPAIRING

100,000,000 Families Are Your Prospects! Repair electrical appliances for friends and neighbors. Service electrical equipment in stores, etc. Earn up to \$5.00-\$8.00 an hour or more! New shop method home study training. Electronic Kit makes it now possible. Rush name for FREE Book, and Special PAY LATER form.

CHRISTY TRADES SCHOOL
 3214 W. Lawrence Ave., Dept. A-8803, Chicago 25

FALSE TEETH

That Loosen Need Not Embarrass

Many wearers of false teeth have suffered real embarrassment because their plate dropped, slipped or wobbled at just the wrong time. Do not live in fear of this happening to you. Just sprinkle a little FASTEETH, the alkaline (non-acid) powder, on your plates. Holds false teeth more firmly, so they feel more comfortable. Does not sour. Checks "plate odor" (denture breath). Get FASTEETH at drug counters everywhere.

POPULAR MECHANICS

ADD \$4000 A WEEK TO YOUR PAY CHECK



Loafer with hand sewn reinforcement

AS "BOSS" OF YOUR OWN SPARE-TIME SHOE BUSINESS!

Turn your free time Saturdays and evenings into real money! Show friends new AIR CUSHIONED Work, Dress, Casual Shoes and Boots. Men's, women's, children's styles. Glove-leather linings, weather-sealed construction, revolutionary new leather soles with twice the wear guaranteed! You get immediate Commissions up to

\$5.00 a pair, plus big Bonus, FREE Shoe Offers, extra Cash Awards. Miracle value \$8.95 and \$9.95 men's dress shoes add to your income. No experience or investment needed. Samples supplied. Write today for FREE Outfit.

CHARLES CHESTER SHOE CO.
Dept. C-03, Brockton, Mass.

THE ORIGINAL PACKAGED
BOAT KITS

- World's Largest Line—New Fiberglass Hulls. Over 200 styles Boats-Kits, Formed-Hulls, Semi & Custom finished. All types: Prams, Cruisers, Racers, Inboards, Outboards. Easy to build. Professional results. Dealers - Agents Inquire.

Send 15c for 3-Colored Catalogs 52 pg. Kit Catalog plus 20 pg. Hardware and 8 pg. Armor Glass books. (SPECIAL OFFER!) All 3-colored CATALOGS plus "Boating Handbook"...all for \$1.

CUSTOM • CRAFT

MADE ONLY BY *Custom Craft*

*** BOAT PLANS, PATTERNS FRAME PACS**

- Over 400 Plans-Patterns, Frame Pak Kits. Prams, Kayaks, Racers, Runabouts, Catamarans, Cruisers - In-Outboards (6' to 40') Wood, Plywood and Steel. **Send 35¢ for 120 pg. Plan Catalog.** Catalog plus "Boat Building Handbook"... Send \$1.00.

Buffalo 7 L, N. Y.

MONEY in WORMS

Sell 20,000 fishworms per week @ \$4 per 1000 from a bed 3 feet wide and 8 feet long. We teach you how to raise and where to sell fishworms and crickets. Write for free literature.
CARTER WORM RANCH, PLAINS, GEORGIA
Read our success story in LIFE MAGAZINE, December 28, 1959 Issue

GROW MINIATURE TREES
FREE! SEEDS & PLAN

New Fascinating HOBBY or HOME BUSINESS OPPORTUNITY! Learn little-known techniques for growing living "Ming" Trees only inches high. Beautiful Elm, Cherry, Orange, Cypress, Peach, etc., that BLOSSOM AND BEAR TINY TASTY FRUIT. Help Fill demand for these sensational dwarfed Trees. **FREE SEEDS** (8 kinds) and Plan. State your age. Write:
MINIATURE TREE NURSERIES, Dept. K-3 (Home-Growers Division) Gardena, Calif.

MAKE EXTRA CASH

SHARPENING LAWN MOWERS THE MODERN WAY



\$275.00
F.O.B. Pasadena

Start your own shop! Full or spare time. Earn many dollars in a short time... average \$5.00 per hour. Many mowers need sharpening. With MODERN'S Extra Heavy Duty LAWN MOWER SHARPENER AND BED KNIFE GRINDER you have 6 machines in one. All operations are done quickly and easily. You make money from the start. Write for free details.

MODERN MFG. CO.
160 N. Fair Oaks Ave. Dept. Pasadena, California 10-4

FREE CAREER BOOKLET



To guide you to a successful future in
**ELECTRONICS
RADIO-TV
COMPUTERS
ELECTRICAL
ENGINEERING**

This interesting pictorial booklet tells you how you can prepare for a dynamic career as an Electrical Engineer or Engineering Technician in many exciting, growing fields:

- MISSILES • AVIONICS • AUTOMATION
- SALES • DEVELOPMENT
- ELECTRICAL POWER • ROCKETRY
- RADAR • RESEARCH

Get all the facts about job opportunities, length of study, courses offered, degrees you can earn, scholarships, part-time work — as well as pictures of the Milwaukee School of Engineering's educational and recreational facilities. No obligation — it's yours free.

MILWAUKEE SCHOOL OF ENGINEERING

MAIL COUPON TODAY!

Milwaukee School of Engineering
Dept. PM-360, 1025 N. Milwaukee St., Milwaukee, Wis.

Please send FREE "Your Career" booklet I'm interested in

- Electronics Radio-TV Computers
- Electrical Engineering Mechanical Engineering

Name _____ Age _____

Address _____

City _____ Zone _____ State _____

I'm eligible for veterans education benefits.
Discharge date _____

FREE!
100
**WORLD-WIDE
STAMPS**
...just
released!

HURRY! SEND TODAY for colorful, valuable collection of 100 World-Wide stamps. Get new issues of past 12 months. From far corners of the world . . . Ghana, Togo, China, Polynesia, India, Australia, Honduras, Iceland and many others. Wonderful new additions to your collection. All different, all genuine, topicals, pictorials, bi-colors, mint and used. Limited supply. Only one to a collector. Plus free complete, helpful "Stamp Collector's Guide" and other offers for your **FREE** inspection. Send name, address, enclose 10¢ for handling and postage. Garcelon Stamp Company, Dept. 3PMX, Calais, Maine.

GARCELON STAMP CO., Dept. 3PMX
Calais, Maine — Rush **FREE** 100 Different Stamps, Collector's Guide, other offers. Enclosed 10¢ for handling. (PLEASE PRINT).

**MY SPARE TIME HOBBY
MAKES ME
\$5⁰⁰ an hour
CASH PROFIT**

— Grover Squires

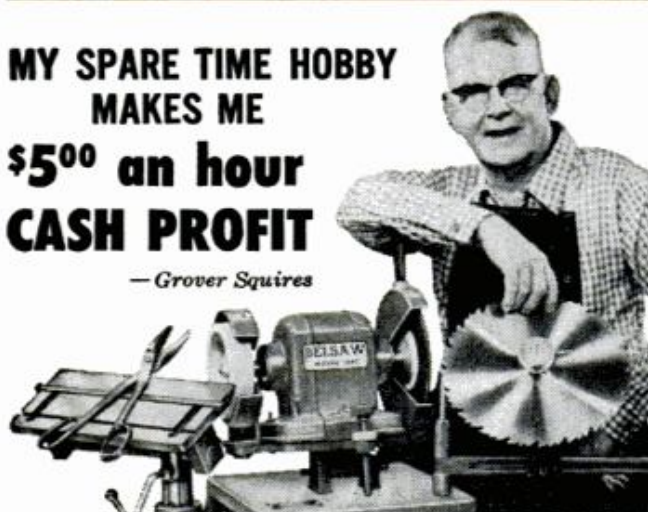

START YOUR OWN SPARE TIME BUSINESS
You can turn your spare time into Big Cash Profits with your own **COMPLETE SHARPENING SHOP . . .** Grind saws, knives, scissors, skates, lawn mower blades . . . all cutting edges. Your Own Cash Business with no inventory . . . right at home . . . no experience needed.
FREE BOOK tells how you can start your own spare time business while you are still working at your regular job. Low Cost — time payments only \$15.00 a month. Send coupon today.

BELSAW SHARP-ALL CO., 710 Field Bldg., Kansas City 11, Mo.
Send Free Book "LIFETIME SECURITY". No obligation.
Name _____
Address _____
City _____ State _____

For sportsmen
6 to 60!



Broad line of models

KITS less motors, from **\$39⁹⁵**

Complete kits with motors from \$109.95
Send 50¢ for 22-page catalog.

ARNOLD-DAIN CORP.

Box 78, Mahopac, N. Y.
Dealer Territories Available

Now!

TEST YOUR OWN for
TV & RADIO TUBES filament breaks



All of Them — Even Picture Tube

Nearly half of TV service calls are due to defective filaments. Tester shows if filaments are good. Insert tube in tester. Light shows if tube is burned out. Easy, safe to use. One service call saved pays for tester. Metal case. AC or DC. Checks fuses, appliances, etc. Only \$3.98 ppd. or C.O.D. plus charges. Deluxe Model \$4.98. Instructions. Guaranteed.

GEIGER ENGINEERING CORP., Dept. AB-114
6349 N. Western Ave., Chicago 45, Ill.

"YOU ARE UNDER ARREST!"

Help Bring Crooks to Justice Through Scientific
CRIME DETECTION!



We have taught thousands this exciting, profitable, pleasant profession. Let us teach you in your own home. Learn Fingerprinting, Firearms Identification, Police Photography, Secret Service Methods thoroughly, quickly, at small cost. Over 800 of all American Bureaus of Identification employ I.A.S. students or graduates. Write for **FREE** "Blue Book of Crime."
(A Correspondence School Since 1916)

Institute of Applied Science, 1920 Sunnyside Ave., Dept. 1353, Chicago 40, Ill.

Build Vibrating Health Massage Table

For less than \$10.00. Save up to \$150.00. Free treatments at home for backache, headache, neuritis, arthritis, muscular and nervous tension, reducing and etc. Further information free or.

Send \$2.00 for complete plans and instructions.
Specialty Designs Box 4123 N.E. Station Dearborn, Mich.

Secrets of VENTRILOQUISM
Now Revealed!



Easy to learn in 60 to 90 days with our Home Study Course. **RESULTS GUARANTEED.** Make Money! Be Popular! Have Fun! Big Opportunity! Radio, Television, Stage Appearances! For **FREE** information regarding price and terms **WRITE.** You must state your age. Dummy Catalog 25c.

MAHER HOME COURSE OF VENTRILOQUISM
Box 36, Studio PM-3, Kensington Station
Detroit 24, Michigan



PELLET FIRING
LUGER AUTOMATIC

- MAGAZINE LOADING CLIP
- OVER 15 MOVING PARTS
- FULLY AUTOMATIC

ONLY
\$198

Automatic full size model of a Luger Automatic pistol — contains over 15 moving parts. Loads 8 complete rounds which snap into the hard butt simulating a Luger. Fires 8 bullet shaped pellets Has automatic slide action.

MOST AUTHENTIC MODEL GUN WE'VE EVER SEEN

Comes to you with working parts disassembled with cleverly engineered springs, full instructions, supply of pellets and specially designed belt holster. **Full Money Back Guarantee.** Simply send \$1.98 plus 27c shipping charge or order C.O.D. From:

HONOR HOUSE PROD. CORP., Dept. LL-3, Lynbrook, N. Y.

LIVING FENCE



Amazing Fast Growing Red Rose

See the sensational Red Robin Living Fence (Gloire Des Rosomanes) that's sweeping the country! Surround your property with beauty and protection for as little as 12c a foot. Plant this spring, have a vigorous Living Fence bursting with fragrant red roses this summer. Grows up to 6 feet. Not a multiflora. Keeps out intruders, noise. Available only from Ginden Nursery. Send name, address for free full-color landscape book, prices, guarantees, etc.

GINDEN NURSERY CO. Dept. 3113 San Bruno, Calif.

FREE OUTFIT STARTS YOU IN BIG MONEY SHOE BUSINESS!

We furnish everything FREE to set you up in your own profitable full or spare time shoe business. Just 3 easy sales a day brings up to \$84 a week EXTRA! Repeat orders mean big, steady profits. No experience or investment needed. You feature over 150 fast-selling styles in dress, sport, work shoes for men, including beautiful Nylon mesh shoes with Air Cushion insoles. Also special kinds of shoes for different occupations. Amazing range of sizes and widths. Fit customers stores are unable to take care of. Start now by selling to friends, neighbors, relatives. Everyone is your prospect. Send post-card Today for FREE Selling Outfit!



WRITE TODAY!

Mason Shoe Mfg. Co., Dept. G-16, Chipewa Falls, Wis.

Learn ACCOUNTING Business Administration

Bookkeeping, secretarial and allied subjects at home in your spare time or attend nationally approved resident school. Write for FREE Success Book giving complete details on courses, plans, rates and employment opportunities. G.I. approved. Write Dept. A



Hills BUSINESS UNIVERSITY AND EXTENSION SCHOOL
629 W. MAIN ST. OKLAHOMA CITY 2, OKLAHOMA

MAKE \$5⁰⁰ AN HOUR IN SPARE TIME BIG, EASY "AT HOME" PROFITS—METALIZING

It's so easy to earn Big Money right at home in fascinating new spare time business. Little easy-to-run table-top machine returns Cash Dollars for a few cents cost. We furnish everything to put you in business for yourself, "eternalizing" baby shoes, and other keepsakes. Write TODAY for full facts FREE. No salesman will call on you. No obligation.

WARNER ELECTRIC, 1512 Jarvis, Dept. M-2-C, Chicago 26, Ill.

Model K312

CHARGES 12-VOLT CAR BATTERY OVERNIGHT

ONLY \$14⁹⁵ POSTPAID

Avoid run-down battery troubles—own this high-grade SCHAUER Charger. Has automatic circuit breaker. Pays for itself many times over in longer battery life; sure, quick starts. Get yours now. If your dealer can't supply, send check or money order. Money-back guarantee. The best made, most beautiful charger you can own is a SCHAUER. Other 6 and 12 volt models available. Send for free catalog.

SCHAUER MFG. CORP. 4532 Alpine Avenue Cincinnati 42, Ohio



These men are getting practical training in ...

ELECTRICITY

ELECTRONICS



ON REAL

Motors • Generators
Switchboards • Controls
Modern Appliances
Automatic Electronic
Control Units

TELEVISION

Radio Electronics



ON REAL

TV Receivers
Black & White and Color
AM-FM and Auto Radios
Transistors • Printed
Circuits • Test Equipment

Train in NEW Shop-Labs of COYNE

In Chicago—Electrical and Electronic Center of the World. Prepare for a better job and a successful future in a TOP OPPORTUNITY FIELD. Train on real full size equipment at COYNE where thousands of successful men have trained for 60 years—largest, oldest, best equipped school of its kind. Professional and experienced instructors show you how, then do practical jobs yourself on more than a quarter of a million dollars worth of equipment. No previous experience or advanced education needed. Employment Service to Graduates.

Start Now — Pay Later — Liberal Finance and Payment Plans. Pay most of tuition after graduation. Part-time employment help for students. Choose from nine yearly Starting Dates.

Mail Coupon or Write to Address Below for Free Book — "Guide to Careers." Whether you prefer ELECTRICITY, TELEVISION-RADIO or COMBINED ELECTRONICS TRAINING, which includes both fields, this book describes all training offered.

Information comes by mail. No obligation and NO SALESMAN WILL CALL.

B. W. Cooke, Jr., Pres. Founded 1899
COYNE ELECTRICAL SCHOOL

Chartered as an Educational Institution Not for Profit
1501 W. Congress Pkwy., Chicago 7, Ill., Dept. 30-3C

MAIL COUPON OR WRITE TO ADDRESS BELOW

COYNE ELECTRICAL SCHOOL
New Coyne Building, Dept. 30-3C
1501 W. Congress Pkwy., Chicago 7, Ill.

Send BIG FREE book and details of all the training you offer. However, I am especially interested in:

Electricity Television Both Fields

Name _____

Address _____

City _____ State _____

(I understand no Salesman will call)



EARN \$125 A WEEK AND UP

BE AN AUTO DIESEL EXPERT—LEARN A TRADE YOU LIKE

You learn fast in our shops because you learn with tools on real equipment. Students short of money may earn most of their expenses by doing part-time work. Experienced instructors explain WHY and show you HOW, then you DO IT YOURSELF. Many of our graduates earn \$125 a week and up. Approved for veterans. Day and evening classes. Free bulletin-write today.

MAIL THIS COUPON TODAY!

NASHVILLE AUTO-DIESEL COLLEGE
226 7th Ave., No., Dept. 86, Nashville, Tenn.
Please send without obligation free catalog.

NAME _____
(please print or write plainly)

ADDRESS _____

CITY _____ STATE _____

LEARN TO MOUNT BIRDS



ANIMALS, FISH, PETS
Be a Taxidermist. Save your hunting TROPHIES. Have a fine home-museum. Hunters, save and MOUNT your beautiful DUCKS, QUAIL, DEER, TAN skins and FURS.
Great Fun. Spare-time PROFITS.
FREE BOOK Tells ALL about it. 100 fine wild-game pictures. 48 pages.
Send TODAY, don't delay. Get this WONDERFUL, FREE BOOK, MEN AND BOYS. Learn Taxidermy. Double your hunting pleasure. Rush letter or POSTAL today. STATE AGE. N.W. SCHOOL OF TAXIDERMY, Dept. 2503 Omaha, Neb.

FOCUS YOUR  **of BENJAMIN**

AMAZING NEW Line of REPEATERS

WITH THE LATEST IMPROVEMENT IN FAST, SURE, GRAVITY LOADING ACTION AND PIGGY-BACK SHOT MAGAZINE

A Shot is placed in Firing Position each time Bolt is Pulled Back and Closed. Flash Ammo Count on Full View Magazine.

\$18.95

No. 2600 BENJAMIN Super 35-Shot BB Gas Pistol. Safe—No Pumping—Uniform Hi-Power. For Target & Small Game. \$17.95
No. 2620 BENJAMIN 20-Shot Cal. 22 Gas Pistol. Economical. \$19.95
No. 1300 50-Shot BB Air Pistol \$22.50
No. 1320 BENJAMIN 35-Shot Cal. 22 Air Pistol \$24.50

No. 3600 BENJAMIN Super 100 Shot BB Gas Rifle. Non-Toxic—Safe—Convenient—Uniform Hi-Velocity Power. \$20.95
No. 3620 BENJAMIN Super 85 Shot Cal. 22 Gas Rifle. . . . \$20.95
No. 3100 Super 100 Shot BB Air Rifle. Adj. Shooting Force \$23.95
No. 3120 BENJAMIN Super 85 Shot Cal. 22 Air Rifle. . . . \$25.95

FREE Catalog All Models Benjamin Single Shot & Repeaters—Cal. BB or 177 or 22. Also, Special Hunting & Fishing Knife Offer.

BENJAMIN AIR RIFLE CO., 896 MARION ST., ST. LOUIS 4, MO.

WORLD'S LOWEST PRICED CALCULATOR! Not \$3.95 \$2.03 in Penna. including 3% Tax.
NEW! NEW! NEW!
TOM THUMB ADDING MACHINE But Only **\$1.97**

With beautiful Leatherette carrying case. **MADE IN AMERICA BY AMERICANS**. Beware of cheap imported imitations. Adds Up To One Billion—1,000,000,000. Subtracts—Multiplies—Divides.

Mistake Proof—Positively 100% Accurate—Lightning Fast—Shock Proof Solid Steel Mechanism

GUARANTEED FOR YOUR LIFETIME

Ideal for Housewives, Shoppers, Students, Engineers and Tax work. Take it to the Super Market—Save \$\$\$ every week. We pay postage if you send check, cash or money order—or just send your name & address and pay postman \$1.97 plus postage. Immediate Delivery—10 Day Free Trial—Satisfaction Guaranteed—money refunded by return mail. Special Gift Offers 2 Machines for only \$3.49. Agents Wanted—Make easy money selling a Top Quality Calculator at our unbelievably low price.

TOM THUMB ADDING MACHINE
P.O. Box 5066, Dept. M-10 Philadelphia 11, Penna.



**WANT MORE MONEY?
GET INTO PHOTOGRAPHY**

Coast to coast, high-paying jobs in photography are waiting for people with that "know-how" to fill them. You can quickly, easily qualify at home with the world-famous NYI Learn-by-Doing Method. Write today for free catalog. Also resident training in N. Y. Our 50th Year. Approved for Veterans.

NEW YORK INSTITUTE OF PHOTOGRAPHY
Dept. 49 10 West 33 St. New York 1, N. Y.



FREE

MUSCLE BUILDING INFORMATION

Sensational New Methods
Less Time—Less Effort—Better results
BODY-TONE, Box 638, North Miami 61, Fla.



Fishermen

Take Note!

In the

APRIL ISSUE

watch for

SNEAK UP ON THE BASS

a feature article that tells you how to cast and troll with quiet motors

cabana marrone



**PLAN YOUR FUTURE NOW...
have a business of your own**

Luxurious, high-fashion fur now being ranch-raised in U.S.A. and Canada. All select, pedigreed, registered stock. Easy and economical to raise in any climate. One pair should produce 10 to 15 young per year. Warranty assures life and production. You may qualify for membership in CNBA (Cabana Nutria Breeders Association), the largest and strongest Nutria association. Free training program. Cabana Marrone Nutria garments nationally advertised.

Cabana Marrone available only through authorized distributors. Write for complete information. Distributor inquiries invited.

CABANA NUTRIA INC.
Dept. 71 636 West Lemon Arcadia, Calif.

I'll Send You This Handsome SAMPLE CASE-FREE



**and Show You How to Make
Up to \$30.00 in a Day**

WRITE for this FREE Tailoring Sample Case packed with 100 beautiful, big-value suit and overcoat fabrics. Take orders from friends, fellow-workers, others, for fine quality, made-to-measure clothes. Pocket big cash profits in advance. Because wearing our suits and overcoats brings more orders, we make it easy for you to get your own clothes without the cost. No experience is needed. **SATISFACTION GUARANTEED SEND NO MONEY.** Rush your name, address, and age—today!

**J. C. FIELD & SON, INC., Harrison & Throop Sts.
DEPT. C-1720 CHICAGO 7, ILLINOIS**

TERMITES?

**GET RID OF
THEM YOURSELF!**

Don't pay up to \$300 and more to get rid of termites or prevent infestation. Do-it-yourself—Easily! Quickly! Inexpensively with "TERM-OUT" solution. Send 10¢ for fact-filled handbook.



COMPASS RESEARCH
701-A INVESTMENT BLDG., PITTSBURGH 22, PA.

PROFIT IN YOUR SPARE TIME

FIX SMALL GASOLINE ENGINES
Outboard • Powermower • Chain Saw • Tractor
MAKE EXTRA MONEY—or, repair your engines and SAVE. Illustrated, easy-to-understand, Home Study Course. FREE information. Write TODAY!



LINCOLN TECHNICAL INSTITUTE
Suite 3-E, 472 Market Street, Newark 5, New Jersey

MEN PAST 40

**Afflicted With Bladder Trouble,
Pains in Back, Hips, Legs,
Nervousness, Tiredness.**

If you have these troubles, particularly bladder trouble, then your condition may be traced to Glandular Inflammation . . . a constitutional disease. Neglect of this condition often leads to premature old age and sometimes incurable malignancy.

The Excelsior Medical Clinic has a New Free Book that tells how thousands of men have been successfully treated here at Excelsior Springs for Glandular Inflammation by **NON-SURGICAL Methods**. They found soothing relief and a new outlook in the future of life.

This Free Book may prove of utmost importance in your life. Write Today. There is no obligation.

Excelsior Medical Clinic, Dept. B6129, Excelsior Spgs., Mo.



WHY DOESN'T MY PAY CHECK GROW?

"Some day I'll really get a break and go right on to the top." That's wishful thinking.

You know that the "breaks" go to the man or woman who is prepared to take advantage of them—to the person who can fill the better job and is worth more money. He makes the "breaks" instead of waiting for them.

You can influence your own future by preparing now for the step forward—so that openings come because you are equipped for them—not as the result of luck.

DON'T LIMIT YOURSELF

During our more than 50 years, over 1,400,000 ambitious men and women have turned to LaSalle training for more money—larger success in life—and greater job security.

Prepare now. Send the coupon below—check the business field of your choice and we'll send you without obligation our FREE book describing the opportunities and complete information on that field.

Send the coupon Now. It may be the turning point in your life to that better job and more money.

Accredited Member, National Home Study Council

MAIL THIS COUPON TODAY

LASALLE Extension University

A Correspondence Institution

417 S. Dearborn St., Dept. 364R, Chicago 5, Ill.

Please send free book on the subject I have checked.

- | | |
|---|--|
| <input type="checkbox"/> Accounting | <input type="checkbox"/> Bookkeeping |
| <input type="checkbox"/> Law: LL.B. Degree | <input type="checkbox"/> Foremanship |
| <input type="checkbox"/> Business Management | <input type="checkbox"/> Stenotype-
(Machine Shorthand) |
| <input type="checkbox"/> Traffic and Transportation | <input type="checkbox"/> Sales Training |
| <input type="checkbox"/> Industrial Management | |

Name.....Age.....

Address.....

City.....Zone....State.....

ENJOY BOATING NOW AND
PAY AS YOU PLAY WITH A

Taft KIT BOAT

MASS PRODUCTION
MAKES THESE PRICES
POSSIBLE . . . Only Taft,
world's largest boat kit
maker, offers such quality
at such prices . . . EASY
TERMS, too!

SEND FOR
FREE
NEW COLOR
CATALOG

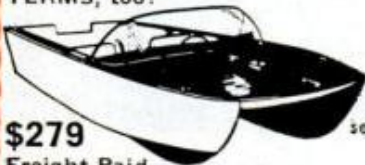

\$279

Freight Paid

14 FT. CAT KIT

18-ft. roominess,
seaworthiness, at low mass
production price.

RUNABOUTS

12 runabouts, from
\$99. New, HOT model:
16-ft. raceabout and
all accessories at
"package" price.



16 Ft.
Raceabout—
low as \$17.57 per month

CRUISERS

Ten 18-ft. cruisers, luxury at mass
production prices. From \$375.

NEW For Kids!

Sensational 8-ft. sailing dinghy,
and perky little "Bumble Bee"—
8-ft., 3 point hydro—30 m.p.h.,
with 5-10 h.p. motor.

TAFT MARINE WOODCRAFT

PM-360 636 39th Ave. N. E. • Minneapolis, Minnesota

FOR BETTER WATER SKIING

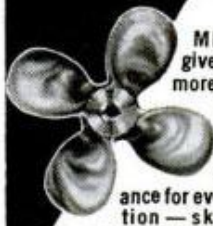

Fit your outboard motor with the
MICHIGAN PROPELLER designed to
give you greater thrust, quicker pull-ups,
more skiing buoyancy. Send postcard for
your **FREE** copy of our new 1960 **OUT-
BOARD CATALOG** NOW! It contains
propeller recommendations carefully
engineered to provide better perform-
ance for every specific motor-boat-load combina-
tion — skiing, speed, cruising or all around
operation; also, fine skis, boat accessories. **MICHIGAN
WHEEL CO.**, Grand Rapids 2, Mich., Dept. PM

SHORTHAND IN

Famous **SPEEDWRITING** shorthand. 120 words
per minute. No symbols: no machines: uses ABC's.
Learn at home or through classroom instruction.
Low cost. 500,000 graduates. For business and
Civil Service. Typing available. 37th Year.
Schools in over 400 cities. Write for **FREE** booklet.

Speedwriting
Dept. 1503
55 W. 42 St., N.Y. 36, N.Y.

6
WEEKS

'How to Make Money with Simple Cartoons'



A book everyone who likes to draw
should have. It is free; no
obligation. Simply address

**FREE
BOOK**

CARTOONISTS' EXCHANGE
Dept. 93-D Pleasant Hill, Ohio

Turn your spare time into \$\$\$

WATCH REPAIRING



Learn this profitable trade
at home the Swezey Way

Opportunities now for full or part time earnings in watch repairing
are the best in years. Unique Swezey System teaches you at home
step by step how to repair all types of American and Swiss watches.
Professionally prepared training from recognized trade school,
established 1908. You learn modern shop methods. Special tools
provided for practice. No previous experience needed. Age is no
barrier. Diploma awarded. Tuition is only \$5 a month. Send for
FREE SAMPLE LESSON without obligation. No salesman will call.

CHICAGO SCHOOL OF WATCHMAKING

2330 N. Milwaukee Ave., Dept. 130, Chicago 47, Illinois

HOW TO RETIRE WITH EXTRA INCOME



• Men everywhere are making money
sharpening cutlery, saws, scissors, and
tools. **TREYCO** No. 330 **SERVICE-
MASTER** puts you in business. Make
up to \$5 an hour and more at home in
your spare or full time. Start now—
Write for helpful Free Money Making
Plan.

TREYCO PRODUCTS

334 Niagara Ave., N. Tonawanda, N. Y.



You too, can chirp if
you've remembered:
through

EASTER SEALS

you help the crippled

National Society
for Crippled Children
and Adults
2023 W. Ogden Ave.
Chicago 12, Ill.



Not everyone does as well, but T. N. CODY, who started a business of his own, reports...

For 12 months I've averaged

\$800 PER MONTH INCOME



—most of it clear profit for me!

Many men have discovered how to be independent, to be free of layoffs and bosses. C. G. Naples grossed more than \$200 his first week. A father-son combination grossed \$44,000 their second year. H. Lemon says, "I netted \$133 in one 8-hour day."

How much you make depends largely on you. You need no special skill, no large investment. Start part time if you wish.

NO SHOP NECESSARY • Our Electric Deterger shampoos rugs, carpets right on floor—removes dirt and grime and helps to show their natural color and beauty. So efficient and safe it is used by largest railroads and hotels.

► **This is not a lease proposition. You own the machine, you work when and where you please and all the money you take in is your own. You take no risk. Machines fully guaranteed.**



MAIL COUPON TODAY FOR FREE BOOK

VON SCHRADER MFG. CO.
310 "R" Pl., Racine, Wisconsin

Without obligation send me **FREE** booklet about your RUG DETERGER and tell me how I can start my own permanent, profitable business.

Name _____

Address _____

City _____ Zone _____ State _____

make your own Gems 36⁵⁰
The Gem Maker comes complete with all necessary equipment, including a super-charged diamond blade for sawing, and all the wheels for grinding, shaping and polishing; also complete instructions. The complete equipment as shown, less motor and belt for only \$36.50, f.o.b., Burlington, Wisconsin. Write today for information and literature.

B&I MANUFACTURING CO.
Dept. P, Burlington, Wis.

Learn MECHANICAL DENTISTRY

To make Crowns, Plates, Bridgework, etc., for Dentists. Easy practical way to learn mechanical dentistry at home in spare time. **FULL EQUIPMENT OF TOOLS AND MATERIALS INCLUDED WITH COURSE.** Low tuition. Easy terms. Write for **FREE BOOK** about this money making profession that is not affected by machine age.

McCARRIE SCHOOL OF MECHANICAL DENTISTRY
207 N. Broad St., Dept. 98, Philadelphia 7, Pa.

**New Table Top Invention Puts You In...
PROFITABLE RUBBER
STAMP BUSINESS**

Home Operators now make **\$9.40 AN HOUR** in business once monopolized by a few big companies

Special rubber stamps bring high prices—cost only pennies to make on new, low-cost table top machine. Take 27 cents worth of material, make perfect stamps, the kind businesses and offices now buy by the dozen at \$1.80 each. Make up to \$9.40 an hour. Start in spare time in your own home. Run machine on kitchen table using ordinary electrical outlet. Make any kind of stamp. We'll send you free information without obligation about this established, highly profitable business, now open to individuals for the first time. For free information send name today on a post card to **Rubber Stamp Div., 1512 Jarvis, Dept R-2-C, Chicago 26, Ill.**

ENGINEERING



Photo of Heald Students in Electrical Laboratory

Enroll Now for New Term

Heald College Ranks FIRST West of the Mississippi in "Who's Who in America"

Send for **FREE** Information

Heald Engineering College
Est. 1863

Van Ness at Post, Dept. P.M.
San Francisco, California

American Industry Steps Up Its Demand for Trained Engineers. Train Now at Healds

BACHELOR OF SCIENCE DEGREE, 30 MONTHS

SAVE 2 YEARS' TIME

Degree Courses:

- Electronic Engineering
- Electrical Engineering
- Highway Engineering
- Mechanical Engineering
- Structural Engineering
- Civil Engineering
- Architecture

Diploma Courses:

- TELEVISION Color TV
- Electronic Technician
- Industrial Electronic Tech.
- Tool & Die Design
- Architectural Drafting
- Mechanical Drafting
- Structural Drafting

Approved for Veterans

NAME _____
STREET _____
CITY _____
STATE _____

RADIO SHACK FLASH!

Send Coupon for Latest
FREE
ELECTRONICS CATALOG
plus every new issue for 1960



For the newest and best in electronics equipment—stereo, hi-fi, ham radio, tapes—mail coupon today for Radio Shack's latest FREE 312 page catalog. Also get every new edition for next 12 months, Free. Satisfaction guaranteed or your money back. Mail coupon now.

Radio Shack Corp., 730 Commonwealth Ave., Boston 17, Mass. Dept. 60C3
Send FREE Electronics Catalog—Also every new issue for 12 months, a full year's subscription Free.

Name _____
Address _____
Postoffice _____
or City _____ Zone _____ State _____

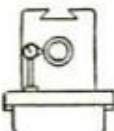

— TIPS & TECHNIQUES —
MACHINE TOOL RECONDITIONING
& THE ART OF HAND SCRAPING (4th printing)
SEND FOR FREE FOLDER DESCRIBING
ILLUSTRATED MANUAL FOR MACHINISTS
Machine Tool Publications, 382 Holly Ave., St. Paul 2, Minn.



Colorcretors are Needed Everywhere

C-9



More Colorcretors are needed to supply growing demand for the enduring, colorful beauty possible only from Colorcrete. Time-worn concrete, stucco and other old or new masonry walls are quickly transformed into clean freshness from a selection of 30 tints, tones and shades. Cementitious base—tough, tenacious, enduring. Colorcrete is applied under pneumatic air pressure by authorized Colorcretors. Machine is easy to operate and readily mobile. Opens up opportunities for men of modest capital. Broad markets with high income potentials. Write for Opportunity Book.

COLORCRETE

COLORCRETE INDUSTRIES, INC.
570 Ottawa Ave., Holland, Mich.



HOME-IMPORT BUSINESS . . .

Men, women. Make big profits buying low cost imports abroad (see examples at left) and selling to friends, stores or by mail order. Famous world trader guides you—shows you how to find thousands of exotic imports for full or spare time business, how to pocket profits in advance on foreign drop shipment plan. Full details FREE! Airmail reaches us overnight. Write Today!
MELLINGER CO., 1717 Westwood
Dept. C253, LOS ANGELES 24, CALIFORNIA



BIG EARNINGS WAITING for TYPEWRITER REPAIRMEN

Skilled men are in demand in the new, uncrowded field of typewriter repair. You'll quickly step into a big-pay job or business of your own, full or part time. EARN while learning easily at home under expert guidance. Materials, tools, typewriter supplied. Write TODAY for FREE book.
TYPEWRITER REPAIR SCHOOL, INC.
Dept. C-10, 150 Park Ave., E. Rutherford, N. J.
Lic. by New Jersey Dept. of Educ.

Finish HIGH SCHOOL AT HOME

Complete 4 Yrs. in 12 Months

Learn More! Earn More! Enter professional or technical schools. Advance Socially. Live a Happier, Fuller Life. Individual Courses or complete schedule. **WRITE FOR SCHOOL BULLETIN.**

ACADEMY FOR ADULTS
30 W. Washington, Dept. PH-360 Chicago, Ill.

OWN CALIFORNIA LAND

STATE GOV'T LANDS. 500,000 Acres as low as \$2. per acre—min. offer 40 to 640 Acres. Ranch and Farm Tracts. Southern and Northern California Locations.

NO HOMESTEADING! NO IMPROVEMENTS! NO SALES TO ATTEND! You select, apply and BUY DIRECT through the mail. Lists & maps now available. **WRITE RESEARCH DIV.**

PIONEER RANCHES 8228 Sunset Blvd., Dept. 9
Hollywood 46, Calif.
LARGEST LAND CORPORATION OF ITS KIND IN THE WORLD



"Old Hank's really flipped—
he thinks he can fly."

POPULAR MECHANICS

100 U. S. STAMPS

Yours **10c**
FOR ONLY



2¢ Washington
75 Years old!

YES! We'll rush you 100 all-different U.S. Stamps - including famous "History-in-the-Making" Issues - for only 10¢! (Standard catalogue value guaranteed at least \$2.50.) Also Airmails, Special Delivery, Postage Dues, High Denominations, etc. Some over 75 years old! All for only 10¢ with approvals. (Offer open to adults only.) Don't delay. Rush name and address - with 10¢ to help cover shipping, handling - NOW to: LITTLETON STAMP CO., Dept. PM-3, Littleton, N. H.

Million Dollar Inventory - All Famous Brands



SAVINGS NEVER LESS THAN 50% UP TO 70% OFF REGULAR PRICES
HEADQUARTERS FOR ALL SPORTS CAR TIRE SIZES
→ SEND FOR YOUR FREE CATALOG! ←

RELIABLE TIRE CO. • 728 MORGAN BLVD. CAMDEN 4, N. J.

KILLS

• NO CHEMICALS, GASES, ETC.

- MOSQUITOES • MOTHS, MILLERS
- FLIES, GNATS • FISH FLIES, ETC.

OVER 1/4 ACRE ANYWHERE

No insect recovery. Harmless. Guaranteed. Built to last 25 years. Beautiful outdoor lighting. Plug into any 110 volt socket.

NO AREA CONTAMINATION
Uses up to 200 watt bulb. Grid cost 10¢ per month. Complete with fly attractor. Dead insect catcher. Cord. Directions, Etc. Very reasonable price - Write to:

SING SING BUG CHAIR, INC.
Box P 3708, Oak Park 37, Mich.



BOX SIZE - WT. 12 1/2" x 8" x 8" 1 LB.

TRAINED AND SKILLED MEN IN CLOCK AND WATCH REPAIR

Are Needed in Watchmaking, Electronics, Defense, Aviation, and other technical and precision instrument fields. NOW IS THE TIME TO LEARN THIS VALUABLE TRADE. But, Before You Enroll in Any HOME STUDY Course in Watchmaking, Write for Your Copy of "LEARN THE FACTS."

KANSAS CITY SCHOOL OF WATCHMAKING
1226 Admiral Blvd. Kansas City 6, Missouri

RUPTURED

BE FREE FROM TRUSS SLAVERY

Surely you want to THROW AWAY TRUSSES FOREVER, be rid of Rupture Worries. Then Why Do you put up with wearing a griping, chafing and unsanitary truss the balance of your life? If you do, it will NOT be through necessity but through choice on your part.

Now there is a new modern Non-Surgical treatment that is designed to permanently correct rupture. These Non-Surgical treatments are so certain, that a Lifetime Certificate of Assurance is given. Write today for our New FREE Book that gives facts that may save you painful, expensive surgery. Tells how non-surgically you may again work, live, play, love and enjoy life in the manner you desire. There is no obligation. Excelsior Medical Clinic, Dept. H6124, Excelsior Springs, Mo.

FOR YOU BETTER PAY and a BRIGHTER FUTURE IN AUTO MECHANICS AND DIESEL



Your spare time pays off BIG with our world-famous **SHOP TESTED Home Training**

MAKE YOUR FUTURE AS BRIGHT AS THEIRS

In a matter of months, you can quit your no-future job, for a big-pay, big-future career as an Auto-Diesel Mechanic. Free Illustrated Book gives you the facts. Send coupon below. No Obligation. No Salesman will call.

All Phase Training

N. T. S. students become skilled, all-around mechanics. Crystal-clear lessons, Shop-Tested manuals, real professional equipment, make it easy to learn. Big equipment kits, yours to keep. Earn as you learn...we show you how. Graduate Advisory Service.

N.T.S. Training is Better, More Complete, Lower Cost BETTER...

Because training is SHOP-TESTED in Resident School Shops & Labs. MORE COMPLETE...You learn all phases of Auto Mechanics & Diesel. LOWER COST...One low tuition covers entire cost of course and all equipment.

Unlimited Opportunities

Trained mechanics make top money...are in demand at dealer shops, garages, large bus and truck lines, construction projects, government labs, factories, and many others.

YOU GET AND KEEP ALL THIS PROFESSIONAL EQUIPMENT



NATIONAL TECHNICAL SCHOOLS
WORLD-WIDE TRAINING SINCE 1905
4000 S. FIGUEROA ST. LOS ANGELES 37, CALIF., U. S. A.

FREE!

Illustrated Fact Book & Actual Lesson
Mail coupon now.

Complete TV-Radio Electronics training also available.

RESIDENT TRAINING at Los Angeles!
If you wish to take Resident Training at Los Angeles, in our Big, Modern Shops & Labs, check special box in coupon for full information.

NATIONAL TECHNICAL SCHOOLS

WORLD-WIDE TRAINING SINCE 1905

MAIL NOW TO
NATIONAL TECHNICAL SCHOOLS, Dept. DB-30
4000 S. FIGUEROA ST., LOS ANGELES 37, CALIF.
Send for FREE Auto-Diesel Opportunity Book and actual Lesson.

NAME _____ AGE _____

ADDRESS _____

CITY _____ ZONE _____ STATE _____

Check if interested ONLY in Resident School training at Los Angeles.

VETERANS: Give date of Discharge _____



Member



ENGINEERING

HOME
STUDY
COURSES

Courses written by world authorities in all branches of engineering and science. Step-by-step instructions using methods proved successful by thousands of our graduates. One hour each day in your spare time will start you off to higher pay, security and prestige. Fill in the coupon to-day and indicate the course of interest. We will send you a complete outline of the course with a booklet describing the Institute and our advanced teaching methods.

CIVIL ENG.
SURVEYING
ARCHITECTURE
FORESTRY
STRUCTURAL
MECHANICAL ENG.
INDUSTRIAL ENG.
REFRIGERATION
DRAFTING
ELECTRICAL ENG.
RADIO
ELECTRONICS
TELEVISION
AERONAUTICAL ENG.
HIGH SCHOOL
CHEMICAL
MATHEMATICS
ACCOUNTING

MAIL THE COUPON TODAY

Canadian Institute of Science & Technology Ltd.,
744 Century Bldg., 412, 5th St. N.W., Wash., D.C.

NAME.....

ADDRESS.....

CITY..... STATE.....

COURSE OF INTEREST.....

Canadians: Send to C.I.S.T., 744 Garden Bldg.,
263 Adelaide St. W., Toronto, Ont.



C. I. S. T.

BUILD and FLY Bensen HELICOPTER

Simple to fly — build it yourself, with engine or as inexpensive glider type which can be mounted on floats or boat. Order 3-

view drawing, specs and photo of Glider for \$1 or motor powered Gyro-Copter \$2. Building plans and kits also available.

Send
\$1
or
\$2

BENSEN AIRCRAFT CORP., Dept. PM-30
Raleigh-Durham Airport, Raleigh, N. C.

Name

Address



NEW FIBERGLASS LAPSTRAKE & PLYWOOD BOAT KITS

Most complete line. 8' to 23'. Prams, row-boats, outboards, cruisers.

MAIL 50c (coin)
REFUNDABLE
for BIG COLOR
CATALOGS



U-MAK-IT, DeLAND, FLORIDA • DEPT. 12

TOOLS WHOLESALE

\$100
PUTS YOU IN
BUSINESS

Start your own business, sell tools to your friends and neighbors, or buy tools for your own use and SAVE MONEY \$\$\$

A MILLION DOLLAR INVENTORY AT YOUR FINGERTIPS. NO STOCK TO CARRY. ORDER AS YOU NEED IT.

BUY AT WHOLESALE PRICES. Extra \$25.00 profit on your accumulated purchases. \$1.00 refund on first purchase or refunded if you are not 100% satisfied.

THOUSANDS!! of Nationally Advertised items of Hand Tools, Power Tools, Machinist Tools, Tool Chests, Paint Sprayers, Light Fixtures, Appliances, Guns, Gifts, Toys and other items too numerous to mention.

WE SHIP COAST TO COAST
Wholesale Disc. up to 50% off

SILVO HARDWARE CO., Dept. PM-3 107 Walnut St., Phila. 6, Pa.



100
POUND
SET
\$12.80

Extra
Plates Only
12c Pound

BARBELLS

140-Pound, CHROME DELUXE Barbell-Dumbbell set only \$19.80. This is our feature set and is the finest ever manufactured.

Training with adjustable weight is the BEST way to keep fit; the ONLY way to develop great strength and a perfect body. As the oldest and best equipped barbell company, BUR gives value and prices no one can equal.

SEND FOR FREE CATALOG
BUR BARBELL CO.
Lyndhurst 9, New Jersey

REAL ESTATE BE A BROKER

PAYS BIG! SEND FOR FREE, BIG, ILLUSTRATED CATALOG NOW! Graduates report making substantial incomes. Start and run your own business quickly. Men, women of all ages, learn easily. Course covers Sales, Property Management, Appraising, Loans, Mortgages, and related subjects. STUDY AT HOME or in classrooms in leading cities. Diploma awarded. Write TODAY for free book! No obligation.

FREE
BOOK
TELLS
HOW

Approved for World War II and Korean Veterans
WEAVER SCHOOL OF REAL ESTATE (Est. 1936)
2020R Grand Avenue Kansas City, Mo.

MAKE MONEY! REPAIR HYDRAULIC JACKS



Earn While You Learn At Home
Make up to \$5 an hour, full or part-time, in the competition-free field of Hydraulic Jack Repair. Millions of jacks in auto service stations, truckers, body shops, riggers, farms, need servicing. We show you NOW. Easy step-by-step directions.

Get Folder PM-2 & free bonus offer

Institute of Hydraulic Jack Repair
P.O. BOX 50 • BLOOMFIELD, N. J.
A Correspondence School Licensed by N.J. Bd. of Ed.

FREE GUIDE Reveals 200 Ways to Make Extra Money

YOU can turn your spare hours into cash (\$25 to \$100 a week)! Ask for Free Subscription to Opportunity Magazine, nationwide guide to extra cash for millions of men and women. Contains hints, plans, hundreds of offers. No matter what your age, experience, or occupation—write TODAY for next 5 issues FREE. Send no money—just your name.

OPPORTUNITY, 850 N. Dearborn, Dept. 134, Chicago 10, ILL.



Mr. "N" Made \$9,700 Last Year By Selling Just 20 KEEP/SAFES a Month!

Like Mr. "N" you can profit with KEEP/SAFE—the fine personal safe that undersells all others. Only safe sold direct. 95% of homes, farms and small businesses are prospects. \$30 to \$71 profit per sale, plus bonuses up to \$12 a safe. Choice territory, chance to become district agent. FREE DEMONSTRATOR! Get details, giving address including county.

JOHN D. BRUSH & CO., INC.
575 West Ave. Rochester 11, N. Y.

Learn BAKING At Home

Baking is one of America's high industries in wages. Nearly depression-proof. Thorough basic home course lays sound foundation. If you have aptitude, write for FREE BOOKLET, "Opportunities in Commercial Baking." National Baking School, 835 Diversey Pkwy., Dept. 1353 Chicago 14, Illinois





**OFFICIAL SPREAD
EAGLE SHIELDS**
Silver or Gold

Finest quality with reinforced backs and pins for heavy duty. A quick flash of one of these gleaming, official-looking badges instantly shows who has the power! Your choice: Special Officer, Deputy Sheriff, Constable, Watchman, Sheriff, Police, Special Police, Private Detective, Civilian Defense, Special Investigator. Standard Size: \$1.98. Miniature: \$1.25.

SPECIAL OFFER! FREE! — Authentic Badge Carrying Case FREE with each badge.



REGULATION POLICE HANDCUFFS \$5.95
With New, Exclusive CUFF-STOP

Latest type—features exclusive Cuff-Stop that locks handcuffs automatically. Made of hard-tempered steel with jewelry polished nickel surface. Fitted with 2 tamper-proof locks that only matching key will open. Used internationally by Law Enforcement and Private Detective Agencies. \$5.95. Deluze Leather Cuff Case: \$2.75.

All prices postpaid. **SATISFACTION GUARANTEED.** Send cash, check or money order and save C.O.D. charges. \$1.00 deposit with all C.O.D. orders.

BIG THREE ENT., INC. 1109 Sixth Ave., N. Y. 36, N. Y. Dept. PM-360

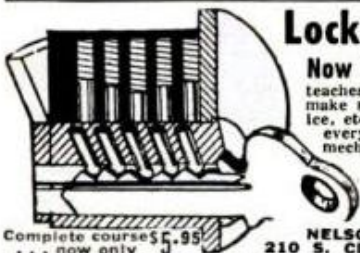

Locksmithing AND KEY MAKING

Now Made Easy! Practical up-to-date course teaches you how to pick locks, de-code, make master keys, repair, install, service, etc. New self-instruction lessons for every handyman, homeowner, carpenter mechanic, service station operator, fix-it shop, hardware dealer, gunsmith. 53 easy illustrated lessons. Full price only \$5.95 postpaid or C.O.D. plus postage. Satisfaction or refund guaranteed.

NELSON-HALL CO., DEPT. CP-2
210 S. Clinton Chicago 6, Ill.

FREE AMAZING NEW BOOK "HOW TO ANSWER ADS"



Never before have you seen anything like this. Tells you in simple language the correct way to answer ads. Gets you quicker replies—better results, and greater satisfaction. Will save you time and money and it's **ABSOLUTELY FREE**. No obligation whatever. Every reader of advertising should have this booklet. Send a postcard for your copy **NOW**. **F. W. JOHNSON**, Popular Mechanics Magazine, Room 600-A, 204 East Ontario Street, Chicago 11, Ill.

make it with **60¢** worth of sand & cement
SELL IT FOR \$20.00

every home a prospect for these patented "LIFETIME"
CONCRETE INCINERATORS

Make big profits manufacturing rust proof, fire proof, almost indestructible concrete incinerators in your own backyard or garage . . . full or part time. Sell to home-owners, hardware, department and garden supply stores. Phila. manufacturer doing big volume with Sears, Roebuck; large department stores. Easy to follow instructions and all needed equipment supplied. Exclusive protected franchise—No competition! Territories going fast. Write immediately for full details. Dept. PM-360, T. C. TOR, 318 Rancocas Ave., Delanco, N.J.

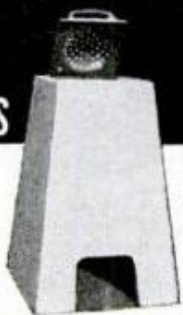

If you have an idea for improving, producing or saving anything—an idea for new uses, or for something new and useful

Don't Sit On It! SELL IT!

Ideas or inventions have a value. The simplest ideas that save time, effort or money—or that produce markets, customers, consumers—have value. Don't waste them. Industry and investment capital need new ideas!

YOUR IDEAS!

They want to and will buy them—big and small—when priority of origin is certified. International Idea Marketing Industries is your instrument for establishing priority and selling your idea.

SELLING YOURS!

International Idea Marketing Industries is a service founded to help you and protect your idea, (1) to assure you protection of and the promptest possible sale of your ideas at a full and fair price (2) to make available to industry a means for the knowledge of and the purchase of millions of ideas that otherwise never come to the attention of its directorates.

The I • I. M. I. exists for you. Use it. If you have an idea—

Don't Sit On It! SELL IT!

Write today for full information on how I • I. M. I. helps you.

Reference: Your Better Business Bureau

International
IDEA MARKETING INDUSTRIES, Inc.

Registry Division
Idea Marketing
U. D. National Bank Bldg.
Upper Darby, Pennsylvania
Rush the free I • I. M. I. Information booklet to:
Name _____
Address _____
City _____ Zone _____ State _____

Draw **CARTOONS**



Learn at Home in Spare Time ...
EARN BIG MONEY

You don't need previous training or art ability with the "Famous System of Manual Training!" With this modern streamlined method, you learn rapidly, easily ... start to cartoon immediately, without tedious study or exercises.

WIDE DEMAND FOR CARTOONISTS ... EARN WHILE YOU LEARN
... Magazines, newspapers, movies, television, ad agencies - all are searching for new cartoon ideas and talent. As a successful, Continental-trained Cartoonist, your earnings are not limited. Many of our students start earning after first few lessons. A wonderful pastime, too.

WE SUPPLY EVERYTHING... As our student, you receive **FREE** of extra cost a big 15-piece Professional Kit with all equipment and materials you need, and valuable Articulated Model to help you draw any human pose.

GET ALL THE FACTS FREE... Big, colorful Free Catalog gives all details, plus pages of useful information. Use coupon now.

Continental Schools, Inc.
DEPT. A-3, 4201 S. BROADWAY, LOS ANGELES 37, CALIF.

Continental Schools, Inc.
Dept. A-3 4201 S. Broadway, Los Angeles 37, Calif.
Please rush me your Free Catalog and other information by return mail. No charge or obligation, no salesman will call.

NAME _____
ADDRESS _____
CITY _____ ZONE _____ STATE _____



DO MAGIC JUST LIKE PROFESSIONAL MAGICIANS

IT'S EASIER THAN YOU THINK
THRILL, ASTONISH AND AMAZE OTHERS
WITH YOUR SENSATIONAL MAGIC

**RUSH 25c NOW - TODAY FOR
PROFESSIONAL MAGIC CATALOG**
160 Pages! • 800 Illustrations! • 1000 Mysteries!
HOUSE OF 1000 MYSTERIES • 202-45 PINWOOD TR. • Trumbull, Conn.

FREE TRICK INCLUDED!!

Superior's New Model 70 UTILITY TESTER®
FOR REPAIRING ALL ELECTRICAL APPLIANCES
MOTORS • AUTOMOBILES • TV TUBES

As an electrical trouble shooter the Model 70:

- Will test Toasters, Irons, Broilers, Heating Pads, Clocks, Fans, Vacuum Cleaners, Refrigerators, Lamps, Fluorescents, Switches, Thermostats, etc.
- Will test all TV tubes for open filaments, inter-element shorts, burned out tubes, etc.
- Measures A.C. and D.C. Voltages, A.C. and D.C. Current, Resistances, Leakage, etc.
- Will measure current consumption while the appliance under test is in operation.
- Incorporates a sensitive direct-reading resistance range which will measure all resistances commonly used in electrical appliances, motors, etc.
- Leakage detecting circuit will indicate continuity from zero ohms to 5 megohms (5,000,000 ohms).

As an Automotive Tester the Model 70 will test:

- Both 6 Volt and 12 Volt Storage Batteries • Generators • Starters • Distributors • Ignition Coils • Regulators • Relays • Circuit Breakers • Cigarette Lighters • Stop Lights • Condensers • Directional Signal Systems • All Lamps and Bulbs • Fuses • Heating Systems • Horns • Also will locate poor grounds, breaks in wiring, poor connections, etc.

Model 70 comes complete including 64 page book, only... **\$15.85**

SHIPPED ON APPROVAL
NO MONEY WITH ORDER - NO C.O.D.

Try it for 10 days before you buy. If completely satisfied than send \$3.85 and pay balance at rate of \$4.00 per month for 8 months - **No Interest or Finance Charges Added!** If not completely satisfied, return to us, no explanation necessary.

MOSS ELECTRONIC, INC., Dept. D-726
3849 Tenth Ave., New York 34, N.Y.
Please rush Model 70. If satisfactory, I will pay on terms specified. Otherwise I will return tester.

Name _____
Address _____
City _____ Zone _____ State _____
All prices net, F.O.B. N. Y. C.

DAN LURIE
America's
Champion
Muscle Builder

**BUILD YOUR MUSCLES FAST
WITH DAN LURIE BARBELLS**

Get results as no other method can. See as low as your arms, chest, legs grow like magic. **948**
no other method compares. Get \$10.00 **BODY MOLD COURSE FREE** with order. Results guaranteed. Buy direct and save.

50 lb. set \$ 9.48 • 100 lb. set \$15.98
150 lb. set \$23.48 • 200 lb. set \$29.98

Semi-steel sets approx. 10% higher. Extra wts. 15c per lb. Send 50% cash, balance COD., F.O.B. Plant. Order today.
DAN LURIE BARBELL CO., 52-M3 Bristol St., Dept. 59C, Bklyn. 12, N.Y.

Send 10c For Catalog

ELECTROPLATE
ANY OBJECT IN HOME SHOP GARAGE.

on any object

NOW with our NEW **ELECTROCHEMICAL** outfit. You can easily do your own plating with same **LUSTER** and **DURABILITY** as by more expensive equip. Outfit comes completely ready to start plating immediately. With instructions on plating metal & non-metal objects as Tools, Auto Parts, Silverware, Jewelry, Baby Shoes, 1001 other articles with **COPPER, CHROME, NICKEL, GOLD, etc.** **SEND NO MONEY.** Everything sent C.O.D. for low price of **ONLY \$5.95** or send \$5.95 now and receive it postpaid. Money back in 7 days if not satisfied. M.Z. Sales Co., Dept. G-32, 113 W. 42nd St., N. Y. 36, N. Y.

DOLLS!

Learn to make, repair and sell dolls and accessories at home. Excellent money making opportunities. May we send **FREE** informative booklet? No obligation!

NORM & SUE'S DOLL HOSPITAL SCHOOL, Studio M-30
11826 San Vicente Blvd., Los Angeles 49, Calif.

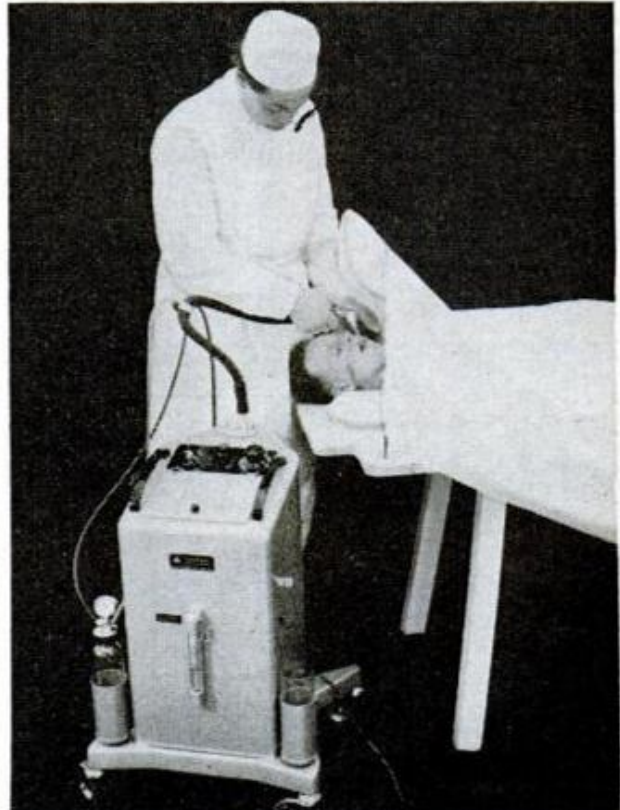

Dragerworks, Heinrich und Bernhard Drager LUBECK, West Germany

Artificial Cougher

Artificial fits of coughing, needed by persons unable to cough and for artificial respiration, are achieved with a German bronchial machine. A tracheotomy tube, entering through the mouth, connects the gate valve and vacuum tank of the machine to the patient's bronchial system. When the valve opens, a sudden pressure causes an expiratory air impulse, pulling secretion into the machine via the tube.

Материал, защищенный авторским правом

Better Than Your Own

SHOE STORE AT HOME



Two-Eyelet Hit With Cushioned Comfort

No investment, no experience needed. Just show magic cushion comfort to friends, neighbors, co-workers. Advance commissions to \$4.00 a pair, plus Cash Bonus, Paid Vacation, \$25.00 Reward Offer. Outstanding values for men, women, children. Money back guarantee. Shoe samples supplied without cost. Write TODAY for FREE new 84 page catalog and full details.

TANNERS SHOE CO., 524, BROCKTON, MASS.

75 POWER TELESCOPE 25X-45X-75X \$398

NEW 3 in one telescopes, 3 variable 25X-45X-75X magnification. Brass bound. 25 power for ultra bright images. 45 & 75 power for long range. Guaranteed to bring distant stars, moons, objects, sports 75 times closer.

Most powerful scope sold anywhere near this amazing low price. American made, 5 sections. Opens 36", closes 1 ft.; contains 4 ground & polished lenses. Can also be used as powerful compound microscope. Mass production enables us to offer telescope complete at \$3.98 postpaid. Money back guarantee.

CRITERION CO., Dept. PMB-79, 331 Church St., Hartford, Conn.

NO JOB WORRIES

PLASTEX INDUSTRY needs manufacturers on small scale for big production of Lamps, Clock Stands, Art Goods, Novelties in Plastic Marble imitation. No Experience necessary. 1/2¢ material makes regular 10¢ store sellers. Moulds furnished for fast production. Small investment brings good profit. Big wholesale orders now being placed. Ambitious men have chance for real prosperity and job security. Our NEW FREE booklet will interest and benefit you.

PLASTEX INDUSTRIES, Dept. A
3400 Third Ave. New York 56, N.Y.

SIGN PAINTING

Home-Study Course - Only \$5.95

Teaches you commercial sign painting and sign building as it is being done TODAY in leading shops all over the country. Complete practical course for self-instruction. Shows latest methods of truck lettering, office doors, wood letters, reflecting signs, plastics, sprayed signs, gold leaf, silk screen process, up-to-date alphabets, money-making business information, etc.

SATISFACTION GUARANTEED OR REFUND!

Contains all the instruction of a high-priced correspondence course. Full price, only \$5.95, postpaid. Or C.O.D. plus postage. No risk—order today. Satisfaction or money back! Order "Sign Painting Course." NELSON-HALL CO., 210 S. Clinton St., Dept. 2CP-2, Chicago 6, Ill.



Shrinks Hemorrhoids New Way Without Surgery Stops Itch - Relieves Pain

For the first time science has found a new healing substance with the astonishing ability to shrink hemorrhoids and to relieve pain - without surgery.

In case after case, while gently relieving pain, actual reduction (shrinkage) took place. Most amazing of all - results were so thorough that sufferers made astonishing statements like "Piles have ceased to be a problem!"

The secret is a new healing substance (Bio-Dyne*) - discovery of a world-famous research institute.

This substance is now available in suppository or ointment form under the name Preparation H.* Ask for it at all drug counters - money back guarantee. *Reg. U.S. Pat. Off

94.6% OF BAILEY GRADUATES ARE EMPLOYED AT TOP PAY IN THE FIELDS WHICH THEY WERE TRAINED!



DIESEL-AUTO MECHANICS DESPERATELY NEEDED!

We have a far greater demand for our students than we can fill! We can show you an actual waiting list of leading companies throughout the world who have tried Bailey graduates - found them outstanding, and are coming back for more!

Bailey Graduates are Successful . . . RECEIVE BIG PAY - HAVE SECURE FUTURE!

The Famous Bailey Course prepares you for BOTH Diesel and Gasoline Mechanics. This is a must - due to the advent of using Diesel principles, such as 'Fuel Injection' on passenger cars . . . use of gasoline engines for starting Diesel engines, etc. You learn all this at Bailey in the amount of time ordinarily required to learn just one of these subjects, **ALL FOR THE PRICE OF ONE.**

Don't be satisfied with a 'futureless', one-type job - learn how you can make big money now! Write today for Free Booklet that takes you on a step-by-step camera tour through our spacious, modern shops - See Bailey students in action as they Learn-by-doing with the Famous Bailey Method of training! We provide you with housing and part time jobs while in school, plus nation-wide placement service for graduates.

BAILEY Technical SCHOOLS

1634 S. GRAND ST. LOUIS 4, MO.

MAIL TODAY!

Please mail immediately this free booklet without obligation.

FREE BOOKLET



Name.....
Address.....
City..... State.....
APPROVED FOR VETERAN... NON-VETERAN

WANTED!

**Mechanically Inclined
Men to Qualify for
CUMMINS DIESEL
FACTORY TRAINING**



If you are interested in High Pay Jobs and Advancement in the Diesel field... here's your opportunity! Qualified Factory-Trained men are in demand by highway builders, diesel manufacturers, truck line operators everywhere. Interstate can help you qualify for tuition-free Cummins factory training and big pay diesel jobs! Write for complete information about Cummins-approved home training.

Get the Facts Today!

WRITE INTERSTATE TRAINING SERVICE

Dept. A-3, Portland 12, Oregon

RUSH information about Cummins tuition-free Factory Training and approved Home Study programs.

Name _____

Address _____

City _____ Zone _____ State _____

ELECTRIC WELD - BRAZE & CUT

REPAIR MOST EVERYTHING MADE OF METAL

Home Appliances, Auto parts, Farm-garden equipment, toys. Make and repair playground equipment, lawn chairs, tables, ornamental iron work, gates, wagons, etc. Solder, heat, bend, and straighten, with terrific heat from arc torch.



Cut and weld up to 1/4" steel plate. A million uses for Home, auto, farm, inventors, factories, etc. Works from any home 110

volt plug-in. Complete with dark welder's mask, arc torch, supply of carbon welding and brazing rods and complete Welding Instruction Book. Efficient—durable—1 year guarantee. Wt. only 4 lbs.

SEND ONLY \$3 postage on arrival or send \$12.95 and we will send postpaid. Ideal gift for mechanically minded home owners, relatives, friends. Order now for early delivery. Available only from
MIDWAY WELDER Dept. DPM-3 Kearney, Nebraska

FREE

EICO

CATALOG

**Build Your Own
Hi-Fi, Radios,**

Ham Gear, Test Inst., — Save 50%

Get started in ELECTRONICS the easy EICO way. No technical knowledge needed to build EICO kits. Simple, step-by-step "Beginner-Tested" pictorial instructions guide you all the way. LIFETIME service & calibration guarantee. Mail coupon now!



EICO, 33-00 Northern Blvd., L. I. C. 1, N.Y.
Please send FREE catalog & name of local dealer. Dept. PM-3

Name _____

Address _____

City _____ Zone _____ State _____



Stimulating, adventure-packed reading for young boys and girls

A perfect blending of scientific information and exciting adventure. Each book \$2.95. At your bookstore, or order direct from Popular Mechanics, 200 E. Ontario Street, Chicago 11, Illinois.

**After the city,
Before the state
The ZONE keeps your mail
From being late**



The Post Office has divided 106 cities into postal delivery zones to speed mail delivery. Be sure to include zone number when writing to these cities; be sure to include *your* zone number in *your* return address — after the city, before the state.

Make More Money in One of Today's **FASTEST-GROWING** Industries

We'll train and establish you in YOUR OWN LIFETIME BUSINESS

start part time if employed!

IN YOUR TOWN there's a real opportunity right now for you to meet the growing demand for cleaning of costly carpets and upholstery—services for which homeowners are ready to pay good money. Old mechanical methods have proved to be harmful to fabrics so the field is wide open with our exclusive, safe, scientific absorption method of cleaning.

This business is easy to learn and quickly established. There's no overhead, no shop needed—you operate from home and provide all services in your customers' homes. Just 2 average jobs a day net \$8,750 first year in this \$750 million a year industry! If now employed, start part-time.

We Help You Grow

Under our unique cooperative program, you are fully trained through a nearby dealer and at our 50-hour training school. You're kept up-to-date through a monthly magazine, nat'l conventions, and at regional meetings where Hdqtrs' staff come to you in your area. You're backed by nat'l advertising in consumer (*McCalls*, *Parents' House & Garden*, etc.) and trade magazines. Others of over 27 continuous services which help assure your success include: Individual counseling (staff of specialists give you prompt, expert counsel), ad kits, folders, product development, etc. "Staff at Hdqtrs to the last man is the best friend I have in business. They're always willing to do everything possible to guide me to even greater success," says J. Hoak of Charleroi, Pa.



OUR 30th YEAR

6 WAYS TO MAKE MONEY

You get exclusive use of unique absorption process which cleans carpets and upholstery without harmful scrubbing, soaking or shrinkage. It's acclaimed by housewives, mfrs and backed by *McCalls* and *Parents' Seals*. Five other profitable services are soil retarding, mothproofing, flame proofing, spotting and carpet repairing. Thus, on most jobs you multiply profits. "Headquarters say gross \$9.00 per hour. I gross up to \$12.00. Many dealers I know do even better," says Dan Chilcott of N. Platte, Neb.

EASY TERMS If needed, we help finance you. Everything furnished. Write for details today.

Send for FREE



booklets

"OWN A BUSINESS" COUPON

DURACLEAN CO., O-163 Duraclean Bldg., Deerfield, Ill.

Please rush FREE 16-page booklets which detail how I may own my own business. I understand I am under no obligations and no salesman will call.

Name.....

Address..... County.....

City..... State.....

LEARN TO DRAW IN 3 WEEKS

YES! In just 3 weeks you can be on your way toward high-pay career or hobby in Commercial Art, Painting, Cartooning, Fashion, TV Art, etc. Learn at home, in spare time. TWO 22-pc. art outfits included free of extra charge. **LOW COST**—only 20c a day! Send for **FREE** Book describing easy method. No salesman will call.

Washington School of Art, Studio 143, Port Washington, New York.

Learn LANDSCAPE GARDENING

AND GROWING OF PLANTS. Latest information on propagation, soil-testing, plant growth regulators, garden design. Start a profitable business or wonderful hobby. Unique and modern home study course—accredited. Earn your certificate at home. May I send FREE, and without obligation, my *Informative Booklet*?

NORM MORRIS NATIONAL LANDSCAPE INSTITUTE
DEPT. M-30 11826 SAN VICENTE BLVD., LOS ANGELES 49, CALIF.

INVENTORS

If you have an invention that you believe has merit, write us at once for copy of copyrighted booklet "How to Go About Selling Your Invention." **FREE**—Just send name. **Kessler Sales Corporation** • Dept. D-53 • Fremont, Ohio

26 YEARS IN BUSINESS AT THE SAME ADDRESS.
Our entire stock of very slightly used **EXTRA MILEAGE TOP GRADE Tires**, (Written Insurance Guarantee). **SEND AD**

WHY PAY MORE? **FREE PASS. TUBE**
EVERYBODY MAY DEDUCT 10% off ON EVERY TIRE

12 MOS. Written Guarantee. White Walls \$1.00 extra				
600-16	\$6.92	670-15	\$6.82	700-15(6)
600-16(6)	8.82	710-15	6.92	750-16(8)
650-16(6)	9.32	760-15	6.92	700-17
750-14	7.72	800-15	6.92	750-17
800-14	7.72	820-15	6.92	650-20
750-16(6)	9.82	700-16(6)	9.92	700-20
				11.82
				10.00-22
				20.92

Thousands of tires shipped all over the U.S.A. All tires shipped F.O.B. Phila. Send Check or M.O. with this ad. Dept. 2. No C.O.D.

STANDARD 834 N. Broad St., Philadelphia 30, Pa.

can open the door to a BETTER JOB at BIGGER PAY for YOU

TODAY, CHOOSE YOUR CAREER! Then take the first easy step toward preparing for the goal you can reach in spare time at home. Or, if you are in work you like, learn how you can earn quicker promotions and bigger pay. For 63 years AMERICAN SCHOOL has helped many thousands of ambitious people succeed. Think seriously about the subjects listed. Fill in and mail coupon today.

AMERICAN SCHOOL, Dept. G345, Drexel at 58th, Chicago 37, Ill.

Without obligation, send FREE information on the subjects I have checked.

<input type="checkbox"/> Accounting	<input type="checkbox"/> Diesel Technician	<input type="checkbox"/> Machinists
<input type="checkbox"/> Apprenticeship Courses	<input type="checkbox"/> Drafting—Building Trades	<input type="checkbox"/> Mechanical Engineering
<input type="checkbox"/> Architecture & Building	<input type="checkbox"/> Drafting—Machine Trades	<input type="checkbox"/> Mechanical Technology
<input type="checkbox"/> Automotive Technician	<input type="checkbox"/> Electrical Engineering	<input type="checkbox"/> Metalworking Courses
<input type="checkbox"/> Better Foremanship	<input type="checkbox"/> Electricity—Practical	<input type="checkbox"/> Plumbing—Practical
<input type="checkbox"/> Bookkeeping	<input type="checkbox"/> Electronics—Industrial	<input type="checkbox"/> Private Secretary
<input type="checkbox"/> Business Management	<input type="checkbox"/> HIGH SCHOOL COURSES	<input type="checkbox"/> Retail Merchandising
<input type="checkbox"/> Civil Engineering	<input type="checkbox"/> Human Relations	<input type="checkbox"/> Sheet Metal Work
<input type="checkbox"/> Contracting	<input type="checkbox"/> Instrumentation	<input type="checkbox"/> Tool Making

NAME _____ OCCUPATION _____
HOME ADDRESS _____ AGE _____
CITY _____ STATE _____

Accredited Member NATIONAL HOME STUDY COUNCIL

ENGINEERING

DEGREE IN 27 MONTHS

Students given option of studying engineering under accelerated program leading to Bachelor of Science Degree in 27 months; or the standard four-year program leading to Bachelor of Engineering Degree in 36 months. The B.S. degree in Mathematics, Chemistry, or Physics (including Nuclear Physics) may be earned in 36 months. By attending classes year-round, students can graduate in 3 years and have one year of experience and income in the time usually needed to complete a four-year college course. Preparatory courses. Thorough, practical program. Individualized instruction.

Keeping pace with progress in science and engineering
Campus. Dorms, gym, playing fields. Superior faculty. 2,000 students. New Dana Science Building. Low tuition. Earn board. G.I. approved. Enter March, June, September, December. Students from 50 states, 40 foreign countries. Send coupon for free catalog, full information. Enroll now!

INDIANA TECHNICAL COLLEGE

530 E. Washington Boulevard, Fort Wayne 2, Indiana

Please send me free information on 27 mo. B.S. DEGREES in:

Aeronautical Chemical Civil Electrical
 Mechanical Electronics

on 36 mo. B. E. DEGREES in:

Aeronautical Chemical Civil
 Electrical (Power or Electronics) Mechanical Metallurgical

on 36 mo. B.S. DEGREES in:

Mathematics Chemistry Physics

Name _____

Address _____

Catalog of 2900 Novelties 10c

New! Send 10c for amazing catalog of novelties, live animals, scientific supplies, hobbies, funmakers, planes & boats, looms, magic tricks, joke articles, unusual seeds, gadget timesavers, cameras, optical goods, projectors, movies, lucky jewelry, religious novelties, disguises, musical instruments, stamps, coins, puzzles, fortune tellers, radios, auto & bike accessories, telescopes, magnifiers, compasses, banks, smokers' gadgets, artists' supplies, printing sets, engines, motors, shockers, knives, billfolds, guns, rifles, sports, books, games, plants, etc. Send 10c.
JOHNSON SMITH COMPANY Dept. 471 Detroit 7, Michigan

MANUFACTURE THIS BEAUTIFUL CONCRETE OUTDOOR FIREPLACE

Right In Your
Own Backyard

\$4.00 Worth of
Sand & Cement
produces this
Attractive
Fireplace.



**Sells on Sight
from \$60. to \$80.
Easy to start your
own Profitable
Business.**

The General Fireplace
Molds and Process are the most
amazing and foolproof ever invented.
Simple to operate. Two men can produce five fireplaces a day.

BIG DEMAND!!

Sell all you produce to Department Stores, Homeowners, Parks, Nurseries and Picnic Groves. Fireplaces sell on sight. No experience necessary. We supply full operating instructions and equipment plus the know-how that spells BIG PROFITS. This is an outstanding opportunity for men of vision and small capital to get into a busy rich paying field. Don't delay, be the only exclusive manufacturer in your own home town. Mail coupon at once for full details as to how you can reserve your territory. **Molds sold only on exclusive franchise.**

GENERAL ENGINES CO., Inc., Dept. MF-30
ROUTE 130, THOROFARE, N. J.

Mr. Tor of Philadelphia writes:
Sold 250 in first 4 months. Selling to Sears Roebuck, John Wanamaker, and Gimbel Bros. in Philadelphia area.

Name _____
Address _____
City _____ Zone _____
State _____



An Easy Way to Earn

EXTRA MONEY

For Your

NEW CAR!

POPULAR MECHANICS—the magazine that helps you to *save money* on hundreds of projects—now offers you an opportunity to earn *extra money* as a spare-time or full-time subscription representative for POPULAR MECHANICS and *all other* leading national magazines.

Thousands of men, and women too, are earning substantial sums daily through this pleasant, convenient and profitable work. What *they* are doing, you can do too, just as easily and successfully. The rapidly growing interest of men in all kinds of practical crafts has created millions of potential subscribers for POPULAR MECHANICS — one of the easiest of all magazines to sell.

MAIL THE COUPON NOW!

Few ways of earning extra money at home are so convenient to engage in, so easy to start, so certain to add worthwhile amounts to your personal or family income. Let us send you complete details of our plan, free supplies—everything you need to start earning extra money at once.

POPULAR MECHANICS, Dept. 160
250 West 55th St., New York 19, N. Y.

Please send me, without obligation, complete details of your subscription plan.

NAME _____

ADDRESS _____

CITY & ZONE _____

STATE _____

LEARN MEAT CUTTING AT NATIONAL

Pay After Graduation



The steady dependable trade of Meat Cutting taught easily in 8 short weeks. **YOU LEARN BY DOING** under actual meat market conditions in big modern school at Toledo.

For beginners or men with experience. Get a profitable store of your own. Remember, **PEOPLE MUST EAT!** Big pay jobs. Free employment help. Thousands of successful graduates.

Buying, cutting, percentage, pricing, advertising, selling, etc. A complete retail meat education. National School established 37 years. Get National training **NOW**. Pay your tuition in easy weekly

payments after you graduate. Send coupon for **FREE** school catalog — **TODAY**. G.I. approved.

National School of Meat Cutting, Inc., Dept. 50-C, Toledo 4, Ohio
 Send me your **FREE** school catalog on National Training at Toledo in Meat Cutting, Meat Merchandising and Self Service Meats. No obligation. No salesman will call.

Name _____ Age _____
 Address _____
 City _____ State _____
 Approved for Veterans

LEARN WHILE YOU SLEEP!



Hypnotize self, others while asleep with amazing hypnotic phonograph records, tapes. Free catalog lists 200 unusual records, tapes & equipment for sleep-learning & hypnosis experimenters. Sleep-Learning Research Ass'n., Box 24-D, Olympia, Washington.

\$3.25 OR 2 FOR \$6.00!
 With 40 ft. of wire. Additional wire 3c ft. **TESTED AND GUARANTEED.** Write for free list of all types of telephones. Shipments FOB Simpson, Pa.
TELEPHONE ENGINEERING CO., Dept. 3 80, Simpson, Pa.

OWN YOUR OWN BUSINESS



Free booklet tells how! Build and operate this profitable drive-in — seasonal or year 'round. Mail coupon now.



RICHARDSON Corporation
 Dept. PM-3, P.O. Box 790, Rochester 3, N. Y.
 Please send me **FREE** booklet on your tested, franchised refreshment stand.

Name _____
 Address _____
 Place _____

DRAINS cellars, cisterns, wash tubs; **\$7.95**
IRRIGATES - CIRCULATES - SPRAYS

1,001 uses. Stainless shaft. Won't rust or clog! Use 1/8 HP motor or larger... 3/4 HP for up to 3000 GPH; 450 GPH 80' high; or 1800 GPH from 25' well. 1" inlet; 3/4" outlet. Coupling included free. **\$7.95.**
HEAVY DUTY BALL-BEARING PUMP. Up to 7,500 GPH; or 3,000 GPH from 25' well. 1 1/4" inlet; 1" outlet. **\$12.95**
Postpaid if cash with order. MONEY BACK GUARANTEE
 Centrifugal and Gear Pumps in All Sizes
LABAWCO PUMPS, Belle Mead 7, New Jersey

LEARN UPHOLSTERY

in your spare time
 run your own
 business
AT HOME

FREE BOOK with sample lessons with course
YOU MAKE SLIPPER CHAIR CLUB CHAIR OTTOMAN
PLUS SLIP COVERS Yours to Keep or Sell

BE YOUR OWN BOSS
 Earn more from the start! Set up your own profitable business, in your own home, enjoy steady income, independence for life. **You're in demand** in the booming field of Custom Furniture Upholstery. **Right off you start learning and earning** with tools, complete frames, fabrics and materials, included **FREE** with N. Y. State-approved UTS course. You learn skilled professional custom upholstery, reupholstery, furniture finishing, repairs, how to make beautiful slip covers, cushions and draperies. **EARN WHILE YOU LEARN**, in your spare time **AT HOME**... the UTS easy way.

FREE ILLUSTRATED BOOK — FREE SAMPLE LESSON
 Get ready for well-paid job and big profits, from steady work, as your own boss, running your own business. Mail coupon **NOW** for **FREE BOOK!** Training in N. Y. School also available. **VET APP'VD. ACCREDITED BY N.H.S.C.**

UPHOLSTERY TRADES SCHOOL
 Dept. MC-310, 721 E'way, N. Y. 3, N. Y.
 Please send me **FREE** book, "Your New Way to a Successful Career," and **FREE** sample lesson. No obligation—no salesman will call.
 Home Study Training in N. Y. School

Name _____ Please Print Plainly
 Address _____
 City _____ Zone _____ State _____
 Check if Korean Veteran

Want **BIG PAY**—
Your Own Business?

Be a

LOCKSMITH



You can quickly step into a well-paid job or start a big-profit business of your own. Shortage of locksmiths means opportunities everywhere, spare-time or full-time.

EARN EXTRA MONEY FROM THE START!
All Special Tools, Supplies Furnished Free

Age, education, minor physical handicaps don't matter in this growing, steady-income trade. You learn fast at home—gain practical experience through well-illustrated lessons. You do real jobs under the personal guidance of experts. Only school of its kind.

For a future as your own boss, or in a big pay job, send for **FREE** illustrated book. Mail coupon at once. No salesman will call. Licensed State of N. J.; Accredited Nat'l. Home Study Council. Approved for Veterans. **LOCKSMITHING INSTITUTE**, Dept. 103, 150 Park Ave., E. Rutherford, N. J.



LOCKSMITHING INSTITUTE, Dept. 103,
150 Park Ave., E. Rutherford, N. J.

Please send **FREE** and without obligation illustrated book.

Name _____

Address _____

City _____ Zone _____ State _____

High School at Home

MANY FINISH IN 2 YEARS

No classes. No time wasted going to and from school. Progress as fast as your time and abilities permit. Standard H.S. texts supplied. Thousands enroll each year in this 63-year-old school. Send for **FREE** descriptive booklet.

AMERICAN SCHOOL, Dept. H-345
Drexel at 58th St., Chicago 37, Ill.

Without obligation, please send **FREE** descriptive booklet.

Name _____

Address _____

Accredited Member National Home Study Council

It's EASY to be Why be Average?

Now you can be dramatically taller! Amazing "ELEVATORS" shoes instantly add the all-important height you need to make you a **BIG** man; give you the boost you need to command everyone's respect. It's your secret because smartly-styled "ELEVATORS" look, feel like other fine shoes! Give yourself a lift. Mail coupon **NOW** for Free Style Booklet!



THE ORIGINAL AND GENUINE
ELEVATORS
HEIGHT-INCREASING SHOES
"YOUR PERSONAL PEDESTAL"
A TRADE MARK OF STONE ISLAND CO., INC.

BROCKTON FOOTWEAR, INC.
Dept. 6-30, BROCKTON 68, MASS.

Please send Free Booklet and name of nearest dealer. I understand this will be held in strict confidence and no salesman will call.

NAME _____

PLEASE PRINT

ADDRESS _____

CITY _____

STATE _____

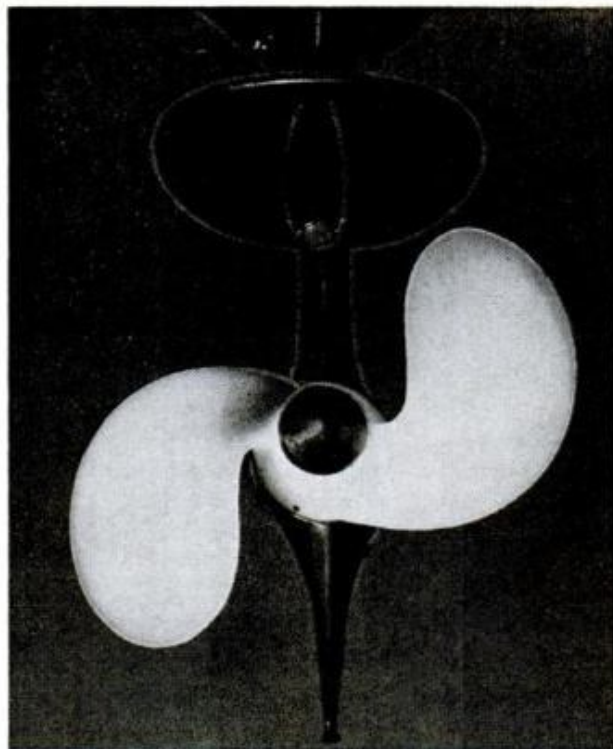

Grish Bros., St. John, Ind.

Tough Plastic Makes Durable Prop

Molded from nylon resins, a new propeller for outboard motors up to 12 horsepower is noncorrosive, almost unbreakable, and is flexible enough to increase pitch at high speeds, giving a variable-pitch effect.



There's a world of



buyer satisfaction behind



known brand names!



A Brand Name is a
maker's reputation



BRAND NAMES FOUNDATION, INC.
437 FIFTH AVENUE, NEW YORK 16, N.Y.

TRAIN AT HOME

in Your Spare Time or in the Great Allied School

1338-42 South Michigan Ave. Chicago 5, Ill.

DRAFTING—All Branches
• Mech. • Structural • Aeronautical

ENGINEERING
• Industrial Engineering
• Tool Engin. & Designing

ELECTRONICS

AUTO MECHANICS

AIR CONDITIONING
Refrigeration — Heating & Cooling

TOOL & DIE MAKING
Machinist Trade

Choose the Allied Way for Best Pay

SEND FOR **FREE** BOOKS

Prepare for the best jobs in your spare time at home. With ALLIED'S practical home study program you can progress so rapidly that big new opportunities will soon be open to you. Students planning a career in engineering can begin their training in short courses at Home or at Allied Institute and continue progressively toward an Engineering Degree in 31 months. Allied is approved by Industry, National Home Study Council, Department of Education, Office of Public Instruction, State of Illinois, U. S. Department of Justice.

ALLIED INSTITUTE OF TECHNOLOGY,
1338-42 South Michigan Ave., Dept. PM-30, Chicago 5, Ill.
Send me without obligation information on your courses:

- | | |
|---|--|
| <input type="checkbox"/> MECHANICAL DRAFTING | <input type="checkbox"/> AUTO MECHANICS |
| <input type="checkbox"/> STRUCTURAL DRAFTING | <input type="checkbox"/> ELECTRONICS |
| <input type="checkbox"/> ELECTRONIC DRAFTING | <input type="checkbox"/> AIR CONDITIONING |
| <input type="checkbox"/> AERONAUTICAL DRAFTING | <input type="checkbox"/> REFRIGERATION |
| <input type="checkbox"/> INDUSTRIAL ENGINEERING | <input type="checkbox"/> TOOL & DIE MAKING |
| <input type="checkbox"/> TOOL & DIE DESIGNING | |
| <input type="checkbox"/> HOME STUDY <input type="checkbox"/> RESIDENT <input type="checkbox"/> VETERAN <input type="checkbox"/> NON-VETERAN | |

NAME AGE.....
ADDRESS
CITY..... COUNTY..... STATE.....

Exclusive with Scott Mitchell
ZEREM 8 IN 1 SOCKET WRENCH
Available in Inches or Millimeters

One single drop forged steel wrench has the 8 most popular sized sockets to do every conceivable nut tightening job on car, in home, shop or industry. Instant swiveling action of socket head brings desired size into position—saves precious time, money and space—and there's no danger of losing sockets. Overall length 9 1/2". Available in 7/16, 1/2, 9/16, 19/32, 5/8, 11/16, 3/4 and 7/8 inch SAE Openings OR 1 1/2, 1 3/8, 1 1/2, 1 5/8, 1 3/4, 1 7/8, 1 9/8, and 2 1/8 inch SAE Millimeter Openings. Precision made in West Germany. Specify inches or mm when ordering. plus 35c p.p. & hdig.

Rugged 6000 Lb. Test NYLON TOW CABLE

If ever stuck in snow, mud or ditch, there's nothing handier to have in your car than a super-strong, All Nylon Tow Cable. Test proven to over 6000 lbs. pull, more than enough for even the biggest trucks and cars. One end has heavy steel snap clamp while other end is looped. Measures 15 ft. long. Also invaluable in home and for industry. **\$2.98** plus 25c p.p. & hdig.

FAST—Powerful—Durable SINGLE HAND WRENCHES

Time is money and these versatile Single Hand Wrenches can outperform in speed and service any ordinary wrench. Jaws snap back on tempered steel spring and solidly grasp any object to be tightened or loosened. Wrenches made of Drop Forged Steel with polished steel heads. 10" wrench jaws open to 1 1/2"; 8" wrench to 1 1/4" and 6" wrench to 5/8". A really necessary set for every home owner and mechanic. Complete set of 3 wrenches— **\$2.98** plus 35c p.p. & hdig.

MONEY BACK GUARANTEE—Send Check or M.O.—C.O.D. plus fee
SCOTT-MITCHELL HOUSE, INC. Dept. HC26, 415 South Broadway, Yonkers, N. Y.



300 POWER.....
Telescope Lens Kit only **\$3.98** postpaid
Conquer Space. Explore the Universe, Planets, Moon Craters, New Stars, etc. Complete Lens Kit consists of 80 inch focal length ground and polished objective lens, eyepiece lenses for 50 POWER, 100 POWER, 150 POWER, 200 POWER, 250 POWER, 300 POWER, and all necessary lens fittings. Easy to make from simple step by step instructions. (Tripod and mount not included.) Money back guarantee.
BUSSE SALES CO., Hartford, Conn., Dept. PM-83

You Can Have a HE-MAN VOICE

Send today for FREE booklet "Voice Power and Personal Power" by Eugene Feuchtinger. Just send your name, address and age. Mailed in plain sealed envelope. No obligation.



PREFECT VOICE INSTITUTE
210 S. Clinton, Studio CP-2, Chicago 6, Ill.



SEND FOR THIS **FREE!**

Make money. Know how to break and train horses or ponies. Write today for this book FREE, together with special offer of a course in Animal Breeding. If you are interested in Gaiting and Riding the saddle horse, check here (). Do it today—now.

BEERY SCHOOL OF HORSEMANSHIP
Dept. 1103 Pleasant Hill, Ohio

FORTUNES IN DIVING
Train at Home in Spare Time

Write Today for Amazing Free Booklet
Here is one of the greatest opportunities of our time. Make big money fast in Skin and Lung Diving. Trained divers needed in hundreds of industries and by government. Build a successful business of your own. Hourly rates among highest paid in any field. Training program by E. R. Cross, world famous master diver. Get the facts now. Mail coupon for FREE BOOKLET TODAY!
DIVEMASTER, Dept. PM-30
5637 W. 63rd Place, Chicago 38, Ill.
Send me free information about Diving.
Name Age.....
Address
City State.....

GET READY FOR THE SPACE and SCIENCE ERA! SEE SATELLITES, MOON ROCKETS CLOSE-UP



AMAZING OPTICAL BUYS

and OTHER SCIENTIFIC BARGAINS



See the Stars, Moon, Planets Close Up!

3" ASTRONOMICAL REFLECTING TELESCOPE



60 to 180 Power — Famous Mt. Palomar Type! An Unusual Buy! Assembled—Ready to use! You'll see the Rings of Saturn, the fascinating planet Mars, huge craters on the Moon, Star Clusters, Moons of Jupiter in detail. Galaxies! Equatorial mount with lock on both axes. Aluminized and overcoated 3" diameter high-speed f/10 mirror. Telescope comes equipped with a 60X eyepiece and a mounted Barlow Lens, giving you 60 to 180 power. Low-cost accessory eyepiece available for higher powers. An Optical Finder Telescope, always so essential, is also included. Sturdy, hardwood, portable tripod. FREE

with Scope.—Valuable **STAR CHART** plus 272 page "**HANDBOOK OF HEAVENS**" plus "**HOW TO USE YOUR TELESCOPE**" BOOK.
Stock No. 85,050-H.....\$29.95 postpaid

KNOW THE TRUTH ABOUT POWER. Telescope experts will confirm that an Astronomical Telescope will only give you practical powers to about 50 or 60 times per inch of objective diameter—powers above this only produce empty magnification—make viewing dim, difficult and unsatisfactory.

4 1/4" ASTRONOMICAL TELESCOPE! UP TO 255 POWER!



With this scope you can see everything as above but with greater power plus will split finer stars. Mirror has twice the light gathering power. Mirror guaranteed to give theoretical limit of resolution. Rack and pinion focusing, hardwood tripod, real equatorial mounting—only one adjustment follows stars! Aluminum tube 6" power finder telescope, 2 standard size eyepieces and mounted Barlow lens give you powers of 40X, 90X, 120X, and 255X. Low-cost accessory eyepiece available for higher powers. FREE with Scope.—Valuable **STAR CHART** plus 272 page "**HANDBOOK OF HEAVENS**" plus "**HOW TO USE YOUR TELESCOPE**" BOOK. Shipping weight 25 lbs.

Stock No. 85,006-H.....\$74.50 f.o.b.



NEW BINOCULAR-TO-CAMERA HOLDER

For Exciting Telephoto Pictures Will Fit Any Camera Bring distant objects 7 times nearer with a 35 mm. camera, 7x50 binocular and our NEW BINOCULAR-TO-CAMERA HOLDER. Ideal for long-range shots of wild life, ships, planes, people, etc. Camera and binoculars attach easily. Use any binocular or monocular—any camera, still or movie. Take color or black and white.

Full instructions for taking telephoto's.
Stock No. 70,223-H.....\$11.50 postpaid



BUILD A SOLAR ENERGY FURNACE

A fascinating new field. Build your own Solar Furnace for experimentation—many practical uses. Easy! Inexpensive! Use scrapwood! We furnish instructions. This sun powered furnace will generate terrific heat—2000° to 3000°. Fuses enamel to metal. Sets paper aflame in seconds. Use our Fresnel Lens—14 3/4" diameter... f.l. 14".
Stock No. 70,130-H... Fresnel Lens... \$ 6.00 Pstpd.

BEGINNER'S LENS KITS! FUN FOR ADULTS! FUN FOR CHILDREN!

Kits include plainly written, illustrated booklet showing how you can build lots of optical items.
Stock No. 2-H—10 Lenses.....\$1.00 Postpaid
Stock No. 5-H.....45 Lenses.....\$ 5.00 Postpaid
Stock No. 10-H.....80 Lenses.....\$10.00 Postpaid

INSTRUCTION BOOKLETS

	Stock No.	Price Pstpd.
How to Build Projectors.....	9014-H	30c
Homebuilt Telescopes.....	9006-H	40c
Photography With Your Telescope.....	9058-H	25c
ALL ABOUT TELEPHOTO LENSES.....	9036-H	60c
ULTRA CLOSE-UP Photography.....	9042-H	60c
The Camera Lucida.....	9059-H	20c
Infra-red Light and Its Uses.....	9040-H	75c
Homemade Stereo-Adapters.....	9032-H	30c
Homemade Stereo-Viewers.....	9034-H	30c
"Building a Condenser Enlarger".....	9038-H	40c
Time in Astronomy.....	9054-H	60c
FUN WITH OPTICS.....	9050-H	50c
HOW TO USE YOUR TELESCOPE.....	9055-H	60c

(Includes directions on how to take photographs thru your telescope)

HAND SIGHTING LEVEL

Described in Popular Mechanics March 1958 issue, page 212

Sight it like a Telescope. Gives you a level line of sight, for laying out gardens, drives, new construction, ditches, etc. Complete instructions included.

Stock No. 105-H.....\$2.50 postpaid

'FISH' WITH A MAGNET

Go Treasure Hunting On The Bottom



Great idea! Fascinating fun and sometimes tremendously profitable! Tie a line to our 5-lb. Magnet—drop it overboard in bay, river, lake or ocean. Troll it along the bottom—your "treasure" haul can be outboard motors, anchors, fishing tackle, all kinds of metal valuables. 5-lb. Magnet is war surplus—Alnico V Type—a terrific bargain. Lifts over 125 lbs. on land—much greater weights under water. Order now and try this new sport.

Stock No. 70,183-H. 5-lb. Magnet.....\$8.50 Postpaid
15 3/4 lb. size. Will lift over 250 lbs.
Stock No. 85,088-H. 15 3/4 lb. size.....\$22.50 F.O.B.
Shipping weight 22 lbs. Barrington, N. J.

War Surplus American-Made 7x50 Binoculars

Big savings! Brand new! Crystal clear viewing—7 power. Every optical element is coated. An excellent night glass—the size recommended for satellite viewing. Individual eye focus. Exit pupil 7mm. Approx. field at 1,000 yds. is 376 ft. Carrying case included. American 7 x 50's normally cost \$195. Our war surplus price saves you real money.



Stock No. 1533-H.....only \$55.00 pstpd. (Tax included)



Terrific Buy! American Made! OPAQUE PROJECTOR

Projects illustrations up to 3" x 3 1/2" and enlarges them to 4 ft. wide. No film or negatives needed. Projects charts, diagrams, pictures, photos, lettering in full color or black-and-white. Operates on 115 volt, A.C. current. 6-ft. extension cord and plug included, operates on 60 watt bulb, not included. Size 12" x 8" x 4 1/2" wide. Weight 1 lb., 2 oz. Plastic case with built-in handle.

Stock No. 70,199-H.....\$7.95 Postpaid

Take Telephoto Shots Thru 7x50 MONOCULAR

This is fine quality. American made instrument—war surplus! Actually 1/2 of U. S. Govt. 7 x 50 Binocular. Used for general observation both day and night and to take fascinating telephoto shots with your camera. Brand new, \$95 value. Due to Japanese competition we close these out at a bargain price. Directions and mounting hints included.



Stock No. 50,003-H.....\$15.00 Postpaid

NOTICE: Edmund is now headquarters for Math Learning and Teaching Aids! See dozens of offerings in our FREE Catalog H.



NEW! CIRCULAR SLIDE RULE!

Pocket Size—Fast—Easy to Use! Multiplies, divides, figures fractions, percentages, squares, cubes, roots, proportions, circumferences, areas, retail prices, fuel consumption. Faster, easier to learn and use. Directions included.
Stock No. 30,336-H.....\$4.95 postpaid



CLOSE OUT! MECHANICAL DRAWING SET

Original Price \$18.00
Our Price Only \$8.00 Pstpd.

American mfr. couldn't compete with foreign imports—thus you get a terrific bargain, even far below import prices. 10 handsome pieces in velvet-lined case. Nickel plated brass—precision American-made. We guarantee you'll be satisfied or money refunded.

Stock No. 50,200-H.....\$8.00 Postpaid

FREE CATALOG-H

128 Pages! Over 1000 Bargains!
Yours for the asking

America's No. 1 source of supply for experimenters, hobbyists. Complete line of Astronomical Telescope parts and assembled Telescope. Also huge selection of lenses, prisms, war surplus optical instruments, parts and accessories. Telescopes, microscopes, satellite scopes, binoculars, infrared sniperscopes, math, learning and teaching aids.



REQUEST CATALOG-H

ORDER BY STOCK NUMBER. SEND CHECK OR MONEY ORDER. SATISFACTION GUARANTEED!

EDMUND SCIENTIFIC CO., BARRINGTON, NEW JERSEY



CLASSIFIED ADVERTISEMENTS



Advertisements in this section \$1.30 per word, each insertion, minimum 10 words, payable in advance.

To be inserted under proper classification, copy must be in our office the

18th of the second month preceding date of issue

F. W. Johnson, Manager, Classified Advertising

Popular Mechanics Magazine, 200 East Ontario Street, Chicago 11, Illinois

YOU'LL PROFIT

By reading and answering the classified ads in this section. Hundreds of opportunities for you to make and save money

AUTOMOBILES, MIDGET CARS

GO-CARTS And parts wholesale. 35¢ for wholesale price list and go-cart plans. Go-Cart Wholesalers, 3511 Hixson Pike, Chattanooga 5, Tennessee.

¼-MIDGET Plans and material list \$2.00. How to make 1/12-mile approved track and Go-Kart formula. 50¢. Build your own Kart from our parts list 25¢. Rockey, Galveston, Indiana.

SAVE—When buying new car. We show you how. Literature free. Price Research Bureau, Box 15, Tonawanda, N. Y.

NON-PROFIT Organization offers automobile literature—old, modern and foreign; dealer books, service manuals, glossy photographs; free motor magazines. Write immediately; get on free mailing list. Auto Maniacs, Stockbridge, Mich.

METROPOLITAN Owner's handbook, new, 320 pages \$3.00. Volkswagen handbook \$2.00. Souping the Volkswagen for more power, speed. Renault owner's handbook \$3.00. 1959 Indianapolis Race Yearbook \$2.00. Catalog 200 automobile books free. Clymer, Los Angeles 6, Calif.

CATALOG On parts kits for golf buggy or Jr. sports car. 25¢. Indus Corporation, 1815 Madison, Indianapolis.

CROSLY Parts new, used. Gene's, 1915 South H. Fort Smith, Arkansas.

MIDGET Kart racers. New. Factory constructed. Assemble in 20 minutes. Push it. Motorize it. \$33.95 check or money order prepaid. Benzick, 421 Sixth S.E., Minneapolis, Minnesota.

ANTIQUE Automobiles. Three 8½x11 pictures. Ideal for framing. Send \$1.00 to: 1900 Automobiles, P.O. Box 101, Lathrup Village, Michigan.

AUTO SUPPLIES AND EQUIPMENT

THERMOLENE New, summer, winter auto cooling system conditioner, pump lube, and thermostat cleaner. Stops squeaks, wear and corrosion. Mixes with any anti-freeze or water. No draining or flushing, just drive. No caustics, salt, acid or chromates. Half the reg. cost. superior quality. 2 cans, 8 oz. ea. concentrated, \$1.00 p.p. Motorists, dealers, dist's guarantee. Write: Kutil, 2521 Budd St., River Grove, Illinois.

BECOME Expert on skidmarks. Under-stand evidence at collisions. New slide rule already used by officers, lawyers, adjusters for simple, scientific, accurate study of automobile accidents. Tested in courts, courts-material. Computer, manual, \$2.00. Science-Safety Products, University Station, Shawnee, Okla.

MAKE Old cars run like new. Guaranteed. \$3.95 postpaid. Newco, Box 164-B, Hunlock Creek, Penna.

WATER Injection for better engine performance. Operational report and building instructions \$1.00. Hamilton, 735 E. Halliday, Pocatello, Idaho.

AUTO Shop welding repair training in world's largest non-profit welding school. Low tuition. Free booklet. Hobart Welders, Box M-301, Troy, Ohio.

DON'T Be locked out of your car. Use Hide-A-Key system. For details write to John Pyskaty Locksmith, 3458 W. 62nd St., Chicago 29, Ill.

JEEP Parts! For military and civilian. At great savings. Largest inventory. Catalog for owners and dealers. Inquiries invited. American Auto Parts Co., 1830-PM Locust, Kansas City, Mo.

AMAZING Discovery. Master Glaze, puts brilliant glass-like surface on cars. Free sample, information. Big commissions. Master Glaze, Dept. 920, 7720 Harwood, Milwaukee, Wis.

PROTEKT-A-DOR. Prevents car door damage parking lots, garages. Easily installed. \$1.00 pair. 2 pairs \$1.75. Old Copper Mine Farm, P.O. Box 476, Orange, N. J.

JUST Out! New 388-page, illustrated catalog offering savings up to 50% on over 100,000 auto parts and accessories, many hard to get. All makes (1920 to 1960 models), trucks, foreign and sports cars. Also Hollywood accessories, custom styling, hi-speed equipment. Send 25¢ for postage, packing—refundable on first order. Whitney, 1919 PM-3 Archer, Chicago 16, Ill.

GIANT Auto parts catalog. Thousands special accessories, speed, power, performance. Mileage, custom equipment. Send 25¢ (refundable). Newhouse Automotive Industries, 5805-PM3 Beverly, Los Angeles 22, Calif.

JEEP Owners—V8 conversions. Read Jeep Owners ad, page 26.

CUSTOMIZE! Bubble fender skirts give your car that expensive long, low look. Free literature. Skirts, 5401 W. Warren, Detroit 10, Michigan.

TRAILER Hitches. Custom made. 1960 Ford, Mercury. 4000 lbs. capacity. Guaranteed. Bolts on in 3 places. \$15.00 Other 59-60 models. Inquire prices. Custom, 6221-N Astor, Spokane, Washington.

NEW And used parts at savings. Complete guaranteed parts service for all models cars and trucks, 1924 and later. Largest in the West. Jeep and army parts specialists. Newest type shifting hubs for all jeep and all military and latest production front end drive vehicles. \$27.50 and up. Also, foreign car parts. Write: Pioneer Auto and Truck Parts Co., 734 W. 13th Avenue, Denver 17, Colo.

PARTS, Model "A." List 25¢ (refundable). Matco, Box 135, San Pedro, Calif.

WEASEL Parts and tracks, unused. Symington of Seattle, 4603 Union Bay Place, Seattle 5, Wash.

RING-Valve job while driving. \$6.00 postpaid. (9th successful year.) Guaranteed! Yellow Cab test-proven. Motaloy, Grantham, Penna.

FREE! New catalog. Speed, power, mileage increasing equipment. Discounts! Almqvist Engineering, Milford PM5, Penna.

EVERY Car owner needs our fast, efficient cleaning polishing cloths. New idea, no mess. Sample set prepaid \$1.00. Meyer Company, Box 868, Galesburg, Illinois.

1909-1934 FORD Parts. Illustrated catalogue 50¢. Mark Auto, Layton, New Jersey.

CRANKSHAFT Grinder. Hand operated. Makes bearings fit without taking engine apart. \$4.00. Literature. L. D. McGee, 719 Cascade St., Wenatchee, Wash.

AUTO TRAILERS

BUILD Expanding eight foot trailer. Accommodates five. Literature 10¢. Framar Company, Wilmington, Mass.

PICKUP Coach kits. Blueprints. Literature 10¢. Comstock Trailers, Parsons, Kansas.

CAMPING Trailers, travel trailers, tents, equipment. Also plans, parts. 25¢ for 1960 catalog. Easy Camping, Inc., 128-A Chicago, Evanston, Illinois.

TRAVEL Luxuriously with home convenience at automobile speed in self-sustained, power-controlled, air-conditioned, motorized trailer. Light plant, bath, refrigeration, radio, TV, 26 or 35 ft. Write: Frank Motor Homes, Brown City, Mich.

MOTORCYCLES, BICYCLES, MOTORSCOOTERS AND SUPPLIES

HARLEY-Davidsons—Used bargains. New, used parts, accessories, all models. Bulletin 25¢. Knuth's (Factory Dealer), 1753 Muskego, Milwaukee, Wis.

MOTORCYCLE Parts. New, used. List 25¢. Ballak, 811 N. 9th, St. Louis 1, Mo.

RECONDITIONED Motorcycle motors. Chrome accessories. Complete stock Indian parts. Expert rebuilding. Fast service. Indian Motorcycle Sales, Kansas City 27, Missouri.

WHIZZER Motorbike \$20, Travis bike motor \$7, Go cart with engine \$45, engines \$3 up. (Mailorder only). Send 25¢ (35¢ for First Class Mailing) for new Directory-Catalogue Number 94 listing these and hundreds of other bargains in midget cars, motorscooters, homebuilders parts, plans, etc. Midget Motors Directory, Athens, Ohio.

ITALIAN Motorscooter. Good condition. \$150. Forman, 6934 Nansen, Forest Hills, N. Y.

"BEST Deals on Wheels" Leopard motorcycles \$199.50; Tessa motorscooters \$299.50; Contessa scooters \$399.50. Motorcycles \$375 up. Newest catalog 25¢. Motorcycle Import Corp., 505-A Fifth Avenue, New York 17.

AVIATION

ANTI-GRAVITY Engine. Completely designed. Diagrams, details, physics, plus "Man in Flight." Send \$2.00 today. Knowledge, 2900-9th Street, Rock Island, Illinois.

AVIATION Surplus bargain catalogue. One dime. Box PM8, Thomasville, Penna.

DUCTED Fan design. Used in air sleds and flying platforms. Specifications and six pages of drawings. \$2.00. Tyna-Turbine, Box 373, Chandler, Arizona.

BUY Gov't surplus: Aircrafts; engines; helicopters; boats; Jeeps; misc. Buy direct now from gov't. Send for "Depot Directory & Procedure" \$1.00. Gov't Surplus Sales, Box 425-PM, Nanuet, New York.

"THE Bush Pilot," Alaska's Aviation Magazine features stories about bush flying. Published monthly. \$3.50 per year. Box 3535, Anchorage 5, Alaska.

AEROMOBILE Ground effect vehicle plans, 7 views, photos \$5.00. Aeromobile, Neponset, Illinois.

PROPELLERS, Plans, supplies for airboats and snowplanes. Latest designs, prompt delivery. Catalog 25¢. Banks-Maxwell, Box 3301E, Ft. Worth 5, Texas.

BARGAINS, Gov't surplus planes, electronic equipment, boats, trucks, helicopters, etc. Send \$1.00 for listings, locations and procedure to buy. P.O. Box 8356, Minneapolis 16, Minn.

HOME BUILT Helicopter Handbook \$1.00. Directory \$1.00. Urshanair, 4332 N.P. Station, San Diego 4, California.

MISSILE Engineering books (new). Lists, 10¢. Mathematics, Box 52, Woodlyn, Penna.

HELICOPTER - Completely engineered. You build from our drawings. Parts available. Send \$2.00 for photo, 3 view drawing, specifications and design information. Helicopter Research Co., Box 121, La Mirada, California.

BATTERIES, GENERATORS

BATTERY Repair manual \$3.00. Automobile body repair and paint guide \$2.25. Satisfaction guaranteed. Bayer Publications, 938G Betty Avenue, Neenah, Wis.

ELECTRICAL SUPPLIES

APPLIANCE Parts, accessories wholesale. New enlarged catalogue 25¢. Seco, 26 South 20 Street, Birmingham 3, Ala.

CONDUIT Bending guide and bending protractor. \$1.90. Pal-Notes, Underwood, N. D.

ELECTRO-SCRIBE! Engraves all metals, \$2.00. Beyer Mfg., 10511-H Springfield, Chicago 43.

REPAIR Electric motors. Interesting, profitable. Free details. Modern, Box 8715, Kansas City 14, Mo.

LAMP, Electrical parts, wholesale. Thousands of items for repairing, converting. Catalog 25¢. Brown Lamp, Box 305, Clayton 5, Mo.

APPLIANCE Parts-Supplies Wholesale. Catalogue 25¢. SECO, 26 South 20th St., Birmingham 3, Alabama.

LAMPS, 25¢ Brings parts catalog. Refunded first order. Gyro, 5208P N.W. 35th Ave., Miami 42, Florida.

BURGESS Electric sprayer \$7.99 postpaid. Sprays anything. Falco, 1122 Prospect, Lansing 12, Mich.

WELDING, SOLDERING, PLATING

BUILD Or buy efficient inexpensive 350 ampere welder. Guaranteed plans 25¢. Free welder kit catalog. LeJay Manufacturing, Minneapolis, Minnesota.

ACETYLENE Welding outfits. New, arc-welders. Eagle Welding, Dept. PM, 5085 Broadway, Chicago 40, Ill.

WELDERS, 110/220, \$39.50. Morris, 1070 Inner Drive, Schenectady 3, New York.

PLATING Equipment, supplies. Complete line of anodes, solutions. Home workshops, industrial sizes. Hollywood Bronze Supply, Dept. C, 1624 East First, Los Angeles 33, California.

WELD, Solder, cut, braze, 1/8" welder complete \$8.95. Flame torch, \$3.95. Postage 50¢. 75 ampere transformer welder 1/4", \$24.95 complete. f.o.b. Essay Mfg. Co., Quincy 69, Mass.

FREE Catalog, welders, welder kits. Build 350-ampere welder using aircraft generator, plans 25¢. Dunbar Manufacturing, Minneapolis 8, Minnesota.

MACHINERY, TOOLS, SUPPLIES

SCREWDRIVERS, 24" Long. What you've always needed. Details free. Robert G. Vaughn, 357 Church St., Greensboro, N. C.

TOOL Life increased 2500% with inexpensive coolant formula. \$2.00. Ronrick, Box 6001, East Side Station, Flint 6, Michigan.

PERFORATED-Board tool hooks. New ultra-locking non-falling type. 5 1/2 dozen 2" \$3.00 postpaid U.S.A. OK Engineering Company, Box 421, Barre, Vermont.

SHEET Metal brakes, 36", \$37.00; 49", \$52.00; 61", \$80.00; 24" shear, \$42.00. Free folder. Vyke Mfg. Co., P4158 Jason St., Denver 11, Colo.

PRECISION Horizontal milling machine. Plans \$1. Miniature swivel base machine vise, Plans \$1. McKIn Manufacturing Co. Venice, California.

SURVEYING INSTRUMENTS

NEW And guaranteed factory rebuilt transits and levels, sale or rent, with purchase option. We will repair, trade or buy old instruments. Write for list M-30. Warren-Knight Co. (Manufacturers of Surveying Instruments), 136 N. 12th St., Philadelphia 7, Penna.

ENGINES, MOTORS, DYNAMOS

DIESEL Injector parts and fuel pumps wanted. GM51-53-71-110. Bares, 7120 Carnegie, Cleveland 3, Ohio.

WINDING Data, 275 motors, single and three phase \$1.10. Data Company, 512 Kensington, Kansas City 24, Mo.

50% DISCOUNT On new, air cooled, two cylinder 14 hp. motors with centrifugal clutches. Write Finco, Inc., Aurora, Ill.

REWIND Motors yourself. Complete instructions, \$1.00. Catalog. Lewis Manufacturing, Howell, Michigan.

BOATS, OUTBOARD MOTORS

WHOLESALE Direct from the factory. Fiberglass runabouts, fishing boats, pontoon boats, houseboats and boat trailers. Build it yourself: pontoons only—molded hulls only. Free catalog. Osage Mfg. Co., Box 117-M, Osage, Minn.

FULL Size, cut-to-shape boat patterns, blueprints, 7 1/2-38 feet. Big new 88 pg. illustrated "Build a Boat" catalog of naval architect-designed Catamarans, cruisers, runabouts, skiffs, outboard boats, sailing, racing, houseboats, 50¢. "How to Build a Boat" booklet \$2.50. Equipment catalog \$2.00. Cleveland Boat Blueprint Co., Dept. A-66, Box 1651, Cleveland, Ohio.

NOW, Fly your boat. Easily installed kit converts your boat to a flying boat. Send \$1.00 for photographs, flying instructions. Gyrocraft Inc., 1932 Nelson SE, Grand Rapids, Michigan.

MARINE Conversions, Willys to Cadillac, kits and parts. Catalog and conversion hints free. Barr Marine, 2706A Castor Avenue, Philadelphia 34, Penna.

I Want to send you proof of the wonderful pulling power of Popular Mechanics classified pages. What's your proposition? Write me today. Include literature if possible. F. W. Johnson, Manager Classified Advertising, Popular Mechanics Magazine, 200 E. Ontario St., Chicago 11, Ill.

MARINE Conversions, Ford, Chevrolet, Jeep engines. Catalog 25¢. Lehman Manufacturing Company, 800 Elizabeth Avenue, Linden 4, N. J.

NEW, Used, rebuilt marine motors. Marine conversions, fittings. Free catalog. Stokes Marine Supply, Dept. 24, Coldwater, Michigan.

SAVE Money. New, used outboard motor parts. Send wants. Stamp appreciated. Outboard Motor Mart, 229-M State, Boston 9, Mass.

SAILS, Sailboat equipment. Steering wheel kits, etc. Canvas, fiberglass. Wood screws 50% discount. Building a boat? See us first. Catalogue. Alan-Clark, 75 Chambers, New York City.

FRAME Kits, plans or full-size patterns for 35 inboards and outboards. Prepared for amateur builders. New 80 page illustrated catalog, 50¢. Glen Designs, 9152 Rosecrans, Bellflower, Calif.

300 BOAT Plans, patterns. Catalogs \$1.00. Motors, \$62.00. Marinecraft, Box 161-M, Brighton, Mass.

FIBERGLAS Permanent boat waterproofing. Special 25% discount. Complete kits, \$9.45 up. Guaranteed materials. Easy application. Full instructions. Free literature. Mail post card. Ajax Plastics, P. O. Box 1323, Fort Worth, Texas.

MONEY-Saving boat supplies. Outboard, inboard, sail, gameroom, gear, equipment, hardware, jewelry, instruments, controls, refrigeration. New inboard gasoline-diesel engines. We take old engine in trade—by mail. 125 page illustrated catalog, \$1.00 (rebated, first order). Free floating key ring sent with catalog order. Boat Equipment Unlimited, Oceanport 2, N. J.

STURDY All metal fishing boat easy to build costing from \$15.00 to \$25.00. Complete plans. Send \$1.00. Bob & Lee, Box 81, Hope, Kans.

PROPELLERS, Plans, supplies for airboats, snowplanes. Catalog 25¢. Banks-Maxwell, Box 3301F, Ft. Worth 5, Texas.

ATHLETIC EQUIPMENT, BODY BUILDING COURSES

BACKACHE Sufferers. Many helped. Free literature. Lou Stein, 311 Delsea Dr., Woodbury, N. J.

FREE Muscle building information. Body-Tone, Box 638B, North Miami, Florida.

JUDO—20 Best tricks. Offense-defense. Easy to learn. Fully explained. Brief Judo dictionary added. Plain wrapper. Send \$1.00 to: National, P.O. Box 63-M, Brooklyn 14, N. Y.

DYNAMIC New muscle building course transforms frail underdeveloped bodies into power-packed physiques \$2 (no c.o.d.). Powerama, Box 51, Flushing 52, N. Y.

DEADLIEST Oriental fighting arts. Using only breath, sand, straw, pebbles. Developed strength. Break planks bare handed utilizing Karate, Kung-fu mysteries. \$3.98. Oriental Book Sales, P. O. Box 1183, Oakland 7, Calif.

JUDO - Complete course, only \$1.00. 1112 Tipton St., High Point, N. C.

TRIM Your waistline in one minute a day! New 1-Minute Waistliner Method includes latest exercord equipment with instructions. \$2.00 ppd. Write for brochure. Pacific Mart, 1953(34) Camden Ave., Los Angeles 25.

CAMPING EQUIPMENT AND TENTS

VACATION Every weekend with compact camping trailer. Tent folds out to accommodate five—takes just one minute to set up complete camp anywhere! Wives love its neatness, roominess. Fully illustrated brochure free. Heilite Trailers, 1403 South Sacramento, Lodi, California.

CAMPING Equipment, tents, world's largest selection. Send 25¢ for new 160 page catalogue—handbook—camp site directory. (Print name, address). Morsan Tents, 10-21R 50th Ave., Long Island City 1, New York.

SPORTING GOODS, GUNS, FISHING TACKLE, ARCHERY, TRAPPING

BIZIBUG For spinning. New action! More bass! Free literature and introductory offer. Shaw Tackle Company, R. 2, Montevallo, Alabama.

ANTIQU Guns, decorators to Patersons. Large photo illustrated catalog \$1.00. Jackson Arms, Box 8065-PM, Dallas 5, Texas.

MOLDS For fisherman's sinkers, jigs, squids, casting and spinning lures. Free catalog. Sweet's Molds, Tonawanda 1, New York.

10,000 GUNS. Antiques, moderns, swords, armour. Every description. Giant catalog \$1.00. Agramonte's, Yonkers 2 G. N. Y.

MOLDS—For casting your own fishing sinkers. Free illustrated booklet. Reading Instrument Co., Box PM78, Reading, Penna.

CROSSBOWS! Hunting—Bows! Factory prices! Jayco, Box 1355, Wichita, Kansas.

BIG Money raising crickets and 12 inch African fishworms. Free literature. Carter Ranch, Plains, Georgia.

FREE—Wholesale catalog. Beads. Spinners. Lure parts. Sinker molds. Jigs. Reels. Finny sports (ME), Toledo 6, Ohio.

AMAZING Wholesale sporting catalog. Save 70%. Tremendous selections. Econ-O-Mart, Whippany 2, New Jersey.

KILL Submersed water weeds which foul up motor propellers, tangle fishing gear, with R-H Weed Rhap-20, Granular 2,4-D. Inexpensive, easy to use, sure results. For free information write Reesor-Hill Corporation, Box 36PM, Jacksonville, Arkansas.

MINNOW Graders. Free circular. Crescent Mfg., Box 3303, Ft. Worth, Texas.

WATERPROOF Triple thick polyethylene bags. Keep food, clothes, sleeping bag dry—carry home fish, game. 13" x 13" x 36". 2 for \$1. Trader Jim, 6715-A E. 25th, Tulsa, Okla.

5000 GUNS, Swords, war relics. Catalog 50¢. Smith Firearms, Runnemed, N. J.

HOW To catch fish with smell. Secret formulas, new recipes. \$1.00. Johnson's, 312-M Lake Avenue, Ithaca, New York.

FISHING Tackle wholesale, nationally advertised brands 25¢ in coin for catalog refunded with order. Tackle, Box 24, Hutchinson, Kansas.

FISHING Kit: pole, line, bait. Pan fish, game fish. \$1.50 complete. Fishing Kit, Box 451, Escanaba, Michigan.

GUARANTEED Weedless lures. Write for catalog. Weedless Bait Company, Atkin, Minnesota.

JAP Rifle altering to 30-06, \$6.00. Japshells, \$3.95. Catalog 10¢. T. P. Shop, West Branch 11, Mich.

SLEEP In your car on a Kar Snoozer. Adjustable \$11.95 prepaid. Kar Snoozer Mfg. Co., 141 W. Louisiana, Dallas 24, Texas.

RED Wigglers 1000, \$4.50. 5000, \$20.00. Bulk 1000, \$4.00. 5000 \$17.50. Post paid. Catfish Capitol Worm Farm, Savannah, Tennessee.

NEW, Car top carrier converts to picnic table and benches at campsite. Free literature. Scholz & Company, 2116 Linneman, Glenview, Illinois.

CATFISH Bait. Send dollar for magic ingredient and new processing method. Make baits so potent I guarantee "you catchum" or no pay. George Wylie, Clay Center 5, Kans.

KLEIN'S 100 Page bargain all-sports catalog—"Nobody undersells Klein's" is sent for 25¢ (refunded with first order). Kleins-PM, Chicago 24.

KETCH-Em-All. Finest fish bait ever devised. Standard package \$1.00. Overstreet Laboratory, Route 3, Lufkin, Texas.

RAISE 1/4-Inch diameter tropical giant worm. Send \$2.00. Guaranteed. Bayer Publications, 938G Betty Avenue, Neenah, Wisconsin.

JAP Rifle altering to 30-06, \$6.00. Japshells, \$3.95. Catalog 10¢. T. P. Shop, West Branch 11, Mich.

FREE—Information on Coe bows. Coe Archery, Otter Lake, Mich.

PISTOLS! Rifles. Knives. Cuckoo clocks. Bargains! Circular. Joe Berger, Belzoni, Mississippi.

FLY-MAKERS! 1960 Free catalog. Beginner's fly-tying kit only \$7.00. Send to: D. H. Thompson, 335 Walnut Ave., Elgin, Illinois.

FISHERMEN! Lurezem bait oil doubles your catch or double your money back. \$1 postpaid. (dealers wanted). McGregor Sportsmen Company, McGregor, Texas.

AUTO-Target for .22 rifle, revolvers changes position as hit automatically. \$10. Brietenfeldt Manufacturing, Marathon, Wisconsin.

EARTHWORMS, CRICKETS, FROGS

OUR Famous Rocky Mountain hybrid worms. Mixed sizes. 10,000—\$19.95 postpaid. Dewey's Worm Ranch, Henderson, Colo.

FANTASTIC Profits raising redworms: Large breeders 1,000—\$3.50, 3,000—\$9.95. Medium 3,000—\$5.85, 10,000—\$16.75. Free instructions. Consultation service. Georgia Farms, Richland 18, Georgia.

RAISE Fishworms and rabbits on \$500 month plan. Free details. White's Rabbitry, Mt. Vernon, Ohio.

\$1,000 MONTHLY Possible, raising earthworms, African giants! Backyard, garage, basement. Complete illustrated booklet, explains raising, feeding, packing, marketing. Send 25¢! Ozark Worm Farm-J, Willow Springs, Missouri.

\$200.00 WEEKLY Possible, raising earthworms, basement, backyard, garage. Illustrated booklet \$2.00 explaining raising, feeding, marketing. Gay Worm Ranch, Box 13072, Dallas 20, Texas.

BIG Money raising fishworms and crickets. We teach you how to raise and where to sell. Free literature. Medium redworms, 3000, \$5.95; 10,000, \$16.95. Carter Redworms, Plains, Georgia.

FREE Picture folder, "How to Make \$3,000 Yearly, Sparetime, Backyard, Raising Earthworms!" Oakhaven-56, Cedar Hill, Texas.

WANTED, Men, women worm raisers. Sherwood, Dept. V-2A, Monmouth, Maine.

PROFIT. Raise worms. \$3.00 per 1,000, postpaid. Free literature. Mill Creek Ranch, RFD, Noel, Missouri.

MAKE Money raising worms. Free literature. Maxwell, Rt. 2, Irving, Texas.

FROGS. Wild jumbo. Proven best for breeders. Large supply. Oso Pier, 6124 Ocean Dr., Corpus Christi, Tex.

LABORATORY Controlled worm bedding \$2.49. James W. Steward, 601 Union S.E., Grand Rapids 6, Mich.

BINOCULARS, TELESCOPES, MICROSCOPES, MAGNIFIERS

REFLECTOR Telescope kits direct from factory. From \$7.75. Other optical do-it-yourself kits. Free booklet. Hampton, P.O. Box 772, Sparta, N. J.

REFLECTING Telescope, 60X, completely assembled. Guaranteed observatory clearness. Free information. Skyscope, P.O. Box 55, Brooklyn 28, N. Y.

TELESCOPES, Mirrors, binoculars, microscopes, accessories. Free catalog. National Optical Company, 505 New York Avenue, Union City, New Jersey.

50 POWER Microscope \$3.95. 75 power \$4.95. DX Radio, Box 5938, Kansas City 11, Missouri.

AMAZING Prices precision binoculars. "Binocular Selecting," catalog free. Prentiss Importers, Mercury Bldg., West Los Angeles 25, Calif.

BINOCULARS, Telescopes, microscopes: Terrific values \$3.98 up. Request free money-saving catalogue. Criterion, Dept. P-88, Hartford, Conn.

PRISMS, Cased, 146x51 MM, \$2.50. Spots Industries, Box 2705, Los Angeles, Calif.

BUILD Your own reflector telescopes. Complete kits: mirrors, eyepieces, tripods, all other accessories. Request free illustrated literature. Criterion Manufacturing, Dept. DPM-62, Hartford, Conn.

DYNASCOPE—Amazing world-famous reflector telescope. Request free brochure. Criterion, Dept. DP-65, Hartford, Conn.

WAR Surplus bargains: Millions of lenses, instruments, telescopes, binoculars, components and complete line of astronomical telescope items. World's greatest optical market-place! Send only \$1.00 for beginner's 10-lens kit and big instruction booklet Stock 2-CH. Write for Catalog CH free! Edmund Scientific Co., Barrington, New Jersey.

PLANTS, SEEDS, BULBS, NURSERY AND GARDEN SUPPLIES

GINSENG Bringing \$12 pound. Have seeds, plants. Goldenseal. Full information. K. Collins, Viola, Iowa.

GROW Dwarf trees! Instructions and seeds 35¢. Mail Order Specialties, 1439-PM-E Sabraton Ave., Morgantown, W. Va.

WHOLESALE Seedsman, nurseryman. Shade trees, azaleas. Bill Wentzell, Elmer, New Jersey.

PETS—DOGS, BIRDS, RABBITS, HAMSTERS, ETC.

HAMSTER'S Golden \$2.75 pair. Albino's whitebands creams. Free literature. Edge-water Hamstery, 106 Carter, Goshen, Ind.

UNUSUAL Pets—raccoons, skunks, squirrels, monkeys, birds, snakes, turtles. Catalog 10¢. Ray Singleton, Rattlesnake Station, Tampa, Fla.

GOLDEN Hamsters—Pedigreed breeders \$3.85 pair. Albino Whitebands. Literature. Moore's Hamster Ranch, Shepherdstown 25, West Virginia.

MAKE Money raising chinchillas, mink, rabbits, caviar for us. Free catalog. Keeney Brothers, New Freedom 2, Penna.

RAISE Rabbits on \$500 month plan. Free details. White's Rabbitry, Mt. Vernon, Ohio.

HAMSTERS—Ideal pets, \$2.95 pair. Free booklet. Jer-fre's Hamstery, 1447 Apple, Muskegon 13, Michigan.

SKUNKS, Reptiles, hawks, raccoons. Illustrated catalogue, 25¢. Trails End Co., St. Stephen, S. C.

RAISE Rabbits, make money. Information and prices sent free. Write: Johnson, 683, Kansas City 41, Missouri.

FREE Rabbit facts folder. Rabbit magazine, markets, dime. Associated Rabbitries 3, Hickman Mills 34, Mo.

EARN \$10,000 Yearly raising Angora rabbit wool for us. Information 25¢ coin. American Angora Company, Malta 12, Montana.

ANGORAS, Chinchillas, New Zealand, world's most profitable rabbits. Catalog free. Grinsteads, Edwardsville, Illinois.

FUR BEARING ANIMALS

MINK Raising information free. Complete. Lake Superior Mink Farm, Superior, EE1, Wisconsin.

FARMS, FARM LANDS, REAL ESTATE

FLORIDA Homesites \$10 down, \$10 monthly buys your homesite in Central Florida's finest retirement and vacation community in the high ridge section near Sebring. On 84 square mile Highlands Lake. Free community parks and beaches. Get free color brochures, house plans; Learn how we help you plan, finance, build your low-cost, tax-exempt home. Write Florida Realty Bureau, Inc., Dept. E2M3, Lake Placid, Florida (AD58101).

FLORIDA—2 1/2-Acre estates, 165'x660', \$995 payable \$15 monthly. Beautifully wooded premium properties. Wendell Wood, Fountain, Florida.

CENTRAL Florida developments. Traller homesites; also lakefront and highway lots; acreage. No interest. From \$295.00. Terms. Victor Roepke, DeLand, Fla.

MR. Property Owner—Want a map of your property? Write Deed-Ettes, Mt. Pocono, Penna.

FREE Strout catalog! Farms, homes, businesses, resorts, retirement properties. Over 3000 values in 36 states. 58 years' service. World's largest! Write Strout Realty, 7-MF S. Dearborn, Chicago 3, Ill.

FLORIDA Homesites in the booming Tampa Bay area are available now at Willow Shores for the low, introductory price of only \$895. These are large 80x100' plots only 21 miles south of Tampa on Route 301, near schools, churches and shopping. Enjoy boating, swimming, and fishing all year long. Only \$10 down and \$20 per month buys your Florida homesite. Beautiful ¼-acre (or larger) waterfront lots on the Little Manatee River are only \$25 down and \$50 per month, full price \$2295. Send \$10 down payment to reserve your Florida homesite now (down payment refundable within 45 days for any reason) and Willow Shores will send you your contract, plat showing location reserved for you, and colorful descriptive literature. Send \$10 to: Gulf Coast Land and Title Company, Developers; Dept. PM; 632 South Tamiami Trail; Sarasota, Fla.

FLORIDA. Nice homesites, \$345 at \$10 monthly. Folder free. Howard Vernor, DeLand, Florida.

OZARKS! America's best place. Ten lovely timbered acres \$195. \$5.00 monthly. Descriptions mailed free. Write: Armstrongs, Shook, Missouri.

BUYING Real estate? Know correct mortgage payments. Handy 160 page book shows monthly payments necessary to pay off mortgage. All interest rates from 3% to 7% including intervening fractions. Used by bankers, brokers, appraisers. Now available to public. Send \$1.00 to D. Behrend, Box 8124, Pittsburgh 17, Penna.

CANADIAN Tax sale lands, average price five dollars an acre. Small monthly payments. Farms, timber, hunting and fishing camps, minerals. Limited number of properties. Write at once for free catalogue. Tax Sale Service, Room 105, 120 Bloor Street, West, Toronto 5, Canada.

FLORIDA'S Sunnyland Village. Pre-development sale. \$10.00 down. \$10.00 month. Water mains, paved streets, R.E.A. Electricity (under const.). Write: Box 768, Brooksville, Florida.

FLORIDA—Silver Springs area. ¼ acre waterfront homesites. \$795.00, \$10.00 month. Free color photos. Write: Smith Lake Estates, Box 5681, Belleview, Florida.

OPPORTUNITIES! Government land, U. S. Alaska, Canada. Sledge Surveys, Macon, Mississippi.

FLORIDA Homesites \$395. No money down! Lovely ¼ acre sites in Central Florida hills, lake, grove area \$395, no money down, \$10 a month. Suburb of Ocala, near Silver Springs. Streets, utilities. 22 mi. to Gulf Beaches. Fish, hunt. Invest or retire. Free color folder. Write Dept. 618-H, Rainbow Park, Box 521, Ocala, Fla.

FOR Sale: ¼ acre homesite in Florida—private lake, free country club privileges, white sandy beaches right at property. Fishing, pier, club house, dock site, lovely homes, hard-paved roads, electricity, phones, tested pure water—all available. Certified high, dry land near healthful bubbling waters of Silver Springs. Only \$10.00 monthly. Between Ocala and Dunellon. Total cost \$595, no hidden extras. Free photos, booklet. Write to Rainbow Lakes Estates, Dept. A-2, 819 Silver Springs Blvd., Ocala, Florida.

FLORIDA Lot bargain! Only \$149 full price! (for limited time). No money down, \$5 per month. On US #441-27 between Ocala and Orlando. High and dry. Hard surface streets, electricity, phones, schools, churches. 3000 fishing lakes closeby. Write for free photos. Dept. 214, Orange Blossom Hills, Box 1222, Leesburg, Florida.

TRACTOR Equip, beef herd! 240-acre Ozarks stock farm on highway, ready for profit with 20 Hereford cows, bull, tractor, farming machinery included! See picture in catalog—good modern 6-room house, 3 bedrooms, lovely rural setting, 50-ft. barn, poultry house, garage, granary, machine shed, other outbuildings. 160 acres tillable, rest timber, 7 ponds in pasture for handling 75 head stock, over 40 fruit trees. On state blacktop, ½ mile store, only 2 town. Priced to sell, \$22,500 complete, one-third down. Free 160-page Spring catalog, over 900 photos, bargains coast to coast! United Farm Agency, 2825-PM Main St., Kansas City 41, Mo.

FLORIDA? Going to live, work, build home, buy land in Florida? Get the true facts first! New confidential Florida report reveals pitfalls when buying land; tells how to check claims of land promoters; discusses jobs, climate, towns, etc. Avoid costly mistakes! Send \$1.00 to GP Enterprises, 545 Fifth, Dept. PM, New York City.

CANADIAN Vacation lands: \$5.00 acre. \$10.00 month. All sizes. Fishing, hunting, investment, vacationing. Free information. Land Corporation, 130-C Shaftesbury, Downsview, Ontario, Canada.

FARM MACHINERY AND SUPPLIES

ELECTRIC Welders. New, heavy-duty, 180 amp. Free trial. Dealerships open. 20 year warranty. 8159 South Pleasant Department A1, Minneapolis 20, Minn.

GARDEN Tractor—Nationally known—now sold at discount. Eliminates all hand hoeing, also tills. Nothing like it. Patent 2742840. Discount catalogue free. Autohoe, DePere 68, Wis.

PROFITABLE OCCUPATIONS

MAKE Money making new greaseless doughnuts in kitchen. Sell stores. Free recipes. Michael, 3605 South 15th, Minneapolis 7, Minnesota.

BECOME Independent with your own franchise business. Thousands earning handsome incomes. Request interesting facts today. National Franchise Reports, PM-528, 333 North Michigan, Chicago 1.

BIG Money raising fishworms and crickets. Free literature. Carter Wormery, Plains, Georgia.

BUY Wholesale: 100,000 nationally advertised products. Appliances, cameras, sporting goods, housewares, watches, typewriters, tools, clothing, etc. Discounts to 60%. Buy-Rite, Box 258, Hawthorne 1, New Jersey.

\$200 WEEKLY Extra introducing buyers to sellers, weekends. Men, women enjoy learning real estate by listening to records. First lecture free. Lee Institute, Brookline, Mass.

MAILORDER Beginner's literature. Write Carnahan Bros., 9610 Acacia, Pontana, Calif.

AUCTIONEERING—Home study course. Diploma granted. Auction School, Ft. Smith, Ark.

RAISE Pheasants on \$100 week plan. Little capital and space can make you independent. Free details. Great Central System, Columbus 1, Kansas.

VENDING Machines. No selling. Operate a route of coin machines and earn amazing profits. 32-page catalogue free. Parkway Machine Corporation, Dept. #25, 715 Ensor Street, Baltimore 2, Maryland.

GROW Mushrooms. Cellar, shed and outdoors. Spare, full time, year round. We pay \$4.50 lb. dried. We have 29,000 customers. Free book. Mushrooms, Dept. 99, 2954 Admiral Way, Seattle, Wash.

EARN \$240.00 A month at home, spare time doing only two \$5.00 invisible mending jobs a day. Big money paid for service that makes cuts, tears disappear from fabrics. Steady demand. Details free. Fabricon, 6236 Broadway, Chicago 40, Ill.

MAKE Flexible molds. Cast plaques, figurines. Free sample. Tooker, 1045-M Fairview, Hamilton, Ohio.

INVESTIGATE Accidents—Earn \$750 to \$1,000 monthly. Thousands of insurance companies, airlines, steamship lines urgently need Accident Investigators. Make excellent full time or spare time income. Free book! No obligation. GI approved. Write: Universal Schools, CT-3, Box 8227, Dallas 5, Texas.

ENJOY Camping: Make big profits while you play, with Heilite Camping Trailer dealer franchise. Sets up into complete camp in just one minute; attracts crowds wherever shown! Write for dealer program. Heilite Trailers, 1516 South Sacramento, Lodi, California.

MAGAZINE Subscriptions. Highest commissions. Bonus. Qualified Agencies, 451JA Kingston, Brooklyn 25, N. Y.

NEW Soilless method raising nightcrawler, redworms. Three Oaks Ranch, Dresden, Tenn.

START A magazine subscription business. Earn generous commissions on Popular Mechanics, Good Housekeeping and all others. Best commissions, bonus, all materials sent free. No experience needed. Write Popular Mechanics, Room 3-P, 250 West 55th St., New York 19, N. Y.

"FORMULA For Success" pamphlet \$1. Jayson, Box 41, Watertown, S. D.

PROFITABLE Hobby. A bargain. 26 chinchillas, accessories, food, 6 pens, \$675. Louis Dufresne, 593 Seventh Ave., Troy, New York.

FREE Book "990 Successful, Little-Known Businesses." Work home! Plymouth-7W, Brooklyn 4, New York.

NEW! Additional income! For full information send international reply coupon. Bleicher, Sulzbacherstr.88P, Nurnberg, Germany.

BOOKS, PERIODICALS, PICTURES, POSTCARDS

LOCATE Any book. No obligation. Aardvarks Search Service, Santee, Calif.

BOOKFINDING Our specialty. Try us. Babcock, 412 Lulu, Wichita 11, Kansas.

OUT-Of-print books at lowest prices! You name it, we find it! Fast service. No obligation. International Bookfinders, Box 3903-PM, Beverly Hills, Calif.

BRITISH Book bargains—Any subject. Catalogues free. Transatbooks, Wantagh, N. Y.

FREE Catalog. Self-help books. Write: Wilshire, 8721 Sunset, Los Angeles 46P.

BOOKFINDERS! All subjects. Send wants! Jaher Book Service, 183 Hazelwood Drive, Westbury, N. Y.

"SCIENCE Milestones." Records march of science starting 400 years before Christ, right up to date. Amazing facts revealed. 312 pages packed with startling information that will thrill you. A real history of science. \$5.00. Literature free. Popular Mechanics Press, 200-SM East Ontario St., Chicago 11, Ill.

NATIONAL Geographic magazines, 1888-1960, any issue. Periodical Service, Box 465-PM, Wilmington, Delaware.

NEW And used books, magazines, courses, etc., bought, sold, traded, rented in "Book Trader's Magazine" 15¢. Two different copies 25¢. Pioneer Periodicals, 6376-PMA Windsor Lane, San Jose 29, California.

GOOD Books. Huge stock. K. Gaisser, 1242 Broadway, Toledo 9, Ohio.

TRADE In your books and pocket books at full price here! List 20¢. Werewolf Bookshop, Verona, Penna.

SELF-HELP Books all subjects. Free catalog. Dept. A, Box 102, Providence, R. I.

SPARETIME Repeat profits taking magazine subscriptions. Special offers. Cassell Agency, Boynton Beach, Florida.

CAMPING Maps, U. S. A." New guide book lists thousands of campsites, facilities in all 48 states. Authentic, 1960 edition. \$2.00. Books, Box 106, Highlands, N. C.

10,000 BOOKS! Bargains! Free catalog! Treasure-Site, 6990 Aberdeen, Upper Darby, Penna.

SAVE 20% to 80% on books. Free catalog Discount Reader's Service, MC5435 Upland Way, Philadelphia 31.

FREE Unusual magazines. Over 900 illustrated brochure, many foreign. Rush quarter (postage). Friendships, Osprey 32, Florida.

BUY Books wholesale. All types covered. Lowest wholesale sources given. Directory \$1.00. Baron Publishers, 1423 Mulberry St., Scranton 10, Penna.

GAMES, TOYS, NOVELTIES

25 NOVELTY Signs, 8½x11, only \$1.00. Murdoch, Stuart Hall, Bryn Athyn, Pa.

MAGIC TRICKS, PUZZLES, JOKER NOVELTIES

EXCLUSIVE Tricks! \$2.50 precision made vanishing coin for \$1.00 plus "Top Hat Topics" booklets. Lou Tannen, 120 West 42nd Street, New York 36, N. Y.

BE A magician! Large professional catalog of latest tricks, 35¢. Ireland, C-109 North Dearborn, Chicago 2, Illinois.

500 TRICKS, Douglas famous 120-page catalog now available just 10¢. Fastest service to magicians everywhere with latest in magic or parlor, stage, pocket. Send 10¢ today. Douglas Magicland, Dept. 11, Dallas, Texas.

3100 NOVELTIES, Jokes, tricks, gadgets, funmakers, hobbies. Big catalog 10¢. Johnson-Smith, D-498, Detroit 7.

WORLD'S Finest professional magic. Joker novelties. Giant illustrated catalog 10¢. Top Hat, Evanston 12, Illinois.

PROFESSIONAL Catalog, 175 pages, 25¢. Williams, 900 Plymouth, Ellwood City, Penna.

CATALOG, Free trick, 25¢. (1,500,399 tricks, jokes). Magico, Box 4373-P, San Antonio 7, Texas.

3000 TRICKS, Pocket, parlor, stage. World's finest magic catalog (408 pages), \$2.50. Kanter's, M-1311 Walnut, Philadelphia 7.

CIGARETTES Disappear mysteriously. Thumb-it, 5 routines, \$1. Scheetz, Sellersville, Penna.

HOUSE Of 1000 Mysteries! Famous coast to coast! Professional magic! Pocket tricks! Secrets! Illusions! Mind reading! Joke novelties New giant surprise catalog! 160 pages! 1000 items! 800 illustrations! Rush 25¢ for deluxe edition and free magic trick. Vick Lawston, 202-47 Pinewood, Trumbull, Conn.

OLDEST Chinese puzzle \$1. Blocks and 20 newest \$2. Puzzles, 639B Adelaide, Santa Monica, Calif.

MAGIC Tricks, joker, funny items. \$4.00 value \$2.98. Carolina, 719 Mangum, Durham, N. C.

COINS, TOKENS, CURRENCY

WORLD'S Greatest 94-page bargain catalogue \$1.00. (Deductible first \$10.00 order). Brilliant proof sets—1957 \$3.75; 1959 \$4.50; 1960 \$2.75. Fifteen different Indian cents \$2.25. Retail Guidebook \$1.75. Bebee's, 4514 North 30th, Omaha 11, Neb.

INDIAN Head cents, two different only 15¢. Approvals, Littleton Coin Company, Littleton R1, New Hampshire.

COIN Sets—Uncirculated: Bulgaria (6) \$1.25; Vatican (6-Case) \$1.30; Laos (3) 80¢; Albania (4) \$1.00. Jolie, Roslyn Heights, New York.

ALL These Lincolns for \$2.95: (Only one lot to a customer) 1909VDB, 1909-P, 1910-P, 1911-P, 1912-P, 1913-P, 1915-PD, 1916-DS, 1917-DS, 1918-DS, 1921-PS, 1922-D, 1924-PS, 1929-DS, 1930-DS, 1934-D, 1939-D, 1954-S, 1955-S. Wholesale list 15¢. Guidebook \$1.75, 1960 proof set \$2.50. Al Johnson, Box 35, Colorado Springs, Colo.

12 DIFFERENT Mexico \$1.25 postpaid. Dedmon, 1002 W. St. Charles, Brownsville, Texas.

WOW! Indian cent, foreign coin, bargain lists, 10¢. Hutchinson's, Box 4747, Philadelphia 34, Penna.

HUGE Profit for coins from circulation. List, 10¢. Return our 35¢ Lincoln cent album with 60 different pennies from pocket change. Receive \$74.40 profit. P.O. Box 87, Santa Barbara, Calif.

FOR Sale 1913S, 1924S, 1931P, 1932D, 1938S, 1939D cents. All six for \$2. Gasser, Box 34615, Los Angeles 34, California.

BRILLIANT Uncirculated United States five dollar gold pieces, \$15.00. Twenty dollar, fine, \$45.00. Rare Coin Company, 31 North Clark St., Chicago 2, Ill.

LARGEST Coin magazine, 200 pages, 40¢. Scrapbook, 7320-J Milwaukee, Chicago 31.

EIGHT Different Indian cents \$1.00. Collector's Bargains, New Hope, Penna.

FREE List! U. S. coins. Lowest prices! Hugh's Coins, Hickory, N. C.

RAREST CC mint dollar, 1885 uncirculated \$7.50. Coin catalogue 50¢. Shultz, Salt Lake 10, Utah.

NEW 1960 Giant U. S. coin catalogue 25¢. Ace, 107 N. Dearborn, Chicago 2.

COIN News Magazine, 35¢, subscription \$3.00 year. Dept. P, 231 North 18th, E. Orange, N. J.

NUMISMATICS Largest newspaper. Semi-monthly. Sample 25¢. \$2.00 yearly. Numismatic News, Box 452, Iola, Wis.

FREE Bonus offer! U. S. bargain list, 10¢ (refundable). Economy Sales Company, Mansfield, Massachusetts.

SIXTEEN Page 1960 retail price list of USA and Canadian coins for 10¢. Our selling prices on thousands of coins and coin collectors' supplies. Bryson Incorporated, 612A White, Toledo 5, Ohio.

U.S. Coin list 10¢. Contains over 100 illustrations; 5,000 delightful bargains. Stoney, 260 Washington, Boston 8, Mass.

LINCOLNS 50 Assorted dates, mints. Condition good to uncirculated. In coin folder. Send \$5.00 plus 35¢ toward postage. (No c.o.d.'s). New cleaning cloths for coins \$1.00 prepaid. Meyer Co., Box 868, Galesburg, Illinois.

SPECIAL Old Morgan dime, quarter, half dollar, 28 page coin catalogue, \$2.00. Hobby Sales, Box 4054, St. Paul 16, Minn.

CASH By return mail for large 1¢, 2¢, 3¢ Flying Eagle cents, shield nickels, U.S. gold. Send coins for quickest action. Centre Coin Co., 5B Centre St., Hempstead, N. Y.

RARE Unc. 1899-P Silver Dollar, \$5.00 each. Butts, Box 889, Torrington, Wyo.

FREE Bargain list! U. S. coins. Jeff's, Box 105A, Newton, N. C.

30 DIFFERENT Foreign coins \$1.00. Nice lot. Some older and larger coins included. Alfred Szego, Box 187, Jackson Heights 72, N. Y.

20—INDIANS \$1.75 Postpaid. Free buying-selling lists. Send stamped envelope. United, 101 Cranston, Providence, R. I.

LINCOLN Cents: 1913-S; 1926-S; 1923-S; 1924-S; 1921-S; 1933-D; 1927-S; 1928-S; 1939-D only \$4.00. Berry, Box 306, Westminster, Calif.

THREE Brilliant uncirculated Mexican silver dollar \$1.00. Universal Services, Box 675, San Antonio 6D3, Texas.

AMERICAIN'S Buying prices plus grading guide—10¢. ACA, 5754 Geary, San Francisco, Calif.

BARGAIN Coin pricelist, 10¢ (refundable). Farley, 204 Tanguy, Logansport, Ind.

BOUGHT! Lincoln pennies—all years, Catalog \$1.00. J. DeSanty, 20 Summer St., Norwich, Conn.

\$9,000.00 for 1913 Liberty Head nickel. We paid \$6,500.00 for one silver dollar, \$2,300.00 for one cent. Thousands of others we paid \$20.00 to \$1,400.00 each. Wanted certain dates: Cents before 1932—\$2,000.00; Nickels before 1940—\$275.00; Dimes before 1943—\$4,000.00. Canadian coins—1921 Nickel \$200.00, 1889 Dime \$250.00, 1875 Quarter \$75.00, 1921—50¢—\$1,000.00. Hundreds of others listed in our catalogue worth \$100.00 to \$25,000.00 each. For complete allcoin information, before sending coins, purchase our large illustrated guaranteed Buying-Selling Catalogue \$1.00. Catalogue dollar refundable. Thousands of persons have sold us coins. Incorporated 1938. Worthycoin Corporation (K-440-C), Boston 8, Massachusetts.

STAMP COLLECTING

FREE Mint set. Approvals accompany. Stampco, 5151 Princeton, Memphis 17, Tennessee.

FREE! 25 Egypt, 5¢ handling. Approvals. Bellett, Mapledale, Hazel Park, Mich.

40,000 VARIETIES Available on approvals, ¼¢ upwards. Keigwin, Box 933B, Daytona, Florida.

21,000 ALL Different stamps, yours for only pennies a day on our systematic payment plan. Details free. Sjoquist, 1435 Cherrydale, San Jose 25, California.

GIANT-Size issues collection: Laos elephant set, Brussels Fair, Olympic. Jet aircraft, Boy Scout, Somali animals complete. Romania flags. Togo set, diamond popes, UN set, etc., plus big stamp dictionary and approvals. Everything 10¢! Stampex, Box 47-KM, White Plains, N. Y.

FREE. 250 Peelable hinges and 20 different Brazil with approvals. Jaydee, 218 Dickinson S.W., Grand Rapids 7, Mich.

ROCKETS! Satellites! 10¢ with approvals. Schaefer, Californiastrasse 16, Wiesbaden, Germany.

LIQUIDATING Collections, 2¢ approvals. Job lots. Moredan, X424, Boston 17, Mass.

FREE! \$1.00 Worth, your choice, from first selection. No strings! Adults only. Rush request now. Philatelics, Dept. RF, New Paltz, N. Y.

U.S. \$1, \$2, \$5. Special—10¢, with approvals. Stevens, Box 24, Bay Station, Brooklyn 35, New York.

FREE Collections—Canada, Philippines, world wide, many others, each over \$5.00 value. Many other attractive premiums free with purchase of sensational foreign approvals. Topval, Box 486B, Redlands, Calif.

OUR Specialty, 1000 worldwide stamps \$1.00, 3500, \$3.00. Guaranteed. Harrison's Stamps, 1435 First Ave., Oakland 6, Calif.

PARTICULAR? Want unusual stamps on approval. Try Bayou Stamps, Box 4126, Pensacola, Florida.

150 DIFFERENT United States stamps, fabulous value only \$1.00. Free United States price list. Universal, Box 6, Kenosha 5-C, Wisconsin.

25 DIFFERENT Russia 5¢ to applicants for our bargain approvals. Somith Stamp Co., Box 83-MR (Rugby), Brooklyn 3, New York.

500 DIFFERENT Germany, valued over \$10.00. Only \$1.00 with unique approvals. Universal, Box 6, Kenosha 5-A, Wisconsin.

500 DIFFERENT Hungary, valued over \$10.00. Only \$1.00 with unique approvals. Universal, Box 6, Kenosha 5-B, Wis.

ENJOY Stamp collecting! Write for "Penny-provals." Penny-proval Service, New York Building, Saint Paul 1, Minn.

INTRODUCING Our better United States approvals we offer 15 United States stamps including Columbian, Bi-Centennials, famous American, airs, others; only 10¢. Ocean Stamps, Box 64-PM, Brooklyn 29, New York.

FREE Packet! Five different foreign countries. Request fascinating approvals. Coral, Box 7095 (Ludlam), Miami 55, Fla.

10 BEAUTIFUL Mint British Colonies 10¢ with approvals. Bennett, Candor 3, N. Y.

PENNY Approvals, Thousands. Bargains for pennies. Gifts with purchases. Penny Stamps, Orange, California.

UNITED Nations. Five different 10¢. Approvals. Anderson, 1112 Harrison, San Francisco 3, Calif.

TERRIFIC Value. Eight complete mint sets 10¢ with approvals. Beatties, 58 Glenagar, Islington, Ontario, Canada.

25 DIFFERENT Commemoratives 1893 up 10¢. U. S. approvals. K&B, Box 70, Brooklyn 23, N. Y.

FREE Sample! Interesting, informative, illustrated. National Stamp News, Anderson, South Carolina.

FREE 50 Worldwide, mailed with inexpensive approvals. University Stamps, P.O. Box 95, Tamiami Station, Miami 44, Florida.

TRADE Your duplicates toward our approvals! (Foreign only.) Complete information, 10¢. Variety Stamps, Box 98-P, Newton Highlands 61, Mass.

307 WORLDWIDE Different stamps only 25¢. Approvals. Niagastamp, St. Catharines 671, Ontario.

MINT U.S. at face! Older commemoratives only. Send 25¢ for all different packet with first selection mint U.S. approvals. Western, Box 1689P, Salinas, California.

1000 DIFFERENT Worldwide stamps \$1.00. Valued over \$20.00. Universal, Box 6, Kenosha 5, Wisconsin.

60 DIFFERENT U. S. (30 commemoratives) 25¢. No approvals. Seidenberg, Appleton, Wisconsin.

GIANT Approvals, thousands different, 1¢ and 2¢ each. Wahl's Stamp Exchange, 7006P Farragut, Chicago 31, Ill.

ALBUM Only 10¢! Hundreds of spaces! Stampart Company, Hartford 1, Conn.

UNITED States commemorative collection containing 33 different—10¢. Approvals. White, 516-A Avenue L, Brooklyn 30, New York.

SELL Your surplus good grade stamps. Write, describing fully what you have. Vanroy Shirk, Lebanon, Pennsylvania.

AMAZING OFFER! 200 United States stamps — including commemoratives, airmails, high denominations to \$1.00. Only 10¢ to approval applicants! Illustrated bargain lists free. Mystic Stamp Co., Dept. 80, Camden, New York.

100 STAMPS, 10¢ With approvals. Smith, 508A Brooks, College Station, Texas.

OLD Scarce U.S. seconds on approvals. Slight imperfections, lowest prices. Hernefield, Clintonhill Sta., Newark 8, N. J.

100 OLD United States between 1861 and 1935, \$1.00. Roush Stamps, 51 Chestnut, Mansfield, Ohio.

225 STAMPS For only 10¢! This mammoth value includes airmails, pictorials; stamps from strange countries cataloging up to 25¢ each! Also approvals. Mystic Stamp Company, Camden 80, New York.

UNITED States price list, 116 pages, price 25¢. Mark Hanna, 335 Fifth Ave., Pittsburgh 22, Penna.

SELL Stamps to our readers. Your ad in this space will be read by thousands of stamp buyers. I'll prove that to you. Write now for Folder "S." F. W. Johnson, Classified Advertising Manager, Popular Mechanics, 200 E. Ontario St., Chicago 11, Ill.

14,000 DIFFERENT! Amazing new plan builds your collection systematically, country by country. Only 50¢ weekly. Free details. L. G. Ware, Stepney 75, Conn.

U. S. Mint flag set, complete, \$1.00. Free list. Brooks, 2323 Avenue X, Brooklyn 35, New York.

103 DIVERSIFIED British colony stamps only 10¢. Approvals. Niagastamp, St. Catharines 671-A, Ontario.

102 DIVERSIFIED Worldwide stamps 10¢. Approvals. Linstamp, St. Catharines 618, Ontario.

PENNY Approvals! Regardless catalogue! Kloster, 4164—52nd St., San Diego 5, Calif.

25 DIFFERENT Large American commemoratives 10¢. With approvals. Linstamp, St. Catharines 618-A, Ontario.

INTERESTING Worldwide animal stamp collection 10¢. With approvals. Niagastamp, St. Catharines 671-B, Ontario.

ECONOMICAJ, 1/2¢-3¢ Approvals, 33,000 varieties. Dresel, Box 128-N, West Englewood, New Jersey.

105 BRITISH Colony stamps, all different 10¢. Approvals. Crown Stamp Company, 901, Virgil, Ontario.

A System that brings you 100 to 400 different new stamps of your own choice, each and every week. What every collector has dreamed about. Nothing else like it. This is entirely different. Complete details sent by return mail, merely by sending \$1.00 for one full year's membership or \$1.50 for two years. Las Vegas Stamp Service, 558 Oakley Blvd., Las Vegas, Nev.

50 DIFFERENT Stamps free! Approvals. Marford, Box 48, Queens Village 29, New York.

FREE! Liberia airmail triangle, diamond, midget, mammoth to approval buyers. Plymouth, Dept. A-8, Bell, California.

STAMP Collecting outfit, includes packet worldwide stamps, package hinges, watermark detector, millimeter gauge. Everything 10¢ with approvals. Loraine Brown, Marion, Michigan.

FREE! Wonderful, new 84 page U. S. catalog. Handling 10¢. Norrisco, Milwaukee 7, Wis.

SUPERIOR Worldwide mission mixture. Amazing variety! Six ounces \$1.65. Pound \$3.95. Bay Nielsen, 4545B Harvard, Montreal 28, Canada.

100 DIFFERENT Belgium free. UPU. Brussels Fair, railroad stamps free. Approval applicants only. Trylon, Box 31-P, Brooklyn 30, N. Y.

DAMAGED Old U.S. 1/2 catalog, on approval. K. Swartz, Malden Bridge, N. Y.

15 AUSTRALIAN Commemoratives 5¢. Approvals. Van, Box 981, Columbus, Miss.

U.S. Illustrated list free. Big irresistible discounts. National, Box 60, Boston 1, Mass.

LOOK! Six Queen Elizabeth mint sets from Singapore, Tristan, Malacca, Malta, Antigua, Caymans! 21 brilliant pictorials, 25¢. Attractive approvals. Gannon Stamps, Box 931, Canton 1, Ohio.

MOONE Rocket including 111 different stamps, 10¢ with approvals. Finney, Box 89, El Monte, Calif.

U. S. Commemoratives: 202 different \$2. Moseley, 6 Hanley Downs, St. Louis 17, Missouri.

1075 DIFFERENT \$1.00 with approvals. Klondike, 682 Jefferson, Elgin, Illinois.

HUNDREDS Of free commemoratives and bi-colored stamps to buyers from our 1/2¢, 1¢ and 2¢ approvals. Orana, 704 S. Main, Santa Ana, Calif.

FINE U.S. stamps. \$5.00 Coolidge of the 1938 Presidential series, and the \$5.00 Hamilton of the 1954 series. Both for only \$1.00. Fine U.S. approvals included. Willett Co., P.O. Box 338, Dept. 45, Yorktown Heights, N. Y.

OLD U.S.; foreign pictorials free with approval purchases. Stamp Farm, M2-20, Oxford, Wis.

TERRIFIC Stamp bargain! Israel, Iceland, Vatican assortment—Plus exotic triangle set. Also fabulous British Colonial accumulation. Plus large stamp book. All four offers free. Send 10¢ to cover postage. Empire Stamp Corp., Dept. PM, Toronto, Canada.

MANCHUKUO Stamps free with approvals! LaRoche, 38 South Pine, Albany 8, New York.

U.S. Stamps. Giant bargain catalog, 20¢. Raymax, 35-VZ Maiden Lane, New York City 38.

DEALERS — Wholesale list. Postage 4¢. Frank, 5031 Queensberry, Baltimore 15, Maryland.

BIG U.S. price list free! Bailey, 45-G Bromfield, Boston, Mass.

200 DIFFERENT U.S. stamps \$1.00. Approvals included. Shelron, Box 907-K, New York 8, N. Y.

FREE! Over 100 different, \$2.50 value, including space satellite, Israel, British, U.S., first U.N., Siberia. Approvals. Send 25¢ for mailing. Horace Gatewood, Winston-Salem, N. C.

WEIRD Diamond shape coffee stamps. Lovely flower triangle! First American big commemorative. Greenland, Idol Dancer, etc. 10¢ with approvals. Capital Stamp Co., Ferrysburg 2, Michigan.

WOW! 110 All different Germany 10¢ Zeppelins, semi-postals, airmails, high values, etc. Giant catalog, bargain lists included with beautiful approvals. Jamestown Stamp, Dept. A30PM, Jamestown, N. Y.

FREE. Stamps freaks! World's largest and smallest stamp; many other fantastic shapes, sizes, designs. Plus bonus collection from Aden to Zanzibar. 115 different genuine foreign postage stamps in all! Collector's Guide; approvals; big bargain catalog. Send 10¢ for mailing. Harris Co., Dept. F112, Boston 17, Mass.

77 DIFFERENT U.S.A., 25¢. Approvals. Utechs, 1143D North Keeler, Chicago 51.

FREE! 25 Different Turkey plus world's only octagonal stamp, plus Abyssinia Red Cross set; to those requesting approvals. C. V. Cleveland, 806 North Humphrey, Oak Park, Illinois.

FREE! Giant bargain catalog—New edition listing thousands of bargains including U.S. and B.N.A. stamps, packets, mixtures, albums, accessories and supplies; sent with beautiful approvals. Jamestown Stamps, Dept. E30PM, Jamestown, N. Y.

FREE — Mint British colonies from Brunel, Solomon Islands, Negri Sembilan, Sarawak, St. Christopher, Nevis, Trengganu, Gilbert Ellice. Free with approvals. Viking, Great Neck 8, N. Y.

CASH For precancels and commemoratives. Judd, 661 Platt, Toledo, Ohio.

FREE—5 Australian commemoratives to applicants for our 1-2¢ approvals. Superior Stamps, Box 5021, Detroit 35, Mich.

508 DIFFERENT World-wide from Formosa, Morocco, Indonesia, etc., cataloging over \$15.00, only 35¢. Offer to adults only. Approvals. Littleton Stamp Company, Littleton Q1, New Hampshire.

100 FOREIGN, 20 U.S. commemoratives. 10¢. Approvals. Weckerling, 806E Orange, Weslaco, Texas.

FREE! Over 100 different, \$2.50 value, including space satellite, Israel, British, U.S., first U.N., Siberia. Approvals. Send 25¢ for mailing. Horace Gatewood, Winston-Salem, N. C.

2000 U.S. Mission mixture, absolutely unpicked \$1.00; 15,000, \$5.00. Wesley Road, Box 285, Cedar Rapids 5, Iowa.

30 MINT U.S. commemoratives \$1.00. Kelley, 15 Francis Avenue, West Bridgewater, Mass.

INDONESIA Mint sets. Colorful scenes of Bali, Java, Sumatra, Borneo. 19 values. Mint high value temple sets, 6 values, includes the rare 25 Rupiah. Maylaya mint sets of Japanese occupation. Colorful scenes from different states. 10 values. Catalogue prices over \$25 U.S. All for \$2 U.S. Limited quantities. Approvals. All Far East and British stamps on request. Columbia Stamps, 3871 Hoskins Road, Vancouver, B. C., Canada.

115 UNUSUAL including \$1 U.S., Jets, helicopter triangle, Pope diamond, sputnik, Ghana, Israel, U.A.R., Vatican, stamps pictured in Life Magazine. 10¢ with approvals. Rosen, 238M 8 Ave., Paterson 4, N. J.

GREATEST Premium! World-wide collection! Over 1000 different stamps from Angola, Nigeria, Ecuador, Macao, other exotic lands. Includes triangles, airmails, sport, animal, ship, map stamps. Catalog value over \$25.00. This exciting collection given to qualified customers. Request approvals, details, today. Odd Stamps Co., Dept. A7, Box 31, Redondo Beach, Calif.

FREE! Sport stamps with approval. J. F. Butchell, Box 15, Limaville, Ohio.

TERRIFIC Bargain lots: hundreds of stamps \$1. Extra special \$2. Giant assortment including sets, packets \$5. High value packet \$3. Samples, something different, free with order. Persille, 436 N. Y. Ave., Brooklyn 25, N. Y.

8 DIFFERENT U. S. airmails free! Approvals accompany. Dee, Box 926, Ormond Beach, Florida.

READ "Philatelic Investor" for best buys! One year \$1.00. Box 431, Kenosha, Wisconsin.

FREE! Set of seven Nigerian stamps with approvals. Fire Island Stamp Company, Box 37A, West Islip, New York.

FOUR Ounces U. S. mixture dime with approvals. Ladwig, 2871 Mary, Omaha 12, Nebr.

FREE! 50 Different. Approvals. Ehrlich's, 426 Jefferson St. N. E., Washington 11, D. C.

FREE Any volume Scott's International albums, Scott's 1960 catalogues, even master Global Albums free, when you buy our sensational foreign approvals. Bargain Stamps, Redlands 2, California.

WORLDWIDE Collection, 20 different countries guaranteed value \$2.00, only 10¢ with approvals. Martin, 2102 Bentley, Los Angeles 25.

FREE! 25 Different foreign stamps with approvals. Dan Hughes, 6327 South Aberdeen, Chicago 21, Illinois.

FREE Monaco nudes. Stamp Ranch, 902 Addison, Chicago 13, Ill.

UNITED States, Canada, British Colonies! Quality approvals. Enclose 10¢. Peterson, 405 Northwestern Bank, St. Paul 1, Minn.

1002 DIFFERENT Worldwide for approval buyers only. Jacobsen, Crompond, N. Y.

BREAKING Up huge collection. Many unusual stamps. Sold in \$1 lots only. Send \$1 and be surprised! Ace Sales, P.O. Box 5607, Reno, Nevada.

U.S.-Foreign wholesale-retail pricelist. Used, mint, plate blocks. 20¢ deposit. Doyle, Courtney, Missouri.

ICELAND Pictorials—seven selected specials, 10¢. Approvals. Carling, Howard City, Michigan.

FREE! Beautiful pictorial mint set. Bargain packet list. Approvals. Sundal, 1603-A SunValley, Austin, Minnesota.

1¢, 2¢, 3¢ UNMOUNTED Approvals. Kirby, 2001 Orange Grove, Orange, Calif.

50 DIFFERENT Canada including dollar totum 10 cents to approval applicants. Maritime, Box 662, Saint John, N. B.

500 FINE Mixed U.S. 15¢. Wright, 201M Mealey, Hagerstown, Maryland.

U. S. Commemoratives, 1893-1937, twelve different 10¢. Approvals. Carrington, Howard City, Michigan.

U. S. Commemoratives! 150 diff. \$1.00! Illustrated list free! Ewing, 2133 Lunt, Chicago 45.

ENJOY Your stamps. Add few each month from our approvals. You'll be delighted. Postage both ways. Laclede Stamps, 4973A Columbia, St. Louis 9, Missouri.

1000 MIXED. Includes pictorials, 50¢. Knopp, Box 1381, Bristol, Conn.

VOLCANO Triangle, Mexico's largest stamp, Ghana Lincoln statue, new animal set, many others, all large pictorials. 10¢ with approvals. Nomad Stamp Company, Box 117, Shallmar, Florida.

FREE "Mystery" packet. Approvals. Premiums given. Dancer, 75-P8, Mansfield, Ohio.

50 CHINA 10¢. Approvals, gifts. Coast, P.O. 2187A, Santa Ana, California.

FORMOSA: 25 Beautiful large pictorials! Only 10¢ with bargain approvals. Cork, Box 4934, Midland, Texas.

50 DIFFERENT Large mint French Colonies 25¢. Approvals. Stanley McCall, 12316 E. San Bernardino Rd., El Monte, Calif.

MEXICO 25 Beautiful 10¢. Approvals. Salsman, Box 702, Berkeley, Calif.

MYSTERY Packet of over 50 all different free with approvals. Stamp Imports, Peterborough, Canada.

FULL Of surprises! Foreign mission mixture. Unsorted, unpicked. Old, new issues. Great variety. 500, \$1.00. Deluxe blend 500, \$2.00. Mission Mixtures, Box A. Placentia, California.

ZOUNDS! Amazing "strange countries" packet. Free with approvals! Saxon, Orange, California.

SURPRISE Set, fifty British Commonwealth. Free with terrific approvals. Kawartha Stamps, Box 513, Peterborough, Ontario.

U. S. Bargain—51 different 10¢, with U. S. approvals. Stamps, Kennebunk, Maine.

BONANZA! 100 Different pictorials, mostly large, 20¢. Approvals. Curran Stamps, 16 Curran, Whitesboro, N. Y.

OLD U. S.; Foreign pictorials free with approval purchases. Details: Stamp Farm, M2-21, Oxford, Wis.

EXTRAORDINARY! Free! 20 different Finland to those requesting approvals. Rosenbirg, Box 1303, Chicago 90.

LIFE Magazine stamps on approval. 14 different 10¢. B & W, Box 1867, Columbia, Co. Carolina.

THOUSAND Beauties! 2¢-3¢ Approvals! Marshall, Box 451-PD, Long Beach Calif.

NUDES, Natives, Monaco Africa. 50 outstanding 10¢ with worldwide approvals. Gertner, Box 75, New York 33, N.Y.

TREMENDOUS Accumulation. Collections, lots, miscellaneous. Closing out cheaply. Lists free. Alatelto, Maynard, Mass.

MILLION Stamps on approval! 2¢ each! Send for thrilling, giant selection! ABC Stamp Company, San Francisco 1-AE, California.

100 INDIA 25¢. No approvals. Free packet lists. Brandwein, Box 92-P, Bayonne, New Jersey.

F. D. C. Collectors! Subscribe to our foreign mailed direct service. Watch your collection grow. Brumsey, 2418 First, Ft. Myers, Fla.

MAKE Money with stamps! Outstanding profits possible! Free information! Adults Only! Columbia 9268-MT Piney Branch Road, Silver Spring, Maryland.

ADULTS! Like stamps? Then start your own mail-order business. Our free Guidance Program shows you exactly what to do, makes it easy, profitable for you. Details free! Columbia, 9268-MP Piney Branch Road, Silver Spring, Maryland.

ANTIQUES, RELICS, INDIAN GOODS, CURIOS

3 ARROWHEADS Obsidian ancient and catalogue \$1.00. Worcester, 1229B University Ave., Berkeley 2, California.

WANTED—For cash. Antique guns and accessories. Send description including all markings. Wayne Kramer, Great Bend, Kansas.

ANCIENT Grooved stone tomahawk \$3.00. Indian relic list free. Lear's, Glenwood, Arkansas.

4 ARROWHEADS \$1.00. List. Smith, 841 N. Tacoma, Indianapolis 1, Indiana.

10 ANCIENT Stone arrowheads, \$2.00. Stan's, 1054 Lilley, Columbus 6, Ohio.

ILLINOIS: Selling hundreds—Confederate, Civil War, Indian War, western muskets, Kentuckies, Springfields, rifles, pistols, flasks, blunderbusses, flintlocks, frontiers, dueling pepperboxes, Confederate-Union swords, bayonets, bullet molds. 12,000 collectors cartridges. \$20,000.00 Confederate bills. Gold coins, Indian cents. Agates, minerals, fossils. 50,000 Stonegate Indian relics, arrowheads, spearpoints, discoids, gold nuggets, stagecoach guns. Mounted birds, daguerrotypes, holsters, military insignias. Send 35¢ (refundable) for large listing. Heike, Shangrila, Wenona, Ill.

PRECIOUS STONES, MINERALS

GET Free catalog no serious rockhound, gem cutter, jewelry maker, hobbyist or craftsman can be without. Full of bargains, exclusive items, low prices from largest suppliers and authorities in the field. Free, new catalog just off the press, yours for the asking! Write Grieger's, Dept. C-11, 1633 E. Walnut, Pasadena, California.

INDIA Importer has crystal and gem specimens for rock collectors; uncut; this material not perfect enough for gems, but will greatly enhance your collection. India star rubies from 75¢ to \$1.25. Moonstones 65¢ to \$1.00. E. D. Skinner, Box 4252, Station K, Milwaukee 10, Wis.

20 DIFFERENT Beautiful polished gem stones \$2.50. David Wilson, 1865 Poplar, Memphis, Tenn.

"TREASURE Map of Mojave Desert," gems, minerals, recreation, 21"x33" \$1.00 postpaid. Gemac, 808A, Mentone, Calif.

PROSPECTORS! Learn from experienced geologists how to locate and identify rocks and minerals. A comprehensive home study course designed for anyone interested in exploring for valuable ore deposits. Write now for free literature. Pacific School of Mines, Dept. B-1, Box 2538, Palm Springs, California.

FREE Bargain gem list. Lapidary and silversmith catalog, 56 pages, 25¢. O'Brien's, 1116M Wilcox, Hollywood 38, Calif.

"GEMS & Minerals Magazine," largest rock hobby monthly. Field trips, "how" articles, pictures, ads. \$3.00 year. Sample 25¢. Box 687A, Mentone, California.

SEMI-Precious uncut gems. Ten different for \$1.00. Request list 2¢. Prospectors Shop, 201 San Francisco, Santa Fe, New Mexico.

EARTH Science, the rockhounds national magazine. Subscription \$2.00. Sample 35¢. Box 1357-PM, Chicago 90, Ill.

HOBBIES AND COLLECTIONS

COLLECTORS Matchbook covers. 100 different unused, \$1.00. Catalog 25¢. Album \$3.00. Charles Edelman, 1311-C East 84, Cleveland 3, Ohio.

COLLECT Foreign medals, daggers, helmets. Iron Cross with ribbon, \$1.50; Swastika emblem 25¢; catalog 25¢. Hobbies, Box 71-B, Rockaway 94, N. Y.

"THE Collector," newest publication for collectors of anything! Free information. The Collector, Box Four, Millersburg 3, Penna.

NAZI Insignia book, 600 illustrations, and 6 Nazi emblems, \$1.00. Hobbyland, Calgary, Canada.

CROSSWORD "Wattsit" magic word finder. Send \$1. Fabulous, Box 74, Kitchener, Ontario, Canada.

50 CHOICE Oriental seashells, beautifully boxed, identified only \$2.00. Free Naturehobbies catalog for stamps. P. Haas, 57-34 256th St., Little Neck, N. Y.

PHOTOGRAPHY, CAMERAS, PHOTO SUPPLIES

164 PAGE Photographic bargain catalog, listing thousands of photographic bargains. Send 25¢ for your copy, credited on first order. Dept. 1-C3, Central Camera Company, 230 So. Wabash Ave., Chicago 4, Illinois.

PHOTOGRAPHY For pleasure or profit. Learn at home. Practical basic training. Long established school. Free booklet. American School of Photography, 835 Diversey Parkway, Dept. 3441, Chicago 14.

PHOTO FINISHING

GLOSSY Photostamps in sheets of 100, reproduced from any photograph or picture. 1001 uses. Only \$1.35 (lowest price ever). Howard Houck, 2132 Sycamore, Bethlehem, Pennsylvania.

KODACOLOR Developing and printing. Trial offer: 12 exposure roll, send this ad and \$3.00. Southwest Photo, PM3-60, Box 750, Chickasha, Okla.

PHOTOGRAPHS—Oil colored. \$1.00 each. 2 for \$1.75. Guaranteed. Vida Gretano, 1416A Rockland, Pittsburgh 16, Penna.

FREE! Kodak film for life. New Kodak film for every roll you send to develop. Jumbo size. Black and white: 8 exp. 80¢; 12 exp. \$1.05. Kodachrome: 8 exp. \$3.50, 12 exp. \$4.50. Send for price catalog for more savings. Satisfaction guaranteed. Yankee Photo Service, Box 1820-PM, Bridgeport 1, Conn.

A Triple value. Quality, price, service. Color or black and white, 12 exp. (black and white) 59¢. 20 gift photos \$1.00. Holiday Photos, Dept. 16, Box 666, Denver, Colo.

A 3-in-1 value. Price, quality, service. 20 gift photos, \$1.00. 12 exposure rolls (black and white), 59¢. Color or black and white. Interstate Photos, Dept. 11, Box 15, Aurora, Ill.

KODACHROME Processing by Kodak. 8mm. roll or 35mm., 20 exp., \$1.40. Prompt service. Write for mailers and prices. Color Pix, Dept. P, CPO Box 30, Kingston, N. Y.

TWELVE Exposure rolls 49¢. Wallets 20 for \$1.00. Lincoln Studios, Dept. K, Box 13, Lincoln, Nebr.

ENLARGEMENTS, Heavyweight, six 5x 7's or three 8x10's \$1.00. Jack Koons, Huntington Mills, Penna.

FILMS—Developed and printed 50¢—127, 620, 120 film. Color film developed and printed, save 25 to 33½ discount on all color work. World's finest quality. Send for mailers-price list. Apex Photo, Box 511, Paoli, Penna.

MOTION PICTURES AND SOUND EQUIPMENT

16MM. Sound films. Bargain bulletin. Duquette, 97-T Snow, Fitchburg, Mass.

MOVIE Film! Free catalog! ESO-R, 47th Holly, Kansas City 12, Missouri.

16MM. Sound, projectors, films. Sale, rental, exchange. Visit store or write for catalog. National Cinema, 71 Dey St., New York City.

FREE! Blackhawk's big sale catalog 8mm., 16mm. movies, 2"x2" color slides. Biggest selection anywhere! Projectors, cameras, supplies. Big discounts! Get free, every three weeks. 12-page newspaper size bargain list! Blackhawk Films, Davenport 14, Iowa.

5,000 8-16MM. Movie films. Free catalogues. International, Greenvale, N. Y.

MOVIE Camera film: 8mm. roll \$1.50. 16mm. 100' \$3.00. Free processing. Better Films, 742 New Lots, Brooklyn, N. Y.

16MM. Sound shorts. Tremendous assortment features, \$16.50 up. Used 16 mm. sound projectors, \$79.50 up. Catalog. Abbe Films, 417 West 44th Street, New York City 36.

10¢ BRINGS Big new cine manual for the 8mm.-16mm. movie maker. Save money on fresh b&w and color movie film, all home processing equipment. Superior, 448 N. Wells, Chicago 10.

SPECIAL Entertainment—8 mm. b&w, 50 feet \$12.00. 16 mm. b&w, 100 feet \$20.00. Tex, Box 368, Terminal A, Toronto, Canada.

ADD Sound to 8mm. movies. Write: Phototronic, Fort Atkinson, Wis.

16 MM. Sound—8mm. Sale, rental. Entertainment Films, 2021 Broadway, New York City.

BARGAINS 16MM sound features shorts. Bedner, 5300 So. Talman, Chicago.

KODACHROME 8MM. Featurettes, gag stockshots, pictorial titles. Projection sampler \$1.00. Specify interest: cartoons, glamour, foreign varieties, travel. Rose Parade closeout, 50' \$4.95. Dixie Enterprises, P.O. Box 42177, Los Angeles 42, Calif.

COLOR SLIDES

700 TITLE Selections. Colorslides or 8mm. Free list. Title-Color, Dept. FT3, 3618 Marsh Lane Place, Dallas 20, Texas.

COLOR Slides of American beauties. Listings. Slides, Box 384, Chicago 90, Ill.

COLOR Slides from your own color prints 50¢. Curio-photo, 1187 Jerome, New York 52.

TRANSPARENCIES Wanted. Up to \$500.00 each. For information write: American Color, Box 38391, Hollywood 38, California.

MUSIC & MUSICAL INSTRUMENTS

BONGOS. 6" and 7½" heads two-tone wood \$18.00 value \$10.00 postpaid. Instructions free. Arfin Music, 1712 Nostrand, Brooklyn 26, New York.

ELECTRIC Guitars, amplifiers, wholesale. Free catalog. Carvin, PMM, Covina, Calif.

SONGWRITERS. With publisher contacts, want song ideas. Share royalties. No fees. Send poems: Songwriters' Associates, 1650 Broadway, New York City 19-G.

SONGPOEMS And lyrics wanted. Mail to: TinPan Alley, Inc., 1650 Broadway, New York 19, N. Y.

POEMS Wanted for musical setting and recording. Send poems. Free examination. Crown Music Company, 49-C West 32 Street, New York 1.

SONGS Into dollars. Share \$33 million dollars yearly for new songwriters, song poets. Any subject, songs composed, published, promoted by largest firm. Information, appraisal free. Send Nordyke Music Publishers, 6000 Sunset, Hollywood 28 PM, California.

POEMS Wanted for musical setting and recording by America's largest song studio. Send poems. Free examination. Five Star Music Masters, 630 Beacon Building, Boston.

POEMS Needed immediately for new songs and records. Free examination and appraisal. Send poems: Songcrafters, Acklen Station, Nashville, Tenn.

POEMS, Songs serviced. New plan. Sequoia Songwriters, 6419 Primrose, Hollywood 28, Calif.

VIOLINMAKERS, Repairers. Fine tone wood, and all violin supplies. Send for free wholesale new price list. International Sales, 414-MPM E. Baltimore St., Baltimore 2, Maryland.

ACCORDIONS—1960 Models. Lowest discount prices. Save up to 50%. Free home trial. Trades accepted. Big color catalog free. Accordion Manufacturers, Dept. 30-R, 2003 Chicago, Chicago 22.

POEMS Wanted! Best songs recorded free with 7-piece orchestra. Melodies written. Send poems, free examination. Songmakers, 1472-M Broadway, New York 36.

GUITAR Making books, plans, imported woods, tools. List 10¢. Satinwood, 510 East 11th Street, New York 9, N. Y.

MUSICAL Instruments. Overstock. Save to one-half. Free lists. State type. Treasurecraft D43, Box 3103, Modesto, Calif.

ACCORDIONS—Italian manufacturer introduces new models! Special low introductory prices at authorized dealers throughout United States. Insist on a genuine Castiglione accordion. Write for free catalog. Castiglione, Accordion Company, Box 3862, Detroit 5, Michigan.

SWISS Musical movements, \$1.90. Helax, 218 W. 72nd St., New York City 23.

RECORDS Stereo monaural. Big discounts. Noelson, Box 211, New York 5, N. Y.

SONGWRITERS! Money waiting for your poems! Information free! Successful Songs, Box 608, Danbury, Conn.

GUITAR For beginners—easy! Quality professional guitar, plus famous "Play-at-once" course, case, music stand. Easy time payments. Free details. Sale, Bradley Beach 20, N. J.

RADIO, TELEVISION AND ELECTRONICS

AMPEX Tape recorders. Components. Boynton Studio, 10-PM Pennsylvania, Tuckahoe, N. Y.

FIX Your own TV. Save 80%! Send for free illustrated chart showing how! We'll include giant electronics catalog. Zalytron, 220-M West 42 St., New York City.

TUBES—TV, radio, transmitting, special purpose types. Bought, sold, exchanged. Unused only. Send details to Barry Electronics Corp., 512 Broadway, Dept. PM, New York 12, N. Y.

CASH For used short-wave ham receivers, transmitters and accessories. Treger, W9IVJ, 2023 N. Harlem Ave., Chicago 35, Tuxedo 9-6429.

FREE! Giant wholesale catalog on electronics, hi-fi, transistor, scientific, hobby, optics, photographic, housewares, jewelry, tools, novelties, toys. Write: Lektron, 131M Everett Ave., Chelsea 50, Mass.

TAPE Recorders, Hi-Fi components, sleep learning equipment, tapes. Unusual values. Free catalog. Dressner, 69-02M, 174 St., Flushing 65, N. Y.

LEARN While asleep with amazing "Electronic Educator" endless tape recorder. Details free. Research Association, Box 24-N, Olympia, Washington.

GOVERNMENT Surplus radios, parts. Picture catalog 10¢. Meshna, Malden 48, Mass.

ELECTRIC Guitars, amplifiers, wholesale. Free catalog. Carvin, PMR, Covina, Calif.

RADIO And TV tubes at manufacturers' prices! 100% guaranteed! Brand new! No re-brands or pulls! United Radio, Box 1000, Newark, N. J.

TV, Radio tubes 59¢. Any type. Year guarantee. Evergreen Electronics, 2006 Hewitt, Everett, Washington.

JUKES, Bowlers, pool, records. Reasonable. Catalog free. Universal, Sarona, Wisconsin.

RECORDERS, Hi-Fi. Free wholesale catalogue. Carston, 125-PM E. 88, New York City 28.

SOUNDLESS Television commercials with my ingenious device, \$3.25. Picture stays on. Moneyback guarantee. Voice Control, 234 Monroe St., Passaic, New Jersey. Patent Pending.

CRYSTAL Radio kit \$1.00; preassembled \$1.25; phone \$1.75; catalogue. Clearco Crystal Co., 2966 N. 4th, Milwaukee 12, Wisconsin.

RADIO Program religious, your own. Details free. J. Adams, Suite 228, 5153 North Clark, Chicago 40, Ill.

DON'T Buy hi-fi components, kits, tape recorders, until you get our low low quotes return mail. Catalog free. Hi-Fidelity Centre, 1799M 1st Ave., New York 28, N. Y.

BUSINESS OPPORTUNITIES

NEW Home-import mail order profitability! Your mailbox stuffed with money! No selling. No experience. No investment. We supply everything. Free details. Mail Order Distributors (Import Division), 15201 South Broadway, Los Angeles B53C, Calif.

START Your own business on credit (U.S. and Canada). Your own boss. 1383 dealers sold \$5,000 to \$33,500 in 1958. We supply stocks, equipment on credit. 200 home necessities. Sales experience unnecessary. Pleasant profitable business backed by world-wide industry. Write Rawleigh's, Dept. C-U-PPM, Freeport, Ill.

FOURTEEN Magic methods for creating profitable home business. Free details. Dorco, Box 494, Muncie, Indiana.

\$250.00 WEEK Profit possible. Earn at home spare time with fascinating printing method. \$5 start you. Send no money now. Free confidential facts and valuable samples. Screen-Print MH, Los Angeles 61.

Make Extra money—Big cash commissions plus premiums for you and your customers. Sell advertising book matches. Sensational new tenor, glamour girls, hillbillies; dozens others. All sizes. Quick daily sales; big repeat business. Free master kit makes selling easy. No experience necessary. Superior Match, Dept. MX-360, 7530 Greenwood, Chicago 19.

NATURAL Molding rubber, extra thick. Free sample. W. Wooley, 1016-A Donald, Peoria, Illinois.

MAIL-Order home business. Get free copy, "Make Money in Mail-Order." Mailco, 1717 Westwood, Dept. C703, Los Angeles 24.

IMPORT-Export opportunity, profitable, world-wide, mail-order business from home, without capital; or travel abroad. Established world trader ships instructions for no-risk examination. Experience unnecessary. Free details. Mellinger, C703, Los Angeles 24.

WANTED. Small manufacturers: Aggressive industrial development corporation in Iowa community, prepared to assist small manufacturer anxious to grow. Contact: W. E. Petersen, President, Building Corporation, Harlan, Iowa.

OWN A restaurant, diner, food stand in your area. Little or no capital needed! Revealing details free! National Restaurant Owners' Training, Dept. PM-3, Box 73332, Gardena, California.

"50 NEW Home-Business Ideas" booklet, sample free. Spray exotic Velvet-Suede on anything. Flokcraft-MH, Los Angeles 61.

A Natural for sporting goods, boat, hardware, auto dealers, service stations, ambitious individuals. Become dealer for nation's number one camping trailer. Sets up into complete camp in just one minute! Dealer details by return airmail. Hellite Trailers, 1517 South Sacramento, Lodi, California.

MONEY-Saving whitewall tire cleaner! Wipe-on wipe-off. Easy demonstration. One call sales to garages, gas stations, car lots, tire dealers. You sell, they save, we dropship. Demonstration kit, complete instructions. Send \$5. Detergent Engineering Corp., Box 364-B3, Tulsa, Okla.

BIG Money—Operate own fix-it shop. Service household appliances, motors, mowers, saws, skates, etc. Free book. Christy Trades School, A-8903, 3214 Lawrence, Chicago 25.

EARN Money at home. Be your own manufacturer of high quality woven rugs. Big market, big profits. Write for catalogue of weaving supplies. Newcomb Loom Co., Davenport, Iowa.

MAILORDER Beginners no cost plan. Details for stamp. Armstrong's, 154A Darrington S.W., Washington 24, D. C.

WANTED. Men, women. Raise bait for us at home. Full, spare time. Doesn't take up space. We furnish everything. Sherwood, Dept. V-2, Monmouth, Maine.

PROFIT With Popular Mechanics' subscription plan. No investment, no experience needed. Earnings begin immediately when you obtain subscriptions for Popular Mechanics, Good Housekeeping and others. High commissions, bonus. No experience needed. Deal directly with the publisher. Write Popular Mechanics, Room 3B, 250 West 55th St., New York 19, N. Y.

YOUR Own spare time home-operated business. Take over your area as our service distributor keeping retail stores supplied. Nationally advertised 30-year-old line pays up to \$20.00 hour. Under \$100.00 for merchandise gets you started. For samples, highly successful plan, write Novo, 3855 Lincoln, Desk N-85, Chicago 13.

GAME Warden, government hunter, forestry, park and wildlife services announce job openings. All states. Enjoy outdoor work, good pay, real security. Complete information free! Write North American School of Conservation, Dept. DC-173, 1038 S. La Brea, Los Angeles 19, Calif.

GROW Living miniature forest (only inches high) or orchard that bears tasty tiny fruit. Learn amazing dwarfing secrets! Fascinating hobby! Profitable home-business opportunity! Free seeds and plan. (State your age.) Miniature Nurseries, Dept. MH, Gardena, California.

OPERATE Home mail-order business. Vosacek Printing, 4444A1 Ute, San Diego 17, Calif.

BRUSH Plating outfits for plating articles in the home and shop. No tanks necessary, silvering mirrors, spare or full time. Free particulars. Gunmetal Co., Ave. H, Decatur, Ill.

MARKETS Everywhere. Make artistic concrete birdbaths, pottery. Best coloring. Home workshop. Hundred varieties. Hollywood Cementcraft, 8527-S Wonderland, Hollywood 46, California.

CAN You qualify? Selected men. We help establish floor refinishing business. Complete program. Tool Rental, 3602 California, St. Louis 18, Missouri.

CO-PUBLISH "Home Business Digest." Free details! GPO, Box 972-po, New York 1.

AGENTS. Penny and nickel counter and packager, accurate, fast. Sample \$1.00. Details. Sterling, Box 626, Dania, Florida.

12 SPINNING Lures. None better. \$11.00 value. All different. Send \$3.00. Quaker, 438 Sedgley, Philadelphia 40, Penna.

INTERNATIONAL Mailorder business made easy. Individual setup service. Not just instructions. Hermes, 152 West 42, New York City 36.

MAILORDER To motels, churches, institutions. Complete individual set-up, not just instructions. Hermes Advertising, 152 West 42, New York City 36.

QUICK Money! Repairing car batteries. At home! Easy too! Free details! Batteryman, Penrose, Colo.

LEARN Sewing machine repairing. To \$125 weekly. Sparetime. Supplies. Add to present business. Write today! Taylor Service, Box 2126, San Bernardino, Calif.

EARN \$10,000 Yearly raising Angora rabbit wool for us. Information 25¢ coin. American Angora Company, Malta 77, Montana.

WHAT Is this mail order business? Get the one true answer. John Bishop, Box 153B, Ojai, California.

MAIL Trade magazine has moneymaking opportunities galore. Sample 25¢. Donovan, 79-PM Greenbelt, Levittown, New York.

100% PROFIT Selling reconditioned spark plugs. Free sample. Lee, 1608-H Roberts, Houston 3, Texas.

FRANCHISES Make profits! Operate your own independent franchised business as distributor, dealer or agency owner. Nationwide opportunities. National Franchise Reports is the recognized source for information regarding the booming franchise field. Write today for interesting free details of this helpful service. National Franchise Reports, W-528, 333 North Michigan, Chicago 1.

FREE Picture folder, "How to Make \$3,000 Yearly, Sparetime, Backyard, Raising Earthworms!" Oakhaven-38, Cedar Hill, Texas.

VENDING Machines. No selling. Operate a route of coin machines and earn amazing profits. 32-page catalogue free. Parkway Machine Corporation, Dept. #27, 715 Ensor Street, Baltimore 2, Maryland.

SELL Books by mail. 400% profit. Royal, Box 368-X, Cleveland 27, Ohio.

PLASTERCRAFT Molds, liquid rubber, plasters, flocks, candle supplies. Catalog and manual free. Blue Rapids Supply, Blue Rapids, Kansas.

I Got rich in the dry cleaning business with no investment, so can you. Free details. Write: Imperial School of Dry Cleaning, Dept. PMC, 1700 Touhy Avenue, Chicago 26, Illinois.

BIG Money raising fishworms and crickets. Free literature. Carter Farms, Plains, Georgia.

OPERATE Mailorder folio business. Free details. Ballard's, 1834 Edgeland, Louisville 4, Ky.

FREE! Name brands catalog! Your own high profit business. Sell name brands, full or part time. No inventory, no investment. More than 2,000 name brand items; lowest wholesale prices. Watches, jewelry, cameras, hi-fi, stereo radios-phonos, appliances, housewares, hardware, power tools, luggage, musical instruments, garden equipment, sporting goods, toys, many others. 8 floors of name brands. Million dollar inventory. Orders shipped complete in 24 hours! Send for free, beautifully illustrated catalog now! Separate wholesale price list. H. B. Davis Corp., Dept. 11, 145 W. 15 St., New York 11, N. Y.

PLATE Baby shoes, jewelry, gifts. Bronze and colored pearl. We finance home businesses. Booklet free. Platex, 11029 South Vermont, Los Angeles 44.

IF You like motorcycles and money then send for Harley-Davidson dealership book on how to become a franchised dealer of motorcycles and a new line of motor-scooters. Here's a chance to own your own business with a very modest investment. The youth market is beginning to explode and the next few years promise a chance to cash in on it. Write for free illustrated dealership book today. Harley-Davidson Motor Company, Dept. P, Milwaukee 1, Wisconsin.

BUSINESSES, Resorts, motels, investment property, ranches. Our special service dept. at your disposal. No obligation. World's largest. 58 years' service. Strout Realty, 7-MB S. Dearborn, Chicago 3, Ill.

TO \$100.00 Weekly. Sparetime, home operated mailorder business. Successful beginner's plan. Everything supplied. Lynn, 10420-M National, Los Angeles 34.

PIANO Tuning learned quickly at home. Tremendous field! Musical knowledge unnecessary. Information free. Empire School of Piano Tuning, Champaign, Ill. (Founded 1935).

WANT To make big money at home? \$10.00 profit in an hour possible with invisible mending. Make tears, holes, disappear from clothing, fabrics. Steady year-round demand from cleaners, laundries, homes. Details free. Fabricon, 6234 Broadway, Chicago 40, Illinois.

\$70 WEEKLY—Home, spare time. Simplified mail bookkeeping. Immediate income—easy! Auditax, 34757A, Los Angeles 34.

I Want to send you proof of the wonderful pulling power of Popular Mechanics classified pages. What's your proposition? Write me today. Include literature if possible. F. W. Johnson, Manager Classified Advertising, Popular Mechanics Magazine, 200 E. Ontario St., Chicago 11, Ill.

COPUBLISH Mail Sale Advertiser, leading mail order paper. Details, latest copy, dime. Vanroy Shirk, Lebanon, Penna.

11,000 NEW Prospects daily. Baby record books, shoes, albums. Sell mailorder. Use our literature. Write: No-Co-Ro, Capitola, California.

BRONZE Baby shoes: Instructions, equipment and mountings for genuine electroplating process. Largest supplier of all plating equipment, supplies. Free catalog. Hollywood Bronze Supply, Dept. B-3, 1624 East First, Los Angeles 33, Calif.

MAKE \$46 From square foot plywood: jigsaw necessary. Free details. Woodart, Bridgewater, Mass.

FIX Typewriters. Free repair course. Home operated. Remit 25¢ for book explaining free course and agency appointment. Athey, Tarentum, Penna.

OPERATE Profitable mail order business. Write Walter Service, 4159A East 112th, Cleveland 5, Ohio.

EARN Good money sharpening chain saws, scissors, cutters, knives. Free manual. Treycy, North Tonawanda, N. Y.

RE-Cast junk batteries into new. Latest achievements. Battery Laboratories, Bayou LaBatre, Alabama.

BAKE New greaseless doughnuts in kitchen. Sell stores. Free recipes. Montgomery, 3605 South 15th, Minneapolis 7, Minnesota.

\$3.00 HOUR—Home, sparetime, assembling pump lamps. Easy. Free details. Ougor, Caldwell, Arkansas.

PLAQUES—Figurines—molds. Free details. Russo, 1196 Brooklyn, Bklyn 3, N. Y.

BE A notary. Information: Stationers, 515 East 33rd, Kansas City 9, Missouri.

QUICK Profits, with no capital! Take orders for magazines your neighbors like, want. Make cash on the spot! We show how with free kit. Get yours now. Write McGregor Magazine Agency, Dept. 312, Mount Morris, Ill.

"MAILORDER And the Law." Know about required licenses, federal and state regulations, taxes, etc. Only \$1.00. Included free: "Starting a Mailorder Business." Dorf, 186-M Covington Lane, Woodbury, New Jersey.

MAKE Flexible molds. Cast plaques, figurines. Free sample. Tooker, 1045-R Fairview, Hamilton, Ohio.

ENJOY A profitable business of your own selling the "World's Most Usable Bible." Profit from our 26 years experience. International Book Company, Dept. M., Box 118, Wichita 1, Kansas.

CAN The boss! Make strange building plastic from waste. Economical. Bays Laboratory, Chinle, Arizona.

CANDIED Popcorn and potato chip equipment. Eakins, Box 933-AO, Springfield, Ohio.

LEARN Appliance service and repair. Motors, washers, refrigeration, cleaners, everything. Free booklet. Appliance, 11027 South Vermont, Los Angeles 44.

RAISE Rabbits on \$500 month plan. Free details. White's Rabbitry, Mt. Vernon, Ohio.

PROFITABLE Home mail order business! Particulars free. Progressive, Box 422-B, Raymond, N. H.

MUSHROOMS Easier, quicker, cheaper. Magic preplanted trays, Newest facts free. "Mushroom Growing Handbook," illustrated, 96 pages, \$1.85. Spawn \$1.00, both \$2.00. Luxur, 641 South 19th St., Newark 3, N. J.

OPERATE Your own home mail order business. It's profitable. Write: Webb Imports, Pico Rivera, Calif.

"MAIL Order World of Opportunities." Free subscription, details. GPO, Box 972-F, New York 1.

\$400.00 MONTHLY Raising giant worms. Odorless soilless method. Charlie Morgan, Bushnell, Florida.

BOSS Your own home business. Profits 1200% to 3000%! Make, distribute stunning Shellcraft jewelry. Sells itself wherever displayed. Big repeat demand. Details free; Shellcraft, Dept. A, Box 804, Panama City, Florida.

METALIZE Baby shoes: Repair dolls; rebuild batteries; Catalog "75 Ideas" free. Universal, Box 1076-A, Peoria, Illinois.

IMMEDIATE Top earnings. Proven, guaranteed collection system sells on sight to all size businesses. 250% commission. Substantial repeat orders. Now assigning exclusive territory rights. Airmail. Paymaster System, 11 East Twelfth St., Wilmington 1, Delaware.

LIQUID Molding rubber, free sample. Shellcraft supplies. Chaney's, 1907-A East Road, Jacksonville 11, Fla.

HOW To make the money you want—Now! Amazing new book tells you how to do it. Details free. Bruno Enterprises, Chandlerville, Illinois.

HIGHEST Quality liquid rubber, \$10.00 gallon, prepaid. Free details. Steece Bros., Box 177-AM, Sioux Falls, So. Dak.

PRACTICAL Mailorder. Start small. Moneymaker (36), 722 East Silver Spring, Milwaukee 17, Wisconsin.

PROFIT Opportunity Copublish Mail Gazette. Details free. Robey House, 2042E W. Chicago Ave., Chicago 22, Ill.

LEARN "Mailorder Do's and Don'ts", other selections. 50¢. Carruthers, Box 626-A, Dania, Florida.

SELL Books by mail without stock. Big profits. Talliaferro, 832-B Monroe, Fort Worth 2, Texas.

AMAZING Moneymaking opportunity! Work home, sparetime. Typewriter helpful. Samples, instructions 50¢, refundable. Interstate, 37 Besch, Albany 9, N. Y.

OPERATE Profitable low cost mailorder business! Liberty, 210-PMM6 Fifth Avenue, New York 10, N. Y.

HUGE Cash returns! Charted mailorder opportunities. Everything furnished. National, Box 508, Campbell, California.

\$100.00 WEEKLY Selling books by mail. Roe, 2317P Marshall, Chicago 23.

BIG Profits selling ball point pens. Bonomp, 54 Jefferson, Brooklyn 6, N. Y.

MONEY Making mail-order opportunities galore! Free! American Distributors, Box 409-P, Niles, Michigan.

517 FREE Catalogs, sales kits, products samples, 1,000,000 items at wholesale. The greatest bargain of all time. 10 huge directories just off the press, \$2.00 (refundable). Orders shipped prepaid day received. Preskile Enterprises, P.O. Box 7142, Rochester 16, N. Y. Notice: We reserve the right to withdraw offer without notice when present supply is exhausted.

START Your own business trimming windows. Full instructions on trimming, how to get work, etc., only \$1.00. Jem, Box 144, Cranford, N. J.

AMBITIOUS Men, women! Conduct independently owned rug, carpet upholstery cleaning service, using NuMaid Drifoam process. Lucrative year round business. Cooperative starting plan. Williams Products, 90-P Wentworth, Charleston, S. C.

MANUFACTURE Your own plastics—trial unit \$2.00. Hallmark Dental Co., Box 1924, Detroit 31, Mich.

\$200.00 MONTHLY. Spare time. With tablesaw. Write. Holiday House, 7228 4th Plain, Vancouver, Washington.

\$50-100 INCOME Day. School of Spray Painting. Herbert Schmidt, 26th Superior, Sheboygan, Wisconsin.

BECOME Finance specialist. Handsome profits. Tucker Associates, 3633 Warder N.W., Washington 10, D. C.

MONEY-MAKING Opportunity in your own fishing equipment business. Free details. Postal Sales, Div. FB3, 11139 McCormick, North Hollywood, Calif.

\$100 WEEKLY In unique new profit sharing mailorder business, little or no stock to carry. Home Business Digest, 3026 Waterloo, Chicago 13, Illinois.

SELL By mail. High income! Everything furnished. Irvin, Box 1052, Oklahoma City 1, Oklahoma.

FIBERGLASS Awnings—No investment. Part, full time. Fiberlux, 29 Elm Avenue, Mt. Vernon, N. Y.

MAKE Big profits clipping newspaper items! Clip newspaper items for publishers. Some clippings worth \$5 each. You can earn \$25-\$50 weekly in your own spare time business. Particulars free. National, 81-PM, Knickerbocker Station, New York City.

IMPORT, Mailorder, plastics offered in new three-in-one money making opportunities. Free details. Trialpha, 7950 Mammoth, Dept. F30, Van Nuys, Calif.

SELL Cast aluminum sign letters. Good profit. Details. Courtesy, Box C, East Dubuque, Ill.

BE A manufacturer. We supply pre-cut material for exclusive new items. Small investment. Details free. Modern Home Co., Box 172C, Northfield, Ohio.

\$34.70 TWO Hours. Manufacturing concrete products. No selling. Castings #3, 1803 Fremont, Rapid City, South Dakota.

ENJOY Second income by mail! Cox, 84 Chestnut, Saugus 1, Massachusetts.

DOLLS! Dolls! Dolls! We teach you to repair, make, sell all kinds of dolls and accessories including clothing. Study at home. Earn while you learn. Free catalog. Doll Hospital School, Studio MC-30, 11826 San Vicente Blvd., Los Angeles 49, Calif.

CASH From sawdust, tin-cans, newspapers. Over 200 methods. Instructions \$1.00. Charles Company, 42-GPE, Norwood, Ohio.

MOLD Statuary, pottery, tiles, novelties—5¢ materials makes dollar sellers! Particulars free. Marbleizing Service, Edwardsville, Illinois.

EARN Big profits selling imported checkwriters. Hand models \$14.95. Desk models \$39.95. Modern Merchandise, Box 77531-PC, Los Angeles 7, Calif.

MAILORDER Literature for beginners. Cal Enterprises, Box 1592, Beverly Hills, California.

MECHANICALLY Inclined men. Buy, repair, and resell used refrigerators from your home in a few weeks. To \$400.00 monthly part time, sky's the limit full time. An easy way to break into direct to the public servicing if desired. I have published a small manual with a childishly simple, short-cut approach to refrigeration. It makes a repairman of you, not an engineer as most books and schools try to do. Mail \$4.95 for this manual and my treatise, "Make Money in Used Refrigerators and Refrigeration as Compared to Boiling Water." Or mail \$1.00 for treatise only. No c.o.d. Rays Refrigeration, 2210 North 48, East St. Louis, Illinois.

EASY Handwork. Makes profitable articles. Sample free. Sunmade, Brockton 64, Massachusetts.

EARN \$100.00 Weekly part time from your arm-chair and in one year you'll receive a free trip to Europe for two. No selling. No mailorder. Pan Pacific, MAP, Box 595, Laguna Beach, Calif.

LEARN Landscaping and the growing of plants. Start a profitable business part or full time. Free information without obligation. National Landscape Institute, Dept. MC-30, 11826 San Vicente Blvd., Los Angeles 19, Calif.

EXTRA Money with your camera. Free information. Glamourize, Box 467, Warren, Ohio.

MAILORDER! High-class, honest, strictly legitimate. Free details. Mailord Company, (PM), Southampton, New York.

WORLD'S Easiest mailorder business. (Designed especially for beginners). Details free. Tasker, Box 3131, Alexandria, Virginia.

WANTED: Home producers, to be subcontractors. Cast plastic products for manufacturers in our clearing house service. Thousands of easily made items required. Cash in at home, without previous experience. Plastic Service Associates, Dept. 3-PM East Boston 28, Massachusetts.

MONEYMAKING OPPORTUNITIES

OPERATE Home mail-order business. Vosacek Printing, 4444A Ute, San Diego 17, Calif.

MINNOWS Make money in your backyard or farm pond—if you start right. Send for illustrated booklet "Minnow Raising Hits and Misses" \$1.00 postpaid. Daniel Minnow Ranch, Box 9247-B, Fort Worth, Texas.

PROFITABLE Homework! Guaranteed earnings. No selling. Everything supplied. Elvee, 556 Beacon, Manchester, N. H.

MINK Raising information free. Complete. Lake Superior Mink Farm, Superior, EEL, Wisconsin.

VENDING Machines. No selling. Operate a route of coin machines and earn amazing profits. 32-page catalogue free. Parkway Machine Corporation, Dept. #26, 715 Ensor Street, Baltimore 2, Maryland.

GROW Mushrooms. Cellar, shed and outdoors. Spare, full time, year round. We pay \$4.50 lb. dried. We have 29,000 customers. Free book. Mushrooms Dept.: 173. 2954 Admiral Way, Seattle, Wash.

CIGARETTES: Make 20 plain or filter-tips for 9¢. Facts free. Moberly, Box 821, Owensboro, Kentucky.

EARN Money evenings copying and duplicating comic cartoons for advertisers. Adservice, Argyle 1, Wisconsin.

YOUR OWN easy-to-start, home mail-order business, sparetime. Fascinating; profitable! Information free. Alfano, 19-PM Pine, Closter, N. J.

BIG Money raising fishworms and crickets. Free literature. Carter Hatchery, Plains, Georgia.

READ "Progressive Mailtrade," the magazine that tells how to make money by mail. Quarter brings sample and special offer. Progressive Mailtrade, Box 357, Sheboygan, Wisconsin.

WIN Contest money. General Contest Bulletin gives hundreds of tips. Lists current contests, rules. Sample magazine 25¢. General Contests, 1609½ East 5th, Duluth 12, Minnesota.

AMAZING Successes through franchises! Become exclusive franchise holder your territory. Information rushed. National Franchise Reports, MP-528, 333 North Michigan, Chicago 1.

START Big-pay business at home in spare time. No experience needed to operate little table-top machine for bronzing baby shoes. Make \$5.46 profit on every pair. Full particulars free. Send postcard to Mason, 1512 Jarvis, Room CM-2-A, Chicago 26, Ill.

MEN—Women! Start money-making plastic laminating business at home in spare time. Material that costs 11¢ brings back \$2.50. No canvassing or selling but mail orders bring in \$20 a day. Write for full particulars free. Rush name on postcard to Warner, Room CL-2-A, 1512 Jarvis, Chicago 26, Ill.

EASY To start rubber stamp business at home in spare time. Make up to \$9.80 an hour without experience. Facts free. Write to Roberts, 1512 Jarvis, Room CR-2-A, Chicago 26.

SELL Diamonite gems; more brilliant than diamonds. Credit arranged. Catalog 10¢. Diamonite, 2420-M 77th, Oakland 5, California.

MAKE Money writing short paragraphs! No tedious study. I tell you what to write, where and how to sell; and supply list of editors buying from beginners. Many small checks add up quickly. Write to sell, right away. Send for free facts. Benson Barrett, Dept. C-27-N, 7464 Clark, Chicago 26.

IN 1952 I was unemployed, broke. Today own \$18,000 home, drive Cadillac, have bank account. Anyone can do this. Write Norris Cole, 217 West 49th, Bradenton, Florida.

OPERATE Profitable home import business! Details free. Direct Mail Service Company, Box 581, Bakersfield 10, Calif.

\$340.00 MONTHLY With jigsaw. Details. Elkman, 346F North Summit, Sioux Falls, So. Dak.

LEARN Appliance service and repair. Motors, washers, refrigeration, cleaners, everything. Free booklet. Appliance, 11027 South Vermont, Los Angeles 44.

\$50,000 YEARLY Possible. Distribute sales literature your territory. Write Afja, Box 33-D, Southfield, Michigan.

BUILD Dutch windmill and wishing well dog houses. Two plans \$1.00. Craft Shop, Peotone, Illinois.

MAKE Big easy profits making costume jewelry at home in spare time! Quick, easy to make, easier to sell! Details free! Don-Bar, 3511 W. Armitage, Dept. C-192, Chicago 47, Illinois.

START A profitable subscription business in spare time! We need men and women (young or old) as representatives for all leading national magazines. Liberal commissions on all subscriptions. Supplies free. No experience needed. Send this ad with your name and address to: Popular Mechanics, Room 3-O, 250 W. 55th St., New York 10, N. Y.

HUSBANDS And housewives wanted! Big money. Spare or full time cake decorating and candy making. Turn your kitchen into a gold mine. No age, education limits. Complete instruction, learn and earn at home. Write for free facts. Candy And Cake, Dept. 648, Fallbrook, California.

\$200 WEEKLY Buying gold. D'Amico, 24 North Wabash-A Ave., Chicago 2.

MEN, Women, students! Learn how easy it is to earn money selling the highest quality stainless steel pot cleaner on the market. Write: Springfield Wire & Tinsel Company, P.O. Box 638, Springfield, Mass.

INVISIBLE Reweaving: \$5 in one hour possible reweaving burns, tears, moth-holes. Spare-full time. Free details. Skill-Weave, Dept. WC-163, 335 W. Madison, Chicago 6.

MONEY In chemicals. Make own products. Pocket all profits. Others work for you. Details free. Ranslow, 51 W. 32 St., Hialeah, Florida.

FREE Details—How to make big money selling books by mail! Direct Mail Service Company, Box 581, Bakersfield, California.

BIG Money opportunities—Jobs, businesses, investments. Retirement opportunities. Free details. Shoreland, 20 W. Jackson, Suite 1412-K, Chicago 4.

GET Money for newspaper clippings. Free details. Write: Whitted-30A, 2815 Nicholson, Dallas 24, Texas.

NEED Money? Sell Golden Rays letters kits. Free details. Tebe, 36-08A 30 Avenue, Astoria 3, N. Y.

DANDY Homework offer. Wall Monument Works, 1071 Linden, Zanesville, Ohio.

SHOW—Sold! Cigarette vanishing trick. \$1. Details. Scheetz, Sellersville 2, Penna.

EARN Money using any camera. Experience not necessary. Work at home, anywhere—make money! Write today. CPC, Box 1066A, Richmond, Calif.

\$20 DAILY Spare time plating baby shoes, jewelry, novelties. Start with \$3.00. Refundable. Free details. JO-CA 468-D Northwest 79th Street, Miami 50, Florida.

MAKE Money typing. Details 17 proven plans. Crafts, Mulino, Oregon.

MAKE Big money operating your own home mailorder business! Full, sparetime. Specialist's complete instructions show how you can make easy start! Further particulars free. Griffin, 322 West State, Ithaca, N. Y.

AMAZING Scientific discovery. Make fabulous profits. Write Dickerson Sales Co., 815-PM Chase St., Indianapolis 21, Ind.

EXPORT — IMPORT

TERRIFIC Import, gift bargains, catalog 25¢ (refundable). Carle Distributors, 2 Empire Street, Buffalo 12, New York.

FORMULAS, PLANS, ETC.

RESILVER Mirrors—make one-way mirrors. Both \$1.00. Kem-Mir, Park Ridge, Illinois.

LATE, Modern manufacturing formulas. List free. Moon Chemical, Martville, New York.

FORMULAS For latest money-making discoveries. New! Good! Valuable literature free! Miller, Chemist, 1517-D, Tampa, Florida.

FORMULAS: All kinds, latest, best. Literature free. Kemixal, Park Ridge, Ill.

PLASTICS

LAMINATING Supplies. Price list free. Solomson, 4 Beacham, Everett 49, Mass.

LEARN Plastics fabrication for spare time income. Low cost home training now available. Write for free booklet. Interstate Training Service, Dept. D-3, Portland 12, Oregon.

BOXES, Plastic. Free list. Althor, 170 Bay 23 Street, Brooklyn, N. Y.

PLASTIC And supplies for laminating. Colamco, 12 Center, New Haven, Conn.

PLASTICS—Plexiglas, polyester, fiberglass, acetate, vinylite, supplies. Manufacturers' distributor, sheets, rods, tubes, liquids, coatings, films, boat plastics. Large, small quantities. Complete instructive catalog, 25¢. Gem-O-Lite, 5529-A Cahuenga Blvd., North Hollywood, Calif.

NEW Liquid casting plastic, clear, colors. Embed real flowers, butterflies, photos, coins. Send 25¢ for two handbooks "How to Cast Liquid Plastics" and "How to Make Extra Money at Home." Castolite, Dept. C-101, Woodstock, Illinois.

PLASTIC Embedding for fun and profit, no oven. Make beautiful jewelry, decorative panels, science specimen castings. Catalog 25¢. Natcol Plastics, Box 444, Yucaipa, California.

CELLULOID Scrap. Sheets, state thickness, colors. Celluloid, Box 333, Kearny, N. J.

DO-It-yourself casting-molding-modeling plastics! Clear-colors accessories. No experience or machinery necessary. 64 page catalog 25¢. Castacraft Corp., Dept. D-23, P.O. Box 555, Palo Alto, California.

LAMINATE-It yourself, easy, 6x9" package \$1.00; 9x12" \$2.00. Acetate Specialties, Major's, 1740-C Columbia, Chicago 26.

ELECTRIC Laminating kit. Easy. Fun. Profitable. Details. Burr, 330 East Center, Kalamazoo, Mich.

CHEMISTRY

AMAZING New book of science experiments, formulas, and catalogue of laboratory supplies. Only 35¢. National Scientific Co., 13 S. Park Avenue, Dept. PM-3, Lombard, Illinois.

CHEMISTRY Catalog, 25¢. Used list. Laboratory Sales, Box 161-A, Brighton, Mass.

BLOOD Slides, for microscope, stained to show white and red cells, \$1.00. Bay-side Laboratories, Box 58, Bayside 61, N. Y.

FREE—Six 4 inch Pyrex test tubes with every \$4.00 order. Catalog 25¢. Bio Chemical Products, 30 Somerset, Belmont 78, Massachusetts.

232 PAGE Catalog \$2.00. Laboratory Materials, 7319 Vincennes, Chicago, Ill.

CHEMICALS In small quantities, apparatus and glassware. Catalog 25¢. Winn Chemicals, 124M West 23 Street, New York City 11.

ROCKETEERS: Supplies, chemicals. Catalog, plans 25¢. Central Rocket Company, Waupaca, Wis.

RADIOACTIVE Isotope experiments—New, 16 for 60¢. Atomic Researchlab, 10717 Venice, Los Angeles 34, Calif.

ROCKET Supplies for amateur rocketry. Catalog 25¢. Mervin Hill Company, Boltz Pennsylvania.

CHEMICALS And apparatus for industrial, analytical, and private laboratories. Catalog 25¢. Dept. M-50, Biological Supply Co., 1176 Mt. Hope Ave., Rochester 20, N. Y.

ILLUSTRATED Catalog: Chemistry, mineralogy, biology 25¢. Tracey Laboratories, Evanston, Illinois.

AGENTS WANTED

EVERY Man a prospect. Request refundable sales kit offer showing line of belt buckles, tie clasps, money clips, cuff links, lapels, individualized with customer's name and emblems. Cap badges for trucking, bus, taxi, police, firemen also heavy construction emblems. Choice 3000 emblems. Hook-Fast, Box 1425PM, Providence, R. I.

BE The Popular Mechanics representative in your neighborhood and earn big profits in your spare time. Write Popular Mechanics, Room 3-A, 250 West 55th St., New York 19, N. Y.

MEN! Women! 60% profit on cosmetics. Famous nationally advertised Hollywood cosmetics pay 60%. Make \$25 day up. Hire others. For free samples, details, write Studio Girl, Glendale, California, Dept. 1203J.

\$1,000.00 A Month for making dramatic 3-second demonstration of amazing light-weight Presto Fire Extinguisher. New chemical used by Airforce snuffs out fires instantly. Only \$4.95. Terrific commissions. Millions want it. Free kit. Merlite, 114 E. 32nd, Dept. P-66L, New York 16.

WILL You test new items in your home? Surprisingly big pay. Latest conveniences for home, car. Send no money. Just your name. Kristee 72, Akron, Ohio.

SELL Nameplates! Yours; plus 100 order blanks, for \$1. King, 10 Catherine Ave., Waterbury 4, Conn.

BIG Free money-making catalog can make extra money for you! Take orders in your spare time. Show colorful catalog of jewelry, toys, gifts, greeting cards, collector's items and household gadgets. Work your own hours. No experience necessary. For free catalog, write: North Star, Dept. 6-524, 251 East Fifth Street, St. Paul 1, Minnesota.

1000 EMBOSSED Business cards at \$3.99 up to 7 lines. (Black or blue.) Free sample cards and style chart. Palinkus, 1627-PM 33, Lorain, Ohio.

AGENTS And distributors wanted to make over \$15,000 a year with sensational new spray-on shoe shine line. Write Easy Shine Co., Dept. P 360, 74 Washington St., New York, N. Y.

MAKE Money selling famous brand watches. Drake, 9026 Marcella, St. Louis 21, Mo.

POP Up mail box flag. Make money with this needed device. See picture Page 93 P.M. Jan. issue.

BIG Profits. Sell proven family medication. Low wholesale prices. Free sample. Porter's, Box P-907, Piqua, Ohio.

BIG Earnings selling amazing floor treatments, business firms, factories, institutions. Exclusive territory. Free sales kit offer. Sheridan Chemicals, 1417 Sheridan Street, Camden 4, N. J.

GOLD Or silver letters, numbers. Windows, doors, trucks. 1" to 6". 500% profit. Free samples. Atlas, Box 543-T, Oak Lawn, Ill.

RUN A spare-time greeting card and gift shop at home. Show friends samples of our wonderful new 1960 all-occasion greeting cards and gifts. Take their orders and earn up to 100% profit. No experience necessary. Costs nothing to try. Write today for samples on approval. Regal Greetings, Dept. 58, Ferndale, Mich.

BIG Profits. Stamp social security plates, key protectors. Sample 50¢. Catalog free. General Products, 188-PM State, Albany 10, N. Y.

MEXICAN Art goods! Free sample! Send 14¢ stamps mailing. Sylviak, Apartado 9036, Mexico City.

PRINTING, Advertising salesmen—Excellent moneymaking sideline selling decalomania name plates, small quantities. Automobile initials, sign letters. Free samples. Ralco, XL, Boston 19, Mass.

YOUR Ad in this space will get some good agents for you. Yes, I'll prove it. Write for Folder "A", right now. F. W. Johnson, Classified Advertising Manager, Popular Mechanics Magazine, 200 E. Ontario St., Chicago 11, Ill.

SELL Champion, AC, Autolite spark plugs. Reconditioned, electroplated, guaranteed 10,000 miles. 100% profit. Free sample. Lee Plugs, 1608-E Roberts, Houston 3, Texas.

YOUR Own business—Used suits \$1.50; overcoats 65¢; mackinaws 35¢; shoes 12½¢; ladies' coats 30¢; dresses 15¢. Enormous profits. Catalog free. National Mail Order, 2111-AA Roosevelt Road, Chicago 8, Ill.

DON'T Miss our ad under "Salesmen Wanted" in this magazine. National Press.

BUY IT WHOLESALE

LESS Than wholesale. Humorous studio greeting cards, western, etc. Fifteen assorted \$1.00. McLean's, 2703 E. Third, Denver 6, Colorado.

WHOLESALE Catalogs; classified directory listing 115 firms, \$1.00. Ozco, Canaan, Connecticut.

WHOLESALE: 850,000 Items. Supply source directory 25¢. Idealer, Park Ridge, Illinois.

ELECTRIC Guitars, amplifiers, wholesale. Free catalog. Carvin, PMW, Covina, Calif.

BUY Wholesale; 100,000 nationally advertised products. Appliances, cameras, sporting goods, housewares, watches, typewriters, tools, clothing, etc. Discounts to 60%. Buy-Rite, Box 258, Hawthorne 2, New Jersey.

USED And new watches \$2 up. Free list. Southern Watches, 5-PM So. Wabash, Chicago 3.

LARGEST Wholesale supply source in U.S.! Furniture, clothing, appliances, housewares, automobiles and accessories, tools, sporting goods, hobby supplies, farm equipment, imports, new products, bargain merchandise. Free details. Associated Wholesalers, Box 2068-DD, Sioux City 4, Iowa.

BUY Nationally advertised products at discounts to 60%. Appliances, watches, cameras, clothing, housewares, jewelry, toys, typewriters, tools, etc. Stephens Distributing Co., Box 1434, Atlanta 1, Ga.

NEW Multicolor wholesale catalog, automobile catalog, and others. Housewares, appliances, refrigerators, freezers, washers, dryers, television, radios, furniture, clothing, luggage, binoculars, photographs, recorders, cameras, projectors, typewriters, sewing machines, power tools, toys, sporting goods, watches, jewelry. Name brands. Huge discounts. Postcard: Selbyco, Decatur, 154, Illinois.

2,000 PAGES Wholesale catalogs. Write: Mopam, Box 47, Newark, Ohio.

FREE Wholesale catalog! Housewares, appliances, watches, 25¢ refundable. French's, 1804 So. 23rd St., Louisville 10, Kentucky.

EARRINGS 19¢, Billfolds 29¢. Free catalog. Royal, Box 1224, Clarksburg, W. Va.

MONOFILAMENT Fishing reel. Guaranteed tangle-free. Springtime, Box 3911, Seattle 24, Washington.

SAVE 80%. New illustrated wholesale catalog 25¢. Cam, Barrett Hill, Lake Carmel 3, New York.

FREE Catalog offer! Clothing, appliances, tools, etc.! United Wholesalers, 1265-M Broadway, New York 1, N. Y.

WORLD'S Largest wholesale supply! Buy from 257 American, European, Japanese wholesalers. Tailormade suits from Hong Kong. International Buyers, 216-M Jackson, Chicago 6, Ill.

SALESMEN—DISTRIBUTORS

MAKE Extra money—Big cash commissions plus premiums for you and your customers. Sell advertising book matches. Sensational new tenorama, glamour girls, hillbillies; dozens others. All sizes. Quick daily sales; big repeat business. Free master kit makes selling easy. No experience necessary. Superior Match, Dept. M-360, 7530 Greenwood, Chicago 19.

CALENDARS, Advertising novelties, matches. All styles, including religious, varnished, 12 sheet, girls. Hundreds of advertising novelties, book matches, etc. Fleming Calendar Co., Sales Division, 6539 Cottage Grove, Chicago 37, Ill.

ANYONE Can sell famous Hoover uniforms for beauty shops, waitresses, nurses, doctors, others. Miracle fabrics—nylon, dacron, wash 'n wear cottons. Exclusive styles, top quality. Big income, real future. Equipment free. Hoover, Dept. C-100, New York 11, N. Y.

MAKE Extra money selling advertising matchbooks. Free catalog and sales outfit. Matchcorp., Dept. PM-30, Chicago 32.

BUSINESS Kit free! Postcard puts you in business! Complete line 230 shoe styles, jackets! New discoveries pay big commissions. No investment. Send for free kit. Mason, Chippewa Falls K-304, Wis.

\$1,000.00 A Month for making dramatic 3-second demonstration of amazing light-weight Presto Fire Extinguisher. New chemical used by Airforce snuffs out fires instantly. Only \$4.95. Terrific commissions. Millions want it. Free kit. Merlita, 114 E. 32nd, Dept. P-66L, New York 16.

MAKE Up to \$50.00 a day soliciting delinquent accounts. Terrific commissions. Write today. General Finance, 304V Pickwick Bldg., Kansas City 6, Mo.

MAKE Up to \$50.00 a day soliciting delinquent accounts. Terrific commissions. Write today. National Credit, 304Y Pickwick Bldg., Kansas City 6, Mo.

SALESMEN. Big money showing nationally advertised Down-Spout-O-Matic sensation wherever shown. Attaches to all down spouts, uncoils when it rains, recoils after it rains. Once in a lifetime item. Dry basements guaranteed. Commissions advanced. Special sample offer. Campbell Co., Rochelle 63, Illinois.

SERVICE Your area. Agents, dealers, farmers make \$125 up weekly distributing nationally advertised Campbell's Gro-Green Liquid and 100% soluble crystal fertilizer concentrates. No investment. Demonstration kit furnished. Campbell Co., (Est. 1928), Rochelle 5, Ill.

YOUR Free copy of world's biggest sales magazine tells you how and where to make more money on your own in selling. Write Specialty Salesman Magazine, Desk 5B, 307 North Michigan, Chicago 1.

IF You're interested in making money in selling, see the hundreds of exceptional opportunities in Salesmen's Opportunity Magazine. Send name for your copy, absolutely free. Tell us what you're selling now. Opportunity, 848 N. Dearborn, Dept. 17, Chicago 10, Illinois.

SELL The hottest line of fishing tackle in 1960. Over 40 items. Free details. Samples \$3.50 value, \$2.00. Pat's Fishing Tackle, Box 164-P, Sheboygan, Wisconsin.

JOBBERs, Distributors, salespeople. Buy direct from manufacturer. Finest Austrian Aurora Borealis crystal jewelry. Sample necklace and earrings \$3.00. Borucki Jewelry Manufacturers, Box 2018-Noble, Bridgeport, Conn.

DO You sell from your car or truck. Big profits in selling cleaning polishing cloths sets. Sample prepaid \$1.00. Refunded on first wholesale order. Meyer Company, Box 868, Galesburg, Ill.

EARN Big commission full or part time. Build profitable business of your own selling America's largest line low priced business printing. 360 page catalog, samples, hundreds of items used daily by business people. Imprinted ball pens low as \$8.95 for 100. Calendars low as \$5.95 for 100. Free sales kit. National Press, Dept. 8, North Chicago, Illinois.

SALESMEN And distributors, full or part time, sell outdoor advertising pennants. Write: Radder Products, Box 31, Colvin Station, Syracuse 5, New York.

WILL You wear new suits and topcoats without one penny cost and agree to show them to friends? You can make up to \$30.00 in a day even in spare time, without canvassing. J. C. Field & Son, Inc., Dept. C-1826, Harrison & Throop Sts., Chicago 7, Ill.

EPOXY Coatings and other advanced building maintenance materials pay top commissions, repeat orders, protected territories. Paramount, Box 1956, Cleveland 6, Ohio.

EXCELLENT Profits. Signature rubber stamps. Sample, details \$2.00. Boardman Engravers, Houghton, New York.

FREE! Private labels! Exclusive sales! We supply product, plan literature; you provide management, sell wholesale, employ salesmen. Terrific profits and repeats. Sample and details free. Vitamins, 2908-E Beverly Boulevard, Los Angeles 57.

AD Specialty men. New short exclusive prestige line, with large sales potentials. Karvart, 6005 Crescent Blvd., Camden, N. J.

AMERICA'S Hottest item! 50 Star Flag. Sell homes, dealers, institutions, industry, banks, etc. Sample \$5.00. Free particulars. Atlas Flag Corp., Inc., Benton, Ill., or Hahnco, 418 St. Paul St., Rochester 5, N. Y.

POP Up mail box flag. Make money with this needed device. See Picture Page 93 P.M. Jan. issue.

PERSONALIZED Rubber tu-tone door mat with home owner's name. Carry no stock. Deposit is your profit. We ship parcel post c.o.d. for balance. Sample with sales proven name "The Gordons" \$1.00 postpaid. No samples c.o.d. Free details. O'Brien Mats, 2110 San Fernando Rd., Los Angeles 65, Calif. Established 1925.

EMPLOYMENT INFORMATION

LATEST Foreign jobs. Highest wages. Unlimited opportunities. Laborers, clerical, construction electronics, oilfields, Civil Service. \$2.00. (C.O.D.'s accepted). America's leading overseas employment researcher. Plus: newest South American, Alaskan, Venezuelan listings. Universal Research, Box 4912, Baltimore 20, Md.

EXCLUSIVE Job information. U.S.A.-world-wide. Up to \$1500 monthly. Free information. Elsinger, Box 12, Detroit 13, Mich.

BOOMING Latin America! Prosperous Brazil, Venezuela. Only hours from the States. New data regarding jobs, opportunities, conditions. American companies employing, etc. All skills required. Salaries to \$1,650.00 monthly; U.S. tax exempt. Bonuses, living allowances, travel expenses, exciting vacations, and more! First-hand information direct: \$2.00 (\$2.35 airmail) checks or money orders. Latin American Opportunities, Sabana Grande, Apartado 10212, Caracas, Venezuela.

JOBs On ships. \$100 weekly, beginners. Travel, adventure. Write: Seaman's Service, Box 17-M, Brooklyn 8, N. Y.

FOREIGN Jobs—Latin America, Alaska, Canada, up to \$1500 monthly. Up-to-date 1960 foreign service directory gives complete information; hot list of firms hiring for military and civilian construction, aircraft, oil, exporters-importers, mining. How-when-where to apply. 12th successful year. \$1.00. Global Reports, Box 8873-S, Los Angeles 8, Calif.

JOBs On ships and yachts traveling foreign countries. Davenport's, 1354-K, G.P.O. New York 1, N. Y.

COPYRIGHTED Reports. Best paying companies, travel, adventure, promotions. Construction, aviation, shipping, oil fields, laborers, clerical, trades, supervisory, factory, unusual opportunities. Skilled, unskilled. Foreign, stateside. Only \$2.00 (\$2.25 airmail) (COD'S accepted). Satisfaction guaranteed. Included free: Special reports on Alaska, Venezuela, South America. Research Services, Meramec Building, St. Louis 5-PM, Missouri.

FREE Information—U.S.A., overseas jobs. High pay, transportation. Futures, Dept. M, 215 West 34th Street, New York City 1.

COMING To Florida? Send for complete report, jobs, salaries, cost of living. Information you need. \$2.00. Survey, 904 Chamber of Commerce Bld., Miami 32, Fla.

MONTANA. Proposed Libby Dam information. Housing, opportunities, employment, etc. \$1.00. Box 798, Libby Montana.

JOBs In California Newsletter. 50¢ month; \$4.50 year. Monadnock Bldg., San Francisco 5.

U. S. A., Foreign jobs, up to \$1500.00 monthly. Construction, clerical, supervisory, etc. Skilled, unskilled. Free transportation. Unusual opportunities. Complete information plus worldwide project listings. Only \$2.00 (\$2.25 airmail). Satisfaction guaranteed. International Reports, Dept. J, P.O. Box 621, San Jose 6, California.

AMERICAN Overseas jobs. Higher pay. Transportation paid. Men-women. Write today. Free information. Employment Headquarters, 79 Wall Street, Dept. B-6, New York 5.

RICHES Can be yours! Send now for "How to Get a Good Job," power-packed, practical guide with proven plans by former president, Pepsi-Cola International, and expert vocational counselor. Send only \$4.00. Satisfaction guaranteed. Winter and Wiehels, Dept. 10-B, College House, Harvard Square, Cambridge 38, Mass.

BOOMING California! Latest job and business opportunities, housing information. Send \$1.00. Lynmac, Box 447, No. Hollywood, Calif.

JOBs: High pay. Foreign countries, U.S.A. All trades. Write Dept. 55C, National Employment Information, 1020 Broad, Newark, N. J.

SPECIAL SERVICES

RENTAL Library, mail-order books. Dacco, Box 781-M, Ridgecrest, California.

INFORMATION On anything. Ferguson Research Specialists, 116-14 141 St., South Ozone Park 36, N. Y.

EDUCATIONAL AND INSTRUCTION

AUTOSUGGESTION. Home study courses with phonograph recordings. Free brochure. Write Clark R. Bellows, 200 West 57th St., New York 19A, N. Y.

LEARN Asleep or awake. Self-help books, tapes, recordings. Free catalog. Drawer PM-697, Ruidoso, New Mexico.

SECRET Investigations. Experience unnecessary. Investigators particulars free. George Wagner, M125 West 86th, New York City 24.

PROFESSIONAL Investigators. Home study. Badge, certificate, future. Box 41197-F, Los Angeles 41, California.

HIGH School diploma at home. Licensed teachers. Approved materials. Southern States Academy, Station E-16, Atlanta, Ga.

BE A real estate broker. Study at home. Write for free book today. GI approved. Weaver School of Real Estate, 2018P Grand, Kansas City, Missouri.

WANT A diesel job? Higher pay? Advancement? We can help you qualify! Complete diesel, tractor and heavy equipment and Cummins Diesel Engine Shop-method home-training courses available. Write today. Interstate Training Service, Dept. B-3, Portland 12, Ore.

DEVELOP Mind power, personality while asleep. Use your phonograph, recorder. Amazing psychological tapes, records now available. Details free. Sleep-Learning Association, Box 24-N, Olympia, Washington.

STUDY For doctor's degree of psychology, metaphysics and divinity. Correspondence courses only. College of Divine Metaphysics, Dept. P-M, 2811 North Illinois, Indianapolis 8, Indiana.

SING, Speak with power. Self-training records. Amazing! Canfield, 2018-A Fifth Avenue South, Minneapolis 4, Minnesota.

EARN While you learn. Auto and diesel mechanics master this top paying trade. Many graduates earn \$100 a week and up. Approved for Korean veterans. For free information write Dept. No. 256, Nashville Auto-Diesel College, Nashville 3, Tenn.

PHYSICAL Therapy and massage. Home training. Practice privately or work with doctors and hospitals. Free catalogue. National Institute, Desk 4, 159 E. Ontario, Chicago, Ill.

BOOKS, Free general catalog, 100 pages. Text, vocational, educational, instructional subjects. Millions of volumes, new and used. Bargain prices. Books bought. Est. 1902. Long's College Book Co., Dept. PM, Columbus 1, Ohio.

PIANO Tuning pays. Big money in spare time. Learn at home in 30 days. No musical knowledge necessary. Phonograph, records, tools and instructions furnished. Personal instructions available. Free catalog, Capital Piano Tuning School, 3160 S.W. 16th Court, Fort Lauderdale, Fla.

STUDY To be a doctor of psychology, metaphysics, divinity or philosophy. Correspondence courses only. The Neotarian Fellowship, Desk 9, Kansas City 6, Mo.

INVESTIGATOR Training—Robert B. Phillips Sr., Founder, former U.S. Government Special Agent. Write to 1917-K North Kenneth, Chicago 39, Ill.

USED Correspondence courses and books sold and rented. Money back guarantee. Catalog free. (Courses bought.) Lee Mountain, Pisgah, Alabama.

BOOKKEEPERS. Operate your own "Dollar-A-Week" system. Ellis, Box 200, Cedar Grove, North Carolina.

LEARN Appliance service and repair. Motors, washers, refrigeration, cleaners, everything. Free booklet. Appliance, 11027 South Vermont, Los Angeles 44.

MIDWEST Engineering School. Electro-Mechanical. Correspondence, 19023 Hillcrest, Hickman Mills, Missouri.

OPERATE Restaurant or diner. Free booklet reveals plan. Write School of Restaurant Business, Dept. RC-352, 335 W. Madison, Chicago 6, Illinois.

LEARN Real estate business fast. Unlimited opportunities. Economical home-study course. Particulars free. Gordon-Howard Institute, 320 Glover Building, Kansas City 5, Missouri.

ENGINEERING And art degrees earned through home study. Electronics, electrical, mechanical, civil, physics, business administration, accounting, liberal arts. When writing, specify course desired. Pacific International College of Arts & Sciences, primarily a correspondence school. Resident classes also carried. 5719-B Santa Monica Boulevard, Hollywood 38, Calif.

COMPLETE Your high school at home in spare time with 63-year-old school. Texts furnished. No classes. Diploma. Information booklet free. American School, Dept. X345, Drexel at 58th, Chicago 37, Illinois.

"HOW To Train Horses"—A book everyone who likes horses or ponies should have. Free. No obligation. Simply address, Beery School of Horsemanship, Dept. 1103-C, Pleasant Hill, Ohio.

BECOME Tax consultant. Graduates earn \$1,000-\$3,000 every tax season preparing returns evenings. State approved. Union Institute, Lakewood 2J, N. J.

MASTER Watchmaking at home. Free sample lesson. Chicago School, 2328-YC Milwaukee, Chicago 47.

FINISH High School at home, spare-time. No classes. Diploma awarded. Write for free catalog. Wayne School, Catalog HF-103, 2527 Sheffield, Chicago 14.

DIESEL! Learn to operate, maintain and overhaul all type engines—spare time. Write for free book. Utilities Diesel Training, Dept. DC-72, 2521 Sheffield, Chicago 14.

HELP Yourself to abundant living. Our courses have aided students to richer, fuller lives. Learn secret of contentment, happiness. Earn degrees Ps.D., Ms.D. Write for free book. College of Universal Truth Correspondence School, 23-C E. Jackson, Chicago.

LEARN Civil and criminal investigation at home. Earn steady, good pay. Institute Applied Science, 1920 Sunnyside, Dept. 163, Chicago 40, Illinois.

FREE Booklet, 7 Steps to Success. End money worries. Develop prestige. Amazing results. Counselors, 7912 Curragh, Burnaby 1, British Columbia, Canada.

DISK Jockeys in demand. Radio station eager for men and women trained to do and sell own programs. Big money in salary, fees and commissions plus personal appearances. Successful N. Y. disk jockey has trained thousands, will show you how. Free information. No salesman will call. Darwin, Studio B, 1639 Broadway, New York 19, N. Y.

PIANO Tuning pays. Learned easily at home. GI approved. 59th year. Free booklet. Niles Bryant School, Dept. P, 3731 Stockton, Sacramento 20, Calif.

BE A memory machine. Index your mind. Memorize instantly. Never forget. Lesson One, \$1, or complete course, \$20. Memory Research Center, Box 7192-C, El Paso, Texas.

PROFITABLE Welding training available Hobart Welding School, Box M-302, Troy, Ohio, GI approved. Finest equipment in U.S.A. Reasonable prices. Request catalog.

BLUEPRINT Reading. Homestudy. Write Belton, 1059M North Lawndale, Chicago 51.

ANALYZE Handwriting for profit, pleasure. Free sample lesson, catalog reveals plan. Write IGAS, Inc., Dept. 2, Springfield 4, Missouri.

ANALYTICAL? Aggressive? Supervisory caliber? We can help you! Box 426, Cedar Rapids, Iowa.

LEARN Piano tuning at home! Only \$32.95 including tools. Write Tune Craft, Box 5074-M, St. Paul, Minnesota.

OWN Collection agency. Little "gold mine." Franklin Credit, Roanoke, Va.

INVESTIGATORS Trained, men-women. Fascinating, profitable profession, spare time study. Big pay. Details to open own agency any state. Free booklet. Investigator, Box 490, Times Square Station, New York 36, New York.

USED Correspondence courses, books. Satisfaction guaranteed. Catalog 10¢ refundable. Courses bought. Bayles, 78-B Courtright, Wilkes Barre, Penna.

FREE English-grammar correspondence course. Deposit required. Details free. A. Lovelady, 572 Wensley, El Centro, Calif.

ENJOY Life! Be well! Solve personal problems by self-mastery. Free information. Leavitt Science, Clinton, Illinois.

SOLVE Right triangles with new and simple device. 50¢. Tri-calculator, Box 245, Genesee, Michigan.

CIVIL Service. Learn about this field of work and how you can prepare yourself by home study for a high entrance mark. Private organization. Free booklet. No obligation. Franklin Institute, Dept. V50, Rochester 4, N. Y.

STUDY High school and college subjects at home. Free catalog. Technical Training Service, Dept. 146M, Brooklyn 14, New York.

DENTAL Technicians simplified home study course. Accredited A.C.S.C. Write: Denshire School, Box #762, Boston 2, Mass.

EARN Degree from colleges abroad, taking test or courses. No traveling. Aureab, Central Valley, New York.

LEARN Another language at home, easily, quickly, naturally with Linguaphone, the World's Standard Conversational Method. You learn to speak French, Spanish, German, Russian, Modern Greek, any of 34 modern languages available on life-like conversational recordings. It's like living in another country. Complete language course available on free trial. Send for free book and details of free trial. No obligation. Linguaphone Institute, T-83-030 Radio City, New York City 20.

LEARN Tile setting at home. Free details. American Institute of Tile Setting, Box #217, Oakland 4, California.

PROFESSION. College correspondence course. Physical therapy, massage. Diploma. Personal assistance. Northwestern Institute, Box 368, Rock Falls, Illinois.

COLLEGE Credits. Correspondence. Legitimate education. 6715 Hollywood Boulevard, Hollywood 28, California.

SWEDISH Massage. Home study. Diploma. Illinois Licensed School, 3809 Alta Vista, Chicago 13.

IMPROVE Your handwriting legibility through correspondence lessons. Chirography, 5071 Dubois Drive, San Diego 17, California.

COLLEGE Training in electronics, drafting, gunsmithing, auto mechanics, building trades, practical nursing, all college subjects. Technician, engineering levels. Associate degree. Recognized public co-educational school since 1925. Moderate cost. Dormitory, married housing. Trinidad State Junior College, Trinidad 3, Colo.

LEARN By ear with Dormiphone. While you sleep, the amazing new scientific invention works for you. Revolutionary Dormiphonic tools give you a shortcut to learning languages, correct speech; memorizing facts, figures; relaxation, habit training. Saves your time, effort. So simple to use, children benefit. Used by educators, psychologists. Write today for fascinating free book. No obligation. Modernophone, Inc., 320-030 Radio City, New York 20.

PLAYS, STORIES, MANUSCRIPTS

FREE 32 Page brochure to writers seeking a book published (fiction, poetry, non-fiction). Learn how to become a published author in five months, get 40% royalties, publicity and recognition. Write Perry Matson, Exposition Press, 386 Fourth Ave., New York 16, N. Y.

WANT Your book published? Learn how we publish, advertise, promote, distribute. Many successes. Free booklet PM. Vantage, 120 West 31, New York City. Midwest office: 220 S. Michigan Ave., Chicago, Ill.

ADVERTISING AGENCIES, LETTER WRITERS, FOR ADVERTISERS

ADVERTISING Ratebook leading newspapers, magazines, free. Chicago Advertising Agency, Chicago 4.

ADVERTISE: 24 Words, 100 Canadian newspapers, \$5.50. Lists free. Advertising Bureau, 10511-C Springfield, Chicago 43.

NEW Mothers. \$7.50 thousand. Sample \$1.00 hundred. Lorraine, 506 Bevan, Joliet, Illinois.

FREE! Red-hot book, "More Profit From Your Advertising." Lists—best mail order magazines, newspapers. Adservice, 516 Cornelia, Chicago 13.

"AMAZING New Book"—"Profits From Classified Advertising." Tells how and what to advertise. Be sure to read this book before you invest one cent in advertising. Write for your copy now. Just send 10¢ for postage and handling. W. Johnson, Classified Advertising Manager, 202 East Ontario Street, Chicago 11, Illinois.

NOW Ready: New, amazing Classified Advertising Record Book—prepared especially for classified advertisers. Here is a book that tells you instantly whether or not your advertising in any publication is paying you real results. You can tell immediately how many inquiries each publication produced—how much cash received from every ad. Spaces are provided for the name and address of the publication, date of issue, space used, rate, cost of ad, key number, etc. You have a complete record of each publication right before your eyes. Plenty of space to keep accurate record of 28 separate publications. You can have a copy by sending only 10¢ to cover postage and handling. Send for your copy now. W. F. Johnson, Classified Adv. Mgr., Popular Mechanics Magazine, 204 E. Ontario Street, Chicago 11, Illinois.

MAILING Lists most any classification \$5.00 1000. Your circulars mailed with ours \$4.00 1000. Write for our literature. Dixie Mailers, King, N. C.

ADVERTISING, Result-getting ads prepared, placed newspapers, magazines, radio, anywhere! Lowest rates. Catalogue free. Baker Advertising Agency, 189 W. Madison, Chicago 2.

CREATIVE Advertising. Magnetic copy. Dramatic layouts. Moran Agency, Shoemakersville, Pennsylvania.

CARTOONING, COMMERCIAL ART, SHOWCARD & SIGN PAINTING, TATTOOING

PAINT Signs! Use patterns! Alphabet \$1.00. Harwall, PM-360, Byrdstown, Tenn.

"HOW To Make Money With Simple Cartoons." A book everyone who likes to draw should have. It is free; no obligation. Simply address Cartoonists' Exchange, Dept. 93-C, Pleasant Hill, Ohio.

CARTOONISTS Paper, Cartoon markets, lessons, articles, tips. Idea creating. Two introductory copies, \$1.00 postpaid. Hartman, 2776 California Ct., Lincoln 10, Nebraska.

ART, Sign books, courses bought, sold. Barebo, O'Fallon 53, Missouri.

GUARANTEED Cartoon course \$4.95. Art, 711 Empire Bldg., Birmingham, Ala.

YOU Can entertain with chalk talks. Catalog 10¢. Balda The Cartoonist, Oshkosh, Wis.

CARTOON Your way to success! Internationally known instructor, Raye Burns, will personally teach you to create original, salable cartoons at home. Cost of course is very low. Write for free details. Raye Burns School, Box 3583-P, Cleveland 18, Ohio.

LEARN Sign painting at home. Free talent test. Ben Kerns, Box 812-PM, Greenville, S.C.

LEARN Profitable, fascinating tattooing. Illustrated information \$1. Zeis, 728-C Leslie, Rockford, Illinois.

LEARN Sign painting with fascinating system. Straley, 410 S. Western, Springfield, Ohio.

RUBBER STAMPS AND OFFICE SUPPLIES

QUALITY Rubber stamps stock and special. Details free. H. C. Long's Rubber Stamp Shop, 235 S. High Street, Marion, Ohio.

CATALOG! Free from rubber stamp manufacturer. Campfield, Box 798; Springfield 1, Massachusetts.

RUBBER Stamps, labels, sign letter stencils, inks. Illustrated style folder free. Warner, Box 482B, Aberdeen, Maryland.

INDEXED, Cushioned, 3 lines \$1.00, 4 or 5 lines, \$1.50. Signature stamps, \$3.50. (Script, print, or old English.) Free stock stamp literature. Youngers Stamp Shop, Princeton 4, Iowa.

POCKET, 3 Lines \$1.00. Guaranteed. W. J. Specialty, 8464 Manhattan, Detroit 11, Michigan.

FREE—Rubber stamp catalog. Martin, 1425 Major Drive, Jefferson City, Missouri.

FAC-SIMILE Signature stamp, 1x3 inches, or smaller, \$3.50. Write copy exact size desired. Stamp will be deep-cut, true reproduction. Satisfaction assured. L. E. Anderson, P.O. Box 2336, Portland 14, Oregon.

METAL Pocket stamp, 4 lines, \$1.50. Nuccio, 833 South Paulina, Chicago 12.

RUBBER Stamps, 3 lines \$1.00. Grimsleys, Box 5314-A, North Charleston, S. C.

4-LINE Pocket stamp, \$1.00. Self-inking case. Two (different), \$1.50. Retter, 223-PM, Tipp City, Ohio.

THREE Line rubber stamp, 1000 embossed business cards, \$3.95. Reed Press, Mishawaka, Indiana.

THREE Line stamp, pad 90¢. 100 correspondence post cards, personalized \$1.00. Harris Print, 26 Upton, Cambridge 39, Mass.

TYPEWRITERS, DUPLICATORS, OFFICE DEVICES

RECONDITIONED Typewriters, duplicating, printing devices, \$25.00 up. Supplies. Appliances. DixieGraph, King, N. C.

PRINTING, MULTIGRAPHING, MIMEOGRAPHING, GUMMED LABELS

1,000 BUSINESS Cards, Raised letters, \$3.95. Samples. Pioneer, PM-3 Island Park, N. Y.

100 #10 ENVELOPES \$1.95 Postpaid. Letterheads same. Dornfeld, Iron Ridge, Wisconsin.

250 HAMMERMILL 8 1/2 x 11 Letterheads \$2.95. 250 envelopes \$2.95. Samples! Davis, 7609 Spruce Road, Baltimore 22, Maryland.

PRINTING—Business, personal. Fast service. Guaranteed. Fred, the printer, Box 623, Independence, Mo.

ENVELOPES—1000, No. 10, 24 lb. printed, \$6.95 postpaid. 1000 6 3/4, 20 lb. \$4.95 postpaid. Neal Printers, 249 Sunrise, Nashville 11, Tennessee.

BEST Quality printing. Reasonable prices. Samples. Estimates. Fitz, Inc., 347 Worthington St., Springfield, Mass.

50 DECALS: Name, address, \$1. Eddy, 7 Greenacres, West Hartford 7, Conn.

250 LETTERHEADS 8 1/2 x 11, 25 Envelopes \$4.95! Vail, 334, Hicksville, N. Y.

1000 BUSINESS Cards, raised letters, \$3.75. Postpaid. Samples. Ellis, 5909 Highlandview, Sylvania, Ohio.

OFFSET Printing, 1000 8 1/2 x 11 \$4.95. Alpine, Box 676-E, Cupertino, California.

FREE Business printing catalog. Samples. Howprint, 723-C Eunice, Webster Groves 19, Missouri.

MIMEOGRAPHING—Letters, pricelists, formulas, instructions. Lowest prices. Lem's Letter Shop, 5710 Stanton, Detroit 8.

1000 EMBOSSSED Business cards, \$4.00—Name and address rubber stamp, \$1.00. Illustrated folder free! Price Brothers, 406-PM, South Main, Los Angeles 13, California.

PRINTING—All kinds. Best quality, stock, workmanship. Reasonable. Free samples. Hilltop, Box 2253, Oakland 21, California.

BUSINESS Cards (raised letters) 500—\$2.50. C.O.D. Samples free. Picha, 27600M Joy, Livonia, Michigan.

1000 BUSINESS Cards, raised letters, \$3.95 postpaid. Samples. John H. Taylor, R.D.2, Box 215, West Middlesex, Penna.

1000 PRINTED Envelopes 6 3/4, \$5.95; #10, \$7.95; statements, \$5.95. C. Barnes, Box 823, Pulaski, Tenn.

1000 BUSINESS Cards, \$2.99 postpaid. Droney-Graphic, 8814—170 St., Jamaica 32, N. Y.

1000 NAME And address labels in plastic box \$1.00. George, PM3, G.P.O. Box 1547, New York 1.

FREE Catalog, samples, quality work. Willis Printing, Box 661, Albany, Georgia.

FREE Catalogs postpaid printing. Rubber stamps. DM Press, Sebastopol, Calif.

MIMEOGRAPHING—Offset. Complete lettershop services. Samples. Pennway, Drawer 1340, Scranton, Penna.

1,000 NAME And address labels—free plastic box, \$1.00 postpaid. Lynnette's, Box 1-M, Noroton, Connecticut.

QUALITY Custom and standardized printing. Also advertising specialties. Cerny, 9700 West 56th Street, La Grange, Ill.

OFFSET. Highest quality. Free pricelist, samples. Napco Press, 1744 Bath Avenue, Brooklyn 14.

ADS Running under this heading sell printing. Ask me for proof. I'll gladly send you amazing facts. Ask for Folder "P." F. W. Johnson, 200 E. Ontario St., Chicago 11, Ill.

PRINTING OUTFITS AND SUPPLIES

PRINTING Presses, type, supplies. Lists 4¢. Turnbaugh Service, Mechanicsburg, Penna.

RUBBER Stamp presses, supplies. Kiewiet, 2025 Barney Road, Kalamazoo, Mich.

RUBBER Stamp presses, hydraulic operated, electrically heated. Sizes 5"x8", 8"x12", 10"x15". Starting outfits, supplies. Printing presses, supplies. Custom Manufacturing, 507-P N. Jefferson, Springfield, Missouri.

MAKE Your own self-molding rubber stamps and printing cuts. Plexirubber, Argyle 1, Wisconsin.

DO Your own printing. Save money. Simple rules. We supply everything. Print for others; good profit. Raised printing like engraving too. Have home shop. Details free. Kelsey Presses, V-11, Meriden, Connecticut.

TYPE And cuts for printers and rubber stamp makers. Largest selection in U. S. Catalog free. Acme Type, 633 Plymouth Court, Chicago 5.

FOR INVENTORS

INVENTORS—Get the best offer first! Patented or unpatented. Write Carl Sommer, Director, Industrial Invention Sales, 3136-A Sylvania Ave., Toledo 13, Ohio.

INVENTORS—Save high fees! Apply for your patent yourself. New do-it-yourself patent kit now makes it easy. Free "Registration Form." Miss Claire Arden, 806 Wm. Penn Annex, Philadelphia 5, Penna.

INVENTORS—Do you want to sell or license your invention on cash or royalty basis? Write Kessler Corporation, C-53-FI, Fremont, Ohio.

FREE: Legal protection blanks for inventors. Inventors Sales and Engineering Bureau, Dept. 503-D, Box 4973, Washington 8, D. C.

YOU Can easily apply for patents. Save with complete professional kit. Free registration certificate. Patent Associates, 1214 Commonwealth Bldg., Philadelphia 7, Penna.

PATENT Searches \$6.00, including copies of nearest patents. Original world-wide service to inventors, patent attorneys, manufacturers. Free "Proof of Invention" protection form, and "Information Every Inventor Needs." Miss Jean Hayward, 310 Realty Building, Washington 5, D. C.

INVENTORS! Determine patentability of your invention. Searches of the Patent Office Records administered professionally—\$6.00. For free invention protection forms, dependable service write Washington Patent Office Search Bureau, 1426 G Street, N. W., Washington 5, D. C.

PATENTS Skillfully prepared and filed for total service charge of \$200.00 for U. S. and Canada for simple invention, with valuable development and market service. Accurate receipt for any data sent me. Patent search and valuable report \$15.00. 30 years' experience as patent and development engineer. Foreign patents obtained. Joseph O'Brien, 132 Nassau St., New York, N. Y.

INVENTORS' Complete service. Cash-royalties sales. Inventions researched. Patent development engineering. Free invention certificate. George Spector, Licensed Invention Engineer, 3615 Woolworth Building, New York.

INVENTIONS Wanted now by my manufacturer clients. Patented. Unpatented. Write Gilbert Adams, Patent Broker, 80 Wall St., Financial District, New York City.

PATENT Searches, including copies of nearest patents, \$6.00. Reports airmailed within 48 hours. More than 200 registered patent attorneys have used my service. For free invention protection forms, write Miss Ann Hastings, P. O. Box 176, Washington 4, D. C.

PATENT Searchers \$6.00. 48-hour service. Free invention protection forms. Formerly with U. S. Patent Office. Write Raymond L. Smith, Patent Searcher, 620 Sheraton Building, Washington 5, D. C.

PATENT Searchers \$6.00. 48-hour airmail service. Invention protection forms free. Write patent Engineering Service, 711 14th Street, N. W., Washington 5, D. C.

WE Have the markets if you have the ideas. Harvey Engineers, Cambridge 1, Maryland.

INVENTORS: Test the commercial value of your patented or unpatented inventions, quickly and inexpensively. Write for free information. Institute of American Inventors, Dept. 40-B, 635-F St., N.W., Washington 4, D. C.

INVENTORS! Consider our offer first before selling or licensing your invention on a cash or royalty basis. Patented. Unpatented. Inventions on Demand, 79 Wall Street, New York 5, N. Y.

INVENTORS—New lowcost easy to apply for patent kit. Free "Protection and Registration form." Patent Research, 2106 Hamilton, Pultneyville, N. Y.

HIGHEST Cash, royalties. Inventors having good ideas that need developing, drawing, patent search, marketing. Write Inventors Creative Service, 354 South Spring, Los Angeles 13, California.

INVENTIONS Sold commission basis, development, models built. Model Products Co., 544 So. Chelsea, Kansas City 24, Mo.

QUALITY Patent searches, \$6.00. Copies of closest patents forwarded. Free "Protection Certificate." American Patent Search Co., 422 Washington Bldg., Washington 5, D. C.

INVENTORS! Why be broke? Turn your invention into cash. If saleable, we can sell it. Write Universal Inventions, Box 298, Marion, Ohio.

INVENTIONS WANTED

INVENTORS—Get the best offer first! Patented or unpatented. Write Carl Sommer, Director, Industrial Invention Sales, 3136-A Sylvania Ave., Toledo 13, Ohio.

INVENTIONS Wanted: patented, patent pending. 29 years experience promoting inventions. National Service Bureau, 3120 Meramec, St. Louis 18, Mo.

INVENTORS' Complete service. Cash-royalties sales. Inventions researched. Patent development engineering. Free invention certificate. George Spector, Licensed Invention Engineer, 3615 Woolworth Building, New York.

INVENTIONS Wanted now by my manufacturer clients. Patented. Unpatented. Write Gilbert Adams, Patent Broker, 80 Wall St., Financial District, New York City.

INVENTORS! Outright cash sale or royalties for your inventions. Patented. Unpatented. Constant demand from our client manufacturers. Write United States Invention Brokerage, 15 Park Row, New York 38, N. Y.

INVENTIONS Wanted. Patented; unpatented. Tremendous manufacturers lists. Global Marketing Service, 2420 77th, Oakland 5, California.

INVENTORS: Hundreds of manufacturers have requested our assistance in locating marketable new products. Complete information free. Institute of American Inventors, Dept. 40-D, 635-F St. N.W., Washington 4, D. C.

INVENTORS! Consider our offer first before selling or licensing your invention on a cash or royalty basis. Patented. Unpatented. Inventions on Demand, 79 Wall Street, New York 5, N. Y.

ARE You interested in offers from reliable manufacturers for your invention? Patented, unpatented. Harvey Engineers, Cambridge, Maryland.

CASH, Royalty, obtainable for good ideas, inventions. Ketchum's Advertising, B-1058A, Springfield, Illinois.

INVENTIONS Wanted immediately for promoting on cash or royalty. Patented, unpatented. Free booklet outlines royalty rates, requirements. Write Kessler Corporation, C-53, Fremont, Ohio.

FREE List needed inventions. Protection form. Inventors Sales and Engineering Bureau, Dept. 103-D, Box 4973, Washington 8, D. C.

INVENTORS! Don't sell your invention, patented or unpatented, until you receive our offer. Write Universal Inventions, Box 298, Marion, Ohio.

PATENTS FOR SALE

#2,669,000 **CONCRETE** Form holding means. W. A. Seemann, 186 Fig Tree Lane, Martinez, Calif.

UNIQUE Hand garden seed planter for blind and handicapped. Peter Saltzman, Box 124, South Sioux City, Nebraska.

MEDICAL Cabinet. Portable filling device. Combined perforator trimmer for pie crust. No agents. Mrs. M. Butcher, 6052-48 S.W., Seattle, Wash.

MANUFACTURING

MODELS—Small lot manufacturing. Metals, plastics, etc. Milburn, Burlington, Kentucky.

MODELS, MODEL SUPPLIES

SHIP Model kits and fittings: clippers, frigates, etc. Catalog, paint-tool list, book list, 25¢. Model Shipways, Box 85, Bogota, N. J.

MODEL Cars, electrified roadways. Electromat Company, Box 13742, Dallas, Texas.

SHIP Models and yacht supplies complete. Large 68 page catalogue 50¢. Bill Wild's, 510 East 11 St., New York City 9.

"**POWER** Drives Handbook"—36 pages illustrating many types motor drives for model autos, boats, displays, turntables, etc. Mail 25 cents cash, returnable first order \$3.00 or more. Wilson's of Cleveland, Dept. PM, P.O. Box 8995, Ft. Lauderdale, Fla.

LIONEL Trains. Big discounts. Catalog 25¢. Mack Bros., 2043-P Chicago Ave., Chicago 22.

SHIP Models. Most complete line in New England, kits, fittings, plans, books, tools, engines, motors. Illustrated catalog 35¢. James Bliss & Co., Inc., Dept. SM, 342 Atlantic Ave., Boston 10, Mass.

ROCKET Supplies—Nozzles, cones, tubes. Specials also made. Catalog 10¢. Sky Mfg., Mineral Point, Penna.

SHIP And yacht model fittings; blueprints. Send 40¢ for illustrated catalog listing hundreds of items. A. J. Fisher, Inc., 1002-1 Etowah Ave., Royal Oak, Mich.

HOME CRAFTSMEN

NEW Big illustrated catalog. Supplies for leathercraft, metalcraft and numerous small inexpensive crafts. Prompt shipments. Top values. Latest ideas. Send 10¢ today to J. C. Larson Co., Dept. 9627, 820 S. Tripp, Chicago 24.

SHELLCRAFT Catalog and 100 assorted shells \$1.00. Bonita Shells, Bonita Springs, Florida.

101 PATTERNS Of smart gifts, novelties, shelves, action windmills plus "Make Money Jig Sawing." \$1.00. Mastercraft, 35M, 7041 Olcott, Chicago 31.

CRAFT Catalog free. Mosaics, leathercraft, enameling, plastic casting, metal tooling, floralcraft, shellcraft. Many more. Kit Kraft, 203, Studio City, Calif.

CACTUS Wood. Description, prices free. 214C East Yavapai, Tucson, Arizona.

MAHOGANY, Wood, usable scraps. Bargain. List 4¢. S. R. Marks Co., Montgomery 8, Ala.

BELT Sander. Easily made from plans. Also low cost kits. Free literature. Gipple, 121-A School, Buffalo 13, N. Y.

KILN Dried walnut, cherry, etc., hardwoods, blocks, and squares. Midland Lumber Company, P.O. Box 262, Savannah, Missouri.

FREE. New plans catalog. Make 2400 things. Fun. Profit. Craftplans, 1322-A Wabash, Chicago 5.

KNOCKDOWN Cedar chests, also over fifty kits. Catalog 25¢. Giles Kendall Co., Huntsville 2, Alabama.

LEARN Art metalcraft and jewelry making. Complete, inexpensive, home training course now available. Special tools and materials furnished. Write for free booklet. Interstate Training Service, Dept. L-3, Portland 12, Oregon.

WOODWORKING And cabinetmaking course for beginning and advanced home craftsmen. Only complete low-cost home training program available. Write for free booklet. Interstate Training Service, Dept. G-3, Portland 13, Ore.

KNOCKDOWN Cedar chests and lumber. Free price list. Bedford Lumber Company, Shelbyville, Tennessee.

LEATHERCRAFT. Send 10¢ for catalog. Saxcrafts, Inc., 1101 N. 3rd, Milwaukee, Wisconsin.

LEATHERCRAFT: Superior leather, tools, kits. Catalog 30¢. Midas, Box 1255, Huntington Park, California.

FREE Do-it-yourself leathercraft catalog. Tandy Leather Company, Box 791-K34, Fort Worth, Texas.

GRANDFATHER Clock movements, kits, case plans. Wholesale catalog 25¢. Mason-Sullivan, Noroton 7, Conn.

WRITE For free catalogue of craft supplies. New lower than discount prices. Apache Leather Co., 2804 East Washington St., Phoenix, Arizona.

PROFITS To 3,000% making Shellcraft jewelry. We show you how to cash it! Details, illustrated booklet, wholesale catalog 25¢. Shellcraft, Dept. AA, Box 804, Panama City, Florida.

REMODEL Your own home. Save hundreds of dollars. New, amazing book shows you how. Written so you can understand it. Step by step instructions make it easy. Fully illustrated, 400 photographs, hundreds of diagrams, 160 pages. \$3.50. Literature 10¢. Popular Mechanics Press, 200-RH East Ontario St., Chicago 11, Ill.

FREE! Leathercraft catalog. Hundreds of new items. Write MacPherson Bros. Leather Company, Dept. E, 730 Mission St., San Francisco 3, Calif.

PATTERNS. Full size. It's easy to make tables, chairs, beds, chests, shelves, workbenches, toys. Santa Claus lawn designs, and many others. Illustrated circular free. Popular Mechanics Press, 200PL East Ontario St., Chicago 11, Ill.

DO IT YOURSELF

EVERLASTING Welder from junk. Pain Electric, R. 13, Fort Worth 3, Texas.

"**MAKE** Your own will." Save money. Don't postpone this important task. Life's so uncertain. Will form \$1.00. Postpaid. Free instructions. Murphy's, Box 4, Richland, Washington.

FREE Do-it-yourself leathercraft catalog. Tandy Leather Company, Box 791-K34, Fort Worth, Texas.

ELECTRIC Laminating kit. Fun or profit. \$14.95. Therm Appliance, St. Charles, Ill.

FREE Check-list covering 340 classifications of projects, plans, instructions, service and repair information detailed in Popular Mechanics famous series of instructional booklets. These easy to follow booklets cover an extremely wide variety of do-it-yourself data on home remodeling, repair and improvement, hobbies, crafts, boating, games, lawn and garden, and hundreds of others. For your free copy of this helpful list of booklets, write: Service Bureau, Popular Mechanics, Room 517A, 200 East Ontario, Chicago 11, Ill.

HOW To harden steel. \$1.00. PSI, 1342-A East 58th Street, Kansas City 10, Mo.

WATCHES, OLD GOLD, JEWELRY

COSTUME Jewelry supplies, settings, rhinestones, etc. 88 page illustrated catalog. 30¢. Millady, Box 1328, G.P.O., New York City.

FREE Catalog. Costume jewelry parts. Supplies. Reasonable prices. Fast service. Guaranteed quality. Unique merchandise. Folsom's, Box 52, Medford 55, Mass.

HIGHEST Cash for old gold, jewelry, gold teeth, watches, diamonds, silverware, spectacles, platinum, mercury. Free information. Rose Refiners, Heyworth Building, Chicago 2.

WATCH And clock repairing books. Free catalog. North American, 2320-AQ Milwaukee, Chicago 47, Illinois.

HIGHEST Cash paid for old gold, jewelry, gold teeth, diamonds, watches, silver. Mail articles today. Information free. Chicago Gold Refining Co., 6 E. Monroe, Dept. 2058, Chicago 3.

WATCHMAKERS' Jewelers', lapidaries' catalog 25¢. Bengal, 8910 Venice, Culver City, California.

10 SWISS Watches \$18.00. Catalog 25¢. Berkowitz, 1150 Castle Hill, New York City 62.

WATCHMAKERS' Tools, materials, supplies, watches. Catalog. Gales, Box 1000, Chicago 90, Illinois.

WHOLESALE Quality jewelry findings, chains, charms. Fraternal, religious emblems. 100% satisfaction guaranteed. Catalog 10¢, refundable. PM-3-60, Caraday, Box 22, West Hempstead, New York.

EASY To make costume jewelry. Catalog 10¢. Introductory kit including catalog \$1.00. J & M Novelties, Dept. CC-3, Box 173, Broadview, Ill.

WATCHMAKERS Journal contains watch repairing instructions. Sample copy 25¢. Box 3218-M, Daytona Beach, Fla.

JEWELLED Escapement Swiss watch, dollar a jewel. Colored illustration 32 models, 25¢. Chandler's, Box 478, Copperhill, Tennessee.

SELL Jewelry from Germany. Dozen introduction samples 50% discount. Send \$2.00 to Vander Velde, 4839 Mildred, Grand Rapids 8, Mich.

FOR THE HOME

MAKE Fancy cookies 5¢ dozen. Automatic Cookiepress from Sweden. Makes 2 sizes—15 designs. Write: The Maillette, 1502 South Lowell, Santa Ana, California.

BUILDING, Remodeling, repair problems. Any question answered. Request details. Norman Ritcher & Associates, Crystal City, Mo.

OF INTEREST TO WOMEN

DRESSES 24¢; Shoes, 39¢; men's suits, \$4.95; trousers, \$1.20. Better used clothing. Free catalog. Transworld, 164-G Christopher, Brooklyn 12, N. Y.

MAKE Money weaving rugs at home for neighbors on \$79.50 Union loom. Thousands doing it. Booklet free. Union Loom Works, Dept. 3, Boonville, N. Y.

SELL Fine fabrics. Get yours wholesale. Box 863, Norwalk, Conn.

"8 MISTAKES Parents Make." Every parent should have this new book about child training. It is free; no obligation. Simply address Parents Association, Dept. 673, Pleasant Hill, Ohio.

HOUSEWIVES, Teachers, students, office workers, if you need extra cash each week but household or other duties prevent you from taking a part-time job, learn how you can earn by accepting orders to Popular Mechanics, Good Housekeeping and all other magazines. No experience needed. Write Popular Mechanics, Room 3W, 250 West 55th St., New York 19, N. Y.

KILL The hair root! With the famous Mahler hair removal epilator, you can destroy unwanted hair permanently in the privacy of your own home. Send 10¢ for "New Radiant Beauty" booklet to Mahler's Inc., Dept. 250C, Providence 15, Rhode Island.

CHILDREN'S Book. Illustrates 500 games, stunts, handicrafts. \$1.00. Steven Brock, 496 Kenton St., S.E., Grand Rapids 8, Michigan.

PERSONAL

BORROW \$100 To \$600 by mail. Quick, easy, private. No co-signers. Repay in 24 small monthly payments. For the amount you want write today to Dial Finance Co., 410 Kilpatrick Bldg., Dept. C-1, Omaha 2, Nebraska.

MYSTIFY Your friends. Tell day of week any date, in seconds, mentally. Self-addressed stamped envelope and \$1. Winsett, Box 289, Key Largo, Florida.

"27 MONEY Saving Tips." Send \$1.00. Save hundreds. Economy, Box 127, Huxley, Iowa.

LOANS By mail. \$50 to \$600 for any purpose. Employed men and women eligible. Confidential. 2 years to repay. Write for free loan application. American Loan Plan, City National Bldg., Dept. PM-2240, Omaha 2, Nebraska.

LODGE Emblem neckties \$1.60. Uniform neckties \$1.00. All colors. Barnett, Box 723, San Bernardino, California.

BIBLE Questions answered. Stamped envelope. Bylon, 17167 Bentler, Detroit 19, Michigan.

BORROW By mail. \$100-\$600. Anywhere. Air mail service. Postal Finance, 200 Keeline Building, Dept. 17-C, Omaha 2, Nebraska.

REMAILING SERVICE

REMAILS — 25¢, \$3.00 month info. Kenny, 8420 Laddie Rd., Minneapolis 21, Minn.

GUARANTEED Secret remails 25¢. Monthly \$2.50. From 'way down east. Idease, Kennebunk, Maine.

RENT Confidential mailing address. Agents since 1950. Details free. William McLaughlin, 800 Stewart, Columbus 6, Ohio.

WIESBADEN, Germany, remails \$1.00. German newspaper \$1.00. Helke Roberson, Box 6054, Wiesbaden, Germany.

SAN Francisco remails and forwarding. \$4.00 month. Souvenirs, Box 783, San Francisco 1, Calif.

SECRET Mail receiving, forwarding, re-mailing. Letters 20¢, \$2.00 monthly. Hart's, 5212 Bayeret Rd., Jacksonville, Fla.

HAWAII — Secret mail address. \$3.00 month. Details free! Write today: Fobel, 617-P, Kuaaina, Kailua, Hawaii.

LETTERS Remailed 25¢. Monthly rates. Sunset, Box 45, Hutchinson, Minnesota.

BOSTON Remailing-forwarding 25¢. Monthly \$3. Selby Service, Box 12-M Chestnut Hill 67, Boston, Mass.

SECRET Mail address \$3 monthly. Ramps, 3452 Field Ave., Detroit 14, Mich.

COLOURFUL Mexico, prompt, confidential re-mailing service. 20¢ letter. Monthly \$2. Torne, Apartado 1050, Mexico City.

BENSON'S, 152 West 42, New York 36, \$3.00 month no remailing charge.

REMAILS 25¢. Monthly rates. Campbell, 130 E. Dorothy Lane, Dayton 19, Ohio.

CONFIDENTIAL, Prompt remailing 25¢. Monthly \$3.00. Ked Riding, 1038 Palm St., Las Vegas, Nevada.

DALLAS, Confidential, prompt remails 25¢. Monthly service \$2.00. Winford's, Box 9525, Dallas 14, Texas.

REMAILS 25¢. V. Wessinger, 1815 Carlton St., Charleston 51, S. C.

REMAILS 25¢. Monthly \$3.00. Secret prompt receiving-forwarding. Lillian's, Box VC3011A, No. Hollywood, Calif.

SOUTH America remails 3 for \$1. Includes postage. Larios, Brownorte 382, Santiago, Chile.

TROPICAL Venezuela. Reairmails — \$1.00. Sabana Grande, Apartado 10212, Caracas, Venezuela.

SECRET Mail. Receiving, forwarding. \$4.00 month. Loyd Moffitt, 2911 North Flagler, West Palm Beach, Florida.

JAPAN 2 Reairmails \$1. 3 seamaill \$1. Ross, 911 Nishihara-cho, Shibuya-ku, Tokyo.

HOLLYWOOD, California! Remails 25¢. 80 movie stars' addresses, \$1.00. Dozen picture cards, \$1.00. Evelyn Gino, Box 2968.

REMAILS — Salem, Dallas, Independence, Portland, \$50. A. Hanks, 244 Water, Sheridan, Oregon.

REMAILING Letters from this snazzy spot 25¢. Anderson, Box 13412, Phoenix, Arizona.

SALT Lake City, 16, Box FG44. Remails 25¢. Complete confidential mail service \$3.00 monthly.

SECRET Mail receiving-forwarding system. Hedgpath, Box 830, Alhambra 23, California.

TREASURE FINDERS

UNDISCOVERED Wealth! Transistorized M-scope detects gold, silver, jewelry, etc. Lightweight, guaranteed. From \$59.50, easy terms. Free catalog. Fisher Research, Dept. C-1, Palo Alto, Calif.

445 TREASURES, United States map 2x3 feet, plus catalogue. \$1.00. Foul Anchor, Rye 2, N. Y.

GOLD-Silver detectors. Geiger counters. Violates for tungsten, etc. Best available. Guaranteed. Information free. Detectron, Dept. 6, Sylmar, California.

TREASURE Locators, "Screen." Special model. Batteries V. last 1000 hrs. \$185.00. Literature in English and Spanish. Free catalog. Adolfo Vicente, 659, Escobar St., Havana, Cuba.

METAL Locator kits and assembled models from \$39.90. Transistorized and underwater models available. Free catalog. Electronic Applications, Dept. M, Box 8, Arlington 10, Virginia.

DISCOVER Buried loot, sunken treasure, gold, silver, coins; battlefield and ghost town relics, with powerful transistorized locators pioneered and perfected by Goldak. Low as \$79.50. Free, exciting information; literature on maps. The Goldak Co., 1544 West Glenoaks Boulevard, Glendale 1, California.

TREASURE! Map, handbook, 25¢. Locators. Howe, 811 Kansas, Atchison, Kansas.

FOR SALE—MISCELLANEOUS

FOR Sale. Books, novelties, household items. Write for information. H. A. Wernly, 514 E. Allegheny Ave., Philadelphia 34, Penna.

HEARING Aid batteries, wholesale. Free list. Habs, Box 51, York, Penna.

BALL Pens \$22.00 per thousand. Assemble yourself. Large users only. Permarite, 712 Broadway, New York 3, N. Y.

WANTED—MISCELLANEOUS

HIGH Prices paid for used magazines, comics, etc. Buying price list, 25¢. (Refundable). Darcy, 39 Ludlow St., Saratoga Springs, N. Y.

QUICKSILVER, Platinum, silver, gold. Ores analyzed. Wholesale Terminal, Norwood, Mass.

MISCELLANEOUS

POST Card calendar computes day of week for any date, 1800 through 2000, fast, simple, 25¢ each. Novelty Calendars, P.O. Box 626, Norfolk 1, Va.

LET Us tell you how to turn the reading habits of your friends into profit for you. \$10.00, \$25.00 or \$50.00 can easily and quickly be made under our Popular Mechanics subscription plan. No experience needed. Write Popular Mechanics, Room 3M, 250 West 55th St., New York 19, N. Y.

U. S. Relief map. Durable plastic. 27½" x 21", frame, mounting. Guaranteed. Only \$12.50 postpaid. Personal checks accepted. Loeber, 234PM Wyatt Ave., Lincoln, Ill.

INCOME Taxes. Short forms completed \$2.00. Avoid errors. Any individual long form checked for accuracy \$2.00. All business forms checked. Reasonable rates. Audiproof, 3525 Crestaire, Baton Rouge, Louisiana.

JAPAN: Buy direct. Gifts, novelties, dolls, kimonos, 26 page catalogue, manufacturers' names, addresses, business information. Send \$1.00. Clarence Yamagata, 202 Naka 7 Bldg., Marunouchi, Tokyo.

FREE Listings. Buy or sell through Southwestern, 1306 South Darlington, Tulsa 12, Oklahoma.

BOOKS On antiques and their prices. Free circular! P. Warman Publishers, Uniontown, Penna.

RECEIVE Magazine samples. Mails. Catalogues. Bargains from everywhere. Get listed 25¢. Rorick, Cincinnati 26, Ohio.

GET Samples, opportunities, magazines, catalogs, offers galore! Your name in 5000 big mail directories, 25¢. Results guaranteed. King's, Moorestown, Ontario, Can.

LEARN To relax. Reduce nervous tension. 27 minute LP record, \$3.98 ppd. Write: Records, 1919 Ridgeland Road, Rockford, Illinois.

WESTERN Bolo ties with hand polished gem stones, \$3.00 each. Cash or M.O. Satisfaction guaranteed. Import Service Co., Box 877, Karnes City, Texas.

ORNAMENTAL Iron designs. Book of 1600 beautiful, practical designs for railings, columns, etc. Free literature. Cunningham, 3881 South 3200 West, Salt Lake City 4, Utah.

YOUR Name wanted. We'll send 1000 publishers, mailers, wholesalers your name, on our list one year 25¢. Dixie Mailers, King, N. C.

CIGARETTES: Make 20 plain or filter-tips for 9¢. Facts free. Moberly, Box 915, Owensboro, Kentucky.

100,000 PRODUCTS Wholesale — Free catalog! Send postcard: Econ-O-Mart, Whippany 15, New Jersey.

SUPER Memory overnight! Success guaranteed! Bijou, Box 1727-M, Hollywood 28, California.

BLOWTORCH? Start it working for you at home. Easy. Profitable. Different. Unlike other torch work. Instructions \$1.00. Applecraft, 303 West Arch, Yorktown, Indiana.

BE Taller, instantly. Send shoe size and \$2.00 to High Boys, 5524 Santa Monica Blvd., Hollywood 38, Calif.

NAME Service. Hundreds of beautiful names you have never heard. Baby's \$1.00. Name Service, Kent, Ohio.

TAPE, Cloth, adhesive, 4" x 60 yds., wt. 4 lbs. government cost \$7.12. Only \$1.50 per roll prepaid. J. Gudín, 6909 Superior Ave., Cleveland 3, Ohio.

BIGGER Pay check? Better job? What do you want out of life? Discover hidden abilities, talents. Work better, easier. Earn more! Personal-O-Graph, prepared from your personal questionnaire by professional psychologists, shows your strong points, suggests ideal job. Confidential. Free airmail details. Psychologic Testing Institute, Dept. PM-1, 951 Willard, Chicago 22.

SEASHELL, Jewelry craft catalog 25¢. Crafts, 1416 Boylan, Clearwater, Florida.

HOW To improve your golf score. \$1.00. Satisfaction. Albetco, Box 843, Union, N. J.

POLISHED Brass social security plate. Leather case. Fits wallet. Lasts lifetime. Dollar bill. Postpaid. Please print. Pete Misisco, Southwick, Mass.

70 BIBLE Lessons 25¢. Bulletin, Box 87, Cathedral Station, New York City 25.

GLITTERING leather picture 6x9. Hand carved frame \$1.50. Artistic catalog, leather folder, papaya seeds. 35¢. Mexicana, 1104 Calexico, Calif.

SOCIAL Security cards, stamped brass, \$1.00. Clark, 112 Francis, Lockport, Ill.

STICKER Signs. Your wording. 28x5, 25¢. "Come back soon if not before." New Droll's Dime Undelay. Wayne Press, Box 3, Jefferson, Iowa.

MIRROR — Transparent back. Watch, photograph people, secretly! 8"x10", \$2.00; 16"x20", \$5.00. One-Way Mirror, PM-360, Box 625, Mt. Vernon, N. Y.



America is a Better
America —
thanks to Advertising!



SUPER JU JITSU

Now get tough double quick!

A course of instruction in the art of practicing and using this method of applying LIGHTNING-QUICK Super Ju Jitsu. Be Dangerous! These amazing lessons show you how it's done... in a big illustrated home-study course. The weapons are just your BARE HANDS—they can be used effectively if you know how and practice the art. Easy to learn; quick. Full 76-lesson course only \$5.95 postpaid—or COD, plus postage. Satisfaction or your money back guaranteed! Order "super Ju Jitsu Course."

NELSON-HALL CO., 210 S. Clinton St., Dept. 8CP-2, Chicago 6, Ill.

BRONZE FOUNDRY



Schools • Home Workshops • Inventors

Make your own castings of aluminum, copper, bronze, silver. Foundry sets are available in four sizes, capacity 1 1/2 lb. to 36 lb. of red brass. 2400 Deg. F. blast furnace included with each. Write for Free Circular.

KANSAS CITY SPECIALTIES CO. DEPT. P-3, P.O. BOX 6022, MARYSVILLE, KANSAS

LEARN TO OPERATE or REBUILD EARTH MOVING EQUIPMENT



Complete Mechanics Course covering Diesel engine transmissions; torque converters; fuel injection systems; track assemblies; final drive assemblies; steering systems; idlers; rollers; power transfer systems; cable control systems; hydraulic control cylinders & welding pertaining to heavy equipment such as bulldozers, scrapers, loaders, off-highway trucks, etc. Course time—540 hours —10 weeks to 13 1/2 weeks. Convenient payment plan. Write for details. Approved for vets and civilians

Learn to operate bulldozers, cranes, motor scrapers, crawler tractors, draglines, off-highway dump trucks, etc., on 1,700 acre Greer Training Area 60 miles S.W. of Chicago, Ill. on Route 66. Courses include operation, equipment care, preventive maint., stake reading, etc. Minimum classroom instruction. You learn by actually operating the equipment. 200 hour (5 week) complete course in the operation of bulldozers, loaders, scrapers, dump and off-highway trucks as low as \$425. Classes start every Monday. Reserve your space today. Approved for vets and civilians

Greer TECHNICAL INSTITUTE
ATT: T. Q. Hutch, Box 278, Braidwood, Ill.

"\$10,784 IN ONE YEAR NEW!"

SERVICING RADIATORS!

— Sidney Radiator Shop, Sidney, Mont. Make good money servicing auto-truck-tractor radiators with new Inland 1-Piece Radiator Shop. Easy to test, clean and repair radiators. Inland, world's largest radiator equip. mfr., trains you free. Small down payment starts you. "Pays-for-itself" Purchase Plan. Profitable dept. for garage or service station. Write for free information!



INLAND MFG. CO.
Dept. PM-3
1108 Jackson St., Omaha 2, Nebr.

Save 1/2 on New ACCORDIONS



IMPORTER-TO-YOU PRICES!
over 40 new models from Italy!
5 DAY FREE TRIAL

Buy on EASY TERMS!

Small Down Payment!
Low as \$9.90 Monthly

All Famous Makes!

Get in on these sensational values in world's finest Italian-made accordions! Play most popular instrument of all — for fun, leadership and profit! 40 newest models of glorious tone and breath-taking beauty offered at the

amazing low prices—save 50% off mfr's list prices! Buy direct from world's largest dealer. Small down payment; easiest terms on balance. Extra bonus gifts FREE if you buy during sale. Trades-ins accepted. Try before you buy on FREE 5-day No-Risk Plan. Satisfaction guaranteed or money back. Double guarantee!

RUSH COUPON TODAY!

See how easily you can now own and play a fine accordion. Rush coupon now for big new COLOR Catalogs and Low Discount Prices... ALL FREE! No obligation. Write to:

Accordion Manufacturers & Wholesalers Outlet, Dept. R-30
2003 W. Chicago Ave., Chicago 22, Ill.

Accordion Manufacturers & Wholesalers Outlet, Dept. R-30
2003 W. Chicago Ave., Chicago 22, Ill.

FREE BONUS GIFTS

- for promptness
- E-Z Lessons
- Music Stand
- DeLuxe Case
- other gifts, too!

MONEY BACK GUARANTEE

FREE
COLOR CATALOGS
and low discount prices

Send FREE Color Catalogs and low discount prices.

NAME _____
ADDRESS _____
CITY _____ ZONE _____ STATE _____

Check here if you have accordion.

OUR NATIONS GREATEST NEED

"Change and Challenge in the Labor Force,"

U. S. Secretary of Labor, James P. Mitchell

This article, part of Mr. Mitchell's speech in the ILLINOIS LABOR BULLETIN, will give you a clear picture of our nation's great need for skilled craftsmen at present and in years to come. POPULAR MECHANICS hopes to fill this need by keeping you informed on the latest manpower needs of America. For more information write Skills for America, POPULAR MECHANICS, 200 East Ontario, Chicago 11, Ill.

At a time when automatic machines and mechanized techniques are coming into widespread use, the *skill of the individual worker has more meaning and value than ever before.*

Our need for trained and ingenious workers, each with his gifts at their fullest development, has increased in direct proportion to the ingenuity and complexity of our machines. It has placed an exclamation mark upon their individuality.

We are beginning to see that we have a considerable manpower problem, and are moving to find solutions for it. There is room to wonder, however, if enough people are aware of the problem, if enough people are attacking it, to achieve the kind of results we are going to need to guarantee the strength, security and prosperity of our country in the years ahead.

The demand for skilled workers has been out-running the supply for several years now. Our industry is short of engineers and scientists, short of clerical help, short of managerial personnel, short of craftsmen, short of qualified semiskilled workers. The pinch gets tighter as the economy grows and as our national appetite for goods and services grows in billion-dollar gulps.

The implications of these current shortages for the future health of the economy are the subject of some recent studies by the U. S. Department of Labor. The charts below point out what some of these anticipated changes will mean.

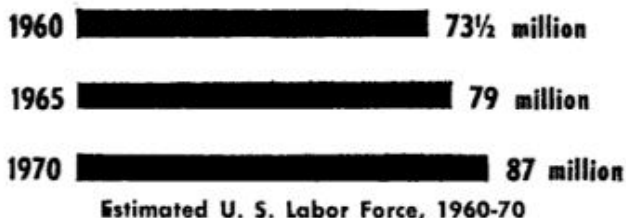

The chart shows that 13 1/2 million workers are expected to be added to the labor force between 1960 and 1970. At the rate the population is growing, achieving this size labor force will not be a problem.

We can expect the labor force, which stood at 73 1/2 million in 1960, to reach the expected 87 million by 1970.

The problem is: *will they be the highly skilled, highly trained workers we will need to man an increasingly complex defense system and to satisfy an ever rising level of consumer demand?* They can and should be, but there are some difficulties.

Of the 13 1/2 million additional workers who will be in the labor force in 1970, almost fifty percent will be young and inexperienced (under 25) and another forty percent will be relatively older (45 years and older). The remainder will be between 25 and 34, and there will be an actual decline in the prime working age 35-44.

This changing balance of age is a matter of startling significance to a nation which has traditionally sought the young male worker between 24 and 44 at the expense of all other groups. We are going to have to change our attitude toward the older worker and the youthful worker if we are going to succeed in our search for the quality skills necessary to achieve the economic growth our technical accomplishments have made possible, and which our population growth has made necessary.

By 1970 we will need about:

Three million additional professional and technical workers.

Five million more craftsmen and operatives.

One million additional proprietors and managers.

Three and one-half million more clerical and sales workers.

One and one-half million more service workers.



FREE

Charlie Mc

BOAT TALKS

- A. Painting the Boat.
- B. Fiberglassing Deck and Cabin tops.
- C. Fiberglassing the Center Board well.
- D. The Brightwork Finish.
- E. The Repair of the Broken Spar.

Write to . . . Dept. PM

FREE GUIDEBOOK



GLASS PLASTICS CORP. 1605 W. Elizabeth Ave. Linden, N. J.

ENGINEERING DEGREE IN 27 MONTHS

B. S. degree (27 mo.): Aero., Chem., Civil, Elec., Mech. & Electronics, E.E. (36 mo.); Aero., Chem., Civil, Electrical, Mechanical, Metallurgical, B.S. (36 mo.); Math., Chem., Physics. Prep courses. Demand for grads. Campus, 20 bldgs.; dorms; gym. Low rate. Earn board. G.I. appr. Enter March, June, Sept., Dec. **1630 E. Washington Boulevard Fort Wayne 2, Indiana** Keeping pace with progress

INDIANA TECHNICAL COLLEGE

BUILD MUSCLES & HEALTH with BODY BUILDER

Only **\$100**

This new Chest Pull Body Builder develops powerful he-man muscles F-A-S-T. Ideal for the beginner to give him a real start in championship muscularity and perfect for the more advanced body builder to combine with his regular training for faster, all around muscle growth. Body Builder is wonderful for developing massive arms, shoulders, chest and back. Mail your order today. Only \$1.00 postpaid. No C.O.D.

MEDFORD PRODUCTS, Inc.
Dept. 904E, P. O. Box 39, Bethpage, New York

Shop PM Ads for Exciting Direct-Mail Offers

7 OUTBOARD PROPS IN 1
YOU VARY THE PITCH with "MULTI-PITCH"

With a flick of your wrist, change to any of SEVEN pitches, without tools. Select BEST pitches for your cruising, racing, skiing. Special "trolling pitch" cuts trolling speed IN HALF!

from **\$27.75**

Models for almost all 25-45 hp outboard motors. Ask your dealer or write manufacturer.

GUARANTEED • OVER 10,000 IN USE

LESNOR-MAEHR MARINE CO., INC. • FLORAL PARK, L.I., N.Y.

200 Amp. PORTABLE GASOLINE ENGINE WELDER
Government Cost \$2,940.00

Yours \$197.50

Most compact welder obtainable for the big jobs in out of the way places. Generator is capable of delivery of double overload or continuous service at 200 Amps. use up to 1/4" welding rod. Engine is manufactured by Ranger Aircraft and is a 2 cylinder, 4 cycle 10 H.P. at 3200 RPM. Fully governed for varying loads. You need to supply only cables and electrodes for welding. Units weigh approx. 150 lbs. (less oil & gasoline) and are approx. 22" W x 33 1/2" L x 17" H. All units used but guaranteed and checked before shipment. Parts available both new and used. Engine sold separately (attach your own P-2 or R-1 generator) checked and tested \$125.

ESSE RADIO COMPANY 42 W. South Street Indianapolis 25, Ind.



The Beautiful Schober CONSOLE PIANO

—only small organ with two full 61-note key-boards and 22 stops. Requires only 2'x3'2" floor space! Commercial value approximately \$1600 or more.

BUILD THIS SUPERB Schober ORGAN FROM SIMPLE KITS and save over 50%!

Give Your Family A Lifetime of Musical Joy With A Magnificent Schober Electronic Organ!

Now you can build the brilliant, full-range Schober CONSOLE PIANO or the larger CONCERT MODEL with simple hand tools! No skills are needed; no woodworking necessary. Just assemble, clearly marked electronic parts guided by step-by-step instructions. You build from kits, as fast or as slowly as you please . . . at home, in your spare time — with a small table serving as your entire work shop.

Pay As You Build!

Start building your organ at once, investing just \$18.94! The superb instru-

ment you assemble is as fine, and technically perfect, as a commercial organ . . . yet you save over 50% on quality electronic parts, high-priced labor, usual store mark-up!

THE GREAT CONCERT MODEL meets specifications of **American Guild of Organists**

Free Booklet

Send for 16-page booklet in full color describing Schober organs you may build for home, church or school, plus articles on how easy it is to build

your own organ and how pleasant it is to learn to play. Also available is 10" LP demonstration record (price \$2.00 — refundable on first order). Send for literature. No obligation and no salesman will call.

Mail This Coupon For FREE Schober Literature And Hi-Fi Demonstration Record TODAY!

The Schober Organ Corp., Dept. PM-2
2248 Broadway, New York 24, N. Y.

Please send me FREE full-color booklet and other literature on the Schober organs.

Please send me the 10" hi-fi Schober demonstration record. I enclose \$2.00 (refundable on receipt of my first kit order).

Name.....

Address.....

City..... Zone... State.....

START A BUSINESS this quick way

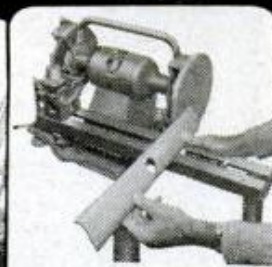

with these 2 machines
you can sharpen
**ALL HAND AND POWER
LAWN MOWERS**

**FOR ROTARY POWER
MOWER BLADES**
The Foley 314 Grinder
puts a perfect cutting
edge on all rotary power
mower blades.

Here's a business you can start in spare time, and begin to make a CASH PROFIT right away. The Foley Lawn Mower Sharpener handles up to 3 or 4 reel type mowers per hour. Prices run \$2.00 to \$3.00 for hand mowers, \$5.00 to \$8.00 for power mowers. You get 99¢ profit out of each dollar.

With the Foley Grinder you can sharpen rotary power mower blades, rip, cross-cut and combination circular saws, dado heads, ice skates, knives, scissors, shears, all sharp-edged tools.



FREE PLAN tells how to put yourself right into a home business that will pay you \$3 to \$6 an hour. Send coupon today for FREE BOOK on how to sharpen power mowers and Special Combination Money Saving Offer. No obligation—no salesman will call.

FOLEY MFG. CO.
307-0 Foley Bldg., Minneapolis 18, Minn.
Send Free Plan on lawn mower business and
Special Combination Offer.

NAME _____

ADDRESS _____

FIBERGLASS or PLYWOOD

FACTORY-DIRECT
PRICES

FREIGHT
Paid to You

18 FT. CRUISERS, 8 Models: from \$379



50 Models
8—18 Ft.
12, 14, 16, 18 ft. runabouts, ski-
models, convertibles, utilities:
\$114 up. 8, 10, 12, 14, 16,
18 ft. racing, fishing, utilities:
\$41.95 up.

FIBERGLASS 14 & 16 ft.
From \$299 (at right)

Interlocking units (lower right
photo) snap together, bond into
1-piece boat easily assembled
in one evening.



FIBERGLASS
14 ft. Sail Boat
\$299 with sail



Luger's preformed
preassembled units
are easily assembled by anyone. Equal
factory-built yet save 1/2 to 3/5. FREE
catalog has all details, trailers, ac-
cessories, paint, Fiberglass supplies.

**MONEY-BACK GUARANTEE
EASY TERMS 1/4 DOWN**

SEND FOR FREE
COLOR CATALOG

LUGER BOAT KITS

Dept. B-3, 9200 Access Rd., Minneapolis 20, Minn.

Manpower Requirements for U. S. by Occupational Group, 1960-1970



While demand for workers in these groups, which require high levels of training and education, will be constantly increasing, the numbers of laborers will remain about the same and farmers will be steadily diminishing.

The implication is obvious: the increasing complexity of our machines and techniques, coupled to the snow balling need of our big population, demand greater productivity from the individual worker. *More and more, we need to attract quality personnel into the skilled, technical, and professional occupations—and to give them the training and the stimulation to bring their best talents to full development.*

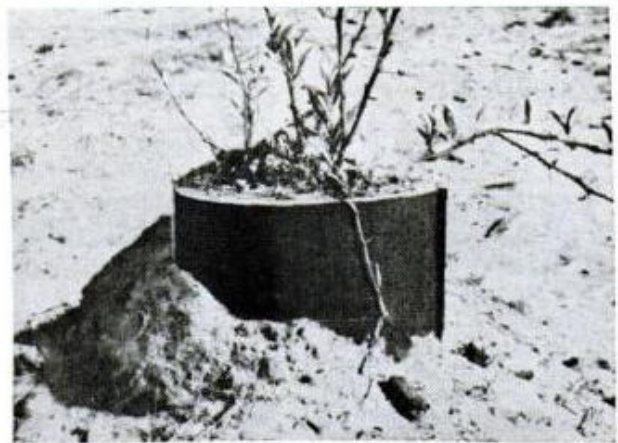

Roofing Paper Protects Trees

Two Florida fruitgrowers bundle the trunks of young citrus trees in mufflers of asphalt roofing paper to ward off the capricious and sometimes freezing winds of winter. H. A. Dooley and P.V. Proctor, of Volusia County, protected their 120 acres of trees during the cold 1958-59 season by first banking the trees with soil, the usual method, then wrapping the asphalt-impregnated felt around the bank. The cylinders reached the lower limbs and prevented the wind from eroding away the insulating soil, which would allow trees to freeze. Other trees nearby, unprotected by roofing paper, froze.

Get into.. PLASTIC LAMINATING AT HOME!



THIS MAN ..
... is taking out of the machine a Plastic Sealing Job — ordered by mail — only 11c in material cost brings back \$2.58 in cash by mail. Capacity of machine: **\$25.00 profit per hour of operation.**

Get **ORDERS** and **CASH** from your mailman—do work in **SPARE TIME** at home—or expand into **FULL TIME** business. Send coupon for Free facts about the newest and most fascinating of all home operated businesses. For the first time a simplified machine brings the fabulous profits of **Plastic Sealing** and **Plastic Laminating** within the reach of the small operator. Anyone can learn to operate the machine with a few minutes practice—then with our **Magic Mail Plan** can get mail orders pouring in daily with cash in every envelope. **No canvassing—no selling.** We even

Make up to \$5 an Hour..
MAGIC MAIL PLAN!

supply the circulars you mail to bring back cash and orders. Don't waste a minute. Rush your name. We'll send you **FREE** and postpaid, pictures, prices, details, and all the facts you need to start. Mail coupon or send name on postcard. No charge. Warner Electric Co., 1512 Jarvis Av., Dept. L-2-C, Chicago 26, Ill.

Make Thousands of Beautiful Art Creations

COSTUME JEWELRY • CIGARETTE BOXES TRAYS • CANDLESTICKS • COASTERS LAMP BASES • BOOK ENDS...ALL IN SPARKLING COLORED PLASTIC



WARNER ELECTRIC CO., 1512 Jarvis Av. Dept. L-2-C, Chicago 26, Ill.
At no cost to me, please rush complete details postage prepaid. I am under no obligation.

Name.....
Address.....
City..... Zone..... State.....



START NOW — EARN TOP PAY
Graduates in Auto Mech., Diesel Mech., Welding, Body & Fender, Refrig., Air-Conditioning, and Mach. Tool & Die earn highest pay. Train in the largest trade school in the world. Day—evenings—part time. Free Placement assistance while training and after graduation. Veteran Approved.
Write for details. Box C

GREER shop training
2236 S. Michigan Ave., Chicago 16, Ill.

Outdoor Living Is the Life!

◆

NEXT MONTH WE GIVE YOU A SPECIAL SECTION TELLING HOW TO LIVE OUTDOORS AT HOME

YOU NEED THIS

FREE GIANT 1960 B-A CATALOG

A Complete Buying Guide for Everything in
RADIO 1960 TV ELECTRONICS
ANNUAL CATALOG 601
BA
SINCE 1937

204 KING-SIZED PAGES
EVERYTHING IN RADIO TV AND ELECTRONICS
100'S OF NEW ITEMS LISTED HERE FOR 1st TIME
21 PAGES OF BARGAINS NOT IN ANY OTHER CATALOG

BURSTEIN-APPLEBEE CO.
Dept. PM, 1012 McGee St., Kansas City 6, Mo.
 Send Free 1960 B-A Catalog No. 601.

Name.....
Address.....
City..... State.....

SEND FOR IT TODAY

FREE! AIRMAILS!



Fabulous collection of all-different genuine Airmail Stamps from remote corners of the world — Africa, Europe, Exotic Orient, everywhere! World's Largest Airmail, Flying Doctor, Bomber, \$2.00 Helicopter, many others. PLUS Collection of thrilling Space-Age stamps . . . Sputniks, Jets, fantastic Moon Rocket stamps. Both of these remarkable collections — containing stamps worth up to 25c each! — for only 10c to cover mailing costs. Extra: Other sensational stamps for your free examination, plus Big Bargain Catalog. Rush 10c today to:

Jamestown Stamp Co, Dept. F30PM, Jamestown, New York
RUSH my Free Airmail Collection and other offers.
 I enclose 10c for mailing costs.
PLEASE PRINT

Name

Address

City & State

NO MORE STALLED ENGINES

Mr. Motorist: You have waited a long time for the Aldo Semi-Automatic Control! Simple to install by anyone—in minutes. Complete instruction sheet with drawings included. Anyone can operate it—man, woman or teenager. Thousands in proven all-weather operation. Sure starts in any weather. Patented spring loaded feature giving same operation as present automatic choke but with positive hand control. **NO MORE STALLED ENGINES CAUSED BY AUTOMATIC CHOKE FAILURE.**

Fits all Models.

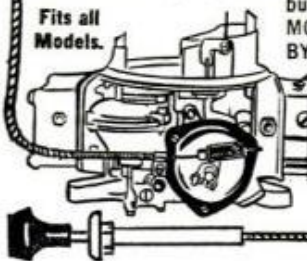

Saves gas, too!
only \$4.95
 Send check or money order, postage prepaid. Guaranteed.
SUPERIOR CONTROLS
 P.O. BOX 436, Crystal Lake, Ill.

Shop PM Ads for Exciting Direct-Mail Offers

Direct Reading Master Caliper



You'll agree that this all steel, easy-to-read caliper is perfect for every job.

- Big 4" scale reads directly in 32nds.
- Becomes a gauge simply by tightening thumbscrew.
- Closes automatically with built-in spring action.

Order either outside caliper as shown, or inside type. Only \$2.49 postpaid. Two for \$4.49. Made in U.S.A.

INTERNATIONAL PRODUCTS
 2581 Annapolis St., Palo Alto, California

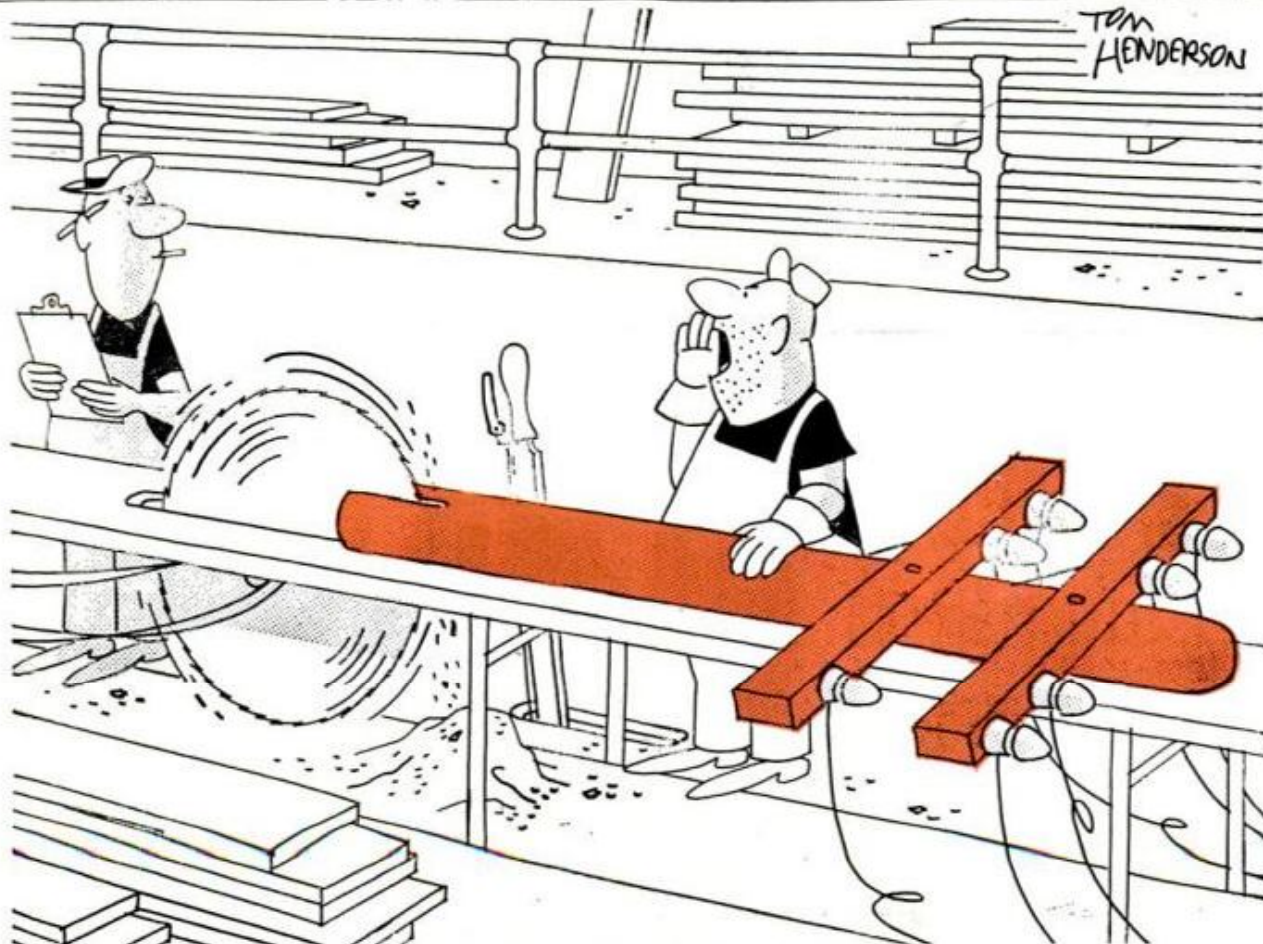

TOM HENDERSON

"Hey, Mike! Who sold us this last load of logs?"



MENDS EVERYTHING!

but a **BROKEN HEART...**
and **THE CRACK OF DAWN**
(Well, just about everything)

You've got a fix-it problem? DURO-PLASTIC has the answer. Name your weapon! DURO-PLASTIC ALUMINUM, PLASTIC RUBBER, PLASTIC PORCELAIN REPAIR, Liquid STEEL, rust REMOVER, handy-patch . . . and others in tubes and cans. Available at all better hardware, automotive, paint and variety stores. From \$1.00 to 39¢ (in Canada \$1.29 to 49¢)

WOODHILL CHEMICAL CO. Cleveland 14, Ohio



POPULAR MECHANICS MAGAZINE

now complete on
MICROFILM

VOLUMES ONE THROUGH NINETY-SIX

Early volumes of POPULAR MECHANICS have been eagerly sought as collector's items. Now the monumental new microfilm collection makes this wealth of reference material available to all libraries.

Begun in 1902 as a weekly, POPULAR MECHANICS was one of the first "picture" magazines. It also pioneered the do-it-yourself idea, and its files contain plans for almost any project desired.

Ninety-six volumes — \$750.00 for the set.

UNIVERSITY MICROFILMS, Inc.

313 North First Street

Ann Arbor, Mich.

AVIATION CAREER

SPECIALIZED EDUCATION / PROFESSIONAL TRAINING... only 16 months to 2 years

Top-pay prestige positions, bright future in aviation. Job opportunities waiting for you as soon as you're ready. Air-frame and Powerplant Technician, Aeronautical Engineering Technologist, Business or Executive Pilot. Classes in Miami.

SEND FOR FREE 48-PAGE BOOK

Embry-Riddle Aeronautical Institute
Dept. B Miami, Florida (Founded 1926)

Name.....

Address.....

City.....Zone.....State.....

FOR INDUSTRY OR HOME-CRAFT 8" TILT ARBOR SAW
BUY DIRECT FROM FACTORY



COMPLETE AS SHOWN—LESS BLADE

NOW \$1485 WAS \$29.95

5/8" NEW DEPARTURE BALL BEARING SPINDLE PRECISION GROUND CAST IRON TABLE

Ideal for light factory work — excellent for the home workshop — that's the new Model 590B 8" TILT ARBOR SAW. Over 300,000 sold already! Does everything same as saws costing 4 times as much — cross cuts, rips, bevels, mitres, dados, cuts compound angles. Adjustable depth of cut: 0" to 2 1/4". Blade tilts to 45°. Heavy duty all cast iron and steel construction. Precision ground cast iron table. Sealed NEW DEPARTURE ball bearings never need lubrication. Price includes massive cast iron mitre gauge and patented motor drive that fits any motor. All parts and labor guaranteed 10 years.

SPECIAL BARGAIN . . . This saw is our 1959 Model — brand new — shipped in factory sealed cartons. Sold and guaranteed from factory to you at fantastically low price.

MONEY BACK GUARANTEE . . . This saw and parts are guaranteed 10 years! Try it for 10 days. If not completely delighted — **FOR ANY REASON** — return for immediate refund. Order Model 590B. **SENT EXPRESS COLLECT—Send check or M.O. \$3.00 deposits on C.O.D.'s • Open account to rated firms**

AMERICAN MACHINE & TOOL CO. ROYERSFORD 34, PA.

Our 30th Year Manufacturing Quality Power Tools
Pennsylvania residents add 4% sales tax

Do You Know This Old-Timer?

(Answer to quiz, page 14)



1910 Maytag-Mason

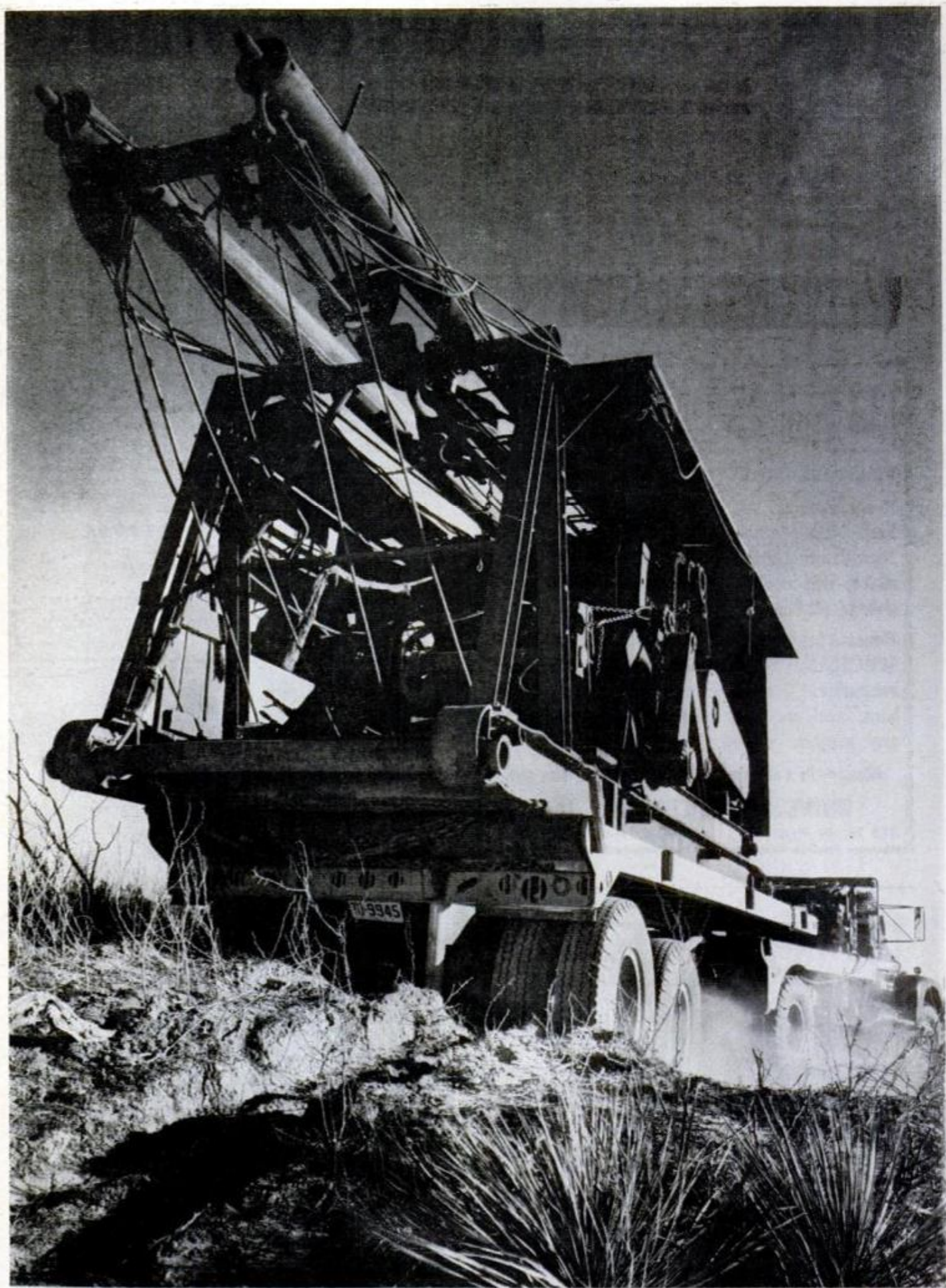

OIL RIG HAULER: Roy Fox, Odessa, Texas. "Firestone Steelcords take haul-trails that eat up other tires"

TRAIL-BREAKING TIRES HELP "WILDERNESS EXPRESS" BRING IN BRUSH-COUNTRY OIL!

Firestone

proved where profit depends on performance

Churning through tire-mauling back oil country is routine to Firestone truck tires. That's because Firestone tires undergo 425 million miles of test driving yearly to prove they can take anything in stride. Such testing resulted in Shock-Fortified Cord for truck tires and Firestone Rubber-X, longest-wearing rubber ever used in Firestone tires. Truckers to whom profit depends on performance find performance depends on Firestones for less cost-per-tire-mile and on-time deliveries. See your nearby Firestone Dealer or Store.

Copyright 1960, The Firestone Tire & Rubber Company



Transport*

Super Mileage Lug*

Super All Traction*

Rib Excavator*

Rock Grip Excavator*

All Traction*

*Firestone T.M.

*Here's owner proof of
Firestone truck tire
performance!*



GYPSUM HAULER: Alex C. Smith, Akron, N.Y. "I can expect 60,000 miles a tire with Firestones in tough hauling... I get even more!"



BULK OIL HAULER: Ted Kurk, Cheektowaga, N.Y. "Firestone tires keep all my deliveries on schedule in the city and upstate both."



WHOLESALE MEAT TRUCKER: Peter Smith, St. Clair Shores, Mich. "Tire maintenance dropped 90% with Firestones. I'll buy nothing else!"

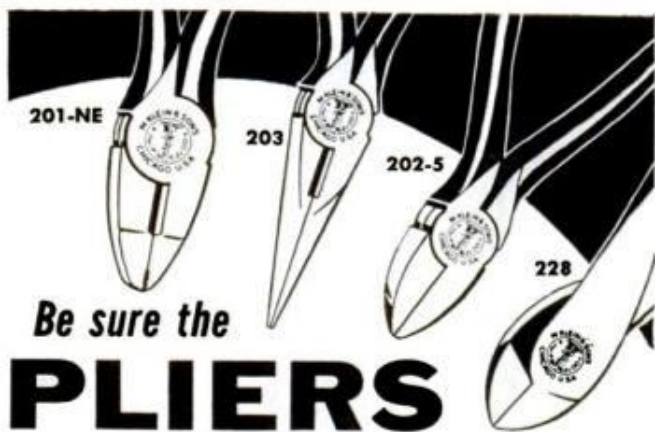

Be sure the
PLIERS
 you use are
KLEINS

"Since 1857" the name Klein has stood for the finest in tools. Linemen, electricians and good workmen everywhere prefer Kleins because of the high standard of quality that is back of every pair. Now Klein Pliers are available in a wider selection of styles and sizes than ever before.

Ask your supplier for genuine Klein Pliers or write for a new Klein Plier Catalog.
 FREE Klein Plier Catalog. On request.

Mathias KLEIN & Sons
 Established 1857 Chicago, Ill., U.S.A.
 7200 McCORMICK ROAD • CHICAGO 45, ILLINOIS

Take Correspondence Courses

For a Better Education

*you will be prince
 and
 princess
 of the road*



on a smooth-running, high performing, 1960 BSA Royal Tourist twin—the motorcycle with the really royal ride.

BSA MOTORCYCLES
 The most popular motorcycle in the world

Send this coupon for a colorfully illustrated free catalog of the new 1960 BSA models.

Name _____
 Address _____
 City _____ State _____
 Age _____

Western:
HAP ALZINA
 3074 Broadway
 Oakland, Calif.
 Eastern:
BSA INCORPORATED
 639 Passaic Ave.
 Nutley, N. J.

Dept. PM-3



Iron-A-Way Co., P. O. Box 326, Peoria, Ill.

In-the-Wall Ironing Cabinet

Iron and ironing board are kept in one place with an ironing-board cabinet that can be hung on or recessed in the wall. A mirror-covered door, concealing the cabinet, is provided with a switch that turns on the unit when the door is opened and shuts it off when the door is closed. When recessed, the unit occupies a wall space of 4 by 14 by 44 inches. The ironing board, made of steel, has a flameproof cover. A steam or electric iron comes with the cabinet. An automatic timer limits use of the iron and shuts off the current at the end of a preset period.

**Heartbeat Stimulator
 Implanted in Chest**

Implanted near the heart, a transistorized unit with its own battery supply maintains the heartbeat of certain cardiac victims for periods of about 10 years. Approximately the size of a large pocket-watch, the instrument consists of a bipolar electrode made up of a small patch of silicon rubber that is applied to the surface of the heart. Two steel needles protrude from the undersurface of the electrode penetrating the underlying heart muscle. Former electronic mechanisms used to maintain heartbeat were temporary and had to depend upon an external power supply. The new unit was developed by Drs. William M. Chardack and Andrew A. Gage at the Buffalo, N. Y. Veterans Administration Hospital. According to Dr. Chardack, "a lifetime of the unit from between five and ten years may be expected. Only a minor skin incision would then be required to replace the entire unit by a new one."

Funpacked FOLBOT fits in every home or car

Famous PORTABLE and FOLDING Folbots

Most seaworthy, all colors and sizes, 1 to 4 seaters. Exclusive low and high seats, SWIVEL backs. Comfy. Cruising, fishing, hunting. Use motors, Sails, Paddles. NO upkeep. Goes anywhere. PREFAB or Factory Finished on \$15 monthly terms.

BIG TRAVEL CRAFT from **\$88** PREFAB

FREE catalog

MAIL COUPON TODAY

to: FOLBOT CORP., P.M. Charleston, S. C.

Name.....

Address.....

City..... State.....

\$89.- Complete SAIL RIG

factory finished Folbot \$159 up

WILHOLD WATERPROOF GLUE

super strength

- full bodied
- easier to use
- sure to hold

BEST FOR YOUR BOAT

ABSOLUTELY 100% WATERPROOF RESORCINOL GLUE

Write for free catalog today.

ALWAYS DEPENDABLE

WILHOLD GLUES, INC.
Los Angeles 31, Calif.; Chicago 44, Ill.

J.M. Res.

CHORD ORGANS SAVE UP TO 1/2

Importer-to-You Prices

5 Day FREE Home Trial

Startling value and performance! Buy direct from importer — amazing savings. Hand-crafted in Italy. Anyone can play. E-Z Terms. Bonus Gifts. Free Home Trial. Money Back Guarantee. Piano-keyboard models. New! Send for color catalogs, low discount prices.

BUY DIRECT!

Play at Sight—No Lessons Needed!

FREE Color Catalog Rush Coupon

PHILHARMONIC ORGAN CORP., Dept. R-30
2003 W. Chicago Ave., Chicago 22, Illinois

Rush color Catalogs and Discount Price List.

NAME.....

ADDRESS.....

CITY & ZONE..... STATE.....

MAKE UP TO \$6 AN HOUR WITH EASISHARP

Earn **BIG PROFITS** sharpening all types of scissors and pinking shears. We show you how to make money immediately, either full or part time. Have your own business and a steady income. No experience required, any man or woman can sharpen scissors in less than two minutes... pinking shears in less than five minutes. Every homemaker, barber, tailor, dressmaker uses scissors that need sharpening two to five times a year. Be the first in your locality to own this amazing, proven money making, portable, electric machine. Weighs only 12 lbs. Write immediately to:

SERR-EDGE MACHINE CO., 4471 West 160th St., Cleveland 35, Ohio

MONEY MAKING PLAN SENT FREE

MEN NEEDED NOW—BIG PAY OPPORTUNITIES FOR JET ENGINE MECHANICS AND TECHNICIANS

Learn at Home in Spare Time or in Atlantic Jet Training's Own Modern Airport Shop—Work on Jet Engines. Practical training covers all phases for top paying jobs including Flight Line Maintenance, Shop Overhaul Maintenance, Inspectors With Airlines, Air Bases, Manufacturers and Government Missile Projects. FAA Licensed Instructor. Employment Service.

MAIL COUPON TODAY FOR FREE BOOK

ATLANTIC JET TRAINING, INC. Dept. PM-30
Municipal Airport Jet Engine Training Shop
Zephyrhills, Florida

Rush FREE Book, "YOU and the JET Industry." (No Salesman will call)

Name..... Age.....

Address.....

City..... Zone..... State.....

Check preference: () Home Study () Resident

FREE! LAFAYETTE'S 1960 CATALOG

304 GIANT-SIZED PAGES

CONTAINS

HUNDREDS OF EXCLUSIVE LAFAYETTE ITEMS NOT IN ANY OTHER CATALOG OR AVAILABLE FROM ANY OTHER SOURCE—SEND FOR YOUR COPY NOW!

See the newest and finest in Stereo Tuners, Amplifiers, Cartridges and Music Systems

- TAPE RECORDERS • PUBLIC ADDRESS SYSTEMS • AMATEUR EQUIPMENT
- INDUSTRIAL SUPPLIES • RADIO & TV TUBES AND PARTS • INSTRUMENTS
- TELESCOPES, BINOCULARS, MICROSCOPES & CAMERAS

LEADERS IN HI-FI

OUR 39th YEAR

The most complete electronic supply catalog crammed full of everything electronic at our customary down-to-earth money-saving prices.

The largest selection of hi-fi components and systems; greatest savings on Lafayette endorsed "best-buy" complete systems.

EASY PAY TERMS AVAILABLE — 10% DOWN — UP TO 18 MONTHS TO PAY

Lafayette Radio P.O. BOX 222
JAMAICA 31, N. Y.
DEPT. LC-6

Send FREE LAFAYETTE Catalog 600

Name.....

Address.....

City..... Zone..... State.....

CUT OUT AND PASTE ON POST CARD



BILL STERN, Dean of
American Sportscasters, says...

**"GIVE ME 1 MINUTE TO PROVE
CAPE CORAL, FLORIDA
IS FOR YOU!"**

"Use the next few seconds to fill out and mail the coupon below. Receive the big FREE book that gives you all the fabulous facts about CAPE CORAL. Learn why thousands of families have invested millions of dollars in this waterfront community of Country Club luxury with its endless variety of beautiful homes; miles and miles of landscaped, paved streets and wide waterways — boating, fishing, bathing — all the wonderful pleasures that make CAPE CORAL exactly what you've been dreaming about!"

1/4 acre Homesites for as little as
\$20 DOWN \$20 MONTHLY

Send for the most exciting book of its kind
ever written! — **"THE CAPE CORAL STORY"**

It's yours for the asking—

ABSOLUTELY FREE Send No Money,
Please

CHAMBER
OF
COMMERCE
MEMBER
Lee County
and Ft. Myers
Dade County
Florida State

--- MAIL THIS COUPON TODAY! ---
Gulf Guaranty Land & Title Co., Dept. MS22
1771 N. Tamiami Trail, Fort Myers, Florida
Please rush my FREE copy of "The Cape Coral
Story" in full color.

Name
Address
City Zone State



Next Month

How do the
FALCON
owners like their
"COMPACT"?



Read their report
in the
APRIL ISSUE

**ESCAPE THE
GRAVITATIONAL
PULL OF
EVERYDAY CARES**

OUT OF THIS WORLD
By Dr. Dan Q. Posin

DR. DAN Q. POSIN

Discover the mysteries of Space Science and Electronic Magic in a new fascinating way. Authentic information so cleverly and simply written that you will be amazed at the knowledge you will absorb effortlessly. For a delightful experience in "painless" education, read "OUT OF THIS WORLD."

AVAILABLE AT YOUR FAVORITE BOOKSTORE OR WRITE DIRECT — \$3.95
POPULAR MECHANICS PRESS—200 EAST ONTARIO ST. CHICAGO 11, ILL.

POPULAR MECHANICS

CUT-TO-FIT HOMES CUT BUILDING COSTS

CHOICE OF 57 DESIGNS

ORDER NOW

SAVE UP TO 1/3



INTERNATIONAL MILL AND TIMBER CO.
DEPT. PM30 .. BAY CITY, MICHIGAN

Build your own home and save the builders' profit — plus savings in lumber and labor with Sterling Ready-Cut-Homes. Anyone can assemble with simple, easy to follow plans furnished. Every house complete with all lumber, roofing, nails, glass, hardware, paint, doors and windows marked ready to erect. Freight paid. Complete building plans ready for filing at low cost. Sold separately if desired. Write today!

PRICED FROM \$2150 UP
Five Easy Payment Plans
Send 25c for NEW COLOR CATALOG

ADVANCED DESIGN — REMARKABLE PERFORMANCE

BOAT TRAILER KIT Only \$59.50

Assemble and Own This High Quality Trailer — Save 1/3! Handles Boats to 16'. Other Models for Larger Craft. All parts furnished to assemble to a few pieces locally purchased pipe. Cuts freight costs. Trailer completely engineered—no special skills or tools required—assemble & tighten U-Bolts. Separate parts also available. Easy terms.

Write today for illustrated catalog. Enclose 10c for postage and handling.

Reference—First National Bank, Kingsport, Tenn.

TRAILER PRODUCTS COMPANY, INC.
Dept. PM-3, P.O. Box 176, Kingsport, Tenn.



ENJOY YOUR OWN BUSINESS

Start earning at once — No special experience required

A shop in itself—automatic, foolproof.

Down payment; Balance in low monthly payments from earnings.

SMITH-NIELSEN EQUIPMENT CO., Mfr. of Saw Grinders
902 N. NORMANDIE — SPOKANE, WASH. — FA 8-6680
Teletype SP13

STAND-ALL Model 7

SHARPENS 10 types of saws, including rip and crosscut handsaws, hacksaws, bandsaws, circular saws.

RETOOTHs saws of 5 to 16 point size.

CROWNS — adjusts to any standard crown.

HOOKS from —5 to 21 degrees.

BEVELS from 0 to 30 degrees.



119 JIG SAW PATTERNS

FULL-SIZE . . . trace on wood and saw out. Clever, ORIGINAL designs, things you can make to **SELL**. Wall shelves, lawn signs, planters, book ends, others. **\$1** postpaid

BURGESS VIBROCRRAFTERS, INC.

Rush \$1 today. DEPT. C-139, Groyslake, Illinois

FREE THE HISTORY OF THE COMPASS SEND FOR YOUR COPY

New DINSMORE **Celebrity** COMPASSES

in Beautiful GOLD or SILVER

A jeweled, precision instrument—designed for modern cars. Full, indirect illumination. Sharp, clear letters. Silver or gold Celebrity models \$7.45, standard models \$5.95. Illuminated \$6.95

APPROVED BY AUTO MAKERS
Fine Quality Compasses for over 31 Years

DINSMORE INSTRUMENT CO.
1802 Kelso St., Flint 1, Michigan



Write for Folder

Build a low cost PONTON BOAT with a "Perma-D" KIT

You can now have all the fun—and economy—of building your own pontoon boat. Pontoons are made with standard 55-gal. steel drums fastened to platform frames with "Perma-D" Pontoon Brackets. The "Perma-D" Pontoon Boat Kit includes two nose cones, outboard motor mount, brackets and tie rods for pontoons, with complete instructions for building frame, pontoons, deck. **Dealer inquiries invited.**

Write for circular on "Perma-D" pontoon boat kit, dock and float brackets, boat mooring bars, springboard, boat canopy, etc.

"Perma-D" DIVISION, Central Machine Works Co.
1235 Central Ave. • Minneapolis 13, Minnesota



catch more fish!

order your new 1960

HEDDON CATALOG!

Heddon's all-new 64-page Catalog is crammed with latest fishing tips, tricks from the experts. Features "Liar's Licenses" • pictures, descriptions of game fish • "Sonar", all purpose lure • "Sonics", lures that catch fish by SOUND • "Hi-Tail", greatest surface action bait in years • "Ultra Sonic", tiny fishing miracle • "Mark" series rods • And special introductory price tackle offer • Use as fishing manual • Only 25 cents.



JAMES HEDDON'S SONS
180 WEST STREET • DOWAGIAC, MICH.

CHECK YOUR CHOICE Here's my 25c. Please rush Deluxe Catalog Send your FREE 32-page pocket catalog

Name _____ (please print)

Address _____

City _____

State _____



Heddon

Top Medical Achievement of 1959: Genetics Research

Biochemical genetics—the scientific field that deals with man's origins, his mode of development and reproduction of characteristics—was selected by deans of 84 medical schools as the field of greatest medical achievement during 1959, according to the American Medical Association.

Many biochemical geneticists are looking to the day when man can plan himself to the extent of improving his intelligence, physique and resistance to disease. One dean, Dr. Stafford L. Warren of the University of California, described one experiment that brought a better understanding of the biochemistry of nerve impulses. This might result in better methods of treatment for mental health problems.

"It has been possible to trace, on a brain-wave detecting device, records of the learning process," he said. "As an animal at our center learned a particular task during the past year, a tracing of a new electrical activity in a particular brain area could be recorded. This could be erased with drugs that caused the animal temporarily to forget, but the tracing returned as the drugs wore off."

Dr. Thomas H. Hunter, dean of the University of Virginia School of Medicine hailed the April announcement, by British investigators, that an irregular number of chromosomes inside living cells are re-

sponsible for grave conditions such as Mongoloid idiocy and, possibly, leukemia. Chromosomes are the microscopic life-threads that carry genes of heredity—such as eye, hair and skin color—like beads on a string; they are found inside germ cells that unite to form new organisms. "These findings," said Dr. Hunter, "clearly and unequivocally label such abnormalities as genetic in origin."

The deans praised the work being done in genetic research centers throughout the country. They said that among other projects scientists were investigating:

1. The phenomenon, technically known as transduction, through which a virus can carry genetic material from one cell to another, a significant step in the field of transplantation of organs.

2. Certain diseases in which, because of hereditary abnormality, the patient fails to manufacture an enzyme, or manufacture an abnormal enzyme that will not work. (Enzymes act as catalytic agents on other body substances, causing them to break up.)

3. The possibility of moving heritable traits from one cell to another.

4. The role of genetic influences on such diseases as hypertension, coronary ailments, schizophrenia and diabetes.

5. The role of genetic analysis in the understanding of the mechanics of cancer.

RUPTURED?

Write for New Relief FACTS FREE!

ENJOY NEW FREEDOM of action, peace of mind and comfort at work or play. Proven, patented MILLER holds your rupture back Day and Night — will bring you lasting relief! Has helped thousands of others!

For FREE facts in plain wrapper—Send Name and Address to

Dept. 1-C, **FRED B. MILLER** Manufacturer, HAGERSTOWN, MARYLAND

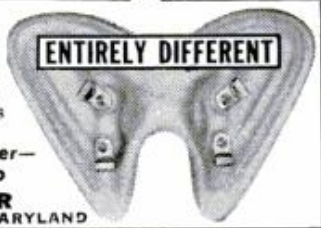

American families are
better housed —
thanks to Advertising!

FREE FOR INVENTORS

Newest list of Needed Inventions as requested by hundreds of manufacturers seeking new products. Also free: Legal Invention Protection Blank.

INVENTORS SALES & ENGINEERING BUREAU
Dept. 603-D, Box 4973 Washington 8, D.C.

NEW shop type ac arc welder

NEW ac power or weld anywhere

Here's how YOU can get those "Big Profit" Welding Jobs

Every day, men like yourself depend on Hobart welders like these to help produce big profits doing construction, repairs, metal fabrication, etc. You'll like Hobart's rugged strength and built-in features that assure long, trouble-free life—professional results, every time.

hardsurfaces and heats metal for bending and forming. Meets REA requirements . . . it's an all around shop welder.

① **The 180 amp. "HUSTLER"** is a complete welding package (including accessories). It welds, cuts, burns holes, starts a Big Paying Business of Your Own!

② **The 200 amp. "POWER/WELD"** furnishes DC current for welding and simultaneously supplies 110/220 volt power for running lights, tools, motors, pumps, sprays, etc. It can also be used as an emergency power source to run brooders, milking machines, etc.

Write today ...HOBART BROS. CO., BOX M-30, TROY, OHIO, Ph. FE 2-1223



**REMOVE UNWANTED
WATER EASILY,
QUICKLY WITH A
Little Giant
BASEMENT BAILER**

Ideal for home use, safe and economical to operate, is the Little Giant screened "Basement Bailer". Can be used in basement, under house or anywhere seepage occurs. Operates when completely under water . . . no expensive plumbing required. For information, write:

Little Giant PUMP COMPANY
3810 N. Tulsa, Oklahoma City, Oklahoma

**BOAT PLANS—PATTERNS
& FRAME KITS**

Designed by a Naval architect & specially prepared for amateur builders.

New 80-page catalog illustrates over 35 "Build-it-Yourself" power boats with step-by-step photos and instructions for building your own boat at a big savings.

Send for your copy now
Only 50c

GLEN L. 9152T Rosecrans
Bellflower, Calif.



**HOME IMPROVEMENT
LIBRARY**

POPULAR
SERVICE
BUREAU
MECHANICS

12 AUTHORITATIVE MANUALS
FOR ONLY \$2.00

★ Now sold together in a service packet for the first time—a complete library of Popular Mechanics' home service, repair and improvement booklets—all 12 offered at one low group price. Listed below are only a few of the many topics covered:

★ Additions and Remodeling—How to modernize kitchens: how to work with concrete around the home: how to lay linoleum and tile: how to refinish floors and woodwork: how to remodel basements and attics: how to modernize walls and ceilings.

★ Basic Service and Repairs—House wiring and electrical repairs: plumbing repairs made simple: how to paint inside and out: how to cure your leaky basement: how to winterize your home: how to insulate your home.

★ The home owner who owns the HOME IMPROVEMENT LIBRARY will be prepared. Send your order in at once!

ONLY \$2.00

SERVICE BUREAU POPULAR MECHANICS, Room 517
200 E. Ontario, Chicago 11, Ill.

Enclosed find remittance in the amount of \$2.00. Please rush the complete HOME IMPROVEMENT LIBRARY (12 booklets).

Name.....
Address.....
City..... State.....

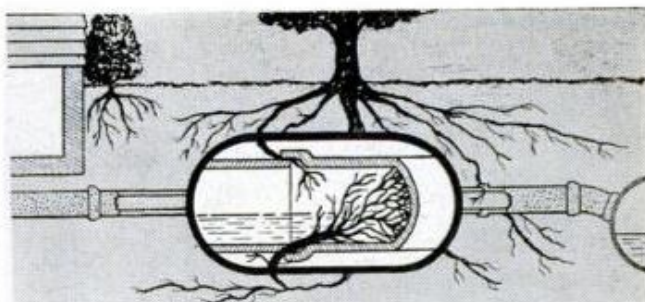

**END SEWER-LINE ROOT MESS,
SAVE ON COSTLY REPAIRS!**

Roots are just naturally thirsty. They force their way through joints in your sewer line, eventually clog it. Toilets and sinks "back up", soon overflow. Now you can avoid costly digging or mechanical cleaning this easy, permanent way.



Pour one box of revolutionary Hercules R-D into toilet bowl. R-D kills and decomposes roots permanently, often overnight. To keep sewer lines root free, apply R-D twice a year. Safe to handle. Safe in septic tanks. Don't wait for trouble. Get R-D now from your plumbing or hardware dealer. It works, or your money back. Only \$3.95 for 2 lb. box. Send for literature.



HERCULES CHEMICAL CO., INC.
416 Broadway, New York 13, N.Y.

**FREE ALLIED'S
MONEY-SAVING 1960
ELECTRONIC SUPPLY CATALOG**



**SAVE ON EVERYTHING
IN ELECTRONICS**

Send for the most widely used Electronic Supply Guide. See what's newest (including products available only from ALLIED), see what's finest. **SAVE ON:**

• Everything in Stereo Hi-Fi Music Systems & Components • Knight-Kits® —Best in Build-Your-Own • Tape Recorders & Phono Equipment • TV Tubes, Antennas, Accessories • Parts, Tubes, Transistors • Amateur Equipment • Tools • Technical Books • Public Address Systems • Test Equipment.

Save most at ALLIED. Write for FREE 1960 Catalog today!

ONLY \$2 DOWN
on orders up to \$50; only \$5 down up to \$200; \$10 down over \$200

FREE SEND FOR VALUE-PACKED CATALOG

ALLIED RADIO, Dept. 197-C
100 N. Western Ave., Chicago 80, Ill.

Send FREE 1960 ALLIED Catalog

Name _____

Address _____

City _____ Zone _____ State _____

**ALLIED
RADIO**
our 40th
year

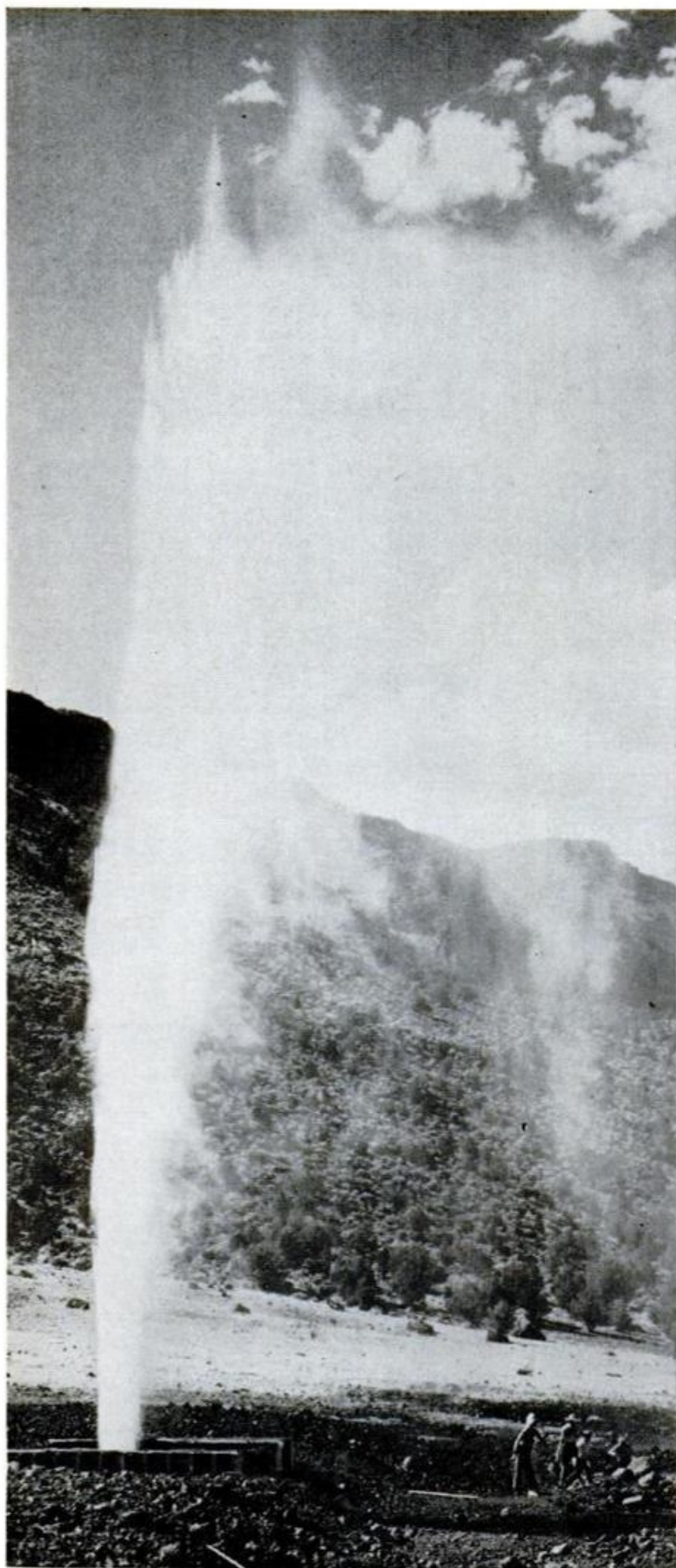

Perpetual Spouter Is Born in Oregon

Charles Crump, a rancher in southern Oregon, today irrigates his fields with water from a geyser-like flow that began spouting on his property last July. Despite predictions by engineers that the loose soil through which it jets would crumble, blocking its passage, the spouter has continued to plume water to heights of between 150 and 200 feet, or some 30 to 80 feet higher than Old Faithful in Yellowstone National Park. Geologists say the spouter is not a true geyser because it is not an intermittent, eruptive hot spring in which discharges, caused by the expansive force of highly heated steam, occur at more or less frequent intervals. Nonetheless, it is known as Crump's Geyser, for the rancher not only has it on his property, but he was the first to see it in action. Crump had leased out a section of his land, which abounds in hot springs, to a company which drilled a well in a search for high-temperature water that could be used to make power. The company abandoned the site after drilling 1684 feet. Crump, curious because the well was seemingly a failure, visited the site frequently. On July 1, when he inspected it at 1:15 p.m., bubbling water was present at the well casing, and the hole was free of debris, indicating an eruption had occurred. As he and a neighbor watched, the spouter erupted at 1:55 and has been flowing ever since. Crump's gain, however, was a loss for hot-spring activity in the area: A hot spring 100 yards east and a geyser 100 feet north have become inactive.



“The 1960 Plymouth is the
performance king in its field . . .

*it can drill through hard bends and switchbacks
as adroitly as many top-rated sports cars,”*

SAYS TOM McCahill of MECHANIX ILLUSTRATED.

One of America's best known automotive experts goes “flat out” in his praise for the Solid '60 Plymouth. Tom McCahill took a Fury 4-door hardtop equipped with the 361-cubic-inch, optional Golden Commando V-8 engine, and really put her through her paces.

According to “Uncle Tom,” the Commando power plant “. . . can whizz out 0-60 mph in 8.2 seconds.”

As this famous auto expert discovered, “The big payoff on a Plymouth comes when you put it on the road.” But don't take his or anybody's word for it—*you* put a Plymouth on the road. Get her out on the roughest, toughest terrain you know. See if you share Tom McCahill's and our belief that the Solid Plymouth 1960 with new Dura-Quiet Unibody “. . . is the performance king in its field.”

A Chrysler-engineered product, built a new solid way to give you solid satisfaction.

SOLID PLYMOUTH 1960

LOOK!
New!
Improved!



POCKET-SIZE BLOW TORCH only \$2²⁵

Now—solder, braze, fix leaks. Do wiring, plumbing, loosen frozen nuts and bolts, 1001 odd jobs. Butane gas blow torch gives intense 3500° pin point flame that lasts ½ hour, turns on or off. Extra "chargers" 49¢ for two. Send \$2.25, check or money order for Jet King Blow Torch with one charger, or send \$2.95 for complete soldering kit: Blow Torch, two chargers, soldering tip, roll of solder. Send coupon now!
Money back guarantee!

Kidde Manufacturing Co., Inc., 304 Farrand St., Bloomfield, N. J.

Send me _____ JET KING BLOW TORCHES @ 2.25 ea.*

Send me _____ JET KING SOLDER KITS @ 2.95 ea.*

Send me _____ Boxes of Extra Chargers @ .49 per box.

My check, _____ money order _____ for \$ _____ is enclosed
(*Add \$1.00 Extra per unit for Canada)

NAME _____

STREET _____

CITY _____ STATE _____

new FROM HEATHKIT® transistor clock radio



EASY TO ASSEMBLE... COMPLETELY PORTABLE
... UP TO 500 HOURS ON BATTERIES

Take it with you... on trips, to the beach, in a boat... Nothing to plug-in, just goes and goes on inexpensive batteries. Lulls you to sleep, wakes you up, tells time and plays all day long. Leather carrying case available. **ONLY \$45.95.**



HEATH COMPANY

Benton Harbor 17, Michigan

is a subsidiary of Daystrom, Inc.

Send the latest Free Heathkit Catalog.

NAME _____

ADDRESS _____

CITY _____ ZONE _____ STATE _____

Note: Price subject to change without notice.

Experimental Reactor Will Distill Sea Water

Two U. S. government agencies will use nuclear energy to distill huge quantities of fresh water from sea water, beginning January, 1962, at Port Loma, Santa Monica, Calif. The Department of Interior is building a \$2,000,000 flash distillation unit there which is capable of producing at least one million gallons of fresh water a day. It will take its power, most of the time, from an experimental, nuclear-powered reactor the Atomic Energy Commission is building at a cost of \$4,000,000.

The reactor will be used in experiments to determine whether it is suitable to provide power for industries producing primary metals, petroleum, coal, chemical, food and paper products. At times the conversion plant will be powered by other fuels. To prevent radioactivity from entering into the distillation process, the reactor has three barriers to separate it from the conversion equipment. In operation, high purity water will circulate through the reactor, will be heated, and then converted to low-pressure steam in a boiler. The low-pressure steam will then heat the sea water in the flash evaporator. It is hoped that the flash distillation unit, operating at higher than normal temperatures, can produce water at low cost.

Normally, to produce 50 million gallons of distilled water per day (10 percent of the water used in Southern California) gas-fired boilers would utilize 20 percent of the gas now used in the area. This would seriously affect the balance of fuel supply, whereas a nuclear reactor could supply this heat at about the same cost and, if the experiment proves successful, the heat would be readily available.

Planes Are Hired Hands For California Farmers

Airplanes are helping California farmers produce crops efficiently and economically by sowing seed and spraying fertilizer, says Milton D. Miller, University of California agronomist. He estimates that 15 percent of the state's three million acres of cereal grain and hay crops are sown by planes. They include barley, wheat, oats, rye, vetch, alfalfa, trefoil, clover and rice. Rice growers, Miller said, are the greatest users of planes for seeding; some 95 percent of the 300,000 acres of rice planted are seeded from the air. All told, in 1958, California farmers hired 221 firms with 702 pilots and apprentices flying 1389 planes to give crop protection by spraying 5,308,542 acres with chemical fertilizers, herbicides, insecticides or fungicides.

Beauty...

backed by
**SCIENTIFIC
MARINE
ENGINEERING**



Every Penn Yan is built to scientific principles of marine design. As a result, Penn Yans are superbly maneuverable,

fast, durable and safe. They are built—as they have been for nearly 40 years—to give greater satisfaction longer.



FREE catalog describes complete new line. Write Penn Yan Boats, Inc., 34th St., Penn Yan, N. Y.

Penn Yan Boats

Works
in
seconds!



**Loosens Rusted Bolts
nuts, screws, "frozen" parts!**

**LIQUID
WRENCH**
SUPER-PENETRANT

The super-penetrating rust solvent that quickly loosens rust and corrosion.

**AT ALL HARDWARE
AND AUTO STORES**

RADIATOR SPECIALTY COMPANY
CHARLOTTE, N. C.



shaw

shoes are designed for men whose feet are part of their job!

Here's a sturdy work oxford, with all the styling, fit and comfort of a dress oxford! Shaw's high value features include full cushion insole heel to toe with metatarsal pad and cushion side arch support . . . oil resistant Neoprene sole . . . steel arch . . . Nylon stitched . . . plus the finest leathers and craftsmanship, in black or Cordovan color. **AT STORES EVERYWHERE**, or write us for details.



IDEAL FOR

mechanics, filling station men, mailmen, factory workers—anyone who wants comfort and style in a work oxford! Also available as high shoe.



ARCH

Today's
top values,
\$10.95 to \$14.95

M. T. SHAW, INC.
Coldwater, Michigan



"37 Years of Quality Shoemaking"

Here's Big Earning Power You Can Buy Today



There's no need for builders, landscaping or grading contractors to do without the latest in efficient, profit-producing equipment. The John Deere Credit Plan is a personalized form of purchase agreement that brings a full line of fine industrial tractors and equipment within easy reach. See your nearby John Deere Industrial dealer or send coupon below for the information you need.

**Free Facts!
Send Coupon
Today!**

Name _____
Street _____
City _____ State _____



John Deere Industrial Division
Dept. 2409, Moline, Illinois

U.S. Navy Men in Antarctica Thank a Ham Radio Operator

When men of the U.S. Naval Support Force stationed at McMurdo Sound, Antarctica, during the past six years have wanted to make personal calls to their families, they have relied on Julius Madey, a 19-year-old ham radio operator at Clark, N. J., to "patch" their short-wave conversations into the telephone circuits. Julius, an electronics engineering student at Rutgers University who, in 1958, was given the Edison Radio Amateur award for his contributions to public service, has spent as many as 90 hours a week passing messages to and from the Sound, or sending along to the Navy men such prized information as baseball and football scores. Last November, as a gesture of thanks, the Navy men flew him to Antarctica with an invitation from the Secretary of Navy to inspect their



base. His first stop on arrival was at the short-wave station, earning him further gratitude from the Navy radio operators, one of whom has said, gratefully, of Julius's service: "You can depend on him; he's always there."



LICKITY LOG SPLITTER

Ends Wood Splitting Drudgery

Hydraulic power splits profits from waste wood
 • 7 HP trailer model • two speed • auto shift
 • auto stroke. Power "squats" to receive large diameter logs without "dead" lift—eighteen ton smooth hydraulic force cuts right through knots, 26" stroke handles up to 30" length, any diameter. Your name on a postal card will bring literature.

THE WACO AIRCRAFT CO., Dept. D, Troy, Ohio
 Dealer Inquiries Invited

NEW FROM V-M



THE IDEAL AMPLIFIER FOR YOUR CUSTOM INSTALLATION! \$89.95* List

THE VOICE OF MUSIC DELUXE STEREO AMPLIFIER

Precision-built, this AC type amplifier has a built-in pre-amplifier and integral controls. Output sockets, Dual-channel, push-pull output of 28 watts (peak); 14 watts (peak) each channel. Jack panel with stereo inputs for *phono*, *tape*, *tuner* and a monophonic input for TV. Outputs to drive a stereo or monophonic tape recorder.

ASK YOUR DEALER ABOUT THE COMPLETE LINE OF EXCLUSIVE V-M 'STERE-O-MATIC'® 4-SPEED RECORD CHANGERS —THE WORLD'S FINEST! From \$50.00 List*

*Slightly higher West
the Voice of Music®

V-M CORPORATION, BENTON HARBOR, MICHIGAN. WORLD FAMOUS FOR THE FINEST IN RECORD CHANGERS, PHONOGRAPHS AND TAPE RECORDERS

Ask For Boat Selector



ALUMA
Craft

*America's
Best Built
Boats*

Helps you pick your best boat buy

Explains standards by which men who know boats judge boats. Gives photographic proof of Aluma Craft's beautiful advanced fiber glass and aluminum designs for 1960, and the quality construction behind every smart new model. Many outstanding new features. See the attractive *Yacht Club Fleet, Family Cottage Fleet, Fishing Fleet* and *Wilderness Aluma Craft Fleet*.

You'll want this unique Boat Selector because it's packed with factual, helpful information. Mail the coupon for your copy.

ALUMA CRAFT BOAT CO.

1519 N.E. Central Ave., Minneapolis, Minnesota

GENTLEMEN: Please rush the 1960 Boat Selector Catalog at no cost or obligation.

NAME _____

ADDRESS _____

CITY _____ STATE _____

This Month's "Great Pioneer in Science"

(Page 16)



Louis Pasteur (1822-1895)

FREE Vacation Guide to TENNESSEE

Tells all about the Great Smoky Mts. National Park, Tennessee's 22 Great Lakes and water sports, battlefields, homes of 3 presidents, fine family accommodations, etc. Mail coupon today.

MOUNTAINS • LAKES • HISTORY



**40 Pages
116 Pictures
41 in Color**

TENNESSEE DIVISION OF INFORMATION
2160 Cordell Hull Building, Nashville, Tenn.

Please send Free Vacation Guide

NAME _____

ADDRESS _____

CITY & STATE _____



Tom McCahill Reports on: Facts about Replacement Mufflers

Today's automotive tastes have caused very complex designs and some weird engineering. Underslung styling, high compression engines, and power-assist gadgets have become common. This has created new problems in maintenance. Let's consider mufflers, for instance.

Typical current hopped-up Detroit gargantuas demand a different type of food than old-time cars. They take to 100-plus octane gas like a cookie to a needle, and they pump acid-loaded fumes into the muffler that can eat a hole through it like a rat through cheese. This calls for better-designed mufflers. They must be built to nestle into the maze beneath today's underslung wagons. This is doubly tough with dual exhaust systems, and it all results in shorter muffler life.

Mufflers are the most common replacement item on modern automobiles. The big question is: What are the muffler kids doing to increase muffler life? The answer: there are only three things they can do. First, use heavier steel. Second, design the interior to reduce acid-loaded condensation and avoid cold spots. Third, coat mufflers with corrosive-resistant materials. AP mufflers stand out on all three counts like a well-filled Bikini at a kids' swimming pool. APs have more and heavier internal parts, much heavier outer shells and heads than other mufflers. AP's exclusive "Dri-Flow" design eliminates cold spots—cuts down on corrosive condensation. And AP offers more mufflers with rust-resistant coating than any other manufacturer. Yet AP mufflers sell for the same price as inferior gas traps.

These are among the reasons why AP is the world's largest manufacturer of replacement mufflers. Look for the big AP "Free Muffler Check" sign. More than 100,000 automotive experts, coast to coast, install AP mufflers and tail pipes.



THE AP PARTS CORPORATION

14-P AP BUILDING, TOLEDO 1, OHIO

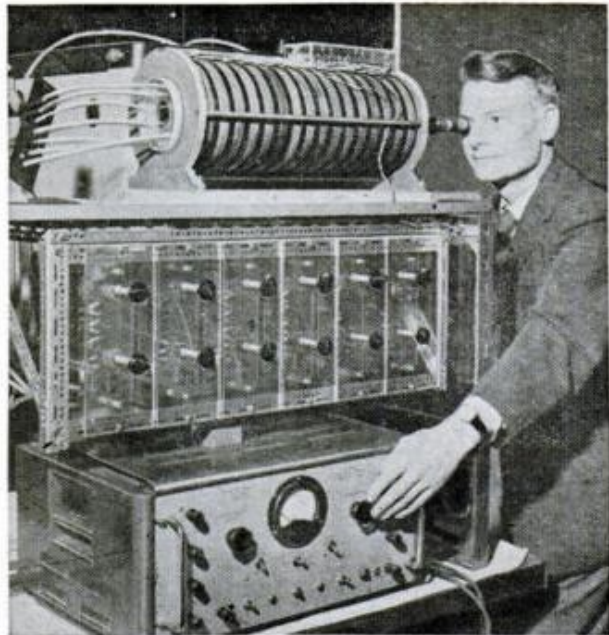

Light Magnified 50,000 Times

British scientists have developed a light-intensifier that makes pulses of light energy 50,000 times brighter and turns images too faint to be seen by the naked eye into visible patterns that can be photographed. The intensifier is expected to be used in astronomy and hospital X-ray examinations. Its developers at the Imperial College of Science, London, say the ability to photograph sky bodies by almost instantaneous exposure through the intensifier would largely overcome the problem of disturbances in the earth's atmosphere encountered with lengthy telescope exposure, and opens up the prospect of examining spectra of some of the faintest stars.

The intensifier comprises a glass vacuum tube about 18 inches long by 2 inches in diameter. It operates by focusing the original faint picture onto a light-sensitive cathode inside the tube. The cathode emits electrons which are passed through five dynodes situated along the length of the tube. From every 20 or so photons (atoms of light) that fall on the cathode, one electron is produced. Each electron from the cathode hits each successive dynode at high speed, being accelerated along its course by more than 1000 volts of electricity. Each dynode will produce some five new electrons and these in turn hit the next dynode (a dime-size film of aluminum encased between a layer of aluminum oxide and one of potassium chloride) to be multiplied again. At the end, at least 3000 electrons are produced for each one leaving the cathode. An accelerating electric field throws them against a fluorescent screen, producing a visible flash of light 50,000 times brighter than the source.

Needle-Thin Radar Will Identify Missiles

More than a dozen needle-narrow microwave beams, fired from a unique radar system, will track ICBMs thousands of miles away and identify their warheads. To be developed for Advanced Research Projects Agency by Raytheon, the radar, called "Pincushion," will keep a continuous track on the missiles. The beams, fired from a parabolic, five-story-high antenna, will help produce sharp, high-definition target "pictures." The 80-ton radar is to be completed by late 1961.

Undersea Phone and TV Cables Will Link British Peoples

Undersea cables which carry "piped" television and telephone calls will link the whole of the British Commonwealth. First link will be a Britain-to-Canada cable, ready by 1961. By 1964, Canada and Australia will be joined, as will all main parts of the Commonwealth within the decade. The television pictures carried in the cables will be delayed TV, which are relayed immediately after the event but take about two hours in transmission. Cost of the global link will be over \$200 million.

The proof is in the puffing

and P. A. has the flavor most favored in the U. S. A.

- always tastes fresh
- mild, mellow flavor
- cool 'n' steady burning

**America's Largest-Selling
Smoking Tobacco!**

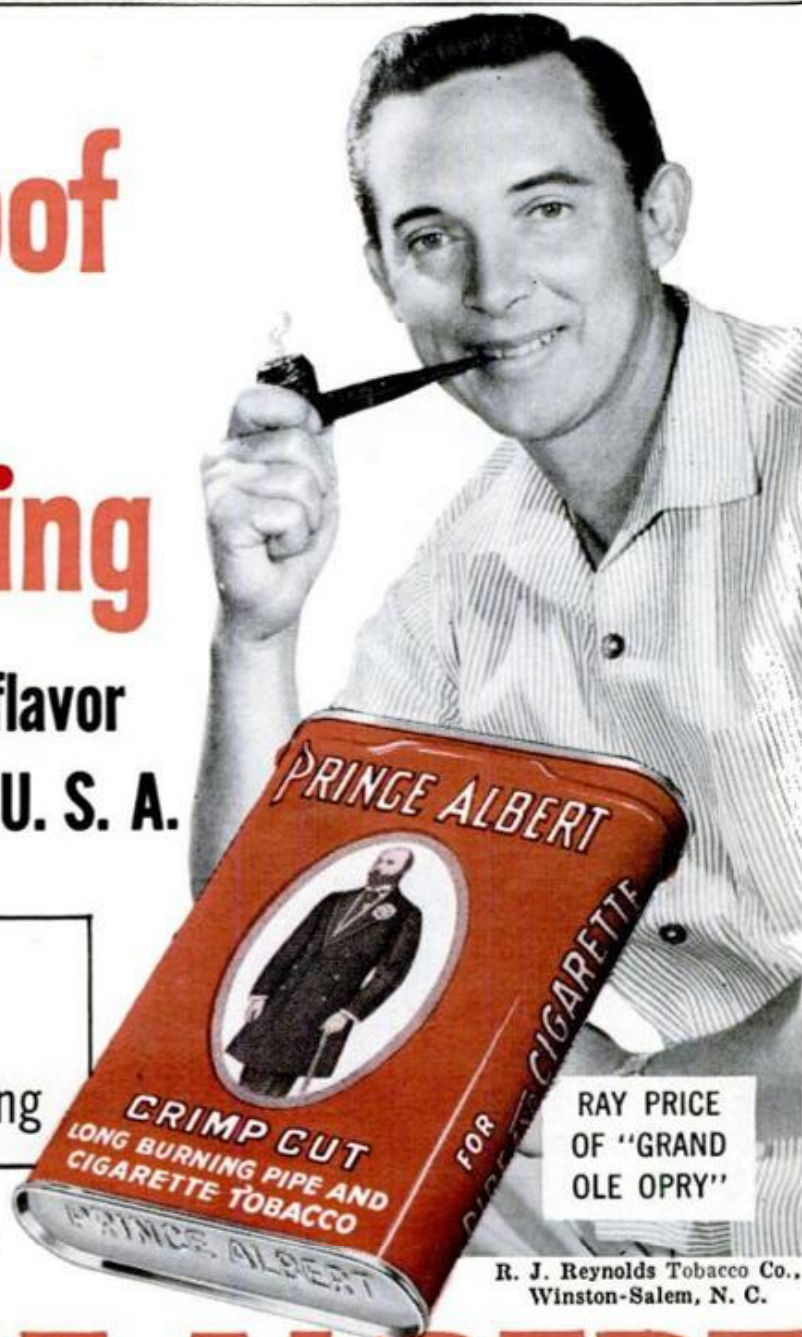

R. J. Reynolds Tobacco Co.,
Winston-Salem, N. C.

PRINCE ALBERT

Racing hobbyist discovers oil!



Recently, L. C. Kirby, of Dallas, Texas, discovered the richest, most complete motor oil in the world—new Pennzoil Z-7! He says:

"My hobby is my Allard Special. I redesigned and modified it—now I race it in class AA modified. When I discovered Pennzoil Z-7, I could actually *feel* the difference. More horsepower! Never any bearing trouble, even with a blower pumping 20 pounds. This calls for top performance at all times. And I get it with Pennzoil Z-7!

This amazing Pennsylvania oil is so rich it gives double the protection demanded—so complete it needs no extra additives. Refined from 100% pure Pennsylvania crude, it contains exclusive Z-7—an almost magical power ingredient that keeps engine parts so clean that the oil can go on lubricating long after most oils would wear out.

Ask your dealer for Pennzoil Z-7 by *name*. If he doesn't have it, he can get it for you.

*Richest, most
complete motor oil
in the world.*

Member Penn. Grade Crude Oil Assn.,
Permit No. 2, Oil City, Pa.



Mysteries of the Moon

By Paul Brock

Imminent journeys of man to the Moon may soon solve the mystery of what scientists call "Moon illusions." Some of these illusions have not been explained by even the most practical men of science.

For instance, look at the way the Moon fools us about its size as it rises and crosses the night sky. If we stand upright, the Moon on the horizon looks about three times the size of the Moon when it is overhead, but camera film shows it to be practically the same size all the while it is visible. Astronomers have been trying to explain this illusion for centuries, saying the Moon looks larger on the horizon because we compare it with trees and buildings in the line of sight, or that dust particles in the air distort our view. But any sailor will deny this, for at sea, without trees and dust, the illusion is just as great.

Oddly enough, the Moon's size stays normal if we look at it through a tube, or bend over and look at it through our legs. A man with one eye has no illusion.

One reason that the Moon's illusions are baffling is that there is usually some truth in them. Many doctors believe that certain abnormalities occur with the new moon in the human mind and body, but they don't know why. This is the origin of the word "lunacy," derived from the Latin "luna."

Farmers of former days used the magical influence of the Moon in their farming. An increasing moon was favorable to productivity, a waning moon the opposite, they thought. Under a waxing moon, grain was cut, eggs put under hens, sheep sheared and manure spread. Seeds were sown under a waning moon, so that plants could grow with the Moon. Even today, apple growers in Devonshire, England, gather fruit under a waning moon, believing that apples bruised at that time can be preserved without ill effect. In a series of experiments, Dr. Rudolph Steiner reported that maize planted two days before the full moon "ran away" from that planted two days later. Canadian farmers, in a test, reported that maize planted with the waxing moon yielded 30 to 40 percent more than that planted with the waning moon.

Another mystery is that the full moon is nine times as bright as a half moon, instead of being only twice as bright.

Such "Moon illusions" are a long way from being solved. Many scientists feel that the first men on the Moon will explain them. But others say that the lunar pioneers will face a great many additional illusions.

RAIN BIRD

Precision-JET*

*the greatest
lawn sprinkler
yet!*

Model
No. 25PJ-DA
on Sled
Base



*Pat.
Pend.

**NO BACK OR
SIDE SPLASH!**

Here is the greatest advance in lawn sprinklers since Rain Bird introduced the part circle sprinkler. New, exclusive Rain Bird arm enables the Precision Jet to confine water to desired areas while walks, driveways and patios stay beautifully dry. There's no puddling, no water waste with Precision Jet... There's just the even precipitation of water *where it's needed!*

A Complete Line of the Finest Sprinklers Made!

Precision Jet can be used alone or in combination with other fine Rain Bird sprinklers. See your local dealer, or write for PJ literature.

National Rain Bird Sales & Engineering Corp.
627 N. San Gabriel Ave. • Azusa, California

Here's one more proof...

PLIOBOND is the one adhesive that does the work of many

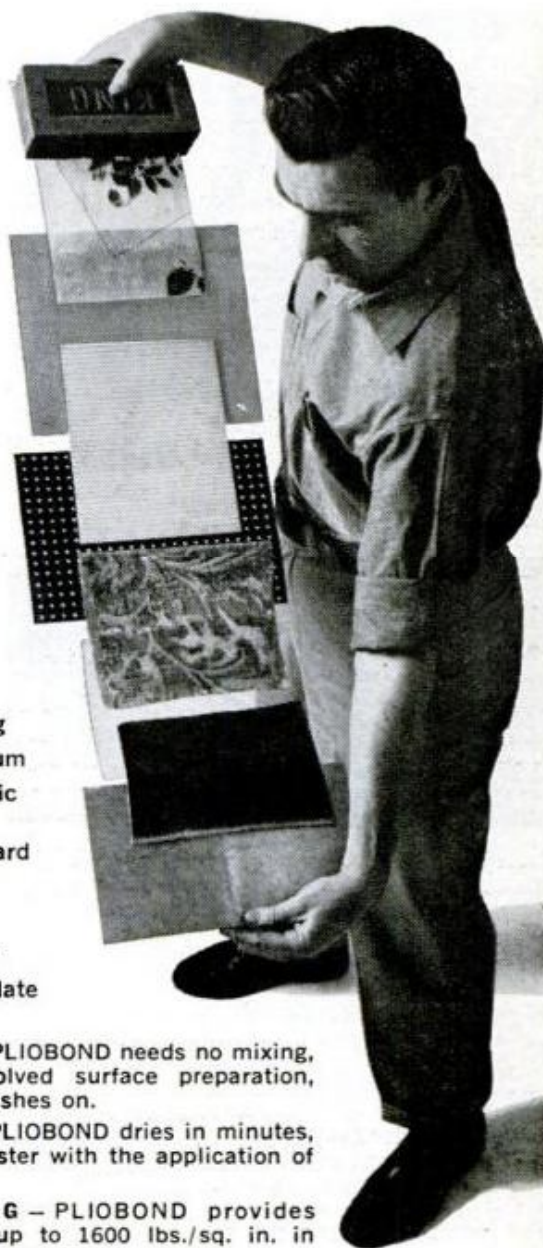

- Brick
- Plastic sheeting
- Aluminum
- Synthetic Rubber
- Hardboard
- Fabric
- Glass
- Leather
- Steel plate

EASY—PLIOBOND needs no mixing, no involved surface preparation, just brushes on.

FAST—PLIOBOND dries in minutes, even faster with the application of heat.

STRONG—PLIOBOND provides bonds up to 1600 lbs./sq. in. in shear tests.

LASTING—PLIOBOND resists heat, cold, water, most chemicals, oil—and age.

Goodyear, Chemical Division
0-9459, Akron 16, Ohio



Pliobond
BY
GOOD YEAR

CHEMICAL DIVISION

Pliobond—T. M. The Goodyear Tire & Rubber Company, Akron, Ohio

**GIVE
AMERICAN
CANCER
SOCIETY**

HIGH QUALITY — LOW PRICE!

NEW HAHN POW-R-BOY
"66" ROTARY TILLER

**pulverizes even
hard-packed soil!**

So light and well-balanced, women and children operate it easily. Instantly adjustable depth bar. Instantly detachable wheels. Five models, 2½ to 3½ h.p. Pulverizes to 6" depth, 16" swath — 24" with extension tines. New optional reverse drive. ONE-YEAR GUARANTEE. As low as \$124.95 in most areas.



WRITE TODAY
FOR FREE FOLDER
HAHN, INC. Dept.
EVANSVILLE 7, INDIANA PM-30



a world of difference
in **POWER**
and **SMOOTHNESS**



Rugged precision cut gears, heavy duty stainless steel bail and bearing-anchored gear mechanism provide a world of difference in power and smoothness.

2065 NL
\$29.95

NEW Shakespeare SPINWONDER®

Ingenious *Verti-Cross* level-wind, super smooth multiple disc drag, powerful 4 to 1 gear ratio and corrosion-defying construction are plus features of the new Spinwonder. Precision built by Shakespeare . . . world leader in reel design and engineering for over 60 years.

VERTI-CROSS® LEVEL-WIND

Variable speed level-wind (slower on forward motion) alternates a layer of cross with a layer of level winds. Eliminates line wedging, lets line flow off smoothly for longer casts.

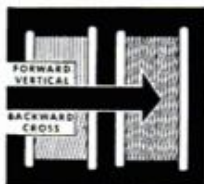

TWO SPOOLS WITH BUILT-IN MULTIPLE DISC SUPER-SMOOTH DRAG — STANDARD WITH EACH REEL

Salt water proven multiple disc drag (metal and leather disc construction) won't freeze up under the severest pressure—or burn out! No. 2065 with two factory filled spools, (One 200 yds. 6-lb. monofilament). Extra spool (225 yds. 10-lb. monofilament) all only . . . \$32.50
No. 2065 NL Two spools no line . . . \$29.95



NEW! FREE FISHING CATALOG

All fishermen will enjoy this big new 32 page catalog. "Techniques and Tackle to Catch Big Fish." Newest in reels, rods and lines. Plus pocket calendar showing best days to fish.

SHAKESPEARE COMPANY, Dept. PM-3, KALAMAZOO, MICH.
Please send me, absolutely free, your big new fishing catalog and 1960 pocket fishing calendar.

Name _____
Address _____
City _____ Zone _____ State _____

Urban Areas Engulf Resources

Urban growth in the United States—by causing cities and suburbs to spread out—is quietly locking up some of the nation's treasure in natural resources.

In California, where population has been increasing about 500,000 a year, the loss of resources is considered so serious that strong action has been taken in some instances to protect valuable natural assets.

New families require new roads, houses, stores and so on, and the buildings themselves require such raw materials as sand, gravel, cement and gypsum. Hundreds of tons of these materials are used every month in California. And here's what is happening, according to Harold B. Goldman, California Division of Mines' sand and gravel expert:

Producers of low-cost raw materials at first work deposits close to consuming areas. As the expanding community engulfs the mining operation, the residents regard the operation as a nuisance and apply close controls. The operators often leave at that point for another natural deposit which may not be so easily worked and which is farther away. This kind of move adds cost to obtaining materials.

Many undeveloped mineral deposits are now ringed by population centers and cannot be exploited owing to the difficulty of hauling materials through these cities.

Alarmed at the subtle but insidious effects of its explosive population growth, Santa Clara County implemented a plan to protect agricultural land from the onslaught of urbanization. In 1958, it set aside 40,000 acres in "greenbelts" zoned exclusively for farm use. Factories are banned.

In Los Angeles, consulting engineers were called to study sand and gravel resources in the San Fernando Valley. Areas suitable for production have been firmly zoned as gravel-pit sites. After depletion, they are to be restored for home sites.

Pits and quarries can be made more acceptable in a community through camouflage, using a protective strip of trees and shrubs to make a parklike area. On occasion, unusual byproducts are obtained from a mining operation. For example, a worked-out quarry has been filled with water and made into a recreation area. In Fresno an adobe-brick operation also helped level the ground for irrigation.

Recovering resources does not need to mean destruction to good farmland. It is entirely possible to strip off the topsoil and "bank" it until the operation has been completed. Then the soil is replaced.

How to build a BETTER CAR

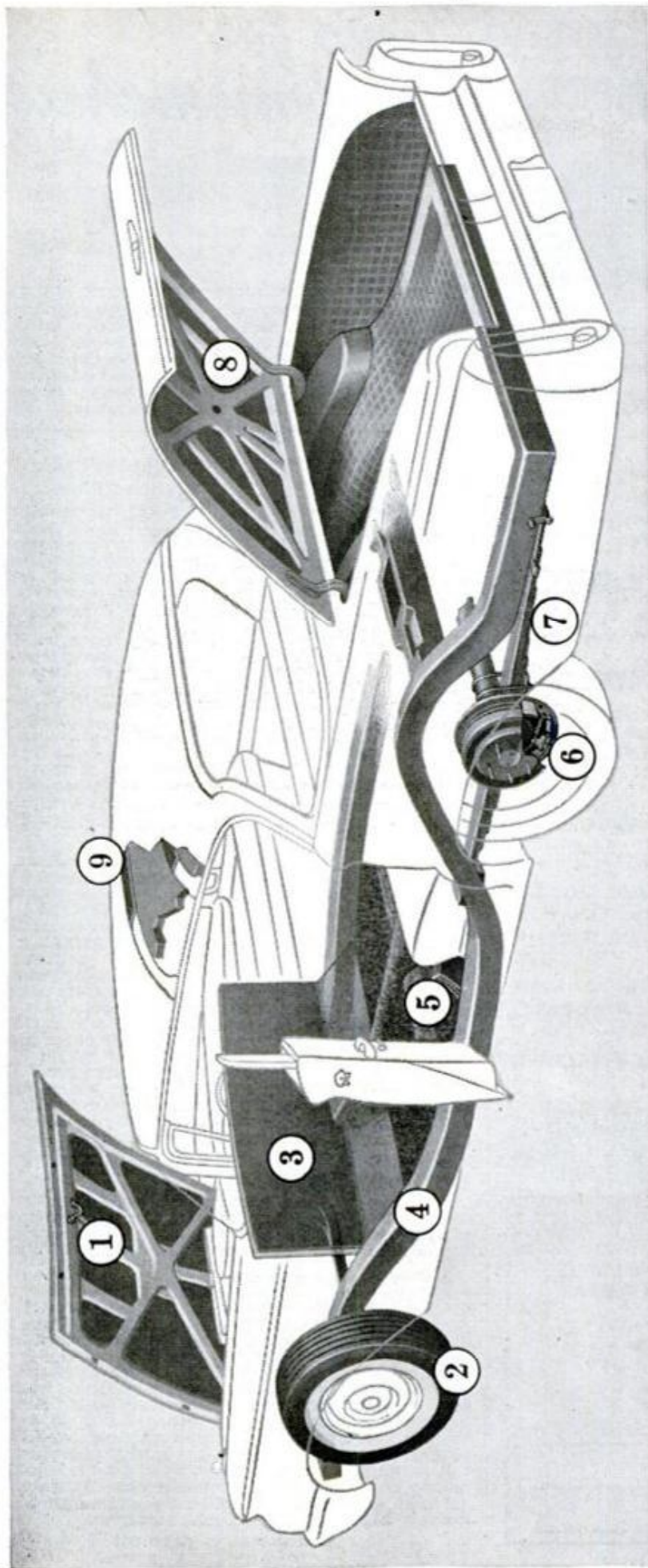

1. To prevent hood flutter and "drumming" use a double, rather than single, panel construction. Sandwich in a thick layer of asphalt-impregnated insulation to absorb engine sound. Hinge from the front for extra safety.
2. For extra traction and a softer ride use large tires (8.00 x 14).
3. To protect front seat passengers from engine sound and heat, use compound insulation for the dash panel. Install a thick blanket of high density glass fiber reinforced with a heavy mastic-impregnated face board.
4. For extra safety, use a box-type frame where the side rails safely surround the passenger compartment. These will act as effective side bumpers, help protect passengers in case of collision.

5. To check road noise, use asphalt-impregnated waffle paper on toe riser and on floor panels in front of seats. Also under rear seat. Next, cover floor panel with a heavy jute pad. Finish with "wall-to-wall" carpeting. Use a mastic deadener on underside of floor panel.
6. To eliminate the need for periodic adjusting, install self-adjusting brakes.
7. For maximum riding comfort install extra wide (2½"), extra long (60") rear springs with six leaves rather than four.
8. Build deck lid in same manner as hood: double-panel insulated construction. Cover trunk floor with waffle insulation and rubber mat. Install decorative side panels. Leave plenty of room for maximum luggage load.

Install spare tire in back of trunk away from normal-usage area.

9. To obtain an even greater degree of protection from heat, cold, and noise, place strips of waffle-felt insulation between roof bows and roof panel. Install four glass-fiber blankets on the underside of the roof panel between the bows.

... BUT IT'S EASIER TO BUY A

MERCURY

(WE'VE DONE ALL THE WORK FOR YOU)



Build a Liberty Home Yourself

SAVE \$5000⁰⁰ OR MORE



THE AMHERST

EASY TO BUILD... NO FINANCING PROBLEMS

Beat high building costs. The revolutionary new Liberty Ready-Cut method gives you a beautifully designed home... EASY TO ASSEMBLE... at unbelievably low cost. Everything is precision cut for exact fit... saving days of costly labor. You receive all framing and finish lumber, assembled windows, pre-fit mortised doors, oak flooring, insulation, self-sealing roof shingles, nails, paints, hardware, plus complete building plans and instructions.

78 DESIGNS... UNLIMITED PLAN VARIATIONS

Scores of beautiful homes to choose from, with designs and floor plans you can vary to suit your needs.

ALL THESE BUILDING SERVICES AVAILABLE

only with Liberty Homes

FINANCING NO PROBLEM—Liberty Homes are approved by lending institutions everywhere. Acceptable for FHA financing.

UNCONDITIONAL GUARANTEE—Your Liberty Home is covered by an unconditional guarantee for quality, quantity and soundness of construction.

SOLD DIRECT TO YOU—Liberty has no salesmen. You buy direct and save sales commissions. You make your own decision without high pressure tactics of any kind.

SAVE \$5000—You save on material cost, labor cost, contracting fees. You eliminate all middleman's profits, architect's fees and costly material waste.

100% QUALITY—Only materials of unquestioned quality are used. Your home will last a lifetime.

FREE CONSULTATION—The Liberty way is the foolproof way. However, Liberty's building consultants are ready to help you day or night. There's a Liberty Home near you... just ask us for the address.

Priced from \$3700... Freight Prepaid

FIND OUT ABOUT THE MOST SENSATIONAL HOME BUILDING OPPORTUNITY IN AMERICA TODAY.

Clip this coupon. Mail it with 25¢ for your **BIG** full-color catalog.

MAIL TO **LIBERTY HOMES**
1203 LAFAYETTE AVENUE, BAY CITY, MICHIGAN

NAME _____

STREET or RFD _____

CITY _____ STATE _____

Clinic for Homemakers

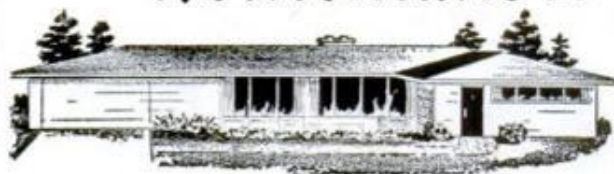

As a service to our readers in solving the hundreds of problems pertaining to a home—inside or out—the editors of *Popular Mechanics* invite you to present your problems to The Clinic Editor for help and advice. Address your questions to The Clinic Editor, *Popular Mechanics Magazine*, 200 East Ontario Street, Chicago 11, Ill.



Wallpaper Over Textured Plaster

Q—The walls of my living and dining room are plastered and textured and have been decorated with paint for many years. The texturing appears to have been done with a sponge, the surface being quite rough but lacking any regular pattern. I've often wondered if it is possible to apply wallpaper over this plaster. On some areas I believe it would be

possible, but on others where the texturing seems to be more deeply worked, I'm rather doubtful. Can papering be done satisfactorily over a textured wall?—T.H., N.J.

A—It can be done, of course, but we hesitate to recommend that you try it. If you experiment with a small piece of wallpaper of your choice you will see why. No matter how carefully you work it is practically impossible to force the paper to assume the contour of the surface without breaking at some point. It is difficult to keep the sheet straight while it is being applied. It is not possible, at some points along the edge of the sheet, to form a perfect butt joint with an adjacent sheet. This, of course, is due to the irregularity of the surface. Finally, in order to adhere securely, the paper must take the contour of the surface over which it is applied. In doing this it will reproduce the irregularities of the texture pattern, which may, or may not be desirable. These are reasons why we hesitate to advise for or against the application of paper over a textured wall surface.

Are Old Tools Valuable?

Q—Recently I was about to discard a number of old woodworking tools (they're family heirlooms), when a friend told me they are valuable as antiques. Are they? And how valuable?—N.A., Wis.

A—We do not appraise antiques. It is true, as you have been told, that certain old woodworking tools are quite widely sought by collectors. It is probable that the value that attaches to the individual tool is determined, to some extent at least, by such factors as condition, whether in working order or not, and its desirability to the serious collector. Also, it is quite probable that a very special value attaches to some items simply because of rarity, and not because of any use value to the collector. As an example, old surfacing planes and molding planes are fairly common and sell at what are usually considered very reasonable prices, but an original bow drill used by an early colonial craftsman would likely command a relatively high figure due to its scarcity.

(Continued to page 94)

“All personnel . . .
 clear the firing area . . .
 stand by for
 countdown . . .
 minus 10 . . .
 . . . 9 . . . 8
 7 . . . 6 . . .
 . 5 . . . 4 . . .
 3 2 . . .
 . . . 1 . . .”

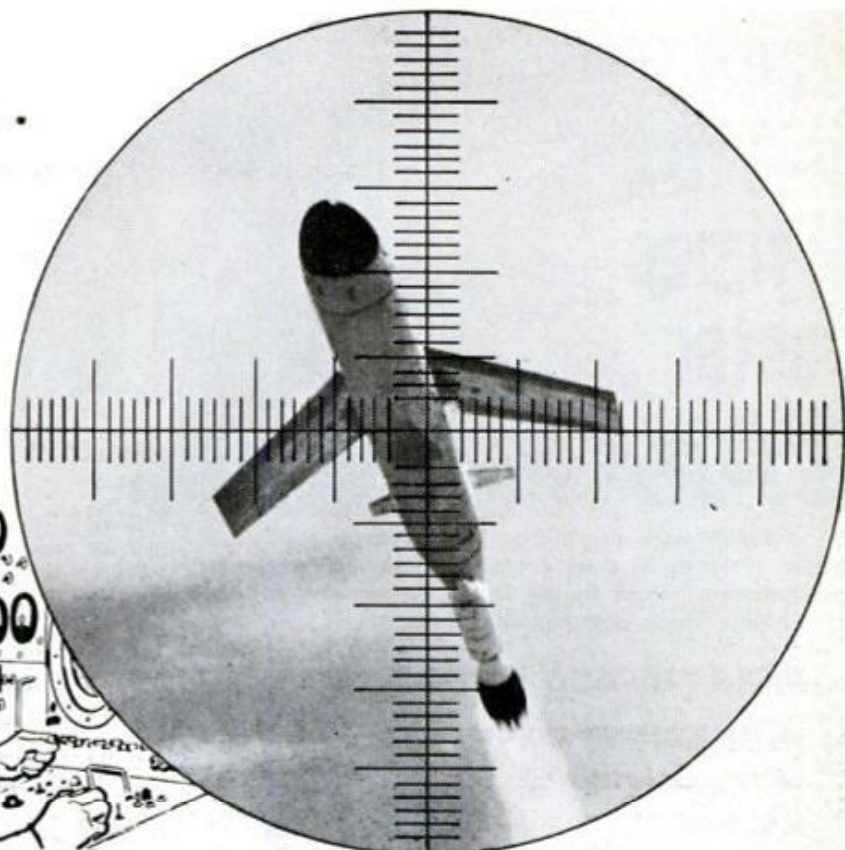
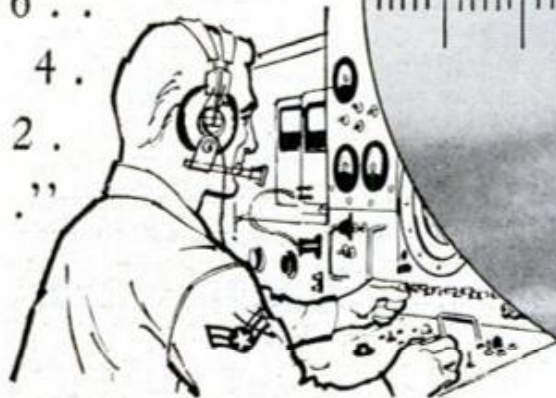

YOU MAY HANDLE A SITUATION LIKE THIS...

If you measure up to the Aerospace Team

A man in this situation requires cool judgment and an aptitude for advanced technical training. This is the kind of man who can measure up to the qualifications of the U. S. Air Force. He is the kind of man who can build a career in the Aerospace Age that will be meaningful and rewarding.

Are you that man? As a trained and experienced Air Force technical specialist, you

will have the opportunity to work with the intricate equipment of the Aerospace Age—the age of air and space travel. You will enjoy steady advancement and solid security. And you will be superbly prepared for the future.

If you would like to learn more about the many unique advantages that go with a career in Air Force blue, fill in and mail this coupon today.

U.S. AIR FORCE

There's a place for tomorrow's leaders on the Aerospace Team

PASTE COUPON ON POSTCARD AND MAIL TO:

Airman Information, Dept. MM03, Box 7608, Washington 4, D. C.

Please send me more information on my opportunities in the U.S. Air Force. I am between the ages of 17-34 and reside in U.S.A. or possessions.

Name _____

Address _____

City _____ Zone _____ County _____ State _____

Paint it 4 to 8 times faster with a **SPRAYIT**®



Do a week's worth of painting in a week-end, and do it better, with one of these professional-quality compressor paint sprayers! Made by the world's largest manufacturer of portable spray painting equipment.

SPRAYIT 400 — \$39.95

- ¼ h.p. motor-compressor
- adjustable nozzle
- 8 ft. hose
- unbreakable nylon gun
- sprays any type paint



Tough-hearted compressor keeps a steady 18 lbs. pressure in the spray gun. Sprays exterior and interior oil, latex paint, water-soluble, multi-color, stains, lacquers, enamels, varnishes, insecticides, etc. Precision made, guaranteed for a full year.

SPRAYIT HOME-PAK — \$39.95

- extra-powerful compressor
- uses any ¼ or ⅓ h.p. electric motor
- pulleys and belt included
- professional type spray gun
- 15 ft. hose



Best dollar-for-dollar buy in spray painting equipment! Powerful enough to spray your house. Compressor delivers 2.5 c.f.m. at 30 lbs. pressure—for faster spraying than outfits costing much more. Sprays any exterior or interior paint.



SEND for new "HOW TO SPRAY" book 10c brings you picture book of tips and techniques for professional-looking results every time. Shows how to paint a house in a week-end. Dozens of ideas.



THOMAS INDUSTRIES INC., Dept. PM
207 E. Broadway, Louisville, Ky.

Write your name and address in margin, and mail with ten cents.

(Continued from page 92)

Drilling Small Hole In Plaster



removed. Is there a way to do it?—N.O., Ore.

Q—I need to drill several small holes in plaster. Using a twist drill seems to chip out the plaster around the hole. I tried resharpening the drill at different angles but did not succeed in correcting this tendency. I also tried sticking tape over this point where the hole was to be drilled, but this didn't help as small pieces of plaster came out when the tape was

A—If the twist drill could be held perfectly straight while the hole is being drilled you would not experience this trouble. The fact that in drilling by hand you tend to wobble a bit causes the drill to bind against the side of the hole. This is what breaks out the small pieces of plaster. If you have a high-speed portable electric drill you can usually drill holes in plaster without chipping. But if you must use a hand drill, then it's best to improvise a suitable "bit". Cut off the head of a nail, the body of which is smaller than the diameter of the hole required. Flatten the pointed end slightly and then grind the flattened point to an included angle of about 10 deg. Make a light punch mark in the plaster at the point where the drill is to enter, then start the drill, using very light pressure at first. A drill improvised in this manner is quite reliable as it does not bind and rarely causes chipping.

Open Joints In Tile Floor



Q—Some months ago I laid tile in my kitchen and now I notice that some of the joints have opened and several of the tiles are loose in front of the sink. My problem is what to do. If some of the tiles are loose then isn't it likely that they will all loosen in time? And should I replace only the loose tiles or should I relay the whole floor?—W.R., Okla.

A—Several questions immediately come to mind. The answers to these might pinpoint the cause of the trouble. Did you follow the instructions for laying tile in all details? Did you smooth, by sanding or planing, the old floor, and did you use a recommended underlayment? Did you make sure that you were spreading the right amount of cement, not too much or too little, but precisely the amount recommended by the manufacturer of the tile? How old was the cement? Had it always been kept in a tightly closed container? We raise these questions because in so many instances, trouble with tiled floors occurs simply because installation instructions have not been carefully followed. However, instructions cannot always be all-inclusive. For example, failure of a tile floor may be due to some condition peculiar to the room or the structure, or the location of the structure in which the tile have been installed. That's one reason it is not always possible to say with certainty what caused the trouble. In your case, we are inclined to guess that the cause of loose tiles here and there over the floor and particularly in front of the sink—where the floor gets hard service—is simply insufficient cement in the areas affected. If this conclusion is correct then it probably will be best to lift the loose tiles, clear away all old cement, apply new cement under each individual tile and replace, pressing the individual tiles into all-over contact with the subfloor or underlayment.

NEW **BT₃** ENDS TUNE-UP GUESSWORK!



NEW TUNE-UP CONCEPT BALANCES CARBURETION, COMPRESSION AND IGNITION TO RESTORE NEW CAR POWER!

Maintain the new car power, performance and economy that was designed into your GM car. Get a BT-3 tune-up . . . the *balanced* tune-up, three ways.

With this new concept, your compression, ignition and carburetion are checked, adjusted and restored to new car condition. Every replacement part is factory approved. For example, all carburetor parts are genuine parts for Rochester-GM

Carburetors . . . original equipment on more new cars than any other carburetor. And the whole step-by-step, scientific procedure of BT-3 is factory recommended.

Stop wherever you see the BT-3 sign, and enjoy the new car performance that only a balanced tune-up can give. Or if qualified service is your business, contact your nearby UMS distributor to learn how to give BT-3 to your customers.

GM
ROCHESTER CARBURETORS
GENERAL MOTORS

America's
number one
original equipment
carburetors

ROCHESTER PRODUCTS DIVISION OF GENERAL MOTORS, ROCHESTER, NEW YORK

Too much flexing wears out people and tires...

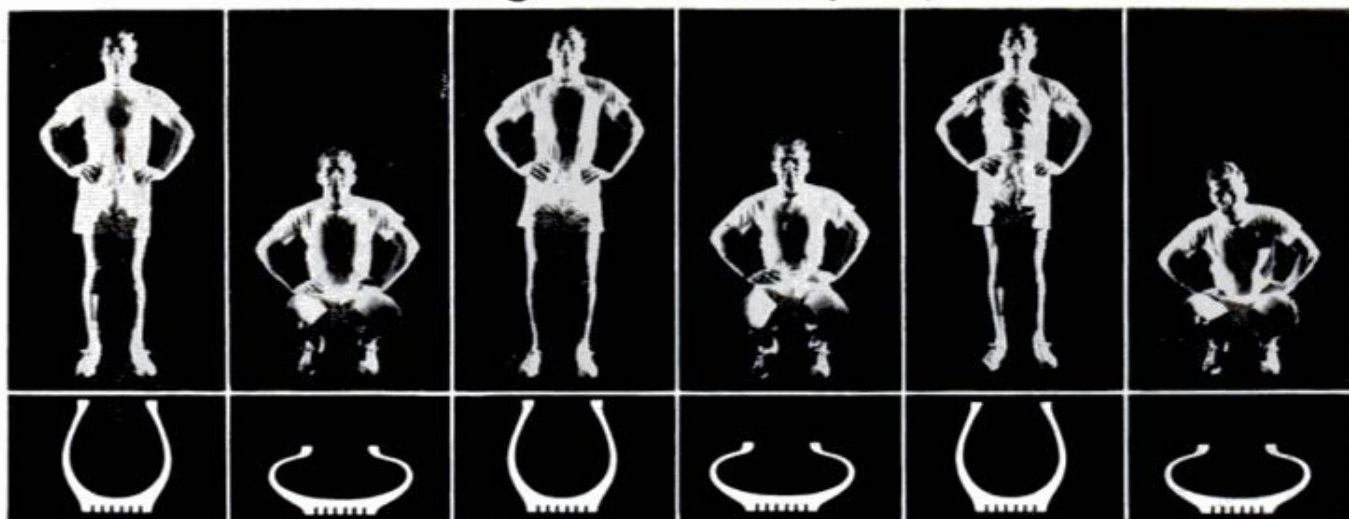

The new *Low Profile* tire shape flexes less reduces heat build-up, increases mileage!

THE TIRE THAT DOESN'T GET TIRED

**SAME AIR PRESSURE . . .
BUT—LOOK AT THE DIFFERENCE**



ORDINARY TIRE



U.S. ROYAL
LOW PROFILE* TIRE

ORDINARY TIRE SHAPE flexes excessively building up intense heat that murders tires, pushes the temperature of ordinary tires above the crucial 240°F. danger zone. "**LOW PROFILE**" TIRE shape keeps temperatures well below danger zone. Running hours at top highway speeds, U.S. Royal "Low Profile" tires stay cooler, keep you far safer.

PIONEERED BY U.S. RUBBER AS THE ANSWER TO GREATER TIRE SAFETY

Takes regular air pressure . . . yet it's lower and wider to keep you safe at top highway speeds

Excessive flexing heats up a tire just the way it heats up *you!* And at today's highway speeds the tortuous heat build-up wears out ordinary tires fast, increases blowout risk.

New U.S. Royal "Low Profile" tires were designed specifically to overcome this hazard. Though they take the same air pressure as ordinary tires, they're lower and wider to flex less, run cooler, wear better.

No need to risk tire failure. "Low Profile" tires cost no more than ordinary tires. See the *complete* line in 5 popular price ranges for every model car at your U.S. Royal Dealer.



U.S. ROYAL LOW PROFILE* TIRES

US United States Rubber
Rockefeller Center, New York 20, N. Y.

*"Low Profile" is U.S. Rubber Company's trademark for its lower, wider shape tire.

We're Going to Work Miracles

The atom's power is ready to unlock a treasure chest of arctic oil, dig open an Alaskan harbor, open the spigot for Colorado's shale . . .

By Dr. Edward Teller

WHEN YOU LOOK AT A MAP of Alaska, you will observe Point Hope, at the northwest corner, projecting out into the Arctic Ocean. Above Point Hope the shore is exposed to the polar ice pack—which even in summer is never far offshore. Ships can travel north of this point only one month in twelve.

But below Point Hope, the shore swings to the southeast and the sea is free of ice three months of the year. Nearby are coal deposits and, somewhat farther, oil that might attract commerce except for one vital lack: There is no harbor, no good anchorage for seagoing ships.

If all goes well we expect to make an artificial model harbor on this bleak coast in the spring of 1961. It will be a small harbor, and yet it will be an

Dr. Edward Teller, "father of the hydrogen bomb," is director of the University of California Radiation Laboratory at Livermore





In a matter of milliseconds, five nuclear bombs will blast open a new harbor in Alaska. The channel will be 1800 feet long and 750 feet wide; the inner harbor, about a half mile long and a quarter mile wide

Deep-buried bombs fling only surface material into air. Radioactive substances stay near the zero point

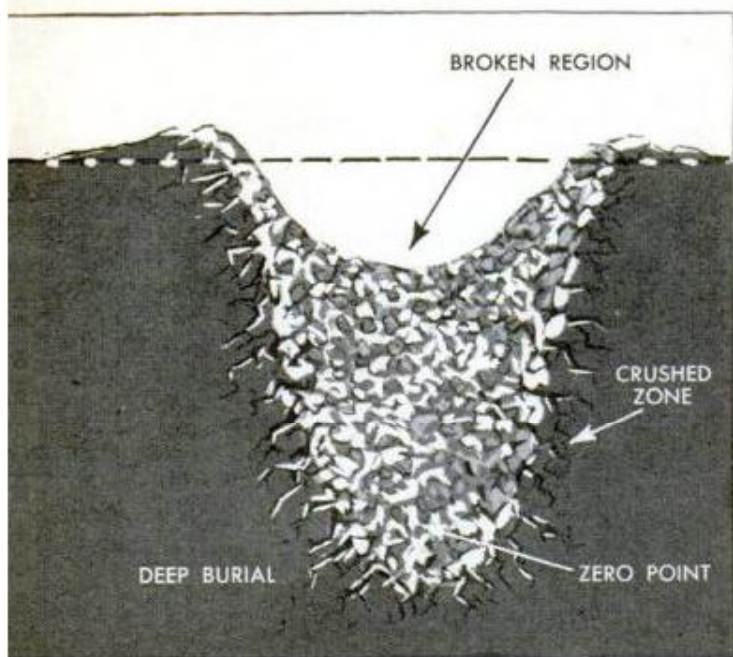

experiment of great hope for the future. The harbor will be excavated in an instant—in a matter of milliseconds—by the explosion of five nuclear bombs having approximately as much power as 500,000 tons of TNT.

In that tiny interval of time this energy will move 20 million tons of earth and rock. It will blast out a channel 1800 feet long and 750 feet wide and at the same time create an inner harbor a quarter of a mile wide and half a mile long. The minimum water depth will be around 30 feet.

The site is 100 miles north of the Arctic Circle, below Point Hope and Cape Thompson, at the mouth of Ogotoruk Creek.

Project Chariot, as the harbor is called, may become very worthwhile in the years to come, but it is intended mainly as a demonstration that will usher in the age of peaceful uses of atomic explosions. We expect to show that this new kind of power can perform large earth-moving jobs with proper safety and at less cost than conventional methods.



The remote site was chosen deliberately to allay any fears of radioactive contamination. However, there will be very little contamination. To accomplish this, we will use a trick to prevent the possible escape of fission products.

If the nuclear devices were to be exploded at shallow depths, almost all radioactive particles would be thrown up into the atmosphere. So we will bury the bombs deep—about 400 feet below the surface for the small ones and possibly 700 feet for the larger ones. Each blast will transmit its energy to the rock above it, flinging only the surface materials into the air.

We expect that all except 10 or 20 percent of the radioactive byproduct will be trapped at the deep zero points and we hope that it will remain practically immobilized in the fused rock. It is possible that we shall succeed even better and that all but a very small percentage of the radioactivity will be safely contained underground. In a short time, possibly two weeks, it will be

Shading indicates Project Chariot harbor; the blue line shows how harbor can be enlarged, if desired

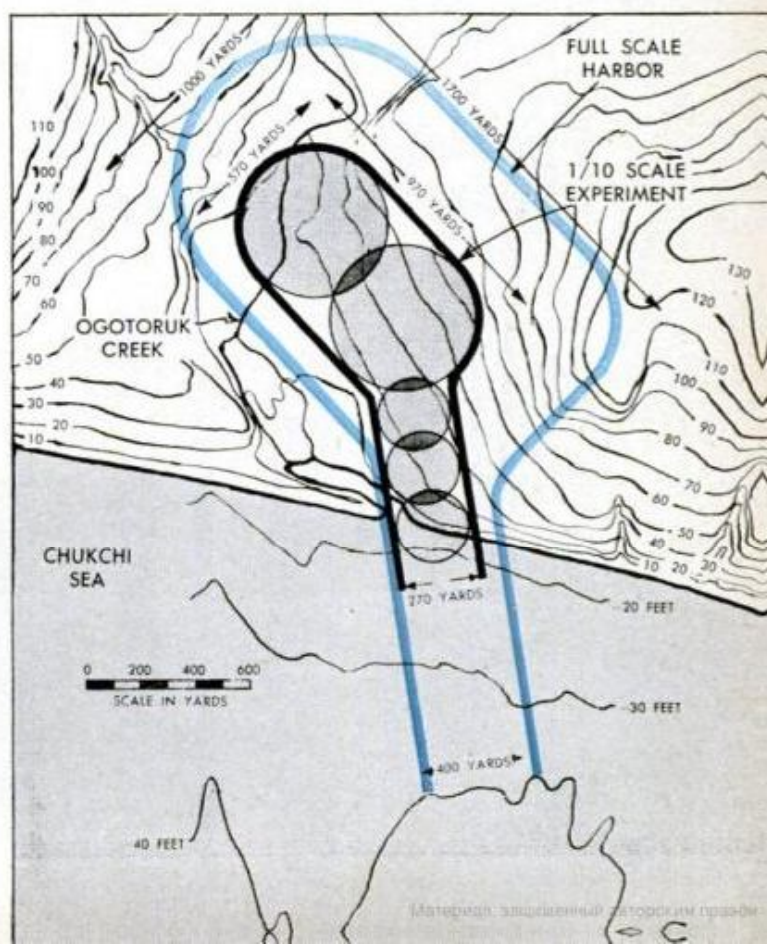

possible for people to work safely in the immediate vicinity of the explosion.

The mechanics of this are based on several underground test shots that have been made at our Nevada test site. The bombs ranged from one tenth of a kiloton to 23 kilotons in power and were detonated at different depths below the surface. From these experimental shots, we learned a great deal about underground blasts and how much fallout to expect.

Preparations for building the Alaskan harbor are under way now. Last summer 140 people from the Atomic Energy Commission, other government organizations and several universities started surveys in the area. They are studying the geology and making biological surveys of the plant and animal life. They are investigating the food "chains" and the habits of the few local Eskimos, their food sources and their hunting and fishing areas.

Similar surveys will be made at some future date after the creation of the harbor. Thus we will learn whether any local conditions were changed by the blasts. This is indicative of the care and caution with which we are approaching this first large demonstration.

I believe that the dangers from fallout in the weapons-testing program have been greatly exaggerated; nevertheless, this worry exists and so we are trying to develop "clean" bombs. Within a few years,

we may be able to produce explosives that are completely clean, with no radioactive fallout and no local residual contamination.

Project Chariot is part of the AEC's Plowshare program for exploring constructive, peaceful uses of nuclear explosives. Studies have been going on for several years and the whole Plowshare subject is now declassified with the exception of the black box that contains the nuclear explosive itself and which we might call Hamlet, as it is the main actor in the drama. Our present necessary secrecy requires that Hamlet shall not appear on the stage for the time being.

If Chariot is successful, we will have the knowledge and experience for creating a harbor wherever one is needed. Its size and shape can be tailored to the local requirements. Several future locations have been considered, as has the possibility of sea-level canals that would be dug in roughly the same fashion as Chariot's entrance channel.

With similar techniques, we can remove the overburden from large bodies of low-grade ore and at the same time shatter the ore so that it can be mined by ordinary means or by one of the suggested leaching processes. Deep ore bodies that are too expensive to mine today may also yield to nuclear mining.

The AEC has established estimated charges for nuclear explosives, including

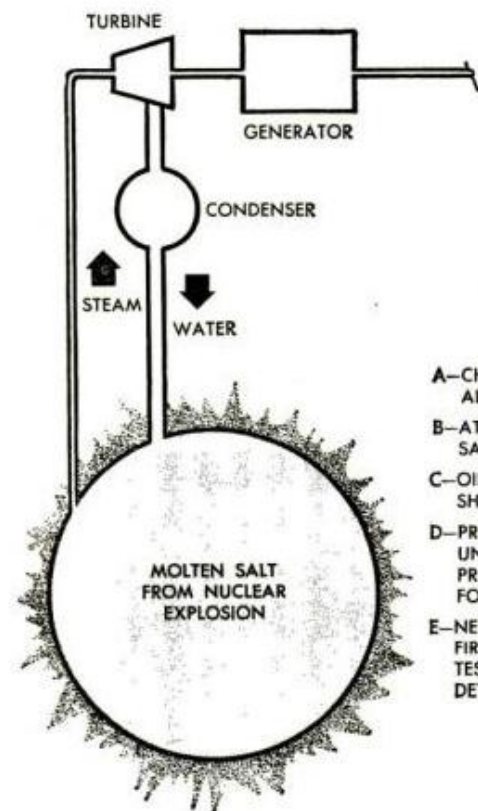

Five experiments of the Atomic Energy Commission's Plowshare program are located on the map. Project Gnome will test the possibility of "mining" heat from an underground nuclear blast to generate electricity. Simplified drawing shows how water would be pumped into the deposit of heat and then extracted as steam to run a turbine

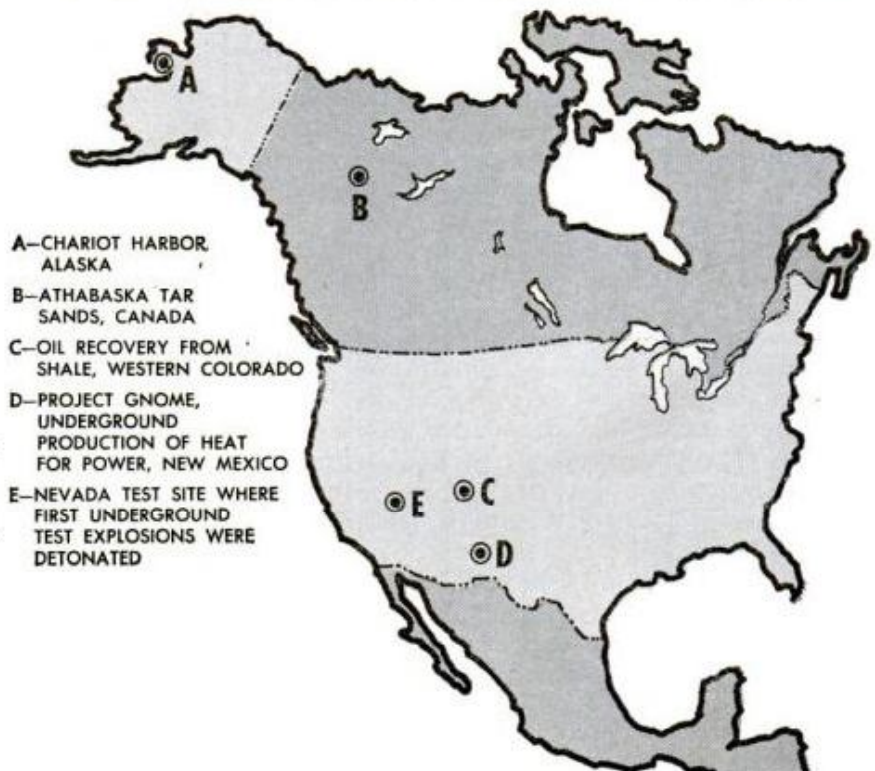

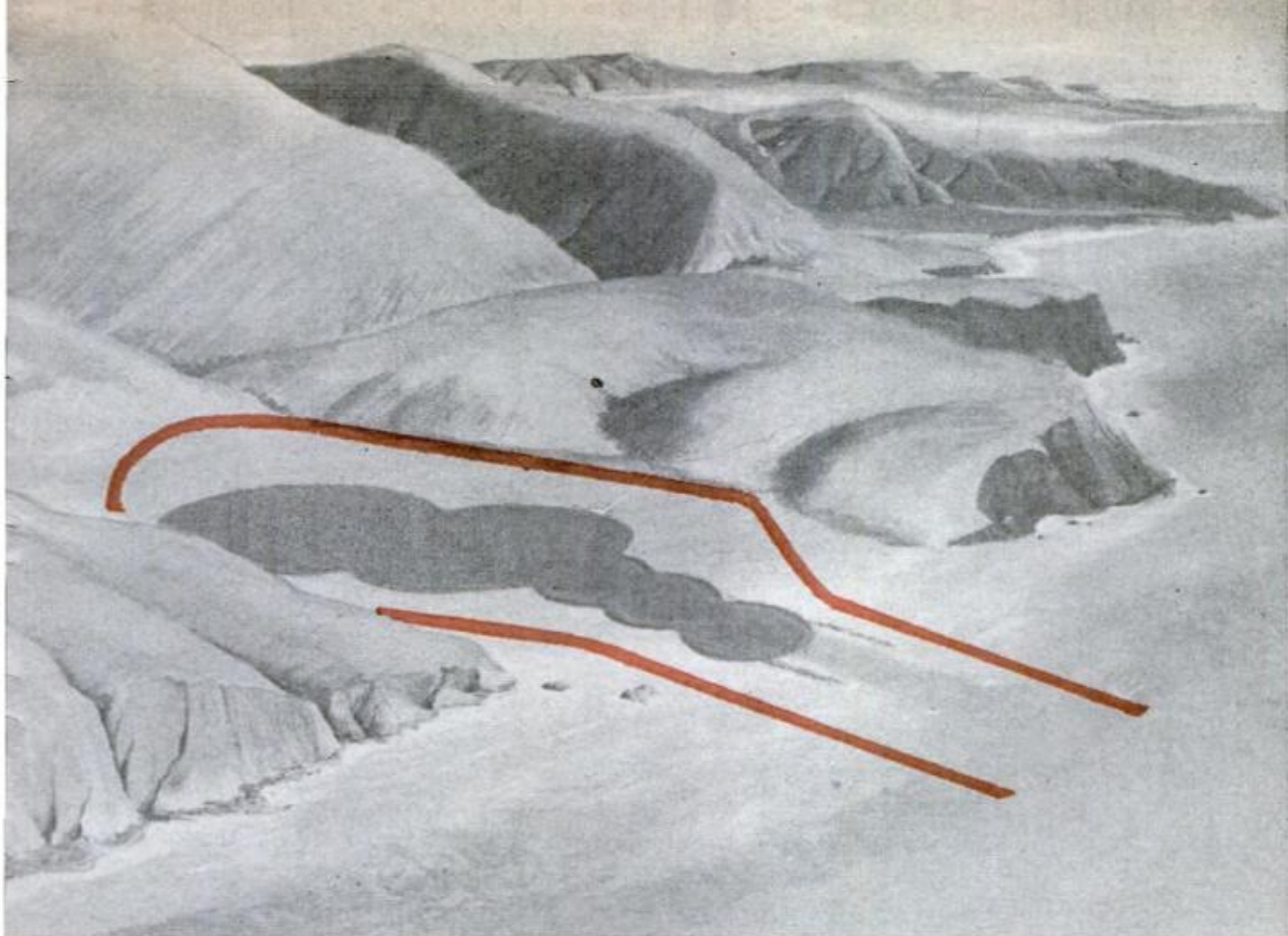

Project Chariot in Alaska not only will test the possibility of excavating a harbor by nuclear bombs but will also make accessible nearby coal and oil deposits. If needed, the harbor can be expanded to the red line

their emplacement by the commission. Estimates range from a half million dollars for a few-kiloton yield to a million dollars for a megaton bomb. Larger ones would cost only a little more. Future developments may decrease the charges. For the kinds of work we have in mind, we believe the nuclear explosives are cheaper than conventional explosives and in some cases can do work that is quite impractical by any other means.

People talk about putting the cart before the horse, and in this absurd age this is not so unusual; all of us have seen horses carried along in trailers. In a somewhat similar way, we may be able to use nuclear energy to make available more of the old conventional fuel which nuclear energy is supposed to replace. In particular we might use nuclear explosions in oil production.

Why should anyone do that? Because a nuclear reactor emits dangerous radiations and so needs heavy shielding, which makes it clumsy as a motor for a small vehicle. Furthermore, an accident to any moving vehicle driven by a reactor might get us into real trouble. If fission products stored up in the reactor get loose, there will be enough concentrated radioactivity in the neighborhood to constitute a serious hazard. For the purpose of transportation, the light and compact energy package that is gasoline or oil remains better than anything else known or expected. Yet our in-

expensive oil stocks are nearing the point where their decline can be foreseen.

It might be possible to extract more petroleum from deposits that are regarded as depleted by exploding nuclear devices in the formations, shattering the oil sands and perhaps also providing the heat so that the oil may flow more freely.

In the Athabaska River region of northwest Canada there exists a tar sand that contains as much petroleum as all the oil of Arabia. On a hot day the tar drips from the exposed banks, yet no cheap way of extracting it has been found.

A proposal that is being studied by the Canadian Government and the Richfield Oil Company is to explode a 10-kiloton charge at the bottom of a 1200-foot hole in the Athabaska tar sands. From what was learned at the underground test shots in Nevada, we would expect the explosion to create a huge bubble in the earth which almost at once would fill up with shattered rock falling from above. We hope that the radioactive products of the explosion will be trapped in the bubble's glassy lining. If the rock in and above this bubble is sufficiently broken up, and if the material does not get compacted and does not resolidify too rapidly, we have opened a passage for a heating fluid to the tar sands and we can thaw out the petroleum. In fact, the heat of the explosion itself might be used.

(Continued to page 278)

AN EYE ON SPACE

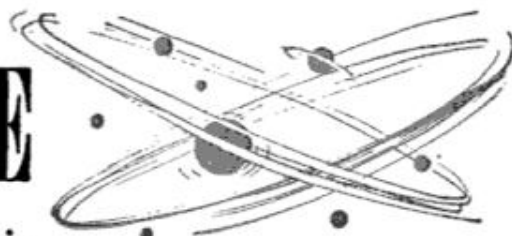

By Dr. Dan Q. Posin

PROFESSOR OF PHYSICS, DE PAUL UNIVERSITY
SCIENTIFIC CONSULTANT AND ADVISOR, COLUMBIA BROADCASTING SYSTEM

NOW THAT WE are getting ready for manned space travel, it would be well to prepare ourselves mentally for what awaits us. It is not too early to think seriously about the other "worlds" in space, because we Earthlings probably will be making personal landings on the Moon in about five years or sooner; and on Mars and Venus within 10 years.

The Moon, because of its relative nearness, will be the first tramping ground. There is no air on the Moon, no water, no vegetation. The Moon clearly is not a prospective paradise, although because of its low gravity, walking, jumping and scrambling around will be a picnic. And, in view of the photographs taken by Lunik 3 of the other side of the Moon, we now know somewhat better what to expect as we walk, jump and scramble over our satellite.

The planet Mars certainly will prove exciting. It has about one-tenth the atmospheric pressure of Earth; there is snow at the Martian poles, and snowfall has been observed in other regions; there is, seemingly, some sort of vegetation and some water. The remote possibility remains that Mars had beings who reached the peak of their culture billions of years ago, and who built great engineering projects. This was the view of the American astronomer, Percival Lowell. And recently, a Russian scientist has suggested that the two small Martian Moons are artificial satellites put up perhaps several billion years ago. In any case, at least some low form of life is expected to be found on Mars.

Venus has become increasingly interesting of late. A balloon sent up by Earthlings not long ago, carrying a large camera-telescope, rose above nearly all of our atmosphere and took some fine pictures of Venus. Upon analysis, these showed that Venus has water vapor. Therefore, Venus may have bodies of water, vegetation and some types of life. A discouraging development, however, is that a new measurement of temperature through a study of radiations from Venus, indicates an average temperature of more than 560 degrees F. When we recall that water boils at 212 degrees F. on Earth, we wonder how life could be present at such a supertemperature. We must not forget, however, that the value of 560 degrees F. is only an average. Tropical values are higher in temperature on Venus, but polar regions may be low enough to permit some life forms to exist.

Other planets are not likely to have life on them. Mercury is barren and has a temperature that rises to more than 770 degrees F. (on the side facing the sun). There is no atmosphere on Mercury. Jupiter has ammonia and marsh gas in its atmosphere. So does Saturn. Uranus, Neptune and Pluto are too far away from the sun, hence too cold to support life as we know it.

But, there are certain bodies that we have neglected for a long time. Some of the Moons of Jupiter and Saturn, despite being cold, may have favorable atmospheres.

If I were leading a program of manned exploration, I'd vote for space ventures in this order: our Moon, Venus (closer to us than Mars), Mars, the Moons of Jupiter, the Moons of Saturn. Ready to buy *your* ticket?

(For a table of information about our Solar System, turn to page 238.)

First of the BIG Small Cars: The COMET



By Arthur R. Railton

Neatly finned, the Comet is stylish. You'll get no small-car reputation with this good looking parked in your big-car neighborhood

IT HAD TO happen. It was inevitable. Just as a Mercury must be bigger than a Ford, so Mercury's compact car must be bigger than Ford's.

The Comet, the new compact car sold by Lincoln-Mercury dealers, is the first of several "big" small cars that will be appearing shortly. Whether all will be "big brothers" of the earlier compacts remains to be seen. Certainly, the Comet is.

Except for sheet metal, it is virtually a carbon copy of the Falcon, sharing most of the Falcon's body shell. It is 14 inches longer over-all. Of these 14 inches, $4\frac{1}{2}$ are in a longer wheelbase (114.0 Comet, 109.5 Falcon), about $1\frac{1}{2}$ inches are in front overhang, and the remaining 8 inches are behind the rear axle in added trunk room. With the exception of trunk space, interior dimensions are identical with the Falcon's (trunk volume is 26.6 cubic feet, almost 3 cubic feet more than the Falcon has). Comet station wagons even share the Falcon's wheelbase.

As you would expect on a car named Comet, it has tailfins. But these are modest, unassuming fins that accentuate the "big-car" look without domineering. Even the I-hate-fins crowd won't object to these. Because of the fins (and a few other styling tricks), this car has a scaled-down big-car look about it. It is just enough longer, just enough more horizontal to eliminate completely the roller-skate look of the Falcon, despite its blood relationship.

Most noticeable part of the car is its roofline which is patterned after the Thunderbird town-car styling. (This roofline is becoming as common to Ford products as the flattop is to GM products.)

There's a lot of Mercury in the Comet's front-end styling. It has dual headlights and even sports gunsights on the fenders





Well-proportioned and roomy are Comet's two station wagons: This four-door, plus a two-door. Both have 109.5-inch wheelbase

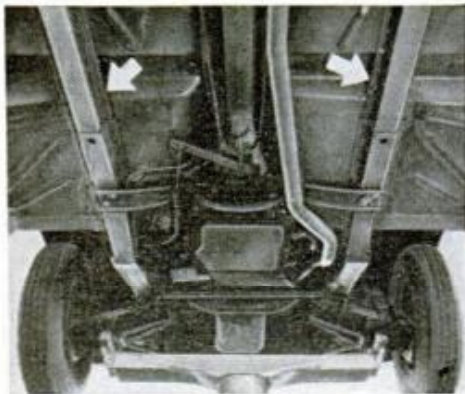

Although it is essentially a Falcon shell, the Comet's is not identical. Arrows point to two structural members that are added to floorpan to reinforce the longer body

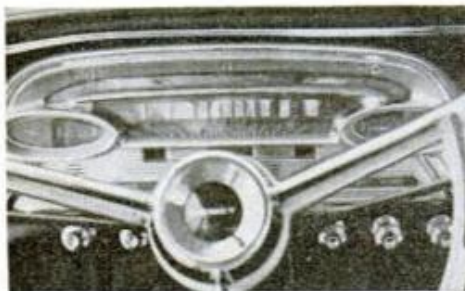

Instruments are neat and easy to read. The hardware is more substantial, upholstery is richer than in the other new compacts. Below, four-door has a trim profile

All Comet sedans have this distinctive roof. Unlike its little brother, the Comet has the luxury of four headlights set in a concave aluminum grille.

Interiors are beautifully done without any feeling at all of austerity. Once you step inside the Comet the compact-car image evaporates.

Ride is excellent, being quiet, soft and relaxed. Suspension is conventional, high coils in its front independent system (with Falcon's unusual single-strut lower arm), long leaf springs in the rear with normal Hotchkiss. The leaf springs are 50 inches long, 2 inches wide with full-length butyl liners for quietness and dampening.

Steering is unhurried, with plenty of the big-car feel that Dearborn planners are convinced you want (no power options are offered). Over-all ratio is 27 to 1. Turn-circle diameter is 39.3 feet, which is slightly over two feet more than the Valiant's, six inches more than the Falcon's and exactly the same as Corvair's.

Acceleration, too, is unhurried, even by compact-car standards and it's downright crawlish by V8 standards. Even with the 3.56 rear axle, it is unlikely that you'll get to an honest 60 miles per hour in less than 21 seconds. Although no comparison tests have been run by *PM* at this time, it is estimated that economy will be 10 percent less than the Falcon's. Thus, if the Falcon gets 22 miles per gallon around town, the Comet will get about 20.

The engine is, as in the Falcon, a six-cylinder, inline, water-cooled, front-mounted power plant with 144.3-cubic-inch displacement. Horsepower is rated at 90 and compression is 8.7 to 1. Rumors are that the Comet was originally planned with more displacement (the stroke was to be 3.00 inches instead of 2.50, but time ran out and it had to be marketed with the Falcon engine). This 2.50-inch stroke (shared with the Falcon) is the shortest in the industry and should give excellent durability.

Because it weighs about 250 pounds more than

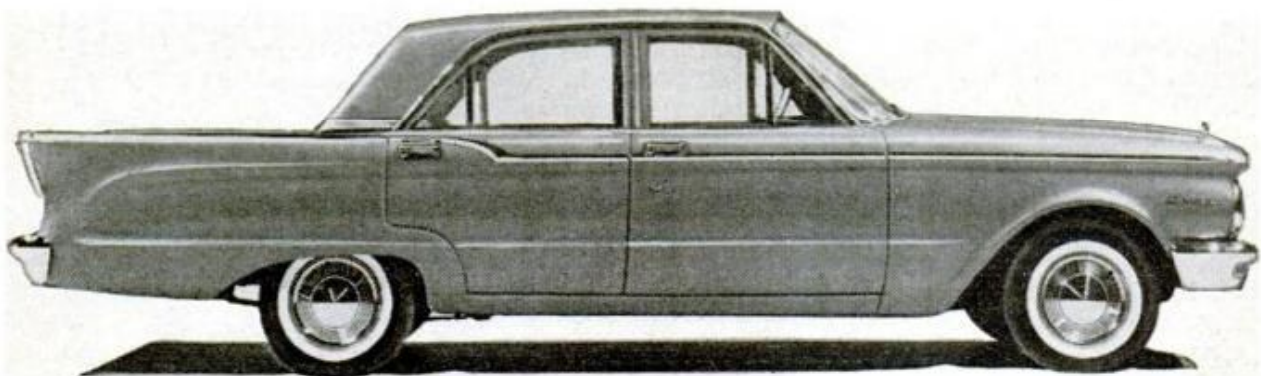

Right, certainly nobody will say that this interior shows any austerity. Below, the trunk space is large although so low that the spare tire is horizontal

the Falcon and yet it has no more power, the Comet is not "hot" by any standard.

But it does look and feel like a full-size automobile. By standards of just a few years ago, it is a full-size automobile. It is, no doubt, the size automobile the Ford-Chevy-Plymouth cars would be if the industry had not lost its sense of proportion.

It is almost identical in over-all size to the 1954 Plymouth. Both have a 114-inch wheelbase, both are 194 inches long (to be precise, the Comet's is 194.9). There has been a reduction in height of course, the Comet being 9.1 inches lower than the 1954 Plymouth. The Comet is narrower also.

But the big difference (here is where the engineer takes credit) is in weight. This new Comet weighs only 2412 pounds, making it 624 pounds lighter than the 1954 Plymouth. This lightness means more economy, less tire wear, better performance per horsepower and a generally more nimble automobile. Yet despite its lightness, it is roomier, handsomer, more comfortable than the low-price cars of only six years ago. Here, then, is added evidence of the return to reason the public demanded—and even more evidence is on the way. ★ ★ ★

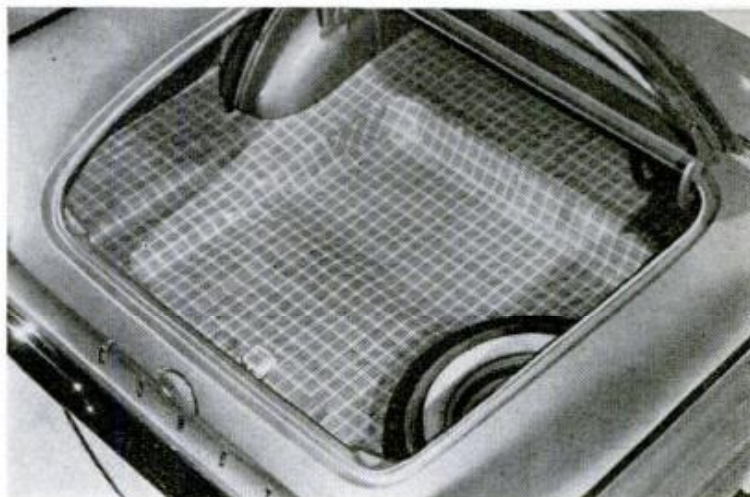

Chrysler 300F

America's only sports-type touring car, the Chrysler 300F, offers a handshift gearbox. The four-speed transmission is an extra-high performance option for competition use. It is the French Pont-a-Mousson fully synchromesh transmission and comes only with a 400-horsepower engine option.

Standard is a 375-horsepower engine and Torque Flite automatic transmission.

The interior has four separate contoured seats with a tachometer-carrying console covering the floor hump.

Right, stubby lever of the four-speed transmission. Finger points to the tachometer. Below, the 300F

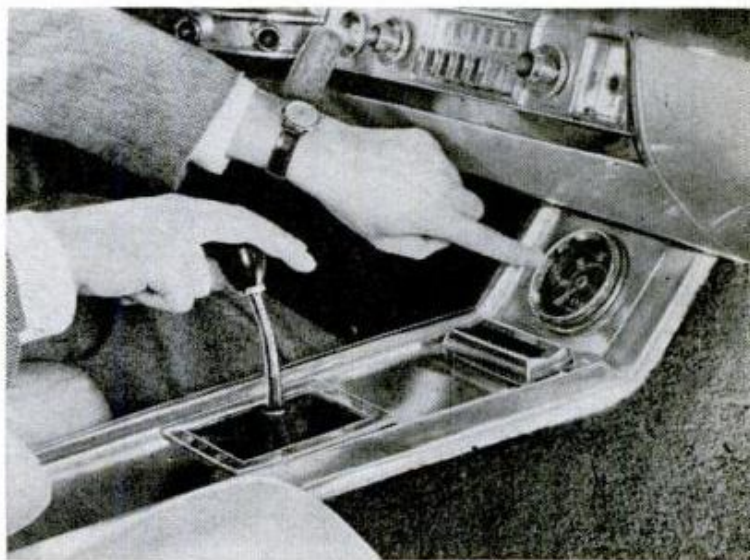

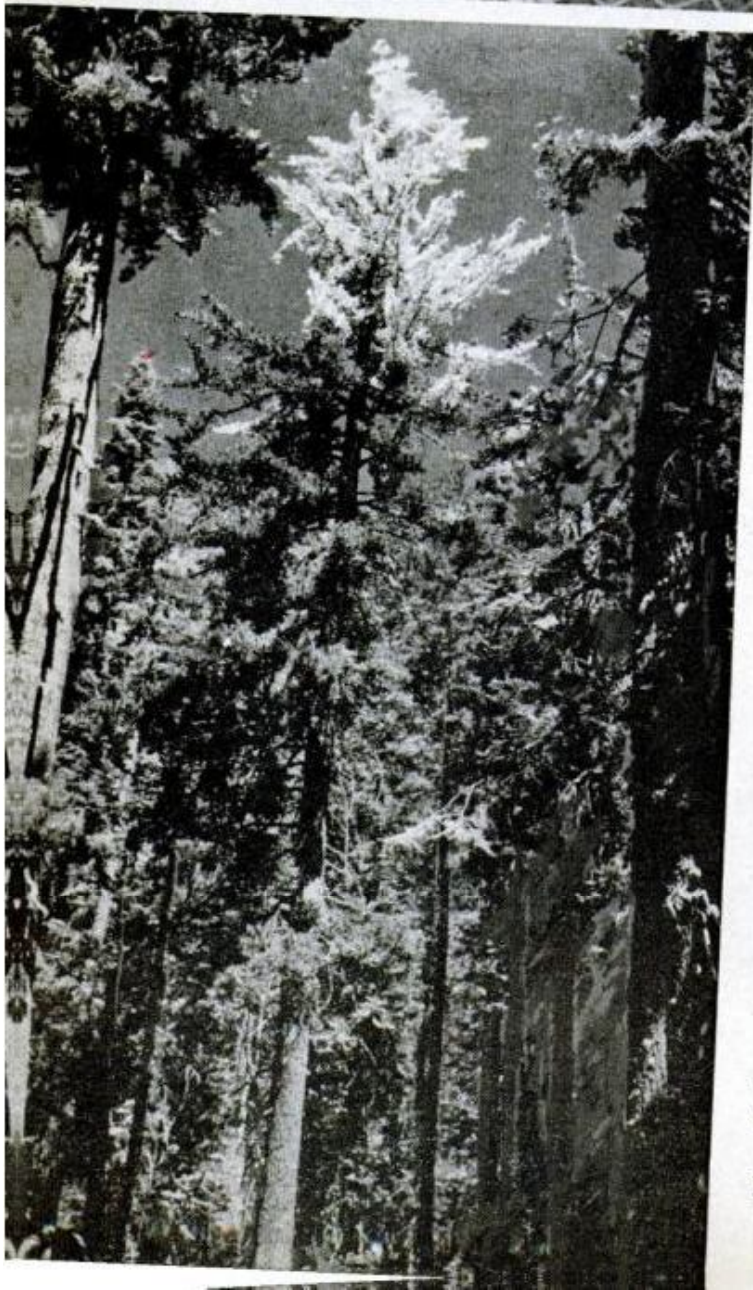

Should We Let Nature Take Its Course?

By J. D. Ratcliff

This sugar pine has been attacked by mountain pine beetles (*dendroctonus monticolae*) and its top killed
American Forest Products Industries photo

106

POPULAR MECHANICS

Left, two Canada geese, trapped in a net, are removed by a biologist so that they can be tagged for study

POSSIBLY YOU SAW these news items:

- A few months ago thousands of pounds of fish poison were dumped in the Deerfield River in Massachusetts. Object: After destruction of trash fish, the stream would be restocked with trout.

- The U.S. Senate recently passed a bill to set up an eradication program for dogfish sharks in Pacific fisheries. Object: Destruction of a pest which each year consumes thousands of tons of food fish.

- Lately, woolly aphids which suck sap of fir trees have been costly pests in Maine forests. To control them the U.S. Forest Service not long ago imported aphid-eating beetles from West Germany.

- Several years back, imported Barbary sheep were stocked in arid western states as a big game animal—with no thought that they would ever increase enough to become a nuisance to farmers and ranchers.

On the surface, all these projects look worthy. But there is growing evidence that they can backfire—and with disastrous consequences.

We like to think of nature as orderly and “balanced.” Actually it is as tippy as an overloaded canoe, and man is the great boat rocker. Almost anything can upset the balance—with catastrophic results.

Ecology, one of the least known but most fascinating of the sciences, deals with matters of this kind. It is the study of the complex relationships that exist between living creatures and their environments. No form of life stands entirely alone. Bacteria enrich soil, and worms aerate it so it can produce plants. The plants in turn are consumed by rabbits, and the rabbits by foxes. The foxes die, provide nourishment for soil microbes, and the whole cycle starts again.

Knowingly or not, man must follow the same set of ecological rules that govern destinies of whales, mice and sparrows. Each year these rigid rules assume increasing importance—as a growing population exerts even greater pressure on the available food supply.

Almost anything can tip nature's skittish balance. In 1939 a great windstorm uprooted thousands of spruce trees on Colorado's White River Plateau. Normally, bark beetles are kept under control by woodpeckers. But the birds couldn't get at insects feasting on fallen trees. Result: Beetles, with everything favoring them, increased prodigiously. In numbers which overwhelmed the bird population, they

Skeletons of once mighty trees dramatize the fact that disease and insects kill as much timber as fire

American Forest Products Industries photo





U.S. Fish & Wildlife Service photo

Two-day-old antelope kids shortly after they were tagged at the Sheldon National Antelope Refuge, Calif.



U.S. Department of Agriculture photo

Testing a poison, an entomologist places it on a fire-ant mound; colony will then be examined daily

swarmed forth to attack. In a few days they destroyed 400,000 trees in one check area. In a single mass flight millions of the insects fell into a small lake. Washed ashore, they made a drift six feet wide and a foot deep. By 1951 they had devastated hundreds of square miles of Evergreen forest—destroying five billion feet of lumber worth \$25 million! Then weather intervened to restore a semblance of order. A severe freeze killed the beetle population.

Ecological relationships often have baffling ramifications. Thus New York's St. Patrick's Day parade traces quite directly to a fungus—the one which a century ago destroyed the potato crop in Ireland. The famine that followed launched waves of immigrants to the New World. Charles Darwin related the amount of honey produced in an English village to the number of old

maids! Old maids had cats, cats ate birds and birds ate bees. Thus, a relationship between maiden ladies and honey produced.

There are scores of examples where apparent enemies are friends in disguise. We object to insect "pests"—but without insects, plants would go unpollinated and life would soon vanish from the earth. Farmers complain of the fox that eats an occasional chicken, but foxes earn their keep by subsisting mainly on crop-destroying rodents.

Wild ducks nest in May and skunks and crows feast on their eggs. Bad, we say. But is it? Ecologists aren't so sure. They point out that food and protective cover are sparse during early spring and that newly hatched ducklings would likely be destroyed by predators. When a first clutch of eggs is destroyed, ducks often lay a second—at a later and more favorable date.

Female gypsy moths and their egg masses are clustered at the base of a tree. Gypsy moths, imported from Europe in 1869, have caused millions of dollars in tree damage. At right is an infestation of tent caterpillars

American Forest Products Industries photos

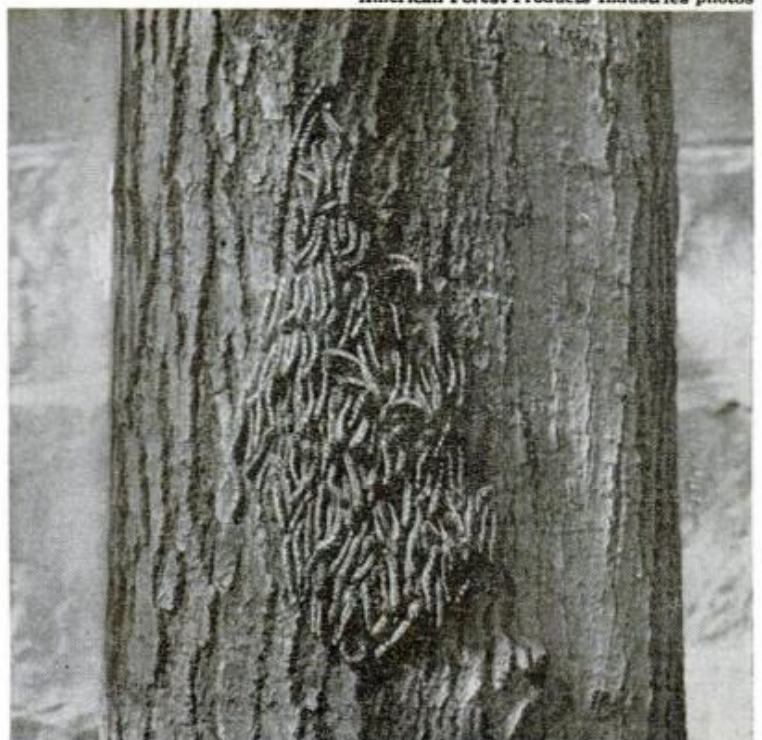

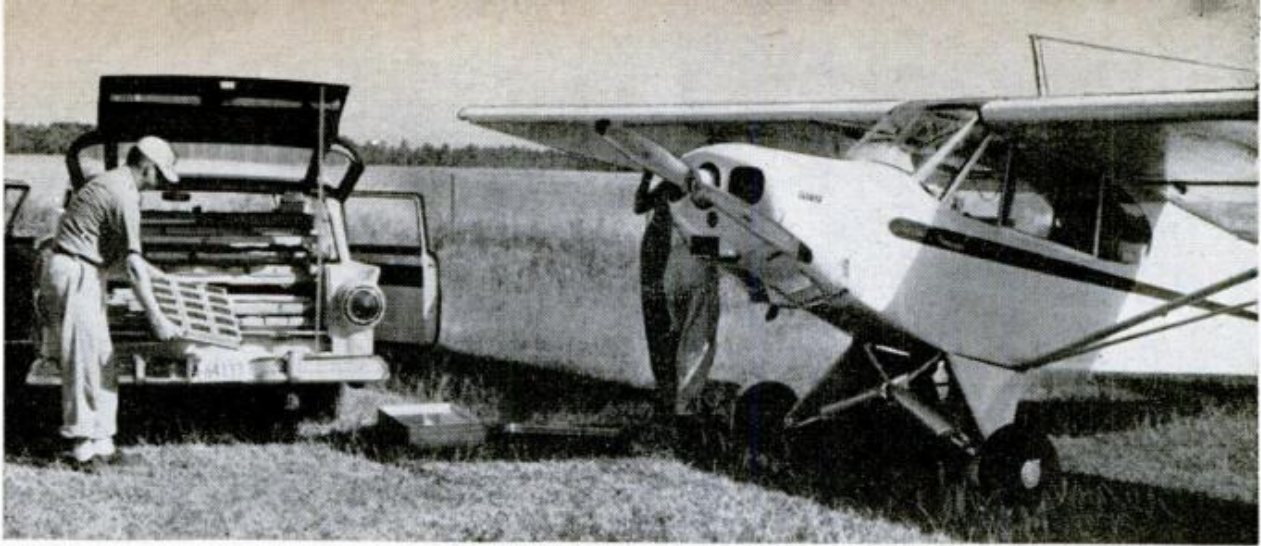

U.S. Department of Agriculture photo

Radiation-sterilized screwworm flies are loaded onto a plane for distribution in an area where the flies are a nuisance. Since a female mates only once, her union with a sterile male ends her productivity

Experience on a western lake offers a good example of the friendly enemy relationship. Sportsmen felt the trout catch would soar if fish-eating otters were destroyed. A program of otter extermination got under way. Instead of increasing, the trout disappeared! An ecologist found the reason. Otters fed mainly on sickly, slow-swimming fish. Thus, they actually aided in maintaining the health of others. With otters gone, sickly fish passed their diseases to healthy ones, and all perished.

A similar situation arose in Ireland's Lough Corrib, one of Galway's most popular sporting lakes. Officials decided to war on coarse fish, hoping to increase the trout population. A slaughter of pike and perch followed. As is so frequently the case, things didn't work out as planned. Trout turned to snails and aquatic insects previ-



U.S. Department of Agriculture photo

Irradiated screwworm-fly pupae are placed in boxes to mature; these pupae grow into sterile adult flies

Portable blacklight insect trap, which collects a variety of species, is used by entomologists in survey work. Animals feeding on one another—as the coyote with rabbit, at right—help maintain nature's balance

U. S. Department of Agriculture and Fish & Wildlife Service photos

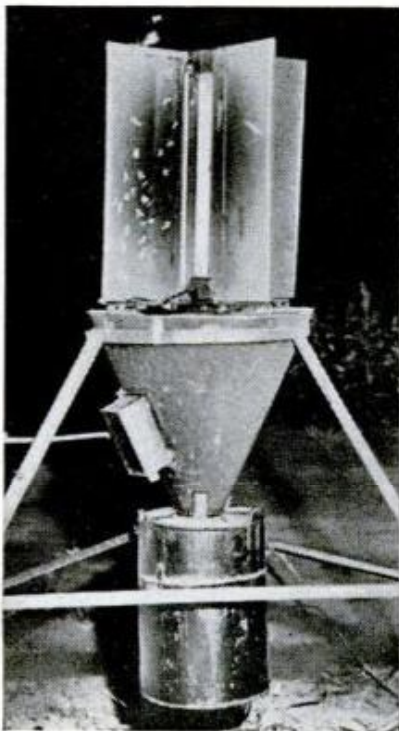



In just two months, water hyacinths spread to cover an area of two square miles on the Nile near Khartoum

ously consumed by pike and perch. On this diet, they developed worms, sickened and appeared to be dying off.

In Alaska, wildlife officials decided to rid streams of Dolly Varden trout, which consume salmon eggs. A bounty of five cents a tail spurred wholesale destruction. With trout gone, there was an enormous increase in sticklebacks—a small, spiny fish. They developed an even greater appetite for salmon eggs than the trout.

Of all the forces acting to tip nature's scales, man is among the most formidable. Says Clifford C. Presnall of the U.S. Fish and Wildlife Service: "Man is the most efficient, ruthless predator on earth." A case in point is the destruction of 60 million buffalo that once roamed the North American Continent—the greatest big game herd in historic times. Thousands of animals were slaughtered to provide a single table delicacy, buffalo tongues. Repercussions

Sudanese workers, walking on a bed of water hyacinths up to three feet thick, spray to get rid of the plant



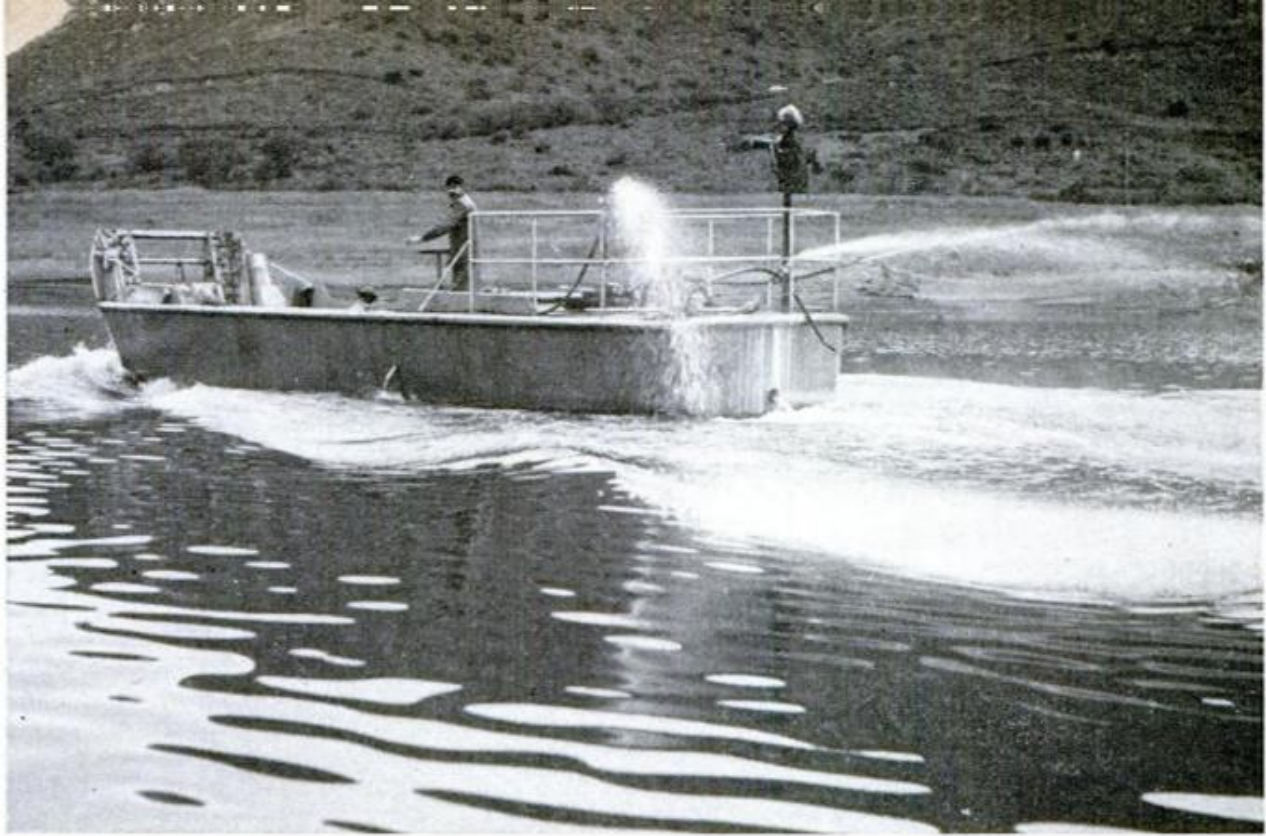

Mud-stirring carp were killed and removed from San Diego water reservoir to improve the quality of the water

were enormous. Indians, dependent on buffaloes, faced starvation. The big animals were natural prey for wolves. When they were gone, wolves turned to cattle. Settlers then declared war on wolves and virtually eradicated them. Coyotes moved into this "biological vacuum" and became a major pest in their own right, destroying sheep and other domestic animals. But are coyotes bad? Ecologists think not, since crop-destroying rabbits and field mice have al-

ways been major items of the coyote diet.

Man's obliteration of buffalo was almost complete. He is widely—and unfairly—blamed for total eradication of another species, the passenger pigeon. The last one on earth died in the Cincinnati Zoo in 1914. At one time, this bird was present in almost incomprehensible numbers. In 1804 one flight darkened the sky for several hours. It was estimated to be 240 miles long, one mile

(Continued to page 242)

Five million stunted crappie were killed in Big Bear Lake, Calif., before lake was stocked with rainbow trout

California Department of Fish & Game photos

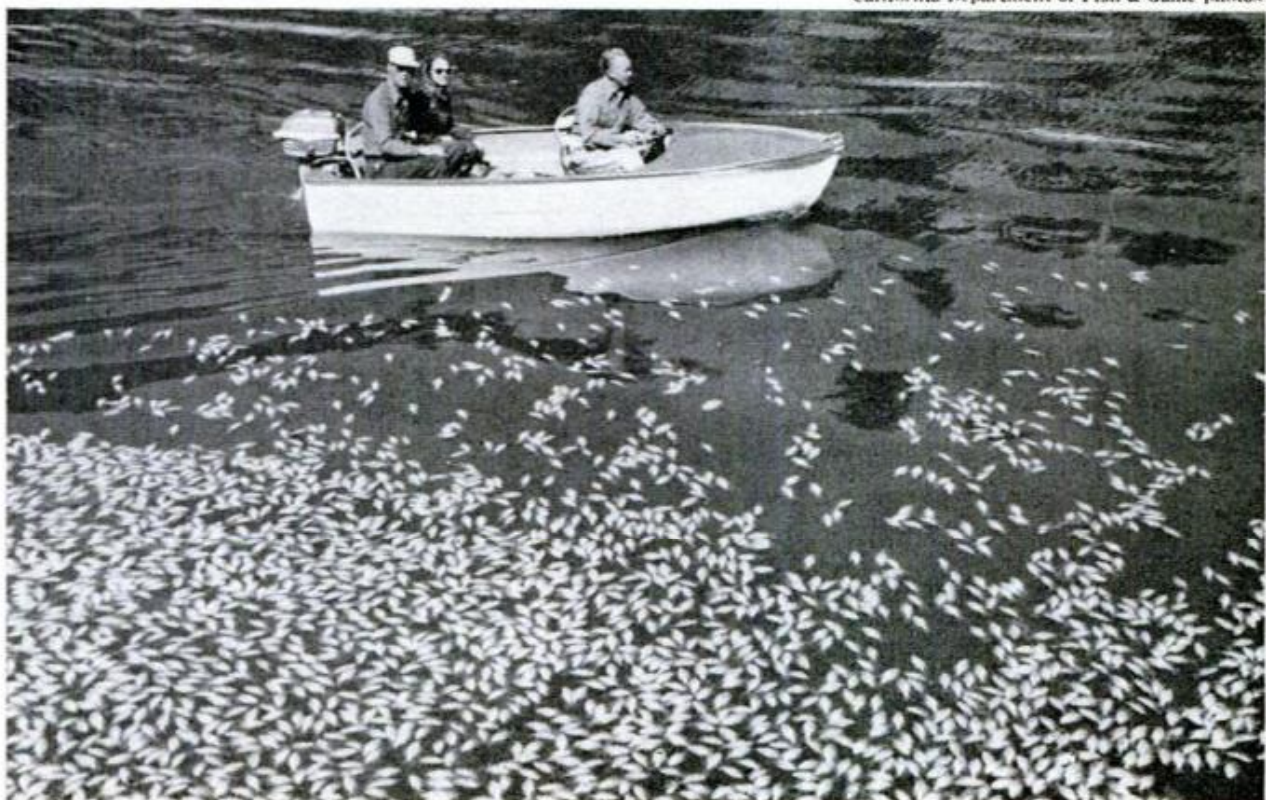



DETROIT LISTENING POST

By Art Railton

HOW THIN CAN you slice the cake? That's the dilemma of the industry. A few years back the concern was the diminution of models, now it's the multiplication.

Talk about population explosion! Detroit is having a model explosion. New ones are popping up like mushrooms in the rain. Comet is out with a full line, including two wagons. Falcon offers two wagons. Lark added a four-door wagon and convertible this year. American added its four-door sedan and now offers a new Custom line with the overhead-valve six. Corvair adds a two-door coupe and is "testing" public reaction to its Monza GT coupe.

Next year will come the Buick-Olds-Pontiac compacts (all will have the same small V8 engine), Dodge's stretched Valiant, Corvair's buslike station wagon.

How thin can you slice it?

At the moment, all is bullish. Falcons make up 27 percent of total Ford Division sales. When Falcon wagons are out in volume, the percentage will jump sharply (Rambler American, for example, sells 40 percent wagons). Soon Falcon sales will equal big-Ford sales. Soon the tail wags the dog. Valiants already amount to 40 percent of Plymouth production.

The compacts are busting the business wide open. And the not-too-amazing thing is that they don't seem to be hurting imports at all—not even the large-size imports. The compact revolt may have given these imports the air of respectability they needed. No longer is it off-beat for an adult American to want a smaller car—it's becoming fashionable as well as sensible.

Word is that the 1961 Rambler American is more stylish than anything American Motors has done to date. Those who have seen it are goggle-eyed. Gone is its present obesity. It will have modern, forward-looking flat roof, thin doors, straight sides. It retains the same floor pan and length.

It will have the overhead-valve six, which has just been made optional on the present car. With this more efficient engine (same displacement as the old flathead six), power is up so much that a 2.87-to-1 rear

axle can be used, boosting gas economy. This is the ratio used in the Ambassador V8, so no added tooling is required.

Apparently, however, weight is reduced not at all. It will remain the heaviest of the compacts. Perhaps this is good. People seem to like the heavy feel. They have been taught to equate heaviness with quality. Heavy doors sound better, safer, more expensive. Heavy cars are believed to ride better, to hold the road better, to offer more protection. These things are not true, but the public believes they are true.

Next year will be a big styling year at General Motors. The following year, 1962, will be a big engineering year. Thus the ball is bounced from one budget to another, to keep you buying and to keep salesmen happy. Maybe the GM transaxle will have to wait for 1962, although some say '61.

GM has a problem in its distinctive flat roof. Every car from Corvair to Cadillac has it. So much an identification device has it become that you can't see the car for the roof. Noticed how long it takes to decide whether it's a Pontiac or an Oldsmobile? Or Chevrolet? Or Corvair? Well, GM is out to change that. Next year you'll see variety in roof lines. Cadillac is going to the neat, well-tailored roof featured in this year's Eldorado Brougham. Olds 98 will get a distinctive roof, Buick also.

Ford is having roof trouble as well. Too much of a good thing. From Thunderbird down to Comet, it uses the town-car roof (they're even trying to hypo ailing Lincoln with it this year). This, too, will change.

Plymouth is due for some fin-shrinking. What about the argument that fins provide stability? Well, the boys will come up with a new gimmick. Something to do with balance. Whatever it is, you'll be convinced. The industry learned a lot along the wide track.

Poor Buick. After completing the most spectacular performance feat in history it has been told to keep its mouth shut. Remember the pledge? You can't advertise performance. (Word may have leaked before you read this, but maybe not.)

A 1960 Buick covered an unbelievable 10,000 miles in under 5000 minutes—an average of over 120 miles per hour for almost 3½ days! That's running, kids.

It happened at Daytona. Two tries were required. The first Buick was washed out when a gas-line block leaned out the fuel mix, burning up the valves. Nine sets of tires were used. Refueling was done at 120 miles per hour. Only 29 minutes of pit stops were required. The only part that failed was a fan pulley.

Some test, some car! But Buick isn't suppose to talk about it. Let's see how strong the pledge really is!



Army's Helicopter Fires Surface Missiles

Enemy tanks may hesitate to interfere with the operations of the Army's newest helicopter — it's equipped with surface-to-surface missiles that are fired directly from the whirlybird. A missile rack, extending

straight out from each side, carries three missiles on either side. It is reported that the missiles, when equipped with an armor-detecting warhead, can knock out any known tracked steel vehicle.

Gravity Meter Detects Hidden Cavities, Pits Beneath Streets

Hidden pits and cavities beneath city streets can now be detected before a dangerous cave-in occurs with a special gravity meter. Riding on a rubber-tire buggy, the instrument consists of a small mass at the end of a spring. When it passes over a

cavity, the mass weighs less and the spring contracts and a gauge registers the difference. Readings are taken every 10 feet along the street. In trial runs it has discovered storm sewers and cavities that otherwise were undetected.

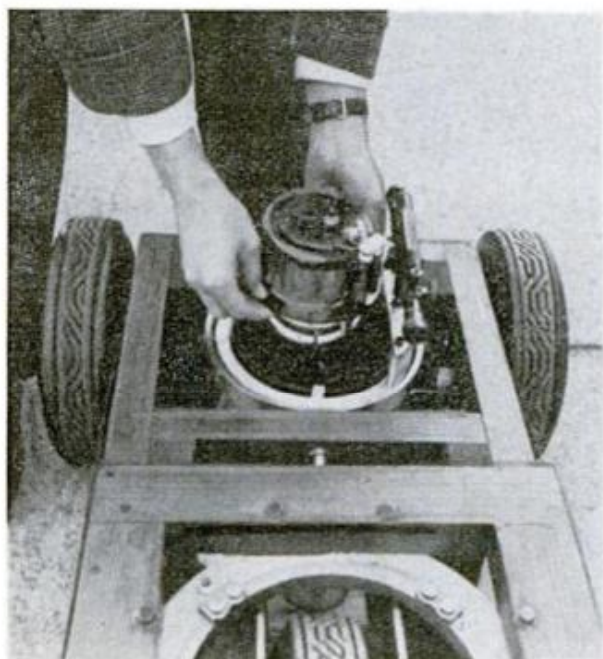

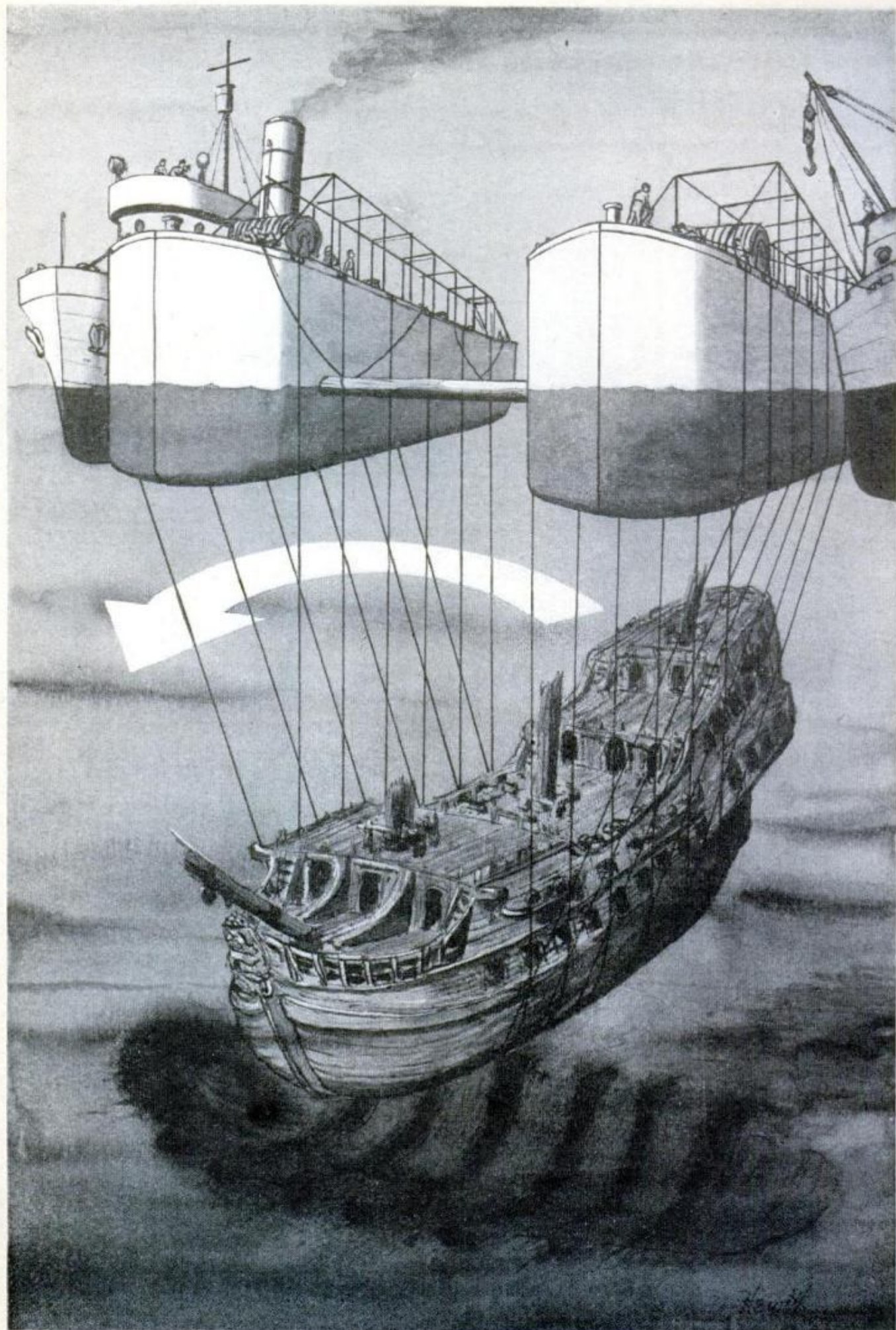

From an American-Swedish News Exchange drawing

Swedish Navy Salvagers Move 17th-Century Ship With Tunnels and Cables

HISTORICALLY IMPORTANT and physically difficult, a naval salvage operation in Stockholm harbor has now gone through its first phase. The Swedish man-of-war *Vasa*, which capsized and sank in the harbor in 1628, has been lifted by giant pontoons and towed, still submerged, a half mile into shallower water. Her equipment, ordnance and ballast are being removed as she rests on the bottom.

The delicate and arduous task of moving the hull—which, with equipment and ballast aboard weighed about 700 tons—involved the digging of six tunnels under the hull. Directed by Commodore Edward Clason, commandant of the Stockholm Navy Yard, divers, working at a depth of 60 feet, carved the tunnels. The divers were handicapped by murky waters which limited the beam of even the most powerful lamp to a mere few feet. When the tunnels were completed, cables were passed through them to enable the pontoons to lift and move the hull.

At first, divers tried to drive heavy nails or clamps into the sides of the *Vasa*, which rested upright on her keel, but after three centuries under water the oak had become as hard as stone and nails would not enter the planks. As a result, the tunnels were made to accommodate the cables.

Already, some 800 objects have been removed from the ship, including several cannon, a hand-carved figurehead of a lion, the ship's rudder and hundreds of ornaments in wood. The stores of the *Vasa* are also expected to yield several barrels of untapped beer.

While the hull was well preserved under layers of mud, some 1000 iron nails in it are now useless. There are, however, about 20,000 wood pegs which are still in good condition.

Eventually the *Vasa* will be placed in a special roof-covered dry dock on public display. She will be completely reconstructed and new pieces substituted for those missing.

The *Vasa*, a 136-foot galleon with a 34-foot beam, was built for the navy of King Gustavus Adolphus. She sank at the outset of her maiden voyage in August, 1628, with an estimated 400 persons aboard. An amateur naval archeologist, Anders Franzen, found the hull in 1956 after carrying on a search for many years.



No Redcaps Need Apply

Travelers arriving or departing at the Central Railway Station in the West German town of Cassel may use, free-of-charge, lightweight baggage carts made of tubular steel mounted on balloon tires to trundle luggage along the platform. The carts rest on their frames for easy loading and are left standing, after use, for other travelers.

Blast of Horn Changes Slides

High-frequency sound from two small hand-held horns will not only change slides in a new slide projector but will change the focus of the lens to compensate for transparencies that may "pop" in their mounts. The horns, whose sound frequency is inaudible, may be as far as 100 feet or more from the projector and still actuate it. The sound-receiving unit is housed in a metal cylinder attached to the projector. The projector may be converted from sound-actuated automatic operation to manual operation by a switch.

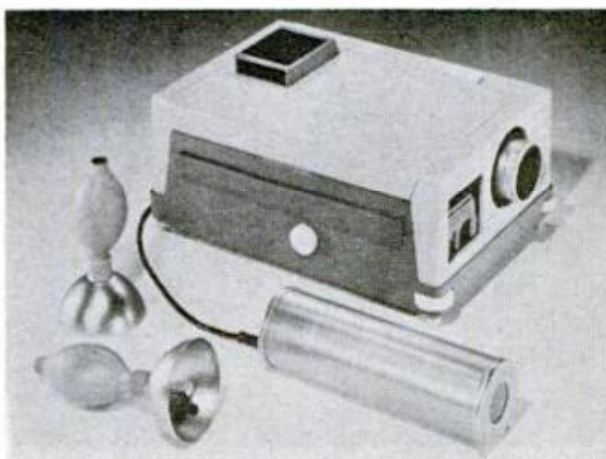



Dr. Herbert Pollack points to an area of ink that would not show on an X ray, if this stamp were a forgery

X-Ray Detectives

Two scientists make a hobby of peering into mysteries, ancient and modern, with the X-ray camera

X ray shows nearly 40 percent of a Persian bowl was restored and its sections pieced together with wires



Photos courtesy of Memorial Art Gallery, Rochester, N.Y.

POPULAR MECHANICS



Photo courtesy of The Brooklyn Museum

Two Madonnas and child on the same piece of wood. X ray disclosed a faker had forged one atop the other

THE "X" in X ray stands, as in algebra, for something unknown. A two-man team of scientific investigators, however, are proving that pictures made with X rays can make a great contribution to the world's store of knowledge. Using the X-ray camera—much as Sherlock Holmes used the magnifying glass—they are turning up clues to all sorts of mysteries in the fields of science, art and industry.

The X-ray detectives are Charles F. Bridgman, of Rochester, N.Y., and Dr. Herbert C. Pollack, of Chicago. Since they started sleuthing together, in 1952, they've been providing graphic answers to such tough questions as these:

- How honest was an Egyptian who practiced embalming 5000 years ago?
- Did someone break a 16th century Persian bowl before it was bought by an upstate New York art gallery?
- Is a seemingly rare and valuable postage stamp worth the paper it's printed on?
- Did Indians whose bones are buried in mounds in Illinois have diseases of modern man?

X rays—discovered and named in 1895 by Wilhelm Konrad Roentgen, professor of

physics at the University of Würzburg, Germany—today are familiarly used in medicine and industry to locate broken bones and to determine the soundness of castings and welds. But the interests, training and skills of the X-ray detectives have led them to turn the rays to more unusual investigations.

The Men, the Ray

Bridgman studied fine arts and sciences at Colgate University and is associate editor of a medical photography magazine published by Eastman Kodak Company. Pollack has practiced clinical roentgenology (the science of using X rays) in Chicago since 1940, and, along with others, has acted as X-ray consultant to the Chicago Art Institute. The two met at a Chicago stamp-club meeting, where Bridgman demonstrated how stamp forgeries can be detected by X ray. He found a kindred spirit in Pollack, who had conducted similar experiments as early as 1928. Their nonmedical research in the past few years has resulted in two exhibits of X-ray photographs (radiographs) of ceramics, fossils and insect specimens, and of art and stamp forgeries, which they regularly loan to museums throughout the world.

X ray had quite a humble beginning as an investigative tool. Roentgen discovered that under certain conditions a small

Editor's Note: Because of their regular work and previous commitments, Pollack and Bridgman will not accept additional material for X-ray examination.

vacuum tube emitted an invisible ray that penetrated opaque objects and would leave a shadow picture of what was inside on a photographic plate. He called the ray "X" because it was new to him. (We now know, of course, that X rays are part of the electromagnetic spectrum and thus are related to radio waves, heat or infrared rays, and visible light waves, among others.) Even though Roentgen knew little about the rays, he established some famous firsts with their use. The radiograph he made of his wife's hand heralded the science of medical radiography; his X-ray pictures of factory-made objects—a shotgun and shells, for example—presaged their role in industrial radiography: Today, pipelines carrying oil cross-country are X rayed at the seams to insure against leakage. Tank cars get the same treatment. High-speed radiographs have even been used to analyze the action of a bullet shattering a row of light bulbs.

X rays make a better detection tool than Sherlock Holmes could ever have dreamed existed because they allow investigators to peer into an object without first tearing it apart.

Solving Ancient Mysteries

Working with X-ray cameras like those found in many doctors' offices, Bridgman and Pollack have learned a lot about such things as mummies that, if unwrapped, might be destroyed. One such investigation even exposed an ancient Egyptian embalmer as being dishonest. When an Egyptian died 5000 years ago, it was customary to kill, embalm and bury his household pets with him. A mummy of one of these, a baby crocodile, was examined by Bridgman. On the outside, the wrappings looked as if they were wound about a body. A radiograph, though, showed the embalmer had been a trickster. He'd substituted a rolled-up piece of cloth. It's not unusual for them to X-ray an eight-foot-high painting or an entire Egyptian mummy case. Often several sheets of film are used for this type of work. However, for one look at the skeleton of a mummy swathed in wrappings, a single piece of film two by seven feet was employed.

X ray also helps solve another mystery created in ancient times. Long ago, Assyrians wrote letters on clay tablets, baked them, then built a clay envelope around them. The address, and information about the letter, were placed on the outside. Without breaking the envelope, how do scholars know whether they have a letter or an envelope with a message inside?

They make radiographs, which distinctly show the outline of an inner tablet.

This nondestructive quality of X ray as an investigative tool allows Bridgman and Pollack to detect hidden paintings on old canvases and find damage and repairs inside pieces of pottery, although they point out that they are not art experts; they leave interpretation of radiographs to art conservators, who also may use chemical analysis, infrared photography and microscopy to learn more about a work of art. In detecting forgeries and fakes, knowledge of the techniques and materials used by the original artists and their followers is invaluable. Chemical analysis of a fragment of pigment can prove whether the paint on a questioned canvas is the same type a famous artist is known to have employed in works that have been conclusively authenticated. Details of brushwork may also be compared with the help of pictures taken through a microscope or on infrared film.

"With X ray, we don't discover so much as we vindicate," they say. "Someone has an idea that something is wrong. One of the best ways to prove or disprove this is through X ray."

Recently, they vindicated the fears of curators of a Rochester, N.Y., art gallery, who suspected that a 16th-century Persian bowl had twice been broken and repaired, because one section glowed more milky-white than the rest. Not until the bowl had been radiographed did the owners learn that more than one-third had been replaced with new clay, that wires helped hold the sections together.

The bowl was an example of expert restoration, but the detectives have proved that other art objects were out-and-out fakes. One of the most skillfully executed was a Renaissance Madonna painting from northern Italy. X ray disclosed that the faker had taken an old panel of wood with a Madonna already on it and painted a new picture over it. The picture, as illustrated, differed in many details. The faker had been thorough, though. He made crack lines on the new picture with a needle to give it the appearance of age.

Detecting Counterfeits

Because Bridgman and Pollack share a strong interest in stamps, they have used X rays to gain insight into the attitudes and procedures of stamp counterfeiters. Bridgman's work in this field has taken him abroad, to crime laboratories in major cities, and to association with Treasury Department investigators in Washington, D.C.

X rays show the inside story. At top right, photo and radiograph of nautilus shell; center, radiographs of a mummy and beetle; bottom, two views of a Cecropia moth: its hollow veins harden into struts for wings

Moth photos courtesy of H. Lou Gibson and Harold Sherwood

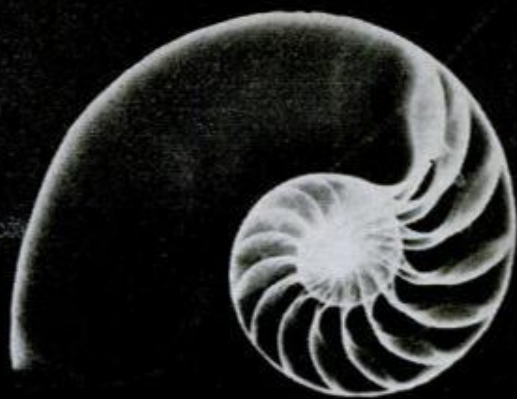
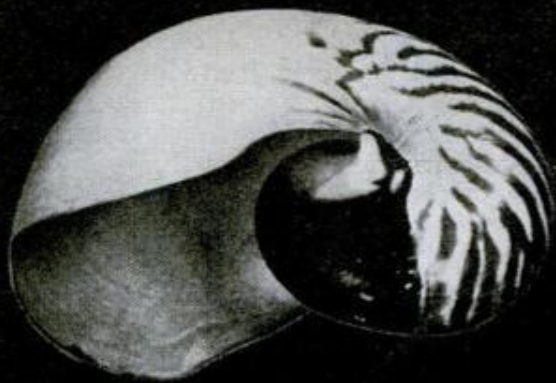

One of the major flaws in most counterfeits can be detected easily by X ray: Many classic issues were printed with metallic inks, whereas most fakes are made with aniline-base inks. Metallic elements in the original inks are dense enough to hold back X rays, so the stamp's design shows on the sheet of radiographic film. Counterfeiters seldom simulate the rare issues any more because the high-value items would be subject to close scrutiny by experts. Pollack says, as a result, that many fakes in circulation are among stamps of small worth. "The market is flooded with imitations of stamps worth about 50 cents." These are not subject to X-ray analysis, which might cost \$10 or even more.

The investigators use three methods of radiography in examining stamps.

To reveal the design of a stamp, or its cancellation, as traced by metallic inks, they use low-voltage radiography, in

which radiation as low as 6000 volts is employed.

To gain a general knowledge of the chemical types of ink used, they use electronemission radiography. Electrons made by X rays, rather than the X rays themselves, trace the image on film. When irradiated with X rays of a suitable wavelength, the metal elements in the ink emit electrons. The quantity of the emission depends on the atomic numbers of the elements present in the inks and paper. Such X rays often show the details of the design of the inks in the stamp and leads to a general knowledge of the chemical types of ink used. These data allow comparisons of an original and a suspected forgery.

To show details of paper structure and watermark without the image of the design or cancellation, the technique of X-ray electronography is employed: Lead is placed in contact with the stamp and

Dr. Pollack uses X-ray machine like those in doctors' offices to make a radiograph. Bowl rests on film

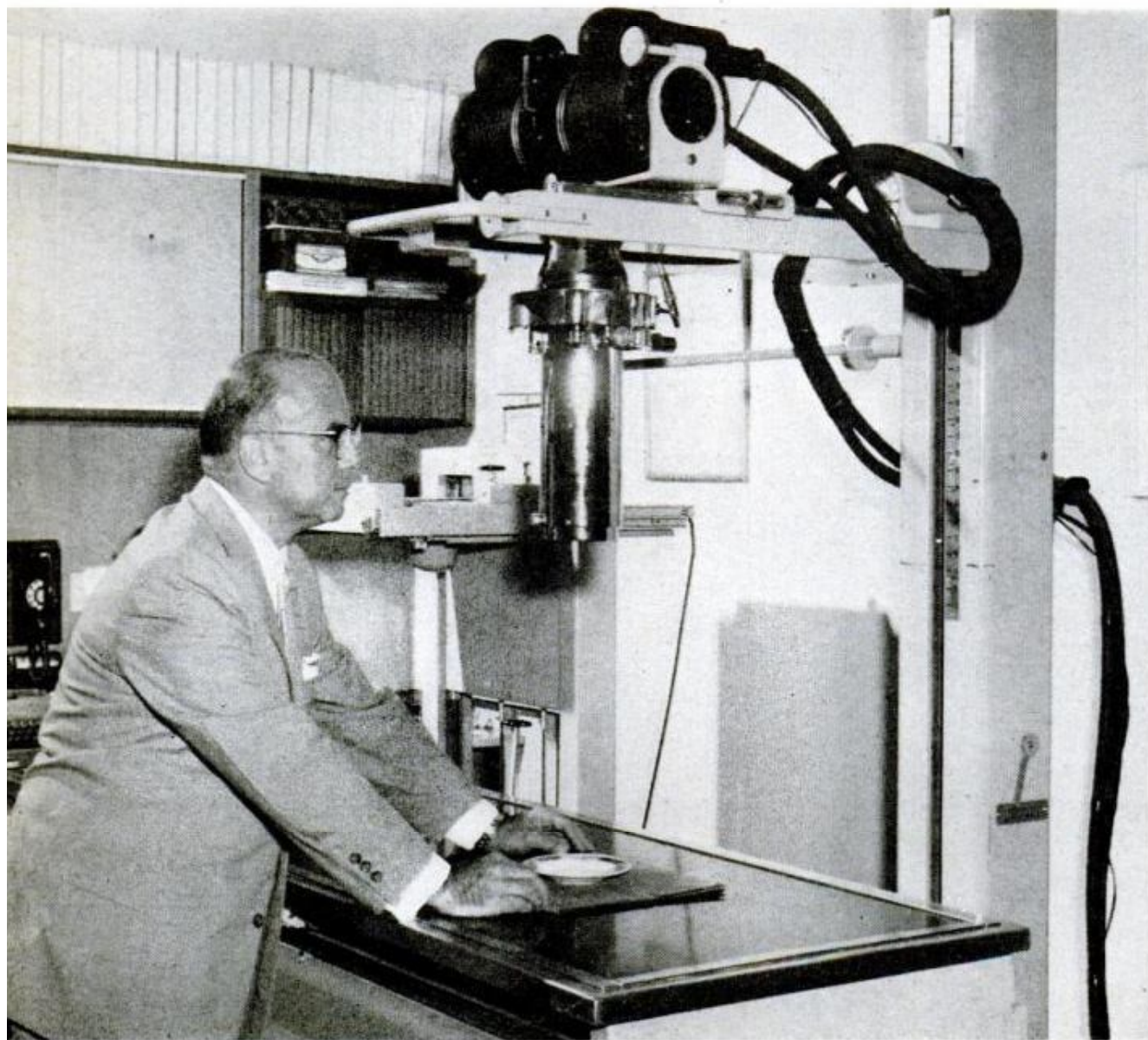



Radiograph of Austrian stamp shows center was removed and inverted. The adhesive used makes dark lines

made to emit electrons. The electron emission is sufficient to penetrate the stamp to the film. Electron emission from metallic ink in the stamp is usually slight, compared to emission from lead; therefore, the ink design is seldom seen. The X rays etch on film the fine details of paper structure and watermark. The technique is useful for showing repairs of damaged or torn stamps. In order to make X rays of stamps, incidentally, Pollack cautions that an individual should first have permission of the Treasury Department.

Fossils, Moths, Beauty

The team has also turned its machines on samples of rock brought up by oil-company drillers to reveal the type of rock structure and fossils at specific points beneath the earth. Analyzing this information, geologists gain clues as to whether oil will be found at a particular site, and how far down. Bones and skulls found in Illinois Indian mounds also gave up information to the X-ray camera. X-ray examination indicated that the Indians were prey to osteomyelitis and bone cancer, as well as other ills of modern man.

An X-ray analysis of a species of large moth was another of the team's contributions to basic science. They showed that ribs of the moth's wings were in reality hollow structures, which the insect filled with body fluid soon after it came out of its cocoon. When the fluid hardened, the moth had wing support for flight.

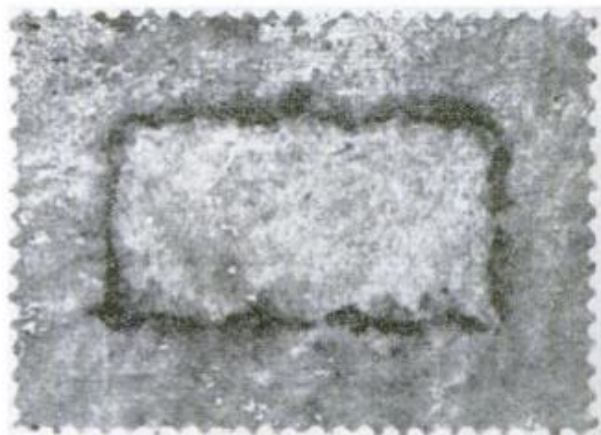

To the trained eyes of these collaborators, X-ray pictures reveal a hundred hidden truths.

They can also be objects of beauty, and the men search out such subjects to X ray. Fossils found on weekend walks to quarries and mines, some of the insects and corals—these subjects, when X rayed, produce pictures with beautiful composition and tracery of lines seldom attained by artists.

One picture of delicateness and whorled beauty is an X ray Bridgman and Pollack made of the chambered nautilus, which lives and moves silently through the ocean. They were not alone in appreciating its beauty, either. A print of it was hung in the wardroom, for the enjoyment of the crew, of another undersea explorer, the atomic submarine *Nautilus*. ★ ★ ★

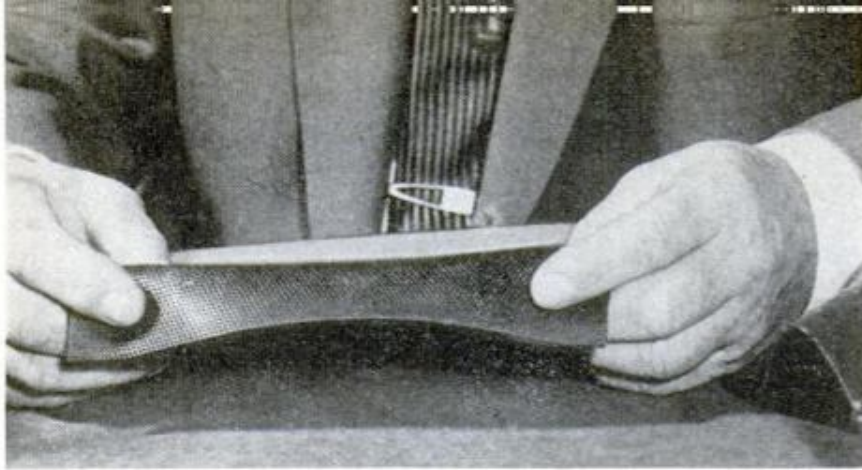

Dr. Kramer holds a sample of the hydraulic skin, inside upward, to show the tiny studs and space for the damping liquid that may speed submarines

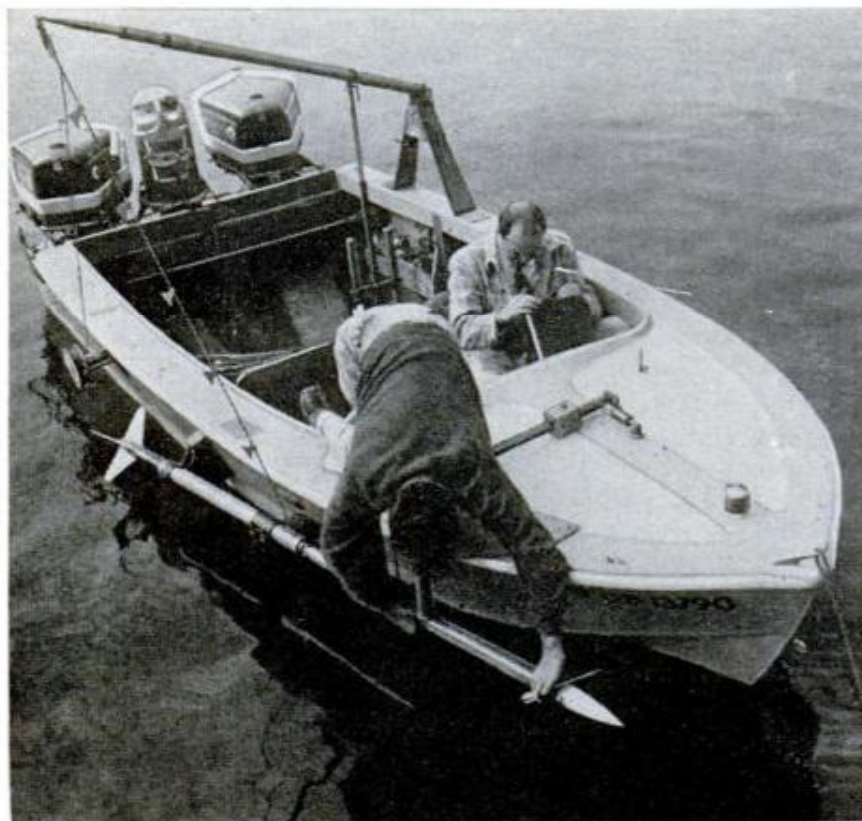

Testing the membrane. A model underwater vehicle is towed by the test boat while sensitive instruments record the comparative frictional drag

Unusual "sandwich" outboard motor arrangement drives the test boat at high speeds. Hooded operator reads instruments and makes test notes



Rubber-Clad Submarines Ahead

BORROWING the secret of the porpoise's effortless swimming speed, a Los Angeles scientist has developed a rubber "hydraulic skin" that reduces the drag of a liquid along a solid surface so effectively that it suggests we may see submarines capable of 70 miles an hour and, with improvements in power, underwater objects that can travel up to 180 knots (207 miles an hour). Dr. Max O. Kramer, vice president of Coleman-Kramer, Inc., Los Angeles, studied porpoises to find out how they can swim with such flashing speed and so little effort. His calculations showed that some factor was cutting the drag of water along their bodies by 90 percent. Working at Marineland of the Pacific at Palos Verdes, Calif., he discovered that the porpoise has a $\frac{1}{16}$ -inch hydraulic skin which damps out turbulence, eliminating much of the drag. After many experiments, the rubber membrane at left above was developed. About $\frac{1}{8}$ -inch thick and covered on one side with tiny studs, it is stretched around an object with the studs on the inside and the space between the studs is filled with a damping fluid. Frictional drag has been reduced up to 60 percent in some tests; further refinements may raise that figure to 90 percent. Use of the skin may cause dramatic changes in water transportation, both on underwater and surface craft, and even in pipelines, where the same principles apply. The United States Rubber Company is planning its manufacture under the trade name "Lamiflo."



Loader Separates Operator From Shovel

Complete separation of the operator's compartment from the shovel is featured on the "new look" front-end loader of Caterpillar Tractor Company. Called "Traxcavator," the machine has a loader located ahead of the operator, which eliminates danger from lift arms and cylinders passing by the operator. A max-

imum dumping height of nine feet makes it easy to dump to the center of high-sided trucks. The bucket capacity is two cubic yards. Standard on the tractor are the hydraulic bucket positioner and lift kickout. In addition to a power shift transmission, a manual selector provides four-wheel and two-wheel drive ranges.

Bicycle Built for Family

Bolted between two standard two-wheel bicycles, a tubular metal carrier enables the cyclists to carry one or two children plus enough luggage for a short camping trip. Manufactured in Germany, the device includes a bar that joins the steering columns so they move in unison.



MARCH 1960

Jet Plane Gets Roller Skate

When Lt. Col. Dwain Lengel, commander of Marine Fighter Squadron 323, saw that tails of F8U-1 *Crusaders* were sometimes banged up in landings, he had a roller skate attached to the tail of one. Although a joke, it worked so well that he's considering skates for all his jets.

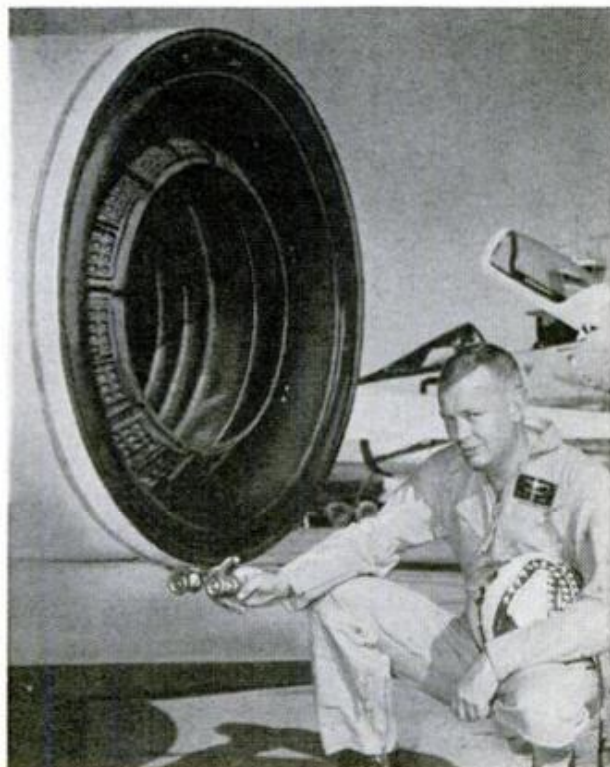

123

POPULAR MECHANICS

**OWNERS
REPORT**

A NATIONWIDE SURVEY

**BASED ON 1,190,084
OWNER-DRIVEN MILES**



Easy to steer and park, the Corvair is a real pleasure car. It hugs the road and loves corners, say owners

Corvair Is Exciting to Drive, But

MARGINAL COMMENTS
BY ART RAILTON
PM's AUTO EDITOR

**Only a professor
could be philosophical
to this extent.** →

**Let's hope that the
"bugs" in this all-new
design won't make Chevy
(and others) revert to
standpattishness.** →

HOW DO THEY like it? How pleased are the Corvair pioneers? Is this all-new car the answer to the motorist's prayer?

To find out, PM surveyed hundreds of Corvair owners from coast-to-coast. These owners had driven their new Corvairs over a million miles at the time of the survey. Here, then, is their story.

What about Chevrolet's boldness? It's easiest to take the well-traveled path, but is it best? The owners, generally, are pleased and like this new Detroit daring.

"Considering the conservatism of Detroit, the Corvair is well nigh a miracle. Chevy's courage in making a complete break with the past and turning out a car with a rear-positioned aluminum engine, smart appearance, and superb suspension has really paid off—and I write this owning a lemon that is so lemony as to be amusing. But I think the Corvair is a magnificent car."—Ohio professor.

"The Corvair will in time set the pace for the small car in the U.S.A. Chevrolet is a pioneer in a previously taboo field with its rear-engine economy auto."—Maryland machinist.

"I think this is the greatest thing to happen to American cars since the beginning."—Florida computer operator.

"This new Corvair is like a wife. You love her and wouldn't part with her for anything, but there are a number of aggra-

HOW GOOD IS THE CORVAIR?

Owners like:

Handling ease	69.7%
Riding comfort	36.8%
Exterior styling	21.9%

Why did they pick Corvair?

Economy of operation.....	50.3%
Engineering features	49.5%
Exterior styling	44.1%

WHAT'S WRONG WITH IT?

Owners dislike:

Poor gas mileage.....	25.6%
Heater operation	15.5%
Stalling, carburetor	13.5%

What should be changed?

Increase gas economy....	10.5%
Improve heater	6.5%
Make better seats.....	4.3%

WILL THE CORVAIR CUT INTO IMPORTED-CAR SALES?

YES say 81%

NO say 19%

Corvair has:

Better service
More room
U.S. styling

Imports have:

Lower price
More economy
Better quality



Needs More Economy, say Owners

vating defects that spoil the charm.”—Wisconsin engineer.

“I have never had as much attention as I have gotten since I bought this Corvair. Men are especially interested (I mean in the car). They ask questions and look it over from top to bottom.”—Ohio nurse.

As with any all-new car (and there never has been an American car that was as all-new as this 1960 Corvair), there have been troubles. And these owners are frank to discuss them. But there has been no trouble at all about suspension. The Corvair has handling characteristics that the owners rave about. Nowhere is there mention of instability.

The best-liked feature is handling and steering ease with 69.7 percent mentioning it.

“After driving a Corvair a standard-size car handles like a dump truck.”—Ohio sales administrator.

“All those adverse claims of Corvair’s competitors about the so-called undesirable rear engine is not true. It handles, takes curves and corners (wet or dry) better than any car I have driven in 20 years.”—Rhode Island executive secretary.

“It’s a car that is a pleasure to drive in the city or on any road. I like the Corvair more every time I drive it.”—Ohio plant manager.

Second on the list of best-liked features is riding comfort with 36.8 percent mentioning it.

← **Here’s what Detroit needed—something fresh, new, something other than fins to make people proud.**

← **Where’s the guy who used to shoot arrows? Now that the public can play the game, he ran off with his bow!**

← **Here is its greatest charm—its pleasant manner on the road. It is giving America a new yardstick in handling.**



Owners also praise its riding comfort. The four-wheel independent suspension flattens out railroad crossings

They love the rear engine. None say it should be up front. All like its traction on ice or snow

Four-wheel independent suspension pays off on rough stuff. →

A meat cutter should know a clean cut when he sees one! →

Economy is not so good as the public expects. PM ran a test on a stickshift Corvair (one with all production "fixes" on it) and got the following: Turnpike driving (60 mph average) 21.9 miles per gallon; rural-road driving (50 mph average) 20.9 miles per gallon; city driving (never over 30 mph) 16.2 miles per gallon. Air temperature 32 degrees, heater operating. On one separate test with heater off (never over 60 mph) 22.5 miles per gallon. →

"I like the quiet, peaceful, comfortable ride it gives. With the engine in the back, engine noise is reduced even more."—Rhode Island machinist.

"I live at Cape Hatteras and roads are rough. This car takes the ruts better than my 1957 De Soto did."—North Carolina retired sailor.

"It doesn't bounce you as most small cars do."—Ohio paper inspector.

Third best-liked feature is styling, with 21.9 percent mentioning it.

"I like the fact that it is uncluttered and easy to wash."—Wisconsin nurse.

"Clean-cut body design."—North Carolina meat cutter.

And Now the Complaints

But all is not perfect. These Corvair owners have reason to complain—and they do it. Leading the complaint list by a wide margin (with 25.6 percent mentioning it) is inadequate fuel economy. They are not getting the mileage they expected.

"My only gripe is gas mileage. For 3077 miles of driving I averaged 16.3 miles per gallon. About 10 percent was start-and-stop travel, about 40 percent was short trips, the remaining 50 percent was trips of over 100 miles. Gasoline costs have averaged 2.1 cents per mile. I have an automatic transmission."—North Dakota county agent.

"I average 18 miles per gallon in city, 20 on long trips. I have automatic transmission. I was hoping to get at least 25, but the dealer now tells me that he doubts if I'll ever get over 20."—Ohio engineering service representative.

"I am averaging 15.9 miles per gallon over-all with automatic transmission. The dealer couldn't bring the city mileage up over 14 so I wrote GM. Their representative, Mr. Horst, checked the car out and got 28 miles per gallon at 40 miles per hour with a tailwind. I wish I had him for a chauffeur."—North Dakota salesman.

"The service manager drove this car a total of 31.2 miles at a speed of 35 miles per hour. There was only one traffic light in the distance. The gas consumed was 1.3 gallons. I cannot see how this is an economy car if I must keep below 35 miles per hour to get economy."—Maryland electrician.

Second on the complaint list is the gasoline heater. This item also appeared on the best-liked list. Apparently, if the heater works well, it is great, but when it doesn't work it's

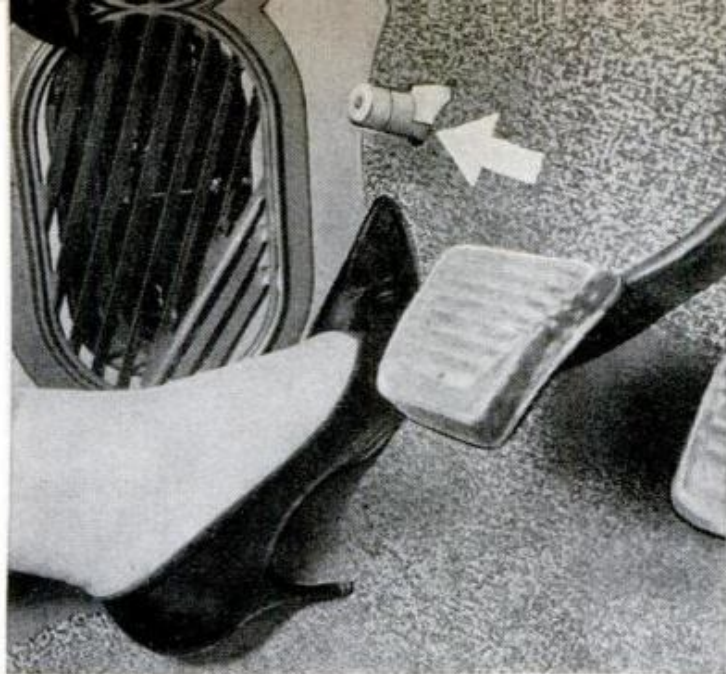

Women can't reach the headlight dimmer switch without lifting the foot, a tiresome chore if continuous

It is not easy to get in and out. Stepdown floor, low roof make entry and exit an art to be learned

a major complaint. It didn't work right for 15.5 percent of the owners.

"I would like better heater controls. It is either off or on. You do not seem to have various degrees to suit the demand at the time."—Wisconsin arc welder.

"Heater noise ruins otherwise soundproof effect of this car. Heater controls too stiff in cold weather and it uses too much gas for the amount of heat that it produces."—South Dakota salesman.

"Heater seems to heat only the middle of the front seat."—West Virginia construction foreman.

Third on the list of complaints is the problem of carburetor icing. Chevrolet made a "fix" on this during the steel-strike shutdown so current production should not have this fault. Cars in the field are being modified by dealers to correct the trouble also. However, some owners (13.5 percent of the total) had trouble—and plenty of it.

← **Heater failed on test car and brrrrrrrr! With no engine heat in front, it's a cold car. When new points were installed, heater worked perfectly thereafter. Production change has quieted heaters on current Corvairs.**

← **Sure, they test new designs under all weather conditions! Who are they kidding?**

Most automatic-transmission owners say they get 17 to 20 miles per gallon in city, 19 to 26 on long trips

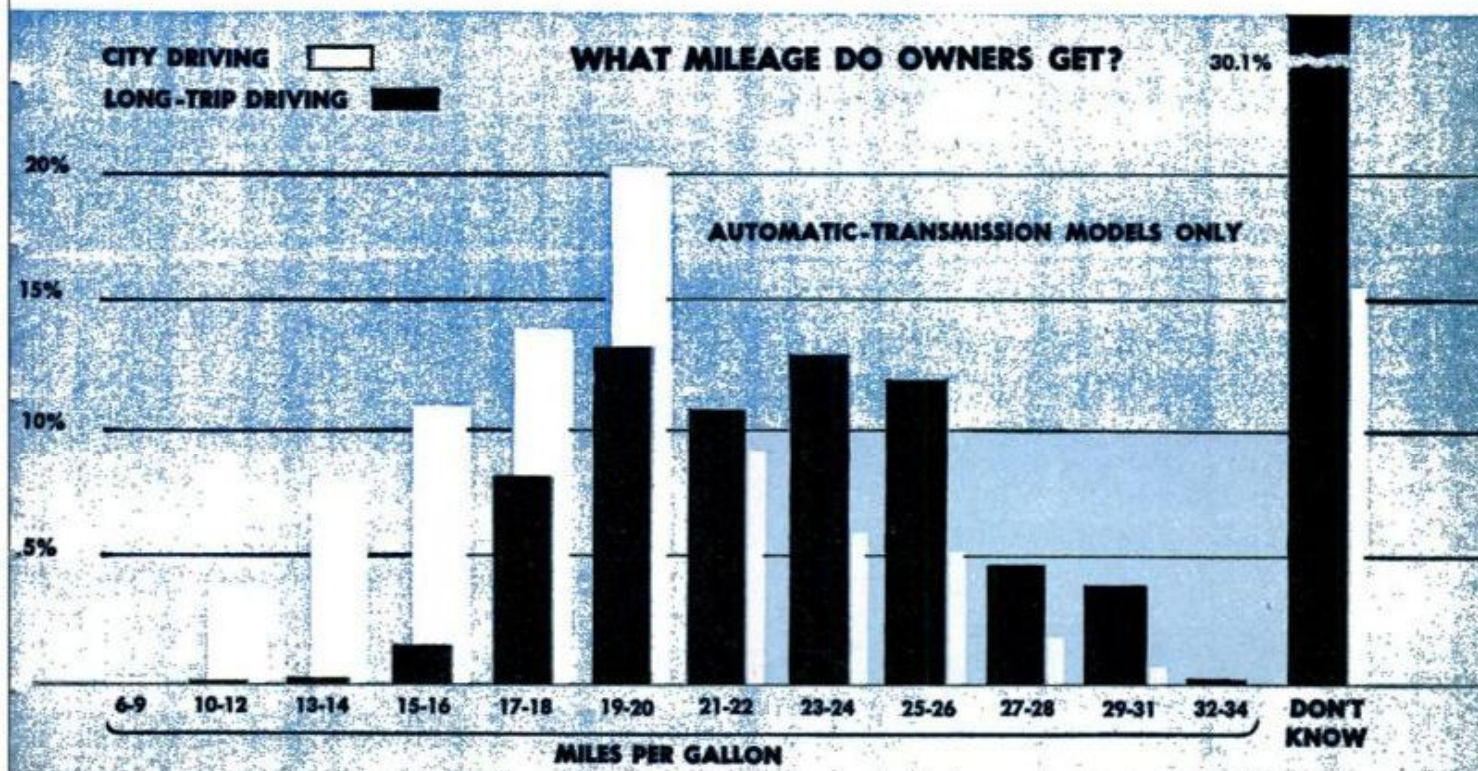



Despite a slow steering ratio, it is a fun car for the family

Wonder if he sells Danish furniture? Or maybe imitations? →

He's right. Detroit didn't jump into the fight—yet. But wait, the bantam-weights will be along later. →

"There appears to be an inherent defect in the carburetors. They ice up at certain temperatures and humidities. You can see frost on them. On a recent 100-mile trip the engine just lost power going up a hill 50 miles from home at 3 a.m. and finally stalled. I could not restart it until the car had stood for about five minutes then it ran fine for 20 miles and stalled out again. In a few minutes, okay, then stalled again." —Rhode Island physician.

"Why has a car that went through tests at 20 below zero developed carburetor icing problems?"—Virginia Marine helicopter crew chief.

"Carburetor icing, but company is supplying a kit to eliminate it."—Wisconsin newspaper publisher.

What About the Imports?

Will the three new compact cars cut into sales of imported cars? Corvair owners think they will, at least 81 percent of them do. Another 19 percent think not, however. Here are some quotations:

"Corvair is bigger, better looking, more powerful than foreign cars in same price range, yet still sensible. I have owned a VW."—Maryland federal analyst.

"I am against purchasing foreign products. It hampers our employment and parts are not always available."—Ohio furniture dealer.

"Corvair will not cut into foreign sales. If one has made up his mind to buy a foreign car, he will not take a substitute. I know!"—Tennessee architect.

"It won't hurt foreign-car sales. It is not as economical as one."—Ohio stenographer.

"Corvair is a different class of car. VWs are not readily available anyway."—West Virginia coal mine superintendent.

"If we improve our labor practices, increase the quality, the Corvair will replace all except the exotic foreign types."—Tennessee securities man.

(Continued to page 272)

SUMMARY OF OWNERS REPORT:

CORVAIR



What about gas mileage?	
Satisfied with it.....	50.8%
Not satisfied	45.4%
No answer	3.8%
Best-liked features	
Handling ease	69.7%
Riding comfort	36.8%
Exterior styling	21.9%
Traction on ice, snow	21.5%
Ease of parking	20.6%
Roadability	19.8%
Most-frequent complaints	
None at all	20.0%
Poor gas economy	25.6%
Heater operation	15.5%
Stalling, carburetor	13.5%
Hard to get in, out	8.4%
Trunk size, shape	7.1%
Had engine trouble?	
No trouble at all	64.5%
Some trouble	27.5%
Considerable trouble	8.0%
What was trouble?	
Carburetor, stalling	17.0%
Fan belt trouble	3.9%
Automatic choke	2.6%
What one thing should be changed?	
Nothing or no answer	31.2%
Improve gas economy	10.5%
Gasoline heater	6.5%
Trunk space	4.3%
Why did they pick Corvair?	
Expected gas economy	50.3%

Liked engineering	49.5%
Exterior appealing	44.1%
Over-all size	43.4%
Initial price	8.8%
What like best in styling?	
Simplicity	44.3%
Large glass area	10.5%
Lowness	7.1%
What like least in styling?	
Lack of front grille	6.0%
Bumper design	5.4%
Rear-end design	3.7%
What like best inside?	
Lack of floor hump	27.3%
Roominess	17.0%
Fold-down rear seat	11.8%
What like least inside?	
Seat comfort, quality	6.0%
Drabness, austerity	5.4%
Lack of arm rests	3.7%
How is dealer service?	
Excellent	55.5%
Average	31.4%
Poor	13.1%
Would buy from him again?	
Yes, would	60.2%
No, would not	13.8%
Don't know, no answer	26.0%
What make was traded?	
Chevrolet	34.6%
Another GM make	11.4%
Ford Motor make	14.4%

Chrysler Corp. make	8.1%
Other U.S. make	5.7%
Foreign make	6.5%
No trade, no answer	19.3%
What make will buy next?	
Another Corvair	31.0%
Big Chevrolet	9.2%
Another GM make	4.7%
Foreign make	2.1%
Chrysler make	1.3%
Ford make	1.1%
American Motors make	1.1%
Undecided	49.9%
Large enough for "family" car?	
Yes, it is	73.7%
No, it is not	22.0%
No answer	4.3%
Is it only car in family?	
Yes, it is	56.6%
No, own another	41.7%
No answer	1.7%
What is other car?	
Big Chevrolet	31.1%
Another GM make	25.3%
Ford Motor make	12.0%
Foreign make	11.5%
Chrysler make	10.0%
American Motors make	2.9%
Stude-Packard make	1.9%
Other U.S. make	5.3%

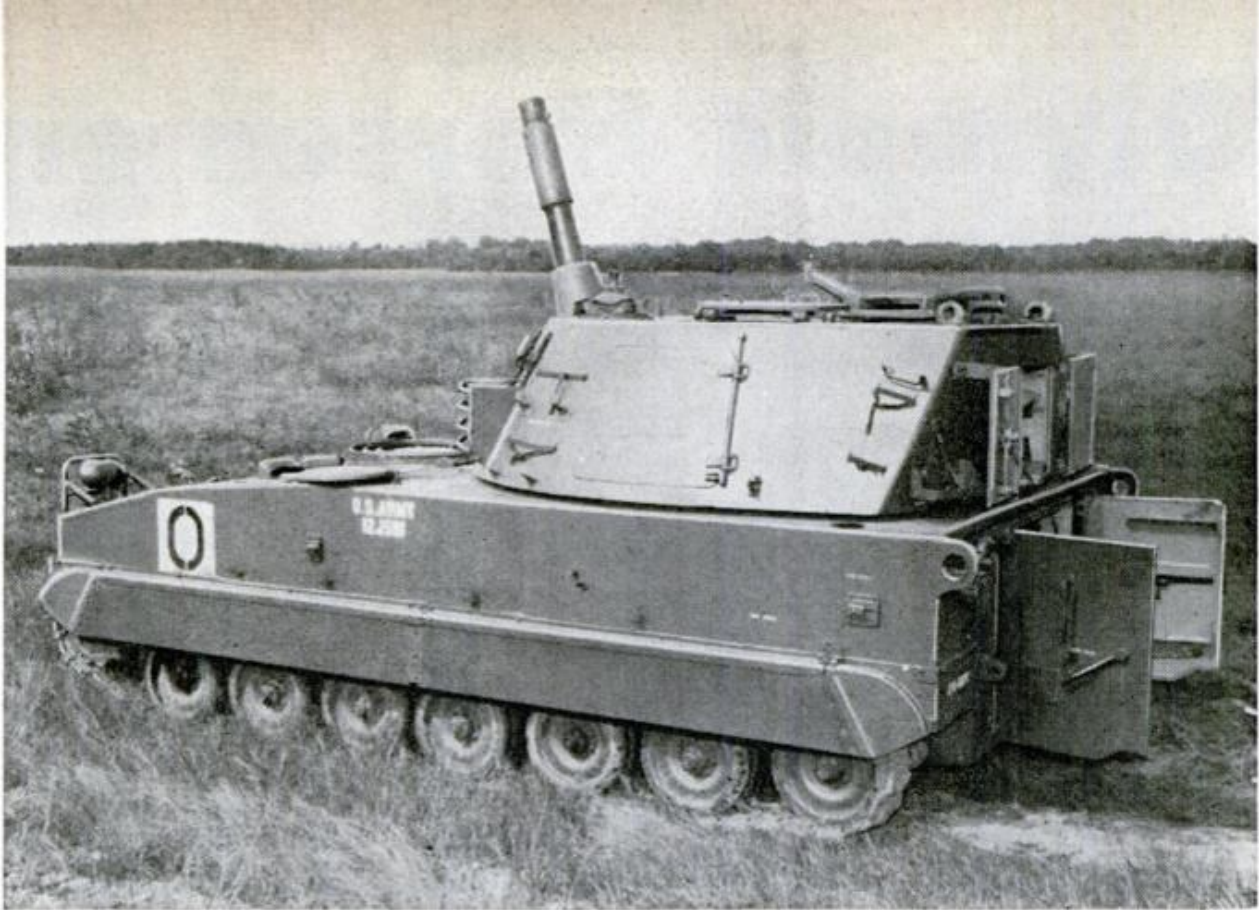

Army Howitzer Weighs Eight Tons Less

Carrying a load of 89 rounds of ammunition, the Army's new howitzer is air-transportable and has an aluminum hull. It is more than eight tons lighter than older types of 105-mm. self-propelled howitz-

ers. The machine has an improved fire-control system and is more accurate. In addition to firing standard howitzer rounds, it can handle a new, longer-range type of projectile.

First Diesel Outboard Motor

Entering the outboard motor market, American Marc, Inc., of Inglewood, Calif. is producing a single-cylinder (two-piston), air-cooled diesel rated at $7\frac{1}{2}$ horsepower, with 15 and 22-horse models planned. Diesels are heavier and more expensive, but operate at lower cost, use less-dangerous fuels, and eliminate ignition systems, carburetor and valves found on gasoline engines.

Safety Switch Cuts Off Car's Power

Protection in the car from fires, smoking wires and continuous horn blowing is possible with a battery switch that cuts off all current. Installed near the battery, the unit is operated from the dash by means of cable and control button. Locking the button in glove compartment prevents car theft.

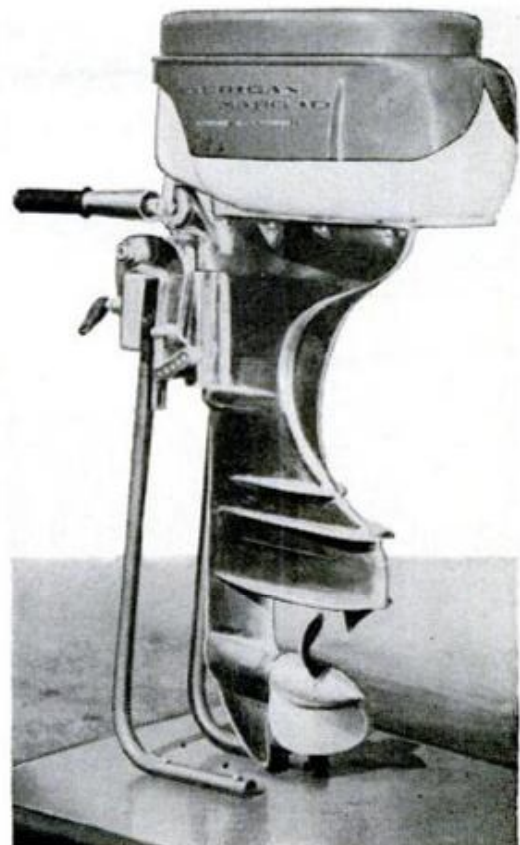

Olympic Horsemen Go to School

By Dale Allen

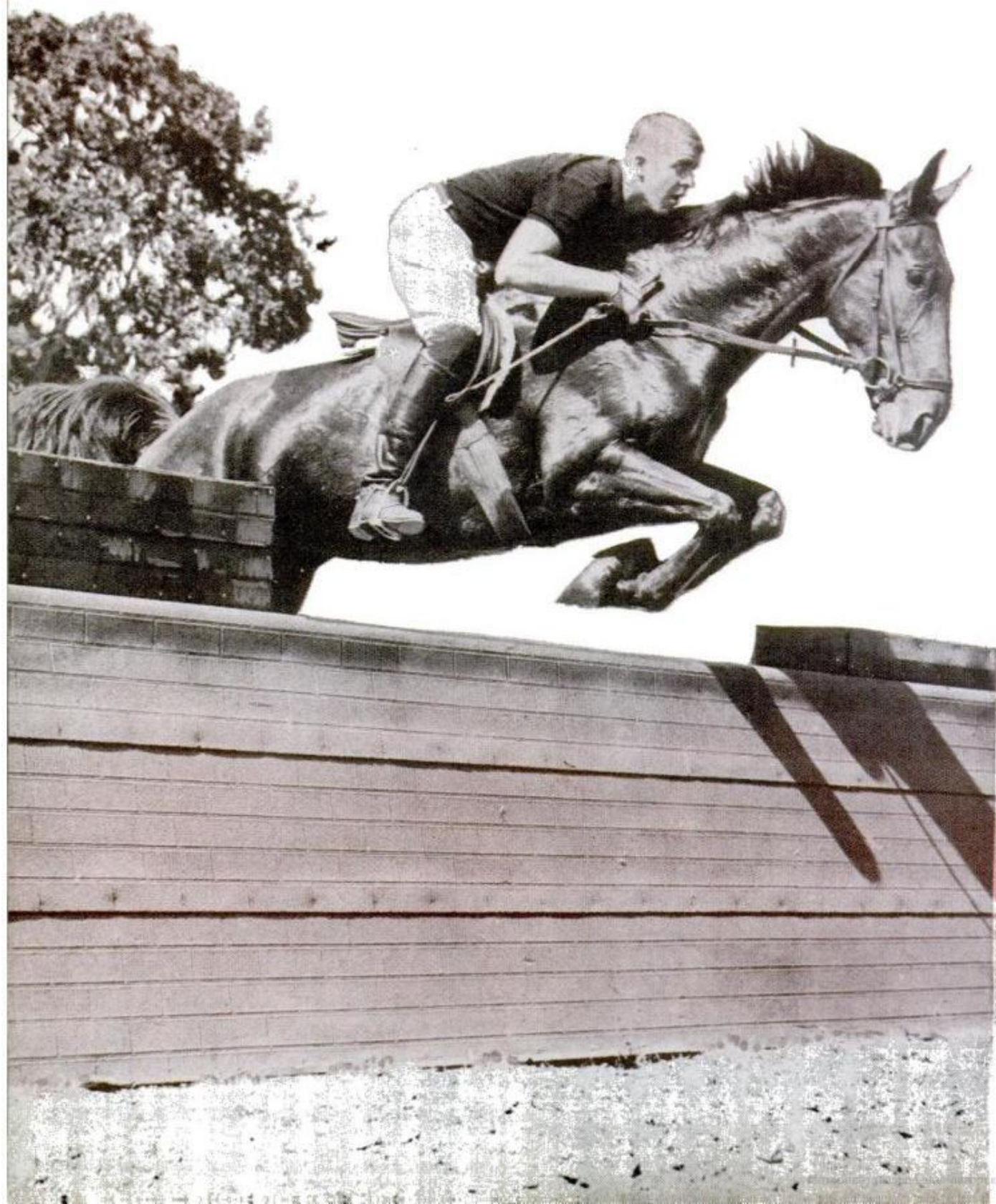

In and out. Preparing for the second day's Olympic events—which include harassing jumping conditions, Walter Staley jumps his horse into a water trough as team trainer Eric Bubbel watches for flaws in his style



SIX YOUNG MEN and 18 horses have been training six hours a day, six days a week, for the past two years to represent the United States in one three-day event at the Olympic Games, which will be held in Rome, Italy, this year, from August 25 through September 11. The men, candidates for the Three-Day Endurance Equestrian Team of three riders and an alternate, can look forward with some confidence to making a good showing, for they are receiving a rigorous schooling—on a specially designed training field at Rancho San Fernando Rey, near Santa Barbara, Calif.—not only in the events in which they will participate, but in exercises devised to add powers of endurance to both horse and rider. By the time they arrive in Rome for their contest—to be held from September 5 through 7—they will have put in 797 full days of training for a total of 4482 hours. Each man will have ridden more than 100,000 miles while putting himself in shape and training the two horses he will take to the Games. Their confidence, however, will be tempered by the knowledge they will be competing in one of the most

grueling tests ever designed to make a rider lose control of his horse. For example, at the 1956 Olympics, held in Sweden, 160 riders started the second day's events, but only 17 finished. Also, they will be riding for the stake of national pride, for the United States has won this event only twice before—at Los Angeles in 1932, and at London, in 1948.

The Three-Day Endurance Equestrian test (there are two other horsemanship events at the Olympics—the Grand Prix de Dressage and Grand Prix Jumping—but they will be entered by two other teams) is, roughly, the horse world's equivalent of the track-and-field decathlon. That is, the competitors must do well in many different events. The first day they will ride in a dressage meet, putting themselves and their horses through a series of complicated steps and motions. The second day is devoted to cross-town and cross-country riding, which must be performed within a time limit, and the third day will be devoted to jumping. What makes the contest tough is the rule that the same rider must keep the same mount through-

Up and over. Ernest Simard, one of six candidates for the U.S. Three-Day Endurance Team, skillfully lifts his horse over a high, wide jump. He and others appear in weekend horse shows to improve selves for Olympics





Ankle-high bars, above, are an exercise rack which help instill in horses the instinct to jump. The rider is John Plumb

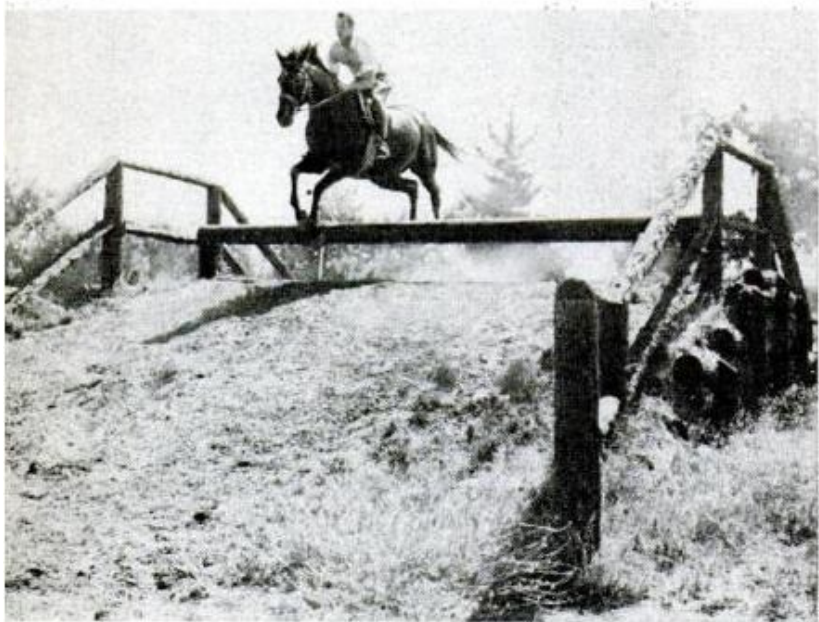

Jumps at a gallop. Preparing for the second day at the Olympics, team candidates (above and below) leap 50 obstacles in five miles

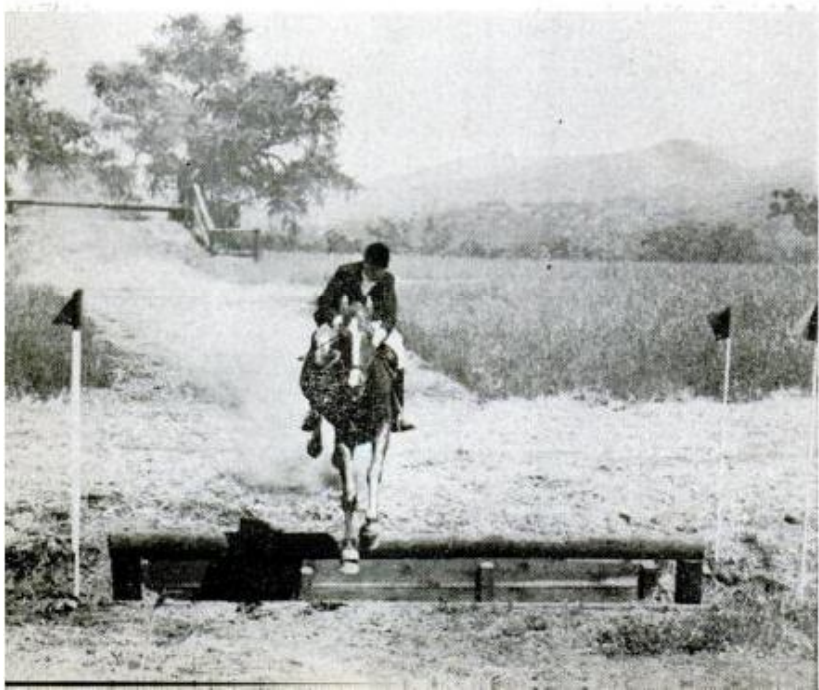

out and he must always keep advancing, except where the rules specify a stop. Otherwise he is disqualified.

The six United States candidates—Walter G. Staley, Jr., Mexico, Mo.; Ernest E. Simard, Monterey, Calif.; John M. Plumb, Syosset, N. Y.; William D. Haggard, III, Nashville, Tenn.; Michael O. Page, Briarcliff Manor, N. Y., and John E. B. Wofford, Milford, Kans.—work out on the ranch under the guidance of team trainer Eric Bubbel, a former Olympic equestrian champion. Each rider, even though he may be as skilled as Walter Staley, who competed in the 1956 Olympics, receives individual instruction. Schooling is not limited to daily training, either. Every second weekend, a complete horse show is held in which candidates compete in duplicates of Olympic events. Several times a year a complete set of equipment is moved to local horse shows, where the candidates perform before large crowds. The team is sponsored by the United States Equestrian Team, Inc., an organization that underwrites the United States' entry into world horsemanship events. This organization took over the sponsorship from the U.S. Cavalry 10 years ago and since has provided, at the ranch, the best training ground any U.S. endurance team has had. Two hundred miles of trails climb from near sea level to 6000 feet and were made to strengthen both men and horses. There are three dressage arenas, a stadium jumping course with regulation Olympic jumps that must be taken at the rate of 380 feet a minute, and a cross-country course that offers 50 fences, ditches or traps.

"We emphasize the essentials at this school—that the horse must be fit to the rider and the rider to the horse, and that, at the end, there is no substitute for plain old guts in both," says John Galvin, the ranch owner and a student of Olympic equestrianism.

"Dressage, the first day's event, receives more attention than any other single phase of our training," says trainer Bubbel. "Each rider takes personal instruction and practice in dressage two days each week, compared with one day of practice on other subjects."

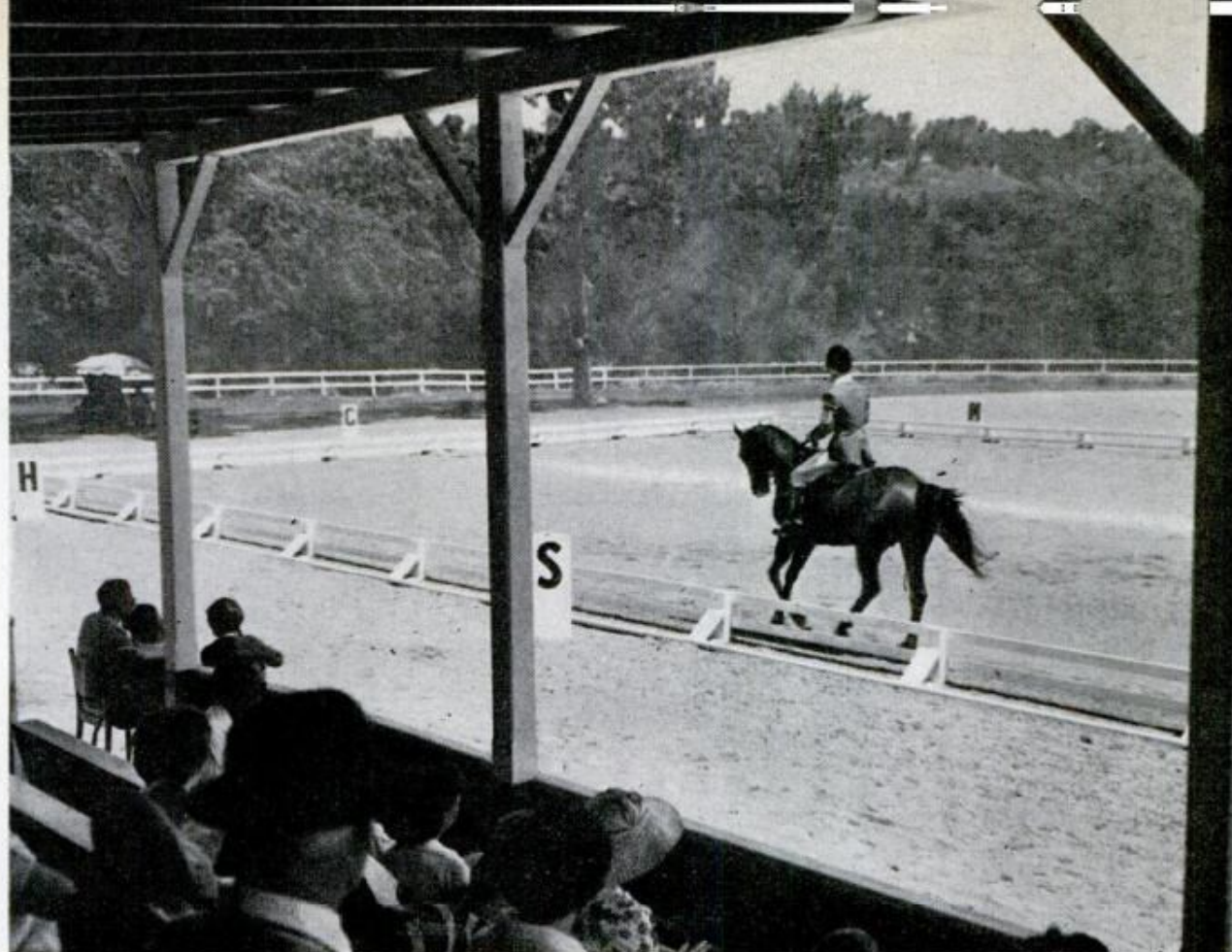

Dressage, perhaps the fastest-growing phase of equestrian sport in the United States, is founded in the classical schools of horsemanship and aims at outstanding achievement in balance, coordination, and subtlety of horse movement. In this test, each competitor, riding in a 20 by 60-meter dressage arena, has exactly 12 minutes to put his horse through a complicated series of steps and movements. There are three dressage arenas at the ranch. Two are outdoors and one is in a steel building constructed especially for training the Three-Day Endurance Team. To help riders check on the movements of themselves and their horses, it is equipped with three 6 by 10-foot mirrors along one side, and two at one end. The dressage arena is marked down the center with seven letters, and along each side with five. Each of the steps and its movements must be done on a course between designated letters. The center lettering, starting at the top is A, D, L, X, I, G, C. At the left, along the side, is F, P, B, R, M. Along the right is K, V, E, S, H.

When a rider starts the dressage, he enters the arena at A, at collected canter, rides to X, in the center, halts, salutes, then proceeds to C at the center of the other end of the arena. He then tracks to the right, to M, crosses at X and K and, while following this route, changes reins at extended trot while rising, then proceeds from K to A at an ordinary trot, sitting. He goes immediately into the next step and continues to do so in a precise order, entirely from memory, until he has completed the required 30 steps and movements. This, of course, puts rider and horse under heavy mental strain, for it requires concentration by both. The rider must remember every step in its order, and the horse must accept the almost imper-

Putting his horse through the paces of dressage, a candidate performs before a weekend crowd in a 20 by 60-meter arena marked with letters, as shown below, which set his course for 30 steps and movements

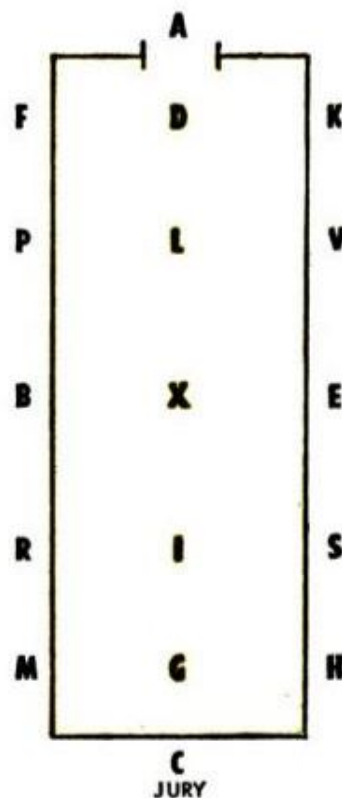

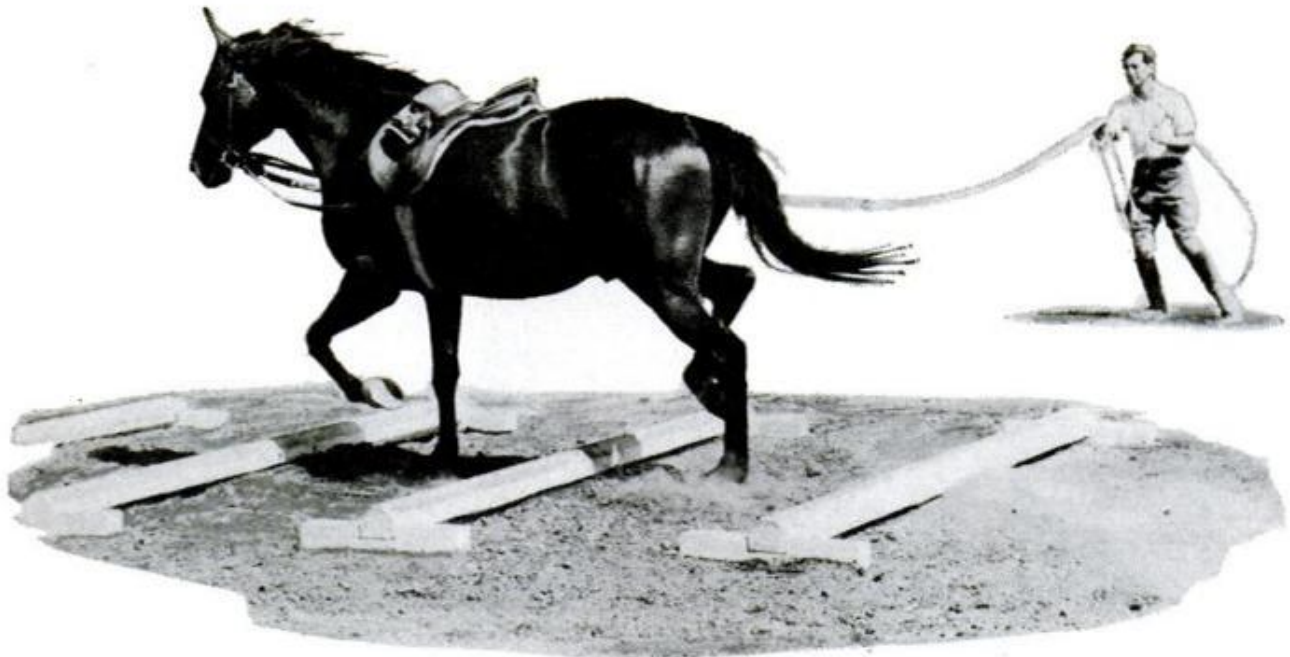

William B. Haggard works his horse on the longe and will also send it over the Calvettas, a group of ground-level bars to help strengthen its legs and to teach the horse to use its feet properly on uneven ground

ceptible signals given by its rider's hands and legs.

"The second day will see riders traveling a rugged, 25-mile cross-country course that is divided into four phases," says Bubbel. "The first phase is three miles through city traffic, where horse and rider must cope with automobiles, pedestrians, parks, zoos or anything else that could be encountered in a city." Without stopping, they go directly into an 11-mile steeplechase in which they must travel at the rate of no less than 600 meters and no more than 690 meters a minute to get maximum score. They will encounter at least eight fences and two water jumps. As the horse must always keep moving forward, the third phase is entered into without rest. It is a six-mile gallop across country that requires traveling 550 meters to the minute. This takes

place, up hill and down, over rough country. If the rider finishes on time, he is given a five-minute rest, the only one allowed during the event. (At the ranch, the riders practice on a well-designed cross-country course one day each week, developing exact timing while riding against a stop watch. They now can ride the maximum of 550 meters a minute in the correct time without being more than two seconds off.)

The fourth phase—five miles of jumping at least 50 obstacles while riding cross country—eliminates the weak, for it tests the stamina, courage and physical condition of horse and rider. In former Olympic meets, contestants have finished with broken arms and legs.

"Our training program for this phase is quite thorough," says the team's manager, Richard Collins, of Pebble Beach, Calif.

Michael Page jumps his horse onto an embankment and off again without deviating from the rhythm of his ride, a prime requirement at the Olympic Games



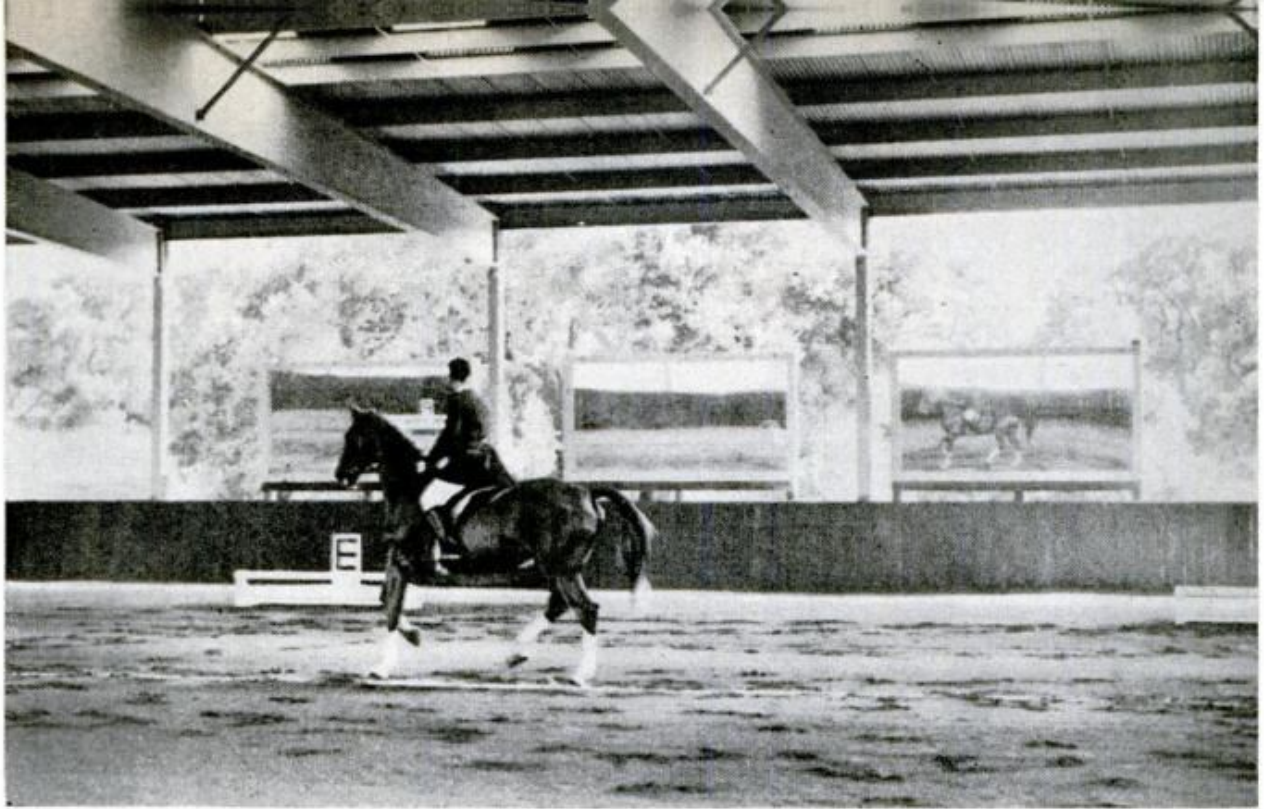

Three of the five mirrors mounted inside one dressage practice arena reflect the controlled movements of one candidate and his horse. Dressage tests the rider's ability to subtly control his horse and keep balance

"We have a rugged course through the hills in which the rider and his mount must jump 30 fences and 20 traps and ditches. These include the same kinds they will encounter in the Olympic Games, among which will be water, slips, slides, fences with ditches adjacent, and farm implements inside buildings and on the trail."

If the rider and his horse are still in shape after the second day's tests, they compete the next day in a 14-jump Olympic stadium course. It is a tough test because by this time both rider and horse are tired, and because the jumps themselves, which go up to seven feet in height, would be demanding, even for fresh competitors with strong horses. Scoring is based on the number of times hooves strike the jump barriers, the horse refuses, and the smoothness of ride.

The schooling is designed to instill the ability to make judgments instinctively. Action and thought must be simultaneous, as was demonstrated by a rider in the 1956 Olympics. Riders are allowed to walk over the course so they may plan their actions. One rider who had studied the course carefully found, during the contest, that as he approached a high jump with a deep, muddy ditch on the other side his competitors had disappeared. Without a moment's hesitation, he circled to his left to gain more speed and jumped his horse over the obstacle and the nine horses and riders who had jumped too short and were struggling in the ditch.

This year the sponsors of the United States Three-Day Endurance Team believe they have men of high quality who will bring their country international honor.

Team trainer Eric Bubbel signals candidate John Plumb, who is taking his horse over one of the 14 Olympic-styled jumps at their ranch training school.



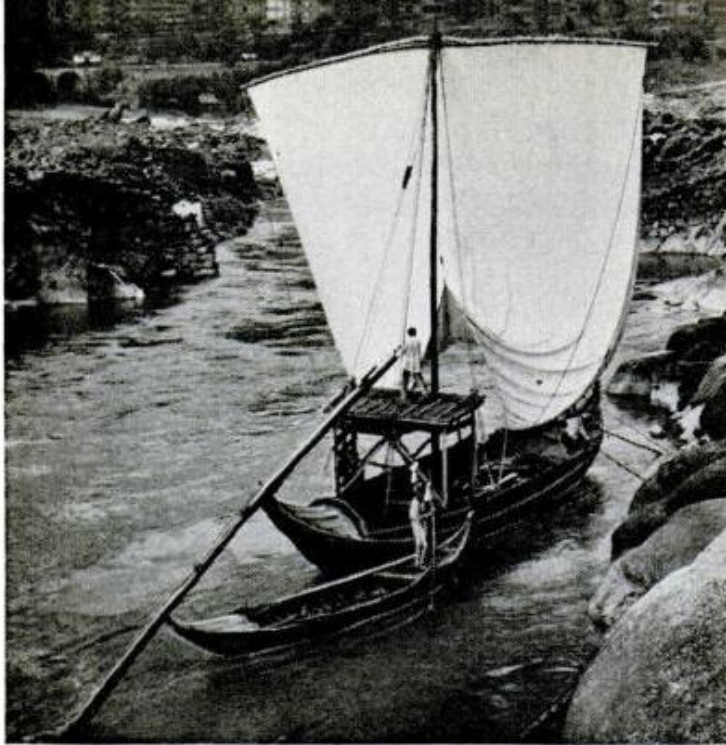

Tall Boat!

Boats that ply the rocky Douro River of North Portugal, transporting grapes used in making port wine, at first glance look as though they have been stretched out of shape. A long wooden sweep, controlled from a high, platform deck, serves as tiller and rudder, and the square-shaped sail looks as though it were hung too high. Actually, the boat, known as a Rabelos, is quite functional in design. Most of the vineyards in the area are located close by the Douro and this river has high rock walls which shut off visibility around bends and prevent the sail from catching the lower winds, thus making a tall sail and high deck necessary.



Fish Dispenser

Fish—rather than cool drinks—come out of a converted pop-vending machine for visitors who wish to feed the seal lions in a Garden City, Kans., park. The machine has a revolving cylinder inside, partitioned off into 83 compartments. Fish are placed in these compartments, which were designed originally to hold the bottles of cold drink. Claude Owens, park superintendent, displays a package of the fish.

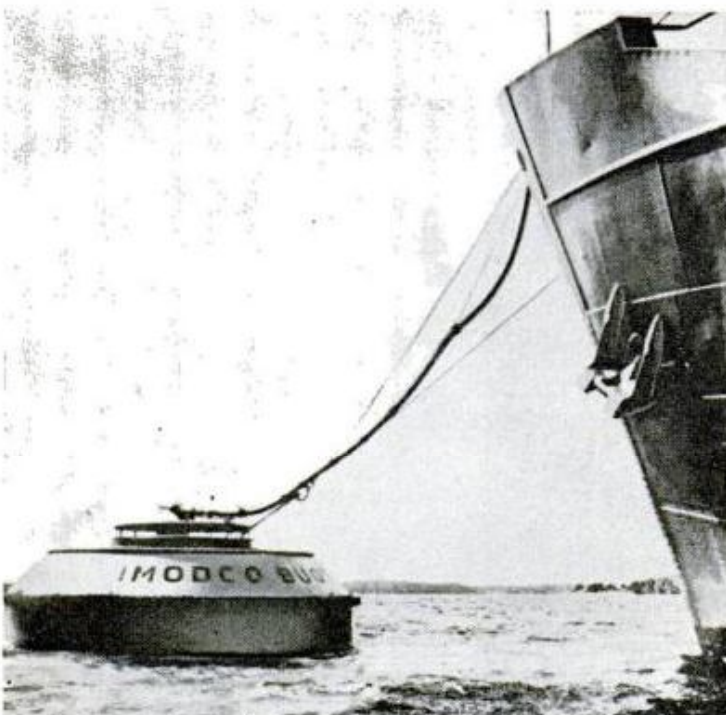

Buoy Unloads Oil

No mere navigational marker, a new buoy which has been put in use off Stockholm, Sweden, is an offshore unloading terminal. It is capable of handling oil tankers of any size. Developed by a Swedish firm which also includes American engineers and businessmen, the buoy is hooked to submerged pipelines which carry the oil ashore. This eliminates the need for docks and harbor facilities. Vessels can swing 360 degrees around the new device, always heading into the wind, thus making it possible for them to unload even in winds up to hurricane force.

☐ Manned rockets, capable of boosting satellites into space and then returning to the launching site, are being studied by Convair engineers.

This Company Loves Tough Problems



Balloon designed by ADL will shoot from a rocket to record density of atmosphere 300 miles above earth

By Wilbur Cross and Hart Leavitt

WHEN A LARGE publishing firm developed a new type of printing plate, but needed a better understanding of the chemistry and physics involved in putting the plate to work, it turned for help to ADL. When a plywood manufacturing company found its gluing machines did not always apply the thin film of glue properly, an executive said, "Let's give the project to ADL." And when another manufacturing company found it did not have facilities to test a new type of parachute cord at high altitudes and low temperatures, it knew exactly who could do the job—the staff members at ADL.

"ADL" is simply the popular name for the Cambridge, Mass., research firm of Arthur D. Little, Inc. During the past 75

years, it has tackled more than 60,000 problems in almost every field of endeavor and built its reputation by finding solutions, as it did for the problems mentioned above. No assignment is ever greeted with surprise at ADL which, as one of the most successful research and development firms in the world, has helped to improve almost every type of product from ladies' girdles to uranium mining machines, from false eyelashes to mud huts.

ADL's accomplishments result, in large part, from its philosophy of encouraging staff members to take fresh and unique approaches to each problem. In fact, the firm will sometimes assign the problem to a man who is not an expert in the field in which it falls. A project that is basically

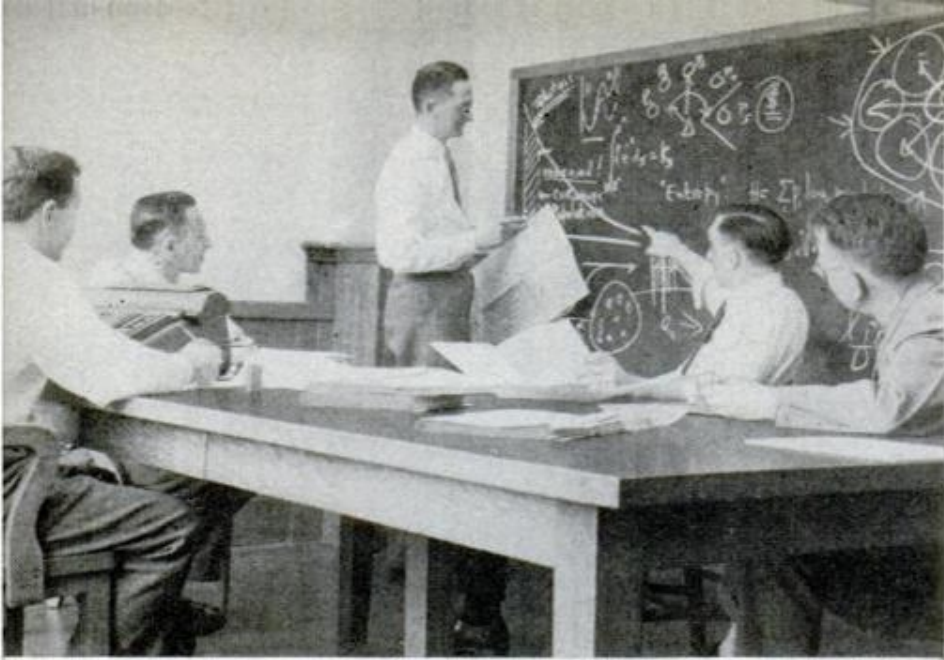

ADL Operations Research Team analyzes what will happen when a company uses manpower, time and money in different ways. The team also studies how to develop equipment and formulas



Egyptian farm workers mix mud with a petroleum by-product, bitumen, which makes their mud huts resistant to rain. ADL suggested the technique as a means of helping solve a housing problem for over 16 million workers



.....

Before: Some Hondurans lived in ramshackle houses made of wood and ADL's problem was to find how they could help make their own houses at low cost

Woman putting steak in broiler works at ADL's Flavor Laboratory, where researchers try new food products. The test here is to measure the effect, on meat, of a new tenderizing substance



one of mechanical engineering may be solved by a staff member whose background is chemistry or electronics. A problem in air conditioning may be handed to a team consisting of a psychologist, a meteorologist and others who have never seen the inside of an air-conditioning unit.

"The Lord deliver us from experts," says the company's president, Dr. Raymond Stevens. He does not mean this in a talent sense, for ADL employs some of the finest thinkers in the world. What he believes, rather, is that every research problem should be approached with an open mind, imagination and a high degree of old-fashioned common sense.

This approach was interestingly demonstrated when a manufacturer of seismographs and other recording instruments came to ADL for help. "We make the finest precision machines in the world," he explained, "but they aren't working properly. The ink won't flow through the recording needle, and we think we need a better type of ink."

The problem was given to Raymond James, who had no experience with either seismographs or ink. James did not rush to the library to bone up on these subjects, nor did he even make a thorough study of

the company's instruments. He simply shuffled around the corridors and thought about what was most important: the end result, which was recording seismograph readings. He found the answer one day while staring in thought at the floor. Noticing the whitish glaze on the waxed surface and the scratch marks that stood out against it, he began to wonder. Instead of using ink, the best of which could run dry, why not use a stylus on a soft surface? The theory was tested, put in practice with plastic instead of wax, and resulted in one of the most valuable developments in the client's long history.

Time and again, ADL has put this kind of homely imagination to valuable scientific use. One such development, which has saved millions of dollars for the steel industry, came about, partially, because of an ice-cream cone. While doing research for Republic Steel, Dr. Bruce Old noticed the dangerous practice of "tapping" blast furnaces. Workmen, in order to take samples of molten steel, had to knock out a clay plug at the furnace flow hole with a steel bar. It was slow and difficult work and exposed the man to splattering slag. Dr. Old wondered how to lessen the danger. His moment of inspiration came when

.....
After: ADL representatives suggested that lime be mixed with mud, which could be made into weather-resistant bricks. The firm also drew up house plans



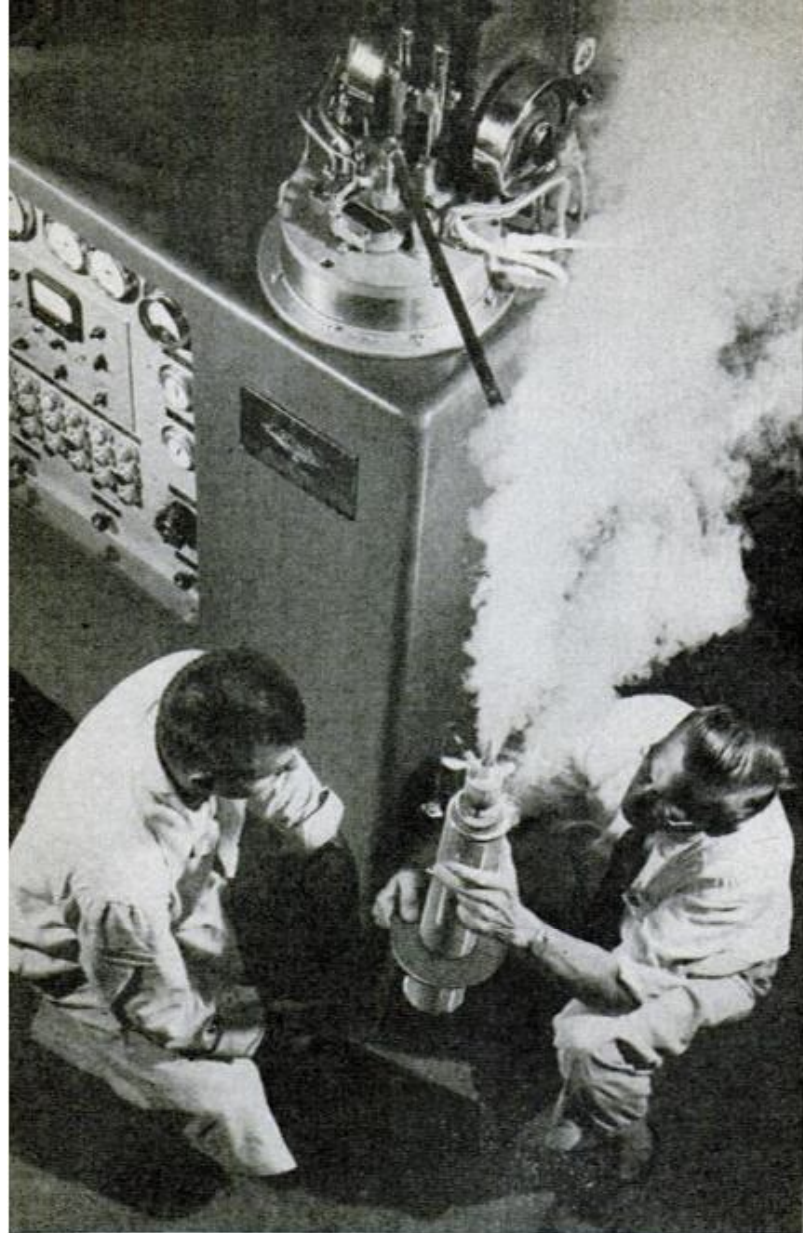

One of the few products ADL makes is a helium liquefier for attaining temperatures as low as -270 degrees C. It is used by 85 percent of this country's low-temperature research labs

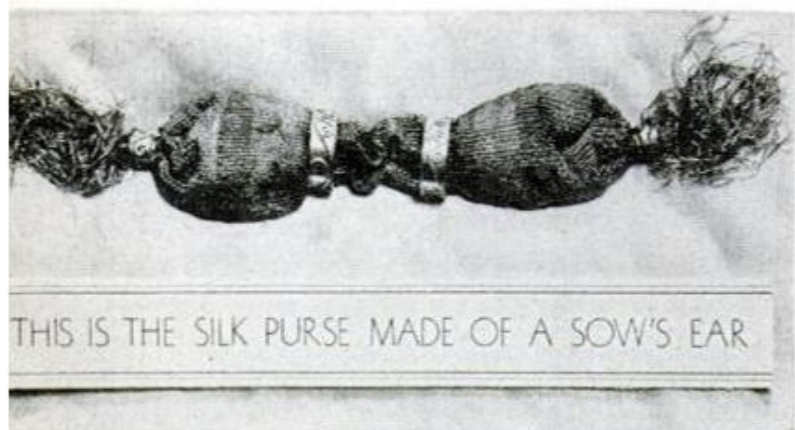

THIS IS THE SILK PURSE MADE OF A SOW'S EAR

To show the futility of negative thinking, Arthur D. Little, founder of the firm, made a "silk purse from a sow's ear." It illustrates the company philosophy of taking fresh approaches

he saw a child sucking an ice-cream cone. It reminded him of the shaped charges of explosives, used during World War II, fixed to long poles, to blast barbed-wire entanglements. Because of the shape, the force was directed forward, away from the user. Old tried a similar device for the "tapping" process. It worked so well it is now employed in 80 percent of all U. S. blast furnaces.

ADL's common-sense approach is nowhere better illustrated than in the perplexing case of the mud huts. In 1952, the Egyptian government was faced with a crisis in an age-old problem: housing for some 16 million farm workers on whom much of the economy of the country depended. The workers lived in huts of sun-baked clay made after the manner of their ancestors 5000 years before. When the rainy season came, the huts would disintegrate. Not only were the costs of tents and prefabs too high, the farmers refused to occupy such unfamiliar dwellings.

In desperation, Egypt contracted with ADL to have staff members Drs. Charles Harford and Earl Stafford flown to Cairo to search out a solution. They made field tests which were supplemented by law work back at ADL's Cambridge offices and came up with an answer: Let the farm workers continue to build the traditional mud huts they preferred. But show them how to mix the wet clay with bitumen, a cheap petroleum by-product abundant in Egypt. Bitumen barely changed even the color of the huts, yet it made them rainproof.

ADL's approach to problems has stood the test of time, for it was formulated 75 years ago by a man who knew how to combine genius with the common touch: Arthur Dehon Little. Forced to quit Massachusetts Institute of Technology at the age of 22, in 1885, Little faced the world with no job, no assets, but with a remarkable working philosophy. There were four characteristics he would demand of himself (and later of his associates): "The simplicity to wonder, the ability to question, the power to generalize, the capacity to apply."

(Continued to page 260)



Women in Giant "Sewing Bee" Prepare Fabric for Blimps

In what might be called the world's largest "sewing bee," scores of women in Litchfield Park, Ariz., spend eight hours a day cutting and cementing together huge envelopes of rubberized fabrics. Their job is making gigantic U.S. Navy blimps. On hands and knees, they cut the fabric according to pattern. When the envelopes are inflated, they stretch a block long and several stories high. The end result is a blimp finally completed in Akron, Ohio.

Chemical Spray "Prunes" Trees

Sprayed onto lemon trees, a chemical, maleic hydrazide, "prunes" by retarding new growth without harming older foliage or preventing the development of fruit. Experiments were carried out by Ventura Coastal Lemon Company with a spray that consisted of a 500-parts-per-million concentration of maleic hydrazide in water. The chemical caused fast-growing limbs to die—and by diverting the trees' energy, encouraged the production of better fruit. It had previously been used to inhibit the growth of fast-growing plants such as ivy.





Two climbers negotiate a tricky "chasm" in one building while another maneuvers on a vertical brick wall that's almost as formidable as a mountainside

Amsterdam's Saturday Mountain Climbers

AMSTERDAM, the capital of a land that's flat as flat can be, is nurturing a group of mountain-climbing enthusiasts who practice on a "mountain" in the center of the city every Saturday afternoon.

The climbers are members of the Amsterdam section of the Austrian Alps Association. They practice on a training tower used by the city's firemen. This way, they manage to keep in shape for their holidays in the Alps of Italy, Austria and Switzerland...or their rehearsals for those formidable giants in the Ardennes and Eifel Mountains of Germany.

Clad in heavy boots, sweaters and wool caps, and carrying ropes, axes and the tackle they use for climbing real mountains, they put on a spectacular show every weekend for their fellow Amsterdammers.



POPULAR MECHANICS



Firemen's training tower in Amsterdam serves as a mountain for members of the Austrian Alps Association

Two climbers in a practice rescue operation are supported on a slender but amazingly strong nylon rope

He made it to the top! Next he'll try the Eifel Mountains and the Ardennes—then on to the Alps



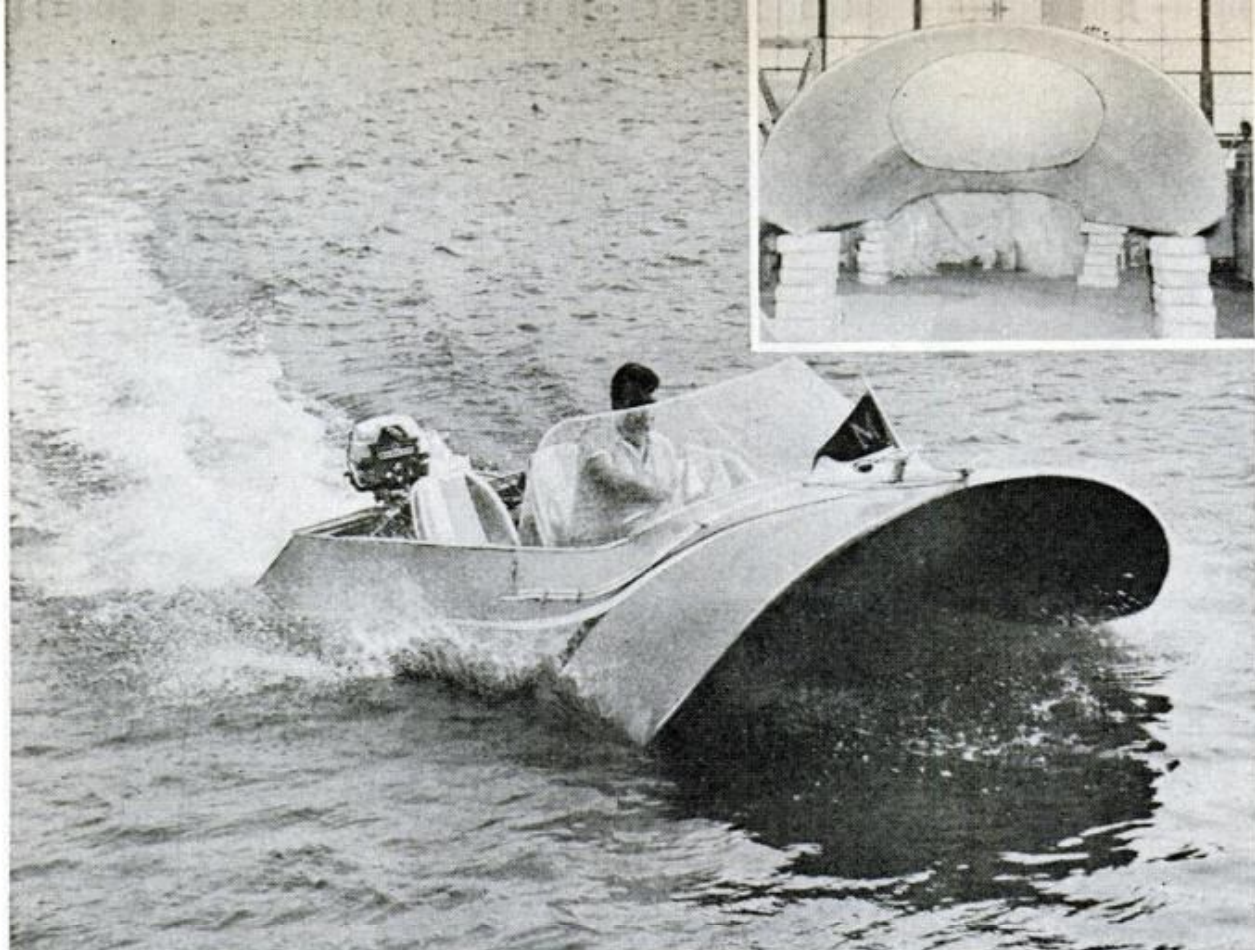

All-Aluminum Catamaran Uses Crescent-Shaped Hull

Its crescent-shaped hull skimming the water on edges of aluminum, a new catamaran streaks along at speeds up to 50 miles per hour when powered by a 35-horsepower motor, and up to 22 miles per hour on a 16-horsepower outboard. The boat is 14 feet long and 8 feet wide and has a cockpit beam of 45 inches. The hull is

made of welded tubular aluminum covered with a high-stress aluminum alloy. It has upholstered bucket seats which contribute to the smooth ride. The experimental catamaran was built by a commercial builder seeking experience in this type of construction and, as yet, there is no plan to put the design into commercial production.

Trim Elevators for Boat

Stern elevators suitable for both inboard and outboard motor boats can be adjusted to give the desired planing attitude by a new control system. When the boat is moving, water pressure against two stainless steel elevators is introduced into two hydraulic cylinders where it provides power so the boater can adjust the elevators. The system has finger-tip controls.

Look, Fishermen — No Hands!

Fishermen now can have both hands free for fishing and still control their boats when they are moving at low speed. A new tiller control, boxed in cast titanium, responds to foot pressure, allowing a fisherman to adjust direction for current, wind drift and the changing shoreline. Its manufacturer says the control will turn a fishing boat 360 degrees in approximately 20 feet.

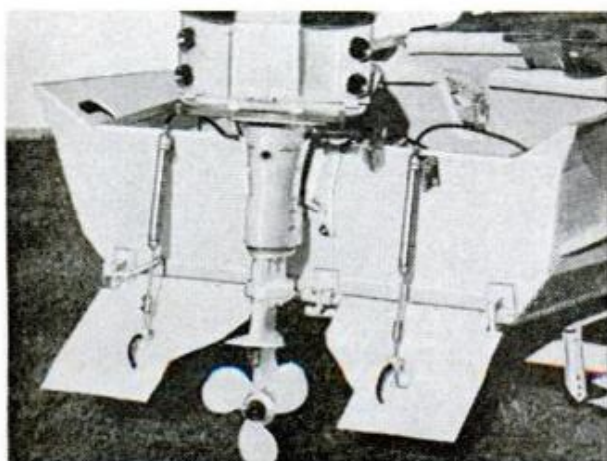

"Pontoon" Tires Float Marsh Buggy

Churning through swampy areas carrying prospectors for oil, a 4000-pound marsh buggy actually floats on its five-foot-high "pontoon" tires. The tires measure 42 inches wide and 18 inches at the hub. When inflated to proper pressure, they can float the unusual vehicle through marshes and swamp areas while it carries a 4000-pound payload. The marsh buggies will find use in oil exploration and as personnel carriers.



Largest Mail Sorter Zips Through Letters

Doubling the capacity of any existing machine, the world's largest letter-sorting machine handles 36,000 letters an hour. The machine, installed in the Detroit post office, can be equipped with as many as 12 separate operator keyboards, each handling intermixed letters. As a letter is placed automatically on a scanning board, the operator reads the address and presses a destination key on the console. The letter drops into the conveyor system which consists of 161 letter carts constantly in motion. An electromechanical code signal then releases the letter into the proper sorting bin, of which there are 279. The sorting bins (right) are arranged in tiers for easy access. When any of the bins is near capacity, an alarm signal at the supervisor's control station gives a warning. Automatic counting devices register the number of letters sorted by each operator.



☐ The Federal Aviation Agency has established 60 as the mandatory age for retirement of airline pilots.



NEW BEDS may be created from older ones with a conversion kit that fits most styles. It combines a steel support for springs and mattress with an adjustable plate to fit the headboard, and does away with the need for a footboard or side rails. The kit comes with either casters or nylon glides. The manufacturer says conversion may be made with only a few ordinary tools—a 5/16-inch drill bit, drill, screwdriver, hammer and measuring tape

Harvard Mfg. Co., 7619 Grand Ave., Cleveland 14, Ohio

DRYING TRAY for drip-dry clothing is made of rubberized fabric set in a steel frame, and folds easily for storage. An upright in the form of an inverted U lifts up to make a rack from which clothes hangers bearing wet clothing may be suspended. The frame leans toward the tray's center so water cannot drip to the floor. It may be adjusted from 30 to 54 inches in height to accommodate dresses and trousers. Metal parts are rustproof

Welmaid Products, Inc., 1529 Armitage Ave., Chicago 22, Ill.

LEMON PEELER designed for the home chef or "mixologist" has an adjustable blade to permit cutting peels of varying thicknesses. It is made in Italy of stainless steel with an ivory handle. The peeler measures 5½ inches long and fits the hand comfortably

The Lighthouse, Inc., Dept. 245, Plymouth, Mass.

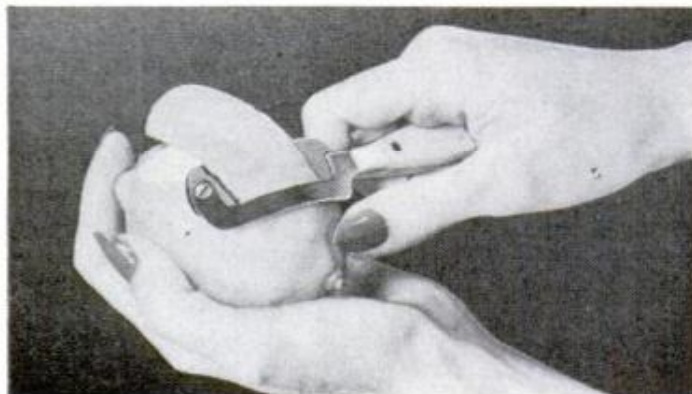
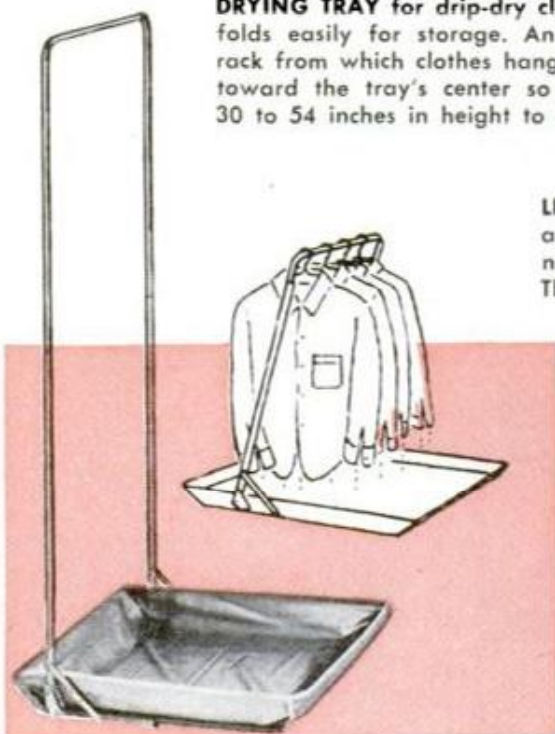

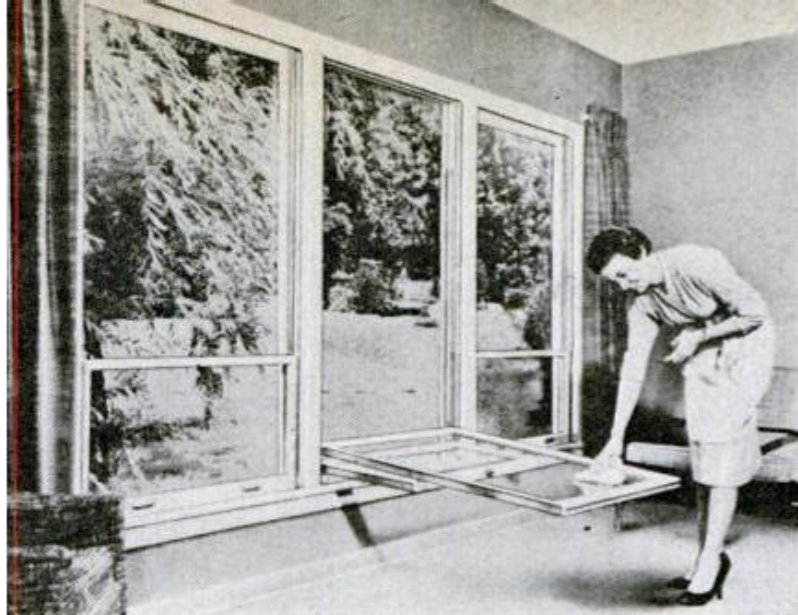

TILTING PICTURE WINDOW can be swung downward into a room to lie flat for easy cleaning. The window, with side frames of rustproof metal, can be raised or lowered in the conventional manner. It also may be tilted at an angle for ventilation.
 Safety Window Hardware Corp., 121-127 Thirtieth Street, Brooklyn 32, N. Y.

PORTABLE STEP, which comes in 11 colors, has a built-in safety device: When weight is put on the rubber-treaded platform, the casters on which it moves retract, lowering the base to grip the floor. In its lowered position, the platform will not wobble or slip. When weight is removed, the casters again lower to rolling position and the unit can easily be moved, with the foot, to a new location. The step stands 14 inches high, has bumpers completely around it, and can be used as a stool.
 Cramer Posture Chair Co., Inc., 625 Adams, Kansas City 5, Kans.



CORD CADDY, made of a plastic built to withstand bumps without breaking, permits you to reel up appliance and lamp cords to prevent entanglement and floor clutter. It is attached by removing the outlet faceplate, setting the caddy in place, and replacing the plate. It is easy to use: Unused cord is reeled around the caddy, then pulled through a slot which holds the loops neatly. Two of the cord reels may be installed on one wall outlet, an advantage in the use of kitchen appliances.
 Brittain Sales Corp., 777 Copley Rd., Akron 20, Ohio

STORAGE CHEST for the protection of sweaters and other small woolen garments against moths is made from aluminum laminated to paperboard. The chest measures 3 by 12 by 15 inches, and is collapsible for storage when not in use. Moth balls or flakes may be placed in the chest, which will retain larva-killing vapors.
 Bala Products, Box 337, Bala-Cynwyd, Pa.

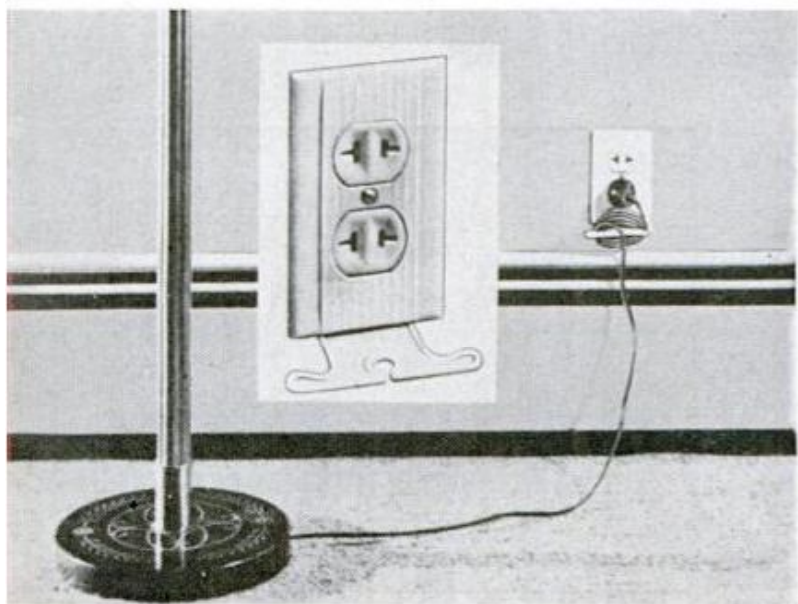

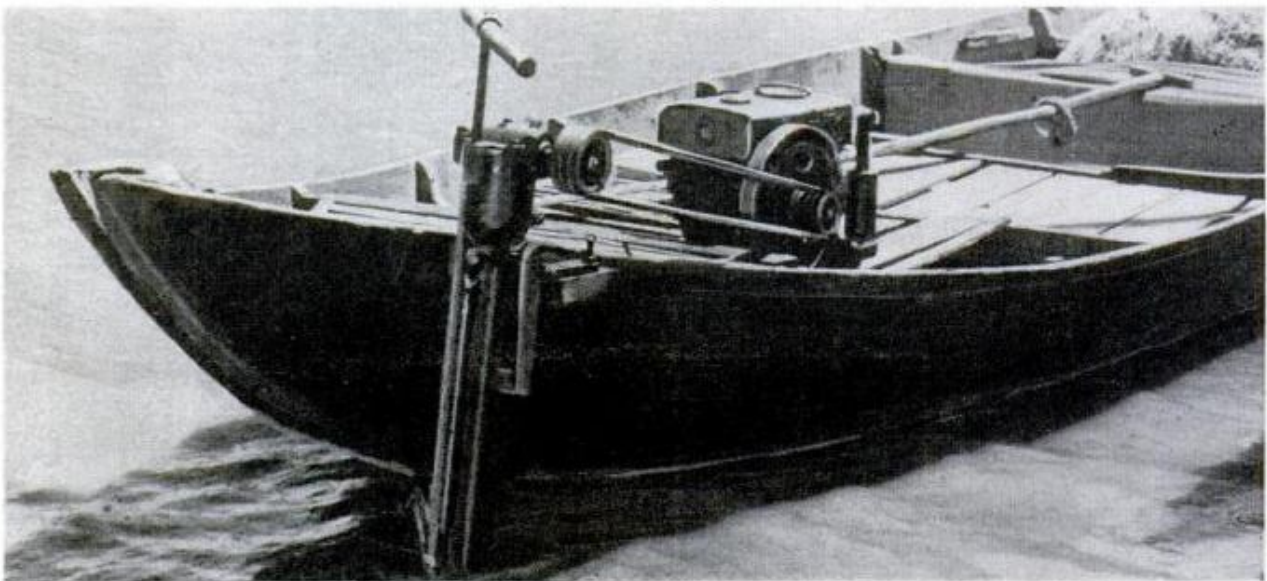

Fishing Junks Get Diesel Power

One hundred fishermen in South Vietnam no longer have to paddle their junks laboriously to pull in fish-laden nets. They are the first to receive a 2½-horsepower diesel engine that was designed particularly for their boats, which have bottoms of bamboo mats. Ordinary engines shake the fishing junks apart. The new diesel has a V-belt drive and mounts on the side of the boat. It has a retractable propeller assembly, so as to not drag bottom when the junk slips out to fish under thatch sails. The engine was designed in Japan.

Number, Please!

Whenever you write us to

- Renew your subscription
- Change your address
- Order your own or a gift subscription

... In fact, whenever you write us,
**PLEASE INCLUDE YOUR CITY POSTAL
 ZONE NUMBER IN YOUR ADDRESS**

*This insures better delivery.
 It helps you and it helps the postman.*

Clockwatcher's Paradise



← **YACHT TIMER** is a five-minute reverse starter timer which goes any number of revolutions for any length race. Each pastel-color "pie-cut" section of the dial represents one minute



→ **MOST COMPLICATED** watch is this jeweled-lever time piece that chimes on the minute, quarter hour and hour, gives phases of moon and is calendar that shows year, month and day

The Watchmakers of Switzerland photos

→ **ROAD-MAP** watch measures distances on standard maps in kilometers and miles. Mileage is seen through the aperture in dial

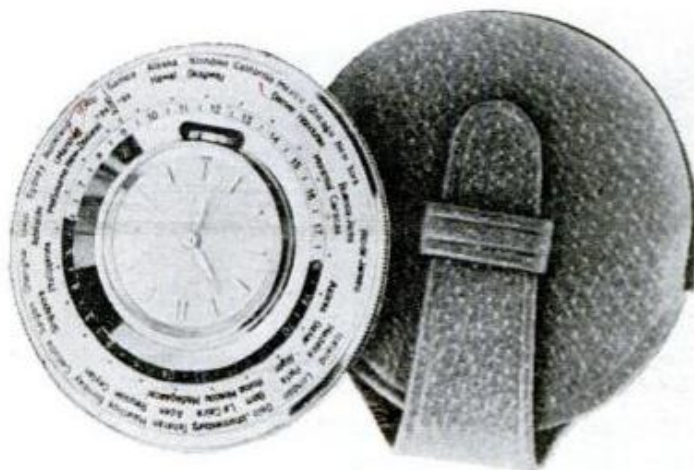

↑ **WORLD-TRAVELER** watch tells the time in 24 cities around the world. It has a protective pigskin case

↑ **PULSOMETER** tells time and pulse rate. Doctor starts sweep hand, counts 20 beats, stops hand and reads beats per minute on dial

→ **SLIDE RULE** watch has outer rim that turns for calculations. It multiplies, divides, takes cube root and acts as a stop watch



Physical Fitness Factory

By
Jack B. Kemmerer

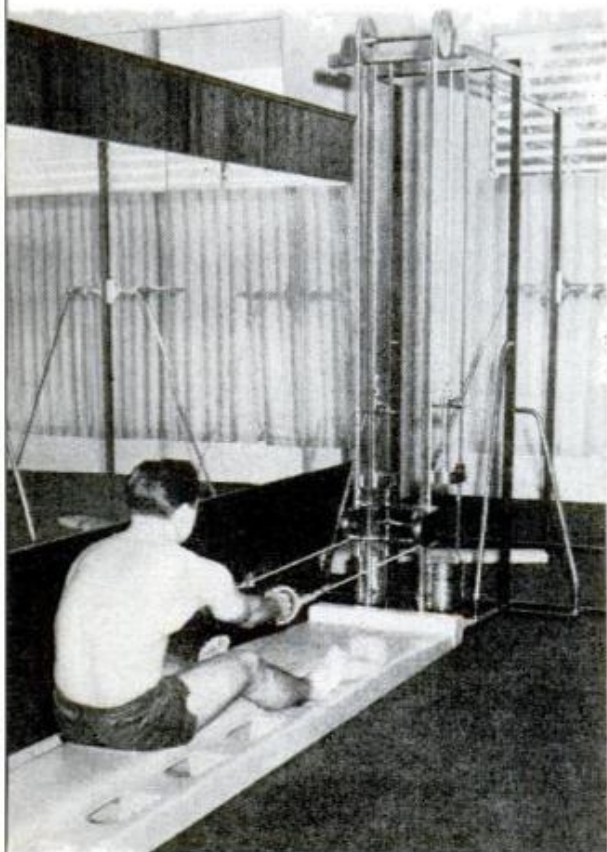

Excess weight on the sides and thighs is removed with Vic Tanny's Lat Pulley

PHYSICAL FITNESS—that nemesis of the overweight and the underweight—suddenly is enjoying rejuvenated popularity. Body builders like Charles Atlas, Joe Weider and Dan Lurie, striving to provide better bodies, are finding zealous students for their offerings.

Why the need? Automation, is the most frequent answer. Because machines instead of muscles are doing the work, people have become sluggish, sickly and sometimes emotionally disturbed. Now they are finding in physical exercise real constructive fun.

One muscle-builder, however, has looked automation squarely in the eye. He's taken the machines of the automatic age and put them to work making people physically fit.

Vic Tanny, physical culture expert, has designed and built a set of complex machines that can remake any part of the body. His gyms across the country look like factories, except that the people in them work the machines instead of letting the machines work them. Weight-resistant pulleys and bars force the individual to use his own muscles to operate them.

To Tanny, there is no such word as "reduce." He tags his process, "normalizing" the body.

"When a person comes to us for help," says Tanny, "the gym manager evaluates weight, height, age, condition, needs and desires of the person. Then a program is started to bring that person to normal."

In the United States, only 10 percent of the people can be called normal, according to Tanny's

Pulling and contracting on Long Pulleys, this young lady will add inches to bust line and reduce or build up hips

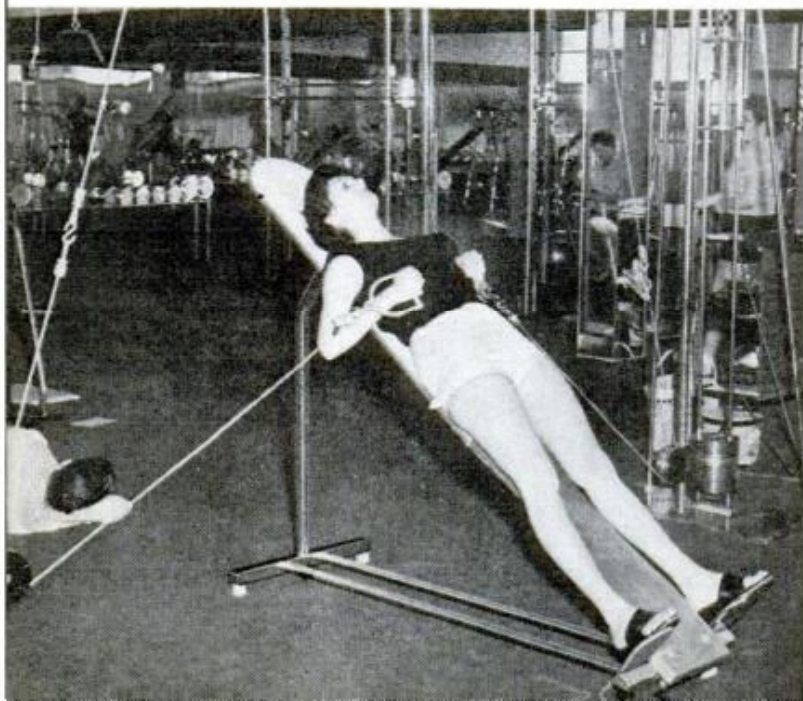

Women find Tanny's Leg Extension Table a convenient way to develop their thigh muscles



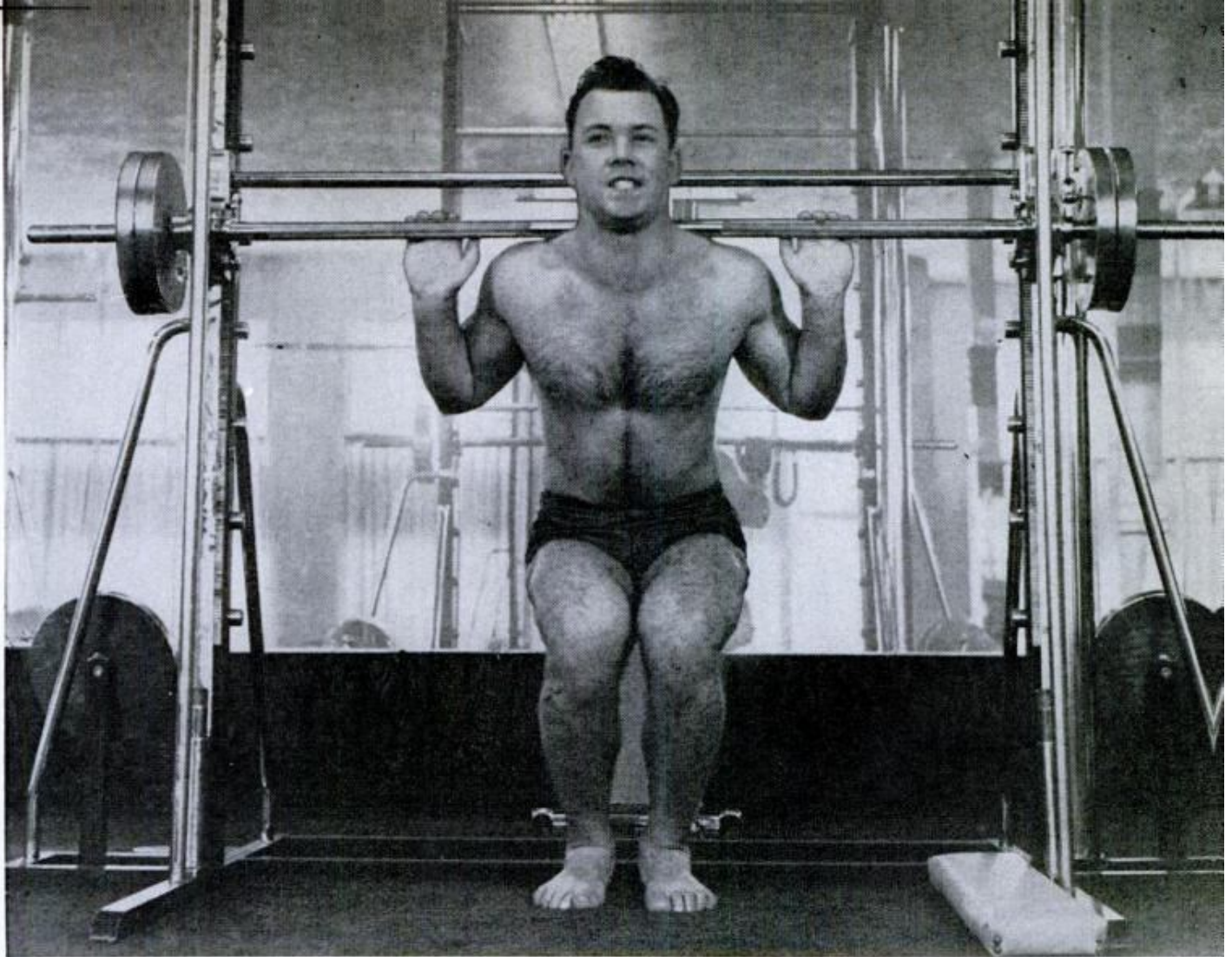

One application of the Smith Bar: as trainee tries to stand while raising weight, he develops lower body definition. Of the other 90 percent, 20 are underweight and 70 overweight.

In starting a program for a new member, Tanny's instructors assign each person to the pieces of equipment aimed at his particular development. If someone wants to get his thighs or chest into shape, he is assigned to the Smith Bar, which is equipped

with variable weights which he must move with his legs or arms.

If an otherwise charming young thing wants to develop her bust or build up her thighs and hips, she is assigned to the Long Pulley, which adds inches and firms the bust muscles. One fascinating machine is the Jungle Pulley. It has six different work-

Six persons can use the Jungle Pulley at one time. Any part of the body can be strengthened. Here fore and upper arm are worked on

This girl is using the Jungle Pulley for upper arms and back

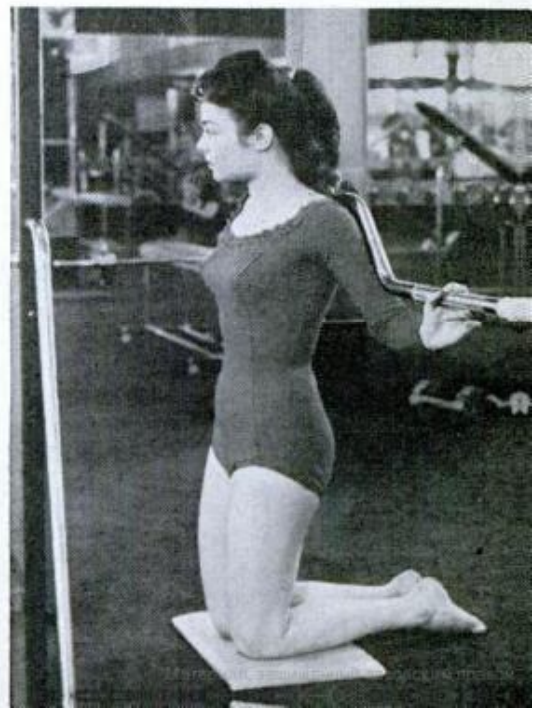
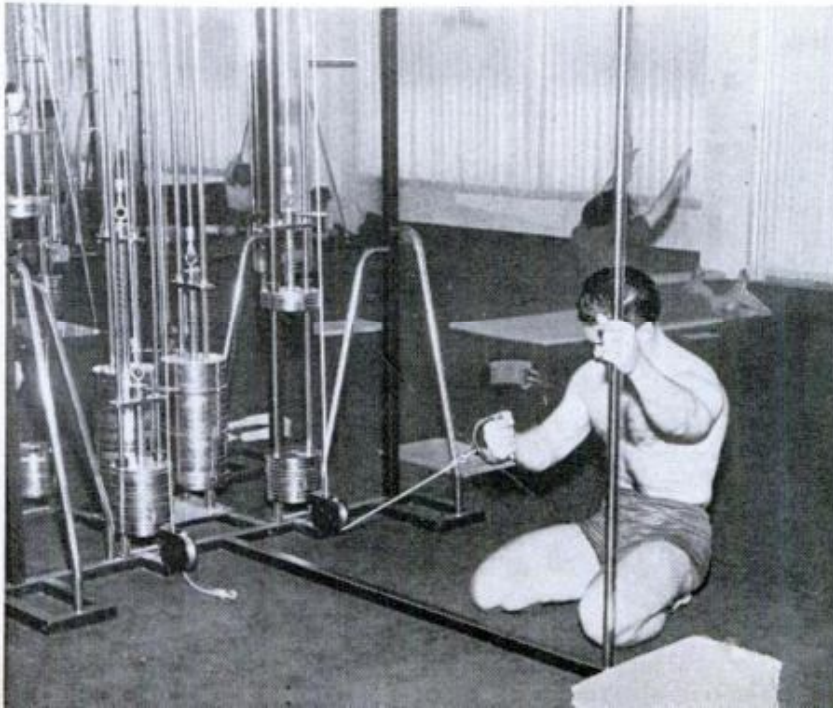

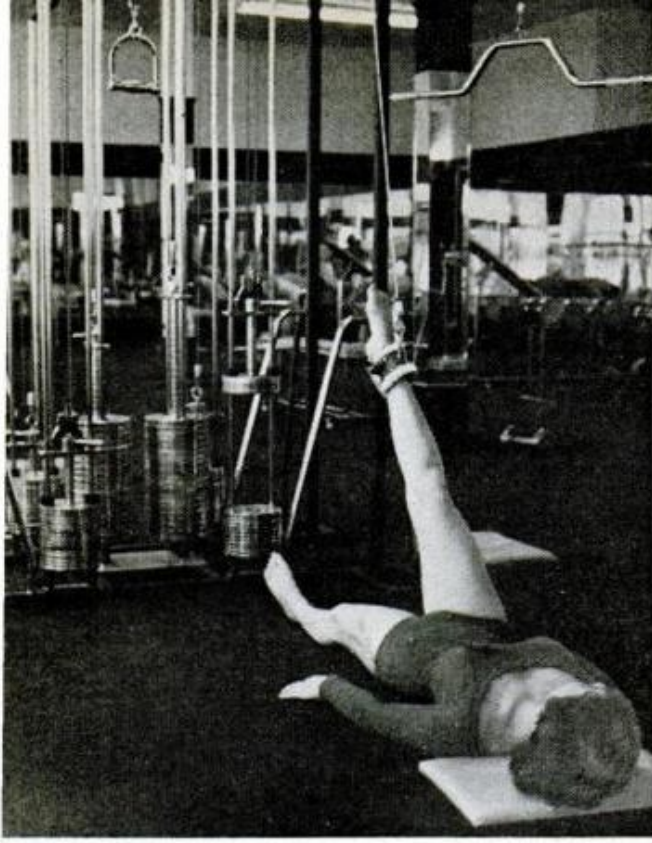

Thigh muscles are developed quickly by lowering one of the weights on the Jungle Pulley



Another Smith Bar application, these weights and pulleys develop leg, thigh muscles when they are raised, lowered

ing positions that develop any part of the body. These and other machines are found in each Tanny gym, valued up to \$50,000.

Once the person is introduced to the equipment, he spends his first two weeks in a basic conditioning program. By the fourth week, the training is tailored to his own needs.

Through proper use of these machines, Tanny's gyms help people do many things with their bodies. It is quite easy for members to gain or lose 10 to 20 pounds, add or lose two to four inches at the bust line and add or lose one to two inches on the thighs.

The normalizing period lasts as long as each person wants. It lasts until he or she has gained or lost the weight desired or developed the muscles needed. By gradual strengthening of muscles, the Tanny method allows a person to stop whenever he wants. Thus he or she can build the exact muscular structure desired, without forming bulging muscles.

Women actually have been greater users of Tanny's principle of body building than men. This, Tanny admits rather candidly, is because women are more figure conscious than men. ★★★

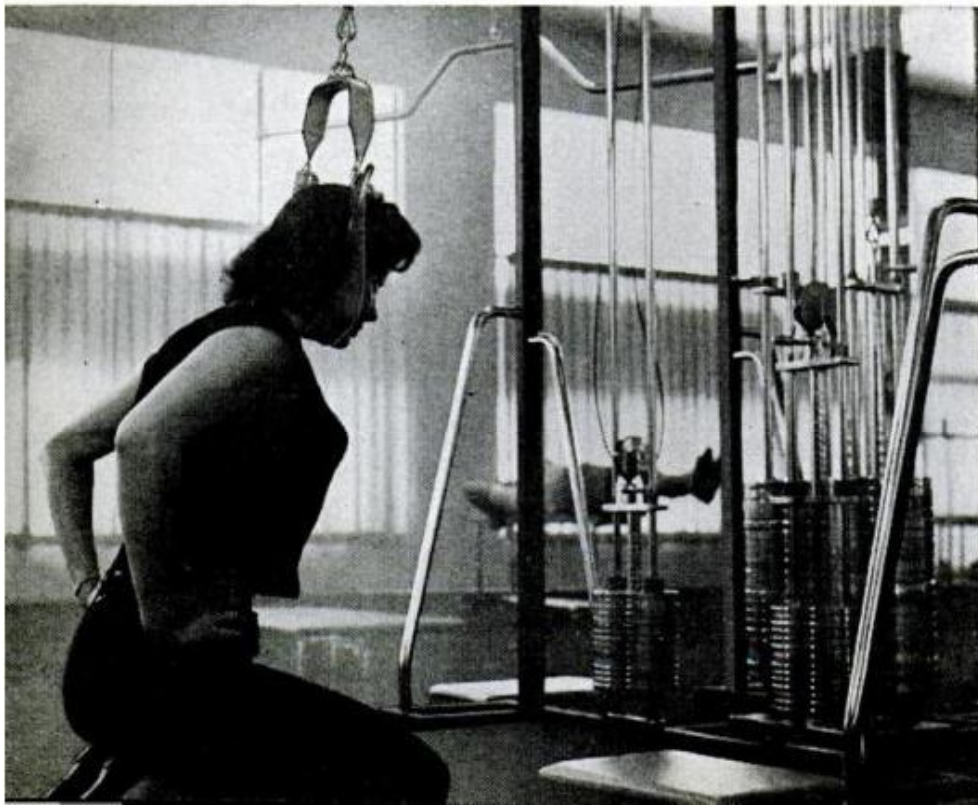

Double chins and wrinkles find their cures with this mechanism on the Jungle Pulley. It lifts the head to help correct possible posture defects at the same time

Long Lever Swings Boat Onto Dock

With an L-shape lever, one man can lift a boat weighing up to 500 pounds from the water and tilt it on its beam for cleaning. The lifter is made of three-inch pipe. The hinge at the fulcrum is formed by a pipe sleeve rotating around a hinge pin of smaller pipe that has been secured to the edge of the dock.



Custom Auto Body Finished in Mosaic

Few custom car bodies can equal the one designed by Niklos Bel-Jon, a San Francisco artist. After obtaining a 1938-model car, he replaced the top and hood with Fiberglas and added Fiberglas fins. Over all of this, he applied thousands of aluminum mosaic pieces. A year and a half of spare-time work and a considerable amount of money turned the car into an eye-stopper.

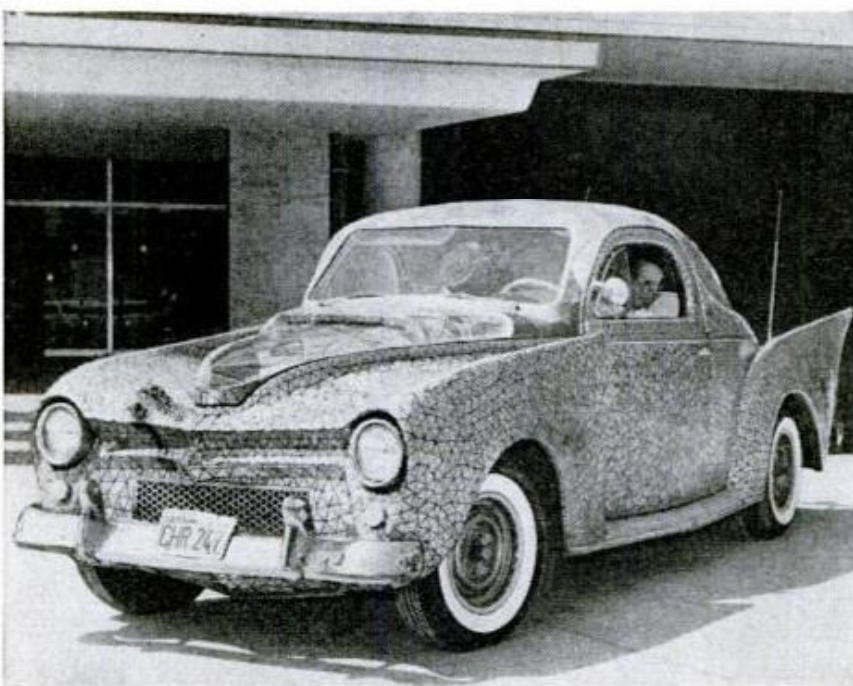

Beware! Your Ears May Give You Away

"Earprinting" — using characteristics of the human ear for identification — soon may serve law-enforcement bodies as a valuable adjunct to fingerprinting. Developed by A. V. Iannarelli, an Alameda County, Calif. deputy sheriff, the new method can be used where fingers are mutilated from burns. Iannarelli anticipates that it will replace footprinting of babies, too. With hundreds of ear pictures on file, he has found that even two ears on the same head are different, and that identical twins have different ears. He says that basic ear features stay the same for life.

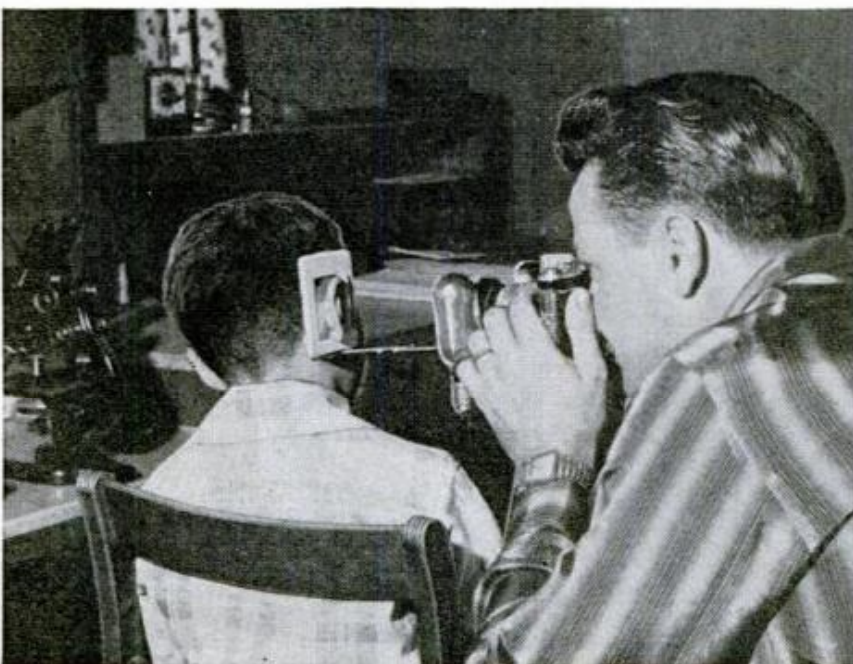

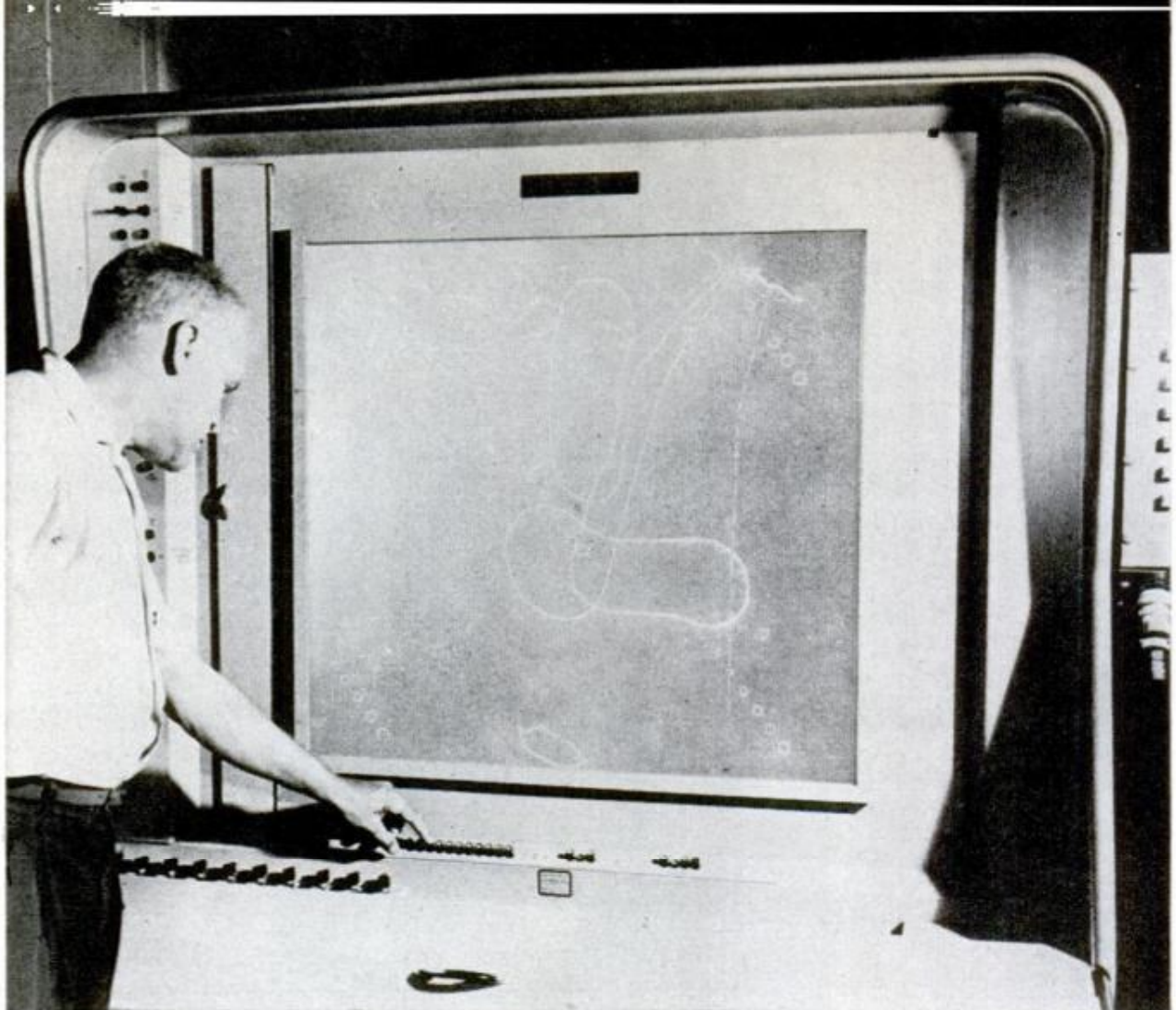

U.S. Navy photo

Huge "TV Screen" Plots Aircraft Thousands of Miles Away

Airplanes approaching from thousands of miles away are plotted by a new system, Iconorama, that resembles a huge television screen. Radar information about such planes is fed to the machine, causing a stylus to scratch a trace on a slide that is then automatically projected in register, and with an identifying color, onto the

viewing screen. Iconorama handles four times as much information as that plotted by clear plastic panels in use since World War II, and will be installed in top U.S. air-defense centers. In a special application at Pacific Missile Range, Point Mugu, Calif., viewers wear polarized glasses and see objects up to 50,000 feet in three-dimension.

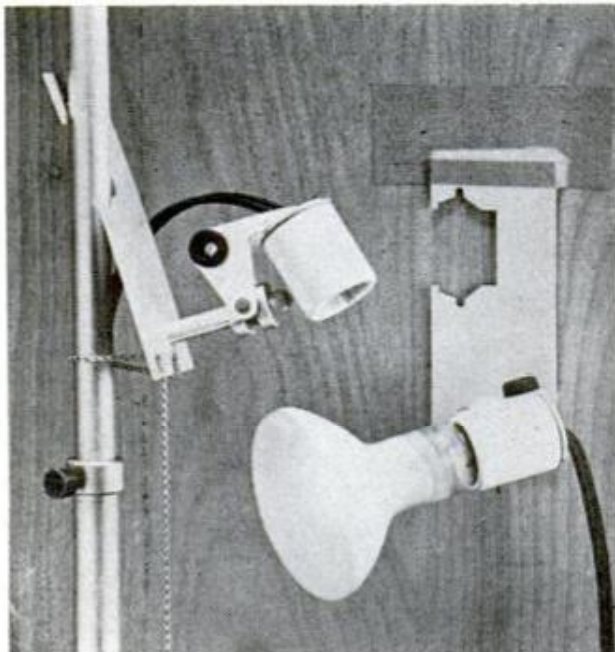

Tape Holds Photo Lamp

Compact enough to fit in your pocket, a photo-lamp mount can be attached to a wall or mounted on a stand. Its versatility enables the photographer to travel light and still have top or backlighting without booms or overhead rigging. The lamp is held to the wall by a special tape that supports it securely without marring the surface. A notch and chain arrangement locks the light on a stand, pipe, piece of furniture or door. Complete directional control is provided by a swivel which has a tension adjustment. Heat-insulated finger grips allow the photographer to turn the lamp without burning his fingers. The socket of the lamp is porcelain, the cord is neoprene and the other components are made of aluminum and brass. A supply of tape is furnished with each mount.



Small Electric Boat Sneaks Angler Into Good Fishing Holes

Only 7 feet long and 42 inches wide, an electrically-powered Fiberglas fishing boat will ease its occupant into remote brushy areas where the big ones lurk. When fitted with a low-powered outboard motor, the boat will also negotiate rougher water. The craft's quiet-running electric motor is located in a center well and is powered by

a six-volt car battery. The inventor, an airline pilot who now manufactures the craft, has also devised a control system by which he steers the craft with his knee while using a foot pedal for speed control. This arrangement leaves both hands free for fishing. The craft can be carried atop a car or in a station wagon.

Giant "Football" Protect Freight

Pneumatic cushions that inflate like giant footballs protect crates and valuable freight from damage during shipment by rail. Placed between boxes or between the ends of the freight cars and the boxes, the cushions replace wooden braces formerly used, and soften the jolts caused when trains start or stop suddenly or cars bump together. After they are placed between the crates, the cushions are inflated from a compressed-air line. When the train jolts, they compress, easing any fractional movement of the crates and preventing uncontrolled slides that are a major cause of freight damage in railroad transportation. At the destination, the cushions are deflated, rolled and returned to the shippers to be used again.

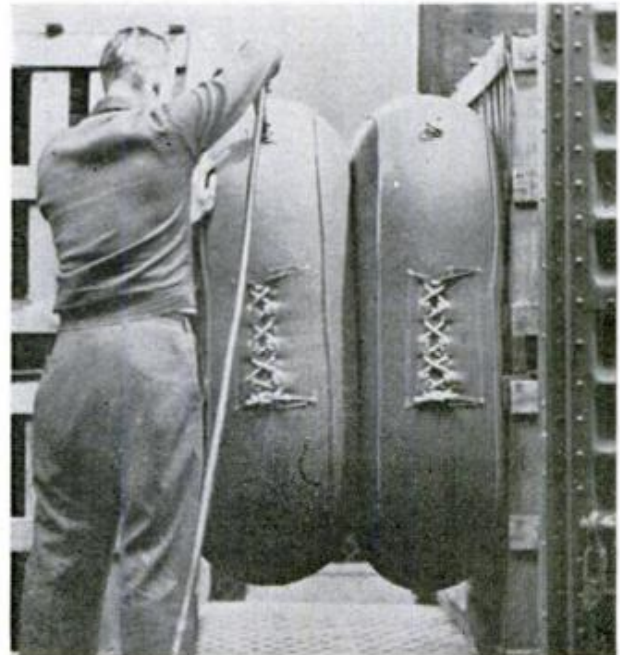



Helping a lady visitor make selections from their varied stock of small and medium-size cactus plants are "Cactus Slim" Moorten, his wife and son

Cactus to Order

By Robert Franklin Ames

GIANT HIGHWAY-CONSTRUCTION MACHINES have been stopped cold by a cactus out in the Southwest—but it wasn't because the prickly plant couldn't be crushed aside easily.

Generally, the machines were waiting while the plant was removed tenderly—and cautiously—for replanting by a tall, thin Californian named Chester Moorten. (If you live in the West, he's the one you know as Cactus Slim.)

Moorten and his wife, Patricia, of Palm Springs, have been rescuing irreplaceable cactuses for years. Some of the plants saved may have taken a century to grow.

Large plants, shipped in big tubs, were planted around this desert-landscaped home. After they took hold, other smaller varieties were added





"Harvesting cactus plants is mostly a matter of knowing how to pick them up," says cautious Cactus Slim

At first, plants were given to neighbors and friends for landscaping their lawns.

"This was a time when Westerners spent thousands of dollars duplicating Midwestern lawns," Moorten recalls. "I knew that desert plants could be used to make interesting landscapes, but at first no one thought much of the idea."

As time went on, though, demand grew, and he now gets orders from every state. He couldn't find enough plants to fill requests so he began to plant seedlings. While many cactuses mature too slowly for nursery stock, others, especially miniatures and small ornamentals, can be developed easily, he says. ★ ★ ★

Small plants are easy to tote about, but some large ones require the power of a tractor-mounted hoist



Robert Franklin Ames photos

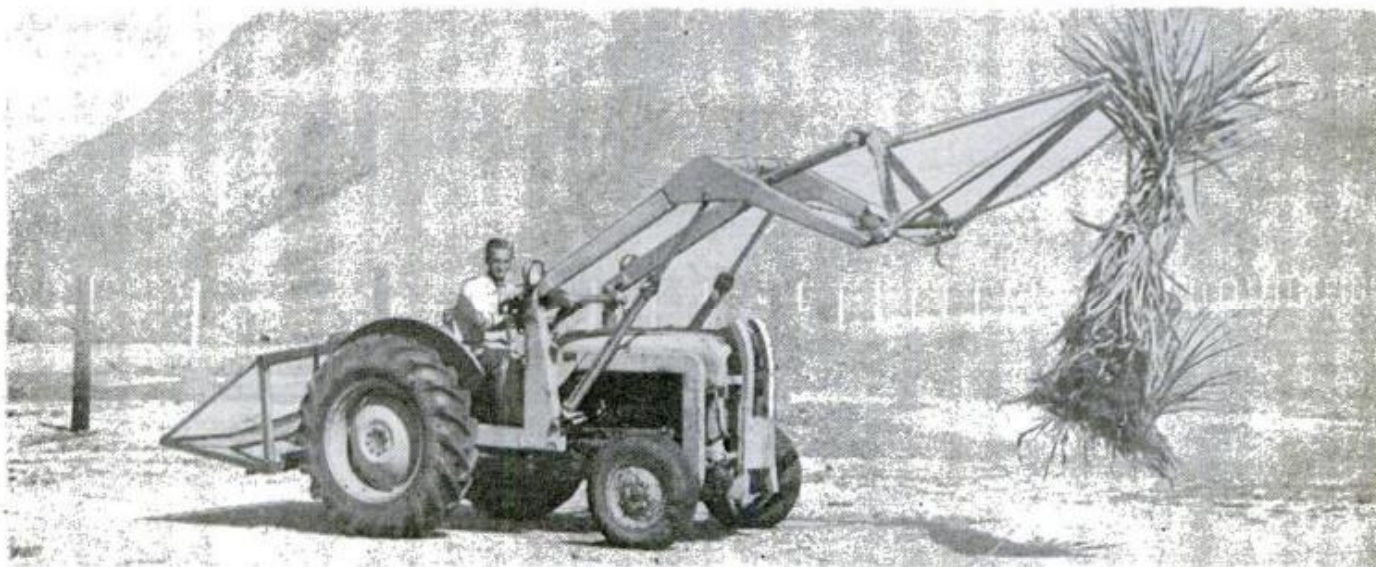

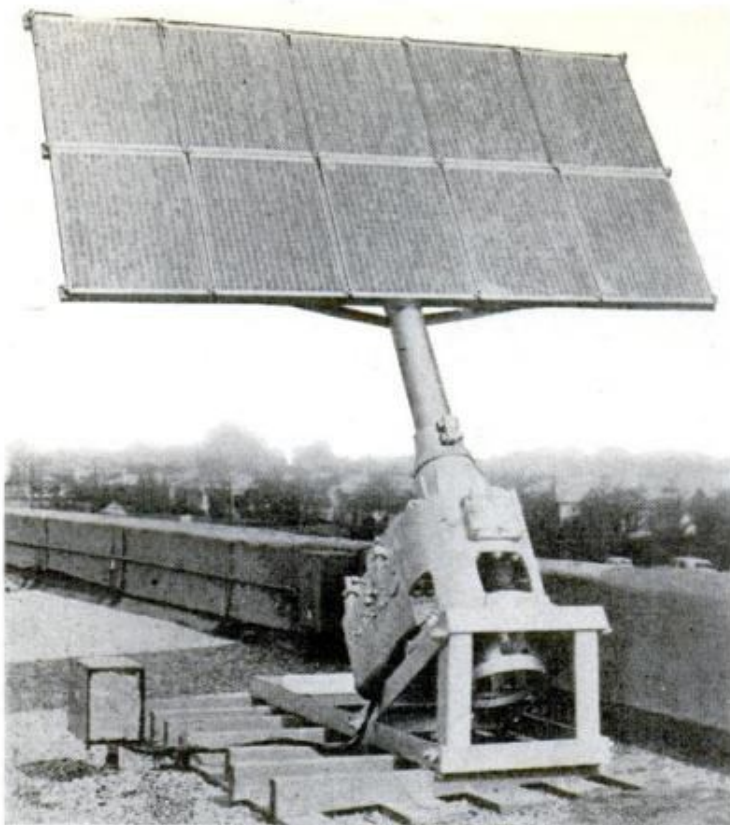

Salt Water Made Fresh By Energy From Sun

Conversion of salt water into fresh water at the rate of three gallons per hour has been accomplished by an instrument powered entirely by solar energy. The salt-water converter operates on the principle of ionization. As brine flows through a series of electrodes, an electrical current causes the sodium and chlorine ions to separate. These ions form in deposits on the electrodes and can later be removed. The giant generator that furnishes power converts light into electricity by means of 7800 silicon solar cells. These cells are attached to a four by eight-foot panel. Ten individual small panels in various combinations provide outputs of from 6 to 60 volts, and current flows ranging from one-half to five amperes.

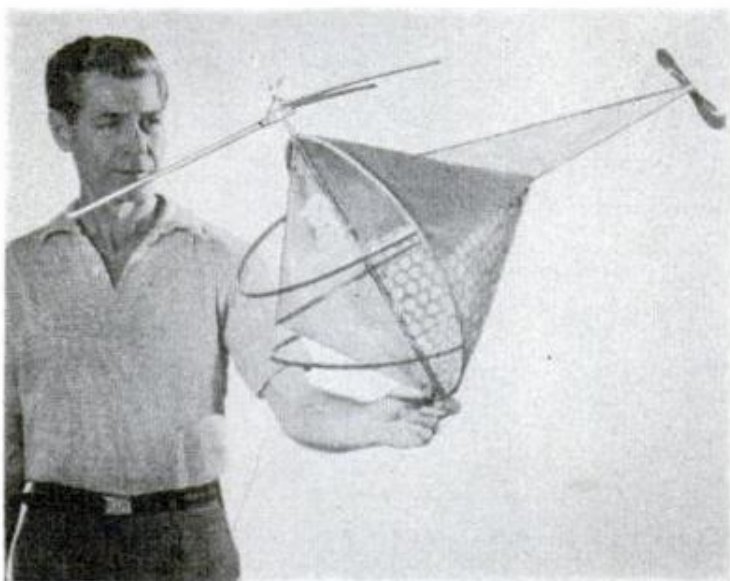

Helicopter Kite

Wind rotating the blades of a new helicopter kite stabilizes the toy to prevent the yawing and dipping common to other designs. Cone-shaped, with the large end at the front open to the breeze, the kite rises quickly when string is let out. A plastic cut-out of a pilot sits in front attached to the bridle string, and is held in taut concentration as though actually controlling maneuvers. The kite has side ports to let out surplus air and a plastic sheet is fastened to the front to prevent side winds from building up pressures that might spin the cone into a dive.



Morse-Code Sender Has Typewriter Keyboard

Anyone can send wireless messages in Morse code with a machine that has a typewriter keyboard. The machine, manufactured in Sweden, transmits the appropriate dot and dash signal for each key as it is pressed. Invented by a Norwegian radio operator, it is being installed in many lifeboats throughout Scandinavia.

Ⓞ Packaged instant bread that takes about 35 minutes to mix and bake now is included in field rations for the armed forces.

High-Pressure Oxygen Aids in Radiotherapy

ENCOURAGING results are reported by St. Thomas' Hospital, London, in treating cancer by high-pressure oxygen and radiotherapy. Anesthetized patients in the apparatus—first of its kind—breathe high-pressure oxygen. This assures a normal concentration of oxygen around cancer cells—which are often deficient in oxygen and thus up to three times less sensitive to radiotherapy than normal cells.

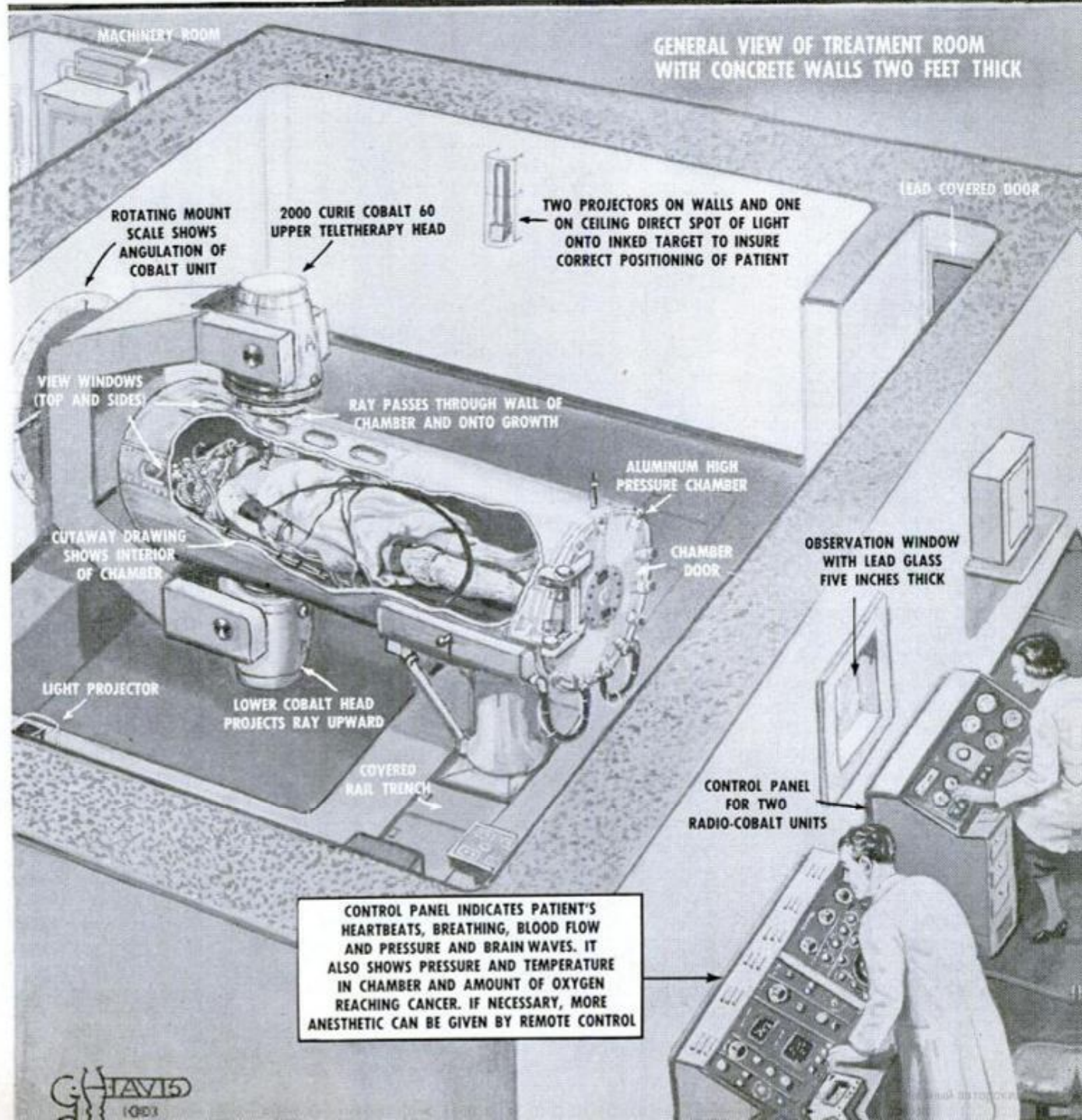



Annual Boating Section

Dinghy and small motor were handy for short trips ashore

OFFSHORE CRUISING

AFTER STOWING the last carton of provisions on board our 25-foot outboard cruiser, *Sea Joy*, the "mate" (my wife, Joy) took in the docking lines and we were on our way, bound for Key West 150 miles away. The twin motors dug in and beat a steady rhythm, pushing 3500 pounds of boat and load with ease down the Miami River to Biscayne Bay, one mile away then, good-by Miami!

Leaving on the tail-end of an ebb tide, we glided past sleek sailing yachts tied up at fancy hotel docks, big freighters and a miscellany of commercial craft. In a twinkling, the river was behind and the sparkling blue water of Biscayne went flashing by as speed was upped from the river's five-mile-per-hour limit to a brisk 20 miles per hour.

A warm breeze and bright sun made it an ideal day for our departure on a long-planned offshore cruise. The objective: two weeks of solid relaxation, skin diving, swimming in crystal-clear water, fishing, dinghy sailing, water skiing and anything else that might appeal to the mood of the moment. After several river and lake cruises by outboard and a number of ocean trips on medium to large sailing auxiliaries, we were ready to try offshore cruising by outboard boat.

The outboard's shallow draft allowed the skipper to run close to interesting shores, permitting an intimacy with places along the route that isn't possible with larger, deep-draft boats. At the same time, a well-built outboard cruiser, such as the all glass-fiber Larson model we used, can be taken offshore where only sky and water greet

the eye. Out there you are on your own, except for the distant help that a radio-telephone can summon for emergency assistance when in distress.

The wide sea is all yours except for the welcome sharing of it with a passing freighter or other commercial vessels. No crowded waterways here, with hot-rod boaters, fishermen, skiers, skin divers, fleets of small sailboats and other miscellaneous craft vying for the same water, mooring and shore facilities. For real relaxation and a new dimension in boating, try a cruise offshore.

A 20-foot cabin cruiser can accommodate a family of four or five quite comfortably, offering an inexpensive vacation package including fishing, water skiing, clamming, sightseeing and the thrill of going to sea in your own ship. In some coastal areas, offshore cruising provides an opportunity to "go abroad," even if only a short distance from the U.S. continental limits.

The 5000 miles of coastline on three sides of the United States offer every variety of offshore cruising. On the Atlantic side one can cruise on the rugged, cool Maine coast during the summer and bask in the semitropical warmth of southern Florida while the snow piles high in the North. Interesting East Coast cruise areas include Bar Harbor, Me., the Massachusetts coastline from Cape Anne to Cape Cod, Long Island Sound, Albermarle Sound, Chesapeake Bay and 1500 miles of Intracoastal Waterway. Some areas are wild; others are well stocked with shoreside establishments that permit eating and sleeping ashore in



Sea Joy passes through Jewfish Creek, one of many interesting channels between Miami and Key West

BY OUTBOARD

the best manner regardless of where you tie up for the night. The choice is yours, so plan accordingly, including stops for fuel as necessary.

Florida offers just about every variety of semi-tropical offshore cruising you could want, including foreign travel to the Bahama Islands, a British possession. Of course, anyone venturing on a voyage as extensive as the latter must be a qualified seaman, sail in a well-equipped, seaworthy boat, and time the cruise to coincide with favorable weather. Strong winds can produce a very lumpy Gulf Stream that must be crossed before reaching the shelter of the islands.

Bahamas and Gulf cruises are good just about any time of the year, except in January when fog and howling northwesters are likely to make boating unpleasant in any size of craft. During late summer and fall months, boats at sea must keep a sharp lookout for storm developments. This means listening to official weather broadcasts regularly and being able to "read" a reasonably accurate two to three-hour forecast from a study of existing weather conditions.

We tuned in the nearest weather station on radiotelephone at all scheduled times when under way or planning to leave a port. A summary of each broadcast was entered in the ship's log as a matter of record and to aid shipboard short-range forecasting. Before leaving home port it's a good idea to enter the frequencies of such stations in your radio log book. Be sure to include all the stations along the cruise route since your equipment may not be powerful enough to pick up the home-port station. Broadcasts from a station in the locality being cruised also tend to be more accurate. Modern hurricane-tracking methods give the prudent sailor plenty of advance notice of the approach of the not-so-gentle lady windstorms.

By
Earl Wobeck



Author Wobeck sets compass monitor to the planned compass course to simplify navigation when the boat rolls at sea



"First Mate" Joy Wobeck doubles as cook and steward, and the day starts right with a hearty bacon-and-egg breakfast aboard



Above, Coast Guard "Courtesy Examination" at Hewes dock before shoving off. Below, Joy gets a lesson in wearing a life vest



Almost the entire Gulf Coast is dotted with interesting islands and island chains that are seldom more than 20 miles offshore and usually visible from the mainland. Their protection permits leisurely cruising in bays and lagoons when the water is rough on the "outside." Of course, the reverse can be true when you cross a wide bay or sound and a strong wind is blowing straight off the land or parallel with the coast. This happened to us on the second leg of our cruise, outward bound from Marathon to Key West. A strong northwest wind kicked up a very uncomfortable chop on the inside route, so we simply switched to the Atlantic side and traveled in the company of shrimpers, freighters and even a submarine that came close to admire our trim little ship. For an added bonus, a troupe of porpoises did several tumbling acts close aboard.

The Intracoastal Waterway is sort of a canal-type freeway for shallow-draft boats, both pleasure and commercial. Charts and guide books covering its entire length, from New York City to Port Isabel, Tex., and across the border from Mexico





In another form of salt-water cruising, an outboard runabout heads under the Golden Gate Bridge. Right, lower units are tilted out when the boat is moored

are available at small cost. On the Waterway, you can cruise in protected waters most of the time except for a few stretches of open water along the west coast of Florida. When there are no heavy seas running and the urge is strong to do deep-sea fishing or cruising, it is a simple matter to run through a pass to the open sea.

The scenery along the Waterway is as varied as the trip is long. Along the Florida Keys we found lonely islands that were visited only by birds and an occasional outboarder like ourselves. There was usually a white sand beach close at hand when we wanted it. Almost everywhere there are clear waters and interesting reefs for skin diving. Now and then we would run through a channel crossed by the highway to Key West. Such places usually have a small settlement where fuel and supplies can be bought, mail posted and special cravings for ice cream and other delicacies satisfied. At the coming of dusk we usually headed for a quiet, protected cove and dropped the anchor just far enough off shore to pick up a little breeze and be away

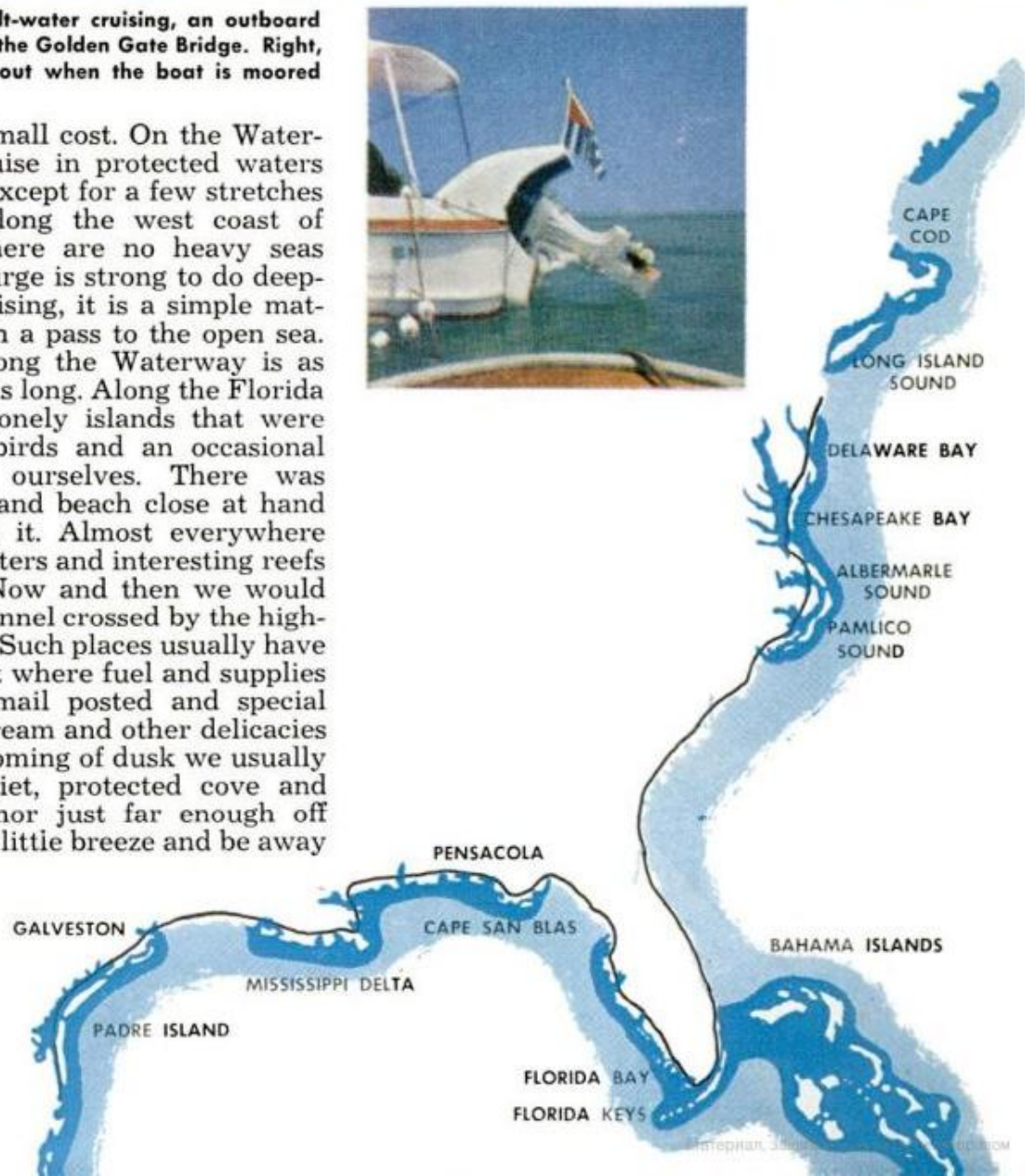



In offshore cruising at its best, a cruiser heads out of Nassau for a day of big-game fishing in the Atlantic

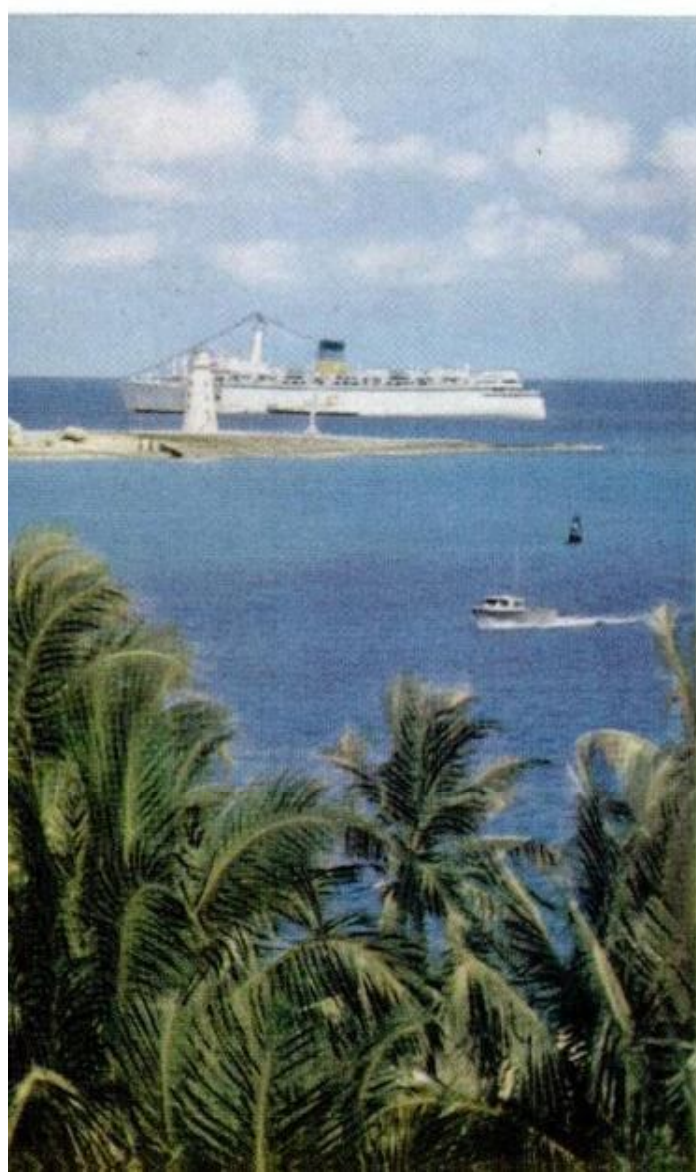

from insects. In the remaining light, the collapsible swimming ladder would be slipped in place and over we'd go for a swim in two to three fathoms of pure but "lightly salted" water. Sometimes swimming was combined with sailing in the eight-foot dinghy that we carried in the cockpit or towed when the sea wasn't too rough. The dinghy was fine for exploring narrow inlets and negotiating the shallow water found around most of the Keys islands. With a six-horsepower Mercury clamped on its transom when not sailing, explorations were never hampered because of lack of wind.

Evenings at island anchorages always started with a complete dinner, cooked by the mate on a two-burner alcohol stove. After dinner the dishes were washed and the ship's log was brought up to date, adding details to the short notes that had been entered in haste during the busy day. Except on moonless nights, there was always enough light to see the outlines of other islands in the distance and the subtle gradations of light, from the moonlit water lapping softly at the boat to shadows cast on the water by the palm trees, and finally

In a well-equipped boat you can even "go abroad" to Nassau arriving in the company of big cruise ships



Sea Joy departs from Miami, loaded for the long trip and headed toward Key West. Right, skipper installs cruise fuel tanks in the cockpit. Tanks are secured by tie-down straps which are permanently fastened to the deck. Fuel lines are concealed behind bulkheads and overboard vents are installed



the total blackness in the thick forest beyond. The raucous croaking of the overly noisy parrots during the daytime gradually gives way to a more melodious ensemble of sweeter-singing birds in the evening. Finally, all is quiet—the fresh salt air and many activities have taken their toll, and we fall asleep.

Occasionally, for a change of pace and to give the mate galley-duty relief, we would put in at a yacht club or other docking facility for the night. Docking fees at most places are reasonable. At Marathon, for one dollar, we had a well-protected dockside mooring close to town, fresh water for filling our tanks and washing down the boat and shower facilities. The friendly woman who operates Powell's City Pier, even let us use her car after telling us where to go for lobster and steak dinners and pointing out some of the local attractions. Other favorite stopovers include Travenier Key, Islamorada and Key West Yacht Club. Travenier is a bird-watchers paradise; deep sea and Keys fishing is excellent off Islamorada and Marathon and the food is superb (and inexpensive) at the Key West Yacht Club.

Shrimp boats come all the way from Galveston to fish off Key West. We were lucky to be at Marathon when some of

(Continued to page 248)

Below, radio direction finder was mounted on the forward bulkhead in the Sea Joy's head, which saw double duty as radio room. This kit-built unit also has a standard broadcast band for music and news



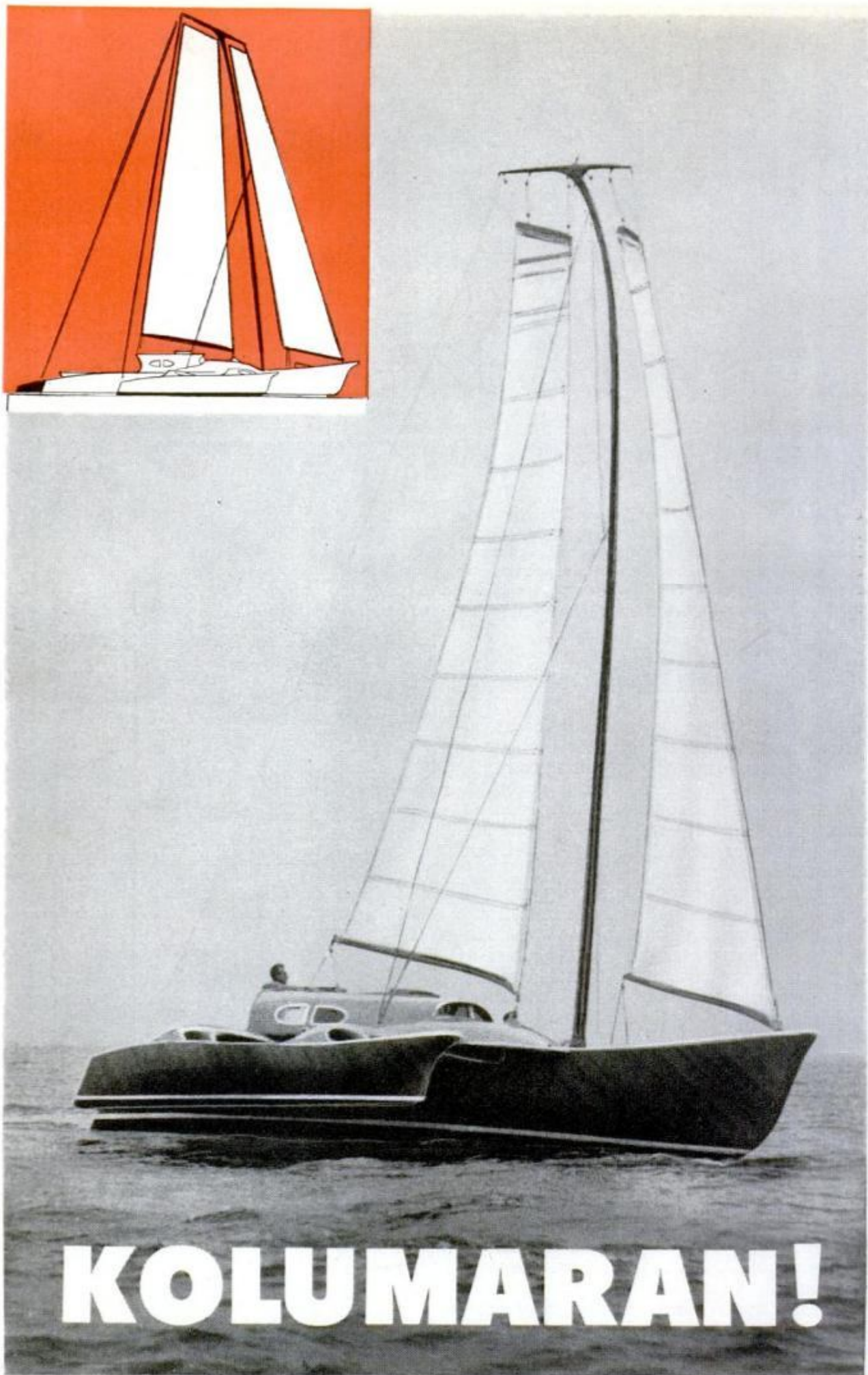
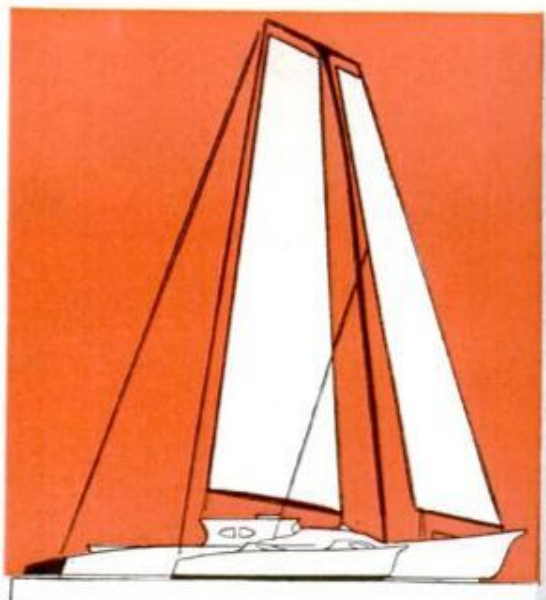

KOLUMARAN!

see Sept. 60, 32

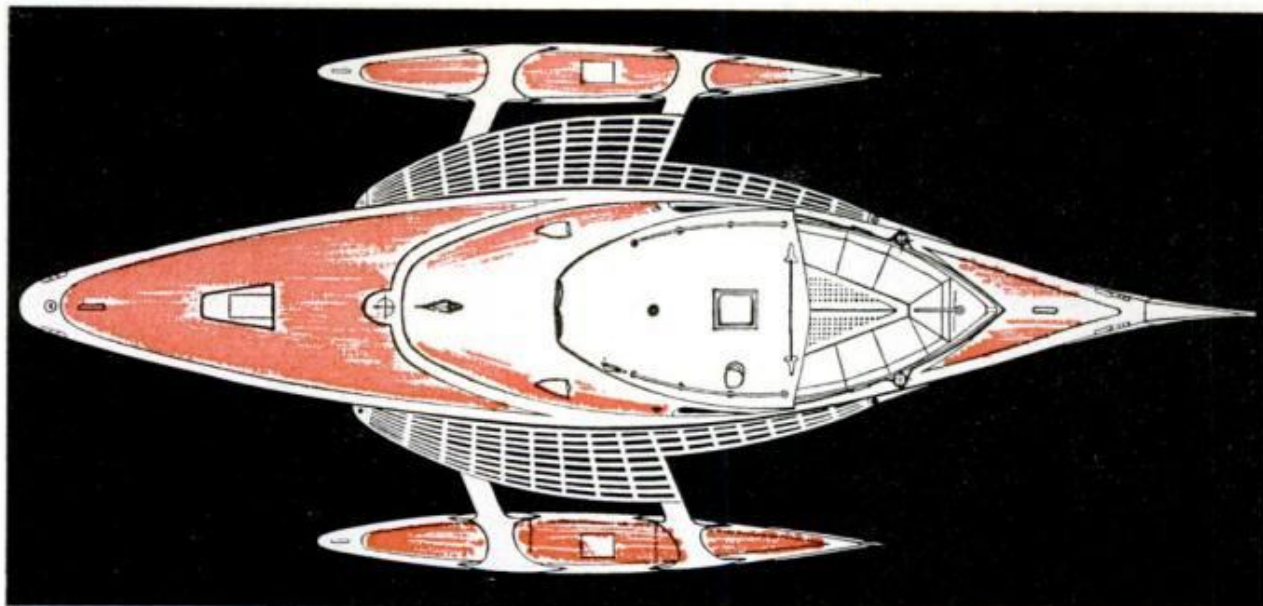

No, not a space ship, but the flowing lines of *Kolu Naia's* deck plan. Stern and faired rudder are at right

Story and photos by Thomas E. Stimson, Jr.

HERE'S A NEW WORD for your boating vocabulary — kolumaran, meaning a three-hulled boat. And here's a fine example, the *Kolu Naia*, Polynesian for "three porpoises."

Designed and owned by Dean Kennedy of San Diego, a Convair aircraft engineering illustrator, the *Kolu Naia* was intended to combine the speed, stability and shallow draft of multi-hulled sailing craft with the roomy utility of a cruising sailboat. The result is shown here and on the cover.

Deck length is 38 feet; beam is 19 feet across the outriggers. The 44-foot mast supports 550 square feet of sail, designed in this unusual high aspect-ratio shape for high-speed sailing even in light, high breezes that conventional boats can't reach.

Inside, the 8 by 16-foot cabin, with 6 foot, 8-inch headroom, provides plenty of room for four sailors. The ride is a comfortable

one, top, since the outrigger design keeps the craft from rolling. Tank tests show that she won't capsize even in 100-mile winds, but she sails well in light air.

Hull construction is cross-laminated mahogany plywood, covered with glass fiber, in an aircraft-style construction, which puts the strength in the skin and minimizes heavy internal bracing. The sails shown here are working test shapes of Mylar plastic; later sails will be Dacron.

The whole project boils down to a trim sailboat that'll go anywhere with its eight-inch draft, slide through surf and over beaches, ride a trailer, and scoot along at 25 or 30 knots with the right wind.

Kennedy plans to market a 26-foot scaled-down version, the *Kolu 26*, in plan form for backyard construction, and regards this as the first of a long line of kolumarans. ★ ★ ★

Left, photo and sail plan both reflect the unusual high aspect-ratio sails and tall, gaff-topped mast design. Clean design cuts water resistance to a minimum; boat here is ghosting along at 12 to 15 knots, but leaves only a riffled wake. At right, dock view shows molded glass fiber cabin trunk and topsides. Mast and outrigger spars are box spars covered with glass fiber. Outriggers have a total of seven compartments

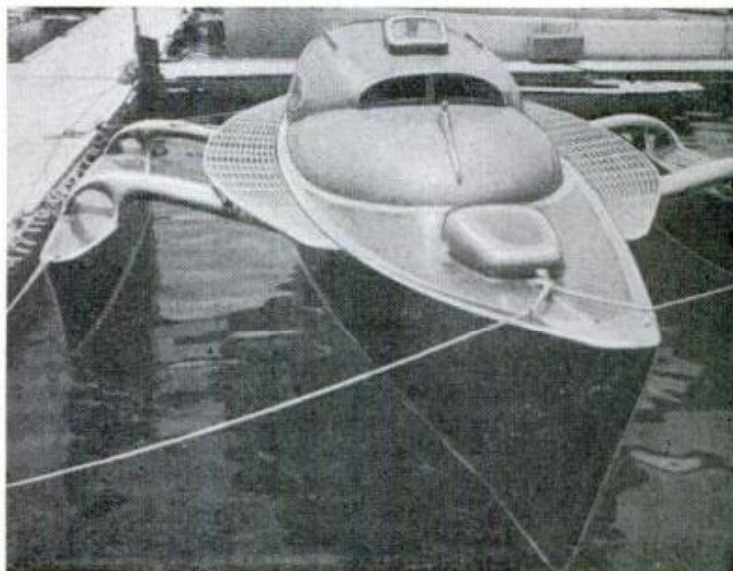

THREE NEW BOATS FOR 1960



Cruiser Buttons Up, Sleeps Four

Canvas roof and side curtains close in the topsides of a new 21-foot outboard cruiser. Thus the entire cockpit area becomes a second cabin. The boat sleeps two couples in complete privacy with room to spare. The head is also enclosed. The rear area can be opened for cockpit space during the day, or left covered to protect cargo in bad weather.

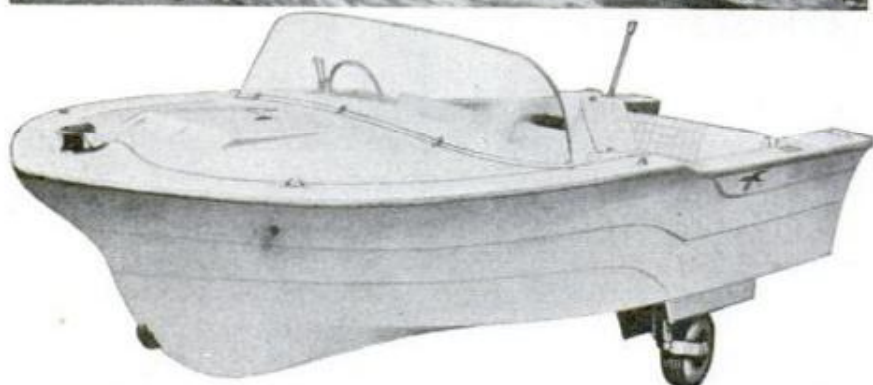

Boat's Wheels Retract in Water

Built-in retractable wheels, similar to aircraft landing gear, eliminate the need for a trailer with a new amphibious outboard runabout. The boat tows just like a trailer, but allows better rear vision. Launching is simple—you just back it into the water. The wheels retract hydraulically into a well that makes a seat on the inside, and hatches close tight over the well.



"Two-for-One" Boat Uses Sail or Motor

For the occasional boater who can't decide whether to buy sail or power, here's one that combines the two. A trim 15-foot outboard, it handles nicely with a 35-horsepower motor; step the jointed aluminum mast and lower the bilgeboards and twin rudders, and it becomes a snappy catboat with 135 square feet of sail. Built of one-piece molded glass fiber, its rigging breaks down and stows neatly inside the hull. The manufacturer also builds a 14-footer using the same rig.

For better boating

**TRIM
SHIP!**



Feb-1961 Boating Annual

WHAT'S WRONG with this picture? It's a typical outdoor scene in this age of family boating; a young family out for a spin. This is on Florida's Silver River, but could have been anywhere that small boats operate, which is everywhere there's water.

But something's wrong. The boat's digging in a bit too much at the stern, throwing water to the sides, and as a result it's not only losing speed and stability, but it's burning more fuel than it should. Dad neglected to be careful about loading, and the boat's heavy astern with Mom and the picnic gear and two heavy gas tanks bunched right at the rear. Sure, he could overpower the weight and plane it with twice that load, but he'd lose efficient cruising-range fuel consumption.

At right, the underwater camera shows what's happening—and what should be happening—on the bottom where it really counts. At the top, with the load badly placed astern and the motor at cruising speed, it just can't stay on a plane. Center, same load, engine wide open, it forces its way onto a plane but still throws a lot of water, a sure sign that it's not operating at its best. Bottom, back at cruising speed but with the load moved forward to the balance point, the hull cuts the water cleanly, leaving a minimum wake without the telltale side-splashing.

Trimming your boat can be more important than you think. Even with a normal load, a small improvement in trim can give more speed for less fuel, and make the boat safer and more maneuverable.

The spectacular boating photographs on these pages were made for P.M. by Bruce Mozert at Florida's Silver Springs.

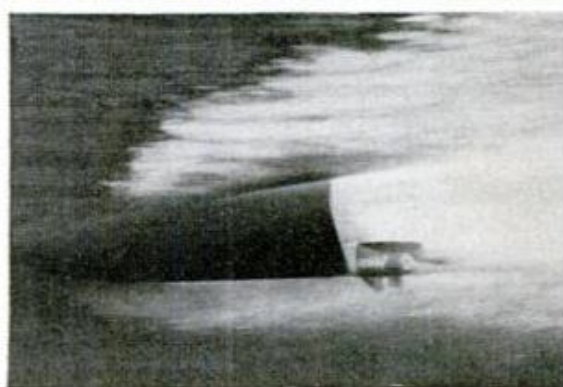

Well trimmed with a load of about half its capacity, this 15-foot runabout glides easily along, wet to the waterline, at a speed of about five miles an hour. The bow enters smoothly and the wake is minimum, with the motor throttled back to an easy pace for moving away from the dock or for easing past other boats or through narrow channels. At this speed the boat does not lift, but knifes through the water, shoving it easily aside

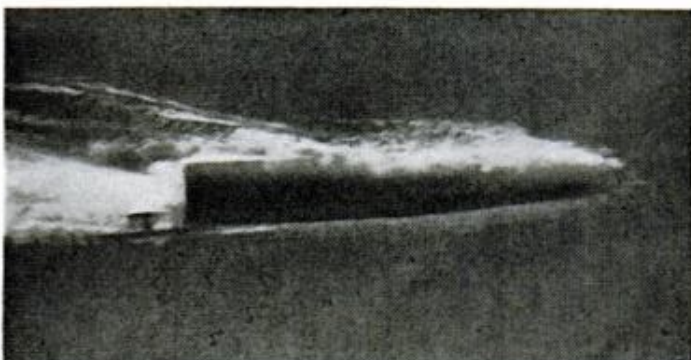

As the speed increases, the hull soon reaches a point where water resistance forces it upward, bow first. The driver, throttling forward fast to avoid a long "mushing" period, forces the boat through this transition stage and it swoops quickly up and over its bow wave as a car rides over a smooth dip. With this boat, the bow comes up at around eight miles an hour, and it planes under this load at 15

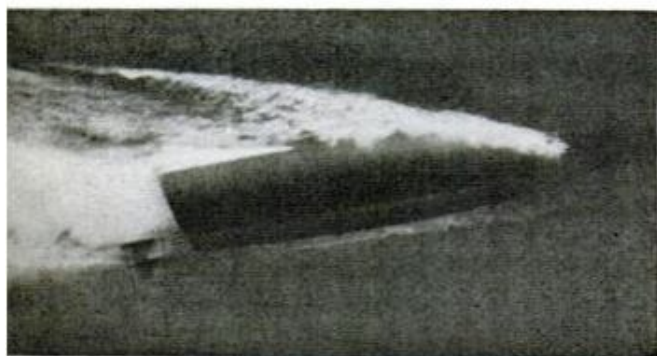

On its feet and skimming along nicely just under 30 miles an hour, the hull is two-thirds out of the water and the motor has an easy time moving it along at an efficient three-quarter throttle. As the boat levels off at full throttle, the driver eases back on the power until the motor is running at its best r.p.m. (marked on the control unit). The boat, shoved onto its feet by the surge of power, stays up, level and steady, for a smooth ride

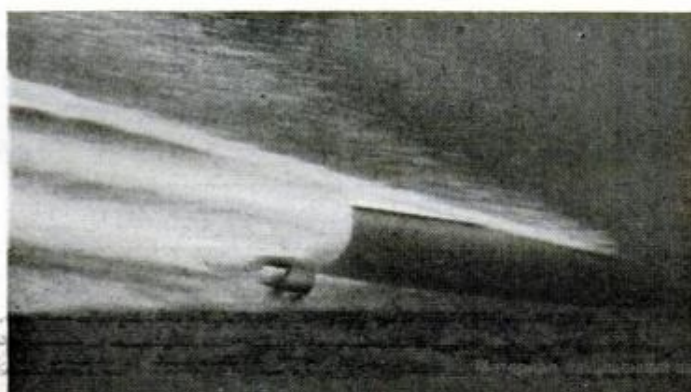



Heavily overloaded forward, this boat shows what happens when you reach that transitional stage and can't plane. The heavy bow can't climb as it should, so it's forced to shove water aside, wasting power and wobbling badly. (This is an exaggerated situation, of course, and most boaters know better than to ride on the foredeck, but this boat, like most modern outboards, is so inherently stable that we went to extremes to illustrate errors)



Heavy aft, the boat needs every ounce of thrust in its big 45-horsepower motor to come up on its feet. When the motor is slowed to its cruising range, the stern drops back into the water, throwing a heavy side wave and leaving a wake that would rock boats for a block in any direction. With the motor working hard enough to plane with this load, gas "mileage" drops about 20 percent and the boat tends to wobble and "porpoise" badly



Balance across the beam is equally important, but easier to maintain. If Mother would just slide over to the port side and take the portable icebox with her, this boat would level off nicely and Dad wouldn't have so much trouble getting it to plane. Underwater shot shows the uneven water resistance to a tilted hull that makes it slow and unstable. Note the school of bluegills in this underwater photo



Trimming a boat is like balancing a seesaw — And just as easy if you follow these tips

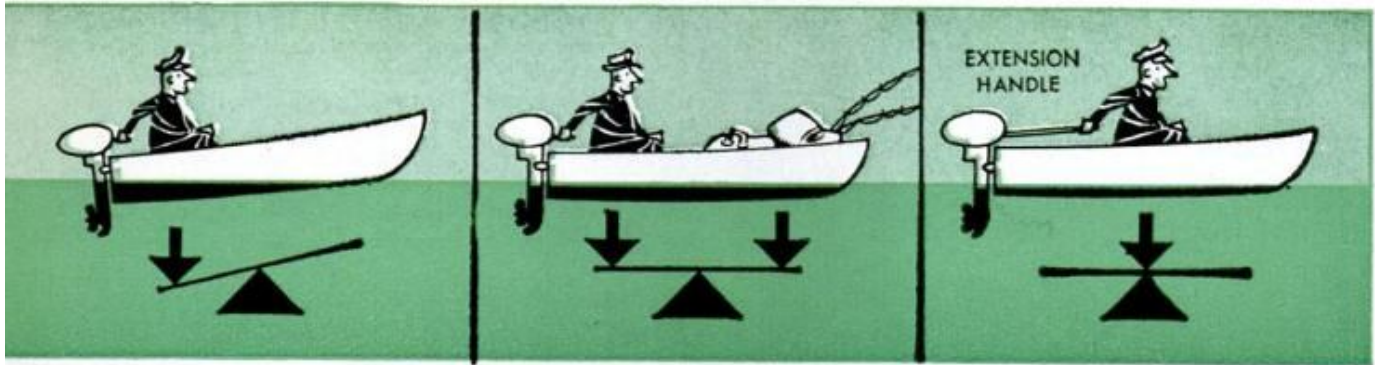

Lone operator with an outboard is up against it—all the weight is behind the boat's point of balance; bow rises

But he can help if he'll move his gear and fuel tank forward to offset his weight. A few good-sized rocks can help, too

Extension handle solves the problem by letting the driver move up over the balance point but still handle the motor

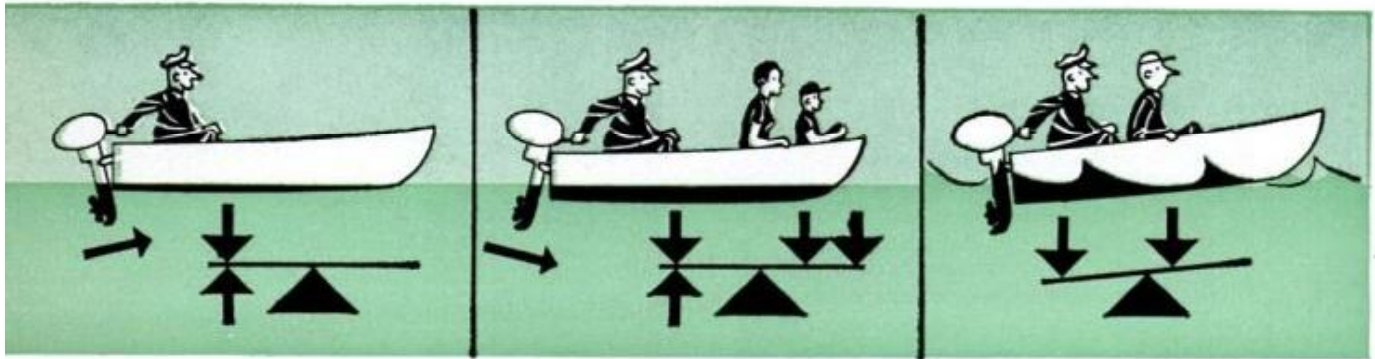

Changing the tilt of the motor can help, too. Here a lone operator has moved the lower unit forward to attain upthrust

Downthrust works the same way, though not as well, by balancing a heavy bow and keeping stern down for control

Sometimes it's good sense to load off-balance. Here both men are seated well back to lift the bow over heavy waves

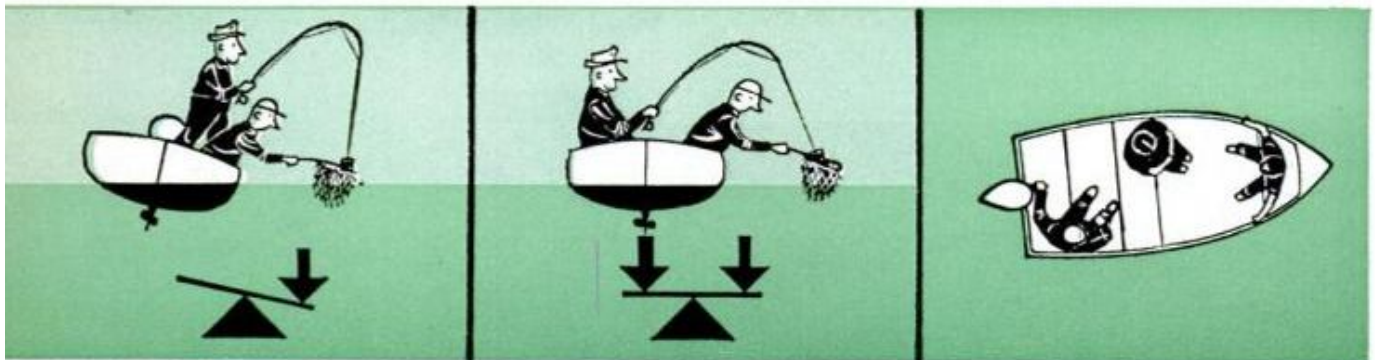

The same principles work across the beam. If both men stand up on the same side, they'll probably be in with the fish

If one stays on one side while his partner leans over the other, the boat stays level and the fish is easy to land with safety

Man on port side compensates for the driver, and the boat runs level. Move gear and passengers until trim and level

Several factors affect the way a boat rides on the water — trim, power, motor tilt, propeller, hull design, even wind or waves. Each boat has a basic point of balance, though, and with a little trial-and-error experimenting you'll find the best load distribution for your particular situation.

Good trim is a happy combination of all those factors, but there's no set formula for finding it. A speedometer and tachometer will help, for when it's right you'll get maximum speed for the r.p.m. you're running. Find your boat's balance and you'll have more fun—safer—for less money.

Boatman's Burden

You, Your Boat, and the Law

FORTY MILLION AMERICANS can't be that wrong—sport boating is a lot of fun. One of the big reasons for its popularity is the casual and carefree air that surrounds boating and boaters. But like hunting and other active sports it's fun with built-in responsibilities.

A pretty simple act—or failure to act—can do a lot of damage on the water, and

can land you in court or even in jail on a civil or criminal charge or complaint. Today's guest on your boat can become tomorrow's plaintiff if something goes wrong.

The principles of legal responsibility on water are very much the same as those in owning a home or driving a car, but there are some basic differences that every boat owner should know. Here are a few:

As owner, you are responsible for damage caused by your boat, not only when you're aboard but also if it's being operated by a member of your family or another person with your knowledge or consent. Laws determining the extent of liability vary widely from state to state to federal statute. In some cases the liability is limited to the value of your boat if the accident occurs without your knowledge or participation, but it's best to make sure that the boat is handled by a qualified, responsible driver. Almost any kind of misconduct in your boat could lead to a negligence charge or claim



All boats are equal under the law—there is no privilege in size, use or status when placing the blame for a collision. Though some courts handle boating accident cases by automotive standards and will allow a division of damages according to blame, others (including most inland courts) follow the doctrine of contributory negligence, which will not allow you to recover damages if your own negligence has contributed to the accident, even as little as one percent



The law charges you, as owner, with the responsibility of keeping a safe boat, and with the liability for injury or damage caused by any unsafe condition aboard. What's more, you're responsible for an unsafe condition even if you don't know about it and though it isn't visible to an ordinary inspection. Fortunately, the law also recognizes the hazards involved in boating, and requires others to exercise caution





Guests aboard, especially if they're on business, are entitled to a safe boat, and to a warning of any unsafe condition or operational hazard. Again, they must be careful, but the owner is required to protect them from themselves by preventing dangerous practices such as standing on slippery decks under way

A drifting boat, like a skidding automobile, is still your responsibility whether you're aboard or not. Start and test your motor before casting off, avoid drifting around other boats, and be sure that your mooring is secure enough for any weather that might be expected to arise while you're gone or asleep



You must keep a proper (and qualified) lookout in every direction from which trouble might be expected to arise. A stiff neck won't be a valid excuse if you dawdle in front of a big boat that can't stop or turn quickly, and your failure to look behind you could be called contributory negligence if it runs you down

Failure to comply with federal, state and local laws for identification and safety equipment could get you in trouble if an accident resulted from your failure. Check the regulations and be sure to have the proper markings and the required lights, signals, fire extinguishers, and Coast Guard-approved life preservers



Learn and observe the "rules of the road"—but remember that whether you have the right of way or not, you are required to do everything in your power to avoid a collision even if the other boat is obviously in the wrong. Boating law is based on common sense; it works best if you supplement it with courtesy

Operating or mooring your boat in such a way that it interferes with navigation is not only very bad manners and a dangerous practice, but is a violation of most boating laws. Moor your boat in an out-of-the-way place, away from channels or bridges and never where other boats must maneuver to pass yours



On strange waters, check the local regulations for speed and power limits, restricted areas and other pitfalls before starting out. Boating laws are usually quite liberal, but a simple thing like the local definition of the word "dangerous" could make a big difference, especially when you're boating with strangers



If you are in a collision, you must render aid to the other boat and its occupants whether you're at fault or not. If you are present but not involved, by all means render what aid is needed, but be careful, or your carelessness could add to the damage. Hit-and-run driving is a mighty serious offense on the water

If you trailer your boat, drive accordingly and don't let a smooth-pulling modern trailer lull you into forgetting it's back there. Since local and state laws vary widely on speed limits, light and signal requirements, and handling laws, take time to check near your entry point before trailering across a strange state



Qualify yourself for safe boat ownership and stay out of trouble the easy way by learning the rules first. You should be familiar with your local and state laws, the Motorboat Act of 1940, the Federal Boating Act of 1958 and the Coast Guard Regulations. And while you're at it, teach your family these laws, too

Whether your boat is a 16 or 61-footer, it's a good idea to have insurance—not only hull coverage, but liability insurance as well. Homeowners with small boats may be covered by their homeowner's liability insurance—check your policy to find out. Boating protection, in most cases, can be purchased at small cost



Cartoons by John Bolt

The U.S. Coast Guard has published an excellent pamphlet with the highlights of the federal statutes and Coast Guard Regulations, plus a collection of safety suggestions for the small boat owner. To get a copy, contact the nearest Coast Guard Group Office, District Office, or Marine Inspection Office, or write the Coast Guard at Washington 25, D. C. Ask

for pamphlet CG-290, *Pleasure Craft*. It's free. Copies of the Outboard Boating Club's *Digest of State Boating Laws* and *Digest of State Trailer Laws* are available to the public through the OBC's free library. For copies or for a list of the subjects available through the library, address the Outboard Boating Club of America, 307 North Michigan Ave., Chicago 11.



NEW FOR YOUR BOAT

Cockpit seat cushions, thrown from the boat and snapped together in the water, make a four by eight-foot emergency raft. Made of two-inch vinyl sponge covered with plastic, this set could float a dozen swimmers.

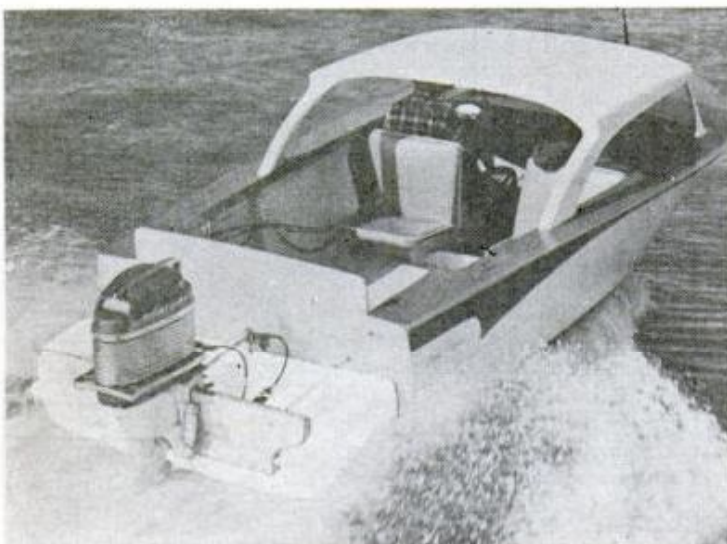

Overboard fuel tank doubles as a flying transom and adds planing surface while removing gas and gas tanks from the cockpit. The glass-fiber tanks are available in 37, 65 or 85-gallon sizes; come with a complete mounting kit.

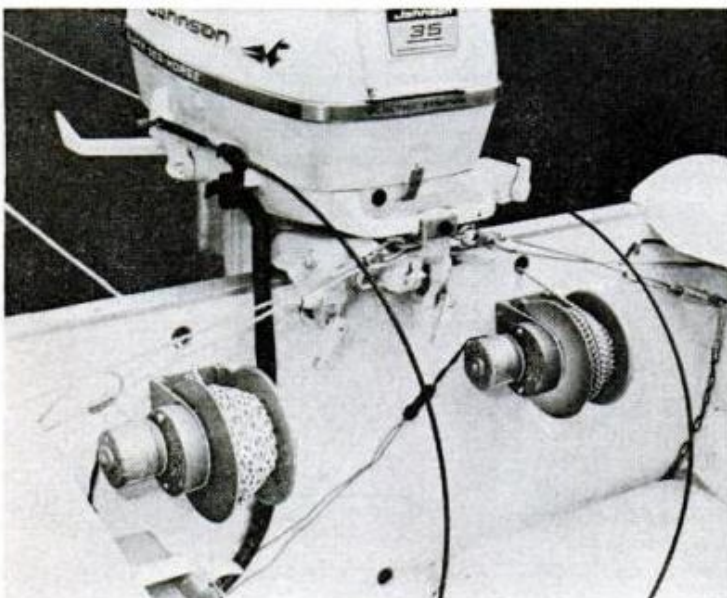

Motorless bilge pump, below, operates on boat's forward motion; pumps two gallons a minute from any moving boat. Spinning impeller siphons water out through screened intake. All plastic and brass, the pump is noncorrosive in salt water.

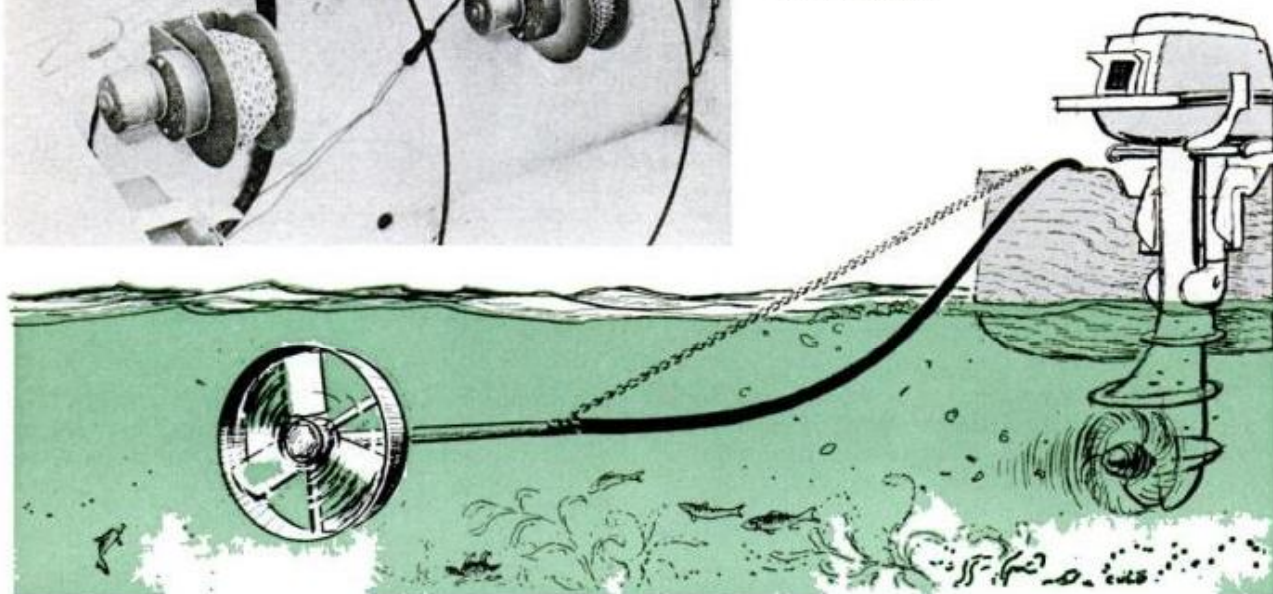

PM Reports on

The JET BOAT



Flat out, the Turbocraft water-jet boat scoots along near 40 miles an hour. A lot of inboards will do that, but this one could be doing the same thing in three inches of water or through white-water rapids

By Dick Kirkpatrick

BILL HAMILTON and John Buehler are out to change the boating business — and they may very well do just that. Hamilton, a New Zealand inventor and industrialist, has developed a practical water-propulsion unit for small boats; Buehler, president of Indiana Gear Works, Inc., of Indianapolis, is building the units in this country and causing a lot of comment, for the boat, the Buehler Turbocraft, does things that no other boat will do, and in some cases does them faster, safer, and more efficiently for less cost than conventional inboards.

Basically, Hamilton's jet unit works under Newton's First Law of Motion, which says that for every action there is an equal and opposite reaction. When the jet unit shoots a stream of water out the back, the boat goes forward—fast.

But the biggest advantage to the boater is that the boat needs no propeller, rudder, or underwater appendages of any kind. As a result, it needs only enough water to float the hull to operate at full efficiency. Since it slides over rocks, through brush, over weedbeds and sandbars, it can operate

in water that even an airboat can't navigate.

Imagine what that could mean to a family living in, say, Kearney, Neb., where the Platte River is "a mile wide and a foot deep." Hundreds of miles of water that defy conventional boats are open to a boat that can be launched in ankle-deep water, runs in less than that, and is almost impossible to hang up on an obstruction.

Maneuverability is great, too, since there's nothing under the hull to trip the boat in a turn. Test drivers have never been able to spill it, even in the most violent maneuvers. It even has brakes—you can throw the motor into reverse at any speed, and stop the boat almost within its own length from full speed.

All that and efficiency, too. Using standard inboard power, the Turbocraft will operate at about 30 percent less cost than a comparable outboard; 10 percent less than a propeller-driven inboard. The boat sells somewhat higher than comparable inboards, but offers compensations by opening water that's never been boated, from Florida swamps to Washington rapids.

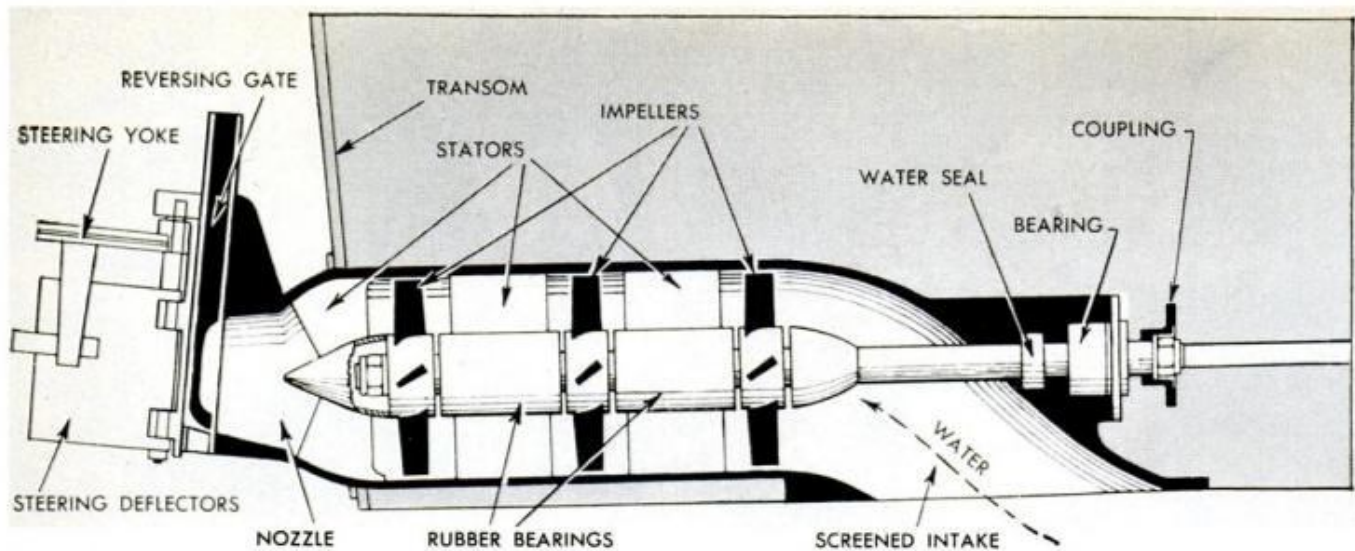

Above, the basic works of a Hamilton water-jet unit. Water comes in at right through a half-inch grid, passes through turbine and shoots out between the steering deflectors at left. Reversing gate here is in neutral position; drawings below show forward and reverse positions. Bottom photo shows exterior view

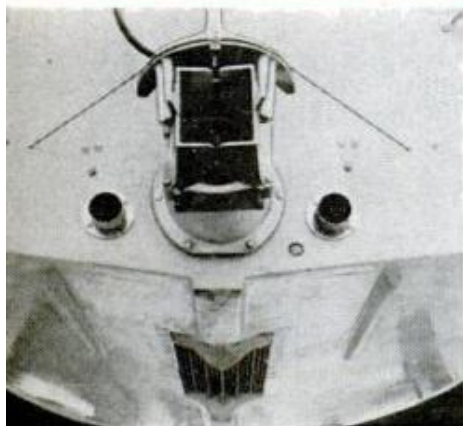
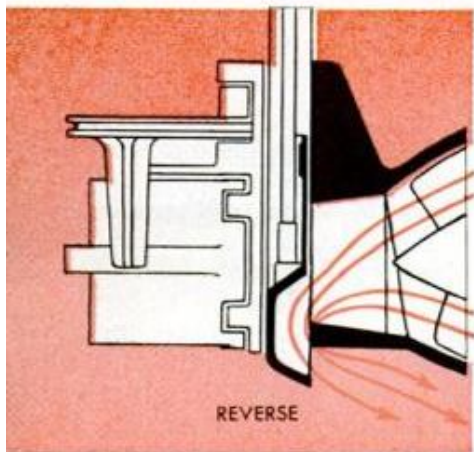
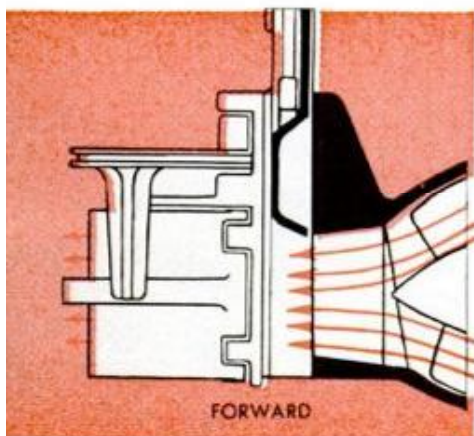

IN OPERATION, the jet unit works like an axial-flow pump, sucking water in through the intake under the hull, running it through three sets of impellers and stators, then out the nozzle. The third stator is reverse-twisted, so the flow is straightened to avoid torque or unnecessary spray. Crammed by the turbine through a narrow nozzle, the jet flow bursts out at around 65 miles an hour, generating about 750 pounds of thrust and moving 2250 gallons of water per minute. On the way out, the stream passes between two steering deflectors, which take the place of a rudder and steer by deflecting the stream to either side. There is no transmission. The unit has a reversing gate which is up out of the way during forward motion, drops down to close the nozzle for neutral, and directs the jet flow back under the hull for reverse thrust (see drawings) above and left.

Three power combinations are currently available on the production model Turbocraft, a 16-foot runabout. They are a 107-horsepower Ford six, a 109-horsepower Graymarine six, and a 135-horsepower Interceptor V-8 which gives the boat a top speed just under 40 miles an hour. Efficiency falls off with the 135-horsepower engine at full throttle, so future designs with higher power will probably use dual turbines. Another future Turbocraft will use a two-section turbine and 25-horsepower engine in a 12-foot boat for light utility and sports use. It should do around 23 miles an hour on the smaller boat.

The first ride in a jet boat is quite an experience. Acceleration is smooth but very fast—up to a plane in about two boat lengths. The jet unit comes out of the water as the boat comes up, but the spray isn't bad unless the acceleration is extreme, and the above-water jet is the secret behind the boat's performance. Steering is very light, since there's no rudder, and the deflectors provide a self-centering effect that's similar to the caster action of your car's front wheels. Controls are standard, with a foot throttle and a simple hand lever for controlling the reversing gate.

The Hamilton jet unit is not available separately. Technical problems would make installing your own a tough job, anyway, but the units are being installed by other boat manufacturers in the East, West, and South under license from Indiana Gear Works.



EVERY BOATER'S first question about any new boat is "What'll it do?" This one does a lot of things, mostly spectacular, but all with a hard practical purpose. Here, from top to bottom, it turns inside its own length at low speed; then turns in a tight circle at 40 with no danger of spilling. It runs through rapids and rocks with gay abandon, since it'll survive any knock that doesn't hole the hull, and the glass-fiber hull is plenty tough. It'll plane through less than three inches of water and run in water too shallow to float the hull. And it'll bust through brush that would stop any other craft on the water, simply because there's nothing to hang up—and plenty of brute thrust to push it. One freak can stop it—flat-leaved weeds or lily pads can plaster themselves over the intake at very low speeds, but a quick blast in reverse will blow them away. Anything small enough to get through the intake grid simply passes on through the turbine and goes out the nozzle. The boat looks and sounds like any other inboard runabout, and rides the same, but there the resemblance ends. Its spectacular performance puts the Turbocraft in a class of its own.

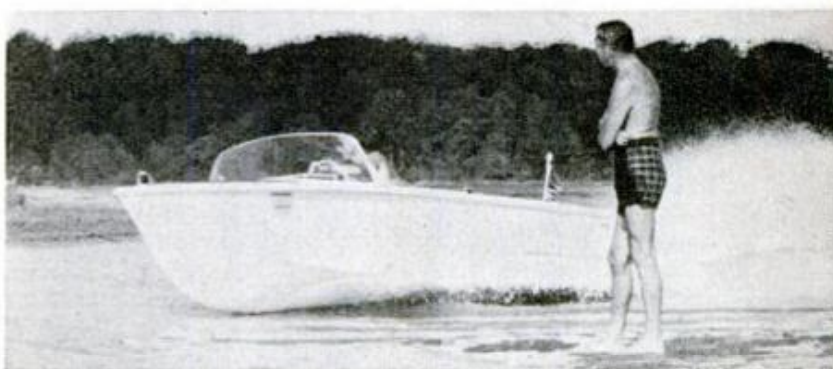



SINK-PROOF YOUR BOAT

By Earl Wobeck

WILL YOUR BOAT sink or remain afloat if it springs a bad leak or capsizes? If you don't know, it will be well worth your while to find out and fit the boat with whatever amount of additional flotation is required to provide a comfortable margin of safety. Although most manufactured boats have sufficient flotation for normal load conditions, it would be prudent to offset the weight of any unusually heavy equipment added to the boat with buoyant material to float it. This may be done by fitting foamed plastic, such as Styrofoam, in unused spaces as in Fig. 1.

Foamed plastic is filled with countless air spaces, each one separate from the others. It will not deteriorate from normal exposure; no amount of mechanical damage will affect its buoyancy, and it is very easy to shape, permitting it to be owner-installed in any accessible place. Cost is quite small, about \$2.00 per cu. ft. at marine-supply stores. Air tanks, or sealed air spaces are not recommended since they may develop leaks due to accidental damage or deterioration of the container. If this occurs unnoticed, the owner is unaware that his boat has lost its ability to remain afloat in the event it is swamped, although

it may submerge slowly or possibly not at all, if the above-water portions of the punctured air chambers remain airtight.

The primary concern of this article, is the boat that has not been provided with flotation, be it manufactured, or the home-built variety. Wooden boats are not excluded since they become waterlogged to a certain extent when in use. Also, some types of wood, such as oak and certain mahoganies, have a very low buoyancy factor. Hulls constructed primarily of these woods have much less buoyancy reserve than do those made of cedar, one of the most buoyant of native boat-building woods. Resin-coated glass fiber has no positive buoyancy. Boats using it as a primary material, require much flotation.

There are two foolproof ways of determining the amount of flotation required to make a boat unsinkable. One method involves application of weight capacity and flotation formulas developed by the Boat Engineering Committee of Outboard Boating Club of America. While these formulas are recommended practice for commercial boat builders, home craftsmen are encouraged to use them. Anyone who is familiar with high-school mathematics can

To make your outboard cruiser unsinkable, total the weights of equipment, maximum number of passengers to be carried by boat, and the hull weight, if glass fiber or metal. Then divide by 55, number of pounds 1 cu. ft. of foamed plastic will float, and install this amount as shown

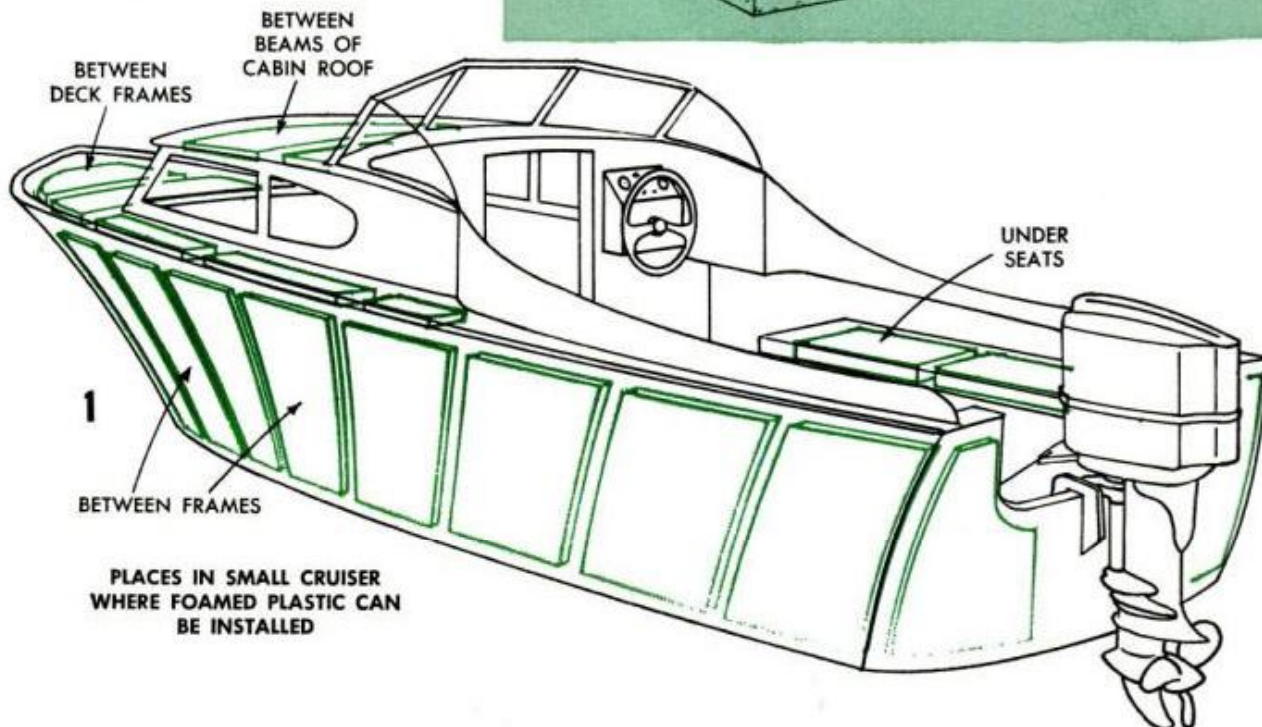
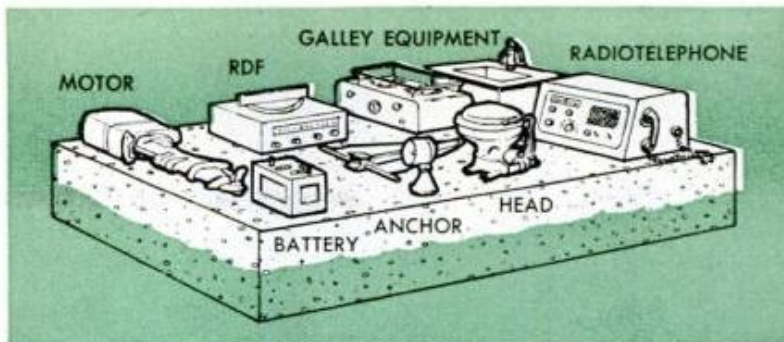

2. Below, after outlining the shape of foamed plastic to fit space in boat, it is cut with handsaw

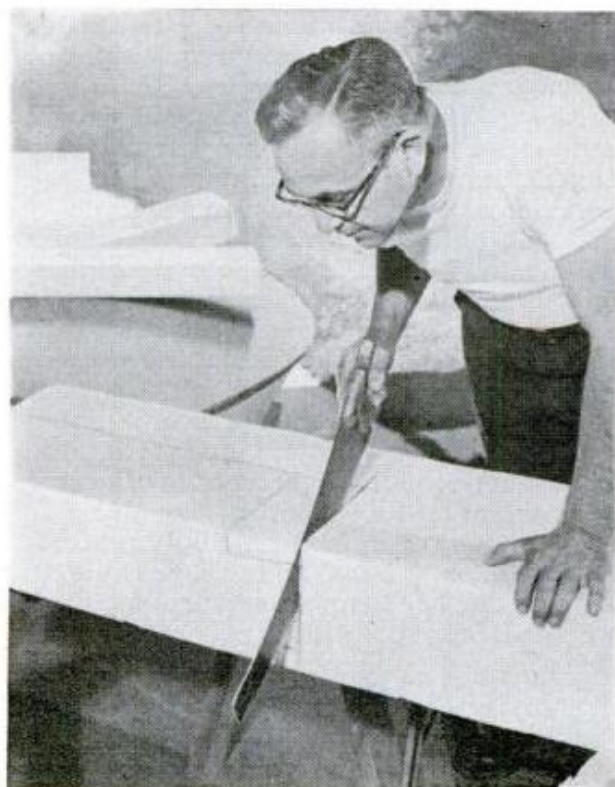

3. Below, plastic board is positioned under deck so it can be marked for trimming to deck curvature

Photos courtesy Dow Chemical Co.



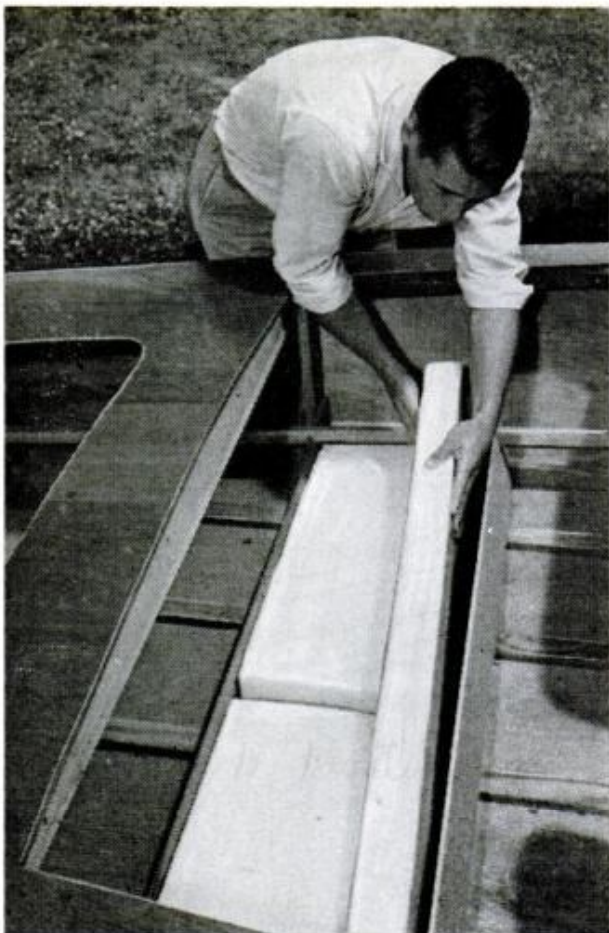

4. To ease job of filling space under seat with foamed plastic, three pieces are used instead of one

apply the formulas to any boat, but not without considerable work. A copy of the formulas may be obtained from O.B.C.

A much easier, less precise method, but one which will do the job just as well, requires that you simply total the weights of all nonbuoyant equipment attached to your boat and divide this figure by the number of pounds 1 cu. ft. of foamed plastic will float (55 lbs. in the case of Styrofoam), inset, Fig. 1. Weights of items that can't be placed on a scale usually can be found in marine-supply catalogs or manufacturer's specifications. If the boat is of wooden construction, disregard the small items of hardware, such as cleats, running lights, etc. For glass-fiber and metal boats, include the weight of the hull as well, unless there is enough wood attached to float the bare boat. Don't forget to add the approximate weight of the maximum number of passengers to be carried.

At this time it is a good idea to make sure that the boat is not being overloaded with equipment and passengers. If the load or weight capacity of the boat is not given by the manufacturer or designer, here is an easy way of determining it. Block up the boat so that the water line is level. Then remove equipment that might be damaged by moisture and fill the hull with

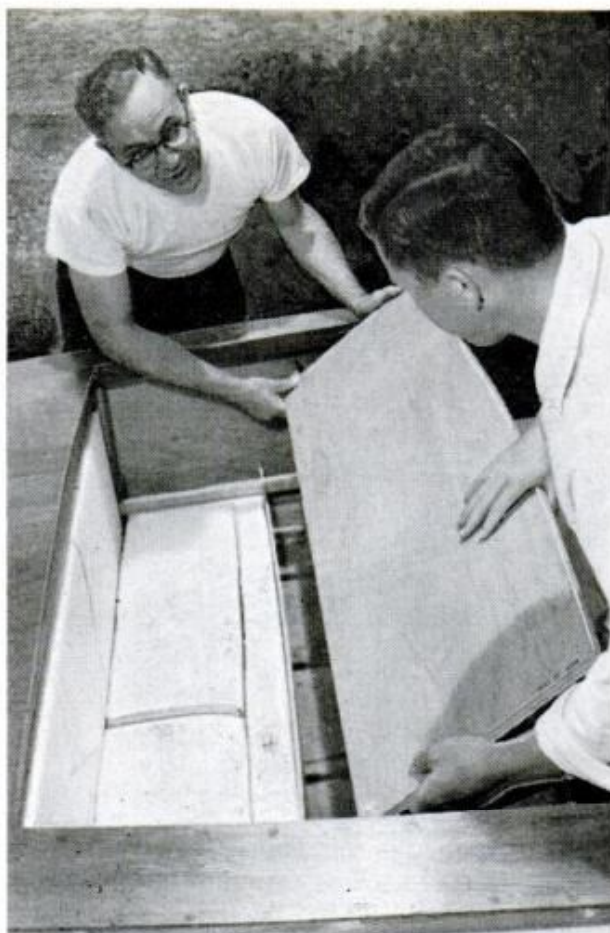

5. When screwed in place, bottom and back of seat hold plastic and protect it from possible damage

water as in Fig. 6, noting the gallons required to bring the water level inside the boat up to the transom cutout. Multiply the total gallons by 231 (cubic inches per gallon) and divide by 1328, which will give the hull capacity in cubic feet. The latter divided by 12.5 is the maximum weight of passengers and equipment that should be carried in the boat. If your intended boat load exceeds this figure, carry fewer passengers, install lighter equipment, or use a smaller motor to stay within the limit.

Having determined the amount of flotation needed for your boat, note the dimensions of the spaces in which foamed plastic can be installed. Foamed plastic is available in plank and board form, so you will want to purchase sizes that will best suit the spaces available. Use the blue-tinted type that is fire resistant and order the amount needed plus 20 percent to allow for waste when cutting it to fit.

Try to get a balanced distribution of flotation, keeping it as high as possible to prevent the boat from overturning when swamped. More flotation is needed at places where heavy equipment is installed. Gas and oil will dissolve Styrofoam, so don't locate it in the bilges.

Foamed plastic can be cut easily with a handsaw or knife. Using a crayon, outline

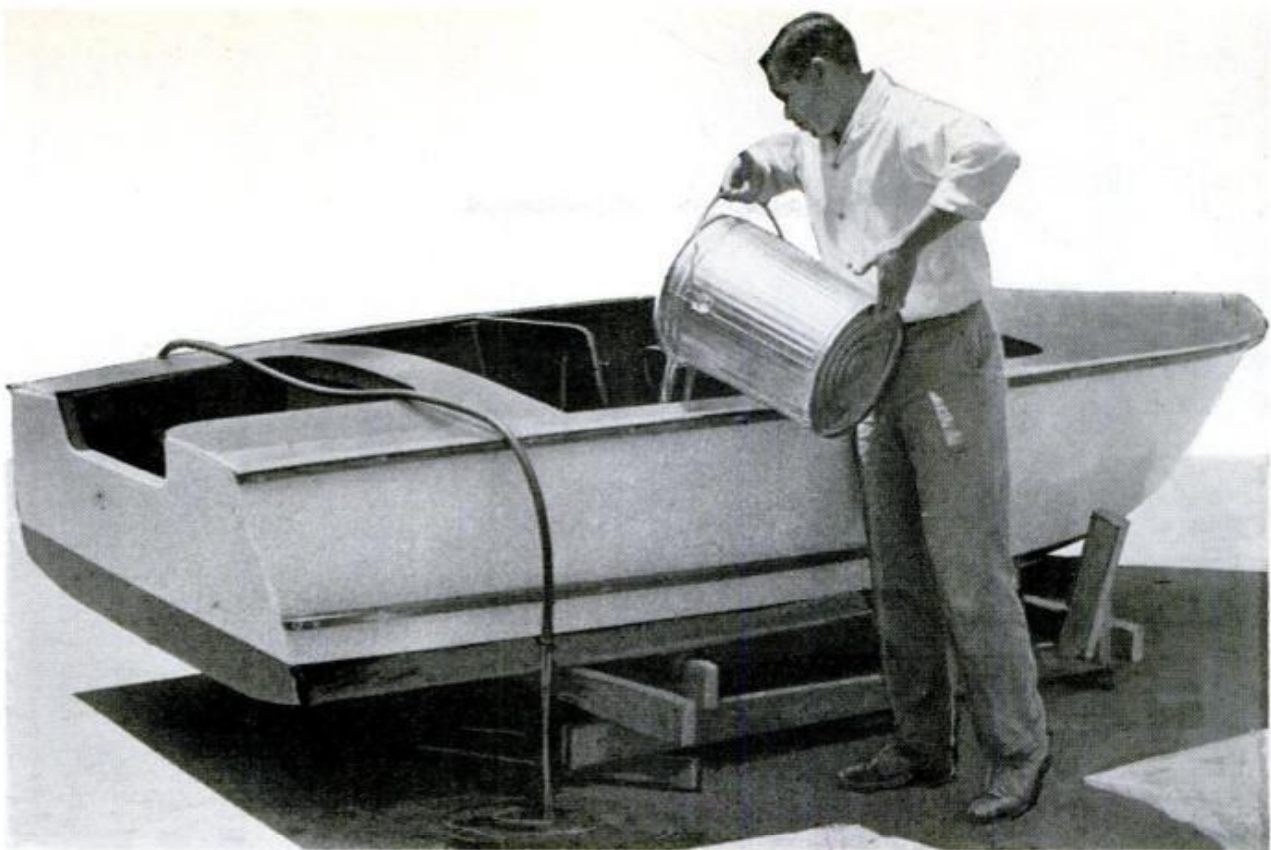

6. Boat is filled to transom cutout with measured water, as means of determining load capacity of hull

the required shape on the plastic and saw it off as in Fig. 2. When installing a large piece on the underside of a deck, Fig. 3, some extra shaping is necessary to make it fit flush. The top must be trimmed to conform to the curvature of the deck and notches made to take the framing members. In a runabout, large pieces can be located under the seats and behind the rear-seat back, Figs. 4 and 5. Note that multiple pieces are used so that the spaces can be filled completely. In this case, the material

is not notched at the bottom to take the battens on the hull bottom, keeping it out of the bilge area.

Foamed plastic must be fastened down regardless of where it is located. In most cases, a batten or sheet aluminum strip clamped over the material will do. In exposed places it should be boxed in with $\frac{1}{4}$ -in. plywood to protect it from surface damage as in Fig. 7. It may be painted, but use only coatings recommended by the foamed-plastic manufacturer. ★ ★ ★

7. Foamed-plastic piece located next to motor-well bulkhead is boxed in with protective panel of plywood

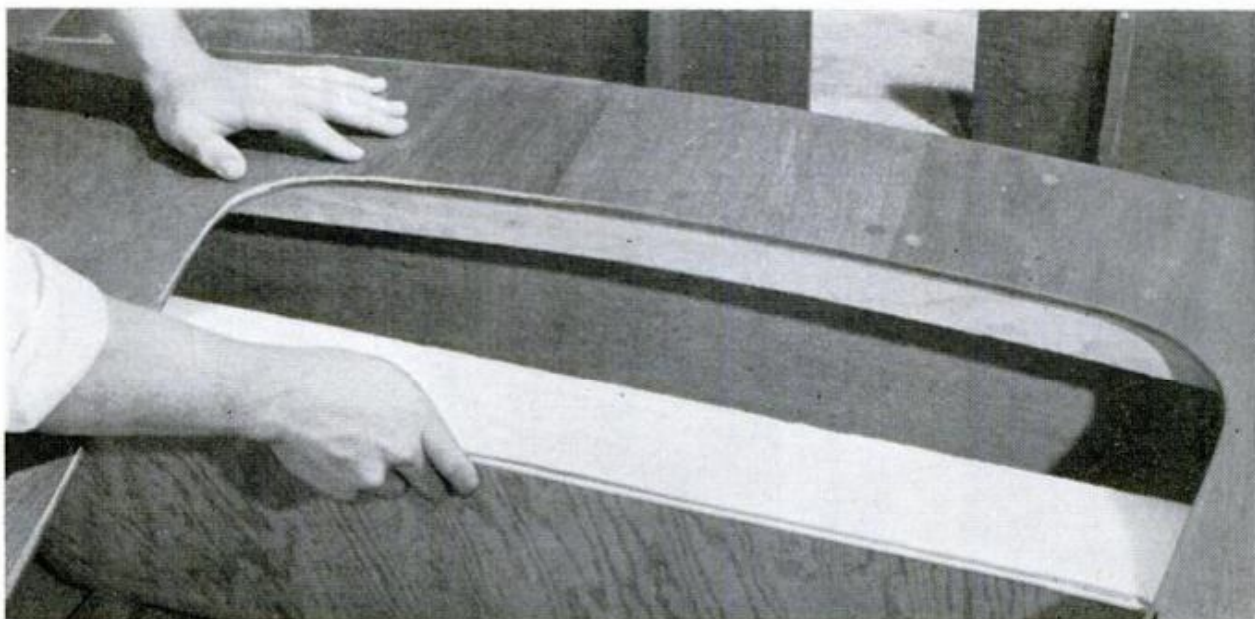

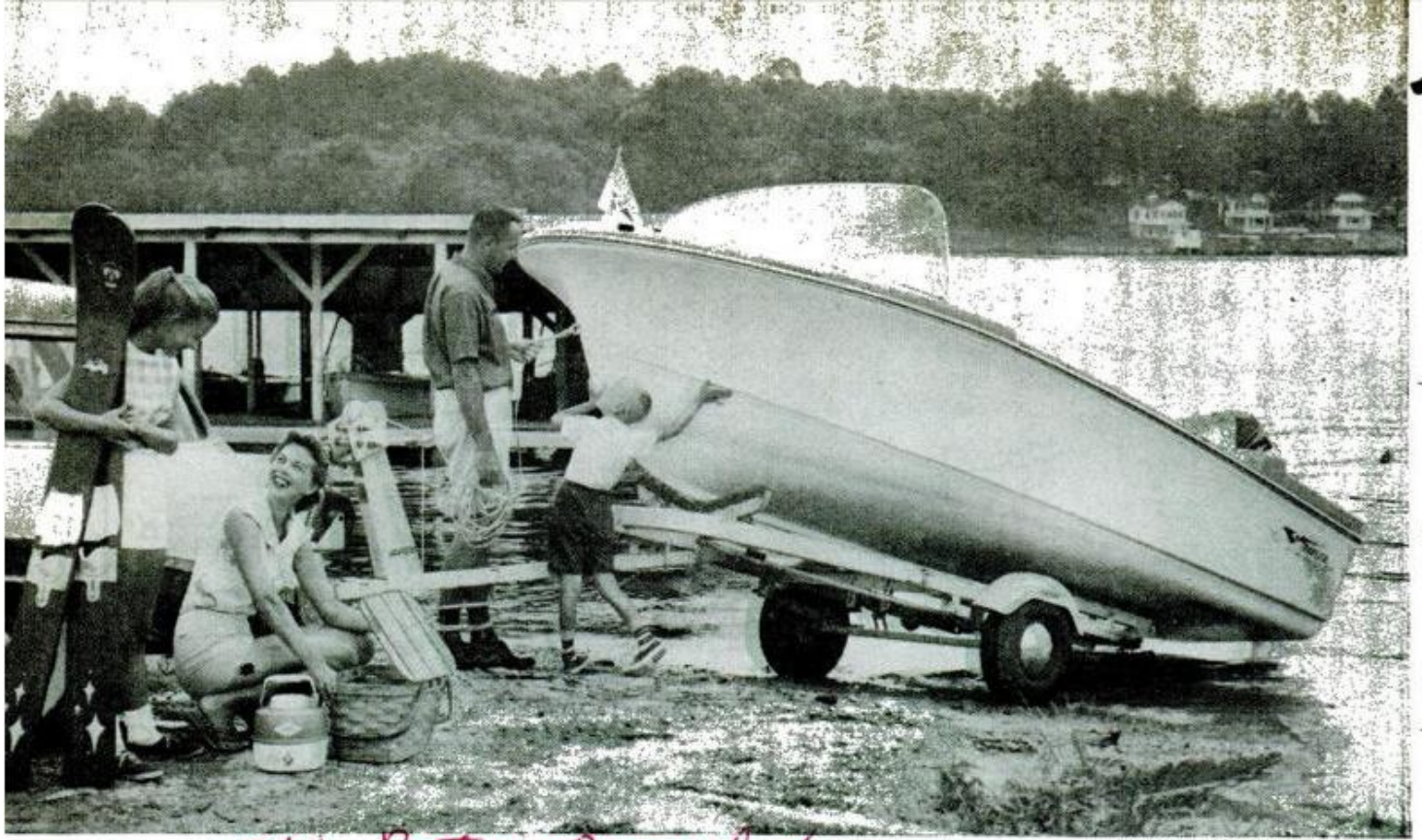

1961 Boating Annual ✓

Arkansas Traveler photos

TRAIL IT RIGHT!

By Scott Morgan

WHILE TOWING A TRAILER loaded with a heavy boat is an easy job for most modern cars, even when traveling long distances, the boat itself may not get through the season unscathed. Incorrect loading, or a trailer that is unsuited to the boat may result in damage to the finish, warped bottom, loose transom, or even a wrecked trailer and boat. While the repair of such damages often is difficult and costly, prevention is quite easy.

Taking first things first, let's consider the suitability of the trailer you have or intend to buy. Of primary importance when buying a boat trailer is to be sure the capacity as rated by the manufacturer, exceeds the weight of boat and everything

that is to be hauled on or in it. A trailer with a load limit that just equals the total weight of boat load, is too small. In use, tires may blow, welds break, launching and retrieving will be difficult and it is likely to give a "mushy" feeling when maneuvering in highway traffic.

Almost as important as load capacity, is the design and provision of supports for the boat hull. Make sure that the trailer you buy has an adequate number of keel rollers and husky stern and bow cradles or bunks, Figs. 3 and 4. These should be located so that there is a balanced distribution of support points, otherwise unsupported parts of the hull may develop unflattering curves, especially where there are major concen-

1. While skipper winches boat on trailer, "first mate" uses stern line to prevent it from being blown sideways



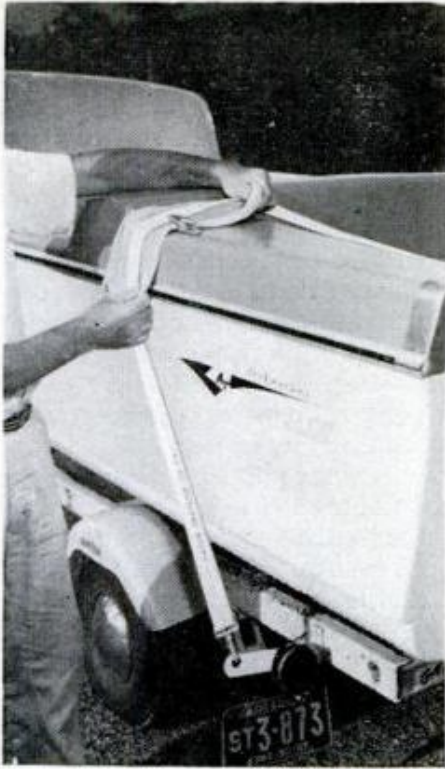

2. For long trips padding is placed under tie-down strap at sheer to prevent strap from marring finish

trations of weight. In addition to making it easy to roll the boat on or off the trailer, keel rollers bear much of the weight of the boat. Stern bunks and bow cradle support the outboard parts of the hull and keep it upright.

Since the support members on a trailer usually are adjustable, a session with a wrench the first time the boat is loaded on it will assure proper hull support. Keel rollers should be pushed firmly against the keel of the boat and tightened in place as in Fig. 7. Next the winch stand is loosened and moved so that the bow stop contacts

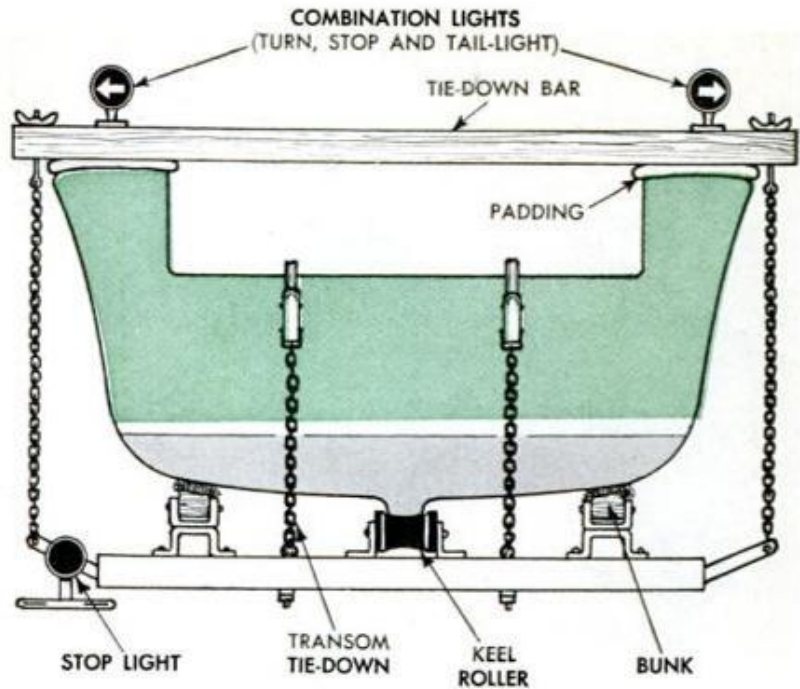

3. Equipment for securing afterend of heavy boat should include transom tie-downs and tie-down bar

the stem, after which it is tightened down. The bow cradle should be checked to be sure that both sides are in contact with the bow. If it cannot be adjusted to fit the bow, correction may be obtained by remounting it slightly aft, or by fastening facing strips on the cradle to give the required angle. Stern bunks must be adjusted vertically to fit tightly against the hull bottom and be moved horizontally so that the afterend of each is flush with the outside of the transom. If the bunks do not support the transom, the weight of the motors will be supported at a point where the hull has no

4. Boat must be supported by rollers and bunks on trailer at close intervals to avoid strain on hull

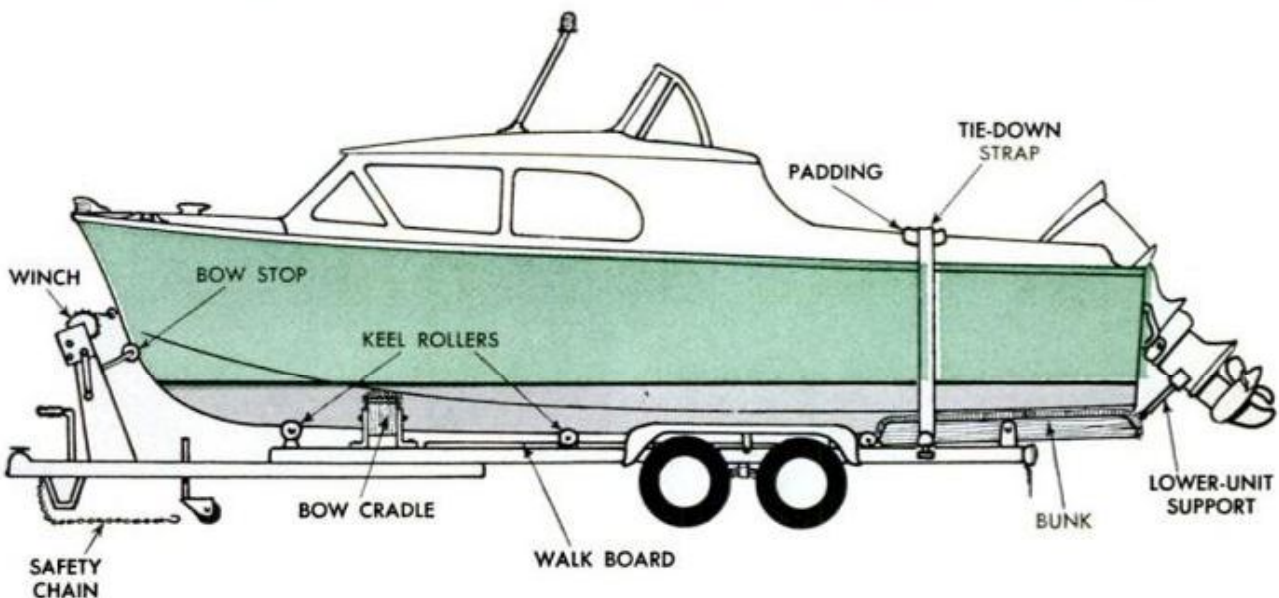



5. Scissors jack, tire-patching kit and pump, lanterns and wrench to tighten hitch are carried for emergencies

structural members, which may cause a "hook" or concave surface on the planking. A hook produces an adverse effect on a boat's performance and usually is difficult to repair.

While adjustable parts permit some "tailoring" of a trailer to fit a boat, don't try to trail a 20-ft. cruiser on a trailer that was designed for a light runabout. Remember the weight-capacity requirement.

6. Last step in loading boat for trailing is to connect trailer lights to car's electrical system, being sure they operate correctly before driving off



186

After you have fitted your trailer to the family "ark," or sleek runabout, as the case may be, the next step is to install a stout hitch on the car, if you have not already done so. The hitch should be attached directly to the car frame for safety. Cruisers and other heavy boats require a 2-in. ball; 1 7/8 in. for boats weighing less than 1500 lb.

The next consideration is tie-down equipment. For lightweight boats and short trips with heavier boats, a tie-down strap is sufficient for securing the stern end to the trailer. For long trips with a heavy boat, a bar should be used as in Fig. 3. In either case, it is wise to place padding between the tie-down and deck to prevent chafe as in Fig. 2. When fastening a bar in place avoid unnecessary pressure, as this can force the hull out of shape. At the bow, a heavy shock cord is tied to the bow eye and secured to the winch stand. Leave the winch line attached but remove the handle to prevent wear on the drum. To provide positive security when making a sudden stop, transom tie-downs should be installed and clamped in place as in Fig. 3. Motors that are carried any distance on the transom should be held in tilted position by a lower-unit support bracket as indicated in Fig. 4. This prevents the propeller from striking the pavement on an uneven road and reduces the strain on the transom.

Trailer lights are important for night driving, not only for common-sense safety but to meet the requirements of the state traveled. For a quick check on required lights and other regulatory data, write Outboard Boating Club of America for their "Digest of State Boat Trailer Laws."

7. Roller that does not contact keel is moved up against hull so that it shares important job of supporting outboard motors mounted on transom of boat



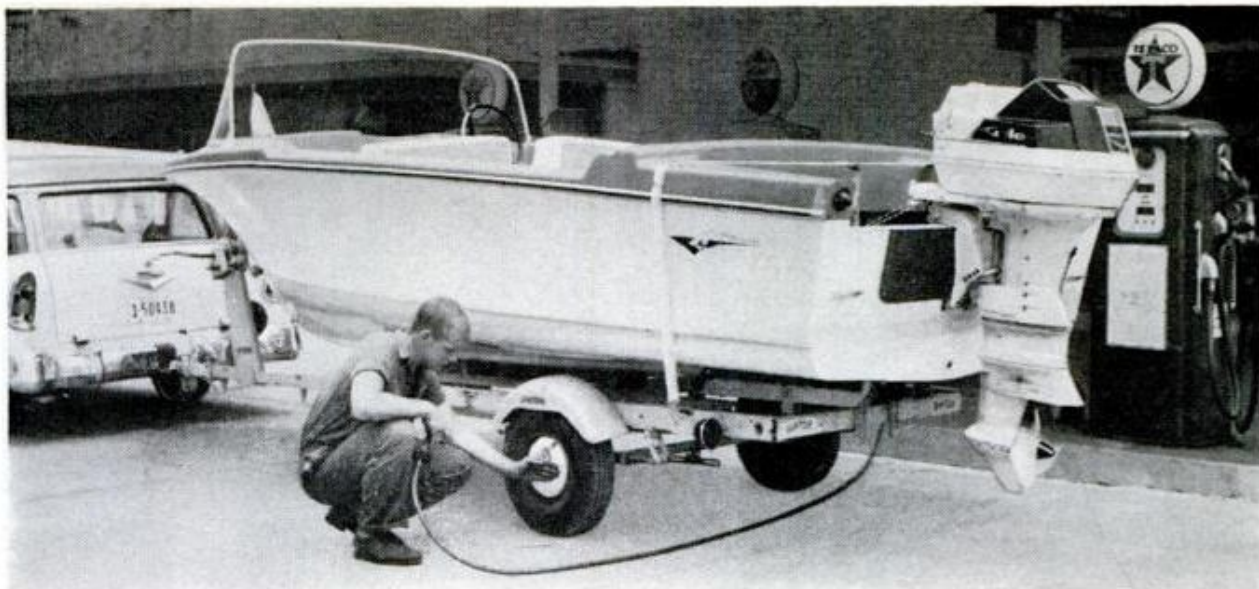

8. At each service stop trailer-wheel bearings are checked for overheating by touching hand to wheel cap

Minimum lights should include a combination tail, stop and directional light on each side at the back of the trailer where they can be seen easily by overtaking traffic. The lights, of course, are operated by the car's electrical system, which is coupled to it by means of a connector as in Fig. 6.

Changing a tire out on the road requires a few special tools, Fig. 5. You need a scissors jack to raise the wheel off the ground. A large adjustable wrench is needed for tightening the hitch-ball nut and other nuts that may have worked loose. A tire-patching kit and pump may save the day when you have a flat and no spare is available. Combination-light lanterns provide good illumination and safety when changing a tire at night. On-the-road repair can be kept to a minimum, if the

trailer is maintained properly and most likely trouble sources are checked at service station stops. When checking tire pressure, touch your hand to the wheel cap, Fig. 8. If it is overly hot, the bearing may be defective or be in need of grease.

Loading and launching usually is a simple operation, but it is important to use precautions here, too. On windy days, or when a current is running, have an assistant hold the boat in alignment with the trailer until it is completely launched or loaded. A good way of doing this is to fasten a stern line to the upwind or upstream side of the boat as in Fig. 1. Winches, stabilizer rollers and walkboards, Fig. 9, take much of the work out of launching and take it easy on your boat and trailer. Use them properly.

★ ★ ★

9. Walkboard on modern trailer permits boater to launch and retrieve craft without getting feet wet

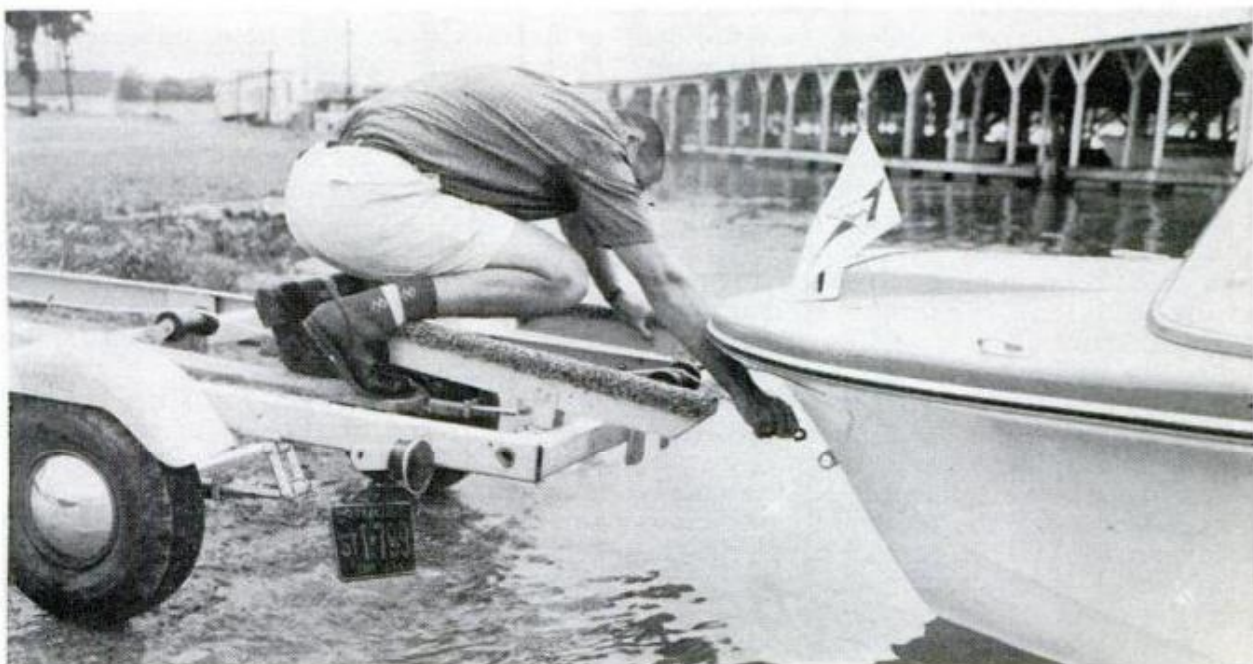

The CRAFTSMAN

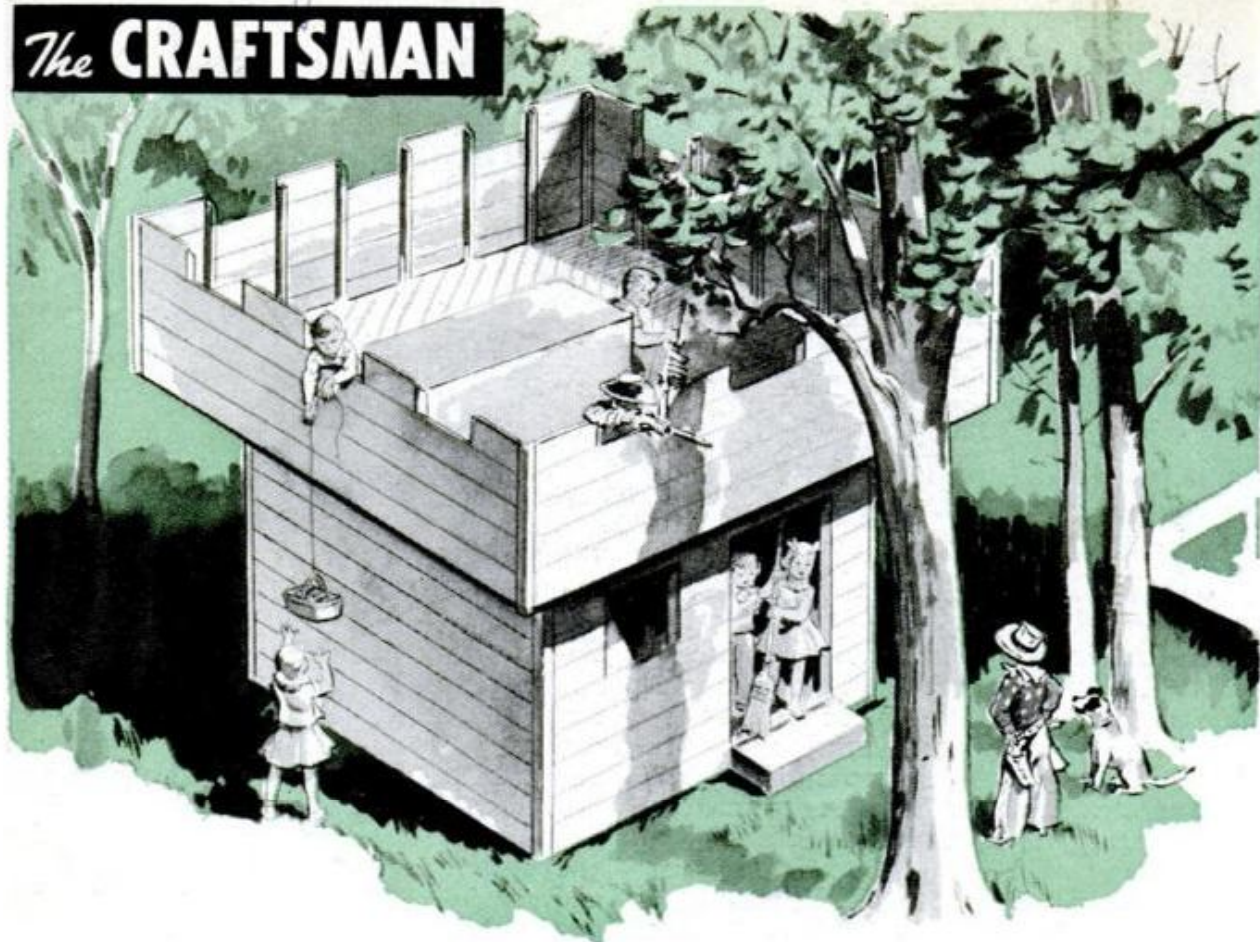

Garden Tool Shed Combined With Play Fort

DESIGNED AS A combination playhouse and tool shed, this sturdy back-yard fort uses simplicity of construction with no sacrifice in strength or interior space. Begin making the fort by laying a cinder-block base on which to set the frame. The frame for the lower section is made entirely of 2 x 4s secured with simple face-to-face or face-to-butt nailing, requiring no complex cut-out joints. When the frame is completed, the flooring, 1 x 6-in. tongue-and-groove sheathing, is nailed diagonally to the floor joists. Before adding the siding, a partition in the center of this lower section is added to divide the playhouse from the tool shed. By dropping the center member of the partition 24 in. from the floor, one 4 x 8-ft. sheet of tempered hardboard can be cut to suffice for the entire job.

The lowered member also serves as a guard against which lawn mowers, wheelbarrows and other equipment may be run without danger of puncturing the hardboard. Doors for the tool shed are simple frames made of 2 x 4s and covered with 1 x 8-in. V-bevel tongue-and-groove siding, the same siding that is used to cover the rest of the fort. Hang the doors from 4-in. strap hinges screwed to the corner

frame posts so that they swing inward to close at the center. The 2 x 4s at the sill and top plate serve as doorstops making a center post unnecessary. To complete the lower section of the fort, nail the siding to the frame starting an inch or so from the ground and working up. This will partly conceal the cinder-block base and, in appearance, help pull the fort closer to the ground. Finish the corners with 1/2 x 2-in. trim.

Begin making the upper section of the fort by nailing 2 x 6-in. floor joists to the lower frame. Lay in floor sheathing and nail a 36-in. piece of 2 x 4 to each corner. Now nail 2 x 2 x 36-in. studs all around at regular intervals as indicated in the diagram. When the siding has been added, a space will remain between the siding and the studs which will allow for drainage. The space between the 2 x 6-in. joists and the frame of the lower section will serve to ventilate both the playhouse and the tool shed. In laying the floor, allow for a covered stair well so that access may be had to the playhouse deck by means of a ladder. Cover the upper deck with linoleum and stain all exposed surfaces inside as well as out.

Charles A. Goodrum, Alexandria, Va.

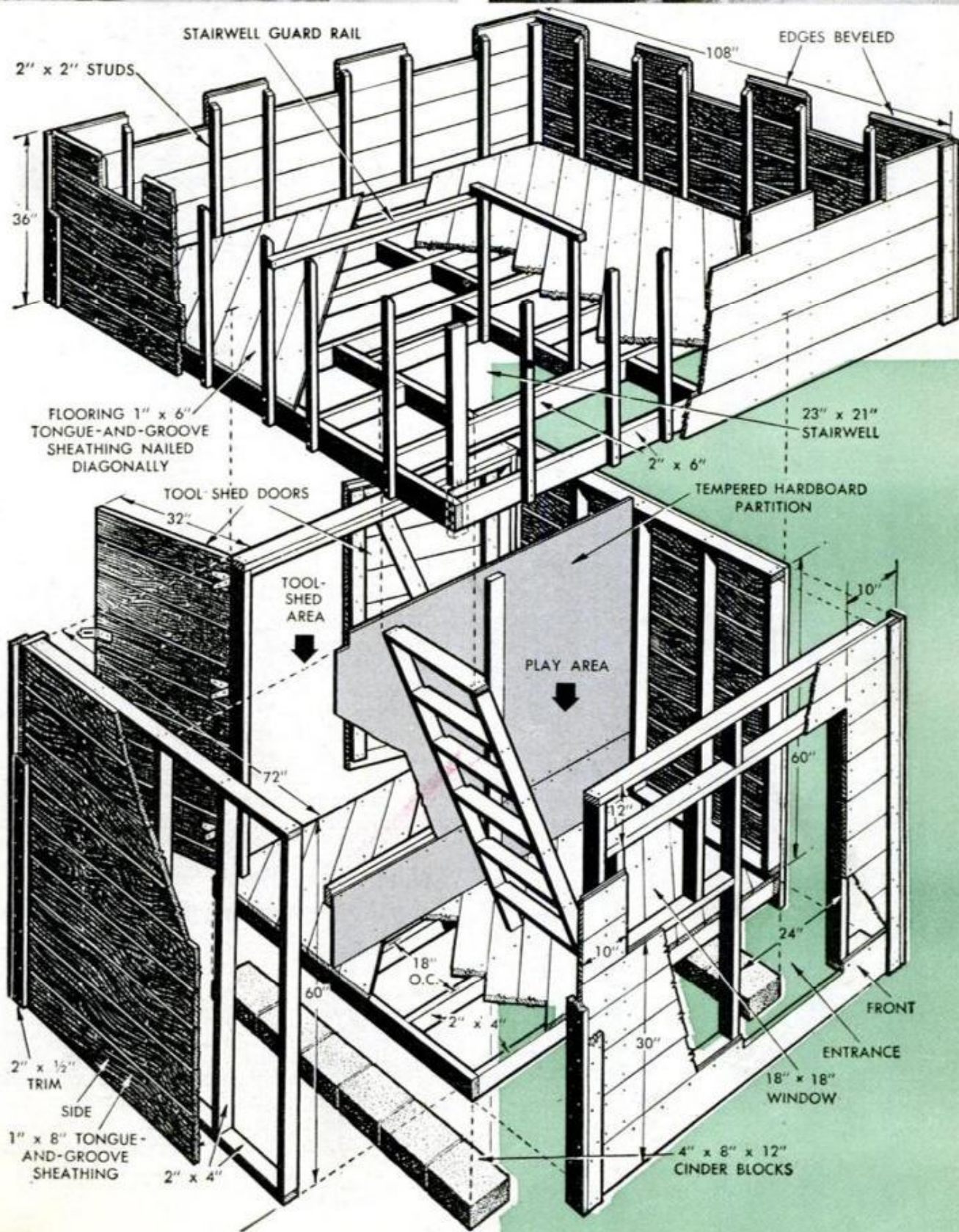
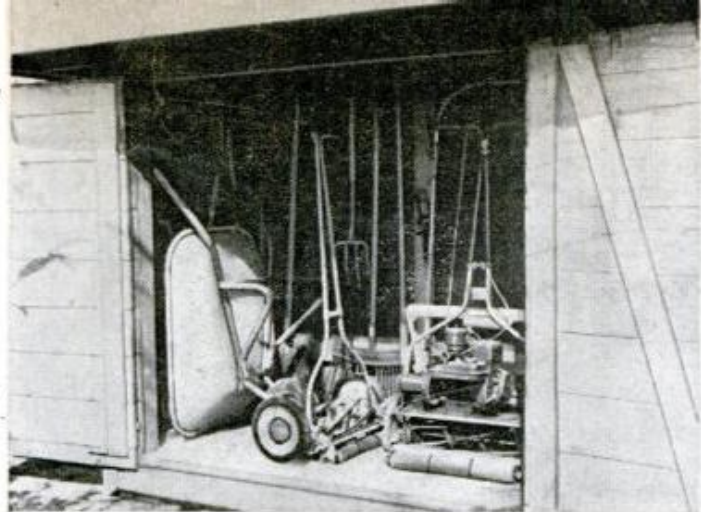

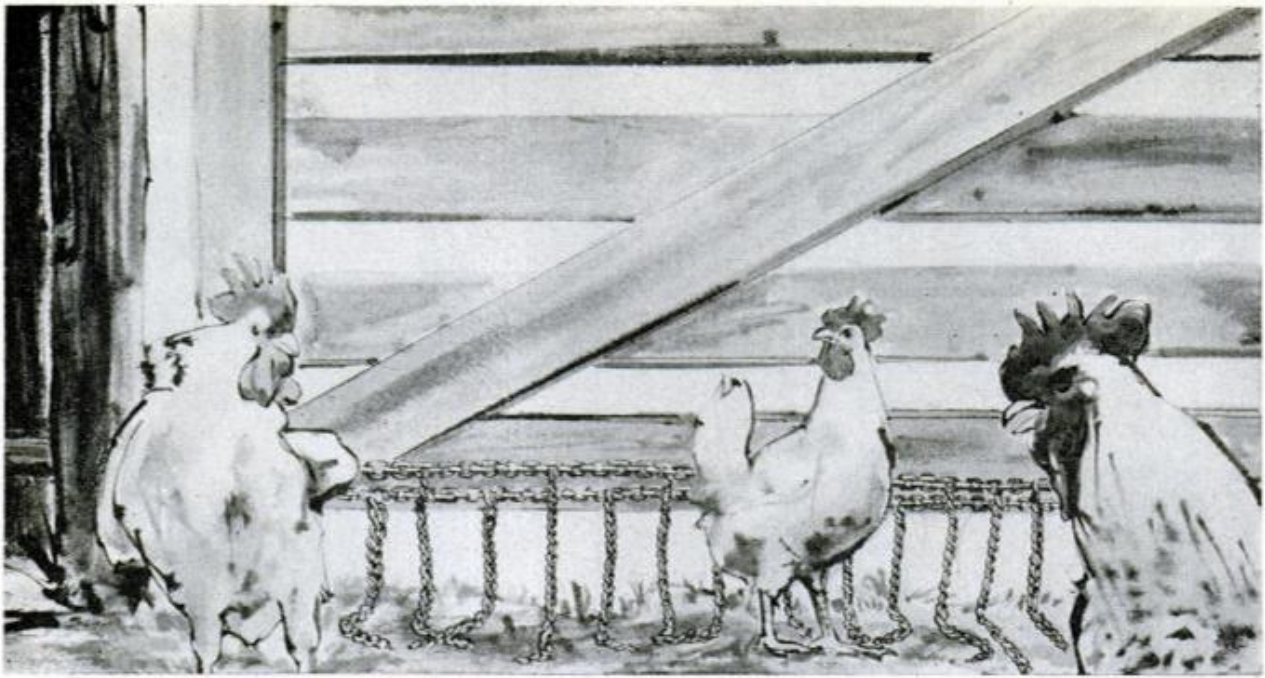

Tire Chains on Gate Serve as Poultry Guard

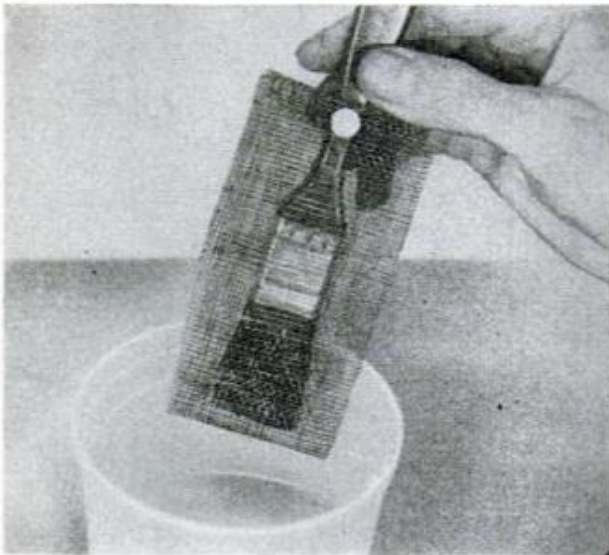

Chickens and other farm poultry can be prevented from escaping through the ruts under a gate by using a few old tire chains. Nail the chains to the bottom of the gate so that a good portion of each one lies along the ground. The chains will serve as a continuous barrier as the ruts are deepened by rain and the passage of tractors and other farm implements.

W. D. Terrill, Oak Park, Ill.

Screening Protects Bristles Of Soaking Paint Brush

The bristles of a paint brush won't become curved and spread from resting on the bottom of a container of solvent if the brush is fitted with a support. The support may be made out of a piece of window screening cut slightly wider than the brush and long enough to be folded over the bristles and the ferrule. Allow clearance between the end of the bristles and the fold and tack the support to the handle.

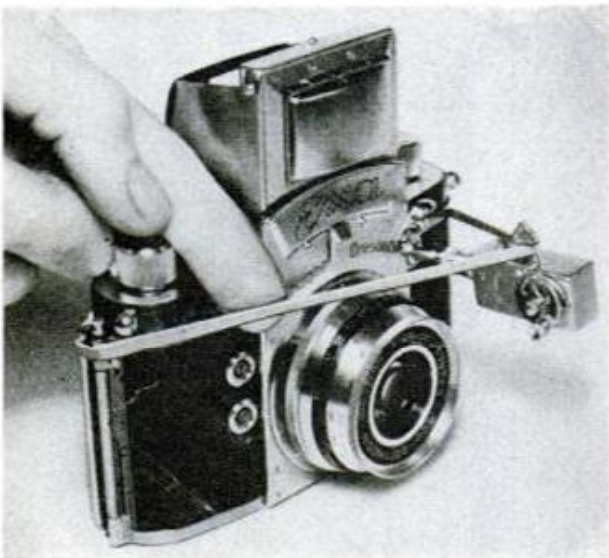

Rubber Band Helps Self-Timer Snap Reflex-Camera Shutter

The springs of most self-timers are usually not strong enough to trip the shutter of a single-lens reflex camera. To give the timer a little help, use a rubber band as shown. Place it around the camera and hook it around the self-timer's arm. The pressure the rubber band exerts will aid the timer arm in its downward movement and help to trip the shutter.

J. A. Comstock, Wellsboro, Pa.

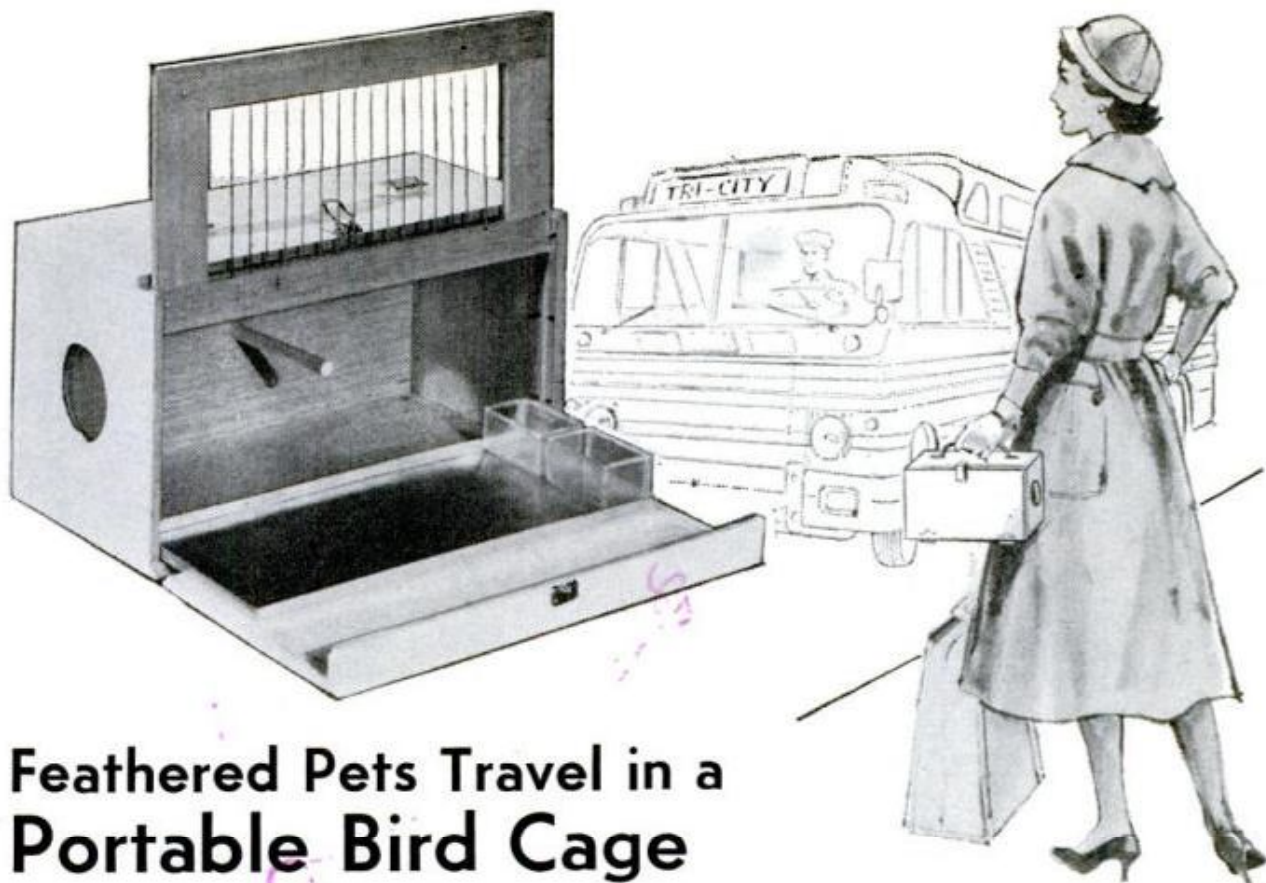

Feathered Pets Travel in a Portable Bird Cage

THIS portable bird cage allows you to take a pet bird along whenever you travel. Cut all parts from $\frac{1}{4}$ -in. plywood as indicated in the drawing and assemble all except the front panel with brads and glue. Mount the front panel on 1-in. strap hinges at the bottom. It is locked shut at the top with a small case lock. Make the top and bottom sections of the barred sliding panel

by drilling $\frac{1}{16}$ -in. holes in a piece of plywood, and ripping it down the center. Tongue and groove the four sections of the panel, insert the rods in the holes and assemble the panel with glue. Since stain or varnish may prove fatal to your pet, cover the cage with plastic leather. Cover the air opening with wire screen, add a perch, a pull-out tray and a leather-strap handle.

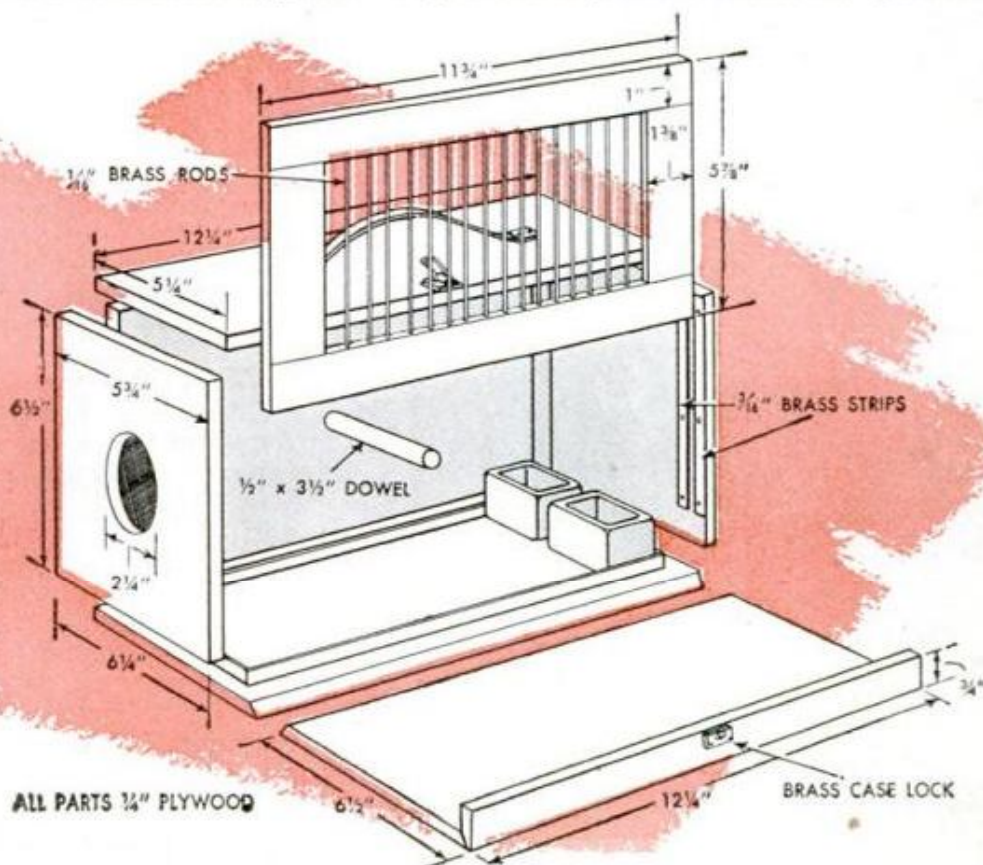

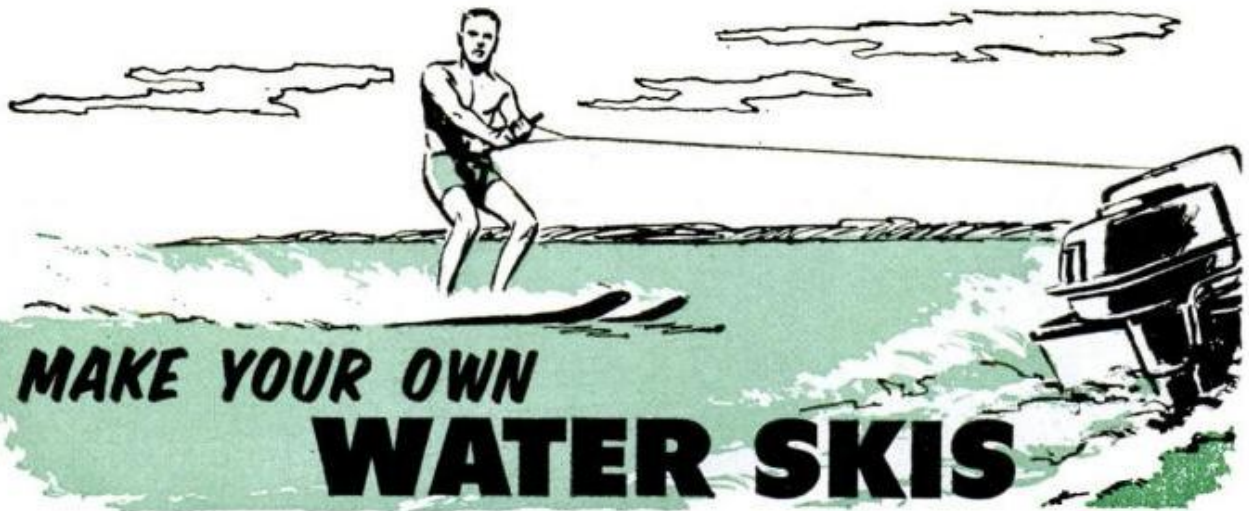

By William B. Vincent

The water skiing enthusiast who is handy with a few tools can make his own skis in a short time and know he has equipment combining beauty, ruggedness and all the versatility his skill may demand of them. The material needed to make the skis consists of a piece of $\frac{5}{8}$ x 69 x 16-in. marine-grade plywood, a piece of glass-fiber cloth measuring 36 x 40 in., 1 qt. of polyester resin with enough catalyst to activate it, and one complete set of ski bindings.

Begin by ripping the plywood into two

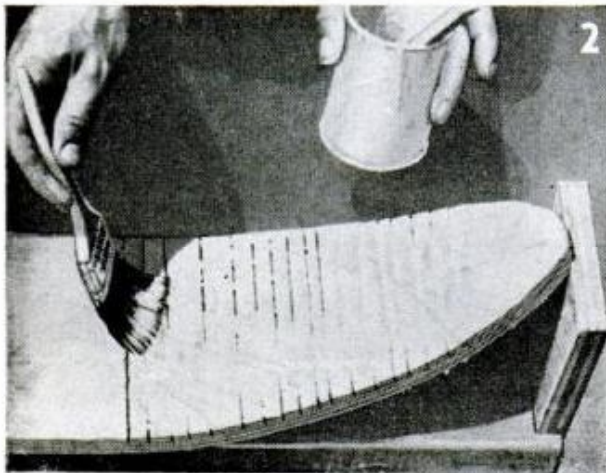
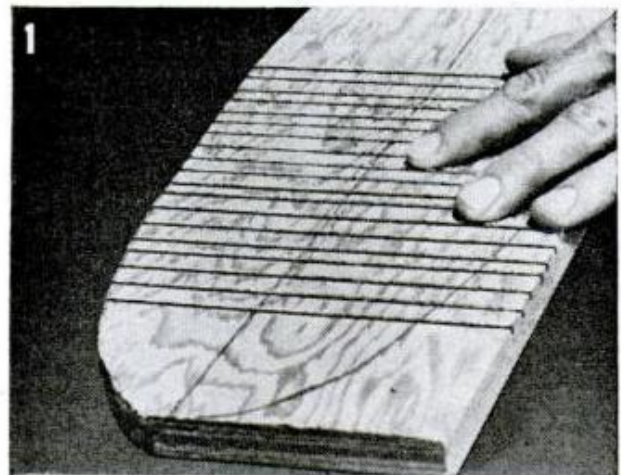
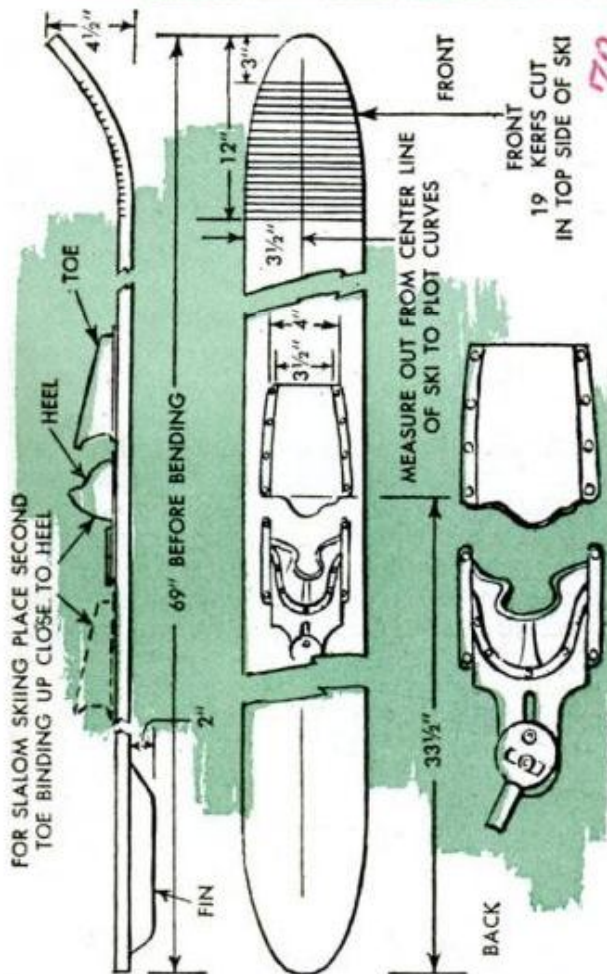

lengths 7 in. wide and trim both ends to the proper rounded shape. Starting 3 in. from one end saw a series of kerfs about $\frac{1}{2}$ in. apart, as shown in Fig. 1. Make them just deep enough to touch, but not cut, the last ply. The last kerf should be exactly 12 in. from the tip of the ski. A permanent bend is made by supporting the tip on a piece of wood $4\frac{1}{2}$ in. high, as shown in Fig. 2. Hold down the body of the ski with weights. If pressure is applied from the back forward, the stress will be more evenly distributed. As the first step in the glassing process, cut the required pieces of glass-fiber cloth to size and lay them out

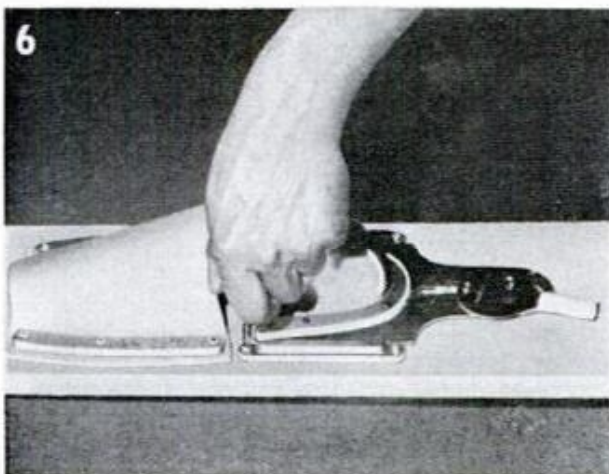
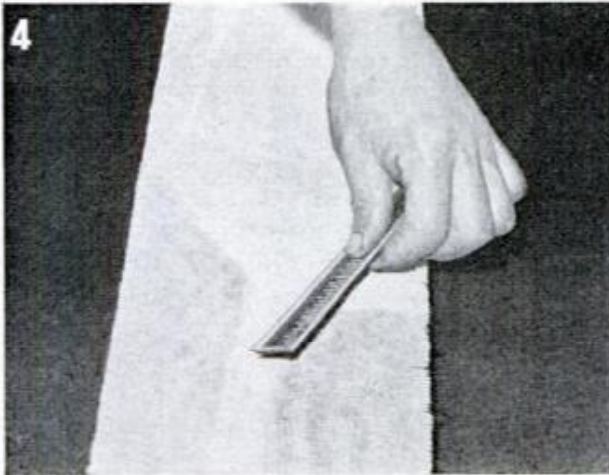
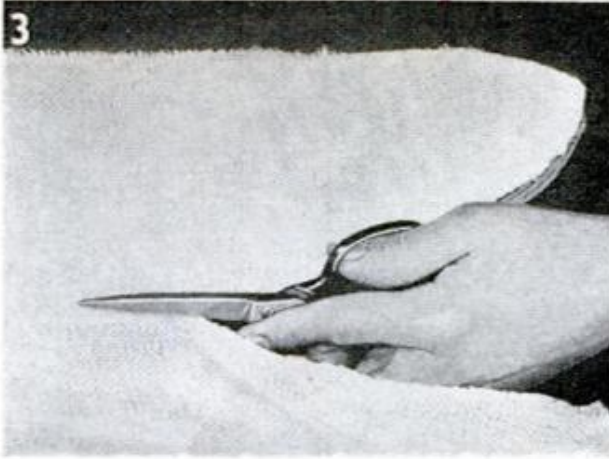

in order, so that no time is wasted once the resin is applied. Most resins have a pot life (congealing or "setup" time) of less than $\frac{1}{2}$ hr. When you are ready to begin the process of glassing, mix the catalyst with the resin, using the exact proportions recommended by the manufacturer, and immediately apply a base coat with a brush or a roller. While this coat is still tacky, smooth the glass-fiber cloth on and apply a second coat being careful to work out the bubbles and to fill in any voids with resin. Before the resin hardens, trim the glass-fiber cloth flush with the ski edges as is shown in Fig. 3. The block and weights may now be removed once the resin is dry. Work may now be begun on the rest of the ski surface.

After applying a coat of resin over the entire top surface of the ski, smooth on a length of cloth, following the same procedure as before. When the resin has set, turn the ski over and repeat this process on the bottom side. Operations can be speeded up considerably at this point by working on one ski while the resin is setting on the other. To cover the large flat surfaces smoothly and to keep the resin from setting before it can be worked, stand the ski on one end and pour the resin down its length, spreading it smooth from the center with a squeegee as indicated in Fig. 4. At this point a $2\frac{1}{2}$ -in. strip of cloth is applied to the edges, so that it overlaps the top and bottom edges by about 1 in.

The fins may be either screwed on or they may be laminated into the ski. Fig. 5 suggests how they may be laminated using two layers of cloth on each side, set with resin to hold them in a vertical position on the center line. If ski jumping is anticipated, it is advisable to use two fins 1 in. high, set 2 in. on either side of the center line. Two fins are recommended so that when the ski hits the water, the impact will not cause it to tip and throw the skier off balance. Skis made according to the design indicated in the diagram are fine for slalom (using one ski) and for the conventional style of skiing.

Before adding the bindings, sand the entire ski and add one last coat of resin. For maximum comfort and efficiency, the bindings should be mounted so that the heel section just touches the toe section when the heel is fully advanced as seen in Fig. 6. Before driving the screws, drill a pilot hole at each location. In cases where the bindings require holes to be drilled through the ski, drill an oversized hole first. Place a sheet of wax paper under the ski and fill the hole with resin. When it is dry, redrill the hole with the proper sized drill. The screws will hold securely and the mountings will be completely sealed. ★ ★ ★

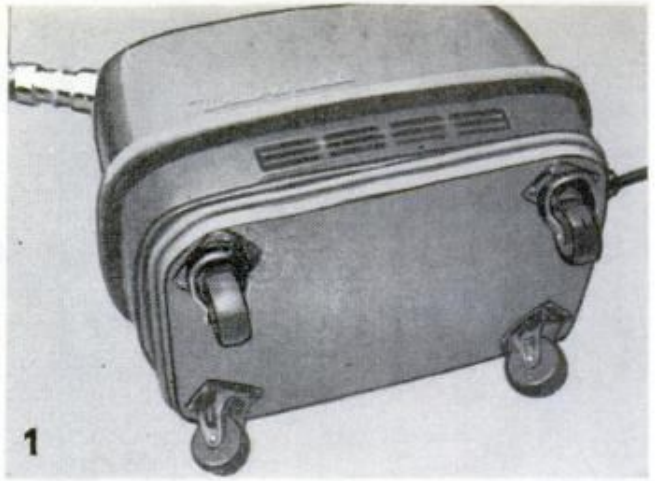

1

1. It's easy to put that vacuum cleaner on wheels. Attach four casters to a piece of plywood and secure the plywood to the bottom of the cleaner with self-tapping screws. In order to protect the furniture from nicks and scratches, staple a piece of heavy weather stripping all around the edges of the plywood

Solving HOME PROBLEMS

2



2. Weatherproof name tags for garden flowers and plants are made by wrapping small strips of cardboard in aluminum foil. Engraved deeply into the aluminum with a ball-point pen, the identifying names will also be pressed into the cardboard. In this manner, they will remain legible and unaffected by changes in the weather for some time

3



3. Large desk blotters used flat on bench or table surfaces won't get that dog-eared look if the corners of the blotter are first cut round. If you desire them cut to the size and shape of the working surface, fasten the corners to the table edges with tape. Blotters which are to receive extra-hard usage can be glued to a piece of heavy cardboard

4. Rustic and attractive in appearance, a coat and hat rack is quickly made using the head ends of ordinary clothespins. Cut the pins to the desired length and snug fit them into holes drilled in a rectangular piece of wood. Secure the pins with a dab of glue, and sand and finish the rack with varnish or stain to suit your individual taste

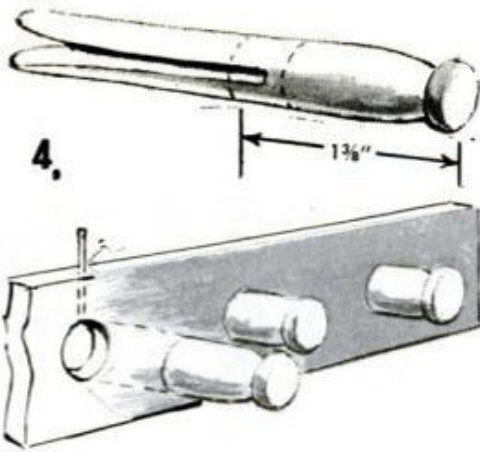

5. Doors that are constantly kicked or flung open are stopped without a jolt by this chain and spring combination. A flexible chain runs through a door spring and both are fastened to the door and frame. As the door flies open the spring absorbs the shock and the chain completes the stop

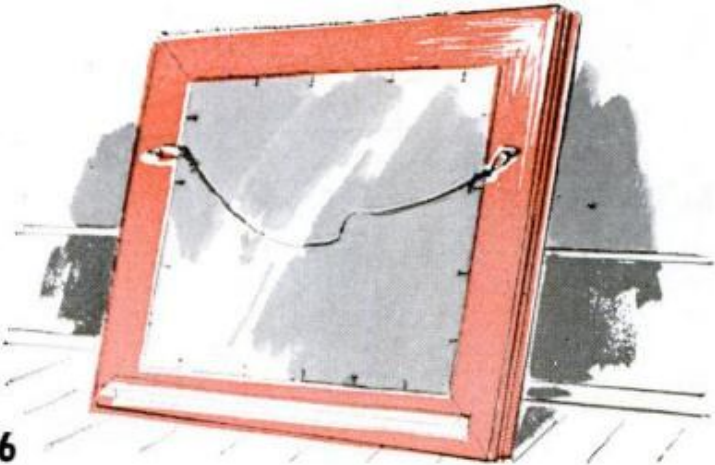

6. Small framed pictures won't tilt at an angle if a strip of cellophane tape is used to keep them in place. Fold a strip of tape lengthwise with the adhesive side out. Fasten one side of the folded tape to the bottom of the frame and press the frame to the wall so that the other side of the tape will hold it firmly in place

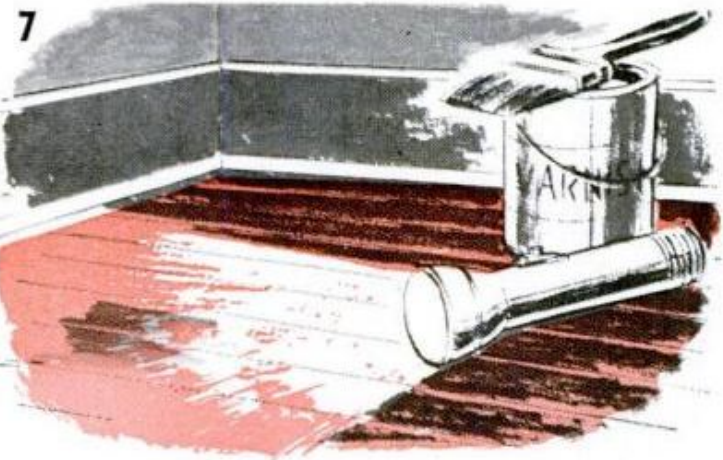

7. Next time you apply clear varnish to a floor, avoid the risk of missing a few spots by using a flashlight to show up the unvarnished areas. The finished portion will reflect the light, while the spots missed will reveal themselves by their dull and lusterless appearance

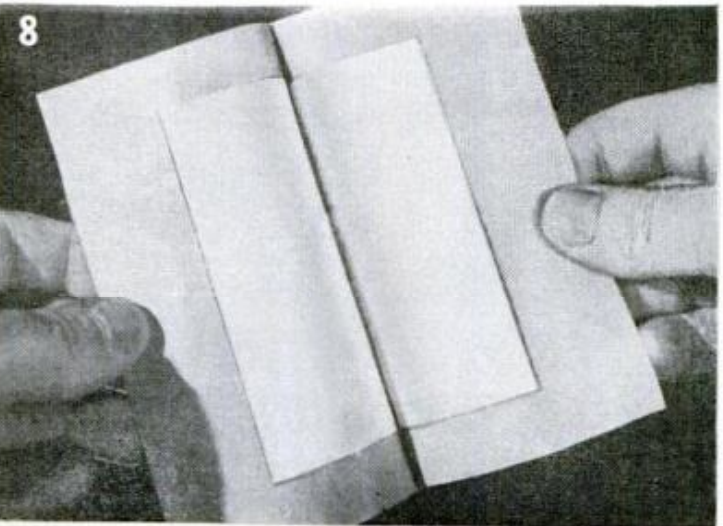

8. Wallpaper patches too thick to blend in with the rest of the wall can be reduced to half thickness by coating both sides with glue and placing them between two pieces of heavy wrapping paper. When the glue dries, pull the paper off. The patch will separate into two layers. Soaking in warm water will remove the paper



Shelf Mounted Between Studs

To set up a temporary shelf in a garage, cut a piece of wood so that it fits snugly between two of the garage studs. Drive two nails into each end of the wood and bend them upward at right angles. Insert the shelf and tap the nail heads into the studs.

Gambrel for Skinning Small Game

Rabbits and other small game are easy to skin if hung on this simple gambrel. Drill two holes in a piece of wood. Double a 4-ft. length of cord, tie the ends together and knot it at four 4-in. intervals. Insert 1½-in. loops through the holes to hold the animals legs while you do the skinning.

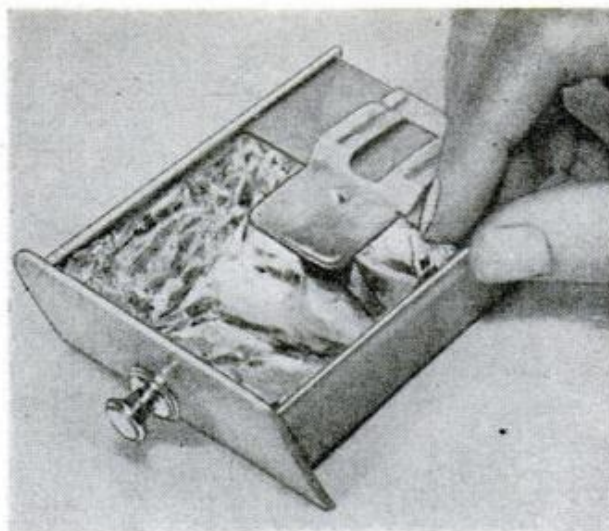
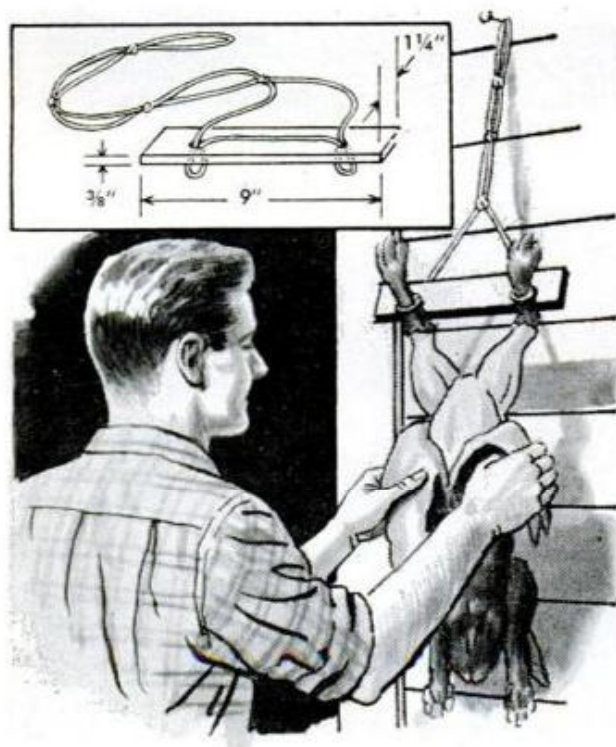

Auto Ash Tray Lined With Foil

Automobile ash trays lined with aluminum foil are easy to clean since the foil can be lifted out, emptied, and put back again. The foil also acts as a reflector so that the driver need not take his eyes off the road and grope in the dark for the ash tray.

Raincoat Used as Storage Bag

Button a plastic raincoat over heavy coats and clothes. It makes a good storage bag. Or use it to protect street clothes hung up in a dusty shop. The clothes in turn help keep the coat's shape by preventing the hanger from creasing and damaging the shoulders.



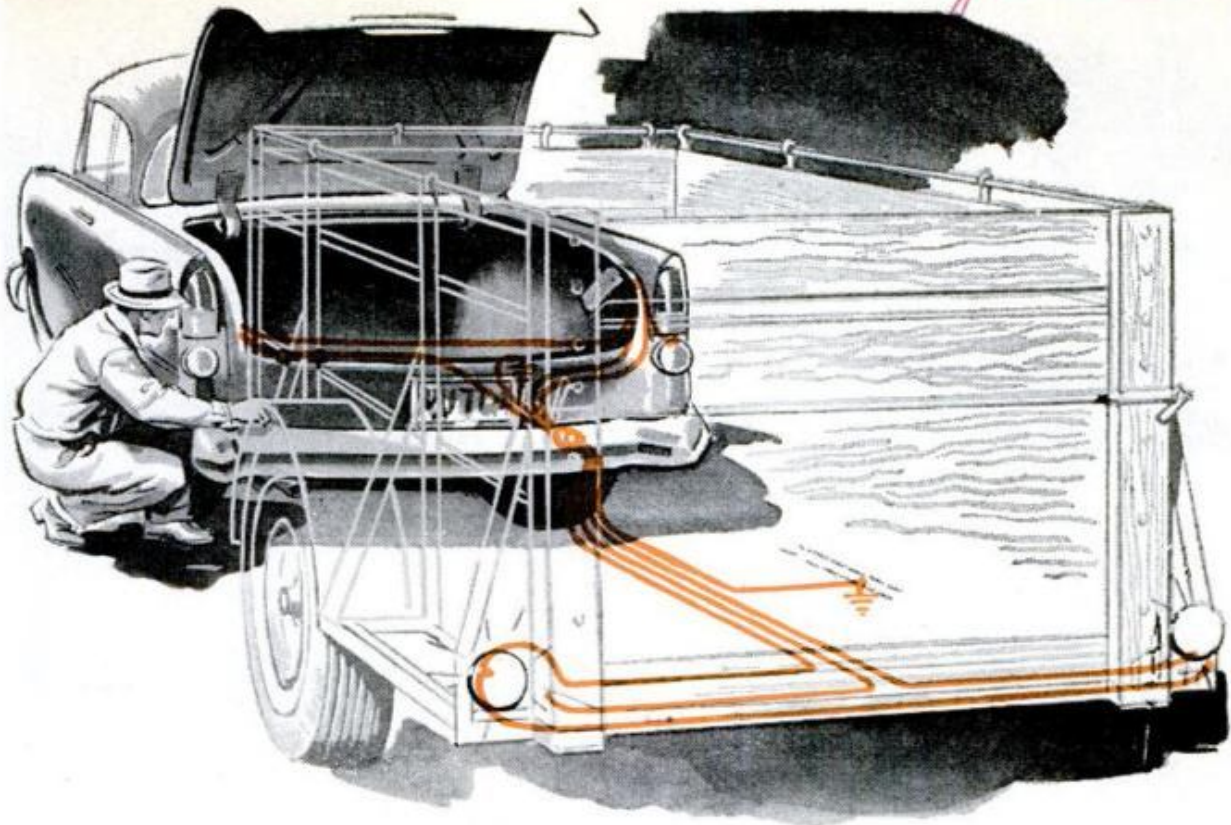

Turn-Signal Lights Switch to Trailer

THIS SIGNAL-TRANSFER system is designed to eliminate the danger that arises when a trailer hides the rear lights of its towing vehicle from traffic. The system consists of two three-way toggle switches, two stop-and-turn taillight units, a four-pole weatherproof electrical coupling, and whatever length of 16-gauge, double-conducting wire is necessary to equip your car and trailer. Essentially the setup involves extending the car's rear-light circuit through the coupling to a similar circuit in the trailer. A connection is made from the car's running-light wires to the corresponding wires of the trailer taillight units. This allows running lights on both car and trailer, eliminating any blind spot. The car's stop-and-turn filament, however, is bypassed by means of the toggle switches and the current is relayed directly to the trailer units when the switches are thrown. This is necessary because the factory-installed flasher is unable to handle the front, dash, and rear signal lights of the car, plus the additional load of the trailer bulbs. Wired directly, without the switches, the trailer lights would flash at a very slow interval, defeating their own purpose, and eventually the added load would burn out the flasher unit. When the trailer is not in use, the switches can be thrown so that the current is restored again to the car's signal lights.—Richard C. Crawford, San Francisco, Calif.

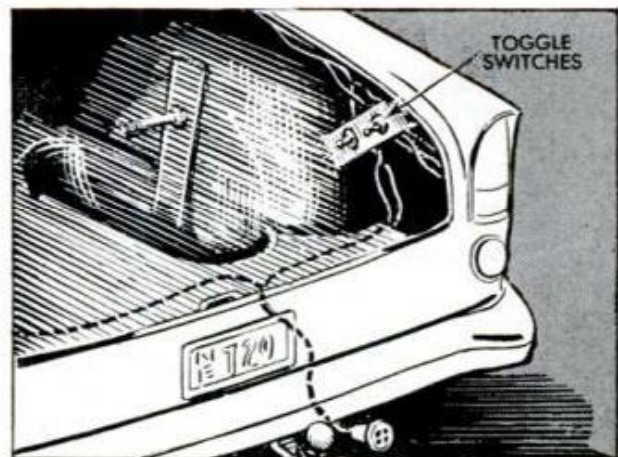
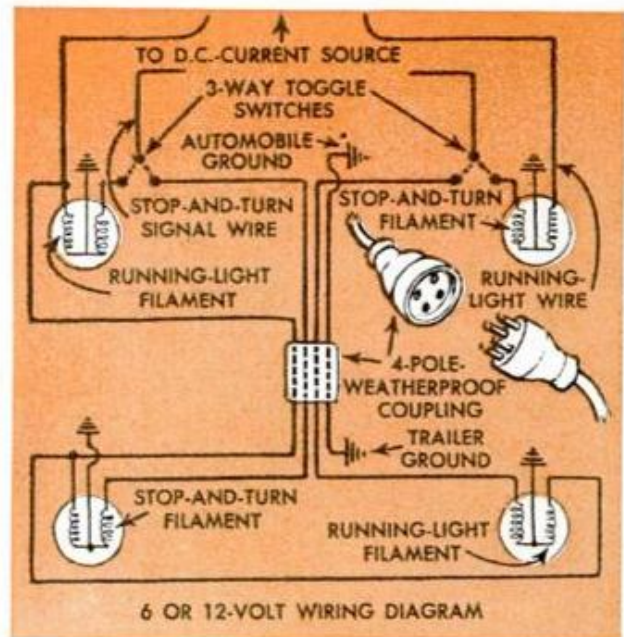



BUILDING THE **PM** HOUSEBOAT

Part IV

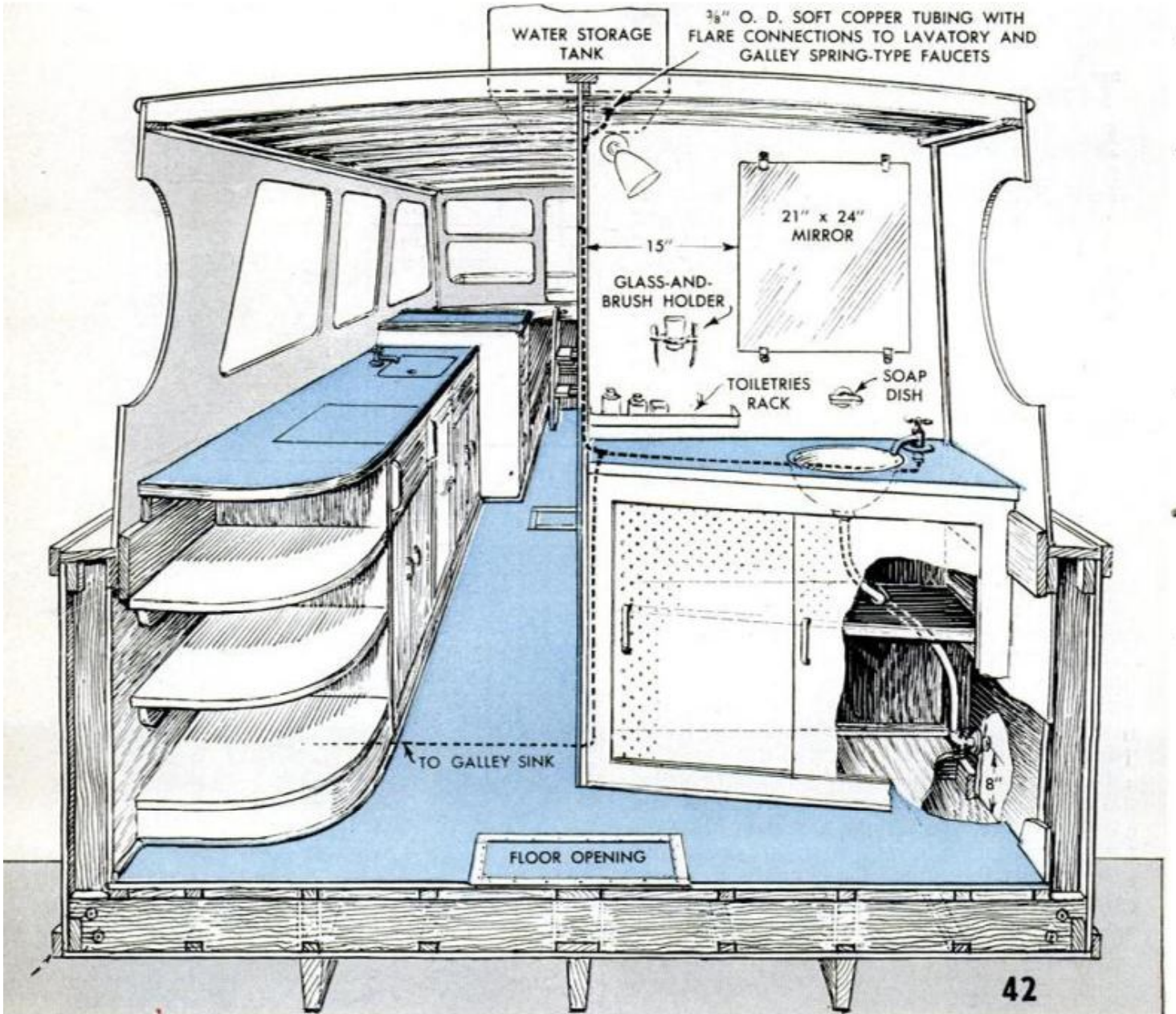

I NSTALLATION of the enclosed head and the hanging (clothes) locker, Figs. 42 and 47, completes the cabinet work on the starboard side of the cabin. In referring back to Part III, you will see that the enclosed head is located next in line to the dining nook. Resume work by erecting the forward wall, or bulkhead, of the enclosed head. This is a $\frac{1}{4}$ -in.-plywood panel which extends from the floor to ceiling. It is fastened at the ceiling to the aft face of the roof beam directly above and also to the aft face of hull frame 6. This should bring it against the seat framing of the nook to which it also is fastened. A cleat provides a nailing surface for the bulkhead at the floor line. As for width, the bulkhead should measure $\frac{1}{4}$ in. less than the overall length of the dining seat. In studying Fig. 43, you will note that a grooved vertical member placed at the outer edge of the bulkhead not only provides a nailing corner for a 9-in. facing panel but conceals the copper tubing from the overhead water tank. A gap in this member at a point below the vanity top permits the tubing to be connected to the lavatory faucet by means of a T-fitting. As shown in Fig. 42, the water pipe continues down below the floor and eventually is connected to the galley faucet. Fig. 43 details the built-in vanity which is installed next. This is wedge shaped, being 9 in. wide at one end and 20 in. at the other, and contains a lavatory basin plus storage shelves. Start out by making the front framework first from 3-in.-wide material, 1 in. thick. Grooves in the pieces form tracks for two bypassing doors of perforated hardboard. In cutting the grooves, make those in the upper member twice as deep as those in the bottom member so you will be able later to insert the doors. The vanity top is supported at the rear by a cleat attached to the bulkhead. After the circular opening is cut in the top for the lavatory basin, the surface and the edge are covered with colorful plastic laminate. Notice that the front framework has to be notched to fit over the coaming member, and that a quarter-round molding is used to hide the joint where the bulkhead meets the cabin wall.

With the vanity installed, you can tackle the cabinet that houses the water closet. This is detailed in Figs. 44 and 45. It is designed to also serve as a seat, the top being fitted with double cushions which are stood on end to make the hinged cover accessible. Like the dining nook, the water-closet cabinet consists of an inner framework of 1 x 2s covered with $\frac{1}{4}$ -in. plywood. Before this cabinet can be built in place, a watertight bulkhead must be fitted across the cabin at frame 8. As you will see in studying Fig. 48, this is a $\frac{3}{8}$ -in. panel which is fas-

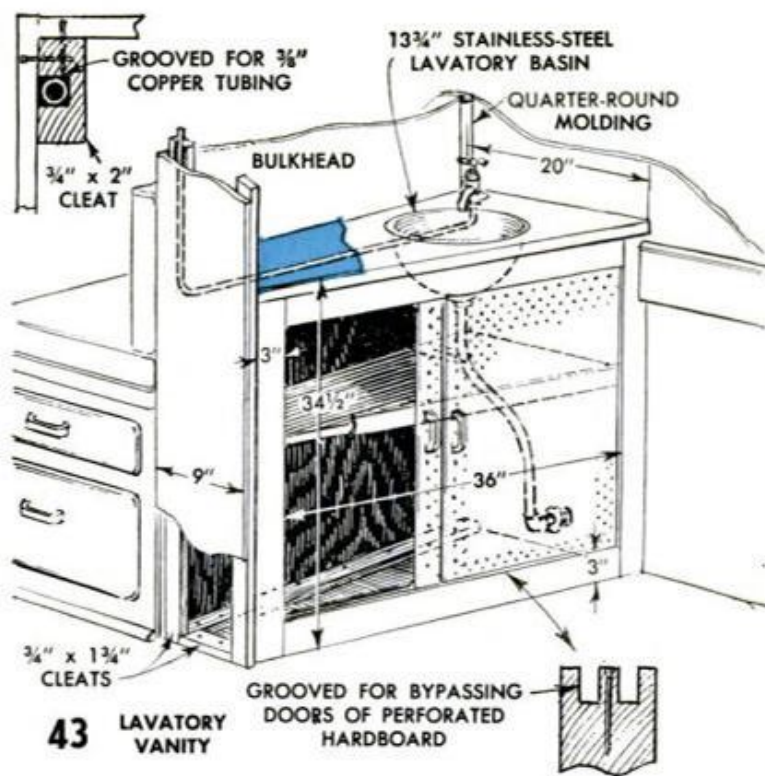

43

LAVATORY VANITY

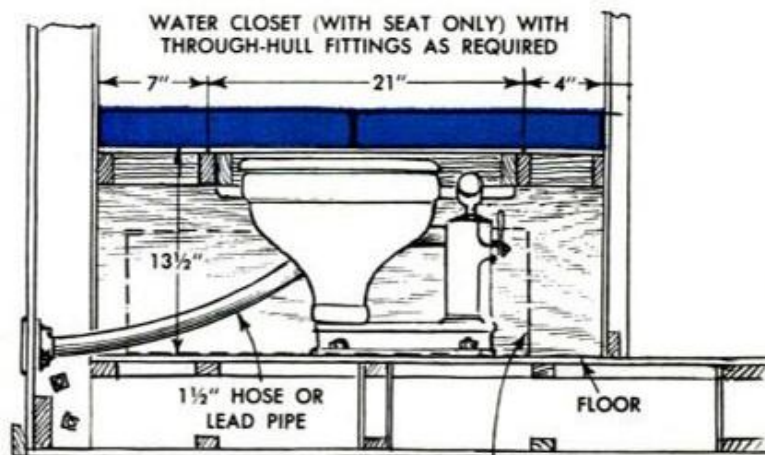

44

DOTTED LINE REPRESENTS CHLORINATOR (OPTIONAL) FOR USE ON RESTRICTED WATERS

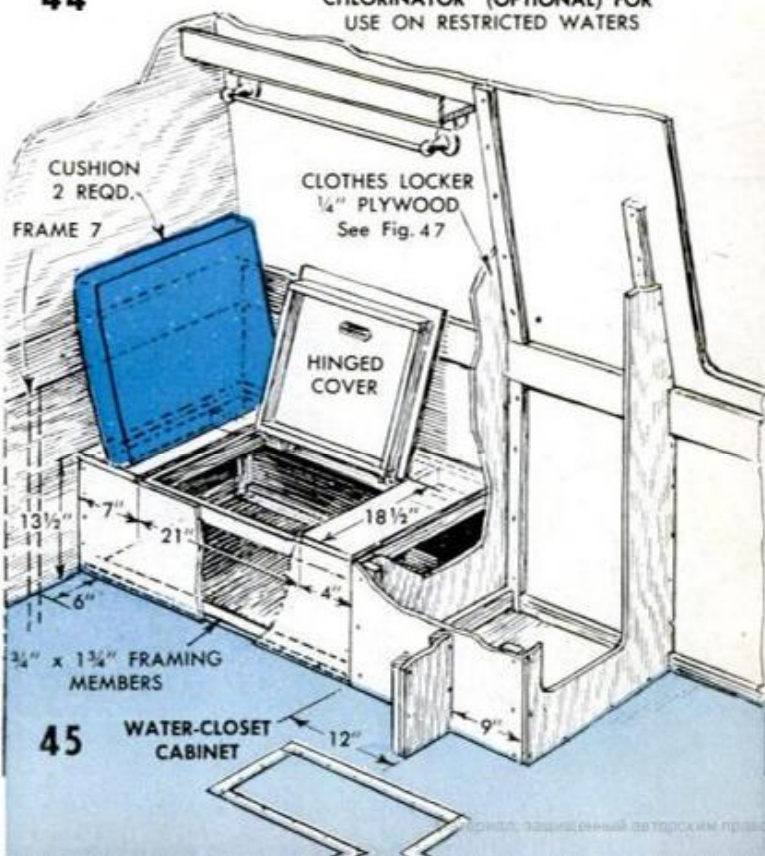

45

WATER-CLOSET CABINET

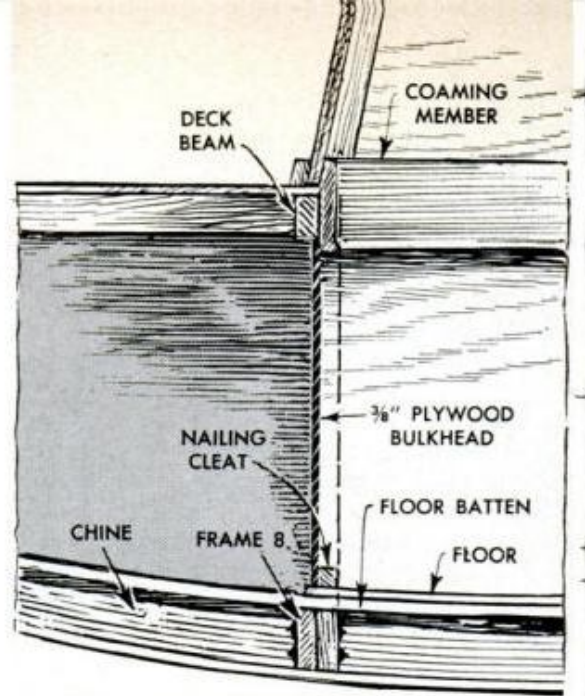
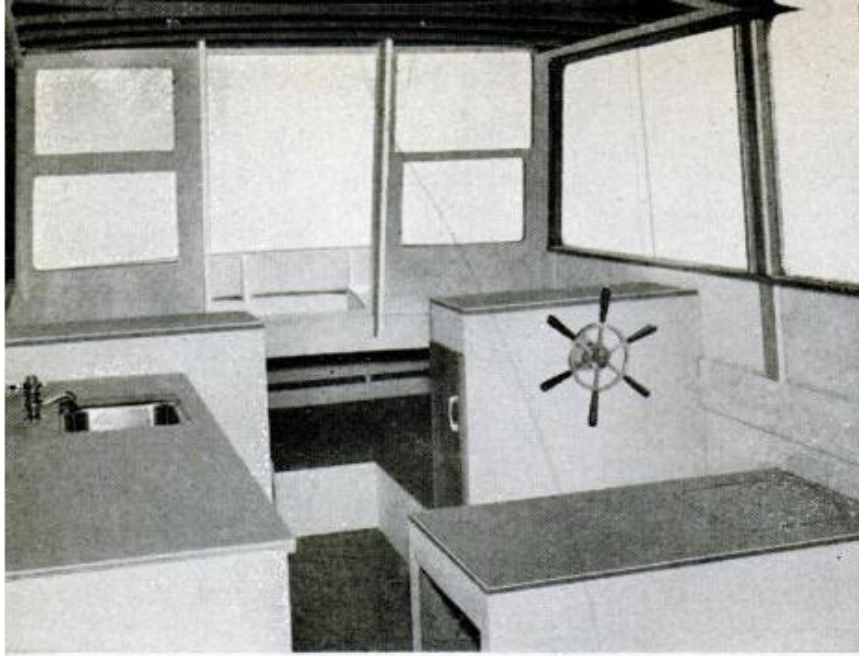

48 HOW BULKHEAD SEALS OFF AFT HATCH

tened to the aft faces of the frame side members, to the aft face of the coaming member and to a cleat screwed and glued to the floor and into the top edge of the bottom frame member.

Set this panel in bedding compound and fasten it in place from the hatch side. Overall length of the water-closet cabinet is 32 in. and is located 6 in. aft of frame 7. Overall width of the hinged cover is 21 in. and the cross members in the top of the cabinet are spaced accordingly to support the overhanging lip. As shown in Fig. 44, the cross members are located 7 in. and 4 in. respectively from the ends. The 13½-in. height of the cabinet will accommodate a standard marine water closet. The through-the-wall fitting for the drain hose is located at a point just below the water line. To make the hose connection, it will be necessary to remove a section of the side wall inside the cabinet. There's space within the cabinet for a chlorinator which is a requirement if you navigate restricted waters.

The hanging locker is detailed in Fig. 47. This also is made of ¼-in. plywood, and like the others, is backed up at the corners and edges with 1 x 2 members to which the plywood is nailed. It measures 21 x 23 in. and extends from floor to ceiling. An alcove is formed in the upper part and faced with a ¾ x 3-in. projecting trim piece to keep the contents in place. The locker is left without a door and a horizontal clothes rod is installed inside for coat hangers. The back of the locker, incidentally, serves to support the end cleat of the water-closet cabinet. Details concerning the door and door opening of the enclosed head are found in Figs. 43, 45 and 47. Cleats, as before, are used to support the ¼-in. plywood wall, these being fastened to the underside of the roof batten, as well

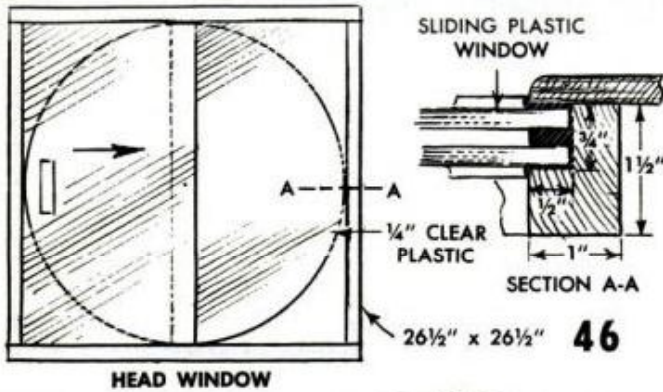

HEAD WINDOW

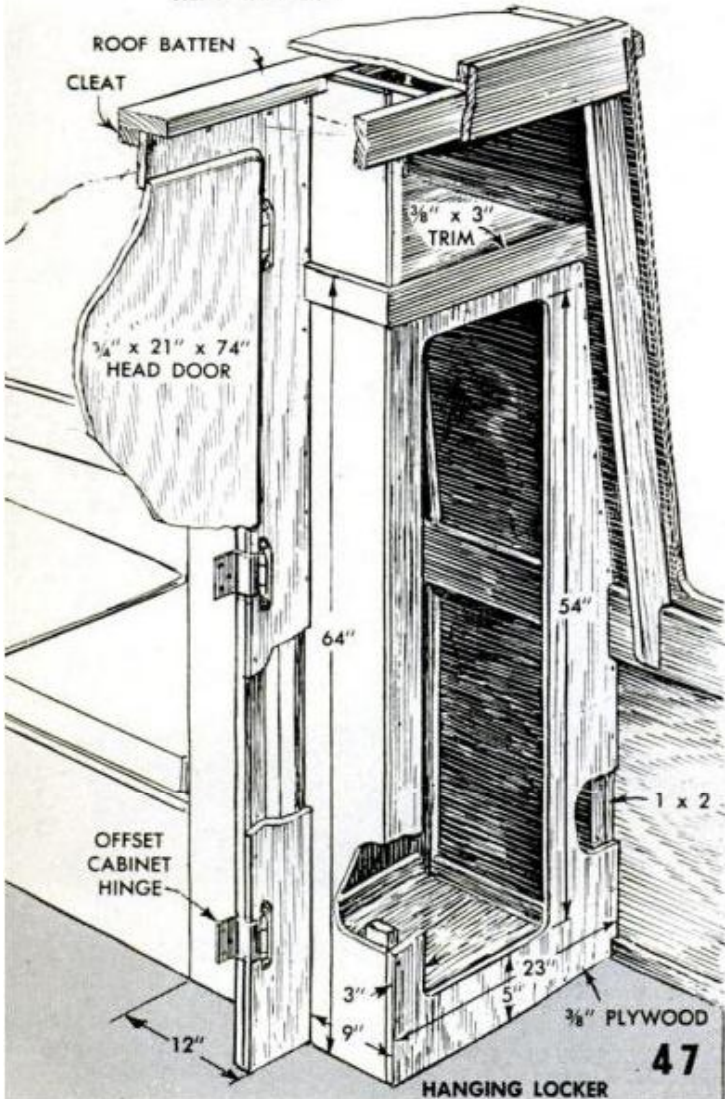

HANGING LOCKER

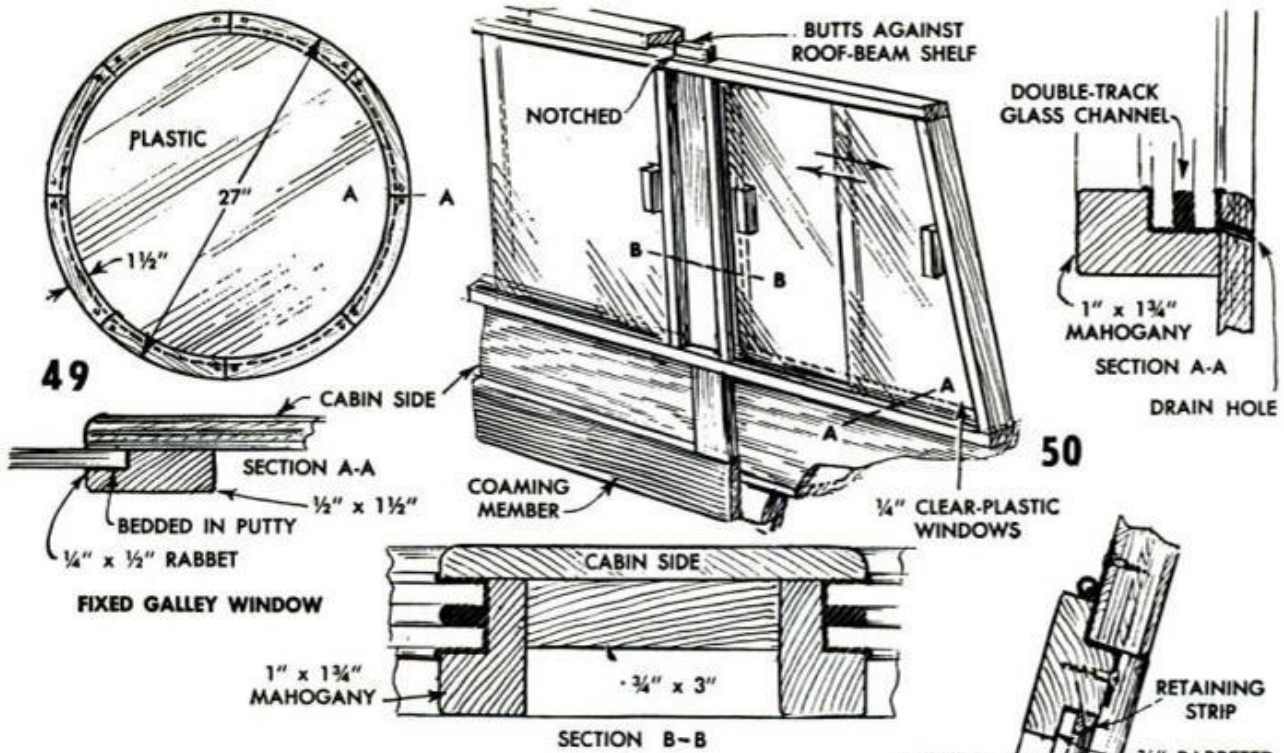

as to the hanging locker, the vanity and the floor. The door is $\frac{3}{4}$ in. thick and has a lip all around to lap the opening. Three offset cabinet hinges are used to hang it, after which a rim-type latch is added to lock it.

Completion of the head and the hanging locker completes the cabinets on the starboard side. Since the galley will interfere with the framing of the windows if done later, the latter should be installed next. The two circular windows differ in that the one on the port side is fixed, whereas the one in the enclosed head is made movable. You have a choice of using either glass or

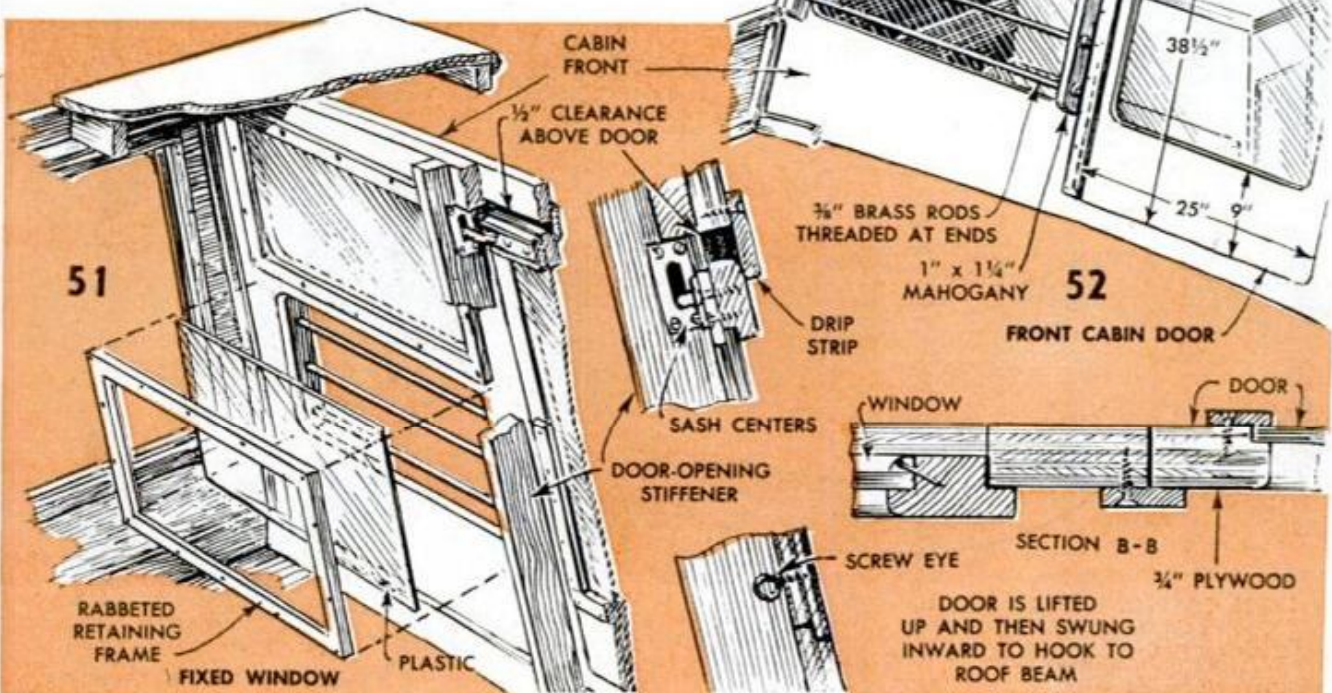
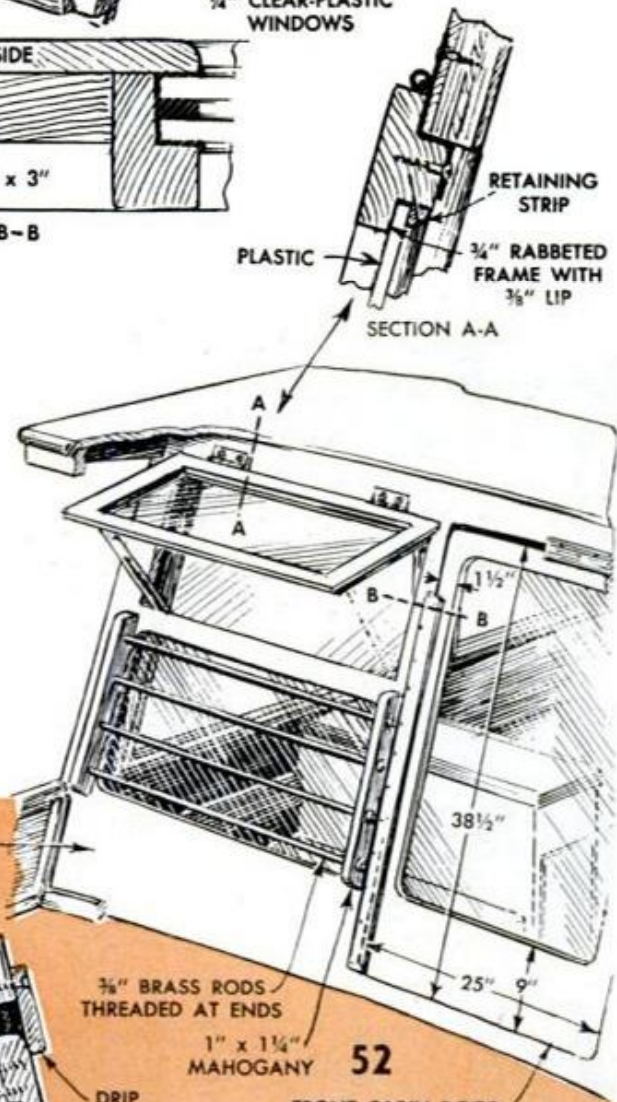

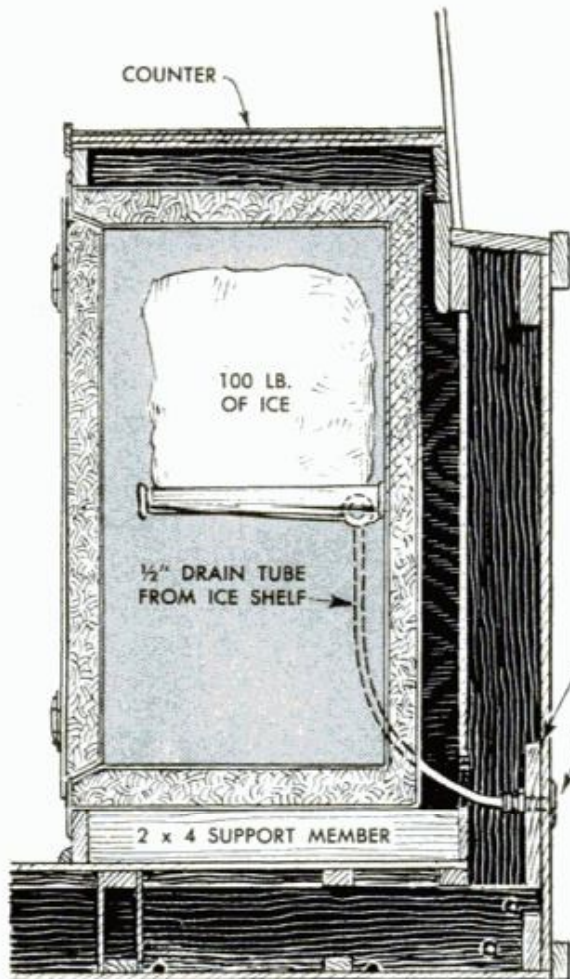

53 SECTION THROUGH ICE BOX

clear plastic for the windows. Plastic has one big advantage over glass in that it can be sawed to fit the openings. For this reason, plastic was used in the PM houseboat. Fig. 49 details the fixed, circular galley window. This is a 25-in. disk of plastic which is centered over the opening, on the inside, and held with a mahogany frame. The plastic is bedded in putty to make it watertight, and the circular frame is in six sections, each rabbeted to fit over the edge of the plastic as in section A-A. Short screws are used to hold it in place. In the case of the sliding head window, the plastic is cut to fit standard double-track metal channels. Fig. 46 shows how the channels are held in rabbeted members assembled in a square frame and then centered over the circular opening in the cabin wall.

The same double-track channel is used in

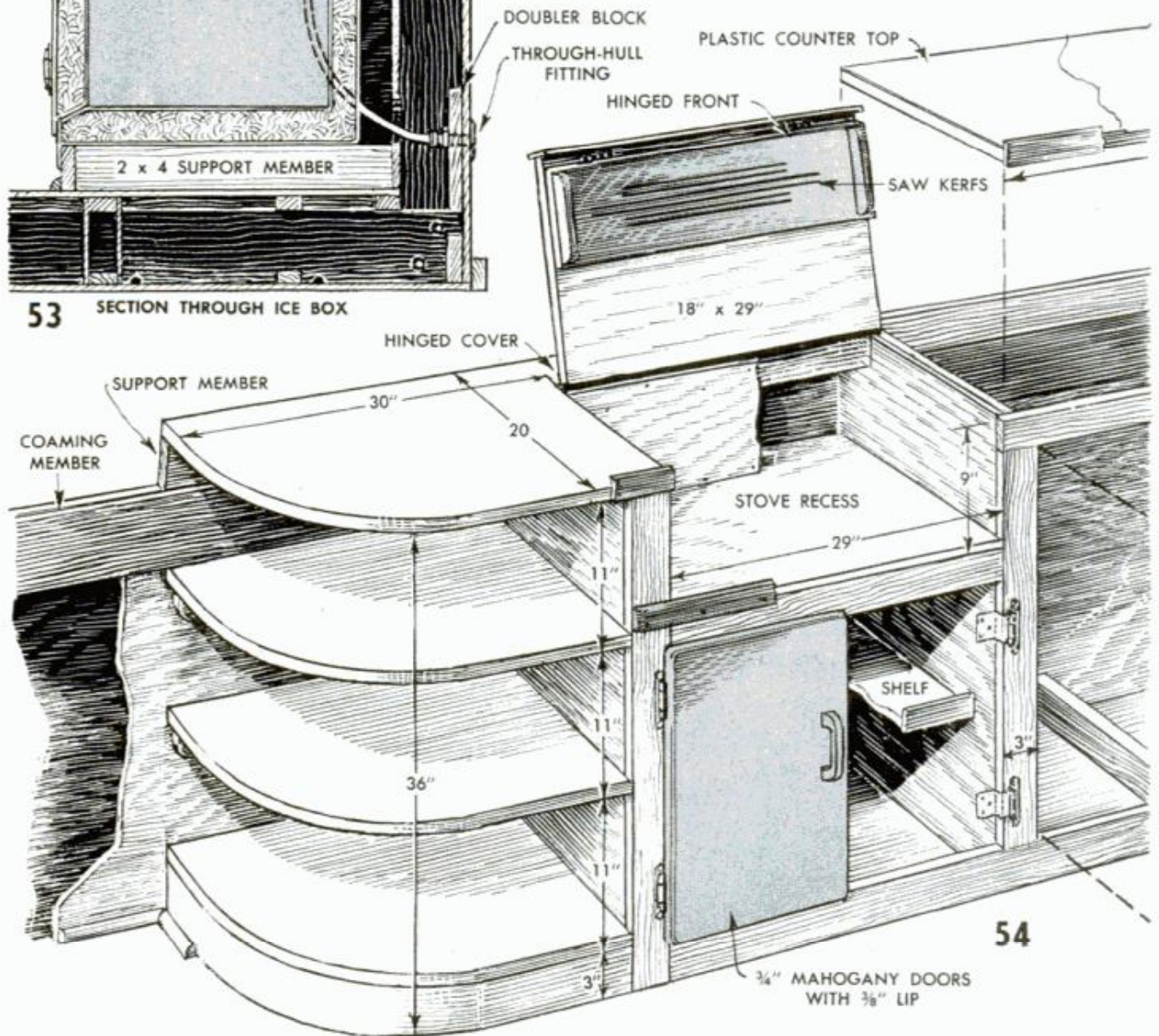

FLOOR COVERED WITH LINOLEUM OR VINYL TILE

HOUSEBOAT BLUEPRINTS

If you prefer to work from plans larger than magazine-size, blueprints can be purchased at \$10.00 per set of eight sheets by writing to Popular Mechanics, Blueprint Dept., 200 East Ontario St., Chicago 11, Ill.

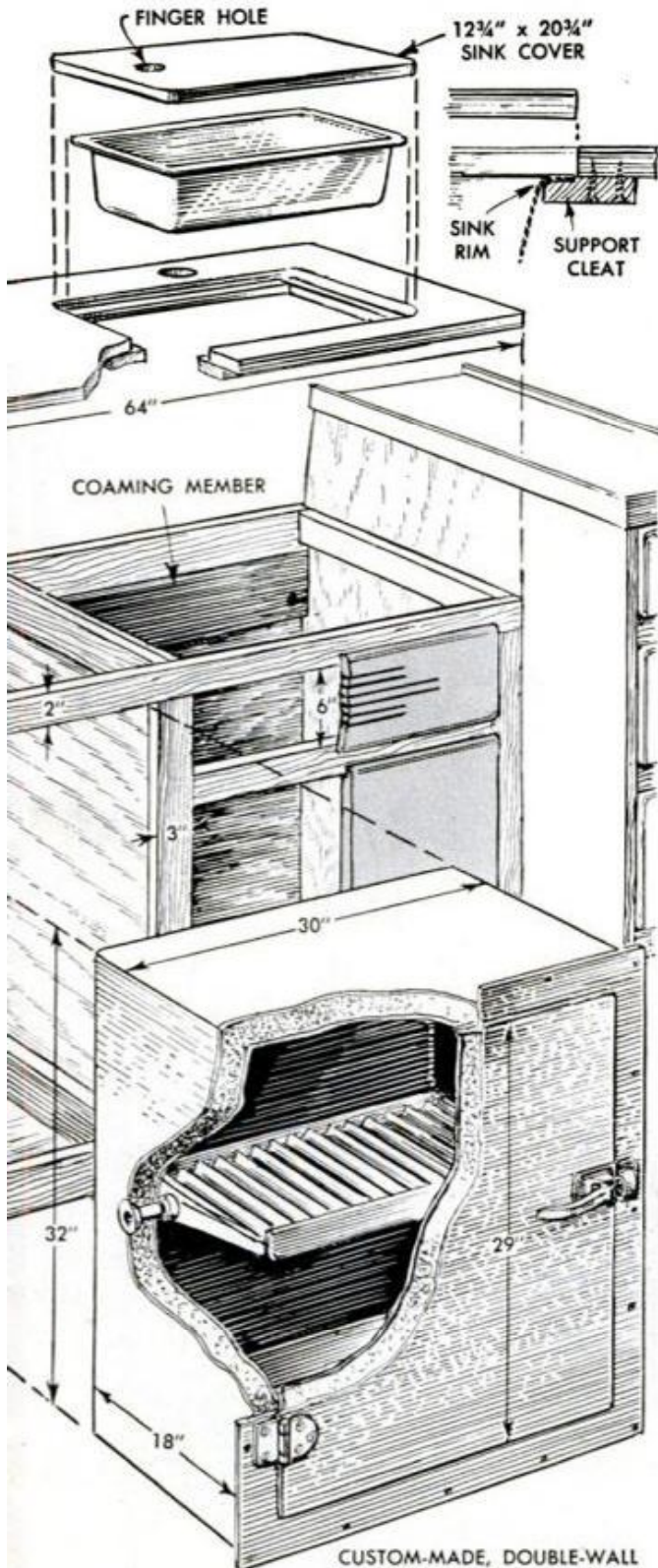

CUSTOM-MADE, DOUBLE-WALL ICE BOX FORMED FROM 20-GA. GALVANIZED SHEET METAL AND INSULATED WITH GLASS FIBER



Two-piece hinged cover conceals stove housed in recess in galley counter. Front of cover is mahogany

all the other sliding windows. Sections A-A and B-B, Fig. 50, show how it, too, is held in rabbeted mahogany members and assembled in a single unit to suit the window openings. In studying section B-B, you will see that $\frac{3}{4}$ x 3-in. vertical posts are first added to stiffen the plywood at points between the window openings. These members rest on the coaming members and butt against the underside of the roof-beam shelves. The frame assembly is notched to fit over the posts, after which it can be fastened in place with glue and screws driven in from the outside. Both starboard and port window-frame units are made alike. Handles of plastic or metal are attached to the plastic and a felt strip is cemented to one bypassing pane to fill the gap between. All the windows in the front wall of the cabin are fixed except the windshield. This is hinged to swing outward and thus give the helmsman a better view forward from a standing position when docking. The frame for the windshield is a double-rabbeted affair (see section A-A) which is designed to lap the opening like a lip door. A standard adjustable windshield bracket holds it open. The three other front windows are installed in the same manner as the circular galley window, the plastic being held with rabbeted retaining frames as shown in Fig. 51. Sectional details accompanying Fig. 52 show how the forward door is hinged at the top with special hardware called sash centers. Slotted plates, plus a $\frac{1}{2}$ -in. clearance above the top of the door, permit the latter to be lifted up to clear the bottom rabbet before swinging it inward and overhead. A hook attached to a roof beam engages a screw eye in the

(Continued on page 246)



Light Warns Drill Operator When Bit Contacts Buried Pipe

When drilling through a concrete floor, one excavating contractor uses the warning device shown above to avoid damaging buried electrical conduit or pipe, the layout of which is unknown. When the bit makes contact with the pipe, the circuit containing the flashlight battery and bulb is completed, lighting the bulb as indicated.

H. Muller, Danboro, Pa.

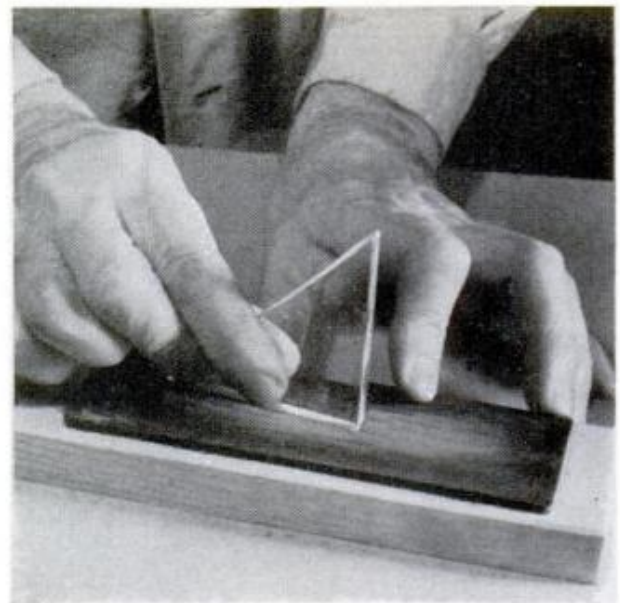

Edges on Transparent Plastic Polished on Leather "Stone"

Cut edges on small pieces of transparent plastic can be polished to a clear finish on a "grinding stone" consisting of a piece of shoe leather cemented to a wooden block as shown above. Jeweler's rouge is used as an abrasive, which is worked into the leather with a putty knife before use and as often as necessary during a job.

Walter E. Burton, Akron, Ohio

Merry-Go-Round Improvised From Wagon Wheel and Axle

Children on one Midwest farm get hours of fun out of this improvised merry-go-round, which is a wooden-spoked wheel from an old high wagon. Painted in bright colors, the wheel is mounted on the original axle after the latter is placed in a hole dug to a depth to give the desired height from wheel to ground.

C. F. Marley, Nokomis, Ill.

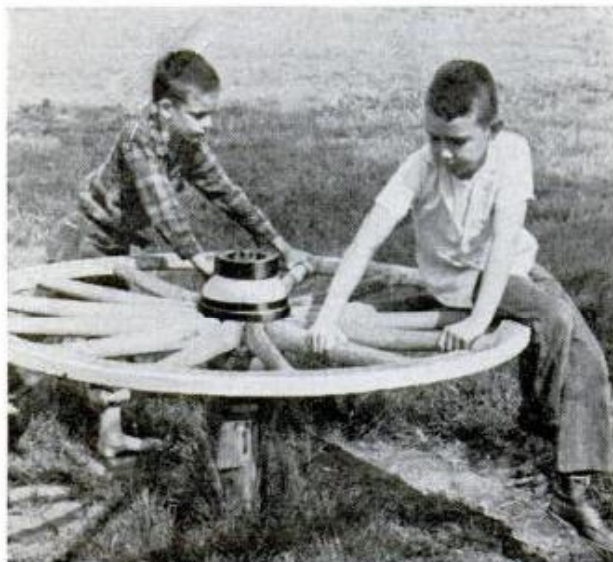

Broken Panel in Garage Door Replaced the Easy Way

Here is an easy way of repairing a damaged panel in an overhead garage door. First trim off the edges around the panel on the inside of the door flush with the bottom of the grooves in which it is set. Then remove the damaged panel, cut a new one from 1/8-in. plywood, and set it in a bedding of calking compound. Fasten the panel in place with quarter round.

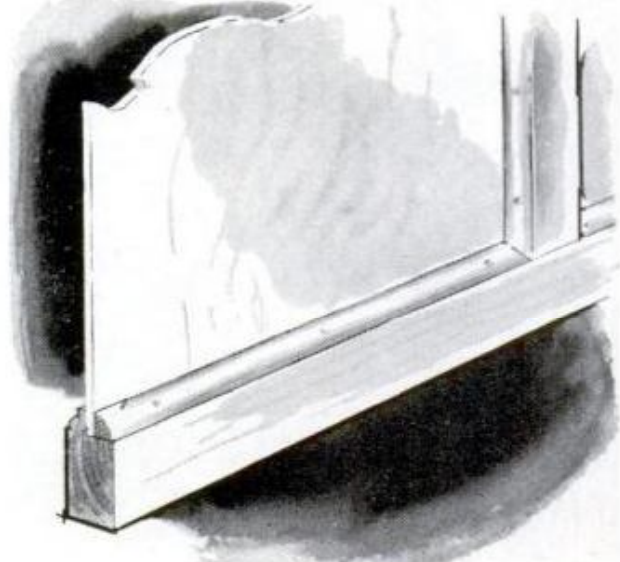

GARDEN GATE GIVES PRIVACY

By Hi Sibley

"CHARMING" is the word that best describes this white-painted garden gate and lattice fence which separate the lawn from garden area of a Western home. Parts for the gate, gateway and fence are cut and assembled as shown in the drawing and details. Dowels may be substituted for spindles on the gateway, if a lathe to turn them is not available. Full-size patterns of arch segments and gate top should be made to ease the job of cutting them.

Horizontal members between post and arch ends consist of a beveled top piece glued and nailed to a straight-edged bottom piece as shown. Both are cut from 1-in. stock. A thumb latch and hinges are installed so that the gate swings inward.

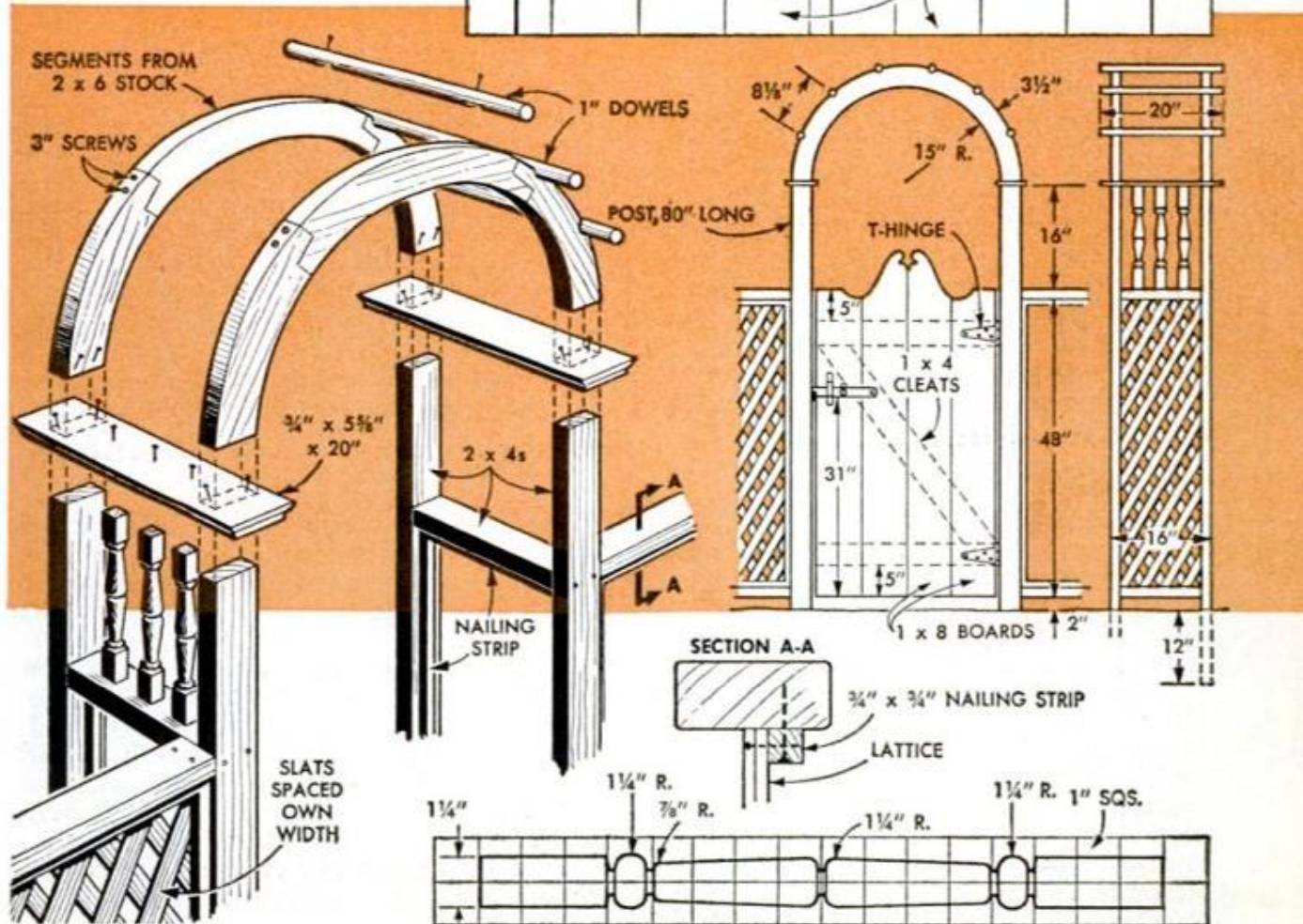
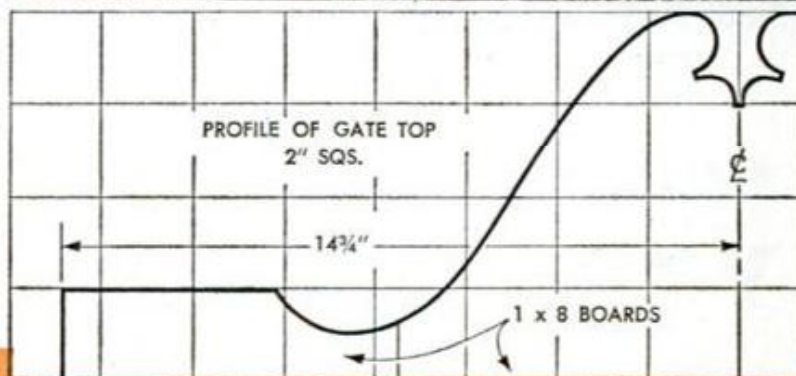
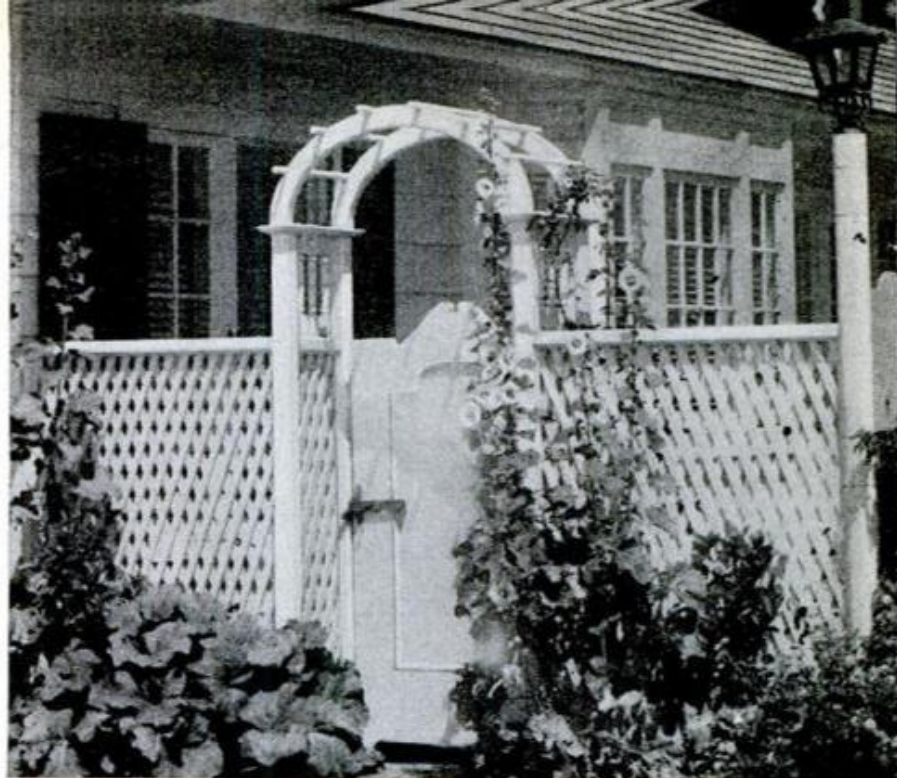

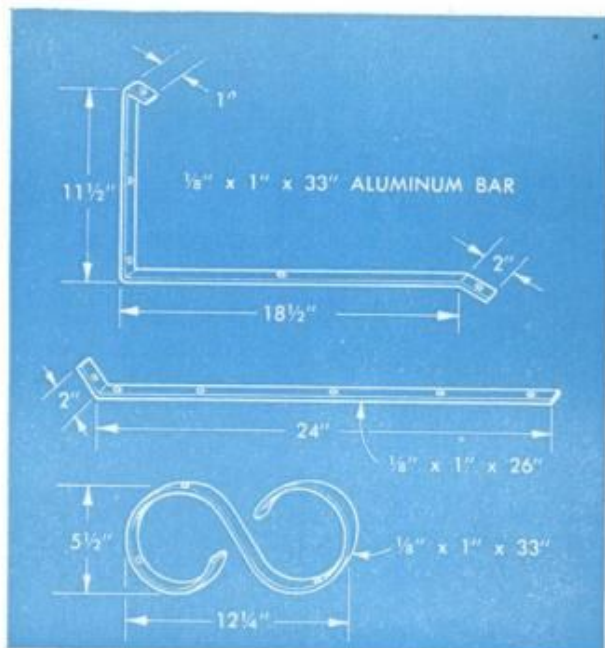

Since there will be other things to do outside when another month rolls around, you'll be wise to

START NOW TO MAKE YOUR OWN GLASS-FIBER

By James A. Lockhart

AN EVENING or two and only a few common tools are all it takes to convert a panel of colorful glass fiber into a handsome and durable window awning. What's more, you can hang it and forget it. It requires no painting and will withstand the weather indefinitely. Being translucent, the glass fiber keeps the hot sun out yet lets the light in, and, of course, the material is extremely lightweight.

The decorative end brackets are made of flat, bar-stock aluminum which you will

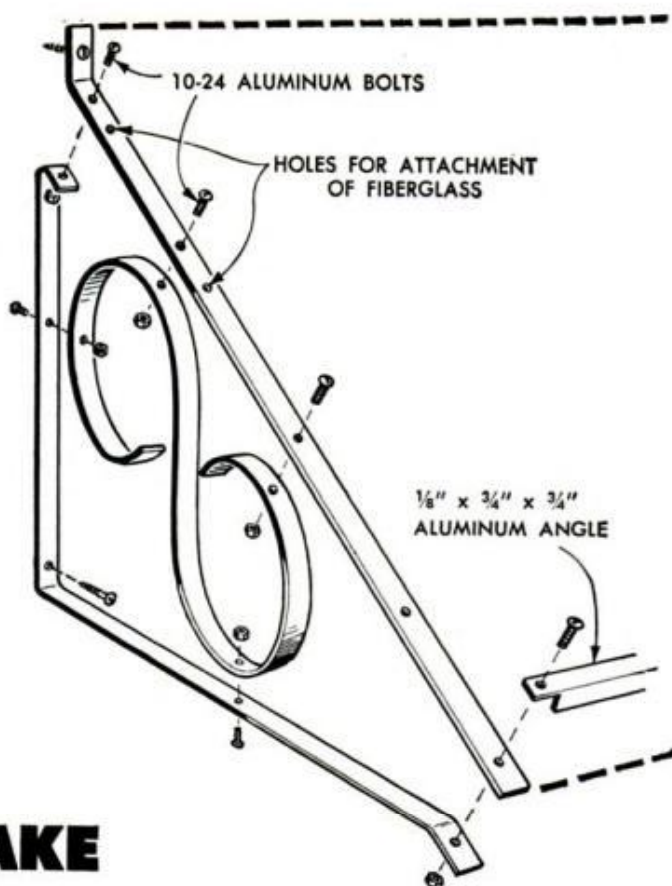

find in hardware stores and in some lumber yards, usually in 6-ft. lengths. Each bracket consists of three parts and each pair of brackets is joined across the front with a length of 3/4-in. aluminum angle. The length of the latter will vary from window to window but the size of the bracket will suit practically any window of average size.

Forming the parts is easy, the straight bends are made in a vise, whereas the scrolls are duplicated by using a 1-lb. coffee can as a bending form. Both the can and

WORKING WITH TRANSLUCENT PLASTIC

Although glass-fiber panels contain some 25 percent glass, the material can be cut easily with an ordinary handsaw. However, when an electric power saw is used, it is recommended that the saw be equipped with an abrasive cutoff wheel or with a metal-cutting blade having teeth but no set. Whereas corrugated panels must be sawed, flat-type panels can be cut with ordinary tin shears. A grease pencil is ideal for marking the plastic for cutting. In many cases, the project can be planned so that no cutting is required at all. An awning, for example, can be designed to make use of a full standard-length panel.

While a nail can be driven through the material, it is best to drill a pilot hole. When screws are used to fasten the panels, the holes should be made slightly smaller than the screws to prevent surface cracking when the screws are driven home. In all cases, it is recommended to back up the hole with a wooden block. Also, regardless of the type of fastener used, it should be rustproof, such as aluminum, galvanized or cadmium plated, to avoid the formation of rust stains on the plastic. Where important, the fastener also should have a soft-rubber washer around its head to assure a watertight seal.

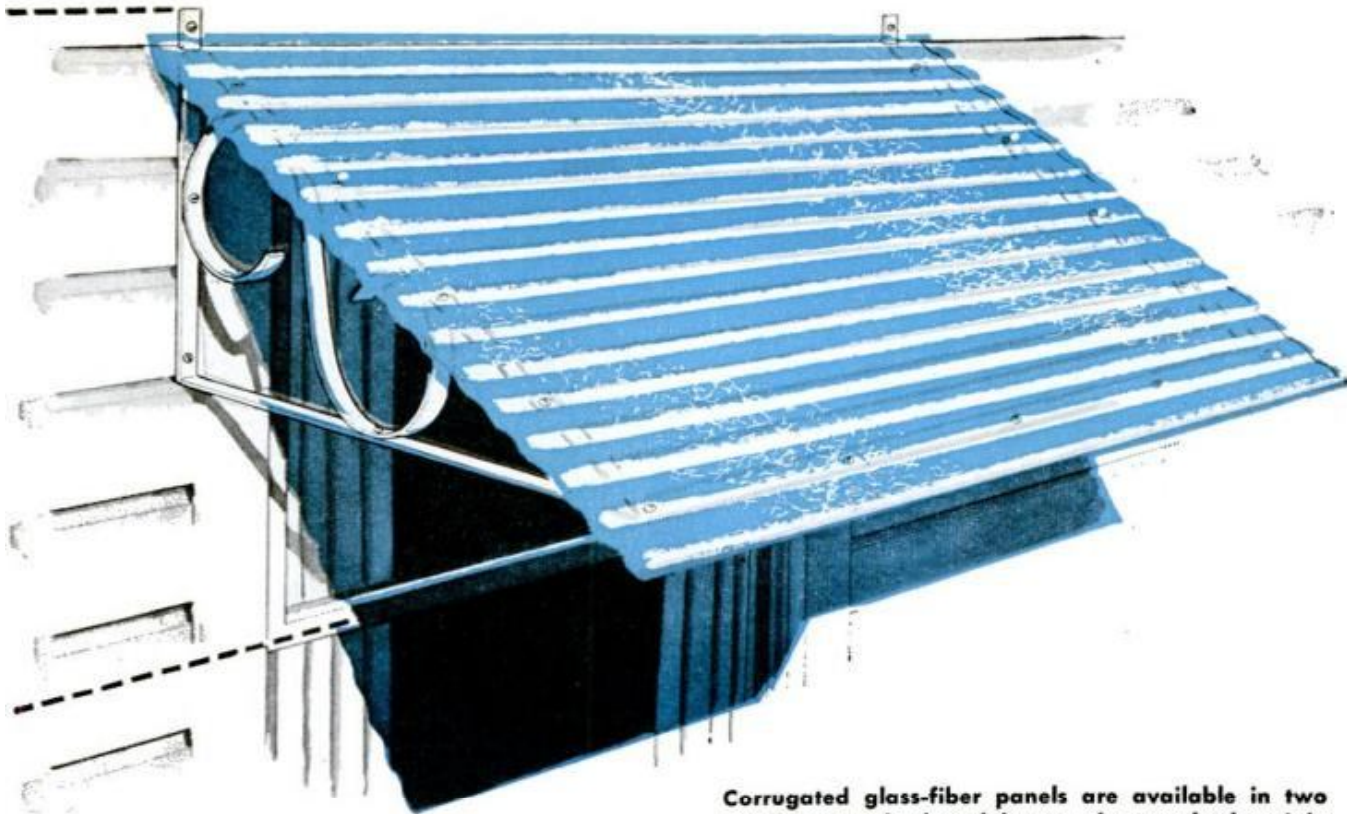

Corrugated glass-fiber panels are available in two weights, standard and heavy, the standard weight being ideal for awnings. Panels measure 26 x 96 in. and have 2½-in. corrugations. They are resistant to humidity, salt-water air and temperature changes

AWNINGS

the aluminum are clamped together between the jaws of a machinist's vise, the can being held by its rim. Being fairly soft, the aluminum is easily wrapped around the rim of the can as shown in the photo below. The trick is to keep moving the aluminum strip in the vise as the bending progresses. Wrapped in one direction, the work is then turned over to form the second loop. The completed scroll should measure about 12 in. long. The lengths of the two other parts of the bracket are given in the drawing at the left. In assembling the brackets, be sure to use aluminum bolts to avoid an electrolytic action resulting when steel and aluminum are combined. Since holes must be drilled in the brackets for mounting them, as well as for attaching the glass-fiber panel, it will be advantageous to drill them beforehand. Although aluminum will stay bright and shiny for a while, it will corrode and become dull in time. In view of this, it would be best to paint the brackets and to do so before attaching the glass-fiber covering.

The length of the latter is dependent upon the width of the window. An awning for the average single window should measure about 60 in. which will allow for a 5-in. overhang at the sides and front. The ¾-in. aluminum angle supporting the glass fiber

along the front edge of the awning is notched at the ends for attaching to the brackets. Here, as you will notice, a single bolt holds all three members together. If corrugated glass fiber is used, the holes for the bolts should be made in the areas between the ridges at least along the ends where the panel is bolted to the brackets. The brackets can be screwed to the house, using, as before, aluminum screws instead of steel. ★ ★ ★

Scroll part of bracket being bent around coffee-can form. Both can and work are clamped in vise



TV SNACK-TRAY SET

By John Jefchak



Made entirely of wood, TV snack-tray set is useful and attractive addition to living-room furnishings

Feet on bottom of tray hold tray in place on TV table and provide finger clearance when on flat surfaces

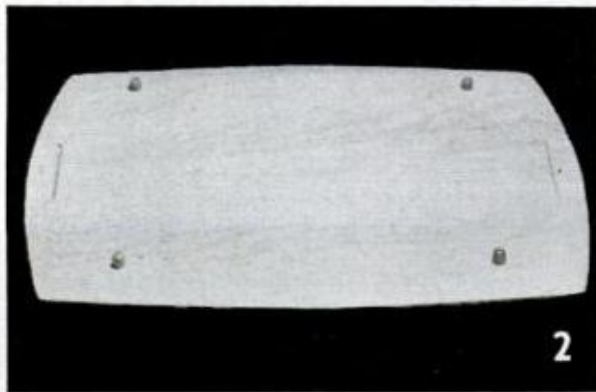

HERE is a TV snack-tray set that will please the most discerning of modern hostesses. It was designed and built by PM editors expressly for readers who prefer the "solid feel" and durable beauty of all-wood furniture. Trays are a big 17 x 22-in. lunch size, each of which has four short feet that bear against the top rails of the table, holding it in place, Figs. 1, 2 and 3. These feet also provide finger clearance, making it easy to pick up trays from a flat surface. Peg stops on the inside legs of the table, Figs. 5 and 6, bear against the outward edge of the outside legs when the table is set up to receive the tray, eliminating the need for

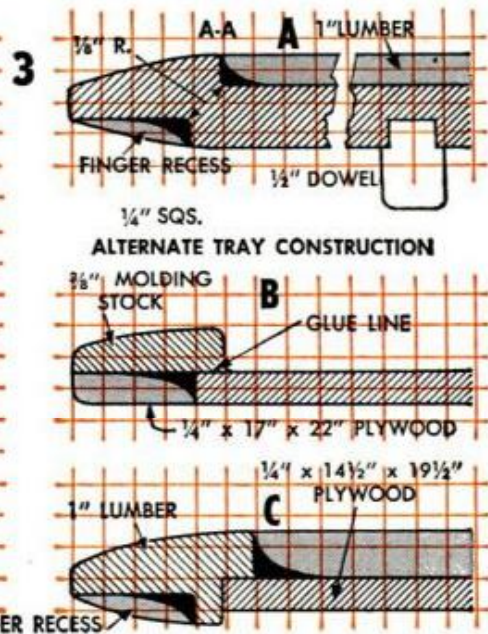
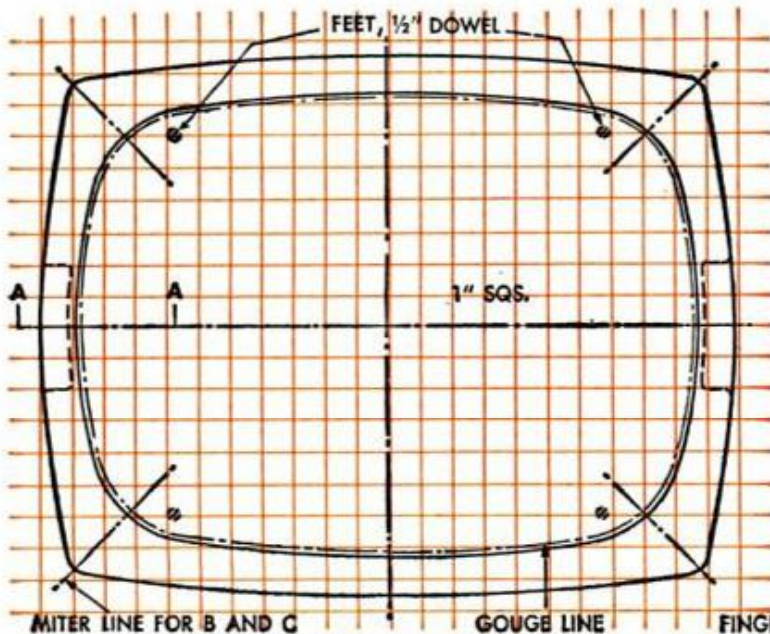

OF DURABLE BEAUTY

friction catches to hold it in place as is the case with most metal sets. This important feature permits a loaded tray to be removed from a table without having to grasp the latter with one hand while separating them.

Construction details of this snack-tray set have been kept simple so that almost anyone should be able to build it with little difficulty, even those whose only experience with tools is limited to the use of a borrowed hammer or saw. Power tools are not an absolute necessity. They simply make the work easier and faster. The type of wood used for the project depends upon individual preference. Softwoods (pine, redwood, cypress, etc.) are economical and easy to work but they lack the strength and beauty of hardwoods, such as walnut, mahogany and oak. At this point you should decide on the type of finish to be applied to the completed set, since it may affect the selection of wood. While paint will cover walnut and pine equally as well, you can't expect to make pine look like beautifully-grained walnut simply by applying a finish of stain and varnish.

Begin the project with construction of the trays, then make the folding tables, followed by the storage rack. With this sequence, if an error in construction is made, it can be noted easily and corrected without much difficulty or without affecting the finished product. Plastic-resin glue is the only fastening used for all joints, except the two-piece legs which are fastened with glue and dowels.

The tray was formed from two pieces of 1 x 10 x



When table is folded, tray nests between upper halves of legs for compact storage

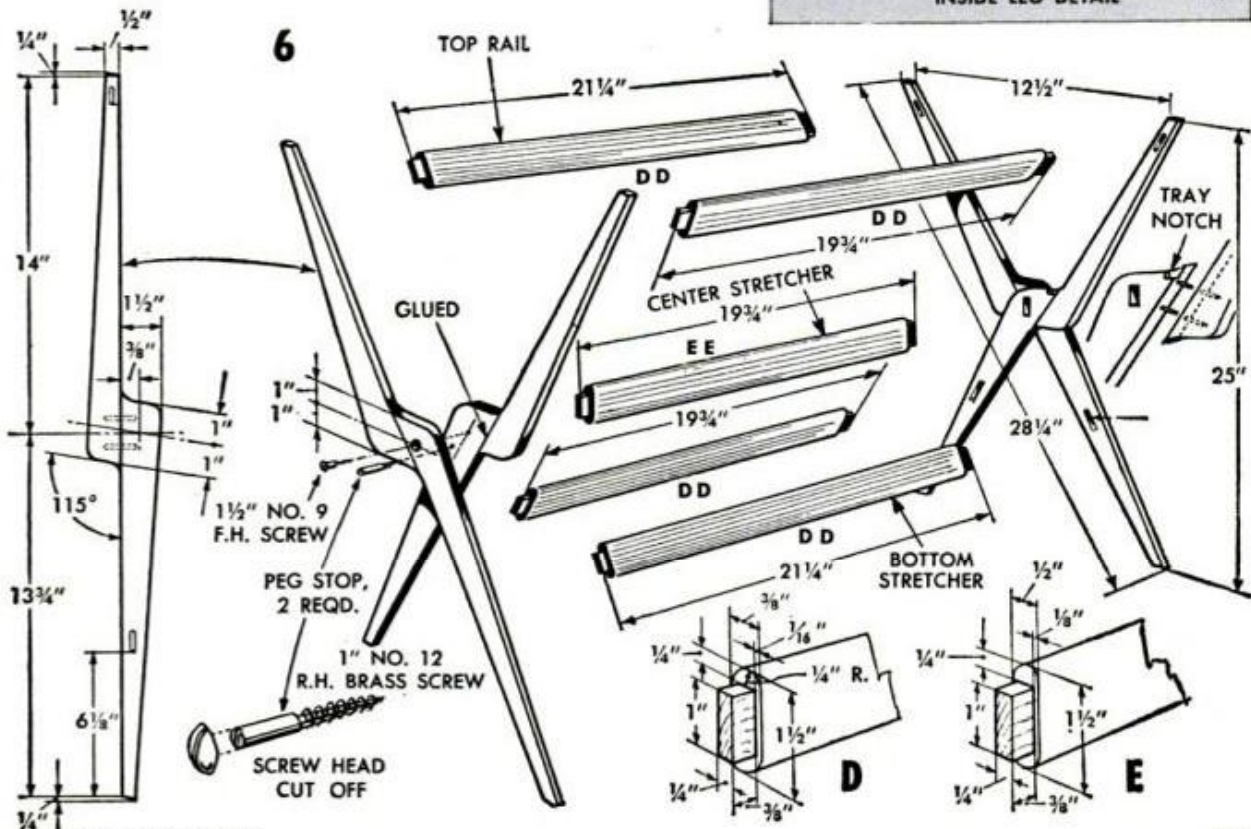
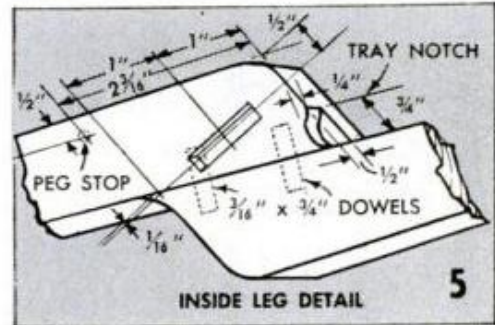

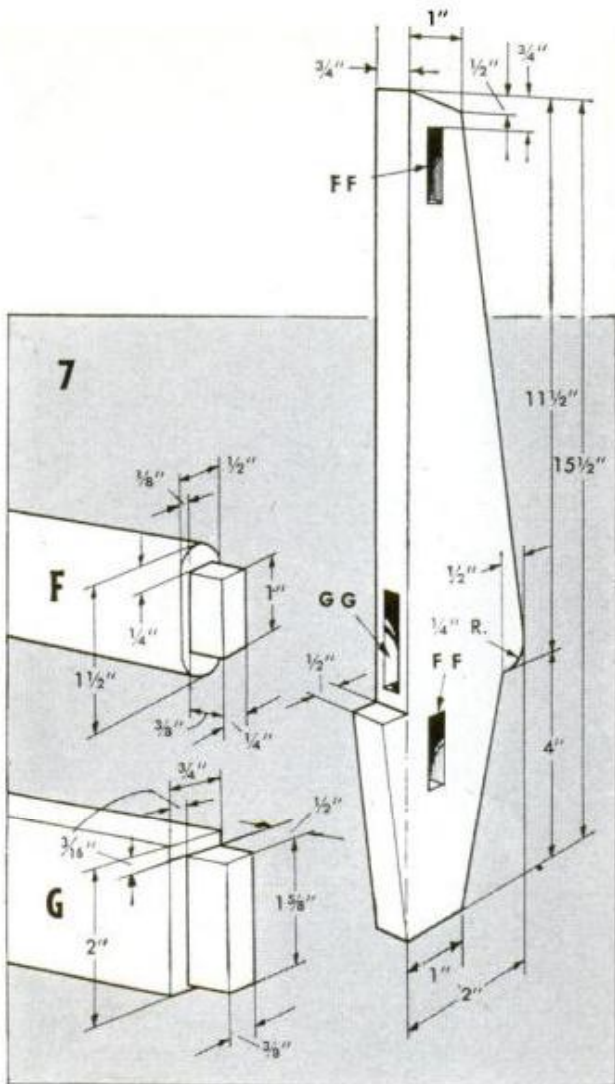

24-in. lumber edge-glued together. Finger recesses and the recess in the tray top were routed out with a router bit chucked in a drill press. This also may be done with a portable router, or by hand with a gouge. In either case, waste is removed only to the gouge line indicated in Fig. 3. Then the inside edges are rounded to a 1/8-in. radius and, at the same time, the upper edge of the recess is worked to the finished dimensions as shown.

Details B and C show easy ways of making a tray when router tools are not available. In each case, plywood is used for the tray bottom. The tray recess is formed by a raised border consisting of mitered end and side pieces of solid stock glued to the bottom as indicated. Note the location of miter lines for this purpose in the top view of the tray. Rubber-headed tacks are substituted for the feet in this case.

Next the leg assemblies are made. Each leg is glued up from two pieces of 3/4 x 1 1/4 x 16-in. stock, with two dowels fitted in each joint as shown in Figs. 5 and 6. The dowels strengthen the leg at the axis and save on material. Single-piece construction is permissible if hardwood is used. Note that facing edges of leg halves form a straight line, making it necessary to taper only one edge lengthwise. Locations for the tray notch (in which the tray edge rests when stored as in Fig. 4), peg stop, mortise for center-stretcher tenon and placement of reinforcement dowels of leg joints

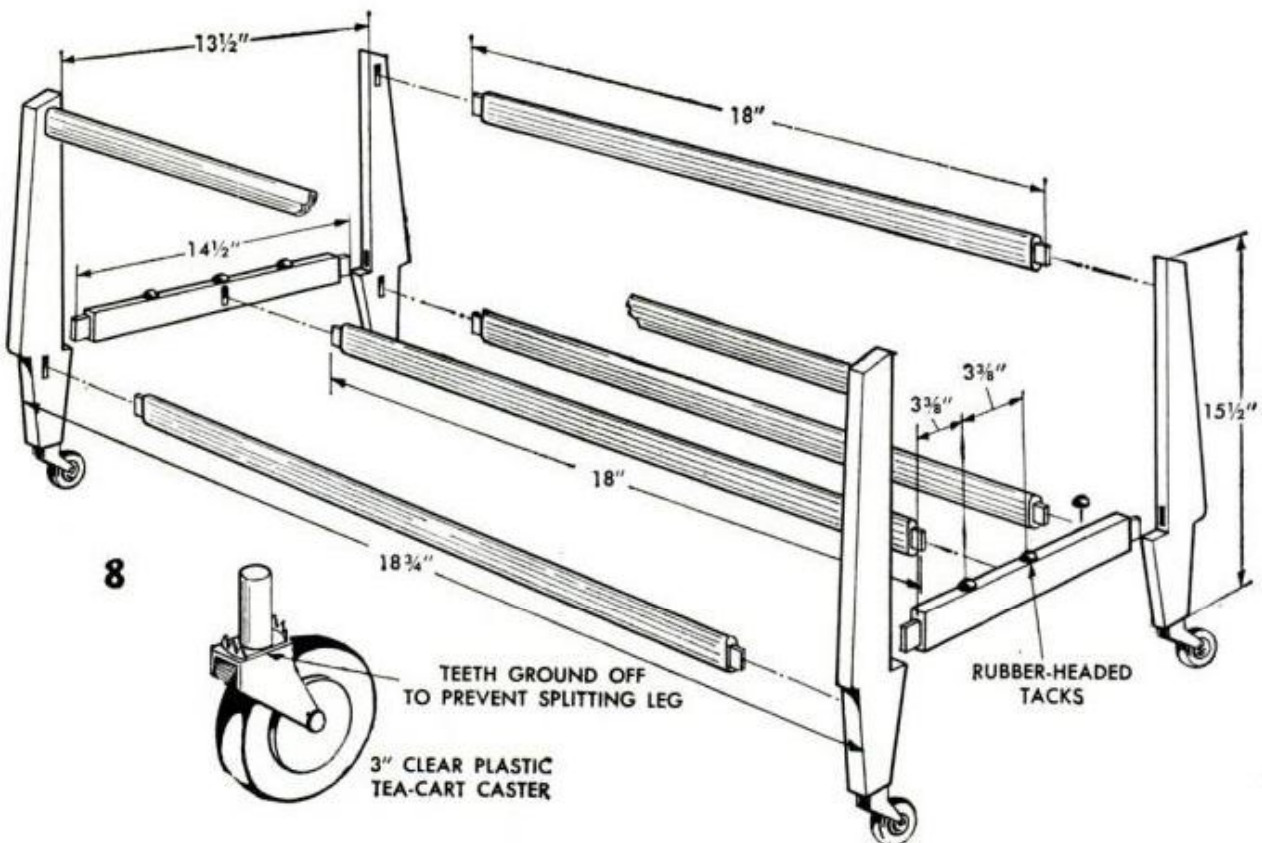

are given in Fig. 5. Dimensions for tenons are given in details D and E. To assure a perfect fit of trays on tables so they can be used interchangeably, assemble one unit before starting the others, omitting the glue until later. The first unit can then be disassembled and the legs used as patterns when locating the pivots and peg stops on the legs of the other units.

Locations of the top rails depend upon the style of tray used. For tray styles A and B, the distance from the tops of inside legs to the upper edge of the attached rail is $\frac{1}{2}$ in.; $\frac{1}{8}$ in. for the outside ones. For tray style C, uppermost edges of both rails should be flush with the tops of the legs. When cutting mortises, use a drill press to remove most of the waste. Then finish with a $\frac{1}{4}$ -in. chisel. All edges on the table are dressed down to a soft radius.

The function of the storage rack is to provide a handsome display-type storage facility for the tables and make it easy to carry them to and from the place of use. Its construction is simple and the lines are of the same contemporary styling as the tables, the offset characteristic of the leg profile being reproduced in both pieces. Begin by cutting out the legs, the detailed dimensions of which are given in Fig. 7. Mortise dimensions are taken off the tenons, details F and G. Note that the overall length of the rack, Fig. 8, is $\frac{1}{4}$ in. less than the distance between inside legs of the tables. This is necessary to provide clearance when the latter are placed on the rack. Check this dimension on the tables before cutting the longitudinals and adjust the length of them if necessary. Since $\frac{1}{2}$ -in. finished-size stock for the longitudinals may be difficult to obtain, $\frac{3}{4}$ -in. material can be used for all members to save time. When installing the casters on the rack, it is advisable to file or grind off the teeth on opposite sides as shown, to avoid splitting the leg ends. Rubber-headed tacks nailed on the upper edges of the end pieces spaced $3\frac{3}{8}$ in. apart help to keep the tables in position on the rack when it is being pushed.

Before applying a finish to your tray set, sand all surfaces with fine-grit sandpaper and dust with several changes of cloths. For a natural finish, apply two coats of sealer, rub with steel wool between coats and apply furniture wax. If a more durable finish is desired, apply a coat of sealer, sand with 6/0 garnet paper and follow with two coats of varnish. If stain is applied, follow with two coats of varnish and finish with wax. Spar varnish is best for a set that is to be used outside much of the time. For a painted finish, select a good grade of high-gloss enamel or lacquer of the desired color and apply enough coats to produce a mirror-smooth surface. ★ ★ ★

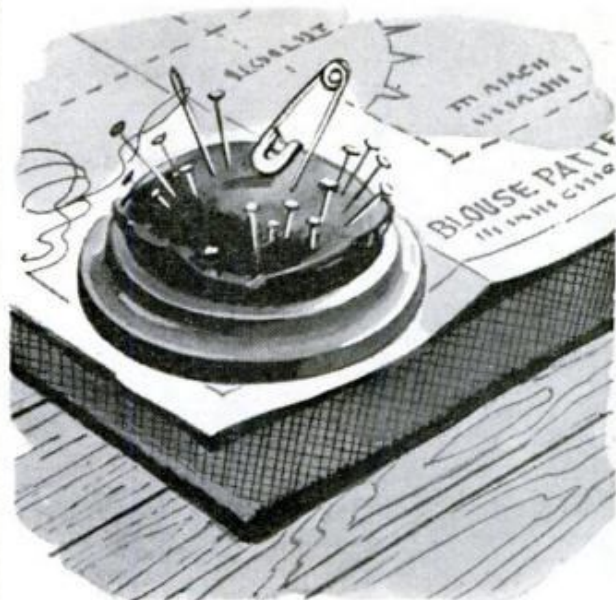

Pincushion Glued to Caster Cup Used as Dress-Pattern Hold-Down

To speed the job of pinning pieces of a pattern to the material, one enterprising amateur dressmaker glued a pincushion to a rubber caster cup as shown and used it as a hold-down. The flat, non-skid surface of the cup and the added weight helps to keep the combination pincushion and hold-down in the position placed on the pattern.

D. Spichuk, Brooklyn, N. Y.

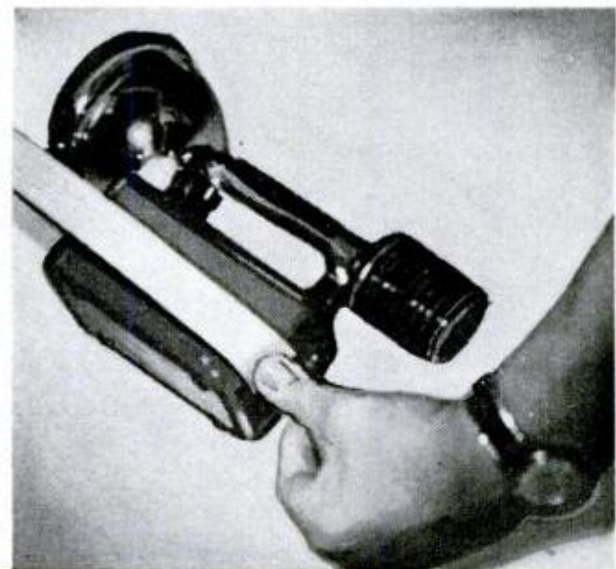

Reflective Tape on Flashlight Makes It Easy to Find in Dark

When there is need for a flashlight or other type of portable, battery-powered light, usually it is too dark to locate by sight. To make such lights "visible" in the dark, simply apply a strip of reflective tape on the case, encircling it as indicated in the photo below.

R. M. Woodbury, Natick, Mass.

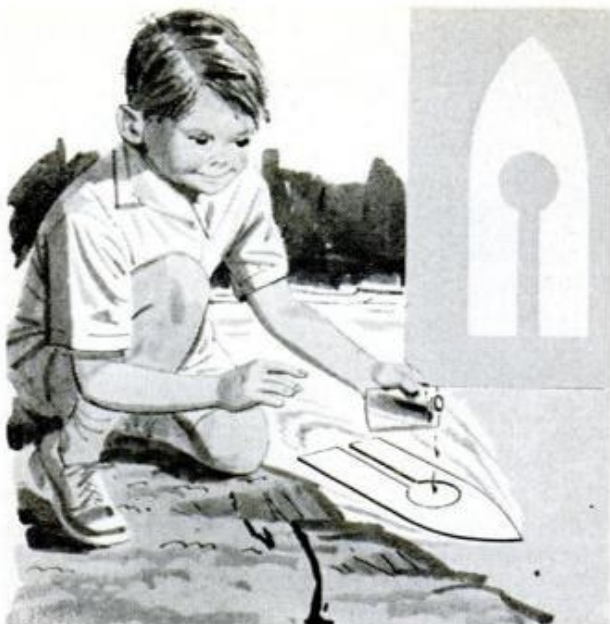

Oil Spreading on Water Drives Model Boat

Small boys will find hours of entertainment with this "jet propelled" boat. The boat is made of thin wood with a keyhole-shaped section cut from the center. A few drops of oil placed in this cut-out section will tend to spread and escape to the rear. This will force the boat forward and cause it to skim along the surface of the water.

To renew the worn rubber tips of a movie-camera tripod, give them a heavy coat of liquid rubber. Apply the rubber directly from the tube. If several coats are needed allow each to dry before adding another. Place the tips in a warm place overnight to cure the rubber.



Tool Handles Wrapped in Foil Remain Free of Paint and Tar

On a roofing or painting job, you can prevent the handles of your tools from becoming smeared with paint or tar by covering them with a piece of aluminum foil. The foil can be slipped on in a second and is as easily removed. In most cases the foil will stay in place once it is tightly wrapped but it can be further fastened with rubber bands if desired.

When painting your house, play it safe and position the ladder so that the distance from the base of the ladder to the house is equal to about one quarter of the height of the ladder.

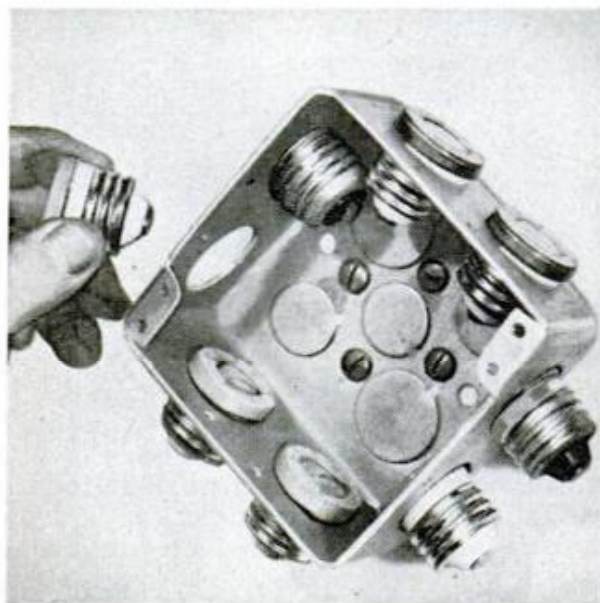

Electrical Junction Box Holds Spare Fuses

You can use an electrical junction box as a holder for spare fuses by removing the knock-outs from the sides. Screw the junction box somewhere near your electrical switch box and insert the spare fuses in the holes. The next time a fuse blows there will be no need to search as the spares will be there where you need them.

Tight and sticking drawers should not be planed because subsequent contraction of the wood may make the drawer too loose. It is best to sand the edges of the drawer lightly and either apply a bit of powdered graphite or rub the edges with soap.

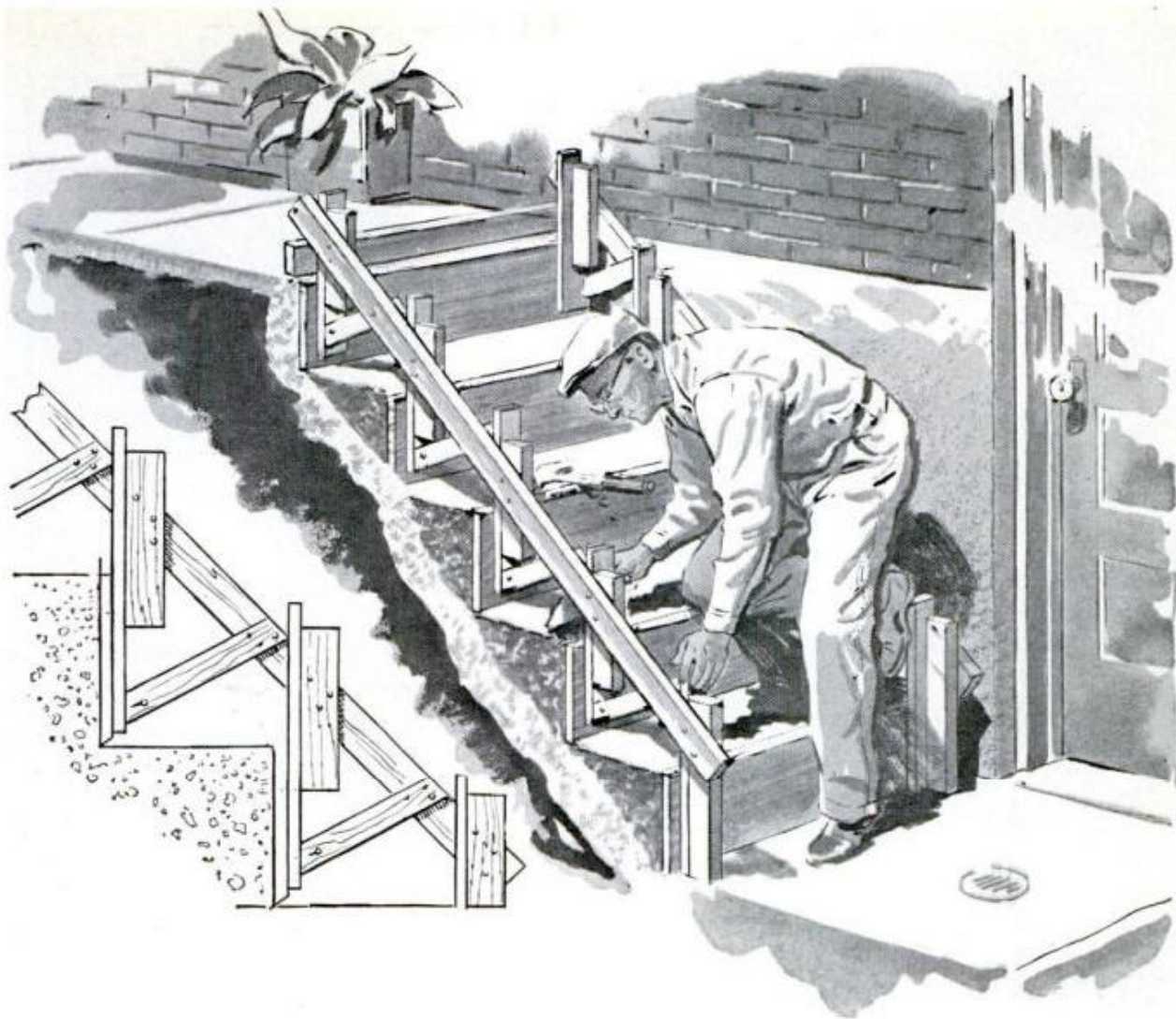

Solid-Unit Form for Pouring Concrete Steps

Pouring concrete steps is not difficult if this solid-unit form is used. The form is made of stringers and cleats of 2 x 4-in. stock, and risers of 2-in. stock. The braces are 1 x 4-in. scrap cut to the necessary length. A riser height of 9 in. and a tread width of 12 in. are recommended. Begin by chalking an outline of the steps on the wall along which the steps are to rise. Use this as a guide by which to indicate on the

stringers the angle and location of the risers. Using these guide lines, nail the cleats to the stringers and mount the stringers one on either side of the stair well. Secure them at the top as illustrated and at ground level with stakes driven into the ground. Nail the risers to the cleats as shown in the drawing, with vertical and diagonal braces. The form is now a solid unit ready for the concrete.

Knob on Carpenter's Square Makes Handling Easier

Fitted with a small wooden knob, a carpenter's square is easier to lift from a flat surface or to move into various positions on the work. Screw a threaded rod into an undersized hole drilled into the knob. Cut the extending portion of the rod short and screw it into a hole tapped in the square. Then file the rod flush with the surface of the square.

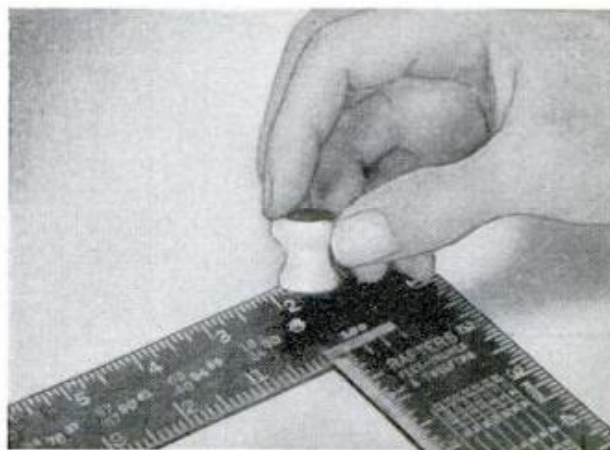

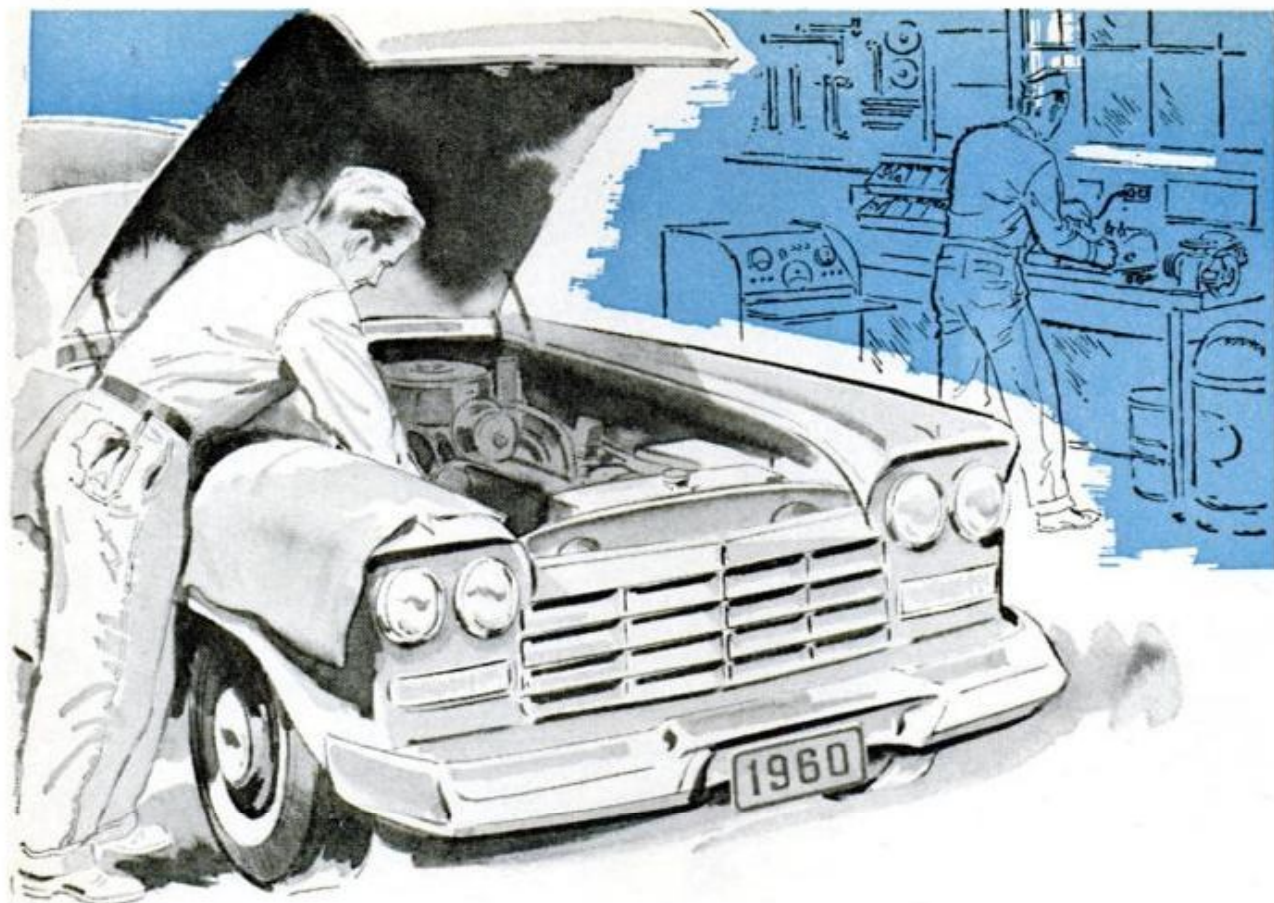

Trouble Shooting THE TOUGH ONES

By Ben L. Davis

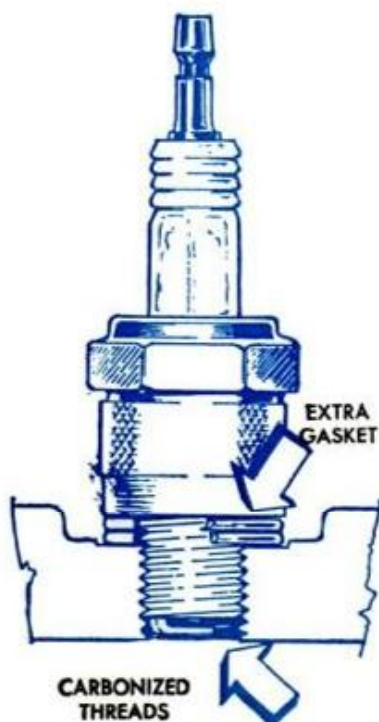

CAN ONE CYLINDER in an engine produce pinging? A recent experience with a '57 Plymouth V8 taught me that it certainly could. The engine had just been given a tune-up job, yet at normal running temperature and a fair amount of acceleration it produced an odd noise, like a marble rolling in the air cleaner. Since the engine didn't run hot, overheating could be written off as the cause. Deciding on a quick recheck of the whole tune-up job, I first checked the carburetor, but an analyzer indicated normal functioning. Next the timing was rechecked, but a stroboscope test okayed the ignition at idle and for degree of advance. A machine check of the distributor got me nowhere. By this time I was becoming a bit irritated. Whatever its source, the noise was not due to carburetion or timing. Of course, improper choice of plugs or faulty setting could cause the pinging. I started checking the plugs and they seemed all right until one of them in the right bank came out minus its gasket. I thought little of this until I inserted a magnet in the plug seat and came out with not one, but *two* gaskets. Here, then, was the trouble. The extra gasket lifted the plug away from its proper seat and cooling surface. The plug ran hotter than it should have and caused the noise.

Unusual Locations Where Trouble May Occur

Bumper Guards

Though they were meant as a means of protecting the front end of the car, the bumper guards of the '54 Plymouth are designed with such an angle that it is easy for another bumper to ride over them with possible damage to the grillwork. This is especially true in tight street-parking conditions. The cost of replacement with guards having a more suitable angle may prove to be money well spent.



Rusted Parking Lights

Among the many little things that automobile designers cannot foresee but which mean headaches to the car owner are the wires leading to the parking light sockets of the '58 Rambler. Water running down these wires is likely to rust out the sockets and make their replacement necessary. To prevent this, the wires should be repositioned in such a fashion that the water runs away from the sockets and not down toward them.

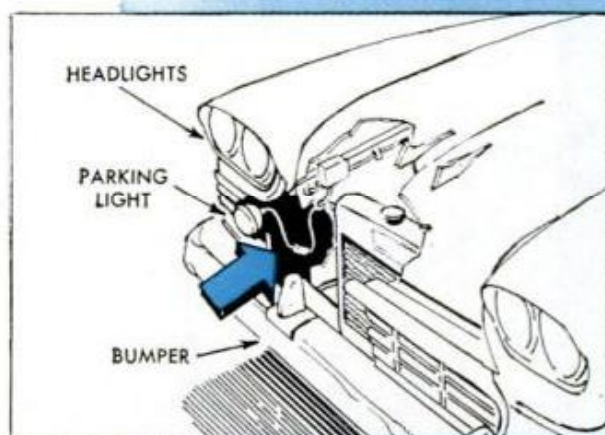

Cooling Fan

If your '57 Buick consistently runs hot and there is nothing in the cooling system which will bear the blame, check to see that an inadequate fan is not the cause of your problems. It is possible that the car may be still equipped with the four-bladed factory original. Replace this old one with a new five-bladed unit available at your dealer and your cooling problems will be as good as over.



Loose Handbrake Lever

It is a good idea to check the lever of the handbrake mechanism on the '54 Chevrolet. It sometimes comes loose from its threaded link. To prevent this from happening, screw the lever in tight. Then drill a small hole through both lever and link and insert a $\frac{1}{16}$ -in. cotter pin. The mechanism will continue to operate efficiently with no possibility of its ever working itself loose.

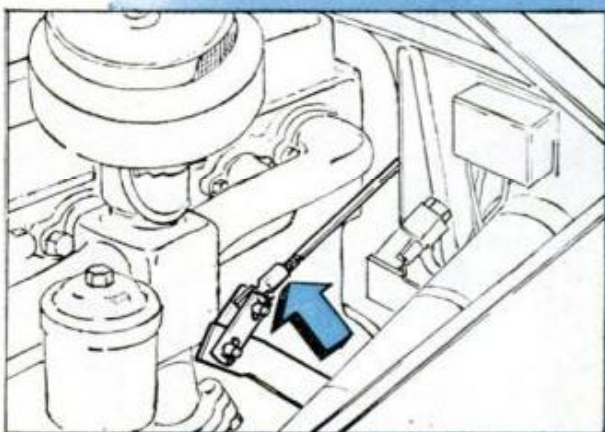

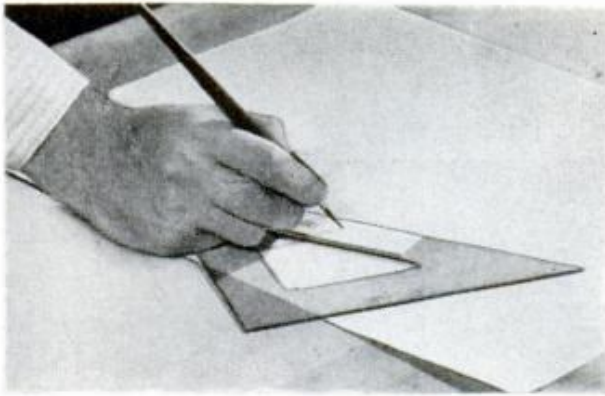

Tape and Sandpaper Are Aids For the Busy Draftsman

The busy draftsman will find that a piece of adhesive tape placed on one side of his triangle provides a convenient surface on which to wipe the lint and dust from the point of his pen. A piece of sandpaper can also be placed on the triangle to help keep a sharp point on drawing pencils when fine, precise work is to be done.

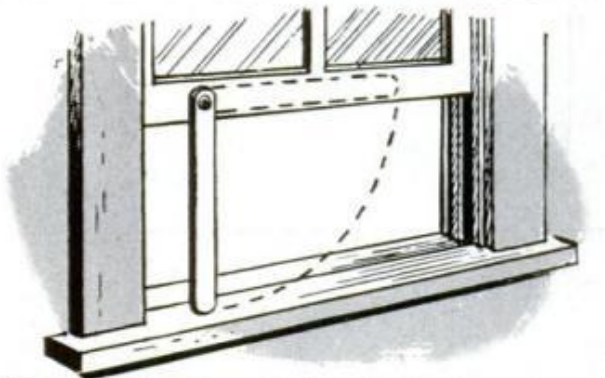

Permanent Barn Window Support Swings Away When Not in Use

If a piece of wood of suitable length is screwed to the bottom of the sash of a barn window, it will serve as a permanently available support with which to prop the window open. It may be swung down when the barn is to be ventilated, or pushed up to a horizontal position and out of the way when it is not in use.



Adhesive Tape Is Guide In Using Stapler

When it is necessary to staple a number of pages at exactly the same distance from the edge of the page, a piece of adhesive tape placed at the desired point on the stapler will act as a guide. The tape can be removed if desired or left in place for future use. A wider piece of tape can be marked with the spacing needed for several different stapling jobs.

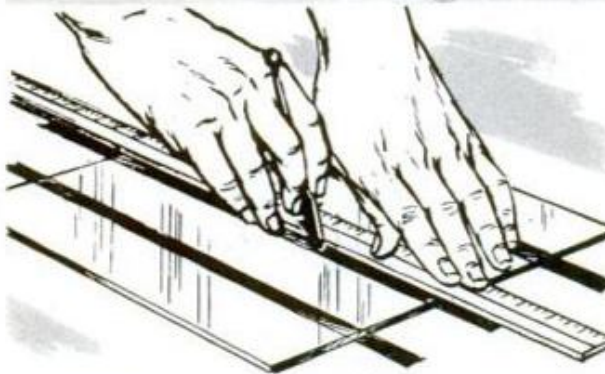

Simple Aids and Hints For Cutting Glass

A piece of glass will not slip as you attempt to cut it if two strips of rubber tape are first placed on the workbench. Two strips of wood about 12 in. long, nailed at right angles to a top corner of the bench will also keep the glass from slipping and help you align it for straight cuts.

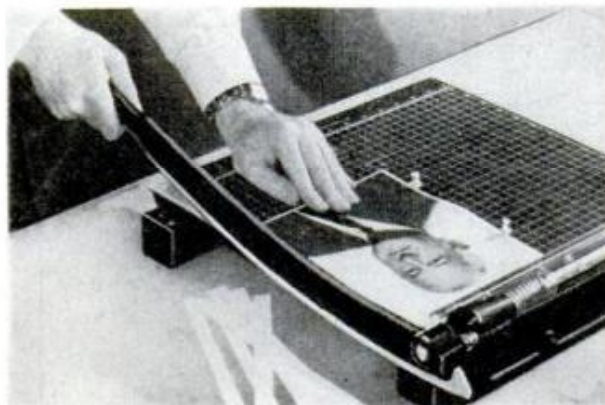

The Easy Way to Accuracy On a Paper Cutter

Tacks used as stops assure accurate measurement when you cut a number of photos on a paper cutter. Insert the tacks part way into the table the desired distance from the cutting edge. To keep from marring the table with tack holes, use a strip of heavy illustration board instead. Glued to the table, it can be ripped off later and the glue washed off with warm water and soap.

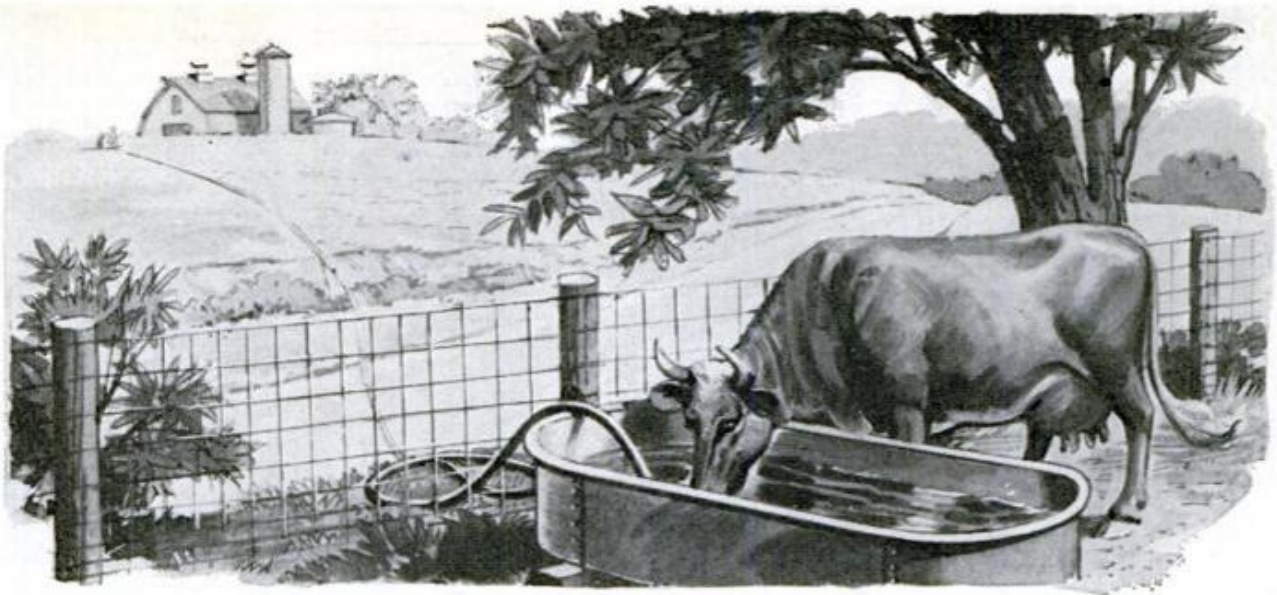

Water "Piped" From Well to Pasture

While temporarily pasturing a cornstalk field where water was unavailable for the cattle, one farmer "piped" water in from a well in a pasture across the road, as shown in the illustration. From the well the water was carried by means of a pipe laid across the ground. To solve the problem of crossing the road with the water line, several

feet of ordinary garden hose were used at this point. The hose was laid across the road when the tank was being filled and removed and hung on a nearby fence post when not in use. Before doing this, permission should be obtained from the local highway authorities.

A. M. Wettach, Mt. Pleasant, Iowa

Watering Trough for Sheep Made of Tub and Odd Parts

A watering trough suitable for sheep can be made out of a washing-machine tub and a few odd pieces of plumbing equipment. Mount the tub on a water pipe, as shown in the photograph below, and fit it with an automatic float valve to keep the water level constant. An electrical heating unit may then be suspended in the water and plugged in during the severe winter months to keep the water from freezing.

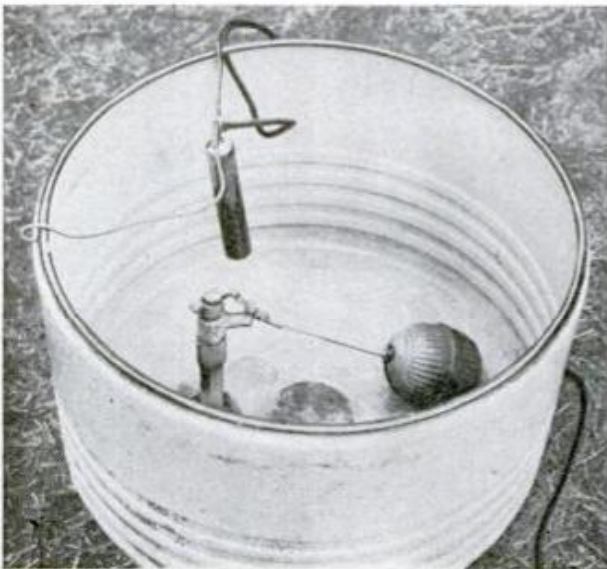

MARCH 1960

Trough Filled Automatically From Tank Wagon

To keep hogs on pasture supplied with fresh water with a minimum of attention, one farmer has connected a trough to a tank wagon by means of a hose. A float valve in the trough holds the water level low so that a steady supply prevents an accumulation of water from becoming stale. Bolted to a slightly elevated platform, the trough is held level and is kept free of mud and trash.

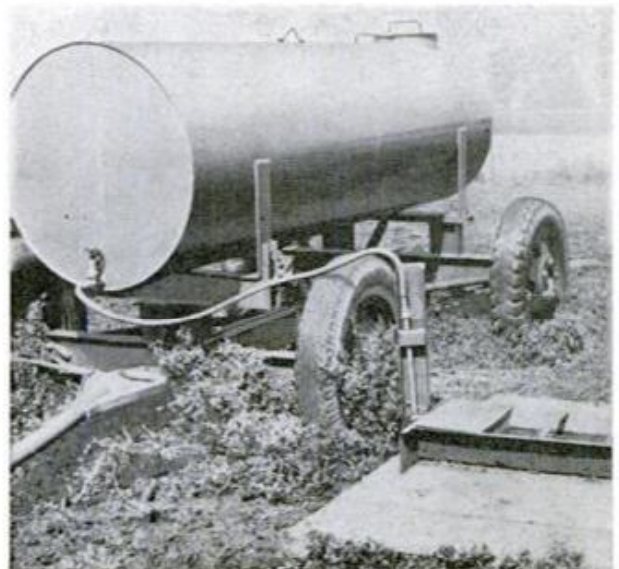

217

SHOP NOTES

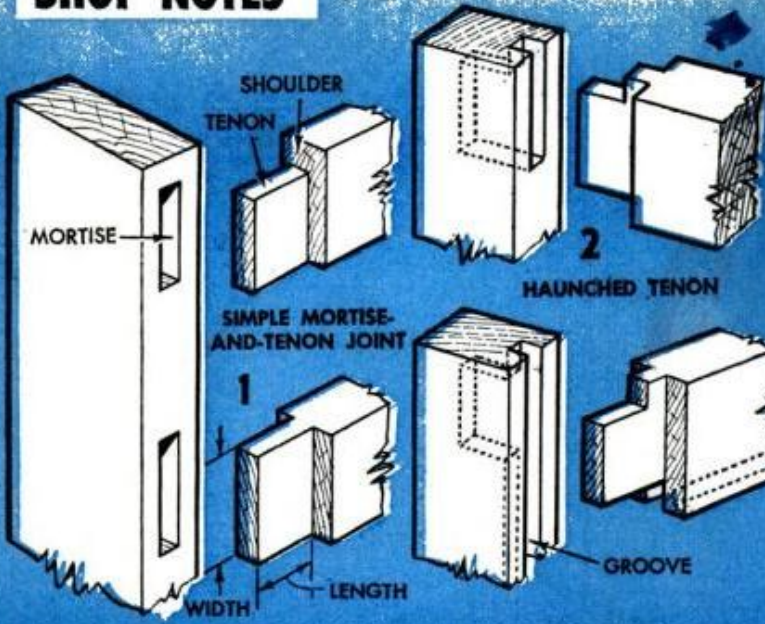

AVERAGE TENONS			
WORK THICKNESS	THICK	MIN. LENGTH	MAX. WIDTH
1/4"	3/8" - 1/2"	3/4"	3"
3/8"	3/8"	1 1/8"	4"
1/2"	3/4" - 3/8"	1 1/8"	5"
3/4"	3/8"	1 1/4"	5"
1 1/8"	3/4" - 1/2"	1 1/2"	5"
1 3/8"	1/2"	2"	5"

HOW TO CUT MORTISE-

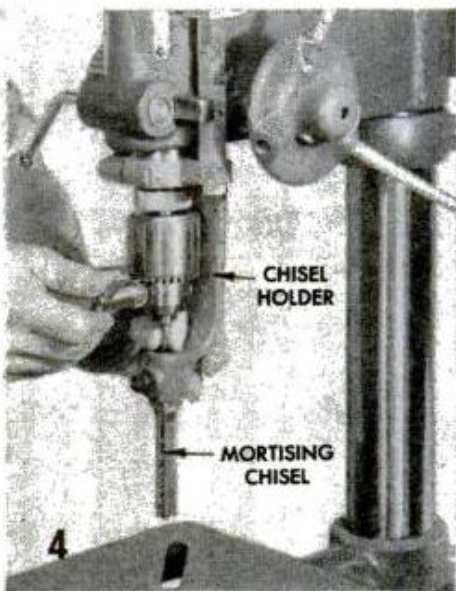

TWO TOOLS, a circular saw and a drill press, make you the boss of the strongest joint in woodworking—the mortise and tenon. Possessed of many variations, the simpler styles shown in Figs. 1, 2 and 3 are most useful. The simple mortise and tenon, Fig. 1, is used extensively in framework construction, such as kitchen cabinets. When the rail stock is narrow, a haunch (shoulder) often is added to prevent twisting, Fig. 2. The haunch also is used as an automatic “fill” for the groove in making paneled frames. When the groove is the same size as the tenon, all the stock is grooved as a first operation, after which the mortises and tenons are made. If the groove is narrower than the tenon, it should be run last, stopping the

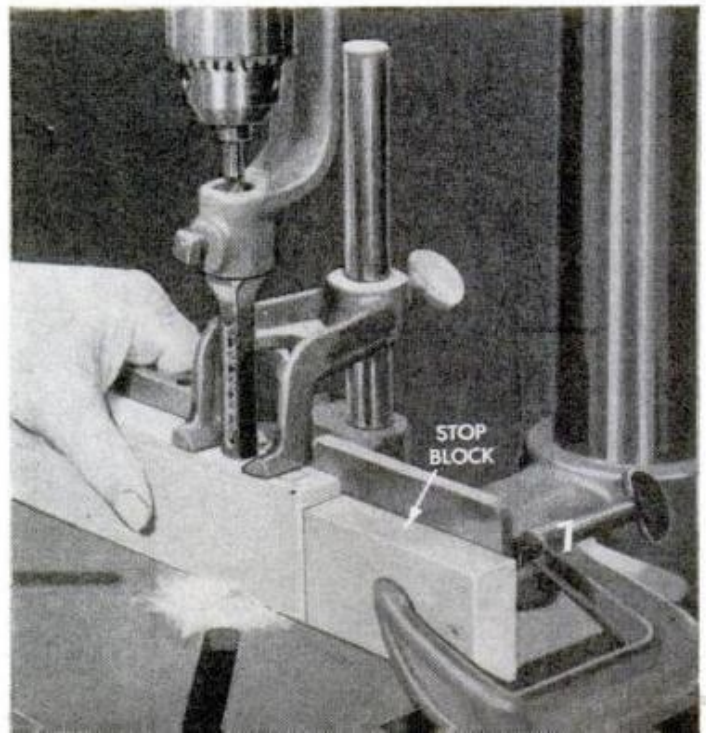
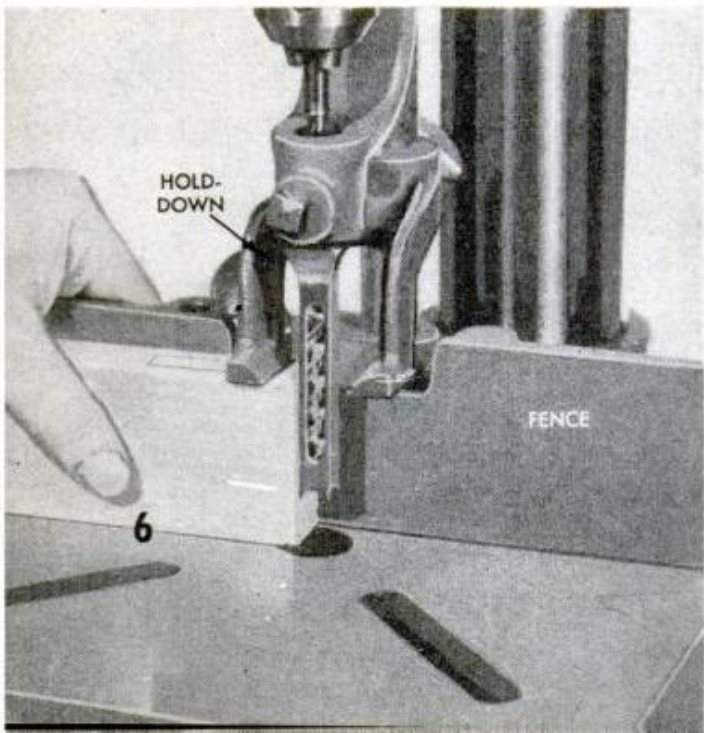

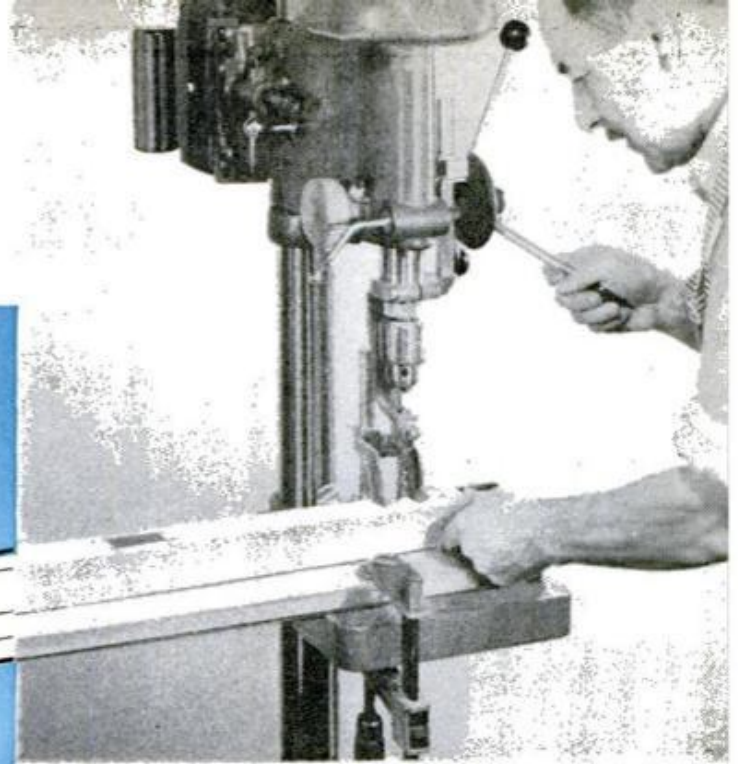
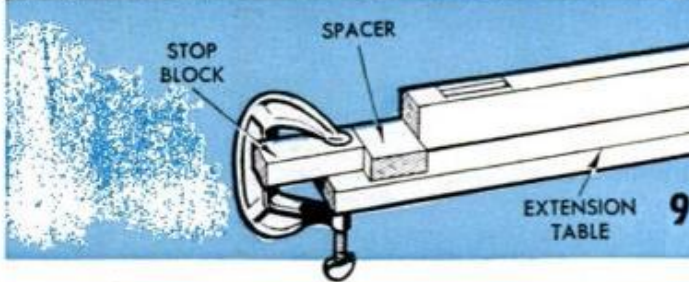
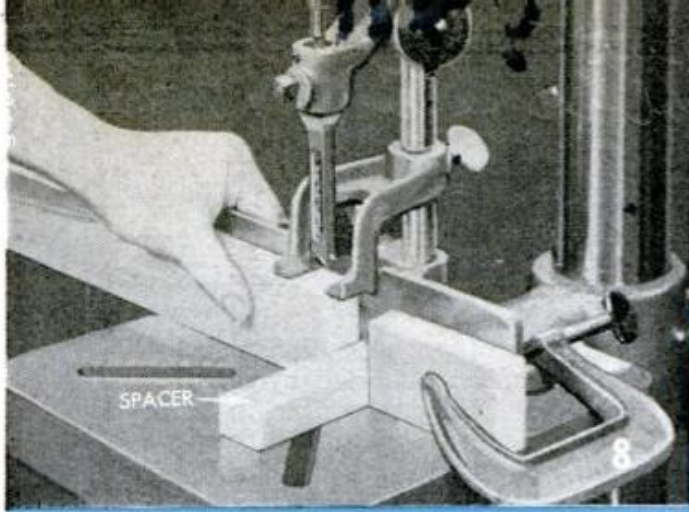

AND-TENON JOINTS

By
Sam Brown

cuts short of the ends of the work. The barefaced tenon, Fig. 3, is often used in cabinet construction having plywood ends.

Average dimensions for tenons are given in the table. The general rule is to make the tenon thickness $\frac{1}{4}$ to $\frac{1}{2}$ the thickness of the work stock. Tenon width and length can vary greatly but the width should not exceed 5 in. If a wider tenon is needed, it should be divided into twin tenons with a space between to avoid a weak mortise.

The mortise usually is cut first because its width is nonadjustable, whereas a tenon can be sawed fat or thin as needed. Mortising is done on the drill press with the use of a mortising chisel fitted in a special holder. The chisel is mounted first, after which the bit is slipped inside of it, Fig. 4, and held by the chuck. A clearance of about $\frac{1}{32}$ in. between chisel and bit is needed to prevent overheating, Fig. 5. The drill press should run at 1800-2800 r.p.m. for softwood; 900-1400 r.p.m. for hardwood.

A mark should be made on the work to show the required depth of cut ($\frac{1}{8}$ in. deeper than the tenon length) and the depth stop is set to maintain this depth, Fig. 6. From here on the procedure will vary with the job. Most work will have four or more similar joints to be made. When this is the case, the required guide marks should be penciled on one master piece, which is used in making the required drill-press and saw settings. All similar cuts should be made at the same time. Cutting similar mortises is done with the use of a stop block and spacer. The first chisel cut is set by a stop block, as in Fig. 7; the

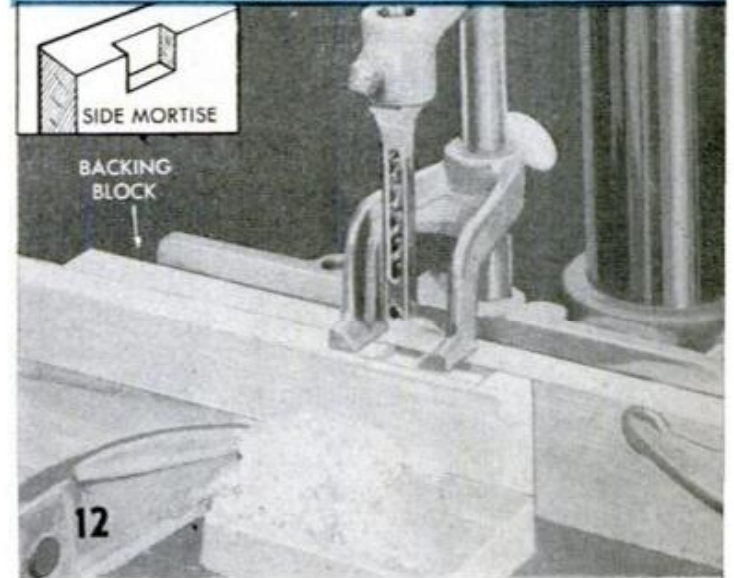
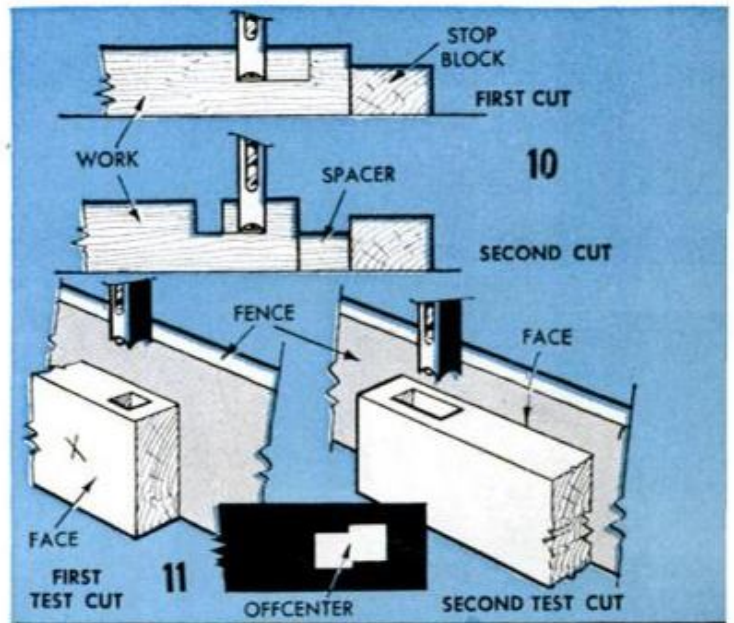

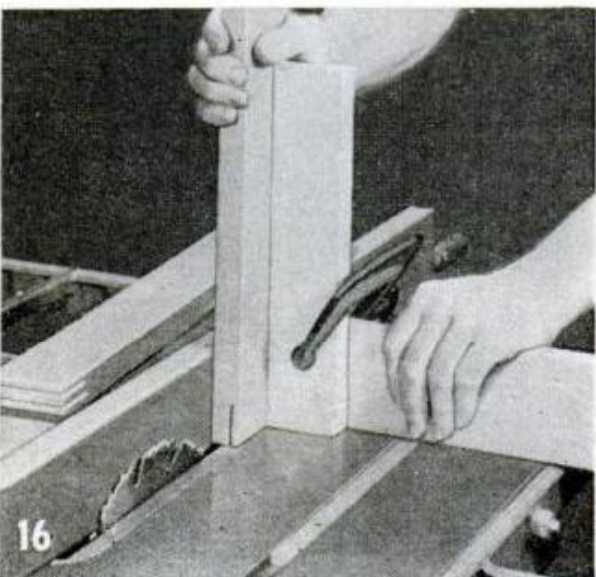
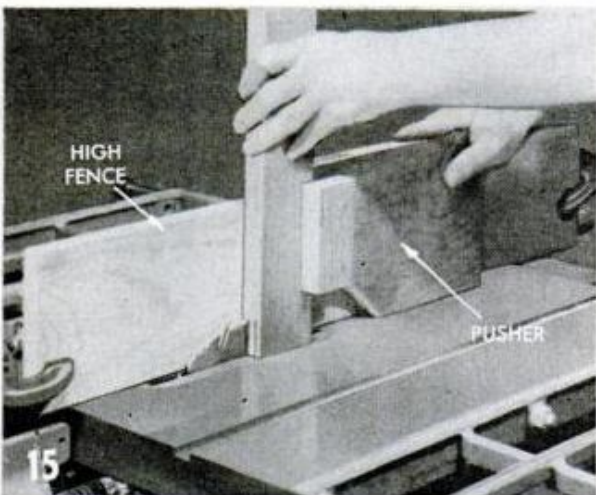
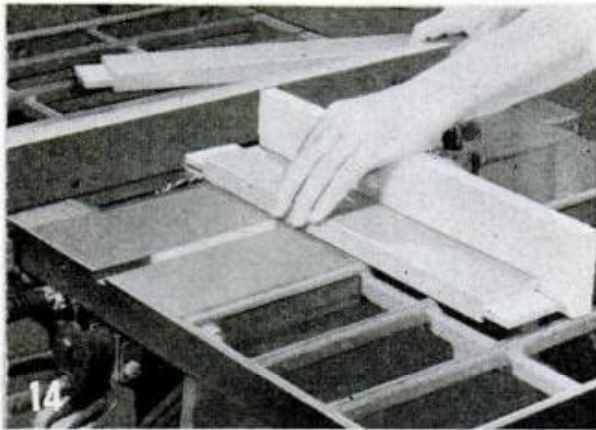
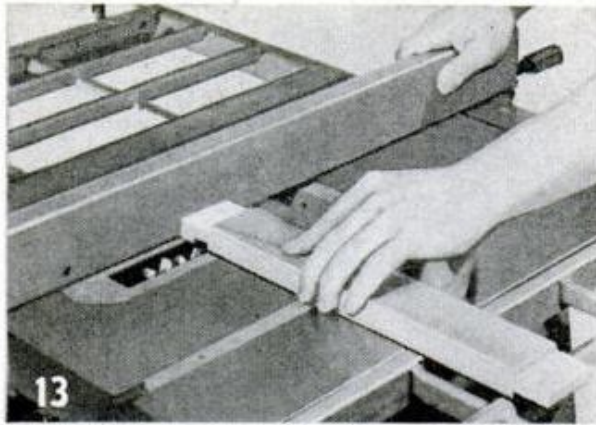

cut is set by a stop block as in Fig 7 the
 opposite end of the mortise is located by means of a spacer, Fig. 8. The width of the spacer is the length of mortise minus the width of the chisel, as can be seen in Fig. 10. After the two end cuts are made, the wood between can be cut out by taking successive bites of about $\frac{2}{3}$ the width of the chisel. Extra working room needed for long work can be obtained by clamping a board to the drill-press table in front of the fence, Fig. 9.

Properly positioned, the face side of the work should be kept against the fence for all cuts. However, when you have right and left members, this is not practical unless you set up right and left-hand stops. The simpler way is to center the mortise exactly so that right and left-hand parts can be cut with the same setup, reversing the work, face in and face out. This will produce perfect work provided the work stock is of uniform thickness, which is the usual case. The initial setting of the fence should be checked carefully with test cuts made on a scrap of the work stock, Fig. 11. Make one cut with the face side out, then reverse to put the face side in and make a second cut. If the two show a jog, Fig. 11, it is obvious you are offcenter.

The side mortise, Fig. 12, is a housed joint rather than a mortise and tenon. However, it is cut with the mortising chisel and is often used in frame construction. It easily is cut by using a backing block and hold-in, as shown. A good amount of pressure is required in making all mortising cuts, but it should not be overdone. It is better to use a slow, steady feed and it is helpful to lift the chisel frequently. Cutting both end holes first, as shown, is recommended. If you use the alternate system of working from one end to the other, do not make the final cut less than $\frac{2}{3}$ the width of the chisel; a narrow cut tends to "bend" the chisel or to force the work away from it.

All the tenon parts first are cut to net length, including the length of the tenons. Do this exactly, using a stop block for all similar parts. With the stock cut to net length, you can proceed with the tenons. When just a few tenons are needed, the system of flat sawing with the dado head, Fig. 13, is reasonably fast and perfectly safe. Even a single saw is not too slow for just a few pieces, although this cut normally is used only for the shoulders, Fig. 14. The minimum safe setup to saw the cheek cuts is a high fence and pushboard, as shown in Fig. 15. Somewhat better is the miter-gauge facing in combination with a clamped upright and the regular fence, as shown in Fig. 16. This gives support in all directions and is fast and safe. Naturally, if you do a lot of tenon work, it is worthwhile to make or buy a regular tenoning

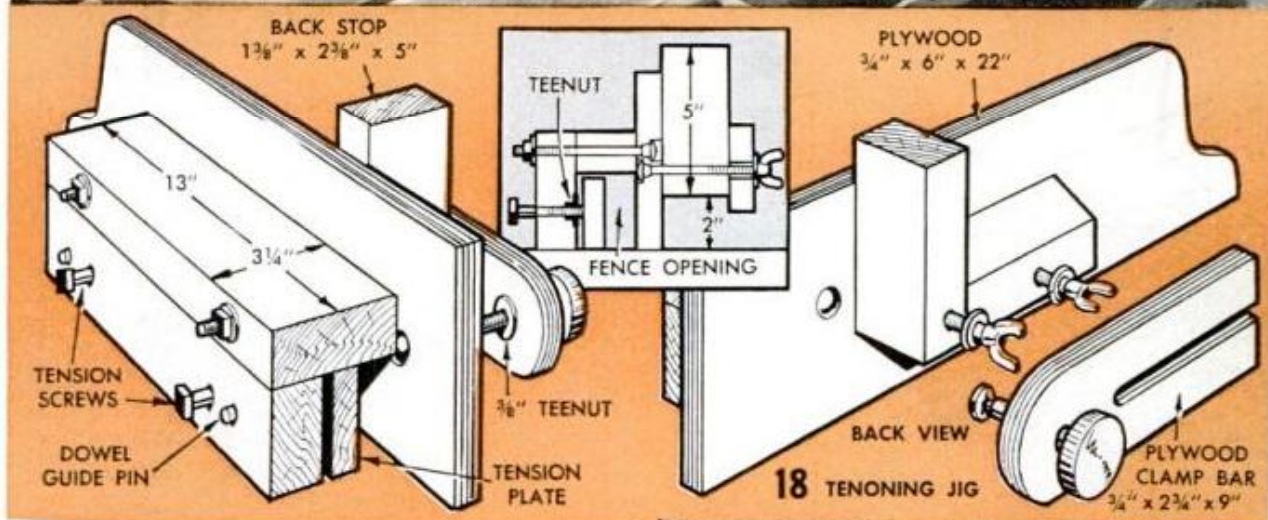
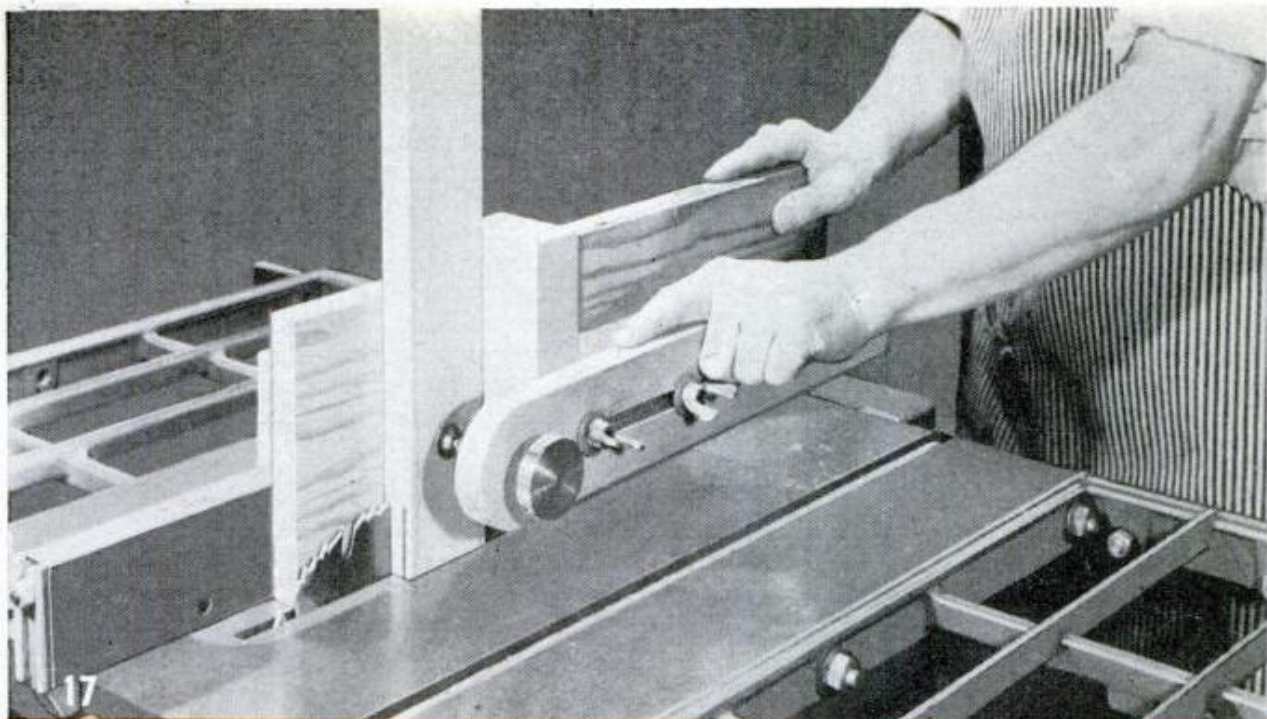
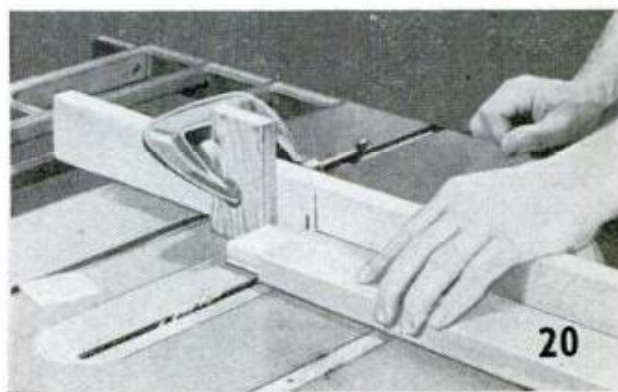
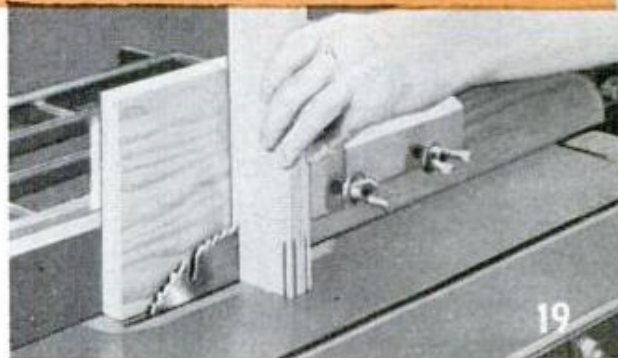
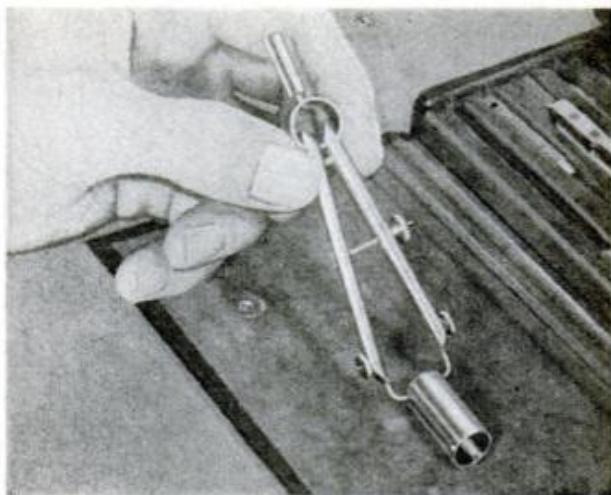

fig. A good homemade fence-riding style is shown in Fig. 18. It is fitted with a tension plate so that it can be made an exact snug, sliding fit on the regular fence. Even without the clamp bar, Fig. 19, it is much better than the high fence and pushboard idea.

Tenons should be made a good press fit. Like other operations, all similar pieces should be cut at the same time. In the usual method of working, the stock is turned face out, face in for the two cheek cuts. This will produce uniform tenons provided the stock is of uniform thickness. Of course, you can make a test joint first, adjusting the fence carefully to make a tenon which is too large for an easy hand fit but goes together nicely with a few taps of a mallet. The cheek cuts are usually made first in order to preserve maximum end surface to ride on the saw table. The shoulder cuts are an easy job and can be set to length with the regular fence, Fig. 14, or as in Fig. 20 with a stop block fastened to the miter-gauge facing. ★ ★ ★





Dividers Become Calipers For Small Precision Work

If you are doing small precision work, a fine pair of calipers can be made by converting the bow dividers of a drafting set. The points of the dividers are replaced with curved wire tips cut from the ends of ordinary paper clips. Be sure to make the tips of equal size. The calipers may be used for either inside or outside measurement simply by reversing the tips as the job requires.—R. Hanscom, Elmhurst, Ill.

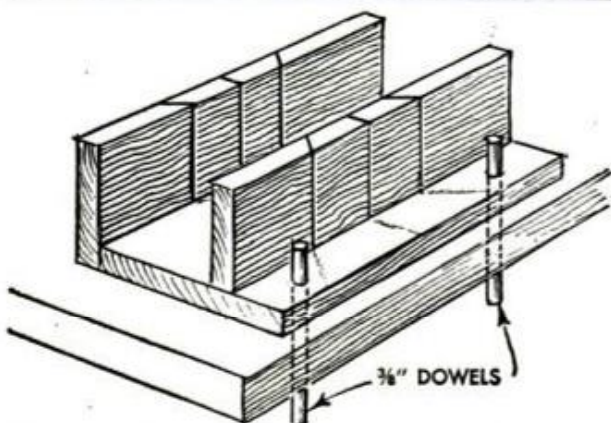

Dowels Hold Miter Box Firmly on Workbench

Your miter box won't slide around on the workbench when in use if it is held fast with two or three dowels. In making the box, allow the bottom piece to project an inch or two along one side. Drill holes through this piece and into the bench so that snug fitting dowels may be inserted. Make the holes in the box slightly larger so that it may be removed when not in use.

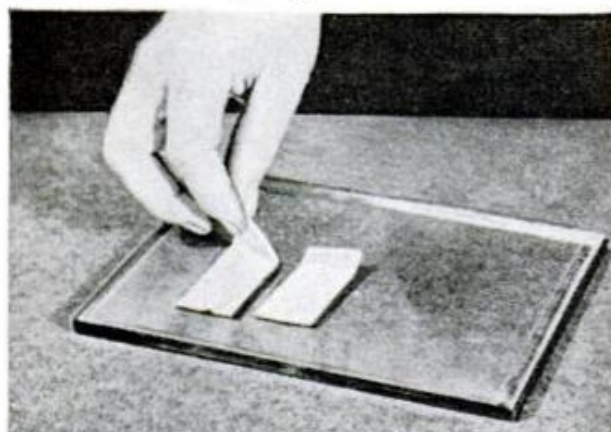

Precut Tape Placed on Glass Simplifies Wrapping Problems

Wrapping and packaging is made easier if the tape is first cut into strips of the required length and placed on a sheet of plate glass. The glass has no effect on the tape's adhesive quality and the strips are available as needed. This leaves both hands free to tackle the packaging job.

Michael Ligocki, Gary, Ind.

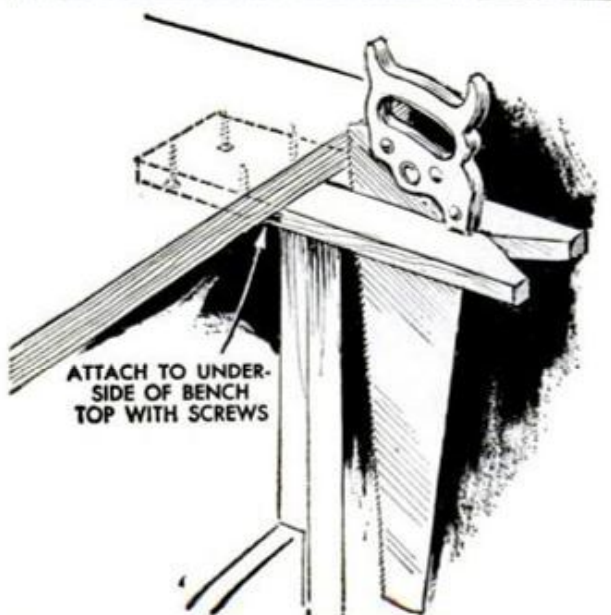

Workbench and Odd Corners Make Storage Nooks for Saws

To keep a handsaw conveniently at hand place it in a slotted board attached to the underside of the workbench. This keeps the saw from "wandering off" and insures against the chance of its being dropped and damaged while a job is in progress. If your shop is equipped with several saws, a longer board may be required or they may be stored in a slotted shelf placed against one wall. If wall space is limited, and a board projecting from the bench is in the way, bend a brass rod about 3 ft. long at right angles and attach one side to a board. The board may be mounted on the wall at eye level and the saws hung from the rod by their handles.

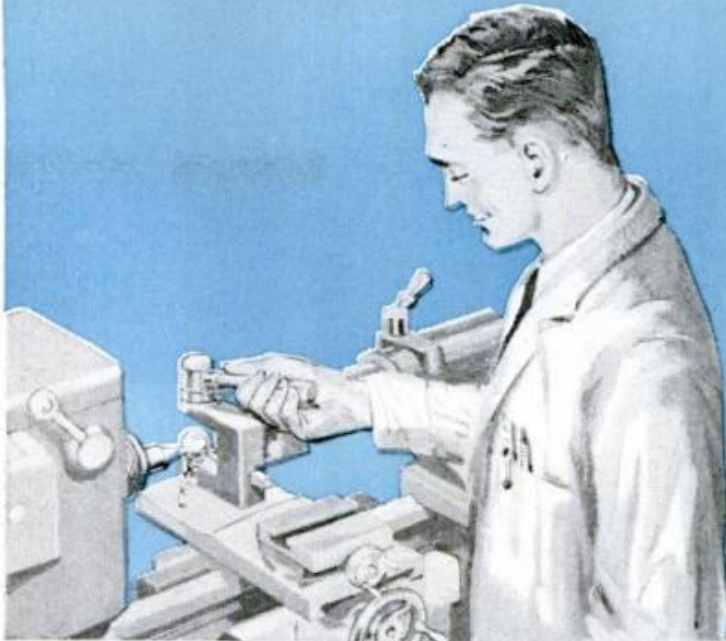
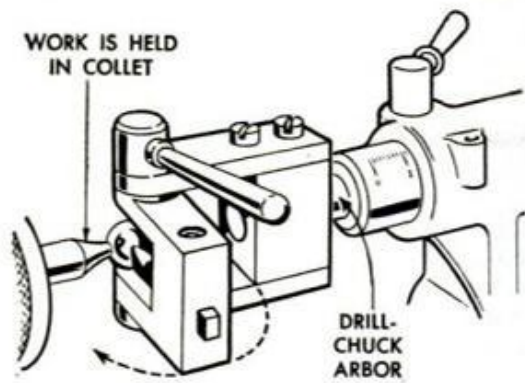

RADIUS TURNING TOOL

TURNING perfectly shaped balls or other spherical work is no trick at all with this radius tool which mounts in the tailstock. It will turn a ball from $\frac{1}{8}$ to $\frac{3}{4}$ in. in diameter by a mere swing of a handle. It does away with difficult lateral adjustment since the cutting edge of the tool is set permanently at exact lathe-center height and the tool itself is automatically aligned with the lathe centers when it is placed in the tailstock. Longitudinal adjustment is made by advancing or backing off the tailstock quill.

Using the tapered shank from a discarded reamer simplifies the tool, which for the most part, is machined from rounds and flats of cold-rolled steel. The pull-apart drawing dimensions the parts and shows how they go together. The tapered shank is a press fit in part A, and the swivel yoke, part B, pivots freely between extending arms. The square hole for the $\frac{1}{4}$ -in. tool bit can be formed by first boring a hole and then working it square with files. The important thing is the location of the hole. The top of it must be at exact lathe-center height. In use, take very light cuts at high lathe speeds.—C. W. Woodson, Chicago.

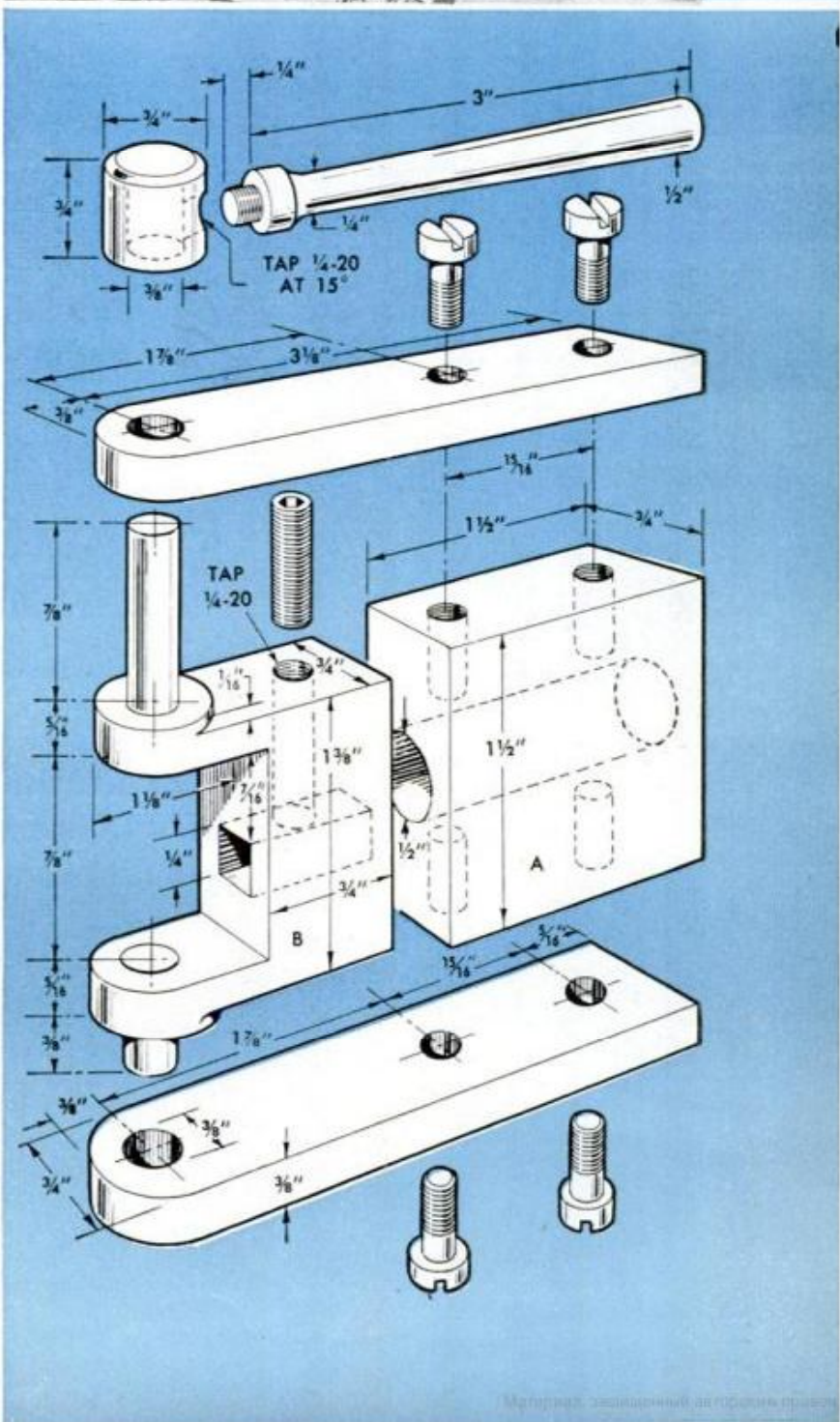

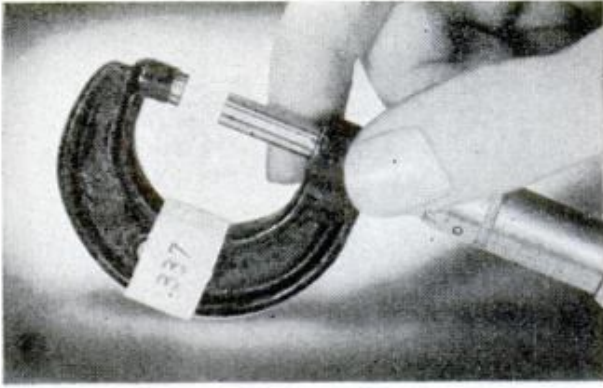

Tape Attached to Micrometer Records Measurement Figures

To prevent errors when taking micrometer measurements, jot down the figures on a piece of gummed-paper tape attached to the side of the "mike." When several measurements must be taken, attach the tape to the workbench or to some other convenient surface. Figures written in pencil can be erased and the tape used several times.—H. Hanscom, Elmhurst, Ill.

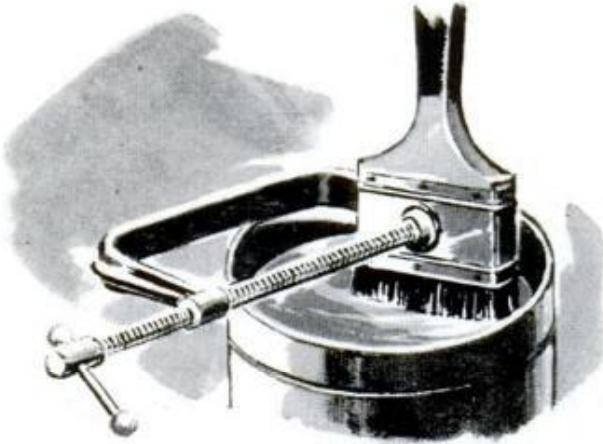

Suspending Brush in Solvent Prevents Bending of Bristles

Paintbrush bristles will become bent and ruined if the brush is allowed to rest on the bottom of a can of solvent. To prevent this, hold the brush against one side of the can with a C-clamp so that the bristles are held above the bottom. Several brushes can be suspended in the solvent if holes are drilled in the handles. Run a piece of wire through these holes and place the wire over the can.—Daniel Bousha, Jackson, Mich.

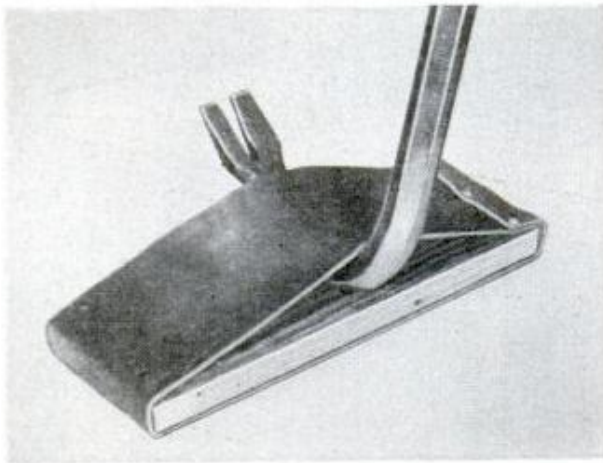

Pad Protects Wooden Floors And Aids Removal of Nails

A simple device makes it unnecessary to mark up a fine wooden floor when removing nails with a crowbar. Wrap a piece of inner-tube rubber around a piece of wood measuring about $\frac{1}{2} \times 3 \times 8$ in. and fasten it with tacks. When removing nails, slip the crowbar under the rubber. The block affords the necessary prying leverage. The rubber holds the block to the crowbar while also serving as a protective pad.

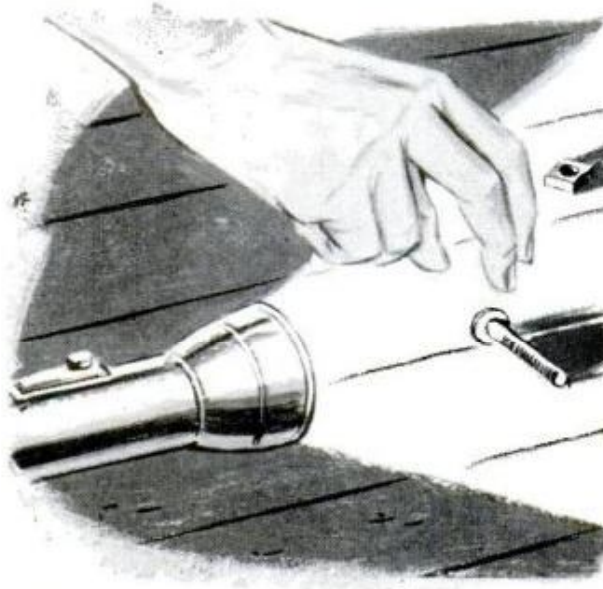

Suggestions for Care and Use Of the Versatile Flashlight

To locate small items, such as nuts and screws when they accidentally fall to the floor, beam a flashlight across the floor rather than down on it. The item will cast a longer shadow and be easier to spot. An old tea strainer, minus its handle, wired to the head of the flashlight will protect the lens against breakage when it is stored with tools. In emergencies, such as roadside automobile repairs, clamp the flashlight into a small wrench and drive the handle of the wrench into the ground. This will hold the light steady and allow you to direct the beam where you need it, leaving your hands free to do the necessary work.

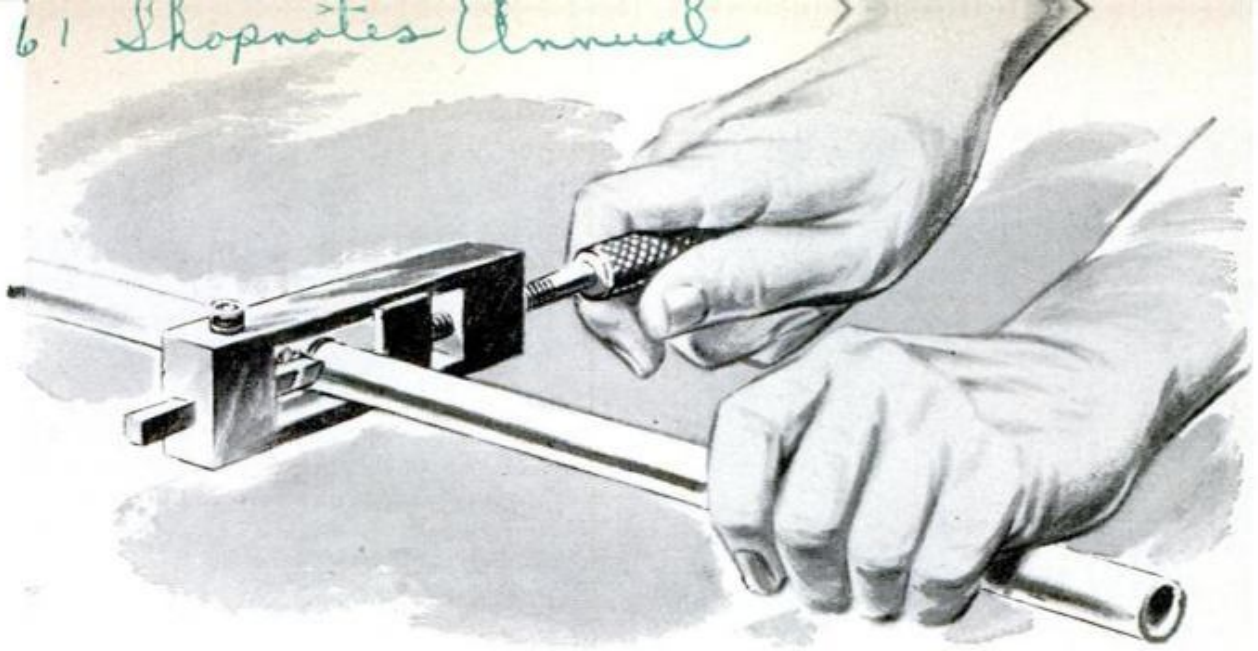

TUBING CUTOFF TOOL

USED in much the same manner as a conventional pipe cutter, this shopmade cutoff tool does a neat job on thin-wall tubing up to $\frac{3}{4}$ in. O.D. Instead of employing cutting wheels, the tool makes use of a lathe tool bit. With the tubing cradled in a V-jaw, pressure is brought to bear against the cutting bit by turning the handle a little at a time as the tool itself is rotated around the tubing. The severed end will be smooth and undistorted.

In making the body of the tool, a 4-in. length of $\frac{3}{4}$ x 1-in. cold-rolled, steel bar is used. The ends are first squared and then a $\frac{3}{4}$ -in. slot is cut in it with an end mill by mounting the work in the lathe milling attachment. After this, the rounded ends of the slot are filed square. Next, one end of the work is drilled and tapped for the threaded shank of the handle, after which the opposite end is drilled and filed square to receive a $\frac{1}{4}$ -in. tool bit. The latter is ground to form a thin-blade parting tool and is locked in place with a socket-head capscrew. The $\frac{3}{4}$ x $\frac{3}{4}$ x 1-in. sliding V-jaw is filed to move freely by two outside members riveted to it to form flanges. The jaw is held loosely to the end of the handle by a cross pin which enters a groove in a tenon turned at the threaded end of the handle.

C. W. Woodson, Chicago

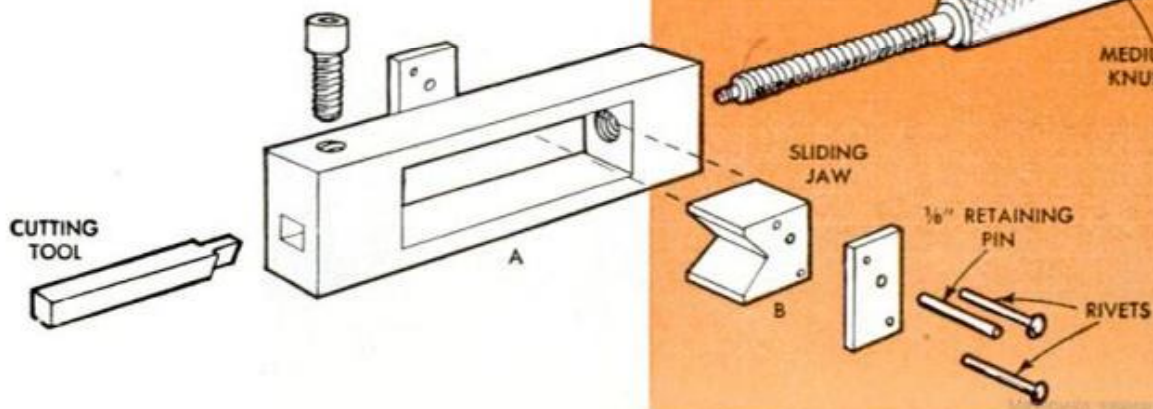
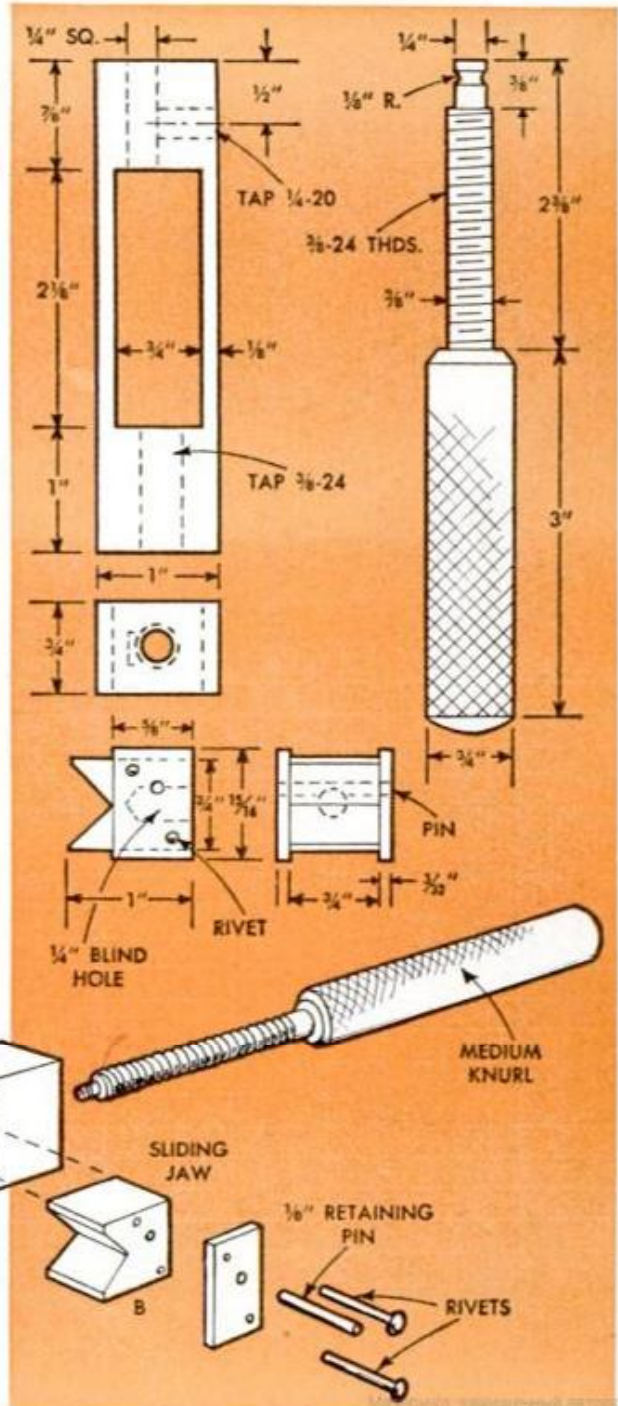

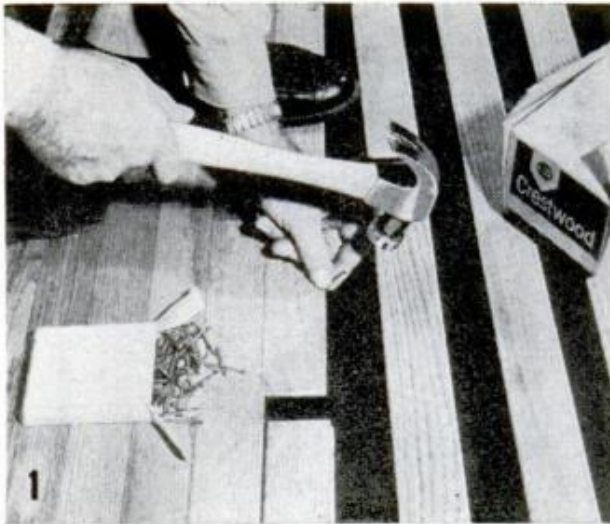

On the MARKET

for Do-It-Yourselfers

1. REMODELER'S HARDWOOD FLOORING comes in a nested package containing material to cover 25 sq. ft. of floor area, including cutting waste. Carton also contains correct number of nails and complete installation instructions. Individual flooring boards are $\frac{3}{8}$ x 2 in. sectional size, are prefinished and come in random lengths. Cartons are 8'-2" long
E. L. Bruce Co., Memphis 1, Tenn.



2. PAINTBRUSH CLEANER removes oil and latex paints, and all ordinary enamels and varnishes from brushes. Brush is simply dipped in cleaner and then rinsed under water faucet. Product also can be used for reconditioning brushes in which paints and varnishes have hardened over a long period of time. Simply soak brush in cleanser and rinse in clear water
Enterprise Paint Mfg. Co., 2841 S. Ashland Ave., Chicago 8, Ill.

3. PRECUT WOOD PICTURES are now available as kits in a wide range of subjects. Parts are keyed and are cut to exact size so that they fit together in a manner similar to the parts of a jigsaw puzzle. All that is necessary is to glue the parts of the picture to a panel which is furnished with the kit. Light sanding and finishing brings out color of woods
Albert Constantine & Son, Inc., 2050 Eastchester Rd., New York 61, N. Y.

4. READY-MIXED WALLPAPER ADHESIVE can be used when hanging nearly all types of wall coverings such as common wallpapers, grass cloth, silks and vinyls. Will not cause stains, even when work is done during periods of high humidity when slow-drying characteristics of ordinary pastes sometimes soften color pigments used in design patterns of wallpapers
Resistance Coating Corp., 966 Nepperhan Ave., Yonkers, N. Y.

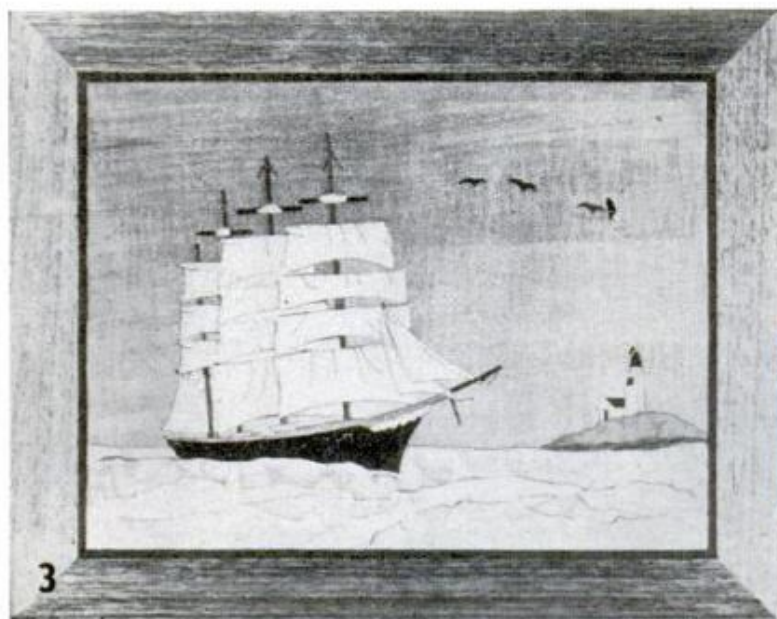



5

5. LIQUID GOLD-PLATING SOLUTION plates nearly all common metals except aluminum and stainless steel. Plating is done without electricity or any special equipment. Plating time is about three minutes and of course the coating will not corrode or tarnish if the necessary steps in the plating process are properly carried out. Especially suited to plating small objects such as jewelry fittings, medals, buttons, etc.

Panther Products, Inc., 2165 Morris Ave., Union, N. J.



6

6. CORRUGATED METAL ROOFING is now being supplied in 31-ft. rolls. Rolled strips are available in 15 and 30-in. widths. Strips come with integral lap flange crimped 1½ in. wide on each edge. One flange is coated with a mastic material which seals joint in final application. Roofing is simply unrolled and nailed in place as pictured. Material is also finding use as siding, ceiling and ornamental fencing

Ceco Steel Products Corp., 5601 W. 26th St., Chicago, Ill.

7. PLASTIC TAPE seals worn threads in leaky faucets, shower heads, automatic-washer hose—any threaded connection that must hold water under pressure. Withstands heat and cold in a wide range. Usually a single wrapping of tape will form an effective watertight seal when the thread has been tightened to normal tension. Not affected by sunlight, moisture, or concentrated solvents or acids. Comes in handy roll

Minnesota Mining & Mfg. Co., 900 Bush Ave., St. Paul 6, Minn.

8. MULTICOLOR PAINT is sprayed from a pressurized container and is available in 14 pastel colors that find a wide range of both household and industrial uses. Won't soften previously painted surfaces, dries quickly to a smooth, nontextured finish that can be recoated with a solid color whenever desired. Coating resists scratching and chipping and is especially resistant to abrasion due to its elasticity

Benjamin Moore & Co., 511 Canal St., New York 13, N. Y.



7

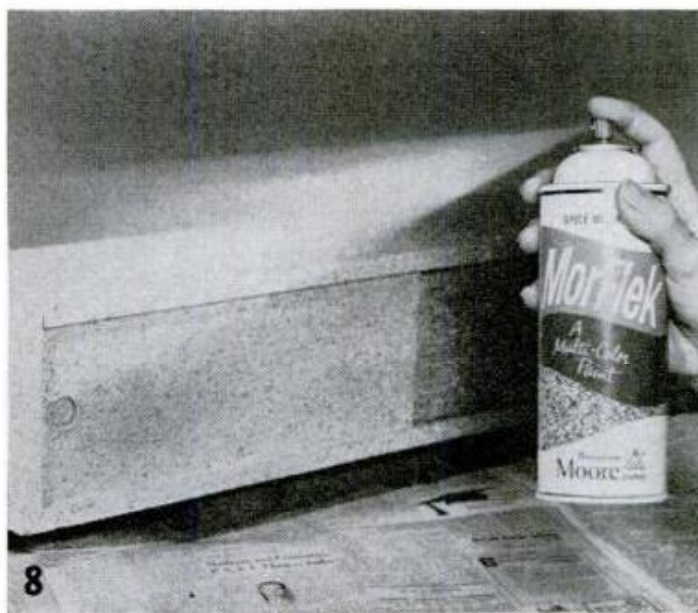

8

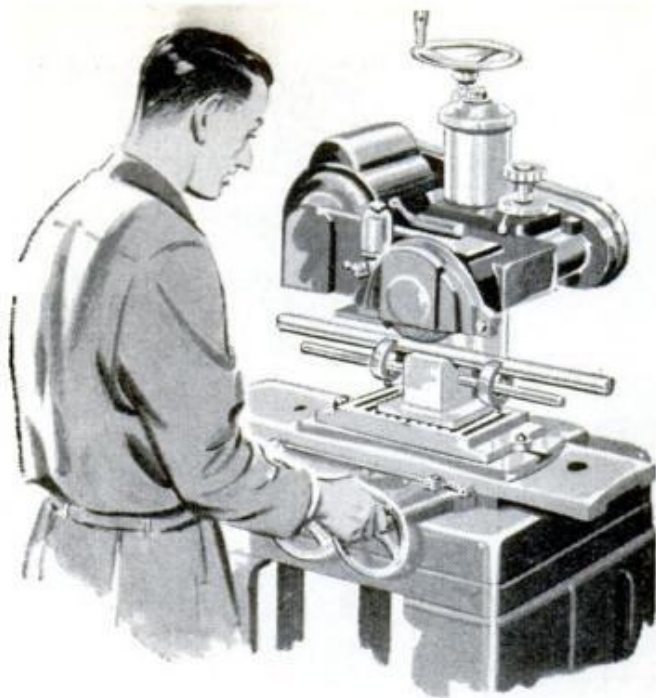

CLAMP FIXTURE Holds Round Stock For Machining

By Robert Hill

I HAVE TRIED several suggested methods for holding round stock for machining but none of them proved more reliable than the fixture shown. There are no difficult machine operations involved in making this simple, effective fixture, and the purpose it serves will facilitate many setups on a grinder, drill press and milling machine.

The side surface of the workpiece is completely exposed to action of the cutting tool or abrasive wheel as there are no external clamps to obstruct free movement of the latter. A special type ring clamp, metal block and clamp bar make up the parts. You can use any steel block of suitable size for the body of the fixture and weld a piece of flat steel to it to provide a clamping flange on the bottom of the fixture. The body has a 90 deg. V-slot milled across the top to seat the workpiece. A $\frac{5}{8}$ -in. hole drilled through the flange $\frac{1}{2}$ in. below the

groove takes the clamp bar with a snug press fit. The ring clamps are made on a lathe, although rings cut from a piece of pipe may do on light work.

To make the rings on a lathe, bore out a piece of round stock, boring it to produce rings of the desired size. Then cut off the rings with a parting tool. Width and thickness of the rings will depend on the gripping strength required for your work. Rings $\frac{1}{2}$ -in. thick and $\frac{1}{2}$ -in. wide will handle most work. After cutting off the rings, sections are ground from each one to produce jaws, the ends of which are faced off and made concave so they will hold firmly against the sides of the round workpiece. Setscrews tapped into the rings to bear against the clamp bar provide the clamping force.

On a magnetic chuck the lower flange needs no clamping, but clamps can be used if desired. For a drill-press table or a non-magnetic chuck, standard clamps are required to hold the fixture to the machine table. The fixture unit must be machined square to produce accuracy in the work it holds. When welding the plate to the body of the fixture be careful that the welding heat does not warp the plate. If this happened, the fixture would not hold the workpiece accurately in relation to the cutting tool or abrasive wheel.

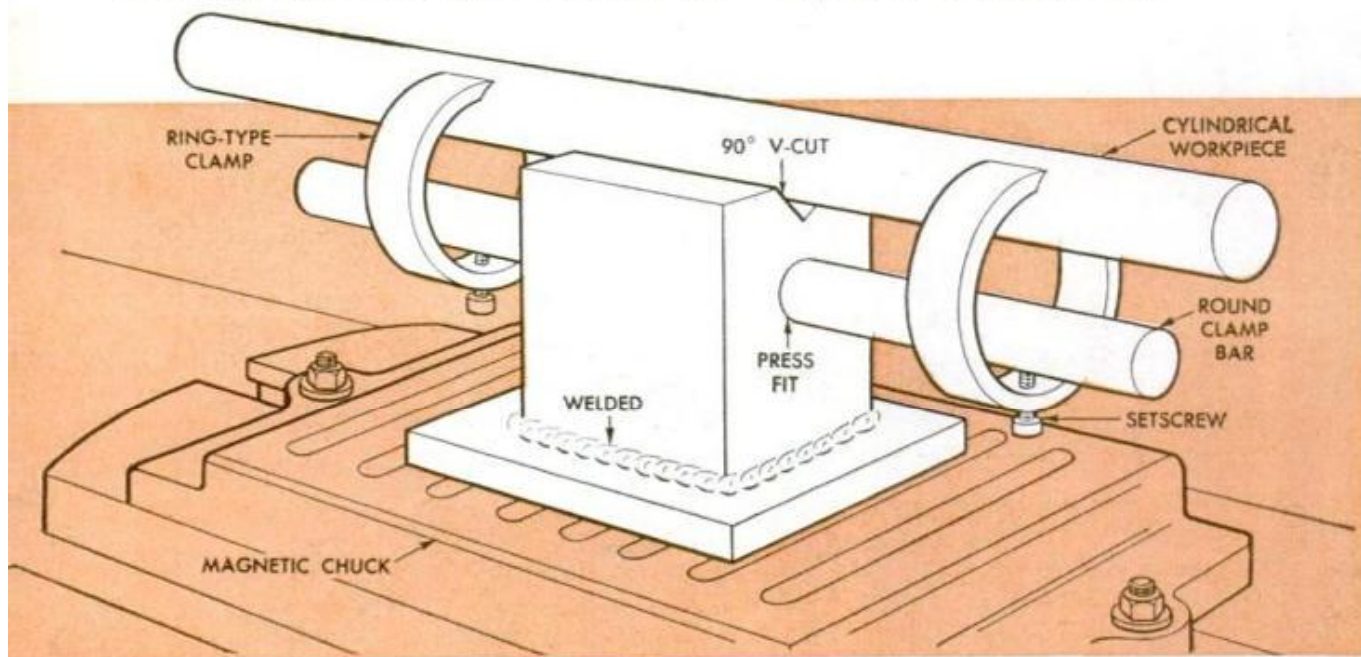



1

1. METRIC TAPS are now being produced in all sizes and pitches as a stock item by an American manufacturer. The new taps are made from high-speed steel, spiral flutes are ground from the solid after hardening. Flutes ground spirally give taps greater chip clearance, lower torque requirements and permit taps to be operated at greatly increased speeds

Shearcut Tool Co., 7045 Darby Ave., Reseda, Calif.

2. AIR OPERATED MARKING TOOL does a fast, accurate job of engraving parts numbers and other data on aircraft and missile components, also jigs, tools and fixtures. Engraving tip, or graver, is carbide tipped for cutting hard metals and is held in collet for easy removal. An air regulator, furnished as standard equipment, adjusts speed of cutting tip

Thor Power Tool Co., La Grange Park, Ill.

3. QUICK-CHANGE TOOL HOLDER replaces the conventional tool post on your lathe. Outstanding features are a saving in setup time when compared with conventional methods and the high precision with which changes are made. The cutting tool will return to the original setting with a variation of not more than .0001 in. Changes are made in seconds

Karl A. Nelse, 404 Fourth Ave., New York 16, N. Y.

4. 10-IN. TILTING ARBOR SAW is available with or without floor stand and with or without motor. Machine is heavy for heavy-duty jobs. Cast-aluminum ripping fence locks at the front of the table. Miter-gauge groove in table is undercut to take projecting lip milled on miter-gauge bar. This permits the miter gauge to clear the table without falling to the floor

Atlas Press Co., 2024 N. Pitcher St., Kalamazoo, Mich.



SHOPPING FOR TOOLS

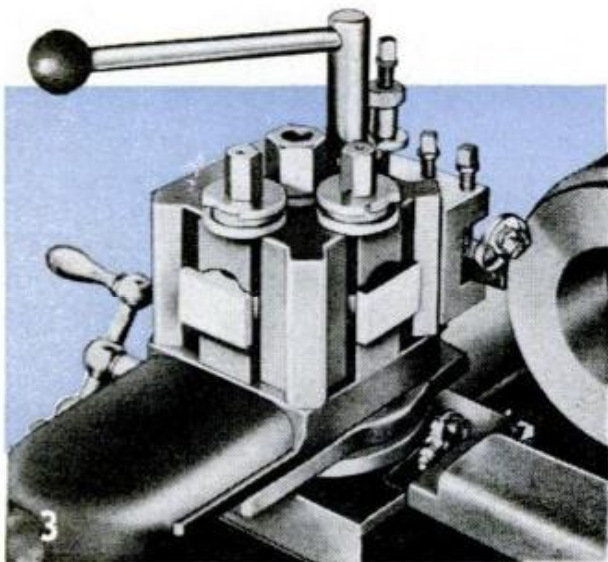

MARCH 1960



229

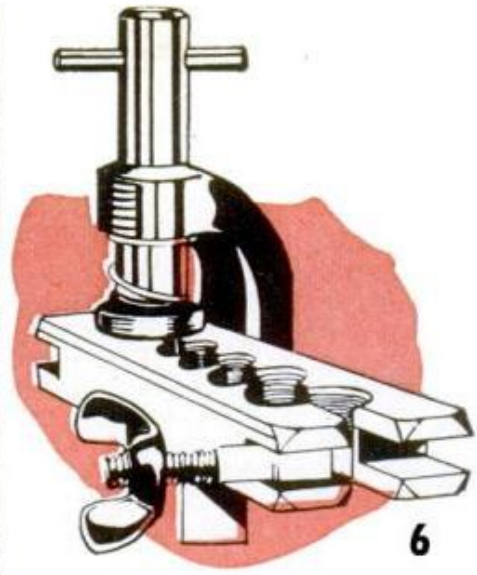
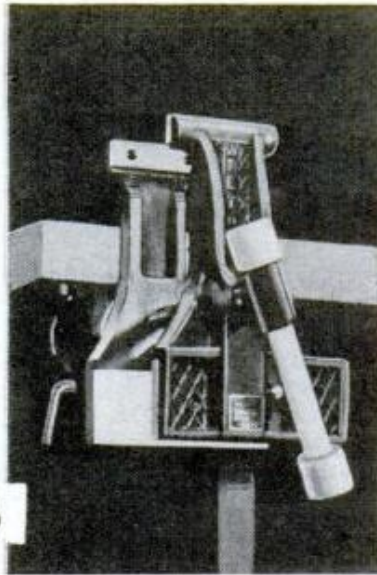
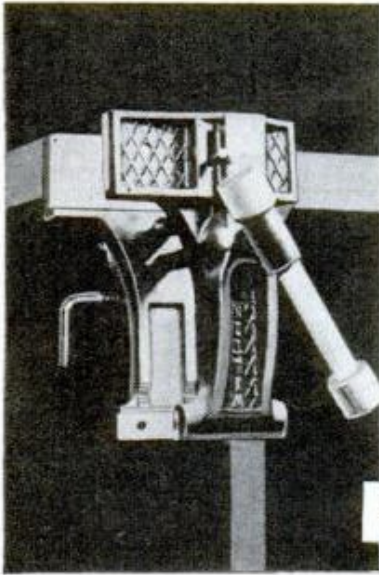

5. UNIVERSAL TURRET VISE is both a woodworking and metalworking vise combined in a swiveling head that can be locked in either of the two positions pictured. Has 3 x 7-in. woodworking jaws and 1 x 4-in. serrated jaws for metalworking. Holds pipe or tubing $\frac{1}{4}$ to $4\frac{1}{2}$ in. dia.
Wilton Tool Mfg. Co., Inc., Schiller Park, Ill.

6. FLARING TOOL works in a manner similar to an arbor press except that the flaring plunger is hammer actuated. Tubing to be flared is placed in correct size hole in the split block. Flaring plunger is then placed over end of tubing and given a light tap with a hammer
The Schaul Mfg. Co., 6300 Roland Ave., Cleveland 27, Ohio

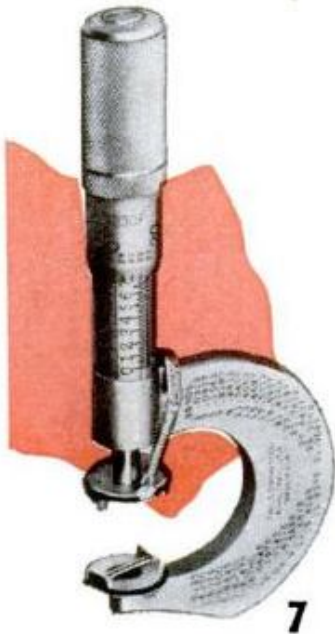

7. THREAD-MEASURING WIRE CARRIERS for attachment to common micrometers and measuring machines having $\frac{3}{8}$ -in. dia. anvils, were designed primarily for checking wear of thread plug gauges, but also have other applications in inspection. Capacity to $\frac{3}{4}$ -in. dia.
Standard Gauge Co., Inc., Poughkeepsie, N. Y.

8. HIGH-SPEED SPINNER cleans paint rollers and brushes thoroughly. Paint-laden brush or roller is inserted in spinner, which is then placed in container with solvent. Pulling on nylon cord rotates brush or roller in solvent. Remove brush, pour out solvent and spin dry
The Westway Mfg. Corp., 1100 Columbia Rd., Westlake, Ohio

9. MICROMETER HEAD is designed for use in electronic equipment requiring extra-fine adjustment and also for machine tools, fixtures, special gauges and tools where micrometer accuracy in settings is required. Length with setting at 0 is $4\frac{3}{8}$ in. Thimble dia. is $2\frac{1}{8}$ in.
The L. S. Starrett Co., Athol, Mass.

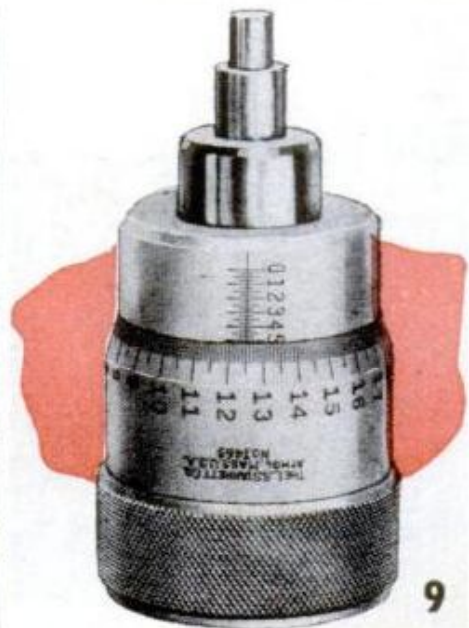
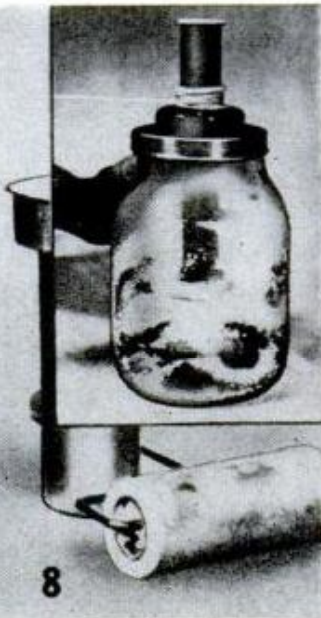

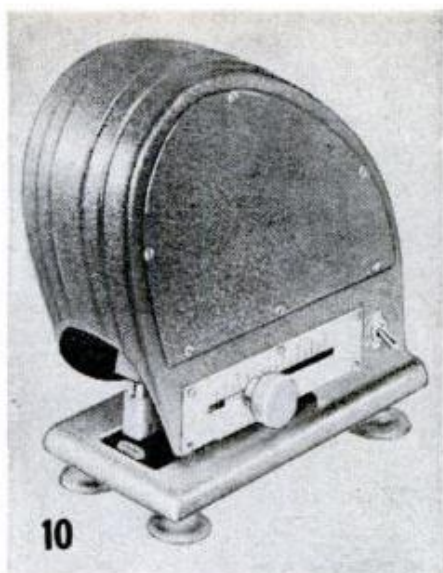

10



11

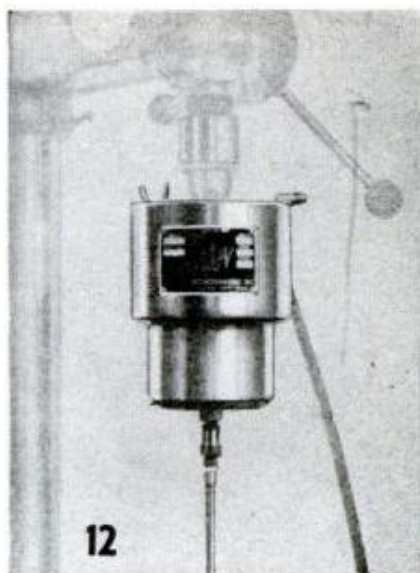

12

10. AUTOMATIC ELECTRIC STAPLER speeds up the job of stapling correspondence, reports, booklets, paper bags, envelopes, records and any material on typed or mimeographed sheets. Driver is operated by solenoid. Therefore it operates only as work is fed to it
The Staplex Co., 777 Fifth Ave., Brooklyn 32, N.Y.

11. NIPPERS are now available with carbide cutting tips for extra long life on harder materials. The tips, or jaws, are fastened in toothed seats by small screws and may be removed for regrinding after wearing dull. Available with tips for cutting wire and tile
The L. S. Starrett Co., Athol, Mass.

12. METAL DISINTEGRATOR can be used on a drill press, has practical uses in small shops. It does just what its name implies, disintegrates metals by means of a spindle which is vibrated electromagnetically at an extreme rate. Removes broken taps, drills, etc.
Jiffy Disintegrators, Inc., 1503 E. 11 Mile Rd., Royal Oak, Mich.

13. PAINT ROLLER has self-contained paint supply, eliminates need for pans, reduces dripping. Consists of a roller similar to conventional paint roller carried in a special guard, the cap of which screws onto a plastic bottle. Just squeeze bottle to feed paint to roller
Portable Electric Tools, Inc., 320 W. 83rd St., Chicago 20, Ill.

14. PORTABLE TOOL KIT consists of motor unit and fixed handle which is attachable to any one of four units to make a shaper, sander, router, and electric plane. In addition to units pictured there are accessories available which increase range of basic units
Sears, Roebuck & Co., 925 S. Homan Ave., Chicago 7, Ill.



13

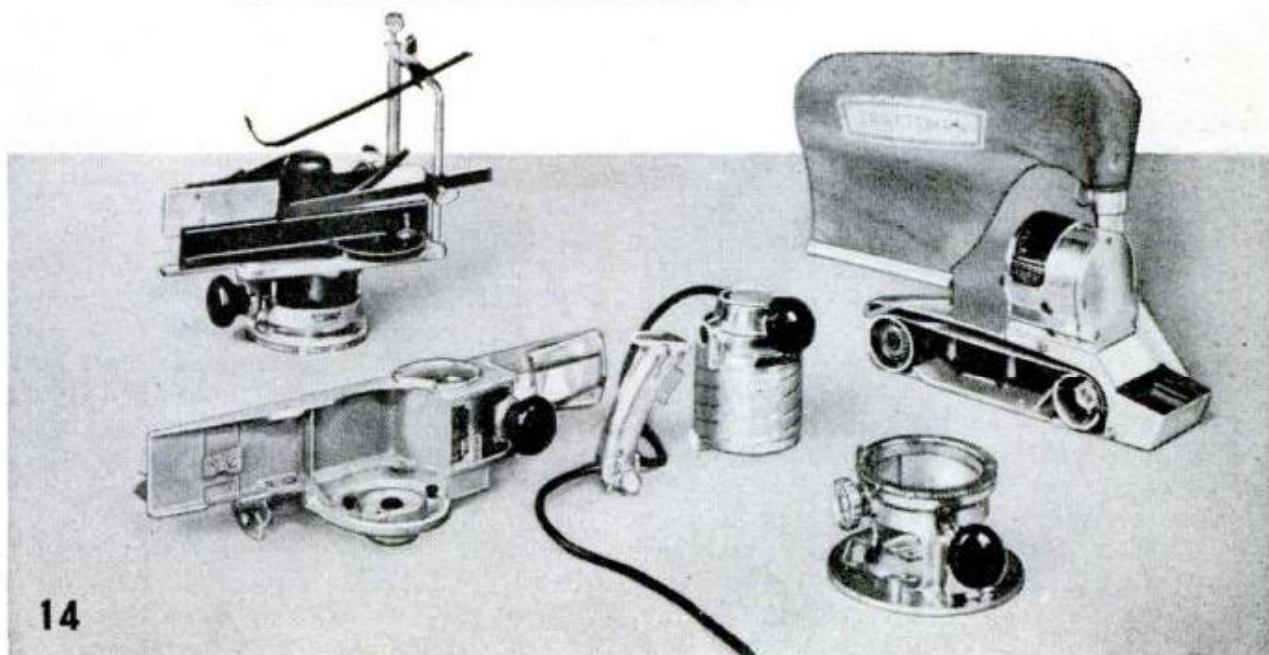

14

RADIO

TV

HI-FI

ELECTRONICS



Custom-Built Stereo Fidelity

PART III

Selecting Your Amplifier

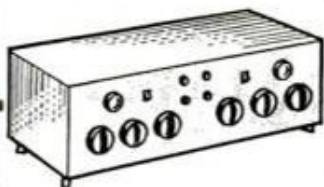

By Lothar Stern

WHEN YOU TURN ON the switch of a music system, hi-fi or otherwise, a number of different components go to work for you. At one end of the chain there's the pickup device, a record player, radio tuner or tape mechanism, which converts the energy from a program source (a disc or tape record or a radio signal) into equivalent electrical impulses. On the other there's the loudspeaker which changes these electrical impulses into corresponding sound waves. In between these components there's the *amplifier* which strengthens the feeble signals from the pickup device to the point where they can drive the speaker to the loudness level you want.

Every music system has some sort of amplifier. But while you can spend as little as \$5 for a simple phono amplifier (not hi-fi, of course) you can also lighten your coffers by as much as \$200 without expending any particular effort in that direction. The effort comes in when you try to select the one that offers the most for your money in a system which meets your personalized stereo requirements.

The development of high-fidelity amplifiers has reached a stage where the ear is no longer a good judge of absolute

quality. In contrast with loudspeakers, whose differences are quite audible in a listening-comparison test, the variations between high-quality amplifiers are much more subtle. In fact, any major flaws are likely to show up only after prolonged listening in the home, to a variety of program material. That's why every hi-fi-amplifier manufacturer carefully checks all aspects of his product with elaborate test equipment and makes the results available to the prospective buyer in the form of electrical specifications. Your ultimate satisfaction with the amplifier you buy depends upon your ability to evaluate these specifications and to correlate them to your needs.

Is it hi-fi, or isn't it? Who's to say? What may sound like high fidelity to the tolerant listener may be totally unacceptable to the more astute observer. The trouble is that

the hi-fi industry, as a group, has been strangely silent as to the specifications which constitute real high fidelity. And the absence of any official word has sanctioned the use of the "hi-fi" label on any amplifier barely capable of emitting a squawk.

In this regard, our hat's off to the Heathkit Co. for publicizing a set of standards which reflects its feelings on this controversial subject. The standards omit some vital statistics, but can serve as a guide.

Quality amplifiers, Heath contends, fall into three categories:

PROFESSIONAL amplifiers, which are so nearly perfect that they cause no audible change in the program material.

HIGH FIDELITY units which are slightly less perfect but still introduce no obvious deterioration of the sound.

HEATH-PROPOSED STANDARDS FOR AMPLIFIER CLASSIFICATION

CLASSIFICATIONS	Harmonic Distortion at Rated Power Output	Intermodulation Distortion at Rated Power Output	Frequency Response at Rated Power Output
PROFESSIONAL	2% or less at 20 cps 3% or less at 1000 cps 2% or less at 20,000 cps	1% or less, using frequencies of 60 and 6000 cps, mixed at ratio of 4 to 1	± 1 db from 20 to 20,000 cps.
HIGH FIDELITY	2% or less at 30 cps 7% or less at 1000 cps 2% or less at 15,000 cps	2% or less	± 1 db from 30 to 15,000 cps
UTILITY	3% or less at 60 cps 1% or less at 1000 cps 3% or less at 7000 cps	3% or less	± 1 db from 60 to 7,000 cps

NOTE: Any amplifier that meets professional standards at a certain power rating may have a higher power rating for high-fidelity purposes and a still higher one for utility purposes. A unit which meets neither professional nor hi-fi standards may still be satisfactory as a utility amplifier.

Table 1. There's no definite line between hi-fi and lo-fi. Here's one proposed standard for rating amplifiers

UTILITY amplifiers which meet minimum specifications considered adequate for sustained, satisfactory listening.

The technical specifications considered adequate to meet these standards are tabulated in Table I and interpreted in the pictorial representations and characteristics curves of Fig. 2. They mean simply this:

An amplifier must be able to supply enough electrical power to drive a loudspeaker to full-orchestra volume in your particular listening area. And at the peak of this power, it must not change, add to, or subtract from the program material by a greater amount than specified for the given classifications.

If all manufacturers would agree on a set of standards such as these, or if they would all measure their equipment in the same way, or at least publish their specifications using the same frame of reference,

the selection of an amplifier would be as simple as A, B, C. Unfortunately, this is not the case. In fact, there's a saying in the industry that the last manufacturer to publish his specifications has the best product. The inference is that this data can be colored — confused — to make it look better without actually being false. This being so, you'll have to reduce the variety of data furnished by different concerns to a common level in order to make a wise choice.

The Power Rating. The amount of amplifier power you need depends mainly on the speaker system you select. While the actual sound power developed by a full orchestra, even at maximum volume, may be only a fraction of a watt, loudspeakers are notoriously inefficient devices. The most efficient of them convert only about 50% of the applied amplifier power into equivalent sound. Some of the least efficient units

MEET THE DECIBEL

The apparent loudness of a sound does not change in direct proportion to its power. Because the ear responds logarithmically to a change of power it is necessary to employ a logarithmic standard of measure when describing loudness. Such a unit of measure is the decibel—db for short.

When we double the actual power of a sound, we increase its loudness level by 3 db, and this is about the smallest change in volume that can easily be recognized by the average ear. A critical listener might be able to detect a barely perceptible change in volume when the level is varied as little as 1 db, but only when listening under ideal conditions. Accordingly, if the frequency response of an amplifier is flat within 1 db from 20 to 20,000 cycles, even a critical listener would not be able to detect any difference in the over-all balance of the amplified sounds.

Measurements have shown that the ratio between the loudest and softest passages of music when played by a large orchestra is about 70 db. This is called the dynamic range of music. In actual recording, this range is somewhat compressed. Soft passages are accentuated to overcome the surface noise of records and tapes; loud passages are attenuated to prevent excessive distortion. Still, the range of hi-fi program material is in the neighborhood of 50 or 60 db, and for proper reproduction, an amplifier must have a similar range.

The dynamic range of an amplifier is limited by its inherent hum and noise level, which is

usually specified as so many db below maximum output. If the hum and noise level of an amplifier is stated as being "—50 db," meaning 50 db below maximum power output, and if we adjust the volume so that the strongest musical peaks are reproduced at maximum amplifier power, the very softest passages would be on the same level as the inherent hum and noise. Obviously, the lower the noise level in an amplifier, the better.

Why so Loud? Noise is everywhere—in the street, in an office, even in your own home after everyone is in bed. How much noise? Measurements show that the noise level in a very quiet room is about 40 db above the threshold of hearing. At orchestra hall, the peak sound level during the loudest passages might reach 110 db.

If a recording with a dynamic range of 50 db is reproduced in your living room at full-orchestra level, the softest passages might be reproduced at about 60 db. This is 20 db above the residual noise in a very quiet room.

Now maybe you don't like the idea of having a full orchestra in your living room and you turn down the volume to a maximum level of—say 80 or 90 db. At this level the softest passages are reproduced at only 30 or 40 db, and some of the music might be lost—masked by the ever-present room noise.

Not every musical selection has such soft passages and chances are that you won't miss much by turning down the volume a bit. But you can readily see why hi-fi—real hi-fi—should be played loud.

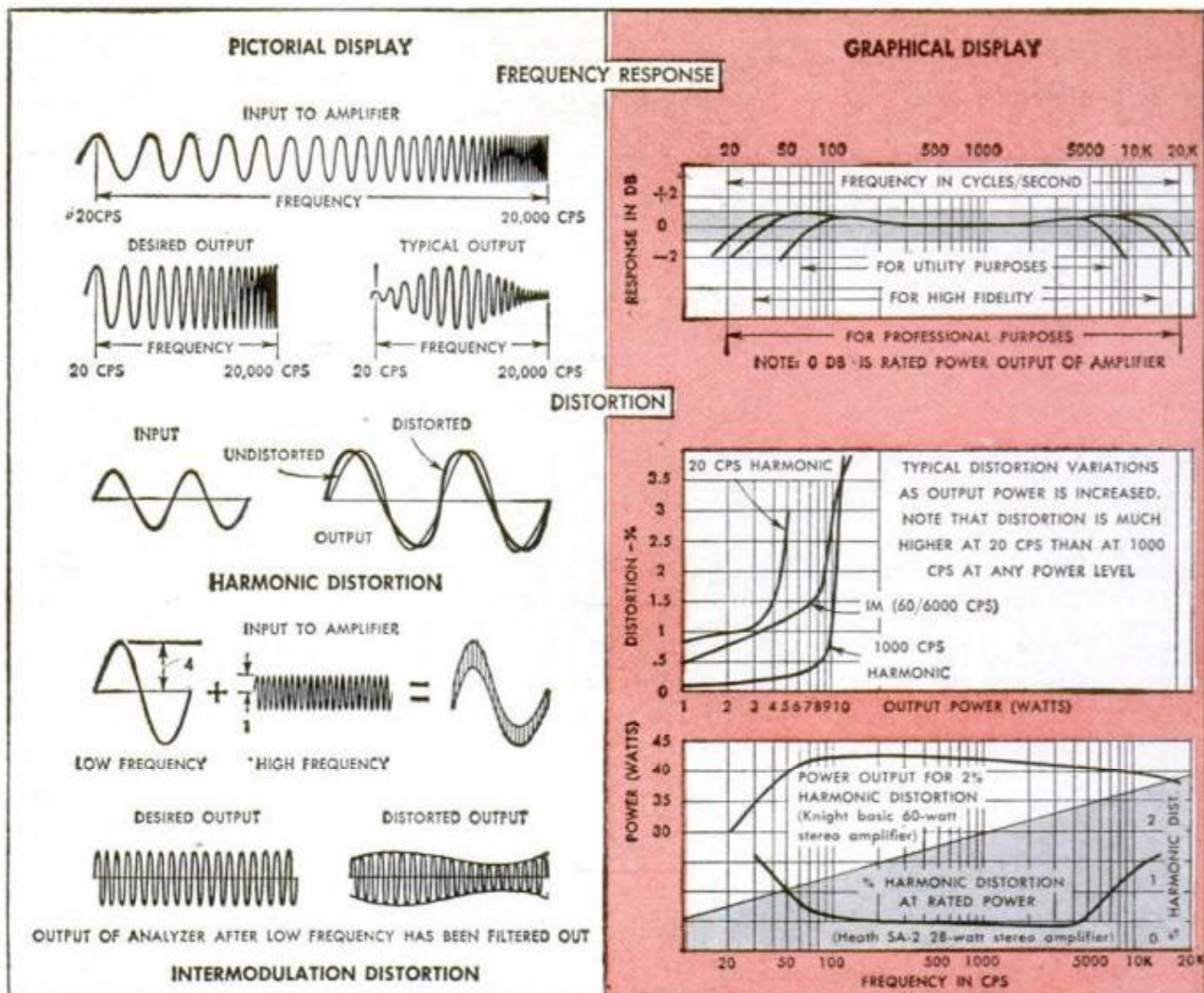

Fig. 1. Factors influencing amplifier quality. Graphs, right, show typical methods of presentation

waste as much as 99% of the applied power. Efficiency, of course, is no indication of speaker quality, but the inefficient units require more driving power and that means a larger, more expensive amplifier.

This, incidentally, is a good argument for selecting your speaker first. Then, if the speaker manufacturer tells you it takes 10 watts to drive the unit to full orchestral level, there's not much point in buying a high-powered amplifier. But if it takes 30 watts—well, you can't send a boy to do a man's job.

As an added consideration, you may want to drive two sets of speakers from the same amplifier so that you'll have music both upstairs and downstairs, or in two different rooms. That will take just twice as much amplifier power, and if you add still more speakers, the required power rises proportionately.

The absolute maximum power an amplifier can deliver depends upon the number and types of output tubes employed. One set of tubes may be able to provide a maximum of 10 watts while a different set may deliver 100 watts or more. Sound quality, however, decreases rapidly as the maximum power output of any amplifier is ap-

proached. That's why the published power output rating never refers to the absolute maximum, but rather to some arbitrary lower level at which, in the opinion of the manufacturer, the deterioration of the sound is not excessive.

But here's the rub. In the absence of any official standard, there can be considerable difference of opinion as to what constitutes excessive deterioration. What's more, there are numerous ways of "gilding the lily" just in the way that the specifications are written, or in their subsequent interpretation. Here's what I mean.

Originally the term power output referred to the continuous *effective* power an amplifier could deliver in response to an applied sinusoidal signal. Lately, the term *peak* power has been appearing with ever-increasing frequency. Now peak power refers to the maximum *instantaneous* power available from the amplifier — and that's just twice as great as the *effective* power. In other words, an amplifier rated at 10 watts continuous effective power will deliver 20 watts of peak power, and that's an important consideration when comparing amplifier specifications.

Even more recently, the term *music*



Fig. 2. Kit-built amplifiers rival factory-built components in appearance and performance, but at much lower cost. Above units include basic power amplifiers, complete integrated amplifiers and preamplifiers

power was developed, and this adds even more confusion. At best, an amplifier rated in terms of music power would be just as good as one rated in terms of continuous effective power. At worst, the former could exhibit overload tendencies which would seriously increase distortion at the rated power level. When judging amplifiers, therefore, it is important to know the type of power referred to in the specifications.

FREQUENCY RESPONSE. It is generally agreed upon that the human ear at its best can hear only those sounds within a frequency range of 20 to 20,000 cycles per second. The actual frequency content of music is probably somewhat narrower but, be that as it may, a good amplifier should be able to treat all audible frequencies alike, without any serious discrimination.

With electronic equipment it is generally easier to amplify frequencies in the mid-audio range than those at the extreme ends of the band. As a result, the response of an amplifier may suffer at the very low and very high frequencies, as shown in Fig. 1.

Fortunately, the human ear is not very critical when it comes to estimating the loudness differences between two sounds. Even a very critical listener can't differentiate between the original recording and the resulting reproduction unless the amplifier response varies by more than 1 db. But for critical evaluation you should know the response of an amplifier at its *maximum rated output power*.

Some frequency response specifications fail to mention the power level at which the measurements were taken. Others may specify a 1-watt level or normal listening level. This is perfectly legitimate, but you can't compare such specs with others specifying the response at full rated power. The reason is that frequency response deteriorates as full power output is approached and this must be taken into consideration in any comparative amplifier evaluation.

HARMONIC DISTORTION. No amplifier is perfect. All of them tend to change or distort the signal and this introduces new frequencies which were not present in the original program.

We've already mentioned that mid-audio frequencies are easier to reproduce than those at the high and low ends, and this applies to distortion as well as frequency response. To say that harmonic distortion is X% has little meaning unless the frequency and power level is also specified. This is shown in the second and third graphs of Fig. 1 which clearly indicate the manner in which the distortion varies in typical amplifiers. A hypothetical amplifier, as represented by the second graph, may have very low harmonic distortion at 1000 cycles, up to a particular power level, but the same unit may distort 20-cycle signals excessively even at low power.

The third graph in Fig. 1 shows the most common methods employed by hi-fi-amplifier manufacturers to give complete data

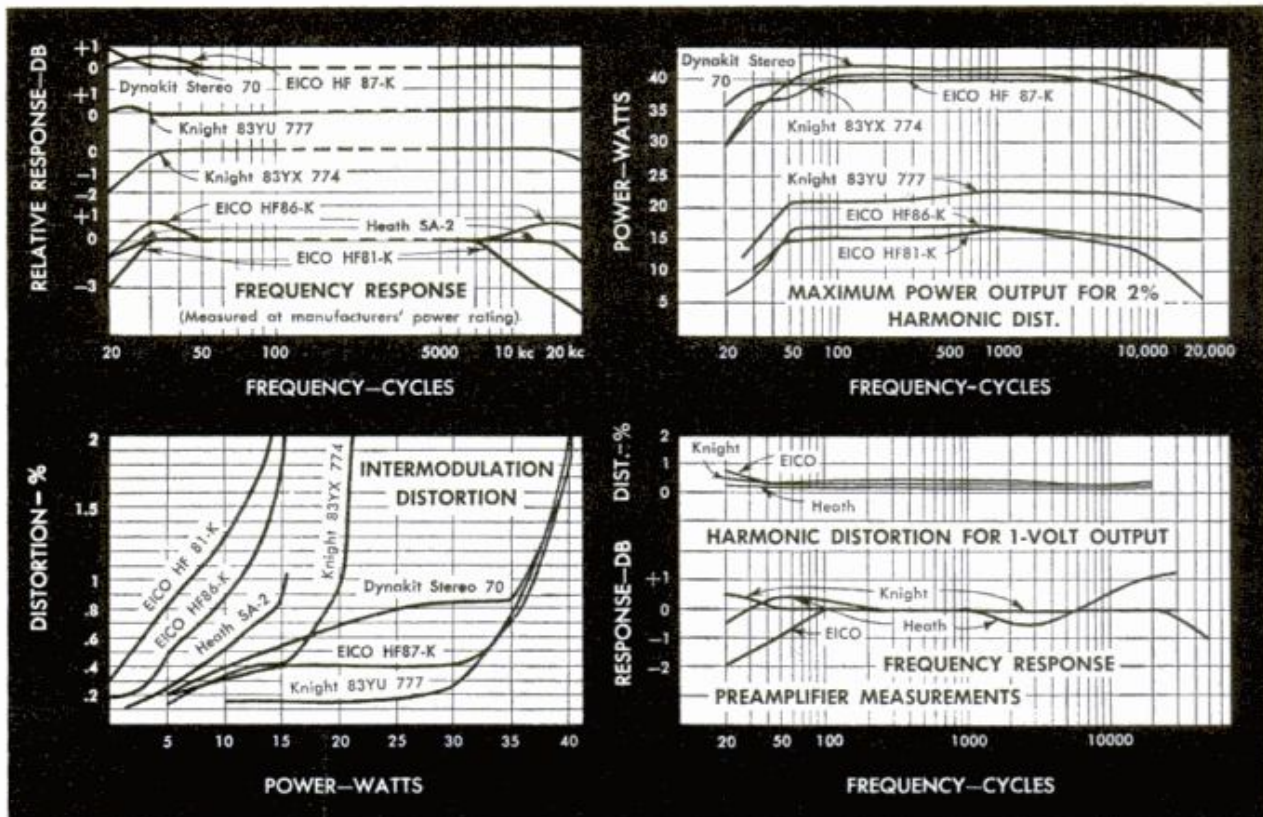

Fig. 3. Measurements on kit-built units closely coincide with manufacturers' published specifications

pertaining to harmonic distortion. The upper curve shows the amount of continuous power available at each frequency without exceeding 2% distortion. This particular amplifier is rated by its manufacturer at 30 watts per channel (60 watts stereo) and the curve shows the conservative nature of this rating. The lower curve shows another way of presenting similar information. In this case the amount of actual distortion at each frequency is plotted at the rated continuous power output of the amplifier. Note how distortion increases at each end of the frequency spectrum, but that it remains well below 2% even at 30 and 15,000 cycles.

INTERMODULATION DISTORTION. This form of distortion results from interaction between tones of different frequencies within the amplifier. It is perhaps the most annoying form of distortion since it gives rise to the production of new frequencies which are harmonically unrelated to those of the original signals.

Like other forms of distortion this interaction between frequencies increases as the power output of the amplifier approaches its maximum limit, as shown in the center graph of Fig. 1. A set of curves such as these, for each amplifier under consideration, would be most valuable in helping you make your final selection.

Seldom will you find all of the pertinent amplifier data given in a catalog or advertisement. Yet, because high-fidelity ampli-

fiers are sold chiefly on the merits of these specifications, full information must be available. My suggestion—make your tentative selection on the basis of rated power output and price, as given in catalogs and advertisements, then write for complete technical data and compare.

If you're starting from scratch, even if you don't expect to invest in a stereo speaker system immediately, you'd be wise to buy a stereo amplifier. And with good reason. The two individual channels of a stereo amplifier can be connected together for monophonic operation, but a single-channel amplifier can't be used for stereo—not without buying another one. And two monophonic units cost far more than a stereo amplifier of similar quality. You'll want stereo eventually, so you may as well prepare for it right from the start.

Amplifier Kits

Not everyone enjoys "rolling his own", but if you do, you can spend a few pleasant evenings building a hi-fi amplifier and save up to 50% in the bargain. Amplifier kits are available in almost as great a variety as factory-built units. They are designed to the same standards and judged by the same specifications. A few kit-built amplifiers are illustrated in Fig. 2 and the actually measured specifications for these and some other kits are given in Fig. 3.

If the ease with which some of these kits

(Continued to page 240)

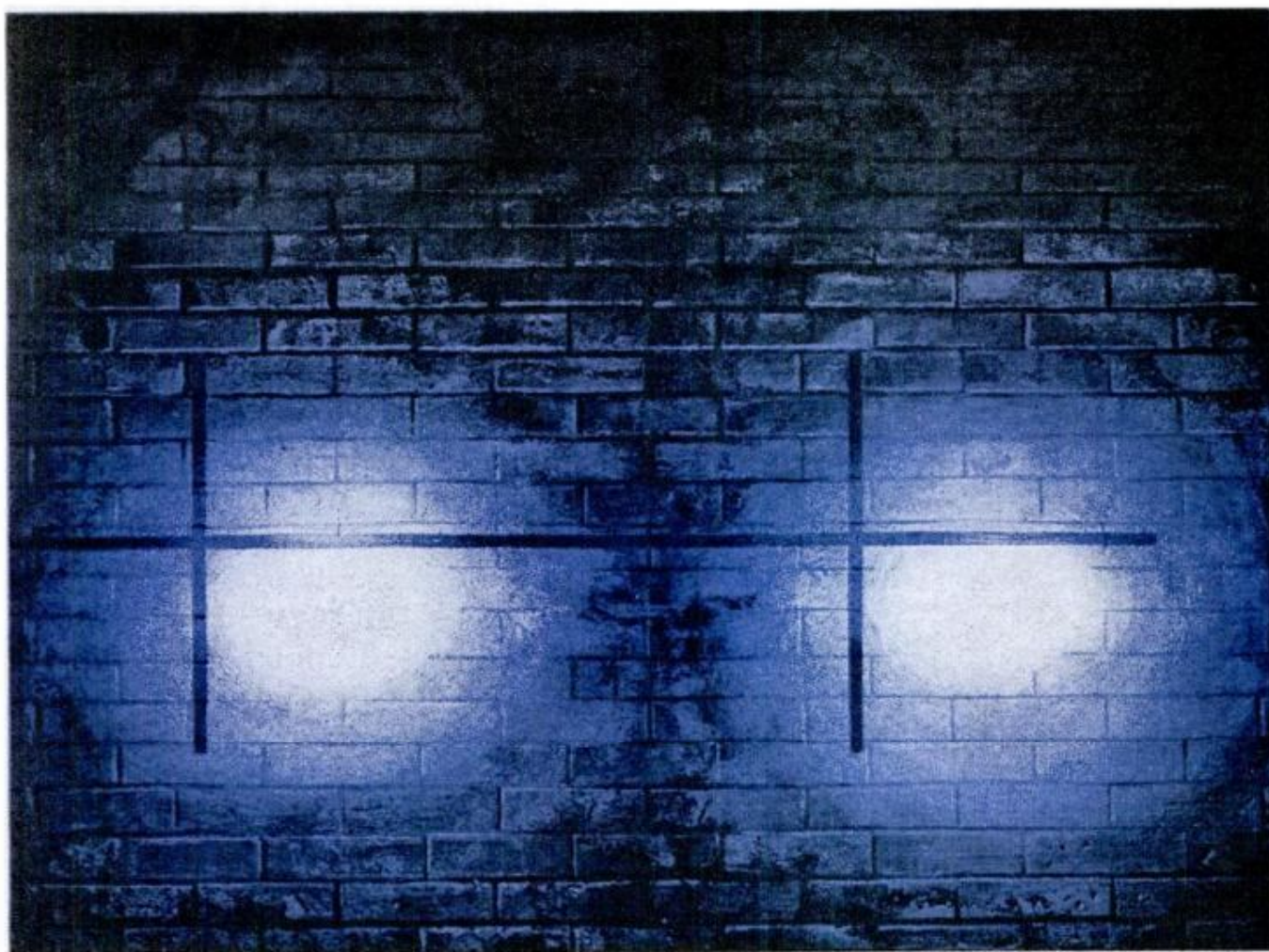

Falcon's new parabolic reflector gives you greater vision for night driving.

Why does the Falcon have single headlamps and dual horns?

Single headlamps cost less to replace. They're *right* for an economy car. But before Ford engineers would OK them for the Falcon, they had to devise a single-light system that would not sacrifice safety.

Result? A new parabolic reflector so efficient Falcon drivers can actually see farther in the face of oncoming traffic than with any dual system.

This same foresighted engineering is found in a single, *adjust-it-yourself* carburetor, bolted-on front fenders that cut repair costs, a gas tank accessible from the trunk, and an aluminized muffler that lasts up to twice as long as ordinary types.

Dual horns cost more! But horns almost never need replacement so there's no long-range economy in skimping on the original installation. And dual horns are better. No

single horn gives the quality of sound of two horns. And there's added safety in the warning power of two horns.

That's hidden quality that means *long-range* economy. You'll find it throughout the Falcon. It's there in the sound-conditioned roof, in underbody members that are zinc-coated for protection against rust, in a finish that *never* needs wax, a new battery mount that makes batteries last longer.

Economy where it *pays*... quality where it *counts!* That's the Falcon; the easiest car in the world to own.

THE
1960
FORD

FALCON

FORD DIVISION, Ford Motor Company.



STAINLESS STEEL OIL RING, U.S. PAT. NO. 2,789,872

Sealed Power *Stainless Steel* oil ring does things no other ring can do!

Stainless steel oil rings deliver superior oil control—and for easily understood reasons. First, stainless steel resists the corroding and pitting effects of the gases of internal combustion engines. This means the oil ring surface stays clean. There is nothing for sludge or carbon to cling to. Thus the return oil vents stay open and you get the *long lasting* oil control you expect.

Second, stainless steel has no significant tension loss at engine operating temperature. This is unlike carbon steel oil rings. No tension loss assures proper tension of the side rails of the oil ring against the cylinder walls—even in tapered and out-of-round bores. Again, this proper tension is exerted for the entire life of the ring which means better oil control longer.

Sealed Power KROMEX PISTON RING SETS Preferred Performance

Pistons • Pins • Sleeves and Sleeve Assemblies
Valves and Valve Parts • Tappets • Water Pumps
SEALED POWER CORPORATION • MUSKEGON, MICH.

PLANETS OF OUR SOLAR SYSTEM

(See page 102)

PLANET	DIST. FROM SUN (MIL. OF MILES.)	LENGTH OF YEAR Relative to Earth	VEL. OF ESCAPE MI/SEC.
Mercury	36.0	88 days	2.2
Venus	67.2	224.7 days	6.3
Earth	93.0	365.25 days	7.0
Mars	141.5	1.886 yr.	3.1
Jupiter	483.3	11.86 yr.	37.0
Saturn	866.1	29.46 yr.	22.0
Uranus	1782.5	84.02 yr.	13.0
Neptune	2793.2	164.79 yrs.	14.0
Pluto	3675.0	248.44 yrs.	6.6

PLANET	RATE OF ROTATION Relative to Earth	MASS Relative to Earth	DEN-SITY grams cc.	DIAM-ETER (Miles)
Mercury	88 days	.04	2.86	3,000
Venus	?	.80	4.86	7,700
Earth	1 day	1.00	5.52	7,900
Mars	24 hrs. 37 min.	.11	3.96	4,200
Jupiter	9 hrs. 55 min.	317.	1.34	86,700
Saturn	10 hrs. 14 min.	95.	.71	71,500
Uranus	10 hrs. 40 min.	14.7	1.27	32,000
Neptune	15 hrs. 40 min.	17.2	1.58	31,000
Pluto	?	.7	5.3	6,500?

PLANET	GRAVITY AT SURFACE	MOONS	DIAMETERS OF MOONS	DISTANCE TO MOONS (Miles)
Mercury	.27	—	—	—
Venus	.85	—	—	—
Earth	1.0	1	2160.0	240,000
Mars	.38	2	105	5,800; 14,600
Jupiter	2.46	12	15 to 3,200	112,600 to 14,800,000
Saturn	1.17	9	300 to 3,550	115,000 to 8,034,000
Uranus	.92	5	150 to 1,000	80,000 to 334,000
Neptune	1.12	2	3000; 200	220,000 to 5,000,000
Pluto	.9	—	—	—

(Reprinted from Dr. Dan Q. Posin's book, *Out of This World*, published by Popular Mechanics Press.)

NEW! FROM DU PONT

DUCO[®]

ANTI-RUST

PAINTS

stop rust...for all metals, new or old

Another contribution from Du Pont Research! Anti-Rust Paints for every surface. "Duco" Anti-Rust Primers for damp-proof priming of rusted metal; for clean steel, tin and aluminum; for all galvanized and copper surfaces! "Duco" Wrought Iron Black for exterior or interior use. "Duco" Chrome Finish Aluminum Paint. And for colored top coats doubly durable Du Pont "Duco" Enamel. These new Anti-Rust Paints . . . today's best protection for metal, indoors and out . . . are all at your Du Pont dealer's—now.



Buy the paint that's worth the work—the beauty lasts



BETTER THINGS FOR BETTER LIVING . . . THROUGH CHEMISTRY



SUPREME VERSAMATE

Versamate . . . a wonderful tool that fits any power drill —reduces speed to give seven times more power. Drives screws of all sizes. Inexpensive extras make it a nut and bolt driver, heavy-duty drilling unit. See your tool dealer today!



\$9.95

For Portable Drill Users...

CHOOSE THE ATTACHMENTS THAT DO THE BIG JOBS!

Versamatic triples portable drill usefulness. *Reverses!* Drives and removes screws, nuts, bolts. Boosts power 7 times. Set includes regular and Phillips-type bits, and 1/4" square drive adapter. For heaviest drilling jobs in steel and concrete, add a 1/2" Supreme Brand Chuck.

\$14.95

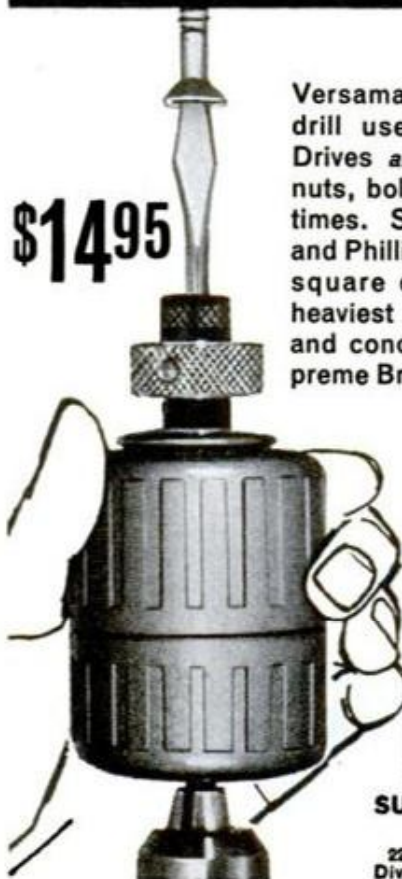

SUPREME VERSAMATIC



SUPREME PRODUCTS CORPORATION
2222 S. Calumet, Chicago 16
Div. of A • S • R Products Corp.

Selecting Your Amplifier

(Continued from page 236)

meet the Heath-proposed standards intimates that these standards are low, let me assure you that this is not true. It takes high quality parts and careful attention to circuitry to obtain appreciable undistorted power at the extremes of the audio-frequency range. The fact that the results shown were obtained without any effort towards optimizing the performance is a tribute to kit-manufacturers' integrity in rating their components.

Two Units or One?

Every amplifier consists of two basic parts: A preamplifier and a basic power amplifier. Some of them have both of these parts mounted on the same chassis; with others, you buy and install the two units separately. The preamplifier furnishes all of the operating controls, while the power amplifier just sits there and converts the signal from the preamplifier into power for driving the speaker.

The separate-chassis units are more flexible—often provide more control functions—but they're not necessarily better. Their main advantage is that they permit the heat-producing power amplifier to be mounted separately, in some well-ventilated location, while the cool-running preamplifier can be installed with other components in a more restricted space. This is particularly important with amplifiers which must deliver a great deal of power and most units rated in excess of 40 watts are of the two-chassis variety.

Flexibility Prevents Obsolescence

Electrical specifications aren't the only things you must consider when selecting your personalized stereo-fidelity amplifier. There's also versatility — both of control functions and of eventual applications. The modern stereo amplifier is not the simple device of its outdated counterparts. It's a complicated maze of controls and switches needed to handle the conflicting requirements of the various program sources, and for proper adjustment of the resulting sound to virtually duplicate that of the original orchestra. Some of these controls are used so seldom that their inclusion seems hardly worthwhile; others are an indispensable part of high fidelity and stereo. To ascertain that the amplifier you buy has all of the desired controls, you should become familiar with their functions and how they affect overall quality and flexibility.

Input Jacks. Every amplifier should have enough input jacks to handle a variety of

(Continued to page 284)

BUY **GRAVELY** FOR

MORE PERFORMANCE

MORE POWER

MORE FOR YOUR MONEY

Why tolerate equipment you have to push, pull and pamper? The Gravely and its Rotary Mower attachment solves your toughest mowing problems!

Whether you cut and mulch heavy, tough weeds over the roughest ground, or mow the finest lawn, Gravely does the job *better!* Because Gravely, with its *extra* power (now 6.6 HP) and versatility, does more tough jobs other tractors can't!



30 Tools



PERFECT SEEDBED WITH ROTARY FLOW



POWER CULTIVATE GARDENS



MOW FINE LAWNS



HAUL HALF-TON LOADS

SINCE 1922

UNMATCHED PERFORMANCE!

Choose the tools that fit your jobs from 30 year-round attachments. All powered by one Gravely tractor!

Do the job *better* because power attachments are driven direct from the engine by splined steel shafts and gears. No belts or chains to slip, wear or break. More power at the *working tool!*

A **FREE** demonstration by your local sales and service representative will show you, beyond doubt, that the Gravely and its attachments will do your jobs *better, faster, easier.* Compare. You will see that you get *more power, more performance, more for your money!* . . . Available on installment plan.

WRITE FOR FREE 24-PAGE BOOKLET!

Big, 24-page illustrated booklet, "*Power vs Drudgery*", shows how the Gravely solves your lawn and garden problems . . . Write for it today!



FREE! MAIL NOW

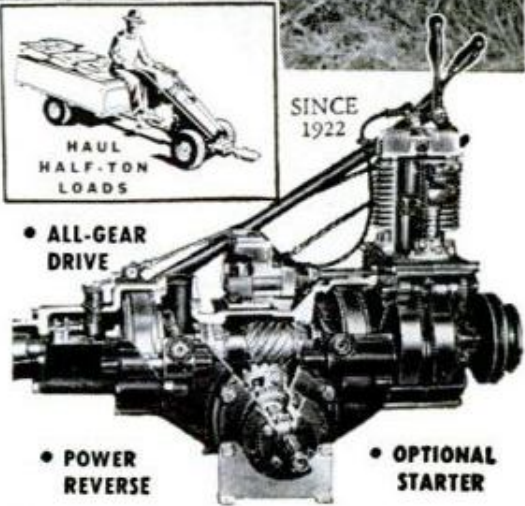

• ALL-GEAR DRIVE

• POWER REVERSE

• OPTIONAL STARTER

Power attachments *securely* mounted by only four bolts. Balance, easy handling, simple controls. Cutaway view shows Gravely's clean, compact, power-engineered design—the reason for its remarkable performance. Make the wise choice — choose Gravely!

GRAVELY TRACTORS, INC.

P.O. BOX 601-C DUNBAR, W. VA.

Please send "*Power vs Drudgery*" Booklet and dealer's name to:

Name _____
Address _____
Town _____ State _____

ONLY ONE PLIER GIVES YOU BOTH

1. Reinforcing Rib
for ADDED STRENGTH
WHERE YOU NEED IT!

2. Machined Undercut
Channels... SMOOTH-
WORKING, CAN'T SLIP
UNDER ANY LOAD!



Only CHAN-
NELLOCK gives
you these power-
grip features. That's
why thousands of skilled
mechanics—year in, year out—buy
CHANNELLOCK in preference to any
other plier. They prefer its terrific grip-
ping power, its all 'round usefulness.
And you will, too! Available in three jaw
capacities: $\frac{3}{8}$ " , $1\frac{1}{2}$ " and 2". Ask your tool
supplier for a genuine CHANNELLOCK
Plier. If he's out of them, ask him to
order one for you.

Write for Catalog of Complete Line of Pliers

CHAMPION DEARMENT TOOL COMPANY

Meadville 1, Pennsylvania

Should We Let Nature Take Its Course?

(Continued from page 111)

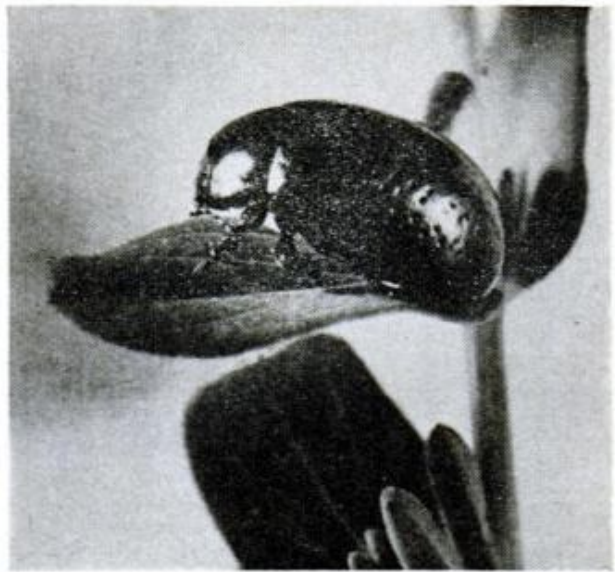

U.S. Department of Agriculture photo

By destroying thousands of acres of Klamath weed, the imported Klamath weed beetle became a hero

wide and to contain $2\frac{1}{4}$ billion birds! But even a prodigious slaughter program—for food, for sport, even for fertilizer—could not make any very real inroads on such a population. The passenger pigeon died off when the forest, his natural habitat, was cut to make way for farms.

Almost anything can upset nature's precarious balance—even engineering projects. Construction of the Welland Canal, which by-passes Niagara Falls, opened the way for a disaster of costly proportions. The lamprey, a rasp-toothed, eel-like fish—"the Dracula of the Great Lakes"—slipped in from the sea, leaving natural enemies behind. On a wholesale scale, it started attaching itself to food fish, sucking them dry of blood. The market catch of trout and whitefish in Lakes Huron and Michigan stood at \$8 million a year in pre-lamprey days. It fell to zero. There was similar devastation in other lakes.

The research program, now nearing completion, has developed a poison lethal to the lamprey larva but harmless to food fish. Once it has done its work, gigantic restocking operations will get under way.

There are dozens of examples of man's tinkering with nature's balance to his own great cost. Historically, one of the greatest examples of this occurred early this century when well-meaning conservationists decided to make Arizona's Kaibab Forest a deer refuge. To provide ideal conditions, deer enemies—wolves, mountain lions and coyotes—were destroyed. Hunting was banned. From all outward appearances, a

(Continued to page 266)



NEW!
MARLITE
RANDOM
PLANK...beautiful random paneling
you can install this weekend!

Most rooms can be modernized in a weekend with new Marlite Random Plank. Here, for example, is Italian Cherry—one of six exclusive Trendwood® finishes for any interior, any decor. It's made in 16" wide by 8' long planks (1/4" thick) for easy installation over furring strips or existing walls . . . needs no painting or further protection. And all melamine plastic finished Marlite paneling resists stains, mars, dents—stays like new for years with an occasional damp cloth wiping. See your building materials dealer today, or mail coupon below.



Marlite®
plastic-finished
WALL and CEILING PANELING

Marlite Division of Masonite Corporation,
Dept. 342, Dover, Ohio

Please send free full-color remodeling folder
on new Marlite Random Plank.

Name _____

Address _____

City _____ State _____

ANOTHER QUALITY PRODUCT OF MASONITE® RESEARCH



You can do more with

DELTA

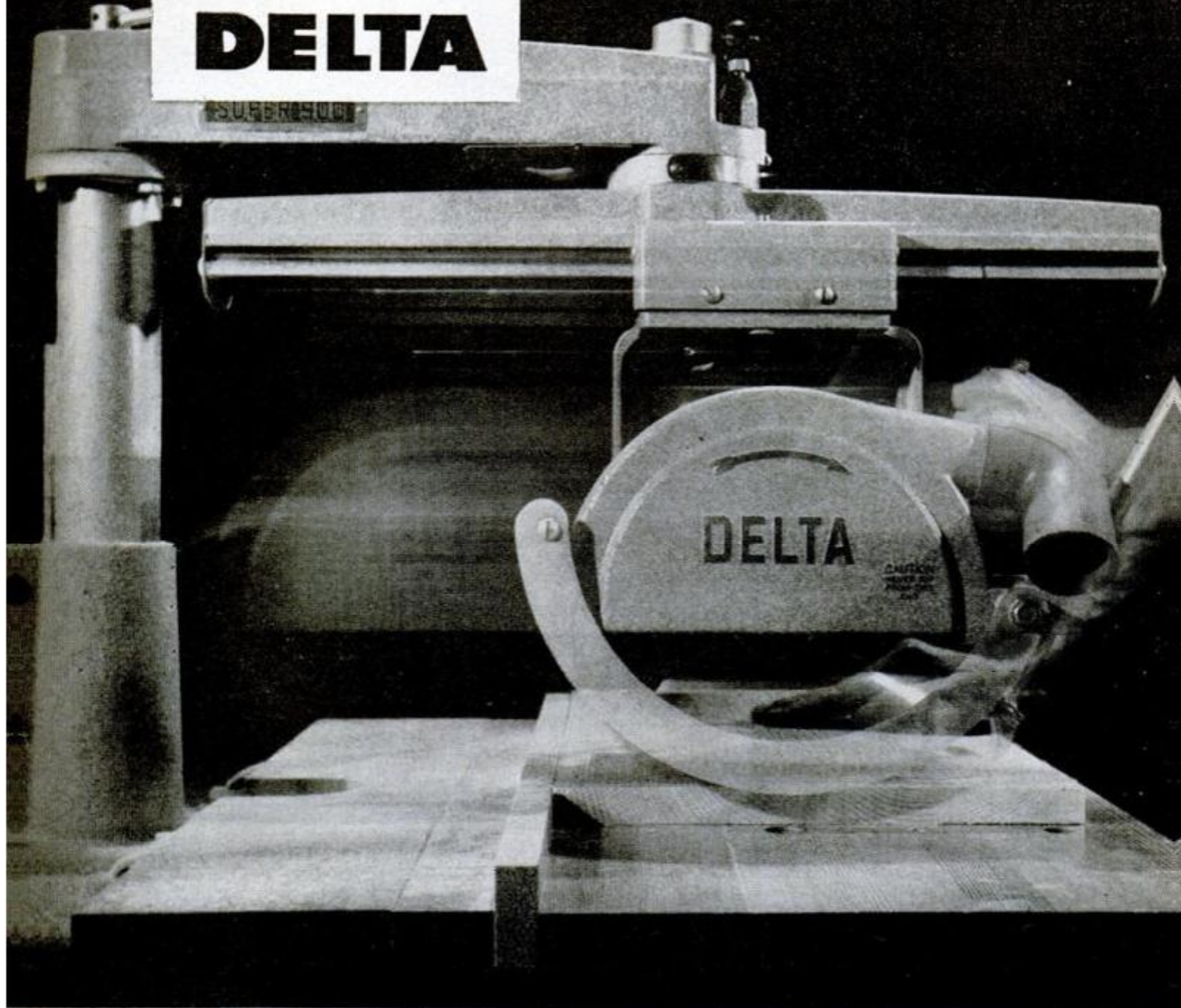

CUTTING MOULDINGS such as this extra large cove moulding is easily done with the regular blade. By simply adding the moulding cutter-head you can cut an endless variety of shapes.

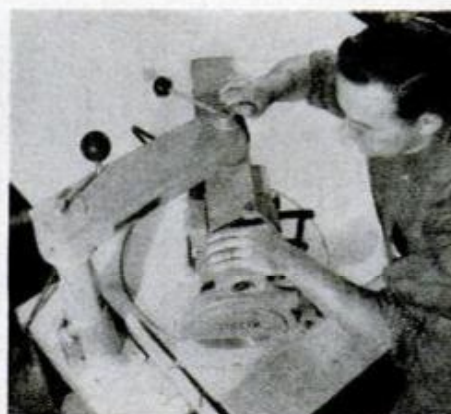

CIRCLE CUTTING is not limited to only one diameter—another advantage of exclusive “Turret Arm” action. You’ll really appreciate how easy it is to do this unusual operation with complete accuracy.



SAFE RIPPING of narrow strips is assured because you can lock the fence quickly in the “up front” position. Handy push grip provides smooth, steady feeding action from start to finish.

Материал, защищенный авторским правом

"Super 900" Radial Saw

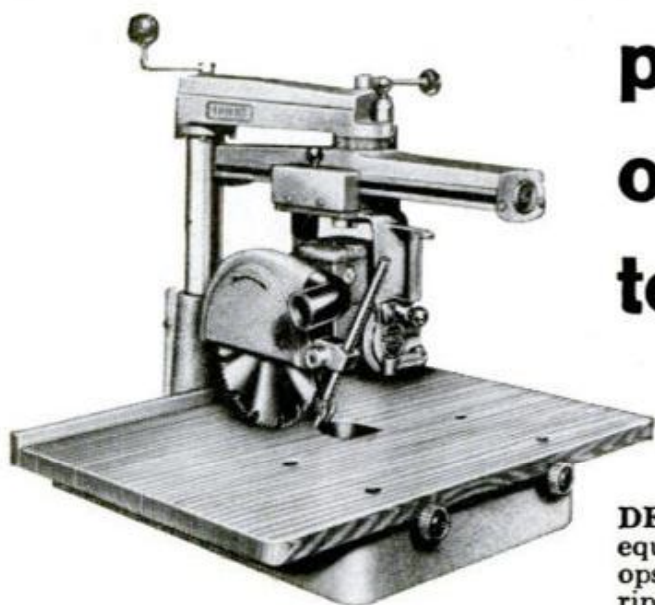

**puts more
of your skill
to work**

DELTA "SUPER 900" RADIAL SAW—equipped with powerful motor that develops up to 2 H.P.; cuts 2½" thick stock, rips up to 24" wide.

Here's a workshop workhorse that tackles the toughest jobs you've got—and delivers perfection every time! This rugged Delta Radial gives you precision that is actually built in, yet is easy to use right from the start. You get all the flexibility that Delta "Turret Arm" action provides. Swing, spin or tilt the head—you'll do dozens of operations conveniently, safely because the cutting tool stays over the table throughout a 360° swivel. With this machine you never have to worry about alignment. Thanks to Delta's exclusive, new "Micro-Set" Miter Stops, you can be sure of perfect 90°

and 45° cuts for the *life of the machine*.

There are many other unequalled features you'll recognize. And because you know tools, you'll appreciate the industrial quality that Delta's 31 years of experience build into every power tool. So whether you're adding more versatility or starting a one-tool workshop—get the finest! See the Delta "Super 900" Radial Saw and full range of money-saving accessories when you visit your Delta Dealer (he's listed under "TOOLS" in the Yellow Pages) or see it in action at your leading Department, Hardware or Building Supply Store. Don't wait!

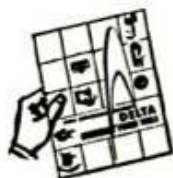

See the world's most complete line of home workshop power tools and accessories—pictured and described in this colorful, **FREE** Homecraft catalog. Write to: Rockwell Manufacturing Company, Delta Power Tool Division, 502C N. Lexington Ave., Pittsburgh 8, Pa. In Canada: Rockwell Manufacturing Co. of Canada, Ltd., Guelph, Ont.



Cut it with WISS

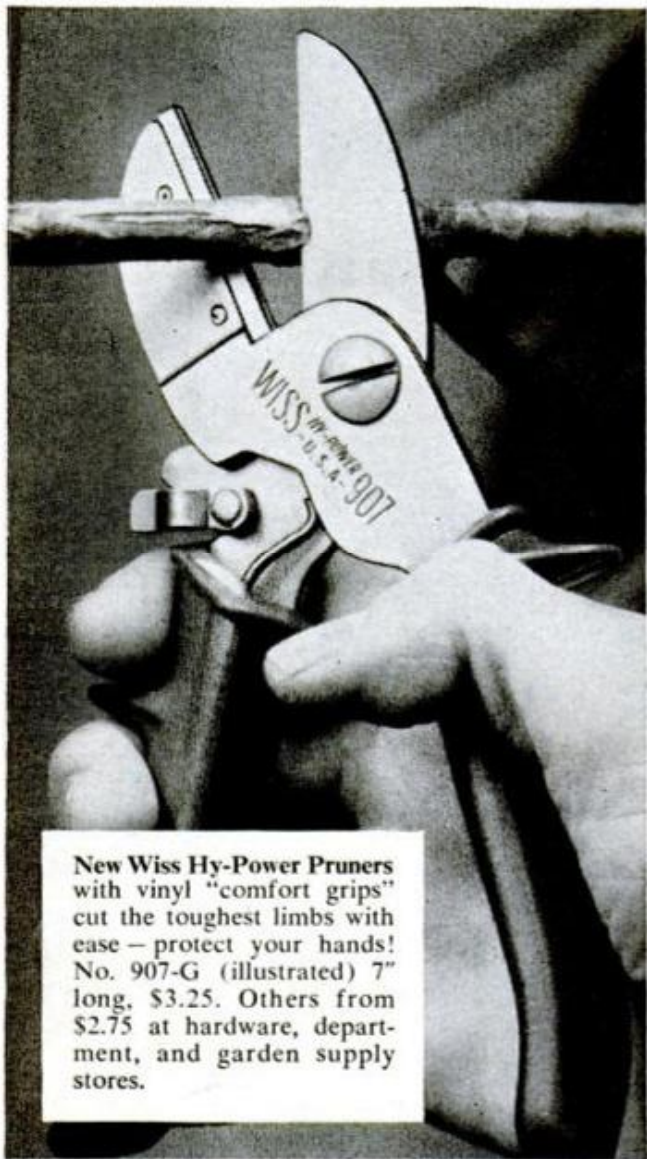

New Wiss Hy-Power Pruners with vinyl "comfort grips" cut the toughest limbs with ease — protect your hands! No. 907-G (illustrated) 7" long, \$3.25. Others from \$2.75 at hardware, department, and garden supply stores.

OTHER FINE WISS CUTTING TOOLS

GRASS SHEARS

No. 701

\$2.75



Easiest cutting, fastest cutting grass shears you've ever used, with molded vinyl handle grips and special closing latch. Others from \$1.39 to \$4.95.

TIN SNIPS

No. V-13

\$2.50



Only seven inches long, these "mighty midget" snips cut metal, vinyl, rubber, leather. Others 10" to 17" in aviation, combination and solid steel styles.

J. WISS & SONS CO., NEWARK 7, N. J.

World's Largest Manufacturer of Shears, Scissors, Pinking Shears, Skalloping Shears, Metal Cutting Snips and Garden Shears

PM Houseboat

(Continued from page 203)

door to hold it up out of the way. You'll notice in studying Fig. 52 and section B-B that the clearance at the top of the door is covered on the outside by a strip fastened to the cabin front. Similar strips are attached to the face side of the door opening along the two sides. The door itself is a panel of $\frac{3}{4}$ -in. plywood cut to fit the opening. The opening for the glass in the door itself can be rabbeted if you have the tools. If not, the plastic can be held with rabbeted strips screwed to the inside. Protective grilles, consisting of brass rods held in mahogany cleats, are placed over the lower windows behind the foredeck seats. The after cabin door has no glass, and is hinged on the starboard side of the opening with a long piano hinge. Both doors should be fitted with locks.

The one cutaway drawing in Fig. 54 shows the entire galley at a glance, which is built in place just aft of the port locker. The galley offers complete cooking and food-preparation facilities; including a two-burner alcohol stove, a roomy 100-lb. ice box, a sink with running water and storage space galore in cabinets and shelves. All counter surfaces are covered with plastic laminate. You will notice that both the stove and sink recesses are provided with covers to form an unbroken work area, the tops of the covers being faced with matching plastic laminate. The sink cover is merely a lift-out panel, whereas the cover over the stove recess is a folding affair that stands upright when open. The insulated ice box is a custom-made item which a local tinshop can provide. While the width of the aisle doesn't permit the door of the box to open fully, it will open sufficiently wide to provide convenient access. Of course, if you prefer, the ice box can be fitted with two doors. Before you start installing the galley, the port side of the cabin should be fitted with a plywood wall below the coaming member, keeping in mind that an opening should be left for attaching the ice-box drain hose, Fig. 53, as well as the sink hose, to through-the-hull fittings. All doors, trim, stove-recess front are mahogany. In studying Fig. 54, you will see how the counter top is supported at the rear edge by a $\frac{3}{4}$ -in. member which rests on top of the coaming member. Shoe molding is put down around the base of all cabinets after the floor is covered with linoleum. The lift-out bilge covers in the floor, Fig. 42, are strips of flat, chrome steel screwed to the edges of the panels so they overhang all around and form a lip.

(To be concluded next month)

Look how much you lose when Spark Plugs misfire!

All spark plugs tend to misfire intermittently as they wear, and modern high horsepower engines make it difficult to tell when such misfiring occurs. But as the chart below shows, spark plugs that fire only part of the time waste gas by the gallon. For example, if your

car gets 16 miles per gallon at 60 miles per hour, one misfiring spark plug can drop your mileage 7.3% to 14.8 – two can drop it 19% to 30.7% – three can drop it to 30.7% to less than 12. You lose mileage at all speeds, and the higher the speed, the greater the loss.

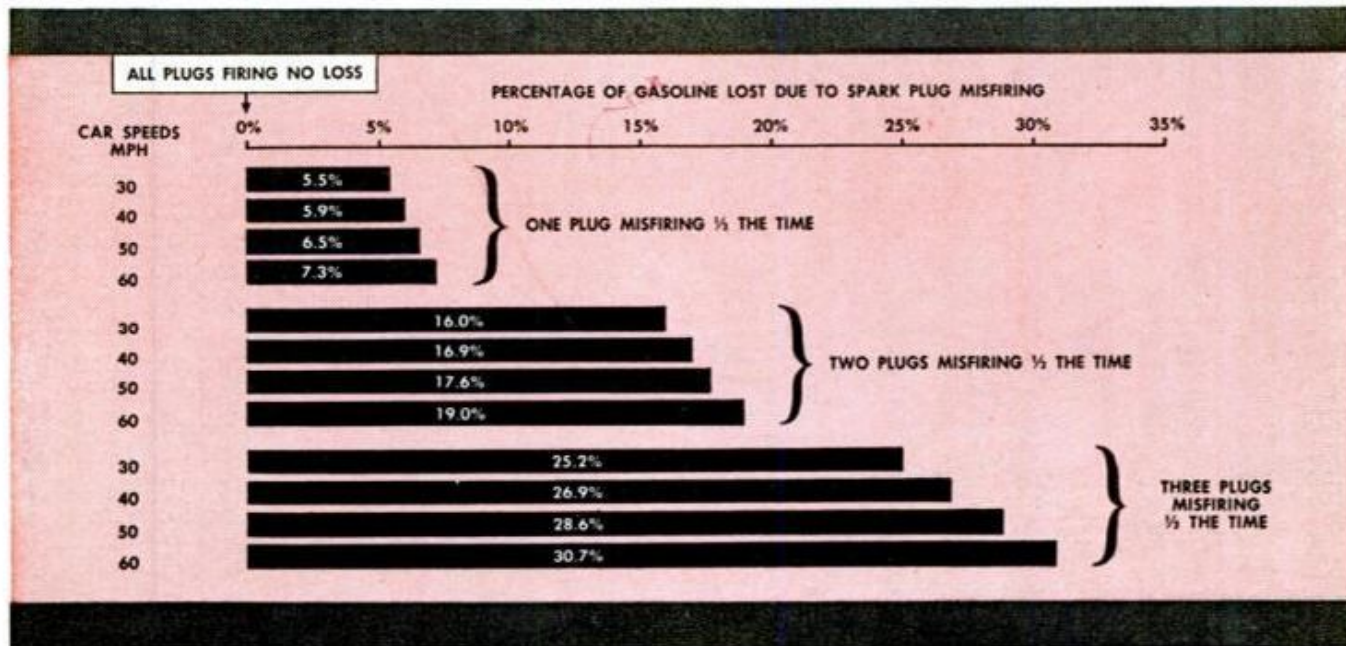

To get the best mileage from your car, replace your spark plugs at least every 10,000 miles with new ACs. AC Fire-Ring Spark Plugs will pay for themselves through the improved mileage you'll get. ACs have such mileage-producing features as exclusive leakproof Conductaseal center electrode bond for uniform heat range, and superior Buttress Top insulator for greatest resistance to electrical flashover leakage. These plus many other advancements have kept AC in the forefront of spark plug development for 51 years. See your dealer, ask for ACs — and save.

AC SPARK PLUG THE ELECTRONICS DIVISION OF GENERAL MOTORS

AC PRESENTS THE ART CARNEY SHOW, NBC-TV, April 8

They must
be the best!



Every AC features the exclusive Hot Tip that heats faster, cools faster to stay clean longer.

AC Fire-Ring Spark Plugs

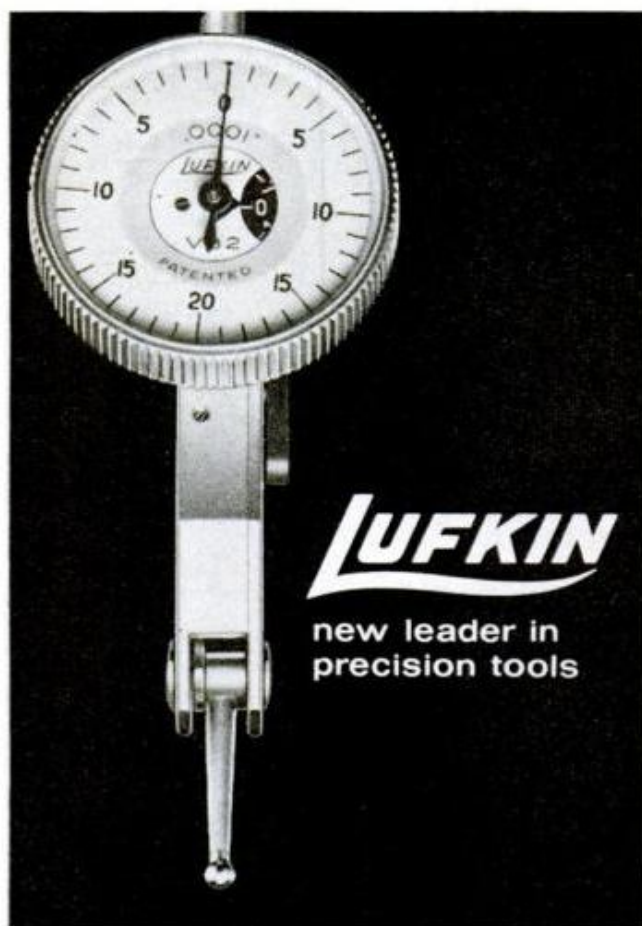

Here's why Lufkin's indicator is the most sensitive!

It is made with the precision of a fine watch, with jeweled bearings.

The ball-bearing mounting is an exclusive feature that reduces friction, assures greater accuracy.

And this Dial Test Indicator has a 180° contact point swivel. The dial has clear, easy-to-read graduations to .0001" . . . and a switch lever for full reverse action.

Mount this V32 on a Lufkin Miti-Mite Holder with its rigid ($\frac{5}{16}$ " center post and you have a vertical testing setup that stays firmly in place. (There's a 50-lb. pull magnet in the base.)

YOUR INDUSTRIAL DISTRIBUTOR
is the man to see for Lufkin precision
tools. Lufkin, Saginaw, Michigan.



Offshore Cruising by Outboard

(Continued from page 165)

them came in with their catch. Local processors buy them, after which the shrimp are cleaned and packed in ice for shipment to market. For 50 cents we got all the fresh shrimp we could eat for the next few days. Watching the unloading of live turtles at Key West was equally interesting; the live turtles, some of them weighing 500 pounds, are kept in pens built in the water, where they remain until butchered.

In many areas the Intracoastal Waterway is the offshore sailor's only means of reaching the open ocean, since roads to launching sites do not extend to the coast. This great waterway, like most land highways, has conveniently spaced fuel and servicing stops, making it possible to cruise as far as time and money will permit. Since fuel and water tankage is limited on a small cruiser, it is wise to plan your stops before shoving off from home port or launching site for a cruise through strange waters.

For a list of waterfront service stations and free charts of the area you expect to cruise, write Texaco Waterways Service, 135 E. 42 St., New York 17. While these charts are not intended to be used for navigation, they give fairly accurate layout of the Intracoastal Waterway and adjacent waters with location and description of navigation lights and radio beacons, tide tables and other valuable information. Use only official government-published charts for plotting courses and navigation. Other publications that give helpful information include the *Coast Pilots*, *Inland Waterway Guides*, *Cruising Guide to the Bahamas* and books authored by small-boat skippers who have cruised your area.

Be sure to have all publications covering your cruising area on board. Study them beforehand and memorize important landmarks and coastal features to make navigation easier at nighttime, or in an emergency when there is little time for close study of charts and references. Remember, there are no convenient filling stations where you can stop for service or directions—you're on your own offshore.

Turning to the cruising possibilities on the Pacific coast, you can trail an outboard cruiser to the Bay of California for tropical cruising on Mexican waters, or launch directly into the Pacific at numerous places along the coasts of California, Oregon and Washington.

Offshore cruising is at its best in the Puget Sound area where, with sufficient fuel supply, one could sail in sheltered waters almost the entire distance to

(Continued to page 250)

USE THE TOOL PROFESSIONALS USE!

ARROW
All-Purpose HEAVY DUTY

STAPLE GUN



MODEL T-50 ONLY \$12.50

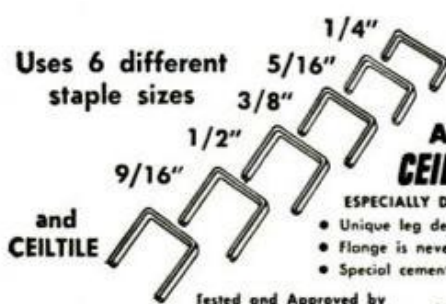

Uses 6 different staple sizes

ARROW'S CEILTILE® STAPLES!

- ESPECIALLY DESIGNED FOR FASTENING CEILING TILE
- Unique leg design drives flush, holds tight!
 - Flange is never fractured . . . CEILTILE penetrates perfectly!
 - Special cement coating provides tremendous holding power!

Tested and Approved by Major Ceiling Tile Manufacturers: and other leading manufacturers



SHOOTS A STAPLE WHEREVER A NAIL CAN BE DRIVEN!

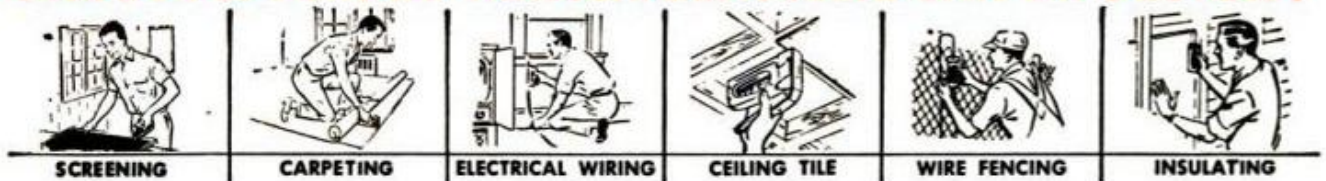

Here's the tool no work bench should be without! Do hundreds of nailing and fastening jobs with this powerful, chrome plated, all steel Arrow Automatic Gun Tacker! Shoots a staple wherever you'd drive a nail! Easier!

Faster! Shoots 100 staples a minute! Cheaper! 100 2-pronged staples cost less than 5c. Arrow's Patented jam-proof mechanism insures a long life of trouble-free performance. Grip it! Feel its perfect balance . . . experience its comfortable shock-absorbing action — and you'll know why Arrow Tackers are the preferred tools of professionals everywhere.

You always have one hand free to hold material!

NEW! MODEL NO. JT.21 JUNIOR STAPLE GUN

For Those Light Household Fastening Chores



This powerful little tool chock-full of quality features never before found in a stapling gun at this amazing low price!

- Unique Safety Compression Handle.
- Safety Lock.
- Non-Jam Loading Mechanism.
- Special Shock-Absorbing Bumper.

- Visual Refill Window.
- Built-in Staple Lifter.
- Loads 100 staples in 2 sizes: 1/4" and 5/16". Locks to fit in pocket for easy carrying. Comes in attractive colors; makes ideal gift for housewife.



ONLY \$4.95

Available at leading hardware, lumber, building supply and stationery stores.

ARROW FASTENER COMPANY, INC.

1 JUNIUS STREET • BROOKLYN 12, N. Y.

"PIONEERS AND PACESETTERS FOR OVER A QUARTER CENTURY"

NOW you can
easily
DESIGN your own
V-BELT DRIVES



...New
DRIVE DESIGNER
for light machines
gives you correct
pulley and V-belt
sizes by merely
turning a dial.

Using this simplified **DRIVE DESIGNER**, Gates Vulco V-Pulleys and the highly flexible "2000 Series" Gates Truflex V-Belts — available at hardware and implement stores everywhere — it is a simple matter to design a drive which will give you long, trouble-free service at whatever machine speed you desire.

Truflex V-Belts Ideal for Small Pulley Drives

Special, Flex-Weave cover enables Truflex V-Belt to bend easily around small pulleys ...results in far longer belt life.

Send for **NEW V-Belt Drive Designer Today!**



The Gates Rubber Company, Sales Division, Inc.
Dept. 15-999 So. Broadway, Denver 17, Colorado

Please send me the new Gates Truflex V-Belt **DRIVE DESIGNER** by return mail. I am enclosing 25¢ to cover cost of handling and mailing.

Name.....
(Please Print)

Address.....

City.....Zone.....State.....

Gates Truflex V-Belts

Alaska. Thousands of islands off the coasts of Washington and British Columbia make the area ideal for cruising. Other good offshore spots include the San Francisco Bay area, the Santa Cruz Islands 10 miles off Santa Barbara, and the Santa Catalina Islands 18 miles off Long Beach.

A good boat for offshore cruising is one that will not pound excessively when heading into choppy water at moderate speeds. The hull design of such a boat is a compromise between a deep-draft vessel and a planing type, resulting in some loss of speed but gaining in stability; a deep-draft vessel automatically has a lower center of gravity than one of shallow draft. To avoid pounding and have an easy ride, buy a boat that has a well developed V-bottom which has a fairly sharp entrance at the bow.

Construction of an offshore boat must be first class, using good materials and somewhat heavier frames and planking than one might find in a boat designed for use on rivers and small inland lakes. Modern materials and construction methods make it possible to produce boats that are comparatively lightweight, dry, roomy and much easier to maintain than older boats. Check the method used for fastening the transom into the hull since it is possible for powerful outboards to crack the transom or even tear it out with the twisting action produced by propeller thrust. All outboard transoms should have ample bracing which in wooden and plastic boats takes the form of knees or braces fastened to the transom and longitudinal members. Metal-hulled boats also must have adequate bracing at the transom. Such bracing should either be welded or riveted to the hull or longitudinal members—never spot welded.

The bow of a vessel that is subjected to hard treatment by slamming into rough seas can be another source of trouble. Planking that is poorly attached to the stem has been known to split wide open when the going is rough. Don't let this happen to you. Also, check the boat of your choice to see that frames are not spaced too far apart and that proper fastenings have been used in sufficient quantity.

Glass-fiber hulls should have extra layers of cloth laminated in the stem area of the bow, keel, chines, transom joints and other stress areas. This, in addition to reinforcing material like marine plywood, wooden strips, or preformed glass fiber laminated to the hull bottom and chines on the inside, serves as stiffening material. Without it, the hull will give below-standard performance. Metal hulls should be reinforced in a similar manner.

A dry boat is a happy boat! In this
(Continued to page 252)

ALADDIN READI-CUT HOMES



from
\$3,000 to
\$10,000

Choice of
115 designs

WE PAY THE FREIGHT

Read how you can save up to \$5,000



Thousands of Aladdin Read-Cut Homes, built 50 years ago, are sound and livable today. Finest Quality Materials *plus* Sturdy Construction have made Aladdin the World's Largest Read-Cut manufacturer with homes in 49 states and 38 foreign countries. **YOU SAVE 3 WAYS:** 1. Through Aladdin's Tremendous Buying Power and Advanced Manufacturing Methods. 2. Waste is Eliminated — you don't pay for short ends and unusable materials. 3. You can Save 30% on Labor by doing all or part of the work yourself. (More than half our customers build their own Aladdin Homes!) All materials are precision cut at the mill — ready to use. Easy-to-read blueprints and special instruction book simplify every step. Latest 5 to 8 room designs — Ranch, Cape Cod, Split Level. Beautiful 1960 72-page "Book of Homes" in color tells how you can save. Send for it today.



Highest Quality — Best Construction



Mail to THE ALADDIN COMPANY, Bay City, Michigan 60-33

I enclose 25c for your 72-page
BOOK OF HOMES

NAME _____

STREET _____

CITY _____

ZONE _____ STATE _____

PLEASE PRINT NAME AND ADDRESS

respect, be sure that windows, hatches and ventilators are watertight when closed.

Deck hardware should be located in the proper place, heavy enough to handle line and tackle of the size required for the boat, and fastened properly. The latter means that cleats, bits and chocks are through-bolted (bolts must pass through the hull or deck) to a framing member or block on the inside face of the planking. Be sure that all fastenings and hardware are of good quality bronze or stainless steel. This is a must since you will be relying on them to hold an anchor in a blow, to secure dock lines, possibly tow a disabled vessel, tow skiers and many other functions. Poor fittings can cause accidents and ruin an otherwise enjoyable cruise. Chromium or brass-plated steel fittings are no good on an offshore cruiser. When drenched with sea water, they become unserviceable overnight. Our cruiser had a chromium-plated brass cap on a steel fill pipe of the water tank that became so frozen with rust that we had to free it with wrenches. A thick coating of heavy grease kept the threads from corroding during the cruise.

If you are in doubt about the safety requirements as applied to a boat you own or plan to buy, ask a member of the Coast Guard Auxiliary to check it over. He will be glad to do it and will tell you what changes or additions may be necessary before the boat will pass the regular "Courtesy Examination." Important here are proper venting of spaces housing gasoline tanks and provision for proper fuel-tank vents, so that highly explosive gasoline vapors do not collect inside the boat. The *Sea Joy* required some venting changes but a prelaunching inspection by a helpful Miami Coast Guard Auxiliary captain made it possible to make the changes while the boat was still out of the water. Such foresight can mean the difference between departing on schedule or being delayed several days in port.

Be sure the running lights are correct and that they are located according to regulations. Since we had expected to cruise in international water on *Sea Joy*, it was necessary to change the white running lights so that the one amidships showed a 20-point beam forward and the one on the after part of the vessel showed a 10-point beam aft. This was accomplished easily by removing the lens of each light and applying a mask formed from strips of plastic tape to block out the unwanted sector of the lights. Removable masks sold for this purpose are available for some lights.

To be absolutely sure your boat will remain afloat in the event of a collision, it

should be provided with sufficient flotation material. Most manufactured boats are provided with some type of flotation, usually foamed plastic but sometimes only sealed air spaces. The latter now are considered a poor second choice because of the possibility of rupturing the enclosures in a collision.

An enclosed cabin is just about a must for offshore cruising for maximum safety, comfort and to permit locking up valuable equipment when the boat is left unattended. A semi-enclosed cabin cruiser provides some of the safety features of a fully-enclosed model, but is a poor second choice for comfort and seaworthiness in really rough seas. Large cresting waves can throw many gallons of water into such a boat, swamping it in short order. While running offshore from Marathon to Key West, there were a number of times when the bow caught such waves, taking streams of solid water over the foredeck and cabin top. With all windows and hatches closed, not one drop stayed on board, and we were completely dry below. A high windshield on the flying bridge further prevented the water from running into the cockpit.

The convertible top was a most welcome piece of equipment. It not only protected us from rain and spray but also kept the crew cool and comfortable, especially when anchored or at dockside. To comply with the daily "operation suntan," the top was folded out of the way quickly by releasing the two stern shrouds.

An enclosed cabin also permits installation of an enclosed head (most desirable if you have guests on board), an adequate, permanent galley, ice box, and comfortable sleeping quarters for at least four. With screens on the windows, insects won't disturb pleasant dreams or get in the soup.

On most small cruisers, the enclosed head doubles as a hanging locker, which was the case on *Sea Joy*. Our shore clothes were kept in a zippered plastic clothes bag, which was hung on a hook bolted on the forward bulkhead. Here they were kept out of the way, yet dry and wrinkle-free, for the entire cruise.

The head also served as radio room on the *Sea Joy*, the Heathkit radio-direction finder being mounted on a bracket attached to the forward bulkhead.

The lack of a built-in ice box or refrigerator on a boat is not a serious fault. We used a large aluminum ice chest. When having a beach party, the ice chest was simply lowered into the dinghy and rowed ashore. At home the ice chest does duty as the cold pantry for picnics, camp-outs and other outings.

(Continued to page 254)



WHAT A DIFFERENCE TWO CYLINDERS MAKE! THAT'S WHY YOU'LL LOVE THAT LARK V-8

In the field of domestic engines, two more cylinders make the difference between adequate transportation and spirited performance ➤ And sometimes performance is fun, particularly when the price is just a little more than the "6" ➤ The Lark V-8 in standard form pulls 180 hp at 4500 rpm and 260 ft. lb. of torque at 2800 rpm. With optional 4-barrel carburetor and dual exhausts, you get 195 hp at 4500 and 265 ft. lb. at 3000 so that drivers can turn zero to sixty in just over nine seconds ➤ Economical, too! In last year's Mobilgas Run, The Lark V-8 with automatic transmission topped all other eights ➤ The Lark V-8 is rugged. It runs on five massive main bearings and (here's the hooker), piston travel per mile in high gear (3.31 rear) is only 1380 feet. Engine revs per mile in high gear is an easy 2550 ➤ See your Studebaker Dealer and try The Lark V-8. You'll love it!

LOVE THAT **LARK** *BY STUDEBAKER*

Getting a good night's sleep is a must if you are to enjoy a busy cruising schedule the next day. If you are accustomed to sleeping on a soft mattress 365 nights of the year, sleep will not be comfortable or easy to come by on hard seat cushions that double as bunk mattresses. On board a small cruiser there isn't room for cabin seat cushions and also sleeping mattresses. Therefore, if the hard cushions are optional on the cruiser you intend to buy, leave them off and buy or make up your own from foam rubber or urethane foam. They should be a minimum of two inches thick. Being of cellular structure, such foamed material is buoyant, so that it can be used for emergency life-saving equipment, too.

Nights usually are quite cool on the water; therefore it's wise to take along an ample supply of warm blankets. Even though daytime temperatures in the Florida Keys were frequently over 90 degrees, we had all available covers on by morning.

For outboard power on an offshore cruiser it is advisable to have twin motors. Although two 25-horsepower motors will cost considerably more than one 50-horsepower motor, the added safety of having a spare that is operational more than justifies the greater expenditure. We used two Mark 78 Mercuries with fine results. If you're interested in economy of operation,

don't buy motors that must be run at top speed to move the boat at its designed cruising speed. Get the next largest size, so that they can be run at about three-quarters throttle, which will save on fuel and engine wear. If only a single motor is used, a smaller spare should be carried for emergencies. Since most small inboard-powered cruisers have only one engine, it is wise to carry a small outboard on board for emergency use, with a demountable or fixed mounting bracket for it on the transom. Remember that it can get awfully lonesome out of sight of land in a boat that is without power.

A good power plant that is installed and serviced properly is of little avail if you run out of gas just over the horizon from the last fuel stop. To avoid this annoyance, two things must be done. First, adequate fuel tankage must be provided. Tanks should be of the permanent type, such as the 18-gallon Tempo tanks installed on *Sea Joy*. With the 35-gallon stern tank built into the boat, this gave us 71 gallons capacity, plus a six-gallon remote tank for emergencies and for the small motor.

The next step, after assuring an adequate fuel supply, is to know the hourly fuel consumption of your motors. This is too important to accept the word of a previous

(Continued to page 257)

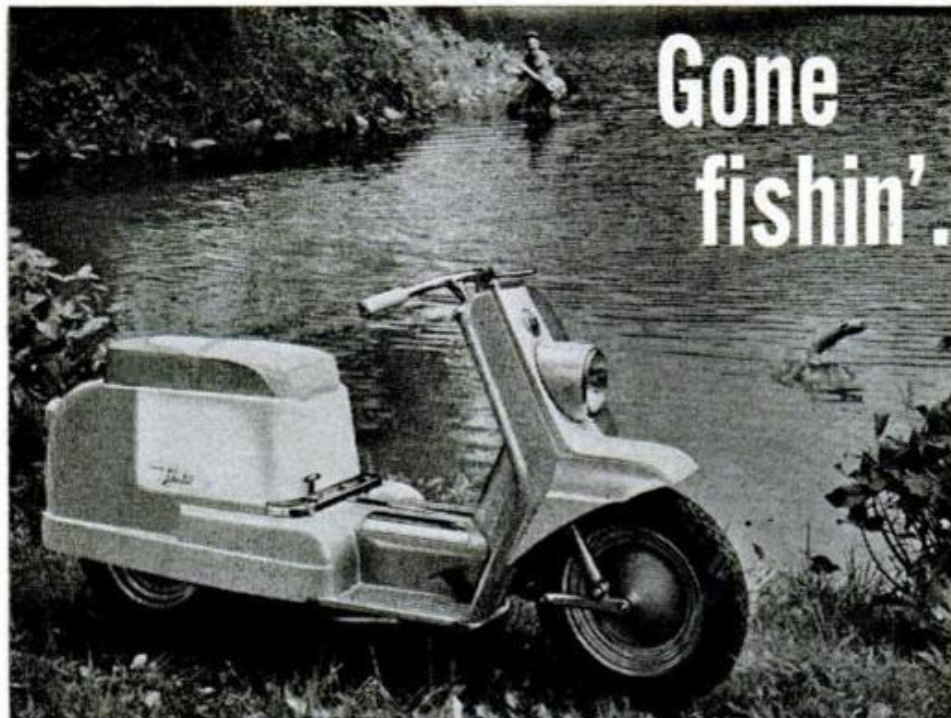

Gone
fishin'... on a

**HARLEY-
DAVIDSON**

TOPPER

HARLEY-DAVIDSON MOTOR CO.
Dept. P, Milwaukee 1, Wisconsin

Send me more information on
the Harley-Davidson Topper.

Name..... Age.....

Address.....

Angling for your favorite trout stream is twice the fun on a Harley-Davidson Topper. Plenty of room in this scooter for meal and creel, too. Fishing is just one of many activities that give more pleasure because you get there on a Topper.

The Topper boasts a host of new scooting features developed by the world's leading builder of 2-wheeled vehicles—see it at your Harley-Davidson dealer or mail coupon for colorful folder.

FOR CLEANER, SHARPER CUTS



SALE!

40-Piece Set Regularly
24.95—Now Only

\$19⁹⁹

These prices until
April 1, 1960

CRAFTSMAN KROMEDGE TAP AND DIE SETS

You get smooth, exact cuts with far less effort when you use one of these Craftsman Kromedge Sets. The cutting edges on these alloy steel tools are impregnated with tough, hard chrome that resists rust. And the sets are built to the exacting tolerances of the Metal Cutting Institute.

The 40-piece, 17-cut set has capacity up to 1/2 inch. Rugged plastic case. Take advantage of the special price—only \$2 down on Sears Easy Payment Plan.

CRAFTSMAN KROMEDGE FOREIGN CAR TAP AND DIE SETS

Unconditionally guaranteed, same quality as other Kromedge sets, but specifically designed for foreign car enthusiasts. The 11-cut Whitworth set has up to 1/2-inch capacity; Metric, 3 to 12mm capacity.

SATISFACTION GUARANTEED OR YOUR MONEY BACK

59-Piece All-Purpose Set for Garage, Farm or Shop

Widest range of cuts for every job. Cuts National Coarse (USS) Threads 1/4-20 to 3/4-10, National Fine (SAE) 1/4-20 to 3/4-16. Machine screw sizes 5-32 to 12-24; 1/8 and 1/4 pipe threads. Has 23 taps; 23 round dies; 5 screw extractors; 2 tap and reamer wrenches; machine screw tap wrench; 2 adjustable-guide die stocks; screw driver; thread gauge. Fitted wood box with plastic top. **\$52.95.**

28 Pieces
Metric (European)
or
Whitworth (English)
\$22⁹⁵

SEARS

ROEBUCK AND CO.

©1960; SEARS, ROEBUCK AND CO



CREATED FOR THE PARTICULAR CRAFTSMAN Porter-Cable 7/8 HP ROUTER

From the manufacturer of the world's finest professional routers comes this extremely accurate Model 100 with many exclusive Porter-Cable features. Its high-speed, powerful motor assures chip-free cutting of difficult laminates. Plus features include twin molded plastic knobs, sealed ball bearings, precision micrometer-ring depth adjustment, non-marking base, lightweight for easy handling. Wide variety of bits, cutters and templates makes it the most versatile and useful production tool in any shop. Motor can be used interchangeably with Plane or Shaper Table attachments. *See this router demonstrated at your Porter-Cable Dealer.*

PORTER-CABLE MACHINE COMPANY
6143 Marcellus Street, Syracuse 4, New York

FREE! YOUR CHOICE OF ROUTER CARRYING CASE or 5-PIECE ACCESSORY KIT

Up to \$15
in free accessories
with your purchase
of a Porter-Cable
Model 100 Router!



ROUTER CARRYING CASE—carries everything you need to the job—router, templets, cords, etc. Special built-in shelf for bits, cutters, templet guides. "Fold-away" front puts everything in easy reach.

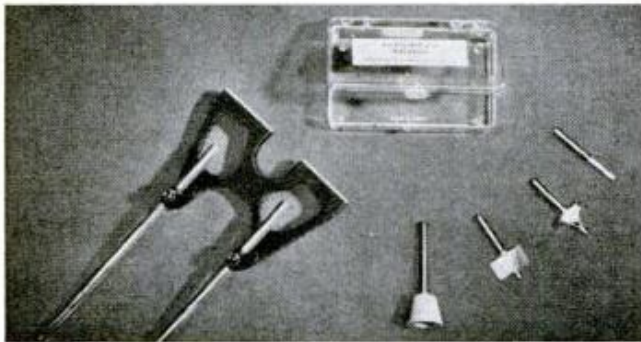

ACCESSORY KIT—basic assortment of bits for grooving, dadoing, decorative edging, rabbeting . . . plus a router edge guide for precision parallel routing.

* * *

See this **BIG Money-Saving Special** at your Porter-Cable dealer **NOW**—this limited offer expires **July 9, 1960**.

Porter-Cable
Quality Power Products

FREE GUIDE . . . send for complete Porter-Cable **POWER TOOL** Guide.

Porter-Cable Machine Co.
6143 Marcellus Street, Syracuse 4, N. Y.
Please send me **FREE** copy of your illustrated Power Tool Guide.

NAME _____

ADDRESS _____

CITY _____ ZONE _____ STATE _____



owner or dealer. Instead, run fuel consumption checks when you are in familiar waters, keeping an accurate log of hourly consumption of gas at cruising speed. If your rig is not equipped with a tachometer, note the miles traveled as per charted course. After checking fuel consumption at cruising speed, do the same for top speed and a slow speed. Then you can figure easily the amount of fuel that will be needed on any run. Record this data in the log book so that you will not have to trust to memory. When checked annually, such fuel-consumption information also indicates the condition of the motors.

Shiny new motors are a temptation to thieves. To assure keeping the motors for the entire cruise, it's a good idea to install a locking device on the transom. When locked in place, the motors also can't be lost overboard. Carry a spare propeller, spare spark plugs and necessary tools to do minor servicing. Check all control linkages and fastenings carefully each day before shoving off.

While ancient Polynesian seamen navigated their boats with remarkable accuracy without the aid of a compass, modern spare-time boaters will be better off with a good marine compass. This is one piece of navigational equipment that is absolutely necessary on all boats that are to be sailed out of sight of land.

All coastal waters of the United States, its territories and possessions have been charted. Copies of these charts are available from the Coast and Geodetic Survey, Commerce Dept., Washington 25, D.C., and at authorized sales agents. To find the sales agent nearest you, write to the above address, requesting a list of *Publications Relating to Nautical Charts*. Be sure to specify the general area or areas for which you want a list.

Charts contain a wealth of information about the area. A good coastwise navigator must first study the general use of charts and then study in detail the charts that are to be used. Free courses in piloting, seamanship, navigating, engine maintenance and other subjects are given by more than 200 local squadrons of the United States Power Squadrons, a civilian organization dedicated to promoting safe boating. Similar instruction may be obtained from your nearby Coast Guard Auxiliary Flotilla. In my opinion, every prospective boat owner should take at least the basic piloting and seamanship course before taking a boat out for the first time. The lessons learned in these classes can save your life.

Electronic navigation and communica-

(Continued to page 258)

NEW BELSAW MULTI-DUTY POWER TOOL



SAWS

PLANES

MOLDS

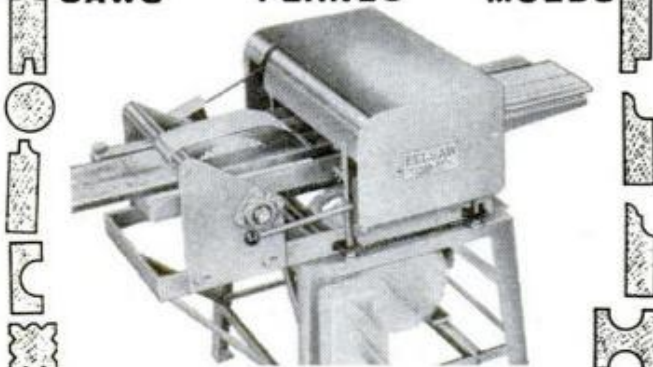

Now you can use this ONE power feed shop to turn rough lumber into high-value moldings, trim, flooring, furniture... ALL popular patterns.

RIP...PLANE...MOLD...separately or all at once by power feed... with a one horsepower motor. Use 3 to 5 HP for high speed commercial output.

LOW COST... You can own this MONEY MAKING POWER TOOL for only \$3000 down payment

Send coupon today

BELSAW POWER TOOLS 900 Field Bldg., Kansas City 11, Mo.
Send me complete facts on the MULTI-DUTY Power Tool.
No obligation.

Name _____

Address _____

City _____

State _____

Bridgeport **INNER-SEAL GARAGE DOOR CUSHION**



Easy To Put On With
Hammer and Nails
Packaged: 8, 9, 10,
16 ft. lengths

**The Best
Protecting
Overhead
GARAGE
DOOR
Weatherstrip
Cushion
You Can Buy!**

X SERIES

- ★ Slanted to shed water
- ★ Tough, lively rubber
- ★ Seals out snow, water, dirt, drafts
- ★ Rot-resistant, will take years of hard wear
- ★ Prevents slamming and glass breakage
- ★ Cuts fuel bills
- ★ Prevents door from freezing to floor

AVAILABLE AT HARDWARE AND BUILDING SUPPLY STORES

Bridgeport Fabrics, Inc., Bridgeport 9, Conn.

tions devices, until recently limited to large ships and luxury yachts because of high cost and bulk, are now manufactured to meet the demands of the small-boat market. Volume sales have kept unit prices down, and use of transistors has reduced the size of the units and their power requirements.

One of the most helpful devices for the small-boat skipper is the radio direction finder. The RDF on the *Sea Joy* was assembled from a kit a week before we left on the cruise. The unit was quite accurate and cost about half the price of a comparable assembled RDF. In addition to functioning as an RDF, the unit also has a standard broadcast band that permitted us to have news and music.

With an RDF on board you can take compass bearings of radiobeacons on shore and obtain a navigational fix, locating your boat at sea. Complete operating instructions are included with each unit.

For safety reasons a radiotelephone (two-way radio) is almost a must on a cruiser that is to be used for offshore trips. The device also provides the convenience of allowing you to talk to persons anywhere on shore via the Bell System and other cooperating telephone companies. Most current models are partially transistorized to reduce battery drain and physical size of the unit. The 30-watt, five-channel Raytheon unit installed on the *Sea Joy* took up no usable space, was simple to install and easy to use. A radio-equipped outboard can call the U.S. Coast Guard for help, if necessary, on the international "Calling and Distress" frequency of 2182 kilocycles. Just knowing you can call the Coast Guard for help if it is needed will add a lot to your boating pleasure.

Radar and depth-sounder units are less essential on small boats, although they are worth considering if you do your boating in areas of high fog incidence.

The cautious skipper in a well-made and well-equipped boat can have the time of his life cruising the salt water. Nothing can beat it for a real boating vacation. ★ ★ ★

QUOTE:

"It is the scientists who now face the great frontiers; theirs is a unique world-wide fraternity dedicated to the mastery of nature, not the mastery of men; in them we find the vision and spirit and purpose which have constituted the elements of leadership in the past."

—MARK W. CRESAP, JR.
President, Westinghouse
Electric Corporation

POPULAR MECHANICS

PEEL PAINT OFF



Furniture



Floors



Boats



Woodwork



KLEAN-STRIP PAINT REMOVER

Fast • Clean • Non-inflammable

THE KLEAN-STRIP CO., INC.

2340 S. Lauderdale, Memphis 6, Tenn.

Constantine's Catalog & Manual for WOODWORKERS

ALL-NEW! 1960 Edition. More than a catalog—a manual, too! 130 pages—exciting new items! Since 1912, world's most complete source for rare imported & domestic woods at rock-bottom prices. Inlays, bandings, carvings, hard-to-find hardware, inlaid wood picture kits, new brass hardware, etc. Plus tools, plans, projects. Enclose 25c (refunded on 1st order). Get FREE year's subscription to "Chips & Chats" too. Write NOW!

ALBERT CONSTANTINE and SON, INC.
2050 Eastchester Rd., Dept. C-5, New York 61, N. Y.



GUNK degreases

At better automotive supply and hardware retailers everywhere.



Cleans engines, garage floors, power mowers, greasy walls economically and safely.
In aerosol or pour spout cans.



GUNK CHICAGO CO., River Forest, Illinois
serving the Midwest and Southwest
RADIATOR SPECIALTY CO., Charlotte, No. Carolina
serving the East, Southeast and far West



Heavy Duty Type ALLEN PUNCH PRESSES

Model BT-5
5 ton
\$199.50
fob
less motor

Hundreds of Different model combinations
1 to 12 ton capacities
Moderate in price
Fully guaranteed
See your supply dealer or write for Free catalog giving complete information and prices on our Heavy Duty Punch Presses.

ALVA ALLEN INDUSTRIES, Dept. PM, Clinton, Mo.

Do-it-YOURSELF with a

Dor-Ro BATH FIXTURE KIT

Includes REVOLUTIONARY FASTENERS for Installing Ceramic Bath Fixtures in Either Ceramic or Plastic Tile Bathrooms

3 SIMPLE STEPS...

1. IN CUT HOLE - INSERT FASTENER, BENDING LOCKING TABS
2. FILL FASTENER OPENINGS WITH PLASTER OF PARIS
3. PLACE FIXTURE IN POSITION

BLACK or WHITE
14.95
prepaid



COLORS: Ivory, Green, Grey, Pink, Maroon, Blue - 20.95
prepaid

Dor-Ro

MAIN STREET, CHESTER, MASS.

KIT INCLUDES:
SOAP and GRAB
SOAP HOLDER
TINSELER and TOOTHBRUSH
TINSELER HOLDER
2 TOWEL HANGERS 11" x 12" 19.95
NECESSARY FASTENERS



EVEN BETTER FIT
Patented



The King of Spring

... Springfield Garden Tiller!

When Spring weather hits and gardening fever gets in your blood, remember you can double your gardening enjoyment with a Springfield rotary tiller.

And of all rotary tillers, Springfield is the king for easier tilling, cultivating, weeding. Here's a big $3\frac{1}{4}$ HP beauty that handles with real tailor-made ease. You can change *tilling width* and *tilling depth* in seconds... without tools. You can easily adjust *handlebar height* and *engine balance* to your exact requirements. And all *controls*, including *optional reverse*, and *Quick-Lok clutch* are located on the handlebars for fingertip action.

Yes, Springfield is today's top tiller value. Check in at your dealers and check out its many high performance features.

Its first five minutes in use will convince you that for gardeners, here is the King of Spring.

Quick Manufacturing, Inc.
Springfield, Ohio
The House of Power



Garden Tillers • Riding Lawn Mowers • Walking Power Mowers



\$4.49

FEEL

Jet Rocket driving power

Swing this beauty by True Temper. Feel the precision balance and control that give you greater driving power than any wood-handled hammer can.

Note the forged-steel head permanently locked to the tubular-steel handle. And it has a cushion grip that won't slip — even when wet. Here, for certain, is a great hammer buy. See the JET ROCKET at your hardware store now. True Temper, 1623 Euclid Avenue, Cleveland 15, Ohio.

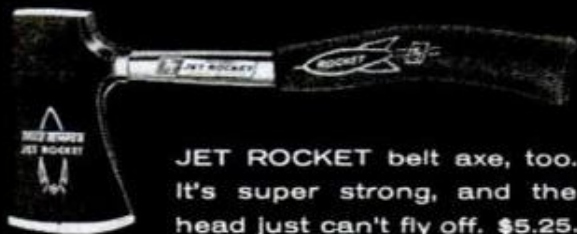

JET ROCKET belt axe, too. It's super strong, and the head just can't fly off. \$5.25.

TRUE TEMPER®

THE RIGHT TOOL FOR THE RIGHT JOB

This Company Loves Tough Problems

(Continued from page 140)

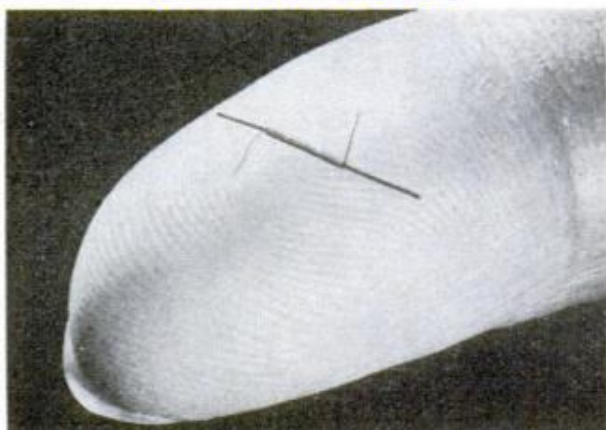

Tiny cryotrons were applied by ADL as switches, making a small-sized, but effective, computer possible

Little solved his personal problem—unemployment—by hiring out to study other men's problems. He and his first partner, Roger Griffin, found it hard going to put the above precepts to test. The first year they earned only \$600, largely by analyzing samples of sugar. Industry looked upon these new "researchers" skeptically; and even among the ranks of pure scientists they were considered oddballs, for the accepted theory was that industry and science could never marry. Some 25 years later, when the steady growth of his company had long since confounded his critics, he expressed the battle this way: "We have been fighting such expressions as 'What's the use?' 'It isn't done.' 'It isn't practical,' and all the other wretched substitutes for hard, earnest, straight thinking."

To prove the futility of negative thinking, Little, in 1921, performed one of his most graphic experiments. Exasperated at hearing industrialists ignore their problems because, as they said, "You can't make a silk purse out of a sow's ear," he decided to disprove the proverb itself. He found that mulberry leaves chewed by silkworms were transformed by a tiny gland at the back of the worm's head into a sticky fluid that was ejected through two microscopic ducts in front, coagulating to form a strong filament of silk. Little then experimented until he obtained a glue-like fluid from cooked sow's ears. This was filtered, boiled and treated with acetone, then placed in a small ejection pump with holes $\frac{1}{1000}$ of an inch in diameter. When forced through the holes, the liquid formed silk-like threads, which were woven into soft, pliable cloth. This material, dyed red and blue, was made into a "silk" purse. It is still on display in the ADL museum.

(Continued to page 262)

"WALKING" SUSPENSION

One of the most intriguing—and rewarding—features of Chevrolet's revolutionary Corvair is its superbly smooth, supple ride. The reason for it lies in a suspension system unique among U.S.-built compact cars: independent suspension at all four wheels.

Here's how it works: each wheel on a Corvair rests on its own deep coil spring, which absorbs road shocks independently of the other wheels. Say, for example, that you're cruising along a choppy dirt road and your left rear tire suddenly sinks into a rut. In any other U.S. compact car, the *right* rear wheel would react as violently as the left to that jolt—which is only natural, since both rear wheels are locked together on a single axle. But in a Corvair, the wheels are divorced from each other, so you virtually "walk" over the ruts.

This "walking" suspension helps keep your Corvair glued firmly on the pavement for extra traction and control on slippery roads. What's more, those resilient coil springs won't squeak,



which means a quieter ride. And Corvair's independent suspension cushions the car's overall weight for a soft, comfortable way of going.

This 4-wheel independent suspension is, of course, a tremendously important advance in the design of compact cars. A five-minute turn at the wheel will show you just how important. The man to see is your Chevrolet dealer—and there's no better time than now. . . . Chevrolet Division of General Motors, Detroit 2, Michigan.

Technically speaking, Corvair is probably the most fascinating car to come down the U.S. pike in the past 49 years. Here are some of the engineering advances you'll find: an air-cooled "pancake" six engine, mounted in the rear . . . unit construction . . . an amazing unit combining engine and transmission in one compact package.

corvair
BY CHEVROLET

NOW! a hi-compression
staple gun
for only
\$4.95



With Exclusive
Push-button Loading
and Built-In
Staple Extractor.

Indispensable for home use...and never before priced so low! This compact, all steel, powerful SWINGLINE 101 staple gun is ideal for insulation, carpentry, upholstery, screening, wire fencing, plus thousands of other uses. Handle locks to fit pocket. Lightweight, maneuverable, jam-proof! Staple sizes $\frac{1}{4}$ ", $\frac{3}{16}$ ". Send for FREE book—"Tips for Tacking".

Swingline® INC.

Dept. PM-3-0, Long Island City 1, New York

DREMEL MOTO-TOOL
THE "POCKET SIZE MACHINE SHOP"

Handiest tool you'll ever own. Its high speed is ideal for precision grinding, polishing, carving, drilling, engraving, de-burring, sharpening, and hundreds of other household and workshop uses. Eliminates time-consuming hand work — gives the finished job a professional look. Weighs only 13 oz.—handles easily as a pencil. Does fine detail work with pin point accuracy. Fastest, most powerful tool of its kind — develops 27,000 RPM. Widely used by tool and die makers, model builders, craftsmen, lab technicians, repair men, gun smiths, schools, etc.
SEE YOUR DEALER
or write for FREE
catalog on the
complete Dremel
line of power
tools.



MOTO-TOOL KIT No. 2
(as shown) incl. Model
No. 2 Moto-Tool, 23 ac-
cessories (high-speed
steel cutters, grinding
wheels, etc.) in a sturdy
storage case.....\$27.50

MODEL No. 1.....\$14.85
MOTO-TOOL MODEL No. 2.....\$19.95
MOTO-TOOL KIT No. 1.....\$23.50

QUALITY POWER TOOLS SINCE 1934

DREMEL MFG. CO. Dept. 110C, RACINE, WIS.

Little died in 1935, but the company still practices the same positive approach and each creative staff member (most are from 27 to 37 years old) is encouraged to go his own way in seeking answers. There are few titles, no protocol regarding rank and hardly a closed door anywhere along the office corridors. Men and women (there are a good many women on the staff) are constantly stopping in hallways to discuss projects, even ones they have no connection with. They have the prerogative of going or phoning anywhere. The fact that they exercise this right is shown in these statistics! Although ADL has only 1200 employees, its telephone bill is third largest in Boston and its air travel bill 10th largest in the United States.

These costs, however, represent money well spent. ADL, with a gross of about \$14,000,000 a year, operates for profit, and is one of the few research organizations of its size which does so. Most others are nonprofit groups.

"We are not do-gooders," declared president Stevens recently. "We are quite willing to reform the world, but we insist on being realistic about everything we do. We are a profit-making organization."

This direct, blunt approach is one reason why ADL has accomplished wonders in developing the economies of debt-ridden nations which have asked for advice. Any country that has to squeeze dollars from its budget to pay for a plan is much more likely to use that plan than if it were a free handout from the U. S. government. Puerto Rico is a good example. Several years ago, it hired ADL to prescribe a cure for its economic ills. ADL representatives studied labor potential and resources and helped develop some 500 new productive enterprises, stimulating 36,000 new jobs and a \$46,000,000 payroll. In Honduras, ADL has shown the government that by putting lime onto the clay of rutted, impassable roads, they can be given a smoother and harder surface. In the Philippines, the firm provided professional guidance in developing cooperatives for small farmers. Its staff members have provided equally dynamic solutions for the problems of other countries as well.

A single development in one field, ADL has found, can sometimes lead to a dozen more in widely divergent fields. During World War II, the firm developed an odor-neutralizing solution so U. S. espionage agents behind enemy lines could escape sharp-nosed bloodhounds. From this developed a new set of formulas for doing away with unwanted smells, including a remedy for a dejected manufacturer of

(Continued to page 264)

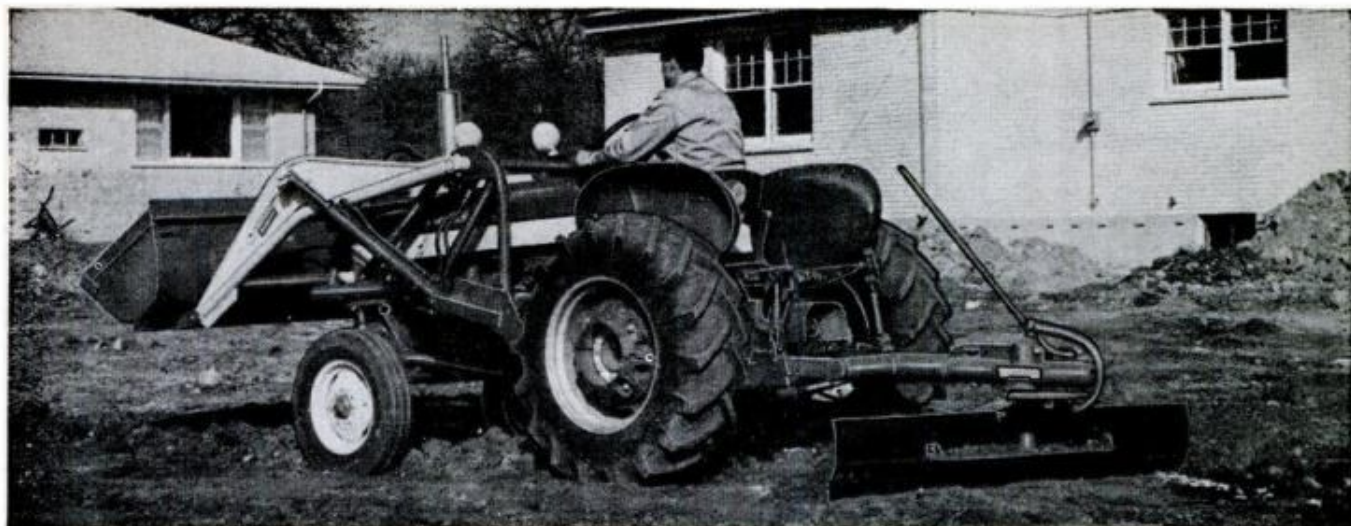

Step into a profitable year 'round business with an International 240 Utility tractor

Earn steady profits with a rugged, low-cost 38.5 hp International 240 Utility! Dozens of homeowners, business, and industrial plants in your neighborhood are prospects. Landscape, trench, load, mow, clear snow, do countless other utility jobs, with an economical "240". A complete line of equipment is available to keep you busy the year 'round. A small down payment can start you in a full-time business of your own.

See your nearby IH dealer for a demonstration of International 240 power, brawn, and performance. Or write today for free catalog.



INTERNATIONAL HARVESTER

Dept. PM-3, P. O. Box 7333, Chicago 80, Ill.

CHANGE SPARK PLUGS REGULARLY

• FOR HANDS • FOR FLOORS • FOR WALLS

QUICKEE®

SPECIALIZED CLEANERS

Send for FREE HAND CLEANER SAMPLE. Dept. PM

At Stores Everywhere / Quickee Products, Inc., Yonkers, N. Y.

\$ POPULAR MECHANICS MEANS MORE MONEY IN YOUR POCKETS

YOU CAN EARN \$10, \$25, \$50 NOW!

Handling orders for POPULAR MECHANICS and other magazines your friends read! Commissions—Bonus—DETAILS FREE!

POPULAR MECHANICS Dept. 360-C
250 W 55th St. N.Y. 19, N.Y.

Name.....

Address.....

City..... State..... Zone.....

Figure the costs... it pays to

GO CUSHMAN.

A sleekly styled, precision engineered Cushman scooter saves you money all-around—on initial investment, operating costs, upkeep and maintenance, taxes and insurance. You find enjoyment in the safe, sure way it handles . . . in a sensation of dynamic ruggedness. And it goes everywhere, parks anywhere.

Ask your dealer for demonstration or write for information

The smart 1960 Road King



CUSHMAN MOTORS

1041 No. 21st, Lincoln, Nebraska
A subsidiary of Outboard Marine Corporation, maker of Johnson and Evinrude outboard motors

**Build
Extra Storage
Space!**
It's easy with



**Aluma-Slide
SLIDING DOOR TRACK**

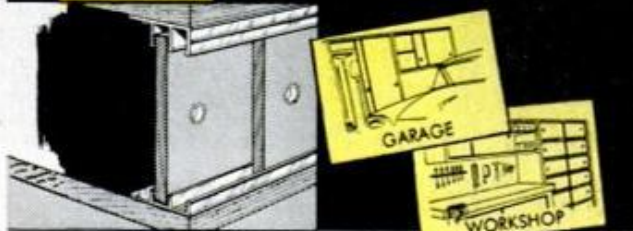

For 1/8 to 3/4-in. panels of plywood, hardboard, perforated panels and glass.

Now, build your own extra storage cabinets. Installation is easy and fast! You'll think of dozens of more uses. Aluminum track sets come packaged ready to use. No special tools needed.

At Hardware & Lumber Dealers

MACKLANBURG-DUNCAN CO.

OKLAHOMA CITY, OKLA.

MAKE HOME IMPROVEMENTS NOW

**New
FORMICA®
Laminated Plastic
sink top?**



It's easy: use Formica Safe-Bond, the new non-toxic, non-flammable adhesive that "tells" you when to contact. And surprise "the missus" with Formica laminates in the smart new Raymond Loewy designs. Get Formica Safe-Bond and sheet stock at your local lumber dealer. Formica Corp. Cincinnati, Ohio.

a product of

CYANAMID

leather coats whose product was repelling customers because room temperatures brought out its latent animal odors. Another example is the development of chlorella, a one-celled green plant of the seaweed family. It can be grown without soil, in water to which small amounts of chemicals have been added. When dried it forms a light powder with the odor of fresh pumpkins and can be used for animal fodder. ADL started out merely to learn how to increase the output per square foot of water. But staff members could not resist curiosity about chlorella. One scientist wondered whether it had significance as a human food base, especially for nations with little arable land. Another member found chlorella has possibilities as a new source of engine fuel.

But of all the wonders ADL has helped accomplish in the past none will probably compare with what is yet to come. This is evident in the areas being explored by Lt. Gen. James M. Gavin, former Chief of Research and Development for the U.S. Army, who joined ADL in 1958 after an explosive retirement from the service at the age of 51. He came to the firm because of what he refers to as the "regenerative" atmosphere, "the feeling of receptivity to new ideas, of willingness, and communication of thoughts and facts, of hunting and searching."

Currently, Gavin is still interested in the missile field—but not so much for military use as for peace-time applications. As he explains it, there are at least three examples of such applications: (1) Chemical developments in the missile industry which point towards a new family of plastics; (2) The application of the principle that guides ground-to-air missiles to targets to a new surveying technique; (3) Harnessing the powerful missile flame to "jet drilling," a new way of extracting ore.

General Gavin still packs his military wallop, however, and launches attacks at lethargy and smugness wherever he encounters them. "This is a decade of decision," he says. "There will be those who would say that with a higher gross national product, the superiority of the West is assured. This is at best very misleading and at worst, critically dangerous . . . Only industry, imagination, a sense of dedication on the part of each of us, can prevail in this contest."

It looks as though General Gavin, like his ADL colleagues, was taken into the company as a vigorous exponent of the same rugged principles that led Arthur Dehon Little to prove that he could make a silk purse out of a sow's ear any day of the week. ★ ★ ★

LIFT 3 TONS 9" IN 30 SECONDS!
Complete HYDRAULIC LIFT KIT

- For Lift Trucks • Fine for Snow Plows, Disc Harrows, etc. • To Tip Farm Wagons
- Hydraulic Presses

KIT CONTAINS:

- 1) **HYDRAULIC PUMP** with 24" handle, 2 qt. oil reservoir, adjustable release valve, filler plug, 3/8" P.T. port. Universal mounting holes — Pump rated 1500 P.S.I., .80 cu. in. per stroke.
 No. G-1500P . . . Shpg. wt. 15 lbs.
 F.O.B. Chgo. \$29.50
- 2) **HYDRAULIC HOSE ASSEMBLY** — 8 ft. long, wire braid constructed. Rubber jacket, smooth neoprene core, 3/8" P.T. male fittings.
 No. G-HX83 . . . F.O.B. Chgo. \$3.50
- 3) **HYDRAULIC CYLINDER** — 2 1/4" bore, 9" stroke, 1 1/2" piston rod stainless steel. Clevis mount, both ends.
 No. G-C562 . . . Shpg. wt. 15 lbs.
 F.O.B. Chgo. \$17.95
- 4) **HYDRAULIC FLUID**, 2 qts.
 No. G-811 . . . F.O.B. Chgo. \$1.00

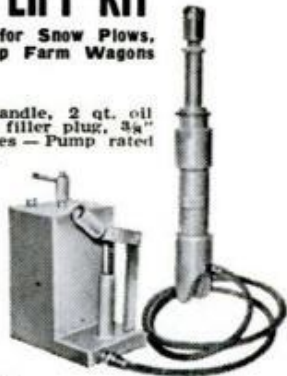

Included in it are fittings, and instructions — just pour in oil, connect hoses, and go to work! It's easy!



SAVE MONEY—ORDER COMPLETE KIT! Items can be ordered separately if desired.

COMPLETE KIT:
 No. G-K116A Shpg. wt. 38 lbs. F.O.B. Chgo. \$51.40

FREE CATALOG . . . Tremendous Savings on Hydraulic Equipment, Diesel Parts, Electric Generator Sets, Electric Motors, Welding Equipment, Hand Tools, etc. Write for your **FREE COPY** Today!

GROBAN SUPPLY COMPANY

1139 South Wabash Ave., Dept. G Chicago 5, Ill., WEBster 9-3793

**BUY DIRECT
 • SAVE ON •
 TILLERS • TRACTORS**

Full line of attachments for mowing, gardening, farming
 2-3-4 H.P. TILLERS 12"-16" CUT.

**FREE CATALOG
 & PRICE LIST**

5-6-7-9 H.P.
 2 wheel &

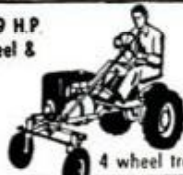

RED-E TRACTOR CO.

4th Street
 RICHFIELD, WISCONSIN

Underwater Spark Shapes Metal

In a crackle of electricity, a flash of fire and a clap of man-made thunder, a small disk of metal is suddenly "exploded" into a new shape.

All this, oddly enough, takes place underwater as part of a new technique that one researcher—Adolf Kastelowitz, director of manufacturing research for Republic Aviation Corp.—says has brought precision to the shaping of lightweight metal.

Small sheets of metal 1/16-inch thick already have been shaped experimentally in the laboratory. Researchers now are working on a more powerful version of the electrical metal-shaping device for heavier metal operations.

By charging storage condensers to 20,000 volts, then discharging this power between two underwater electrodes, they make a spark that generates a powerful shock wave in the water. The shock wave blasts the metal into the shape of the die upon which it rests.

Kastelowitz says the system promises to be useful in working some newer steel and titanium alloys that require heavy, complicated equipment to achieve the necessary close tolerances and aerodynamic smoothness.

Starrett
 SINCE 1880
 WORLD'S GREATEST TOOLMAKERS

**NEW
 PRECISION
 TOOLS**

BUY THROUGH YOUR DISTRIBUTOR

THE L. S. STARRETT COMPANY • ATHOL, MASSACHUSETTS, U.S.A.

**FREE Starrett®
 NEW TOOLS
 BOOKLET**

Illustrates and describes 88 new Starrett Tools including new Satin Chrome Steel Tapes; Master Vernier Height Gages and Calipers; many new Micrometer Calipers; Inside Micrometers, Micrometer Depth Gages and Micrometer Heads; Satin Chrome Combination Sets, Protractors Dividers and Trammels; Dial-Master Indicators and Dial Bore Gages; Mechanics' Tool Chests; and many others. Send for your free copy today. Use the coupon.

STARRETT TOOLS are carried by leading Industrial Supply Distributors and Hardware Tool Stores

THE L. S. STARRETT COMPANY
 Dept. AP Athol, Massachusetts

Please send my free copy of the Starrett New Tools Booklet.

Name.....

Occupation.....

Address.....

City.....Zone.....State.....

Any man will enjoy new

AIRGRATE YELLO-BOLE

1. Smokes sweeter!

Imported briar bowl lined with *real honey*. Starts caking the instant you light up. Hence, no break-in.



2. Smokes drier and healthier!

Metal grate condenses moisture, tars, nicotine. No wet heel.



3. Smokes cooler!

Air-vented chamber draws in fresh air. Aluminum fins and shank throw off heat, cool the smoke.

Famous honey-lining!

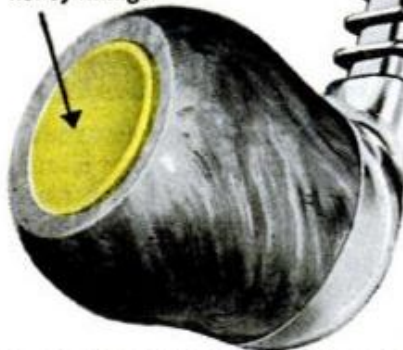

\$295

Extra interchangeable bowls — \$1.50 each

"Icepak" Set—Airograte Yello-Bole Pipe plus two extra bowls, \$5.95

Other Yello-Bole Pipes, also of imported briar \$1.95 to \$4.95

Send for FREE FOLDER, YELLO-BOLE PIPES, Inc., Dept. Y80, N.Y. 22

EMERSON ELECTRIC

NEW POWER For Your Tools...

There's an Emerson Electric Motor for every tool... sanders, saws, joiners, pumps, lathes, drills, buffers, etc... Home workshop or commercial. Operate in any position... exclusive dust-proof contact points. One year guarantee.



multi
duti
MOTORS

Write today for prices and FREE MOTOR SELECTOR GUIDE...tells you the exact motors you need for your tools.

EMERSON ELECTRIC of St. Louis
8100 Florissant • St. Louis 36, Mo



U.S. Fish & Wildlife Service photo

Banded ducks are placed in box to be fluoroscoped for the detection of lead pellets in the flesh or crop

deer paradise was in prospect. Actually, disaster lay ahead.

With no enemies to hold them in check, the deer population skyrocketed from an initial 4000 to 100,000. Since canyons and semidesert hedged the forest, the animals couldn't move elsewhere. When food supplies were exhausted, starvation took over and 60,000 animals died in the 1924-25 period. Meanwhile, severe damage had been dealt the forest. It could no longer support even the small initial deer population. Thus, in the final analysis, apparent enemies were in reality the best friends of the deer; life depended on these enemies.

One more historical example of what can happen. In 1869, a Medford, Mass., scientist unwittingly opened a Pandora's box. He imported gypsy moths from Europe, hoping to cross them with silkworms to produce a hardy breed on which a U.S. silk industry might be based. In Europe the gypsy moth is no great problem; it has enough natural enemies to keep it in check. But when it came to the U.S., these enemies were left behind. Result: It bred prolifically and attacked forests to do damage high in the millions of dollars.

A similar situation arose in Australia and New Zealand. Last century, rabbits were imported for sporting purposes. With natural enemies left behind and other conditions ideal, rabbits increased at an explo-

(Continued to page 268)

CRACK IN BOWL?

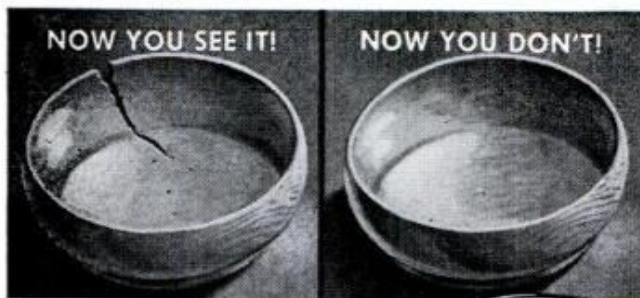

No muss — no fuss with easy-to-use Plastic Wood. Resists grease and water.



For surest results always use GENUINE

PLASTIC WOOD

Handles like putty—hardens into wood!

SMALL! POWERFUL!

ECONOMY TRACTOR

Unequaled value! Low price!
America's finest tractor. Ruggedly built. Easy to operate. 790 lbs. Borg-Warner clutch, trans. and diff 140 to 1 reduction. 40% more drawbar pull than ordinary tractors 8-1/4 H. P. engine. 20 quick change implements. HOOD, FENDERS.

Thousands In Use Write for complete details.
Engineering Products Co.
1005-K-3 Anoka Ave.
Waukesha, Wis.

Jiffy SAWHORSE BRACKETS

NO NAILS NO SCREWS NO BOLTS

Now a sawhorse in a jiffy! Just use Jiffy Brackets and 2x4s. Sold by hwd. and bldg. supply stores everywhere, or order direct. \$1.95 A pair. *Higher W. Coast*

GRAND HAVEN STAMPED PRODUCTS CO.
Grand Haven, Mich.

Carry your tools in safe HUOT HIP-ROOF TOOL BOXES

You owe your tools a HUOT
For men who treat their tools with pride! The models shown here are made with heavy gauge steel and full length piano hinges that never get out of line. Heavy duty hasps and latches, welded double corners. Bright blue hammerlin boxes, red tote trays. Many models—write for free bulletin. Treat your tools to a Huot!

Model 503—20"—\$9
Model 502—19"—\$7.10
HUOT MFG. CO.
555 N. Wheeler St. St. Paul 4, Minn.



98¢ to \$2.98

HOT RODS

for everybody!

All-Plastic Jet and Electric Power Models by Monogram

At Hobby Shops and Other Stores

Hot Rodding is fun with Monogram authentic and popular models. Easy-to-assemble kits. No tools needed. Here are six new models — Dragsters, Rods and a classy Sports Coupe. Exhibition models, jet power models, electric power models. All have rubber tires, the last word in fascinating details and colorful decorative decals.



SPORT COUPE. '32 Ford. Assemble as street coupe or hot rod. Vista dome top. Plated parts. Regular model \$1.98. Motorized model \$2.98.

DEUCE HOT ROD. '32 Ford roadster. The all-time hot rod classic. Big engine. Extra carburetors. Tuned exhausts. Not powered. 98¢



SLINGSHOT DRAGSTER. Scaled from winning drag strip racers. Dummy Chrysler engine and 6 carbs. Power with CO₂ capsule. 98¢

LONG JOHN DRAGSTER. New streamlined model. Brilliant red and silver with overall decal. Jet power model 98¢. Motorized model \$1.98.

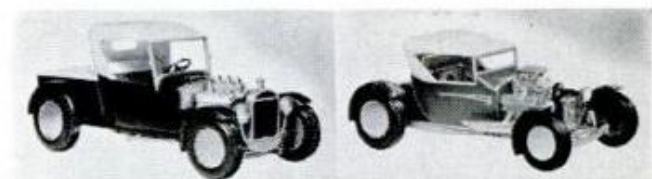

BLACK WIDOW. Ford "T" Pick-Up Rod. Removable top and fenders. Chevrolet V-8 engine. Plated parts. Regular model \$1.49. Motorized model \$2.49.

GREEN HORNET. "Show" Rod. Removable top, body and fenders. Converts into "rail job." Plated parts. Regular model (not powered) \$1.49.



Electric motorized kits include motor, nylon drive gears, steel drive shaft and battery holder. Jet power models have receptacle for power cartridge. Some kits with chrome plated parts. Assembly instructions included. Monogram Models, Inc., Chicago 32, Ill.

Monogram

Four Star Plastikits

sive rate. They ruined thousands of acres of sheep range by grazing vegetation down to the bare soil. Then wind took over to create a "living drought." Heroic measures—introduction of rabbit diseases, trapping, poisoning—were required to bring things under control.

Nature herself often provides a set of conditions ideal for a particular species. This happened last year in the irrigated valleys of California and other western states where there was an explosive increase in field mice. Checks indicated populations up to 3000 per acre! The mice ate roots of grain and pasture grasses, then turned to other crops. Officials were on the point of declaring the affected regions disaster areas—then the mice dwindled in numbers. Why? No one knows.

Perhaps the most dramatic example of wild population increases is offered by Norway's famed lemmings—little mouselike rodents. Normally, they live in the high mountains and cause little trouble. But occasionally, population takes a violent upswing, and the rodents are driven to the lowlands in search of food. Driving relentlessly on, swimming streams, eating farms clean, they finally reach the sea. They plunge in and drown. Instinct apparently propels them to their deaths. In Miocene times, land bridges existed over the Baltic

and North Seas. Apparently lemmings are blindly attempting to follow these routes that led their ancestors to lands of plenty.

Nature has a number of weapons to check unruly population increases in any species. Her heavy artillery: Disease and starvation. But there are other means—some extraordinarily complex. Tiny wasps, for example, control many potentially dangerous insect pests by laying eggs in insect grubs. When eggs hatch, the larvae consume the grub. May beetles, which buzz around lights on spring nights, might become serious pests but for a little fly—the *Pyrgota* fly. It darts in, punctures the beetle shell with its oviduct and thrusts an egg inside. When the young hatches, it consumes vital organs of the beetle.

Food scarcity or plenty is illustrated by the clearly defined rabbit-lynx cycle long observed by Canadian trappers. Rabbits are the diet staple of lynxes. When one is plentiful, so is the other. Conversely, their populations decline together.

Every piece of land has a firmly fixed "carrying capacity." Durward L. Allen, Department of the Interior ecologist, asks us to imagine a bus load of passengers set down in the arctic tundra. Within a short time, all would die for lack of food. Precisely the same thing happens with any animal species. Attempts are often made

Only Eclipse Mowers



RIDING MODELS

Make lawn mowing almost fun! The Eclipse Deluxe "Ranger" mows up to 5½ acres a day. It's ruggedly built with auto-type tubular steel frame. Has two forward speeds and reverse. Big canvas "Sun-Brella" is an optional accessory... fits on to tow-bar pin at rear of mower. Try it soon at your Eclipse dealer.



REEL-TYPE

Preferred by many who take special pride in their lawns... Eclipse precision reel-type mowers—18" to 25" models—give a smooth shearing action that's ideal for Bermuda, Zoysia, and St. Augustine, as well as blue grasses.

SEE THE BIG "E" LINE
AT YOUR DEALERS SOON...

POPULAR MECHANICS

to stock game birds on unproductive land. Almost always they perish within a few days or weeks.

Protection from enemies is similarly essential. Along this line, Michigan had an unusual experience. The state was once one of the nation's best quail regions. When bird population began to drop, conservationists stepped in. The bobwhite was declared a songbird and further hunting was stopped. Instead of increasing, quail virtually disappeared. The reason soon became apparent. Early this century, Michigan farms were bordered by forests and hedgerows, which provided excellent quail shelter. Gradually, more intensified cropping became the rule and bird shelters were put to plow. Their natural habitat destroyed, the bird population dropped.

Curiously enough, the abundance or lack of food appears to have a marked effect on breeding habits. In times of food scarcity, litters of rodents are smaller and fewer. This appears to carry over even to the bird world. Several years ago, hawk nests were studied during a period when field mice were plentiful. Nine nests produced 22 birds in a season. During a low-mouse year, only two hawklings were hatched in the same nests.

Have all man's nature tinkering had bad results? By no means. As ecological knowl-

edge has grown, scientists have often been able to step in and ward off potentially dangerous situations. Thus, a few winters ago a large number of wild ducks were marooned on the Snake River in Idaho. With the best will in the world, sportsmen proposed a feeding program to keep them alive. An ecologist investigated. He found the ducks infested with parasitic disease. That was why they lacked strength to fly south. A feeding program would have kept them alive and permitted them to pass their disease to healthy ducks the following year—with possibly disastrous results. Better to let them die, the scientist decreed.

While some species have disappeared—largely because of changing land use—others have found new conditions advantageous. Thus, there are far more deer and quail today than when the first settlers stepped ashore in North America. New species have been introduced and have thrived handsomely. The pheasant, brought in from Asia late last century, is an example. Prior to 1905, not more than 500 pheasants had been stocked in the prairie states. Yet they liked their new home and thrived so well that eager hunters were able to take 42 million of these birds in the 1940-50 decade in the Dakotas, Nebraska, Iowa and Minnesota.

(Continued to page 270)

give you MOW-ABILITY*

ROTARIES

You get power to spare with 4-cycle Briggs & Stratton engines on all Eclipse mowers. Your Eclipse dealer will be glad to show you all the new features that make an Eclipse mower your best buy in the long run. New wind-up starter is furnished on W-20 and W-22 Duo-Masters.

GRASS CATCHER (Optional extra)

Collects clippings as they leave discharge chute. Easily attached. Fits all Eclipse walking rotary models.

EASY CUTTING HEIGHT ADJUSTMENT



It's brand new and exclusively Eclipse! A simple twist of one control adjusts all four wheels simultaneously. Select any cutting height between 1 1/8" and 3 1/8"—even while mower is operating.



13 MODELS PRICED FROM \$69.95

MARCH 1960

- *DESIGN AND CONSTRUCTION TO OUTPERFORM
- ALL ORDINARY MOWERS YEAR AFTER YEAR—
- FOR THE LOWEST ANNUAL OPERATING COST

RUGGED AS A RHINO

Inside and out—from stem to stern—Eclipse mowers are built to "take it." Many Eclipse mowers 20, 30, or even 50 years old are still on the job and cutting efficiently.



DURABLE AS A CAT

Eclipse mowers seem to have "9 lives"—just don't die easily. To assure long life, repair parts are available for many years after the expected life of the average mower.



POWERFUL AS A BULL

Equipped with job-matched 4-cycle engines, Eclipse gives you a bonus of reserve power. You can operate your mower at safer, quieter and more economical half speed.



• **THE ECLIPSE LAWN MOWER CO.**
• Div. of Buffalo-Eclipse Corporation
• 3014 Railroad St., Prophetstown, Illinois

ECLIPSE



James G. Groendyk of Upper Saddle River, N. J., checks the mighty engine of his 1931 Duesenberg Convertible Roadster

"Quaker State protects the engine of my classic Duesenberg and my new car too!" This Duesenberg Model J boasted the most powerful engine of its day. Its huge 420 cu. in. straight 8 was rated at 265 h.p., and it was guaranteed to give 92 miles per hour—in second gear. Its condition today—better than new! Smart motorists rely on Quaker State Motor Oil. Refined only from 100% Pure Pennsylvania Grade Crude Oil, the world's finest, Quaker State assures complete, long-lasting protection.

*Available most everywhere
... always ask for
Quaker State by name.*



QUAKER STATE OIL REFINING CORP., OIL CITY, PA.
Member Pennsylvania Grade Crude Oil Association

The same ecological rules that prevail in the animal world are also at work in the plant world. A particular species, finding conditions to its liking, thrives—often at man's cost. The Klamath weed, called St.-John's-wort in Europe, offers a striking example. Klamath is the great destroyer of range land; it chokes out grass and is poisonous to cattle. It virtually ruined 400,000 acres of California range land and blighted additional tens of thousands of acres in other western states. A good case might have been made for accepting the weed as a natural part of the western environment. Department of Agriculture scientists felt differently. They thought they could tilt the ecological scales in man's favor in a novel manner. They set out to find an insect which would eat the weed, since destruction by spraying would have been too expensive. They found what they wanted in Australia—a little beetle. Introduced in 1947, it has cleared the weed from tens of thousands of acres. Ranchers around Fortuna, Calif., were so grateful that they erected a monument to the beetle!

Australia had a similar experience. Thirty million acres of potentially good grazing land were ruined by cactus. To clear it away would have cost an impossible \$2 billion. Australian bug hunters solved the problem by searching the world and finally finding a cactus-hungry moth in Argentina.

Thus, we will continue to tinker with nature—with results sometimes good, sometimes bad. But from now on a better understanding of man's place in his environment is essential. Human existence depends on it. Observes John H. Storer in his book, *The Web of Life*: "The subject of ecology is so vast and complex that no human mind has ever fathomed all its secrets. Many of them can probably never be unraveled, but the basic principles are known. On the functioning of these known principles depends the future of all human life." ★ ★ ★

Titanium "Blasted" Into Shape By Small Explosive Charge

Powdered titanium has been "blasted" into simple metal objects at the U.S. Naval Ordnance Test Station, China Lake, Calif.

The powdered titanium is put in a small die and is rammed into a solid piece by a piston which is driven by a small explosive charge.

The forces appear to be so great that metals can be bonded together by this method that cannot by normal rolling methods. It also appears possible to bond dissimilar materials.

pull the trigger...
spray paint

7 times faster than brushing!



Speedy Sprayer ONLY \$32.00 less motor

Paints anything from a house to a toy. Saves its cost on the first major job! Speedy Sprayer does in minutes what brushing takes hours. Finish is smooth, flawless. Uses any 1/4 h.p. motor with 1/2" shaft. No. 780 Outfit—10 ft. air hose, tire chuck, quart gun, less motor, only \$32.00. Every workshop should have it. At leading stores.

Free! Write for "How To Spray" Booklet and folder.

W. R. BROWN CORPORATION

Specialists in Portable Paint Sprayers for Over 37 Years
2635 N. NORMANDY AVENUE, CHICAGO 35, ILL.



GENUINE ALNICO MAGNETS

AMAZING, PERMANENT, NON-ELECTRIC, HIGHLY PRACTICAL. Conduct interesting experiments. Hundreds of uses. Retrieve valuable steel items such as guns, tackle from fresh or salt water; tools from tanks & drains. GUARANTEED. Try any magnet one week.

MONEY BACK IF YOU ARE NOT WELL-PLEASED
M-710 (Wt. 53 oz.) Has pull of 225 lbs. on steel block. \$18.00
M-625 (Wt. 70 oz.) Has pull of 125 lbs. on steel block. \$10.00
M-575 (Wt. 18 oz.) Has pull of 75 lbs. on steel block. \$ 7.00
M-500 (Wt. 13 oz.) Has pull of 50 lbs. on steel block. \$ 5.00
M- 90 (Wt. 5 oz.) Has pull of 15 lbs. on steel block. \$ 3.50
M-102 Pocket Magnet. 5 lb. pull. 2 for. \$ 1.50
M- 47 Hot Pad Magnets. 10 for \$1.00. 50 for \$ 4.87
M- 35 Hobbyist assortment of 8 magnets. \$ 2.00

Send M.O. or check. We pay postage. Sorry no C.O.D.'s.
MIAMI MAGNET COMPANY, 3240 N. W. 27TH AVE. MIAMI 42, FLORIDA

Tractor with the "Most"



SPEEDEX

9 h.p. B. & S. powered model S-23 shown is today's "MOST" Tractor. Compare with anything on the market at its \$475 price. Two other riding models (4 h.p. & 5 1/4 h.p.) and 3 h.p. walking model

also use complete line of "unit-design" tools. Full year guarantee; sold on 10 day money-back guarantee. Color FOLDER gives complete information and dealer's name. Send 10c for it today.

SPEEDEX TRACTOR COMPANY, 367 No. Freedom St. RAVENNA, OHIO



BUILD THE BEST!

build quality money-saving

knight-kits

A PRODUCT OF ALLIED RADIO

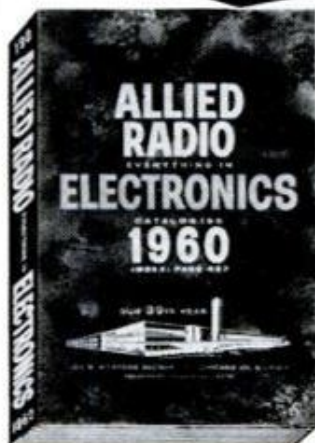

see them all in
ALLIED'S
1960 ELECTRONIC
SUPPLY CATALOG

FREE

build your own...
it's easy...it's fun!
SAVE UP TO 50%

See the 1960 KNIGHT-KIT line—available only from ALLIED. KNIGHT-KITS are lowest in cost, convenience-engineered for easiest assembly—the only kits with money-back guaranteed specifications. Send today for the 1960 ALLIED Catalog—select your KNIGHT-KITS—and...

HI-FI KITS



INSTRUMENT KITS



HOBBY KITS



HAM KITS

world's largest stocks



EASIEST TERMS
only \$2 down on
orders up to \$50

FREE
catalog

ALLIED RADIO

100 N. Western Ave., Dept. 24-C, Chicago 80, Ill.

Rush FREE 1960 ALLIED Catalog

Name _____

Address _____

City _____ Zone _____ State _____

Owners Report on the Corvair

(Continued from page 128)

More Best-Liked Features

The following quotations describe additional best-liked features in order of frequency of mention, beginning with the fourth-ranking feature, traction on ice and snow:

Amazing how few front-engine advocates you'll meet on an icy hill! →

"Drove more than 200 miles over fresh snow on Highway 40 from Ohio to Maryland. Without chains I climbed some grades that other cars and trucks were unable to climb."—U.S. Navy sailor.

We're still looking for the man with that bow and arrow. →

"I do a lot of hunting. Have had the Corvair over all kinds of roads and through fields. Traction is perfect."—West Virginia postal clerk.

"Parks in spaces that other cars can't get into which is a big time and walking saver to me as space is at a premium where I live and work."—District of Columbia bus operator.

Economy was way down on the best-liked list, at the top of the gripes. →

"This car corners very well. I think every car should be built this way. It would be safer on the road today."—North Carolina machinist.

"If you should turn too sharply or go too fast, errors in steering can easily be corrected and are not so dangerous as on a larger car."—North Carolina insurance woman.

"Much better gas mileage than the 1957 Chevrolet V8. About 8 miles per gallon better and it burns regular instead of premium gas."—South Carolina airman.

"I average 1000 miles per week. The Corvair cruises at 65 miles per hour and apparently isn't under any strain. At 5000 miles the tires show no undue wear. I get 23.5 miles per gallon on long trips."—Florida traveling salesman.

"I like its compactness. It is just the right size car for anybody who is economically minded."—Virginia insurance salesman.

Who sat on the roof? →

"Smallness makes it easy to clean and wax, easy to park."—Wisconsin Air Force member.

"On a recent move from Wisconsin, I transported a wife, four children and a dog plus luggage. We found more usable space than in the two front seats of our former station wagon."—Minnesota hospital executive.

"Unusual pickup for a small car."—Tennessee engineer.

"Wonderful engineering accomplishment. I was wondering which company would wake up to the fact that the engine belongs in the rear. Remember when we used to put bags of sand in the trunk for traction? And in a collision, you do not have to worry about getting a lapful of engine, which can be fatal."—Virginia Navy man.

However, steering is too slow. The car would be more enjoyable, more nimble if the ratio were faster. →

"Air-cooled engine. No worry about water, hoses or anti-freeze."—Nebraska bookkeeper.

"Gets about easily in heavy traffic."—Virginia student.

"I will not buy another car without a gas heater. I deliver newspapers at 4 a.m. and it is very nice to have a warm car in two minutes."—Tennessee newspaper agent.

"No transmission bulge on floor. Seats six comfortably."—Utah ammunition destroyer.

And More Complaints

The following quotations describe the things owners don't like about the Corvair. They are listed in order of frequency of mention, beginning with the fourth most frequent:

Average 1930 car was 72 inches high; today it is 56 inches high. Where does it end? In a crick in the back, that's where. →

"It should be made simpler to enter and leave this car. Especially for women. To enter from the sidewalk is like stepping into a gopher hole. When getting out, legs have to

(Continued to page 274)

STANLEY
7/8 HP ROUTER
 ONLY \$69.95



NEW SAFETY SWITCH
 Locks shaft automatically. Change bits fast with just one wrench.



FAST DEPTH ADJUSTMENT
 Unique depth gauge sets bit for cuts as fine as .004"—in seconds!



PERFECT VISIBILITY
 Spotlight and open base let you see where you are, where you're going.

The power tool that puts new skills in your hands

Of all portable power tools, Stanley's "router with the light" is the one that helps you most in fashioning and finishing fine furniture or wood work of any kind.

Perfectly balanced, the H264 fits and feels right in your hands. You know you can achieve just the right mortise, bead, edge or dado because this is a tool designed to make exacting cuts exactly right. The exclusive Stan-

ley spotlight spots the line and lights your way along it. The open base always lets you see what you are doing.

See the Stanley H264 wherever you buy tools. Heft it. You'll want it. For fully illustrated book, "Operation of the Modern Router," enclose 25¢ to Stanley Electric Tools, Division of The Stanley Works, 6203 Myrtle St., New Britain, Conn.

Prices slightly higher in Canada • Canadian office: Hamilton, Ont.

STANLEY

Electric tools built for the professional, priced for everyone

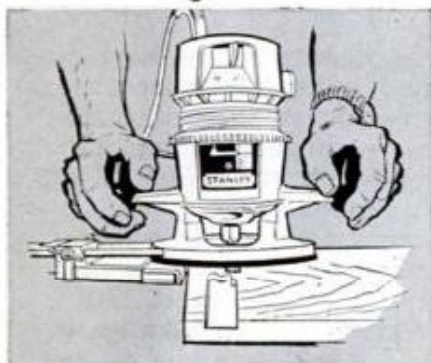

Cutting of dados can be done fast and accurately with the router. You are sure of exact fit, finer craftsmanship when making bookcases, cabinets, dressers, etc.

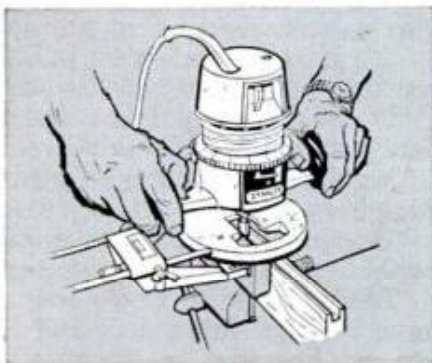

A Stanley router lets you cut true grooves or slots in the sides, back and front of drawers, boxes, trays, etc. You can even cut a perfect groove on a 3/4-in. narrow edge!

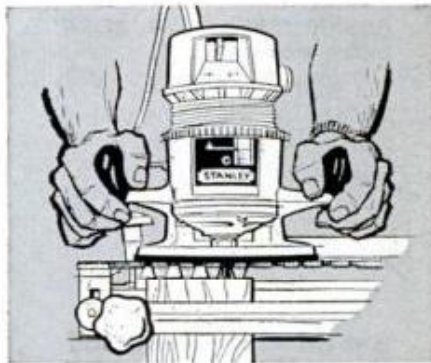

The dovetail joint, very difficult to cut by hand, is done easily and perfectly with the versatile Stanley router and dovetail template—just like the professional!

Word of warning: Don't carry a can of gas under the hood if you plan to run the heater. The right mix of air and gas will explode when heater ignition comes on. Won't hurt you, but sure will inflate the hood. →

If it weren't rounded off, he wouldn't be able to get his feet through the opening. →

Another production fix. Now Corvairs have conventional parking brake handles. →

Dome-light bulbs are imported and when they fail, replacements are as scarce as antifreeze in Wolfsburg. →

Funny about the fan belt. Everybody who looked at it said it wouldn't work. Chevy engineers tested, tested and tested—they insisted it would work. It didn't. But it now has been fixed in production. →

Psychological blunder. With the small 10-gallon tank, you can almost see the needle move down at 70 miles per hour. →

Get rid of overhang and excess length and you automatically make any car stronger, more rigid. Lark found that out. →

be raised to the point where your knees touch your chin."—New York housewife.

"My wife drives the car and when she leaves the seat all the way forward, I cannot get in at all. Once in, there is plenty of room."—Ohio salesman.

"I think it would be almost impossible to vacation with it as there is no storage space. I had to find a short-handled snow shovel to get it into the trunk. There is no room to carry a gas can either. One would not dare drive all night up here where all-night stations are far apart."—North Dakota rural mail carrier.

"Trunk must be closed. If occasionally I have an object to haul which must protrude I cannot do it."—Wisconsin contractor.

"Front seat slopes too much to the back. Should be leveled a little more and raised four inches."—Colorado custodian.

"Don't like rounded-off rear seat."—Rhode Island machine operator.

"Cheap cardboard interior finishing."—Maryland dental school instructor.

"Parking brake trouble. Very soft metal in the key that drops into the ratchet."—Rhode Island inspector.

"Stock of parts is very poor. We had to wait six weeks for a small heater switch through the cold months of October and November. It was finally fixed by taking the switch off a new Corvair which had not been sold yet."—Wisconsin bookkeeper.

"Dome light has burned out three times. Unable to get proper cartridge type bulb."—Vermont engineer.

"Poor dealer service. Dealer claims no training for mechanics. Advises me to expect delays due to new car."—Delaware housewife.

"Headlight dimmer switch is inconveniently located on the floor. One would get tired if driving a long distance at night."—Tennessee nurse.

"Fan belt trouble. Cog belt turned over and was replaced with a smooth V-belt, which works fine."—Ohio millwright.

"Fan belt broke at 1550 miles. For women Chevrolet should provide an extra belt and wrench."—North Carolina occupational therapist.

"At first I thought the price was too high, but after having driven it I can see it's well worth it."—Wisconsin executive.

"Can buy a six-cylinder Chevy just as cheap."—Tennessee owner.

"Would like a Park gear as I sometimes fear the brake might not be enough on a steep hill."—New Hampshire summer theatre sponsor.

"Gas tank too small. Have to stop every 2½ hours for gas."—New Hampshire physician.

"It's a long reach with a bag of groceries in one hand to reach inside and unlock the rear door."—Ohio social worker.

"Doors do not open in same manner. Front and rear inside handles work in different directions."—Virginia homemaker.

"Angle of windshield picks up much sun glare. Also steams up easily."—Rhode Island photographer.

"Bumpers do not give enough protection against minor parking bumps."—Virginia inspector.

"Back air grille is too low and will get damaged. But I have been in three rear-end accidents already. Damage to my car has just been superficial. I think it is one of the safest and sturdiest cars on the road."—Utah electronics technician.

Here are a few miscellaneous complaints and suggestions,

(Continued to page 276)

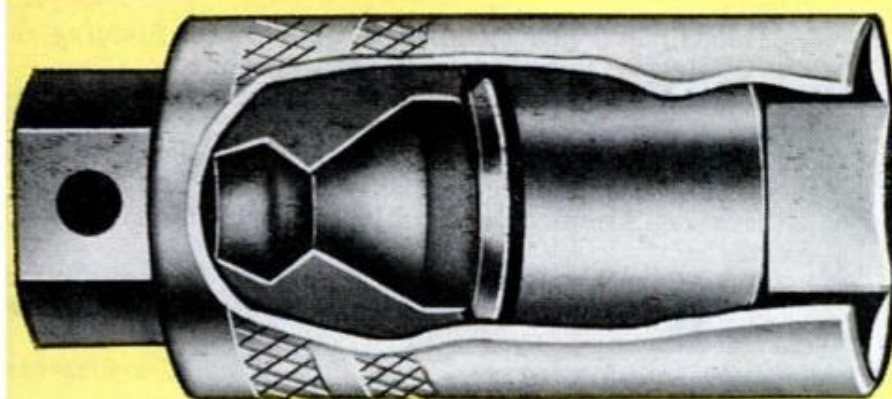

PROTO'S SPARK PLUG HOLDING SOCKETS. Revolutionary neoprene insert prevents burned hands, cracked porcelains, damaged electrodes. Available in $\frac{3}{8}$ " (No. 5026HP) and $\frac{1}{2}$ " drive (No. 5326HP). Both sockets fit all standard 14mm plugs in domestic and foreign cars. Turn with fingers, flat wrench, ratchet, torquer. Look for counter display-demonstrator. You'll find over 2,200 quality Proto tools at auto parts, hardware and industrial outlets. Professional performance guaranteed.



Division of Pendleton Tool Industries, Inc.

2202 Santa Fe Avenue, Los Angeles, Calif. • 502 Allen Street, Jamestown, N. Y. • 1702 Oxford East, London, Ontario, Can.

SOLVING CRIMES BY HYPNOSIS

*— a fascinating
feature to watch for*

in the

APRIL POPULAR MECHANICS



Custom Sportsman (CSP-15G)

CLEAN LINES — BRIGHT ACTION — SPARKLING BOAT!

Fiber glass is wonderful the Traveler way. And you'll see it as perfection in this 15-ft. deluxe runabout. Smartly flared bow; perfected lapstreak hull gives dry, comfortable ride. Bright colors molded into hull and deck. Matching upholstery features seat back stretch pockets and approved life preserver seat cushions. See it at your nearest Traveler dealer's.

Free: Write for full-color catalog on the exciting 1960 models—both aluminum and fiber glass.

Arkansas Traveler Boats, 2006 E. 14th St., Little Rock, Ark.

You Get MORE with
 **Arkansas TRAVELER**

Serious fault is the erratic action of front brakes when wet. They are not even reliably capricious. In some rains, even heavy ones, brakes are unaffected; in others, they pull to one side dangerously. →

Miscellaneous comments: Here's a car that is hard to be matter-of-fact about. List all its faults (as this story has) and it sounds very poor indeed. Yet it's far from that. If you like good machinery, well-thought-out design, sure-footed suspension, economy tempered with power, needle-threading steering and excellent road sense, you'll like the Corvair. But if you aren't willing to put up with low seats, hard-to-close rear doors, an unconventional trunk, you won't like it. It's a car you'll either love or detest—there's no so-so about it. As you may have suspected, this writer likes it.

made by a small number of owners but enough so that they are of interest:

"In wet weather brakes become erratic."—Tennessee physician.

"Hooks should be installed in the rear for hanging clothing."—West Virginia professional soldier.

"Speedometer cable needs to be changed. Needle vibrates."—North Carolina Army man.

"Gasoline indicator reads empty when about 3.5 gallons are left."—Ohio mechanical engineer.

"How can I hook up and pull a trailer if I want to?"—Ohio carpenter.

"Rear door handles are placed wrong. Women and children cannot close doors from inside."—North Carolina radio station owner.

"Horn button very hard to get to."—North Carolina textile manager.

"Corvair engine is not built for dusty conditions, but the air cleaner is easily serviced and is quite efficient."—South Dakota pastor.

Finally, here is a summation by a Corvair owner that tells the whole story:

"To rate the Corvair excellent over-all would be stretching it a bit. To rate it average over-all would be an understatement. Many features are excellent such as the full seating capacity, full legroom, simplicity of design with nothing spectacular or unnecessary. Its ease of braking, with no bounce or dive, just a steady deceleration, like closing your fist. I suppose every new car has to have the bugs worked out of it by trial and error, but unless you make mistakes you never know just where you stand anyway."—Virginia civil service clerk. ★ ★ ★

FREE!
BELT HOLSTER
 NOW WITH EVERY
EVANS TAPE
 Sizes from 6 ft. to 12 ft.



CLIPS ON BELT!

YOURS FREE! — A fitted belt holster with each EVANS "White-Tape" that you buy! Metal-reinforced holster provides great on-the-job convenience — clips to the belt, for easy carrying and quick measuring.

On Evans Tapes only at your hardware dealer

Evans RULE CO.

Factories at:
 Elizabeth, N. J. and Montreal, Que.

Exclusive Double-Bearing HEAVY-DUTY PUMPS
 IRRIGATE • DRAIN • CIRCULATE • SPRAY
 Use 1/4 HP motor or larger 1 HP for up to 7,500
 GPH; 1,000 GPH 60' high; or 3,000 GPH from 25' well.
 1 1/4" inlet; 1" outlet. Stainless shaft.
TYPE X—2 oil-less bronze bearings. Won't rust. **\$10.95**
TYPE XB—Ball bearing model. **\$12.95**
 Postpaid if cash with order. Rush your order today
MONEY BACK GUARANTEE
 Centrifugal and Gear Pumps in All Sizes
LABAWCO PUMPS, Belle Mead 2, N. J.



IS THIS OFFER TOO GOOD TO BE TRUE?

We Pay All Freight For Your FREE Home Trial!



GRINDER
SANDER
30" LATHE
4" TILTING TABLE SAW
HORIZONTAL DRILL PRESS
VERT. DRILL PRESS

It's true. We pay all freight for your FREE home trial. Factory to you only \$79.95. Handles big jobs. 100% ball bearing. Think of the fun you'll have and the money you'll save with your own workshop. Only \$10 down delivers \$79.95 Supershop prepaid to your home. Write for full details, color brochures, FREE home trial plan. Mail postcard now.

Power Tools Division UNITED INDUSTRIES, Inc.
 129 Yates Ave., Beloit, Wisc.

POPULAR MECHANICS

4 WAY WELDER only 14.75 F.O.B.

SIMPLE, EASY-TO-USE
ANYONE CAN WELD, BRAZE, SOLDER, CUT,
HEAT MOST ANY METAL WITHOUT EXPERIENCE



Sent complete with twin carbon arc torch, welder's shield, carbon, welding and brazing rods. Ready to use.

Over 200,000 in use in homes, garages, farms, shops, factories everywhere. Save money—earn money, making and repairing auto bodies and parts, fenders, furniture and railings, farm equipment, machinery, lawn mowers, toys. Does 1001 jobs on iron, steel, bronze, brass, aluminum, etc. Operates on any properly wired 110 AC or DC line.

SEND ONLY \$3 Pay postman \$11.75 plus C.O.D. charges. Simple instructions included. Ideal lifetime gift for hobbyist, mechanic, hot rodder, homeowner. Order direct on 10-day money back guarantee or write for literature FREE.
FOUR WAY WELDER CO., Dept. F2-C
1810 S. Federal St. Chicago 16, Ill.



Get New 132 Page Catalog of WOOD AND WOODWORKING MATERIALS

WORLD'S LARGEST SELECTION—Lowest Prices
Your buying guide for finest kiln dried domestic and rare imported woods, inlays, bandings, matched plywood, moldings, ornaments, etc. Biggest selection of tools and hard-to-find hardware. Packed with scroll saw patterns, projects, wood facts and money making ideas. Enclose 25c (refunded on first order) to help pay mailing and handling costs. Write today to **CRAFTSMAN WOOD SERVICE COMPANY**
2729 S. Mary Street, Dept. A-3, Chicago 8, Ill.

WATERBURY FOR TILLING PLOWING MOWING

A FULL LINE 3 to 9 HP
2 WHEEL • 4 WHEEL
FREE CATALOG • LOW PRICES • DEALERS WANTED
Many attachments available

WATERBURY
Box 2734-D, Milwaukee, Wis.

Print Your Own

Cards, Stationery, Advertising, Circulars, labels, photo and movie titles, church work, tags, etc. Save money. Sold direct from factory only. Raised printing like engraving, too.

Own a Printing Business
Print for Others, Good Profit. Have home shop. Junior press \$15; Senior \$29 up. We supply everything. Easy rules. Pays for self in short time. Write for free catalog of outfits and all details.
KELSEY PRESSES, C-37 Meriden, Conn.

FOR PANELING... BUILT-INS... CABINETS... FURNITURE

The Complete Interior WOOD FINISH

in One Can

READY TO USE
A finer clear, semi-gloss for natural wood beauty. Non-darkening. ANYONE can use Deft... it's so easy.

Wherever paints are sold, or write Dept. PM Deft, 1526 W. 228th St., Torrance, Calif.

Free Shop Chart on Wood Finishing,

Write Dept. SSPM.



Dr. Grabow PRE-SMOKED PIPES

Cool, sweet and mild from the first puff. No breaking-in because they're mechanically pre-smoked with fine tobacco

finest imported briar

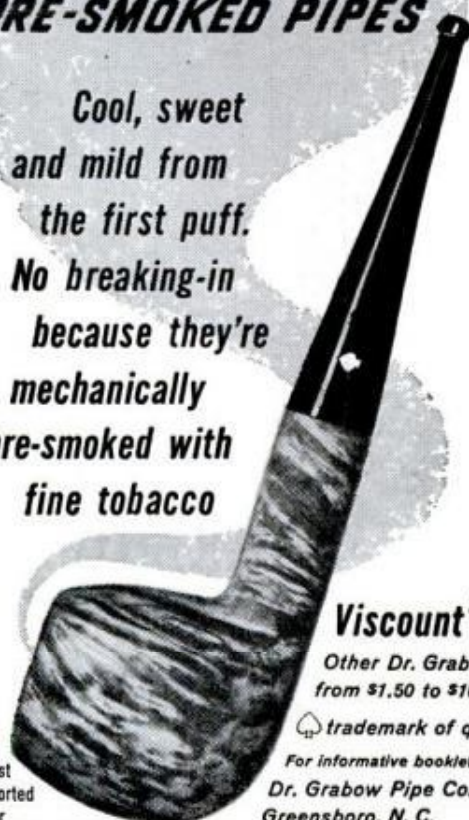

Viscount \$5.

Other Dr. Grabows from \$1.50 to \$10

trademark of quality

For informative booklet write: Dr. Grabow Pipe Co. Greensboro, N. C.

NEW INSULATION FOR MASONRY WALLS!

- WATER-REPELLENT
- CUTS HEATING COSTS —doubles insulating value of walls
- EASILY INSTALLED

At last there's an insulation to go into cores of concrete block, or into cavities in brick wall construction. New Zonolite Masonry Fill doubles insulating value, installs in a jiffy, stays permanently dry. Costs only a few cents a foot, gives lasting comfort, saves fuel. Ideal for homes, garages, breezeways, commercial or farm buildings.

ZONOLITE®
Masonry Fill Insulation



ZONOLITE COMPANY, Dept. PM-30
135 South La Salle Street, Chicago 3, Illinois
Please rush booklet MF-2 on Zonolite Masonry Fill Insulation.

Name _____
Address _____
City & Zone _____ State _____

AT LUMBER & BUILDING SUPPLY DEALERS'



**SPEED
THE JOB
WITH A**
Red Devil
PUTTY KNIFE!

Professionals know that the *right* putty knife or wall scraper mean easier, cleaner work. Red Devil makes 108... every shape, size, stiffness and "feel." What kind's best for you? Find out from the most helpful dealer in your neighborhood... the one who sells Red Devil Tools:

Glass Cutters • Wall Scrapers • Glaziers' Tools
Wood and Paint Scrapers • Hardware Specialties
Putty Knives • Floor Polishers • Paint Conditioners

Red Devil Tools.

Dept. PM-3, UNION, N. J., U. S. A.

PLEASE SEND ME
FREE BOOKLET
"How To Repair
Broken Windows."



Name _____

Address _____

City _____ Zone _____ State _____

2902

We're Going to Work Miracles

(Continued from page 101)

Ordinarily oil wells would then be drilled into the shattered area to pump the liquefied tar to the surface where it could be refined into various petroleum products.

An even more difficult and ambitious problem, one that might be called only a dream, is to extract the hydrocarbons that are trapped in the oil shales of Colorado, Utah and Wyoming. An experiment is being considered for performing an explosion in this area. In this case much more heat is required to liberate the oily substance from the shale. The heat of the nuclear explosion will not suffice. Actually the explosion is considered only for the purpose of breaking the shale. Once this is done, one might start an underground fire in the shale. The heat of the fire would then drive out some of the valuable hydrocarbons.

Experience Needed

But this is all speculation; we have had no experience in shattering or heating or modifying an underground petroleum deposit. At best the first attempts will not be perfect. The probability that either project will succeed may not be very high, yet success would increase the world's available supply of oil by billions of barrels. It is worth the venture when the reward can be so great. What we should like to do is to perform exploratory explosions in a really safe manner and observe the results. The results may be surprising and all surprises need not be disappointments.

If producing oil may be called a dream, we might be excused if we call the next possibility a real pipe dream. This has to do with producing heat underground and then mining the heat and changing it to electricity. We can create the heat cheaply — that we know. The question remains whether a pipe or system of pipes can be installed in the hot area cheaply enough and whether the pipes will stand many consecutive explosions, or that we can draw off the heat at an economical cost.

Project Gnome will tell us a great deal about this method of producing electricity. The plan is to explode a 10-kiloton device in a thick bed of natural salt 1200 feet below the surface near Carlsbad, N. Mex. The salt is very dry, hence very little steam will be created that could dissipate the heat. We hope that the blast will melt considerably more than 1000 tons of material, creating a pool of molten salt having a minimum temperature of around 1500 degrees. Air or carbon dioxide would then be bubbled through this reservoir of heat and the re-

(Continued to page 280)

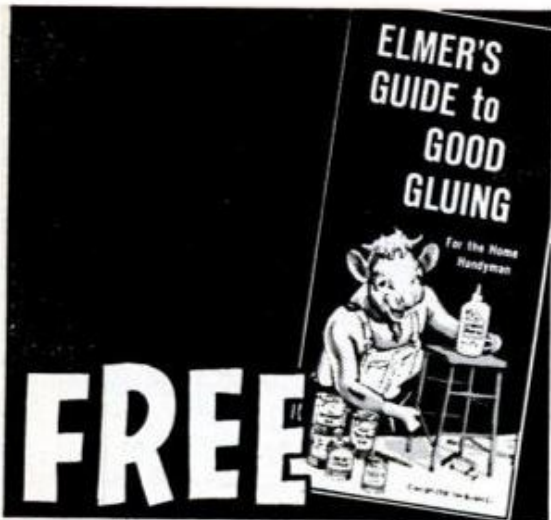

FREE

for glue-it-yourselfers!

The ins and outs of gluing. Hints, tips and short-cuts. Tells you what glue to use for every job indoors and out. Send a stamped, self addressed envelope for your free copy. The Borden Company, 350 Madison Ave., N.Y. 17, N.Y.



G E A R S

In Stock — Immediate Delivery
Gears, speed reducers, sprockets, thrust bearings, flexible couplings, pulleys, etc. A complete line is carried in our Chicago stock. Can also quote on special gears of any kind. Send in your blueprints and inquiries.

Send for Complete Catalog No. 10
CHICAGO GEAR WORKS
440-50 N. Oakley Blvd., CHICAGO 12, ILL.



Hand-rubbed finish
without rubbing

McCLOSKEY HEIRLOOM®

The specially developed finish for antiques, furniture, wall cabinets and paneling

Flows on silken smooth, leaves no brush marks, never a sheen variation. Heirloom is extremely pale, nonyellowing, nonstaining—sets up dust-free in 1 to 2 hours, hardens overnight.

Send for free booklet, "How to Finish Furniture, Wall Cabinets and Paneling with HEIRLOOM Varnishes."

McCLOSKEY VARNISH CO.

Dept. 213, 7600 State Rd.
Philadelphia 36, Pa.



HERE'S A MONEYMAKER FOR YOU!

make from \$3 to \$6 an hour with the FOLEY SAW FILER

Ask yourself these three questions: 1. Do I really want to get ahead *faster*? 2. How can I do it? 3. Am I willing to use my spare time? If you answer "Yes" to questions 1 and 3—then we have a positive answer for you on No. 2. Men make from \$3 to \$6 an hour sharpening hand, band and circular saws with Foley Saw Filers. No experience needed, to turn out sharp, smooth-cutting saws with this automatic machine. Start in spare time—no canvassing.

HERE'S THE WAY TO START

Read "Money Making Facts"—shows you how others have added hundreds or thousands of dollars to their incomes in this steady, repeat, CASH business. Start your own business in your basement or garage, no overhead, small investment. With *Time Payment Plan* the Foley can more than pay for itself out of profits. Send for "Money Making Facts"—mail coupon now. No salesman will call.

HERE'S PROOF

"When Mr. Patrick got his Foley Saw Filer in March 1946 he made a good and wonderful investment. He has done so well that we bought a house and paid for it; bought a new car, built an addition to our house. Nicest of all, it's all paid for."
Mrs. Leslie Patrick.

"I made \$765 last year filing saws, and it sure comes in handy. I do this work in my spare time."
—James B. Williams

"Last year's profit amounted to \$3,000. Not so bad for a one-man outfit."
—Charles C. Hough.

"I have done 4 or 5 thousand saws in my spare time in the 4½ years since I got the outfit, and they are all coming back with repeat orders."
—Len Crego.

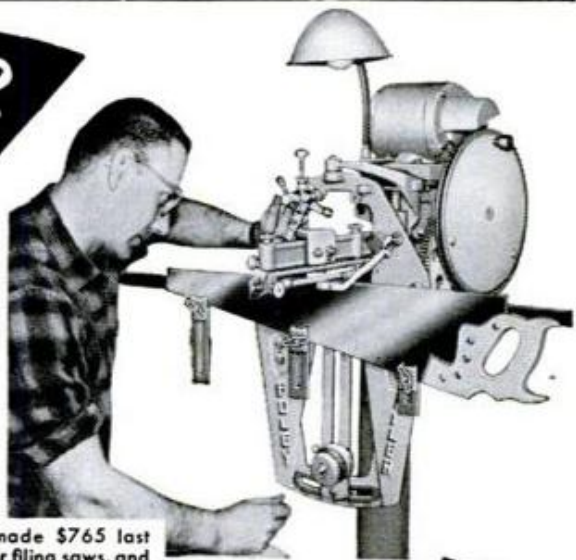

FOLEY MFG. CO., 316-0 Foley Bldg., Minneapolis 18, Minn.

Send me free book "MONEY MAKING FACTS" and Time Payment Plan.

NAME _____

ADDRESS _____

"Why should I worry about my battery—

*I've got
warning
lights!"*



Warning lights for your battery and oil pressure are not enough! Your car needs a Stewart-Warner "Twin Gauge" Panel. Here's why: A generator warning light indicates only that your generator is not delivering a charge. But the ammeter in the "Twin Gauge" Panel tells actual rate of current flow... helps prevent generators from burning out and overcharging or discharging of battery. And the Stewart-Warner Oil Pressure Gauge in the Twin Panel tells exact oil pressure, helps assure safe engine operation. Choice of standard black enameled steel as illustrated or deluxe panel of Colonial White grain finish Royalite.

Ask for it at your service station,
garage, or automotive parts store.



1840 Diversey Parkway, Chicago 14, Illinois

sulting superheated air or steam would be piped to the surface to operate an ordinary electrical powerplant. Project Gnome is a very small scale experiment; for economic power production thermonuclear devices in the megaton range could be used to create vast underground deposits of heat. When this will become possible and whether it will ever become important, we certainly do not know.

We believe we will be able to produce new things underground that we can later mine. We can make isotopes underground, and some of these isotopes will be valuable. We might be able to produce diamonds, not of gem-stone quality but as a fine powder which has industrial uses.

There is enormous potential in using nuclear energy underground to create the heat and pressure needed to carry out strange chemical reactions that may produce entirely new types of materials never seen on the face of the earth. The problems are: to produce them from materials which are already present in the underground location, to mine them cheaply—for instance, in the form of a fluid—but more than anything else to recognize which are the really interesting materials one can obtain this way.

Water Important

A fluid that is even more important than oil is ordinary water, and it has been proposed that we regulate the flow of water on the surface or underground by means of nuclear explosions. One suggestion is to shatter a formation so that a subsurface flow of water would be trapped in the shattered area, from which it could be pumped. There is a chance that the water would leach out some radioactive products and carry these with it. Our present experience indicates that any leaching would be so slow that the radioactive products would have decayed to a safe state by the time they have moved a significant distance. However, this is one more reason why we must strive to produce clean explosives, and until we have clean explosives, we must proceed with the greatest caution.

Nuclear explosions could be used to produce cheap earth-fill dams, to deflect rivers and to decrease the cost of hydroelectric projects.

There have been suggestions that we could bomb a hurricane out of existence. This seems extremely difficult. The energy in a hurricane is too great. Another proposal has been to use a nuclear explosion as a trigger that would modify climate or weather. The late mathematician John von Neumann suggested that a nuclear explo-

(Continued to page 282)

**BIG SAVINGS NOW
ROCKHOUNDS
UP TO 33% OFF**

**WE DARE YOU
TO COMPARE**

This "25X Ruper" Magnifier with any magnifier you now use! Full 1/2" diameter corrected lens! Nickel plated metal folding frame. Equivalent to other \$6 magnifiers.
Order as: T130-255 \$1.00

GENUINE GEMS OFFER
10 Beautifully polished Baroque Gems of Citrine Topaz, Amethyst, Rock Crystal, Morganite and Aquamarine. 5/8" sizes ... total weight 50 carats.
Order as: 5-12-5 \$1.00

STERLING SILVER BRACELET CHAIN
7" length ... angel wing design. Sterling silver chain and clasp. A regular \$1 value.
Order as: 522-5 now only 55c

SPECIAL OFFER IN JEWELERS PLIERS
High polish, full chrome finish. Chain nose—the most useful jewelry pliers known. Better than most pliers that usually sell for \$2.00.
Order as \$24-5 ... introductory offer \$1.00

BLACK MEXICAN MALACHITE
Rare, banded Psilomelane that looks just like scarce green African Malachite except bands are black and gray. Excellent for cabochons or polished specimens. Generous 8 oz. piece at special advertised bargain price!
Order as: 222-5 Only \$1.00

STERLING SILVER WIRE BARGAIN
\$2.30 worth of silver wire for \$1. Offer contains nine 6" lengths of Rd. Bead, Twist, 1/2 Rd., Bezel, 1/2 Rd. Silver wire.
Order as: 5-9-5 \$1.00

BAROQUE GEMS IN SPECIAL ASSORTMENT
A big 2-oz. bag of ass't sizes from 3/8 to 3/4". Highly polished gems of Mexican Amethyst, Bird of Paradise Agate, Abalone Rainbow Pearl, etc. Very useful lot of gems for jewelry and for decorating hand bags. Don't pass this value up!
Order as 537-5 bag only \$1.00

GET AN EXCITING PEARL
Intact in Mother Oyster
3 year old, unopened oyster, guaranteed to contain GENUINE CULTURED PEARL suitable for fine jewelry use. From deep sea direct to you ... just open can and remove!
Order as: 28-5 Only \$1.25

YOU JUST CAN'T GO ROCK HUNTING WITHOUT IT!
ESTWING PROSPECTOR PICK
Forged all-steel one-piece head-handle prospecting pick with the new blue everlasting nylon cushion handle grip—non slip. 13 inches long with 7" head which weighs 22 oz. Guaranteed unbreakable.
Order as 7-60-5 now only \$4.75

NEW epoxy ADHESIVE
So good it's replacing rivets
MIRACLE ADHESIVE — you've seen it on T.V. and in LIFE — it bonds materials stronger than anything else. Aircraft industry using it instead of Rivets—replaces nails and screws. Perfect for jewelry making — Unconditionally guaranteed! Kit of 2 jars with complete instructions.
Order as: 21-5 only \$1.50

SMOKY QUARTZ OR SMOKY TOPAZ
Also known as Scotch Cairngorm. Brilliant, sparkling, faceted 13 x 18 mm. Oval Gem. You also get large catalog of jewelry mountings for mounting these lovely gems.
Order as: V94-155 each \$1.00

"COLLECTORS' SPECIAL"
4 Unusual 1 inch polished specimens: Carnelian, Blue, Green, and Gray Brazilian Agate. Normal Retail Value \$3. All 4 offered on "Let's get acquainted" spectacular deal.
Order as: 29-5 Only \$1.00

YOU CAN MAKE ROCK CRYSTAL STAR EARRINGS
Everything you need — including 1 pair 1/2" handcut faceted genuine Brazilian Rock Crystal sparkling stars; 2 sterling silver bails and 1 pair sterling silver ear wires — ready for mounting. A normal \$3.50 value. Now yours on our "Let's Get Acquainted" offer.
Order as: 5-155 now only \$1.00

Full cash refund if not more than pleased.

JEWELRY CRAFTS CATALOG FREE

All items sold on Money Back Guarantee
PRICES INCLUDE TAXES AND POSTAGE
ORDER BY MAIL Send Check or Money Order.
AND SAVE! 1633 E. WALNUT PASADENA, CALIF.

KEEP CAR PERFORMANCE LIKE NEW—REPLACE WORN PARTS

NOW! HOME CRAFTSMEN CAN OWN THIS PROFESSIONAL ARC WELDER

EASY TERMS ONLY \$98.50 F. O. B.

Trindl "DO-IT-YOURSELF" ARC WELDER

FREE WRITE FOR COMPLETE DETAILS AND EASY PAY PLAN

Now you can own a Trindl full 125 amp Industrial Welder at a price far less than smaller machines. With a Trindl 125A you can weld metals up to 1/2 inch thick. Operates off either 110 or 220 volt line, properly wired. 16 heat stages from 20 to 125 amps. Make and repair anything of metal around the home, garage, farm or shop, like a professional. No previous experience or training needed. Full "do-it-yourself" instructions with each machine. Complete only \$98.50 f.o.b. factory, or write for details. Trindl manufactures a complete line of heavy duty welding machines. Dealer inquiries invited.

Trindl PRODUCTS Ltd., Dept. T2-C
1807 So. Clark St., Chicago 16, Ill.

Guaranteed 12 MONTHS IN CONTINUOUS OPERATION



ever work with aluminum?



fitting is easier
with SURFORM tools

Trimming and fitting aluminum screens and screen doors is a typical home handyman job. Aluminum is a clean, easy to cut material when you use the right tools. One very right tool is any SURFORM tool with a fine cut blade. Pocket tool, flat or half-round file is perfect for smoothing rough edges or trimming to fit.



SURFORM File
trims door edge

For free folder on miracle speed SURFORM® tools, write Stanley Tools, Dep't. 6203, New Britain, Conn.

STANLEY®

**TOOL
CARE**



Give precision tools the care they deserve. Free catalog to toolmakers and machinists.

GERSTNER TOOL CHESTS
460 Columbia St. Dayton 7, O.

HOME appliances



run so **SWEET**
last longer too
WHEN OILED REGULARLY WITH
3-IN-ONE OIL

Always use REGULAR or OIL SPRAY for general jobs:
ELECTRIC MOTOR OIL for heavy duty. BUY ALL THREE!

sion could throw up dust of the right particle size. The particles should be bigger than the wavelength of sunlight so they would shut out the sunshine, but they should be smaller than the heat radiation emitted by the earth. Thus the usual balance between incoming and outgoing radiation would be changed in the region where the explosion has produced dust. In this way, we could govern much bigger energies than that of the explosion itself. There is just a chance that we really could influence weather.

For the time being, we are not planning anything along these lines. Weather modification is mentioned only as an example of the possibilities that might arise in the distant future.

Plowshare is still a very new and untried enterprise. It cannot prosper without two necessary ingredients—careful thought and careful experiment. So far we have tried to give the problems careful thought, but we are woefully short on actual experience. The field is full of new possibilities. It may well be that the main application of nuclear energy will be along lines of which no one has yet thought. ★ ★ ★

Supersonic Waves Detect Cancer Tissue

Russian engineers report that they have developed a machine that is quicker than X rays in detecting changes in human body tissues that give first warnings of cancer and other diseases. The machine shoots supersonic waves into the body and measures the difference in their passage through healthy and abnormal tissues. It's as simple as having an X ray, the engineers say, but without any radiation or other discernible dangers.

Called UZD-4, the apparatus was developed over the last three years by Moisei Gurevich, a radio engineer at the USSR Research Institute for Medical Instruments in Moscow. Gurevich stressed the fact that the device doesn't detect cancer as such, nor does it indicate if the tissue differences are harmful. That decision is left for the doctor.

The machine, about the size of a large refrigerator, can measure changes in human tissue composition down to one percent or less. The UZD-4 has an oval-shaped apparatus that is placed against a section of the patient's body which has been covered by a rubber pad coated with glycerine or water. When the sound waves are sent through the body, their reaction is noted on a small round televisionlike screen. Places as small as one centimeter in width in which tissue is starting to harden or decay can be detected.

SURPLUS SALE

GOVT SURPLUS
EXCESS INVENTORY
BANKRUPT STOCK

POWER PLANTS

• Marvelous buy in new condition government surplus plants and brand new plants and generators direct from factory. All FOB

- 1000-w plant \$159.95
 - 2500-w plant 259.95
 - 3500-w plant 319.95
 - 7500-w plant 549.00
 - 3000-w 115-v DC Generator . . . \$54.75
 - 1000-w 115-v AC Generator . . . \$4.70
 - 5000-w 115-230-v AC Generator . . . \$199.25
- Other sizes from 500 to 10,000-W



SPEED REDUCER

• ITEM #1310. 80-to-1 gear reduction unit. 8 roller bearings, multiple gears. Reduces standard motor to 21 rpm — increases torque. Shafts 5/8" input, 1 1/4" output. Power winches, revolving signs, door openings, etc. Govt. cost \$66. SALE \$8.98 Ppd.



115-V AC WATER PUMP

• ITEM #246. Genuine Surplus. Rupp electric pump. Use for draining, circulating, empty tubs, fluid transfer. Rustproof housing. Cap. 500 gph. 1" outlet and inlet. 7" x 4" x 4". Wt. 5 lbs. \$8.95 Ppd. SALE . . . \$8.95 Ppd.



FISH-WORM AC SHOCKER

• Item #670. Harvest worms, clear private ponds of coarse fish. Powerful 110-v AC hand geared generator creates powerful electric field in ground or water. Amazing results. • Also fascinating for experimental—use for fun at parties. Has Super-Alnico magnets. Govt. cost over \$12. SALE . . . \$3.89 Ppd.



GOVT. GEARED BATTERY MOTOR

• ITEM #573. Powerful geared-down motor. Runs on 6 or 12-v. Use for golf cart, boat, farm winch, etc. Reversible. Speed 25-85 rpm. Wt. 35 lbs. Govt. cost \$250 . . . \$18.95 FOB
• Many other values — get catalog.



TRUCK-BOAT WINCH

• ITEM #311. Powerful ball-bearing winch. Reversing switch mounted on winch. For cars, trucks, docks. Use on 6 or 12-v battery. 1000-2000 lb. pulling capacity. Will hold up to 40' cable. Wt. 54 lbs. Govt. cost \$280. SALE \$46.75 FOB



HYDRAULIC EQUIPMENT BARGAINS

Savings to 80%. Build loaders, diggers, presses, etc. All brand new.
• Control Valve, 1 or 2 way . . . \$18.00 Ppd.
• Tractor Pump 1000 psi . . . 45.50 Ppd.
• 12-v Motor & Pump 1000 psi. 16.95 FOB
• 2-Way cyl, 2 1/2" bore, 9" str. 12.91 FOB
• Hyd. Press-gauge 1500 lb. . . 3.49 Ppd.
Many other types, sizes, items.



SPECIAL OF THE MONTH!

STANDARD DIAL PHONE

• ITEM #715. Modern hi-efficiency attractive dial phone. Use for extension to main line on private system. Use several for complete private system, etc. Complete. Work on any system. Govt. cost \$25. SALE \$8.95 Ppd.



AIR COMPRESSOR BARGAINS

• For painting, cleaning, tires, termites. Assemble own outfit.
• ITEM #450. DeLuxe Kit. Compressor, tank, gauge, regulator, paint gun, relief valve, fittings, hose, instructions. List \$52. SALE \$46.95 FOB
• Air Components. Compressor 1-cyl. \$21.50. Air tank \$11.95. Regulator \$3.95. Pop-off \$1.95. Press, Gauge \$1.89. Finest Paint Gun \$11.50. Auto Switch \$4.75.



SEND FOR BIG, FREE 1960 CATALOG OUR BIGGEST YET. 1000's of BARGAINS IN SURPLUS and NEW EQUIPT. FOR HOME, FARM, SHOP, BUSINESS.

MONEY BACK GUARANTEE

• Order direct from ad. Send check or money order. 25% deposit on C.O.D. orders.

SURPLUS CENTER
LINCOLN, NEBR DEPT 805

KEEP CAR PERFORMANCE LIKE NEW—REPLACE WORN PARTS

KING MIDGET

World's Lowest Priced Car. Rider Agents Wanted. Send 25c for 32 page picture book, full details, dealer price. Or send \$1 (refunded first order) for this plus Service and Repair Manual and 16 5x7 photos of car and factory.



MIDGET MOTORS CORPORATION, Athens 1, Ohio

ADJUSTABLE MITER BOX & CORNER CLAMP

2 TOOLS IN ONE
Adjusts to any angle!
No. 44—COMBINATION MITER BOX AND CORNER CLAMP
Holds the wood and holds your saw. Uses any handsaw for accurate cuts from 0° to 180°. Full 3" capacity. Sides of joints exposed for nailing, gluing. \$2.75 PPD.
No. 33 Works the same as No. 44, but without saw guide attachment. \$1.75 ppd.



SAW SHARPENING IS EASY

Super Filer No. 11 joints and sharpens hand and circular saws 6" to 10" with all teeth correct in height, depth, pitch, bevel. When file hits steel roller, teeth are finished. Saw runs true with no side pull. Includes 8" file. \$9.95 PPD.



"TRU-CIRCLE" saw set automatically sets teeth at 10° or more. \$2.95 PPD.

MONEY BACK GUARANTEE
A. D. McBURNEY, 5908 Hollywood Blvd., Hollywood 28, Cal., Dept. A-30

BUILD 'EM YOURSELF

with DOT

TEENUTS®

and
EASI-BILD® PATTERNS!

TEENUTS . . . the flush-mounting, "can't-slip" nut that needs no washer . . . is now specified in 10 popular Easi-Bild patterns! Get them both at Hardware, Variety and Lumber stores!

*T. M. Reg. U. S. Pat. Off.

Columbia Fastener Company Chicago 8, Illinois

It's a winner! DRAGSTER SPECIAL



Powerfully built for safety, durability... *real speed* at the races! New heavy chassis, low center of gravity make Dragster Special racetrack safe for speeds up to ? mph... eligible for all classes of races! Throttle and brake are foot controlled, mechanical steering system has proper settings for best performance on all types of tracks! See the Dragster Special today—it's in a class by itself! For full details and brochure write:

YAZOO DRAGSTER SPECIAL, YAZOO SALES CO., INC.
P. O. BOX 4207, JACKSON, MISSISSIPPI.

Special Offer 25¢

Hear these authentic recordings of dramatic events from

"The Amazing World of Short Wave Listening"

narrated by Alex Dreier, Radio-TV "Man on the Go"

- President's voice from outer space!
- Actual capture of a desperate criminal!
- Radio amateur at Little America!
- Ships at sea . . . aircraft in action!

S-107
receiver
\$94.95

4 short wave bands plus standard broadcast. Phono and headset jacks, built-in speaker.



MAIL COUPON TODAY!



hallicrafters...
DEPT. 14, CHICAGO 11, ILL.

Gentlemen: Please rush by return mail my recording, "The Amazing World of Short Wave Listening." I enclose 25¢.

NAME _____

ADDRESS _____

CITY _____

STATE _____

program sources. It would be frustrating indeed should you want to install an additional signal source, say a tape recorder or TV tuner, at some later date only to find that you don't have enough inputs. With the amplifier you buy you should at least consider the following inputs:

1) Separate inputs for magnetic and ceramic phono cartridges (you may want to change from one to another some time in the future and the two have different amplifier requirements).

2) Radio tuner input—one for each stereo channel.

3) Tape head input. Someday tape players may become as popular as record players are today. Though not essential at this time, this may save the cost of a separate preamplifier later.

4) Microphone input. If you ever want to use your amplifier for public-address purposes, this one comes in very handy.

5) At least one and preferably two high-level auxiliary inputs, for routing the signal from other equipment through your hi-fi system.

Selector Switch. The selector switch of a stereo amplifier connects any desired signal or pair of signals to the input of the amplifier. Usually this switch affects both amplifier channels simultaneously, though in some units separate selector switches are provided for each channel. The former method is far more convenient to operate, though the latter offers some slight increase in versatility.

Mode Switch (sometimes called Function Switch.) This one is used on stereo amplifiers only. Since such amplifiers must handle monophonic as well as stereo signals, the switch sets up the amplifier for either type of operation. Typical positions are: Stereo; Stereo Reverse—which reverses the apparent positions of the two halves of an orchestra; Monophonic A and Monophonic B—which permit playing a monophonic signal source through both amplifier channels simultaneously; Channel A and Channel B only. These last two positions are not included in all stereo amplifiers. They permit playing a monophonic source through only one of the amplifier channels, a function which is of questionable value.

Volume or Level Control. Normally, this control needs no explanation. In stereo, however, there are two types. With some stereo amplifiers the volume of the two channels can be adjusted independently in order to obtain precise balance between the two stereo signals; with others, a single control varies the volume of both channels simultaneously while a separate Balance

(Continued to page 286)

WAR SURPLUS AND OTHER **BARGAINS** **SAVE UP TO 90%**



PORTABLE HAND TACHOMETER Stewart-Warner. Hand held ideal instrument for checking speeds on saws, shafts, pulleys, engines, etc. Sturdily constructed, can be used clockwise or counter-clockwise. Will check speeds from 100 to 4,000 R.P.M. Two tips supplied. Approx. GOVT. COST \$19.50. New in original factory cans. **\$12.50** ppd.

DC JET GENERATOR ARC WELDING KIT Complete with GE Type CM-77 Generator (30 volts D.C., 400 Amp., 3000 RPM up; ampere rating is for continuous duty, intermittent ampere is 500 to 600 amps.), also 2 rheostats, 1 voltage regulator, 1 voltmeter, 1 electrode holder, 2 ea. 25 ft. lengths No. 0 welding cable, 1 welder's mask, 1 toggle switch, 10 lb. vacuum packed 1/4 in. welding rods, pair welder's gloves & spline coupling. All units guaranteed pre-tested. Wt. 110 lbs. Approx. GOVT. COST \$700. All items, now only **\$64.50**.

*G.E. Generator noted above can be purchased separately. Makes deluxe heavy-duty welder comparable to the finest commercial welders available. Wt. 90 lbs. Approximate GOVT. COST \$600. Gen. alone—**\$49.50**.



BUILD YOUR OWN ARC WELDER, LIGHT PLANT OR BATTERY CHARGER \$37.50

Kit incl. 1 Navy NEA-5 Gen. combination AC-DC type. AC 115 V. DC 24 V., 200-300 Amps. 2 complete generators in 1, yet no larger than reg. gen. Ideal for home, shop and farm lighting plants. Delivers 1200 Watts AC, DC side for charging batteries, welding and operating war surplus motors. Also in kit: 2 Voltage Regs., AC & DC, Reverse Current Relay, 30' New Welding Cable, 1 Ammeter, Rheostat, Electrode Holder, Toggle Switch, Welder's Shield, Wiring Diagram for kit. Wt. under 100 lbs. Approx. GOVT. COST \$650. Kit—**\$37.50**. Navy NEA-5 Gen. as above, purchased separately, **\$23.50**.

DOUBLE-V SPLINE 3" PULLEY For P-1, R-1, GE Gen. shown above. Heavy-duty machine-broached steel. Heavily constructed, will handle any job. Set screw locked. Shpg. Wt. 3 lbs. NEW. **\$5.95**.

SOUTH WIND HEATER & ACCESSORIES Mfg. for govt. antarctic expeditions for jeeps and half-tracks. Heating unit puts out over 20,000 B.T.U.'s. Burns any type gas. 6 volt system. Dim: 8 1/4" W x 18 1/2" L x 9 3/4" H. Fuel consumption extremely low, 1 gal. per 8 hrs. Terrific for trucks, boats, tractors... farms, warehouses, ranches, boat houses, cabins, etc. Complete with service & installation manuals and over 360 components. Approx. GOVT. COST \$550. Shpg. wt. 120 lbs. gross. NEW **\$39.95**.

\$2940 NAVY AIR-COOLED POWER UNIT Most compact engine ever assembled. Portable, net wt. 150 lbs. 200 Amp. Gen. self-starter capable of delivery of double overload or continuous service at 200 Amps. Mfd. by Ranger aircraft. 2 cylinder, 4 cycle, 10 HP, 3200 RPM. Fully governed for varying loads. This unit makes one of the finest arc welders obtainable. Also makes excellent boat engine. Shipped complete with rheostat & voltage reg. All units checked & pre-tested in our shop. Complete **\$185**.

Engine same as above with deluxe welding accessories as follows: rheostat, voltage reg., dry charged 24 V. battery, 50' heavy duty welding cable, 1 electrode holder, 1 hood, pr. of gloves, voltmeter. All this only **\$225**.



BENDIX GEROTOR PUMP & MOTOR—NEW!

Use wherever fluid pumping required. Excellent for hydraulic installations. Has 3/4" pipe connections, built-in relief valve adjustable up to 1500 lbs. Max. cap. 6 GPM. 1 1/2 H.P., 24 V. motor. Use on 12 to 36 V. Approx. GOVT. COST **\$350. \$8.75**.



ELECTRIC PUMP WITH CONTROL UNIT

Runs on 12 or 24 V. Centrifugal type. Draws 5.2 AMPS. Has built-in removable filtering screen. Great for bilge, circulating or sump pump... bait tanks, etc. Pumps 500 GPH. Complete with on and off switch rheostat, explosion-proof motor, 2 speeds (hi & lo). Mfd. by Ingersoll-Rand. Shpg. Wt. 7 lbs. Approx. GOVT. COST **\$195. NEW—\$8.95**.



SENSITIVE ALTIMETER in 20 ft. increments. 0 to 35,000 ft. (inches of Mercury). Famous Pioneer. Tested & inspected in our own instrument lab. Guaranteed perfect. Approx. GOVT. COST **\$150. Wt. 2 lbs. \$13.95**



ELECTRIC STORAGE BATTERY WINCH

Powerful reduction gear, fully reversible, ball bearing, safety locking device. Will handle from a 1000 to more than 2000 lbs. pull. Use on 6, 8, 12, 24, 32 V. battery. Holds 50' of 1/4" cable. For tractors, boats, tow trucks, etc. Complete with mounting bracket for mounting in any position. Approx. GOVT. COST **\$400. NEW. \$46.50**.



NEW 1960 CATALOG! Tremendous catalog—our biggest ever—fully illustrated—1000s of bargains in war surplus & other items. Send 25c in coin for your copy today or free copy with order. Where ppd. indicated applies to US only. Other prices FOB Culver City, Cal. Send cash, check, money order. 50¢ dep. COD.



AIRBORNE SALES CO., INC. DEPT. PM 360
8501 Stellar Drive, Culver City, Calif.

Parker Line No. 10

WOOD BORING DRILL SET
EXTRA WIDE RANGE 1/4" TO 1 1/4"



Now!
A Wood Boring Drill Set
with an
extra wide range
from 1/4" to 1 1/4"
Yours for
only **\$2.75**

New 10 piece set fits all 1/4" electric drills and drill presses. Bore faster, cleaner, truer holes in wood, plastics, panelboard, plaster, compositions. New plastic case gives you permanent, moisture resistant container for your bits. Hardened tool steel — rugged construction. Sold at leading hardware stores.

Set includes universal shank and wrench.

Buy the **Parker Line**

PARKER MANUFACTURING CO.
WORCESTER 1, MASS., U. S. A.

New Self-locking perforated board fixtures
DOUBLE YOUR STORAGE SPACE
without remodeling!

Just insert Easy Hang fixtures into perforated board. They automatically lock into position. Ideal way to double your storage space in closets, playroom, kitchen, workshop. Fast! Low cost!

Dozens of styles and sizes.

Free, new idea folder tells all!

Turnbuckles, Inc.

Turnbuckles Inc., Dept. PM, Box 333, Michigan City, Ind.
Rush free folder showing how to double my storage space.

Name _____
Address _____
City _____ State _____

Control permits compensation for the differences in the individual signals. Both methods are satisfactory though the former is somewhat more flexible while the latter is a bit easier to use.

Tone Controls (Fig. 4B). All hi-fi amplifiers have separate tone controls for both bass and treble frequencies. Some stereo amplifiers have separately adjustable tone controls in each channel while with others the controls affect both channels simultaneously. Here there is a definite advantage in being able to adjust each channel individually. Not only does this permit compensation for differences in loudspeaker characteristics, it also permits equalization of different-quality signals, such as in FM-AM stereo transmissions. The separate controls, therefore are definitely preferred.

Loudness Control. The human ear is a strange device. If you were to listen to a number of single-frequency tones, all played with exactly the same amount of power, they would sound equally loud only if they were played at a very high volume level. At low levels, even if all tones had the same power, the high and low-frequency tones would sound much softer than those in the mid-range. This phenomenon of the ear is illustrated in Fig. 4A.

The curves in this graph represent equal-loudness contours for audio frequencies at various loudness levels. For example, if you were to listen to a 1000-cycle tone played at an intensity of 40 db, a 50-cycle tone would have to be played with a relative intensity of 72 db in order to sound equally loud.

Now if a record were played through an amplifier having a flat frequency response (this would be an ideal amplifier), the reproduction would sound like the original rendition only if played at the same volume level as the original. If the volume were reduced substantially, some of the high and low frequencies would not be heard.

To compensate for this deficiency of the ear, many amplifiers include Loudness Controls which automatically change the amplifier's frequency response to boost high and low frequencies as the volume level is reduced. Some manufacturers contend that such controls are unnecessary since the same purpose can be accomplished with the tone controls. Even if this were true (it isn't, since few tone controls have the required range for adequate compensation) a loudness control would still provide a great convenience. By automatically compensating for the deficiencies of the ear, it greatly simplifies adjustment.

Scratch Filter. Records have a way of becoming worn—noisy, scratchy. Most of this noise is concentrated at the higher audio frequencies and can be eliminated by

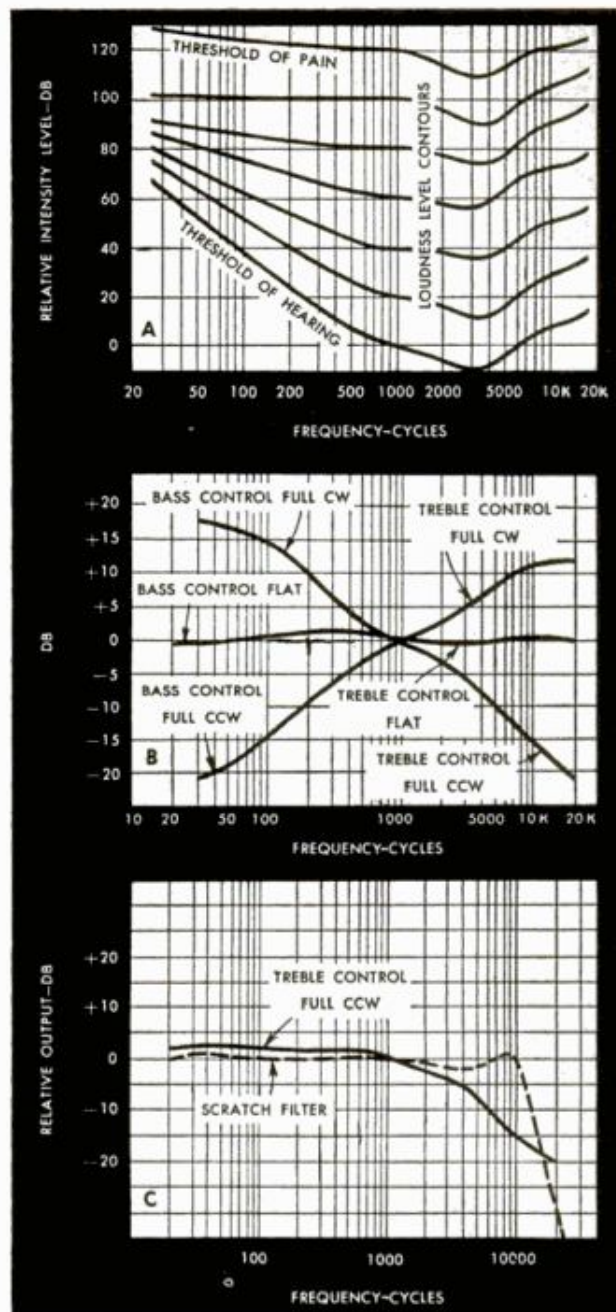

Fig. 4. A. Sound intensity needed for equal loudness of all tones at various basic levels. B. The effect of tone controls in typical amplifier. C. Effect of scratch filter as compared with typical treble control action

reducing the amplifier response in the high-frequency region. This is the function of the scratch filter. True, some of the high-frequency music is lost in the process, but what's left is far more enjoyable.

The treble tone control, if turned down, can accomplish essentially the same function as the scratch filter. The filter, however, has a much sharper cutoff slope, see Fig. 4C, so that less of the high-frequency music is lost in the process.

Rumble Filter. All record players have a certain amount of vibration which is transmitted to the phono cartridge. If moderately severe, this can cause some very unpleasant low-frequency noise whenever a

(Continued to page 288)

SHOPMATE®

TWIST-LOCK POWER TOOLS

NOW! OWN A WHOLE WORKSHOP OF FINE POWER TOOLS
at a tiny fraction of what you'd expect to pay!



A. \$19.88



B. \$9.95



C. \$9.95



D. \$9.95



TWIST IT'S ON!

TWIST IT'S OFF!

REVOLUTIONARY TWIST-LOCK POWER TOOLS GIVE AMAZING PERFORMANCE AT UNHEARD-OF LOW COST!

You pay for only one motor with new Shopmate Twist-Lock Power Tools. Yet you get full direct power and precision control to handle any building, repairing or remodeling job.

A. POWERFUL 2.9 AMP. DRILL . . . with geared chuck, lifetime mirror finish, multi-ball thrust bearing. Powers all Twist-Lock Tools. Model SD-2500 . . . \$19.88

MODEL 740 CG 2.6 AMP. 1/4" DRILL (Illustrated with attachments) . . . \$18.88

B. JIG SAW . . . seven saws in one: scroll, jig, rip, band, coping, crosscut, hack saw. Bevels to 45°, cuts 2x4's. Complete with 3 blades. Model TLJ-58 . . . \$9.95

C. 5 1/2" CIRCULAR SAW WITH BLADE . . . cuts 2x4's, bevels to 45°. Model TLC-500 . . . \$9.95

D. OSCILLATING SANDER . . . with 25 square inches of sanding surface. Sands, finishes any material satin smooth. Model TLS-18 . . . \$9.95

E. VERTICAL DRILL STAND . . . turns your drill into precision drill press. Model TLV-27 . . . \$12.95

F. POWER TRIMMER . . . with 13" Swedish Blue Steel Cutter Bar, precision ground to stay sharp. Model TLT-13 . . . \$12.95

G. HORIZONTAL DRILL STAND . . . adapts drill for bench grinding, sharpening, etc. Model TLH-26 . . . \$2.00

Twist-Lock Adaptor Included Free with Each Tool!



G. \$2.00



F. \$12.95



E. \$12.95

(All Shopmate 740 CG Drills accept Twist-Lock Attachments except older models with serial numbers 95A, B, C, D, E or F.)

FREE! MAIL COUPON TODAY FOR COMPLETE INFORMATION!

PORTABLE ELECTRIC TOOLS, INC.
 320 W. 83RD STREET, CHICAGO 20, ILLINOIS
 CANADA: 452 BIRCHMOUNT RD., TORONTO, 13, ONT.

PORTABLE ELECTRIC TOOLS, INC. PM-360
 320 W. 83rd St., Chicago 20, Ill.

OK! Send free information on these remarkable new low cost power tools.

Name.....

Address.....

City..... Zone..... State.....



If your wife is nagging
you about shabby
WOOD FLOORS
Refinish them yourself in
just ONE DAY with



FABULON

the fabulous FLOOR FINISH

Give your floors the armor-like protection of FABULON, the original "bowling-lane" finish for home use. Applies easily with brush or roller. Your wife will love her FABULON-ed floors. . . NO MORE WAXING OR SCRUBBING. At paint, hardware and lumber stores everywhere. For comprehensive manuals on all phases of wood finishing, send 25c in coin to . . .



PIERCE & STEVENS CHEMICAL CORP.
710 OHIO STREET • BUFFALO 3, N. Y.
Available in Canada—Le Page's, Toronto 18, Ont.

New "PULL-GEAR" SPEED-REDUCING PULLEY

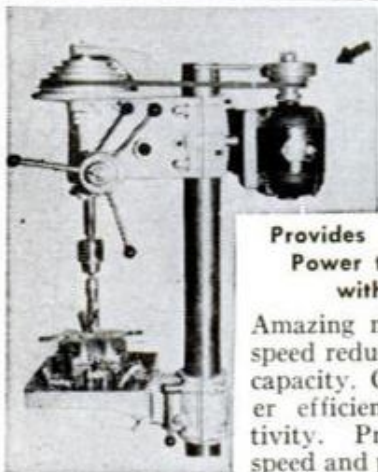

Provides Correct Speed and
Power to Drill Up to 1 3/8"
with 1/2 H.P. Motor

Amazing new internally geared speed reducer doubles drill press capacity. Greater power, greater efficiency, greater productivity. Provides the correct speed and power for larger drill-

ing, reaming, tapping and boring on light presses. Easily installed in five minutes. Adaptable to all type machines. Spindle speed range 45 to 3000 RPM. Write for Literature.

PULL-GEAR CO. 25427 Mound Rd.
Warren, Michigan

Boston, Mass.—Chandler & Farquhar Co., Longwood 6-7800
Chicago, Ill.—Chicago Supply & Tool Co., Everglade 4-3933
McMaster-Carr Supply Co., Andover 3-3161
Cleveland, Ohio—Reynolds Machinery Co.
Hillside, N. J.—Tool Specialties Co., Murdock 6-8700
Los Angeles, Calif.—Almquist Brothers, Ludlow 8-9111
New York City—Rudolf Bass, Walker 5-0440
San Diego, Calif.—Acme Tool & Supply Co., Cypress 8-7181
Seattle, Wash.—Star Machinery Co.

record is played. The rumble filter does the same thing at the low-frequency end of the audio spectrum as the scratch filter does at the high end. It reduces the amplifier response to this extraneous noise while keeping the loss of the desired music to a minimum.

Phono Equalization. Until some five or six years ago, various recording firms differed in their opinions on how a record should be cut. In reproducing amplifiers, therefore, it became necessary to include a number of equalizing filters so that all records could be properly reproduced.

In recent years, recording firms have standardized the recording process in conformance with RIAA recommendations and the various filters are no longer essential. Still, many amplifier manufacturers continue to incorporate them in their products on the premise that you might have a library of older records. If you do, by all means select an amplifier which offers this feature. If not, this is one feature which need not influence your selection.

Phasing Switch. The two speakers of a stereo system must operate in exactly the same way if optimum stereo quality is desired. If the connections of the speaker wires to one amplifier channel were reversed, the cones of the two speakers would move in opposite directions, causing cancellation of some audio frequencies.

An amplifier which incorporates a speaker phasing switch reduces the job of reversing the connections of improperly hooked up speakers to a mere flick of the switch. Otherwise, the job requires a screwdriver but, in either case, it's not difficult. The main advantage of the switch is in the case of FM-AM stereo broadcasts whose phasing sometimes does not correspond with the standard phasing of stereo records and tapes. In such cases it is far simpler to flick the switch than to repeatedly reverse the speaker connections at the back of the amplifier.

Tape Output Jacks. Most, but not all, amplifiers have two separate output jacks for feeding the signal from any program source to a tape recorder. These are essential if you plan on eventual expansion of your system to include a tape recorder. Preferably, the jacks should be arranged in the circuit so that the amplifier's tone and volume controls do not affect the signal sent to the recorder.

Special Considerations

Can you build an amplifier kit? If you are mechanically inclined and have had some experience in handling a soldering iron, you shouldn't encounter any difficulty

(Continued to page 290)

The NEWEST and FINEST: Buck's 400 Series

CHROME EDGE CHISELS

You get: ★ The Finest Cutting Edges
★ Tough Tenite II Handles with Inserted Steel Caps
★ Rust Proof Tools



1"-\$2.90

3/4"-\$2.70

1/2"-\$2.40

3/8"-\$2.30

Plastic pocket Kit-4 Sizes \$10.30

Most complete line of Chisels, Gauges and Carving Tools
CATALOG AVAILABLE!

BUCK BROS. INC.
RIVERLIN WORKS MILLBURY, MASS.

TINY CRYSTAL SET RADIO PLAYS FOR 10 YEARS!

NO TUBES—TRANSISTORS—BATTERIES OR "PLUG-INS" NEEDED



Smaller than a pack of cigarettes. 1960 model never runs down or burns out. Guaranteed to receive local radio stations most anytime, anywhere—without EXTRA ANTENNA WIRES. Easy thumb station tuner. Chrome black plastic case. BUILT IN SPEAKERPHONE—NO SEPARATE DANGLING EARPHONE. American made and service guaranteed.
SEND ONLY \$2.00 (cash, ch., mo) and pay postman \$4.99 COD on arrival or send \$6.99 for postpaid delivery. Sent complete—Ready to listen! No extras to buy. Free long distance antenna enclosed if you order at once.
Midway Co., Dept. TPM-3, Kearney, Nebr.

GET THE HABIT OF READING OUR CLASSIFIED ADS.

Wonderful Opportunities Amazing Bargains

OUTWORKS THEM ALL

Prepares the toughest soils in one operation. All-purpose tiller-tractor tills to 12" deep—12" to 40" wide. 3 models; 7 rotor styles including mulchers. 40 attachments include all tractor tools, mowers, snow plow. Tough chain-gear drive. Send for details.

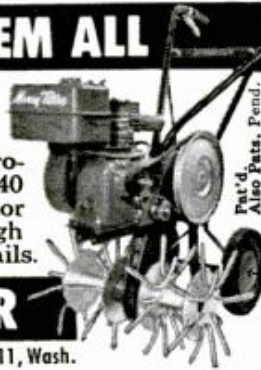

MERRY TILLER

Northern Life Building, Box 1829, Seattle 11, Wash.

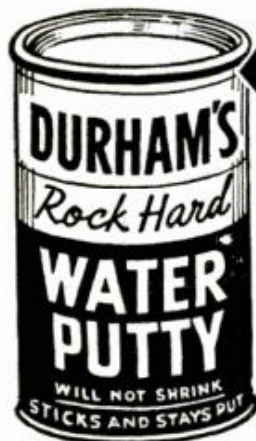

The Modern PLASTIC for lasting Home Repairs

PERMANENTLY mends cracks or holes in wood, tile, stone or plaster. Sticks and stays put—Does not chip, shrink or fall out. Easy to use. Economical. Mold it, chisel it, polish or paint it. The big 4-lb. can is obtainable from your lumber, paint or hardware dealer at \$1.40; or will be shipped direct postpaid (in U. S.) for \$1.75. Complete satisfaction guaranteed or your money refunded.

DONALD DURHAM CO.
Box 805-T Des Moines, Iowa

UNUSED SURPLUS 1-1/2 HP - 4 CYCLE - 2000 CFM

PORTABLE MOTOR AND BLOWER

An unusual Surplus Value. An engine driven blower for ventilating manholes, sewer, cellar, mine, tanks, etc. Powerful 2000 CFM centrifugal blower has 4" ID inlet and outlet. Simply connect flex pipe below and ventilate, circulate or use for drying. Comes with tools, 3 gallon Safety Gas Can, Oil Can, Oiler & tool case.

4" Steel FLEX TUBING for use with above blower - 21 ft. length ONLY . . .



HYDRAULIC CYLINDERS

1500 PSI Double Action CYLINDER - Bore 1-1/2", Shaft 9/16", Stroke is adjustable 1-3/16" to 4-3/8", length 14-1/2". No. H-84. **395**

1500 PSI, long stroke cylinder - Has Stroke of 15-5/8", Bore 1-3/8", Shaft 1", Length 22". No. H-14
Cost Gov't approx. \$120.00 **795**
Palley Catalog Price \$11.75

New 1500 PSI Dbl. Action Cylinder. Ideal for clutch or throttle control when used as a master & slave. Has 5/8" bore, 4-1/8" stroke, 7/16" shaft, 9-5/8" closed length. Parts are 1/4" tube (7/16-20 thread). No. H-60 **375**

1500 PSI Dbl. Action HYD. CYLINDER Has 2-3/8" bore, 1 1/2" stroke, 1-1/4" shaft, 30 1/4" lgh. Gov't cost approx. \$75.

NEW LOW PRICES No. H-53AU - USED . . . **1275**
No. H-53AN - NEW . . . **1975**

1500 PSI Double Action Cylinder - Bore is 1-7/8", Shaft 7/8", Length 12". Stroke adjustable from 3-3/4" to 6-1/2".
Cat. No. H-10U - USED . . . **675**
Cat. No. H-10N - NEW . . . **1075**

1500 PSI Long Stroke CYLINDER - Has 1-1/2" Bore, 1" Shaft, Stroke is 26-3/8", eye-to-eye lgh. 32-3/4".
Catalog No. H-355U . . . **1475**

1000 PSI VICKERS PUMP
A piston type, positive displacement Hydraulic Pump. Displaces .507 cu. in. per revolution. Capacity: 6 GPM at 3000 RPM with 1000 PSI or 3 GPM at 1500 RPM. Cat. No. H-P4USU . . . **2250**
PUMP MOUNT for above. No. H-PM-1. Adapts pump to 1/2" key slot drive. Has ball bearings . . . **1195**

SAVE HYD. HAND PUMP **675**
No. H-P3USU
Operates at 1500 PSI. Displaces .19 GPM at 30 cycles per minute. Has capacity of 1.5 cu. in. per a stroke cycle. Has built-in check valve. Regularly \$17.50

FOUR WAY HYDRAULIC VALVE
No. V-13USU
Sliding piston type with built-in relief valve to limit stroke. Pressure balanced in neutral position. Has 5/8" AC tube ports.
Reg. Catalog price \$12.75 **788**

4-WAY HYD. VALVE
No. H-V7A-1 **395**
A spring loaded, poppet type valve. Pressure balanced. Off in neutral. Has 1/4" tube ports. Cost Gov't approx. \$30

TO ORDER - Send check or M.O. 1/2 deposit with C.O.D.s. All prices are F.O.B. Los Angeles Warehouse. All items sent postage or freight collect.

palley's
2263 E VERNON AVE., DEPT. PH-30.
LOS ANGELES 58, CALIFORNIA

NEW 12 VOLT SEALED BEAM LAMP **Only 429**
Pistol grip type with removable stand and 4-hole foot mount. Has sealed beam, 5" lamp and aiming sight. Uses 12V. battery. With amber, green & red clip-on lenses. Easily adapts as Blinking red emergency light. Ideal for spot or signal light on boat, truck, car, farm, etc.

2500 lb. LIFT HOIST
Ideal for garages, shops, on boats, jeeps, trucks, etc. Has 24 to 1 ratio through a worm gear drive. Has free-spool, pull-out clutch and a three-speed crank. Comes with 18 ft. of 3/16" high tensile strength steel cable. Lifts up to 2500 pounds. **375**
MOUNT for HOIST \$5.00

100 TO 1 HEAVY DUTY REVERSIBLE GEAR HEAD MOTOR
A real "workhorse" in a compact, rugged gear head motor. Gear ratio is 100 to 1—gives the 24V. DC motor tremendous take-off power. Has clutch set at 375 ft. lbs. Take-off shaft is 1-1/16" dia. **2450**

NEW 3-3/4 HP ELECT. MOTOR
An ideal motor to operate a portable winch such as tow truck or utility boat. Series wound for continuous duty. Rated 3.75HP at 2300 RPM. Draws 240 Amps on 24 volt DC. Has 5/8" diameter drive shaft **895**
NEW—ONLY **1295**

VANE TYPE VACUUM PUMP
No. H-PV-3 USU
Positive displacement type. Built to withstand extreme range of operation. Has capacity of 15 cu. ft. of free air at 1500 to 4500 RPM. Provides 4 to 10 inches of mercury SUCTION and 16 to 20 inches of mercury PRESSURE with pressure differential of 24 in. mercury max. Normal oil consumption is 150cc per hour. Has 3/4" pipe ports. Used but XInt. PUMP MOUNT No. H-PM-2 - Has ball bearings and foot mount . . . **1695**

85 TO 1 RATIO GEAR DRIVE
For use where tremendous power at a low take-off speed is desired. Drives through a train of 6 gears that rotate on self-lubricating high speed roller bearings. The take-off shafts are 1-1/4" and 3/8" in diameter. Has 180° offset drive. Overall size: 6"x4"x2-1/2". NEW . . . **995**

DOUBLE HANDLE 1000 lb. HOIST **1988**
Portable. Has 21 to 1 gear ratio. A double handle for speed and power. Has automatic brake. With 20 ft of 1/4" steel cable.



Easy way to **REFINISH** furniture



Professional refinishers strip off the old finish before applying the new. You, too, can do this easily with Wonder-Paste. This famous remover softens up the finish right down to the wood. Comes off clean in one easy stroke of your putty knife. Stays put on uprights. Harmless to hands.

At paint and hardware stores.

● Send 25c for illustrated Refinishing Manual

Write for free Wonder-Paste folder

Wilson-Imperial Co. 118 Chestnut St., Newark 5, N.J.

POWER TOOLS MAKE YOUR WORK EASY



World's **THRIFTIEST** Light Plants

700 Watt, push button start, 115 v., 60 cye. AC. 2.2 HP. easy starting Briggs eng. No wiring necessary; just plug in and operate. Plenty of current for any oil burner, freezer, brooder, emergency lights, etc. which require up to 700 watts. Ideal for television and radios. Complete with voltmeter and built-in winding to charge 6 v. auto batteries. (Item 24) Wt. 75 lbs. Easily fits in car trunk. Be prepared for storm. **\$143.50**

1200 Watt Plant (Item 45) same as Item 24 but larger generator and engine with 50% greater output. **\$199.50**

ELECTRONIC BRAIN Now Available On All Our Plants

Up To 100,000 Watts!
Allows plant to saunter along at a thrifty idle till electricity is called for. Then instantly . . . automatically, plant comes up to full speed with a steady 115 volts of power. When demand stops, the BRAIN returns plant back to that same thrifty idle. Saves gas, doubles engine life! If BRAIN desired, specify & add 3 lb. and \$35 to plant price.



MASTER AIR COMPRESSOR

COMPARE! This is the only compressor built with a **NO RUST** stainless steel tank. Safe up to 500 lbs. (Item 209) High pressure type (4 c.f.m.). Large volume of air for heavy duty spraying, inflating truck & auto tires, greasing, sand blasting, etc. Piston type 2" bore compressor with built-in air filter. Master built with high strength alloys and precision bearings. Tank, 12"x24", 2100 cu. in. cap. Equipped with automatic switch that starts and stops motor to maintain desired pressure (up to 150 lbs.) and check valve, safety valve, gauge, shut-off valve, 20 ft. air hose and tire chuck. lbs. per sq. in. Beautifully balanced on ball bearing wheels and rubber tires. Don't take chances with used or surplus equipment. Our compressors are factory new and are guaranteed **SAFE**. Low factory prices. 1/2 HP. Model (Cap. 85 lbs.) **\$109.50**

Regularly \$175. (Item 209) **\$129.50**
1/2 HP. heavy duty model, Rep. Ind. motor and unloader switch. (Item 209a)

ELECTRIC PUMP

FILL TANKS—DRAIN CELLARS—IRRIGATE \$29.50

Powerful completely enclosed G.E. motor direct connected to a 1" pump, portable, pumps anything, std. thrd., use any hose, foot valve incl. free. 10 day money back guar. **\$29.50**

Wt. 26 lbs. Item C853



HEAVY DUTY D-C ARC WELDER

Use as portable or shop welder. Up to 300 amps, Senior model. Made for years of trouble-free, continuous service. Will handle light or heavy jobs. Easily welds up to 3/4" plate using 1/4" rods. Built-in air cooling system. Arc is easy to strike and hold, because of specially designed arc stabilizer. Hi-lo switch and dial control gives wide range of welding heats. Run welder at 2600 rpm. with tractor, jeep or 15 hp. gas engine, or 7 hp. elec. motor and triple V belt or flat pulley. You can pay more, but you can't buy a better welder. Wt. 110 lbs. \$400.00 value. **\$119.50**

WELDING KIT. Two 10 ft. leads, welding helmet, electrode holder, ground clamp. Sold only with welder at. **\$10.50**

Send 10c for 100 page Catalog—FREE with order. Prices f.o.b. factory—Send check or M.O.

MASTER MECHANIC MFG. CO., Dept. A-36 Burlington, Wis.

Southern Customers Order from Dept. A-36, Box 65, Sarasota, Florida

even if you've had little or no previous electronic experience. Basic amplifiers—the high-power, separate-chassis variety—are particularly easy. They contain mostly large, easy-to-handle parts and the recommended wiring is uncrowded. Preamplifiers and integrated amplifiers are somewhat more involved and these are usually not recommended as a "first project." Still, if you're meticulous in following instructions, even these will pose no problems.

Printed circuit boards have virtually taken over in kit-built electronic equipment. Of the various amplifiers and preamplifiers tested, only the EICO products still employ point-to-point wiring techniques. Printed-circuit boards can be manufactured at very little extra cost and add little to the price of the kit. They do, however, reduce wiring time and greatly decrease the chances of wiring errors.

But printed circuits also have their disadvantages. Though easier to build originally, they are far more difficult to service than point-to-point wired components. In the event of an inadvertent wiring error or an eventual parts failure, it'll take much more time to track down and replace the offending part—a fact to which most service technicians will attest.

Where to Buy Hi-Fi Components

No matter where you live, a wide selection of hi-fi components is as close to you as your corner mail box. That's because these components are sold through regional and national distributors, who handle most major brands. Even if you don't live in one of the larger cities where the units are on display in dealers' showrooms, you can make your selection from catalogs available free of charge from many distributors. While catalog descriptions are usually sketchy, the same distributors can supply additional manufacturers' literature for any particular unit in which you may be specifically interested.

For component kits you will have to look a bit farther. Though a number of kit manufacturers sell their products through the same distributors and dealers handling factory-assembled units, some of them sell only through their own factory outlets. These publish their own catalogs which you can obtain without cost or obligation. A careful comparison of these products is an interesting, informative and essential part of selecting your personalized high-fidelity equipment. ★ ★ ★

You can obtain a list of major distributors and kit manufacturers by sending a stamped, self-addressed envelope to the Popular Mechanics Electronics Dept.

CABINET MAKING



FURNITURE BUILDING



POWER PLANING

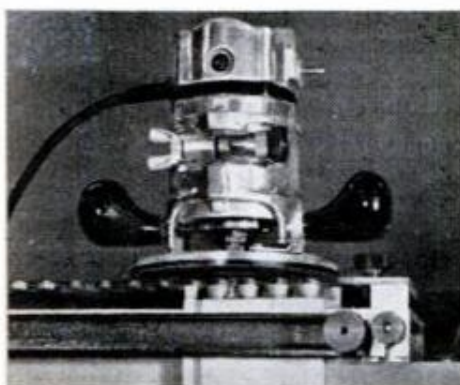
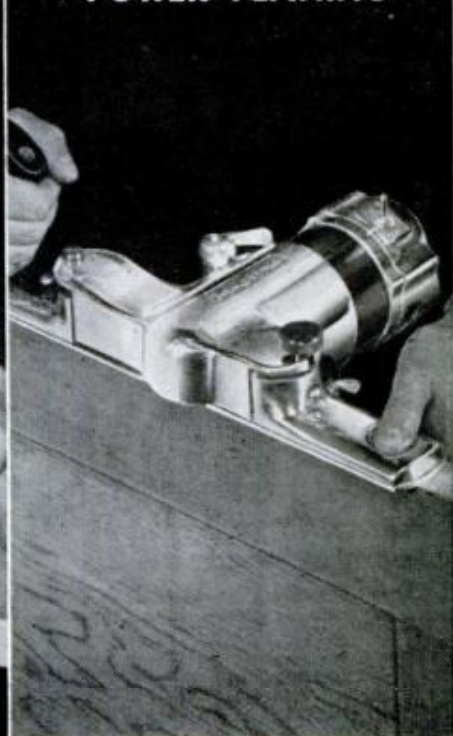

DRAWERS *Dovetail Attachment* makes it easy to build beautifully fitting, professional quality drawers. And those "natural grip" handles give you complete control.

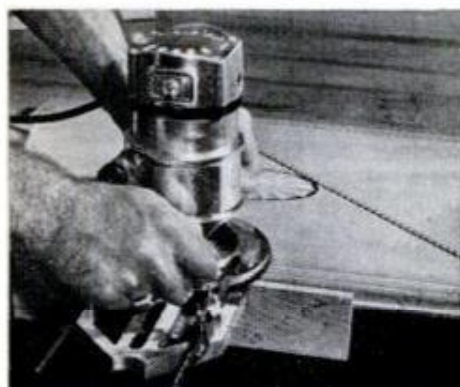

INLAID TABLES, TRAYS You can turn out jobs like these with a professionally crafted look; yet they're duck soup with a B&D Router and inlay strips.

Bet you didn't know B&D Routers are so versatile ...and so easy to use!

A Black & Decker $\frac{3}{4}$ HP Heavy-Duty Router makes it so easy, it makes you an expert! You'll turn out furniture, inlaid tables and trays, decorative what-not shelves, cabinets, paneling, special molding and lots more. You'll make professional cuts—produce professional-looking projects—with amateur ease.

To start with a Router is almost a woodworking shop in itself. And Black & Decker has added *special* features designed to help the beginner. Check the projects and features on this page. Then try a B&D Router in a choice of Routing and Planing Kits, at your dealer's next chance you get. You won't want to put it down!

50th YEAR

For 40-page Router manual (a 50c value!) send only 25c in coin to: THE BLACK & DECKER MFG. CO., Dept. D-030, Towson 4, Md.



Black & Decker®

QUALITY POWER TOOLS

"I SAW MYSELF 10 YEARS FROM NOW!"



It happened one payday . . .

Fred worked on the line next to me. Nice guy. Married. Two children. Been on the same job 10 years.

As we walked away from the pay window together he said, "Funny. Each week I get to feel like I'm letting my family down. You know. Not getting ahead so I can give them the things they need."

His words hit me all of a sudden. I could see myself saying the same thing—10 years from now!

Not only that. I could see the same job. Same thin paycheck. Same worries.

I thought about Fred all day. Then that night

I saw an ad for I.C.S. It told about the job opportunities that open up with I.C.S. training. How people had found new careers and job success.

I mailed the coupon and that was the start. In just a few months my boss discovered I was an I.C.S. student. He was so pleased he decided to move me off the line. A year and two raises later I was made an assistant supervisor.

What about Fred? He's still working on the line. Still hoping for the future.

I told him about I.C.S. But so far he hasn't done anything. I guess some people never will.

How about you?

For Real Job Security—Get an I. C. S. Diploma!

I. C. S., Scranton 15, Penna.

Accredited Member,
National Home Study Council

INTERNATIONAL CORRESPONDENCE SCHOOLS



BOX 89953C, SCRANTON 15, PA.

(Partial list of 258 courses)

Without cost or obligation, send me "HOW to SUCCEED" and the opportunity booklet about the field BEFORE which I have marked X (plus sample lesson):

- ARCHITECTURE and BUILDING CONSTRUCTION**
 - Air Conditioning
 - Architecture
 - Arch. Drawing and Designing
 - Building Contractor
 - Building Estimator
 - Carpenter Builder
 - Carpentry and Millwork
 - Carpenter Foreman
 - Heating
 - Painting Contractor
 - Plumbing
 - Reading Arch. Blueprints
- ART**
 - Commercial Art
 - Magazine illus.
 - Show Card and Sign Lettering
 - Sketching and Painting
- AUTOMOTIVE**
 - Automobile
 - Auto Body Rebuilding and Refinishing
 - Auto Engine Tuneup
 - Auto Technician

- AVIATION**
 - Aero-Engineering Technology
 - Aircraft & Engine Mechanic
- BUSINESS**
 - Accounting
 - Advertising
 - Business Administration
 - Business Management
 - Cost Accounting
 - Creative Salesmanship
 - Managing a Small Business
 - Professional Secretary
 - Public Accounting
 - Purchasing Agent
 - Salesmanship
 - Salesmanship and Management
 - Traffic Management
- CHEMICAL**
 - Analytical Chemistry
 - Chemical Engineering
 - Chem. Lab. Technician
 - Elements of Nuclear Energy
 - General Chemistry
 - Natural Gas Prod. and Trans.
 - Petroleum Prod. and Engr.
 - Professional Engineer (Chem)
 - Pulp and Paper Making

- CIVIL ENGINEERING**
 - Civil Engineering
 - Construction Engineering
 - Highway Engineering
 - Professional Engineer (Civil)
 - Reading Struc. Blueprints
 - Sanitary Engineer
 - Structural Engineering
 - Surveying and Mapping
- DRAFTING**
 - Aircraft Drafting
 - Architectural Drafting
 - Drafting & Machine Design
 - Electrical Drafting
 - Mechanical Drafting
 - Sheet Metal Drafting
 - Structural Drafting
- ELECTRICAL**
 - Electrical Engineering
 - Elec. Engr. Technician
 - Elec. Light and Power
 - Practical Electrician
 - Practical Lineman
 - Professional Engineer (Elec)
- HIGH SCHOOL**
 - High School Diploma

- Good English
- High School Mathematics
- High School Science
- Short Story Writing
- LEADERSHIP**
 - Industrial Foremanship
 - Industrial Supervision
 - Personnel-Labor Relations
 - Supervision
- MECHANICAL and SHOP**
 - Diesel Engines
 - Gas-Elec. Welding
 - Industrial Engineering
 - Industrial Instrumentation
 - Industrial Metallurgy
 - Industrial Safety
 - Machine Shop Practice
 - Mechanical Engineering
 - Professional Engineer (Mech)
 - Quality Control
 - Reading Shop Blueprints
 - Refrigeration and Air Conditioning
 - Tool Design
 - Tool Making
- RADIO, TELEVISION**
 - General Electronics Tech.

- Industrial Electronics
- Practical Radio-TV Engr'g
- Practical Telephony
- Radio-TV Servicing
- RAILROAD**
 - Car Inspector and Air Brake
 - Diesel Electrician
 - Diesel Engr. and Fireman
 - Diesel Locomotive
- STEAM and DIESEL POWER**
 - Combustion Engineering
 - Power Plant Engineer
 - Stationary Diesel Engr.
 - Stationary Fireman
- TEXTILE**
 - Carding and Spinning
 - Cotton Manufacture
 - Cotton Warping and Weaving
 - Loom Fixing Technician
 - Textile Designing
 - Textile Finishing & Dyeing
 - Throwing
 - Warping and Weaving
 - Worsted Manufacturing

Name _____ Age _____ Home Address _____

City _____ Zone _____ State _____ Working Hours _____ A.M. to P.M. _____

Occupation _____

Canadian residents send coupon to International Correspondence Schools, Canadian, Ltd., Montreal, Canada. . . Special low monthly tuition rates to members of the U. S. Armed Forces.

NEW, Direct-At-Cost

GUARANTEED CONTINUABLE PROTECTION



Provides **EXTRA** income while you are accidentally disabled!

Helps pay those higher-than-ever doctor and hospital bills!

Helps replace savings or possible loss of income!

Pays your family as much as \$15,000 if you lose your life, sight or limbs by accident!

Perhaps you believe the hospital care protection you now own is enough to safeguard your family should an accident put you, the family breadwinner, on the shelf.

If so, just consider this:

Hospital costs have actually doubled within the past ten years alone . . . Has your present coverage kept pace?

Doctor and surgical costs have also gone up . . . Is your present coverage able to meet today's *increased* cost of medical care?

And what about income protection? . . . Does your present coverage, if any, take care of what is often the biggest single item of expense in an accident — *income lost because you're no longer on the job?* (The Commercial Travelers loss-of-time benefits are paid direct to you whether your income is affected or not, and regardless of extra expenses caused by an accident.)

MORE PROTECTION Per Dollar

Serving business, professional and technical men, students and all other preferred male risks *direct* and solely or their mutual benefit, this strong old non-profit association literally gives you *protection at cost*. Members' charges are based solely on the full cost of insurance protection, necessary reserves and operating expenses. Pioneer in personal protection since 1883, the Association has paid more than \$125 million benefits to its members and now has resources of more than \$12 million for their future protection. This is world-wide coverage. We are licensed both in New York and Canada.

POLICIES NOW GUARANTEED CONTINUABLE!

Besides being exceptionally economical, broad-coverage accident insurance policies now being written by The Commercial Travelers of Utica offer you the vital *extra* protection of being *guaranteed continuable for life*. This means that now only *you*, the policyholder, can terminate this coverage. And the favorable low rates now prevailing can be changed *only* if there is a general rate adjustment, up or down.

All Kinds of Accidents are Covered except suicide and losses caused by war or while engaged in military service at time of war, insurrection or riot, or as a passenger in military aircraft or a pilot or paid crew member of any aircraft. *No other accident exclusions!* All kinds of civilian passenger air travel covered, as are hobbies, recreational hazards and other avocational risks!

3 PLANS AVAILABLE

Benefits are paid from first day for each accident for as many as 104 weeks of total, or total and partial disability combined, as shown below, whether your income is interrupted or not. *Coverage is continuable for life.*

Choice of Amounts

Total disability, weekly, up to 104 weeks . . .

\$ 75.00 \$ 50.00 \$ 25.00

Partial disability, weekly, up to 26 weeks . . .

\$ 37.50 \$ 25.00 \$ 12.50

Loss of life, to age 70 . . .

\$ 15,000 \$ 10,000 \$ 5,000

Loss of life, after age 70 . . .

\$ 3,000 \$ 2,000 \$ 1,000

Loss of both hands or feet, or one hand and one foot, or sight of both eyes, *payable in addition to weekly indemnity* . . .

\$ 15,000 \$ 10,000 \$ 5,000

Current Quarterly Cost

\$ 10.50 \$ 7.00 \$ 3.50

No Age Limit for Continuing Accident Coverage, but you must be at least 18 and under age 55 to join.

OTHER LOW-COST BENEFITS GUARANTEED CONTINUABLE

Broad Sickness Insurance *guaranteed continuable* without modification of benefits to age 65, and Surgical and optional Hospital Room benefits *guaranteed continuable for life* are also available to preferred-risk men at modest added cost.

For Employed WOMEN, there's Accident, Sickness and Hospital & Surgical Insurance, and for HOUSEWIVES and other preferred-risk women not necessarily employed there is an excellent Accident Expense policy that is *guaranteed continuable for life*.

SEND CARD, BUT NO MONEY!

Whether you now have partial protection, or none at all, it will pay you to get complete information now on these desirable, low-cost Commercial Travelers guaranteed continuable coverages. So fill out the card right now, while the matter is uppermost in your mind. It may well be the most significant card you ever mailed.

FILL OUT AND MAIL YOUR CARD TODAY! ➔

MERCURY is the world's

No. 1 outboard in

Reliability!

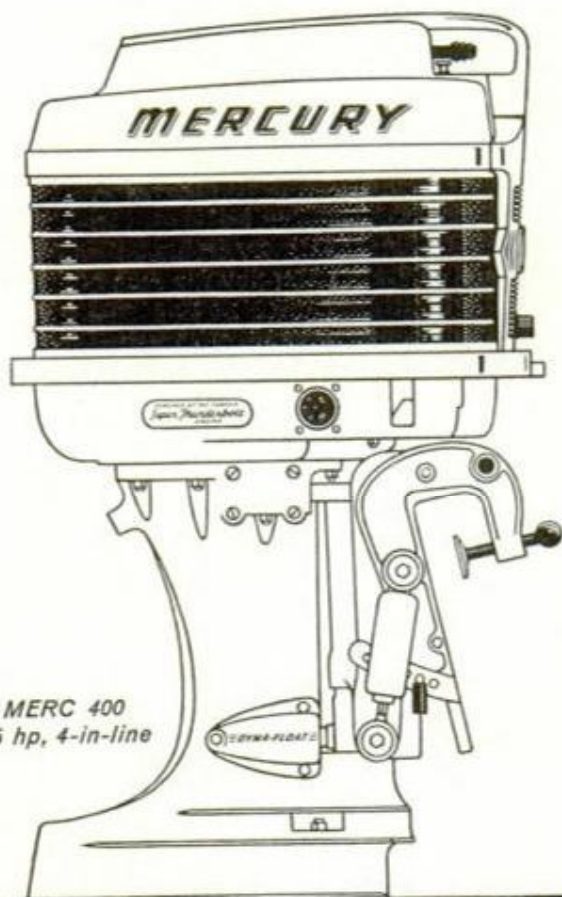

MERC 400
45 hp, 4-in-line

Reliability is a built-in bonus you get in every Mercury — reliability proved in Mercury's world record 50,000 mile endurance run and Mercury's 107.9 mph world record. Mercurys outrun and outlast all other outboards because Mercurys are safety-engineered to thrive under treatment far rougher than you will meet in normal boating use!

Because of such Mercury features as exclusive Hydraulic Dyna-Shock Absorbers and Safety-Tilt Switch, forged aluminum clamp brackets, "Flo-Torq" Safety Clutch, and one-piece "Uni-Cast" gear housing, this Merc 400 can slam over a log time after time without damage to the motor, as demonstrated in the proving ground test below.

See your dealer for a demonstration of these and other features which make Mercury the World's No. 1 Outboard! Nine new models, 6 to 80 hp, in twins, fours and sixes.

Write for free catalog.

© 1960 KIEKHAEPER CORPORATION, FOND DU LAC, WISCONSIN

No. 1 in POWER...PERFORMANCE...ENGINEERING...
FUEL ECONOMY...STYLING...FEATURES...SAFETY.

