

AUGUST 1958

35 CENTS

# POPULAR MECHANICS MAGAZINE

WRITTEN SO YOU CAN UNDERSTAND IT

REG. U.S. PAT. OFF. TRADE MARK GREAT BRITAIN No. 40428

REG. U.S. PAT. OFF.

—See Page 85

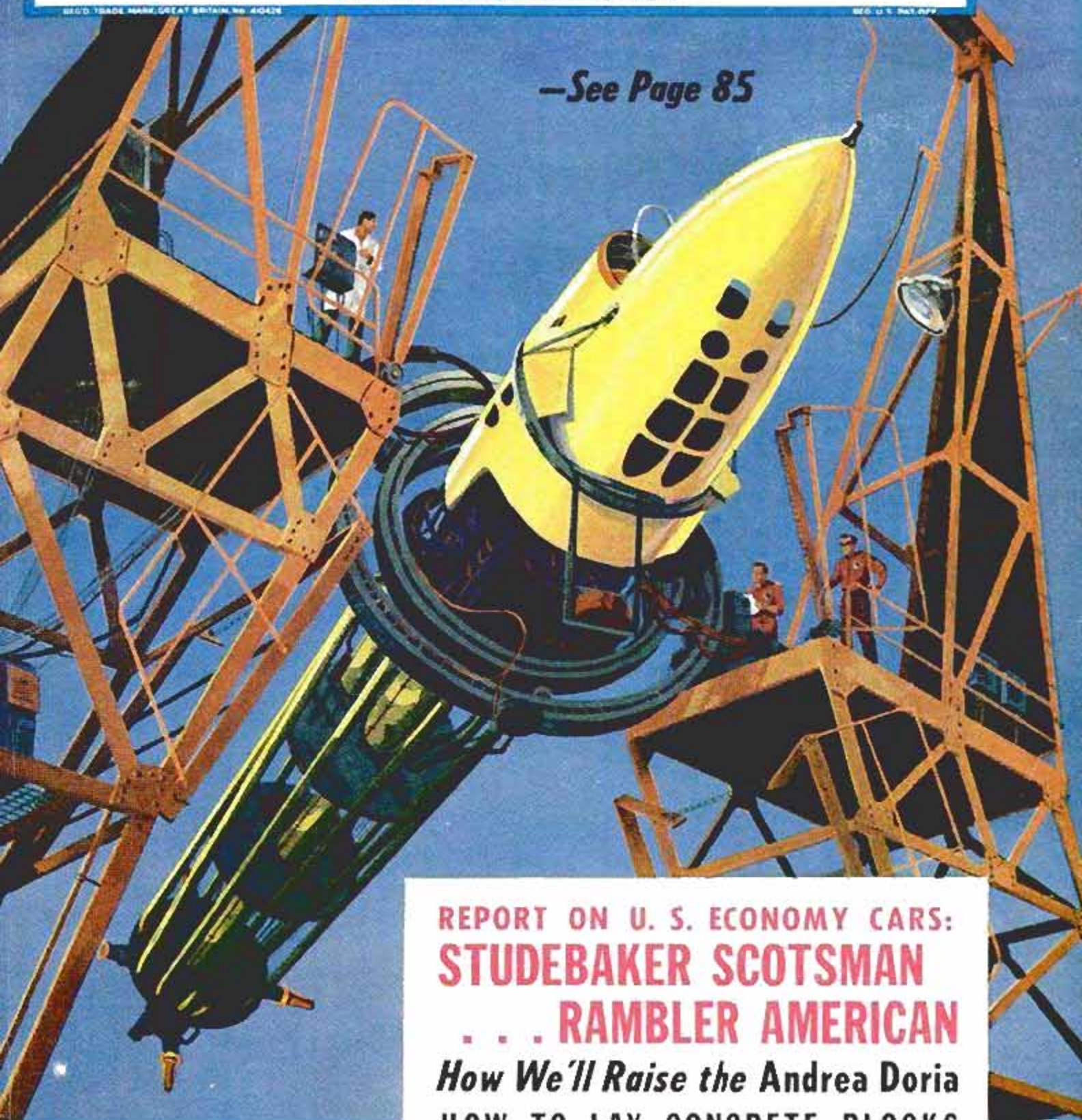

REPORT ON U. S. ECONOMY CARS:  
**STUDEBAKER SCOTSMAN**  
... **RAMBLER AMERICAN**

*How We'll Raise the Andrea Doria*

HOW TO LAY CONCRETE BLOCKS



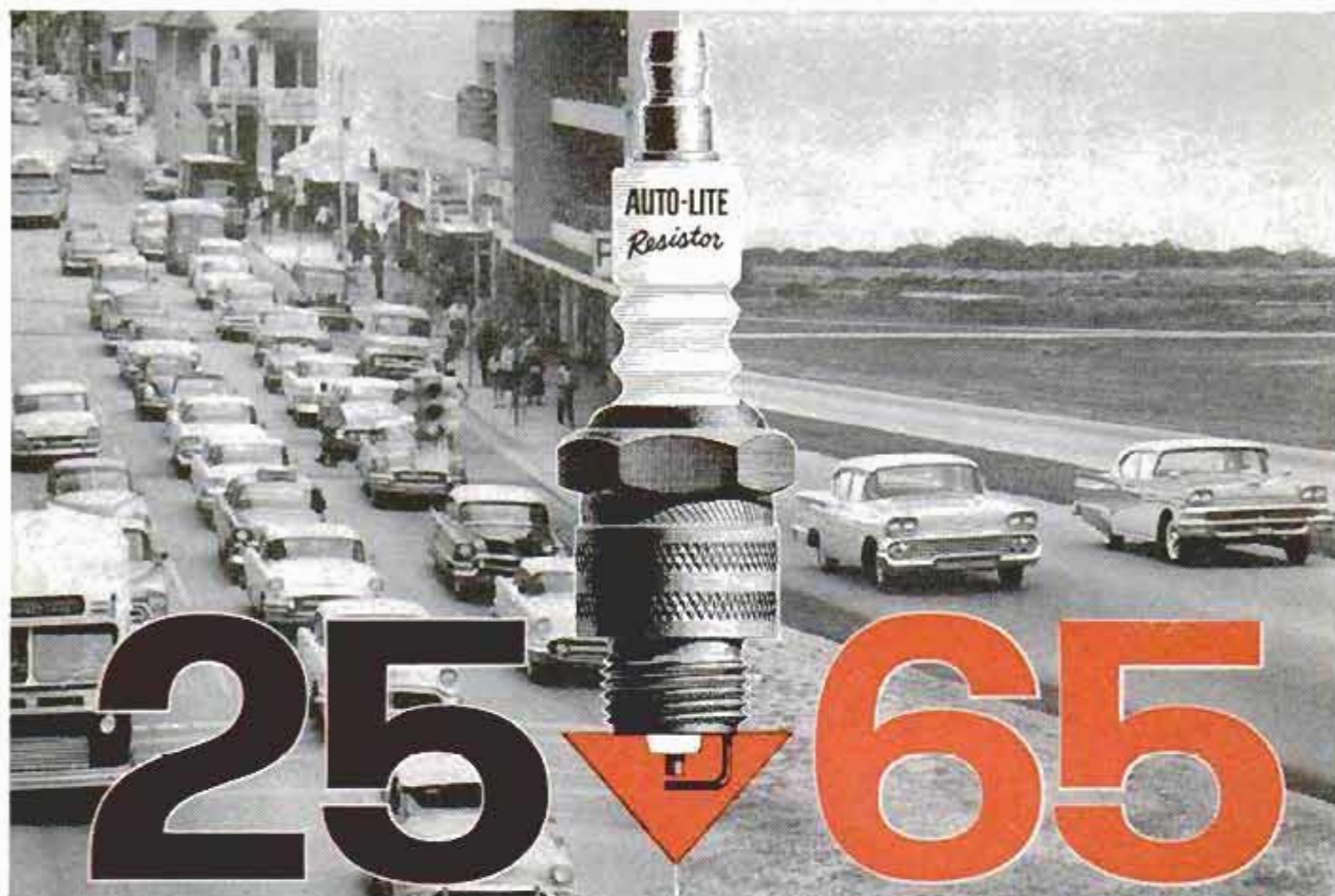

**IN TOWN TRAFFIC . . .** some spark plugs, designed for high speeds, become fouled and cause misfiring and loss of power when driven at low speeds.

**ON THE HIGHWAY . . .** some spark plugs, designed for low speeds, misfire causing power loss and invite destructive pre-ignition when driven at high speeds. Why gamble when . . .

## Auto-Lite Resistor Spark Plugs with **POWER TIP** "Fire Up" your engine\* at all speeds!



If you drive at both town-traffic and highway speeds, here's why you should use Power Tip . . . the first spark plug ignition-engineered for today's engines and today's driving.

YOU CAN SEE  
 THE BIG NEW  
 DIFFERENCE IN  
 SPARK PLUGS!



At low speeds, the projecting Power Tip is in the thick of combustion where it gets hot quicker and stays hot to burn fouling deposits away *clean*. At higher speeds, the projecting tip is in the path of the incoming air-fuel mixture where it stays cooler to effectively *check* power-robbing pre-ignition. Ask your garage or service station to install Auto-Lite . . . the *only* spark plugs with Power Tip . . . and start enjoying top performance and economy from your car at *all speeds*.



Ordinary Tip      Power Tip

Power Tip protrudes farther into the combustion chamber for better ignition. Fuel burns more evenly and completely to give top performance and economy at *all speeds*.

\*Power Tip, with or without Resistor, is ignition-engineered for overhead-valve V-8 engines and for most overhead-valve 6-cylinder engines in all these cars—Buick, Cadillac, Chevrolet, Chrysler, De Soto, Dodge, Edsel, Ford, Hudson, Imperial, Lincoln, Mercury, Oldsmobile, Nash, Packard, Plymouth, Pontiac, Rambler, Studebaker.

# AUTO-LITE RESISTOR SPARK PLUGS WITH **POWER TIP**

Auto-Lite makes a complete line of spark plugs, including Standard, Resistor, Marine, Small-Engine, Transport, and Aircraft.



**New Valuable Guide for Men**

# "HOW TO MAKE WOOD A BEAUTIFUL PART OF YOUR HOME"

Wood grains, patterns, textures you can choose! Striking effects you can create! Practical new designs, plans and ideas! Hundreds of the things you want to know about natural wood finishing, decorating and building . . . yours for just 50c in one 56-page booklet . . . by Monsanto, makers of REZ—world's most colorfully complete line of natural wood finishes!

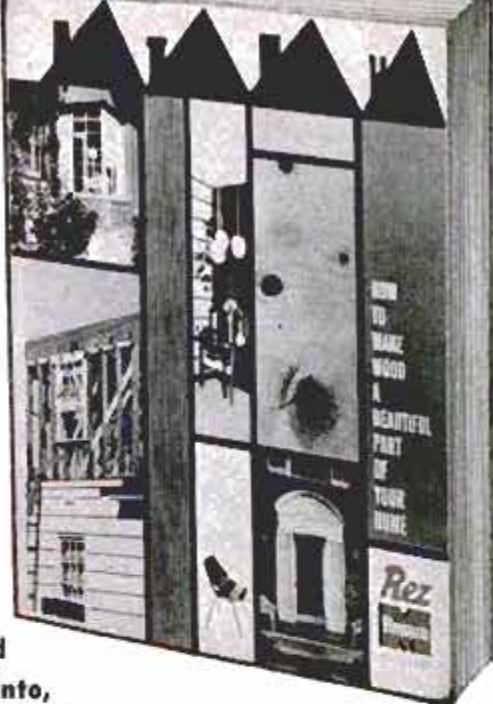

Monsanto has prepared a wonderfully helpful booklet for you — a complete how-to-do-it guide for decorating with wood and REZ natural grain sealer-finishes. Now you can choose from hundreds of wood grains and patterns, textures, colors and finishes

and achieve exactly the results you want every time.

See the woods you want for your home . . . Woods—light, sun-warm and refreshing. Woods — of rich dark tones. Woods—with dramatic whorls and patterns. Woods—with subdued grain tracings of quiet charm. Compare the most popular practical woods and plywoods. You actually see how their nature-grown beauty is enriched with a colorful variety of REZ grain-revealing finishes.

New booklet shows how natural wood becomes part of your color scheme with Color-Toned REZ. Outside, you can capture the charm and "feel" of forest, desert, mountain, seacoast or country landscape on your siding, carport, fence, trim or patio . . . inside, you can follow the same color scheme on paneling, cabinets, doors, valances, woodwork — coordinate wood color with carpeting, draperies and upholstery.

Saves you money . . . helps you select your favorite wood in the least expensive grade for your use—buy lumber, paneling, unfinished furniture and finish it easily in a few hours—enjoy all the luxury of good wood at low cost.

Easily adaptable ideas — illustrated ways to make home improvements you've always wanted — get more living space with built-ins, add on a family patio-porch, convert your basement into an activity room or rathskellar. 35 new designs. Guide plans. Easy to build.

New ideas in wall paneling . . . money-saving suggestions. How you can install and finish paneling yourself—save 25% to 60% of total cost you pay for wood.

Built-in, multipurpose cabinets you can custom-build to save space, make better use of existing storage area and open up more floor space for active use.

Different fence designs for beauty, privacy, sun screen, wind protection.

A treasure-chest of valuable additions to your home. Ways to make old rooms into new rooms with storage walls, book shelves, room dividers, closet stretchers.

Professional wood finishing made easy! Amazingly simple, sure ways to create a satiny, hand-rubbed look without rubbing or waxing . . . any color effect on any wood and enrich the natural beauty of the grain . . . a "bleached" or blond look without chemically bleaching. Tricks by master craftsmen you can use to bring out the distinctive best of redwood, pine, gum, fir, cedar, oak, birch and others.

REZ solves every wood-finishing problem for you: no cracking or peeling, controls grain raise, ends mottled and uneven colors, protects against spotting from alcohol and water, defies stains and abuse. Brush it on as easily as water . . . REZ penetrates, seals, finishes — lasts for years — will not peel or blister — guards woods from sun and weather outside — gives lasting beauty inside.

REZ—T.M. Monsanto Chemical Company

## USE HANDY COUPON



Monsanto Chemical Company  
P.O. Box 643, Dept. PM  
St. Louis 1, Missouri

Send me the color-filled, 56-page guide, "How to make wood a beautiful part of your home." I enclose 50c.

Name \_\_\_\_\_

Address \_\_\_\_\_

City \_\_\_\_\_ Zone \_\_\_\_\_ State \_\_\_\_\_

This One



DDZ7-R4B-8E71

AUGUST 1958

1



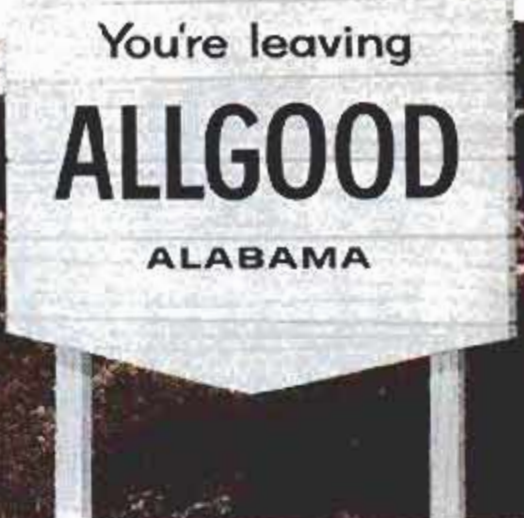

FROM **Allgood to Christmas**

1647 MILES—82¢



***For less than 1/20th of a cent a mile, a new AC Oil Filter keeps oil clean, protects your engine!***

If you're an average driver, you'll travel over six times the distance from Allgood, Alabama, to this little mining town of Christmas, Arizona—a total of 10,000 miles each year! Your car's engine must endure every type of driving, any of which can affect its performance and efficiency.

Engine parts are as precisely machined as a fine watch! That's why it's so important to give them the low-cost added protection of a new AC Oil Filter every 5,000 miles. An AC Oil Filter cleans all of the oil in the engine every 30 seconds at normal speeds—protects the precision parts from possible damage by dirt, dust, grit and bits of metal as small as 1/100,000th of an inch.

So, the next time you change the oil in your engine—change to a new AC Oil Filter, too! Your nearby AC Dealer will tell you how little it costs, how much it does for your engine.



**CHANGE OIL AND FILTER, TOO!**

Watch Walt Disney Studios' ZORRO every week—ABC-TV

AC SPARK PLUG  THE ELECTRONICS DIVISION OF GENERAL MOTORS



# Popular Mechanics Magazine

Registered in U. S. Patent Office and Canada

H. H. WINDSOR, Founder

H. H. WINDSOR, JR., Editor and Publisher

Managing Editor

RODERICK M. GRANT

Assistant Managing Editor

WAYNE WHITTAKER

Shop Notes and Crafts Editor

JAMES R. WARD

Associate Editors, General Features

CLIFFORD B. HICKS

ARTHUR R. RAILTON, Automotive

KENNETH N. ANDERSON

Associate Editors, Shop Notes and Crafts

WAYNE C. LECKEY W. CLYDE LAMMEY

Radio-Television, Electronics Editor

LOTHAR STERN

Assistant Editors

SHELDON A. MIX, General Features

JAY W. HEDDEN, EARL WOBCEK, Crafts

JOHN DALEN, ARLENE HIRSCH, Makeup

Art Staff

FRANK BEATTY, Director

HENRY NEHRBASS, Assistant Director

RICHARD A. POTTS, Art Editor

Eastern Editor

RICHARD F. DEMPEWOLFF

Empire State Bldg., New York City 1

Western Editor

THOMAS E. STIMSON, JR.

Suite 1010, 3460 Wilshire Blvd.  
Los Angeles 5, Calif.

London Manager

DOUGLAS W. WEDDERSPOON

Eagle House, Jermyn St.,  
London S.W. 1, England

Director, Bureau of Information

ALLAN CARPENTER

Advertising Offices

Chicago: 200 E. Ontario St., Whitehall 4-0100;  
New York: Empire State Bldg., 350 Fifth Ave.,  
LONGacre 5-7580; Detroit: General Motors  
Bldg., TRinity 5-8711; Cleveland: Hanna  
Bldg., 1422 Euclid Ave., PRospect 1-0456; Los  
Angeles: 3460 Wilshire, DUnkirk 2-8458; San  
Francisco: Russ Bldg., 235 Montgomery St.,  
Yukon 2-0823.

Published monthly by Popular Mechanics Company,  
200 E. Ontario St., Chicago 11, Ill. H. H. Wind-  
sor, Jr., president; Wm. Harrison Fetridge, exec.  
vice-pres.; Franklin S. Forsberg, operations vice-  
pres.; D. F. Windsor, vice-president and secretary-  
treasurer; H. H. Windsor III, vice-president; W. T.  
Windsor, vice-president; Joseph R. Buel, Jr., ad-  
vertising manager; Alan M. Doyce, circulation  
manager. Single copy in the United States and  
Canada, 35 cents; subscription rates in the United  
States and possessions, Canada and countries of  
the Pan-American Postal Union, 1 year \$3.50; 2  
years, \$6.00; 3 years, \$8.00. To all other coun-  
tries add \$1.00 a year over United States prices  
for overseas postage. If you plan to move, notify us  
at least 30 days in advance so you will not miss  
an issue. Give both your old and new addresses.  
Entered as Second Class Matter, September 15,  
1903, at the Post Office at Chicago, Illinois, under  
Act of March 3, 1879. Entered as Second Class  
Matter at Post Office Dept., Canada. Registered  
as Second Class Matter at the Post Office at  
Mexico, D.F., Mexico, June 20, 1950.  
Copyright 1958 by Popular Mechanics Company.  
Copyright under International Copyright Union.  
Copyright in France. All rights reserved under  
Pan-American Copyright Union. Printed in the  
United States of America.

FOREIGN EDITIONS:	MECANIQUE POPULAIRE (French)	MECANICA POPULAR (Spanish)	POPULAER MEKANIK (Danish)	POPULAR MEKANIK (Swedish)	POPULARE MECHANIK (German)
Volume 110	AUGUST 1958			Number 2	

Address all communications to: 200 E. Ontario St., Chicago 11, Ill.

## In This Issue...

The Sun Is Really in Business	57
How We'll Raise the Andrea Doria	64
They'll Defend the America's Cup	69
What Engineers Say About Today's Cars	74
The Owners Report on the Studebaker Scotsman and the Rambler American	78
Miracles Ahead on Your Telephone	89
Free Energy in the Sky	106
Fangio Talks About Racing	110
The Midget Racers Are Flying Again	118
This Car Has Electric Brains	128
Radio, TV and Electronics	133

## For the Craftsman...

Twin Vanity Dressing Tables	137
Cooking Aids for Campfire Meals	146
How to Lay Concrete Blocks	164
Trick Titles for Your Home Movies	172
Check Your Radial Saw for Accuracy	181

## Regular Departments...

Do You Know This Old-Timer? (Quiz)	12
Detroit Listening Post	77
How Would You Do It!	154
What's New for Your Home	98
Shopping for Tools	189
Solving Home Problems	150
Clinic for Homemakers	194

Turn to detailed index on page 52. Sources of additional information on items in this issue are shown on the Where-to-Find-It List, available without charge by writing the Bureau of Information, Popular Mechanics, 200 E. Ontario St., Chicago 11, Ill.

## Next Month...

AMATEUR ROCKETRY has boomed in popularity since Sputnik I beeped across the heavens, but it's old stuff to a group in California that has launched over 300 rockets with an unmarred safety record. The sign beside their desert launching stand testifies to their precautions in "These Rocketeers Play Safe," a September feature





# ACROSS THE DESK



## Telegram From the Philippine Embassy

PLEASE ACCEPT OUR GRATITUDE FOR EXCELLENT STORY "CHANGING FACE OF THE PHILIPPINES" IN MAY ISSUE. BECAUSE OF EXCELLENCE OF ARTICLE, WE WOULD LIKE TO REQUEST YOUR PERMISSION TO REPRINT IT IN PHILIPPINE AND AMERICAN NEWSPAPERS. DUE CREDIT WILL BE GIVEN POPULAR MECHANICS MAGAZINE.

PHILIPPINE AMBASSADOR TO THE U.S.  
CARLOS P. ROMULO  
WASHINGTON D.C.

Thanks to his excellency the Ambassador. Permission granted. Many other requests for reprints of this article have been received, one of them from a New York investment house.

☆☆☆

## Readers Like Family Camping

Campers—perhaps even more than fishermen—like to share their experiences. Reader reaction to Joe Bell's two-part article, "Four Weeks of Camping on a Family Budget," was sudden and intense. A good many readers took the time to write us

of their experiences. Many are proud of the fact that they have traveled farther at less expense than the Bell family. The purpose of the article, of course, was not to describe a vacation on the lowest possible budget, but simply a vacation on a modest budget, and one that would draw the members of a family close together. Here are some excerpts from readers' letters:

"Total cost of our trip (8000 miles in 30 days) was \$385.69, or less than \$3.00 per day per person. . . ."

"I too would like to share the thrill of a family vacation for three people on \$425 in which we traveled 9500 miles in 24 days. . . ."

"Camping is about the only way a family of modest means can afford a traveling vacation. On one California trip we traveled 5600 miles in three weeks for only \$285. . . ."

☆☆☆

## Swish Draws Enthusiasm

Glen Witt, designer of the Swish, 15-foot outboard boat for which plans appeared in our Craft Sections of March, April and May, has been plenty busy answering questions about this sports runabout. From his marine design shop in Bellflower, Calif., comes this letter, quoted in part:

"This design that has been featured in (Continued to page 5)

## "Heirloom" with modern storage space... Build it yourself with Western Pine Region woods



Built by Lande's Early American,  
No. Hollywood, Calif.

Here's a piece of furniture with all the storage space you could ask for. Turn it out easily and economically with Western Pine Region woods.

Straight-grained, soft-textured, they're easy to work. Thoroughly dried and seasoned, they take any finish, or can be waxed and rubbed to a natural glow.

Choose from ten Western Pine Region woods for your next remodeling or furniture job. Your lumber dealer can suggest the correct wood to give beauty and value you can be proud of.

**FREE! 6 FINISH BOOKLETS**... feature unusual COLOR AND TEXTURE ideas for finishing Western Pine Region woods in traditional or contemporary designs. Plus tips on installing, sanding, painting or staining these distinctive woods. Write to WESTERN PINE ASSOCIATION, Dept. 308-N, Yeon Bldg., Portland 4, Oregon.



## Western Pine Association

member mills manufacture these woods to high standards of seasoning, grading and measurement  
Idaho White Pine • Ponderosa Pine • Sugar Pine  
White Fir • Incense Cedar • Douglas Fir • Larch  
Red Cedar • Lodgepole Pine • Engelmann Spruce

Today's Western Pine Tree Farming Guarantees Lumber Tomorrow



(Continued from page 4)

*Popular Mechanics* for a three-month period has attracted considerable attention. During the time that the *Swish* has been on display, we have been jammed. In fact on several Saturdays we could hardly contain them in the lobby of our new building. We are of course looking for customers but we did not realize that they would come in



such bunches. We have also received numerous phone calls from various parts of the United States.

"We have enclosed a snapshot taken of a model of the *Swish* sitting on the deck of the original prototype. This model was built by an interested customer who desired to learn the basic principles of construction on a small model."—Glen L. Witt, Naval Architect, Bellflower, Calif.

☆☆☆  
**Correction**

In the article on "Radio Controlled Garage Doors" in the July issue of *Popular Mechanics* the transistor symbols and battery connections are shown incorrectly. The transistors suggested for the transmitter are actually PNP types, while those for the receiver are NPN types. To prevent damage to both sets of transistors, the battery connections must be reversed. In the receiver, the wire from switch S1 should go to the positive battery terminal and the ground connections to the negative terminal. In the transmitter, the wire from switch S1 must go to the negative post of the car battery and the ground connections to the positive terminal.

☆☆☆

**To the Editor:**

An Olde Tymer in the Horseless Carriage business—a reader of your wonderful magazine—I am much interested in your reprints of the "Significant Sixteen." [Color reprints of this feature from the February

(Continued to page 6)

# Looking for Something?



## GARDEN EQUIPMENT



pottery, poultry, elevators,  
hoists, corsets, refrigerators  
whatever you need—

Find It Fast  
In The  
Yellow Pages



Advertisers displaying this emblem make your shopping easy



139 DIFFERENT TYPES & SIZES

... ALL  
**EXTRA  
TOUGH**

YOU'LL  
**PREFER  
PROTO  
PROFESSIONAL  
FLAT WRENCHES**

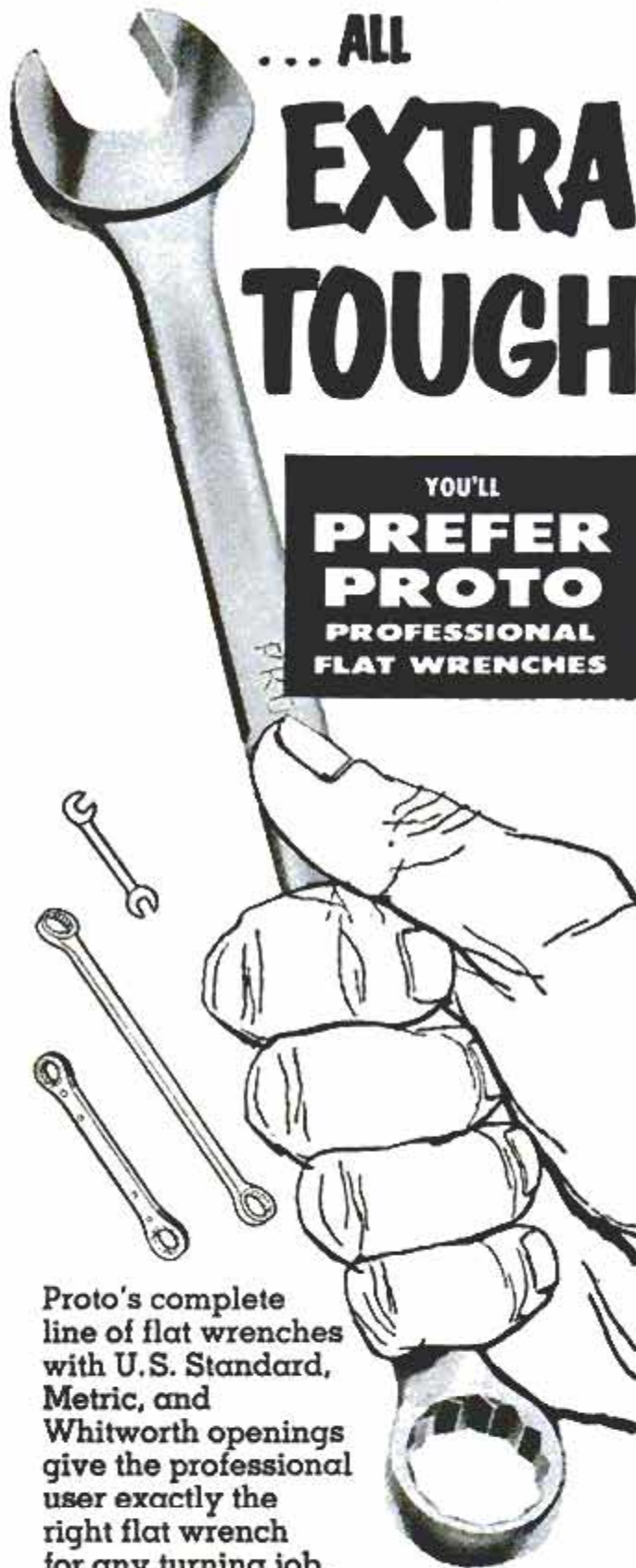

Proto's complete line of flat wrenches with U.S. Standard, Metric, and Whitworth openings give the professional user exactly the right flat wrench for any turning job. Send 10 cents for big tool catalog.



2209 Santa Fe Ave.  
Los Angeles 54, Calif.

(Continued from page 5)

1958 automobile section are still available at 25 cents.]

I am the oldest service-station operator and repair shop in Canada. I purchased my first barrel of gasoline and a quantity of oil Feb. 8, 1899. I installed an air compressor and tank in 1900. What I have in mind is to frame the prints and place them in Brantford Museum.

Tom Brown,  
Brantford, Ont., Can.

☆ ☆ ☆

**To the Editor:**

The *Boy Mechanic* goes on forever! The enclosed photo is the result of my son's discovery of a set of this favorite in the Nutley Public Library. My own boyhood



days in the early twenties were enriched by the possession of a set of these very interesting books, and even yet, they contain much of interest.

The picture shows my son Michael, 15, and his re-creation of a once famous model "Old Four." In building this, he carefully followed the original directions, and used only the specified materials.

The frame is of spruce and the wings are built up of steamed bamboo as per the directions. The motors consist of 400 feet of rubber band, and the propellers are hand-whittled.

We think that perhaps this is the first time this model has been built and flown for many, many years. It flies quite well—

(Continued to page 8)



# 5 reasons why ACCOUNTING



offers you

**MORE MONEY and SUCCESS**

**SEND FOR FREE  
SAMPLE LESSON**

**REASON #1.** If you were an expert accountant right now, chances are you would find yourself in one of the best paid fields of business.

**REASON #2.** The demand for accountants is great—everywhere. All businesses must have trained accountants to cope with ever-growing requirements. It's a field offering wide opportunity—always—to the man who knows.

**REASON #3.** You can fit into any business, anywhere in the country—because accounting principles are universal. Think what this means in terms of security and independence!

**REASON #4.** Accounting is open to all. Any man or woman of good intelligence, who enjoys figure work and is willing to follow LaSalle's systematic "problem method" plan, can rapidly qualify for a highly profitable, enjoyable lifetime career . . . and he doesn't have to finish his training before beginning to "cash in."

**LASALLE**  
417 S. Dearborn St.,  
CHICAGO 5, ILL.

**REASON #5.** Without losing a day from your present work, you can prepare in spare hours at home, at low cost, under LaSalle's step-by-step "Problem Method" of "learning by doing." This famous plan accounts for LaSalle's remarkable record of having trained one out of every 13 of all Certified Public Accountants in the U. S. . . . and of having put many thousands of others into high-paying careers.

**Send today for Free Sample Lesson** and "Opportunities in Accounting." Learn about the several great fields of opportunity . . . and LaSalle's time-tested plan for helping men and women to rapid advancement, higher income and greater prestige. The coupon below will bring this information to you—without cost or obligation.

**Accredited Member, National Home Study Council**

**SEND FOR FREE BOOK**



**LaSalle Extension University**  
A Correspondence Institution

Dept. 864H, 417 S. Dearborn St., Chicago 5, Ill.  
Please send me, free of all cost or obligation, free sample lesson and your latest book, "Opportunities in Accounting."

Name.....Age.....

Address.....

City, Zone, State.....



(Continued from page 6)

and creates quite a sensation on the local flying model scene with all of the howling gas models!

Thought the staff of *Popular Mechanics* might be interested to hear of this. Incidentally, I have never missed an issue since 1920.

Emmett Moore,  
BSA, Inc.,  
Nutley 10, N. J.

☆ ☆ ☆

**To the Editor:**

Afghan dogs, rare in North America, come of ancient and royal lineage, having been bred for centuries back by the nobles of Afghanistan for hunting purposes.

Presumably the Asian Afghans were pampered pets but it's doubtful if they ever had a cushier set-up than the Afghans pictured here have in Sudbury, Ontario.

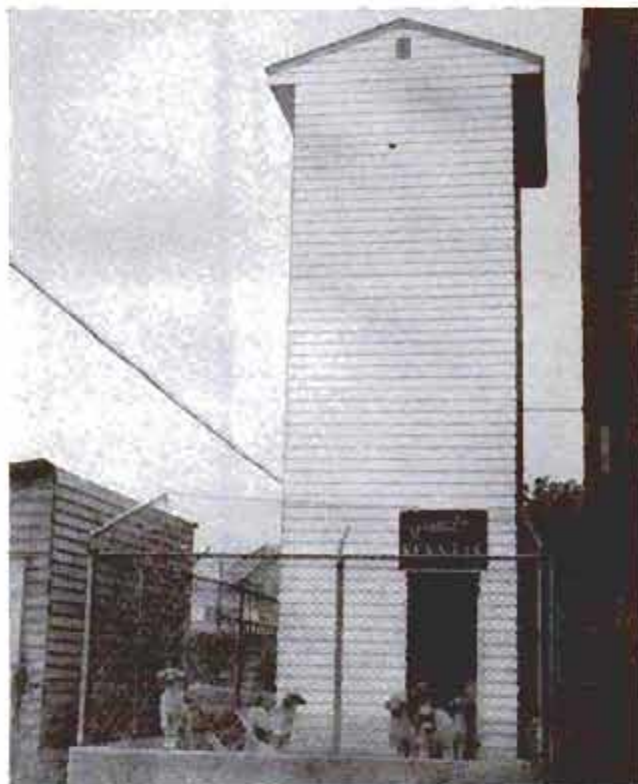

The Sudbury Afghans—father, mother and seven pups—owned by John Joseph Clements, live in royal luxury in this three-story doghouse.

A narrow staircase leads from the ground to the top floor, where the Afghans sleep on regular beds, with pillows and everything. When hungry or at feeding time they descend to the dining room on the floor below.

M. W. Bowman,  
Windsor, Ont.

☆ ☆ ☆

☞ Three out of four physicians in Russia are women.



Train AT HOME for a GOOD JOB in

**AUTO MECHANICS**

A better job with more pay will mean *better living* for you. It can mean a fine home, a new car, nice vacations, and good educations for the kids. If you would like to earn up to \$125 a week and more—and be able to afford better living, *train yourself* in Auto Mechanics. You can do it with CTI showing you how—and you can learn at home in spare time!

**GOOD JOBS ARE WAITING EVERYWHERE** because there are over 60 million cars and trucks on the road—7 million new ones each year. One-third are in the heavy-repair classification. Skilled mechanics are needed to keep these cars operating. You can be one of them—make big money, enjoy lifetime security—even open a shop!

**EARN AS YOU LEARN** just as many CTI students do. They make up to \$15 a week and more in spare time. Some start their own shops by graduation time. CTI Shop-Method Home training, based on resident school practice, makes every step easy.

**DIESEL MECHANICS OR BODY-FENDER TRAINING** is also yours at no extra cost. A wonderful chance to give yourself a well-rounded education. Only CTI gives you this extra choice! Get the facts: Mail coupon.



**YOU PRACTICE WITH THIS TUNE-UP KIT**

Kit includes a Compression Tester, a Vacuum Gauge and Fuel Pump Tester, an Ignition Timing Light, and a portable steel case. These professional instruments help you locate engine troubles, let you get useful practice. You keep this kit!

**MECHANIC'S TOOLS TOO**

You'll use these tools to get real experience. They'll increase your interest, stamp you as a "pro." You'll earn spare time cash with them. No extra cost for tools—you keep them.



**MAIL COUPON TODAY!**

**MAIL TODAY FOR 2 FREE BOOKS**

COMMERCIAL TRADES INSTITUTE  
1400 Greenleaf Ave., Chicago 26  
Dept. A-850

Send your new Auto Mechanics book and Sample Lesson. BOTH FREE.

Name \_\_\_\_\_ Age \_\_\_\_\_

Address \_\_\_\_\_

City \_\_\_\_\_ Zone \_\_\_\_\_ State \_\_\_\_\_





# TO THE MAN WHO MAY BE WORRIED ABOUT HIS JOB

Job worry comes easy nowadays. Many businesses are off. Jobs are not as plentiful.

But worry gets you nowhere. If anything, it dulls your judgment and weakens your performance. In time, it can cause your downfall.

How then, in light of present conditions, can you avoid worry? By facing the facts squarely and by planning wisely. Here are some facts that will help you:

1. Job security is greatest among skilled, highly trained specialists. The right training, for example, can triple your chances of advancement, reduce chances of layoff by 60%.
2. High-pay jobs are still plentiful in certain key industries. Chemical. Electronics. Engineering. Sales and service. Most white collar jobs. These are positions for which special training can help you qualify.
3. I.C.S. training helps provide job security. In good times or bad, I.C.S. students get



ahead. And no other school has so many of its former students now in management and supervisory positions.

A sensible plan is to turn your worries into a program of action. Let I.C.S. prepare you quickly and thoroughly for steady progress in your present line of work. Or for a rewarding career in any of more than 200 "blue chip" job fields. I.C.S. Courses are used by 3000 leading companies. You get personalized instruction. Up-to-date texts. The famous I.C.S. diploma.

Write today for the *three* free books that outline job opportunities in your field of interest and explain the I.C.S. method. No obligation. Just mark and mail the coupon.

For Real Job Security—Get an I. C. S. Diploma!

I. C. S., Scranton 15, Penna.

Accredited Member,  
National Home Study Council

## INTERNATIONAL CORRESPONDENCE SCHOOLS



BOX 64299H, SCRANTON 15, PENNA.

(Partial list of 259 courses)

Without cost or obligation, send me "HOW TO SUCCEED" and the opportunity booklet about the field BEFORE which I have marked X (plus sample lesson):

### ARCHITECTURE and BUILDING CONSTRUCTION

- Air Conditioning
- Architecture
- Arch. Drawing and Designing
- Building Contractor
- Building Estimator
- Carpentry and Millwork
- Carpenter Foreman
- Heating
- Interior Decoration
- Painting Contractor
- Plumbing
- Reading Arch. Blueprints

### ART

- Commercial Art
- Magazine & Book Illus.
- Show Card and Sign Lettering
- Sketching and Painting

### AUTOMOTIVE

- Automobiles
- Auto Body Rebuilding and Refinishing
- Auto Engine Tuneup
- Auto Technician

### AVIATION

- Aero-Engineering Technology
- Aircraft & Engine Mechanic

### BUSINESS

- Accounting
- Advertising
- Business Administration
- Business Management
- Cost Accounting
- Creative Salesmanship
- Managing a Small Business
- Professional Secretary
- Public Accounting
- Purchasing Agent
- Salesmanship
- Salesmanship and Management
- Traffic Management

### CHEMICAL

- Analytical Chemistry
- Chemical Engineering
- Chem. Lab. Technician
- Elements of Nuclear Energy
- General Chemistry
- Natural Gas Prod. and Trans.
- Petroleum Prod. and Engr.
- Professional Engineer (Chem)
- Pulp and Paper Making

### CIVIL ENGINEERING

- Civil Engineering
- Construction Engineering
- Highway Engineering
- Professional Engineer (Civil)
- Reading Struc. Blueprints
- Structural Engineering
- Surveying and Mapping

### DRAFTING

- Aircraft Drafting
- Architectural Drafting
- Drafting Machine Design
- Electrical Drafting
- Mechanical Drafting
- Sheet Metal Drafting
- Structural Drafting

### ELECTRICAL

- Electrical Engineering
- Elec. Engr. Technician
- Elec. Light and Power
- Practical Electrician
- Practical Lineman
- Professional Engineer (Elec)

### HIGH SCHOOL

- High School Diploma

- Good English
- High School Mathematics
- Short Story Writing

### LEADERSHIP

- Industrial Foremanship
- Industrial Supervision
- Personnel-Labor Relations
- Supervision

### MECHANICAL and SHOP

- Diesel Engines
- Gas-Elec. Welding
- Industrial Engineering
- Industrial Instrumentation
- Industrial Metallurgy
- Industrial Safety
- Machine Design
- Machine Shop Practice
- Mechanical Engineering
- Professional Engineer (Mech)
- Quality Control
- Reading Shop Blueprints
- Refrigeration and Air Conditioning
- Tool Design
- Tool Making

### RADIO, TELEVISION

- General Electronics Tech.

- Industrial Electronics
- Practical Radio-TV Eng'g
- Practical Telephony
- Radio-TV Servicing

### RAILROAD

- Car Inspector and Air Brakes
- Diesel Electrician
- Diesel Engr. and Fireman
- Diesel Locomotive

### STEAM and DIESEL POWER

- Combustion Engineering
- Power Plant Engineer
- Stationary Diesel Engr.
- Stationary Fireman

### TEXTILE

- Carding and Spinning
- Cotton Manufacture
- Cotton Warming and Weaving
- Loom Fixing Technician
- Textile Designing
- Textile Finishing & Dyeing
- Throwing
- Warming and Weaving
- Worsted Manufacturing

Name \_\_\_\_\_ Age \_\_\_\_\_ Home Address \_\_\_\_\_  
 City \_\_\_\_\_ Zone \_\_\_\_\_ State \_\_\_\_\_ Working Hours \_\_\_\_\_ A.M. to P.M. \_\_\_\_\_  
 Occupation \_\_\_\_\_

Canadian residents send coupon to International Correspondence Schools, Canadian, Ltd., Montreal, Canada. . . . Special tuition rates to members of the U. S. Armed Forces.



# HOW TO FIX ANY PART OF ANY CAR

QUICKLY--EASILY--RIGHT!



**FREE 7-DAY TRIAL**

Whether you're a beginner or an expert mechanic — now you can "breeze through" any "fix-it" job from simple carburetor adjustment to complete overhaul. Just look up job in index of MOTOR'S Brand-New Auto Repair Manual. Follow simple step-by-step directions, clear pictures. Presto—the job is done!

No guesswork! MOTOR'S MANUAL takes you from "scratch" — shows WHERE to start, WHAT tools to use. Covers EVERY job on EVERY car listed — from 1949 thru 1958!

Everything You Need to Know "Boiled Down" from 176 Official Shop Manuals

BIG NEW, REVISED, ENLARGED, Edition contains the "meat" from 176 OFFICIAL shop manuals — simplified for YOU. 23,438 essential repair specifications on 24 different makes. Over 1,000 big pages. More than 2,900 "this-is-how" pictures, 225,000 service and repair facts. Leads beginners every step of the way. Time-saving factory repair procedures for experts. Instructions and pictures so clear you CAN'T go wrong. Used by U. S. Army and Navy.

Try Book FREE 7 Days

Just mail coupon. (Attach it to postcard if you wish.) Make Manual prove what it's got. Unless you agree this is the greatest time and work saver you've ever seen—return book in 7 days, pay nothing. Mail coupon today for: MOTOR BOOK Dept., Desk 1H, 250 West 55th Street, New York 19, New York.

**MOTOR'S AUTO REPAIR MANUAL**

Covers ALL Models — 1949 thru 1958

- |             |             |
|-------------|-------------|
| Buick       | Jeep        |
| Cadillac    | Lincoln     |
| Chevrolet   | Mercury     |
| Chrysler    | Nash        |
| Clipper     | Oldsmobile  |
| Continental | Packard     |
| De Soto     | Plymouth    |
| Dodge       | Pontiac     |
| Edsel       | Rambler     |
| Ford        | Studebaker  |
| Hudson      | Thunderbird |
| Imperial    | Willys      |

Same FREE Offer On MOTOR'S New Truck Repair Manual

Covers EVERY job on EVERY popular make gasoline and Diesel truck made since 1949. FREE 7-Day Trial. Check proper box in coupon.



MAIL COUPON NOW FOR 7-DAY FREE TRIAL (Attach to Postcard for Fast Action)

**MOTOR BOOK DEPT.**  
Desk 1H, 250 W. 55th St., New York 19, N. Y.  
Rush to me at once (check box opposite book you want):

MOTOR'S New AUTO REPAIR MANUAL. If O.K., I will remit \$2 in 7 days, \$2 monthly for 2 months and a final payment of \$1.95 (plus 35c delivery charges) one month after that. Otherwise I will return the book postpaid in 7 days. (Foreign price, remit \$10 cash with order.)

MOTOR'S New TRUCK REPAIR MANUAL. If O.K., I will remit \$3 in 7 days, and \$2 monthly for 3 months, plus 35c delivery charges with final payment. Otherwise I will return book postpaid in 7 days. (Foreign price, remit \$11 cash with order.)

Print Name..... Age.....  
Address.....  
City.....Zone.....State.....

Check box and save 35c delivery charge by enclosing WITH coupon in envelope entire payment of \$7.95 for Auto Manual or \$9 for Truck Manual. Same return-refund privilege.

## BE A DIESEL-AUTO MECHANIC EARN \$450 MONTH AND UP

WHY WORK FOR LOW PAY or worry about being laid off? We have a nation-wide waiting list of good pay jobs for our graduates.

THAT'S YOUR GUARANTEE that we offer the best in Diesel-Auto training. Costs less because you get both Diesel and Auto training for the price of one.

WITH OUR PRACTICAL "learn-by-doing" shop practice method, we train you thoroughly in less time.

IF YOU'RE DRAFT AGE:—Our catalog contains information vital to you!

Part-time jobs and housing provided. Write at once for free booklet.

**WORLD FAMOUS**  
**BAILEY TECHNICAL SCHOOLS**  
1634 S. GRAND AVE. • ST. LOUIS, MO.

**75 POWER TELESCOPE \$3.98**  
NEW 3 in one telescopes. 3 variable 25X 45X-75X magnification. Brass bound. 23 power for ultra bright images 45 & 75 power for long range. Guaranteed to bring distant stars, moons, objects, sports 75 times closer.

Most powerful scope sold anywhere near this amazing low price. American made, 5 sections. Opens 36", closes 1 ft.; contains 4 ground & polished lenses. Can also be used as powerful compound microscope. Mass production enables us to offer telescope complete at \$3.98 postpaid. Money back guarantee.

CRITERION CO., Dept. PMB 60, 331 Church St., Hartford, Conn.

## Hotels Call for Trained Men

Record-breaking travel means nation-wide opportunities and a sound substantial future for trained men in hotels, motels, clubs, apartment house positions. Fascinating field; fine living; quick advancement. You can qualify at home or through resident classes in Washington. Previous experience proved unnecessary. Placement Service FREE. Write for FREE Book. Course Approved for ALL Veteran Training. 42nd Year. LEWIS HOTEL TRAINING SCHOOL, Room DM-312, Wash. 7, D.C.

**Learn ACCOUNTING Business Administration**

Bookkeeping, secretarial and allied subjects at home in your spare time or attend nationally approved resident school. Write for FREE Success Book giving complete details on courses, plans, rates and employment opportunities. G.I. approved. Write Dept. A.

**Hills BUSINESS UNIVERSITY AND EXTENSION SCHOOL**  
619 W. MAIN ST. OKLAHOMA CITY 2, OKLAHOMA

## GIANT 6 FOOTERS 59c

Wow! Genuine Neoprene government surplus (never used) . . . giant 6 ft. across, 21 ft. around . . . at a fraction of original cost. Durable. Can paint on advertising message, inflate and fly. Visible for miles. Great for attracting crowds to fairs, openings, school proms, gas stations. Fun for young and old in backyards or picnics, at the beach, etc. use as water markers & buoys. Order today — 59c. 2 for \$1.

**Special 13' — \$1.95 ea.**  
Calif. Res. Add Sales Tax.  
We pay postage on prepaid orders.

**FRANK SALES** 3930 SUNSET BLVD., DEPT. PM888  
LOS ANGELES 29, CALIF.



# Learn Radio-Television

## Servicing or Communications by Practicing at Home in Spare Time

N.R.I. SENDS kits with which you practice building circuits common to Radio and TV sets. You LEARN-BY-DOING to locate Radio-TV troubles. As part of N.R.I. Servicing Course, you build Vacuum Tube Voltmeter and AC-DC receiver. Use VTVM to conduct experiments, earn extra money fixing sets in spare time.

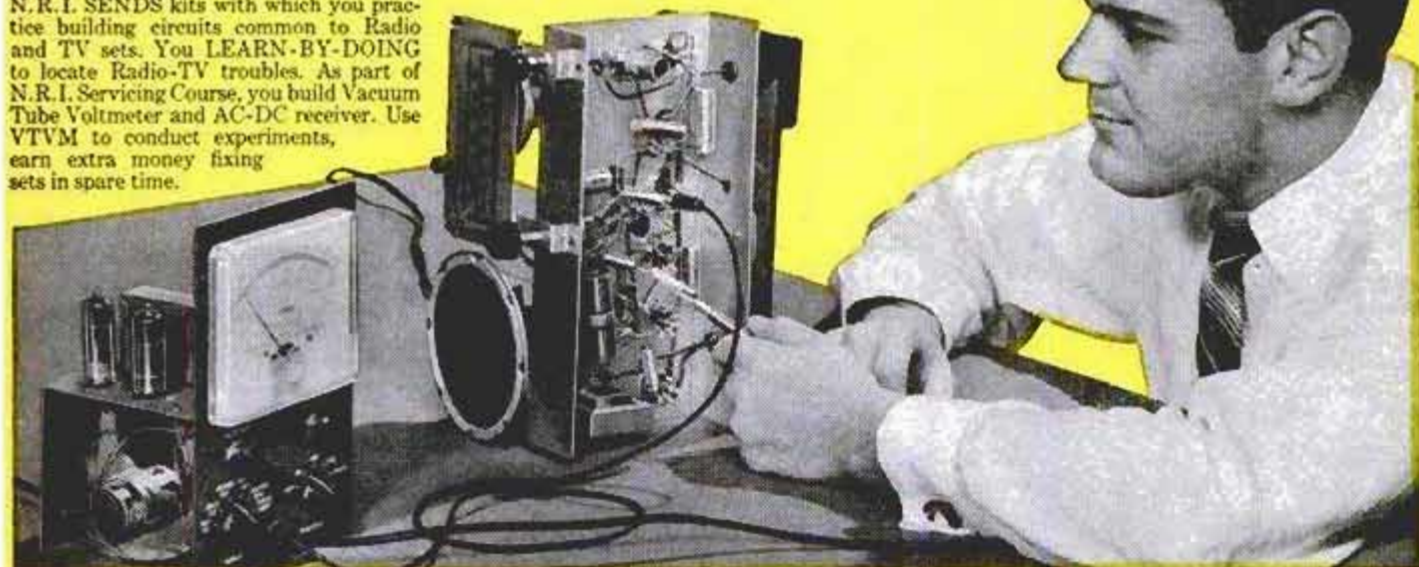

**RADIO-TV BROADCASTING** (see above) offers important positions as Operators and Technicians. **RADIO-TV SERVICING** Technicians (see below) needed in every community. Their services are respected, their skill appreciated.



### N.R.I. TRAINED THESE MEN FOR SUCCESS

"I was repairing Radios by 10th lesson. Now have good TV job." **M. R. LINDEMUTH**, Fort Wayne, Ind.

"Doing spare time repairs on Radio and TV. Soon servicing full time." **CLYDE HIGGINS**, Waltham, Mass.

"I had a successful Radio repair shop. Now I'm Engineer for WHPE." **V.W. WORKMAN**, High Point, N.C.



"There are a number of NRI graduates here. I can thank NRI for this job." **JACK WAGNER**, Lexington, N.C.



**VETERANS** Approved Under G. I. Bills

## Fast Growing Field Offers You Good Pay, Success, Bright Future



**J. E. SMITH**  
Founder

Bigger than ever and still growing fast. That's why Radio-TV has special appeal to ambitious men not satisfied with their job and earnings. More than 4,000 Radio and TV stations. More than 150 million home and auto Radios, 40 million TV sets. Color TV promises added opportunities. For the trained man, there are good jobs, bright futures in Radio-TV Servicing or Broadcasting.

Training PLUS opportunity is the ideal combination for success. So plan now to get into Radio-TV. The technical man is looked up to. He does important work, gets good pay for it. Radio-Television offers that kind of work. NRI can supply training quickly, without expense of going away to school. Keep your job while training. You learn at home in your spare time. NRI is the OLDEST and LARGEST home study Radio-TV school. Its methods have proved successful for more than 40 years.

### Added Income Soon - \$10, \$15 a Week in Spare Time

Soon after enrolling, many NRI students start to earn \$10, \$15 a week in spare time fixing sets. Some pay for their training and enjoy extra luxuries this way. Some make enough to start their own Radio-TV shops. NRI training is *practical*—gets quick results. Easy to understand, well illustrated lessons teach you basic principles. And you LEARN-BY-DOING by practicing with kits of equipment which "bring to life" things you study.

### Find Out What NRI Offers

NRI has trained thousands for successful careers in Radio-TV. Study fast or slow—as you like. Diploma when you graduate. Mail coupon now. Paste it on a postcard or mail in envelope. **ACTUAL LESSON FREE**. Also 64 page catalog that shows opportunities, shows equipment you get. Cost of NRI courses low. Easy terms. **NATIONAL RADIO INSTITUTE**, Dept. 8HA, Washington 16, D.C.

### SEND FOR BOTH FREE

**National Radio Institute**

Dept. 8HA, Washington 16, D.C.

Mail me Sample Lesson and 64-Page Catalog FREE. (No salesman will call. Please write plainly.)

Name \_\_\_\_\_ Age \_\_\_\_\_

Address \_\_\_\_\_

City \_\_\_\_\_ Zone \_\_\_\_\_ State \_\_\_\_\_

Accredited Member National Home Study Council





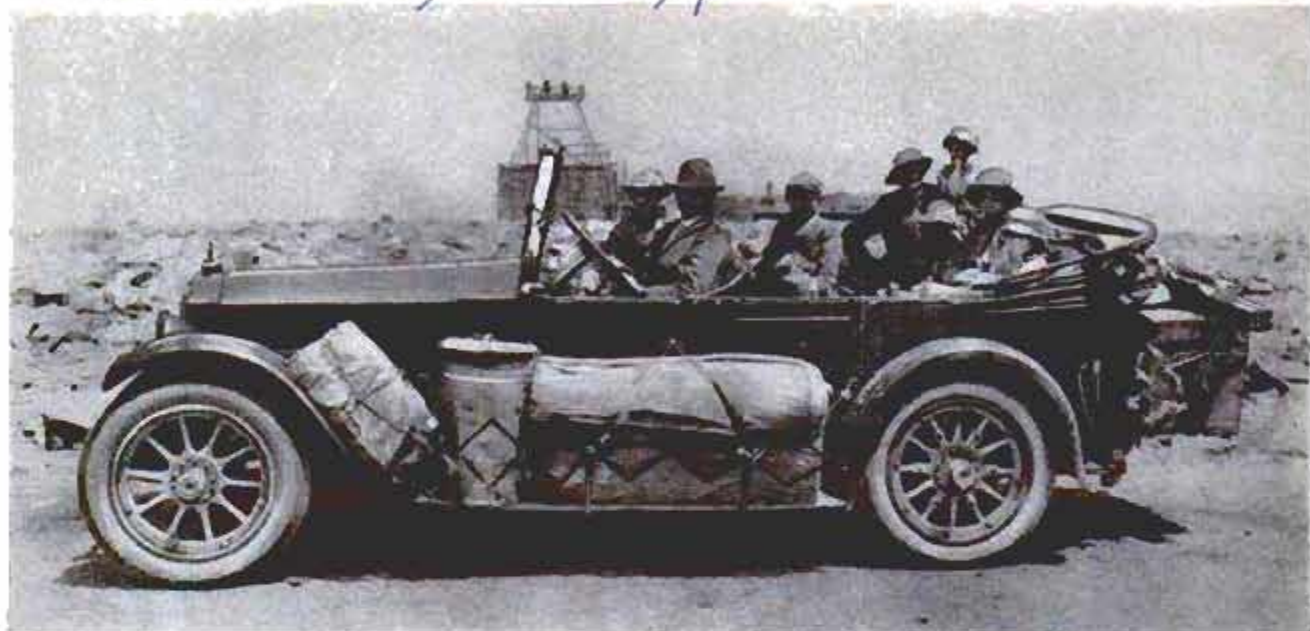

U. S. Forest Service photo

## Do You Know This Old-Timer?

HERE'S ANOTHER famous name, with a hood profile that kept its family resemblance for many a year. Those well-laden running boards and hog-tied trunk in the rear certainly served a purpose in those pioneering days. The photographer tells us

this picture portrays the O. N. England family of Lodi, Calif., atop Pikes Peak on July 23, 1919 after 4500 miles of touring, and they were still on their way to Miami, Fla. Recognize the car and model year? If not, turn to page 218.

## CLEANS YOUR CARBURETOR while you drive...

Hard starting, stalling, high gas consumption and poor performance all come from a dirty, gummed-up carburetor. And every carburetor gets dirty—inside. GUMOUT dissolves gum and varnish deposits quickly and completely. You just add GUMOUT to your gas tank every two or three months. It cleans as you drive! There's nothing like GUMOUT. Available at all auto supply stores, or wherever automotive products are sold.

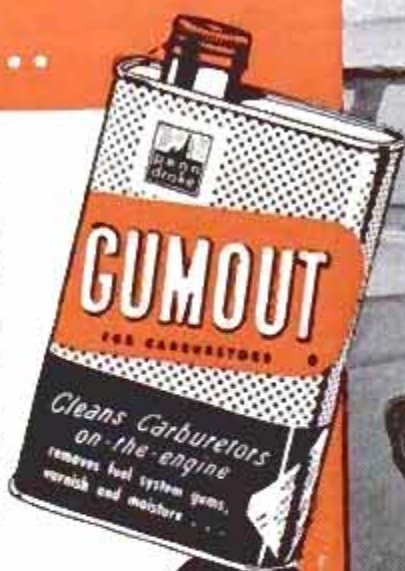

PINT  
\$1.50

GUMOUT is great for power mowers, too. Insures trouble-free operation, full power.

Write for FREE 46-page Carburetor Handbook.

8-OZ.  
89c



GUMOUT DIVISION • Pennsylvania Refining Co., 2671 Lisbon Road, Cleveland 4, Ohio





# INVENTORS

**L**earn how to protect your invention. The U. S. Patent Laws provide that any new and useful art, machine, article of manufacture, or composition of matter, or any new and useful improvement thereof, may be patented if the act of invention is involved. Therefore, every inventor with a valuable invention should take advantage of the Patent Laws and proceed for patent protection in order to safeguard his rights.

A patent gives the inventor the exclusive right to prevent others from making, using, or selling the invention claimed in the patent for a period of seventeen years.

The Patent Laws were enacted for the benefit of the inventor to give him protection for the features of his invention which are patentable. These features must be properly and concisely set forth and claimed in a formal application for patent, in order to comply with the requirements of the Patent Laws. For that reason, unless the inventor is familiar with patent matters, he should engage a competent registered patent attorney or agent to represent him. We are registered to practice before the U. S. Patent Office and are prepared to serve you in the handling of your patent matters.

A specially prepared booklet entitled "Patent Guide for the Inventor", containing detailed information with respect to patent protection and procedure, together with a "Record of Invention" form will be promptly forwarded to you without obligation upon request.

**CLARENCE A. O'BRIEN & HARVEY JACOBSON**

*Registered Patent Attorneys*

**81-H DISTRICT NATIONAL BUILDING**

**WASHINGTON 5, D. C.**



## CARPENTERS AND BUILDERS GUIDES



PRACTICAL STOREHOUSE OF MODERN CONSTRUCTION INFORMATION (4 vol. set) for carpenters and all woodworkers. Explains in easy language and by profuse illustration principles, advances, short cuts, trade secrets, all based on the NEWEST information.

Vol. 1 - Tools, steel square, saw filing, joinery, furniture, etc. Vol. 2 - Builders' mathematics, drawing plans, specifications, estimates, etc. Vol. 3 - House and roof framing, laying out, foundations, etc. Vol. 4 - Doors, windows, stair building, millwork, painting, etc. 4 vols. 1904 Pages. 3700 Illustrations. Whole set only \$8.

CIRCLE NO. 8 IN COUPON



## TV TELLS HOW TO ANSWER RADIO T.V. QUESTIONS SERVICE LIBRARY

HERE IS LATEST INFORMATION ON A NEWLY FORMED FOR RADIO SERVICE MEN, BEGINNERS AND STUDENTS.

TWO COMPLETE VOLUMES—566 Pages—1045 Illustrations and Diagrams, 1001 Important Facts and Figures on Modern T.V., Radio, Electronic Devices, INCLUDES TRANSISTORS & Transistors Circuits, Rectifiers, Record Changers, P.A. Systems, Phonograph Pick-ups, S.F., Auto Radio, Short Wave.

Basic principles, Construction, Installation, Operation, Repairs, Trouble Shooting, How to get Sharp, Clear T.V. Pictures, Install Aerials, How to Test, Explain COLOR SYSTEMS, Methods of Convergence, Tuning, etc. Includes Ultra High Frequency, Quick ready reference or use as a home study course. Only \$8 for BOTH volumes.

CIRCLE NO. 3 IN COUPON



## MATHEMATICS MADE EASY

A COMPLETE HOME STUDY COURSE - Starting with the first principles of arithmetic, advancing step by step through the various stages of mathematics, including the rules and calculations for mechanical and electrical problems. New EASY correct methods. Includes plane and solid geometry, trigonometry, algebra, calculus, etc. Practical tests, reference tables and data. How to use slide rule. 752 Pages. 550 Illustrations. Priced at only \$3.

CIRCLE NO. 11 IN COUPON

## WELDERS GUIDE

Covers Electric, Oxy-acetylene, Thermit, Unalloyed welding for sheet metal, spot and pipe welds, pressure vessels and aluminum, copper, brass, bronze and other metals. Air-plane work, surface hardening, hard facing, cutting, brazing, etc. 608 Pages. Fully illustrated. Only \$3.

CIRCLE NO. 10 IN COUPON

## REFRIGERATION & AIR CONDITIONING

FOUR BOOKS IN ONE - Basic principles, servicing, operation, repair of 1. Household Refrigeration 2. Special Refrigeration Units 3. Commercial & Industrial Refrigeration 4. Air Conditioning Systems. A GOLD MINE of essential information. Completely up-to-date. 1360 Pages. Fully illustrated and indexed. Priced at only \$6.

CIRCLE NO. 14 IN COUPON

## NEW MACHINISTS AND TOOLMAKERS HANDBOOK

MODERN MACHINE SHOP PRACTICE - 5 PRACTICAL BOOKS IN ONE. New from cover to cover. Tells how to set up and operate lathes, screw and milling machines, shapers, drill presses and all other machine tools. A COMPLETE INSTRUCTOR AND REFERENCE BOOK. 1728 Pages. Fully illustrated. Priced at only \$6.

CIRCLE NO. 4 IN COUPON

## HOME APPLIANCES

HOW TO REFRIGERATORS TO FIX Washers and Dryers Teasters Ironers Ranges

Many other GAS and ELECTRIC APPLIANCES Handy Reference for Electric & Gas Servicemen, Mechanics, Dealers and Homeowners. Explains clearly and simply how to locate troubles, how to test, reassemble and connect. Wiring diagrams. 1000 Facts. Easy to read Answers. All your questions. 664 Pages. Illustrated. Only \$6.

CIRCLE NO. 2 IN COUPON

PRACTICAL ELECTRICITY A COMPLETE HANDBOOK - Quick, simple reference. Complete instruction and practical information on the rules and laws of electricity - Maintenance of Machinery - A.C. and D.C. Motors - Armatures - Wiring Diagrams - House Lighting - Power Wiring - Meters - Batteries - Transformers - etc. Simple to understand. 1520 Pages, 2600 Illustrations. Priced at \$5.

CIRCLE NO. 13 IN COUPON

## OIL BURNERS

New, complete, explaining in detail both domestic and industrial oil burners. Includes electrical hook-ups and wiring diagrams. Fully covering the theory, construction, installation, operation, testing, servicing and repair of all equipment. Indexed for ready reference. Over 616 Pages, 320 Illustrations and Diagrams. Only \$2 - CIRCLE NO. 28 IN COUPON

## 7-DAY FREE EXAMINATION

SEND NO MONEY - Pay the postman nothing! We are glad to send you any of the Audel Guides for FREE examination in your home. We take all the risks and leave the decisions to YOU. There is no obligation! If you decide to keep the books you may pay for them under our astounding easy-pay plan of only \$2 a month.

### HERE IS ALL YOU DO

IT'S EASY TO ORDER: In the Mail-Order Coupon just draw a circle around the number of Audel Guides you want us to send for FREE EXAMINATION. We will send them to you at once to help you build a brighter future by increasing your SKILL in any profession at all you are not COMPLETELY satisfied, return the books, and that will end the matter!

## ADDITIONAL IMPORTANT TITLES

Audel Guides are the best in their fields, written in clear simple fashion, lavishly illustrated. Circle numbers wanted in the MAIL ORDER COUPON at right. All sent for FREE EXAMINATION.

No. 1	AUTOMOBILE MECHANICS GUIDE, 1693 Pages	\$4.00
No. 5	TRUCK & TRACTOR GUIDE, 1276 Pages	3.00
No. 6	PLUMBERS & STEAMFITTERS GUIDES, 4 Book Set	8.00
No. 7	PAINTING & DECORATING MANUAL, 464 Pages	2.00
No. 9	DIESEL ENGINE MANUAL, 640 Pages	3.00
No. 12	WIRING DIAGRAMS, 304 Pages	2.00
No. 13	ELECTRIC LIBRARY, 7000 Pages, 10 Book Set	20.00
No. 23	BLUE PRINT READING, 448 Pages	2.00
No. 25	MASONRY & BUILDERS GUIDES, 4 Book Set	8.00
No. 27	ELECTRIC MOTOR GUIDE, 1036 Pages	3.00
No. 28	SHEET METAL PATTERN LAYOUTS, 1152 Pages	7.00
No. 30	SHEET METAL WORKERS HANDBOOK, 448 Pages	2.00
No. 31	MECHANICAL DRAWING GUIDE, 192 Pages	2.00
No. 32	MECHANICAL DRAWING & DESIGN, 480 Pages	3.00
No. 33	ELECTRONIC DEVICES, 304 Pages	3.00
No. 34	ELECTRICIANS EXAMINATIONS, 272 Pages	2.00
No. 35	ELECTRIC POWER CALCULATIONS, 480 Pages	3.00
No. 36	ELECTRIC DICTIONARY, 9000 Terms	3.00
No. 37	POWER PLANT ENGINEERS GUIDE, 1268 Pages	5.00
No. 38	ENGINEERS AND FIREMANS EXAMS, 544 Pages	2.00
No. 39	OPERATING ENGINEERS LIBRARY, 3 Book Set	12.00
No. 40	PUMPS, HYDRAULICS & AIR COMPRESSORS, 1760 Pages	6.00
No. 41	HOUSE HEATING GUIDE, 1008 Pages	3.00

## MAIL THIS COUPON TODAY!

THEO. AUDEL & CO. - Self Improvement Publishers Since 1879 P8  
69 W. 33rd Street, New York 18, N.Y.

Please mail me for 7 days' FREE EXAMINATION the books I have circled at right. I agree to mail \$2 in 7 days on each book or set ordered, and to further mail \$2 a month on each book or set ordered until I have paid the purchase price, plus shipping costs. If I am not completely satisfied with my Audel Guides I may return them.

NAME \_\_\_\_\_

ADDRESS \_\_\_\_\_

OCCUPATION \_\_\_\_\_

EMPLOYED BY \_\_\_\_\_

1 2 3 4 5 6 7 8 9 10 11 12 13 14 15 25 26

27 28 29 30 31 32 33 34 35 36 37 38 39 40 41

SAVE SHIPPING COSTS! Check here if you enclose complete payment with order. We pay postage charges. You have some return privilege.

## New Table Top Invention Puts You In... PROFITABLE RUBBER STAMP BUSINESS

Home Operators now make \$9.40 AN HOUR in business once monopolized by a few big companies



Special rubber stamps bring high prices—cost only pennies to make on new, low-cost table top machine. Take 27 cents worth of material, make perfect stamps, the kind businesses and offices now buy for the dozen at \$1.80 each. Make up to \$9.40 an hour. Start in spare time in your own home. Run machine on kitchen table using ordinary electrical outlet. Make any kind of stamp. We'll send you free information without obligation about this established, highly profitable business, now open to individuals for the first time. For free information send name today on a post card to Rubber Stamp Div., 1512 Jarvis Ave., Dept. R-2-J, Chicago 26, Ill.

## Your OWN—Modern DIAL TELEPHONES

For private circuits or extensions to main line; easy to rig up. Invaluable for residential, farm, industrial, estate uses. Surplus phones, slightly used, fully standard, base complete with dial, bell, cord, etc. Instructions and diagram included.

Working order guaranteed 100% GOV'T COST: \$32.50

\$8.50 ea. Send check or C.O.D. plus postage

BOHNSACK EQUIPMENT COMPANY  
Box 10 Germantown, N. Y.

## ELECTRONICS • RADIO-TV • COMPUTERS

At this pioneer school of technology, you can earn an A.A.S. degree (2 yrs) or a B.S. degree (4 yrs) in preparation for a successful career as an engineering technician or engineer. Scholarships, part-time work, job placement help available. Write for FREE career booklet. Give age and course preference.

MILWAUKEE SCHOOL OF ENGINEERING  
PM 858, 1025 N. Milwaukee Street, Milwaukee, Wisconsin

## Mechanical Dentistry

A profession offering unlimited opportunities. Most modern and complete course embracing every branch from Plate to Porcelain Work, which prepares you to work for Dentists or start your own business. Individual instruction—practical training in day or night school. No books—no classes. Catalog upon request.

McCARRIE SCHOOL OF MECHANICAL DENTISTRY  
207 N. Broad Street Dept. 79 Philadelphia 7, Penna.

## YOU ARE UNDER ARREST!

Help Bring Crooks to Justice Through Scientific CRIME DETECTION!

We have taught thousands this exciting, profitable, pleasant profession. Let us teach you in your own home. Learn Fingerprinting, Firearms Identification, Police Photography, Secret Service Methods thoroughly, quickly, at small cost. Over 800 of all American Bureaus of Identification employ I.A.S. students or graduates. Write for FREE "Blue Book of Crime."

(A Correspondence School Since 1910)

INSTITUTE OF APPLIED SCIENCE, 1920 Sunnyside Ave., Dept. 135C, Chicago 30, Ill.

## FREE OUTFIT STARTS YOU IN BIG MONEY SHOE BUSINESS!

Run your own profitable shoe store! Business from home! Represent fast growing million dollar firm in spare or full time. We give you—FREE—complete Starting Outfit that makes you \$217.00 EXTRA each month for just 2 easy orders a day. You feature 195 fast-selling dress, sport, work shoe styles for men and women. Air-cushion shoes, many other special features! Sizes 2½-15—widths AAAA to EEEE. Draw on 200,000 pair stock. Also horsehide jackets. Start now selling to friends, folks where you work. Rush postcard for FREE Outfit!

MASON SHOE, Dept. F-224, CHIPPEWA FALLS, WIS.



# Train yourself to be a top-pay mechanic in Air Conditioning and Refrigeration by practicing at home with real equipment!

R. C. ANDERSON  
President  
COMMERCIAL TRADES  
INSTITUTE



Job experts agree that opportunities for success are best in old, established industries which continue to grow. This is very true of the Air Conditioning and Refrigeration field. It is expanding so rapidly that thousands of good jobs are created each year. Yet, there's practically no competition for many of these well-paid openings because *not enough trained men are available!*

It's easy to get that vital training. You need not give up your present work nor leave your family. You can learn at home in spare time by practicing with real equipment. Yes, CTI sends you 23 big training kits, along with valuable "here's how" instruction. For full information, just fill out and mail coupon below.

## Why thousands of mechanics are needed

Over 150 million refrigerating units are in use today—are in need of repair and service. And the industry keeps booming! Each year, 3 million refrigerators, 1 million freezers and 2 million air conditioners are produced. You see these units in homes, stores, offices, restaurants, hotels—the applications are endless. Even autos now come with built-in air conditioners. *No wonder trained refrigeration mechanics are in demand—are so well-paid!*

## CTI offers a quick, easy way to learn

You learn *fast*—you learn *right*—because you get all parts and tools to build a complete, heavy-duty, commercial-type, 1/4 h.p. condensing unit (shown at left). You do 10 service and trouble-shooting jobs. You keep this equipment.

## You get experience by training with kits



Above left is photo of tools in just one kit. You get other tools, tubing, much equipment. In another kit (right), you get motor, fan, pulley, service tools. Kits are sent on planned schedule so that you learn in easy stages. Kits develop skill, speed training. *No extra cost for kits!*

## You may earn extra cash as you train

CTI training is so practical that many students do repairing in spare time. They work with local dealers or "on their own." They earn extra cash, get added experience. Some land full-time jobs while students, others open shops.

## Mail coupon for two FREE booklets

The story on job and business opportunities in the vast Air Conditioning and Refrigeration industry is fascinating. It's told in an interesting booklet which you can have free. We'll send it, along with training information, if you mail coupon. *Act today!*



## BE YOUR OWN BOSS

The Air Conditioning and Refrigeration industry is one of the easiest in which to start a repair and sales business. You mail coupon—we'll send facts.

## COMMERCIAL TRADES INSTITUTE

1400 GREENLEAF AVENUE  
CHICAGO 26, ILLINOIS

DEPT. R-507

Tell me how I can qualify for a better job or a business of my own. Send booklet, *Success in Air Conditioning & Refrigeration*, and Lesson Sample. Both FREE

Name \_\_\_\_\_ Age \_\_\_\_\_

Address \_\_\_\_\_

City \_\_\_\_\_ Zone \_\_\_\_\_ State \_\_\_\_\_



Get all the facts first—Then decide



# Learn at Home

*in your spare time*

## to Fix Electric Appliances



### Better Pay—More Opportunities

Get into a field where there is important work and opportunity for the trained man. Millions of electric appliances are sold every year. Every wired home now has an average of 8. Many of them need service and repair. Owners pay well to have them fixed quickly, properly. This is your opportunity for a better job, your own part time or full time business. NRI can give you the training you need, at home, in your spare time.

### Spare Time Earnings Start Soon

Soon after starting you will be able to earn extra cash fixing toasters, clocks, fans, vacuum cleaners, etc., for neighbors and friends. Keep your job while learning and earning. Put spare time to work for you. Work in your basement, garage, spare room. You'll be amazed how easily, quickly you, too, can start earning many extra dollars. NRI shows you how. Even before you finish training your spare time earnings may pay for the course and equipment.

### NRI Sends Tester to Learn and Earn

You need proper equipment to service today's automatic appliances. With this course you get parts to build professional type, multi-use Appliance Tester. You learn to use it. Takes guess work out of servicing. Mail coupon for FREE book and Sample Lesson. See how easy it is to learn. Find out about NRI—a school that for more than 40 years has been training men through home study, for success, good pay jobs. Our reputation, record, experience back up this course. Write now to: National Radio Institute, Dept. AH8, Washington 16, D. C.



**FREE Lesson and Book**  
Mail this NOW!

**NATIONAL RADIO INSTITUTE**  
Dept. AH8, Washington 16, D.C.

Send me Lesson and Book Free. No Salesman will call.

Name \_\_\_\_\_ Age \_\_\_\_\_

Address \_\_\_\_\_

City \_\_\_\_\_ Zone \_\_\_\_\_ State \_\_\_\_\_

ACCREDITED MEMBER NATIONAL HOME STUDY COUNCIL



## HIGH WAGES!

Make big pay in the construction industry as an operator of Bulldozers, Draglines, Shovels, Back Hoes, Scrapers and Motor Graders. Learn these skills NOW! Machines of major manufacturers are used in our training program. Contractors need operators of earthmoving machines and pay high wages to our graduates. Don't be satisfied with just a job . . . learn a career!

**VETERANS: Ask about G.I. Benefits!**

Write TODAY for FREE School Catalog, no obligation, to either address

**National School  
of Heavy Equipment  
Operation**

P.O. Box 8243, Dept. DM-1  
Charlotte, N. C.

**Western National School  
of Heavy Equipment  
Operation**

P.O. Box 527, Dept. DM-1  
Weiser, Idaho

## BECOME AN EXPERT IN TRAFFIC

Traffic men earn \$4,000 to \$10,000 and up. Thousands of firms need experts on rates, tariffs, regulations. We train you thoroughly in spare time at home for executive traffic jobs. Personal training under traffic authorities. Placement counsel and help. Write for free 48-page book "Traffic Management—the Fast Growing Profession."

LASALLE Extension University, 417 So. Dearborn St.  
A Correspondence Institution Dept. 2547, Chicago 5, Ill.

## REAL ESTATE BE A BROKER

PAYS BIG! SEND FOR FREE, BIG, ILLUSTRATED CATALOG NOW! Graduates report making substantial incomes. Start and run your own business quickly. Men, women of all ages, learn easily. Course covers Sales, Property Management, Appraising, Loans, Mortgages, and related subjects. STUDY AT HOME or in classrooms in leading cities. Diploma awarded. Write TODAY for free book! No obligation. Approved for World War II and Korean Veterans

WEAVER SCHOOL OF REAL ESTATE (Est. 1936)  
2020R Grand Avenue Kansas City, Mo.



**ENGINEERING  
DEGREE IN  
27 MONTHS**

B.S. Degree, Aero., Chem., Civil, Elec., Mech. & Electronic Engineering (inc. Radio, TV), 36 mo. B.S. degree in Math., Chem., Physics. Prep courses. Demand for grads. Spacious campus. 20 bldgs.; dorms, auditorium, gym. Low rate. Earn board. G.I. approved. Enter Sept., December, March, June. Catalog.

1688 E. Washington Blvd.  
Fort Wayne 2, Indiana  
Keeping pace with progress

**INDIANA TECHNICAL COLLEGE**

## RUPTURED

**BE FREE FROM TRUSS SLAVERY**

Surely you want to THROW AWAY TRUSSES FOREVER, be rid of Rupture Worries. Then Why Do you put up with wearing a griping, chafing and unsanitary truss the balance of your life? If you do, it will NOT be through necessity but through choice on your part.

Now there is a new modern Non-Surgical treatment that is designed to permanently correct rupture. These Non-Surgical treatments are so certain, that a Lifetime Certificate of Assurance is given. Write today for our New FREE Book that gives facts that may save you painful, expensive surgery. Tells how non-surgically you may again work, live, play, love and enjoy life in the manner you desire. There is no obligation. Excelsior Hernia Clinic, Dept. 8305, Excelsior Springs, Mo.



# INVENTORS

If you believe that you have an invention, you should find out how to protect it. The first step is to have a search made of the prior pertinent U. S. patents. If a report on this search indicates that the invention appears patentable you can apply for a patent, and the specifications and claims should be prepared.

The firm of McMorrow, Berman & Davidson, with offices in Washington, D. C., is qualified to take the necessary steps for you. We can make a preliminary search on your invention, advise you whether we think it can be patented, and prepare your application for patent.

Unless you are fully familiar with the U. S. Patent Laws, we recommend that you engage the services of a Registered Patent Attorney to protect your interests. The patent laws are *your* laws. A patent gives you the right to prevent others from making, using or selling the invention claimed in your patent for a period of 17 years.

Use these patent laws for your protection. Investigate whether your invention can be patented. If you have what you believe to be an invention, we suggest that you have this firm make a search for you.

*Send for a copy of our Patent Booklet entitled "How To Protect Your Invention," containing information about patent protection and patent procedure. Along with this we will also send you an "Invention Record" form, for your use in writing down and sketching details of your invention. We will mail them promptly. No obligation. They are yours for the asking.*

**McMORROW, BERMAN & DAVIDSON**

*Registered Patent Attorneys*

**PATENTS • COPYRIGHTS • PATENTS**

**135-Z VICTOR BUILDING, WASHINGTON 1, D. C.**



Make your interest in

# AUTO MECHANICS & DIESEL PAY OFF!



OUR FAMOUS SHOP METHOD HOME TRAINING PREPARES YOU FOR BIG TIME PAY AT HOME IN SPARE TIME

## YOU GET AND KEEP ALL THIS EQUIPMENT



Complete set of professional tools and All-Metal Tool Box. Same top-quality equipment used by expert mechanics everywhere. Use them, display them proudly.



"Motor Analyzing Set" contains Standard Engine Vacuum Fuel Pump Tester, Remote Starter Switch, Modern Timing Light, Standard Compression Tester. Plus compact carrying case & instructions.



Top-quality Socket Wrench with Fittings. Real professional tools you'll use during your lifetime career in repairing all types of engines, from foreign cars to big diesel jobs.

Nearly 60 million cars and trucks on our roads! If you could talk to owners of garages, service stations and car dealerships (as we do every day), you'd realize America's DESPERATE NEED FOR TRAINED MECHANICS.

Take your choice—One modern course prepares you for Auto-Mechanic jobs, Airplane Mechanics, Farm Machinery Repair, all Diesel Jobs, Experimental Labs, Government Work, Engine Specialties, etc. A qualified, ALL-AROUND Mechanic always has a good job.

Every phase is Shop-Tested! Streamlined lessons, diagrams, manuals are easy to understand. Earn as you learn. Free Graduate Employment Service.

FREE!  
VALUABLE BOOK  
& SAMPLE LESSON  
JUST SEND COUPON

RESIDENT TRAINING AT LOS ANGELES! If you wish to take Resident Training at Los Angeles, in our big, modern Shops & Labs, check special box in coupon for full information.

APPROVED FOR GI TRAINING  
**NATIONAL SCHOOLS**  
Los Angeles 37, California

**NATIONAL SCHOOLS**  
TECHNICAL TRADE TRAINING SINCE 1905  
LOS ANGELES 37, CALIFORNIA

MAIL NOW TO  
NATIONAL SCHOOLS, Dept. DB-88

4000 S. FIGUEROA ST.  
LOS ANGELES 37, CALIF.

Send for FREE Auto-Diesel Opportunity Book and Sample Lesson.

NAME \_\_\_\_\_ AGE \_\_\_\_\_

ADDRESS \_\_\_\_\_

CITY \_\_\_\_\_ ZONE \_\_\_\_\_ STATE \_\_\_\_\_

Check if interested ONLY in Resident School Training at Los Angeles

VETERANS: Give date of discharge \_\_\_\_\_



WHY PAY MORE!  
25 YEARS IN BUSINESS  
AT THE SAME ADDRESS  
"We Have No Rent to Pay."  
That is Why We Can Sell For Less.  
**FREE** GUARANTEE BOND given with each used tire sold. We guarantee the amount of service you pay for. SEND AD.  
EVERYBODY  
MAY DEDUCT 10% off ON EVERY TIRE

"EXTRA SPECIAL" TOP QUALITY  
all size 4-ply pass. FREE TIRE with 2  
or more of these — W.W. \$1.00 Ex.

12 MOS. PRORATED \$8.72  
WRITTEN GUARANTEE EA.

600-16	\$5.22	670-15	\$5.32	700-15(10)	\$9.22	700-20	\$11.52
600-16(10)	6.72	710-15	5.42	750-16(8)	10.72	750-20(10)	15.72
650-16	5.62	760-15	5.82	700-17	10.02	750-20(8)	13.32
650-16(10)	7.12	800-15	6.22	750-17	11.02	825-20	19.42
750-16(10)	8.02	820-15	6.22	600-20	9.22	900-20	19.42
640-15	4.92	700-16(10)	8.22	650-20	11.52	1000-20	20.62
1100-20	20.32	WHITE WALLS	\$1.00 EXTRA.	1100-20	20.72		

Thousands of tires shipped all over the U.S.A. All tires shipped F.O.B. Phila. Send Check or M.O. with this ad. Dept. 2. No C.O.D.

**STANDARD 834 N. Broad St., Philadelphia 30, Pa.**



## HOME-IMPORT BUSINESS . . .

Men, women, Make big profits buying low cost imports abroad (see examples at left) and selling to friends, stores or by mail order. Famous world trader guides you—shows you how to find thousands of exotic imports for full or spare time business, how to pocket profits in advance on foreign drop shipment plan. Full details FREE! Airmail reaches us overnight. Write Today! **MELLINGER CO., 1717 Westwood Dept. P258, LOS ANGELES 24, CALIFORNIA**

## TASOPE PHOTO-ENGRAVING PLANTS



Material Cost Of This Cut 3/4c  
Selling Price \$1.00 And Up

Establish your own profitable PHOTO-ENGRAVING business. Make cuts for newspapers, printers, and advertisers. Make etched name plates, plaques, etc. Instructions furnished, no experience necessary. Sold direct from factory since 1931. First five hundred cuts sold locally or by mail will pay for plant and pay you well for your time. Write for FREE catalog.

TASOPE, DEPT. PM8, AURORA, MO.

## BUILD YOUR OWN AIR CONDITIONERS

From Junked Refrigerators for a Few Dollars. INSTRUCTION BOOKS SHOW YOU HOW. 75c EACH  
"HOW TO BUILD a Low Cost Air Conditioner"  
"HOW TO BUILD an Automobile Air Conditioner"  
"HOW TO BUILD a Low Cost Home Freezer"  
"HOW TO BUILD an Electrostatic Precipitator"  
"HOW TO BUILD a Low Cost Dehumidifier"  
Complete "Install-It-Yourself" Air Conditioner kits for home and automobile, 2 Ton capacity. Brand New Parts—\$119.00 and up.  
KOOL ENGINEERING CO., Dept. E-8, 1318 N. Clybourn, Chicago 10, Ill.

SPECIAL OFFER  
2 Books—\$1.00  
3 Books—\$1.50  
or all 5 for \$2.00

**FREE!**  
Instructions  
and Literature  
on kits.

## JEEP OWNERS

RE-POWER NOW WITH A V-8 ENGINE — Use **FORD • CHEVROLET • MERCURY** in 2 or 4 Whl-Dr. Jeeps, Jeepsters, Sta-Wgn, Trucks, M. J. and Kaiser cars. Conversion Kits \$43.25 to \$59.85. If you want fast action tell us which engine you wish to use, give us year, Model (2 or 4 Whl-Dr) of your vehicle. Send Min. \$15.00 Dep. and we will ship correct kit, Bal. COD. Send full amt. for Prepaid shipment. Wire, phone or write for free details. Also Kits for FORD 6 engine.

**HOOSIER MACHINE PRODUCTS CO.**

312 S.E. 6th St. Phone CR 6-3442 Pendleton, Oregon, U.S.A.



## HOTTEST THING ON Jeep FRONT WHEELS

STOP FRONT DRIVE DRAG IN 2 W. D. Warn Hubs on your 4 w. d. disengage the front drive in 2 w. d., give it double-duty value with free-wheeling 2 w. d. economy, performance, plus normal 4 w. d.—automatically, with Warn Lock-O-Matics, manually with Warn Locking Hubs. See your dealer soon!  
WARN MFG. CO., INC.  
Riverton Bx 6064-AB, Seattle 88, Wn.

**WARN HUBS**



# Men 17 to 55—GET FREE FACTS!

See How **DeVry Tech** Can Prepare You For A Profitable Future In Many Fields

## from **Communications** to **Guided Missiles, etc.**



**No Previous Technical Experience Or Advanced Education Needed!**

Laborers and bookkeepers, store clerks, shop men, farmers, salesmen—men of nearly every calling—have taken the DeVry Tech program and today have good jobs or service shops of their own in Electronics. You don't have to quit your present job. If you are 17 to 55, see how you may get yourself ready for a future in the fast-growing Electronics field.

Whether you prepare at home or in our well-equipped Chicago or Toronto Laboratories, you get sound, basic training in both principles and practice. At home, you use educational movies. You build actual circuits and test equipment. You read simple directions, follow clear illustrations. When you finish, you are prepared to step into a good job in this excitingly different field. You may even start a service shop of your own. Mail coupon for free facts today.

Get **FREE** Booklet!

We'll give you a free copy of an interesting booklet, "Electronics and YOU." See for yourself how you may take advantage of the opportunities in this fast-growing field.



**Radar**



**Automation Electronics**



**Television**



**Micro-Waves**



**Computers**



**Broadcasting**



**Your Own Service Shop**

**FREE EMPLOYMENT SERVICE**

Puts you in touch with job opportunities—or helps you toward a better position in the plant where you are now employed.

**Draft Age?**

We have valuable information for every man of draft age; so if you are subject to military service, be sure to check the coupon.

# DeVry Technical INSTITUTE

**Chicago 41, Illinois**

Formerly DeFOREST'S TRAINING, INC.

"One of North America's Foremost Electronics Training Centers"  
Accredited Member of National Home Study Council



DeVry Technical Institute

4141 Belmont Ave., Chicago 41, Ill., Dept. PM-8-0

Please give me your FREE booklet, "Electronics and YOU," and tell me how I may prepare to enter one or more branches of Electronics as listed above.

Name \_\_\_\_\_ Age \_\_\_\_\_

Street \_\_\_\_\_ Apt. \_\_\_\_\_

City \_\_\_\_\_ Zone \_\_\_\_\_ State \_\_\_\_\_

Check here if subject to Military Training.

DeVry Tech's Canadian Training Center is located at 626 Roselawn Avenue, Toronto 12, Ontario

2040



# (Check the Kind of Body YOU Want!)

RIGHT IN THE COUPON BELOW

... and I'll Show How EASILY You Can Have It!

*Charles Atlas*

Twice winner and holder of the title "The World's Most Perfectly Developed Man."



JUST tell me where you want it—and I'll add SOLID INCHES of powerful muscle SO FAST your friends will grow bug-eyed with wonder. I'LL SHOW HOW you can be a new man in just 15 minutes a day—in your own home—or it won't cost you a penny!

I myself used to be a 97-lb. weakling. Men called me "Skinny." Girls made fun of me. THEN I discovered my great new muscle-building system—"Dynamic Tension." It turned me into such a specimen of MANHOOD that today I hold the title "THE WORLD'S MOST PERFECTLY DEVELOPED MAN."

"Dynamic Tension" is the easy, NATURAL method you can practice in your own room—JUST 15 MINUTES A DAY—while your chest and shoulder muscles begin to swell . . . those arms and legs of yours bulge . . . and your whole body starts to feel "alive," full of zip and go!

## FREE My 32-Page Illustrated Book Just Mail the Coupon

Send NOW for my famous book showing how "Dynamic Tension" can make me a new man. 32 pages, packed with photographs, valuable advice, answers many vital questions. This book is a real prize for any fellow. Yet I'll send you a copy absolutely FREE. Just glancing through it may change your life. Rush coupon to me personally: CHARLES ATLAS, Dept. 88, 115 East 23rd St., New York 10, N. Y.



CHARLES ATLAS, Dept. 88, 115 East 23rd St., New York 10, N. Y.

Dear Charles Atlas: Here's the Kind of Body I want:

(Check as many as you like)

- |  |  |
|--|--|
| <input type="checkbox"/> More Weight—Solid—in The Right Places | <input type="checkbox"/> Powerful Arms and Grip    |
| <input type="checkbox"/> Broader Chest and Shoulders           | <input type="checkbox"/> Slimmer Waist and Hips    |
|  | <input type="checkbox"/> Powerful Leg Muscles      |
|  | <input type="checkbox"/> Better Sleep, More Energy |

Send me absolutely FREE a copy of your famous book showing how "Dynamic Tension" can make me a new man. 32 pages, crammed with photographs, answers to vital health questions, and valuable advice. I understand this book is mine to keep and sending for it does not obligate me in any way.

NAME \_\_\_\_\_ (please print or write plainly)

ADDRESS \_\_\_\_\_

CITY \_\_\_\_\_ ZONE \_\_\_\_\_ STATE \_\_\_\_\_

# EARN \$100 A WEEK AND UP

## BE AN AUTO-DIESEL MECHANIC—EARN WHILE YOU LEARN

Many of our graduates earn \$100 a week and up. You learn fast in our school and shops because you learn with tools on real equipment. Experienced instructors explain WHY and show you HOW, then you DO IT YOURSELF. One of the best equipped technical schools in the United States. Thirty-nine years' experience training men. Successful graduates in 48 states and many foreign countries. Approved for veterans. Day and evening classes. Free bulletin—write today.

**NASHVILLE AUTO-DIESEL COLLEGE**  
226 7th Ave. N., Dept. 86, Nashville, Tenn.

## FREE GERMAN STEEL HUNTING KNIFE

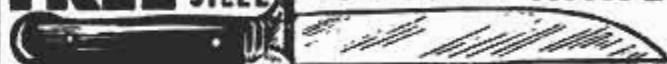

4-INCH BLADE

We give you handiest hunting and fishing knife you've ever had! Has 4-INCH LONG highly tempered steel blade—VERY SHARP! Attractive handle. We send knife FREE to acquaint you with our below-wholesale bargains. Please send 25c for handling. NO LIMIT—but send 25c handling for each knife. Order TODAY! HUNTING KNIFE, Dept. K-328, Box 881, St. Louis, Mo.

## earn \$15 as TAX EXPERT HOUR

Our students earn as much as \$3,000 in 3 short months preparing income tax returns in spare time. Also operate lucrative year-round Business Tax Service. Dignified home-office business. Experience unnecessary. We train you; help you start. State approved home training program. Write today for free prospectus.

UNION INSTITUTE, 68 Hudson, Hoboken 20M, N. J.

## OWN a BUSINESS!



### Earn \$8,750.00 your First Year!

Start part time if you wish. We locally train you, furnish everything to clean and mothproof rugs, upholstery on location by world-wide process. Quickly established. No shop needed. Just 2 average jobs a day bring \$8,750 net profit in year. Employ others and multiply profits. You get National Advertising, Parents' Seal, 25 other regular services. Easy terms. Send today for free booklets.

DURACLEAN CO., 8-168 Duraclean Bldg., Deerfield, Ill.



## WESTERN WEAR and MERCHANDISE

- BOOTS • PANTS
- HATS • CHAPS
- SHIRTS • JEWELRY
- SADDLES and SADDLERY EQUIPMENT

## WRITE FOR FREE CATALOG



P. O. BOX 1785 GH

FORT WORTH, TEXAS



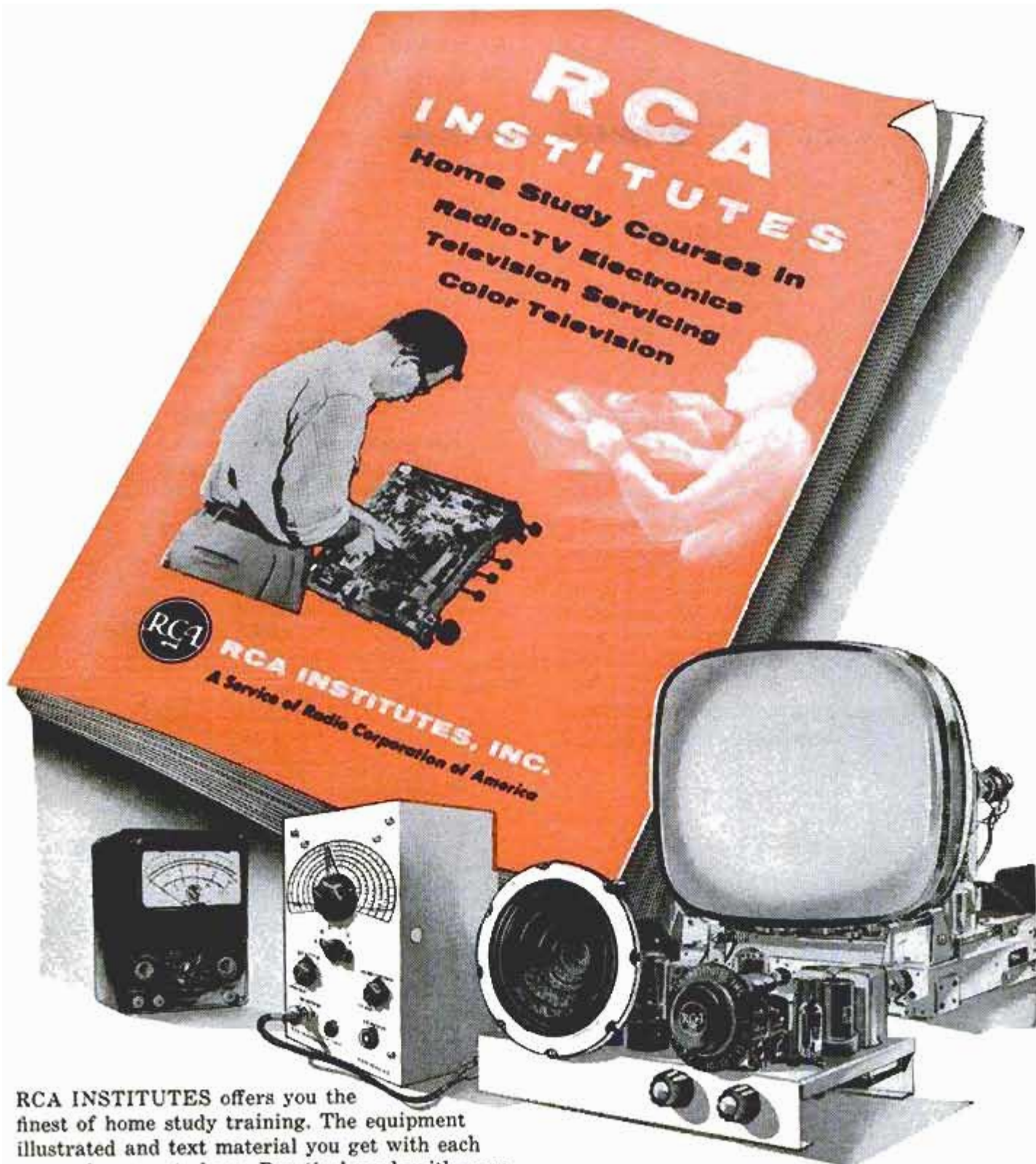

RCA INSTITUTES offers you the finest of home study training. The equipment illustrated and text material you get with each course is yours to keep. Practical work with very first lesson. Courses for the beginner and the advanced student. Pay-as-you-learn. You need pay for only one study group at a time.

**Send for this  
FREE Book Now** 

[ RESIDENT SCHOOL courses in New York City offer comprehensive training in Television and Electronics. Day and evening classes start four times each year. Detailed information on request. ]

**RCA INSTITUTES, Inc. Home Study Dept. PM-88**

A Service of Radio Corporation of America  
350 West Fourth Street, New York 14, N. Y.

Without obligation, send me FREE 52 page CATALOG on Home Study Courses in Radio, Television and Color TV. No salesman will call.

Name.....  
please print

Address.....

City.....Zone.....State.....

Korean Vets! Enter discharge date.....

**CANADIANS** — Take advantage of these same RCA courses at no additional cost. No postage, no customs, no delay. Send coupon to: RCA Victor Company, Ltd. 5001 Cote de Liesse Rd., Montreal 9, Quebec  
To save time, paste coupon on postcard.



# DRAFTSMEN



## CASH BIG PAY CHECKS!

Train Now for  
more success,  
greater security

LEARN AT HOME IN SPARE TIME  
(or at college in Chicago)

Check the want ads in any newspaper—SEE the big-pay opportunities open to you as a draftsman. What's more, you can learn this well-paid, prestige profession at home — quickly, easily! No special talent needed. Get complete, step-by-step Chicago Tech lessons in the mail, spend a few pleasant hours studying each week. In a short time you'll be a well-trained draftsman, ready to take your pick of many good jobs. Act now!



Free Information—Mail Coupon Today!

Get FREE TRIAL LESSON plus information about C.T.C. practical training. Learn what successful Chicago Tech graduates say about high pay and opportunities in drafting. No charge, or obligation.

## CHICAGO TECHNICAL COLLEGE

K-216 Tech Bldg., 2000 So. Michigan Ave.  
Chicago 16, Illinois

Mail me FREE lesson with facts about big opportunities in DRAFTING.

Name \_\_\_\_\_ Age \_\_\_\_\_  
Address \_\_\_\_\_  
City \_\_\_\_\_ Zone \_\_\_\_\_ State \_\_\_\_\_

WANT  
**MORE  
MONEY?**  
GET INTO  
**PHOTOGRAPHY**

Coast to coast, high-paying jobs in photography are waiting for people with that "know-how" to fill them. You can quickly, easily qualify at home with the world-famous NYI Learn-by-Doing Method. Write today for free catalog. Also resident training in N.Y. 48th Year. Approved for Vets.

NEW YORK INSTITUTE OF PHOTOGRAPHY  
Dept. 49 10 West 33 St., New York 1, N.Y.

## A Trade That Pays in Many Ways CLOCK AND WATCH REPAIR

Offered by KCSW'S HOME STUDY Course

Practical, complete training in every phase of clock and watch repair. Many enthusiastic graduates are either employed or in business for themselves. Our method has proved very successful in training those who were not progressing under previous inefficient methods.

**WATCH REPAIR** opens the door to numerous business and trade opportunities. Write today for your copy of "OPPORTUNITIES AHEAD." Courses in Diamond Setting and Engraving also Offered.

**KANSAS CITY SCHOOL OF WATCHMAKING**  
1226 Admiral Blvd. Kansas City 6, Missouri

## High School Course at Home Many Finish in 2 Years

If you did not or cannot finish high school, here is your opportunity. Study in spare time at home. Go as rapidly as your time and abilities permit. Course equivalent to residential school—prepares for college exams. Standard texts supplied. Credit for subjects already completed. Single subjects if desired. Diploma awarded. Be a High School graduate. Start studies now. Free Bulletin. Write today.

**AMERICAN SCHOOL, Dept. HC45**

Drexel at 58th, Chicago 37, Illinois

Accredited Member NATIONAL HOME STUDY COUNCIL



## Print Your Own

Cards, Stationery, Advertising, Circulars, labels, photo and movie titles, church work, tags, etc. Save money. Sold direct from factory only. Raised printing like engraving, too.

### Own a Printing Business

Print for Others, Good Profit. Have home shop. Junior press \$18; Senior \$29 up. We supply everything. Easy rules. Pays for self in short time. Write for free catalog of outfits and all details. **KELSEY PRESSES, C-37 Meriden, Conn.**

**MEN  
PAST  
40**

## Troubled With GETTING UP NIGHTS

Pains in Back, Hips, Legs, Tiredness

Then your troubles may be traced to Glandular Dysfunction . . . a constitutional disease. Neglect of this condition often leads to premature old age and sometimes incurable malignancy.

The Excelsior Medical Clinic has a New Free Book that tells how thousands of men have been successfully treated here at Excelsior Springs for Glandular Dysfunction by NON-SURGICAL Methods. They found soothing relief and a new outlook in the future of life.

This Free Book may prove of utmost importance in your life. Write Today. There is no obligation. **Excelsior Medical Clinic Dept. 6119, Excelsior Spgs., Mo.**

# INVENTORS

WE recommend that you take the following preliminary steps toward patent protection. Make a disclosure of your invention; sign, date and have your disclosure witnessed by two people who understand your invention; authorize us to conduct a preliminary search among previously granted U. S. patents for similar types of invention. We give you a report on the probable patentability of your invention and our recommendation for further course of action.

Let us send you a copy of our instructive booklet, "Patent Protection for Inventors" and our convenient "Evidence of Invention" disclosure form. No obligation.

**VICTOR J. EVANS & Co.** *Merlin M. Evans*  
REGISTERED PATENT ATTORNEY

430-J MERLIN BUILDING, WASHINGTON 6, D. C.





# I'd like to give this to my fellow men... while I am still able to help!

I was young once, as you may be—today I am older. Not too old to enjoy the fruits of my work, but older in the sense of being wiser. And once I was poor, desperately poor. Today almost any man can stretch his income to make ends meet. Today, there are few who hunger for bread and shelter. But in my youth I knew the pinch of poverty; the emptiness of hunger; the cold stare of the creditor who would not take excuses for money. Today, all that is past. And behind my city house, my

summer home, my Cadillacs, my Winter-long vacations and my sense of independence—behind all the wealth of cash and deep inner satisfaction that I enjoy—there is one simple secret. It is this secret that I would like to impart to you. If you are satisfied with a humdrum life of service to another master, turn this page now—read no more. If you are interested in a fuller life, free from bosses, free from worries, free from fears, read further. This message may be meant for you.

By Victor B. Mason

I am printing my message in a magazine. It may come to the attention of thousands of eyes. But of all those thousands, only a few will have the vision to understand. Many may read; but of a thousand only you may have the intuition, the sensitivity, to understand that what I am writing may be intended for you—may be the tide that shapes your destiny, which, taken at the crest, carries you to levels of independence beyond the dreams of avarice.

Don't misunderstand me. There is no mysticism in this. I am not speaking of occult things; of innumerable laws of nature that will sweep you to success without effort on your part. That sort of talk is *rubbish!* And anyone who tries to tell you that you can *think* your way to riches without effort is a false friend. I am too much of a realist for that. And I hope you are.

I hope you are the kind of man—if you have read this far—who knows that anything worthwhile has to be *earned!* I hope you have learned that there is no reward without effort. If you have learned this, then you may be ready to take the next step in the development of your karma—you may be ready to learn and use the secret I have to impart.

## I Have All The Money I Need

In my own life I have gone beyond the need of money. I have it. I have gone beyond the need of gain. I have two businesses that pay me an income well above any amount I have need for. And, in addition, I have the satisfaction—the deep satisfaction—of knowing that I have put more than three hundred other men in businesses of their own. Since I have no need for money, the greatest satisfaction I get from life, is sharing my secret of personal independence with others—seeing them achieve the same heights of happiness that have come into my own life.

Please don't misunderstand this statement. I am not a philanthropist. I believe that charity is something that no proud man will accept. I have never seen a man who was worth his salt who would accept

something for nothing. I have never met a highly successful man whom the world respected who did not sacrifice something to gain his position. And, unless you are willing to make at least half the effort, I'm not interested in giving you a "leg up" to the achievement of your goal. Frankly, I'm going to charge you something for the secret I give you. Not a lot—but enough to make me believe that you are a little above the fellows who merely "wish" for success and are not willing to sacrifice something to get it.

## A Fascinating and Peculiar Business

I have a business that is peculiar—one of my businesses. The unusual thing about it is that it is needed in every little community throughout this country. But it is a business that will never be invaded by the "big fellows". It has to be handled on a local basis. No giant octopus can ever gobble up the whole thing. No big combine is ever going to destroy it. It is essentially a "one man" business that can be operated without outside help. It is a business that is good summer and winter. It is a business that is growing each year. And, it is a business that can be started on an investment so small that it is within the reach of anyone who has a television set. But it has nothing to do with television.

This business has another peculiarity. It can be started at home in spare time. No risk to present job. No risk to present income. And no need to let anyone else know you are "on your own". It can be run as a spare time business for extra money. Or, as it grows to the point where it is paying more than your present salary, it can be expanded into a full time business—overnight. It can give you a sense of personal independence that will free you forever from the fear of lay-off, loss of job, depressions, or economic reverses.

## Are You Mechanically Inclined?

While the operation of this business is partly automatic, it won't run itself. If you are to use it as a stepping stone to independence, you must be able to work with your hands, use such tools as hammer and screw driver, and enjoy getting into a pair of blue jeans and rolling up your sleeves. But two hours a day of manual work will keep your "factory" running 24 hours turn-

ing out a product that has a steady and ready sale in every community. A half dollar spent for raw materials can bring you six dollars in cash—six times a day.

In this message I'm not going to try to tell you the entire story. There is not enough space on this page. And, I am not going to ask you to spend a penny now to learn the secret. I'll send you all the information, free. If you are interested in becoming independent, in becoming your own boss, in knowing the sweet fruits of success as I know them, send me your name. That's all. Just your name. I won't ask you for a penny. I'll send you all the information about one of the most fascinating businesses you can imagine. With these facts, you will make your own investigation. You will check up on conditions in your neighborhood. You will weigh and analyze the whole proposition. Then, and then only, if you decide to take the next step, I'll allow you to invest \$15.00. And even then, if you decide that your fifteen dollars has been badly invested I'll return it to you. Don't hesitate to send your name. I have no salesmen. I will merely write you a long letter and send you complete facts about the business I have found to be so successful. After that, you make the decisions.

## Does Happiness Hang on Your Decision?

Don't put this off. It may be a coincidence that you are reading these words right now. Or, it may be a matter that is more deeply connected with your destiny than either of us can say. There is only one thing certain: If you have read this far you are interested in the kind of independence I enjoy. And if that is true, then you must take the next step. No coupon on this advertisement. If you don't think enough of your future happiness and prosperity to write your name on a postcard and mail it to me, forget the whole thing. But if you think there is a destiny that shapes men's lives, send your name now. What I send you may convince you of the truth of this proverb. And what I send you will not cost a penny, now or at any other time.

VICTOR B. MASON  
1512 Jarvis Ave., Suite M2J  
CHICAGO 26, ILLINOIS



Bob Eaton, says:



HOW WOULD YOU LIKE TO  
"BE BOSS" OF YOUR OWN

**\$10,000** A YEAR

**SHOE BUSINESS?**

(and you can start in spare time!)

No investment, no overhead, no stock to carry—yet you can easily do a \$10,000 business your first year! Steady repeats build your business bigger. If now employed, take orders spare time for *Guaranteed Comfort* dress, work, casual shoes and boots. Over a quarter million pairs in stock. Simple 2-finger demonstration makes shoe selling a snap. Immediate Commissions, Cash Bonus, Paid Vacation, FREE Shoe Offers, Cash Awards.



ORDINARY SOLE IS "STIFF AS A BOARD!" Every step is like a hammer blow. You feel worn out all day.



CHESTER PATENTED AIR CUSHION SOLE is soft—comfortable—flexible. Like "floating on a cloud" all day.

**NEW! RIPPLE SOLE SHOES**  
for Men and Women



THEY "SOFTEN SIDEWALKS"—END FOOT FATIGUE!

180 other smart styles. Revolutionary new leather sole with twice the wear guaranteed! Sizes 4 to 18, widths AAAA to EEEE. Fast direct-from-factory service.

**"TRADE-IN SALE OF OLD SHOES"**

SELLS NEW SHOES FOR YOU!

Only Charles Chester Offers your customers cash for old worn-out shoes! It's dramatic, different, appeals to "trade-in" conscious America—helps you get profitable orders faster. No pick-up or delivery on your part. We handle all details and donate serviceable old shoes to charity.

Send for FREE New Selling Outfit!

Write NOW if you want the security, independence and big steady income of a business of your own. You can't lose!

Write to: Bob Eaton, CHARLES CHESTER SHOE CO.  
Dept. M-583, Brockton 64, Mass.

**MAIL COUPON RIGHT THIS MINUTE!**

Mr. Bob Eaton, CHARLES CHESTER SHOE CO.  
Dept. M-583, Brockton 64, Mass.

I'd like to own a prosperous, independent business with Chester Shoes. Send all equipment I need ABSOLUTELY FREE—without obligation.

Name \_\_\_\_\_

Address \_\_\_\_\_

City \_\_\_\_\_ Zone \_\_\_\_\_ State \_\_\_\_\_



**college graduates get ahead faster!**

You see it in your own city. They have higher incomes . . . advance more rapidly. Grasp your chance for a better life. Industrial growth . . . automation . . . technical advances create career opportunities for engineers, accountants, management experts. Share rewards awaiting college men. Important firms visit campus regularly to employ Tri-State College graduates. Start any quarter in this world-famed college. Approved for veterans.

**Bachelor of Science degree in 27 months**

In Mechanical, Civil, Electrical, Chemical, Aeronautical, Radio (TV-Electronics) Engineering. In 36 months a B.S. in Business Administration (General Business, Accounting, Motor Transport Management majors). Superior students may accelerate. 36-week course in Drafting. Internship program: technical fundamentals stressed; comprehensive courses with more professional class hours. Small classes; personalized instruction. Enrollment limited. Preparatory courses. Beautiful campus. Well-equipped, new and modernized buildings and laboratories. Enter Sept., Jan., Mar., June. Earnest, capable students (whose time and budget require accelerated courses and modest costs) are invited to write Jean McCarthy, Director of Admissions, for catalog and book "Your Career in Engineering and Commerce."



**TRI-STATE COLLEGE**

488 College Avenue • • • Angola, Indiana

Learn to **MOUNT BIRDS**



**Tan SKINS, make up FURS**

Be a Taxidermist. Double your hunting fun. We teach you at Home. Mount Birds, Animals, Fish, Heads, common specimens. Fun and profits. Decorate home and den **MAKE MONEY**. Mount game, tan for others. Big profits in spare time. **WRITE TODAY.**

100 game pictures in **FREE BOOK**

Illustrated, get your copy. It's

Now Free. Send post card. State your AGE.

**FREE BOOK** NORTHWESTERN SCHOOL OF TAXIDERMY

Dept. 2508 Omaha, Nebraska

**250 POWER . . . .**



Telescope Lens Kit

only \$3.49 postpaid

Conquer Space. Explore the Universe. Planets, Moon Craters, New Stars, etc. Complete Lens Kit consists of 80 inch focal length ground and polished objective lens, eyepiece lenses for 50 POWER, 100 POWER, 150 POWER, 200 POWER, 250 POWER, and all necessary lens fittings. Easy to make from simple step by step instructions. Tripod and mount not included. Money back guarantee.

**BUSSE SALES CO., Hartford, Conn., Dept. PM-72**

**FIX OUTBOARD MOTORS**

**POWERMOWERS, AND ALL SMALL 2 & 4-CYCLE GASOLINE ENGINES**

MAKE EXTRA MONEY—or, repair your own equipment and SAVE! Fully illustrated, easy-to-understand, Home Study Course. Write today for FREE information.

**LINCOLN TECHNICAL INSTITUTE**  
SUITE 8E, 472 MARKET STREET, NEWARK 5, N. J.

**\$1 BRINGS YOU \$18**

Discover Flek-Kraft and Earn \$\$\$\$\$ AT HOME

Earn up to \$15.00 per hour spare time. Amazing new Velvet-fiber spray instantly makes any object (Lamps, Radio & TV Cabinets, Figurines, Signs, Auto dash boards, toys, furniture, draperies—anything) worth expensive \$\$\$\$ Prices . . . like magic, you can spray anything with this beautiful new suede-like finish that feels like rich Velvet.

**EARN UP TO \$300.00 PER WEEK SPARE TIME**

Imagine, materials cost only 3c per square foot. (Average TV or radio cabinet can be beautifully sprayed with this startling new 3-dimensional Velvet finish in 15 minutes at a cost of only 34c in materials. Your charge for this job is at least \$10.00.)

**REPRESENTATIVES IN YOUR AREA URGENTLY NEEDED**

Own your own business. Work at home in your spare time. Help fill the huge growing demand for this amazing new beautiful Velvet-fiber finish. Orders come from stores, offices, homes, architects, auto dealers, everywhere. Possible \$20,000,000.00 worth of jobs to be done. Investigate today—be first in your area! Actual samples in 10 Radiant Colors. Booklet of 50 Home Business Opportunities and Confidential Details all sent free! Send No Money. Write: Coast Industries, Los Angeles 61, Calif., Dept. B-B.



# The Mechanism of Mind



## WHY YOU ARE AS YOU ARE—

## and *What You Can Do About It!*

**D**ID you ever stop to think *why* you do the things you do? Have you often—when alone—censured yourself for impulsive urges, for things said or done that did not truly represent *your real thoughts*, and which placed you at a disadvantage? Most persons are *creatures of sensation*—they react to instinctive, impelling influences which surge up within them and which they do not understand—*or know how to control*. Just as simple living things involuntarily withdraw from irritations, so likewise thousands of men and women are content to be motivated by their undirected thoughts which haphazardly rise up in their consciousness. *Today you must sell yourself* to others—bring forth your best abilities, manifest your personality, if you wish to hold

a position, make friends, or impress others with your capabilities. You must learn how to draw upon your latent talents and powers, not be bent like a reed in the wind. There are simple, natural laws and principles which—if you understand them—make all this possible.

For centuries the Rosicrucians (not a religious organization) a world-wide movement of men and women devoted to the study of life and its hidden processes, have shown thousands how to probe these mysteries of self. Renowned philosophers and scientists have been Rosicrucians—today men and women in every walk of life owe their confidence and ability to solve personal problems to the Rosicrucian private, *sensible* method of self-development. To learn what the Rosicrucians can do for you regardless of your present position in life, send **TODAY** for your free copy of the book, "The Mastery of Life." There is no obligation. Please address your request to Scribe Y.L.V.

**The ROSICRUCIANS (AMORC) SAN JOSE, CALIFORNIA, U.S.A.**



# ENGINEERING



Photo of Heald Student in Electrical Laboratory

American Industry Steps Up Its Demand for Trained Engineers. Train Now at Healds

## BACHELOR OF SCIENCE DEGREE, 27 MONTHS

### Degree Courses:

- Radio-Electronic Eng.
- Electrical Engineering
- Highway Engineering
- Mechanical Engineering
- Structural Engineering
- Civil Engineering
- Architecture

### Diploma Courses:

- TELEVISION  Color TV
- Radio-Electronic Tech.
- Industrial Electronic Tech.
- Tool & Die Design
- Architectural Drafting
- Mechanical Drafting
- Structural Drafting

Approved for Veterans

Heald College Ranks **FIRST** West of the Mississippi in "Who's Who in America"

Send for **FREE** Information Heald Engineering College

Est. 1862

Van Ness at Post. Dept. P.M. San Francisco, California

Enroll Now for New Term

NAME \_\_\_\_\_  
 STREET \_\_\_\_\_  
 CITY \_\_\_\_\_  
 STATE \_\_\_\_\_



## STOP TV TUBES from BURNING OUT

**Amazing NEW TUBE-GUARD** Guaranteed To Extend Life Of All TV Tubes

Save \$20 to \$100 Per Year On Costly Tube Replacements

No installation! Just Plug it in!  
\$2.00 only!

Tried and tested and proved 100% effective for three years and longer by a well known TV laboratory. Tube-Guard now in use in thousands of homes. No hook-ups, adjustments or tampering with TV Set. Just plug your Television or Radio Cord into "Tube Guard"; when then plugs into your electric outlet. "Presto!"—it works like a Rheostat. Automatically controls application of electricity, eliminating current surge which causes tube burnout. **FINEST INSURANCE YOU CAN BUY**—Works on - Television Sets - Radio - Hi-Fi equipment - Phonographs - Tape Recorder, etc. **ONLY \$2.00 ppd.** Satisfaction Absolutely Guaranteed or Money Back

NU-TRONICS CO., INC. BOX 66-M, Bogota, New Jersey

Millions have done it so can YOU!



## Stop being SKINNY like I was

Quickly **GAIN 25 LBS.** of HANDSOME, POWER-PACKED MUSCLES like I did

Send for these 5 AMAZING PICTURE COURSES

**All 5 FREE** before \$1 price goes back

1. How to GAIN MIGHTY ARMS
2. How to GAIN A BIG CHEST
3. How to GAIN A MIGHTY BACK
4. How to GAIN POWERFUL LEGS
5. How to GAIN A GRIP OF STEEL

Also **FREE** Photo Book of Strong Men

Send 10¢ for postage for all 6 items

Jowett Institute, Dept. PM-88, 220 Fifth Avenue, N.Y. 11, N.Y.



## New talent needed for Commercial Art ...



Walter J. Wilwerding

### Art Talent Hunt announced by nationally known illustrator

If you like to draw, this Talent Hunt may be your big chance. Artists are needed, nationwide, for advertising, magazine illustrating, cartooning, landscape and portrait painting. Now you can find out—at no cost or obligation—if you have talent worth training for a money-making career. Just take free *Art Talent Test* at home. A simple test of natural talent. Mail coupon today. Get free estimate of your talent.



**ART INSTRUCTION, INC.,** STUDIO 8138 • 500 South 4th Street • Minneapolis 15, Minn.  
 Please send me your *Talent Test*, without cost or obligation.  
 (PLEASE PRINT)

Name \_\_\_\_\_ AGE \_\_\_\_\_  
 Address \_\_\_\_\_ Apt. \_\_\_\_\_  
 City \_\_\_\_\_ Zone \_\_\_\_\_ County \_\_\_\_\_ State \_\_\_\_\_



# BEAT THIS FOR A NEW JOB!

**Pays Up to \$100 a Week to Start—No Selling of Any Kind Required—Car Furnished or Mileage is Paid on Yours—Business Expenses Paid—Jobs Now Open—We Teach You at Home in Spare Time—You Can Qualify in 6 Weeks!**

During the past few years, Auto Claim Adjusting has been having a spectacular growth. Insurance companies everywhere are looking for people who know how to handle this specialized work

—and are prepared to pay a top salary to any man who can fill the bill. Not only do they pay top salaries; in addition, they offer every opportunity for rapid advancement to executive positions and the high bracket incomes that go with them. And in addition—and because experienced help is so scarce—they offer many fringe benefits practically unheard of in many other kinds of businesses.



Eric P. McNair, L.L.B.

## The Terrific Accident Toll Created It!

Why is all this true? You'll find the complete story and the answer in the records compiled by Federal, State and Local authorities. According to these records, more than 25,000,000 auto accidents occurred last year. This means that twenty-five million claims had to be settled—More Than 69,000 Claims Every Day!

But before a single adjustment could be made—before a single claim could be settled—some Claim Adjuster had to investigate the accident!

## Work That MUST Be Done

These investigations cannot be put off. Delays can cost money! Insurance companies cannot afford to let claims drag on—and mount up! They must be settled, because huge reserves of money are tied up by law when claims are unsettled.

It is easy to see why the Claim Investigator plays a leading part in almost every one of the twenty-five million auto accidents that occur each year, and why the demand is so great that there is bound to be a shortage of trained men. There is always a desperate need for trained experts who can take over and make fair and prompt decisions.

## But Money Isn't ALL You Get!

The foregoing are facts...facts you can easily verify if you care to check with any insurance company or any law office. And it explains why even beginners in the field of Claim Investigating can count on a good starting salary of as high as \$400 a month.

But a salary like this is only the beginning. Insurance companies, for example, usually furnish their Claim Investigators a company car and the company pays for the upkeep. Or if he drives his own car the company pays him a mileage allowance to cover operating costs. Nor is that all. Company executives realize the importance of the Claim Investigator's work. Most companies segregate him from the noise of the general office—and install him in a private office of his own—with a private secretary.



## HOW YOUR EXPENSES ARE PAID

When a Claim Investigator's work takes him away from his office, the company pays his expenses while he is gone. These expenses may cover travel—meals—living at good hotels, and include incidentals such as cab fares, tips and business entertainment. On top of all these "extras" you usually get a liberal sick leave allowance, hospitalization insurance, life insurance, a pension plan and many other benefits the average working man never dreamed of.



And remember that the Claim Investigator's life is filled with new experiences and new interests. No two cases are alike! Each day presents exciting new problems, and back of it all is the deep, inner satisfaction of having solved them fairly, justly.

## You Associate with Important People

In this kind of work you meet interesting people, important people, influential people such as lawyers, police officers, judges. Each one is a new adventure. These are the kind of people worth knowing. They are the kind of people who can help you to get ahead faster and those acquaintances often develop into life-long friendships worth far more than financial gain.

## If You Prefer, a Business of Your Own

Even with all these benefits some men prefer to operate their own business. No matter how ideal the job, they want to be "on their own." There are few greater opportunities to do this today than those open to you in the field of Claim Investigating. You can even make your own home your headquarters. You have no office rent to pay—almost no overhead. Your chief expense is the investment of a few dollars for stationery, business cards and office record sheets.

You can even start in your spare time—keeping your regular job until the day arrives when your spare time income is more than the amount of your regular pay. Then you can devote full time to this fascinating work and start to build for a brilliant future—start to win the kind of financial security attained by few men in other fields.



## NO EXPERIENCE NEEDED—SOME HIGH SCHOOL EDUCATION IMPORTANT

It's easy to get into Auto Insurance Claim Investigating and Adjusting, once you have learned basic facts. It does not matter in the least what kind of work you may be doing now. Many men in the most humdrum, small pay jobs have thrown off the shackles that bound them to desk or work bench and quickly learned the fundamentals that made it possible for them to step into big pay jobs as Automobile Claim Adjusters. And all they had to start was a driving desire to get ahead and the determination to see it through!

## SEND TODAY FOR FREE PORTFOLIO

I have prepared a special Portfolio in which I explain carefully to you my "20 Steps to Success as an Automobile Insurance Claim Adjuster." It tells just what to do to get into this fascinating, fast-growing business. There is no charge for this Portfolio—now or any other time. No salesman will call and you will not be under the slightest obligation by sending for it. Mail the handy coupon below to Eric P. McNair, President, Liberty School of Claim Investigating, Dept. 98, Libertyville, Illinois.



**MR. ERIC P. McNAIR, President, Dept. 98  
Liberty School of Claim Investigating  
LIBERTYVILLE, ILLINOIS**

Please rush me your Portfolio on the "20 Steps to Success" that clearly explains how I can quickly qualify as an Automobile Insurance Claim Adjuster. It is clearly understood that no salesman will call on me, and that everything you send me now is absolutely FREE, and places me under no obligation whatsoever.

My Age.....

My Name.....  
(Please Print)

Address.....

City..... Zone or R.D..... State.....





**YOU**  
can  
acquire

**LAW NIGHTS AT HOME!**  
**LL. B. DEGREE**

LaSalle's famous Law Library—used as reference in many Law libraries and Law offices—has enabled thousands to master Law surprisingly fast, in spare hours at home, for business and professional advancement.

These 14 remarkable volumes, compiled by leading professors and lawyers, cover the whole basic field of Law in condensed, orderly, simplified manner.

You advance rapidly with this great library, plus special lectures furnished. We guide you step-by-step with personalized Problem Method of instruction . . . you learn by doing—handling legal problems—not by memorizing rules.

Send for two FREE booklets, "Law Training for Leadership," and "Evidence," answering questions about Law and its value to you, and telling how LaSalle Law graduates are winning rapid advancement in business and public life. Mail coupon below. No obligation.

**LA SALLE EXTENSION UNIVERSITY**  
**A Correspondence Institution**

417 S. Dearborn St. Dept. 864L Chicago 5, Ill.

Send me your two FREE booklets described above, without obligation.

Name.....Age.....

Street.....

City, Zone & State.....

**Shrinks Hemorrhoids**  
**New Way Without Surgery**

**Science Finds Healing Substance That Relieves Pain—Shrinks Hemorrhoids**

For the first time science has found a new healing substance with the astonishing ability to shrink hemorrhoids and to relieve pain—without surgery.

In case after case, while gently relieving pain, actual reduction (shrinkage) took place.

Most amazing of all—results were so thorough that sufferers made astonishing statements like "Piles have ceased to be a problem!"

The secret is a new healing substance (Bio-Dyne\*)—discovery of a world-famous research institute.

This substance is now available in suppository or ointment form under the name Preparation H.\* Ask for it at all drug counters—money back guarantee. \*Reg. U. S. Pat. Off.

**GROW MINIATURE TREES**  
**FREE! SEEDS & PLAN**



New Fascinating HOBBY or HOME-BUSINESS OPPORTUNITY! Learn little-known techniques for growing living "Ming" Trees only inches high. Beautiful Elm, Cherry, Orange, Cypress, Peach, etc., that BLOSSOM AND BEAR TINY TASTY FRUIT. Help Fill demand for these sensational dwarfed Trees. FREE SEEDS (8 kinds) and Plan. State your age. Write:

MINIATURE TREE NURSERIES, Dept. K-8, (Home-Growers Division) Gardena, Calif.

**\$2.95 OR 2 FOR \$5.00!**



TESTED AND GUARANTEED  
Write for free list on all types of telephones. Shipments F.O.B. Simpson, Pa.

TELEPHONE ENGINEERING CO., Dept. 888, Simpson, Pa.



**Exclusive Double-Bearing HEAVY-DUTY PUMPS**

IRRIGATE • DRAIN • CIRCULATE • SPRAY  
Use 1/4 HP motor or larger . . . 1 HP for up to 7,500 GPH; 1,000 GPH 60' high; or 3,000 GPH from 25' well.

1 1/2" inlet; 1" outlet. Stainless shaft. TYPE X-2 oil-less bronze bearings. Won't rust. . . . **\$10.95**

TYPE XB—Ball bearing model. . . . **\$12.95**

Postpaid if cash with order. Rush your order today

**MONEY BACK GUARANTEE**  
Centrifugal and Gear Pumps in All Sizes

**LABAWCO PUMPS, Belle Mead 2, N. J.**

**LEARN MEAT CUTTING AT NATIONAL**  
**Pay After Graduation**



**National School of Meat Cutting, Inc., Dept. 50-6, Toledo 4, Ohio**

Send me your FREE school catalog on National Training at Toledo in Meat Cutting, Meat Merchandising and Self Service Meats. No obligation. No salesman will call.

Name.....Age.....

Address.....

City.....State.....

Approved for Veterans

The steady dependable trade of Meat Cutting taught easily in 8 short weeks. YOU LEARN BY DOING under actual meat market conditions in big modern school at Toledo.

For beginners or men with experience. Get a profitable store of your own. Remember, PEOPLE MUST EAT! Big pay jobs. Free employment help. Thousands of successful graduates.

Buying, cutting, percentage, pricing, advertising, selling, etc. A complete retail meat education. National School established 35 years. Get National training NOW. Pay your tuition in easy weekly payments after you graduate. Send coupon for FREE 52 page school catalog — TODAY. G.I. approved.



## Be a Drain Tile Manufacturer

T-5

A manufacturer in Ohio made 167,000 tile in his first year of operation—924,000 in his sixth year. A plant in Wisconsin averages 3 million annually. It's a business where the markets are broad and the profit-potentials truly amazing.



Champion—  
Superfine  
Concrete Tile

This can be  
Your Big  
Opportunity

Champion concrete drain tile are used for farm drainage—road building—drain fields—building construction. Champion machine makes world's best tile—dense, strong, truly round. Yet at costs so low that Champion manufacturers always have a price advantage. Makes all sizes from 3' to 12'. Simple—compact—requires little space—easy to operate. Available on 3-year payment plan. Write for free Champion Book and other valuable information.

W. E. DUNN MFG. CO.

522 W. 24th St., Holland, Mich.



## CABINET MAKING

### LOW COST HOME TRAINING COURSE FOR BEGINNERS & ADVANCED CRAFTSMEN

Make money. Learn skills and secrets of fine woodworking and tool use. Professionally prepared shop method training tells and shows how. Covers everything. Easy to master.

### INTERSTATE TRAINING SERVICE

DEPT. F3, PORTLAND 13, OREGON



Write for  
Free Booklet

## HYDRAULIC JACK REPAIRS

### Earn While You Learn at Home

Millions of jacks in gas & auto-service stations, trucks, body-shops, riggers, factories, farms need servicing. We show you HOW—easy step by step directions—what tools to use. EARN UP TO \$5 an hour, in spare time, in your own basement or garage. Start your own business NOW. Write for folder  $\pm$  PM-8 & free bonus offer.

Institute of Hydraulic Jack Repair

P.O. Box 50, Bloomfield, N. J.



## RUBBER STAMPS

Finest Quality Supplies and Equipment for manufacturing rubber stamps.

Write for Price List.

LOUIS MELIND CO.

3526 N. Clark

Chicago 13



## WAR SURPLUS BARGAINS

\$500,000.00 INVENTORY  
for QUICK LIQUIDATION

Surplus items—hundreds of them for home, shop, factory, farm and outdoor use. New items, used items, reconditioned items—all at tremendous savings—all priced for quick sale.

Page After Page of Values

This big catalog shows page after page of amazing money saving values. Write for your copy today. Send 10c to cover postage, mailing, etc. Write today! SEND TODAY FOR YOUR COPY.

**STARK'S** 10c  
212 W. Madison St.  
Dept. PM-388,  
CHICAGO 6, ILL.

# TELEVISION RADIO • ELECTRONICS

These two **FREE** books  
will show you how

You get all information by mail.  
NO SALESMAN WILL CALL



19 BIG KITS  
YOURS TO  
KEEP



SHOP-METHOD HOME TRAINING IS—  
BETTER—Proved and tested in  
Resident School Shops  
and Laboratories

MORE COMPLETE—You learn  
ALL PHASES of Television-  
Radio-Electronics

LOWER COST—You get Servicing,  
Communications, and Advanced  
TV in One Master Course at  
One Low Tuition.

## TOP PAY... UNLIMITED OPPORTUNITIES LIFETIME SECURITY CAN BE YOURS!

You are needed in the Television, Radio, and Electronics industry! Trained technicians are in growing demand at excellent pay—in ALL PHASES, including Servicing, Manufacturing, Broadcasting and Communications, Automation, Radar, Government Missile Projects, and many others.

NATIONAL Technical SCHOOLS HOME TRAINING trains you at home for business of your own, good jobs in industry, and many technical job opportunities leading to supervisory positions.

YOU LEARN BY BUILDING EQUIPMENT WITH KITS AND PARTS WE SEND YOU—plus new TV picture tube. All at no extra charge. FREE book gives you all the facts. Don't wait. Mail coupon TODAY!

EARN AS YOU LEARN. We'll show you how to earn extra money right from the start. Many students pay for their course—and more—while training. So can you!

## YOU GET...

- Friendly Instruction and Guidance
- Job Placement Service
- Unlimited Consultation
- Diploma—Recognized by Industry
- EVERYTHING YOU NEED FOR SUCCESS!

SHOP-METHOD HOME TRAINING  
COVERS ALL PHASES OF INDUSTRY

1. Television, including Color TV
2. Radio AM & FM
3. Electronics for Guided Missiles
4. Sound Recording and Hi-Fi
5. FCC License
6. Automation and Computers
7. Radar & Micro-Waves
8. Broadcasting and Communications

Accredited by National Home Study Council

## NATIONAL TECHNICAL SCHOOLS

WORLD-WIDE TRAINING SINCE 1905

4000 SO. FIGUEROA ST., LOS ANGELES 37, CALIF., U. S. A.

Approved for GI Training

### RESIDENT TRAINING AT LOS ANGELES

If you wish to take Resident Training at Los Angeles in our big, modern Shops, Labs, and Studios, check special box in coupon.

## NATIONAL TECHNICAL SCHOOLS

WORLD-WIDE TRAINING SINCE 1905

GET FAST SERVICE—MAIL NOW TO  
NATIONAL SCHOOLS, DEPT. RB-88  
4000 S. Figueroa St., Los Angeles 37, Calif.

Rush free TV-Radio "Opportunity" Book and sample lesson.  
No salesman will call.

Name \_\_\_\_\_ Age \_\_\_\_\_  
Address \_\_\_\_\_  
City \_\_\_\_\_ Zone \_\_\_\_\_ State \_\_\_\_\_

Check here if interested ONLY in Resident Training at Los Angeles.



**Now... 1/2 price!**

# ADDING MACHINE

IT ADDS, SUBTRACTS AND CALCULATES TO

# ONE BILLION!

NOT \$3.95  
**FREE**  
HOME TRIAL!

**1<sup>98</sup>**

SAVE 50% on newest, finest super-speed Adding Machine. Why pay \$3.98 and 4.98 for models that add to one million when Wizard Calculator adds, subtracts, calculates to ONE BILLION—one thousand times higher—yet costs only \$1.98! 100% accurate. Never makes mistake. Never needs repair, adjustments or lubrication. 10-year replacement guarantee. Not cardboard, plastic or tin. Machine's mechanism of Korium Steel. Has clearing lever that clears machine to zero. Works silently. Even child can operate it. Press numbers; see totals pop into view like cash register. Save dollars at markets, keep running total of what you spend. Know your bill BEFORE you get to check-out counter. Comes ready to use, with aluminum stylus. 101 uses. Fits pocket or purse. Slim, modern design. Imported from West Germany. **SOLD ONLY BY MAIL, ONLY BY US!** Rush \$1.98 cash, check or M.O. for prompt FREE delivery anywhere in U. S. or Canada. COD's plus fee & postage. Money back guarantee. Hurry. New shipment from Germany will cost more.



**THORESEN Inc., Dept. 6-H-118**  
885 WATER STREET NEW YORK 2, N. Y.

**Buy Surplus DIRECT FROM UNCLE SAM**  
**LOW AS 1¢ ON THE DOLLAR!**



Ever check prices in Gov't Surplus stores? Terrific bargains, but you can beat them a mile by ordering direct. Exciting Surplus Reports list latest U.S. offers, tell exactly where and how to order—one item or a thousand items. It's simple, it's easy, no red tape. Accuracy is guaranteed!

**FANTASTIC BARGAINS IN THINGS YOU NEED**  
**Almost Anything FOR HOME, FARM, SHOP, OFFICE**

Savings beyond belief! Pennies for products costing dollars elsewhere—many never uncrated! Autos, furniture, sporting goods, electronic equip't, machinery, etc. Tractors have sold for \$75, typewriters \$7, motors 56¢. Save, save, save—or re-sell for huge profits. \$10 purchase may bring you \$100, \$500, even more! Rush \$2 for the next 3 Monthly Reports, or \$1 for the current issue. Fast action gets the best bargains!

**SURPLUS CLEARING HOUSE, Dept. B-178**  
1038 South La Brea Ave., Los Angeles 19, California

## RECESSIONS? LAYOFFS? not for **LOCKSMITHS**

**LOCKSMITHING** is not affected by recessions, layoffs or strikes. Get into this well paying, uncrowded field now. Learn from experts in spare time. Make money while learning. All special tools, equipment supplied. Low rates. Illustrated, easy lessons.

**INSTITUTE OF LOCKSMITHING, Dept. P-105**  
150 Park Ave. East Rutherford, N. J.

Lic. by N. J. State Board of Ed. Apprd. for Vets. **SEND FOR FREE BOOKLET**

## Secrets of **VENTRILOQUISM** Now Revealed!

Easy to learn in 60 to 90 days with our Home Study Course. **RESULTS GUARANTEED.** Make Money! Be Popular! Have Fun! Big Opportunity! Radio, Television, Stage Appearances! For FREE information regarding price and terms WRITE. You must state your age. Dummy Catalog 25¢. **MAHER HOME COURSE OF VENTRILOQUISM** Box 36, Studio PM-8, Kensington Station Detroit 24, Michigan

## STUDY TO BE A DOCTOR of Psychology or Metaphysics

Obtain a Pa.D., Ms.D., or Ph.D. Be a Teacher, Lecturer or Accredited Practitioner. Teach others how to achieve Health, Happiness and Contentment. Chartered by State. Correspondence Courses only. Write for FREE book telling how.

**THE NEOTARIAN FELLOWSHIP**  
Desk 8, Pickwick Building Kansas City 6, Missouri

## LEARN CODE THE E-Z WAY

New... E-Z CODE Jr. uses electric pencil and printed-wiring. Draw electric pencil down lettered slot and buzzer sounds dots and dashes. Operates on single flashlight battery. At your local radio parts distributor. Write for free code booklet and name of your nearest store.



DEPT. EC  
**AEROVOX CORP., New Bedford, Mass.**

**I Made \$14,839**  
in 1 Year  
**SERVICING RADIATORS!**

Are you earning under \$8,000 a year? Many now making \$10,000-\$12,000-\$15,000 a year servicing auto-truck-tractor radiators the Inland way. Easy to learn. Inland, largest radiator equipment mfg. offers complete package—equipment, merchandising, "Pays-for-itself" financing, free training. \$305 down for equipment starts you. Profitable dept. for garage or service station. Write **INLAND MFG. CO., Dept. PM-8, 1108 Jackson St., Omaha 2, Nebr.**

## BE A CLAIM INVESTIGATOR



**INVESTIGATE ACCIDENTS!** Many earning \$750 to \$1000 a month. Thousands of insurance companies, airlines, steamship lines and Government Offices need Claim Investigators. Also big opportunities for your own spare time business. We train you at home. National Placement Service FREE of extra charge. Bill King writes: "Your course has paid off for me with large earnings. You can quote me—your Adjuster Training Course is worth many times the cost." Write TODAY for FREE book.

**UNIVERSAL SCHOOLS**  
University Park, Dept. PM-8, Box 8202, Dallas 5, Texas

## ACCOUNTANT BECOME AN EXPERT

**PREPARE NOW FOR A TOP PAYING POSITION IN THE ACCOUNTING FIELD.**

The demand for skilled accountants—men who really know their business—is increasing. National and state legislation is requiring of business much more in the way of Cost Accounting, Business Law, and Federal Income Tax. Men who prove their qualifications in this important field are promoted to responsible executive positions.

**SEND FOR FREE SAMPLE LESSON**  
Knowledge of bookkeeping unnecessary. We train you from ground up, or according to your individual needs. Low cost; easy terms.

Send name and address on the lines below for sample lesson and free illustrated book describing the LaSalle Accounting training and the opportunities in this highly profitable field.

**LASALLE EXTENSION UNIVERSITY**  
*A Correspondence Institution*  
417 S. Dearborn St., Dept. 864WA, Chicago 5, Ill.

Name.....  
Address.....  
City.....Zone.....State.....



Train for a **GOOD JOB**  
and a **REAL FUTURE** in

# Electricity Electronics

in the great shops of  
**COYNE**

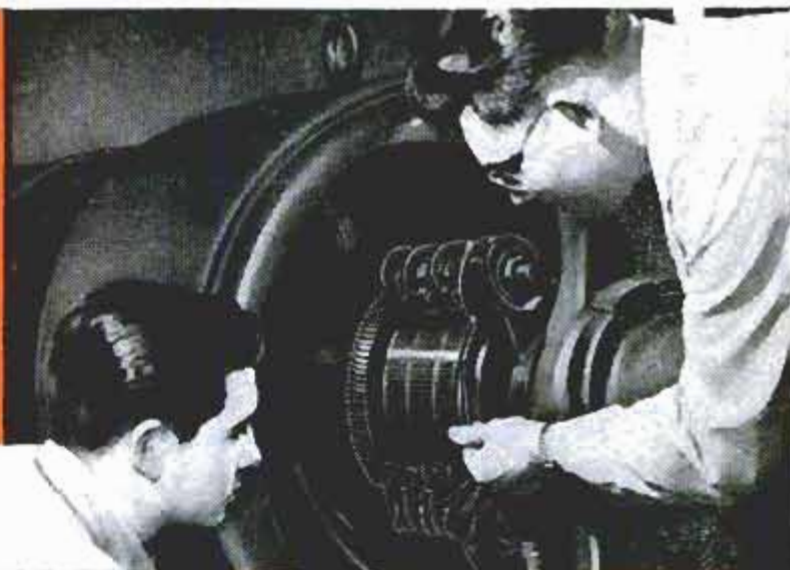

Largest, Oldest and Best Equipped School of its Kind in U.S. Train the Coyne way for a better job in *Electricity-Electronics*—a field that offers a world of opportunities now and in the years ahead. In industry—in the home—New developments and fabulous growth are creating increasing job opportunities. **AUTOMATION ELECTRONICS**—one of the more recent applications of Industrial Electronics to manufacturing processes—promises to create additional demands for trained Electrical-Electronics men such as we have never seen. Coupon brings details. **LARGEST, OLDEST AND BEST EQUIPPED SCHOOL OF ITS KIND IN U.S.**

**TRAIN IN CHICAGO SHOPS**—Practical work plus technical training. No advanced education or previous experience needed. Lifetime Employment Service to Coyne Graduates.

**START NOW—PAY LATER**. Training offered to **VETS** and **NON-VETS** alike. New liberalized credit terms and Finance Plans. Part-time employment service to students.

**COYNE ELECTRICAL SCHOOL**  
**CHARTERED NOT FOR PROFIT**  
500 S. Paulina Street, Chicago, Dept. CB-3E

**MAIL COUPON FOR FREE BOOK.** "Guide to Careers" gives you all the facts, answers your questions. All information will come by return mail. No obligation and no salesman will call, so send coupon now!



Coyne Electrical School, Dept. CB-3E  
500 S. Paulina St., Chicago 12, Ill.  
Send **FREE BOOK** and details of the training you offer in Electricity-Electronics.

Name \_\_\_\_\_

Address \_\_\_\_\_

City \_\_\_\_\_ State \_\_\_\_\_

(I understand no Salesman will call.)

## LAW FREE BOOK THE LAW TRAINED MAN

Write today for a **FREE** copy of illustrated law book, "THE LAW-TRAINED MAN," which shows how to earn the professional Bachelor of Laws (LL.B.) degree through home study of the famous Blackstone Law Course. All necessary books and lessons provided. Moderate cost; convenient monthly terms. Write for **FREE** law training book today. **Blackstone School of Law, 307 N. Michigan Ave. Dept. 50-C, Chicago 1, Illinois**  
Founded 1890



## HIGH SCHOOL DIPLOMA

Earn a High School Diploma at home! Prepare for better job, more pay. Study in spare time. No classes. Materials furnished. Certified teachers. Valuable diploma awarded. Write Today for Complete Information  
**SOUTHERN STATES ACADEMY**  
Box 144A Sta. E Atlanta, Georgia

## MONEY in WORMS

Sell 20,000 fishworms per week @ \$4 per 1000 from a bed 3 feet wide and 8 feet long. We teach you how to raise and where to sell fishworms and crickets. Write for free literature.  
**CARTER WORM RANCH, PLAINS, GEORGIA**

Better Than  
Your Own

**SHOE STORE  
AT HOME**



Two-Eyelet  
Hit With  
Cushioned  
Comfort

No investment, no experience needed. Just show magic cushion comfort to friends, neighbors, co-workers. Advance commissions to \$4.00 a pair, plus Cash Bonus, Paid Vacation, \$25.00 Reward Offer. Outstanding values for men, women, children. Money back guarantee. Shoe samples supplied without cost. Write **TODAY** for **FREE** new \$4 page catalog and full details.

**TANNERS SHOE CO., 861 BROCKTON, MASS.**



# 1000 AND 1 USES!

*Pliobond* by  
**GOOD YEAR**

Super-glues "anything to anything" — super-quick!

At chain, hardware and hobby stores everywhere.

Pliobond—T.M. The Goodyear Tire & Rubber Company, Akron, Ohio



BE A CONSTRUCTION EQUIPMENT

# MECHANIC



Greer trains you to earn top pay. Complete Mechanics Course covering Diesel engine transmissions; torque converters; fuel injection systems; track assemblies; final drive assemblies; steering systems; idlers; rollers; power transfer systems; cable control systems; hydraulic control cylinders & welding pertaining to heavy equipment such as bulldozers, scrapers, loaders, off-highway trucks, etc. Course time — 540 hours — 10 weeks. Convenient payment plan. Write for details.

## OPERATE EARTH MOVING EQUIPMENT

Wanted: Men to operate bulldozers, trucks, loaders & scrapers (4 wk.—200 hrs.) \$375; motor graders & compactors (4 wk.—200 hrs.) \$375; 7 wk. combination of above (350 hrs.) \$650; cranes, dragline & backhoe operation (4 wk.—200 hrs.) \$375; construction-type dump truck, trailer dump & off-highway truck course (2 wks.—100 hrs.) \$195. All courses include preventive maintenance—Special weekend courses available—60 miles from Chicago—Economic housing & board — Write for details NOW.

Please send FREE information on

- CONSTRUCTION EQUIPMENT MECHANICS TRAINING  
 HEAVY EQUIPMENT OPERATORS TRAINING

Name \_\_\_\_\_ Age \_\_\_\_\_  
 Address \_\_\_\_\_ Phone \_\_\_\_\_  
 City \_\_\_\_\_ State \_\_\_\_\_



**Greer TECHNICAL INSTITUTE**  
 ATT. M. H. Hutch, Box 278, Braidwood, Ill.

## FREE! U.S. STAMPS PLUS COMPLETE U. S. CATALOG



Sensational Get-Acquainted Offer — From World's Largest Stamp Firm! FREE . . . scarce genuine postage stamp, as illustrated, picturing first U.S.A. (issued in 1847) PLUS Big collection of 30 all-different United States-19th century, valuable \$1 stamp, etc. PLUS collection beautiful Commemoratives including American Revolution, Wild West, 1893 Columbian, many others. EXTRA: Big Bargain Catalog of all U.S. Postage issues; other exciting offers; Stamp Collector's Guide. Send 10c to help cover mailing costs. Mail Coupon Today!

**H. E. HARRIS & CO.**

4198 Transit Building, Boston 17, Mass.  
 Rush my United States stamps and other offers. I enclose 10c for mailing expenses.

Name ..  
 Address ..  
 City & State ..



## SHEET METAL MACHINES

Brakes form angles, locks, pans, etc. Quick eccentric clamp. All steel construction.  
 15"—16 gauge steel.....\$28.00  
 36"—22 gauge steel.....\$37.00  
 48"—24 gauge steel.....\$52.00  
 Floor stand.....\$ 8.00  
 15"—24 gauge Folder.....\$17.50  
 36" Pan and Box brake.....\$60.00  
 1/4 x 3 Adjustable Bender.....\$14.00  
 16 gauge 7" Bench Shear 3 adj. gauge.....\$16.50  
 30"—20 gauge Curve Former.....\$12.00

ORDER DIRECT OR SEND FOR FREE CATALOG  
**VYKE MFG. CO., P-4158 Jason St., Denver 11, Colo.**



## BARBELLS

100 POUND SET \$11.80

Extra Plates Only 10c Pound

140-Pound, CHROME DELUXE Barbell-Dumbbell set only \$18.80. This is our feature set and is the finest ever manufactured.

Training with adjustable weight is the BEST way to keep fit; the ONLY way to develop great strength and a perfect body. As the oldest and best equipped barbell company, BUR gives value and prices no one can equal.

SEND FOR FREE CATALOG.

**BUR BARBELL CO.**  
 Lyndhurst 9, New Jersey



## For Many Uses! Metal Turning Lathe

Only \$49.95

F.O.B. Lansing, Ill.  
 15 1/2" bed with 4 1/2" swing.  
 7" between centers.  
 Satisfaction Guaranteed.  
**FREE FOLDER**  
 Write for it today!

Rosemoor Manufacturing Co.  
 Box 147J, Lansing, Ill.

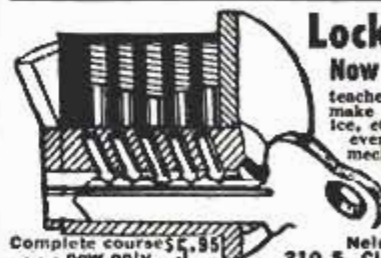

## Locksmithing AND KEY MAKING

Now Made Easy! Practical up-to-date course

teaches you how to pick locks, de-code, make master keys, repair, install, service, etc. New self-instruction lessons for every handyman, homeowner, carpenter, mechanic, service station operator, fix-it shop, hardware dealer, gunsmith. 28 easy illustrated lessons. Full price only \$5.95 postpaid; or C.O.D. plus postage. Satisfaction or refund guaranteed.

Complete course \$5.95 . . . now only

Nelson-Hall Co., Dept. MS-2  
 210 S. Clinton Chicago 6, Ill.

## Own and Play the ACCORDION

for fun...for popularity...for profit!  
 Buy direct at amazing savings from America's biggest importer of fine Italian made accordions. **5 DAY FREE TRIAL!** Easy Terms. Free Lessons—Easy to learn. Personalized selection service. Trade-ins accepted. Write today for big Color Catalog and our low wholesale prices. **FREE!** Accordion Manufacturers & Wholesalers Outlet  
 2003 West Chicago Avenue • Dept. R-88 • Chicago 22, Illinois

## Would You Like to Make \$1,000 A MONTH?

That's what Stanley Hyman made selling the amazing new Presto Fire Extinguisher! Many others "cleaning up"—so can you! Amazing tiny new extinguisher ends fires fast as 2 seconds. Guaranteed for 20 years! Sells for only \$4.95. Write for free sales kit.  
**MERLITE INDUSTRIES, Presto Div.,**  
 114 E. 32nd St., Dept. P-15M, New York 16, N. Y.

## LEARN WHILE YOU SLEEP!

Improve mind, body and personality with amazing new university-tested method. \$2.00 rushes 100 page fact-filled illustrated book of complete instructions. Satisfaction guaranteed. Free folder on request. Sleep-Learning Research Ass'n. Box 24-N Olympia, Wash.



# NOW! EARN GOOD MONEY IN TV REPAIR ... *within one short week!*

**ALL 3 FREE!**

**COLLECT \$5 TO \$10 PER CALL—HANDLE ANY JOB, ANY SET**

Now, after 5 years research—a streamlined professional training technique that *obsoletes all others!* Within 7 days you achieve full knowledge and ability to earn \$5 to \$10 per call... make \$150 a week. Handle any TV set with confidence! Yes—and without paying big prices for training, or studying long months! Developed by electronics scientists in cooperation with major TV mfr's., the new *Symtronic* method is the most practical ever devised! **FREE SAMPLE LESSON** gives amazing proof! Use it on your set or a friend's—repair it—convince yourself you can make big money *immediately* in your own TV business! Write today for **FREE LESSON** and details on how to get 1000 *your-name-and-address* business stickers **FREE**. too! Hurry—Offer limited!

ELECTRONIC ENGINEERING, Dept. B-178, 1038 South La Brea, Los Angeles 19, California



## ... Swiss or American

Unique Sweeney System starts you making repairs right away. Develops your skill step-by-step. Teaches modern methods... professional short cuts. Learn by personal attendance or spare time home study. Free Sample Lesson. No obligation. Write today!

**CHICAGO SCHOOL OF WATCHMAKING**

2330 Milwaukee, Dept. 188, Chicago 47, Ill.

## Finish HIGH SCHOOL AT HOME

Complete 4 Yrs. in 12 Months

Learn More! Earn More! Enter professional or technical schools. Advance Socially. Live a Happier, Fuller Life. Individual Courses or complete schedule. **WRITE FOR SCHOOL BULLETIN.**

**ACADEMY FOR ADULTS**

30 W. Washington, Dept. PM-88, Chicago, Ill.

## MAKE TREMENDOUS PROFITS

Have fun! Earn Big Money! Cast plaster figurines, bookends, plaques, novelties at home in your spare time with X.L. rubber molds! **NO EXPERIENCE NEEDED!** Molds and rubber for 3 molds, only \$1.50 ppd. Send 25c (refunded with order) for 40 page catalog now!

**PLASTIC ARTS STUDIO** 3403 S. MADISON, DEPT. PM2 MUNCIE, INDIANA

## YOU CAN EARN BIG PAY

Have Job Opportunities in **DRAFTING**...

Read "The Engineering Draftsman," a career guidance article by Popular Mechanics Magazine Pages 210 and 211

**SALE 20 X 50**  
REGULARLY \$74.50  
SAVE \$44.55!

High powered, whisper-weight (27 oz.) color corrected, Achromatic binoculars. 7" high! EZ to hold. EZ to focus. Instant finger-tip adjustment. Made in Japan. *Including case and straps!*

Hard Coated throat. **\$29.95**

USE 30 DAYS. If not satisfied return for refund. Add 10% Tax

Add \$1 postage, handling.

UNITED BINOCULAR CO., 8043 S. Western,

CRF-2408, Chicago 20. DEALERS WANTED



c.o.d.'s require \$2 deposit.

## Don't Neglect Slipping FALSE TEETH

Do false teeth drop, slip or wobble when you talk, eat, laugh or sneeze? Don't be annoyed and embarrassed by such handicaps. **FASTEETH**, an alkaline (non-acid) powder to sprinkle on your plates, keeps false teeth more firmly set. Gives confident feeling of security and added comfort. No gummy, goeey, pasty taste or feeling. Get **FASTEETH** today at drug counters everywhere.

## Midget Pocket Size Radio

**TAKE WITH YOU WHEREVER YOU GO!** Plays day & night forever at no expense. No batteries. No electric connections. Clip to metal object and start listening. Hearing-aid type speaker phone. Full broadcast band tuner. New germanium diode rectifier replaces tubes. Self-powered. Plastic case smaller than cigaret package. Lifetime guarantee. **Complete. Ready to Play. \$3.99**



## High Voltage Electric Shocker

Gives a real, powerful electric shock. High voltage electric **GENERATOR**. Use for fun, experiments, lights, etc. Used phone generator. Costs \$20 new. Good working condition. 5-lbs. Postpaid... **\$3.95**



## Catalog of 3100 Novelties 10c

Send 10c for amazing catalog of novelties, live animals, scientific supplies, hobbies, funmakers, planes & boats, looms, magic tricks, joke articles, unusual seeds, gads, get timesavers, cameras, optical goods, projector movies, lucky jewelry, religious novelties, disguised musical instruments, stamps, coins, puzzles, fortune tellers, radios, auto & bike accessories, telescopes, magnifiers, compasses, banks, smokers' gadgets, artists' supplies, printing sets, engines, motors, shockers, knives, billfolds, guns, rifles, sports, books, games, plants, etc. Send 10c (3 for 25c—get for friends!). **JOHNSON SMITH & CO. Dept. 657 Detroit 7, Michigan**

## 12-Foot BULL WHIP

**HARD HITTING! LOUD CRACKING!** Experts knock ashes off cigars. Yank people off feet. Used by trainers, ranchmen. Loud cracker like shot-gun blast. 4-ply hand plaited all leather. With loop handle.

6-ft. \$1.98. 8-ft. \$2.69. 10-ft. \$3.29. 12-ft. \$5.45.

Johnson Smith Company, Dept. 657, Detroit 7, Mich.

## BIG BOOM CARBIDE CANNON

**\$4.40**

Sounds like dynamite blast! **BRILLIANT FLASH!** Mighty roar echoes for blocks. Fine July 4th noisemaker, starting gun, celebrations, etc. Safe. No recoil. Hundreds of shots for few cents. Uses carbide. Fast firing. Attractively made of heavy cast iron. Money back guarantee. 9-in. Cannon

\$3.95 plus 45c post. SEND \$4.40. 17-in. \$8.95 plus 55c post, send \$9.50. Ammunition 39c tube (500 shots); 3 tubes \$1.00 postpaid. **JOHNSON SMITH CO. DEPT. 657 Detroit 7, Michigan**

## ENGINEERING DEGREE IN 27 MONTHS

### B. S. DEGREE IN

**Aeronautical, Chemical, Civil, Electrical, Mechanical and Electronic Engineering (inc. Radio and TV)**

Also B.S. DEGREE in 36 mo. in Mathematics, Chemistry, Physics (inc. Nuclear Physics), Engineering Science prep. courses. Thorough, practical program. Individualized instruction emphasized. Government approved for G.I.'s.

### Keeping pace with progress in science and engineering

Spacious campus; 20 bldgs.; dorms, gym, playing field. Modern, well-equipped labs including new physics lab and wind tunnel. Low tuition. New terms start quarterly. Enter September, December, March or June. Big demand for graduates. Students from 43 states and 49 foreign countries. Many earn a major part of their college expenses in this large industrial center. Send coupon for free catalog and full information. Enroll now!

## INDIANA TECHNICAL COLLEGE

588 E. Washington Boulevard, Fort Wayne 2, Indiana

Please send me free information on 27 MO. B.S. DEGREES in:

Aeronautical  Chemical  Civil  Electrical   
Mechanical  Electronics

on 36 MONTH B.S. DEGREES in:  
Mathematics  Chemistry  Physics

Name \_\_\_\_\_

Address \_\_\_\_\_



**Now 1/2 price!**

**SWISS ARMY Type**

**9-in-1 Knife**

Formerly  
**\$1.98**

**88c**

plus 12c postage

1958  
Model

Korium  
Steel

- ★ Awl
- ★ File
- ★ Knife
- ★ Can Opener
- ★ Scissors
- ★ Corkscrew
- ★ Jackknife
- ★ Screwdriver
- ★ Bottle Opener

Your Portable  
Work Shop

9 practical tools in one. Each separate; easy to open & close. No jamming or slipping. Rugged Korium steel. Bone handle. Metal ring. Replaces multitude of tools you can't find when needed. Fits pocket yet opens to almost 5 inches long! Keep in workshop, basement, kitchen, tool shop, car glove compartment. "Lifesaver" in emergencies! Thousands sold at \$1.98—now SLASHED to only 88c plus 12c for postage & handling, while supply lasts. Rush \$1 for prompt delivery anywhere in USA or Canada. (Extra Special: 3 for \$2.75 postpaid). Satisfaction guaranteed or money back. Sold only by mail, only by us, direct to you.

MOTO-MATIC CO., DEPT. 6-H-114 585 WATER STREET, NEW YORK 2, N.Y.



# BE YOUR OWN MUSIC TEACHER

Send for Free Book Telling How Easily You Can Learn Piano, Guitar, Accordion, ANY Instrument This EASY A-B-C Way

NOW IT'S EASY to learn music at home. No tiresome "exercises." No teacher; just START RIGHT OUT playing simple pieces. Thousands now play who never thought they could. Our pictured lessons make it easy as A-B-C to learn to play popular music, hymns, classical, and any other music. Low Cost. One million students, including TV Star Lawrence Welk. (Our 60th year.)



**Mail Coupon for FREE BOOK**

Find out why our method can teach you quickly, easily, inexpensively. Write for FREE Book. No obligation. No salesman will call. Mention favorite instrument. Mail coupon today.

**U. S. SCHOOL OF MUSIC**  
Studio 308,  
Port Washington, N. Y.



U. S. SCHOOL OF MUSIC, Studio 308, Port Washington, N. Y. Please send me Free 36-page illustrated Book. I would like to play (Name instrument).

Instrument \_\_\_\_\_ Have you \_\_\_\_\_  
Instrument? \_\_\_\_\_  
Name \_\_\_\_\_  
Address \_\_\_\_\_ (Please Print)  
City \_\_\_\_\_ Zone \_\_\_\_\_ State \_\_\_\_\_

# INVENTORS

PROTECT YOUR INVENTION BY A U. S. PATENT. SEND FOR FREE "INVENTION RECORD" FORM AND "PATENT INFORMATION EVERY INVENTOR SHOULD HAVE."

**CARL MILLER**  
REGISTERED PATENT ATTORNEY  
WOOLWORTH BLDG., 36th FLOOR, 88A  
NEW YORK CITY

# INVENTORS

Whether an invention is patentable can be substantially determined by a search of the U. S. Patent records. Without obligation, write for information explaining the steps you should take to secure a patent.

**JOHN N. RANDOLPH**  
Registered Patent Attorney  
801 Victor Building, Washington 1, D.C.



# INVENTORS

U. S. Patents protect your inventions. Our free book of "Instructions on Patent Procedure for Inventors," also "Certificate of Invention" form sent without obligation.

**C. A. SNOW & CO.**  
REGISTERED PATENT ATTORNEYS  
428 SNOW BUILDING WASHINGTON 1, D. C.

# INVENTORS

Send for **PATENT INFORMATION** **REGISTERED PATENT ATTORNEY**  
Book and **INVENTOR'S RECORD** **ASSOCIATE EXAMINER**  
without obligation **U. S. PAT. OFF. 1922-1929**  
**GUSTAVE MILLER** Patent Attorney & Advisor  
**88-PM WARNER BUILDING** **U. S. NAVY DEPT. 1930-1947**  
**WASHINGTON 4, D. C.** **PATENT LAWYER**

# GET THE HABIT OF READING

OUR CLASSIFIED ADS.

Wonderful Opportunities Amazing Bargains

# INVENTIONS WANTED

If you want to market, or sell, your invention for cash or royalties. Write for our Free Booklet. Send no drawings. We also welcome hearing from firms, or private capital, wishing to review inventions in any field. We will be glad to send notice of our clients' inventions.

**GLOBAL MARKETING SERVICE**  
2420 77th Ave. Dept. PD Oakland 5, Calif.

# INVENTORS

I shall be pleased to furnish you, upon request, with full information relative to patent procedure—without any obligation on your part.

**PATRICK D. BEAVERS**  
Registered Patent Attorney

934 Victor Building Washington 1, D.C.



# I'll Set You Up For Life In Your Own BIG PAY SHOE BUSINESS



With The ONE Shoe Line That Serves Everyone From Baby to "Pop" and "Mom!"

Only 8 orders a day can make you up to \$32.00 a day, \$180.00 a week, \$600.00 a month. It's no trick at all to make big money full or spare time with America's most comfortable shoes. Amazing new "Spring-Step" cushion design proves it by amazing 2-minute demonstration. Over 200 styles for men, women, boys, girls and infants! Profits are BIG—repeat orders sure. No experience needed. Everything furnished. Send for Free "Portable Shoe Store" today.



Amazing 2-Minute DEMONSTRATION Does Your Selling Job for You FAST!

I Give Producers Their Own Shoes AS A BONUS!

ORTHO-VENT SHOE CO. 1188 BRAND ROAD SALEM, VIRGINIA

## PLATE AUTO CHROME

NEW! MONEY - SAVE MONEY - PLATE ANY METAL IN HOME SHOP BY CARROT



NOW with our NEW PORTABLE SELF-POWERED ELECTROCHEMICAL outfit. You can easily do your own plating. Not a paint. But a hard durable metal plate, equal to commercial plating. Get your own plating kit with instructions on plating metal and non-metal objects as Tools, Auto Parts, Silverware, Jewelry, Baby Shoes and 1001 other articles with Chrome, Nickel, Copper, Gold, etc. SEND NO MONEY. Everything sent C.O.D. for the low price of ONLY \$3.95 or send \$5.95 now and receive it post-paid. Money back in 7 days if not satisfied. M. Z. SALES CO., Dept. G-24, 113 West 42nd St., New York 36, N. Y.



## NOW The Short Cut to Learning You've Been Waiting for



### LEARN "BY EAR" WITH THE DORMIPHONE

A Scientific Discovery that Works for You . . . Awake and Asleep

Now, at last, an easy shortcut to learning. With this amazing new tool, you "start" to learn while awake—then the Dormiphone takes over while you go off to sleep. Do you want to learn a language—memorize a speech, facts, figures, formulae—correct your speech—break bad habits? Eliminate drudgery—Simple—helpful—practical. Used by educators, psychologists, people of all ages, occupations.

Find out HOW the Dormiphone works. Write for FREE Book—Get the Scientific Evidence NOW!

MODERNOPHONE, INC., 236-088 Radio City, New York 20, N.Y.  
Gentlemen: Please send me your FREE Book—no obligation.

NAME \_\_\_\_\_  
ADDRESS \_\_\_\_\_  
CITY \_\_\_\_\_ ZONE \_\_\_\_\_ STATE \_\_\_\_\_

My main interest in Dormiphones is for:

<input type="checkbox"/> Language Learning	<input type="checkbox"/> Speech Improvement
<input type="checkbox"/> Memorization	<input type="checkbox"/> Sleep Inducement
<input type="checkbox"/> Habit Correction	<input type="checkbox"/> School or College Work

# TRAIN AT HOME

in Your Spare Time or in the Great Allied School

1338-42 South Michigan Ave. Chicago 5, Ill.

**DRAFTING—All Branches**  
• Mech. • Structural • Aeronautical

**ENGINEERING**  
• Industrial Engineering  
• Tool Engrg. & Designing

**ELECTRONICS**

**AUTO MECHANICS**

**AIR CONDITIONING**  
Refrigeration — Heating & Cooling

**TOOL & DIE MAKING**  
Machinist Trade

Choose the Allied Way for Best Pay

SEND FOR FREE BOOKS

Prepare for the best jobs in your spare time at home. With ALLIED'S practical home study program you can progress so rapidly that big new opportunities will soon be open to you. Students planning a career in engineering can begin their training in short courses at Home or at Allied Institute and continue progressively toward an Engineering Degree in 31 months. Allied is approved by Industry, National Home Study Council, Department of Education, Office of Public Instruction, State of Illinois, U. S. Department of Justice.

ALLIED INSTITUTE OF TECHNOLOGY, 1338-42 South Michigan Ave., Dept. PM-88, Chicago 5, Ill.

- Send me without obligation information on your courses:
- |   |  |
|---|--|
| <input type="checkbox"/> MECHANICAL DRAFTING    | <input type="checkbox"/> AUTO MECHANICS    |
| <input type="checkbox"/> STRUCTURAL DRAFTING    | <input type="checkbox"/> ELECTRONICS       |
| <input type="checkbox"/> AERONAUTICAL DRAFTING  | <input type="checkbox"/> AIR CONDITIONING  |
| <input type="checkbox"/> INDUSTRIAL ENGINEERING | <input type="checkbox"/> REFRIGERATION     |
| <input type="checkbox"/> TOOL & DIE DESIGNING   | <input type="checkbox"/> TOOL & DIE MAKING |
| <input type="checkbox"/> HOME STUDY             | <input type="checkbox"/> RESIDENT          |
| <input type="checkbox"/> VETERAN                | <input type="checkbox"/> NON-VETERAN       |

NAME \_\_\_\_\_ AGE \_\_\_\_\_  
ADDRESS \_\_\_\_\_  
CITY \_\_\_\_\_ COUNTY \_\_\_\_\_ STATE \_\_\_\_\_



# Free! AIRMAIL COLLECTION



Get this spectacular collection of all-different, genuine Airmails from strange, far-away countries in Asia, Africa, Europe, the exotic Orient! World's largest airmail, scarce \$27 stamp, old Zeppelin, many, many others. A truly remarkable collection containing stamps worth up to 40c each at catalog prices! PLUS Bargain Catalog and other unusual offers. Send 10c for mailing costs. **ACT NOW!**

JAMESTOWN STAMP CO. Dept. F88PM, Jamestown, N. Y.

RUSH my Free Airmail Collection and other offers. I enclose 10c for mailing costs.

Name .....

Address .....

City & State .....

## MAKE STRIPES with new PAINT PEN

**Straight, curved, single or double** With any color paint, stripe furniture, bikes, autos, model planes, toys, linoleum, wall-board. Clean, crisp decorative lines. Can't clog or smear. Also use with glue, tempera, textile paint or underglaze... on wood, glass plastic, ceramics, metals, fabrics and paper. Ask your dealer or order direct.

**DEALERS** Master paint stripping tool in display carton. Write for discounts. Order now.

**HOBBY** "Professional" results every time. Simple, easy to use.

**MFRS** Ask about heavy duty industrial stripping tools.

**DOUBLE STRIPE MODEL \$3.25**  
5 COMBINATIONS. . . .

Single 1/16" stripe model \$1.25

Other single stripe models 1/8", 1/32", 3/64", 5/64", 3/32" & 1/8"

Complete Kit \$5.00 (all 7 tips)

Extra tips 90c ea.

Extra 1/4" tip..\$1.20

**WENDELL MFG. CO.** 4234 LINCOLN AVE., Dept. 343 CHICAGO 18, ILLINOIS



## TRAIN TO OPERATE HEAVY EQUIPMENT CONTRACTORS NEED MEN NOW

The big federal and state super highways program is now in progress. Train to operate bulldozers, shovel, motor-grader, scrapers, etc. YOU can make big pay in the construction industry if you learn these skills. NOW contractors WANT our graduates.

Write or call TODAY for full information.

**THE MIDDLE-WEST SCHOOL OF HEAVY EQUIPMENT OPERATION**  
SAXTON, KENTUCKY  
(Phone Jellico, Kentucky—Harrison 4-6653)

THE MUSCLE MAN SAYS



## I'LL GUARANTEE YOU RIPPLING MUSCLES

**IN 8 WEEKS OR MONEY BACK** You can have tremendous power, look bigger, have more confidence. This tested way. Revolutionary new "Body Build" courses build your body in a way no other method can match. Get course FREE with order. Lowest factory price.

**DAN LURIE BARBELLS**  
50 lb. set \$ 8.98 • 100 lb. set \$14.98  
150 lb. set \$21.98 • 200 lb. set \$27.98  
Extra wts. - 1 lb. per lb. 50% cash, balance C.O.D. FOB Plant

DAN LURIE BARBELL CO.  
52-M-8 Bristol St., Dept. 859-H, Bklyn 12, N.Y.

FREE! SEND FOR NEW SPORTS & HEALTH CATALOG

## SIGN PAINTING

Home-Study Course - Only \$5.95

Teaches you commercial sign painting and sign building as it is being done TODAY in leading shops all over the country. Complete practical course for self-instruction. Shows latest methods of truck lettering, office doors, wood letters, reflecting signs, plastics, sprayed signs, gold leaf, silk screen process, up-to-date alphabets, money-making business information, etc.

**SATISFACTION GUARANTEED OR REFUND!** Contains all the instruction of a high-priced correspondence course. Full price, only \$5.95, postpaid. Or C.O.D. plus postage. No risk—order today. Satisfaction or money back! Order "Sign Painting Course." NELSON-HALL CO., 210 S. Clinton St., Dept. 245-2, Chicago 6, Ill.



## EARN UP TO \$10,000 YEARLY LEARN PIANO TUNING & REPAIRING

Now you can be a piano tuner-technician with our sure-fire low cost home study course. No musical knowledge necessary. Piano tuners are taught—Not born. Tuner-technicians greatly in demand. Your business will be operated in your own home. Pay as you learn. Don't miss this opportunity. Write today. No obligation.

**ERIE PIANO SCHOOL, 362 W. 8th St., Erie, Penna.**

## MEN WANTED

Earn \$100 Per Week and up  
**AUTO DIESEL MECHANICS**

Master a trade with a future—Learn Auto-Diesel mechanics in our shops. You learn with tools on real equipment. Earn while you learn. Many of our graduates earn \$100 per week and up. No previous experience necessary. Day and night courses. Approved for veterans. Write for free bulletin.

**NASHVILLE AUTO-DIESEL COLLEGE**

226 7th Ave., N., Dept. 75 Nashville 3, Tenn.

## SEND ME



every month so I am sure to see each new issue. Here's

- \$3.50 for 1 year
- \$8.00 for 3 years

name .....

address .....

city .....

zone .....

state .....

Hand this order to your newsdealer or send it to  
**POPULAR MECHANICS**  
200 East Ontario St. Chicago 11, Ill.



# BIG REWARDS

for Industry's Most-Wanted Men



Chemical Lab Technician

Elec. Engineering Technician

Radio-TV Technician

Aeronautical Technician

General Electronics Technician

Industrial Electronics Technician

With the right training, you can qualify for big-pay jobs in these vital industries. Start yourself on an exciting, rewarding career and at the same time help fill a desperate need. I. C. S. can

show you how! I. C. S. spare-time training is recognized and used by leading companies throughout the U.S. and overseas. Send today for full details including three free books:

1. "How to Succeed" 36-page guide to advancement.

2. Opportunity Handbook in field of your choice.

3. Sample lesson (Math) to demonstrate I. C. S. method.

For Real Job Security—Get an I. C. S. Diploma! I. C. S., Scranton 15, Penna. Accredited Member, National Home Study Council

## INTERNATIONAL CORRESPONDENCE SCHOOLS



BOX 49299V SCRANTON 15, PENNA.

(Partial list of 259 courses)

Without cost or obligation, send me "HOW TO SUCCEED" and the opportunity booklet about the field BEFORE which I have marked X (plus sample lesson):

### ARCHITECTURE and BUILDING CONSTRUCTION

- Air Conditioning
- Architecture
- Arch. Drawing and Designing
- Building Contractor
- Building Estimator
- Carpentry and Millwork
- Carpenter Foreman
- Heating
- Interior Decoration
- Painting Contractor
- Plumbing
- Reading Arch. Blueprints

### ART

- Commercial Art
- Magazine & Book illus.
- Show Card and Sign Lettering
- Sketching and Painting

### AUTOMOTIVE

- Automobiles
- Auto Body Rebuilding and Refinishing
- Auto Engine Tuneup
- Auto Technician

### AVIATION

- Aero-Engineering Technology
  - Aircraft & Engine Mechanic
- ### BUSINESS
- Accounting
  - Advertising
  - Business Administration
  - Business Management
  - Cost Accounting
  - Creative Salesmanship
  - Managing a Small Business
  - Professional Secretary
  - Public Accounting
  - Purchasing Agent
  - Salesmanship
  - Salesmanship and Management
  - Traffic Management

### CHEMICAL

- Analytical Chemistry
- Chemical Engineering
- Chem. Lab. Technician
- Elements of Nuclear Energy
- General Chemistry
- Natural Gas Prod. and Trans.
- Petroleum Prod. and Engr.
- Professional Engineer (Chem)
- Pulp and Paper Making

### CIVIL ENGINEERING

- Civil Engineering
- Construction Engineering
- Highway Engineering
- Professional Engineer (Civil)
- Reading Struc. Blueprints
- Structural Engineering
- Surveying and Mapping

### DRAFTING

- Aircraft Drafting
- Architectural Drafting
- Drafting Machine Design
- Electrical Drafting
- Mechanical Drafting
- Sheet Metal Drafting
- Structural Drafting

### ELECTRICAL

- Electrical Engineering
- Elec. Engr. Technician
- Elec. Light and Power
- Practical Electrician
- Practical Lineman
- Professional Engineer (Elec)

### HIGH SCHOOL

- High School Diploma

- Good English
- High School Mathematics
- Short Story Writing

### LEADERSHIP

- Industrial Foremanship
- Industrial Supervision
- Personnel-Labor Relations
- Supervision

### MECHANICAL and SHOP

- Diesel Engines
- Gas-Elec. Welding
- Industrial Engineering
- Industrial Instrumentation
- Industrial Metallurgy
- Industrial Safety
- Machine Design
- Machine Shop Practice
- Mechanical Engineering
- Professional Engineer (Mech)
- Quality Control
- Reading Shop Blueprints
- Refrigeration and Air Conditioning
- Tool Design
- Tool Making

### RADIO, TELEVISION

- General Electronics Tech.

- Industrial Electronics
- Practical Radio-TV Eng'g
- Practical Telephony
- Radio-TV Servicing

### RAILROAD

- Car Inspector and Air Brake
- Diesel Electrician
- Diesel Engr. and Fireman
- Diesel Locomotive

### STEAM and DIESEL POWER

- Combustion Engineering
- Power Plant Engineer
- Stationary Diesel Engr.
- Stationary Fireman

### TEXTILE

- Carding and Spinning
- Cotton Manufacture
- Cotton Warming and Weaving
- Loom Fixing Technician
- Textile Designing
- Textile Finishing & Dyeing
- Throwing
- Warming and Weaving
- Worsted Manufacturing

Name \_\_\_\_\_ Age \_\_\_\_\_ Home Address \_\_\_\_\_

City \_\_\_\_\_ Zone \_\_\_\_\_ State \_\_\_\_\_ Working Hours \_\_\_\_\_ A.M. to P.M. \_\_\_\_\_

Occupation \_\_\_\_\_

Canadian residents send coupon to International Correspondence Schools, Canadian, Ltd., Montreal, Canada. . . . Special tuition rates to members of the U. S. Armed Forces.



GET READY FOR THE SPACE ERA! SEE THE SATELLITES... THE MOON ROCKETS

# AMAZING TELESCOPE BUYS AND OTHER OPTICAL BARGAINS



See the Stars, Moon, Planets Close Up!

## 3" ASTRONOMICAL REFLECTING TELESCOPE

60 to 160 Power — Famous Mt. Palomar Type! An Unusual Buy!



Assembled—Ready to use! You'll see the Rings of Saturn, the fascinating planet Mars, huge craters on the Moon, Star Clusters, Moons of Jupiter in detail. Galaxies! Equatorial mount with lock on both axes. Aluminized and overcoated 3" diameter high-speed f/10 mirror. Telescope comes equipped with a GOX eyepiece and a mounted Barlow Lens, giving you 60 to 160 power. Low-cost accessory eyepiece available for power up to 320. An Optical Finder Telescope, always so essential, is also included. Sturdy, hardwood, portable tripod. Valuable STAR CHART and 272-page "Handbook of Heavens."

Stock No. 85,050-M. \$29.50 f.o.b. (Shipping wt. 10 lbs.)

## 4 1/4" ASTRONOMICAL TELESCOPE!

UP TO 270 POWER!



With this scope you can see everything as above but with greater power plus will split finer stars. Mirror has twice the light gathering power. Mirror guaranteed to give theoretical limit of resolution. Rack and pinion focusing, hardwood tripod, real equatorial mounting—only one adjustment follows stars! Aluminum tube. 6 power finder telescope. 2 standard size eyepieces and mounted Barlow lens give you powers of 40X, 90X, 120X, and 270X. Low-cost accessory eyepiece available for power up to 540. Free handbook and Chart. Shipping weight 25 lbs. Stock No. 85,006-M \$74.50 f.o.b.

## MAKE YOUR OWN ASTRONOMICAL TELESCOPE

See December, 1957 issue of POPULAR MECHANICS—Pages 188-192. 4 1/4" MIRROR KIT—Contains ready-to-use 4 1/4" diameter concave, aluminized objective mirror, lenses for 1" focal length eyepiece, and aluminized first surface diagonal mirror.

Order Stock No. 50,074-M. Price \$16.25 postpaid

Same as above except 3" diam. mirror—\$9.95 postpd.

Stock No. 50,081-M. Price \$9.95 postpd.

We have additional eyepieces, tubes, tripods. In fact everything you need to build telescopes.

**New! 2 in 1 Combination! Pocket-Size 50 Power MICROSCOPE and 10 Power TELESCOPE**  
Useful Telescope and Microscope combined in one amazing, precision instrument. Imported! No larger than a fountain pen. Telescope is 10 Power. Microscope magnifies 50 Times Sharp focus at any range. Handy for sports, looking at small objects, just plain snooping. Send Check or M.O. Satisfaction Guaranteed. Order Stock No. 30,059-H. \$4.50 Postpd.

## SALE! TERRIFIC WAR SURPLUS BARGAIN! AERIAL CAMERA LENSES

Gov't. Cost \$1218—Now Low as \$39.50 Used Made by B & L and E.K.—24" F.L. f/6, in 23" long Lens Cone. Use as long range, Big Bertha Telephoto lens—for Richest field (wide field, low power) telescope, etc. Lenses are 4" dia.—precision 4-element type, Aero Tessar and Aero Ektar (no choice). Easily removed. Diaphragm (f/6 to f/22) is included. Opens approx. 1" to 3 1/2". Lens and cone—wt. 25 lbs. Sturdy carrying trunk—wt. 26 lbs.

Stock No. 85,059-M 24", used. Price \$39.50 f.o.b. Utah  
Stock No. 85,060-M 24", new. Price \$59.50 f.o.b. Utah

## HAND SIGHTING LEVEL

Described in Popular Mechanics March 1958 issue, page 212. Sight it like a Telescope. Gives you a level line of sight, for laying out gardens, drives, new construction, ditches, etc. Complete instructions included. When images of bubble, reticle horizontal line and object are coincident, object is level with eye of observer. May be used to measure differences in elevation between two points. Stock No. 105-M. \$2.50 postpaid

## BUILD A SOLAR ENERGY FURNACE

A fascinating new field. Build your own Solar Furnace for experimentation—many practical uses. Easy! Inexpensive! Use scrapwood! We furnish instructions. This sun powered furnace will generate terrific heat—2000° to 3000°. Fuses enamel to metal. Sets paper aflame in seconds. Use our Fresnel Lens—14 3/4" diameter f.l. 14". Stock No. 70,130-M. Fresnel Lens \$ 6.00 Postpd.

Stock No. 70,130-M. Fresnel Lens \$ 6.00 Postpd.

## STEREO MICROSCOPE



American-Made Instrument at Over 50% Saving. Up to 3" Working Distance—Erect Image—Wide 3-Dimensional Field. Used for inspections, examinations, counting, checking, assembling, dissecting. 2 sets of objectives on rotating turret. Standard pair of wide field 10X Kellner Eyepieces give you 23 power and 40 power. Helical rack and pinion focusing. 10-DAY TRIAL... Complete satisfaction or your money back. Order Stock No. 85,036-M. Full price... \$99.50 f.o.b. Barrington, N.J. (Shipping wt. approx. 11 lbs.) Send Check or M.O.

Check, Measure, Inspect with this

## 6 POWER POCKET COMPARATOR

(Complete with Leather Case)

MEASURES • Angles • Radii • Circles • Linear—in both decimal inches and millimeters.

Used to check layouts, machining on tools, dies, gauges; to check threads, chamfers, wear on cutting tools, etc.

Stock No. 30,061-H... New Low Price... \$19.50 Postpd.



## NEW! STATIC ELECTRICITY GENERATOR

See a thrilling spark display as you set off a miniature bolt of lightning. Absolutely safe and harmless. Stands 14" high. Turn the handle and two 9" plastic discs rotate in opposite directions. Metal collector brushes pick up the static electricity, store it in the Leyden jar type condenser until discharged by the jumping spark. Countless tricks and experiments. 24 page instruction booklet included. Stock No. 70,070-M. \$10.95 Postpaid

## WAR SURPLUS AMERICAN-MADE 7 x 50 BINOCULARS



Big savings! Brand new! Crystal clear viewing—7 power. Every optical element is coated. An excellent night glass—the size recommended for satellite viewing. Individual eye focus. Exit pupil 7mm. Approx. field at 1,000 yds. is 376 ft. Carrying case included. American 7 x 50's normally cost \$195. Our war surplus price saves you real money.

Stock No. 1533-H... only \$55.00 postpd. (Tax included)

## DIRECT MEASURING POCKET MICROSCOPE

— 50 POWER

Fountain pen size, makes direct reading measurements; for checking small parts and dimensions under powerful magnification. Precision, glass etched reticle calibrated for measurements up to 1/10" by .001" divisions.

Stock No. 30,225-M. \$7.95 Postpd.



6X FINDER TELESCOPE—base fits any diameter tube. Stock No. 50,121-M. \$8.00 postpaid

MOUNTED BARLOW LENS—double and triple your telescope's power. For Standard 1 1/4" eyepiece holders. Stock No. 30,200-M. \$8.00 postpaid

KELLNER EYEPIECE—Large 50° field—mounted and ready to use. 1 1/4" outside diameter. Stock No. 5223-M. \$7.95 postpaid

MOUNTED HERSCHEL WEDGE—40mm x 55mm—10° angle—mounted with diagonal holder for reflectors for solar observation. Stock No. 30,266-M. \$5.50 postpaid

REFLECTING TELESCOPE EYEPIECE MOUNT—Rack and pinion focusing—takes standard 1 1/4" eyepieces. Stock No. 50,077-M. \$9.95 postpaid

# FREE CATALOG-H

Yours for the asking

America's No. 1 source of supply for experimenters, hobbyists. Complete line of Astronomical Telescope parts and assembled Telescopes. Also huge selection of lenses, prisms, war surplus optical instruments, parts and accessories. Telescopes, microscopes, satellite scopes, binoculars, infrared sniper scopes, etc.

REQUEST CATALOG-H



ORDER BY STOCK NUMBER. SEND CHECK OR MONEY ORDER. SATISFACTION GUARANTEED!

EDMUND SCIENTIFIC CO., BARRINGTON, NEW JERSEY





# CLASSIFIED ADVERTISEMENTS



Advertisements in this section \$1.25 per word, each insertion, minimum 10 words, payable in advance. To be inserted under proper classification, copy must be in our office the 20th of the second month preceding date of issue  
**F. W. Johnson, Manager, Classified Advertising**  
 Popular Mechanics Magazine, 200 East Ontario Street, Chicago 11, Illinois

## YOU'LL PROFIT

By reading and answering the classified ads in this section. Hundreds of opportunities for you to make and save money

### AUTOMOBILES, MIDGET CARS

**BUY Wholesale.** New and used automobiles, trucks, tires, accessories, tools and equipment. Make unusual auto profit without investment. Own your car free of cost. Save big money for yourself and friends. Wholesale price list, instruction book, and wholesale source directory \$3.00. Satisfaction guaranteed. Bob Belmont, Box 258, Hawthorne 11, N. J.

**MIDGET Car, 2 seater.** Build at home. Plans \$2.00. Clark's, Box 407, Alamogordo, New Mexico.

**EXACT, Official retail prices.** Any car and equipment \$1.00. Briggs, Box 52, Hempstead, N. Y.

**BOY'S Power driven auto.** Build your own. Plans, parts list, 35 cents. B. Sypher Co., Sta. F., Toledo, Ohio.

**BOOKS, Hundreds of subjects.** Big 1958 book catalog — 10¢. Popular Mechanics Press, 200-BC East Ontario St., Chicago 11.

**BUY Wholesale!** Late model used cars. Wholesale price list and buying instructions \$2.00. M. D. Arquilla, Harrietta, Michigan.

**HUNDREDS Of automobile catalogs.** Old, new and foreign; dealer books, glossy photographs, service manuals; free motor magazines listed by non-profit club. 4¢ stamp brings all information. Auto Maniacs, Stockbridge, Michigan.

**1958 SUPERIGNITIONER.** Starting, pep, mileage. Kaisers, Varitypers, IBMs, mimeographs. EG. Elmsford, N. Y.

### AUTO SUPPLIES AND EQUIPMENT

**REVOLUTIONARY Gasoline saver device!** Particulars, send 10¢, refundable. Grable Enterprises, 26314 Normandy, Roseville, Michigan.

**RING-Valve job while driving.** \$6.00. Literature. Motaloy, Grantham, Penna.

**NEW And used parts at savings.** Complete guaranteed parts service for all models cars and trucks, 1924 and later. Largest in the West. Jeep and army parts specialists. Newest type shifting hubs for all jeep and all military and latest production front end drive vehicles. \$27.50 and up. Write. Pioneer Auto and Truck Parts Co., 734 W. 13th Avenue, Denver 17, Colo.

**SAVE Money on Jeep and army truck parts.** Large inventory. Catalogs for Jeep or G.M.C. owners. American Auto Parts Co., 1830 Locust, Kansas City, Mo.

**FREE! New catalog.** Speed, power, mileage increasing equipment. Discounts! Almqvist Engineering, Milford PM5, Penna.

**METAL Emblems, souvenir decals.** Lists 10¢. Box 504, Nyack, N. Y.

**AUTOMOTIVE Books.** Send for 1958 book catalog — 10¢. Popular Mechanics Press, 631 N. St. Clair St., Chicago 11.

**ENGINES, Chevrolet, Ford, Oldsmobile, etc. 1955, 1958 near new.** Reasonably priced. Ledbetter Enterprises, 1015 West 17th, Tezakana 4, Texas.

**OFFENHAUSER—1958 Catalog** available on all items manufactured and distributed. Only 35¢. Offenhauser Equipment Corp., 5156 Alhambra Ave., Los Angeles 32, Calif.

**SUN Portable carburetor tester** for automobiles, trucks, marine. List price \$120.00. Net \$60.00. Condenser tester \$5.00. Wilt Surplus Sales, 7829 So. Racine Ave., Chicago 20, Illinois.

**PISTONS Unlimited.** Save 50%. Buy direct. 17028 Ermanita, Torrance, Calif.

**NEW Four cylinder Ford parts.** Catalog 25¢. Mark Auto, Layton, New Jersey.

**NEED Overhaul?** 10,000 mile guarantee! \$3.95. Effess, 3017 Moffat, Toledo 6, Ohio.

**PARTS Model A. Others.** Express needs. Matco, Box 135, San Pedro, Calif.

**PARK First time everytime!** New invention ends parking problem forever! Guaranteed to work. Only \$2.98. House of Baird, Lock Haven 8, Pennsylvania.

**FREE Giant auto parts catalog.** Thousands scarce accessories stores don't have. Gadgets, custom equipment. Send 25¢ postage (refundable). Newhouse Automotive Industries, 5805-PM-8 Beverly, Los Angeles 22, Calif.

**FREE! 1958 Automotive catalog.** 280 pages, 75,000 items. Parts of every description for stock cars, hot rods, custom cars, trucks, and station wagons. Save up to 50%. Same day service. Quality guaranteed or money back. Send 25¢ (refundable, first order). J. C. Whitney, 1919 PM-8, Archer, Chicago 16, Ill.

**AUTO-Bed conversion kits** with complete instructions. Works on all two and four door sedans, club coupes, station wagons, convertibles. Reclines back of front seat, making a complete bed in your car when needed. Only \$19.95. Send cash, check or money order, along with make and model of car. Auto-Bed Co., Reidsville 6, Georgia.

**JEOP Owners — V-8 conversions.** Read Jeep Owners ad, page 18.

**TOOL Caddy — Sturdy fabric,** attaches spare tire. Pockets fifteen tools, flashlight, maps. Neatness, eliminates rattling, damage. \$2.98 c.o.d. guaranteed. Free literature. Steiner, 156Q West 86, New York 24, New York.

**VOLKSWAGEN Bekows cartop carriers.** Welded steel construction, varnished wood slats. Free brochure. \$40 and \$35 f.o.b. Sporting Motorists Agency, Box 333, Ann Arbor, Michigan.

**BARGAIN. Exciting Little Library** booklets. 25¢ each. How to use tools, painting, welding, home improvement, games, models, plastics, lamp making, glass blowing, boats, photographs. Free Little Library catalog. Popular Mechanics Press, 200-LB East Ontario St., Chicago 11.

### AUTO TRAILERS

**AUTHORITATIVE Trailer books.** How To Build Trailers \$3.00. Mobile Home Manual \$1.98. How To Buy Trailers \$1.98. Satisfaction guaranteed. Trail-R-Club of America, Box 1376-1, Beverly Hills, Calif.

**BUILD Expanding eight foot trailer.** Accommodates five. Literature 10¢. Pra-Mar Company, Wilmington, Mass.

**CABIN Trailer kits.** Pleasure or business. Write Burlington Manufacturing Company, Burlington, Iowa.

**DON'T Buy anything** until you've seen the "new look" in camping. New camp trailer, a new cartop camper, new camp kitchen. Free illustrated brochure. Write: Helite Trailers, Inc., Dept. P.M., Lodi, California.

**PICKUP Coaches.** Trailer blueprints. Literature 10¢. Comstock Trailers, Parsons, Kansas.

**DO-It-Yourself.** The convertible camping trailers new simplified construction. Compact, lite weight, sleeps 6. Literature 10¢. Falco, Box 65, Gloversville, N. Y.

### MOTORCYCLES, BICYCLES, MOTORSCOOTERS AND SUPPLIES

**DOODLEBUG Motorscooter \$10,** Indian \$17, fiberglass sport car \$75, less engines. Whizzer engine \$3, Harley \$10. Crosley pickup \$60. (Mailorder only). Send 25¢ (35¢ for first class mailing) for directory-catalogue number 84, listing these and hundreds of other bargains in midget cars, motorscooters, homebuilders parts, plans, etc. Midget Motors Directory, Athens, Ohio.

**HARLEY - Davidsons — Used bargains.** New, used parts, accessories for all models. Bulletin, catalog 25¢. Knuth's (Factory Dealer), 1753 Muskego, Milwaukee, Wis.

**PARTS, New, used.** List 10¢. Ballak, 811 N. 9th, St. Louis 1, Mo.

**RECONDITIONED Motorcycles and motors.** Chromium accessories. Complete stock Indian parts. Expert rebuilding. Fast service. Indian Motorcycle Sales, Kansas City 27, Missouri.

**WHIZZER Motors.** \$20.00; midget race car reasonable; motorscooter \$6.00; Cushman two-speed \$20.00. Send 25¢ (35¢ first class mail) for catalog #32 jammed with sensational bargains in wheels, motors, motorscooters, midget cars, motorbikes, construction plans, etc. Gail, 1313 Jefferson, Toledo, Ohio.

### AVIATION

**PROPELLERS, Plans, supplies** for airboats and snowplanes. Latest designs, prompt delivery. Catalog 25¢. Banks-Maxwell, Box 3301E, Ft. Worth 5, Texas.

**BOOKS; Hundreds of subjects.** Big 1958 book catalog — 10¢. Popular Mechanics Press, 200-BC East Ontario St., Chicago 11.

**BUY Surplus aircrafts; fuselages; assemblies; aircraft engines; helicopters; instruments; electronics; radiotelephones; misc.** Buy direct now from U. S. Government. Depot list and procedure \$1.00. Brody, Box 8-PM, Sunnyside 4, New York City.



**HELICOPTER** Mechanics urgently needed. Train at home. Write Southern Cross Helicopter Institute, 345B Sip, Jersey City 6, N. J.

**BOOKS, Aviation.** Free catalog. Aero Publishers, 2162-PM8 Sunset, Los Angeles 26, California.

**AIRLINE Careers.** Starting salary \$3400 up. Short, easy course. G.I. approved. Free catalog L. McConnell Airline School, 1030 Nicollet, Minneapolis, Minnesota.

#### BATTERIES, GENERATORS

**EDISON Nickel storage batteries.** Any voltage, any amperage. Unconditionally guaranteed. Power plants, generators, motors. Literature. Hawley Smith Co., Croton Falls 1, N. Y.

#### ELECTRICAL SUPPLIES

**LAMP.** Electrical parts, wholesale. Thousands of items for repairing, converting. Catalog 25¢. Brown Lamp, Box 305, Clayton 5, Mo.

**HOUSE Wiring—Electrical repairs.** Booklet. Send for 1958 book catalog—10¢. Popular Mechanics Press, 633 N. St. Clair, Chicago 11.

**LAMPS—Parts catalog** containing wiring instructions, 25¢. Gyro Lamps, 3438P N.W. 54 Street, Miami, Fla.

**FLUORESCENT Fixture kits—Inexpensive, easily assembled.** Catalog free. Shoplite, 650M Franklin, Nutley 10, New Jersey.

#### WELDING, SOLDERING, PLATING

**PLATING Equipment, supplies.** Complete line of anodes, solutions. Home workshops, industrial sizes. Hollywood Bronze Supply, Dept. C, 1624 East First, Los Angeles 33, California.

**NEW.** Timesaving oxy-acetylene outfit welds, cuts, heats, brazes. Just change tips. Light, compact, portable. Thrifty to operate, ruggedly built. Complete outfit and instructions only \$84.50. Special economy plan for supplying gas cylinders. Write for free literature. Dept. M. Linde Company, 30 East 42nd St., New York 17, New York.

**FREE Factory catalog.** Welder kits, supplies. Build 350 ampere welder from aircraft generator. Plans 10¢. LeJay Manufacturing, Minneapolis, Minnesota.

**ACETYLENE Welding outfits,** new \$54.50, arcwelders \$56.50, Eagle Welding, Dept. P.M., 5085 Broadway, Chicago 40, Ill.

**WELDERS,** 110/220, \$39.50. Morris, 1070 Inner Drive, Schenectady 3, New York.

#### MACHINERY, TOOLS, SUPPLIES

**VACUUM Hand pumps,** 20 ft. lift, water, oils, gasoline. Free catalogue. Jess W. Wright, 18 Thea Lane, Huntington, N. Y.

**ENGINEERS, Architects, draftsmen.** Divided utility tray, transparent green plastic, springs clip to the drafting machine, \$2.50 postpaid. Designers Travel Tray, Box 374, Burbank, Calif.

**OIL Drum cement mixer assembly kit.** Circular. Nu-Way-Do Co., Newaygo, Mich.

**AMAZING Carbide lathe bit.** Eliminates grinding. \$6.90 prepaid. Free literature. Treycro Products, North Tonawanda, New York.

#### ENGINES, MOTORS, DYNAMOS

**WINDING Data,** 275 motors, single and three phase, \$1.10. Data Company, Box 7631, Kansas City 28, Mo.

**ALTERNATING Current generators,** 750 watt \$42.50, twincylinder compressors with 1/2 horse \$22.00, motors, 1 horse \$38.50. Butler, 1885 Milwaukee, Chicago.

**REWIND Motors yourself.** Complete instructions \$1.00. Lewis Mfg., Howell, Michigan.

**DIESEL Injector parts wanted.** GM51-71-110. Bares, 7120 Carnegie, Cleveland 3, Ohio.

**GAS Engines: Briggs Stratton.** From \$29.95. Brand new. Details free. Northern, 172 Merrimac Street, Boston 14, Mass.

#### BOATS, OUTBOARD MOTORS

**PERMANENT Lettering for boats, vehicles, homes, businesses, cast bronze, polished natural or chrome.** Three sizes in script and three in block letters. Write for circular. Boat Names Company, 426 West 5th St., Kansas City, Mo.

**FORDS And Jeeps 100% marine engines** with famous Convo-Kits. Deluxe catalogue 25¢ coin. Oscomotors, 3627B Lawrence, Philadelphia 40, Penna.

**FREE Catalog!** Boat kits, trailers, fiberglass, marine hardware. Luger Industries, Dept. M-8, 9200 Access Rd., Minneapolis 20, Minnesota.

**FULL Size, cut-to-shape boat patterns,** blueprints, 7 1/2-38 feet. Big new 88 pg. illustrated "Build a Boat" catalog of naval architect-designed cruisers, runabouts, skiffs, outboard boats, sailing, racing, houseboats, 50¢. "How to Build a Boat" booklet, \$2.50. Hardware and equipment catalog, \$2.00. Cleveland Boat Blueprint Co., Dept. A-66, Box 1651, Cleveland, Ohio.

**NEW. Used, rebuilt marine motors.** Marine conversions, fittings. Free catalog. Stokes Marine Supply, Dept. 24, Coldwater, Michigan.

I want to send you proof of the wonderful pulling power of Popular Mechanics classified pages. What's your proposition? Write me today. Include literature if possible. F. W. Johnson, Manager Classified Advertising, Popular Mechanics Magazine, 200 E. Ontario St., Chicago 11, Ill.

**FIBERGLAS Permanent boat waterproofing.** Special 25% discount. Complete kits, \$9.45 up. Guaranteed materials. Easy application. Full instructions. Free literature. Ajax Plastics, Dept. PM, P.O. Box 1323, Fort Worth, Texas.

**MARINE Conversions.** Ford, Chevrolet, Jeep engines. Catalog 25¢. Lehman Manufacturing Company, 972D Broad Street, Newark 2, New Jersey.

**BUILD Small boats.** Send for 1958 book catalog—10¢. Popular Mechanics Press, 633 N. St. Clair St., Chicago 11.

**BOAT Plans.** Full size patterns. Frame kits. Modern inboards and outboards for amateur builders. Complete new catalog 50¢ or specify requirements. New speedboat inboard hardware catalog 25¢. Glen Designs, 9152 Rosecrans, Bellflower, Calif.

**PROPELLERS.** Plans, supplies for airboats, snowplanes. Catalog 25¢. Banks-Maxwell, Box 3301F, Ft. Worth 5, Texas.

**FIBERGLASS Your boat!** Wholesale prices. Send for information, sample. Aqua Glas, Box 99, Altadena, Calif.

**KITS—Build, sell.** Water skis, boats and accessories. Make money at home. Send for free catalogue and tips. Hill Mfg. Co., 1901 So. 75 St., West Allis 19, Wis.

**SAVE Money.** New, used outboard motor parts. Send wants. Stamp appreciated. Outboard Motor Mart, 229-M State, Boston 9, Mass.

#### ATHLETIC EQUIPMENT, BODY BUILDING COURSES

**CONFIDENTIAL Herculean technique** revealed. Details. Cincotta, 148 Broadway, Saugus, Mass.

**FREE Muscle building information.** Body-Tone, Box 638B, North Miami, Florida.

**NEW Body, health, strength, muscles.** Gain, reduce. Any age. Easy! Amazing guaranteed discovery uses only a rope! Free details. Roperise, 4834 Art, Studio 1-A, San Diego 15, California.

**JUDO.** Defeat bullies. 36 lessons \$1.00. 1112 Tipton, High Point, N. C.

**BARBELLS.** Dumbbells. Courses. Booklet 10¢. Good Barbell Co., Siloam Springs, Arkansas.

#### SPORTING GOODS, GUNS, FISHING TACKLE, ARCHERY, TRAPPING

**JAP Rifle** altering to 30-06, \$6.00. Jap-shells, \$3.95. Catalog 5¢. T. P. Shop, West Branch 11, Mich.

**SKIN Divers,** used equipment, guaranteed. Dower, 215 Essex, Holyoke, Mass.

**GOLF Balls—Play the famous English** tournament "Dunlop 65," \$9.00 dozen. Best Buys, P.O. Box 338, Hamilton, Bermuda.

**BUY Wholesale!** 25,000 nationally advertised products. Get amazing dealer catalogs. Complete details free. American Wholesalers, 1841-A Levee, Dallas 7, Tex.

**MOLDS For fisherman's sinkers, jigs, squids, casting and spinning lures.** Free catalog. Sweet's Molds, Tonawanda 1, New York.

**BIG Money raising crickets and 12 inch African fishworms.** Free literature. Carter Ranch, Plains, Georgia.

**5000 BARGAINS.** Firearms, binoculars, war relics. Catalog 50¢. Smith Firearms, Rummende, N. J.

**154 PAGE Catalog—A real "dream book"** for fishermen! It's free! Netcraft Company, Dept. B8, Toledo 13, Ohio.

**AMAZING Wholesale sporting catalog.** Save 70%. Tremendous selections. Econ-O-Mart, Whippany 2, New Jersey.

**ILLUSTRATED Trapping secrets, baits, lures, traps, supplies.** Catalog 10¢. Pete Rickard, Box 8, Cobleskill, N. Y.

**50¢ BRINGS Biggest bargain catalog!** 10,000 guns! Kentuckies, Colts, Lugers, Mausers, hunting guns, Armour, swords, ammunition. Agramonte's, Yonkers 2-G, N. Y.

**GIRDLE Shank fishhook holds worms.** (M) 6 hooks, 60¢. A. S. Pinckney Mfg. Co., 1000 No. Serrano, Los Angeles 29, Calif.

**FISH-O-Matic catches fish automatically.** Only 79¢. For free information write: Lucky Strike Bait Company, 4111 Grant St., Gary, Indiana.

**BUY Wholesale!** 100,000 nationally advertised products. Appliances, cameras, sporting goods, housewares, watches, typewriters, tools, clothing, etc. Discounts to 80%. Buy-Rite, Box 258, Hawthorne 29, New Jersey.

#### EARTHWORMS—CRICKETS

**BIG Money raising fishworms and crickets.** Free information. Large hybrid breeder redworms, \$4 per 1000, postpaid with free raising instructions. 5000, \$17.50. Medium size 3000, \$6.50; 10,000, \$19.95. Carter Redworms, Plains, Georgia.

**BED-Run size Colorado hybrid worms,** 5000, \$12.00; 10,000, \$19.50; 20,000, \$37.50; postpaid. Dewey's Worm Ranch, Henderson, Colo.

**KEEP Fishworms alive indefinitely** with Aquapot system. Dollar brings details, diagram. Mrs. C. P. Wilson, 1206 Parkside Dr., S. Reading, Penna.

**EARTHWORM Raising.** Big paying business. Operated anywhere, sparetime. No experience. No capital. Free details. Goocher's Earthwormery, Box 883, Menlo Park, California.

**AFRICAN Giant redworms.** 100—\$2.00. (Dealers quoted.) Ozark Worm Farm-J, Willow Springs, Missouri.

**FREE Picture folder, "How to Make \$3,000 Yearly Sparetime, Backyard, Raising Earthworms!"** Oakhaven 56, Cedar Hill, Texas.

**DO-It-Yourself booklets,** 32 different home and hobby projects. Send for 1958 book catalog 10¢. Popular Mechanics Press, 631 N. St. Clair St., Chicago 11.

**"TROPICAL Wonder" baitworms 4" to 7".** 100, \$2.00. Raising booklet 50¢, wholesale. Inquire Rodman's Baits, Willow Springs, Missouri.

#### BINOCULARS, TELESCOPES, MICROSCOPES, MAGNIFIERS

**REFRACTOR And reflector telescopes.** Also mirrors, lenses, tripods, etc. Free illustrated catalog. Suffolk Science, Mattituck, N. Y.

**DYNASCOPES—Sensational new reflector telescopes.** Send for details. Criterion Co., Dept. DP 47, Hartford, Conn.

**REFLECTOR Telescope kits \$7.25 (3") to \$175. (12").** Mirrors, cells, focusing mounts, tripods, eye systems. Anything, everything in telescopes. Optics, also binoculars, microscopes, optical instruments. Free catalog. Also ready to use telescopes from \$25. Esco Products, Oakridge, N. J.

**REFLECTING Telescope, 60X,** completely assembled \$29.75. Guaranteed observatory clearness. Free information. Skyscope, P.O. Box 55, Brooklyn 28, N. Y.

**SPECIAL Sale,** amazing prices precision binoculars. Folder, "Binocular Selecting," catalog free. Prentiss Importers, Mercury Bldg., West Los Angeles 25, Calif.

**ANOTHER First—The Escope 5" reflector** completely assembled, 115X \$59.95. Free information. Esco Products, Oakridge, N. J.



**BUILD** Your own reflector telescopes. Complete kits; mirrors, eyepieces, tripods, all other accessories. Request free illustrated literature. Criterion Manufacturing, Dept. DPM 44, Hartford, Conn.

**WAR** Surplus bargains: Millions of lenses, instruments, telescopes, binoculars, components and complete line of astronomical telescope items. World's greatest optical market-place! Send only \$1.00 for beginner's 10-lens kit and big instruction booklet Stock 2-CH. Write for catalog CH free! Edmund Scientific Co., Barrington, New Jersey.

**BINOCULARS**, Telescopes, microscopes. Terrific values \$3.98 up. Request free money-saving catalog. Criterion, Dept. P 69, Hartford, Conn.

**AMAZING** New telescope. Free circular. Telescope Sales, 3562 Third, Detroit 1, Michigan.

**BUY** Direct from manufacturer. Mirrors, kits, lenses, parts for astronomical telescopes. Mirrors, lenses repolished. Price list on request. Kistner, Box 74, Wakefield, New York 66, New York.

**BINOCULARS**, Microscopes, telescopes. Free information. Hughes Mailorder Service, Box 45, Jeffersonville, Indiana.

### PLANTS, SEEDS, BULBS, NURSERY AND GARDEN SUPPLIES

**WORLD'S** Greatest cash crop. Free information. Write Ginseng Gardens, Asheville, N. C.

### PETS—DOGS, BIRDS, RABBITS, HAMSTERS, ETC.

**EARN** \$10,000 Yearly raising Angora rabbit wool for us. Information 25¢ coin. American Angora Company, Malta 12, Montana.

**LIVE** Texas horned toads, \$1.25 each. Pair, \$2.00. Postpaid, guaranteed. Tex's, Box 253, Brownwood, Texas.

**RAISE** Rabbits successfully by knowing facts. 48 page illustrated book describing 25 breeds. Housing, feeding, breeding, marketing, etc. Plus bulletin. 25 cents. American Rabbit Association, 36 Arba Building, Pittsburgh, Penna.

**MAKE** Money raising chinchillas, mink, nutria, rabbits, cavies for us. Free catalog. Keeney Brothers, New Freedom 2, Penna.

**RAISE** Rabbits on \$500 month plan. Plenty markets. Free details. White's Rabbitry, Delaware, Ohio.

**WE** Pay \$3.50 lb. dried. Grow mushrooms, cellar, shed and outdoors. Spare, full time, year round. We have 25,000 customers. Free book. Washington Mushroom Ind., Dept. 171, 2954 Admiral Way, Seattle, Wash.

**HAMSTERS**—Ideal pets, \$2.95 pair. Free booklet. Jer-Fre's Hamstery, 2218 East Broadway, Muskegon 13, Mich.

**STRAIGHT** Cooners! World's oldest kennel. Combination hounds, rabbit, fox, beagles, deerhounds, bird dogs. Puppies of all breeds. Prices reasonable. Trial. Free catalogue. Raccoon Mountain Kennels, Box 464, Boaz, Alabama.

**SPORTSMEN**: World's largest kennels offers 500 bird dogs, straight cooners, combination hounds, beagle hounds, rabbit hounds, small squirrel dogs, fox and deer hounds. Catalogue free. Smokey Mountain Kennels, Cleveland, Tennessee.

**RAISING** Rabbits? For more profit and enjoyment, study "National Rabbit Raiser Magazine," 422-D South 6th Street, Minneapolis 15, Minnesota. Subscriptions still \$2.00.

**HAMSTERS**—Golden: Young, \$3.00 pair, breeders, \$4.00 pair. New mutation, \$5.00 pair. Adirondack Hamstery, Prospect 20-V, New York.

**VITAMINS** For dogs. Zip food supplement from beef. 45 grams. Send \$2.00. Guaranteed. William O. Withrow Co., 2805 Colorado, Los Angeles 41, Calif.

### FUR BEARING ANIMALS

**MINK** Raising information free. Complete. Lake Superior Mink Farm, Superior, E.E. Wisconsin.

**NUTRIA** Facts free. Breeders reasonable. Surley Nutria Farm, Mansfield 5, Texas.

### FARMS, FARM LANDS, REAL ESTATE

**OZARK** Specialty farms. Terms. Description mailed free. 20 years service. Armstrongs, Shook, Missouri.

**OPPORTUNITIES!** Government land. U. S., Alaska, Canada. Sledge Surveys, Macon, Mississippi.

**FLORIDA:** 2½ Acres, near gulf. Elevation 50 feet up. Farming, citrus, poultry, electricity, good roads. \$15.00 down and month, price \$695 up. Information and picture free. Russell Hancock, Box 765, Brooksville, Florida.

**FREE** Strout catalog! Farms, homes, businesses, resorts, retirement properties. Over 2900 values in 34 states. 57 years' service. World's largest! Write Strout Realty, 7-MF So. Dearborn, Chicago 3, Ill.

**HOMESITES** \$15 Monthly—California's finest garden section. Morro Bay's scenic shores. Wonderful fishing, boating. Fertile soil, softest water, temperate climate, congenial community. Free literature. Richard Otto, Department M, San Luis Obispo, California.

**FLORIDA.** Nice homesites, \$345 at \$10 monthly. Folder free. Howard Vernor, DeLand, Florida.

**MOTELS.** Free bulletin, 150 bargains, free photos. Continental, 1102 Grand, Kansas City, Missouri.

**2¼ ACRE** Homesites \$795, \$20 monthly. Russell Hancock, Box 765, Brooksville, Fla.

**NAPLES**, Florida, homesites, 60x135 blacktop streets, 7 minutes from Naples Beach, protective zoning, prices from \$499. \$10 down, \$10 month. No interest. Write for free brochure. Naples Manor, 904 5th Ave. So., Naples, Fla.

**TEXAS** Resort and retirement property at 5 beautiful lakes. Lots \$127.50. Easy terms. Folder free. GS-28, Box 50, Kingsland, Texas.

**SCENIC** Bit of Oregon! Neat buildings on this 20-acre town-edge farm; really a lot for your money, only \$7,000 and the view is worth that! Right for fruit, berries, grain, livestock. 12 acres tillable, 3½ wooded, now all grazing land, 19 fruit and nut trees. Modern 6-room 3-bedroom home. Valley and mountain view. Buys like this are rare, so better hurry! Only \$7,000, half down. Free fall catalog, bargains coast to coast! United Farm Agency, 2825-PM Main St., Kansas City 41, Mo.

### FARM MACHINERY AND SUPPLIES

**SENSATIONAL** Garden tractor. Hoes between plants and rows, including strawberries. Eliminates hand hoeing. Nothing else like this. Patent 2742840. Also tills. Fantastic offer to first few inquiries. Auto Hoe, DePere 68, Wisconsin.

### PROFITABLE OCCUPATIONS

**WHOLESALE!** Nationally advertised merchandise. Fabulous profits, savings. Write: Wholesale Buyers, 111 Meramec, St. Louis 5-PC, Missouri.

**ETCH** Nameplates, signs with car battery. Graphic, Box 9647, Jackson, Miss.

**SPARETIME** Money. New plastic laminating to 24x29½ without machine. Trial kit \$1.00. Volvo, Cresskill, N. J.

**BECOME** Independent with your own franchise business. Thousands earning handsome incomes. Request interesting facts today. National Franchise Reports, PM-528, 333 North Michigan, Chicago 1.

**BUY** Wholesale! 100,000 nationally advertised products. Appliances, cameras, sporting goods, housewares, watches, typewriters, tools, clothing, etc. Discounts to 80%. Buy-Rite, Box 258, Hawthorne 3, New Jersey.

**IF** You can trace, start your own business. Kit \$2.00. Refundable. Paulco, Box 245, Sun Valley, Calif.

**MAKE** Flexible molds. Cast plaques, figurines. Free sample. Tooker, 1045-M Fairview, Hamilton, Ohio.

**VENDING** Machines—No selling. Operate a route of coin machines and earn amazing profits. 32-page catalog free. Parkway Machine Corporation, Dept. 25, 715 Ensor Street, Baltimore 2, Maryland.

**AUCTIONEERING**—Home study course. Diploma granted. Auction School, Ft. Smith, Ark.

**BUY** Wholesale! 25,000 nationally advertised products. Get amazing dealer catalogs. Complete details free. American Wholesalers, 1841-B Levee, Dallas 7, Tex.

**RAISE** Pheasants on \$100 week plan. Little capital and space can make you independent. Free details. Great Central System, Columbus 6, Kansas.

**MONEY** Plans! "Secret Journal." Grandpa, two daughters made \$2500 first month! Work home. Publicoes, Oceanside, Calif.

**BIG** Money raising fishworms and crickets. Free literature. Carter Wormery, Plains, Georgia.

**BAKE** New greaseless doughnuts in kitchen. Sell stores. Free recipes. Michael Ray, 3805 South 15th, Minneapolis 7, Minn.

**FREE** Book "505 Odd, Successful Businesses." Work home. Pacific, Oceanside, Calif.

**WE** Pay \$3.50 lb. dried. Grow mushrooms. Cellar, shed and outdoors. Spare, full time, year round. We have over 25,000 customers. Free book. Washington Mushroom Ind., Dept. 99, 2954 Admiral Way, Seattle, Wash.

**SAVE** Money! Buy wholesale! Free catalog general merchandise. Norris, 487-M Broadway, New York City.

**MAKE** Money writing short paragraphs. Information free. Barrett, Dept. CX-27, 7464 No. Clark, Chicago 26.

**SKYROCKET** To success via mailorder. Amazing facts revealed. Fortune Enterprises, Addison, Illinois.

**FREE** Book "990 Successful, Little-Known Businesses." Work home. Plymouth, 1610-43 Street, Brooklyn 4, N. Y.

**HOME** Mailorder beginner's manual, sources, methods, opportunities, 25¢. Carahan Bros., 9610 Acacia, Fontana, Calif.

**EARN** \$240.00 A month at home, spare time doing only two \$5.00 invisible mending jobs a day. Big money paid for service that makes cuts, tears disappear from fabrics. Steady demand. Details free. Fabricon, 6236 Broadway, Chicago 40, Ill.

**PROFESSIONAL** Card reading taught reasonable. Results guaranteed. Winzinger, 7205 33rd St. No., St. Petersburg 14, Fla.

**MAGAZINE** Subscriptions—Largest commissions. Bonus. Qualified Agency, 451LA Kingston, Brooklyn 25, N. Y.

**EARN** Big money at home! Operate your own mailing list business. Complete details prepared by expert. \$1. Klein, Box 109, White Plains, N. Y.

### BOOKS, PERIODICALS, PICTURES, POSTCARDS

**MAGAZINES**, Comics. Wholesale-retail catalogue 10¢. Stamps or coins. Backdates. 1181 E. Lombard, Baltimore 2, Md.

**FREE** Catalog. Self-help books. Write: Wilshire, 8721 Sunset, Los Angeles 46P.

**ALASKA!** Informative, interesting booklets, magazines! Send \$2.00. Alaska Specialties, Ketchikan, Alaska.

**EDUCATIONAL**, Business opportunity, personal improvement books. Rainone Publications, Middle Village 79, New York.

**"SCIENCE** Milestones." Records march of science starting 400 years before Christ, right up to date. Amazing facts revealed. 312 pages packed with startling information that will thrill you. A real history of science. \$5.00. Literature free. Popular Mechanics Press, 200-SM East Ontario St., Chicago 11, Ill.

**JOHN** Friend, bookfinder, can get the books you want. Free search service. Box 2570PM, Long Beach 1, California.

**EXCITING** Catalog packed with books covering most everything. Think of it—From cover to cover you will find described and illustrated hundreds of books telling how to fix and how to build almost anything. How to remodel your home: do your own decorating, plumbing, electrical work, carpentry, painting, furniture making and refinishing. How to build your own boat, home workshop tools. Best books on photography, welding, hobbies, homecraft. How to make a home freezer. Send now for 1958 book catalog—only 10¢. Popular Mechanics Press, 200-BC E. Ontario St., Chicago 11, Ill.

**NATIONAL** Geographic Magazines, 1888-1956. Periodical Service, Box 465-PM, Wilmington, Delaware.

**RARE** Magazines, catalog 10¢. Nationwide Exchange, Box 1375-P, San Antonio 6, Texas.

**BOOKFINDERS!** All subjects. Send wants! Jaher Book Service, 183 Hazelwood Drive, Westbury, N. Y.



**OUT-Of-print books at lowest prices!** You name it, we find it! Past service. No obligation. International Bookfinders, Box 3003-PM, Beverly Hills, Calif.

**AMAZING** Free catalog British books. Any subject. Transbooks, Box 1-PMZ, Wantagh, N. Y.

**500 ENJOYABLE**, Helpful, informative, instructive books. Dime brings valuable catalog. Richman, 253-A West 14th St., New York 11, N. Y.

**10¢ BOOKS**, 1800 Titles. Catalog 10¢. Lincoln's, 1501 East Oklahoma, Enid, Okla.

**BRAD Lee's** "Your Politics" and "Operation Cobalt." 25¢. Box 8, Forest Hills 75, N. Y.

### MAGIC TRICKS, PUZZLES, JOKER NOVELTIES

**279 MAGIC Tricks** only 15¢. Bookmaster, 2432 Fernwood, San Jose 6, California.

**3100 NOVELTIES**, Jokes, tricks, gadgets, funmakers, hobbies. Big catalog 10¢. Johnson-Smith, D-491, Detroit 7.

**STINKERS**, (El Skunko), 35 for \$1.00. Potent! (Harmless!) "Ameri-Trix," Philadelphia 44.

**PROFESSIONAL Catalog**, 175 pages, 25¢. Williams, 900 Plymouth, Ellwood City, Penna.

**BREAKAWAY Fan** 50¢ (Comedy magic!) Catalog free! Box 1352-PM, Philadelphia 5.

**WORLD'S** Finest professional magic. Joker novelties. Giant illustrated catalog 10¢. Top Hat, Evanston 12, Illinois.

**BE A magician!** Large professional catalog of latest tricks. 35¢. Ireland, C-109 North Dearborn, Chicago 2, Illinois.

**COMEDY Juggling props** \$3.50. (Easy! No skill!) 4462-PM Germantown, Philadelphia.

**SMOKEBOMBS**, Gigantic! 25¢. 7—\$1.00. (Nonpoisonous.) 4463-PM Greene, Philadelphia 44.

**PATEST Service** to magicians for over 30 years. Send 10¢ for Douglas famous catalog, 500 tricks, containing magic for pocket, parlor, stage, with balls, coins, cards, cigarettes, ropes, silks, apparatus. Douglas Magicland, Dept. 10, Dallas, Tex.

**"VENTRILLO,"** Voice-thrower 25¢. Ventriloquist puppet 75¢. Box 971-PM, Philadelphia 5.

**CLOWN.** "How to Be a Clown" for fun or profit. Professional copyrighted instructions with makeup and expression charts. \$1. Enterprises, Box 7755, Washington 4, D. C.

**ITCHING Powder**, trick matches, cigarette loaders, 13 packages \$1.00. Arlane's, Philadelphia 44.

**VENTRILLOQUISM**, easiest method. Details free. Smith, 2125 N. Bigelow, Peoria, Ill.

**WHOLESALE!** Thirty 10¢ trick novelties \$1.00! (Profit!) 1746-PM Market, Philadelphia 3.

**25¢ JUMBO Rabbits** feet \$12.00 gross. 39¢ pens, \$1.60 doz. (carded). Pocket stamp 80¢. Comic licenses (150) \$2.25. Prepaid. Collanders, 19½ Crossman, Jamestown, N. Y.

**GIANT** Twenty foot burning stinky bomb. Makes 640 disgusting stinkys, \$2. Kits, 1452 Drake, San Pablo 10, California.

### COINS, TOKENS, CURRENCY

**60 ASSORTED** Coins, \$1.00. 60 assorted bills, \$1.00. Oddehon, Box 482, St. Louis, Mo.

**READ "Collecting U. S. Coins for Pleasure and Profit"** illustrated book. Send one dollar for the book and our buying list. Texas Coin Exchange, Inc., 2011 Cedar Springs, Dallas 1, Texas.

**7 DIFFERENT** Icelandic coins. Sent postpaid \$1.00. P.O. Box 809, Reykjavik, Iceland.

**RAREST** CC mint dollar 1885 uncirculated \$5.00. Illustrated catalogue 25¢. Schultz, Salt Lake City 10, Utah.

**START** Your own coin collection. Information, price lists, 10 different dates. Lincoln cents prior 1921, \$1.00. Louis Bell, Masonic Building, Decatur, Alabama.

**CANADA** Ten different large cents \$1.00. Thirty different small cents \$2.00. Philacoin, Regina, Canada.

**SHOCKINGLY** Low prices! U. S. coins. Astounding list only 10¢. Hugh's, 522-P, Second Ave., N.W., Hickory, N. C.

**PROOF**-Sets of coins. 1958 set only \$2.75; 1957, \$3.00; 1956, \$4.00; 1955, \$6.00; 1954, \$7.00; 1953, \$12.00; 1952, \$18.00; 1951, \$29.00; 1950, \$47.00. Complete set 1950-1958 inclusive, \$120.00. Postpaid. Prompt shipment. Money-back guarantee. Free price list. Dan's—Dan Morafka, A.N.A., 1946 Clement Street, San Francisco 21, California.

**OLD Money** wanted. Do you know that coin collectors pay up to \$100.00 for certain U. S. cents? And high premiums for all rare coins? We buy all kinds. Send 5¢ for large coin folder. May mean much profit to you. Numismatic Co., Box 750-A, Costa Mesa, Calif.

**LET'S** Get acquainted special—Scarce Lincoln cents 1909vdb, 1916s, 1921s, 1923s, 1924s. 25¢ each or all five \$1.00. Free price lists with order. Reynolds Coin Shop, Kresge Bldg., Flint 2, Michigan.

**BEAUTIFUL** Silver Mexican peso \$1.00. Whittle, Box 4414, El Paso, Texas.

**JOIN "Coins of the Year"** club. Receive sets yearly. Box 376, Magnolia, Arkansas.

**GET Profit** and pleasure in collecting old coins. Send 10¢ for 56-page illustrated coin catalog. You'll be delighted with it. Send for it now. B. Max Mehl, Box 750-B, Costa Mesa, Calif. Largest rare coin establishment in U. S. Established 58 years.

**32 PAGE** Informative U.S. illustrated coin list 10¢. Stoney, 192 Washington, Boston 8, Mass.

**COINS** From Formosa, Vatican, etc., plus foreign banknote, 10¢ with coin approvals. Littleton Coin Co., Littleton 81, New Hampshire.

**BARGAINS**, U.S. coins: 1893 Columbian world's fair half dollar, \$1.00. Ten different Indian pennies, 75¢. Two-cent piece, and 3-cent piece, \$1.00. Gold ¼ eagle, \$9.00. Gold ½ eagle, \$12.50. Beautiful coin bracelet, \$1.00. Many coins available. What do you need? Rare Coin Company, 31 North Clark, Chicago 2.

**COMPLETE** United States coin bargain lists, Indianhead cent, 10¢. Economy Sales, 156-A Dean, Mansfield, Mass.

**INDIAN** Cent plus Bargain Lists 10¢. Hutchinson's, Box 4747, Philadelphia 34, Penna.

**COIN** Collector's Magazine, large gloss illustrated pages. Sample 25¢. Subscription \$2 year. "Flying Eagle," 229 South 11th St., Newark, N. J.

**BRILLIANTIZE** Coins safely. Prepaid, guaranteed \$1.00. Stephenson's, Inc., Ames, Iowa. Dealers needed.

**LINCOLN** Cents—1916-S, 1917-S, 1918-S, 1921-S, 1923-S, 1924-S all for \$2. Gasser's, Box 34615, Los Angeles 34, California.

**LARGEST** Coin magazine. 180 pages, 35¢. Scrapbook, 7320-J Milwaukee, Chicago 31.

**6 DIFFERENT** Canadian cents before 1937 in Whitman coin board, plus "Canadian Bulletin" \$1.00. Maries, Box 833, Calgary, Canada.

**STARTER** Collections. 20 different Indian cents \$2.50; 13 different liberty nickels, \$2.50; 20 different Barbour dimes \$5.00 in folders, postpaid. Prager, 470 27th Avenue, San Francisco, Calif.

**1958 GIANT** U. S. coin catalog 25¢. Ace, 107 N. Dearborn, Chicago 2.

**UNCIRCULATED** Silver dollars. 1879-O through 1885-O, \$2.50 each. Butts, East P. Torrington, Wyo.

**WORLD'S** Greatest bargain catalogue \$1.00. (Deductible on \$10.00 order.) 1959 Guidebook \$1.75; premium handbook \$1.00. Any 5 Whitman folders \$1.75. Large dollar bill \$3.75. \$5.00 gold \$11.95. 1958 proof set \$2.65. Bebee's, 4514 North 30th, Omaha 11, Nebraska.

**SAN Francisco** mint closed! The 1955 cents and dimes are in short supply and great demand. The pair brilliant uncirculated for 25¢. Free coin lists. Bryson Incorporated, 612A White, Toledo 5, Ohio.

**TWENTY** Different Indian cents \$2.50; list. Collector's Bargains, New Hope, Penna.

**U. S. commemorative**, uncirculated and bargain list, \$1. Delmaco, Box 1123, Wilmington 99, Del.

**LINCOLN** Cents: 1921-S, 1923-S, 1924-S, 1925-S, 1926-S, 1928-S, 1933-D, 1927-S, only \$3.00. Berry, Box 306, Westminster, California.

**WOW!** Silver dollar. Brilliant, uncirculated. 1879-P only \$1.50! Postpaid. And you get our new price list with it free! Free also, with your order a brilliant, uncirculated, Mexican coin! Thousands of coins in stock. Proof sets. Gold. Silver dollars. Cents, etc. We also buy coins. What do you have? And please name your price. Postal Products Company, Fast Mail Order, Joe Gordon, A.N.A., 5614-MC California Street, San Francisco 21, Calif.

**100 MEXICAN** Coins \$1.00. Coins, 328 Eleventh, West Bend 2, Wisconsin.

### STAMP COLLECTING

**LOOK!** Six different Queen Elizabeth mint sets! Dominica, Gibraltar, Virgins, etc. 21 bicolors, 25¢! Attractive approvals! Gannon Stamps, Box 931, Canton 1, Ohio.

**FREE** Two sets French Colonies, approvals, 10¢ handling. R. Butler, Worthington, Missouri.

**500 DIFFERENT** Worldwide 50¢. Doreen Sales, Box 21, Galesburg, Illinois.

**50 DENMARK**, 10¢ With approvals. Salsman, Box 702, Berkeley, Calif.

**FREE** 5 Mint British Colonies to approval applicants. Handling 5¢. Miller, Box 600, Gulfport, Miss.

**FREE** Mint set! Request approvals. Stampco, 5151 Princeton, Memphis 17, Tennessee.

**FREE!** 15 Mint French Colonies; interesting approvals accompany. Tropicana, Box 449M, Hollywood, Fla.

**FAMOUS** Americans, old U. S. flags, presidents, commemoratives with approvals, free gift, 10¢ handling. Metropolitan Stamps, Box 312SE, Jackson Heights, N. Y.

**50 LARGE** U. S. commemoratives 10¢ with approvals. Jack Clancy, Box 2187, Portland 14, Ore.

**66 DIFFERENT** France only 10¢ with approvals. Eppley, Box 501, Bensenville, Ill.

**FREE!** Giant bargain catalog—New edition listing thousands of bargains including U. S. and B. N. A. stamps, packets, mixtures, albums, accessories and supplies; sent with beautiful approvals. Jamestown Stamp, Dept. E88PM, Jamestown, N. Y.

**115 DIFF.** 10¢; 1000 Mixed 60¢; 5000, \$2.50. Harris, Belleview, Florida.

**SILVER** Box mystery. Over 100 stamps. Approvals. \$1.00. Schoepfer, Box 93, Queens Village 29, New York.

**GIGANTIC** Collection free. Includes triangles, early United States, animals, commemoratives, British Colonies, high value pictorials, etc. Complete collection plus big illustrated magazine all free. Send 5¢ for postage. Gray Stamp Company, Dept. PM, Toronto, Canada.

**FREE**—Valuable U.S.A. (1) Scarce genuine postage stamp picturing first U.S.A., issued in 1847! (2) Big collection 30 all-different United States; ancient 19th century, valuable \$1 stamp, etc. (3) Collection beautiful commemoratives. (4) Collectors guide; big 64-page bargain catalog including all U.S. postage issues; other exciting offers! Send 10¢ for mailing expenses. Harrisco, 4166 Transit Bldg., Boston 17, Mass.

**TOPS!** Free book, "How to Collect Stamps." Send for your copy today! Approvals. Littleton Stamp Co., Littleton 81, N. H.

**FREE**—Mint British Colonies from North Borneo, Caymans, Seychelles, Dominica, Papua, New Guinea, Sarawak, Brunei. Free with approvals. Viking, Great Neck 8, New York.

**100 DIFFERENT** U.S.—50¢. Approvals. Utechs, 1134D North Keeler, Chicago 51.

**FREE!** 15 Different Manchukuo, plus world's only octagonal stamp, plus Abyssinia Red Cross set; to those requesting approvals. C. S. Cleveland, 808 North Humphrey, Oak Park, Illinois.

**WOW!** 110 All different Germany 10¢. Zeppelins, semi-postals, airmails, high values, etc. Giant catalog, bargain lists included with beautiful approvals. Jamestown Stamp, Dept. A88PM, Jamestown, N. Y.

**NEWFOUNDLAND** 30 Different \$1.00. Free list. Burts Stamps, Lewisporte, Newfoundland, Canada.

**FREDERICK** Chopin, Croatian Legion, airmails, first U.N. set, packets, surprises, free with purchases. Details, approvals. Stamp Farm, M2-2, Oxford, Wis.



U. S. Mint flag set, complete, \$1.00. Free list, Brooks, 2323 Avenue X, Brooklyn 35, New York.

SEND For your free copy of the Peter Postage Price List. Hi Dee Co., Box 111, Hillside Branch, New Hyde Park, L. I., N. Y.

VATICAN C1-8 mint. \$1.00 to Vatican approval applicants. Caribbean, Box 266, Miami 45, Fla.

FREE! 50 British Empire. 5¢ handling. Approvals. Kensington Stamps, Buffalo 15, N. Y.

KENYA—Queen set of 6 including 1/- value free. Approvals. Lee Hoover, Box 3594, Portland 8, Oregon.

MONACO "Lourdes diamonds" popes, saints. Free to approval buyers. William Deems, 226c Race, Ravenswood, W. Va.

UNITED STATES. \$1.00 buys 7 fine unused. #643, #645, #646, #651, #657, #680, #688. Approvals accompany. Whitton Faine, Westport 11, Connecticut.

TRADE Your duplicates toward our approvals. (Foreign only.) Details free. Variety Stamps, Box 98-T, Newton Highlands 61, Mass.

BRAZIL: 2000 Used, plus 1000 mint, plus 50 commemoratives, \$2.00. (Registered.) Petteer, Box 72, Fortaleza, Ceara, Brazil.

GERMANY—Large collection commemoratives, pictorials, Hitlers, occupations, etc. 25¢. K. I. Noble, 38-48 Victoria, Fair Lawn, N. J.

AIRMAILS. Forty-nine different, 10¢. Approvals. Valley's, Box 414M, Spring Valley, California.

1000 DIFFERENT With fine approvals. Request details. Jacobsen, Crompond, N. Y.

FREE Stamp wallet, perforation gauge sent to new approval customers. Robert J. Clark, Box 28-P, Wilmette, Ill.

45 DIFFERENT. Surprise. Free to approval applicants. Collier, Chamblee, Ga.

FREE! Large illustrated catalog listing U.S., U.N., B.N.A., Br. Coins; sets, singles, packets, coins and special offers. Extra "How To Recognize Rare Stamps." Kenmore, Milford C960, New Hampshire.

MISSION Mixtures and packets, foreign or U. S. Samples 25¢ each. 6 for \$1.00. Stamps, Box 461, Alexandria, Va.

105 DIFFERENT Worldwide from Liberia, Macao, etc., cataloging over \$2.75 only 10¢. Approvals. Goliath, Bethlehem 11, New Hampshire.

300 FOREIGN. 50 Used U. S. comm., 50 Turkey, 1 surprise pkg. All diff. \$1.00. Perry Stamp Co., Box 432, Lyndhurst, New Jersey.

SPACE Stamps, large pictorials, free! Approvals. Dorf, 186 Covington Lane, Woodbury, New Jersey.

100 DIFFERENT 10¢ With approvals. Roger Davis, 525 Main St., New York Mills, N. Y.

FREE U. S. stamps. 1943 flag, commemoratives included in collection of 25 different, plus valuable \$5.00 stamp. All for 10¢ mailing charge. Approvals. Willett Co., Box 338-A, Yorktown Heights, N. Y.

FREE 50 Worldwide introducing inexpensive approvals. University Stamps, P.O. Box 95, Tamiami Station, Miami 44, Florida.

FREE! Over 100 different, \$2.50 value, including space satellite, Israel, British, U. S., first U. N., Siberia. Approvals, catalogue. Send 10¢ for mailing. Gatewood, Box 346, Winston-Salem, N. C.

WORLDWIDE. 50 All different, absolutely free, just to introduce our incomparable approvals. Kent Stamp Company, GPO Box 87, Brooklyn, N. Y.

64 PAGE U.S. catalog free. Stone, 192 Washington, Boston 8, Mass.

1000 DIFFERENT Worldwide stamps \$1.00. Valued over \$20.00. Universal, Box 6, Kenosha 5, Wisconsin.

14,000 DIFFERENT! Amazing new plan builds your collection systematically, country by country. Only 50¢ weekly. Free details. L. G. Ware, Stepney 75, Conn.

INTRODUCING Our better United States approvals, we offer 15 United States stamps including Columbian, Pan-Pacific, famous American, airs, others; only 10¢. Ocean Stamps, Box 64-PM, Brooklyn 29, New York.

UNITED States price list, 116 pages, price 25¢. Mark Hanna, 335 Fifth Ave., Pittsburgh 22, Penna.

U. S. approvals. Low prices. Eagle Stamps, Romine Ave., Pittsburgh 26, Penna.

ECONOMICAL 1/2¢-3¢ Approvals. 33,000 varieties. Dresel, Box 128-N, West Englewood, New Jersey.

UNITED States commemorative collection containing 33 different—10¢. Approvals. White, 516-A Avenue L, Brooklyn 30, New York.

SELL Your surplus good grade stamps. Write, describing fully what you have. Vanroy Shirk, Lebanon, Pennsylvania.

AMAZING Offer! 200 United States stamps—including commemoratives, airmails, high denominations to \$1.00. Only 10¢ to approval applicants! Illustrated bargain lists free. Mystic Stamp Co., Dept. 80, Camden, New York.

100 STAMPS, 10¢ With approvals. Smith, 508A Brooks, College Station, Texas.

OLD Scarce U.S. seconds on approvals. Slight imperfections, lowest prices. Hernefield, Clintonhill Sta., Newark 8, N. J.

100 OLD United States between 1861 and 1935. \$1.00. Roush Stamps, 51 Chestnut, Mansfield, Ohio.

UNITED States approvals. Select copies, used—mint. Kingsbury, Fairfax, Vermont.

ICELAND 10 Different beautiful stamps for only 10 cents to applicants for our good old fashioned approvals. Old Colony Stamp Co., Dept. A, Milford, Connecticut.

1-2¢ EACH! Thousands of exciting worldwide stamps. Free examination. Cole, Box 223-A, Buffalo 21, N. Y.

225 STAMPS For only 10¢! This mammoth value includes airmails, pictorials, stamps from strange countries cataloging up to 25¢ each! Also approvals. Mystic Stamp Company, Camden 80, New York.

100 DIFFERENT Austria. 10¢. Approvals. Aronson, Box F, Newton Centre 59, Mass.

WEIRD Diamond shape coffee stamps. Lovely flower triangle! First American big commemorative. Greenland, idol dancer, etc. Free with approvals. Capital Stamp Co., Ferrysburg 2, Mich.

25 DIFFERENT Commemoratives 1893 up 10¢. U. S. approvals. K&B, Box 70, Brooklyn 23, N. Y.

FREE Stamp collection. 100 different stamps from Europe, Africa, Asia, Scandinavia, Balkans, etc. 3¢ to approval applicants. Tatham Stamp Company, Springfield 30, Massachusetts.

FROM Fabulous Las Vegas comes the most unique system of building real value collections ever devised. This system developed after years of study by expert philatelists. The one sure way of filling those blank spaces in your album and completing country by country. This system puts your duplicates to work for you and gives you what you want. For limited time only, \$1.00 for one full year's membership. Las Vegas Stamp Service, 558 Oakey Blvd., Las Vegas, Nevada.

TWO \$5.00 United States stamps plus 20 different, 10¢, with United States approvals. Irwin, Box 1105, Brooklyn 30, N. Y.

FREE! 25 Different pictorials. Approvals. Marford, Box 48, Queens Village 29, New York.

FREE 102 Worldwide stamp assortment. Approvals. Send dime for handling. Linstamp, St. Catharines 618, Ontario.

FREE 1958 Illustrated U. S. price list. H & S, 45 Bromfield, Boston, Mass.

SELL Stamps to our readers. Your ad in this space will be read by thousands of stamp buyers. I'll prove that to you. Write now for Folder "S." F. W. Johnson, Classified Advertising Manager, Popular Mechanics, 200 E. Ontario St., Chicago 11, Ill.

FREE 103 British Colony stamps. Approvals. Enclose 10¢ for handling. Niagastamp, St. Catharines 671, Ontario.

FREE Packet! Angola, Azores, Mongolia, Nepal, Palestine. Fascinating approvals. Coral, Box 7095, (Ludlum) Miami 55, Fla.

FIRST U. N. set. Among world's prettiest. Only 10¢. Approvals. Welles, Box 1246R, New York City 8.

ALBUM Only 10¢! Hundreds of spaces! Stampmart Company, Hartford 1, Conn.

MONACO Nudes complete 25¢. Approvals. Royal Stamp Company, Tamaqua, Penna.

FREE! Ghana's first stamp! Approvals. Keating, 2520-P Boulevard, Jersey City, New Jersey.

800 MIXED U.S. Various issues 25¢. Monjar, Fairmount, Cincinnati 14, Ohio.

FREE! Wonderful, new 84 page U. S. catalog. Handling 10¢. Norrisco, Milwaukee 7, Wis.

25 PHILIPPINES 10¢. Worldwide approvals. Moffat's, 740-A Milton, Rock Hill, South Carolina.

## ANTIQUES, RELICS, INDIAN GOODS, CURIOS

SCALPING Knife, spearhead, thunderbird \$4.00. Catalog free. Arrowhead, Glenwood, Arkansas.

## PRECIOUS STONES, MINERALS

SEMI-Precious uncut gems. Ten different for \$1.00. Request list 26. Prospectors Shop, 201 San Francisco, Santa Fe, New Mexico.

EARTH Science, the rockhounds national magazine. Subscription \$2.00. Sample 35¢. Box 1357-PM, Chicago 90, Ill.

ROCKHOUNDS: Free circular. Come visit Heike's rockhound paradise, Wenona, Illinois.

TEN Polished gems, baroque shaped, only \$1.00. Bargain lists, gems, jewelry mountings, 25¢. Gem cutting equipment, 25¢. O'Brien's, 1116N Wilcox, Hollywood 38, Calif.

CUT Gems, make jewelry—For profit or fun. 100 page magazine tells how; where to get supplies. Sample 25¢ or request free literature. Lapidary Journal, Del Mar 2, Calif.

## HOBBIES AND COLLECTIONS

INSECTS Are profitable. Write for want list. No investment. Nature Lab, 12 Prospect St., Bloomfield, N. J.

NAZI Insignia, 12 different \$1.00. Medals, patches, armbands, flags, daggers. Illustrated lists, 15¢. Hobbyland, 1207 1st St., W. Calgary, Canada.

INVENTING Can be an interesting and profitable hobby. Write for complete particulars. Institute of American Inventors, Dept. 40-E, 635-F St., N.W., Washington 4, D. C.

FREE 3-Color American flag armband with order of 100 new military insignias. Postpaid \$2.00. N. Kimmel, 10436 Cheviot Dr., Los Angeles 64, California.

COLLECTORS Matchbook covers. 100 different unused, \$1.00. Catalog 25¢. Album \$3.00. Charles Edelman, 1311-C East 84, Cleveland 3, Ohio.

## CAMERAS, PHOTO SUPPLIES

FREE! Free! Send for your new 72 page photographic catalog. Over 5,000 new and used items at huge savings. For your free catalog, write to Dept. 128. Central Camera Company, 230 S. Wabash Avenue, Chicago 4, Illinois.

150 35MM. Slide titles \$1.00. Benton, 11503 Ruthelen, Los Angeles 47, Calif.

3-D VIEWER. Two scenic, \$2.00. Stereo, 1017 E. Pike, Seattle 22, Wash.

PHOTOGRAPHY For pleasure or profit. Learn at home. Practical basic training. Long established school. Free booklet. American School of Photography, 835 Diversey Pkwy., Dept. 3441, Chicago 14.

## PHOTO FINISHING

KODACOLOR Film processed, 90¢. Prints, 32¢ each. 25% discount with this advertisement. Mayfair Photos, Box 617-M, Toledo 1, Ohio.

SUPERIOR Quality. Prompt service. 8 jumbos in album 40¢. 16 contacts 50¢. Jumbo reprints 5¢. Satisfaction guaranteed. Also complete color film finishing service. Write for free circulars and mailers. Fast-X-Photo, Box A, Jersey City, N. J.

KODACHROME Processing by Kodak. 8mm. roll or 35mm., 20 exp., \$1.35. Prompt service. Write for mailers and prices. Color Pix, Dept. P, CPO Box 30, Kingston, N. Y.

8-HOUR Service on deluxe jumbo prints. 8-exposure roll developed and 8 jumbo prints 40¢. 12 exposure 55¢. 16 exposure 70¢. 35mm. 20 exposure 75¢. 36 exposure \$1.25. Jumbo deckle-edge reprints 4¢ each. Contact prints made if specified. Bay Photo Service, P.O. Box 210, Oakland, California.



**TWELVE** Exposure rolls 39¢. Wallets 20 for \$1.00. Lincoln Studios, Dept. K, Box 13, Lincoln, Nebr.

**CUSTOM** Work—One day service out of lab. 8 exposure 40¢; 12 exposure 60¢; 35mm. fine grain, 20 exposure \$1.00. Jumbo prints. Zipp Photo Co., Box 307, St. Andrew Station, Panama City, Fla.

**TWO** Beautiful prints from each picture on roll. 8 exposure 40¢; 12 exposure 50¢. Thirty-seven years of satisfied customers. Quick Service. Lens Photos, Dept. J-4, Janesville, Wis.

**FREE** Roll 120, 620 or 127 Ansco film to introduce our film developing service. Reg. 50¢. 1 to customer. Return ad with order. Specify film size, print name, address and include 15¢ for handling: Imperial Photo, Dept. 27, Box 124, Dyker Heights Station, Brooklyn 28, N. Y.

**PARTICULAR?** 8 Jumbos—40¢, 12, 60¢. Special: 35mm., 36 exposures \$1.45. Intro. offer. Flash Foto, Box 36M, Brooklyn 4, N. Y.

**FAST** Efficient service. 8 exposure rolls 40¢, 12 exposures 60¢. Merritt Studio, Oakland, Miss.

**TWELVE** Exposure roll developed jumbo size in book 50¢. Other bargains. Write. Gems, Box 1601, York, Penna.

**FAST** Film service. Black and white: 8 exposure 40¢; 12 exposure 60¢; 20 exposure \$1.00. Reprints 5¢. Kodachrome: Processing 90¢. Prints 32¢ each. Anscochrome, Ektachrome \$1.40; Kodachrome \$1.50. Mounted. Finest quality over 40 years. Mailers. Mail Order Photo Service, Box 297, Watertown, Wisconsin.

**12 BILLFOLD** Satin finish and one 5x7. Send negative or picture. \$1.00. Mortimer, Salyersville, Ky.

**PARTICULAR** People send their films to Club Photo, Box 5208, Chicago 80. Trial roll 25¢ with ad, jumbo prints, free mailers.

**COLOR** Processing—High quality, fast service and low prices. Kodachrome developing 85¢; prints 27¢. Kodachrome: 35mm. processing, 20 exposures; \$1.45; 36 exposures, \$2.25. Send for complete price list and free mailers. Photo-Mail, Box 216M, Madison Square Station, New York City 10.

**OIL** Colored 8x10 enlargement complete with never tarnish gold metal frame from any negative, snapshot, or old photo, only \$2.95 work guaranteed. Ambrose Studio, 623 Smithfield Street, Desk 10, Pittsburgh 22, Pennsylvania.

### MOTION PICTURES AND SOUND EQUIPMENT

**16MM.** Sound, projectors, films. Sale, rental, exchange. Visit store or write for catalog. National Cinema, 71 Dey St., New York City.

**5,000 8-16MM.** Movie films. Free catalogues. International, Greenvale, N. Y.

**MOVIE** Camera film: 8mm. roll \$1.50, 16mm. 100' \$3.00. Free processing. Better Films, 742 New Lots, Brooklyn, N. Y.

**SAVE 50%!** Guaranteed-fresh color, b.&w. movie film! 8mm., 16mm. Free catalog! Eso-R, 47th Holly, Kansas City 12, Missouri.

**FREE** Catalog. Save dollars. Fresh 8mm., 16mm. b&w and color film. Home processing equipment. Superior Bulk Film Company, 448 No. Wells, Chicago 10.

**16MM.** Films, sold, bought, exchanged \$5.00. Bryant Supply Co., Emporia, Va.

**FREE!** Blackhawk's big sale catalog 8mm., 16mm. movies, 2"x2" color slides. Biggest selection anywhere! Projectors, cameras, supplies. Big discounts! Get free, every three weeks, 12-page newspaper size bargain list! Blackhawk Films, Davenport 14, Iowa.

**FREE—8-16MM.** film and list. Color and b&w movies of all types. Adrian Co., Dept. M, Box 412, Northridge, Calif.

### MUSIC AND MUSICAL INSTRUMENTS

**VIOLIN** Makers supplies. Free catalog. 309 W. Fourth, Los Angeles 13.

**YOU** Write the words—We write the music. Our songs broadcast currently, recorded by Victor, MGM, Decca. Ethical offer. Jomar Music, Suite 12, 5880 Hollywood Blvd., Hollywood 28, Calif.

**ACCORDIONS,** Wholesale to everyone. Save up to 60%. All national known brands. Free catalogue. Del Principe, 29 South Cicero, Chicago 44.

**VIOLINMAKERS,** Repairers. Fine tone wood, and all violin supplies. Send for free wholesale new price list. International Sales, 414-MPM E. Baltimore St., Baltimore 2, Maryland.

**WRITE** Songs. Big money and reputation. Write for information. J. Gordon Pub. Co., 4700 South California Avenue, Chicago.

**SONGS** Into dollars. Share \$33 million dollars yearly for new songwriters, song poets. Any subject, songs composed, published, promoted by largest firm. Information, appraisal free. Send Nordyke Music Publishers, 6000 Sunset, Hollywood 28 PM, California.

**SONGPOEMS** And lyrics wanted. Mail to: TinPan Alley, Inc., 1650 Broadway, New York 19, N. Y.

**POEMS** Wanted for new songs and recording. Immediate consideration. Send poems. Songcrafters, Box 6145, Acklen Station, Nashville, Tenn.

**YOUR** Songs arranged and recorded for publisher's presentation. For information write: Vance Studios, 3409 Grand Ave., Oakland, Calif.

**POEMS** Wanted for new songs. Send poems. Immediate consideration. Crown Music Company, 49-C West 32 Street, New York City.

**ELECTRIC** Guitars, amplifiers, wholesale. Free catalog. Carvin PMM, Covina, California.

**FREE** Demonstration records. Complete music service for songwriters. Jerry Colonna, Box 888M, Burbank, Calif.

**SONGS** And poems wanted. U. S. Music Studios, Box 222A, Belmont, Mass.

**POEMS** Wanted for musical setting and recording by America's largest song studio. Send poems. Free examination. 630 Five Star Music Masters, Beacon Building, Boston, Mass.

**WANTED!** Poems, lyrics, songs. Publishing. Bengol, 93 Jefferson, Chelsea 50, Mass.

**SONGS** Needed for new record label. Olenik Records, Mount Morris, Michigan.

**ACCORDIONS!** Lowest wholesale prices guaranteed. Save up to 75%. Free home trial. Trades accepted. Free color catalog. Accordion Manufacturers, Dept. 88-R, 2003 W. Chicago, Chicago 22.

**BUILD** Your own hi fidelity sets. Details. Arkay Dist. Co., P.O. Box 581, Church St. Station, New York City, N. Y.

**FREE** Wholesale musical instrument catalog. Complete lines of instruments and accessories. Nationally famous brands. Strauss Music Company, Clifton 70, New Jersey.

**VIOLIN** Bows. Synthetic strands. Regular or ladies' 1 oz. Special, \$3.50 each, postpaid. Reginald Bowman, 1007 Pineheights Avenue, Baltimore 29, Md.

### RADIO, TELEVISION AND ELECTRONICS

**RADIO** Course only \$22.95. Includes all tubes, parts, tools, instructions. Write for full information. Progressive "Edu-Kits" Inc., Dept. 557B, 1186 Broadway, Hewlett, N. Y.

**TELEVISION** Remote control. Regular \$19.95. Limited quantity, \$6.95. Television Engineers, Kenosha, Wisconsin.

**PORTABLE** Radio repairs \$3.00. Transistorized \$5.00. Parts additional. Jerome, Dalton 2, Penna.

**WORLD'S** Tiniest radio. Real deal. Dealers wanted. Radio, P.O. Box 20739, Los Angeles 6, California.

**FREE!** Wholesale bargains. Radios, electronics, inventions, gadgets. Imperial-Z, 2324 N. 3rd St., Milwaukee 12, Wisconsin.

**REJECT** Television sound from your chair, no wires or adjustments to television. Complete kit and instructions \$9.95. Delmaco Products, Box 1123, Wilmington 99, Del.

**GOVERNMENT** Surplus radios, parabolic reflectors, sniperscopes, mine detectors, parts. Catalog 10¢. Meshna, Malden 48, Mass.

**RECORDERS,** Hi-Fi. Free wholesale catalogue. Carston, 215-PM East 88, New York City 28.

**FREE!** Giant bargain catalog. Transistor "Sun" radios, kits, portables, audio, electronics, photographic, optics, tools, household. Write Lektron, 131M Everett Ave., Chelsea, Mass.

**TAPE** Recorders, hi fi components, tapes. Unusual values. Free catalog. Dressner, 69-02M 174 St., Flushing 65, N. Y.

**SIMPLE** Television repairs. Marvelous booklet or book. Send for 1958 book catalog—10¢. Popular Mechanics Press, 633 N. St. Clair St., Chicago 11.

**ELECTRIC** Guitars, amplifiers, wholesale. Free catalog. Carvin, PMR, Covina, California.

### BUSINESS OPPORTUNITIES

**I** Got rich in the dry cleaning business, so can you. Free details. Write: Imperial School of Dry Cleaning, Dept. PMC, 1700 Touhy Ave., Chicago 26, Illinois.

**NEW** Business. Sharpen body and fender files. Necessary machinery easily built and assembled. Free details. E & M Service, 657 Lowell, Denver 4, Colo.

**INTERNATIONAL** Home import mail-order business! Experience unnecessary. Earnings unlimited. Foreign Traders, Meramec Building, St. Louis 5-PC, Mo.

**NEW** Bathroom deodorizer. Hangs on wall. Banishes odors bathroom, kitchen. Lighting seller. Samples sent on trial. Kristee 100, Akron, Ohio.

**AUTOMOBILE** Accessories. Tremendous profits. Exclusive franchises. Steiner, 156M West 86, New York 24, New York.

**MAKE** Extra money. Cash commissions. Everybody buys easy-to-sell advertising book matches. Union label. All sizes. Cuts for all businesses. Powerhouse selling kit free. Steady repeat business. No experience necessary. Superior Match Co., Dept. MX-658, 7526 S. Greenwood, Chicago 19.

**INVISIBLE** Reweaving: \$5 in one hour possible reweaving burns, tears, moth-holes. Spare-full time. Free details. Skill-weave, Dept. C-168, 335 W. Madison, Chicago 6.

**\$200 WEEKLY** Reported! No selling. Free booklet. T. J. Surface, Roanoke 4, Virginia.

**THE** Law says, "You must keep records." Use our "Simplified Mailorder Book-keeping System." Recommended for small businesses, agents, salesmen, self-employed persons, mailorder "beginners," etc. \$1.00. Tasker's, Box 3131, Alexandria, Virginia.

**WANTED:** Home producers, to be subcontractors. Cast plastic products for manufacturers in our clearing house service. Thousands of easily made items required. Cash in at home, without previous experience. Plastic Service Associates, Dept. 8-PM, East Boston 28, Massachusetts.

**CRUDE** Working sample 25¢. Finished \$1. Swanson, 2817 N. 24th Place, Milwaukee 6, Wis.

**WOULD** You like an \$82.50 Heibros men's or women's watch absolutely free? If so, rush 25¢ for details. Jerry Richey, Route 3, Scottsburg, Indiana.

**MONEY** Available for investment in worthwhile mail order enterprise. Will finance your idea if qualified. SMM, Box 432-B, Detroit 31, Michigan.

**GO** In business. My two formulas: Dust Down, and Hand Cleaner, both for \$5.00. Smith, Marlboro St., Hamlet, N. Car.

**OWN** Your own business for less than \$100. Simple, easy. Profits 500-1000%. Learn doll repairing. Write Cradleland Doll Hospital, Little Neck, New York.

**JUST** Mix water with magic powder to make today's hottest biggest profit automobile specialty. \$1 pays \$10.00 and more. No polishes, cleaners, compression seal but faster seller, terrifically new, decidedly different. Details free. Zingo Products, 4346—14th Ave. N., St. Petersburg, Florida.

**SENSATIONAL** Profit opportunity. Amazing new device enables any handyman do professional TV repairs without experience or training. Do most \$5, \$10, \$20 service jobs in half hour. Up to \$200 month easily possible. Evenings, weekends. Big demand. Start immediately. Free! Write Electronic Engineering, Dept. BC-178, 1038 S. LaBrea, Los Angeles 19.

**\$5000 YEARLY.** Spare time at home. Nothing to buy. No local selling. Dignified. Guaranteed. Home Harvest, 1933 Lakeview Road S.W., Albuquerque, New Mexico.

**OPERATE** Profitable mailorder business! Write: Bond, 1637-H West Vernon, Phoenix, Arizona.

**\$400.00 MONTHLY** Raising redworms, mealworms, crickets. Clean soilless method. Free brochure. Charlie Morgan, 116E, Bushnell, Florida.



**MAIL Order!** Succeed with your own proven mail order business. No inventory. We dropship and show you how easy big profits can be made. Write Giftime, 919 Walnut, Dept. 106, Philadelphia 7, Penna.

**FREE!** Secrets — Dollar making mail plans. Unknown! Opportunities, Sumas, Washington.

**CANDIED** Popcorn and potato chip equipment. Eakins, Box 933-A8, Springfield, Ohio.

**"EVERYBODY Likes candy"** — Make professionally home. (Our 47th Year.) Ragsdale Candies, B107, East Orange, New Jersey.

**OPERATE** Mailorder folio business! Details, stamp. Ballard's, 425 East Catherine, Louisville 3, Ky.

**PROFITABLE** Mailorder merchandise business. Everything supplied. Lester, 2311 Foxhills, Los Angeles 64.

**YOUR Own high profit business.** Sell name brands, full or part time. No inventory, no investment. More than 2,000 name brand items; lowest wholesale prices. Watches, jewelry, cameras, hi-fi radios, phonos, appliances, housewares, hardware, power tools, luggage, musical instruments, garden equipment, sporting goods, toys, many others. 8 floors of name brands. Million dollar inventory. Send for free, beautifully illustrated catalog now! Separate dealer price list. H. B. Davis Corp., Dept. 11, 145 W. 15 St., New York 11, N. Y.

**SELL** By mail, 20 lesson course by recognized specialist teaches you how to start in sparetime, with limited capital. Free details. Alfano, 19 Pine, Closter, New Jersey.

**RAISE** Rabbits on \$500 month plan. Plenty markets. Free details. White's Rabbitry, Delaware, Ohio.

**SALES-By-Mail** could be your opportunity. Valuable food for thought free. Rawson Wood, 3974 Milwaukee, Chicago 41.

**BIG Profits** importing, free details! Mullins, 2029 Long Street, Kingsport, Tenn.

**MONEY Plans!** "Secret Journal." Grandpa, two daughters made \$2500 first month! Work home. Publicco, Oceanside, Calif.

**REBUILD** Batteries; repair dolls; make rubber stamps. "75 ideas" free. Universal, Box 1076-A, Peoria, Ill.

**BIGGEST** Money makers in the field: Acme saw and lawnmower sharpeners. Free literature. Max Mfg. Co., 138 Stockton Ave., San Jose 26, Calif.

**TO \$100.00 Weekly.** Sparetime, home operated mailorder business. Successful beginner's plan. Everything supplied. Lynn, 10420-M National, Los Angeles 34.

**LEARN** Real estate by listening to records. Lee Institute, Brookline 46, Mass.

**CAMERA Owners!** Earn \$50.00 week-ends! Instructions \$1.00, information free! Kline, 935-PM North Austin, Chicago 61, Illinois.

**COLORGLAZED** Concrete pottery made without molds. Patented method. Cemetery products, novelties, tiles. Basement leak-sealing. Money-making projects. Booklet, details free. Men only. National Potteries Company, Grand Rapids, Minnesota.

**PIANO** Tuning learned quickly at home. Tremendous field! Musical knowledge unnecessary. Information free. Empire School of Piano Tuning, Champaign, Ill. (Founded 1935).

**BUY** Direct from factories—Appliances, cameras, watches! Free details! Cam Company, 6810PM-20th Ave., Brooklyn 4, N. Y.

**WANT** To make big money at home? \$10.00 profit in an hour possible with invisible mending. Make tears, holes, disappear from clothing, fabrics. Steady year-round demand from cleaners, laundries, homes. Details free. Fabricon, 6234 Broadway, Chicago 40, Illinois.

**\$70 WEEKLY**—Home, spare time. Simplified mail bookkeeping. Immediate income—easy! Auditax, 34757A, Los Angeles 34.

**MINK** Raising information free. Complete. Lake Superior Mink Farm, Superior, E.E1, Wisconsin.

**MAKE** Flexible molds. Cast plaques, figurines. Free sample. Tooker, 1045-R Fairview, Hamilton, Ohio.

**NATURAL** Molding rubber, extra thick. Free sample. W. Woolley, 1016-A Donald, Peoria, Illinois.

**TREMENDOUS** Possibilities in mail order. I retired after five years. Write Norris Cole, 217 West 49th, Bradenton, Florida.

**VENDING** Machines—No selling. Operate a route of coin machines and earn amazing profits. 32-page catalog free. Parkway Machine Corporation, Dept. 26, 715 Ensor Street, Baltimore 2, Maryland.

**I** Want to send you proof of the wonderful pulling power of Popular Mechanics classified pages. What's your proposition? Write me today. Include literature if possible. F. W. Johnson, Manager Classified Advertising, Popular Mechanics Magazine, 200 E. Ontario St., Chicago 11, Ill.

**BIG** Money raising fishworms and crickets. Free literature. Carter Farms, Plains, Georgia.

**11,000 NEW** Prospects daily. Baby record books, shoes, albums. Sell mailorder. Use our literature. Write: No-Co-Ro, Capitola, California.

**BAKE** New greaseless doughnuts in kitchen. Sell stores. Free recipes. M. Ray, 3605 South 15th, Minneapolis 7, Minnesota.

**FIX** Typewriters. Inexpensive home course teaches factory secrets. Free booklet. Athey, Tarentum, Penna.

**PLATE** Baby shoes, jewelry, gifts, bronze and colored pearl. Free booklet. Platex, 11029 South Vermont, Los Angeles 44.

**COPUBLISH** Mail Sale Advertiser, leading mail order paper. Details, latest copy, dime. Vanroy Shirk, Lebanon, Penna.

**FREE** Catalog. Contains hundreds of businesses, farms and income properties throughout U.S., Canada. Specify type and location desired. Deal direct with owners. U. I. Buyers Digest, 1608 Hillhurst, Dept. PM-3, Los Angeles 27, Calif.

**WE** Pay \$3.50 lb. dried. Grow mushrooms. Cellar, shed and outdoors. Spare, full time, year round. We have 25,000 customers. Free book. Washington Mushroom Ind., Dept. 172, 2954 Admiral Way, Seattle, Wash.

**FREE** Book "505 Odd, Successful Businesses." Work home. Pacific, Oceanside, Calif.

**VENDING** Machines make money. Free catalog. Rake, 609P Spring Garden, Philadelphia 23, Penna.

**MARKETS** Everywhere. Make artistic concrete birdbaths, pottery. Chemical coloring. Home workshop. Stucco-rock walls. Hundred varieties. Hollywood Cementcraft, 8527-K Wonderland, Hollywood 46, Calif.

**FREE** Folio "\$5,000-\$45,000, Unlimited Vacations." No merchandise. Unknown! Work home, sparetime! Haylings, Carlsbad, Calif.

**MAKE** \$46 From square foot plywood; jigsaw necessary. Free details. Woodart, Bridgewater, Mass.

**FREE** Picture folder, "How to Make \$3,000 Yearly Sparetime, Backyard, Raising Earthworms!" Oakhaven 38, Cedar Hill, Texas.

**"MAILORDER** Laws and Regulations" and "Mailorder Rules for Beginners." Learn about necessary licenses, different taxes, legal requirements, etc. Both books, \$2.00. Tasker, Box 3131, Alexandria, Va.

**GROW** Orchids at home. Profitable, fascinating. Successful home grower explains special light, temperature and humidity conditions orchids need. Free: Full details. Orchids, 100 S. Vermont, Los Angeles 4.

**\$34.70 TWO** Hours. Manufacturing. No selling. Carlayne Castings, 1803 Fremont, Rapid City, South Dakota.

**MAKE** Money selling recipes and household hints by mail. Information free. Barrett, Dept. CA-27, 7464 No. Clark, Chicago 26.

**MAKE** \$50,000.00 Yearly from home. Informative plans free. Fortune Enterprises, Addison, Illinois.

**LEARN** Sewing machine repairing. To \$125 weekly. Sparetime. Supplies. Add to present business. Write today! Taylor Service, Box 2126, San Bernardino, Calif.

**SEPTIC** Tank truck for sale. Fully equipped. Excellent opportunity. Electric Cesspool Cleaning Co., Boston 34, Mass.

**FINANCIAL** Success through sleep teaching. Free details. Margaret Ruffner, Donna, Texas.

**INDEPENDENCE** For life. Little investment. Men-women. Details. Capt. William Lewis, Tampa 9, Florida.

**LIQUID** Molding rubber, free sample, shellcraft supplies. Chaney's, 1907-A East Road, Jacksonville 11, Fla.

**NO** Door-to-door or store selling. Yet your sales pyramid. Nothing else like it. 70% profit. National, Box 291, Addison, Ill.

**SELL** Dealers, users delayed action switch. Turns automobile headlights off automatically after walking approximately 200 feet. Edco International, 19303 Grand River, Detroit 23, Michigan.

**\$50.00 WEEKLY**—Writing up Bible orders. Stephenson's, Rattlesnake Drive, Missoula, Mont.

**MOTEL** Supplies business and mailorder to institutions. New! High income. Investigate. Hermes Advertising, 152-C West 42, New York City 36.

**BRONZE** Baby shoes: Instructions, equipment and mountings for genuine electroplating process. Largest supplier of all plating equipment, supplies. Free catalog. Hollywood Bronze Supply, Dept. B-3, 1624 East First, Los Angeles 33, Calif.

**FLEXIBLE** Rubber molds for plaster and Marbleite figurines. Sample and large illustrated catalog 25¢, refunded on first order. K-C Novelties, Dept. 83, Southampton, Mass.

**"50 NEW** Home-Business Ideas" booklet. Sample free. Spray exotic Velvet-Suede on anything. Flockcraft-AT, Los Angeles 61.

**START** Your own business on credit (U.S. and Canada). Be your own boss. 1425 dealers sold \$5,000 to \$32,000 in 1957. We supply stocks, equipment on credit. 200 home necessities. Sales experience unnecessary. Pleasant profitable business backed by world-wide industry. Write Rawleigh's, Dept. H-U-PPM, Freeport, Ill.

**GROW** Expensive herbs for us! Big profits home-business of your own. Year around profitability! We supply everything necessary! Send for free rare seeds and revealing plan (State your age.) National Herb Exchange, Dept. AT, Gardena, Calif.

**CASH** From sawdust, tin-cans, newspapers. Over 200 methods. Instructions \$1.00. Charles Company, 12-XAK, Norwood, Ohio.

**GROW** A living miniature forest or orchard (only inches high), that bears tasty tiny fruit at home. Learn amazing dwarfing secrets! Fascinating hobby. Profitable home-business opportunity. Free seeds and plan. (State your age.) Miniature Nurseries, Dept. AT, Gardena, California.

**HOME-Import** mail order business—Import profitable items below wholesale. Experience and product investment unnecessary. Full, spare time. Famous world trader guides you. Free list "157 Imports," details. Mellinger P708, Los Angeles 24.

**WANTED**—Limited number intelligent men and women to work at home on exclusive mail order business proposition. No selling, we furnish everything including literature, names, addresses, stock and ship items for you. Free details. Mail Order Distributors (Franchise Division), AT, Los Angeles 61.

**OPERATE** Profitable mail order business. Write Walter Service, 4159A East 112th, Cleveland 5, Ohio.

**\$250.00 WEEK** Profit possible. Earn at home spare time with fascinating printing method. \$5 starts you. Send no money now. Free confidential facts and valuable samples. Screen-Print AT, Los Angeles 61.

**EXPORT-Import** business made easy. Complete setup service, not just instructions. Hermes, 152 West 42, New York City 36.

**EXCITING** Mail order business. Something new. Guaranteed money makers. Campbells Service, Millwood, Kentucky.

**SUCCESSFUL** Profits in mail order. Write: Sunshine, Box 1686, Boston 5, Mass.

**YOU** May be missing the opportunity of your lifetime without knowing it! Alert yourself to profits in the booming franchise field. Distributorships, dealerships, agencies, retail operations available nationwide. Stop looking, start earning! Request interesting details today. National Franchise Reports, W-528, 333 North Michigan, Chicago 1.

**EXCLUSIVE** Distr. Amazing discovery! Crushed, redwood cedar! Add water, brush on. Cedarizes closets, cloak, powder, rest rooms! Stores, homes, builders, hotels, clubs, schools, theaters big buyers. Free kit! Plant, 90 Summit, Brookline, Mass.

**WANTED** To buy: A mail order business or correspondence course, active or inactive. Armstrong Enterprises, 520 N. Michigan, Room R-929, Chicago 11, Illinois.



**OPPORTUNITY Knocks**—Learn to repair digs, cigarette burns, etc., on furniture without refinishing. Latest piano factory methods. Very small investment brings tools, supplies, and instructions. Personal instructions in piano tuning also given. Details free. Bethel Piano Co., 226 Greenwood Ave., Bethel, Conn.

**CRAZY Cards.** Two sets 25¢. Catalog free. Dohn-GA-Marks, Broadview, Ill.

**EARN Money.** Sharpen cutters, scissors, saws. Precision machinery. Treycro Products, N. Tonawanda, N. Y.

**GET Into** the profitable rental business, free plan. Beran Manufacturing Company, 906 Dullin, San Antonio 10, Texas.

**BUY Wholesale!** 30-80% discounts! Nationally famous brands. Typewriters, housewares, appliances, watches, furniture, musical instruments, cameras, tools, etc. Consolidated Distributors, Clifton 1, New Jersey.

**QUICK Profits, with no capital!** Take orders for magazines your neighbors like, want. Make cash on the spot! We show how with free kit. Get yours now. Write McGregor Magazine Agency, Dept. 310, Mount Morris, Ill.

**MAIL Order** advertising agency executive reveals sensational no-risk advertising and merchandise methods. Start in office or home; minimum capital; positive profits. Free details: Impact! 3407 Prospect Avenue, Dept. 11-8, Cleveland 15, Ohio.

**BUY Wholesale!** 100,000 nationally advertised products. Appliances, cameras, sporting goods, housewares, watches, typewriters, tools, clothing, etc. Discounts to 80%. Buy-Rite, Box 258, Hawthorne 1, New Jersey.

### MONEYMAKING OPPORTUNITIES

**MAKE Money** writing short paragraphs! No tedious study. I tell you what to write, where and how to sell; and supply list of editors buying from beginners. Many small checks add up quickly. Write to sell, right away. Send for free facts. Benson Barrett, Dept. C-27-V, 7464 Clark, Chicago 26.

**TREMENDOUS Profits** making Mexican foods. Instructions \$1.00. John Currie, Box 2756, San Antonio 6, Texas.

**FREE!** Money-making homework opportunities galore. Write: Soles Service, Windsor, Missouri.

**BIG Profits** quick! Make and sell costume jewelry. Details free! Modern Craft, Box 11088-M, St. Petersburg 33, Florida.

**TWO New folios.** Coins, driving. Write Patterson, 1916 Elm, New Albany, Indiana.

**OWN A** collection agency. Pays big. Franklin Credit, Roanoke, Virginia.

**MAKE \$5,000** Yearly sparetime raising mink, chinchillas, nutria, etc. Free booklet reveals proved plans. Write Pura, 588 Mt. Pleasant Road, Toronto 1, Canada.

**STAMPED Envelope** brings opportunity mail. McClellan, Box 7212MI, San Antonio, Texas.

**\$15,000 PROFIT** In one year possible, on \$5.00 weekly. Fabulous but true. Minimum of attention, respectable field. 15% profit can be guaranteed. Experience unnecessary. Proof, complete detailed plan, only \$1.00. Satisfaction or refund. Columbia Enterprises, 8203-P, Grubb Road, Silver Spring, Maryland.

**BUY Wholesale!** 30-80% discounts! Nationally famous brands. Typewriters, housewares, appliances, watches, furniture, musical instruments, cameras, tools, etc. Consolidated Distributors, Clifton 2, New Jersey.

**BOOKS;** Hundreds of subjects. Big 1958 book catalog—10¢. Popular Mechanics Press, 200-BC East Ontario St., Chicago 11.

**OPPORTUNITY Earnings** to \$20.00 per hour part, full time proven business, tobacco line. Franchise details. Henford, Dept. PM, P.O. Box 59, Paramus, N. J.

**MAKE Over \$300** monthly at home with typing and direct mail. 42 page booklet tells how I did. \$2. Bea Johnson, Box 7454, Atlanta, Ga.

**TODAY'S** Newest booming spare time business is coin-operated laundries. Fact-filled report \$1.00. Laundrette, 681 Portola Drive, San Francisco, California.

**\$100.00 WEEKLY.** Raise redworms soil-less way. Charlie Morgan, Bushnell, Fla.

**AMBITIOUS?** Become realtor, lecturer, minister, public adjuster; other dignified, lucrative professions. Auriad, Central Valley, New York.

**PROFIT-Makers** all lines. Huge discounts. Home opportunities. Free illustrated details. Trello, 14042 Erwin, Philadelphia-16E.

**DISTRIBUTE** Wholesale catalogs at \$1.00 profit each. Send \$1.00, refundable, for sample, details. Discount, Box 1660, Chicago 90.

**MEN—Women!** Start money-making plastic laminating business at home in spare time. Material that costs 11¢ brings back \$2.50. No canvassing or selling but mail orders bring in \$20 a day. Write for full particulars free. Rush name on postcard to Warner, Room CL-2-H, 1512 Jarvis, Chicago 28, Ill.

**EARN Money** evenings copying and duplicating comic cartoons for advertisers. Adservice, Box 133, Station "E," Louisville 8, Kentucky.

**EASY To start** rubber stamp business at home in spare time. Make up to \$9.80 an hour without experience. Facts free. Write to Roberts, 1512 Jarvis, Room CR-2-H, Chicago 26.

**WIN Contest** money. General Contest Bulletin gives hundreds of tips. Lists current contests, rules. Sample magazine 25¢. General Contests, 1609½ East 5th, Duluth 12, Minnesota.

**MAKE \$200.00** Monthly spare time with jigsaw. Free details. Elkman, 346F North Summit, Sioux Falls, South Dakota.

**MAKE Money**, operating mail order business, selling business cards. Vosacek Printing, 4444A Ute, San Diego 17, Calif.

**START Big-pay** business at home in spare time. No experience needed to operate little table-top machine for bronzing baby shoes. Make \$5.46 profit on every pair. Full particulars free. Send postcard to Mason, 1512 Jarvis, Room CM-2-H, Chicago 26, Ill.

**CIGARETTES—**Improved roller makes 20 for 9¢. Facts free. Moberly, Box 821, Owensboro, Kentucky.

**AMAZING** Successes through franchises! Become exclusive franchise holder your territory. Information rushed. National Franchise Reports, 333 North Michigan, Chicago 1.

**FREE Folio** "\$5,000-\$45,000. Unlimited Vacations." No merchandise. Unknown! Work home, sparetime! Haylings, Carlsbad, Calif.

**READ Progressive** Mailtrade, the magazine that tells how to make money by mail. Dime brings sample and special offer. Progressive Mailtrade, Box 357, Sheboygan, Wisconsin.

**BIG Money** raising, fishworms and crickets. Free literature. Carter Hatchery, Plains, Georgia.

**SELL Titania** gems. Far more brilliant than diamonds. Catalog 10¢. Diamonite, 2420-M 77th, Oakland 5, California.

**VENDING Machines—**No selling. Operate a route of coin machines and earn amazing profits. 32-page catalog free. Parkway Machine Corporation, Dept. 27, 715 Ensor Street, Baltimore 2, Maryland.

**JOIN The** prosperity parade with a mail order bookshop in your own home. Valuable information free. Practical Publications, 3974-P Milwaukee, Chicago 41, Ill.

**WE Pay \$3.50** lb. dried. Grow mushrooms. Cellar, shed and outdoors. Spare, full time, year round. We have 25,000 customers. Free book. Washington Mushroom Ind., Dept. 173, 2954 Admiral Way, Seattle, Wash.

**FREE "4000 Word Report"** on new depression-proof business opportunities. Fortune Enterprises, Addison, Illinois.

### FORMULAS, PLANS, ETC.

**BOOK 10,000** Formulas \$5.00. A. Hanlon, Malvern, Penna.

**75 ONE** And two ingredient formulas, \$1.00. Frost, Box 852, Passaic, N. J.

**PRACTICAL** Formulas. Lists free. Cummings, Chemist, Gordon Ave., Syracuse 4, N. Y.

**LATE, Modern** manufacturing formulas. List free. Moon Chemical, Martville, New York.

**FORMULAS** For latest money-making discoveries. New! Good! Valuable literature free! Miller, Chemist, 1517-D, Tampa, Florida.

**FORMULA:** All kinds, latest, best. Literature free. Kemixal, Park Ridge, Ill.

**MANUFACTURE** Profitable specialties. Free literature plus sample formula. Alpha-Midwest, La Porte, Indiana.

### PLASTICS

**LAMINATING** Supplies. Free price list. Solomson, 46 Cornhill, Boston 8, Mass.

**BOXES, Plastic.** Free list. Althor, 170 Bay 23 Street, Brooklyn, N. Y.

**PLEXIGLAS.** Square foot cost, 1/16" \$1.20; 1/8" \$1.52; 3/16" \$1.86; 1/4" \$2.21; 3/8" \$3.23; 1/2" \$4.36. Colors add 10%. Send 15¢ for postage. Artistocrat Plastics, 23 Sussex Avenue, Newark, N. J.

**LEARN** Plastics fabrication for spare time income. Low cost home training now available. Write for free booklet. Interstate Training Service, Dept. D-3, Portland 13, Ore.

**PLASTICS—**Plexiglas, acetate, vinylite, polyester, fiberglass, epoxy, styrofoam, polyethylene, mold materials, cements, supplies. Instructive, informative wholesale-retail catalog, 25¢. Gem-O-Lite, 5527 Cahuenga, North Hollywood, Calif.

**ADHESIVE** Backed foam tape. 101 uses for do it yourself trade. 162 inch roll \$1.00 postpaid. Little Falls Import Co., Little Falls, N. J.

**EIGHT Laminations** \$1.00. Sample free. Al Gehm, 559 Tonawanda, Buffalo, N. Y.

**PLASTIC** Sheets. All types, plexiglas, acetate, vinylite, laminating plastics, and supplies. Covers, folders. Free price list catalogues. Arthur Blank and Co., 44 Causeway, Boston 14, Mass.

**PLASTIC** Catalog. Includes mold making, casting instructions, 25¢. Gel, Box 251, Union, N. J.

**PLASTICS!** Casting, molding, modeling and accessories. Illustrated catalog 25¢. Castacraft Corp., Dept. C-64, P. O. Box 555, Palo Alto, California.

**NEW Liquid** casting plastic, clear, colors. Embed real flowers, coins, photos. New Manual shows fine things you can make at home and sell at big profit. Send 25¢. Castolite, Dept. J-101, Woodstock, Illinois.

### CHEMISTRY

**EXPERIMENTERS:** Bargains galore catalog, 25¢ (refundable). Hagenow Laboratories, Manitowoc, Wisconsin.

**CHEMICALS** And apparatus for industrial, analytical, and private laboratories. Catalog 25¢. Dept. M-50, Biological Supply Co., 1176 Mt. Hope Ave., Rochester 20, N. Y.

**ILLUSTRATED** Catalog: Chemistry, mineralogy, biology 25¢. Tracey Laboratories, Evanston, Illinois.

**ROCKETS!** Large, comprehensive volume, \$1.00 postpaid. Fabian's, 4370-D Clark, Montreal 18, Canada.

**GIANT** Illustrated catalog of chemicals in small quantities, apparatus, glassware. Send 25¢. John H. Winn, 124M West 23 Street, New York 11, N. Y.

**CHEMICALS.** Glassware catalog 25¢. Laboratory Sales, Box 161-A, Brighton, Mass.

### AGENTS WANTED

**NEW** Combination aluminum door stop with built in weatherstripping. Wholesale \$5.95. Free details. Alumalife Industries, Hamonton, N. J.

**\$25 DAY.** Easy. New fire extinguisher. Retail \$2.95. Profit \$2.00. Free sales kit. Edconco, 115 East 44th Street, Dept. P8, New York 17, New York.

**HAWAIIAN** Candy gifts. Catalogue 20¢. Maier Products, 3109 Waialae, Honolulu.

**NEW** Car thief signal: Lightning seller. Samples sent on trial. Northwest Electric, 91, Mitchell, South Dakota.

**BIG** Profits. Stamp social security plates, key protectors. Sample 50¢. Catalog free. General Products, 188-PM State, Albany 10, N. Y.

**GOLD** Or silver letters, numbers. Windows, doors, trucks. 1" to 6". 500% profits. Free samples. Atlas-T, 544 West 79th, Chicago 20.

**PRINTING,** Advertising salesmen—Excellent money-making sideline selling decalcomania name plates, small quantities. Automobile initials, sign letters. Free samples. Ralco, XL, Boston 19, Mass.



**FREE Sample!** Beautiful feather pictures. Sylviak, Apartado 9036, Mexico 1, D. F.

**AGENTS — 300% Profit** selling genuine gold window letters; stores and offices. Free samples. Metallic Sign Letter Co., 1217-D West Newport, Chicago.

**EASY Handwork** makes fast-selling useful articles. Sample free. Sunmade Company, Brockton 64, Massachusetts.

**YOUR Own business — Used suits \$1.50, overcoats 65¢, mackinaws 35¢, shoes 12½¢, ladies coats 30¢, dresses 15¢.** Enormous profits. Catalog free. Nathan Portnoy Associates, 2109-AA Roosevelt Road, Chicago 8.

**BE The Popular Mechanics** representative in your neighborhood and earn big profits in your spare time. Write Popular Mechanics Magazine, Room 305M, 200 E. Ontario St., Chicago 11.

**WHOLESALE Clothing catalog** plus real merchandise samples. Bostonian, 14-B Dock Square, Boston 8, Mass.

**SEND No money, just your name,** for 21-card assortment of beautiful Christmas cards on approval. Show sensational \$1 value to friends, neighbors. \$75.00 to \$500 possible between now and Christmas. We'll include free catalog with 76 other money makers; also free samples popular name-imprinted cards. Wallace Brown, 11 E. 26th St., Dept. H-242, New York City 10.

**NEW Invention—Patented, low cost consumer product, no competition, million dollar potential.** Write Austin Co., 3440 Main, Hartford, Conn.

**RUN A spare-time greeting card and gift shop at home.** Show friends samples of our new 1958 Christmas and all occasion greeting cards and gifts. Take their orders and earn to 100% profit. No experience necessary. Costs nothing to try. Write today for samples on approval. Regal Greetings, Dept. 84, Ferndale, Michigan.

**EARN \$12,000 Yearly—Only two sales daily.** World best seller, the Holy Bible. (Illustrated) Protestant or Catholic. Margareta's, P.O. Box 92, Hazleton 7, Penna.

**EXCLUSIVE Line** of personal initialed buckles, belts, cap badges, 3000 emblems. Hook-Fast, Dept. PM, Roanoke, Va.

**\$13.50 HOURLY Profits possible,** introducing 5 valuable farm books your area. Published by Popular Mechanics. Farmers buy on sight. Details free. Popular Mechanics Press, 200 E. Ontario, Dept. 64-B, Chicago.

**EXCLUSIVE Territories! Hottest automotive item ever!** \$1.00 seller, up to 300% profit. Fantastic demonstrator. Sell retail and wholesale. Maco Products, Falls Church 4, Virginia.

**YOUR Ad in this space** will get some good agents for you. Yes, I'll prove it. Write for Folder "A" right now. F. W. Johnson, Classified Advertising Manager, Popular Mechanics Magazine, 200 E. Ontario St., Chicago 11, Ill.

**DAMASCENE Earrings!** Exotic oriental-ism. Huge profit. Ohga, PM-115, Sigakokusatu, Japan.

**I'LL Send you free stocking sample** newest advancement in hosiery since discovery of nylon. Full-length; stays up without supporters; amazingly comfortable. Patented. Make money fast introducing to friends at 70¢ a pair less than nationally advertised price. American Mills, Dept. 657, Indianapolis, Ind.

**GOLDMINE Of 600 money makers.** Free copy. Specialty Salesman Magazine, Desk 5B, 307 North Michigan, Chicago 1, Ill.

**STAMPED Linens** for embroidery or painting. Buy direct from manufacturer and save. Send for free catalog. Merrilee, 16 West 19th St., Dept. 331, New York 11, N. Y.

**MAKE Your spare time profit time!** Over 700 fascinating items! Gifts for men, women, children, the home! Distinctive greeting cards, stationery, toys, novelties, jewelry, cosmetics, gadgets at prices to fit every pocketbook. No minimum order. Make up to 92% profit! Write today for exciting details, colorful catalog. Greetings Unlimited, 8-194 Park Square, St. Paul 1, Minn.

**SELL Beautiful paintings** at give-away prices. Imported. Hand painted by oriental artists on silk canvas. Framed in carved cedar. Look like \$60 value. Sample \$2.50 postpaid. Free details. Hrebenyar Company, 4436-C Hamilton Scipio Road, Hamilton, Ohio.

**MEN And women — 122% profit** selling nationally advertised famous Turtle Wax-Plastone products for car and home. Finest quality made. Unconditionally guaranteed. Super fast and easy to use. Amazing 30-second demonstration. Products now sold in over 100,000 stores around the world. Choice restricted territories open. Large, continuous all-year earnings. Unlimited sales field. This is the first sales opportunity in 10 years with our company. Act now! Send today for free details. Plastone, Dept. OI-8, Chicago 51, Illinois.

**CHRISTMAS Cards—Impressive album** of personal and business designs, with customer's name imprinted on both cards and envelopes. Deluxe cards that pay deluxe commissions. Prices: 25 for \$3.95 and up. Men or women, club groups or church organizations can easily earn \$300 to \$500, plus bonuses. Old established manufacturer furnishes album of sample cards and selling kit. You can take orders for better Christmas cards! Experience unnecessary. Write Process Corp., Dept. 5, 1954 S. Troy, Chicago 23, Illinois.

**INCREASE Income!** Show friends wonderful box assortments of Christmas and all occasion greeting cards. Tremendous values. Low prices. Profits to 100% plus bonus. No experience necessary. Write for feature assortments on approval. Free sample album of personal Christmas cards and stationery. New England Art Publishers, North Abington M-85, Mass.

**SHINE Shoes** without polish. New invention. Lightning seller. Shoes gleam like mirror. Samples sent on trial. Kristee 51, Akron, Ohio.

**AGENTS Wanted** for good lines for motorists, garages. Write: Willis, Kootenay Bay, B. C., Canada.

**SEND Only 25¢ for 50 fine Christmas cards.** Introductory offer to prove how easily you make \$25 to \$200 showing friends our thrilling new Christmas cards and gifts. Free personal album, assortments on approval included. Boulevard, 235 S. Wabash, Dept. 555-G, Chicago 4.

**TREMENDOUS Profits!** Every man, woman and child a customer. Used suits \$1.50, pants 35¢, dresses 20¢, shoes 20¢. Operate from store, home, car. Free catalog. Superior, 1250-A Jefferson, Chicago 7.

**SHOW Thrilling \$1 values** in newest Christmas card assortments, stationery, gifts. Keep up to 50¢ of every dollar. Big line; complete price range. No experience needed. Get assortments on approval; personal portfolios free; \$1 gift offer. Cardinal, 1400 State, Dept. 79-R, Cincinnati 14.

**I'LL Prove you can make tumbled stone jewelry easily.** Instructions, samples, 10¢. Avery, 332 Columbia Blvd., Wood Ridge, N. J.

**BEAUTIFUL Feather pictures!** Free details, sample 20¢ stamps. Apartado 1668, Mexico 1, D. F.

**60% PROFIT On cosmetics — Famous** nationally advertised Hollywood cosmetics pay 60%. Make \$25 day up. Hire others. For free samples, details, write Studio Girl, Glendale, Calif. Dept. 1288G.

**BUY Wholesale! 30-80% discounts!** Nationally famous brands. Typewriters, housewares, appliances, watches, furniture, musical instruments, cameras, tools, etc. Consolidated Distributors, Clifton 4, New Jersey.

**CASH Commissions** at once, taking orders for magazines every family wants! No experience needed. For free money-making kit, with everything you need, write McGregor Magazine Agency, Dept. 300, Mount Morris, Ill.

**ASTOUNDING Profits.** Newest baby safety items. P.M., Box 429, Atlanta 1, Georgia.

#### BUY IT WHOLESALE

**MEN'S 100% Nylon stretch** sox. Retail \$1.00, sample dozen \$4.00, lot discounts. Millen, 791 East 160th, Bronx 56, New York.

**DOUBLE Refund!** Brand name catalog, all types merchandise. \$1.00 deposit, \$2.00 returned, first order. Legitimate discounts. Fully guaranteed. Discount, Box 1660, Chicago 90.

**UP To 70% off,** nationally advertised merchandise, 106 page catalog, over 4,000 items, \$1.00. Refundable first order. Keystone Industries, 1311 Morse, Chicago 26, Illinois.

**30% BELOW Wholesale—300,000 manufacturers.** Anything, 300 other sources. Guaranteed \$2.00. Wholesale Digest, Ralls, Texas.

**EULOVA, Benrus watches, men, ladies,** like new. \$4.95 up. Folder, 200 illustrations, free. Cosmos, 81 E. 125th St., New York City, Dept. 139.

**BUY Wholesale.** New and used automobiles, trucks, tires, accessories, tools and equipment. Make unusual auto profit without investment. Own your car free of cost. Save big money for yourself and friends. Wholesale price list, instruction book, and wholesale source directory \$3.00. Satisfaction guaranteed. Bob Belmont, Box 258, Hawthorne 11, N. J.

**100 BLADES \$1.00.** Top quality double edged razor blades, individually wrapped, in display carton. Artee Sales, Box 794-BE, Chicago 90, Illinois.

**14KT. Gold i.d. expansion band.** Beautifully cased, \$3.00. Bracelets, 602 Roberts, Utica, N. Y.

**BUY Wholesale! Tremendous discounts!** United Wholesalers, 1265-M Broadway, New York 1, N. Y.

**WHOLESALE Automobile catalog—Discounts to 25% or savings to \$1200.00 or more.** Also big multicolor wholesale catalog: Housewares, appliances, binoculars, luggage, radios, phonographs, recorders, projectors, typewriters, sewing machines, furniture, watches, jewelry. Name brands. Huge discounts. Postcard: Selbyco, Decatur 159, Illinois.

**BUY Wholesale! 30-80% discounts!** Nationally famous brands. Typewriters, housewares, appliances, watches, furniture, musical instruments, cameras, tools, etc. Consolidated Distributors, Clifton 3, New Jersey.

**MY Six 80% money-saving catalogues.** Amos Mail Order, Yountville, Calif.

**WHOLESALE Catalog clothing, shoes, linens, housewares.** Bostonian, 14-C Dock Square, Boston 8, Mass.

**USED And new watches \$2 up.** Free list. Southern Watches, 5-PM So. Wabash, Chicago 3.

**BUY Wholesale! 100,000 nationally advertised products.** Appliances, cameras, sporting goods, housewares, watches, typewriters, tools, clothing, etc. Discounts to 80%. Buy-Rite, Box 258, Hawthorne 4, New Jersey.

**ELECTRIC Guitars, amplifiers, wholesale.** Free catalog. Carvin PMW, Covina, Calif.

**BUY Wholesale! 25,000 nationally advertised products.** Get amazing dealer catalogs. Complete details free. American Wholesalers, 1841-C Levee, Dallas 7, Texas.

**HANDMADE Western boots.** Wellingtons. Jodhpurs. Free catalog. Hall Boots, Box 7302, El Paso 5, Texas.

#### SALESMEN—DISTRIBUTORS

**WILL You test new items** in your home? Surprisingly big pay. Latest conveniences for home, car. Send no money. Just your name. Kristee 30, Akron, Ohio.

**MAKE Money!** Take big profit orders, famous fruit trees. Including sensational discovery, Starkrimson Delicious apple! Also dwarfs, shrubs, roses, vines. Sales outfit free. Stark Bro's, Desk 30189, Louisiana, Missouri.

**BIG Money-making opportunity.** Exclusive line uniforms, jackets, pants, shirts, coveralls, sportswear. Advertising embroidered. Every business prospect. Get selling outfit free! Master Co., Dept. H-06, Ligonier, Indiana.

**AD Matches!** Sell amazing designs—10, 20, 30, 40 and 240-light book matches. Bigger spot cash commissions; every business a prospect. Low prices for high quality. Repeats. Start without experience; men, women; full, part time. Buy nothing! Sales kit furnished. Match Corp., Dept. PM-104, Chicago 32, Illinois.

**BIG Cash commissions!** Complete line 230 shoe styles, also jackets. Postcard brings you free kit! Mason, Chippewa Falls K-110, Wisconsin.

**SALESMAN, Retired,** reveals behind-the-scenes selling secrets. 35 unusually successful years. Free details. Nebrick, 30891 Ridgeway, Farmington, Mich.

**SELL The only blue ribbon pictorial Bible** containing all the features necessary for complete Bible information. 1958 edition, top commission. International Book Co., 322 N. Market, Wichita 1, Kansas.



**MAKE** Extra money. Cash commissions. Everybody buys easy-to-sell advertising book matches. Union label. All sizes. Cuts for all businesses. Powerhouse selling kit free. Steady repeat business. No experience necessary. Superior Match Co., Dept. M-858, 7528 S. Greenwood, Chicago 19.

**WILL** You wear new suits and topcoats without one penny cost and agree to show them to friends? You can make up to \$30.00 in a day even in spare time, without canvassing. Progress Tailoring Co., 500 S. Throop St., Dept. C-326, Chicago 7, Ill.

**WANTED**—County distributors: Man with car to call on service stations, garages and car owners. First class job, large earnings. Jet Products, Wampum, Penna.

**TAKE** Over your area as a service distributor keeping retail stores supplied. Our nationally advertised 27-year-old line gives you 66 $\frac{2}{3}$ % mark-up. Tremendously successful money-making plan. Write K. S. Harris, c/o Novo, 1166 Milwaukee, Chicago 22, Ill.

**MAKE** Big money selling the Security hand pressure dry chemical fire extinguisher. Information free. Hurry. Hudson Mfg. Co., Sheridan 6, Michigan.

**SIMPLE** Demonstration of our new invention amazes business and professional men. Write Frank Brown, Jr., Dept. P-7, Box 97, Milan, Missouri.

**IF** You're interested in making money in selling, see the hundreds of exceptional opportunities in Salesmen's Opportunity Magazine. Send name for your copy, absolutely free. Tell us what you're selling now. Opportunity, 848 N. Dearborn, Dept. 17, Chicago 10, Illinois.

#### EMPLOYMENT INFORMATION

**SUNNY** New Orleans and vicinity classified job opportunities \$1.00. Callibotte, 908 Congress St., New Orleans, La.

**FASTEST** Growing city in the south, Jacksonville, Florida. Sunday classifieds mailed, \$1.00. Box 249, Ft. George Star Route, Jacksonville, Florida.

**JOBS** Overseas! Janecek Development Co., 1090 Hub Station, New York 55, N. Y.

**COPYRIGHTED** Reports. Best paying jobs with travel, adventure, promotions. Construction, aviation, shipping, oilfields, laborers, clerical, trades, supervisory, factory, unusual opportunities. Skilled, unskilled. Foreign, stateside. Men, women. Only \$2.00 (\$2.25 airmail) (c.o.d.'s accepted), including registration-advisory service. Satisfaction guaranteed. Included free: Special reports on Alaska, Venezuela, South American opportunities, husband and wife foreign jobs. Research Services, Suite 514-PM Meramec Building, St. Louis 5, Missouri.

**CALIFORNIA** Facts. Living conditions. \$1.00. Confidential. Langdon, 526 Alandale, Los Angeles 36.

**HIGH** Paying jobs, opportunities, foreign, U.S.A. All trades. Companies pay fare. For information write Dept. 57J, National Employment Information, 1020 Broad, Newark, New Jersey.

**FOREIGN** Jobs—Latin America, Alaska, Canada, up to \$1500 monthly. Up-to-date 1958 foreign service directory gives complete information; hot list of firms hiring for military and civilian construction, aircraft, oil, exporters-importers, mining. How-when-where to apply. 11th successful year. \$1.00. Global Reports, Box 8873-S, Los Angeles 8, Calif.

**FREE** Information—U.S.A. overseas jobs. High pay, transportation. Futures Unlimited, Dept. M, 215 West 34th Street, New York City 1.

**LAS** Vegas! New booklet now available on fabulous jobs, salaries, living conditions. Send \$1.00 today! Maxwell, P.O. Box 4148, Las Vegas, Nev.

**GET** A government job. Secure future, men and women needed. Free information. Central Career Service, 2023 $\frac{1}{2}$  West Superior, Duluth 6, Minnesota.

**JOBS** On merchant ships; no previous experience necessary. For information how to obtain your Merchant Mariner Documents, (federal law requirement). Send \$1. Address Mariners Information, Box 504, Long Beach 1, California.

**JOIN** The merchant marine. For information write Box 8391, Jacksonville, Fla.

**TEXAS** Jobs—Dallas classifieds \$1.00. Richardson, 1529 Fairfax, Paris, Texas.

**AMERICAN** Overseas jobs. High pay, men, women. Transportation paid. Free information. Write: Transworld, Dept. 5D, 200 West 34th St., New York City.

**JOB**-Getting and advancement. Copyrighted pamphlet \$1.00. Details free. Educators Placement Service, Gainesville, Fla.

**YOU** Want good overseas job? Write, Employment Headquarters, 79-B Wall Street, New York City 5.

**EMPLOYMENT** Bulletin listing overseas, U.S. jobs for men, women. We also provide a brand new service never offered before. Your working abilities are evaluated from an application form you fill out and return to us. Then we send letters of recommendation on our stationery to employers seeking your particular skills. Amazing results reported. Send \$3.00 for employment bulletin plus literature. Jobs, Suite 1005AA, 79 Wall St., New York City.

**JOB** Hunting? "The Job Interview" opens doors, 25¢. Alumnae Advisory Center, 541 Madison Avenue, New York City 22.

#### SPECIAL SERVICES

**TRANSLATIONS**—Any language, any field. Postal Box 1995, Dallas, Texas.

**BIRTH** Certificate necessary for social security. Millers Service, Inverness, Fla.

**INFORMATION** On anything. Ferguson Research Specialists, 116-14 141 St., South Ozone Park 36, N. Y.

**ECONOMICAL** Bookkeeping by mail. Write H. R. Havey, Accountant, 1104 Minnie, Port Huron, Mich.

**AUSTRALIA**. General information supplied, people, trade, opportunities, statistics. Retainer \$5.00 when applying. Australian Informat., P.O.B. 30, Mascot, N.S.W. Aust.

#### EDUCATIONAL AND INSTRUCTION

**WAKE** Up your mind! Be what you desire! Smash worries, fears, indecisions, inferiority. Life-changing facts free. Write Box 1924-G, Louisville 1, Kentucky.

**USED** Correspondence courses and educational books, bought, sold, rented. Catalog 10¢. Educational Exchange, Menlo, Georgia.

**WELDERS** Earn big money. Easy to learn arc, gas, automatic welding. New equipment, low cost training in non-profit school. GI approved, free booklet. Hobart Welding School, Box M-881, Troy, Ohio.

**MASTER** Watchmaking at home. Free sample lesson. Chicago School, 2328-YH, Milwaukee, Chicago 47.

**LEARN** Another language at home, easily, quickly, naturally with Linguaphone. The World's Standard Conversational Method. You learn to speak French, Spanish, German, Russian, Modern Greek—any of 34 modern languages available on life-like, conversational recordings. It's like living in another country. Complete language course available on free trial. Send for free book and details of free trial. No obligation. Linguaphone Institute, T-83-088 Radio City, New York 20.

**POWER** Words bring success. Increase your vocabulary. Home study course. Test your power words \$1.00. Argyle, Flat Rock, North Carolina.

**COMPLETE** Your high school at home in spare time with 61-year-old school. Texts furnished. No classes. Diploma. Information booklet free. American School, Dept. XC45, Drexel at 58th, Chicago 37, Illinois.

**BECOME** Tax consultant. Licensed home training. Union Institute, Hoboken 2M, N. J.

**LEARN** To remember anything easily. Free particulars. Modern Memory, Box 452, Petaluma, Calif.

**KNOW** The truth about creating for profit. Details free. D. A. Wing, CPC, Croton Road, Newaygo, Michigan.

**USED** Correspondence courses bought and sold. Free catalogue. C. B. Dudley, E. Broad St., Athens, Ga.

**LEARN** While asleep! Exciting details free. Research Association, Box 24-NN, Olympia, Washington.

**USED** Correspondence courses, educational books. Satisfaction guaranteed. Catalog 10¢ refundable. (Courses bought.) Bayles, 78-B Courtright, Wilkes Barre, Penna.

**SELF**-Education self-improvement books. Lists free. Franks, 3121 South Racine, Chicago 8.

**LEARN** Civil and criminal investigation at home. Earn steady good pay. Institute Applied Science, 1920 Sunnyside, Dept. 16C, Chicago 40, Ill.

**LEARN** Window trimming using crepe paper, etc. Full course only \$3.00. Free details, Jem, Box 144, Cranford, N. J.

**FINISH** High School at home, spare time. No classes. Diploma awarded. Write for free catalog. Wayne School, Catalog HF-86, 2527 Sheffield, Chicago 14.

**PROFESSIONAL** Investigators correspondence school. Badge, diploma, future. Box 41197, Los Angeles 41, California.

**ENGINEERING** Degrees earned through home study. Electronics, electrical, mechanical, civil, physics. When writing, specify course desired. Residence classes also available. Pacific International University (operating as a College of Engineering only at present), 5719-B Santa Monica Boulevard, Hollywood 38, Calif.

**BE** An investigator. Write for free details. State age. National Detective Academy, Dept. P, P.O. Box 1082, Scottsdale, Arizona.

**EARN** Degree. Free bulletin. Home-study only. Midwestern Bible School, 1060 Broadripple, Indianapolis.

**STUDY** To be a doctor of psychology, metaphysics, divinity or philosophy. Correspondence courses only. The Neotarian Fellowship, Desk 9, Kansas City 6, Mo.

**STUDY** For Doctor's degree of psychology, metaphysics and divinity. Correspondence courses only. College of Divine Metaphysics, Dept. P-M, 2811 North Illinois, Indianapolis 8, Indiana.

**WE** Pay \$3.50 lb. dried. Grow mushrooms. Cellar, shed and outdoors. Spare, full time, year round. We have 25,000 customers. Free book. Washington Mushroom Ind., Dept. 174, 2954 Admiral Way, Seattle, Wash.

**HIGH** School diploma at home. Licensed teachers—Approved materials. Southern States Academy, Box 5344-MX, Station E, Atlanta, Georgia.

**BOOKKEEPERS!** Increase your earnings! Operate your own simplified "Dollar-A-Week" bookkeeping and tax service. Full or spare time. Details free. No obligation. Ellis, Box 200, Cedar Grove, North Carolina.

**BE** A real estate broker. Study at home. Send for free catalogue. Midwest School of Real Estate, 68 North Chicago Street, Joliet, Illinois.

**LEARN** Appliance service and repair. Motors, washers, refrigeration, cleaners, everything. Free booklet. Armstrong, 11027-A South Vermont, Los Angeles 44.

**BE** A real estate broker. Study at home. Write for free book today. GI approved. Weaver School of Real Estate, 2018P Grand, Kansas City, Missouri.

**USED** Correspondence courses and books sold and rented. Money back guarantee. Catalog free. (Courses bought.) Lee Mountain, Pisgah, Alabama.

**EARN** While you learn. Auto and diesel mechanics master this top paying trade. Many graduates earn \$100 a week and up. Approved for Korean veterans. For free information write Dept. No. 256, Nashville Auto-Diesel College, Nashville 3, Tenn.

**INVESTIGATOR** Training. Phillips Secret Service System, 1917-B North Keneth, Chicago 39.

**PHYSICAL** Therapy and massage. Home training. Practice privately or work with doctors and hospitals. Free catalogue. National Institute, Desk 4, 159 E. Ontario, Chicago, Ill.

**EARN** College degrees, correspondence. Metropolitan University, Box 86-M, Glendale 5, California.

**BOOKS**. Free general catalog, 100 pages. Text, vocational, educational, instructional subjects. Millions of volumes, new and used. Bargain prices. Books bought. Est. 1902, Long's College Book Co., Dept. PM, Columbus 1, Ohio.

**FINGERPRINTING** Course with diploma \$12.00. School of Fingerprinting, Box 185, Fairfield, Alabama.

**COLLEGE** Correspondence courses, for Doctor of Psychology, Metaphysics, Divinity. Catalogue. Dr. Dorothy B. Arnheiter, Forest Park, Greenwood Lake, New York.



## PLAYS, STORIES, MANUSCRIPTS

**AUTHORS**—Free brochure tells how your book can be published, nationally advertised, promoted. Write today! Bardley Hall Press, Dept. M7, 363 Lexington Ave., New York City 17.

**WANTED:** Book manuscripts, all subjects considered. Greenwich Book Pub., Attn. Mr. Zealand, 489 Fifth Ave., New York City.

**WANT** Your book published? Learn how we publish, advertise, promote, distribute. Many successes. Free booklet PM. Vantage, 120 West 31, New York City. Midwest office: 220 S. Michigan Ave., Chicago, Ill.

**FREE!** Writer's market list! If you're interested in writing fiction or articles for leading magazines, or book publishers, Daniel S. Mead, prominent literary agent, has prepared a catalogue of markets which is a "must" item. For free copy write: Daniel S. Mead, 915 Broadway, Dept. PM, New York 10, N. Y.

## CARTOONING, COMMERCIAL ART, SHOWCARD & SIGN PAINTING, TATTOOING

**LEARN** Profitable, fascinating tattooing. Illustrated information \$1. Zeis, 728-C Leslie, Rockford, Illinois.

**LEARN** Sign painting at home. Free talent test. Ben Kerns, Box 812-PM, Greenville, S. C.

**LEARN** Sign painting with fascinating system. Straley, 410 S. Western, Springfield, Ohio.

**"HOW To Make Money With Simple Cartoons."** A book everyone who likes to draw should have. It is free; no obligation. Simply address Cartoonists' Exchange, Dept. 98, Pleasant Hill, Ohio.

## ADVERTISING AGENCIES, LETTER WRITERS, FOR ADVERTISERS

**BEFORE** Advertising—Get instructive Ad-Guide and newspaper-magazine rate-book, free. Chicago Advertising Agency, Chicago 4.

**MAILING** Lists most any classification \$5.00 1000. Your circulars mailed with ours \$4.00 1000. Write for our literature. Dixie Mailers, King, N. C.

**ADVERTISING.** Result-getting ads prepared, placed newspapers, magazines, radio, anywhere! Lowest rates. Catalogue free. Baker Advertising Agency, 189 W. Madison, Chicago 2.

**"AMAZING New Book"**—"Profits From Classified Advertising." Tells how and what to advertise. Be sure to read this book before you invest one cent in advertising. Write for your copy now. Just send 10¢ for postage and handling. W. Johnson, Classified Advertising Manager, 202 East Ontario Street, Chicago 11, Illinois.

**MILITARY** Mailing lists. Military family men. Annual salaries all over \$4200. Free offer. Military Mailers, P.O. Box 98, Kew Gardens 15, New York.

**NOW Ready:** New, amazing Classified Advertising Record Book—prepared especially for classified advertisers. Here is a book that tells you instantly whether or not your advertising in any publication is paying you real results. You can tell immediately how many inquiries each publication produced—how much cash received from every ad. Spaces are provided for the name and address of the publication, date of issue, space used, rate, cost of ad, key number, etc. You have a complete record of each publication right before your eyes. Plenty of space to keep accurate record of 28 separate publications. You can have a copy by sending only 10¢ to cover postage and handling. Send for your copy now. W. P. Johnson, Classified Adv. Mgr., Popular Mechanics Magazine, 204 E. Ontario Street, Chicago 11, Illinois.

## RUBBER STAMPS AND OFFICE SUPPLIES

**3 LINE** Goldtone metal pocket printer, self-inking, \$1.00. James, Box 246-P, Lawndale, California.

**HIGHEST** Quality stamp, plus pad and case, \$1.00 postpaid. Three lines. Marnels Service, Box 101, Nutley 10, N. J.

**NEW!** Rubber stamp catalog. Campfield, 14 Beaufort Circle, Springfield 4, Mass.

**AIR** Mailed, 3 lines, regular \$1.80, now \$1.00. Guaranteed. C. P. Marshall Company, Dept. 4, Payne Road, Bethel, Conn.

**THREE** Line rubber stamp, 85¢. Hallenbeck, 302 Osborn, Loudonville 11, N. Y.

## TYPEWRITERS, DUPLICATORS, OFFICE DEVICES

**FACTORY** Rebuilt typewriters. Direct to you, wholesale. All models, \$27.50 up. Apply: Typewriters, 5139 N. Clark, Chicago 40, Ill.

**RECONDITIONED** Typewriters, duplicating, printing devices, \$25.00 up. Supplies. Appliances. DixieGraph, King, N. C.

## PRINTING, MULTIGRAPHING, MIMEOGRAPHING, GUMMED LABELS

**EXCELLENT** Printing—Low prices. Post card brings catalog, samples. Demarest, 3286 Wheeler Street, Hapeville, Georgia.

**ATTRACTIVE:** Stickers, labels, circulars, cards. Samples, Fame, 291 Ellis, San Francisco 2, Calif.

**FREE** Illustrated printing catalog. Quality Press, 13199 McDole, Saratoga, Calif.

**QUALITY** Commercial printing. Reasonably priced. Samples. Porter Printing, 123 E. Robinson, Jackson, Michigan.

**FREE** Catalog, postpaid printing. D M Press, Sebastopol, California.

**BUSINESS.** Personal printing—Labels, rubber stamps, accessories. Illustrated catalog, free! Brose, 196-A, Clerk, Jersey City 5, N. J.

**MIMEOGRAPHING**—Letters, pricelists, formulas, instructions. Lowest prices. Lem's Letter Shop, 5710 Stanton, Detroit 8.

**1500 PERSONALIZED** 1/8"x1 3/4" Labels \$1.00. Your 3 line name and address printed with blue ink on fine quality white gummed paper. Money back guarantee. Hamilton-Ward, Dept. 10B, Westfield, Mass.

**OFFSET** Printing, 24 hour service—\$6.75 1000 8 1/2"x11. National Letter, 251 W. 42 St., New York City 36.

**BUSINESS** Printing, Offset. Free catalog. Tech, Box 748, Freeport, New York.

**MIMEOGRAPHING.** Printing. Top quality. Reasonable prices. Frajimidot, New Lebanon Center, N. Y.

**MIMEOGRAPHING.** Typing, mailing. Martin, 270 Old Bergen Rd., Jersey City 5, N. J.

**1000 NAME** And address labels, \$1.00, postpaid. Kindred Tribune, Kindred, North Dakota.

**FINE** Printing—Offset, letterpress, from \$5.00 per M. Flexart, 59 1/2 Elm, Stonington, Conn.

**FREE** Book, \$1 value, about photo offset printing. Details, free price list. Advergraphic, 121 E. 27 St., New York City 16.

**1,000 BUSINESS** Cards, Raised letters, \$3.50. Samples. Pioneer, Island Park PM-8, New York.

**100 NOTE** Sheets—3 line imprint \$1.00 postpaid. T. C. Specialties, Coudersport, Penna.

**BUSINESS** Forms, salesbooks, orderbooks. Estimates. Mandelstamm, 1128 Hyde Park, Chicago 15.

**100 EACH** 8 1/2"x11 Letterheads, 6 3/4 envelopes, carefully printed, \$2.00. Postpaid. Race Printers, Hudson, New York.

**500—6 3/4 ENVELOPES** \$3.50 Postpaid. Statements same. Stanley Press, Lake Katrine, N. Y.

**ADS** Running under this heading sell printing. Ask me for proof, I'll gladly send you amazing facts. Ask for Folder "P." F. W. Johnson, 200 E. Ontario St., Chicago 11, Ill.

## PRINTING OUTFITS AND SUPPLIES

**10x15 C&P** Press \$175; 26" Advance lever cutter \$175; 8x12 Golding lever press \$90; 8x12 multicolor \$125; gold stamping outfit \$125. Chas. Schlinger, Waseca, Minnesota.

**TYPE** Cases from manufacturer. Catalog. King McKay Company, 23179 Telegraph Road, Detroit 41, Michigan.

**MAKE** Your own printing press. Wickizer, 564 Hooper Road, Johnson City, New York.

**MAKE** Your own self-molding rubber stamps and printing cuts. Flexirubber, Argyle 1, Wisconsin.

**RUBBER** Stamp making presses, hydraulic operated, electrically heated. Sizes 5"x8", 8"x12", 10"x15", starting outfits. All kinds supplies. Custom Manufacturing, 507-P N. Jefferson, Springfield, Mo.

**DO** Your own printing. Save money. Simple rules. We supply everything. Print for others; good profit. Raised printing like engraving too. Have home shop. Details free. Kelsey Presses, V-11, Meriden, Connecticut.

## PATENT ATTORNEYS

**INVENTORS**—If you believe that you have an invention you should find out how to protect it. The firm of McMorro, Berman & Davidson is qualified to take the necessary steps for you. Send for copy of our patent booklet "How to Protect Your Invention" and "Invention Record" form. No obligation. McMorro, Berman & Davidson, Registered Patent Attorneys, 134-W Victor Building, Washington 1, D. C.

**INVENTORS:** Protect your invention. Joseph Lindecker, Reg. Patent Attorney, 7339 Kolmar, Skokie, Ill.

**C. A. Snow & Co.**—M427, Snow Building, Washington 1, D. C. Registered Patent Attorneys. Write for information.

**INVENTORS**—Take these preliminary steps toward patent protection. Sketch and describe your invention. Sign, date and have this disclosure witnessed by two people who understand your invention. Have us make a preliminary search among U.S. patents already granted for similar types of invention. We report on the probable patentability of your invention and recommend your further course of action. Write for our instructive booklet, "Patent Protection for Inventors" and convenient "Evidence of Invention" disclosure form. Victor J. Evans & Co., 431-J Meritt Building, Washington 6, D. C.

**INVENTORS:** Without obligation, write for information explaining the steps you should take to secure a patent. John Randolph, Registered Patent Attorney, 803 Victor Bldg., Washington 1, D. C.

**PATENTS.** "Proof of Invention" free. E. E. Vrooman, Registered Patent Attorney, 507 McKim Building, Washington 5, D. C.

**"INVENTOR'S Guide"** and "Record of Invention" free on request. Frank P. Ledermann, Registered Patent Attorney, 134 Nassau Street, New York City.

**INVENTION** Record form free and "Patent Information Every Inventor Should Have." Carl Miller, Registered Patent Attorney, Woolworth Building, New York.

**INVENTORS:** Learn how to protect your invention. Unless the inventor is familiar with patent matters, he should engage a competent registered patent attorney or agent to represent him. We are registered to practice before the U. S. patent office and prepared to serve you in handling your patent matters. "Patent Guide for the Inventor" containing detailed information concerning patent protection and procedure with "Record of Invention" form will be forwarded to you upon request—without obligation. Clarence A. O'Brien & Farvey Jacobson, Registered Patent Attorneys, 81B-C District National Building, Washington, D. C.

## FOR INVENTORS

**MORE** Ideas than money? Write National M&E, Drawer 1340, St. Louis 1, Missouri.

**WE** Have the markets if you have the ideas. Harvey Engineers, Cambridge 1, Maryland.

**INVENTIONS** Pay inventors—When profitable sales are certain from constructions soundly patented, and wise steps taken to reach the best markets. I help inventors to make the most profit with low definite fees for all services. 30 years' experience as patent-development engineer. U. S. and foreign patents secured. Joseph O'Brien, 132 Nassau St., New York 38, N. Y.

**PATENT** Drawings made—Fast confidential service. Norval Riggs, 1112 Stanley, North Las Vegas, Nevada.



**INVENTORS**—If you believe that you have an invention you should find out how to protect it. The firm of McMorrow, Berman & Davidson is qualified to take the necessary steps for you. Send for copy of our patent booklet "How to Protect Your Invention" and "Invention Record" form. No obligation. McMorrow, Berman & Davidson, Registered Patent Attorneys, 134-V Victor Building, Washington 1, D. C.

**INVENTORS**—This firm is registered to practice before the United States Patent Office and available to assist you in the preparation and prosecution of your patent application. "Patent Protection for Inventors" booklet containing detailed information and steps to take toward patent protection sent promptly upon request. No obligation. Victor J. Evans & Co., 432-J Merlin Building, Washington 6, D. C.

**INVENTORS**—Send for free Patent Information book and Inventor's Record. Registered Patent Attorney, Associate Examiner, Patent Office 1922-29, Patent Attorney & Advisor, Navy Department 1930-47, Gustave Miller, 88A Warner Building, Washington 4, D. C.

**INVENTION Record form free and "Patent Information Every Inventor Should Have."** Carl Miller, Registered Patent Attorney, Woolworth Building, New York.

**INVENTORS**, Don't sell your invention patented or unpatented until you receive our offer. Write Cowgill, Box 298, Marion, Ohio.

**INVENTIONS** Wanted now by my manufacturer-clients. Patented, unpatented. Write Gilbert Adams, Patent Broker, 80-A Wall Street, Financial District, New York City.

**INVENTORS**: Information on patent procedure furnished on request, without obligation. John Randolph, Registered Patent Attorney, 802 Victor Bldg., Washington 1, D. C.

**INVENTORS**: Test the commercial value of your patented or unpatented inventions, quickly and inexpensively. Write for free information. Institute of American Inventors, Dept. 40-B, 635-F St., N.W., Washington 4, D. C.

**PATENT** Searches \$6.00. 48-hour airmail service. Invention protection forms free. Write Patent Engineering Service, 711 14th Street N.W., Washington 5, D. C.

**INVENTORS**: Learn how to protect your invention. Unless the inventor is familiar with patent matters, he should engage a competent registered patent attorney or agent to represent him. We are registered to practice before the U. S. Patent Office and prepared to serve you in handling your patent matters. "Patent Guide for the Inventor" containing detailed information concerning patent protection and procedure with "Record of Invention" form will be forwarded to you upon request—without obligation. Clarence A. O'Brien & Harvey Jacobson, Registered Patent Attorneys, 81A-G District National Building, Washington, D. C.

**PATENT** Searches, including copies of nearest patents, \$6.00. Reports airmailed within 48 hours. More than 100 registered patent attorneys use my service. For free invention protection forms, write Miss Ann Hastings, P.O. Box 176, Washington 4, D. C.

**PATENT** Searches \$6.00. 48-hour service. Free invention protection forms. Write Raymond L. Smith, Patent Searcher, 620 Sheraton Building, Washington 5, D. C.

### INVENTIONS WANTED

**INVENTIONS** Needed immediately for manufacturers. For additional information write Kessler Corporation, 581W, Fremont, Ohio.

**ARE** You interested in offers from reliable manufacturers for your invention? Patented, unpatented. Harvey Engineers, Cambridge, Maryland.

**GREATER** Income from your invention or new product when handled by us. Send particulars to Exquisite Products, Box 1, Cincinnati 18, Ohio.

**SUPERIOR** Promotions. Patented; unpatented inventions. Information booklet, free. Superior, 338-344 North Rodeo, Beverly Hills, Calif.

**INVENTORS**, Don't sell your invention patented or unpatented until you receive our offer. Write Cowgill, Box 298, Marion, Ohio.

**INVENTIONS** Wanted: Patented, patent pending. 27 years experience promoting inventions. National Service Bureau, 3120 Meramec, St. Louis 18, Mo.

**INVENTIONS** Wanted. Patented; unpatented. Tremendous manufacturers lists. Global Marketing Service, 2420 77th, Oakland 5, California.

**INVENTORS**: Hundreds of manufacturers have requested our assistance in locating marketable new products. Complete information free. Institute of American Inventors, Dept. 40-D, 635-F St. N.W., Washington 4, D. C.

**INVENTIONS** Wanted now by my manufacturer-clients. Patented, unpatented. Write Gilbert Adams, Patent Broker, 80-A Wall Street, Financial District, New York City.

### MANUFACTURING

**MODELS**—Small lot manufacturing. Metals, plastics, etc. Milburn, Burlington, Kentucky.

**MANUFACTURE**—Foam plastic toys, cushioning, life preservers, etc. Expands up 30 times. Send \$3.00 for kit containing chemicals, hand mixing instructions, uses, prices. Foam Products, Box 427, Warner Robins, Ga.

### MODELS, MODEL SUPPLIES

**SHIP** Models. Most complete line in New England. Kits, fittings, plans, books, tools, engines, motors. 1958 illustrated catalog 35¢. James Bliss & Co., Inc., Dept. SM, 342 Atlantic Ave., Boston 10, Mass.

**BALSA** Wood and model aircraft. 40-page catalog 25¢. Sig Co., Montezuma, Iowa.

**SHIP** And yacht model fittings; blueprints. Send 35¢ for illustrated catalog listing hundreds of items. A. J. Fisher, 1002-1 Etowah Ave., Royal Oak, Mich.

**ROCKETS**. 4 Different plans. Hold altitude records. \$1. Rocketry, Spencer, Iowa.

**ROCKET** Parts, fuel ingredients, plans. Price list, fuse samples 25¢. Central Rocket Company, Waupaca, Wisconsin.

**SEND** For big 312-page hobbycraft catalog with thousands of hobby items. Planes, trains, boats, crafts. Send \$1 to Petey-Q Model Sales, 519 Davis St., Evanston, Ill. \$1 refunded with first order of \$5 or more.

**SHIP** Model kits, fittings and plans including clippers, trawler, fishermen, frigates, privateer, etc. Towboat of 1900 for HO gauge \$3.95. 1958 catalog 25¢. Model Shipways, Box 85, Bogota, N. J.

### HOME CRAFTSMEN

**FREE** "Do-it-yourself" leathercraft catalog. Tandy Leather Company, Box 791-Y26, Fort Worth, Texas.

**GUITAR** Making, books, plans, imported woods, tools. Free list. Store, 510 East 11th Street, New York 9, N. Y.

**LEARN** Art metalcraft and jewelry making. Complete, inexpensive, home training course now available. Special tools and materials furnished. Write for free booklet. Interstate Training Service, Dept. L-3, Portland 13, Oregon.

**KNOCKDOWN** Cedar chests and lumber. Free price list. Bedford Lumber Company, Shelbyville, Tennessee.

**WOODWORKING** And cabinetmaking course for beginning and advanced home craftsmen. Only complete low-cost home training program available. Write for free booklet. Interstate Training Service, Dept. G-3, Portland 13, Ore.

**MAKE** Cash from your workshop. 2150 actual size artist-drawn patterns. Free catalog. Craftplans, 1322-A Wabash, Chicago 5.

**101 PATTERNS** Of smart gifts, novelties, shelves, action windmills, plus, "Make Money Jig Sawing." \$1.00. Mastercraft, 85M, 7041 Olcott, Chicago 31.

**LEATHERCRAFT**. Send 10¢ for new 102-page catalog of tools, supplies, kits, including metalcrafts, enameling, ceramics, all other crafts. Complete stock. Reasonable. Since 1910. Sax Bros., Dept. PM-8, 1111 N. 3rd, Milwaukee, Wis.

**JUSTOSTOP**. Gets professional results from your power saw. Free brochure. Anderson Company, 1110 West 68th Street, Los Angeles 44, Calif.

**FANCY** Walnut, maple and cherry. Squares, blocks, lumber. Midland Lumber Company, P.O. Box 124, St. Joseph, Mo.

**HOME** Workshop books. Send for 1958 book catalog—10¢. Popular Mechanics Press, 631 N. St. Clair St., Chicago 11.

### DO IT YOURSELF

**ELECTRICAL** Wiring blueprints. Detailed, self-explanatory blueprints supplied for switch controls, receptacle connections. Others on request. Receive folder and 4 blueprints, \$1.50 postpaid, cash or m.o. only. Gilpar Enterprises, Box #51, Milltown, N. J.

**BUY** Picture frames from us in mitered pieces, you do gluing and nailing yourself. Save big money on frames, also get free delivery. Chesapeake Picture Frame Co., Box 533, Baltimore 3, Maryland.

**WIRE** Your home for music, hi-fi, \$10.95 a room. Details free. H & B, Box 8338, Denver 10, Colorado.

**HOW** To remodel, basement, attic. Booklet or book. Send for 1958 book catalog—10¢. Popular Mechanics Press, 633 N. St. Clair St., Chicago 11.

**AUTOMATIC** Transmission only \$7.95! Convert midget racers, power mowers, garden tractors yourself. Only 1 screw. Amazing results. New automatic clutch takes load off engine, no stalling, smooth-as-silk pickup. Specify bore: 1/2", 3/8", 3/4"; standard 3" x AB pulley assembly. Guaranteed. Send check or m.o. Mercury Clutch Division, Canton 6, Ohio.

**FORWARD**. Neutral, reverse automat gear transmission. 1/2 to 4 h.p. \$28.90. Build your child's auto, midget racer or suitable for mowers, tractors, etc. Send check or m.o. Free literature. Rider-mower Company, Muscatine, Iowa.

**AIR** Conditioners, home, automobile. See Kool Engineering ad page 18.

"HOME Improvement Guide." New, amazing 192 page volume. Packed with ideas, plans for remodeling, decorating, landscaping, built-in projects. \$2.95 pre-paid. Popular Mechanics Press, 200-HG East Ontario St., Chicago 11.

### WATCHES, OLD GOLD, JEWELRY

**WATCH** And clock repairing books. Free catalog. North American, 2320-AV Milwaukee, Chicago 47, Illinois.

**WATCHMAKERS'**-Jewelers' supplies, instructions. Catalog 25¢. Bengal Wholesalers, Culver City, California.

**HIGHEST** Cash for old gold, broken jewelry, gold teeth, watches, diamonds, silverware, spectacles, platinum, mercury. Free information. Rose Refiners, Heyworth Building, Chicago 2.

**FREE** Folder. New costume jewelry supplies. Modern Craft, Box 11088-R, St. Petersburg 33, Florida.

**LEARN** Watchmaking. Material and instructions supply catalog for start \$1.50. Refund not o.k. Stewart's, 211 N. 7th St., St. Louis 1, Mo.

**FREE** Catalog. Costume jewelry parts. Supplies. Reasonable prices. Fast service. Guaranteed quality. Unique merchandise. Folsom's, Box 52, Medford 55, Mass.

### TOBACCO, SMOKERS' SUPPLIES

**CIGARS** For less. Free list. Tobacconist, 228 N. Clark, Chicago 1.

### RAZORS, BLADES, SHARPENING

**100 BLADES** \$1.00. Top quality double edged razor blades, individually wrapped, in display carton. Artee Sales, Box 794-BF, Chicago 90, Illinois.

**FREE** Sample razor blade, from Germany. Revolutionary accomplishment. First time in U.S.A. Paul Weil, Dept. A19, Box 157, New York City 31.

### OF INTEREST TO WOMEN

**60% PROFIT** On cosmetics—Famous nationally advertised Hollywood cosmetics pay 60%. Make \$25 day up. Hire others. For free samples, details, write Studio Girl, Glendale, Calif. Dept. 1288G.

**EXQUISITE** Laces, braids, embroideries, 40 yards, \$1.25 pound. Nairia Edwards, Rt. 1, Box 46-B, Sylacauga, Ala.



**FREE**—Big new wholesale catalog! Up to 50% saving for you, family, friends on nationally known gifts, jewelry, toys, appliances, Christmas cards, etc. Also make money selling part time! Write: Evergreen Studios, Box 845D, Chicago 42, Ill.

**WANT** Extra cash? Send your name for money-making Christmas card samples on approval. Showing them to friends pays you as much as 50¢ to \$1.25 profit per item \$150.00 easy! Free personal album; 30th anniversary gift offer. Midwest, 1113 Washington, Dept. 501-T, St. Louis 1, Mo.

**HOUSEWIVES** Wanted! Big money. Spare or full time cake decorating and candy making. Turn your kitchen into a gold mine. Complete, instruction course, learn and earn at home. Write for free facts. Candy & Cake, Dept. 110, 3209 W. Olympic, Los Angeles 6.

**DRESSES** 24¢; Shoes 39¢; men's suits \$4.95; trousers \$1.20. Better used clothing. Free catalog. Transworld 164-S Christopher, Brooklyn 12, N. Y.

**SELL** Fine fabrics. Get yours wholesale. Box 863, Norwalk, Conn.

**WE** Pay \$3.50 lb. dried. Grow mushrooms. Cellar, shed and outdoors. Spare, full time, year round. We have 25,000 customers. Free book. Washington Mushroom Ind., Dept. 176, 2954 Admiral Way, Seattle, Wash.

#### FOR THE HOME

**THERMASSAGE** 4-Way heat-vibrator pillow \$11.95. Wrimus Co., Box PM 93, San Bernardino, California.

#### PERSONAL

**BIBLE** Questions answered. Stamped envelope. Bylon, 17167 Bentler, Detroit 19, Michigan.

**"YOU Can find out!"** Confidential information developed, any matter, person, anywhere. Officially licensed. Established 1922. Equitable Service Bureau, 15 Maiden Lane, New York City.

**LOANS** By mail. Borrow \$50 to \$500 for any purpose. Employed men and women over 25, eligible. Confidential, no co-signers. Up to 2 years to repay. Low monthly payments. Supervised by Nebraska banking department. Loan application sent free in plain envelope. Give occupation. American Loan Plan, City National Bank, Dept. PM-8, Omaha 2, Nebraska.

**BORROW** Money by mail. \$100-\$600. Anywhere. Air mail service. Postal Finance, 200 Keeline Building, Dept. 658P, Omaha 2, Nebraska.

**GAIN** Self confidence, memory power, magnetic personality by recordings. Invaluable Psychologist, Box 24-NN, Olympia, Washington.

**HANDWRITING** Analysis instructions. Delight friends. \$1.00. Box 886, Astoria, Oregon.

**INTERCEPT** Opportunity! Now, employ strategy of professionals in locating best jobs, answering ads, interview impression, etc. Today's foresight molds tomorrow's outcome. \$1 to Valon, Box 9235, Chicago 90, Illinois.

**COBRA.** Self-defense street-fighting tricks. Designed to help peaceful adults. \$2. Gaucho, 846-S7 Sunnyside, Chicago 40.

#### REMAILING SERVICE

**EUROPE** Re-airmails Paris, Brussels \$1.00 cash each. Special commissions expertly executed. Wdowiak, Box 475, Brussels, Belgium.

25¢. **FREE** Address. d'Martinis, 83-75 Woodhaven Blvd., Woodhaven 21, New York, N. Y.

**REMAILING**, Receiving-forwarding address for rent. William McLaughlin, 800 Stewart, Columbus 6, Ohio.

**GATEWAY** To Ozarks. Remails 25¢. Receiving, forwarding \$3.00 monthly. Kings-X, Box 1, DeSoto, Missouri.

**CANADA** Remails \$3 monthly. A. Kuitunen, 219 Belsize Drive, Toronto, Ont., Canada.

**PARIS** Reairmails, classifieds \$1.00. B. Brown, American Express, 11 Rue Scribe, Paris, France.

**REMAILS** 25¢. Receiving, forwarding \$3.00 monthly. Classifieds 50¢. Confidential. 34 Ardmore Road, West Hartford 7, Conn.

**HAVANA** Remails 50¢. Information \$1.00. Magazines, stamps \$1.00. Frank Pozo, Neptuno 632, Havana, Cuba.

**CHICAGO**, Remails 25¢ each. Prompt, confidential. Royal Trading Company, Box 821, Chicago 90, Ill.

**CONFIDENTIAL** Receiving-forwarding 25¢. Consolidated Services, Box 5454, Roanoke, Virginia.

**NEW YORK** City remails. Letters, cards, 25¢. Confidential. 10 scenic postcards \$1.00. Mermelstein, P.O. Box 395, Times Square Station, New York 36, N. Y.

**LETTERS** Remailed 25¢. Jerry Love, 1419 E. 83rd, Los Angeles 1, Calif.

**REMAILING** Free. Confidential forwarding \$2.75 monthly. Sanchez, 425 East Fifth, Brooklyn 18.

**HOUSTON** Remails 25¢. Monthly \$3.00. Remailing Services, Box 18114, Houston, Texas.

**SAN FRANCISCO** remails 25¢. Receiving-forwarding \$3.00 monthly. Kent, Box 4606.

**ROSE** Bowl city, remails 25¢, 6 for \$1. Bennett, 312 No. Raymond, Pasadena, Calif.

**REMAILS** 25¢. Monthly, \$3. Chicago Mail, 509 N. Union, Chicago 10, Ill.

#### TREASURE FINDERS

**GOLD.** Silver metal detectors. Geiger counters for uranium. Violites. Sensational new fully guaranteed models. None finer. Information free. Detecron Corp., 5528 Vineland Ave., North Hollywood, Calif.

**FIND** Buried treasure, gold and silver, with Goldak's sensational 3½ lb. "find-it" locator, only \$64.50. Write for free literature on complete line of mineral, metal locators; Geiger and scintillation counters. Goldak, 1541 W. Glenoaks Blvd., Glendale, Calif.

**FREE** Literature—Light weight, guaranteed metal detectors. Geiger counters and mineralights. Kits and assembled models. Electronic Applications, Dept. M, Box 8, Arlington 10, Virginia.

**TREASURE** Locators. Newest treasure finder in 20 years. Guaranteed M-scope. Transistorized. Proven performance. Terms. Catalog. Fisher Research, Dept. C-1, Palo Alto, Calif.

**INDICATOR.** Locates uranium, buried money, minerals. Price \$25.00. Dirt samples tested free for oil. Horton's Surface Oil Survey, Belle Rive, Illinois.

#### FOR SALE—MISCELLANEOUS

**THROW** Away paper bags for vacuum cleaners. Send make and model for information on ordering. Ripplinger's, 1926 Gravois, St. Louis 4, Mo.

**ILLUSTRATED** Catalog unusual gifts. 25¢. Myco, Box 25-PM8, Runnemede, New Jersey.

**HEARING** Aid batteries, wholesale. Free list. Habs, Box 51, York, Penna.

#### WANTED—MISCELLANEOUS

**QUICKSILVER.** Platinum, silver, gold. Ores analyzed. Wholesale Terminal, Norwood, Mass.

**COINS:** Gold, Indianheads; many others. Describe fully. Coins, Amsterdam 1, Mo.

**SCRAP** Mercury (quicksilver) containers supplied — Tantalum, tungsten, silver, platinum. Metallurgical Products Company, Established 1909, 35th & Moore Sta., Philadelphia 45, Penna.

#### MISCELLANEOUS

**DON'T** Die without a will. Two forms and do-it-instructions \$1.00. AtoZ Printing Service, 474 E. Hazelhurst, Ferndale 20, Mich.

**FREE** Wholesale catalog. Watches, tools, binoculars, appliances. West Coast Sales, Riverbank, California.

**EXPOSED!** "How to Win Prize Contests" \$1. Guaranteed. Erickson, 250-B McLaughlin, Muskegon, Mich.

**WANT** More business? Here's an amazing opportunity to increase your sales. Talk to thousands of interested readers of "Mecanica Popular." Our Spanish Edition covers the Latin American countries like a blanket. They're real mailorder buyers. Classified rate 75¢ per word. Try an ad in our next issue. Classified Advertising Department, Popular Mechanics Magazine, 200 East Ontario Street, Chicago 11, Ill.

100,000 **PRODUCTS** Wholesale — Free catalog! Send postcard: Econ-O-Mart, Whippany 15, New Jersey.

**RECEIVE** Magazines, catalogs, profitable homework opportunities, 10¢. Star, Leming, Texas.

**NOVELTY** Bow ties for Hallowe'en, parties, clubs, carnivals, banquets, lodges. Made up for special color orders. H. Young, 5015 N. 5th St., Philadelphia 20, Penna.

**GET** Samples, opportunities, magazines, catalogs, offers galore! Your name in 8500 big mail directories 25¢. Results guaranteed. King Services, Mooretown, Ontario, Canada.

**GIFT** For weavers. Power winder, \$25.00. Sava Rugila, 158 Victor Street, Highland Park 3, Michigan.

**BUY** Wholesale! 100,000 nationally advertised products. Appliances, cameras, sporting goods, housewares, watches, typewriters, tools, clothing, etc. Discounts to 90%. Buy-Rite, Box 258, Hawthorne 2, New Jersey.

**17J** WATCHES \$10.00. Catalog 10¢. Southwestern Imports, 1306 South Darlington, Tulsa 12, Okla.

**WIPERS** — Cheese cloth. Wiping and polishing. Cotton blown for super softness. 15 yards \$1.00. Abbott Wiping Cloth, 4048 Main St., Philadelphia 27, Penna.

**SADDLES,** Boots, Western wear, leather goods. Free catalog. Silver Spur, Box 1785-N24, Fort Worth, Texas.

**ATTRACTIVE** "Shopping in Britain" catalog. Yours for 25¢. Heritage Mailing Service, 210-PMA8 5th Avenue, New York 10, N. Y.

**GREAT** Sport. Catch fish. Monofilament fly reel, ideal for junior fishermen too. Details free. Pflueger "Progress" fly reel, exclusive monofilament adapter, 300 feet 6# line. Only \$3.95 complete, postpaid. (Special) no c.o.d.'s. Springtime Company, Box 3911, Seattle 24, Wash.

**SEND** Us wool for blankets. Free literature. West Texas Woolen Mills, 421 Main, Eldorado, Texas.

**JAPAN:** Buy gifts, novelties direct, dropship. New 24 page catalog, manufacturers' names, addresses, business information. Send \$1.00. Clarence Yamagata, 202 Naka 7 Bldg., Marunouchi, Tokyo.

**ORNAMENTAL** Iron designs. Book of 1700 beautiful, practical designs for railings, columns, etc. Free literature. Cunningham, 3881 South 3200 West, Salt Lake City, Utah.

**SUPER** Memory overnight! Success guaranteed! Bijou, Box 1727-M, Hollywood 28, California.

**SECURE** Your future with an exclusive franchise. Fascinating, profitable opportunities reported nationwide. Request details. National Franchise Reports, MP-528, 333 North Michigan, Chicago 1.

**WRITE** For free catalog. New government surplus-GI self-instruction books. Value over \$7 each. Mathematics, history, foreign languages, accounting, farming, auto mechanics, establishing new business, etc., \$1.00 each postpaid. Choose from over 60 courses. Sual Co., Dept. N, Elsinore, California.

**BUY** Wholesale! 25,000 nationally advertised products. Get amazing dealer catalogs. Complete details free. American Wholesalers, 1841-D Levee, Dallas 7, Tex.

**RECEIVE** Magazine samples, mails, catalogues, offers from everywhere. Get listed 25¢. Rorick, Cincinnati 26, Ohio.

**YOUR** Name wanted. We'll send 1000 publishers, mailers, wholesalers your name, on our list one year 25¢. Dixie Mailers, King, N. C.

**CIGARETTES**—Make 20 for 9¢. Facts free. Moberly, Box 810, Owensboro, Kentucky.

**WE** Pay \$3.50 lb. dried. Grow mushrooms. Cellar, shed and outdoors. Spare, full time, year round. We have 25,000 customers. Free book. Washington Mushroom Ind., Dept. 175, 2954 Admiral Way, Seattle, Wash.

**CESSPOOLS.** Septic tanks, clogged drains. How they function and how to keep them working. Free literature. Chemical Cesspool & Drain Cleaning Co., Boston 34, Mass.

**MEXICAN** Food recipes \$1.00. Chef Paul, 1307½ N. 4th Pl., Lamesa, Texas.



## WHERE-TO-BUY-IT INDEX

### AUTOMOTIVE

Italians build most economical "car".....	105
Blank cartridge fires to warn truck driver tire is going flat (Ku-Lin Tire Saver, 2981 Pontiac, Denver, Colo.).....	105
Remote-controlled rear-view mirror (Alted Corp., Box 118, Bangor, Mich.).....	115
Rubber hose opens garage door when automobile passes over (Challenger Lock Co., Inc., 4865 Exposition Blvd., Los Angeles 16, Calif.).....	115

### AVIATION

X-7s recovered by parachute.....	84
Flight simulator tests planes.....	85
Ultramodern control tower will be 150 feet high.....	115
Automatic bombing and navigation system ready for Air Force.....	116
Converted truck serves as mount for testing aircraft engines.....	116
Five hours—coast to coast will be easy for jetliner.....	123
Flying Navy cannon increases firepower.....	126
Poles for power line "planted" by helicopter.....	131
Model plane sets endurance record of 5 hours, 29 minutes.....	132
Wheeled litter for rescue work.....	132

### BOATING AND FISHING

Miniature inboard motor powers small boats (John W. Roby & Associates, 9045 16th St. S.W., Seattle 6, Wash.).....	68
He built a hatchery for catfish.....	109
Boat from car hoods.....	114

### CONSTRUCTION

Big bag of air helps contractor build houses.....	95
Automatic garage to park 230 cars.....	104
Pair of dollies lift big appliances.....	114
San Francisco's floating highway.....	121
Giant crane helps build nuclear plant.....	122
America's "narrowest house" is only 10 feet wide.....	127

### HOUSE AND HOME

Stainless steel hoops for plastic pipe prevent splitting (Manufacturing Corp., P.O. Box 434, Mansfield, Ohio).....	73
Roll-on garden grows on concrete (Horticulture Inc., 443 Delaware Ave., Buffalo 2, N. Y.).....	101
Curtained wall cabinet provides space to hang 16 pairs of shoes.....	105
Miracle kitchen.....	117

### MISCELLANEOUS

Campers' delight—five-minute tent (Sky Camp Stores, Inc., 9237 Long Beach Blvd., South Gate, Calif.).....	63
Trolley gives kids a "ride" in best Toonerville style (Bally Mfg. Co., 2640 Belmont Ave., Chicago).....	83
Curved tower aids Navy in communications study.....	88
Two-wheeled golf cart has glass-fiber body (Cerc Mfg. Co., 555 Exchange Ct., Wheeling, Ill.).....	88
Plint-sized parasol made from handkerchiefs (Klemm Kraft, P.O. Box 60, Planetarium Station, New York City 24).....	88
His electronic piano has rinky-tink tone.....	95
Vacuum scoops up leaves from city's park and streets.....	96
Attachment converts spreader to forage dispenser (John Deere Co., Moline, Ill.).....	97
Roaming kitchens teach cooking.....	101
Ice-cream scoop has built-in heat (United States Rubber Co., Rockefeller Center, N. Y.).....	114
Lip tattoo for livestock applied with special gun (Animal Fashions, Div. of Inland Mfg. Co., 1108 Jackson St., Omaha 2, Neb.).....	115
Sleek Canberra will have no visible funnels.....	122
Canada's population is expected to triple by year 2000.....	220

### OFFICE, SHOP AND STORE

Both sides of document microfilmed at same time (Documat, Inc., 385 Concord Ave., Belmont 78, Mass.).....	85
Rollers enable draftsmen to make lengthy drawings in one strip (Aqua Sportsmen, Inc., Norwood, Cincinnati 12, Ohio).....	96
Sliding blade cutter swivels for angle cuts (Safety Cutter Co., Edison Way at 11th, Menlo Park, Calif.).....	132

### OUTDOOR SPORTS

Rope made of plastic floats on water.....	68
Baseball on a rope aids boy batters.....	73
"Wildcat" rifles designed for big game and varmints (Bill Atkinson and Paul Marquart, Prescott, Ariz.).....	100
Hand pump raises roof of air-tube tent (Pyramid Co., 1384 Broadway, New York City).....	104
Grid announcers use board to keep up with player substitutions (Merrell Features, 208 N. Wells St., Chicago 6).....	127

### SCIENCE

Phone call via moon uses bouncing signals.....	73
One loaf of fish, please.....	73
Plant tranquilizer.....	84
Polio respirator feeds at mouth.....	84
Electronic brain recognizes numbers.....	85
Radio-controlled models aid in river study.....	97
"Red hot" rectifier takes 1300 degrees F.....	115

### WHAT'S NEW FOR YOUR HOME

Clip-on cord attaches to door.....	98
Near-boiling water is constantly available.....	98
Flexible shower arm.....	98
Medicine safe.....	98

(Continued to page 54)

**FREE!**

**100  
WORLD-WIDE  
STAMPS...  
just  
released!**



Rush coupon for scarce, beautiful stamps shown, and more — FREE! Asia, Africa, Europe — every corner of the world. The newest, hardest-to-find stamps issued in a year — some not even cataloged yet! All genuine, all different, mint and used, pictorials, bi-colors from Antarctica, Siam, Israel, everywhere. Because this offer is unique, it may never be offered again. Due to scarcity, only one packet to each collector. So add this rare offer to your collection, plus helpful FREE "Stamp Collector's Guide" and other offers for your free inspection. RUSH name, 10c for postage, handling to GARCELON STAMP CO., Dept. 8PMW, Calais, Maine.

**GARCELON STAMP CO., Dept. 8 PMW**

Calais, Maine. Rush FREE World-Wide Stamps, Collector's Guide, other offers. Enclosed 10c for postage, handling. (PLEASE PRINT)

Stamp Collector's Guide



**I'LL FINANCE YOU**

...in your own  
**SCREEN PRINTING  
BUSINESS**

Yes, I'm prepared to train you and establish you in your own spare time business... even if you are now employed. I'll give you Credit, Financial Assistance. Mail Coupon Now!

**PRINT WITHOUT A PRINTING PRESS!**

Amazing but true! The Screen Print method requires no expensive Press and can be done in your own home. Start in Kitchen, Spare Room, Garage! Easy! Fascinating!

**PRINT BEAUTIFUL SIGNS, POSTERS, BANNERS, FABRICS** — anything in hundreds of colors. Use fabulous new "glowing" fluorescent colors. Can be seen for miles. No Art ability needed — we supply everything.

**HELP SUPPLY DEMAND IN YOUR AREA!** Just about every kind of business (drug, department stores, hardware, liquor stores, gas stations, theaters, jewelers, mortuaries, auto dealers, florists, beauty shops, real estate, etc.) can use Screen Printed things to increase business.

**SOME \$100 JOBS USE LESS THAN \$10 WORTH OF MATERIALS**... you pocket the difference for your labor and know-how. \$400.00 A WEEK EARNINGS POSSIBLE? Yes, some earn less, but Mr. J. T. Anderson reports he earns over \$400.00 a week printing Greeting Cards certain times of year. Get your share Now. Mail Coupon Today!

**FREE SAMPLES — MAIL COUPON NOW**

Mr. C. J. Nowak, Screen Print Co., 15127 S. Broadway  
Los Angeles 61, California, Dept. 28

Dear Mr. Nowak! I am genuinely interested. Please rush your "FINANCIAL ASSISTANCE PLAN" Revealing Screen Print HOME BUSINESS Details, Real SAMPLES, and "HOW TO" BOOKLET. I am under no obligation now or ever.

Name \_\_\_\_\_  
Address \_\_\_\_\_  
City \_\_\_\_\_ Zone \_\_\_\_\_ State \_\_\_\_\_





# Get into... PLASTIC LAMINATING AT HOME!



Get **ORDERS** and **CASH** from your mailman—do work in **SPARE TIME** at home—or expand into **FULL TIME** business. Send coupon for Free facts about the newest and most fascinating of all home operated businesses. For the first time a simplified machine brings the fabulous profits of **Plastic Sealing and Plastic Laminating** within the reach of the small operator. Anyone can learn to operate the machine with a few minutes practice—then with our **Magic Mail Plan** can get mail orders pouring in daily with cash in every envelope. **No canvassing—no selling.** We even

Make up to \$5 an Hour.  
**MAGIC MAIL PLAN!**

supply the circulars you mail to bring back cash and orders. Don't waste a minute. Rush your name. We'll send you **FREE** and postpaid, pictures, prices, details, and all the facts you need to start. Mail coupon or send name on postcard. No charge. Warner Electric Co., 1512 Jarvis Av., Dept. L-2-J, Chicago 26, Ill.

**THIS MAN . . .** is taking out of the machine a Plastic Sealing Job—ordered by mail—only 11c in material cost brings back \$2.58 in cash by mail. Capacity of machine: **\$25.00 profit per hour of operation.**

**Make Thousands of Beautiful Art Creations**  
COSTUME JEWELRY • CIGARETTE BOXES  
TRAYS • CANDLESTICKS • COASTERS  
LAMP BASES • BOOK ENDS...ALL IN  
SPARKLING COLORED PLASTIC



**WARNER ELECTRIC CO., 1512 Jarvis Av.**  
Dept. L-2-J, Chicago 26, Ill.  
At no cost to me, please rush complete details postage prepaid. I am under no obligation.

Name \_\_\_\_\_  
Address \_\_\_\_\_  
City \_\_\_\_\_ Zone \_\_\_\_\_ State \_\_\_\_\_

## WANT A CAREER WITH A FUTURE?

Turn to pages 210, 211 and read what Popular Mechanics has to say about a well-paid, prestige profession in this month's **Skills For America** article: **THE ENGINEERING DRAFTSMAN**

**Learn BAKING At Home**

Baking is one of America's high industries in wages. Nearly depression-proof. Thorough basic home course lays sound foundation. If you have aptitude, write for **FREE BOOKLET**, "Opportunities in Commercial Baking." National Baking School, 835 Diversoy Pkwy., Dept. 135C, Chicago 14, Illinois

### 2 WAY PORTABLE RADIO SET

**SENDS — RECEIVES UP TO 10 MILES AS SHOWN**  
with built-in antenna or hundreds of miles with outside antennal Works on 80 and 40 meter (Novice) amateur radio-bands—also Aircraft and overseas broadcast (3 to 8 mc). **PORTABLE SELF-CONTAINED POWERED WITH STANDARD PORTABLE RADIO BATTERIES. NO AC PLUG-INS NEEDED!** Take it with you everywhere you go—on trips, vacations, camping—Keep in contact with home. Friends. Has 5 watt crystal controlled transmitter—Sensitive Regenerative Receiver. Send-Receive switch. Wt., only 3 lbs. Size, only 6"x4"x4". **TESTED — PROVEN — SIMPLIFIED — PRACTICAL** — Full information given on quick easy to get license.

**SEND ONLY \$3.00** (bill, ck. mo) and pay post-man \$12.95 COD postage on arrival or send \$15.95 for postpaid delivery. Complete kit includes all parts, tube, coils, plastoid cabinet, easy instructions. (Set of batteries \$3.49; crystal \$1.49.) **COMPLETELY WIRED AND TESTED POSTPAID \$19.95.** A regular \$49.95 value—Order now before price goes up. **GUARANTEED—AVAILABLE ONLY FROM: WESTERN RADIO DEPT. BNM-8 KEARNEY, NEBR.**

**GENUINE 360 POWER 3" REFLECTING TELESCOPE**

**COMPLETE WITH 50X, 120X, 150X, 360X magnifications, 4X finder scope, folding tripod, plus "Handbook of Heavens" & Magic Star Finder**

Only **\$26<sup>95</sup>**

Never before a precision reflecting telescope sold with all these features, for anywhere near this low price. Professional observations guaranteed with this powerful astronomical telescope. Equipped with special **WIDE-ANGLE** lens for observing satellites, stars, nebulae, comets, Saturn's rings, Jupiter, Mars, Moon's detail, other celestial phenomena with observatory clearness, amazing closeups guaranteed on all objects. Will "split" close double stars. Acclaimed by experts optically & scientifically correct, for serious astronomical work. Completely assembled ready to use. Eyepieces give full range of powers, 50X, 120X, 150X, 360X. 3 inch f12.5 mirror aluminized & overcoated, guaranteed to resolve to Dawes limit. Special ventilated aluminum mirror housing for use in all climates. 3' hardwood folding tripod. Equatorial, alt-azimuth mount compensates for earth's rotation & permits automatic tracking of astronomical objects. Take long range photos with ordinary box camera. 36" Bakelite phenolic tube. 4X finder scope sights target fast. Completely portable; scope instantly removable from tripod for easy storage & carrying to remote areas. Included with this amazing precision instrument, 270 page book "Handbook of the Heavens," Magic Star Finder. Satisfaction guaranteed or money refunded. Sent complete, nothing else to buy at amazing low price of **\$26.95**. Send cash, check, or money order. Shipped by express F.O.B. Shipping weight 10 lbs. Dept. DPM 6, OPTIK INSTRUMENTS CO., 509 Fifth Ave., N. Y. 17, N. Y.

**HOME STUDY** can open the door to a **BETTER JOB** at **BIGGER PAY** for YOU

**TODAY, CHOOSE YOUR CAREER!** Then take the first easy step toward preparing for the goal you can reach in *spare time at home*. Or, if you are in work you like, learn how you can earn quicker promotions and bigger pay. For 61 years **AMERICAN SCHOOL** has helped many thousands of ambitious people succeed. Think seriously about the subjects listed. Fill in and mail coupon today.

**AMERICAN SCHOOL, Dept. GC45, Drexel at 58th, Chicago 37, Ill.**

Without obligation, send **FREE** information on the subjects I have checked.

<input type="checkbox"/> Accounting	<input type="checkbox"/> Contracting	<input type="checkbox"/> Mechanical Engineering
<input type="checkbox"/> Apprenticeship Courses	<input type="checkbox"/> Diesel Technician	<input type="checkbox"/> Mechanical Technology
<input type="checkbox"/> Architecture & Building	<input type="checkbox"/> Drafting—Building Trades	<input type="checkbox"/> Metalworking Courses
<input type="checkbox"/> Automotive Technician	<input type="checkbox"/> Drafting—Machine Trades	<input type="checkbox"/> Plumbing—Practical
<input type="checkbox"/> Better Foremanship	<input type="checkbox"/> Electrical Engineering	<input type="checkbox"/> Private Secretary
<input type="checkbox"/> Blueprint Reading	<input type="checkbox"/> Electricity—Practical	<input type="checkbox"/> Retail Merchandising
<input type="checkbox"/> Bookkeeping	<input type="checkbox"/> Electronics—Industrial	<input type="checkbox"/> Salesmanship—Outside
<input type="checkbox"/> Business Management	<input type="checkbox"/> HIGH SCHOOL COURSES	<input type="checkbox"/> Sheet Metal Work
<input type="checkbox"/> Civil Engineering	<input type="checkbox"/> Machinists	<input type="checkbox"/> Tool Making

NAME \_\_\_\_\_ OCCUPATION \_\_\_\_\_ AGE \_\_\_\_\_  
HOME ADDRESS \_\_\_\_\_  
CITY \_\_\_\_\_ STATE \_\_\_\_\_

Accredited Member NATIONAL HOME STUDY COUNCIL



# EARN MORE - LEARN AUTO DIESEL MECHANICS

## OR TRAIN WITH OTHER GREER DIPLOMA COURSES

- |  |   |
|--|---|
| <input type="checkbox"/> AUTO MECHANICS        | <input type="checkbox"/> REFRIGERATION      |
| <input type="checkbox"/> DIESEL MECHANICS      | <input type="checkbox"/> AIR CONDITIONING   |
| <input type="checkbox"/> BODY & FENDER REPAIR  | <input type="checkbox"/> MACHINIST TRADE    |
| <input type="checkbox"/> GAS-ARC WELDING       | <input type="checkbox"/> ADVANCED MACHINIST |
| <input type="checkbox"/> PIANO TUNING & REPAIR |   |

Skilled men are needed in every part of the country. Earn top pay in established shops or start your own business. Greer's expert instruction and actual shop training teaches you how. You learn by doing—quick, easy courses using the latest tools and equipment. Day, evening and part time instructions available.

Job placement and convenient living accommodations are yours while training. Contact GREER'S FREE JOB PLACEMENT SERVICE when you enroll if you wish part time or full time employment.

## ENGINEERING DEGREE COURSES

- DIESEL AUTOMOTIVE ENGINEERING 27 MOS.
- REFRIGERATION & AIR COND. ENGINEERING 18 MOS.
- WELDING ENGINEERING 18 MOS.

All Courses Approved  Civ. or  G.I.

Please rush me free literature on the trade indicated, at no obligation.

NAME \_\_\_\_\_ AGE \_\_\_\_\_  
STREET \_\_\_\_\_  
TOWN \_\_\_\_\_ ZONE \_\_\_\_\_ STATE \_\_\_\_\_

Established 1902

**GREER SHOP  
TRAINING**  
Box H, 2236 S. Michigan Ave.  
Chicago 16, Illinois

## "HOW I DOUBLED MY INCOME In Less Than A Year, As A CUSTOM UPHOLSTERER"



Alvin Lederkramer, Former Low Salaried Auto Mechanic — Now Earning Big Pay

"When I enrolled for UTS training I was an auto mechanic earning a meager salary. While learning I earned good spare-time money. After graduation, I got a job in upholstery with better pay than ever before. Now, less than one year later, I've doubled my income. Soon, I'll get into my own business. The future looks bright, thanks to UTS."

**WHAT DO YOU WANT? Your Own Profitable Business—A Steady Job — Substantial Sparetime Earnings — A More Secure Future? They're all waiting for YOU in Good Times and Bad in the Big-Opportunity Field of Custom Furniture Upholstery.**

The big nationwide housing boom has created a great demand for trained upholsterers. Prepare for this well-paid trade — easily, quickly. You can earn as you learn to make good money all year 'round at home, in your own shop, or in a well-paid job. The practical N. Y. State-approved UTS Course teaches you professional custom furniture upholstery, reupholstery, slip-covers, furniture finishing, window cornice, cushion, and drapery making. Course includes—FREE—ALL tools, complete frames and materials.

**FREE ILLUSTRATED BOOK — FREE SAMPLE LESSON!** Our FREE book, "YOUR NEW WAY TO A SUCCESSFUL CAREER" with FREE Sample Lesson shows you how. **WRITE TODAY!** Training in N.Y. School also available. Upholstery Trades School, Dept. GM-305, 721 B'way, N.Y. 3

MAIL COUPON TODAY

**MATERIALS FREE WITH COURSE YOU MAKE**

SLIPPER CHAIR  
CLUB CHAIR  
OTTOMAN  
PLUS SLIP COVERS  
Yours to keep or sell

APPROVED FOR **VETERANS**

UPHOLSTERY TRADES SCHOOL, Dept. GM-305  
721 Broadway, New York 3, N. Y.

Please send me FREE book with FREE Sample Lesson. No obligation—no salesman will call.  
 Home Study  In N. Y. School Training

Name \_\_\_\_\_ (Please print plainly)  
Address \_\_\_\_\_  
City \_\_\_\_\_ Zone \_\_\_\_\_ State \_\_\_\_\_  
 Check if Korean Veteran

(Continued from page 52)

Rain diverter stops soil erosion.....	99
Bed vibrator .....	99
Helical springs for chairs with flat cushions.....	99
Water-powered vegetable peeler.....	99

## Radio-Television, Electronics

A transistorized stroboscope.....	133
Electronics today .....	136

## Craftsman and Shop Notes Index

### AUTOMOTIVE

Magnetic cigarette "holder" for auto instrument panel.....	156
Checking ignition trouble.....	156
Flexible taillight mountings make them break-resistant.....	156
Clean clips protect car fuses.....	156
Pad eyes inside car-trunk lid permit tying it down.....	156
Spark plugs selected to suit special driving conditions.....	184
Mercury in distributor cap assures positive contacts.....	192

### BOATING AND FISHING

Rack eliminates loose-air-tank hazard in boat.....	145
Water-soaked burlap keeps fish alive in boat.....	145
Clothespin fishing-rod rack.....	170
Flushing large outboard motors.....	170
Fishing gear on lake bottom found with waterproof light.....	170
Rubber-tire "gaskets" reduce noise and wear on floats.....	170
Buying a used outboard calls for careful check of major parts.....	170

### FARMING

Welded-pipe gate .....	141
Shop-built farm mowers.....	160
Cleated ramp in cattle chute serves as shed door.....	185
Cattle now treat themselves to insecticide.....	185
Stanchions pulled shut by rope while standing behind cows.....	185
Overhead-axle cart designed for hand-picking sweet corn.....	185

### HOUSE AND HOME

Twin vanity dressing tables.....	137
Small wedge used for spacing picture molding at ceiling.....	144
Putty holder on paint pail aids last-minute caulking.....	148
Paint roller used on wire fence saves both time and labor.....	152
How would you do it?.....	154
Novel hanging planter turned from wood.....	157
New "dry brush" technique produces antique finish.....	159
Pivoting crossbar for clothes hanger.....	159
Skidproofing mixture for steps is sand-paint solution.....	162
So old they're new.....	163
Caulking under screen molding seals out water damage.....	168
"His" and "hers" workshop.....	169
Infrared pest-control box.....	171
Resistor added to doorbell permits volume control.....	178
Safety rack for ironing board.....	178
Reflective tape over keyhole.....	178
Complete home-movie center located in cabinet.....	179
Extension brackets "clamp" paint-roller to ladder shelf.....	180
Seal knots and sap streaks.....	180

### LAWN AND GARDEN

Flexible "rung" of chain makes ladder safer against trees.....	148
Entire ant colony destroyed with "one shot" treatment.....	168
Portable drill starts mower.....	168
Landing net pole lets you pick fruit from high branches.....	168

### MISCELLANEOUS

Machine-stitched stockings better for shoe polishing.....	148
Tumbler holds magnifying glass.....	168
Tar-paper rolls lifted safely with pail and looped rope.....	178
Sandpaper target adds fun to tiddlywink game.....	178

### OFFICE, SHOP AND STORE

Knitting needle substitutes for missing stencil stylus.....	140
Rubber band on architect's scale keeps it right side up.....	140
Steaming renews pitted surface of shop drawing board.....	140
"Self renewable" glue brush.....	140
Paper held on drawing board without thumbtack damage.....	140
Pencil compass used for inking.....	140
"Skidproofing" bookends.....	140
Crayon "blackboards".....	149
Note storage in book cover.....	158
Hot water and wooden block keep crayons "sharpened".....	178

### OUTDOOR LIVING

Cooking aids for campfire meals.....	146
Vacuum-bottle caps marked to identify contents.....	148
Kitchen range becomes outdoor fireplace.....	153

### PHOTOGRAPHY

Permanent photochemical labels made from colored plastic tape.....	158
Low-cost adjustable stands from pipe and plywood.....	158

(Continued to page 55)

**NOTICE**—It is the intention of this magazine to provide its readers with information regarding the latest developments in the mechanical arts. Except where otherwise indicated, this magazine has no information as to any unexpired patents in respect of the developments reported herein. In the event that commercial use is to be made of any of the developments reported herein, it is suggested that legal counsel be consulted to avoid liability for patent infringement. It is not the purpose of this magazine to encourage patent infringement but, as indicated, it is the intention of this magazine to report on the latest developments in the mechanical arts.



(Continued from page 54)

- Developing part of film roll before exposing all of it.....158
- Weight keeps paper box closed.....158
- Wax keeps stains off prints.....179

### SHOPPING FOR TOOLS

- Height indicator.....189
- Soldering "pencil".....189
- Paint-roller pail.....189
- Nontoxic penetrant.....198
- Engine-turning tool.....190
- Hand-powered stud driver.....190
- Combination countersink, pilot drill.....190
- Portable electric jigsaw.....190
- Air-powered impact wrench.....191
- Ladder brackets.....191
- Tubing cutter.....191
- Adjustable drill.....191
- Steel "sandpaper".....191

### SOLVING HOME PROBLEMS

- Bathroom fixtures cleaned with common table salt.....150
- Safeguard youngsters from pushing out screens.....150
- Keeping track of pins for sewing.....150
- Modify dog leash for easy tethering.....150
- Childproof lock on bathroom door.....151
- Paper plates can be reused.....151
- Labels made attractive on canned fruits and juices.....151
- Heavy books protected from shelf wear.....151
- Handle on cork convenient when opening a bottle.....151
- Keep cut ends of ribbon from raveling.....151

### WORKSHOP HINTS

- Pocket knife holds chalk line.....141
- Hose is wire-cutting jig.....141
- Sawing saves boards when dismantling wooden boxes.....144
- Putty knife cleaned of paint on slotted can.....144
- White marks indicate receptacle openings.....144
- Notch accessory switch for touch control.....144
- Slots in screwheads cleaned with hacksaw blades.....148
- Removing broken drill bit.....153
- Gun tool is power wire brush for special cleaning jobs.....153
- Nails "drilled" into wood to prevent splitting.....152
- Drill motor hung overhead by eyebolt in handle.....152
- Driving nails in hardwood.....152
- Modified nut permits use on smaller diameter screw.....153
- Singeing new rope removes "splinters".....178
- Emergency cotter pin.....185
- Wooden chuck protects gear when machining in lathe.....188
- "Renewing" worn hacksaw blade.....188
- Turning marked for drilling by using lathe tool bit.....188
- Modified V-block aligns drill.....188
- Impact puller removes badly rusted cotter keys.....192
- Wooden block aligns bit when drilling pipe.....192

## GET INTO ELECTRONICS

V.T.I. training leads to success as technicians, field engineers, specialists in communications, guided missiles, computers, radar, automation. Basic & advanced courses in theory & laboratory. Assoc. degree in 20 mos. B.S. obtainable. ECPD accredited. G.I. approved. Graduates with major companies. Start Sept., Feb. Dorms, campus. H. S. graduate or equivalent. Catalog.

**VALPARAISO TECHNICAL INSTITUTE**  
DEPT. D VALPARAISO, INDIANA

## STOP RUPTURE SUFFERING!

**WEB GUARANTEES LASTING RELIEF —OR YOUR MONEY BACK!**



Thousands have overcome disabling ruptures with the natural support of Web's patented design. Satisfaction—or full price refunded. Write for free book!

**WEB TRUSS CO., Dept. M-8, HAGERSTOWN, MD.**

## GET INTO RADIO-TELEVISION



**Prepare for Big Pay Jobs or Your Own Business —TRAIN AT HOME IN SPARE TIME! Earn While You Learn**

Good pay jobs are waiting for men who know **RADIO-TELEVISION**. Learn at home, get valuable, interesting, actual, practical experience with kits and equipment we send. Earn extra cash servicing sets while learning. No previous experience needed. Rush coupon for big book and Sample Lesson... **FREE!** No salesman will call. Our 27th year.

**FREE!**  
60 Page Catalog and Sample Lesson

**Sprayberry Academy of Radio-Television**  
1512 Jarvis Ave., Dept. 10-K, Chicago 26, Ill. 1  
Rush catalog and complete lesson... no obligation.

NAME.....  
ADDRESS.....  
TOWN..... STATE.....

## Direct From Importer!

Save \$250 on Painting Jobs with help of **Electric PAINT SPRAYER**

Same type form. adv. on TV for **19.95**

**7.99**

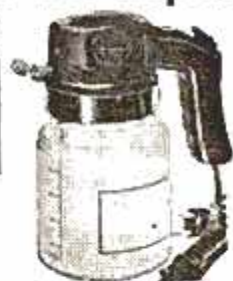

New model. New powerful motor-pump. New adjustable **MAGIC SWIVEL NOZZLE**, sprays UP, DOWN, SIDEWAYS without tilting jar! **STAINLESS STEEL & Brass** parts. Rustproof! 25-oz. jar. Cuts painting time up to 75%. Do average room in less than hour. Press button & spray. No stiff arms or sore muscles from carrying sloppy, dripping brushes. Paint screens, walls, ceilings, floors, cabinets; refinish furniture, etc. Gets into cracks, rough surfaces that brush can't even reach! Completely safe — easier to clean than brush! Approved by professionals. Takes deodorants, lacquers, disinfectants, polishes,

etc. Mothproof clothes, spray plants, paint car, etc. Same type formerly adv. on TV for \$19.95—now **SLASHED** to new low \$7.99. **Ni-Power Model** sold only by mail, only by us. No. 95 **SPECIAL!** Deluxe Model with **JEWELED Tip** for fine, precision work. Built-in **COPPER FILTER**, heavy-duty electric cord. Same features as in \$24.95 models. Now only \$9.99. No. 95-D

## NEW HANDY

Made by John Oster Mfg. Co. Cummins Div.



List \$21.95

One Time special! New **HANDY 1/4"** Electric Drill at **HALF PRICE!** Precision made by John Oster Manufacturing Co. 1,800 RPM, 1/4" chuck, self-lubricating sintered bronze bearings, die-cast aluminum housing, satin finish—with full pistol grip and automatic trigger lock! New, first-quality, fresh from factory. Only 150 in stock at this price. First come, first served. 10-day trial. Money back guarantee. No. 142 List \$21.95. OUR PRICE... **11.95**

## 13-Piece Set of Chrome Vanadium DRILLS



\$5.95 Value

**1.98**

Imported from W. Germany

Terrific value from Germany. 13 precision Chrome Vanadium Drills from 1/16 through 1/2" by 64ths, enclosed in two handy indexed jackets for quick, finger-tip selection. Drill through woods, plastics, aluminum, iron, even thick-gauge steel! You'll get years of A-1 service from these hi-speed drills. Mail coupon below. No. 13. 13-piece set, only \$1.98. **EXTRA SPECIAL!** 60 piece set complete with metal index; \$24.95 value. Only \$9.99. Order by No. 1360.

## Huge 108 Sq. Feet Plastic Drop Cloth



**99c**

One-Piece! No Seams! Wipes Clean!

Transparent plastic drop cloth with 101 uses! Protects furniture & floor when painting. Paint can't stick; just shake; dry paint falls off. Can be cut and sewed into garment bags, aprons, tablecloths, shopping bags, deep-freeze bags. Place over appliances, carriages, outdoor furniture, lawnmowers, etc. Protects against dampness, dust, corrosion, grease. **WATER-PROOF.** 9x12 size (108 sq. ft.) No. 4..... **99c**

## DUREX HOLE SAW

with new automatic **SLUG EJECTOR**

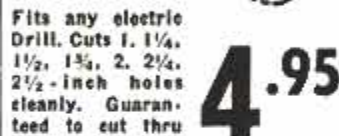

Fits any electric Drill. Cuts 1. 1/4, 1 1/2, 1 3/4, 2. 2 1/4, 2 1/2 - inch holes cleanly. Guaranteed to cut thru woods, plastics, metals — even tough, rugged **FORMICA!** You get alloy tool head, 7 shatterproof blades, the automatic slug ejector and 1/4-inch drill bit. One of the handiest time & work savers around. Indispensable for home owners, hobbyists, amateur handy-men. No. 199..... **4.95**

**THORESEN, Inc., Dept. 6-H**  
585 Water Street, New York 2, N. Y.  
RUSH items listed below. My money back if I'm not satisfied. (Minimum order: \$2.98)

Check, cash or money order enclosed. Ship postage paid.  
 Send COD plus postage and COD fee.

NO.	QUANTITY	ARTICLE	PRICE

PRINT NAME.....  
ADDRESS.....



*Since 1903...*

**PARTNER  
IN PROGRESS** *to the*  
**AUTOMOTIVE  
INDUSTRY**

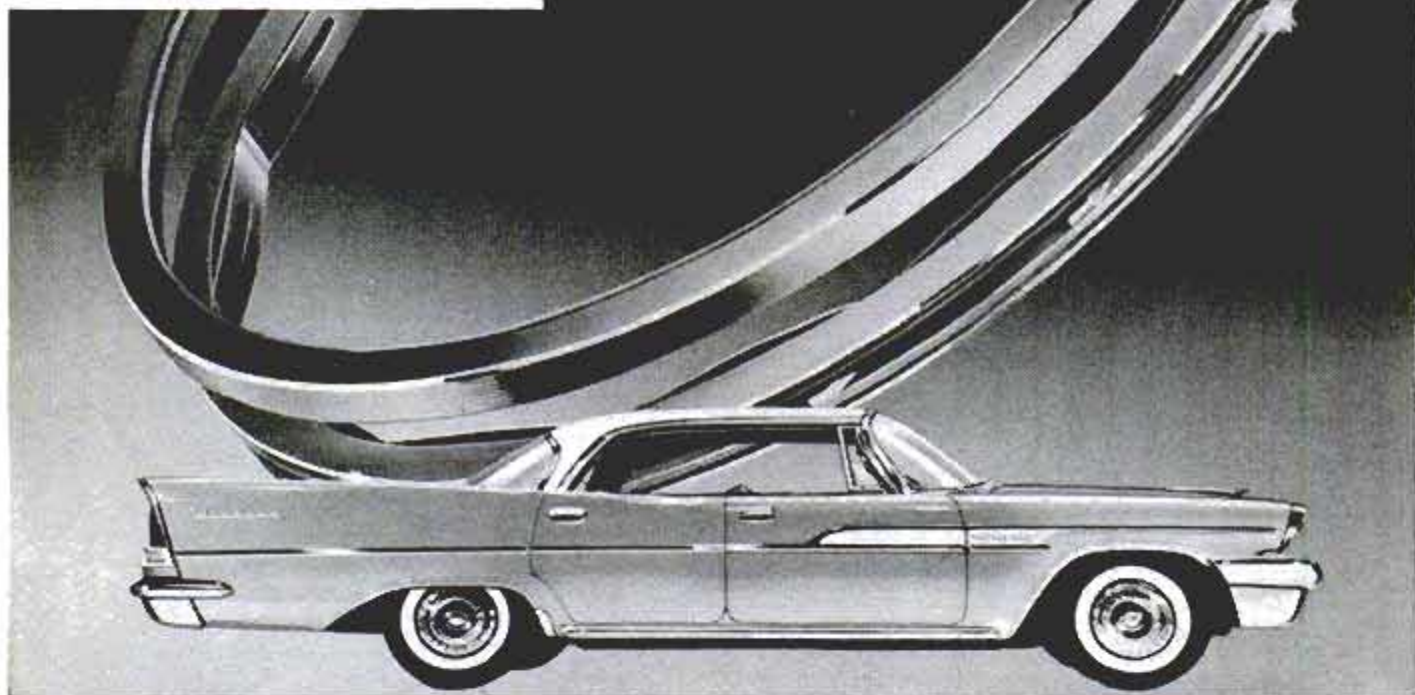

**CHRYSLER**—one of the leading engine manufacturers using Perfect Circle piston rings for original equipment.

Behind the world-wide preference for Perfect Circle products is a history of more than half a century of PC engineering leadership—and more. There's a history, too, of unceasing creative research and scores of contributions to the advances achieved by the automotive industry, year after year.

You benefit from the PC heritage of leadership every

time you buy a car, truck or tractor equipped with Perfect Circle piston rings or other components that bear the mark of Perfect Circle. And you're sure to benefit when you ask for Perfect Circle piston rings when it's time to overhaul your engine. Perfect Circle Corporation, Hagerstown, Ind.; The Perfect Circle Co., Ltd., Don Mills, Ontario, Canada.

**PERFECT CIRCLE  
PISTON RINGS**

### **AUTO-PILOT**

a new  
dimension  
in driving ...



Auto-Pilot—a product of Perfect Circle research and engineering—prevents unintentional speeding in city, country and turnpike driving, yet keeps full engine power at your instant command. Lets you keep your eye on the road—and off the speedometer. Provides "robot throttle," permitting restful highway cruising with your foot off the accelerator pedal. Available now on the magnificent 1958 Chrysler and Imperial motor cars. Auto-Pilot is manufactured by the Speedostat Division of Perfect Circle Corporation.



# The SUN Is Really In Business

By *Thomas E. Stimson, Jr.*

**S**OME OF THE SUNSHINE that falls on Santiago Peak in California operates a radio repeater station for the Forest Service. The sunlight is changed into electricity, which is stored in a 12-volt automobile battery so the station can transmit at night or in cloudy weather as well as when the sun

is shining down on the mountain station.

At Los Angeles harbor the Coast Guard is testing a solar converter that takes power from the sun and stores it in a battery. The battery operates a flasher beacon throughout the night. At Palm Springs, Calif., sunshine drives an electric clock. In South

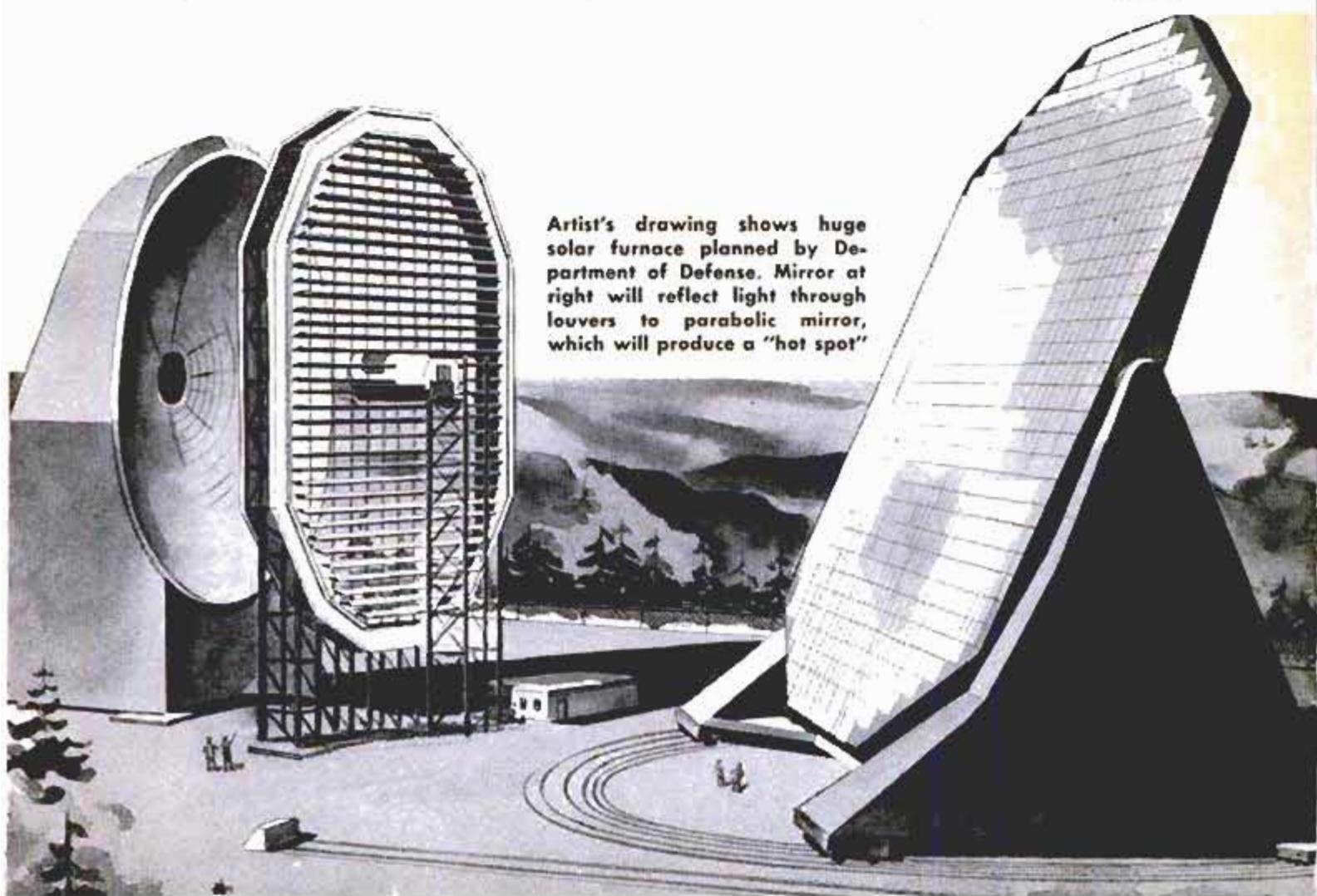

Artist's drawing shows huge solar furnace planned by Department of Defense. Mirror at right will reflect light through louvers to parabolic mirror, which will produce a "hot spot"



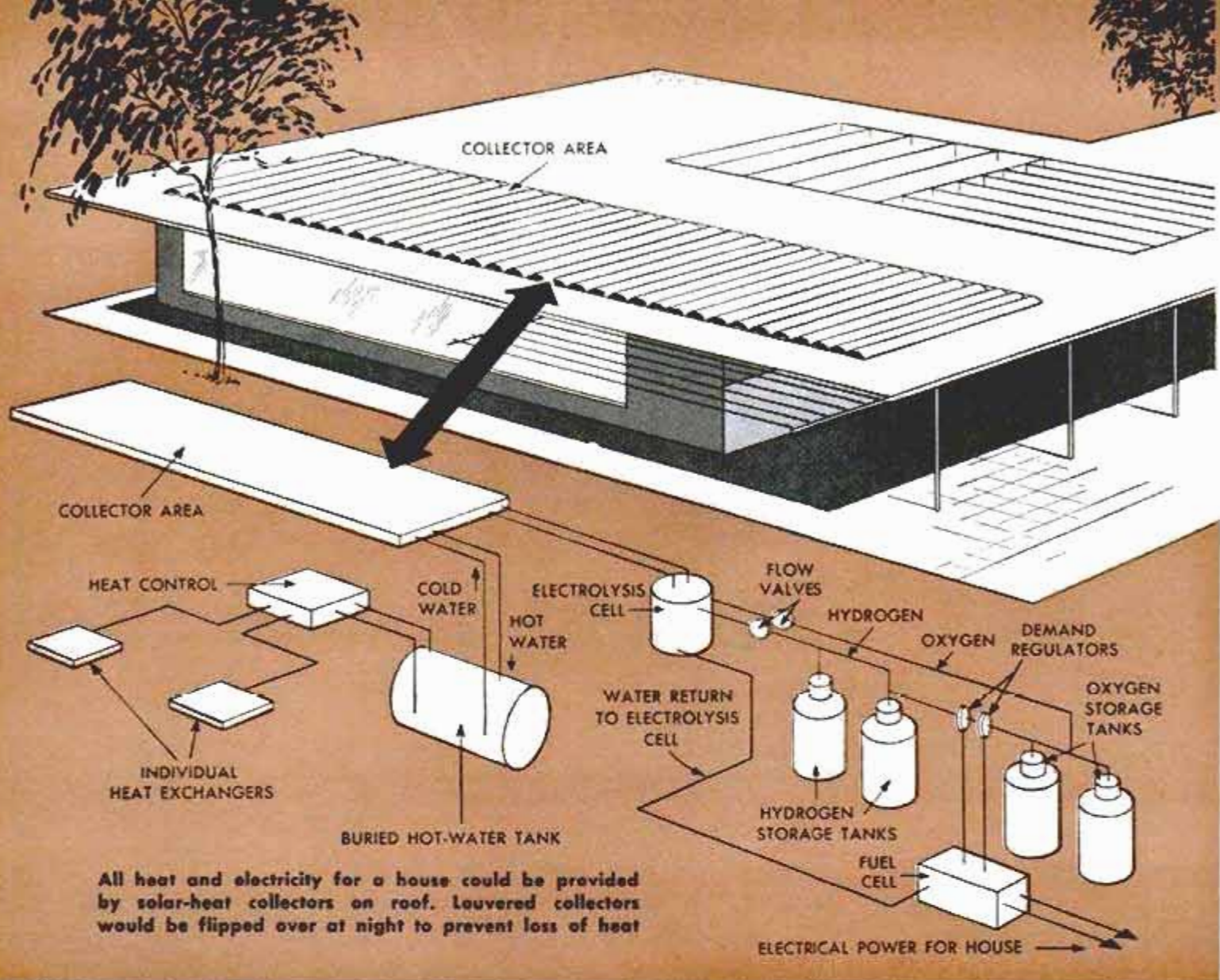

Africa, the sun supplies power for operating remote telephone circuits.

Flashlights that store up the energy of sunlight are being tested, as are sun-powered highway warning lamps. Model ships and toy trains using sunlight for propulsion have been built. Portable radio

receivers powered by the sun are on the market. Solar cells on earth satellites change sunlight into electrical energy to power radio equipment.

All these devices have one thing in common: They use an array of small, dark disks for converting light into electrical energy. The disks, or silicon solar cells, never wear out. They are the forerunners of a way of extracting electricity from sunshine in large amounts.

H. Leslie Hoffman, president of Hoffman Electronics Corporation in Los Angeles, Calif., believes that the solar home of the future not only will be heated and cooled by sunlight, but it also will obtain all the electricity it needs from the sun.

He estimates that a 20 by 40-foot area on the roof, coated with solar cells, would develop 8.8 kilowatts of electrical energy. An average of six hours of sunshine per day would provide 1584 kilowatt-hours of electricity per month. This is about six times the requirements of the average household.



Panel of solar cells provides power for a miniature electric pump which pumps water in a steady stream from fountain



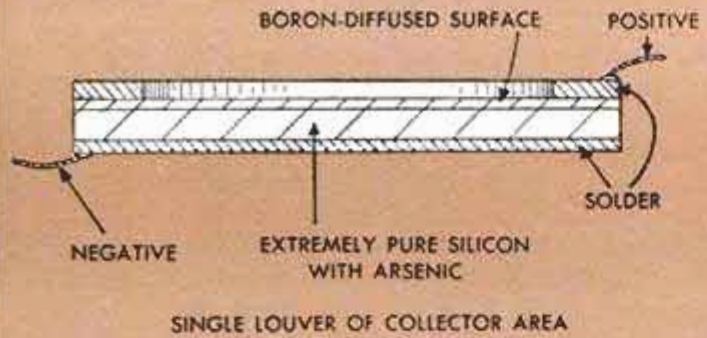
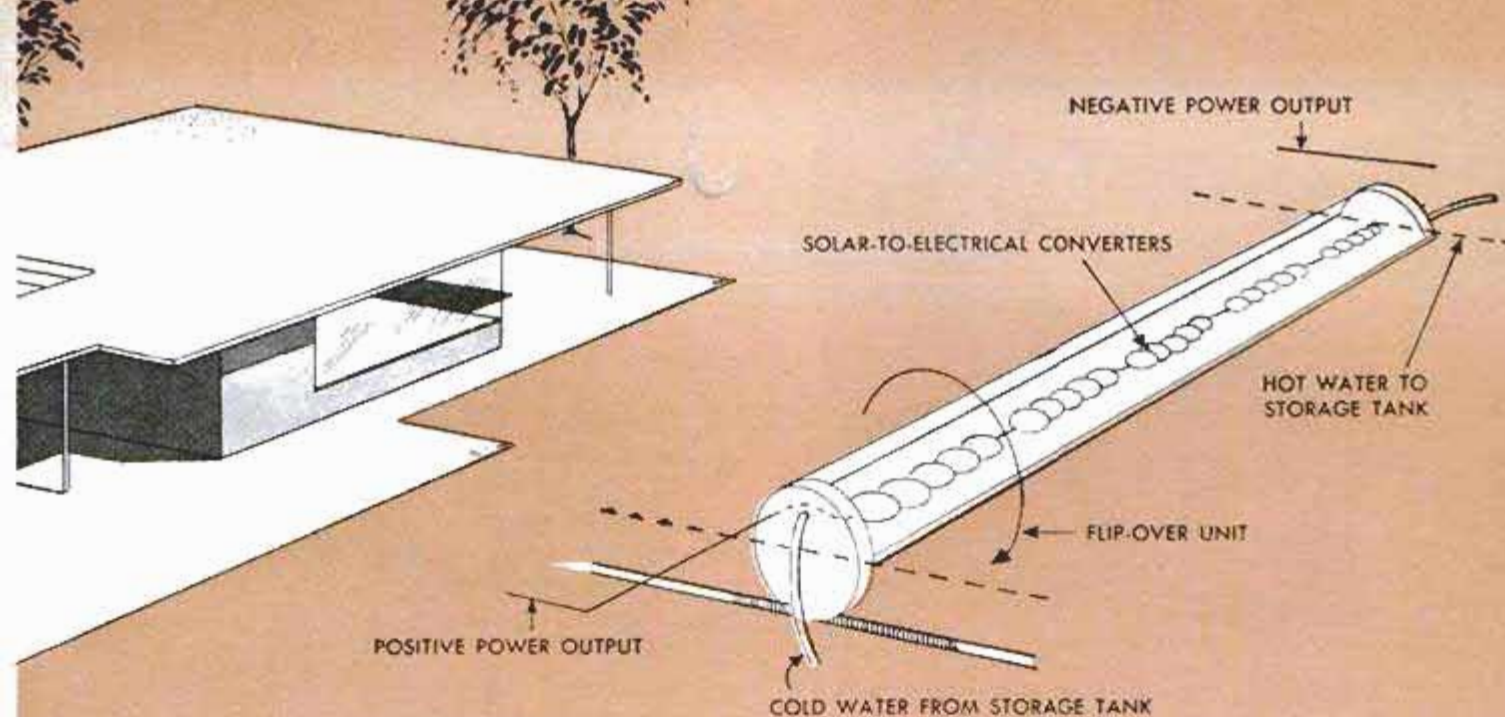

Right, here are stages of solar-cell preparation: Pure silicon is cast into an ingot which is sliced

Hoffman technician cements in place the 20 solar cells which will operate a clock in Palm Springs, Calif. Sunlight powers the clock 24 hours a day

Completed clock is mounted in sunlight on a wall. Solar cells convert the sunlight into electricity, which is stored in a battery to operate the clock

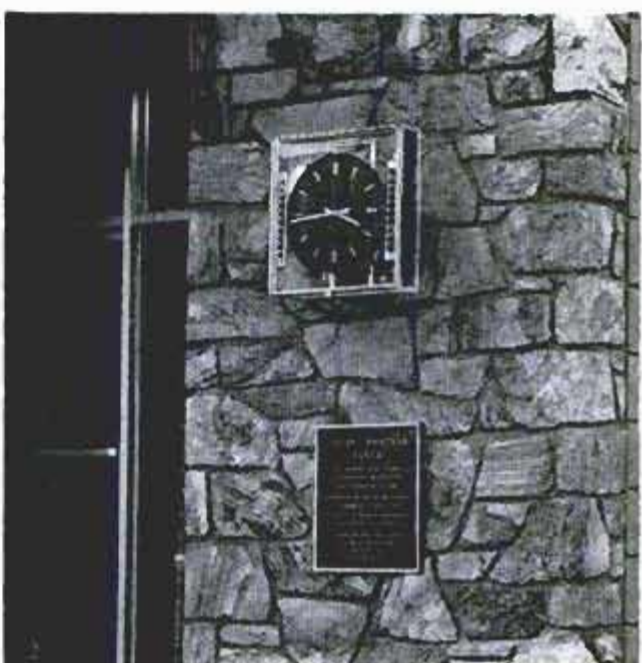



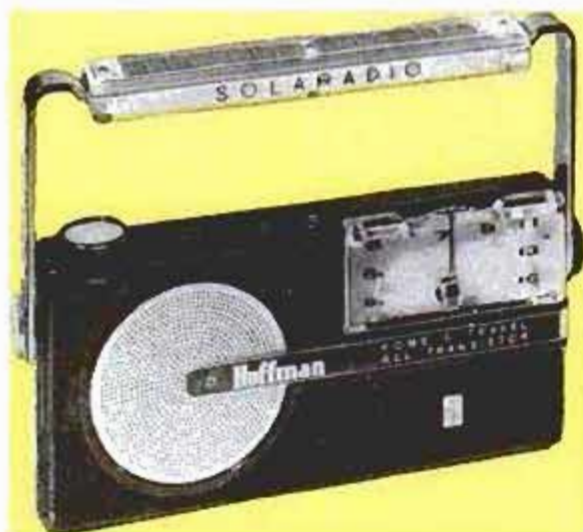

Solar cells charge battery of portable radio



Flashlight stores sunlight for use after dark

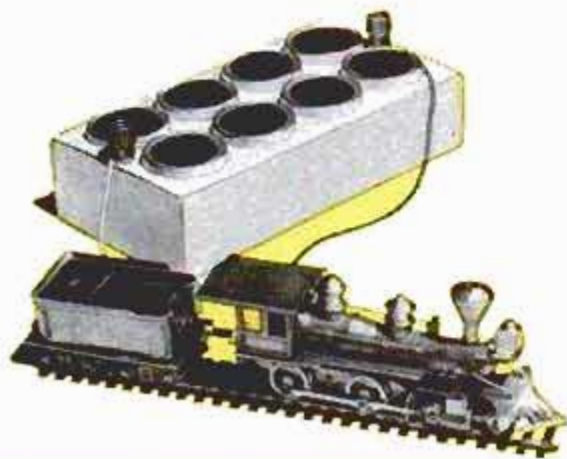

Solar energy turns wheels of model locomotive

↓ Cells in wing whirl model-plane propellers



The electricity has to be stored, of course, and the obvious way to do it is to use ordinary but expensive storage batteries. The Hoffman scientists suggest a simpler, cheaper way. They would change the electricity into gases, then convert the gases back into electricity as it is needed.

It would work this way: Electricity from solar cells on the roof would operate an electrolysis apparatus that would break down water into the hydrogen and oxygen gases of which it is composed. The gases would automatically be stored under pressure, since the action of electrolysis creates pressures as high as 3000 pounds per square inch. Tanks located in a small closet would hold enough gas to operate the house for a month.

From these storage tanks the gases would be piped to a number of units called fuel cells. The cells have the ability of converting hydrogen and oxygen back into water, at the same time releasing useful amounts of electricity. The water created by the cells would flow back to the electrolysis apparatus, ready to be broken down into gases again. The fuel cell, described in the February 1958 issue of *Popular Mechanics*, is an old laboratory curiosity for which few uses have been found in the past. Each cell delivers one volt. Amperage depends on size of the cell.

A couple of dozen fuel cells could power a 24-volt DC system that would light a house and operate all its appliances. Lamps and motors, of course, would need to be of the DC type. Or, with more cells and a transistorized converter, ordinary 110-volt AC current could be created.

### Solar Electric—Heating System

Norman Regnier of the Hoffman organization sees no reason why such a solar electric system can't be combined with a solar heating plant similar to those already in use in a number of experimental homes and in a small office building. A solar-heating plant consists of water pipe that

Highway-warning flasher stores electricity from cells





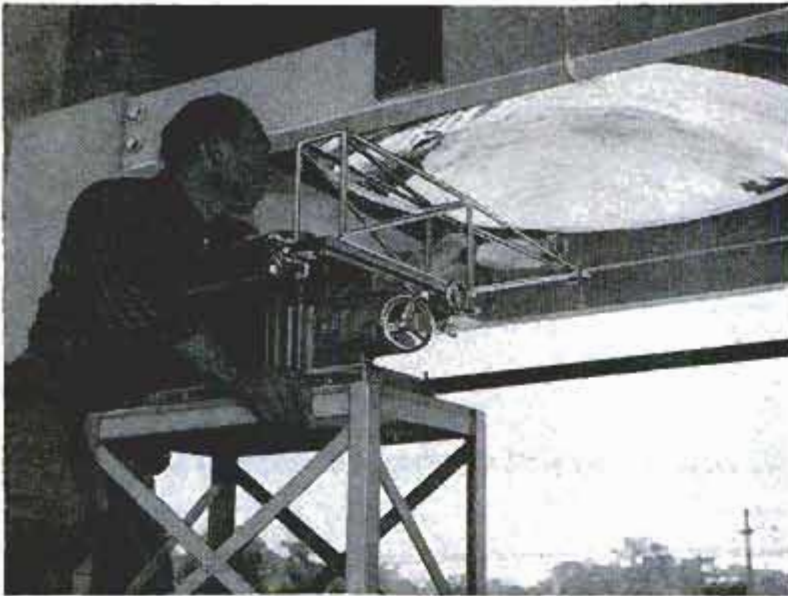

In tower furnace, sunlight reflects from flat mirror up to paraboloid, then to 6000-degree focal working spot

is laid back and forth across black panels facing the sun. Usually the panels and pipe are covered with glass to conserve the heat. Water that circulates through the pipe is heated well above 100 degrees by the sun and is then pumped to an insulated storage tank from which it is withdrawn at will.

Regnier proposes that double-walled glass or plastic tubing be used in place of the usual water pipe, and that a row of silicon solar cells be placed inside each length of tubing. Being transparent, the tubing would allow the sun's rays to strike the cells. Water, of course, would flow through the tubes and would be heated by the sun. Even though the water gets hot it would help keep the silicon cells cool and would thus increase their efficiency.

An ordinary solar-heating panel has one drawback: It radiates heat to the night sky after dark. Hot water in the storage tank loses some of its heat unless the piping is disconnected. One way to avoid this is to mount each length of pipe or tubing on a louver that is rotated to face downward after dark, then turned face up again in

the morning. The louver system has the advantage, too, that it can be rotated from east to west during the day to follow the sun and thus absorb the greatest amount of heat. One solar home now under observation in Phoenix, Ariz., uses the louver system. The Phoenix solar house will use the sun for space heating and domestic hot water only; no solar electric system is contemplated.

### Hyperpure Silicon

Silicon is the second most abundant element of the earth's crust, yet in the hyperpure state that is required for creating a solar cell it costs \$100 or more per pound. This extremely pure material is first melted in a furnace, a trace of pure arsenic is mixed with it, and it is then drawn out in the form of a round crystal or ingot. Next the ingot is cut into thin slices and the slices are reheated. Boron gas is blown across the slices and some of the boron penetrates the hot upper surfaces. After cooling, terminal areas are etched on the top and bottom of each slice and are plated

Left, air-sea rescue unit has solar radio. Below, cells drive model carrier





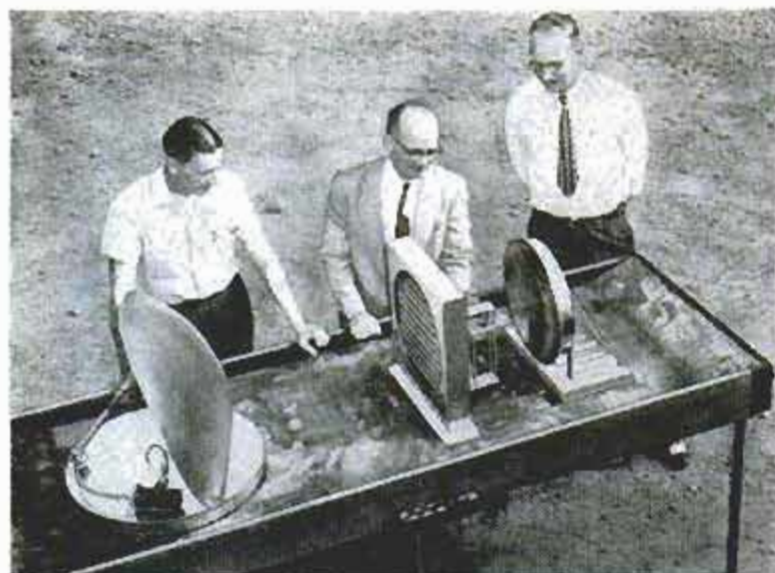

Solar engineers inspect model of huge experimental furnace to be built in New Mexico for use by Department of Defense

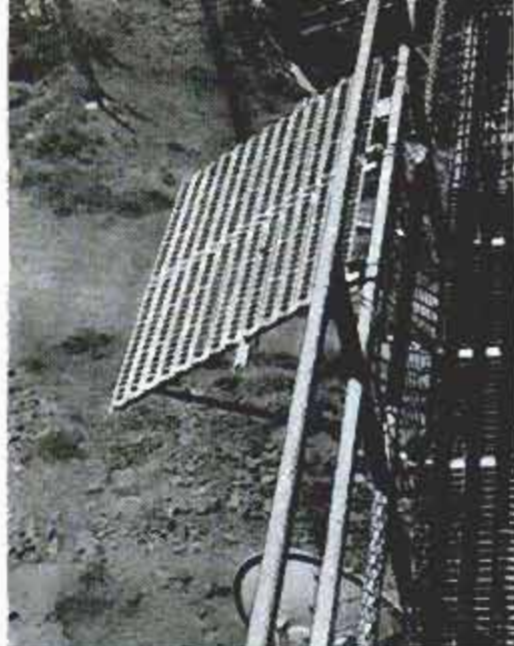

Panel of solar cells operates a radio repeater station for the Forest Service

so that electric connections can be soldered to them.

When sunlight or even light from an incandescent lamp falls on one of these slices, or cells, a very complex action occurs. The engineers describe it in such terms as "photons, crystal-valence bond, dipole layer, and hole-electron pair." They talk about "holes that flow in one direction and electrons that flow in another." In any event, a silicon solar cell produces electricity when exposed to light.

A cell about the size of a half dollar produces a tenth of an ampere and four tenths of a volt under load. Voltage doesn't change, but amperage depends on the size of the cell. When the area is doubled, amperage is doubled. Too, amperage is doubled if the amount of sunlight is doubled, as is possible with such a concentrator as a reflector or reading glass. Amperage can be increased up to eight times by increasing the amount of light, though soldered connections will melt at about five times ordinary sunlight.

The first silicon solar cells were developed by Bell Telephone Laboratories and worked with efficiency as high as six percent in converting light into electricity. Today, cells of 10-percent efficiency are being manufactured. Fourteen percent efficiency has been obtained in the laboratory and the theoretical maximum efficiency is 22 percent. Silicon solar cells are most sensitive to the red end of the visible spectrum and the near infrared.

Silicon is not the only material that has photoelectric properties. Selenium cells, used in photo light

meters, are cheaper but don't deliver as much power. Cadmium sulphide, used in infrared or heat detectors, likewise produces less power than silicon. Germanium is good but not stable. Gallium-arsenide is excellent in theory, but no satisfactory way of manufacturing cells from the material has been found.

Sunshine is free, yet a good-size electric plant that uses the sun is far from cheap. Four years ago, silicon solar cells cost \$25 apiece. Today the price is down to four or five dollars, but hundreds or even thousands of cells are required for a big plant. One goal of the Hoffman organization is

(Continued to page 220)

In Cassegrainian type of solar furnace, rays reflect from primary to secondary mirror, then back through hole in primary

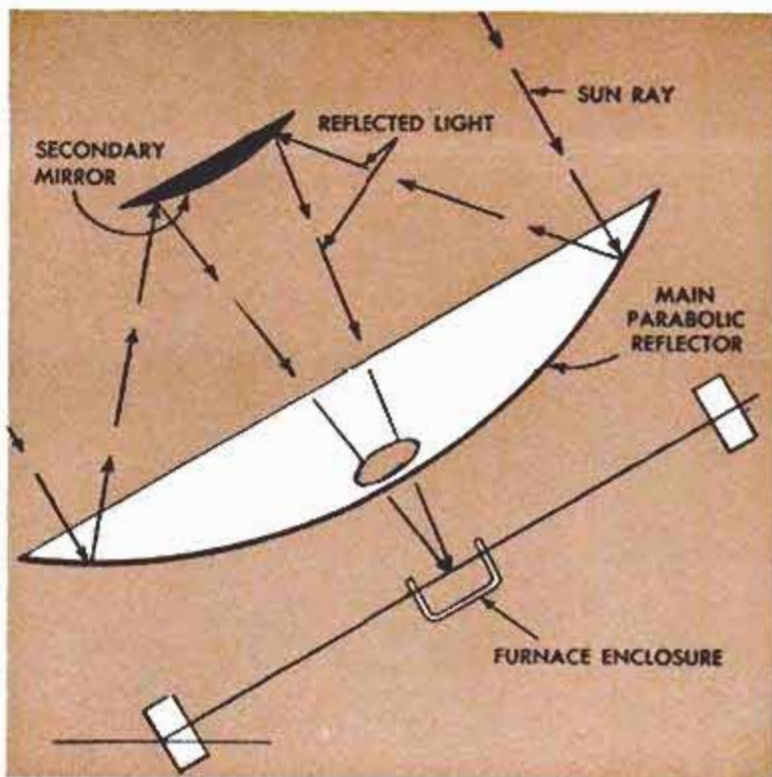



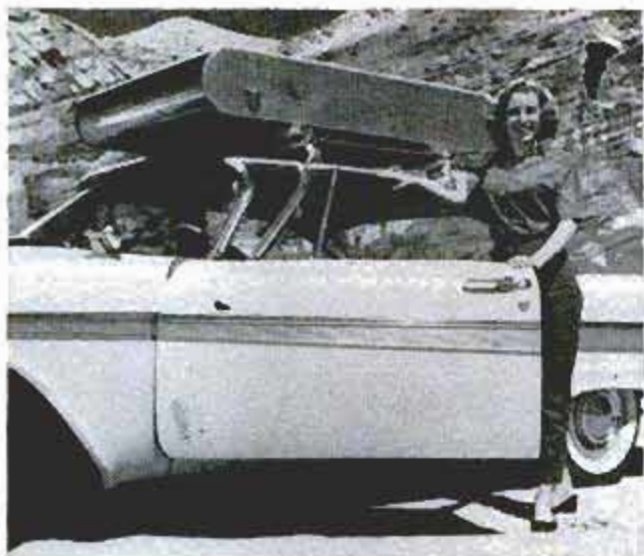

## Campers' Delight— Five-Minute Tent

HERE'S A TENT that can be set up by a woman in five minutes—the dream of road-weary travelers nettled by struggles with unruly shelters. This “dream” tent is carried in an aluminum case atop the car and opens easily into a well-equipped room measuring 8 by 13 feet. Furnishings include four folding cots with sleeping bags, four folding chairs, a stove with bottled gas, an aluminum counter, a food-storage compartment and a sink with running water. To set up housekeeping, the woman camper rolls the carrying case down tracks to the car's side. Then she opens the door and swings the counter down. The vinyl-coated nylon tent is durable, lightweight and resistant to rot and mildew. It has a floor, a door that can be zipped up and two four by five-foot windows with screening and zipper flaps. Supported by telescoping poles, the tent is designed to stay cool, yet it can be heated with only a small lantern. The price is \$695.

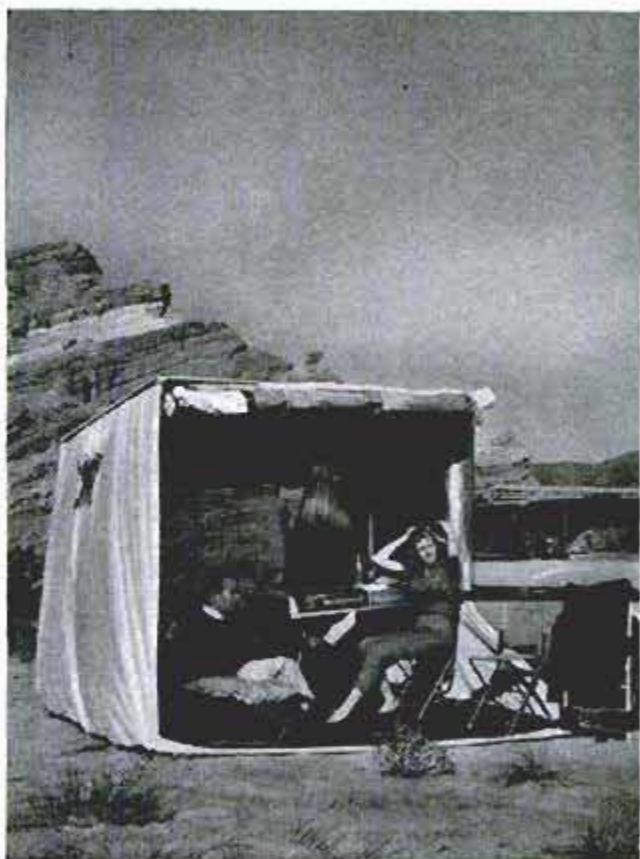





Author is helped into his diving gear. To do 20 minutes' work on the *Doria*, he'll have to spend 10 minutes descending, an hour and 45 minutes coming back up

Right, the *Doria* listed heavily not long before she turned on her side and sank. Salvaging her 29,000-ton hulk will be the most difficult marine-salvage job in history

## HOW WE'LL RAISE

By John E. Sherwood

Diving Coordinator, *Andrea Doria* Project

**BY THE TIME** you read this, we should be hard at work preparing to raise the *Andrea Doria's* \$40,000,000 hulk with a sort of underwater "skyhook" of ponderous gang balloons. If it works we will have pulled the biggest marine-salvage job in history.

The Italian Line's big luxury cruise ship rests on her starboard side in 225 feet of water about 50 miles off Nantucket Island, where she sank following her spectacular collision with the *Stockholm* on July 25, 1956.

Getting her up will be a tricky affair. This is the deepest king-size salvage attempt ever tackled in open sea. The Navy's submarine *Squalus* sank in 240 feet and set a precedent that ships could be raised in the open sea. Our divers, in order to maneuver and to rig the complex gear devised for the big lift, will use standard U. S. Navy diving suits and helmets.

The fantastic \$3,500,000 scheme for salvaging the liner was born in August 1956. It was the joint brain child of Armando Conti, president of the AAA Salvage Company of Trenton, N. J., and Richard Meyer, president of the Barque Marine Company of Wyandotte, Mich. Any attempt to pull the *Doria* from her grave had to involve new ideas. In a relatively simple salvage operation, divers can go down, seal ports, close hatches and plug the hole in

a sunken ship, then pump out the water. The process involves sending men inside the ship, which is fine in reasonably shallow water. But under the pressure of depths such as those where the *Doria* rests, a man would barely dive to his job when he'd have to come up. Air lines could foul and even break. The chance of men getting trapped in dark spaces, or snagging lines on steel projections would be great.

### Huge Collapsible Tanks

Conti and Meyer concocted an ingenious system for lifting the hulk slightly off the bottom, then slowly inching her back into shallows. To do this, they plan to use huge collapsible tanks, called Sealdbuoys, measuring about 52 feet long and 15 feet wide. The massive two-ton "sacks" are made of  $\frac{3}{8}$ -inch corded rubber, folded over and clamped at the edges with steel bars. The tanks were originally devised by U. S. Rubber Company for hauling and storing liquids. When full, they look like giant toothpaste tubes; empty they are flat envelopes. Conti and Meyer decided they'd make ideal inflatable buoys to help hoist the *Doria* off the bottom. Here's how the job will be tackled:

About 90 of the big Sealdbuoys will be lowered along the sides of the wreck. Within the next year, if all goes as planned, divers will be attaching togglelike strong-





## the **ANDREA DORIA**

backs behind the *Doria's* portholes more than 200 feet beneath the Atlantic Ocean. These will provide anchors for the buoys.

Up on the surface a pair of tenders will be positioned, one on each side of the wreck below. Both boats will trail a floating pipe or "air manifold" that sprouts individual feeder tubes to each submerged rubber tank. Through this complex, crews will start pumping air to the Sealdbuoys as soon as the last one is in place. Sealdbuoys at the bow and stern of the *Doria* will be inflated first. Radio-operated valves, controlled from the decks of the ore boats, will pop open in sequence, inflating the rest of the buoys in succession, gradually working toward the *Doria's* midship.

When all the Sealdbuoys are inflated they'll be tugging upward against the ship's weight with 18,000 tons of lifting force—enough to give her nearly neutral buoyancy but not enough to raise her to the surface. At this point, according to carefully engineered plans, the mighty liner should rumble to upright position, raising a cloud of silty murk on the bottom. If she doesn't, a few additional buoys hitched to the starboard side will roll her easily.

### **Mammoth Cradle**

Once she's right-side-up, we dive again—this time to thread 70 four-inch steel cables under her hull. The ends of these will be hoisted to the surface and hitched to a pair of Great Lakes ore boats, which will

be positioned above the *Doria*. These cables will provide a sort of mammoth sling or cradle for the hulk.

The holds of the ore boats will then be flooded with sea water until their decks are nearly awash. Slack in the cables will be taken up, and then the flooded compartments of the ore boats will be pumped out. As they rise in the water, they'll haul the *Doria* up with them—about 10 feet off the bottom. Then tenders or tugs will tie on to the ore boats and pull them, along with the *Doria* down below, toward shallower water until the sunken liner grounds again. This process will be repeated about six times until the *Doria* has been moved some 18 miles shoreward, where the water is only 100 feet or so deep. Here divers can really go to work on her. At that shallow depth, where divers can work with relative ease, they'll patch the 75-foot-long hole in her side, seal her hatches and pump her out.

It sounds easy. Actually, the difficulties of working in 35 to 40 fathoms are enough to discourage anyone. A diver can work on the bottom for only about 20 minutes at a time. To do it, he spends 8 to 10 minutes descending. Then it takes him one hour and 45 minutes to come back up in tedious stages, as the pressure in his suit is decreased gradually to prevent bubbles of gas from forming in his blood and damaging internal tissues in the various forms of "bends."

Under such conditions, a diver has to know just what he's doing every instant.



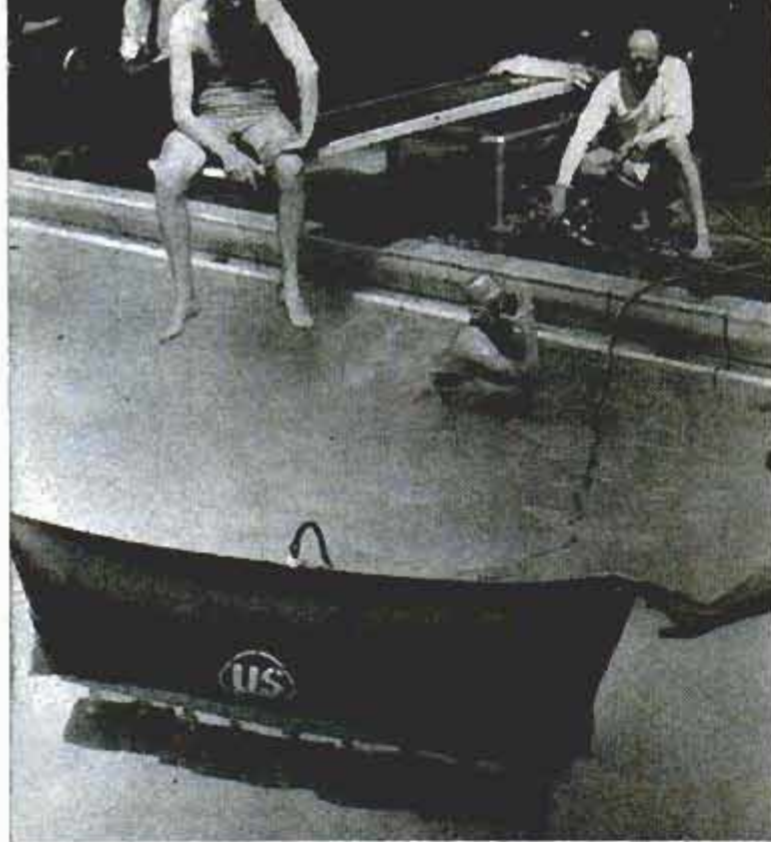

Providence Journal-Bulletin photo

Model of the Seald buoy is tested in a swimming pool. Rubber bags for the *Doria* job will measure 52 feet long, 15 feet wide

Our 30-man team, including New Zealanders, Canadians, Italians and Greeks, was handpicked from all over the world. Some are specialists in underwater demolition; others are underwater riggers who will see that gear is properly set for the lift.

### Exploratory Dives Come First

Our first dives will be exploratory. Going over the side from a salvage boat and a couple of tenders, we'll determine the amount of marine growth on the hull. We don't know how much animal life might encrust the surfaces on which we'll have to work. The degree of list at which the *Doria* rests on the bottom will be important. The men who fasten Sealdbuoys to the portholes must be able to walk under the starboard side to work. If they can't, we'll have to excavate for them. Working in the gloom beneath that hulk won't be fun. First, the demolition crews will go under to blow out certain portholes. They'll do this with a pliable underwater explosive that has the consistency of putty. A ring of explosive is molded around the port. Caps, resembling thumbtacks, are stuck into the ring and fused electrically. Series of charges will be detonated simultaneously. Behind the holes they blow open, the riggers will then rig steel bars, to which cable and Sealdbuoys will be attached.

Threading 70 four-inch steel cables under the sunken ship to make a cradle for the ship will present some tricky problems, too. If the bottom is mud or silt we're all right. We'll dive with powerful jetting hoses. Water forced through the nozzles

will drill tunnels under the *Doria's* bottom. Hawser will be threaded through the holes first, and the 700-foot-long cables fished through behind it. To simplify the job, the cables may be laid out on the ocean floor on the port side of the wreck, so that when she rolls upright, she will turn up onto the cables. Then we'll just have to fish the ends out.

### Stakes Are High

Whether or not these elaborate plans work and the *Andrea Doria* is floated no one can say for sure. The stakes are high in any case. The \$40,000,000 liner, though much of her expensive trapping and machinery has been devastated by salt water, might actually be refitted to ply the seas again. Possibly she'll be broken up and sold for scrap at a handsome price. And there is some valuable cargo aboard. Besides American and Italian currency in the purser's

safe, and the jewelry and money in safe-deposit boxes, there are 200,000 pieces of mail in a waterproof compartment. More than 12,000 cases of wine, plus other bottled goods, should be as good as if it had been stored in a dry warehouse. Other valuable cargo is equally salvageable.

Against this are all the hazards of the job. Out on the unprotected Atlantic where the *Doria* went down, storms and submarine currents may roll the ship, shift the bottom silt, and in a matter of hours destroy months of work performed by the divers. If a bad storm came up in the middle of a "lift," the whole shebang could go to the bottom. If the bottom is hard or rocky, the job may take many months longer than anticipated.

Actually, no one expects these problems to stand in the way of eventual success. No detail has been overlooked. The men got a thorough shakedown on the equipment long before the project was under way. At present our key men are in Milwaukee, Wis., raising the sunken freighter *Prins Wilhelm V*, down since 1954 in Lake Michigan. Methods and equipment for the *Doria* job are being tested under actual salvage conditions.

It's possible that we won't be able to float the *Doria*. That won't be disastrous. Once we've got her in shallow water, the men can go down and haul out the cargo. Then the hulk will be blown up on the bottom and the pieces raised for scrap. According to Mr. Meyer, "We can't lose under any circumstances if we can get her up. And I believe we will." ★ ★ ★



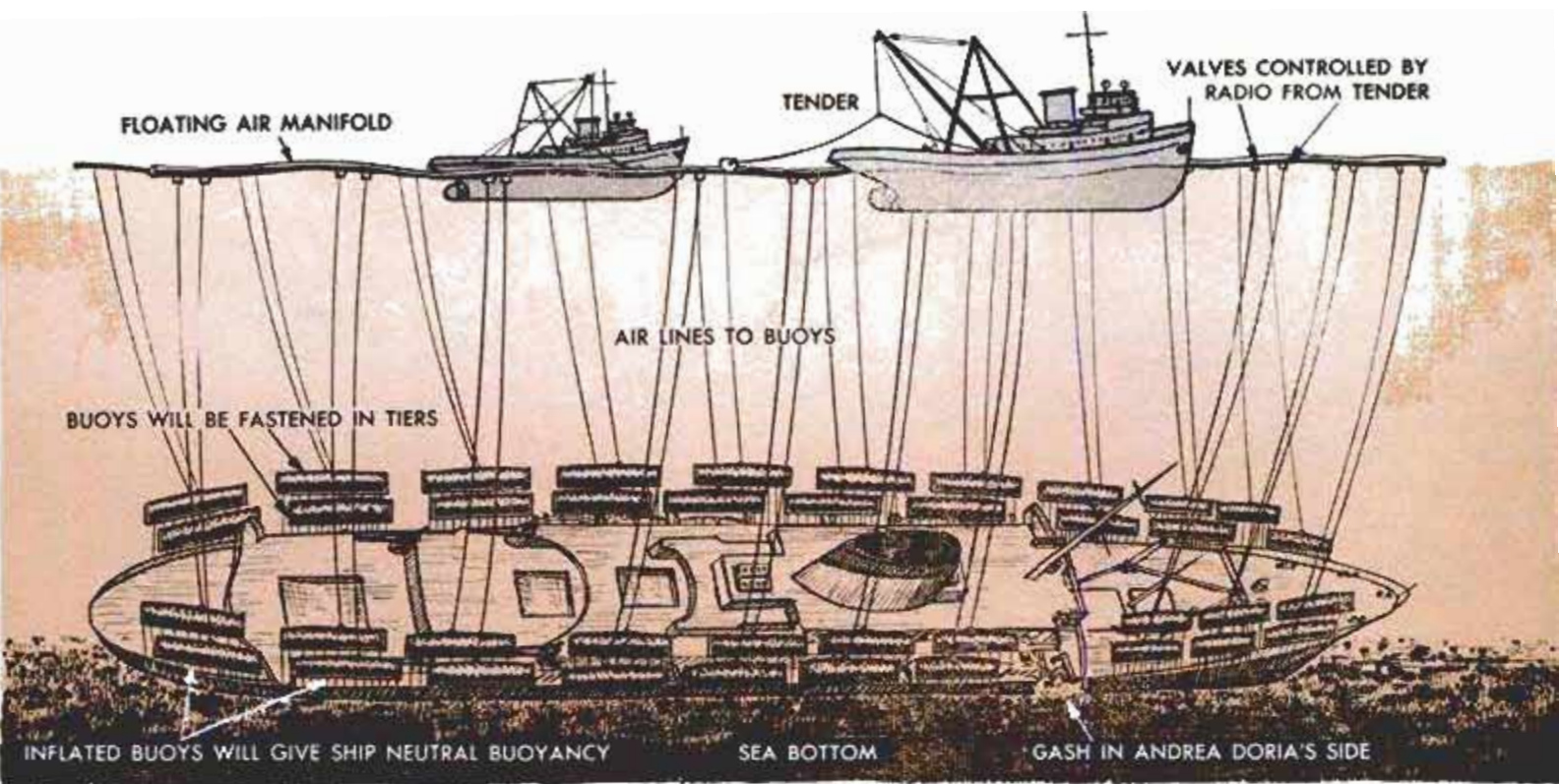

Attached to the hull, huge Sealdbuoys will be inflated to right the *Doria* and lift her off the bottom

Once she clears the bottom, she'll be suspended in a sling beneath ore boats and moved toward the shallows

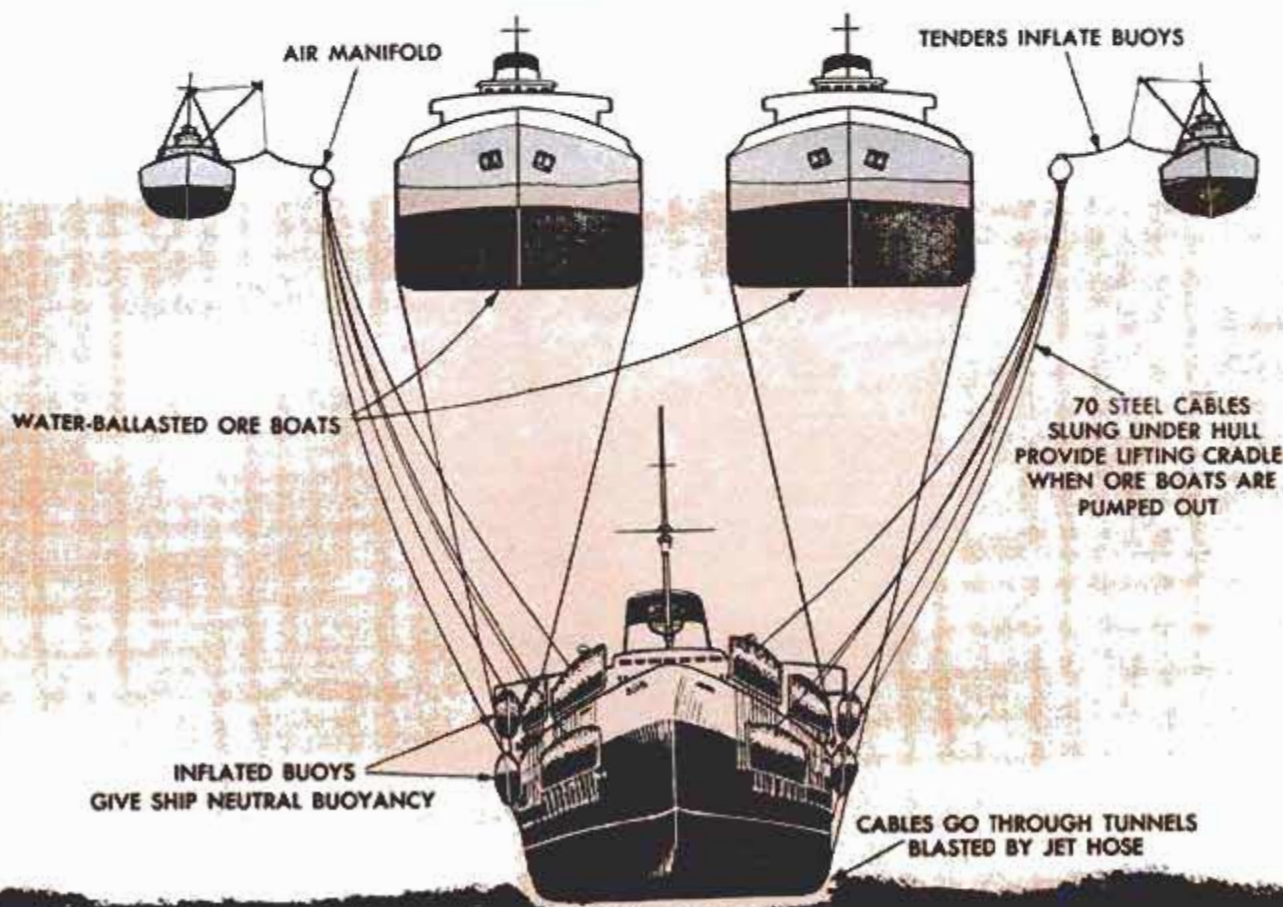



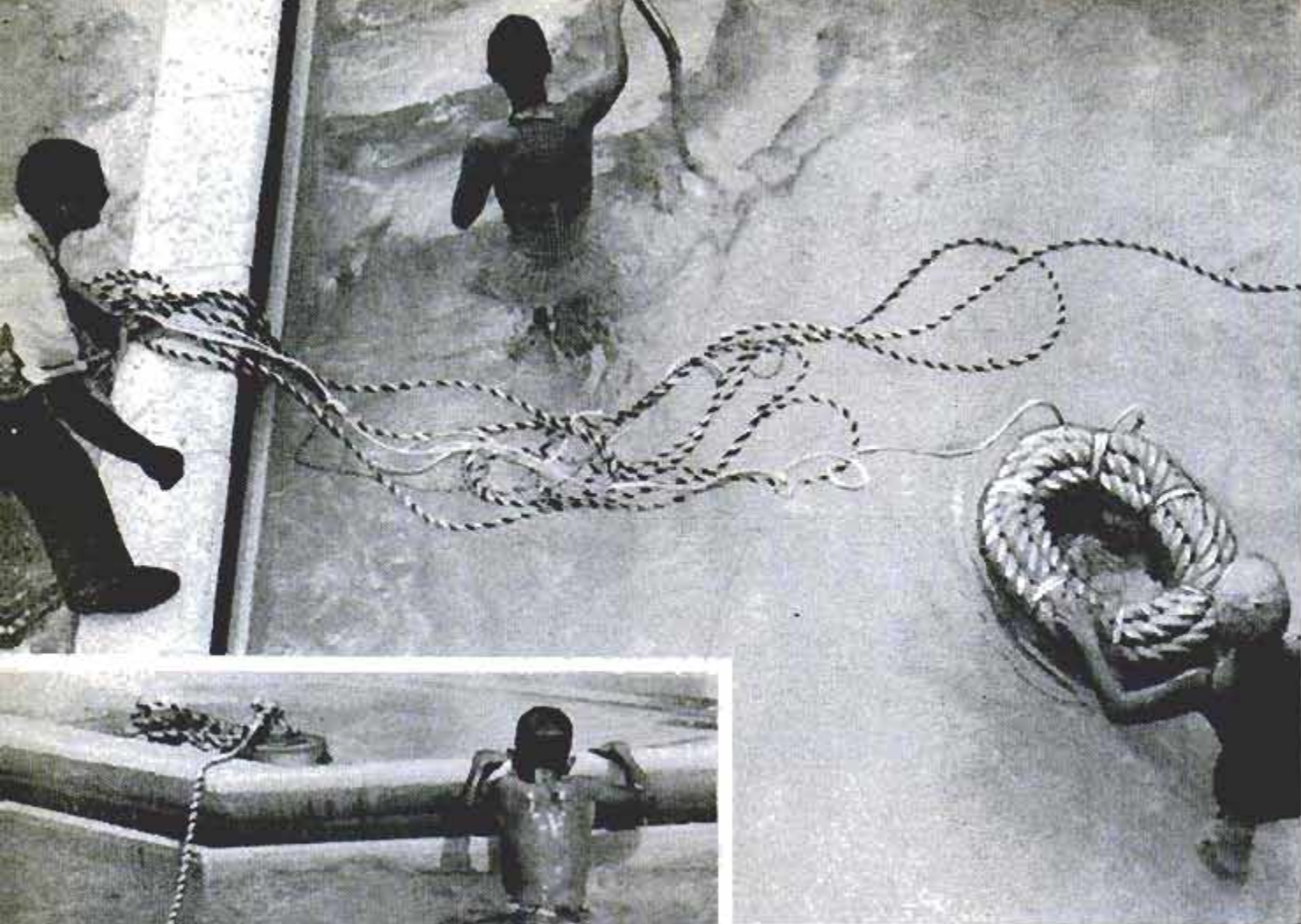

## Rope Made of Plastic Floats on Water

Plastic rope that comes in all colors of the rainbow and floats on the water is finding its way into many back-yard swimming pools this summer. Made of a woven synthetic fiber, it looks like ordinary Manila rope. However, its maker claims, it's 35 percent lighter and 75 percent stronger. Because it's waterproof, it can be stored wet.

## Miniature Inboard Motor Powers Small Boats

Even little prams now can be driven by inboard motors. A new three-horsepower inboard weighs only 33½ pounds. It is mounted forward of the transom, with the

shaft running through a watertight fitting in the hull. The propeller assembly is bolted beneath the hull. The engine can be demounted to power other machines.







Rosenfeld photo

Vim, one of the four potential defenders of the Cup, has the clean, uncluttered lines of the 12-meter class

## **THEY'LL DEFEND THE AMERICA'S CUP**

By Richard F. Dempewolff

**O**N THE WHITE-CAPPED Atlantic south of Rhode Island's Narragansett Bay shores, gleaming spinnakers balloon against a backdrop of spray and sky these days. Four sleek yachts cleave the sea like driven splinters as they vie for the honor of defending the *America's Cup* against the first British challenger in 20 years.

By the middle of next month, one of these slim beauties will have proven itself the fleetest and most maneuverable under the widest variety of wind, sea and weather. Then, September 20, the crew of the chosen boat will set sail from Newport to do battle with England's craftiest yachtsmen in their new 12-meter cup boat, *Sceptre*.

Fourteen times since 1851, when the 101-foot *America* beat an entire fleet of British yachts in a race around the Isle of Wight to bring home a cup affectionately referred to by yachtsmen as "The Olde Mugge," England's best boats and crews have tried unsuccessfully to recapture the Victorian silver trophy. Twice Canadian challengers have met defeat. But never, in all those contests, has the fabulous international boat race been sailed by a breed of craft as small and trim as the new "12s."

Until last year *The Olde Mugge*, which

Spinnaker ballooning, the *Vim* glides swiftly before the wind. Built in 1939, she is the only "old" boat

Rosenfeld photo

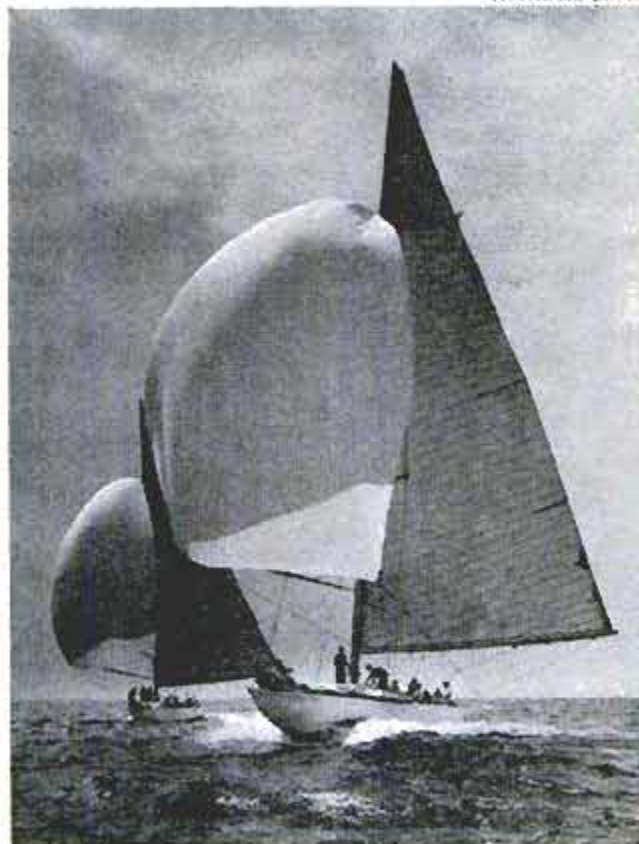



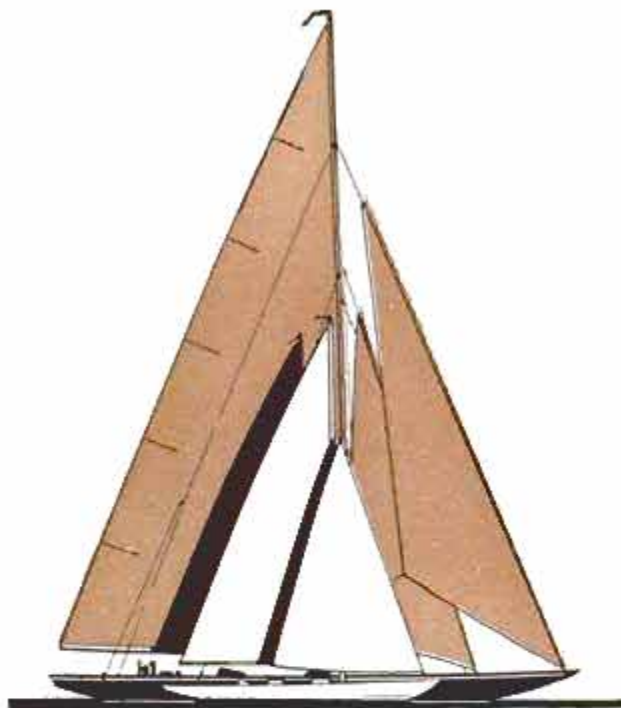

Sketch compares the smaller 12-meter boats with one of the old J-boats. *Ranger* under sail at right was the last of the big J-class. Today she would cost a prohibitive \$3,500,000. Rule change permits the smaller and less costly boats to try for the Cup

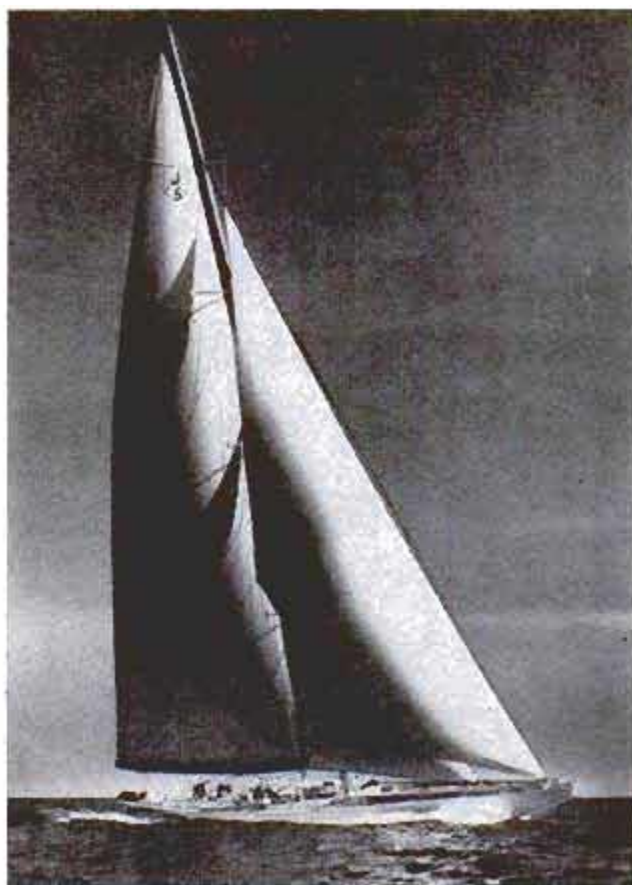

Rosenfeld photo

the *America's* owners presented to the New York Yacht Club as a trophy open to international challenge, carried with it a craftily worded deed of gift. Under its conditions: 1. The race had to be sailed in defender's waters; 2. Challengers had to sail the Atlantic (as daintily specified) "on their own bottoms."

As a result, contenders for the *America's* Cup became 130-foot, ocean-going "J class" yachts, described by one sportsman as "huge ships operated by 20 sailors and one millionaire." *Ranger*, last of the J-boats, which defended the Cup against T. O. M. Sopwith's *Endeavour II* in a noisily disputed decision in 1938, cost her owners close to \$1,000,000 for one season of racing. That was more pocket money than even millionaires could readily afford for a silver trophy, and it was the last *America's* Cup race held. Today, "fun money" is even more scarce and, according to experts, a boat like the *Ranger* would stand its owners a prohibitive \$3,500,000.

### Change in Rules

About a year and a half ago the rules were changed, eliminating the challenger's sea-voyage requirement and allowing boats of the smaller 12-meter class to battle for the coveted trophy. Almost instantly the flurry began. In England an 11-man syndicate headed by yachtsman Hugh Goodson made plans to build the sleek 12-meter challenger *Sceptre*. At a small shipyard on

an Argyllshire loch under a cloak of dark secrecy, Scottish experts began the painstaking job of designing and building a long, smooth hull.

Americans leaped to the challenge. A whirl of excitement swept yachting circles like a summer squall as syndicates formed, carefully guarded plans materialized and heavy lumber began to curl upward from building-shop floors. For months, behind closed doors of a towing tank at Stevens Institute in Hoboken, N. J., experimental models of the proposed new 12s were tested, changed and retested in an effort to reach the ultimate in streamlined efficiency. "After a century of successful American competition," explains Carlton Mitchell, navigator for one of the groups, "nobody wants to be the first to lose the Cup."

Out of it all came the four slivers now fighting it out off Brenton Light:

*Weatherly*, designed by Philip Rhodes, was built by veteran sailboat builder William Luders for a syndicate headed by Henry Mercer.

*Columbia*, a brainchild of Olin Stephens, designer of the 20-year-old 12-meter *Vim*, was put together by the famous Nevins boatyard for Henry Sears' syndicate, which includes Briggs Cunningham.

*Easterner* designed for Chandler Hovey of Boston by Raymond Hunt, was constructed by the Graves shipyard in Marblehead, Mass.



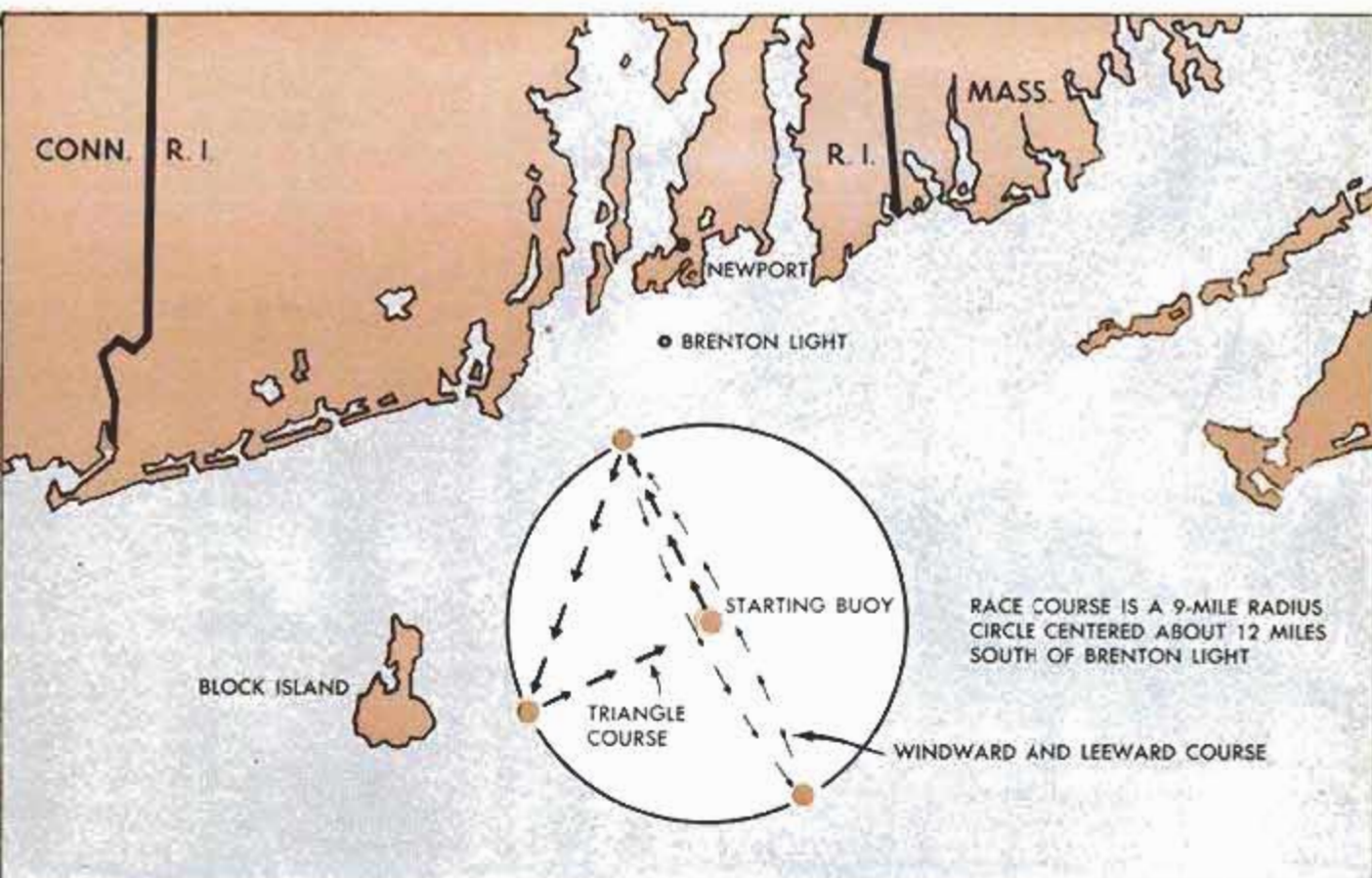

Race course shown on map includes a leeward-and-windward race and a race along a triangle inside the circle

*Vim*, a 12-meter boat designed by Olin Stephens, was originally built for Harold Vanderbilt in 1939. The only one of the four U. S. contenders in existence when the fun started, she has been completely stripped down and refurbished by her new owner John Mathews, and already holds a formidable racing record.

#### What's a 12-Meter Boat?

Just what is a 12-meter boat? It is not, as many landlubbers think, a racing sailboat 12 meters long. That would be too simple. The measurement is based on a complex formula involving the ratio of length, to sail area, to freeboard (the height of the hull area that shows above water), to something called "girth difference." The last item involves the difference between the circumference of the hull measured at specified points fore and aft. As one man lucidly explains it, "To find the winner of a beauty contest the judge runs a tape around the lady at two places.

The difference between those measurements would be her girth difference. It's the same with a boat."

The job of the boat designer, Phil Rhodes points out, is to juggle all those items until he gets the speediest, most efficient combination, and still makes the answer to the formula come out to 12 meters. "Shorten the hull and you've got to fatten her to stay inside the rules," says Rhodes. "This slows her down—but you get more sail area to speed her up, and you can add an extra crewman for every 250 square feet of sail. Make a long, slim hull that's really fast, and when you work out the formula, you discover you haven't enough sail to take advantage of the hull."

Upshot of all this is that by the time competing architects get through adding here, shaving there and swapping one advantage for another, they all come out with 12-meter boats looking nearly as though they had been poured from the same mold. All but one of the new contenders measure

	<i>Sceptre</i>	<i>Columbia</i>	<i>Vim</i>	<i>Weatherly</i>	<i>Easterner</i>
Length, over-all	70'	69'-7"	70'-3"	69'-0"	65'-0"
Length, waterline	40'	45'-0"	46'-6"	45'-6"	?
Beam	12'-0"	12'-0"	11'-10"	11'-10"	12'-0"
Draft	?	8'-11"	8'-10"	8'-10"	9'
Weight of keel (lb.)	44,800	36,000	?	36,000	?
Displacement	76,160(?)	51,520	?	57,000	?
Sail area (sq. ft.)	2,000	1,985	?	1,900	?



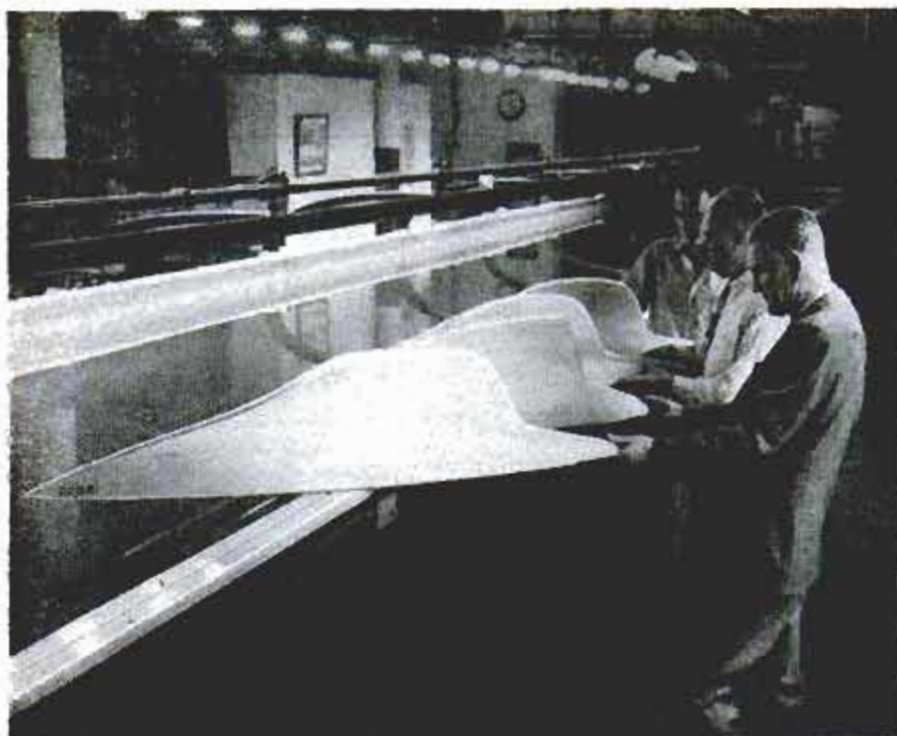

Rosenfeld photo

Officials of Stevens Institute towing tank compare models of the hulls of the four 12-meter boats that will vie for honor of defending the Cup

about 70 feet long and close to 44 feet at the waterline. Oddly, this waterline measurement comes out to just about 12 meters.

#### Cost Is a Tenth of J-Boats

How fast will they go? "Figure maximum speed at 1.3 times the square root of the length at waterline if you want it accurate," says Rhodes. That comes to about 10 knots for the new boats. Though a 70-foot yacht is no midget, these craft will cost less than a tenth of what J-boats would cost to build and race. "J-boats are only twice the overall length," Rhodes points out, "but the actual volume goes up by the cube of the length—which means they're really eight times bigger. Hence the fabulous cost." Each new 12-meter owner figures about \$300,000 for this year's try. It's still not a cheap race.

#### Shortest Boat

The only nonconforming design among the new 12-meters is *Easterner*, a configuration arrived at by Ray Hunt, a canny New Englander noted for his unusual and often successful approaches. This boat is four feet shorter than the others, with a long sloping keel, but wider and flatter. "She's a skimmer," comments Rhodes. "But," he adds cautiously, "she can carry more sail. I don't know. Maybe she's got something."

Olin Stephens, father of *Vim* and the new *Columbia*, just smiles. "A good 12-meter boat is a 12-meter boat," he says. "Our most revolutionary 'secrets' involve inches, not feet."

Despite such conformity, cup-boat owners and designers jealously guard their inches during early stages of planning and construction. Secrecy surrounding Britain's *Sceptre* was so intense that yachtsmen recalled the old days when Nat Herreshoff, Bristol, Conn., designer and builder of many a famous cup boat, posted tough bouncers armed with cudgels at the gates of his shop with orders to bounce the clubs off anyone attempting to enter the premises without authorization.

Even *Sceptre's* builders didn't go that far, but it's a fact that anyone visiting Stevens Institute's towing tank during tests of the hull models for the

U. S. boats had to have clearance to get in. Although testing models of his different ideas in a towing tank can't tell a designer if he has the unbeatable combination, the meticulous studies of water flow around various hull shapes will quickly show up a dud or what yachtsmen know as a "one-weather design"—a boat that may go like

(Continued to page 226)

Sliding gracefully through waters near Scotland is the *Sceptre*, first America's Cup challenger in 20 years



POPULAR MECHANICS



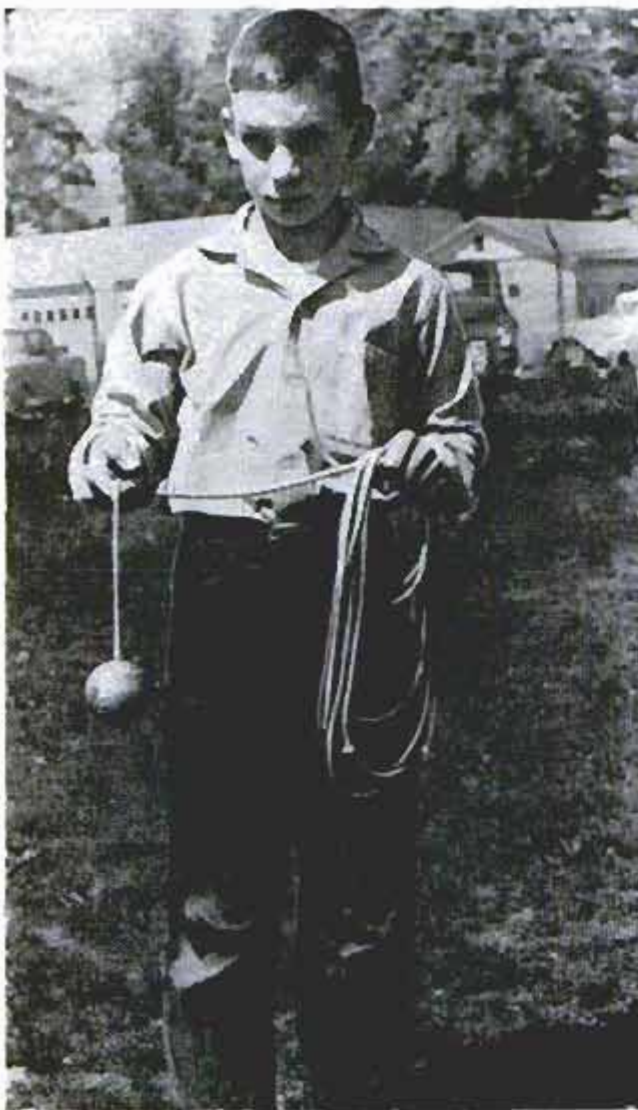

## Baseball on a Rope Aids Boy Batters

Little League and Babe Ruth League players in Richmond, Mich., sharpen their batting skill by swinging at a baseball fastened to the end of a rope. This method eliminates the need for catchers, fielders and backstops during practice sessions. The "pitcher" stands in the center of a circle, about 30 feet in diameter, and swings the ball past the batters on the perimeter. The rope runs through a quarter-inch hole drilled in the center of a regular baseball. A knot is tied at the end of the rope.

## Phone Call Via Moon Uses Bouncing Signals

Long-distance telephone calls may be "routed" by way of the moon within a few years. Air Force studies found no appreciable loss of quality when voice transmissions were bounced off the moon to receivers on other continents. It had been assumed that jagged mountains and craters on the moon would distort radar signals used in the voice transmissions.

## Stainless Steel Hoops for Plastic Pipe Prevent Splitting

Hoops of stainless steel can be used in place of flat straps when fittings are joined to plastic pipe. They prevent splitting in the pipe often caused by the straps. The hoop is looped over the pipe, the fitting is pushed in, then the two loops are twisted by the fingers. A final turn with pliers tightens the hoop.

## One Loaf of Fish, Please

South Africans can now add protein to their diet by eating a new bread which contains a light brown, but odorless and tasteless, flour made from fish.

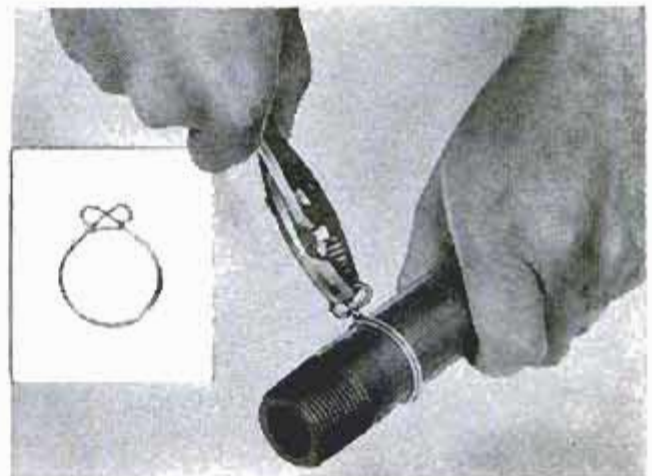



# WHAT ENGINEERS SAY ABOUT



EVERYBODY IS taking a poke at Detroit these days. Some say the auto industry deserves the criticism, others say it is being used as a scapegoat for the recession.

To find out how the men who design American automobiles feel about the cars they design, Popular Mechanics surveyed a group of automotive engineers. The box in the upper right-hand corner of the next page explains how the survey was made.

This article is the result. Questionnaires were returned unsigned, at our request.



## Question: What postwar innovations have been of most benefit to the consumer?

1. AUTOMATIC TRANSMISSION .....	48.8%
2. VARIOUS POWER ASSISTS .....	41.8%
3. INCREASED GLASS AREA, VISIBILITY .....	23.3%
4. HIGH-COMPRESSION, COMPACT V8 ENGINE .....	22.3%
5. IMPROVEMENT IN BRAKES .....	11.6%
6. SAFETY FEATURES .....	11.6%
7. CLEANER BODY LINES .....	9.3%

Here, in order of frequency of mention, are quotations from the automotive engineers' answers to PM's question: "What postwar automotive innovations have been of most benefit to the consumer?"

The torque converter automatic transmissions introduced since the war are a great advance and constitute the greatest single postwar innovation. (48.8% agree.)

Power brakes, power steering, power seats and windows are all innovations that are convenient although not altogether beneficial. . . . Power steering and power brakes, since we seem bent on building big cars. (41.8% agree.)

Full-vision rear windows. . . . Tremendous improvement in visibility. . . . View of all fenders from driver's seat. (23.3% agree.)

High-compression engines. . . . Compact V8 engines. . . . Short-stroke engines. . . . Better maneuverability due to acceleration. Less driver strain at sustained high speed. . . . More efficient V8 engines. (22.3% agree.)

Increased use of power brakes and the bonded brake linings. . . . Improved braking, although still inadequate in many cases. (11.6% agree.)

Genuine concern for safety as expressed in interiors. . . . Deep-center steering wheels. (11.6% agree.)

Basic body styles are cleaner and more functional. (9.3% agree.)

Other important postwar innovations mentioned by the engineers (but each of them by fewer than nine percent) are described by the following quotations:

Filling the cube by stylists. . . . Full-width bodies.

Greatly improved handling, including improved suspension.

Turn indicators.

Durable and attractive interiors. . . . Vinyl upholstery.

All-steel station wagons. . . . Attractive station wagons.

Air conditioning.

Rear luggage compartment of an appreciable size.

Forced-air heaters which draw in clean, fresh air.

Improved ride and comfort. . . . Foam-rubber seat padding.

Better headlights and the antidive front suspension.

Chrome-plated piston rings.

Improved power-weight ratio.

Noise reduction.

Ball-joint front suspension.

Lower hood lines.

Improved windshield wipers (but blades still need improvement).



# TODAY'S CARS

## HOW PM's SURVEY WAS CONDUCTED:

Questionnaires were distributed during the national convention of the Society of Automotive Engineers in Detroit. The particular session was one of two devoted to passenger cars and its subject was the small car and its place in America. This may have resulted in some bias in the sample, although both advocates and opponents of the small car were in attendance. All returned questionnaires were tabulated.



### Question: What postwar innovations have been detrimental to the consumer's interest?

1. EXCESSIVE HORSEPOWER ..... 51.1%
2. BODIES MADE TOO LONG ..... 41.8%
3. WRAP-AROUND WINDSHIELD ..... 25.6%
4. CARS ARE TOO HEAVY ..... 20.9%
5. EXTREME EMPHASIS ON STYLING ..... 16.3%
6. CARS ARE TOO LOW ..... 16.3%
7. CARS ARE TOO WIDE ..... 11.6%

Here, in order of frequency of mention, are quotations from answers the engineers gave to PM's question: "What postwar automotive innovations have been detrimental to the consumers' interest?":

Engines have become too big, have more horsepower than needed. . . . Engines too large since 1954. . . . Excessive power leading to high fuel consumption. Excessive compression ratios. (51.1% agree.)

Excessive length and width with an actual decrease in seating comfort. . . . Longer over-all length with no more usable space. . . . Unnecessary size. (41.8% agree.)

Wrap-around and compound-curve windshields add too much to cost and also reduce visibility by increasing distortion. . . . High replacement cost and bad vision of wrap-around windshield. (25.6% agree.)

Excessive weight that handicaps braking. . . . Too much weight on front wheels. (20.9% agree.)

The tyranny of the stylists. Emphasis on childish features. . . . Style trends which rob panels of potential stiffening by virtue of shape. Pillarless bodies. . . . Styling has sacrificed safety, comfort and efficient use of space. More liable to damage, more expensive to repair. (16.3% agree.)

Lowering of car results in increased size of driveshaft hump. . . . Interior too low. (16.3% agree.)

Too great an increase in width. (11.6% agree.)

Additional answers from the engineers: Increased complexity ultimately results in higher maintenance and insurance costs plus higher first cost.

Larger, softer tires make steering harder or make power steering necessary.

Increased rear overhang.

Yearly style changes.

Massive bumpers, excessive chrome parts.



### Question: What innovations were neither beneficial nor detrimental, but just for change's sake?

1. ALL STYLING INNOVATIONS ..... 46.5%
2. MULTIPLE LIGHTS, HEADLIGHTS AND TAILLIGHTS ..... 27.9%
3. WRAP-AROUND WINDSHIELD ..... 25.6%
4. CERTAIN POWER ASSISTS ..... 23.3%
5. EXCESSIVE TRIM, ORNAMENTATION ..... 23.3%
6. COMPLICATED SUSPENSION SYSTEMS ..... 16.3%
7. PUSH-BUTTON TRANSMISSIONS ..... 11.6%

Here, in order of frequency of mention, are quotations from answers the engineers gave to PM's question: "What postwar innovations have been neither beneficial nor detrimental, but just innovations for the sake of innovation?":

Most interior and exterior ornamenta-

tion that has tended to raise the cost of the vehicle. . . . Excessive sculpturing of sheet metal. . . . Styled and unreadable instruments. . . . Bulky styling. (46.5% agree.)

Double headlights, triple taillights . . . Multiple taillights . . . more than two, that is. . . . Frenched headlights. (27.9% agree.)



Wrap-around windshields. (25.6% agree.)  
 Too many power assists. Power deck lids, power windows, electric door locks. . . . Some accessory innovations, such as portable automobile radios, power radio antennas. (23.3% agree.)  
 Excessive chrome trim. . . . Excessive use of bright metal. . . . Ostentatious decorative styling. (23.3% agree.)  
 Windbag suspension. . . . Torsion-bar suspension. . . . Air suspension. (16.3% agree.)  
 Push-button transmission controls. . . .

Removal of shift lever from steering column. (11.6% agree.)  
 Here are some interesting answers which were mentioned by fewer than 10 percent:  
 Increased rate of model change and excessively wide choice of engine options.  
 Blinding taillights. They should be bright enough, but not overdone.  
 Automatic headlight dimmer.  
 Extreme lowness so a hat can't be worn inside the car.  
 Dual exhaust systems.

### Question: What engineering development is most needed for today's automobile?



- |  |       |
|--|-------|
| 1. GASOLINE ECONOMY .....                | 48.8% |
| 2. SMALLER CARS .....                    | 23.3% |
| 3. SIMPLER CARS .....                    | 23.3% |
| 4. LIGHTER CARS .....                    | 20.9% |
| 5. MORE SENSIBLE, PRACTICAL ENGINES..... | 20.9% |
| 6. IMPROVED BRAKES .....                 | 16.3% |
| 7. MORE DURABLE BODY.....                | 16.3% |

Here, in order of frequency of mention, are quotations from answers to PM's question: "What engineering development is most needed for the automobile today?":

We should produce a more economical car to compete with foreign cars. However, we must offer more interior room, performance, trunk space, quietness and ride smoothness. . . . Economy of operation to conserve our supply of fossil fuel." (48.8% agree.)

While most European cars are too small for a single family car, most American cars are at the other extreme. We have vacated almost completely the more practical in-between sizes. Car size could be decreased by smaller engines. (23.3% agree.)

The automobile has become complex, requiring experts in many fields for maintenance. For certain income levels, our products are too costly to maintain at acceptable efficiency. . . . Greater thought to servicing is required. (23.3% agree.)

Get the weight down to about 3000 pounds. . . . If cars were smaller and lighter we could abandon unnecessary features and concentrate on basic advances such as independent rear suspension, unit body and frame, scientific seating, fuller use of new synthetic materials. (20.9% agree.)

We need a relatively small and light-weight aluminum air-cooled engine with a companion automatic transmission that is simple, dependable and reasonable in cost. . . . Engines should be able to use lower grades of fuel and still provide present power and economy. (20.9% agree.)

Better brakes. (16.3% agree.)

Rustproof treatment. Stainless or aluminum exhaust systems. . . . Greater durability. No rusting for 10 years. (16.3% agree.)

Here are some additional comments by the engineers:

We need better windshield wipers, especially under adverse conditions.

Better low-speed fuel mileage.

A device to conserve fuel when the engine is idling, as in traffic.

Extensive research on exhaust control.

Either an 18 or a 24-volt electrical system or a central power system for accessories (probably hydraulic) because we are apparently going to build bigger cars.

Reduce wind noise at high speeds.

Mandatory crash padding on the instrument panel and no protruding knobs.

More miles per gallon by variable valve timing. Elimination of floor tunnel, hump.

Independent four-wheel suspension.

Car body should be designed around the human dimensions, not styled for advertising. Lower silhouettes afford little ride or handling improvement, yet are difficult to enter and leave.

There is too much uniformity in the American cars. The 16 or so different makes do not cover, by far, the tastes of all.

Station wagons were evolving into the only good sensible body that was coming out of Detroit, but now the stylists are ruining most of them.

A small-to-medium-size car is needed which must not be austere. A new package idea is needed since a small car cannot be a large car scaled down as long as you cannot scale people down. ★ ★ ★



**WHAT WILL THE 1959 models be like?**

In general, not specific, terms, here is what you'll be seeing this Fall:

● The trend will continue, only more so. There is no switch from the movement toward bigger, flashier, more luxurious cars. Only one company moves the other way—Studebaker. But who would suggest its recent sales history is one to copy?

● Engineering innovations are minor. It is a year of quiescence for technical men. It's an exciting year for the stylist and product planner (who is supposed to know what the public wants—he tells the stylist what the public will buy).

● It's a year for watching costs — the industry is discovering perhaps it can't afford the luxury of unlimited models, unlimited options, unlimited choices. There will be more "standard" items and that probably means higher prices.

● More emphasis on rear-end styling. The grille is less important, less expensive to fabricate, too. Most will be sheet-metal stampings, instead of expensive, multipiece chrome-plated castings of a few years back. Rear ends are something to behold. Fancy, shiny and flamboyant, they range from soaring vertical fins to broad, flattened wings extending horizontally like a gliding seagull's. Jet tubes are common and run the length of the rear fender. In some cases, they end in taillights, in others in backup lights. Taillights are bigger, bigger, bigger. You'll be dazzling, coming and going, in 1959.

#### Glass and More Glass

● Glass is everywhere and curving in all directions. Receding-hairline windshields will be common to all but the independents. These are the compound-curve designs that curve upward as well as sideways. Rear windows wrap around as sharply as today's windshields. Roofs are flatter and appear to float above the passengers like a parasol. An open, airy look results. You ride in the draft-free comfort of a glassed-in sedan and yet feel like a high-school kid in a convertible with the top down. It'll take 25 years off your age!

● Engines are bigger and more powerful, but this will be whispered, not shouted. Economy is the public mood and there will be cheaper automatic transmissions, more economical carburetors. Hoods are lower. To permit this, air cleaners are mounted vertically beside the engine in some cars.

● There will be a flurry of new, exciting, revolutionary, they-said-it-couldn't-be-done innovations to tempt you. Split front seats will give the passenger a chance to adjust his half without bothering the driver. Pivoting seats will make getting in and out easier for men, more graceful for



## DETROIT LISTENING POST

By Art Railton

women. Vacuum-operated door locks will keep you secure inside your living room on wheels. Electronic mirror tilters will eliminate the glare from overtaking drivers. Special headrests built into slumber seats will make sleeping easier on long trips.

#### GM's Steamroller

Chevrolet may be the freshest look on the 1959 highway. General Motors stylists (for all divisions except Cadillac) have thrown away the rule book and are said to be giving 1959 models completely new personalities. Some GM cars make the dream cars of only a few years back look like old-fashioned surries with the fringe on top. If the public takes to its new, modern, crisp look, GM could sell 60 percent of the market — an unbelievable share.

Ford's new body retains the image you have learned to recognize. It returns again to huge wagon-wheel taillights (the fellow who decided the public wanted four oval taillights on the 1958 Ford must be slightly redfaced at this). There's a lot more of the Thunderbird look to the new Ford also.

Chrysler products will retain the same sweptwing personality, although by extensive front and rear changes the various makes are being made less similar. Headroom has been improved on hardtop models by a stylish but practical sculpturing of the roof.

**American Motors will continue to look like American Motors. And if the public taste doesn't change, it will continue to sell like nobody expected it to.**

When will all these wonders unfold themselves? Here's an unofficial calendar. Clip it to your wallet so you'll know when the temptation is about to appear.

September: De Soto, Buick, Oldsmobile and probably Cadillac.

October: Ford, Plymouth, Dodge, Chrysler, Imperial, Chevrolet, Pontiac, Edsel, Rambler.

November: Studebaker, Mercury and Lincoln.

Can you wait?





## The **STUDEBAKER SCOTSMAN...**

COMMENTS BY  
ART RAILTON,  
PM's AUTO EDITOR

**How to describe this car? It's a plain Jane—a dull, unexciting machine. It has no glamour and knows it. But if you're inclined toward asceticism, it's a car that will work hard at little expense while asking no preferential treatment. You'll get no thrills on it, but no thrills with it.**

ATOP A BARREN DASH, THE SPEEDOMETER LOOKS LIKE IT WAS ADDED AS AN AFTERTHOUGHT



**W**HY DO PEOPLE buy the Studebaker Scotsman? *PM* asked hundreds of owners from coast to coast and the answer is, as you might expect, "economy." Almost one half (49 percent) say they bought the Scotsman for its economy of operation. Another large group (27 percent) bought it for its low initial cost.

What do owners like most about the Scotsman? Again, economy—54.9 percent of the owners list economy of operation and upkeep as the best-liked feature.

What do owners complain most frequently about in the Scotsman? Again, economy—"not enough gas mileage" is listed by 16.9 percent of the owners in our survey as a complaint.

Thus the Scotsman is an economy car in the mind of the public. It is Studebaker's answer to the foreign car. It is Studebaker's bid to capitalize on the public's suddenly awakened interest in automotive economy.

What specific features do owners like about their new Scotsman? Here, in order of frequency of mention, are quotations from owners' questionnaires describing the best-liked features:

"I drive 600 miles a week and have driven this Scotsman 13,500 miles. It averages 22 miles per gallon. I have spent \$10 on repairs and this was for brake adjustment, points, plugs and tune-up. I recommend this car to any salesman on an expense account."—Indiana salesman.

"I am saving over \$1 a day over a 1952 Big Three station wagon just in gas alone."—New Jersey radio serviceman.

"I like the price and gas mileage. It is lightweight and is not hard on tires like other cars."—Iowa farmer.

(Continued to page 81)





## and the **RAMBLER AMERICAN**

**E**CONOMY OF OPERATION may be important to owners of the Rambler American, but it is not the feature they like most. The feature that heads the best-liked list is handling ease with over 58 percent of the owners mentioning it.

Second on the list comes economy, which includes cost of upkeep as well as gasoline bills, with almost 42 percent mentioning it.

The third best-liked feature, with just over a third of the owners mentioning it, is ease of parking.

Asked to give the principal reason they bought the American, the owners overwhelmingly gave economy of operation top billing with almost 63 percent mentioning it. Another 7.8 percent list the low original price, also a factor in economy.

What do they complain about? The most frequently mentioned complaint by Rambler American owners involves water leaks, both in the passenger compartment and in the trunk—13.7 percent. Second on the complaint list is insufficient gasoline economy—not as much as advertised, with 10.7 percent mentioning it. Third most-frequent complaint is lack of room, headroom particularly, say 9.3 percent.

Here, in order of frequency of mention, are quotations from owners describing the most popular best-liked features:

"It handles beautifully and is a real pleasure to drive in traffic."—Tennessee chemist.

"Driving under any conditions requires a minimum of effort. It handles very easily at highway speeds as well as in congested traffic."—New York salesman.

"Low original cost. Low upkeep. Good trade-in. Minimum

(Continued to page 83)

COMMENTS BY  
ART RAILTON,  
PM's AUTO EDITOR

*What about this car? Although without frills, it is stylish and has no air of self denial. Priced under \$2000, it doesn't look as though every penny has been pinched out of it. It may be a workhorse, but it retains the chic look so necessary to attract buyers.*

SIMPLICITY ITSELF, THAT'S THE AMERICAN'S INSTRUMENT PANEL







## AN ENGINEER'S ANALYSIS

By **DALE KELLY, SAE**  
Registered Professional Engineer

## 1958 Studebaker Scotsman

**MODEL TESTED:** 1958 Studebaker Scotsman four-door sedan with six-cylinder L-head engine, hand-shift transmission with overdrive.

Rear-axle ratio: 3.54 to 1. Wheelbase: 116.5 inches. Tires: 6.40 by 15. Weight: 2890 pounds with gas tank half full (55% on front wheels, 45% on rear).

Mileage on car at time of test: 400 miles. Barometer: 29.12 inches. Temperature: 69 deg. F. Payload: 200 lb.

### ACCELERATION TIME FROM STANDING START (in seconds)



Ignition timed for:	0 to 20	0 to 40	0 to 60	0 to 70	¼ mile
Regular gasoline.....	3.2	10.0	24.0	33.0	23.0
(First gear to 33 m.p.h., second gear to 50 m.p.h.)					
Premium gasoline .....	No improvement noted				
<i>(Gasoline had following octane ratings by Research method: Regular 90; Premium 97.)</i>					

### FUEL ECONOMY (miles per gallon)



Ignition timed for:	Steady 30 m.p.h.	Steady 50 m.p.h.	Steady 70 m.p.h.	Traffic Route
Regular gasoline.....	28.7	24.3	17.1	13.4
<i>(Steady-speed tests made in overdrive; traffic-test in 1st, 2nd and 3rd gears. In traffic test, car makes 10 full stops per mile and is driven fast enough to average 15 m.p.h.)</i>				

### ESTIMATED AVERAGE ANNUAL GASOLINE BILL: \$145 for 10,000 miles

*(Based on exclusive use of regular gasoline.)*

### SPEEDOMETER ERROR (miles per hour)



Speedometer reading .....	20	30	40	50	60	70	80
True speed .....	22	29	37	45	54	63	73

### ODOMETER ERROR (miles traveled)

Odometer registered 107 miles for an actual distance of 100 miles



### DRIVER'S VISION

Driver could see part of road 18 feet in front of car, full width of road 26 feet in front of car.

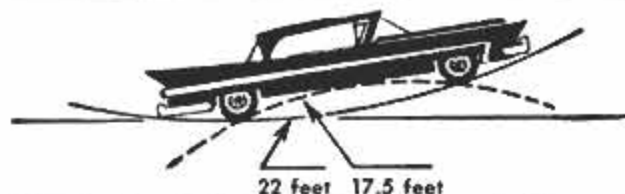

### GROUND CLEARANCE (unloaded car)

Worst dip that could be crossed.....	22-ft. radius
Worst hump that could be crossed.....	17.5-ft. radius
Deepest rut that could be negotiated.....	7.5 in.
Curb clearance for door opening.....	13 in.

### MISCELLANEOUS

#### STEERING

Steering-wheel turns for 100-ft. circle.....	0.80 turn
Curb-to-curb turn-circle diameter.....	40.5 feet
Wall-to-wall turn-circle diameter.....	43.5 feet
Steering-wheel turns, lock-to-lock.....	5.0 turns

#### TRUNK CAPACITY

13 cartons (one cubic foot each)

**CENTER OF GRAVITY:** 22.5 inches

**WATER RESISTANCE:** Fair

Splash-pan: No leaks. Ignition, brakes unaffected.

High-pressure test: All four doors leaked slightly, trunk leaked badly.

**OVER-ALL DIMENSIONS (inches)**

Length: 203.5	Width: 76.5	Height: 60.0
---------------	-------------	--------------

### OBSERVATIONS

Speedometer is of the rotating-drum type, very similar to the type that replaced the pointer speedometer about 1915 and was in turn replaced by the pointer type in the early 1930s. I consider the present version a little less legible than that made in 1915. Furthermore, many drivers of above average height will find it located out of sight behind the steering-wheel rim.

Air cleaner does a poor job of silencing noise made by air rushing into carburetor.

Test car had no engine-oil filter. Windshield wipers entirely dependent on engine vacuum with no assist from a booster pump (optional at extra

cost). The wipers, therefore, quit operating whenever the throttle is wide open (a frequent occurrence in overdrive-equipped cars).

Floor is nearly flat, both in front and back, with no doorsill to step over or no uncomfortable depressions in which to place feet.

Rear-axle ratio is 3.54 to 1 instead of the 4.10 or 4.56 usually used with overdrive. As a result, gasoline mileage is good and the engine, making only 2400 r.p.m. at 75 m.p.h., is extremely quiet at high car speeds.

Gasoline gauge registers zero when there are actually 3½ gallons available in the tank.



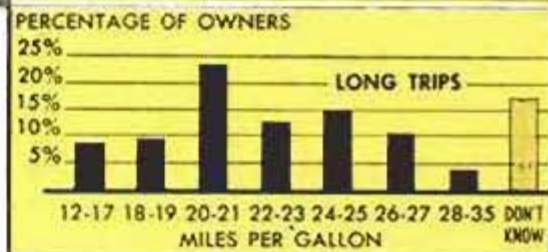
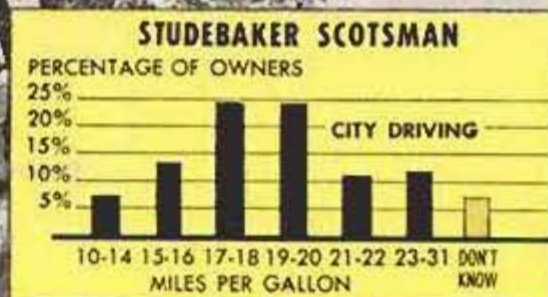

OWNERS SATISFIED WITH GAS ECONOMY...63.5%  
 OWNERS NOT SATISFIED .....36.5%

Second on the best-liked list is ease of handling, say Scotsman owners.

"Steers wonderfully. Has short turning radius and is not affected badly by crosswinds."—Oklahoma soil conservationist.

"I like the way it maneuvers into parking spaces."—Iowa motel operator.

"Ease of handling. Light, sure-footed feeling which keeps driving from feeling like work."—Illinois engineer.

Third on the list is the low initial cost.

"Its low initial cost made it possible for me to have a new car."—Texas minister.

"Only full-size wagon at the price."—Illinois mechanic.

*For those who want a wagon, this is a good buy. You can drive it home for \$2100 and it is a full-size car.*

**But They Complain**

All Scotsman owners are not completely satisfied, although 25 percent do not make a single complaint. There are others, however, who expected more economy than they are getting, 16.9 percent to be exact.

"I bought the car for high mileage. I get 19 miles per gallon. That isn't so bad, but when the salesman promises you 25, the lower figure doesn't make you happy."—Michigan field editor.

"It doesn't give nearly the gas mileage I was led to expect. I get 20 miles per gallon on trips."—Washington clergyman.

"I like the economy, but it is not the 22 miles per gallon I was told to expect."—Indiana engineer.

Second on the complaint list are body rattles with 14.5 percent of the owners mentioning them.

"Persistent body rattles. Developed differential noise at 7300 miles."—New York welder.

*As you can see on the chart above, most owners say they get from 17 to 20 m.p.g. in the city, 20 to 25 on trips. See data on opposite page.*

*Body is solid, vibrationfree and apparently durable. A few minor body noises developed.*

(Continued to page 208)

**Summary of Studebaker Scotsman Owners' Opinions:**

**OVER-ALL RATING: Excellent 50.9% Average 35.8% Poor 13.3%**

<b>Best-liked features</b>	Considerable trouble..... 2.4%	All others .....19.4%
Economy of operation..... 54.9%	<b>What was engine trouble?</b>	No trade, no answer..... 7.2%
Handling ease..... 47.6%	Oil leaks..... 4.1%	<b>What make will buy next time?</b>
Initial low cost..... 25.8%	Poor gas mileage..... 3.3%	Studebaker..... 51.6%
Exterior styling..... 19.4%	No pep..... 2.4%	General Motors make..... 4.8%
Riding comfort..... 11.3%	Idling trouble..... 1.6%	Chrysler Corp. make..... 4.0%
Roadability..... 10.5%	<b>How is dealer service?</b>	Ford Motor Co. make..... 3.2%
Roominess..... 10.5%	Excellent..... 55.2%	All others..... 8.1%
<b>Most-frequent complaints</b>	Average..... 28.8%	Undecided, no answer.....28.3%
None at all..... 25.0%	Poor..... 16.0%	<b>Also own another car?</b>
Not enough gas mileage..... 16.9%	<b>Would buy from him again?</b>	No, Scotsman only car.....71.8%
Body noises, rattles..... 14.5%	Yes, would..... 58.9%	Yes, own Chevrolet..... 5.6%
Water leaks..... 11.3%	Undecided, no answer..... 22.6%	Yes, another Stude..... 5.6%
Sluggish, not enough power..... 11.3%	No, would not..... 18.5%	Yes, own Ford..... 4.8%
Poor heater, defroster..... 6.5%	<b>What make was traded?</b>	Yes, other makes..... 12.2%
Poor workmanship..... 6.5%	Studebaker..... 30.7%	<b>Approve industry styling trend?</b>
<b>Had trouble with engine?</b>	General Motors make..... 17.7%	Yes, approve it..... 50.8%
No trouble..... 84.6%	Chrysler Corp. make..... 12.9%	No, do not approve..... 45.2%
Some trouble..... 13.0%	Ford Motor Co. make..... 12.1%	No answer..... 4.0%



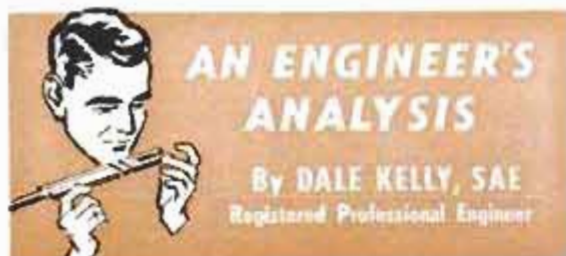

## AN ENGINEER'S ANALYSIS

By DALE KELLY, SAE  
Registered Professional Engineer

# 1958 Rambler American

**MODEL TESTED:** 1958 Rambler American two-door sedan with six-cylinder L-head engine, handshift overdrive transmission.

Rear-axle ratio: 4.125 to 1. Wheelbase: 100 inches. Tires: 5.90 by 15. Weight: 2590 pounds with gas tank half full (56% on the front wheels, 44% on rear).

Mileage on car at time of test: 700 miles. Barometer: 29.16 inches. Temperature: 83 deg. F. Payload: 200 lb.

### ACCELERATION TIME FROM STANDING START (in seconds)



Ignition timed for:	0 to 20	0 to 40	0 to 60	0 to 70	1/4 mile
Regular gasoline.....	3.3	9.0	19.0	27.2	21.2
(First gear to 25 m.p.h.; second gear to 45 m.p.h.)					
Premium gasoline .....	No improvement noted				
<i>(Gasoline had following octane ratings by Research method: Regular 90; Premium 97.)</i>					

### FUEL ECONOMY (miles per gallon)



Ignition timed for:	Steady 30 m.p.h.	Steady 50 m.p.h.	Steady 70 m.p.h.	Traffic Route
Regular gasoline.....	34.0	27.0	19.5	18.2
<i>(Steady-speed tests made in overdrive; traffic-test in 1st, 2nd and 3rd gears. In traffic test, car makes 10 full stops per mile and is driven fast enough to average 15 m.p.h.)</i>				

### ESTIMATED AVERAGE ANNUAL GASOLINE BILL: \$123 for 10,000 miles

*(Based on exclusive use of regular gasoline.)*

### SPEEDOMETER ERROR (miles per hour)



Speedometer reading .....	20	30	40	50	60	70	80
True speed .....	16	26	35	45	54	64	74

### ODOMETER ERROR (miles traveled)

Odometer registered 102 miles for an actual distance of 100 miles.



### DRIVER'S VISION

Driver could see part of road 13 feet in front of car, full width of road 17 feet in front of car.

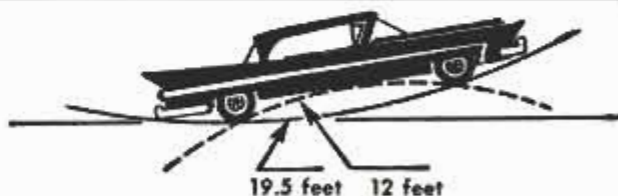

### GROUND CLEARANCE (unloaded car)

Worst dip that could be crossed.....19.5 ft. radius  
Worst hump that could be crossed.....12-ft. radius  
Deepest rut that could be negotiated..... 8 in.  
Curb clearance for door opening.....13.5 in.

## MISCELLANEOUS

### STEERING

Steering-wheel turns for 100-ft. circle....0.65 turn  
Curb-to-curb turn-circle diameter.....35.5 feet  
Wall-to-wall turn-circle diameter.....38 feet  
Steering-wheel turns, lock-to-lock.....4.4 turns

**CENTER OF GRAVITY:** 22.8 inches

### TRUNK CAPACITY

8 cartons (one cubic foot each)

### WATER RESISTANCE: Fair

Splash-pan: No leaks. Brakes uneven after test.  
High-pressure test: Slight leakage into trunk.

### OVER-ALL DIMENSIONS (inches)

Length: 178.0      Width: 72.5      Height: 59.5

## OBSERVATIONS

Windshield, though curved, does not wrap around at the ends. It gives undistorted vision and does not interfere with entry and exit. The parking-brake handle, however, may get in the way of driver. In first gear, the knob on the shift lever is so close to the steering wheel that the driver's knuckles get rapped when turning the wheel.

Front-seat headroom is only a fraction of an inch less than that in some top-price cars. Low driveshaft tunnel, front and rear, interferes very little with leg comfort.

Ground clearance is excellent under the center of the car and at the rear.

Driver has an excellent view of the road close in front of the car. Steering wheel requires rela-

tively little winding for a given curve and the car makes a U-turn in 3 to 7 feet less than a Ford, Chevrolet or Plymouth.

Daytime legibility of instruments is satisfactory, but the speedometer pointer is almost invisible at night. Speedometer error is too high. At only 35 miles per hour, the speedometer of test car read five miles per hour high.

Luggage space in the trunk is good for a small car except that the spare tire takes up nearly all the floor.

Gasoline filler pipe overflowed when an attempt was made to fill it at 14 gallons per minute (normal filling speed). After the car was allowed to run out of gas, it required two gallons of gas to move the gas-gauge pointer.



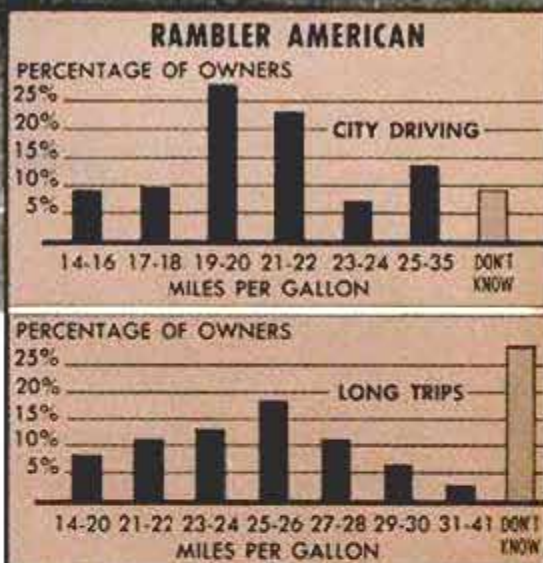

operating cost. Best dollar-for-dollar buy on the market."—California owner.

"I'm a rural letter carrier. This is very hard on a car. On my previous car (not a Rambler) I spent \$500 in 50,000 miles on upkeep. So far on this American, I have spent \$1.40 in 15,000 miles."—Indiana owner.

"Relatively low cost of operation. I get 22 miles per gallon in the city."—Virginia clerk.

"Short wheelbase makes for easier parking."—Georgia salesman.

"We have always had big cars before. But this drives so easily, is so easy to park that I'll never again go back to a heavy car."—Vermont housewife.

"Extremely peppy. Has fast acceleration."—New Jersey secretary.

"Quick pickup. Very fast on the go. You have to watch that it doesn't run away."—Massachusetts packer.

"The engine gives plenty of pickup. Seems to be geared for passing at from 40 to 60. After 70 miles per hour, it starts getting flat. However, I like this and believe it is geared right. Pulls well in the mountains."—Colorado engineer.

### But They Complain Too

Rambler American owners do have complaints, although 25.9 percent of them can find nothing at all wrong with the car. Here, in order of frequency of mention, are the top items on the least-liked list:

"Body design allows water (rain or melted snow) to seep into trunk and onto floor of car. Have had as much as an inch on floor after a storm."—Maine supervisor.

"When opening trunk lid in the rain, the water runs off lid right into trunk."—Washington electrician.

(Continued to page 212)

OWNERS SATISFIED WITH GAS ECONOMY... 74.5%  
OWNERS NOT SATISFIED.....25.5%

**Most owners claim 19 to 22 miles per gallon in city, about 25 on trips, above. The American is the most economical domestic car PM has tested. See opposite page.**

**Windshield wipers are noisy. They sound like an old man with asthma. In a slight rain, this noise is annoying. In a hard rain, it's a strong, reassuring sound.**

## Summary of Rambler American Owners' Opinions:

**OVER-ALL RATING: Excellent 65.9% Average 29.7% Poor 4.4%**

### Best-liked features

Handling ease.....	58.5%
Economy of operation.....	41.9%
Ease of parking.....	34.6%
Performance.....	22.9%
Over-all size.....	22.0%
Riding comfort.....	17.1%
Exterior styling.....	14.6%

### Most-frequent complaints

None at all.....	25.9%
Water leaks.....	13.7%
Not enough gas mileage.....	10.7%
Lack of interior room.....	9.3%
Poor workmanship.....	9.3%
Transmission trouble.....	8.3%
Hard riding.....	7.3%

### Had trouble with engine?

No trouble.....	83.2%
Some trouble.....	14.8%

Considerable trouble..... 2.0%

### What was engine trouble?

Carburetor, choke.....	7.9%
Fuel pump.....	1.5%
Oil consumption.....	1.0%

### How is dealer service?

Excellent.....	48.7%
Average.....	40.3%
Poor.....	11.0%

### Would buy from him again?

Yes, would.....	76.6%
Undecided, no answer.....	8.8%
No, would not.....	14.6%

### What make was traded?

General Motors make.....	22.9%
Ford Motor Co. make.....	14.7%
Rambler.....	10.2%
Chrysler Corp. make.....	10.2%
Nash or Metropolitan.....	9.8%

All others.....16.6%  
No trade, no answer.....15.6%

### What make will buy next time?

Rambler or American.....	55.1%
General Motors make.....	2.0%
Ford Motor Co. make.....	0.5%
Chrysler Corp. make.....	0.5%
All others.....	3.4%
Undecided, no answer.....	38.5%

### Also own another car?

No, American only car.....	60.5%
Yes, own Chevrolet.....	5.9%
Yes, own Ford.....	5.9%
Yes, own Nash, Rambler.....	4.4%
Yes, all other makes.....	23.3%

### Approve industry styling trend?

No, do not approve.....	62.4%
Yes, do approve it.....	29.3%
No answer.....	8.3%





## **X-7s Recovered By Parachute**

Lockheed X-7s, fastest "air breathing" missiles in the United States, are safely landed by parachute and nose spike after each flight and flown again. This permits first-hand study of the ramjet and aids engine development. Each recovery and reflight also saves taxpayers \$350,000 in missile-research costs.

## **Plant Tranquilizer**

Fruits and vegetables can recover from the shock of sudden cold snaps, prolonged rain or drought with the help of a chemical tranquilizer. The chemical, developed by the United States Rubber Company, increases yields when sprayed on certain plants. Scientists are not certain how the chemical works, but believe it corrects a hormone deficiency.



## **Polio Respirator Feeds at Mouth**

Lightweight, portable respirators that can be mounted to the backs of wheelchairs enable polio patients to get breathing aid without entering the old-style chest shells. The new respirator feeds air into a tube at the patient's mouth. Operated by a 12-volt battery, it also is equipped with a blower unit. Each unit weighs 20 pounds.

## **Tooth Decay Reduced**

Tooth decay can be reduced by half if your diet contains as little as one half of one percent of extracts from oat hulls, according to researchers at the University of Wisconsin.



## Flight Simulator Tests Planes

Aeronautical engineers in France are testing their theories with the aid of a huge flight simulator. The machine can spin a full-size mockup of a plane fuselage like a gyroscope, as shown on the cover of this issue. The plane, in mockup form, is installed in concentric rings inside a gantry framework. The flight simulator has been particularly helpful in perfecting cockpit installations. It was developed by the French National Society for Aeronautical Research and Construction.

## Electronic Brain Recognizes Numbers

Massachusetts Institute of Technology's Lincoln Laboratory has developed an electronic "brain" that can recognize the sounds of numbers spoken by humans. The computer reportedly has 98-percent accuracy in analyzing the sounds of digits.

## Both Sides of Document Microfilmed at Same Time

Photographs of both sides of a document can be made simultaneously by a new microfilming machine that uses 16-millimeter film. The device records up to 7200 images on a 100-foot roll of film and signals with a chime and a red signal when a new roll is needed. The unit, about half the size of a desk, has an illumination control for paper shades and will take paper thicknesses up to  $\frac{1}{4}$  inch.



AUGUST 1958



## Trolley Gives Kids a "Ride" In Best Toonerville Style

This trolley can't go anywhere, but it rocks and rolls in true Toonerville style. It also clangs a bell and flashes a headlight on and off. The "motorman" can control the "speed" of the trolley by operating a small lever on the coin box.



85



Reprinted from *Time* magazine

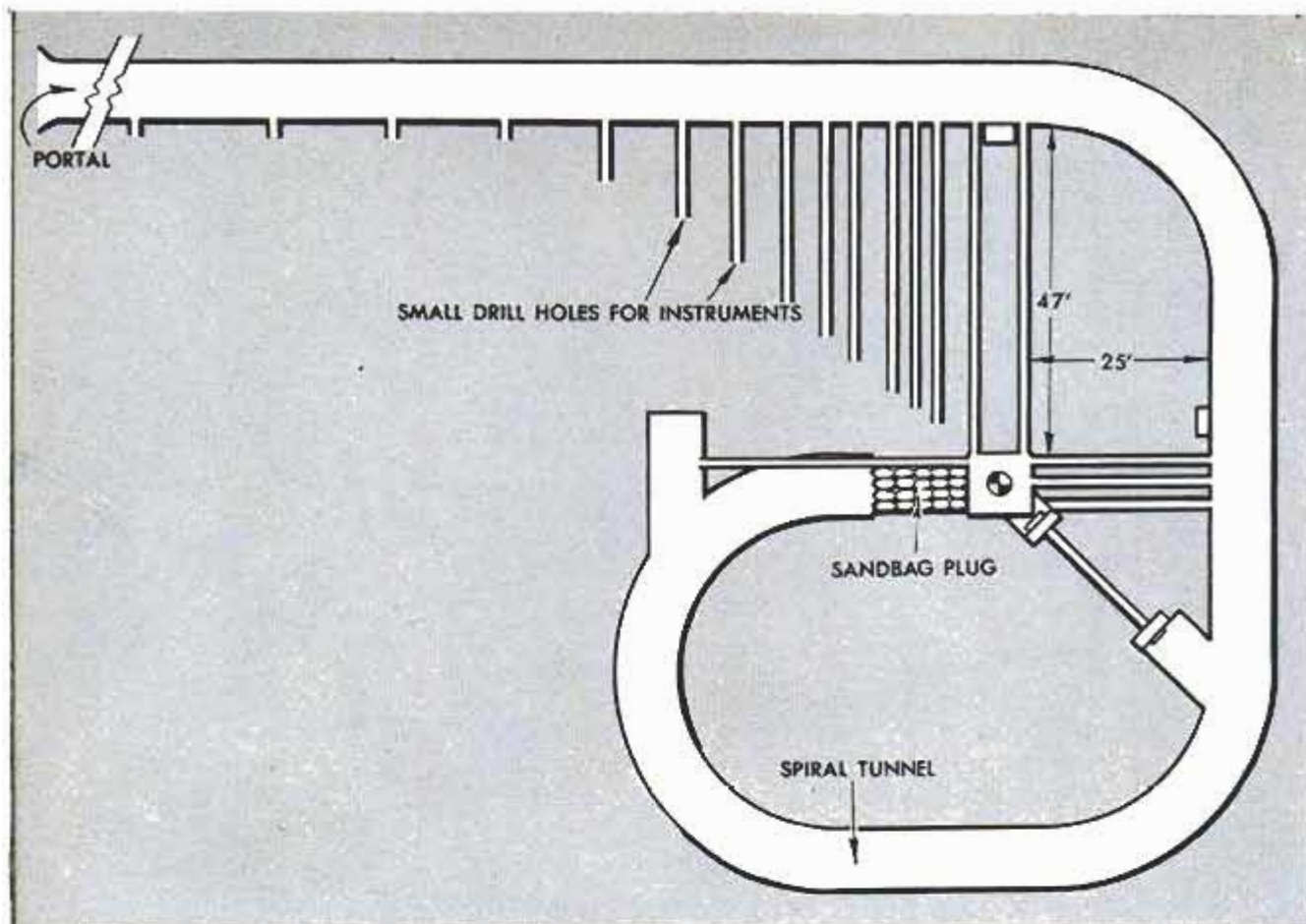

Diagram shows how tunnel for underground atomic test was cut as a sort of spiral so it would be sealed off by blast, trapping radioactivity

## Will We Dig Ore With A-Bombs?



**I**T MAY BE POSSIBLE to rejuvenate old oil fields, open up vast deposits of low grade ores, and create huge underground water reservoirs for arid regions, all with atomic bombs.

That's the opinion of AEC scientists who are studying the results of deep underground atomic blasts that they touched off this year and last at their Nevada test site. One of the explosions, the Rainier shot, was a "tiny" atom bomb only a tenth as powerful as the bomb dropped on Hiroshima, yet it crushed 500,000 tons of rock and broke up an additional 200,000 tons.

The intense heat of the explosion dissipated quite rapidly and yet three months later some of the rock still had a temperature of 190 degrees Fahrenheit, close to the boiling point of water.

The bomb was exploded at the end of a tunnel 900 feet below the surface of a mesa, in porous, water-saturated volcanic tuff. The tunnel was curved somewhat like a spiral so that it would be sealed by the

blast, preventing any escape of radiation.

Spectators saw nothing but a ripple in the earth and numerous spurts of dust from dislodged rocks when the bomb was fired. Few of them felt any shock, though a slight tremor was recorded at scattered seismograph stations as far away as Alaska.

To study the effects of the bomb, the Atomic Energy Commission drilled exploratory holes from the surface of the mesa and from a point in the original tunnel. By examining the corings that were brought out by the drills the scientists were able to trace the story of what the explosion had done.

When the bomb went off, its terrific pressure pushed out the walls of the small chamber at the end of the tunnel and created a spherical cavity 110 feet in diameter. The walls of the cavity were fused by the intense heat into a four-inch-thick layer of black, glasslike material. The surrounding rock for a distance of 75 feet was crushed almost into sand, then squeezed so



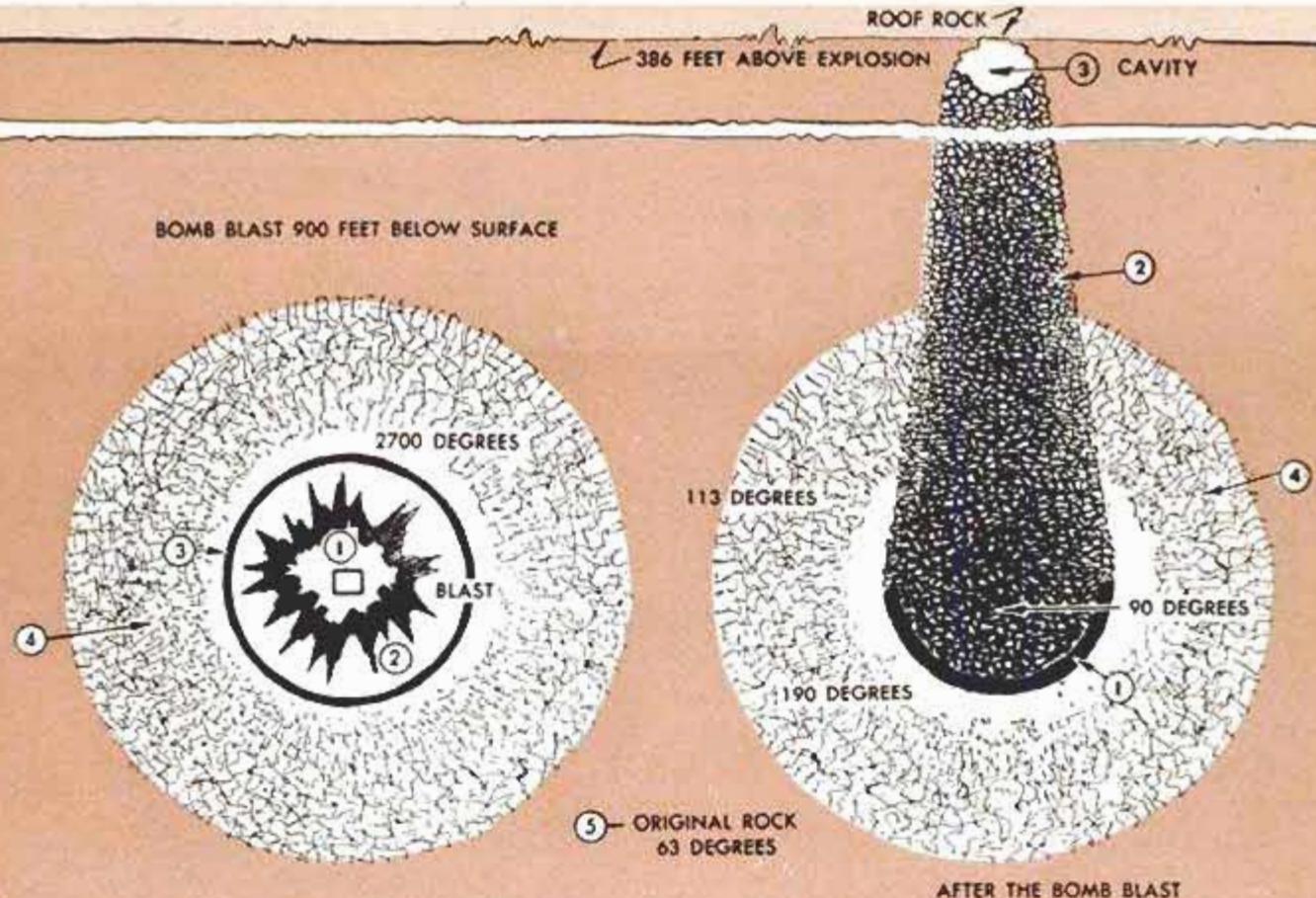

Drawing at left shows how blast in tunnel, 1, made spherical cavity, 2, with walls of fused glass-like rock, 3, which trapped radiation. Surrounding rock, 4, was crushed and compacted by pressure. Drawing

at right shows collapse of cavity roof, after blast, leaving bowl, 1, of fused material and 386-foot high tower, 2, of broken rock. Temperatures at right were taken three months after the explosion

hard that it became impermeable to water. Farther away, the rock was unchanged, though it "jumped" sufficiently to seal the access tunnel 200 feet from the explosion point. The blast also shattered large amounts of rock in the tunnel as far as 400 feet away.

Almost immediately after the explosion the spherical cavity collapsed. The upper half of the glassy lining fell to the floor, and the unsupported rock above it caved in. Additional rock collapsed from above, then more rock. This continued until a strong rock layer 368 feet above the explosion point was reached. In effect, a "chimney" of loose, unconsolidated material was produced.

Aside from a little radioactive gas in the chimney, virtually all radioactivity was confined to the mass of glass-like liner that lay in the lower portion of the original cavity.

Main purpose of the Rainer shot was to learn whether a nuclear weapon that was tested underground would eliminate the usual radioactive clouds, fallout, and flash and noise of an ordinary test. The experiment was a complete success. No radiation escaped to the atmosphere and there appears little chance that ground water could become contaminated.

In this test the underground rock cooled off quite rapidly because of its high water content. The heat turned the water into steam, which then escaped through pores and fissures. In relatively dry rock, temperatures of possibly 1000 degrees might have persisted for months.

Scientists think that a much bigger bomb, exploded in dry rock, would create a great storehouse of heat which could then be tapped and converted into power. Dr. Willard F. Libby of the Atomic Energy Commission says that this may be done. The idea would be to pump water through the hot area, producing superheated steam that would be used to drive an electric generator. Some preliminary research on the idea is being done now.

Another possibility is to use underground atomic blasts to recover more oil from depleted oil fields. Petroleum engineers say that no more than a third of the crude oil in an underground pool is extracted by pumping. Secondary recovery methods produce a little more, but possibly 50 percent remains in the ground. Still more should become available by an underground blast. The pressure created by the explosion would help free the oil trapped in relatively nonporous rock

(Continued to page 216)



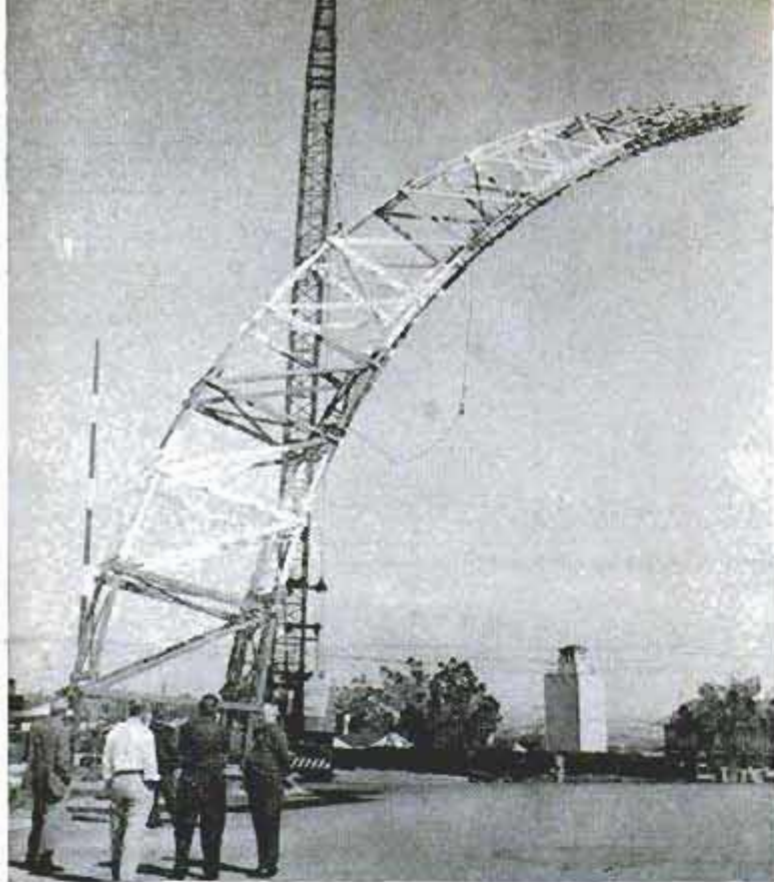

## Curved Tower Aids Navy In Communications Study

Findings from a 78-foot curved tower will enable contact to be made with ships up to 5000 miles away. Made of wood, with minimum metal fittings, the tower was erected on Point Loma, near San Diego, Calif., to help the Navy solve electronic problems of communication with missile and nuclear-powered ships. It supports two close-tolerance tracks that provide a railway for a carriage containing electronic instrumentation for signal interchanges with model ships in a lead-covered field adjacent to the tower. The carriage can be lowered, raised or stopped to give any desired vertical angle. Cost to build the unique structure was \$17,000.

## Two-Wheeled Golf Cart Has Glass-Fiber Body

Gas mileage for a new two-wheeled golf cart is listed as "36 holes per half-gallon." The heavy-duty gasoline engine is mounted in rubber and equipped with a large muffler for quiet operation. It uses no batteries and requires no special servicing for the winter months. Weight of the vehicle is 165 pounds but it will climb hills and accelerate without wheel spin. The body is glass fiber and available in four colors.



## Pint-Sized Parasol Made From Handkerchiefs

Among the new gift ideas from Japan is a pint-sized parasol made from two colored handkerchiefs. One handkerchief is rolled tightly into a handle. The other has a series of cardboard struts attached to the outside edges and connected to a small cardboard slide that can be moved to open or close the umbrella. Other novelties, such as flowers, hats or books, also can be made with ladies' handkerchiefs.







Sky-to-earth telephone enables passenger on Northwest Orient Airlines to receive call relayed by radio

# MIRACLES AHEAD ON YOUR TELEPHONE

*Reprinted  
"PM High Lights"*

**R**EACHING ACROSS the kitchen counter, a housewife presses a button on a streamlined gadget resembling a miniature radio. "One, one—five—seven, five, eight, oh," she says to a built-in microphone. On a two-inch-square screen in the face of the instrument, light glows and the image of a man appears. "Darling," says the housewife, "stop off on the way home and pick up a pie." The face on the screen grins. A voice comes from the miniature loudspeaker, "Sure thing, honey. Be home in half an hour."

A peek into the distant future? Not so distant as you think. Bell Laboratories' director of apparatus development, Robert Nossaman, thinks a production-model TV phone may be available to any subscriber within 15 years. Last year Nossaman's boys built an experimental model, with a switch that cuts off the picture if you're answering

By Richard F. Dempewolff



American-Swedish News Exchange photo  
Swedish WeGo-Phone has small loudspeaker beside dial so individuals or groups can talk back and forth





"Mike" and loudspeaker let freight agent talk with hands free

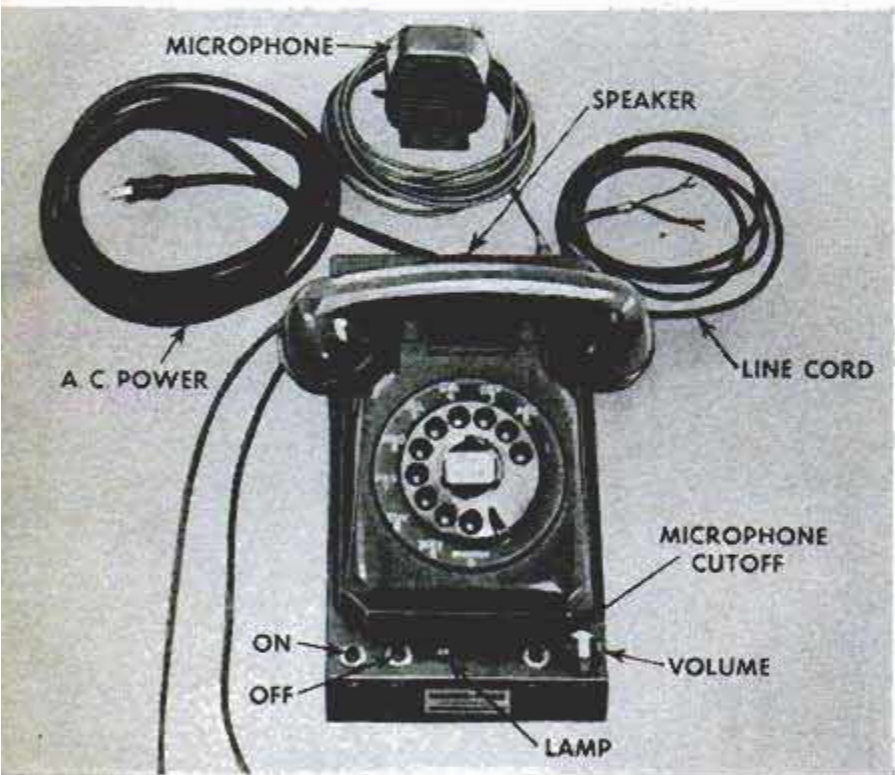

Below, the tiny variable-volume control beside phone amplifies the reception over any telephone as much as 16 decibels



from the shower, or want privacy for any reason.

Already, a loudspeaker-telephone for use on regular customer service has gone into production in Sweden. Known as the WeGe-Phone, the instrument has microphone and speaker built into a single unit. Conversations can be held between two or more people, as though chatting in the same room. For privacy, a built-in handset can be detached for use. Most prophetic feature, however, is the tiny loudspeaker opening designed for a future miniature TV tube. A similar phone, developed by Stromberg Carlson, was marketed in this country last year. It resembles a standard desk set, with separate mike.

One hurdle to practical TV-phones is the amount of electronic information necessary for transmitting voice and picture over existing telephone lines. Now that may be licked. Last winter, General Electric scientists announced a "slow-scan TV," which can be sent out over conventional telephone wires. Instead of transmitting 30 complete pictures every second as commercial TV does, slow-scan sends a new image only once in five or ten seconds. The party on the other end might jump around on your telephone screen, but he'd come in loud and clear.

Actually, scientists at Bell Telephone Laboratories' research plant in New Jersey admit they have all the necessary hardware and know-how to produce TV telephones right now. But they doubt that many subscribers would want to pay "several dozen dollars" for a three-minute call just to see the expression on somebody's face across town. Even when the cost factor is solved, nobody is sure residential subscribers will go for an extra fee just to peer at each other remotely. But telephone officials do believe they'll soon be making TV telephones for special business applications. A magazine make-up man, for instance, could flash his pages on the TV-phone screen while he talked with the printer about corrections. Maps, architectural renderings, blueprints and such will be television-phonied anyplace, eliminating time-consuming verbal description. Right now, a closed-circuit



## WANT A BEDTIME STORY? SKI CONDITIONS?

### ADVICE ON ANYTHING? JUST DIAL A NUMBER

IF YOU WANT TO KNOW where the fish are biting off Long Island, just dial GR 7-9015 in New York. In Chicago, dial CE 6-2969, and a prayer for the day will be intoned. In Los Angeles, WE 3-6111 will steer you to the latest shopping bargains. Other numbers will bring you an electronic voice with stock quotations for the day.

Nearly every major American city has climbed on the band wagon with special telephone services from time and weather data to advice for the lovelorn. Throughout Chicago's suburbs, devout people can dial one of several numbers, and a clergyman's voice will relate religious teachings to help lift one's spirits for that particular day. Vermont's Alcoholic Rehabilitation Commission sponsors a talk-back service that is advertised in the newspaper. "If you WANT a drink," says the copy, "that's your business. If you want to stop and can't, dial 2-9631." Anyone calling gets a recorded pep talk stressing courage, and suggesting that the caller visit an address where Alcoholics Anonymous will take him in hand.

In London, a "live" dial service manned by 100 volunteer answerers, is designed for people contemplating suicide. "Call us first" is their motto. When you do, someone keeps you on the phone while someone else rushes over to the address to offer personal assistance.

Another tricky British "talk back" is the "dial M for Menu" service in Hull. When you do, you get a three-minute discussion of possible dishes for the day's table fare. The service was thought up by a bachelor. You can also dictate letters right to the post office in England. And Hull has an electronic Santa Claus who delivers a message to the kids at Christmas if they dial "North Pole."

Actually, Europe is way ahead of the United States in talk-back telephone services. One reason: their networks are smaller and more adaptable. Ours is forever trying to catch up with ordinary service demands.

Most phenomenal telephonic potpourri, perhaps, is in Vienna, where electronic geni, aroused by simple dialed numbers, will sing you lullabies at night, tell fairy tales to the children, or wake you with a time and weather report in the morning at a prespecified time. Some numbers will respond with a resume of the day's headlines, others drone off leading stock quotations. In Zurich, a housewife who's stuck with a fallen cake can dial for a better recipe. Switzerland's talk-back numbers will spiel off the world news in any of three languages, depending on which number you dial. And if a musician is trying to tune an instrument, he has simply to dial the right digits, and a foolproof electronic "A" will put him straight.

telephone-television system is in operation for rapid confirmation of reservations in New York's Pennsylvania Railroad Station. Many banks have installed Data Vision, a similar system, that permits tellers to check account balances and signatures in central files, miles from the teller's cage.

One major frustration about to bite the dust is the "busy signal." New automatic electronic-telephone exchanges already are eliminating this nuisance. In Sweden, if you dial a number through the new L. M. Ericsson exchange, it's no longer necessary to "try again" if the number you want is busy. Just hang up and forget it. The exchange's brain "memorizes" your call, stacks it with any others that might be waiting for the same number, then rings back each caller on a "first come, first served" basis as the line clears. In England, a similar exchange developed by Pye Telecommunications does the same job noiselessly, using electronic "valves" instead of switches. Since there are no moving contacts, the exchange is great for mines or explosive atmosphere. No dustfree air-conditioned rooms are necessary.

Within the next couple of years, an experimental electronic exchange will do the same things for 3000 customers in Morris, Ill., marking the start of a gradual change to electronic switching throughout this country.

These robot exchanges have other tricks designed to please and help the harried customer. For one thing, they won't "ring" your phone. Instead you'll be gently alerted by a musical tone. Furthermore, if you call a number that doesn't answer, you'll get a signal telling you to go ahead with your message. Your call is then instantly and automatically switched to a "talk back" number, where anything you have to say is magnetically recorded. When your pal comes home, he dials the "talk back" number. Electronic wizardry plucks the tape for his phone number and plays

Experimental model of a TV picture-phone shows small receiver and transmitter. Extra line is needed  
Bell Telephone Laboratories photo

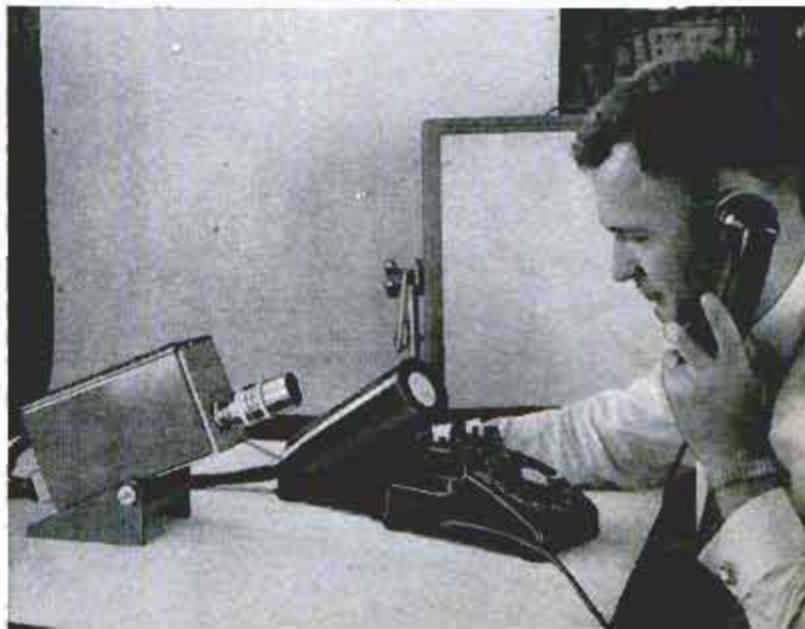





Caller turns knob on Dialaphone to name of person or company and perforated tape automatically makes call

back your message—and any others that might be waiting—without benefit of any “answering service” operator. By rigging connections in any given way, such an exchange can be tied up to group numbers to provide paging systems, permit remote letter dictation or simultaneous telephone

conferences between half a dozen parties.

Some of the new electronic-telephone geni are so uncanny people don't have to do any talking at all—transistors and tubes do it for them. Right now, the Automatic Electric Company of Northlake, Ill., can provide you with an electronic telephone

Sensing “fingers” at top inside Dialaphone translate directory-tape holes into electrical impulses

Directory tape for the Dialaphone is interchangeable and fits into instrument as a film into camera

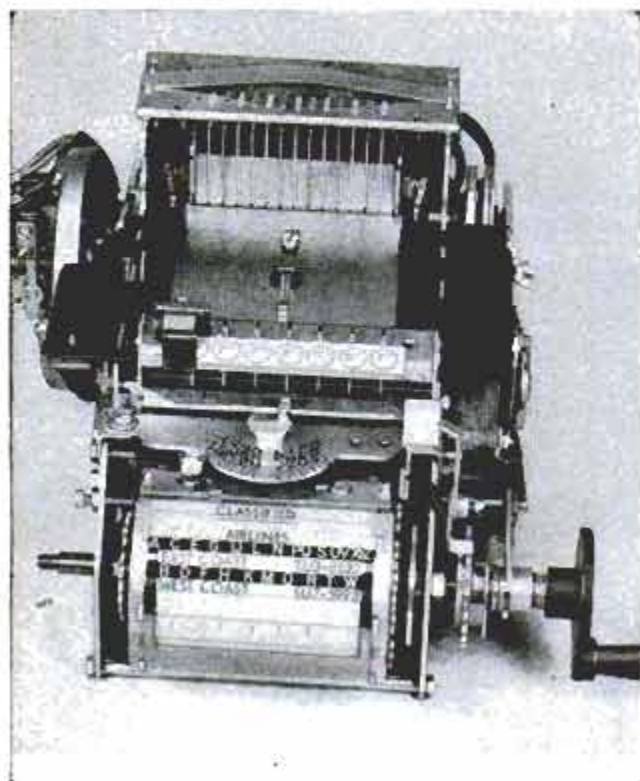





Bell engineer demonstrates "Audrey"—electronic device that reacts "intelligently" to 10 spoken numbers

watchdog to guard your property. Dubbed the "electronic sentry," this shoe-box-size robot will put in a call to the proper people whenever it senses trouble due to fire, thievery, atmospheric pressures, temperature, water levels in tanks, boilers and such. The little unit gets its information from thermostats, pressure gauges, burglar detectors and any other control you choose

to hook it up to. Whenever its sensitive brain is "frightened" by one of these sensory gadgets, the sentry automatically connects itself across the telephone line, dials the proper authority—police, firemen, plumber or whoever's needed—selects the right message from a bank of tapes and transmits a recorded warning until help comes.

Left, radio-paging device buzzes to signal that phone call is being held. Right, operator sends out signal

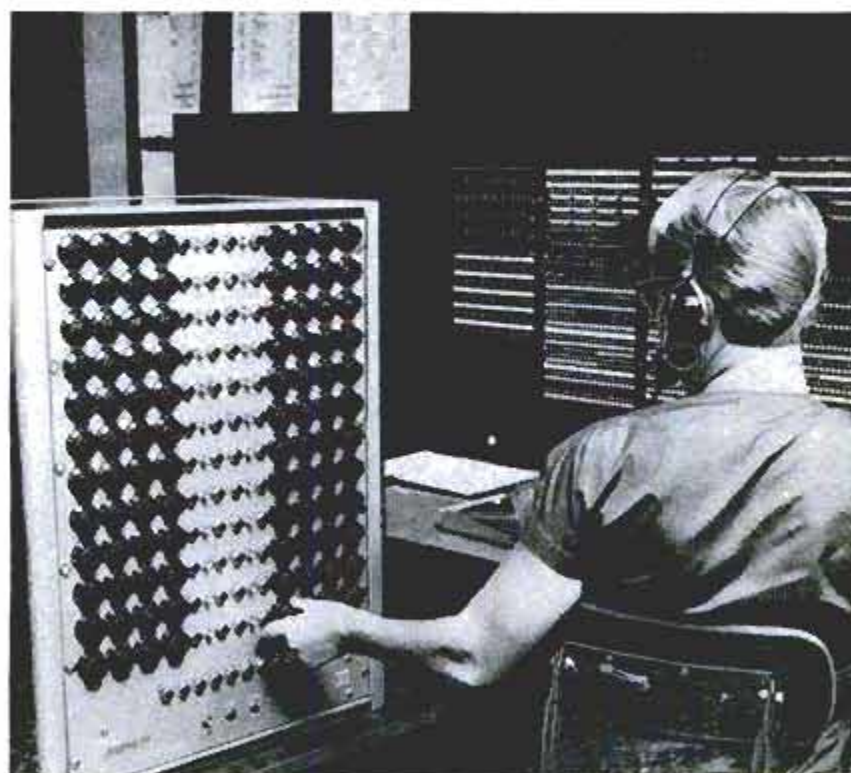





Left, movement of coins in slot tell caller how much time remains. Right, unit gives and takes messages

If the robot "watchdog" doesn't raise your goose pimples, American Telephone and Telegraph may do it with their Dataphone, recently perfected at Bell Labs. This telephonic device enables business machines to "talk" to each other at a rate of 1000 words a minute. The Dataphone takes impulses from a data-processing brain and turns them into tones on a magnetic tape. The tones are transmitted over telephone lines. At the other end, another device switches the tones back to impulses and feeds them into business machines that

can print the information on paper. A.T.&T. president, Frederick Kappel, reveals that his Dataphone robot can deliver 7000 supermarket inventory items in 16 minutes, for instance, or process and transmit a similar quantity of payroll data to a field force.

Pushing the communications experts to constantly speedier and more efficient service are chatty Americans who now place 228,000,000 calls from some 65,000,000 telephones every day (more than half the

(Continued to page 202)

Operator of speaker-phone can set up a conference between remote and local stations by extra push buttons





## His Electronic Piano Has Rinky-Tink Tone

Applying modern techniques to an old-fashioned method of making music, Ed Landrum of Dallas, Tex., has produced an electronic player piano with a rinky-tink tone. The player piano originally made music when air, pumped by a set of bellows, was blown through a pattern of holes in a roll of paper. The perforations in the paper governed the plunking of the various piano keys. Landrum, who found the piano in a used-furniture store, decided to devise a new playing mechanism for it. Instead of pumping air through the holes as the paper roll was turned, Landrum had a row of wire brushes sweep the paper. When a hole moved under a brush, an electric contact was made. This activated a solenoid that made the proper key plunk. Adding the rinky-tink effect was a bit easier than rebuilding the action. He just stuck thumbtacks in hammers that hit the treble strings.



## Big Bag of Air Helps Contractor Build Houses

Raising the roof of a demountable house made by Transa Homes Corporation takes only six minutes when a big rubber bag of air does the work. The job formerly required 16 husky men, or a crane, and up to 3½ hours' time. The bag, developed by

B. F. Goodrich Aviation Products, is positioned under the 2000-pound roof section and inflated with an ordinary air compressor. Air pressure is less than one pound per square inch. Deflating the bag lowers the 4500-pound hinged floor and side walls.

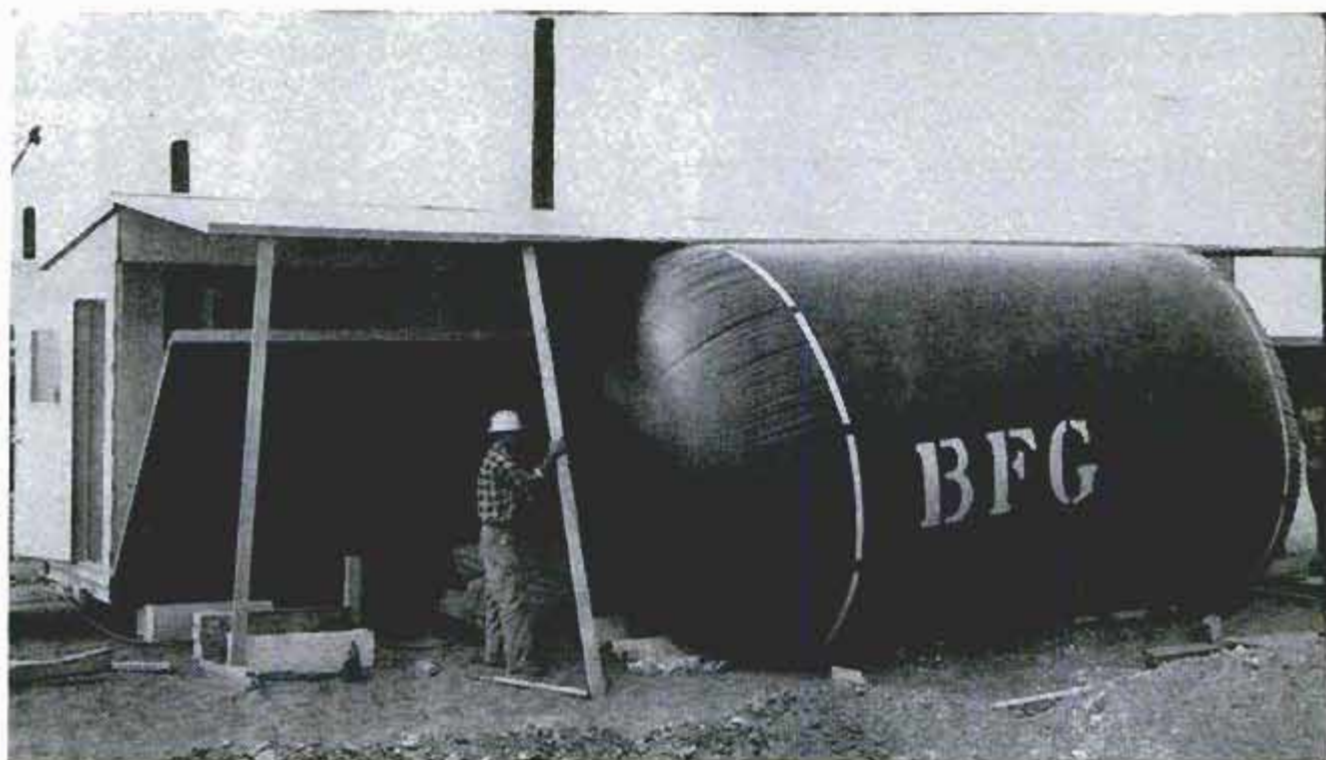



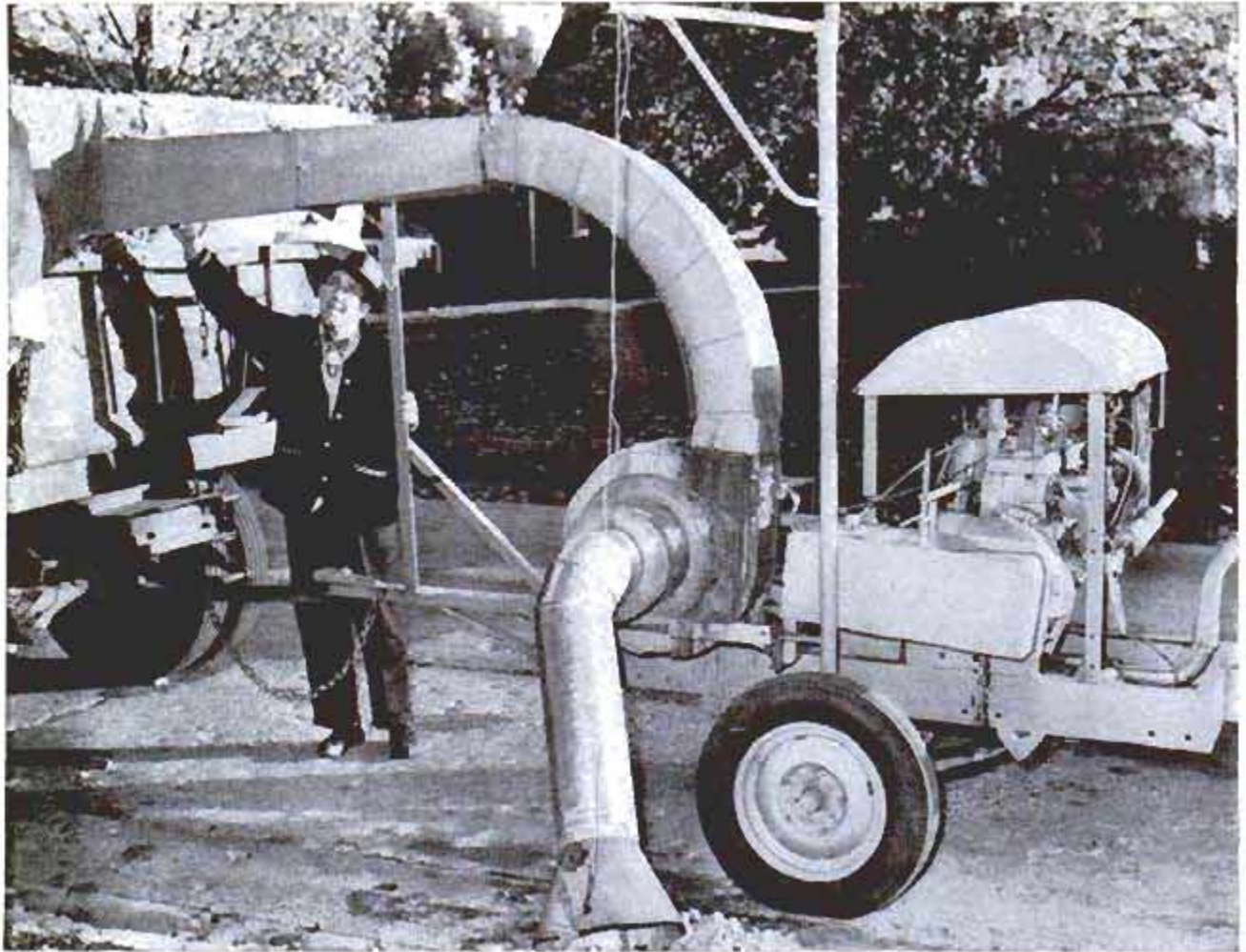

### Vacuum Scoops up Leaves From City's Parks and Streets

Built on a vacuum principle, a leaf-picking machine can accomplish in one hour what it used to take workers in Parchment, Mich., half a day to do. Leaves

on streets and in parks are sucked into a 12-inch flexible tube, pulverized by fan blades, then passed through another tube into a sealed truck.

### Rollers Enable Draftsmen to Make Lengthy Drawings in One Strip

Lengthy drawings can be made in one continuous strip by attaching a roller to each end of your drafting board. On one

roller is the unused paper. After this paper is used it is moved onto the roller at the other end of the board.

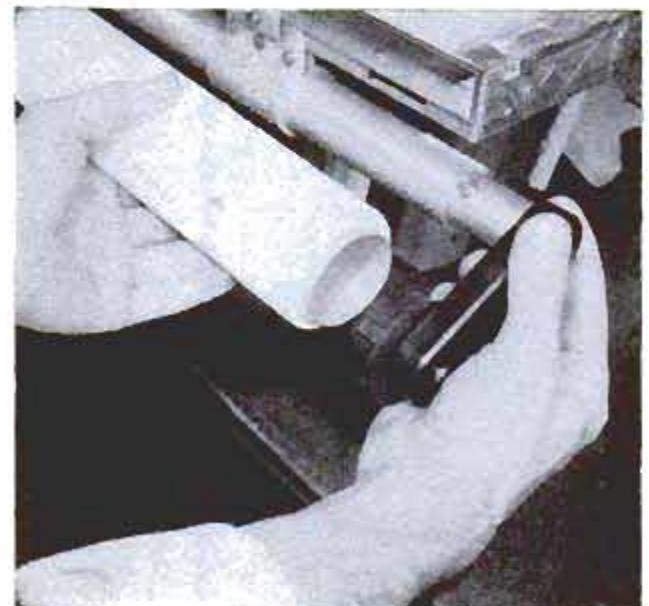
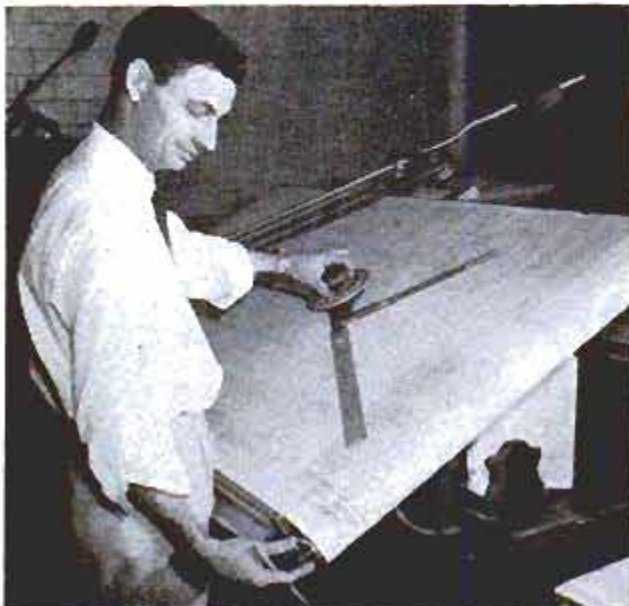



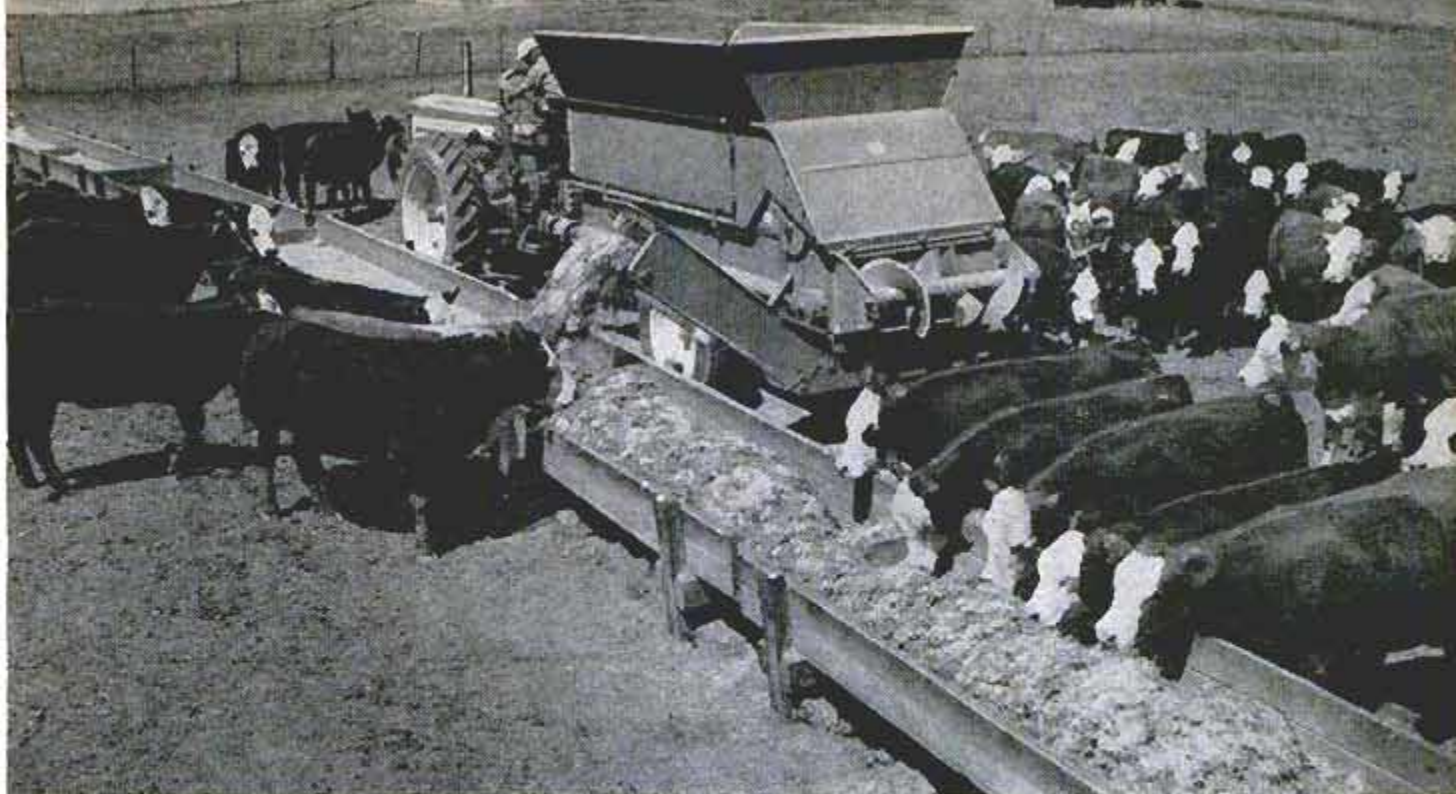

### **Attachment Converts Spreader to Forage Dispenser**

With a new attachment the farmer can convert a manure spreader to a self-unloading forage box. The John Deere attachment permits farmers to unload chopped material to the side into feed bunks, and to the rear and side into elevator hoppers, trench and bunker silos. It can be used to handle chopped hay and corn, grass and corn silage. The single control within reach of the driver provides two unloading speeds.

### **Radio-Controlled Models Aid in River Study**

Designed to simulate the movement of real towboats on the Ohio River, radio-controlled model boats are used by the Army Corps of Engineers in studies of river navigation. The model boats push tiny barges over the surface of a scale-model river. Folded wire is placed along the banks of the "river" to represent trees, fences and other obstructions which retard the flow of water in an actual stream. Information obtained from the studies will be used to build new locks and dams.

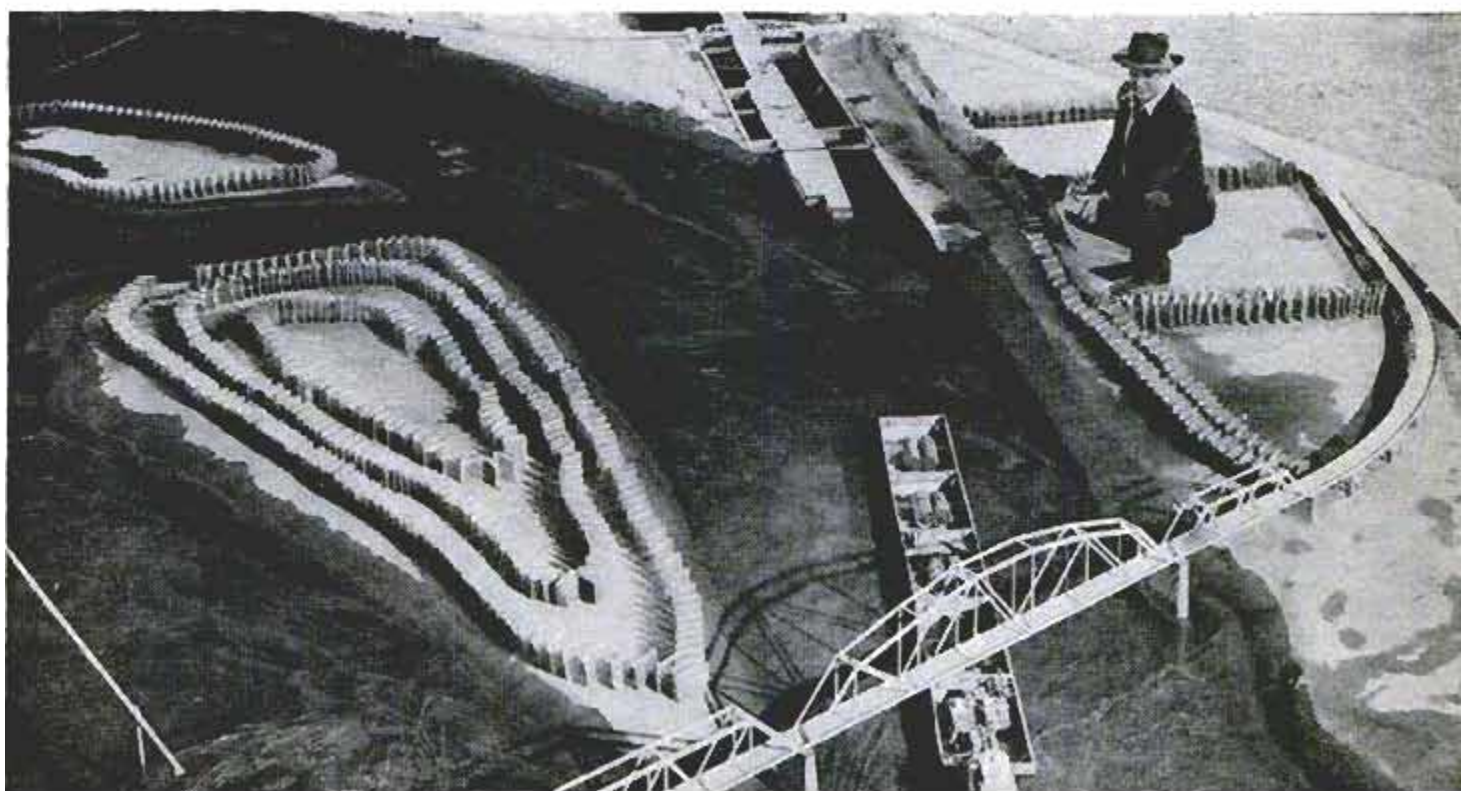



# WHAT'S NEW FOR Your Home

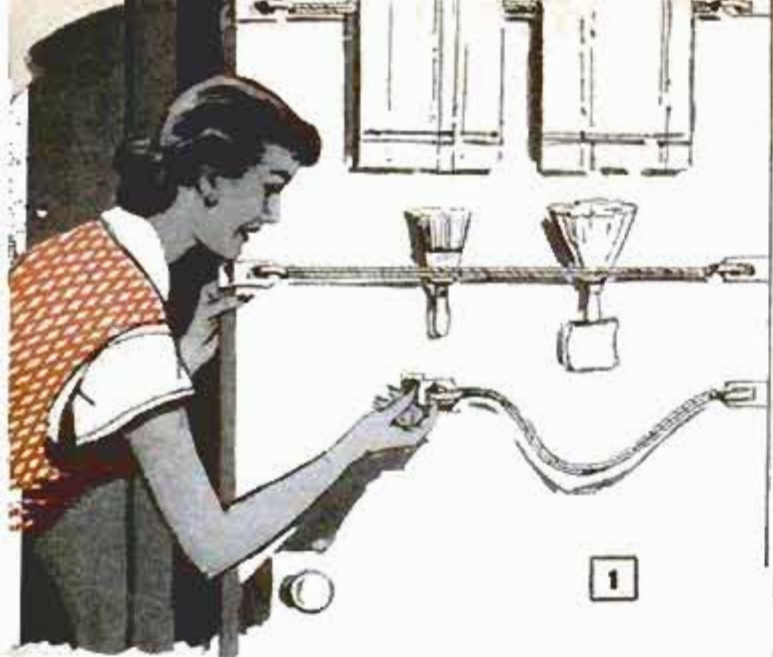

**1. CLIP-ON CORD** attaches to the edges of a door and is held in place by the tension on a double length of elastic line. The device can be used in the kitchen or bathroom or carried on trips for use in hotels or motels. The clip-on hanger will hold hosiery or other light garments after washing. Attached to a closet door, it can serve as a tie rack.  
Lecture Industries, 98-09 Metropolitan Ave., Forest Hills 75, N. Y.

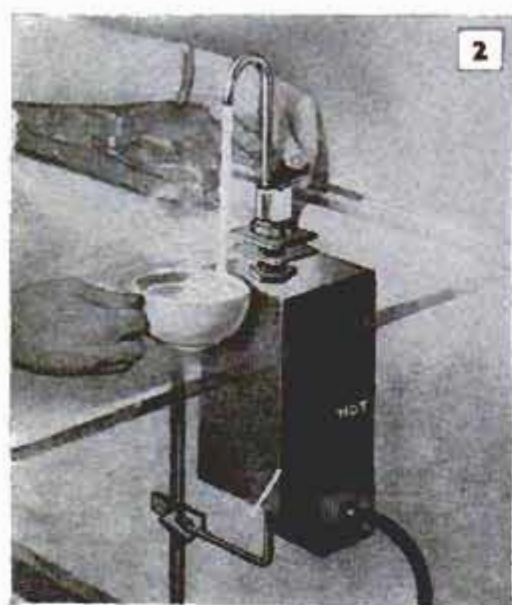

**2. NEAR-BOILING WATER** for preparing instant coffee, tea, soup or hot chocolate is constantly available from a two-quart unit that can be built into a kitchen cabinet. The tank, warmed by a 750-watt electric heater, can deliver up to 80 cups of hot water per hour. It refills automatically and a preset thermostat keeps the water at the desired temperature.  
Delta-T-Inc., 25 Canfield Rd., Cedar Grove, N. J.

**3. FLEXIBLE SHOWER ARM** can be adjusted to put the spray of the shower head at the proper height for the person using it. The chrome-plated flexible pipe is 24 inches long and fits all half-inch threaded shower arms. Your present shower head can be attached to the end of the flexible arm. The shower arm has a vinyl plastic lining to prevent leakage.  
Shur-Lock Home Products, 610 W. Willard, Kalamazoo, Mich.

**4. MEDICINE SAFE** provides a place to keep aspirin, sedatives and other drug supplies handy, yet safely guarded by lock and key. The all-steel box also can be used to keep razor blades out of the hands of small children. It has a baked white enamel finish and fits snugly in a bathroom wall cabinet. The box is 13 inches long, 5½ inches high and 3½ inches deep.  
H. S. Precision Products, Floral Park, N. Y.

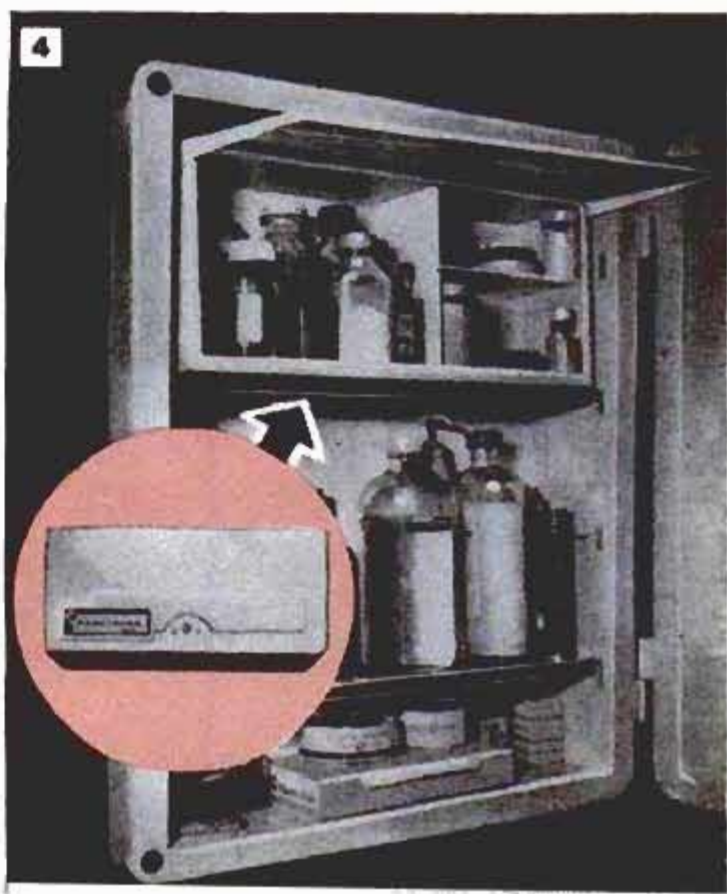
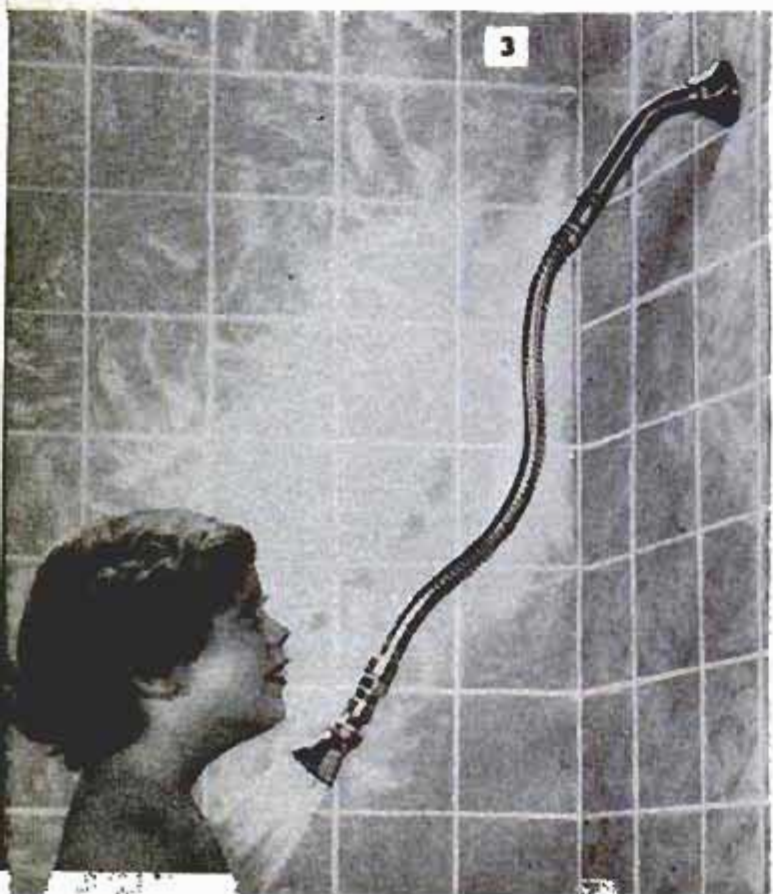





**5. RAIN DIVERTER** stops soil erosion at the bottom of the downspout by routing water to areas where it will do no damage. The galvanized metal device has two standard hose connections. It's available in models to fit either round or rectangular downspouts.

Neo Products Corp., Erie, Mich.



**6. BED VIBRATOR** converts any bed into a "tranquilizer" to relax people with taut nerves. The vibrating device and its electric motor are mounted on an H-shaped frame that replaces the bed slats.

Basile-Witz Furniture Ind., Inc., Waynesboro, Va.

**7. HELICAL SPRINGS**, for chairs with flat cushions, are encased in plastic. The plastic muffles spring noises and prevents rust when springs are used in outdoor furniture. The helical springs are stretched straight across the seat opening in parallel rows to form a flat spring bed.

No-Sag Spring Co., 21590 Hoover Rd., Detroit 13, Mich.



**8. WATER-POWERED VEGETABLE PEELER** is attached to the kitchen faucet. When the water is turned on, turbine blades on the bottom spin around, throwing the vegetables against the rough edges on the inside of the unit. The abrasive action scrapes off flakes of peeling which wash out as the water drains.

Reliable Labs. Inc., 3238 Fenkell Ave., Detroit 18, Mich.

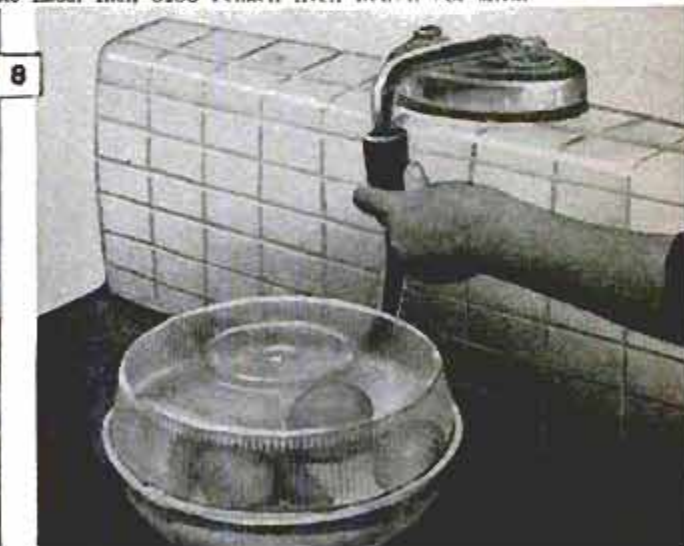



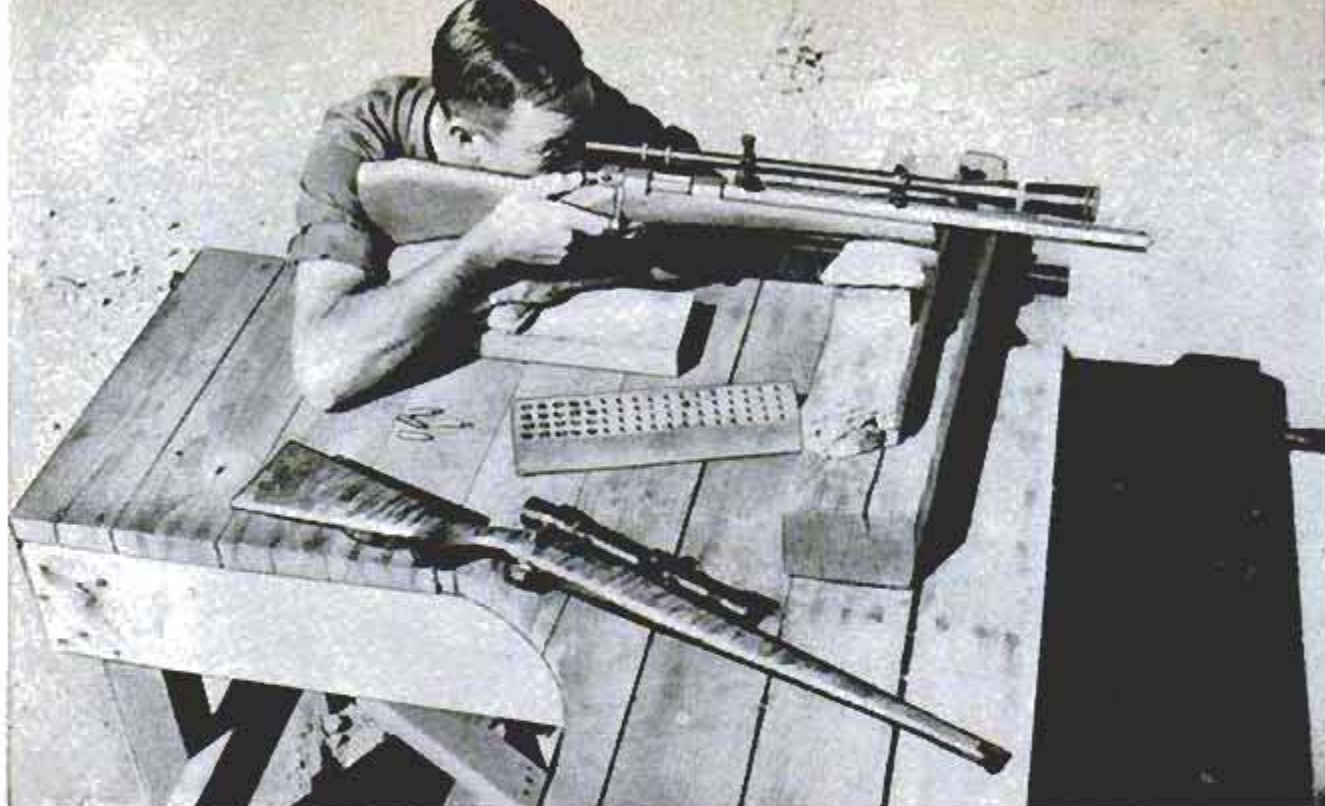

Paul Marquart, one of the two men who are producing the new "wildcats," tests a couple of the varmint rifles

## "Wildcat" Rifles Designed for Big Game and Varmints

TWO NEW "WILDCAT" calibers are stirring interest among gun enthusiasts. The rifles are believed to be the largest and the smallest sporting calibers made in America. The big rifle, a .475 Magnum, was designed for hunting Africa's biggest game.

Small-bore rifle is at left, big-game weapon at right. Wildcat calibers are built on older actions

It packs a four-ton wallop at a range of 35 to 50 yards, and will puncture  $\frac{3}{4}$ -inch steel plate at that distance. The little weapon is .17-caliber. It fires a 25-grain slug at 3759 feet per second and will down small game at 200 yards or better.

Here's penetration power of two calibers at 50 yards. Plate at left is  $\frac{1}{2}$ -inch steel, one at right  $\frac{3}{4}$ -inch

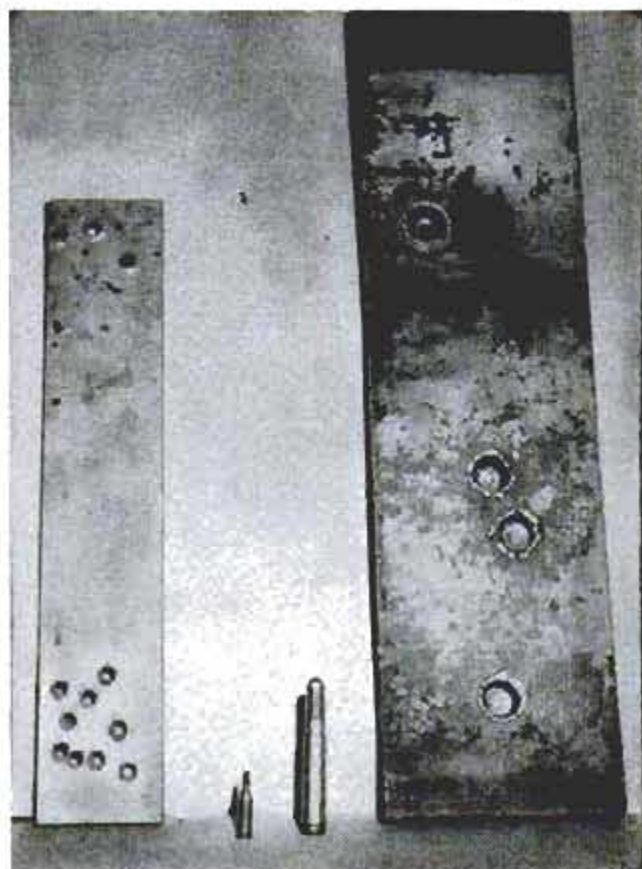



## Roaming Kitchens Teach Cooking

Thanks to a fleet of "kitchens on wheels," the Japanese are learning the latest American cooking methods. Eight buses are roaming Japan to promote the use of American wheat. Each bus is equipped with a gas stove, sink, refrigerator, kitchen utensils and a public-address system. The "tail-gate talks" reach 30,000 people monthly.



## Powder Dissipates Car-Radio Static

A powder that can be injected by the automobile owner into his auto tires is said by the manufacturer to dissipate static interference in the car radio.



## Roll-on Garden Grows on Concrete

Flowers growing on concrete? It's possible with a new "carpet" of artificial soil, chemicals and seeds. The mat, only a quarter of an inch thick, unrolls to cover an area one foot wide by 18 feet long. After it is in place, even on concrete, all that is

required is to water the mat to promote flower growth. In addition to the embedded seeds, the mat contains organic matter, plant foods, hormones, minerals and other growth stimulants. Each roll produces more than 30 different varieties of flowers.

TRADE NAME: FLOWERAMA

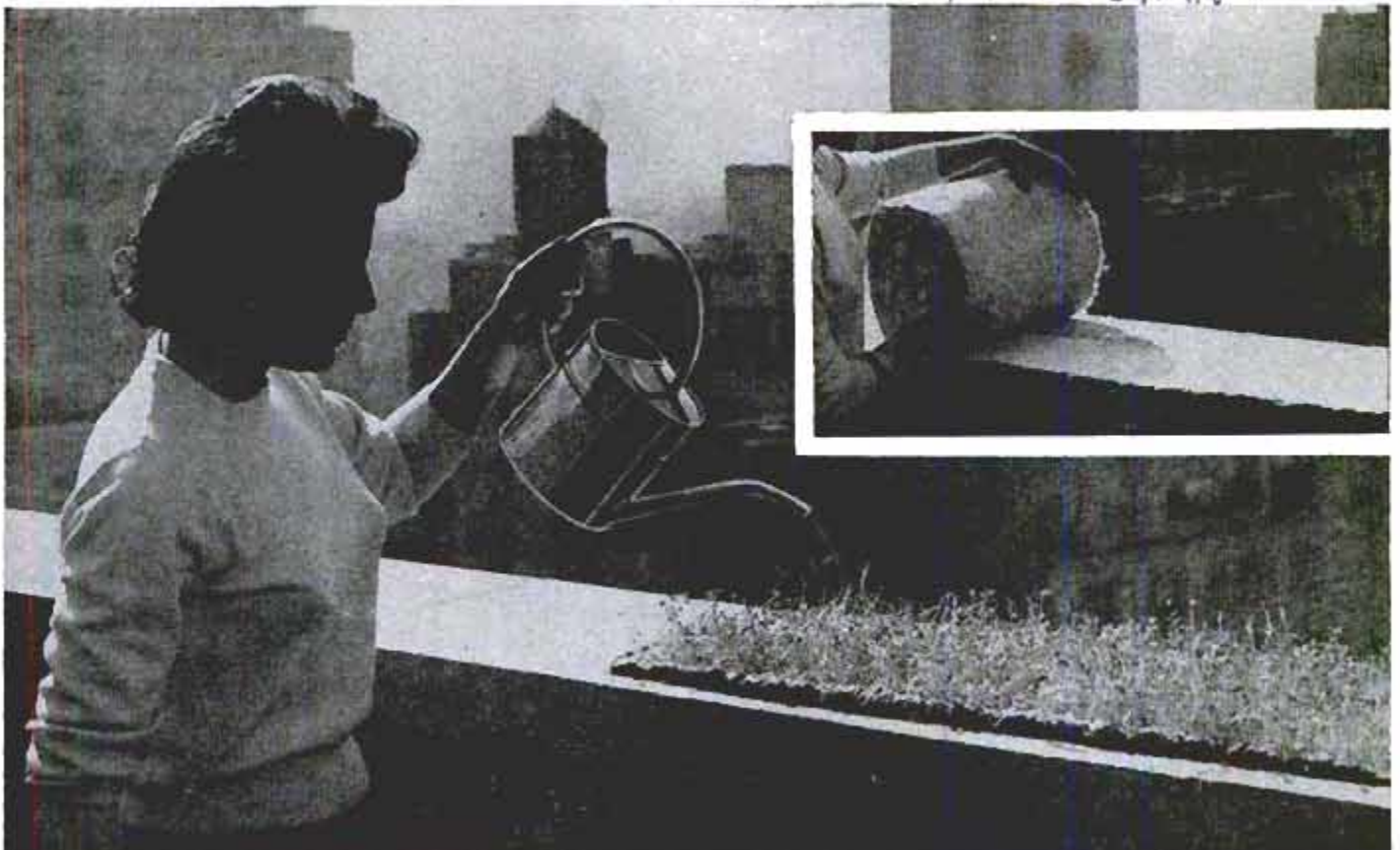



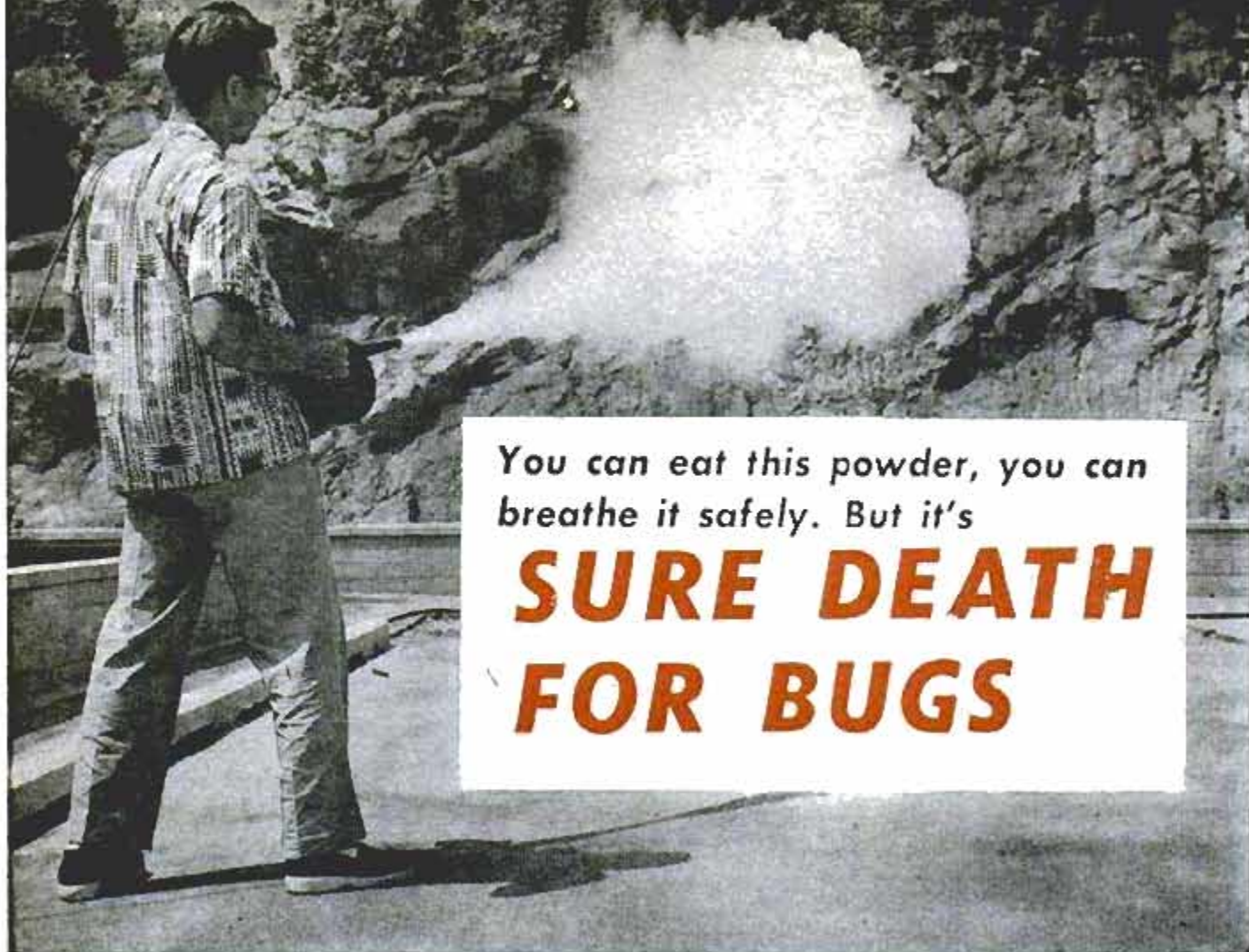

You can eat this powder, you can breathe it safely. But it's

## **SURE DEATH FOR BUGS**

Power duster, demonstrated above, will spread powder into attics to prevent dry-wood termite infestation

By Ewart Thomas

**A FLUFFY WHITE POWDER** that you can inhale or stir into your coffee in perfect safety is killing many household pests faster and more efficiently than the most poisonous insecticides.

The dust is sure death to ants, cockroaches, dry-wood termites and a variety of other insects. Yet, in spite of its lethal qualities, it is perfectly harmless to warm-blooded animals. It has been used for years as an ingredient in face powders, could even make a safe baby powder.

Recently in Los Angeles a homeowner was desperate over a swarm of cockroaches infesting his house. He had tried all the available roach killers without effect. As a last resort he phoned the entomology department of the University of California at Los Angeles and explained his problem to Dr. I. Barry Tarshis.

"It just happens we are studying a powder that is giving a 100 percent kill in the laboratory," Dr. Tarshis told him. "It isn't on the market yet but we can give you half a pound. Use a hand duster and spread it under the refrigerator and the sink and behind the stove. Don't be afraid of it; the stuff is harmless."

Seven days later not one cockroach could

be found in the home, and they haven't reappeared since.

What kind of miracle powder is this? It is a finely ground silica aerogel, an extremely fine and porous dust that has a great capacity for absorbing oil or water. It is inert and nontoxic. Yet insects that crawl across a film of the material shrivel and die. They actually dry up.

The powder has a physical instead of chemical action. Because of this, its discoverers believe that insects may never be able to develop a resistance to it, as has been the case with many insecticides.

The brand new technique in insect control is an outcome of studies started two years ago at UCLA under the direction of Dr. Walter Ebeling, chairman of the entomology department. The research was performed by Walter Ebeling and Robert E. Wagner who were working on pests of wood structures, by I. Barry Tarshis who was working on insects that annoy man and animals, and by Roy J. Pence who was working on pantry pests and insects that attack fabrics.

Dr. Ebeling had been interested to learn whether the way an insecticide is applied has any effect on its useful life. He was



working with dry-wood termites at the time, and he applied an insecticide in the form of a mist to a group of wooden test blocks, in the form of a vapor to another group of blocks, and as a dust to a third group. Seventeen months later Robert Wagner placed each group of blocks in separate control chambers containing dry-wood termites and watched the results.

Strangely, none of the insects that crawled over the blocks treated with the mist or with the vapor was affected by the poison applied to the wooden surfaces. Yet every insect that moved across one of the dusty blocks died soon afterward. More study showed that in all three cases the insecticide itself had decomposed with age and was no longer lethal. There was only one possible conclusion: In the case of the dusted blocks it was the inert diluent, the nontoxic powder used to give body to the insecticide, that was doing the killing.

The investigators found that dust is a killer because it adsorbs or disrupts the waxy film that covers an insect's body and normally prevents loss of moisture by evaporation. Without the protection of this lipid layer an insect becomes dehydrated and perishes. In many cases enough dust is picked up by its feet and transferred to its body to break down the protective layer. In several minutes or several hours, depending on type, the insects loses a fifth or more of its weight by evaporation and that's the end of it.

Of the many kinds of diluents that are used in insecticide dusts, the research group found that several highly sorptive natural clays and diatomaceous earths are quite effective killers.



Small hand duster applies film of silica aerogel under refrigerator to control cockroach infestation

Some of these extremely fine dusts are being used today to prevent new infestations of dry-wood termites. The dusts are not effective against subterranean termites or against dry-wood termites already established in a building; they are used in new structures to prevent infestation, and to prevent reinfestation in old structures that have been fumigated. From five to ten pounds of dust in an attic, enough to form a visible film on all surfaces, kills any termite that crawls through it.

#### Flies Can Avoid Dust

At present the powder doesn't appear to be equally effective against all household pests. Carpet beetles and clothes moths,

(Continued to page 218)



New dust also is being used against vinegar flies, in cages at left. Block of wood in wind tunnel tests adherence of dust to wood surfaces

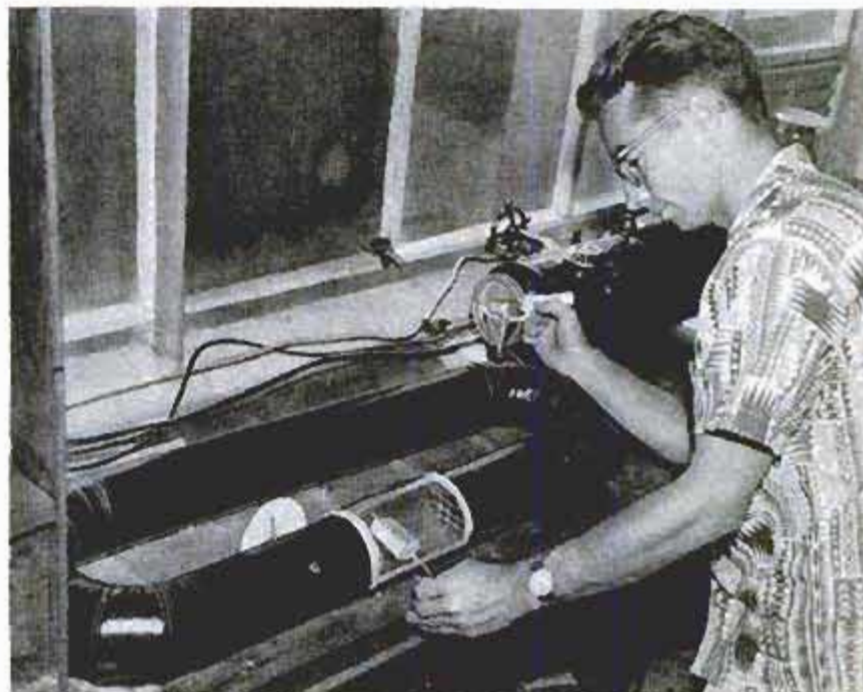



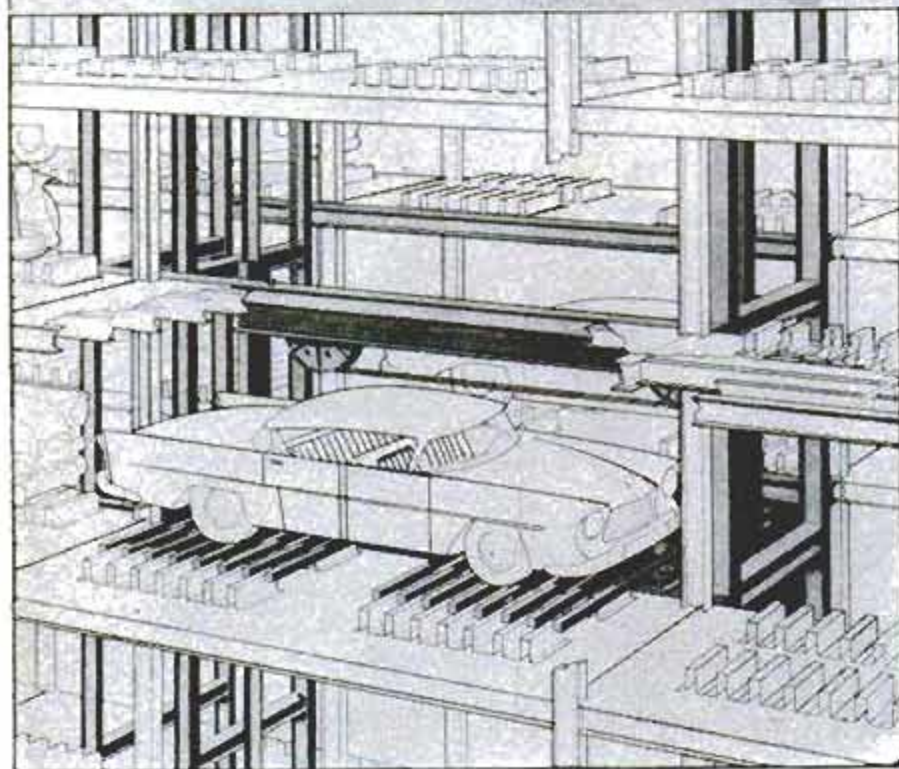
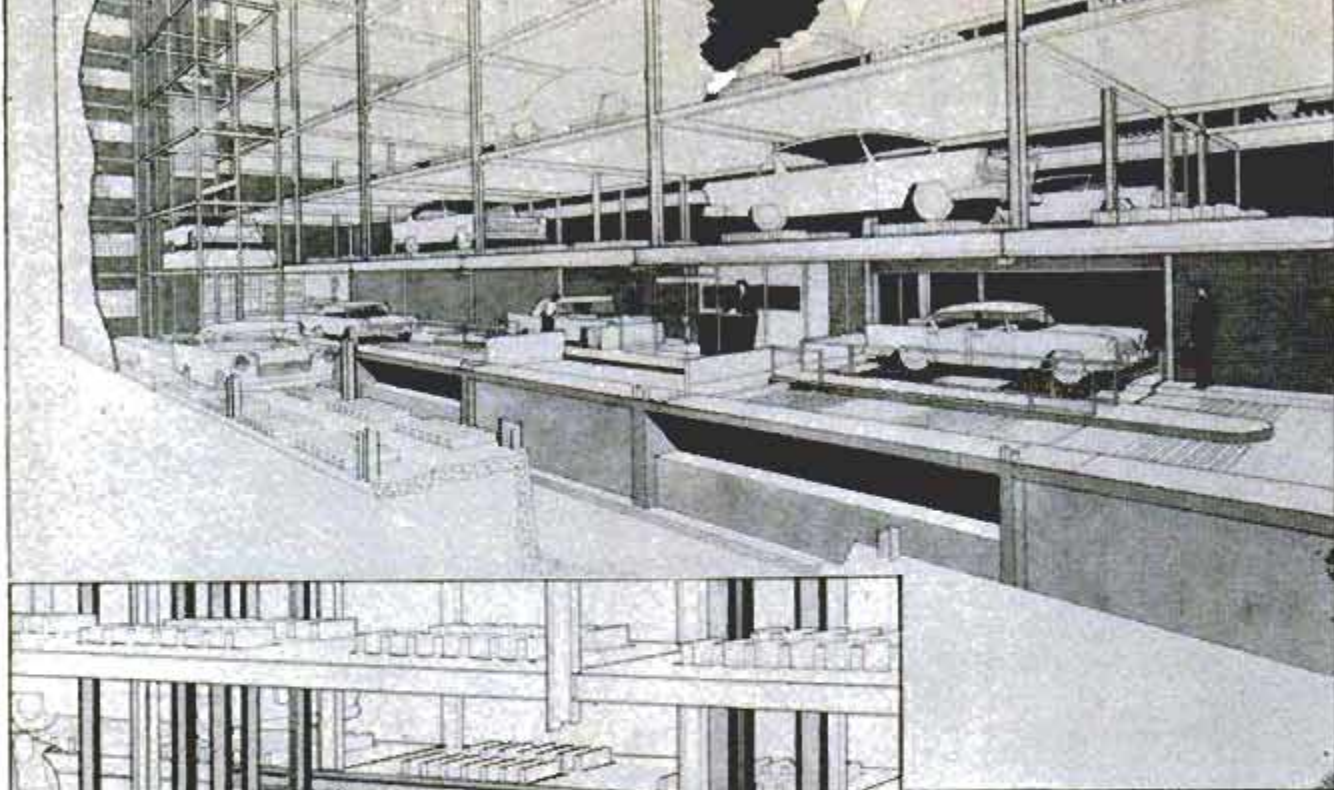

## Automatic Garage To Park 230 Cars

Though parking or discharging as many as three cars a minute, an eight-story garage in New York will need just one employee — a cashier. Cars will be left in ground-floor “lockers” that will be moved vertically and horizontally by elevator to an assigned space. The garage will house 230 autos.

## Hand Pump Raises Roof of Air-Tube Tent

Among the new tents that can be erected quickly, and without poles, is one that is supported by inflated rubber struts. The heavy-duty rubber tubes in the walls and ceiling are inflated with a hand pump which is supplied with the tent. The camper simply spreads the tent on the ground

and drives the metal stakes, also furnished with the tent, at the front, back and sides. Then, the tubes are pumped up and the guy lines are set. Four sizes range from 7 by 7 feet to 10 by 14 feet. The tent is made of fire-resistant material and has a sewn-in floor.





## Italians Build Most Economical "Car"

It may not be the world's fastest "car," but it certainly is the most economical. It is a four-wheeled vehicle (properly called a quadricycle, perhaps) that gets its power from its four riders. Built in Turin, Italy (a city famed for its fine cars), the vehicle has a top speed of about 22 miles per hour with all feet pedaling. Only the left-front rider steers. The steering gear is from an old Peugeot car.

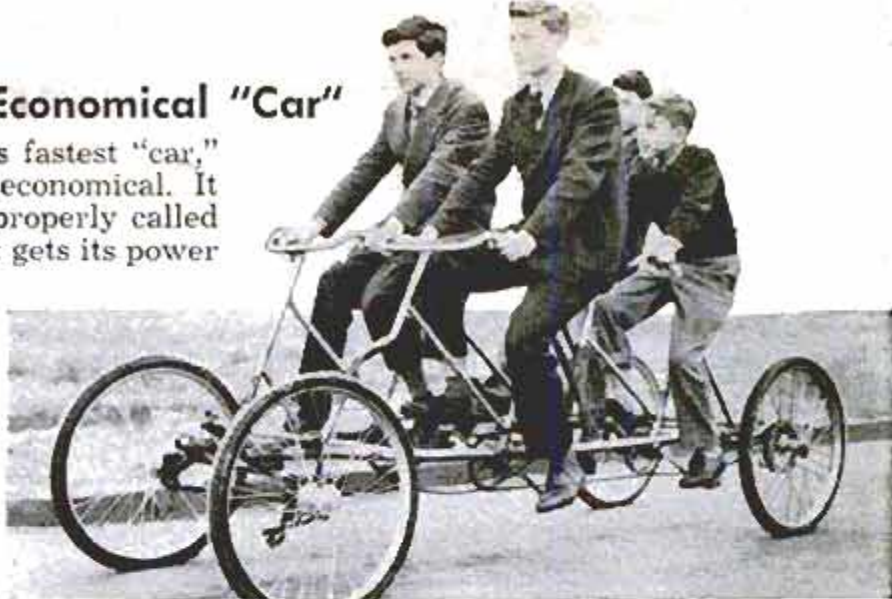

## Curtained Wall Cabinet Provides Space to Hang 16 Pairs of Shoes

If your extra pairs of shoes are getting in the way of the dust mop, you can find a solution in a wall cabinet manufactured in Germany. It holds 16 pairs of shoes. They are hung neatly on patented clips and can be removed with as little strain as it takes to pull down a window shade. Once a pair of shoes is taken out of the cabinet, the others can be covered for the day by closing a draw curtain.



## Blank Cartridge Fires to Warn Truck Driver Tire Is Going Flat

To help truck drivers prevent damages due to running on soft tires, a company in Denver, Colo., offers an alarm device that fires a .32-caliber blank cartridge. The device mounts on the inside of the rim and "feels" the tire's air pressure through a small opening. When the tire loses air, the

tire flap no longer holds the pressure pin in front of the firing pin and a powerful spring drives it into the cartridge, firing the blank charge. The loud bang is heard by the truck driver who can correct the trouble before the tire becomes seriously damaged.

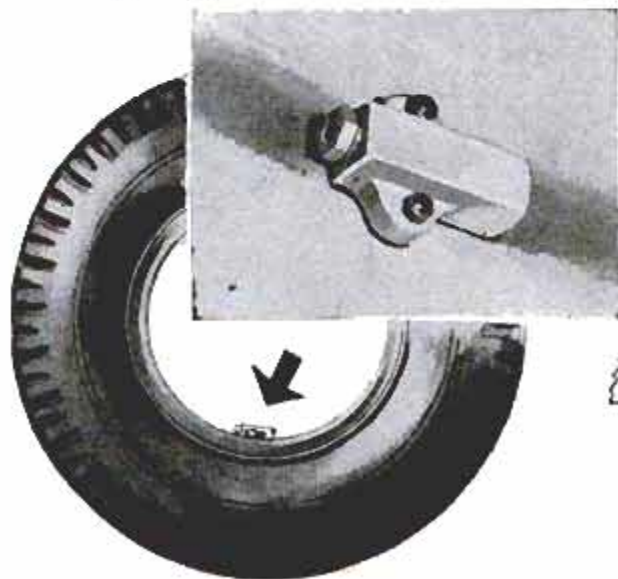

Tire flap (1) holds pressure pin (4) in front of firing pin (3). When air pressure drops, spring drives pin into blank (5). Left, closeup of warning device

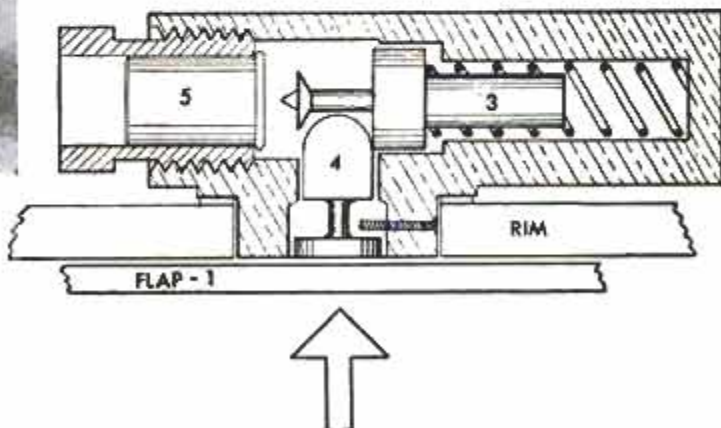



# FREE ENERGY IN THE SKY



Multiple-exposure photo of radiation glow when released nitric oxide merged with free atoms of oxygen

By Michael Gladych

**YOU CAN GET something for nothing** is no longer just the spiel of confidence men. A group of Air Force scientists has proved that the idea is legitimate. A small research ramjet missile called HARE, groomed at Rensselaer Polytechnic, New

York, may soon be flying around without a drop of fuel and remain flying as long as there's oxygen in the air.

Of course, there will be a cost for the rocket that launches this fuelless jet into the upper atmosphere. But once there, the

Diagram shows how oxygen molecules split into free "hot" atoms of oxygen after they absorb heat energy

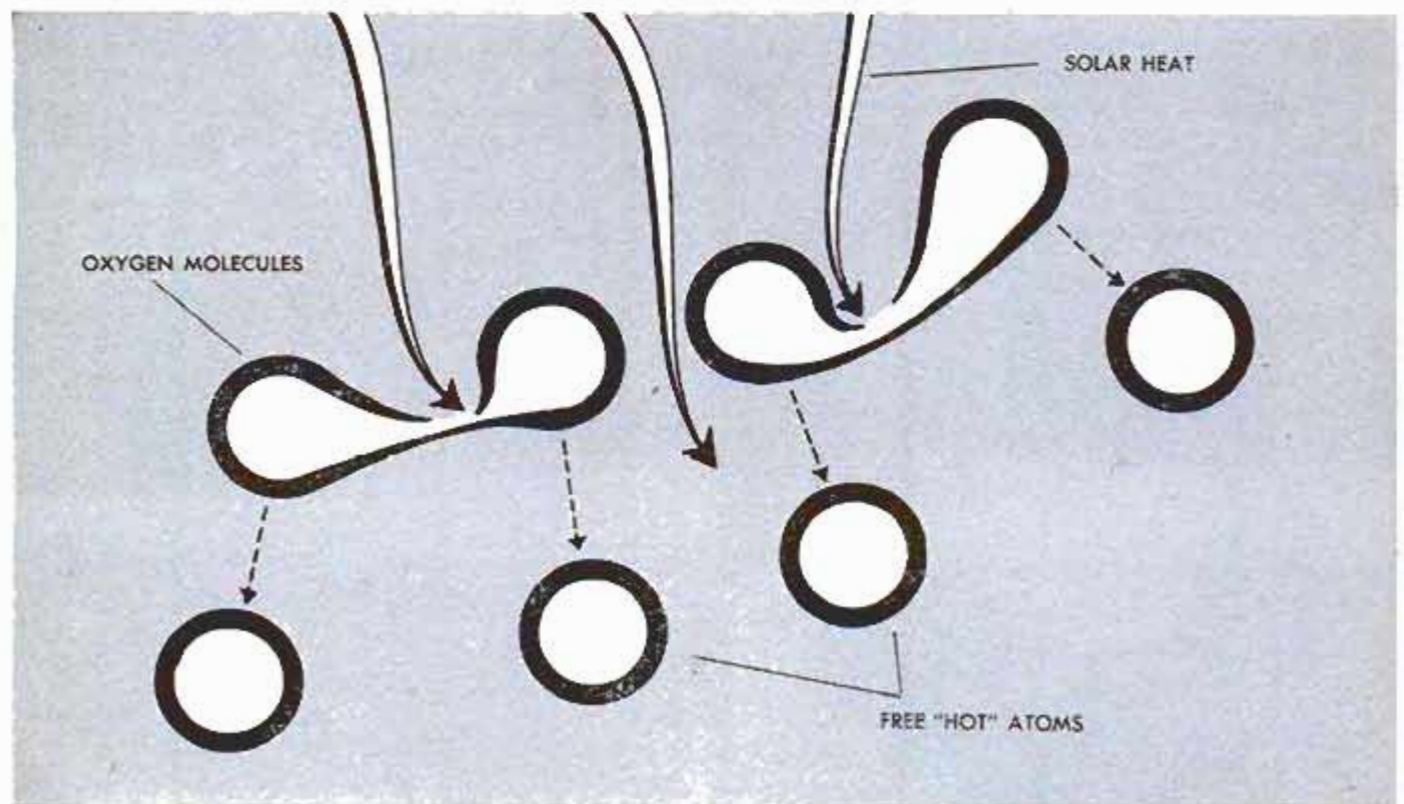





**HARE discoverers: (From left) Dr. Murray Zelickoff, Dr. Frederick Marmo, L. Aschenbrand, Jerry Pressman**

HARE will fly at twice the speed of sound, and forever if so desired.

HARE stands for High Altitude Recombination Energy—a scientific name for a most ingenious trick. As you know, an ordinary jet engine guzzles barrels of fuel for one reason only—to heat up the air sucked in through the air intake. That hot air expands, swooshes out the tail pipe and thrusts the jet forward.

There is no free fuel 60 miles up where the HARE missile will fly, but there is free thrust-producing heat energy, if you know

how to tap it. The men who puzzled out the HARE idea are Dr. Murray Zelickoff, Dr. Frederick Marmo and their associates, Jerry Pressman and L. Aschenbrand. They are scientists at the Geophysics Research Directorate of the Air Force Cambridge Research Center, Bedford, Mass.

This is how they did it: For years, scientists have known that we were not getting all the heat energy that the sun put out. Scientific sleuths had a shrewd theory about this. Some of the sun rays hitting the upper atmosphere, they thought, were

**Drawing of HARE jet, which will be launched by rocket. It has been successfully tested in laboratory**

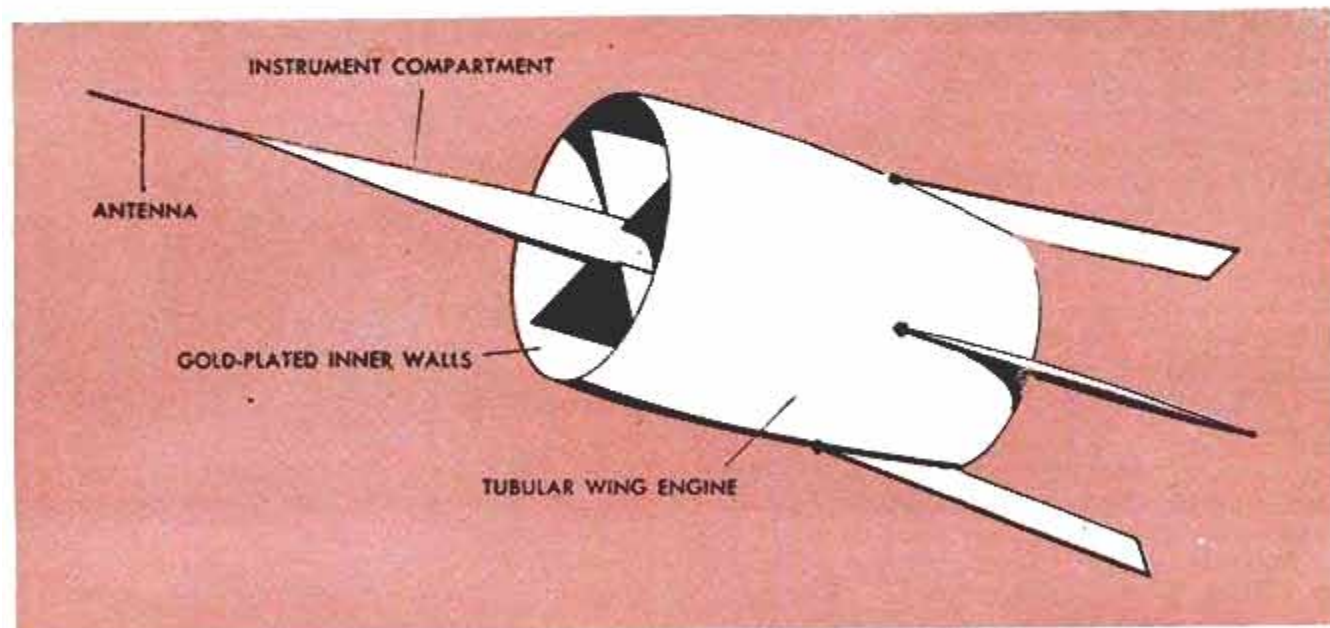



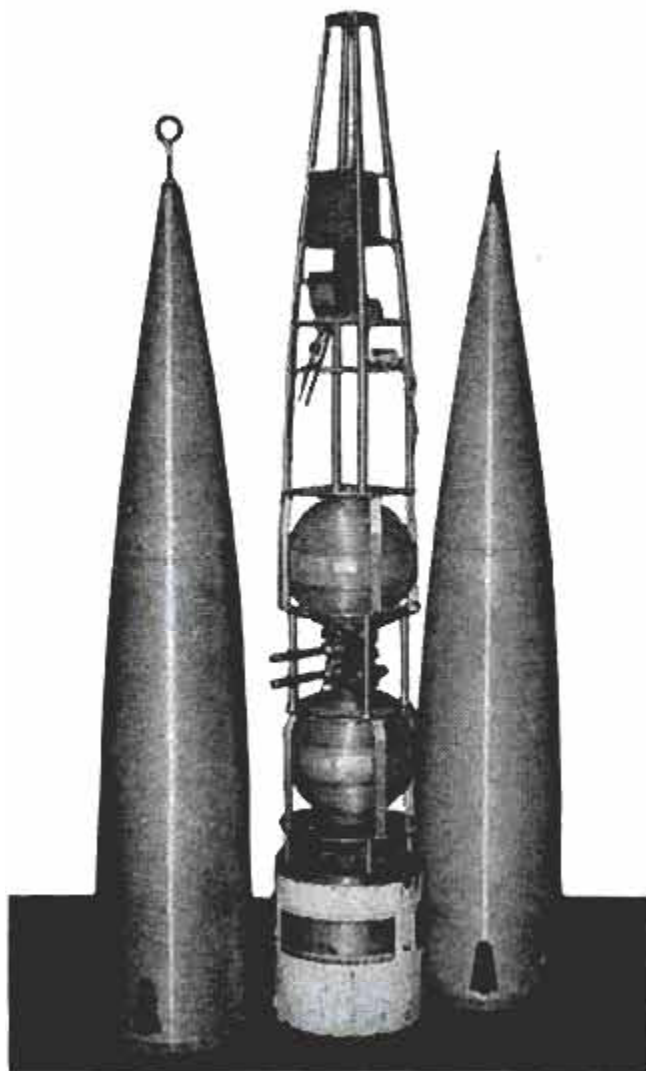

Nose cones of Aerobee rocket flank the apparatus that released nitric oxide at altitude of 60 miles

waylaid by oxygen molecules. After absorbing the solar heat, the molecules split into so-called free atoms of oxygen. Now, if it were possible somehow to get those free atoms into the very thin air and knock them together, they would recombine into molecules again and give out the stolen heat. (See drawing, bottom of page 106.)

To test this theory, Dr. Zelikoff and his colleagues sent up an Aerobee rocket with 20 pounds of nitric oxide to the altitude where the free atoms were supposed to be. If there were any free atoms of oxygen around, the nitric oxide would seize them, turn itself into nitrogen dioxide and give out reddish-yellow radiation glow that could be seen from the ground.

The Aerobee blasted off and the scientists scanned the dark sky with their cameras. A short while later they saw that when the nitric oxide was released at about 60 miles up, there was a glow almost as intense as moonlight.

Once the theory was proved, Prof. Paul Harteck of Rensselaer Polytechnic moved in with a suitable jet design. His "bird" would scoop the high-altitude air, recombine the free atoms into molecules and use the released heat to expand and blast the same air out of its tail pipe. Professor

Harteck's HARE jet will look like a coleopter, which is a fancy name for a flying stovepipe. (See drawing, bottom of page 107.) The HARE is simply a wing airfoil bent tip-to-tip into a ring or a tube. This tubular wing will give the necessary lift to keep the HARE aloft. It works the same as a rounded-out box kite. The inside of the airfoil tube will act as a jet engine.

The HARE will be rocket-launched, which means it will have considerable forward speed to begin with. The free atoms will be scooped up, and to help them get together and release their stored-up heat energy, the inside of the wing-engine will be gold-plated. Gold, explains Prof. Harteck, has a peculiar knack for getting free heat from the free atoms. As the free atoms recombine, the air inside will heat itself to 550 degrees centigrade. Of course, it will expand and, plugged on one side by the scooped cold air, it will shoot out the back and push the HARE missile along.

The HARE jet model has already been tested in the laboratory and it performs well although there is one drawback—its size. Since the oxygen atoms at an altitude of 60 miles are few and far between the thrust produced at best would be less than one pound. Since the thrust necessary for a jet fighter is about 10,000 pounds, you'll see why the HARE must be whittled down to midget size and featherweight.

Prof. Harteck refuses to speculate on the future offspring of his experimental HARE. At the moment it's merely a research tool and it doesn't matter how small it has to be. But Dr. Marmo thinks that as soon as the little HARE starts chasing the free atoms around the sky, there may be a way of making it larger. "If you look at the small HARE as a 'module,'" he says, "we might be able to join them together like a honeycomb into a sizable craft."

This larger HARE may be able to carry a payload of scientific instruments. It may be used to help the intercontinental ballistic missile score a bull's-eye by radar-nudging. It may make weather forecasting a safer bet by scanning the weather below and sending the information down by radio.

In case you are thinking of free trips for all on HARE airliners of the future, here is disappointing news. The scientists don't think that a HARE jet can ever be built large enough to carry a man. And no matter how large, the HARE will never put the jet-fuel merchants out of business. There are no free atoms of oxygen at low levels. The pressure of ground level life is too much for them and they stay hitched in docile and heatless molecules. So, HARE is good only between 60 and 70 miles up—probably the only place in the world where you can get something for nothing. ★ ★ ★



# He Built a Hatchery for Catfish

TO STOCK HIS quarry lakes, 86-year-old Bert Ross of Ottawa, Kans., built a hatching machine that produced 70,000 catfish in 1957. He expects that total to be tripled in 1958. The machine, which cost Ross and his son Harold about \$500 to build, has eight wire mesh egg boxes that nest in a tank filled with lake water. Each box has a paddle simulating the actions of a fish tail. A 1/4-horsepower motor operates the paddles and keeps the water circulating constantly during the hatching process. Down at a nearby lake, a 1/2-horsepower motor is used to pump the water into the machine. A morning and evening check on the machine is all the supervision that is necessary.

## Feeds 'Em Dry Buttermilk

The newly hatched channel cats are fed dried buttermilk and finely ground, specially made chicken feed for two weeks. Then they are placed in natural ponds, where they fight off their enemies and grow to a length of five inches by September. Ross calls the tiny fish to "dinner" at 7 a.m. and 6 p.m. each day by beating on an iron drum near the water's edge. As they respond to his call, he sprinkles the chicken feed in the pond.

## Gets Eggs With Milk Cans

He gets eggs for his hatching machine by placing large milk cans on the bottoms of ponds known to have channel catfish. He and his son check the cans every three days. The eggs they find in the cans are carried to the hatchery and deposited in the tanks. Seven to nine days later, heads and whiskers appear, connected to an egg sack that is soon absorbed by the cats as food.

Ross considers a 60-percent hatch normal, but is able to score 95 percent in 45 to 85-degree water. He likes to concentrate on channel catfish because the demand for them exceeds the supply. They earn about 15 cents apiece for him.



Bert Ross's channel catfish are hatched in wire boxes. Later he moves them to natural ponds and feeds them twice daily

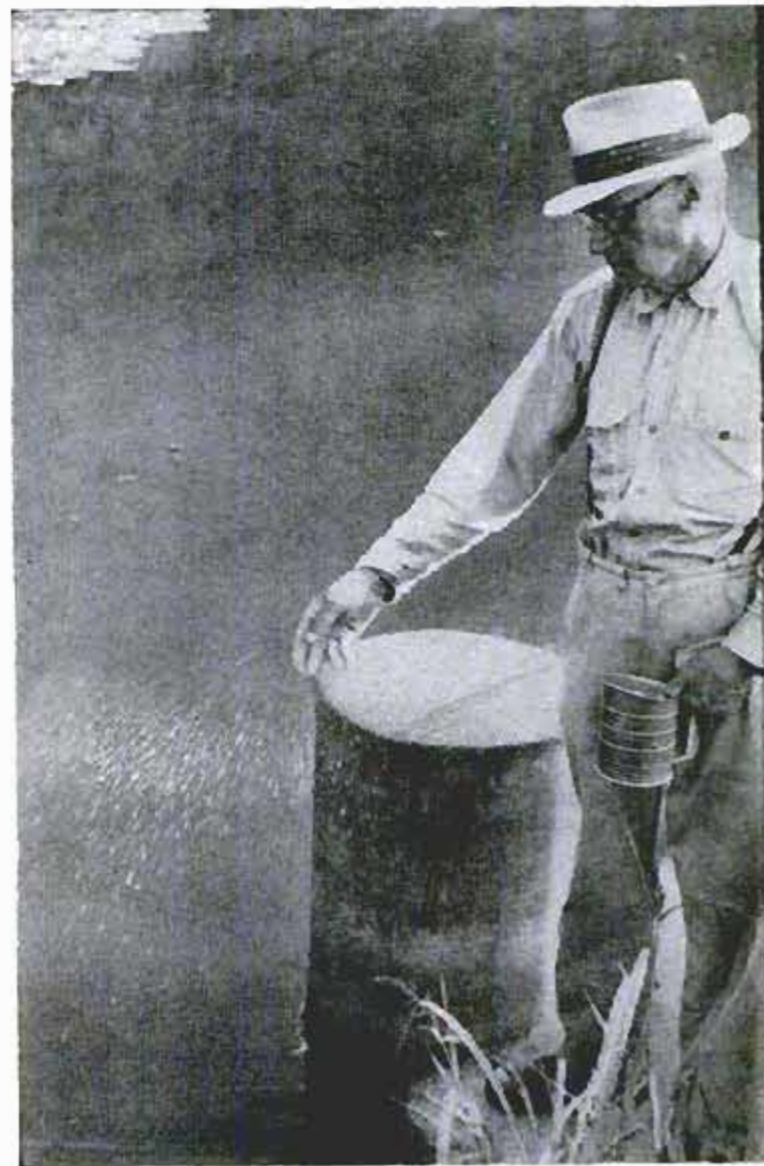



Reprinted from...



Fangio holds up "rookie" stripes (see photo page 113) after passing driver test at Indianapolis Speedway

# Fangio Talks

about the Indianapolis 500 and European Grand Prix racing. Arthur R. Railton, *PM* Automotive Editor, interviews the World's Champion racing driver from Argentina and his manager, Marcello Giambertone.

Railton and Fangio look over *Mecanica Popular*, *PM*'s Spanish edition that the champion reads in Argentina. The interview was held in New York's St. Moritz hotel



**QUESTION:** Mr. Fangio, would you like to explain, for the record, why you did not race at Indianapolis?

**FANGIO:** I would like to have raced there, but I must have a good car and the training necessary to drive a good race, to be able to compete with the best drivers there. I must have a chance to win, at least.

**Q:** Then there were two reasons: One, the lack of sufficient training time on the track and two, the Dayton car was not fast enough. Is that right?

**FANGIO:** Yes. Actually, it was only after I tested the car that I found out it did not have a very good background. I had to drive it on the track to find out.

**GIAMBERTONE:** We didn't go to Indianapolis to race. We only went there to test the Dayton car to see if we would race.

**FANGIO:** With that car I didn't have a chance.





Photo by D. M. Bartley

Fangio won the 1957 Cuban race in this Maserati. During the '58 race, he was kidnaped by the revolutionists

**Q: How old is the Dayton car?**

**GIAMBERTONE:** This is its third year. It ran in 1956, in 1957 and again in 1958. It's an old car. All last year it was stored in a wooden shack.

**FANGIO:** They told me they would change the engine and perhaps the car would go faster. Maybe yes, maybe no. They didn't know because they never tested the engine on the bench. They were going to assemble it and install it in the car. But it was too late to change engines.

**Q: How fast did you drive the car?**

**FANGIO:** I drove it 142 miles per hour while the other cars on the track were making 146 and 147. It didn't have a chance.

**Q: Did you have enough training time?**

**FANGIO:** I was in Indianapolis 15 days but I only had two days of training.

**GIAMBERTONE:** We arrived on May 4th. He made 12 laps in the morning, 14 in the afternoon. The car wasn't doing too well. It rained on the 5th and 6th. On the 7th he made eight laps and the car stopped. Something was wrong with the carburetor. Later he went about 30 laps before taking his driver's test. On May 10th it ran beautifully in the test. He made 10 laps at 115 miles per hour, 10 at 120, 10 at 125 and 10 at 130. The race officials were enthused about the precision of Fangio's driving during his test.

**Q: Do you think, Mr. Fangio, that the rules are unfair to new drivers?**

**FANGIO:** No, they are fair. The driver's test they give is very well done. I have no criticism of the test or the procedures. Everything is very well organized. They

take more precautions at Indianapolis than anywhere I have ever driven. It is the safest of all tracks both for the driver and the public. There are 33 cars in a small circuit and they have to make the best possible selection of cars and drivers. And they do.

**Q: How do you like the Indianapolis track itself?**

**FANGIO:** It is very good for speed.

**Q: Does it require a lot of training to drive it well?**

**FANGIO:** Yes, it takes a lot of time. At least 15 days of practice driving, one after the other. The other drivers helped me a great deal during my training period.

**GIAMBERTONE:** They were very kind to us. We want to thank everyone for the hospitality at Indianapolis.

**Q: What is the hardest thing to learn about driving at Indianapolis?**

**FANGIO:** The confidence you must have in your car to go into the curves fast.

**Q: Is this something psychological?**

**FANGIO:** Not psychological, but mathematical. Once you learn, it is like running on a rail. After that, it's easy.

**Q: Does the Indianapolis race require more endurance for the driver than a Grand Prix race?**

*"I would like to come back. But if I don't have a chance to win a race, I shouldn't be in it."*







*"Courage is not the important thing. You have to know how to figure your speed and how to go safely into a curve. I don't think of auto racing as going into a battlefield or challenging death."*

**FANGIO:** I don't know, but 200 laps at Indianapolis must be very hard on a driver.

**Q:** Would the closed circuit at Indianapolis be monotonous to the driver?

**FANGIO:** I've never raced at Indianapolis, but I don't think it would be monotonous for the driver. It might be monotonous for the public, but not for the driver.

**Q:** Do you think any European car could win at Indianapolis?

**FANGIO:** No. For Indianapolis you need a specially made car.

**GIAMBERTONE:** We are very grateful to Crawford, Bryan and other drivers who gave advice to Fangio. They taught Fangio how to go around corners. He was going around them like they do in Europe, accelerating. Here it's different. If you accelerate while going around a corner you go off the track. You can't race here the way they do in Europe. I doubt if a European could win this race even with the best car. The Indianapolis driver starts racing on a dirt track and learns to drive around curves without accelerating. At Indianapolis Fangio, in spite of being the world's champion, had to learn all over again.

**FANGIO:** These Indianapolis drivers start on small dirt race tracks. Later they go to bigger races and finally to Indianapolis. The Indianapolis race driver is highly specialized.

**Q:** Will any Europeans come to Indianapolis and race?

**FANGIO:** I doubt it. But anyone who does come will have to come with plenty of time to learn.

**GIAMBERTONE:** Let me explain it this way: Fangio is like a general practitioner

who treats general ailments of the body. He does everything. You wouldn't go to him if you had a heart ailment, you'd go to a heart specialist. These Indianapolis drivers are "heart specialists" in racing. If they had to drive in Europe's Grand Prix, they wouldn't be able to do anything.

**Q:** Did you have a language problem because you don't speak English?

**GIAMBERTONE:** No. We had a friend with us who speaks English well. And there is something else: International racers have their own special language. They understand each other with their eyes.

**Q:** Would you like to come back to Indianapolis and race with a good car next year?

**FANGIO:** From now to next year is a lot of time, but I would like to come back. But if I don't have a chance to win a race, I shouldn't be in it.

**Q:** Did the Dayton group invite you to race in its car?

**FANGIO:** Of course. They told me the car had 420 horsepower, that it was the best car available there. So I came over to try out the car with no strings attached. I told them that if what they told me was true, I would race. I don't want the best car in the race, but I do want one that will at least give me an even chance.

**GIAMBERTONE:** The car owners are fine people, but they are not professional racing people. They are in the foundry business. They have a mechanic who had never been at Indianapolis before. He is a "midget racing" mechanic. Fangio drove the car 218 laps and found out it wasn't good enough so he didn't race.

**Q:** What is the difference between an Indianapolis car and a Grand Prix car?

**FANGIO:** Well, to begin with, the Indianapolis car has no gearshift. It isn't necessary. And the brakes are almost unnecessary. They are used very little. European cars have as many as five gears. There are a lot of curves to go around. The cars have to be able to go this way and that way, to the right, to the left. At Indianapolis it is all to the left.

Champion Fangio won the 1957 Sebring 12-hour race in the 4.5 Maserati. His arms are muscled like a boxing champion's  
Photo by D. M. Bartley





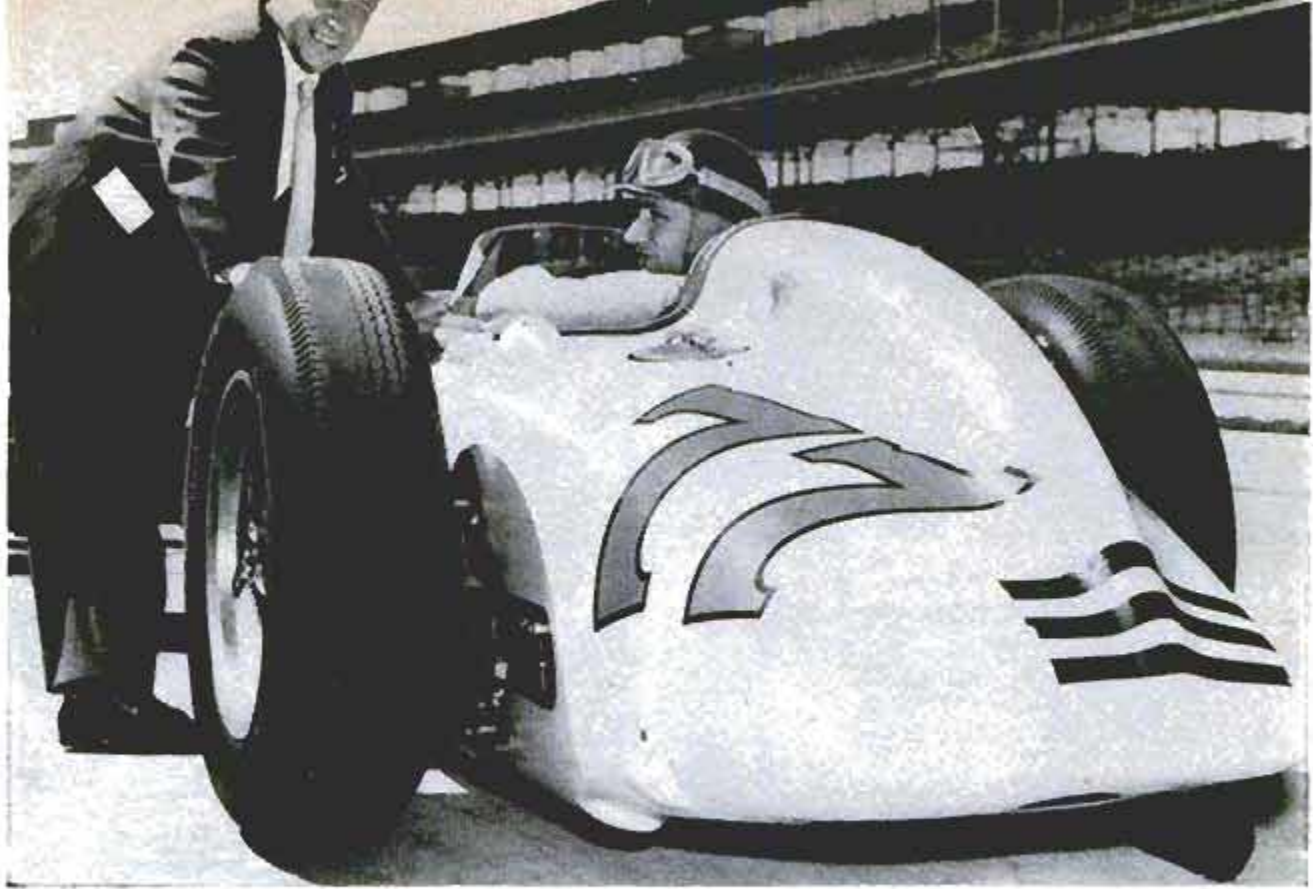

Giambertone, Fangio and Dayton car. Stripes on tail mark Fangio as "rookie" (first time at Indianapolis)

**Q: What about the engines?**

**FANGIO:** The Meyer and Drake is good for Indianapolis but it wouldn't be very good in Europe. First of all, the formula in Europe is 2½ liters, this engine is too big. And the European engines have to go through gears so they develop more revolutions. They go up to 8000 and 9000 revolutions per minute. The Indianapolis engines get only up to 6000 or so.

**Q: Does anything worthwhile come from auto racing? Is racing worth the risk?**

**FANGIO:** I think there are more engineering developments from Grand Prix racing than from Indianapolis. After all, Indianapolis is a round-and-round race. It isn't like normal driving where you stop, turn right and left. Nowhere does the public use a car as it is used in Indianapolis. Once the driver has learned the trick of making the corners it is almost like a straightaway.

**Q: Why do you think Americans have more interest in the round-and-round race than the Grand Prix type?**

**FANGIO:** I think it is because this way the promoters can charge a fee to everyone who watches the race. It's a matter of business.

**Q: What percentage of the victory depends on the car, what percentage on the driver's skill?**

**FANGIO:** Seventy-five percent is the car, 25 percent the driver. When you become famous, the companies offer you the best car to drive so it is easier to win because 75 percent is the car.

**Q: What type of person makes the best driver?**

**FANGIO:** Any type. We are all the same. What is needed is a lot of training and running in many races. Nobody is born knowing how to race, nobody is special.

**Q: Of all the cars you have raced, which one did you like the best, which had the best "feel?"**

**FANGIO:** The Mercedes I raced in 1954 and 1955.

**Q: How important is bravery to a driver?**

**FANGIO:** Courage is not the important thing. You have to know how to figure your speed and how to go safely into a curve. I don't think of auto racing as going into a battlefield or challenging death.

**Q: There is talk of banning racing here because of the accidents. Do you think races could be made safer?**

**FANGIO:** They are taking the necessary precautions, especially at Indianapolis. When the necessary measures are not tak-

(Continued to page 198)

*"This is my last year. This year I am only racing to satisfy a few commitments. I am too old. I am semi-retired."*





See Nov 58, p. 10

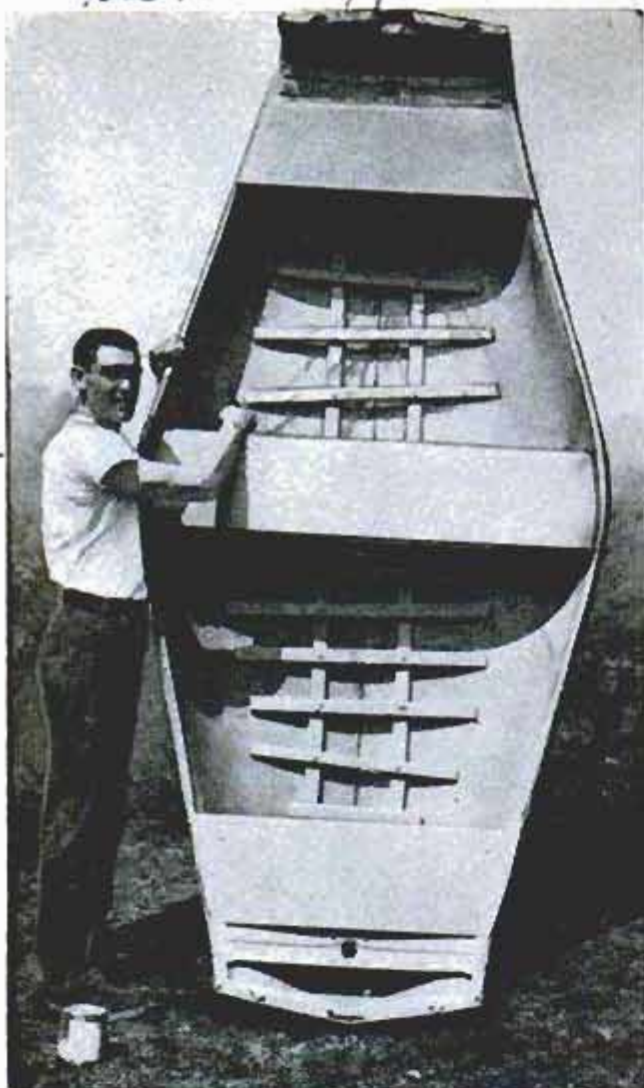

### Boat From Car Hoods

Welding together two 1948 automobile hoods, Ohio Highway Patrolman Charles Beverage produced a nine-foot boat for fishing and duck hunting. Cost: \$12.

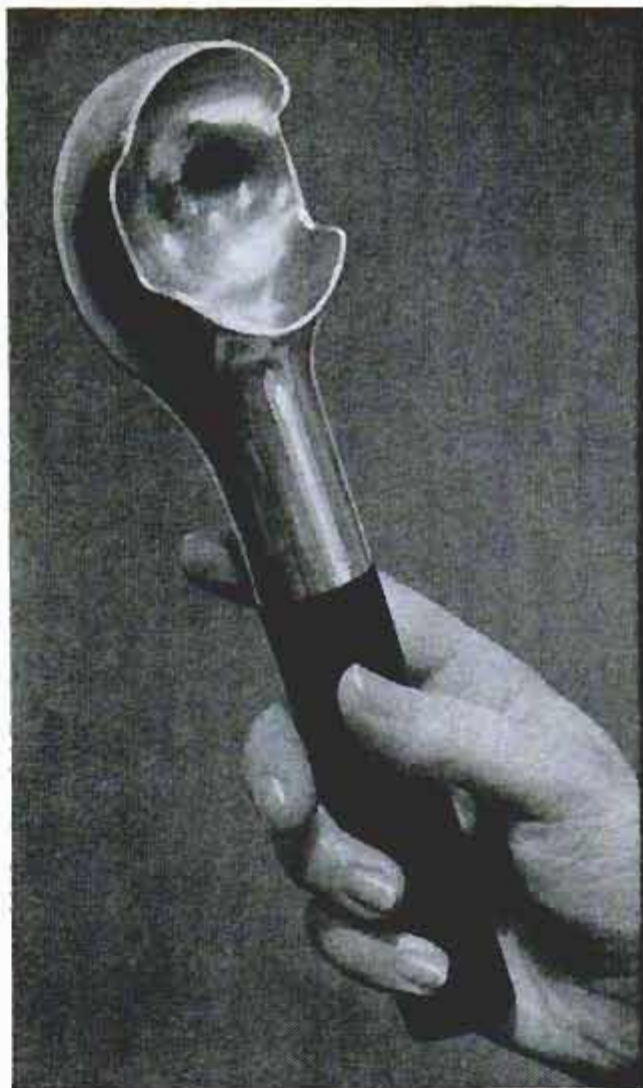

### Ice-Cream Scoop Has Built-in Heat

To prevent ice cream from freezing to the metal, a streamlined scoop has a heat-retaining liquid sealed into its aluminum head. The liquid stays at room temperature.



### Pair of Dollies Lift Big Appliances

Twin dollies make it easy to move heavy appliances away from the wall. Made of channel steel, the dollies have flush brass rollers at the wall end and a pair of rubber-wheel ball-bearing casters at the front end. The appliance has to be raised only three fourths inch in order for the dollies to be slipped underneath. The front caster body is equipped with a rubber bumper that prevents injury to painted or porcelain cabinet finishes. A lifting bar is part of the kit.



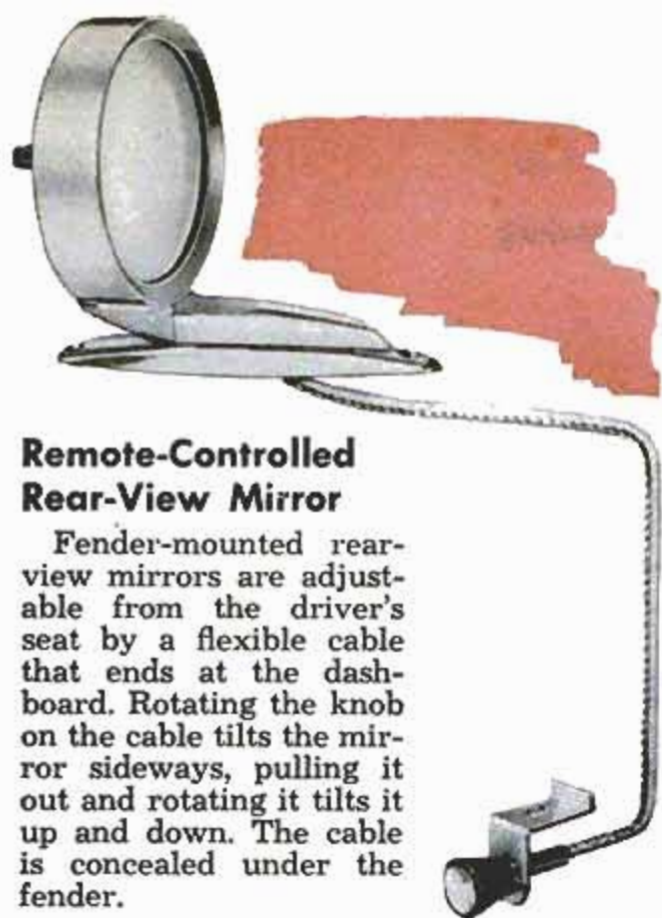

### Remote-Controlled Rear-View Mirror

Fender-mounted rear-view mirrors are adjustable from the driver's seat by a flexible cable that ends at the dashboard. Rotating the knob on the cable tilts the mirror sideways, pulling it out and rotating it tilts it up and down. The cable is concealed under the fender.

### Lip Tattoo for Livestock Applied With Special Gun

Farmers and ranchers can now stamp a permanent identification mark on the upper inside lip of livestock with a special tattoo gun. Number dies are set in the recoil gun and the animal's lip is swabbed with a local anesthetic. Pulling the trigger releases ink-coated needles that press the tattoo mark on the drug-numbered lip.

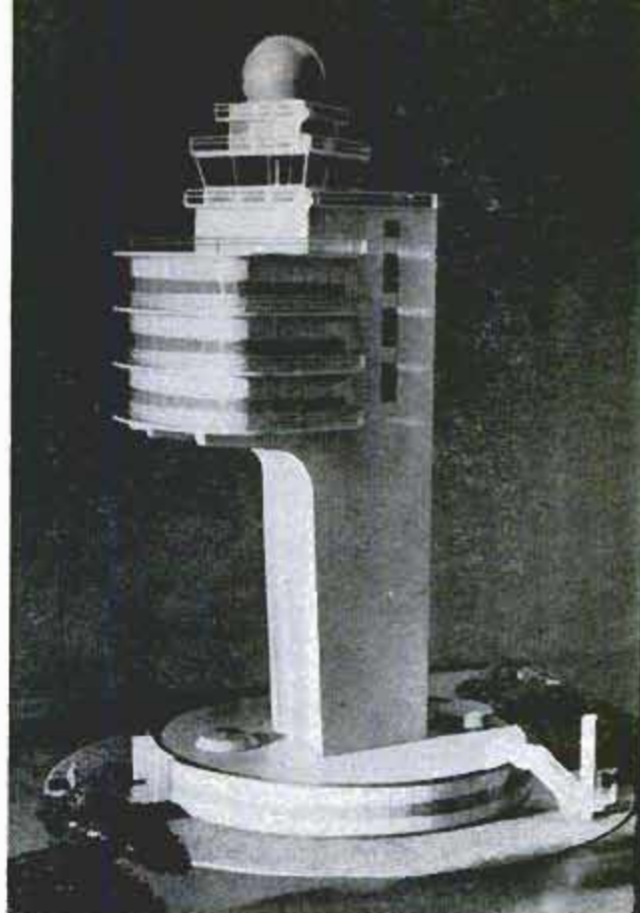

### Ultramodern Control Tower Will Be 150 Feet High

Newark Airport's new control tower will cost \$1,750,000 and will be 150 feet high, twice the height of the present tower. A concrete shaft, enclosing an elevator, will extend 117 feet upward. At the 65-foot level will be three floors of offices, and atop the tower will be the control cab and equipment rooms.

### ← Rubber Hose Opens Garage Door When Automobile Passes Over

Driving over a section of rubber hose with your car operates a new kind of garage-door opener. The weight of the car compresses air in the hose and unlatches the door, which then opens automatically by the tension of its own springs. The door may be opened from the garage or house by pressing a small rubber bulb.

### "Red Hot" Rectifier Takes 1300 Degrees F.

Scientists at Westinghouse have developed a "red hot" rectifier that is capable of changing alternating current to direct current at temperatures above the melting point of metals like magnesium and aluminum. This clears a major hurdle in the search for high-temperature electronic control equipment demanded by rockets, missiles and high-speed aircraft. The rectifier, made of silicon carbide, can function in temperatures up to 1300 degrees F.

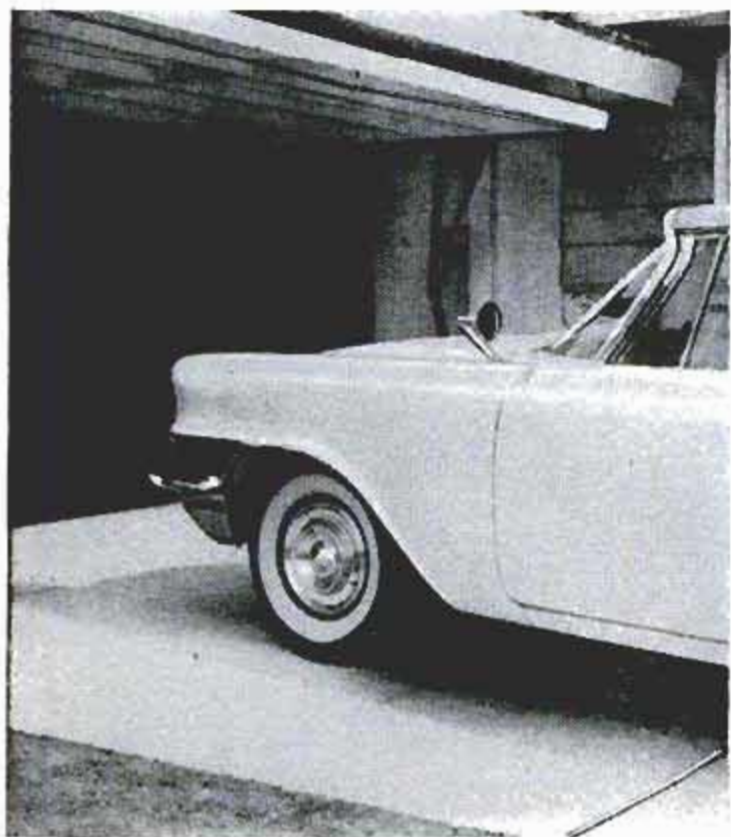





## Automatic Bombing and Navigation System Ready for Air Force

Air Force bombers can now be equipped with transistorized electronic brains for automatic bombing and navigation. In addition to a transistorized digital computer, the system includes a partially transistor-

ized radar, incoding and decoding devices, decimal-display devices, the plane's instruments and navigational equipment. It can perform 62,500 basic computations a second and processes flight and other data.

## Converted Truck Serves as Mount for Testing Aircraft Engines

Built to flight-test Rolls-Royce engines after 1400-hour overhauls, a mobile testing frame fashioned from a 1949 truck has "flown" more than 630,000 miles in nine years and has had 2250 aircraft engines on

its back. Fitted on the steel frame is an engine nacelle facing from a North Star aircraft. Saddle tanks holding 175 gallons of aviation fuel are outboard of the frame, and a 25-gallon oil sump is behind the cab.

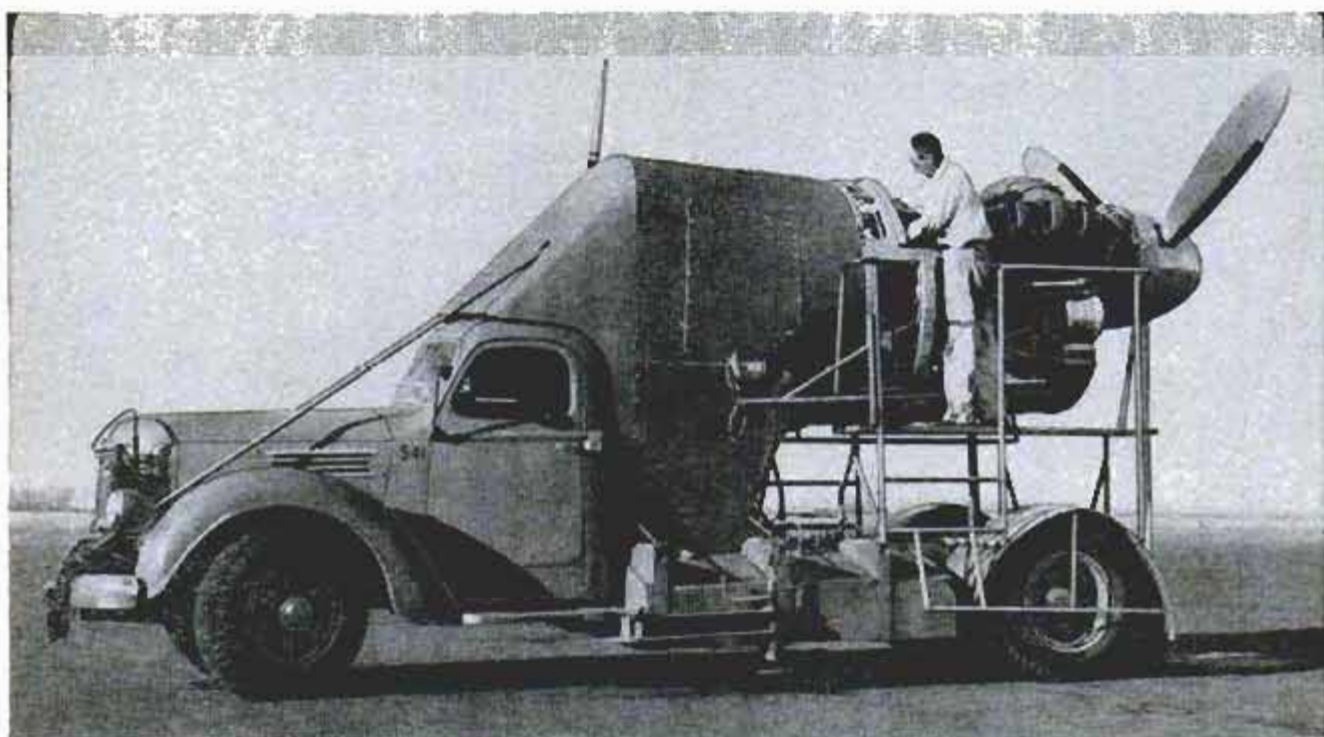



# MIRACLE KITCHEN

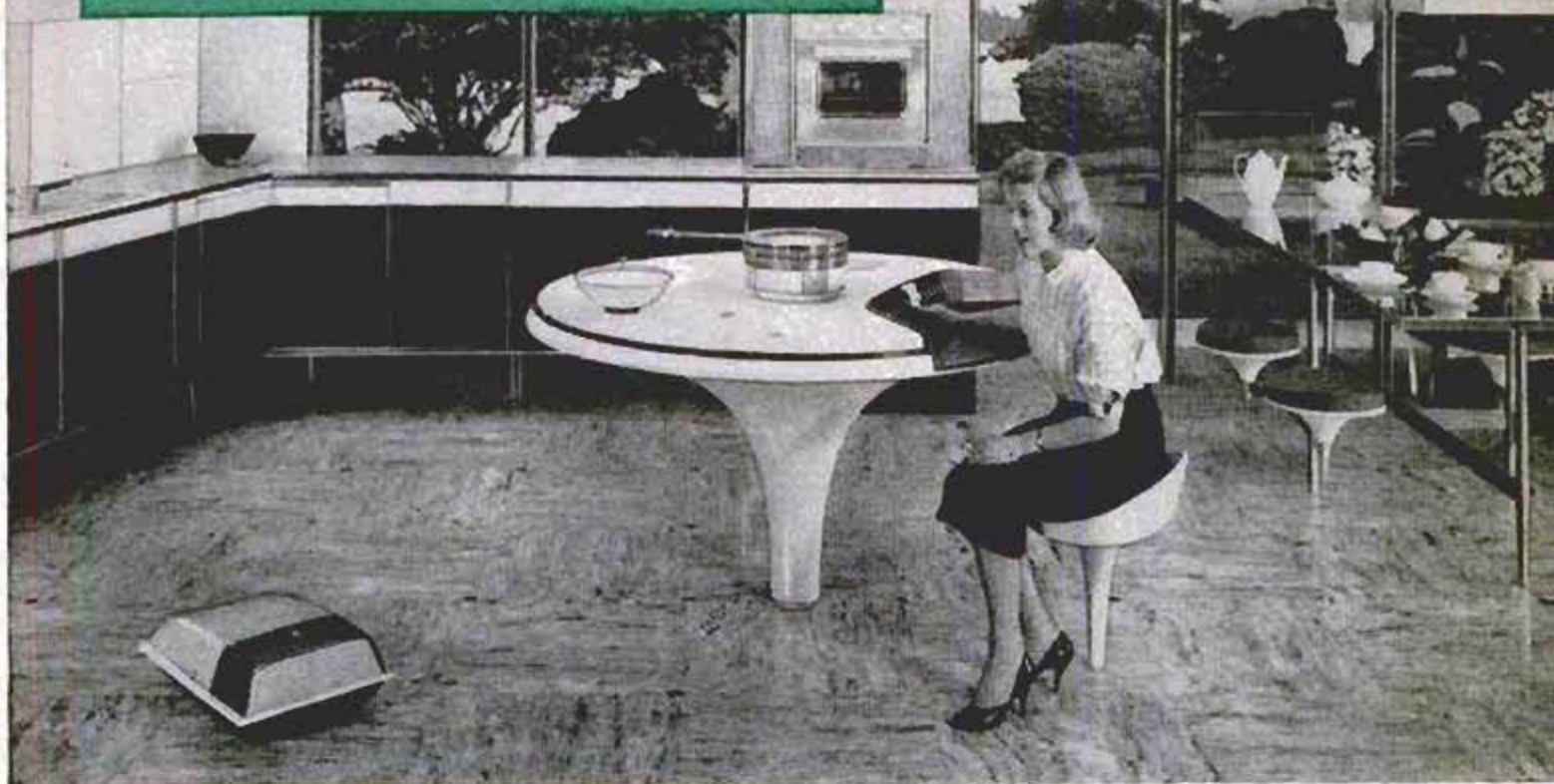

Battery-powered robot cleaner emerges from beneath cabinet at push-button signal and scrubs kitchen floor

COLD MILK or hot coffee from a faucet, an electronic oven that bakes muffins in 60 seconds, and a robot floor scrubber are featured in a push-button kitchen built by the Whirlpool Corporation. The kitchen is used to test and demonstrate home appliance ideas from the company's laboratory. Also featured in the "dream kitchen" is a closed-circuit TV and intercom system to monitor the front door and the baby's room.



Tiny disks on circular range, above, cook electronically; refrigerator drops down from cabinet, left; and below, beverages are dispensed automatically

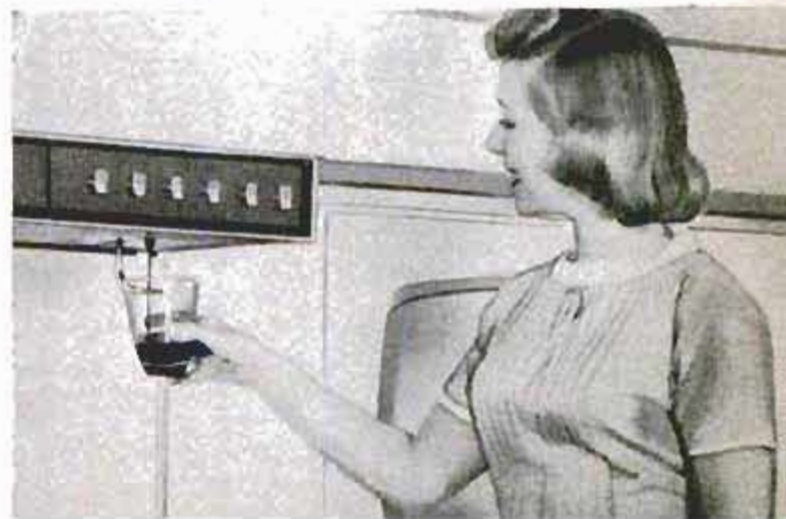
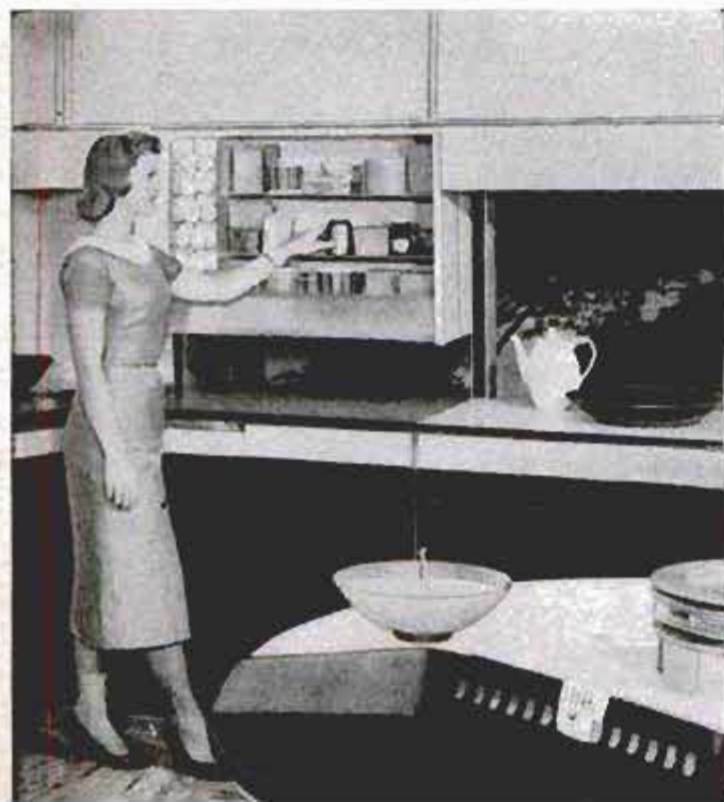



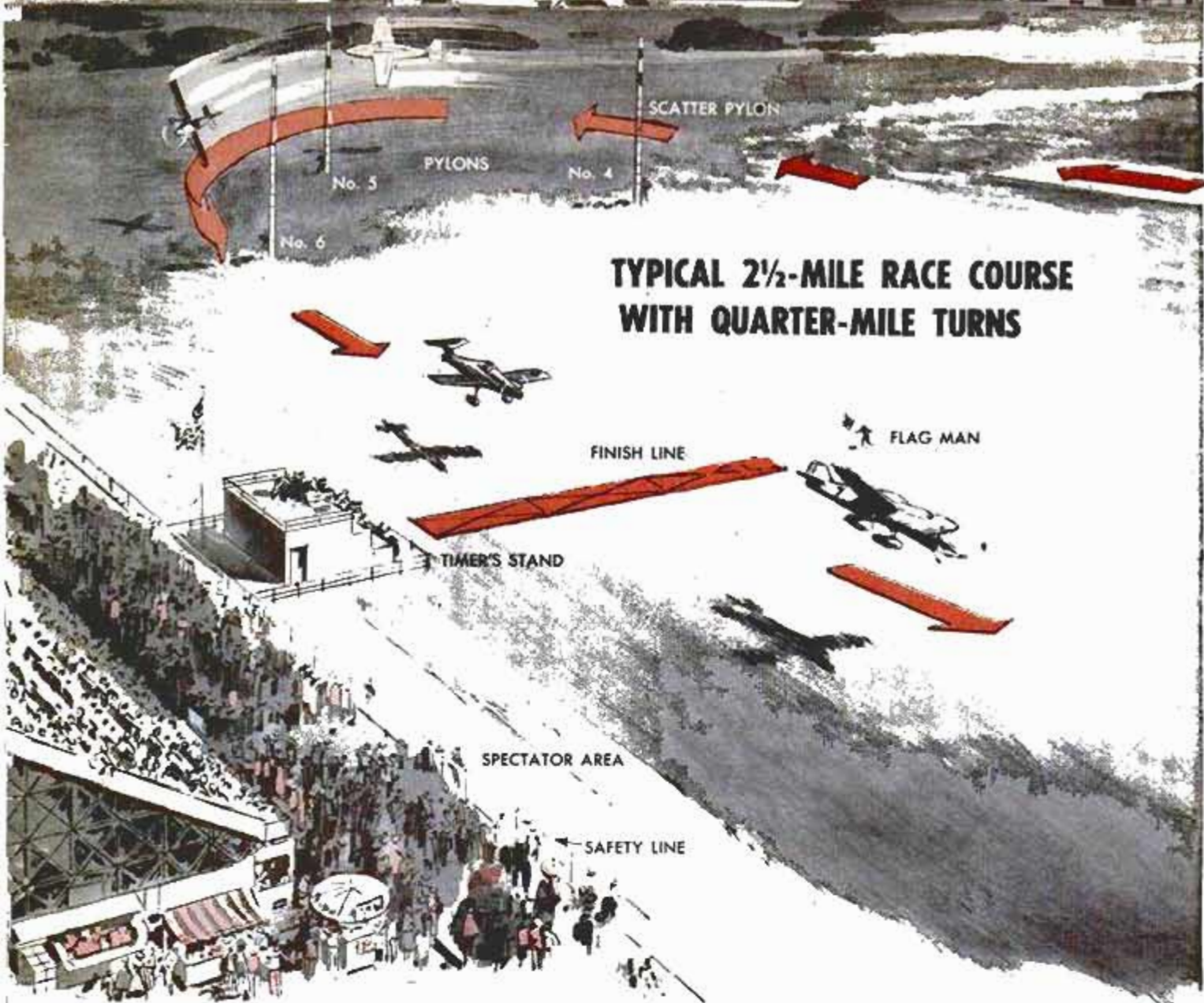

## TYPICAL 2½-MILE RACE COURSE WITH QUARTER-MILE TURNS

# THE MIDGET RACERS ARE

Photos by Anthony Linck and John C. Durand



**R**EMEMBER WHEN racing pilots like Roscoe Turner and Jimmie Doolittle were setting speed records at the Thompson Trophy races in Cleveland each fall?

Those exciting closed-course races ranked with the Indianapolis "500" as the nation's top contests in speed, and Hollywood film makers made several movies around them.

Small planes were popular with the air racers. In 1932, for example, Doolittle—the same flier who 10 years later was to become a war hero by bombing Tokyo—won the Thompson Trophy in a tiny Gee Bee Super Sportster, a plane so small that it was dubbed "the flying milk bottle." But Doolittle was able to average 252 miles per hour in the tiny plane.

Midget-racer Bill Falck gets trophy after winning 1957 Fort Wayne Industries Race, biggest of year. He also won \$1400



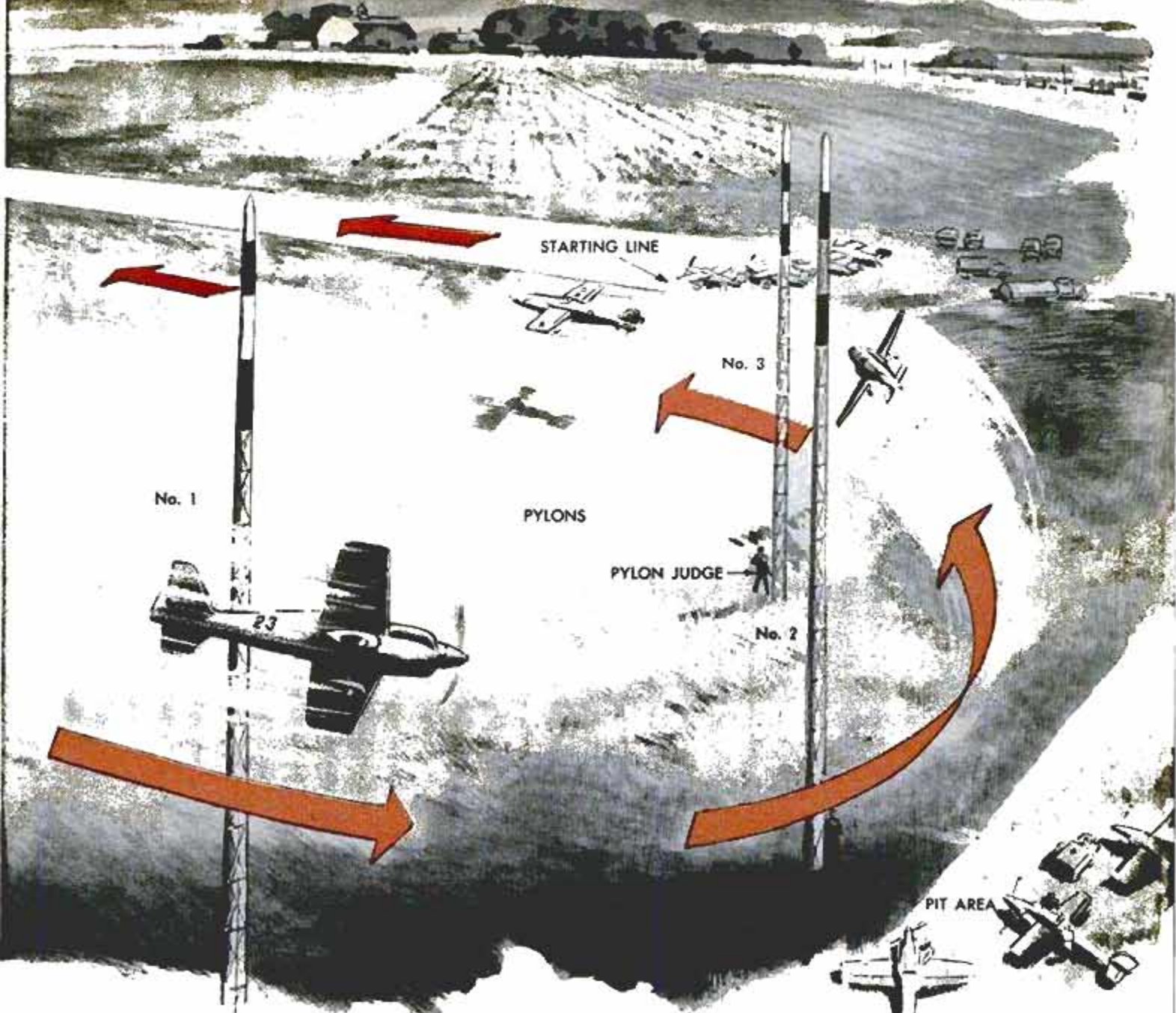

# FLYING AGAIN

By J. A. West

By 1949, flying speeds had become so great that the annual Thompson Trophy contests of plane against plane were called off. It was no longer safe for the lowflying aircraft to fly close to sonic speeds in turbulent air around a course that required sharply banked turns. The lives of spectators and nearby homeowners were in danger, too.

But today, closed-course racing is making a comeback on the wings of midget airplanes. The tiny ships are proving real crowd pleasers. Racing fans enjoy watching the midgets speed around the 2½-mile course.

With an average wingspan of 14 to 16



Midget racers approach starting line. Race's start is "race horse" variety, with all planes lined up and engines running. The speed record for midgets set last year, is just under 209 miles per hour





## TYPICAL MIDGET RACER

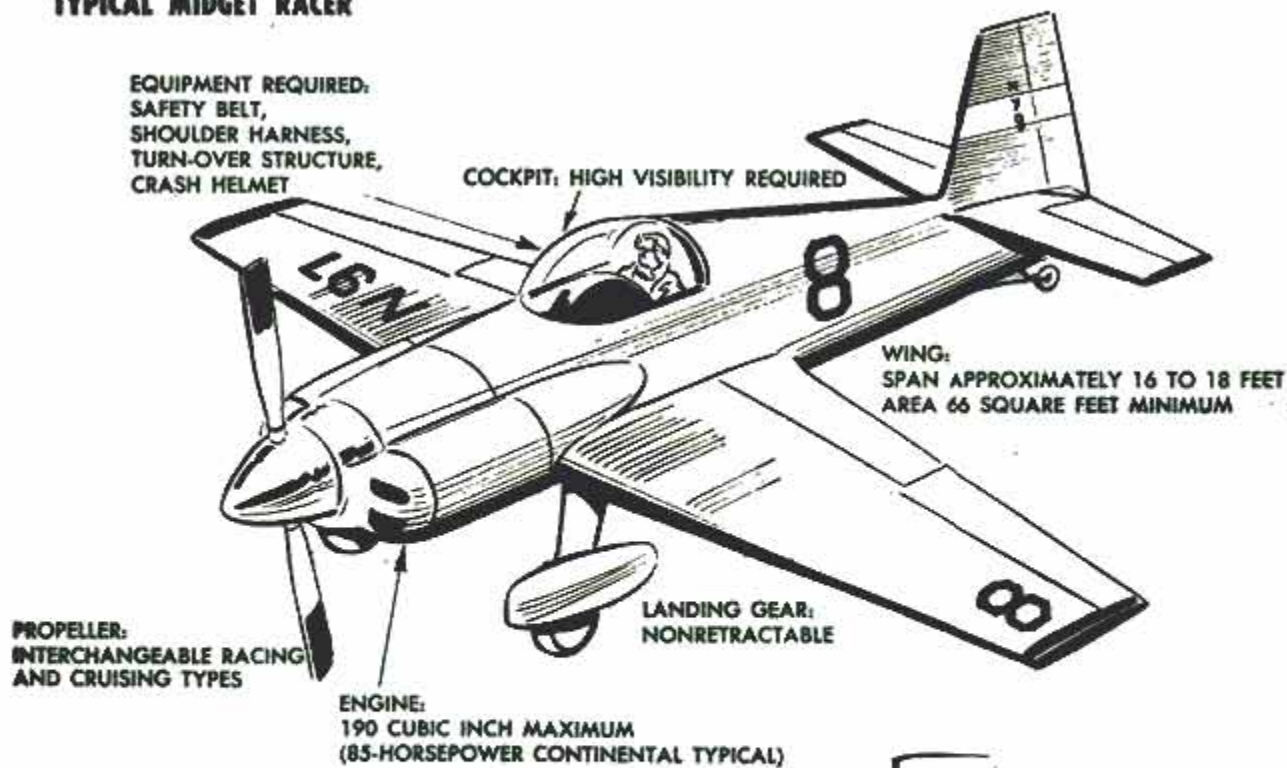

feet and a length of 9 to 12 feet, the midget planes are powered by 190-cubic-inch displacement engines that permit an airspeed of about 200 miles per hour. In winning the big race at Fort Wayne, Ind. last year, Bill Falck of Warwick, N. Y. went the 12 laps in 9:9.2, at an average speed of 196.65. His prize was \$1400.

Most of the planes are built from scratch by their owners, who often double as pilots. When possible, parts from production aircraft are used, but fabrication of parts is usually necessary. Often a winner's prize money is invested in improvements on his plane. Several of the midget planes have been built for a cash outlay as low as \$3000.

Specifications for the midgets are stringent, and alterations and changes permitted on engines are extremely limited. For example, no dimensional change in bore or stroke is permitted. Nor can the dimension of the valve lift be changed. Water injection is forbidden, and there can be no alteration in the length of the connecting rod between the center of the



wrist-pin hole and the center of the crank-pin hole. It's also against the rules to use a pump or blower to increase carburetor-inlet pressure.

Wooden or metal propellers may be used, but they must have fixed pitch in flight. A minimum of 66 square feet of wing area is required. The dry, empty weight of each plane has to be at least 500 pounds.

Most major midget races are sanctioned by the National Aeronautic Association and flown by the rules of the Federation Aeronautique Internationale. Before a plane can be entered in a sanctioned race it must have an airworthiness certificate from the Civil Aeronautics Administration. ★ ★ ★

Pushing airplanes around the runways is not much of a problem when they weigh little more than 500 pounds





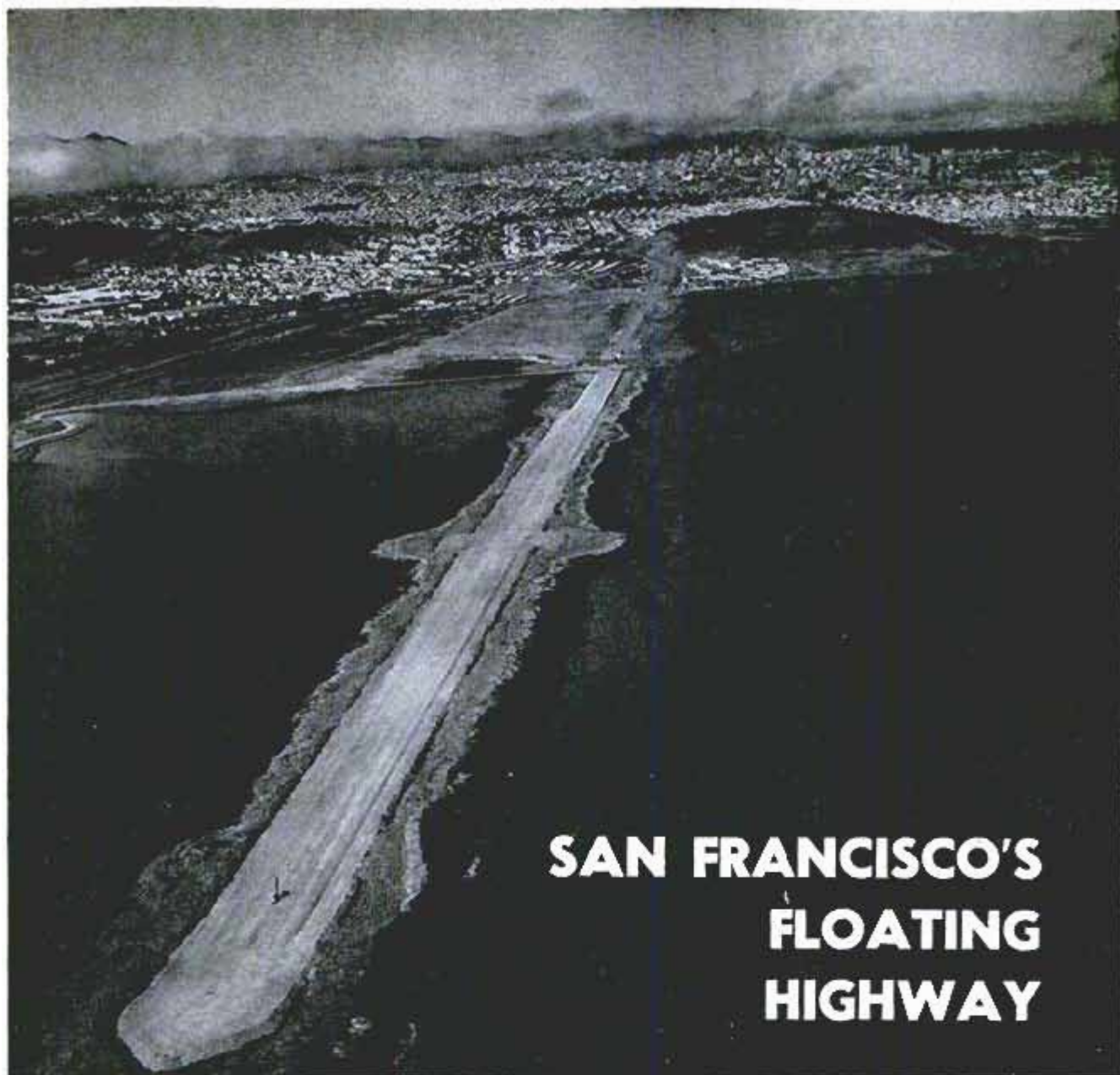

## SAN FRANCISCO'S FLOATING HIGHWAY

Engineers used 5,500,000 cubic yards of dirt in building the highway. Complete project cost \$8,000,000

**CONNECTING** suburban South San Francisco to metropolitan San Francisco, a new 6-lane freeway floats on a bed of soft black mud for two of its 3.6 miles. Built at a cost of \$8,000,000, the floating highway bypasses a congested area that has long been a traffic bottleneck. Using dirt material from nearby sites, a unit of dump trucks, bulldozers, tractors and steamrollers worked five years to float a fill on the mud of San Francisco Bay's tidal marshes. Skeptics thought the floating section would sink, but engineers kept it afloat by successfully working out a formula for displacing deep mud with dry fill.

The two-mile section that crosses open water rests on mud that is 90-feet deep in places. It took five years to complete the freeway





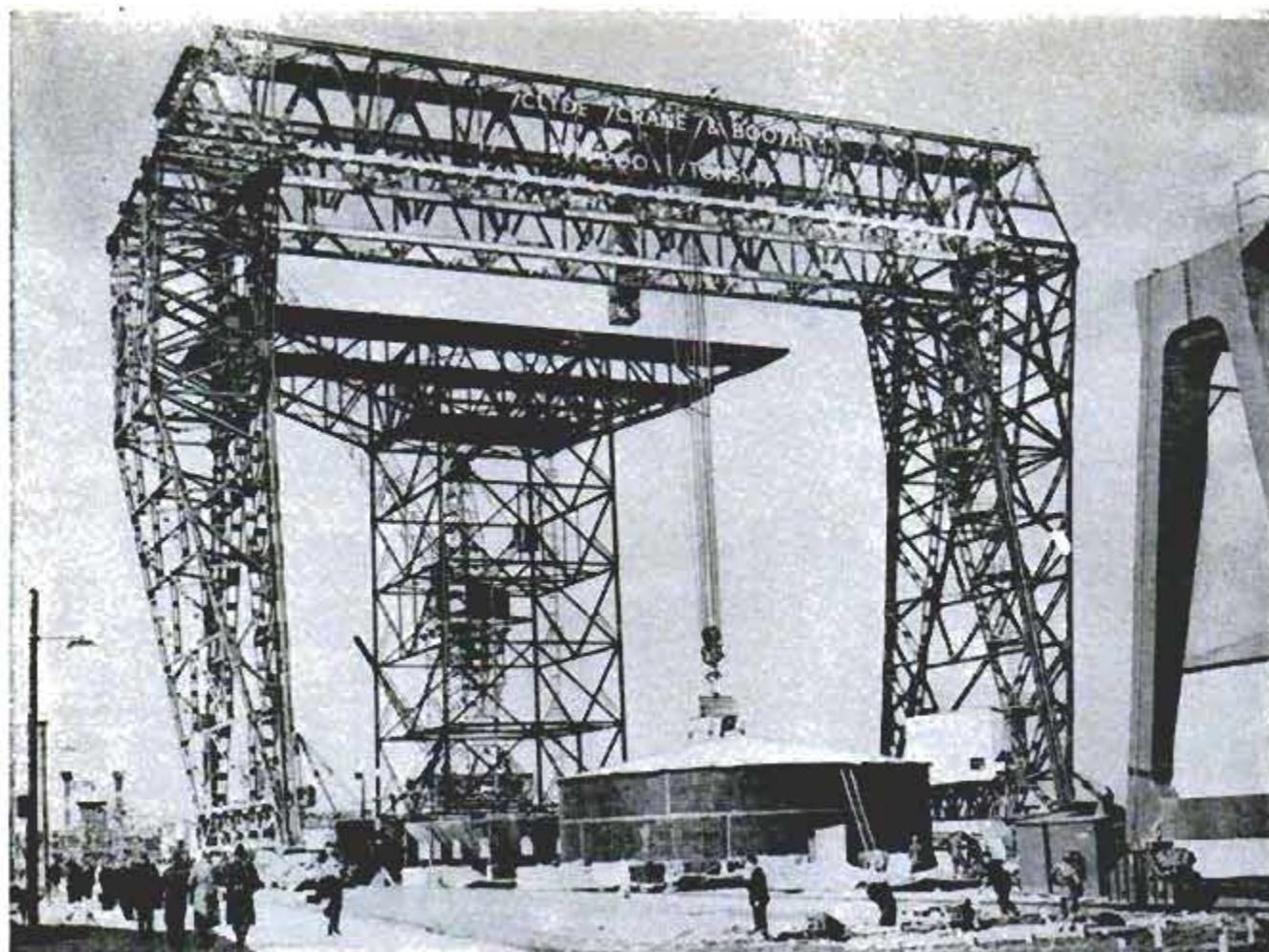

## Giant Crane Helps Build British Nuclear Plant

Construction of a nuclear power station at Bradwell, England, is being rushed with the help of a 185-foot-high crane nicknamed the "Goliath." Nearly 700 tons of steel and 13,000 nuts and bolts were used

to build the Goliath, which is believed to be the largest crane of its type in the world. It is mounted on eight four-wheel bogies that run on railroad tracks. The giant crane cost approximately \$1,120,000.

## Sleek Canberra Will Have No Visible Funnels

Largest British superliner to be built since the *Queen Elizabeth* and *Queen Mary* is the sleek *Canberra*, now under construction in Belfast. The 45,000-ton vessel will have sweeping lines uncluttered by normal

funnels. The *Canberra* will be powered by turboelectric propulsion. Costing \$42,000,000 and scheduled for completion in 1960, she will carry 2250 passengers and a crew of 1000 at a cruising speed of 27½ knots.





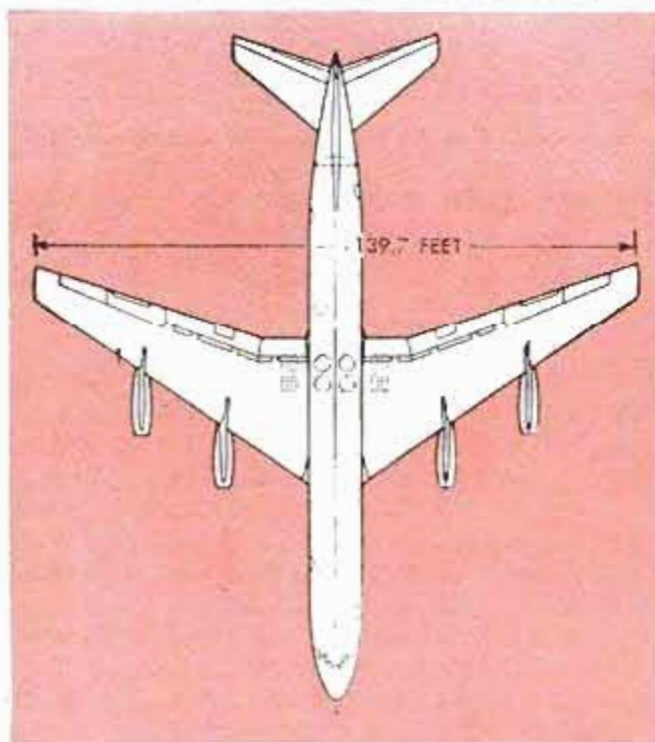

## Five Hours—Coast to Coast Will Be Easy for Jetliner

CAPABLE OF spanning the North American continent in less than five hours, the Douglas DC-8 jetliner will begin flying for at least 17 different airlines late next year. Intercontinental models will be able to fly nonstop between principal cities of Europe and the United States in either direction. The DC-8 has four turbojet engines, providing a cruising speed of 590 miles per hour. It will accommodate from 118 to 176 passengers. Span of the sweptwings is just under 140 feet, and the plane's length is more than 150 feet, from the weather radar in the nose to the tips of the sweptback horizontal stabilizer. The vertical stabilizer rises 42 feet from the ground. Cost of each DC-8 is approximately \$5,000,000.

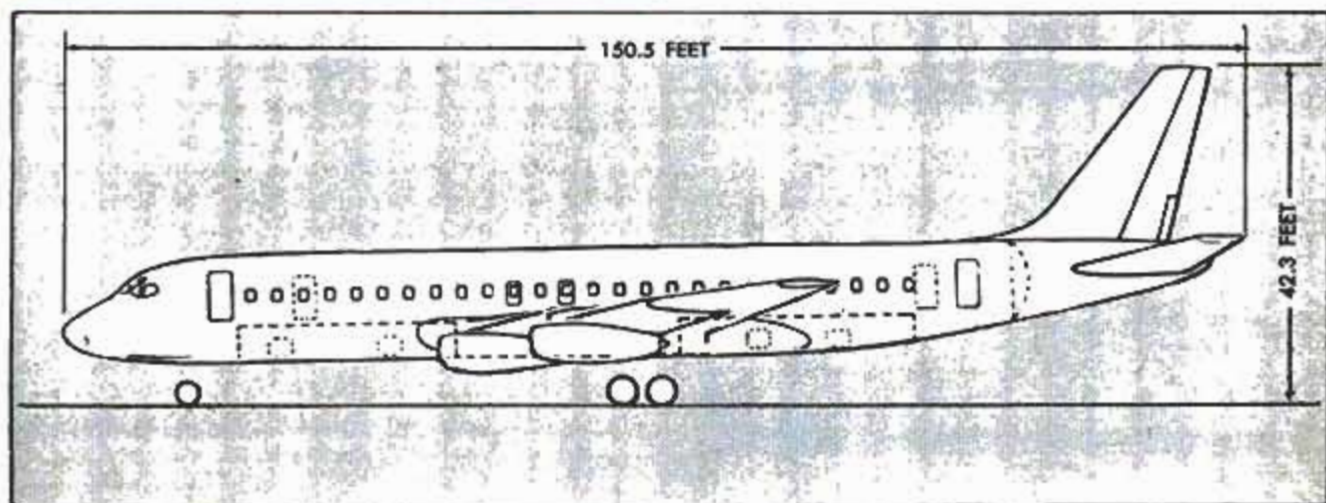



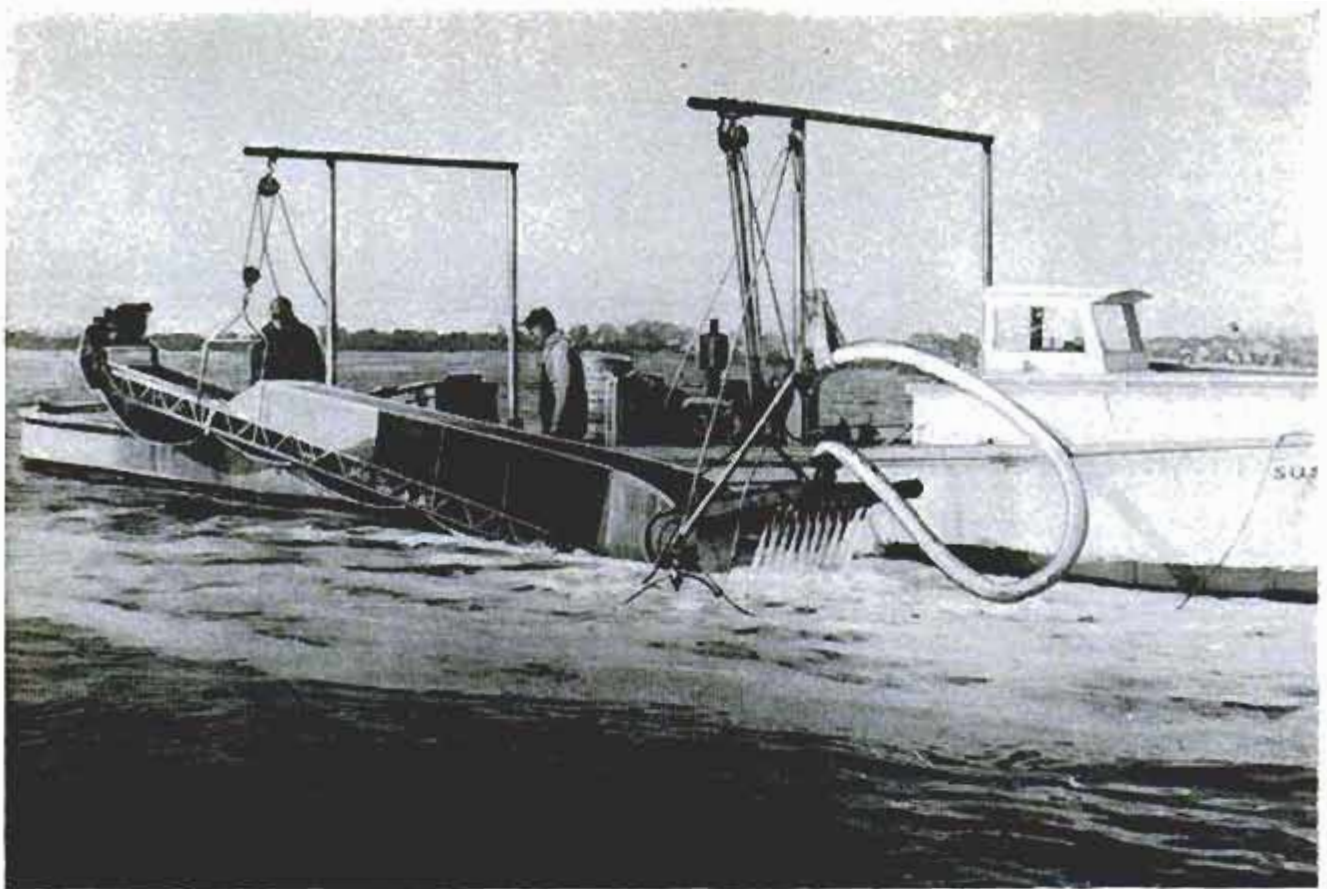

Hydraulic jet streams shown before being lowered to clam bottom, 6 to 12 feet down in Chesapeake Bay

## JET STREAM

Conveyor belt powered by small air-cooled engine allows sand and silt to fall through one-inch mesh



**A MECHANICAL DIGGER** using hydraulic jet streams to blast soft-shelled clams from Chesapeake Bay and its inlets has helped lift Maryland to top position among clam-producing states.

The digger is a 22-foot steel dredge towed beside a small workboat. At the dredging end is a pair of runners joined by a 30-inch manifold from which 11 steel tubes protrude. The manifold is attached to a hose connected to a six-inch pump on deck. The manifold and runners are hinged to a steel scoop. Bypassing the rear end of the scoop is a steel-mesh conveyor belt.

The pump delivers water under 30-pounds pressure to the manifold. Riding along with the runners on the bottom, 6 to 12 feet below the surface, the jet streams from the tubes blast out bottom material. Clams whirled through the scoop fall on the belt. The belt carries the clams to deck level, where they are picked by hand. One clam boat can dredge 1200 to 1300 square feet an hour and bring up 30 to 100 bushels of clams a day. Canadian tests of the rig have indicated that near 100 percent of the clams blasted out by the jets are trapped in the scoop and less than one percent are broken.

The dredge was invented by Fletcher



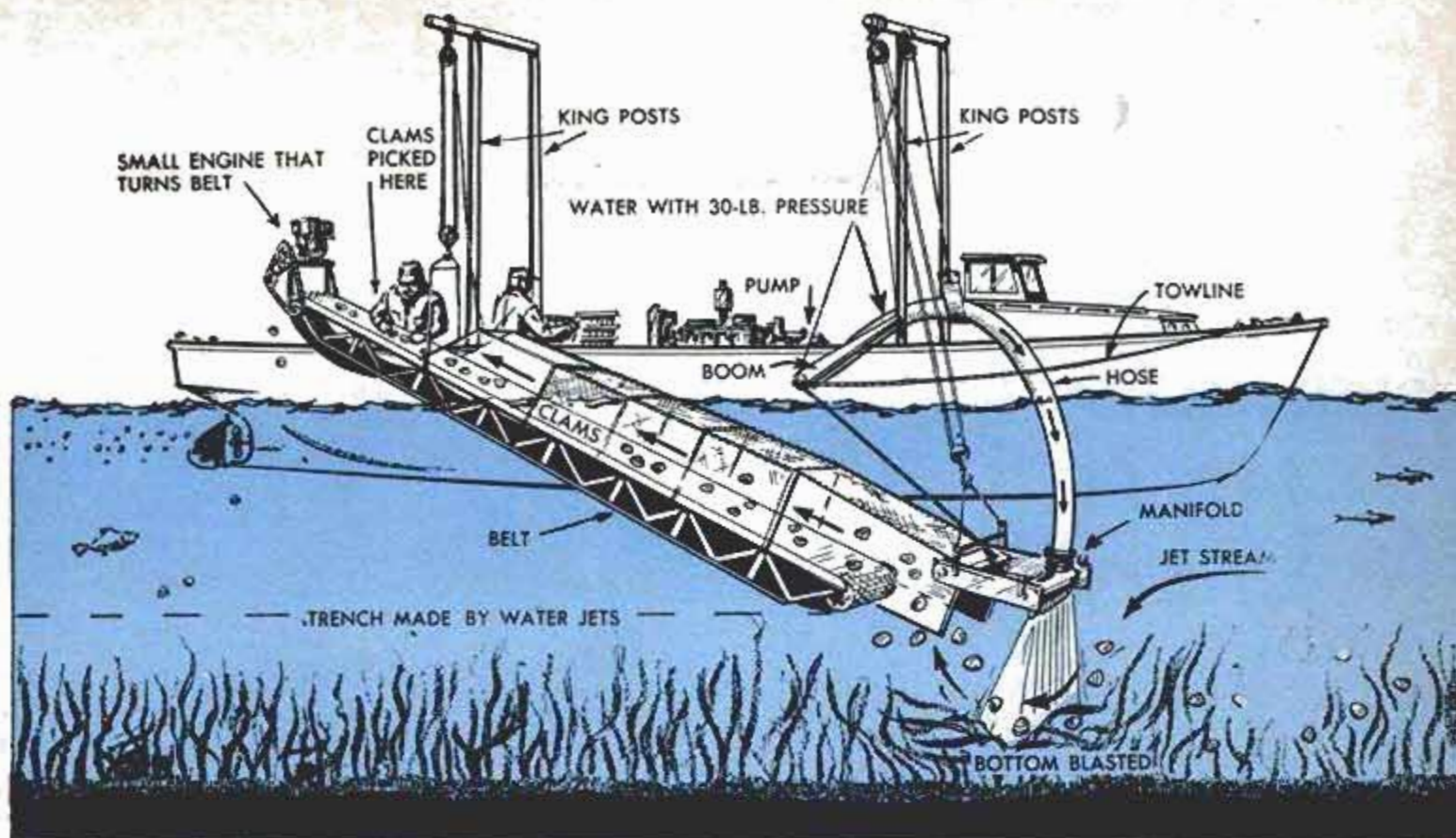

Outrigger boom prevents the 22-foot steel dredge from rubbing against side of small clam workboat

# DIGS CLAMS

By W. E. Huelle

Hanks, Jr., of Oxford, Md., who dug clams as a boy on Maryland shores. The slow, back-breaking effort made him wonder if there might be a better way. After the war he got busy with an old tractor in shallow water. With a pump rigged to a single jet, he flushed clams into a scoop dragged behind the tractor. He improved on the device and patented it. ★ ★ ★

Belt brings clams to deck level, where they are picked off. A boat can raise 30 to 100 bushels of clams daily

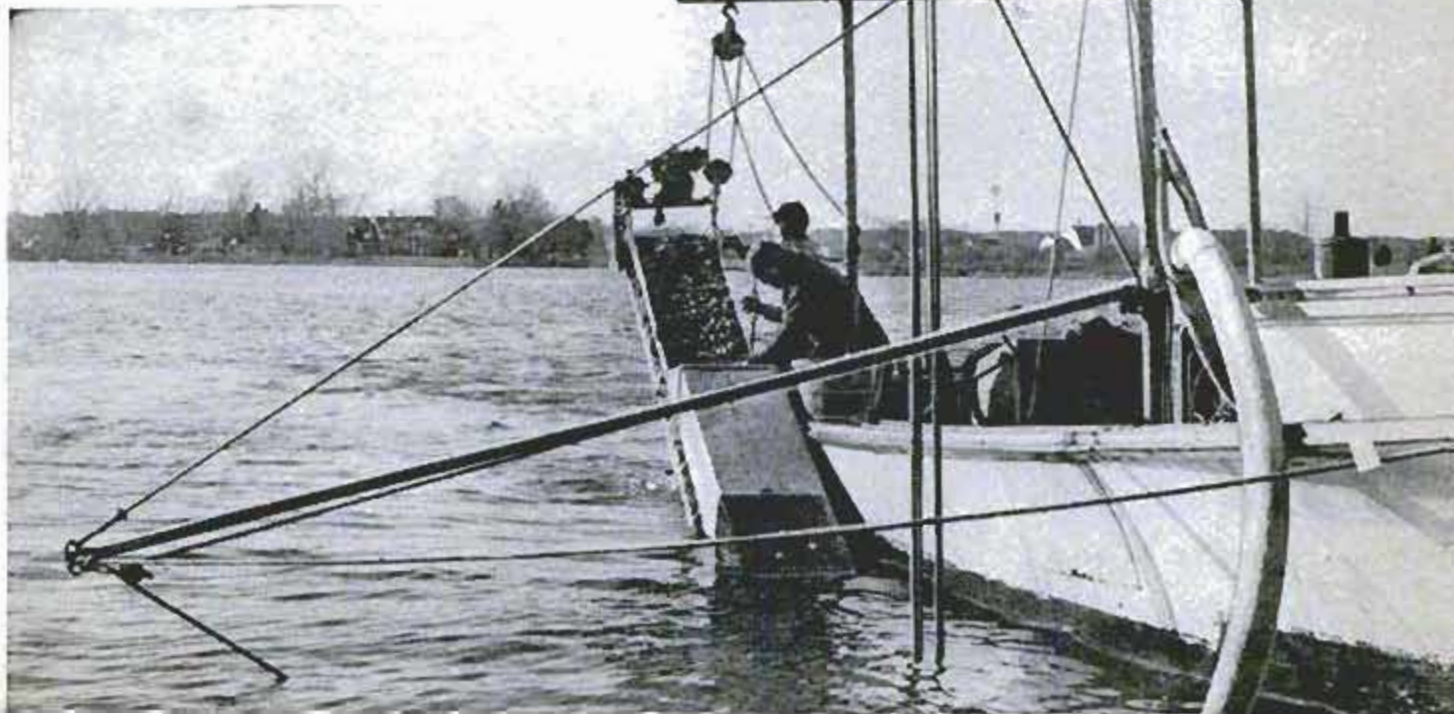





## ***Flying Navy Cannon Increases Firepower***

CARRIED in an underwing gun container, a double-barreled 20-millimeter automatic cannon adopted by the Navy has eight times the firing rate of its World War II counterparts. The cannon, called the Mark II, can fire 4000 high-explosive shells per minute. Its speed is possible because

a single revolver cylinder feeds cartridges to both barrels. The container, or pod, can be attached to the aircraft in seconds and can be instantly jettisoned by a pilot while in flight. Two of the pods and guns can equip a plane with the power of 16 World War II 20-millimeter cannon.

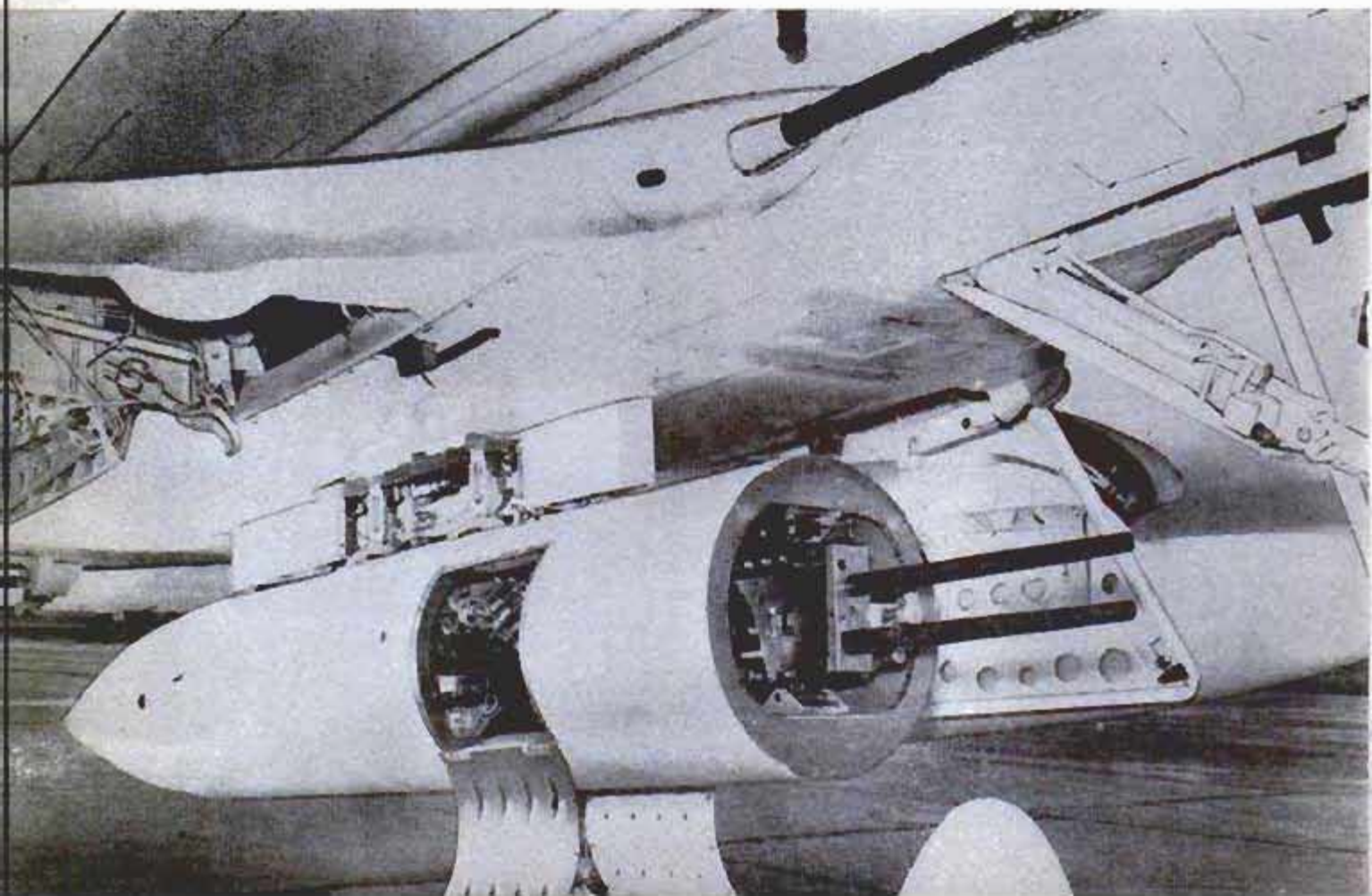





## America's "Narrowest House" Is Only 10 Feet Wide

Built on a tiny lot created by an oversight in a real estate transaction, a stucco home in Long Beach, Calif., is believed to be the narrowest house in America. It's 10 feet wide, three stories high and gains space by judicious use of built-in conveniences. The first floor has a front porch, a living room large enough for a piano as

well as other furnishings, and a kitchen with a dining area that seats six persons comfortably. Stairs lead to the second floor where there are two bedrooms, a hall and a bathroom with tub and shower. A steep stairway leads to the third floor which has a small attic, a laundry room and between them, a 9-by-15-foot sun deck.

## Grid Announcers Use Board to Keep up With Player Substitutions

Coaches, scouts and sportscasters can now keep track of the 22 men on a football field by referring to a board containing a slot for each position on the two teams. There is also a slot for downs. Into each slot or position fits a spool on which there are four white panels for names and

numbers of the players at that position. Equipped with spring-pressed balls at each end, the spools are quickly and easily snapped in and removed. They are rotated in their slots by means of serrated rings. The board measures  $11\frac{3}{4}$  by  $8\frac{1}{8}$  inches and fits neatly in a carrying case.

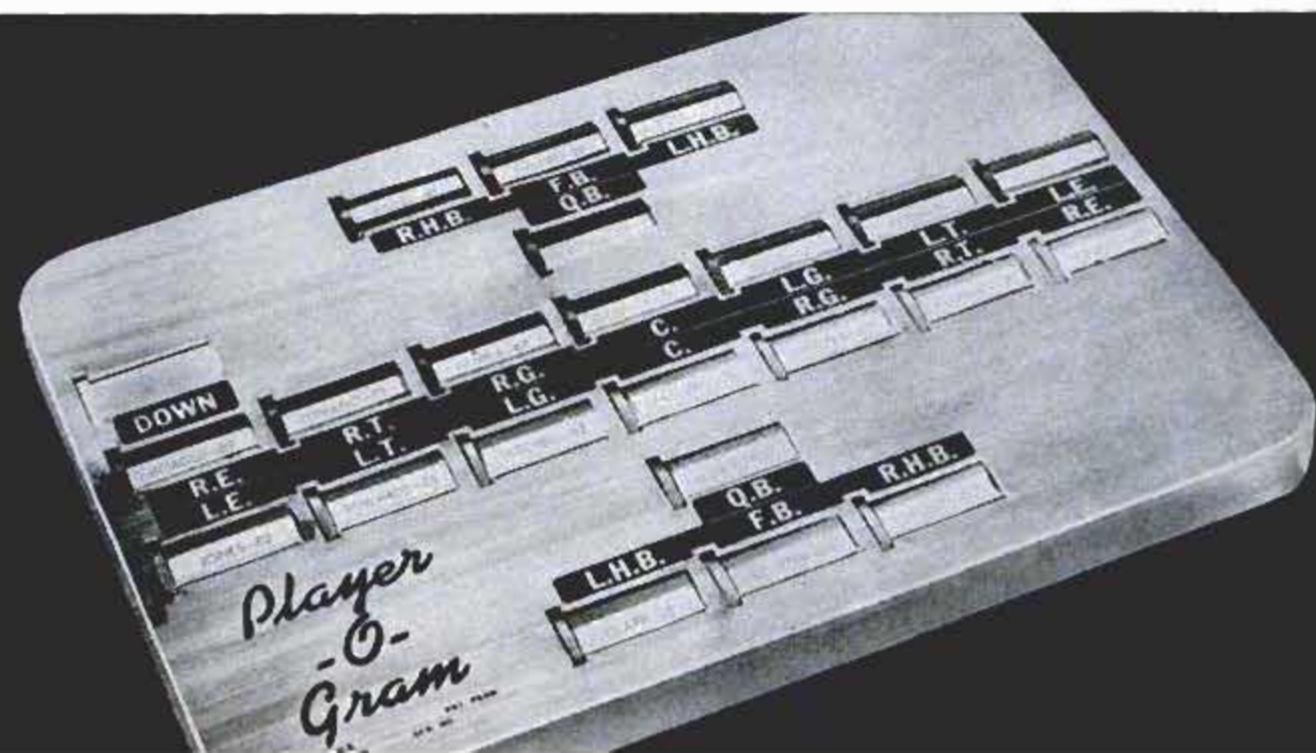





## *This Car Has Electric Brains*

**"Dream car" developer James Butler demonstrates how nearly invisible button is pressed to open door**

**By Jack and Donna Krivdo**

**P**EDESTRIANS AND MOTORISTS alike may be startled occasionally by the sight of a car tooling along a road in the Los Angeles area with nobody at the wheel. A couple of men are sitting in the back seat but they make no effort to reach for the controls as the car heads straight for a brick wall.

Fortunately, the car comes to a halt, with plenty of room to spare, and the passengers step from the driverless vehicle. They show no evidence of tension or strain as a result of their apparent close brush with tragedy.

One of the men is James P. Butler, an instructor at El Camino College, who has developed this experimental "dream car" in which buttons and switches handle nearly all the mechanisms automatically.

The braking system, for example, works automatically. That's the reason the car didn't crash into the brick wall. Butler says the brakes are controlled by a narrow-scope sound beam which is transmitted from the left front side of the car and reflected back to a receiver on the right side by obstructions in the path of the vehicle. The beam, Butler adds, will be reflected by any obstruction as wide as a telephone pole.

The constant sound signal has a frequency of about 20,000 cycles per second, at the low end of the ultrasonic scale but above the range of most human ears.





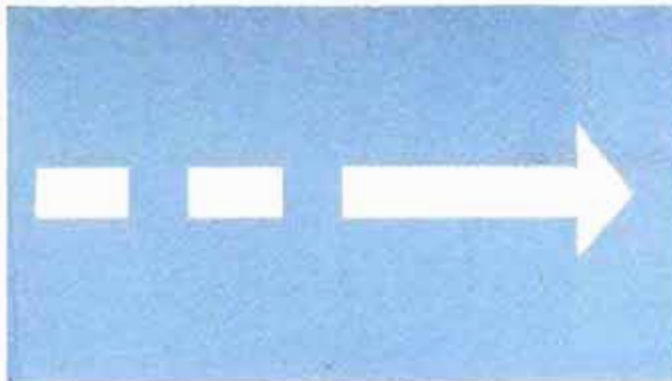

Rear grille of car is functional, serving as vent for air circulator and as intake for tail-pipe firing. Pipes fire on "nitro" to start, then on "low" fuel after warm-up. Spark plugs are set in the tail pipes

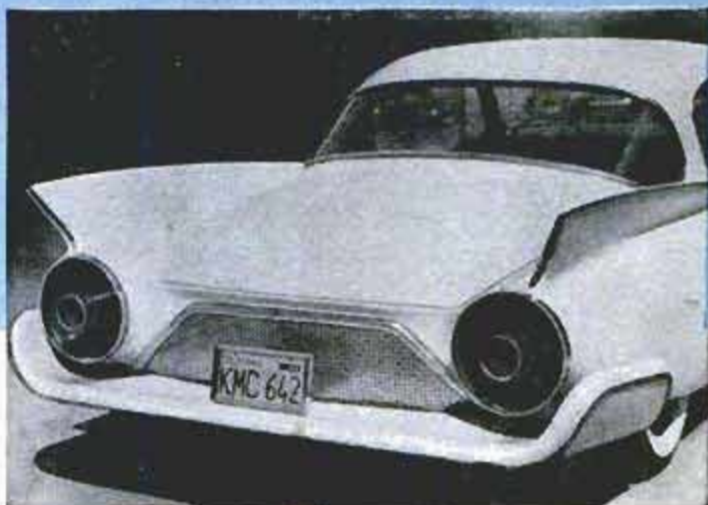

Pressing on the accelerator pedal, to produce greater car speed, also increases the amount of current flowing to the transformer that is linked to the sound source. This creates a stronger signal that travels farther. Thus, at a car speed of 15 miles per hour, the range is 30 feet. But at 50 miles per hour, the range increases to about 150 feet, according to Butler.

When the reflected sound is picked up by the receiver, the car's brakes are automatically applied, but quite lightly. If the sound continues to be reflected back to the

car the brakes are again applied, but with greater pressure. This braking action in normal highway traffic would hold Butler's car back a safe distance from another vehicle in front of it.

However, Butler claims, if the sound beam still is reflected by an obstruction after the "second stage" of braking, the system automatically goes into its panic-stop stage. Then the brakes are jammed on full and the car's ignition is turned off.

Butler says the automatic braking system can be built and installed in a car for

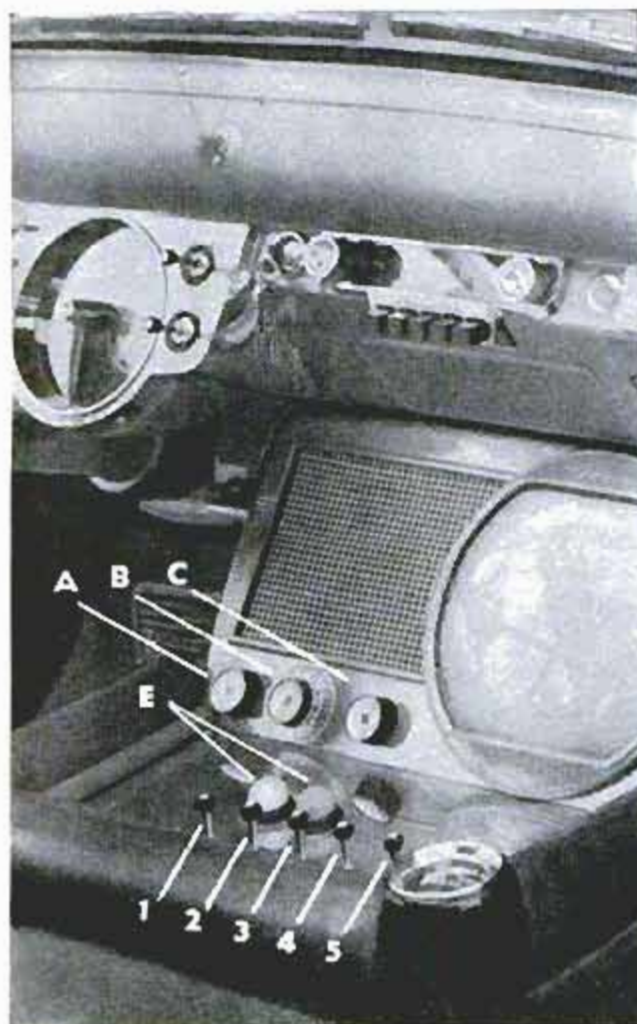

Instrument panel includes: A. Sound control for automatic brake unit; B. Selector for automatic steering; C. Range control for audio unit; D. Screen with "blipping" light to indicate if systems are working; E. Lights that will tell if trunk or hood is open; 1. Emergency fuse unit; 2. Switch to open, close trunk; 3. Open, close hood; 4. Blower control; 5. Tail-pipe firing



less than \$100, although he has no immediate plans for marketing the device.

Besides the automatic braking system, Butler's "dream car" has automatic steering controls, a "tail-pipe firing" device, switches that raise the hood and the deck lid, or trunk, an electric door control and a 110-volt alternating-current circuit which powers, among other things, a record player. The car also features both six and 12-volt direct-current circuits and a screen under the dash which shows a "blipping" light when the system is performing properly or a constant red light if there is a short circuit or a power failure.

According to Butler, the automatic steering system involves three basic parts: Radio beams, a sound monitor and a compensator that performs like a gyroscope.

The sound monitor is a device that checks the operation of the electrical equipment in the system. The compensator holds the car on a straight line. The radio beams under the car "read" the normal road crown and apply corrections to the steering mechanism to make up for the right-hand drift which Butler has "built into" the front wheels.

By presetting a series of relays, Butler claims, the car will automatically turn at a predetermined corner, then straighten itself. The system is set for 90-degree cornering and, at present, can make 15 successive turns without resetting the switches. The equipment also can be set to ignore a certain number of corners, then turn at a pre-selected corner.

Details of the automatic steering device have not been revealed, except that the electronic equipment is linked to hydraulic cylinders. These hydraulic cylinders, in

Body of car was converted from 1955 Studebaker, with rear recontoured

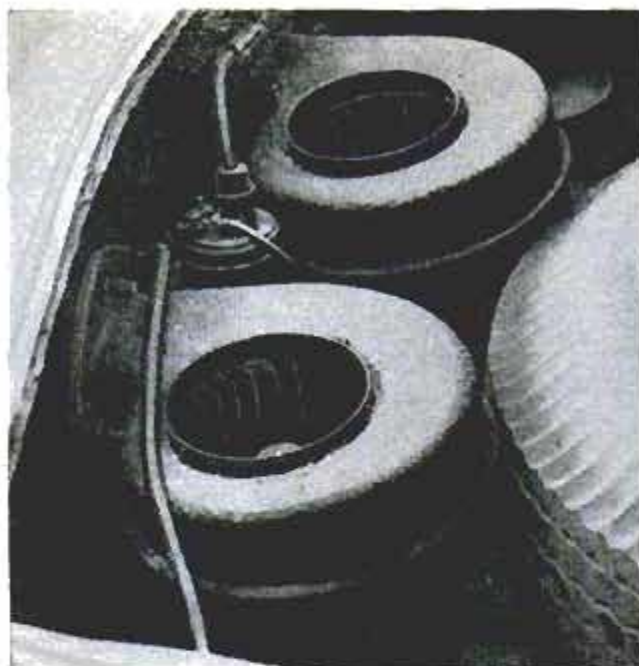
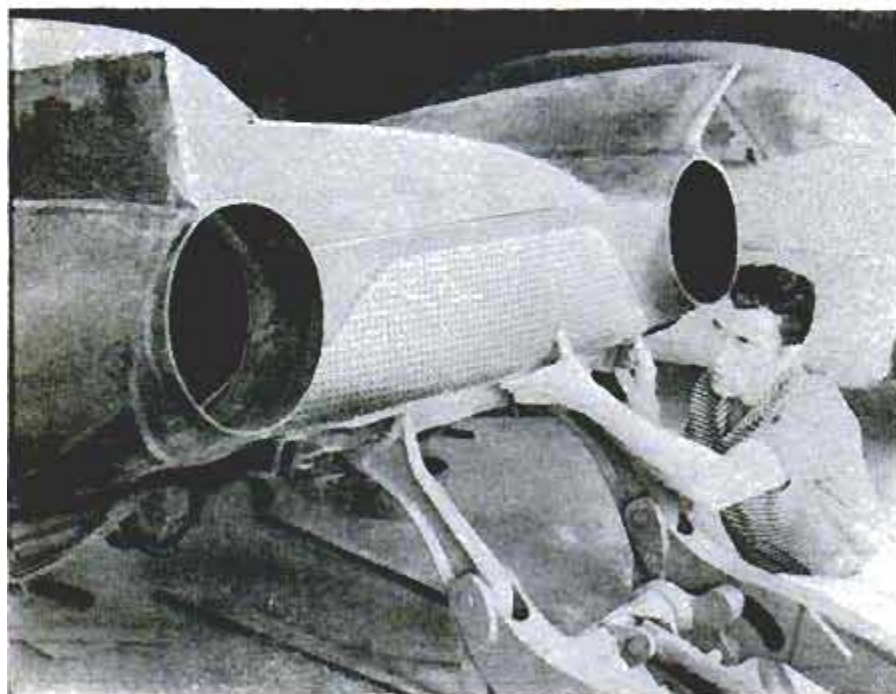

Blowers for tail-pipe firing are mounted in rear of trunk. Coil starts firing of the exhaust plugs

turn, are connected to the steering rods.

In addition to the automatic steering system, Butler says, his car has a conventional manual steering system that overrides the automatic controls. The car also can be steered by a set of toggle switches on the instrument panel which, like the manual controls, can override the automatic device.

The "tail-pipe firing device" is an auxiliary thrust unit that can be used at high speeds. Operating somewhat like a ramjet, Butler claims it can produce an estimated 1000 pounds of thrust. The device is started on "nitro" after the car has reached a speed of 80 miles per hour. Then the main engine is turned off and the speedometer speed jumps to 110 miles per hour within five or six seconds on power of the thrust unit alone, according to Butler.

Ordinarily, a ramjet does not function at air speeds below 350 miles per hour. Butler says his car has blowers that produce the necessary air speed through the unit. The tail-pipe firing equipment is strictly experimental. It is also very noisy and uses one and a half gallons of fuel per mile.

Butler estimates that he has about \$12,000 and 600 hours of his spare time invested in the electronic car. He now plans to build another "dream car," using plastic materials. ★★★





## *Poles for Power Line "Planted" by Helicopter*

HELICOPTERS helped build a three-mile stretch of 12,000-volt power line over almost inaccessible terrain in California's Los Padres National Forest. Whirlybirds "planted" 59 poles, one at a time. The poles

were picked up at a staging area and transported by a rope sling, then dropped into previously dug holes and tamped in place by a worker who had arrived on the job by helicopter.



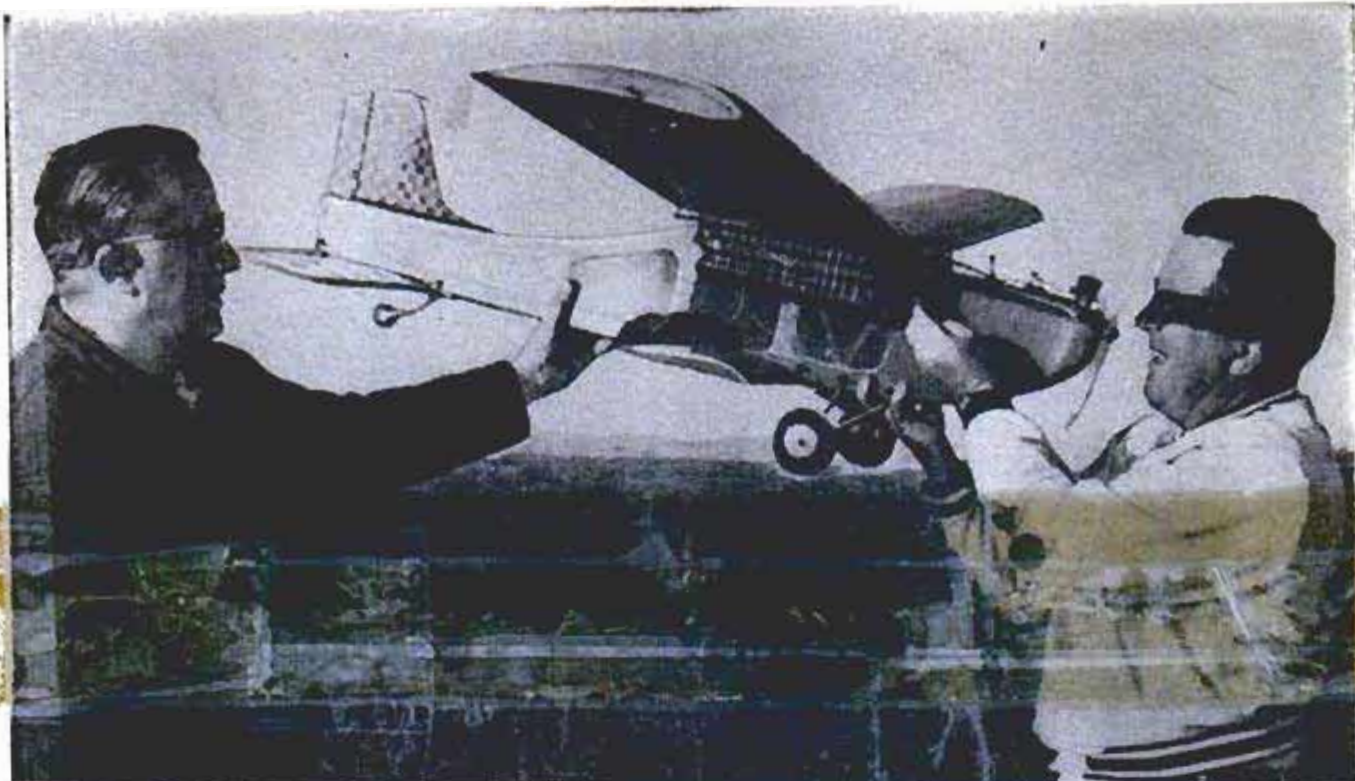

## Model Plane Sets Endurance Record of 5 Hours, 29 Minutes

Nearly doubling the world's endurance record, held by the Russians, a model plane built in Van Nuys, Calif., stayed aloft 5 hours and 29 minutes. The old mark was 3 hours and 6 minutes. The champion has a .450-horsepower engine.

## Sliding Blade Cutter Swivels for Angle Cuts

Cardboard, plastic sheets, leather and paper can be cut safely with a new sliding blade cutter device. The blade travels on a rod, which swivels for angle cuts. It will cut several sheets of paper at a time and can cut materials up to 18 inches long.

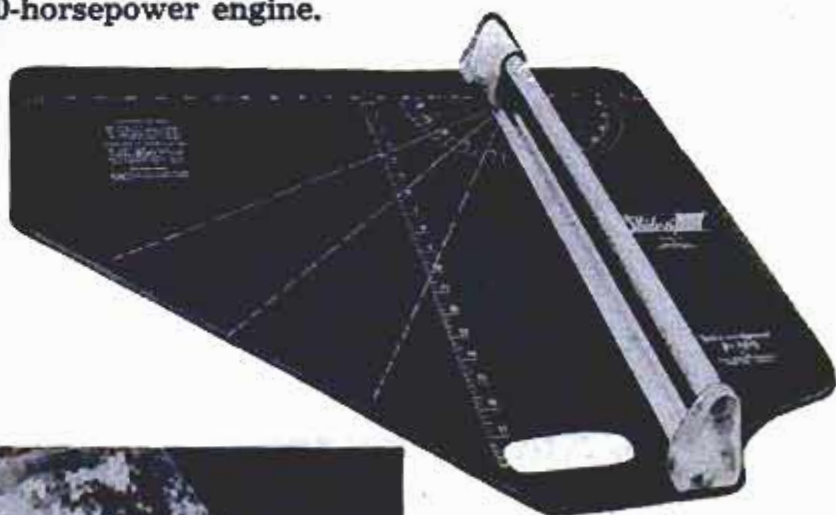

## Wheeled Litter For Rescue Work

Up to 500 pounds of weight can be moved over rough terrain with a wheeled unit that also can be used to remove casualties during rescue work. Only one person is needed to move a litter patient on the unit which rolls on inflated nylon bags. Air to inflate the low pressure roller bags is carried in a reservoir within the steel tubing of the frame. The unit weighs 15 pounds.

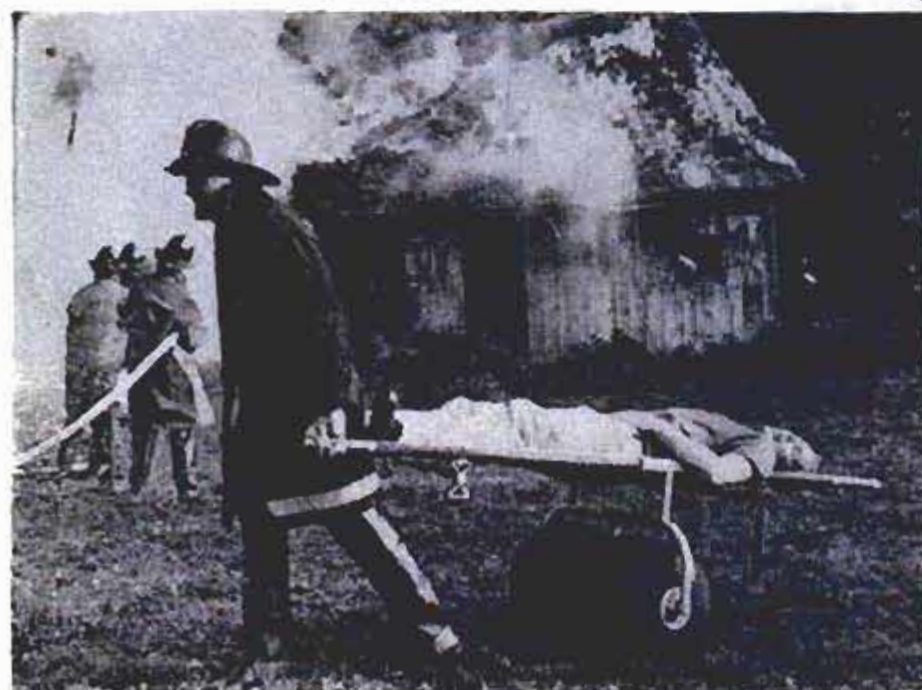



# Radio Television Electronics

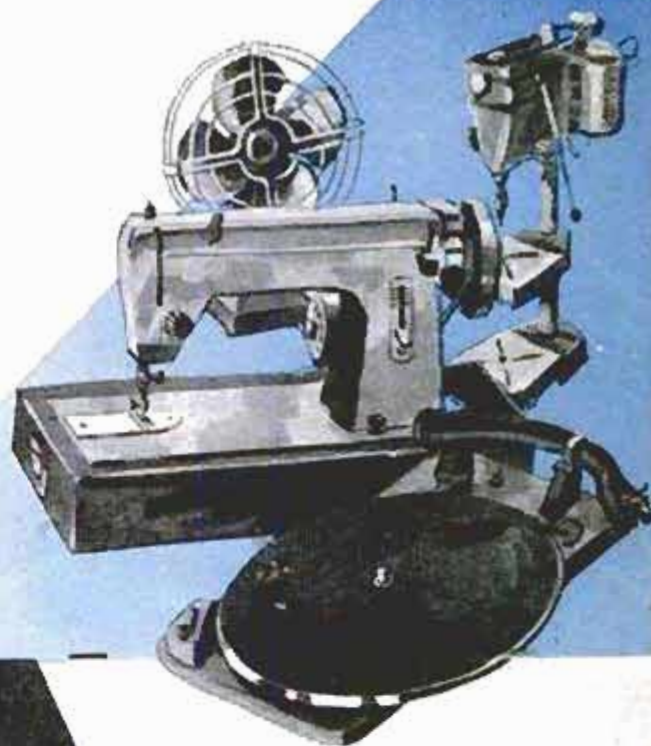
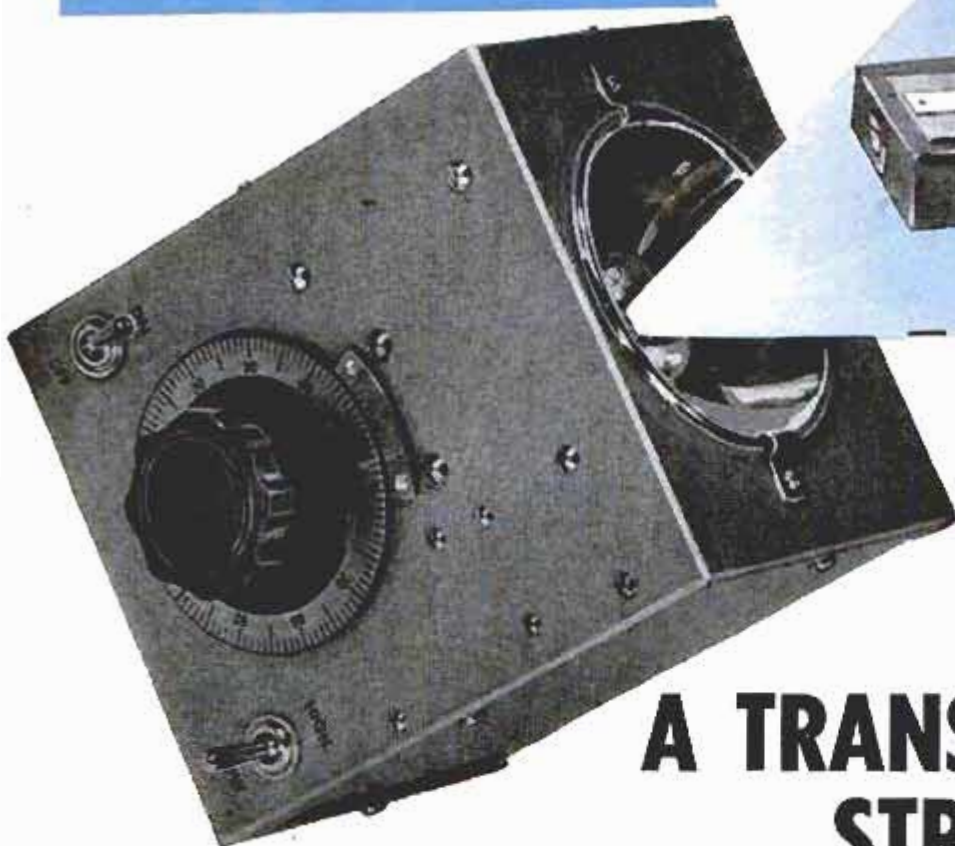

## A TRANSISTORIZED STROBOSCOPE

By J. E. Pugh, Jr.

**N**O ONE OBSERVING the use of a stroboscope for the first time can help but be impressed with the unique characteristics of this interesting instrument. Under the glare of its single bulb, a rapidly whirling fan or any other rotating or reciprocating piece of machinery will appear to slow down or come to a complete stop. This permits visual observation of the performance during actual operation, thus pinpointing troubles which would be difficult to trace with other methods.

Electronic stroboscopes, using vacuum or gas tubes, have been used for years in laboratories and repair centers for mechanical and electromechanical devices with excellent results. Now, however, the availability of suitable low-cost transistors makes it possible to build a stroboscope having the advantages of vacuum-tube types plus a few of its own. Most important of these is brought about by the low power consumption of transistors which permits the design of a fully portable, battery-

operated instrument. In addition, the long life expectancy and ruggedness of transistors, coupled with the low operating voltages and current, virtually assures trouble-free performance and reliability. Battery operation, further, eliminates the ever-present danger of shock when working around grounded objects with a.c. line operated devices.

Pulses of light, properly timed and of short duration, provide the motion-freezing ability of the stroboscope. If an object is rotating or reciprocating at a regular rate, and if it is illuminated for only an instant at the same point of each rotating cycle, it will appear to be motionless. If a rotating object is illuminated at a rate which is slightly slower or faster than its actual motion, it will seem to move very slowly either in its true direction, or in the opposite direction, respectively.

To be truly useful, a stroboscope should be able to generate pulses of light at any frequency within the reciprocating or rotating range of most mechanical equipment. In the transistor stroboscope this is



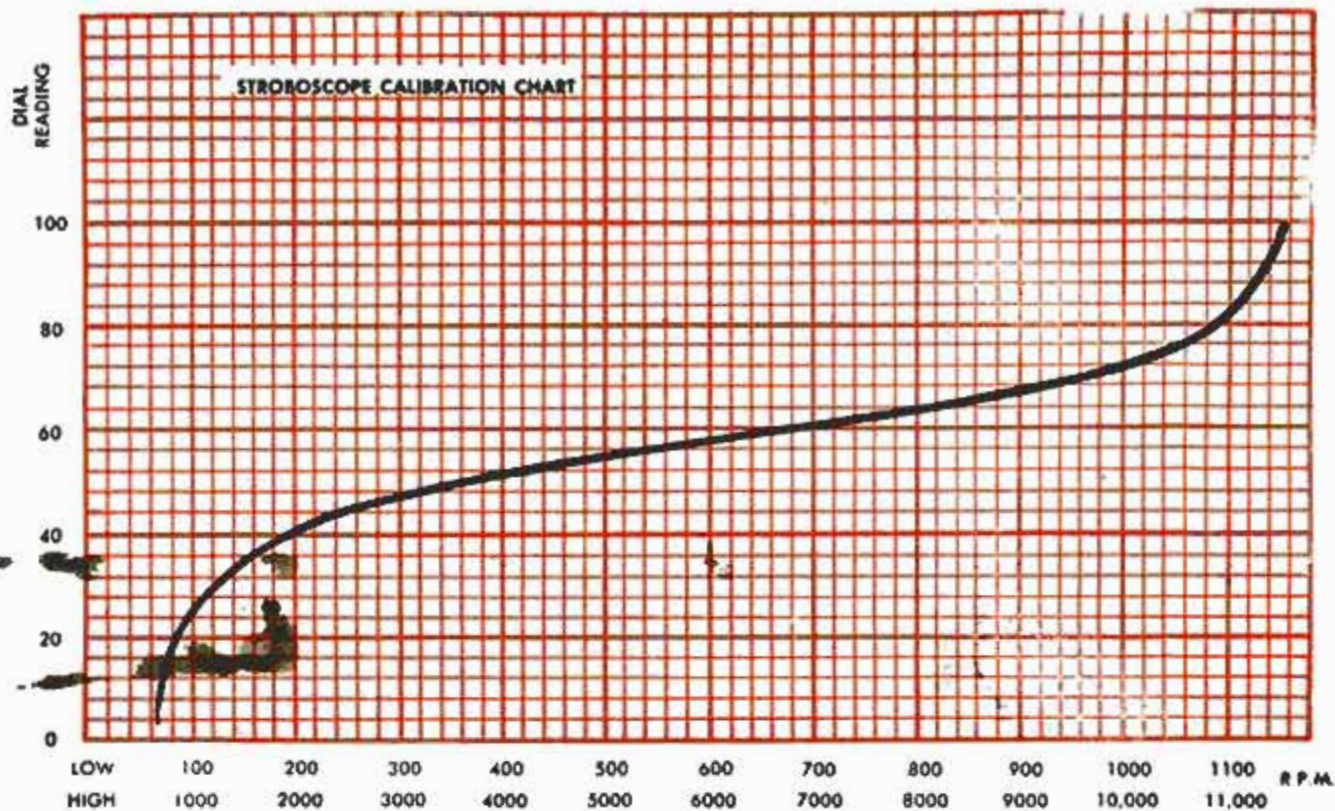

Fig. 1. Calibration chart for original model. For greatest accuracy units must be individually calibrated

accomplished with a two-stage electronic circuit consisting of a variable pulse generator, V1 in the schematic of Fig. 2, and a pulse amplifier, V2. The blocking oscillator used as the pulse generator can produce low-voltage signals ranging from 100 to 10,000 pulses per minute, in two steps. Step one, with switch S1 in the Low position, gives frequencies from 100 to 1000 p.p.m., while step two, the High position, provides 1000 to 10,000 pulses per minute, depending on the setting of potentiometer R4. The approximate calibration is shown in Fig. 1, which gives the dial readings for various pulse frequencies.

The pulse amplifier stage, V2, steps up the low-voltage pulses from the generator to a level (approx. 200-v.) required for reliable firing of the neon bulb.

The entire unit is powered by 6 flashlight cells connected in series for a total of 9 volts. In the interest of conserving battery life, a 1-watt neon bulb is employed. The output of this bulb is somewhat limited, requiring subdued external lighting for proper observation. Maximum current drain, even at the top end of the high range, does not exceed 130 ma. (about 5 ma. at the bottom of the low range) so that a single set of batteries should last well over 100 hours during intermittent operation.

**Construction.** The entire stroboscope is housed in a 4 x 5 x 6-in. aluminum case and weighs just a little over 3 lb., including batteries. The wiring, as shown in Fig. 3, is relatively simple and noncritical. One part of the aluminum case serves as the

chassis for mounting all parts except 5 of the 6 battery holders. These are mounted in the case cover and should be installed after the main chassis wiring has been completed so that they can be properly placed to prevent interference with the chassis-mounted parts.

Transistors, though rugged and durable in operation, are easily damaged by the application of excessive heat. To prevent this damage when soldering the leads of V1 to the 5-terminal tie point, hold each lead with a pair of long-nosed pliers between the soldering point and the transistor body. Leads should be soldered with a very hot iron and as rapidly as possible, after making sure that these are connected to the proper points. The small diagram in Fig. 2 permits transistor lead identification.

V2, a power transistor, is fastened to the chassis, but insulated from it with fiber spacers and shouldered washers, see Fig. 3. Contact to the elements of this unit is made with a solder lug inserted between the transistor body and one of the washers, and two tube-socket pins salvaged from a miniature 7-pin tube socket. The latter provide a good contact for the transistor's base and emitter pins but a small piece of thin insulation material, such as mica, or even paper, should first be slipped over the pins to keep the connectors from touching the transistor body.

The reflector, a plastic photoflash type available from most camera shops, requires a 3-in. chassis mounting hole and is held

(Continued to page 200)



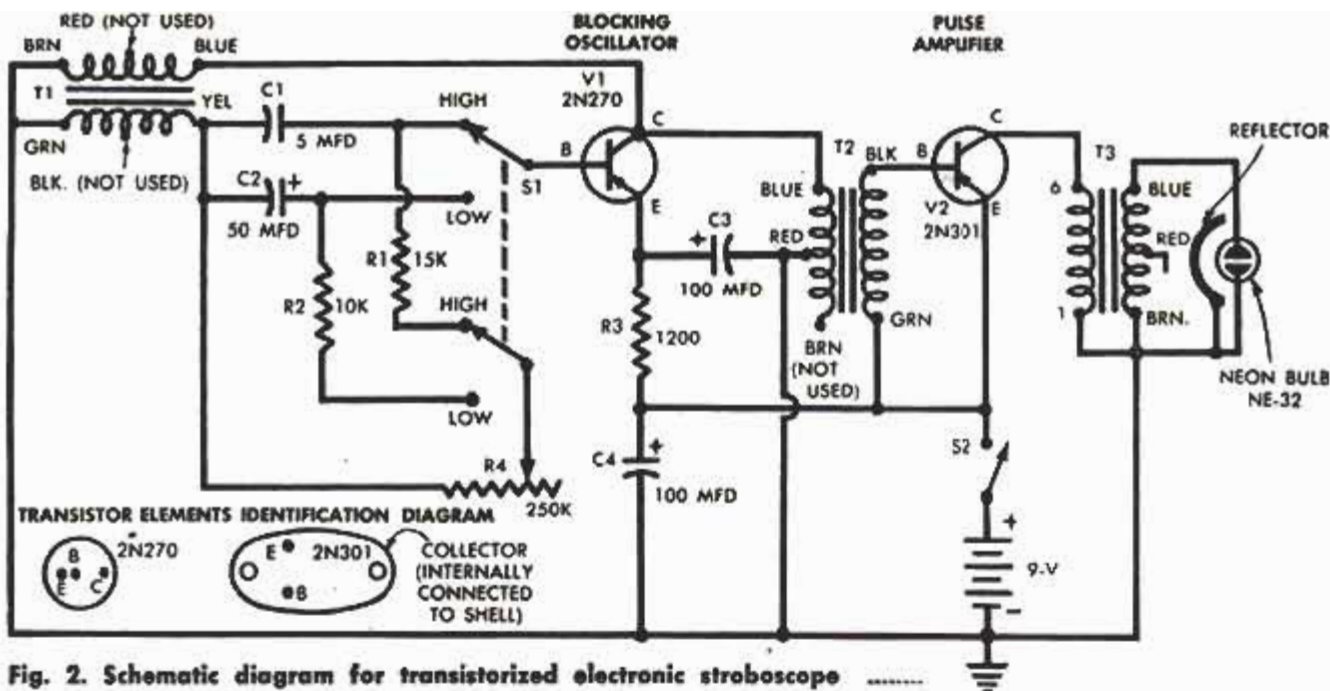

Fig. 2. Schematic diagram for transistorized electronic stroboscope

### LIST OF MATERIALS

**RESISTORS:** (All fixed resistors are 1/2-watt+10%. K=1000 ohms). R1=15K; R2=10K; R3=1.2K; R4=250K potentiometer, log. taper, Ohmite type CA 2541.  
**CAPACITORS:** C1=.5 mfd., 200-volt tubular; C2=50 mfd., 25-volt electrolytic; C3, C4=100 mfd., 25-volt electrolytic.  
**TRANSFORMERS:** T1=audio transformer, 500:500 ohms, Argonne AR-162 or equiv.; T2=audio transformer, 200 C.T.: 16 ohms, Argonne AR-124 or equiv.; T3=universal output transformer; Knight 62G023 or equiv. (Use 4000:9 ohms turns ratio).  
**TRANSISTORS:** V1=RCA 2N270; V2=RCA 2N301.  
**MISCELLANEOUS:** S1=D.P.D.T. toggle switch; S2=

S.P.S.T. toggle switch; B1=six 1.5-volt flashlight cells, Type D (No. 2); neon lamp=GE type NE-32.  
**HARDWARE:** 3-in. reflector, Kodak part No. CW-129837, or equiv.; bulb socket, double-contact, bayonet candelabra; dial, ICA type 2170; aluminum case, 4x5x 8-in., ICA type 29442; battery holders for type D flashlight cells (6 required); five-terminal tie point (one lug grounded); two-terminal tie point (one lug grounded); 2 metal spacers, as required for bulb-socket mounting; 2 fiber spacers, for mounting V2. 2 shouldered fiber washers; 2 1/2 x 1/2-in. right-angle brackets; 2 1/8-in. cable clamps for mounting reflector; screws, nuts, hookup wire, rosin-core solder.

Fig. 3. Pictorial diagram. Insert shows mounting details for bulb-socket assembly and power transistor

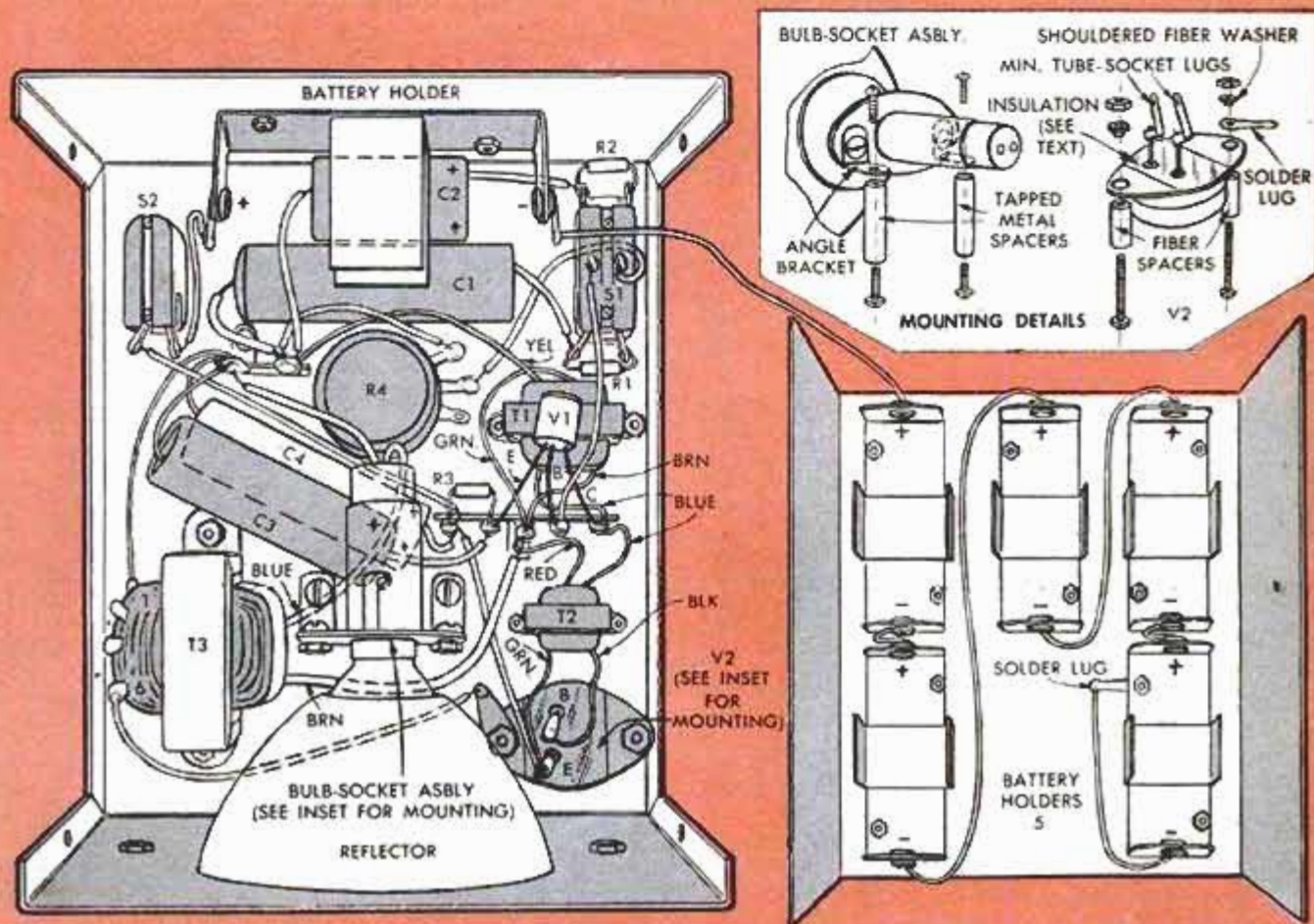



# Electronics Today

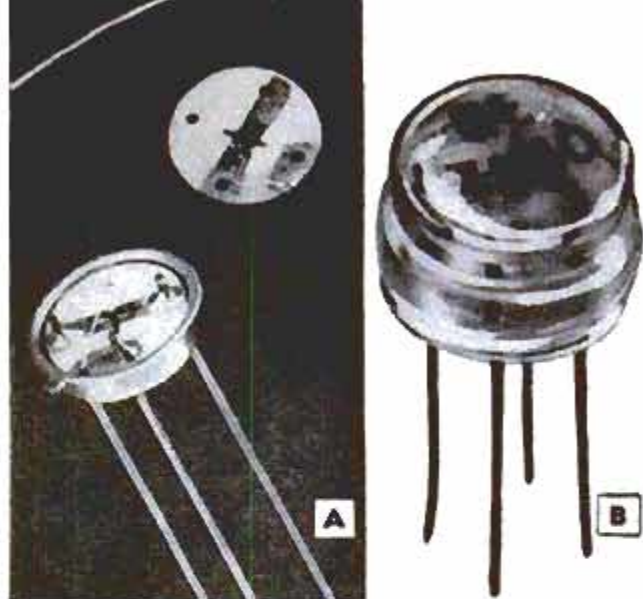

THOSE TOUGH little transistors are getting tougher. When conventional impact tests proved ineffective, units built with GE's new fixed-bed mounting technique, Fig. A, were shot from a 12-ga. shot gun into a telephone book—and still worked. And indications are that future transistors will be still cheaper. Glass housings, rather than metal, Fig. B, are said to reduce casing costs by as much as 90 percent.

High-voltage rectification at mass-production costs is now available with new "expandable" silicon rectifiers. Tiny units, Fig. C, rated at 400-v. and 750-ma., can be used individually or fastened together in minutes to meet any high-voltage requirements. Hand-held stack of 10 series-connected units has peak-inverse voltage rating of 4000 v.

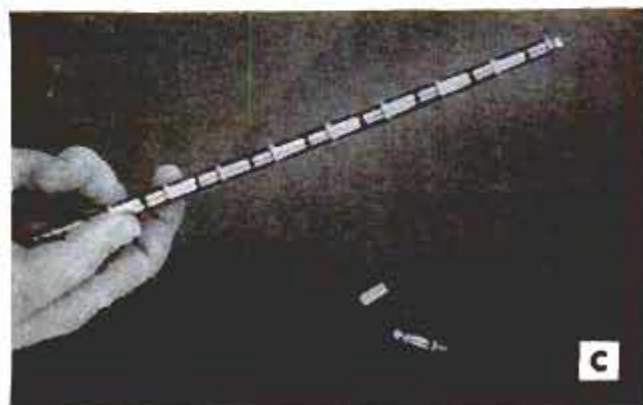

Marvel in miniaturization, new voice recorder, Fig. D, weighing less than 3 lb., measures only 2 x 4½ x 6 ⅝ in. Features thumb-controlled stop-start microphone, visual battery-life indicator, and instant playback by using mike as earphone. Tape magazine holds enough tape for one hour's recording.



Not a game of "blind man's buff," Fig. E, but an environmental test of binaural hearing aids (concealed in eyeglasses) carried out at Grand Central Station at peak of rush hour. To pass the test, the subject had to identify voices and direction of examiners.

Marine radiotelephone for outboard motor cruisers, Fig. F, is especially designed for limited-space applications. Despite small size, only 5½ x 10 x 14 in., unit provides 20-w., 6-channel operation from 12-v., storage-battery power source.





# The CRAFTSMAN



## TWIN VANITY DRESSING TABLES

**S**ISTERS sharing a room, whether they are twins or not, will be delighted with these twin vanity tables. The vanities are alike, but individual, as one is right-handed, the other left-handed. The latter factor also permits a number of attractive arrangements, such as alignment along a wall as in the illustration, or back-to-back, as in Fig. 4.



Constructed of  $\frac{3}{4}$ -in. plywood, the vanities get much of their professionally finished appearance by the use of plastic laminate on the horizontal surfaces, and as edge trim to conceal the end grain of the wood.

These particular vanities were covered with Formica plastic laminate, available in a variety of colors and patterns that can be chosen to match or provide a

To assure that plastic laminate cemented to edge will project, top is placed on scraps of laminate

Top is clamped or blocked so it will not move and plastic laminate strip is pressed firmly on cement

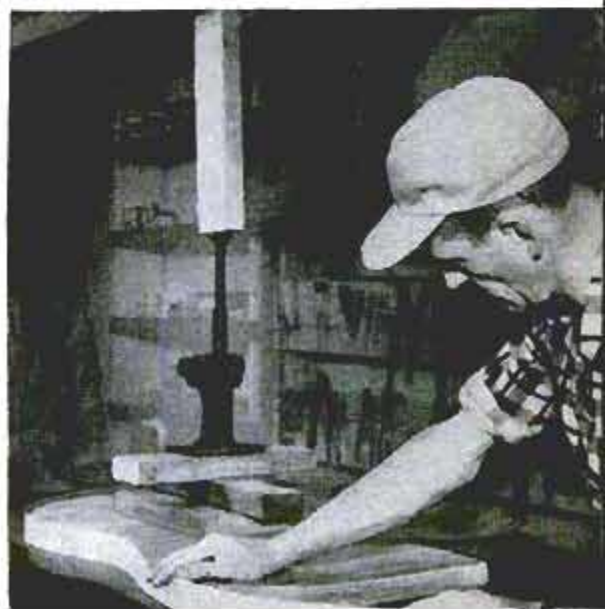



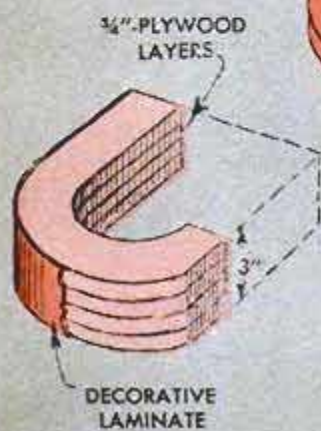
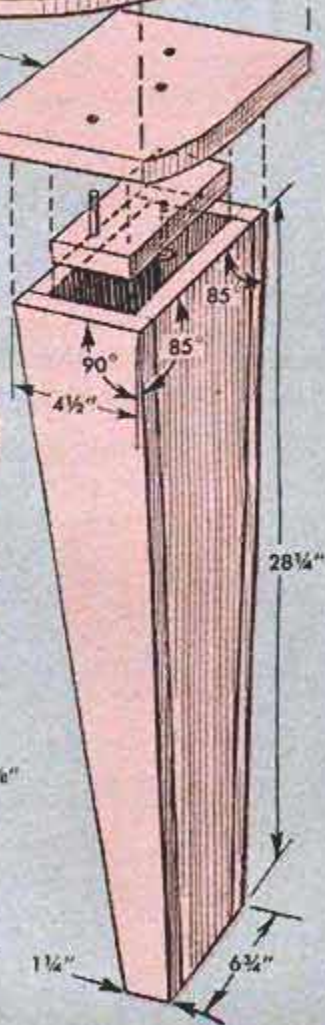
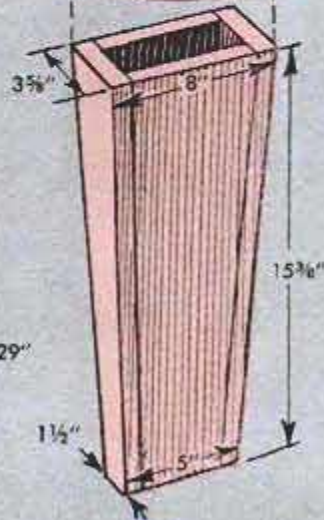
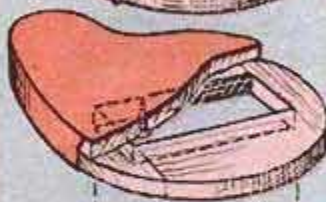
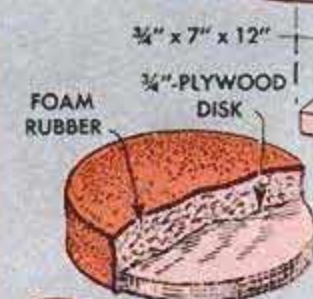
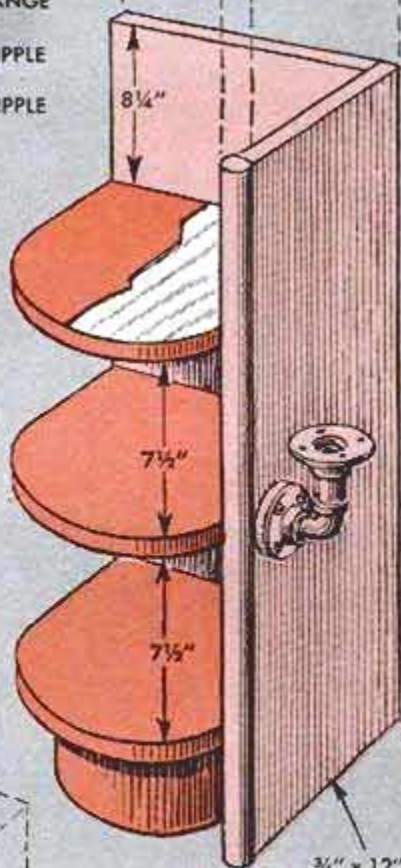
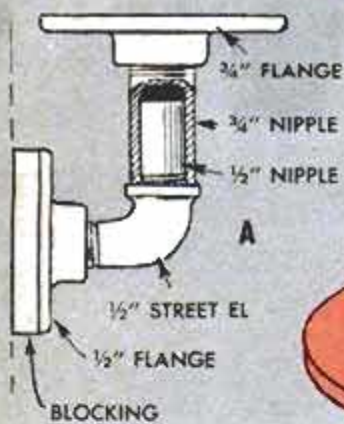
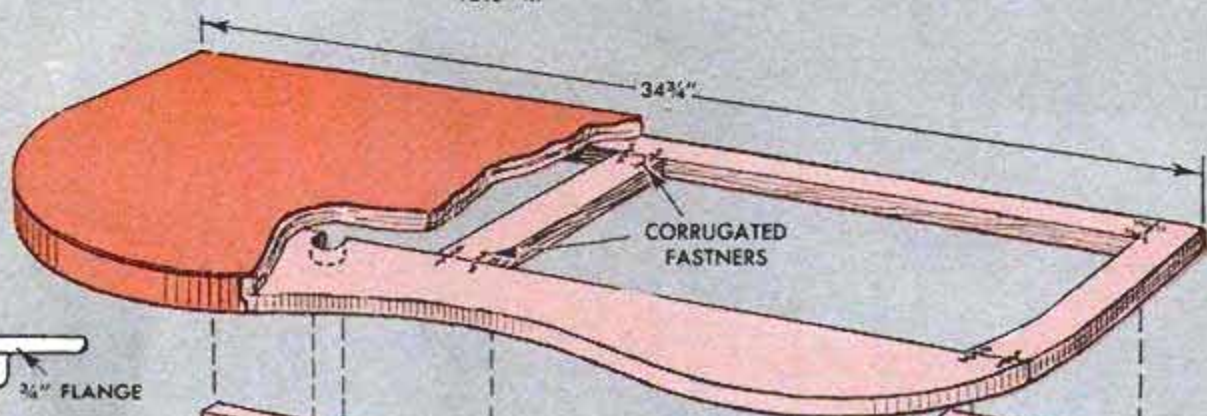
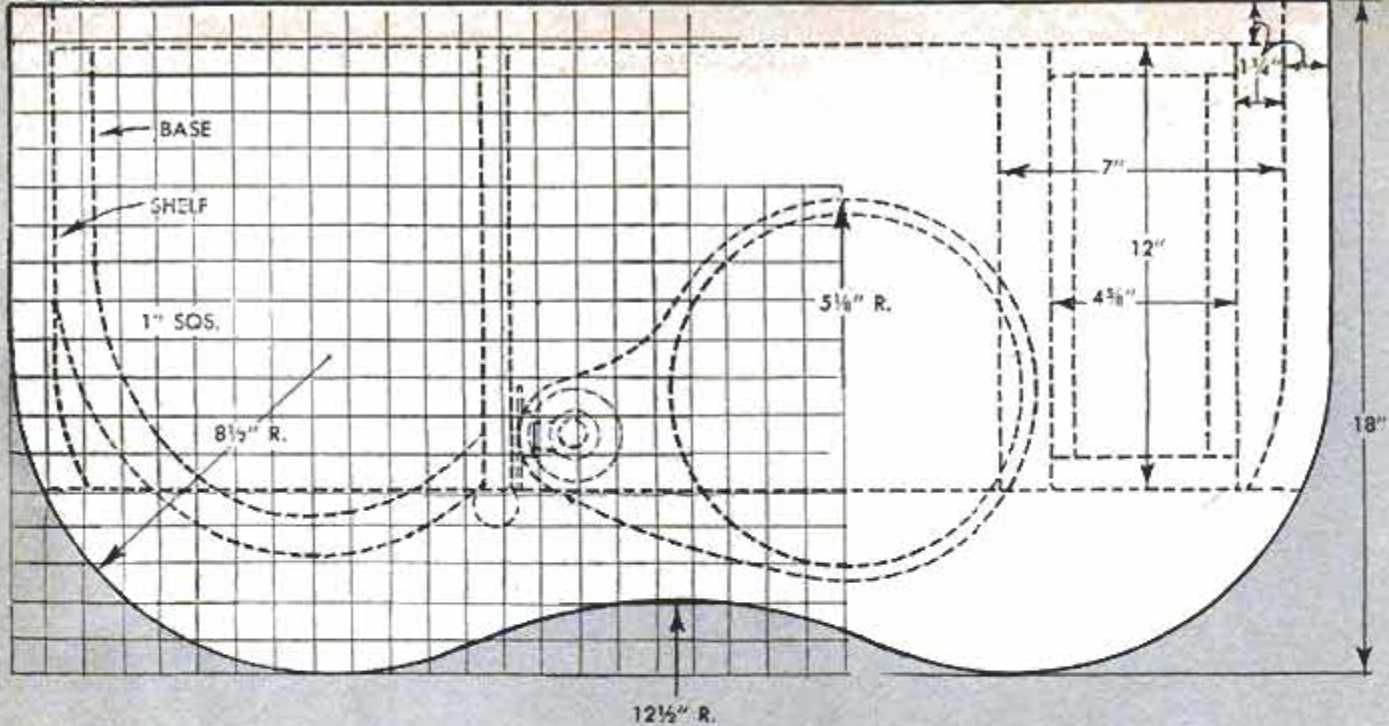



contrast to the color and decor of a room. Wood-grain patterns are also effective.

Details of construction are shown in Fig. 3. The squared pattern provides the shapes and dimensions of the vanity top, the frame that fits under the top, the shelves and the seat top. For twin vanities, two of each item are cut and assembled. For the opposite-hand unit, the shelves and seat pieces are inverted and placed on the opposite side. The shelf back and partition also are shifted to the opposite side. Corrugated fasteners and glue are used to assemble the frame for the top. The solid top piece then is glued and screwed to the frame. Then a strip of laminate is cemented to the edge of the assembled top. To assure a light projection of the laminate at both top and bottom, scraps of laminate are placed under the top, Fig. 1. The top then is clamped or blocked so it will not move, Fig. 2, and the laminate is applied with contact adhesive. The projecting edges of the laminate are then filed flush with the surface of the top. Laminate now is applied to the surface of the top, using a roller, Fig. 6, or an ordinary rolling pin to press the laminate in full contact with the top. Like the plastic edging strip, the edges of the top piece are allowed to project slightly and worked down first with a plane, Fig. 5, then carefully filed even with the surface of the edge facing. Plastic laminate is cemented to the shelves and seat tops in the same way. The lower, left-hand detail in Fig. 3 shows how layers of  $\frac{3}{4}$ -in. plywood are stacked and cut to form a base under the lower shelf. The dowel on the front edge of the shelf partition is a closet pole, which measures about  $1\frac{3}{8}$  in. in diameter. A flat is planed its full length and it is fastened to the partition with glue and

Laminate is applied to top after edge is covered. Projecting edge is planed flush, then filed flush



Because vanities have a right and left-hand design, they can be arranged in several ways. One way is back-to-back as shown here

long finishing nails, set and puttied over. Detail A in Fig. 3 shows how the seat support is fabricated from pipe fittings. Disks of  $\frac{1}{4}$ -in. hardboard are used to block out the support so the seat can pivot without touching the partition. The cushion for the seat is made from a disk of foam rubber cemented to a disk of plywood. Foam-rubber cushions of the right size and shape sometimes are available. When a disk of foam rubber is used, it is covered with sheet plastic upholstery that is wrapped under the edge of the plywood disk and tacked. The cushion is screwed to the assembled leg-and-seat support. ★ ★ ★

Roller or rolling pin is used to press laminate to top. Move roller from center outward to remove air







## ← Knitting Needle Substitutes For Missing Stencil Stylus

If a regular stylus is not available when ruling or tracing must be done on a duplicator stencil, a plastic knitting needle is an excellent substitute. It will not cut or gouge the stencil, as other makeshift tools often do. As a precaution, check the point of the needle for roughness. Any rough spots can be smoothed with fine sandpaper or emery cloth.

## Rubber Band on Architect's Scale Keeps It Right Side Up

Keeping the right scale up when working with an architect's scale is no problem if you use a rubber band. Twisted and stretched from end to end, the rubber band identifies the top of the rule at a glance.

## Steaming Renews Pitted Surface Of Shop Drawing Board

When the surface of a drawing board becomes pitted with numerous thumbtack holes, it can be made smooth again by steaming which swells the wood fibers and closes the holes. To steam it, first sponge the board with water and let it soak for a minute or so. Then apply a hot pressing iron to create steam and "iron" the board until it is hot and dry. If a board is badly pitted and beyond the steam treatment, it can be resurfaced by covering it with  $\frac{1}{8}$ -in. tempered hardboard. Then masking tape is used instead of thumbtacks to hold the drawing.

F. L. Trudeau, Tweed, Ont., Canada

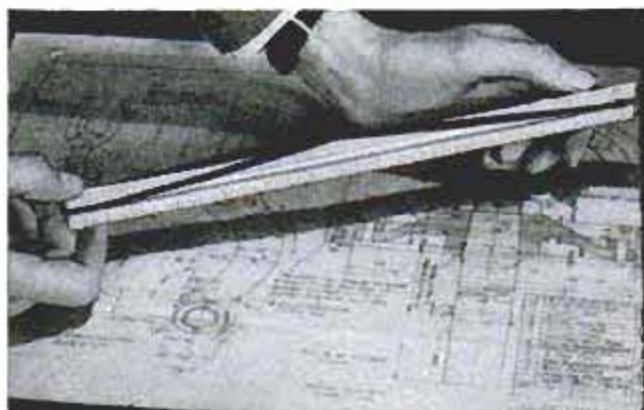

## Paper Held on Drawing Board Without Thumbtack Damage

When a large pad or tablet of paper is used for sketching it can be held on a drawing board securely without the need of piercing the sheets of paper with thumbtacks in the usual manner. Lift the sheets of paper and force the thumb tacks through the cardboard backing to which the sheets are attached. The sheets then can be torn off one at a time and the tablet will remain in position on the board until the last sheet is removed.

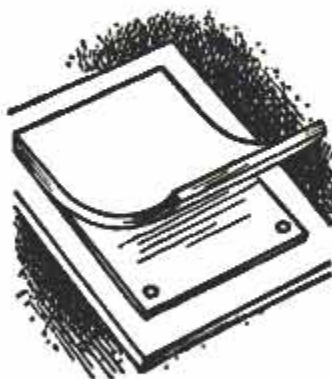

## "Self Renewable" Glue Brush

"Self dispensing" and renewable, this glue applicator solves the messy problem of maintaining glue brushes. It consists of a length of sash cord fitted in a length of  $\frac{1}{4}$ -in. tubing. Fray the projecting end of the cord to form a brush. After it has been used on a gluing job, pull the glue-soaked portion out of the tube and cut it off, leaving a fresh "brush."



## Pencil Compass Used for Inking

An ordinary school-type compass in which a pencil usually is clamped can be used for drawing inked circles by using a ball-point pen cartridge. The cartridge is wrapped to increase its diameter.

## "Skidproofing" Bookends

Sponge rubber cemented to the bottoms of bookends will prevent them from sliding under the weight of books and also will protect the finish of furniture on which the bookends are used.



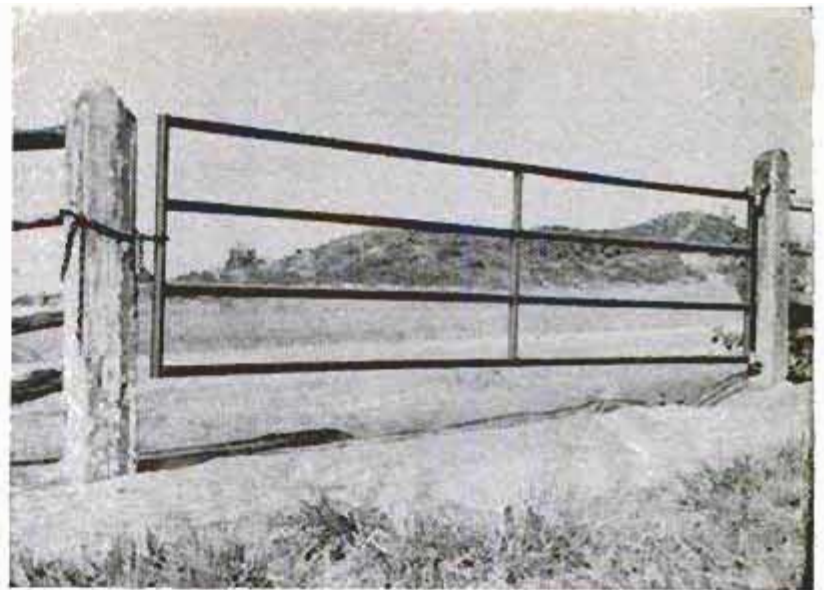

## Welded-Pipe Gate

Welding is used at all joints in this extra-long gate that is made from 1½-in. steel pipe. No diagonal braces are required to keep it from sagging. Sockets welded at the upper and lower corners of one end of the gate are lengths of ¾-in. pipe. These sockets fit over pins bolted through the gate post. The pins are L-shaped lengths of ¾-in. steel rod, threaded at one end to permit turning on a large nut. A large nut and two washers are welded to each pin, as indicated in the lower left-hand detail, both to support the gate and to keep the vertical portions of the pins the correct distance away from the gatepost. The upper hinge pin is longer than the bottom one, which permits the gate to be lifted onto the upper pin, then dropped to the lower pin, when the gate is installed. This pin-and-socket setup permits quick and easy removal of the gate when that is necessary, such as for replacement of the gatepost.—Hi Sibley, Nuevo, Calif.

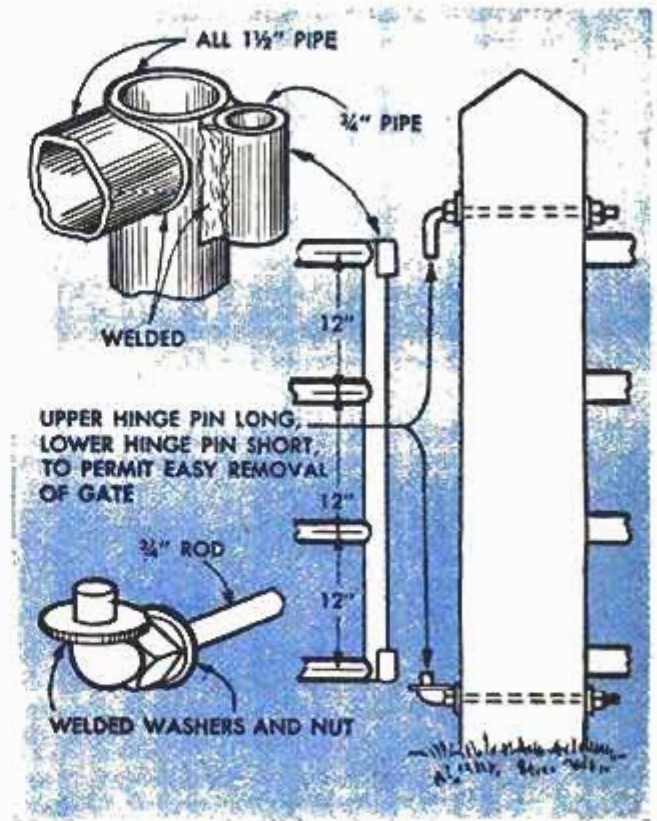

## Pocket Knife Holds Chalk Line

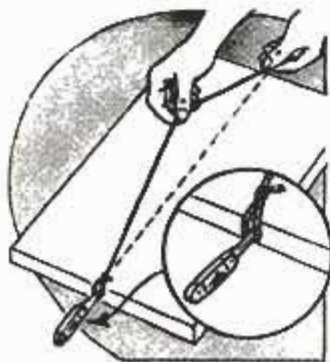

is pulled against the back edge of the blade where it will not be cut. An ice pick can be used in the same manner.

Give yourself an extra "hand" when holding a chalk-line the length of a board, by using a pocket knife as shown. Force the knife blade into the wood at the end of the board, sharp edge up, and loop the string over it. The string

## Hose Is Wire-Cutting Jig

When a number of wires of identical short lengths are to be cut, speed the job by using a jig made by plugging a length of rubber hose as indicated. The hose is cut to the length desired for the wires, allowing for the inserted cork.



A number of lengths of wire can be cut before the jig has to be emptied. A length of metal tubing can be used too.





# DECORATIVE *Painted* GLASSES

By Igor and Nancy Lobanov  
4305 GREEN GROVE DRIVE, CORPUS CHRISTI, TEXAS

**A**LTHOUGH freehand painting of colorful and artistic designs or caricatures on beverage glasses usually requires the talent of an experienced artist, here is a method that anyone can use with admirable results. It simply involves making a tracing of a printed design and cutting a stencil from it that is used as a guide, when painting the design on a glass. If oilbase paints are used, the glasses can be used 48 hrs. after painting. However, glasses that are to be repeatedly washed in a strong detergent should be decorated with china-type paint. Use of the latter requires heating the painted glass in an oven to render the colors permanent.

The first step in decorating your glasses, is to find a design that will be suitable for the size and purpose for which they will be used. To be effective, the design must be simple, using not more than two colors and few inside lines or textures. Sources for such designs are book illustrations, magazines and newspapers. Drawings of animals make excellent subjects. Your initials also,

Desired design to be applied to glass is first traced on strong paper, outlining all parts to be cut out

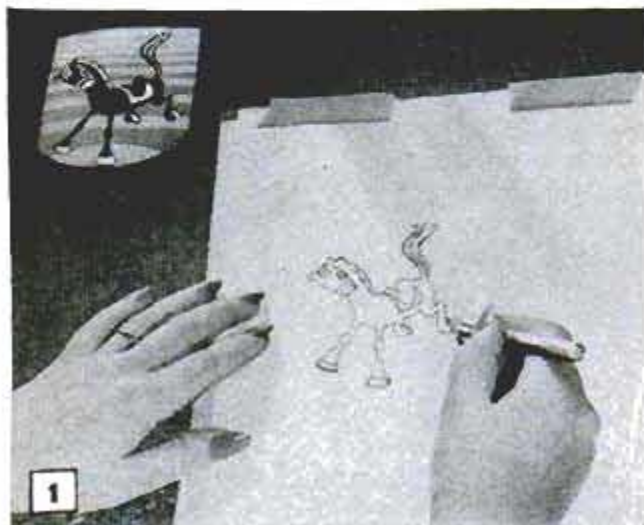

may be applied to glasses in this manner.

After selecting the desired design, trace an outline and important details of it on heavy but translucent paper, such as vellum. The tracing is then taped to a square of cardboard and cut out to produce a stencil as in Fig. 2. Use a razor-sharp knife for this so as not to tear the paper. Next, tape the stencil to the glass on which the design is to appear and apply the base coat of white paint. This is a thin coat that is used to outline the design and important elements within and serves as a guide for applying the colors. If china paint is used for the base coat, it will dry in a few minutes, while oil paint must be left to dry overnight. When applying the base coat, use light strokes and brush into the design to avoid tearing the paper and to prevent paint from running under the stencil. It may be necessary to hold down narrow projections of the stencil, when painting over them. When the paint is dry, remove the stencil and tape it on the next glass to be decorated.

After design is cut out to form stencil, it is taped to glass and base coat of white paint is applied

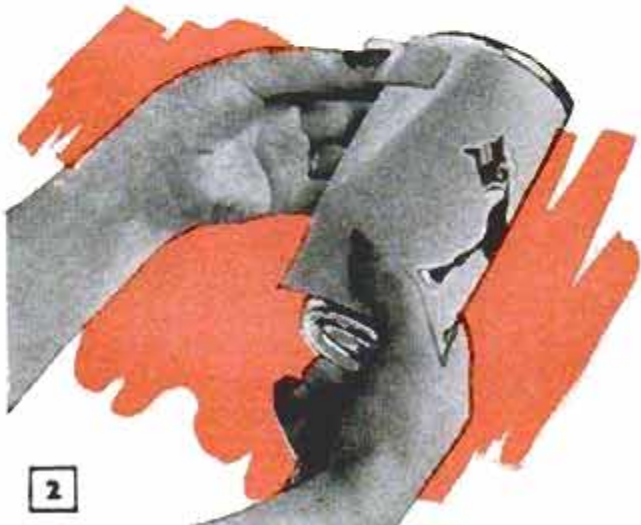



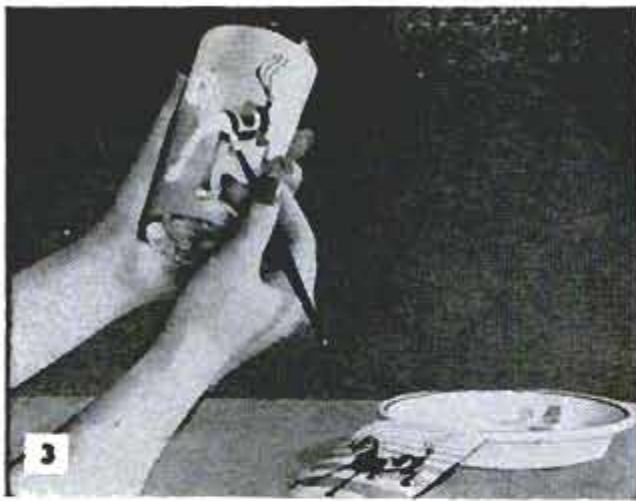

Above, apply paint with light strokes, brushing inward to prevent paint from running under stencil

With the basic outline established, now apply the colors, using a medium-small artist's brush for the large areas and a small one for the fine details, Figs. 4 and 5. Use the original design for reference and paint carefully following the outline and avoiding going over the same spot too often, as this will build up pigment and leave an uneven surface. Since most brands of china paint darken during the heat-treating process, use a slightly lighter shade than called for to compensate for the anticipated change. When the design is completely painted, oil-base painted glasses are set aside for 48 hrs. for drying before use. Glasses decorated with china paints require a glaze coat before baking to protect the colors from fading and washing off in use. Then, place the glasses in an unheated kitchen-range oven and over a period of 1 hr., slowly advance the temperature to 350 deg. to prevent glass breakage, Fig. 6. Bake for 45 min. and turn the heat off, keeping the door closed for 1½ to 2 hrs. to allow the glasses to cool slowly. After washing the glasses, they are ready for use.

Coat of glaze is applied on design before heating in oven to prevent colors from washing off glass



Fig. 4, when thin base coat of white paint is dry, colors of design are brushed on, using medium-small brush for large areas and small brush for details

After painted glasses are placed in cold oven, heat is gradually raised to 350 deg. to prevent breakage

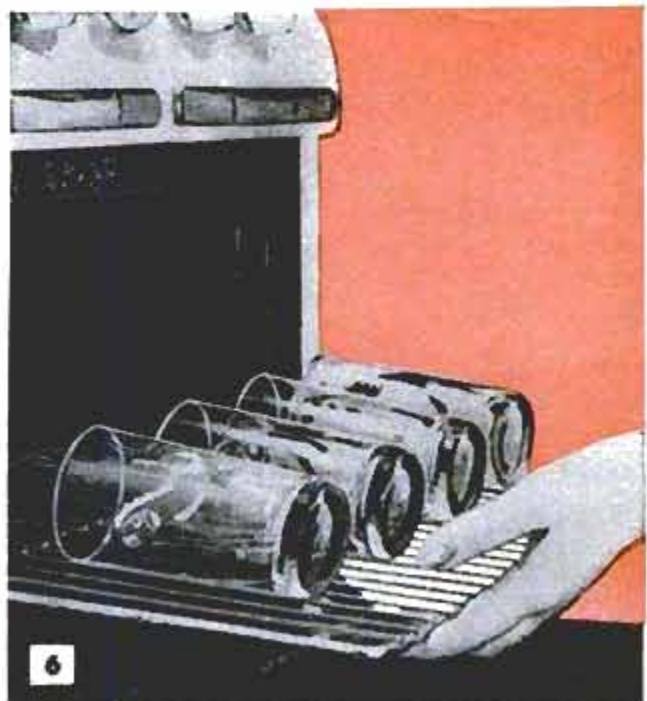



## Sawing Saves Boards When Dismantling Wooden Boxes



Wooden fruit boxes and crates are a good source of small dimension lumber for building bird-houses, doll houses and other small projects, provided the containers are dismantled without splintering the boards. To do this, simply saw off the nailed portion of the sides and bottom as close to the inside face of the ends of the box as is possible, as shown in the illustration. Use a square when marking the sides and bottom for cutting and cut one board at a time, so that the usable portion of each board will have squared ends ready for use. The thicker lumber of the box ends also may be salvaged and used for cleats, blocking and many other purposes, after the remaining stubs from the sides and bottom are hammered off as in the detail.

Andrew Vena, Philadelphia, Pa.

## Small Wedge Used for Spacing Picture Molding at Ceiling

For uniform spacing between a ceiling and picture-type molding being nailed into position, use a small wedge as shown. In use, the wedge is inserted between the molding and ceiling, holding the molding tightly in place while nailing it. Hook and wedge are advanced for each nail driven.

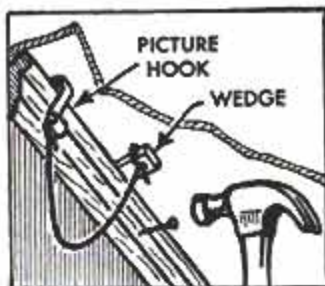

## Putty Knife Cleaned of Paint On Slotted Can

When a putty knife is used for scraping paint or varnish after application of wet chemicals, it can be quickly cleaned without mess by pulling the blade through slots cut in the side of a can as shown. Paint scraped off the knife falls to the bottom of the can for easy, quick disposal.

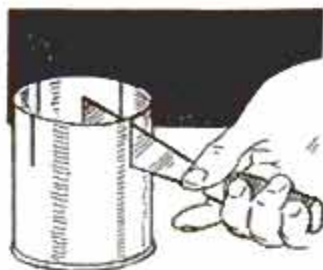

## White Marks Indicate Receptacle Openings

White marks, painted on the face and edges of an electric receptacle plug or box to mark the prong entrances, indicate at a glance the position of these openings for easy insertion of a male plug. The marks are enameled on the receptacle the exact width of the openings.



## Notch Accessory Switch For Touch Control

Without observing closely, it is not possible to detect whether some electrical accessory switches have been turned on or off. To avoid this problem, file a notch on one edge of the "on" part of the control. Then you can determine its position by touch. — Ed Packer, Oak Park, Ill.



☐ The heat from a sun lamp when directed upon a freshly painted surface will speed the drying process. When using the lamp, it is necessary to provide good ventilation. Howard E. Moody, Upper Jay, N. Y.

☐ A plastic berry basket stapled to the wall makes a handy holder for a ball of twine. Passed through the basket's bottom, the twine can be cut any length without dislodging the ball.



# Rack Eliminates Loose-Air-Tank Hazard in Boat

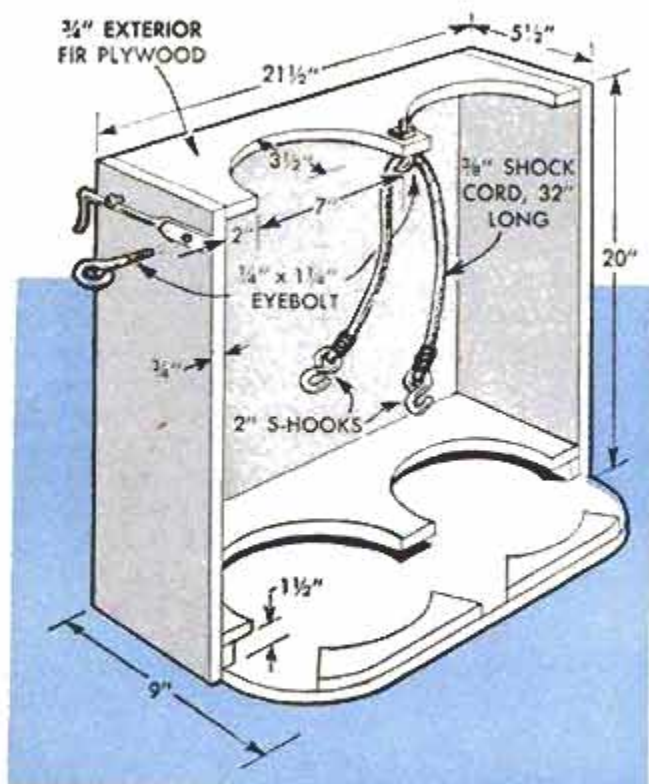

Easily built plywood rack holds securely two standard-size compressed-air tanks of the type used for most self-contained underwater-breathing apparatus

Compressed-air tanks used for skin diving can be dangerous if allowed to roll around freely in the bottom of a moving boat. To eliminate this hazard Bud Boyett of Silver Springs, Fla., designed and built this simple rack of  $\frac{3}{4}$ -in. exterior-grade plywood, assembling it with waterproof glue and No. 10 brass flatheaded wood screws. A length of shock cord, passed through an eyebolt is used to hold the tanks in place. Hooks on the ends of the cord slip into other eyebolts on the sides of the rack. The latter eyebolts also hold hooks on the rack sides. These hooks are bent from  $\frac{1}{4}$ -in. steel rod, one end being flattened and drilled to accept the eyebolts. The opposite ends are bent down at 90 deg., and are fitted in eyebolts located in the side of the boat. Thus, the rack and tanks can be lifted from the boat as a unit and taken ashore.



Rack and tanks are removed and replaced in boat as a unit. Hooks on rack fit into eyebolts located on bulwark of boat at location convenient for divers

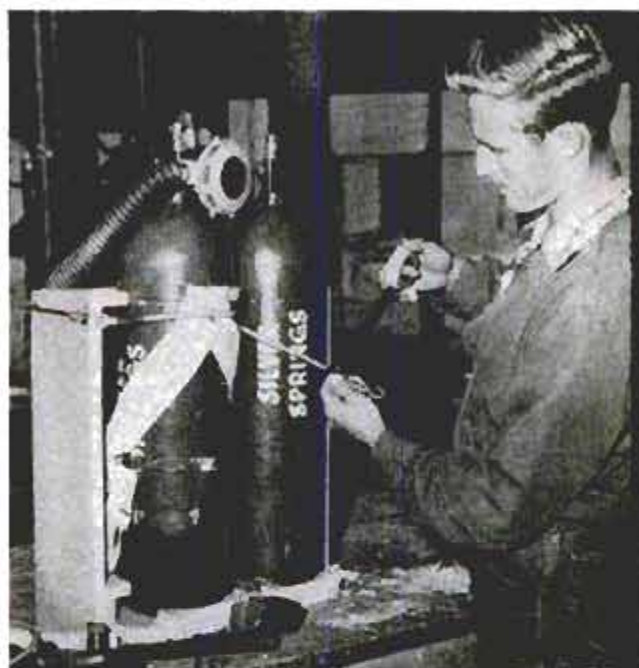

## Water-Soaked Burlap Keeps Fish on a Stringer Alive in Boat

When a stringer of fish must be lifted into a boat while being rowed to a new location, wrap them in a water-soaked piece of burlap or an old sheet. Bass can stay alive under these conditions for 15 or 20 minutes. If the trip will take a longer time, stop the boat and drop the fish over the side for a few moments to give them a "breathing spell" before they are returned

to the boat and wrapped in the wet burlap.  
Clinton R. Hull, Santa Ana, Calif.

☐ Holes  $\frac{1}{8}$  in. deep and  $\frac{1}{16}$  in. larger in diameter than the clamp pads of an outboard motor were drilled in the transom of his boat by one owner to keep the motor from shifting and to prevent scratching the paint.



# COOKING AIDS FOR CAMPFIRE MEALS



Rubbing coat of soap on bottom of pot before placing it on open campfire reduces amount of soot deposited on it. Grime rinses off with soap when washed

"Hunter-trapper fire" is made by arranging short lengths of poles as in log-cabin construction to form pyramid shape for hot all-purpose campfire



Below, deep-pit fire facilitates placing a grill over the flame at the desired height for convenient frying, braising and water heating. Flat rocks or poles may be used to prop grill in level position



**M**EALS COOKED OUTDOORS over an open campfire needn't lack for a good variety of prepared foods, when improvised cooking facilities and aids are used as illustrated. Just about anything can be cooked or baked in this manner to the satisfaction of most palates, including bread and biscuits. Of course, for baking you will need a reflector oven, which is a sheet-aluminum enclosure made in the shape of a lean-to that is open at the front. In use, the open end is placed next to a hot fire so that the heat is reflected toward the food being baked. To make an oven of this type, simply cut and fasten together four sheets of light-gauge aluminum to form the lean-to suggested and attach a wire rack to the sides at about 2 in. from the bottom. The oven should be collapsible for easy carrying.

For hints on how to make a fire that is best suited for each cooking need, see the article, "Tips for Outdoor Cooking," published in last month's issue of *Popular Mechanics Magazine*. Be sure to take along matches, a good knife, hatchet, soap and aluminum foil, in addition to the necessary pots and pans. Just about any solid food can be cooked or roasted in the live coals of an open fire when wrapped and sealed in aluminum foil. A cylindrical-shaped jar or bottle makes an excellent rolling-pin substitute when making biscuits. After a trial or two, you will be able to reduce equipment to the minimum to suit your particular needs. ★ ★ ★

When no newspapers or other readily combustible materials are at hand for starting fire in wet weather, look for a dry, dead limb and slash it to produce fine shavings that can be ignited with flame of match







Right, handy for making biscuits to be baked in reflector-type oven, is cylindrical-shaped bottle used to roll dough flat to uniform thickness. Aluminum foil stretched over bottom of upturned wooden box provides clean, nonsticking flat surface for rolling. Foil can be washed and reused

Below left, plastic tumbler is excellent for cutting biscuits from rolled dough. Simply press open end of the tumbler into dough and then, flip cut-out piece into pie or cookie tin for baking. Dip rim of the tumbler in flour before cutting each biscuit to prevent dough from sticking to it

Below right, chicken parts wrapped in aluminum foil "packets" are placed in bank of live coals for roasting. To do this, place each piece of chicken on small square of heavyweight foil, fold in half and crimp open ends together to seal natural juices inside. Roast for about one hour

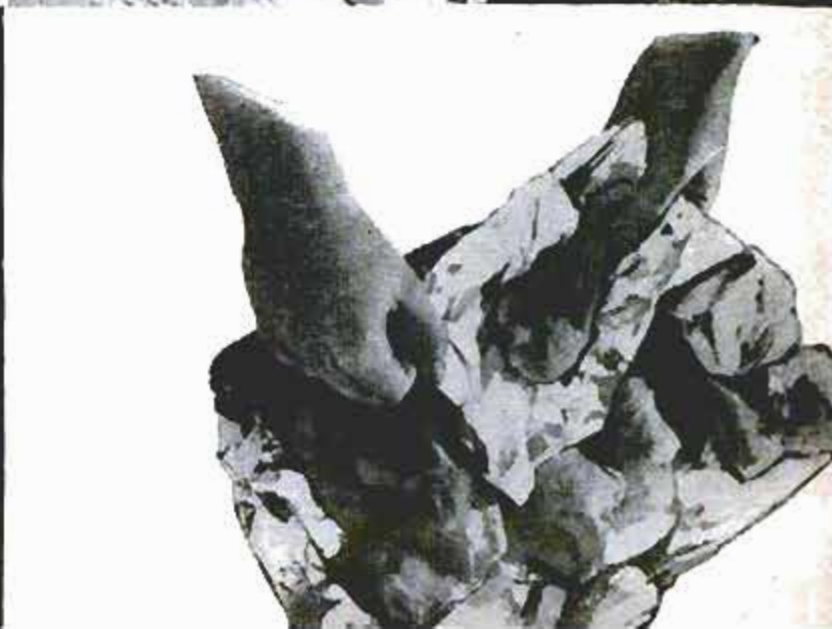





## Vacuum-Bottle Caps Marked To Identify Contents

Picnic kits containing two vacuum bottles and a sandwich box in a carrying case are handy to take on outings, but having hot liquid in one bottle and cold in the other can cause some confusion. To avoid this, paint "C" on one bottle cap, and "H" on the other with red nail polish.

## Slots in Screwheads Cleaned With Hacksaw Blade

Slots in screw heads that have become burred and damaged or filled with paint so that a screwdriver blade cannot be inserted, are cleaned with a section of hacksaw blade.



## Putty Holder on Paint Pail Aids Last-Minute Calking

While applying that last coat of paint on your house you may find small areas that require calking. A small lump of putty can be carried right on the paint pail with this holder bent from sheet metal. The putty is forced over a nail soldered to holder.



## Machine-Stitched Stockings Better for Shoe Polishing

Discarded stockings used for polishing shoes will not stretch and roll into rope-like strips if they first are cross-stitched with a sewing machine. The stitching will counteract the natural tendency of the yarns to roll into the cylindrical shape into which they originally were knitted. The flattened cloth then is ideal for polishing.



## Flexible "Rung" of Chain Makes Ladder Safer Against Trees

When using a ladder to work on trees, one homeowner found he could make the ladder safer to use by adding a flexible "rung" between the rails at the upper end. The rung consists of a chain 8 in. longer than the span between the rails. When the ladder is placed against a tree the flexible rung conforms to the shape of the trunk, providing more resistance to slipping, and also preventing the ladder from sliding sideways. The chain ends are secured to the ladder by  $\frac{1}{4}$ -in. bolts fitted in holes drilled in the rails. A washer is used under the nut and under the head of the bolts. To prevent the holes from becoming oversized by the filing action of the thread bolts, lengths of pipe are fitted in the holes to act as "bushings" that protect the wood.

R. M. Woodbury, Ellsworth, Maine.





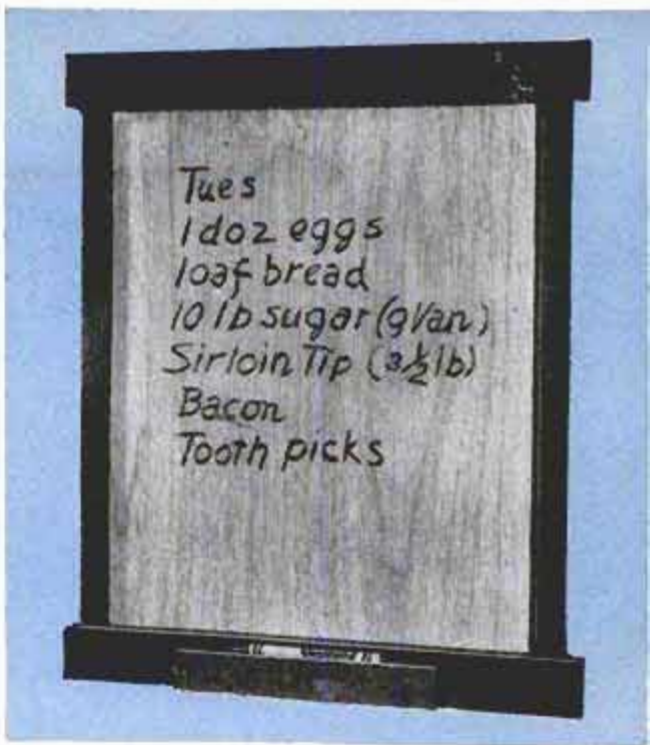

## CRAYON "BLACKBOARDS"

PERSONAL MESSAGES, grocery lists and workshop figures are "erased" from these crayon boards with a dry cloth. Plastic-coated hardboard, used for wall coverings, is the writing surface. For the workshop, no frame is needed on the board, but elsewhere a frame, such as shown in the detail and photos, should be used. A metal tray faced with hardboard and fitted with "keyhole brackets" soldered to one edge, is a self-framed crayon board that can be hung or used as a serving tray.

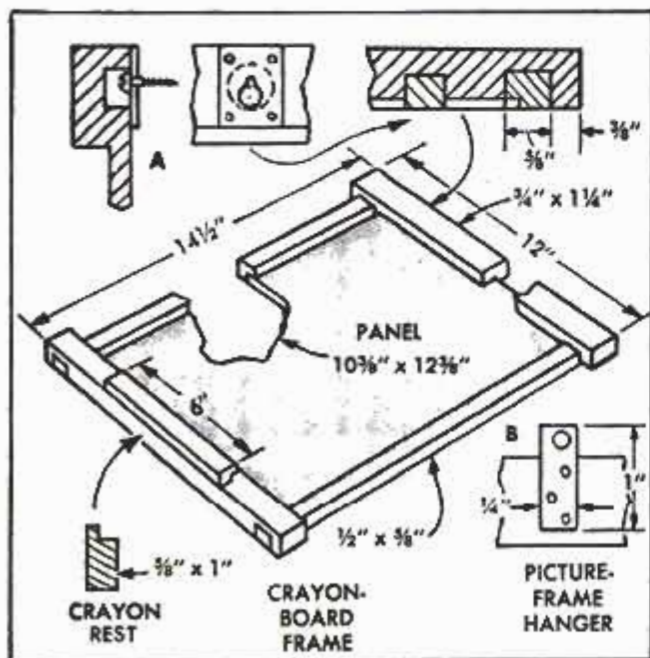
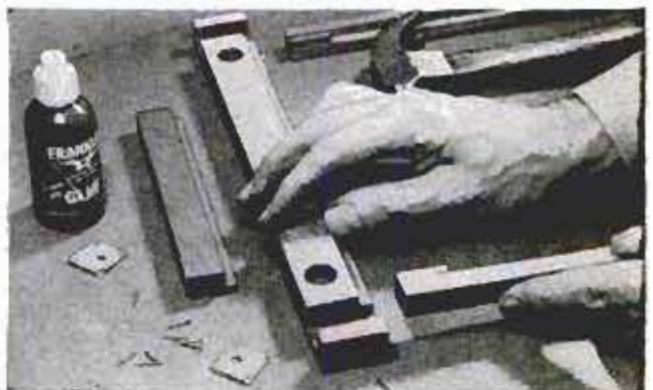

Detail above shows frame construction for board, below is assembly for crayon-board serving tray

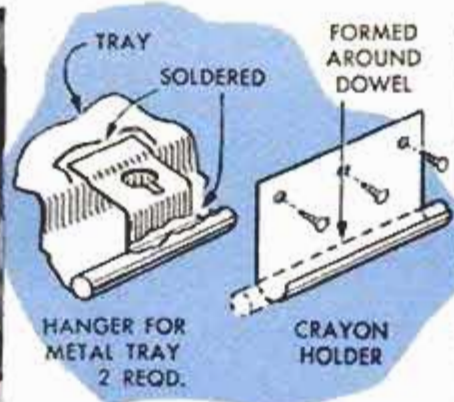
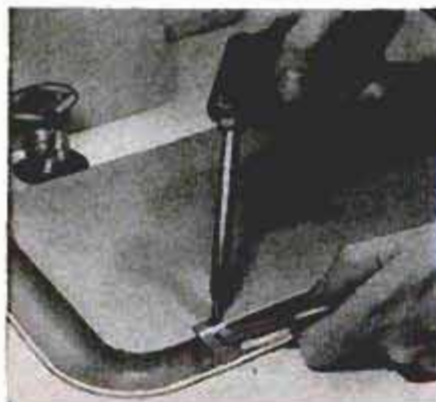



# Solving HOME PROBLEMS



**1. COMMON TABLE SALT** will do when you run out of cleanser powder for removing stubborn stains from your bathroom fixtures. It works best when sprinkled on a cloth impregnated with paraffin. Rinse and dry around faucets and drains to prevent any corrosive action of the salt residue

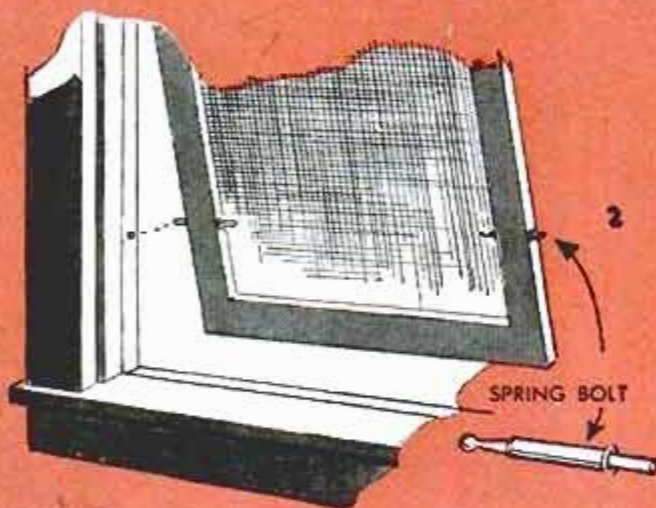

**2. PUSHING AGAINST A SCREEN** has caused the death of more than one child. To safeguard your own youngsters fit the upstairs screens with spring bolts in the manner shown, to engage holes in the window frame. Few children are able to operate bolts which must be released to open screen

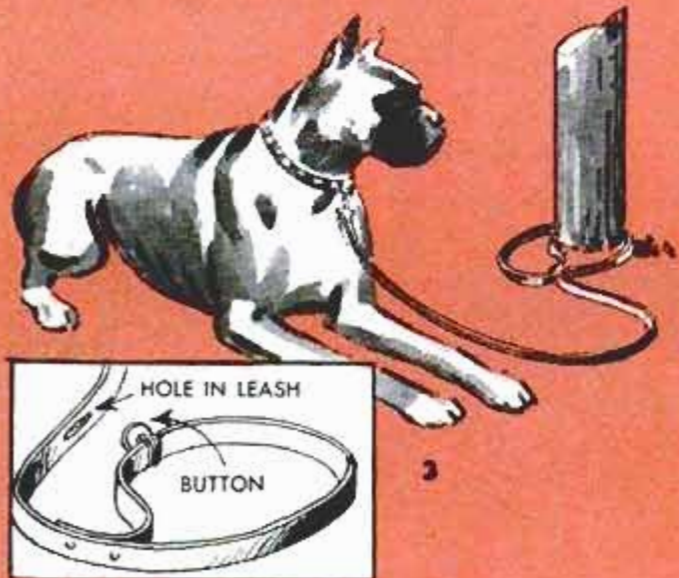

**3. A GOOD WAY** to fix the end of a leash so a dog can be tethered to a post or other object without having to knot the leash is to add a button and button hole to the strap as shown in the detail. Bind the button to the hand-loop part of the strap with fine, strong wire

**4. KEEPING TRACK OF PINS** in a sewing-machine drawer when you do not have a pincushion is no problem if you make use of an empty thread spool and a rubber band. Simply twist the rubber band over the spool a couple of times and insert the pins around the spool and under the band





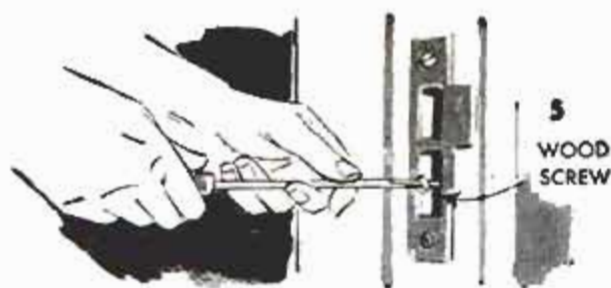

**5. CHILDPROOFING THE LOCK** on a bathroom door is easily done by driving a flatheaded wood screw in the bolt recess so it is flush with the surface of the striker plate. This prevents throwing the lock bolt. Screw can be removed when having guests



**6. A SUPPLY OF PAPER PLATES** can be made to last for several family picnics if you provide wax paper liners for them and serve the food on the paper. In addition to keeping the plate clean, the wax paper gives a smoother surface than a plate

**7. HOME-CANNED JUICES** and preserves presented as gifts or entered in judging contests take on a novel decorative look when the labels are cut with pinking shears. For added interest, the labels can be mounted at an angle and even cut in free-form shape



**8. HEAVY BOOKS** can be protected from shelf wear along the bottom edges of the pages by pasting a wrap-around paper flap to the inside of the front-cover jacket. Flap is held in place by back cover when protecting edges yet pulls free when book is opened

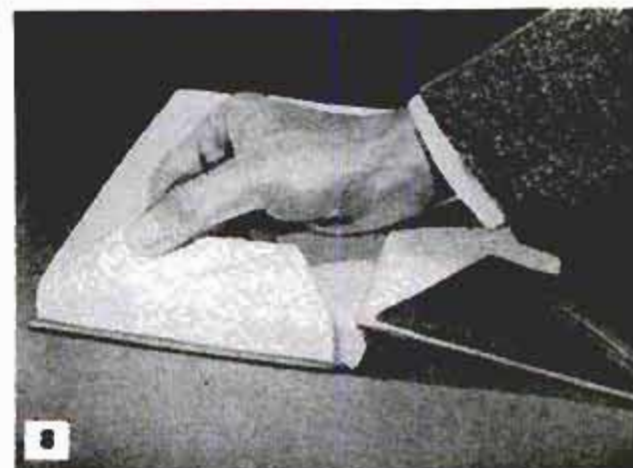

**9. HANDLE ON A CORK** makes it extra convenient when necessary to open a bottle repeatedly as it keeps cork from wedging tightly. Simply wrap a length of adhesive tape around the cork as shown in the detail so as to provide a tab at the top

**10. ONE WAY** to keep the cut ends of ribbon from raveling is to coat them with nail polish. The polish, which dries quickly, binds the threads so they can't work loose. Apply the polish somewhat sparingly and use clear polish so as not to color the ribbon

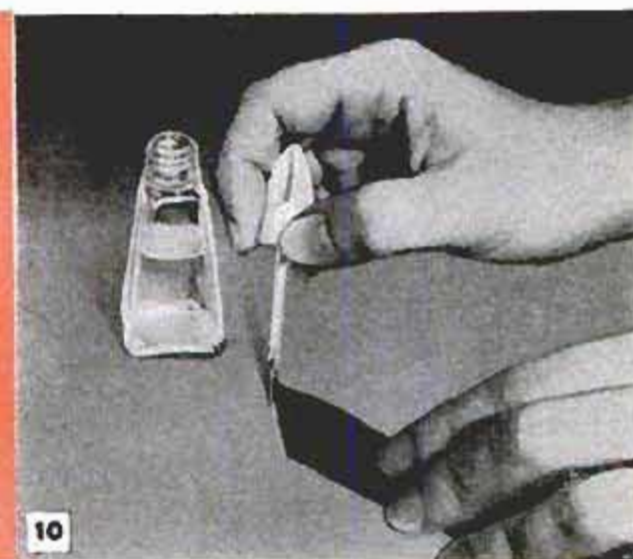
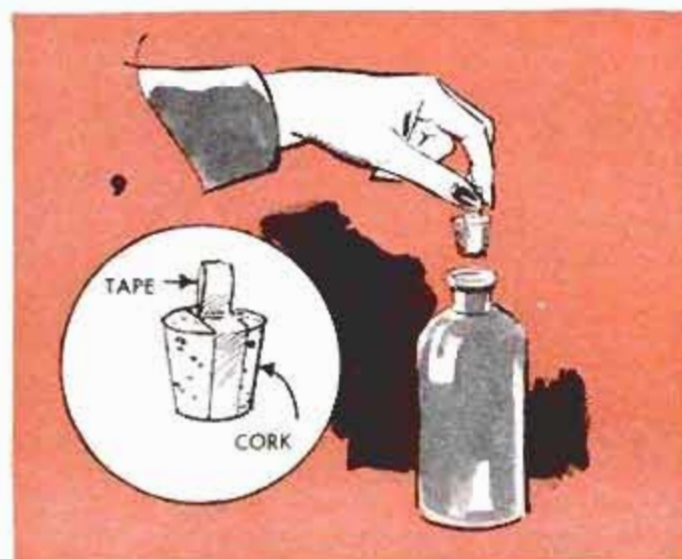





## Paint Roller Used on Wire Fence Saves Both Time and Labor

Using a roller makes painting a woven-wire fence a simple task, as compared to the tedious job of painting it with a brush. Also, there is no mess, as compared with spray-gun application. Special roller covers with long-nap fibers are available, although a regular cover can be used.

## Gun Tool Is Power Wire Brush For Special Cleaning Jobs

If you are looking for a small rotary wire brush for a special job, try using the end section of a gun-cleaning tool. The small bronze wire brush on the end of the tool becomes a rotary power brush when it is chucked in a drill motor or drill press, and is ideal for cleaning metal filigree or removing rust and corrosion from inside a length of tubing.

## Nails "Drilled" Into Wood To Prevent Splitting

If it is necessary to drive finish nails close to the edge of a piece of wood, you can avoid the splitting and bulging of the wood that ordinarily occur by using a "drill and drive" technique. Chuck a nail in a hand drill and "drill" it into the wood most of the way, then hammer flush.

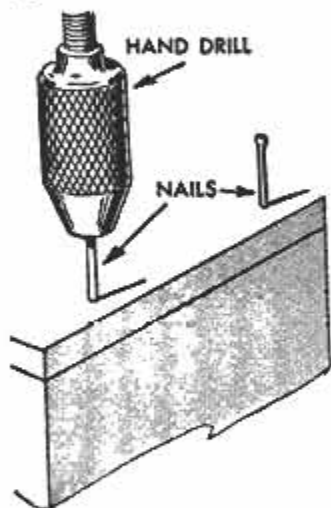

## Driving Nails in Hardwood

When driving nails in hardwood, dip them in linseed oil. The oil will serve to lubricate the nails.

## Removing Broken Drill Bit

Removing a broken drill bit from a valuable workpiece can pose a baffling shop problem, especially when the broken drill is of comparatively small diameter.

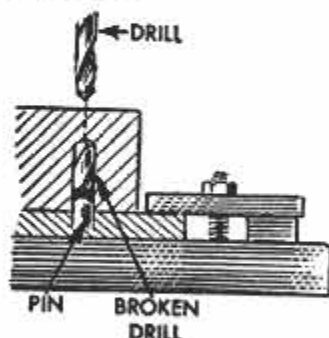

When it is possible to work from both sides of the workpiece, the method detailed is often used. First, drill a blind hole in a piece of stock of any convenient size, the hole being the same diameter as the broken drill. Seat a pin in the blind hole with the end projecting about  $\frac{1}{4}$  to  $\frac{3}{8}$  in.; place the unit on the drill-press table, lining up the pin with the chuck, and clamp in place. Place the workpiece as indicated in the detail and drill from the opposite side, using a drill bit slightly smaller in diameter than that of the broken drill. When the drill points touch, remove the work and drive out the broken drill with a pin punch.

Frank L. Rush, Columbus, Ohio.

## Drill Motor Hung Overhead By Eyebolt in Handle

To keep an electric drill motor clear of bench clutter when using it on a job, fit an eyebolt in the top end of the handle so that it can be hung on a convenient overhead hook. To install the eyebolt, remove the drill-motor handle and drill and tap a hole to accommodate a shortened eyebolt. (Removing the handle eliminates the chance of dropping metal shavings into the motor.) Use a locknut on the bolt if there is room inside the handle, or tighten it on the outside.







## Kitchen Range Becomes Outdoor Fireplace

If you know where there is an old-fashioned wood-burning kitchen range, you can do as one outdoor-living enthusiast did, and build this unique and attractive "fireplace." The cook does not have to contend with an open flame, as with an ordinary fireplace or barbecue pit, and food even can be baked in the oven. First a concrete slab 6 in. thick was poured to support the weight of the fireplace. When the concrete was cured thoroughly the range was positioned and the stones mortared up

around it. Sheet asbestos was placed between the range and the rocks to keep excess heat away from them. The fireplace would be equally attractive if built of any of several kinds of brick, flagstone or split rock. Concrete or cinder blocks also could be used. In the latter case, the blocks should be plastered with mortar to provide a smooth, "modern" appearance. Flue tiles are positioned over the stovepipe opening in the range to form a chimney.

C. G. Brooker, Rapid City, Mich.

## Modified Nut Permits Use on Smaller Diameter Screw

While repairing a fluorescent lamp one week end, a homeowner discovered that he had no 8-32 nut to fit the screw. He made a 10-32 nut do the job by reshaping it. The larger nut was placed in the jaws of a vise and squeezed until the narrow axis of the flattened hole in the nut provided a snug fit for the screw. This stunt can be used with

other nuts if the number of threads per inch is the same as that of the screw. In all cases the nut should be replaced with one of the correct size as soon as is practicable. As a reverse, a nut can be modified to fit a screw of the next larger size by running a tap of the proper size through it.

R. T. Stewart, Winston-Salem, N. C.



# HOW WOULD YOU DO IT?

By Enno R. Haan

EVERY HOMEOWNER runs across an occasional maintenance problem that he wishes could be made less time-consuming and laborious. Because a homeowner is called on to be anything from a tree surgeon to a cabinetmaker, this lack of information on some subjects is not surprising. Shown on these two pages are some representative problems that a homeowner might encounter, plus their solutions. Most of the solutions are just a simple matter of know-how, although a simple jig or fixture in some cases—as when planing the edge of a door—is required to reduce the workman's time and labor to an absolute minimum and assure a satisfactory job.

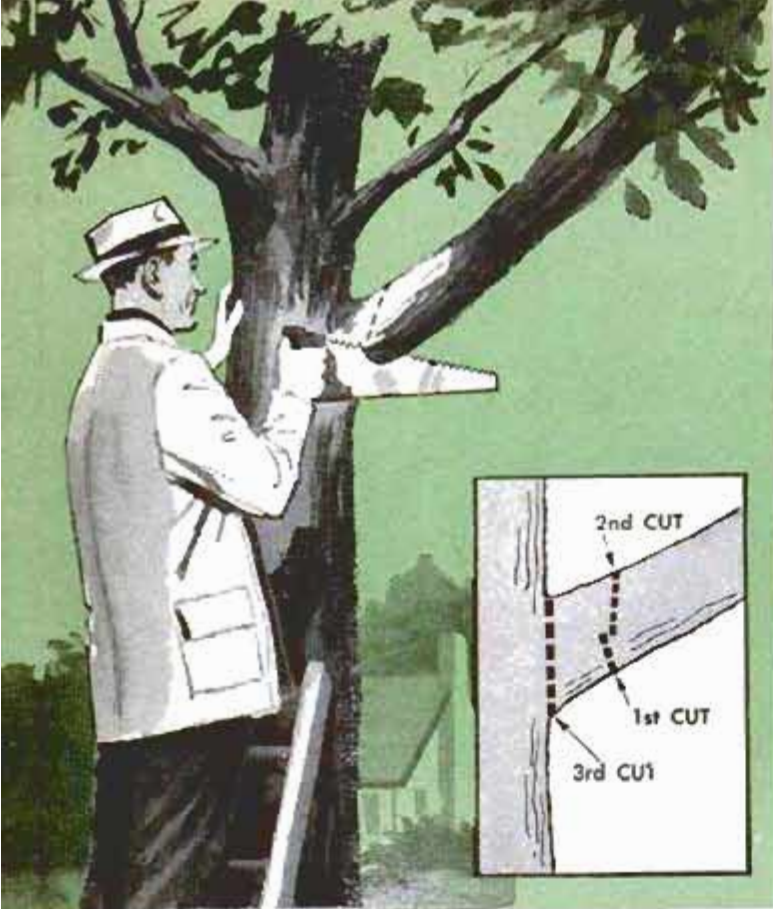

**Q. Above, how do you cut off a tree branch so it does not strip bark from the trunk?**

A. Branches 2 in. or more in diameter should be cut upward from the bottom and slightly around the sides first, about 4 to 6 in. from the trunk. Then a downward cut, made slightly outside the first, and joining it, will sever the branch without tearing the bark. The stub of the branch is sawed off close to the trunk and the exposed wood is coated with tar, asphaltum paint or roofing cement. Small branches that can be held up while sawing require only the first and second cuts made in line next to the trunk



**Q. Above, what method is used to fracture pieces of flagstone to produce straight edges?**

A. To break a flagstone evenly along a predetermined line, score the surface about  $\frac{1}{8}$  in. deep on both sides with a cold chisel and hammer. Do not attempt to cut that deep in one pass, but score to that depth gradually, going over the lines continuously. After both sides have been scored, apply sharper blows from the center of the stone outward to produce the fracture. Any slight irregularities remaining can be chipped away with hammer and chisel



**Q. Left, what is an easy way to hold a door on edge for planing or installing a latch?**

A. A simple holder or "door jack" can be improvised in a few minutes from three lengths of 1 x 2 or 2 x 4 stock nailed together as indicated. Set the door on the base piece, which extends on both sides of the door to prevent it tipping, and clamp the vertical piece to the door. To avoid making clamp marks, or damaging the finish of the door, use hardboard or plywood pads between the clamp and door. Also use a pad between the door edge and door jack



**Q. Right, how can noises that occur in water pipes when faucets are closed be eliminated?**

**A.** Noises in water pipe result when the air chambers in the system become filled with water that gradually has absorbed the air. The water should be shut off at the main valve and the system drained. Hammering noises also may be caused by movement of a long horizontal pipe not fastened securely. Block it at the end which takes the thrust. If the noises persist, install a commercial-type shock absorber

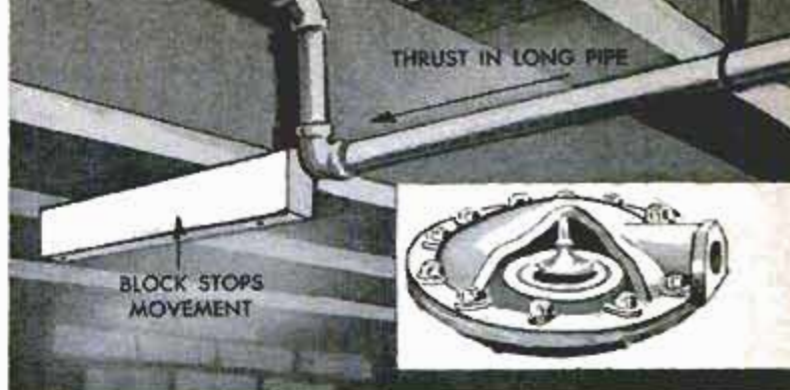

**Q. Right, to prevent strong winds from blowing away asphalt shingles, what can be done?**

**A.** After replacing any missing shingles, cement down all shingles on the windward side of the roof. Use quick-setting asphalt cement, applying two daubs of not less than 1 in. in diameter under each shingle near the corners. When it is necessary to re-cover an entire roof, use interlocking shingles or those having an adhesive on the underside. It is not advisable to nail the outer corners of the shingles to prevent the wind from blowing them, as each nail then presents a potential water leak

**Q. Left, what is an easily applied, long-lasting seal for a leaking rain-gutter joint?**

**A.** First, remove all traces of paint from the gutter a few inches on each side of the joint and brush away loose dirt and dust. Apply roofing cement on all cleaned areas when the metal is perfectly dry. The cement will not adhere to wet surfaces. When the cement has become tacky, embed in it a piece of plastic screening. The screen will adhere to the cement, providing a reinforcement for the patch, to prevent it from cracking. When the roofing cement has dried thoroughly, apply a second coat to "sandwich" the reinforcing plastic screen. This screening-and-cement repair also can be used to patch holes and rusted-out areas in rain gutters



**Q. Left, what method assures good adhesion of concrete patches on a sidewalk edge?**

**A.** Dress down the edges of the hole to be patched with a cold chisel, undercutting it so the patch will be self-locking in shape rather than a V-shape. Let firmly embedded stones in the old concrete project for added anchorage. Provide a retaining board held by stakes along the open side of the patch. Wet the edges of the old concrete thoroughly, as dry concrete absorbs moisture from the new, which will weaken it and allow it to crack. Coat the edges of the holes with grout—a paste of cement and water—then pour in properly mixed concrete, smoothing it to match the surface of the old walk. Keep wet burlap bags on the patch for several days to season it

**Q. Right, how is a panel-type door repaired to hold stiles pulled loose from crossrails?**

**A.** Clamp stiles and rails together and drive 3½ or 4-in. No. 14 or 16 roundheaded wood screws into pilot holes counterbored ¾ of the stile width. Use one screw for crossrails 3 in. wide, two for 4 to 6-in. widths, and three for all the wider stiles

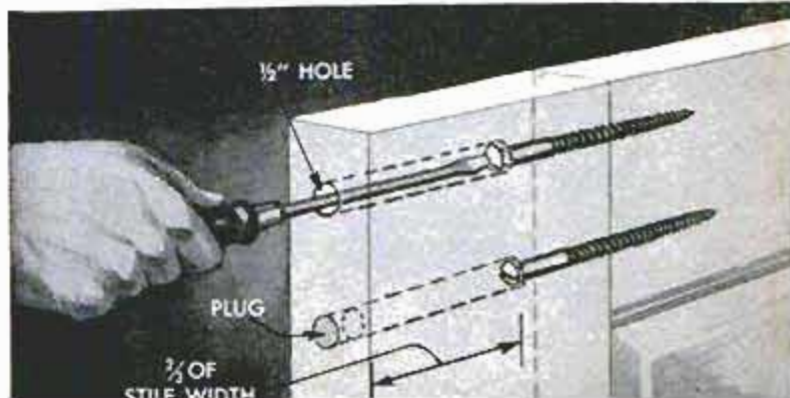





### Magnetic Cigarette "Holder" For Auto Instrument Panel

Keep a pack of cigarettes securely in position any place on the instrument panel of your car with this "holder," consisting of a wide rubber band to which a small, flat magnet has been cemented with "glue anything" cement.

### Checking Ignition Trouble

When checking ignition trouble in an engine, do not forget the wires fitted into the distributor cap. Lifting the rubber boots on these wires often discloses deteriorated insulation. Wires may not have been pushed completely into the cap and the contacts have become corroded. Distributors that rotate under vacuum advance may cause worn wires.



### Flexible Taillight Mountings Make Them Break-Resistant

When broken taillights on his truck became a problem, one farmer attached the lights to flexible strips of discarded belting, reducing breakage to a minimum.

Charles L. Stratton, Windham, N. H.

### Clean Clips Protect Car Fuses

If fuses blow frequently in your car, the trouble could be loose or corroded fuse clips. To correct this situation, wrap a piece of fine sandpaper or emery cloth around the fuse and rotate it gently in the fuse clips. Once cleaned, bend the clips inward to increase their tension and contact. Do not coat the clips with grease, to prevent corrosion as grease is an insulation, and may hasten corrosion formation.

M. Robert Beasley, Jackson, Mich.



### Pad Eyes Inside Car-Trunk Lid Permit Tying It Down

Because push-button locks are used on the trunk lids of most cars, and the handle has been eliminated, there is no projection to which a cord can be tied when the lid is held open by a bulky item. It is not advisable to permit the lid to swing freely, as it may become twisted and sprung so that it will not fit properly. Also, it definitely blocks vision through the rear window. The solution to the problem is to attach two light pad eyes or lock staples to the inner panel of the trunk lid with self-tapping screws. The trunk lid then can be held down against a bulky load by passing cords through the pad eyes and around the rear bumper.

John H. Ellis, Warrensburg, N. Y.



# Novel Hanging Planters Turned From Wood

HANGING PLANTERS are extremely popular, and these two turned pieces will be a welcome addition to the collection of any "indoor gardener." The oval-shaped planter is turned from a block of pine 4 in. thick, or from a number of pieces clamped and glued to form a block of the correct thickness. Before turning the planter obtain a bowl that can be used as a waterproof liner, then turn the inside of the planter to accommodate this liner. Both to improve the appearance of the outside of the planter, and to disguise the glue joints, in the case of the built-up block, V-grooves are turned as indicated. The wood now is smoothed with fine sandpaper, then 4/0 steel wool. Dip a soft cloth in shellac and hold it against the rotating turning until a fine, glossy finish results. As indicated in the detail, clips bent from copper wire are used to suspend the planter from a brass chain. The straight-sided planter is made in a similar manner, but the rough turning is assembled from two wooden jigsawed rings glued to a disk base. On the original planter it was determined that a clay flowerpot was the correct size for a liner, and



the inside of the planter was turned to accept it. As with the oval-shaped planter, V-grooves are used on the straight-sided type to improve appearance and to hide the glue joints. Three screw eyes are driven into the upper edge of the planter, and fitted with copper rings and chains.

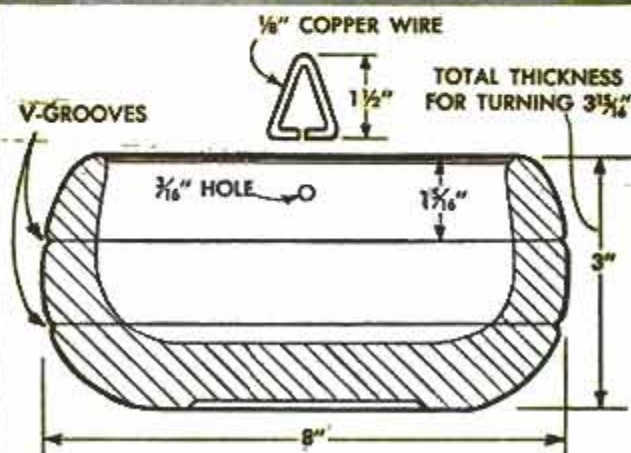
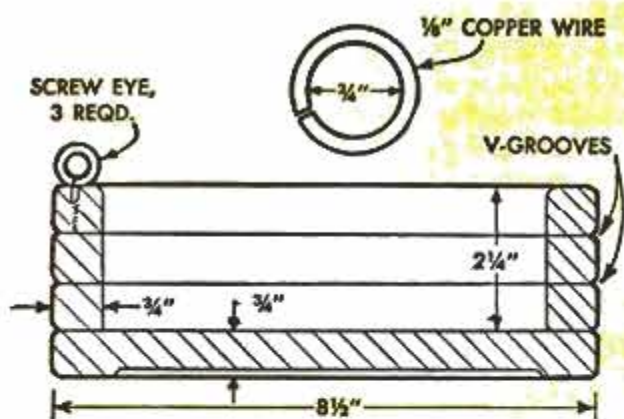





## Permanent Photochemical Labels Made From Colored Plastic Tape

Photochemical labels that last indefinitely in spite of exposure to darkroom chemicals and immersion in liquids that make other marking systems unsatisfactory, can be made easily from 1½-in. strips of colored plastic tape. The letters are cut out after the tape is applied to the object being labeled. This provides two sets of letters if you are careful.

Ron Anderson, Minneapolis, Minn.

## Low-Cost Adjustable Stands From Pipe and Plywood

Rigid stands for studio camera lights, shop lights and similar applications can be made inexpensively from plywood scraps and pipe fittings. A pipe flange is screwed to the base, which can be any shape, such as shown in the photo, and a length of pipe is screwed into it. The upper end of the pipe is drilled and tapped to accommodate a lock screw that clamps a length of smaller-diameter pipe inside at any position.—Frank A. Javor, Newark, N. J.

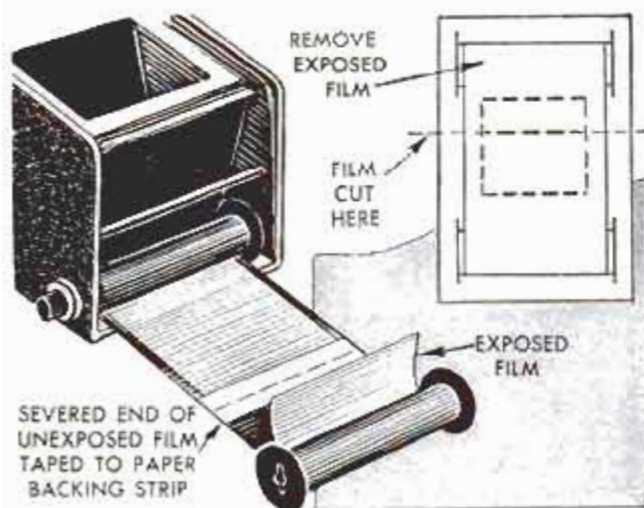

## ←Developing Part of Film Roll Before Exposing All of It

The exposed portion of a partly used roll of film can be removed and developed without the need of waiting to expose the rest. To do this, open the camera in total darkness, remove the spool containing the exposures and cut the film, but not the paper backing, about midway where it crossed the exposure frame of the camera. Next, fasten the end of the unexposed film to the paper backing with a strip of ½-in. drafting tape, cut previously and placed within easy reach. Now, unroll the exposed portion of the film from the spool, removing the tape at the end carefully so the paper backing is not torn. Place the film in a lightproof container until development. Reroll the paper backing on the empty spool and insert it in the camera. Advance the film so you skip one frame.

## Weight Keeps Paper Box Closed

There is less chance of accidental opening of a box of photographic paper while the enlarger or printer light is on if a heavy weight, such as the one shown, is glued to the lid. Also, the weight will cause the lid to close automatically. When the box is empty, a new supply of paper can be transferred to it.—Ken Murray, Colon, Mich.



## Note Storage in Book Cover

To keep slips of paper, notes and the like from falling out of a study book, tape an envelope inside the book cover as shown. Position the envelope flap toward the bound edge of the book.

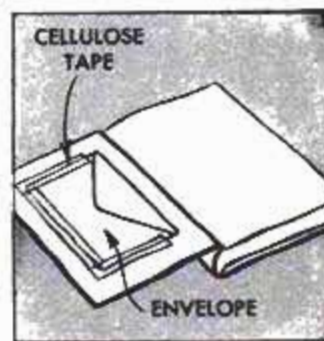



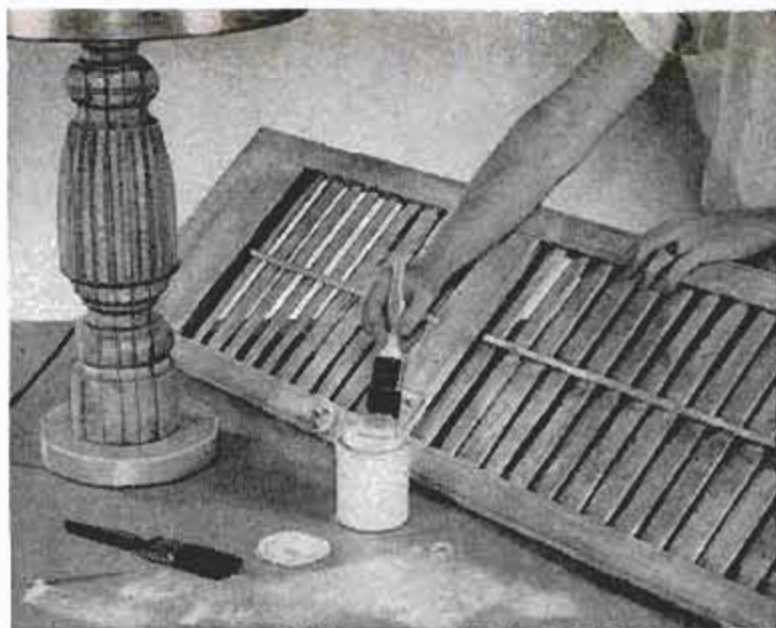
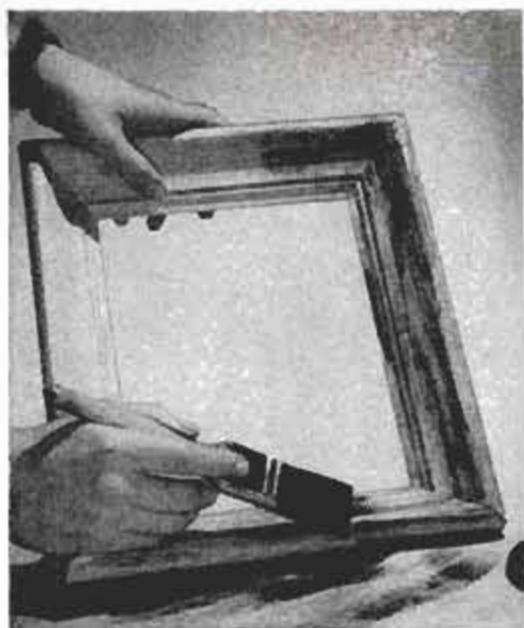

Photos courtesy E. I. du Pont de Nemours and Co.

## New "Dry Brush" Technique Produces Antique Finish

"Dry brush" is the name given a new technique in painting that makes it simple to apply an "antique" or pleasantly weathered finish to wood. Use of the technique makes it possible to make lamps from cut-down table legs and finish them to match an antique decor. Wooden shutters can be finished in the same manner, as well as picture frames and numerous other wooden items. Preliminary sanding is not necessary, as the rough surface of the wood increases the effect of the unusual finish. Wiping away the wet paint with a cloth to achieve an antique effect also is eliminated

by the one-step dry-brush method. Simply dip the brush into paint and remove the excess by pressing the brush against the edge of the paint can. Complete "drying" the bristles by brushing smoothly on a testing surface until most of the paint is removed. Then, apply the brush lightly to the article to be painted, using light strokes so the highlights of the wood grain or raised surfaces produce an interesting dappled finish. Paintbrushes having nylon bristles are best for dry-brush painting of unsanded surfaces, as this type bristle does not wear as rapidly as other materials.

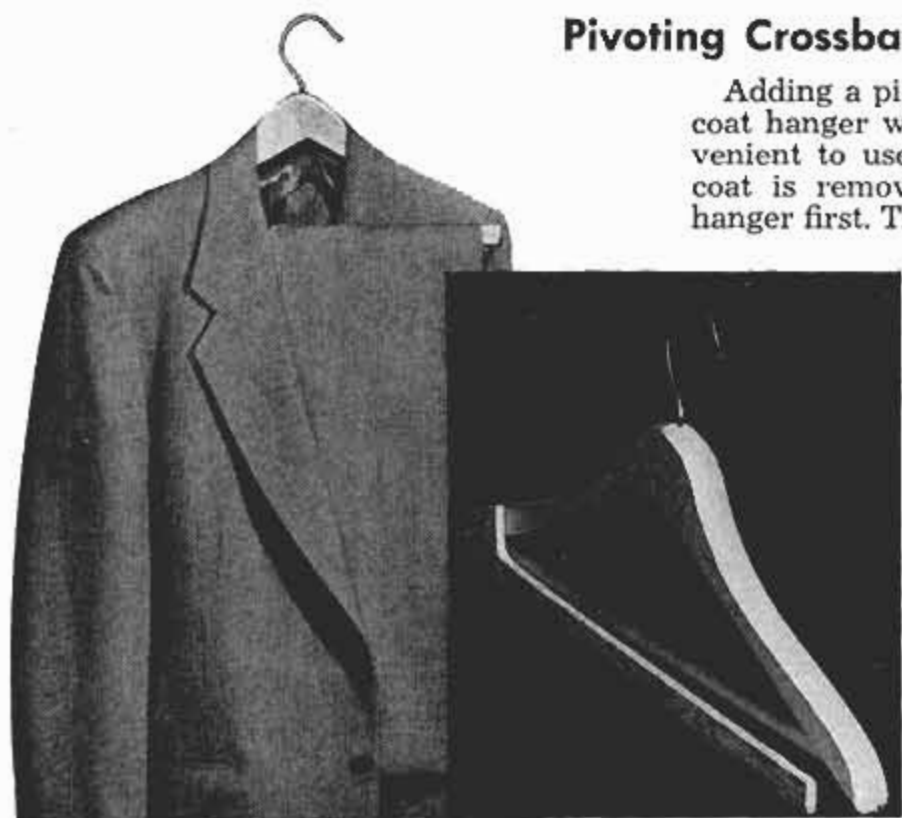

### Pivoting Crossbar for Clothes Hanger

Adding a pivoting crossbar to a wooden coat hanger will make it much more convenient to use for a suit. Because a suit coat is removed first, it is placed on a hanger first. Then, later, when the trousers are placed on the crossbar, the coat must be removed. When a crossbar is pivoted to one end, as shown in the inset photo, placing the trousers on the bar requires only that it be pivoted outward enough to allow them to slip over the bar's end. Use a rustproof brass or aluminum hinge, and smooth the edges of the auxiliary crossbar so that there is no roughness to snag or tear the cloth.—A. V. Malone, Los Angeles, Calif.



# SHOP-BUILT

By A. M. Wettach

**D**ESIGNED AND BUILT by experienced farmers, these mowers will cut almost anything that grows above ground—grass along the lane, on the lawn, tall weeds in the fence rows and brush in the pasture up to 6 or 8 ft. tall. As you'll note, the units are made in both walking and riding types. Frames and other fabricated parts are assembled by welding scrap steel angles, flats and sheet metal, and by adapting auto and truck brake drums, salvaged



**1. TRICYCLE-TYPE ROTARY MOWER** is powered by an air-cooled engine which drives rotary blade through a worm gear. Also drives rear wheel through V-belt

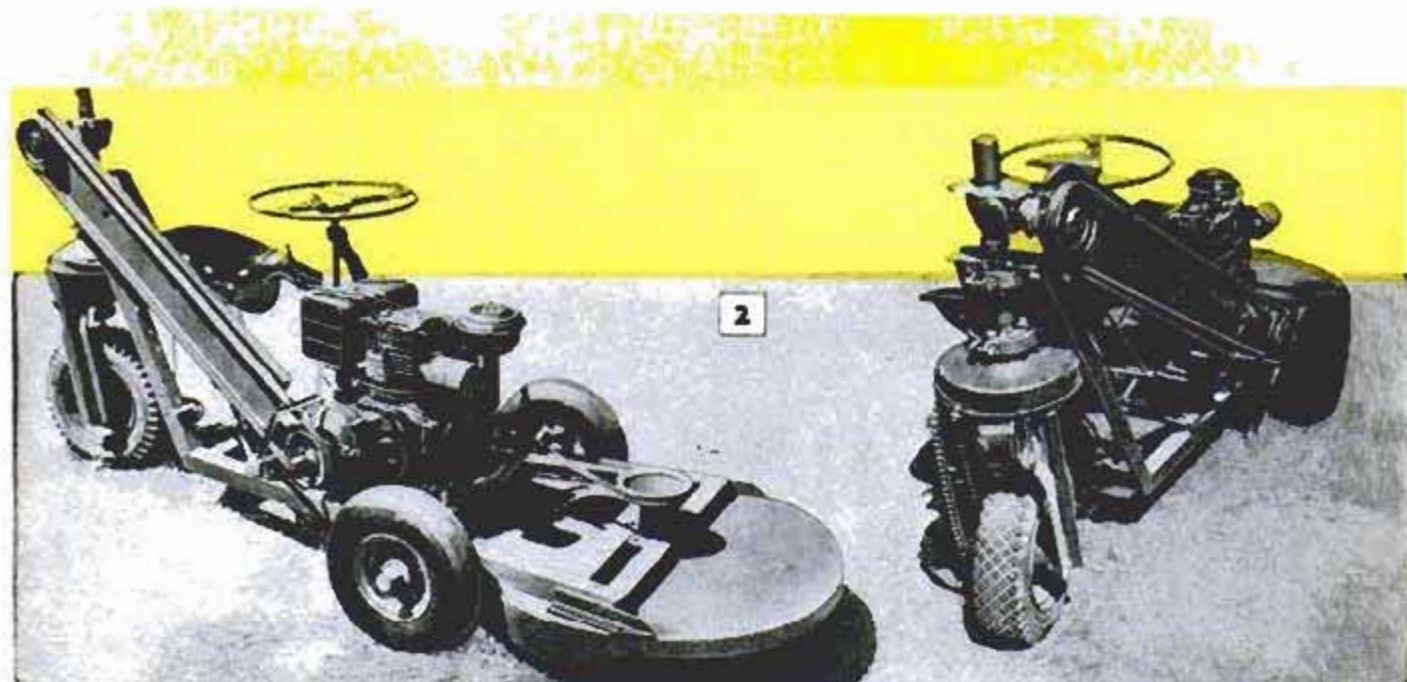

**2. FRONT-MOUNTED ROTARY MOWER** is designed for fence-row work and mowing driveway and road shoulders. Steers by means of single caster wheel which is also the drive wheel. Caster wheel is power driven from engine by means of long V-belt and roller chain as will be seen from rear view above. It is powered by 3½-hp. engine. Frame and caster-wheel yoke are made from steel angle joined by welding

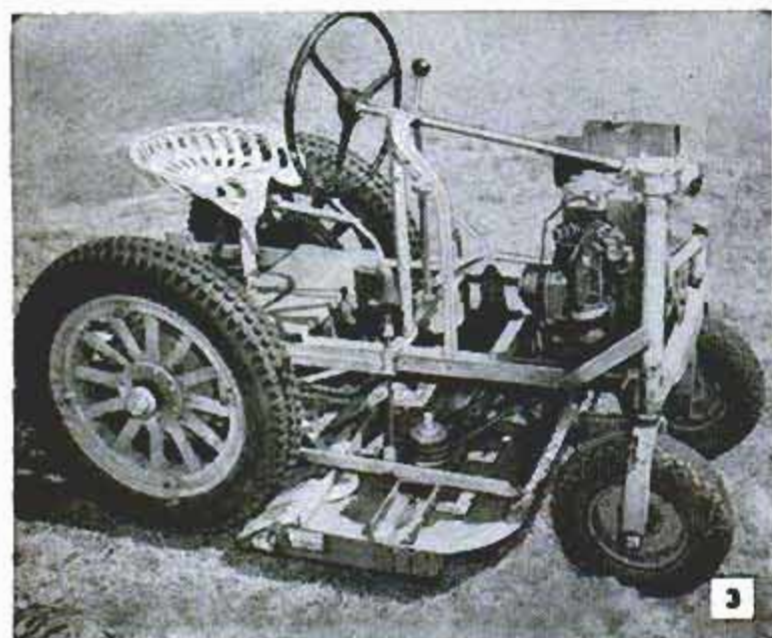

**3. FRONT-STEERING** four-wheel mower is rotary type having two auto transmissions mounted in line to control both ground speed and blade speed. Frame is welded steel angles and parts of old car frame. Rear axle is cut down from an old car. Original artillery-spoked wooden wheels are utilized as will be noted. Front wheels are caster mounted in yokes and are controlled by salvaged auto-type steering unit



# FARM MOWERS

farm-machine parts, auto-steering gears and wheels, transmissions—anything that will serve the purpose is used; appearance doesn't count as these machines are made for rough service. Smaller units, Figs. 1 to 6 inclusive, are powered by standard air-cooled engines. The heavy brush cutter, Fig. 7, is built up around a large farm tractor. Note that the units are made in both rotary and sickle types, those in Figs. 4 and 5 being made especially to get the tall weeds that grow in fence rows between the wire and the standing crop. ★ ★ ★

**4. NARROW-TREAD WALKING MOWER** has sickle mounted in front so it will get the tall weeds that grow on narrow strip between fence, standing crop

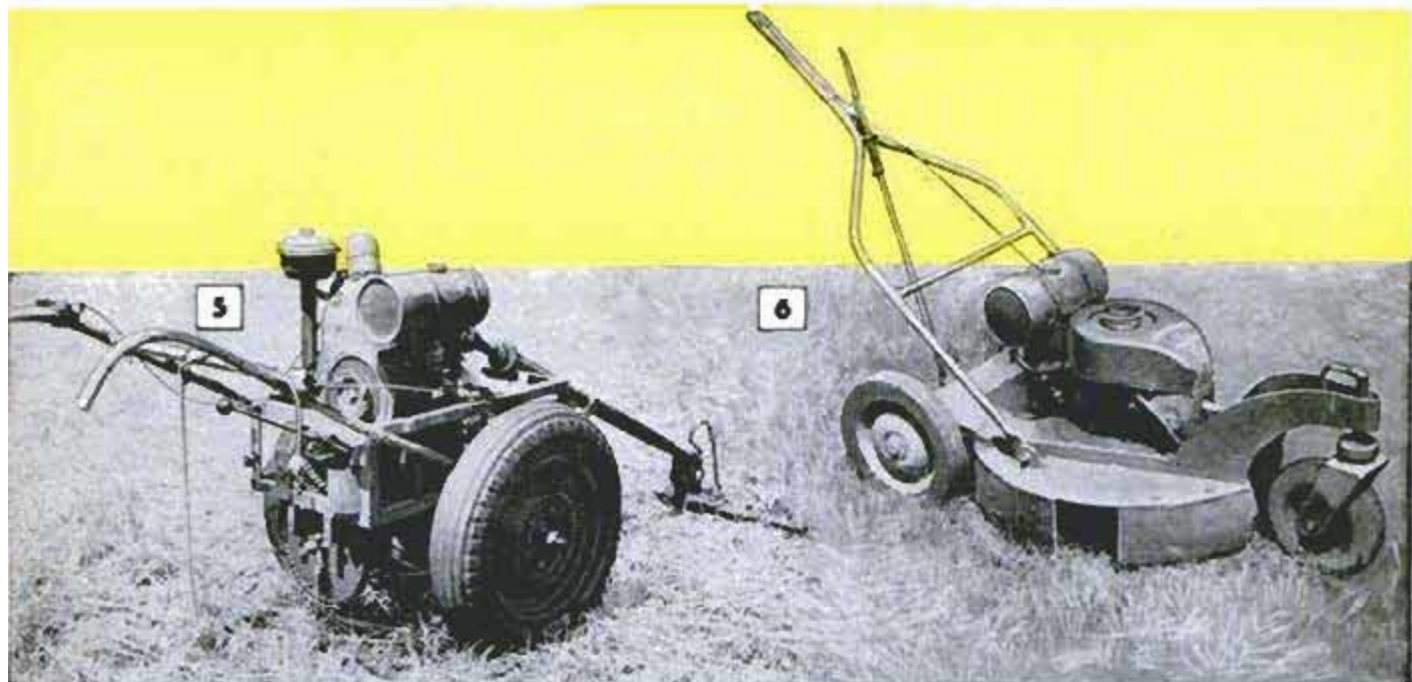

**5-6. MOWER** pictured in Fig. 5 above is similar to that shown in Fig. 4, except that it does not have the swiveling caster wheels with which the latter is fitted. Auto transmission gives three speeds forward and reverse, a handy feature when mowing a roadway shoulder, fence row, or lawn where it is necessary to work close to shrubbery. Fig. 6 shows push-type rotary mower of more nearly conventional design

**7. HUGE ROTARY MOWER** is not made for lawn mowing! It's built up around a big field tractor with offset rear axle for clearance. Blade will shear off undergrowth with trunks up to 5 in. in diameter, cuts saplings to shreds like a leaf mulcher. Machine was designed for clearing second growth from land, cutting volunteer shrubs, brambles from pasture and woodlands, trimming shoulders on secondary roads





## Skidproofing Mixture for Steps Is Sand-Paint Solution

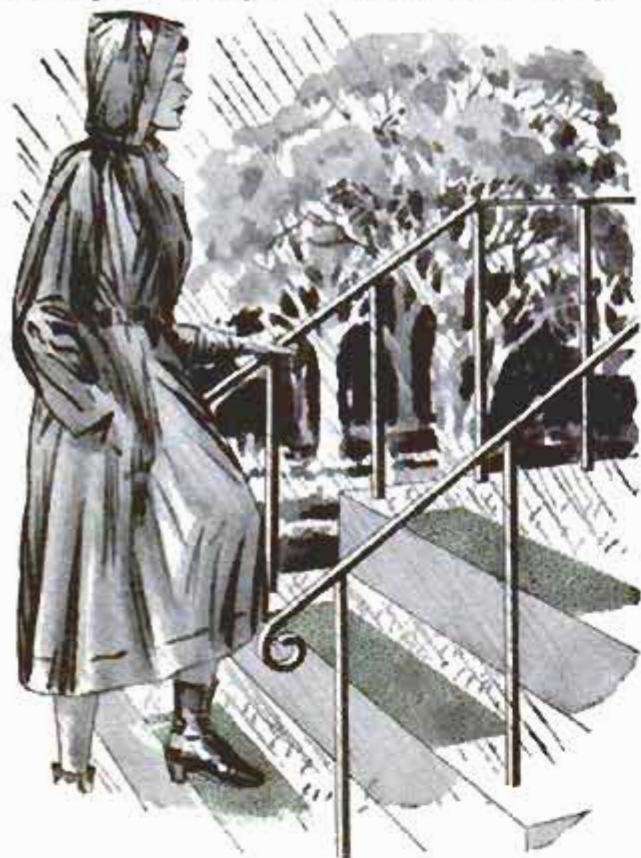

One method often used to skidproof wooden or concrete porch steps that become slippery in a rain is to paint them, then sprinkle sand on the wet paint. One homeowner devised a method he found even better, which was to mix the sand directly into the paint before it was applied. Fine, clean sand is stirred into paint that has been thinned to prevent the sand from causing the paint to become too thick. A shallow container is used to hold the paint, so the brush will reach the bottom, and can be used to stir the paint, and to assure that a generous amount of sand is picked up with each brushful of paint. For best results, the paint should be stirred vigorously every few minutes. The advantage of having the sand mixed with the paint is that as the paint wears away, more sand particles are constantly exposed. This assures a skidproof surface as long as the coating of paint lasts.

Robert L. Sargisson, Berwyn, Ill.

☐ A prime coat of shellac on metal will permit using paints that ordinarily do not adhere well to metal surfaces.

## Hooks on Indoor Clothesline Permit Quick Installation

Temporary clotheslines hung indoors can be put up and removed in moments if the ends are fitted with screen-door hooks. Screw eyes are driven into the walls to receive the hooks. — Charles V. Mathis, Wildwood-by-the-Sea, N. J.

## Water-and-Detergent Solution Removes Wallpaper Quickly

To remove wallpaper over which rubber-base paint has been applied, use a solution consisting of liquid detergent, 2 oz., in 1 gal. of very hot water. Brush this solution over an entire wall three times, applying one coat immediately after another. Very little of the solution will run down the wall, most of it penetrating through the paint and wallpaper. The solution will not damage the paint on woodwork, and is not harmful to your hands. The floor should be covered with several layers of newspaper so that the wet wallpaper will not adhere to the floor when it falls after being scraped from the wall.

Neal Singletary, Jr., Ponca City, Okla.

☐ Instead of discarding nylon stockings, use them as holders for moth repellents. Drop a half dozen or so moth balls in a stocking and hang it in the closet where off-season clothes are stored.



## Linoleum Patching "Plaster"

Holes broken or worn in linoleum can be repaired by using a patching "plaster" made of cork and white shellac. Chop the cork into very small pieces—a food grinder can be used for this—and mix the powdered cork with the white shellac until the mixture is the consistency of paint. Trowel it into the hole in the linoleum and, when dry, touch up with paint to match the pattern and make it inconspicuous.





Above, strong arm was needed to lift cast-iron cooking pots that were hard to clean and many times heavier than stainless steel and aluminum cooking utensils used today



Upper right, 100-yr. old stocking form was used to prevent hand-knit stockings from shrinking after washing, nearly same as adjustable metal sock-drying frames now in use

# SO OLD THEY'RE NEW

Right, hand-cranked sewing machine of 1850s had same basic design as modern machines. Later, foot-treadle operation was added to free both hands for guiding the fabric

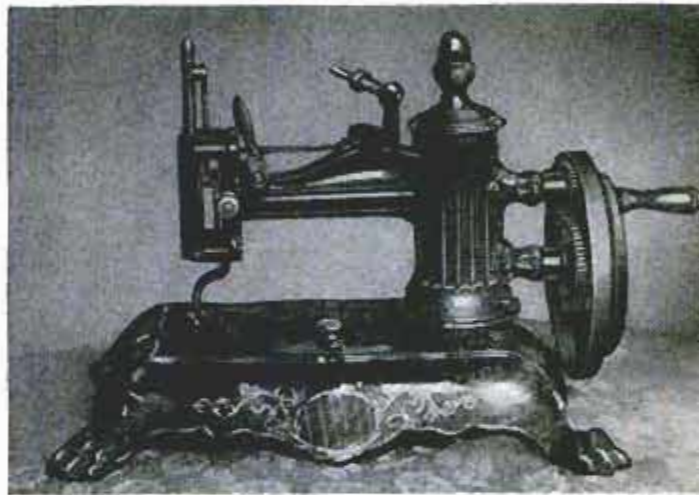

Below left, mortar and pestle was used for grinding pepper and other spices. Now spices rarely are ground by housewives though some use small hand mills for grinding pepper

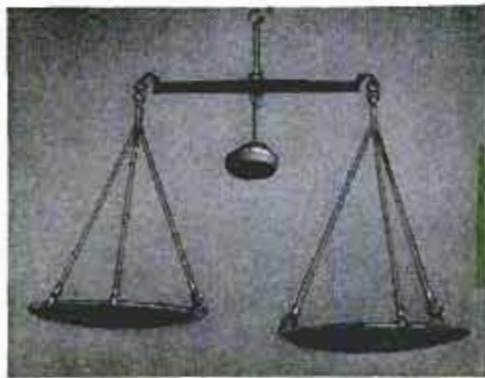

Above, center, balance-type scales were used in most country homes for checking weight of small items such as butter fresh from the mold, proportions of medicinal herbs. Object being weighed is placed on one tray, counterweight on other

Above right, most modern housewives have the butcher grind meat for them at time of purchase. Grandma's contemporaries had to grind their own in hand-turned sausage grinder. Sausage skin to be filled is slipped over opening in end

Right, early model of flatiron had hollow core in which iron insert was placed, after heating it in glowing coals of fireplace fire. Pressing clothes with heavy iron was tiresome chore compared with today's lightweight electric iron





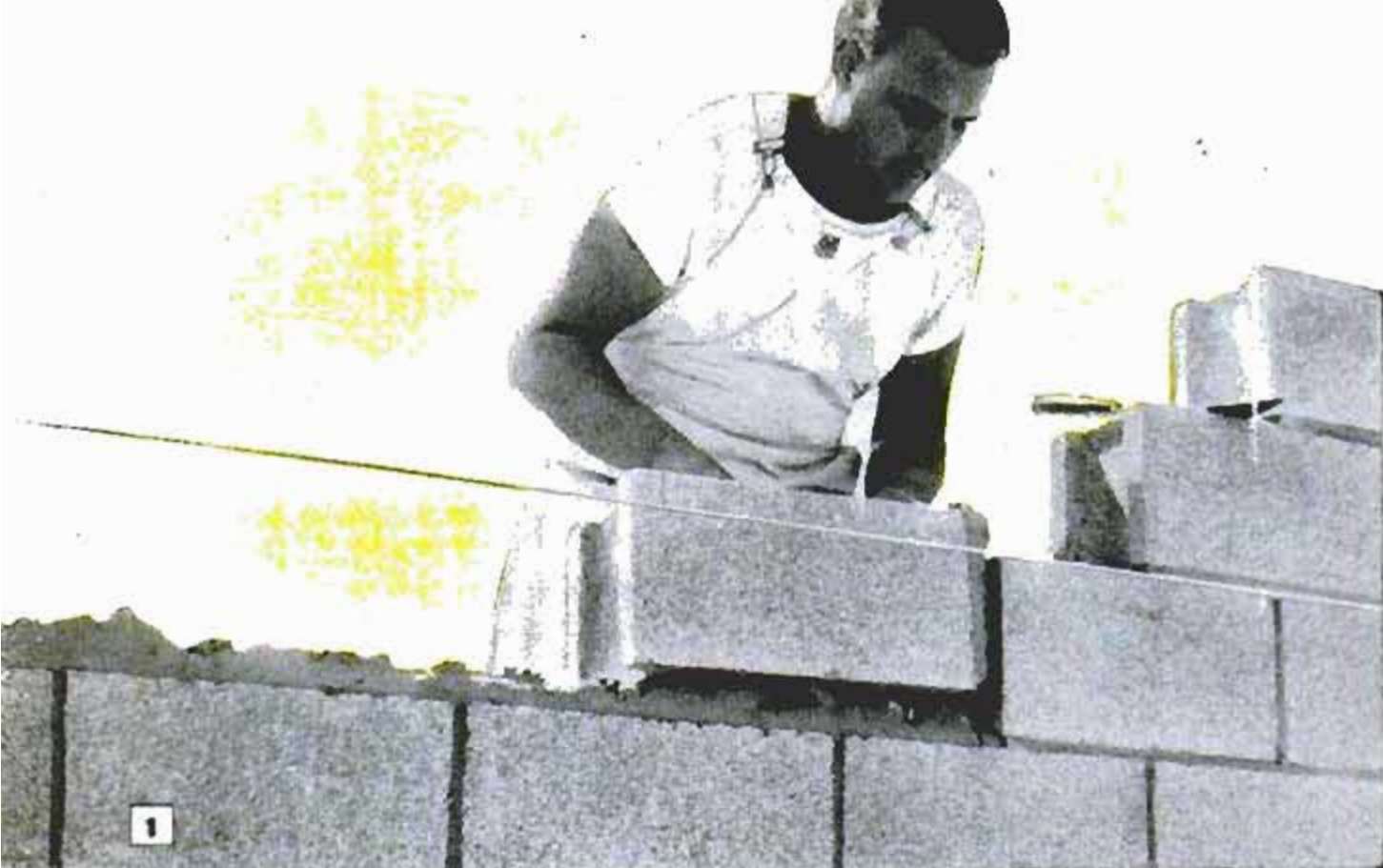

Photos and information courtesy  
Louisville Cement Co.

# HOW TO LAY CONCRETE BLOCKS

**I**F YOU WATCH carefully when a professional is building a concrete-block wall, you will notice that he makes certain checks and measurements constantly. This is the secret of his professionalism, and an amateur who uses these same checks and measurements can do a job that is close to professional, both in appearance and strength. Patience is the amateur's substitute for the professional's experience.

The first step in building a wall is to square it with adjacent walls. The 3-4-5 triangle method can be used for this. One

wall is measured off in 3 units, the adjacent wall in 4 units, and the hypotenuse of the triangle then must be 5 units if the corner is square. When constructing a wall, the corners are built up first, Fig. 12. Also, note particularly that in most of the photos a taut cord is used to check the straightness of the wall. This cord is used from the first course to the last. After the corners are built up, blocks with no mortar are spaced along the foundation between the corners to determine whether a shortened block will be needed, or a slight

"Course pole," straightedge marked off in 8-in. spaces, is used to assure courses are keeping correct height

Trowel handle is used to tap blocks into alignment, using straightedge or edge of long level as a guide







Full bed of mortar is spread on foundation to receive first course of block, assure maximum strength

Below, after block is carefully measured for right length it is cut by using mason's hammer and chisel

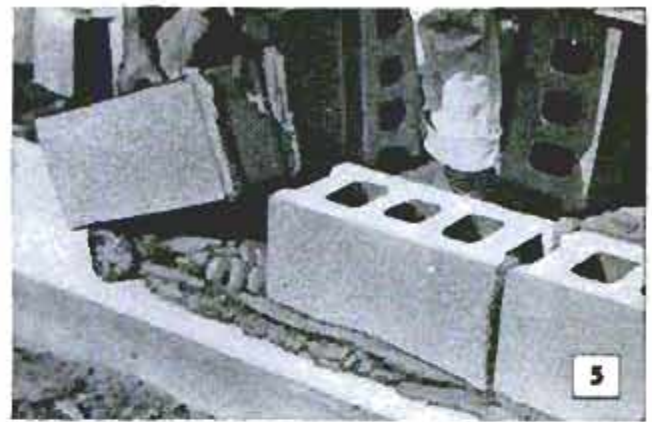

Mortar is spread on one end of block, which is pressed against adjacent block to form  $\frac{3}{8}$ -in.-wide joint

Rough edges of cut block then are chipped with hammer to make them smooth as possible for appearance

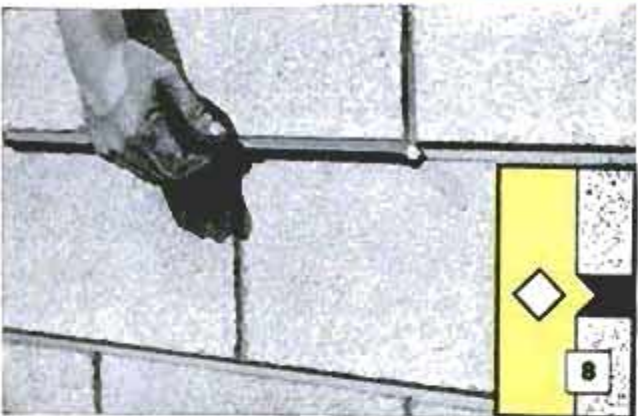
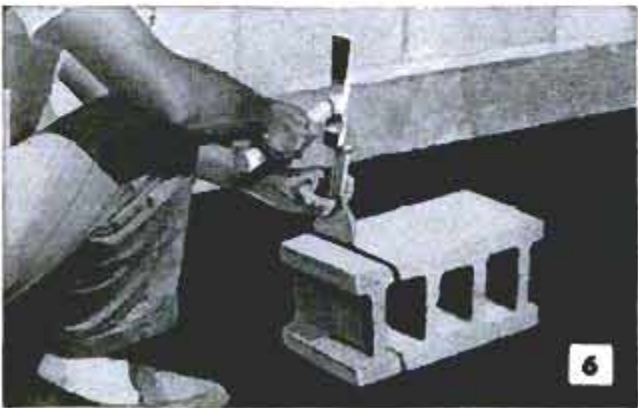

After blocks have been set, and mortar is still plastic, forming tool is used to shape joints uniformly

Full bed of mortar under each block assures good bond. Excess is picked up with trowel and reused



As blocks are placed, trowel is used to remove excess mortar, trowel point compacts mortar in joints

When building up a pilaster (column) full, heavy bed of mortar assures complete bond under all blocks







Marking off foundation, or laying out blocks without mortar, indicates required spacing of blocks or need of partial block between built-up corners

## HOW TO LAY CONCRETE BLOCKS

Enough mortar should be used under each block so that it is forced out under all edges, assuring a complete bond. Note the constantly necessary alignment cord that is moved up for each course of block

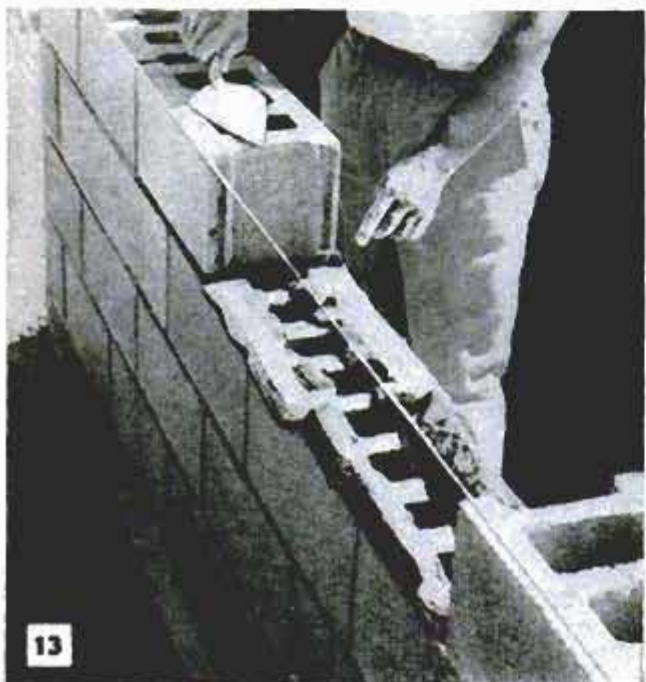

increase or decrease in the average width is needed to fill out the length. Measuring off the length, Fig. 12, is another way of doing this. Note in Fig. 4 how a full bed of mortar is spread and furrowed along the foundation to assure a good bond for the first course of blocks. One end of each block, Fig. 5, also is mortared. Fig. 1 shows how each block is tipped toward the workman so he can see the edge of the lower block, then is slipped down and sideways against the adjacent block. Even when a chalkline is used, a straightedge should frequently be placed against the faces of the blocks to assure alignment, Figs. 3 and 17, and the tops should be leveled, Fig. 15. Occasionally place the level diagonally across a corner to make sure that the courses in adjacent walls are at the same level. Another check is to use a rule, Fig. 14, or a "course pole," Fig. 2, to make sure the courses are at the proper level and even with each other. The course pole is a straightedge marked off in 8-in. spaces. Concrete blocks are  $\frac{3}{8}$  in. short in length and height of a true dimension to allow for a  $\frac{3}{8}$ -in. mortar joint. Vertical alignment also is checked, Fig. 16. These measurements and checks are made constantly, as the blocks must be moved before the mortar sets. If a block is moved after the mortar is no longer plastic, it must be removed, the mortar scraped away and fresh mortar applied. All blocks should be positioned with the thicker ends of the webs facing up, Fig. 18, to provide maximum mortar area. There are two ways to apply mortar, one by spreading, as in Fig. 20. The other way is to "wipe" it on as in Fig. 21. In all cases, enough mortar must be applied so that it is forced out on all sides, Figs. 10 and 13. For pilasters (a widened portion of the wall forming a vertical column) as in Fig. 11, the mortar bed is spread over the full faces of the blocks.

When fitting the closing block in a course—the last block to be fitted—it must have a full  $\frac{3}{8}$ -in. joint on either end. Mortar is wiped on both ends before it is inserted and a trowel is used to compress the mortar firmly. When a block must be cut, measure it carefully to be  $\frac{3}{4}$  in. shorter than the space into which it is to fit, and cut it neatly as possible, Fig. 6; then chip it to smoothness, Fig. 7. Excess mortar is wiped away with the trowel, Fig. 9, and returned to the mortar board to be reused. The trowel point is used to compact the mortar, then a forming tool, Fig. 8, is used to make all joints identical.

The trowel handle is the only tool used to tap the blocks into alignment, as in Fig. 19. If a tap of the trowel handle does not move a block, the mortar has set too firmly. ★ ★ ★





Rule, instead of course pole, can be used to assure that block courses are maintaining proper 8-in. height

Each block also is plumbed when placed in position. Trowel handle gently taps the blocks into alignment



As each block is placed on mortar bed, it is leveled. For this job a long level is better than a shorter one

Long level is used here as a straightedge to align faces of blocks as they are fitted into the wall

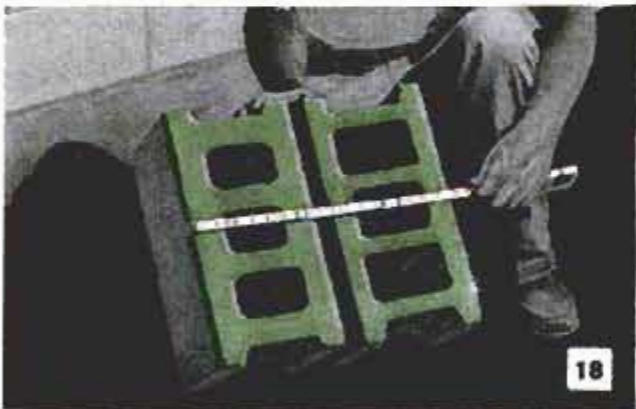

Cement blocks have thicker webs on one side. Thick webs are faced up to provide greater mortar area

Mortar can be applied in two ways. First way, and easiest for an amateur, is simply to trowel it on

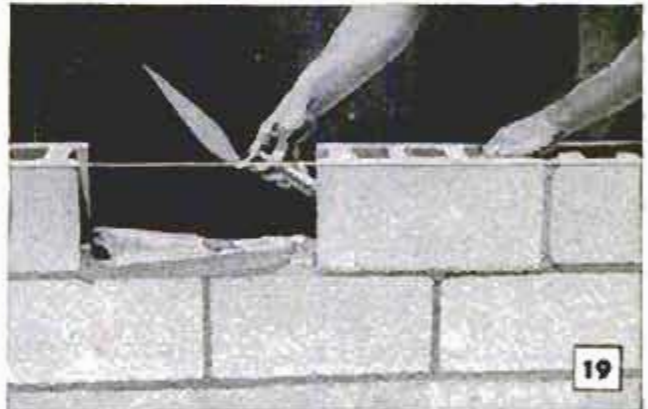

Each block is tapped endwise to force out excess mortar and reduce vertical joint to standard 3/8 in.

Second method of applying mortar is to "wipe" it onto blocks from trowel as shown in photo below







### Portable Drill Starts Mower

When his gasoline-powered lawn mower proved difficult to start, one homeowner chucked a rubber sanding disk — without sandpaper — in his 1/4-in. portable electric drill and held it against the flywheel of the motor to start it.

### Landing Net Pole Lets You Pick Fruit From High Branches

When picking apples or other fruit from a high tree as shown at the right, the fruit can be picked from the ground by using a fisherman's landing net lashed to a long pole. The rim of the net is used to "pluck" the fruit so it drops into the net itself.

### Tumbler Holds Magnifying Glass To Examine Live Insects



Students who are required to study live insects under a magnifying glass may have a problem in keeping them in place under the glass. One method of doing this is to imprison the insect in a glass tumbler and then use the top of the tumbler to support the magnifying glass.

### Entire Ant Colony Destroyed With "One Shot" Treatment

If you are troubled with anthills in your lawn, here is a method to get rid of the entire colony with one treatment. Invert a small clay flowerpot over the anthill and pour several tablespoons of carbon tetrachloride through the drain hole of the pot. Plug the hole with a cork and allow the pot to remain in this position for several hours. The carbon tetrachloride will seal off the air supply and the ants will smother.

### Calking Under Screen Molding Seals Out Water Damage

To prevent water from running under screen molding where it rots the wood and rusts the screening, apply a strip of calking compound to the edges of the screen before nailing down the molding. The calking fills the screen mesh and assures a good seal. Any surplus calking compound is removed by using a small paintbrush and a solvent such as benzene or turpentine.

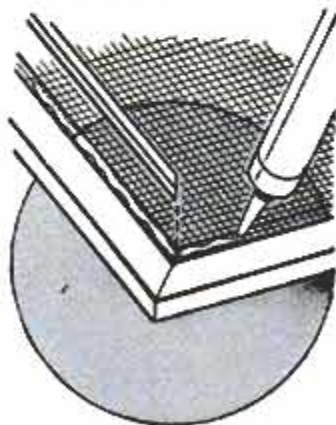



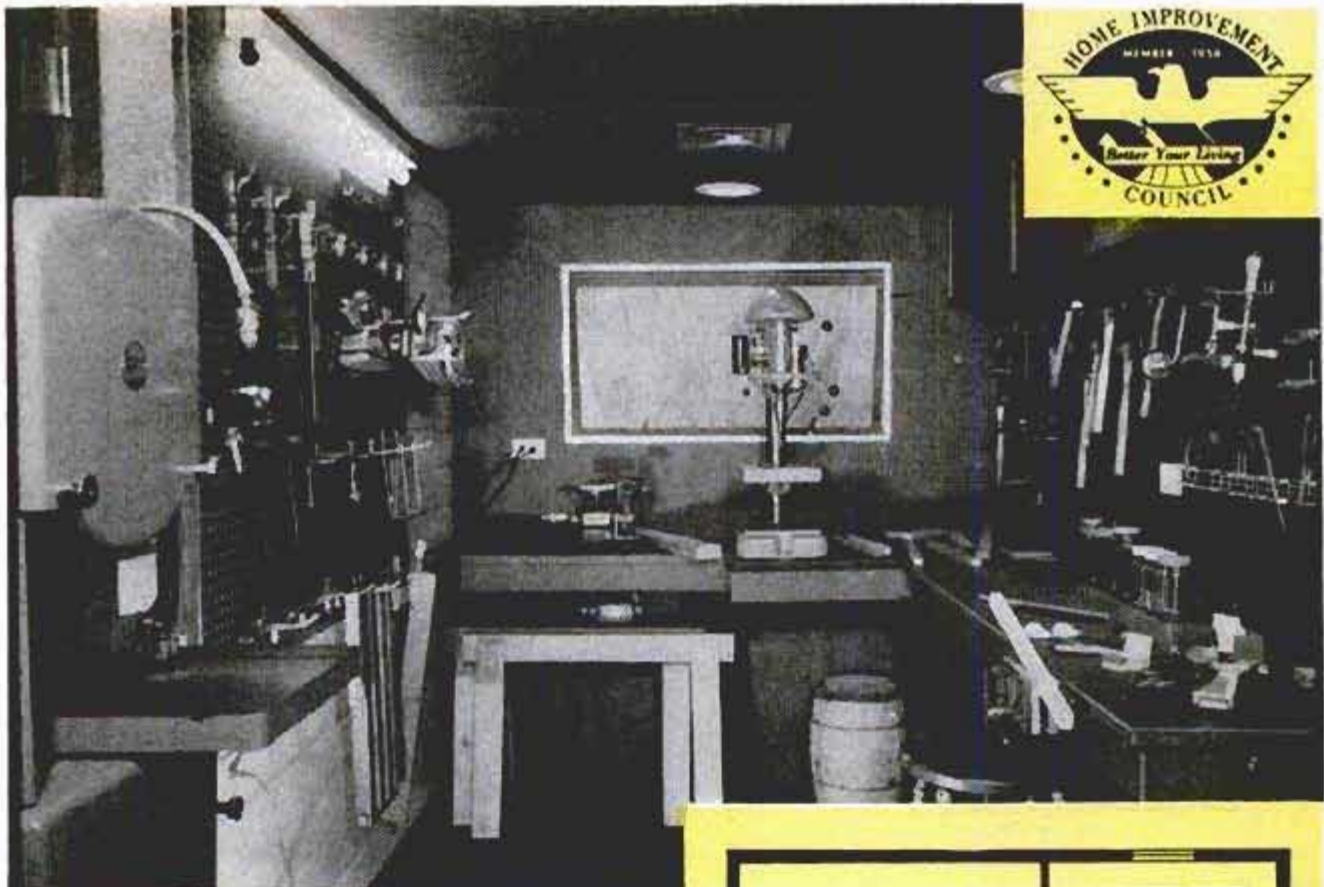

Photos and information courtesy Masonite Corp.

# "HIS" AND "HERS" WORKSHOP

IF YOUR WIFE has confiscated part of your workshop for her hobby and gardening activities, follow the example of one husband who rearranged his equipment and workspace to leave one end of the shop for her exclusive use as shown. Although in this case the workshop is located in an enclosed breezeway, the same idea can be used for dividing and compacting a basement workshop. By hanging all small tools on the walls, storing materials in cabinets and locating large power tools next to walls, not only is your workshop more functional but ample space is left over for your wife's activities.

Cabinets throughout the workshop are made of 1/4-in. tempered hardboard nailed to a framework of lumber. All doors are of the sliding type, also made of hardboard. Workbenches are of conventional construction, except that work surfaces are covered with tempered hardboard to provide a smooth, tough surface. Perforated, tempered-hardboard panels nailed to wall studs at each end of the workshop, provide convenient storage for shop and gardening tools and equipment. These are hung on wire fixtures that are inserted in the perforations. All surfaces are left unpainted.

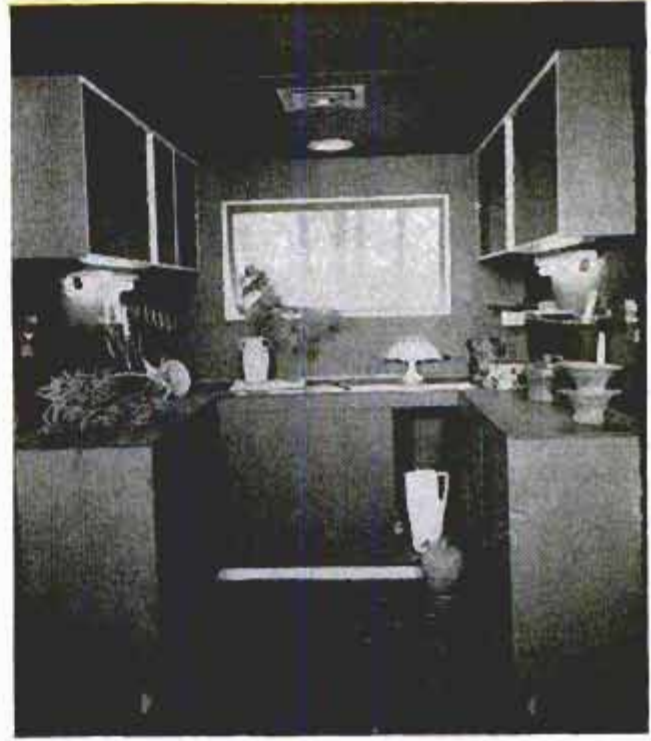



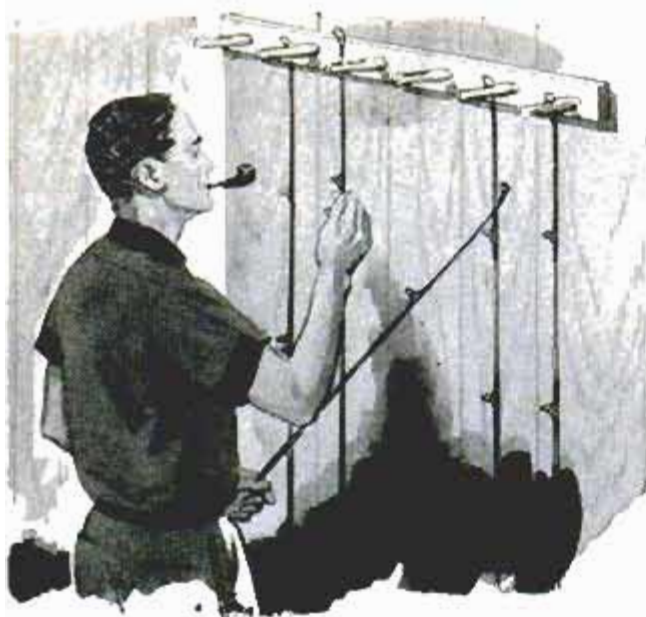

### Clothespin Fishing-Rod Rack

This novel rack for fishing rods consists of a length of 1 x 2 and a number of ordinary wooden clothespins. The heads of the clothespins are removed and they then are cemented in 1/2-in. holes drilled in the wooden strip which can be screwed to the wall at a convenient height.

John A. Comstock, Wellsboro, Pa.

### Fishing Gear on Lake Bottom Found With Waterproof Light

Lost fishing tackle in a lake or river often can be recovered by searching the bottom with the aid of a flashlight. The light is tied in a waterproof, plastic bag and lowered on a heavy cord. Use care not to stir up mud on the bottom.

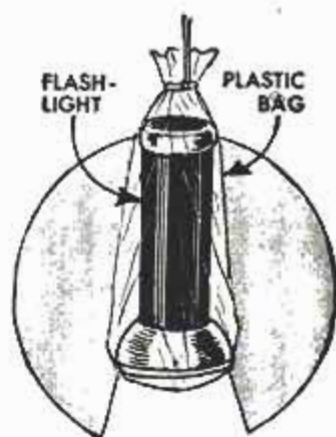

### Flushing Large Outboard Motors

To flush an outboard motor without removing it from the transom, fit a boot, consisting of a length of inner tube with one end sealed, over the lower end of the unit. Run the motor in neutral while a garden hose discharges water into the boot.

### Rubber-Tire "Gaskets" Reduce Noise and Wear on Floats

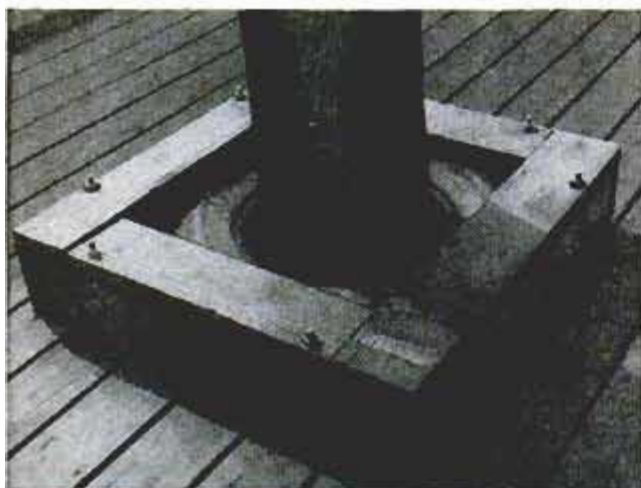

Where piers or floats are secured by pilings so they can move up and down with tides and waves, noise and wear can be reduced considerably by the use of rubber "gaskets." The gaskets are old automobile tires that are dropped down over the pilings and held in place on the float decks by boxes. The boxes are built of 2 x 6s around the pilings. Other lengths of 2 x 6 are bolted to the top edges of the boxes to form "flanges" that keep the tires in place. When a tire wears out, it is replaced by removing the flanges and replacing it with another, which takes only a short time.

S. C. Wilson, Port Blakely, Wash.

### Buying a Used Outboard Calls for Careful Check of Major Parts

When buying a used outboard motor it is important to check these major items if you want reasonably good assurance of getting a good buy: Compression, crankshaft bushings, cylinders, propeller bushing and needle-valve response.

To check the compression, turn the motor over several times and note the "pull" and "bounce." If compression is low, you can expect worn cylinders and pistons, worn or stuck rings or a defective cylinder gasket. Examine the crankshaft bearings for dirty oil accumulations on the armature plate, which would indicate a faulty upper-bearing assembly.

After removing the spark plugs, look for

excessive carbon accumulation in the cylinder head. Heavy deposits of carbon reduce the efficiency of the motor. But don't reject a motor for this reason alone if it passes the other tests. A propeller bearing can be checked by exerting up-and-down pressure on the shaft and watching for oil seepage around the bearing and excessive play in the bearing.

As a final test, insist that the motor be run in a tank. At this time see if the needle valve responds to adjustment. Also, check the wiring, fuel connections, gasoline line and smoothness of operation, particularly when idling. If these few points check out favorably, the motor is probably safe to buy.



# INFRARED PEST-CONTROL BOX

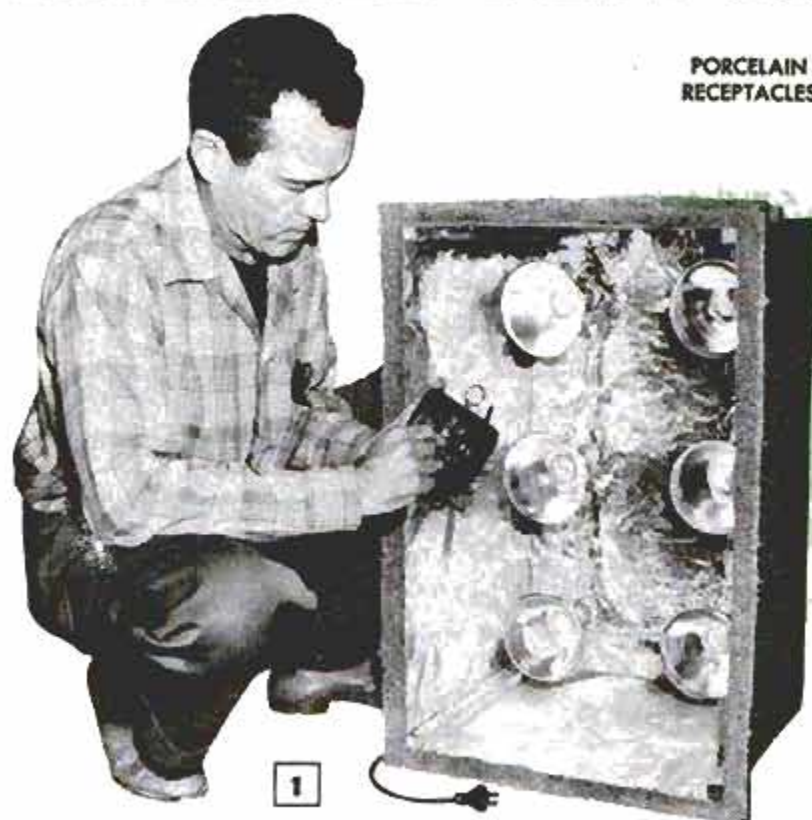

PORCELAIN RECEPTACLES

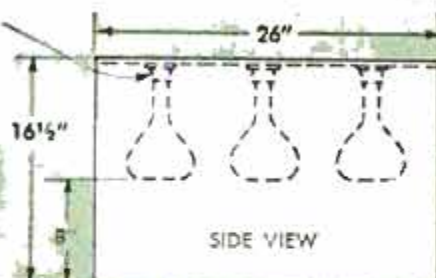

SIDE VIEW

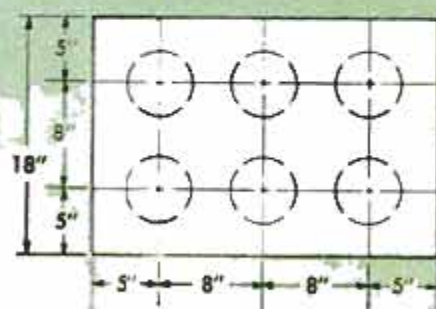

TOP VIEW

By Roy J. Pense

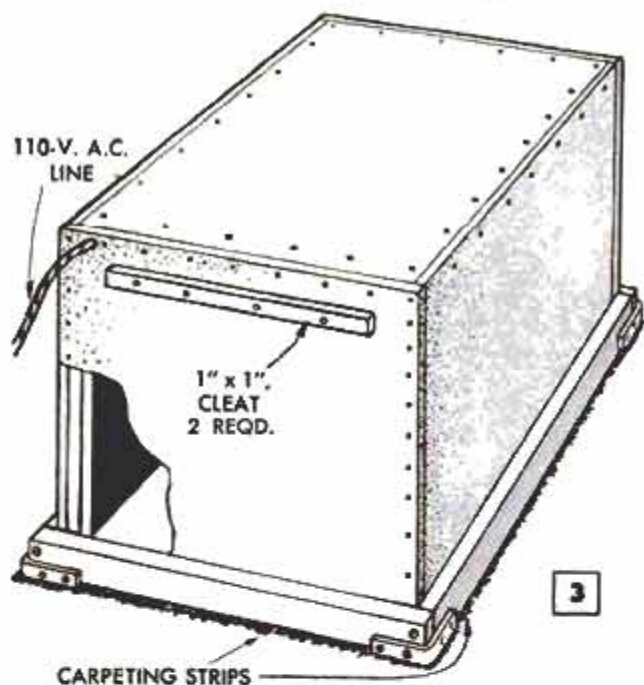

110-V. A.C. LINE

1" x 1" CLEAT  
2 REQD.

CARPETING STRIPS

**HARD-TO-GET-AT** termites or powder-post beetles that infest a hardwood floor can be easily exterminated, when they are exposed to infrared radiation produced by a battery of heat lamps mounted in an aluminum foil-lined box as illustrated. In use, the box is plugged into a 110-volt outlet and placed face down on the floor so that the infrared rays penetrate it. A five-minute exposure kills beetles in  $\frac{3}{8}$ -in. thick flooring, while seven minutes is adequate for  $\frac{1}{2}$ -in. flooring. No exposure should last more than 10 minutes to avoid scorching the wood. A darkroom timer with alarm bell should be used to time the

exposures accurately, Fig. 1. Killing effect is confined to the area under the box, that may then be moved to a new location. Lateral heat transfer often excites unnoticed larvae in adjacent boards, causing them to break to the surface and reveal their presence. Used in this manner, the unit also may be used to detect termite infestation.

To make an infrared pest-control unit, construct an open box of the dimensions shown. Wallboard, insulating board, plywood or hardboard may be used for this purpose, using 1 x 2-in. stock for framing members to which the top, sides and ends are nailed, Fig. 3. The lamps should be spaced exactly as shown in Fig. 2. For safety, asbestos-covered heater wiring and cleated porcelain receptacles are required. The interior of the box is covered with aluminum foil stapled in place. Bottom edges are faced with strips of carpeting to avoid scratching the floor. For handles, a 1 x 1-in. cleat is nailed to each end.

The device was designed at the University of California at Los Angeles for use by pest-control operators and is said to be more effective than fumigation and chemical-control methods. The lethal effect of the infrared is confined to thin flooring and does not kill termites in thick lumber. The unit is not recommended for use on varnished floors because of blistering, nor should it be used on humid days. It does not harm shellacked or waxed floor.



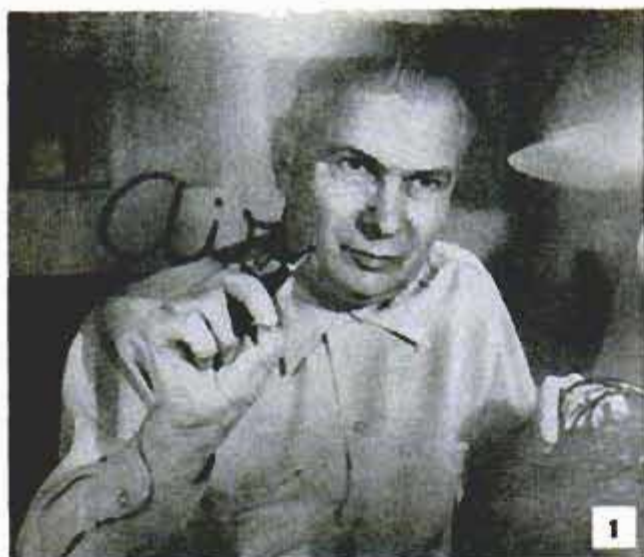

Panel of glass on which title is written must be sparkling clean and free of bubbles, cracks and other defects that distort objects filmed through it

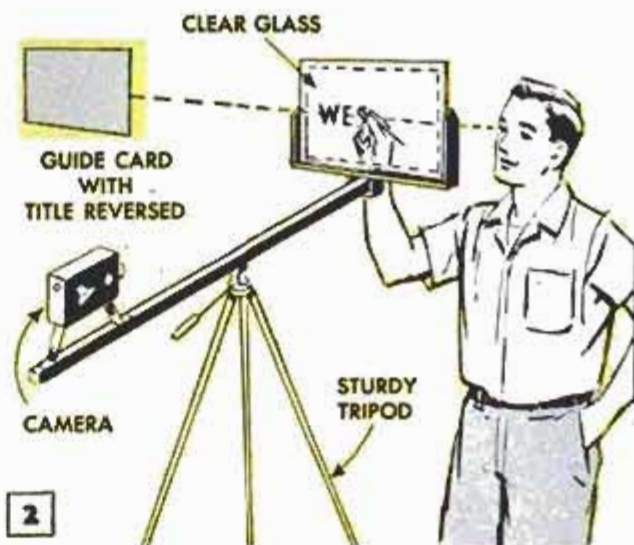

Writing title in reverse on glass is easy, when a guide card with title written in reverse is prepared and located at eye level directly above the camera

# Trick Titles

## for Your Home Movies

By E. R. Haan

**H**ERE ARE SOME suggestions for unusual titles that will start your home-produced movies with punch and give them a professional touch. Your friends will wonder how you've managed to write a title "on air," how a pile of letters can arrange themselves into words and how a wave of your hand magically produces a title. Many mystifying, animated effects such as these are surprisingly easy to produce without much expense or special equipment.

### Writing on Air

One of the simplest ways of producing a trick title is to write the words on a pane of glass so that they appear to remain suspended in air as shown in Fig. 1. One way to do this is to mount the camera on a tripod, facing the subject who is to do the writing. A large pane of glass is then propped or clamped in a vertical position in front of the subject at right angles to the lens axis as in Fig. 3. If the camera is of the focusing type, it is adjusted for a depth of field to include a distance of 6 to 8 in. beyond the glass, so that the subject's face and hands are in focus. The background scene desired should be composed within the limits of the pane of glass, as carefully checked in the viewfinder.

The effectiveness of this illusion depends largely on the selection of a location and background material that would not be associated with the use of a pane of glass for this purpose. After practice-writing the title backwards several times, you are ready to start shooting it. When illumination is necessary, photoflood lamps are positioned on either side of the camera as shown in Fig. 3. It is important that the lamps be placed as shown, to prevent reflections from entering the camera lens. Also for this purpose, you can make a holder for a pane of glass as shown in Fig. 2. For purposes of illustration, the glass shown, is about half the desired size. A guide card with the title written in reverse on it may be used as a writing aid, when filming this type of title.

### Reverse Motion Effects

Highly unusual title effects can be made by projecting film strips in reverse, after shooting them expressly for this purpose and splicing them in a movie. For example, a reversed film strip may show letters flitting over a background and assembling themselves into a title. To produce this effect, you simply film the letters while they are being blown from the background as in Fig. 4. For shooting a title on a ver-





tical surface, the camera must be mounted in an upside-down position on a tripod. This can be done by making a U-shaped bracket to accommodate your camera as shown in Fig. 10. When filming a horizontally placed title, the camera is aimed at the title so that it is filmed in an upside-down position, Fig. 4. This camera position makes the title appear right-side up, when it is spliced into the film reversed end to end and with the emulsion on the same side as that on the film. By doing this, the last action filmed will appear first in the projected picture with all action in reverse.

When using an 8-mm. camera for film-reversal title, remember that the processed film has perforations on one edge only. Therefore, a reversed strip must be positioned so that the perforations appear on the same side throughout the movie. As this reverses a title as it would appear in a mirror, it is necessary to write or print the title in this reversed position, when shooting it. The title strip must then be refocused when projecting it.

Letters can be blown off a horizontal background with a vacuum cleaner, Fig. 4. A small diameter tube taped to one of the cleaning attachments, provides the proper air stream, when the hose is coupled to the blowing outlet on the vacuum. This setup

Below, to avoid reflections when writing title on glass, photoflood lamps must be placed 3 ft. from it and at an angle of 30 to 45 deg. from lens axis

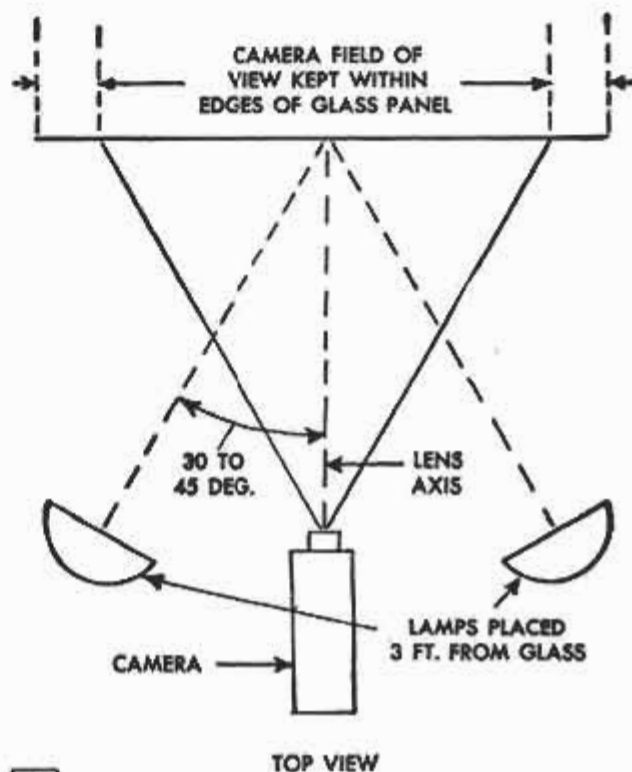

3



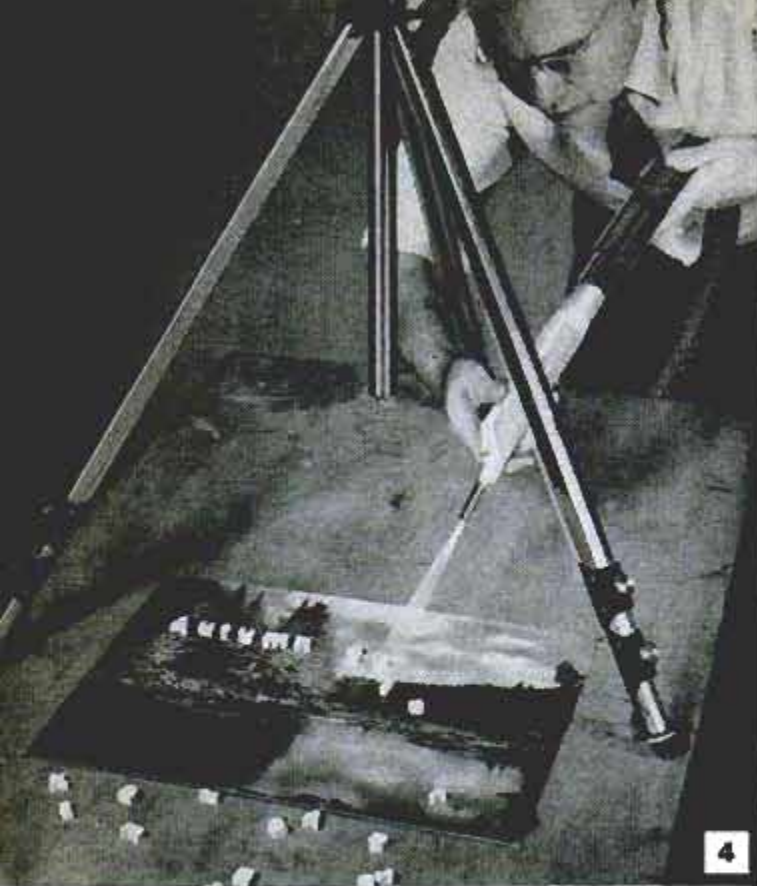

enables you to move paper or plastic block letters off the background while the tube is held out of view of the camera. The speed at which the letters move can be controlled by varying the distance between tube and letters. Lightweight paper and metallic-foil letters are least controllable and will move erratically, unlike heavier block letters. On multiline titles, the air stream may be directed from above so that the letters are dispersed in all directions. A little practice and experimenting soon

Distance from vacuum-cleaner nozzle to letters determines speed at which letters are blown off picture

makes you adept at obtaining the desired speed and direction of letter movement. Start blowing away the letters at the end of the title and continue toward the beginning, so that when the reversed film is projected, the title appears on the screen in the proper reading sequence.

#### Variations of Reverse-Motion Effects

You can make use of gravity in dropping letters individually, or drop them line by line from a title held on an angled background, Fig. 6. Then, the reversed projected film will show the letters disengaging themselves from a pile and rising into position on the background to form a title as in Fig. 5. When filming a title of this type, the letters are arranged to rest on pins that project through the background board. The letter is held by means of a grooved block, Fig. 6. The background is angled as shown to prevent the letters from falling forward, when the pins are pulled. This angle may be varied to control the speed of letter fall. The camera is placed so that the lens axis will be at slightly less than a right angle to the background to keep the pins out of view. Camera view should include the surface of the base block on which the letters collect. When you are ready to shoot the title, begin with removing the pins of the last letter of the last word. Do this carefully to avoid dislodging other letters. Some letters need only one pin for support but most require two. When drilling the holes for the pins,

Letters filmed as they drop from pins appear to reassemble on background, when film is projected in reverse

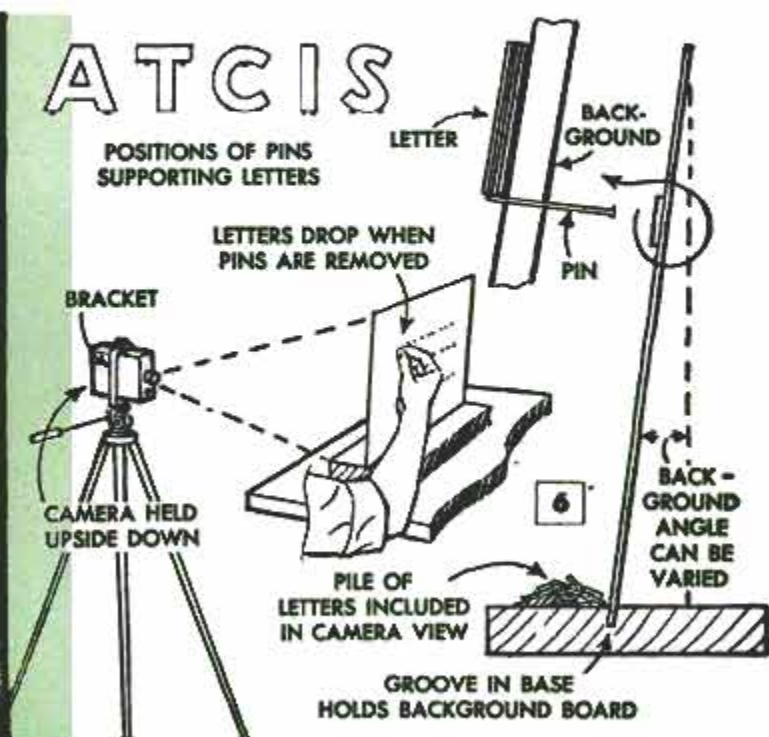
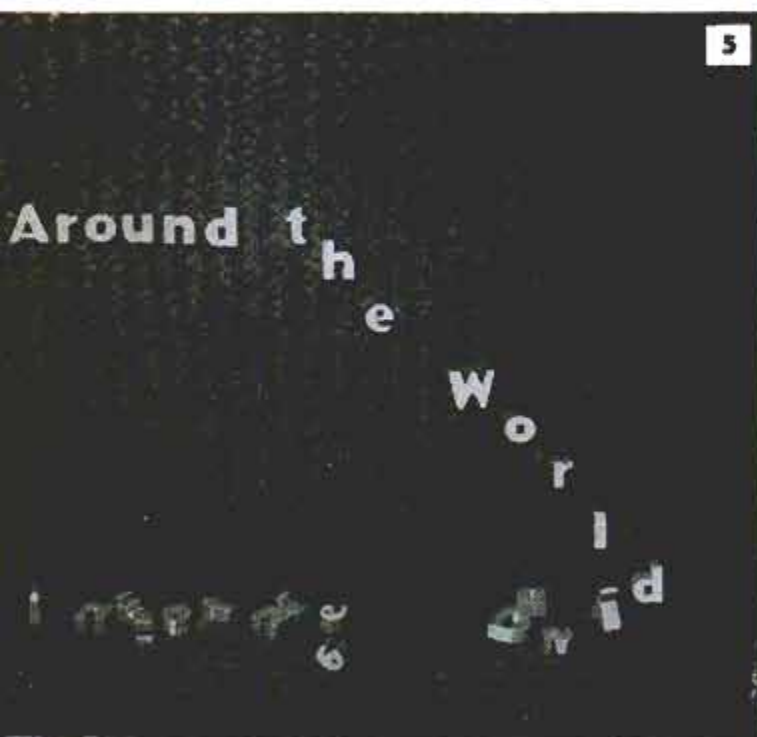



place the background on a horizontal surface and assemble all the letters on their lines. Then, mark the locations of the pin holes and drill them.

Another interesting illusion obtained by reversed motion consists of making the lines of a title suddenly appear when your hand is passed over the background as in Fig. 7. To get this effect, shoot the action of pushing away letters that are loosely laid on a horizontal background as in Fig. 8. For 16-mm. film, use your left hand to sweep the letters toward the left out of the field of view, starting with the lowest line and working backward to the first word of the title. For 8-mm. film, the title is set up in reverse and the right hand is used for removing the letters from left to right. The letters are collected under the palm and are pushed along with thumb. When projected, the reversed title strip shows the first line appearing first from left to right in normal reading sequence. Chalk-written titles on a blackboard may be produced similarly by filming the erasing angle.

Water from a wave that runs up on a beach seemingly produces a title in wet sand after filming the title in the following manner. First, block off the title area with wide boards arranged to form a V-shaped barricade as in Fig. 11. This will keep the water from interfering while you are scratching the title in the sand and when shooting it for the desired reading time. Then, you remove the boards and immediately start the camera, before the next wave obliterates the title. For good results, experiment with the depth of the letters required to permit a wave to completely remove all traces of the title.



Title that is filmed in reverse as hand sweeps it off background appears as if by magic, when projected

For a reversed-motion title that is quite difficult to do but not impossible, if you have the time and patience, have squirrels spell out a short title for you. This is done by placing nuts on a light-colored background, to spell out the title. Locate your camera on a second-story elevation almost directly above the title area and run it only when squirrels come to remove the nuts. For this you need a telephoto lens. For best results, camera position and location must not be changed once the first exposure is made. Also, the title area must be free of changing shadows.

Your garden hose can be made to "squirt" a title on a wall or other suitable background. This is the reversed action of washing off a title as shown in Fig. 9. The letters must be made of material that is

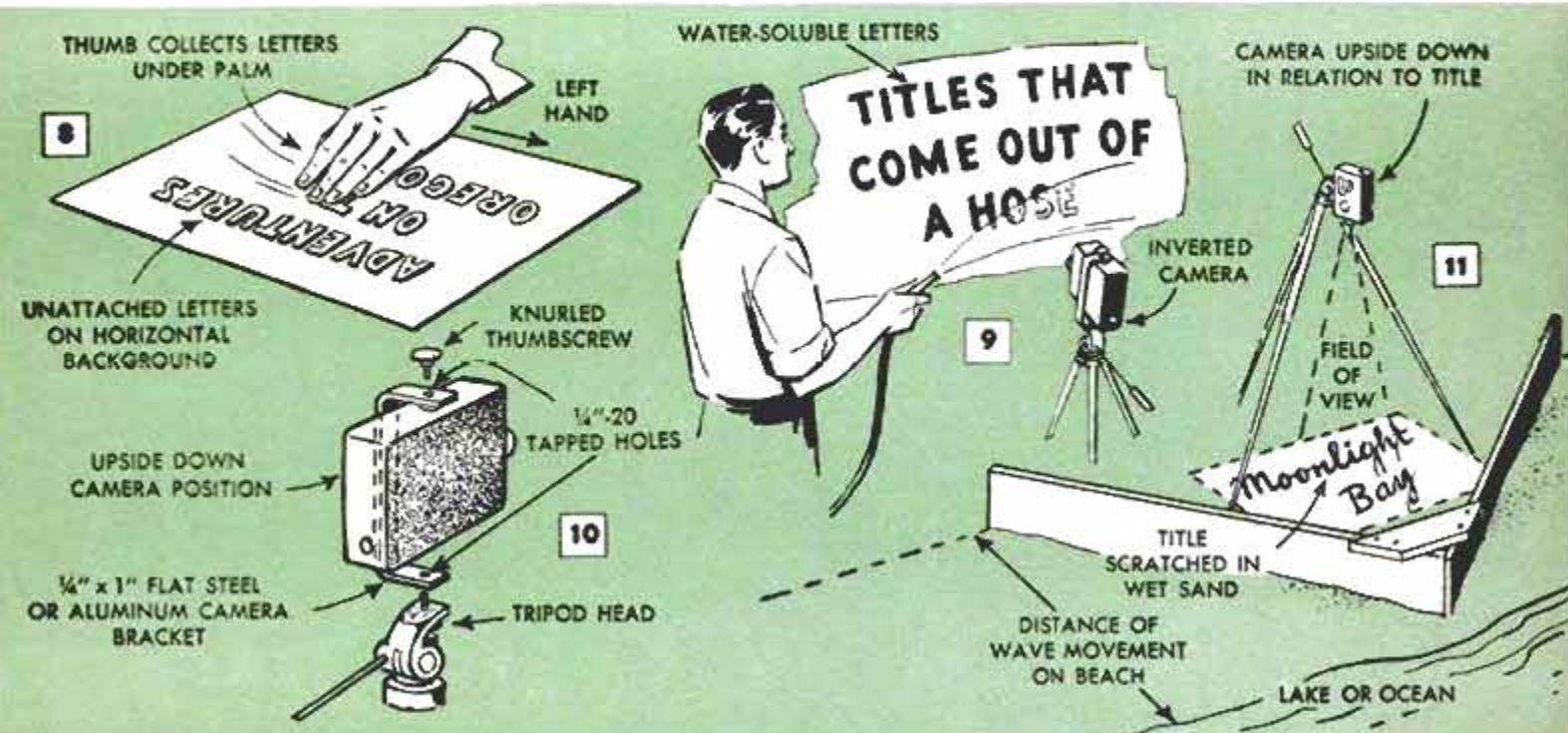



water soluble, such as moist mud, some cold-water paints, etc., so that the title can be flushed off the background without a trace. When doing this, start with the last letter, pointing the hose nozzle toward the right. Maximum water speed is necessary since this makes it harder to observe the water "returning" to the hose upon reversing the film run.

### Titles by Simulated Movement

The impression of movement can be produced by making a sequence of single-frame shots for each letter of a title as it is advanced toward its assembly position in the title. Movement of the letters can be slowed by exposing two or three frames for each position. If your camera can't make single-frame exposures, use the release in the usual manner and expose as few frames as possible. To set up such titles for filming, arrange the background horizontally below the camera as in Fig. 12. Make a single-frame exposure of the background with the first letter of the title placed at its edge. Then, advance the letter about  $\frac{1}{2}$  in., take the second exposure, advance it another  $\frac{1}{2}$  in. and place the second letter at the edge of the background for the

third exposure. Continue advancing all the letters and adding new ones between exposures as required. When each letter arrives in title position, line it up with the others, using a ruler. For added amusement, you can intentionally misspell words and make the corrections when the title is completed. While the letters are enroute to their title positions, they can be made to appear to jump, turn somersaults and perform other amusing antics.

A "self lengthening" line is another example of simulated movement. To obtain this effect, slightly lengthen a line between single-frame exposures. An entire title can be so formed, each letter growing as indicated in Fig. 13. A further application involves making a sketch next to the title being filmed. To do this, trace a photo projected on a square of ground glass as in Fig. 14. Start to mark the "moving" line on the smooth side of the ground glass with a grease pencil. Then, film this with single-frame exposures as you lengthen it, turning the projector off when making the exposures. If ground glass is unavailable, you can make a good substitute for it by taping tracing paper to a pane of glass. A "self-lengthening line" can be made to trace the

Fig. 12, to simulate letter movement, sequence of single-frame exposures of each are made as title is assembled

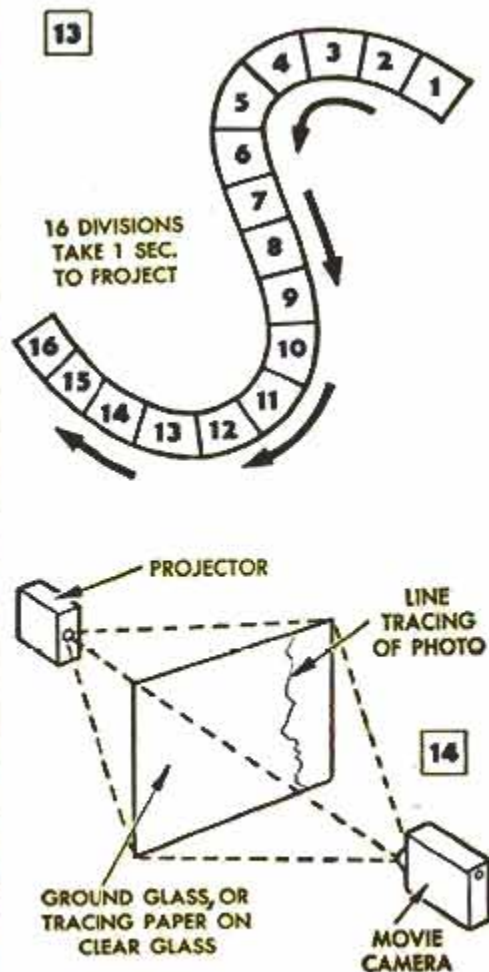





Title that appears to grow in size is made by shooting sequence of single exposures as camera is moved in

route of a trip on a map and spell out the points visited. This can be varied by using a tiny, toy auto on the map that will appear to run along the route traveled.

Completely different in effect, a title can be made to appear small in the distance and advance toward the camera, increasing to full size as in Figs. 14 and 15. This is done by making single-frame exposures as the camera, mounted on a track as in Fig. 16, is moved short distances toward the background.

### Titles That Whirl

There are different ways of making a title whirl and slowly come to a stop for reading. One method involves reversed action. After the title is adhered to a background that can be revolved as in Fig. 18, the necessary film footage is exposed for the desired reading time. Next, the background is rotated very slowly at first, then with increasing speed. If desired, this trick can be combined with the title-advancing trick, in which case the camera is moved backwards slowly on a track while the title

is spinning. The rotating title blurs and decreases in size. The reversed projection will show the small blurred title advancing, enlarging and coming to a stop for reading.

A title also can be made to appear as if it is spinning by using single-frame exposures. The title background, pivoted centrally, is rotated about a quarter turn, and given a single-frame exposure. This is continued for two complete turns. On the third turn, two frames are exposed, four frames on the fourth turn. For the fifth turn, the turn distances are halved and 4-frame exposures are made at each stop. For the sixth turn, the distances turned are halved again and 16 frames are exposed. The first eight are 4-frame exposures and the rest, 5-frame exposures. On the seventh and succeeding turns, the number of stops per revolution is decreased and the number of frames exposed is increased, until the title assumes a horizontal position required for reading. Then, the title is exposed for the proper reading time, processed and spliced on the movie for which it was made. ★ ★ ★

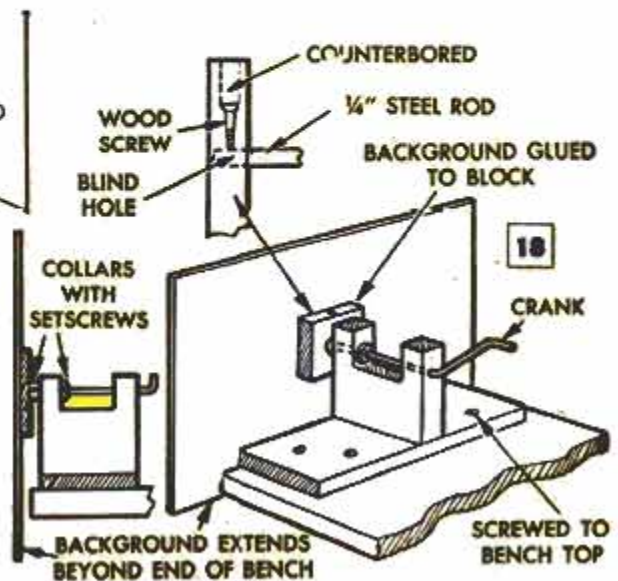
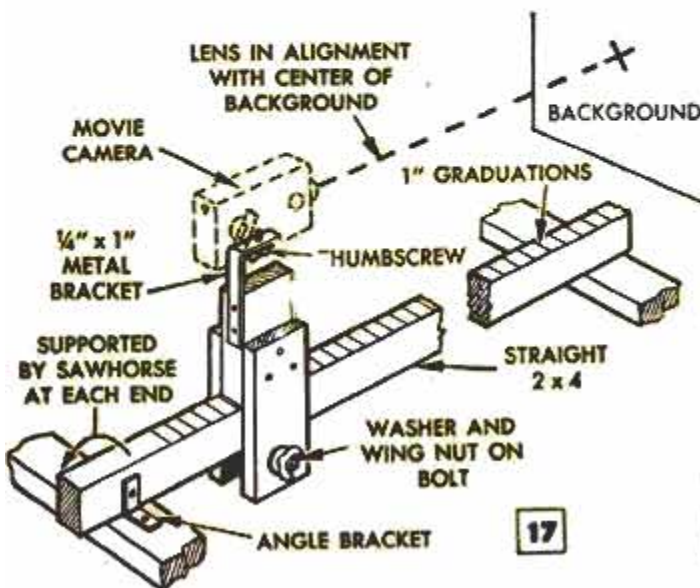



# Sandpaper Target Adds Fun to Tiddlywink Game



To add a new twist to the old game of tiddlywinks, cement a sheet of medium-grit sandpaper to a square of plywood, draw circles and numerals on the paper as of plywood. Draw circles and prop the board at about a 45-deg. angle to provide a sloping target for the disks snapped at it. The disks, falling upon the sandpaper, will tend to remain in place unless touched by other disks during succeeding shots. The trick, of course, is to snap the disks so that they will come to rest on the highest numbers.

## Singeing New Rope Removes "Splinters"

If a heavy hemp rope used for hand hauling or hoisting, or as a temporary handrail, has coarse fiber ends projecting from it like tiny spines that injure the hands, the rope may be made smoother to handle by singeing it in a clean, hot flame such as that of a propane torch, blow torch, or even the kitchen gas burner. Set the torch down, and holding a foot or so of the rope at a time, pass this back and forth through the flame just slowly enough to burn away all loose fibers, but quickly enough to prevent burning the rope or overheating it. Wear gloves for safety. Rotate the rope through the flame.

## Hot Water and Wooden Block Keep Crayons "Sharpened"



Children who draw with wax crayons do much better work if the crayons are kept pointed. One method of sharpening them is to peel off the paper wrapping as necessary and dip the crayon ends into hot water to soften them. The softened ends are pointed by rolling them under a wooden block.

## Safety Rack for Ironing Board

To keep children from toppling an ironing board leaning against a wall, and possibly being injured, one homeowner attached a towel rack to the wall under which the board end fits.

## Tar-Paper Rolls Lifted Safely With Pail and Looped Rope

Lifting rolls of tar paper to the roof of a building can be done safely by using a pail attached to the end of a rope. The roll of paper is placed in the pail as indicated and a loop of line is passed around the roll. Lifting on the rope tightens the loop securely.



## Resistor Added to Doorbell Permits Volume Control

When a house is quiet, an ordinary doorbell can sound like a fire alarm, especially if children are sleeping. Quieting the bell can be done easily. Remove one of the wires from the bell, and connect to this wire and the binding post on the bell, an adjustable or variable wire-wound resistor up to about 10 or 15 ohms. The correct value is a matter of experiment and depends on the bell voltage. Rheostats from electric-train sets, power resistors from radio receivers and pieces of heater coils are all suitable.

Robert Hertzberg, Long Island, N. Y.

## Reflective Tape Over Keyhole

To aid in unlocking a door at night, attach a strip of reflective tape over the keyhole. "Cut out" the keyhole by firmly pressing the key through the tape after the tape is pressed in place.



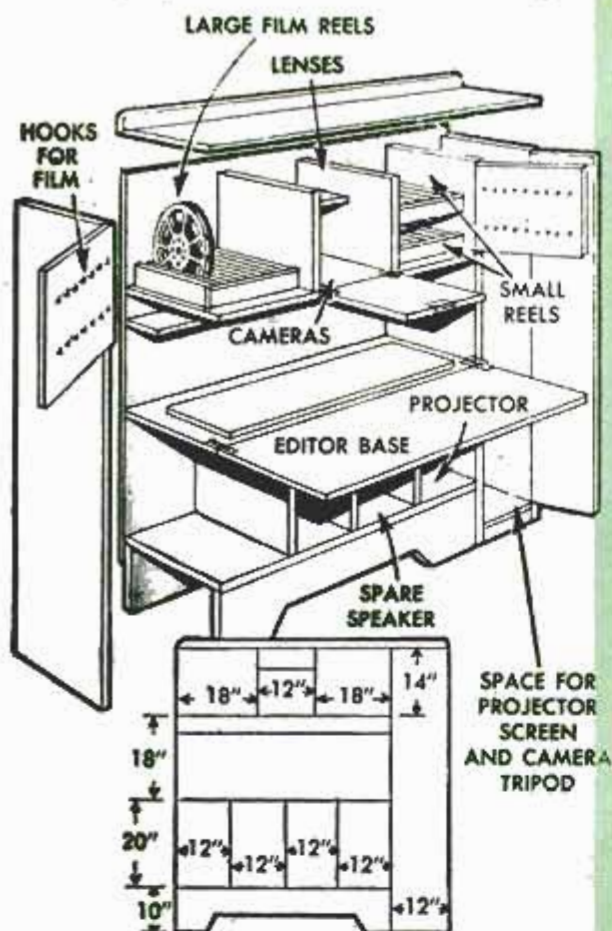

## Complete Home-Movie Center Located in Cabinet

As with any hobby that is allowed to grow, home-movie making eventually gets to the point where storage of equipment becomes a problem. This cabinet was designed as a solution to this situation, being a complete home-movie center. Editing viewer is mounted on a plywood panel that is kept in the large central compartment behind a bottom-hinged door that drops down to form an editing desk at comfortable seat height. Above the editing compartment is a locked cabinet for a camera and lenses. On either side of this cabinet are divided storage sections for large and small film reels. Numbered hooks or pegs are located on the insides of the reel-compartment doors to permit hanging short lengths of film during an editing operation. The lower section of the cabinet has several compartments for storage of such items as projectors and lights, and there is even room for a tape recorder or accessory speaker, if a sound projector is included in the equipment. On the right side of the cabinet, with its own door, is a vertical compartment that will accommodate a folding projection screen up to a size measuring 50 x 50 in. Several tripods and folding lamp stands also can be fitted in this compartment. A cabinet built to the dimensions shown, and with a front-to-back

measurement inside of 15 in. will accommodate the largest 16-mm. equipment. If 8-mm. equipment is used exclusively, or if the projection screen and other equipment are small, the cabinet can be reduced in size by about 10 percent. Availability of space may also dictate that the cabinet be made smaller than shown. Although the entire cabinet can be made of  $\frac{3}{8}$  or  $\frac{1}{2}$ -in. plywood, it is suggested that the bottom and top, as well as the desk surface be made of 1-in. solid stock.

Bell and Howell Company.

## Wax Keeps Stains off Prints



Prevent corrosion on the metal parts of a heated photoprint drier from staining the belt, which will stain the prints, by treating the belt edges with ferrotype polish, or a paraffin-lighter fluid solution.



## Extension Brackets "Clamp" Paint-Roller Pan to Ladder Shelf

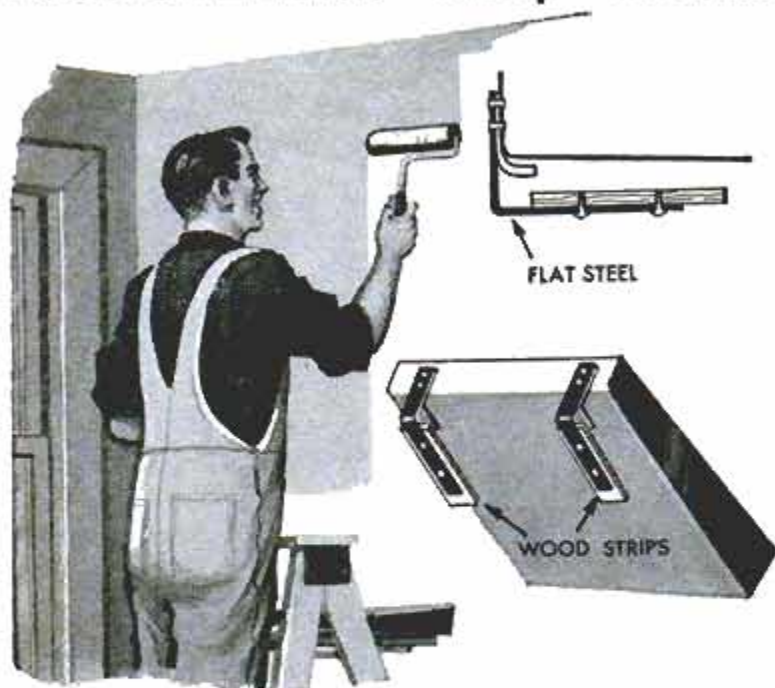

Have you ever accidentally knocked a paint-roller pan from a stepladder? You can prevent this from happening again by installing longer clamping brackets on the pan as illustrated. First, form two L-shaped brackets from  $\frac{1}{16}$  x 1 x 8-in. lengths of flat steel, locating the bend in each to permit a snug fit when the pan is clamped on the paint shelf of the ladder. Next, four holes are drilled in each bracket, spaced so that the short leg can be riveted to the back of the pan and the long leg can be screwed to a  $\frac{1}{2}$  x 1 x 6-in. wooden strip as shown in the drawing. Stove bolts may be used in place of rivets to fasten the brackets to the pan, if desired. When doing this, include a rubber washer on each bolt to seal them in the holes.

### Seal Knots and Sap Streaks

Before you paint or varnish new wood, seal all knots and sap streaks with a prepared sealer or white shellac. Sand the defective area smooth, fill any cracks or breaks in the knot or discoloration, then apply sealer.

Be sure to allow for the thickness of the wooden strips when determining the point at which to bend the brackets.

Albert Brownly, Woodville, Mass.

☐ The best way to paint a screen-door spring, is to stretch it between two nails to open the coils, then apply thin enamel.

## Beautiful, Useful Furniture You Can Build WITH FULL-SIZE PATTERNS

You can make sturdy, good-looking furniture, toys, valances, metal lamps—even a 12-foot utility outboard with PM Full-Size Patterns. They were all drawn by a professional designer and built in our shop to test fit of parts and construction details.

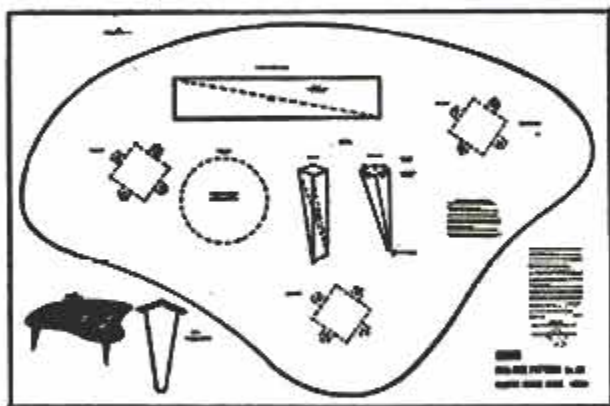

No. 116. Palette Coffee Table

Above is an actual photograph of Pattern No. 116, a Palette Coffee Table, which is  $31\frac{1}{2}$  x  $47\frac{1}{2}$  inches at its widest points. It can be made in one evening, if you have a bandsaw for making the curved cuts. Pattern includes complete construction and finishing details. 50c.

Modern Cocktail Table, No. 103. This table is 40 x 19 inches;  $15\frac{1}{2}$  inches high. With its metal grill inserts and plank top, it's modern in design and solid as a rock. One pattern—costs only 50 cents.



Love Seat, No. 114. Designed in the Lawson style, this love seat goes with either modern or traditional settings. Uses sagless-type wire springs and foam-rubber padding. Two patterns in the set: \$1.00.



Trundle Beds, No. 102. These beds save space and are safer for youngsters as there is no ladder to climb; have storage headboards, and use standard-size mattresses. Three patterns: \$1.50.



Order today! And ask about the other 20 patterns, all guaranteed to be good—or your money back!

Minimum order \$1.00

**POPULAR MECHANICS PATTERNCRAFT**  
200 EAST ONTARIO STREET CHICAGO 11, ILLINOIS



## CHECK YOUR RADIAL SAW FOR ACCURACY

By R. J. De Cristoforo

A FEW SIMPLE accuracy checks carried out periodically can keep your radial-arm saw performing at top efficiency. Radial saws are rugged machines made to give service over long periods of time with only ordinary care. The efficiency and all-around handiness of the units are achieved by locating the mechanical parts and provisions for adjustment above the worktable rather than below it as on a table saw. The smaller radial units are exceptionally light and therefore easily portable and often are moved about to and on the job. Because of these features the radial saw is frequently subjected to unusual stresses and accidental knocks that result in slight misalignment of parts. Also, the table is of necessity made from wood which may change dimension slightly when subjected to hard service or unusual variations in temperature and humidity. You are not likely to discover minor inaccuracies in cutting material to dimension until you begin assembling parts.

Sometimes the scale pointer on the radial arm gets accidentally knocked out of position, or the automatic stop gets out of adjustment, causing a variation from 90 deg. in crosscut travel, Fig. 1. This also results in an inaccurate angle cut at

All radial saws have a means of leveling work table so that its surface is parallel with radial arm. Parallelism of table and arm is checked as in Fig. 3

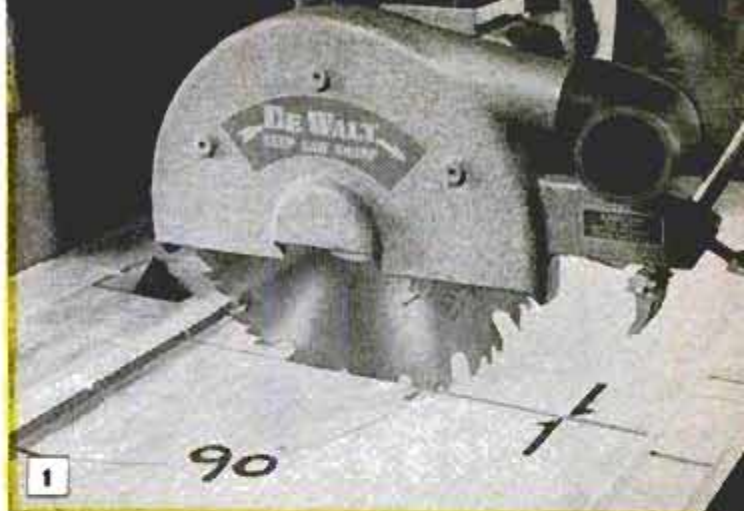

Crosscut must be precisely at 90 deg., as otherwise parts cut to size will not fit in assembly

Surface of radial-saw table is checked for flatness with carpenter's square. Level table by planing

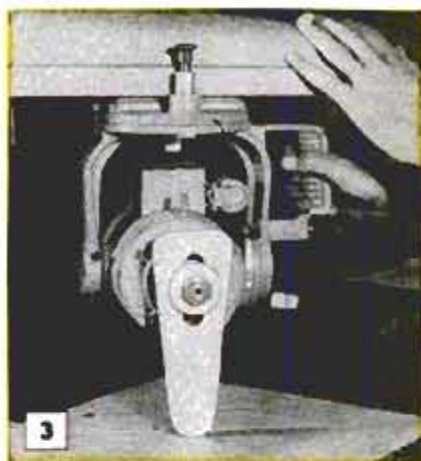
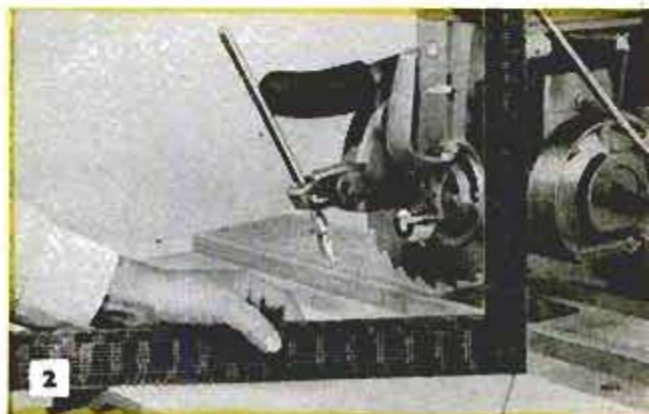

Above, checking parallelism of table and arm. See Fig. 4. Below, blade must be perpendicular to table surface as otherwise it will cut a bevel

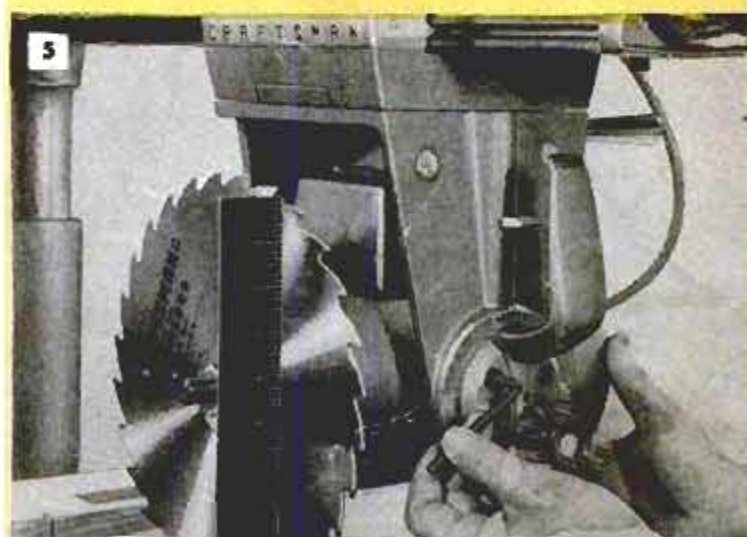
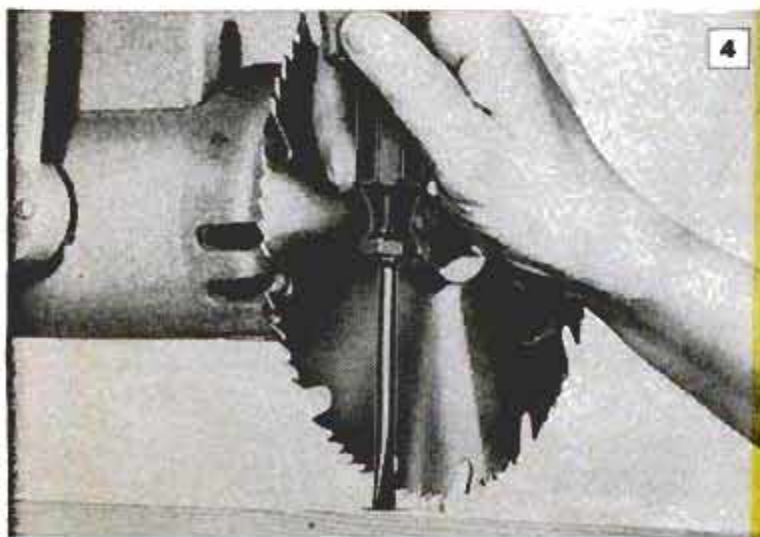



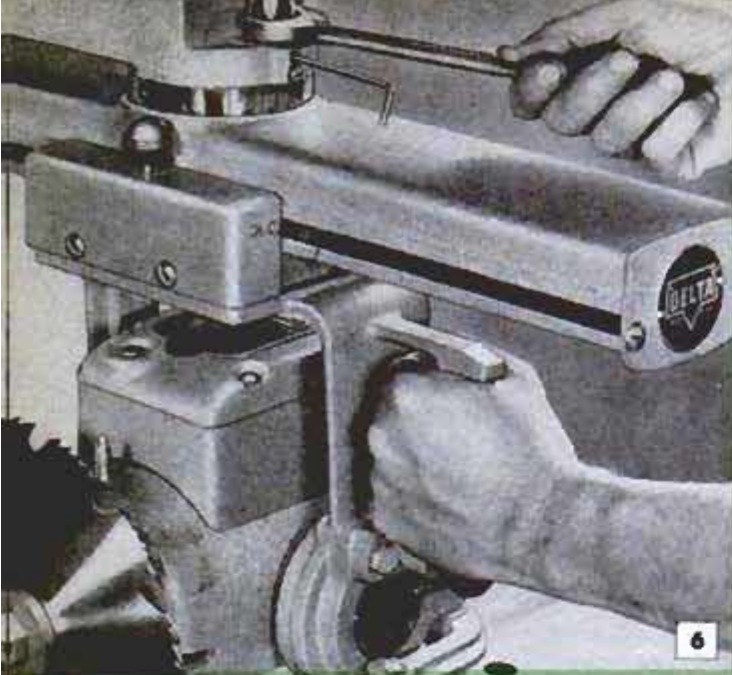

Blade must travel parallel to arm. All machines have adjustment for correcting runout, or "heeling." See Figs. 7 and 8 for method of checking

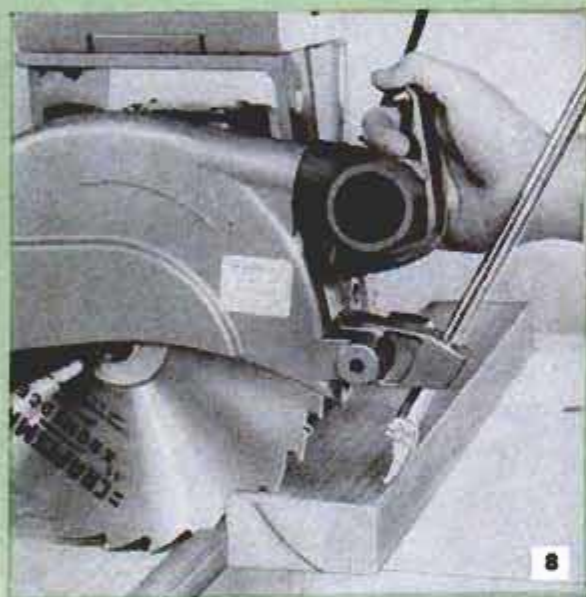

After adjusting as in Figs. 6, 9 and 10, run trial cuts on same size stock to determine accuracy

Remove cover plate to adjust swivel lock. Adjustments vary on different makes of radial saws

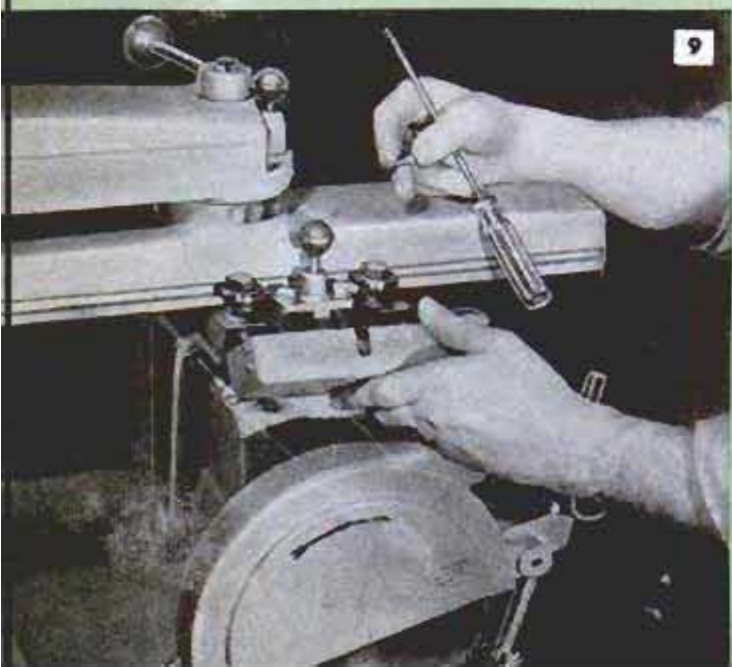

any point between 90 and 45 deg., Fig. 11. To check, run a crosscut through a fairly wide board and check accuracy with a carpenter's square. Readjust the pointer on the angle scale and test again in the same way. When the cut comes out "right on the head" be sure to tighten the pointer securely in the correct position, and don't forget to re-adjust the stops on the arm, if the machine is so equipped, Fig. 6.

It's easy to overlook a check of the table top. The latter is always made from specially selected wood, but usage and other possible causes may develop irregularities that can be discovered only by using a straightedge as in Fig. 2. First, check all the screws or bolts holding the table in position to see that none are loose. Then move the straightedge (a carpenter's square will do) over the table surface, noting and marking any high or low places. Level the table, if necessary, by light hand planing and sanding.

To check parallelism of the table surface with the radial arm, make an adjustable indicator from hardwood and fit it on the saw arbor as in Fig. 3. Remove the strip that serves as a ripping fence, rearrange the filler strips between the rear edge of the fixed portion of the table and place the ripping fence between the rear edge of the strips and the clamps. Tighten the latter. This clears

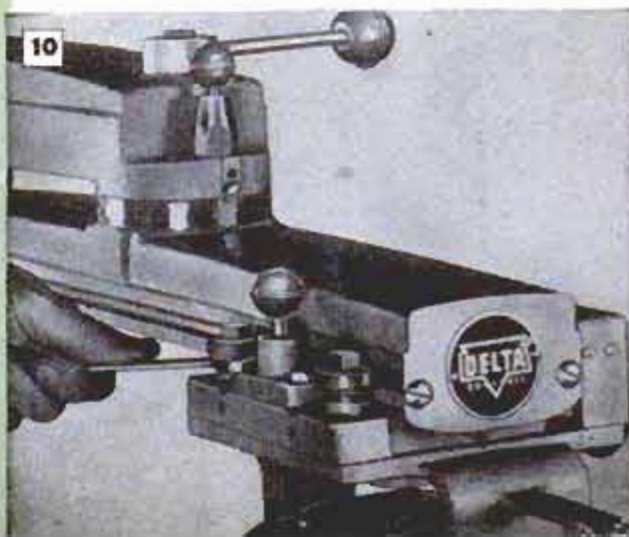



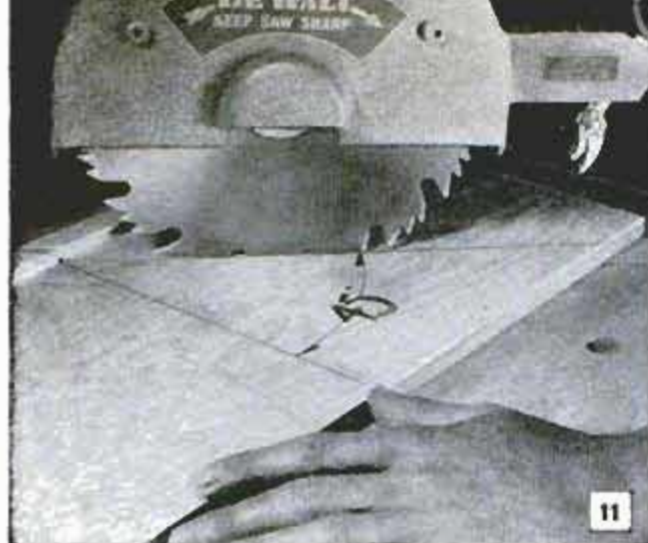

When making adjustments for square crosscut be sure also to check the 45-deg. setting. It may also be necessary to adjust the automatic stop-pin setting

the surface of the table so that the indicator, Fig. 3, can travel across the full width of the table. Swing the radial arm to the right-hand, 45-deg. position. Now move the yoke slowly back and forth, swinging the radial arm to a new position at each stroke until you reach the left-hand, 45-deg. position. This simple test generally will show up the slightest tilt of the table in relation to the arm. Level the table, if necessary, with the adjusting screws, Fig. 4.

After these tests have been made and any necessary corrections taken care of, you'll need to check the blade for squareness with the table, Fig. 5. Make sure the motor is locked in the 90-deg. position, then bring the square up to the blade. Be sure the blade of the square is located between set teeth on the saw blade. If any adjustment is necessary, loosen the lock on the yoke swivel, Fig. 5, tilt blade to correct position, tighten the lock and readjust the stop pin. Set the scale pointer to indicate the correct blade position at any angle.

You may find that all other adjustments check out correctly but still you note a drag in the cutting action. Unless you are using a dull blade, which results in a similar drag, this peculiarity of the cutting action usually indicates that the teeth of the blade are not tracking in the cut, that is, the teeth coming up are cutting into the side of the kerf made by the teeth going down. This inaccuracy is known as "heeling." One way to check to determine which way the blade is canted is to crosscut a 2 x 4, stopping the blade at approximately the point pictured in Fig. 7. This will indicate which side of the kerf is being widened by the canted blade, Fig. 8. All radial saws

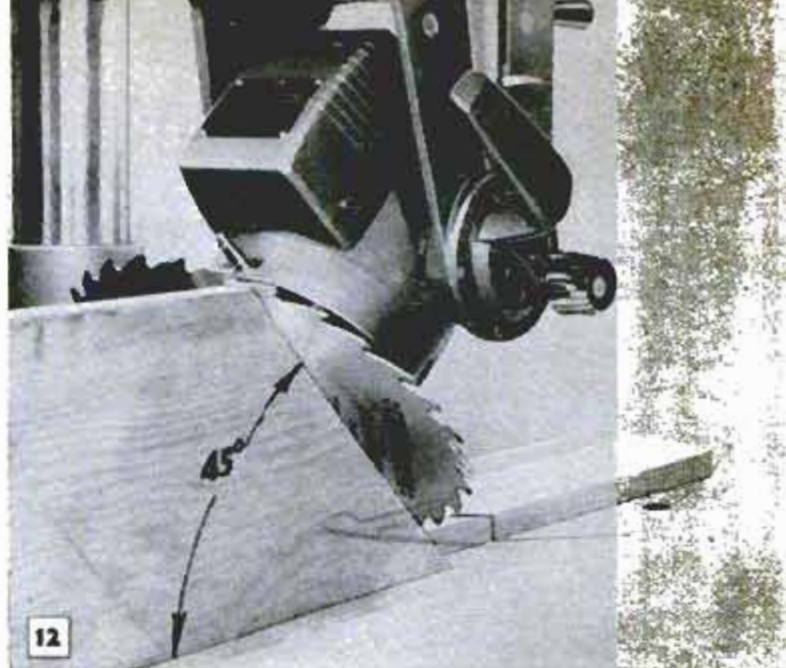

Above, check 45-deg. tilt with template that will span blade. Below, tighten the locking lever on tilting mechanism occasionally to assure accuracy

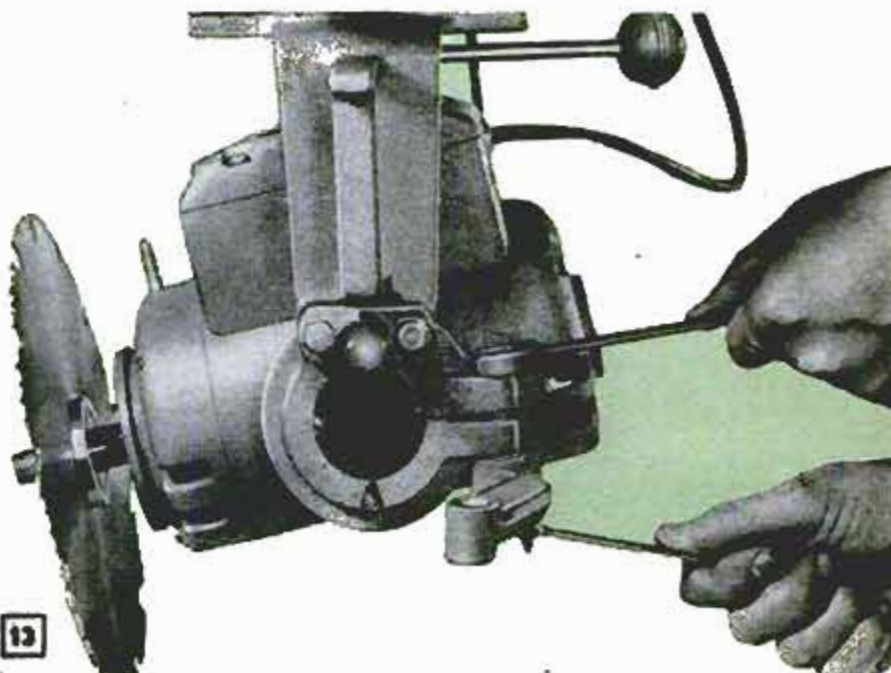

have an adjustment for tracking the blade parallel to the arm. Figs. 9 and 10 picture one type. In any case, the trial cuts necessary to make the correct adjustment should be made with a blade in perfect condition, newly sharpened and correctly set.

Another point of adjustment that gets frequent use is that provided for setting the blade for bevel cuts up to 45 deg., Fig. 12. Some owners of radial saws make a test template like that pictured and keep it handy for checking the setting. Others use a T-bevel set with a protractor, care being taken to see that the blade of the T-bevel does not contact the set teeth of the saw blade when making the check. All radial units have some means of tightening the bevel lock on the yoke. Fig. 13 pictures one type and the method of tightening it. In setting up for bevel cuts it's important



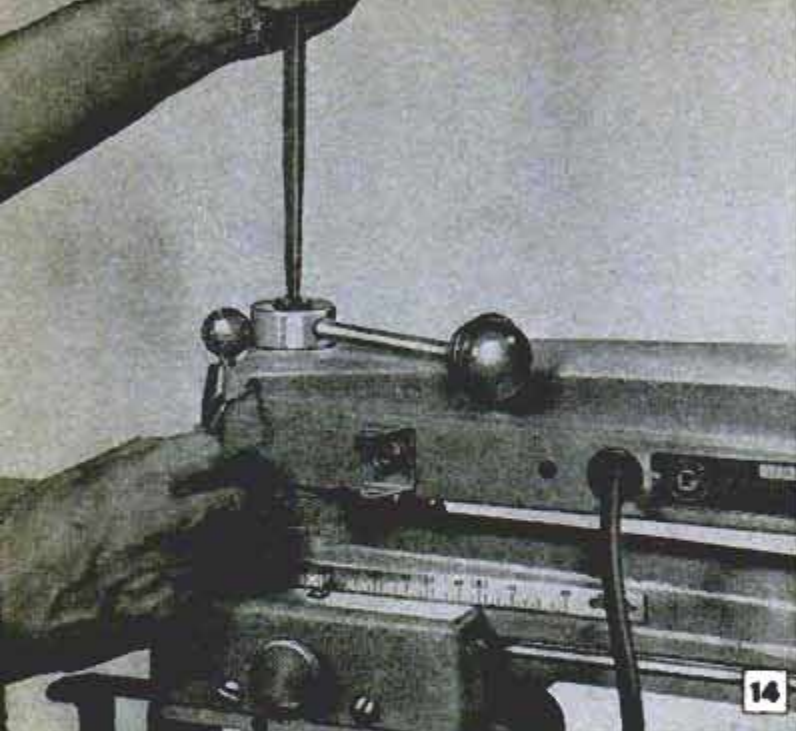

Consult your instruction manual for method of making this adjustment on locking lever. Method may vary

that the motor be locked firmly in position as otherwise inaccuracy will result.

Another adjustment that is sometimes overlooked on dual-arm machines is that pictured in Fig. 14. It's important to make sure that the lever-actuated lock operates positively as otherwise the arm may shift while a cut is being made. Should it shift even slightly it will cause the saw blade to bind.

Checking for accuracy of ripping cuts is often necessary as the in-rip and out-rip scales on the radial arm can become inaccurate either by accident or by incorrect adjustment. In the in-rip position the yoke is swiveled to bring the blade between the motor and the fence. The reading for width of cut (width of strip desired) is taken from the in-rip side of the scale on the radial arm. Fig. 28 shows the in-rip position of the blade and motor. In the out-rip position the yoke is swiveled through 180 deg. from the first position, placing the motor between the blade and the fence, which is the reverse of the position pictured in Fig. 28. This latter position enables you to make ripping cuts up to the maximum ripping capacity of the unit. To check for accurate

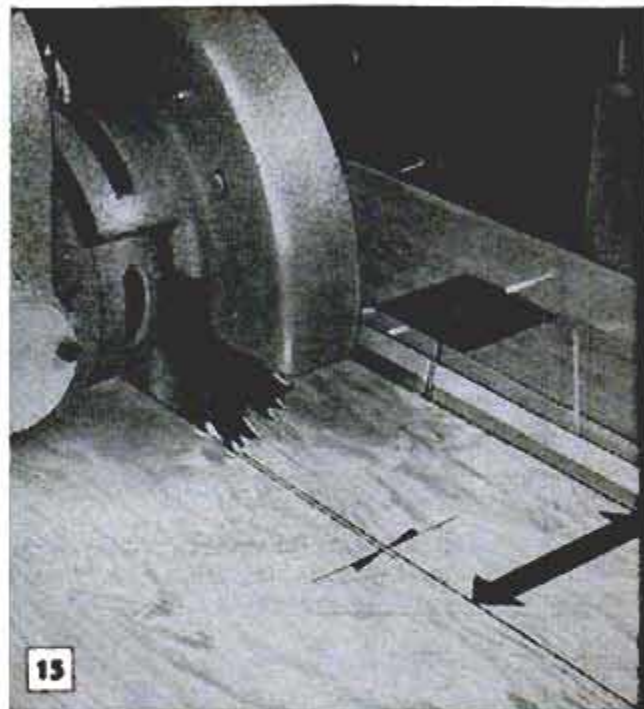

Check accuracy of ripping scales by ripping board to given width. Setup pictured is for in-ripping

setting, locate the yoke in the in-rip position, determine the desired width of the strip to be ripped from the stock and then measure from the face of the ripping fence to the point of a set tooth on the saw blade. Be sure to select a tooth which is inclined (by the set) toward the ripping fence, not away from it. Now note the reading on the ripping scale. It should agree with the measurement you have just made from fence to blade. If it does not, then the scale must be adjusted to the correct position and locked in place with the screws provided. On some machines only the pointer can be adjusted. The scale is fixed.

If you are purchasing a new machine, all the checks described should be made at the time the machine is set up for operation. When it leaves the factory the machine is correctly adjusted, but handling may result in some minor misalignment of parts. Of course, the various checks for accuracy described above are only general for all makes of smaller radial-arm units. Always refer to the instruction manual that comes with the machine before making any specific adjustments. Follow the instruction manual in all details. ★ ★ ★

## Spark Plugs Selected To Suit Special Driving Conditions

Did you ever average your auto-trip mileage over a period of time? The figure may surprise you. If, for example, 60 percent of your driving turns out to be trips of 6 miles or less, then about 60 percent of the time the car is in use the engine is never warmed to full operating temperature. Under these conditions it's good econ-

omy to install spark plugs of a somewhat higher heat range than that of the standard plug. In return you'll get more miles per gallon of fuel, top engine performance and longer spark-plug life. You'll also have less trouble with fouled plugs and oil dilution, especially during the colder months.—Champion Spark Plug Co.



## Cleated Ramp in Cattle Chute Serves as Shed Door

The cleated ramp of this cattle-loading chute is hinged at the bottom so it can be raised to serve as a door on the shed. No other door or gate is necessary. The height of the ramp can be varied by changing the position of a 2 x 4 brace which is slipped between the boards on the side of the chute. A rope-and-pulley system may be attached to the ramp to make it easier to raise, especially when all the cattle are not removed from the shed at one time.

Merle Klocke, Edina, Mo.

## Emergency Cotter Pin

When faced with the problem of replacing a cotter pin in an emergency, the common bobby pin proves to be a successful substitute and is usually available.

Victor H. Lamoy, Upper Jay, N. Y.

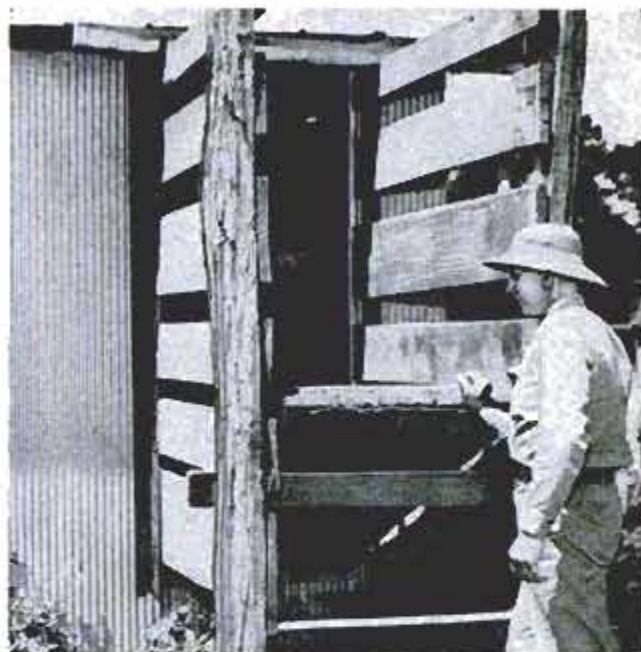

## Cattle Now Treat Themselves To Insecticide

When entering or leaving the barn, cattle treat themselves for fly control by walking under this wrapped log chain strung across the entrance. The chain is wrapped with burlap sacks, tied with binder twine, and the roll soaked with a mixture of DDT and fuel oil or kerosene. Additional liquid is poured over the chain every two weeks. Wire the chain to sag within 18 in. of the ground so it will drag over the cattle, brushing on a thin film of the insecticide.

## Stanchions Pulled Shut by Rope While Standing Behind Cows →

Being kicked by a young or nervous animal while standing alongside cows to close their stanchions no longer is a worry for one farmer who has rigged a remote control to close the stanchions. A light rope is tied to the stanchion, as shown in the photo, then passed to a pulley above and out to an overhead beam behind the cow so it can be closed while at a safe distance away.—Kenneth R. Imig, Watseka, Ill.

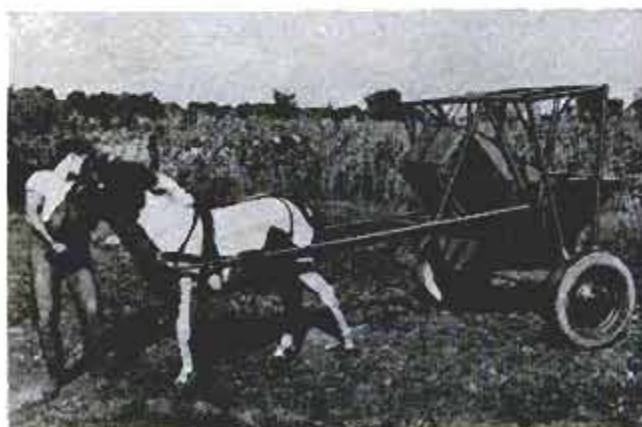

## Overhead-Axle Cart Designed For Hand-Picking Sweet Corn

This unique cart, used for hand-picking sweet corn, is built up from a 55-gal. oil drum. Sheet metal is used to extend the sides, front and back. The "overhead axle" frame is of welded steel tubing, designed so the automobile-type wheels straddle two rows. Stub trailer axles or front-wheel spindles are welded to the A-frame ends to provide axles.

John Krill, North Lima, Ohio.



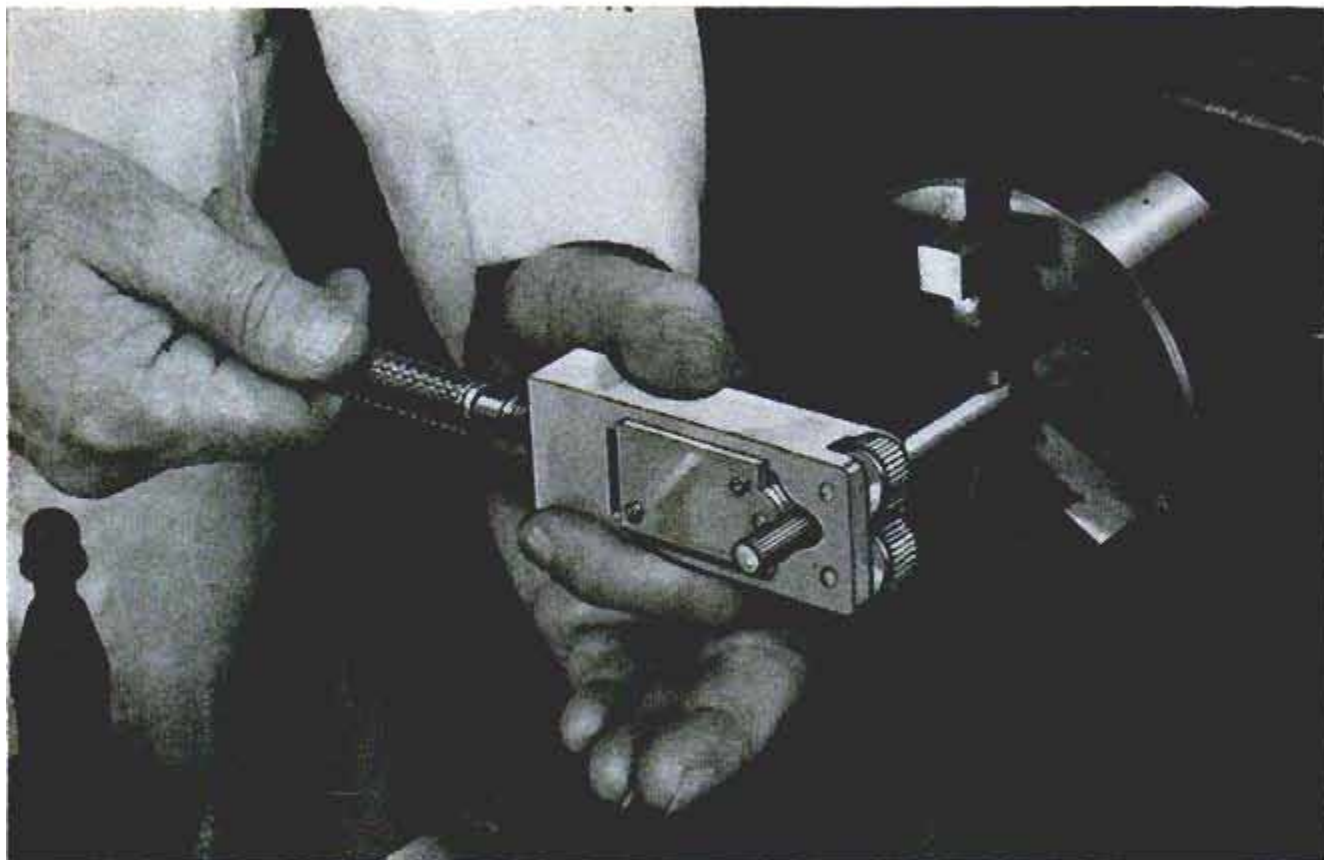

## HANDY ACCESSORIES FOR YOUR LATHE

**S**SMALL SHOPS usually get those special jobs that call for skill and experience in utilizing existing equipment and accessories to handle the work efficiently. Often special setups are necessary and tools must be made to handle small production runs where the machine time per piece must be reduced to the minimum.

A useful shop-made accessory for the metal lathe is the hand knurling tool pictured above and detailed below. Dimensions given are only suggestions. You can make the tool somewhat larger or even smaller to suit the work to be done. The tool is intended, of course, only for light, fast knurling on small-diameter work. The

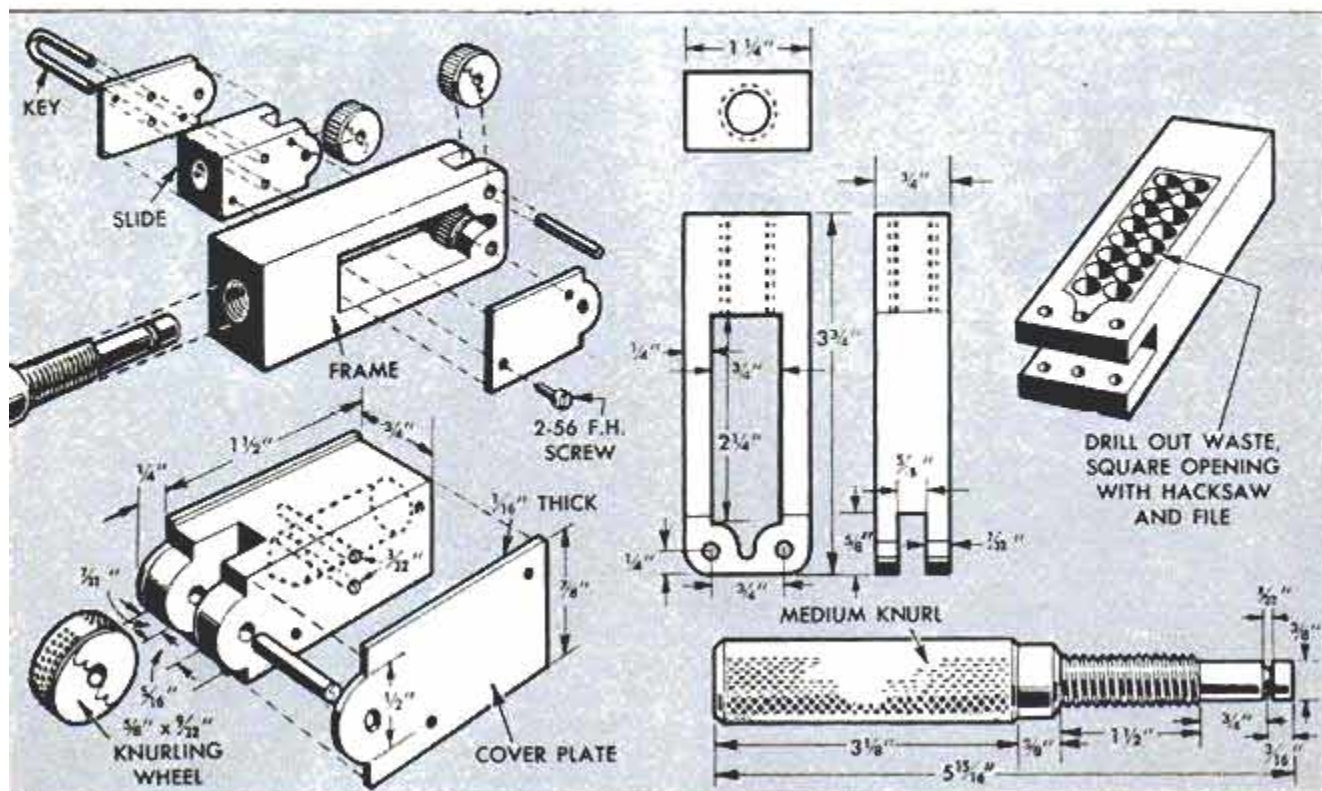



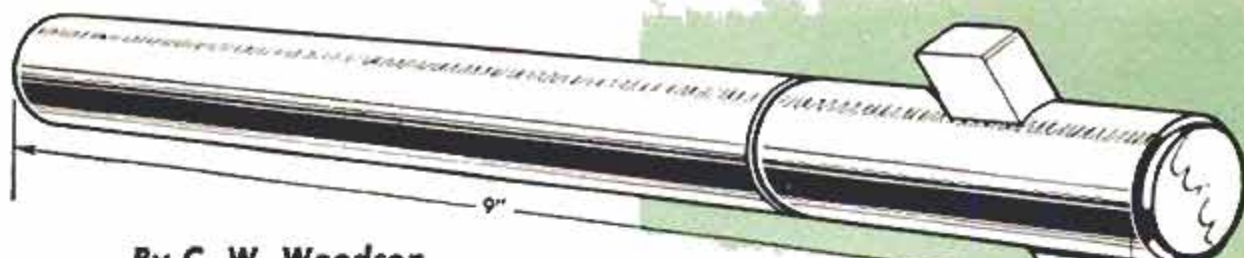

By C. W. Woodson

frame can be made from cold-rolled stock or from tool steel and the slot carrying the slide can be milled and finished to the required shape with files. Or the waste can be drilled out as suggested and the opening squared with hacksaw and files.

In either case, care should be taken to assure a close fit of the slide and, of course, it is essential that the holes taking the knurling-wheel spindles be precisely in line in both the frame and slide. It will be noted that the slots for the knurling wheels in both the frame and slide are given as  $\frac{5}{16}$  in. wide. If you use a  $\frac{5}{16} \times \frac{5}{8}$ -in. wheel (a standard size), then the width of the slots can be increased to give about  $\frac{1}{4}$ -in. clearance. When the parts have been finished, make a trial fit of the slide in the frame with the cover plates, or guides, in place. There should be a slight drag in the movement of the slide. If it turns up slightly loose after milling or filing to width, remove one plate and reduce the width until it is a snug, sliding fit. If the slide is slightly loose, the third knurling wheel may tend to climb slightly, resulting in a rough knurl on the work.

A boring bar with 45 and 90-deg. interchangeable tips comes in handy for those special boring jobs. Two sizes are detailed at the right, A to E inclusive. Each tool consists of a shouldered round bar, two sleeves and two interchangeable tips, one 45 and one 90-deg. The details show the unit in two sizes, for  $\frac{3}{16}$  and  $\frac{1}{4}$ -in. square tool bits. In the 90-deg. position the tool can be used for boring through, for threading and for working shallow bores of large diameter. In the 45-deg. position the tool is used in running counterbores with a square shoulder and in truing a blind hole such as that cored in a casting. Details A and B show assembly of the parts in the 90 and 45-deg. positions, the bar being drilled, shouldered and tapped to take sleeve and tips. When assembled with the bit in place, tightening the tip locks the tool bit securely. A setscrew is not necessary. The tip and sleeve are a smooth, telescoping fit to prevent any tendency to chattering due to looseness of the telescoping parts. When using this type of boring bar, care should be taken to keep the overhang to the minimum permitted by the depth of cut.

★ ★ ★

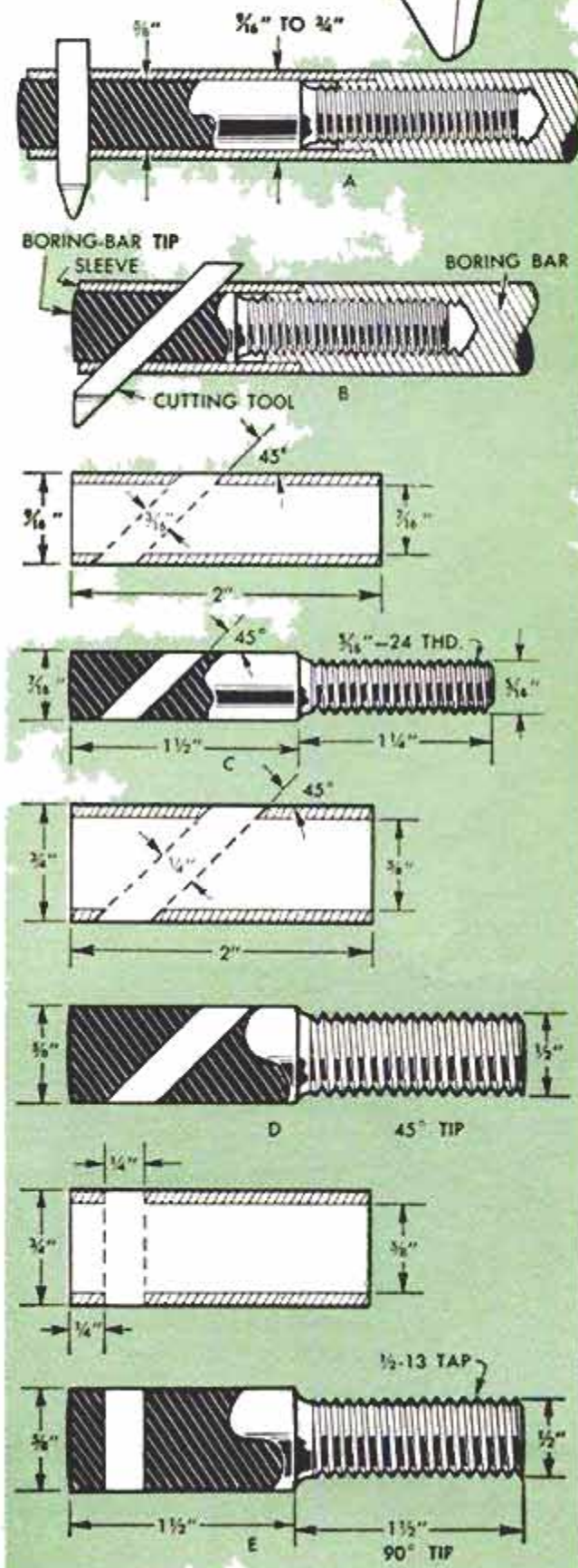



## Wooden Chuck Protects Gear When Machining in Lathe

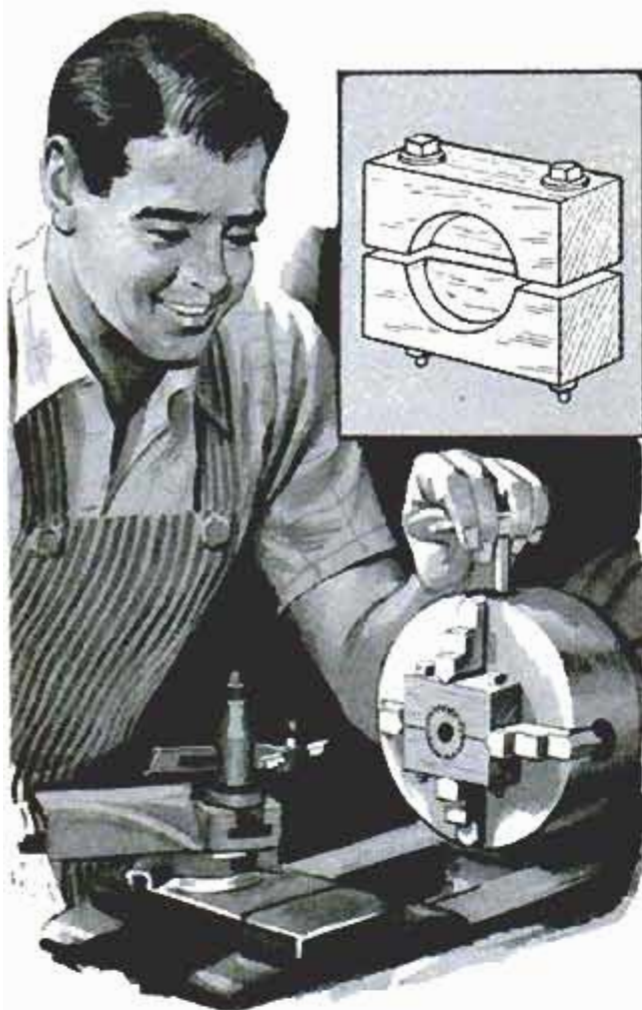

Gears, disks and odd-shaped parts can be mounted accurately in a lathe without being damaged if a wooden chuck similar to the one shown in the detail is used. It is made from a block of wood that is recessed the desired diameter, then drilled to accommodate a bolt on each side of the recess. The block then is sawed in half in line with the grain of the wood. Clamping action of the chuck is assured by the width of the saw kerf. In use, the chuck is held in a four-jaw chuck or mounted on a faceplate.—C. W. Woodson, Chicago.

## "Renewing" Worn Hacksaw Blade

When one or two teeth in a hacksaw blade break off, the rest of the blade quickly wears, as the teeth adjacent to the missing ones are subjected to greater shock when cutting. To eliminate this action, and thus lengthen the useful life of the blade, grind the teeth adjacent to the broken ones so they taper down toward the notch formed by the missing teeth. The tapering hollow thus formed will slide over the work being cut instead of "snagging" as the broken teeth would. The modified blade cannot of course, be used as vigorously as the regular blade.

D. A. Rogers, Minneapolis, Minn.

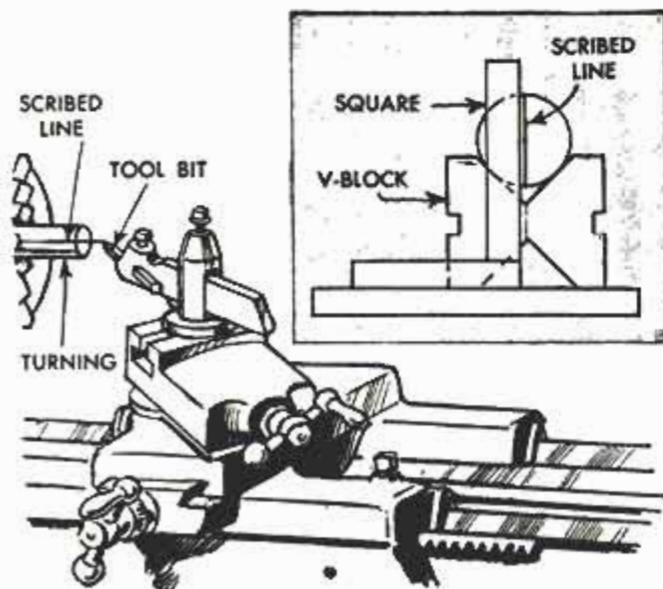

## Turning Marked for Drilling By Using Lathe Tool Bit

Where absolute accuracy is not necessary, a piece of round stock that has been turned can be marked for cross drilling by using the lathe tool bit before removing it from the chuck. Center the tool on the workpiece, then use the crossfeed to mark the end of the stock. The carriage is moved the length of the stock to mark it lengthwise. When the stock is removed from the lathe, it is placed in a V-block and a square used to align the mark on the end of the work to be exactly vertical as shown in the smaller detail. The work then is clamped, centerpunched and drilled.

Frank LaSaracina, New York City.

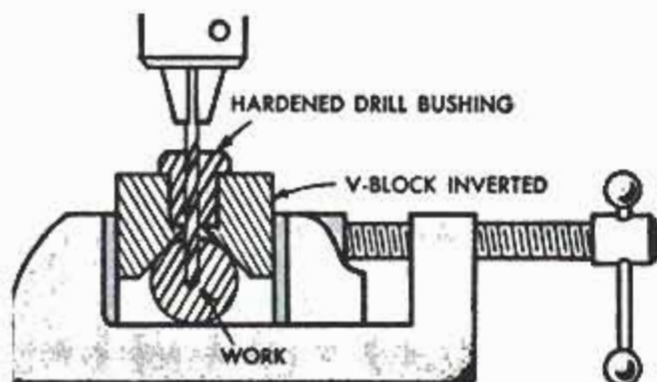

## Modified V-Block Aligns Drill

Fitted with a hardened bushing and inverted in a drill-press vise, an ordinary V-block makes an effective jig for cross-drilling round work accurately through its radius. By raising or lowering the V-block in the vise, work of various diameters can be centered, and by changing bushings to fit the size drill desired, holes of any size can be cross-drilled through the center of the work.



# SHOPPING FOR TOOLS

**1. HEIGHT INDICATOR** can be assembled with any desired number of riser blocks to take measurements for transfer at any height required by the nature of the work. A sensitive dial indicator is actuated by the gauge-block column as it moves up or down over the 1-in. range of the micrometer head. Dial is readable from distance of several feet, reducing possibility of error

Brown & Sharpe Mfg. Co., Providence 1, R.I.

**2. SOLDERING "PENCIL"** has power consumption of 20 watts and copper tip is only  $\frac{1}{8}$ -in. in diameter. Gets into places conventional soldering irons and gas flame won't reach. Especially advantageous for repetitive soldering jobs on very small parts and in radio and TV wirings, also measuring-instrument assembly and hi-fi. A 30-watt, pencil-size iron also is available

Caig Cosmopolitan, 507 Fifth Ave., New York City 17

**3. PAINT-ROLLER PAIL** is designed with several new and helpful features. A ledge, or stop is provided for the roller when it is not in use. Pail has corner pouring lip, making it easy to empty either paint or solvent without spilling. Has a wire handle by means of which the pail can be carried even when it is filled with paint. Available for 9, 14 and 18-in. paint rollers

Cole Products Corp., Austin, Tex.

**4. NONTOXIC PENETRANT** shows up shrinkage cracks, porosity, grind cracks and other defects in metals. Two-part formula consists of liquid and dusting powder, each being applied to surface separately. Liquid is applied first, allowed to stand 5 to 8 min. and is then wiped off. Then surface is sprinkled with powder. Any defects will show as thin red lines on surface

E & G Co., P.O. Box 453, Latham, N.Y.

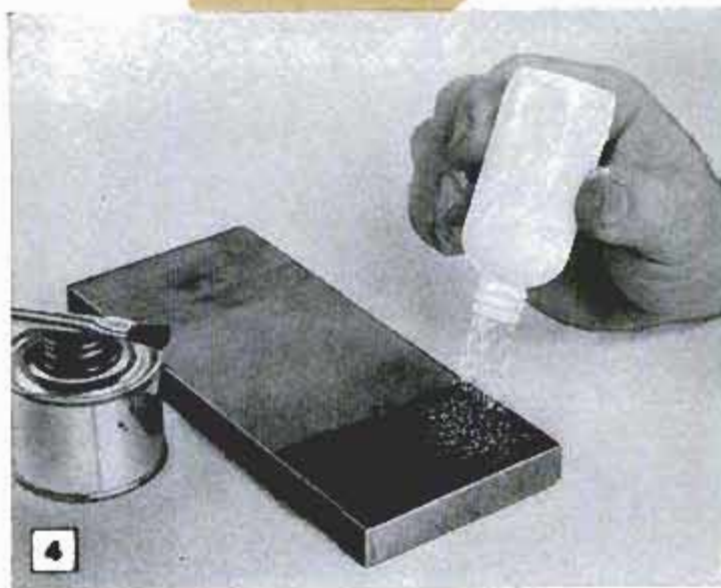
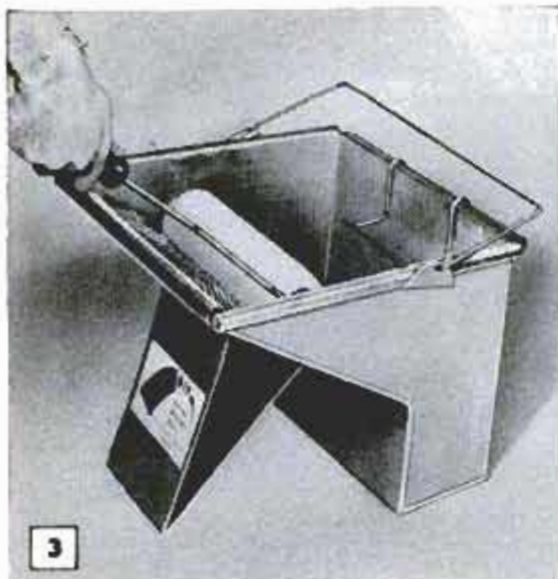
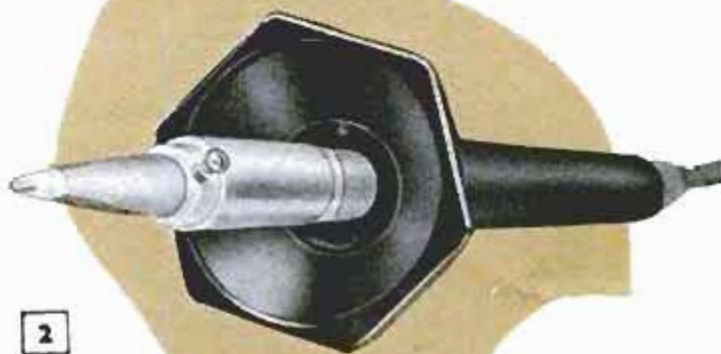



# SHOPPING FOR TOOLS

(Continued from preceding page)

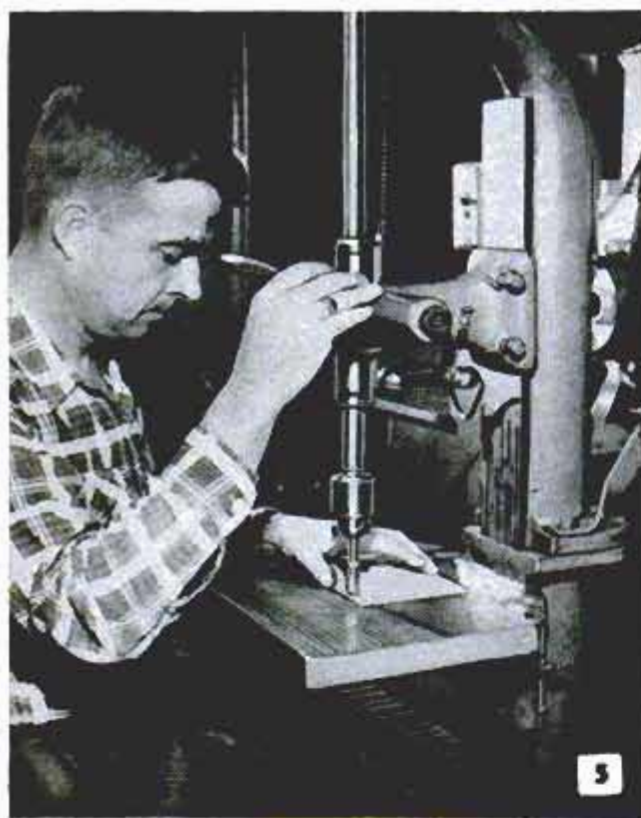

**5. ENGINE-TURNING TOOL** requires no lubricants or cutting compounds. Mounted in drill press it produces that "jeweled" finish (also known as spot finish) on machine-tool ways and slides, instrument panels, and gun parts such as bolts and breech blocks. Abrasive-impregnated rubber tip in steel holder does the work.

R. E. Hutchinson, Burbank Road, Sutton, Mass.

**6. HAND-POWERED STUD DRIVER** seats studs and nails in masonry with only a few hammer blows. Three interchangeable driving pins are supplied with each driver, one for 1/4-in. studs, one for 5/32-in. studs and one for nails. No springs or cartridges are required for driving. The unit consists of 5 simple parts.

John K. Gieling, 300 Fourth Ave., New York City 10



**7. PORTABLE ELECTRIC JIGSAW** has built-in light, right and left tilt to 45 deg. in either direction, a side handle and a ripping fence and circle guide. Has power and speed sufficient to cut off and rip 2 x 4s, make intricate scroll cuts, cut metals and plastics. Blade is driven at 2650 strokes per min.

Portable Electric Tools, Inc., Chicago

**8. COMBINED COUNTERSINK, PILOT DRILL** for drilling screw holes in one stroke of drill press or portable electric drill. Won't burn or clog due to use of conventional-type twist drill bit. Drills pilot hole for screw threads, a clearance hole for screw shank and countersinks for the screw head in one operation.

Arrow Metal Products Co., 421 W. 203rd St., New York City 34

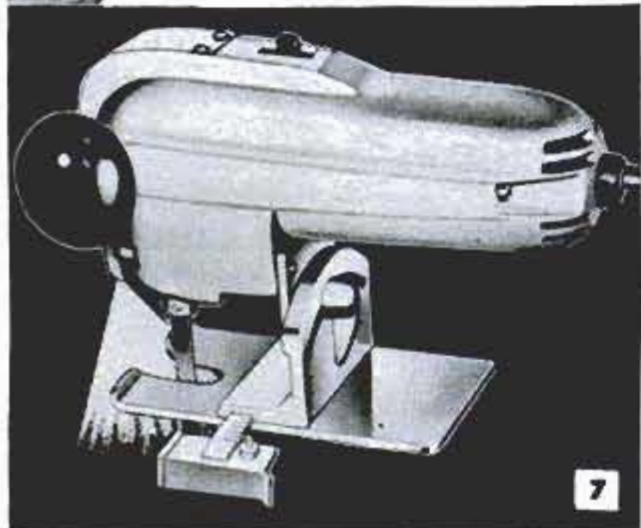





9

**9. AIR-POWERED IMPACT WRENCH** of  $\frac{3}{8}$ -in. heavy-duty capacity features an all-steel nose housing to withstand the severest usage. Impact mechanism operates only when a certain torque resistance is built up. Has  $\frac{1}{2}$ -in. square drive, 6000 r.p.m. motor  
Aro Equipment Corp., Bryan, Ohio

**10. LADDER BRACKETS** attach to your stepladder, do double duty for holding storm sash and screens for washing and painting and also can serve as a saw horse for holding framing stock and plywood for cutting to size. Adjustable to any point on ladder leg  
R. A. Ness & Co., 5083 Elston Ave., Chicago 30

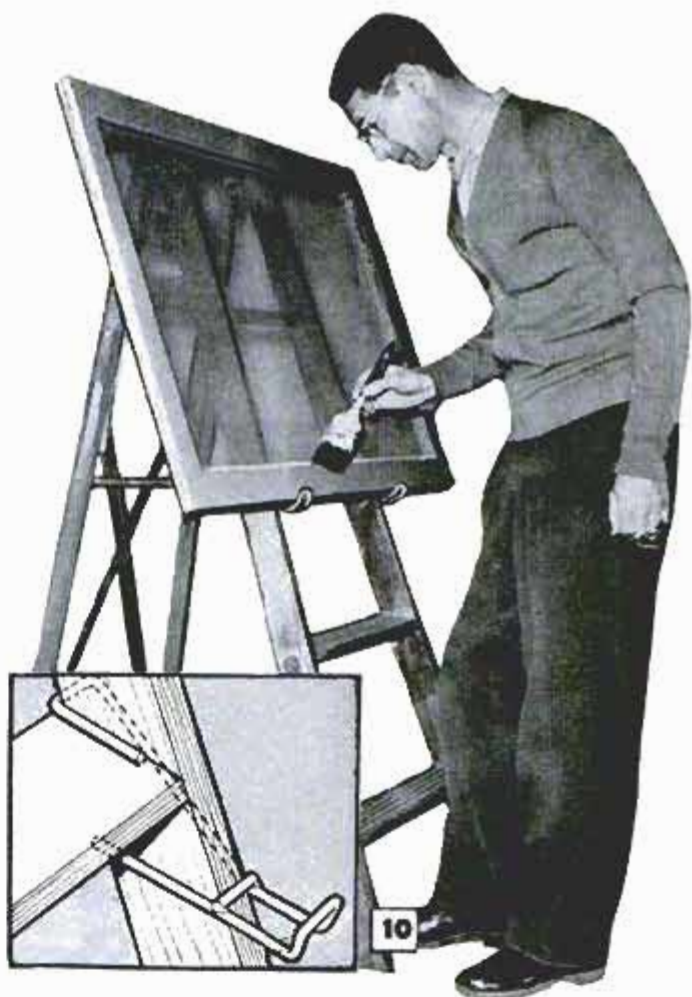

10

**11. TUBING CUTTER** features four rollers positioned so that all sizes of tubing within its capacity are supported by two rollers while being cut. This arrangement prevents distortion and gives a clean sharp-edged cut on all sizes from  $\frac{1}{8}$  to  $3\frac{1}{2}$  in.  
Erie Tool Works, Erie, Pa.

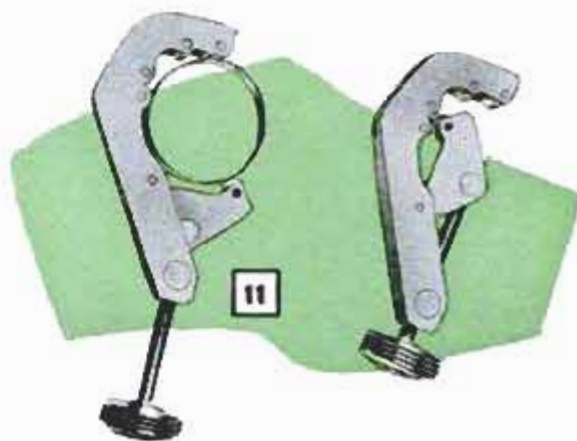

11

**12. ADJUSTABLE DRILL** consists of a slotted shank and two individual blades, or cutters, which are adjustable by loosening clamping screws and setting a spreading screw. Cutters are mounted on steel balls in individual races to maintain precise accuracy  
Erie Precision Products Co., 1346 E. 12th St., Erie, Pa.

**13. STEEL "SANDPAPER"** comes in 4 x 5-in. sheets which are perforated in a regular pattern, the projections, or burrs, extending on one face. Tools for special purposes are made by attaching the sheets to rounds, squares and blocks of hardwood  
Red Devil Tools, Union, N.J.

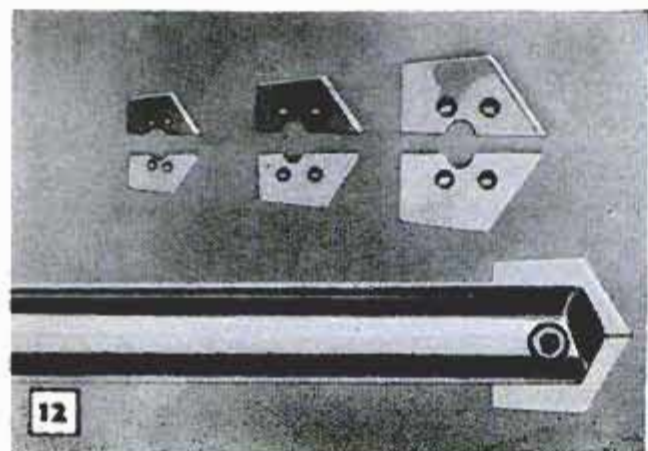

12

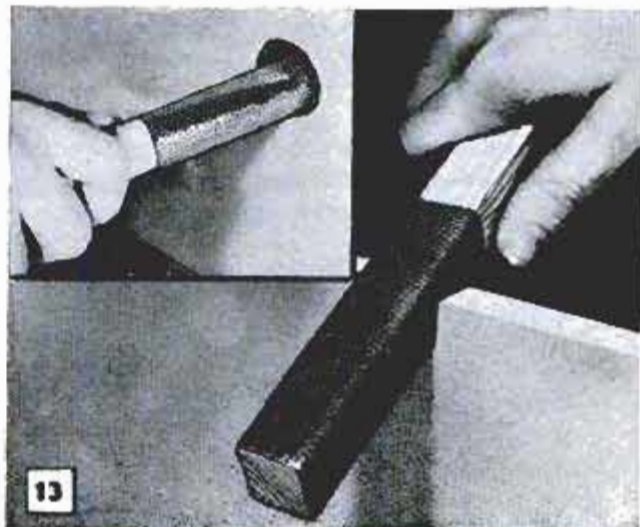

13



## Impact Puller Removes Badly Rusted Cotter Keys

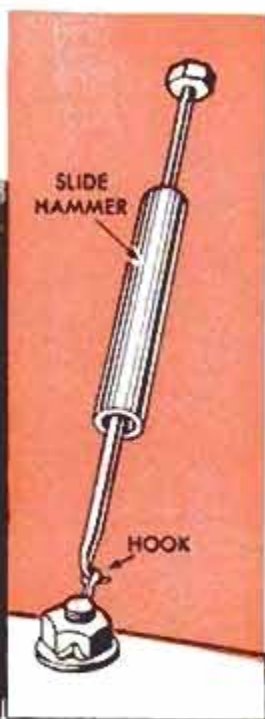

The most stubborn and rusty cotter key is pulled easily with this impact puller. To make it, file or grind one end of a  $\frac{1}{4}$  x 12-in. steel rod to a long taper and bend it to form a hook. Then drill a  $\frac{3}{16}$ -in. hole lengthwise through a  $\frac{3}{4}$  x 4-in. length of cold-rolled steel (a hollow auto kingpin also can be used). Slide this "hammer" over the rod. Thread the end of the rod and turn on a nut. Peen the threads or tack-weld the nut so it cannot loosen. In use, the hook of the puller is fitted in the eye of a cotter key and the hammer slides along the rod and against the nut. Although the hammer of the puller is fairly light, its impact is great.

## Wooden Block Aligns Bit When Drilling Pipe

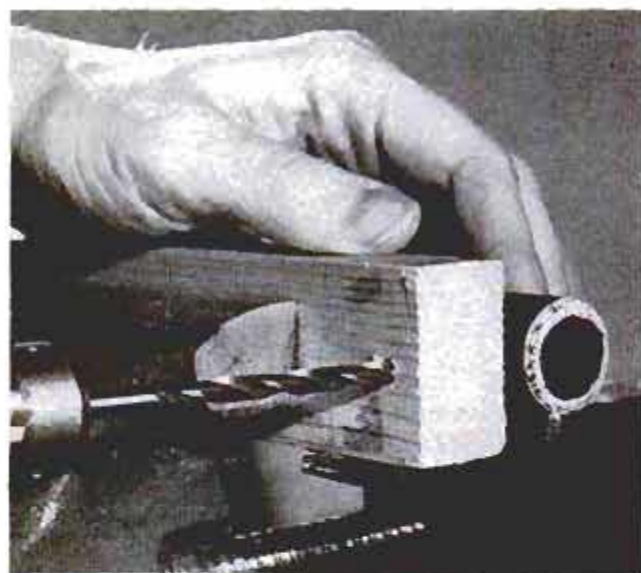

Keeping a drill bit from "drifting" when drilling into a curved surface, such as a pipe or tubing, can be a problem when using a portable electric drill. One method of keeping the bit aligned is to clamp the tubing in a vise with a wooden block. Drilling through the block first forms a "jig" that will keep the bit in line. If a number of workpieces are to be drilled, assemble a jig somewhat like a miter box, so the tubing fits in it snugly when the assembly is clamped in a vise.

## Mercury in Distributor Cap Assures Positive Contacts

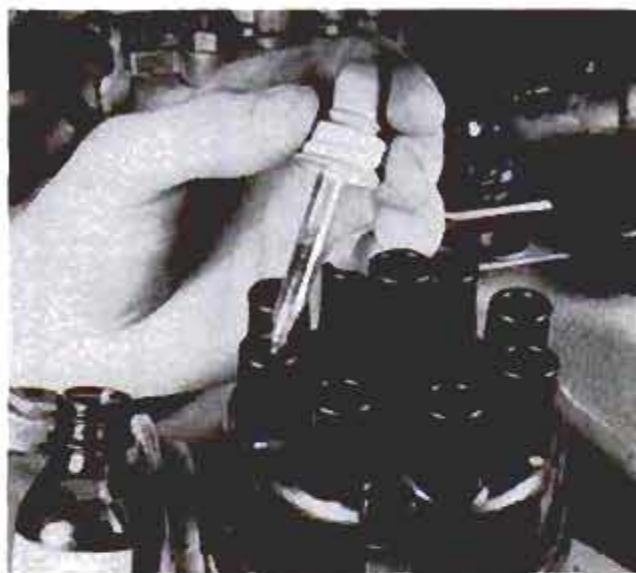

When an engine miss is traced to poor contact between the wires and the terminal sockets in a distributor cap, one mechanic places a drop or two of mercury in each terminal socket. When the wires are pushed into place, the liquid mercury flows around the wire ends and assures a positive contact, such as exists in a mercury switch. The mercury can be used, of course, only when a distributor is mounted in a vertical or near vertical position on the engine, as it is on most late-model V8s.





**\$9.95 SAFETY BRAKE**

Stops blade instantly—prevents "coasting" after motor has been turned off.

Get both attachments

**FREE**

with purchase of



**\$12.95 SABRE SAW ATTACHMENT**

No belts or pulleys needed. Attaches right on motor shaft. Cuts up to 2-inch depth.

# Sears Craftsman Accra-Arm 10" Radial Saw

**Offer good only until Aug. 30!** With almost \$23 worth of free attachments, America's most wanted power tool is a finer buy than ever! Clearly the equal of any \$395 saw you can buy, it cross cuts, rips, dados, miters, compound miters, drills, shapes, sands, buffs and does dozens of other operations.

And no tool is easier to use... with all controls in front and color-coded, too. Just \$2.90 a week in convenient monthly payments makes it yours on Sears Easy Payment Plan. See it demonstrated at Sears Stores or order from the Sears Catalog at home or your nearest Catalog Sales Office.

**SATISFACTION GUARANTEED OR YOUR MONEY BACK**

© 1958, SEARS, ROEBUCK AND CO.



**\$10 DOWN**  
**\$239**  
**CASH**

Kromedge Blade for 3-to-5 times longer wear

Extra large, easy-to-level warp-resistant table

Heavy Duty Motor Develops 2 HP

Uses standard accessories with exclusive double-end motor shaft

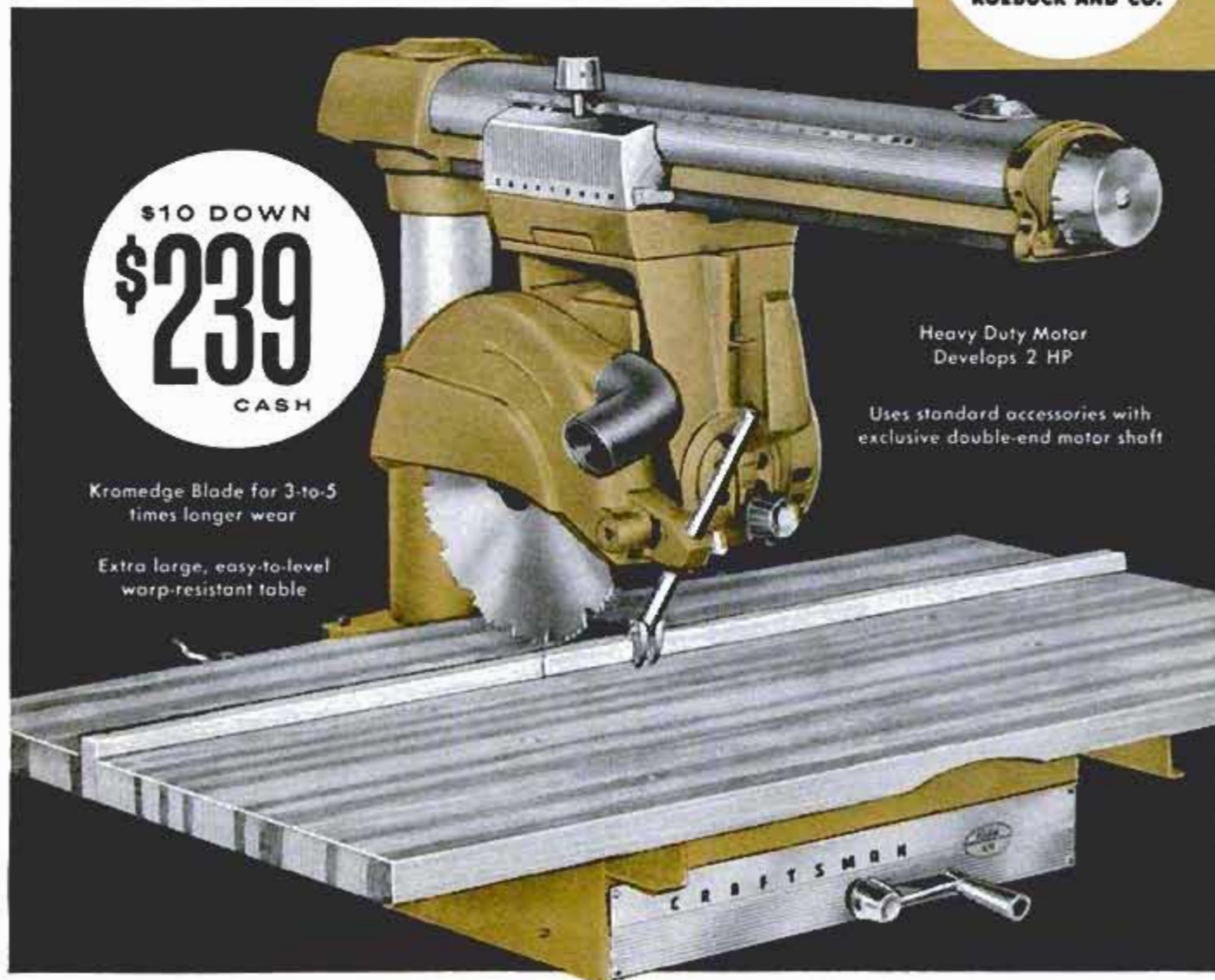



**NICHOLSON'S  
HANDY FILE  
WORKS WOOD  
WORKS METAL  
WORKS PLASTICS**

How's this for versatility? The Nicholson or Black Diamond Handy file can be used on woodworking projects . . . to sharpen axes, spades and other tools . . . to shave down plastic panels for partitions and built-ins.

The Handy file is really two files in one: one side is double-cut for fast stock removal. The other side is single-cut for fine smoothing and sharpening. The handy hang-up hole lets you store this file easily in your shop or tool shed.

It's at your hardware dealer's now. Better pick one up soon.

**FREE BOOK:** "File Philosophy" — big new edition, dozens of illustrations. How to choose, use and care for your files. Write for your copy.



**NICHOLSON FILE COMPANY**  
Providence 1, R. I.

(In Canada: Nicholson File Company of Canada Ltd., Port Hope, Ontario)

**NICHOLSON FILES**  
**A FILE FOR EVERY PURPOSE**

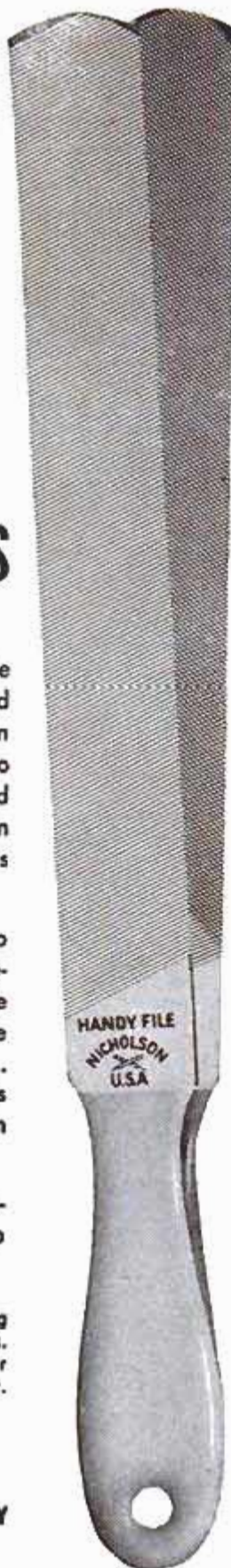

*Clinic for  
Homemakers*



As a service to our readers in solving the hundreds of problems pertaining to a home—inside or out—the editors of *Popular Mechanics* invite you to present your problems to The Clinic Editor for help and advice. Address your questions to The Clinic Editor, *Popular Mechanics Magazine*, 200 East Ontario Street, Chicago 11, Ill.



**Rolling Lawn**

**Q**—I've been told that spring is not the time to roll a lawn, that the job should be done in the fall. Spring rolling, I'm told, packs the soil causing it to dry out and crack later on. The packed soil also will prevent absorption of water. But if the lawn is rolled in the fall freezing and thawing during the winter will break up any hard crust formed by rolling. Right?

L. E., Ohio

**A**—Sounds quite logical, except that the main purpose of rolling a lawn is to level the irregularities caused by frost action. In good practice the time to roll a lawn is determined more by its general condition and not so much by season or custom. The more variable factors which govern procedure to some extent are: Age of the sod, type of soil, relative mildness or severity of the preceding winter, moisture content of the soil at the time of rolling and the thickness, or density, of the turf. Ordinarily, old, established lawns, well maintained, do not require rolling from season to season, especially when growing on fairly light soils where drainage is good. On heavy, wet soils considerable frost action may take place during an open winter, necessitating spring rolling to level irregularities and press the grass plants back into the soil. In any case, and at any time during the season, never roll the lawn when the soil is wet. Always wait until it dries out on top, and then roll only lightly, repeating the procedure at intervals, if necessary. Rolling is permissible at any time when a lawn has been spot-seeded or when the soil over comparatively large areas has been reworked and reseeded. Rolling new seeding levels high spots, firms the loosened soil and presses the seed into contact with the top soil without covering it too deeply. Many homeowners do roll lawns in the fall. This can be considered permissible on soils which are loose and loamy and do not tend to pack under the roller.

**Removing Rust Stain**

**Q**—I have an older type bathtub I would like to install in a summer home. The enamel is rather badly rust stained, due, I suppose, to a dripping faucet at some time or other. The stain appears along the bottom of the tub at the center and is especially bad around the drain outlet. The enamel seems to be rather rough in this area. What can I use to remove the stains and smooth the enamel surface?—C. N., Me.

**A**—We always hesitate to recommend attempts to reclaim old enameled bathroom fixtures, especially a tub in the condition you describe. One reason is that the enamel finish is fired on the

(Continued to page 196)



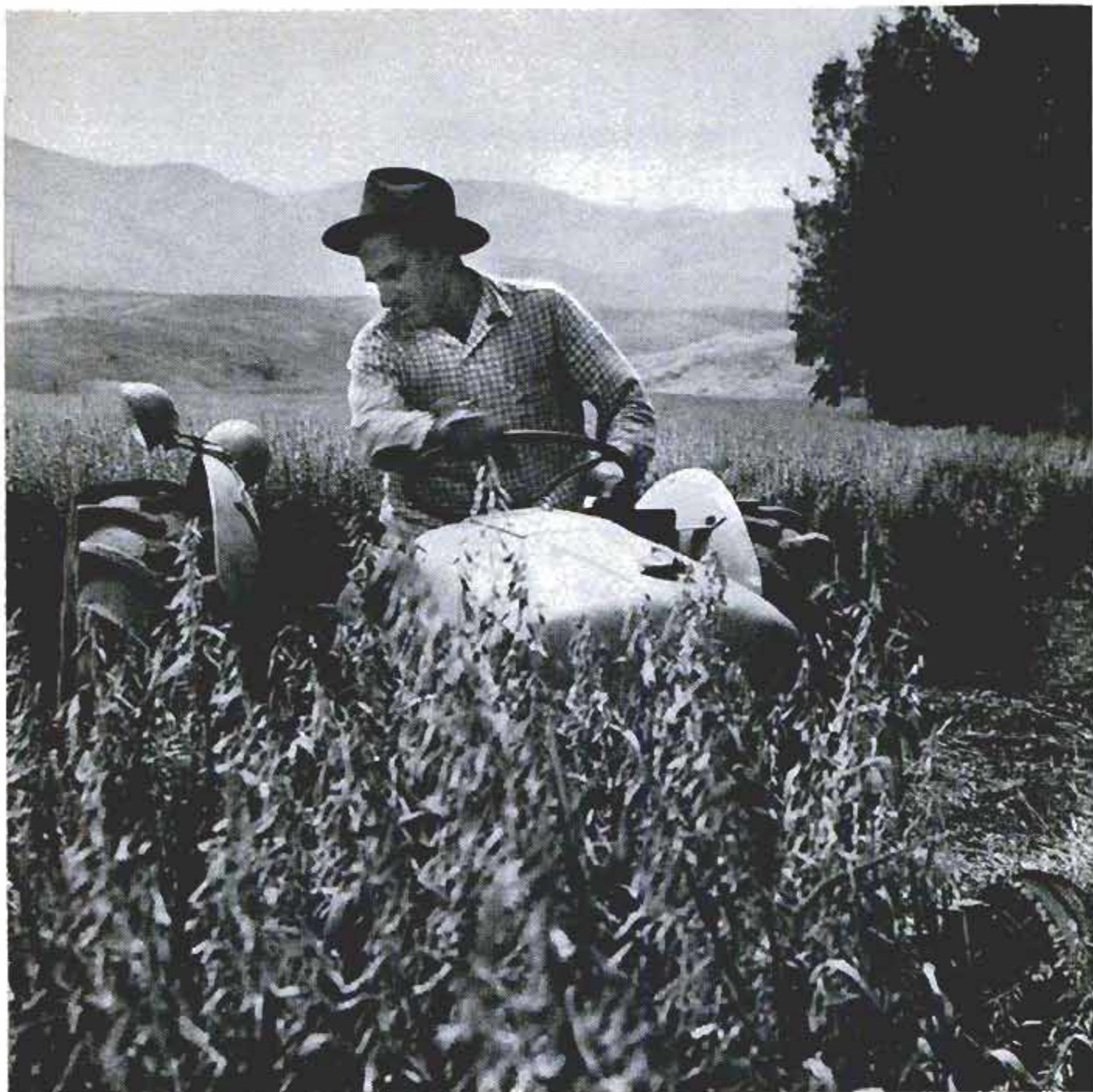

In tractors as in motor cars, Champion spark plugs deliver *full-firing power!*

Q. Why does every major U.S. tractor maker use Champion spark plugs?

A. Champions give full-firing power. Put new Champions in your car every 10,000 miles. You'll get an *immediate* boost in horsepower...and save gasoline, too!



*World's favorite spark plug—engineered for every car built by Ford, General Motors, Chrysler, American Motors, Studebaker-Packard and every major foreign maker*

**CHAMPION**



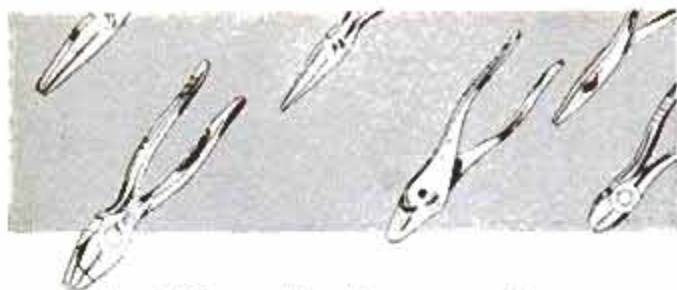

# skilled hands reach for...



Skilled mechanics . . . thousands of them every year . . . reach for and buy Channellock pliers. Why? Ask them. They'll tell you they like the positive gripping power . . . the rugged strength . . . the precision balance . . . the all 'round handy "feel" of these quality pliers. And you will too!

**CHAMPION DEARMENT TOOL COMPANY**  
MEADVILLE, PENNSYLVANIA

**ASK YOUR TOOL SUPPLIER FOR**  
*Genuine* **CHANNELLOCK PLIERS**

metal at very high temperatures and once the glass-smooth surface becomes pitted and discolored as you describe it is not possible to restore the surface to its original smoothness. You can remove the stain, at least to a degree, by using any one of several preparations available for the purpose. But in the pitted area the stain can be removed only by abrading the surface to some depth with a rubbing compound (available from your paint dealer) or with some other preparation containing an abrasive. Use of such materials removes the gloss and exposes unsupported pigments contained in the original finish. You might try applying peroxide to the stained areas and sprinkling immediately with a kitchen scouring powder. Rub the mixture over the stained areas and then allow to stand for an hour or so. Then wash off. Repeat on the pitted areas if necessary.

### Water in Basement

**Q**—I've lived at the present location for 10 years and have never had any trouble with water backing into my basement through the floor drains until just lately. Now water comes in during every rain-storm to a depth of 2 or 3 in. Takes about 24 hr. for it to run out. What can be done to prevent this?

T. R., N. J.



**A**—You do not give us much detailed information on which to base our answer. But we'll assume, for example, that inasmuch as you have floor drains these lead directly to the storm sewer, that you have checked with the street department and they tell you that the storm sewer is clear, that the gutter downspouts empty into tiles that are connected to the basement drains. From these assumptions we can make the deduction immediately that the water is coming into the basement from the gutters and is not backing from the storm sewer. And this can only mean that the drain is clogged at some point between the foundation and the street. Obviously, the thing to do is have the drain rodded to clear the obstruction. Sometimes a length of heavy-gauge wire worked into the drain from the basement outlet will do the trick. However, if tree roots have grown into the tile, or if it is clogged with an accumulation of packed debris such as leaves, then you should have the job done by a contractor. He will have special equipment for removing tree roots and other obstructions.

### Colored Fillers For Plaster Cracks

**Q**—I want to use a filler on fine plaster cracks which is colored to match the paint I'm going to apply to the wall. I want the filler to match exactly so there is no chance of it showing through the paint. How can I accomplish this, what kind of colors must I use and what are they mixed with in order to fill the cracks?

S. A., Ill.



**A**—Of course, we wonder why it is necessary to match the paint color so closely. Ordinarily this is not necessary. Plaster patching material is commonly used for the purpose. However, if you wish the patching material to match the paint you must have some good reason and the best way to accomplish the desired result is to use the wall paint as the coloring material. Perhaps the best way to do this is to mix a small quantity of the paint to be used on the wall with sufficient whiting (precipitated chalk) to make a paste heavy enough so that it can be picked up and applied with a putty knife.





Powerful 5-HP Gravely, America's most versatile small tractor, does every lawn, garden and field job *faster, easier, better!*

Choice of 30 performance-proved tools. All-Gear Drive, Power Reverse, Push-Button Starter optional.



New 24-page "Power vs Drudgery" Booklet shows how Gravely power and performance can solve YOUR problems. Write for it today!

**GRAVELY TRACTORS, INC.**  
BOX 863 DUNBAR, W. VA.

**FIELD-TESTED SINCE 1922**

Whoosh!  
It's an  
**"MFG"**  
Corry Utility



12½ feet of tough MOLDED FIBER GLASS... fast, smooth, highly maneuverable... built to perform! (Note reverse lap between keel and chine.)

Other "MFG" models in 12½ and 15-foot sizes at \$375, \$495, \$525 and \$565 f.o.b. factory.

**MOLDED FIBER GLASS BOAT COMPANY**  
71 Fourth Avenue, Union City, Pennsylvania

And it costs only

**\$325**

f.o.b. factory  
Write today for  
colorful literature



Wash or scrape  
old paint off  
with

**HEAVY-BODIED KLEAN-STRIP**



**REPAIRING?  
REMODELING?  
REFITTING?**

Any fastening job worth doing deserves USA-made Southern Screws, tops in dependability and permanence.

**SOUTHERN QUALITY  
MAKES THE DIFFERENCE!**

BUY *Southern Screws*  
BUY 'EM BY THE NAME...  
BUY 'EM BY THE BOX  
AND SAVE!



At leading hardware and building supply stores

# How to select a paintbrush

A good brush performs better... wears longer... saves you money



Check these points when buying your next paintbrush.

First, look for a full stock of bristles in a firm, strong setting (1). Avoid brushes with loose bristles. Then inspect the individual bristles closely (2). They should be finely tapered, with slightly curled tips. Look again and be certain a generous portion (at least 10 to 20 per cent) of the bristles have tips which are split or "flagged" (3).



Your final assurance of a brush which will give the best painting performance is bristles of varying lengths (4), but with a high proportion of longer lengths.



If the brush you look at passes all these tests, it will have a greater working and paint-holding capacity and eliminate excessive dipping. It will (5) release any type finish smoothly and evenly on any surface.



One short cut to selecting a good brush is to look for the black and yellow tag, signifying a brush with TYNEX nylon bristles (6). Properly made paintbrushes with tapered bristles of improved Du Pont TYNEX nylon give you better painting performance. They pick up a full paint load at every dip and give velvet-smooth paint-out. With proper care, brushes with durable bristles of TYNEX clean easily... rinse thoroughly... are quickly ready for another job.



One short cut to selecting a good brush is to look for the black and yellow tag, signifying a brush with TYNEX nylon bristles

(6). Properly made paintbrushes with tapered bristles of improved Du Pont TYNEX nylon give you better painting performance. They pick up a full paint load at every dip and give velvet-smooth paint-out. With proper care, brushes with durable bristles of TYNEX clean easily... rinse thoroughly... are quickly ready for another job.



**FREE**—"How to Choose and Use a Paintbrush." This booklet tells how to paint walls, ceilings, trim, furniture, radiators and do other special jobs. Gives tips on the correct painting stroke, how to hold a paintbrush, how master painters dip their brushes, how they clean them. Tells what kind of paintbrush to use for each painting job. Write to E. I. du Pont de Nemours & Co. (Inc.), Polychemicals Dept., Room 538, Du Pont Building, Wilmington 98, Delaware.



TYNEX is the registered trademark for Du Pont nylon bristles.



**TYNEX**<sup>®</sup>  
NYLON BRISTLES

BETTER THINGS FOR BETTER LIVING... THROUGH CHEMISTRY



# SOUTH BEND COLLETS

GRIP TRUE • RUN TRUE • STAY TRUE

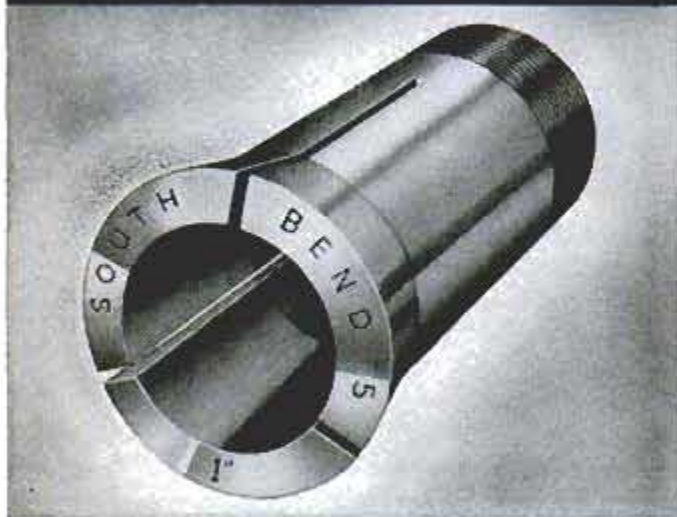

**RED ARROW STEEL COLLETS**—Threads ground from solid after hardening for exceptional accuracy, strength and durability. Carefully machined for extremely accurate concentricity, true centering and dependability. These precision collets bring out the best in any machine.

**BRASS COLLETS**—Ideal for infrequently used sizes or holding soft stock. Readily machined for tapers or irregular shapes. Easily rebored when worn.

### Specifications of South Bend Collets

Popular sizes shown in table. Nos. 2 and 4 available from stock. South Bend Collets are interchangeable with 2-A, 3-C, 4-C and 5-C. Write for complete information.

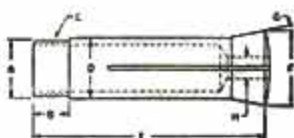

Collet No.	3	4-K	5	
Sizes of Lathes Used On	9"	10-K	10", 13", 14 1/2", 16", 16-24", 2-H, 1 1/8" col.	
A. Thread Diameter, in.	.642	.767	1.242	
B. Thread Length, in.	3/4	1 1/8	3/4	
C. Threads per in.	26	26	20	
D. Body Diameter, in.	.6495	.8425	1.2495	
E. Collet Length, in.	2 1/8	3	3 3/8	
F. Head Diameter, in.	.852	1.160	1.452	
G. Angle of Head, degree	12	15	10	
H. Maximum Capacity, in.	3/8	5/8	1 1/8	
PRICES	Red Arrow	\$4.80	\$4.95	\$5.95
	Brass	\$1.95	\$2.30	\$3.20

**SIZES:** 1/8" to capacity by 1/8" increments. Sets by 16th, 32nds, and 64ths. Decimal and metric hole sizes and square or hexagonal holes at slightly higher prices.

**SOUTH BEND LATHE**  
SOUTH BEND 22, INDIANA  
Building Better Tools Since 1906



Up to 24 months to pay

## Fangio Talks

(Continued from page 113)

en, as in some countries, the public always gathers in the most dangerous spots.

**Q: Would you like to see the Mexican Road Race revived?**

**FANGIO:** Yes, but it should be for stock cars only.

**Q: Are you going to race after this year?**

**FANGIO:** This is my last year. This year I am only racing to satisfy a few commitments. I am too old. I am semi-retired.

**Q: Is there any indication that this country is becoming more interested in Grand Prix racing?**

**FANGIO:** Yes. It seems that some promoters are thinking now of having races of the Grand Prix type over here.

**GIAMBERTONE:** We talked with Tony Hulman, the owner of the Indianapolis speedway. He wants to hold a Grand Prix race at the track with Formula One cars involving at least five or six Americans.

**Q: Mr. Giambertone, do you think a race like the Indianapolis race would draw a big crowd in Europe?**

**GIAMBERTONE:** Very much so. I have been thinking about holding one there.

**Q: Who do you think is the best American driver in the Grand Prix circuit?**

**GIAMBERTONE:** Phil Hill is the best, next is Harry Schell, then Masten Gregory and Carroll Shelby in that order.

**Q: Mr. Fangio, you are a General Motors distributor in Argentina. Are American cars getting too big to sell down there?**

**FANGIO:** The problem is not their size, but their high price. In my country, people like big cars.

**Q: How will the small Chevrolet sell in Argentina—the smaller car expected in '60?**

**FANGIO:** If they bring out a small car, it will have great acceptance. The public is beginning to buy smaller cars. In most cases only one or two persons ride in a car with room for six persons. Especially here in the United States. There is no reason to waste so much space.

**Q: Do you think Chevrolet is doing the right thing?**

**FANGIO:** Surely. You need both sizes of cars, big and small.

**Q: Will the smaller Chevrolet outsell the big one in Argentina?**

**FANGIO:** Yes, maybe two to one, particularly if it is priced right. A smaller car is easier to drive in traffic. For long distances you need bigger cars. They are more stable, high winds don't shake them so much.

**Q: Do you like automatic transmissions?**

**FANGIO:** It is very practical for city driving. ★ ★ ★



## TINY ELECTRIC MOTORS — KITS HELP TEACH SCIENCE FACTS

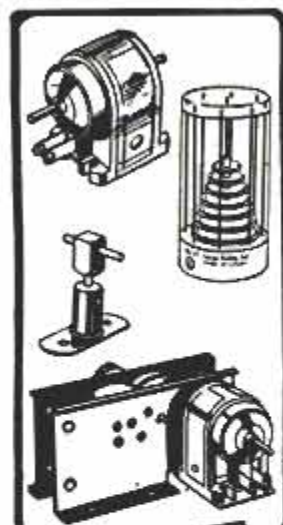

Applying electric drive to research and hobby projects combines pleasure with instruction. Wilson's motors and kits will help you learn basic scientific facts easily.

- No. 8-100 Hi-Drive Motor, 3-6V. . . . . \$2.50
- No. 9-100 Same for 12V. . . . . \$3.00
- \*No. 3-100 Tiny Atom Motor, 1 1/2-3V. . . . . \$2.00  
For 6V. \$2.50 For 12V. \$3.00
- \*No. 14 Adjustable shaft supports kit. . . . . \$3.00
- \*No. 77 Set of 7 large pulleys \$3.00
- No. 1300 Small accessories kit \$1.00
- No. 3700 Large accessories kit. \$3.00
- No. 4000 De Luxe accessories kit with motor. . . . . \$5.00
- \*No. 3000 Vart-speed gear unit \$4.00
- No. 1049 Gear train with Hi-Drive motor No. 8-100. . . \$5.95  
Same with No. 9-100 Motor. . \$6.45

\* Item illustrated. Ask for FREE Cat.

All motors have ALNICO magnets

Remit with order and we pay postage in U.S.A. No C.O.D. Add 3% Sales Tax for delivery in Ohio. Write Dept. PM.

For quick delivery see your local dealer — or order direct



**WILSON'S OF CLEVELAND**

425 Lakeside Ave., N.W. • Cleveland 13, Ohio

## KING MIDGET



FOR 1958

More power, beautiful styling, New Features. Still World's Lowest Priced Car. Drive it for 75c a week. Rider agents wanted. Earn your own car. If no dealer near you send 25c for 32 page picture book with full details and dealer price. Or send \$1 (refunded first order) for this and Service Manual, plus Repair Manual, plus 15 5x7 photos of car and factory.

**MIDGET MOTORS CORPORATION**

Athens 1, Ohio

**1** You can turn one tool into twenty-four with **Black & Decker** **MAGIC SWITCH ATTACHMENTS** **24**

**Free!** 32 Illustrated PAGES!

... from LUMBER, BUILDING MATERIAL & HARDWARE dealers ... a 32-page Sakrete booklet with simple step-by-step instructions for building, patching or repairing with SAKRETE. SAKRETE and water is all you need to make high strength, uniform concrete or mortar.

Buy SAKRETE in moisture-proof, dust-tite bags. Get your free booklet and SAKRETE ... today!

INSIST ON GENUINE

**SAKRETE**

Advertised and Sold Nationally



© 1958



**Take those bumps  
in stride . . .  
go Gabriel!**

Looking for a better ride—a safer ride—under any road conditions? Then Gabriel Adjustomatic Shock Absorbers are the answer.

Only Gabriel Adjustomatics let you choose the ride you want. They're adjustable three ways . . . soft, for a well-cushioned ride—normal, for average driving at average speeds—firm, for maximum stability and safety at high speeds.

The result? Greater roadability, on any car, with any type suspension. And positive ride control that insures safety and comfort for you and your family. For a whole new riding experience, go Gabriel . . . get Adjustomatics.

The Gabriel Company • Cleveland 15, Ohio





## A Transistorized Stroboscope

(Continued from page 135)

in place by two 1/8-in. cable clamps. Before the reflector is mounted, the hole in its back should be enlarged to approximately 1 3/16 in. dia. This permits the neon bulb to be placed deeper into the bowl for proper focusing of the resultant light beam. A half-round file can be used for this purpose.

The lamp socket is mounted on metal spacers with 1/2 x 1/2-in. angle brackets. The front edge of the socket should be about 7/16 in. from the back edge of the reflector and their respective holes should be exactly aligned. After the correct socket location has been determined, the reflector should be removed until wiring and soldering are completed, to prevent accidental damage.

Use a flexible stranded wire, about 8 in. long, to connect the battery holder in the main chassis to those in the cover. Note that the negative end of the battery string is grounded to the cover by means of a solder lug under one of the battery-holder mounting screws. This prevents operation of the circuit while the two halves of the case are separated, but this can be circumvented for testing purposes by temporarily connecting the case and cover together with a piece of hookup wire.

After all wiring has been completed and carefully checked, the reflector and batteries may be installed. Make sure that the batteries are inserted in the holders with the polarity indicated in the pictorial diagram. Finally, insert the neon bulb in its socket and assemble the two halves of the case. The bulb should start to blink as soon as the switch is turned on, with the spiral element of the bulb being brighter than the cylindrical element. If the opposite is true, reverse the lamp in the socket.

To use, merely point the stroboscope at a rotating device and slowly turn the potentiometer dial until the device begins to slow down and, finally, stop. Both speed ranges of the stroboscope should be tried.

As a word of caution: Never stick your finger or the stroboscope into the machinery being observed. It may look like it's standing still, but it really isn't.

Note: Properly calibrated, the stroboscope can be used as a fairly accurate tachometer for measuring the speed of rotation or vibration. While Fig. 1 gives an approximate calibration chart; for greater accuracy each instrument must be individually calibrated.

~~Calibration instructions using an oscilloscope or a strobe disc can be obtained free by sending a stamped self-addressed envelope to Popular Mechanics Radio, TV and Electronics Dept.~~

★ ★ ★



In engine reconditioning

## FEDERAL-MOGUL means FINE PERFORMANCE!

Any engine will perform better when reconditioning includes Federal-Mogul bearings. They are *engineered* for the job. If the crankshaft has to be turned down, there are Federal-Mogul bearings in the correct under-size to fit it. Federal-Mogul reborable bearings can be align bored. For heavy-duty jobs, Federal-Mogul sintered copper-alloys are the answer. That's why mechanics **PRE-FER** Federal-Mogul bearings . . . they are designed to restore fine performance. Ask *your* mechanic!



FEDERAL-MOGUL SERVICE  
Division of Federal-Mogul-Bower Bearings, Inc.





# BOAT KITS

8'-18': 50 Models

\$41.75 up: Frt. pd.  
Money-back  
guarantee.  
Write now.

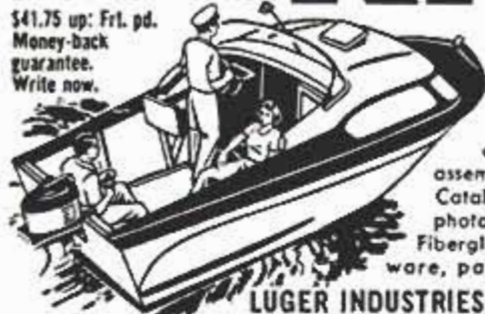

**FREE COLOR CATALOG**

Cruisers, convertibles, runabouts, fishing. Easily assembled by anyone. FREE Catalog has natural color photos, complete details, Fiberglass, accessories hardware, paint. Write Today.

LUGER INDUSTRIES, INC., Dept. D-8

9200 Access Road, Minneapolis 20, Minnesota



Get New 132 Page Catalog of  
**WOOD AND WOODWORKING MATERIALS**

**WORLD'S LARGEST SELECTION—Lowest Prices**  
Your buying guide for finest kiln dried domestic and rare imported woods, inlays, bandings, matched plywood, moldings, ornaments, etc. Largest selection of tools and hard-to-find hardware. Packed with scroll saw patterns, projects, wood facts and money making ideas. Enclose 25¢ (refunded on first order) to help pay mailing and handling costs. Write today to **CRAFTSMAN WOOD SERVICE COMPANY** 2729 S. Mary Street, Dept. A-8, Chicago 8, Ill.

**make your own Gems 36<sup>50</sup>**

The Gem Maker comes complete with all necessary equipment, including a super-charged diamond blade for sawing, and all the wheels for grinding, shaping and polishing; also complete instructions. The complete equipment as shown, less motor and belt for only \$36.50, f.o.b., Burlington, Wisconsin. Write today for information and literature.

**B&I MANUFACTURING CO.**  
Dept. P. Burlington, Wis.

**Find HIDDEN TREASURES**

GOLD, SILVER, PRECIOUS METALS with the Famous Model 27 Metal Detector. Lightweight, ultra-sensitive, low cost. None finer. Also GEIGER COUNTERS for uranium and the VIOLITE for tungsten. INFORMATION FREE

**THE Detectron CORP.**  
5528 Vineland Ave., No. Hollywood, Calif.

**CUT ANY SIZE — ANY SHAPE WITH Spearhead Cutter**

Handy pocket size — cuts leather, asbestos, rubber, cork, etc. — round 1/4" to 6" — any size straight and odd shapes. **Send Check or Money Order!**

**935** POSTPAID

**ZIMMERMAN PACKING — NORWOOD 1<sup>st</sup>, OHIO**

**TOP SPEED BETTER SKIING or FUN**

**MICHIGAN AQUA-JET** propellers win twice as often in the "National Stock Outboard Championship" as all other wheels, custom-built included. Inexpensive stock propellers, requiring no alteration of lower unit, each specifically engineered for motor used (5 HP and larger). Send card for FREE 1958 catalog — the Outboarder's Bible. Shows how to get better performance from specific motor-boat-load combination for racing, skiing, cruising, pleasure — also fine line of boat fittings. Michigan Wheel Co., Dept. PM-8, Grand Rapids 3, Mich.

# CRESTOLOY PLIERS

are individually tested!

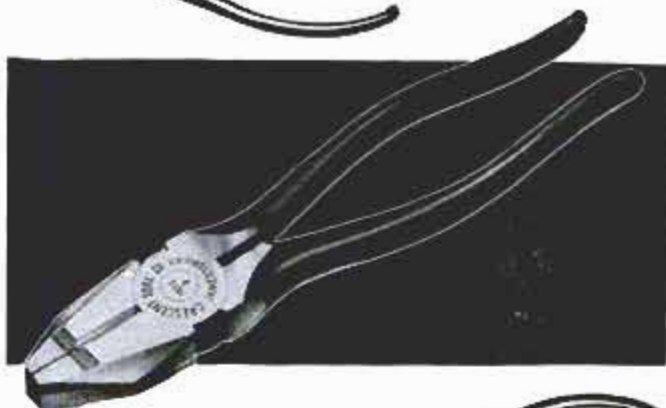

Every Crestoloy Plier is factory tested for ease of cutting, correct tempering and strength, and individually tagged to indicate that it has tested satisfactorily. There are no finer pliers at any price. Seventeen patterns...all popular sizes. Sold by hardware dealers everywhere.

## GET YOUR COPY



Forty pages, profusely illustrated. Tells how to do it easier and better with 30 different hand tools. Tips on care and maintenance. Send a dime with the coupon or get a copy FREE with the purchase of any Crescent Tool.

**CRESCENT TOOLS**

*Give Wings to Work*

*Sign of the Artisan  
Symbol of Excellence*

To Crescent Tool Co., Jamestown, N. Y.

Enclosed find 10¢ for my copy of  
"HOW TO USE HAND TOOLS."

Name .....

Address .....





MADRID SPAIN

Big news on the road today is Quaker State. It's the years-ahead motor oil that keeps car engines like new. Refined from pure Pennsylvania oil stocks, Quaker State provides cleaner, more thorough lubrication for all cars. That's why more and more car owners the world over ask for **Quaker State** ... *it's the best motor oil money can buy!*

**QUAKER STATE OIL REFINING CORPORATION, OIL CITY, PA.**  
Member Pennsylvania Grade Crude Oil Association



Hotel telephone with built-in alarm clock can be operated by the clerk or set by guest in his room

## Miracles Ahead on Your Telephone

(Continued from Page 94)

world's total of 111,500,000). In another 20 years, the experts expect those figures will double. Even with high-speed electronic exchanges, present transmission facilities could never carry the load. So, while line crews are busy building radio relays and stringing thousands of miles of wire and coaxial cable each year, the laboratory wizards are taxing their ingenuity to find new ways of crowding those channels. According to Dr. Claud Shannon at Bell Labs, an ordinary telephone wire can carry some 28,000 tiny "bits" of information each second, but an average spoken message only conveys 40 bits per second. So Shannon is trying to squeeze conversation into solid lumps for transmission.

One upshot of this is a piece of electronic magic called a "vocoder." While you talk, this incredible robot turns your voice into a series of hoots, whistles and beeps that shoot over the lines in record time. At the other end, the sizzling cacophony is converted back to words. The device enables 10 times more data to be sent over one wire. The rub is that no human voice ever sounded like the vocoder, whose electronic vocal chords make everything come out sounding like 33 $\frac{1}{3}$  played in 78 time on a 1915 phonograph.

To keep up with the gabby public, even the familiar old table-set phone is destined for a face lifting soon. One current phone item skidding into obsolescence is the dial. The new electronic switching systems can handle 100 digits per second. The lumbering dial takes 12 seconds to transmit seven digits, so it's a hindrance. Consequently, sometime in the next 10 years, when long-distance dialing allows you to sit in your home and dial direct to a friend in almost any major city, you probably won't actually "dial" him. Bell Laboratory scientists

(Continued to page 204)



# News about the Carter Automotive Training Program



If you qualify, you can attend  
a Carter School in your area

Trained auto mechanics are in short supply, and each year the shortage grows. That can mean steady work at good pay, because if you are a Carter School graduate you will have a thorough training in engine tune-up, fuel systems and auto electrics. Complete intensive training course includes carburetion, circuits, trouble diagnosis.

To qualify for a school in your area you should now be regularly employed in automotive service work, or in an establishment offering engine tune-up service.

Primarily, we are interested in young men who are "engine enthusiasts," who recognize the automotive service field as offering a life-time career.

● Write us, stating your background and tell us why you want this training. You may qualify!

Carter Carburetor, Div. of QCF Industries, Inc.  
Dept. 820M • St. Louis 7, Missouri

## FREE POWER TOOL GUIDE

Handy condensed reference for every hobbyist and shop. Pictures, specs and prices of quality Porter-Cable saws, sanders, drills, routers, planes, attachments and accessories. Write for free catalog 206.

PORTER-CABLE MACHINE COMPANY  
8148 Marcellus St., Syracuse, N. Y.



**MONEY...  
IN HIDDEN  
TREASURES**

Find it... with a GOLDAK Treasure Finder. Send for FREE literature on complete line of mineral & metal locators, underwater detectors, etc., priced as low as \$64.50.

In celebration of its 25th year, GOLDAK CO. introduces new transistor instruments for greater sensitivity - less weight - low cost flashlight batteries. Write for information today!

GOLDAK CO. 1542-S GLENOAKS BLVD.,  
GLENDALE, CALIFORNIA

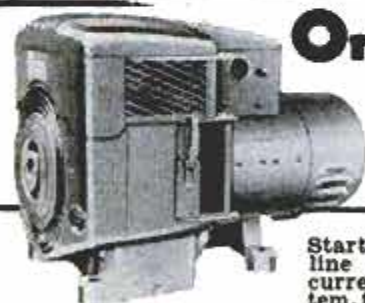

## Onan Emergency Electric Plants

Start automatically when high-line power is cut off, supply current for lights, heating system, freezer, water pump, stove, all appliances and machines. Prevents losses and hardships. Plant stops automatically when power is restored. Compact, easy to install. 500 to 150,000 watts A.C. Priced from \$319.00.

Write for Free Folder

**PORTABLE  
MODELS**  
500 to 10,000  
watts. Supply  
plug-in power  
anywhere!

**D. W. ONAN & SONS INC.**  
3584A UNIVERSITY AVE. S.E. • MINNEAPOLIS 14, MINN.

## Build your own "Holiday House"

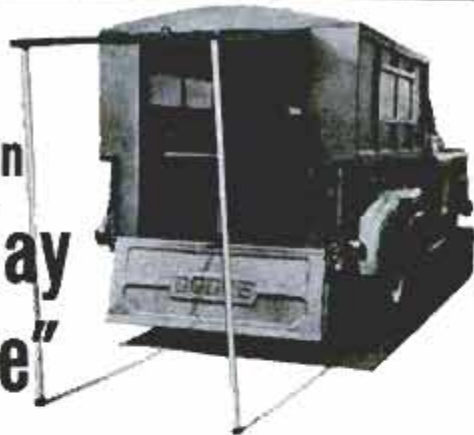

— you can take it with you!

This is the way to camp out—for a weekend or on a cross-country trip! The "Holiday House" is not a house-trailer, not a tent, but a weatherproof house-on-wheels. You build it and mount it on your pick-up truck or trailer.

Weatherproof Homasote Insulating-Building Board forms the "skin". For years, Homasote has been used for this purpose on trucks and on the finest house trailers.

Easi-Bild® Pattern #594 (\$2.00) illustrates each construction problem and lists all materials for this project—not a blueprint, but an easy-reading, easy-to-follow plan that gives you professional results.

See your lumber dealer for Easi-Bild Patterns and Homasote Boards, or mail coupon today.

\*T. M. Reg. Easi-Bild Pattern Company

**HOMASOTE COMPANY, Trenton 3, N. J.**

Send me the literature checked below:

- Homasote (72-pg.) Handbook—10c     Panel-Tile (on 4' x 8' panels)  
 Easi-Bild (64-pg.) Catalog—35c     Trussed Arch Construction

Name .....  
Address .....  
City ..... Zone ..... State ..... H-1  
IN CANADA: TORONTO, ONT.—P.O. Box 35, Station K—MONTREAL, P.Q.—P.O. Box 20, Station N



## HOME REPAIR TIP NO. 48



Wrap splices in electrical wires neatly, safely with "SCOTCH" Brand 33 Plastic Electrical Tape. Thin plastic tape stretches to conform tightly, has high insulating quality, makes waterproof wrap. Resists sunlight, oil, wear and corrosion. UL approved for electrical use, ideal for wrapping splintered tool handles, other heavy duty jobs. Get "SCOTCH" 33 Plastic Electrical Tape in 39¢ or 75¢ rolls at your favorite store now.

**BETTER BUY TWO!**

Made by  
Minnesota Mining & Mfg. Co.  
St. Paul 6, Minn. © 3M Co., 1958



pull the trigger...

## spray paint

7 times faster than brushing!



*Speedy Sprayer*

ONLY  
**\$32.00**  
less motor

Paints anything from a house to a toy. Saves its cost on the first major job! Speedy Sprayer does in minutes what brushing takes hours. Finish is smooth, flawless. Uses any 1/4 h.p. motor with 1/2" shaft. No. 780 Outfit—10 ft. air hose, tire chuck, quart gun, less motor, only \$32.00. Every workshop should have it. At leading stores.

Free! Write for "How To Spray" Booklet and folder.

**W. R. BROWN CORPORATION**

Specialists in Portable Paint Sprayers for Over 37 Years  
2635 N. NORMANDY AVENUE, CHICAGO 35, ILL.

have already perfected one device for the job called the "polytonic coder." You'll simply punch out the combination on 10 numbered buttons without lifting the receiver. This done, you'll lift the receiver and find your friend's phone already ringing. Another gadget, working on similar principles, uses a barrel-shaped affair, like the odometer on your car, at the phone's base. You set up the number you want just as you'd spin the mileage on an odometer, lift the receiver—and there's your party. Most fantastic of all, however, is Bell Laboratories' Audrey. An offspring of Voder, Bell's mechanical talking robot, Audrey is a panel of tubes and condensers that will "dial" a number for you when you have spoken it into the phone. "We've got her to the point where she can be adjusted to recognize any one person," says an A.T.&T. official. "She'll even dial a number spoken in a Scotsman's brogue."

Another number-getter designed to save manicured fingernails is the Dialaphone, a sort of combination phone book and robot dialer already being produced by James Kilburg Corporation in San Mateo, Calif. It's about the size and shape of a desk-top "squawk box." To operate it, the caller turns a small handle until the name of the party he wants shows up in a slot window. Then he pushes a button, the gremlins go to work, and when he picks up his phone the party he wants is on the line. The Dialaphone's private gremlin is a memory tape, prepunched with several hundred frequently called numbers, in code. As a name appears in the window, the perforations designating the phone number for that person fall in place on a decoder that transmits the number to the exchange in a fraction of a second. "If you can think of a man's name, you don't need to remember his number," says Kilburg. "And the Dialaphone never dials a wrong number."

The new coast-to-coast dialing poses an interesting stickler—the national directory, which would be a classic volume about 10 feet thick. Hence, several ingenious solutions are already in the works. Graphic Microfilm of New England has come up with the idea for a boxlike affair not much larger than a big-city directory. Numbers for the entire network, stored on microfilm inside the box, can be brought into position and projected on a screen by simply flipping a lever.

The hard fact is that many of "tomorrow's" telephonic fantasies exist today. Want to call Tokyo from an airplane flying 15,000 feet above Wisconsin? You can do it. Two Northwest Orient Airlines' planes have a phone in the passenger cabin for

(Continued to page 206)



Superior's New  
Model TD-55

# TUBE TESTER

Quickly and Efficiently Tests Radio and TV Tubes Including: Seven Pin Miniatures; Eight Pin Sub-Minars, Octals and Loctals; Nine Pin Novals.



Speedy, yet efficient operation is accomplished by:

1. Simplification of all switching and controls.
2. Elimination of old style sockets used for testing obsolete tubes (26, 27, 57, 59, etc.) and providing sockets and circuits for efficiently testing the new Noval and Sub-Minar types.

You can't insert tube in wrong socket. It is impossible to insert the tube in the wrong socket when using the new Model TD-55. Separate sockets are used, one for each type of tube base. If the tube fits in the socket it can be tested.

"Free-point" element switching system. The Model TD-55 incorporates a newly designed element selector switch system which reduces the possibility of obsolescence to an absolute minimum. Any pin may be used as a filament pin and the voltage applied between that pin and any other pin, or even the "top-cap."

Checks for shorts and leakages between all elements.

The Model TD-55 provides a super sensitive method of checking for shorts

and leakages up to 5 Megohms between any and all of the terminals. Continuity between various sections is individually indicated. This is important, especially in the case of an element terminating at more than one pin. In such cases the element or internal connection often completes a circuit.

Elemental switches are numbered in strict accordance with R.M.A. specification.

One of the most important improvements, we believe, is the fact that the 4 position fast-action snap switches are all numbered in exact accordance with the standard R.M.A. numbering system. Thus, if the element terminating in pin No. 7 of a tube is under test, button No. 7 is used for that test.

The Model TD-55 comes complete with operating instructions and charts. Housed in rugged steel cabinet. Use it on the bench—use it for field calls. A streamlined carrying case, included at no extra charge, accommodates the tester and book of instructions.

**\$26<sup>95</sup>**  
NET

**SHIPPED ON APPROVAL  
NO MONEY WITH ORDER—NO C.O.D.**

Try it for 10 days before you buy. If completely satisfied then send \$6.95 and pay balance at rate of \$5.00 per month for 4 months—**No Interest or Finance Charges Added.** If not completely satisfied, return to us, no explanation necessary.

MOSS ELECTRONIC DIST. CO., INC.  
Dept. D-488, 3489 Tenth Ave., New York 34, N. Y.

Please rush one Model TD-55. If satisfactory I agree to pay \$6.95 within 10 days and balance at rate of \$5 per month. If not satisfactory, I may return for cancellation of account.

Name \_\_\_\_\_

Address \_\_\_\_\_

City \_\_\_\_\_ Zone \_\_\_\_\_ State \_\_\_\_\_

All prices net. P.O.B., N.Y.C.

## BRONZE FOUNDRY

Schools • Home Workshops • Inventors

Make your own castings of aluminum, copper, bronze, silver. Foundry sets are available in three sizes including 2400 Deg. F. blast Furnaces. \$26.50; \$33.50; and \$46.00 f.o.b. Marysville or Lakewood. Free Circular.

KANSAS CITY SPECIALTIES CO. (Dept. ) Box 6022, Marysville, Kans. P-8 or Box 7543, Lakewood, Colo.

## NEW, IMPROVED CALCULATOR FOR WOODWORKERS only 25c

Instantly gives information on lumber, nails, concrete mixes, painting materials, etc. Convenient, simple to read. Just set dial for nail specifications, to convert linear to board feet, find bit sizes for screws, compare characteristics of woods. 6" diameter heavily varnished cardboard. Send 25c, no stamps, please to Greenlee Tool Co., Columbia Avenue, Rockford, Illinois.

## 95% PROFITS YEAR 'ROUND

Be your own boss, Operate a SIMPLEX lawn-mower sharpening service in your community. One compact machine grinds all mowers, sharpens cutlery. Low investment, 95% profit. Pays for itself in average month.

### SIMPLEX

—4 Machines in One!  
Reel Grinder—sharpens any mower reel in or out of mower.  
Bed Knife Grinder—grinds with either round or cup wheel.



Rotary Blade Grinder—hollow grinds any rotary mower blade.  
Cutlery Knife Grinder—sharpens cutlery, tools, scissors.

Send for free, money-making details!  
The FATE-ROOT-HEATH Company • Dept. PM-8, Plymouth, Ohio

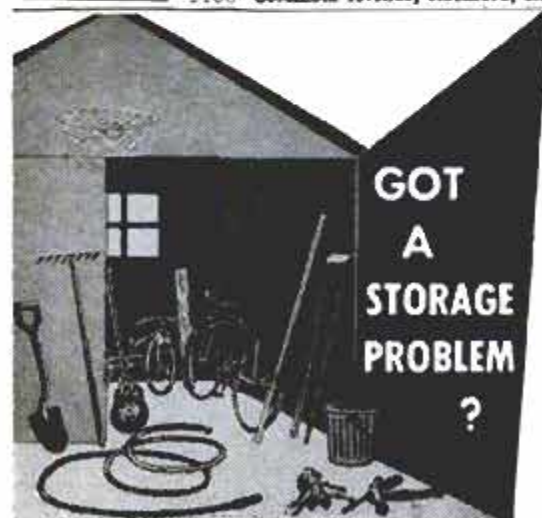

**GOT  
A  
STORAGE  
PROBLEM  
?**



Then you need TURNBUCKLES Perforated Board fixtures to end space-wasting clutter and to keep everything neatly in place until needed.

TURNBUCKLES do-it-yourself fixtures come in a wide variety of shapes and sizes . . . fit easily into any wall-hung perforated board . . . and hold everything from clothing and kitchen utensils to hand tools and garden equipment.

Send for your free copy of space-saving suggestions for home, farm and workshop.



## TURNBUCKLES, Inc.

BOX 333, MICHIGAN CITY, INDIANA

NAME \_\_\_\_\_

ADDRESS \_\_\_\_\_

CITY \_\_\_\_\_ STATE \_\_\_\_\_



anyone able to place or receive calls. Right now the call must be made within 175 miles of Chicago or Detroit, where the two radiotelephone stations equipped to handle this traffic are located. Lights flash and a bell rings when there's a call for someone aboard.

You can count on seeing lots more radiotelephonics for everyone. Last year Stromberg Carlson introduced a miniature radiotelephone receiver about the size of an electric razor. Anybody can buy one. It fits in vest pocket or handbag. If you're out shopping or strolling the streets within eight miles of home or office, and there's a phone call for you, the tiny transistor radio will start buzzing. Just head for the nearest pay phone, dial a prearranged number and you'll be piped in to the call. How does it work? In the cities where the service is available, a special operator intercepts all calls to your telephone when a flipped switch on the instrument tells her you're going out. On a compact transmitter resembling an adding machine, she broadcasts the signal that tickles your radio buzzer wherever you are. Then she patches you in to the caller when you dial in.

In the Hamburg, Germany, railroad station, when you drop your coins for a long-distance call, they slide into a long sloping slot; callers can gauge how much talk time

is left by watching the coins drop away.

A new kind of phone box is already appearing on American street corners. Strapped to lamp posts, the brightly painted aluminum cases contain outdoor telephone sets with direct connection to police or fire departments. When the handset is lifted, a light flashes on a console at headquarters—no dialing necessary. The emergency is immediately reported, and the man at the console knows where it's from by the position of the light.

If all this is here, what's in store for the future? At Massachusetts Institute of Technology, Dr. W. N. Locke is busy working on an electronic translator of the printed word. When a current study of language sounds is finished, Dr. Locke believes that an electronic device can be built that will automatically translate foreign languages.

That one's still a long way off. And there may be disadvantages that will rule it out. Even some of the current radiotelephone systems, while convenient, have disadvantages. Not long ago, a policeman was writing out a ticket for a St. Paul, Minn., cab driver when the cab's two-way radiophone suddenly blared: "Slow down, 445, a cop's chasing you." The officer grabbed the transmitter from the dashboard and acknowledged the tip. "This is 445," he said. "We got him." ★ ★ ★

# "Summertime and the wheeling is easy"

## HARLEY-DAVIDSON

# DUO-GLIDE

Here's outdoor fun for all the summers and years to come...with plenty of room for gal or pal. Only the Duo-Glide gives that easy miracle ride — thanks to new swinging-arm rear suspension coupled with Hydra-Glide front fork and spring-loaded seat post.

Cushioned comfort plus 74 cubic inches of dynamic OHV power! First in safety too — new hydraulic rear brake — big surface front brake — stop this streamlined beauty on a dime.

Make a date to test ride the Duo-Glide at your dealer's today. His liberal trade-in deals and the convenient monthly terms make it easy to own a Duo-Glide.



HARLEY-DAVIDSON MOTOR CO.

Dept. P, Milwaukee 1, Wisconsin



## Automatic Saw Set...

### MAKE EXTRA PROFITS!

Set 400 teeth per minute on hand or band saws, 4 to 16 point, with the BeMaCo Automatic Saw Set. Fast, accurate, true hammer-anvil action sets teeth uniformly, eliminates tooth breakage. Used profitably by saw shops and manufacturers everywhere. Every machine positively guaranteed! Write for details—today!

Saw  
Machine  
Division  
35-C

## BEAVER MFG. CO.

PO Box 434  
800 ISIS AVENUE • INGLEWOOD, CALIF.

Works in seconds!



Loosens Rusted Bolts  
nuts, screws, "frozen" parts!

## LIQUID WRENCH

The super-penetrating rust solvent that quickly loosens rust and corrosion.

AT HARDWARE STORES, GARAGES  
SERVICE STATIONS, EVERYWHERE  
**RADIATOR SPECIALTY CO.**  
Charlotte, N. C.

## MONEY MEN ALL FREE

THE PLASTEX Industry needs manufacturers on small scale and for big production of Lamp and Clock Stands, Art Goods and Novelties in Plastex and Marble imitation. Experience unnecessary. The material makes regular 10¢ store sellers. Rubber moulds furnished for speed production. Small investment brings good returns. We are now placing big Chain Store Orders with manufacturers. Ambitious men have chance for real prosperity. Our Free booklet will interest and benefit you.

**PLASTEX INDUSTRIES, Dept. A**  
3400 Third Ave. New York 56, N. Y.

## 10" TILT/ARBOR SAW BUILD-IT-YOURSELF from GIL-BILT KITS-PLANS

Sturdy wood, steel, and aluminum construction, NEW DEPARTURE ball bearings. Capacity and performance of floor saws selling for \$150.00 and up. Plans, all metal parts in kit with 10" comb. blade \$29.90, less blade \$22.95, F.O.B. St. Louis. Detail PLANS-PATTERNS only \$1.00 postpaid.

Build-it-yourself 12" and 16" Bandsaws, 6" Belt Sander, Shaper. Simplified plans, build easily with hand tools only. Advertised and sold for 12 years, over 35,000 units in use. Money back guarantee. FREE CATALOG.

**GILLIOM POWER TOOLS, Dept. 80-H, Lambert Field, St. Louis 21, Mo.**

## BOAT KITS BUY DIRECT... SAVE 2/3! NO DEALERS - FREE FREIGHT

SAVE... on the Finest Quality Boat Kits. Lowest Prices, Mahogany Decks, Frames, Prows, Rovers, Cruisers, Runabouts. Over 40 Models of simple to construct boats and frame kits. SEND 10¢ FOR NEW COLOR CATALOG... Boats, Paints, Hardware, trailers, fiberglass etc. Over 2000 items for your boat.

BUY ON EASY  
CREDIT TERMS

Boat Plans-Patterns-Frame Kits

Craig Craft  
Tonawanda, N. Y.

Build over 50 modern boats from large scale plans, available with FULL-SIZE patterns, new PRE-FAB frame kits! All types: prows to cruisers, 6 to 25 ft. Best buy for Amateurs! SEND 10¢ for CATALOG.

# NEW midget pliers added to KLEIN line



Hardly larger than a package of your favorite cigarettes, these new Klein Midget Pliers will simplify many of those small jobs where space is confined.

Midgets in size but giants in performance, they solve major problems when wiring up electronic assemblies; making model trains, airplanes, automobiles, or in any extremely small or confined work.

These new midgets are additions to the famous Klein line of high-quality pliers that are backed by over a century of manufacturing experience. See your hardware dealer.

- |                                 |            |
|---------------------------------|------------|
| No. 257-4 Oblique Cutting Plier | Size 4 in. |
| 321-4½ Long Nose Plier          | 4½ in.     |
| 322-4½ (Without Knurl)          | 4½ in.     |
| 224-4½ End Cutting Plier        | 4½ in.     |



### Free Bulletin on Klein Pliers

Bulletin 758 lists the many various pliers in the Klein line. A copy is yours for the asking. Write for it today.

Mathias **KLEIN** & Sons  
Established 1837  
7200 McCORMICK ROAD • CHICAGO 45, ILLINOIS





## The Studebaker Scotsman

(Continued from page 81)

"Rattles in dashboard and door panels."—New Jersey special patrolman.

Third most-frequent complaint involves rain leaks, with 11.3 percent mentioning them.

"Leaks water into back of station wagon. Spare-tire well rusted already. Will not start after a night rain."—Kansas salesman.

"Car fills up with dust on a dirt road. Leaks water when it rains."—Ohio appliance serviceman.

### What About Industry Trend?

We ask owners if they approve or disapprove of the industry trends in styling. Scotsman owners are almost evenly divided on the question with 50.8 percent approving the current trends and 45.2 percent opposing it (the other 4.0 percent is undecided).

Some of the statements these owners make about the industry are of interest:

"The industry should achieve beauty through lines rather than through makeup, i.e., don't use chrome like rouge. Rome at its fall was making the fanciest chariots on earth and the Huns rode in on ponies and the Goths and the Vandals took over. A car is a car, not an expression of social rating."—New York salesman.

"This Scotsman is a start in the departure from the trend that broke the demand for cars in America. This is not a depression but a buyers' boycott of goods made by the manufacturer to his own taste rather than to buyers' tastes."—Nebraska cattle rancher.

"Make the car the 'thinking' public wants, not the car the 'dreaming' public imagines. This Scotsman is the only realistic approach to private transportation manufactured in the country today. I am disgusted by the current attempts to cater to insecure egos."—California sales representative.

"Why do companies paint cars the same color as the paved roads, or near the same color. I have nearly had terrible accidents for this reason alone. Light gray cars traveling at high speed are on you before you see them because that color is not noticeable at a distance."—Michigan gasoline-station owner.

"I would like cars with tops strong enough to support the body without crushing on rollover accidents. I see no reason for the thinnest support posts for the roof."—New York physician.

"Cars should be made slightly shorter and the bodies made out of better material, material that will not rust through in two years if not undercoated, and material that can be hammered out without stretching when dented."—New York mechanic.

### More Best-Liked Features

The following quotations describe, in order of frequency of mention (ranging from 19.4 percent down to 2.4 percent) the additional best-liked features as selected by owners:

"It has good clean styling with practically no chrome to rust. It has enamel hub caps."—Ohio engineer.

"Styling is fine. No unnecessary fringes."—Illinois owner.

"It's as smooth riding as higher-priced cars. Has plenty of room."—Pennsylvania mechanic.

"Holds the road nicely at 65 miles per hour."—Illinois salesman.

It would seem that this great industry could keep water out after all the years of trying.

A sensitive point with Studebaker. Its 1953 coupes were the handsomest cars built in America, but they didn't sell.

Perhaps it's time to select colors for visibility rather than style. After all, they put zebra stripes on switch engines to prevent accidents.

Only an engineer would brag about enameled hub caps. Anybody who sells cars knows that well-placed trim loosens buyers' purse strings. Look at the 1958 Oldsmobile.

(Continued to page 222)





## Using too much oil?... call for HASTINGS

Excessive use of oil is your first sign of worn-out piston rings. And worn-out piston rings mean power drop-off—costly wastage of gas and oil—expensive repairs later on.

See your motor specialist the minute oil-pumping warns you there's trouble ahead. When he recommends new piston rings, ask for Hastings. They're engineered exclusively

for replacement service . . . to stop oil-pumping, save gasoline, restore lost performance.

Get new car performance from your present car—with Hastings. Truly your best investment for thousands of extra miles of trouble-free driving. Hastings Manufacturing Co., Hastings, Mich. Piston Rings, Casite, Wear Reducer, Oil Filters, Spark Plugs

TOUGH ON OIL-PUMPING  
GENTLE ON CYLINDER WALLS

U. S. PATENT NOS. 2614899, 2712971



# HASTINGS PISTON RINGS

# PREFERRED

by Leading  
Appliance Manufacturers  
NOW AVAILABLE TO YOU!

EMERSON ELECTRIC



# MOTORS

First choice of manufacturers for 68 years!  
Now you can choose from 21 different designs from 1/4 to 1 H.P. Write for free catalog No. M-174. The Emerson Electric Mfg. Co., St. Louis 21, Mo.

EMERSON-ELECTRIC

of St. Louis . . . Since 1890



# free

## ALLIED'S Big Value ELECTRONIC SUPPLY BARGAIN SUPPLEMENT

send for it!



**BIGGEST VALUES EVER:**  
Biggest savings ever!  
Send for your FREE copy today.

SAVE MOST ON HI-FI, KITS,  
EVERYTHING IN ELECTRONICS

Send for our latest Supplement packed with bargains and new products! Top buys in famous KNIGHT-KITS, new Hi-Fi systems and components, stereo, recorders, amateur gear, P.A. systems, test equipment, TV accessories, electronic parts, tubes and tools. Save as never before!

## ALLIED RADIO

ALLIED RADIO CORP., Dept. 5-H8  
100 N. Western Ave., Chicago 80, Ill.

Send FREE ALLIED Supplement No. 175

**FREE**

Name \_\_\_\_\_

Address \_\_\_\_\_

City \_\_\_\_\_ Zone \_\_\_\_\_ State \_\_\_\_\_





Courtesy Ford Motor Co.



## THE ENGINEERING DRAFTSMAN

As you look around at the modern, sleek factories, office buildings or homes which seem to rise up overnight—or at the parade of shiny new products available in stores—or at the news items you read daily announcing some marvel of science and engineering, do you ever wonder how these accomplishments came to be or who has been responsible for their creation? What we see is the end result of what amounts to years of planning and patient research. But behind the scenes, in the development processes, are countless individuals working together, each relying on the others' skills and abilities in their efforts to perfect their company's product or service. Scientists, engineers, technicians, draftsmen, skilled craftsmen, and others, all contribute their creative talents to the joint venture of product or project development. And right in the forefront of the development team is the draftsman, a highly specialized professional whose services are invaluable to the success of any project.

The drawing board is the beginning of nearly all the constructive and productive activity that man undertakes. No matter whether it's factory layout, dam construction,

"Drafting? This is a career with a future! Good draftsmen are in high demand; they're paid well; and drafting is the best possible background for advancement into the engineering profession. Training is a must of course . . . the kind you get through private technical schools is excellent. My professional skills, my present job, and the promotions I've received since starting in drafting were due to the thorough training provided by the technical school I attended and the opportunities I've had to apply my training to the practical work of design. I'd recommend a technical school education to any man who wants to become a draftsman."—George Wasko, Machine Designer, Venables Machine & Tool, Cleveland, Ohio.





oil drilling, or manufacturing, much before production is begun, every detail of the project must first be set forth on paper. It's the draftsman with his exact skill that gives tangible, graphic meaning to the ideas and sketches of the engineer, architect or designer with whom he works.

Drafting is a career in which the full creative and imaginative powers of the individual are given expression. The draftsman has an aptitude for detail and for visualizing objects. His work must be neat, but above all accurate. A thorough knowledge of drafting techniques and a background in mathematics and the basic sciences are an important part of his special knowledge. The draftsman must know the product or service of his employer thoroughly, so he can translate ideas into detailed drawings. A knowledge of materials is also useful since the draftsman must often make calculations concerning the strength, quality and cost of materials.

Draftsmen are employed by almost every type of industry and will usually specialize in a particular branch of drafting. Some of the major classifications are architectural, structural, mechanical, civil engineering, aeronautical, electrical, product design, chemical engineering and industrial piping drafting.

There are, of course, various levels of draftsmen within each specialized field; each strata of draftsman depending on individual experience, knowledge and ability. The beginner enters the profession as a tracer doing routine copy work, making corrections or preparing drawings for blueprinting. Men with formal training begin as junior draftsmen. As experience is acquired, an able junior will advance to senior draftsman, and chief draftsman. From these top drafting positions, promotions to design and engineering positions are very possible with additional training in mathematics and science.

Employment opportunities in drafting are excellent! Present reports indicate shortages of trained men available to industry at this time. Because of this shortage, trained draftsmen are experiencing higher wages and rapid advancement. The future is also very promising for as long as the engineering and scientific occupations grow, draftsmen will be required as supporting personnel.

To plan a career in drafting, attention should be given to the educational requirements needed. Training is essential because the nature of the work is so complex and the draftsman's responsibility for accuracy is so great. A high school education is basic. Mathematics, such as algebra, geometry and trigonometry are necessary in order to become completely competent. Mechanical drawing, lettering procedure, a study of physics and other sciences is needed. Mechanical shop courses are also valuable. Drafting technique and procedure must be mastered.

Some of the most highly recommended sources of training in drafting are private technical schools, trade schools or through the comprehensive courses provided by home study schools. These institutions offer complete educational programs in drafting technique, and enable the student to concentrate on a particular field of drafting so he may be able to enter the industry as a specialist. Many also provide career courses leading to engineering degrees.

You will find these schools in *PopularMechanics*. We suggest you make a study of the courses they offer. Write to them and ask their advice regarding the career of drafting.

Experienced draftsmen agree that the opportunities in this profession are excellent. The finest training is available through the schools represented in the pages of *PopularMechanics*. If your interests lead you toward this field, make your decision — now — to become an engineering draftsman. Then enroll in the school of your choice.



"My background as a draftsman? I trained under professional draftsmen at a private technical school that specializes in drafting. This gave me the technical knowledge I needed to begin my career."—Eugene Brazina, Architectural Draftsman, Kawneer Co., Cleveland, Ohio.



"Any man applying himself to his studies and his work can succeed immediately in drafting with a technical school education. My education through a private technical institute opened up a whole world of opportunities for me."—Mathew Perito, Head of Drafting Dept., Motors Div., Ohio Electric Mfg. Co., Maple Heights, Ohio.

"Men with technical school diplomas in drafting are much in demand now. Industry knows these men have received a specialized, concentrated education designed to fit the requirements of the individual's particular job or unique ability. I specialized in tool and die design at a technical institute. This training definitely prepared me for my career."—John Bllobran, Process Engineer, Chevrolet Cleveland, Pressed Metals Div., G. M. Corp.





## The Rambler American

(Continued from page 83)

**Economy is what you make it. With tiresome self control, a good driver can get 25 to 27 miles per gallon. Normal driving will get you 20 or so. The difference between this and the small foreign car is that regardless of how hard you drive the import, you'll probably get 25 to 30 miles per gallon. With care you can get 40.**

**Both test Americans (the one Kelly used and the one Railton used) were well assembled. Both were tight, rattlefree on rough pavements.**

**This fellow will have more cause for complaint after he sees the upcoming 1959 cars.**

**If you want room for several children, luggage space, sprightly performance and automatic transmission, you should settle for about 20 miles per gallon over-all. This car provides all that.**

**Has good acceleration. Even above 55, it takes off quickly for passing.**

→ "Multiple body leaks, but most have been corrected after several trips to the shop."—California physician.

→ "I am disappointed with the mileage. I get 19 miles per gallon in the city. This is not economy in a small car. Why can't we get the 25 to 32 miles per gallon we were told we'd get?"—Wisconsin stationary fireman.

→ "Gas mileage isn't what you should get on a small car. I average 24.3 miles per gallon on long trips."—Wisconsin salesman.

→ "The headroom is very bad. A hat cannot be worn comfortably. Difficult to get in and out."—Illinois teacher.

→ "After driving a larger car for so many years, I miss the spacious interior."—California office manager.

→ "Very poor workmanship on body. Springs weak. After driving this car almost 11,000 miles I had to replace all four tires. When it was delivered, the headlights did not work, the U-bolts holding the rear axle were loose, the gears would not shift properly, right door didn't fit."—Ohio distributor.

→ "A spot weld in the top brace has come loose. This is a difficult repair job. It seems to me that for the price, strict control of workmanship is in order."—Illinois salesman.

### What About Industry Trends?

As you might expect, the owners of the Rambler American, a maverick car in the industry, are not completely pleased with the industry trends of design. In fact, 62.4 percent of them do not approve the trends.

→ "I bought this car first, because it appeals to me, and second, because I disapprove strongly of the trends in styling. The industry should cut out the fancy styles, the increased horsepower, extra trim, tinsel and extra length."—Pennsylvania physician.

→ "Since the American is the 'big' car in my family (I also own a Metropolitan), you can see I'm a bug on small cars. I did not buy it because it was cheap. I would be willing to pay up to \$1000 more if someone would come out with a small, classy car with clean, straight lines and maybe a few, just a few, more horses."—Pennsylvania superintendent.

→ "I disapprove of the trends. Stop making bigger, lower cars. We live in homes, our cars are for transportation. The average owner puts miles on a car in short-trip driving. He gets a vacation once a year."—Oregon stationary fireman.

→ "I oppose the trends. The industry should limit top speeds to the speed limit of the state."—Indiana minister.

→ "I am happy to support an American manufacturer who has the courage to build a small car when others are interpreting demand to be for larger cars."—Ohio librarian.

→ "This American is a step in the right direction. The small foreign cars are too small as I have two children. I want good dependable transportation and this seems to be it."—Massachusetts serviceman.

### More Best-Liked Features

Here, in order of frequency of mention, are the additional best-liked features as described by owners:

→ "It has enough power to get out of tight spots and enough speed on the highway."—Indiana brakeman.

→ "Large enough for all practical purposes without being a mobile monster."—New Hampshire chaplain.

→ "Excellent fast steering."—Missouri minister.

(Continued to page 214)





**INTERIOR WOOD PROJECTS** Seals, primes, finishes. Nothing else to use from raw wood to bar-top finish. Dries in 30 minutes.

**MORE THAN A WOOD FINISH**

**PROTECTS TOOLS FROM RUST**  
Coat tools with Deft. Non-Sticky. Makes table-saw tops smoother.

**DRAWERS, WINDOWS** will not stick. Coat runners & slides for smooth operation.

**PROTECTS NEW WOOD** against warping, darkening, grime, fingerprints, pencil marks.

See your dealer or write for free Deft booklet.  
DESMOND's, 1826 W. 54th St., Los Angeles 62, Calif.

**MASS PRODUCTION MAKES THESE PRICES POSSIBLE!**

Only world's largest boat kit maker can deliver such quality at such prices! Write for free color catalog, kits from \$42.00, frt. inc. 12 ft. runabout \$99.50 frt. inc. **FREE COLOR CATALOG!**  
**TAFT MARINE WOODCRAFT**  
Dept. PM-858 636 39th Ave. N.E. Minneapolis 21, Minn.

**DRAINS** cellars, cisterns, wash tubs; **\$7.95**  
**IRRIGATES - CIRCULATES - SPRAYS**

1,001 uses. Stainless shaft. Won't rust or clog! Use 1/6 HP motor or larger... 3/4 HP for up to 3000 GPH; 450 GPH 80' high; or 1800 GPH from 25' well. 1" inlet; 3/4" outlet. Coupling included. **FREE \$7.95.** **HEAVY DUTY BALL-BEARING PUMP.** Up to 7,500 GPH or 3,000 GPH from 25' well. 1 1/4" inlet; 1" outlet. **\$12.95** Postpaid if cash with order. **MONEY BACK GUARANTEE.** Centrifugal and Gear Pumps in All Sizes. **LABAWCO PUMPS, Belle Mead 7, New Jersey**

**Build Your Own FIBERGLASS SWIMMING POOL**  
**30' x 15' for approximately \$500.00**

Instruction Book With 3 dividend systems — \$1.00  
**Fiberglass and Resin — Wholesale**  
Free Price List  
**HENTON CONSTRUCTION CORP.**  
3902 South Port Corpus Christi, Texas

Carry Your Keys On a

**KEY-BAK Key Reel**

Your keys are SAFE when you carry them on a KEY-BAK Key Reel. KEY-BAK is pocket watch size, sturdily constructed, 24" long steel chain. Swedish clock spring reels in keys, keeps them safe and handy at your side. Wear it on the belt! Get KEY-BAK Key Reels from your hardware or key shop.

OVER A MILLION KEY-BAKS SOLD!

WEST OF MISSISSIPPI  
Lummis Mfg. Co.  
2242 E. Foothill Blvd.  
Pasadena, California

EAST OF MISSISSIPPI  
CTL Company  
1710 W. Stewart Ave.  
Wausau, Wisconsin

**ONLY \$2.95**

Say "RIDGID OOR" for drop-head pipe dies unequalled for easy work, good threads and extra long service!

Larger RIDGID Drop-Head Dies offer same easy work features.

111R, 1/8" to 1 1/4",  
12R, 1/8" to 2".

No wonder pipe "pros" have bought hundreds of thousands of them, the easy way they snap into the ratchet ring handle... the smooth clean way they cut 1/8" to 1" pipe threads... the quick way the dies reverse for close-to-wall threads. You'll like OOR's, too, for your home or your shop—get 'em at your Hardware Store!

**The Ridge Tool Company**  
Elyria, Ohio, U. S. A.



The industry may have reached the point of diminishing returns on riding comfort. All cars are comfortable. Expensive, big cars are just more comfortable. It takes a sensitive tailbone to detect the difference.

Biggest improvements in this model over its 1955 ancestor are the open wheel covers and the resulting 35½-foot turn circle.

You don't think of this when buying a car, but it becomes a millstone every Saturday morning thereafter.

If manufacturers are going to offer handshift transmissions they must make them effortless. It can be done. Perhaps it is time to admit the old way was best—put the shift lever back on the floor and eliminate arm-breaking linkage.

Peppy performer. Has the agility so important to a small car. But lacks good balance somehow. Why do some hammers feel good, others poor? All drive nails, but some have balance, some don't. Same with cars. Rear end walks crablike on washboard corners. Excellent cornering on smooth road. Squeeze-type door handles are stiff, almost impossible for child to use. Trunk restricted due to horizontal spare tire. Difficult to get into rear seat. Narrow opening for feet is barbed with seat hardware. Car has no basic faults. With continuous improvement of a few weak points, it will be a great competitor among the world's finest small cars.

"Its size is a relief from the oversize cars of today."—Alabama architect.

"I've ridden in some of the low-price Big Three cars and they don't ride any better."—Illinois carpenter.

"I like the simplicity of design. I hate loads of chrome."—Texas fashion artist.

"It holds the road very well and at 65 miles per hour it is just cruising along."—Wisconsin merchant.

"Corners nicely without too much body lean and discomfort to passengers."—Colorado nurse.

"Has a feeling of solidity that's excellent for such a small car. Free from rattles."—New Jersey supervisor.

"You don't need a 10-acre field to turn around in."—California retired owner.

"I like the quiet little 90-horsepower L-head engine better than the 130-horsepower valve-in-head that was in my 1956 Rambler."—Kansas salesman.

"Engine designed so most adjustments and minor repairs can be done without special tools."—New York owner.

"I am six feet tall and have legroom with comfort in the front seat, but not too much in the back."—Pennsylvania factory superintendent.

"Simple to wash and polish."—Pennsylvania inspector.

"I can see over the wheel and hood."—Ohio teacher.

"Has good heater and defroster, but should have separate control for defrosting."—New York technician.

"Wonderful glove compartment."—Pennsylvania owner.

"Complete instruction book that makes repairs and adjustments by owner easy."—Oregon retired owner.

#### More Complaints

Also in the order of frequency of mention are the following complaints as described by the American owners:

"Shifting is difficult. Can't get it into second gear without forcing it. Then when clutch is released it often pops out of gear."—Wisconsin salesman.

"I have trouble with shifting which may be a weakness of the car but think it could be corrected by a competent mechanic."—Washington banker.

"Bad ride on short bumps."—Massachusetts engineer.

"Floor mats of poor quality and tend to slide and bunch up."—Minnesota contractor.

"Emergency brake pulls out too far. A knee buster."—New York foreman.

"Tends to stall in wet weather. Automatic choke not yet adjusted right."—New Jersey retired owner.

"Grease leaks from door handles."—Pennsylvania teacher.

"Doors don't open beyond 75 degrees. They don't stay open in detent provided. If they opened wider it would be easier to get in and out."—Wisconsin architect.

"It uses oil (two quarts in 500 miles) but I hope that with complete break-in this will stop."—Maryland teacher.

"Beginning to rattle and squeak at 5000 miles."—West Virginia university staff member.

"Poorly constructed seats. Broken twice. Driver's position awkward."—Texas buyer.

"Ladies tear stockings on front-seat backs when getting into rear seat. Hard to get into rear of car."—Wisconsin service-station owner.

"Windows in rear should roll down."—Missouri owner.

"Light dimmer switch too close to clutch."—Wisconsin physician.

There you have it, the good as well as the bad, as described by the owners. For an engineer's analysis turn to page 82.



# WELD IN A JIFFY! IT'S DYNAMIC



Now any one can weld, cut, braze or solder almost any metal quick, safe and easy with this professional type welder. Make repairs in home or shop and farm; repair auto bodies and fenders, build wrought iron furniture, railings, fences, etc. — 1001 metal items. No previous experience necessary. Designed to operate on any properly wired 110 V. A.C. line. Order today! Literature on larger industrial equipment on request.

DYNAMIC WELDER COMPANY, 1808 S. Federal St., Dept. D2-H, Chicago 16, Ill.

**EASY PAY PLAN**

Low down payment. Pay as you USE. Money back guarantee. Act now!

only **\$38.50** i.o.b. Factory

**BUY GREAT NECK HAND TOOLS**  
... for long-lasting performance



**Precision Balanced NAIL HAMMER**



One-piece, forged steel, rubber-cushioned, no-slip grip

**GREAT NECK SAW MFRS., Inc.**  
MINEOLA, N. Y. — SEE YOUR LOCAL STORE

RETAIL PRICE \$125.00  
FACTORY TO YOU \$79.95

**SUPERSHOP** includes precision-built 8" tilting table saw, vertical and horizontal drill press, 30" lathe, sander, grinder. 100% BALL BEARING. Write for FREE catalog, full details, trial plan. Easy Pay Plan.



**POWER TOOLS, INC.**

110 YATES AVENUE  
BELOIT, WIS.

## Save on all PLUMBING JOBS

When You Build · When Making Improvements · Repairs · Maintenance



Get **POPULAR MECHANICS Home Plumbing Guide**



How to plan plumbing installations, select materials and fixtures.

How to save money on all plumbing jobs using approved methods.

Easy to Do Professional-Like Jobs and Save Over One-Half

Get the Popular Mechanics **HOME PLUMBING GUIDE**. It shows how you can do every kind of plumbing job yourself and save from a few to hundreds of dollars. Covers plans, layouts, installation, maintenance and repair. Shows what materials to get and use, where to get them and how to do a proper job with approved methods. Few, other than the simplest tools are required and some of these can be rented. Don't pay high prices for work you can do yourself. Get the **HOME PLUMBING GUIDE** for only \$3.95. You will be amazed how jobs you thought difficult are simplified.

Clip This Ad and Mail. Money Back if Not Pleased

Invest only \$3.95. Use the book for 7 days. Then if you are not satisfied return it for full refund of your money. Sent C.O.D. (U.S.A. only) if you prefer.

- 15 Ways to Save Money
- All about modern home plumbing
- How to use plumbing tools
- Getting acquainted with pipe
- Planning home plumbing systems
- Installing and maintaining home drainage systems
- Private sewage disposal systems
- Causes and cures of drainage troubles
- Installing home water lines
- Private water supply systems
- Water Heaters
- Water Conditioning
- Water system troubles and cures
- Installing and caring for fixtures
- What to do with valves and faucets

Over 500 How-to-do-it Pictures Guide You



POPULAR MECHANICS PRESS, Dept. 858, 200 E. Ontario St., Chicago 11

## BRITISH JUNGLE CARBINES

'24.95 Never before offered!

### BURMA!

Stock #R524 .303 Caliber Jungle Carbine Enfield No. 5 developed for rough usage and bitter fighting in jungles of Burma, Borneo and Malaya. First rate condition. Sold previously high as \$100. Special refinements that give distinctive silhouette are *Jungle flash hider, sporting rifle type stock, and built-in rubber butt plate!* Precision calibrated Enfield sights. Only military weapon ever made with lines, and fast handling qualities of a modern sporting rifle. 10-shot bolt action repeater. 100 rds. M1. Target ammo, \$1.50; 20 rds. Softnose Hunting ammo, \$2.95. For extra select carbine add \$5 (Stock #R52R).

**FIRST "WORLD GUNS" EDITION** \$2

348 pages jam-packed with never-before published material. Over 1200 weapons illustrated — over 1500 rifles, pistols, daggers, swords, muskets, armor described and priced to sell right from catalog. New 1000 paragraph glossary of little known gun terms. Top curtain weapons and many other spectacular unpublished guns, 400 yrs. of firearms shown!

TO ORDER, SPECIFY STOCK NUMBER. Send check, cash or M.O. For C.O.D. send 1/2 deposit or more. Shipped F.O.B. Pasadena. Expr. charges collect. Calif. resid. add 4% state tax. 10-DAY MONEY BACK GUARANTEE.

### GOLDEN STATE ARMS CORP.

386 W. Green St., Pasadena 82, Calif.

now's the time for

# DAP

**KWIK-SEAL®**

Put a clean, white, water-proof joint around tubs, sinks, lavatories with DAP KWIK-SEAL. Point tiles and fill cracks, too. Get handy KWIK-SEAL tube with dispenser nozzle at hardware, paint and building supply dealers. DAP makes a caulking, glazing or sealing product for every home need.

**DICKS-ARMSTRONG-PONTIUS, inc.**  
Dayton 3, Ohio



Do the job  
in  
*half the*  
time  
with a



## ELECTRIC SCREWDRIVER!

It's for the contractor, the electrician and plumber, for the cabinet maker and boat builder, for outboard motor repair, for the upholstery, seatcover and convertible-top trim shop, for carburetor and general tuneup work, for sheet metal, air conditioning and TV work . . . for every job where screws are used.

With this set you can quickly drive and remove wood screws, socket head screws, and Phillips head screws. Shanks for other screw types are also available. Included is a chuck and adaptor for quick change to a 1/4" drill and a set of high speed drills.

The famous StouX all-angle design has no equal for working in limited space.

Check the yellow pages or write to



**Albertson & Co., Inc.**

SIOUX CITY, IOWA, U. S. A.

## TROUBLESOME WOOD HATCHWAY?

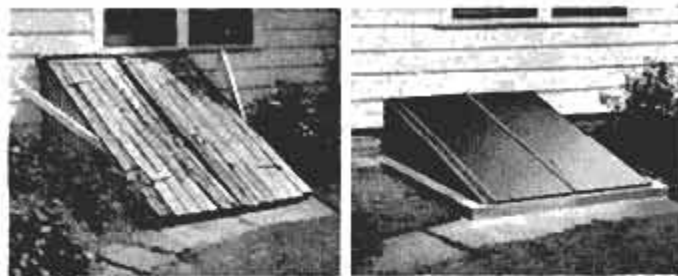

## REPLACE IT!

With a modern Bilco Basement Door.  
All-steel, weathertight, spring-operated.  
Do it yourself in just 3 to 4 hours.

**Bilco**

AMERICA'S FINEST  
BASEMENT DOOR

Write today for  
FREE illustrated  
replacement folder.

THE BILCO CO., Dept. 127  
NEW HAVEN 5, CONN.

Please send me complete information.

NAME .....

ADDRESS .....

CITY ..... STATE .....

## Will We Dig Ore With A-Bombs?

(Continued from page 87)

formations, and the heat of the blast would make the oil flow more freely.

The thought of creating underground water reservoirs is based on the expectation that a controlled blast could shatter immense quantities of rock underneath the run-off canyons of mountain ranges in arid areas. Rainwater from mountain storms would then percolate underground and be stored, instead of running off along surface channels and evaporating.

Dr. Libby says that the cost of moving big quantities of earth and rock by atomic explosions is pretty low. He mentions the construction or improvement of harbors as one possible job for atomic bombs. There are still others. The creation of radioactive isotopes on a mass scale is one possibility, new and useful chemicals from nuclear explosions in thick coal seams is another.

As an aid to mining, there have been suggestions that big mineral deposits that are so low grade they can't now be worked at a profit could be profitably mined if broken up by an atomic blast. One buried bomb could shatter a whole mountain of low-grade copper ore, for instance, and the ore would then be ready for transportation to a concentrating mill. It might even be practical to leave the ore where it is and to leach the valuable minerals from it with liquids that would trickle down through the shattered formation.

The AEC has created a special department called Project Plowshare to investigate all such peaceful uses of controlled atomic explosions. The work is centered at the University of California's Radiation Laboratory at Livermore, Calif.

One of the Project Plowshare studies will determine the feasibility of using atomic bombs to dig a harbor on the coast of Alaska. Personnel from the University of California Radiation Laboratory are gathering geological and ocean data, as well as cost figures, in connection with the proposal to blast a deep-water haven for ships between Cape Thompson and Cape Sepings, above the Arctic Circle.

The scientists also will try to learn what effects such an atomic explosion would have upon the people and the fish and wildlife of the area.

The AEC has pointed out that commercial fishing and the development of rich mineral deposits in the area have been hampered by lack of a suitable harbor. If the studies show the project would be successful, the AEC said, the atomic excavation could take place in 1960. ★ ★ ★



# POPULAR MECHANICS FULL-SIZE PATTERNS

Quick • Easy  
Economical  
Beautiful Designs



Wasting time, transferring blueprint measurements? Wasting money, by making a cut in the wrong place and ruining your wood? If so, you'll want the full-size patterns listed below. All you have to do is trace the design on wood, saw and assemble.

Popular Mechanics Press has printed a new supply of these invaluable patterns. Designed by John Bergen, noted furniture designer, they give all necessary details for professional-looking work.

You can't go wrong with these patterns! If any of them doesn't please you, return it for full refund.

## Order from this listing

**No. 101. Crulette, Utility Outboard.** Length 12 feet, beam 4 1/2 feet. Complete material list and step-by-step instructions included. Ideal for fishing, general use. Four patterns in set **\$2.00**

**No. 102. Trundle Beds.** Space-saving beds are safer for young people. 90 x 45 1/2 inches. Top bed 40 inches high; lower bed 23 inches high. Three patterns in set **\$1.50**

**No. 103. Modern Step Table.** Handsome table, illustrated above, is designed to be companion piece to No. 104. 28 x 18 inches, upper step 24 inches high. One pattern **50 cents**

**No. 104. Modern Cocktail Table.** Matches No. 103 above. 40 x 19 inches, 15 1/2 inches high. Beautiful original design with plank top and metal grille inserts in sides. One pattern **50 cents**

**No. 105. Toys for the Children.** "Giraffe Drawing Board" and "Bucking Bronco" riding toy. Pattern includes assembly instructions and painting suggestions. One pattern **50 cents**

**No. 106. Juvenile Chest Robe.** Has two drawers, shelf and hanging storage space. 30 inches wide, 16 inches deep, 39 inches high. Two patterns in set **\$1.00**

**No. 107. Cupola and Weathervane.** Cupola is 24 x 24 inches, 34 inches high, plus height of weathervane, which can be made of metal or tempered hardboard. One pattern **50 cents**

**No. 108. Personal Work Bench.** Top is 44 x 20 inches, 35 inches high. Provides lots of work space in small area. Drawer and sliding doors. Two patterns in set **\$1.00**

**No. 109. Valances and Trims.** For interior use around windows, cabinets, etc., and for exterior use on porches and gables. Twelve different designs are given. One pattern **50 cents**

**No. 110. Decorative Wall Shelves.** Modern shelf with metal trim is 28 x 16 x 8 inches. Traditional shelf is 29 1/2 x 16 x 8 inches. Can be made with or without drawers. One pattern **50 cents**

**No. 111. TV Chair.** Seat 22 inches deep, 24 inches wide. Over-all, 27 1/2 x 32 1/2 inches, 26 1/2 inches high. Sagless type wire springs and foam rubber. Two patterns in set **\$1.00**

**No. 112. Modern Tub Chair.** Seat 22 inches deep, 24 inches wide. Over-all, 28 x 27 x 27 inches. Foam rubber upholstery over sagless type wire springs. Two patterns in set **\$1.00**

**No. 113. Sofa Bed.** 78 3/4 x 29 3/4 inches, 33 inches high, with removable bolster. Uses standard size 4 1/2 inch foam rubber or other mattress. Two patterns in set **\$1.00**

**No. 114. Love Seat.** Uses sagless type wire springs with foam rubber padding. 48 inches between arms, 21 inches deep. Over-all, 55 1/2 x 29 inches. Two patterns in set **\$1.00**

**No. 115. Corner Table.** Another companion piece for Nos. 103 and 104. Table is 29 1/2 x 29 1/2 inches, 18 inches high. Upper diagonal step is 8 inches high. One pattern **50 cents**

**CIRCLE THE NUMBER YOU WANT  
AND MAIL THIS COUPON TO:**

POPULAR MECHANICS PRESS, 200 E. Ontario St., Chicago 11

Send me the Full-Size Patterns whose numbers I have circled: 101 102 103 104 105 106 107 108 109 110 111 112 113 114 115  
If not satisfied with any pattern, I will return it within 7 days for a full refund of its purchase price. NOTE: Minimum order \$1.00

Remittance enclosed  Send C.O.D. (\$2.00 or more) I enclose \_\_\_\_\_

Name \_\_\_\_\_

Address \_\_\_\_\_

City \_\_\_\_\_ Zone \_\_\_\_\_ State \_\_\_\_\_

## a quick change to consistent cut-offs

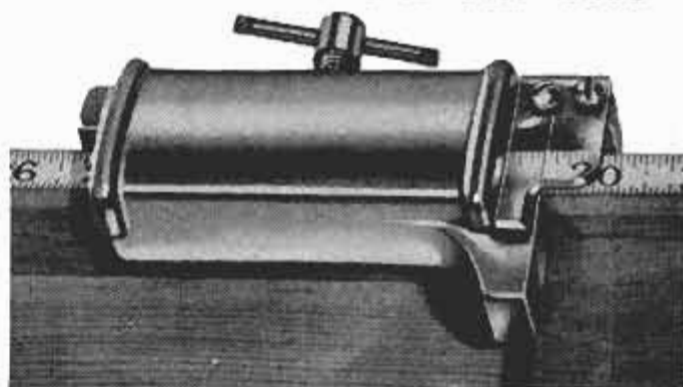

WITH THE NEW COMET "FENCE" QUICK-STOP GAUGE Tack a steel tape on any standard 3/4" fence. Clamp on the COMET QUICK-STOP GAUGE and line up the hairline with the desired cut-off length. Get accurate cut-offs, time after time... change to new cut-off lengths in seconds. Save time... materials. See the sturdy, compact, weather-proof COMET QUICK-STOP GAUGE... and the entire line of COMET radial arm saws, table saws, band saws, and complete home workshops at your dealer... or write for information.

**COMET** MANUFACTURING COMPANY

2033 Santa Fe Avenue, Los Angeles 21, California

a division of The Siegler Corporation Dept. PM-8

wsg 1

**New!  
Battery  
Powered!**

**JABSCO  
"WATER PUPPY"  
PUMP**

**SELF-PRIMING!  
LOW COST**

**Easy  
to install...**

**BOATS—**  
Bait Tanks  
Water Systems  
Wash Downs  
Bilge Pumping

**TRAILERS—**  
Sinks or  
Wash Basins  
Car and  
Trailer Washing

**CAMPERS—**  
Running Water  
Washing Gear  
Boats & Motors  
Boat Pumping

**DO-IT-  
YOURSELVES—**  
Projects Galore!

JabSCO's self-priming "Water-Puppy" D. C. Pump makes outdoor life more fun, more practical. The compact "Water-Puppy" is easy to install, powered by any storage battery. Connections for 3/4" garden hose or standard pipe fitting. Dependable, maintenance and service free.

6 v. \$26.50, 12 v. \$27.00, 24 v. \$28.00,  
32 v. \$28.50.

See your dealer or write direct.  
Specify battery voltage when ordering.

**JABSCO PUMP COMPANY**  
2031 N. Lincoln St., Burbank, Calif.





**168,635 miles...  
and just like NEW!**

This is an actual photograph of a set of rings taken from a 1955 Mercury owned by Mr. Doyle Keeling of Houston, Texas.

Mr. Keeling, who has used Wynn's Friction Proofing in his car since the day he bought it, recently had his engine torn down and overhauled. He was so impressed with the condition of the rings after 168,635 miles, that he sent them to Wynn Oil Company.

Notice the fine surface polish on the rings... the like-new brightness and the sharp, clean edges. Here is 168,635 miles of proof that Wynn's Friction Proofing doesn't merely coat metal with a thin film, but actually *impregnates metal*... proof that this in-the-metal protection means less repair costs, greater performance, a longer life for your car's engine.

Wynn's Friction Proofing for Auto Engine is unconditionally guaranteed and carries the Car Life Seal of Merit awarded for *Superiority, Efficiency and Performance*. Add a pint to your car's crankcase with each oil change or every 1000 miles.

THE *Proof* IS IN

THE *Performance!*



Also available in Canada and everywhere in the free world.

\*Friction Proofing is Wynn's Trade Mark for its exclusive metal conditioner which reduces friction between moving metals by chemically smoothing and sealing the surfaces. Manufactured by Wynn Oil Company, 1151 West Fifth Street, Azusa, California, U.S.A.

## Sure Death For Bugs

(Continued from Page 103)

for example, are not as easily controlled with the powder as some other insects, though studies are not complete.

Houseflies are one of the most difficult of all pests to control and not even the new silica aerogel powder has been completely satisfactory so far. The powder kills flies, to be sure, but it's difficult to apply it in sufficient quantities to vertical surfaces, such as walls, on which flies like to rest. It may be that a satisfactory way of dusting the powder onto every surface of a dairy barn, for instance, will be found.

A single application of the new powder will get rid of a nest of bees in your attic. As one of the entomologists remarks, "The powder has proved to be 100 percent effective against bees that have colonized in attics and walls."

Garden and agricultural pests are outside the scope of the present studies and the UCLA scientists can't say whether the powder will become important in field applications. One drawback may be the fact that rain, sprinkler irrigation, or even ordinary dew temporarily reduces the efficiency of the material. Already, however, in a greenhouse laboratory, the powder has made a complete kill of plant mites that had become highly resistant to ordinary chemical insecticides.

The killer dust is still in its infancy and there hasn't been time to explore all its possibilities; even so, it is opening up new horizons in the control of household and structural pests that entomologists never dared consider before.

In its present applications alone it is so valuable that at least one company is preparing to market the powder as an insecticide in the very near future. You should be able to buy it across the counter within the next few months. ★ ★ ★

## Do You Know This Old-Timer?

(answer to quiz, page 12)

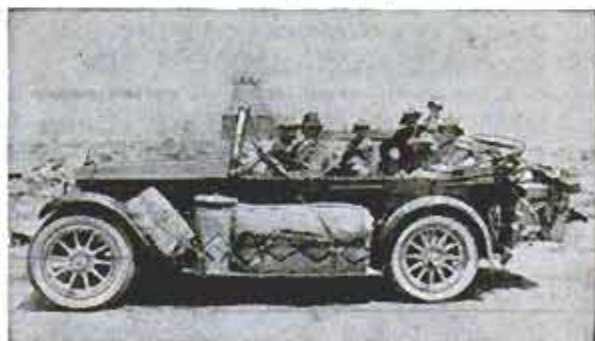

**1918 Packard 6-Cylinder**

1  
SEE CORRECTION,  
POPULAR MECHANICS



FOR A BETTER JOB . . . MORE MONEY . . . LEARN . . .

# DRAFTING

AT HOME . . . QUICKLY . . . IN SPARE TIME

Regardless of age, education, or where you live, you can share the benefits enjoyed by these men with C.E.I. diplomas. Just a few short months of spare-time study can also bring YOU big pay, rapid advancement, job security. Write for full facts today!



Eugene Brazina Architectural Draftsman  
 George Wosko Machine Designer  
 Mathew Perito Designer  
 John Bilabron Process Engr.

**VETERAN APPROVED!**

COMPLETE EQUIPMENT FREE OF EXTRA COST!

free LESSON AND SUCCESS BOOK



**MAIL COUPON NOW!**

CLEVELAND ENGINEERING INST. DEPT. PM-8H  
 6300 Euclid Ave. Cleveland 3, Ohio

Mechanical  Aeronautical  Architectural

MY NAME \_\_\_\_\_ AGE \_\_\_\_\_

ADDRESS \_\_\_\_\_

CITY \_\_\_\_\_ STATE \_\_\_\_\_

No Obligation — No Salesmen A-1802

**CLEVELAND ENGINEERING INSTITUTE**

## 8" TILT ARBOR SAW SOLD BELOW COST!

Our 1957 model. Precision ground cast iron table. Massive cast iron mitre gauge. Patented motor drive fits any motor. Adjustable depth of cut; 0" to 2 1/4". Blade tilts 0° to 50°. Sold and guaranteed direct from factory. Sent express collect, less blade. If you are not delighted — for any reason — return for immediate refund. Send check or M.O. or write for free tells-all folder.

ONLY \$9.95 Was \$24.95



AMERICAN MACHINE & TOOL CO., ROYERSFORD 57, PA.

## NEW - MIDGET SHORT WAVE RADIO



**WORLD WIDE RADIO—ANYTIME—ANYWHERE!**  
 Hear Europe, Africa, Russia, Australia, South America—ANYWHERE IN THE WORLD ANYTIME! Gets ALL foreign radio stations .55 mc. to 42 mc. Not much larger than a postcard—WT. only 3 lbs.! Complete with Roll-out antenna. Gets regular American broadcasts All Radio Amateur bands 160-80-40-20-15-10—Ships, Aircraft, Police, Citizens bands—NOTHING LIKE THIS MIDGET ALL-WAVE RADIO ANYWHERE ELSE AT ANY PRICE! No AC plug-ins required! Wonderful for home, traveling, Scouting, Radio Amateurs—ANYONE! YOU CAN HEAR MOST EVERYTHING—EVEN "SPUTNIK'S."

SEND ONLY \$5.00 (bill ck. mo) and pay postman or send \$16.95 for P.P. delivery. Complete easy to wire kit includes all parts, tubes, broadcast coil, cabinet, instructions. (Set of batteries \$3.49 extra). COMPLETELY WIRED AND TESTED POSTPAID IN USA ONLY \$21.95! Worth \$49.95 or more. Get your SPACE RAMBLER now for WORLD-WIDE LISTENING PLEASURE! AVAILABLE ONLY FROM:  
**WESTERN RADIO Dept. BRM-8 KEARNEY, NEBRASKA**

# CASH FILING SAWS

Make from \$3 to \$6 an hour spare time or start a full time business with the **FOLEY SAW FILER**



Here is a steady repeat CASH business you can start at home. No experience is necessary to turn out perfect cutting saws. With a Foley Saw Filer you can file hand, band and cross-cut circular saws. Easy to operate—no eyestrain. You will find you can make from \$3 to \$6 an hour—\$20 to \$30 a week in spare time as a starter.

**FREE BOOK "MONEY MAKING FACTS"** shows you how to get plenty of saws to file. Time payments if desired. Send coupon today—no salesman will call.

**FOLEY MFG. CO., 843-B Foley Bldg. Minneapolis 18, Minn.**

Send me free book "MONEY MAKING FACTS" and Time Payment plan.

Name \_\_\_\_\_

Address \_\_\_\_\_

City \_\_\_\_\_ State \_\_\_\_\_





## The Sun Is Really in Business

(Continued from page 62)

to develop methods of producing the cells at such low cost that the public can buy them in huge quantities.

### Sun Used for Research

One of the ways this may come about is by using the sun itself as a research tool. Solar furnaces, actually solar-heat concentrators, are especially valuable for making high-temperature studies of very pure materials. The furnaces provide a "pure" heat less likely to contaminate the material that is being heated than conventional fuel sources.

One new solar furnace, on the grounds of the Stanford Research Institute in California, creates heat up to 6000 degrees Fahrenheit. The apparatus is in the form of a tower and consists of a flat heliostat mirror at ground level and a curved paraboloid mirror that is mounted 32 feet overhead. The flat mirror tracks the sun and reflects its rays to the paraboloid, which concentrates them in a sharply defined hot spot or target area. Materials that are placed in the hot spot are rapidly brought up to temperature without overheating their containers.

Solar furnaces are not cheap, but Burt J. Bittner of Gulton Industries, Inc., in Albuquerque, N. M., has found a way of manufacturing 5000-degree furnaces at a fraction of the usual cost. He spins glassfiber and plastic into the shape of a 36-inch parabolic bowl, then aluminizes the bowl's surface to create a mirror. The lightweight mirror costs much less than a glass or metal paraboloid, and remains cooler in use.

Bittner's furnaces are unique in another respect. They employ the Cassegrainian optical system that is used for some purposes in large astronomical telescopes. The curved reflector has a hole in its center. Sunlight is reflected from the curved reflector to a small secondary mirror in front of it, thence through the hole to a target area at the rear. High temperature research is conducted at the target area behind the mirror, in comfort and without danger to the reflecting surfaces.

Two enormous solar furnaces are planned by the Department of Defense at locations in Massachusetts and New Mexico. The

one in New Mexico will consist of a flat heliostat mirror, 147 feet tall and 150 feet wide, and a parabolic mirror 108 feet in diameter. A Venetian-blind type of shutter in front of the parabola will be used to control the amount of light reaching it from the heliostat. Temperatures of up to 7000 degrees will be obtained in a five-inch "hot spot" at the focal point. A hearth located at the top of a tower will be used for conducting high-temperature studies.

### Solar Furnaces Are Research Tools

Solar furnaces have many uses. They are valuable in research on cermets, the combinations of ceramic materials and metals that are desired by aircraft and rocket designers. They are used to find out more about thermal shock, and about the electrical conductivity of materials at high temperatures. Studies can be made of ignition characteristics of the solid rocket propellants. Especially, the furnaces are useful in the preparation of pure materials. It is because of this that they may lead the way to building larger silicon cells at low cost.

Electricity is so cheap in most built-up areas that you may never need a solar power plant. But the picture is different in remote areas where cheap central-station power isn't available. Mountain cabins, as an example, could have all the electricity that is needed, at no operating cost. Even the nuisance and cost of hauling fuel to operate a generator plant would be avoided.

Another field in which solar cells may become important is that of creating power for pumping water. Inventors have been intrigued for a long time with the idea of using the sun for this purpose. Many ingenious machines have been built and at least one solar pump is on the market now. But most such devices are expensive and inefficient compared to other pumping systems now in use.

The solar cell may change this picture. Its efficiency is extremely high compared to solar-heat engines and it produces electricity directly from the sun. Some investigators say the silicon solar cells not only will provide the power for pumping deep wells and operating long irrigation canals, but that eventually solar electricity will lift ocean water up to coastal cities after the salt content has been removed by other solar methods. ★ ★ ★

---

## Canada's Population Is Expected to Triple by Year 2000

Sparsely populated Canada is expected to gain 37,000,000 residents in the next 42 years. Although Canada has the second largest area on earth, its present population of 17,000,000 is only slightly larger than

that of New York State. But its annual rate of increase, 2.8 percent, approaches the explosive rates of some countries in Latin America and Asia, according to the Population Reference Bureau, Inc.



**India WEAPONS SALE!**  
**LATE MODEL NO. 4 ENFIELD RIFLE!**  
 .303 Cal. 10-shot bolt action



**TRIM LINES**  
 Best deer rifle ever made!  
**\$15<sup>95</sup>**

The rugged new Model No. 4 kept in beautiful condition by Indian regiments. Peep sight, long range calibrations. Excellent hunting length, 25½ bbl. Positive safety. We remove all cosmoline and oil lightly. Ready for your trip! Limited offer. This gun sold as high as \$50 until our fabulous special purchase.

.303 AMMO SPECIALS 100 rds. target (military) ammo, \$7.50. 40 rds pinpoint hunting ammo, \$5.90

**NEW BOOK!** 1200 RARE GUNS PICTURED!  
 288 pages! 1000 paragraph glossary. Over 1500 pistols, rifles, daggers, swords, muskets, armor. By special permission order now. Our supply limited. 410 yrs. of firearms shown! Fascinating and amazing! Money back if does not make you flip!

**\$2<sup>00</sup>** post-paid

TO ORDER: Send \$10 deposit, pay balance C.O.D. Shipped F.O.B. Los Angeles. 10-day money back guarantee. Test fire if you wish. Calif. resid. add 4% state tax.

Dept. 59, 1206 Maple Ave.  
**THE ELLNER CO.** Los Angeles, Calif.

**LIMITED SUPPLY! BRAND-NEW, BALL BEARING SINGLE PHASE ELECTRIC MOTORS**  
**FAMOUS BRAND! SAVE WAY OVER HALF**



Powerful CAPACITOR MOTORS with heavy starting torques to handle every heavy-duty job. NEW, ball bearing models that mount IN ANY POSITION. 230-Volts, 1140 R.P.M. 60 cycle, single phase. Standard mounting and shaft size. PERFECT FOR: refrigeration, saws, machine tools, blowers, grain elevators, wood-working tools, pumps and farm equipment. FULLY GUARANTEED! Save \$\$\$\$.

**ORDER DIRECT FROM THIS AD TODAY!**

1½ HP (Reg. \$172.00) Ball Bearing	..... only \$57.50 job
2 HP (Reg. \$231.00) Ball Bearing	..... only \$79.50 job
3 HP (Reg. \$292.00) Ball Bearing	..... only \$115.00 job

FREE CATALOG of Machinery Wholesale Buys Phone Taylor 9-1365  
**ROBERTS ELECTRIC CO., Dept. PM-830, 849 W. Grand, Chicago 22**

**INVEST IN**



**U.S. SAVINGS BONDS**

**SAFE AS AMERICA**

**FABULOUS, NEW**  
**5 FOOT LONG BALLOONS**

**Twist Into A Thousand Shapes!**  
 GIRAFFES-DACHSHUNDS—Pets of All Kinds

Made of Live Latex **200 FOR \$1** Add 25c Postage and Handling

**Delight Kiddies — Grown-Ups, Too!**  
 Fantastically flexible Live Latex! Like no other balloons you've ever seen! Twist 'em, bend 'em — they won't break! Cut them in half or any size — twist, and they reseat! The kiddies will have a whole of a time making them into Davy Crockett hats, pretzels, giraffes, lions, fish — a whole zoo! You'll want them for unusual party or recreation room decorations! Live up a party with a contest for making the funniest shape of all! Complete instructions.

Almost 5 feet long when inflated. Balloons this size usually sell up to 25c each!

Send only \$1 now. Plus 25c postage and handling for 200 in a variety of gay colors! Supply limited at this low price, so order several sets NOW for GUARANTEED PROMPT DELIVERY. MONEY BACK GUARANTEE.

**MURRAY HILL HOUSE**  
 Dept. B-17-D, P.O. Box 251, Bethpage, L.I. N.Y.

**Shower of PROFITS!**



\$25,000 yours this year demonstrating how you RUN YOUR CAR WITH AMAZING LECTRA FUEL IGNITERS!  
 Exclusive distributorships available if you qualify. BY FAR THE HOTTEST AUTO ITEM EVER SOLD.  
**ELECTRA — BENSON BLDG., JENKINTOWN, PA.**  
 Send for FREE SAMPLE TODAY!

**ELECTRIC WELD - BRAZE & CUT**  
**REPAIR MOST EVERYTHING MADE OF METAL**



Home Appliances, Auto parts, Farm-garden equipment, toys. Make and repair playground equipment, lawn chairs, tables, ornamental iron work, gates, wagons, etc. Solder, heat, bend, and straighten, with terrific heat from arc torch. Cut and weld up to ¼" steel plate. A million uses for Home, auto, farm inventors, factories, etc. Works from any home 110 volt plug-in. Complete with dark welders mask, arc torch, supply of carbon welding and brazing rods. Solder, flux, and complete Welding Instruction Book. Attractive—portable—efficient—durable—1 year guarantee. Wt. only 8 lbs.

**SEND ONLY \$3.00** cash, ck, mo and pos postman \$6.95 plus COD postage on arrival or send \$9.95 plus \$1.00 postage and we will send postpaid. Ideal gift for mechanically minded home owners, relatives, friends. Order now for early delivery. Available only from:

**MIDWAY WELDER** Dept. DPM-8 Kearney, Nebraska

**You get BIG FUN . . . BIG POWER in the new TRIUMPH**

**PLUS** Amazing "Slick-Shift", the new, completely automatic clutch operation.

Get more fun out of life! Mount a sleek and powerful Triumph . . . show your pals what fun-on-wheels can be like. Features Continental economy, models average 75 to over 100 m.p.g. Triumphs are precision-built, designed for ultra-high performance. Available in racing, road and cross-country models. In brilliant colors with sparkling chrome.

See your Triumph dealer for a demonstration ride.  
 The Tiger T-110, 40 cu. in. (650 c.c.)



**FREE** Please send me the new 1958 full color Triumph catalog showing your complete range of models with specifications.

Check here for name, address and telephone number of nearest Triumph dealer. Dept. E.

In the West: **JOHNSON MOTORS, INC.**  
 267 W. Colorado St., Pasadena 1, Cal.

In the East: **THE TRIUMPH CORPORATION**  
 Towson, Baltimore 4, Md.

NAME: \_\_\_\_\_ AGE: \_\_\_\_\_  
 STREET: \_\_\_\_\_  
 CITY: \_\_\_\_\_ STATE: \_\_\_\_\_  
 TELEPHONE NUMBER: \_\_\_\_\_



Only moderately economical by foreign-car standards. It does provide more passenger room and more luggage space than all but the biggest imports.

There is room for improved seat design in all cars. Studebaker's seats are good, as the doctor says. Some low-slung, ultrasoft seats of more stylish cars are not always comfortable on long trips. Seats that are good for the driver are not always good for the passenger either.

Heater is strictly economy. It is recirculating, brings in no fresh air. On "high" blower noise is unbearable.

Body is austere. Dash makes a truck cab look luxurious. It's a tough thing to sell—austerity. Try talking yourself into spending \$1800 for something you can't brag about. Car lacks agility, feels lazy, sluggish. Shifting is unnecessarily laborious, a job for the muscular. Kept slipping out of second, too. Brakes are excellent. Windshield not over-wrapped. No distortion. Easy to get in, out front seat; hard to get in, out rear seat of two-door model. Ride is good. Engine quiet except over 60 m.p.h. Aspiration noticeable, but not annoying on acceleration. Basic fault of car: Lacks imagination. Like some people, it is solid, dependable, practical, but dull, almost boring.

"Drove this car in a blizzard and was impressed with roadability. Went through areas where many other heavier and more powerful cars were unable to travel. Had no snow tires or chains either."—Illinois owner.

"Economical and has more room than the small foreign cars."—California mechanic.

"With a half-ton load in my station wagon I topped a 5000-foot rise in a 5-mile stretch in high gear. Never had to change at any point. I passed all makes and models parked with hoods raised to let motors cool. My temperature gauge never went above normal. I believe Studebaker has best cooling system on market."—Tennessee traveling salesman.

"Good visibility."—Wisconsin telegrapher.

"Quality of construction excellent."—California telephone employee.

"Expect low upkeep because of simple mechanical features of the car."—Indiana chemist.

"Engine runs smoothly and quietly."—Oklahoma owner.

"Starts easily in minus-15-degree weather and warms up fast."—Pennsylvania mechanic.

"I work on a ranch. This car is good for bad roads. Gas tank and oil pan can hardly get touched as the frame really protects them both."—New Mexico cowboy.

"The twin-drive rear end is excellent. The seats in station wagon are erect and physiologically correct. The seat cushion is short enough that it does not shut off circulation from feet and ankles."—Washington osteopathic physician.

"Easy to work on, if necessary."—New York mechanic.

#### And More Complaints

Also in order of frequency of mention are the following complaints by Scotsman owners, ranging from 11.3 percent down to 2.4 percent:

"While it is a six-cylinder, it ought to have a little more power to take hills better, otherwise I have no complaints."—New York secretary.

"Heater is not big enough. Poor defroster."—Minnesota mailman.

"Can't operate hot-water shutoff for heater from inside the car."—Massachusetts general manager.

"Workmanship in general is a little sloppy in places, but I have noticed this on some high-priced cars too."—Connecticut designer.

"Cheap and tinny. Upholstery on doors is only cardboard, mats are all worn through already."—New Jersey owner.

"Delivered with a noisy air cleaner. Also poor soundproofing in doors. Cleaner has been replaced."—Oregon serviceman.

"Back seat not comfortable, too low. Upholstery not tough enough."—Indiana maintenance man.

"In some sitting positions you can't see the speedometer."—Indiana steelworker.

Doors designed to be closed by armrest pulls. Do not operate satisfactorily without them. I had to buy them as extra equipment to get doors to close."—Minnesota librarian.

"No dome or dash lights."—Michigan vice president.

"Transmission very noisy. Jumps out of reverse. Shifts into second very hard."—Maine farmer.

"Gear-shift linkage very stiff until about 4500 miles, then loosens up good."—Arizona electrician.

"Rear windows don't go down. This is a case of carrying economy too far."—Ohio steelworker.

That is what the owners think about the 1958 Studebaker Scotsman. For the engineering report turn to page 80.



# VENCO ELECTRIC TRUCK WINCH



For Farmers,  
Sportsmen,  
Contractors

Easily installed, no power take-off, no drive lines. Front or rear cab mount. Complete with dash panel switch, cable, wire rope and hook. Reversible motor with automatic brake. 3000 lbs. capacity.

Send for catalog and nearest dealer.

2828 NEWELL  
**VEN CORP., LOS ANGELES 39, CALIF.**



## WORRY WON'T CURE CANCER

If cancer is detected in its early, localized stage, the chances for cure are very much better. Play it safe and smart. See your doctor for a checkup every year.

And fight cancer with a check!

Mail it to  
**CANCER**, in care  
of your local  
post office  
—NOW



**AMERICAN  
CANCER  
SOCIETY**



Drill concrete  
**WITHOUT**  
a drill!



**PHILLIPS  
RED HEAD**

A concrete anchor that cuts its own hole, then expands to become threaded anchor for any standard 1/4" bolt. Holds hundreds of pounds. Can't come out. Install by hand in 2 minutes or with impact hammer in 22 seconds.

**HOME DRILL AND  
ANCHOR KIT \$1.85**

Driver and 4 Red Heads.  
\$2.00 (postpaid) by mail  
if your dealer cannot  
supply you.

**PHILLIPS DRILL CO.**  
Dept. H-8908  
Michigan City, Indiana



## Genuine JACUZZI JET PUMP

Jacuzzi's mighty new "Mijet" supplies high pressure running water for cabins ... drains cellars, boats ... fills tanks. It's a real jet pump. Bronze impeller and built-in jet. Stainless steel shaft. Pump pulley provided. Power it with any electric motor or gas engine with rotating drive shaft. Has no gears. Needs no lubrication. Weighs only 10 lbs. Postpaid if cash with order. Money-back guarantee. Only — **\$29.95**

**JACUZZI BROS. INC., 4100 Bayless Ave., St. Louis 23**

## JOINT AND SHARPEN ALL SAWS



**SUPER  
FILER  
NO. 9**

SO EASY to joint and file saws like new. Two hardened steel rollers keep teeth same height. All teeth cut, saw runs true and smooth. \$2.95 ppd.

**"TRU-CIRCLE" SAW SET**  
Automatically sets teeth at 10 or more \$2.95 ppd.



**SUPER  
FILER NO. 11**

For both hand and circular saws. Steel rollers give all teeth correct height, pitch and bevel. \$9.95 ppd.

**SUPER DRILL GRINDER**

Sharpens round shank drills like new, using hand or power grinders. \$2.95 ppd.

send for **FREE CATALOG**

A. D. McBURNEY, 5908 Hollywood Blvd., Hollywood 28, Calif., Dept. A-88

## WELD, BRAZE



**SOLDER, CUT**

## ANYONE CAN WELD AT HOME

Homeowners, mechanics, farmers, hobbyists! Make repairs at home, farm or shop on fenders, bodies, bicycles, machinery—almost anything of metal. No experience needed. Welder comes complete with twin carbon arc-torch and accessories at low, low price. Operates from any properly wired 110 V. A.C. or D.C. line. Order from this ad. 10 day money back guarantee. Literature on larger equipment FREE.

**FOUR-WAY WELDER CO., Dept. F2-H 1810 S. Federal St., Chicago 16**

## FOUR-WAY

**WELDER**  
of 1001 uses  
only **\$14.75**

**F.O.B. FACTORY**

**WELDER**



**NEVER AT THIS LOW PRICE!**  
**GENUINE 150-POWER**  
**ACHROMATIC TELESCOPE**

with Achromatic Lens and  
 4-POWER FINDER attached

ONLY  
**\$18.95**  
 PREPAID



**EXTRA BONUS GIFTS:**

- 273 page book, "Handbook of the Heavens"
- Magic Star Finder Dial
- 220X & 400X Eyepiece lenses

**5 Magnifications 18X—35X—65X—85X—150X**  
 Brings the Moon, Planets, Stars, Satellites, People  
 150 Times Closer, Clearer, Sharper

Never before has an ACHROMATIC 150X telescope with range finder and tripod sold for anywhere near this amazing low price! Now you can not only explore the heavens and bring the moon, planets, stars, satellites 150 times closer, but you can observe all distant objects, people, ships too, because all pictures are erect, not upside down as in all astronomical telescopes. The kind of needle-sharp color-free viewing only a genuine achromatic lens can bring you. Ready for immediate use. 5 precision lenses bring you viewing at 18X—35X—65X—85X—150X. Tubes extend to 43" made of bakelite, finished in camera bellows black, trimmed with gleaming brass. 4 power finder scope (30mm Lens) mounted on main tube is feature usually found on more expensive telescopes—brings difficult objects on target before observing with main scope. For extra stability 5 ft. hardwood folding tripod is equipped with heavy cast iron head fitted with Criterion's famous 360 degree all aluminum mount that locks instantly in any position. Obtainable only from Criterion Co. shipped prepaid, 4 famous gifts—273 page book "Handbook of the Heavens," Magic star finder dial that aids in locating stars ANYWHERE at ANYTIME of the year. 220X & 400X eyepiece lenses included free for experiments. You must be completely satisfied with this super offer or your money back in full. Shipped Complete, nothing else to buy at amazingly low price of **\$18.95**. Without tripod **\$14.95**. Send Cash, Check, or Money Order today  
 Dept. PMA24, CRITERION CO., 331 Church St., Hartford, Conn.

**MANUFACTURE THIS BEAUTIFUL**  
**CONCRETE OUTDOOR FIREPLACE**

Right In Your  
 Own Backyard

**\$4.00 Worth of**  
**Sand & Cement**  
 produces this  
**Attractive**  
**Fireplace.**



**Sells on Sight**  
 from \$60. to \$80.  
**Easy to start your**  
**own Profitable**  
**Business.**

The General Fireplace  
 Molds and Process are the most  
 amazing and foolproof ever invented.  
 Simple to operate. Two men can produce five fireplaces a day.

**BIG DEMAND!!**

Sell all you produce to Department Stores, Homeowners, Parks, Nurseries and Picnic Groves. Fireplaces sell on sight. No experience necessary. We supply full operating instructions and equipment plus the know-how that spells **BIG PROFITS**. This is an outstanding opportunity for men of vision and small capital to get into a busy rich paying field. Don't delay, be the only exclusive manufacturer in your own home town. Mail coupon at once for full details as to how you can reserve your territory. **Molds sold only on exclusive franchise.**

**GENERAL ENGINES CO., Inc., Dept. MF-88**  
 ROUTE 130, THOROFARE, N. J.

Mr. Tor of Philadelphia writes:  
 Sold 250 in first 4 months. Selling  
 to Sears Roebuck, John  
 Wanamaker, and Gimbel Bros.  
 in Philadelphia area.

Name .....  
 Address .....  
 City ..... Zone .....  
 State .....



Strolling with paddle takes more energy and skill than poles, which have push-plates six inches square

**Plastic Shoes Enable Man**  
**To Walk on Water's Surface**

Ever since Biblical times, and maybe before that, man has been trying to walk on water. Now he can—with the help of two Styrofoam blocks 4½ feet long, 15 inches wide and 7 inches deep. Styrofoam is an expanded plastic material that is nonabsorbent and weighs about two pounds per cubic foot. Speed and maneuverability are possible in the water shoes through coordination of leg muscle and a thrust from two push poles or a two-blade paddle. Capable of supporting more than 200 pounds, the water shoes can be towed by a boat equipped with an outboard motor. They open new areas in aquatic sports such as polo, golf, tag, volleyball and badminton. Fishermen can also use them.

The water walker inserts his feet in standard water-ski bindings that are mounted on wooden plates  
 Fred S. Gilley, Scituate, Mass.





# SURPLUS SALE

WAR SURPLUS  
EXCESS INVENTORY  
BANKRUPT STOCK

## SUMMER CLOSE-OUT SPECIALS

To reduce our tremendous Govt. surplus inventory, we offer hundreds amazing close outs. Send for summer list. Typical buys all prepaid to you are:

- Surveyors Levels—Leading make... \$42.95
- Govt. Air Compressor 110-v 60-c... \$21.95
- Blackhawk Hand Hydraulic System... \$26.95
- New 1957 Outboard Motors—20% off
- Modern Dial Extension Telephones... \$ 9.95
- Hand Crank Fish-Worm Shockers... \$ 3.89
- Hydraulic Speed Reducer... \$49.50
- 7x50 Finest Binoculars... \$26.81
- 8400 gal. Centrifugal Pump... \$24.61
- 300 amp. Air Craft Generator... \$26.51

## TRUCK WINCH



• Runs 6 or 12 volt batt. Reversible. Capy. over 1000 lbs. Cost \$280. SALE ..... \$46.71 FOB

## IRRIGATION PUMPS

• 2 1/2". 16,500 gph. Centrifugal. All bronze ball bearing. New. Govt cost \$103. SALE \$49.50 FOB.



## SPECIAL OF THE MONTH!

### SPEED REDUCER

• Wonderful 80-to-1 gear reduction unit, contains 8 roller bearings, multiple gears. Decreases speed—increases torque. Reduces standard motor to 21 rpm. Shaft 3/8" input, 1 1/4" output. Many uses—power winches, revolving signs, door openings, etc. Govt. cost \$66. SALE ..... \$8.49 Fpd.



### ELECTRIC CAR MOTOR

• Runs on 6 or 12 volt batt. Powerful gear reduction. Reversible. Cost \$295. SALE ..... \$19.72 FOB

ORDER FROM AD or get free catalog.  
**BURDEN SALES COMPANY**  
810 West "O" St., LINCOLN, NEBR.

## "TI-NEE" BATTERYLESS TUBELESS LIFETIME RADIO

"TI-NEE" RADIO IS GUARANTEED TO WORK FOR YOUR LIFETIME! USES NO TUBES, BATTERIES OR ELECTRICAL PLUG-INS. Never runs down! SMALLER THAN A PACK OF CIGARETTES! RECEIVES LOCAL RADIO STATIONS MOST ANYTIME, ANYWHERE WITHOUT EXTRA ANTENNA. Uses semi-conductor crystal diode Hi-Q Tuner. Beautiful black gold plastic cabinet. Built-in Speakerphone. **SEND ONLY \$2.00** bill, ck. no and pay postman \$4.99 COD on arrival or send \$6.00 for postpaid delivery. SENT COMPLETE READY TO LISTEN—NOTHING EXTRA TO BUY EVER! Extra long distance Aerial kit included free to receive stations up to 1,000 miles away. **AMERICAN MADE.** Available only from: **MIDWAY COMPANY, Dept. GPM-B, Kearney, Nebraska**



## INSTALL YOUR OWN AUTOMATIC GARAGE DOORS

Save Up To \$150 — Brand Name Unit

This is a genuine door operator, motor driven in both directions; and is one of the finest units available. It is delivered completely assembled and tested. Some of the features are: 1/4 H.P. motor, ease of installation (complete descriptive literature with drawings), safety clutch, easily adjusted limit switches, quick disconnect in case of power failure, light goes on when door opens, motor protected by thermal cut out, requires only 1" headroom, will operate doors up to 8 ft. high and 18 ft. long. Order 3 and become a dealer. Save 10%. If not fully satisfied, return within 10 days for full refund. Door operator only \$69.95—with transmitter and receiver \$129.95 complete. Extra transmitter for second car \$25.95. Send check or money order for prompt prepaid shipment. **HUGHES PRODUCTS COMPANY, 2 Lake Drive East, Wayne, New Jersey**

## NEW DELTAGRAM YEARBOOK

All of 1957's top-flight issues of this popular home workshop magazine handsomely bound in durable, hard covers. Fully illustrated and packed with helpful ideas. Features "how to" projects complete with detailed drawings, step by step instructions and bills of materials. Only \$1.50—write: **Rockwell Manufacturing Co., Delta Power Tool Division, 502H N. Lexington Ave., Pittsburgh 8, Pa.**

## SAVE TIME, MONEY, MILES

### OPERATING YOUR CAR

**HULL AUTO COMPASS** cuts time on the road to a minimum, saves wrong turns, wasted gas, car and tire maintenance. Economical, smart. \$5.50 to \$7.95. At your dealer's or write for literature.

World's most widely used auto compass and small boat accessory.



**HULL MFG. CO., P. O. Box 246-D-8, Warren, Ohio**

# STOP

ENGINE STALLS-VAPOR LOCK-LOW MILEAGE

## INSTALL A MILESMASTER®

### FUEL PRESSURE REGULATOR



Let MilesMaster help you enjoy better, more economical motoring. Sold everywhere . . . only \$6.95, plus installation.

Money Back Guarantee Dept. K

**MILESMASTER, INC. Exeland, Wisconsin**

**EXTRA! ANOTHER Scoop!**

**SENSATIONAL NEW BENJAMIN BB REPEATERS...**  
The Only Repeating Guns on the Market with...  
**Piggy-Back SHOT MAGAZINE**

**★ BENJAMIN SUPER 100 SHOT BB CO. GAS RIFLE \$14.95**  
**★ BENJAMIN SUPER 100 SHOT BB AIR RIFLE \$21.95**

THE REVOLUTIONARY NEW GRAVITY FEED ACTION THAT LOADS BB AMMUNITION automatically!

A shot is placed in firing position each time bolt is pulled back and closed. Finest quality. Powerful — Accurate — Economical. Use indoors or out. New Bar-V sight.

**FREE** Ask for Catalog All Models Benjamin Single Shot and Repeaters . . . Cal. BB or 177 or 22. ALSO, SPECIAL OFFER ON HUNTING AND FISHING KNIVES, ETC.

No. 3600 Benjamin Super 100 Shot BB Gas Rifle. No Pumping . . . Auto Loading. →  
No. 3600CS Deluxe Gas Rifle with Custom Stock — \$17.95  
No. 3100 Benjamin Super 100 Shot BB Air Rifle with Regular Stock. Economical. — \$21.95  
No. 3100CS Deluxe Air Rifle with Custom Stock — \$24.95

**BENJAMIN AIR RIFLE CO.**  
MARION ST. ST. LOUIS 4, MO. U.S.A.

**\$14.95**

you can always

# BE SURE OF A JOB

WITH A

## FOLEY SAW FILER

Have you been laid off—or afraid you may be? If you want security, plus a bigger income too—don't look for a job—start your own spare time business. In his first 2 months J. P. Robitaille earned \$300 with his Foley Saw Filer. From his starting day R. T. Hart made \$600 in 4 months. Frank P. Layne wrote—"In our town of 2,800 instead of 200 to 300 saws I did over 1,500 the first year, averaging about \$1.50 each."

**FREE** booklet "MONEY MAKING FACTS" shows you how to get business. The Foley sharpens hand, band and circular saws. Use our Time Payment Plan—pay for the machine out of your CASH profits. Send coupon today—no obligation, and no salesman will call.

**FOLEY MFG. CO., 875-S Foley Bldg., Minneapolis 18, Minn.**

Send Free Booklet and Time Payment Plan on Foley Saw Filer.

Name \_\_\_\_\_  
Address \_\_\_\_\_  
City \_\_\_\_\_ State \_\_\_\_\_





**BEHR PROCESS**  
**ACRYLIC STAIN #36**

This is absolutely the most durable exterior finish ever developed for redwood. The miraculous properties of this 100% Pure Acrylic Low Luster finish impregnates the wood with an "elastic-glass-like" film that is practically impervious to any kind of weather. No thinning necessary. Buy Behr Process 100% Pure Acrylic Stain #36. Pt. \$1.50, Qt. \$2.60, Gal. \$8.10. Guaranteed! At your dealer or order direct. Postage Prepaid.



**LINSEED OIL PRODUCTS CORP.**

redwood paint specialists  
 1614 Talbert Ave., Santa Ana, California

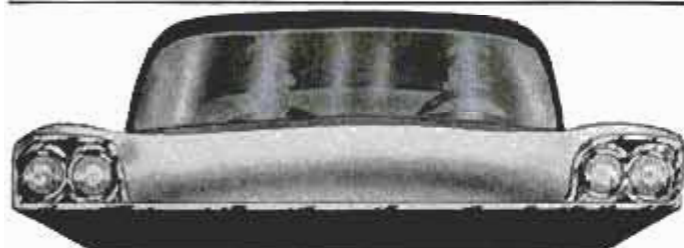

**WANT LOW COST AIR RIDE?**



**Rear AIR LIFT Units  
 Cost Less Than Week End Trip!**

**AIR LIFT SPRING CONTROLS** are air inflatable rubber cylinders designed to control, cushion and stabilize the action of the spring suspensions on your car — by regulated air pressure.

**FRONT AIR LIFT SPRING CONTROLS** give improved roadability, prevent sagging springs and contribute to **SAFER DRIVING**

**REAR AIR LIFT SPRING CONTROLS FOR OVERLOADS AND TRAILER HAULING** "Over a Million Sets in Use"

**AIR LIFT COMPANY**

Lansing, Mich. In Canada: 18 Hook Ave. — Toronto 9, Ontario



**FREE**—reprint of **SPEED AGE** article, How to Ride on Air for \$25. Write Dept. 48

## They'll Defend the America's Cup

(Continued from page 72)

a deer in a fair breeze and light sea but is no good at all in heavy weather.

"We started with a long model," explains Phil Rhodes. "It paid off for running before the wind, but not on 'speed made good.' The tank told us how long to make our boat for over-all sailing."

Since nobody knows what will be blowing off Newport on September 20, no designer in his right mind would build a one-weather cup boat, even if it were a sunny-day world-beater. What the towing tanks did for designers of the new 12-meter boats was to help them all arrive at virtually the same shape—a happy combination. To emphasize the narrow margins of "radical improvement," one of the new 12-meters uses special aluminum screws inside instead of the usual brass—to save nine pounds of total weight in a boat weighing some 18 tons!

### Crew Wins the Race

Since it's a safe bet that the hulls of all the new 12-meters will be more evenly matched than any cup contenders in history, due to the nearly identical scientific planning that went into each, winning the race may rest largely on the performance of crew and afterguard. Says Rhodes: "In terms of winning, crew is most important, sail comes second, and hull is third."

Any rabbits that may be pulled out of the hat this year in the way of revolutionary topside rigging will be kept well under wraps until the day of the big race. Sopwith once made the mistake of trying out a radical quadrilateral jib during a warm-up run. It was the bombshell for his cup race with *Endeavour I*. Across the harbor, watching through binoculars from an innocuous little six-meter sloop, was Sherman Hoyt, famous American yachtsman, who promptly cabled the "hot" news home. On the day of the race, the U. S. contender *Rainbow* showed up at the starting buoy with an identical jib, thus equalizing what may have been a winning difference.

Despite official secrecy, the word is already floating around about a few new ideas that will or may be tried. All the syndicates are fooling with new and lighter sail materials. *Sceptre's* 90-foot mast boasts a new alloy said to be lighter and stronger than any such mast ever before built. But Bill Luders would probably tell you the same about the long, hollow piece of white metal fabricated in his own shops for the *Weatherly*. *Sceptre* has saved more weight by using plastic plumbing pipe instead of

(Continued to page 228)



**WAR SURPLUS** AND OTHER BARGAINS **SAVE 90%**



**"BIG 12" ARC WELDING & BATTERY CHARGING KIT**

With Deluxe Accessories consisting of one R1 300 Amp Gen., 30' welding cable, welder's adjustable helmet, electrode holder, 300 AMP ammeter, 300 AMP shunt, Rheostat, Giant Toggle Switch, 300 AMP reactor coil arc Stabilizer, Voltage Reg., Reverse Current relay, 1 pr. heavy duty welder's gloves. All units guaranteed pretested. Approx. GOVT. COST \$750. Most items new—all perfect. **\$49.50.**

\*400 AMP Gen. with above accessories—**\$64.50.**



**"SUPER 9" 200 AMP WELDING KIT**

With Deluxe accessories consisting of one 200 AMP Gen., adjustable helmet, electrode holder, 30' welding cable, rheostat, giant toggle switch, voltmeter, voltage reg., 1 pr. heavy-duty welder's gloves. All units guaranteed pre-tested. Approx. GOVT. COST \$500. Most items new—all perfect. **\$26.00.**



**WELDER'S HELMET** Heavy duty construction. Flip-up type. Adjustable head-band. A \$12.75 value. **NEW \$6.95** ppd.

**WELDING CABLE GAUGE 00**, heavy duty, neoprene jacket, fiberglass insulation. NEW. Approx. GOVT. COST \$92.50 Length 50', will handle from 200 to 500 Amps. **\$14.50.**

**REVERSIBLE REDUCTION GEAR** Tremendous inertia power for 6-12-24 volt winch with 2 power take-off! Use on boats, trucks, wreckers, etc. Fantastic power for pennies of original cost. Weight 55 lbs. Approx. GOVT. COST \$475.00. New—**\$17.95.** 2 for **\$34.50.**



**E-7 GENERATOR** Leece-Neville—12 Volt—50 AMP. Terrific gen. for any 12-volt system for boats, cars and trucks. Approx. GOVT. COST \$175. NEW. **\$14.95.**



**REACTOR COIL ARC STABILIZER**



Will handle any gen. up to 400 AMPS. Wt. 12 lbs. **\$9.95.**

**THROTTLE CONTROL SOLENOID**



Use as welder or motor control. Has 6" shaft, 1" travel. Wt. 5 lbs. **\$7.50.**

**HEAVY-DUTY RHEOSTAT** Ideal for regulating voltage on electric welders. Rated 5.75 Ohms, 100 Watts with double windings & dual female 25 amp., 125 V. receptacles. 7" hi x 5 1/4" D. Shpg. wt. 2 1/2 lbs. Approx. GOVT. COST \$25. Brand New. **\$2.25** ppd.



**NEW DESCRIPTIVE CATALOG** Thousands of bargains in war surplus & other items. Hundreds of pictures. Send 25c in coin for your copy today! Ppd. prices in USA only. Other prices FOB Culver City, Calif. Send cash, check or money order. 50% deposit on COD.



**AIRBORNE SALES CO., INC** DEPT. PM858  
8501 Stella Drive, Culver City, Calif.

**MAKE UP TO \$20 A DAY WITH**



**EASISHARP**

Big profits in your spare time sharpening scissors. We show you how to start making money immediately. This is your chance now to have your own business and a steady income. Sharpen a pair of scissors in less than two minutes. A child can operate it. Weighs only 10 lbs. Every home, barber, tailor, dressmaker—everybody uses scissors and all need sharpening two to four times a year. Don't let some one else beat you to this opportunity. Write immediately to

**MONEY MAKING SALES PLAN FREE**

**SERR-EDGE MACHINE CO., 9731 Lorain Ave., Cleveland, Ohio**

**"MINIATURE MACHINE SHOP**

No Bigger Than A Typewriter, Outperforms Machines Many Times Its Size!



That's what a popular publication says about UNIMAT in their 3 page feature story in the May issue. If you want a reprint of this story plus complete information about this amazing 10 in 1 combination precision tool write to:

**AMERICAN EDELSTAAL, INC., UNIMAT DIV., Dept. 388, 350 B'way., N.Y. 13**



American families are better housed — thanks to Advertising!



**MENDS MOST ANYTHING**

*"HOLDS LIKE IRON"*

Used by fine furniture makers. Ideal for home and office. In 1/4 oz. or 2 1/2 oz. sizes.

**CHROME VANADIUM 29 Pc. DRILL SET**

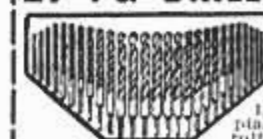

Specialty made for speed drilling. In sturdy plastic tool roll. Finest alloy steel drills hardened and precision ground to the sharpest, longest lasting cutting edge obtainable; will easily and cleanly bite through hardwoods, plastics, aluminum, iron and the toughest steels. Unconditionally guaranteed for thousands of drillings. Full jobber length. Sizes by 64ths from 1/16" to 1/2". NOW... **\$6.49** ppd. Also available with Turned Down Shank to fit all 1/4" drills. In individual pocket roll... **\$8.95** ppd.

**60 Pc. Set WIRE GAUGE CHROME VANADIUM DRILLS**

Top quality German import high test Chrome Vanadium Drills designed for speed drilling through toughest steels, woods, plastic, iron and aluminum. Precision ground, long-lasting cutting edges. Guaranteed to give years of satisfaction. A full 60 pc. set. Nos. 1 through 60. A \$14.95 value—**\$5.40** NOW ONLY... **\$6.65** PLUS 13c PP. & HDLG. Same set above with Huot Metal Index... **\$6.65** PLUS 13c PP. & HDLG. Also Available 20 Pc. Set — Nos. 61-80 **WIRE GAUGE DRILLS** In plastic kit with marked pocket for each drill. **\$2.50** ppd.

Send Check or M.O. C.O.D. fee extra. **MONEY BACK GUARANTEE**

**SCOTT-MITCHELL HOUSE, INC. DEPT. F-8, 415 S. BROADWAY YONKERS, NEW YORK**

**FREE Tyler SPYRAL HACKSAW BLADE!**



Demonstrate for yourself why Tyler SPYRAL Hack-saw & Coping Saw Blades are America's number 1 choice for making precision & intricate CLEAN cuts of wood, metal, plastic, tubing, etc. Saw in circles, right or left, up or down. Available at your dealer. **OFFER LIMITED!** Since you will receive your FREE blade from your local dealer, you must fill out the coupon to the right & mail it to us. Offer is not valid unless you give us your name & address as well as that of your dealer. When dealer receives your FREE Tyler Blade, he will notify you by postcard.

**MAIL COUPON FOR FREE BLADE!**

**TYLER MFG. CO., INC., Dept. PM-8**  
1005 W. Arbor Vitae Ave., Inglewood, Calif.  
Your Name \_\_\_\_\_  
Address \_\_\_\_\_  
City & State \_\_\_\_\_  
Name & address of my Saw Dealer is: \_\_\_\_\_



## Absorbs Moisture!

# SPECO HUM-I-DRI

removes dampness . . . stops mildew in closets, basements, tool rooms, storerooms, laundries, recreation rooms, enclosed porches . . .



HUM-I-DRI eliminates rust and moisture damage. Just place it in any wet location. It will remove up to 10 times its weight in moisture from the air. Ready for use. No "baking" or drying. Low cost refills available. See your dealer.

Write for free bulletin!

Standard H-5 Unit . . . . . \$1.95

Large H-10 Size . . . . . \$3.95

**SPECO INC.**

Cleveland 9, Ohio  
Dept. PM-8

## POCKET SIZE BLOW TORCH

only  
**\$1.95**  
with charger



Butane gas blow torch gives intense 3500° flame. Solders, brazes, fixes leaks. Perfect for wiring, plumbing, loosening frozen nuts and bolts, 1001 odd jobs. Carry in your pocket. Each charger lasts 1/2 hour, turns on or off. Extra chargers, 49¢ per box of 2. Get Jet King Butane Blow Torch at hardware stores. Or, send check or money order, we pay postage. For \$1 more (total \$2.95), get Soldering Kit; torch, tip, 3 feet cored solder, extra charger. Good for TV, radio, jewelry. \* Add \$1.00 in Canada

KIDDE MANUFACTURING CO., INC., Dept. PM-85  
42 FARRAND ST., BLOOMFIELD, N. J.

Send me \_\_\_\_\_ JET KING BLOW TORCHES @ 1.95 ea.\*  
Send me \_\_\_\_\_ JET KING SOLDER KITS @ 2.95 ea.\*  
Send me \_\_\_\_\_ Boxes of Extra Chargers @ .49 per box.  
My check, \_\_\_\_\_ money order \_\_\_\_\_ for \$ \_\_\_\_\_ is enclosed

NAME \_\_\_\_\_  
STREET \_\_\_\_\_  
CITY \_\_\_\_\_ STATE \_\_\_\_\_

MONEY BACK GUARANTEE

copper. So far she's running with woven synthetic sails, but there's a rumor she may break out a revolutionary plastic sheet-type of sail similar to polyethylene or Mylar on the day of the race. If so, she'll be riding several hundred pounds lighter. To help the crew speed their job of line handling in the corners, her sheets and halyards come in five bright color codes instead of the usual spanking white. The only other fascinating fact known about *Sceptre's* built-in materials is that several gold sovereigns were tossed into the molten lead for good luck when her keel was cast.

But for all the new wrinkles, Stephens, Rhodes and Hunt, who have watched innovations come and go, emphasize Harold Vanderbilt's pithy quote: "Mistakes are made frequently in yacht races, and Fortune generally smiles on the yacht that makes the fewest." Old-timers like to recall the hair-raising race of Sopwith's J-class *Endeavour* against Vanderbilt's *Rainbow* in 1934. *Endeavour* took the first three races that year, and most experts who saw the contest admit she was far and away the faster boat. But Sopwith's crew goofed several times, while Vanderbilt's topnotch afterguard and forecastle crew, working like demons with split-second precision, snatched the next four straight—and the Cup.

So, according to those who should know, the Cup and the day, next month, will probably go to the snappiest deck gang and afterguard—unless some quirk of wind or weather picks a particular winner with a built-in affinity for just that combination.

★ ★ ★

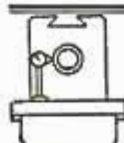

— JOB TESTED KNOW-HOW —  
**MACHINE TOOL RECONDITIONING**  
& THE ART OF HAND SCRAPING (3rd printing)  
SEND FOR FREE FOLDER DESCRIBING  
ILLUSTRATED MANUAL FOR MACHINISTS  
MACHINE TOOL PUBLICATIONS, 362 Holly Ave., Saint Paul 2, Minn.

**NEW!** for 4-wheel drives  
**FREE-LOCK**  
**Auto-Lock HUB**



**The Hub a Child can engage**

Willys • Dodge • GMC • International • Ford  
Chevrolet • Land Rover • Marmon Herrington

A revolutionary advancement. Merely set arrow to "in" position and Walk away! It's simple, safe, sure! Ruggedly constructed of finest tool steel by aviation precision standards. Fully guaranteed 1 year.

If dealer cannot supply, write for literature and prices

**FREE-LOCK CORPORATION**

6301 NORTH FEDERAL BLVD., DEPT. C • DENVER 21, COLORADO



**BUILD A DIVING LUNG**  
All parts & instructions for assembly. 38 cu. ft. tank. 45 min. dive time. **39<sup>95</sup>**

**TWO-TANK UNIT** - All parts & assembly instructions. Two 22 cu. ft. tanks. Approx. 1 hour dive time. **150 val. 45<sup>95</sup>**

**U.S.A.F. 16-POCKET VEST**  
**NEW LOW PRICE - 3.49**

Has 14 individual, outside pockets for objects, 2 inner pockets (11" x 8") and a leather pistol holster. Sturdy, yet lightweight with adjustable tie-straps on the back for a snug, comfortable fit.

**KNIFE-FORK-SPOON**  
**3 PC. SET ONLY 1.89**

Blades are heavy duty stainless steel made to fold easily into the handle of each. Consists of a knife with sharp edge, a three tined fork and a spoon. In plastic carrying case.

**9-IN-1 SWISS ARMY TYPE KNIFE**  
9 practical tools in one: Jack knife, saw, scissors, can opener, Phillips head screwdriver,awl, large knife, bottle opener and a standard screwdriver. Rugged steel blades. Easy-to-open.

**NEW 1.78**

**palley's**  
2263 east vernon ave. dept. PM-88 Los Angeles 58, Calif.

**100% NYLON COVERALLS**

100% NYLON in Air Corps Blue. Has 6 pockets with zipper closures. Waist is adjustable. Has sleeve pocket for pencil. Also full zipper front and at the ankles in good condition.

**Now 4.88**

**RUBBER BOATS**  
A collapsible, portable rubber boat. Made to top Gov't specs. Reconditioned and ready to use. Ideal for lake, ocean or river.

**1-2 MAN 22.95**

**NEWS-PIECE ALUMINUM OARS** - 6 feet long. Per each **1.69**

**GI CANTEENS**

Genuine U.S. Army Equip. Finest stainless steel for lifetime service. **SAVE!**

**NEW 1.49 USED 99¢**

**ALUMINUM CANTEENS NEW 1.49**

**CANTEEN CUPS Only 39¢ ea.**

**CANTEEN BELT \$1.29 ea.**

**PHILIPPINE MAHOGANY PLYWOOD** **SAVE 50%**

Both sides sanded with face side unjointed. Bonded with finest resin adhesive. Weather & Water resistant. Shipped by LOW truck rates. **FROM IMPORTER**

Minimum order accepted 100 lbs. (4) 1/4" or (8) 1/8" sheets.

3 ft. x 6 ft. x 2mm (1/8") **1.79** 4 ft. x 8 ft. x 1/4" thick **4.49**

18 sq. ft. - \$5.00 Value **1.79** 32 sq. ft. - \$9.50 Value **4.49**

at prices LESS THAN WHOLESALE! **SEND FOR SAMPLE!**

**TRANSLUCENT FIBERGLAS PANELS**

Finest quality. Available in many widths and lengths. We shipped over 1 million feet last year. Full color selection. **FREE sample 39¢**

**SAVE 60%** and booklet on request. 8 1/2 sq. ft. value **59¢**

**HEAVY WROUGHT IRON TRELLIS**

Use them for patio roof supports, room dividers, etc. Sturdy 1 1/2" diameter, black tubular supports with a beautiful wrought iron filigree between. 12" wide by 8 ft. high (can be cut to 7 ft.) with mounting flanges. Flat or Corner style.

**FLAT TYPE 9.95**

**CORNER TYPE 17.95**

**112 HP - POWER SAW**

**3400 RPM RIPS - CROSSCUTS**

**CUTS A FINISHED 2x4 LIKE A KNIFE THROUGH BUTTER**

**COMPARES TO SAWS SELLING UP TO \$49.50**

**1998** Complete with 5-1/2" blade

A rugged, professional type, adjustable saw. Will cut any angle from 0 to 45°. Has an adjustable (0 to 6") rip fence. Safety-trigger switch on handle. Full 1/2 HP Universal AC-DC, 110-120 Volt, 60 cycle motor. Weighs only 8 1/2 lbs. **SAVE AT PALLEY'S**

**DO IT YOURSELF BUT DO IT BETTER WITH THE RIGHT MATERIALS!**

**Get Popular Mechanics DO-IT-YOURSELF Materials Guide**

The Key to Buying and Using Lumber, Hardware and Other Home Workshop Materials

The right lumber. The right grade. The right fastenings, nails, screws, glue and other hardware. These are all just as important as the right design and the right kind of workmanship. It's true, whether you're fixing up the house, making a fine piece of furniture or knocking out a time-killing gadget. Get Popular Mechanics Materials Guide. Fills a long-felt need of home owners and home workshop fans. Has how-to-do-it information too. Send only \$3.50 for postpaid delivery. Money back if you want it in 5 days.

**192 Fact filled pages. 667 how-to-do-it pictures**

Popular Mechanics Press, Dept. 858, 200 E. Ontario St., Chicago 11

**NEW MAGIC RADIO WALKIE TALKIE!**

**YOUR OWN POCKET SIZE RADIO STATION!**

BROADCASTS TO ANY HOME OR CAR RADIO WITHOUT WIRES OR HOOKUPS! Wt. only 6 oz. Size, 1 1/2" x 2 1/2" x 1 1/2". Built-in telescoping antenna. Powerful Transistor-sensitive microphone, frequency setter, break-in switch! Runs for weeks on self-contained flashlight batteries. Durable plastic case. With this Radio Talkie you CAN TALK TO YOUR FRIENDS UP TO A BLOCK OR MORE AWAY! Talk up to 1 mile or more between two automobiles. **INSTANT OPERATION!** Just push button to talk! No license needed. Uses inductive field magnetic radiation. Useful and real fun in a million ways! **GUARANTEED TO WORK. 1 YEAR SERVICE GUARANTEE.**

**SEND ONLY \$3.00.** (cash, c.k. mo) and pay postman \$3.98 COD postage or send \$12.00 for prepaid delivery. **COMPLETE READY TO OPERATE** with instructions and hundreds of ways and tricks for broadcasts thru any radio you desire. Price only go up soon, so get your **NEW POWERFUL RADIO-WALKIE TALKIE NOW!** Available only from **WESTERN RADIO, Dept. RPM-8, KEARNEY, NEBR.**

**PORTABLE POWER PLANT 1000 WATT A.C.**

For Electric Saws, Pumps, Flood Lights, Pipe Threaders, Drills, Radio, Deep Freeze, Etc.

**Saves Time, Labor, Money**

Famous Briggs & Stratton 4 cycle air cooled engine, with automatic recoil rope start, driving ballbearing generator that delivers full 1000 watts, 115 volt A.C. 60 cycle. Size 20 1/2" x 12" x 16". Shpe. Wght. 100 lbs. **\$159.50**

F.O.B. Chicago

**FREE! SUMMER 1958 CATALOG**

60 VALUE-PACKED PAGES of unsurpassed War Surplus and newly manufactured Equipment. Bargains for farm, home, factory, workshop. Write letter today.

**GROBAN SUPPLY CO. 1141 SOUTH WABASH AVENUE CHICAGO 5, ILLINOIS**

**BIG profits in ARC WELDING**

with these low cost welders!

**"HUSKY BOY" air cooled welder**

**Earn extra money**

... or save time and replacement parts. Do your own repairs, construction and metal fabrication with one of these low cost Hobart welders.

A surprisingly low investment puts you in the profitable welding trade. Hundreds of opportunities exist and a Hobart helps you capitalize on them. Send for complete information - no obligation.

**"Handy Andy" home type welder**

**Shop type welder**

**HOBART BROS. CO., Box M-88, Troy, Ohio**



Fast cutting  
Top quality

**GENSCO**

## SWEDISH WOOD CHISELS

Woodworking projects have that little extra professional touch when Gensco Swedish Wood Chisels are used. They're tops: hand ground, razor sharp blades, Tenite II handles are unbreakable and fire resistant... won't pull loose, sizes from 1/4" to 2".

Buy these accurate cutting, easier to use Gensco Wood Chisels at all leading hardware stores today. Available in sets of 4, 6 or 11 chisels in vinyl coated canvas rolls.



Set 300-4  
1/4", 1/2", 3/4" and 1"



Bushman  
ALL-PURPOSE 21"  
Bow Saw

**GENSCO**

**GENSCO TOOLS**

A DIVISION OF

GENERAL STEEL WAREHOUSE CO., INC.

1832 N. Kostner Ave., Chicago 39, Illinois

## Better Tubeworking results assured with **IMPERIAL**

Hi-Duty No. 274-FA 2-in-1 tube cutter carries own spare cutting wheel... built-in reamer... flare cut-off groove. Clean, right-angle cuts. Leaves no burrs. For 1/8" to 1 1/8" O.D. tubing. Other cutters 3/4" to 2 1/4" O.D.



**CUTTERS**

Blue Dot No. 364-FH lever-type benders bend hard or soft tubing up to 180°. Individual benders for 1/8" to 7/8" O.D. Bends copper, steel, stainless steel, aluminum. Also combination tubing benders for 2 to 7 sizes. Gear-type benders — 3/8" to 1 1/8" O.D.



**BENDERS**

No. 500-F flaring tool rolls 45° flares in the air. Doesn't score tubing. Burnishes flare. For 3/16" to 3/8" O.D. tube. Other flaring tools — 1/8" to 2" O.D.—45° and 37°. Also double flaring tools.



**FLARING TOOLS**

SEND TO: for VALUABLE HANDBOOK and CATALOG

The Imperial Brass Mfg. Co., Dept. PM-88  
6300 W. Howard St., Chicago 48, Ill.

Send 36-page Imperial Tube Working Handbook and Catalog. Also name of nearest dealer.

Name .....  
Address .....  
City ..... Zone ..... State .....



## WHY DEPEND ON SOCIAL SECURITY!



ADD TO YOUR INCOME • UP TO \$5.00/HR. SHARPENING ALL TYPES OF LAWN MOWERS

Modern Manufacturing's precision Lawn Mower Sharpener and Bed Knife Grinder makes it easy for you to earn extra cash on a full or part time basis. Many mowers need sharpening. Do it in your basement or garage. Anyone can learn to operate this sharpener. Write today for free brochure, Dept. 10

\$27500  
F.O.B. Pasadena

**MODERN MFG. CO.**

160 N. Fair Oaks Ave.  
Pasadena, Calif.



**Glu-Bird**  
MAKES IT  
**EASIER!**

**WILHOLD PRODUCTS**

LOS ANGELES 31, CALIF., CHICAGO 44, ILL.



## EXPLORE FOR TREASURE!

Find gold, silver, coins, jewelry, battle relics! M-SCOPE Treasure-Metal Locators Used World-wide. Guaranteed Proven Performance. Transistors, Fiberglass cases, lightweight. Also Geiger, Scintillation Counters, Mineralights. FREE Detailed Catalog. Easy Terms. **FISHER RESEARCH LAB., INC.** Dept. PM-2, Palo Alto, Calif.

## Jiffy SAWHORSE BRACKETS

NO NAILS NO SCREWS NO BOLTS

Now a sawhorse in a jiffy! Just use Jiffy Brackets and 2x4s. Sold by hwd. and bldg. supply stores everywhere, or order direct. \$1.95 A pair. Higher W. Coast

**GRAND HAVEN STAMPED PRODUCTS CO.**  
Grand Haven, Mich.

## DO MORE PLANING JOBS WITH LOW COST BELSAW

LOW DOWN  
PAYMENT  
EASY TERMS



Exclusive MONEY-MAKING Features: Full 12 1/4" x 6" capacity • Power feeds at 14" to 34" a minute • Provides for Grinding Knives in the Cutter-head • Attachments for Jointing, Rabbling, Tongue, Matching, Groove. Convert low cost rough lumber into high priced stock. Easy to make flooring and popular patterns. Send Today for FREE Literature and Prices.

Belsaw Machinery Co., 2059 Field Bldg., K.C. 11, Mo.

## GENUINE ALNICO MAGNETS

AMAZING, PERMANENT, NON-ELECTRIC, HIGHLY PRACTICAL. Conduct interesting experiments. Hundreds of uses. Retrieve valuable steel items such as keys, tackle from fresh or salt water; tools from tanks & drains. **GUARANTEED.** Try any magnet one week. Money back if you are not well-pleased.

No. M-710 (Wt. 53 oz.) Has pull of 225 lbs. on steel block...	\$18.00
No. M-625 (Wt. 70 oz.) Has pull of 125 lbs. on steel block...	\$10.00
No. M-575 (Wt. 18 oz.) Has pull of 75 lbs. on steel block...	\$7.00
No. M-500 (Wt. 13 oz.) Has pull of 50 lbs. on steel block...	\$5.00
No. M-300 Kit of Flat Bars 5 Pairs (10 Magnets).....	\$3.00
No. M-250 Kit of Round Rods 5 Pairs (10 Magnets).....	\$2.50
No. M-47 Hot Pad Magnets, 10 for \$1.00.....	50¢ for \$4.50
No. M-35 Hobbyist assortment of 8 small magnets.....	\$1.50

Send M.O. or check. We pay postage. Sorry no C.O.D.'s.

MIAMI MAGNET COMPANY, 3240 N.W. 27th Ave., Miami 42, Fla.



## AMERICA'S BEST

### 1500 WATT PLANT

115v. 60 cyc. AC Push Button Start. Powered by a 3.6 HP. Clinton engine. Combines big output with easy portability. Provides emergency power for operating any oil burner, sump pump, freezer, television, lights, communications systems, etc. which require up to 1500 watts.

Item 22. Wt. 110 lbs.

Reg. \$475 value. Factory price... **\$239.50**

1750 Watt Plant Powered by 4.5 HP Briggs engine. Electric starting & battery charging built-in! Factory price... **\$279.50**

2500 WATT PLANT—Push Button Start (Item 21) 110/120 v. 60 cyc. A.C. A rugged powerful plant. Reg. \$645. Spec. **\$329.50**



## ELECTRIC HOIST



2000 lb. CAPACITY. A fortunate purchase from the Air Force enables us to offer these powerful 2000 lb. electric cable hoists at a fraction of their value. Perfect for material handling, boat hoists, elevators, lifts on assembly lines, etc. Two separate 22 ft. lift cables with independent controls permit leveling the load and controlling it perfectly. Rugged ball bearing motors of geared down design 110 volts. Available for A.C. or D.C. Please specify. Makes a terrific portable hoist with our 273 D.C. light plant at \$99.75. Offered at less than 33% of regular cost (Hook not included). Wt. 145 lbs. A.C. Model, Item 847A... **\$149.50**  
D.C. Model, Item 847... **\$129.50**

## MASTER AIR COMPRESSOR

COMPARE! This is the only compressor built with a NO RUST stainless steel tank. Safe up to 500 lbs. (Item 209) High pressure type 14 c.f.m. large volume of air for heavy duty service. For paint spraying, inflating truck & auto tires, greasing, sand blasting, etc. Piston type 2" bore compressor with built-in air filter. Master built with high strength alloys and precision bearings. Tank, 12"x24", 2100 cu. in. cap. Equipped with automatic switch that starts and stops motor to maintain desired pressure (up to 150 lbs.) and check valve, safety valve, gauge, shut-off valve, 20 ft. air hose and tire chuck. Beautifully balanced on ball bearing wheels and rubber tires. Don't take chances with used or surplus equipment. Our compressors are factory new and are guaranteed SAFE. 1/2 H.P. heavy duty model, rap. incl. motor and unloader switch. Item 209A, low factory price... **\$129.50**  
1/2 H.P. model, Cap. 3 c.f.m.—85 psi, Item 209... **\$109.50**



Tank Tested up to 500 lbs. per sq. in.

## JET STEAM MASTER

Now, a super efficient portable steam generator that produces live steam at 100 lbs. pressure in 60 seconds from a cold start! Produces large volume of high pressure steam on 2 pints of fuel oil. Instantly cleans sticky grease, dirt, rust, oil paint, etc. off implements and road machinery. Pays for itself in a few weeks. Sterilizes soil. Sterilizes as it cleans—milk equipment, etc. Fully automatic—oil fired with new, built-in lifetime bronze water circulating pump. Draws water from faucet or bucket. Simple and safe—anyone can use it; built-in safety valve. Complete with 12 ft. of hi-pressure steam hose and new triple efficiency steam gun that automatically mixes in soap solution if desired. Wt. 250 lbs. Item 463. Special factory price... **\$349.50**



## HEATING & VENTILATING FAN

(Item 10) Easily installed in furnace pipes. Forces even heat to all rooms. Over range removes kitchen smoke and odors. Powerful, continuous duty motor, 110-120v. AC. Mount in wall or ceiling to ventilate any area. Quiet, super-efficient fan moves huge volume of air. (400 to 600 CFM.)  
8" Pipe, wt. 5 lb. .... **\$6.85**  
9" Pipe, wt. 6 lb. .... **\$7.85**  
10" Pipe, wt. 7 lb. .... **\$8.85**  
12" Pipe, wt. 8 lb. .... **\$9.85**  
HEAVY DUTY FAN. Semi-enclosed motor, suitable for spray booths, restaurant exhausts, poultry houses, etc. 10" Fan, wt. 8 lbs. Item 10E... **\$11.95**  
12" Fan, wt. 10 lbs. Item 10H... **\$12.95**



## SAVE middleman profits BUY DIRECT from MASTER MECHANIC factory

(Item 24)



### 700 WATTS PUSH BUTTON START

115 v. 60 cyc. AC Powered by a rugged 2.2 HP easy starting Briggs engine. No wiring necessary; just plug in and operate. Plenty of current for any oil burner, freezer, brooder, emergency lights, etc. which require

up to 700 watts. Ideal for television and radios. Complete with Voltmeter and built-in winding to charge 6 v. auto batteries. (Item 24.) Wt. 75 lbs. Easily fits in car trunk. Be prepared if storm knocks out power lines. Reg. \$275 value... **\$143.50**

1200 Watt Plant (Item 45) same as Item 24 but larger generator and engine **\$199.50** with 50% greater output.

## Double Acting Hydraulic Cylinder



A powerful cylinder mfd. by Messrs Harris which develops both a pushing and a pulling action. Will push 8,100 lbs., with a 1000 PSI pump pressure. Cylinder is 3 3/4" O.D. with 5 1/2" stroke—standard heavy duty clevises on both ends. Has standard 1/2" pipe thread openings. Can be used for tilting buckets or blades, raising or lowering implements, hydraulic presses, etc. Can also be used as an air cylinder. (Item 802) Wt. 17 lbs. Reg. \$68 value. Special... **\$14.95**

### OTHER DOUBLE ACTING CYLINDERS

- 6" stroke - 1 1/2" bore..... **\$ 8.95**
- 8" stroke - 3" bore..... **34.00**
- 10" stroke - 3" bore..... **34.80**
- 16" stroke - 3" bore..... **43.00**
- 24" stroke - 3" bore..... **47.50**
- 42" stroke - 5" bore..... **75.00**
- 60" stroke - 5" bore..... **125.00**

We have all sizes of cylinders available.

### HYDRAULIC CONTROL VALVE - 4 way

open center valve with built-in adjustable relief. Controls 1 double, or 2 single acting cylinders. Equalizing feature permits easy control even under heavy loads. 3/4" pipe thread on inlet & outlet, 1/2" on cylinder outlets. Easily mounted, finger tip control. Wt. 16 lbs. (Item 822)... **\$21.95**

### HYDRAULIC KIT



Complete Hydraulic Kit consists of hydraulic hand pump with built-in 2 gal. reservoir and Item 802 hydraulic cylinder described above. Pump has a built in relief valve and is rated at 10 tons. Kit is ideal for presses, jacks, snow-plows, etc. Pump is 29" long—6" diam. with 3/4" ports. A terrific value! **\$39.50** (Item 836). Wt. 50 lbs. Pump only (Item 836a) only... **\$23.50**  
HYDRAULIC HOSE COUPLERS Connect or disconnect hydraulic lines without loss of oil. 1/2" pipe threads. (Item 819) per set **\$3.95**

## GIANT METAL SHEARS

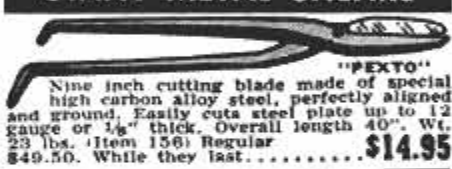

"PEXTO" Nine inch cutting blade made of special high carbon alloy steel, perfectly aligned and ground. Easily cuts steel plate up to 12 gauge or 1/4" thick. Overall length 40". Wt. 23 lbs. (Item 156) Regular **\$49.50**. While they last... **\$14.95**

## AIR HAMMER



SAME HAMMER. Originally designed to hammer dents out of auto bodies, fenders, etc. Complete with 2 different shaped arms, a set of 5 bumping dollies, and 20 ft. of heavy duty air hose. Hammer can also be used without arm. Uses 4 CFM at 60-100 PSI.

WITHOUT ARM  
ORIGINALLY COST \$175.00  
SPECIAL \$39.50

## EXCLUSIVE! NEW!

### LIGHTWEIGHT WATER COOLED DIESEL GENERATOR PLANT

Never before available! Now offered exclusively by Master Mechanic. A low priced, lightweight, continuous duty, Diesel generator set. Powered by a super rugged, exceptionally smooth running, one cylinder Diesel engine. Operates at conservative 1750 r.p.m. and delivers full 1750-2000 watts of power. Operates on low cost fuel oil. Wt. only 240 lbs. representing a triumph of Diesel Engineering. Complete with fuel filter, oil pressure gauge, control box with duplex receptacle and voltmeter. (Item 830) Special factory price... **\$429.50**

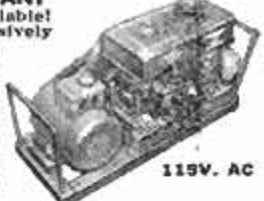

115V. AC

## HI-FLO Centrifugal PUMP

Completely self-priming! No foot valve required. Tremendous capacity—100 gal. per min. Special impeller enables pump to handle muddy or sandy water. Simple to operate—simply start engine and watch the water go. Powered by a rugged, easy-starting 2 HP Briggs engine. Pre-lubricated sealed bearings for years of heavy low-cost service. Big 1 1/2" Model, Item 502. Wt. 70 lbs. Factory price... **\$134.50**



2" Model (150 gal. per min.) with 3.6 hp engine. Item 502B—00 lbs. Special... **\$169.50**

## RUBBER HOSE

Genuine Neoprene Hose—outlasts ordinary rubber 3 to 1. Reinforced with super tough cotton cord plies—yet completely flexible. Equipped with standard thread male and female fittings. Pump water for irrigation, stock tanks, home-barn, fire fighting, etc.—or pump gas and fuel oil. Volume factory prices—save more than 60%.



TERRIFIC VALUES!

Size	Price	Size	Price
1"x10'	5.95	1 1/2"x50'	29.50
1 1/4"x10'	7.95	2"x10'	16.80
1 1/2"x20'	10.95	2"x10'	9.50*
1 1/4"x25'	13.95	2"x14'	21.50
1 1/2"x50'	24.95	2"x50'	47.50
1 1/4"x100'	49.95	2 1/2"x10'	21.75*
1 1/2"x10'	10.95	2 1/2"x17'	37.50
1 1/2"x25'	14.75	3"x10'	25.50*
#0-charge Hose		4"x15'	44.95

### NEW ITEMS: (Too late to illustrate)

1. MINE DETECTORS: Used by plumbers, contractors, water dept. etc. for detecting buried metallic or non-metallic objects. Finds buried sewers, water pipes, wires, etc. Complete in carrying case. Batteries \$10.00 extra. **\$39.50** Gov't Cost \$600. Our price...

## MASTER D.C. ARC WELDER

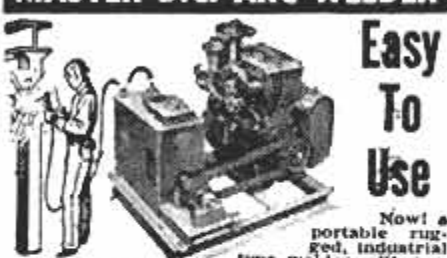

Easy To Use

Now a portable rugged, industrial type welder with terrific performance, yet at a price hundreds of dollars less than you'd expect. Senior model made for years of trouble-free, continuous service. High capacity DC welding unit enables you to tackle any job with confidence—easily welds anything up to 2" plate using from 1/16" to 1/4" rods. Built-in stabilizer and cooling system makes arc easy to strike and hold. Dual control rheostat provides low heat soldering, brazing and welding from 30 to 300 amps. Complete with instructions, guarantee and triple V-belt or flat pulley. Easy to hook up and easy to operate.

WELDER ONLY - DUAL CONTROL MODEL. Same as above, but drive with your tractor, jeep or gas engine of 14 HP or more. (Item 38a.) Wt. 110 lbs. \$450 value **\$119.50**

WELDER ONLY—INDUSTRIAL MODEL same as above but with ceramic rotary type rheostat providing 74 different heat settings for all types of welding (Item 38b) **\$129.50** \$500.00 value...

COMPLETE POWER MASTER (Illustrated above) powered by a 16 hp., air cooled Wisconsin engine. Wt. 480 lbs. (Item 280) Complete with welder costing \$1200. Factory Special... **\$449.50**

WELDING KIT Two 10 ft. leads, welding helmet, electrode holder, ground clamp. Sold only with welder at... **\$10.50**

Send check or M.O. Prices f.o.b. Factory. 10 day Money back guarantee. SEND 10c for... **MASTER MECHANIC MFG. CO., DEPT. A-88 Burlington, Wis.** **BIG NEW Catalog**



# HOW TO JUMP THE SLUMP!

Here's a way to cash in on present job trends and avoid the current dip!



While some men are out of work or just hanging on, many others are actually advancing into more responsible, high-pay jobs.

Men on the way up are taking advantage of one known fact: *Skills pay off in good times or bad!*

Look at the employment picture:

Although more people are employed in the nation than ever before, the latest labor facts show a sharp rise in unemployment among unskilled, untrained workers.

BUT, the SKILLED man's job is the most secure. His odds for holding a job are four times better than the untrained man's. And he's in line for promotion, pay increases, great new job opportunities.

**I. C. S. method develops skills fast!**

You seldom see an I. C. S. man out of a job. No other school has so many of its former students now in management and supervisory positions.

What I. C. S. is doing for today's successful young men, it can do for you. At home. In your spare time. As rapidly as your time and ability permit.

Find out how! Mark and mail the coupon below. It brings you three valuable books at no cost, no obligation. Three books that can guide you through these critical times, that can help you *jump the slump*. But act quickly.

For Real Job Security—Get an I. C. S. Diploma! I. C. S., Scranton 15, Penna. Accredited Member, National Home Study Council

## INTERNATIONAL CORRESPONDENCE SCHOOLS



BOX 74299H, SCRANTON 15, PENNA.

(Partial list of 259 courses)

Without cost or obligation, send me "HOW TO SUCCEED" and the opportunity booklet about the field BEFORE which I have marked X (plus sample lesson):

- |  |  |  |  |   |
|--|--|--|--|---|
| <p><b>ARCHITECTURE and BUILDING CONSTRUCTION</b></p> <ul style="list-style-type: none"> <li><input type="checkbox"/> Air Conditioning</li> <li><input type="checkbox"/> Architecture</li> <li><input type="checkbox"/> Arch. Drawing and Designing</li> <li><input type="checkbox"/> Building Contractor</li> <li><input type="checkbox"/> Building Estimator</li> <li><input type="checkbox"/> Carpentry and Millwork</li> <li><input type="checkbox"/> Carpenter Foreman</li> <li><input type="checkbox"/> Heating</li> <li><input type="checkbox"/> Interior Decoration</li> <li><input type="checkbox"/> Painting Contractor</li> <li><input type="checkbox"/> Plumbing</li> <li><input type="checkbox"/> Reading Arch. Blueprints</li> </ul> <p><b>ART</b></p> <ul style="list-style-type: none"> <li><input type="checkbox"/> Commercial Art</li> <li><input type="checkbox"/> Magazine &amp; Book Illus.</li> <li><input type="checkbox"/> Show Card and Sign Lettering</li> <li><input type="checkbox"/> Sketching and Painting</li> </ul> <p><b>AUTOMOTIVE</b></p> <ul style="list-style-type: none"> <li><input type="checkbox"/> Automobiles</li> <li><input type="checkbox"/> Auto Body Rebuilding and Refinishing</li> <li><input type="checkbox"/> Auto Engine Tuneup</li> <li><input type="checkbox"/> Auto Technician</li> </ul> | <p><b>AVIATION</b></p> <ul style="list-style-type: none"> <li><input type="checkbox"/> Aero-Engineering Technology</li> <li><input type="checkbox"/> Aircraft &amp; Engine Mechanic</li> </ul> <p><b>BUSINESS</b></p> <ul style="list-style-type: none"> <li><input type="checkbox"/> Accounting</li> <li><input type="checkbox"/> Advertising</li> <li><input type="checkbox"/> Business Administration</li> <li><input type="checkbox"/> Business Management</li> <li><input type="checkbox"/> Cost Accounting</li> <li><input type="checkbox"/> Creative Salesmanship</li> <li><input type="checkbox"/> Managing a Small Business</li> <li><input type="checkbox"/> Professional Secretary</li> <li><input type="checkbox"/> Public Accounting</li> <li><input type="checkbox"/> Purchasing Agent</li> <li><input type="checkbox"/> Salesmanship</li> <li><input type="checkbox"/> Salesmanship and Management</li> <li><input type="checkbox"/> Traffic Management</li> </ul> <p><b>CHEMICAL</b></p> <ul style="list-style-type: none"> <li><input type="checkbox"/> Analytical Chemistry</li> <li><input type="checkbox"/> Chemical Engineering</li> <li><input type="checkbox"/> Chem. Lab. Technician</li> <li><input type="checkbox"/> Elements of Nuclear Energy</li> <li><input type="checkbox"/> General Chemistry</li> <li><input type="checkbox"/> Natural Gas Prod. and Trans.</li> <li><input type="checkbox"/> Petroleum Prod. and Engr.</li> <li><input type="checkbox"/> Professional Engineer (Chem)</li> <li><input type="checkbox"/> Pulp and Paper Making</li> </ul> | <p><b>CIVIL ENGINEERING</b></p> <ul style="list-style-type: none"> <li><input type="checkbox"/> Civil Engineering</li> <li><input type="checkbox"/> Construction Engineering</li> <li><input type="checkbox"/> Highway Engineering</li> <li><input type="checkbox"/> Professional Engineer (Civil)</li> <li><input type="checkbox"/> Reading Struc. Blueprints</li> <li><input type="checkbox"/> Structural Engineering</li> <li><input type="checkbox"/> Surveying and Mapping</li> </ul> <p><b>DRAFTING</b></p> <ul style="list-style-type: none"> <li><input type="checkbox"/> Aircraft Drafting</li> <li><input type="checkbox"/> Architectural Drafting</li> <li><input type="checkbox"/> Drafting Machine Design</li> <li><input type="checkbox"/> Electrical Drafting</li> <li><input type="checkbox"/> Mechanical Drafting</li> <li><input type="checkbox"/> Sheet Metal Drafting</li> <li><input type="checkbox"/> Structural Drafting</li> </ul> <p><b>ELECTRICAL</b></p> <ul style="list-style-type: none"> <li><input type="checkbox"/> Electrical Engineering</li> <li><input type="checkbox"/> Elec. Engr. Technician</li> <li><input type="checkbox"/> Elec. Light and Power</li> <li><input type="checkbox"/> Practical Electrician</li> <li><input type="checkbox"/> Practical Lineman</li> <li><input type="checkbox"/> Professional Engineer (Elec)</li> </ul> <p><b>HIGH SCHOOL</b></p> <ul style="list-style-type: none"> <li><input type="checkbox"/> High School Diploma</li> </ul> | <ul style="list-style-type: none"> <li><input type="checkbox"/> Good English</li> <li><input type="checkbox"/> High School Mathematics</li> <li><input type="checkbox"/> Short Story Writing</li> </ul> <p><b>LEADERSHIP</b></p> <ul style="list-style-type: none"> <li><input type="checkbox"/> Industrial Foremanship</li> <li><input type="checkbox"/> Industrial Supervision</li> <li><input type="checkbox"/> Personnel-Labor Relations</li> <li><input type="checkbox"/> Supervision</li> </ul> <p><b>MECHANICAL and SHOP</b></p> <ul style="list-style-type: none"> <li><input type="checkbox"/> Diesel Engines</li> <li><input type="checkbox"/> Gas-Elec. Welding</li> <li><input type="checkbox"/> Industrial Engineering</li> <li><input type="checkbox"/> Industrial Instrumentation</li> <li><input type="checkbox"/> Industrial Metallurgy</li> <li><input type="checkbox"/> Industrial Safety</li> <li><input type="checkbox"/> Machine Design</li> <li><input type="checkbox"/> Machine Shop Practice</li> <li><input type="checkbox"/> Mechanical Engineering</li> <li><input type="checkbox"/> Professional Engineer (Mech)</li> <li><input type="checkbox"/> Quality Control</li> <li><input type="checkbox"/> Reading Shop Blueprints</li> <li><input type="checkbox"/> Refrigeration and Air Conditioning</li> <li><input type="checkbox"/> Tool Design</li> <li><input type="checkbox"/> Tool Making</li> </ul> <p><b>RADIO, TELEVISION</b></p> <ul style="list-style-type: none"> <li><input type="checkbox"/> General Electronics Tech.</li> </ul> | <ul style="list-style-type: none"> <li><input type="checkbox"/> Industrial Electronics</li> <li><input type="checkbox"/> Practical Radio-TV Eng'g</li> <li><input type="checkbox"/> Practical Telephony</li> <li><input type="checkbox"/> Radio-TV Servicing</li> </ul> <p><b>RAILROAD</b></p> <ul style="list-style-type: none"> <li><input type="checkbox"/> Car Inspector and Air Brake</li> <li><input type="checkbox"/> Diesel Electrician</li> <li><input type="checkbox"/> Diesel Engr. and Fireman</li> <li><input type="checkbox"/> Diesel Locomotive</li> </ul> <p><b>STEAM and DIESEL POWER</b></p> <ul style="list-style-type: none"> <li><input type="checkbox"/> Combustion Engineering</li> <li><input type="checkbox"/> Power Plant Engineer</li> <li><input type="checkbox"/> Stationary Diesel Engr.</li> <li><input type="checkbox"/> Stationary Fireman</li> </ul> <p><b>TEXTILE</b></p> <ul style="list-style-type: none"> <li><input type="checkbox"/> Carding and Spinning</li> <li><input type="checkbox"/> Cotton Manufacture</li> <li><input type="checkbox"/> Cotton Warping and Weaving</li> <li><input type="checkbox"/> Loom Fixing Technician</li> <li><input type="checkbox"/> Textile Designing</li> <li><input type="checkbox"/> Textile Finishing &amp; Dyeing</li> <li><input type="checkbox"/> Throwing</li> <li><input type="checkbox"/> Warping and Weaving</li> <li><input type="checkbox"/> Worsted Manufacturing</li> </ul> |
|--|--|--|--|---|

Name \_\_\_\_\_ Age \_\_\_\_\_ Home Address \_\_\_\_\_  
 City \_\_\_\_\_ Zone \_\_\_\_\_ State \_\_\_\_\_ Working Hours \_\_\_\_\_ A.M. to P.M. \_\_\_\_\_  
 Occupation \_\_\_\_\_

Canadian residents send coupon to International Correspondence Schools, Canadian, Ltd., Montreal, Canada. . . . Special tuition rates to members of the U. S. Armed Forces.



**Now available... direct to you from the Publisher**  
BRAND NEW EDITION OF THE WORLD FAMOUS

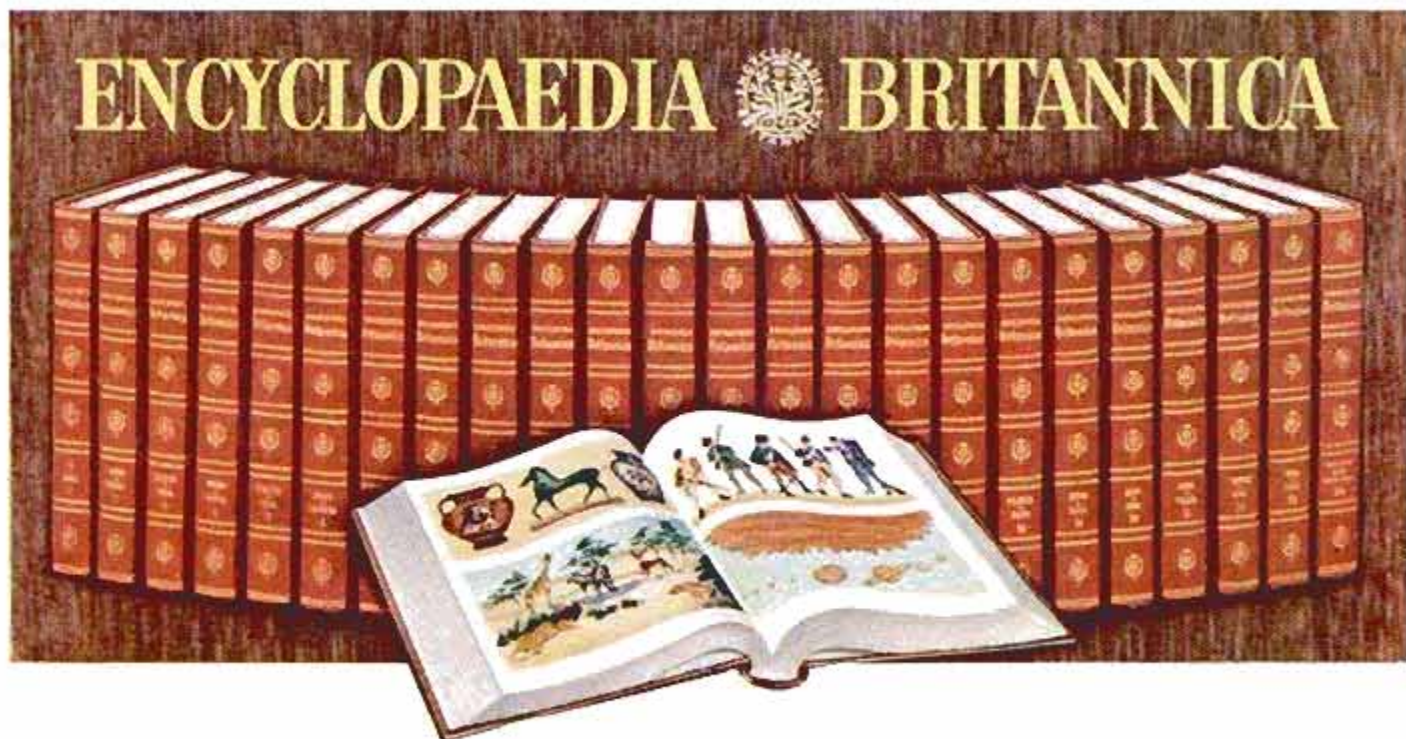

*You Get All 24 Volumes Now... Pay Later*

## On Easy... Book a Month Payment Plan

■ Yes, the latest edition of Britannica—the greatest treasure of knowledge ever published—is now being offered on a remarkable direct-from-the-publisher plan that puts this world-renowned reference library within reach of every family. All 24 volumes will be placed in your home NOW... you pay for it later on convenient budget terms. It's as easy as buying a book a month.

### Savings Passed on to You

You may wonder how we're able to make this truly amazing offer. First, because of the great demand for this magnificent set, we have ordered a tremendous printing. This enormous printing materially reduces our costs and, under a remarkable *direct-from-the-publisher plan*, we pass these savings on to you.

### New Edition is Profusely Illustrated

The new Britannica almost "televises" information with 23,494 magnificent illustrations. But it does not merely show "attractive" pictures—it is the work of 5,565 of the world's greatest authorities.

Britannica in your home can give you the broad knowledge that makes people listen when you talk, enabling you

to speak factually and intelligently on the widest range of subjects.

### Essential for Homework

For students, Britannica is indispensable. It is the largest and most complete reference set published in America. Its use develops the active, alert minds that bring success in school and later life.

Britannica has always been the symbol of a good home. It is a treasure house of knowledge that can open a richer, fuller, more successful life to every member of your family.

### Preview Booklet Offered FREE

Simply fill in and mail the coupon today, and we will send you... *without cost or obligation*... a copy of our beautiful new booklet which contains an exciting preview

of the latest edition of Encyclopaedia Britannica. Send no money—not even for postage. It's yours *absolutely free!*

In color so beautifully etched it gives the illusion of a third dimension, you will see art treasures of famous museums, world landmarks, scientific wonders. Also pictured is the most magnificent scenery on the North American continent, a cruise through France, the mysterious Orient, a Pacific island, and a rocket trip to the moon.

### Offer Limited

Just as soon as we receive your coupon, we will send your illustrated, free booklet. There is no obligation, of course. However, this offer is necessarily limited, so mail the coupon *today*.

	<b>ENCYCLOPAEDIA BRITANNICA, DEPT. 7-H</b> 425 N. Michigan Avenue, Chicago 11, Illinois Please send me, <i>free and without obligation</i> , your colorful Preview Booklet. Also include complete information on how I may obtain ENCYCLOPAEDIA BRITANNICA <i>direct from the publisher</i> , on the Book a Month Payment Plan.
	Name _____ (Please print) Address _____ City _____ Zone _____ State _____ In Can., write E. B. Ltd., Terminal Bldg., Toronto, Ont.



SIMONIZ MAKES IT

# A TERRIFIC NEW CAR POLISH!

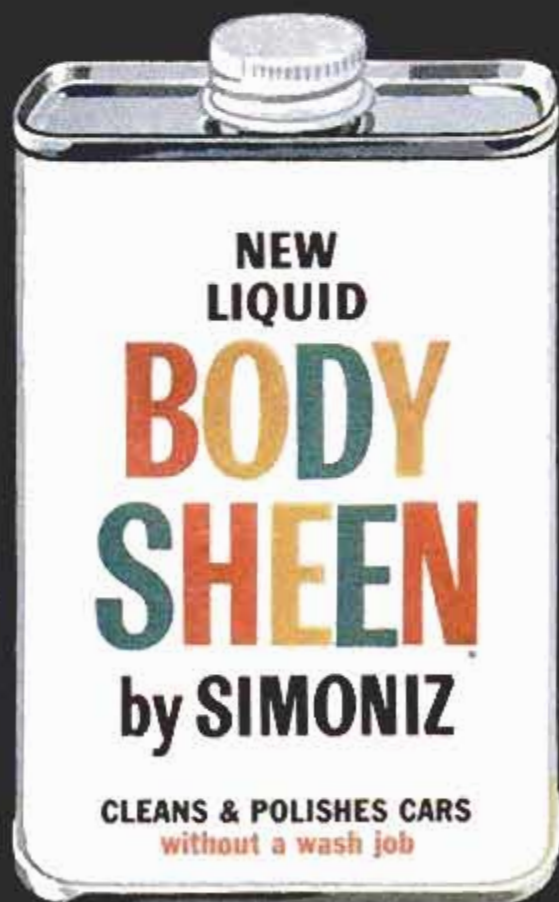

NOW — \$1.49