

SEPTEMBER 1955

35 CENTS

POPULAR MECHANICS

MAGAZINE

WRITTEN SO YOU CAN UNDERSTAND IT

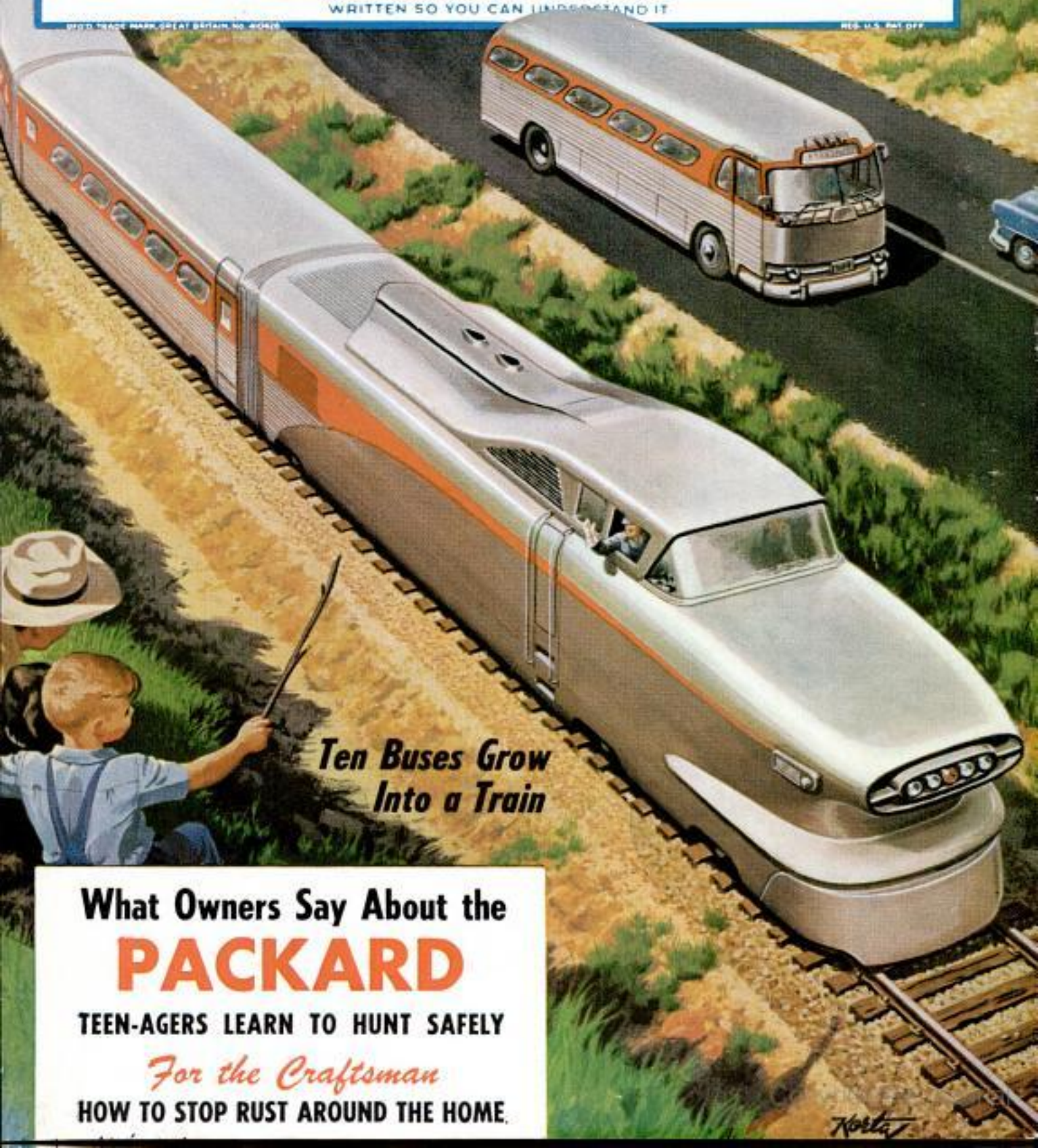

*Ten Buses Grow
Into a Train*

What Owners Say About the

PACKARD

TEEN-AGERS LEARN TO HUNT SAFELY

For the Craftsman

HOW TO STOP RUST AROUND THE HOME.

Kortz

Learn how homeowners everywhere save money by installing their own

MATICO TILE FLOORING



*MATICO's New Improved
Install-It-Yourself System
Makes It Easy!*

Yes, you can enjoy colorful, durable MATICO Asphalt Tile Flooring in your home at amazing low cost by installing MATICO yourself. You can't buy a more economical type of luxury flooring than MATICO. It lasts for years... is easy to keep sparkling clean and comes in 28 striking decorator colors that can't wear off because colors and marbleization go clear through the tile.

It's a cinch to install, too, with MATICO's tested install-it-yourself instruction booklet... tile calculator... and special

tool kit. Why, you can finish a room in just a few hours.

Why put up with a dingy, worn-out floor when it costs so little to install a MATICO tile floor yourself.

See your classified telephone directory for the name of your MATICO dealer.



1—Mark straight lines through the center of the room in both directions, using a chalk and line.

2—With a notched trowel, spread adhesive evenly over floor and allow to "set."



3—Press tiles into position. You can walk on MATICO as soon as floor is in place.



MASTIC TILE CORPORATION OF AMERICA
Houston, Tex. • Joliet, Ill. • Long Beach, Calif. • Newburgh, N.Y.

Manufacturers of:
• Cafetti • Aristoflex • Parquetry • Maticork • Asphalt Tile
• Rubber Tile • Vinyl Tile • Cork Tile • Plastic W-II Tile

MASTIC TILE CORPORATION OF AMERICA
Dep't. M2-9, P.O. Box 986, Newburgh, N. Y.

Please send me MATICO's money-saving install-it-yourself instruction kit and complete color chart.

Name

Address

City..... Zone..... State.....

4C-172

Texaco Tips On Car Care

How to enjoy → smoother starts

Often times, a partially clogged carburetor is the cause of stalling and difficult starting. To prevent the impurities which jam up your carburetor, drain and clean the fuel pump sediment bowl. Doing this at regularly scheduled intervals will help you get smoother starts and freedom from stalling.

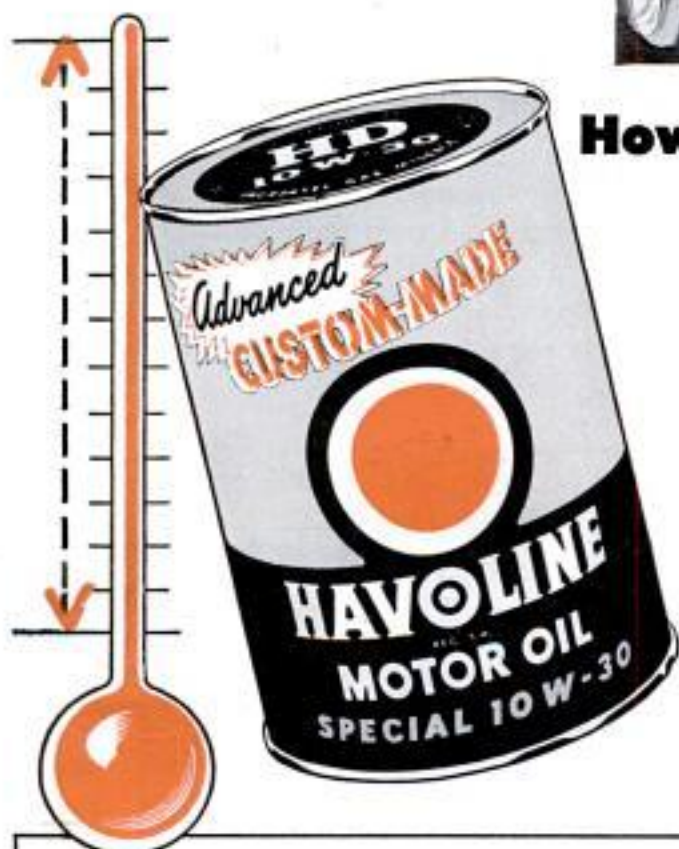
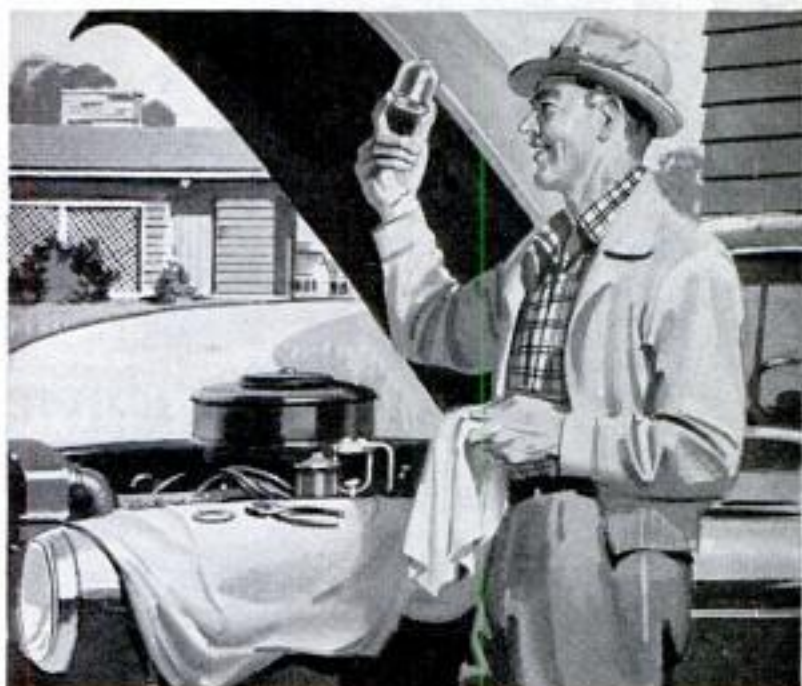

How to assure faster pickup, better gasoline mileage

Use the newest member of the Havoline Motor Oil family — Havoline Special 10W-30. Independent road tests proved this all-temperature motor oil best for your car. It's "light" for cold starts, has "body" to withstand heat. Test cars using Havoline Special 10W-30 accelerated faster, using less gasoline—and engines stayed clean. For more engine "zip," and longer engine life, change to Havoline Special 10W-30. See your Texaco Dealer, the best friend your car has ever had.



TEXACO DEALERS IN ALL 48 STATES

Texaco Products are also distributed in Canada and in Latin America

TUNE IN: TEXACO STAR THEATER starring JIMMY DURANTE, on TV Saturday nights, NBC.



After initial adjustments are made, as in photograph, "Mr. Meticulous" automatically performs critical operations in making junction tetrode transistors—tiny experimental devices which may find important uses in the telephone system.

The machine we call "Mr. Meticulous"

Bell Laboratories scientists, who invented the junction transistor, have now created an automatic device which performs the intricate operations required for the laboratory production of experimental model transistors.

It takes a bar of germanium little thicker than a hair and tests its electrical characteristics. Then, in steps of $1/20,000$ of an inch, it automatically moves a fine wire along the bar in search of an invisible layer of positive germanium to which the wire must be connected. This layer may be as thin as $1/10,000$ of an inch!

When the machine finds the layer, it orders a surge of current which bonds the wire to the bar. Then it welds the wire's other end to a binding post. Afterward, it flips the bar over and does the same job with another wire on the opposite side!

Once only the most skilled technicians could do this work, and even their practiced hands became fatigued. This development demonstrates again how Bell Telephone Laboratories scientists work in every area of telephony to make service better.

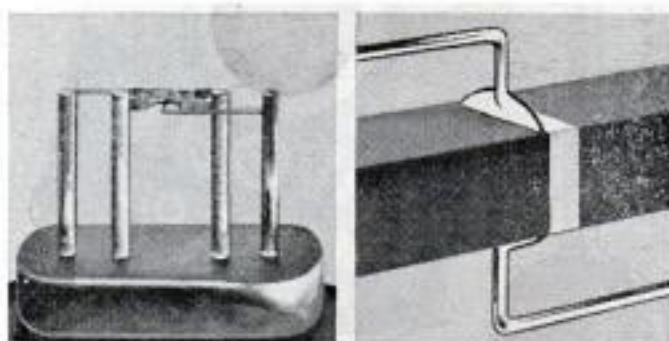

Transistor made by new machine is shown in sketch at left, magnified 6 times. At right is sketch of area where wires are bonded. The wires are $2/1000$ inch in diameter, with ends crimped to reduce thickness.

BELL TELEPHONE LABORATORIES

Improving telephone service for America provides careers for creative men in mechanical engineering.



Popular Mechanics Magazine

Registered in U. S. Patent Office and Canada

H. H. WINDSOR, Founder

H. H. WINDSOR, JR., Editor and Publisher



Next Month

EVER SEE a vehicle that you drive from a walking position? This flat-bed Jeep has a folding steering post that permits the driver to control it while he walks or crawls behind, dodging bullets. Right now, the little Jeep is undergoing a series of ruinous tests on the Army's "torture rack"—Aberdeen Proving Grounds. There, new tanks and other war machines of our ground forces roar through mud, dust and swamp, up frightening grades, and spin along on highways of undulating concrete and roads consisting of loose, jagged granite rocks. Next month, in an exciting feature, the men who deliberately drive our war weapons to destruction give surprising answers to "Can Our Tanks Take It?"

Information not listed on articles in the index, starting on page 74, frequently is listed in the WHERE-TO-FIND-IT LIST, which is available to readers without charge. A copy may be obtained by writing to the Bureau of Information, Popular Mechanics, 200 E. Ontario, Chicago 11, Ill.

Published monthly by Popular Mechanics Company, 200 E. Ontario St., Chicago 11, Ill. H. H. Windsor, Jr., president; Wm. Harrison Petridge, exc. vice-pres.; D. F. Windsor, vice-president and secretary-treasurer; H. H. Windsor III, vice-president; W. T. Windsor, vice-president; Clover L. Perkins, advertising manager; Alan M. Deyoe, circulation manager. Single copy in the United States and Canada, 35 cents; subscription rates in the United States and possessions, Canada, Philippines and countries of the Pan-American Postal Union, 1 year \$3.50; 2 years \$6.00; 3 years \$8.00. To all other countries add \$1.00 a year over United States prices for overseas postage. If you plan to move, notify us at least 30 days in advance so you will not miss an issue. Give both your old and new addresses.

Entered as Second Class Matter, September 15, 1903, at the Post Office at Chicago, Illinois, under Act of March 3, 1879. Entered as Second Class Matter at Post Office Dept., Canada. Registered as Second Class Matter at the Post Office at Mexico, D. F., Mexico, June 20, 1950. Copyright 1955 by Popular Mechanics Company. Copyright under International Copyright Union. Copyright in France. All rights reserved under Pan-American Copyright Union. Printed in the United States of America.

Volume 104 SEPTEMBER 1955 Number 3

Address all communications to: 200 E. Ontario St., Chicago 11, Ill.

Managing Editor.....Roderick M. Grant
 Assistant Managing Editor.....Wayne Whittaker
 Shop Notes and Crafts Editor.....James R. Ward
 Radio-Television, Electronics Editor.....Lothar Stern
 Associate Editor.....Clifford B. Hicks
 Associate Editor, Automotive.....Arthur R. Railton
 Associate Editor, Shop Notes and Crafts.....Wayne C. Lecky
 Assistant Editor, Shop Notes.....W. Clyde Lammy
 Assistant Editor, Crafts.....Frank N. Stephany
 Assistant Editor, Makeup.....John C. Dalen
 Automotive Correspondent.....Leo Donovan
 Art Director.....Frank Beatty

Assistant Editors

Leonard F. Hilts, Jay W. Hedden, Elliott H. McCleary, Emily Mullaney
 Eastern Editor.....Richard F. Dempewolf
 Empire State Bldg., Room 2906, New York City 1
 Western Editor.....Thomas E. Stimson, Jr.
 Suite 1010, 3460 Wilshire Blvd., Los Angeles 5, Calif.
 London Manager.....Douglas W. Wedderspoon
 Eagle House, Jermyn St., London S. W. 1, England
 Director, Bureau of Information.....Allan Carpenter

200 E. Ontario St., Chicago 11

Advertising Offices

Chicago: 200 E. Ontario St., Whitehall 4-0100; New York: Empire State Bldg., 350 Fifth Ave., Longacre 5-7580; Detroit: General Motors Bldg., TRinity 5-8711; Cleveland: Hanna Bldg., 1422 Euclid Ave., PRospect 1-0456; Los Angeles: Tishman Bldg., 3460 Wilshire, DUNkirk 2-8458; San Francisco: Russ Bldg., 235 Montgomery St., YUKon 2-0823.

In This Issue . . .

Ten Buses Grow Into a Train	81
They're Planning Your Home in the Sun	88
Detroit Listening Post	90
Jet Planes Head for the Melting Point	92
Operation Ditch	98
If I Were a Student Today	103
Britain's Atom-Age Carrier	109
What's New for Your Home	114
Owners Report on the '55 Packard	118
Teen-Agers Learn to Hunt Safely	126
They Pry Into the Lives of Fish	132
Motorcycles Invade the Wilds	138
He Builds Windproof TV Masts	146
"Cowboys" Lasso a Rhino	152
Radio, TV and Electronics	157

For the Craftsman . . .

Coloring With Stain	161
Wrought-Iron Telephone Table	165
Building Block Set	169
Solving Home Problems	178
Patterncraft—Twin-Bed Headboard	182
Stop Rust in Your Home—Part I	186
How to Patch Plaster	192
Winterize Your Car's Electrical System	197
Make Your Own Aluminum Storm Sash	201
Check up on Saw Alignment	208
Plain Tapered Turnings	214
Shopping for Tools	218
Clinic for Homemakers	224

Other items, and manufacturers of available products described, are listed on pages 74, 76 and 77

**Now see
the most amazing NEW power tool
in years . . .**

Porter-Cable's revolutionary

ROUTO-JIG!

**Portable jig saw! High speed router! Precision shaper!
You get all 3 in this low-priced quality tool!**

Just convince yourself—see *and try* the sensational tool that puts dozens of new skills at your fingertips! Use the versatile new Routo-Jig as a portable jig saw, for cutting intricate contours and freehand shapes, for fast, accurate plunge cutting. Use Routo-Jig as a portable router, for mortising, grooving, dadoing, rabbetting. Use Routo-Jig as a shaper, with its own precision table—for moulding, beading, joining.

You'll find hundreds of money-saving uses for the Routo-Jig in your workshop and around your home—in cabinet work, furniture and toy making, home improvements of every kind. You'll do work of truly professional quality, faster and easier than ever before!

Like every Porter-Cable tool, the Routo-Jig is *quality-built* for years of dependable service. Right now, your dealer makes you the special introductory offer described on the opposite page—*saves you a cool \$7.00*. Read about it—see him today!



IT'S A JIG SAW!

Routo-Jig is a new kind of portable jig saw with *rotary* action—for intricate contours or straight cut-off work in wood up to 1" thick. No starting hole required. Sturdy cutting bit reduces blade breakage to a minimum.



IT'S A ROUTER!

Routo-Jig converts to a high-speed, efficient portable router in *seconds!* Special bits available for fast, easy work in wood, plastics, compositions. 24,000 R.P.M. speed for clean, smooth, *finished* cuts in every application.

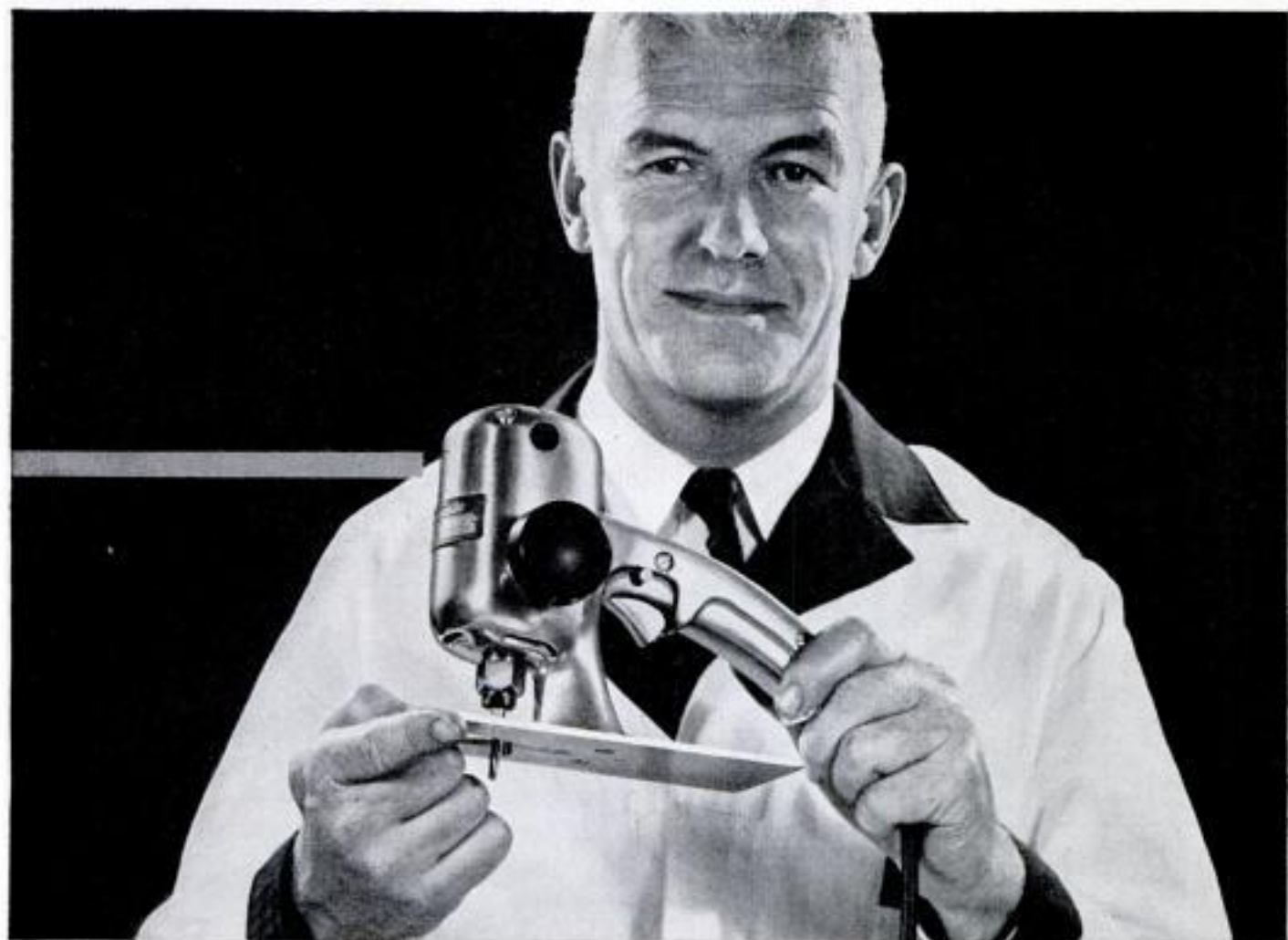

Limited time only — Special introductory offer saves you **\$7⁰⁰**

List price of the Model 140 Routo-Jig with jig saw and router bases is \$49.95. Model 5020 Shaper Table, regularly priced at \$12.00, is yours for *just \$5.00 additional* during the introductory period!

a \$61.95 value for only

\$54⁹⁵

See it demonstrated at your dealer's— or mail coupon today!

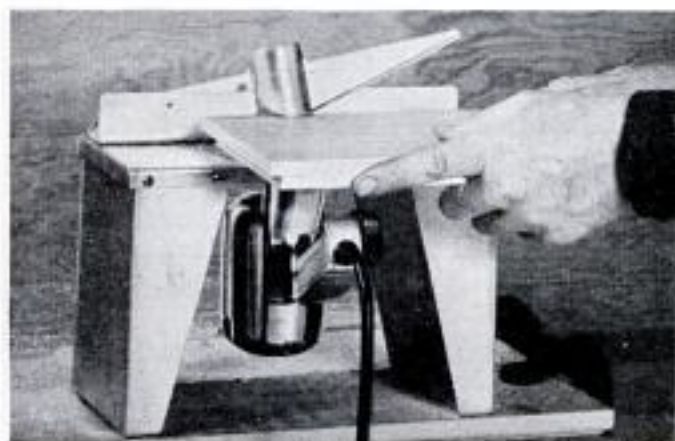

IT'S A SHAPER!

Husky accessory Shaper Table makes Routo-Jig a precision Shaper and Joiner. Quick, accurate, professional results on difficult rabbet cuts, moulding cuts, joiner work. Adjustable fence, built-in safety guard.

Porter-Cable

Quality Electric Tools

PORTER-CABLE MACHINE CO.
5149 N. Salina St., Syracuse 8, N. Y.

Yes, send me a complete catalog sheet on the Model 140 Routo-Jig, and the name of my nearest dealer.

Name _____

Address _____

City _____ Zone _____ State _____

This one



UDWY-X1L-KGFC

SEPTEMBER 1955

5

Copyrighted material

Hold Tight!

Get a Better Grip on Your Work with PROTO Professional-Quality Pliers

Sensational "Multi-plier" multiplies your gripping power 10 times!

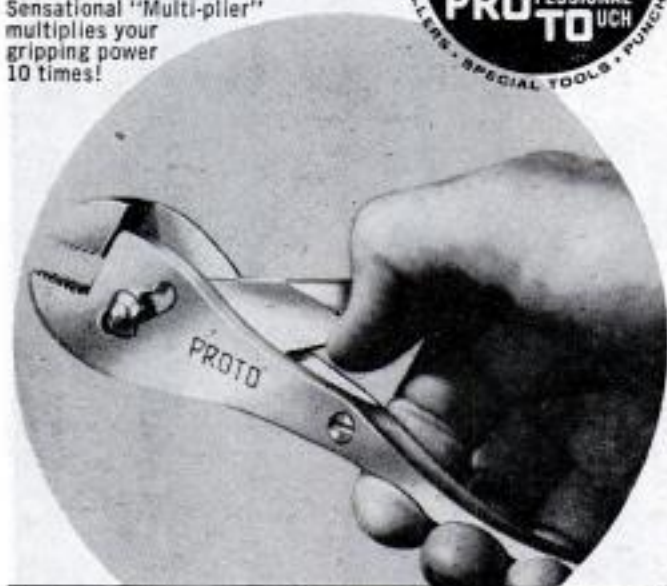

Try Comfortable PROTO *Handeze* Plier Grips



More hand comfort with replaceable, colorful vinyl plastic grips! Three sizes fit most pliers. Many PROTO Pliers already equipped. See your dealer!

There's no substitute for the *right* plier when you need it. Choose exactly the ones you need from PROTO's huge line—standards, midgets, side cutters, end nippers, slip-joint and special purpose pliers—all made from fine steels. You'll get powerful leverage, and comfortable, positive-grip handles. Buy the ones you need from your PROTO Dealer! Send 10¢ for catalog of entire line to

PLUMB TOOL COMPANY
2255Q Santa Fe Ave.,
Los Angeles 54, Calif.



5595 Eastern Factory, Jamestown, N.Y. • Canadian Factory, London, Ont.

ACROSS THE DESK



To the Editor:

In view of your recent article on "They Build Their Own Planes" (PM, June 1955) I thought perhaps you could use the enclosed photo of the "Doodle Bug," a sport plane that I designed and built myself. I finished the plane in December 1954 and have a total of 80 hours on it now. It is a very stable ship, has no bad characteristics and performs very well. It has tip tanks and wheel pants of glass fiber; the wings are aluminum, flush riveted back 40 percent of



the chord. The fuselage is tubular construction covered with fabric, the tail group is of the same construction. The gear is one-piece spring steel. The fuel capacity is 25 gallons. I have made several cross-country flights, one of 700 miles nonstop. The "Bug" was built in our one-stall garage and then the wings fitted to the ship at the International Airport. The ship was built in my spare time which covered a period of about 14 months. I am flight engineer for Continental Air Lines on the DC-6 run from El Paso, San Antonio and Houston. I am a member of the Experimental Aircraft Association.

L. K. Heuberger,
El Paso, Tex.

To the Editor:

I read with great interest an article in your *Popular Mechanics Magazine*, June 1955 issue, entitled "TV Crosses the Horizon" by Richard F. Dempewolff.

I have just imported a German "Telefunken" 17-inch television set, and am experimenting with trying to pick up a television station from Santiago, Cuba, on channel 2. This station actually originates

(Continued to page 8)

This **FREE SAMPLE LESSON** will prove you can become an expert **BOOKKEEPER... ACCOUNTANT** OR **C.P.A.**

This well-paid
LaSalle-trained
Accountant's
success could
be yours.



FREE SAMPLE LESSON

We offer you this free sample lesson so that you can *prove to yourself* that you CAN master Accountancy—quickly, thoroughly—in spare time at home.

You will see exactly how LaSalle's famous "Problem Method" works . . . how you are led step-by-step through actual accounting work—*learning by doing* and not by study of theory alone. First you tackle easy problems, then more difficult ones—until soon you master them all. And at every step you have the close personal guidance of LaSalle's large staff of C.P.A. instructors.

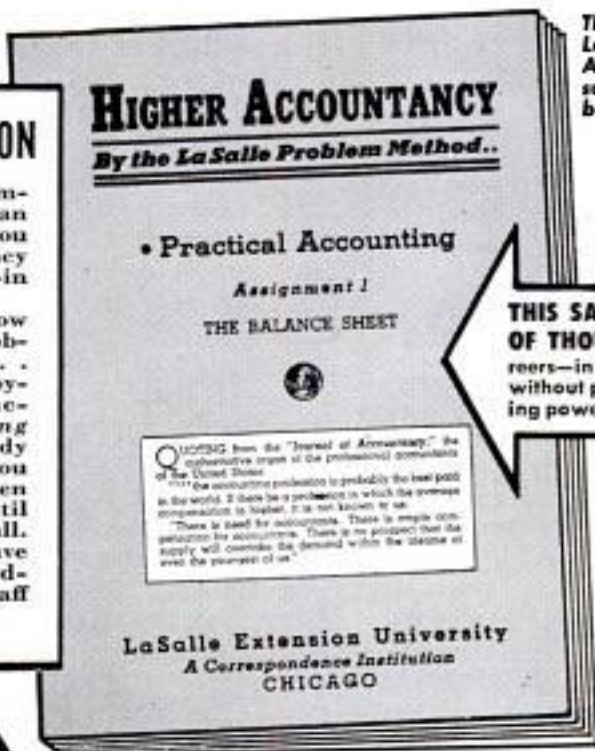

THIS SAME LESSON HAS STARTED HUNDREDS OF THOUSANDS toward well-paid accounting careers—in business, government, and as C.P.A.'s. Even without previous knowledge, progress is rapid—earning power climbs fast. This sample lesson shows why.

If you have been envying the high incomes and good jobs enjoyed by thousands of men and women Accountants today . . . incomes ranging from \$4,000 to \$10,000 and more per year . . . why not launch such a career for yourself?

Do you doubt that you can?

Then let us send you—without cost or obligation—the same Lesson Number One with which LaSalle has started several hundred thousand

men and women toward successful accounting careers. We want you to see for yourself how this remarkable method, originated by LaSalle, makes Accountancy simple, interesting, practical, and certain . . . how it leads you step-by-step to a complete mastery of Accounting—and on up to the coveted degree of Certified Public Accountant if you so aspire.

It doesn't matter whether you've had previous bookkeeping experience, or whether you don't know a debit from a credit. Whether you wish to qualify as an expert bookkeeper, advanced accountant, cost accountant, auditor, government accountant, income tax specialist, or public accountant . . . you'll find in LaSalle's Problem Method the exact plan to prepare you rapidly and inexpensively—in spare hours at home—without losing a day from your present job.

So right now, today . . . if you are an adult, employed, and earnestly ambitious for rapid advancement in this highest-paying of all professions . . . send your name and address on the coupon below. We'll send the free sample lesson—plus our 48-page book outlining today's career opportunities and how you can qualify for them. A coupon like this has started many thousands toward greater success. It can do the same for you. Mail it today!

Clip Coupon . . . Mail TODAY!

LaSalle Extension University . . . A Correspondence Institution
Dept. 964H, 417 S. Dearborn Street, Chicago 5, Illinois

YES, I want to see how LaSalle's "Problem Method" works . . . how I can qualify for high-pay Accountancy positions. Send Free Sample Lesson—also your 48-page book, "Accountancy, the Profession That Pays"—all without cost or obligation.

Name Age

Street Address

City, Zone & State

Present Position



**Nearly 10%
of all C.P.A.'s
in the U.S. have
been trained by the
LaSalle Problem
Method**

GOOD-PAY JOBS IN 5 BIG FIELDS

If you were an expert accountant right now, chances are you would find yourself among the highest-paid of all professional men and women. Surveys show that accountants earn more than those in other major professions.

There are five big fields of opportunity open to Accountancy-trained men and women . . . opportunities that are wide open and highly inviting, offering maximum income and job security in good times or bad. And under LaSalle's "Problem Method" you can start earning while still learning—either in spare-time or full-time employment . . . or in business for yourself with no capital required.

Get the latest information by sending for our 48-page book, "Accountancy, the Profession That Pays" . . . plus free sample lesson. The coupon at right will bring both to you without cost or obligation. LaSalle Extension, 417 S. Dearborn St., Chicago 5, Ill.

DON'T WASTE ANTI-FREEZE THIS WINTER!

Two New Compounds Give Your Radiator 4-WAY Protection



NEW PERMATEX COOLING SYSTEM CLEANER AND CONDITIONER



CLEANER IN TOP—

- Cleans out rust and scale
- Dissolves oil and grease

CONDITIONER IN BOTTOM—

- Stops rust reforming*
- Stops leaks and seepage*

*Exclusive with Permatex

No other product you can buy today gives you this complete, 4-way protection for your car's cooling system. New Permatex Cleaner removes all rust, scale, lime, oil and grease... to both increase your radiator's efficiency, and help your heater work better during cold weather. The Conditioner keeps rust from reforming and stops leaks and seepage (exclusive Permatex features). You don't waste anti-freeze—don't risk a frozen radiator. Permatex Cooling System Cleaner and Conditioner is quick and easy to use yourself (only 4 steps—against 5 with any other product).

Beat winter to the punch! Get this new Permatex product at your service station or auto supply shop, now.

PERMATEX COMPANY, INC.

Brooklyn 35, N.Y.

Kansas City 15, Kans.

Over 50 Chemical Products
for Better Automotive Maintenance

(Continued from page 6)

from Havana but is relayed down by co-axial cable. Ever since installing the set I have picked up American stations on channels 2, 3, 4, 5, and 6.

Whether this reception is a freak or not I do not know, but the signals come in every day and the quality of pictures as reported by my friends who have seen American TV in New York is on a par and sometimes clearer than in the U.S.A.

The signals will be very strong from about 9:30 a.m. to 11:30 a.m., then come in again at 2:00 p.m. to 4:00 p.m., again at 7:00 p.m. and generally fade out by 9:30 p.m. I pick up North Carolina, South Carolina, Tennessee and Atlanta, Ga., but the most powerful is WUSN-TV, on channel 2, Charleston.

As you can readily observe I am picking up signals in a range of 1200-1500 miles and where I live the signal would have to "jump" our highest mountain which is to my north, an elevation of 7000 feet.

My antenna is about 48 feet high and I do not use a booster, but the set is a custom-built fringe-area circuit. The Cuban signal from Santiago comes in without any difficulty, but the American signal is subject to fade-outs as mentioned in your article.

Trevor A. Bitter,
United Estates, Ltd.,
Kingston, Jamaica, B.W.I.

To the Editor:

Enclosed is a picture of my portable shingle machine, which I designed and built. I had it on show at the Northeastern Steam Engine Rodeo on the Kewaunee Country fair grounds at Luxemburg, Wis. This machine can be operated by two or three men and is adapted to sawing small tracts of cedar or other soft timber into shingles.

Martin Hessel,
Green Bay, Wis.



(Continued to page 10)

PICK YOUR OWN SUCCESS STORY FROM THIS PAGE

These are the true stories of people who seemed trapped in routine, low-pay shaky jobs. Handicapped by lack of proper training, they couldn't get the things they wanted out of life—more money, a job they liked, security and happiness.

They are a small sample of the thousands of men and women—young and old—who turn to I. C. S. for help. Their will-to-learn plus I. C. S. training have changed the course of their lives.

Are you discouraged with your job and pay and feel you can't improve yourself because of lack of specialized education? Well, these men and women were in the same boat. With I. C. S. training, one of these success stories could be about you.

I. C. S. is the oldest and largest correspondence school. 277 courses. Business, industrial, engineering, academic, high school. One for you. Direct, job-related. Bedrock facts and theory plus practical application. Complete lesson and answer service. No skimping. Diploma to graduates.



Wins \$3000 contest—"After my I. C. S. courses I secured a new position," says Mr. Cecil Rhodes. "My income has more than doubled and I recently won a \$3000 sales contest."



From clerk to Assistant Estimator, thanks to I.C.S. "Any way you look at it," writes Mrs. Edna James, "the time and money one spends for I. C. S. Courses will be repaid a thousandfold."



"As a college graduate, I found I.C.S. very valuable." Robert Lee took the I. C. S. Course in Advertising, is now Promotion Manager for a large corporation. "I. C. S. got me started on the way up," he says.



From \$162 to \$395 a month—"I.C.S. made my engineering work more interesting," Frank Bachtik tells us. "I was a Jr. Draftsman making \$152 a month. My present income is \$395.25 a month."

3 FREE BOOKS—a 36-page pocket-size guide to advancement, a gold mine of tips on "How to Succeed." Also a big catalog outlining opportunities in your field of interest and a sample I. C. S. lesson text.

For Real Job Security—Get an I. C. S. Diploma! I. C. S., Scranton 9, Penna. Member, National Home Study Council

INTERNATIONAL CORRESPONDENCE SCHOOLS



BOX 92299J, SCRANTON 9, PENNA.

Without cost or obligation, send me "HOW TO SUCCEED" and the opportunity booklet about the field BEFORE which I have marked X (plus sample lesson):

- | | | | | |
|--|---|--|---|--|
| <p>ARCHITECTURE and BUILDING CONSTRUCTION</p> <ul style="list-style-type: none"> <input type="checkbox"/> Air Conditioning—Refrig. <input type="checkbox"/> Architecture <input type="checkbox"/> Architectural Interior <input type="checkbox"/> Building Contractor <input type="checkbox"/> Building Maintenance <input type="checkbox"/> Carpenter and Mill Work <input type="checkbox"/> Estimating <input type="checkbox"/> Heating <input type="checkbox"/> Painting Contractor <input type="checkbox"/> Plumbing <input type="checkbox"/> Reading Arch. Blueprints <p>ART</p> <ul style="list-style-type: none"> <input type="checkbox"/> Cartooning <input type="checkbox"/> Commercial Art <input type="checkbox"/> Fashion Illustrating <input type="checkbox"/> Magazine Illustrating <input type="checkbox"/> Show Card and Sign Lettering <input type="checkbox"/> Sketching and Painting <p>AUTOMOTIVE</p> <ul style="list-style-type: none"> <input type="checkbox"/> Auto Body Rebuilding <input type="checkbox"/> Auto Elec. Technician <input type="checkbox"/> Auto-Engine Tune Up <input type="checkbox"/> Automobile | <p>AVIATION</p> <ul style="list-style-type: none"> <input type="checkbox"/> Aeronautical Engineering Jr. <input type="checkbox"/> Aircraft & Engine Mechanic <p>BUSINESS</p> <ul style="list-style-type: none"> <input type="checkbox"/> Advertising <input type="checkbox"/> Bookkeeping and Accounting <input type="checkbox"/> Business Administration <input type="checkbox"/> Business Correspondence <input type="checkbox"/> Public Accounting <input type="checkbox"/> Creative Salesmanship <input type="checkbox"/> F. d. e. l. Tax <input type="checkbox"/> Letter-writing Improvement <input type="checkbox"/> Office Management <input type="checkbox"/> Professional Secretary <input type="checkbox"/> Retail Business Management <input type="checkbox"/> Sales Management <input type="checkbox"/> Stenographic-Secretarial <input type="checkbox"/> Traffic Management <p>CHEMISTRY</p> <ul style="list-style-type: none"> <input type="checkbox"/> Analytical Chemistry <input type="checkbox"/> Chemical Engineering <input type="checkbox"/> Chem. Lab. Technician <input type="checkbox"/> General Chemistry <input type="checkbox"/> Natural Gas Prod. & Trans. <input type="checkbox"/> Petroleum Engineering <input type="checkbox"/> Plastics <input type="checkbox"/> Pulp and Paper Making | <p>CIVIL, STRUCTURAL ENGINEERING</p> <ul style="list-style-type: none"> <input type="checkbox"/> Civil Engineering <input type="checkbox"/> Construction Engineering <input type="checkbox"/> Highway Engineering <input type="checkbox"/> Reading Struct. Blueprints <input type="checkbox"/> Sanitary Engineering <input type="checkbox"/> Structural Engineering <input type="checkbox"/> Surveying and Mapping <p>DRAFTING</p> <ul style="list-style-type: none"> <input type="checkbox"/> Aircraft Drafting <input type="checkbox"/> Architectural Drafting <input type="checkbox"/> Electrical Drafting <input type="checkbox"/> Mechanical Drafting <input type="checkbox"/> Mine Surveying and Mapping <input type="checkbox"/> Plumbing Drawing and Estimating <input type="checkbox"/> Structural Drafting <p>ELECTRICAL</p> <ul style="list-style-type: none"> <input type="checkbox"/> Electrical Engineering <input type="checkbox"/> Electrical Maintenance <input type="checkbox"/> Electrician <input type="checkbox"/> Contracting <input type="checkbox"/> Lineman <p>HIGH SCHOOL</p> <ul style="list-style-type: none"> <input type="checkbox"/> Commercial <input type="checkbox"/> Good English <input type="checkbox"/> High School Subjects <input type="checkbox"/> Mathematics | <p>LEADERSHIP</p> <ul style="list-style-type: none"> <input type="checkbox"/> Foremanship <input type="checkbox"/> Industrial Supervision <input type="checkbox"/> Leadership and Organization <input type="checkbox"/> Personnel-Labor Relations <p>MECHANICAL AND SHOP</p> <ul style="list-style-type: none"> <input type="checkbox"/> Gas—Electric Welding <input type="checkbox"/> Heat Treatment <input type="checkbox"/> Metallurgy <input type="checkbox"/> Industrial Engineering <input type="checkbox"/> Industrial Instrumentation <input type="checkbox"/> Industrial Supervision <input type="checkbox"/> Internal Combustion Engines <input type="checkbox"/> Machine Design-Drafting <input type="checkbox"/> Machine Shop Inspection <input type="checkbox"/> Machine Shop Practice <input type="checkbox"/> Mechanical Engineering <input type="checkbox"/> Quality Control <input type="checkbox"/> Reading Shop Blueprints <input type="checkbox"/> Refrigeration <input type="checkbox"/> Sheet Metal Worker <input type="checkbox"/> Tool Design <input type="checkbox"/> Toolmaking <p>RADIO, TELEVISION</p> <ul style="list-style-type: none"> <input type="checkbox"/> Industrial Electronics <input type="checkbox"/> Practical Radio TV Eng'ng <input type="checkbox"/> Radio and TV Servicing <input type="checkbox"/> Radio Operating | <ul style="list-style-type: none"> <input type="checkbox"/> Television Technician <p>RAILROAD</p> <ul style="list-style-type: none"> <input type="checkbox"/> Air Brakes <input type="checkbox"/> Car Inspector <input type="checkbox"/> Diesel Locomotive <input type="checkbox"/> Locomotive Engineer <input type="checkbox"/> Section Foreman <p>STEAM AND DIESEL POWER</p> <ul style="list-style-type: none"> <input type="checkbox"/> Combustion Engineering <input type="checkbox"/> Diesel—Elec. <input type="checkbox"/> Diesel Eng's <input type="checkbox"/> Electric Light and Power <input type="checkbox"/> Stationary Fireman <input type="checkbox"/> Stationary Steam Engineering <p>TEXTILE</p> <ul style="list-style-type: none"> <input type="checkbox"/> Carding and Spinning <input type="checkbox"/> Cotton, Rayon, Woolen Mfg. <input type="checkbox"/> Finishing and Dyeing <input type="checkbox"/> Loom Fix'g <input type="checkbox"/> Textile Des'ing <input type="checkbox"/> Textile Eng'g <input type="checkbox"/> Throwing <input type="checkbox"/> Warping and Weaving <p>MISCELLANEOUS</p> <ul style="list-style-type: none"> <input type="checkbox"/> Domestic Refrigeration <input type="checkbox"/> Marine Engineering <input type="checkbox"/> Ocean Navigation <input type="checkbox"/> Professional Engineering <input type="checkbox"/> Short Story Writing <input type="checkbox"/> Telephony |
|--|---|--|---|--|

Name _____ Age _____ Home Address _____

City _____ Zone _____ State _____ Working Hours _____ A.M. to P.M. _____

Occupation _____

Canadian residents send coupon to International Correspondence Schools, Canadian, Ltd., Montreal, Canada. . . . Special tuition rates to members of the U. S. Armed Forces.

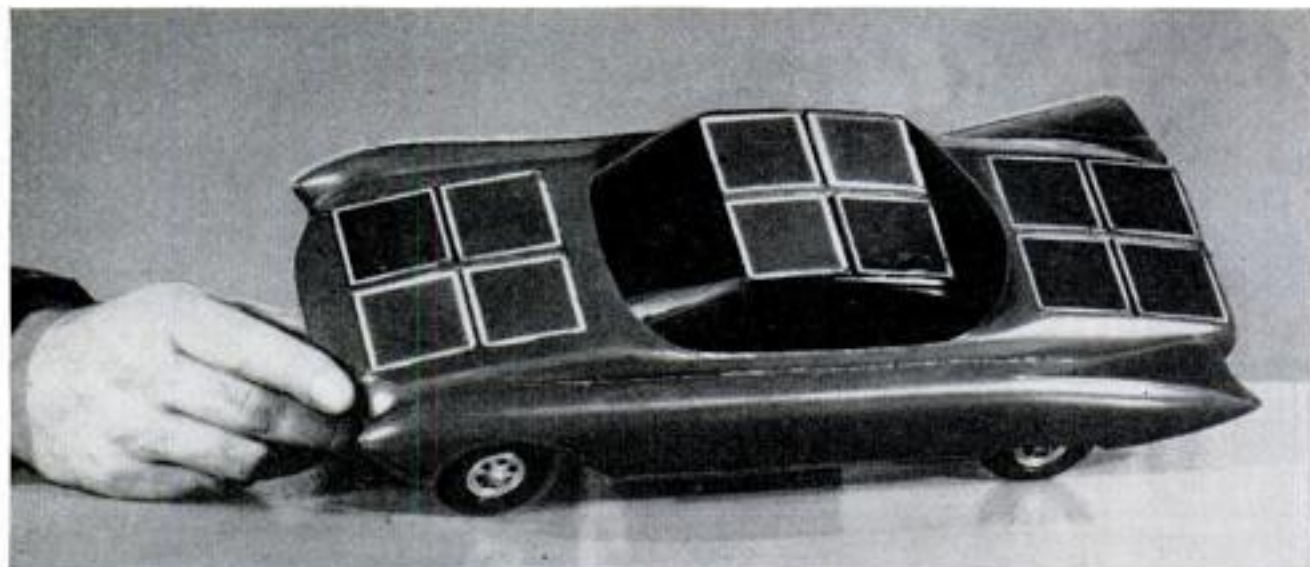

(Continued from page 8)

"Sunmobile"

Rays of light from Old Sol power a new car. Of course, the car is only 15 inches long but it demonstrates a possible power source of the future. Atop the "sunmobile" are 12 squares, each a photoelectric cell which converts light into electric current. The current then is used to power the model car. The cells are made of selenium, an element that has the property of turning light into electric power.

The "sunmobile" is being shown this

month at the General Motors' Powerama in Chicago. GM officials emphasize that solar power has no practical application to the automotive industry at present.

The little 15-inch car is one of the smallest exhibits at the Powerama. One of the largest is the new lightweight, high-speed train shown on our cover and described in a feature starting on page 81.

Occupying a 1,000,000-square-foot area on Chicago's lakefront, the Powerama dramatizes the importance of diesel and aircraft power in our modern economy.

New greaseless way to keep your hair neat all day



**Prevents dry, unruly
"feather-duster hair"**

New Vitalis keeps hair in place and prevents dryness with V-7, the *greaseless* grooming discovery.

You never have an overslick, plastered-down look. Try it. You'll like it.



ANOTHER FINE PRODUCT
OF BRISTOL-MYERS

New VITALIS® Hair Tonic with V-7.

POPULAR MECHANICS

Copyrighted material

You Practice **SERVICING** with Kits I Send You



Nothing takes the place of **PRACTICAL EXPERIENCE**. That's why NRI training is based on **LEARNING BY DOING**. You use parts I send to build many circuits common to Radio and Television. With my **Servicing Course** you build the modern Radio shown at left. You build a **Multitester** and use it to help make \$10, \$15 a week fixing sets in spare time while training. All equipment is yours to keep. Coupon below will bring book of important facts. It shows other equipment you build.

You Practice **BROADCASTING** with Kits I Send You



As part of my **Communications Course** I send you parts to build low-power **Broadcasting Transmitter** at left. Use it to get practical experience. You put this station "on the air" . . . perform procedures demanded of broadcasting station operators. An **FCC Commercial Operator's License** can be your ticket to a bright future. My **Communications Course** trains you to get your license. Mail coupon. Book shows other equipment you build for practical experience.

I Will Train You at Home in Spare Time to be a **RADIO-TELEVISION Technician**



TELEVISION Making Jobs, Prosperity

25 million homes have Television sets now. Thousands more sold every week. Trained men needed to make, install, service TV sets. About 200 television stations on the air. Hundreds more being built. Good job opportunities here for qualified technicians, operators, etc.

N.R.I. Training Leads to Good Jobs Like These

I TRAINED THESE MEN

"I have progressed very rapidly. My present position is Studio Supervisor with KEDD Television, Wichita."—Elmer Frewaldt, 2026 Stadium, Wichita, Kans.

"Fix sets part time in my shop. Made about \$500 first three months of the year. Could have more but this is about all I can handle."—Frank Borer, Lorain, Ohio.

"I've come a long way in Radio and Television since graduating. Have my own business on Main Street."—Joe Travers, Asbury Park, New Jersey.

"I didn't know a thing about Radio. Now have a good job as Studio Engineer at KMMJ."—Bill Deltzell, Central City, Nebraska.

BROADCASTING: Chief Technician, Chief Operator, Power Monitor, Recording Operator, Remote Control Operator. **SERVICING:** Home and Auto Radios, Television Receivers, FM Radios, P.A. Systems. **IN RADIO PLANTS:** Design Assistant, Technician, Tester, Serviceman, Service Manager. **SHIP AND HARBOR RADIO:** Chief Operator, Radio-Telephone Operator. **GOVERNMENT RADIO:** Operator in Army, Navy, Marine Corps, Forestry Service Dispatcher, Airways Radio Operator. **AVIATION RADIO:** Transmitter Technician, Receiver Technician, Airport Transmitter Operator. **TELEVISION:** Pick-up Operator, Television Technician, Remote Control Operator.



J. E. SMITH, President National Radio Institute Washington, D. C. Our 40th Year

America's Fast Growing Industry Offers You Good Pay, Success

Training PLUS opportunity is the **PERFECT COMBINATION** for job security, advancement. When times are good, the trained man makes the **BETTER PAY**, gets **PROMOTED**. When jobs are scarce, the trained man enjoys **GREATER SECURITY**. NRI training can help assure you and your family more of the better things of life. Radio is bigger than ever with over 3,000 broadcasting stations and more than 115 MILLION sets in use, and Television is moving ahead fast.

Start Soon to Make \$10, \$15 a Week Extra Fixing Sets

My training is practical, complete; is backed by 40 years of success training men at home. My well-illustrated lessons give you basic principles you need and my skillfully developed kits of parts "bring to life" things you learn from the lessons. I start sending you special booklets that show you how to fix sets the day you enroll. Multitester you build with my parts helps you discover and correct set troubles, helps you make money fixing neighbors' sets in spare time while training. Many make \$10, \$15 a week extra this way.

Mail Coupon — Find Out What Radio-Television Offer You

Act now to get more of the good things of life. I send actual lesson to prove NRI home training is practical, thorough. My 64-page book "How to be a Success in Radio-Television" shows what my graduates are doing and earning. It gives important facts about your opportunities in Radio-

Television. Take NRI training for as little as \$5 a month. Many graduates make more than the total cost of my training in two weeks. Mail coupon now to: J. E. SMITH, President, Dept. 5JA, National Radio Institute, Washington 9, D. C. Our 40th year.

Good for Both—FREE

AVAILABLE to all qualified VETERANS UNDER G.I. BILLS

MR. J. E. SMITH, President, Dept. 5JA National Radio Institute, Washington 9, D. C. Mail me Sample Lesson and 64-page Book, FREE. (No salesman will call. Please write plainly.)

Name Age
Address
City Zone State
VETS write in date of discharge



Mail Today-Tested Way to Better Pay

World Famous KORIAM Hunting Knives

Just arrived from Solingen, Germany

3.95

DIRECT FROM IMPORTER TO YOU
Take your choice—all one low price!

These unique hand forged hunting knives are made by world-renowned craftsmen of SOLINGEN, GERMANY. Sharp, rugged blades are genuine KORIAM steel. The handsome, unusual designs have won recognition in sports circles throught Europe. American hunters and fishermen, too, have been quick in expressing their enthusiastic approval. Over 100,000 already sold here! Now you, too, can get your favorite design—direct from the importer at a rock-bottom price! The blades are actually sharp enough to shave with; will stand up against most rugged treatment. Genuine leather scabbards tailored for each knife—metal tipped for sharp pointed models. Lengths 9 to 10 inches. The tough, sturdy KORIAM steel made in Germany assures you years of dependable service. Their sleek graceful lines also provide ideal rec room or den decorations. Dandy gifts for men—and a sportsman's delight! Import supply limited. The low \$3.95 price for both knife and scabbard means you'll have to act fast! Send \$3.95 for prompt prepaid delivery, or order COD plus postage. Your money back if not delighted. Check desired model in coupon below.



A
Rhino
Maiden
Golden
Hued
Handle

B
Black
Forest
Hunting
Knife

NEW DELUXE
MODEL

C
Monarch
Stag &
Chrome
Handle
with
Tri-Color
Etched
Blade

FREE!

3 COLOR POLICE FLASHLITE

This famous 3 color police flashlight yours FREE for trying a Koriam Knife! Yes! It's yours to keep, even if you return the knife for full refund! Thousands sold for 1.98 and 2.98. Used by police everywhere. Push button color control: RED, GREEN or WHITE beams seen miles away. Get one free with each Koriam Knife ordered—while the supply lasts! RUSH COUPON NOW! This amazing offer will not last!



REG. 1.98

SPECIAL!

Swiss Army Knife



CAN
OPENER

10
TOOLS
IN
ONE

SCISSORS KNIFE

SAW

AWL

World-Famous Utility Knife

... deep-cut price ...

World famous utility knife used by Swiss Army Officers—now made by West Germany's cutlery craftsmen! Recognized by sportsmen as the most compact multi-purpose tool ever devised. Only 3 1/2 inches closed. No more searching for that needed tool! 10 precision-built tools always at hand! A "life-saver" for hunters, fishermen, hobbyists, motorists, mechanics. Terrific value at \$3.95. Order yours now!

MAIL TODAY!

Free Gift Coupon

THORESEN'S, Dept. 6-K-800B
352 Fourth Avenue, New York 10, N. Y.

RUSH Koriam Knife checked below on 5-day home trial. Include deluxe leather sheath plus FREE 3-Color FLASHLITE. If not satisfied, I'll return knife for quick refund and will KEEP flashlight for my trouble.

CHECK MODEL DESIRED:

A (Rhino Maiden) B (Black Forest) C (Monarch) D (Swiss Army)

Name _____

Address _____

Town _____ Zone _____ State _____

INVENTORS

Learn how to protect your invention. The U. S. Patent Laws provide that any new and useful art, machine, article of manufacture, or composition of matter, or any new and useful improvement thereof, may be patented if the act of invention is involved. Therefore, every inventor with a valuable invention should take advantage of the Patent Laws and proceed for patent protection in order to safeguard his rights.

A patent gives the inventor the exclusive right to prevent others from making, using, or selling the invention claimed in the patent for a period of seventeen years.

The Patent Laws were enacted for the benefit of the inventor to give him protection for the features of his invention which are patentable. These features must be properly and concisely set forth and claimed in a formal application for patent, in order to comply with the requirements of the Patent Laws. For that reason, unless the inventor is familiar with patent matters, he should engage a competent registered patent attorney or agent to represent him. We are registered to practice before the U. S. Patent Office and are prepared to serve you in the handling of your patent matters.

A specially prepared booklet entitled "Patent Guide for the Inventor", containing detailed information with respect to patent protection and procedure, together with a "Record of Invention" form will be promptly forwarded to you without obligation upon request.

CLARENCE A. O'BRIEN & HARVEY JACOBSON

Registered Patent Attorneys

51-J DISTRICT NATIONAL BUILDING
WASHINGTON 5, D. C.

AFTER SHAVING
**Dims Shine
 Feels Fine
 Doesn't Show**



Also available
 in Canada

Finishing touch for every shave!
 Neutral tint — crisp scent!

MENNEN
 AFTER-SHAVE TALC
FOR MEN

**"How to
 Become a
 Mail Order
 Millionaire"**



Read the inside facts about hundreds of "little fellows" who are running Mail Order businesses from their homes—many making \$20,000 and more every year! Learn how small investments (\$16.80 in one case!) have mushroomed into profits of thousands. This incredible

**SENT
 FREE!**

RUSH NAME ON
 POSTCARD TODAY

reprint from *Mechanics Illustrated* will be sent absolutely free, along with details showing how you can quickly master the secrets of getting orders and money in your daily mail, in a business that's all yours. Rush name today. A postcard will do.

The L. W. SURVEY 805 Larrabee St., Dept. 19,
 Los Angeles 46, California

Learn ACCOUNTING
 Business Administration

Bookkeeping, secretarial and allied subjects at home in your spare time or attend nationally approved resident school. Write for FREE Success Book giving complete details on courses, plans, rates and employment opportunities. G.I. approved.



**Hills BUSINESS UNIVERSITY AND
 EXTENSION SCHOOL**
 619 W. MAIN ST. OKLAHOMA CITY 2, OKLAHOMA

REAL ESTATE
BE A BROKER

PAYS BIG! SEND FOR FREE, BIG, ILLUSTRATED CATALOG NOW! Graduates report making substantial incomes. Start and run your own business quickly. Men, women of all ages, learn easily. Course covers Sales, Property Management, Appraising, Loans, Mortgages, and related subjects. **STUDY AT HOME** or in classrooms in leading cities. Diploma awarded. Write TODAY for free book! No obligation.

**FREE
 BOOK
 TELLS
 HOW**

Approved for World War II and Korean Veterans
WEAVER SCHOOL OF REAL ESTATE (Est. 1936)
 2020 R Grand Avenue Kansas City, Mo.

BUILD LUGGAGE AT HOME
WE SELL YOUR PRODUCTS!

ONLY NEW HOME MONEY-MAKING PLAN IN YEARS!

Make Luggage and cases for traveling, photographers, musicians, salesmen, electronics, tools, portables, 1001 other items. Also repair Luggage. No special equipment needed. **BIG PROFITS.** We supply complete instructions, materials—everything. Write for free details and Business Plan. **ABARSI CASE-CRAFT, Dept. G-9, 805 W. Sunset Blvd., Los Angeles 12, Calif.**



INSURED TIRE SERVICE
POPULAR BRANDS

FREE INSURANCE POLICY given with each used tire sold. We guarantee the amount of service you pay for.
 NOWHERE CAN SUCH QUALITY BE FOUND AT SUCH LOW PRICE!

SPECIAL!
 Deduct 10% on orders for 2 or more used tires

**YOU CAN'T
 LOSE!!**

Super Quality — Rugged Performance — 15 Months Insured Service			
600x16	\$3.65	670x15	\$3.95
650x15	3.85	670x16	4.05
650x16	4.25	700x15	3.95
670x15	4.45	700x16	4.65
700x15	4.85	700x16	5.05
700x16	5.45	700x17	5.85
700x17	6.45	700x18	6.85
700x18	7.45	700x19	7.85
700x19	8.45	700x20	8.85
700x20	9.45	700x21	9.85
700x21	10.45	700x22	10.85
700x22	11.45	700x23	11.85
700x23	12.45	700x24	12.85
700x24	13.45	700x25	13.85
700x25	14.45	700x26	14.85
700x26	15.45	700x27	15.85
700x27	16.45	700x28	16.85
700x28	17.45	700x29	17.85
700x29	18.45	700x30	18.85
700x30	19.45	700x31	19.85
700x31	20.45	700x32	20.85
700x32	21.45	700x33	21.85
700x33	22.45	700x34	22.85
700x34	23.45	700x35	23.85
700x35	24.45	700x36	24.85
700x36	25.45	700x37	25.85
700x37	26.45	700x38	26.85
700x38	27.45	700x39	27.85
700x39	28.45	700x40	28.85
700x40	29.45	700x41	29.85
700x41	30.45	700x42	30.85
700x42	31.45	700x43	31.85
700x43	32.45	700x44	32.85
700x44	33.45	700x45	33.85
700x45	34.45	700x46	34.85
700x46	35.45	700x47	35.85
700x47	36.45	700x48	36.85
700x48	37.45	700x49	37.85
700x49	38.45	700x50	38.85
700x50	39.45	700x51	39.85
700x51	40.45	700x52	40.85
700x52	41.45	700x53	41.85
700x53	42.45	700x54	42.85
700x54	43.45	700x55	43.85
700x55	44.45	700x56	44.85
700x56	45.45	700x57	45.85
700x57	46.45	700x58	46.85
700x58	47.45	700x59	47.85
700x59	48.45	700x60	48.85
700x60	49.45	700x61	49.85
700x61	50.45	700x62	50.85
700x62	51.45	700x63	51.85
700x63	52.45	700x64	52.85
700x64	53.45	700x65	53.85
700x65	54.45	700x66	54.85
700x66	55.45	700x67	55.85
700x67	56.45	700x68	56.85
700x68	57.45	700x69	57.85
700x69	58.45	700x70	58.85
700x70	59.45	700x71	59.85
700x71	60.45	700x72	60.85
700x72	61.45	700x73	61.85
700x73	62.45	700x74	62.85
700x74	63.45	700x75	63.85
700x75	64.45	700x76	64.85
700x76	65.45	700x77	65.85
700x77	66.45	700x78	66.85
700x78	67.45	700x79	67.85
700x79	68.45	700x80	68.85
700x80	69.45	700x81	69.85
700x81	70.45	700x82	70.85
700x82	71.45	700x83	71.85
700x83	72.45	700x84	72.85
700x84	73.45	700x85	73.85
700x85	74.45	700x86	74.85
700x86	75.45	700x87	75.85
700x87	76.45	700x88	76.85
700x88	77.45	700x89	77.85
700x89	78.45	700x90	78.85
700x90	79.45	700x91	79.85
700x91	80.45	700x92	80.85
700x92	81.45	700x93	81.85
700x93	82.45	700x94	82.85
700x94	83.45	700x95	83.85
700x95	84.45	700x96	84.85
700x96	85.45	700x97	85.85
700x97	86.45	700x98	86.85
700x98	87.45	700x99	87.85
700x99	88.45	700x100	88.85
700x100	89.45	700x101	89.85
700x101	90.45	700x102	90.85
700x102	91.45	700x103	91.85
700x103	92.45	700x104	92.85
700x104	93.45	700x105	93.85
700x105	94.45	700x106	94.85
700x106	95.45	700x107	95.85
700x107	96.45	700x108	96.85
700x108	97.45	700x109	97.85
700x109	98.45	700x110	98.85
700x110	99.45	700x111	99.85
700x111	100.45	700x112	100.85
700x112	101.45	700x113	101.85
700x113	102.45	700x114	102.85
700x114	103.45	700x115	103.85
700x115	104.45	700x116	104.85
700x116	105.45	700x117	105.85
700x117	106.45	700x118	106.85
700x118	107.45	700x119	107.85
700x119	108.45	700x120	108.85
700x120	109.45	700x121	109.85
700x121	110.45	700x122	110.85
700x122	111.45	700x123	111.85
700x123	112.45	700x124	112.85
700x124	113.45	700x125	113.85
700x125	114.45	700x126	114.85
700x126	115.45	700x127	115.85
700x127	116.45	700x128	116.85
700x128	117.45	700x129	117.85
700x129	118.45	700x130	118.85
700x130	119.45	700x131	119.85
700x131	120.45	700x132	120.85
700x132	121.45	700x133	121.85
700x133	122.45	700x134	122.85
700x134	123.45	700x135	123.85
700x135	124.45	700x136	124.85
700x136	125.45	700x137	125.85
700x137	126.45	700x138	126.85
700x138	127.45	700x139	127.85
700x139	128.45	700x140	128.85
700x140	129.45	700x141	129.85
700x141	130.45	700x142	130.85
700x142	131.45	700x143	131.85
700x143	132.45	700x144	132.85
700x144	133.45	700x145	133.85
700x145	134.45	700x146	134.85
700x146	135.45	700x147	135.85
700x147	136.45	700x148	136.85
700x148	137.45	700x149	137.85
700x149	138.45	700x150	138.85
700x150	139.45	700x151	139.85
700x151	140.45	700x152	140.85
700x152	141.45	700x153	141.85
700x153	142.45	700x154	142.85
700x154	143.45	700x155	143.85
700x155	144.45	700x156	144.85
700x156	145.45	700x157	145.85
700x157	146.45	700x158	146.85
700x158	147.45	700x159	147.85
700x159	148.45	700x160	148.85
700x160	149.45	700x161	149.85
700x161	150.45	700x162	150.85
700x162	151.45	700x163	151.85
700x163	152.45	700x164	152.85
700x164	153.45	700x165	153.85
700x165	154.45	700x166	154.85
700x166	155.45	700x167	155.85
700x167	156.45	700x168	156.85
700x168	157.45	700x169	157.85
700x169	158.45	700x170	158.85
700x170	159.45	700x171	159.85
700x171	160.45	700x172	160.85
700x172	161.45	700x173	161.85
700x173	162.45	700x174	162.85
700x174	163.45	700x175	163.85
700x175	164.45	700x176	164.85
700x176	165.45	700x177	165.85
700x177	166.45	700x178	166.85
700x178	167.45	700x179	167.85
700x179	168.45	700x180	168.85
700x180	169.45	700x181	169.85
700x181	170.45	700x182	170.85
700x182	171.45	700x183	171.85
700x183	172.45	700x184	172.85
700x184	173.45	700x185	173.85
700x185	174.45	700x186	174.85
700x186	175.45	700x187	175.85
700x187	176.45	700x188	176.85
700x188	177.45	700x189	177.85
700x189	178.45	700x190	178.85
700x190	179.45	700x191	179.85
700x191	180.45	700x192	180.85
700x192	181.45	700x193	181.85
700x193	182.45	700x194	182.85
700x194	183.45	700x195	183.85
700x195	184.45	700x196	184.85
700x196	185.45	700x197	185.85
700x197	186.45	700x198	186.85
700x198	187.45	700x199	187.85
700x199	188.45	700x200	188.85
700x200</			

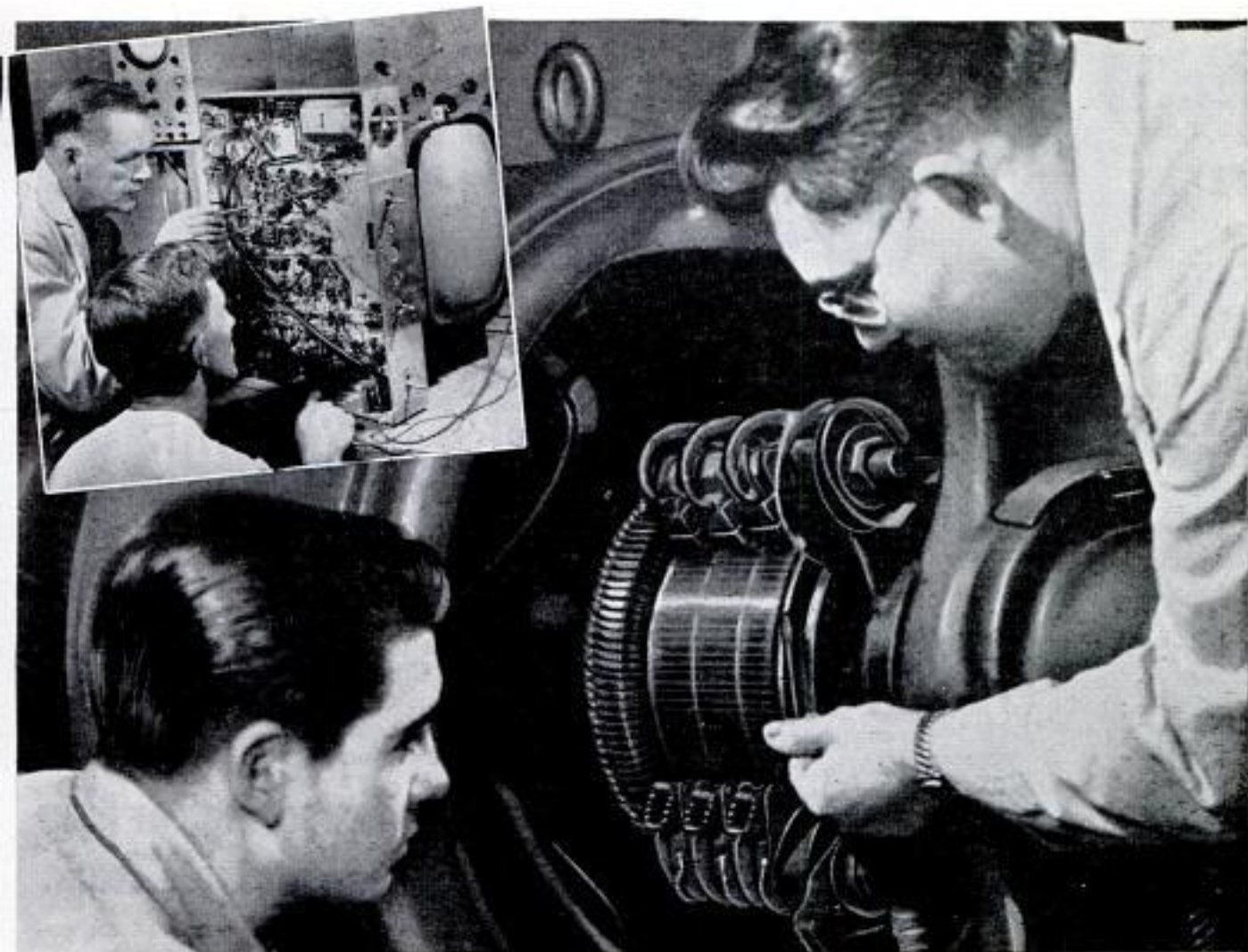

TRAIN FOR A FUTURE IN

Electricity or Television-Radio

**IN GREAT SHOPS OF COYNE—
Largest, Oldest, Best Equipped
School Of Its Kind In The U. S.**

Prepare quickly at Coyne for a career with a future!

Whether 17 or up to 45 years of age, prepare for your future now. Don't be satisfied with a "No Future" job. Train the Coyne way for a better job in a field that offers a world of opportunities in the years ahead.

WE TRAIN YOU IN CHICAGO

Learn the easier, practical way at Coyne, on real, full size equipment. No advanced education or previous experience needed. You learn better the Coyne way.

Train in the shops of Coyne—where thousands of successful men have trained for over 56 years—Coyne is the largest, oldest, best equipped school of its kind—established in Chicago in 1899.

FINANCE PLAN Enroll now. You may pay most of tuition later. We have a special plan for men of draft age.

CLIP COUPON NOW for big new illustrated Coyne book. No obligation; no salesman will call. Get vital facts now!

**APPROVED
FOR
VETERANS**

Mail Coupon

Today for

**BIG FREE
BOOK**

"Guide to Careers
in ELECTRICITY and
TELEVISION-RADIO"



B. W. COOKE, President
COYNE ELECTRICAL SCHOOL
500 S. Paulina St., Chicago 12, Ill., Dept. 65-72H

Send BIG FREE book and details of your training offer. This does not obligate me and no salesman will call. I am interested in:

ELECTRICITY TELEVISION-RADIO

Name.....

Address.....

City..... State.....

B. W. COOKE, Pres. **COYNE** FOUNDED 1899

ELECTRICAL SCHOOL

A TECHNICAL TRADE INSTITUTE OPERATED NOT FOR PROFIT
500 S. PAULINA ST., CHICAGO, Dept. 65-72H
ELECTRICITY ★ RADIO ★ TELEVISION ★ REFRIGERATION ★ ELECTRONICS



For Good Pay, Interesting Work, Security

Learn Electric Appliance Repair

AT HOME IN SPARE TIME

Build a better future. Get into a field where there is important work and the security that comes from knowing a good trade. The electrical appliance repair business offers OPPORTUNITY FOR YOU. Every wired home today has an average of 8 electrical appliances. Up to 10 million new appliances are sold every year. Owners pay well to keep them in repair and enjoy the convenience they provide. That means there's a fast growing need for trained men.

Opportunities Increasing For Men Who Know This Profitable Trade

You may want to be your own boss so you can enjoy the profits of your business. Or you may want to qualify for the better job of Service Manager or Supervisor in an Appliance Servicenter. Or perhaps you want to supplement your income doing electrical appliance repairs in your spare time. Opportunity in this growing field is great. Send for free book and see what the Electrical Appliance field offers you!

Pick up \$3, \$4, \$5 an Hour in Spare Time Starting Soon

Start soon to fix electric toasters, clocks, fans, vacuum cleaners, etc. for neighbors and friends. Spare time work done in your basement, garage, or spare room can earn you \$3 to \$5 an hour. See how easy it is to increase your earning power—how you can pay for this training many times over with spare time earnings.

Learn and Earn With This Appliance Tester You Get

This course includes the parts to build this sturdy portable appliance tester that helps you find electrical defects quickly and easily. You use it to learn and do actual electrical and appliance repair jobs. This multi-use tester helps you start making money soon after your training starts.



ACT NOW! Get Free Book And Sample Lesson

Actual lesson proves our method is clear, practical. Book gives facts about Electric Appliance opportunities and details of our training. Act now to make your future more secure.

Train Now for Greater Security Low Price—Easy Terms

Today's automatic electrical appliances need expert servicing. The man who knows a good trade like appliance repair has a secure future. Put your spare time to good use. Invest \$2.50 down and \$5.00 a month in a better future. Write Electrical Appliance Training, National Radio Institute, Dept. AJ5, Washington 9, D. C.

MAIL COUPON TODAY

NATIONAL RADIO INSTITUTE

Dept. AJ5, Washington 9, D. C.

Please send me Electrical Appliance Training Lesson and Book Free. (No salesman will call.)

Name _____ Age _____

Address _____

City _____ Zone _____ State _____

INVENTORS

If you believe that you have an invention, you should find out how to protect it. The first step is to have a search made of the prior pertinent U. S. patents. If a report on this search indicates that the invention appears patentable you can apply for a patent, and the specifications and claims should be prepared.

The firm of McMorrow, Berman & Davidson, with offices in Washington, D. C., is qualified to take the necessary steps for you. We can make a preliminary search on your invention, advise you whether we think it can be patented, and prepare your application for patent.

Unless you are fully familiar with the U. S. Patent Laws, we recommend that you engage the services of a Registered Patent Attorney to protect your interests. The patent laws are *your* laws. A patent gives you the right to prevent others from making, using or selling the invention claimed in your patent for a period of 17 years.

Use these patent laws for your protection. Investigate whether your invention can be patented. If you have what you believe to be an invention, we suggest that you have this firm make a search for you.

Send for a copy of our Patent Booklet entitled "How To Protect Your Invention," containing information about patent protection and patent procedure. Along with this we will also send you an "Invention Record" form, for your use in writing down and sketching details of your invention. We will mail them promptly. No obligation. They are yours for the asking.

McMORROW, BERMAN & DAVIDSON

Registered Patent Attorneys

PATENTS • COPYRIGHTS • PATENTS

135-K VICTOR BUILDING, WASHINGTON 1, D. C.

DRAFTSMEN



**CASH BIG
PAY CHECKS!**

**Train Now for
more success,
greater security**

**LEARN AT HOME IN SPARE TIME
(or at college in Chicago)**

Check the want ads in any newspaper—SEE the big-pay opportunities open to you as a draftsman. What's more, you can learn this well-paid, prestige profession at home—quickly, easily! No special talent needed. Get complete, step-by-step Chicago Tech lessons in the mail, spend a few pleasant hours studying each week. In a short time you'll be a well-trained draftsman, ready to take your pick of many good jobs. Act now!



Free Information—Mail Coupon Today!

Get FREE TRIAL LESSON plus information about C.T.C. practical training. Learn what successful Chicago Tech graduates say about high pay and opportunities in drafting. No charge, or obligation.

CHICAGO TECHNICAL COLLEGE

M-253 Tech Bldg., 2000 So. Michigan Ave.
Chicago 16, Illinois

Mail me FREE lesson with facts about big opportunities
in DRAFTING.

Name _____ Age _____

Address _____

City _____ Zone _____ State _____

Automatic STOP-THIEF SAFETY BOX RINGS

5 Hours at
Slightest Touch

**MAKE \$1,000
A MONTH**

Selling Only 3 a Day!



It's easy to make big money introducing new solid steel safety box with built-in alarm. 10-second demonstration convinces owners of stores, taverns, homes, offices they need "stop-thief" protection for cash, jewelry, valuable papers, etc. You make up to \$16.45 on each one. Fully guaranteed. \$1,000 Burglary Policy at no extra cost to each buyer.

Write for FREE Sales Kit NOW!

Start earning big money fast with money-making kit sent FREE. For full-size Demonstrator on 30-day money-back trial, enclose \$20. Write:

Alarm-O-Safe Division, MERLITE INDUSTRIES
114 East 32nd St. Dept. A-19 New York 16, N. Y.

Sells 40 Boxes in
Just 10 Minutes!
"The order
I wrote this
afternoon
will be the
most money
I ever made
in a 10-minute
period. I took an
order for 40 ALARM-
O-SAFES... the
most wonderful
product I have ever
sold."—Ed Alter, Pa.



**KEEP YOUR CAR
BATTERY
FULLY CHARGED
AT HOME!**



With a NORKO CHARGER, you charge your battery at home—overnight—without disconnecting cables or removing battery from car. And you get better service—much longer life—from a battery kept fully charged.

**Priced as low
as \$14.95**

A dependable NORKO CHARGER is the handiest automotive device you'll ever own. Quickly pays for itself. Operates from 110-volt home power. Compact, lightweight; sets on floor or shelf or hangs from wall. Models for 6 and 12-volt batteries. Sold by most auto stores.

If your dealer can't supply, send for FREE catalog. Many thousands of wise motorists own NORKO CHARGERS. Get yours now.

SCHAUER MANUFACTURING CORP.

4532 Alpine Ave.

Cincinnati 36, Ohio

TELEPHONES

Desk Stand Style

Slightly used but in excellent condition

Many Valuable Uses

Inter-House Phones House to Barn, etc.
Loud Speakers Microphones
Educational Purposes, Toys, etc.



Come complete, ready to use with wiring diagrams included. **\$2.75** Postpaid in U.S.A.

Two complete for only \$5.00
TELEPHONE LAMP KIT—with illustrated instructions for making Desk Telephone Lamp including all parts (harp, nipples, push switch, cord, plug, etc.) \$8.50 Ppd. (Shade is not included).

MICROPHONE, Dept. X3002, 1760 W. Lunt Ave., Chicago 26, Ill.

earn as TAX EXPERT

**\$15
HOUR**

Our students earn as much as \$3,000 in 3 short months preparing income tax returns in spare time. Also operate lucrative year-round Business Tax Service. Dignified home-office business. Experience unnecessary. We train you; help you start. State approved home training program. Write today for free prospectus.

UNION INSTITUTE, 68 Hudson, Hoboken 208, N. J.

LEARN PLASTICS



**COMPLETE LOW COST SHOP METHOD
HOME TRAINING NOW AVAILABLE**

Get in on Big Money opportunities in Plastic molding, casting, forming, carving, etc. Earn as you learn with Interstate's professionally prepared course. All plastic materials furnished.

**WRITE FOR
FREE
BOOKLET**

INTERSTATE TRAINING SERVICE
DEPT. C-3, PORTLAND 13, OREGON

WRITE: BREVITYPE INSTITUTE, SAN DIEGO, CALIF., DEPT. 1821

**LEARN THE WORLD'S SIMPLEST,
SPEEDIEST SHORTHAND** WRITE FOR
FREE LESSONS

FREE—please send me typical lessons, details on Brevitype—world's simplest, speediest shorthand—first machine shorthand to eliminate coding. Tell me how I learn Brevitype in 1/2 the time through your personally guided home-study course. Show me how switching to Brevitype, as hands-on here, prepares me for security as a stenographer, secretary, court or hearing reporter here, and abroad, in business or Civil Service—helps me increase my salary 50% to 100%. Include costs and budget plans.

**BREVITYPE
THE EASY-TO-LEARN MACHINE
SHORTHAND**



Guaranteed by
Good Housekeeping
as a safe investment
MODERN:
TYPEWRITER KEYBOARD!
NO CODING! FAST ABC!

THE BREVITYPE
MACHINE, WHICH
CARRIES THIS SEAL,
COMES WITH
THIS COURSE

Work with and keep all of this practical, commercial type equipment

"YOU LEARN BY DOING! THAT'S WHY D.T.I. GETS REAL RESULTS!"



21 INCH

Build and keep D.T.I.'s NEW 2 Unit TV Set—ideal for custom installation. (D.T.I. also offers home training without the TV set.)



Television, Radio, Electronics, has created thousands of good jobs; jobs with money, respect, position; jobs you may choose among—if you only had training. DeVRY Training is modern, thorough, practical—followed by a real Employment Service. Thousands have stepped into good pay—why not you? No need to leave home; no need to quit your present job; no special preliminary training required. Fill out coupon below and get the full story. Men 17 to 45 preferred.

Amazingly effective NEW home training in
TELEVISION RADIO ELECTRONICS

NEW STYRENE ELECTRO-LAB® SPEEDS LEARNING

Simply place a pictorial diagram under transparent Styrene base. Follow the diagram. Wiring is tremendously simplified. Work a total of over 300 learn-by-doing projects—a wonderful way to get practical experience.

*Trade-mark

One of America's Foremost Television Training Centers



You build and keep a quality Oscilloscope—almost a necessity for Television servicing. Helps you earn while you learn. You also build and keep a Vacuum Tube Voltmeter—a highly versatile test unit you can use when you are ready to make real money! IF PREFERRED, you may get all your preparation in D.T.I.'s big Chicago training laboratories—among the finest. (See building pictured below.) Valuable information for men subject to military service.

YOUR OWN HOME MOVIES

Movies are a remarkable feature of the D.T.I. System. You use a movie projector and many reels of films. Run off each film as often and as slowly as you want. A wonderful aid to help make important points crystal-clear. Get the full story! Send in that coupon.



Mail Coupon Today

DEVRY TECHNICAL INSTITUTE
4141 Belmont Ave., Chicago 41, Ill. Dept. PM-9-L

I would like complete facts including "89 Ways to EARN MONEY in Television-Radio-Electronics."

Name _____ Age _____

Street _____ Apt. _____

City _____ Zone _____ State _____

2 D.T.I.'s training is available in Canada.

89 WAYS TO EARN MONEY IN TELEVISION RADIO ELECTRONICS

DEVRY TECHNICAL INSTITUTE
FORMERLY
DEFOREST'S TRAINING, INC.
CHICAGO 41, ILLINOIS



**YOU
can
acquire**

LAW NIGHTS AT HOME! L. L. B. DEGREE

LaSalle's famous Law Library—used as reference in many Law Libraries and Law Offices—has enabled thousands to master Law surprisingly fast, in spare hours at home, for business and professional advancement.

These 14 remarkable volumes, compiled by leading professors and lawyers, cover the whole basic field of Law in condensed, orderly, simplified manner.

You advance rapidly with this great library, plus special lectures furnished. We guide you step-by-step with personalized Problem Method of instruction . . . you learn by doing—handling legal problems—not by memorizing rules.

Send for two FREE 48-page booklets, "Law Training for Leadership," and "Evidence," answering questions about Law and its value to you, and telling how LaSalle Law graduates are winning rapid advancement in business and public life. Mail coupon below. No obligation,

LA SALLE EXTENSION UNIVERSITY A Correspondence Institution

417 S. Dearborn St. Dept. 964L Chicago 5, ILL.

Send me your two FREE booklets described above, without obligation.

Name.....Age.....

Street.....

City, Zone & State.....

EAT ANYTHING WITH FALSE TEETH

If you have trouble with plates that slip, rock and cause sore gums—try Brimms Plasti-Liner. One application makes plates fit snugly without powder or paste, because Brimms Plasti-Liner hardens permanently to your plate. It relines and refits loose plates in a way no powder or paste can do. No need to pass up your favorite foods. With plates held firmly by Plasti-Liner, **YOU CAN EAT ANYTHING!** Simply lay soft strip of Plasti-Liner on troublesome upper or lower. Bite and it molds perfectly. *Easy to use, tasteless, odorless, harmless to you and your plates. Removable as directed. Money back if not completely satisfied. Special Bonus Offer!* Send only 10¢—we send you 35¢ package of Tri-Dent Denture Cleaner! Hurry, offer expires Nov. 30, 1955. Plasti-Liner Inc., Buffalo 11, N. Y.—Dept. 35.



BRIMMS PLASTI-LINER THE PERMANENT DENTURE RELINER

**A "GOOD HAND" HELPS YOU SUCCEED!
LEARN TO WRITE WELL**

Your Name
beautifully written, plus special pen-point for shaded writing. **Only 10¢**

Handwriting quickly improves with our easy-to-understand picture lessons! Put your spare time to good use; send today for FREE BOOKLET, "How to Become a Good Penman," or check volumes wanted below at \$1 each: Business Writing Artistic Writing Card Writing Bird & Design Flourishing Engraving Alphabets, COMPLETE SET \$4.50. Ask for price list of penman's supplies.

TAMBLYN SCHOOL of PENMANSHIP
S.A. Ziller, Pres., 442 Ridge Bldg., Kansas City, Mo., USA

GROW MINIATURE TREES
Grow authentic, LIVE dwarf trees!
Fascinating hobby! Fabulous profit!

SEND FOR FREE SEED & INSTRUCTIONS!

MINIATURE NURSERY CLUB
Dept. JJ-9, Box 8794,
Los Angeles 8, Calif.

MONEY in WORMS

Make thousands of dollars raising and selling fishworms and crickets—Start in backyard or basement—No odor—No experience necessary. Free Literature—No obligation. Write **CARTER WORM RANCH, PLAINS, GEORGIA**

'How to MAKE MONEY with Simple CARTOONS'

A book everyone who likes to draw should have. It is free; no obligation. Simply address **FREE BOOK**

CARTOONISTS' EXCHANGE
Dept. 99D Pleasant Hill, Ohio

**CUT BUILDING COSTS 3/5!
Make Your Own Concrete BLOCKS and BRICKS
To Use or Sell**

New superior moulds make absolutely square, true, easy-to-lay blocks which will pass any building code. Production is fast . . . easy. One durable \$30 machine will make four 5"x8"x12" blocks per minute—1,000 a day. Pays for itself in one day! Sell blocks for big profit . . . or save 75 building cost for yourself. **POST CARD BRINGS FREE FOLDER.**

ECONOMY MFG. CO.
DEPT. P STONE MOUNTAIN, GA.

SOCK-O World's Most Powerful
SUPER SLINGSHOT
SILENT • RIFLE FAST • POWERFUL • ACCURATE
Great for small game, targets. 45 lb. pull. BIG sturdy Sock. Lively. Raw rubber. Sweet shooting! FREE! 100 steel balls, rubber and target. FREE!!! Thrilling SURPRISE PACKAGE with Two slings at \$2.95. Hurry, get 2! Guaranteed. Approved by American Small Game Sling-shot Assoc.

SOCK-O, PM, 4860 W. 137 St., Hawthorne, Calif.

Tells How You Can Learn to MOUNT BIRDS!

FREE BOOK

Learn At Home
Men, Boys, Hunters, Fishermen, mount and save your lovely wild-game trophies. Be a Taxidermist. Mount Birds, Animals, Heads, Fish, Tan skins. YOU learn easily, quickly in spare time. Have a grand home-museum. The finest and the greatest hobby known, for sportsmen. Fun, real profits.

Yes, FREE, Beautiful strange, valuable Book, telling all about Taxidermy. Contains over 100 beautiful game-pictures. And it's yours FREE, if you rush your request. You can mount all kinds of wild-game, and common specimens too. We can positively **TEACH YOU**. So GRASP this opportunity. **RUSH** letter or postal for this amazing **FREE BOOK**. Don't delay. State your AGE. **N. W. SCHOOL OF TAXIDERMY, 2509 Elwood Bldg., Omaha 2, Neb.**



National Schools Graduates Prove
**AGE & PREVIOUS EDUCATION
NO BARRIERS TO SUCCESS!**

Get into **HIGH-PAYING
TELEVISION
ELECTRONICS-RADIO!**

Are you
between
17-55?

LEARN AT HOME
IN SPARE TIME!

Are you
alert, sincere,
ambitious?



Master all Phases with our amazing
**Shop-Method Home Training & Practical
Equipment! We have trained Thousands
for Big-Pay Jobs! WE WILL TRAIN YOU!**



SET REPAIR IS PROFITABLE!

Our easy Shop-Method Lessons & Manuals cover this Profitable Field! **LOW TUITION.** Opportunity to **EARN AS YOU LEARN!** Free Placement Assistance. Help with technical and personal problems. Send coupon for free **ILLUSTRATED BOOK, "Your Future in TV-Radio-Electronics."**

**OPPORTUNITIES WIDE OPEN IN THESE
AND OTHER SPECIALIZED FIELDS!**

Leadspeaker Systems TV-Radio Service,
Hi-Fi, F.M., Tape Recording Installation-Repair
Your own business Sales and Distribution

COLOR TV & ELECTRONICS

— America's Fields of the Future!
Thousands of **TRAINED TECHNICIANS** will make "small fortunes" in the next few years.



**ATTENTION DRAFT-AGE
MEN!** National Schools
training prepares you for **HIGHER
RATINGS & PAY GRADES!**

NATIONAL SCHOOLS

TECHNICAL TRADE TRAINING SINCE 1905

Los Angeles 37, California Chicago: 323 W. Polk St.
In Canada: 811 W. Hastings St., Vancouver, B. C.

50 YEARS' EXPERIENCE

training Men Like Yourself for Success!

**KNOW YOUR
SCHOOL!**

These are the national headquarters of National Schools' famous Shops, Labs & Studios. Get your Home Training and "sheepskin" direct from Los Angeles, recognized as a major "World Center of Electronics!"



**APPROVED FOR G. I. TRAINING
BOTH HOME STUDY AND RESIDENT COURSES OFFERED**



YOU RECEIVE THIS PROFESSIONAL MULTITESTER—a must for every Technician! Also standard parts to build Receivers, Oscillators, Signal Generator, Continuity Checker, Short Wave & Standard Broadcast Superhet Receiver, many other units. All part of your course, all yours to keep. Mail coupon today!

You can't buy
these Valuable
Books, but we
send them **FREE!**
MAIL COUPON!



ACT NOW! MAIL NOW TO NEAREST OFFICE!

(mail in envelope or paste on postal card)

NATIONAL SCHOOLS, Dept. RB-95

4000 S. FIGUEROA ST., LOS ANGELES 37, CALIF. OR 323 WEST POLK ST., CHICAGO 7, ILL.

Please rush **FREE TV-Radio Book & Sample Lesson.** I understand there is no obligation, no salesman will call.

NAME _____ BIRTHDAY _____ 19 _____

ADDRESS _____

CITY _____ ZONE _____ STATE _____

Check if interested **ONLY** in Resident Training at Los Angeles. **VETERANS:** Give date of Discharge _____

You can have a career instead of a job

Industrial growth . . . automation . . . technical advances create tremendous opportunities for engineers, accountants, management experts. Share the rewards awaiting college trained men in engineering and commerce. Important concerns visit campus regularly to employ Tri-State College graduates. Start any quarter in this world-famed college. Approved for veterans.

Bach. of Science degree in 27 months

In Mechanical, Civil, Electrical, Chemical, Aeronautical, Radio (TV-Electronics), Administrative Engineering; Business Administration and Accounting. 36-weeks course in Drafting. Intensive program: technical fundamentals stressed; comprehensive courses with more professional class hours.

Small classes: personalized instruction. For earnest, mature students whose time and budget requires accelerated courses and modest costs. Preparatory courses. Beautiful campus in friendly college town. Well-equipped, new and modernized buildings and labs. Enter Sept., Jan., March, June. Write Jean McCarthy, Director of Admissions, for "Your Career in Engineering or Commerce".



TRI-STATE COLLEGE

495 College Avenue

Angola, Indiana

Say You Saw It in Popular Mechanics

AFTER BATH OR SHOWER—

DRY OFF!

Cool Off!

with new
pure white!

He-man
scent!



59¢

3 OZ. ECONOMY SIZE

Remember, It's Dangerous to Pay Less if You Want Better Tires



EXPERIENCE IS THE BEST TEACHER. OUR MANY YEARS PROVES YOU CAN'T GET MORE. WHY PAY MORE? LOW OVERHEAD—LARGE VOLUME SALES & SMALL PROFITS BRING YOU THESE "LOWEST PRICES."



WHAT GOOD IS A TIRE WITHOUT A TUBE? 22 YEARS AT THIS ADDRESS. ANNIVERSARY SALE. GOOD USED TIRES — NOT RECAPS

FREE If you buy 2 or more Passenger 4-ply tires, WE GIVE ONE tire FREE, on each order, on request. Does not include W.W. or Truck Tires. —FREE TUBES—

Specialists in Truck Tires—Selected for Toughest Jobs—Tops in Value

36 MOS. WRITTEN GUARANTEE WITH EVERY TIRE					
600-16	\$5.52	475-19	\$4.82	700-15(6)	\$7.52
600-16(6)	5.92	640-15	4.22	750-16(6)	8.72
650-16	5.72	670-15	5.52	700-17	8.82
650-16(6)	6.62	710-15	5.52	750-17	10.32
700-16	6.02	760-15	5.82	825-15	12.92
750-16(6)	7.32	800-15	5.92	800-20	9.02
550-18	4.52	820-15	5.92	650-20	9.82
550-17	3.72	670-16	5.32	32x6(8)	12.02
650-15	5.52	760-16	7.02	32x6(10)	13.92
700-15	4.92	700-16(6)	7.32	750-15	10.72

WHITE WALLS \$1.00 EXTRA

"EXTRA SPECIAL" Lot "NEAR NEW" all size 4-ply pass. FREE TIRE with 2 or more of these also.—W.W. \$1.00 Extra Factory Tested Tube with each tire—ANNIVERSARY SPECIAL **\$7.62 EA.**

Thousands of tires shipped all over the U.S.A. All tires shipped F.O.B. Phila. Send Check or M.O. with this ad. Dept. 2. No C.O.D. **STANDARD 834 N. Broad St., Philadelphia 30, Pa.**

RUPTURED

BE FREE FROM TRUSS SLAVERY

NOW there is a new modern Non-Surgical treatment that permanently corrects rupture. These Non-Surgical treatments are so certain, that a Lifetime Certificate of Assurance is given. Write today for our New FREE Book that gives facts that may save you painful and expensive surgery, and tells how non-surgically you may again work, live, play and love and enjoy life in the manner you desire. There is no obligation.

Excelsior Hernia Clinic Dept. 8305 Excelsior Springs, Mo.

Secrets of VENTRILOQUISM

Now Revealed!

Easy to learn in 60 to 90 days with our Home Study Course. **RESULTS GUARANTEED.** Make Money! Be Popular! Have Fun! Big Opportunity! Radio, Television, Stage Appearances! For FREE Information regarding price and terms, WRITE. You must state your age. Dummy Catalog 25c. **FRED MAHER SCHOOL OF VENTRILOQUISM** Box 36, Studio PM-9 Kensington Station Detroit 24, Michigan

LOOK! A MILLION THRILLS!

High Power **BINOCULARS**

30 DAY FREE TRIAL
Finest Precision Optics
Money Back Guarantee
Easy Pay Plan

33 Models
\$9.95 UP

BUSHNELL Binoculars

Free! Catalog & Book "How to Select Binoculars"

Dept. M9 43 E. Green Pasadena, Calif.

GARAGE YOUR CAR

Vinyl Plastic **ADD YEARS TO ITS LIFE!**

PORTABLE GARAGE



\$10 value
NOW ONLY \$6.95
POSTPAID

Beautiful opaque-white waterproof garage covers any car, anywhere, in seconds! Protects finish from rain, salt air corrosion, sun, dust! Keeps animals, prowlers away! Strong! Durable! Folds easily to small, compact size. Also covers boats, furniture, machinery, etc. Check or money order; no C.O.D. Immediate shipment.

GOTHAM HOBBY CORP. Dept. M9, 107 E. 126th St., New York 35

LOWEST
PRICES!
HIGHEST
QUALITY!

AMAZING
RECEPTION!

ENTIRELY
DIFFERENT!
NEW!

SAVE MONEY

NEW ULTRA-VIDEOSONIC long range TV

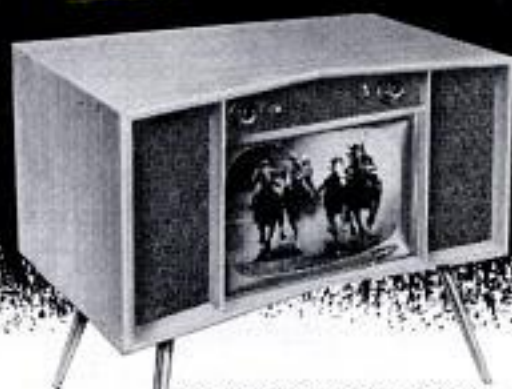

The **SUPER CONSTELLATION**—the most magnificent, unique Low Boy TV you've ever seen. The screen is 21-inch "plus", Unbelievably low price!

MIDWEST

FACTORY-TO-YOU LOW PRICES 30-DAY TRIAL PERIOD



The **CONQUEROR**—the greatest performance ever. Fabulous picture screen is 21-inch "plus". Priced extra low.



The **TOWN & COUNTRY**—long range TV at its best. Famous MIDWEST screen is 21-inch "plus". Sensational low price.

ONLY MIDWEST DARES TO GIVE YOU A 30-DAY TRIAL

You and you alone are the final judge of MIDWEST quality and performance because we give you the privilege of a 30-day trial right in your home! If you don't agree with thousands, that here is a TV receiver that meets all our claims for quality, tone and performance, return the set to us. Any money you've paid us will be refunded at once. No other manufacturer has dared to make this offer.

MAIL COUPON FOR FREE 1956 VALUE- PACKED CATALOG OF MIDWEST ULTRA-VIDEOSONIC TV RECEIVERS

We want you to have one—they're absolutely free! Honestly, our catalog is jam-packed with a wealth of information on the new MIDWEST 1956 models, including comprehensive technical data, beautiful illustrations, complete instructions for ordering through the 30-day trial plan and a host of other interesting, informative facts about how to buy the right kind of TV set. Your catalog will show you how MIDWEST sets are specially engineered to deliver day-in, day-out trouble-free performance with the clearest, brightest picture you've ever seen. And wait until you see the beautiful styles and designs, the luxurious finishes that will lend charm and distinction to your home.

ALL SETS CARRY FAMOUS MIDWEST WARRANTY!

FREE



YOU CAN'T BEAT MIDWEST FACTORY-TO-YOU LOW PRICES ON TV

MIDWEST has no dealers—no retail outlets—no tremendous advertising budget. That's why our prices are lower—much lower! Make us prove it . . . write for our catalog and see for yourself. BUT, while our prices are low, our quality is HIGH. No time, effort, or materials have been spared to produce these magnificent TV receivers. The new MIDWEST 1956 catalog is full of beautiful TV receivers from Table Models to Consoles. Giant, new screens are 21-inch "plus." You'll find one you like at the price you can afford.

HUNDREDS OF THOUSANDS OF SATISFIED CUSTOMERS

We here at MIDWEST Radio & Television Corporation are proud of the reputation we have built over the last 36 years. Thousands of families have discovered, as we know you will, that MIDWEST is the most honored name in the industry. MIDWEST has always delivered a product of the highest quality at a price that everyone can afford.

YOUR FRIENDS AND NEIGHBORS WILL BE IMPRESSED

When the huge screen, 21-inch "plus", of your new MIDWEST Ultra-Video-sonic TV lights up and brings you the clearest, sharpest picture you've ever seen . . . even if you're in the poorest fringe area . . . your friends will be simply amazed. And when the golden tones from the Panasonic speaker floods the room . . . well, that will top it all off, and everyone will know that you own the very best television receiver in the neighborhood, a MIDWEST Ultra-Video-sonic TV.

MIDWEST RADIO & TELEVISION CORP., DEPT. A-2
909 Broadway, Cincinnati 2, Ohio

Send FREE 1956 MIDWEST TV Catalog. No obligation on my part.

NAME _____

ADDRESS _____

CITY _____

STATE _____

MIDWEST

RADIO & TELEVISION CORP. • DEPT. A-2 • 909 BROADWAY, CINCINNATI 2, OHIO



IF YOU "EAT, SLEEP
AND LIVE" CARS...

TURN YOUR HOBBY INTO A CAREER!

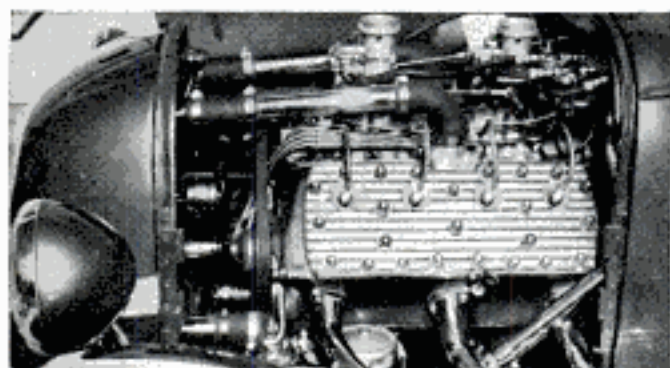

Get America's Big-time, Big-future

AUTO MECHANICS & DIESEL COURSE *at home in your spare time!*

Los Angeles' National Schools, America's automotive Technical Trade School since 1905, now brings its famous resident Shops and Faculty direct to you at home—to prepare you to earn more money, with job security, in today's fast-moving, opportunity-filled Auto Mechanics Industry! Get your home training from the "Car Capital of the World"—America's most auto-minded city, center of Hot Rod and Sports Car activity! Mail coupon right now!

"SHOP-METHOD" HOME TRAINING!

YOU MASTER ALL PHASES, INCLUDING DIESEL! All lessons fully illustrated. Latest equipment covered.



THIS SET OF LIFETIME TOOLS IS YOURS! Also all-metal tool box. Part of your course, yours to keep. **EARN WHILE YOU LEARN!** We show you how to start Spare Time Earnings soon after enrollment.

ATTENTION MEN OF DRAFT AGE. Learn how you can achieve higher rating and pay. Mail coupon *at once!*

APPROVED FOR G. I. TRAINING. Both Home Study & Resident Courses. Free help with technical and personal problems—Job Placement Service.



Send for **FREE FACT-BOOK AND SAMPLE LESSON!**

NOW! 2 offices to serve you faster!
Mail coupon today to one nearest you!

NATIONAL SCHOOLS

Technical Trade Training Since 1905

LOS ANGELES 37, CALIFORNIA

IN CANADA: 811 West Hastings Street, Vancouver, B. C.

MAIL NOW TO OFFICE NEAREST YOU!

(mail in envelope or paste on postal card)

NATIONAL SCHOOLS, Dept. DB-95

4000 S. FIGUEROA STREET OR 323 WEST POLK STREET
LOS ANGELES 37, CALIF. OR CHICAGO 7, ILLINOIS

Send **FREE** Auto-Mechanics Book and Sample Lesson.
No obligation, no salesman will call.

NAME _____ BIRTHDAY _____ 19__

ADDRESS _____

CITY _____ ZONE _____ STATE _____

Check if interested **ONLY** in Resident School Training at Los Angeles.
VETERANS: Give Date of Discharge _____

Bean's Free Fall Catalog



Just Off the Press

Fully illustrated, 104 pages, showing Hunting Footwear, Clothing, and one hundred and twenty other leather and canvas specialties of our own manufacture for campers and hunters.

L. L. Bean, Inc., 328 Main St., Freeport, Maine
Mfrs. Hunting and Camping Specialties

**BE A
LEADER
IN
AVIATION**

Parks graduates are known world-wide as leaders in aviation — their education is the finest offered. Advance faster . . . earn more in less time! Become a Parksman!

B.S. degree in 3 yrs. from Saint Louis University — Aero. Eng., Aero. Adm., Maint. Eng.

Non-degree courses—A & E Mechanics, Private, Commercial, Instrument, Flight Instructor and Multi-engine Ratings . . . CAA-Approved.

All Parks schooling approved for Veterans. Write for full information.

PARKS COLLEGE ARNOLD HALL
EAST ST. LOUIS, ILL.

SHINE WITHOUT 'POLISH'

New Invention! • Sells Like Wild



Replaces messy pastes, liquids. Simply glide over shoes—and rub! —you have a lustrous, long-lasting shine. No mess, no fuss. Shoes gleam like mirror. For Men's, Women's, Children's Shoes. *Take orders! Earn money!*

SAMPLES FOR TRIAL

Sample offer sent to all who send name at once. Postcard will do. **SEND NO MONEY—just your name.** KRISTEE CO., Dept. 683, AKRON 8, OHIO

AGENTS START BUYING SERVICE AT HOME

GET BIG NAME MERCHANDISE

for your clients up to 40% less than reg. price. Operate sparetime. Sales easy as you can give sizeable discounts, still make fat comm. Postcard brings free plan.

AMERICAN BUYERS SERVICE

HERTEL STATION, DEPT. R, BUFFALO 16, NEW YORK

**GET
UP TO
40%
OFF**

Free Book on Arthritis And Rheumatism

HOW TO AVOID CRIPPLING DEFORMITIES

An amazing newly enlarged 44-page book entitled "Rheumatism" will be sent free to anyone who will write for it.

It reveals why drugs and medicines give only temporary relief and fail to remove the causes of the trouble; explains a proven specialized non-surgical, non-medical treatment which has proven successful for the past 36 years.

You incur no obligation in sending for this instructive book. It may be the means of saving you years of untold misery. Write today to The Ball Clinic, Dept. 756, Excelsior Springs, Missouri.

Accept Colorful Booklet FREE

Portrays Picture-Fact way that registers information quickly through fact-revealing pictures

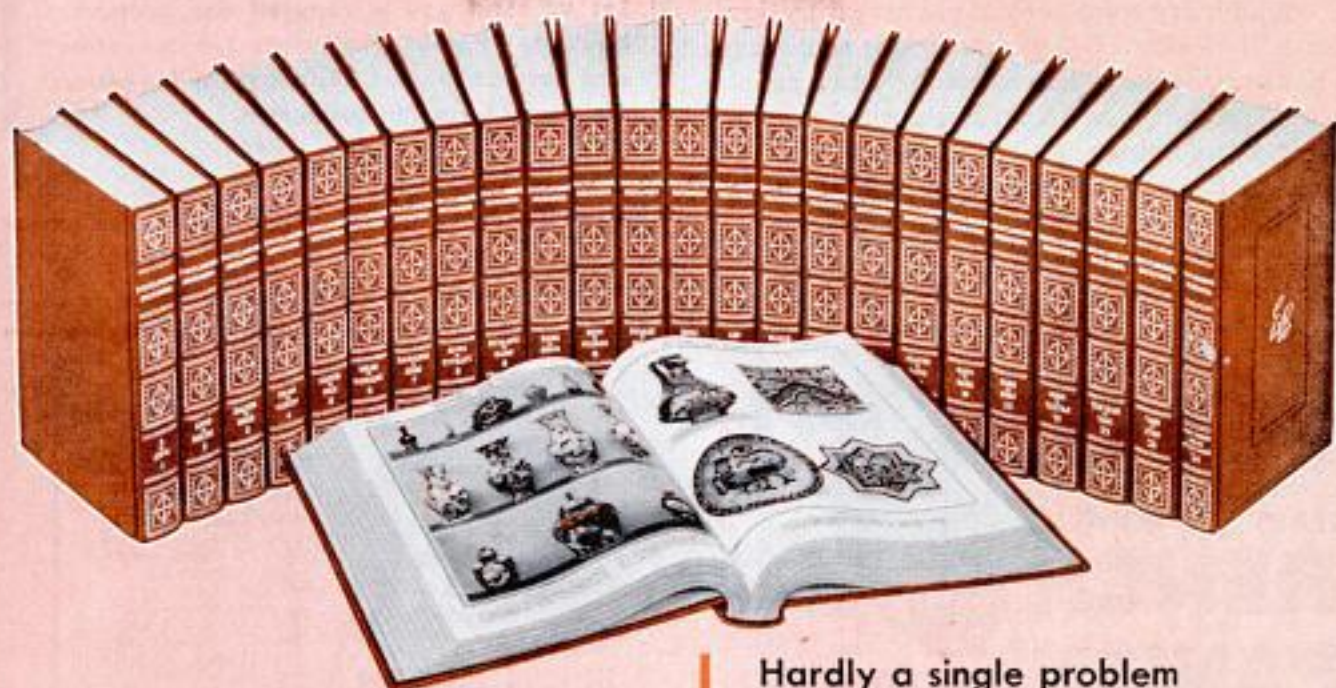

Anyone can afford Britannica.
No one can afford to be uninformed.

Hardly a single problem
arises in daily life that this
great work cannot help you solve.

Yes, now anyone can own and profit by the greatest of all encyclopaedias the **Famous Encyclopaedia Britannica** Get all 24 volumes Now—on the easy Book a Month Payment Plan

The New Edition of the world-famed ENCYCLOPAEDIA BRITANNICA is now available.

Unlike old-fashioned "dry as dust" references, this great 24-volume encyclopaedia almost "televises" the information for you. It attempts to convey with pictures, facts that would take thousands of words. Actually 25,181 pictures, plus charts, maps and drawings are used in this way. It is called the Picture-Fact presentation, that makes an encyclopaedia fascinating to look through, thrilling to consult.

But this new edition does not merely show "attractive" pictures. It is the work of 4,891 of the world's best minds. The final authority on factual knowledge. A constant inspiration that will enrich the lives of yourself and your family.

Now to acquaint new thousands with this great advancement in the realm of knowledge, ENCYCLOPAEDIA BRITANNICA, nearing its 200th birthday, is offering a colorful 32-page booklet free on one condition. That condition is simply—you show it to a

neighbor. There is no other obligation.

Accept while they last, one of these valuable booklets. Mail the coupon now while this deluxe booklet is still available.

You'll be delighted—you'll thank us for sending it. If you have a family—by all means don't miss this free offer.



This Booklet **FREE** on Show-It-To-A-Neighbor Plan

ENCYCLOPAEDIA BRITANNICA INC., DEPT. 24-G
425 N. Michigan Avenue, Chicago 11, Illinois

Please let me have the FREE PREVIEW BOOKLET and complete details about the Book a Month Payment Plan. I agree to show booklet to a neighbor—there is no other obligation.

NAME

ADDRESS

CITY ZONE STATE

In Canada, write E. B. Ltd., Terminal Bldg., Toronto, Ont.

INVENTORS

WE recommend that you take the following preliminary steps toward patent protection. Make a disclosure of your invention; sign, date and have your disclosure witnessed by two people who understand your invention; authorize us to conduct a preliminary search among previously granted U. S. patents for similar types of invention. We give you a report on the probable patentability of your invention and our recommendation for further course of action.

Let us send you a copy of our instructive booklet, "Patent Protection for Inventors" and our convenient "Evidence of Invention" disclosure form. No obligation.

VICTOR J.
EVANS & Co. *Merlin M. Evans*
REGISTERED PATENT ATTORNEY
130-K MERLIN BUILDING, WASHINGTON 6, D. C.

SEND FOR
Free Record
START SPEAKING
FRENCH
OR
SPANISH ALMOST OVERNIGHT!

HERE'S the easiest way to learn FRENCH, SPANISH, Russian, German, Italian, Japanese or Brazilian. Listen to FREE 2-sided non-breakable record. Let your eyes follow words in FREE sample lesson. Almost at once you'll be chatting in a new language with a perfect accent! That's all you hear! No memorizing needed. Just listen—imitate! It's that easy! Offer may end soon. Rush 25c to help cover cost of special packaging, shipping. State language you want. We'll also send free information on full Cortina course. CORTINA ACADEMY, Dept. 649, 136 W. 52nd St., New York 19.

Learn ELECTRIC APPLIANCE REPAIR
IN
YOUR SPARE TIME AT HOME



START YOUR OWN BUSINESS

ONE BUSINESS THAT IS NOT AFFECTED BY STRIKES, DEPRESSIONS OR POLITICS

WITH A POTENTIAL MARKET OF 50,000,000 CUSTOMERS

New shop-method, home-training system gives you electrical know-how that used to take years to learn. Learn at home by building valuable testing kits, repairing your own and neighbors' appliances. It is not unusual for appliance repairmen to charge on the basis of \$5.00-\$8.00 an hour.

FREE ILLUSTRATED BOOK

Shows you how you learn every phase of electrical appliance. How to make money while you learn. Write today for your FREE copy.

CHRISTY TRADES SCHOOL
Dept. D-4603
4804 North Kedzie Ave., Chicago 25



BURNS MARTIN

Dept. 817, 121 Summer St.,
Boston 10, Mass.

FREE CLOTHING CATALOG

We SPECIALIZE in large-size men's clothing. Sizes 44 to 72 and 17 to 22 fitted perfectly from America's LARGEST STOCK of BIG MEN'S shirts, slacks, suits, pajamas, etc. Top quality at low prices, so send for your NEW BIG CATALOG NOW. It shows EVERYTHING for the big man . . . and it is FREE!

TASOPE PHOTO-ENGRAVING PLANTS



Material Cost
Of This Cut 3/4c
Selling Price
\$1.00 And Up

Establish your own profitable PHOTO-ENGRAVING business. Make cuts for newspapers, printers, and advertisers. Make etched name plates, plaques etc. Instructions furnished, no experience necessary. Sold direct from factory since 1931. First five hundred cuts sold locally or by mail will pay for plant and pay you well for your time. Write for FREE catalog.

TASOPE, DEPT. PM-9, AURORA, MO.



MECHANICAL DENTISTRY

A profession offering unlimited opportunities. Most modern and complete course embracing every branch from Plate to Porcelain Work, which prepares you to work for Dentists or start your own business. Individual instruction—practical training in day or night school. No books—no classes. Catalog upon request.

McCARRIE SCHOOL OF MECHANICAL DENTISTRY
207 N. Broad Street Dept. 43 Philadelphia 7, Penna.

Send for **FREE** 112 page
Illustrated Catalog of Farm, Home,
and Workshop Bargains.

Write to **WELLWORTH TRADING COMPANY**
Dept. E-9

1832 S. WABASH AVE. CHICAGO 16, ILL

FULL SIZE MODEL KITS!



\$5.95

THE ORIGINAL — Improved

Complete, improved detail, easy to build. The original kit. Wood with pieces for gun metal finish. ORDER THESE MODELS DIRECT. Ideal for use at home room.

NEW illustrated catalog of 7 models. For Catalog, Send 10¢ to:

O'BRIEN GUNCRAFT (B) P.O. BOX 657 MADISON, WIS.

Learn BAKING At Home

Baking is one of America's high industries in wages. Nearly DEPRESSION-PROOF. Thorough basic home course lays sound foundation. If you have aptitude, write for FREE Booklet, "Opportunities in Commercial Baking."

NATIONAL BAKING SCHOOL
835 Diversey Parkway Dept. 1356 Chicago 14, Ill.



POPULAR MECHANICS

Copyrighted material

THERE'S A "SECRET" TO EASY AUTO REPAIRS... and this giant book is it!



FIX CARS THIS EASIER, FASTER WAY!

Now! Even beginners can handle practically ANY job on ANY make, model or part!

TUNE UP, pep up, fix up ANY automobile . . . even if you've never repaired a car before! Handle practically any job "slick as a whistle"!

A tune-up? New rings? Ignition or carburetor troubles? Brake or clutch problems? A valve job? Something wrong with power steering or an automatic transmission?

This giant, 4 3/4 pound CHILTON REPAIR MANUAL tells what to do . . . then shows you just how to do it.

No guess work! You handle repairs easier and faster than you may have dreamed.

YOU WON'T "MISS" WITH DATA LIKE THIS TO GUIDE YOU!

Chilton covers practically every part of every model of the leading 20 car makes from June 1940 . . . over 600 models!

Tells what work-saving shortcuts to take . . . what adjustments to make . . . what parts to use . . . what mistakes to avoid . . . even what tools to use. "Minor" details, often so puzzling to beginners, are made crystal clear.

From beginning to end, it's an honest-to-goodness HOW-TO-FIX-IT guide that you use right at the bench.

Contains 904 giant pages; 58 Quick Guide Troubleshooting Charts; 353 Quick Check Data Tables and thousands of service and parts specifications. Almost 3,000 pictures make things doubly clear.

Use Manual for 10 days AT OUR RISK. If it's not all you expect return it postpaid AND DON'T OWE US A PENNY! Send coupon to Dept. PM-95 Chilton Co., 5605 Chestnut St., Philadelphia 39, Pa.



GIANT ENLARGED EDITION

904 BIG PAGES — WEIGHS 4 3/4 POUNDS! ALMOST 3,000 HOW-TO-FIX-IT PICTURES!

Covers Every Model of These 20 Makes Since 1940

BUICK	DE SOTO	HENRY J.	MERCURY	PLYMOUTH
CADILLAC	DODGE	HUDSON	NASH	PONTIAC
CHEVROLET	FORD	KAISER	OLDSMOBILE	STUDEBAKER
CHRYSLER	FRAZER	LINCOLN	PACKARD	WILLYS

BY THE WORLD'S LARGEST AUTOMOTIVE PUBLISHERS!

Published in big new, revised edition each year by CHILTON home of Motor Age, Automotive Industries, Commercial Car Journal magazines, etc. IT PAYS TO GET THE BEST! (Chilton Books are sold by leading book stores.)

PRACTICE 10 DAYS FREE!

THE CHILTON CO., Dept. PM-95
5605 Chestnut St., Philadelphia 39, Pa.

Send me the big 904-page CHILTON "ALL CARS" REPAIR MANUAL (Price \$6.95) for 10-day FREE EXAMINATION. If I like Manual, I will then promptly remit \$1.95 (plus 45¢ postage and handling); then send \$2.50 each month for two months. Otherwise I will return manual postpaid in 10 days and owe you nothing. **SAVE!** Send \$6.95 with order and we pay postage-handling charge. Same return privilege.

Name

Address

City, Zone, State

(OUTSIDE U.S.A.—Price \$8.95 cash with order. 10-day return privilege with money refunded.)

EARN BIG PAY

Industry needs skilled mechanics. GREER, leader for more than 50 years in the Trade School field, can train you quickly—You "learn by doing," using the finest equipment, under the supervision of expert technicians.

APPROVED FOR CIVILIANS OR GI'S

—CHOOSE YOUR TRADE—

CHECK HERE	WEEKS
<input type="checkbox"/> DIESEL MECHANICS	20
<input type="checkbox"/> AUTO MECHANICS	20
<input type="checkbox"/> BODY & FENDER	16½
<input type="checkbox"/> GAS-ARC WELDING	4-12
<input type="checkbox"/> REFRIGERATION	13½
<input type="checkbox"/> AIR CONDITIONING	8½
<input type="checkbox"/> MACHINIST TRADE	30
<input type="checkbox"/> ADVANCED MACHINIST (includes tool & die)	32½
<input type="checkbox"/> PIANO TUNING & REPAIR	36

CHOOSE YOUR ENGINEERING COURSE

These courses are intended as terminal education for men who wish to enter the Diesel-Automotive and Refrigeration-Air Conditioning fields as technicians. These courses are designed to prepare men for supervisory positions. Students with a high school education, or equivalent, will be accepted.

<input type="checkbox"/> DIESEL AUTOMOTIVE ENGINEERING	2 years
<input type="checkbox"/> REFRIGERATION & AIR COND. ENGINEERING	18 months

HOME STUDY COURSES

Learn at Home — Approved for Civilians & G.I.s. Write for detailed information on Courses in

- PLASTICS
 REFRIGERATION & AIR-CONDITIONING
 DIESEL ENGINES

FREE EMPLOYMENT HELP

Start your career with Greer by checking your interest above and mail coupon for complete information at no obligation.

NAME _____ AGE _____

STREET _____

TOWN _____ ZONE _____ STATE _____

Established 1902 — Over 50,000 Graduates.
 53 years of continuous trade school experience
 to guide your training.

GREER SHOP TRAINING
 Box 1, 2236 S. Michigan Ave.
 Chicago 16, Illinois



WIN YOUR WAR against INSECTS!

NEW miracle Lindane kills flies, sandflies, mosquitoes, flying moths, wasps, spiders, roaches, silverfish. Simply light amazing EXTERMO cones, containing Lindane—and insects are killed. Lights easily, burns like a cigarette! No oily spray or residue—no tricky gadgets. 16 EXTERMO Cones and burner \$1 postpaid. Full year's supply, 48 Cones, \$2. GUARANTEED or your money back. Sorry, no C.O.D.'s. Mail to **AVON-STRAND, CO. 2620 So. Dearborn, Chicago Ill.**

OWN a Business

If employed, start part time. Alert Dealers can gross \$5 hourly profit on own service plus \$3 on EACH serviceman. Clean, revive, moth-proof rugs & upholstery on location. No shop needed. Services nationally advertised. Repeat customers. Easy to learn. We locally train and assist you. Quickly established. Easy terms. Send today for FREE booklet. No obligation.

DURACLEAN CO., 5-109 Duraclean Bldg., Deerfield, Ill.

SEND FREE!

Make money. Know how to break and train horses. Write today for this book FREE, together with special offer of a course in Animal Breeding. If you are interested in Gaiting and Riding the saddle horse, check here () Do it today—now.

BEERY SCHOOL OF HORSEMANSHIP
 Dept. 1109 Pleasant Hill, Ohio

MONEY in DONUTS

Make new gross sales donuts. Start in kitchen. No smoke. Sell stores. Cash daily. No experience necessary. Free recipes. No obligation. Write to **MARTIN RAY CO., 3605 SO. 15th AVENUE, MINNEAPOLIS 7, MINN.**

BECOME AN EXPERT IN TRAFFIC

Traffic men earn \$4,000 to \$10,000 and up. Thousands of firms need experts on rates, tariffs, regulations. We train you thoroughly in spare time at home for executive traffic jobs. Personal training under traffic authorities. Placement counsel and help. Write for free 48-page book "Traffic Management—the Fast Growing Profession."

LASALLE Extension University, 417 So. Dearborn St.
 A Correspondence Institution Dept. 964T Chicago 5, Ill.

How To Hold FALSE TEETH

More Firmly in Place

Do your false teeth annoy and embarrass by slipping, dropping or wobbling when you eat, laugh or talk? Just sprinkle a little FASTEETH on your plates. This alkaline (non-acid) powder holds false teeth more firmly and more comfortably. No gummy, gooey, pasty taste or feeling. Does not sour. Checks "plate odor" (denture breath). Get FASTEETH today, at any drug counter.

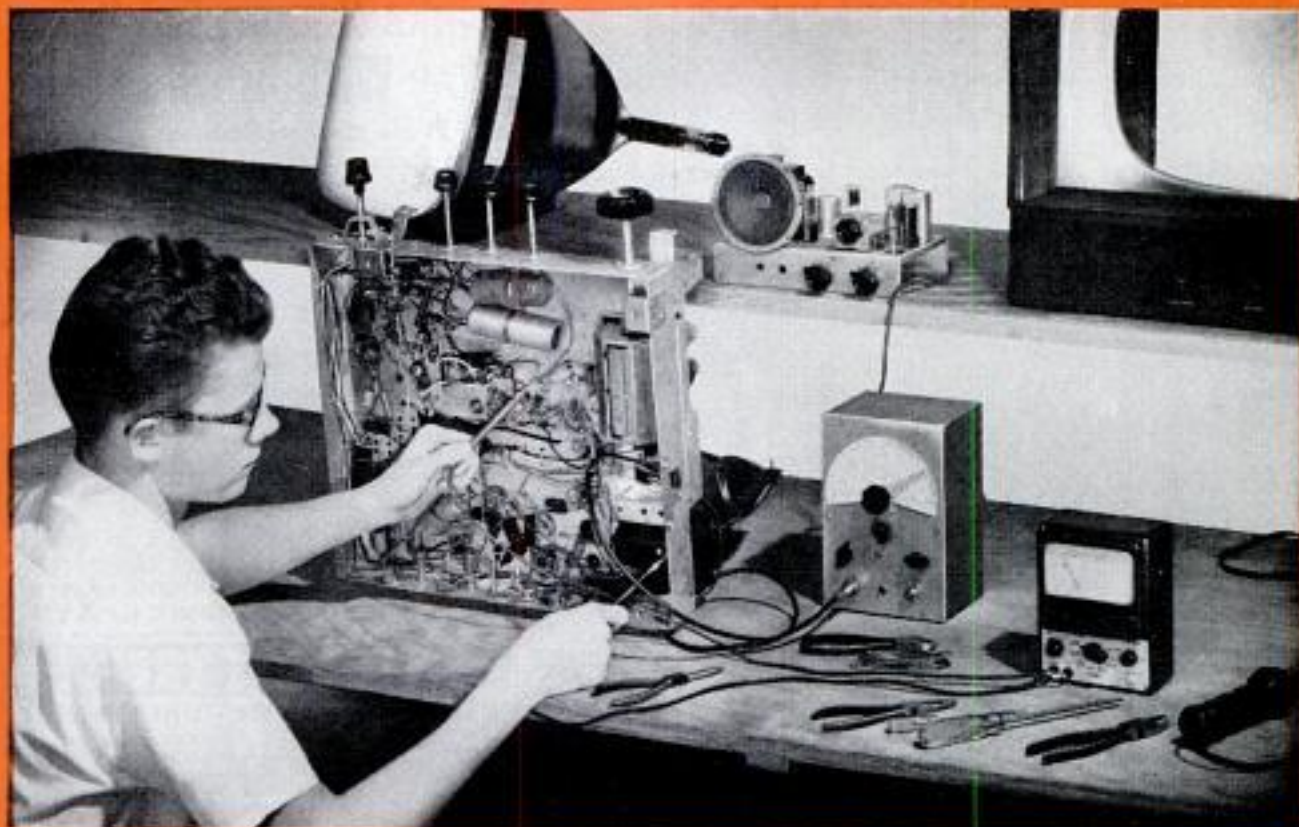

NOW... RCA TRAINS YOU AT HOME IN RADIO-TV ELECTRONICS

NEW AND UP-TO-DATE HOME STUDY COURSE . . . Clearly written by men with years of servicing and teaching experience. Easy to understand step-by-step instruction.

NO PREVIOUS EXPERIENCE REQUIRED. This Home Study Course was specifically prepared for students with no previous electronics training . . . for those who want a sound foundation in this exciting field.

A PRACTICAL COURSE . . . You receive completely workable kits and perform valuable experiments to demonstrate the theory learned. In fact, many students will be able to do service work *even before* they complete all the lessons.

YOU BUILD AND KEEP THESE FINE INSTRUMENTS SHOWN

- a multimeter
- a 6 tube superheterodyne receiver
- an r.f. signal generator
- a television receiver

SINCE 1909, RCA INSTITUTES trained thousands of men in Radio-TV Electronics in our Resident Classes. Many have well-paying jobs in industry; some have established their own business. *Now* this opportunity is available to you at home.

"PAY-AS-YOU-LEARN" PLAN . . . There is no binding contract. You pay for one study group at a time, as

you progress through the course. The cost for everything—including the high quality equipment that you receive and build—is amazingly low. **RCA INSTITUTES**—a service of Radio Corporation of America—is licensed by the New York State Education Department . . . recommended by radio and television service organizations.

**SEND FOR
FREE
CATALOG
NOW**



RCA INSTITUTES, INC.
A SERVICE OF RADIO CORPORATION OF AMERICA
350 WEST FOURTH STREET, NEW YORK 14, N.Y.

RCA Institutes, Inc., Home Study Dept. PM-95
350 West 4th Street, New York 14, N. Y.

Without obligation, send me **FREE CATALOG** on the Home Study Course in Radio-TV-Electronics. No salesman will call.

Name _____ Please Print

Address _____

City _____ Zone _____ State _____

WHAT ALL AUTO MECHANICS WANT TO KNOW

1664 PAGES



This Big Practical Book gives full information with working diagrams covering the principles, construction, ignition, service and repair of modern cars, trucks and buses.

Diesel Engines, Hydrumatic & Fluid Drives Fully Explained.

A complete Guide of 1664 pages, with over 1500 illustrations showing inside views of working parts, with instructions for service jobs.

IT PAYS TO KNOW

How to fit pistons—How to locate engine knocks, How to fit connecting rod bearings—How to service main bearings—How to recondition valves—How to time valves—How to adjust fan belts—How to adjust carburetors and chokes, How to rebuild a clutch—How to service automatic transmissions—How to service brakes—How to adjust steering gear—How to cope with ignition troubles—How to service distributors—How to time ignition—How to "tune up" an engine.



\$4 COMPLETE • PAY \$1 A MO. TO GET THIS ASSISTANCE FOR YOURSELF SIMPLY FILL IN AND MAIL COUPON TODAY.

Step up your own skill with the facts and figures of your trade. Audels Mechanics Guides contain Practical Inside Trade Information in a Handy Form. Fully illustrated and Easy to Understand. Highly Recommended. Check the book you want for 7 DAYS FREE EXAMINATION. Send No Money. Nothing to pay postman.

MAIL ORDER



Check NOW!

You Can Look Over Any Guide In Your Own Home — Start the Easy Payments If Satisfied

MAIL THIS TODAY



AUDEL, Publishers, 49 W. 23 St., NEW YORK 10, N. Y.

Please send me postpaid for FREE EXAMINATION books marked (x) below. If I decide to keep them I agree to mail \$1 in 7 Days on each book or set ordered and further mail \$1 monthly on each book or set until I have paid price, otherwise I will return them.

- AUTOMOBILE MECHANICS GUIDE, 1664 Pages, \$4
- TRUCK & TRACTOR GUIDE, 1299 Pages . . . 4
- DIESEL ENGINE MANUAL, 575 Pages . . . 2
- MACHINISTS HANDY BOOK, 1650 Pages . . . 4
- WELDERS GUIDE, 400 Pages . . . 1
- BLUE PRINT READING, 416 Pages . . . 2
- MATHEMATICS & CALCULATIONS, 700 Pages. 2
- SHEET METAL PATTERN LAYOUTS, 1100 Pages 4
- SHEET METAL WORKERS HANDY BOOK, 388 Pgs. 1
- MECHANICAL DRAWING GUIDE, 160 Pages . . 1
- MECHANICAL DRAWING & DESIGN, 480 Pages 2
- AIRCRAFT WORKER, 240 Pages . . . 1
- TELEVISION SERVICE MANUAL, 434 Pages . . 2
- RADIONANS GUIDE, 1040 Pages . . . 4
- ELECTRONIC DEVICES, 216 Pages . . . 2
- ELECTRIC MOTOR GUIDE, 1000 Pages . . . 4
- WIRING DIAGRAMS (Light & Power), 272 Pgs. 1
- ELECTRICIANS EXAMINATIONS, 250 Pages . . 1
- ELECTRIC POWER CALCULATIONS, 425 Pages. 2
- HANDY BOOK OF ELECTRICITY, 1440 Pages. . 4
- ELECTRIC DICTIONARY, 9000 Terms . . . 2
- ELECTRIC LIBRARY, 7000 Pages (12 Book Set) 18
- SHIPFITTERS HANDY BOOK, 250 Pages . . . 1
- REFRIGERATION & Air Conditioning, 1280 Pgs. 4
- MILLWRIGHTS & MECHANICS GUIDE, 1200 Pgs. 4
- POWER PLANT ENGINEERS GUIDE, 1500 Pages 4
- ENGINEERS & FIREMANS EXAMS, 525 Pages . 1
- PUMPS, Hydraulics & Air Compressors, 1658 Pgs. 4
- OPERATING ENGINEERS LIBRARY (3 Books) . . 9
- MECHANICAL DICTIONARY, 950 Pages . . . 4
- GARDENERS & GROWERS GUIDES (4 Book Set) 6
- CARPENTERS & BUILDERS GUIDES (4 Book Set) 6
- PLUMBERS & Steamfitters Guides (4 Book Set) 6
- MASONS AND BUILDERS GUIDES (4 Book Set) 6
- PAINTERS & DECORATORS MANUAL, 450 Pgs. 2
- HOUSE HEATING GUIDE, 1000 Pages . . . 4
- OIL BURNER GUIDE, 384 Pages . . . 1
- HOME APPLIANCE SERVICE GUIDE, 800 Pages 4

Name _____
 Address _____
 Occupation _____
 Employed by _____ P-9

Shrinks Hemorrhoids New Way Without Surgery

Science Finds Healing Substance That Relieves Pain—Shrinks Hemorrhoids

For the first time science has found a new healing substance with the astonishing ability to shrink hemorrhoids and to relieve pain—without surgery.

In case after case, while gently relieving pain, actual reduction (shrinkage) took place.

Most amazing of all—results were so thorough that sufferers made astonishing statements like "Piles have ceased to be a problem!"

The secret is a new healing substance (Bio-Dyne*)—discovery of a world-famous research institute.

This substance is now available in suppository or ointment form under the name Preparation H.* Ask for it at all drug counters—money back guarantee. *Reg. U. S. Pat. Off.

EARN EXTRA MONEY GROWING MIDGET TREES!

AT HOME • SPARE TIME • FOR FUN AND PROFITS!

It's New! Amazing! FULL GROWN living dwarf trees—only 12 INCHES HIGH! Elm, orange, oak, cypress—any kind! ALL BLOOM and even BEAR FRUIT! Perfect, healthy specimens, but miniature! Make costly home decorations and beautiful expensive centerpieces (sold for over \$1,500 each). It's Fast! A new fascinating artistic HOBBY—a new \$88888 HOME BUSINESS! Real seed and nutritional new growing plan detail. DOTSE ABSOLUTELY FREE!

FREE! GENUINE SEED AND PLAN

NATIONAL NURSERY GARDENS, Dept. M-9
 8463 SOUTH VAN NESS, INGLEWOOD 4, CALIFORNIA

FALSE TEETH KLUTCH holds them tighter

KLUTCH forms a comfort cushion; holds dental plates so much firmer and snugger that one can eat and talk with greater comfort and security; in many cases almost as well as with natural teeth. Klutch lessens the constant fear of a dropping, rocking, chafing plate. 35c and 60c at druggists . . . If your druggist hasn't it, don't waste money on substitutes, but send us 10c and we will mail you a generous trial box.

KLUTCH CO. Box 5593-I ELMIRA, N. Y.

"I MADE \$45 In My FIRST SPARE HOURS As A Lucky Heart Representative!"

Mr. Greenwood, Calif.

You, Too, Can Earn This Easy Way!

Need extra money? Mr. Greenwood made \$45.00 cash in his first spare hours. A busy mother in California made \$715 in just spare time. Now it's your turn to cash in!

NO EXPERIENCE NEEDED!

Just show exclusive quality Lucky Heart Cosmetics to people you know and like. Nationally advertised Perfumes, Skin Creams, Hair Products, Negro beauty aids needed in every home sell on sight. A \$10.00 order can pay you \$5.00 cash profit! It's easy to take ten big orders in several hours and have \$50.00 extra money to use as you please! ACT NOW.

Write today for full facts and amazing FREE Display Case Offer!

LUCKY HEART, Dept. 86J
 400 Mulberry Street, Memphis 2, Tenn.

Write for FREE DISPLAY CASE OFFER!

**Do YOU Want to Qualify for
A BETTER JOB AT BIGGER PAY?**



CLIMB TO SUCCESS!

in Spare Time at Home

• Jobs are calling—calling to those who want more responsible jobs, in bigger pay brackets, with increasing chances for promotion—and who have the ambition to devote some of their spare time to acquiring necessary knowledge and skill. As little as just a few hours a week, in time you can easily spare, can produce surprising results in lifting you up to higher and higher levels of employment, income and security—even eventually to management positions or a business of your own. In the coupon below are listed some of the large number of training opportunities offered by AMERICAN SCHOOL—now in its 58th year. Check the one that interests you most and fill in your name and address. Or if you prefer some other career, write the subject in the margin. Then mail the coupon without delay.

—FULL INFORMATION...NO COST...NO OBLIGATION—

AMERICAN SCHOOL, Dept. G645, Drexel at 58th, Chicago 37, Ill.

Without obligation, please send FREE and postpaid, full particulars about the subject checked below.

- | | | |
|--|---|---|
| <input type="checkbox"/> Accounting | <input type="checkbox"/> Diesel Technician | <input type="checkbox"/> Mechanical Engineering |
| <input type="checkbox"/> Apprenticeship Courses | <input type="checkbox"/> Drafting—Building Trades | <input type="checkbox"/> Mechanical Technology |
| <input type="checkbox"/> Architecture & Building | <input type="checkbox"/> Drafting—Machine Trades | <input type="checkbox"/> Metalworking Courses |
| <input type="checkbox"/> Automotive Technician | <input type="checkbox"/> Electrical Engineering | <input type="checkbox"/> Plumbing—Practical |
| <input type="checkbox"/> Better Foremanship | <input type="checkbox"/> Electricity—Practical | <input type="checkbox"/> Private Secretary |
| <input type="checkbox"/> Bookkeeping | <input type="checkbox"/> Electronics—Industrial | <input type="checkbox"/> Retail Merchandising |
| <input type="checkbox"/> Business Management | <input type="checkbox"/> HIGH SCHOOL COURSES | <input type="checkbox"/> Salesmanship—Outside |
| <input type="checkbox"/> Civil Engineering | <input type="checkbox"/> Machine Shop Operations | <input type="checkbox"/> Sheet Metal Work |
| <input type="checkbox"/> Contracting | <input type="checkbox"/> Mathematics & Slide Rule | <input type="checkbox"/> Tool Making |

Name _____ Occupation _____

Home Address _____ Age _____

City _____ State _____

Canadian Residents: Write American School, 1610 Sherbrooke St., West, Montreal

EARN WHILE YOU LEARN AT HOME

How to Make Money in PHOTOGRAPHY

If you are OVER 17—good pay, fascinating work await you in photography! Start making money quickly in sparetime—step into your own studio or exciting job.

LEARN-BY-DOING method trains you at home! Write TODAY for FREE catalog. Also Resident Training, 46th Year! GI Approved.

NEW YORK INSTITUTE OF PHOTOGRAPHY
Dept. 49, 10 W. 33 St., New York 1, N.Y.

Send for FREE BOOK

LEARN LOCKSMITHING

Learn this fascinating, profitable trade from experts in your spare time at home! Age or physical handicap no disadvantage. Year around, steady income. Full or part time. Practical, illustrated lessons. You can make money even while learning! All materials and special tools supplied without extra charge.

INSTITUTE OF LOCKSMITHING, Dept. P-70
15 PARK AVENUE RUTHERFORD, N. J.
Lic. by N.J. State Board of Education
Approved for Veterans

send for FREE BOOKLET

SHORTHAND IN 6 WEEKS

Write 120 words per minute
Age no obstacle—LOWEST COST

Famous SPEEDWRITING shorthand. No symbols; no machines; uses ABC's. Easiest to learn and use. Fast preparation for a better position. Nationally used in leading offices and Civil Service, 120 words per minute—50% FASTER than Civil Service requirements. Over 300,000 taught by mail or through classroom instruction. The very low cost will surprise you. Typing available. 32nd Year. Schools in over 400 cities in U.S., Canada, Cuba, and Hawaii.

WRITE FOR FREE BOOKLET TO SCHOOL OF

Speedwriting
Dept. 1509-5, 55 W. 42 St., N.Y. 36

This Sealed Book LOANED To You

THOUSANDS EVERYWHERE ACCLAIM THIS New Psychology Of Life!

Have you unrealized hopes? Are the better things of life always just beyond your reach?

Times have changed—but have you? Adopt a new psychology of life and MASTER YOUR PROBLEMS. It takes no greater mental effort to achieve results when you know how.

Let the Rosicrucians show you how, by the use of simple laws, you can apply the powers of your mind to bring about startling changes in your life. If you are sincere in your desire, write for the free Sealed Book. It will point out how you may obtain this most helpful information. Address: Scribe N.Q.K.

The Rosicrucians (AMORC)
SAN JOSE CALIFORNIA

"My selling time actually shows me a profit of

\$20 TO \$25 AN HOUR

with Science's New Midget Miracle, the
PRESTO Fire Extinguisher

says M. R. Stanley of Montana. Many others "cleaning up"—so can YOU!

THIS is an amazing new kind of fire extinguisher. Tiny "Presto" (about the size of a flashlight) does job of bulky extinguishers that cost 4 times as much, and are 8 times as heavy. Ends fires fast as 2 seconds. Fits in palm of hand. Never corrodes. Guaranteed for 20 years! Sells for only \$3.98! Over two million already sold!

Show it to civil defense workers, owners of homes, cars, boats, farms, etc., and to stores for re-sale. Make good income. C. S. Mellous made \$175 in just first 5 days. C. Kama, \$1,000 a month. Write for FREE Sales Kit. No obligation.

(If you want a regular Presto to use as a demonstrator, send \$2.50. Money back if you wish.)

**MERLITE INDUSTRIES, Dept. 59, Presto Div.,
114 East 32nd St., New York 16, N. Y.**

(In Canada: Mopa Co., Ltd., 371 Dowd St.,
Montreal 1, P. Q.)

Science's
New Midget
Miracle—
"PRESTO"

"YOU ARE UNDER ARREST!"

There's a Thrill in Bringing a Crook
to Justice Through Scientific

CRIME DETECTION!

We have taught thousands this exciting, profitable, pleasant profession. Let us teach you, too, in your own home. Learn Finger Printing, Fire Arms Identification, Police Photography and Criminal Investigation thoroughly, quickly and at small cost.

Be A
**FINGER
PRINT
Expert**

FREE!!!
Send for Thrilling
"BLUE BOOK
OF CRIME"

Over 800 of All American Bureaus of Identification employ students or graduates of I. A. S. You, too, can fit yourself to fill a responsible crime detection job with good pay and steady employment. But don't delay—get the details now. Let us show you how easily and completely we can prepare you for this fascinating work, during spare time, in your own home. Write today stating age.

INSTITUTE OF APPLIED SCIENCE

(A Correspondence School Since 1918)

1920 Sunnyside Ave., Dept., 1356, Chicago 40, Ill.

SAY YOU SAW IT IN POPULAR MECHANICS

America's Great Diamond Values

OUT OF
PAWN...

SAVE UP
TO 50%
and more
Diamonds
from Estates,
Banks, and
Unredeemed
pledges

**GENUINE
DIAMONDS**

VALUES FROM \$10 TO \$10,000

TOP
QUALITY

Send for
Brand New
36 PAGE
FREE
ILLUSTRATED
CATALOG

Over 100,000
satisfied customers
have bought their
diamonds from
Berman's

MONEY-BACK GUARANTEE

ALL DIAMONDS RESET IN BRAND
NEW MODERN MOUNTINGS

Our Reference: Your own bank or any mercantile agency.

Berman's Diamond Loan Bank
Dept. P —BERMAN BLDG., BALTO. 1, MD.

WORTH 2¢ or \$2000 ?

DISCOVER HIDDEN TREASURE!

Amazing FREE Stamp Identifier (profusely illustrated) clearly shows difference between the many rare and common U. S. stamps that look exactly alike. Extra! Big illustrated U. S. Catalog; 64 pg. Collector's Guide. Other special offers for your free consideration. Mailed with Roosevelt commemorative stamps. Send 10c for handling.

H. E. Harris & Co., 1104 Transit, Boston



FREE BOOK



ON RUPTURE CARE
Contains much helpful information. Shows how thousands have been helped by the comfortable, safe WEB Truss. Write today to:

WEB TRUSS CO. Dept. M-9 HAGERSTOWN, MD.

MAKE TREMENDOUS PROFITS

Have fun! Earn Big Money! Cast plaster figurines, bookends, plaques, novelties at home in your spare time with N.L. rubber molds! NO EXPERIENCE NEEDED! Molds and rubber for 3 molds, only \$1.50 ppd. Send 25c (refunded with order) for 40 page catalog now!

**PLASTIC ARTS STUDIO 3403 SO. MADISON, DEPT. PM2
MUNCIE, INDIANA**

CABINET MAKING



**LOW COST HOME TRAINING COURSE
FOR BEGINNERS & ADVANCED CRAFTSMEN**

Make money. Learn skills and secrets of fine woodworking and tool use. Professionally prepared shop method training tells and shows how. Covers everything. Easy to master.

INTERSTATE TRAINING SERVICE
Write for Free Booklet DEPT. F3, PORTLAND 13, OREGON

Double Your Income In DRAFTING

SEND FOR FREE
SUCCESS BOOK

**CLEVELAND ENGINEERING INSTITUTE
DEPT. PM 9E
6300 Euclid Ave. • Cleveland 3, Ohio**

Aeronautical Mechanical

NAME.....

ADDRESS.....

CITY..... STATE.....

No Obligation — No Salesmen

APPROVED
FOR
VETERANS

RECEIVE THIS SET
OF INSTRUMENTS AT
NO EXTRA COST



"MY SALARY HAS INCREASED 50% SINCE GRADUATING FROM C.E.I.," says H. L. ADAMS. "... a great part of this advancement and increase in salary I credit to C.E.I. training and to the thoroughness and personal direction of its instructors."

CLEVELAND ENGINEERING INSTITUTE

17 pt. Self-Cleaning Plug Alone Shows 8 hp Gain and 7 mph Greater Speed!

Eddie Edmunds
CHASSIS DYNAMOMETER CHART

Model: _____ Date: _____
Make: _____ Year: _____
Make: _____ Year: _____

Power Test

Test Condition	17-Point LIFE-TIME	Conventional	17-Point LIFE-TIME
HP at 2000 RPM	44	36	52
MPH at 2000 RPM	47	40	54

NOTE: CONVENTIONAL TEST BEING LIFE-TIME AND 17-POINT TESTS
WAS 3000 RPM

Recommendations:



Tustin Auto Parts

100 West Main Street Tustin, California Phone BRanch 2-6022

Continental Mfg. Co.
Culver City, California

Dear Sirs:

We received your 1954 Buick Super Chassis Test Card showing 17-Point LIFE-TIME Spark Plugs installed on your 1954 Buick Super Chassis. We are pleased to provide approximately 500 of a 17-Point LIFE-TIME Spark Plug set to you for your car. We will ship you 500 of these plugs with the following values:

17-Point LIFE-TIME Spark Plug	\$1.15	500	\$57.50
17-Point LIFE-TIME Spark Plug	\$1.15	500	\$57.50
17-Point LIFE-TIME Spark Plug	\$1.15	500	\$57.50
17-Point LIFE-TIME Spark Plug	\$1.15	500	\$57.50

These are available in other standard sizes. Please check your spark plug.

The above 17-Point LIFE-TIME Spark Plug set is an excellent thing to have on the way to the next Continental Motor Show. We will ship you 500 of these plugs with the following values:

TUSTIN AUTO PARTS

R. Johnson *R. Cox*

HOW 17 PT. FIRING WORKS

Note electrodes closely. A circular arcing area (four concave segments). Gap being the same from all points. Electricity has property of arcing from coldest point. Current also arcs more readily from apex of two planes than from the face of a flat, metallic surface.

Note that there are 16 apexes (where two planes meet) — all the same distance from the center electrode. Normal heat and spark erosion are spread around the entire 360 degrees and around the whole circumference of the center electrode.

FULL ROTATING SPARK

allows overall cooler electrode temperature for greatly increased life. Hotter spark prevents fouling, yet the rotating and cooling effects minimize the common faults of burning, erosion, blistering and insulator failure. Compare this principle with the conventional 2-point spark plug design.

PLATINUM-NICKEL ALLOY ELECTRODES—Metallurgists' first major step beyond platinum aircraft plug electrodes. Arcing points of this material have continued to function after the equivalent of 120,000 car-miles.

SPECIAL SINTERED CORUNDUM INSULATOR—Made of gem-like mineral which conducts heat 20 times better than ordinary porcelain. Special shape is designed to vaporize and exhaust wet carbon and oil.



- INDIVIDUAL INSPECTION**—Each LIFE-TIME Spark Plug is tested for firing in oil and for resistance to 30,000 volts/CM.
- PERMANENT GAP**—After months of use LIFE-TIME Spark Plugs make at exact factory pre-gap.
- SELF CLEANING FOR LIFE**—Confined puffs exploding in chamber formed by multiple electrodes reclean arcing surfaces with each firing stroke.



NOW...

**ORDER REGISTERED SET
FOR YOUR CAR AT POPULAR PRICE!**

Dealers and Distributors: The LIFE-TIME Spark Plug is now in full production. Write for full details. Distributors: Please inquire as to status of your territory.

50,000 CAR MILES!

Before LIFE-TIME development, the spark plug was the most often replaced part of your car. Engineers agreed that "creeping paralysis," gradual electrode disintegration, carbon buildup, widening gap, could waste one gallon in ten. The LIFE-TIME Plug has now gone far beyond the life of the average set of tires, the average battery. This plug still fired clean, hot and steady at 50,000 car miles!

Most spectacular spark plug research breakthrough in 50 years allows us to include this unique and unprecedented warranty with every set of LIFE-TIME Spark Plugs. We GUARANTEE GREATER GAS MILEAGE — GREATER ACCELERATION — A MAJOR POWER INCREASE — OR YOUR MONEY BACK.

YOU RECEIVE BY MAIL

this registered set of LIFE-TIME Spark Plugs in proper series (heat range and gap) for the car you indicate in coupon. NOW AVAILABLE FOR AMERICAN & EUROPEAN PASSENGER CARS, TRUCKS, BOATS, FARM EQUIPMENT, INDUSTRIAL ENGINES.

8 HORSEPOWER GAIN!

Dear Car Owner:

The real test of a spark plug is "What will it do in my own car?" Take the above dynamometer test on a 1951 Buick Super. It shows an 8 horsepower gain with Life-Time 17-point plugs. This was a 12 1/2% hp gain at 2000 RPM. You don't need a dynamometer with Life-Time plugs. You can feel the difference both in your ride and your pocketbook. Try a set and let me hear from you about them. Many thanks!



Frank Williams
Inventor of the LIFE-TIME Spark Plug

LIFE-TIME Spark Plug Division,
CONTINENTAL MANUFACTURING CORP.,
Washington Blvd. at Motor Ave.,
Culver City 88, California

Gentlemen: Please mail postpaid _____ set(s) (registered) of LIFE-TIME Spark Plugs in proper heat range and gap for my car at \$1.15 per plug (Set of six, \$7.14. Set of eight, \$9.52). (Or send \$1 per set, balance C.O.D.) California residents add 3% tax.

Make of my car is..... Year.....
Model..... No. Cyl.....
I enclose \$..... (check, cash or money order)
Name.....
Address.....
City..... Zone..... State.....

LET CAR EXPERTS GUIDE YOUR HANDS THROUGH ANY AUTO REPAIR



**QUICKLY--
EASILY--RIGHT!**

**FREE
7-DAY
TRIAL**

**MOTOR'S
AUTO
REPAIR
MANUAL**



SUPPOSE you had an automobile factory engineer standing right beside you . . . guiding your hands through every step of even the toughest car repair job! Think how you'd "bliss through" every job! No wonder, then, 2,000,000 MOTOR'S Auto Manuals have been sold. No wonder so many thousands of beginners and expert mechanics alike are already using MOTOR'S brand-new AUTO REPAIR MANUAL. It shows you, in step-by-step words and pictures, factory-approved repair procedures for fixing ANY part of ANY car, 1940 through 1955!

No guesswork! MOTOR'S Manual "starts from scratch" — leads you through entire job with easy step-by-step directions, clear "how-to" pictures. Tells WHERE to start, what TOOLS to use, how to remove, repair and replace parts. You CAN'T go wrong.

1000 Big ILLUSTRATED Pages
NEW, REVISED, ENLARGED Edition contains the "meat" from over 100 OFFICIAL shop manuals—simplified for YOU in Over 1,000 big pages, 23,426 essential repair specifications on 777 chassis car models. More than 2,500 "this-is-how" pictures, 225,000 service and repair facts. Leads beginners every step of the way. Time-saving factory repair procedures for experts. Used by U. S. Army and Navy.

Try Book FREE 7 Days
SEND NO MONEY! Pay postman nothing. Make Manual PROVE to you what it's got. Unless you agree this is the greatest time and work saver you've ever seen—return book in 7 days and pay nothing. Mail coupon today for MOTOR Book Dept., Dept. 19, 250 W. 55th St., New York 19, N.Y.

**Covers 737 Models
—1940 thru 1955
All These Makes**

- | | |
|-----------|------------|
| Buick | Hudson |
| Cadillac | Kaiser |
| Chevrolet | Lincoln |
| Chrysler | Mercury |
| Crosley | Nash |
| De Soto | Oldsmobile |
| Dodge | Packard |
| Ford | Plymouth |
| Frazer | Pontiac |
| Henry J | Sudbaker |
| Willis | |

2,000,000 Copies Sold!

**Same FREE Offer
On MOTOR'S Truck
and Tractor Manual**

Covers EVERY job on EVERY popular make gasoline truck, tractor made from 1940 thru 1954. FREE 7-Day Trial. Check proper box in coupon.



MAIL COUPON NOW FOR 7-DAY FREE TRIAL

MOTOR BOOK DEPT.
Desk 19, 250 W. 55th St., New York 19, N. Y.

Rush to me at once (check box opposite book you want):

MOTOR'S New AUTO REPAIR MANUAL. If O.K., I will remit \$2 in 7 days, \$2 monthly for 2 months and a final payment of 66¢ (plus 35¢ delivery charges) one month after that. Otherwise I will return the book postpaid in 7 days. (Foreign price, remit \$9 in cash with order.)

MOTOR'S New TRUCK & TRACTOR REPAIR MANUAL. If O.K., I will remit \$2 in 7 days, and \$2 monthly for 3 months, plus 35¢ delivery charges with final payment. Otherwise I will return book postpaid in 7 days. (Foreign price, remit \$10 cash with order.)

Print Name..... Age.....

Address.....

City..... State.....

Check box and save 35¢ delivery charge by enclosing WITH coupon entire payment of \$8.56 for Auto Repair Manual (or \$8 for Truck & Tractor Repair Manual.) Same return-refund privilege.



SAVINGS NEVER LESS THAN 35% UP TO 60% OFF REGULAR PRICES

SEND FOR YOUR FREE CATALOG!

**FACTORY FRESH BRAND NEW TIRES
B.F. Goodrich • Firestone**

FIRST QUALITY 4 Ply BLACKWALL TIRES		FIRST QUALITY HEAVY DUTY TRUCK TIRES	
670 x 15	FULL PRICE 13.97750 x 15 16.00	700 x 15	FULL PRICE 6 ply 26.12
710 x 15	15.42600 x 16 12.59	600 x 16	6 ply 18.03
SPECIAL! SPECIAL! WHITE WALL TIRES		650 x 16	6 ply 21.80
670 x 15	FULL PRICE 16.85 710 x 15 18.62	750 x 20	10 ply 48.00
	600 x 16 15.17	825 x 20	10 ply 56.70
		900 x 20	10 ply 70.32
		1000 x 20	12 ply 89.00

DOUBLE LIFETIME GUARANTEE
All Tires Carry Mfg's. Full Lifetime Guarantee plus 5 & 5 own iron-clad guarantee of quality and value!

LATEST TUBELESS TIRES NOW AVAILABLE!

Order by Mail—send check or M.O. All prices include excise tax, sold F.O.B. Camden, N. J. Motorists, Farmers—Truck Owners, Garage men—Gas Stations—we have the most complete stock of tires anywhere! OPPORTUNITY FOR YOU to make REAL MONEY—sell to your friends, neighbors, etc. Become a part time Sales representative—Sell at a discount and make profits too! Write us today for full information!

S & S TIRE CO. 1400 HADDON AVE. CAMDEN 3, N. J.



GIANT BALLOONS

They're really BIG—surplus U.S. Govt. (new overage) Neoprene weather, target balloons. GREAT FUN in the backyard: at parties, picnics, dances, fairs, TERRIFIC for high school and college PROMS. They attract BIG CROWDS to business openings, civic events, conventions, exhibitions, trade shows. ORDER TODAY! Approx. inflated sizes:

- 18 in. dia., 3 for 70c
- 3 ft. dia., 49¢—5 ft. dia., 99c
- 10 ft. dia., \$1.59—13 ft. dia., \$1.95
- 15 ft. dia., \$2.50

Postage paid on prepaid orders. Calif. residents please add sales tax.

VOLUME SALES CO., War Assets Division
Dept. PM955 3930 Sunset Blvd. Los Angeles 29, Calif.

PRINTS POST CARDS

Learn how both large and small businesses are boosting sales with new advertising machine. Write today for FREE illustrated BOOK of unique advertising plans, money-making ideas for your business. **Cardmaster, 1920 Sunnyside, Dept. 12-K, Chicago 40, Ill.**



LAW FREE BOOK THE LAW TRAINED MAN

Write today for a FREE copy of illustrated law book, "THE LAW-TRAINED MAN," which shows how to earn the professional Bachelor of Laws (LL.B.) degree through home study of the famous Blackstone Law Course. All necessary books and lessons provided. Moderate cost; convenient monthly terms. Write for FREE law training book today.

Blackstone School of Law, 225 N. Michigan Ave.
Founded 1890 Dept. 56 Chicago 1, Ill.

FOR BIG MEN ONLY!



SIZES 10 to 16 WIDTHS AAA to EEE

We SPECIALIZE in large sizes only sizes 10 to 16; widths AAA to EEE. Low-Tops; Wing Tips; Hand-Sewn Mocassins; Cordovans; Dress Oxfords; Work Shoes; Sox; Slippers; Rubbers. Enjoy the finest in fit, comfort, style at amazing low cost. Mail only. Write TODAY for FREE Style Book!

SEND FOR FREE CATALOG

KING-SIZE, INC.
617 BROCKTON, MASS.

HERE'S YOUR BIG OPPORTUNITY TO INCREASE BUILDING SKILL!



This 182-page idea and fact book, containing 200 pictures and plans, is your FREE bonus book. See offer at right and in coupon.

You will be surprised how much these skill books can add to your earnings
Examine the 6 Volumes at Our Risk!
See How Quickly They Help to Solve Many Problems
ACT NOW AND GET FREE BONUS BOOK

• Whether you are carpenter's helper, high-pay craftsman or aspiring contractor, AMERICAN TECHNICAL SOCIETY offers you this no-obligation opportunity which can lead to better jobs and bigger income. Send no money—just mail the coupon and receive 6 authoritative Building Skill Books for 10 days examination, plus 182-page Free Bonus Book which is yours whether you keep or return the 6 vol. set. Check through the more than 2400 pages of easy-to-understand information covering all subjects thoroughly, from foundations to final finishing. Learn to read blueprints easily and accurately. Speed up knowledge of how to estimate for new construction or remodeling. How problems can be solved quickly and completely are revealed. Time-saving methods proved by specialists are detailed for you. Mail coupon now.

(A year's consulting privileges given with these books at no extra cost.)

AMERICAN TECHNICAL SOCIETY—Publishers Since 1898
 Dept. G619, Drexel Ave. at 58th St., Chicago 37, Illinois

I would like to examine your 6-Volume Set of Building Skill Books. I will pay delivery charges only, but if I choose I may return them express collect. If after 10 days I prefer to keep them I will send you \$4 plus postage and pay the balance at the rate of only \$5 a month until \$39.65 has been paid. The FREE Bonus Book is to be my property whether I keep or return the 6-Volume Set.

Name _____

Address _____

City & Zone _____

Please attach letter giving employer's name and address. If self employed, give business man's name as reference. Men in service please give home address.

**AQUA-LUNGS
 FROGMEN SUITS
 SPEAR GUNS**



Send for these valuable booklets—TODAY!

- **SELF-CONTAINED DIVING**—Fact-packed guide, covers many kinds of equipment. Explains effects of underwater pressure. Decompression table shows time you may safely swim at different depths. 95c VALUE . . . SEND COIN NOW, ONLY 25c.
- **DIVING GEAR**—Catalog richly illustrated, latest foreign & domestic equipment (masks, swimfins, snorkle tubes, frogmen suits, spearguns, "Aqua-Lungs") 24-PAGE CATALOG . . . SEND COIN NOW, ONLY 15c.

Dept. PM-4, U. S. DIVERS COMPANY
 1045 Buxton Ave. W. Los Angeles 24, Calif.

Super Powerful All Channel TV RECEPTION IN ALL DIRECTIONS



- Rocket DIRECTRONIC MOTORLESS TV ANTENNA**
- 360° Electronically Switched Beam
 - No Motors
 - No Roof
 - Orientation "around the compass" reception WITHOUT Rotors. Clarity of picture will amaze. It's so bright, so sharply defined. AX-599 "Serviceman's Array" contains Hi-Pac molded insulator of extremely high tensile strength, 18 hi-tensile aluminum alloy elements, 1 set of connecting stubs (3), Universal U-Clamps for masts to 1 1/2", Directronic Beam Selector, 7 1/2 feet of Tri-X Cable, 25% deposit on C.O.D. orders, please. Money Back Guarantee.
 - No Ghosts
 - Flick of Switch Clears Picture Instantly

AX-599 Directronic \$16.95 You pay postage
 NATIONAL ELECTRONICS OF CLEVELAND
 5608 EUCLID AVE. Dept. P-9 CLEVELAND 3, OHIO

COLOR PRINTS

FROM YOUR COLOR FILMS
 KODACHROME • ANSCOCROME
 EKTACHROME • ANSCO COLOR
 4x5 50c | 5x7 \$1 | 8x10 \$2 Satisfaction or money back
25¢
 2 1/4 x 3 1/4
 AUTHORIZED ANSCO COLOR LABORATORY
COLORFAX LABORATORIES
 Dept. J95, Box 3521, Georgetown Sta., Washington 7, D. C.
 Minimum order \$1
 No COD's, please

CHEMISTRY



BIG LABORATORY GIVEN FREE!

Are you looking for a WONDERFUL FUTURE that can start at home right now? The NATIONAL SCHOOL OF CHEMISTRY offers a fascinating correspondence course in PRACTICAL CHEMISTRY which will give you a wonderful education that can be used almost immediately to increase your income and your position in life, with prospects of a GLORIOUS FUTURE!
 The course is very THOROUGH, yet specially prepared to be easy to all regardless of lack of previous training. Very little theory . . . this is a PRACTICAL course with HUNDREDS of fascinating EXPERIMENTS and valuable FORMULAS! Students learn, almost from the start, how to make chemicals and chemical products of commercial value, how to convert wastes into money, etc. THERE IS A GOLD MINE IN CHEMISTRY! Why not share in it? We will open your eyes to GOLDEN OPPORTUNITIES you've never dreamt of; for this is a GOLDEN AGE for those who possess special KNOWLEDGE!
 An extensive laboratory of chemicals and equipment is included with the course at no extra cost! Just send 25c for your first lesson and CHEMICAL KIT; full details will be included. If you send \$1.00 we will send first 5 lessons and supplies, including "How To Make 100 New Chemicals." Absolutely no obligation! START YOUR NEW CAREER TODAY!

NATIONAL SCHOOL OF CHEMISTRY
 POST OFFICE BOX 606-A REDWOOD CITY, CALIFORNIA

Check the Kind of Body You Want



Charles Atlas

...and I'll Prove How EASILY You Can Have It!

Just tell me, in coupon below, the kind of body you want—and I'll give it to you SO FAST your friends will be amazed! "Dynamic Tension," my easy, 15-minutes-a-day method, will make your chest and shoulders bulge... arms and legs surge with power... your whole body feel "alive!"

FREE BOOK 32 pages on how "Dynamic Tension" changed me from a 97-pound weakling into "World's Most Perfectly Developed Man"—and how I'll prove it can change YOU too. Mail coupon NOW!

CHARLES ATLAS, Dept. 8W,
115 East 23rd St., New York 10, N. Y.

Dear Charles Atlas: Here's the Kind of Body I want:
(Check as many as you like)

- More Weight—Solid—in The Right Places
 Broader Chest, Shoulders
 Powerful Arms, Legs, Grip
 Slimmer Waist, Hips
 Better Sleep, More Energy

Send me absolutely FREE a copy of your famous book "Everlasting Health and Strength"—32 pages, crammed with photographs, answers to vital questions, and valuable advice. No obligation.

NAME _____ AGE _____
(please print or write plainly)
ADDRESS _____
CITY _____ STATE _____

Multi-Million Dollar Business Now Being Split Up Among Home Operators in Small Communities

Inexpensive Table Top Machine Pays Profits UP TO \$9.20 AN HOUR

The multi-million dollar Rubber Stamp Business is now being taken over by small home operators throughout the U.S. Men and Women who operate this inexpensive machine can turn out large numbers of Rubber Stamps with special wording of all kinds. Material costing only 27c makes a stamp that sells for \$1.80. The machine is easy for anyone to operate. It molds as many as six Rubber Stamps at a time, each with different wording such as names, addresses, notices, stock numbers, prices and other "copy" needed by offices, factories and individuals. At full capacity, it can earn as much as \$9.20 an hour for the operator! You don't need experience to get into this big profit business at home. We supply everything, including complete instructions and eight ways to get orders for stamps coming in fast. Start making up to \$9.20 in one hour right away. We'll mail full particulars FREE and no salesman will call. Be first in your locality. Rush coupon.

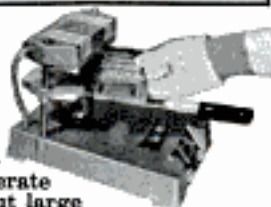

RUBBER STAMP DIV., Dept. R-2-K **FREE!**
1512 Jarvis Ave., Chicago 26, Ill.

Please mail all facts showing how I can get started in the profitable Rubber Stamp business at home in spare time. Everything you mail me is FREE and no salesman will call.

NAME _____
ADDRESS _____
CITY _____ Zone _____ STATE _____

INVENTORS

PROTECT YOUR INVENTION BY A U. S. PATENT. SEND FOR FREE "INVENTION RECORD" FORM AND "PATENT INFORMATION EVERY INVENTOR SHOULD HAVE".

CARL MILLER
REGISTERED PATENT ATTORNEY

WOOLWORTH BLDG., 35th FLOOR, 95A
NEW YORK CITY

INVENTORS

Whether an invention is patentable can be substantially determined by a search of the U. S. Patent records. Without obligation, write for information explaining the steps you should take to secure a patent.

JOHN N. RANDOLPH

Registered Patent Attorney
201 Columbian Building, Washington 1, D. C.



PATENTS

C. A. SNOW & CO.

REGISTERED PATENT ATTORNEYS
WRITE FOR INFORMATION TO
428 SNOW BUILDING, WASHINGTON 1, D. C.

HELPFUL BOOKS

Send post card asking for FREE catalog
Popular Mechanics Press, 200 E. Ontario, Dept. 601, Chicago 11

INVENTIONS WANTED

If you want to market, or sell, your invention for cash or royalties, write for our Free Booklet. Send no drawings. We also welcome hearing from firms, or private capital, wishing to review inventions in any field. We will be glad to send notice of our clients' inventions.

GLOBAL MARKETING SERVICE
1404 Mitchell Street Dept. PD Oakland 1, Calif.

INVENTORS

Send for **REGISTERED PATENT ATTORNEY**

PATENT INFORMATION Book and **INVENTOR'S RECORD** without obligation

GUSTAVE MILLER Patent Attorney & Advisor
95-PM WARNER BUILDING U. S. NAVY DEPT. 1930-1947
WASHINGTON 4, D. C. **PATENT LAWYER**

INVENTORS

I shall be pleased to furnish you, upon request, with full information relative to patent procedure—without any obligation on your part.

PATRICK D. BEAVERS
Registered Patent Attorney
934 Columbian Building Washington 1, D. C.

NOW-POWER YOUR MODEL PLANES, BOATS, RACE CARS!

Real **DIESEL ENGINE**
Fully Assembled 1/7 HP!

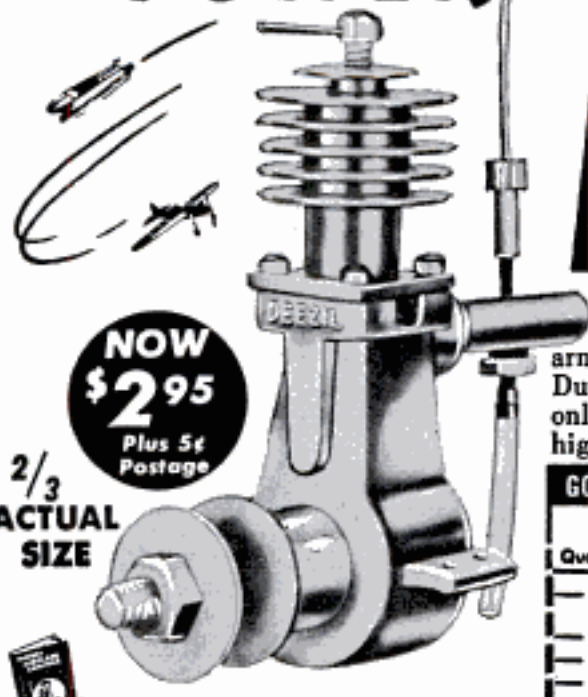

Not a toy! A real Diesel Engine that runs at 7500 RPM and produces 1/7 HP! Precision-tooled as carefully as giant army engines! Cylinder honed to .0001 and hand-fitted to pistons. Durable! 100% metal except for neoprene tubing. Yet weighs only 5 oz.! Easy operating instructions. Over 100,000 sold at higher price. Now at a special low, low price!

NOW \$2.95
Plus 5¢ Postage

2/3
ACTUAL SIZE

SPECIAL!

196-PAGE BOOK ON MODEL ENGINES. Covers everything hobbyists should know. Only \$1 Postpaid. FREE with purchase of \$5 or more.

CHESS COMPUTER. Gives opening moves of the 16 leading chess variations. Only \$1 Postpaid. FREE with purchase of \$10 or more.

GOTHAM HOBBY CORP., Dept. M-9, 107 E. 126th St., New York 35.

I'm enclosing cash, check, or money order. Send me postpaid:

Quan.	Item	Amount	Quan.	Item	Amount
	DIESEL ENGINE.....	\$3.00		Also send these genuine accessories:	
	Prop (Free Flight).....	35¢		Flywheel (boat or car)	75¢
	Shut-Off Valve.....	\$1.25		Tank	50¢
	Test Mount	\$1.25		Spinner	75¢
	Fuel Pump	75¢		Control Wire	75¢
	Fuelmix (Express Collect Only).....	\$1.00		Control Handle	\$1.00
	Model Engine Book	\$1.00		Electric Motor	\$1.95
				Chess Computer	\$1.00

Name _____
Address _____
City _____ Zone _____ State _____

\$ _____
TOTAL AMOUNT



WORLD'S LOWEST PRICED ADDING MACHINE

IDEAL FOR BUSINESS AND PERSONAL USE—GUARANTEED ACCURATE. Not a toy. Operates with only a finger flick. Adds, subtracts, multiplies, divides. Counts up to one billion. Pays for itself over and over. Ideal Gift—for Business, Income Tax and School use. **MONEY BACK GUARANTEE.** Send name and address. Pay postman only \$2.95 plus postage. (Send full cash if outside U.S.) Beautiful rich-looking Leatherette Case included at no extra cost. Money back in 10 days if not delighted. **AGENTS WANTED.**

Vest Pocket Size
FREE TRIAL \$2.95

only
TOTAL COST SEND NO MONEY

CALCULATOR MACHINE CO., (Mfgs.)
Box 84 Dept. 5-55 Glenview, Illinois

"NOW I'M WORKING STEADY — Earning Good Wages in CUSTOM UPHOLSTERY"



says John Piatkowski, former house painter.

"Anybody who has been a house painter knows this business is a feast or a famine. I averaged about \$45 a week—always worrying about making ends meet. Since taking UTS Training, things are looking up. I'm working steady—doing very well in this fine shop. My future looks good in upholstery."

WHAT DO YOU WANT? Your Own Profitable Business—A Steady Job—Substantial Sparetime Earnings—A More Secure Future? They're all waiting for YOU in the Big-Opportunity Field of Custom Furniture Upholstery.

The big nationwide housing boom has created a great demand for trained upholsterers. Prepare for this well-paid trade—easily, quickly. You can earn as you learn to make good money all year 'round at home, in your own shop, or in a well-paid job. The practical N. Y. State-approved UTS Course teaches you professional custom furniture upholstery, reupholstery, slip-covers, furniture finishing, window cornices, cushion, and drapery making. You get—FREE—ALL tools, complete frames, and materials.

FREE ILLUSTRATED BOOK WITH SAMPLE LESSON! Our FREE book, "YOUR NEW WAY TO A SUCCESSFUL CAREER" with Sample Lesson shows you how. **WRITE TODAY!** Training in N. Y. School also available. UTS, Dept. DO-305, 721 B'way, N. Y. 3

MATERIALS FREE WITH COURSE YOU MAKE

- SLIPPER CHAIR
- CLUB CHAIR
- OTTOMAN PLUS SLIP COVERS

Yours to keep or sell

MAIL COUPON TODAY

APPROVED FOR VETERANS

UPHOLSTERY TRADES SCHOOL, Dept. DO-305
721 Broadway, New York 3, N. Y.

Send me FREE book with FREE Sample Lesson. No obligation—no salesman will call.

Home Study In N.Y. School Training

Name _____
Address _____
City _____ Zone _____ State _____
 Check if Korean Veteran

If Ruptured

For lasting relief your rupture must **BE HELD BACK DAY and NIGHT.**

Consult Your Doctor.

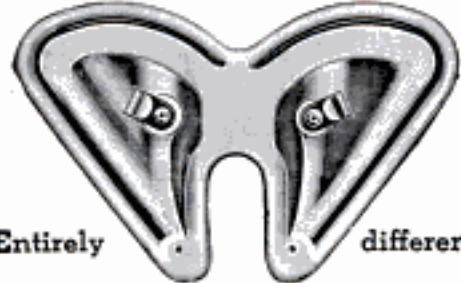

Entirely different

SOFT, FLEXIBLE, and fits neat as a glove. The famous Miller saves you **TIME, MONEY, DISAPPOINTMENT.**

Write for my **FREE** booklet today.

FRED B. MILLER Manufacturer
Dept. PM-A, Hagerstown, Maryland

... TURN CONCRETE INTO GOLD!

MAKE UP TO \$75 A DAY IN YOUR OWN BUSINESS

If you want to have your own business — to start a business on your own — here's your big opportunity! New high speed, low cost General block machine produces up to 1,000 concrete blocks a day. Sell all you make to builders, supply houses, and others for homes, factories, buildings, garages. Cash in on the building boom! You can make profits of 100% to 150% — up to \$75. a day! General block machine equipped with 1/2 h.p. electric motor — or can be supplied with gasoline engine — works anywhere, in little space, indoors or out. Operates from ordinary house light socket. Simple, foolproof 3 step operation — so easy a child can do it. Makes superior 3 core blocks any size from 4" to 12" Also makes chimney, sash, corner and other types. Blocks meet any building code anywhere in the country. Materials — sand, water, cement, available anywhere. Simple illustrated operating instructions and mixing formulas for cement and cinder blocks supplied with each machine. Write for FREE folder with full information.

MOTOR DRIVEN

R.L.T. of New York City reports: "MY GENERAL BLOCK MACHINE PAID FOR ITSELF IN FIRST 2 WEEKS!" Hundreds now in use the world over! Write for FREE details today!

EXTRA

Amazing illustrated book gives floor plans for 6 sensational concrete block bungalows. Tells how to lay blocks, lay out building lines, mix concrete, build steps, porch and concrete floors all at great savings. Written by experts. Can save many times the cost of the machine! Get it now! No strings attached. Send \$1.

BOOK SENT FREE IF YOU BUY MACHINE.
\$1 REFUNDED IF YOU BUY LATER.

GENERAL ENGINES CO.

DEPT. M-95, ROUTE 130, THOROFARE, N. J.



NEW BENJAMIN SUPER CO₂ GAS CARBINE — \$16.50

HI-LO (2 Stage) Jet Power
Cal. .177 or .22

RIFLED
Sheets
Pellets
& Darts



New Benjamin .177 or .22 CO₂ ROCKET Gas Pistol with HI-LO JET POWER. Retail...\$15.00

IDEAL FOR TARGET & SMALL GAME
SAFE — ECONOMICAL — ACCURATE
CONVENIENT — PRACTICAL — NON TOXIC
EASY TO OPERATE—NO PUMPING—NO FLINCHING.
Get 40 SHOTS from each Mr STANDARD SIZE CO₂ (Soda) CARTRIDGE. Up to 1/4" penetration.
Ask your DEALER for DEMONSTRATION.
BENJAMIN AIR RIFLE CO.
896 MARION ST., ST. LOUIS 4, MO., U.S.A.

FREE Folder

ENGINEERING DEGREE IN 27 MONTHS

Big Demand for Graduates

Aeronautical, Chemical, Civil, Electrical, Mechanical and Electronic Engineering (inc. Radio and TV)

Hundreds of young men are earning B. S. ENGINEERING DEGREES annually in this recognized institution — year around operation. New terms start quarterly. Many students earn a major part of their college expenses in this large industrial center.

Low tuition. Competent instruction. Thorough, intense practical program. Modern, well-equipped laboratories including new physics laboratory and modern wind tunnel. Individualized instruction emphasized.

Government approved for G.I.'s. Engineering preparatory courses. Students from 48 states and 21 foreign countries. Enter September, December, March and June. Send coupon for free catalog and full information. Enroll now.

SEND COUPON TODAY

INDIANA TECHNICAL COLLEGE

595 E. Washington Boulevard
Fort Wayne 2, Indiana

Please send me free information on B.S. Engineering Degree in 27 months as checked.

Aeronautical, Chemical, Civil, Electrical,
 Mechanical, Electronics

Name _____

Address _____

LOOK! NEW Electric Greyhound Bus 1955



\$198

Postpaid
Goes
Backward
and
Forward

Here is the sensationally new 1955 scale model Electric Greyhound Bus that captivates every child (and mommy and daddy, too). One flick of the magic lever and off it goes—forward or reverse. Runs for hours. Driven by an electric motor, powered by flashlight battery—safe, economical—easily replaced. Comes completely assembled with headlights, balloon-type rubber tires—durable metal body. **SEND NO MONEY.** Rush your order today. Remit with your order and we pay postage or order C.O.D., plus postage.

MEDFORD PRODUCTS, Inc. Dept. PM7, P. O. Box 209, Cathedral Station, N.Y. 25, N.Y.

FREE! 60 APPROVED EXERCISES, 68 PHOTOS with **FAMOUS DAN LURIE**



LOW DIRECT PRICE

BARBELLS

50 lb. set \$ 8.48 • 100 lb. set \$13.98
150 lb. set \$20.48 • 200 lb. set \$25.98

SEND FOR FREE CATALOG

Order by mail—50% with order Balance C.O.D. Extra WTS. 13c lb. FOB Plant.

DAN LURIE BARBELL CO.

52M9 Bristol St., Dept. 559J, Brooklyn 12, N.Y.
SEE DAN ON T V "BIG TOP" SHOW

\$35,000 BONUS OFFERED BY THE U. S. GOVERNMENT FOR URANIUM

FREE BOOKLET! "HOW TO MAKE MONEY PROSPECTING FOR URANIUM"



Tells where to look, how to stake claims, how to sell, equipment needed—plus many other facts to help you cash-in on rich Uranium rewards. (Please enclose 20c for postage & handling.)

U.S. GEIGER CO. Dept. PM9 195 Sackett St., B'KLYN 31, N.Y.

500 PRINTED NAME & ADDRESS LABELS FREE

Introductory offer! 500 gummed labels with your name or any name and address printed on each—FREE! Stick on letters, packs, books, etc. **LIMIT—4 sets per customer—include 25c per set for packing & handling.**
Western Stationery • Dept. 1256 • Topeka, Kansas



BE A PROFESSIONAL HAIR and SCALP SPECIALIST

MEN — WOMEN

Learn this attractive profession by mail and work from your home or office. Earn up to \$50 and more each day from clients who call on you. **NO CHARGE FOR INSTRUCTION.** You merely use our materials. **ALL PARTICULARS FREE.**

MELVILLE CO.

P.O. BOX 75414, Dept. PM-2, Los Angeles 5, Calif.



OWN a BUSINESS without INVESTMENT

There's big money in your community taking easy orders from garages, service stations, lumber yards for Work Uniforms that advertise! Easy sales, big profits. Repeat business increases future. Represent finest, largest line in the field. Show huge selection of styles, embroidery fabrics, including miracle "wash and wear" Dacron, Orlon, etc. Everything you need to get started sent FREE.
TOPPS, Dept. 619, Rochester, Ind.

250 POWER



Complete Telescope Lens Kit

only **\$3.49** postpaid

Conquer Space, Explore the Universe, Planets, Moon Craters, New Stars, etc. Complete Lens Kit consists of 80 inch focal length ground and polished objective lens, eyepiece lenses for 50 POWER, 100 POWER, 150 POWER, 200 POWER, 250 POWER, and all necessary lens fittings. Easy to make from simple step by step instructions. (Tripod and mount not included.) Money back guarantee.

BUSSE SALES CO., Hartford 1, Conn., Dept. PM 37

Want A Steady Job?

START HIGH AS \$4,205.00 YEAR

MEN — WOMEN, 18-55. Thousands of positions open. Prepare NOW for next examinations. Write immediately for free 36-page book, with list of positions and particulars telling how to prepare. Grade school education often sufficient. Veterans get preference.



FRANKLIN INSTITUTE

(Not Government Controlled)
Dept. G-93, Rochester 4, N. Y.

PORTABLE CAR COVER

Protect Against
RAIN • SUN • DUST
\$6.95 formerly **\$8.95**

Don't risk damage to your car finish when this low-cost car cover protects against weather elements. Long-lasting durable plastic, folds compactly, off and on in a jiffy, sturdy elastic binding gives extra security. State make, model and year—buy direct from mfg. Send \$6.95 plus 35c postage, or send C.O.D. Extra Heavy Plastic Gauge \$8.95 + 45c postage—formerly \$10.95
BEA SALES, Dept. C-2, Rm. 927, 125 E. 46, New York 17



Heavy Vinyl Plastic

LEARN WATCH REPAIRING

AT HOME Modern, original instruction. Prepare for a position or start in business after completing our course. Write Today!
WISCONSIN SCHOOL OF WATCH REPAIRING
2908 N. 44th St. Dept. M Milwaukee 10, Wis.

SPEAK AND WRITE LIKE A

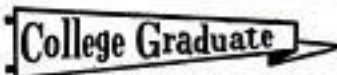

If you lack complete college training in English you can now become an effective speaker, writer, and conversationalist—without going back to school. With the new CAREER INSTITUTE METHOD you can stop making mistakes in English, build up your vocabulary, speed up your reading, acquire real writing skill, learn the "secrets" of fluent conversation. Method successfully used by thousands. Takes only 15 minutes a day at home. Costs little. 32-page booklet mailed FREE upon request. Send card or letter NOW!
Career Institute, Dept. 1059, 25 E. Jackson, Chicago 4



AUTO MECHANICS Earn More!

A BOOMING BILLION DOLLAR BUSINESS!

Skilled CTI Auto Mechanics are needed everywhere. There are over 55 million cars on the highways . . . 50% of which are 10 years old or older! All will eventually need servicing and repairing by skilled **AUTOMOTIVE SPECIALISTS . . . CTI TRAINED MEN**. Every year adds another 5 million prospects. CTI Training includes complete mastery of automotive fundamentals, latest improved short-cut repair techniques, automatic transmission, power-brakes, power-steering, etc. CTI shows you how and helps you get placed in big paying jobs in America's top field . . . the Automotive Industry!

When you are CTI Trained you can very easily open your own Big Money-Making Auto Repair business. We show you how. Start on a part-time basis. Soon you will be enjoying a prosperous full-time business. . . . Secure for life!

SHOP PROVED CTI HOME STUDY PLAN

enables you to learn **QUICKER** and to learn **BETTER**. You learn by doing. You can finance your entire CTI training from part-time earnings made while learning.

AUTOMOTIVE TOOLS GIVEN

as a regular part of the CTI Training Program! You owe it to yourself and your future to **RUSH** your name and address for **FREE** books on **AUTO OPPORTUNITIES**. No obligation.

COMMERCIAL TRADES INSTITUTE

Dept. A-101 1400 Greenleaf, Chicago 26, Ill.

Say You Saw It in
POPULAR MECHANICS

LEARN MEAT CUTTING AT NATIONAL

Pay After Graduation



The steady dependable trade of Meat Cutting taught easily in 8 short weeks. **YOU LEARN BY DOING** under actual meat market conditions in big modern school at Toledo.

For beginners or men with experience. Get a profitable store of your own. Remember, **PEOPLE MUST EAT!** Big pay jobs. Free employment help. Thousands of successful graduates.

Buying, cutting, percentage, pricing, advertising, selling, etc. A complete retail meat education. National School established over 30 years. Get National training **NOW**. Pay your tuition in easy weekly payments

after you graduate. Send coupon for **FREE** 52 page school catalog — **TODAY**. G.I. approved.

National School of Meat Cutting, Inc., Dept. 50-V, Toledo 4, Ohio

Send me your **FREE** school catalog on National Training at Toledo in Meat Cutting, Meat Merchandising and Self Service Meats. No obligation. No salesman will call.

Name _____ Age _____

Address _____

City _____ State _____

Approved for training Korean Veterans

DRESSED FOR A 'MAN-SIZE' JOB



Anvil-Brand



Wear right clothes for the job just as you pick the right tools. Husky, twill Matching Suits by Anvil give you the on-your-toes feeling that makes work easier. Tough cloth, stout stitching, smart design, laundry-tested colors and so economical. At your favorite store.

ANVIL BRAND FACTORIES HIGH POINT, N. C.

105 POWER SUPER TELESCOPE



Everything for the Astronomer, Hobbyist, Student, and Scout in this complete astronomical super value telescope combination. Set comes ready for immediate use, consists of brilliant 33x-65x-105x telescope, 5 foot hardwood Tripod, carrying case for scope, Star Explorer map and 108 page book "Discover the Stars." The 3 foot telescope (closes to 18 inches) is brass bound, has 4 precision lenses that will bring distant objects, people, moon, stars, ships, etc., 105 times closer. All images erect. The sturdily built tripod is equipped with universal mount that has a 360 degree horizontal range and 180 degree vertical range. It locks in any position with one simple adjustment. The Star Explorer map enables you to find any star automatically. This marvelous all purpose instrument is proclaimed by Scientists as a most unusual development. Everyone that has used it is amazed at its performance and value. It will fascinate the entire family. Shipped to you complete, nothing else to buy, at the amazing low price of.....

Satisfaction guaranteed or money refunded. We pay all delivery charges. Send check or money order to DEPT. PMS10

CRITERION CO. 331 CHURCH ST., HARTFORD 1, CONN.

\$11.95
POST PAID

ITALIAN ACCORDIONS AT LOWEST WHOLESALE PRICES

"PAY AS
YOU PLAY"

Small Down Payment
As Little As

\$10 per
month

**DIRECT from
Importer to You!**

SATISFACTION GUARANTEED, or your money back! NOW you can save up to 50% by direct purchase from America's leading distributor of famous genuine ITALIAN ACCORDIONS.

Send for FREE Illustrated Catalog!

**5-DAY
FREE
TRIAL**

ACCORDION MANUFACTURERS & WHOLESALE OUTLET

2003 West Chicago Ave. Dept. P-95, Chicago 22, Ill.



PROTECT YOUR MONEY and other valuables with a STAR Floor Safe

Buy your safe direct and save. Star Safes approved by Underwriters Laboratories. Lower insurance rates. Easily installed in floor or wall, complete with instructions, \$49.00 up. Freight prepaid. Money back guarantee. Write for Cat.

MONARCH SAFE & EQUIP. CO.
7850 Laurel Grove, No. Hollywood, Calif.

STAMMERING

may be overcome by re-education of vocal muscles and speech mechanism. Scientific Home Method for adults & children by EX-STAMMERER based on physiology of speech leads to FLUENT SPEECH. Write:

Dept. A, VOCAL METHODS

P.O. BOX 5123

SAN ANTONIO, TEXAS

LEARN LANDSCAPE GARDENING

A thorough, interesting home study course for those who wish to become LANDSCAPERS, GARDENERS, DESIGNERS, etc., for profit or pleasure. Write today for FREE INFORMATION to:

NATIONAL LANDSCAPE INSTITUTE

Dept. M-95

310 S. Robertson Blvd.

Los Angeles 48, Calif.



DRAW The First Day! NO LESSONS! NO TALENT!

New Amazing Invention—"Magic Art Reproducer." You can draw Your Family, Friends, Anything From REAL LIFE—Like An Artist Even If You CAN'T DRAW A Straight Line! Anything you want to draw is automatically sent on any sheet of paper thru the "Magic Art Reproducer." Then easily follow the lines of the "picture image" with a pencil for an original "professional looking" drawing. Also reduces or enlarges. SEND NO MONEY! Free Trial! Pay Postman on delivery \$1.98 plus postage. Money Back Guarantee.

NORTON PRODUCTS, Dept. 5809T, 296 Broadway, N. Y.

Watch Repairing Pays Big Money Learn at home



Watch repairs in great demand. Train step-by-step in 10 easy lessons. We furnish all tools and 15 jewel watch and practice movement. Turn spare time into cash. A licensed school. Low cost. Send for FREE book today.

ILLINOIS SCHOOL OF WATCH REPAIRING
2870 Elston Ave., Dept. PM95, Chicago 18, Ill.

BUILD HELICOPTER GLIDER



The famous new GYRO-GLIDER, world's simplest and safest aircraft, is now available to amateur builders in plans and kits. Send \$1.00 now for three-view drawings with specifications and ask about kits and detailed building and flying instructions.

BENSEN AIRCRAFT CORP., Dept. PM-9
P.O. Box 2621 Raleigh, N. C.

ONLY \$1 Name _____ Address _____
City _____ State _____

Greatest Thrill in Flying!

I saw my job failure in my family's eyes



... but how they smiled when I.C.S. pulled me through

Take it from me. That's the hard way to discover a mistake.

I thought I was in solid down at the plant with my years of experience. They'd never lay me off.

But they did. And I was in solid—as long as business was good. But when things started getting tight...

"In times like these," the boss told me, "everybody has to pull his own weight and a little more. Experience is more than just adding up years. You have to learn something, too."

I was sore, sure. But when I calmed down I realized he was right. I decided then to start learning. I signed up for an I. C. S. Course, studied at home in my spare time.

Then I went back to the plant. The boss was so impressed with my I. C. S. diploma, he gave me another try... and soon after I even got a raise!

TRAINED men are in demand

It's a fact. Right now there are plenty of job opportunities for trained men. How do you get training and hold down a job at the same time? Simple. Study with I. C. S. at home, in your spare time, at a cost of only pennies a day.

I. C. S. is the oldest and largest correspondence school. 277 courses. Business, industrial, engineering, academic, high school. One for you. Direct, job-related. Bedrock facts and theory plus practical application. Complete lesson and answer service. Diploma to graduates.

3 FREE BOOKS

1. "How to Succeed," a gold mine of job tips that will open your eyes to your own mistakes. 2. An outline of job opportunities in the field of your choice. 3. A sample I.C.S. lesson text. Send for them today.



For Real Job Security—Get an I. C. S. Diploma! I. C. S., Scranton 9, Penna. Member, National Home Study Council

INTERNATIONAL CORRESPONDENCE SCHOOLS

ICS

BOX 22299J, SCRANTON 9, PENNA.

(Partial list of 277 courses)

Without cost or obligation, send me "HOW TO SUCCEED" and the opportunity booklet about the field BEFORE which I have marked X (plus sample lesson):

- | | | | | |
|--|---|--|--|---|
| <p>ARCHITECTURE and BUILDING CONSTRUCTION</p> <ul style="list-style-type: none"> <input type="checkbox"/> Air Conditioning—Refrig. <input type="checkbox"/> Architecture <input type="checkbox"/> Architectural Interior <input type="checkbox"/> Building Contractor <input type="checkbox"/> Building Maintenance <input type="checkbox"/> Carpenter and Mill Work <input type="checkbox"/> Estimating <input type="checkbox"/> Heating <input type="checkbox"/> Painting Contractor <input type="checkbox"/> Plumbing <input type="checkbox"/> Reading Arch. Blueprints <p>ART</p> <ul style="list-style-type: none"> <input type="checkbox"/> Cartooning <input type="checkbox"/> Commercial Art <input type="checkbox"/> Fashion Illustrating <input type="checkbox"/> Magazine Illustrating <input type="checkbox"/> Show Card and Sign Lettering <input type="checkbox"/> Sketching and Painting <p>AUTOMOTIVE</p> <ul style="list-style-type: none"> <input type="checkbox"/> Auto Body Rebuilding <input type="checkbox"/> Auto Elec. Technician <input type="checkbox"/> Auto-Engine Tune Up <input type="checkbox"/> Automobile | <p>AVIATION</p> <ul style="list-style-type: none"> <input type="checkbox"/> Aeronautical Engineering Jr. <input type="checkbox"/> Aircraft & Engine Mechanic <p>BUSINESS</p> <ul style="list-style-type: none"> <input type="checkbox"/> Advertising <input type="checkbox"/> Bookkeeping and Accounting <input type="checkbox"/> Business Administration <input type="checkbox"/> Business Correspondence <input type="checkbox"/> Public Accounting <input type="checkbox"/> Creative Salesmanship <input type="checkbox"/> Federal Tax <input type="checkbox"/> Letter-writing Improvement <input type="checkbox"/> Office Management <input type="checkbox"/> Professional Secretary <input type="checkbox"/> Retail Business Management <input type="checkbox"/> Sales Management <input type="checkbox"/> Stenographic-Secretarial <input type="checkbox"/> Traffic Management <p>CHEMISTRY</p> <ul style="list-style-type: none"> <input type="checkbox"/> Analytical Chemistry <input type="checkbox"/> Chemical Engineering <input type="checkbox"/> Chem. Lab. Technician <input type="checkbox"/> General Chemistry <input type="checkbox"/> Natural Gas Prod. & Trans. <input type="checkbox"/> Petroleum Engineering <input type="checkbox"/> Plastics <input type="checkbox"/> Pulp and Paper Making | <p>CIVIL, STRUCTURAL ENGINEERING</p> <ul style="list-style-type: none"> <input type="checkbox"/> Civil Engineering <input type="checkbox"/> Construction Engineering <input type="checkbox"/> Highway Engineering <input type="checkbox"/> Reading Struct. Blueprints <input type="checkbox"/> Sanitary Engineering <input type="checkbox"/> Structural Engineering <input type="checkbox"/> Surveying and Mapping <p>DRAFTING</p> <ul style="list-style-type: none"> <input type="checkbox"/> Aircraft Drafting <input type="checkbox"/> Architectural Drafting <input type="checkbox"/> Electrical Drafting <input type="checkbox"/> Mechanical Drafting <input type="checkbox"/> Mine Surveying and Mapping <input type="checkbox"/> Plumbing Drawing and Estimating <input type="checkbox"/> Structural Drafting <p>ELECTRICAL</p> <ul style="list-style-type: none"> <input type="checkbox"/> Electrical Engineering <input type="checkbox"/> Electrical Maintenance <input type="checkbox"/> Electrician <input type="checkbox"/> Contracting <input type="checkbox"/> Lineman <p>HIGH SCHOOL</p> <ul style="list-style-type: none"> <input type="checkbox"/> Commercial <input type="checkbox"/> Good English <input type="checkbox"/> High School Subjects <input type="checkbox"/> Mathematics | <p>LEADERSHIP</p> <ul style="list-style-type: none"> <input type="checkbox"/> Foremanship <input type="checkbox"/> Industrial Supervision <input type="checkbox"/> Leadership and Organization <input type="checkbox"/> Personnel-Labor Relations <p>MECHANICAL AND SHOP</p> <ul style="list-style-type: none"> <input type="checkbox"/> Gas—Electric Welding <input type="checkbox"/> Heat Treatment <input type="checkbox"/> Metallurgy <input type="checkbox"/> Industrial Engineering <input type="checkbox"/> Industrial Instrumentation <input type="checkbox"/> Industrial Supervision <input type="checkbox"/> Internal Combustion Engines <input type="checkbox"/> Machine Design-Drafting <input type="checkbox"/> Machine Shop Inspection <input type="checkbox"/> Machine Shop Practice <input type="checkbox"/> Mechanical Engineering <input type="checkbox"/> Quality Control <input type="checkbox"/> Reading Shop Blueprints <input type="checkbox"/> Refrigeration <input type="checkbox"/> Sheet Metal Worker <input type="checkbox"/> Tool Design <input type="checkbox"/> Toolmaking <p>RADIO, TELEVISION</p> <ul style="list-style-type: none"> <input type="checkbox"/> Industrial Electronics <input type="checkbox"/> Practical Radio TV Eng'ing <input type="checkbox"/> Radio and TV Servicing <input type="checkbox"/> Radio Operating | <p><input type="checkbox"/> Television Technician</p> <p>RAILROAD</p> <ul style="list-style-type: none"> <input type="checkbox"/> Air Brakes <input type="checkbox"/> Car Inspector <input type="checkbox"/> Diesel Locomotive <input type="checkbox"/> Locomotive Engineer <input type="checkbox"/> Section Foreman <p>STEAM AND DIESEL POWER</p> <ul style="list-style-type: none"> <input type="checkbox"/> Combustion Engineering <input type="checkbox"/> Diesel—Elec. <input type="checkbox"/> Diesel Eng's <input type="checkbox"/> Electric Light and Power <input type="checkbox"/> Stationary Fireman <input type="checkbox"/> Stationary Steam Engineering <p>TEXTILE</p> <ul style="list-style-type: none"> <input type="checkbox"/> Carding and Spinning <input type="checkbox"/> Cotton, Rayon, Woolen Mfg. <input type="checkbox"/> Finishing and Dyeing <input type="checkbox"/> Loom Fix'g <input type="checkbox"/> Textile Des'ing <input type="checkbox"/> Textile Eng'g <input type="checkbox"/> Throwing <input type="checkbox"/> Warping and Weaving <p>MISCELLANEOUS</p> <ul style="list-style-type: none"> <input type="checkbox"/> Domestic Refrigeration <input type="checkbox"/> Marine Engineering <input type="checkbox"/> Ocean Navigation <input type="checkbox"/> Professional Engineering <input type="checkbox"/> Short Story Writing <input type="checkbox"/> Telephony |
|--|---|--|--|---|

Name _____ Age _____ Home Address _____

City _____ Zone _____ State _____ Working Hours _____ A.M. to P.M. _____

Occupation _____

Canadian residents send coupon to International Correspondence Schools, Canadian, Ltd., Montreal, Canada. . . . Special tuition rates to members of the U. S. Armed Forces.

These 1000's of
NEW facts
NEW ideas
NEW figures
NEW methods

Step up your MACHINE SHOP I.Q.

your key to
stepped-up pay

Just Out

New machines, methods, and materials—great metalworking advances—face every man in the field with urgent need for plenty of new know-how. That's why R. Le Grand, American Machinist magazine editor, took a long-famous handbook, completely revised it, brought it up to the minute, as

The NEW AMERICAN MACHINIST'S HANDBOOK

1579 pages • 774 illustrations • 45 sections covering

Covers feeds and speeds, tools, jigs, fixtures, materials, standards, tolerances, methods—thousands of details. Gives you quick, plain, dependable answers. See how it meets your needs. Just mail coupon.

**MACHINING • FORMING
• ASSEMBLY • MATERIALS
• FINISHING • INSPECTION • FASTENING
• DRAFTING • TOOL ENGINEERING • STANDARDS
• POWER TRANSMISSION • MATHEMATICS**

TRY IT

FREE

10 DAYS Over 4 months to pay

McGRAW-HILL BOOK CO.

Dept. PM-9, 327 W. 41 St., N. Y. C. 36

Send me Le Grand's New American Machinist's Handbook for 10 days' FREE examination. In 10 days I will send \$1.00 plus few cents for delivery, then \$2.00 monthly until \$11.00 is paid, or return book postpaid.

(Print)

Name _____

Address _____

City _____

Zone _____ State _____

Employed by _____

PM-9

Now—Do-it-Yourself and SAVE!

Cement Jobs are Quick, Easy with SAKRETE

Ready-to-use cement!

JUST ADD WATER AND USE!

SAKRETE
CEMENT MIXES

Send 25c for 48-page Book

Photos, diagrams, etc. for hundreds of cement jobs with Ready-mixed SAKRETE. SAKRETE, INC., Dept. 14, Cincinnati 17, Ohio.

SUPER SAFETY SPECIAL!
SUBURBANITE SNO TREADS
Written 26 Mo. Guarantee!
Order ANY pass. size..... **\$8.95**

WE GUARANTEE OUR TIRES TO THE HILT—IN WRITING!

Each Belmont famous brand, quality used tire (NO RECAPS) is a premium tire! You pay for tire safety and mileage. We deliver top quality tires, NOT EXCUSES! BELMONT TIRE—BETTER OR YOUR MONEY BACK!

♦ FREE PASS. TUBES! 35 MO. WRITTEN GUARANTEE! ♦

PASS. TIRES	670-16	\$4.96	700-16(6)	\$8.80	700-20(10)	\$12.43
	670-15	\$4.96	760-15	5.16	750-16(8)	10.10
	600-16	4.76	850-16(8)	7.36	700-17	11.45
	450-15	5.16	800-15	5.46	750-17	12.45
	450-16	5.16	W. WALLS S1 EX.	600-20	9.45	1000-22
	700-16	5.16	TRUCK TIRES	850-20(8)	10.45	1100-22
	700-16	8.26	750-20	\$12.45	700-20(8)	11.45
	710-15	5.16	700-16(6)	9.10	825-20	18.55
					1200-24	43.95

ADJUSTED TIRES, SLIGHTLY USED—\$7.45 ANY PASS. SIZE!

MILITARY Guar. 18 Mos. 750-20 \$12.05 900-16 \$12.45

MUD SNO Guar. 32 Mos. 750-20 \$16.45 900-16 \$15.50

ORDERS RUSHED! Send chk. or M.O. Prices F.O.B., Phila.

BELMONT COR. 11TH & SPRING GARDEN STS. DEPT. M PHILADELPHIA, PA.

KILLS SMALL GAME! **NEW!** Accurate Scope-type Sight Pistol Grip, 250 Pellets FREE!



Scope-Shot

Only \$1.95 postpaid. BIG BAG 250 extra pellets 50c p.p. Blurred, powerful, new-type slingshot. Polished cast aluminum frame. Pistol grip stock. Easily carried. FREE with each SCOPE-SHOT: 250 high-velocity DISINTEGRATING PELLETS that literally explode when they hit, and valuable shooting manual! Satisfaction guaranteed. Pellets only, 250 for 50c p.p. ORDER NOW.

GENERAL SPORTS, 4184-J Apple St., Cincinnati 23, Ohio

ARE YOU MECHANICALLY INCLINED?

Are You Using Your Mechanical Ability to the Best Advantage? If not, investigate a dependable trade where your ability really pays. WATCHMAKING offers you that opportunity. Write for information about this profession which is stable, light clean work; no age or physical limitations. Opportunities for Watchmakers never better.

KANSAS CITY SCHOOL OF WATCHMAKING

Approved for G.I. Training
Both Resident and Home Study Courses offered
1224 Admiral Blvd. Kansas City 6, Missouri

\$2.95 OR 2 FOR \$5.00!

Genuine Telephone Company Upright Telephones, tested and guaranteed with 50 ft. of wire and inter-communication instructions. Complete line of telephones, dial, magneto, etc. Write for free list. All shipments F.O.B. Simpson, Pa. **TELEPHONE ENGINEERING CO.** Dept. 985 Simpson, Pa.

Finish HIGH SCHOOL AT HOME

Complete 4 Yrs. in 12 Months
Learn More! Earn More! Enter professional or technical schools. Advance Socially. Live a Happier, Fuller Life. Individual Courses or complete schedule. WRITE FOR SCHOOL BULLETIN.
ACADEMY FOR ADULTS
30 W. Washington, Dept. PM-95, Chicago, Ill.

RUPTURED?

WE GUARANTEE RELIEF OR YOUR MONEY BACK

Forget rupture pain and worry from trusses that gouge your thighs, hips, or spine — that may aggravate your condition! Cluthe GUARANTEES TO HOLD your reducible groin rupture (inguinal hernia) against strain, with comfort you never dreamed possible. You can work and play again without nagging fear or embarrassment. Amazing lightweight Cluthe has been tested and proved in 500,000 cases. Is individually made by Master Fitters to YOUR measurements. No cutting springs, no straps, no harness to bind your skin, 100% waterproof and sanitary. Wear it bathing or swimming. Send for FREE book, "Help for the Ruptured". Gives scientific, authoritative facts on rupture care and details of UNCONDITIONAL GUARANTEE and 60-day trial offer.

CHAS. CLUTHE & SONS Dept. 31, Bloomfield, N. J.

WOULD YOU LIKE TO RECEIVE STACKS OF LETTERS LIKE THESE EACH WITH MONEY FOR YOU?

I have found a proven formula for quick success in making money. Others I've shared it with also have been successful. Would you like to know about it? It's simpler than you might think — just buying good imports at next-to-nothing foreign prices and selling them in the U.S. by mail order or at wholesale to stores.



To most people, importing smacks of mystery, romance — and "costly" things for collectors. Actually, any capable and ambitious man or woman should learn import-export quickly. And, there are thousands of beautifully made imports obtainable at trifling cost abroad to sell in the U.S. by mail order. There are also great opportunities in exporting U.S. products.



Native villages in Africa, romantic Vienna, bustling Copenhagen, mysterious Hong Kong — yes, countryside hamlets and great cities all over the world produce fascinating products.

Using my plan, you don't have to travel abroad unless you want to. You don't even have to know a foreign language. And, there is no face-to-face selling in mail order.



I have proven this plan with 103 imports — and the opportunities for the sale by mail of thousands more are breathtaking in their possibilities. Hunting knives and binoculars from Germany, silverware from Sheffield, England — hand-carved art objects from Africa — all costing less than \$1 abroad have values up to \$5 or more here and are big sellers by mail order.

Monthly bulletins sent free to those who follow my plan show suppliers of new and desirable imports.



Traders in foreign nations urgently want U.S. Dollars and offer fantastic bargains to get them. They are eager to trade with you or me or anyone who knows the methods I will gladly show you.



As I write this, I am receiving as many as 1,000 cash orders a day for imported clocks — all by mail order. They cost me only 63¢ and I sell them far below the U.S. market — a terrific bargain and a wonderful seller. And, I don't stock them as they are shipped direct to the buyers from abroad, after I receive the cash.



So you see, it is even possible to conduct a business of this kind without investing in merchandise.



Mrs. McGinn, one of my students in Illinois, operates a gift shop and sells Arabian perfume by mail order. F. Basler, N.J., sells Aztec bird feather pictures from Mexico to stores and by mail order.

Mrs. M. G. Bowman imported some beautiful beaded purses from India. A large department store bought her entire import. C. Renick of Pennsylvania imports original oil paintings from Italy and sells them to gift shops.



Mr. G. W. Edgecumbe of California wrote me in part as follows: "Using the plan of buying foreign imports to sell mail order... offering beautiful and unusual foreign dolls... ready market... profitable field..."

You might ask, "Why do you let others in on your plan? Why don't you keep it all for yourself?" The answer is that items for import are countless. No one person could possibly handle even a small proportion of them. There's plenty of business in import-export for you and me and many others.



If you are sincere and really open-minded to a new and different opportunity — one which may change your whole idea of the kind of money you can make in your own full or part time business — write today for full details. Air mail reaches me overnight.

B. L. Mellinger, Director, Dept.
1717 Westwood, Los Angeles 24, Calif.

— AIR MAIL THIS COUPON NOW —

B. L. Mellinger, The Mellinger Co., Dept. E259
1717 Westwood, Los Angeles 24, Calif.

Mr. Mellinger: Without obligation, show me the big profits to be made through World Trade, especially in mail order from my own home.

Print Name _____

Address _____

Town & Zone _____ State _____

not everyone does as well, but E. O. Lockin, who started a business of his own, reports...

for 12 months I've averaged
\$800 PER MONTH INCOME —
 most of it clear profit for me!

Many men have discovered how to be independent, to be free of bosses and layoffs. L. A. Eagles grossed more than \$200 his first week. Others report gross up to \$12,000 per year. How much you make depends largely on you. You need no special skill, no large investment.

No shop necessary. Our **ELECTRIC RUG WASHER** cleans rugs, carpets right on floor... helps to show their natural color and beauty. So efficient and safe, used by largest hotels and railroads.

You take no risk. Machines fully guaranteed.

Write for full information including how to make big profits in **YOUR OWN BUSINESS.**

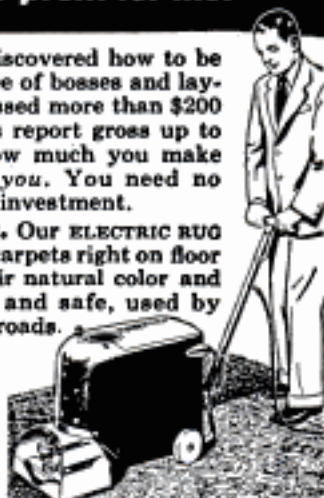

MAIL COUPON TODAY FOR FREE BOOK

VON SCHRADER MFG. CO., 910 "R" PL., Racine, Wis.
 Without obligation, send your **FREE** booklet containing information about your **ELECTRIC RUG WASHER** and how I can start my own permanent, profitable business.

Name _____
 Address _____
 City _____ Zone _____ State _____

SAY YOU SAW IT IN
 POPULAR MECHANICS



15 x 65
 "SUPER VISION"
\$59.50

Exclusive with **UNITED!** Enjoy tremendous power, wide field of view and brilliant illumination. Streamlined designing, using lighter, stronger metals make this **15 POWER** binocular easier to hold and use than many glasses half its power. Water-dust resistant. Objective lens are 65 mm—almost 3" across! 8 1/2" x 9" 1/2" 51 oz. Bears the famous **UNITED "Seal of Quality"** assuring peak performance, quality workmanship and proper pricing. Made in Japan by skilled optical craftsmen to rigid **UNITED** requirements and unconditionally guaranteed!

USER WRITES: "Your 15 x 65 are **TERRIFIC.** Want a pair for my brother, too." *I.T.E., Texas*

30 DAY NO RISK TRIAL. Return for refund if dissatisfied. Cash orders postpaid. C.O.D.'s require \$2.00 deposit. Leather case, straps included! Add 10% Federal tax. **UNITED BINOCULAR CO., 9043 S. Western, Dept. ARP-9508, Chicago 20. DEALERS WANTED.**

WARN HUBS



RUGGED DESIGN
 PROVEN IN USE

WARN MFG. CO., Riverton Box 6064-A7, Seattle 88, Wash.

**AUTOMATICALLY
 FREE-WHEEL 4-W.D.s.
 IN 2-WHEEL DRIVE**

Free-wheeling 2-wheel drive stops front end drag! Cuts front end repairs 50% or more, saves gas, tires; gives amazing pep, performance, handling ease to 4 W.D.s! Warn Automatics engage or disengage front power train as you shift into 4-wheel drive, or out for fast, economical free-wheeling 2-wheel drive use. Automatics only also permit high speed driving in 4-wheel drive. Warn Automatic and Locking models for Willys factory approved, sold only by Willys dealers worldwide. Over 70,000 sets in use around the world. Models for other 4 W. Ds. at dealers or write:

JEEP OWNERS

STA. WAGONS • JEEPSTERS • PICK-UPS!

Take full advantage of 4-wheel drive by installing a Ford V-8 engine—**MORE POWER**—means less shifting, better traction at lower speeds, greater safety, plenty of power in high. All this is now possible by using our F-J adaptor plate. Conversion Kit \$43.25 incl. **FED. TAX.** Write for free details or send check or M.O. for prepaid delivery. Order now for early shipment.

HOOSIER MACHINE PRODUCTS CO.
 312 S.E. 6th St. Pendleton, Oregon

SAVE MONEY ON U S GOV'T SURPLUS

Buy surplus direct from US Government. These are samples of the savings that can be made. Life boat \$12.00. Grinder \$4.69. Shaper \$15. Dump truck \$76.77. Tractor \$75.00. Typewriter \$7.51. Freezer \$50. Spray painter \$15.25. Motor \$4. Hunting, fishing, camping, sporting Equip, jeep, boat, tools. Hundreds others may be purchased at tremendous savings through our Bulletin "Surplus Sales." Price \$1.00. **The Abacus Press, Box 169DDD, Dept. 4, East Hfd. 8, Conn.**

**Do You Make These Mistakes
 in English?**

MANY persons say "between you and I" —use "who" for "whom"—don't know whether to use one or two "e's" or "m's" or "r's." Every time you speak or write you show what you are. A command of effective English brings you added advantages, better opportunities.

You can improve your English through Sherwin Cody's 100% self-correcting invention, if you are ever embarrassed by mistakes in grammar, spelling, punctuation, or pronunciation, write for **FREE** book "How You Can Master Good English in 15 Minutes a Day." No obligation. **SHERWIN CODY COURSE IN ENGLISH, 589 Central Drive, Port Washington, N. Y.**

MOTORIZE YOUR BARBECUE!

Easily rigged up by anyone. Handles whole ham or 4 small chickens. Commercial-quality thrust—2 r.p.m. gear-head motor (110V-AC)—spring-tension bronze bearing permits spit removal—

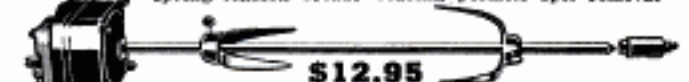

\$12.95
 adjustable meat forks—heavy-duty, chrome-plated spit. Limited time, introductory offer. Postpaid. (\$13.95 Denver and West).

B & R SALES CO. — Dept. PM955 — Muncie, Indiana

MAKE EXTRA MONEY AT HOME!

INVISIBLE REWEAVING

Pays up to \$10 in an Hour!
 Make moth holes, cigarette burns, tears, rips, disappear from all fabrics. Little-known craft pays extra spare-time profits at home. Write today for exciting details **FREE!**

**FABRICON 8342 S. Prairie Avenue
 Dept. 329, Chicago 19, Ill.**

ONLY CIRCUITRACER TESTS

1. Dead Circuits 2. Live Low Voltages 3. Live High Voltages

POINT-OF-CONTACT LIGHT immediately reacts to presence of voltage; tests shorts, grounds, continuity through 20 megohms res. Indicates A.C. or D.C. SAFE—Non-conducting case. A.I.E.E. quality throughout. **SUCCESSFUL**—Over 50,000 now in use by Ford, Bendix Douglas Aircraft, I.B.M., General Electric, Auto-Life. Repairmen endorse **CIRCUITRACER** for auto, aircraft, marine, electrical and radio systems. Completely portable—rugged. Superior to many ohmmeters. **KIT INCLUDES** signal light, neon lamp, batteries, 12-page book "Tracer Tips."

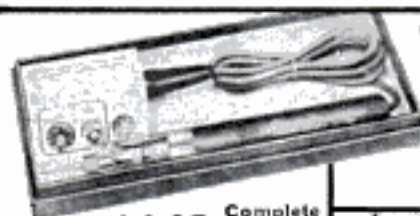

\$4.95 Complete Postpaid

Circuitracer

Money-back guarantee. For C.O.D. send deposit of **\$1.00**
DESCO Mfg. Co. 601A E. Walnut Street, Pasadena 1, California



A COMPLETE LINE OF
DEEP SEA AND SKIN DIVING GEAR, FROGMAN SUITS,
AQUA LUNGS, SPEARS, MASKS, FINS, CAMERA CASES,
SURPLUS, AMERICAN, BRITISH AND JAPANESE
DEEP SEA GEAR
SEND 35c FOR A COMPLETE CATALOG
DIVERS SUPPLY
6906 COAST HIGHWAY
NEWPORT BEACH, CALIFORNIA

A POSTCARD PUTS YOU IN BUSINESS!

Earn \$84.00 EXTRA a Month
on just 5 Sales a Week!

Go into business without spending a cent! My powerful FREE Sales Kit makes it easy to take orders for Mason's fast-selling line of leather jackets. Your friends, relatives, outdoor workers will grab these from you, paying you Big Profits on each order! Just sell 5 of our popular Fleece-lined Leather jackets a week, to make \$84 extra income a month! Besides jackets of Horsehide, Capeskin leather, Suede, Nylon, Gabardine, Wool... take orders for 174 fine shoe styles for men, women, including popular Air-Cushioned work shoes. People MUST buy from you, because we do not sell through stores! To start at once, rush postcard for your free money-making Sales Kit!



FREE KIT!

MASON SHOE MFG. CO., Dept. MA-748 Chippewa Falls, Wisconsin

WHAM-O SPORTSMAN

35-LB. PULL!

HITS LIKE A RIFLE—
KILLS RABBITS, SQUIRRELS.
 Powerful, silent, accurate.
 For hunting, target,
 rousing pests.
 Sportsman's choice
 sold world
 over!



HUNTING SLINGSHOT

Heavy duty 7" ash stock.

40 steel balls, extra rubber, target.

GUARANTEED. * Professional model

of Nat'l Slingshot Assn. If your sporting

goods dealer can't supply you, send \$1.50 to
Wham-O Mfg. Co. BOX 45E San Gabriel, Calif.



DEVELOP A HE-MAN VOICE!

Write for FREE book "How to Strengthen Your Voice for Greater Success" by Eugene Feuchtinger. No obligation. Book will be mailed at once in plain wrapper, postpaid. Just send your name and address. State age. **PERFECT VOICE INSTITUTE, 210 S. Clinton St., Studio JV-2, Chicago 6, Ill.**

LAW

Men and women **STUDY AT HOME** for Business Success and **LARGER PERSONAL EARNINGS**, 44 years expert instruction—over 114,000 students enrolled. LL.B. Degree awarded. All text material furnished. Easy payment plan. Send for **FREE BOOK**—"Law and Executive Guidance"—**NOW!**

AMERICAN EXTENSION SCHOOL OF LAW
 Dept. H-3, 664 N. Michigan Ave., Chicago 11, Illinois

NEW FALSE PLATE

FROM YOUR OLD ONE IN **18 HOURS**

AS LOW AS **\$14.95**



Send us your old broken, cracked or loose plates and we'll transform them into new lightweight wonder plastic plates. NO IMPRESSIONS needed with our revolutionary method. We use your own old plates. We remake them completely in only 18 hours. Missing teeth carefully matched and replaced. We **GUARANTEE TO SATISFY YOU OR REFUND YOUR MONEY.**

SEND NO MONEY—Send us your name today and we'll RUSH COMPLETE DETAILS. Begin to enjoy life right now. Clip this Ad; save it and send for free facts.

CHICAGO DENTAL PLATE LABORATORY • Dept. FN9-55
 30 N. Dearborn St. • Suite 807 • Chicago 2, Ill.

BECOME AN Electrical Engineer



● Major in Electronics or Power
 ● Earn B. S. Degree in 36 Months

Over 50% of the nation's industrial leaders began their careers with engineering training. Prepare now for a rewarding future as an Electrical Engineer or Engineering Technician. Enroll at the Milwaukee School of Engineering.

Plan Your Career—Eight Courses Give You Wide Range of Study

ENGINEERING COURSES

Electrical Engineering-Bachelor of Science Degree
 Save a valuable year through optional year 'round study.
 Electronics major36 months
 Power major36 months

TECHNICIAN COURSES

Electro Technician12 months
 Electronic Technician12 months
 Radio Technician12 months
 Radio and Television Technician18 months

SERVICE COURSES

Electrical Service6 months
 Radio and Television Service12 months

MECHANICAL TECHNOLOGY COURSES — Also available,

Service and Technician courses 6 to 18 months — Heating, Refrigeration, Welding, Air Conditioning and Mechanical —B.S. Degree in Mechanical Engineering with a major in Design, Metal Fabrication, or Plant Engineering. Also, general 3-month preparatory course.

Terms open January, April, July, September
 Prior Military, Practical or Academic training evaluated for advanced credit. Faculty of specialists. 50,000 former students. Annual enrollment from 48 states and 23 overseas countries. 52nd year. Non-profit.

Residence courses only. Send handy coupon today. MS-11A



MILWAUKEE SCHOOL OF ENGINEERING

MILWAUKEE SCHOOL OF ENGINEERING
 Dept. PM-955, 1025 Milwaukee St., Milwaukee, Wis.
 Send free illustrated career booklets Electrical Technology
 Mechanical Technology Radio-Television.

I am interested in.....
 (name of course)
 Name..... Age.....
 Address.....
 City..... Zone..... State.....
 If veteran, indicate date of discharge.....

HARD ALUMINUM

STRONG AS STEEL & FEATHERLIGHT

Hairline accuracy and faster, easier measuring are GUARANTEED by NEW Aluminum straight-edge Rules, T-Squares, Triangles, Curved Elbow Rules and L-Squares. Measure off Boards, Sheetrock, Plywood, Masonite, Beaverboard, Cloth in half the time and much more accurately.

A MEASURING INSTRUMENT FOR EVERY TRADE & JOB—if your rule is not listed here, write for FREE catalog sheets and prices on special lengths of these scientific rules.

EMPIRE MERCHANDISING CO., Dept. TP-9
28 East First St. Mt. Vernon, N. Y.

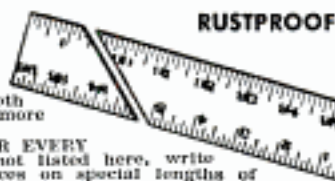

RUSTPROOF

STRAIGHT-EDGE T-SQUARES and RULES

PRECISION MADE—INDESTRUCTIBLE

These are measuring instruments of scientific quality. They'll give you lifetime durability combined with weightless flexibility and precise, easy readings.

STRAIGHT-EDGE RULES		T-SQUARES	
12" .25	48" 3.00	12" .75	48" 9.00
18" .80	60" 4.00	18" 1.75	60" 12.50
24" 1.00	72" 6.00	24" 5.00	On orders under \$1
36" 1.50	84" 8.50	36" 5.50	add 10c for handling.
36" 2.00	96" 12.00	36" 6.00	

SAVE HUNDREDS OF DOLLARS with HOME-A-MINUTE "KIT"

This is not something to fool around with. It is a hard hitting he man system of saving big money when you build or remodel



Design and build your New Home, Attic Flat, Extra Bedrooms or Remodeling—IN MINUTES—with over 100 fiber partitions, Doors, Windows, Kitchen Cabinets, made to scale same as blueprint. THEN, BELIEVE IT OR NOT, YOU, THE LAYMAN, who knows nothing about building, can estimate your own costs—IN MINUTES—after you adjust charts to local prices. Don't build anything until you get this "KIT" if you want to save money. Handbook tells you how. This information should not pass you by. Complete "KIT"

\$3.95 ppd., or COD plus postage. \$1 deposit required on COD orders. Handbook without "KIT" \$1.95 or free literature. Money back guarantee. Return in 10 days. Dealer inquiries invited.

SPECIAL NOTICE!—As a builder, controlling over 3 million dollars worth of home construction, we will ATTEMPT, but not promise, to obtain a special discount to you for your building materials on your new project, thru your favorite, local, Building Materials Supply Dealer. At no charge to you or your Dealer. This is a free service to our customers.

R. J. HALL & CO. 3824 W. ROOSEVELT DR. MILWAUKEE 16, WIS.

Everything You Need For UNDERWATER Sports and Adventure

DIVEMASTER SKIN AND LUNG DIVING EQUIPMENT
Leading nationally known and foreign made products. Inspection tested at money saving prices. Underwater Breathing Apparatus, Swimming Masks and Fins, Diving Masks, Spear Guns, Water Skis, Diving Suits, etc. Send 25c for Illustrated Catalog.

(Dealer Inquiries Invited)

U. A. S. CORPORATION, Dept. PM-9
5637 W. 63rd Place, Chicago 38, Ill.



\$14,839 In 1 Year SERVICING RADIATORS

—REX RYAN, Bloomfield, Iowa

Hundreds earning \$8,000-\$20,000 a year servicing auto-truck-tractor radiators! New Inland equipment makes work easy, insures finest professional workmanship. "Pay-for-itself" financing available. \$100 training course included free by world's largest radiator servicing equipment manufacturer.

WRITE for free folder "Want a business of your own?"

INLAND MFG. COMPANY Dept. PM-9 1108 Jackson St., Omaha 8, Nebr.

60 POWER TELESCOPE \$3.98

VARIABLE EYEPIECE 20X-40X-60X — BRASS BOUND NEW! Three telescopes in one. 3 different magnifications. 20 power for ultra-bright images with 40 and 60 power for extra long range. Guaranteed to bring distant objects, people, sports events, ships, moon, stars, etc. 60 times as close.



Most powerful for any where near the moon. ey. 5 sections. Close to 1 ft. long. Contains 4 ground and polished lenses. Also used as a powerful compound microscope. Directions included. Mass production enables us to offer this instrument at amazing price of \$3.98 complete. Money back guarantee. We pay postage. Get yours now.

CRITERION CO., 331 Church St., Hartford, Conn., Dept. PMB 28

Say You Saw It in POPULAR MECHANICS



... Swiss or American
Unique Sweazy System starts you making repairs right away. Develops your skill step-by-step. Teaches modern methods... professional short cuts. Learn by personal attendance or spare time home study. Approved for veterans. Free Sample Lesson. No obligation. Write today!

CHICAGO SCHOOL OF WATCHMAKING

2330 Milwaukee, Dept. 195, Chicago 47, Ill.

WHEELS WHEELS WHEELS

7" Disc Wheel 3/4" Tire 3/4" sleeve	45c ea.
8" Disc Wheel 1 1/8" Tire 1 1/2" sleeve	70c ea.
7" Disc Wheel 1" Tire 1 1/2" ball bearing	80c ea.
8" Disc Wheel 1 1/8" Tire 1 1/2" ball bearing	\$1.00 ea.
6" Disc Wheel 1.50 semi-pneum. Tire 1 1/2" B.B.	\$1.35 ea.
8" Disc Wheel 2" semi-pneum. T. 1 1/2" B.B.	\$1.50 ea.
10" Disc Wheel 1.75 semi-pneum. T. 1 1/2" B.B.	\$1.50 ea.
10" Disc Wheel 2.75 semi-pneum. Tire 1 1/2" B.B.	\$3.50 ea.
12" Disc Wheel 1.75 semi-pneum. T. 1 1/2" B.B.	\$1.85 ea.

Above wheel prices include hub cap. Plus Postage, C.O.D.'s accepted. AXLES—Sizes 5/16 in., 3/8 in., 1/2 in.—Cut to size—End holes drilled.

UNITED WHEEL STAMPING CO.
12131 S. PEORIA STREET PM-9 CHICAGO 43, ILLINOIS

Family Safe, Partially Used Tires. CHECK MY GUARANTEE & PRICES!
"THE BLATT name famous in tires for 40 years"
FOOLISH TO PAY MORE — DANGEROUS TO PAY LESS!

CHOOSE YOUR FAVORITE BRAND GOOD YEAR Firestone

Not Recaps—16 MONTH GUARANTEE & FREE TUBE	GOOD YEAR	FIRESTONE
600-16 \$4.81	670-16 \$4.71	700-20 \$9.11
650-16 4.71	710-15 4.71	650-16(6) 6.51
700-16 5.21	780-15 4.71	700-16(6) 7.21
640-15 4.81	800-15 5.11	900-20 18.61
700-15 4.51	820-15 5.31	1000-20 15.81
600-20 7.91	850-15 8.51	1100-20 17.51
WHITEWALLS \$1. EXTRA	1000-22 8.51	750-17 15.51
		1000-22 16.81

MILITARY MUD-GRIP TIRES
AA Guar. 20 Mos. AAA 36 Months
900-16 \$8.75 900-16 \$13.91
750-20 9.71 750-20 13.51

If you buy **TIRES** you get an extra tire FREE. 2 or more. Be wise! Why buy only one! (not W.V., Truck or "Adjusted" tires)

FREE TUBE!

U. S. Goodrich, Lee & others.

This pictured, handsome Tire Ash Tray with Your Name on it included with 2 or more Tires! Order now!

SPECIAL TIRES RELEASED BY ADJUSTER:
If a tire is defective in 36 Months, I charge you nothing. Just slightly used. Any car size. World's top tire value. (Whitewalls, too.) **\$7.86**

Send Ck. or M.O. & this ad for instant shipment. FOB Phila. I personally select your tires—as if my future depended on it. Thousands of tires shipped the world over! Read that top line again.

start a big profit business
with a small investment
**EARN UP TO
\$200 a DAY**

**Manufacturing Exciting New
RAINBOW ROCK**

**Concrete Slump Brick
in your back yard**

Earn big building boom profits with Rainbow Rock, the colorful new building brick that's taking the country by storm. Sell all you can make to contractors, builders, building supply houses. **RAINBOW ROCK CUTS LABOR COSTS BY 1/3!** Amazing low cost machine makes modern slump brick 24" long (3 times the length of ordinary brick) in a variety of widths and pastel colors . . . up to 1500 bricks a day! **NEEDS NO SPECIAL SKILL.** Operates indoors or out. Full instructions and valuable mixing formulae supplied. **YOU CAN START EARNING BIG MONEY NOW. PAY AS YOU PROFIT!** A limited number of machines available on easy payment terms. **NOW** is the time to start. Write today for free literature and full information.

GENERAL ENGINES CO., INC.
Dept. MR-95—Route 130,
Theramore, N. J. • Tilden 5-5401



STEEL PIER SENSATION
Luxurious RAINBOW ROCK fireplace wall in living room of the "Home of the Century" in Atlantic City, N. J.'s Steel Pier . . . acclaimed by over 500,000 Summer, 1953 visitors as the most beautiful they'd ever seen! Endorsed by the Pier's famous architect, Wilton F. B. Koelle.



Make beautiful, decorative fences, garden walls, garages, outside walls, room separators, etc.

STOP THAT SLAM!

MAKE BIG MONEY WITH AMAZING INVENTION—STOPS SLAMMING DOORS!

Earn fine profits every day with sensational KANT-SLAM Door Check. Closes heaviest doors silently, positively, automatically. Prevents slamming or leaving door open. Guaranteed 5 years! Easily installed. We supply real KANT-SLAM Demonstrator on easily-carried miniature door. You make big money on quick sales to stores, offices, factories—every building needs 1 to 20. Demonstrator FREE to producers. Write for FREE money-making plans.

**KANT-SLAM CO., Dept. M-11
BLOOMFIELD, IND.**

TRAIN IN THE SOUTH

AIR CONDITIONING—REFRIGERATION—ELECTRICITY—
MAJOR APPLIANCES—ELECTRONICS—TELEVISION

COMMERCIAL TRADES INSTITUTE
200 So. 20th St. Birmingham, Ala.

STUDY INDUSTRIAL DESIGN

You can train at Art Center School in California with practicing professionals for upper-level jobs in INDUSTRIAL DESIGN. Recent graduates have been added to the staff at General Motors, Chrysler, Raymond Loewy, Henry Dreyfuss, etc. Majors in transportation, general product design, structures, community development, furniture design, packaging, display, 4-year degree courses. Learn to combine imaginative design with technical proficiency, coordinate utility and beauty. Stimulating environment. Field trips. Advantages of mild Southern California climate and nearby holiday spots. Coed. Placement service. Established 24 years. New terms Feb., June, Sept. Write for catalog.

ART CENTER SCHOOL, Edward M. Adams, Director
5353 WEST THIRD STREET, LOS ANGELES 5, CALIFORNIA

PUMP WATER FAST!

Drains Wash Tubs, Cellars, Cisterns. Famous #7 pumps 2800 gph. 420 gph. at 75' high or 1600 gph. from 25' well. Sturdy rustproof alloy metal. Six blade impeller. 3/4" inlet, 1/2" outlet. Standard pipe threaded. Uses any 1/2 to 1/2 H.P. Motor. Will not leak or clog. Ironclad guarantee. Send check, M.O., or sent C.O.D. **\$8.95** IN U.S.

brigade, Fill Tanks, Draw Well Water. Heavy duty #8 pumps 7000 gph.—1000 gph. 75' high 3000 gph. from 25' well. Rustproof alloy metal. 8 blade impeller. 1" inlet, 1" outlet. Standard pipe threaded. Will not leak or clog. Iron clad guarantee. Send check, M.O., or sent C.O.D. **\$11.95** IN U.S.

Free Catalogue—Gear Pumps, Large Centrifugal Pumps, Deep and Shallow Well Pumps, Sump Pumps.

MOORE MANUFACTURING CO.
SWEDSBORO 1, NEW JERSEY

free! 1956
ALLIED



**ELECTRONIC
SUPPLY
CATALOG**

**324
value-packed
pages**

**Save on Everything
in TV and Radio
Parts & Equipment**



**Everything for Experimenters,
Builders, Amateurs, Servicemen,
Engineers & Hi-Fi Specialists**

Send for ALLIED's big 324-page value-packed guide to *everything* in TV, Radio and Electronics! Select from the world's largest stocks of High Fidelity systems and components; recorders and phono equipment; TV tubes, antennas and accessories; Amateur station equipment and supplies; P.A. systems; test instruments; latest build-your-own kits; industrial electronic supplies—plus *everything* in electronic parts, tubes, transistors, tools and books. Save on everything in Electronics—send today for your **FREE 1956 ALLIED Catalog.**

**Everything in Electronics
From One Reliable Source**

send for it **FREE CATALOG**

ALLIED RADIO

ALLIED RADIO CORP., Dept. 5-J-5
100 N. Western Ave., Chicago 80, Ill.

Rush FREE 1956 ALLIED 324-Page Catalog

Name _____

Address _____

City _____ Zone _____ State _____

EVEN IF YOU DON'T KNOW A NOTE OF MUSIC NOW...

**YOU CAN LEARN YOUR FAVORITE
INSTRUMENT THIS EASY A-B-C WAY**

No special "talent," no previous training needed. This U.S. School home-study method is so successful because you learn to play by playing real tunes by note, right from the start. And just think, you can learn your favorite instrument for only a few cents a day!

If interested, mail coupon for FREE 36-page Book showing how easy it is to learn any instrument, right at home, in spare time, without a private teacher. No obligation; no salesman will call on you. **U.S. SCHOOL OF MUSIC, Dept. A309, Port Washington, New York. (57th Year)**



U. S. SCHOOL OF MUSIC,
Dept. A309, Port Washington, N. Y.

Please send me your 36-page illustrated Free Book. I would like to play (Name Instrument):

Instrument _____ Have you Instrument? _____

Name _____ (Please Print)

Address _____

Valves Sticking? Get PYROIL



CLEANS, LUBRICATES, RESTORES LOST POWER

25¢ Now... Free 'em
Pyroil "A" added to your gas clings to valves and stems so carbon can't keep valves open. Eliminates overheating. Increases power. Saves gas and repairs. Get Pyroil "A" today.

Write for trial offer, Dept. PM-95, PYROIL COMPANY, La Crosse, Wis., U.S.A., Toronto, Canada.
30¢ SUPER LUBRICANTS • WORLD FAMOUS SINCE 1929

Paint STRIPES with New "PAINT PEN"!

Straight, Curved or Parallel Lines

Use like a fountain pen with any color paint to stripe furniture, bikes, autos, model planes, toys, linoleum, wall board. Beautiful clean, crisp results every time. Can't clog or smear. Also use with glue, tempera, textile paint or ceramic under glaze. Paints on wood, glass, plastic, metals, fabrics and paper. Tool complete with tip for 1/16" stripes only \$1.00 post-paid. Other complete tools with following tips: 1/64", 1/32", 3/64", 5/64", 3/32", 3/16" — \$1.50 each. Extra tips 75¢ each. Entire kit with tool and 7 tips — \$5.00. A 3/4" tip only \$1 each. COD's postage collect.

New! "DOUBLE-STRIPES" 5 Way

Combination Model only \$2.95

Double Stripes — one wide and one narrow or two wide or two narrow at the same time.

FREE — Send postcard for complete information for

—or **ORDER NOW... \$2.95**



\$1.00

DEALERS: Master Paint Stripping Tool in display cartons of 1 doz. **FAST, Profitable** seller. Write for discounts.

HOME CRAFTSMEN! New Paint Stripping Tool gives "professional" results every time, simple, easy to use. Send \$1.00 now.

MANUFACTURERS: Write today for information about industrial and production stripping tools.

WENDELL MFG. CO., Dept. 38
4234 Lincoln Ave., Chicago 18, Ill.

KODACHROME STEREO

20 Exp.—1956 Dated
3 Rolls 9.99 5 Rolls 14.95

ANSCOCHROME STEREO

20 Exp.—1956 Dated
1 Roll 3.50 3 Rolls 9.75
Prices above incl. Dev. & Stereo Mounting

8 mm KODACHROME

FACTORY SEALED PACKS
25 ft. DOUBLE ROLL—1956 DATED
3 ROLLS \$7.19 • 6 ROLLS \$13.75

35mm KODACHROME

20 Exp.—1956 Dated
FACTORY PACKAGES
3 Rolls 5.55 6 Rolls 10.50

35mm ANSCOCHROME

20 Exp.—1956 Dated
FACTORY PACKAGES
1 Roll 2.65 3 Rolls 6.95
Price incl. Dev. & Mtg.

16 mm KODACHROME

FACTORY SEALED PACKS
100 ft.—1956 DATED
1 ROLL \$7.19 • 3 ROLLS \$20.65

MODEL FILM COMPANY DEPT. P-9

78 West 47th St., New York 36, N. Y.

STUDY AT HOME

WITH AN EDUCATIONAL INSTITUTION

Courses in ARTS AND SCIENCES: Philosophy; Education; Letters; Public Health; Medical Jurisprudence; Psychology; Sociology; Physics; Chemistry; Geology; Pol. Science; Theology; Law; Business and Commerce; Accounting; Mathematics; Statistics; Agriculture. **ENGINEERING:** Electrical, Civil, Mechanical, Drafting, Architectural, Steam, Diesel, Aeronautical, Radio, Structural, Mining, Industrial. Petroleum, Refrigeration, Chemical. Send for free catalog. **McKinley-Roosevelt Incorporated, 4610-K32, Sheridan Rd., Chicago 40, Illinois**

BUILD YOUR OWN MIDGET ROADSTER \$25 BUILDS BODY & FRAME



BUILD A PONY ROADSTER or Pick-Up in few spare hours. Uses 2 hp engine, 450 lb. loads, 70 m.p.h., plenty of speed. Designed for **VERY LOW-COST** assembly from **PARTS BOUGHT IN YOUR NEIGHBORHOOD.** Use home tools. Great for kids, sturdy utility car. **COMPLETE** step-by-step plans, 17 large-size pages, 30 "show-how" photos, Body templates, complete material and parts list. Only \$1.95 post-paid. Satisfied or money back.

PONY PLANS, 7641-G TEXHOMA AVE., NORTHRIDGE, CALIF.



CURE SELF-CONSCIOUSNESS!

How to develop a strong, positive personality—get rid of timidity, bashfulness, shyness and fear. Successful self-instruction lessons based on new principles of practical psychology. Healthy self-confidence can be yours! Complete course of 22 home-study lessons. **NOT A BOOK.** Full price only \$6.95 postpaid, or COD plus postage. Mailed sealed in plain wrapper. Satisfaction guaranteed or refund. Order "Curing Self-Consciousness Course" today. **Nelson-Hall Co., 210 S. Clinton St., Dept. JV-2, Chicago 6, Ill.**



FREE GERMAN STEEL HUNTING KNIFE



4-INCH BLADE

We give you handiest hunting and fishing knife you've ever had! Has 4-INCH LONG highly tempered steel blade—**VERY SHARP!** Attractive handle. We send knife **FREE** to acquaint you with our below-wholesale bargains. Please send 25¢ for handling. **NO LIMIT**—but send 25¢ handling for each knife. Order **TODAY!** **HUNTING KNIFE, Dept. K-27, Box 881, St. Louis, Mo.**

**SAY YOU SAW IT IN
POPULAR MECHANICS**

For Racing at its Thrilling Exciting Best...



JUNIOR MIDGET

Get in on Micro-Midget racing, America's newest, most exciting, and fastest growing sport. Speeds up to 30 M.P.H. on a 1/10 mile track. Can be purchased in kit form or complete ready-to-run. Send 25 cents for completely illustrated literature describing all details.

Now available, the **HANDBOOK** for **SMALL RACING CARS.** This handbook is the most complete guide to the sport ever printed and has all the information, facts, specifications, and tips, all rules and regulations, etc. for 1/10 mile, 1/8 mile, 1/4 mile, 1/2 mile, 3/4 mile, and 1 mile C.C. Cars. Only \$1.00.

COMET MANUFACTURING CO., Dept. 16, P.O. Box 1882, Sacramento 9, Calif.

WAR SURPLUS BARGAINS

WAR SURPLUS BARGAINS

\$500,000.00 INVENTORY for QUICK LIQUIDATION

Surplus items—hundreds of them for home, shop, factory, farm and outdoor use. New items, used items, reconditioned items—all at tremendous savings—all priced for quick sale.

Page After Page of Values

This big catalog shows page after page of amazing money saving values. Write for your copy today. Send 10c to cover postage, mailing, etc. Write today! **SEND TODAY FOR YOUR COPY**

10c

STARK'S 212 W. Madison St.
Dept. PM-9
CHICAGO 6, ILL.

NO TANKS USED
NEW SIMPLIFIED METHOD

ELECTROPLATE

ANY OBJECT IN HOME, SHOP, GARAGE OR STAY!
YOUR OWN WILL PAYING ELECTROPLATING BUSINESS.

NOW, using NEW plating kit.

It's easy to electroplate any object. Complete kit and instructions on plating metal and non-metal objects, with nickel, copper, chrome, gold, etc., plus full data on obtaining all the business you desire and make **BIG MONEY** full or spare time. **ONLY \$6.95 SEND NO MONEY**—everything sent C.O.D. plus postage—OR

send \$6.95 now and receive it postpaid. Money back in 7 days if not satisfied.

M. Z. SALES CO., Dept. PM-18, 113 W. 42 St., New York 36, N. Y.

FREE CATALOG of TV KITS

LEARN TV the practical way—

Assemble a TRANSVISION TV KIT in easy stages. Pay as you wire—only \$15 for Starting Package #1. Learn while building a superb 17" to 21" screen TV Set with latest features. Ideal for Fringe Areas, adaptable to WHP. Easy — no instruments or technical knowledge required. Free Catalog describes a great TRANSVISION TV KITS.

Write today to Educational Dept. #1—
TRANSVISION, INC., Dept. PM, NEW ROCHELLE, N. Y.

Catalog of 3000 Novelties 10c

Send 10c for amazing catalog of novelties, five animals, scientific supplies, hobbies, funmakers, planes & boats, looms, magic tricks, joke articles, unusual seeds, gadget time-savers, cameras, optical goods, projectors, movies, lucky jewelry, religious novelties, disguises, tellers, radios, auto & bike accessories, telescopes, magnifiers, compasses, banks, smokers' gadgets, artists' supplies, printing sets, engines, motors, shockers, knives, billfolds, guns, rifles, sports, books, games, plants, etc. Send 10c (3 for 25c—got for friends!).

JOHNSON SMITH & CO. Dept. 183 Detroit 7, Michigan

HOW TO DOUBLE YOUR SALARY! FREE LESSON

MAKE BIG MONEY with your **NATURAL COMMON SENSE** in a high paying, prestige job. Our graduates **PROVE** that you can more than double or triple your salary. Industry desperately needs trained men. Men like you have saved business millions of **\$555** every year. **IEC** can train you for this wide open field of **TIME STUDY**. Your pay is excellent. Your future secure. Wonderful chances for promotion. Write today for your **FREE LESSON**. NO salesman will call. **FREE JOB** help for students. Indicate whether you want home-study or Chicago resident training information.

INDUSTRIAL ENGINEERING COLLEGE 3309B W. WASHINGTON CHICAGO 24, ILL.

BIG MONEY!

AIR CONDITIONING & REFRIGERATION INSTALLATION & REPAIR

Learn at Home in Spare Time!

MORE CTI TRAINED MEN ARE NEEDED!

Industry needs more trained employees. America needs more Air Conditioning-Refrigeration installation and service technicians. Men who know.

Get advanced CTI training. Learn all about **AIR CONDITIONING** . . . for the home, factory, theatre, institutions, trains, airplanes, automobiles, buses, etc. Get the complete Air Conditioning Training . . . **CTI TRAINING**.

Secure the latest facts and service techniques about domestic and commercial **REFRIGERATION** . . . home freezers, refrigerators, locker plants, refrigerated trucks, trains and planes, etc. Over 100,000,000 units now in daily use! Thousands being added daily! All need installation! All will eventually require servicing! Be able to earn Big Money anywhere — everywhere. America's health, security and comfort depend upon training more men NOW.

21 BIG KITS

You learn by "On-the-Job" training. We furnish you with 21 big kits of equipment, supplies and tools. You get practical shop method training. Build and keep your own air conditioner, food freezer, refrigerator or milk cooler. Rush name for free books showing how you can earn while you learn.

COMMERCIAL TRADES INSTITUTE
1400 Greenleaf Ave. Dept. R-101 Chicago 26, Ill.

PERSONAL!

For Men Who Want A SPARE TIME BUSINESS

FREE SAMPLE OFFER

Get the **SALES AGENCY** to sell the amazing new **Kleen-Rite** self-wringing sponge rubber mop. You make up to 100% profit. Write for details.

DAYLESS MFG. CO., Dept. PM9
3257 N. Western Ave., Chicago, Illinois

O.K. Send me complete selling outfit and sample Kleen-Rite mop. \$3.00 enclosed.

Send free details about your selling plan & free sample offer.

Am interested in exclusive distributorship.

Name _____

Address _____

City _____ Zone _____ State _____

SAY YOU SAW IT IN POPULAR MECHANICS

HUNTERS! Confiscated Russian Rifles!

THIS is the Russian Late Model 7.62 MM Mosin Rifle, 28 3/4" barrel. (Dates 1935-6-7). Mechanically perfect. Outside: good.

Bore: fair. Ballistics: 2820 F.P.S. with 150 grain bullet. Ammunition available everywhere in U.S., an excellent hunting cartridge. Hinged floor plate. Russian ordnance marks on receiver include hammer and sickle. The Russians won the International Meet in Venezuela (1954) with this model rifle. These guns were confiscated from Communist revolutionaries and placed on the free world market. They are of the type used by Red Chinese in Korea. The sale of these guns in no way aids any country behind the iron curtain. A Once-in-A-Lifetime collector's item. This is the lowest price we have ever seen which would allow a man to equip himself for big game hunting. Send check, cash or money order. All guns shipped F.O.B. Pasadena, Calif. 25% deposit on C.O.D.

\$14.50

GOLDEN STATE ARMS CORPORATION 59 Armory Bldg., 1165 East Colorado St., Pasadena 1, Calif.

SEND FOR FREE WELDING GUIDE

"Linwelder 100" makes metalworking as easy as woodworking

Weld at home with "Linwelder 100"... no previous experience or training necessary. With this new "weld-it-yourself" method, you simply touch electrode to the work, press a switch... "Linwelder 100" does the rest.



Complete "Selfweld" kit includes "Linwelder 100" machine, welding shield, cable, electrode holder and supply of special "Selfweld" electrodes.

PRICE...\$100

F. O. B. Cleveland, Ohio
Welding guide teaches you how to build wrought iron furniture, farm tools, home equipment... also make repairs, solder, torch heat, cut metal.

THE LINCOLN ELECTRIC COMPANY
Dept. 2903, Cleveland 17, Ohio

Name _____

Address _____

City _____ State _____

Send free "Selfweld" Guide giving more information on do-it-yourself welding.

Send me complete "Selfweld" kit. Enclosed is check _____ money order _____ for \$100.00.

MAKE \$5 PER HOUR WITHOUT A PRINTING PRESS

PRINTING
REVOLUTIONARY
NEW SCREEN METHOD

PRINT colorful signs, posters, banners, fabrics, wall paper, show cards—ANYTHING! Print on any surface. NO printing press or special equipment is needed with this amazing "approved" new printing secret. 300% profit on nearly every job. Easy to learn—NO EXPERIENCE or art ability necessary. Exceptional opportunity. Complete illustrated detailed plan and colorful sample FREE—Write:

SCREEN-PRINT COMPANY, Dept. 29

15127 S. Broadway, Los Angeles 61, Calif.

FREE
complete "BIG MONEY"
Plan and
SAMPLE!

EARN
AT HOME
SPARE or
FULL Time



HANDS TIED?

—because you lack a HIGH SCHOOL DIPLOMA

• You can qualify for an American School Diploma *in spare time at home!* If you have left school, write or mail coupon for FREE booklet that tells how. No obligation of any kind.

OUR 58TH YEAR

AMERICAN SCHOOL, Dept. V-645
Drexel at 58th, Chicago 37, Illinois

Please send FREE High School booklet.

Name _____

Address _____

City & State _____

Canadian Residents: Complete Canadian Course Available. Write American School, 1610 Sherbrooke St., West, Montreal.

Learn CARBURETOR and IGNITION



Start Training at Home For This Clean, High-Class Type of Position

Get in line for a raise—or for more profits in your own shop. Learn testing and adjusting with latest-type scientific motor tune-up equipment. This enables you to locate the trouble exactly, and fix it fast—handling and getting paid for more jobs per day. There's money in this, and it's clean, high-class work which gets the respect and confidence of your customers.

Send for FREE SAMPLE LESSON
Carburetor and Ignition Specialization offers very superior opportunities for better pay and bigger profits because relatively few mechanics know anything about this time-saving, money-making new test equipment. Now our spare-time home-study method teaches you the principles and shortens your shop training. Ambitious men (age 18-55): Send for full FACTS and FREE SAMPLE LESSON at once. Write today to:

UTILITIES ENGINEERING INSTITUTE
2525 Sheffield Ave., Dept. OC-1, Chicago 14

See the Greatest Show on Earth with this GIANT ASTRONOMICAL TELESCOPE

\$1500
FULL PRICE



Delivered ready for use. Has 45X, 75X and 100 power individually mounted eyepieces with brass focusing tube plus sun projector lens for observing sun spots and solar storms. Steel telescope tube 50 in. long. Rigid 6 ft. tripod adjustable to any height. Steel locked mounting with closely machined aluminum tripod head assembly assures extra fine adjustments. This professional type instrument provides full power with clear vision at all times. See the moons of Jupiter, our own moon, planets, milky way, double stars, star clusters, etc. All for only \$15.00 FOB Mattituck. Sent express. COD orders require \$5.00 deposit. Satisfaction guaranteed. 200X and 400X eyepieces available at \$2.00 ea.

SUFFOLK SCIENCE SERVICE
Dept. ATD-9 MATTITUCK, N. Y.

AMAZING NEW TINY RADIO

Really Works—Small as a Pack of Cigarettes!



GETS LOCAL RADIO STATIONS WITH CLEAR BELL-LIKE TONE—NO STATIC OR INTERFERENCE! NEEDS NO TUBES, BATTERIES OR COMPLICATED HOOKUPS! NO AC PLUG INS! Nothing to wear out. Thousands of users—many report years of service. Uses new crystal diode and hi-g coil. SELF-CONTAINED SPEAKER PHONE. Just the tiny radio to take with you ANYWHERE YOU GO—ON TRIPS, VISITING, ETC.—for real fun and enjoyment—ANYTIME. Merely hook to anything that can act as antenna for local reception. Free DX antenna kit included. **SEND ONLY \$1.00** (bill, ck., mo.) and pay postman \$3.00 C.O.D. postage or send \$4.00 for p.p. delivery. COMPLETE READY TO LISTEN. MIDWAY CO., Dept. PPM-9, Kearney, Nebr.

NEW, NATURAL LIGHTWEIGHT DENTAL PLATE



MADE FROM YOUR OLD ONE—New Professional Method gives you natural-looking, perfect-fitting plastic plate—upper, lower or partial—from your old cracked or loose plate without an impression. CLINICAL method means fast service, huge savings. Try new plate full 30 days at our risk. New plates sent you Air Mail same day.

SEND NO MONEY—Just your name and address for full particulars FREE. No cost. No obligation. Act now. CLINICAL DENTAL LAB., 335 W. Madison St., Dept. 28-K, Chicago 6, Ill.

HOW TO GROW ORCHIDS AT HOME

Most enjoyable hobby I know. People drove 100 miles to see this plant... 10 flowers, 6 inches across!
Thomas Hurst-Utah

Learn how you may have real ORCHID FLOWERS blooming IN YOUR OWN HOME within a few weeks. Successful home grower now reveals his secrets. Shows you how to grow gorgeous CATTLEYAS CYMBIDIUMS, EPIDENDRUMS, etc. in your living room. No previous experience needed. World's most fascinating hobby—PROFITABLE HOME BUSINESS. Big profit orders come from friends, neighbors, florists, etc. FREE—real ORCHID SEEDS and full details, including PLAN FOR STARTING YOUR OWN BUSINESS—SEND NO MONEY. Write today.



YEAR 'ROUND ANY CLIMATE NO Green House

FREE! REAL ORCHID SEEDS & \$\$\$ PLAN

TROPICAL FLOWERLAND, Dept. 319
4622 Wilshire Blvd., Los Angeles 5, Calif.

How to Learn ORCHID SECRETS \$1 SEEDS

Remarkable NEW Training Plan by A Reputable OLD School!

NO EXPERIENCE NEEDED
 This *New* PRACTICAL
DELEHANTY PLAN entails
 NO RISK, NO OBLIGATION
Money Back Guarantee

EARN EXTRA MONEY in SPARE TIME in a few weeks! And GOOD FULL TIME JOBS at HIGH PAY...or a PROFITABLE BUSINESS of YOUR OWN in matter of months!

Learn TELEVISION RADIO & ELECTRONICS

AT HOME
 We Furnish ALL Your EQUIPMENT without Extra Charge!



The DELEHANTY SCHOOL

...one of America's foremost Vocational Training Centers for nearly Half a Century with over Half a Million students...has developed this remarkable New Shop-Training-At-Home Method. Perfected by a large staff of electronic experts, engineers, technicians and teachers with extensive practical field experience. Right up to the minute in every phase of TELEVISION, RADIO and ELECTRONICS, including U.H.F., COLOR TV, HIGH FIDELITY, etc.

PRACTICAL SHOP WORK STARTS with FIRST LESSON! with TOOLS and PARTS that WE FURNISH IMMEDIATELY!!

There's no other course quite like this! No need to plow laboriously through difficult uninteresting theory lessons before getting into actual practical work!

The DELEHANTY "LEARN-BY-DOING" method makes every lesson a thrilling new experience! You get a big kit of quality tools and parts with your very first lesson...you start right in with practical shop assignments which are an interesting part of every lesson...nearly 400 shop jobs in all!!

SET YOUR OWN PACE!

DELEHANTY TRAINING lets you study and experiment at your leisure...Order new Training Units only as you want them... Pay as you go at your convenience! You move steadily forward until you attain the high level of technical knowledge and skill that marks DELEHANTY graduates as thoroughly competent RADIO, F-M and TELEVISION TECHNICIANS.

YOU PAY AS YOU GO YOU'RE NEVER IN DEBT!
 When you complete your DELEHANTY TRAINING you will owe nothing!

YOU WILL HAVE AS YOUR OWN PROPERTY:

- 21" TV SET WITH 21" PICTURE TUBE
- SUPERHETERODYNE RADIO WITH ALL TUBES
- MULTITESTER-AMMETER, OHMMETER, VOLTMETER
- OSCILLATORS • MODULATORS
- RADIO TELEPHONE TRANSMITTER • TOOLS
- RF AMPLIFIERS • AUDIO AMPLIFIER
- OTHER ELECTRONIC DEVICES • REFERENCE LIBRARY IN DURABLE LOOSE-LEAF BINDERS



MAIL COUPON TODAY FOR FREE ILLUSTRATED BOOKLET

NO OBLIGATION • NO SALESMAN WILL CALL

DELEHANTY SCHOOL OF TELEVISION PM 955
 115 East 15 Street, New York 3, N. Y.

Please send me by return mail your Free Booklet "How to Achieve Success in Television, Radio and Electronics." This does not obligate me in any way.

NAME _____ AGE _____

ADDRESS _____

CITY _____ ZONE _____ STATE _____

(PLEASE PRINT — Paste on Post Card or Mail in Envelope)

DELEHANTY SCHOOL of TELEVISION

LICENSED BY STATE OF NEW YORK
 115 EAST 15 ST., NEW YORK 3, N. Y.



I HELPED T.E.H. MAKE \$14 A DAY WHILE STILL LEARNING!

T. E. H.—West Virginia. "By the time I finished half your course, I was making \$14.00 per day. I have made enough on the side to more than pay for the course."

H. T. ARMSTRONG

Learn ELECTRIC APPLIANCE REPAIR & SERVICE

WE TEACH:

- How to Repair
- Washing Machines
- Vacuum Cleaners
- Electric Ranges
- Lamps, Motors, Irons, etc.,

- REFRIGERATION and House Wiring
- At Home In Your Spare Time!

For a man handy with tools, and happiest when working with his hands, OPPORTUNITY is Wide Open Today in this great and growing field. Everyone is a customer for the man trained to service electric appliances.

Open Your Own Shop

Our practical Home Course teaches you this business from A to Z—preparing you to take a well paid job or open your own shop. You can actually start in your basement or garage with the tools we send you . . . before finishing.

We Include An **ELECTRICAL APPLIANCE TESTER**
A Big Kit of Tools at NO EXTRA COST

MAIL THIS COUPON for FREE BOOK

H. T. ARMSTRONG
PACIFIC TRAINING SCHOOLS Dept. P-559
11029 S. Vermont, Los Angeles 44

Dear Sirs: Please send me, without obligation, your free booklet and complete details.

Name _____

Address _____

City _____ Zone _____ State _____

TRAINED MEN NEEDED

BIG PAY—GOOD FUTURE

- | | |
|-------------------------------------|--------------------------------------|
| <input type="checkbox"/> TELEVISION | <input type="checkbox"/> ELECTRONICS |
| <input type="checkbox"/> DIESEL | <input type="checkbox"/> AUTO |

WHY WORK FOR LOW PAY or risk being out of a job??? Usually the properly trained man has a steady job . . . through good times or bad. Even back during DEPRESSION there was a big demand for Bailey Trained men.

In only 5½ to 6 months we can train YOU to enter one of the big pay fields!

No previous experience or special education necessary. With our method of training you do not spend years pouring over books, figures, charts and graphs. You learn by rebuilding, repairing, testing and operating the most modern equipment, under the guidance of experienced, courteous and friendly instructors. This method of training gives you the experience and confidence required to step right into the big pay jobs without spending years as a mechanic's helper.

It's EASIER and COSTS LESS than you may think to get this residence shop training . . . we help you find part-time jobs while in school—full-time jobs after graduation. Check subject above in which you are interested and mail for complete information.

BAILEY Technical SCHOOLS

Veteran Approved

1634 S. Grand St. Louis 4, Mo.

NAME.....AGE.....

STREET.....

TOWN.....ZONE.....STATE.....



SAVE GAS! I'LL SEND YOU THIS FREE!

10 DAY FREE TRIAL! SEND NO MONEY! PAY POSTMAN NOTHING!

Uses Report 4, 5, 6 Extra Miles per Gallon with New Miracle Game Air-Flow Needle. (\$1.50 Value)

Up to 25% MORE MILEAGE, FASTER PICK-UP, QUICKER STARTING reported. Phenomenal money-saving results coming from ½ MILLION USERS. Carburetor Engineering Co. reports SAVING OF 72¢ PER DAY. YELLOW CAB CO., FLEET OWNERS, POLICE, EMERGENCY vehicle users. Outstanding performance "approved", FITS ALL CARS AND TRUCKS. INSTALL YOURSELF IN 2 MINUTES with simple twist-of-the-wrist. (Replaces present idle adjustment screw in your carburetor.) AMAZINGLY EASY TO DO!

● TRY IT FREE! JUST SEND NAME AND ADDRESS! ●

PAY NOTHING! Test this revolutionary new automotive discovery in your car AT OUR EXPENSE! Check mileage. (Some users report no improvement—so TRY BEFORE YOU BUY.) If amazed at increased mileage PAY WITHOUT MONEY. Otherwise, just return the "little stinker" and you owe us nothing. Fair enough? Specify make of car, # cyl. and year (8 cyl. cars use 2.) Rush, Free Trial SUPPLY LIMITED, ECONOMY AUTOMOTIVE INDUSTRIES Dept. A-9, 1036 S. LaBrea, Los Angeles 19, Calif.

French STYLE DUELING SWORDS SET \$3.98 OF TWO

Once used in deadly combat—now an exciting sport! Learn right at home. Fun—safe—educational. These swords are made of fine blue spring steel, polished metal guards, turned handles, rubber safety tips. Fencing teaches quick thinking, develops coordination, posture. Since the Middle Ages, Europeans have enjoyed the sport of dueling. *Now advocated by U.S. colleges. Set includes two swords and the booklet, "The Art of Fencing". Special price. MONEY BACK IF NOT COMPLETELY SATISFIED At sporting goods dealers or send \$3.98 to Wham-O Mfg. Co., Box 25E San Gabriel, Calif.



YOURS FREE!

If You're Interested In **BREEDING TROPICAL FISH** For Profit & Pleasure

This handsome, precision-viewing instrument and color slides are yours FREE—just for showing your interest in Tropical Fish Breeding! See gorgeous BETTAS, colorful TETRAS, exotic ANGEL FISH, etc., in the vibrant beauty of full color! Convince yourself Tropical Fish Breeding is the profitable, easy-to-start home business for you! Breed them in your living room, spare-room, anywhere. Success is assured because we'll buy every fish you produce! No experience or costly equipment needed. Start spare-time, on a "shoestring" . . . build a \$10,000 home business! Investigate!

Write today for FREE details on "Profit-Proven" Success Plan & Vuer! (If under 17, ask for plan A.)

TROPICAL FISH BREEDERS OF AMERICA Dept. D-9 Los Angeles 61, Calif.



Get Yourself FIXED FOR LIFE in the Big Pay Shoe Business!

I'll put up the money to Give You a Flying Start!

I give producers their own shoes as a Bonus!

It's no trick at all to make big money—FULL OR SPARE TIME—with America's most comfortable shoes! Amazing new "Spring-Step" cushion design proves it by actual demonstration. Only ORTHO-VENT has it! There is no other shoe in the world like it. Repeat orders are sure . . . steady . . . one try and a customer is sold for life. Profits are BIG. Orders are sure and easy with the most amazing 3-minute demonstration in the history of the shoe business. No experience needed. No investment to make. Everything, including one of the finest sales outfits in America today, with actual cut-aways, furnished free! Be the big-pay ORTHO-VENT man in your territory. Write TODAY! E. C. Brand, Sales Manager.

ORTHO-VENT SHOE COMPANY DEPT. 1159 SALEM, VIRGINIA



**WORLD'S
BEST
WANT-AD
MEDIUM**

CLASSIFIED ADVERTISEMENTS



Advertisements in this section \$1.00 per word, each insertion, minimum 10 words, payable in advance.

To be inserted under proper classification, copy must be in our office the 20th of the second month preceding date of issue

F. W. Johnson, Manager, Classified Advertising
Popular Mechanics Magazine, 200 East Ontario Street, Chicago 11, Illinois

YOU'LL PROFIT

By reading and answering the classified ads in this section. Hundreds of opportunities for you to make and save money

AUTOMOBILES, MIDGET CARS

BOYS' Power-driven auto. Build your own. Plans 25 cents. Sypher Co., Box 39, Sta. P, Toledo, Ohio.

ENGINES, Wheels and equipment for midget cars \$10.00 up. Cauffiel Motors, Temperance, Mich.

SEND For free sample copy. Franson's Motor News, Eugene, Oregon.

BUILD 1902 Rambler, 1909 Hupmobile, antique cars. Authentic 1/2 inch scale plastic model kits. Collectors pair. Both for \$2.00 postpaid. Kaysun, Manitowoc, Wis.

HUNDREDS Of automobile catalogs—American, antique, foreign; dealer books, glossy photographs, shop manuals; free motor magazines—Offered by non-profit club. Write immediately; get on free mailing list. Auto Maniacs, Stockbridge, Mich.

ANTIQUE Automobile color slides, 2x2. Illustrated catalog free. Universal, Box 779A, Beverly Hills, Calif.

AUTO SUPPLIES AND EQUIPMENT

MOTORIST Save money with Redm-Air automatic, calibrated gas saver. Wanted agents. Write Redm-Air, 1450 W. North Ave., Chicago 22, Ill.

INCREASED Mileage 25%. Faster pick-up reported with simple new \$1.50 automotive discovery. Million users already! Send no money—Just make year your car! Use 10 days free. If satisfied pay, otherwise return. Write: Gane, Dept. 49, 1036 S. LaBrea, Los Angeles 19, California.

CROSLY Specialist—Rebuilt cars, motors. Parts new, used. Shipped c.o.d. anywhere. Gene's, 1915 South "H," Fort Smith, Arkansas.

FAST Porting tool. Send for free literature. Lewis Standard Tools, 1621 Rheem, Richmond 5, California.

LACHAPPELLE'S 100,000 Miles treatment, makes any car better longer. Write, Ferns, Box 71827-B, Los Angeles 1, Calif., in Canada, Master, Box 216, Welland, Ontario.

BUY Wholesale nationally advertised auto supply, thousands other products at big discount. Free "Wholesale Plan." American Buyers, Hertel Station, Buffalo 16-G, N. Y.

BOOKLET—How to drive standard and automatic automobiles 25c. Ringer's Auto School, Box 702, Lynn, Mass.

JALOPY Owners crazy! 12 different comic glow stickers, \$1. Deal Signs, Bovey, Minn.

AUTO Supplies and equipment—Chevrolet horsepower, Offenhauser accessories, Zephyr-type transmission gears. Send for free literature. Offenhauser Equipment Corp., Box 32218, Los Angeles 32, Calif.

FORD T parts? Try best source old car parts anywhere. Wisneski, Milwaukee 7, Wis.

WORLD'S Best carburetor. Increase in pep and mileage guaranteed. Complete details \$1.00. Settlemyer Enterprises, P.O. Box 853, Kannapolis, N. C.

CRANKSHAFT Grinder, hand operated. Makes bearings fit without taking engine apart, \$3.75. Literature. L. D. McGee, 719 Cascade St., Wenatchee, Wash.

AUTO Parts 1915 up. Grilles, fenders, body parts, rear ends, transmissions, motors, front ends, mufflers, pipes, springs, tires, tubes, wheels. Acres of cars for parts. Bills Auto Parts, Valley Falls, R. I. Old cars and parts wanted.

FUEL-Injectors, aluminum fuel tanks, carburetors, engine adaptors, speed, power, mileage equipment. Catalog 50c refundable. Moon Automotive, Box 432, Santa Fe Springs, California.

DISCARDED GM71-110 injectors parts wanted. Bonus on HV Bares, 7120 Carnegie, Cleveland 3, Ohio.

GEARS, Axles, and all auto parts for old and up-to-date automobiles. Send your requirements. Auto Gear & Parts Company, Philadelphia 40, Penna.

SAFTI-Brak. Patented automotive device. Warns and prevents sudden brake failure. Inquiries welcomed. Donald Mitchell, Norwood Road, New Haven 13, Conn.

NEW And used parts at savings. Complete guaranteed parts service for all models cars and trucks. 1924 and later. Largest in the West. Army parts specialists. No catalog, write for quotations. Fast mail order service. Pioneer Auto and Truck Parts Co., 734 W. 13th Avenue, Denver, Colorado.

IMPORTANT! Automobile owners, guard against fire, theft, flat tires! Write: Burns, 1967-P Gerritsen Avenue, Brooklyn 29, N. Y.

AUTO Supplies and equipment—Horsepower by Offenhauser, send 25c for latest catalog. Offenhauser Equipment Corp., Box 32218, Los Angeles 32, California.

THERM-O-Spark ignition coil. Assures quicker starting, more mileage, increased power, less oil consumption. Convincing proof free. Wilson Specialties, 70 Sylvan Drive, Morris Plains, N. J.

WONDA-Vu water repellent gives wonderful results on automobile, boat windshields, radio insulators, ignition systems. Guaranteed. Generous supply, \$1.00, postpaid. Box 1971, Corpus Christi, Texas.

GENUINE Motor treatment, Lachapelle's, (patented). Only \$3.00 delivered. Increases compression, power. Saves gas, oil, repairs. Money back guarantee. You can't lose. Free circular. Write Joe Dillon, Authorized Warehouse and Agents Distributor, Box 32213 Bridgeport, Ohio. Exclusive distributorships, agencies open.

JEEP Owners—V8 power. Read Jeep owners ad, page 44.

TAPPET Noises in Mercurys, Fords and Chevrolets stopped with our silencers, Literature. Kaye Products, 2067B S. Layton Blvd., Milwaukee 15, Wis.

PISTONS. Austin, Bantam, Fiat, MG, etc. Any oversize or make. Merryman, Box 422, Ontario, Calif.

SAVE 25% On auto parts, speed equipment accessories—Direct factory outlet. Free catalogue. Auto Accessories, 1819 S. Hackberry, San Antonio 10, Texas.

AMAZING Cloth eliminates windshield fogging. Year's supply, \$1.00 postpaid. Guaranteed. Burnie, 1818P West Haskell, Tulsa, Okla.

AUTO Safety-belts. Fit all cars and persons. \$8.95 each. Send \$3.00. Balance c.o.d. Brochure? Stommel, Box 104, Detroit 31, Michigan.

TIRES—Firestone, Goodyear first line, guaranteed. Hundreds of specials. Save 35% to 60%. Write Bussler Tire Co., Lorain, Ohio.

RADIOS. Custom for 1952-3-4-5 Fords \$38.90. Free literature. Nordic Radio, Box 582, Evanston, Ill.

ALIGN-A-Matic outperforms all drive over alignment devices. \$22.50. Align-A-Matic, 62 Gaston St., W. Orange, N. J.

CAR Burning oil? Losing compression? Try Clifford's Compression Seal Tube, \$2 postpaid. Clifford's Engineering, 1329 Seventh, Aurora, Illinois.

ELECTROPLATE Auto parts, novelties, mirrors. Easy, inexpensive home processes. Free booklet. Tyco Metals, Box 13231-BG, Houston 19, Texas.

AUTO Accessory and parts catalog. 1955 edition—All new! 148 pages. Save up to 50%. Over 50,000 items, including Hollywood accessories, hi-speed equipment, rebuilt engines, all parts and accessories for all cars and trucks! Hard-to-get parts! Send 25c. Refundable. J. C. Whitney, 1919-PM Archer, Chicago 16, Illinois.

FREE Discount catalog—Speed, power, custom equipment. Alquist Engineering, Milford 7P, Pennsylvania.

AUTO TRAILERS

TRAILER Building manual illustrated \$1.00. Booklet 25c. Craftsmann Books, Box 1153, Milwaukee 1, Wis.

EXCEPTIONAL Expanding eight foot trailer. Accommodates family of five. Build yourself. Literature 10c. Framar Company, Wilmington, Mass.

BUILD Your own trailer! Plans for all kinds. Illustrated catalog 10c. Jim Dandy, 125-M, Wausau, Wisconsin.

ASSEMBLE Yourself kits. Slip-on cabin coach for all pick-up trucks. Trailer blueprints. Literature 10c. Comstock Trailers, 846-P, Parsons, Kansas.

MOTORCYCLES, BICYCLES, MOTORSCOOTERS AND SUPPLIES

RECONDITIONED Motorcycles and motors. Chromium accessories. Complete stock Indian parts. Expert rebuilding. Fast service. Indian Motorcycle Sales, Kansas City 27, Mo.

CUSHMAN Motorscooter \$15. Servicecycle \$20. Midget car chassis \$25, less engines. Motorbike engine \$5, outboard \$5. (Mail-order only). Send 25c (35c first class mailing) for directory-catalogue Number 67, just out, listing these and hundreds of other bargains in new and used midget cars, motorscooters, parts, plans, etc. Midget Motors Directory, Athens, Ohio.

WHIZZER Motors \$20.00; Safticycle, completely equipped, \$30.00; motorscooter \$6.00; Cushman two-speed \$20.00. Send 25c (35c first class mail) for catalog #28 jammed with sensational bargains in wheels, motors, motorscooters, midget cars, motorbikes, construction plans, etc. Gail 1313 Jefferson, Toledo, Ohio.

HARLEY-Davidsons — America's finest used bargains! We pay shipping on motorcycles. Genuine new, used parts, accessories for current and obsolete models. Send 25c for bulletin, catalog. Knuth's (factory dealer), 1753 Muskego, Milwaukee, Wis.

AVIATION

PROPELLERS Specially designed for airboats and snow sleds by the world's oldest manufacturer of aircraft propellers. Free literature. Plotter Mfg. Co., G. R. Airport, Grand Rapids 8, Mich.

AIRLINE Steward-purser. Fly 85 hours monthly. Starting salary \$235 up. G.I. approved. Free catalog. Air-Purser School, Room O, 1030 Nicollet Ave., Minneapolis, Minnesota.

AVIATION Surplus bargain catalogue. One dime. Thomasville, Box 22A4, Penna.

LIGHTPLANE Building Manual \$1.00, including construction plans \$2.00, circular 25c. Craftsman Books, Box 1153, Milwaukee 1, Wis.

PROPELLERS, Plans, supplies for air boats, snow sleds. Catalog 10c. Gano Propellers, Box 3344-A, Ft. Worth, Texas.

HELICOPTER, One man. Experimental marvel. Construct own. Instructions \$3.50. Mayberry Company, Box 343, St. Clair Shores, Michigan.

PROPELLERS, Plans, kits for snow sleds, air boats. Immediate delivery, satisfaction guaranteed. Catalog 25c. Banks-Maxwell, Box 3301E, Ft. Worth, Texas.

BATTERIES, GENERATORS

EDISON Nickel storage batteries. Any voltage, any amperage. Unconditionally guaranteed. Power plants, generators, motors. Literature. Hawley Smith Co., Croton Falls 1, N. Y.

ELECTRICAL SUPPLIES

NEW 1955 Lamp parts catalog showing everything you need to make and repair most types of lamps. Everything at lowest wholesale prices. Send only 25c today for both catalog and wholesale price list. Gearon Co., Dept. 503-B9, 27 S. Desplaines, Chicago 6, Ill.

LAMPS — 25c Brings bargain catalog showing all parts for repairing, building. Contains instructions for electrifying vases, oil lamps, etc. Gyro Lamps, 5402P Clark, Chicago 40.

ELECTRIC Pencil: Engraves all metals \$1.50. Beyer Mfg., 16511-H Springfield, Chicago 43.

WELDING, SOLDERING, PLATING

A.C. Welders, 130 amperes, \$39.50. Morris, 1070 Inner Drive, Schenectady 3, N. Y.

ELECTROPLATING Equipment, anodes and solutions for all types of plating. Instructions. Assemble your own plater and save. Free catalog. Ramyr, Dept. E-4, 1624 East First Street, Los Angeles 33, California.

ACETYLENE Welding outfits, new \$48.00; used \$29.00; arcwelders \$56.50. Eagle Welding, Dept. PM, 5085 Broadway, Chicago 40, Ill.

MAGNA-Weld lenses for welders who need glasses. The Magna-Weld lens is an optically ground magnifying inside cover glass 4"x4 1/4". Fits all standard helmets. Number one weak power, number two stronger power. Price \$5.00 each. Satisfaction guaranteed. Industrial Optical Co., P.O. Box 444, Jacksonville, Florida.

A.C. Welders, 4 sizes. Lowest prices. Free literature. Holgerson's Serv., Canton, Kan.

"BUILD-UR-OWN" a.c. welder and a.c. power plant with a good used engine and low cost Hobart generator. Welds anywhere and supplies 5kw stand-by power for any emergency. Write Hobartweld, Box M-953, Troy, Ohio.

NEW And different oxy-acetylene outfit welds, cuts, heats, brazes, with interchangeable tips. No attachments needed. Light, portable. Complete outfit, full instructions, only \$76.50. Special money-saving plan for oxygen and acetylene supply. Write for free literature today: Dept. M, Linde Air Products Company, 30 East 42nd Street, New York 17, N. Y.

SAVE \$100.00. 240 Amp. welder, less cabinet \$125.00. Haun & Son, Industrial Park, E. Syracuse, N. Y.

MACHINERY, TOOLS, SUPPLIES

CRANKSHAFT Grinding equipment bargain. Will finance. Send references. Eaton Roller & Manufacturing Co., Box 304, Eaton, Indiana.

ALLEN Two ton power bench type punch press. \$97.50. Circular. Allen, Dept. PMB, Clinton, Missouri.

TOOL Sale, indicators Federal #D818 \$15.00; drills, taps, others. Genex, P.O.B. 665, San Valley, California.

INSTANT Change kit, four practical tools for any 1/4" drill motor. Two saws, planer, sander; not gadgets. Free literature. Gehlco Tool Co., Box 323, Independence, Kansas.

MILLING Machine: New, heavy duty bench model. Complete, only \$149.50. Southern Machine Tool Co., Conyers 1, Georgia.

SINE Bar, quality iron casting \$2.00. McKin Industries, Box 3172, Lennox, Calif.

FREE, Four fast cutting drill bits. Sizes 5/32"—1/4" with each order for set of instructions and diagram showing how to make them in home work shop. \$1.10 postpaid. Aubrey Pearce, 328 Gulfport St., Hattiesburg, Miss.

COMBINATION Square and marking gauge. Different. Ideal carpenters, woodworkers. Nelson, 7822 S.W. Chestnut, Portland 19, Oregon.

DOG Bone—10 way wrench, fits almost all size nuts and bolts. \$1.00. Elco Products, 60 Holt, Dayton 7, Ohio.

ACCURATE Small English metal working lathe, catalog. Science Now Co., Catskill, New York.

AMAZING Level attachment. Measure fall or pitch with precision of transit. Simple inexpensive, easy to use. Get correct grade when laying sewer lines, driveways, landscaping and construction jobs. Free literature. Carr Manufacturing, Ionia, Michigan.

NEW Steel shelving 6 feet high, 36" wide, 12 inches deep, with 5 adjustable shelves, \$9.95 complete. No c.o.d.'s. Corco Tool, 5636 Lake Park, Chicago 37, Illinois.

ENGINES, MOTORS, DYNAMOS

WINDING Data. 225 motors, single and three phase, \$1.00. Data Company, Box 7631, Kansas City 28, Mo.

REWIND Motors yourself. Complete instructions \$1.00. Lewis Mfg., Howell, Michigan.

NEW Gasoline engines. Save 50%. Catalog 10c. Loren, Box 436, Danville, Illinois.

REBUILT 1 1/2 To 3 h.p. engines \$17.00 to \$37.00. Parts also. Cauffiel Motors, Temperance, Mich.

BOATS, OUTBOARD MOTORS

PLYWOOD Boat plans, 21 for \$1.00. Catalog boat building plans 25c. The Rudder, 15 Murray Street, New York 7.

NEW 12V. batteries for boats, motors, cars, etc. Include box and lid \$12.50 each. No c.o.d.'s. Leibe Supply, Selma, Calif.

CONVERT Fords and Jeeps to 100% marine engines with Osco's world famous Convo-Kits. Deluxe catalogue 25c (coin). Oscomotors, 3627B Lawrence, Philadelphia 40, Penna.

FIBERGLAS Permanent boat waterproofing. Lowest wholesale prices. Guaranteed materials. Easy application. Full instructions. Complete kits, \$12.60 up. Free literature. Ajax Plastics, Dept. PM, P.O. Box 1323, Fort Worth, Texas.

NEW, Used, rebuilt marine motors. Marine conversions, fittings. Free catalog. Stokes Marine Supply, Dept. 24, Coldwater, Michigan.

AIR Boat plans, supplies, catalog 25c. Banks-Maxwell, Box 3301F, Ft. Worth, Texas.

PLANS, Patterns, frame kits for modern boats 12'-22'. Complete selection of modern boats especially for the amateur builder. State your requirements or send 40c for our complete catalog. Glen Designs, Box 568, Compton, Calif.

FREE Catalog! Boat kits, trailers, fiberglass, marine hardware. Luger Industries, Dept. M, 4452 Nicollet, Minneapolis, Minn.

MARINE Conversions for Ford and Jeep engines. Catalog 25c. Lehman Manufacturing Company, 972D Broad Street, Newark 2, New Jersey.

FIBERGLAS Boat coating. Plexiglas boat windshields—clear, blue, green tints. Wholesale-retail. Complete information catalog 15c. Gem-O-Lite, Box 6861B, North Hollywood, California.

FIBER-Glass oars! Hollow—they float! Send for free folder. Plastic Age Co., San Fernando, California.

FULL Size, cut-to-shape boat patterns, blueprints, 7 1/2-38 feet. New 1955 illustrated "Build a Boat" catalog of 50 naval architect-designed cruisers, runabouts, sloops, skiffs, outboard boats, sailing, racing, houseboats, 50c. Small boat hardware catalog, \$1.50. Bigger, better 1955 "How to Build Boats" book, \$2.50. Cleveland Boat Blueprint Co., Dept. A-66, Box 1851, Cleveland 4, Ohio.

BUY Wholesale nationally advertised outboards, thousands other products at big discount. Free "Wholesale Plan." American Buyers', Hertel Station, Buffalo 16-H, N. Y.

BOATS, Outboard motors—Tachometer electronic, ideal for outboards or inboards, magneto or battery ignition. Free literature. Offenhauser Equipment Corp., Box 32218, Los Angeles 32, Calif.

GLASBOTE Plastic and fiberglass for boat covering. Complete information. Buchanan Plastics, Okemos, Michigan.

BOAT Plans: Welded steel, wood, plywood. Outboards, inboards, cruisers, sail. Free literature, please specify type. John B. Clark, N.A., P.O. Box 51, Bay Village, Ohio.

ATHLETIC EQUIPMENT, BODY BUILDING COURSES

"MUSCULAR Manhood", illustrated bodybuilding courses, \$2.50, postpaid. John Schollars, Mercury Press, P.O. Box 897, Albuquerque, N. M.

BUILD Powerful arms, chest, shoulders! 22 exercises, \$1. Fonsad, Box 601-B, 1100 Market, Wilmington 99, Del.

COMPLETE Arm, chest, back muscle building course and apparatus, \$1.00. Joseph Dryer, Box 3527, Chicago 80.

FREE Catalogue, 10c for postage appreciated. Dr. Thompson, 919 Fourth, Manhattan 30, Kansas.

BARBELLS, Exercise equipment. Courses. Free booklet. Good Barbell Co., Reading, Penna.

SPORTING GOODS, GUNS, FISHING TACKLE, ARCHERY, TRAPPING

FREE Fishing catalog—132 pages. Over 3000 hard to find fishing specialties. Netcraft Company, Dept. PM9, Toledo 13, Ohio.

DISCOUNTS; New guns. Big illustrated catalog new, used, dime. Leopold Kay, 845 Riverside Drive, New York 32, N. Y.

BUY Wholesale nationally advertised sporting goods, thousands other products at big discount. Free "Wholesale Plan." American Buyers', Hertel Station, Buffalo 16-I, N. Y.

300 FISH Hooks \$1.00. Sizes 1-12. Free valuable gift with each order. Tedesco Distributors, Cameron, N. Y.

GOVERNMENT Surplus ammunition—45/70 caliber \$6.50 per hundred; 30 carbine, 30/06 government \$5.95 hundred. Also Italian, German, Jap revolvers, rifles. Free list, Hudson, P-52 Warren Street, New York City 7.

BOW-Hunting secrets free! New book "How to Hunt with Bow"—100's tips out-witting big, small game, bow-fishing. Revealing "How to Choose Bow" facts, Bargain catalog included. Save 50% finest tackle. All 3 free! Malibu Archery, 1036-RSE La Brea, Los Angeles 19, Calif.

JEOP Owners—V8 power. Read Jeep owners ad, Page 44.

GUNS, Frontier single actions, Derringers, all parts including frames. Discount to dealers. Send 25c for catalog. E&M Firearms, 333 S. Fairfax, Los Angeles 36, California.

REELS Wholesale, Pfleger supreme \$23.50; Ocean City # 251, \$18.40; South Bend #915, \$11.25; Cox #25C, \$21.95. Prompt delivery, prepaid. Barry Sales, Box 234, Miami 50, Florida.

TROUT Fishing, Stag at Eve, Mallards in Flight, Yacht Race, Colliers, Thorobred, and Palomino coded oil painting kits in size 12"x16". Each kit \$2.95 postpaid, also North Woods Retreat size 18"x24", \$6.95 postpaid. You can paint in oils the first time you try. Send for free literature. Ralox, P.O. Box 1256, Decatur, Illinois.

SWIMMERS! Send \$3.95 for imported French mask. Catalog of skin divers' equipment and books 25c. Aquafun PM, Davenport, Iowa.

180 PROFUSELY illustrated pages antique pistols, swords, daggers, armor, etc. 50c. Robert Abels, M860 Lexington Ave., New York 21.

TENTS, Camping equipment. Send 10c for new 1955 100 page tent, camping equipment catalogue-handbook. Morsan, 10-21R 50th Avenue, Long Island City 1, N. Y.

MOLDS—For making fishermen's sinkers. Free illustrated booklet. Reading Instrument Co., Box 78, Reading, Penna.

5000 BARGAINS, Firearms, binoculars, war relics. Catalog 50c. Smith Firearms, Runnede, N. J.

MOLDS For fisherman's sinkers, jigs, squids, casting and spinning lures. Free catalog. Sweet's Molds, Tonawanda 1, New York.

JAP Rifle altering to 30-06, \$6.00. Japshells, \$3.75. Catalog 5c. T. P. Shop, West Branch 11, Mich.

FISH Crazy about amazing new fish lure. Bite like hungry wolves. Works like magic on any lure. Bottle \$1.00. Results guaranteed or money back. Literature free. Smith-Parish, Rupert, Idaho.

GUNS Traded. Best deals possible. State what you got, state what you want as no lists available at this time. Don't ship, write Mack Greenwood, Washington 18, Indiana.

GUNS! Guns! Guns! New-used hunting bargains. Mausers, Lugers, Kentuckies, Winchester, antique arms. Catalog 50c. Ed Agramonte, Inc., 201 Warburton, Yonkers 20, N. Y.

FREE—New illustrated catalog of everything for archery. Pride Archery Company, R.F.D. #1, Danbury, Connecticut.

BUY Wholesale! Guns, fishing, sporting goods. Save 66%! Free catalogs. National Buyers Service, Box 426EC, Oakland, California.

RED Arrow gun oil. Cleans, lubricates, preserves. Since WWI. Four ounces one dollar. Morotal Company, Box 364-C, Maywood, California.

TAXIDERMY

MODERN Taxidermist magazine, Greenfield Center 2, N. Y. Devoted entirely to taxidermy, methods, photos. Trial year's subscription, \$1.00.

BINOCULARS, TELESCOPES, MICROSCOPES, MAGNIFIERS

BINOCULAR Specialists, all makes repaired. Authorized Bausch & Lomb, Zeiss-Hensoldt, and Bushnell dealer. Tele-Optics, 5514 Lawrence, Chicago 30.

REFLECTOR Telescope kits \$6.25 (3") to \$175. (12"). Mirrors, cells, focusing mounts, tripods, eye-systems. Anything, everything in telescopes. Free illustrated catalog. Also ready to use telescopes from \$26 to \$176. Inquiries to Esco Products, Dept. PM-9, 1428 Willow Ave., Hoboken, N. J. Sales showroom, 166 Church St., New York City.

6 THUMBS On each hand? Even you can assemble our telescope kits from our easy instructions. Enjoy the heavens with a high precision telescope assembled in less than an hour. You'll like our complete line of accessories. Send 10c for catalog of finest quality and newest design astronomical kits. Optical Engineering Co., 164-19 Northern Boulevard, Flushing, New York.

IMPORTERS' Amazing prices, precision binoculars, 22 models. Free trial. Folder, "Binocular Selecting," catalog free. Dealers wanted. Prentiss Importers, Mercury Bldg., West Los Angeles 25, Calif.

SAVE 25%! Get interesting facts. Free 56 page binocular, telescope catalog. \$3.95 to \$250.00! United, 9043 S. Western, A-8608, Chicago 20. Dealers wanted.

LOWEST Prices, all sizes, binoculars, telescopes, microscopes. Also repaired. Free catalogue. Joe's Binocular Sales, 4827 Second Blvd., Detroit 1, Michigan.

TELESCOPES, Microscopes, binoculars, past quarter century. Comprehensive scientific instrument catalog \$1.00. None free. Dollar deductible from orders. Harry Ross, 70 West Broadway, New York 7, N. Y.

BINOCULARS, Telescopes, microscopes. Terrific values \$3.98 up. Request free money saving catalogue. Criterion, Dept. P33, Hartford, Conn.

WAR Surplus bargains! Millions of lenses, instruments, telescopes, binoculars, components and complete line of astronomical telescope items. World's greatest optical market place! Send only \$1.00 for beginner's 10-lens kit and big instruction booklet Stock 2-CH. Write for Catalog CH free! Edmund Scientific Corp., Barrington, New Jersey.

DYNASCOPE—Sensational new reflector telescope. Send for details. Criterion Co., Dept. DP 12, Hartford, Conn.

SHOPPING? All good merchants do! Our buyer flew to Japan to shop. Result—Better binocular and microscope values! 6-800 power! Catalogue on request to dealers only. Tanross Supply, 1075 N.W. 71st St., Miami, Florida. Exclusive Tasco importers.

45X TO 400X telescopes easily made. Five finished lenses and building instructions, \$3.75. Giant astronomical telescope completely assembled with 6 ft. tripod, \$15.00. Free information. Suffolk Science, Mattituck 3, N. Y.

BUILD Your own reflector telescope. Complete kit; mirrors, eyepieces, tripod, all other accessories. Request free illustrated literature. Criterion Manufacturing, Dept. KPMS, Hartford, Conn.

SPECIALISTS! Used microscopes and accessories. Unusual slides. Supplies. Catalog free. Research Scientific Supplies, 60 Wall St., New York City 5.

PETS—DOGS, BIRDS, RABBITS, HAMSTERS, ETC.

CAOE—Bird Magazine (budgies, canaries, etc.) one year, \$3.00. American Cage-Bird Magazine, 3449 N. Western Avenue, Dept. P.M., Chicago 18, Illinois.

HUNTERS! Raccoon Mountain and Short Creek Kennels now combined. Large number of coonhounds, foxhounds, rabbit-hounds, beaglehounds, bird-dogs, puppies. Free literature and pictures. Trial. Dures Thomas, Owner, Box 464, Boaz, Alabama.

UNUSUAL Pets: baby monkeys, ocelots, kinkajous, skunks, etc. Send 10c for complete price list. Eric O. Sonntag, 4001 W. Pico, Los Angeles, Calif.

HAMSTERS—Golden: young, \$3.00 pair; fully developed, \$4.00 pair. Adirondack Hamstery, Prospect 108, New York City.

ENCYCLOPEDIA Of canaries and other cage birds (including budgies) with questions and answers, \$2.75, plus 25c postage. Audubon Publishing Company, 3449 North Western, Dept. P.M., Chicago, Ill.

TALKING Mynah birds, other pets. Herb Miller, 1911-N, Lubbock, Texas.

BEAUTIFUL Pure white pedigreed police puppies. Ansonia Kennels, Mose, N. Dak.

RABBIT Raising facts complete in 48 page illustrated book, by world's largest rabbit association. 10 cents. Address American, 36 Arba Building, Pittsburgh, Penna.

CHINCHILLAS Top-quality registered sturdy young stock, \$75.00 per pair. Slater Chinchillas, 1535 Ruhland Ave., Manhattan Beach, California.

RAISE Money-making Angora, New Zealand rabbits. Particulars free. White's Rabbitry, Jackson, Mich.

MAKE Money raising chinchillas, mink, pigeons, rabbits, cavies for us. Free catalog. Keeney Brothers, New Freedom 2, Penna.

STANDARD Rabbit Journal, Milton 3, Penna. Year \$1.00. Sample dime. Beginners manual 25c.

GROW Mushrooms. Cellar, shed, and outdoors. Spare, full time, year round. We pay \$2.50 lb. We paid Babbitt \$4,165.00 in few weeks. Free book. Washington Mushroom Ind., Dept. 171, 2954 Admiral Way, Seattle, Washington.

MINK Raising information free. Complete. Lake Superior Mink Farm, Superior, EEL, Wisconsin.

MAKE Big money! Raise Chinchilla rabbits. Cash markets supplied. Write today! Rockhill Ranch, Sellersville 15, Penna.

SPORTSMEN: World's largest kennel offers 500 Pointers, Setters, Straight Cooners, Combination Hounds, Rabbit and Squirrel Dogs, Beagles, Fox and Wolf Hounds. Trial. Prices reasonable. Catalogue free. Smokey Mountain Kennels, Cleveland, Tennessee.

GUINEA Pigs. Cash income. Booklet free. Taylors, 426A, Hapeville, Georgia.

RAISE Mink: Free booklet, pen plans, inside secrets, feed, care. Mink are money makers. Investigate today. Lawrence Mould, Brigham City 12, Utah.

PLANTS, SEEDS, NURSERY AND GARDEN SUPPLIES

FERTILIZER. Your own odorless factory. With Activo, make quick, easy from garbage, sawdust, other waste in 5000 pound yearly capacity cabinet. Complete details and plans 35c. Activo Fertilizer, Bridgeton 33, Indiana.

GINSENG, Goldenseal roots bring up to \$12 pound. Full information. F. M. Collins, Viola, Iowa.

BLUE Spruce: 6 for \$2.00. Northern Evergreens, Ellenburg Depot, N. Y.

WORLD'S Greatest cash crop. Free information. Write Ginseng Gardens, Asheville, N. C.

RAISE Your shrubs, trees from seed. Free planting guide, price list. Woodlot Seed Co., Norway, Michigan.

FARMS, FARM LANDS, REAL ESTATE

HOMESITES \$400 — Convenient payments. California's finest garden section. On Morro Bay's scenic shores. Wonderful fishing, boating, bathing. Fertile soil softest water temperate climate, congenial community. Free literature. Richard Otto, Department M, San Luis Obispo, Calif.

FLORIDA—Beautiful retirement homesites near gulf coast. Excellent hunting, fishing in 9 fresh and salt water rivers. 11 bays and gulf. \$250 at \$10 monthly. Free literature. V. M. Mathews, Box 1406, Asheville, N. C.

NEW Strout catalog, just out! Mailed free! Farms, homes, businesses, 35 states, coast-to-coast, over 3,000 bargains described. World's largest; 55 years service. Strout Realty, 7-MF So. Dearborn St., Chicago 3, Ill.

ONLY \$5.00 Down! Full price \$89.50 on easy terms buys big 5000 square foot home-site at Bandera, Texas, heart of "dude ranch country." Electricity, telephone, 1300 feet above sea level. Warm days and cool summer nights make vacation paradise. Hunting, fishing, golfing, swimming, horseback riding. Write for free photographs and details. Bandera Pass Ranch, Dept. 201-B, Bandera, Texas.

FLORIDA, Nice homesites, \$245 at \$10 monthly. Folder free. Howard Vernon, DeLand, Florida.

MINERALS, Grazing, investment, retirement. Timber lands, \$6 acre. Terms. Listings, information free. Write Armstrongs, Shook, Missouri.

SEE Our ad on page 44. The Abacus Press.

TEN Acres Missouri land, \$90. Warranty deed. Free list. John Calvert, Plant City, Florida.

CALIFORNIA Farm and ranch lands, \$15 to \$35 per acre on easy terms. 100% oil and uranium rights. Free catalog. Pacific Tax Sales, 1621-A Cahuenga, Hollywood 28, California.

PROFITABLE OCCUPATIONS

SELL Auto radios. Large profits. Details free. Regent, 920 Erie, Philadelphia 40.

MUSHROOM Spawn plus complete instructions various processes. \$1.00. Luxur, 641 S. 19th, Newark 3, N. J.

WE Operate a successful television rental business by telephone from our home. Details \$1.00. Alpha Television Rental, Box 5173, Austin, Texas.

FOREIGN Employment construction work. If interested in foreign projects with high pay write Foreign Service Bureau, Dept. PM, Metuchen, N. J.

AUCTIONEERING—Home study course. Diploma granted. Auction School, Ft. Smith, Ark.

OVERSEAS, Latin American, Alaska, Canada employment. Originator 1955 "Foreign Service Directory" up-to-minute report on military and civilian construction; oil companies; aviation; transportation; steamship; mining; government job info. How-when-where to apply. Listing firms hiring. \$1.00. Global Reports, Box 883-P, Hollywood 28, Calif.

\$5 To \$10 An hour. I've did it. I'm disabled now. Real genuine offer. Complete information only \$1. Lucas, 2200 Carson St., Pittsburgh 3, Penna.

RAISE Pheasants on \$100 week plan. Little capital and space can make you independent. Free details. Great Central System, Columbus 1, Kansas.

FREE Polio "Up to \$45,000; Unlimited Vacations." No merchandise, equipment. Unknown! Work home, sparetime! Haylings, Carlsbad, Calif.

GROW Mushrooms. Cellar, shed, and outdoors. Spare, full time, year round. We pay \$3.50 lb. We paid Babbitt \$4,165 in few weeks. Free book. Washington Mushroom Ind., Dept. 99, 2954 Admiral Way, Seattle, Wash.

HOME Workers needed! Spare time, full time. Assemble luggage and cases with our complete illustrated step-by-step instructions. We sell your product—Supply everything. Manufacturing representative needed in your area immediately. Unlimited profits possible. Investigate at our risk. Free details. Cascraft, 807-G10 Sunset, Los Angeles 12, Calif.

FREE Book "505 Odd, Successful Businesses." Work home. Expect something odd! Pacific, Oceanside, Calif.

MAKE New greaseless doughnuts in kitchen. Sell stores. Free recipes. Michael Ray, 3605 South 15th Ave., Minneapolis 7, Minnesota.

BE The Popular Mechanics representative in your neighborhood and earn big profits in your spare time. Write Popular Mechanics Magazine, Room 408M, 200 E. Ontario St., Chicago, Ill.

MAKE Money writing short paragraphs! No tedious study. I tell you what to write, where and how to sell; and supply list of editors buying from beginners. Many small checks add up quickly. Write to sell, right away. Send for free facts. Benson Barrett, 1751 Morse, Dept. C-27-J, Chicago 26.

ANNOUNCING Home study course in commercial baking. Practical basic training. Good field for those with aptitude. Free booklet. "Opportunities in the Baking Industry." National Baking School, 835 Diversey Pkwy., Dept. 3436, Chicago 14.

"HOW To Make Money With Simple Cartoons"—A book everyone who likes to draw should have. It is free; no obligation. Simply address Cartoonists' Exchange, Dept. 99CP, Pleasant Hill, Ohio.

FREE! "301 Profitable Small Businesses!" Amazing shoestring plans! Work home! Start sparetime! Deumant Surveys, Kenmore 23-PM, N. Y.

MUSHROOMS Grown boxes, barrels. Manureless process 50c. Spawn \$1.00. Gordons, 553 William, Winnipeg, Manitoba.

CONFIDENTIAL Reports on best paying jobs with travel, adventure and top pay. Construction, aviation, shipping, laborers, clerical, trades, unusual opportunities, all types of work. Foreign and U.S. Only \$2.00, including year advisory service. (\$2.25 airmail.) Guaranteed best service of this type available or double your money back. Research Services, Box 2904-PMA, St. Louis 17, Missouri.

BUY Wholesale thousands nationally advertised products at big discount. Free "Wholesale Plan." American Buyers', Hertel Station, Buffalo 16-B, N. Y.

WHOLESALE Catalog! 30-80% discounts! Typewriters, appliances, housewares, watches, jewelry, etc. Consolidated Distributors, 21-14 Lafayette, Paterson 15, New Jersey.

\$1300 MONTHLY For truck drivers, \$1400.00 monthly for carpenters, electricians, plumbers, mechanics, \$1300.00 for clerks and laborers. Full information and complete foreign listings, with current information on Spain, Korea, Australia, Alaska and Canada, \$1.00. Current information on stateside projects, \$1.00. Dept. 3-I, Opportunities Unlimited, 1110 Commerce Bldg., St. Paul, Minn.

JOBS! Business opportunities. Los Angeles classified air-mailed \$1.00. Bailey, Box 47865, Los Angeles 47, California.

CHICAGO Jobs newsletter. Customized. Details free. Bensen, 408 Mills, Joliet, Illinois.

JOBS To \$1500 monthly. All trades. So. America, The Islands, U.S. Fare paid. Application forms. Free information. Write Dept. 76G, National, 1020 Broad, Newark, N. J.

MAGAZINE Subscriptions. Highest commissions. Bonus. Qualified Publications, 4517E Kingston, Brooklyn 25, N. Y.

LEARN Real estate business for highly profitable lifetime career. Study at home. Modern, complete, quicker course. Diploma awarded. Surprisingly low cost. Free literature. Seavy Realty Institute, 1750-B Colorado Blvd., Los Angeles 41, Calif.

WELDING Pays big money. Learn easily at best equipped school in country. Non-profit school with low cost training. G. I. approved. Write Hobart Trade School, Box M-952, Troy, Ohio.

HOME Mailorder beginners manual, sources, methods, instructions, opportunities, 25c. Carnahan Bros., 5680 Nelson, Cypress, Calif.

ATTENTION Construction, aviation, oilmen! Trades, laborers, truck drivers, clerical, engineers, supervisors, many others. Who to contact for highest paying jobs. To \$1500.00 monthly. Latest copyrighted reports, covering 52 countries. U.S., St. Lawrence project, Spain, Canada, Alaska, South America, Europe. Year registration-advisory service. Application forms. Unconditional money-back guarantee of satisfaction. \$2.00. Airmailed \$2.25. (C.O.D.'s accepted). International Reporter, Box 1047-PT, St. Louis 1, Missouri.

AMAZINGLY Beautiful Hawaii! You can live here! Honolulu help wanted ads airmailed \$1.00. Write today. J. Fobel, 1153 Wilder, Honolulu, Hawaii.

EVERYBODY Likes candy. Learn to make professionally home. Our 45th year. Ragsdale Candies, D6, East Orange, New Jersey.

TYPISTS—Profitable home business. Complete copyrighted information, 50c. Gaunt, 827-A Irving, Chicago 13.

LOS Angeles help wanted classified Sunday edition airmailed \$1.00. Room 404, 1709 W. 8th St., Los Angeles 17, Calif.

DELAWARE Valley, U.S.A. Employment in construction, sales, aircraft, electronics, chemicals, steel, laborers, mechanics, engineers. Philadelphia classified airmailed \$1.00. Robar, Box 1524, Philadelphia 5, Pennsylvania.

BELIEVE In fads? If this fad takes in your town, then a 35c product plus a local newspaper advertisement brings you \$5,000 in three months. Works fine in Canada. U.S.A. possibilities terrific! Startling secret revealed. Details \$1.00. J. Waddell, Box 428, Vancouver, Canada.

MAKE Money at home mailing cards, circulars, featuring fast-selling merchandise. Everything furnished. Orders filled for you. The Wm. F. Liska Co., 102 Birchwood Ave., Cranford, N. J.

BOOKS, PERIODICALS, PICTURES, POSTCARDS

SPARETIME Profits taking subscriptions all magazines. Wholesale catalog free. Cassell Publishers, Westfield, New Jersey.

NATIONAL Geographic Magazines, 1888-1952. Periodical Service, Box 465-PM, Wilmington, Delaware.

BOOKS, Government surplus. Bargain prices. Free catalog listing 50 other free catalogs. Instructional, educational, vocational subjects. Millions of volumes, new and used. Books bought. Est. 1902. Long's College Book Co., Dept. PM, Columbus 1, Ohio.

EIGHT Used pocket novels \$1.00. List for stamp. Trunket, Glenshaw, Penna.

BOOKS Found! Any author, old or new. Rush titles wanted; no obligation. International Bookfinders, Box 3003-PM, Beverly Hills, California.

BOOKFINDERS! All subjects. Send wants! Jaher Book Service, 183 Hazelwood Drive, Westbury, N. Y.

AUSTRALIAN Pictorial magazines, newspapers, viewcards. Assorted parcel, \$1.00, posted. Australian magazine subscription lists, free. Worldwide Magazine Agency, Lakemba, Sydney, Australia.

FLYING Saucer book list free. 35c magazine, 10c. New Era, 320 Melrose Building, Houston 2, Texas.

HOW To live without money. Howard Wildman, 308 W. 58th, New York 19, N. Y.

FABULOUS San Francisco! 10 fascinating photographs, beautiful salon originals created by California photographer! \$1.00. Western Pictorial Guild, 3575 Sacramento Street, San Francisco 18, California.

"SCIENCE Milestones." Records march of science starting 400 years before Christ, right up to date. Amazing facts revealed. 312 pages packed with startling information that will thrill you. A real history of science. \$5.00. Literature free. Popular Mechanics Press, 200-5M East Ontario St., Chicago 11, Ill.

BOOK Catalog, 1000 interesting titles, send 10c. Books Publishing Co., Amityville 3, N. Y.

ATOM Bombed Nagasaki, Japan, 13 photos \$1.00. Makins Pictures, Box 689, Bremerton, Wash.

GAMES, TOYS, NOVELTIES

100 ATTRACTIVE Toy soldiers, guns, tanks, planes. Only \$1.25. Denman, 3045 4th, Boulder, Colorado.

FIFTY Toys, novelties, \$1.00. Parties, shut-in days. Ricka, Box 260, Chicago 90.

MAGIC TRICKS, PUZZLES, JOKER NOVELTIES

MAGIC Trial lessons free. Write today! Magic School, Sparta 9, Michigan.

FREE Deck trick cards with catalog 50c. 1746-PM Market, Philadelphia 3.

EARN Money as a magician; fine hobby. Large professional catalog \$1.25. Holden's, 120 Boylston Street, Boston, Mass.

LEARN Ventriloquism. 3c stamp brings particulars. Smith, 801 Bigelow, Peoria 3, Ill.

VENTRILLO, Professional voice-throwing instrument and catalog 25c. Box 971-PM, Philadelphia 5.

PROFESSIONAL Catalog, 175 pages, 25c. Williams, 900 Plymouth, Ellwood City, Penna.

500 TRICKS, Douglas famous 120-page catalog, only 10c. Fastest service to magicians for 30 years. Send 10c today. Douglas Magician, Dept. 1, Dallas, Texas.

BEST Magic. Joker's novelties. Lower prices. Catalog 10c. Top Hat, Evanston 12, Ill.

DOLLAR Magic set free with catalog 25c. 4462-PM Germantown, Philadelphia.

WOODEN Nickel, catalog, trick, 10c. Magico, 1,500,398 tricks and jokes, Box 1375, San Antonio 6, Texas.

BE A Magician. Large professional magic catalog of latest tricks. 35c. Ireland, C-109 North Dearborn, Chicago 2.

3100 NOVELTIES, Tricks, jokes, gadgets, funmakers, hobbies. Catalog 10c. Johnson-Smith, D101, Detroit 7.

LEARN Ventriloquism. Details without obligations. Harry Harmon, Box 33, Mint Spring, Va.

SENSATIONAL Magician's wand 25c. Vanishes handkerchief! Catalog included. Box 1352-PM, Philadelphia 5.

COINS, TOKENS, CURRENCY

KNOW Your money. Coin premium handbook \$1.00; retail guidebook \$1.75; currency catalogue \$1.50. Irish animal set (8) \$2.45; 15 different Indian head cents \$1.00. Bebe's, 4514 North 30th, Omaha 11, Nebraska.

35 DIFFERENT Foreign coins. \$1.00. Claud Denney, 3406 S. Harwood, Dallas 15, Texas.

OLD Confederate money, three different denominations—\$1.00. Historical Novelties, 515 Cherokee Boulevard, Chattanooga 5, Tennessee.

FOREIGN Coins. 15 different uncirculated \$1.00. Lauren Benson, 2526A Middle Road, Davenport, Iowa.

FORTY Different liberty head dimes, \$9.50; quarters \$21.50; halves \$39.50; dollars \$69.50; big pennies \$25.00. Johnson, 644 E. Valerio, Santa Barbara 3, Calif.

COMPLETELY New Fell's 1955 U.S. coin book. Lists, evaluates every coin ever minted. How many of your coins are worth money—do you know? Over 150 illustrations. Chapters on profits in buying and selling, speculation, investment, etc. Clothbound. Send no money. Pay postman \$2 (plus postage) or send \$2 (postpaid). Refundable. Fell Publishers, 386 M-11 4th Ave., New York City 16.

7 COINS of India (British) \$1.00. Joel Tillberg, Proctor 4, Vermont.

TWENTY Different Indian cents \$1.00. Sayers, 1000 East Unaka, Johnson City, Tennessee.

OLD Money wanted. Will pay \$100.00 for 1894 dime, 8 mint, \$50.00 for 1913 Liberty head nickel (not buffalo). Big premiums paid for all rare coins. Send 4¢ for large coin folder. May mean much profit to you. Numismatic Co., Dept. 20, Fort Worth, Texas.

6-IN-1 Special: Magnifying glass; check list; 25 coin envelopes; giant 60 page bargain catalog; ten different Indian pennies; Mexican ten-peso; All six, \$1.00 postpaid. Ben's Coin Shop, 31 North Clark, Chicago 2, Illinois.

U. S. Large cent, 2c piece and bargain list, only \$1. Delmaco, Box 1123, Wilmington, Del.

FREE! Foreign coin, banknote and coin collectors illustrated catalog to approval service applicants. Send 3¢ postage. Tatham Coinco, Springfield 30, Mass.

YOUR Foreign coins are worth money! New 1955 Fell's International Coin Book. Tells how to identify, learn exact value, etc., of every coin ever minted whether or not you know country of origin. Also includes selling, speculating, investment, buying, etc. Clothbound, profusely illustrated. Send no money. Pay postman \$2.50 (plus postage) or send \$2.50 (postpaid) refundable. Fell Publishers, 386B-7 4th Ave., New York City 16.

MORGAN Dollars: 1878, 1887, 1890, 1891, 1897 8 mint unc. \$2.00 ea. Illustrated catalogue, 25c. Shultz, Salt Lake 10, Utah.

GET Profit and pleasure in collecting old coins. Send 10¢ for 56-page illustrated coin catalog. You'll be delighted with it. Send for it now. B. Max Mehl, 370 Mehl Building, Fort Worth, Texas. Largest rare coin establishment in U. S. Established 55 years.

COIN Collector's Magazine. Over 1000 pages per year. Sample copy 30¢; \$3.00 per year. Hewitt, 7320-J Milwaukee, Chicago 31.

INDIAN Cent with bargain lists 10c. Hutchinson, 3463 "I" Street, Philadelphia 34, Penna.

UNCIRCULATED Standard rolls, 1954 San Francisco. Cents 90, nickels \$3.00, dimes \$6.50, quarters \$13.50, halves \$14.50, mint set \$2.00. Denver cents 1943, \$1.00; 1949 \$3.25; halves, 1948, \$20.00. Dooley, 213 East 11th, Topeka, Kansas.

BARGAIN List, United States coins, Indianhead cent, 10c. Economy Sales, 156-A Dean, Mansfield, Mass.

WORLD'S Greatest magazine for coin collectors and wooden nickel 10c. Lawrence Brothers, Anamosa, Iowa.

STAMP COLLECTING

HAITI. Hurricane Hazel helicopter set. 25c with approvals. Seminole Stamps, Box 1138-P, Coral Gables 34, Florida.

FREE U.S. Illustrated bargain catalogue. Rothberg's, Box 60, Boston 1, Mass.

NUDE, Pioneer, animals packet—10c with approvals! Atlas, Eisenhower, Racine, Wisconsin.

QUEEN Elizabeth miniature collection! Six different colonial sets—21 handsome mint bicolors 25c. Approvals. Gannon Stamps, Box 931, Canton 1, Ohio.

U. S. 40 Different 10c. 40 different commemoratives 20c. Both 25c. Bargain lists. No approvals. Seidenberg, Appleton, Wis.

THOUSANDS Of exciting stamps, all different, yours for 1c, 2c each. Fill your album for pennies! Big collection sent for free examination. Cole, 43-A Rinewalt, Buffalo 21, N. Y.

100 JAPAN 10c. All different, with approvals. Gould's Stamps, Box 631, San Francisco 1, California.

50 DIFFERENT United States 5c with bargain approvals, lists. Bookman, Box 8245-M, Madeira Beach, Fla.

U. S. Classics. Over 50 yrs. old. 15 selected old-timers. Missing in biggest collections. All 15 at less than 1c each. 10c with approvals. Jaro, Box 246-T, New York City 8.

WOW! 153 All different Germany 10c. Zeppelins, semi-postals, airmails, high values. Big bargain lists and approvals included. Jamestown Stamp, Dept. 512, Jamestown, N. Y.

50 DIFFERENT United States 5c with bargain approvals, lists. Bookman, Manatee 1, Florida.

FREE United States price list. Mark Hanna, 335 Fifth Ave., Pittsburgh 22, Penna.

FREE! Giant catalog. Offering thousands of bargains. Sent with beautiful approvals. Jamestown Stamp Co., Jamestown 612, N. Y.

FREE Animals, birds, triangles, flowers, ships, locomotives, kings, dictators, multi-colored, historical, geographical, musical, battles, giants, midgets and over 100 others. Fascinating story approvals. Send 10c handling, please. Lincoln Stamp Co., St. Catharines 318, Ontario.

FREE! Flower triangles, others. Approvals. Delton Page, Box 201X, East Paterson, New Jersey.

50 DIFF. U. S. commemoratives 25c. Mammoth packet list free. Econopackets, Box 163, Riverside 9, Calif.

STAMPS Wanted. Mint and used, collections, accumulations. Good grades only. Buy outright if bargain. What have you? Write, give details. Vanroy Shirk, Lebanon, Penna.

FREE 105 British Colonials, pictorials, Mauritius, Tanganyika, Pakistan, Nigeria, Rhodesia, Singapore. Fascinating story approvals. Send 10c handling, please. Lincoln Stamp Co., St. Catharines 218, Ontario.

50 DIFFERENT Argentine 10c. Approvals. Reuter, 611 W. 40th Pl., Los Angeles 37.

AMAZING Offer! 200 United States stamps—including commemoratives, airmails, high denominations to \$1.00. Only 10¢ to approval applicants! Illustrated bargain lists free. Mystic Stamp Co., Dept. 80, Camden, New York.

100 DIFFERENT Spain 25c. Penny approvals included. Reed, Box 980, Chicago 90, Ill.

OLD Scarce U.S. seconds on approvals. Slight imperfections, lowest prices. Hernefield, Clintonhill Sta., Newark 8, N. J.

SPEND Pennies! Not dollars! Thousands of fascinating stamps to choose from our 1c and 2c approvals. No premiums. Just honest value. Pat F. Knowles, Box 2247, Van Nuys, Calif.

FREE Sample! Interesting, illustrated, informative! National Stamp News, Anderson, South Carolina.

SELL Stamps to our readers. Your ad in this space will be read by thousands of stamp buyers. I'll prove that to you. Write now for Folder "S." F. W. Johnson, Classified Advertising Manager, Popular Mechanics, 200 E. Ontario St., Chicago 11, Ill.

50,000 STAMP Grabbags 25c each. Anderson, Box 1, Reading, Penna.

300 DIFF. World wide 25c. plus surprise packet. Packet list free. Econopackets, Box 163, Riverside 9, Calif.

BARGAIN Hunters attention! Free stamp magazine, 1000 interesting stamps for your approval inspection. Completely catalogued, substantially reduced. Free toms and hinges with purchase. Niagara Stamp Co., St. Catharines 31, Ontario.

WORLD'S Largest stamp (7½ x 14 inches). A real curiosity! Retail for 50c, only 3c to approval applicants. Tatham Stamp Co., Springfield 30, Mass.

WEIRD Diamond shape coffee stamp! Lovely flower triangle! First American big commemorative, Greenland, 160¢ dancer, etc. Free with approvals. Capital Stamp Co., Little Rock 2, Ark.

100 OLD United States between 1861 and 1935, \$1.00. Roush Stamps, 51 Chestnut, Mansfield, Ohio.

TWO \$5.00 U. S. stamps plus 20 different, 10c with U. S. approvals. Irwin Stamp Co., Box 1105, Brooklyn 30, N. Y.

ECONOMICAL ½c-1c-2c-Approvals, 22,000 varieties available. Dresel, Box 270-n, New York 25, N. Y.

225 STAMPS For only 10¢! This mammoth value includes airmails, pictorials; stamps from strange countries cataloging up to 25c each! Also approvals. Mystic Stamp Company, Camden 80, New York.

EXCITING New book, "How to Collect Stamps, Coins, Paper Money." Packed with amazing facts; information worth dollars. Fully illustrated, 160 pages. 75c. Popular Mechanics Press, 200-ST E. Ontario St., Chicago 11, Ill.

TRIANGLES, Birds, butterflies, flowers—Big packet 10c with approvals. South-west Stamps, Box 117, Long Beach 1, Calif.

FREE! Large new profusely illustrated catalog of United States postage issues complete; 64-page, four-color Stamp Collectors' Guide; other unusual offers. Write today! Harrisco, 1039 Transit Bldg., Boston 17, Mass.

TOPICAL Packets, \$2.50 each. 100 automobiles, 105 maps, 75 sports, 105 trains, 110 warriors. All \$10.00. Richard Borden, Box 5447, Minneapolis 8, Minn.

MINT Army navy set 50c. Tipex and Anniversary sheets 50c. Fine U.S. approvals—Plate block list. Charles Meckel, 2101 East Market, York, Penna.

FREE—Scarce Diego-Suarez! Tru-val-u approvals. Brunning, Donaldson St., Rutherford, N. J.

GERMAN Colonies—10 different 25c. Approvals. Sr-Jr Stamp Company, Box 161, Tulsa, Oklahoma.

HI-Powered locals—24 each year, mailed with monthly bulletins. Dues, \$2.00 per year. National Association of Precancel Collectors, Box 101, Wildwood, N. J.

12,000 PENNY Approvals waiting for you. Many from exotic countries, pictorials, airmails, new issues. Tilbury, Box 802, Newark 1, N. J.

\$1.50 VALUE, No junk, approvals, 10c. Bluebonnet, Box 3084, Waco, Tex.

FAMOUS Men, jungle scenes, zoo, United States commemoratives, 100 others. Ten cents with request for thrifty approvals. Casner Stamps, 247-A Riverside, El Paso, Texas.

SEND Now! For 20 beautiful different stamps from San Marino. 15 cents with new approvals. Boger, 3401 Oakmont, Philadelphia 36, Penna.

STRIKING Royal portraits. Two mint complete Southern Rhodesia commemorative sets. Catalog 82c—just 10c with approvals. Viking, Great Neck 8, N. J.

FINE Approvals. Fast, personal service. What countries do you prefer? I'll send their stamps. Skinner, 438 Locust, Long Beach 12, California.

200 DIFFERENT Hungary 25c. Approvals. Wright, 6435 Edloe, Houston 5, Texas.

CANADA—Newfoundland collection including early issues, commemoratives, pictorials and high values. Plus set of fascinating triangle stamps. Plus set of unused British Colonies. Plus large stamp book. All four offers free. Send 10¢ to cover postage. Empire Stamp Corp., Dept. PM, Toronto, Canada.

30,000 DIFFERENT Collector's stamps from all parts of the world for less than 1½¢ each! Send \$12.50 for each book of 1,000 stamps as often as you want. J. Huppert, 1970 E. 18th St., Brooklyn 29, N. Y.

FIRST U. N. set. Among world's prettiest. Only 10c. Approvals. Welles, Box 1246-R, New York City 8.

CANADIAN Wildlife stamps; beaver, moose, bighorn sheep, walrus, bear, 10c with approvals. Richardson Stamps, Niagara-on-the-Lake 23, Canada.

513 DIFFERENT Worldwide from Haiti, Sudan, Libya, etc., cataloging over \$10 only 35c. Approvals. Littleton Stamp Company, Littleton Q1, New Hampshire.

DEALERS—Wholesale list. Postage 3c. Frank, 5031 Queensberry, Baltimore 15, Maryland.

1000 DIFFERENT Worldwide stamps \$1.00. Universal, P.O. Box 6, Kenosha, Wisconsin.

LOOKING For bargains? Try our 1c and 2c quality approvals in books of 1000. Also U.S. Clark Stamp Co., Dept. A-46, Muskegon Heights, Mich.

BEAUTIFUL Triangles, 11 different. A 50c value for 10c. Low priced approvals included. Wolverine Stamp Service, Dept. A-27, Fruitport, Mich.

FREE Complete set of famous Americans, flags, parks and presidentials to approval buyers. Send 5c for 15 of the above stamps plus full particulars. Triboro Stamp Company, 145 Nassau Street, Dept. 109, New York 38, N. Y.

EISENHOWER Stamp, plus worldwide packet, free to approval buyers. Conquistador, 2827K Troy Road, Schenectady 9, N. Y.

UNITED States. Fine mint airmails. #C7, #C8, #C9, #C10. Only \$1.00. Approvals accompany. Whiton Paine, Westport 11, Connecticut.

GIANT Stamp 800 free! Fifteen different including rhinoceros, elephant, snake, tiger, zebu, kangaroo, koalabear, emu, kookaburra, bull, horse, with approvals. Send 10c for postage and handling. Niagara Stamp Co., St. Catharines 51, Ontario.

SOMETHING New—Something different. Try our books of 1000 different stamps. Mostly 1c and 2c, all catalogued for your convenience. Big discounts. Modern Stamp Co., Dept. A-3, Ferrysburg, Mich.

FREE! Fascinating, valuable special lists, collector's supplies, U.S. and foreign stamps, mixtures, packets, sets, singles, coins and paper money. Approvals. Littleton Stamp Co., Littleton 11, N. H.

14,000 DIFFERENT—Yours on our streamlined systematic club plan for only 50c weekly. Big shipment every two weeks. Details free. Sjoquist, Box 217, Valley Stream 75, New York.

FREE—Valuable U.S.A.! (1) Scarce genuine stamp picturing first U.S.A., issued in 1847! (2) Big collection 30 all-different U.S.; ancient 19th century, valuable \$5 stamp, etc. (3) Packet gorgeous U.S. commemoratives. (4) Large illustrated U.S. catalog; 64-page, four-color Collectors' Guide; other unusual offers. Everything for only 10c covering mailing costs! Harrisco, 1047 Transit Bldg., Boston 17, Mass.

MINT Commemoratives at face! Send 25c for surprise packet of all different, mint U.S. commemoratives. Mint U.S. approvals too. Western, Box 1689P, Salinas, California.

FREE U.S. catalogue. Contains almost 1000 illustrations; over 10,000 delightful bargains. Stone's, 192 Washington, Boston 8, Mass.

100 DIFFERENT United States 25c with our fine worldwide approvals. Blanc Stamp Company, A-25625 Koontz, Roseville, Mich.

UNITED Nations—10 different valuable unused stamps only 25c. Beautiful bargain approvals accompany. Sav-On Stamps, Box 5118B, Long Beach 5, Calif.

SERIOUS Adults! 378 different commemoratives, charities, airmails, British, French Colonies, Monaco princes, Netherlands myths, Queen Elizabeths, giant popes, Asia, etc., comprise this outstanding collection cataloguing over \$11.78. Just 25c to introduce pictorial approvals. Kingsway Stamps, Dept. 59, Fulton, Md.

NEW Zealand charities, three scarce complete pictorial sets only 25c. Free list. Bargain approvals. Firland Stamp Co., Box 493, Seattle 11, Washington.

100 FOREIGN, 20 U.S. commemoratives, 10c. Approvals. Weckerling, Box 442E, La Feria, Texas.

INCREASE Income. Start stamp business. Profitable. Write airmail. Smith Company, Halfwaytree 21, Jamaica, B.W.I.

800 MIXED U.S., old, new, 25c. Lists. Weatherby, Fort Myers, Fla.

66 U.S. And Canada 5c. Approvals. Hudson's, Box 4015, Fresno 44, Calif.

ZEPPELIN Stamps. (Scarce.) Four different, 10c, with approvals. Variety Stamps, 57-G Circuit, Newton Highlands 61, Mass.

GIANT Approvals. Thousands different at 1 and 2c each. Wahl's Stamp Exchange, 7068P Farragut, Chicago 31, Ill.

100 DIFFERENT Hungary big commemoratives 50c. Scott, 2853 Midwood, Toledo, Ohio.

25 DIFFERENT Canada, 10c with approvals. Jack Ross, 4410 St. Catherine West, Montreal, Que.

500 FINE Mixed U.S. stamps 15c. Wright, 201 Mealey, Hagerstown, Maryland.

ZEPPELIN Set plus 24 planes, airmails 10c. Approvals. Casto, Box 357, Dunbar, West Virginia.

CORONATIONS, Triangles, animals, sports, free with approvals. Exotic, Box 482, Coral Gables 34, Florida.

41 BEAUTIFUL Austrian landscapes, costumes, only 25c with finest approvals. Henry Paville, 1104 Garfield, Madison 5, Wis.

AIRMAILS! 25 Different Latin Americans—10c with approvals. Riedell, Greensburg, Penna.

200 DIFF. 5c With approvals. Al Gray, Box 708, Hollywood, Calif.

SEVEN Mint fascinating Pacific Islands, Papua, Tokelau, Samoa, etc. Approvals. 10c. Roy Farr, 88 Maple, Hamilton, Canada.

SAN Marino Roosevelt set 10c. Approvals. Bala Stamps, Box 74, Bala-Cynwyd, Penna.

ESTONIA Carrier pigeon set free. Approvals. Canyon Stamps, Box 808, San Fernando, California.

U.S. Mint complete sets specially priced! Flags \$1.00; famous Americans \$7.25; national parks, perforated \$1.50, imperforated \$1.75. Free price list. Brooks, 2352B East 23rd Street, Brooklyn 29, New York.

100 DIFFERENT, British Colonies, Dutch Empire, Belgian Empire and South America. 10c with approvals. Supreme Stamp Service, 2205 So. Grand Ave., Los Angeles 7, Calif.

BRITISH Colonial collection—Hivalues, commemoratives, topicals. Free to approval buyers. Pleasure Stamps, 1865A—52nd, Brooklyn 4, New York.

FABULOUS United States commemorative collection—31 different 10c. Approvals. White, 516-A Avenue L, Brooklyn 30, New York.

ASTONISHING Gift—40 U.S. with superior approvals. Send 5c for postage. Sparta, Box 1062, Rochester 3, N. Y.

GUATEMALA, Cuba, Ecuador. Pictur-esque stamps from Latin America sent on approval. Ridgefield Stamp Company, Ridgefield, Conn.

100 DIFFERENT U.S. 25c. Approvals. Taylor, Box 51, Belvidere, N. J.

AUSTRALIA—50 Different selected pictorials 10c. Approvals. Seven Seas, Box 514-P, Jersey City 6, N. J.

TWENTY-Five foreign stamps one dime with approvals. Buffalo Philatelic Agency, Box 53, Buffalo 15, N. Y.

MONACO Nudes, 10c with approvals. Royal Stamp Company, Tamaqua, Penna.

WANTED—Stamp collections, accumulations. Murray Gold, 63-95P Saunders, Rego Park 74, N. Y.

WANT To receive our lagniappe approvals? Write Guyton, Box 1275, Monroe, Louisiana.

200 DIFFERENT U.S. \$1.00; approvals accompany. MacMar, 55 Auckland, Orchard Park, N. Y.

30 DIFFERENT Commemoratives 1893 up 10c. U.S. approvals. K & B, Box 5, Brooklyn 14, N. Y.

FREE Gifts! Astounding offers! Fabulous prizes! Adventure Studios, Buckland, Connecticut.

FREE C34-6 used U.S. airmails with approvals. North Andover Stamp, North Andover 1, Mass.

43 DIFFERENT Armenia in complete mint pictorial sets. 25c. Approvals. Aronson, 91 Marion, Brookline 46, Mass.

AIRMAILS, Triangles, others. Perforation gauge, magnifying glass. Dime Approvals, Russ, 4105—57th, Woodside 77, New York.

100 DIFFERENT World 10c. Free gift. Bellet, Mapledale, Hazel Park, Mich.

CIPEX Souvenir sheet plus 25 different U.S., 10c. Approvals accompany. Village Stamps, 90-39P 214 St., Queens Village 29, N. Y.

10 MINT Sets 15c. Approvals. K & B, Box 5, Brooklyn 14, N. Y.

PHILIPPINES—30 Different 10c. Approvals. Moffat, 740 Milton, Rock Hill 14, South Carolina.

TREMENDOUS Offer 15 foreign sets. Ten cents approval. Farmer, 4913 Rosewood, Los Angeles 4.

50 SAN Marino 10c with approvals. J. Moyle, Twain Hart, California.

FREE Small pictorials, request approvals. Eagle, 6916 Roosevelt, Philadelphia 49, Penna.

INSTRUCTIVE Book on stamp collecting plus 50 different foreign stamps only 10c with approvals. Pot-O'-Gold, Litchfield, Conn.

ANTIQUES, RELICS, INDIAN GOODS, CURIOS

4 SELECTED Arrowheads \$1.00. List 5c. H. Talburt, Calico Rock, Ark.

8 PERFECT Arrowheads \$2.00. George Smith, 841 Tacoma, Indianapolis, Indiana.

20 FINE Ancient arrowheads \$5.00. List free. Lear's, Glenwood, Arkansas.

4 FINE Indian arrowheads \$1.00. Stone tomahawk \$2.15. List free. Arrowhead, Box 5283, Indianapolis, Indiana.

38 PAGE War: Relics, curios, medals. Price list 25c. Babin, 324 Court, Rochester 7, New York.

PRECIOUS STONES, MINERALS

TEN N. Mex. minerals \$1.50, six fluorescents \$1.00, fool's gold 25c. Literature free. Minerals, Winston, New Mexico.

GEMSTONES, Mineral specimens. Every variety. Lowest prices. Free booklet. Plummer's, 4720 Point Loma Ave., San Diego 7, Calif.

GEMCUTTING — Silvercraft illustrated magazine. Tells how to cut gems, make jewelry. 150 ads illustrating equipment, gems for collectors, cutters. Free literature. Lapidary Journal, Del Mar 2, Calif.

SAPPHIRE, Topaz, tourmaline, garnet, peridot. Five uncut gem specimens, \$1.00. Ten polished gems, baroque shaped, \$1.00. Free big bargain list jewelry, gems, profitable, easy "do it yourself" projects. O'Brien's, 1116M Wilcox, Hollywood 38, Calif.

FIND Tungsten, mercury, uranium with Mineralight. Free brochure. Write Dept. PM8, Ultra-Violet Products, South Pasadena, California.

HOBBIES AND COLLECTIONS

UNUSED Matchbook covers. 100 different \$1.00. 36 page catalog 25c. Match-cover album \$3.00. Charles Edelman, 1311C East 84, Cleveland 3, Ohio.

PAINT in oils the first time you try. Finest coded oil painting kits that money can buy. Size 12"x16" \$2.95; size 18"x24" \$6.95 postpaid. Many lovely subjects from which to choose. Send for free literature. Relax, P.O. Box 1256, Decatur, Illinois.

NAZI Medals, ribbons, armbands, flags, daggers. Big introductory packet \$1.00. Illustrated lists. Medcrafts, 1923 34th St. S.W., Calgary 2, Canada.

INVENTING Can be an interesting and profitable hobby. Write for complete particulars. Institute of American Inventors, Dept. 40-E 631-E St., N.W. Washington 4, D. C.

UNUSUAL Hobby: Authentic army patches, insignias, ribbons, enameled crests, navy rates, 50 assorted for \$1.00. Rex Military, Dept. C, 1186 Broadway, New York City.

HISTORICAL Documents (reproductions) \$1.00. Howard Sawyer, 5813 Benton Hghts., Baltimore 6, Md.

SENSATIONAL "World's largest match book." 15½ inches long, contains 240 matches. A rare show piece for den or bar. A must for match collectors. 3 books each different copy \$1.00 pre-paid. Prompt shipment. Sanzo Specialties, Box 68, Endicott, N. Y.

100 MILITARY Official shoulder patch insignia. Free album. \$5.00. All different. Wolf Appleton, Inc., 566-D Broadway, New York City 12.

GROW Giant crystals. Free booklet. Crystocraft Co., Box 35, College Station, Texas.

FREE! Leathercraft catalogue. Do it yourself! Tandy Leather, Box 397-AH, Tulsa, Oklahoma.

CAMERAS, PHOTO SUPPLIES

BRAND New DeJur "500" projector \$50.00. Terrific bargains. Free catalog. Economart, Box 242, Tarrytown, New York.

BASS Says: Quality cameras since 1910. When in Chicago visit the camera cross roads of the world, or write us for your favorite equipment, new or used. Satisfaction guaranteed. Bass Camera Co., Dept. AG, 179 W. Madison St., Chicago 2, Ill.

CAMERA Repairmen greatly needed! You can learn manufacturers' service methods at home, in your spare time! Free, big illustrated book tells how: Write today. National Camera Repair School, Dept. PM4, Englewood, Colorado.

BRAND New factory packed Argus C3 camera, case, and flash, \$52.95; Argus automatic projector, \$53.95; Kodak Signet camera, \$59.50; Signet projector, \$49.50; Kodak Stereo camera, \$67.50; Ritz binoculars, TX 35, \$24.95, case, \$5.00. Ritz Camera, 607 14th St. N.W., Washington 5, D. C.

BUY Wholesale nationally advertised cameras, photo supplies, thousands of other products at big discount. Free "Wholesale Plan." American Buyers, Hertel Station, Buffalo 16-E, N. Y.

PHOTOGRAPHY For pleasure or profit. Learn at home. Practical basic training. Long established school. Free booklet. American School of Photography, 835 Diversey Parkway, Dept. 3431, Chicago 14.

20 TO 50% Discount everything photographic, giftware. Free catalogue. Dart, 3812 Atlantic Avenue, Brooklyn 24, N. Y.

FREE! Free! Free! Central Camera Co., photographic headquarters since 1899, saves you money on all photographic equipment. Send for Central Camera Co.'s free photographic bargain list today! Central Camera Co., Dept. 9-B, 230 S. Wabash, Chicago 4, Ill.

NEW Argus automatic projector \$48.95. Discounts to 45%. Photo equipment, typewriters, appliances. Free catalog. Camera Shoppe, Box 601YS, Mt. Vernon, New York.

"FILM-ETCH"—Fascinating, new, coloring process. Get details free. Box 406, Quincy 69, Mass.

PHOTO FINISHING

4x6 OR 3 1/4x4 1/2 Glossy prints, 8 exposures 40c, 12 exposures 60c, 16 exposures 80c. Hagner, 1318 West Columbia Avenue, Philadelphia 22, Pennsylvania.

CONFIDENTIAL Rolls developed and glossy 5x7 prints, 8 exposures 50c, 12 exposure 75c. Confidential Photo Service, Box 1515, Tacoma, Wash.

FOR Just \$1.00 we'll make 20 copies of your favorite picture in convenient wallet size. Send any photo or negative for prompt service. Money back if you're not delighted. Mail To-Day Co., Altoona 16, Penna.

12 JUMBOS From any size roll developed 25c, with this ad only. S. Skrudland, Lake Geneva, Wis.

FREE Film! Write for free mailers. Vets Film, Montalvo, California.

TRIAL Offer—Good with ad only. One roll film developed, 8 exposures 25c, 12 exposures 35c. King sized, dated prints from roll only. Don't send negatives. Sir Walter Photo, Raleigh, N. C.

ENLARGEMENTS! Eight 5x7's or five 8x10's, \$1.00. Wilart Enlargers, Box 967, Little Rock, Ark.

12 EXPOSURE Rolls 39c, jumbo prints. Guaranteed work, one day service. Lincoln Studios, Dept. K, Box 13, Lincoln, Nebraska.

PARTICULAR? Custom finishing guaranteed. 8 jumbos 35c, 12—50c. Special! 35mm. 36 exposures \$1.10. Free mailer. Flash-Photo, Box 360, Brooklyn 4, N. Y.

GUARANTEED Quality. Fast service. Eight jumbos in beautiful super pak plastic ring binder albums only 35c. Send for free mailers and particulars of our complete photo finishing service. Grand Fotos, G.P.O. Box 1410, New York 1, N. Y.

20 BILLFOLD Prints from your photograph. Portrait paper, \$1.00. Blackhawk Studio, 1616 26 St., Rock Island, Ill.

SIX Hour service, two sets of pictures from any 8-exposure roll only 35c. Comet Photo Service, Box 280, Minneapolis, Minn.

PAST Quality service. 8 jumbos 35c; 12 for 50c; 35mm., 20 for \$1.00; 36 for \$1.75. Washington Snapshot Service, Box 388A, Benjamin Franklin Station, Washington 4, D. C.

FREE 5"x7" Enlargement, introductory offer with roll. Returned same day received. Finest quality jumbo individually dated prints in handy Super Paks, 8 exposures 35c, 12 exposures 55c. Add 5c roll for return. Globe Photo Co., Dept. PM, Box 3508, St. Paul 1, Minnesota.

HIGH Quality finishing—Rapid service. 8 exp., 35c; 12, 50c; 16, 75c; 20, \$1.00. Camera, Box 280, West Chester, Penna.

ROLLS Finished 25c. 10 reprints 25c. Dick's Photo, Louisville 12, Ky.

FREE 5x7 Enlargement with this ad and trial roll 8 exposures 35c; 12, 50c; 20, \$1.00. Eli Photo, Box 1873A, New Haven, Conn.

SUPER-Jumbo prints, 4 1/2x5 1/2. Bigger. Better. Only 8c each. Free first class postage mailer. Orange Photo Lab, Box 7393, Orlando, Florida.

NO Charge developing film. Pay for prints only. Contacts 3c each. Jumbos 4c. Failures refunded. Same day service. Guaranteed. Square Deal Photos, Hutchinson 2, Kansas.

EKTACHROME—Anscochrome processing. Roll \$1.00. National Color Corporation, Box 55 Northside, Atlanta 5, Georgia.

FREE Roll film (#127, #126, #620, or #616) with every roll developed and printed. 8-exposure 60c; 12-exposure 75c; 16-exposure 95c. All prints oversize. Custom Photo Labs, Box 136-PMA, Berwyn, Ill.

SPECIAL Introductory offer. 8 jumbos 25c, 12—35c. Western Photo, PM95, Box 298, San Francisco 1, Calif.

JUMBO Prints, your roll developed and 8 prints 35c, 12 prints 50c. Special prices on roll film. Jumbo Film Co., Dept. C, Payette, Idaho.

ONE Day service. 35mm. Microdol developing. 20 exposure, jumbo prints \$1.00; 36 exposure \$1.49; 8 exposure rolls 35c; 12 exposure 50c. Reprints 4c. Potocraft, Box 3416, Washington, D. C.

PROFESSIONAL Oversize prints 8—35c; 12—50c; 30 reprints \$1.00. Kaw Photo, Box 528-P, Hutchinson, Kansas.

TWO Beautiful enlargements from each picture on roll—8 exposures 55c, 12 exposures 75c. Cut Rate Photos, Dept. B-4, Janesville, Wisconsin.

TOP Quality. Fast service. 8 jumbos 35c in beautiful super pak album, 16 contacts 40c. Reprints—Jumbos 4c; contacts 3c. Satisfaction guaranteed. Write for free mailers and circulars. Fast-X-Photo, Box A, Jersey City, N. J.

8 OR 8 Picture roll 35c, 12 or 16 picture roll 55c. Each roll developed and printed in handy album pack. Send coin with roll. No c.o.d.'s. Mailing containers sent free. Deluxe Film Service, Box 1268-A, Shreveport, Louisiana.

TWO Beautiful prints from each picture on roll. 8 exposure 40c; 12 exposures 50c. Thirty four years of satisfied customers. Quick Service. Lens Photos, Dept. J-4, Janesville, Wis.

QUALITY Kodak finishing. 8 exposure roll 35c; 12 exposure 50c; 16 exposure 60c. Reprints 4c. Fast service. Guaranteed quality, 40 years continuous operation. Be a satisfied customer. We do color. Send for mailers. Mail Order Photo Service, Box 297, Watertown, Wisconsin.

MOTION PICTURES AND SOUND EQUIPMENT

GUARANTEED Savings! All brands movie equipment! Listings. Fotoales, Box 5908A, Kansas City 11, Missouri.

SALE 16MM. sound feature prints. Adair Company, 6900 Roosevelt, Oak Park, Illinois.

MOVIE-Makers! Save 50% on your 8-16mm. film and do-it-yourself processing equipment. Free catalog. Superior Bulk Film Co., 442 N. Wells, Chicago 10.

ALL Kinds 16mm sound films. Rent, sale. Roshon, 335 Fifth, Pittsburgh 22, Penna.

FREE! Blackhawk's big sale catalog new and used 16mm., 8mm. films; 2"x2" color slides; used 16mm. sound projectors. Biggest stock in U.S.A. Blackhawk Films, 1200 Eastin, Davenport, Iowa.

8-16MM. Silent-sound films. Latest subjects. Free catalogue, sample film 10c. Garden Film, 690 Howard Ave., Brooklyn, N. Y.

TAPE Recorders, tapes, accessories. Unusual values. Dressner, Box 66M, Peter Stuyvesant Station, New York City 9.

5,000 8-16MM. Silent-sound films. International, 2120 Strauss, Brooklyn 12.

MOVIE Camera film: 8mm. roll \$1.50, 16mm. 100' \$3.00. Free processing. Better Films, 742 New Lots, Brooklyn, N. Y.

SAVE 50%! Guaranteed-fresh color, b.&w. movie film! 8mm., 16mm. Free catalog! Ego-R, 47th Holly, Kansas City 12, Missouri.

TAPE Recorders, accessories. Best buys. Boynton Studio, 10M Pennsylvania, Tuckahoe, N. Y.

STOP Searching! Cine adventures as you like them. 50'—8mm. \$4.00, 2 for \$7.00; 100'—16mm. \$7.00, 2 for \$13.00. Danny Davis, Box 1202, Room 668, Chicago 90, Ill.

FREE Sample kit. Make movie titles in color. A-10-2 Movie Accessories, Flatiron Building, New York City 10.

SEND For big bargain bulletin. 16mm. sound and silent films. Gaines, Box 114-PM, Skokie, Illinois.

TAPE Recorders, tapes; lowest prices. Carstan, 215 E. 88, New York City 28.

MUSIC AND MUSICAL INSTRUMENTS

ACCORDIONS—Direct from importer. Save 50% and more! Free trial. Lifetime guarantee. Trades accepted. Free catalog. Write Accordion Outlet, Dept. 93-R, 2003 W. Chicago, Chicago 22, Ill.

PIANOS, Instruments! Bulletin 8 free. Piano Mart, 2461 Oakland, St. Louis, 14.

SWISS Musical movements. Finest. \$2.50. Special tunes to order. Spielman, 131 West 42nd, New York City 36.

SONGWRITERS: Large recording company wants new songs. Royalty basis. National sales, promotion if selected. No charge for melodies. Send songs, song poems. Music Makers, Dept. E-13, Box 2507, Hollywood, California.

SONGWRITERS. Publishers. Music printing. Send for price list. Esquire Music Service, 100 West 42nd Street, New York City.

POEMS Wanted for musical setting by America's largest songwriters organization. Immediate consideration. Five Star Music Masters, 630 Beacon Building, Boston.

POEMS Wanted for musical setting. Send poems. Free examination. Crown Music Company, 1476 Broadway, New York City 36.

PLAY Piano classics without lessons, talent. New game, "Music Like Magic," \$1. K. Irwin, 1629 E. 29 St., Brooklyn 10, N. Y.

SONGWRITING Details. Newart Pubs. G.P.O. Box 1326, Syracuse, N. Y.

SONGS —Poems wanted. Good opportunity. Tunemsmiths, 1609 Vista Del Mar, Dept. U, Hollywood, Calif.

SONGWRITERS—Success, fame, fortune if talented. Songs revised, composed, published, promoted by largest firm. Free appraisal. Since 1943. Postcard to Nordyke Publishing Co., 6000 Sunset Blvd., Hollywood 28, PM, Calif.

WHOLESALE! Musical instruments, phonographs, recorders, watches, appliances, etc. Discounts to 75%! Large catalog 50c (refundable). Strauss Music Company, 25-10, Lafayette, Paterson 23, N. J.

SONGS. Poems wanted! Free examination. Bengol Music, 93 Jefferson Avenue, Chelsea 50, Massachusetts.

POEMS—Urgently needed to set to music! Write clever poems, catchy rhymes. Achieve fame, money in popular music field! Send sample poems. Free evaluation. TinPan Alley, 1650 Broadway, Dept. X, New York City.

SWISS Musical movements, \$1.50. Helax, 218 West 72nd Street, New York 23.

POEMS Needed for new songs. Send poems for free examination, details. Immediate consideration. Songcrafters, 2724 Arcade Station, Nashville, Tenn.

1955 ACCORDIONS — Wholesale. Free catalog. American Accordion Center, PM-3, 5329 Belmont, Chicago.

SONGWRITERS! Send poems, songs. Music Service, 243 West 72nd St., PM, New York City 23.

FREE Records of your song. Your words, my melody. Free information. Johnny Mack's Melody Mart, 1094 West 39th Street, Dept. A, Los Angeles 37.

WANTED! Poems for musical settings. Write Songwriters' Service. Clifton, N. J.

ACCORDIONS. Wholesale to everyone. Save up to 60%. All national known brands. Free catalogue. Del Principe, 29 South Cicero, Chicago 44.

SONGWRITERS! Protect your ideas! Hold all songs, poems! Write for safe correct procedure first! Song Service, Dept. P, 333 W. 56th St., New York 19, N. Y.

WRITE Songs. Big money and reputation. Write for information. J. Gordon Pub. Co., 4700 South California Avenue, Chicago.

POEMS Wanted to be set to music. Free examination. Send poems. McNeil, Master of Music, 510-PM 8, Alexandria, Los Angeles, California.

ELECTRIC Guitars, amplifiers, parts, wholesale. Free catalog. Carvin PM287, Covina, Calif.

VIOLINMAKERS. Repairers. Fine tone wood, and all violin supplies. Send for free wholesale price list. International Sales, 414-M E. Baltimore St., Baltimore 2, Md.

PHONOGRAPH Records 20c. Catalogue. Paramount, MB-313 East Market, Wilkes-Barre, Penna.

BIG Savings all LP records; some 69c! Catalog 20c. Record Discout House, 1108 Winbern, Houston 4, Texas.

RETIRED Church organist composes beautiful music to sacred words. Reginald Belcher, Terrace Place, Morristown, New Jersey.

RADIO, TELEVISION AND ELECTRONICS

MAKE Simple, tubeless, batteryless, distance-getting radio. Genuine Melomite crystal, detector, illustrated instructions. 50c postpaid. Allen, 427-PM5, Clinton, Missouri.

TV Trade-in sets. Philco, Emerson, G.E., Admiral, Motorola, Tele-King, others. List available. 10"—\$17, 12"—\$20 up. Washtek Service Co., 1501 Boston Rd., Bronx, N. Y. DA 3-9281.

RADIO-TV service course. New method. No theory. Learn by experience. Guaranteed results. Complete course \$7.50. Radio Service School, 3502 Mills Avenue, Austin, Texas.

ELECTRIC Brain plays game! Build it! Challenge your friends to beat it! Easy, cheap to make. Rush postcard for full details. Jay Acey, Dept. P-3, Box 132, Greenwich, Conn.

BECOME A radio amateur. Free information on how to pass code and theory FCC examinations. American Electronics, 1205½ Bryant Ave., New York 59, N. Y.

FREE 324 Page 1956 Television, Radio, Hi-Fi, Electronics catalog! World's largest stocks, lowest prices. Everything for experimenters, builders, amateurs, servicemen. Latest build-your-own kits, Hi-Fi, phonos, recorders, P. A., TV accessories. Thousands of parts, tubes, test instruments, tools and books. Write for free copy! Allied Radio Corp., 100 N. Western Ave., Dept. 34-J-5, Chicago 80, Ill.

CRYSTAL Radio experimenters. Write Leslie Hulet, 305 Hope, Lakewood, N. J.

REPAIR Your own TV. Instructions compiled exclusively for your set. Simple as replacing light bulb. Send set name, chassis, model number, \$2.00. LS Engineering Company, Box 4113-PM-9, North Hollywood, Calif.

BUILD 15 Radio circuits at home—Progressive Radio "Edu-Kit" only \$19.95 complete. Free electric soldering iron and radio tester with "Edu-Kit." No radio background required. 30-day unconditional money back guarantee. Order direct or send for free descriptive literature, no obligation. Valuable radio and TV repair guide sent on request, no charge, no obligation. Progressive "Edu-Kits" Inc., Room 33-B, Progressive Building, 497 Union Avenue, Brooklyn 11, N. Y.

ENJOY Color television now! Multicolored screens for any b/w set. Easily attached. Complete details free. Zingo Electronics, Johnstown 76, New York.

TELEVISION Can sell your product faster for less money. Free information. Tele-sales, Box 24A, New York City 19.

FUSED AC line plug protects TV and home. Easily installed. With extra fuses, \$1.00. Plaza Television, 1408 Huntoon, Topeka, Kansas.

ALL Channel figure 8 serials. Light weight. Attic installation. Install yourself. Manufactured by Fred E. Smith, 119 N. Leroy, Fenton, Michigan, Telephone 9-6542.

WALKIE-Talkie. Build wireless two-way portable radiophone for less than \$10.00. Plans 50c. Springfield Enterprises, Box 54-B9, Springfield Gardens 13, New York.

AMAZING Tube tester. Tests all radio and television tubes including main picture tube. Satisfaction guaranteed. \$4.95 postpaid. Fryrick, 225 W. 34th Street, New York 1, N. Y.

62 PAGE. Illustrated, radio beginners booklet 25c. Franks Book Service, 3121 Racine, Chicago 8.

PROTECT Your home and television from costly damage. T.V.-lightning arrester for all sets, easily installed in 5 minutes by anyone, U/L approved. \$3.95 postpaid. Lawrence Sales, Box 131, Ridge-wood, N. J.

TAPE Recorders wholesale. Free catalog. Towers, 935 North 40th, Philadelphia 4.

SAVE Dollars! Repair your own T.V. Complete individual guide. Send make, model and \$2.00. TV Lab, Box 185, Yuba City, California.

BUSINESS OPPORTUNITIES

BECOME Tax consultant. Our students earn to \$3,000 in 3-month season, part-time. We train you—help you start. State approved. Union Institute, 68 Hudson, Hoboken 2B, New Jersey.

\$1,000 MONTHLY Possible in collection agency business. Free details. Write Cole Associates, Syracuse 2, N. Y.

WHOLESALE Catalog! 30-80% discounts! Typewriters, appliances, housewares, watches, jewelry, etc. Consolidated Distributors, 21-11 Lafayette, Paterson 15, New Jersey.

SELL Popular Mechanics and all other magazine subscriptions. Free catalog, supplies. Subscription Service Company, Dept. A., P.O. Box 2070, Birmingham, Alabama.

FLEXIBLE Rubber molds for plaster and Marbleite figurines. Sample and large illustrated catalog 25c, refunded on first order. K-C Novelties, Dept. 175, Southampton, Mass.

LEARN Sewing machine servicing differently. Original trade secrets. Surprisingly odd! Booming! This vocation! \$1.00 lesson, plus details, free. Purdy's, Box 297-M, Weatherford, Texas.

SELL By mail. Modern 20-lesson course by specialist John Moran shows how to start on low capital. Hundreds ideas, sample ads and short cuts. Write Roy R. Poole Co., Sleepy Hollow Road, Rome, New York.

ADVERTISING Book matches—Cash in on big demand; sell union label matches. Cuts for all businesses and political parties. Free powerhouse selling kit, low prices, protection guaranteed on repeat orders. Cash commissions. Superior Match Co. Dept. MX-955, 7530 Greenwood, Chicago.

RUN Cafe, diner. How to get started, menus, foods, revealed in home training. Write for free book "Cafe, Diner Business." School of Restaurant Arts, BU19, Fremont, Ohio.

START Your own business on credit. Your own boss. 1135 of our dealers sold \$5000 to \$30,000 in 1954. We supply stocks, equipment on credit. 200 home necessities. Sales experience unnecessary. Pleasant profitable business backed by worldwide industry. Write Rawleigh's, Dept. I-U-PPM, Freeport, Ill.

OPERATE Profitable magazine subscription service. Earn big Christmas profits. New telephone plan. Handle renewals for all magazines. No experience or investment. Rush name. McGregor Agency, Dept. 500-B, Mt. Morris, Illinois.

START A buying service, buy wholesale thousands nationally advertised products. Make big profits selling at sizable discounts. Postcard brings details. American Buyers, Hertel Station, Buffalo 16-C, N. Y.

FREE Booklet concerning hundreds profitable businesses started sparetime at home. Richard Company, Box 366-P, Hayward, Calif.

FREE "301 Profitable Small Businesses!" Amazing shoestring plans! Work home! Start sparetime! Deumant Surveys, Kenmore 23-PM, N. Y.

TO \$50.00 Weekly. Sparetime, home operated mailorder business. Successful beginner's plan. Everything supplied. Lynn, 10420-M National, Los Angeles 34.

MONEYMAKING Mailorder business plan, free! Write, George Lenhoff, Lincoln 8, Nebraska.

NEW Orleans help wanted columns airmailed \$1.00. Peterson, 1346 Prentiss Ave., New Orleans 22, La.

MAKE Perfumes, other products. Sell mailorder. Catalog free. International, 6347 Parnell PM-9, Chicago 21, Illinois.

MEN Wanted—Build luggage and cases at home. We sell your products, supply complete instructions, materials, everything. No special equipment needed. Free details. Cascraft, 805-G21 Sunset, Los Angeles 12, Calif.

"MAILORDER Laws and Regulations." Discusses federal, state, local licenses, taxes, legal requirements governing mail-order businesses. Play safe. Order today. Only \$1.00. Tasker, 105 East Custis Avenue, Alexandria, Virginia.

DOLLARS Daily! No canvassing! Free proof! Mailmarts, Cincinnati 36-F, Ohio.

TELEVISION Repair business. \$39.50 total cost. Amazing 1 day training. No studying. New proven technique. Make \$15 to \$20 day immediately! No experience needed. Investigate! Free home-business plan. Write Electronic Engineering, 1036-PS So. LaBrea, Los Angeles 19, Calif.

CONCRETE Manufacturing business. Molds for blocks, benches, tables, splash blocks, flower boxes. Circular free. Vyke Co., 2435—15th St., Denver 2, Colo.

SHINE Shoes without polish. New invention. Lightning seller. Shoes gleam like mirror. Samples sent on trial. Kristee 112, Akron, Ohio.

"HOT Dog on a stick." Something new. Dixie Hot Dog Mix. Scientifically blended with spices. Just add water. Sticks, bags all accessories, advertising material furnished. Steady supply and exclusive territories. Also Snow Ball, cotton candy machines, etc. For free information write National Industries, Inc., Wallace, N. C.

SELL Direct and through dealers best concrete sealer and decorator. Extra profit on contract jobs. Aquadry, 5511 W. North Ave., Chicago, Ill.

\$2000.00 OR More possible each month. New revolutionary service. Unlimited earnings. No merchandise. Keep present job. Can operate confidentially. Men or women. Send self-addressed stamped envelope. Checkers Service, P.O. Box 45, Winter Park, Florida.

"MAKING Money With Mushrooms." Simplified book. \$1.00 cash. Money-back guarantee. Mushroom Lab, 32 Kendrick, St. Lawrence, Mass.

WANTED! Home producers, by manufacturers in our clearing house service. Become subcontractor, casting plastic products for these companies. Thousands of easy-to-make items required for consumer-industrial use. Cash in at home, without previous experience. Plastic Service Associates, Dept. 9-PM, East Boston 28, Mass.

VITAMINS! Terrific profits! Direct and mailorder sales to homes, offices, stores and get your own needs wholesale. Details free. VimVite, 2908PM Beverly, Los Angeles 57.

SELL Merchandise by mail from your home. Everything supplied. Big profits. Stephenson's, Rattlesnake Drive, Missoula, Montana.

SELL Folios by mail. Free list gives low cost source. Ballard's, 425 East Catherine, Louisville 3, Ky.

EARN \$2.00 Hourly, making and selling sandals! Youngs, 1308-PM, South First, Arcadia, California.

\$40.00 PROFIT Daily making concrete drain tile in backyard with \$87.50 machine. Circular free. Coeten Products, Cornelia, Georgia.

PLASTERCRAFT Molds, liquid rubber, plasters, flocks, candle supplies. Catalog and manual free. Blue Rapids Supply, Blue Rapids, Kansas.

FREE "At Home Money-Making Plan." Increase your income. Start your own discount business with giant 100 page catalog. Send for free plan today. BTS Products, Oakland 10, New Jersey.

SELL Scotchlite reflective signs and letters by mail for good profit with no investment. Prestoflex Corporation, Mason City, Iowa.

EXCLUSIVE Distributorships available. Exceptionally good auto polish, local advertising assures big sales, investment insured. Details, sample \$2.00 refundable. K-K Products, Route 1, Box 76, San Bernardino, Calif.

NEW Wonder Dow Corning car polish. Cleans, glazes, weatherproofs year 'round. Really works! Send \$1 (refundable) for pint sample and selling plan. United Co., 1035 East 10th Street, Brooklyn 30, N.Y.

HANDY Men in small towns! Assemble and sell the finest three channel aluminum combination storm window. Work full or part time. Your cost— $\frac{1}{2}$ of retail price. \$100 starts you in business. Write for details! All-Time Mfg. Co., Dept. M3, New Britain, Conn.

WHOLESALE! 10,000 Name brand products. 30-80% discounts! New illustrated catalog. Terrific business plans included free! National Distributors, Paramus 7, New Jersey.

FREE Pamphlet, hundreds new small business opportunities. New System, 320 Melrose Building, Houston 2, Texas.

MAKE Money in landscaping—Start your own business, part or full time. Many good paying positions open. Earn while learning. Send for free book. National Landscape Institute, Dept. M-93-C, 310 S. Robertson Blvd., Los Angeles 48.

"100 CASE Histories of Successful Small Businesses." By editors of "Fortune" Magazine. \$4.50 postpaid. Details, Fabian Co., 5160 St. Urbain, Montreal 14, Canada.

MAKE \$5,000 Yearly with a lettership. Start small. Employ others. Publisher, 1018 S. Central, Burlington, Iowa.

OPERATE Profitable mail order business. Splendid opportunity. Write Blair Co., Perkinston, Miss.

TIN-Cans. Turn them into cash. Thirty methods. Instructions 50c. Charles Company, 12-DXB, Norwood, Ohio.

BUY Wholesale. Thousands name brand products. Free literature. Triple J Industries, 132 Berkshire, Bridgeport 8, Conn.

UNCLAIMED Watches pay big profits. All brands. \$4.95 up. Illustrated folder free. Cosmos Sales, 81 East 125 St., New York City 35.

LEARN Sharpen scissors. Profitable, easy instructions, \$1.00. Milton Leiser, Box 85, New York 51, N. Y.

FRANCHISES Make profits! Become exclusive franchised distributor, agency operator. Nationwide opportunities. Information rushed. National Franchise Reports, 333 North Michigan, Chicago 1.

MAKE Tough, attractive building plastic, easily, 88 $\frac{1}{2}$ % waste. 101 uses. 800% profit. Exclusive district. Grab it. Bays Laboratory, Oklahoma City 9.

\$5.00 HOURLY Bronzing baby shoes sparetime! Foster, 1520 Ardmore, Chicago 26.

BUY Wholesale, 800,000 items. Write Info-Center, 216 West Jackson Blvd., Chicago, Ill.

\$26,500 SALES in two weeks! Amazing radio-mail order method. Free details. Broadcast Service, 1413-A Great Northern Building, Chicago 4, Illinois.

BUY Wholesale, resell wholesale or retail. Lowest prices, biggest profits! Complete plan free, catalogue 50c. Thunderbird, Box 871-E, Killeen, Texas.

\$80.00 WEEKLY. Operate our selective mail-order business in your area, sparetime. Write House of Plastics, Paramus 25, New Jersey.

BARGAIN. 20 Ways each to make money from sawdust and tin-cans. Nine ways for glass-bottles. 50c each. 3 for \$1.00. Fender, Box 448-ACP, Kalamazoo, Mich.

OPERATE "Escalator" mailorder system, selling our products or any products. Most revolutionary mailorder system known. Postcard. Selbyco, Decatur 260, Illinois.

MEN-Women wanting \$10,000.00 yearly and better. Just ask tired people to use amazing new product without putting up money. Tested and approved Crosby Research Institute. Hire your own agents. Don't bother us unless you are go-getter. Normal-aids, 657 North Arden, Los Angeles 4, California.

UNUSUAL Opportunity, handspinning Angora wool. Fascinating, profitable. Angora House, PM, Springfield, Illinois.

EXPORT Business made easy! Expect something different. Complete setup, everything furnished. Hermes, 152 West 42, New York City 36.

SAWDUST. Turn it into cash. Forty methods. Instructions 50c. Charles Company, 12-DXA, Norwood, Ohio.

LEARN New product promotion. Start national business from home promoting your own new product ideas. Sell through retailers, wholesalers, chains, agents or by mail. Expert instruction. Details free. Banning AS, 40 South Los Robles Avenue, Pasadena 1, California.

FINEST Formulas for making world's fastest sellers. Literature free! Miller, Chemist, 1517-R, Tampa, Florida.

ADVERTISING Business—City, country. Low overhead, substantial income. Experienced advertising company offers complete setup. Harold, 69-S Bennett, New York City 33.

\$100.00 WEEKLY. Mail-order distributors wanted. Work at home sparetime. Experience unnecessary. Write: National Distributors, 340 Rt. 17, Paramus 1, N. J.

START Electrically operated parking lot. No experience. Amazing profits. Works while you sleep. Read ad on page 257.

YOU'LL Be amazed at the tremendous profit possibilities in the finest quality Bibles available anywhere! Many men make \$30,000 yearly and more! Get my free proven Bible sales course plus catalog of highest quality Bibles and related items. Joseph W. Cain, Wholesaler, Box 5063P, San Antonio 1, Texas.

MAKE Money helping others out of debt. Stop garnishments, save jobs, re-establish credit. Details free. Borum 87, 411 West Walnut, Kalamazoo 42, Michigan.

25 DIFFERENT Products mailed direct to your customers. Big mail order business without investment or inventory. Terrific sellers. Turner Company, 1170 Broadway, New York 1, N. Y.

\$70 WEEKLY—Home, spare time. Simplified mail bookkeeping. Immediate income, easy! Auditax, 34757AR, Los Angeles 34.

SELL Pen and pencil sets—Jeweled pens. Write for catalogue. Supercraft Mfg. Co., Dept. M, 445 Broome St., New York 13, N. Y.

MAKE Extra money between now and Christmas. Sell subscriptions to all popular magazines. Liberal commissions. For supplies write DeSales Magazine Service, 60 East 42nd St., New York 17, N. Y.

MINIATURE Trees. Why pay \$2.00-\$10.00 for growing secrets? Free details. Tiny Trees, Box 3084-P, Chicago 54.

AMBITIOUS? We establish you in your own business, supply catalogues, circulars etc., ship orders under your name, paid or c.o.d., show you exactly what to do. Household items needed in every home. Sell direct, by mail or through agents. Complete details absolutely free. Write Topval Corp., Lindenhurst 618, New York.

\$1,000 MONTHLY. Home, mailorder, free advertising method. Revealing information. Seidel, 6000-AI Sunset, Los Angeles 28.

BUY Wholesale! 100,000 name brand products! Save 66 $\frac{2}{3}$ %! Big profits selling others spare time! Free catalogs! National Buyers Service, Box 426EE, Oakland, Calif.

PRINT Without a printing press! Amazing new method! Print colorful signs, banners, cards, posters, glassware; anything at home. Big profits. Moneymaking opportunity! We supply everything. Beautiful sample, home-business plan free! Write Screen-Print Company, PM-9, Los Angeles 61, California.

FREE. Money making ideas, tips. Crystal, 38 Myles, Levittown, New York.

GET Merchandise orders by mail! Everything furnished—Orders filled. Big profits. Long, McKays Beach, Leonardtown 3, Md.

PROFITABLE Home collection office. Experience unnecessary. Details free. Hyatt, 411 West Walnut, Kalamazoo, Mich.

LIVE As we do. \$15,000 to \$40,000 annually. We vacation 365 days a year in this scenic sportsman's paradise. You can do the same. Experience unnecessary. Our 4,000 word prospectus shows you step by step how to organize and conduct this exceptional and lucrative business. No selling. Involves a public service which is being overwhelmingly accepted. Largely conducted through mail channels. Minimum capital required; start small, expand rapidly. Within a few months you should be paying yourself \$1,000 monthly, inserting the balance into the business. Our money-back guarantee assures your success. The magnitude of this offer makes its value unlimited. Our fee is \$3.00. Air mail your check or money order today. Terry O'Donnell, Farewell, Alaska.

\$25,000.00 BONUS Offered by U. S. government—Fortunes being made in uranium! Free booklet shows "How To Make Money Prospecting for Uranium." Please enclose 20c for handling, postage. Geiger Co., 195-PM5b Sackett Street, Brooklyn 31, N. Y.

\$3.75 HOURLY Minimum, evenings. Preparing tax returns—Simplified! Auditax, 34757AT, Los Angeles 34.

NEED Cash? For "know-how and where," write Business Service, 201 Bank Bldg., Cole Camp, Mo.

MAKE Big money in your spare time! Sell nationally advertised brand name merchandise. Appliances, cookware, housewares, watches, jewelry, dry goods, clothing, sporting goods, toys, gifts, etc. Build a profitable repeat business. Send for free 110 page illustrated color catalog with separate confidential cost sheet. Merit Home Products, Dept. PM9, 107 Manhattan Ave., Brooklyn 6, N. Y.

WHOLESALE! 16-80% Discounts! Appliances, tools, etc. Catalog 25c. Levesque Supply, Atlanta, New York.

NAMES Of ambitious men seeking own business. Recent, 1000, \$6.50. MacLaughlan, 378 Baldwin, Jersey City 6, N. J.

WHAT'S New in mailorder? Let "Mail-order World," published monthly, keep you informed. Sample, 25c. Wayne, 1233 Elden, Los Angeles 6, Calif.

NEW. Unique plan can earn hundreds of dollars for you. Free details. No obligation. Write: Best Distributors, 200 West 34th St., New York City 1, Suite 1003.

EXTRA Money sparetime sharpening farm discs. \$20 to \$25 daily profits. No dismantling—No moving. Simple portable machine sharpens whole disc right on farm. Free plan explains. B. L. Foley Company, Columbia Heights, Minnesota.

"FROG Raising!" Season just starting. Get this year's eggs. New book tells how. Folder 10c. Brool-A, Box 506, New Orleans 1, Louisiana.

DOLLARS: Baby record books, Kitty Kat shoes, My Baby albums, eleven thousand new prospects daily. Sold by mail, use our literature. No-Co-Ro, Oakland 6, Calif.

EARN \$35.00 Daily! Sell Liqui-Moly, new wonder lubricant for cars, trucks, buses, tractors. Used in jet engine, atomic energy plants. Nationally advertised magazines, newspapers, radio, television. Over 3,000,000 cans sold. Territories available. Write Moly Products, 314 Scholes Street, Brooklyn 6, N. Y.

WANT UP to \$100.00 weekly deposited in your mail box? Details free! Smith, 2708-P Ladera, San Bernardino, Calif.

SELL Printed stationery, business cards, by mail! Free catalog, samples. Sutton Printing, Box 853-M, Waycross, Georgia.

BUY It wholesale! Manufacturers, distributors offer 850,000 items. Literature free. Olsen, 1231-A East Third, Duluth 5, Minnesota.

START Home business, sparetime, opportunities unlimited. Write, Heam, Box 8892, Richmond 25, Va.

WHOLESALE Catalog of tools, sporting goods, jewelry, toys, etc. available free. Open your own business. No investment. J. M. Arnoff Company, Dept. X, 24470 Lakeland Blvd., Cleveland 23, Ohio.

ELECTROPLATE Auto parts, novelties, mirrors, baby shoes. Easy, inexpensive home processes. Free booklet. Tyco Metals, Box 13231-MM, Houston 19, Texas.

WHOLESALE. Thousands items. Supply source list. 10c. Idealer, Park Ridge, Ill.

LEARN Sewing machine repair. How to make big money at home sparetime. New machines. Everything supplied. Write Taylor Service, Box 2128, San Bernardino, California.

\$5 TO \$10 An hour. I've did it. I'm disabled now. Real genuine offer. Complete information only \$1. Lucas, 2200 Carson St., Pittsburgh 3, Penna.

IMPORT-Export opportunity, profitable, world-wide, mail-order business from home, without capital; or travel abroad. Established world trader ships instructions for no-risk examination. Experience unnecessary. Free details. Mellinger E701, Los Angeles 24.

REBUILD Batteries; repair dolls; make rubber stamps; silk screen printing. Catalogue "50 Ideas" free. Universal, Box 1076-A, Peoria, Ill.

BREED Rare tropical fish at home. Earn big money! Learn secrets! Help fill huge demand. Amazing opportunity! Free plan. Tropical Fish Breeders, Los Angeles 61, Calif.

HOW And where to obtain capital. Particulars free. Star Service, Wapakoneta, Ohio.

BE Appointed state notary public now. Write, Stationers, Helotes, Texas.

I want to send you proof of the wonderful pulling power of Popular Mechanics classified pages. What's your proposition? Write me today. Include literature if possible. F. W. Johnson, Manager Classified Advertising, Popular Mechanics Magazine, 200 E. Ontario St., Chicago 11, Ill.

FORTUNES Made raising crickets and fishworms. Write for free information. Carter Farms, Plains, Ga.

MAKE Money growing miniature trees on your window sill. Free seed and plan. National Nursery, Dept. FC, Inglewood 4, Calif.

FREE Folio "Up to \$45,000; Unlimited Vacations." No merchandise, equipment. Unknown! Work home, sparetime! Haylings, Carlsbad, Calif.

MONEY In sparetime fixit shop at home. Repeat cash business. Experience unnecessary. No selling. Free booklet explains. Victor Foley Company, Columbia Heights, Minnesota.

WE Love our mailman—He leaves over \$1000.00 monthly in our rural mailbox. My college professor husband drafted a scientific home mailorder method. We bought a Texas ranch, live as we always wanted. Now we sell the Ranch Mailorder Method. Operates anywhere. Inquire: Eveningshade Ranch, Helotes, Texas.

RESILVERING Mirrors, formula 50c; two-way lockout mirrors, (No one sees you), 50c; coppered mirrors, 50c. All \$1.00. Nelko-Mir, Box 3462-J, Chicago 54.

POPCORN And potato chip equipment. Eakins, Box 933-A5, Springfield, Ohio.

MEN—Income from local information. No selling. Neherco, LaVerne, California.

RUBBER Molds for casting plaques, figurines, novelties. Catalog illustrating over 100 fast sellers, 10c. Castcraft Studios, 508-PM Marion Street, Brooklyn 33, N. Y.

NEWEST Spare, full-time home business. \$5 to \$10 hour possible. Paint with suede. The finish with touch and eye-appeal. Beautiful auto dashboards, signs, radios, toys, figurines, lamps—1001 others. Complete, step-by-step instructions sent for no-risk examination. Free details. Coast, Los Angeles 61.

START Home manufacturing business. Make cleaners, soaps, polishes, cosmetics. Free literature. Kemix, Park Ridge, Ill.

IMPORT-Export mailorder opportunities! Details. Warner, Box 6, Fort Scott, Kansas.

NATURAL Molding rubber, extra thick. Free sample. Flock, W. Wooley, 115-A Donald, Peoria, Ill.

BOOKKEEPERS, Keep books, small firms spare time. Manual latest technique by C.P.A., \$3.00. Modern Business, Box 406, Youngstown 1, Ohio.

COPUBLISH Mail Sale Advertiser, leading mail order paper. Details, latest copy, dime. Vanroy Shirk, Lebanon, Penna.

GROW Mushrooms. Cellar, shed, and outdoors. Spare, full time, year round. We pay \$3.50 lb. We paid Babbitt \$4,165.00 in few weeks. Free book. Washington Mushroom Ind., Dept. 172, 2954 Admiral Way, Seattle, Washington.

\$25 WEEKLY Working two hours daily at home. Lycke, Box 2471-A, Cleveland 12, Ohio.

OPERATE Profitable mail order business. Write Walter Service, 4159-A East 112th, Cleveland 5, Ohio.

COLORGLAZED Concrete pottery made without molds. Patented method. Cemetery products, novelties, tiles. Basement leak-sealing. Money-making projects. Booklet, details free. Men only. National Potteries Company, Grand Rapids, Minnesota.

MINK Raising information free. Complete. Lake Superior Mink Farm, Superior, E.E.I. Wisconsin.

FREE Book "505 Odd, Successful Businesses." Work home. Expect something odd! Pacific, Oceanside, Calif.

MONEY In new greaseless doughnuts. Start in kitchen. No smoke. Sell stores. Free recipes. M. Ray Company, 3605 South 15th Ave., Minneapolis 7, Minn.

VENDING Machines—No selling. Operate a route of coin machines and earn amazing profits. 32-page catalog free. Parkway Machine Corporation, Dept. 73, 715 Ensor St., Baltimore 2, Md.

BRONZE Baby shoes. Instructions, equipment and mountings for genuine electroplated process. Free catalog. Hollywood Bronze Supply, Dept. B-3, 1624 East First Street, Los Angeles 33, Calif.

YOUR Own name brand business. No investment; no inventory. Part time or full time. Sell famous brands of appliances, housewares, silverware, radios, vacuum cleaners, lamps, tools, clocks, watches, jewelry, etc., over 1000 items. Join thousands of successful independent dealers. Send for free catalog and dealer price list. H. B. Davis Corp., Dept. W, 145 W. 15 St., New York City.

LIQUID Rubber. Make flexible molds. Free sample. Chaney, 1130 E. 16th St., Jacksonville 6, Fla.

STEADY Profits, home-operated business. Simply add water to concentrates. Make waterless hand cleaner, chrome renewer, etc. Free samples. Western B Aircraft, Los Angeles 19.

GOOD Paying business silvering mirrors, plating articles in the shop and home by late method. No tanks or shop required. Free booklet. Gunmetal Co., Ave. H, Decatur, Illinois.

GROW Orchids at home—Profitable, fascinating. Year 'round, Maine to California. No greenhouse. Gorgeous cattleyas, cymbidiums, etc. Successful home grower shows you how. Full details free. Flowerland, 4623 Wilshire, Los Angeles 5.

FIX Typewriters. Inexpensive home course teaches factory secrets. Free booklet. Write, Typewriter, Tarentum 1, Penna.

\$200 WEEKLY Cleaning Venetian blinds. Free book. Burt, 2434A, Wichita 13, Kansas.

WANT To make big money at home? \$5 profit in an hour possible with invisible re-weaving. Make tears, holes disappear from clothing, fabrics. Steady year-round demand from cleaners, laundries, homes. Details free. Fabricon, 8334-S Prairie, Chicago 19, Ill.

MONEYMAKING OPPORTUNITIES

MAKE Money at home as renewal headquarters for all magazines. Big Christmas sales profits now. Liberal commissions. Supplies furnished. Experience unnecessary. Write for free catalog. McGregor Magazine Agency, Dept. 500-C, Mount Morris, Illinois.

NEWLY Found money in Whitehall's fascinating photo line of Christmas and everyday cards, jewelry, gift items. Personalized stationery, napkins. Send for free samples. You, too, can make big money with Whitehall's photo line. Whitehall Studios, 25 Main Street, Elmira, New York.

START A buying service, buy wholesale thousands nationally advertised products. Make big profits selling at sizable discounts. Postcard brings details. American Buyers, Hertel Station, Buffalo 16-D, N. Y.

FOR Moneymaking mailorder plans write Central Sales Outlet, Robbins, N. C.

BRAND New opportunity. Free details. Reliant Sales Company, Box 55, Bangor, Penna.

LEARN Technical metaphysics and insure your future. Easy, inexpensive correspondence course. Simplest method known. Diploma. Write: Premier College of Technical Metaphysics, 2532 McKenzie St., Vancouver 8, B. C., Canada.

SELL Helbros watches-jewelry. 70% discount. Wholesale catalog 25c. Dorinda, Box 77, Huntington Station, New York City.

MAKE Spare time money preparing and mailing sales literature. Adams Surveys, 3513-AT Sunset Blvd., Los Angeles 26, Calif.

FREE! "301 Profitable Small Businesses!" Amazing shoestring plans! Work home! Start sparetime. Deumant Surveys, Kenmore 23-PM, N. Y.

SCHEMER Magazine. Canfield 1, Ohio. Mailorder and business plans. Year \$2.00, sample 25c.

OPPORTUNITY Mails three months 25c. Donovan, 791 Greenbelt, Levittown, N. Y.

\$1,000 MONTHLY Possible raising earthworms! Backyard, garage, basement. Complete illustrated booklet explains raising, feeding, packing, marketing. 25c postpaid! Ozark Worm Farm-J, Willow Springs, Mo.

"WHAT'S Cooking in Contests" A monthly contest magazine of tips, hints, research to help you win in all types of contests. New \$2000.00 contest now open to subscribers. One year \$3.00; four months \$1.00; sample copy 25c. Robert Spence, Dept. P, 7352 Central Ave., St. Petersburg 7, Florida.

EARN Money evenings, copying and duplicating comic cartoons for advertisers. Adservice, Argyle 1, Wisconsin.

BOOKS! Novelties! Moneymaking opportunities! Free circulars! Edward Koliba, 1310 Ewen Avenue, New Westminster, B.C., Canada.

PRIZE Contests provide fabulous and confidential home income opportunities! Here's how and where to win your share! Send stamp! National Contest Bulletin, Box 2685, Miami 16, Florida.

\$5—\$10 AN Hour teaching driver training in your own car. Complete detailed information \$1.00. Driving School Services, Box 428P, Goleta, Calif.

MAKE Money with camera. Professional secrets \$1.00. Brewer—Photographer, 5880 Hollywood, Hollywood 28, Calif.

RETIRED? Over 60? Want to earn money full-part time? No selling! Get free information! Burns, 1967-P, Gerritsen, Brooklyn 29, N. Y.

BIG Interesting mail. Business opportunities. Magazines, samples, etc. 25c. Oryder, Box 187, Barberton, Ohio.

RAISE Earthworms—Illustrated instructions 25c. Birchall, Box 8065-L, Orlando, Florida.

"MONEY Getter's Bulletin." Prints helpful money-making ideas, plans, tips. Sample 25c; details free. Distributors, Box 831-D, Monessen, Penna.

SELL Titania gems; far more brilliant than diamonds. Catalog free. Diamonite, 1404-M Mitchell, Oakland 1, California.

YOU Cast metal products. Free literature. Box 124, Lynwood, California.

START Your own toy business. Assemble, finish and sell wooden toys. Milled parts and kits available. Write Fulton Mfg. Co., Box 707, Blowing Rock, North Carolina.

EARN \$50.00 Daily making mats, shoes and mud guards from old tires. S and S Patents Inc., 1307 North Clark St., Chicago 10, Ill.

\$5 TO \$10 An hour. I've did it. I'm disabled now. Real genuine offer. Complete information only \$1. Lucas, 2200 Carson St., Pittsburgh 3, Penna.

MAKE To \$300 extra. New! Different! No selling! No mailorder! Details free. J-M Enterprises, 801½-A North Marsalis, Dallas 3, Texas.

DOLLARS In baby record books, baby shoe kits. Liebig Industries, Beaver Dam 2, Wisconsin.

FREE Literature describing moneymaking mailorder plans. Lewis Barlett, Richland, Georgia.

BUILD Sales by recruiting productive distributors selling direct or to retail outlets. Secure most concentrated circulation through classified columns of Salesman's Opportunity. Write for facts. Gilbert, Salesman's Opportunity, Room 1700, 850 N. Dearborn, Chicago 40.

FREE Folio "Up to \$45,000; Unlimited Vacations." No merchandise, equipment. Unknown! Work home, sparetime! Haylings, Carlsbad, Calif.

SPARETIME Profits taking subscriptions all magazines. Wholesale catalog free. Cassell Publishers, Westfield, New Jersey.

GENERAL Contest Bulletin. Issued monthly. Sample, 25c. 1609½ East 5th, Duluth, Minn.

GROW Mushrooms. Cellar, shed, and outdoors. Spare, full time, year round. We pay \$3.50 lb. We paid Babbitt \$4,165.00 in few weeks. Free book. Washington Mushroom Ind., Dept. 173, 2954 Admiral Way, Seattle, Washington.

50,000 ARTICLES Wholesale. Source directory, dime. Nelko, Box 3462-DR, Chicago 54.

FREE Book "505 Odd, Successful Businesses." Work home. Expect something odd! Pacific, Oceanside, Calif.

READ Progressive Mailtrade, the magazine that tells how to make money by mail. Dime brings sample and special offer. Progressive Mailtrade, Box 357, Sheboygan, Wisconsin.

ATTENTION: Typewriter owners. Make handsome profits. Write today. Groves Company, 682, Hastings 8, Nebraska.

START A profitable subscription business in spare time! We need men and women (young or old) as representatives for all leading national magazines. Liberal commissions paid for new and renewal subscriptions. Start earning money in this pleasant work at once! Clip this ad and send with your name and address to: Agency Bureau, Dept. PM, Hearst Magazines, 230 West 55th St., New York 19, N. Y.

LEARN Directing money-raising campaigns for churches, hospitals, institutions. Earned \$3065 in six weeks on my first campaign on \$50 investment. Unlimited field. Course backed by 35 years experience. William Arbogast, 229 East Mason Avenue, Alexandria, Virginia.

400% PROFIT. Seal in plastic the machineless way. Material and instructions \$1.00. Thompson's, Box 482, Mt. Ephraim, New Jersey.

WHOLESALE Watches, jewelry, folders free. Write Updegraff's, 459 North Schenley, Youngstown 9, Ohio.

DENVER Opportunities listings \$1.00. Airmailed. Rivers, 3055 Jackson, Denver, Colorado.

FREE. Home business plan. Samples, details. Fender, Box 448-ACQ, Kalamazoo, Mich.

\$100 OR More month spare time at home. Free information. World Sales Co., Box 179 PM, Ripley, Mississippi.

START A mail order business. Mail your own 8 page catalogue. 35 attractive items. No stock to carry, we ship your orders, 40% profit. Send \$2.00 for sample test 30 catalogues and information. Tepper Co., 111 Fifth Ave., New York 3, N. Y.

SELLING Is easy the copyrighted Elmer Wheeler way! Learn at home from America's super salesman. Earn big money full, spare time. Sure-fire method insures success. Details free. Wheeler, Dept. E-9, 684 N. Michigan, Chicago 11, Ill.

SCHOOL Seniors—Sell classmates America's most beautiful graduation name cards. Largest selection. Highest commission. Outsell all others. Free sample kit. Printcraft, Dept. M, 1509 Maple Street, Scranton 5, Penna.

MAKE Money with your typewriter! Details 25c. Barnett, 4033-89 Verona, Cleveland 21, Ohio.

WANT To go in business for yourself without capital? We show you how. Start part time your own home. Postcard brings details absolutely free. Topval Corp., Lindenhurst 620, New York.

BUY Wholesale! Save 66%!! Appliances, furniture, jewelry, toys, sporting goods, tools. Free catalogs. National Buyers Service, Box 426EB, Oakland, California.

HAVE Home business—Get \$10 orders in every mail. Keep \$8.00. Everything supplied. National, Box 88-W, Dorchester 22, Massachusetts.

HUGE Profits! Jigsaw necessary: 10c brings valuable patterns, illustrated information. Woodart, Bridgewater, Mass.

DO Home mailing. Simple, no selling, good income. Free details. National Industries, 33 Hyde Park Ave., Jamaica Plain 30, Mass.

DON'T Throw away those box tops, wrappers, labels. They are worth money. 25c brings information. Eschem, Box 4227, San Francisco, Calif.

EXCEPTIONALLY Profitable homework for adults. Free information. Baron's Recording, Lynden, Washington.

DO-It-Yourself! Money-making! Savings! Make perfumes, shampoo, remedies. Many useful products. Money-making ideas! 2 formulas and lists free. Tzane, 806AZ Lyon St., San Francisco 15, Calif.

FORMULAS, PLANS, ETC.

MODERN Formulas for today's fastest selling big-profit products. Literature free! Miller, Chemist, 1517-N, Tampa, Florida.

FORMULAS: All kinds, latest, best. Literature free. Kemikal, Park Ridge, Ill.

REAL Manufacturing formulas. Lists free. Cummings, Chemist, Gordon Ave., Syracuse 4, N. Y.

PRODUCT Analysis, manufacturing formulas, processes developed. Moderate fees. Plastics, Box 1574, Boston 4, Mass.

ONE Commercial formula and catalog \$2.00. Milici-PM-Chemist, 1709 W. 7th St., Los Angeles 17, Calif.

PLASTICS

LAMINATING Supplies. Free price list. Solomonson, 46 Cornhill, Boston 8, Mass.

PLEXIGLAS. Cut to size. Clear. Any thickness. Colors. Rods. Tubing. McClarin Plastics, P.O. Box 168H, Hanover, Penna.

PLEXIGLAS, Fiberglass, polyester, acetate, vinylite. Fast service. Wholesale-retail. Catalog 15c. Gem-O-Lite, Box 6861P, North Hollywood, California.

MAKE Money laminating. Complete kit \$2.00. Klein, 1804 Harrison, New York City 53.

PLASTIC Glass. Any size transparent sheets $\frac{1}{8}$ ". \$1.10 square foot. Ultra Plastics Mfg., Pitman 23, N. J.

ACRYLIC Plastic, water clear solution for coating brass lamps, silverware, chrome, fishing rods, tools, lampshades. 8 ounces \$2.00. A. B. Dunn, Department A, Box 5537, Chicago 80, Illinois.

PLASTICS Home-craft course for men and women. Tells and shows how to make hundreds of fast selling plastics products. All plastics and materials for 23 projects included in course. No special tools needed. Course pays for itself. Write for free booklet. Interstate Training Service, Dept. D-3-J, Portland 13, Oregon.

PLEXIGLAS, Lucite. Square foot cost $\frac{1}{16}$ ", \$1.15; $\frac{1}{8}$ ", \$1.52; $\frac{3}{16}$ ", \$1.86; $\frac{1}{4}$ ", \$2.21; $\frac{3}{8}$ ", \$3.25; $\frac{1}{2}$ ", \$4.38. Colors add 10%. Send 15% for postage. Aristocrat Plastics, 55 Clarkson St., New York City.

CHEMISTRY

NEW Idea chemical and apparatus outfits for home experimenting, photo-scales, microscopes, chemicals, biologicals and laboratory supplies in small quantities. Catalog 25c. Established 1931. John H. Winn, 124A West 23rd St., New York, N. Y.

ILLUSTRATED Catalog: Chemistry, mineralogy, biology 25c. Tracey Laboratories, Evanston, Illinois.

CHEMICALS And apparatus for industrial, analytical, and private laboratories. Catalog 25c. Dept. M-50, Biological Supply Co., 1176 Mt. Hope Ave., Rochester 20, N. Y.

CHEMICALS, Supplies, microscopes. Catalog 25c. Laboratory Sales, Box 161-A, Brighton, Mass.

AMAZING New Book of Science. Experiments, formulas and catalogue of laboratory supplies. Only 25c. National Scientific Co., Dept. PM-9, 2204 W. North Ave., Chicago 47, Illinois.

AGENTS WANTED

WOMEN, Men, make money spare time plus new car as bonus for encouragement. Amazing hosiery guaranteed to wear without holes, snags, and runs, or replaced free. For example, lovely 60 gauge nylons guaranteed for as long as 1 1/4 years, or replaced free. Write Wilknit, 1759 Wash., Greenfield, Ohio.

\$204 WEEKLY Selling miracle double-gloss, car wax, paste, glaze and wax, cleans and polishes in one easy operation, outshine them all, wipe on, let dry, wipe off, sells on demonstrations. Details free. 1/2 lb. can \$2. Norman Wiggs & Company, 1406 E. 52nd St., Los Angeles 11, Calif.

MAKE Money introducing world's cutest children's dresses. Big selection, adorable styles. Low prices. Complete display free. Rush name. Harford, Dept. P-4341, Cincinnati 25, Ohio.

IMPORTING Without capital. Become successful U.S.A. resident agent for leading overseas manufacturers. High income, home operated, no risk. Complete arrangements furnished including U.S.A. distribution assistance. Impex, 1974-A Comstock, Los Angeles 25.

SELL Newest rage tall style Christmas, all occasion greeting card assortments in spare time. Unusual wrappings, novelties. Make up to \$1.00 per box plus bonus. Write for feature boxes on approval. 77 free samples personal Christmas cards, stationery, free catalog. New England Art Publishers, North Abington 933-K, Mass.

MAKE More money showing Elmira greeting cards this Christmas! Why more? Because Elmira offers more variety; beautiful cards for every taste, every purse. You get heart-warming, old-fashioned favorites and smartly simple ones for today's tastes. No matter who you sell, Elmira has a style to please everybody from grandmother to young Mrs. Executive. Send today for free personalized samples, catalog and sparkling assortments on approval with personalized stationery, imprinted napkins and lovely gift wrappings! Elmira Greeting Card Co., Elmira 200, N. Y.

\$119.02 IN One day! That's what Mrs. Orr of Minn. made, selling our new, unusual gifts, gadgets, greeting cards, imprinted stationery, toys and jewelry to friends and neighbors. Sell spare time or full time—Up to 100% profit. Write today for big free catalog and complete details. Hurry—Cash in on sensational Christmas profits! Greetings Unlimited, 3605 Park Square, St. Paul, Minn.

PROFIT With your own wholesale, name brand catalog. Appliances, watches, jewelry, gifts, tools. Imprint your name on cover. Full or part-time sales. Details free. Robel Sales, Dept. P.M., 487 Broadway, New York 13, N. Y.

BEAUTIFUL Feather pictures. 200% profit! Free sample. Apartado 9036, Mexico 1, D. F.

MAKE Money at home as headquarters for all magazines. Earn big Christmas profits. Liberal commissions. No experience, capital needed. Supplies furnished. Write McGregor Magazine Agency, Dept. 500-A, Mount Morris, Illinois.

BUY Wholesale thousands nationally advertised products at big discount. Free "Wholesale Plan." American Buyers, Herchel Station, Buffalo 16-A, N. Y.

150% PROFIT Selling 500 name and address labels. Retail \$1.00. You keep 60c profit. Free selling kit. Bruce, Box 71-Y, Boston 1, Mass.

"FUN And Profit in Selling." Beginner's booklet by retired sales manager. Inspires confidence. Helps remove mystery from selling, only \$1.00. Hylsand, P.O. Box 2216, Cleveland 9, Ohio.

NEWLY Found money in Whitehall's fascinating photo line of Christmas and everyday cards, jewelry, gift items—Personalized stationery and napkins. Send for free samples. You, too, can make big money with Whitehall's line. Whitehall Studios, 25 Main Street, Elmira, N. Y.

SELL Sunshine cards, the name quality has made famous. No investment or experience necessary. 21 card deluxe tall slim assortment sells on sight! Imprints, Currier-Ives, religious, gift wraps, many others. Samples on approval, write: Sunshine Art Studios, Inc., Dept. PM-9, Springfield 1, Mass., Pasadena 1, Calif. (Note: East of Rockies address Springfield office.)

CALENDARS. Advertising novelties, matches. All styles, including religious, varnished, 12 sheet, girls. Hundreds of advertising novelties, book matches, etc. Fleming Calendar Co., Sales Division, 6539 Cottage Grove, Chicago 37, Ill.

NEW Plastic mending tape. Just press on! Repairs clothing instantly. Lightning seller. Samples sent on trial. Kristee 72, Akron, Ohio.

BIGGER Profits selling greeting cards. Get list of sensational factory surplus bargains. \$1.25 boxes for 50c. \$1 boxes for 35c—while they last! Big line new 1955 Christmas cards, stationery, gifts. Assortments on approval. Personalized samples free! Midwest Cards, 1113 Washington, Dept. 557-D, St. Louis 1, Mo.

AGENTS-Salesmen: Sell beautiful hand-colored plastic enlargements and sensational new personalized photo compacts, rings, bracelets, lockets, etc. Experience unnecessary. 40% advance commissions. We deliver, collect. Wonderful sideline. Better full time. Free sample outfit. Novel Portrait Co., 3343 North Ave., Chicago, Ill.

AT Last! Something new and sensational in latest tall Christmas cards. Make extra money fast! Show satins, velours, metallics. Gets easy orders. Pays up to 100% profit. 30 free samples. With name 50 for \$1.50. Big line. Amazing convertible pen-pencil, napkins, gifts, stationery. Several \$1.00 boxes on approval. Puro Greetings, 2801 Locust, Dept. 540-L, St. Louis, Mo.

STARTLING Discovery. Cleans white-wall tires like magic. Spray on. Sponge off. Whirlwind seller. Profits galore. Write for free sample offer. **Chemade Products Company, 777 Bayside, Detroit 17, Mich.**

SELL Miracle crosses Lord's Prayer easily read size of pin head in center. Rhodium finish cross has 10 large rhinestones and neck chain gift boxed. Send \$1.00 for sample, \$9.00 dozen. **Herman's, 2 Beaver St., Newark 2, N. J.**

AMAZING Unbreakable plastic housewares for bigger profits. Also tablecloths, drapes, utility covers. Free catalog PM59. **Acclaim, Box 4, New York 40, New York.**

SHINE Cars without polish. New invention. Lightning seller. Cars gleam like mirror. Samples sent on trial. **Kristee 75, Akron, Ohio.**

AGENTS: Sell Mexican feather cards. Good profit. Free sample. **Apartado 7118, Mexico City.**

EASY Handwork makes fast-selling articles. Sample free. **Sunmade Company, Brockton 64, Massachusetts.**

COMBINATION Hand cleaner and spot remover. Millions sold. Sample, quarter. **Murphy Yale, Meriden, Conn.**

AMAZING Tall-Glow, Kodachrome Christmas cards sell swiftly. Free samples. \$52.50 profit on 50 boxes easy! Many cards, stationery, novelties. Profits to 100%. Gift bonuses. Samples on approval. **Hurry—Get sensational mail minder free. Creative, 4401 Cermak, Dept. 518-B, Chicago 23.**

WANTED: Men interested in making up to \$15,000 a year. Exclusive line of personalized articles. No investment. Free information and sales kit. Write **Hook-Past, Box 480 (PM), Rosnoke, Virginia.**

TREMENDOUS Profits! Every man, woman and child a customer. Suits \$1.50, pants 35c, dresses 20c, shoes 20c. Operate from store home, car. Free catalog. **Superior, 1250-A Jefferson, Chicago 7.**

LOWEST Wholesale prices. Thousands of name brand items. Free literature. **Parker Distributors, Box 55 (Dept. C) Williamsbridge Sta., New York City 67.**

FREE Color catalog of religious jewelry. 100% profit. Virgin Mary heart necklace, sample \$1.00 (value \$2.50). Money back guarantee. **Stephen-New York Inc., 1947 Broadway, New York 23.**

CHRISTMAS—All occasion cards, novelties and gift items. Largest selection. Highest profits. Satisfaction guaranteed. Send for sample offer coupon now! **Klots Distributing Co., Dept. 89A, 1012 Western Ave., Toledo, Ohio.**

EARN \$35.00 Daily! Sell Liqui-Moly, new wonder lubricant for cars, trucks, buses, tractors. Used in jet engine, atomic energy plants. Nationally advertised magazines, newspapers, radio, television. Over 3,000,000 cans sold. Territories available. Write **Moly, 314 Scholes Street, Brooklyn 6, N. Y.**

EARN Extra dollars selling cameras, film, projectors, recorders, typewriters, etc. Write: **Gladrose Gift Co., 150-M Broadway, New York 38, N. Y.**

EARN \$200 A week and up! Amazing profits are yours selling Seal-Tite, miracle puncture-proofing discovery! \$1.98 tube stops flats forever. Sure-fire appeal to America's \$6,000,000 motorists! Complete sales kit free on request. **M & M, Dept. M-2, 842 Third Ave., New York City 23.**

WHOLESALE Catalogue! Appliances, cameras, watches! **Anelag Industries, Rochester 1, Wisconsin.**

EARN \$150.00 Per week, giving away stainless steel tableware. **Nueblings-M, Sicklerville, N. J.**

\$5 TO \$10 An hour. I've did it. I'm disabled now. Real genuine offer. Complete information only \$1. **Lucas, 2200 Carson St., Pittsburgh 3, Penna.**

YOUR Own business—Used suits \$1.50, overcoats 65c, mackinaws 35c, shoes 12½c, ladies coats 30c, dresses 15c. Enormous profits. Catalog free. **Moro, 1218AA South Jefferson, Chicago 7.**

HAVE Your own business, buy wholesale, make big profits. Free general mdse. catalog. **Jay Norris, Dept. P, 445 Broome St., New York.**

PRINTING, Advertising salesmen—Excellent moneymaking sideline selling decalcomania name plates, small quantities. Automobile initials, sign letters. Free samples. **Ralco, XL, Boston 19, Mass.**

GOLD Or silver letters, numbers. Windows, doors, trucks. 1" to 6". 500% profits. Free samples. **Atlas-T, 344 West 79th, Chicago 20.**

MAKE Extra money. Sell front door name plates to friends, neighbors. Retail \$1.98; you make \$1.00! Free selling kit. **Modern Engraving Co., P.O. Box 194, Boston 14, Mass.**

\$1.00 PROFIT Selling \$2.95 photo enlargement deal. **Allen Studio, Riegler Bldg., Little Rock, Ark.**

AGENTS—300% Profit selling genuine gold window letters; stores and offices. Free samples. **Metallic Sign Letter Co., 431-D North Clark, Chicago.**

YOUR Ad in this space will get some good agents for you. Yes, I'll prove it. Write for Folder "A" right now. **P. W. Johnson, Classified Advertising Manager, Popular Mechanics Magazine, 200 E. Ontario St., Chicago 11, Ill.**

CALIFORNIA Sweet smelling beads. Sensational sellers. Particulars free. **Mission, 2328 FR, W. Pico, Los Angeles 6, Calif.**

RUN Spare-time greeting card and gift shop at home. Show friends samples of our new 1955 Christmas and all-occasion greeting cards and gifts. Take their orders and earn to 100% profit. No experience necessary. Costs nothing to try. Write today for samples on approval. **Regal Greetings, Dept. 78, Ferndale, Mich.**

WHOLESALE Catalogue! Appliances, cameras, watches! **Cam Company, 6806PM 20th Ave., Brooklyn 4, N. Y.**

EARN \$30 A day! Sell Dab-It, amazing pocket-size, stick-form, "no ring" spot remover. Works like magic! Guaranteed! **M & M, Dept. M-1, 842 Third Ave., New York City 22.**

EASY Money selling the new Pro Candid 35 mm. camaras. Your area is open for anyone to cash in on these fast-selling cameras. Selling kits furnished, cash commissions guaranteed. For complete information write **Beaurine Industries Inc., 500 N. Robert Street, St. Paul 1, Minn.**

REAL Diamond rings. Sell direct. Make big middleman's profit. No investment. Experience unnecessary. Free catalog, details. **Gleamlight, 111-R N. Columbus, Mount Vernon, N. Y.**

\$1,000.00 A Month for making dramatic 3-second demonstration of amazing light-weight Presto fire extinguisher. New chemical used by Airforce snuffs out fires instantly. Only \$3.98. Terrific commissions. Millions want it. Free kit. **Merlite, 114 E. 32nd, Dept. 59B, New York City 16.**

AUTOMOBILE Burglar alarms. Free sample offer. **Novak, 3131-W13, Gary 19, Indiana.**

WHOLESALE! Nationally advertised products. **Davis, 759-K Tilden, Flint 5, Mich.**

CAN You sell a popular product; part or full time? Write **Abundavita, 3422 W. 79th St., Ingewood, Calif.**

WHOLESALE Catalog! Appliances, cameras, watches. Postcard. **Selbyco, Decatur 160, Illinois.**

AMAZING Profits selling Kenya gems. Sparkles more brilliant than diamonds. Customers buy on sight. Fastest seller in years. Free literature. **Kenya Shop, Box 5165-P, Pittsburgh 6, Penna.**

WANTED! Salesmen not satisfied with \$10,000 a year. Old established firm has developed amazing new chemical for use in their famous safety equipment. Prospects including industrial users everywhere. **Jesse Lebow, Texas** has already made over \$6,000 this year. No investment. Earnings advanced. Free use of samples. Write **Dept. 364-Q, Box 272, Littleton, Colorado.**

NEW Wonder Dow Corning car polish. Cleans, glazes, weatherproofs year 'round. Really works! Send \$1 (refundable) for pint sample and selling plan. **United, 1035 East 10th Street, Brooklyn 30, N. Y.**

EXCITING Razor blade deal. Free sample, details. **Nucleus Trading, 2440 Amsterdam Ave., New York City 33.**

60% PROFIT On cosmetics—Famous nationally advertised Hollywood Cosmetics pay 60%! Makes \$25 day up! Hire others. For free samples, details, write **Studio Girl, Glendale, Calif., Dept. PM-95.**

SCHOOL Seniors—Be popular with classmates. Have spending money galore. Details free. **Craftcards, Box 235-L, Pittsburgh 19, Pennsylvania.**

RECEIVE Monthly red hot sales item brochure. \$1.00 registration. \$3.00 gorgeous August item free. **Sales Incentives, P.O. Box 923, San Jose, California.**

NEW 29c Kitchen gadget. 300% profit. Sensational seller—housewife, stores, mail. Two samples 25c. Catalog free. **Dohn-Marks, 2308-Z South 8th Ave., Maywood, Ill.**

YOU Can make a fortune with miracle discovery liquid cloth. Mends everything from boats to finest hosiery. Dries soft, durable elastic texture. Sells so fast production increased 34 times already. It's sensational! **Federal Products, Evanston 5, Ill.**

BUY Wholesale 450,000 products. Literature free. **Carter, Box 6011-B, Chicago 80.**

SCHOOL Seniors—Earn sensational profits selling classmates America's most beautiful graduation name cards. Largest selection. Outsell all others. Free sample kit. **Printcraft, Dept. M, 1509 Maple Street, Scranton 5, Penna.**

NEW Way to make money! Sell nothing yourself. Just offer free item to women for every two they sell for you. Household wares needed in every home. Postcard brings catalogue and details of amazing new kind of money-making plan. Absolutely no obligation. **Topval Corp., Lindenhurst 21, New York.**

BUY IT WHOLESALE

WHOLESALE! Musical instruments, phonographs, recorders, watches, appliances, etc. Discounts to 75%! Large catalogue 50c (refundable). **Strauss Music Company, 25-33 Lafayette, Paterson 23, N. J.**

BARGAINS, Joblots, close-outs. 2000 items. Save to 50%. Clothing, hosiery, toys, toiletries, gifts, jewelry, television, etc. Get acquainted. 25c brings wholesale catalog plus free \$1.00 merchandise certificate. **Reliable Jobbing, 311-B North Desplains, Chicago.**

WHOLESALE Catalog! 30-80% discounts! Typewriters, appliances, housewares, watches, jewelry, etc. **Consolidated Distributors, 21-20 Lafayette, Paterson 15, New Jersey.**

INDIVIDUALS. Nationally advertised merchandise. Wholesale. Tremendous discounts. **Kingsley, Chepachet, Rhode Island.**

BUY Surplus wholesale. Catalogue 25c (refundable). **Thomasville, Box 22A1, Penna.**

YOUR Cost as little as 25c on dollar! Household items needed in every home. Sell direct, by mail or to agents. Catalogue, confidential distributors' wholesale prices and money-making plans absolutely free. Rush postcard to **Topval Corp., Lindenhurst 224, New York.**

BUY Wholesale! Save 66%! Appliances, furniture, jewelry, toys, sporting goods, tools. Free catalogs. **National Buyers Service, Box 426EB, Oakland, California.**

SALESMEN—DISTRIBUTORS

CHAMONIS. Retail \$5.00 to \$6.50, whole skin's, wholesale \$2.50. **Kennedy Importers, Box 644, Solana Beach, Calif.**

GOLDMINE Of 600 money-makers. Copy free. **Specialty Salesman Magazine, Desk 5, 307 N. Michigan, Chicago 1.**

DISTRIBUTORS—Large profits. Terrific repeat orders. **Unique Italian brooms, details free. Write P.M. Peacock, 915 Bryant, San Francisco, California.**

NEW Jobs open in selling! Send name, address for five free issues of **Opportunity Magazine's money-making guide**, listing hundreds of companies who'll pay you well, full or part-time. No experience needed. **Opportunity, 850 N. Dearborn, Dept. 17, Chicago 40, Ill.**

\$5 TO \$10 An hour. I've did it. I'm disabled now. Real genuine offer. Complete information only \$1. **Lucas, 2200 Carson St., Pittsburgh 3, Penna.**

BUSINESS Kit free! Postcard puts you in business! Complete line. **Leather jackets, 100 shoe styles.** New discoveries pay big commissions. No investment. Send for free kit. **Mason Shoe, MC37, Chippewa Falls, Wis.**

SELL Calendars. You make big money daily. **Giant line.** Every business buys. Also business printing, book matches, advertising specialties. **Big sales outfit free.** Write, **Arrow Press, 515-R Fourth Ave. So., Minneapolis, Minn.**

WILL You wear new suits and topcoats without one penny cost and agree to show them to friends? You can make up to \$30.00 a day even in spare time, without canvassing. W. Z. Gibson, 500 South Throop St., Dept. H-826, Chicago 7, Illinois.

EARN \$30 A day showing our famous boots. Part or full time. No experience necessary. Write for free sales outfit. No obligation. Jim Richards Shoe Co., Dept. M-9, Wellesley Hills, Mass.

WHY Work for peanuts? \$16.95 profit per unit possible with amazing new Alarm-O-Safe. Sells itself. No experience needed. Free sales kit. Merlite-Alarm, Dept. A-509, 114 East 32nd St., New York City 16.

AD Matches! Sell amazing designs—10, 20, 30, 40 and 240-light book matches. Bigger spot cash commissions; every business a prospect. Low prices for high quality. Repeats. Start without experience; men, women; full, part time. Buy nothing! Sales kit furnished. Match Corp., Dept. PM-69, Chicago 32, Illinois.

BIG Money-making opportunity. Exclusive line work uniforms. Jackets, pants, shirts, coveralls. Advertising embroidered. Every business prospect. Outfit free. Master Div., 570 Water, Ligonier, Ind.

ADVERTISING Book matches—Cash in on big demand; sell union label matches. Cuts for all businesses and political parties. Free powerhouse selling kit, low prices, protection guaranteed on repeat orders. Cash commissions. Superior Match Co., Dept. M-955, 7530 Greenwood, Chicago.

ANYONE Can sell famous Hoover uniforms for beauty shops, waitresses, nurses, doctors, others. All popular miracle fabrics—Nylon, dacron, orlon. Exclusive styles, top quality. Big cash income now, real future. Equipment free. Hoover, Dept. U-100, New York 11, N. Y.

BUY Wholesale thousands nationally advertised products at big discount. Free "Wholesale Plan." American Buyers, Hertel Station, Buffalo 16-J, N. Y.

GET New shirt outfit free: Make \$90.00 weekly on 3 average orders a day. Famous quality made-to-measure dress and sport shirts at \$3.95 up sell fast to all men. No experience needed. Full or part time. Write: Packard Shirt Co., Dept. 133, Terre Haute, Ind.

GOOD Man can make \$3,000.00 next 90 days. Every house in town wants amazing Nilite glowing curbside house numbers. Automatic selling plan pays profits everyday. Write today for details free. Nilite, 173 W. Madison, Dept. M-80, Chicago.

MONEY-Making opportunity! Take big profit orders for world famous patented varieties fruit trees. Also flowering shrubs, roses, vines. Big sales outfit free. Stark Bro's, Desk 30196, Louisiana, Missouri.

SPRAY—Can fire extinguisher. Sell \$2.00, you make \$1.50. Eleven other profitable pressurized spray can products. Amazing sellers, repeaters. Free literature. Strobel Aerosol Co., 2412XX Market, Louisville, Ky.

MAKE Up to 75c profit on each dollar! Household items needed in every home. Have others sell for you on commission. Sell wholesale to agents. Postcard brings details absolutely free. Topval Corp., Lindenhurst 225, New York.

MAKE \$10,000 Yearly selling old line industrial products. We finance, no investment required. Prospects everywhere. Mail \$1.00 for complete booklet, refunded first sale. Bell Laboratory, Inc., 2421 Kilgore, Orlando, Florida.

AGENTS Salesmen. Sell Futurline auto safety belts. 40% commission. Free details. Home Supply Service, Kiel, Wisconsin.

\$15.20 AN Hour is what W. F. Wydallis reports he earns with amazing Presto fire extinguisher. Sells itself. No experience needed. Free sales kit. Merlite, 114 E. 32nd St., Dept. 59A, New York City 16.

EDUCATIONAL AND INSTRUCTION

A Pleasing dynamic singing and speaking voice can be yours! Use self-training Canfield Voco-Records. Thrilling details! 2018-A—5th Avenue South, Minneapolis 4, Minnesota.

ORTHODOX Bible courses. Earn degree. Free bulletin! Bible School, 517 Merchants Bank Bldg., Indianapolis.

BE A real estate broker. Study at home. Write for free book today. GI approved. Weaver School of Real Estate, 2018P Grand, Kansas City, Missouri.

UNIVERSITY Degrees by residence, correspondence. Golden State University, Box 2883, Hollywood, Calif.

PIANO Tuning pays. Big money in spare time. Learn at home in 30 days. No musical knowledge necessary. Phonograph, records, tools and instructions furnished. Information free. Capitol City Tuning School, 16 Southwest 2nd, Dept. 102, Fort Lauderdale, Florida.

BECOME A doctor of psychology or metaphysics. Learn secret of contentment, happiness. Win degree of Ph.D. or M.S.D. Correspondence only. Free book. College of Universal Truth, 5038-C Broadway, Chicago.

INVESTIGATOR Training. Phillips Secret Service System, 1917-B North Kenneh. Chicago 39.

AUCTIONEERING. Be an auctioneer. Earn big money. Term soon. Write for catalog. Kansas City Auction School, Suite 307, Shankman Building, 3119 Troost, Kansas City, Missouri.

HIGH School diploma at home. Licensed teachers—Approved materials. Southern States Academy, Box 144-MX, Station E, Atlanta, Georgia.

SECRET Investigation. Experience unnecessary. Investigators particulars free. George Wagner, M125 West 86th, New York 24.

GROW Mushrooms. Cellar, shed, and outdoors. Spare, full time, year round. We pay \$3.50 lb. We paid Babbitt \$4,185.00 in few weeks. Free book. Washington Mushroom Ind., Dept. 174, 2954 Admiral Way, Seattle, Washington.

EARN While you learn. Auto and diesel mechanics master this top paying trade. Many graduates earn \$100 a week and up. Approved for Korean veterans. For free information write Dept. No. 256, Nashville Auto-Diesel College, Nashville 3, Tenn.

BOOKKEEPERS! Increase your earnings! Operate your own simplified "Dollar-A-Week" bookkeeping and tax service. Full or spare time. Details free. No obligation. Ellis, Box 200, Cedar Grove, North Carolina.

MEDICAL Laboratory technicians in great demand. We train you in your own home. Catalogue free. Imperial Technical Institute, Box 973-J, Austin, Texas.

USED Correspondence courses and books sold and rented. Money back guarantee. Catalog free. (Courses bought.) Lee Mountain, Pisgah, Alabama.

PIANO Tuning pays. Learn this profitable profession at home easily with patented Tonometer and mechanical aids. No knowledge music necessary. Diploma granted. Write for booklet. Niles Bryant School, 3731 Stockton Blvd., Dept. P, Sacramento 20, California.

STUDY For doctor's degree of psychology, metaphysics and divinity. Correspondence courses only. College of Divine Metaphysics, Dept. P-M, 2811 North Illinois, Indianapolis 8, Indiana.

BECOME An expert real estate broker or salesman. Make money anywhere. Complete home study course. Free information. Kansas City Realty School, Suite 307, 3119 Troost, Kansas City, Missouri.

IT'S Fun learning a language by Linguaphone, world's standard conversational method. At home, quickly, easily learn to speak French, Spanish, German, Japanese, Modern Greek—32 languages available. It's like living in another country. Save time, work, money. Send for free book. Linguaphone Institute, 83-095 Radio City, New York City 20.

COLLEGE Degree—Independent study. Keep employed. Brentwood College, Box 19-721, Los Angeles 19.

PREPARATION Civil Service jobs. Free information. Write: National Training Service, Greenwich, Connecticut.

SPANISH Quickly! Recordings, textbook. Special, \$6.95. Speed-O-Way, Box 32-161, Los Angeles 32, California.

EARN College degree. Remain employed. Fremont College, 915-P Grandview St., Los Angeles 6, Calif.

MIDLAND Linotype School. Charles City, Iowa. Civilian and Veteran Courses. Free placement. Established 1909.

HIGH School—No classes. Study at home. Spare time. Diploma awarded. Write for free catalog HP-57, Wayne School, 2527 N. Sheffield, Chicago 14, Ill.

FINGERPRINTING Course \$12.00—Diplomas awarded. Details free. Alabama School of Fingerprinting, Box 185, Fairfield, Alabama.

BLUEPRINT Reading for machine and building trades. Train at home. Learn to read blueprints with confidence in 10 easy lessons. Earn more pay. Literature free. Belton School, 1059-X North Lawn-dale, Chicago 51, Illinois.

COMPLETE Your high school at home in spare time with 58-year-old school. Texts furnished. No classes. Diploma. Information booklet free. American School, Dept. X645, Drexel at 58th, Chicago 37, Ill.

ELECTRONIC Parts distribution offers you a permanent future at top pay in all areas. No investment required. Write Williams, Box 261, Miami 2, Florida, for information on this desirable, uncrowded field.

"ENGLISH The Easy Way" improves your grammar. \$2. Friday's, 5538 Priscilla, Sacramento 20, California.

WELDING Training pays at Hobart Welding School, Box M-951, Troy, Ohio. VA contract. Best equipment. Catalog free.

WANT A diesel job? New opportunities to increase income. Higher pay. More money. We can help you qualify. Tools. Shop method home training. Write today! Diesel, Tractor, Heavy Equipment Division, Interstate Training Service, Dept. B-3, Portland 13, Oregon.

MIDWEST Engineering School. Home Study Opportunity, 10923 Hillcrest, Hickman Mills, Missouri.

PHYSICAL Therapy and massage. We train you at home. Earn big profits from your own private practice or work with hospitals and doctors. Free catalogue. National Institute, Desk 4, 159 E. Ontario, Chicago, Ill.

LEARN Shorthand at home. Successfully taught system for 26 years. Easily understood. Write Maude E. Frank Secretarial School, Ridge Building, Kansas City, Mo.

MEDICAL Laboratory technicians in big demand by hospitals and physicians. We train you at home. Free catalogue. Century College, 960 Montana St., Chicago 14.

CRIMINOLOGY Membership now available. \$5.00, free details. American Association of Criminology, Box 1122, Boston 3, Massachusetts.

INVESTIGATE Accidents—Thousands of insurance companies, airlines, and steamship lines use claim investigators. Learn this fascinating work—Easily, quickly. Free book, now! Universal Schools, Dept. 109, Box 8202, Dallas 5, Texas.

BE What you desire! Get our simplified behavior control plan free. Write Applied Christian Psychology, Box 1924-V, Louisville 1, Kentucky.

BIG Money in plate or pipe welding. Free catalog. G.I. approved. Tulsa Welding School, 919 E. Second, Tulsa, Oklahoma.

TRAINED Newspaper correspondents always in demand. Profitable vocation for men and women. Easy budget home study course. Recognized school, licensed by New York State Education Department. Freeman School, 227-90th, Brooklyn 9, N. Y.

567 HOMESTUDY Courses, textbooks. Sensational bargains! Free illustrated catalog. Nelson Company, 210 South Clinton, Dept. 8JV-2, Chicago 6.

\$62.50 ENGLISH Course cheap! Unused. Wallace, Box 2307NS-H, Springfield 4, Missouri.

GET U.S. gov't job! Men-women, 18-55. Start high as \$80.00 week. Qualify now! 16,000 jobs open. Experience often unnecessary. Get free 36-page book showing jobs, salaries, requirements, sample tests. Write: Franklin Institute, Dept. H-24, Rochester, N. Y.

PLAYS, STORIES, MANUSCRIPTS

NO Luck finding a book publisher? Write for free Booklet PM. Vantage Press, 120 W. 31, New York.

SPECIAL SERVICES

BOOKKEEPING And tax service for small businesses by mail. \$6.00 monthly. Includes monthly statements, filling in withholding and income tax forms. Details free. Bullock, 5309 Susan, Flint 5, Michigan.

INFORMATION On anything. Ferguson Research Specialists, 116-14 141 St., South Ozone Park 36, N. Y.

SEPTEMBER 1955

65

ARTISTS' SUPPLIES

IF Interested in artist frames, canvas, canvas boards, Red Sable brushes, etc., be sure to get our money saving price lists before buying. International Sales Co., 414 E. Baltimore St., Baltimore 2, Md.

ARTISTS—Obtain photographs "Male models." Selection \$1.00. Free catalog. Giardina, 408K Second Ave., New York City.

CARTOONING, COMMERCIAL ART, SHOWCARD & SIGN PAINTING, TATTOOING

CARTOONISTS: Amateur professional. Prepare for animation with Max Fleischer's plan. Write Vera Goleman, Lincoln Building, New York, N. Y.

LEARN Sign painting at home. Test lesson free. Ben Kerns, Box 812-PM, Greenville, S. C.

"HOW To Make Money With Simple Cartoons"—A book everyone who likes to draw should have. It is free; no obligation. Simply address Cartoonists' Exchange, Dept. 99C, Pleasant Hill, Ohio.

MAKE To \$4.50 hour doing common, pen lettering. National Artists, 801½-K North Marzais, Dallas 3, Texas.

PAINT Signs with master patterns. Set 1¼" to 12" high, with supplies, \$2.00; sample 3c. Eyerly, B-583, Newton, Iowa.

ADVERTISING AGENCIES, LETTER WRITERS, FOR ADVERTISERS

MAILING Lists, most any classification. 1000 names \$5.00. 1000 your circulars mailed with ours \$4.00. 5000 your circulars printed and mailed \$12.95. Write Dixie Mailers, King, North Carolina.

ADS Placed in out of town newspapers and magazines. Low rates. Catalogue free. Ideas that pay. Baker Advertising Agency, Successors Ankrum Agency, 189 W. Madison, Chicago 2.

GUARANTEED Mailing lists. Many classifications, opportunity seekers, farmers, ministers, school teachers, many others, pricelist. Write Ken-West Distributors, 7-K South Harlem Street, Worcester 4, Mass.

FREE! 1955 Advertisers Rate and Data Directory, 52 pages! E. H. Brown Advertising Agency, 20 N. Wacker, Chicago 6.

FREE Adwriting assistance. Mailorder ad reaching 1,600,000 families, nationwide, \$28.70 inch. Magazine, newspaper, rate-book free. Chicago Advertising Agency, Chicago 4.

ADVERTISE: 24 Words, 100 Canadian newspapers \$5.50. Lists free. Advertising Bureau, 10511-C Springfield, Chicago 43.

ADVERTISING Pays. Direct mail specialist. What have you? Smith Agency-A, Excelstor Springs, Mo.

RUBBER STAMPS AND OFFICE SUPPLIES

RUBBER Stamps by professional craftsmen. 3 lines \$1.00. Price list. South Coast Press, P.O. Box 2074, San Bernardino, Calif.

THREE Lines \$1.00. Free stamp pad. Barber, 596 Girard, Marion, Ohio.

LINE 25c; 2-45c; 3-65c. Stamp Works, Auburn, Nebraska.

TYPEWRITERS, DUPLICATORS, OFFICE DEVICES

RECONDITIONED Typewriters, duplicating, printing devices, \$25.00 up. Supplies. Appliances. DixieGraph, King, N. C.

PRINTING, MULTIGRAPHING, MIMEOGRAPHING, GUMMED LABELS

HIGHEST Quality mimeographing free samples, pricelists. Ken-West Distributors, 7-K South Harlem Street, Worcester 4, Mass.

NEW Free catalog offers quality printing plus bonus value features. Lidfino, Box 11121, Ft. Worth 10, Texas.

500 8½x11 LETTERHEADS With size 6¾ envelopes, \$6.95 (postpaid). Sample? C. Hutchison, 4167 Hemphill, Fort Worth 15, Texas.

1000 ENGRAVED Business cards \$3.50 postpaid. Over 25 type styles. Samples sent free. House of Farrell, P.O. Box 452, Buffalo 5, N. Y.

100 8½x11 WATERMARKED Letterheads \$1.00 postpaid, envelopes same. Other printing, samples free. R. Hussey Printing, Abbeville, Miss.

1000 EMBOSSED Business cards, one color \$3.95; two color \$4.50. Samples free. L. Watson, Box 162, St. Charles, Illinois.

\$1.00, 100 LETTERHEADS Or envelopes. Postpaid. Poor Boy PM, Box 1665, Little Rock, Ark.

FREE Catalog, Letterpress, offset printing. D & M Sales, Sebastopol, Calif.

MIMEOGRAPHING—Letters, pricelists, formulas, instructions. Lowest prices. Lem's Letter Shop, 5710 Stanton, Detroit 8.

500 ¾x2¼ FOUR Line gummed stickers 50c. Red border \$1.00. Moritz Printery, Saginaw, Mich.

100 LETTERHEADS, \$1.00, #6¾ Envelopes same, two colors, \$1.50. Broadbrook, Botsford, Conn.

100 LETTERHEADS, 8½ x 11. Carefully printed \$1.00 postpaid. Envelopes same. Race Printers, Hudson, New York.

QUALITY Printing—Reasonable. Free catalog. Foly Printers, 16721 Prospect, Wayzata, Minnesota.

QUALITY Letterheads, envelopes; 500, \$5.00, postpaid. John Schollars, Mercury Press, P.O. Box 897, Albuquerque, N. M.

OFFSET Printing \$6.50-1000; 8½ x 11, 16 lb. National Letter, 1463 Broadway, New York City 36.

1000 EMBOSSED Cards, \$2.95 postpaid. Card samples free. Business printing folio, 10c. Jaynar, 911B Reed, Grinnell, Iowa.

LETTERS, Distinctive I.B.M. copy, 500—\$4.00, postpaid. Johnston, 754 N. Arthur, Pocatello, Idaho.

QUALITY Printing, low prices. Samples free. Gillingham Printing, Milford, Conn.

ADS Running under this heading sell printing. Ask me for proof. I'll gladly send you amazing facts. Ask for Folder "P." F. W. Johnson, 200 E. Ontario St., Chicago 11, Ill.

PRINTING OUTFITS AND SUPPLIES

DO Your own printing. Save money. Simple rules. We supply everything. Print for others; good profit. Raised printing ink engraving too. Have home shop. Details free. Kelsey Presses, V-11, Meriden, Connecticut.

MAKE Your own rubber cuts. Free instructions. Walp, Box 4308-M, Mobile, Alabama.

PRESSES, Type cabinets, supplies. List for stamp. Lincoln Press Company, 220-J Hartwell, Fall River, Mass.

MAKE Your own self-molding rubber stamps and printing cuts. Flexirubber, Argyle 3, Wisconsin.

PATENT ATTORNEYS

PATENTS—Irving L. McCathran, 315 McLachlen Bldg., Washington 1, D. C. Registered Patent Attorney.

INVENTORS—Take these preliminary steps toward patent protection. Sketch and describe your invention. Sign, date and have this disclosure witnessed by two people who understand your invention. Have us make a preliminary search among U.S. patents already granted for similar types of invention. We report on the probable patentability of your invention and recommend your further course of action. Write for our instructive booklet, "Patent Protection for Inventors" and convenient "Evidence of Invention" disclosure form. Victor J. Evans & Co., 131-K Merlin Building, Washington 6, D. C.

INVENTION Record form free and "Patent Information Every Inventor Should Have." Carl Miller, Registered Patent Attorney, Woolworth Building, New York.

REGISTERED Patent attorney offers services. Sanders, 6430 Evans, Chicago 37, Illinois.

C. A. Snow & Co.—M427, Snow Building, Washington 1, D. C. Registered Patent Attorneys. Write for information.

INVENTORS: When you are satisfied that you have invented something of value write me, without obligation, for information as to what steps you should take to secure a patent. Write Patrick D. Beavers, Registered Patent Atty., 935 Columbian Bldg., Washington 1, D. C.

INVENTORS: Learn how you can protect your invention. A specially prepared booklet "Patent Guide for the Inventor" containing detailed information concerning patent protection and procedure together with "Record of Invention" form will be promptly forwarded to you upon request, without obligation. We are registered to practice before the United States patent office and are prepared to serve you in the handling of your patent matters. Clarence A. O'Brien & Harvey Jacobson, Registered Patent Attorneys, 51B-G District National Building, Washington, D. C.

PATENTS. "Proof of Invention" free. E. E. Vrooman, Registered Patent Attorney, 507 McKim Building, Washington 5, D. C.

"INVENTOR'S Guide" and "Record of Invention" free on request. Frank P. Ledermann, Registered Patent Attorney, 154 Nassau Street, New York City.

INVENTORS: Without obligation, write for information explaining the steps you should take to secure a patent. John Randolph, Registered Patent Attorney, 203 Columbian Bldg., Washington 1, D. C.

INVENTORS—If you believe you have an invention, you should find out how to protect it. The firm of McMorrow, Berman & Davidson with offices in Washington, D. C., is qualified to take the necessary steps for you. Send for copy of our patent booklet "How to Protect Your Invention." We will also send you an "Invention Record" form. No obligation. They are yours for the asking. McMorrow, Berman & Davidson, Registered Patent Attorneys, 134-E Victor Building, Washington 1, D. C.

FOR INVENTORS

INVENTORS—Send for free patent information book and inventor's record. Registered Patent Attorney, Associate Examiner, Patent Office 1922-29, Patent Attorney & Advisor, Navy Department 1930-47, Gustave Miller, 85A Warner Building, Washington 4, D. C.

PATENT Searches, including copies of nearest patents, \$5.00. Reports airmailed within 48 hours. More than 100 registered patent attorneys use my service. For free invention protection forms, write Miss Ann Hastings, P.O. Box 176, Washington 4, D. C.

INVENTORS: If you have an invention for sale, patented or unpatented, write Institute of American Inventors, Dept. 40A, 631-E St. N.W., Washington 4, D. C.

"INVENTOR'S Guide" and "Record of Invention" free on request. Frank P. Ledermann, 154 Nassau Street, New York 38, N. Y.

INVENTION Record form free and "Patent Information Every Inventor Should Have." Carl Miller, Registered Patent Attorney, Woolworth Building, New York.

INVENTORS: Information on patent procedure furnished on request, without obligation. John Randolph, Registered Patent Attorney, 203 Columbian Building, Washington 1, D. C.

SEARCHES—Put your patent searches in the hands of a registered patent attorney or agent, as he qualifies to give a worthwhile patentability report. Record of invention form upon request and information on patent protection. Patrick D. Beavers, Registered Patent Attorney, 936 Columbian Bldg., Washington 1, D. C.

PATENT Searches \$5.00. 48-hour airmail service. Invention protection forms free. Write Patent Engineering Service, 711 14th Street, N.W., Washington 5, D. C.

INVENTORS: Learn how you can protect your invention. A specially prepared booklet "Patent Guide for the Inventor" containing detailed information concerning patent protection and procedure together with "Record of Invention" form will be promptly forwarded to you upon request, without obligation. We are registered to practice before the United States patent office and are prepared to serve you in the handling of your patent matters. Clarence A. O'Brien & Harvey Jacobson, Registered Patent Attorneys, 51A-G District National Building, Washington, D. C.

PATENT Searches \$5.00. 48-hour service. Free invention protection forms. Write Raymond L. Smith, Patent Searcher, 622 Sheraton Building, Washington 5, D. C.

IDEAS, Inventions. Use our design, research, development service. You are protected. Write Mechanical Development Co., 218 East Bay St., Savannah, Georgia.

FREE Booklet. Protect and market your invention the inexpensive easy way. **Wulco Patent Association, D-95, 550 Fifth Avenue, New York City 36.**

SELF-Help sales plan, inventions, inventive ideas. Practical, straightforward, simplified. Free outline. **Adman, 255-A Glenwood, Syracuse 7, New York.**

PATENT Pending. No attorney required. Send two five-cent stamps for Patent Search Guide and all information. **Paladin Publications, 203 Atlantic Ave., Bellmore, N. Y.**

EXCLUSIVE: The United States patent office now offers direct help to inventors. Manufacturers are anxious to buy worthwhile inventions direct from owners, under this new plan. Free information. **The Dynavolt Company, 3310 Huntington, Newport News, Virginia.**

INVENTORS—If you believe you have an invention, you should find out how to protect it. The firm of **McMorrow, Berman & Davidson** with offices in Washington, D. C., is qualified to take the necessary steps for you. Send for copy of our patent booklet "How to Protect Your Invention." We will also send you an "Invention Record" form. No obligation. They are yours for the asking. **McMorrow, Berman & Davidson, Registered Patent Attorneys, 134-D Victor Building, Washington 1, D.C.**

INVENTORS—This firm is registered to practice before the United States Patent Office and available to assist you in the preparation and prosecution of your patent application. "Patent Protection for Inventors" booklet containing detailed information and steps to take toward patent protection sent promptly upon request. No obligation. **Victor J. Evans & Co., 132-K Merlin Building, Washington 6, D. C.**

INVENTIONS WANTED

INVENTIONS Wanted. Patented and unpatented. For latest list and particulars of foremost promotion service write, **Superior Inventions, 338-344 North Rodeo, Beverly Hills, Calif.**

INVENTIONS Wanted. Patented; unpatented. Tremendous manufacturers lists. **Global Marketing Service, 1404 Mitchell, Oakland 1, California.**

INVENTORS: Hundreds of manufacturers have requested our assistance in locating marketable new products. Complete information free. **Institute of American Inventors, Dept. 40-D, 631-E St. N.W., Washington 4, D. C.**

INVENTIONS Promoted. Patented or unpatented. A-1 service for inventors since 1911. Write **Adam Fisher Co., 3418 Idaho, St. Louis, Mo.**

INVENTIONS Wanted. Patented or patent pending. 24 years experience promoting inventions. **National Service Bureau, 3120 Meramec, St. Louis 18, Mo.**

INVENTORS. Don't sell your invention patented or unpatented until you receive our offer. Write **Cowgill, Box 298, Marion, Ohio.**

MAKE Money from unpatented inventions, patents. Get "Inventors Hand Book". Tells how. Send \$1.00. We have buyers. **Inventors Creative Service, 354 South Spring, Los Angeles 13, Calif.**

INVENTORS: Inventions needed immediately, all fields. Demand never greater. We franchised one for **Likins**, West Virginia inventor, in 4 months. Write for free special booklet. **Kessler Corporation, 59X, Fremont, Ohio.**

INVENTIONS Wanted now. Patented, unpatented. Free Form "S" on request. **Adams, Patent Broker, 80 Wall Street or 3 Park Row, New York City.**

INVENTIONS Wanted for manufacturing on royalty basis. If you have a working model of a patented or patentable invention, we have the engineering staff, the production equipment and sales know-how to produce and market economically. Prefer product retailing at \$50.00 or more. No gadgets, please. Our company and products are nationally known. Write stating what you have. **Lantz Mfg. Co., Dept. PM-55, Valparaiso, Indiana.**

CASH Buyers for ideas and inventions. Write **National Inventors Institute, 457 Murray Building, Washington 4, D. C., or 4097 East 131st St., Cleveland 5, Ohio.**

INVENTIONS Wanted. Patented; unpatented. Free booklet. **Wulco Patent Association, D-91, 550 Fifth Avenue, New York City 36.**

PATENTS FOR SALE

THIS is your life opportunity! A big complete detailed listing of 657 U.S. gov't owned invention patents; covering farm construction machinery, electronics, aviation and transportation equip. etc. Patents under small license fee from gov't on non-royalty basis. Catalog sent \$3.00 only to **Renoff, 5555 Walnut St., Shelby, Ohio.**

INVENTORS: Test the commercial value of your patented or unpatented inventions, quickly and inexpensively. Write for free information. **Institute of American Inventors, Dept. 40-B, 631-E St., N.W., Washington 4, D. C.**

MANUFACTURING

MODELS—Small lot manufacturing. Metals, plastics, etc. **Milburn, Burlington, Kentucky.**

DESIGNING. Manufacturing, Machinery, parts, inventions, models. **Henry, Engineer, 2136 E. Monmouth, Philadelphia 34, Penna.**

ANY Metal part duplicated. Send 25c with sketch for estimated cost. **Line Tool, Base Line, Michigan.**

MODELS, MODEL SUPPLIES

STEAM Engines, boilers, castings. Catalog 35c. **Anton Bohaboy, 2297 Price, Rahway, N. J.**

BALSA Wood and model aircraft. 40-page catalog 10c. **Sig Co., Montezuma, Iowa.**

SHIP Models and yacht supplies. Complete, large 68 page catalogue 50c. **Bill Wild's, 510 East 11 St., New York City 9.**

SHIP And other scale models. Most complete line in New England. Kits, fittings, plans, books, tools, engines, motors. Illustrated catalog 25c. **James Bliss & Co., Inc., Dept. SM, 342 Atlantic Ave., Boston 10, Mass.**

SHIP And yacht model fittings; blueprints. Send 35c for illustrated catalog listing hundreds of items. **A. J. Fisher, 1002-1 Etowah Ave., Royal Oak, Mich.**

POWER Models. Unusual steam, gasoline and traction engines, fittings, metals. Anniversary catalog 50c. **Chas. Cole, Ventura, Calif.**

HOME CRAFTSMEN

LEATHERCRAFT Supplies at lowest prices. "Craftool" stamps. Catalog 10c. **Crown Leather, 22 Spruce Street, New York 38.**

STYLECRAFT Sure fire hits. "Pre-traced" leather kits. Handbags, billfolds, filigree belts, over fifty other projects. Patterns on leather. Why trace? Just carve, assemble and lace. Large assortment "pre-carved" kits also available. Send 25c for catalog, free folder. Refunded first order. **Apache Leather Company, 2804 E. Washington St., Phoenix, Arizona.**

KNOCKDOWN Cedar chests and lumber. Free price list. **Bedford Lumber Company, Shelbyville, Tennessee.**

129 NEW Full-size jigsaw patterns. Artist-drawn. \$1. **Craftplans, 1321-A South Michigan, Chicago 5.**

FREE "Do-It-Yourself" leathercraft catalog. **Tandy Leather Company, Box 791-H-10, Fort Worth, Texas.**

FREE Handicraft supply and project catalog. **American Handicrafts, Box 1479-CQ, Fort Worth, Texas.**

WOODWORKING Course for home craftsmen. Twenty-two manuals. Over 1000 pages. 75 training projects. Only complete home training program available today. Carefully written, profusely illustrated. Covers everything from wood selection to final finishing. Complete instruction in care and use of all hand and power tools. Prepared by expert manual training instructors. Write for free booklet. **Interstate Training Service, Dept. G-3-J, Portland 13, Oregon.**

VIOLINMAKERS. Amateurs, professionals, fine tone European wood. Complete materials, tools, instructions, patterns. Illustrated catalogue. 10c. **Premier Violin Supplies, Division MVP, 430 South Broadway, Los Angeles 13, California.**

89 FULL Size jig saw patterns of beautiful shelves, ornaments, toys, novelties. Plus "How, Where to Sell." Only \$1.00. **Mastercraft 94M, 7041 Olcott, Chicago 31, Illinois.**

NEW! Largest leather and craft catalog! 1,000's of items. Send 25c (refunded with first order). **Russo Handicraft Supplies, Dept. C2, 245 S. Spring, Los Angeles 12, California.**

LEATHERCRAFT. Send 10c for new 60-page catalog of tools, supplies, kits, including metalcrafts, enameling, ceramics, all other crafts. Complete stock. Reasonable. Since 1910. **Sax Bros., Dept. PM9, 1111 N. 3rd, Milwaukee, Wis.**

LEATHERCRAFT. Metal enameling, beadcraft, shellcraft, metal tooling, textile painting, many other crafts. Free big illustrated catalog. **Kit Kraft, Dept. 229, Studio City 1, California.**

PLASTICS Home-craft course for men and women. Tells and shows how to make hundreds of fast selling plastics products. All plastics and materials for 23 projects included in course. No special tools needed. Course pays for itself. Write for free booklet. **Interstate Training Service, Dept. D-3-J, Portland 13, Oregon.**

BUY Wholesale nationally advertised power, hand tools, thousands other products at big discounts. Free "Wholesale Plan." **American Buyers', Hertel Station, Buffalo 16-F, N. Y.**

LEATHERCRAFT. Everything needed by beginners, advanced hobbyists and professional leatherworkers. Largest stock of supplies in U.S. Moderate-priced tooling leathers, top quality calfskins, tools, supplies, kits. Send 10c for big catalog. **J. C. Larson Co., 820 S. Tripp, Dept. 5450, Chicago 24.**

101 FULL Size patterns. Smart, new, gifts, novelties, lawn figures, shelves, action windmills, alphabets, Plus "Make Money Jig Sawing." Only \$1.00. **Mastercraft 95M, 7041 Olcott, Chicago 31, Illinois.**

SANTA Sleigh reindeer \$1.50. Santa pack 75c. Flying duck kit 60c. **Strother, Box 15, Belington, West Virginia.**

WROUGHT Iron legs, various sizes. One set or a car load. Literature free. **Hibbard's, 624 Leedy, Hampton, Va.**

MAKE Beautiful jewelry. Introductory kit and catalog with easy instructions \$1.00. Catalog alone 25c. **Hobby Jewelers' Supply, Inc., Box 489, Providence 1, R. I.**

LAMP Size cypress knee with nipple installed \$2.00. **Cy Products, Dept. 2-K, Lafayette, La.**

LEATHER, Tools, lacings, supplies. Free catalog. **National Handicraft, 199 William St., New York City 38.**

WOODCRAFTERS—We buy what you make from our patterns, easy to make, no special tools needed, send \$1 for patterns and complete instruction. **Wm. Rice, 188 Pine St., Kingston 8, N. Y.**

DO IT YOURSELF

HAVE Fun—Build backyard roller coaster. Free plan for stamp. **Puncraft, 1013 Garfield, Aurora, Ill.**

MAGIC "Velcoat" sprays fur or velvet finish on any article. Multiplies value. Refinishes shoes, bags, toys, pictures, like new. 6-color kit \$4.95. Single color \$1.00. Literature free. **Velcoat, Box 5172-MA, Tulsa 16, Okla.**

BUILD Inexpensive concrete blockmaker. Motor-hand. Make 500 blocks daily. Write. **C. Lee, Mountain View, Oklahoma.**

HAMBURGER Pattie press. Make your own! Drawings 35c. **Art George Co., 5170 North Hollywood Ave., Milwaukee 17, Wisconsin.**

BURN Discarded oils, safely. Plans \$3.00. **Roy Herrington, Rt. 2, Ontario, Oregon.**

THOUSANDS Nationally advertised brand name products. Discounts to 80%. **Meder, 550-PM Fifth Avenue, New York City 36.**

BRICK Work finished professionally. Brick-Kleen makes ugly lime mortar spots disappear like magic. Safer, non-fuming acid in dry form. Ideal for bar-b-q pits, fireplaces. \$1.00 postpaid can treats approximately 100 sq. ft. **Garman Co., 1253 Grover, St. Louis 23, Mo.**

CLOCK Movements—Gorgeous dials, plans, kits. See ad page 236.

RUSH. Get your gas saver. Send 25c. **Saver, Box 388, Roseville, Michigan.**

BUILD Your own coin game. Place in cafes, bars, clubs, etc. Collect coins weekly. Illustrated plans \$2.00. Jul's Workshop, P.O. Box 1448, Lemon Grove, Calif.

LATEST Enameling on copper kit. No kiln or furnace required. Everything furnished for complete fabrication. \$3.95 post-paid. Now you can make your own lovely earrings, cuff-links, brooches, and many other original jewelry pieces. Ralox, P.O. Box 1256, Decatur, Illinois.

18 FULL-Size patterns. Save money with easy-to-use, professionally designed full-size patterns. Make money selling beautiful, useful furniture. Make modern step and cocktail tables; metal lamps; cupola; 12-foot outboard. All patterns test-built; sold with money-back guarantee. Get your free list of these convenient, economical patterns today. Popular Mechanics Press, 200-HH E. Ontario Street, Chicago 11, Illinois.

MELT Cast iron, brass and aluminum. Make castings for yourself and for profit. Send for literature. Ursutz Burner Co., Box 2293, Globe, Arizona.

FURNITURE — Wrought iron legs and frames! You assemble. Free catalogue. Phillips Furniture, East Peoria 8, Illinois.

GEIGER Counter and metal detector kits. Inexpensive, educational. Free literature. Electronic Applications, 5024 Lee Highway, Arlington 7, Va.

DO IT yourself. What? Repair TV, build furniture, make barbecue, plumbing repairs, build boats, do house wiring, remodel home, lay tile, modernize kitchen, repair home, and scores of other things you can do yourself. Books covering each subject, only 25c. Send for descriptive list. It's free. Popular Mechanics Press, 200-LB East Ontario St., Chicago 11, Ill.

WATCHES, OLD GOLD, JEWELRY

RHINESTONES. Jewelry settings, copper enameling. Sample earring kit and catalog 25c. J & M Novelties, Dept. CK-3, Griffith, Indiana.

MAKE Your own costume jewelry and save money. It's easy. Free sample earrings. Over 5,000 styles in new catalog. 25c. Barry's, 103 Ardsley Court, Newark, N. J.

WATCH And clock repairing books for hobbyists. Free information. North American, Dept. 15-1, 2320 N. Milwaukee, Chicago 47, Illinois.

WATCHMAKERS' — Jewelers' supplies, instructions. Catalog 20c. Bengale Company, Culver City, California.

USED And new watches. \$2.00 up. Free list. Southern Watches, Gray, Georgia.

COPPER Enamelling, complete supplies, information. Valuable catalog free. Bergen Arts, 128MR Main, Hackensack, N. J.

HIGHEST Cash for old gold, broken jewelry, gold teeth, watches, diamonds, silverware, spectacles, platinum. Free information. Satisfaction guaranteed. Rose Refiners, Heyworth Bldg., Chicago 2.

REPAIR Men's expansion watch bands. Instructions \$1.00. Budziak, Box 126, Cicero, Illinois.

COSTUME Jewelry supplies. Catalog and samples. 35c. Largest line in America. Milady-Fair Co., G.P.O. Box 1328, New York City 1.

GOLD, Silver, platinum, diamonds wanted. Cash immediately, highest prices, appraisals made. Wilmot's, 2547 102nd St., Toledo 11, Ohio.

MAKE Costume jewelry for fun and profit. Catalog 25c. Bergen Arts, 128MH Main, Hackensack, N. J.

WATCHMAKERS' Journal contains instructive articles on watch repairing. \$1.00 year. Sample copy 20c. Dean Co., Box 3218-M, Daytona Beach, Fla.

WATCHMAKERS Tools, materials, supplies, watches. Catalog. Gales, Box 1000, Chicago 90, Ill.

RHINESTONES. Send \$2.25 five gross. Value \$5.00. Free bargain list, catalog, jewelry supplies. Ebert, Box p133, East Orange, New Jersey.

EXPANSION Watch bands. Men's, ladies'. Discounts to 70%. List free. Budziak, Box 126, Cicero, Ill.

10 SWISS Watches \$18.00. Catalog 10c. Berkowitz, 1150 Castlehill, New York 62.

TOBACCO, SMOKERS' SUPPLIES

MAKE Your own pipes. Complete instructions, 50c. Briar blocks, stems. Inexpensive tools. Walter Miller, Germantown, Ohio.

PIPE Smokers! Cigar smokers! Free illustrated catalog offers fabulous savings on choice imported and domestic pipes, cigars, tobaccos, supplies. Write Wally Frank, Dept. 25, 150 Nassau Street, New York 38, N. Y.

RAZORS, BLADES, SHARPENING

BEST Shave you ever had. Amazing Twinplex. Money-back guarantee. Description, directions free. Morrow, Box 265, West Hartford, Connecticut.

100 DOUBLE-Edge razor blades \$1.00. Satisfaction guaranteed. Dave Pittel, 4640 Jackson, Chicago 44, Ill.

ATTENTION! Electric shaver \$5.00, knife sharpener \$2.00. Both completely sensational. New items. Unconditionally guaranteed. Free information. Paradine, 1 DeMott Place, Rockville Centre, New York.

FOR THE HOME

FAMILY Portraits — Painted. Cheaper than photographs! Illustrations free! Edorastudios, Ojai, California.

HOW Septic tanks work and to keep working write Mandeville Specialty Co., Mandeville, La.

FOAM Rubber furniture cushions. Factory seconds, 50% discount. Free catalog. Perma-Foam, 429C Central Ave., East Orange, New Jersey.

OF INTEREST TO WOMEN

DRESSMAKERS. Sewers, wholesale lists. Dress suitings, formal fabrics. Box 863, Norwalk, Conn.

GOOD Money in weaving. Weave rugs at home for neighbors on \$69.50 Union Loom. Thousands doing it. Booklet free. Union Looms, 153 Post St., Boonville, N. Y.

PROFITABLE Home business. Make fast-seller chenille monkey trees, dolls, flowers. Terrific holiday demand. Information free. Velva, Bohemia 16, N. Y.

GROW Mushrooms. Cellar, shed, and outdoors. Spare, full time, year round. We pay \$3.50 lb. We paid Babbitt \$4,165.00 in few weeks. Free book. Washington Mushroom Ind., Dept. 176, 2954 Admiral Way, Seattle, Washington.

WANT To make big money at home? \$5 profit in an hour possible with invisible reweaving. Make tears, holes disappear from clothing, fabrics. Steady year-round demand from cleaners, laundries, homes. Details free. Fabricon, 8332-S Prairie, Chicago 19, Ill.

MAKE Copper enameled jewelry for pleasure or profit. Excellent results with beginners' sets. Easy to make ash trays, bracelets, earrings, pins, cuff links as gifts or to sell. For craftsmen, 50 different copper shapes. Enamels in 30 different colors. Tools, findings, late model kilns. Send 10c for catalog. J. C. Larson Co., 820 S. Tripp, Dept. 5475, Chicago 24.

EMBROIDER Stamped linens. Buy direct from manufacturer and save. Send for free catalog. Dept. 822, Merribee, 22 West 21st Street, New York 10, N. Y.

FREE — Big new wholesale catalog! Up to 50% saving for you, family, friends on nationally-known gifts, jewelry, toys, appliances, Christmas cards, etc. Also make money selling part time! Write: Evergreen Studios, Box 846-P, Chicago 42, Ill.

BABY Shoes electroplated—\$1.00 each. Golplate, 1900 Elm, Cincinnati 12, Ohio.

DOLLS — Dressed, undressed, Dollar Doll Club. Peggy's Dolls, Jefferson City 5, Mo.

FREE 50-Piece set tableware plus money-making opportunity. Complete details, \$1.00 (refunded first order). Webster, 223 Hunter, Madison, North Carolina.

MISTY Spanish moss air plant—Dendropogon Usneoides. Growing instructions, 60c coin. J&J, 282 San Marco Ave., St. Augustine, Fla.

LARGE Box beautiful assorted toys. \$6.00 value \$2.00. Toyland, 5139 North Clark Street, Chicago, Illinois.

SALE Priced housewares, appliances, gifts! Free literature. Richeo Products, Box 283, Deerfield, Illinois.

ORIGINAL Recipe for President Eisenhower's favorite beef stew. 50c. E. Timson, 60½ Holt, Dayton 7, Ohio.

QUALITY Carpet warp at reasonable prices. Write today. Carcraft Co., 153 Post Street, Boonville, N. Y.

A Dress shop in your home. No investment. Liberal sales commissions. Write Bellecraft Fashions, 111 YS Eighth Ave., New York City.

FOR SALE—MISCELLANEOUS

WAR Surplus bargains! New government releases arrive constantly, save up to 80%. Blankets, boots, coats, tents, wearing apparel. Send for free war surplus catalog. Sioux Falls Surplus Store, Sioux Falls, South Dakota.

OLD Wall telephones. Working order, oak cabinets, hand crank for ringing. \$3.00 each f.o.b. Telephone Co., Turtle Lake, Wis.

NECKTIES, Nearly new, 5 for \$1.00. Mr. Bernard, 606 Roxboro Place N.W., Washington, D. C.

HEARING Aid batteries, wholesale. Free list. Habs, Box 51, York, Penna.

WANTED—MISCELLANEOUS

LIE Detector wanted. Details, price. Eric Williams, Box 4226, Guayaquil, Ecuador, S. A.

HIGHEST Prices for gold, silver, platinum, diamonds, watches, gold teeth. Satisfaction assured. Goods returned if offer unsatisfactory. United Smelting Works (Old Reliable), 6-B East Monroe, Chicago 3.

QUICKSILVER. Sterling, silver solders, precious metals. Wholesale Terminal, Norwood, Massachusetts.

SCRAP Mercury (quicksilver) containers supplied — Tantalum, bismuth, tungsten. Metallurgical Products Company, Established 1909, 35th and Moore Sts., Philadelphia 45, Penna.

PERSONAL

ANNOUNCING A new test that reveals your true vocational aptitude. If you long to be content, self-confident, and possess greater earning power, address card today for free details to Employment Counselors, 507-AH Professional Building, Baltimore 1, Md.

BORROWING By mail. Loans \$50 to \$600 to employed men and women. Easy, quick. Completely confidential. No endorsers. Repay in convenient monthly payments. Details free in plain envelope. Give occupation. State Finance Co., 333 Securities Bldg., Dept. K-227, Omaha 2, Neb.

BUY Vitamins direct. Amazing savings. Catalog free. Mateoka, White Bear, Minn.

ESPERANTO Explained. Send \$1.00. Esperanto Societo, P.O. Box 4367, San Diego, Calif.

REMAILING 25c. Replies forwarded. Ace Service, Box 186, Tampa 1, Fla.

DALLAS Or Fort Worth Sunday help wanted, and business opportunities sections. \$1.00. Remails 25c. Bush, 4117 Pampas, Dallas 11, Texas.

COLORADO Remails 25c. Violet Turner, 1235 N. Wahsatch, Colorado Springs, Colo.

LETTER. Package, telegram remailing, receiving-forwarding address for rent \$2.00. McLaughlin, 800 Stewart, Columbus 6, Ohio.

SANTA Barbara remail 25c. Amenta Company, Box 512, Santa Barbara, Calif.

DENVER Classifieds \$1.00. Information \$2.00. M. Cassidy, 1124 Elizabeth St., Denver, Colo.

REMAILS 25c. Sunday classified \$1.00. Orbit, Box 3906A, Detroit 27, Michigan.

MEXICAN Legal matters. A. Espejo, Box 234, Hermosillo, Sonora, Mexico.

"HOW Can I find out?" You can! Information confidentially developed. Any matter, person, problem. Worldwide. Officially licensed. Established 1922. William Herman, 170 Broadway, New York City.

LETTERS Remaild 25c. Personal forwarding address. Monthly rates. Hicks Service, Box 1547, Washington 13, D. C.

GOMEZ Trevino—Mexican law practice. Bank references. Box 7112, El Paso, Texas.

PROFIT! Prestige! Publish a magazine under your own name! Only \$3.25 per month! Sample, details 5c! Pilmer, 910 Marion, Pharr 22, Texas.

MEXICAN Law. General Practice Attorney. Apartado 79, Juárez, Chih., México.

DETROIT Or Chicago classifieds 90c. Remails 25c. Bannasch's, 1004 S. Wisner, Jackson, Michigan.

HOUSTON, Texas, is booming. Sunday classified oil news \$1.00. Letters remailed 25c. Hunt, 6701 Ave. Q.

MEXICAN Legal matters. A. Espejo, Box 234, Hermosillo, Sonora, Mexico.

18 VITAMINS, 13 Minerals, 90 days' supply \$3.00. Maze Sales, Valrico, Florida.

EXPERT Handwriting analysis \$1.00. J. French, 87 S. Munn, 408A East Orange, N. J.

EVERY American should have these three plastic pictures, only \$1.00. Capitol United States, Washington monument, George Washington Masonic memorial, Modern Supply, P.O. Box 693, Alexandria, Virginia.

NEW Orleans is booming. Help wanted ads airmailed \$1.00, remails 25c. Brown, Box 7025, New Orleans, La.

YOUR Portrait—Painted. Cheaper than photographic! Illustrations free! Dorstudios, Ojai, California.

CHARGE Accounts opened by mail. Catalog free. Osgoods, 1320-E Prospect, New York City 59.

SECRET Mail address. \$3 month. Hedgpath, Box 830, Alhambra 23, California.

FABULOUS Houston Sunday classifieds \$1.00. Remails 25c. Jordan, 1120 Chenevert, Houston, Texas.

LETTERS Rемаiled from Chicago 25c. Private receiving address \$3 monthly. Swift, Box 516, Park Ridge, Illinois.

REMAILING SERVICE

WONDER State remails—25c. Gene's, 1915 South "H," Fort Smith, Arkansas.

LETTERS Rемаiled historic Philadelphia 25c. Armand Busico, 1035 Jackson St., Philadelphia, Penna.

TREASURE FINDERS

"SNOOPER" Geiger counter. Only \$29.95 complete. Super-sensitive. Pocket size. Find a fortune in uranium. Order now. Send \$5.00 balance c.o.d. Money-back guarantee. Free catalogue—Scintillator and larger uranium and metal detectors. Microscopic Associates PMA, 2322 W. Whittier Blvd., Montebello, California.

URANIUM! Informative booklet gives hot known and potential locations. Government map included free. \$1.00. Uranium Research, Box 1555, College Station, Texas.

URANIUM, Gold, silver treasure. New, power-packed, highly sensitive metal detectors, Geiger counters and mineralights, kits and assembled models from \$12.50. Lightest weight, guaranteed, free literature. Electronic Applications, 5024 Lee Highway, Arlington 7, Va.

AMAZING Triple-action Geiger counter U-238C, combines audio, neon flasher, meter. Guaranteed best available. Also metal detectors and scintillation counters from \$49.50. For radioactive uranium sample send 25c to Goldak Company, 1541 W. Glenoaks Blvd., Glendale, California.

GOLD, Silver, metal detectors. Geiger counters for uranium. Mineralights. Sensational new fully guaranteed models. None finer. Information free. Detectron Corp., 5528 Vineland Ave., North Hollywood, California.

GEIGER Counters, metal detectors, ultra-violet mineralights, from \$29.50 up. Write for free catalogs. The Radiac Co., Inc., 489 Fifth Ave., Dept. 9-PM, New York 17, N. Y.

DISCOVER Uranium! How to make simple tests for uranium, 25c. Mineral Research Laboratory, Box 52, Culver City, California.

INDICATOR: Locates uranium, buried money and minerals. Price \$25.00. Dirt samples tested free for oil. Horton's Surface Oil Survey, Belle Rive, Illinois.

GEIGER Counters and mineral locators, assembled and kits. Free geological advice; Write for details. Frontier Instruments, Box 276, Annandale, Va.

ROCKET Mk II nuclide meter. 6 times as sensitive as a geiger counter. Only \$37.50 complete. Uses 2 supersensitive 1B95 tubes. Weighs less than 3 lbs. Plug-in probe available. 10 day trial period. 1 year guarantee. Write today for free catalogue. Webster Electric Mfg. Co., Dept. B, 3834 Clarke Street, Oakland 9, California.

"SNOOPER" Geiger counter only \$29.95 complete. Super sensitive. Pocket size. Find a fortune in uranium. Order now. Send \$5.00, balance c.o.d. Money-back guaranteed. Free catalog—Scintillators and larger uranium and metal detectors. Precision Radiation Instruments, 4223PMC W. Jefferson Boulevard, Los Angeles 16, California.

BE Advised before deciding to prospect uranium. "65 Questions and Answers" 50c. Chess, Box 2141, Sacramento, California.

GEIGER Counter tubes \$5. Scintillation counter crystals at low cost; circuits \$1. Good prospecting instruments, all types. Free literature. Western Radiation Laboratory, 1107 West 24th Street, Los Angeles 7, California.

QUALITY Geiger counters at unbelievably low prices. Write for illustrated literature. Dept. 1, Electronics Division, Roberts Manufacturing Company, Cleburne, Texas.

"HOW To Make Money prospecting for Uranium." Free booklet. Send 20c for handling, postage. Geiger Co., 195-8a Sackett Street, Brooklyn 31, N. Y.

MISCELLANEOUS

PENCIL Portraits, life size. Send photo. \$5. Deal Studio, Bovey, Minn.

WHOLESALE Catalog! 30-80% discounts! Typewriters, appliances, housewares, watches, jewelry, etc. Consolidated Distributors, 21-13 Lafayette, Paterson 15, New Jersey.

ENVELOPES Addressed and mailed. What's your offer in cash monthly. Mrs. Joannie Graham, Ridgeland, Miss.

ZINC Engravings. From any photograph or drawing. 5 inches, only \$1.50. Free price list. Miller-Holies, 437 E. Market, Alliance, Ohio.

BUY Wholesale thousands nationally advertised products at big discount. Free "Wholesale Plan." American Buyers, Hertel Station, Buffalo 16-K, N. Y.

CATALOG of the most efficient cesspool and drain cleaning equipment. Mail 50c to learn how to fix that faulty cesspool, clogged waste pipe or drain. Free advice on how to do-it-yourself. Send details of your particular problem. Electric Sewer Cleaning Co., Boston 34, Mass.

PRESERVE living flowers to last indefinitely. Interesting hobby. Make money too. Write for free details. Edna Howsare, 419 Whitridge Ave., Baltimore 18, Md.

SELL! Buy! Trade! Anything. In "Trading Post Magazine" — Details free! Thorne's, 525 Dewey, Jackson 40, Michigan.

FOREIGN Address lists, samples imported novelties \$1.00. Burke Associates, Manchester 1, Mass.

AIR Force Academy, Colorado Springs! Construction soon. Town booming. Sunday help wanted columns airmailed \$1.00. Box 249, Manitou Springs, Colo.

70 BIBLE Lessons, 25c. Bulletin, Box 87, Cathedral Station, New York 23.

DISCOVERY Of fire in time saves lives and homes. "Chief" automatic fire alarm will discover fire day or night and give the alarm. Order one for every room in your home. Only \$2.98 each, postpaid if remittance is sent with order. For c.o.d. shipments, send \$1.00 deposit on each alarm ordered. Cronin-Staples Mfg. Corp., Dept. PM, 1514 Park Street, Houston 19, Texas.

LIKE Full mail boxes? Interesting offers galore, 25c. Traylor's Enterprises, La Feria, Texas.

PAINT—A lovely religious painting in oils the first time you try. Christ in the Garden, size 18"x24" \$8.95 postpaid, also Sacred Heart, Angelus, and Old Mission in size 12"x16" each \$3.95 postpaid. Many other subjects from which to choose. Send for free literature. Ralox, P.O. Box 1256, Decatur, Illinois.

MEXICAN Jumping beans of the new crop 1955. Send your order to Joaquin Hernandez, Exporter, Alamos, Sonora, Mexico.

STUPENDOUS Mental power. Adults. Details 10c. Delmar Wisdom, 833 Sunny-side, Chicago 40.

GROW Mushrooms. Cellar, shed, and outdoors. Spare, full time, year round. We pay \$3.50 lb. We paid Babbitt \$4,165.00 in few weeks. Free book. Washington Mushroom Ind., Dept. 175, 2954 Admiral Way, Seattle, Washington.

HOW To paint. Do it yourself. Illustrated instructive book. 25c. Catalog free. Popular Mechanics Press, 200-HP E. Ontario St., Chicago 11, Ill.

PANNING Gold—Free lesson; catalogue of mining, mineral books, supplies. Old Prospector, Box 729D1, Lodi, Calif.

RECEIVE Magazines, samples, catalogues. Mails from everywhere. Offers, hundreds. Get listed 25c. Rorick, Box 86, Cincinnati 26, Ohio.

BOYS! Girls! Make hundreds of different things with Twist-Kraft. Make miniature flowers, figures, animals, furniture, houses and loads of other interesting things with these multi-colored fuzzy wires. To get your complete set, send only \$1 to: E. T. Gilbert Mfg. Co., 228-236 South Ave., Rochester 4, N. Y.

GUARANTEED Toilet and septic tank cleaner. Deodorizes in 48 hours. Reduces the mass to water. No longer necessary to dip. Cheap to use. Money back guarantee. Free folder. Septisan Company, 4343 Monitor Drive, Indianapolis 20, Ind.

BOYS. Put a gasoline engine on your coaster wagon. Send \$1.00 for instructions and drawings. Joseph Davidhizar, Hollisopple, Penna.

PROTECT Your possessions, quickly, permanently with York laundry marking pen, (includes iron-on-tape for dark fabrics). Send \$1.00. Mrs. Wurtz, 646 Prospect Ave., West Orange, New Jersey.

BE Your own plumber. You can. Few inexpensive tools and our instructive book, "Home Plumbing Guide," shows and tells you how. Hundreds of photographs and diagrams. Easy to follow. 160 pages. \$3.50. Catalog free. Popular Mechanics Press, 200PG East Ontario St., Chicago 11, Ill.

CALENDAR, 1 A.D.—9999 A.D., 50c. Carl Walker, Tusculum, Tennessee.

300 BIG Mails guaranteed. Samples, plans, offers, propositions, 12 months listing. \$1.00 refundable. Wright Publications, 2270 Hubbard, Memphis 8, Tenn.

SHRINE And Mason lapel pins. Sterling silver, \$2.00. Bryant, 2139 Sullivant, Columbus 4, Ohio.

FEEL More vigorous, younger, better! Get free catalogue—Unusually potent vitamins. Try Magnums! 100 big capsules \$5.00; 200, \$9.00. Millions used. Money back guarantee. Vitamin-Center, Drawer 2318P, Detroit 31, Michigan.

I want to send you proof of the wonderful pulling power of Popular Mechanics classified pages. What's your proposition? Write me today. Include literature if possible. F. W. Johnson, Manager Classified Advertising, Popular Mechanics Magazine, 200 E. Ontario St., Chicago 11, Ill.

MAKE Life worth living! Get our Behavior Motivation Control plan free. Write Applied Christian Psychology, Box 1924-W, Louisville 1, Kentucky.

JEEP Owners—V8 power. Read Jeep owners ad. Page 44.

HEAT Your home or business for almost nothing. Amazing method, thousands satisfied. Valuable information free. A. Enault, R.F.D. #1, White River Junction, Vermont.

COMICS. Adult, mysteries, weirds, chillers. 50 different! \$2.50 postpaid. Ellis Specialties, 1225 Vine, Philadelphia, Penna.

RADIO, Kitchen wares, clocks, hair clippers, battery shavers, etc. Catalog 20c. Refunded. Sim Taylor, Route 2, Ridgeland, S. C.

FREE: Exciting catalog packed with books covering most everything. Think of it—From cover to cover you will find described and illustrated hundreds of books telling how to fix and how to build almost anything. How to remodel your home; do your own decorating, plumbing, electrical work. Simplified books covering concrete work, carpentry, painting, furniture making and refinishing. How to build your own boat, home workshop tools. Best books on photography, welding, hobbies, homecraft. How to make a home freezer. Send for your free copy now. Popular Mechanics Press, 200-BC East Ontario St., Chicago 11, Ill.

-Road Test My \$3⁹⁵ Carburetor Invention

Get Extra Miles Per Gallon, More Horsepower, Smoother Idling and Faster Pickup—or Don't Pay a Dime!

by Albert Wells

EVER DROP A LIGHTED MATCH in a pail of gasoline? If you did, and you're alive to read this, you know that gasoline won't burn. Only gasoline vapor will burn.

The more raw, unvaporized gasoline your carburetor delivers to the cylinders, the more gas you waste. The more highly vaporized the mixture your carburetor delivers, the more power you get, which means higher speed, better pickup, smoother idling, more miles per gallon.

THE SIMPLE SECRET OF INCREASED POWER AND ECONOMY

There are two ways to get more complete vaporization: (1) by improved carburetion, and (2) by increasing the volatility of the gasoline. My \$3.95 invention is designed to do both.

THE CARBURETOR PROBLEM

Within 5 miles after your carburetor has been tuned to give you more complete vaporization, tiny amounts of petroleum gums, tars, minute flakes of rust and other impurities from your gas tank have begun to foul the jets; even water that the gasoline picked up from condensation in storage tanks is interfering with carburetor efficiency. This gets progressively worse until you lay out \$20-\$35 for a carburetor overhaul. Then it starts all over again.

It was obvious to me that something was needed to re-refine gasoline just before it entered the carburetor—at the last possible second, when no further impurities could contaminate it.



HOW MY INVENTION WORKS

I designed what looks much like an ordinary gas filter. You attach it to your carburetor inlet just as you would a filter. The difference is in what's inside: an element of porous bronze of the type used to meter liquid rocket propellants. Made by fusing together millions of tiny bronze balls, it forms a screen so fine that it actually takes water, gums and tars out of your gas.



Result: better vaporization, and nothing to foul your carburetor. Tune it once and it stays tuned. This gives you more complete combustion, which saves you gasoline, not to mention what it saves on periodic carburetor cleaning and overhaul jobs. And there's nothing to wear out; that's why we call it the Life-Time Fuel Monitor.

TRY IT FOR 30 DAYS AT MY RISK

Try the Life-Time Fuel Monitor for 30 days on this guarantee: unless you are satisfied that it will save you at least 5 times its cost, return it for a full refund. One size fits all cars, light trucks: fill out coupon and enclose \$3.95 (we pay postage) or \$1 deposit now, pay balance and C.O.D. charges on arrival. You can install it yourself in 2 minutes. Continental Manufacturing Corporation, Dept. GP-10, Washington Blvd. at Motor Ave., Culver City, Calif.

DEALERS AND DISTRIBUTORS

For full information on Life-Time Fuel Monitors and Oil Filters, Life-Time Batteries, Spark Plugs and Brake Boosters, write: Continental Manufacturing Corporation, Dept. GP-10, Washington Blvd. at Motor Ave., Culver City, Calif.

Continental Manufacturing Corporation, Dept. GP-10
Washington Blvd. at Motor Ave., Culver City, Calif.

Please send me the Life-Time Fuel Monitor for 30 days' trial.
I Enclose: \$3.95; you pay shipping
 \$1 deposit, will pay balance and C.O.D. on arrival.

NAME _____

ADDRESS _____

CITY _____ ZONE _____ STATE _____

STICK WITH
LEPAGE'S
GLUE
REPLACEMENT CO. - BRAND OF MONEY
 Guaranteed by
 Good Housekeeping
IF NOT AS ADVERTISED RETURN
GLOUCESTER, MASS.

ELECTRIC MOTOR
 **\$1.50** Post paid
 A low-cost, dependable motor with many uses. Ideal for displays, pumps, fans, heaters, toys. No radio interference. Every one guaranteed. Write for free catalog.
PENNSYLVANIA WHOLESALE DISTRIBUTORS
 103 N. 6th STREET PHILADELPHIA 6, PA.

PROFITABLE HOBBIES
 Do **WONDERFUL** things with your spare time! Make beautiful and **UNUSUAL** items for the home, as fascinating gifts, or for **RESALE!** Build a profitable home occupation or hobby! We show you how. Make astonishing jewelry. Ceramics without a kiln. Dolls, toys, puppets, figurines, Planters, Ivory, embedded plastic, etc. Send 25c for big catalog and details. Refunded with first order. Write Dept. PC-102.
PLASTICAST COMPANY
 6612 N. Clark St., Chicago 26, Ill.

SAY YOU SAW IT IN
 POPULAR MECHANICS

NO INVESTMENT! NO INVENTORY!
YOUR OWN MERCHANDISING BUSINESS!
 Sell nationally advertised products right out of the brand new
RAKE CATALOG
 Biggest Price Advantage Ever! Sensational Profits for You!
 Write for **FREE** RAKE COMPANY 708-M Sansom Street
 copy TODAY! Phila. 6, Penna.

THE MASONIC CASUALTY COMPANY
OFFERS  **CHARTERED 1895**
ACCIDENT - HEALTH - HOSPITALIZATION INSURANCE AT COST
 • Non Cancellable • Benefits Not Prorated
 • No Medical Examination • No Paid Agents
 • Coverage On or Off the Job
FIRST 3 MONTHS PROTECTION FOR MEMBERSHIP FEE \$2.00
FOR MASONS ONLY under 56 yrs. of age
WRITE AT ONCE
THE MASONIC CASUALTY COMPANY
 80 BOYLSTON STREET BOSTON 16, MASS.
 NO AGENT WILL CALL

**"Building Beautifiers"
 Can Earn High Incomes**

Colorcrete, a cementitious plastic, gives lifetime beauty and protection to drab, dirty masonry — concrete, stucco, etc. — on all kinds of buildings. Tough, tenacious, enduring. Easily cleaned. Helps to daylight dark interiors. Choice of gleaming white or 30 colors. Applied under pneumatic pressure to form an inseparable bond.

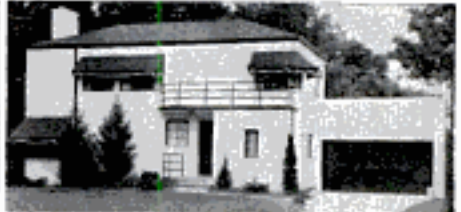

More Colorcretors are needed to supply the ever-increasing demand. Low investment appeals to men of limited capital. Work is easy, fascinating, highly profitable. Broad opportunity to develop a lifetime business. No special ability or experience needed because we supply full instructions and sales cooperation. Colorcrete machine is simple to operate, easy to move around. Write today for Opportunity Book.

Colorcrete Industries, Inc. COLORCRETE
 570 Ottawa Av., Holland, Mich.
IN CANADA: DUNN MASONRY MACHINERY LIMITED
 1020 Dundas Highway, Cooksville, Ont.

RADIO Engineering. All phases radio & electronics theory & practice; television; FM; broadcasting; servicing; aviation, marine & police radio. Prepare for good pay; 18-month course. Graduates in demand by major companies. Enter Jan., March, June, Sept. Regular campus life. Write for catalog.
VALPARAISO TECHNICAL INSTITUTE, Dept. D, Valparaiso, Ind.

PREPARE FOR THE BEST JOBS
IN INDUSTRY
TRAIN at HOME IN YOUR SPARE TIME or at **ALLIED INSTITUTE** in Chicago
 • MECH. ENGINEER
 • DRAFTSMAN
 • TOOL DESIGNER
 • TOOL ENGINEER
 • TOOL & DIE MAKER
 • MASTER MACHINIST

NO RECESSION FOR ALLIED TRAINED MEN
MORE JOBS THAN GRADUATES Shortages of Draftsmen, Designers, Tool Engineers, Machinists, Tool & Die Makers are so widespread that you can pick a highly paid key job and look forward to Achievement and Security.
 You can begin your training in Short Courses and continue progressively to a Bachelor Degree in 26 months.
 Allied is approved by Industry, Dept. of Education, Office of Public Instruction, State of Illinois, U. S. Veterans Admin., U. S. Dept. of Justice. Accredited: C. S. A.
SEND FOR FREE BOOKS
ALLIED SCHOOL of MECHANICAL TRADES
 1338-42 South Michigan Ave. Dept. P-31-9 Chicago 5, Illinois
 SEND ME WITHOUT OBLIGATION INFO. ON YOUR COURSES:
 HOME STUDY RESIDENT VETERAN NON VETERAN
 NAME _____
 ADDRESS _____ AGE _____
 CITY _____ STATE _____

SAVE MONEY WITH THESE NEW DO-IT-YOURSELF BOOKS

- HOW TO PAINT INSIDE AND OUT:** Step-by-step instructions. Easy to follow illus.
- HOW TO LAY LINOLEUM AND TILE:** How to get the best from your labors. Diagrams.
- HOW TO REMODEL YOUR BASEMENT AND ATTIC:** Planning ideas, hints, instructions. Illus.
- HOW TO TAKE CARE OF YOUR LAWN:** Detailed guide to a perfect lawn and healthy shrubs.
- HOUSE WIRING AND ELECTRICAL REPAIRS:** Ideas and instructions for the homemaker. Diagrams.
- SMALL BOATS YOU CAN BUILD:** Plywood dinghy, 15-ft. sailing knockabout, 8-ft. duckboat, etc.
- PLUMBING REPAIRS MADE SIMPLE:** Fix faucet noises, water hammer, clogged pipes yourself.
- FENCES, GATES, TRELLISES AND WALKS:** Variety of fences, etc., with instructions, diagrams.
- BUILT-IN FURNITURE FOR YOUR HOME:** Wall cabinet, wardrobe, linen closet, crib, etc.
- BUILD YOUR OWN BARBECUE:** Stone and brick fireplaces, grills, barbecue pits, etc.
- LAWN AND GARDEN PROJECTS:** Picnic furniture, folding chairs, garden pool, etc.
- THREE LOW-COST HOMES YOU CAN BUILD YOURSELF:** Build your own home—save half the cost.
- 125 SIMPLE HOME REPAIRS:** Stop faucet leaks, replace sash cords, cut glass, etc.
- SIMPLE TELEVISION REPAIRS:** Only a screwdriver, pliers and soldering iron necessary.
- MODERNIZE YOUR KITCHEN:** Planning for convenience and economy. Ideas, diagrams.
- SIMPLE AUTO REPAIRS:** Treasury of troubleshooting tips for motorists, covering engine, etc.
- HOW TO WINTERIZE YOUR HOME:** Prepare for bad weather. Make storm windows, repair roofs, etc.
- HOW TO SET UP YOUR HOME WORKSHOP:** Detailed layout plans for basement conversion. Diagrams.

ONLY 25¢ EACH
6 FOR \$1.25
18 FOR \$3.25

USE HANDY ORDER COUPON BELOW

POPULAR MECHANICS PRESS, 200 E. Ontario, Chicago 11

Gentlemen: Please send copies of book nos.: 1: 2: 3: 4: 5: 6: 7: 8: 9: 10: 11: 12: 13: 14: 15: 16: 17: 18: (circle numbers desired)

Remittance enclosed

Send C.O.D. (\$2.00 or more) I enclose \$_____

Name _____

Address _____

City _____ Zone _____ State _____

POPULAR MECHANICS

Copyrighted material



Get info.. PLASTIC LAMINATING AT HOME!



THIS MAN...
...is taking out of the machine a Plastic Sealing Job — ordered by mail — only 11c in material cost brings back \$2.55 in cash by mail. Capacity of machine: **\$25.00 profit per hour of operation.**

Get **ORDERS** and **CASH** from your mailman—do work in **SPARE TIME** at home—or expand into **FULL TIME** business. Send coupon for Free facts about the newest and most fascinating of all home operated businesses. For the first time a simplified machine brings the fabulous profits of **Plastic Sealing and Plastic Laminating** within the reach of the small operator. Anyone can learn to operate the machine with a few minutes practice—then with our **Magic Mail Plan** can get mail orders pouring in daily with cash in every envelope. **No canvassing—no selling.** We even

Make \$20 to \$30 a Day by.. MAGIC MAIL PLAN!

supply the circulars you mail to bring back cash and orders. Don't waste a minute. Rush your name. We'll send you **FREE** and postpaid, pictures, prices, details, and all the facts you need to start. Mail coupon or send name on postcard. No charge. **Warner Electric Co., 1512 Jarvis Av., Dept. L-18-K, Chicago 26, Ill.**

Make Thousands of Beautiful Art Creations
COSTUME JEWELRY • CIGARETTE BOXES TRAYS • CANDLESTICKS • COASTERS LAMP BASES • BOOK ENDS...ALL IN SPARKLING COLORED PLASTIC



WARNER ELECTRIC CO., 1512 Jarvis Av. Dept. L-10-K, Chicago 26, Ill.
At no cost to me, please rush complete details postage prepaid. I am under no obligation.

Name _____
Address _____
City _____ Zone _____ State _____

ONLY \$495 Freight included **FREE FOLDER**

16 FT. CRUISER

BOAT KITS
12 Models as low as \$39.95 (freight included). Fiberglass boat covering kits, marine supplies, etc. Free folders.

TAFT MARINE WOODCRAFT
DEPT. PM-9 636-39th Ave. N.E., Minneapolis 21, Minn.

Say You Saw It in **POPULAR MECHANICS**

"NEED BACK ISSUES to round out your Shop Notes Files?"

This special offer is being made exclusively to Popular Mechanics readers... We have a few hundred surplus copies of **SHOP NOTES** for 1947, '49 and '52... On the newsstands, the 1947 annual sold for 50c, 1949 and 1952 for \$1.00 each...

Now, while the supply lasts, you can have all three collections of shop projects and do-it-yourself know-how at a saving of 40%!

All orders must be accompanied by your remittance (if your order reaches us too late, we'll refund your money by return mail). Remember—the supply is limited, so send your order today and save over \$1!

Popular Mechanics Press
200 E. Ontario St., Chicago 11, Ill.
SEPTEMBER 1955



\$250 VALUE for only \$149 POSTPAID

AUTOMATIC RETOOTHER
MAKES NEW PROFITS

Cuts new teeth in 50 seconds—any size a to 16 points. Old teeth fall off on chips. Easy to operate. A perfect job.

BURR MFG. CO.
8933-K VENICE BLVD. LOS ANGELES 34, CALIFORNIA

NEW KURMER LADDER SEAT PATENTED **\$12.95** DEL. W. OF MISS. ADD \$1.50 GUARANTEED

For Painters, Repairmen, Homeowners. Safe—Simple—No Ladder Fatigue. Just Hook It On—Folds Out Of The Way. Easy To Get On And Off. Stays Put While Ladder Is Shifted. **KURMER INDUSTRIES, Dept. 1, 4332 N. Gratz St., Phila. 40, Pa.**

YOU BUILD TEICO KITS in one evening. SAVE 50% & LEARN

Easy Instructions | Vacuum Tube Voltmeter
38 Instruments | **KIT \$25.95** Wired \$39.95
Write now for **FREE Catalog**... PM-9

Electronic Instrument Co., Inc. • 84 Withers St. • Brooklyn 11, N.Y.

LEARN TV in KC

UNIVERSAL TV FAMOUS FOR 24 YEARS
1,000's OF SUCCESSFUL GRADS COAST TO COAST

Easy, quick, fascinating. Learn TELEVISION in 36 short weeks of enjoyable companionship in shop training. Wonderful job opportunities. Graduates have choice of many jobs or can establish their own TV repair shop. **YOU CAN START EARNING AS MUCH AS \$150 PER WEEK.** NO limit as time goes on. U.T.S. is an old established school (TV exclusive for 24 years) staffed by expert instructors, headed by one of America's first TV broadcasters. Costs so little to prepare yourself for life. No previous experience needed. Fully approved for Korean Veterans. Also fully approved course in color TV (1st in US). Send coupon now for **FREE** book on TV Electronic opportunities.

WRITE FOR FREE CATALOG

FILL OUT COUPON—

UNIVERSAL TV SCHOOL
1220M Admiral Boulevard, Kansas City, Missouri
PLEASE SEND ME INFORMATION FREE

Name _____ Age _____
Address _____
City _____ State _____
 Check here if Korean Veteran

Get Your Own Copy of Money Saving
NEW 148 PAGE
Auto Parts and
Accessory
FREE!
CATALOG

ORDER NOW!
 This giant 148 page catalog, packed with over 50,000 items for the automotive, truck, taxi, hot rod and custom car owner... is yours FREE with any order for items selected from this advertisement. If you just want the catalog, send only 25¢. Receive part of hundreds and mailing cost refunded on your first order.

NEW EXHAUST CUT-OUT
 Exhaust tone is controlled from the dash. Can be used as a cut out in the country and closed in restricted areas. Or may be used to operate two different toned mufflers. Well constructed of heavy sheet metal. Strengthens the exhaust pipe. UNIVERSAL—Fits All Cars. **\$3.42**
 No. 58-POSTPAID/each

AH-OOO-GAH Chromed HORN
 Here it is for the sport car enthusiast. Not a vibrator or other substitute but a genuine motor driven horn. **\$12.60**
 No. 46—POSTPAID
 6 VOLT, 12 VOLTS

BERMUDA CLANGING BELL
 It's the New "Bop"! Gives a most amusing and commanding two-tone bell sound. Easily installed under car floor by driver's seat. Step on steering. Highly polished. Fits any car. **\$3.95**
 Stock No. 49 POSTPAID

HOW TO ORDER: Send payment in full or 25% deposit with order. Balance C.O.D. When payment in full accompanies order, we pay shipping charges on items marked Postpaid. Others F.O.B. Chicago. Be sure to give make, year, model of car. **SATISFACTION GUARANTEED or Money Refunded.**

J. C. WHITNEY & CO., 1917-P 29 Archer Ave., Chicago 16, Ill.

REAR-VIEW MIRRORS
 Special Curved Convex Glass Gives Curb to Curb Vision—Eliminates Blind Spots—Wider Range of Vision Thru the Larger Window of the Car. **CURVED MIRRORS—2 1/2"x10"** in Metal Case Painted a Neutral Gray Homestead Finish with a Plastic Film to Match. **No. 98—Fits all cars. Give exact year, make & model. POSTPAID, 6c. \$2.94**

Porous Bronze OIL FILTER ELEMENT
 WITH LIFETIME GUARANTEE and Built-in Magnesium Acid Neutralizer

Porous bronze Element never wears out or needs replacement. Lasts for a lifetime of the car. Element removes all harmful particles, yet retains your expensive additives. Lets you drive up to 10,000 miles without changing oil. Fits 98 cars except those with Full Flow Oil System listed below. Stone vent, make, model of car. **\$4.95**
 No. 314—Regular \$4.95
 Element only, POSTPAID
POROUS BRONZE FILTER ELEMENT FOR FULL FLOW OIL SYSTEM—Fits V8 Buick, Olds, DeSoto 32-35; Ford, Merc. 54-55; Chrysler 51-53; Dodge 51-53; Pack. 1955; Ford 46-54; Lincoln 52-54; Chev. 48-54; V8 46-54. Stone vent, make, model of car. No. 117—Regularly \$12.95. POSTPAID, only **\$8.95**

HI-SPEED ELECTRIC SIREN
 Developed especially for the U. S. Navy & Coast Guard. Now used by hundreds of Fire & Police departments, buses, ambulances, etc. Complete with bracket, screws, 10 ft. of cable & push button. Clean Enamel. **\$13.24**
 No. 95—POSTPAID
 8 VOLT or **\$13.70**
 12 VOLT or

WHERE-TO-BUY-IT INDEX

Source of supply appears after items commercially available

AUTOMOTIVE

"Sunmobile"..... 10
 Pint-size 1932 "Ford" has engine in rear..... 87
 German body shop turns Chevrolet into "Le Sabre" dream car..... 112
 Fluorescent light is easy on battery (La Pointe Electronics Inc., 155 W. Main St., Rockville, Conn.)..... 141
 Car warming unnecessary..... 143
 Auto stylist styles his own car..... 145
 Under-hood charger for automobile batteries handles 6 or 12 volts (Paul D. Rosenthal Co., 320 S. Swall Drive, Los Angeles 48, Calif.)..... 156

AVIATION

Planes land automatically on carrier..... 78
 Pilot "treads" air on jet board..... 90
 Swing-up shelters shield mechanics at work on giant planes..... 108
 Small jets on wing tips increase safety during take-off..... 113
 British ejection parachute saves pilot of taxiing plane..... 137
 Twin-engine jet car tests plane equipment..... 137
 Plastic fuel tank undergoes tests (Admiral Corp., 3800 Cortland St., Chicago 47)..... 141
 Pin-wheel plane..... 144
 French jet training plane has butterfly-type tail..... 151
 Portable heliport docks pontoon copters..... 153

CONSTRUCTION

Cranes with long beams erect 22-story building..... 107
 Grille of metal flowers covers Tokyo building..... 123
 Portrait of a highway..... 131

FARM

Process "vitamin cherry"..... 108
 Cow pumps water as she drinks from pendulum trough..... 151
 Paper tarp protects hay and equipment at low cost (Angier Corporation, Framingham, Mass.)..... 151

FISHING

Light on fishing rod warns when fish bite (Jim L. Bishop, Inc., 210 W. 8th St., Kansas City 5, Mo.)..... 100
 Clip on fishhook holds worms (A. S. Pinckney Mfg. Co., 1000 N. Serrano, Los Angeles 29, Calif.)..... 100
 Rait has window for view of fish..... 112
 Self-releasing lure (Netcraft Co., Toledo 13, Ohio)..... 112

HOUSE AND HOME

Corrugated roof unrolls on job (Quaker State Metals Co., Box 1167, Manheim Pike, Lancaster, Pa.)..... 87
 Radio waves cook turkey (General Electric Co., Appliance Park, Louisville 1, Ky.)..... 97
 What's New for Your Home—
 Dry-cleaning device for home use..... 114
 Washing machine requires no rinse tubs..... 114
 Water-heater accessory..... 114
 Salt shaker dispenses salt no matter how damp..... 114
 Pressure pan operates on 120-volt alternating current..... 115
 Window guards that are easily installed..... 115
 Fire extinguisher uses compressed air from air hose..... 115
 Exact temperature for any kind of cooking..... 115
 Fluid dust fighter keeps surfaces clean (Artloom Carpet Co., Howard & Allegheny Aves., Philadelphia, Pa.)..... 142
 Midget greenhouse (Mist Methods Co., Winchester, Tenn.)..... 154

MISCELLANEOUS

Glass-walled pool shows off swimmers..... 90
 180 m.p.g. motor bicycle can also be pedaled (Mopedo Products Inc., Suite 269, Plaza Hotel, New York City 19)..... 90
 Felt blocks of bike bracket clean and oil passing chain (Westfield Mfg. Co., Westfield, Mass.)..... 91
 2500 dinners per hour at broiler festival..... 91
 Ersatz bird wakes slugabeds..... 97
 Pontoon boat (Dallas Engineers, Inc., Dallas, Pa.)..... 100
 Movie-film rewinder (O'Dell Industries, 3987 Lake Michigan Drive, Grand Rapids, Mich.)..... 102
 "Buckaroo" trains backs..... 102
 London sees first commercials..... 102
 Moving get you down? German elevator gives needed lift..... 102
 Boat for resort sight-seers made with aluminum pontoons (Roby-Hutton, P.O. Box 2383, National Station, Springfield, Mo.)..... 107
 Ship TV links key points..... 107
 "Blackout" racing clock shows time and trips starting cannon..... 116
 "Suitcase" rockets guided to target by soldier-technician..... 123
 Television channels cover 89,000 miles..... 123
 Binoculars used in telephoto photography (D. P. Bushnell & Co., Inc., Bushnell Bldg., Pasadena 1, Calif.)..... 136
 Brig has power..... 141
 Mile of paper in two minutes..... 142
 Bus finder..... 143
 Car exercises dogs..... 144
 Craft patterns printed on plywood (Cutcraft, 1433 S. 13th St., Omaha, Neb.)..... 144
 Helicopter tug sweeps up mines..... 150
 Babies showcase for proud dads..... 156
 Toy helicopter..... 218
 Portable camp stove (Turner Brass Works, Sycamore, Ill.)..... 228

(Continued to page 76)

RADIO CONTROL YOUR MODEL
PLANES BOATS CARS

"CUSTOM MIDGET" RADIO **\$9.98**
 LICENSE FREE BAND
 OPERATES SAME AS \$30.00 SETS INCLUDES LONG RANGE TRANSMITTER RADIO, RECEIVER RADIO AND CONTROL ACTUATOR AND 3' EASY ASSEMBLY WITH OUR PARTS AND PLANS \$9.98, PLANS ALONE \$1.
RADIOMODELS BOX 36 DEPT. PM BALTIMORE 6, MARYLAND

DETAILED INFORMATION & RADIO CATALOGUE 25c
 SPECIAL "SUPPLY SOURCE DIRECTORY" & \$7.00 SUPPLY COUPON... **\$1.00**
 BOOK "RADIO CONTROL OF MODEL AIRCRAFT" CONTAINS 14 PLANS **\$3.98**
 RADIO CONTROL GARAGE DOOR DETAILS..... **\$1.00**

WATCHMAKING
 Learn at home • FREE sample lesson • Approved for Vets.
CHICAGO SCHOOL OF WATCHMAKING
 2330 N. MILWAUKEE AVE., DEPT. 195-A, CHICAGO 47, ILL.

PLASTIC SANDWICH MACHINE
PAYS BIG MONEY

EARNS UP TO \$18.00 AN HOUR

This new remarkable **PLASTIC SANDWICH MACHINE** does a permanent, beautiful, professional, protective, plastic lamination job in exactly four minutes time! Amazing earnings possible in your own home or shop, permanently sandwiching **PHOTOS** and **CARDS** of all kinds, clippings, diplomas, etc., between sheets of clear plastic. Laminating machines from \$35.00 up. Rush name for **FREE** sample and illustrated literature.
PLASTIC SANDWICH MACHINE CO.
 6612 N. Clark St., Dept. LM-101, Chicago 26, Ill.

If you like science, you'll like SCIENCE DIGEST!



Yes, a single issue may take you down the ocean's floor with a marine biologist, or up to the earth's ceiling with a jet test pilot!



You'll stand beside doctors as they perfect new cures to help you live longer and better . . . visit laboratories where researchers are opening up new worlds of the atom.



Only SCIENCE DIGEST gives you a ring-side seat every month to the exciting field of science . . . just as it is also the only publication to tell the stories behind the news in plain, easy-to-read language for non-professionals.

Buy the October issue
at your newsdealer now **25c**
Or subscribe 1 year only **\$3**

SCIENCE DIGEST

200 E. Ontario Street, Chicago 11, Illinois

Gentlemen:

Please send me SCIENCE DIGEST for the next year. I enclose \$3 remittance.

My Name _____

Address or RFD _____

City _____ Zone _____ State _____

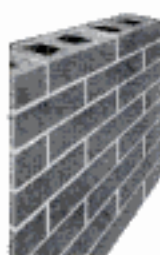

The World's
Most Modern
Masonry



Opportunities Open for Local Manufacturing

From local plants dotting the country has come the Brikcrete used to erect many thousands of buildings—homes, apartments, motels, stores, shopping centers—practically every type of residential, commercial and industrial construction. Why?

Because Brikcrete has more quality features than any other fine masonry—design, size, light weight, insulation properties, range of 14 colors. And a price competitive to lumber! It's an outstanding business opportunity.

High Income Potentials

Freight and distribution costs are by-passed in the manufacture of Brikcrete. By using local aggregates and local labor it's a "direct to user" business. Production economies enable low prices to consumers and generous profit margins to manufacturers.

More plants are needed to operate in protected territories under franchise privileges. Basic machine available on lease or purchase. Write for Brikcrete Book No. 2.

Brikcrete Associates, Inc.
402 West 25th Street
Holland, Mich.

BRIKCRETE

IN CANADA: DUNN MASONRY MACHINERY LIMITED
800 Dundas Highway, Cooksville, Ont.

NOW! A Practical Shop Type
Home Study Course In
AUTOMATIC TRANSMISSION
SERVICING—REPAIR—OVERHAUL

Demand for automatic transmission specialists is terrific! Real big money in this field. You can learn from experts in your spare time at home, shop or garage. Easy to understand, illustrated lessons plus 3 complete transmissions included. (Each student gets a Hydramatic, Dynaflo and Fordomatic). See how easily you can start making money in this wide open field. Send for FREE BOOKLET.

LINCOLN TECHNICAL INSTITUTE
Dept. PM-1, 472 Market St., Newark 5, N. J.
Approved by N. J. Commissioner of Education

MAKE MONEY WRITING

.. short paragraphs!

You don't have to be a trained author to make money writing. Hundreds now making money every day on short paragraphs. I tell you what to write, where and how to sell; and supply big list of editors who buy from beginners. Lots of small checks in a hurry bring cash that adds up quickly. No tedious study. Write to sell, right away. Send for free facts. **BENSON BARRETT**, 1751 Morse Ave., Dept. 27-J, Chicago 26, Ill.



BUILD 15 RADIO

CIRCUITS AT HOME WITH THE NEW DELUXE
1956 PROGRESSIVE RADIO "EDU-KIT"

ONLY **\$19.95** COMPLETE

All parts, instructions, Soldering Iron, Test-er included. 30 Day Money Back Guarantee.
PROGRESSIVE "EDU-KITS" INC.
Room 530-B, Progressive Building
497 Union Ave., Brooklyn 11, N. Y.

Gentlemen: Please Rush me Free Descriptive Literature concerning "EDU-KIT." Also send me Free Radio-TV Servicing Literature. No obligation.

NAME _____

ADDRESS _____

CITY _____

ZONE _____

STATE _____

SCIENCE

Aurora "curtain" of tiny rays forms along magnetic field.....	113
Rope 'scope	117
Implanted magnet moves artificial eye.....	136
Robot "brain" for houses gives life span in minutes (Minneapolis-Honeywell Regulator Co., 2954 Fourth Ave., Minneapolis 2, Minn.).....	142
Stanford "spider" uses radar to chart fall of "stardust".....	150
Embedded wire zips open cast.....	154
Radar pictures travel by phone.....	154
Computer translates Morse code (C. G. S. Laboratories, Inc., 391 Ludlow St., Stamford, Conn.).....	155
Soviets foster redwood tree.....	155
Ultrasonic tape recorder.....	156

Radio-Television, Electronics

Color converter for black-and-white TV (Color Converter, Inc., Columbia City, Ind.).....	157
Low-cost tape recorder sells for \$30 (J & H Sales Co., 1438 Park Rd. N.W., Washington 10, D. C.).....	157
Automatic hi-fi turn-off switch (Slumber Switch, The Hi-Fi Center, Inc., 2630 North Downer Ave., Milwaukee 11, Wis.).....	157
Electronic robot types Morse-code message (Morse Converter, C.G.S. Laboratories, Inc., 391 Ludlow St., Stamford, Conn.).....	157
Airmen's "can-tenna"	157
Battery-operated intercom	158

Craftsman and Shop Notes Index

AUTOMOTIVE

Breaker-point spring repaired by using small rubber band.....	176
Setting carburetor float level with cylindrical gauge.....	207
Dim car lights brightened with aluminum foil.....	230

FARM AND FARMING

Drag chain on feed-bunk floor aids feeding silage to cattle.....	207
Swing gate keeps hogs clear of fence-line feed trough.....	212
Corn planter towed on sled.....	212
Orders written on blackboard speed farm deliveries.....	213
Cistern cover sealed to rim with auto-tire "gasket".....	217
Portable stile folds flat for easy carrying.....	217

HOUSE AND HOME

Rustic soft-drink cooler for patio made from barrel halves.....	173
Speed of cuckoo-clock call slowed by reducing weight.....	177
Solving Home Problems—	
Trouser hanger	178
How to soak toothbrush in antiseptic solution.....	178
Paneled-door joints that have separated can be repaired.....	178
Windows that rattle can be silenced.....	178
Pencil attached to yardstick handy for marking.....	179
Painting bottom edge of door prevents moisture damage.....	179
Dental floss used when sewing buttons on clothing.....	179
Furniture-polish dispenser improvised from large oil can.....	179
Handy kitchen bulletin board.....	180
Fruit for table centerpiece polished with salad oil.....	181
Half-moon wall plaque.....	181
Whatnot shelves assembled from plywood and dowels.....	184
Stove grates on garden wall serve as flowerpot shelves.....	190
Two-way gate kept closed by screen-door springs.....	190
"Wagon seat" serving tray.....	191
"Rolling pin" table lamp.....	194
Chemically softened water will poison house plants.....	196

HOUSEHOLD HINTS

Vase converted to lamp base by removable wooden insert.....	167
Freshly painted drawer knobs held by clothespins on hanger.....	185
String wound on fishing reel prevents usual tangling.....	194
Postage-stamp holder	200
Emergency method of removing key stuck in keyway.....	207
Remove all wax and polish before refinishing floor.....	207
"Trays" for giant ice cubes are empty milk cartons.....	220

MISCELLANEOUS

Dust plug for rifle barrel made from pipe cleaner.....	167
Hardboard panels covering holes keep rats outside building.....	168
Rubbing strips on boat hull are lengths of garden hose.....	168
Paper fasteners used as ties.....	173
"Filling station" for pens.....	173
Book of matches kept dry on trouser belt.....	176
Variable-toned "water flutes" provide party stunt.....	176
Waterwheel drives scraper in water-supply ditch.....	176
Pipe cleaner replaces wick.....	177

(Continued to page 78)

IMPORTANT NOTICE—It is the intention of this magazine to provide its readers with information regarding the latest developments in the mechanical arts. We take no responsibility as to whether the disclosures contained in our articles are covered by patents and advise readers to investigate this subject before making, using, or selling any of the products, machines, or processes described in order to avoid possible liability for patent infringements.

Amazing CAR POLISH Discovery! FAST as a car wash!



Now! MAC'S new Resin Coat. A long-lasting polish that's quick and easy to apply. Fast-acting Solvent Action does it...loosens surface film harmlessly while special resins produce a hard, high gloss that lasts up to 6 months. Just rub on, wipe off. Do a perfect job in minutes—not hours. Nothing like it.

"DON'T WAX IT—MAC'S-IT"

...with MAC'S RESIN COAT!

AT
YOUR
SERVICE
STATION

MAC'S SUPER GLOSS CO., INC.
Los Angeles 42, California

41 SURPLUS TWIST \$2 DRILLS

Less Than 5c Each!

**GENUINE,
HI-GRADE,
CARBON TOOL STEEL,
BRAND NEW**

FOR HAND OR ELECTRIC DRILLS:

Hobbyists! Homeowners! Carpenters! Almost your last chance to get 41 brand-new Carbon tool-steel twist drills for less than 5c each! Usually sells for much more. You get about 5 each of all most-used sizes from needle-sized 1/16" up to and including 1/2". Tempered cutting edges easily bite through steel, aluminum, iron, wood or plastic. Each drill hardened and designed to give 1800 drillings.

29-Piece Vanadium Chrome DRILL SET

Specially made for speed drilling. In sturdy indexed container. Finest alloy steel drills, hardened and precision ground to the sharpest, longest lasting cutting edge obtainable; will easily and cleanly bite through hardwoods, plastics, aluminum, iron and the toughest steels. Unconditionally guaranteed for thousands of drillings. Full jobber length. Sizes by 64ths from 1/16" to 1/2". NOW.....

\$6.95

PLUS 50c HANDLING-POSTAGE Also available with Turned Down Shanks to fit all 1/2" drills. In individual pocket.....

\$8.95 PPD.

Send Check or Money Order. C.O.D., plus postage. Money Back Guarantee.

SCOTT-MITCHELL HOUSE, INC., DEPT. MS-88, 611 BROADWAY, NEW YORK 12, N. Y.

Finest Quality Imported PRECISION PLIERS

ONLY 75c EA.

• Flat Nose • Combination • Snipe • Diagonal Cutter • Round Nose

For Jewelers, Optical Workers, Hobbyists, Craftsmen of all kinds!

These superb German instruments are of drop-forged, heat-treated high quality tool steel, fabricated to most exacting specifications. All over ground and polished to smooth, hard surfaces. Smooth working joints with just the right tension. Jaws meet perfectly to safely and securely hold even the most delicate objects in hard-to-reach corners and angles. Pliers are 4" long.

All 5 for \$3.50 ppd.

11 Pc. DRAFTING SET

Complete Set
\$2.50 plus 25c pp. and tax

High lustre chrome plated instruments of outstanding quality and accuracy. Set includes Plain and Ringhead Bow Dividers, Compasses for use with ink or pencil, Ruling Pens and all necessary parts. Packed in a velvet lined, snap button closure, simulated leather case.



500-WATT POWER PLANT

NEW Gov. Release! \$330⁰⁰
Original Gov. Cost

One Emergency Use
and it's paid for! \$7950
SPECIAL ONLY PRE-PAID

FULLY GUARANTEED

Briggs & Stratton Gas Engine • Compound-Wound Generator

PORTABLE!! Worth its weight in gold in event of power line interruptions—and for many daily farm, home and construction jobs. Priced at less than cost of gas engine alone! OPERATES: Light bulbs up to 500 watts; incubator and brooder heat lamps (keeps chicks alive in power failures); 1/2" electric drills; 6" blade power hand saws (where lines are expensive to run in); food mixers; vacuum cleaners; floor polishers; AC-DC radios; electric hedge trimmers; shallow well pumps; many more machines.
Compound wound generator has max. output of 500 watts, 115 volts DC (although rated by Army at 250 Watts for severe climatic conditions). Powered by Briggs & Stratton 1 1/2 HP, 4-cycle 2700 RPM, easy-to-start engine that operates 3 HOURS ON 1 1/2 GAL. OF GAS. Automatic governor maintains full voltage regardless of load. Standard duplex outlet receptacle with built-in filter and condenser eliminates static in radio reception. Cushion mounted for vibrationless operation. Instruction manual included.

Included! **CARRYING CASE** with

FREE • Handles and "Latch-on" locks

SUPPLY LIMITED! IMMEDIATE DELIVERY! ORDER FROM AD

FREE Catalog of Compressors, Motors and Welders
ROBERTS ELECTRIC CO., Dept. P-311, 849W. Grand, Chicago 22, Ill.

WE PAY SHIPPING

It's the *Cool*est

Jet-action Carburetor
draws in fresh air
that cools the smoke

YELLO-BOLE Carburetor

It's at your dealer's now . . . this marvelous pipe with the tiny Carburetor hole. It draws cooling air right up into the tobacco . . . smokes so cool and mild even *cigarette* smokers enjoy it. The bowl stays drier, too . . . no "wet heel."

Yello-Bole's famous honey-lined bowl eliminates break-in. The instant you light up, fragrant honey begins caking the bowl. Choose your Carburetor from many popular styles. Other Yello-Bole Pipes, \$1.50 to \$2.50. All are imported briar.

For free booklet, write Dept. 8 Yello-Bole, N.Y. 22

REMOVE PAINT EASILY

Wonder-Paste makes paint, varnish, enamel, etc. come off easily—not coat by coat, but all in one scraping. Easily applied with a paint brush. Won't run on upright surfaces. Ideal for furniture, cabinets, trim, floors, etc.

At paint and hardware stores.

Write for leaflet and advice on removing.

Wilson-Imperial Co., 119 Chestnut St., Newark 5, N. J.



Over 5 million cans sold
— it must be good.

IT HOLDS—And How!

For BEST RESULTS you can always depend on Wilhold Glue. Clean to use! Damp-proof! Invisible when dry! In plastic applicators, tubes, jars.

At your hardware or building supply store

WILHOLD WHITE GLUE

WILHOLD PRODUCTS CO., Los Angeles 31 • Chicago 44



Exclusive Double-Bearing HEAVY-DUTY PUMPS

IRRIGATE • DRAIN • CIRCULATE • SPRAY
Up to 7,500 GPH. 3,000 GPH from 25' well. Use 1/4 to 1 HP motor. 1 1/2" inlet; 1" outlet. Stainless shaft.

TYPE X—2 oilless bronze bearings. \$10.95

Won't rust.

TYPE XB—Ball bearing model. \$12.95

Postpaid if cash with order. (West of Miss. add 50c)

MONEY BACK GUARANTEE

Centrifugal and Gear Pumps in All Sizes

LABAWCO PUMPS, Belle Mead 2A, N. J.



ENGINEERING DEGREE IN 27 MONTHS

INDIANA TECHNICAL COLLEGE

B. S. DEGREE, Aeronautical, Chemical, Civil, Electrical, Mechanical and Electronic Engineering (inc. Radio and TV). Drafting, 1-yr. G.I. Gov't. approved. Low rate. Earn board. Large industrial center. Students from 48 states, 21 countries. Demand for graduates. Enter September, December, March, June. Write for catalog. 1695 E. Washington Boulevard, Fort Wayne 2, Indiana.



Have a Motorized Shop at Low Cost

Make Your Own **POWER TOOLS**

Popular Mechanics Book Shows How to Make 60 Machines from Scrap and Discarded Materials

Get SIXTY POWER TOOLS AND HOW TO BUILD THEM, the sensational new Popular Mechanics book. Build your own lathe, drill press, sander, circular and band saw and other power tools at a cost of only a few dollars each. Use old auto parts, pipe and wood and odds and ends that cost little or nothing. Every detail of construction is given in plain language you can understand and follow. Hundreds of pictures and plans show every step to follow in making the power tools you want. Clip this ad and mail with name, address and only \$2.50, or we will send C.O.D. (U.S.A.). You'll be amazed with the fine, practical tools you can make and how little they cost. Your money back if you return the book in 7 days. Order today.



Over 250 Pictures

POPULAR MECHANICS PRESS, Dept. PT-1, 200 E. Ontario St., Chicago 11

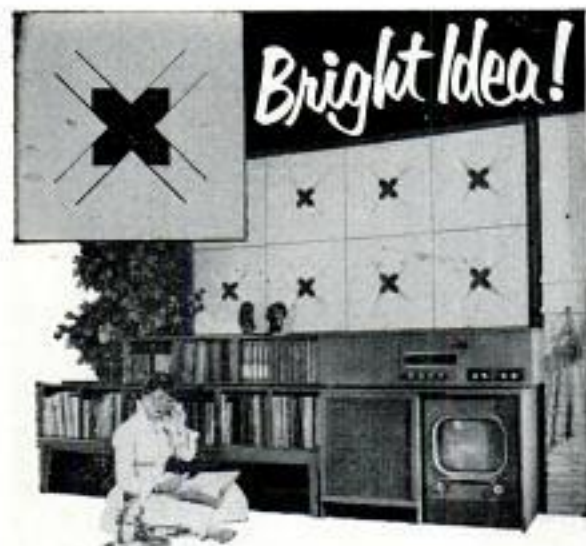

Make with
(RHYMES WITH O.K.) **FIR PLYWOOD**

Exciting new way of decorating with fir plywood. Create bold, colorful designs by "weaving" slits in plywood with dowels or other inserts. Use for dramatic lighting effects, room dividers, fences, doors. Wonderful for remodeling, "do-it-yourself."

FREE BOOKLET—contains step-by-step instructions, ideas, design suggestions. See your lumber dealer or write (USA Only) Douglas Fir Plywood Association, Dept. 99, Tacoma 2, Wash.



Hold it! With the New
BLACK & SKINNER
CIRCULAR SAW VISE



New, easy method for Hand-Sharpener All Circular Saw Blades and Dados

Holds any circular saw blade absolutely rigid for hand filing. Blade easily turned on center stud — retains proper filing angle.

Pat. No. 174609

CLAMPS ANYWHERE — RIGHT ON-THE-JOB
HOLDS ANY BLADE 6" to 10" in DIAMETER

only \$3.95

Made of lightweight, lifetime aluminum — carry it right in your toolbox. Only saw vise of its kind on the market. Only \$3.95 post-paid. Satisfaction guaranteed or money back. Send check or money order to:



BLACK & SKINNER
 1013 East 41st St. Kansas City 10, Mo.

(Continued from page 76)

Candle-powered emergency light mounted on broomstick standard	177
Pocket sewed to tent walls hold miscellaneous items.....	177
Cooled glue remains liquid.....	180
Hinged perches on martin house keep out unwanted tenants..	183
Toy garage puts young car hikers in business.....	185
Flow of ink in ruling pen started on chamomils.....	190
Corkscrew "pegs" for tent driven without hammer.....	194
Bulb provides heat for stovepipe film drier.....	195
Wedge board in sidewalk form eliminates nails and stakes....	200
Small magnet holds loose papers against auto instrument panel	200
Simple flashlight improvised from dry cell and bulb.....	204
Moistening section-box blanks for immediate use in beehives..	212
Garden-hose washers improvised from bottle-cap liners.....	213

TOOLS

Locking socket-head screws.....	184
Gauge clamped to handsaw assures uniform cut.....	194
Cut lengths of wire duplicated by stop gauge on pliers.....	200
Circular-saw blades stored between cardboard disks.....	217
Shopping for Tools—	
Strapbreaker provides a safe means of removing steel strap- ping	218
Combination drill countersinks and counterbores common sizes of wood screws.....	218
High-speed converter multiplies drill-press spindle speeds..	218
Hand tap cuts metric threads in standard sizes and pitches..	218
Self-powered jigsaw has tilting frame.....	218
Nonmarring door vise	218
Saw guard gives full vision from any position.....	219
Mist cooling system.....	219
Electric knife sharpener doubles as a light tool grinder.....	219
Notch filed in tailstock quill locates tool bits on center.....	220

WORKSHOP HINTS

Convertible trouble lamp used as extension cord.....	168
Lawn "table" for one glass made from dowel and can.....	168
Vise provides extra "hand" when clamping work.....	168
Taped block holds small parts.....	173
Broken key section removed with cork and needles.....	176
Borrowed-tool record kept.....	177
Angle "splint" reduces sag in unsupported water line.....	180
Attaching circular shelves to round basement columns.....	180
Putty provides temporary spout when pouring from jar.....	180
Cord suspended on rubber bands protected against kinking....	181
Marking gauge improvised from wooden clothespin.....	183
Steel wool held in clothespin "sands" inside corners.....	184
Applicator for powdered graphite utilizes medicine dropper..	184
Ink pad stored conveniently on slide under table.....	184
Net bags prevent loss of parts soaked in degreasing tank....	185
Adding paste coloring to paint.....	190
Clean molten metal under dross poured through hole in ladle..	194
Set plane iron quickly with thickness gauge.....	195
Lightweight utility horses made from pipe and lumber.....	196
Siding gauge uses saw blade for quick scoring.....	196
Telescope support improvised utilizing camera tripod.....	196
"Outrigger" under stepladder prevents it from tipping.....	200
Strap hinge bent to form flexible ladder hook for paint pail..	204
Angled feeler gauges speed overhead-valve adjustment.....	207
Wax prevents file clogging when working soft metals.....	212
Perfect ovals made with this scriber.....	213
Bushing removed from blind hole by using hydraulic pressure..	217
Marks painted on monkey wrench permit accurate presetting..	217
Insulation stripped from wire by electric brush.....	220
Putty dam around drilling job supplies oil to bit.....	220

**Planes Land Automatically
 On Carrier**

Navy planes can be landed safely aboard carriers despite adverse weather conditions through a new combination of radar and radio. The landing system, developed by Bell Aircraft Corp., has been tested ashore where hundreds of "hands off" landings were made. Further tests will be made aboard a carrier. Radar locates the aircraft to be landed and calculates its altitude, speed and direction. These figures are fed into a computer which determines the necessary course corrections. Radio signals then direct the airplane. The computer takes into consideration the speed of the carrier, its pitch and roll at the instant the plane is to touch the deck. The system also can be used to land aircraft with wounded or fatigued pilots.

This amazing invention can make your engine last longer without an overhaul, save you up to \$250 in repairs. You never change it. This "miniature oil refinery" is

Guaranteed 100,000 Miles!

Every mile you drive, tiny diamond-hard particles of carbon and other abrasives work their way into your oil, get between bearing and cylinder surfaces, wear out your engine.

HOW TO STOP THE DAMAGE

Now, after millions of miles of road testing in government, truck and taxi fleets as well as in hundreds of thousands of private cars, engineers announce:

"results are conclusive. Filtering oil through the Life-Time porous bronze element definitely removes 'danger zone' abrasives, prolongs engine life, reduces overhaul and repair costs."

FACTS ABOUT LIFE-TIME FILTERS

Used in supersonic aircraft as well as in cars, the Life-Time filter is made of millions of tiny bronze balls fused into a screen so fine it takes out all abrasives in the 10-to-40 micron (390-to-1500-millionths of an inch) 'danger zone' that cause major engine damage.

In addition, this "wonder metal" used during World War II and now adapted for the Life-Time filter actually removes acid-producing water from

FREE! ACID NEUTRALIZER \$2.95 value

Made of magnesium—the "sacrifice metal" that acid attacks instead of steel—the Magalizer acid neutralizer is yours to keep free, without obligation, whether or not you decide to keep your Life-Time oil filter after your 10-day free trial!

Dirty oil goes in here. →



Abrasives can't get through porous bronze (greatly magnified). Because of the cone-shaped element (only the original, genuine Life-time filter has this design), particles fall to bottom of case. Only filtered oil can return to circulation in your engine.



oil! Yet it doesn't soak up any of the valuable additives you're paying for in modern oil.

You never change a Life-Time filter; just rinse it out and use it over and over again. This saves you the cost of throwaway pack replacements, besides what you save on engine repairs, save on oil consumption and gain in the resale value of your car.

TRY THIS AMAZING FILTER AT OUR RISK!

Send us the make and model of your car and we'll send you a Life-Time filter to try in your car. If you aren't convinced within 10 days that it will save you twenty times its cost, we'll refund your money without question and let you keep, without any cost, the Magalizer acid neutralizer described below. Ordering is simple:

1. If your car already has an oil filter, send for a Life-Time Conversion Kit which replaces your present throwaway pack with Life-Time porous bronze. Price: \$6.95 for all cars except Buicks with hydraulic lifters and cars with full flow systems, which are \$13.95 (please send make and number of present filter, if you know it). We pay postage.

2. If your car has no oil filter, send \$12.95 for complete unit, including case and element. We pay postage.

3. Or send only \$2 deposit, pay C.O.D. charges on arrival.

Continental Manufacturing Corporation, Dept. FPM-9
Washington Blvd. at Motor Ave., Culver City, Calif.

DEALERS AND DISTRIBUTORS

Write or wire to find out how you can cash in on the "invention that revolutionized the oil filter industry."

Continental Manufacturing Corporation, Dept. FPM-9
Washington Blvd. at Motor Avenue, Culver City, Calif.

Name _____

Make, model, year car _____

Present filter make (if known) _____

Address _____

City _____ Zone _____ State _____

Please ship

Life-Time filter conversion kit
\$6.95
(full flow, \$13.95)

Complete Life-Time filter, with element & housing for \$12.95.

I enclose full price; you pay shipping
 \$2 deposit, will pay C.O.D. charges



California residents add 3% tax.



Graceful Nancy Cooper thrills crowds at the Cypress Gardens' water skiing show.

Dick Pope

owner of fabulous CYPRESS GARDENS, Winter Haven, Florida,

SAYS...

**"The Flawless Performance of
5-RIB CHAMPION SPARK PLUGS
Is An Absolute Must With Us."**

"Water skiing is one of the world's fastest-growing and most thrilling sports," says Mr. Pope. "Many of the spectacular skiing performances seen in magazines, motion pictures and on TV originated here at Cypress Gardens.

"Flawless spark plug firing is an absolute necessity in the boats used to tow the skiers, particularly in precision formations where a "missing" engine could ruin an entire performance. Champions give our boats that reliability. In fact, we have Champions in all our equipment—six Ford wagons, two Lincolns, a Ford Thunderbird, two Ford trucks, a Ford tractor and a score of boats. We know that Champions give us absolute dependability in every engine."

CHAMPION SPARK PLUG COMPANY, TOLEDO 1, OHIO

Champions' steady firing assures the perfect engine synchronization necessary to run these 150-H.P. boats in an even line.



Dick Pope, Jr. makes a sensational jump with his Champion-equipped Mercury outboard hydro.



POPULAR SEPTEMBER 1955 MECHANICS

WRITTEN SO YOU CAN UNDERSTAND IT
VOL. 104 NO. 3

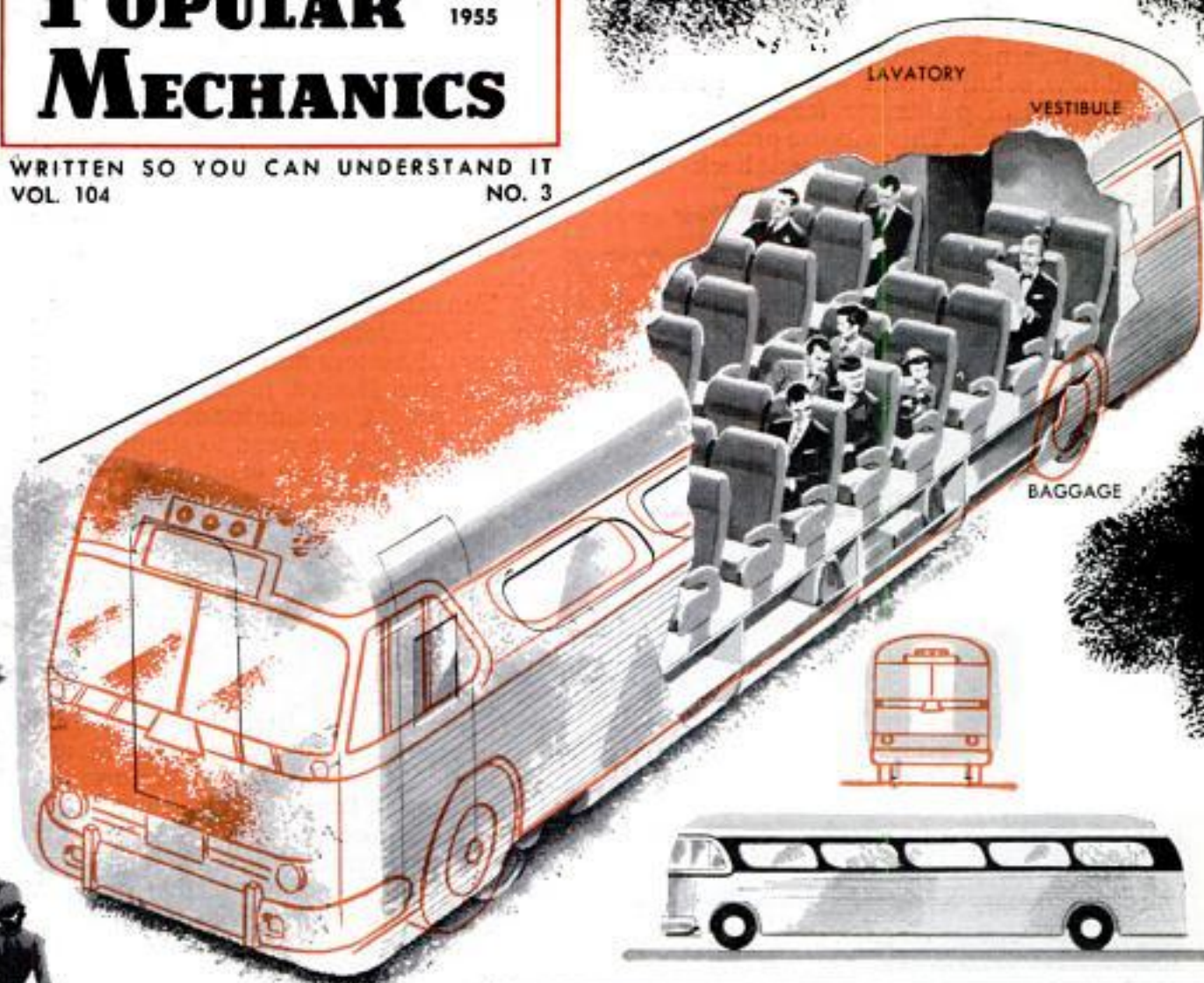

Bus body, indicated in red, is widened and mounted on rail wheels to make the coach. Right, note resemblance of coach to bus

TEN BUSES GROW INTO A TRAIN

By Clifford B. Hicks

BACK IN JUNE 1954, a half-dozen puzzled executives met to solve a problem that has been plaguing the railroads for decades. Out of that meeting rolled a passenger train so unique in concept that it may signal the biggest change in railroading since the diesel-electric locomotive snarled into existence.

Here was the problem pitched to executives of the Electro-Motive Division of General Motors:

For years, planes have been pilfering pas-

sengers from the railroads by offering high-speed travel. Buses have stolen countless others with low fares. Railroads, squeezed from above and below, are currently losing about \$700,000,000 a year on passenger service. Last year a committee of railroad officials asked rail-equipment manufacturers for new ideas that would: Reduce the investment in equipment; reduce operating and maintenance costs, lower the center of gravity, increase average speed, improve riding comfort and reduce the railroads'

passenger deficit. To this, GM executives added one more requirement: That existing parts be used wherever possible.

What was needed, obviously, was some brand-new solution that would punch the stuffing out of passenger fares and offer high-speed travel. This was the problem the Electro-Motive officials batted back and

forth at their conference in La Grange, Ill.

"What we need, say, is something completely new in a passenger train. . . . But it'll have to be a train so inexpensive to build and operate that railroads can't afford not to buy it . . . by the hundreds. . . . Can we chop fares down to a point where the railroads can compete with buses? . . .

Let's think in terms of a train as cheap on a per-seat basis, say, as a bus—or even the family car. . . . Think about it. . . ."

Ten minutes after the meeting broke up, N. C. Dezendorf, vice-president of General Motors and general manager of Electro Motive, made a call to W. H. Harvey, Coordinator of New Products. "Maybe we need to simplify our thinking. What we want, basically, is a new concept of a bus on rails. That's been tried before, I know, and without much success. But no one has ever tried a train of buses on rails. Why don't we try mounting bus bodies on rail trucks, and pull the whole thing with a lightweight locomotive designed specifically for this train?"

Where could Electro-Motive find such bus bodies? Where but in another division of General Motors, the GMC Truck Division at Pontiac, Mich.

Within a couple of days Dezendorf and Harvey were in Pontiac inspecting bus bodies. They came back convinced that a bus body could be mounted on a strong framework that rolled on rail wheels.

That is the simple, basic design of the new train, which is being shown to the public for the first time at the GM Powerama in Chicago this month.

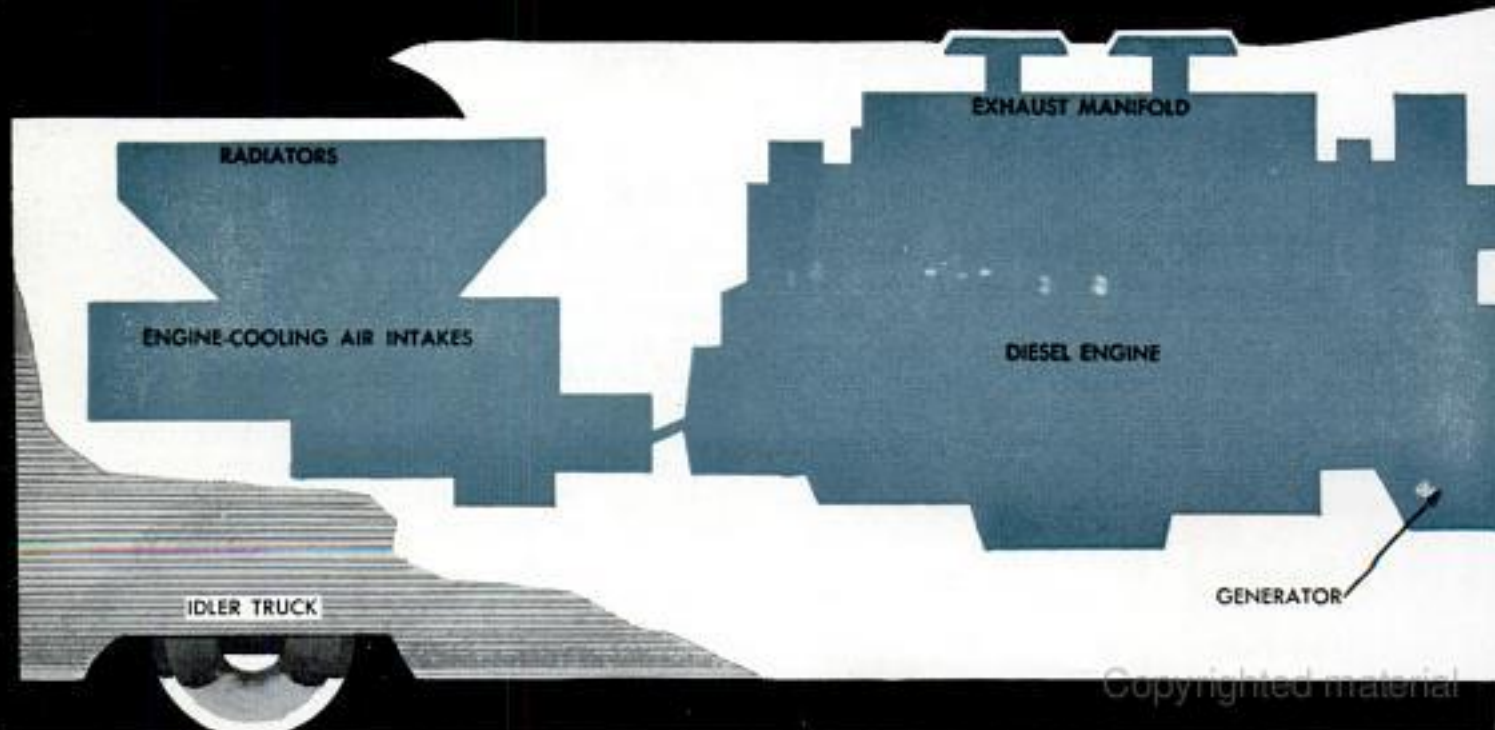
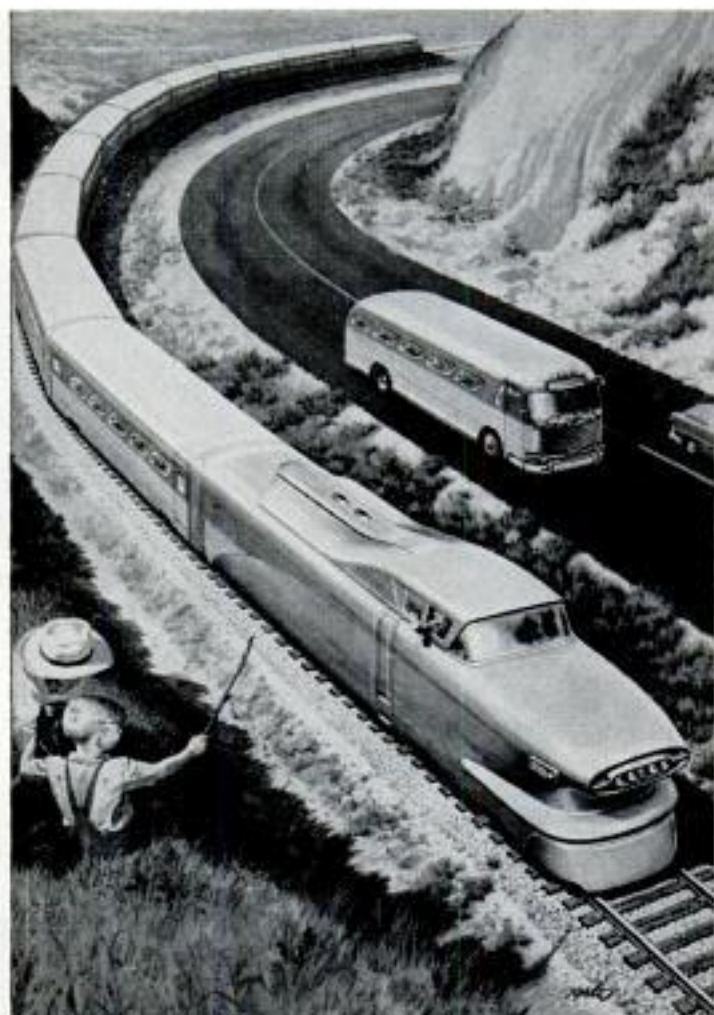

Actually, Electro-Motive has built two of the trains for cross-country display on the major rail lines. When one of them comes your way, take a long look at it, for you may soon be riding such a train whether you're a cross-country businessman or a suburbanite who curses commuter travel. This is one of the few trains that has ever been designed as a complete unit including the locomotive.

Actually, according to Harlow H. Curtice, president of General Motors, the company "has no intention of going into the railroad passenger-car-building business. It is primarily interested in the promotion of the use of its diesel motive power and presents the new cars as a service to its customers."

But the bus-body idea is so novel and so inexpensive you can bet a cross-country fare that it won't die out. The bus body, when it comes off the fabrication line, measures 40 feet long. It is made in two longitudinal sections, so the bus actually is split down the middle. By law, buses are limited to a total width of eight feet. Rail coaches can be built up to 10 feet wide, so to increase the feeling of spaciousness a strip 18 inches wide has been added down the length of the bus between the two sections. This makes it possible to use wide, comfortable seats and still have room for a broad aisle down the middle of the coach.

The undercarriage is simply a strong, steel framework mounted on four wheels. At this point, Doubting Thomas pops up with his question: "Doesn't the thing ride like a boxcar?" It doesn't because you're literally riding on air. Eight synthetic-rubber bellows—two at each corner of the car

—are filled with compressed air from a reservoir inside the coach. When the finished coach is ready to roll, the air pressure is adjusted until the floor of the car is precisely 43 inches above the rails. As you climb on or off the coach, your weight triggers air valves which automatically pump or bleed off compressed air, keeping the car at the same level. An ingenious linkage holds the body on top of this air cushion.

Sections added at each end of the car (replacing the driver and engine compartments of the bus) contain lavatories, entry vestibules and small compartments that may be used for the preparation or serving of food. The two prototype trains have no specific provision for food en route because individual railroads have expressed interest in everything from coin-operated sandwich dispensers to full-scale diners. In these end sections are entry doors. The design permits a small section of the curved roof to be swung up out of the way when the coach is standing at a high platform. Hidden steps swing down into position to serve lower platforms.

Inside the car are 20 double reclining seats. Though this is a train designed to cut fares, passengers still have a genuine feeling of luxury. The coach is beautifully lighted and decorated, with an overhead "package rack" so large it can accommodate a great deal of luggage. Larger suitcases, though, are carried in compartments beneath the coach floor, reached through exterior doors, just as luggage is carried on buses. Below the floor, too, are the air-conditioning unit and the supplementary heating equipment.

Small, sleek locomotive has four traction wheels in front, with two idler wheels for support in rear

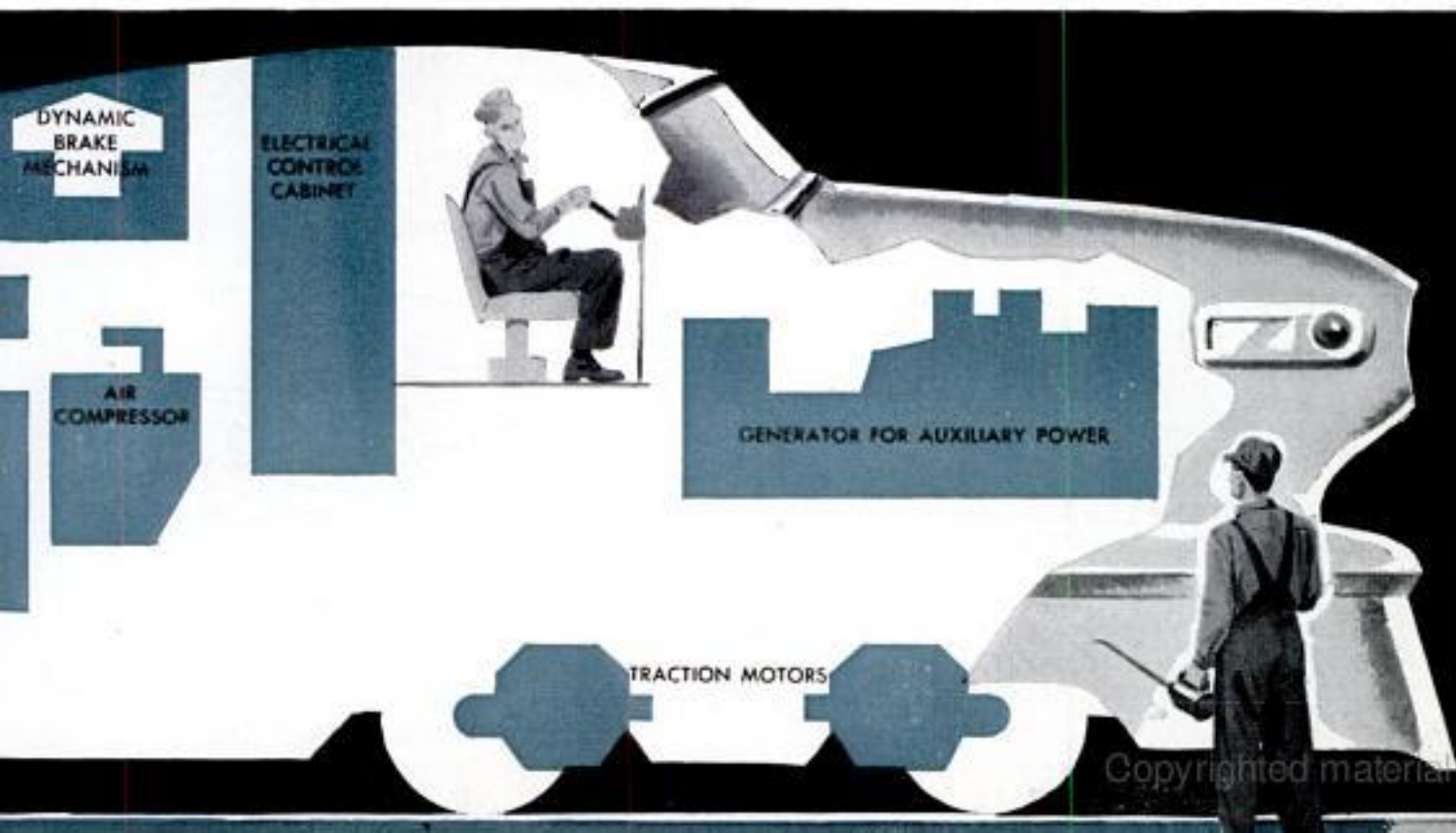

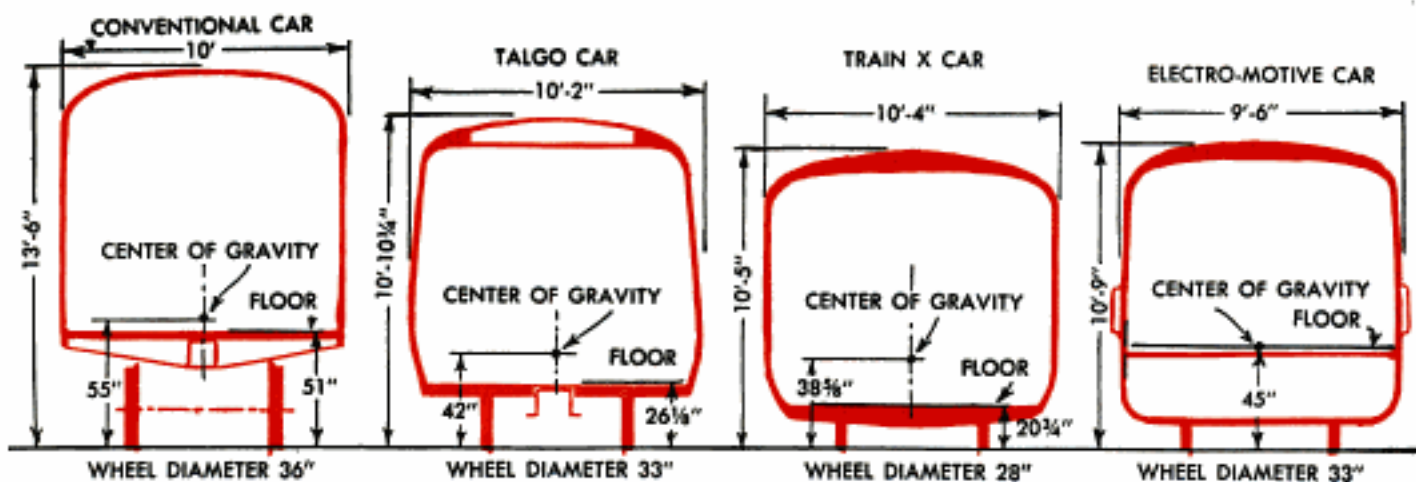

Trend in lightweight trains is toward lower coaches with lower center of gravity, permitting higher speeds

Why build a train out of buses? What's the matter with building trains from scratch? Well, scratch just won't build trains that can lower fares. Streamlined coach trains are built to a specific plan, much like the plan for a big building, and call for all kinds of heavy equipment and specially made parts. In the new train, every piece of equipment from air conditioners (GM's Frigidaire Division) to auxiliary generators (GM's Delco Products Division) are standard parts already in existence. No special dies were required to start turning out the coaches.

Where a conventional luxury streamliner costs around \$2200 per seat, the bus-train, now that design costs are back down the rails a piece, will cost something under \$1000 a seat. This makes it almost as inexpensive as a bus seat, and not far above the cost of a seat in your family car.

Then there's a tremendous advantage in the low maintenance cost. Experience has shown that the average rail coach must be completely overhauled after five to seven

years in service. Seats are torn out and replaced, the car is redecorated, the floor and ceiling are rebuilt, and much of the paneling is reconstructed because it has developed annoying rattles and squeaks over a period of time. All this work costs the railroad from \$35,000 to \$50,000 per coach.

The new coach permits something far different in the way of rebuilding. After five to seven years of service, the car will be run into the shops and the coach, in effect, will be lifted off its underframe, seats and all, and scrapped. A brand new body then will be fastened to the underframe and the coach will be ready for passengers again. Expensive? Actually the cost is only a fraction of the cost of rebuilding a standard coach. And the resulting car really is a new one, for the new body contains all the improvements that have been engineered during the past five to seven years.

The new coaches are just as safe as standard coaches. An ordinary bus body is built to withstand great impact. Actually, the way the car is constructed, the undercar-

Coach literally floats on air in bellows. Valves automatically pump or bleed off air to keep the car level

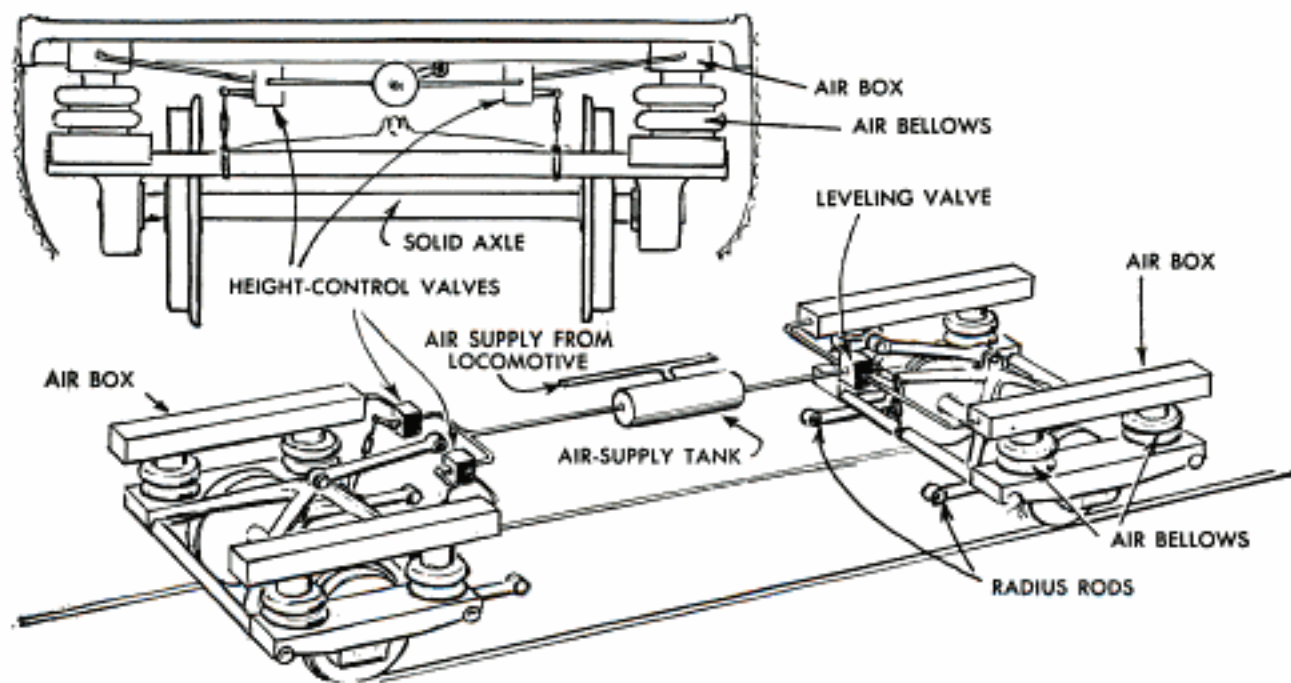

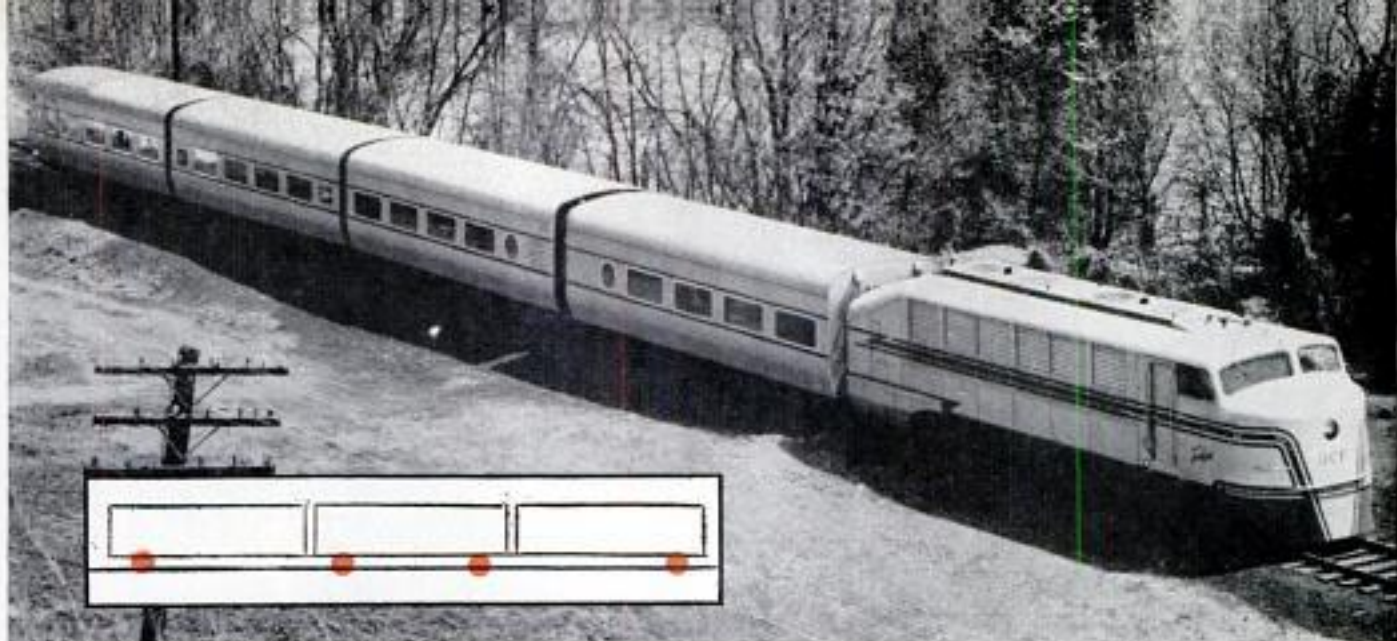

Talgo-type train has three-car unit, plus end car. Outer cars of unit ride piggyback on center car's wheels

riage will absorb virtually all of the shock. Safety specifications of the Association of American Railroads call for a buff resistance in a light train (such as this) of 50,000 pounds. The coach is built to withstand a buff well above this figure.

Each of the two prototype trains has 10 cars, with seats for 400 passengers. As soon as Electro-Motive engineers plunged deep into the rail-bus concept, they were faced with another question: What kind of motive power would do justice to this new train? This, of course, is what GM is most interested in selling.

The locomotive that emerged from the planning sessions is a short, low, sleek job with an aluminum skin. It looks like a cross between an airplane fuselage and a racy sports car, and it performs to match its appearance. A conventional diesel-electric which pulls a 400-passenger train weighs around 320,000 pounds; the new locomotive weighs only 175,000 pounds. The conventional locomotive in comparable passenger

service packs about 2400 horsepower to pull its heavy load; the new locomotive will pull 10 fully loaded cars anywhere in the country with 1200 horses.

The low horsepower means you can go a mighty long way on mighty little fuel. The locomotive, pulling the loaded train at a top speed of 102 miles per hour, consumes only 1.3 gallons of fuel per mile. Ask any railroader whether that is cheap transportation and he'll call it phenomenal. Furthermore, the conventional train requires two, three or even four diesel units because of its weight, but the new train has only one unit to maintain and only one to rebuild when it finally starts losing its horses.

The diesel unit roars away in its cage just behind and below the cab of the locomotive. In the nose of the engine is the supplementary power plant for the train, which provides heat and electricity. Under normal conditions its fuel consumption is only one gallon per hour per coach.

Old-time steam-engine fans will think

Talgo trucks have a built-in mechanism which steers wheels around curves for more comfort at higher speeds

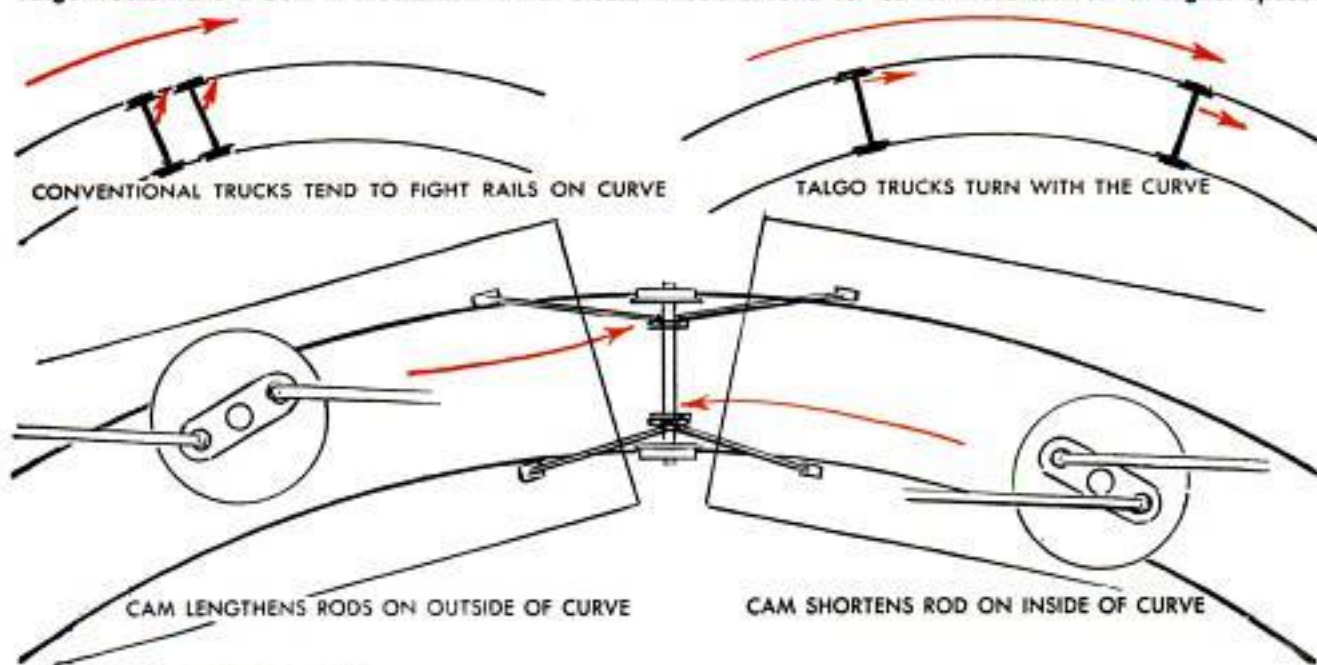

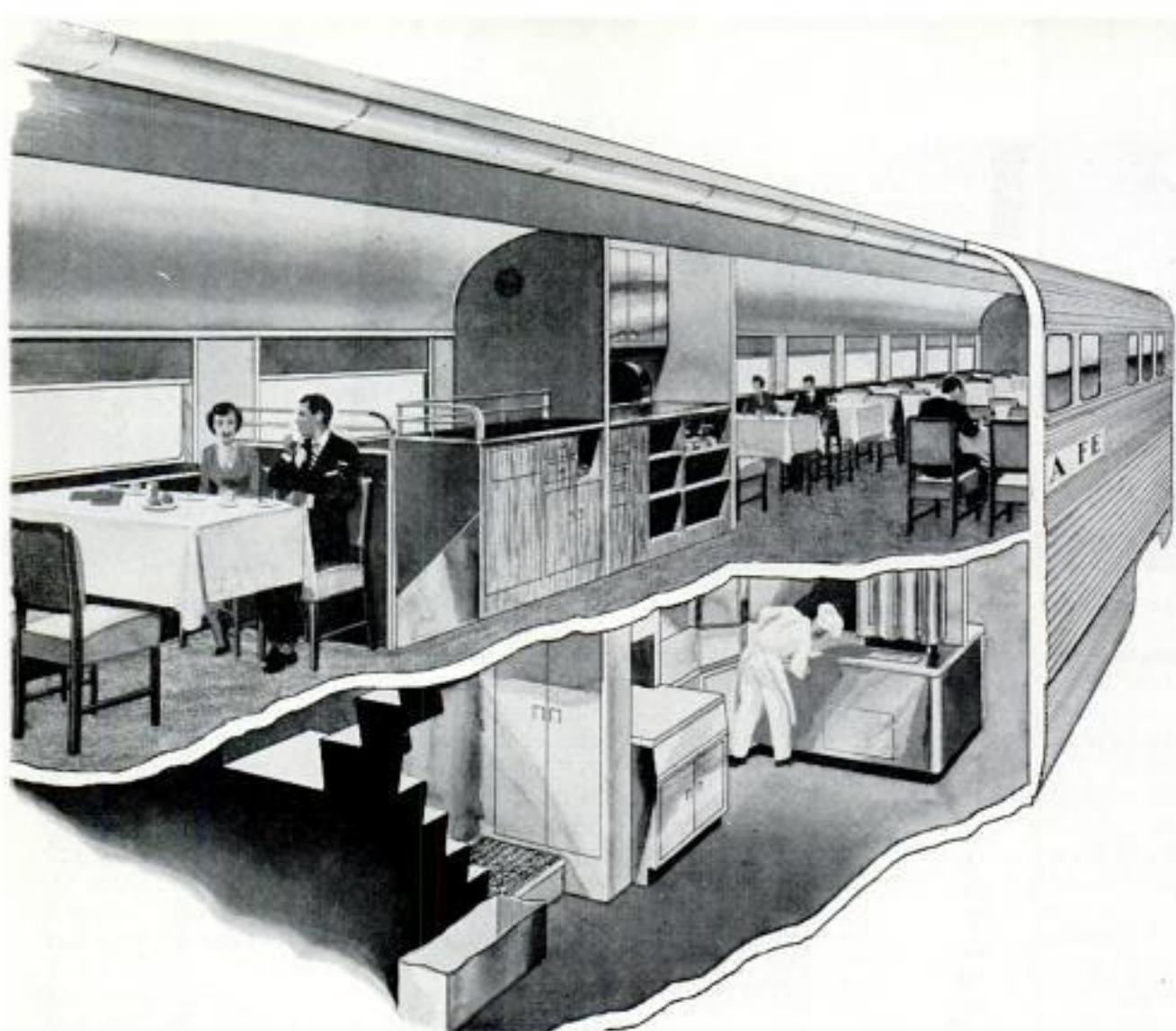

Scenic roads are bucking the trend toward lower cars. Double-deck Santa Fe diner will have a kitchen on the lower level, with dining tables above. Food will move from kitchen to upper level on elevators

the designers have gone loco when they see the wheel arrangement of the new job. Steam engines are classified according to their numerous wheels; some have had 20 or more wheels. The new locomotive has only six wheels. The four at the front end are powered by electric motors, and the two at the rear are simply idler or trailing wheels which support the locomotive.

The light weight of the locomotive and cars is one of the secrets of the low-cost operation of the train, which has a weight

of only 750 pounds per seat. This compares, roughly with about 2000 pounds per seat in a conventional coach.

Bus fares now average about two cents per mile, with rail fares hitting up to 3½ cents. Electro-Motive officials feel that the bus-train can lop fares down to direct competition with bus fares.

The two demonstration trains cost Electro-Motive about \$1,000,000 apiece. Now that the design work is done, officials feel

(Continued to page 256)

"Hi-Level" coach is two feet higher than conventional coach, gives passengers top-story view of scenery

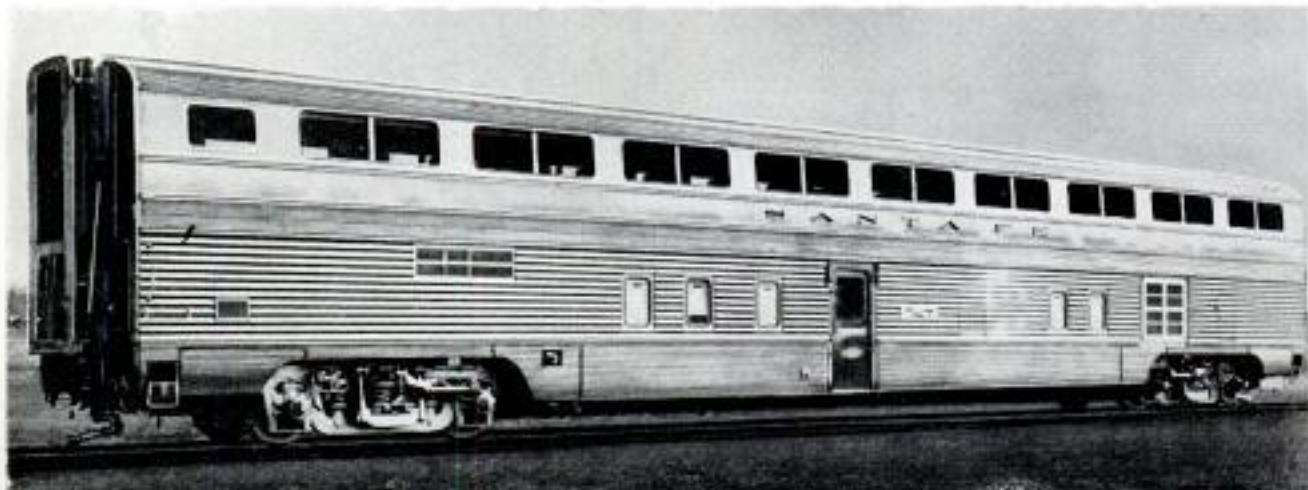

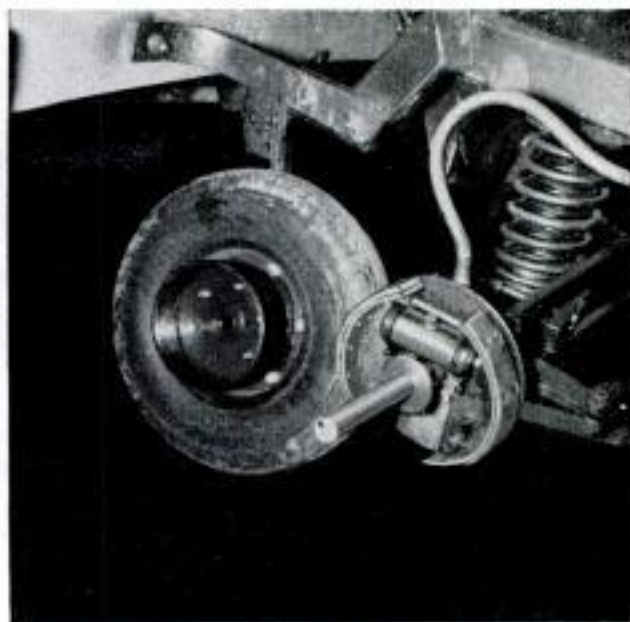
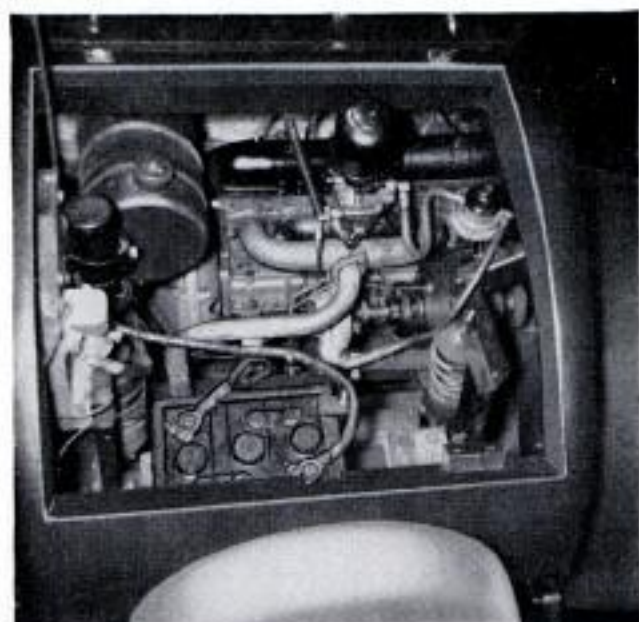

Pint-Size 1932 "Ford" Has Engine in Rear

Starting with four wheelbarrow wheels and an idea, David B. Wood, Jr., designed and built a $\frac{1}{8}$ -model of a 1932 Ford roadster that looks and drives like the real car. Just about everything except the Crosley engine and transmission is handmade. The engine is in the rear, mounted crossways, parallel with the axle. The car has a 66-inch wheelbase. Frame and suspension parts were designed and fabricated by Wood. He even built the brakes, welding and turning the drums from two pieces of flat stock. Handmade brake shoes are expanded by wheel cylinders from a Willys Jeep and a master cylinder from a 1951 Plymouth. A chain drive connects the transmission to



the left rear wheel. The gearshift lever is mounted in the floor. Wood doesn't say what he will do when he has a flat. The spare tire is Ponderosa pine painted white!



Corrugated Roof Unrolls on Job

Roll roofing made of corrugated aluminum can be laid as easily as composition roofing. The material is unrolled across the roof and nailed into place. It also can be applied as siding. No decking or sheathing is required, though it can be used if desired. The aluminum cuts easily and the corrugations, running in the same direction as the rafters, provide fast, unobstructed drainage. The material is rustproof, rat-proof and fireproof.

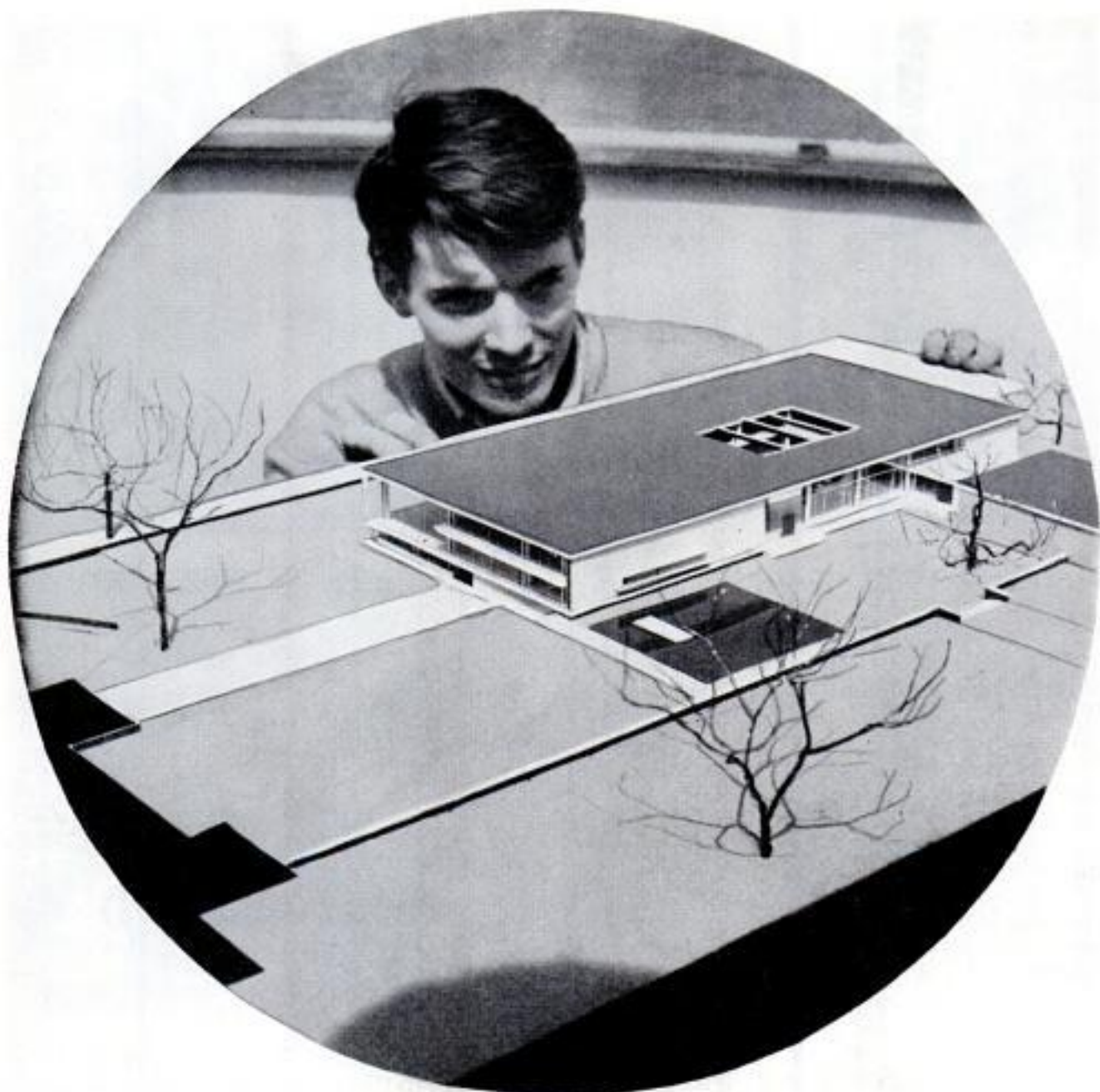

Student inside the laboratory's plastic dome uses sunlight to check the shading problems of house model

THEY'RE PLANNING

Your Home in the Sun

ARCHITECTS at Princeton University have come up with a three-step system for designing your home of the future. They see such a house properly oriented to the sun, and plan it with the sun constantly in mind.

- The first step is to position the house on the site. In the architectural lab, a basic model of the home is placed on a movable board. A powerful light bathes the board in "sunlight." The model then is moved to positions corresponding to the angles of the sun at the house site. Through such experiments the architects determine the best position of the house on the lot.

- In the second step they decide what type of shading blinds to use and build models of them. These miniature blinds are attached to the house model, which is placed beneath the light again. In some cases the architects build larger models of rooms and place them inside a "sun dome" in the building's roof.

- The last step is to decide whether to use opaque, semitransparent or transparent materials for the shading devices.

The result is a house oriented to the sun, taking advantage of Old Sol's heat in the winter but keeping it out of the home during the summer. ★★★



Powerful spotlight simulates the sun. Architects move board to determine sunlight, winter and summer



Twin brothers Victor and Aladar Olgay place model under plastic globe. Lines show path of the sun



Panels of shading material close off a model room. Cardboard man shows how sun would strike human in the full-size room. Below, plastic bubble in roof offers plenty of sunlight for checking a house model



Students at the laboratory test various types of shades. The kind of shade chosen for a particular house depends upon style of house and amount of shade needed. Below, model is maneuvered on board

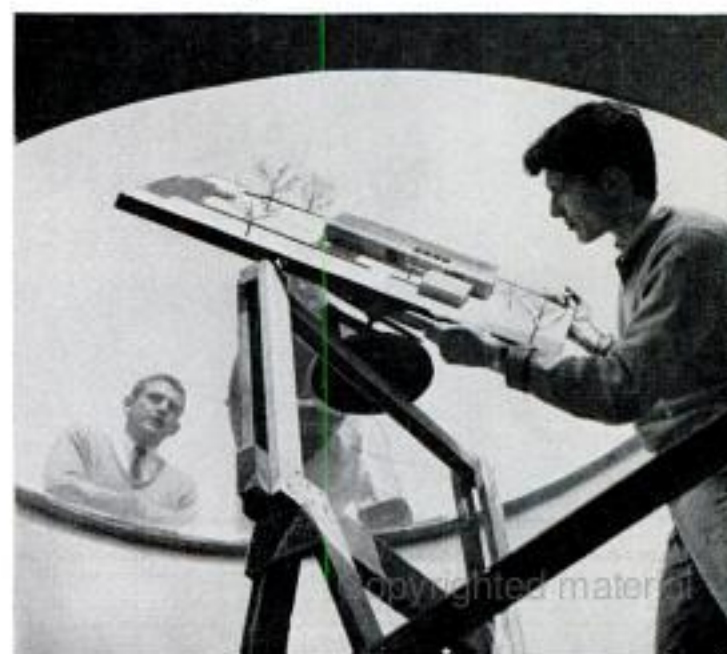



180 M.P.G. Motor Bicycle Can Also Be Pedaled

Light weight and high speed are features of a West German motor bicycle distributed in America. The 72-pound "Mopedo" is propelled by a 1½-horsepower motor to a top speed of 40 miles per hour. It is said to travel as far as 180 miles on a gallon of gasoline and to climb a 10-degree grade in high gear or a 23-degree grade in low gear.

Motor bike is ideal for scooting along the beach or climbing hills. Top road speed is 40 miles per hour

Glass-Walled Pool Shows Off Swimmers

Skin divers at the Milan Industrial Fair accomplished the unique trick of being above-ground and underwater at the same time. The divers performed in a glass-enclosed pool elevated on stilts. Interested onlookers gained new information on the techniques of underwater fishing.

Glass-enclosed swimming pool on stilts draws a large crowd at Milan Fair

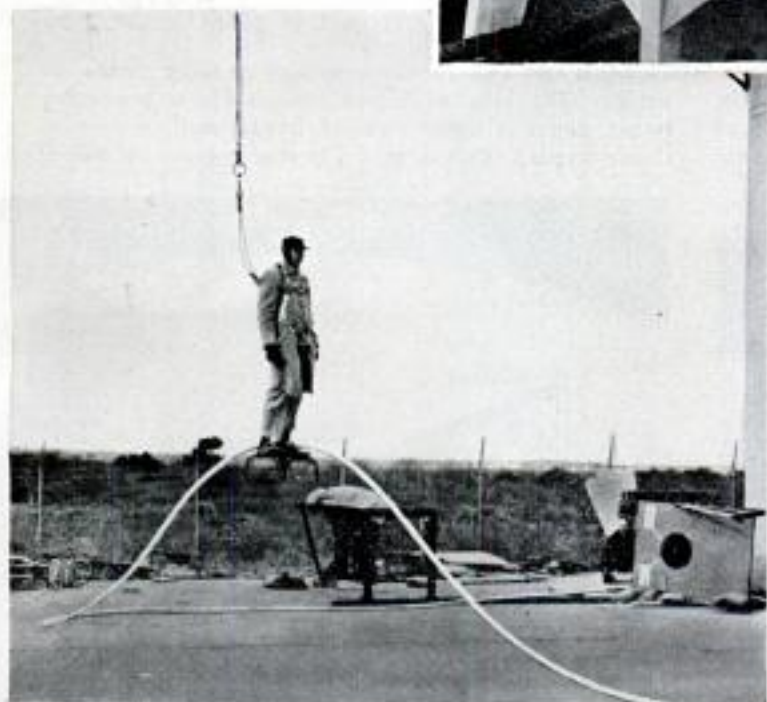
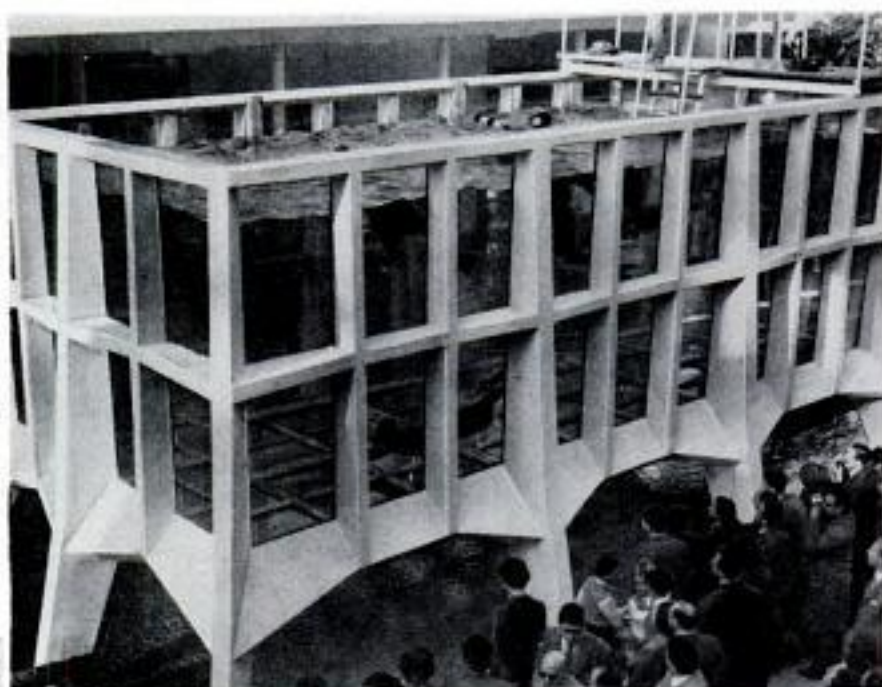

Pilot "Treads" Air On Jet Board

Intensified study of vertical take-off principles has brought forth some brand-new ideas in aviation, the latest of which is a jet board. It is buckled to the pilot's feet and supports him in flight by means of air jets from an attached hose. To hover, the pilot stands still, and to move, he merely leans in the direction in which he wants to travel. Tests of a simplified research model by the National Advisory Committee for Aeronautics show that the pilot has full control over the board, even in gusty winds up to 16 knots.

2500 Dinners Per Hour At Broiler Festival

What is believed to be the world's largest outdoor chicken dinner is served at the annual Maine Broiler Festival, held in the town of Belfast, Me. During the two days of the festival, a 130-man crew works in three shifts to prepare 13 tons of Maine broilers over charcoal-fed barbecue pits totaling 300 feet in length. The birds, brown and hot, are then put on a 100-foot conveyor belt and carried directly from the pits to the serving tables. At the height of the festival, the conveyor brings 2500 dinners per hour to the hungry customers.

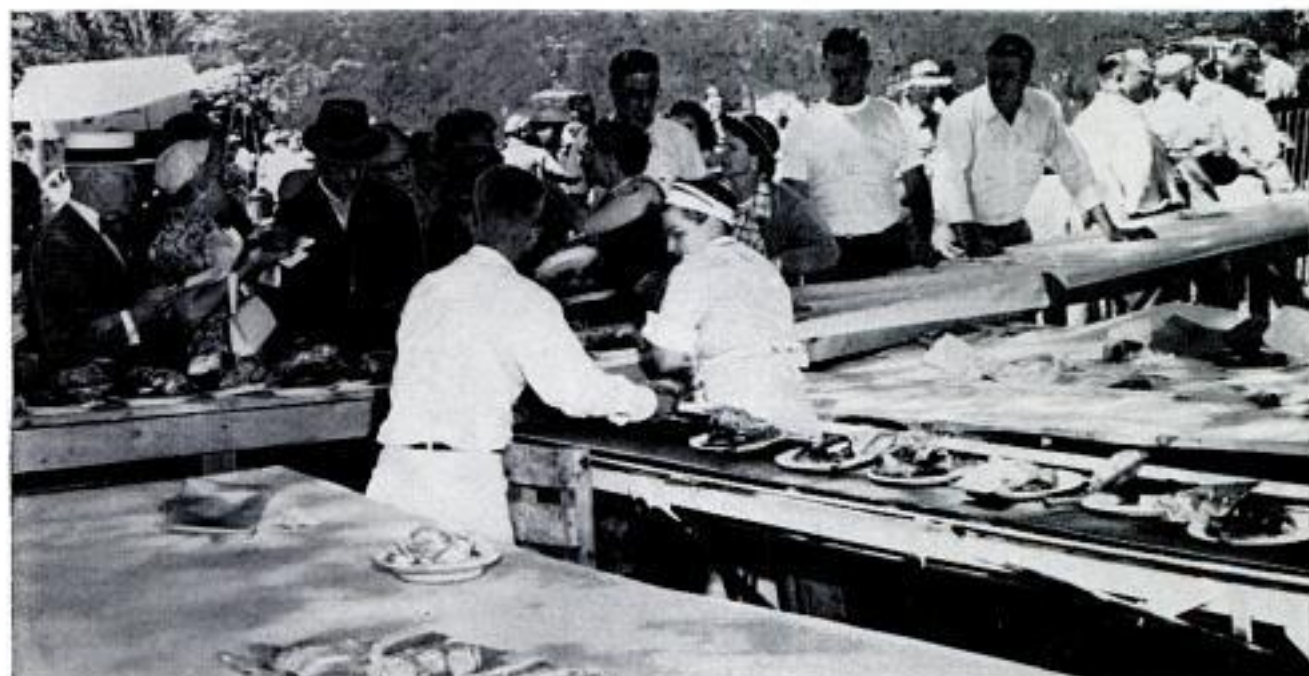

Felt Blocks of Bike Bracket Clean and Oil Passing Chain

Felt blocks, clamped on the chain guard of a bicycle, oil and clean the chain as it passes. The blocks are said to eliminate most of the abrasive wear on both chain and sprocket. A snap-top oil cup is mounted on the top block, which acts as a reservoir for the lubricant. The two oil-impregnated felts wipe dirt and grit from the chain and supply a thin coating of oil to the chain roller pins. Easier pedaling as well as less wear results. The unit lasts at least a year and is easily replaced.

George Westinghouse patented a new invention on an average of every six weeks for 48 years and established 60 manufacturing companies during his lifetime.

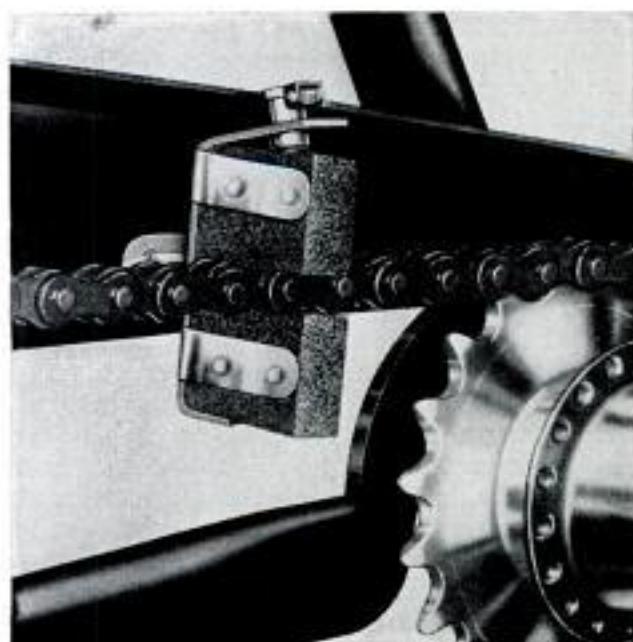

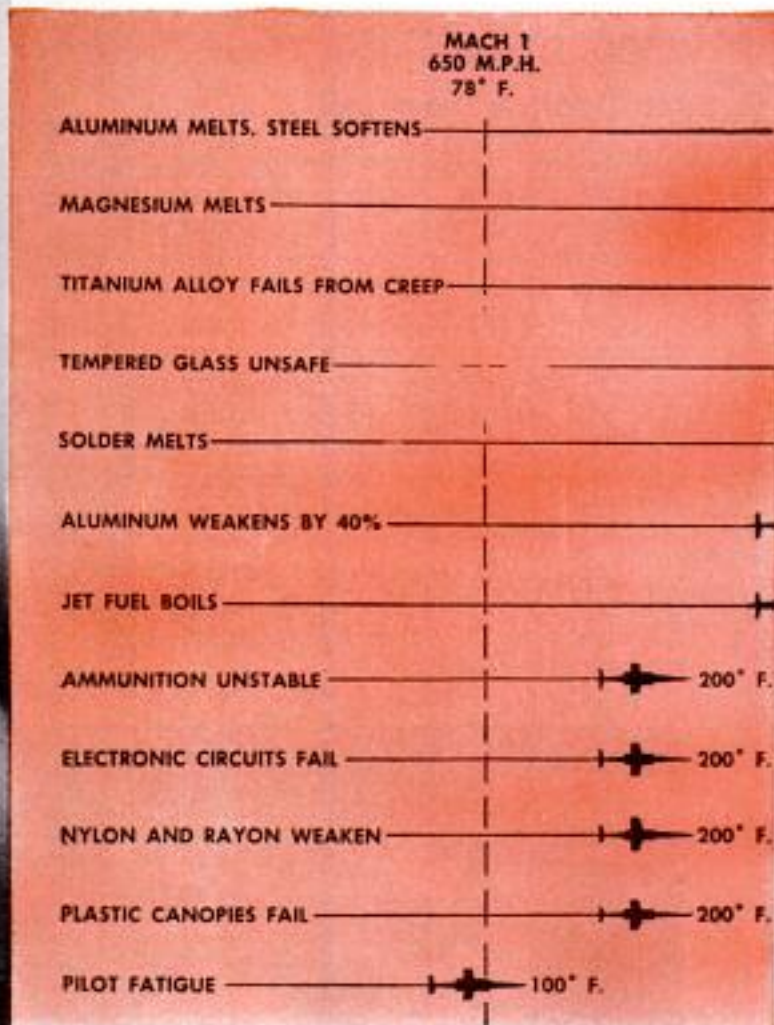

Heat is the biggest problem facing jet and rocket engineers today. Scope of problem is indicated on graph

JET PLANES HEAD FOR

By Thomas E. Stimson, Jr.

REMEMBER, TONY, this is a hot airplane! Don't burn it up!"

Test Pilot Tony LeVier was climbing into the cockpit of the brand new F-104 when Lockheed's Kelly Johnson gave him those final instructions, and Johnson wasn't joking. Aerodynamic heating is a real problem at the speeds at which the new fighter, still on the secret list, is designed to fly.

One pilot had to eject from an F-104 over the Mojave Desert during subsequent testing because of an ordnance failure. Some experts think that the ammunition got so hot from aerodynamic heat that it exploded.

You don't notice this heat in an airliner. At 300 miles per hour the temperature rise is only 16 degrees and the cabin air conditioner takes care of that. But if the airliner could cruise at 1000 miles per hour it would take on 180 degrees of heat simply from friction with the air. At 1500 miles per hour the heat rise would amount to 400 degrees. These temperatures are for flight in the dense air near sea level; at

high altitude they are somewhat less.

What raises the temperature even more is the heat that seeps into a fast plane through the insulation that surrounds the hot jet engine, and heat from the electronic circuits. Even today's military aircraft, not capable of sustained supersonic cruising, must refrigerate the pilot and the electrical gear. Some fighter and bomber planes are equipped with tiny AiResearch cooling units that weigh only 5½ pounds yet have the cooling capacity of 11 household refrigerators. Every bit of this cooling capacity is needed.

Some aluminum alloys lose 40 percent of their strength at 250 degrees, equal at low altitude to a speed of less than 1200 miles per hour. Plastic bubble canopies would soften and collapse at a sustained speed of more than 1000 miles per hour, which creates a heat of 200 degrees. Most radar and radio equipment, designed to operate at a maximum of 160 degrees, gives false signals or fails completely at 200 degrees.

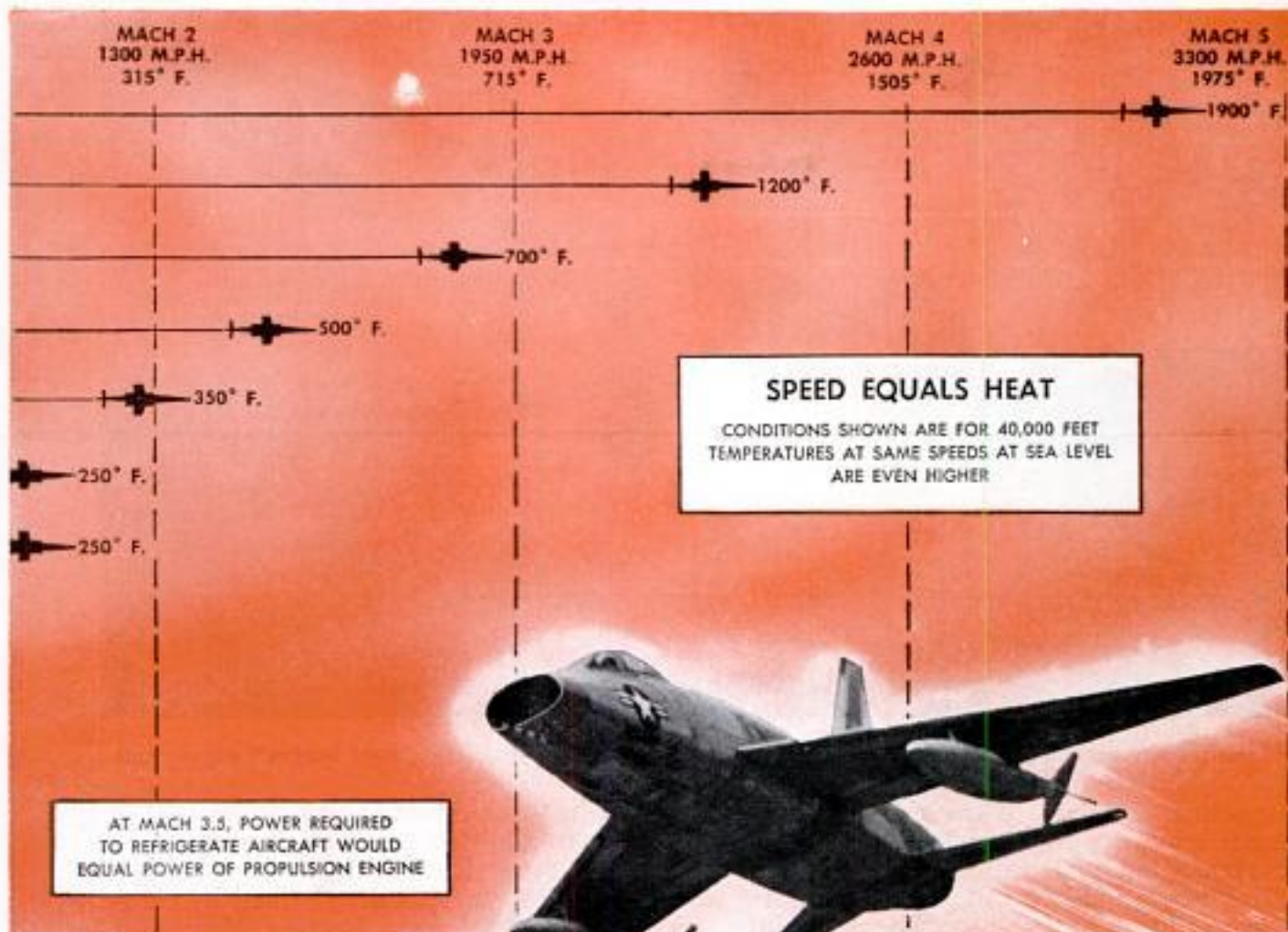

THE MELTING POINT

These and other difficulties have created the so-called heat barrier, now one of the most pressing problems in aviation. To help whip it, aircraft manufacturers have added a new member to their design teams, the thermodynamicist. His job is to find ways of flying at supersonic speeds without actually cooking the pilot and plane.

The campaign to learn how to fly fast in spite of the heat is being conducted on various fronts.

A "hot" wind tunnel that is almost comparable to a blast furnace has been built by the National Advisory Committee for Aeronautics at its Ames Laboratory at Moffett Field, Calif. Temperatures as high as 1200 degrees can be created in the test section of the tunnel at the same time that air speeds of Mach 5 or 6 are obtained. Nearly all common structural aircraft materials would fail under these conditions. Even glass softens at such a high temperature.



Two views of North American F-100, Super Sabre, one of latest and fastest jets in military service. A supersonic fighter, it is made of heat-resistant metals and equipped with automatic cockpit air conditioning



Test instruments are carried in the needlelike nose of the X-3, jet designed for "heat barrier" experiments

Inspection windows in the side of the hot tunnel, consequently, are double, and fused quartz is used for the inner window.

The new tunnel permits studies of many aspects of the heat problem. The possibility of insulating a whole airframe will be investigated. The value of evaporation devices to keep an aircraft cool, and the possible use of "heat sinks" to drain off high temperatures from critical areas, will be studied.

The leading edges of a plane heat up first at high speed, next the trailing edges become hot, finally the rest of the structure warms up. This uneven heating tends to buckle the skin. Structural distortions occur, changing the aerodynamic shape. This problem of transient heating, as well as the stagnation effects that result when the entire structure reaches the same temperature, can be studied with the new tunnel.

Right, tiny air conditioner for Douglas A4D equals 11 refrigerators. Larger unit for Douglas C-133, turboprop transport, could cool three homes. Below, chart shows surface heat rise due to skin friction



An odd thing about the tunnel is that it would actually destroy itself if allowed to operate at the high temperatures that it creates. After the hot air (heated by compression plus electric heating elements) slams through the test section at supersonic speed, it passes through an aftercooler that brings down its temperature to 100 degrees or less. Unless this was done the hot air would burn up the bearings of the compressors that recirculate the air past the heating elements and through the tunnel again.

Other aspects of aerodynamic heating are being studied at Edwards Air Force

(Text continued to page 252)





Speed stripes painted on wing, above left, change color as heat rises to warn pilot of temperature changes on wing surface. Right, pilot is raised into cockpit by small motors. In emergency, pilot in seat is ejected downward and fins visible on side of seat unfold to act as air brakes to slow descent

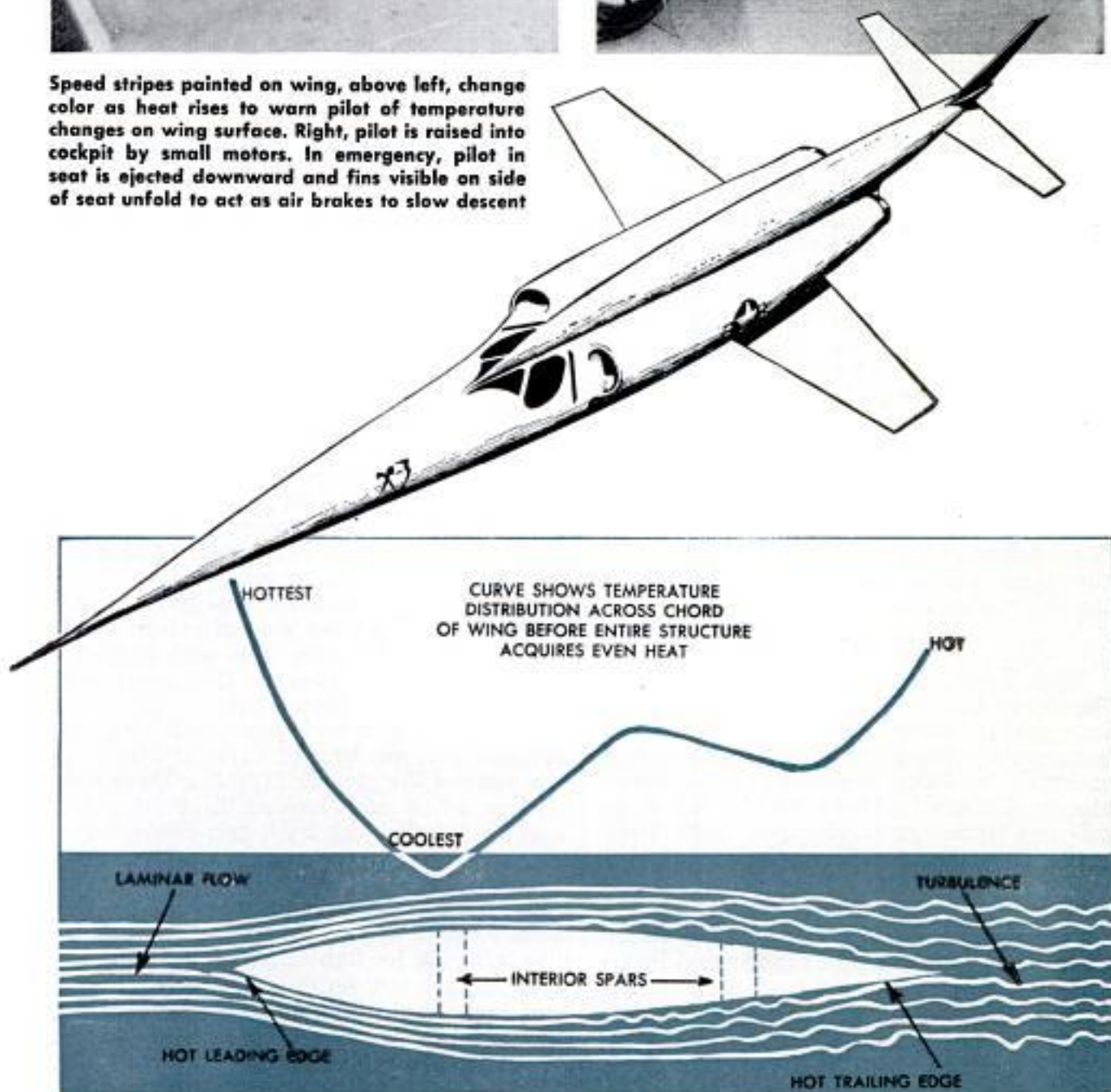

Detroit Listening Post



By Leo Donovan

SANTA CLAUS' sleigh will be filled with new cars this year—at least so the industry hopes. All the 1956 models will be on the streets well before Christmas, in plenty of time for gift shoppers. All but one (the Rambler) will be out before Thanksgiving Day.

The 1956 parade starts with the Lincoln and ends with the Rambler. Both of these extremes will be wearing all-new bodies. But between the Lincoln and the Rambler will come a succession of familiar bodies sporting a variety of face lifts.

By the time you read this, the 1956 Lincoln will probably be in the showrooms. It is set to debut around September 1. It will be followed by the rest of the Ford divisions, including the Continental which is due out early in October. The new, so-called Edsel car is still more talk than reality. This car is supposed to fill the price gap between Mercury and Lincoln.

The Chrysler lines will hit the street during October with Dodge probably first. General Motors' divisions will make their debuts during the period from late October to early November. The Nash-Hudson and Studebaker-Packard lines will appear in the same period except for the all-new Rambler which is set for December.

What to Expect

With a few exceptions (such as Lincoln, Rambler, Continental and the Eldorado brougham), there will be few styling or engineering changes that can be called sensational in 1956, according to advance stories. Generally, there will be the usual off-year appearance changes, both front and rear, with more emphasis on engineering refinements involving added horsepower, improved transmissions.

Push-button control of automatic transmissions is expected on Chrysler and Packard automobiles. Now that muscle is not needed for shifting gears, there is no need to retain the shift lever—hence push buttons. The buttons look and operate just like the push buttons on your radio.

Packard, after discovering a real interest in torsion-bar suspension, will extend the system through its entire line for 1956. It will introduce another exciting mechanical innovation—this one in the rear end.

Somebody in sales has discovered safety. Two of the big producers are going to go all out to sell safety features for 1956. This has been a sensitive area for discussion in recent years, but the attitude is changing.

Some of these safety features have been around for a long time, such as seat belts, padded dashboards, recessed knobs. But with the sales and advertising departments going to work on them perhaps they will be important factors in 1956. In any case, the companies are playing it safe by offering most of the safety features as extra-cost options—you pay your money and take your choice!

At least one, and possibly two, of the 1956 cars will have compression ratios of 10:1, requiring the higher-octane fuels that the petroleum industry will have in the pumps by the end of the year. Engineers predict the increased fuel economy will be noticeable. At an eventual 12:1 ratio, cars should get 30 percent more miles per gallon, engineers say (if the cars are not 30 percent heavier by then).

Smaller Wheels Coming Later

Smaller-diameter wheels (as small as 13 inches eventually, but more likely 14 inches at first) won't be available for the 1956 models because of the production changes involved. But they are on the way.

The 14-inch wheels have been tried on some 1955 cars and they look and handle beautifully even with no chassis changes, according to one proving-ground source. Being smaller they will get more wear per mile, but the rubber companies are planning to build longer life into tires to compensate for the smaller size.

If you are among those who have been a little annoyed by the violent colors available on the 1955 cars, you will probably welcome the news that the 1956 paints will be grayed down somewhat.

The coming model year could be described (in one line of cars, at least) as the year of the glorified tail fin. There was a time when cars looked alike from the rear, but today the back-end character is even more emphatic than that in front. And the trend is expected to continue as the 1957 cars invade the area of jet-plane design. Rear fenders will be longer and higher, like the tail of a jet fighter plane.

If you are still on the fence about a new car, you should be able to do well during the next few weeks. Dealer inventories are about 50 percent above last year and the 1956 cars are on the way!



Ersatz Bird Wakes Sluggabeds

Gentle souls who resent the clanging fury of an alarm clock can now be twittered awake by a "bird alarm." A synthetic canary in a gilded cage starts to chirp when it's time to arise. Its voice is a small music box linked to a clock in the bird's cage. The unit, made in Villingen, Germany, was recently on exhibit at the industrial fair in Hanover, Germany.

Radio Waves Cook Turkey

High-frequency radio waves in a new electronic oven cook a 15-pound turkey in 45 minutes instead of the usual six hours. Developed by GE, the oven may be available in 1957. Unlike previous ovens, the new unit imparts an appetizing browned surface to the meat it cooks. Heart of the unit is a magnetron tube which converts ordinary house current into high-frequency current needed for electronic cooking.



SEPTEMBER 1955

Crystal-Ball Department: THE 1956 AUTOMOBILES

Here is a summary of rumor, speculation and hearsay (some true, some perhaps false) about the 1956 automobiles.

Buick: Major face lift. Unlikely rumor is that air suspension will be used.

Cadillac: Same as Buick. Will offer the Eldorado Brougham, a hardtop version of the luxurious convertible. All-new Hydra-Matic will not be a torque converter.

Chevrolet: Important grille changes. May offer four-door hardtop. Power up.

Chrysler: Rear fenders and front grille new. More power. Transmission is unchanged except for push-button shifting.

Continental: Return of a classic. You'll spot it as a modern descendant of the earlier model. Very lush, but in good taste.

De Soto: Unusual rear-end styling, all-new front grille (no teeth). Power is up.

Dodge: Surprising amount of sheet-metal changes for second-year body. Emphasis at Chrysler Corporation is on rear-end styling. Important engine change. Even more emphasis on the "flashy look" of the Lancer.

Ford: Emphasis on engines and safety features. Grille, chrome and taillights changed. More power. No four-door hardtop expected.

Hudson: Major face lift; identification changes to distinguish it from Nash. The front fenders and grille to be new.

Imperial: Rear-fender changes.

Lincoln: All-new body is long, low and uncluttered—strong bid for prestige market. More power. Current fine handling is retained; soft "boulevard" ride added.

Mercury: Same as Ford, plus addition of a new low-price model.

Nash: Same as Hudson.

Oldsmobile: Major face lift.

Packard: Torsion-bar suspension to be extended to all Clippers. Revolutionary rear end is the big mechanical story. Push-button transmission. Horsepower will be up as will displacement.

Plymouth: Same as Dodge. All Chrysler Corporation cars have push-button operation with Power Flite. Four-door hardtop.

Pontiac: Same as Chevrolet.

Rambler: An all-new body for 1956. Said to be as advanced in styling as tomorrow's dream cars. It will have wrap-around windshield, of course. May even offer a four-door hardtop. Still a six but power up.

Studebaker: Will build two different cars this year: One is the long, low sportster that has been the company's best seller since 1953; the other, an all-new-looking and more conventional family car. Both considered in low-price field.

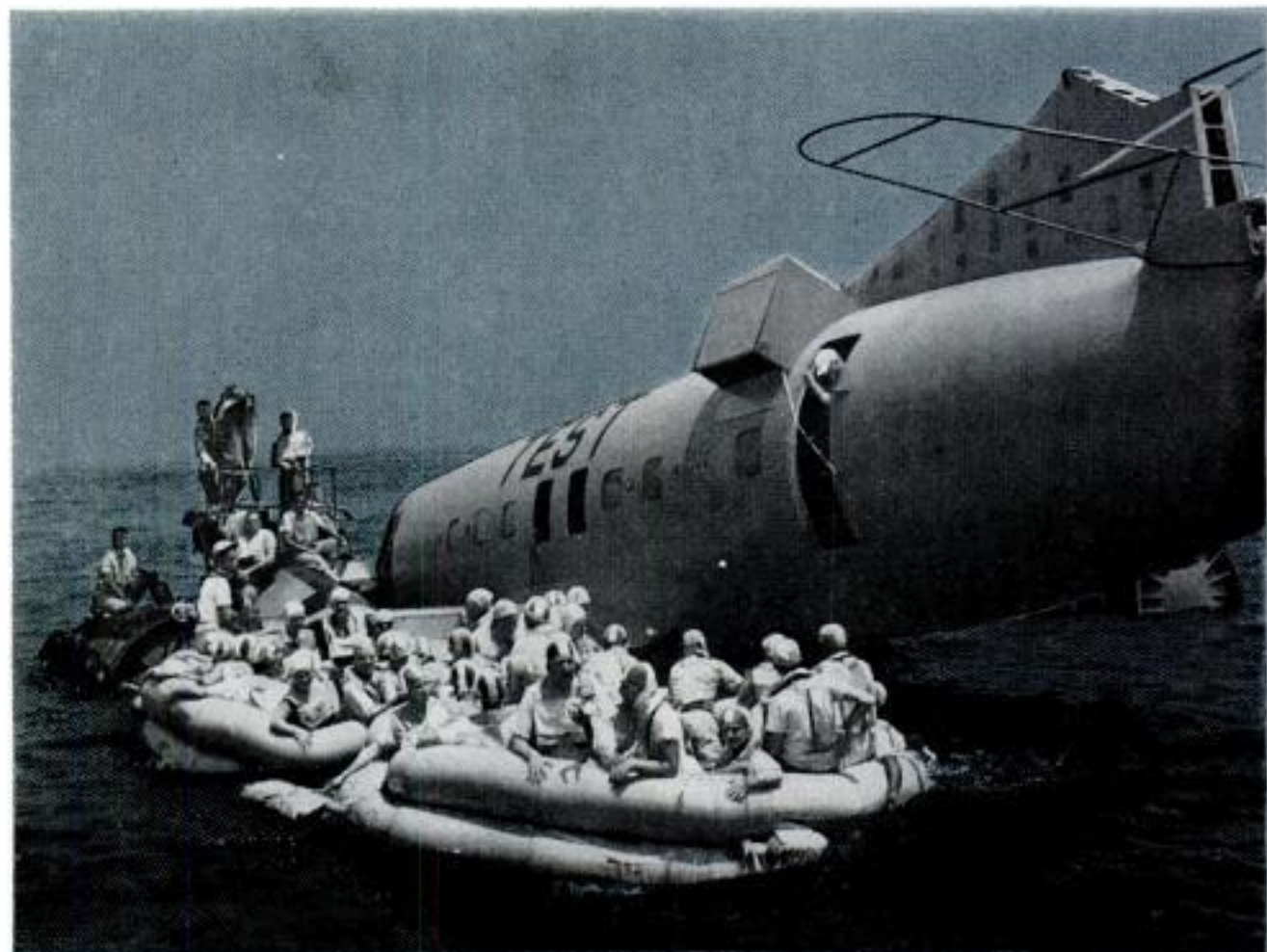

In 4 minutes and 20 seconds, a safe margin, 40 passengers were evacuated from this downed airliner

Operation Ditch

FOR NEARLY A WEEK, early this summer, 40 volunteers, mostly government office workers, ranging from a 65-year-old white-haired grandmother to an 11-year-old boy, became a typical plane load of passengers for a series of survival tests known as "Operation Ditch." Sponsored by the Civil Aeronautics Administration, in conjunction with the airlines and other organizations in aircraft and allied industries, the trials were staged to observe the efficiency of present ditching systems, to try out new equipment and procedures, and to watch the reactions of a typical group of people who might make up a load of passengers on any commercial airliner.

The "ditched" plane was a production-line fuselage of a Martin 404 land-based, twin-engine airliner, with standard seating arrangements. Stripped of engines and wings, it floated on steel drums nose down in the water, just as it would do in a regular ditching. Tail surfaces were removed to indicate they'd been lost in landing, and also so the plane wouldn't nose into the wind. On calm days when the sea wasn't tough enough to suit observers, high-pow-

ered Navy crash boats tore back and forth beside the hulk to make big waves and rough things up for the stoic volunteer survivors, who dubbed themselves "drownies."

Actually, few airlines have ever had to ditch a plane, and most don't expect they'll ever be faced with such an emergency. But every overseas plane is equipped with life jackets for all passengers, enough rafts to accommodate everyone aboard and a set of procedures for the crew to follow.

For Operation Ditch, a United Airlines pilot, copilot and two hostesses played the part of crew on the damp research fuselage. "We followed the procedures taught us at school," explains hostess Roberta Randolph. "There's always time to prepare for a ditching, so these volunteer passengers always had seat belts fastened and life jackets on before the whistle blew. My post was at the forward hatch, over the wing. The other hostess was at the door. Passengers in the center of the cabin were evacuated first—through the door. Those up forward went out the hatch to the wing. Our job was to see that all were safely aboard rafts in record time. Then we

jumped in after them."

A ditched plane will float for about 15 minutes, which should be ample to get everyone safely in rafts and away. But casualties and "goofs" can often make a tight squeak of it. Operation Ditch was no different.

On one test run, minutes were lost when the white-haired grandmother, who couldn't swim, slipped on the wing, sat down and refused to jump across to the raft. Hostess Randolph finally had to roll her aboard. On another run, a raft failed to inflate, another was thrown in on top of it and, as "drownies" leaped into it, the dud underneath suddenly decided to fill up. As it inflated, it heaved people from the top raft into the sea in all directions. The resulting shambles cost about five precious minutes. So did the raft that triggered itself too soon and inflated inside the plane.

"Those misfires were just what we wanted to see," explained one observer. "The human element simulated here is identical to what you might find on any ditched plane. By observing such errors in a test like this, we can see how foolproof our equipment and procedures are."

According to Dr. Barry King of CAA, Operation Ditch was not to prove anything. "Purely experimental," he says, "to see what happens when a plane goes in the ocean. It is the first time this kind of ditching test has been accurately simulated with a land-type plane."

Whatever it proved or didn't, Operation Ditch's "drownies" had themselves a 10-day workout. During the long series of tests, they jumped from starboard exits, port exits and both sides together—into water, into rafts and both ways at once. They slid into rafts on a new pneumatic escape slide, which was originally designed for evacuating people from high doorways of planes on land, but showed itself equally



Garrett Corporation photo
Passengers demonstrate escape from plane via pneumatic slide, originally designed to evacuate people from high doorways of planes on land. After evacuation it can be detached from plane and used as a life raft.

capable of chuting chuters at sea. Attached to the doorsill of the plane, it inflates outward automatically. Trapped passengers can zoom down it like kids on a playground slide. When everyone's out, it can be detached and used as an additional piece of flotation gear.

Chances are millions to one that you will ever ride a plane that has to ditch in years to come. But if you do, everything should go like clockwork—and you can thank the Norfolk "drownies" who survived 10 days of ditching back in 1955. ★ ★ ★

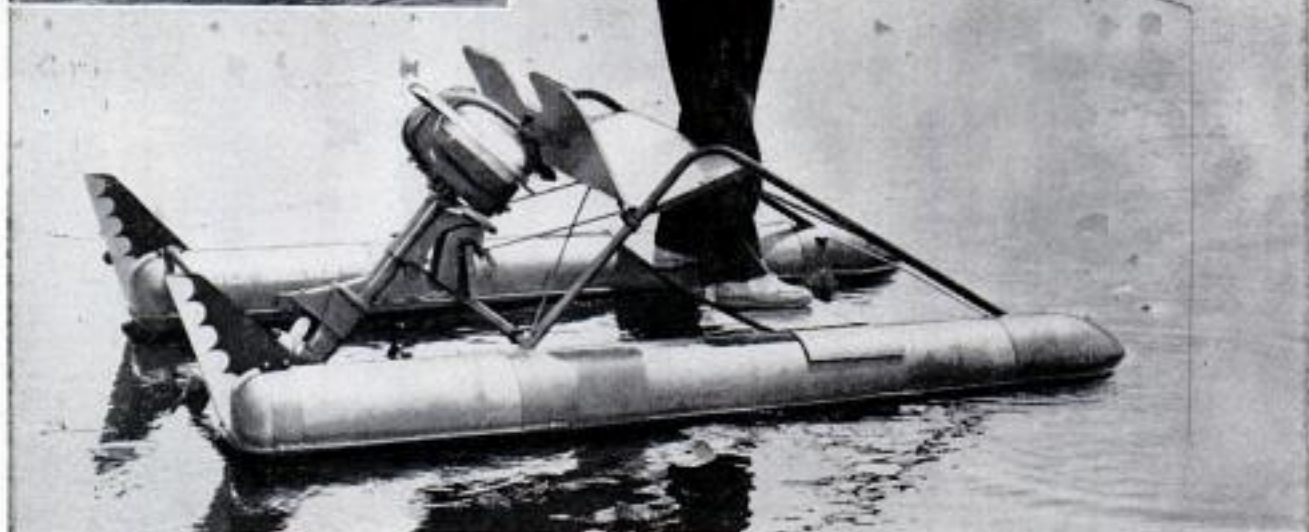

Sportsmen can cruise in marshes and shallow ponds with a pontoon boat that mounts an outboard motor. The 125-pound, 12-foot craft can also be equipped with foot pedals, an engine using an airplane-type propeller, or a sunshade canopy. A seat of marine ply-

Pontoon Boat

wood big enough for two is mounted on tubular-steel framework. The twin pontoons are each divided into four watertight compartments, and are made of molded glass fiber which requires no maintenance. The boat is quickly assembled from a kit.

Clip on Fishhook Holds Worms

There's no need to thread a worm on a new fishhook. On the shank of the hook is a small clip. The angler places two worms under the open clip and then closes it. The clip grips the worms securely, yet permits them to wiggle, giving the bait a live action.

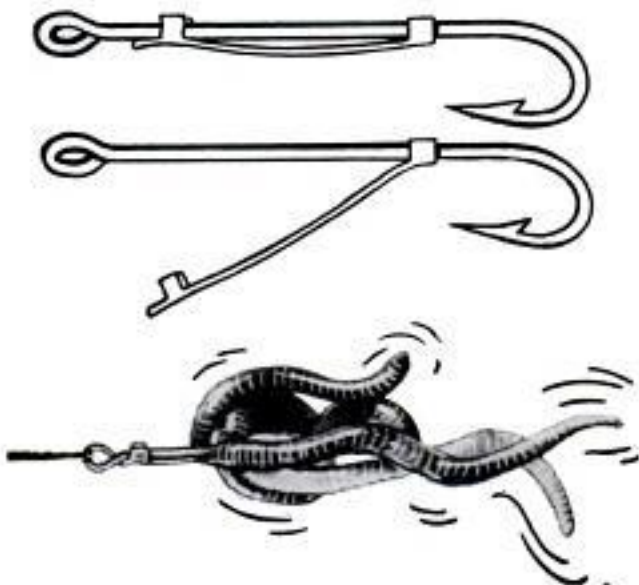

Light on Fishing Rod Warns When Fish Bite

Those lights you see winking at night around the edge of a lake or along a riverbank may not be fireflies. Instead, they may be the sign that some lucky fisherman has a bite, and a small light clipped to his rod is warning him to wake up before the fish gets away. Battery operated, the little light clips to either a casting rod or a cane pole, and lights up at the slightest tug on the line, according to the manufacturer. It also can be used as a flashlight to help you see when baiting the hook.





Coming next month

OUR 1955

SPECIAL SECTION ON HOMES



50 PAGES—with an idea for your home on every page
INTRODUCING

the PM Young-Family House

A split level designed by a noted architect for our readers

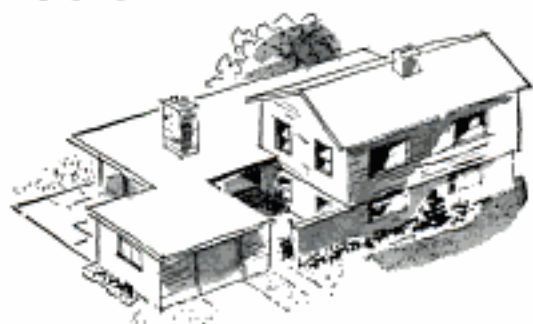

OTHER FEATURES:

- A thousand-dollar tip on the right colors for your home
- How to bring your kitchen up-to-date
- How to build your own carport
- All about electric heating
- Our annual album of prize homes
- One-man remodeling jobs
- A valuable check list for rating your home
- How to plan for future improvements before you build
- A small retirement house with elbowroom
- How to tile a ceiling
- How to make screens
- Many pages of full-color illustrations, photos, diagrams



Look for the 50-Page home section in October



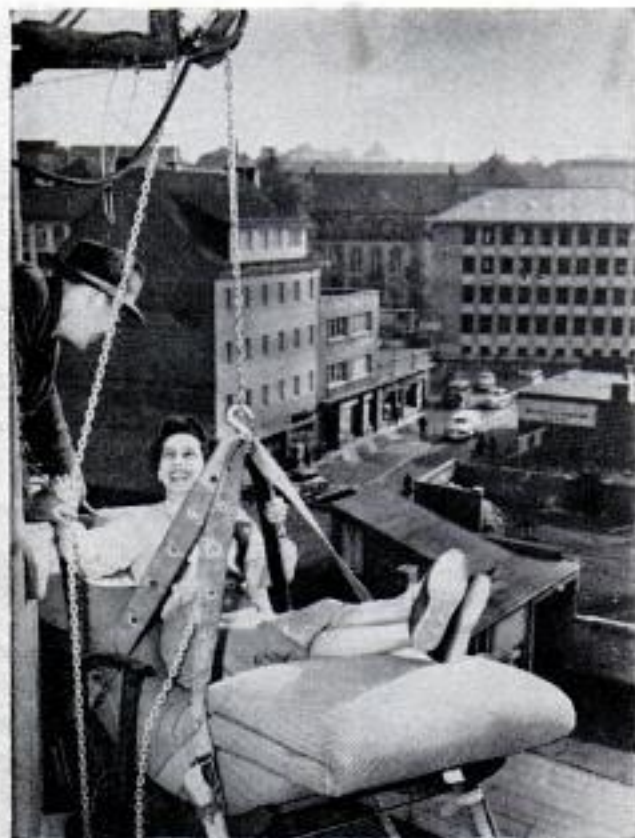

Moving Get You Down? German Elevator Gives Needed Lift

Hoisted to her fourth-floor apartment while seated in a chaise longue, a young German woman recently demonstrated a

furniture lift that speeds moving. It can be mounted in any window and handles loads up to 300 pounds.

Movie-Film Rewinder

Movie film is rewound during projection by equipment designed to fit all 8-millimeter and 16-millimeter projectors. A system of rollers gently leads the film from the center of the upper reel. As the film comes from the projector, it is automatically rewound on a removable hub. A roller plate, hubs, reels and film containers comprise the system.

London Sees First Commercials

Britain's first commercial television station, built near London, is scheduled to begin transmission September 22. Two other commercial TV stations are slated to open in March. The three stations will be able to reach almost 60 percent of the total population of the United Kingdom. It is expected that eventually 40 to 50 commercial stations will serve the nation.



"Buckaroo" Trains Backs

When the chant of "Hit that line!" goes up in the University of Washington stadium this fall, coach Johnny Cherberg's running backs will be glad they have only human linemen to charge, instead of the monster known as "Buckaroo." Buckaroo is a contraption of webbing and springs invented by Cherberg to teach his backfield runners to drive into the line with power and determination. When lunging at the machine, if each player maintains balance and keeps his feet driving under him, everything is fine. But if he fails, the springs snap back, upending him suddenly and roughly.

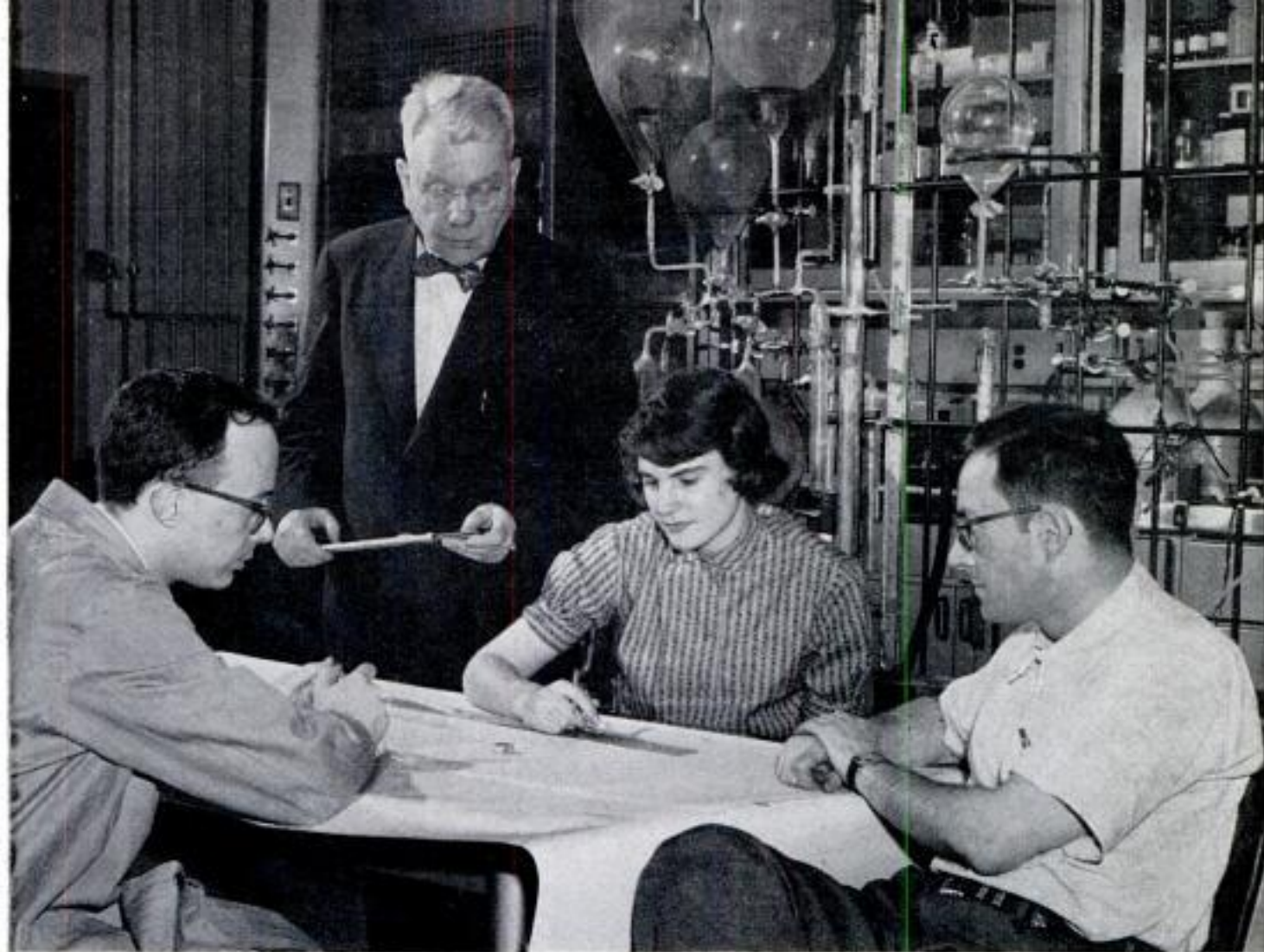

Doctor Urey inspects chart drawn up by his assistants. Equipment behind them measures radioactive carbon

**A renowned professor of nuclear chemistry offers sage advice to youth:
Get into the field of atomic science!**

IF I WERE A STUDENT TODAY

By Dr. Harold C. Urey

MY HIGH-SCHOOL DAYS extended from the autumn of 1907 to the spring of 1911, and the location was Waterloo and Kendallville in northeastern Indiana. My home was in the country near these towns and my stepfather was a farmer, as were most of my relatives. No one was ever able to tell me anything of the world of magnificent wonder in which I have spent most of my life!

Of course, part of this wonder can never be told. I have been privileged to discover a few facts of nature and perhaps to understand some few things which no one ever knew or understood before. The magnificent thrill that comes to one on the occasion of even a small but original discovery must be experienced to be understood. But can you — and I hope you are a young student — hope to enter a field in which this can be done? Well, what

were the chances that a poor farm boy of northeastern Indiana, whose country grade school lasted only seven months a year, would become one of the moderately famous scientists of the 20th century? If it happened to me, it may happen to you. Why not try?

Since World War II nuclear science in its chemistry, physics and engineering phases has come to public notice through the daily press and magazines. Unfortunately, this publicity has concerned weapons of war to such a large extent that many people do not realize the immense interest of the subject for pure science and peacetime technical uses. We hear of the A-bomb, the H-bomb, or thermonuclear bomb, jet planes, rockets with atomic warheads that will carry these weapons thousands of miles, deadly radioactivity of the C-bomb, etc.; and we hear these

Nobel Prize winner and key figure in the development of atomic energy, Doctor Urey is Professor of Chemistry at the Institute for Nuclear Studies of the University of Chicago



Students in training at Argonne National Laboratory learn details of the operation of a research reactor

Urey reads results of test measuring oxygen isotopes. Discovery of hydrogen isotope won him Nobel Prize



things repeated over and over, day after day, until we all, myself included, begin to believe that these destructive things make up all of the subject of nuclear science in its various phases. This is not true and it is the purpose of this article to tell some of the fascinating phases of this subject.

In addition, we all know that some information is classified, that is, kept secret from the public and from other scientists. The constant discussion of "atomic secrets" gives the public the idea that nearly all information is secret, whereas most of it is public and is published in our scientific journals as usual. The *Physical Review* published 6880 large pages during 1954, and a very large fraction of these deal with nuclear physics. What have been kept in the secret category have been weapons and data of direct importance to these, and information in regard to nuclear reactors of all kinds. Much information about nuclear reactors for power purposes is now being made public. During the coming years the scientific and engineering features of nuclear science will become as much a part of the public knowledge as any other part of scientific activity. This will come about as all of us realize that most of the scientific and engineering knowledge is possessed by people on both sides of the Iron Curtain and that there is little knowledge that we

have that others do not have. Moreover, nuclear science will grow beyond our government laboratories and establishments and will become partly privately owned and operated. Also, the military aspects of the subject will become less important in the whole picture than they are now. By the time high-school students of today acquire their doctor's degrees in various phases of this subject, the whole field will look more desirable than it does now.

Nuclear science deals with problems of enormous energies, the transmutation of the elements, the source of the energy of the sun and stars, temperatures of millions and billions of degrees, and the origin of the elements themselves. Particles of matter disappear in the energy of light or into other particles, or they are produced from light or even from nothing but the light energy in a vacuum at high temperature.

Let us look in on scientists at work. A group of scientists is moving about a concrete room. One is in a white jacket; an-

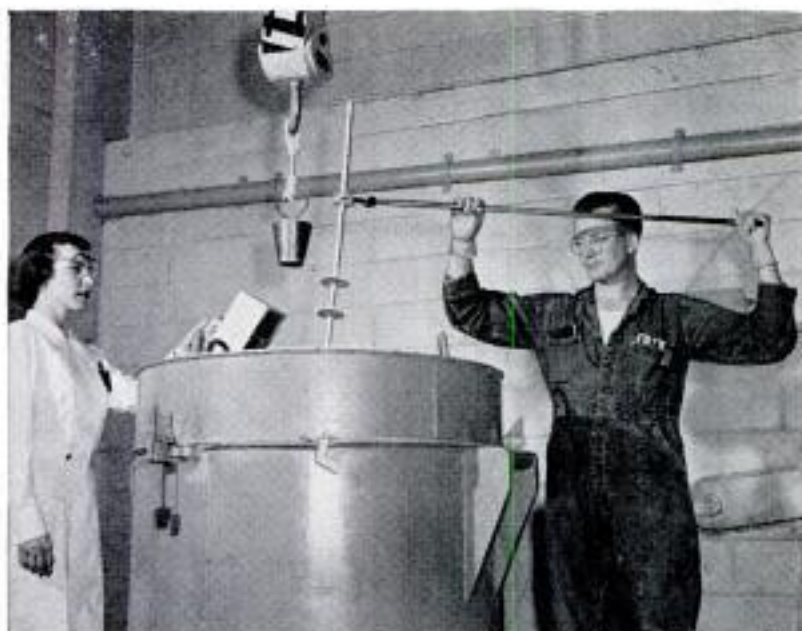

Argonne National Laboratory photo
Chemist calibrates a new radioactive-concrete source. The tube he is lifting with a handling tool contains a chemical solution that decomposes, at a known rate, in the presence of radiation

other in coveralls. There are a number of holes in one wall through which come invisible particles with velocities near the velocity of light. Behind this wall is a cyclotron, or a betatron, or a cosmotron—a complicated mass of metal weighing as much as a cruiser, which is producing these

Students learning of effects of nuclear bombardment conduct experiment in the disassociation of liquids

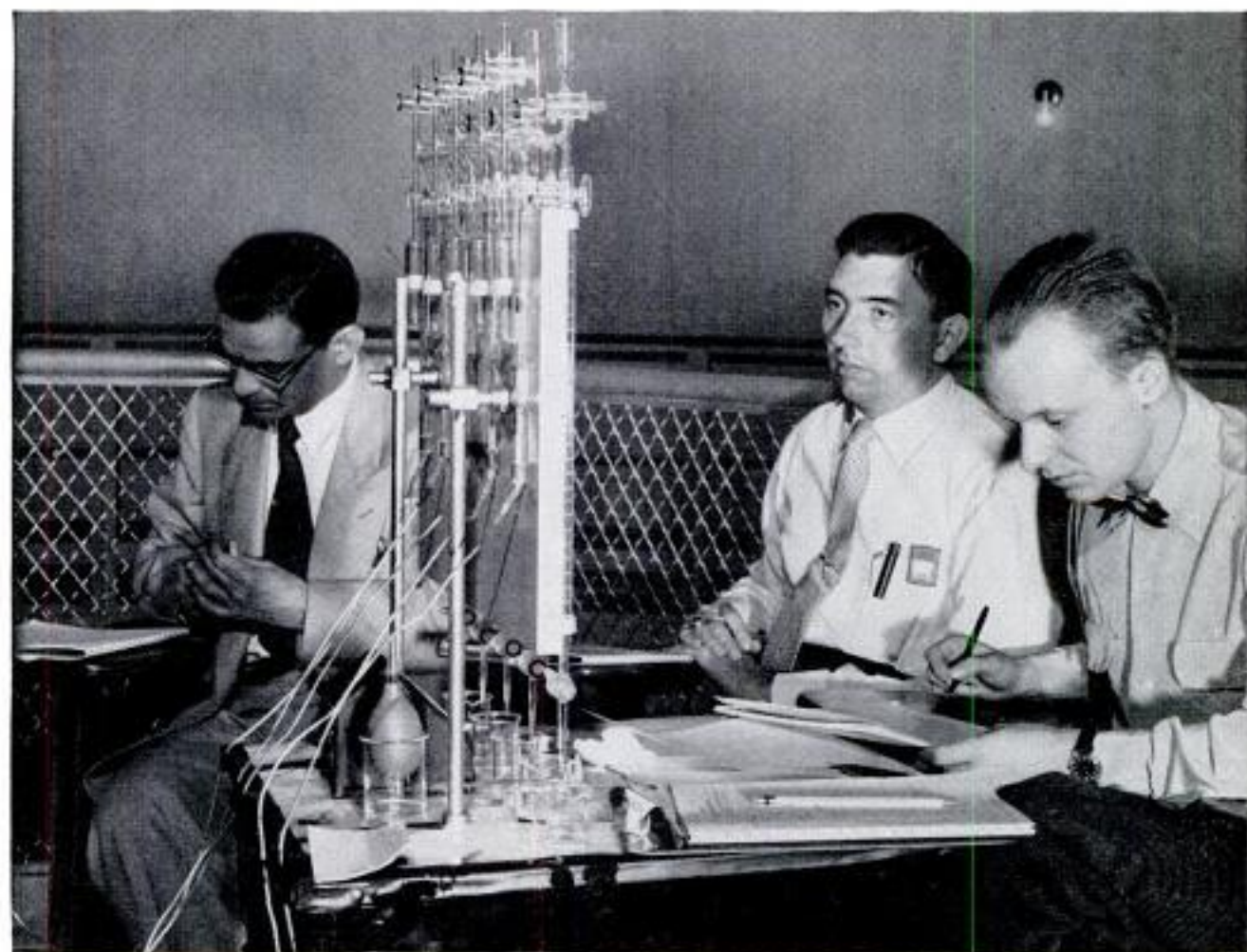

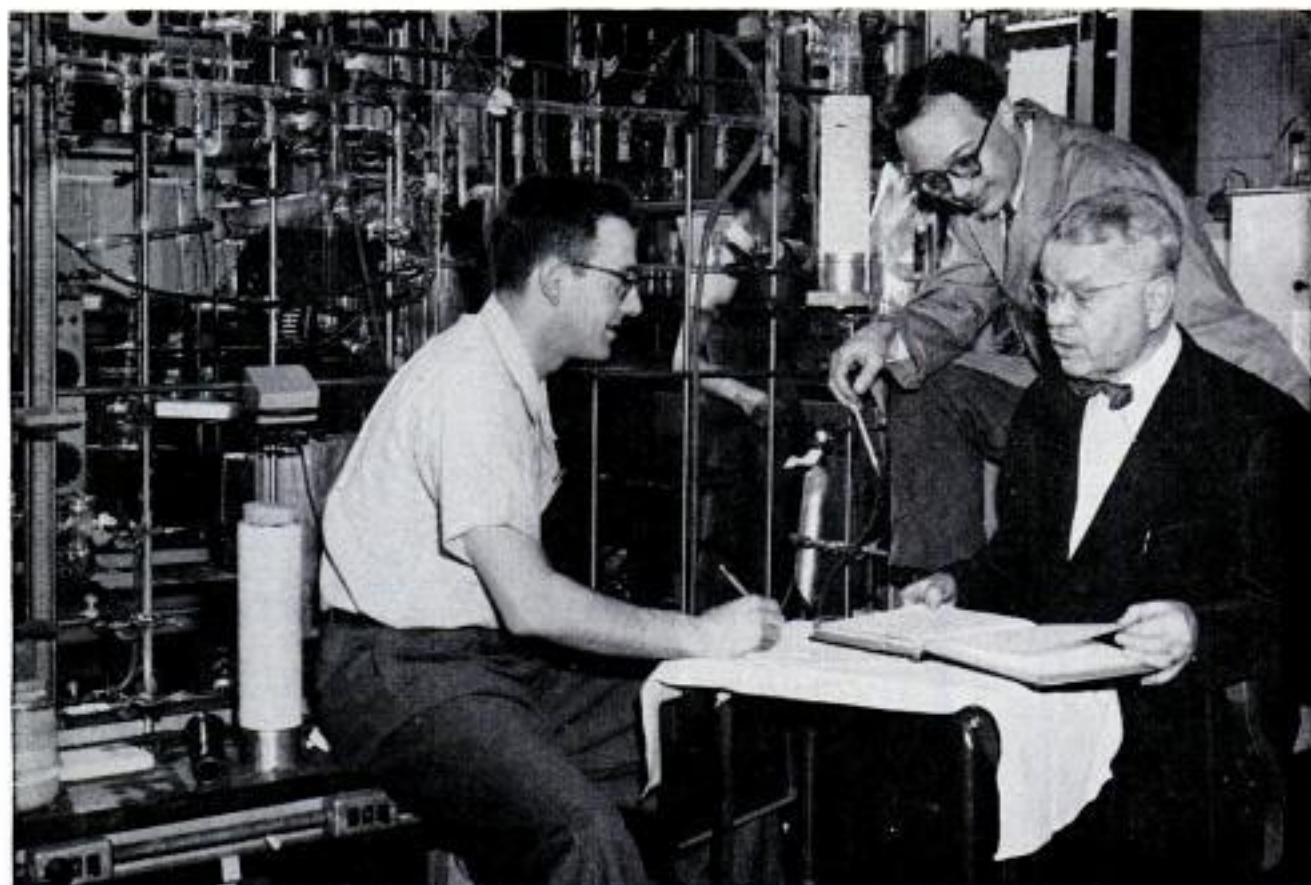

Doctor Urey confers with assistants in laboratory. Vacuum equipment behind them reduces material for testing

Electrons ride radar waves down 16-foot wave guide of microwave linear accelerator. Instrument is useful in cancer research
University of Chicago photo

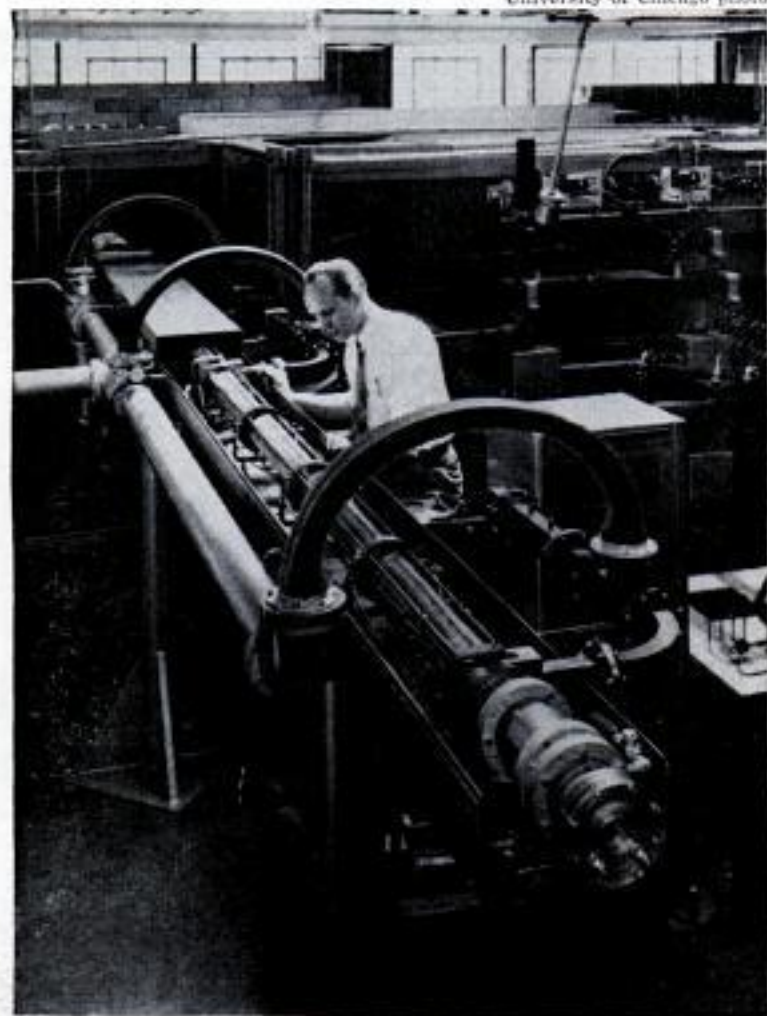

particles, beta rays, neutrons, protons, mesons, etc. The particles are deflected with magnetic fields or material substances, or they produce radioactive substances. The machine is valuable and expensive to operate, and it is scheduled for 24 hours a day and seven days a week.

Or a group of scientists is sending a balloon to 100,000 feet above the earth's surface. That balloon carries instruments to record its height and the intensity of cosmic rays, and a stack of photographic plates. These plates will be developed when they return to earth and they will be examined under a microscope. Here the tracks of nuclear particles of high energy will be found. They record processes of the highest energy we have ever observed.

Or scientists are putting materials into a large reactor. It is covered with a thick shield of concrete to stop the neutrons and gamma rays which would kill the operators if they were exposed to the full intensity for a second. The substances become radioactive and are transferred by mechanical means behind protective walls to

(Continued to page 246)



Boat for Resort Sight-Seers Made With Aluminum pontoons

Three adults ride comfortably in an all-metal paddle boat designed for rental use at lake resorts. Two aluminum pontoons provide buoyancy and make the boat virtually unsinkable. The deck between the pontoons is flat and slip-proof. There are only two controls—an engine control and rudder control. A small air-cooled gasoline engine operates about eight hours on a gallon of fuel. Speed is four miles per hour. Constructed to take the rough treatment rental boats normally get, the unit is said to be damageproof.

Cranes With Long Beams Erect 22-Story Buildings

Cranes are being used as skyhooks (right) to erect four 22-story apartment buildings in New York City. The cranes are equipped with 230-foot beams, said to be the world's longest. They are lifting 50,000 cubic yards of concrete and 6000 tons of reinforcing steel. The buildings are almost 200 feet tall. Two of the cranes working together cover an entire floor, the concrete and steel going from truck to bucket to the spot where they are needed. To do the same job using conventional techniques, eight elevators, eight towers and eight bucket hoists would be required.

Ship TV Links Key Points

TV will soon be used aboard a Canadian navy ship to relay tactical information. A camera will be focused on the plotting chart or table, where the movements of enemy planes and ships are recorded. The bridge and four or five other key points in the ship will be equipped with receivers.





Swing-Up Shelters Shield Mechanics at Work on Giant Planes

Portable steel houses shelter Air Force mechanics working in the field on huge planes like the monster XC-99 cargo-troop transport. The maintenance docks—four units to a plane—roll under and fit over the wings. Cantilevers permit the roof and wall to be raised to a 45-degree angle to admit the wings and then lowered to provide sheltered working space for the mechanics. This electrically driven operation takes only 90 seconds. The floor of the shelter serves as a working platform and can bear the weight of plane engines. The insulated units have both heating and air-cooling equipment.

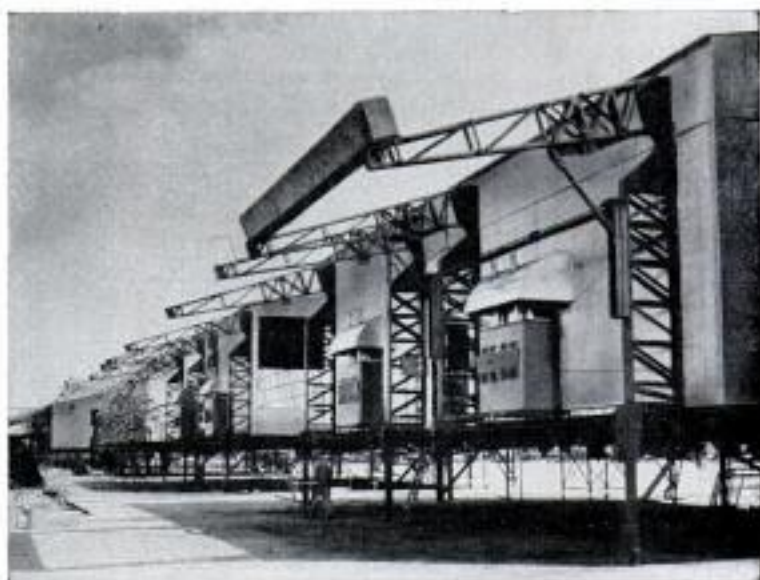

Process "Vitamin Cherry"

Juice from the acerola, Puerto Rican cherry, claimed to contain 80 times as much vitamin C as orange juice, is being processed at a pilot plant at Sabana Seca, Puerto Rico. Formerly, orange juice was commonly believed to be the best natural source of vitamin C. The tart, refreshing juice will be used in infant foods and may later be added to other foods and soft drinks. The tree grows semi-wild in the Caribbean islands and yields four crops a year. A commercial planting of 30,000 trees is expected to yield 900,000 pounds of fruit by the end of 1955.

Britain's Atom-Age Carrier

BRITAIN'S latest aircraft carrier, the *Ark Royal*, will be able to launch an atomic attack or weather the effects of a nearby atomic explosion.

After an atomic attack, the *Ark Royal's* boilers and engines can be run by remote control from hermetically sealed and air-conditioned rooms. Provisions were made for clearing the engine rooms of personnel because the engines would suck in huge quantities of radioactive air. Two remote-control rooms, one forward and one aft, allow the crew to control engines and boilers while the ship speeds out of the contaminated area. Meanwhile, spray nozzles wash the exposed deck.

The vessel carries 100 aircraft and 2200 officers and men. The largest carrier in the British fleet, it has a standard displacement of 36,800 tons (half that of the *USS Forrestal*) and a length of 808 feet. It has two steam catapults, an angled deck and a mirror landing guide. A cutaway drawing of the aircraft carrier appears on the following pages.

★ ★ ★

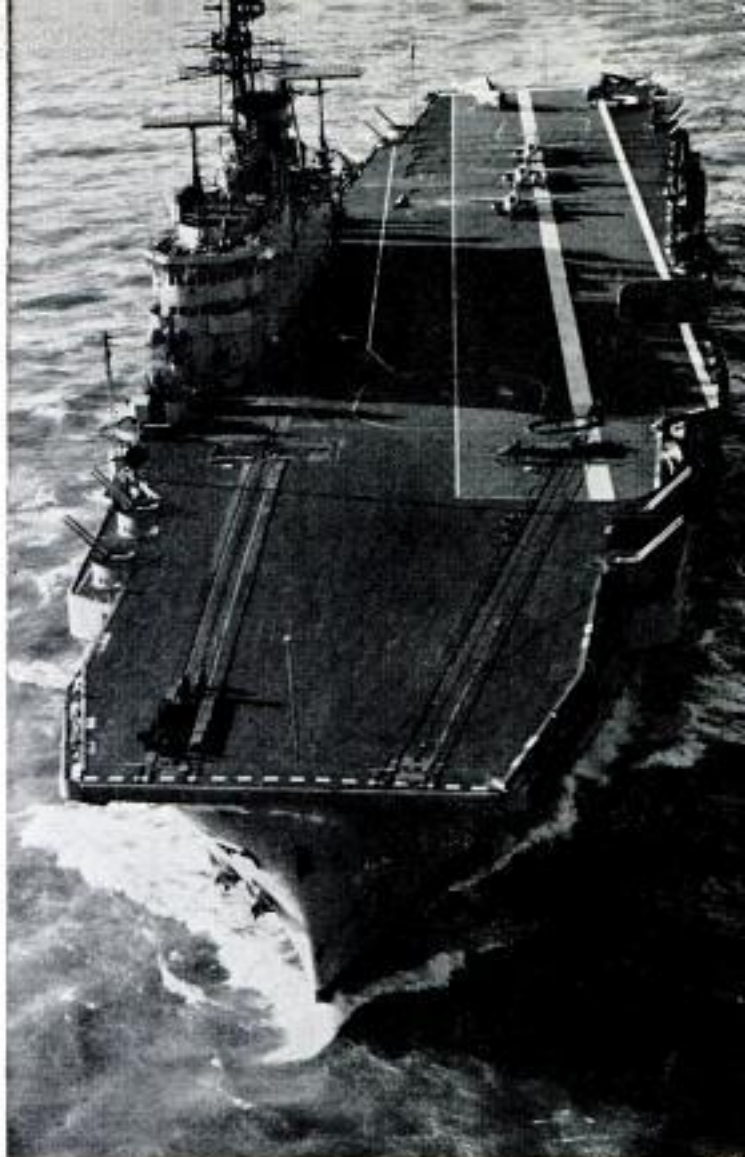

Ark Royal has top speed of over 30 knots. Keel of the recently completed ship was laid May 3, 1943. Modifications to make it most modern carrier afloat slowed delivery. Below, a remote-control center

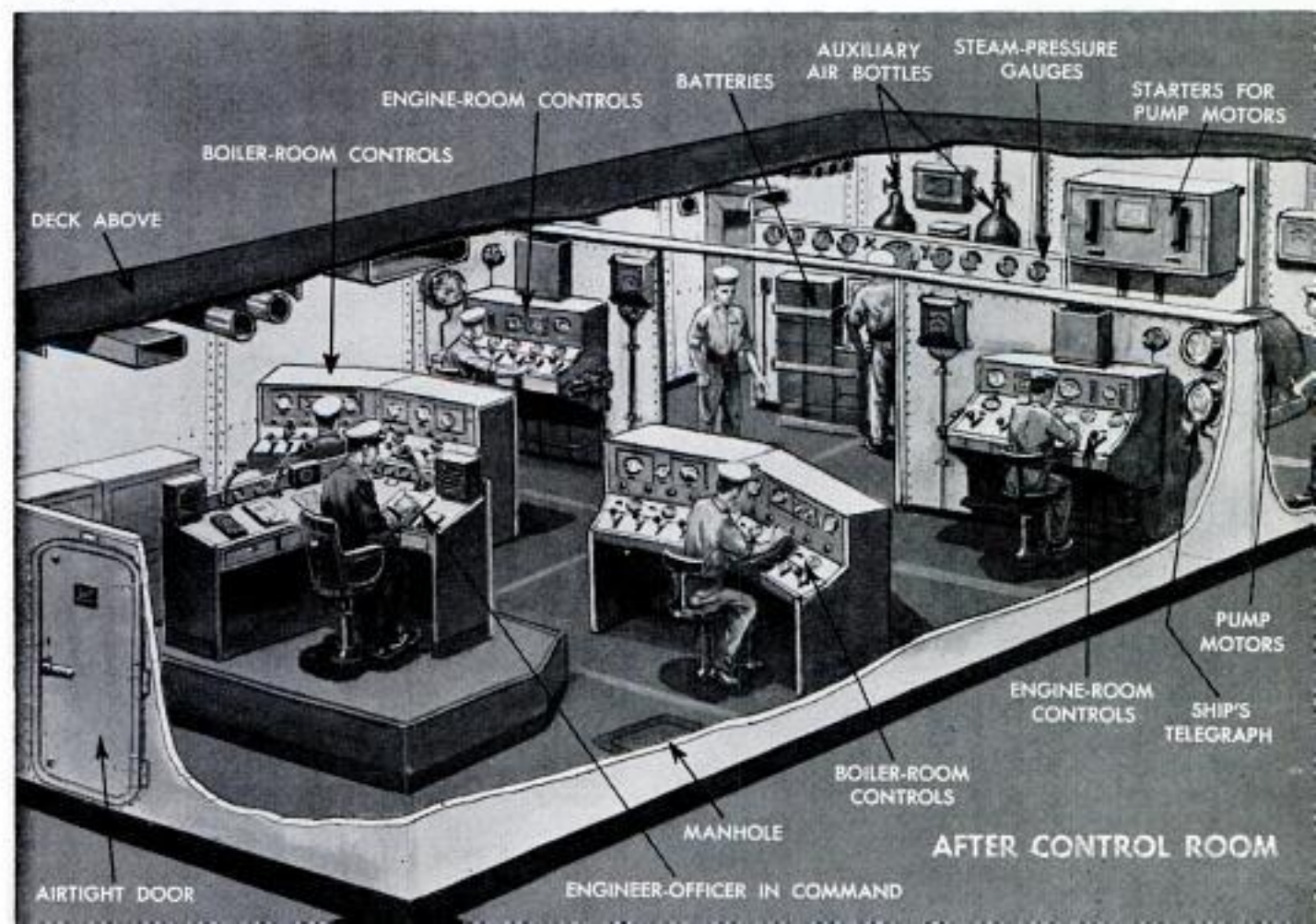

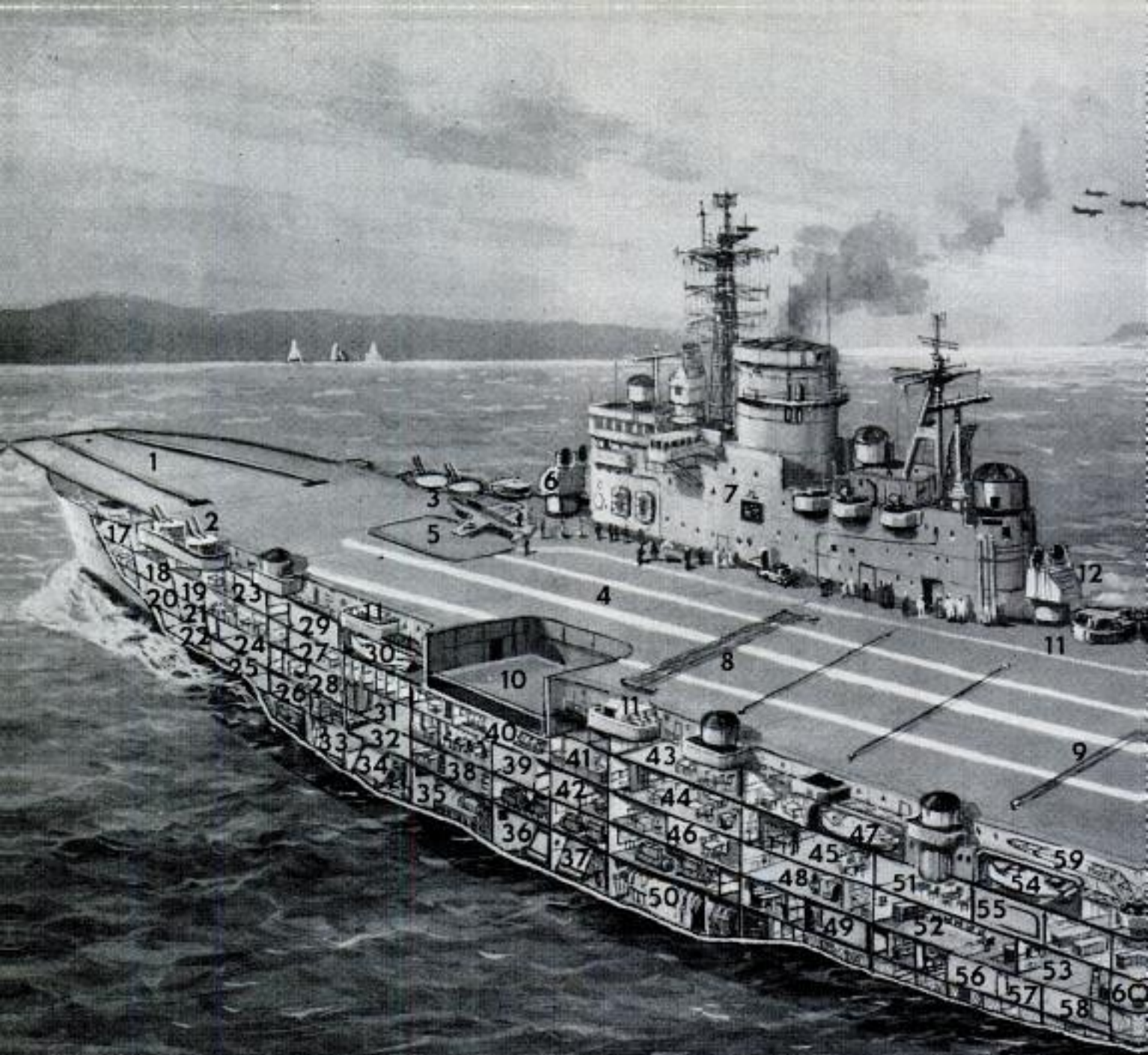

G. HEAVIS
1955

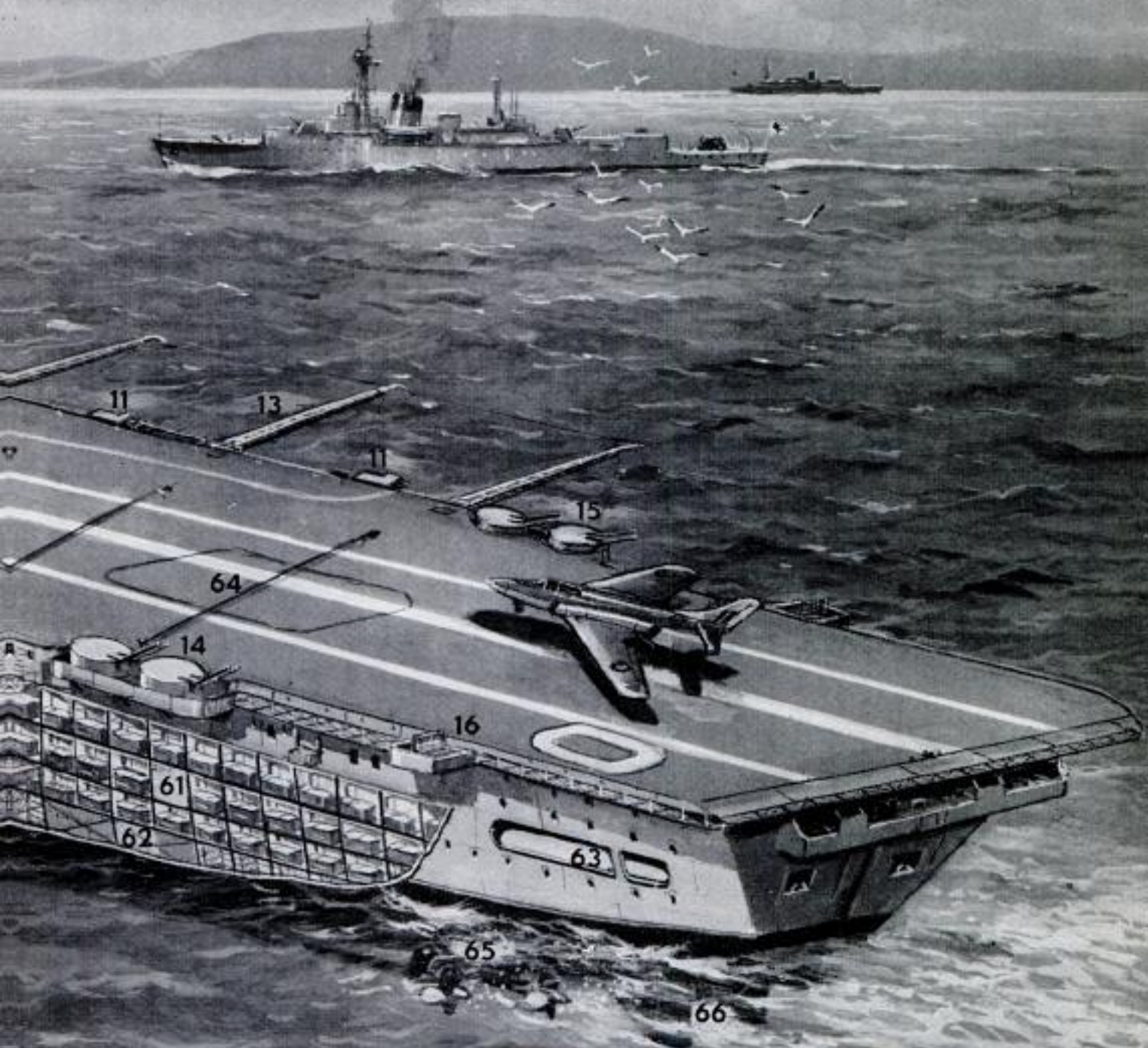

BRITISH AIRCRAFT CARRIER ARK ROYAL

1. steam catapults; 2, 3. dual-purpose guns (4.5-inch); 4. angled flight deck; 5. aircraft lift; 6. director tower; 7. superstructure; 8. arrestor net (lowered); 9. arrestor wires; 10. deck-edge lift; 11. Bofors guns; 12. director tower; 13. radio masts lowered; 14, 15. dual-purpose guns (4.5-inch); 16. deck-landing controller; 17. mess; 18. mess; 19. dining hall; 20. mess; 21. pantry; 22. laundry; 23. air workshops; 24. hospital; 25. stores; 26. forward remote-control room; 27. mess; 28. offices; 29. showers; 30. 32-foot cutter; 31. stores; 32. mechanics' mess; 33, 34. forward boiler rooms; 35. forward port engine room; 36, 37. after port boiler rooms; 38. engineers' offices; 39. mechanics' mess; 40. lift machinery; 41. wash place; 42. lobby; 43. mess; 44. mess; 45. dining hall; 46. recreation rooms; 47.

36-foot speedboat; 48. mess; 49. after remote-control room; 50. after port engine room; 51. mess; 52. dining room; 53. ante-room; 54. 36-foot speedboat; 55. open space; 56. prison; 57. stores; 58. refrigerated stores; 59. crane; 60. captain's lower office; 61. officers' cabins; 62. fresh-water tanks; 63. quarter-deck; 64. after aircraft lift; 65. twin propellers; 66. twin rudders. SUPERSTRUCTURE CUTAWAY: 67. bridge; 68. flying commander's bridge; 69. admiral's office; 70. captain's sea cabin; 71. navigation officers' sea cabin; 72. control room; 73. admiral's sea cabins; 74. executive officers' sea cabins; 75. squadron officers' cabin; 76. planning rooms; 77. switch room; 78. boiler uptakes; 79. operations rooms; 80. fan machinery; 81. briefing room; 82. ready room; 83. fire-control tower



German Body Shop Turns Chevrolet Into "Le Sabre" Dream Car

You don't have to be president of a big automobile company to have a dream car, Maj. Ralph W. Angel, U. S. Air Force jet pilot, discovered. He simply bought a secondhand Chevrolet while stationed in Germany and drove it to the Spohn body works in Ravensburg. He sketched up his idea of a dream car (inspired considerably by General Motors' famed Le Sabre) and turned the Chevrolet over to the body men.

In six weeks, he had his dream car. It is completely custom built as far as sheet metal is concerned. The chassis and engine are stock Chevrolet except for a dual carburetor and a split exhaust manifold that leads to twin exhaust pipes. It cost the major \$4500. Since his return to this country, he has sold the car to a Phoenix, Ariz., used-car dealer. "It attracted too much attention," Angel said.

Self-Releasing Lure

If the angler snags a new lure he can release it by pumping on the line. Pulling the line taut and releasing it operates a small ratchet mechanism built into the lure. The ratchet unscrews the hook from the main part of the lure, which then is retrieved. Extra hooks are provided with the lure and the angler simply screws a new hook into place. The lure is made in six models for casting, spinning and trolling.

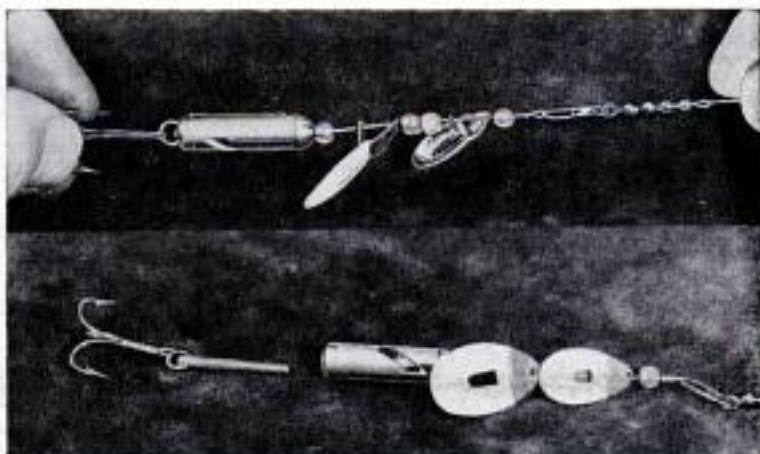

Raft Has Window For View of Fish

Swimmers can observe marine life through a window while relaxing on an air mattress manufactured in Germany. A high rubber rim prevents water from covering the top surface of the window. A hose permits the swimmer to draw off air bubbles which may form under the window to obscure the view. The swimmer can paddle the mattress around a lake or pond while he views the marine life.



Aurora "Curtain" of Tiny Rays Forms Along Magnetic Field

Through simultaneous photographs and radar observations, Cornell University scientists have found that the aurora borealis actually is composed of hundreds of thousands of relatively tiny rays. The auroral display looks like a curtain of shimmering light. The rays which produce this effect are continuously forming and fading along the lines of the earth's magnetic field. They are formed by protons thrown out by the sun, which smash into the earth's outer atmosphere to produce electric fields. The northern lights can shift about 300 to 3000 feet a second. They disturb long-distance shortwave broadcasts but improve television and other high-frequency waves. Cornell scientists analyzed simultaneous radar

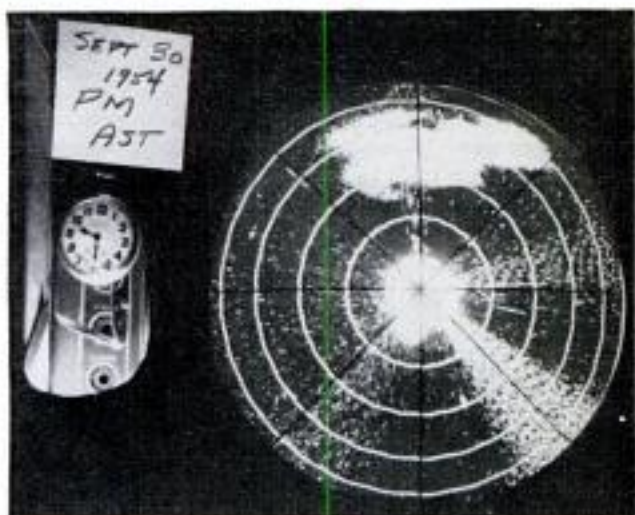

images and photos of the aurora and detected the tiny rays. The scientists have been carrying on experiments with radio echoes from the northern lights since 1951.

Small Jets on Wing Tips Increase Safety During Take-Off

Single-engine take-off performance of the giant twin-engine C-123B transport plane is improved more than 300 percent by the thrust from two small jets, one mounted on either wing tip. The Fairchild J44 turbojet units, rated at 1000 pounds of

thrust each, increased take-off rate of climb with one main engine feathered from 150 to 500 feet per minute. Installation of auxiliary jet engines for emergency use was seen by Fairchild engineers as an important stride forward in twin-engine safety.



WHAT'S NEW FOR

1. DRY-CLEANING DEVICE for home use is an aluminum table-top unit which swishes clothing through dry-cleaning fluid to loosen dirt and then squeezes out the excess fluid. After cleaning, little or no pressing of garment is required. Paper filters furnished with unit permit fluid to be reused a number of times

Remuzit Home Products Co.,
1724 Chestnut St., Philadelphia, Pa.



2. WASHING MACHINE requiring no rinse tubs has a two-way hose that fills it directly from water faucet. Same hose also pumps dirty water into sink drain. Two-way hose saves about 15 minutes on each wash
Central Rubber and Steel Corporation, Findlay, Ohio

3. WATER-HEATER accessory automatically delivers hot water in two temperature ranges from a single heater. For appliances, water is 160-180 degrees; for normal home use, it is 100-140 degrees at faucets
Ithcum Manufacturing Company, 7600 S. Kedzie Ave., Chicago

4. SALT SHAKER dispenses salt no matter how damp the weather—and even under water—when bottom is turned. Operated through a series of gears, an agitator forces salt through holes in top of shaker
Dot-A-Mar, 25 Almerin Ave., Coral Gables, Fla.



5. PRESSURE PAN operates on 120-volt alternating current and, in addition to cooking under pressure, it also fries, steams, boils, braises and sterilizes. Once set, it automatically maintains pressure and temperature. Made of aluminum, the pan has a capacity of four quarts. Heatproof legs permit it to be used on any table top

Aluminum Goods Mfg. Co., Manitowoc, Wis.

6. WINDOW GUARDS that are easily installed by the homeowner in both steel casements and double-hung windows are designed to prevent small children from falling out and also to protect the home against intruders. Units are available to fit all standard windows. Made of cold-rolled steel, they are protected from rust by wax

Hudson Hardware and Oilburner Co.,
5035 Broadway, New York City 24

7. FIRE EXTINGUISHER uses compressed air from the air hose at the gas station in place of CO₂ and soda acid to build up operating pressure. The unit sends a steady stream of water 35 to 40 feet until its 2½-gallon supply is exhausted. A gauge on top tells when pressure is low. Smaller units are planned for later production

Elkhart Brass Mfg. Co.,
1302 W. Beardsley Ave., Elkhart, Ind.

8. EXACT TEMPERATURE for any kind of cooking can be dialed on a new built-in electric range. The dial eliminates the guesswork connected with using conventional controls marked only "low," "medium" and "high." The new-type unit not only heats to exact degree but maintains heat automatically at desired temperature

Admiral Corporation, 3800 Cortland St., Chicago 47



5



6



7

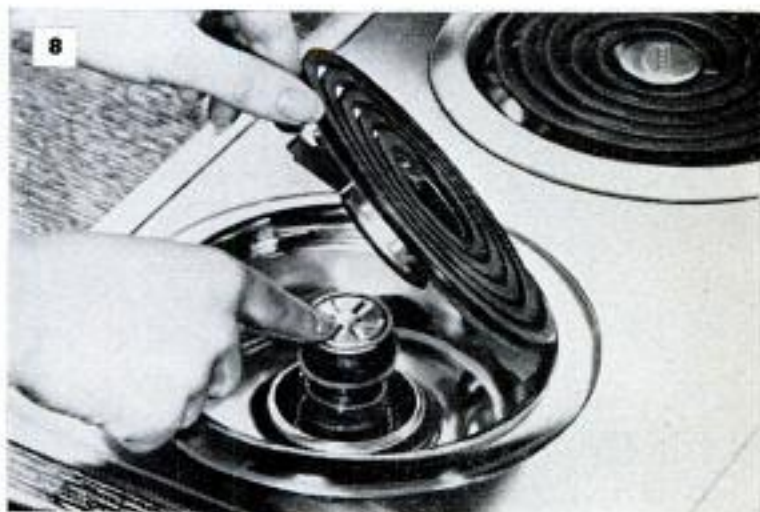

8



Start of race is 35 seconds away. Fluorescent-yellow face of "blackout" clock is almost half eclipsed

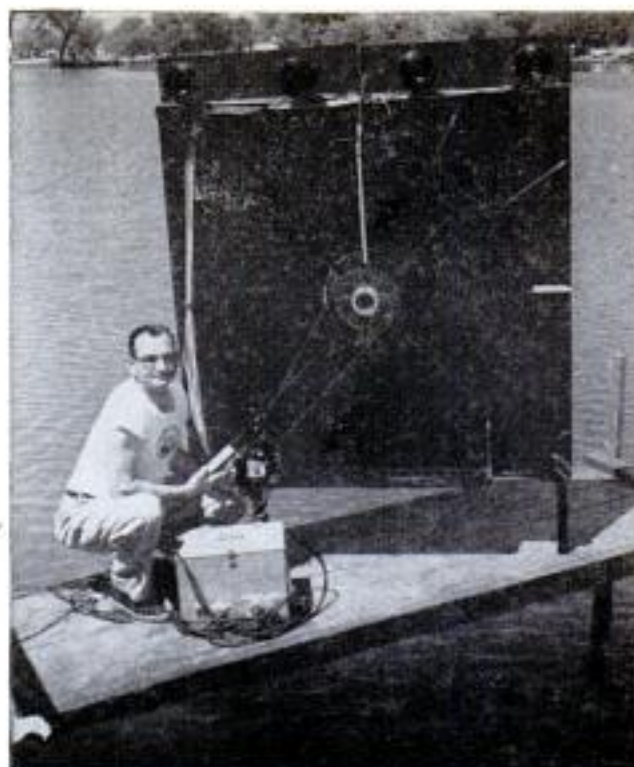

Clock from reverse side, showing bicycle-chain rig that turns blackout mechanism of starting clock

"Blackout" Racing Clock Shows Time and Trips Starting Cannon

EVERYONE gets off to an even start when a new "blackout" racing clock is used. Used to tick off the seconds in the last minute before the race begins, it shows the time left for maneuvering.

The fluorescent-yellow face of the clock is four feet in diameter and can be seen for three miles. As the sweep second hand starts to revolve, the used portion of the minute shows in black on the clockface.

By the time the hand completes its one-minute revolution, the face is completely blacked out. At zero instant two finger springs flick a pair of toggle switches. One stops the electric motor which drives the clock and the other sets off the starting cannon.

Four colored lights on top of the unit are used to give advance warning of starting time before the hand begins to turn.

Boats dart away from starting line. When clock hand makes a full circle, it trips trigger of starting cannon



Rope 'Scope

GLASS FIBERS finer than human hair make up the chief part of an optical instrument that can see around corners. The fibers are aligned in a rope bundle. By looking along the axis of the fibers, you can see an image at the other end, no matter how the rope is looped or twisted. Doctors may use it in internal examinations of the human body. Scientists could observe radioactive materials shielded behind lead walls and engineers could use it to investigate concealed parts of complex machinery. Known as the Fibrescope, it was developed by Dr. H. H. Hopkins and a 27-year-old Punjabi, Dr. Narinder Singh Kapany, at the Imperial College of Science in London. The simple instrument may replace expensive optical systems which are bulky and inflexible.

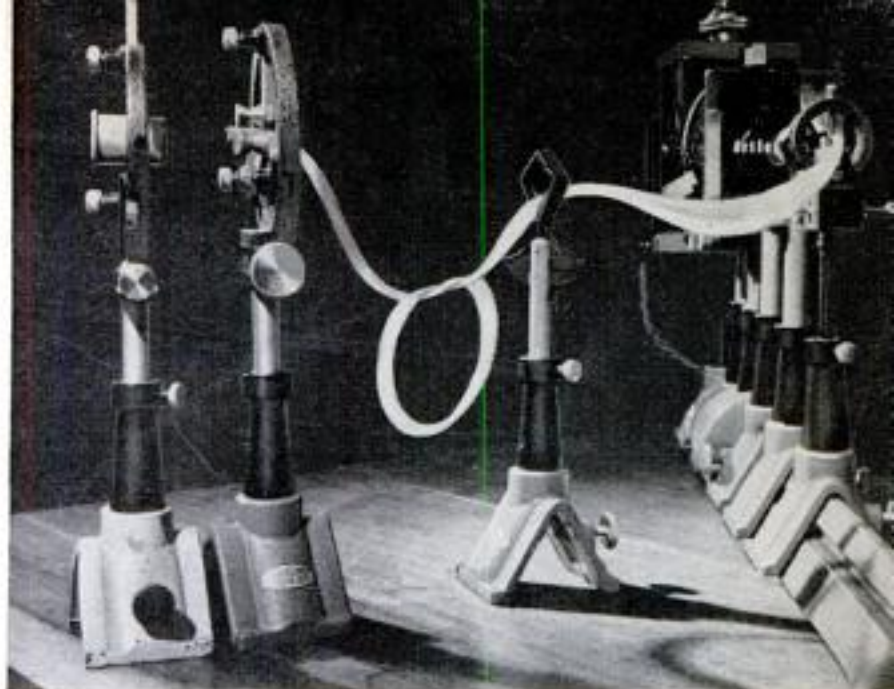

Even when a loop has been tied in the fiber, image at one end can be seen through a lens placed at the other end. Below, Dr. Narinder Singh Kapany adjusts the machine which aligns the glass fibers. Kapany, a 27-year-old Punjabi, is co-developer of the Fibrescope

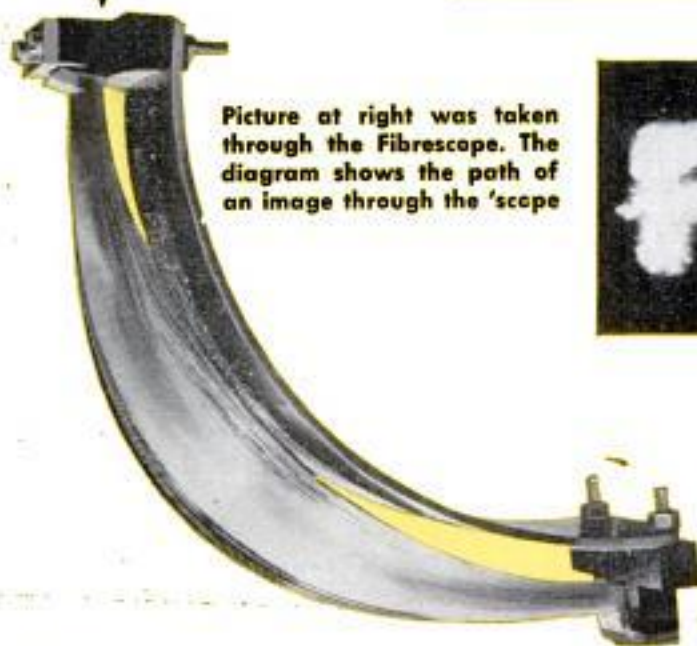
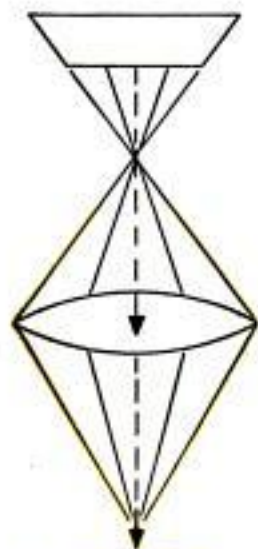
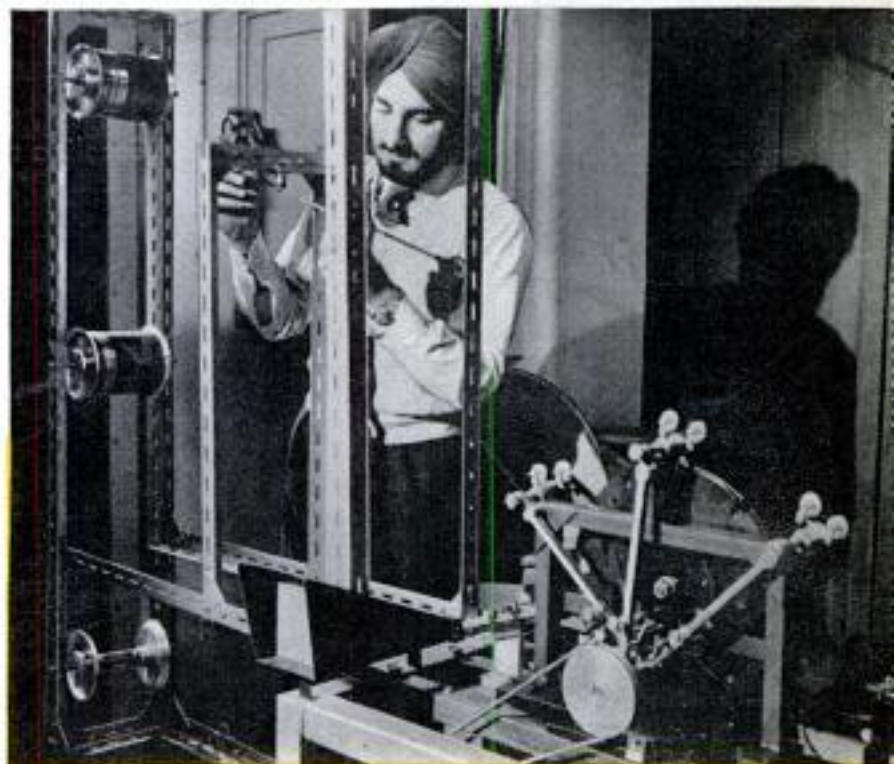

Picture at right was taken through the Fibrescope. The diagram shows the path of an image through the 'scope



OWNERS REPORT:

Torsion-bar suspension

"It rides like you're on a cloud! The levelizer is wonderful."

Minnesota doctor

Exterior styling

"Styling is modern without being overdone."

New York wholesale grocer

Some Complain About

Rattles

"Doors rattle."

Kansas real estate man

Reassembly

"Not enough attention to detail on assembly."

Ohio scientific equipment worker

Handling ease

"I like the ease of handling. Less tiring on long trips."

Iowa contractor

Performance

"Quick pickup. Fast, immediately responsive overtake."

California sailor

Some Complain About:

Rattles

"Rather noisy on rough roads."

Florida mine manager

Gasoline mileage

"Uses too much gas. Unable to get carburetor adjusted properly."

Texas owner



CLYMER TESTS THE CLIPPER CUSTOM

By Floyd Clymer

THE CAR TESTED was the 1955 Clipper Custom four-door sedan with torsion-bar suspension. The test was from Los Angeles to Las Vegas, Nev., then to Beatty, Nev., through Death Valley to Lone Pine, Calif., returning to Los Angeles via the Mojave Desert, a distance of 769 miles, which included some back-road testing.

The test Clipper had Packard's new 352-cubic-inch, 245-horsepower V8 engine with four-barrel carburetor. It is Packard's first V-type car engine since the Twin Six, although Packard has built thousands of V-type aircraft engines. This over-square engine (4-inch bore x 3.5-inch stroke) with 8.5 compression ratio is a lively job with the greatest torque I've ever tested.

Handling characteristics are different

from any other car, due to the torsion-bar system, which has eliminated coil and leaf springs. For stability, both front and rear ends have independent stabilizers to reduce roll and side sway. You can drive into a corner at high speed with this car and the body remains almost level. There is much less roll or sway than with any car using conventional springs. Due to an automatic levelizer, the body of the car remains level fore and aft, regardless of unequal loading. This is excellent for night driving as the headlight beam remains level. I drove at high speeds over extremely rough roads, with very little bounce. It was the most comfortable ride I've ever had with a feeling of security at all times.

(Continued to page 230)

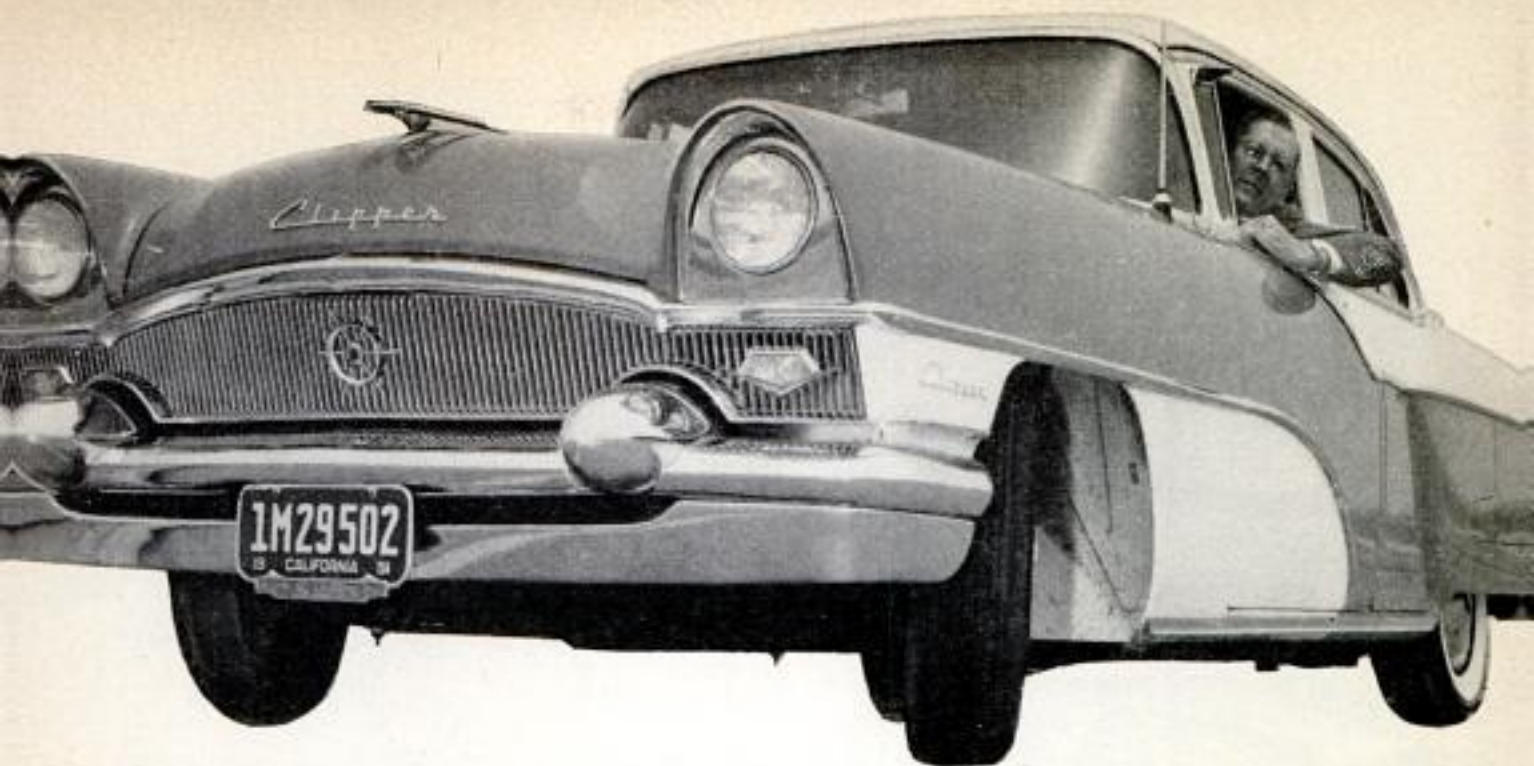

Packard Owners Like Torsion-Bar Ride

By Packard and Clipper Owners

WHAT'S ALL THIS talk about torsion-bar suspension? If you can believe the owners who are riding on it, it's the greatest advance in riding since the primitives rounded off the corners of the square wheel.

The riding qualities of the torsion-bar suspension are far and away the best-liked feature of Packard and Clipper Custom owners in our monthly survey (only the Clipper Custom has torsion bars, the other Clippers have coil and leaf springing).

Here are some of the reasons why the owners think so highly of this new departure in suspension systems:

"It rides like on a cloud! The levelizer is great."—Minnesota doctor.

"Ride is very comfortable without being mushy. Self-leveling feature keeps loaded car from dragging on steep driveways."—New Jersey manufacturer.

"Drove from Cleveland to Huron two times at night and did not have one car signal me to dim my lights even though I had luggage in the trunk. That was due to torsion-bar suspension. It keeps headlights on the road at all times."—Ohio ship's officer.

"We have had as much as 500 pounds of seed corn in the trunk plus two riders in

Clymer "jumps" the Clipper over the crest of a hill. He says the car needs better front-end rebound control

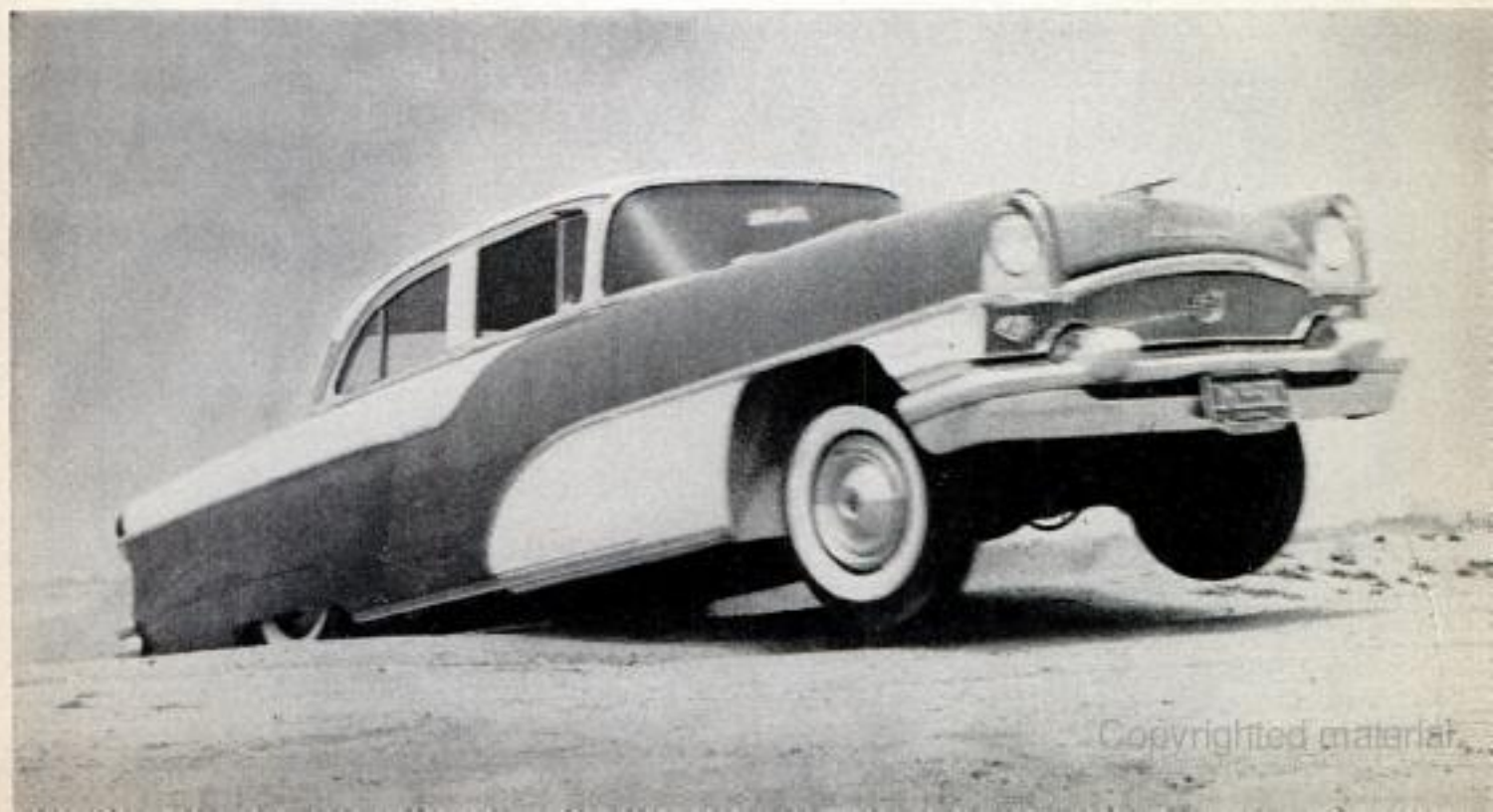

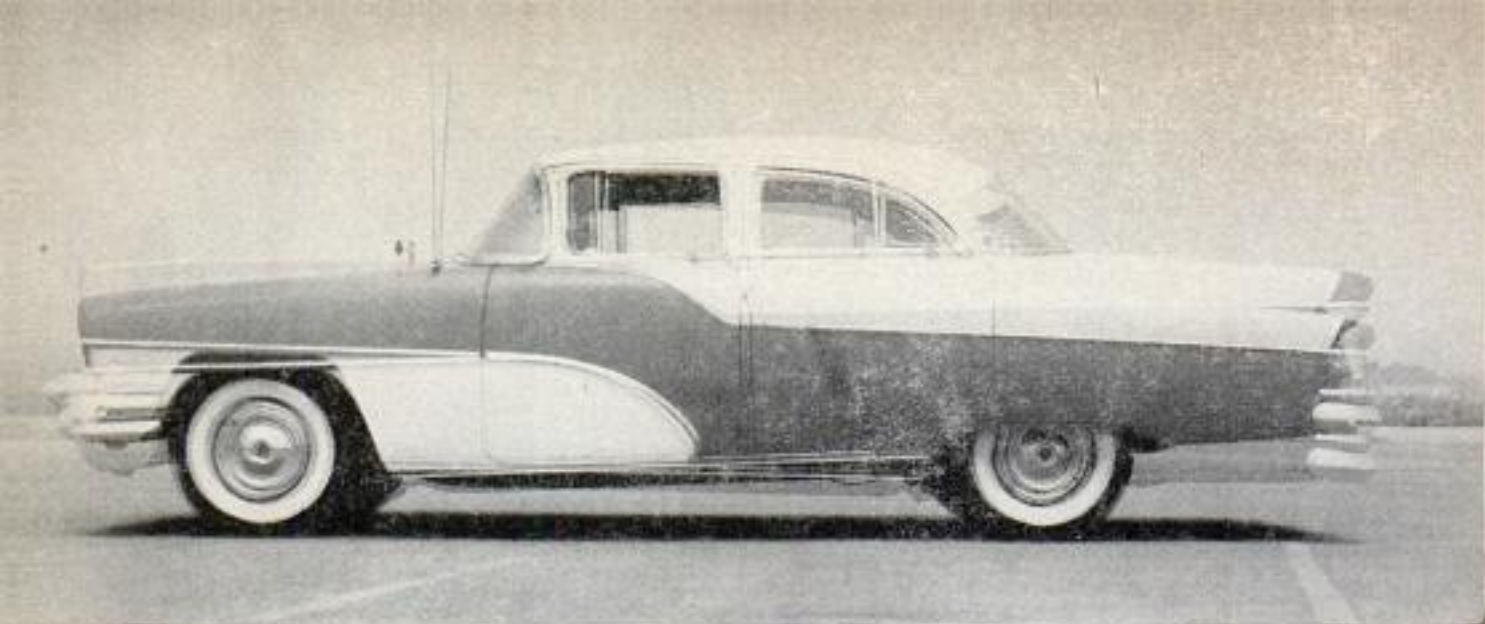

When a load is added to trunk, rear end goes down. Automatically, levelizer goes into action, leveling body



Glove compartment is placed in center of dash, but some owners miss last year's drawer-type design

Two-tone paint styling of the 1955 Clipper Custom is simple and provides a flowing line from front to rear

the rear seat for a 250-mile drive on all kinds of roads and car was always level. However, in the first 800 miles I owned the car I blew three fuses on the levelizer circuit, but after changing to 30-ampere fuses have had no more trouble."—Minnesota real-estate broker.

"Exceptionally easy and smooth ride, but self-levelizer needs improvement. It's noisy and sometimes works too often. Fine for heavy loads though."—Ohio supervisor.

"Torsion bars pop when new, but soon wears off."—Washington, D. C., tailor.

"Very soft, yet on curves it's firm and handles well."—Ohio manufacturer.

Of course, there are some complaints about the new suspension system and some suggestions for improvements.

"Self-levelizer should be wired through the ignition switch."—Ohio housewife.

"Out of adjustment. Car is higher on one side than the other. Rear of car had to be lowered three times. Dealer has no tools to make correct adjustment."—Pennsylvania manufacturer.



Digitized material



PM asked owners in 41 states (in color) to tell you about their experiences with the 1955 Packard

Percentages from PM Poll of Packard and Clipper Owners

Packard Owners

Best-Liked Features

Torsion-bar ride.....	63%
Exterior styling.....	48%
V8 performance.....	43%
Handling ease.....	26%
Interior styling.....	14%

Most-Frequent Complaints

Rattles	14%
Poor assembly.....	11%
Leaks dust.....	6%
Poor gas economy.....	6%
Hood latch.....	6%

54% had no complaints at all

OVER-ALL RATING	
Excellent	97%
Average	3%
Poor	0%

What Should Be Changed?

Needs no changes.....	60%
Improve body work.....	6%
Brake-pedal position.....	6%
Ash-tray location.....	2%

Had trouble with engine?

None	94%
Some	6%
Considerable	0%

What was engine trouble?

Noisy valves.....	6%
-------------------	----

Torsion-bar suspension

Excellent	94%
Poor	6%
No difference.....	0%

Self-leveling feature

Excellent	100%
Poor	0%
No difference.....	0%

Would buy another?

Yes	94%
No	0%
Might	6%

Clipper Custom Owners

OVER-ALL RATING	
Excellent	72%
Average	21%
Poor	7%

Best-Liked Features

Torsion-bar ride.....	62%
V8 performance.....	45%
Handling ease.....	45%
Exterior styling.....	23%
Roominess	10%

Most-Frequent Complaints

Rattles	33%
Poor assembly.....	23%
Uses oil.....	15%
Poor gas economy.....	13%
Poor paint, chrome.....	12%

25% had no complaints at all

What Should Be Changed?

Needs no changes.....	45%
Improve body work.....	13%
More gas economy.....	6%
Change hood latch.....	3%

Had trouble with engine?

None	61%
Some	32%
Considerable	7%

What was engine trouble?

Uses oil.....	12%
Noisy valves.....	10%
Carburetor	7%
Water leaks.....	3%

Torsion-bar suspension

Excellent	89%
Poor	4%
No difference.....	7%

Self-leveling feature

Excellent	95%
Poor	3%
No difference.....	2%

Would buy another?

Yes	64%
No	11%
Might	25%

Clipper Owners

OVER-ALL RATING	
Excellent	73%
Average	22%
Poor	5%

Best-Liked Features

Handling ease	44%
V8 performance	42%
Riding comfort	41%
Exterior styling	23%
Roadability	12%

Most-Frequent Complaints

Rattles	24%
Poor gas economy.....	13%
Poor assembly	12%
Noisy engine	8%
Uses oil	8%

24% had no complaints at all

What Should Be Changed?

Needs no changes.....	52%
Improve body work.....	4%
Move hand-brake handle.....	4%
More gas economy.....	4%
Improve Ultramatic	4%

Had trouble with engine?

None	71%
Some	21%
Considerable	8%

What was engine trouble?

Uses oil.....	12%
Noisy valves.....	10%
Plugs fouling.....	4%
Carburetor	3%
Blown head gasket.....	2%

Does not have torsion-bar suspension system

Would buy another?

Yes	71%
No	5%
Might	24%

"Factory slow in sending adjusting wrenches to dealer. Present setting too low in rear with leveler turned on."—Illinois electrician.

"Noisy when it levels off."—New Jersey steam fitter.

But the suspension is not all that Packard

has that is new this year. The big V8 engine (biggest in the industry) is all new and the owners rate its performance as the second best-liked feature.

"Engine always responds quickly. Power must be used cautiously to prevent spinning rear wheels."—Illinois engineer.

TEST DATA

1955 CLIPPER CUSTOM
Four-Door Sedan with Ultramatic

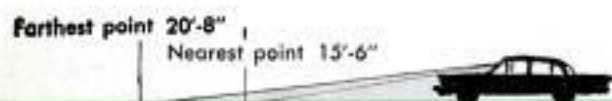

Acceleration Test

¼ mile from zero -	18.9 seconds
½ mile from zero -	29.9 seconds
0 to 30 miles per hour -	4.0 seconds
0 to 60 miles per hour -	12.1 seconds
All acceleration tests using "Dart" (lower driving range)	
Top speed by speedometer -	116 miles per hour
True top speed -	108 miles per hour

Economy Test

Constant-Speed Mileage

At constant 30 miles per hour -	19.2 miles per gallon
At constant 50 miles per hour -	17.2 miles per gallon
At constant 60 miles per hour -	15.7 miles per gallon
At constant 75 miles per hour -	13.0 miles per gallon

Cross-Country Mileage

Los Angeles to Las Vegas, Nev. -	15.3 miles per gallon
Las Vegas to Lone Pine, Calif. -	16.7 miles per gallon
Lone Pine to Los Angeles via Mojave Desert and Angeles Crest Highway -	14.7 miles per gallon

(Premium gasoline used for all testing)



Every month, *Popular Mechanics* brings its readers two reports on automobiles: 1. The test of day-by-day usage as given and told by the owners themselves; and 2. the Clymer road test. Together, these reports tell the complete story of a car

"Fast pickup when needed. Has a top speed of 119 miles per hour on the speedometer."—Michigan salesman.

"Has power to spare but is noisy at low speeds and the Ultramatic seems to grind at 5 to 20 miles per hour."—Kentucky electrical supplier.

Owners' Complaints

So much for the top-ranking good features of the 1955 Packard and Clipper. What are the complaints? The one most frequently mentioned trouble is rattles, followed by poor assembly and sloppy workmanship. A very high percentage (54 percent) of the Packard owners have no complaints at all. There are 25 percent of the Clipper owners and 24 percent of the Clipper owners with no complaints.

"An excellent automobile except the doors rattle."—North Dakota owner.

"Doors rattle. Trunk leaks dust."—Kansas real-estate man.

"Has minor body noise which is hard to locate. Body work rather poorly done for a high-price car."—Minnesota retired owner.

"Upholstery of the headlining was poorly put in."—Florida retired owner.

"Poor attention to detail in factory. Door handles and window cranks fall off."—Indiana insurance man.

Why They Buy Packard

We asked owners to name the one feature that most convinced them to buy Packard. First on the list is previous satisfactory experience with Packard. Second is the torsion-bar suspension, followed by the V8 engine, the exterior styling and the large trade-in allowance given by the Packard dealer.

"This is my fifth Packard and they were all good."—New Jersey inspector.

"I took a ride on a rough road and the torsion-bar suspension sold me."—Wisconsin executive.

"The new V8 engine and the way it stood up under the 25,000-mile endurance test."—California machinist.

"Modernistic styling convinced me."—New York salesman.

"Packard gave me a better trade."—Maryland printer.

Have Engine Trouble?

When a new engine is brought out there is frequently considerable trouble with the early production run. To find out if Packard was plagued that way, we asked owners to describe any engine trouble they had. Of the Packard owners, 94 percent had no trouble at all, 6 percent had some and none had considerable trouble. Among the

(Continued to page 236)

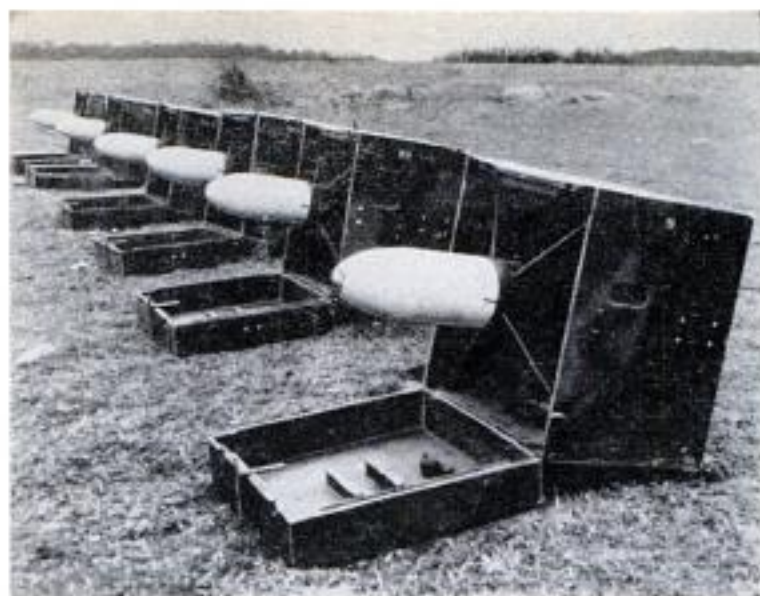

With their warheads thrust forward, the rockets are ready for firing as the boxlike carrying cases become launching stands



The soldier-technician guides the rockets to their target with a tiny "joy stick"

"Suitcase" Rockets Guided to Target by Soldier-Technician

"Suitcase" rockets launched from their own carrying cases are being tested by the French army against tanks, half-tracks and other battlefield equipment. The electronically launched and guided missiles can pierce any known armor plating, according to the French. After a rocket is launched,

it is kept within the sights of a soldier-technician who guides it toward the target with a small stick and a control box. Its deadly accuracy, say French army officials, promises to make it the backbone of anti-tank warfare. The newly developed ground missile is labeled the SS-10.

Grille of Metal Flowers Covers Tokyo Building

Grillwork containing 10,000 metal flowers covers the sides and all the windows of a six-story building in downtown Tokyo. The unusual front serves to attract customers to the teahouse and night club housed in the structure. It is located in the city's Ginza section.

Television Channels Cover 69,000 Miles

Coaxial cables get most of the credit for intercity television relays, but actually microwave radio relay does the bulk of the work, according to the Bell System. At the end of 1954, there were 49,000 miles of radio relay and only 20,000 miles of coaxial cables in the United States. This marks a tremendous expansion of facilities since 1948 when there were only 900 channel miles of relay in the country, all along the East Coast.

☐ In the last five years, Americans have bought more than 350,000,000 electrical appliances.

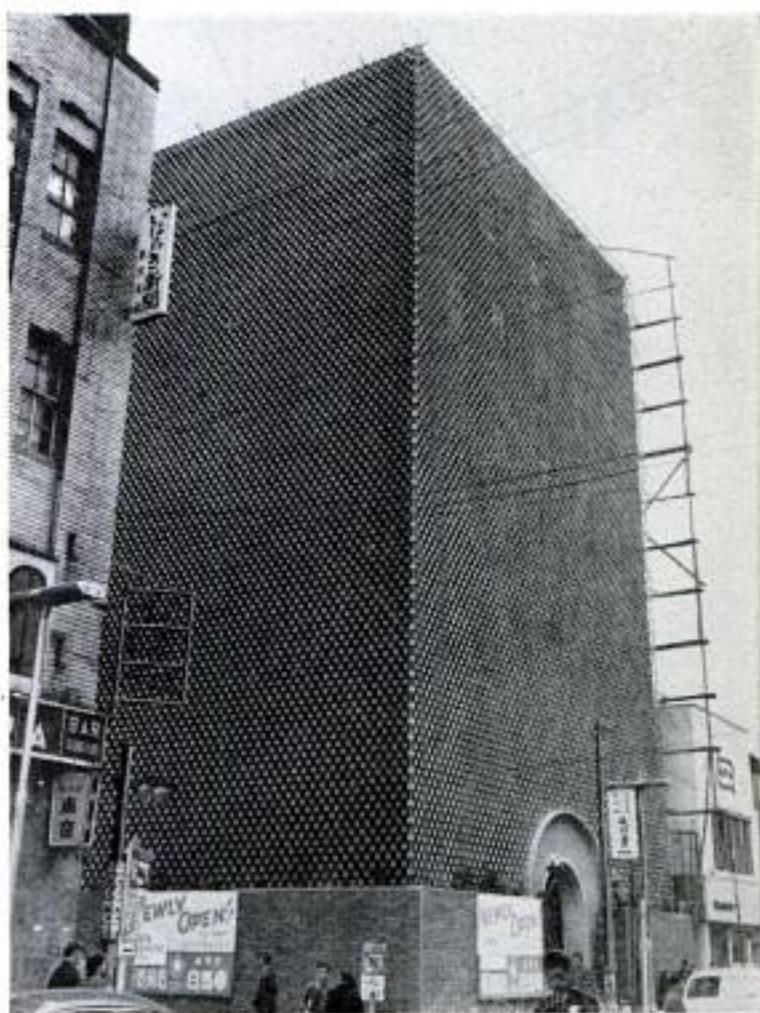



Transparent Mylar has one third the tensile strength of steel. Right, film can be metallized with aluminum

MYLAR

the New Synthetic Film

By O. A. Battista

THAT WIZARD of chemistry, the late Dr. Wallace H. Carothers, started this story back in 1928. Carothers, called the "father of nylon," discovered a good many products in addition to those he sought out. First came nylon, then Orlon and Dacron. And now comes Mylar, a polyester film that looks like cellophane but behaves like nothing ever seen before. Mylar is made largely from chemicals derived from natural gas and petroleum.

At Circleville, Ohio, a big Du Pont plant is turning out Mylar by the mile and every bit of it is bought as soon as it is produced. There's a waiting list for the product because of its unusual properties: Mylar film retains its dimensions and flexibility over a temperature range from minus 75 to 300 degrees Fahrenheit; its tensile strength is a third that of machine steel; it can be mass-produced in sheets as thin as .0075 inch; it has unusual shock resistance and can be bent indefinitely without cracking. It is chemically inert, moisture-insensitive,

solvent-resistant and is unaffected by many acids and alkalis.

These aspects of Mylar's personality fit it for countless jobs. Take the capacitors that help prevent the pitting of dial-telephone relay contacts. Telephone engineers have discovered that Mylar is just what they've always hoped somebody would produce for this purpose. Today Mylar is taking the place of impregnated paper which is used to separate the metal-foil electrodes. It is tougher, cheaper, stands more voltage and needs no impregnation. The new capacitors require no protective housing and are much smaller.

Acoustical tiles are being covered with sheets of Mylar printed in attractive designs. Owens-Corning, the manufacturer, says the film actually improves the tile's soundproofing qualities. It is now possible to produce more attractive acoustical ceilings and walls. In the past, irregular surfaces have limited the decorative effects of acoustical tiles and have made them diffi-

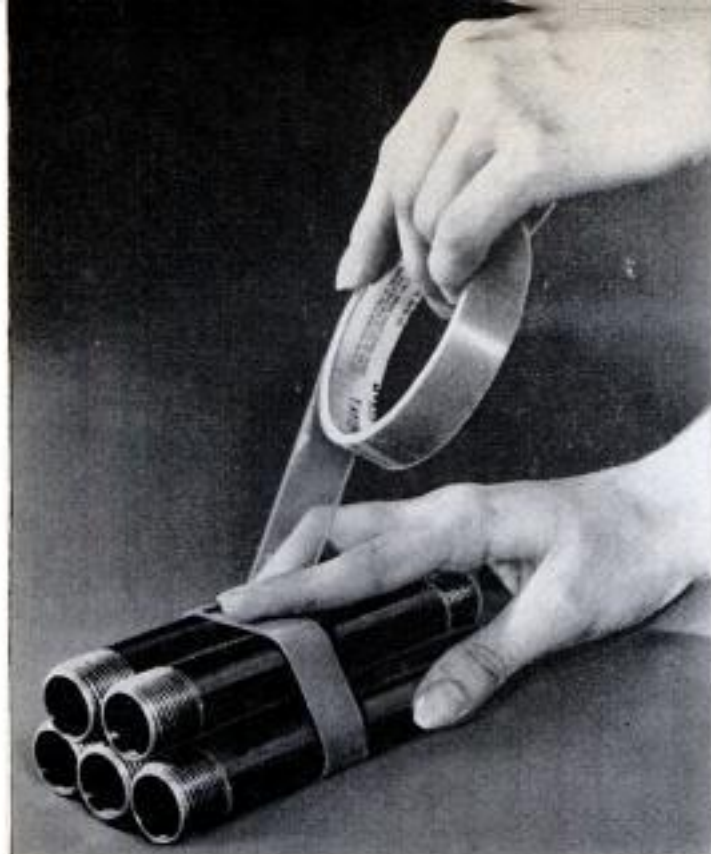

Tapes made of Mylar are surprisingly strong, can be used for bundling, sealing, masking and splicing

cult to clean. Tile made with Mylar is easily washed with soap and water, and the colors remain brilliant for years.

In the field of tape recording, the most common material now in use is a tape of cellulose-acetate film. Mylar tape has greater tensile strength, resistance to wear and dimensional stability. Also Mylar needs no plasticizer, which prevents most films from drying out and becoming brittle. For these reasons Mylar has already made a big name in the sound-recording field. It can be used and stored under extreme conditions of temperature and humidity.

Tapes made from Mylar also are serving in some of the remarkable new electronic "brains," and are telemetering information at airports. Still another type of tape made of Mylar may be used as a substitute for the steel strapping used to hold large cartons together, and for palletizing shipments.

Mylar also is being laminated to metals, making it possible to draw the metals into desired shapes. In this process Mylar protects the sheet steel, eliminating the need for lacquering or tin plating.

When Mylar is laminated to aluminum foil, kraft or asbestos papers, the resulting materials are solvent-resistant and moisture-insensitive. Reverse-printed with wood designs, Mylar can be laminated to inexpensive grades of plywood. The surface of the film then acts as a protective finish for the beautiful wood-grain effects.

Unfortunately, Carothers did not live to see all his brain children reach commercial success. Mylar, the baby of the family, shows promise of overcoming the lead of its older brothers and sisters. ★ ★ ★



Moisture insulation, now under test, is made of a film of Mylar bonded to aluminum foil, then to paper



Sound-recording tape won't shrink, stretch or dry out and is stronger than types now in use. Below, material is ideal for industrial and electrical tapes





First step in any gun-safety course is bench work—learning every detail about the gun and its ammunition

Teen-Agers Learn to Hunt SAFELY

By George Laycock

IN AN EASTERN state last year a youthful hunter aimed carefully at what he thought was the head of a deer. He made his kill, but it was not a deer. It was another hunter.

Such hunting accidents break into the news every fall as legions of hunters take to the fields. In the more crowded sections of the country the danger has become so great that even seasoned hunters often stay home on opening day.

But now officials think they've found a way to cut down the number of hunting tragedies. Their answer lies in education. All across the country boys and girls are enrolling in hunter-safety courses. The training is producing results. Several states

have cut down hunting accidents among young hunters.

This nationwide plan to teach hunter safety to teen-agers had its birth in New York State in 1949. Officials there were distressed by the growing number of accidents, and started searching for a way to reverse the trend. Why, they wondered, couldn't gun safety be taught in much the same way that driving or swimming safety is taught?

This thinking led to a new state law requiring hunter-safety training of every hunter under 17 before he could get his first hunting license. Later the law was changed to include anyone under 21.

That first year it was the game protectors





Pop-up targets require split-second decisions. Boys fire only on game in their sector, and never at the dog

who taught hunter safety. They soon learned that this left little time for enforcing game laws. At this point the New York officials called in the National Rifle Association and asked its members to set up a hunter-safety program.

The NRA, working closely with the National Education Association, designed a four-hour course in gun safety for beginning hunters. By 1952 New York had 1162 instructors qualified to teach the course. There were 19,611 students in their classes that year and, almost immediately, hunting accidents in New York began to drop.

Meanwhile the idea was spreading to other states. By early 1955 five other states, New Jersey, New Hampshire, South Dakota, California and Massachusetts, had passed laws providing for hunter-safety instruction for beginning hunters. A dozen other states were studying similar laws. Across the country there were 8422 qualified instructors, with some in every state.

By the time other states started to take up this plan, Kentucky, where the tradition of the rifleman is strong, was already well along in its own program to teach gun safety to large groups of teen-agers. The program is taught through Kentucky's

system of Junior Conservation Clubs.

There are more than 30,000 young Kentuckians in nearly 700 of these clubs. Behind Kentucky's Junior Conservation Clubs is ex-schoolteacher Ed Adams who started the program in 1944. At their monthly club meetings and at summer camps these boys and girls study a wide range of outdoor activities. But gun-safety instruction ranks high in the program.

"Every one of our club members now gets some form of instruction in gun safety," says Adams. "So far, not one of our club members has been involved in a serious hunting accident."

Ed Adams and Kentuckians in general think they've hit pay dirt in their gun-safety program. They believe their Junior Conservation Club work is one of the best things to hit the state since Dan Boone



Don't Shoot!

Boys demonstrate a common but dangerous practice. Hunters in a party should split the area into zones and never fire into another hunter's zone



RIGHT

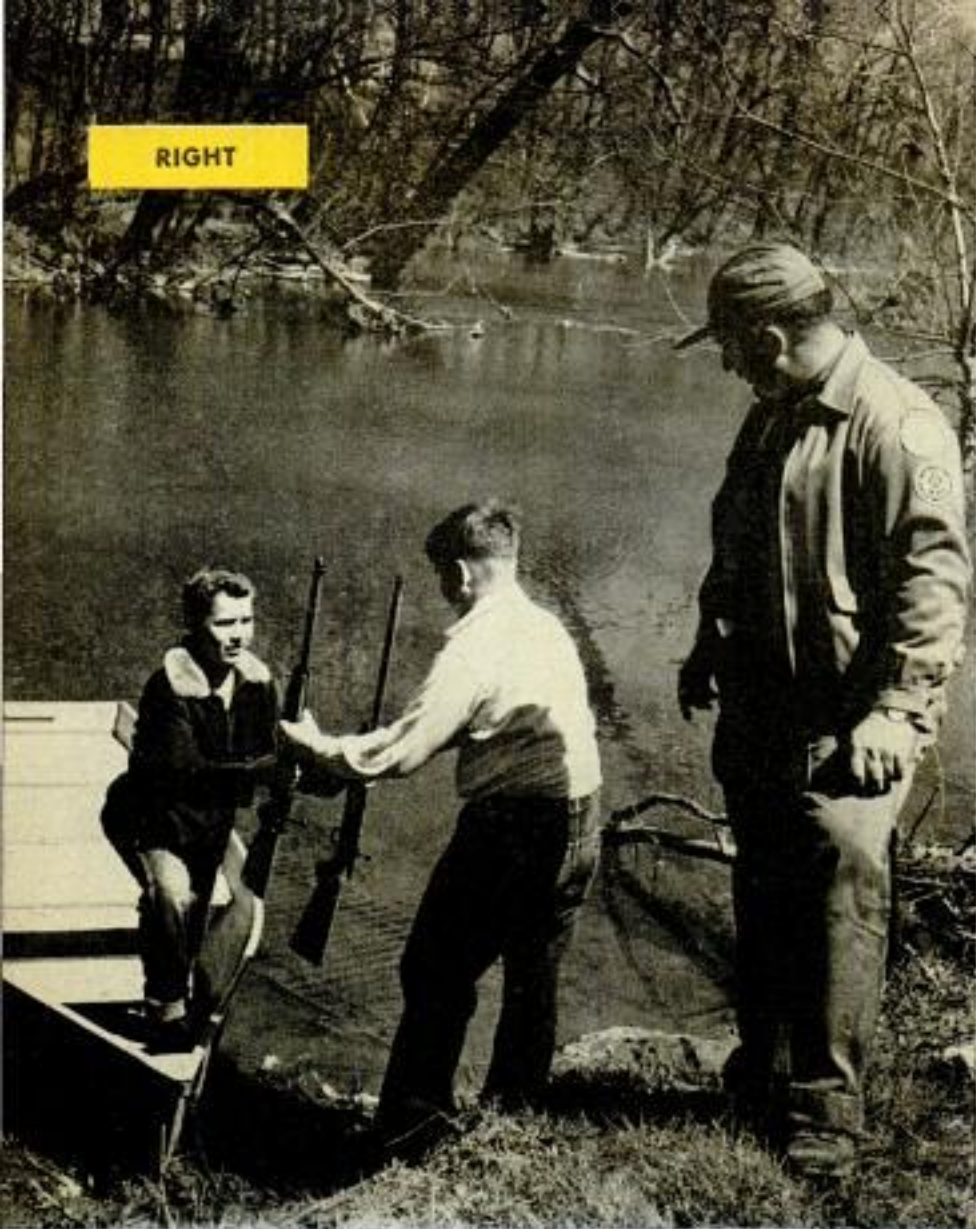

One boy holds both unloaded guns on the bank while the other lad climbs into the boat. Then firearms are handed over before second boy climbs in. Never lean a firearm against a tree. If the hunter in the foreground should bump gun with his elbow, it could fall and kill his companion

WRONG



came through the woods. "These lessons stick with them," Adams says. "In later years when they're hunting they will remember what they've learned in their clubs."

Adams has been told by more than one adult hunter that these trained boys make better hunting companions than most adults who have been hunting for years. One thing that distresses Adams is the fact that many parents aren't keeping up with their children in learning gun safety. "We are losing some of our kids," he says, "by accidents that happen in the home where the parent has left a shotgun, rifle or pistol loaded or where ammunition for these weapons is easily accessible."

Leaders in these gun-safety training programs have no doubt that education is the best attack on the loss of life and limb from hunting accidents. Says the National Rifle Association, "Virtually all hunting casualties are the result of carelessness bred of ignorance, and even one such accident would be entirely too many."

The real part played by carelessness and ignorance in hunting accidents shows up in the NRA's "Uniform Hunter Casualty Report." This report summarizes information on hunting accidents in 24 states and it brings to light some revealing pointers for those who want to go hunting and stay alive. In the states reporting last year, 71 percent of hunting casualties occurred on clear days and 26 percent in open country. In 57 percent of the accidents the gun was fired intentionally. Many victims were mistaken for game.

Among the deaths from guns fired accidentally, a large percentage of

hunter victims were shot when they stumbled and fell. Others were killed when the trigger caught on brush, when putting a gun into a car or taking it out, when crossing fences or when loading or unloading a gun. Still others died as a result of horseplay with a gun that was thought to be empty.

Who are the hunters that cause most of the tragedies? The Hunter Casualty Reports come up with some evidence on this, too. Of the cases reported through the NRA from 1950 to 1953, the offending guns in 38 percent of the accidents were carried by hunters 19 years old or younger.

The hunter-safety program has grown large but not unwieldy. There is still close personal work between instructor and student. "I don't want my classes to be larger than 12 students," says Alan Ward, a certified hunter-safety instructor in Madison County, Ohio. Ward, who is also the county conservation officer, teaches hunter safety in his free time. His classes are typical of the hundreds of hunter-safety classes conducted in all parts of the country.

Each of his classes meets four times. They're supposed to get in an hour's training at each meeting. "But the fourth meeting," says Ward, "is usually on Saturday morning and it often lasts the full morning." During the first three meetings boys and girls learn the parts of a gun, how to take care of a gun and the different kinds of ammunition. They learn the rules for safe gun handling under a variety of field conditions. They learn that a gun improperly handled can be a lethal weapon and that a slip of the finger can kill a man.

Actual gun handling and range practice are an important part of the training and all students



Teen-agers learn that the safest way to climb a tree with a gun is not to climb it at all

Never use a gun to push aside the brush, muzzle or stock first. It may discharge or dirt may clog the muzzle

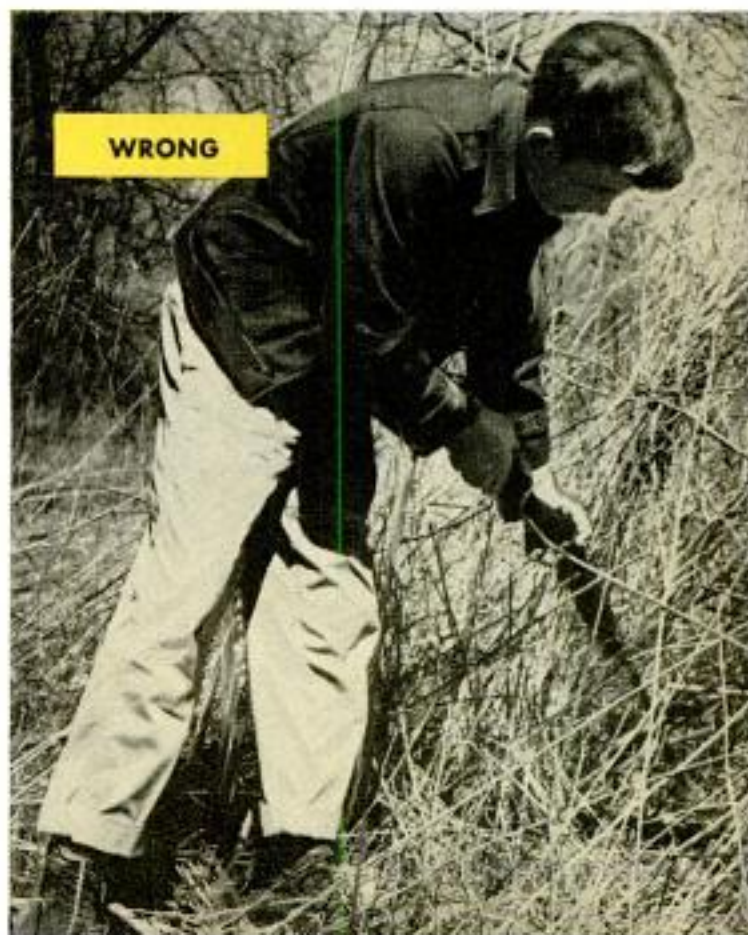
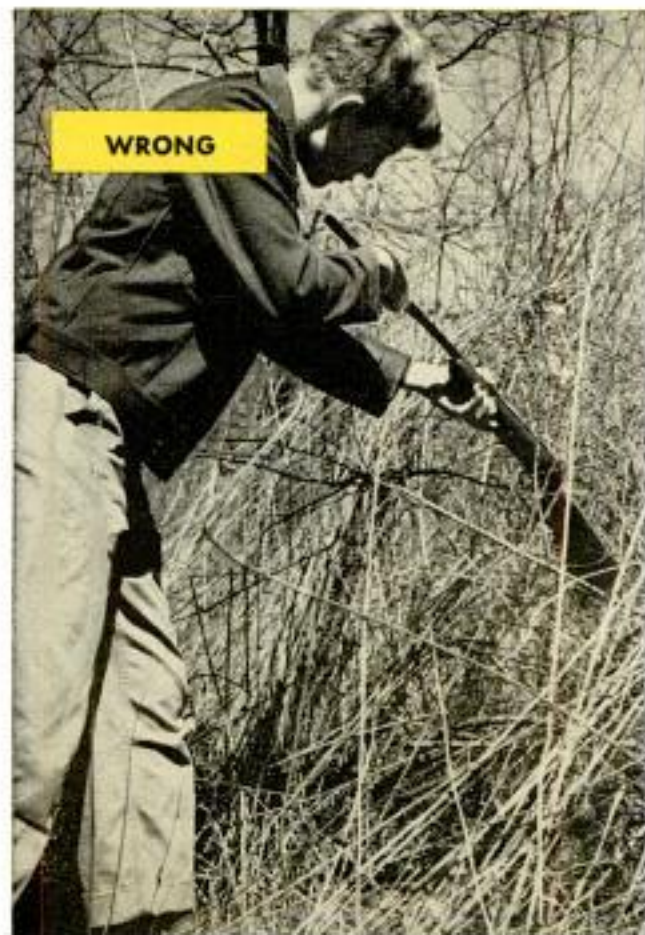



At mockup of fence, instructor teaches teen-agers that one hunter should cross first while other holds both guns. Below, in heavy brush, gun should be held high to minimize chance of catching the trigger



Lone hunter unloads gun, places it through the fence muzzle first, then crosses fence at the next post

are supposed to shoot with either shotgun or rifle before they have completed the course in gun safety.

This four hours of concentrated instruction is enough to give the youthful hunter the knowledge he needs to handle guns safely. It is also enough to give him confidence in his weapon and instill in him some pride in becoming known among his companions as a safe hunter, a hunter who would be a good field companion. Once the teen-agers have completed their course and successfully passed the written quiz, they are given an NRA Safe Hunter shoulder patch and a pocket card.

The gun-safety rules these young hunters learn in hundreds of classes across the country are rules all hunters should know and obey. Among the most important ones are these:

1. Treat every gun as a loaded gun.
2. Always control the direction of the muzzle. There is no excuse for pointing a gun at other people or allowing others in your party to do so.
3. Know what you're shooting. Always identify your game before you point your gun. Too many hunters are shot each year because other hunters mistook them for deer, bears or even rabbits or squirrels.

Other prime rules include: Be sure the barrel is free of obstructions, unload unattended guns, don't mix alcohol with shooting, always unload a gun before crossing obstacles in the field and keep the safety locked until you're ready to pull the trigger.

These safety precautions are becoming standard procedure for a growing number of beginning teen-age hunters. Your future hunting trips promise to be safer ones because we're giving our teen-agers basic training in hunter safety. ★ ★ ★



Technicians used the hearts of 265 pictures in making the mosaic. Photos were first enlarged, then pasted up on four-by-nine-foot panels of hardboard. The completed picture, right, is 60 feet long, 9 feet wide and shows a 26 by 4-mile area

Portrait of a Highway

EVERY ROAD, building and tree along 26 miles of U. S. Highway 41 can be seen in a giant photo portrait made for the Wisconsin Highway Commission. The 9 by 60-foot map shows two miles of area on each side of the heavily traveled thoroughfare between Milwaukee and Chicago.

With such a picture, engineers can hold conferences in their offices and estimate the problems of widening the present highway, building grade separations or clover-leaf intersections, or building a whole new road through less-developed neighboring country.

The aerial pictures used in the mosaic were taken on nine-inch film, with a scale of 500 feet to the inch. Controlled enlargements brought the prints to a 200-feet-to-the-inch scale. Corrections were made to correct errors in scale on the film caused by change of altitude or pitch during photography.

As the pictures were taken with a 60-percent overlap in succeeding exposures and a 15-percent overlap in the flight strips, only the central, most-accurate part of each picture was used for the mosaic. To make the picture, the aerial-mapping technicians used the hearts of 265 pictures. The project was done by the Abrams Aerial Survey Corporation of Lansing, Mich.

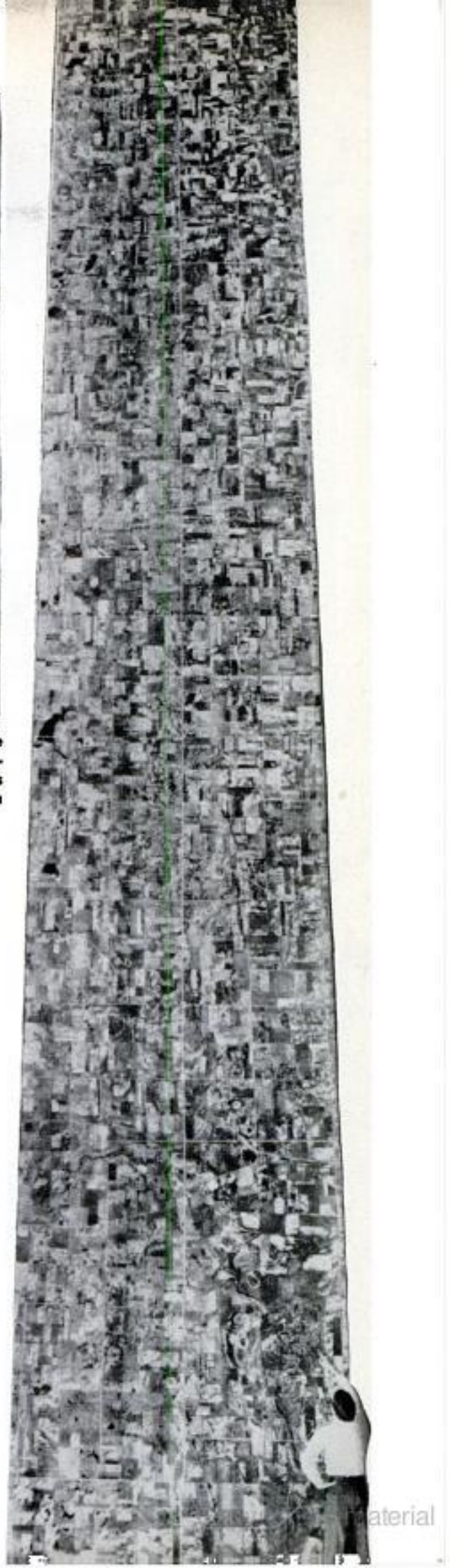



They Pray Into the Lives of Fish

To learn the habits of ocean fish and how long they'll survive as our food supply, California biologists go fishing with an eight-mile line

By Claude M. Kreider

Yellowtail fish (top of page) wears bridle and button tags. Man at left puts float on flag marker as others pay out eight-mile line



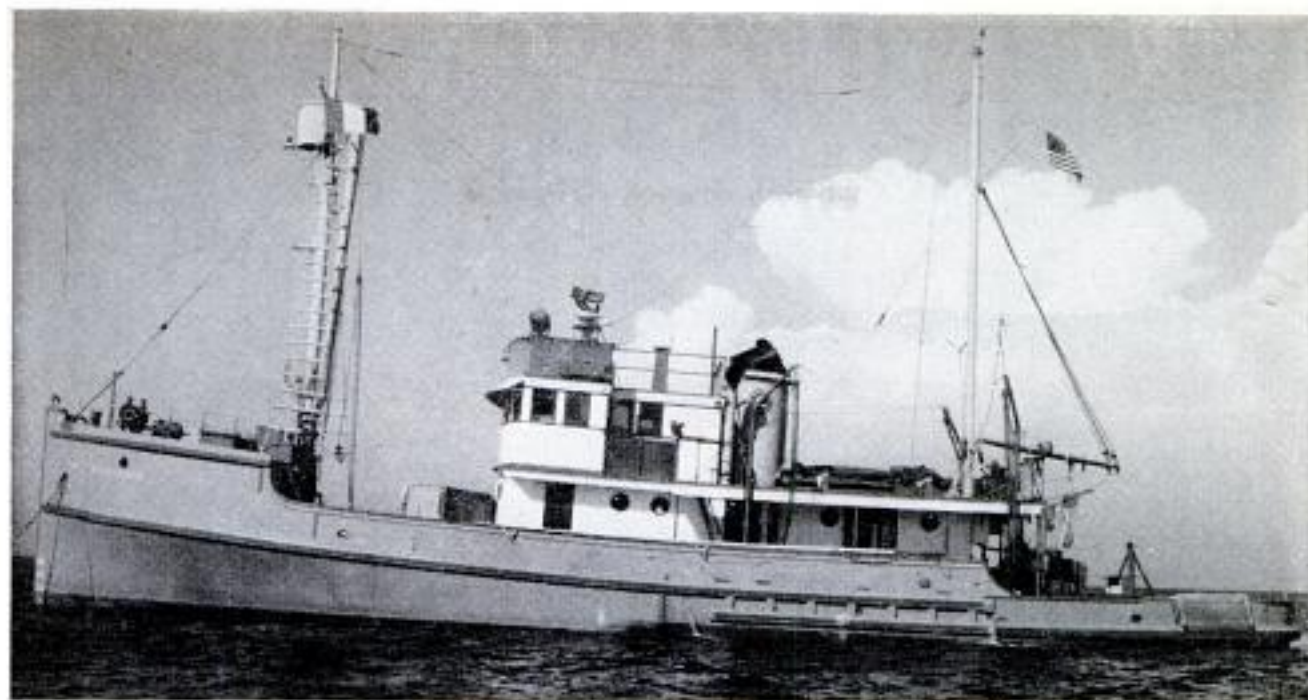

N. B. Scofield was especially built for deep-sea research. It has a 350-horsepower engine, cruises at 10 knots

PROBING THE LIVES of Pacific Ocean fish is a year-round job for marine biologists of California's Department of Fish and Game. They're keeping careful watch of a crop that yields a huge harvest each year.

Over 300,000,000 pounds of tuna were canned last year in southern California. During one month, 66,000 sport anglers in 276 party boats caught 418,000 ocean fish. Meanwhile, sportsmen along the shore fished the rolling breakers, clam hunters scoured the beaches and skin divers plunged for lobsters and abalones.

Can this keep up? The Fish and Game experts intend to find out. Their study of growth, migrations, habitat, food and spawning will form the basis of future regulations to make sure there are always plenty of fish in the sea.

At the Terminal Island Laboratory in Los Angeles Harbor, a crew of 24 trained biologists probes the mysteries of ocean life. The investigators are aided by scientific equipment and a record bureau containing 10,000,000 carefully classified cards. "Field" work is carried out with two specially equipped research vessels. One, the 100-foot, diesel-powered *N. B. Scofield*, cruises thousands of miles in the Pacific on laboratory projects. A team of biologists directs each expedition.

A recent cruise took the *Scofield* to equatorial waters off the western coast of Central America,

where commercial ships operating from California canneries take up to 400 tons of tuna each.

The tuna clippers throw live bait overboard to attract surfacing schools of fish, then "jack pole" them in with barbless hooks. The lower ocean strata had not been touched by the commercial fleets. Man's knowledge of the deep, teeming waters stopped just below the surface.

The *Scofield* fished deeper, with a "long line" eight or nine miles in length. The

Chart shows 26 long-line "sets" made on Jan. 23 to Mar. 18 *Scofield* cruise. Most large tuna were taken at points 5 and 9



Flag-marked floats at 1260-foot intervals upheld line. Dropper lines hung from main line held baited hooks

line, similar to that used by the commercial fishermen of Japan, also resembles a glorified fresh-water trotline. The main line, almost the size of sash cord, carries up to 300 drop lines spaced about 90 feet apart. The droppers, sometimes 90 feet long, end in very large hooks, like those used for swordfish. Sardines serve as bait.

Fast teamwork by the crew permits the vessel to proceed at seven knots while the main line is payed out and the droppers, coiled six to a basket, are attached to rings with a special snap. Stainless-steel oxygen tanks, 24 inches long, serve as floats. One is attached to the end of the line, the others spaced at 1260-foot intervals. On each float is fastened a bamboo pole, carrying a yellow flag, to indicate the "lay" of the completed set.

Setting takes about an hour. After six hours the line is pulled in by a high-speed retriever powered by an electric motor.

Diving biologist prepares to go below to shoot movies of underwater life. Crew member holds cased camera



134

Depending upon the extent of the catch and the size of the fish, recovery and coiling takes about three hours.

In the warm equatorial waters, sharks are a menace and a nuisance. During the Central American cruise, 236 sharks of varied kinds were caught in 26 long-line sets. Dangerous to bring aboard, the fish are cut loose as quickly as possible.

The expedition snagged 78 marlin and sailfish, a 700-pound broadbill swordfish and 16 specimens of rare big-eye tuna, each weighing over 300 pounds.

An important result of the cruise was the capture of 76 giant yellowfin tuna, many weighing over 200 pounds. Yellowfins this big are seldom caught by the commercial boats. It may be that the big ones live deep, that new methods of taking them can develop an entirely new fishery.

Other projects of the *Scofield* have included mile-deep trawling: Large nets are

Hooked shark bares a wicked set of teeth. Expedition caught 236 sharks, cut them loose as soon as possible



POPULAR MECHANICS

Copyrighted material

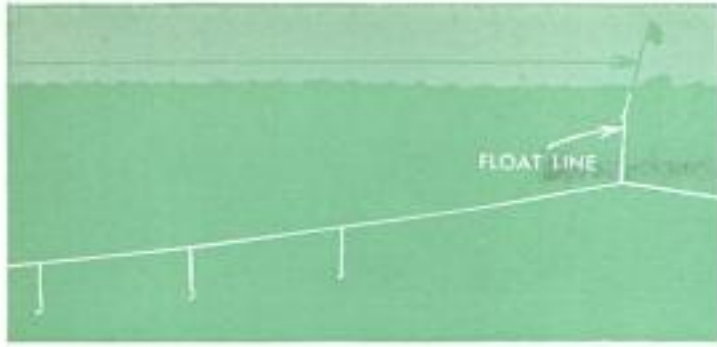

dragged along the sea floor to gather marine life. Two huge, electrically driven drums carry 10,000 feet each of $\frac{5}{8}$ -inch steel cable for use with trawling nets. Recently this deep dredging disclosed an unguessed shrimp bed, and a new fishery and processing plant resulted.

Fish brought up from the deep are quickly tagged so that their later movements can be discovered, then released. The smaller surf and rock fish are marked with a small plastic button attached to heavy nylon thread that is sewn through the back under the dorsal fin. Larger fish carry a "bridle" tag of flexible Vinylite which is inserted through the fish under the backbone and knotted on top in a loose loop. A small core inside the Vinylite casing carries the necessary identification.

Nothing was known of the growth rate of the yellowfin tuna until a fish tagged off the Peruvian coast was caught by a commercial vessel a year later. Although

it was the only one of the 281 tagged fish ever heard of again, the fact that it had gained 25 pounds was duly recorded.

A later tagging project produced far better results. It called for the marking of 10,000 yellowtail, the premier game fish of the southern California coast. By the time 5000 fish were tagged, 300 tags had been returned to the Commission.

The movements of the albacore (longfin tuna), which appear each season along the south coast in tremendous schools, have long puzzled the scientists. The fish appear suddenly and leave as mysteriously, always traveling into the north and west. The species is known in Japanese waters, but it was hard to believe that the fish regularly crossed the Pacific Ocean.

After hundreds had been tagged, an albacore marked off Catalina Island was taken by a fishing boat out of Tokyo. The fish had traveled 4500 miles in 324 days, a straight-line average of 14 miles per day.

The patient biologists are learning much about the migration pattern, distribution and spawning habits of popular California fish. Each tagged fish has an individual record in the department files. When a marked fish is caught and examined, the numbered tag provides a clue to its history.

Even shellfish are under the constant scrutiny of the marine scientists. While some of the biologists dig clams on the beaches, other investigators turn skin diver to study the lobsters and abalones. ★ ★ ★

Sport fishing is combined with research in taking yellowtails for tagging. Caught fish are handled carefully

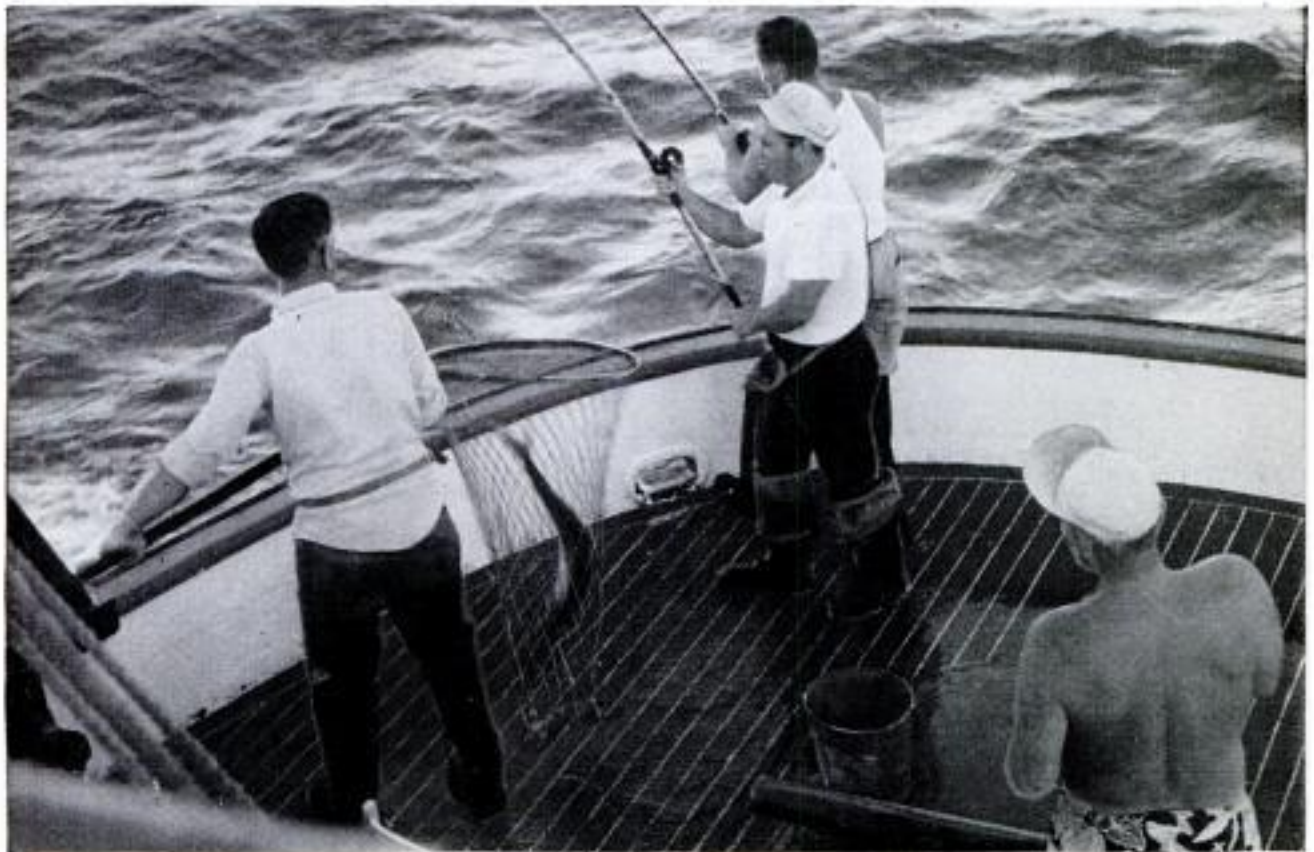



Binoculars can be used as telephoto lenses—one eyepiece for picture taking, the other for view-finding

Binoculars Used in Telephoto Photography

Photographers can take close-up shots of distant subjects by coupling newly designed binoculars to the camera lens to serve as telephoto lens. An adapter unit, available with the binoculars, permits the use of them with almost any type of camera, still or movie, including twin-lens reflex models. One eyepiece of the binoculars

is used for the picture taking, the other becomes a viewer. The 7x50 binoculars provide the equivalent of a 560-mm. telephoto lens. According to the manufacturer, D. P. Bushnell & Company of Pasadena, Calif., ordinary binoculars cannot be used successfully this way because of their low relative-light efficiency.

With standard lens, your photo of a camel behind the bars of the zoo comes out as unexciting as this one



Using binoculars, here's what you shoot. Binoculars are quickly removed from the camera for normal use



Implanted Magnet Moves Artificial Eye

Magnets move a new artificial eye, duplicating the motions of the living eye. The eye was developed at the Veterans Administration hospital in Boston, Mass., and already has been implanted in more than 150 New England veterans who have lost one eye. A tiny magnet is molded into a clear, nonirritating plastic implant, which then is

buried in the eye socket by surgery. The muscles of the removed eye are attached to the implant. An artificial eye then is made to match the patient's good eye, and another magnet is set into it. The eye muscles move the implant, causing the artificial eye to move in the same direction and at the same time as the living eye.

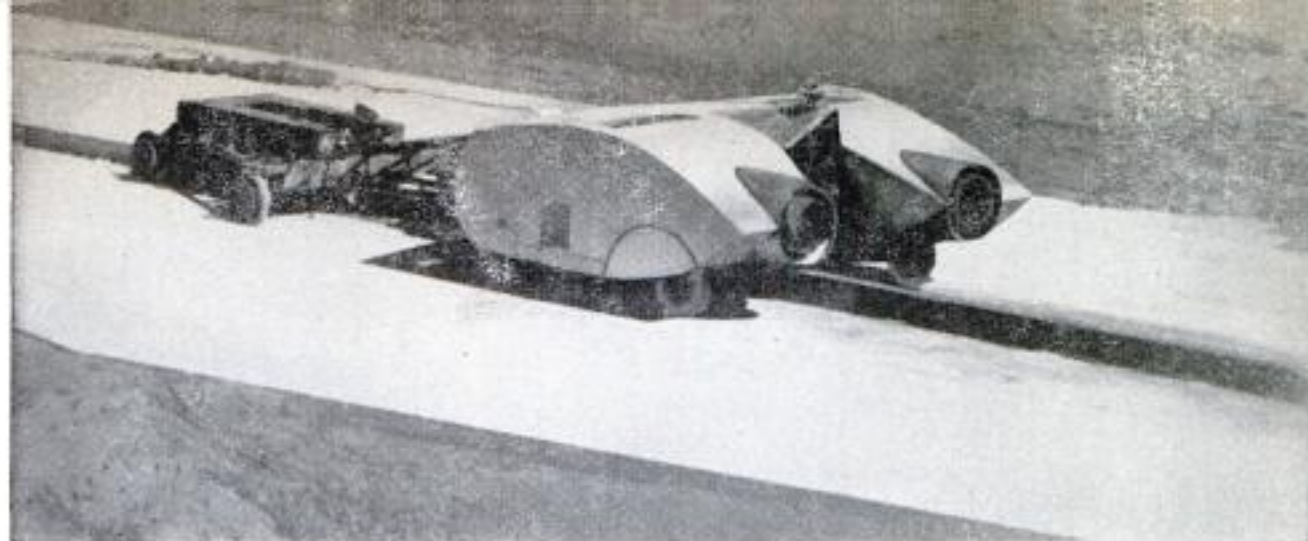

Twin-Engine Jet Car Tests Plane Equipment

Two Allison jet airplane engines power a strange-looking car that pushes a simulated airplane at speeds equal to those of a landing jet plane. The purpose of the device is the testing of aircraft arresting gear. The simulated airplane is a four-wheel, powerless "wagon" on which is loaded steel plates to approximate the weight of the airplane. The jet-powered pusher car drives the "wagon" along a 5000-foot rail until it reaches the desired speed. Then the pusher is braked to a stop and the "wagon" goes ahead on its own to be stopped by the airplane arresting gear undergoing test. The development of arresting gear has taken on new importance

Above, the jet engines push a small cart which is loaded with steel plates to approximate the weight of the aircraft. Below, jet car from the rear, showing how it straddles the guide rail

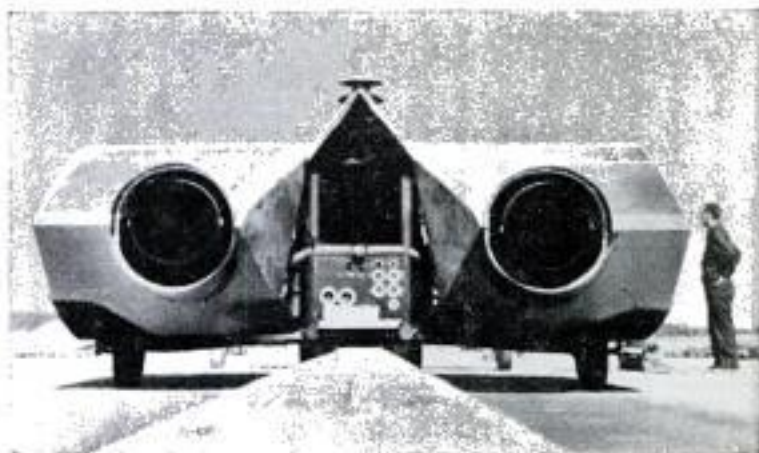

since the advent of high-speed jet planes. As longer runways become necessary, the need has become acute for adequate means of stopping the aircraft.

British Ejection Parachute Saves Pilot of Taxiing Plane

Pilots can bail out of a plane safely when it is only a few feet above the ground with a British-designed ejection parachute. It would prove effective even when the plane is on the ground and heading for a crash. The instant the pilot pulls a small protective blind over his face, the seat takes

charge. He is shot out of the plane by an ejector cartridge and a time-operated gun flicks open miniature parachutes to slow down and balance the seat. Another time switch unfastens the seat harness, enabling the main chute to open while the seat falls away.



Motorcycles Invade the Wilds



Nobody breaks the speed limit along trails like this one on the North Fork of Clearwater River in central Idaho. Below, occasionally, small creeks have to be crossed and the lightweight cycles take them in stride



By David Brazil

THE MOTORCYCLE is invading the wilderness! Back-country packers and their pack animals are astounded when they meet motorcyclists riding nonchalantly along trails high in the mountains far from any road. Lonely foresters stare at tire tracks etched into remote trails and scratch their heads in confusion.

All of this has come about because a few Lewiston, Idaho, cyclists decided to broaden the scope of their activities. Led by E. B. Stranahan, these enthusiasts head for central Idaho's vast primitive area on week ends. Mounting stripped-down American lightweights (Harley-Davidson 8s), they head for remote trout streams or distant peaks on Forest Service pack trails.

At speeds that vary according to conditions from a mile or two to 20 miles per hour, these men travel the wilderness trails at an average of 7 to 10 miles per hour. This is from two to four times as fast as a man or horse can walk over the same paths. Stranahan puts it this way:

"We can take off early in the morning, travel 15 miles beyond the end of the road to a trout stream that doesn't get fished very often.

"That same trip on foot or by pack train," he adds, "would take at least three days—and you'd have to eat all of your fish on the trip.

"Besides," he concludes, "the average workingman doesn't have the time or money it takes to make three-day trips by pack string."

With gripster tires on the rear wheels and their low-gear sprockets (60 teeth), the lightweights climb very steep trails. The boys have a system for getting around the sharp switchbacks on trails that zigzag up the mountains. They lift the front wheel and "float" it around, riding all the while. Gas consumption amounts to less than a gallon per trip.

The stripped-down motorcycles weigh about 150 pounds each.

No spot for jittery riders are trails cut into rock 50 feet above Clearwater River





Each cyclist carries on his back a light packsack and fishing rod protected inside an aluminum tube

When pack horses are met, the boys stop, lift their lightweights off the trail and let the animals pass.

Two to four always travel together. All motors are fully muffled, excepting the last one in the group. As they string along the trail no one has to look back to see if the ones behind are all right as long as the unmuffled motor can be heard. Whenever the tail motor becomes silent the group stops to check. Mufflers must be

Riders travel in small groups, never alone. They can travel about four times as far as they could on foot

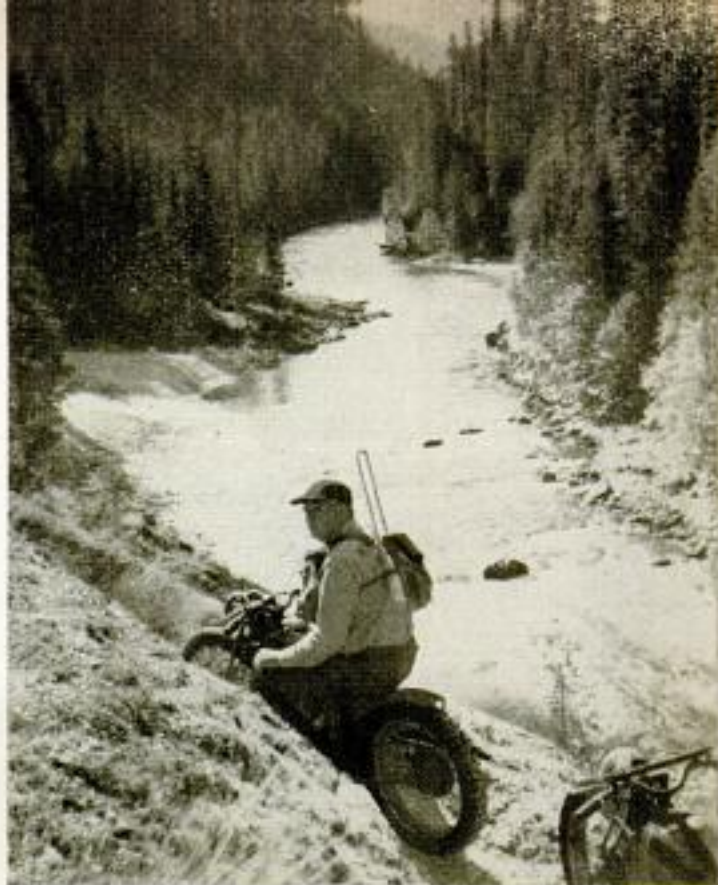

Pioneering the sport of motorcycling in the wilds was E. B. Stranahan, who poses here along Clearwater

mounted higher than usual so they won't be torn off by rocks along the trail.

Because the leader's motor is quiet, there is no danger of frightening pack animals on the trail. When animals are met, a signal is sent back down the line and the tail man turns off his noisy motor.

Spills and falls seldom occur. No one has ever been hurt even though the boys often follow narrow trails along cliffs with dropoffs of 25 to 200 feet. ★ ★ ★

It isn't apparent here, but there is a trail among this rocky confusion and the cycle is following it



Plastic Fuel Tank Undergoes Tests

Tests on a slosh and vibration table have shown that a disposable plastic fuel tank for aircraft is durable enough for military use. The plastic tank, reinforced with glass fiber, would replace the "droppable" aluminum tank which can be salvaged by the enemy and reused. The plastic tank is good only once. It is strong, lightweight and resists weathering, rot and corrosion. It was developed for use by the United States, British and Canadian Air Forces.

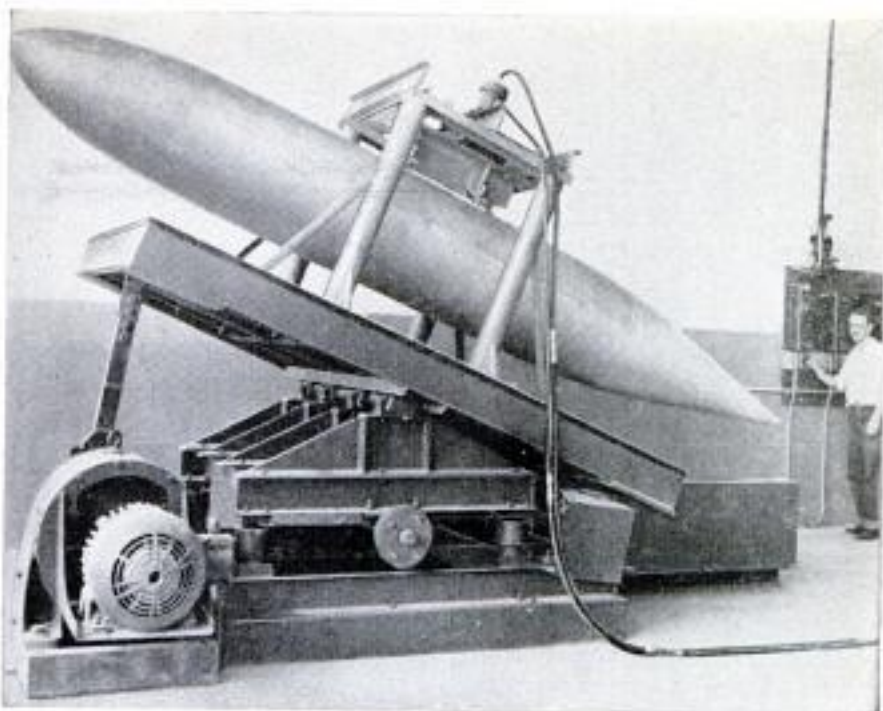

Easy on Battery

Drawing so little power it can be used continuously for 15 hours without depleting the battery, a 15-watt fluorescent light plugs into the car's cigarette-lighter socket. A 35-foot extension cord is provided with the light so it can be used inside the house, camp or tent, if desired. It gives as much light as a 60-watt incandescent bulb, says the manufacturer of the unit.

Brig Has Power

Built to precise scale, an operating model of the U.S. Brig Wasp can do one thing its square-rigged predecessor couldn't do—sail dead into the wind. The quarter-size version of the Navy ship of 150 years ago has an outboard motor tucked under a false quarterdeck. Measuring 27 feet, the brig is complete with 22 sails and rigging, even down to miniature cannon. The vessel was built under the direction of Comdr. C. J. von Zielinski, USNR, whose hobby is building and sailing these ships.



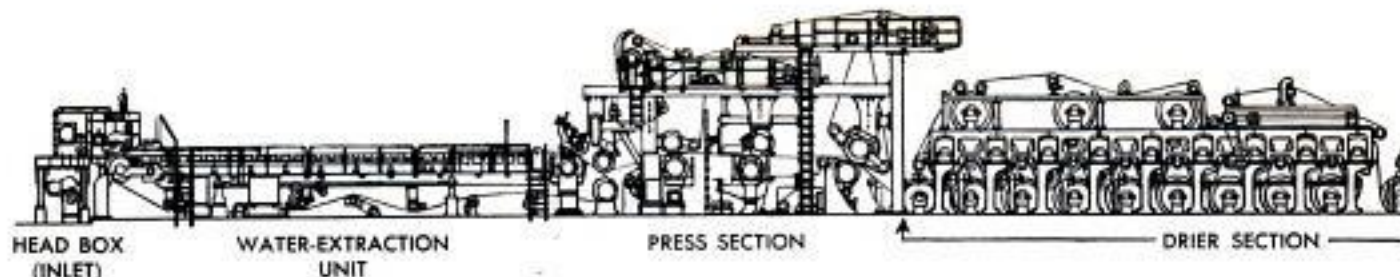

Mile of Paper in Two Minutes

Every two minutes and seven seconds a mile of paper 21 feet wide will be produced by a new machine at East Millinocket, Me. When finally operated at this top speed, the huge papermaker will be the most productive and fastest in the world, according to its builder, the Beloit Iron Works. Over 400 tons of newsprint, enough for 1,500,000 copies of a 40-page newspaper, will be produced each day. Longer than a football field, the 375-foot machine has over 1000 feet of paper in process at any one time. In a half minute it converts a soupy mix-

ture of water and $\frac{1}{2}$ to 1 percent wood pulp into finished stock. The wet material is dropped onto a swiftly moving bronze screen that passes over oscillating vacuum boxes that shake and draw out the water. The sheet of compressed fibers passes through squeezing rollers and is dried further by 54 hollow drying rollers filled with live steam. Pressure rollers compress the paper to give it a good printing surface before it is finally wound onto a reel at the end of the machine. A fully wound reel weighs almost 10 tons.

Robot "Brain" for Houses Gives Life Span in Minutes

Designed for testing home heating, air conditioning and building materials, an electronic "brain" can simulate any kind of house in all sorts of weather. The

machine flashes answers on a radar-type screen and condenses 60 days' actual time to one second. Time required for testing equipment is expected to be shortened by as much as five years. The brain is fed such information as size of a house, size and type of doors and windows, exterior finish, sheathing, insulation and other factors along with the desired weather required for the test. Measuring heat losses and gains as they vary with time is the primary concern of the brain which was developed by the Minneapolis-Honeywell Regulator Company.

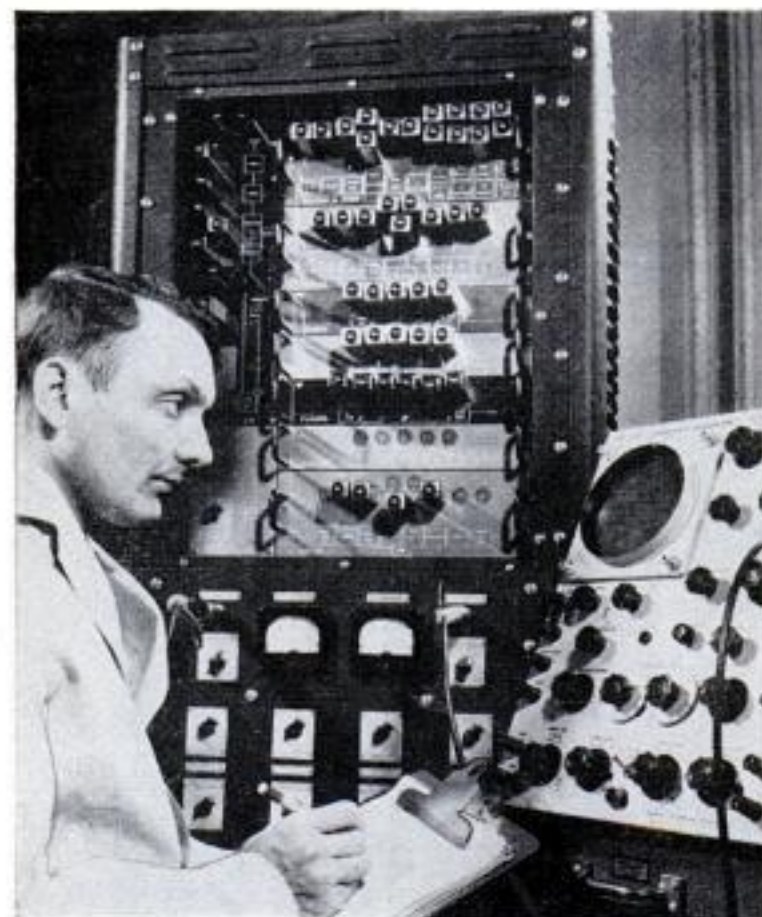

Fluid Dust Fighter Keeps Surfaces Clean

Dust slides right off wallpaper, upholstery and other materials treated with a preparation that fills up pits and crevices that catch dirt particles. The fluid, a colloidal silica, contains particles so small that 600,000,000 of them would be required to cover the head of a pin. Brushed or sprayed on, the silica imparts dust resistance to painted surfaces, wallpaper, window shades, Venetian blinds, lamp shades, upholstery, rugs and draperies.

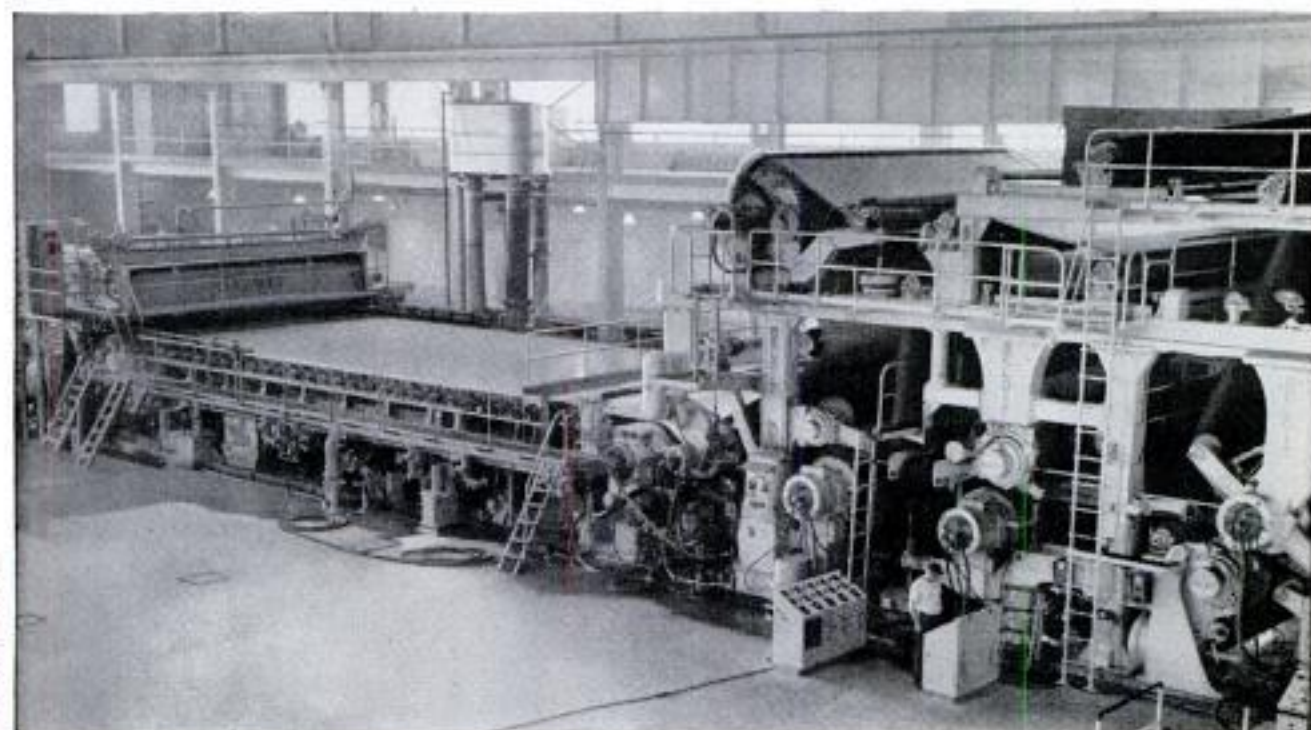
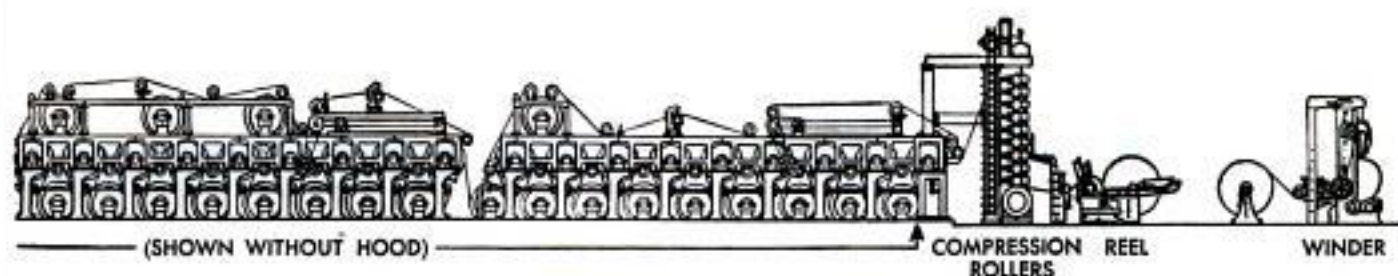

Bus Finder →

Across from Detroit's city hall is a robot answering machine that shows you where you can catch a bus or streetcar in the downtown area. You simply push the button of the transit line you want. A tiny bulb lights up on the map to show you where you can board the bus or trolley.

Car Warming Unnecessary

Warming up your automobile engine on cold winter mornings offers "no real advantage," states P. N. Ku of the National Bureau of Standards. Most people believe that oil will not flow right away if a load is put on the engine too soon, that some of the bearings will lack proper lubrication. Ku, acting chief of the engines and lubrication section of the bureau, believes that little if any damage is caused if the driver waits only until the car motor is turning over satisfactorily. When the motor is turning over, lubricating oil is flowing through the engine.

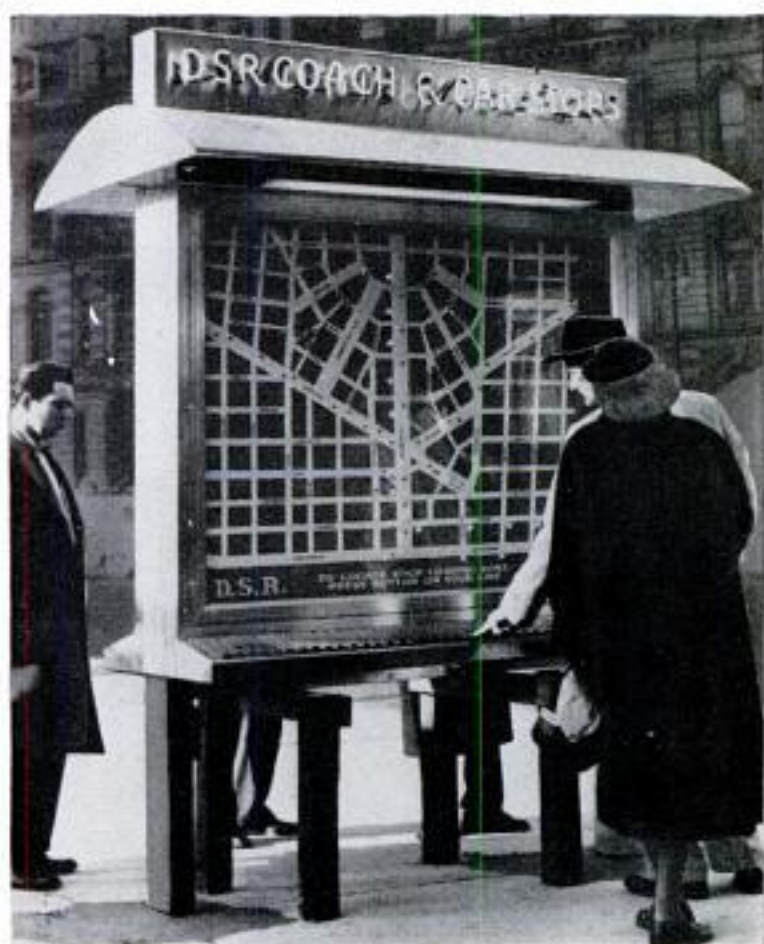



Craft Patterns Printed on Plywood

Patterns for home-workshop projects are printed on $\frac{1}{4}$ -inch plywood. The various parts are pre-painted in nine different colors. The craftsman simply cuts out the parts with a jigsaw or scrollsaw and assembles them with nails or screws. The panels measure 19 by 24 inches and each contains from 1 to 15 projects depending upon the size of the parts. The projects are designed for various age groups and range from wall plaques to bird houses.

Pin-Wheel Plane

You don't have to have pilot training to fly the Helivector, a one-man Pogo stick that may make the ground soldier obsolete. Anybody can fly the aircraft, according to the United States Navy. A large horizontal propeller revolves under the standing driver who guides the aircraft by shifting his weight in the direction he wishes to go. It is said to be capable of speeds up to 90 miles per hour.



Car Exercises Dogs

With six racing dogs to keep in top shape, Dewey Blanton of Columbus, Ohio, has developed a "canine exerciser" that fastens to his station wagon. Blanton built a frame to support a long plank beside the vehicle. Springs fastened to the plank are attached to the dogs' collars, permitting the dogs to run wide. Longer chains keep the dogs in check. The broad plank bumper prevents injury to the dogs as they race along at 35 miles per hour. Best of all, the dogs seem to love the exerciser.

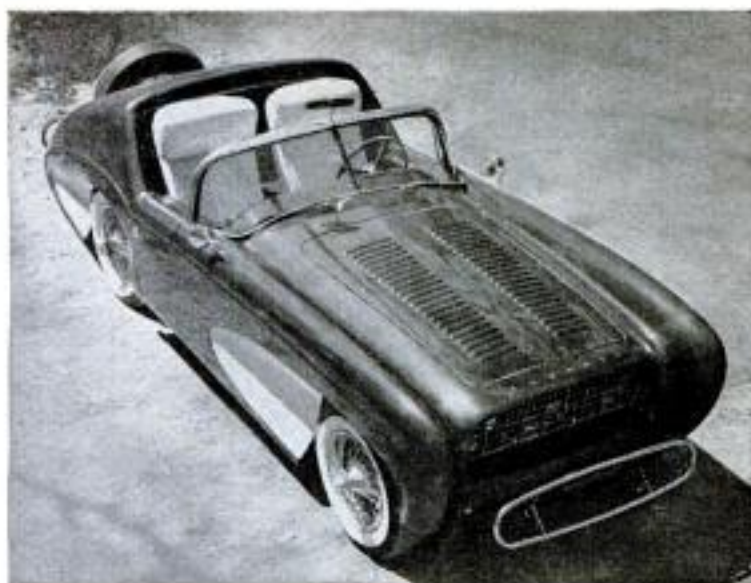

Stylist Flajole demonstrates the sliding roof. Right, with the roof retracted, the car is an open sportster

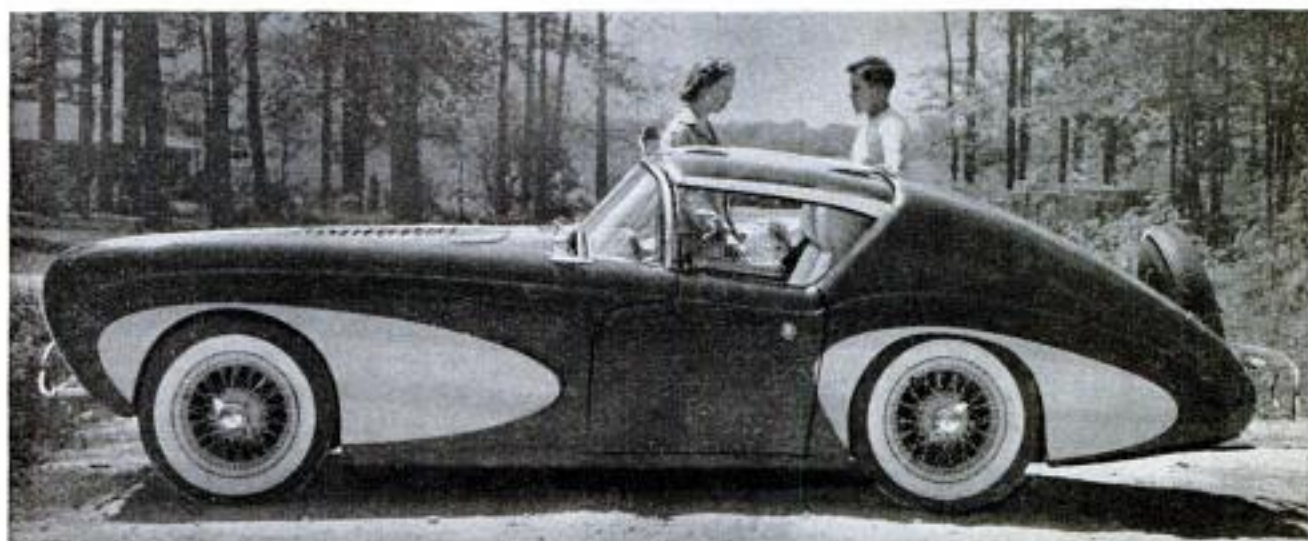

Despite its short wheelbase (100 inches), the Forerunner looks long. Body is all plastic. Chassis is Jaguar

Auto Stylist Styles His Own Car

HOW WOULD A professional stylist design his personal car? What would happen if he were freed of concern for production problems, cost limitations, public buying habits?

One stylist, at least, has answered that question. He is William Flajole of Detroit, Mich., consultant for American Motors and other manufacturers.

Flajole styled his own car and called it the Forerunner. The chassis is a modified Jaguar, but the body is completely Flajole.

Scooped fenders provide a fleet look and at the same time have the functional value of cooling brakes and tires.

Most unusual feature is the retractable Plexiglas roof. The car is a true hardtop convertible. With the top locked forward, the car is weathertight, suitable for any season. In hot weather, the top slides back

into the rear deck to make the car an open sportster.

Bumpers are deceptively delicate in appearance and light in weight. The whole bumper unit, including brackets, weighs only 10 pounds. Yet being an oval of one-inch alloy steel tubing, it is rugged.

The car is a two seater. Its seats are big and comfortable, patterned after those on airliners. They have backs that extend seven inches higher than standard, providing a comfortable headrest for long trips and at the same time hiding a substantial roll bar.

Headlights are recessed in the unobtrusive grille. They are located more than a foot behind the leading edge of the front fenders. There are no chrome gimmicks or decorations on the car which, although small, appears long and massive.



One hand on rope, Orlin Trego, owner of Razien mast, shows how easy it is to balance the 800-pound load

He Builds
**WINDPROOF
 TV MASTS**
*—but would
 rather not*

By Gilbert Hill

Drawing shows mast construction. Sand in bottom section of pipe acts as counterbalance. Trego's 60-foot mast at right survived 85-mile-per-hour winds





Antenna adjustments are easy when mast is tipped over. Motor on top of pole turns the antenna for tuning

BUILD A BETTER PRODUCT and you'll be in business whether you want to be or not, says John Razien of Woodward, Okla.

Razien deals in second-hand steel pipe. He buys it, cleans it and sells it, and is equipped to cut and weld it.

Woodward, up in the northwest corner of Oklahoma, is a long way from television broadcasting stations. Antenna masts are 50 to 100 feet high, heavy and complicated. Combine that top-heavy equipment with the kind of high winds that created the Dust Bowl and it is easy to understand the

maintenance and repair problems of TV-set owners.

Razien started out to help customers who wanted to buy pipe. He built a scale model of a TV mast that they could make themselves. But a lot of people didn't want to. So Tom Lukes, his engineer, built a few and Barney Laird, another employee, began setting them up in his spare time.

The first thing Razien knew, he was in the mast-building business. He had about 25 installed when an 85-mile-per-hour wind struck one night. Woodward is the town that had a tornado eight years ago that



Pin in base is removed so mast can be tipped over for repairs. High winds may necessitate adjustments

wiped out 110 city blocks and killed 90 persons. A lot of people thought another twister had arrived.

When the wind died most of the TV aerials in town were down, but all the Razien masts were standing.

That did it. Razien was in business despite his wishes. He hasn't patented a thing and would rather "just sell pipe—but I

find myself selling pipe for TV aerials at a faster and faster rate."

There are no guy wires on the masts, which "whip like a green limb on a tree, but never fall," says Laird.

The secret, the three men believe, is that the mast itself is set in sand, and has plenty of room to "give" with pressure or even spin if necessary.

Razien first sets a six-inch pipe four to six feet deep. This first pipe is set rigidly in concrete.

The mast itself is a piece of four-inch pipe about 20 feet long. It is set in the six-inch pipe and ordinary river sand poured around it. At the top of this post a bar-steel hinge is welded, and the mast is fastened with a single bolt to the sides of the hinge. The bottom section of the mast is filled with sand as a counterbalance to the top which may extend 40 to 60 feet above the hinge.

Each joint of pipe in the mast is one size smaller than the one below. It is held in place with four $\frac{3}{8}$ -in. steel stud bolts set in the outside post and through holes in the inside post. The fastening makes it possible to assemble the pole at the site.

The completed mast is simple to repair. A pin at the bottom of the mast is released, a rope attached to the base, and the mast is gently tipped to earth while the sand-filled base counterbalances the top section of the mast. After adjustments are made, you pull the rope to swing the bottom end back into place for locking.

Razien estimates that "eight or nine of us" have been busy making and installing masts. It's a good way to sell pipe. If someone would just push the thing and let him provide the pipe, he says, "We could have a real business. But remember—I'm not a manufacturer." ★ ★ ★

Machine cleans dirt and rust from old pipe before it is bolted together, telescope fashion, into TV masts

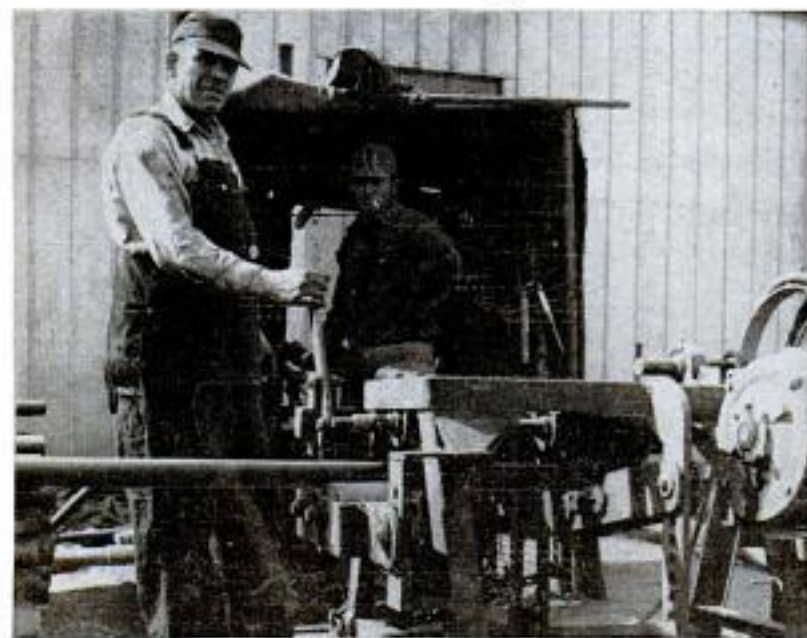

KEEPING UP WITH THE ATOM

WITH THE *Nautilus* already at sea and the second atomic-powered submarine *Sea Wolf* launched during the summer, the Navy has stepped up its plans for nuclear submarines. Four more are scheduled for construction in 1956 and a total of eight including the *Nautilus* are planned for the fleet.

☆☆☆

What happens to tobacco smoke when it is inhaled? This is another assignment given to the medical detectives working with radioactive isotopes. Researchers plan to introduce radioactive compounds into the tobacco plant. The radioactive smoke will then be introduced into experimental animals, and their bodies checked with geiger counters to trace the products of combustion through the organs to their final elimination. Harmless soft beta rays will be used so that it may be practicable to make the tests on human subjects.

☆☆☆

By 1962 it is estimated that nuclear power can be produced at a cost of five to seven mills per kilowatt hour.

☆☆☆

Atomic-powered railway locomotives may become practical in the future, but Forman H. Craton of the General Electric Company's locomotive works believes that for the next 25 years they will meet stiff competition from electric, diesel-electric and gas-turbine-electric types. Some engineers forecast a new era of railway electrification powered by nuclear electric generating plants spaced along the lines, rather than individual atomic plants built into the locomotives themselves.

☆☆☆

Four noted atomic scientists who had key parts in the prewar and wartime development of plutonium have been awarded a payment of \$400,000 for their patent rights by the Atomic Energy Commission. The scientists are Dr. Glenn T. Seaborg, Dr. Joseph W. Kennedy, Dr. Arthur C. Wahl and Dr.

Emilio G. Segre, who did their significant work on plutonium separative processes at the University of California in 1940 and 1941.

☆☆☆

"Gold guns" for treating cancer have been developed by the staff of the Royal Hospital at Chelsea, London, and are now being manufactured for export. Shaped like a heavy automatic pistol, the gun fires radioactive gold isotopes into cancerous areas of the body; it can be set to eject the bullets to the exact depth of the tumor. The gold isotopes lose their radioactivity after ten days or so, and thus can be left in the body without harm to the patient. The bullets, which are "cooked" in atomic piles, are $\frac{1}{10}$ inch long.

"Hot" Bath

Maintenance work at the Hanford atomic plant is done in a "hot" bath. Workmen wearing rubber gloves for protection from dangerous atomic radiation manipulate tools inside a plastic box filled with water (below), which absorbs the perilous rays.



Helicopter Tug Sweeps Up Mines

Helicopters now can sweep up enemy mine fields, cutting down the danger to mine-sweeping vessels. In tests, Piasecki H-21 helicopters were equipped with tow bars, cables and hooks. They towed conventional mine-sweeping gear and demonstrated that they could sweep an initial path through mined waters. Ordinary mine sweepers then can sweep the remainder of the field with greater safety. The tests also proved that a helicopter can tow the gear in sea conditions too rough for surface craft and is more maneuverable for sweeping restricted areas. The helicopter is capable of towing several times its load-lifting capacity. The pilot flies the craft in a nose-down position, which gives the rotors the maximum pull in the desired direction. The "aerial tug" has also passed



tests in which it pulled free heavy trucks that were mired in deep mud. Further tests have shown that vessels stranded on bars or rocks could be towed by helicopters.

Stanford "Spider" Uses Radar to Chart Fall of "Stardust"

Information about radio communications, weather and the solar system is being gathered by a spiderlike radar installation on the Stanford University campus. The "Spider"—some 50 feet across and 20 feet high—charts the path of me-

teoritic particles no bigger than a grain of sand. Signals are beamed upward in six different directions from "corner reflector" antennas, and echoes recorded on film and sensitized paper. The meteoritic dust—10,000,000,000 particles of which hit the earth's atmosphere each day—leaves ionized air in its wake. Long-distance radio waves can be "bounced" off this ionized trail, the Stanford scientists discovered. Meteoritic dust particles are believed to serve as the nuclei for raindrops, and movements of their trails reveal ionospheric wind currents. Information about the "stardust" would help weather studies and knowledge of the meteoritic dust should aid solar-system study.

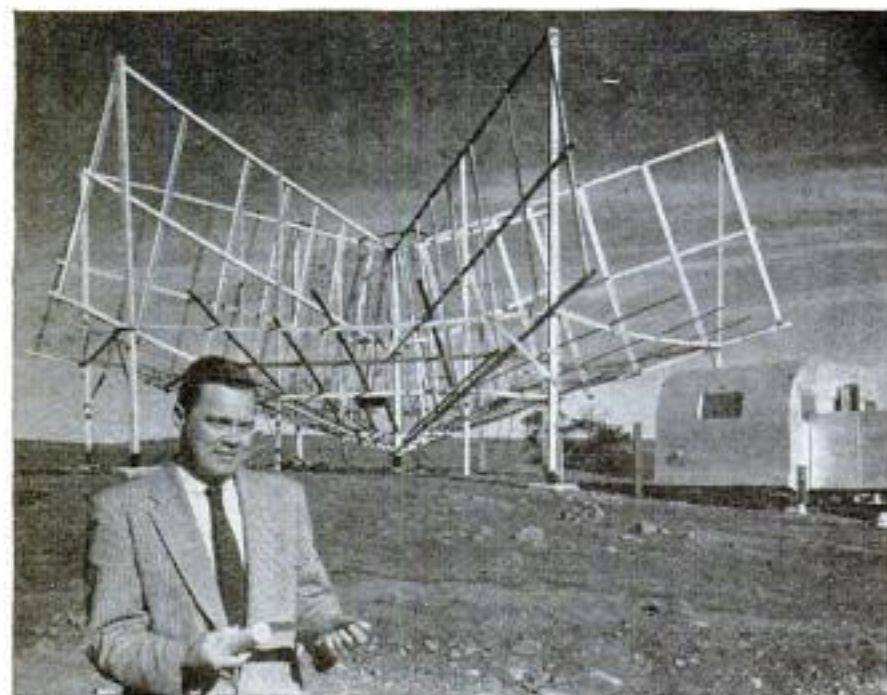

☐ Maine's extension of its turnpike from Portland to Augusta is 63 miles long, and has 90 bridges.

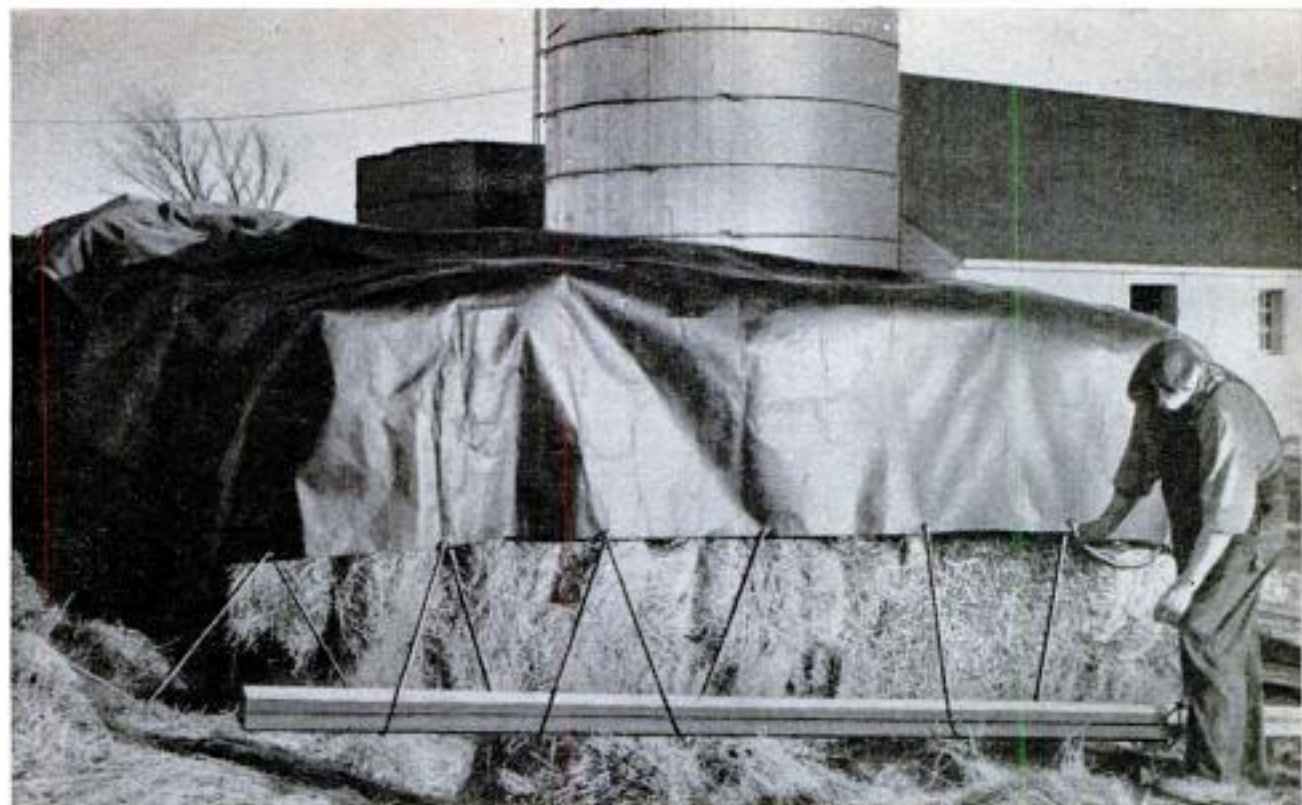

Paper Tarp Protects Hay and Equipment at Low Cost

Low-cost protection from the weather can be provided for haystacks, farm and industrial equipment with a new material called Brownskin Tarp, pressure-laminated asphalt-impregnated kraft paper reinforced

with glass-fiber yarns. Brownskin Tarps come in standard tarpaulin sizes and have grommets placed at 24-inch intervals for securing with rope. Light in weight, the paper tarp is easy to handle.

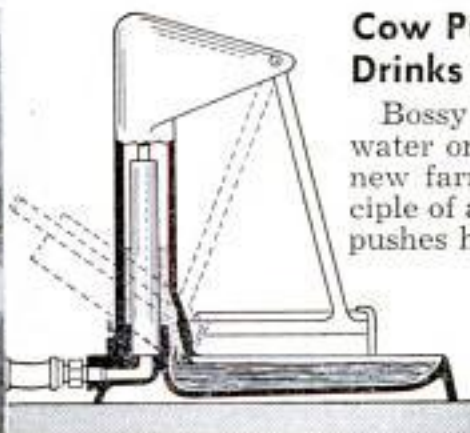

Cow Pumps Water as She Drinks From Pendulum Trough

Bossy pumps her own drink of water on some farms in Germany. A new farm pump works on the principle of a pendulum. Each time a cow pushes her muzzle into a trough, the trough swings to pump water. The pump works so easily that even a young animal soon learns to pump a drink. It can be operated by hand.

French Jet Training Plane Has Butterfly-Type Tail

Built with a butterfly, or V-shaped, tail a new French jet trainer has a top speed of about 500 miles per hour. The trainer, called the Magister, has been ordered in quantity by the French Air Force. It is powered by two jets of 880 pounds' thrust each, has a span of 37½ feet and a length of 32 feet 3½ inches.



"COWBOYS" LASSO a RHINO

By F. Wallace Taber

Photos by Charles Guggisberg



Maneuvered onto a dry-lake bed, mama rhinoceros may prefer tackling the truck to deserting her calf

JUST ABOUT the stubbornest, most cantankerous and downright meanest beast in the world is the rhinoceros. Small wonder that wild-animal collector Piet Jones is in for a rough day when he goes after such a critter.

Usually the order for a rhinoceros comes in the form of a cablegram from a zoo, a circus or even Hollywood. Addressed to Jones in Tanganyika, it says, in effect, "please ship one rhino calf soon as pos-

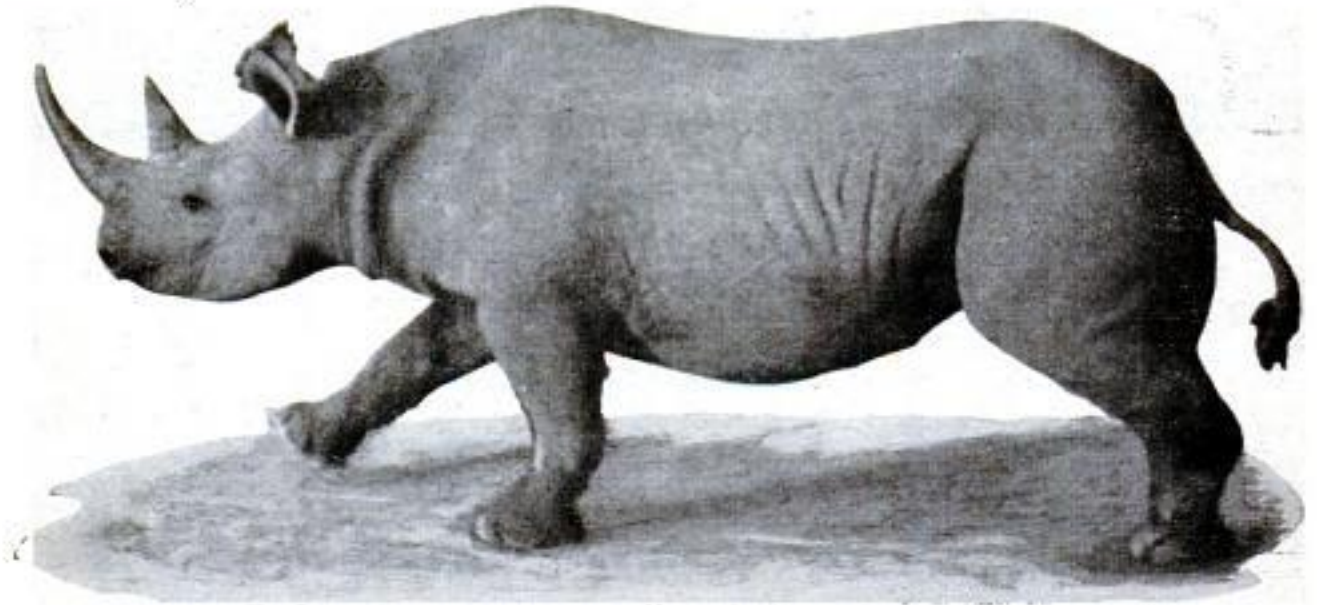

Here's more than a ton of meanness and temper, a rhino determined to protect her calf and escape to brush

Lasso is looped over a forked stick. The open noose soon will be dropped over the head of the weary calf

Tail between legs is a sign that the calf is tired. Truck is maneuvered alongside as animal slows to trot



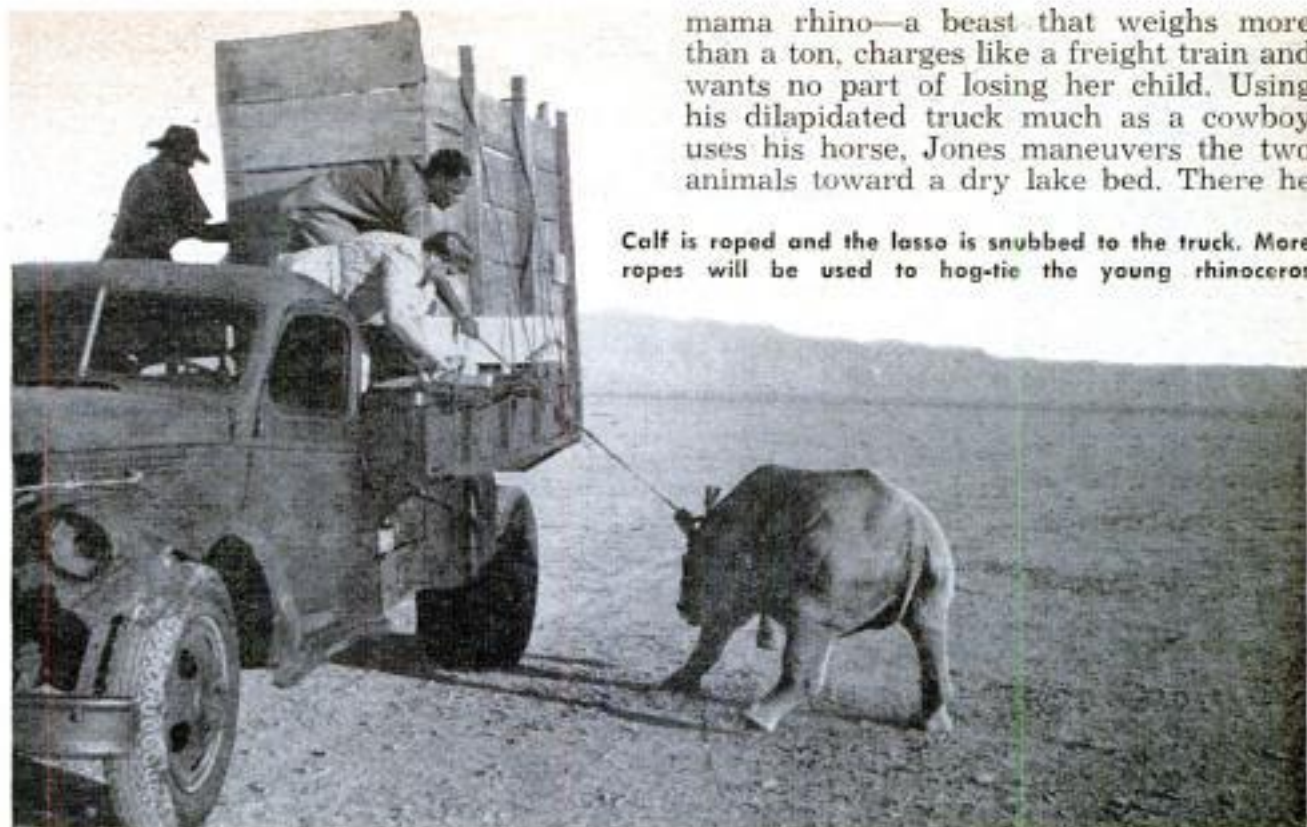

mama rhino—a beast that weighs more than a ton, charges like a freight train and wants no part of losing her child. Using his dilapidated truck much as a cowboy uses his horse, Jones maneuvers the two animals toward a dry lake bed. There he

Calf is roped and the lasso is snubbed to the truck. More ropes will be used to hog-tie the young rhinoceros

sible.” That sends Jones off on a rhino hunt.

He’s armed with a rifle and has the help of his wife and a pair of Mbulu “boys”—actually grown men. There’s no single label for his form of transportation. It’s an ancient truck of mixed ancestry with fenders and doors battered by scores of encounters with rhinos.

Jones reconnoiters brushy retreats that he knows to be rhino haunts until he spots his victim. Usually it’s a half to three-quarter-grown calf accompanied by its mother.

The big trick is to separate the calf from

manages to get between the mother and the calf, and eventually to drive off the mother. At any moment, though, she may prefer to charge the battered truck rather than desert her calf.

After he drives the mother away, Jones pursues the calf in the truck until the animal tires. Carefully he maneuvers the truck alongside the weary behemoth until his wife is able to drop a noose over the calf’s head. Once roped, the animal does a lot of tugging until additional nooses are dropped into place. Then it is worked into a heavy crate, loaded onto the truck and hauled off for shipment. ★ ★ ★

Tired, roped but still undefeated rhino struggles against the ropes that pull it alongside the truck

Hog-tied rhino is virtually harmless. It will be loaded into the strong crate carried in the truck





Midget Greenhouse

Cuttings from plants quickly take root when they are planted in a miniature, mist-filled greenhouse. A fogging nozzle attached to a garden hose sprays 1½ gallons of water per hour into the enclosure, a milk-white plastic dome. The cuttings are planted in concrete sand. A steel-rib framework resting on a circle of bricks supports the protective dome which holds 1000 cuttings at a time. After the cuttings take root they are transplanted.

Embedded Wire Zips Open Cast

Plaster casts are opened like a pack of cigarettes through a system developed in Europe. A piece of strong, fine wire is embedded in the cast when it is made. A loop of the wire is left exposed at one end of the cast. When the cast is to be removed, the loop is hooked in a hand-held reel. Turning a crank winds up the wire (right), cutting open the cast (below) without pain to the patient.

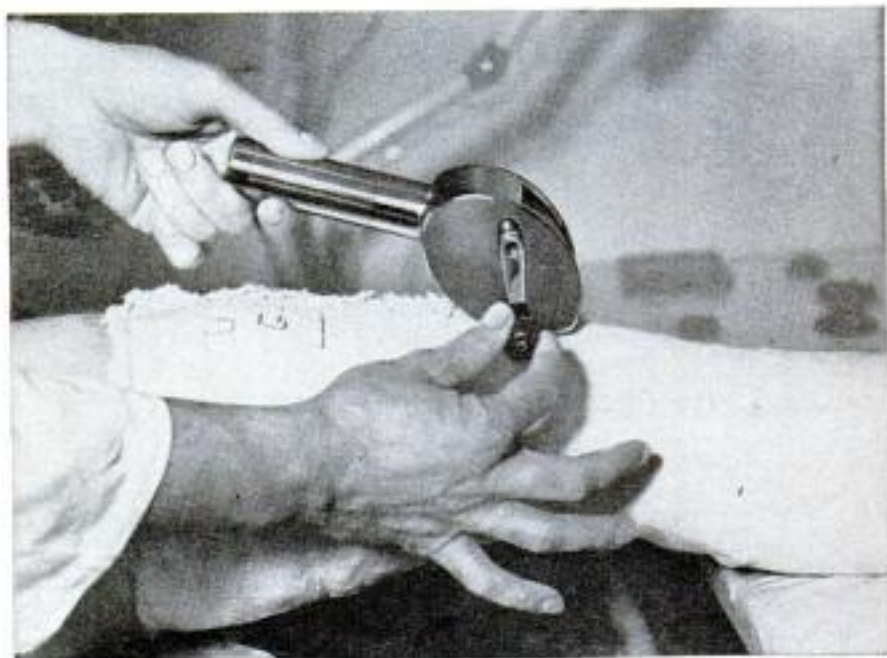

Radar Pictures Travel by Phone

Robot radar antennas connected by ordinary telephone lines to a central monitoring station are possible with a new system. Radio engineers have found a way to "squash" the radar-screen signal so it can be transmitted on standard telephone lines. At present, coaxial cables or microwave relay systems are necessary to carry radarscope pictures. The new system scans the original radarscope picture at 1/100 the usual speed, producing no significant loss of information in the received image.

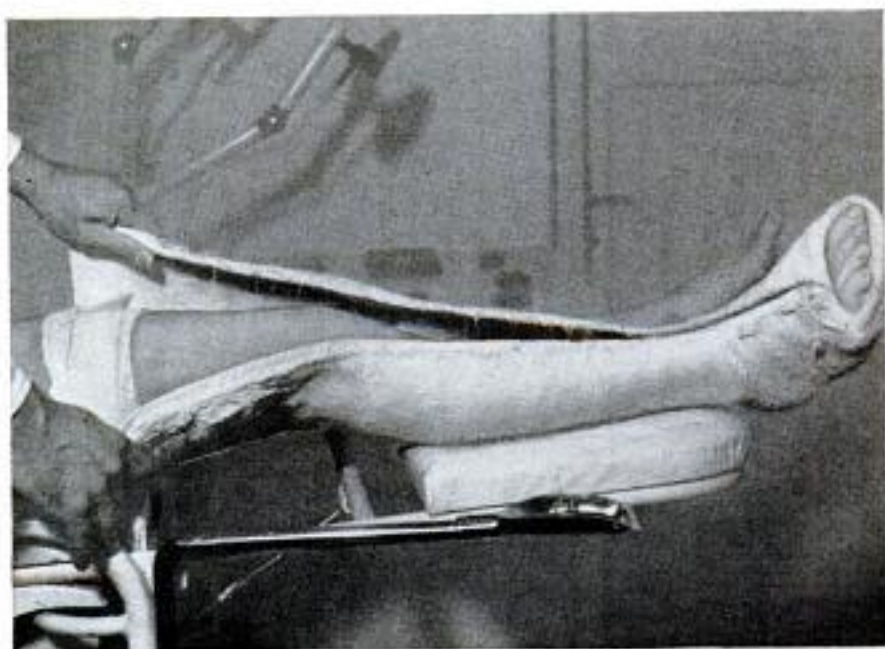



Helicopter settles to rest on canvas "bed" without damage to pontoons. Below, wheels permit landed helicopter to be towed



Portable Heliport Docks Pontoon Copters

Pontoon-equipped helicopters that can't find a wet place to land can now touch down on a canvas heliport. As the copter hovers four feet above the ground, crew members hop out, unlash the disassembled unit from the pontoons and put it together in a minute. A pair of small wheels under the platform permits the copter to be towed away to the hangar after landing.

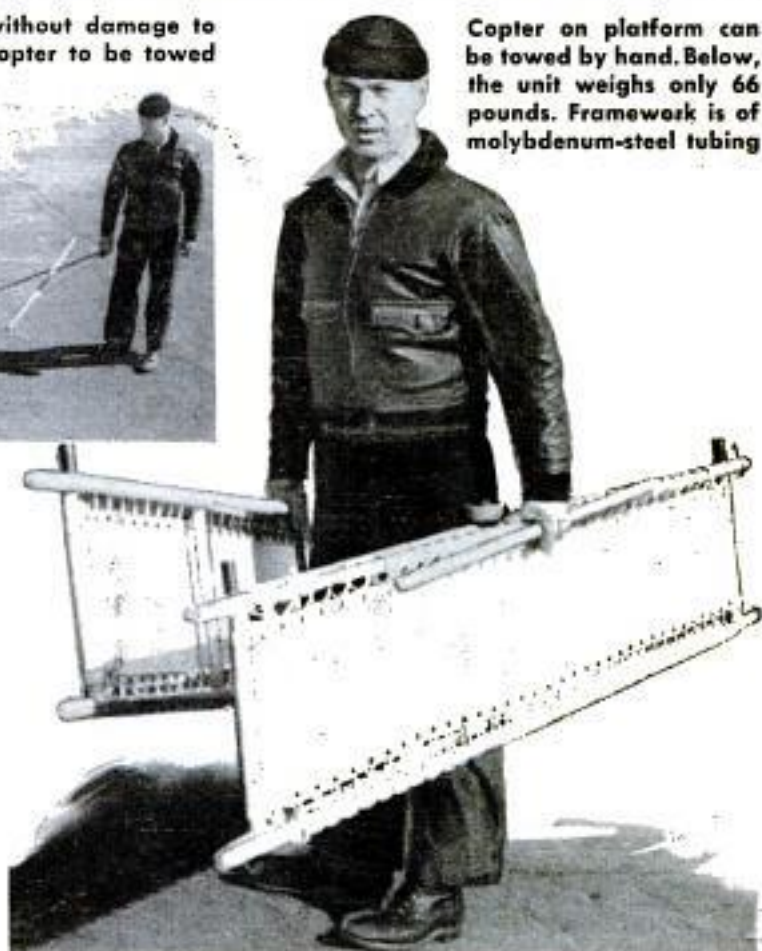

Copter on platform can be towed by hand. Below, the unit weighs only 66 pounds. Framework is of molybdenum-steel tubing

Soviets Foster Redwood Tree

Russian scientists are busily adapting the giant American redwood tree to Soviet use. The first redwood trees were brought from America in the 1860s and used to decorate parks in the Caucasus and on the southern coast of the Crimea. Now, however, the tree is being introduced into the forests of the Crimea and other parts of the Soviet Union. By hybridization of the giant tree, crossing it with larch, cypress and others, the botanists hope to make it grow farther north.

Computer Translates Morse Code

Messages in Morse code are automatically translated and printed by a new electronic instrument. The code converter is a computer that accepts signals from a radio receiver, translates the message and instructs a typewriter which letters to print. Memory circuits permit it to "copy behind" the signal in the same way as a human operator. During this memory phase the instrument determines when a figure rather than a letter is being transmitted and shifts the carriage for numbers.

Babies' Showcase For Proud Dads

Showcase views of newborn infants can be obtained by proud fathers and other visitors in Community Hospital, Long Beach, Calif. Eight bassinets at a time can be arranged under slanting glass, so that babies can be viewed from above, as are goods under a glass counter. The arrangement pleases fathers and saves time for nurses, who are no longer called upon to hold infants up for display to relatives. A stainless-steel bar is provided for visitors to lean on.



Ultrasonic Tape Recorder

Sounds 250 times higher than the average person can hear are recorded on a new magnetic-tape instrument designed for the Signal Corps. The human ear can hear sounds up to 20,000 cycles per second. The new tape mechanism records electronic signals up to five megacycles (5,000,000 cycles) per second. The tape, 10 inches wide, runs from one cylindrical reel to another at a speed of nearly 50 inches per second. A nine-inch disk with six recording heads contacts this tape. The instru-

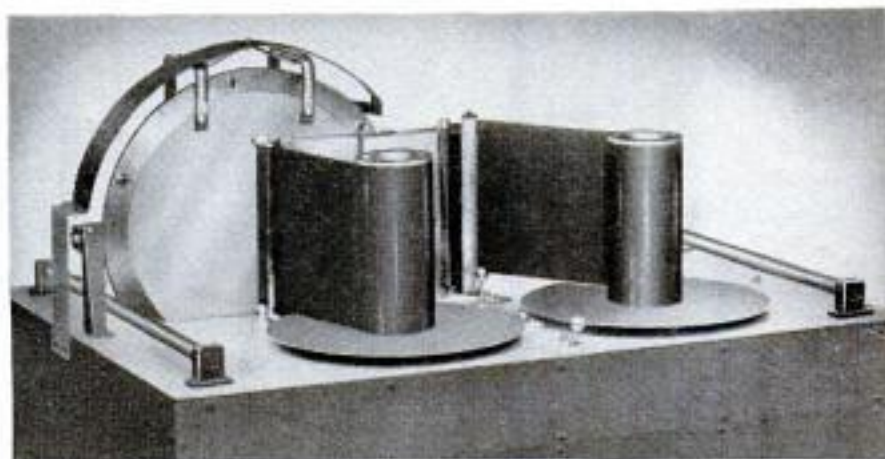

ment was designed, not for sound recording, but to record data on radar, aircraft, computers and complex weapons which involve high-speed phenomena.

Under-Hood Charger for Automobile Batteries Handles 6 or 12 Volts

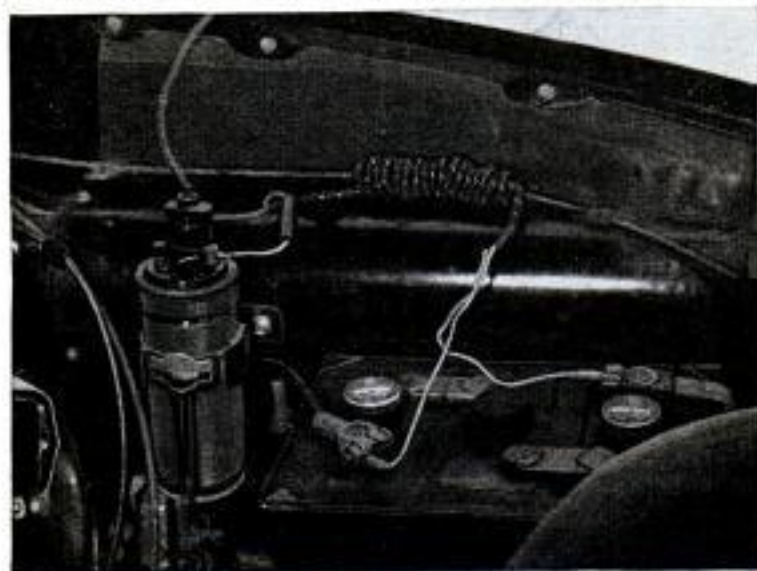

Small enough so it can be mounted on the car's fire wall, a portable battery charger can handle both six and twelve-volt batteries. Or, if desired, it can be hung on a wall of the garage and used to keep two batteries charged in a two-car family. To use it, you simply plug it into any 110-volt a.c. socket. Overcharging is impossible.

☐ Civil Aeronautics Administration figures show that U. S. businessmen, farmers, sports fliers and other nonairline users flew a total of 8,772,000 hours in 1954, compared to 3,200,000 hours for scheduled flights.

Color Converter for Black-and-White TV



Black-and-white TV sets are converted to full color by an adapter that costs about \$150 plus installation. The adapter includes an electronic circuit to reduce the black-and-white picture to 12-inch size. A rotating filter, electronically synchronized, stands in front of the set to add full color to the picture.

Low-Cost Tape Recorder Sells for \$30



Handy to have around the house for leaving messages and instructions, a low-cost tape recorder is simple enough for a child to use. It makes no high-fidelity claims, but it records just like the more expensive models. No toy, it has a four-tube amplifier, a four-inch loudspeaker, crystal microphone and two 150-foot tape reels.

• A switch turns off all hi-fi components when the last record is played. With it, you can go to sleep to the music of favorite recordings. • An electronic robot "listens" to Morse code and types out the message on a teletypewriter at 600 words per minute.

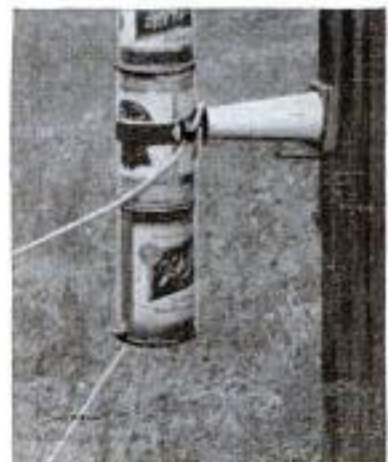

Airmen's "Can-Tenna"

At the Altus Air Force Base in Oklahoma there's a short-wave antenna that proves you should never throw away anything! It is the antenna for a Globe King transmitter and is made of 84 beverage cans that have been soldered together, end to end. Its height is 27 feet, 10 inches, about a quarter wave length of the 40-meter band.

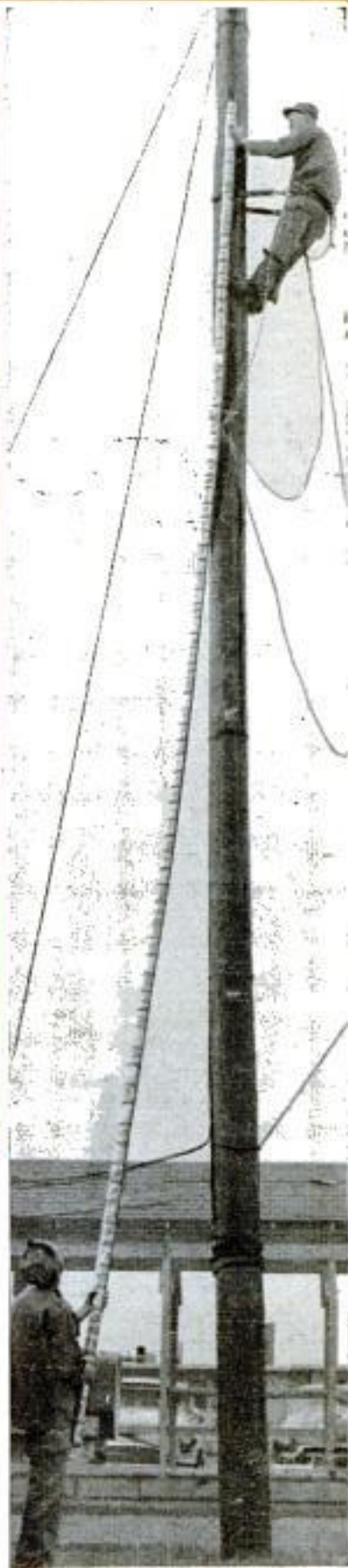

X351

"Electronics Made Easy"

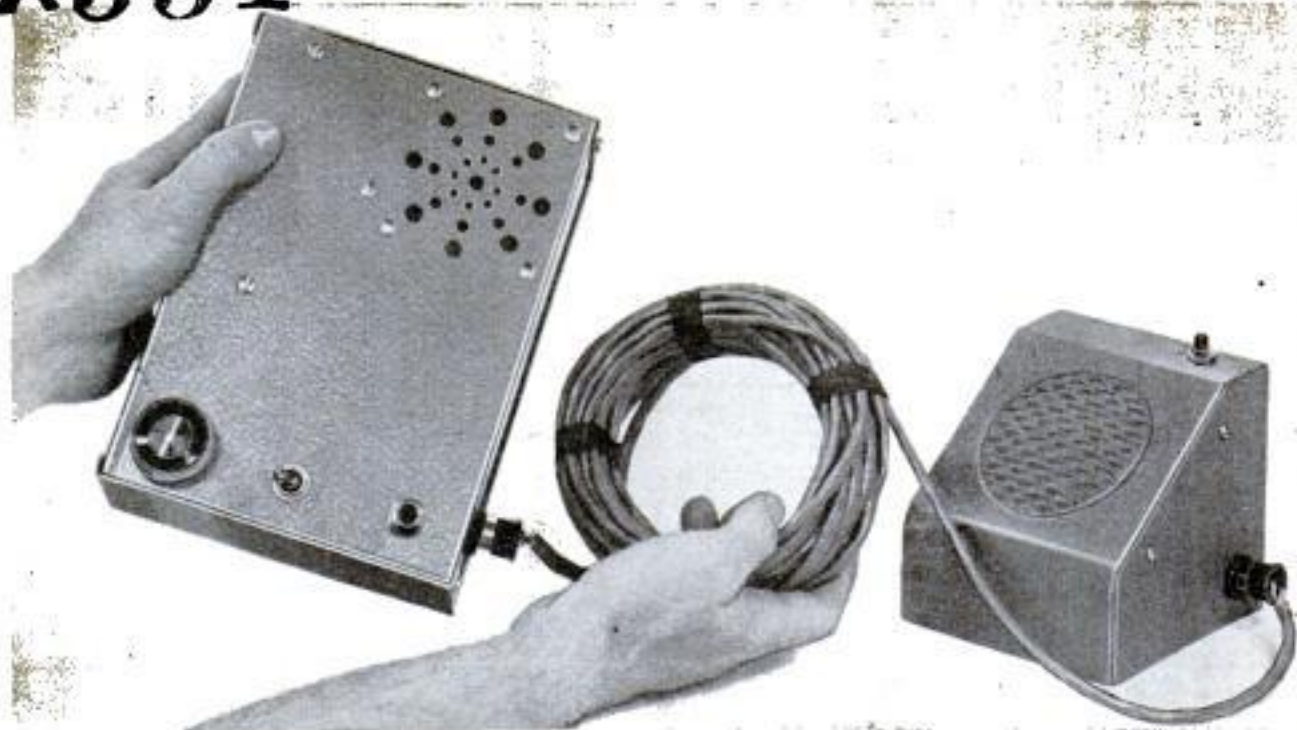

Suitable for use anywhere, this battery-operated intercommunication system is easy and inexpensive to build

BATTERY-OPERATED INTERCOM

By Lothar Stern

INDEPENDENT of external power, a battery-operated intercom system has many uses around the home, farm or shop.

Inexpensive to build, this system has the advantage of low battery drain because power is used only during actual conversation periods. Of course, this requires the operators at both master and substations to depress the press-to-talk buttons when speaking into the set.

To increase the versatility of the system, a monitor switch (Sw 2) is added to the master station. With the switch on, power is applied to the amplifier and the person at the master station hears what is going on at the substation. This is useful for baby sitting or if the person at the substation cannot readily press his switch. Of course, battery power is being consumed while the switch is in the "on" position. Therefore, it should be turned off when monitoring is not required.

The system is sensitive enough to pick up normal conversation from across an average room and to reproduce it with enough power to be easily understood. A call can be heard distinctly even if the person being called is not near the speaker. If desired, the volume control may be

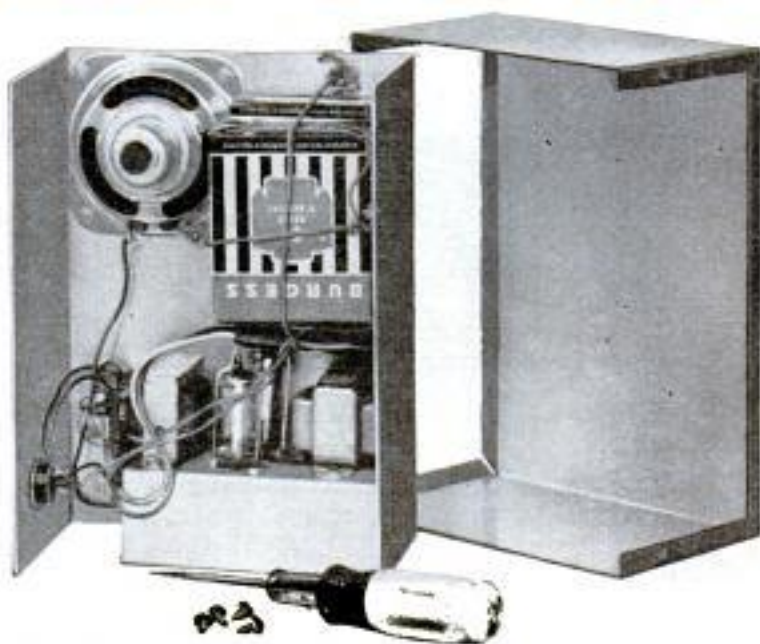

Batteries are held in place above the chassis by wires that are threaded through four ground lugs bolted to the aluminum case

turned down to a level for private listening.

The circuit consists of an amplifier, a switching system and two speakers. It is wired so that the substation speaker is used as a microphone unless the press-to-talk switch at the master station is depressed. Then the master-station speaker becomes the microphone and the other speaker gets the amplifier output. The substation switch merely completes the filament circuit of the amplifier so that power is applied and the substation may initiate calls.

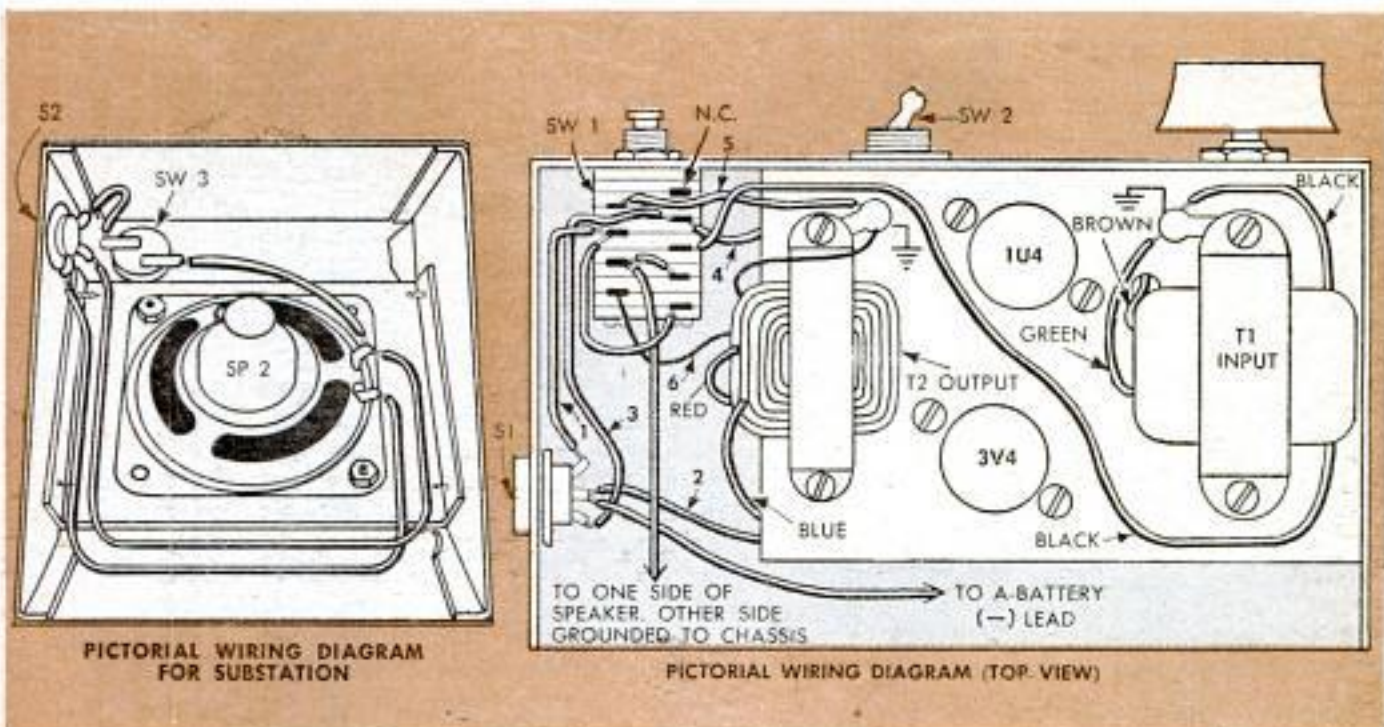

Circuit Details:

The amplifier is composed of a 1U4 voltage-amplifier stage and a 3V4 power amplifier. These tubes receive operating plate voltages from a 90-volt source (two 45-volt B-batteries in series). Filament voltage is obtained from a 1.5-volt A-battery. With all switches in the unactivated positions, the filament circuit is open so the tube fila-

ments are not energized. Although the B-battery is in the circuit at all times, no plate current flows unless the filament circuit is completed.

When the three-pole, two-position press-to-talk switch (Sw 1) at the master station is depressed, the filament circuit is closed so the amplifier is in operating condition. The master speaker becomes the micro-

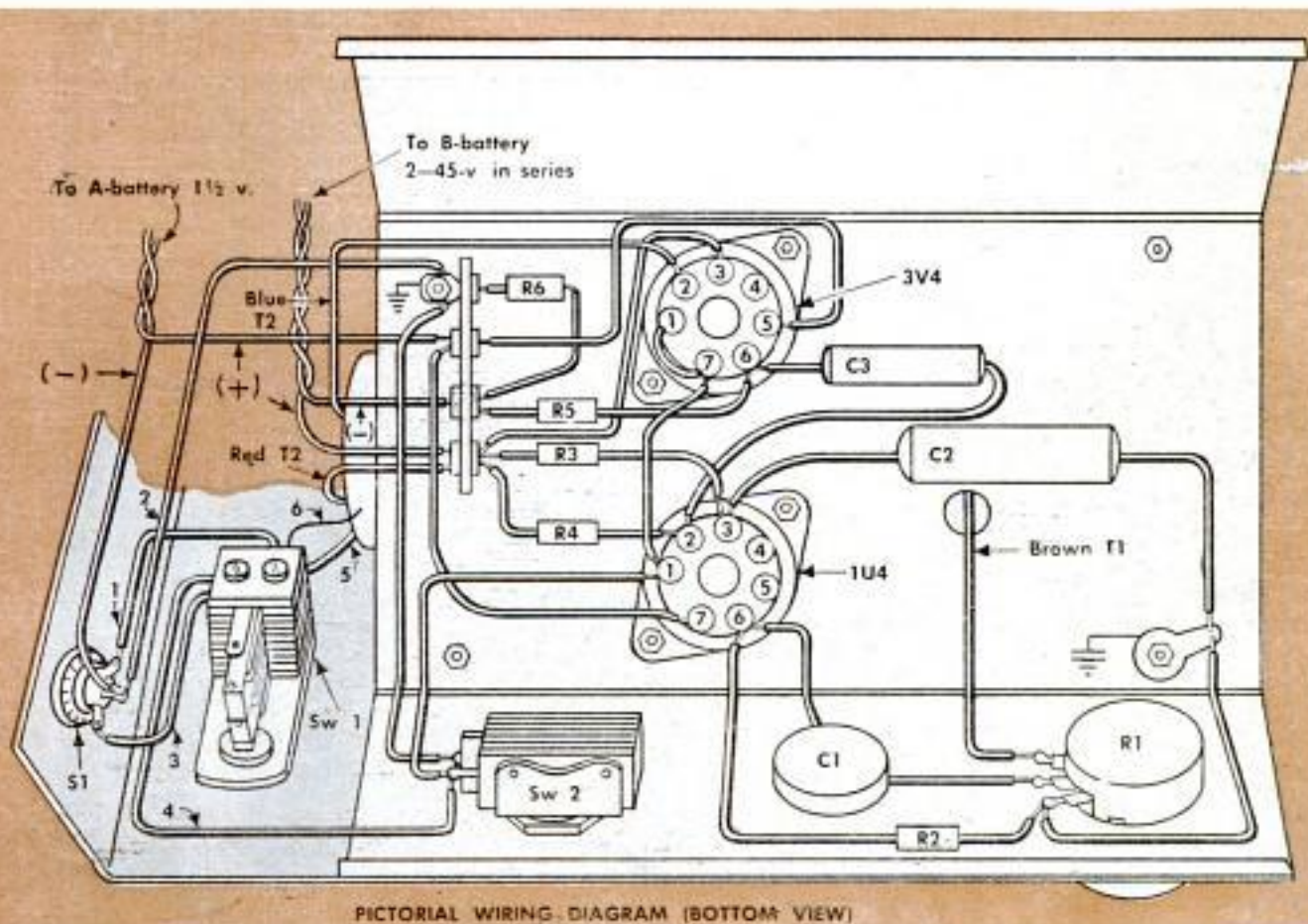

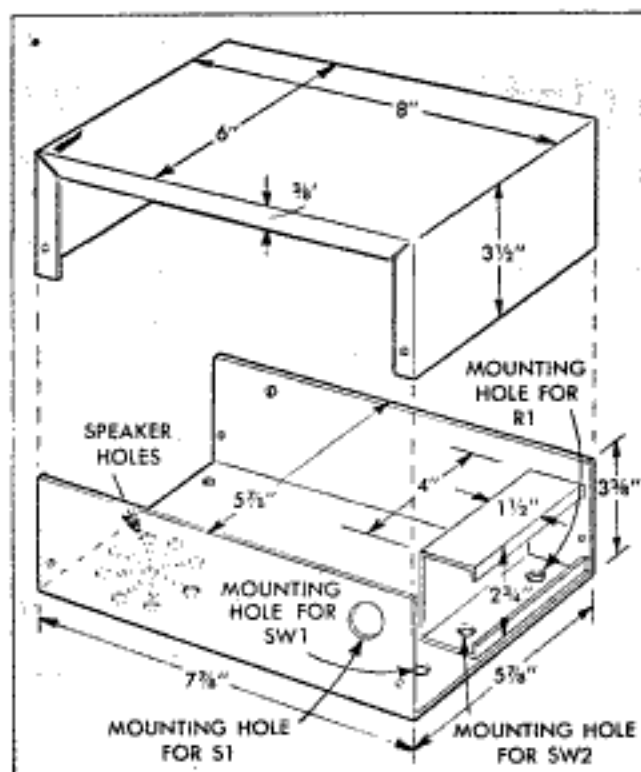

phone so the operator may call the substation. The substation answers the call by pressing the press-to-talk switch (Sw 3) there. This completes the filament circuit, but leaves the substation speaker in the microphone position. The monitoring switch, when closed, completes the filament circuit so it is unnecessary for the substation switch to be depressed to answer calls.

Construction:

The master-station assembly is enclosed in a 3 1/2 x 6 x 8-in. aluminum case. A diagram of it is shown below. The case for the substation speaker and switch is available commercially.

The parts layout is designed not only for ease of assembly, but also for maximum versatility of operation. The master station can be placed on a bench or table, or hung against the wall.

Tubes, transformers and small parts are mounted on a separate chassis. The switch and speaker of the master station are fastened directly to the aluminum case. This permits you to wire the chassis and switch separately and connect them during final assembly. The chassis is held to the case by the mounting nuts of the volume control and toggle switch.

The batteries are held in position above the chassis by two wires that serve as straps (see photo page 158). These wires are threaded through ground lugs bolted to the case itself.

The substation is connected to the master by a three-conductor cable or a two-conductor shielded cable. If the two-conductor cable is used, the shield braid serves as the third conductor or common ground. Any length of cable up to several miles may be used.

To simplify construction, the chassis and case should be made of aluminum for easy

(Continued to page 242)

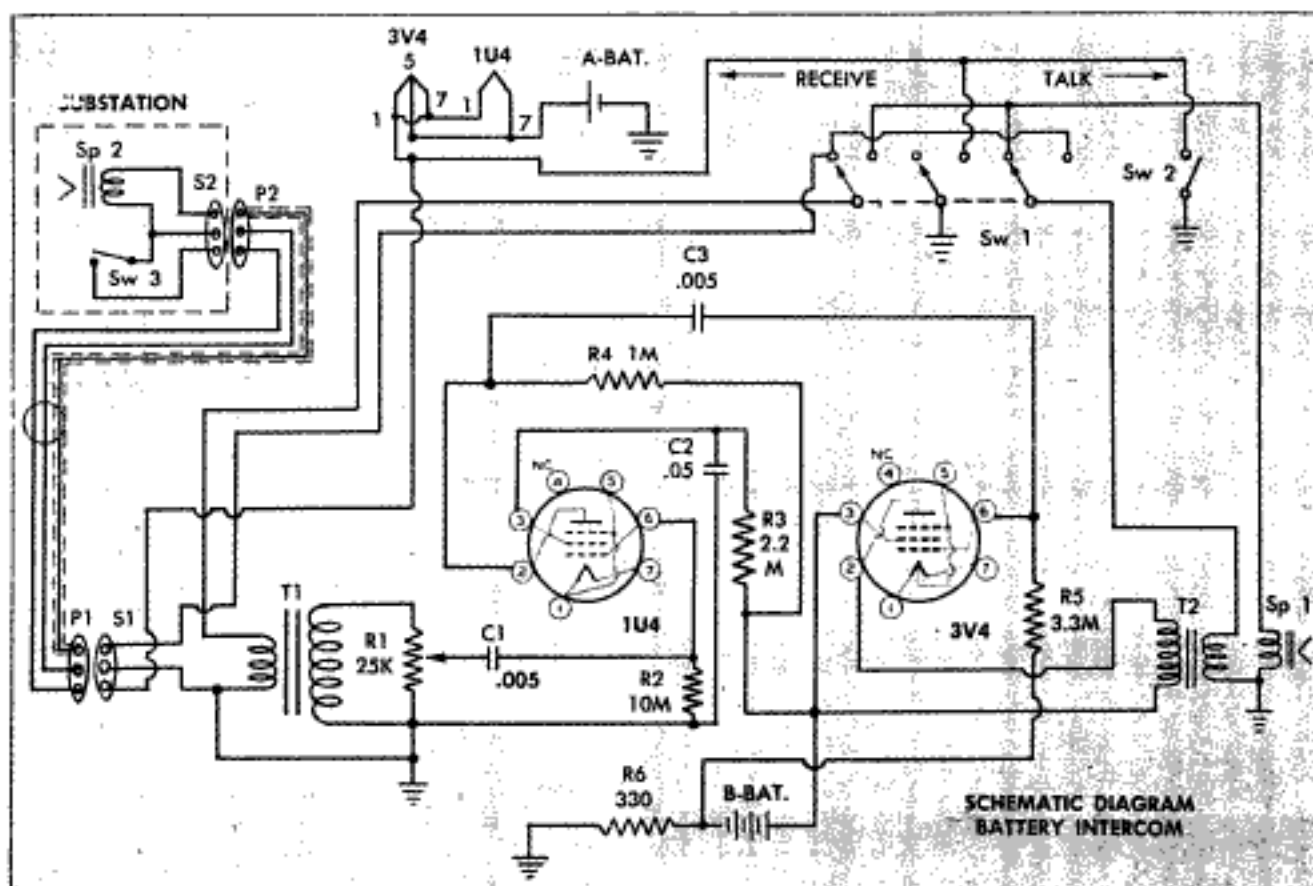

the

POPULAR
MECHANICS

CRAFTSMAN



COLORING WITH STAIN

UNLESS HE simply painted it, the homeowner in the past had no other way of adding gay, exciting color to his woodwork, wall paneling or furniture, now so fashion-right with modern interior stylists.

But what a shame, thought many a do-it-yourselfer, to cover up beautiful wood grain merely to color it. If only there were some way of transforming it into bright colorful tones that would still let the grain show through in all its natural beauty and charm.

Now, thanks to paint manufacturers such as the Martin-Senour Paint Co., the homeowner is no longer limited to the opaqueness of paint. The Martin-Senour people alone have over 169 prescription-mixed custom stains, called Nu-Hue, that offer the week-end decorator a panorama of color containing all the hues of the rainbow.

While there are many bright colors from which to select, strong hues tend to detract from the basic appeal of most wood grains. Best bets are colors that are nature's own,

These three color samples show results when stain is applied to fir plywood. Note how hard and soft grain give driftwood effects to this common-type wood





Yellow stain applied to this planked bedroom wall of knotty pine adds a feeling of glowing warmth to the room

such as muted greens, gray browns, grays and earth reds, like bisque and terra-cotta tints. It is advisable to select a hue that will match the color of existing walls, or use a contrasting color for maximum accent. If furniture, such as cabinets, bookshelves, tables, storage units and room dividers, is painted to match the wall, a built-in look is achieved and the room is given unity as well as the appearance of spaciousness. In selecting contrasting accent colors, choose a color from a fabric or wallpaper in the room. Accent colors go well on doors of cabinets as well as inside both bookshelves and cupboards.

Working with these new stains is com-

paratively simple. Naturally, it goes without saying that the old original finish must be completely removed down to the bare wood. And as color effects vary with the natural growths of wood, it is recommended that the stain be tried first on a scrap of the actual wood to be finished. It is quite possible that varying results will be obtained with the same color on different grades of the same type of wood. This can be controlled to a great extent by wiping. Lighter shades may be produced by wiping the stain with a soft cloth after it has partially penetrated the wood. Likewise, darker shades may be produced by allowing the stain to penetrate more fully



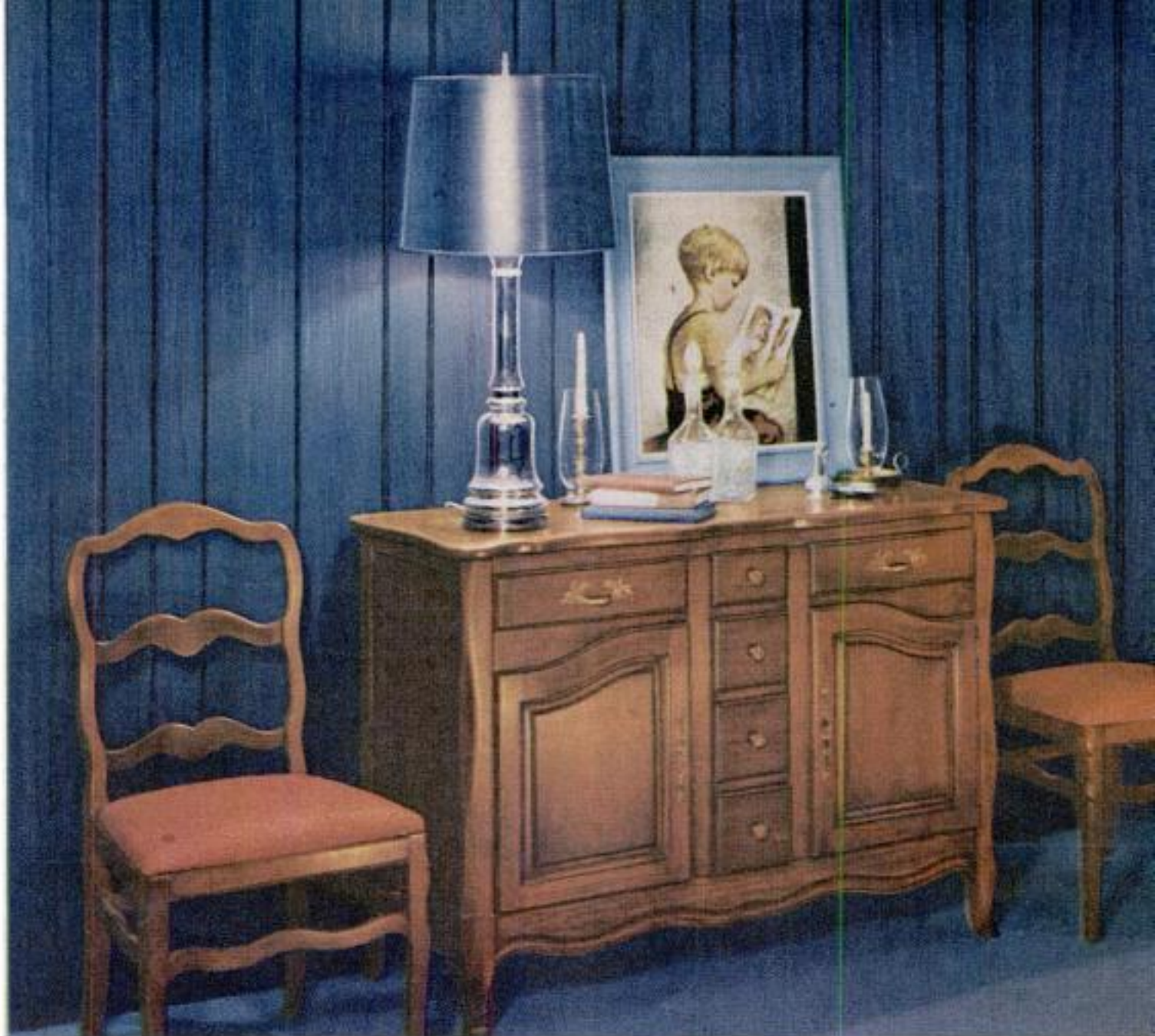

Mahogany furniture stands out in rich contrast against blue-stained background wall of vertical planking

before wiping off the excess with a cloth.

Close-grained woods, like birch, maple, gum, white pine, fir, poplar and cedar, should be sanded thoroughly and dusted well before staining. Brush on one coat of custom stain as it comes from the can and allow it to dry until three fourths of the surface has flattened out. This takes about 15 to 30 min. At this point, the stain is wiped with a soft cloth and then allowed to dry 12 to 15 hours. Finally, one or two coats of spar varnish are applied, sanding lightly between coats with 00 sandpaper. For a rubbed-effect finish, use a dull varnish for the final coat.

In the case of open-grained woods, such

as oak, korina, walnut, chestnut, ash and elm, the pores of the wood must be filled with a stained filler consisting of stain, 1 part and transparent paste wood filler, 1 part. This is packed into the grain by first applying it with a brush, letting it stand until it begins to flatten out and then rubbing it off across grain with a coarse cloth, such as burlap. After the filler has dried thoroughly, it is sanded lightly with 00 sandpaper. From this step on, the finishing procedure is the same as previously mentioned. Special effects may be produced on any type of wood. However, most striking results are obtained on open-grained woods such as those mentioned. ★ ★ ★

TYPE OF WOOD

Birch
Maple
Gum
White Pine
Fir
Poplar
Cedar



CLOSE-GRAINED WOODS

SAND THOROUGHLY with the grain and dust

1. Brush on one full coat of custom-finish stain. Allow to dry until three fourths of the surface has "flattened out" (usually 15 to 30 min.).
2. Remove excess stain by wiping with rag.
3. Allow ample time for drying (12 to 15 hr.).
4. Apply one or two coats of Martin-Senour spar varnish, floor and interior varnish or Lin-X clear glass. Sand lightly between coats with 00 sandpaper.

NOTE: If a dull or "rubbed effect" is desired, use a dull varnish for the final coat.

OPEN-GRAINED WOODS

SAND THOROUGHLY with the grain and dust

1. Apply one coat of stained filler made as follows:
Custom-finish stain, 1 part.
Martin-Senour transparent paste wood filler, 1 part.
2. Brush stained-filler mixture on surface. Allow to dry until three fourths of surface has flattened out.
3. Use coarse cloth, such as burlap; rub across the grain until pores are filled. Use same cloth to remove excess filler from wood. Allow to dry and sand lightly with 00 sandpaper.
4. Apply one or two coats of Martin-Senour spar varnish, floor and interior varnish or Lin-X clear glass. Sand lightly between coats with 00 sandpaper.

NOTE: If a dull or "rubbed effect" is desired, use a dull varnish as final coat.

Oak
Korina
Mahogany
Walnut
Chestnut
Ash
Elm



Whether it's wall paneling or furniture, first step is to sand surface well before applying stain as in step 2

When stain penetrates desired amount, excess is wiped off with soft cloth, step 3



3

2



Finally, protect stain with two coats of spar varnish, sand lightly and top with dull-type varnish



4

Wrought-Iron Telephone Table

By Kenneth Dale Collister

Lightweight and graceful, this wrought-iron telephone table includes a drawer for note pad and pencil plus a shelf for the telephone directory. Complete assembly may be accomplished without welding

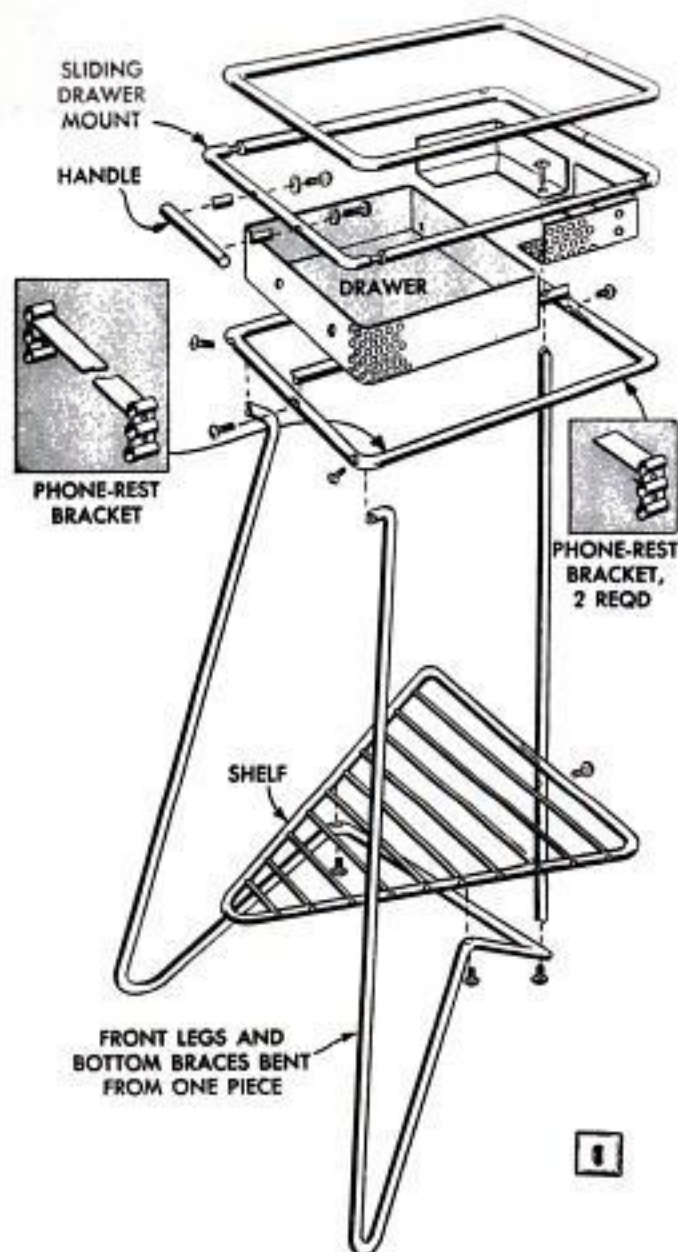

DESPITE ITS graceful appearance and seemingly intricate construction, this modern wrought-iron telephone table is assembled entirely without welding. Except for crossbars in the bookshelf, which are soldered in $\frac{1}{8}$ -in. holes, all components of the table are assembled with 6-32 screws. As indicated in the details in Fig. 4, all holes are either $\frac{3}{64}$ -in. clearance holes or $\frac{7}{64}$ -in. tap holes for 6-32 screws.

The table consists of four main parts, as shown in Fig. 1: The two front legs, the hollow rear leg which permits concealing the phone wire, the shelf for phone books and the phone-rest-and-drawer assembly.

The front legs and braces are bent from a single length of $\frac{3}{16}$ -in. round steel bar, 8 ft. 6 in. long. For accurate bending draw a full-sized pattern of the leg unit on the workshop floor or bench top using the dimensions in Fig. 4.

The rear leg of the table is a 24 $\frac{1}{2}$ -in. length of $\frac{3}{16}$ -in.-o.d. tubing. Both ends are plugged with 1-in. lengths of $\frac{3}{32}$ -in. steel rod. Drill and tap the end of each plug. Then file the ends of the plugged leg to fit against the front-leg assembly and table-top frame as indicated in details D and B in Fig. 4. To permit threading the phone wire through the leg, drill a hole just beyond each plug or cut away a section with a small milling cutter chucked in a hand grinder, as shown in Fig. 3.

The triangular-shaped bookshelf is bent

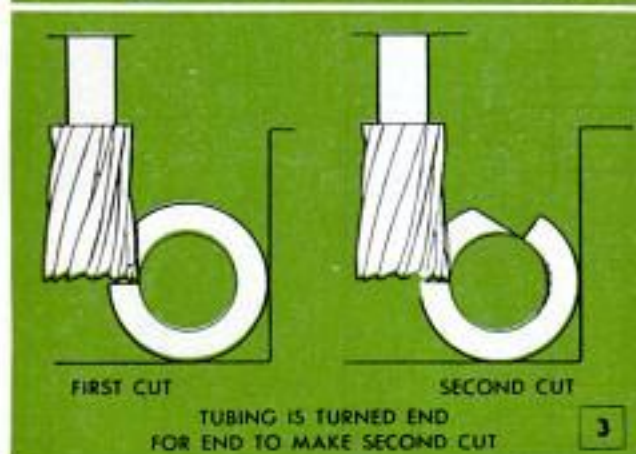
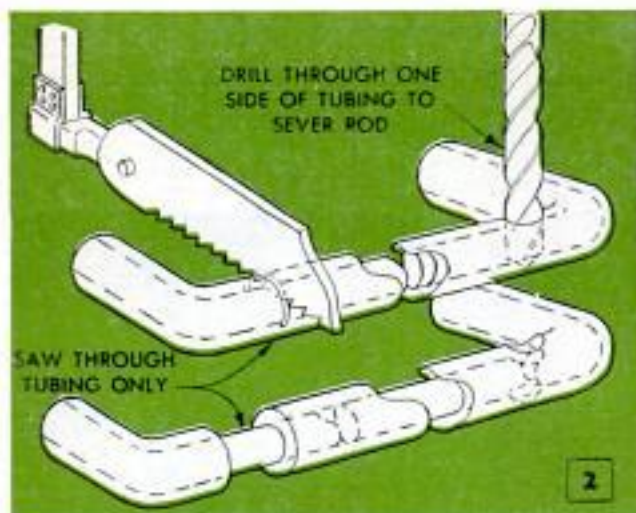

from $\frac{3}{16}$ -in. round steel bar, the ends being half-lapped $\frac{1}{2}$ in., as shown in Fig. 4. The outside half of the lapped joint is drilled for clearance, the inside half is drilled and tapped. A screw passed through a hole in the rear leg is turned into the threaded hole, holding the leg and shelf together. An adjustable T-bevel is used to keep the drill aligned when holes are drilled in each leg of the triangle for the $\frac{1}{8}$ -in. crossbars. The holes then are countersunk to receive the solder with which the crossbars are held in place.

The frame of the phone rest and drawer slide consists of three rectangles. The top and bottom rectangles are bent from $\frac{3}{16}$ -in. round bar, the bottom one being half-lapped in the same way as the shelf. The middle rectangle is the drawer slide. To make them, a length of $\frac{5}{32}$ -in. steel rod is forced through a length of $\frac{3}{16}$ -in. tubing, then both are bent together. After this, the tubing is drilled carefully $\frac{1}{2}$ in. from the rear corners to sever the rod inside, Fig. 2. Next, the tubing only is cut through with a fine-toothed saw $\frac{1}{2}$ in. from the front corners and the slide is pulled apart. The ends of the rod are filed smooth and the rod is lightly lubricated. A drawer-support

- — $\frac{3}{32}$ " DRILL—CLEARANCE HOLE
- — $\frac{3}{32}$ " DRILL—6-32 TAP HOLE

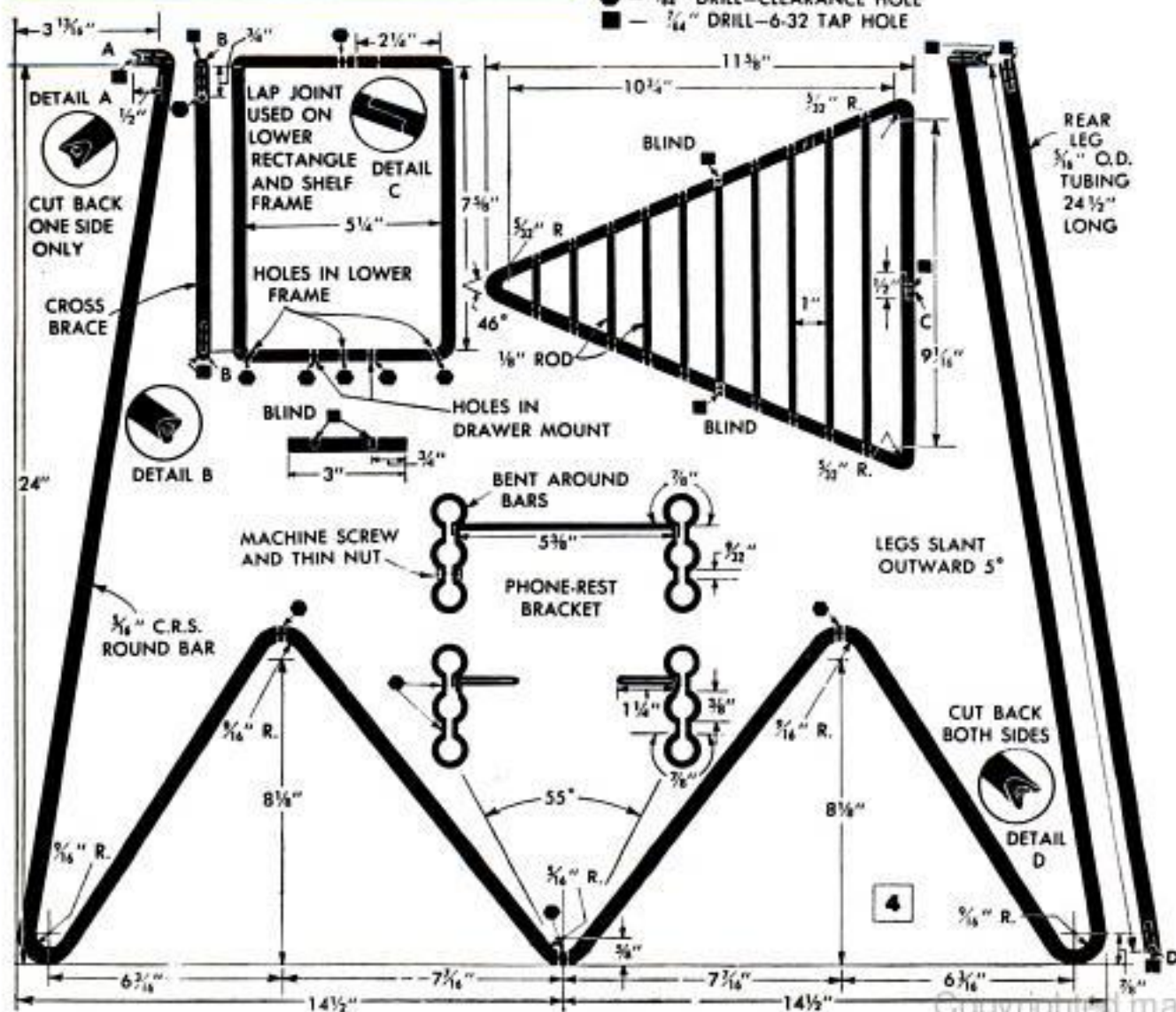

rod is fitted lengthwise in the middle of the lower rectangle, and the three frames are assembled with $\frac{1}{2}$ -in. sheet-metal brackets bent around the bars and tubing, as shown in Fig. 4. The drawer is cut and bent from a piece of perforated sheet metal, available at radio-supply houses. Drawer and drawer-trim dimensions and bends are shown in Fig. 5. A drawer handle is made from a 3-in. length of $\frac{3}{16}$ -in. steel bar and two scraps of tubing.

When assembling the table, the front-leg unit will have to be rebent at its center point to align it under the triangular shelf. Check the detail in Fig. 4 to determine which holes are to be tapped and which are for clearance. Details also show how the ends of various pieces must be filed to provide a good fit with the pieces to which they are joined.

Approximately 24 ft. of $\frac{3}{16}$ -in. round steel bar are required, about 5 ft. of $\frac{3}{16}$ -in. tubing and 32 in. of $\frac{3}{8}$ -in. steel rod.

Clean and smooth the assembled table with emery cloth, then paint it with a dull-black metal enamel or brushing lacquer. A paint sprayer, of course, will do an excellent job of applying either a lacquer or enamel finish. After the finish dries, apply a few drops of oil to the drawer rods. ★ ★ ★

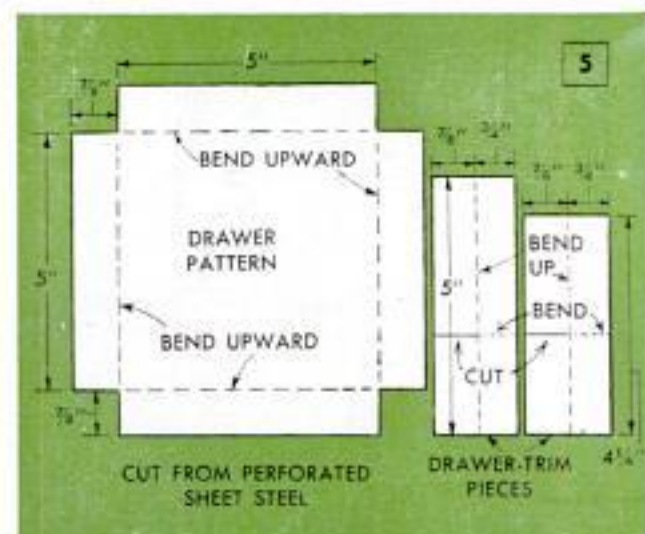

The drawer pull is drilled and tapped and fastened to the drawer from the inside, as below. Handle is spaced $\frac{5}{16}$ in. from drawer front with scrap tubing

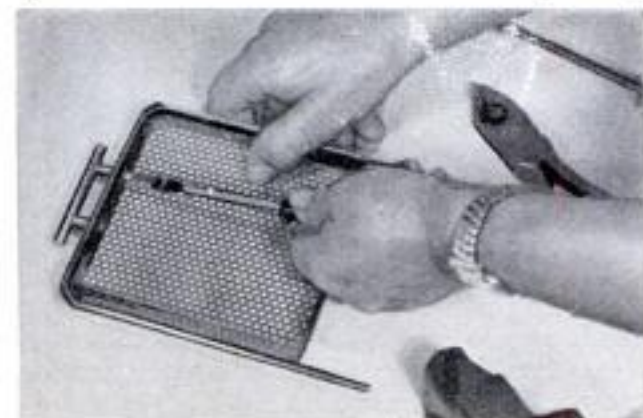

SEPTEMBER 1955

Vase Converted to Lamp Base By Removable Wooden Insert

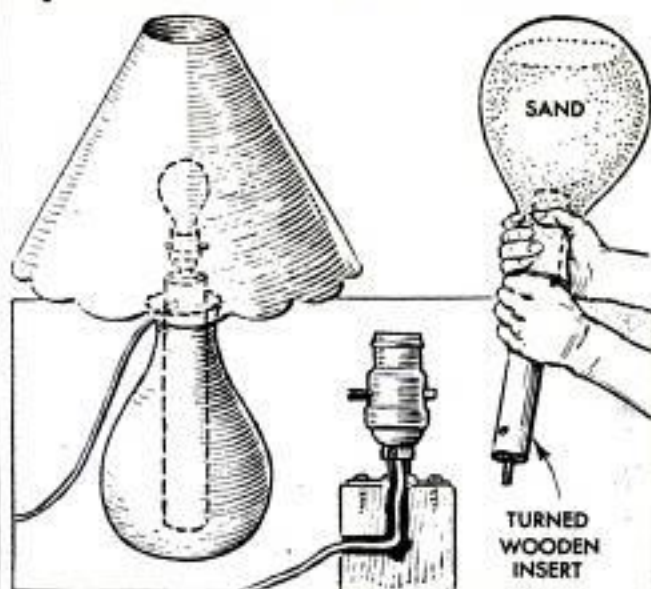

A narrow-necked vase used as a lamp base can be restored to its original form in a few moments if a removable wooden insert is used as the lamp standard. First, make the insert by turning a length of dowel to a diameter slightly smaller than the inside of the vase neck. Cross-drill it near the top for the lamp wire, as indicated in the detail. Next, fill the vase to within a few inches of the top with clean, dry sand. Place the end of the dowel in the neck of the vase and invert the vase. Hold a hand around the insert so the sand does not spill, and slip the insert up through the loose sand until it touches the vase bottom. The latter operation eliminates driving the insert into the sand, which might fracture the vase. Removing the insert and pouring out the sand restores the vase.—Norman C. Dickie, Johannesburg, South Africa.

Dust Plug for Rifle Barrel Made From Pipe Cleaner

To keep dust out of the barrel of a small-caliber target rifle and yet permit adequate ventilation to avoid dampness and rust, one sportsman uses a pipe cleaner as a barrel plug. The cleaner is twisted double so a finger loop is formed on the closed end. The loop permits easy removal of the plug and prevents the cleaner from being forced too far into the barrel.



167
Copyrighted material



Rubbing Strips on Boat Hull Are Lengths of Garden Hose

One boat owner uses lengths of rubber garden hose as easily replaced rubbing strips on the hull of his boat. Galvanized pipe clamps are used to fasten the hose to the wood. The detail shows two methods of installing the hose, depending on the shape of the boat hull and gunwale. Brass screws are used in the clamps, and the installation should be thoroughly waterproofed to prevent rot occurring under the clamps.

Jack Brian, Jackson Heights, N. Y.

Convertible Trouble Lamp Used as Extension Cord



To increase the versatility of a trouble lamp, cut the cord about 1 ft. from the lamp and fit the short cord with a male plug. A female plug on the end of the long portion of the cord converts it to an extension cord for use with an electric drill or

other power tool. To reconvert the cord to a trouble lamp, simply plug the lamp into the extension-cord socket.

Hugh Lineback, Stillwater, Okla.

Hardboard Panels Covering Holes Keep Rats Outside Building

To prevent rats from entering buildings having breaks in the walls or floors, one exterminator covers the openings with 1/4-

in. hardboard. A piece of board measuring an inch or two larger than the opening on all sides is attached with screws inserted through drilled holes. The hardboard, which apparently is not palatable to rodents, has been used in this manner with complete success for several years.

—Courtesy Masonite Corp.

Lawn "Table" for One Glass Made From Dowel and Can

Assembly of a handy one-glass "table" for use on lawn or beach requires only a length of dowel and a shallow tin can. Point one end of the dowel for easy pushing into the ground. Punch a hole in the center of the can bottom and screw it to the opposite end of the dowel, using a washer under the screw-head. Push the dowel into the ground alongside a chair and the table is ready.



Vise Provides Extra "Hand" When Clamping Work

A vise sometimes can be used to provide an extra "hand" when several parts of a job are to be clamped together. The clamp is held in the vise as shown in the illustration. Both hands then can be used to hold the various pieces and to tighten the clamp.



☐ To remove ink spots from varnished wood, rub well with a soft cloth that has been dipped in a mixture of equal parts of vinegar and linseed oil.

BUILDING BLOCK SET

By Hi Sibley

LOOKING FOR A spare-time money-maker to put your shop on a paying basis? This set of interlocking building blocks could very well do it. It's a natural sales product for a home workshop and one that requires a minimum of "tooling up." Made of redwood, for example, the product is already colored to save additional finishing time and expense. And by setting up simple fixtures on the saw and drill press, you can turn out the parts at a production-line rate. Building blocks such as these are always appealing to the small trade and command a nice profit.

While your packaged sets can contain as many as 48 separate pieces, which is the number required to build the two-story dwelling pictured in Fig. 1, you can limit the sets to fewer pieces. Although not keyed in the drawing, the rear wall consists of parts A, H and G. Small versions of the toy are pictured in Fig. 5, showing a blockhouse, garage, cottage and school. Many of the parts in each of these buildings are interchangeable which helps standardize the shapes and thus reduces the number of different blocks required.

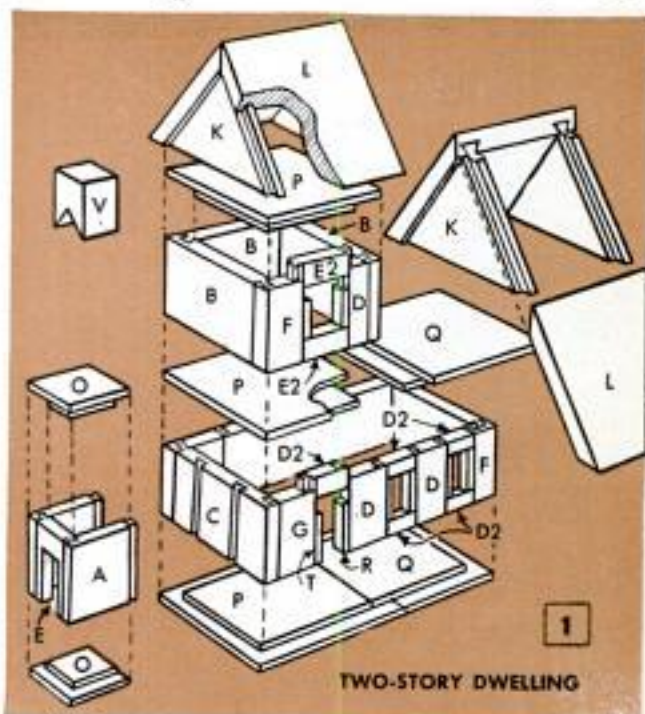

This drawing is keyed with plan drawings on following pages to show at a glance where various parts go



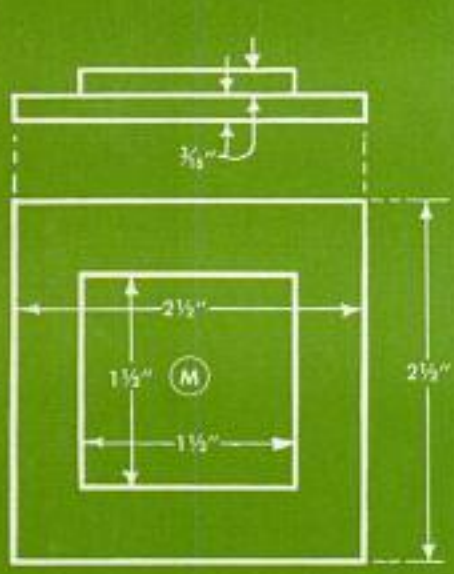
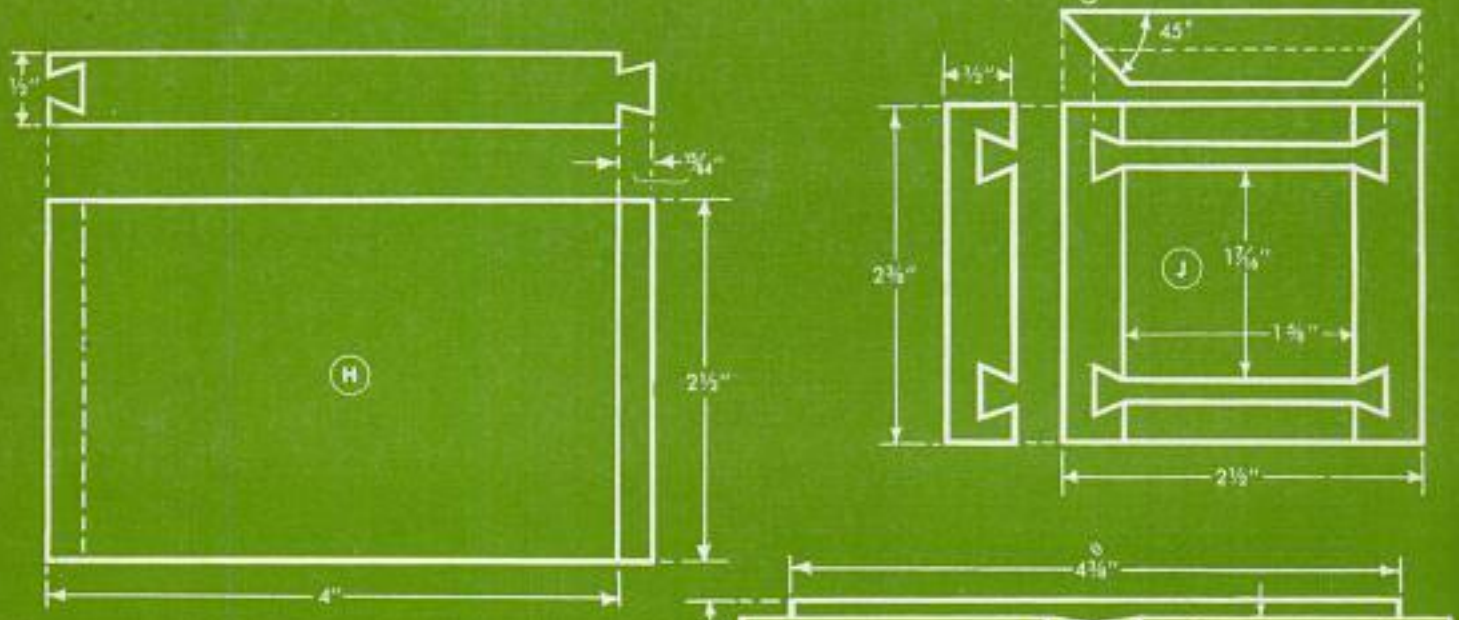
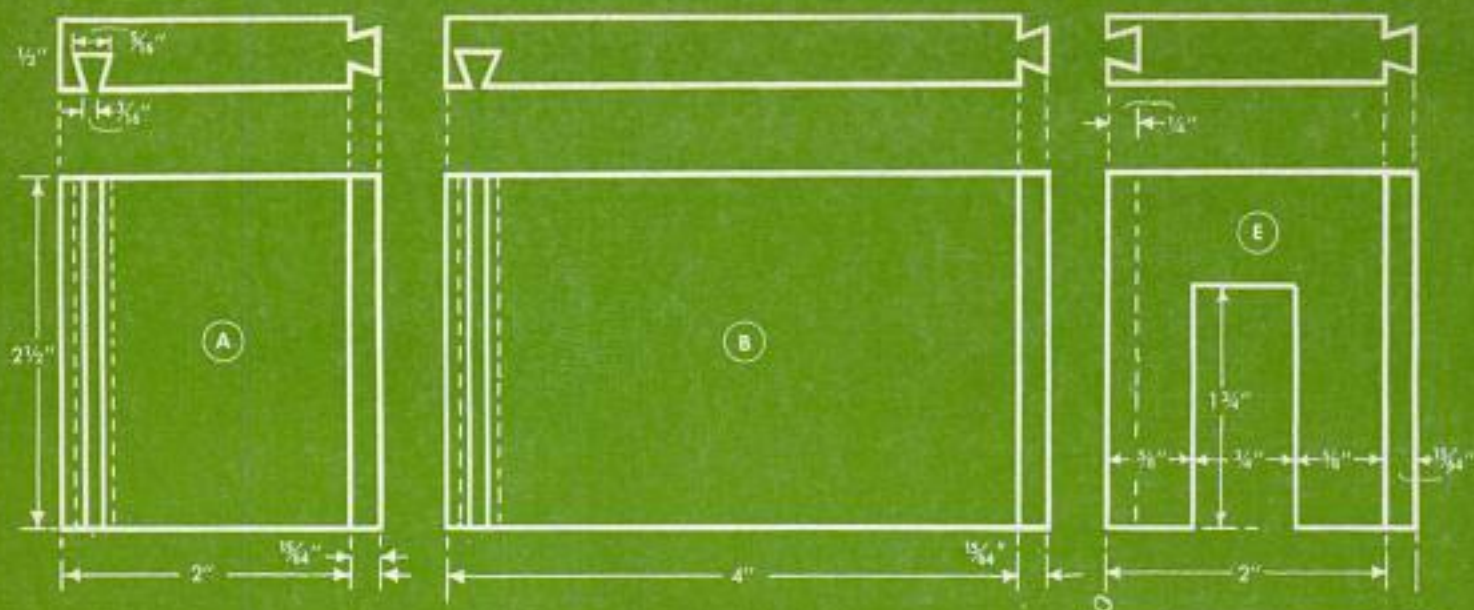

2

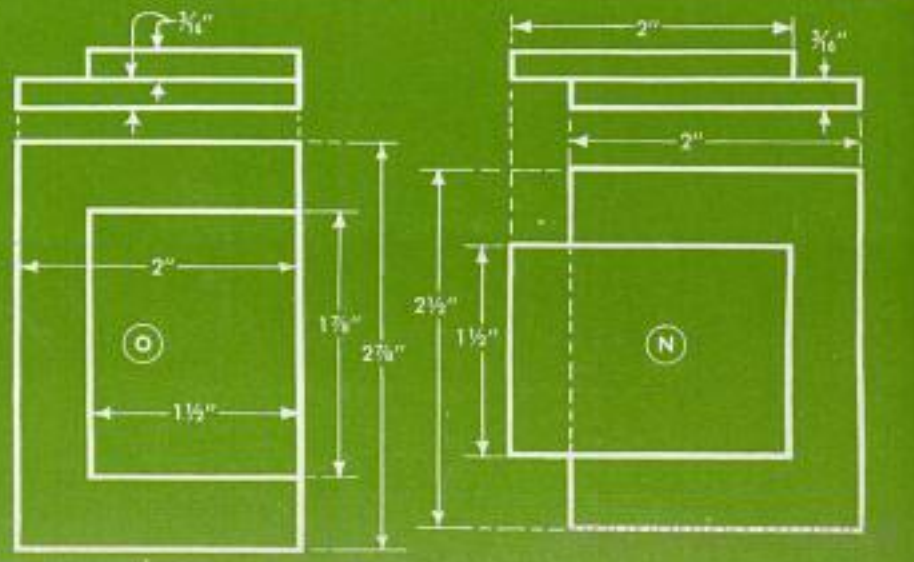
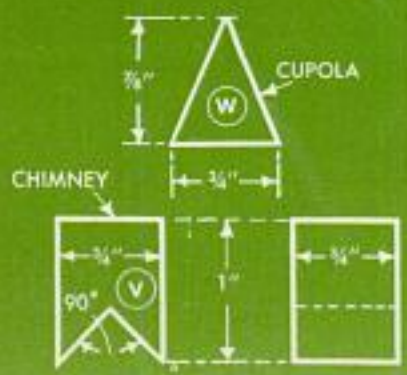
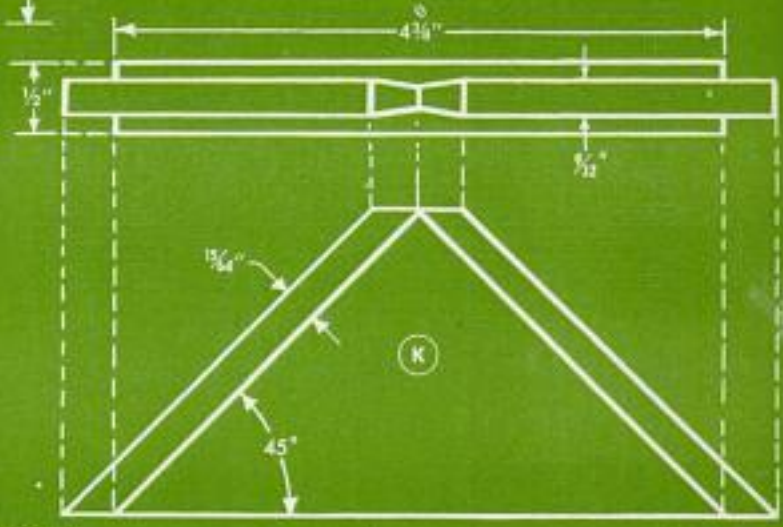

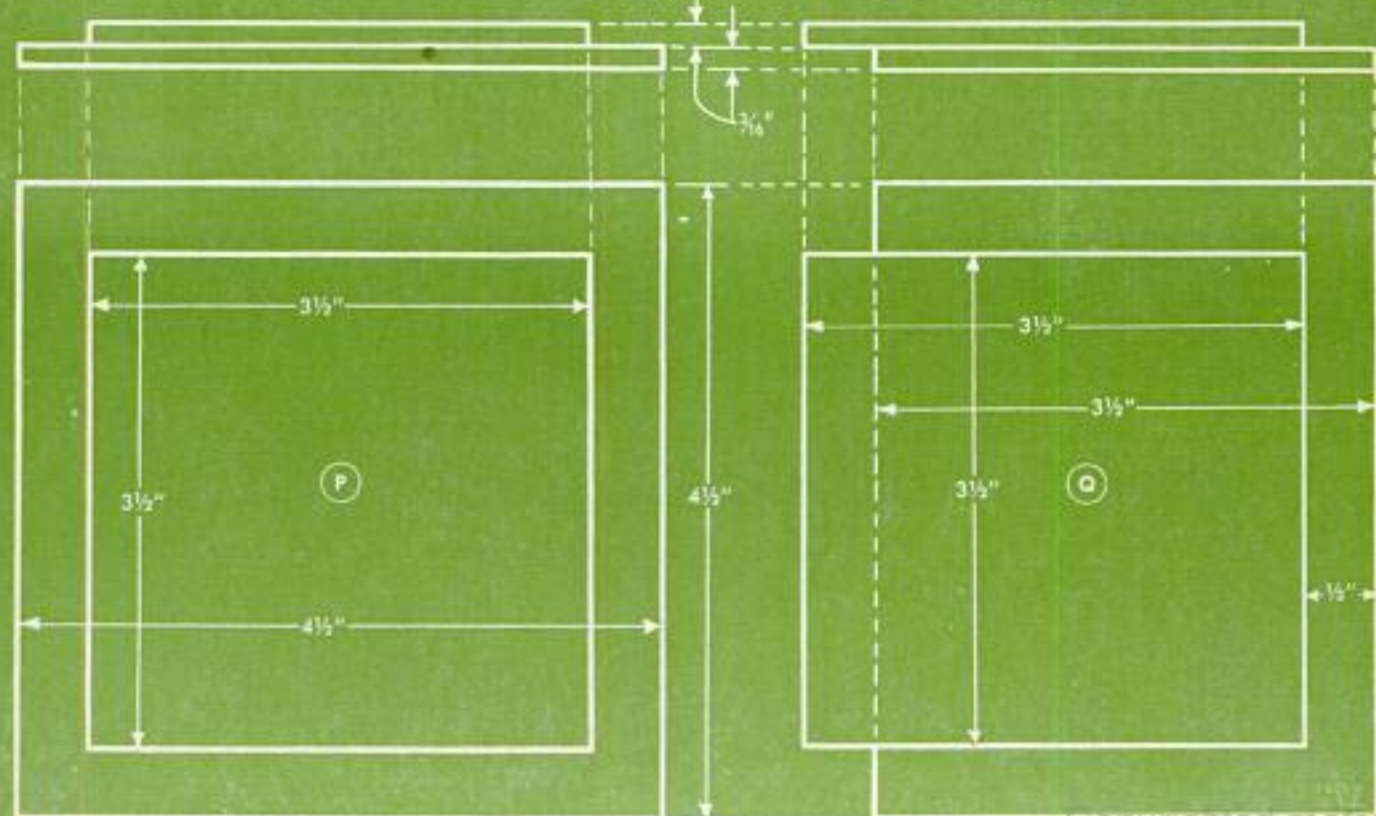
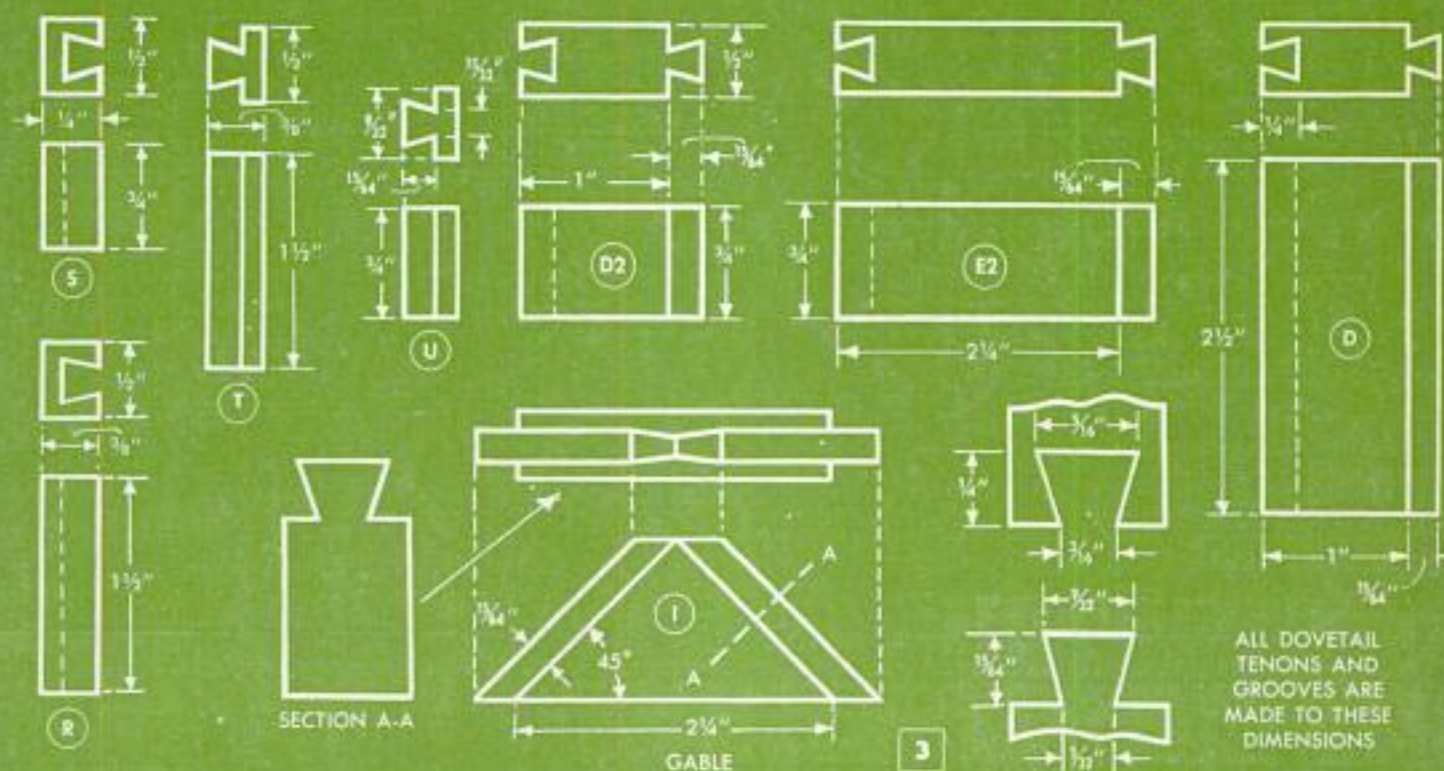
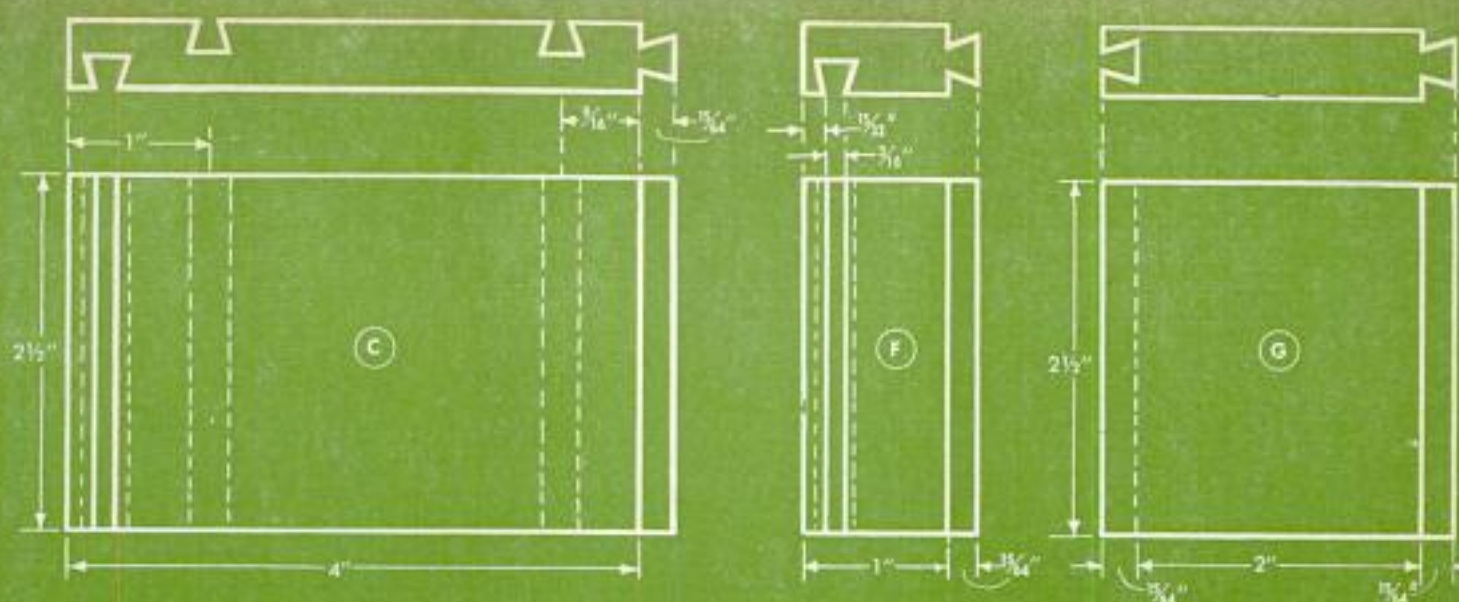

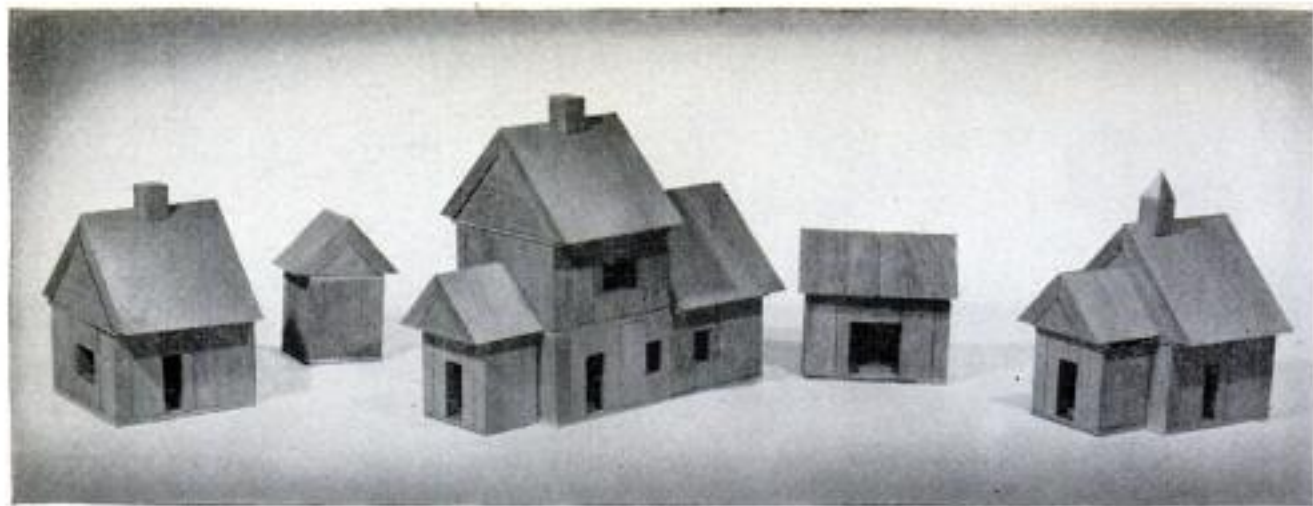

Many of the parts are interchangeable so they can be used with others in building several different units

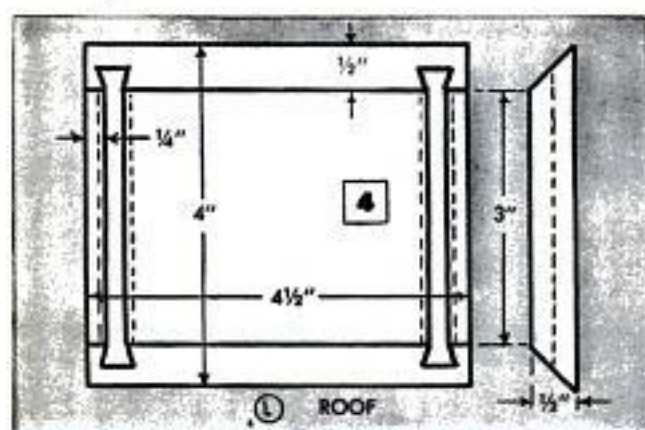

Matching dovetail edges lock the blocks together and the best way to run these edges in a productionlike manner is with a small shaper, although they also may be cut with shaper cutters chucked in a drill press. In either case, the stock is first ripped to size in long strips, run through the shaper to cut the male joint, then again to cut the female joint and finally sliced off on the circular saw to the proper length. Figs. 2 and 3 give the sizes of the various parts required and are keyed with the assembly drawings for quick reference. Fig. 4 shows how the roof boards are grooved on the underside before beveling the two edges. Of course, your finished sets should be boxed complete with a keyed instruction sheet like the one below. ★ ★ ★

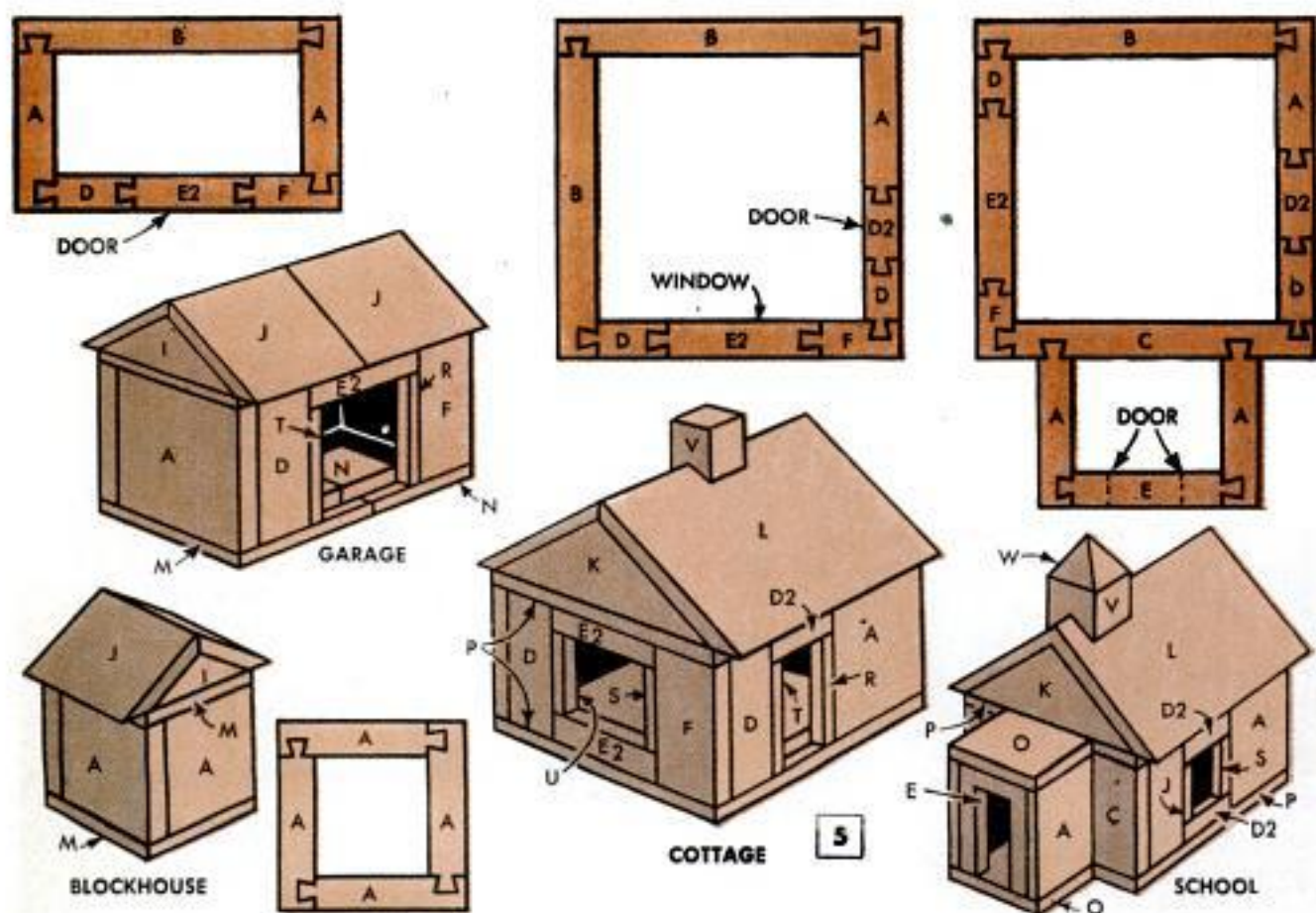

Paper Fasteners Used as Ties

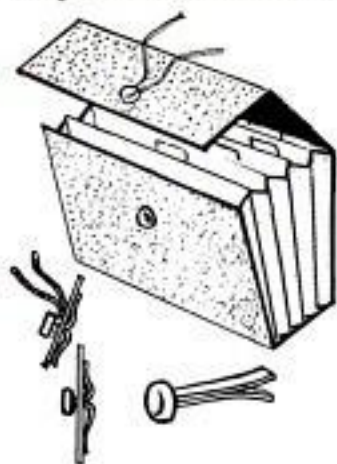

Paper fasteners can be used to make tying devices for folders, envelopes and files. Insert one of the fasteners in the flap and another in the body of the folder, with the heads on the outside. Tie a light cord or strong thread around one head, leaving

loose ends long enough to reach the other fastener and wrap around it several times. These ties can be used on envelopes which have the standard prong fastener to replace the prongs after they have been bent too often and broken off.

Jack Tomlinson, Berkeley, Calif.

"Filling Station" for Pens

An eye dropper fitted into a bracket taped to an ink bottle will eliminate the need for removing the stopper each time a ruling pen or other drawing instrument is filled with ink. The bracket is shaped from light sheet metal to the dimensions given in the detail. A flat girder from a child's construction set might also be used. A particular eye dropper might require a hole of a different diameter from that shown. In use, the eye dropper is filled with the approximate amount of ink needed for a job, then slipped into the bracket and used as shown.

John J. Rea, Urbana, Ill.



SEPTEMBER 1955



Rustic Soft-Drink Cooler for Patio Made From Barrel Halves

This soft-drink cooler is wonderful for serving refreshments at a lawn or patio party, and it is attractive as well as practical. To make it, simply saw a wooden barrel in half, turn it end to end and fasten the halves together with hinges. The cooler in the picture holds 24 bottles with plenty of ice packed around them, but any size of barrel could be used, depending on your needs. As a preservative and finish, give the cooler a coat of dark-red creosote stain. Then bind the top edge with awning canvas tacked in place with upholstery nails, and add a bottle opener and handles for carrying. It is best to keep water in the cooler when it is not in use to prevent the staves from separating.

LeRoy Terrell, Atherton, Calif.

Taped Block Holds Small Parts

To prevent losing parts when disassembling small motors and machines, press the parts onto strips of tape fastened sticky side up on a block of wood. The parts can be placed on the tape in order of removal to simplify reassembly. Also, while the machine is being worked on, the block with its parts can be set aside so it is outside of working area.





1



2



3



4

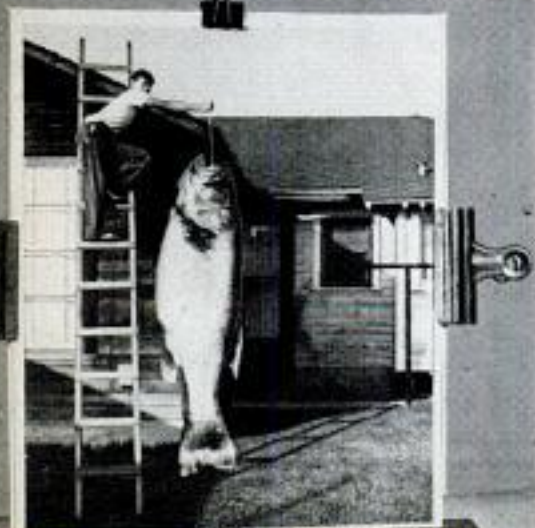

5

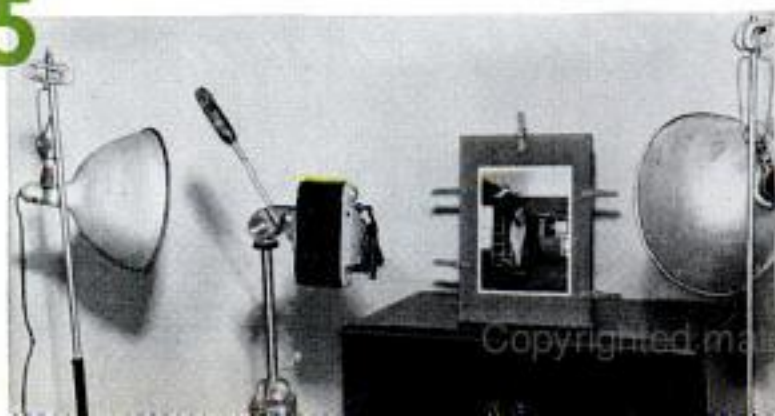



HOW TO MAKE

PhotoKinks 58

INCREDIBLE PICTURES

LAUGH-PROVOKING trick pictures are fun to make and more fun to show. Contrary to popular belief, such pictures can be produced by the amateur photographer, even though he has only limited equipment. Trick shots involve two steps: cutouts and pasteups. The equipment required for them, in addition to a camera and enlarger, is a sharp knife, a sheet of clear glass large enough to hold an 8 x 10 glossy print, and a piece of heavy cardboard of the same size.

The basic print on which the cut is later pasted is made first. See step 1 on the opposite page, and photo B above. This should be a sharp print with good middle tones. Use a ruler on this print to determine the exact size of the cutout needed. Next place the cutout negative, step 2, and photo A, in the enlarger and adjust the size of the cutout image to suit. The print should be made on single-weight glossy paper. Using an old magazine as a cutting board, cut

carefully along the outline of the subject, step 3. Slant the knife away from the subject so that blade undercuts the edge.

The basic print is now placed on the cardboard, the cutout is arranged in place, and the sheet of glass is clamped over the combination, as in step 4. The last step, 5, is to photograph the composite picture. Two lights (house lamps of 150 watts will do) in reflectors are used, one on each side of the camera. The composite is propped up against a solid support, and a check should be made to see that the glass is not reflecting the light. The camera height is adjusted until the lens is 2 or 3 in. above the center of the picture, and then tilted slightly downward until the picture is centered on the ground glass. With a lens opening of f:8, use an exposure of $\frac{1}{25}$ sec. if the camera is 2 ft. from the subject; $\frac{1}{10}$ sec. at 3 ft.; or $\frac{1}{8}$ sec. at 4 ft. On cameras having no focus control, use an inexpensive portrait lens. ★ ★ ★



Waterwheel Drives Scraper In Water-Supply Ditch

The domestic water supply for one town is drawn from a mountain creek through an open ditch several miles long. To keep fish from swimming out of the creek and down the ditch, a screen was placed across the mouth of the ditch. It was found, however, that leaves and other debris often clogged the screen, choking off the flow of water. To eliminate the necessity of cleaning the screen too often, a water wheel was constructed to drive a scraper back and forth over the screen.

Harold L. Monroe, Lomita, Calif.

Book of Matches Kept Dry On Trouser Belt



To keep book matches from becoming wet with perspiration on a hot day, hook them over a belt as shown. With the matches on the belt, there is no need to reach into a pocket with dirty

or paint-smear hands. Also, it is possible to remove a single match and strike it with one hand when necessary.

Willis B. Kern, Arlington, Va.

Breaker-Point Spring Repaired By Using Small Rubber Band

If the breaker-point spring in the distributor of your car should break while driving on the open road, an emergency repair sufficient to enable you to reach the near-

est garage can be made easily by using a rubber band. Simply give the rubber band several turns around the points themselves so that proper contact is made.

Ralph I. Smith, Ossining, N. Y.

Variable-Toned "Water Flutes" Provide Party Stunt

A laugh-provoking stunt at your next party can be set up by providing your guests with variable-toned "water-flutes" and asking them to play tunes. The flutes are made by fitting balloons over the ends of short lengths of tubing and filling the balloons with water through the tubes.



Blowing across the open ends of the tubes produces notes, which are varied by squeezing the balloons. Water forced up into the tubes changes the length of the air column, thus changing the note.

Broken Key Section Removed With Cork and Needles

A tool made from two sewing needles forced through a large cork sometimes can be used to remove a broken key that cannot be gripped with pliers. As shown in the photograph, the needles are pushed through the cork at sharp angles so the points can be forced together against the key. The slender points of the needles can reach farther into the lock than can the jaws of even a pair of needle-nose pliers.

Ed Packer, Oak Park, Ill.



Blunting the point of a nail will permit it to be driven into wood with much less chance of splitting. To blunt the point, place the nail head down on a solid surface and tap the point with a hammer.

Speed of Cuckoo-Clock Call Slowed by Reducing Weight



If the bird in a cuckoo clock gives his call in too fast and frenzied a manner, he can be calmed down by reducing the weight controlling the call. To do this, drill a $\frac{1}{4}$ or $\frac{5}{16}$ -in. hole in the bottom of the weight. Drill a shallow hole first, then check the call. Repeat drill-

ing and checking until the bird calls at the desired speed.

Clinton R. Hull, Santa Ana, Calif.

Pipe Cleaner Replaces Wick

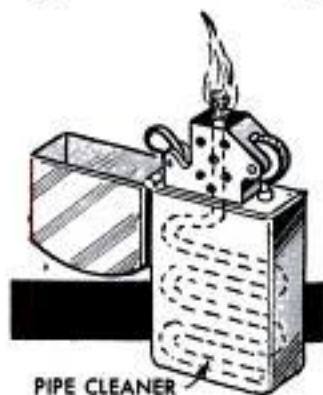

Cigarette-lighter wicks sometimes break off flush with the top of the lighter, making it necessary to take the lighter apart to pull up the old wick. If a pipe cleaner, folded to fit into the case as shown, is used to

replace the old wick, a stub end of the wire will always stick up over the top of the lighter, making it possible to pull up another length easily without having to dismantle the lighter.

M. L. MacDonald, Campbell, Calif.

Candle-Powered Emergency Light Mounted on Broomstick Standard



Uses for this candle-powered lamp range from emergency lighting during a power failure to a decoration at a lawn party. The lamp assembly consists of a dental-floss can to hold a candle, a shallow tin can to take an oil-lamp chimney and a length of broom-

stick for a standard. The cans are screwed to the end of the stick, which is pointed for easy pushing into the ground.

SEPTEMBER 1955



Pockets Sewed to Tent Walls Hold Miscellaneous Items

Canvas pockets of any desirable size can be stitched to the walls of a tent to provide safe storage for glasses, flashlights, cigarettes, shoes and other items. For convenience, the pockets should be located within arm's reach of the camp cot. If a permanent pocket is not desired, a temporary one can be held in place with safety pins.

Borrowed-Tool Record Kept

The problem of remembering who has borrowed your tools and when they are to be returned can be lessened by using a large calendar as a reminder pad. Hang the calendar in a prominent place in your shop. When a friend borrows a tool, ask him when it will be returned. Write the man's name and the tool borrowed on the appropriate date square. It seldom will be necessary to ask a man to return a tool when he sees his name on the calendar every time he visits your shop.





TROUSER HANGER that no longer clamps the cuffs securely still can be used if its ends are fitted with short pieces of rubber garden hose. Cut four rings from the hose, making the rings about $\frac{1}{2}$ in. wide, and then slip the rings over the ends of the hanger as shown above. A sharp knife or razor blade moistened with water will cut hose

Solving HOME PROBLEMS

TO SOAK A TOOTHBRUSH in antiseptic solution, use a glass container of the type in which toothbrushes are packaged. The container permits soaking the brush thoroughly with a minimum of the antiseptic. Place brush in the tube bristle-end-down, as in photo at the left, and prop the tube in a water tumbler overnight

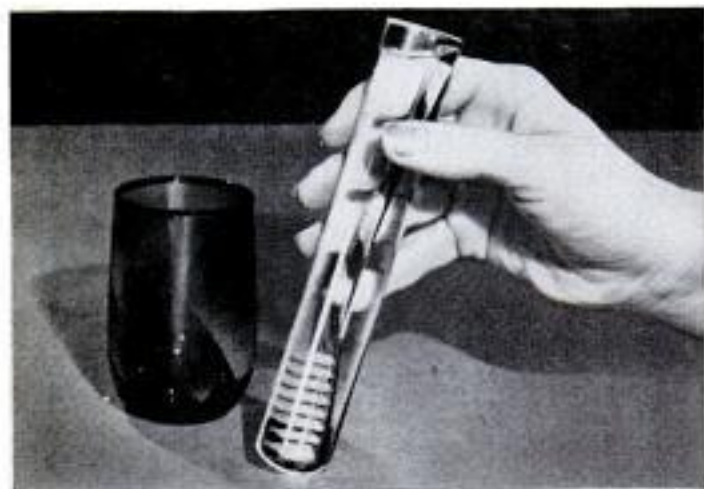

PANELED-DOOR JOINTS that have separated due to expansion and contraction of the wood can be repaired with $\frac{3}{4}$ -in. dowels. When door is thoroughly dry so the wood has shrunk a maximum amount, bring the joints together with bar clamps as in the lower left-hand drawing. Then bore holes at an angle through the stiles and into the rails. Finally, glue dowels in holes and sand ends of dowels flush with door edge

WINDOWS THAT RATTLE even when the sash is locked can be silenced by driving two rubber-headed tacks into the underside of the lower sash as shown below. Rubber heads of the tacks absorb vibration and help to prevent rattling

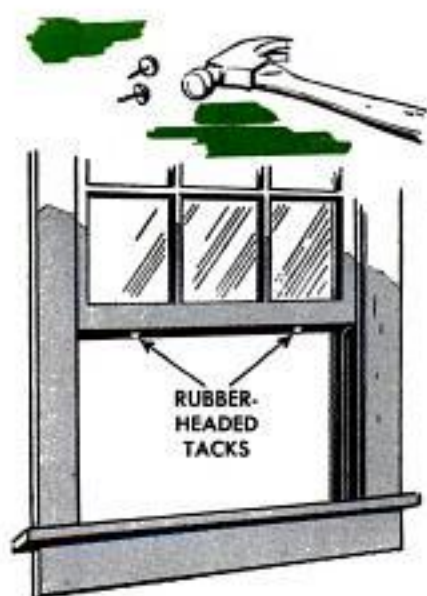
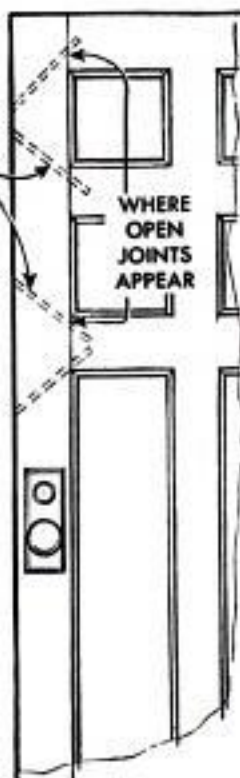



PENCIL ATTACHED TO YARDSTICK with rubber band is always at hand for marking measurements on work, above. Wrap rubber band around yardstick until it is fairly tight, and just replace pencil under the band after each use



PAINTING BOTTOM EDGE OF DOOR is a must if door is to be protected from moisture damage. Taking the door off its hinges is so much trouble that this important job usually is delayed or neglected entirely. However, to paint the bottom edge without difficulty, simply apply the paint with a toothbrush as in the right-hand photo

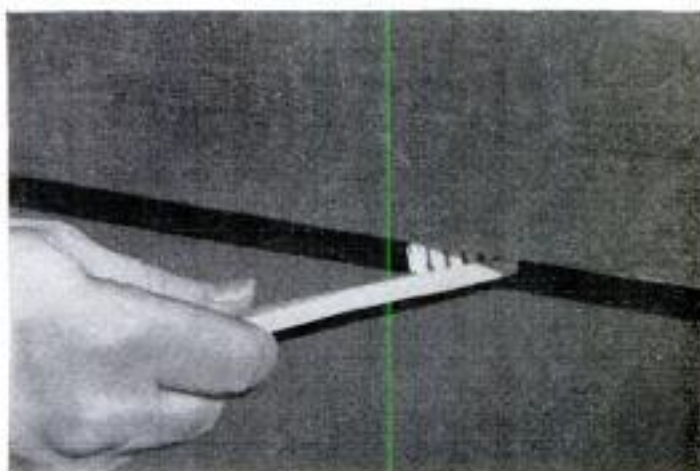

WHEN CLOTHING is given such hard usage that ordinary thread is not sufficiently strong to keep buttons from being pulled loose, use dental floss to sew the buttons in place. The strong dental floss will anchor buttons to clothing that gets the roughest treatment, such as mechanics' coveralls and children's play clothes

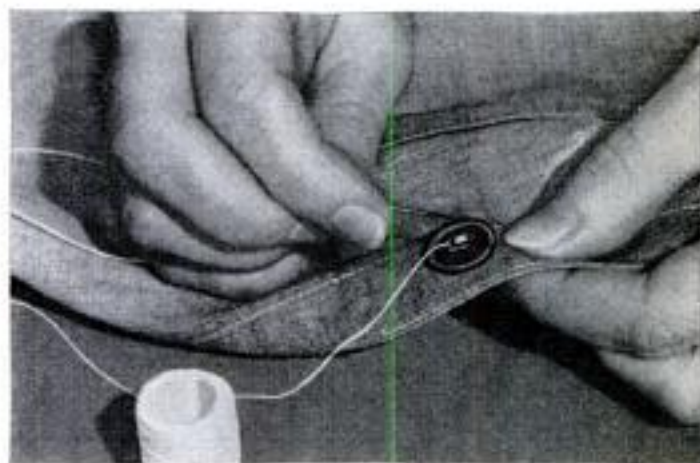

FURNITURE-POLISH DISPENSER improvised from a large oil can is convenient to handle and has two advantages. It prevents wasteful use of polish by dispensing it a drop or two at a time and practically eliminates spillage, as the can may be dropped to the floor or tipped over without losing more than a few drops of polish



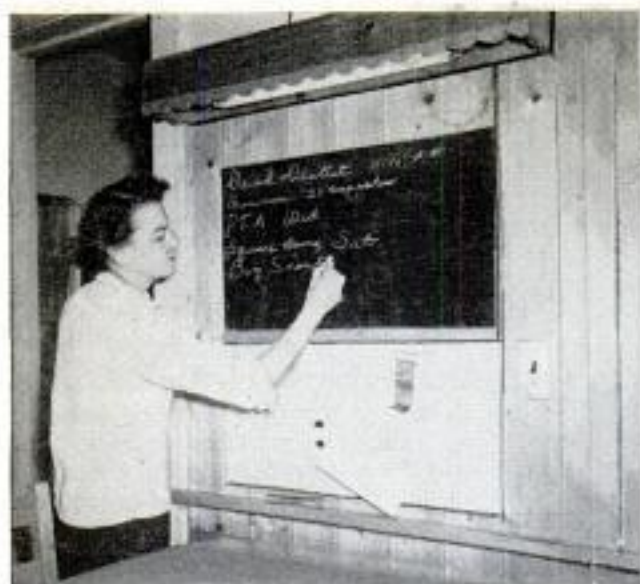

Handy Kitchen Bulletin Board

This combination blackboard and bulletin board in the kitchen has an endless number of uses for members of a busy family. Grocery lists, phone calls and personal memos are written on the blackboard. Letters, cards, cartoons and other items to be shared by all members of the family are thumbtacked to the bulletin board. The blackboard is a piece of painted hardboard and the bulletin board is a section of insulating wallboard. A fluorescent light above the boards is used as a night light for family members coming in late, and to assure that important messages on the boards are not overlooked.

Hal Reed, Hinsdale, Ill.

Angle "Splint" Reduces Sag In Unsupported Water Line

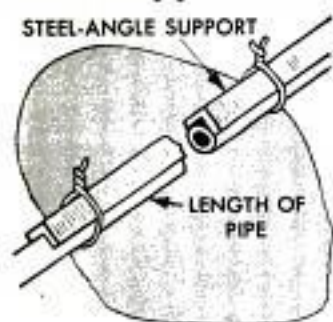

To reduce the sagging of a length of unsupported pipe, wire a steel angle to the upper side as shown, using wire at as many points as necessary to hold the pipe flush against the angle.

The sagging will not, of course, be completely eliminated, but will be considerably reduced. An overhead water line between farm buildings is one example where the angle could be used, since hangers or supports would be impractical.

Cooled Glue Remains Liquid

When it is desirable to keep a water-mixed resin glue in a fluid condition for longer than normal, the "setup" time can be extended by keeping the mixture cool.

In the summer, work with the glue in a cool place. In very hot weather set the glue pot in a pan of ice. It is possible to keep the glue in a fluid state overnight by storing it in a refrigerator. When warmed to 70 deg., the glue will harden in the normal fashion.—D. T. Hurd, Burnt Hills, N. Y.

Attaching Circular Shelves To Round Basement Columns

Long stove bolts fitted in counterbored holes permit attaching circular shelves to round basement columns without the need for drilling and tapping the column. Each shelf consists of two pieces which are drilled edgewise for the bolts before being cut round. After cutting the shelf halves to fit

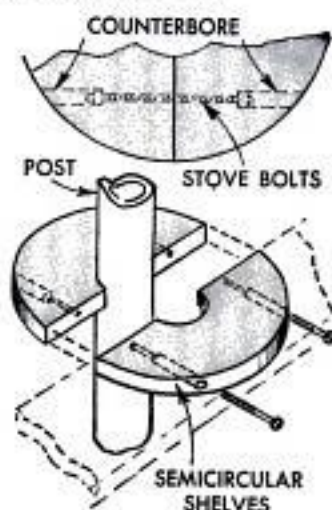

a column, the straight edges of the halves must be planed slightly to provide a tighter fit on the column. For a more finished appearance, plug the counterbored holes with short lengths of dowels.

Putty Provides Temporary Spout When Pouring From Jar

Pouring liquid or powdered material from a wide-mouthed container into a smaller one is no problem if a lump of putty is used. Press the putty to the edge of the larger container and shape it to form a suitably sized spout. A temporary funnel also can be formed from the putty and fitted in the smaller container to further assure pouring without spilling. Modeling clay also may be used for this purpose.



HALF-MOON WALL PLAQUE

By Eugene C. Moysen

If you're looking for something a bit different to set off a dead spot on a wall, or if you'd like to replace a run-of-the-mill wall plaque with an unusual one, this half-moon design will appeal to you. The two little balconies are fine for house plants or as places to display bric-a-brac. The average craftsman will find this an easy one-evening project, the most difficult part of the job being the circular cuts. These can be made with a coping saw, but of course would be easier on a jigsaw.

The pattern for the half-moon is made by scribing two 10-in. circles on $\frac{1}{4}$ -in. plywood. The center point of the second circle is located 6 in. from the center point of the first circle. The horns of the moon will then be located at the points where the two circles intersect. Patterns for the two balconies are shown. The assembly is done with glue and brads or small screws. The original model was given several coats of clear varnish as a finish, but the plaque could be painted or stained any color to suit. Aluminum gelatin molds may be used as flowerpot holders.

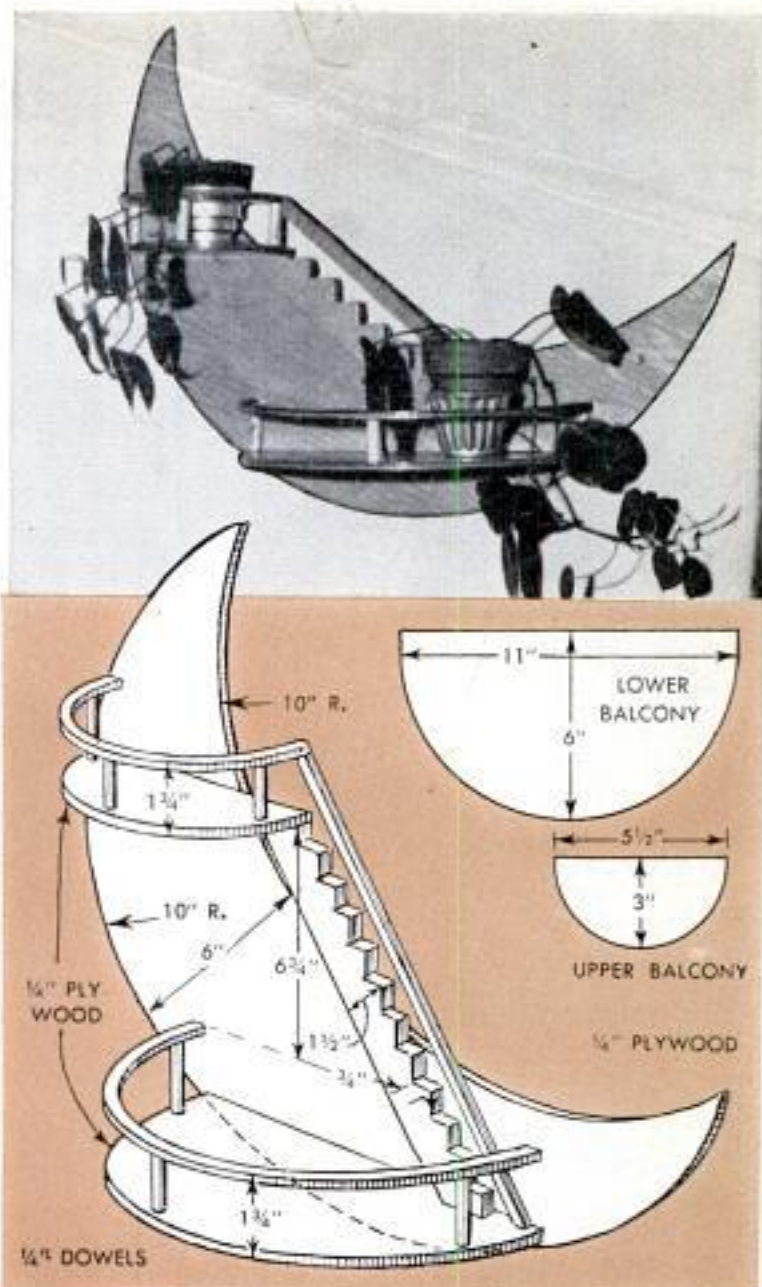

Cord Suspended on Rubber Bands Protected Against Kinking

Looped over an extension cord, as shown, fruit-jar rings or heavy rubber bands can be used to support the cord on nails or hooks when it must be held up out of the

way. The rubber bands do not kink the cord and are removed in an instant when it is taken down. Loops of heavy cord or light rope also can be used in the same manner as the rubber bands.

Enno Haan, Evanston, Ill.

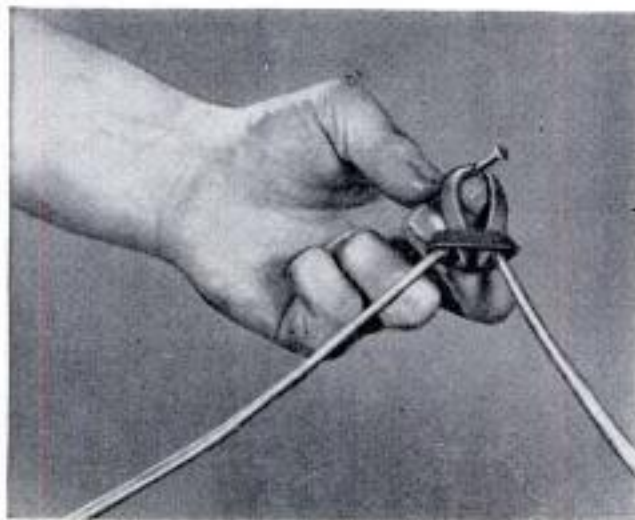

Fruit for Table Centerpiece Polished With Salad Oil

One man who operates a fruit stand advises that apples, oranges, pears and other fruits take on a lovely sheen if they are polished with a good grade of salad oil. Saturate a small cloth with oil and rub it over the surface of each piece and then buff with a dry cloth. Fruit used to decorate the centerpiece of a table will be much more attractive when so treated, and it will also last longer.

Blanche Campbell, Los Angeles, Calif.

Modern Furniture

PATTERNCRAFT

TWIN-BED HEADBOARD

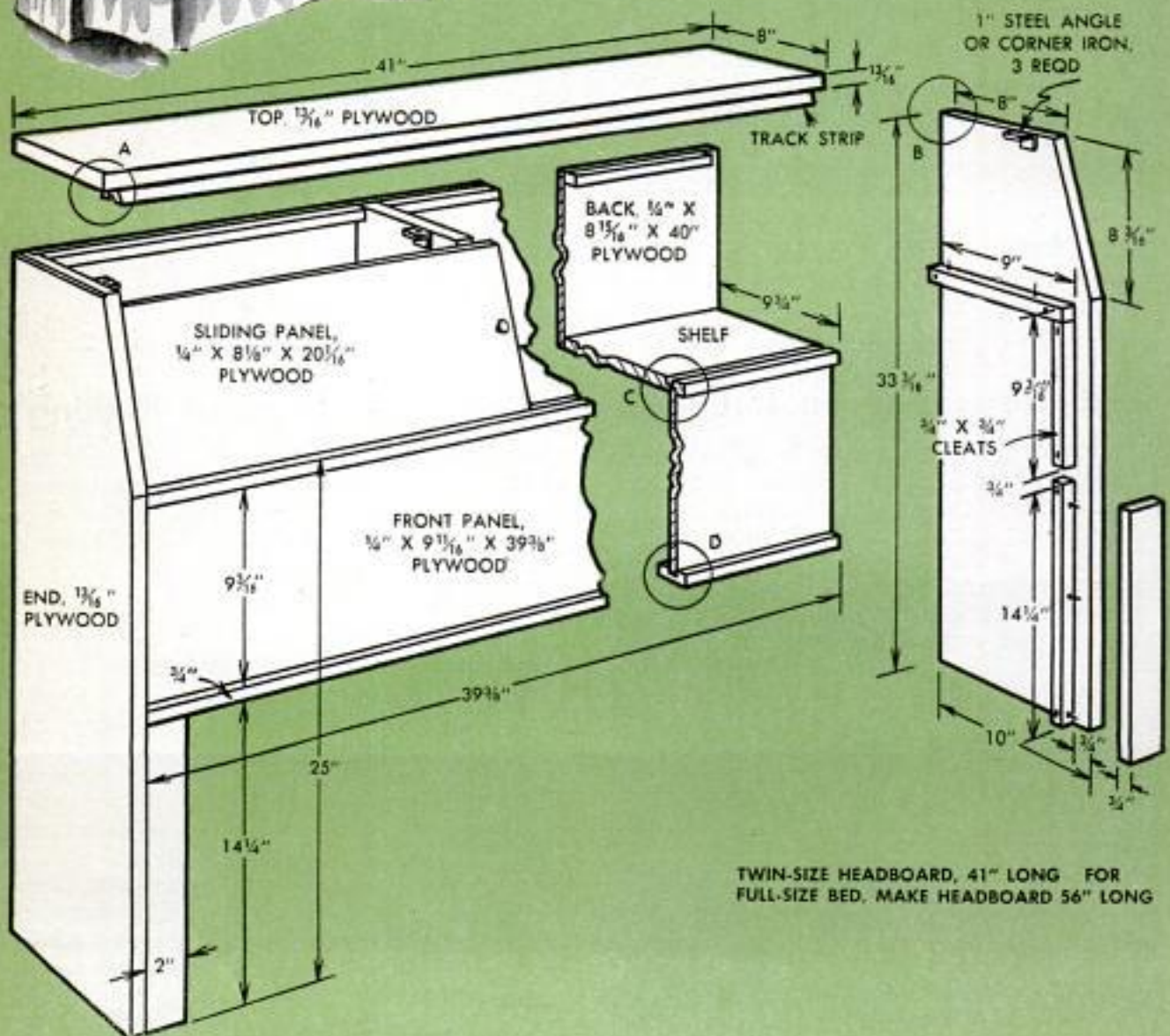
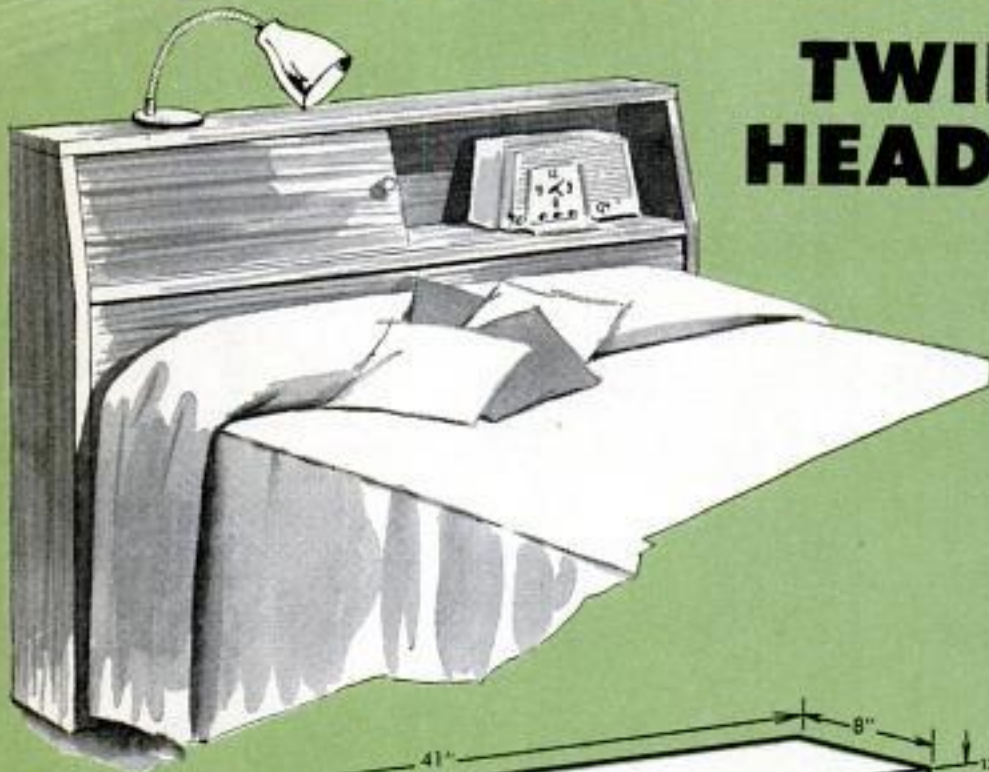

TRACK STRIP FOR SLIDING PANEL GLUED TO UNDER-SIDE OF TOP

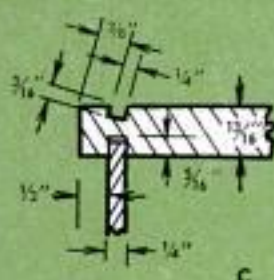
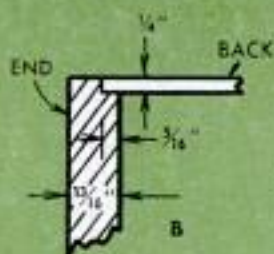
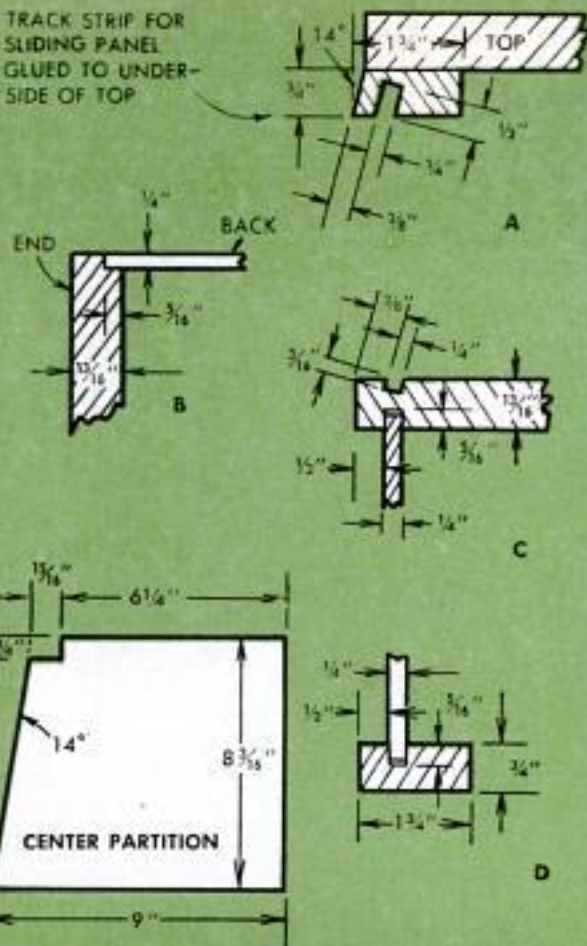

Built of beautifully grained hardwood plywood selected to suit your bedroom furnishings, this twin-bed headboard offers the extra convenience of a utility shelf and a top shelf for books or a reading light. The easy-to-reach utility shelf is divided at the center. One half of the shelf, which is intended for storage, is covered with a sliding panel while the other half remains open for your clock-radio. The top, sides, shelf and partition are of 13/16-in. lumber-core plywood. For the full-length front panel, sliding panel and back, 1/4-in. plywood is used. Grooves for the sliding panel are cut in the shelf, detail C, and in a track strip, detail A, which is fastened along the underside of the top. You will notice that both the track strip and the shelf are grooved at a 14-deg. angle. A headboard of the same design can be made for a full-size bed merely by increasing the over-all length to 56 in.

FULL-SIZE PATTERN

You can take all the guesswork out of making the headboard by using a full-size pattern—together with completely detailed directions. To obtain your pattern, send 50 cents to Patterncraft, Popular Mechanics Press, 200 E. Ontario St., Chicago 11. Ask for Plan No. 119 when ordering pattern

cut of print

Marking Gauge Improved From Wooden Clothespin

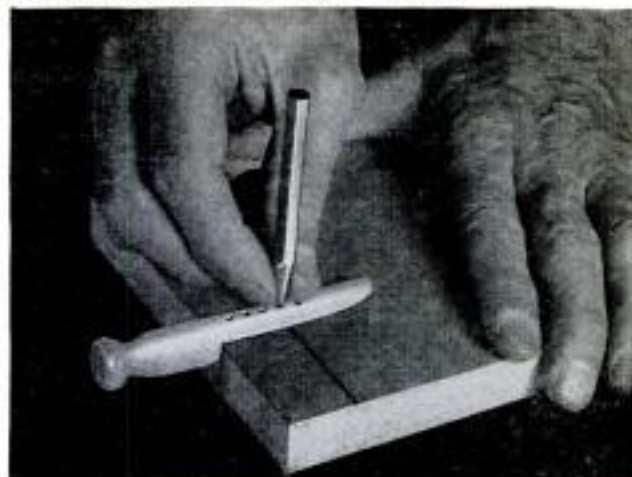

A modified wooden clothespin provides an acceptable marking gauge when standardized measurements are used for marking a number of pieces of lumber to be rough-sawed to width. One leg of the clothespin is cut off and holes are drilled in the remaining leg to receive a pencil.

Hinged Perches on Martin House Keep Out Unwanted Tenants



To keep martin houses free of sparrows until the rightful tenants arrive in the spring, install hinged perches that can be closed over the door holes. Strips are pivoted to the ends of the perches as shown, so all perches can be raised or lowered simultaneously. The perches are controlled from the ground by light cables or cords hooked to the lower ends of the pivoted strips and passed through a pulley or screw eye on the end of the house. A small boat cleat screwed to the martin-house support column is used to hold the lower end of the line after the perches are in position.

Whatnot Shelves Assembled From Plywood and Dowels

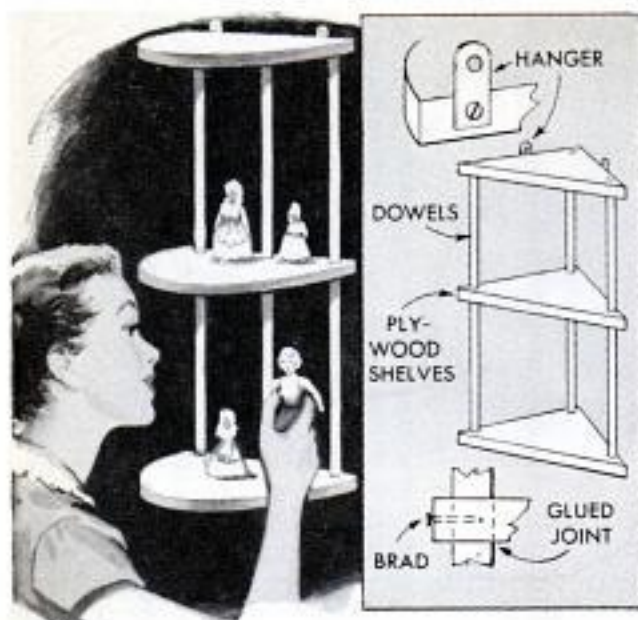

If your wife has asked for whatnot shelves to fit a particular space or corner, use this simple plywood-and-dowel assembly to make them. Two, three or more plywood shelves are cut at the same time to assure identical size and shape. Aligning holes for the dowels are drilled while the shelves are still clamped together. In assembly, glue and brad each shelf to the dowels as shown in the detail. If small bric-a-brac is to be stored on the shelves, $\frac{1}{4}$ -in. plywood and $\frac{1}{4}$ -in. dowels can be used. For larger objects, use correspondingly heavier wood and dowels.

Steel Wool Held in Clothespin "Sands" Inside Corners



loose strands of steel wool and "extending" the reach of your fingers.

When smoothing the inside corners of drawers, cabinets and other locations not easily reached with sandpaper, use a small pad of steel wool held in a spring-type clothespin. The clothespin makes an excellent holder, protecting the hands from

Applicator for Powdered Graphite Utilizes Medicine Dropper

By keeping powdered graphite in a small medicine-dropper bottle and applying it with the glass dropper, you'll find it easy

to gauge the amount used inside locks and other hard-to-reach mechanisms. The long, slender dropper, which is fitted with a leak-proof, screw-on cap, is ideal for directing the powder into otherwise inaccessible places which require lubrication.

Andrew Brennan, Philadelphia, Pa.

Locking Socket-Head Screws

Spotlights, antennas and other parts held on the outside of a car by socket-head screws can be "locked" in place, making them difficult to steal, by drilling out the center of the head as shown. With the center removed, it is almost impos-

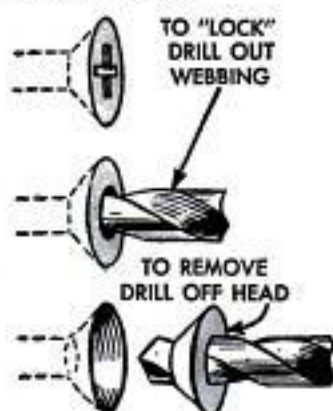

sible to turn the screw with a screwdriver. However, should it later become necessary to remove the screw, this can be done by drilling through the head as shown in the lower detail. The threaded portion of the screw which projects after the accessory is taken off can be removed with lever-jaw or other type pliers.

Ink Pad Stored Conveniently On Slide Under Table

Fitted in a recessed slide under a table top, an ink pad is kept handy for occasional use. The slide consists of two wooden cleats screwed to the underside of the table top. A piece of sheet metal or hardboard nailed across the bottom of the cleats provides a surface on which the ink pad slides. The pad, as shown in the photograph, can be fitted with a wooden frame. The frame permits handling the pad with less chance of getting ink-smudged fingers. If a number of rubber stamps are used, a second slide could be made to store them.

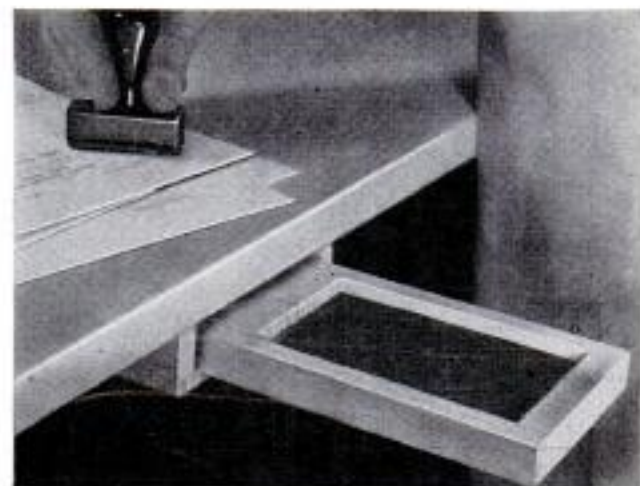

Toy Garage Puts Young Car Hikers in Business

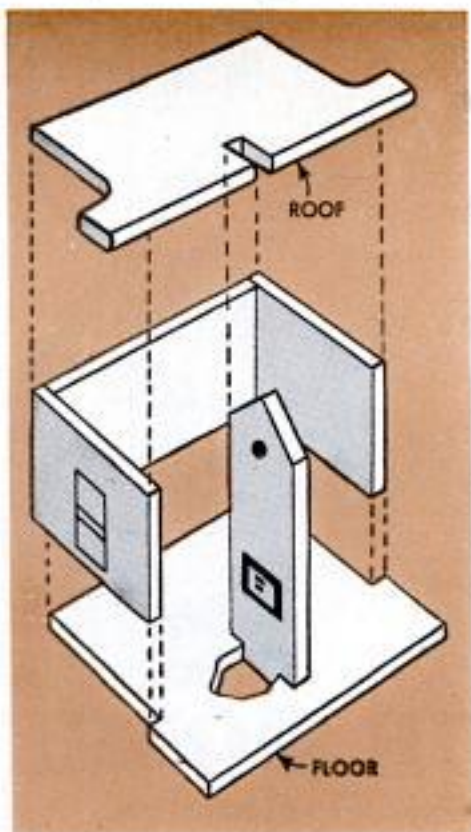

Parking cars just like downtown in this realistic toy garage will while away many an hour for young rainy-day shut-ins. And when the sun comes out, the building itself will double as a handy toy box to keep the cars from underfoot. It's a saw-and-hammer project that Dad can knock together easily in an evening. Wood from a couple of apple boxes will provide all the material that's needed. While

construction is simple, it can be further simplified by forgetting about mortising the pillar into the base and by simply resting the sides of the building on the top of the base and nailing up through the bottom. Simulated doors and windows can be ruled on gummed paper and applied after the building is painted. Size of cars will determine size of garage.—Walter Washington, Chicago

Freshly Painted Drawer Knobs Held by Clothespins on Hanger

The problem of holding freshly painted cabinet-drawer knobs while they dry can be solved neatly by using a wire coat hanger and several spring-type clothespins. Slip the clothespins over the crossbar of the

hanger, then clip the screws of the knobs in the pins. If the knob screws cannot be taken from the cabinet, temporarily turn a screw into the knob. The coat hanger can be hung in any convenient location.

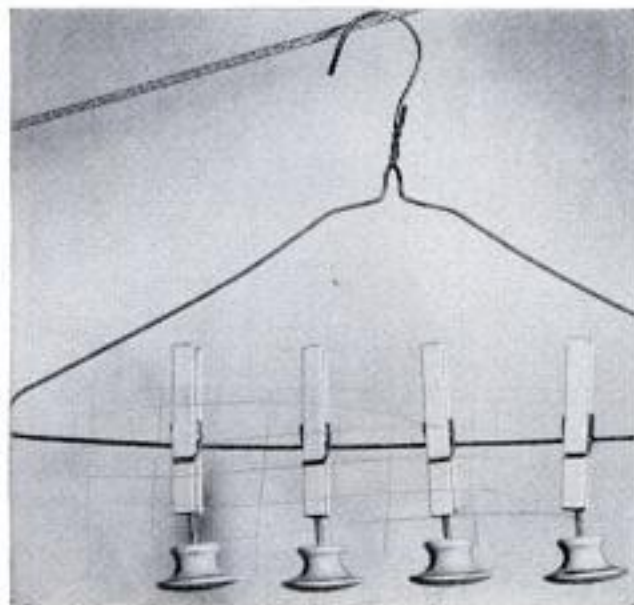

Net Bags Prevent Loss of Parts Soaked in Degreasing Tank

Net bags are used by one mechanic to prevent loss or intermixing when parts from several jobs are soaked in a degreasing tank. The bags are the kind in which onions and other vegetables and fruits are sold. A wire hook is used to lift the bags from the tank so hands need not contact the degreasing solvent.



Frank A. Javor, North Bergen, N. J.



STOP RUST IN YOUR HOME

PART I

By John B. Mullen

RUST AND CORROSION of metals used in gutters, downspouts, flashing, fencing, your car and common household accessories cannot be entirely prevented. However, there are methods of inhibiting corrosion by a careful choice of materials,

correct installation and other practical measures which can do much to prolong the life of home equipment.

Types of corrosion: Corrosion is simply the destruction or dissolving of metal by chemical action. There are several differ-

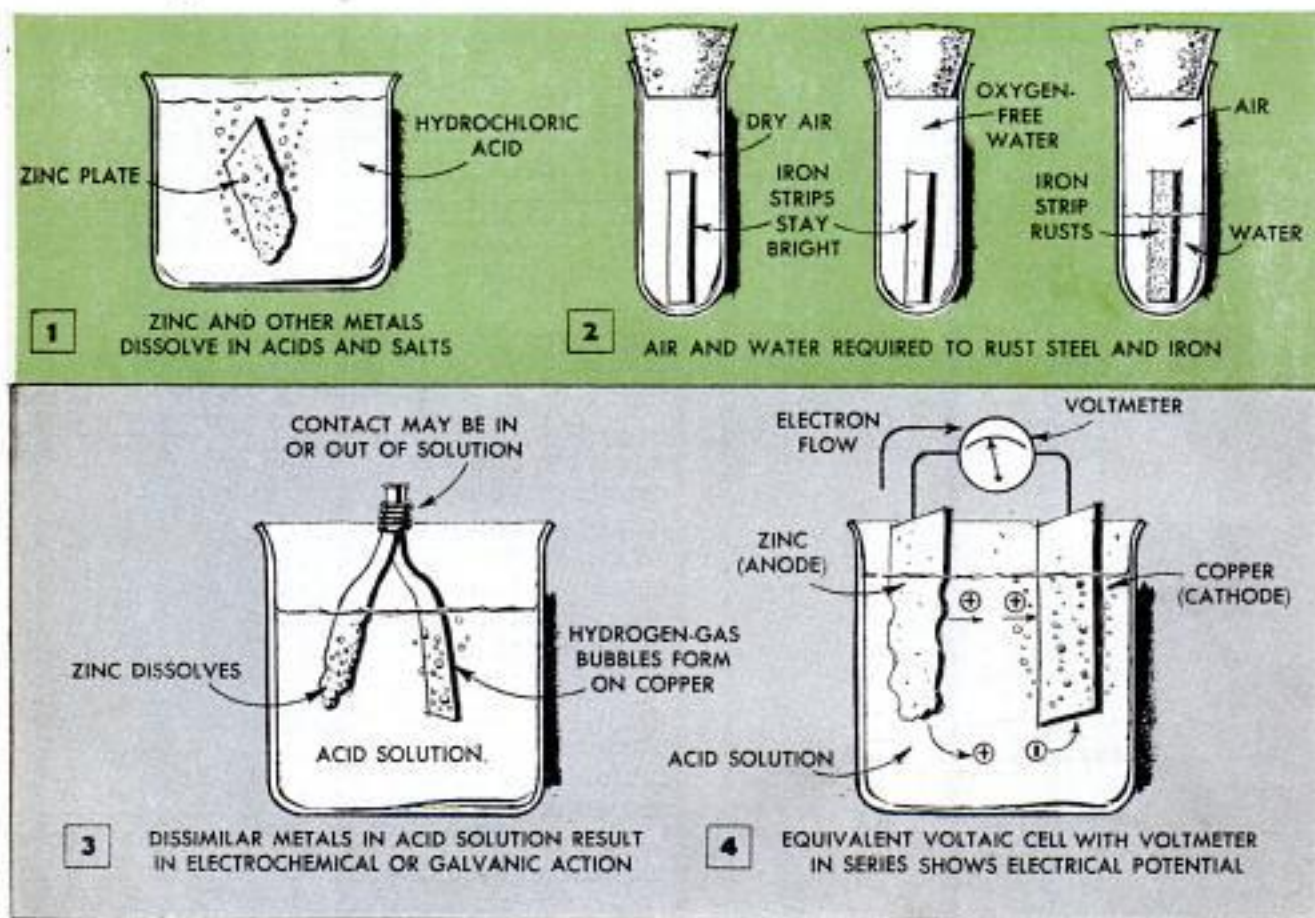

ent things that cause this trouble. What happens to a strip of zinc when it is placed in hydrochloric acid, Fig. 1, is a typical example. Ordinary rusting of iron proceeds in a similar manner, except that both water and oxygen must be present, Fig. 2. Galvanic or electrochemical corrosion is another form which takes place when two different metals are in contact with each other in the same body of water or chemical solution. This contact sets up an electric current (voltaic cell) which causes rapid corrosion of one of the metals. The more-active metal in such a couple is the anode and the electrochemical process which takes place causes the anode to be corroded much faster than it would be if it were not coupled to the other metal, which is the less-active cathode. Cathode action serves to protect this metal instead of corroding it. Often the action takes the form of a discharge of hydrogen ions from the water. The discharge is given off as bubbles of hydrogen gas, Fig. 3. Current flow between the anode and cathode can be measured with a voltmeter as in Fig. 4.

A third type is what is known as concentration-cell corrosion, also electrochemical in nature. This type has a cell made up of two liquids differing in composition which are in contact with the same metal. Such a "couple" produces corrosive results.

Fig. 5 gives the activity relationship of the common metals in the order of their chemical activity. From it one can determine what metal in a given couple will be

"ACTIVITY SERIES" OF METALS

Metals are arranged in order of decreasing chemical activity

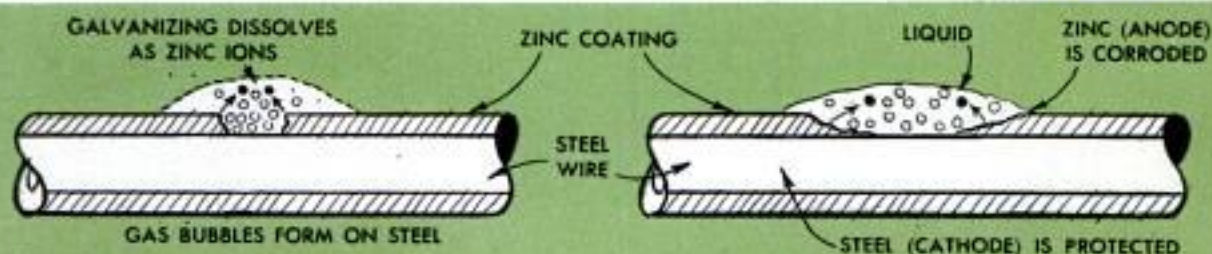
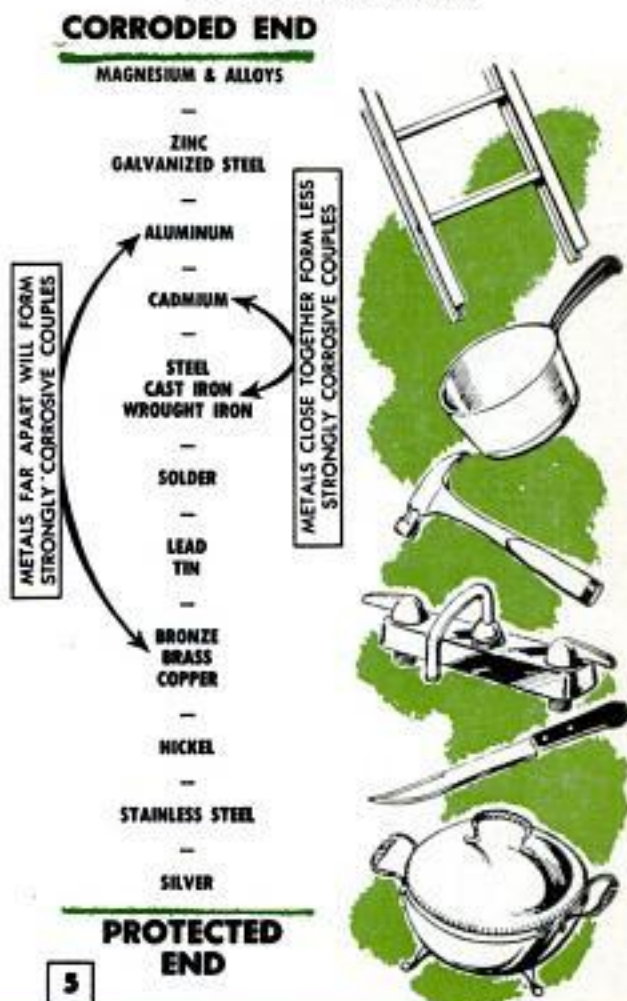

6 STEEL (CATHODE) IS PROTECTED EVEN WHEN GALVANIZING IS BROKEN. ZINC IONS DISSOLVE IN GALVANIC CELL WHICH RESULTS FROM ACTION BETWEEN ZINC AND STEEL

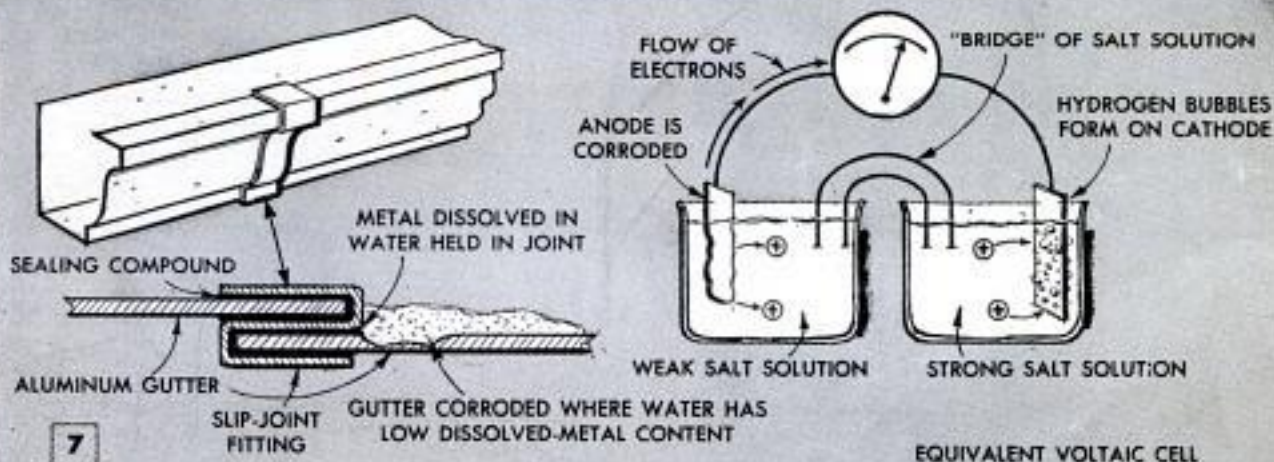

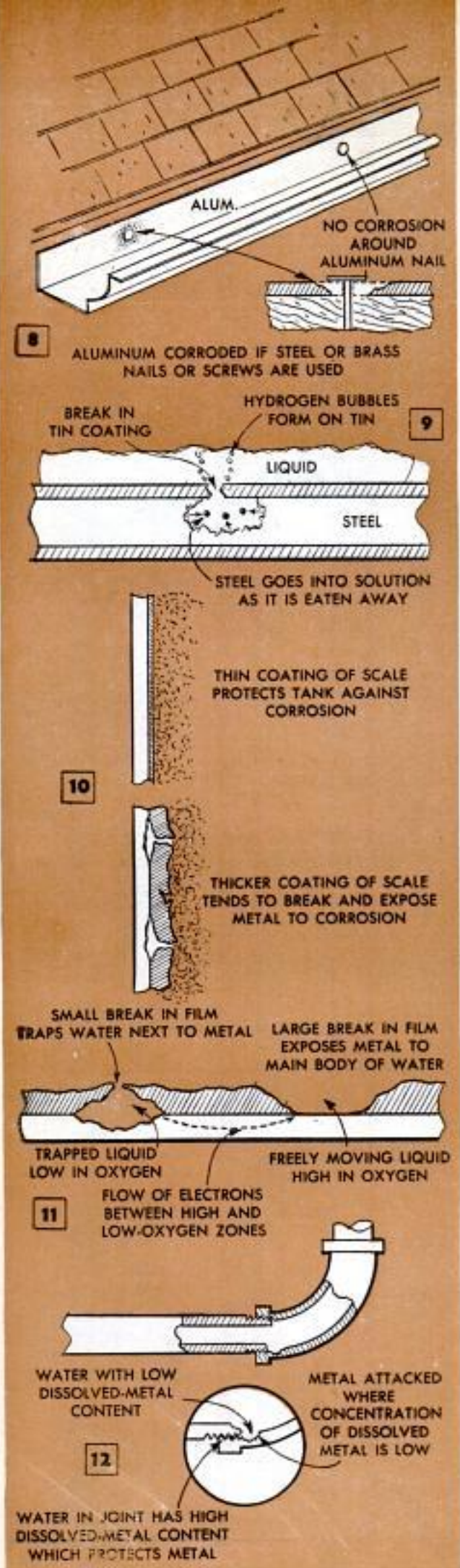

the anode and will be corroded. A study of the table will give a clearer idea of how these corrosion processes work in and on various types of home equipment.

Fencing: A wire fence around the backyard represents a considerable investment. It pays to purchase first quality fencing as this will be heavily galvanized, the coating forming a protective oxide when exposed. Even if the zinc film is broken, as it eventually will be by exposure, it continues to act as a protective film as it is anodic to iron and is dissolved by galvanic action, protecting the wire. The process, shown in Fig. 6, continues until the zinc is dissolved and rust appears. Painting the fencing with a weather-resistant paint interposes a film which prevents the iron-oxygen "couple" when water is present. Because of this, rust will be inhibited as long as the paint film remains unbroken. As a further protective precaution, fencing should always be attached to posts with galvanized fasteners. At the time of installation, stretch the wire with the bottom strand above ground. It will help to keep grass and weeds trimmed short along the length of the fence.

Siding: Uncoated nails used to attach wooden siding to house framing can cause unsightly discoloration of the wood when they rust. The corrosion coating that forms also affects the holding power of the nail. Use heavily galvanized nails, or aluminum nails, to prevent this trouble. If uncoated nails have been used and rust stains already have appeared, the nailheads should be set below the surface and the holes filled with putty after the first coat of paint. Allow the putty to dry and then sand smooth before applying the final coat of paint.

Gutters and flashing: Gutters should have sufficient pitch throughout the length to drain completely. Corrosion usually starts at the joints where soldering flux may remove the protective galvanizing. Scrape or wire-brush the joints and apply red lead or zinc-chromate primer and follow with a finish coat of rust-inhibiting paint. Gutters installed with slip-joint connectors may be subjected to concentration-cell corrosion, Fig. 7. Here two areas of the same metal become anode and cathode in contact with a corrosive body of water consisting of pure water on the one side and a relatively strong solution of dissolved metal on the other. To prevent this, seal the joints with calking compound. Use coated nails or screws on galvanized gutters and downspouts, aluminum fasteners on gutters and downspouts of aluminum, Figs. 8 and 9. Always install flashings so that water cannot become entrapped and thus set up a corrosion cell. It's best to mop in flashings with hot asphalt. Copper

flashings, gutters and downspouts installed with copper fastenings will usually last the life of the building.

Pipes and fittings: The scale that forms in hot-water tanks and pipes in hard-water areas is a principal cause of frequent repairs. Heat speeds precipitation of the calcium salts in hard water, forming a scale which in time cracks and loosens, exposing bare metal. Water entrapped behind the breaks sets up what might be called oxygen-cell corrosion, Figs. 10 and 11. Where the scale breaks away, Fig. 11, water with the normal amount of oxygen in it is in contact with the fully exposed metal which becomes the cathode of a voltaic cell. Where the oxygen content is low under the "blister," the metal becomes the anode and is corroded rapidly. These processes result in deep pits which eventually cause leaks. The conditions are difficult to overcome but draining and flushing of the tank and hot-water lines periodically will help. Also, the use of artificially softened water in the system will help to hold in check corrosion of the metal parts due to the effects of

scale. However, do not drain a hot-water heating system at the end of the season and replace with fresh water. This practice fills the pipes and boiler with oxygen-saturated water and corrosion will follow until the oxygen is again used up. Much longer life will result if the system is never drained.

It's important to repair leaky valves and faucets in the plumbing system immediately as there is always the possibility of the formation of a corrosive concentration cell, Figs. 12 and 13. Fig. 14 shows how corrosion often develops in pipes.

Electrical equipment: Corrosion damage to electrical equipment usually occurs in switches, plugs and sockets in damp locations indoors and out. When electrical connections are made it is imperative to use a noncorrosive flux. Details A, B and C in Fig. 15 show how to make wire connections. It is essential that all connections be mechanically tight before soldering. Screws must be driven tightly on connectors. Corroded contacts on switches of the type shown in Fig. 16 can be cleaned with sandpaper or a wire brush (be sure the current is off) and coated with petroleum jelly.

(Continued next month)

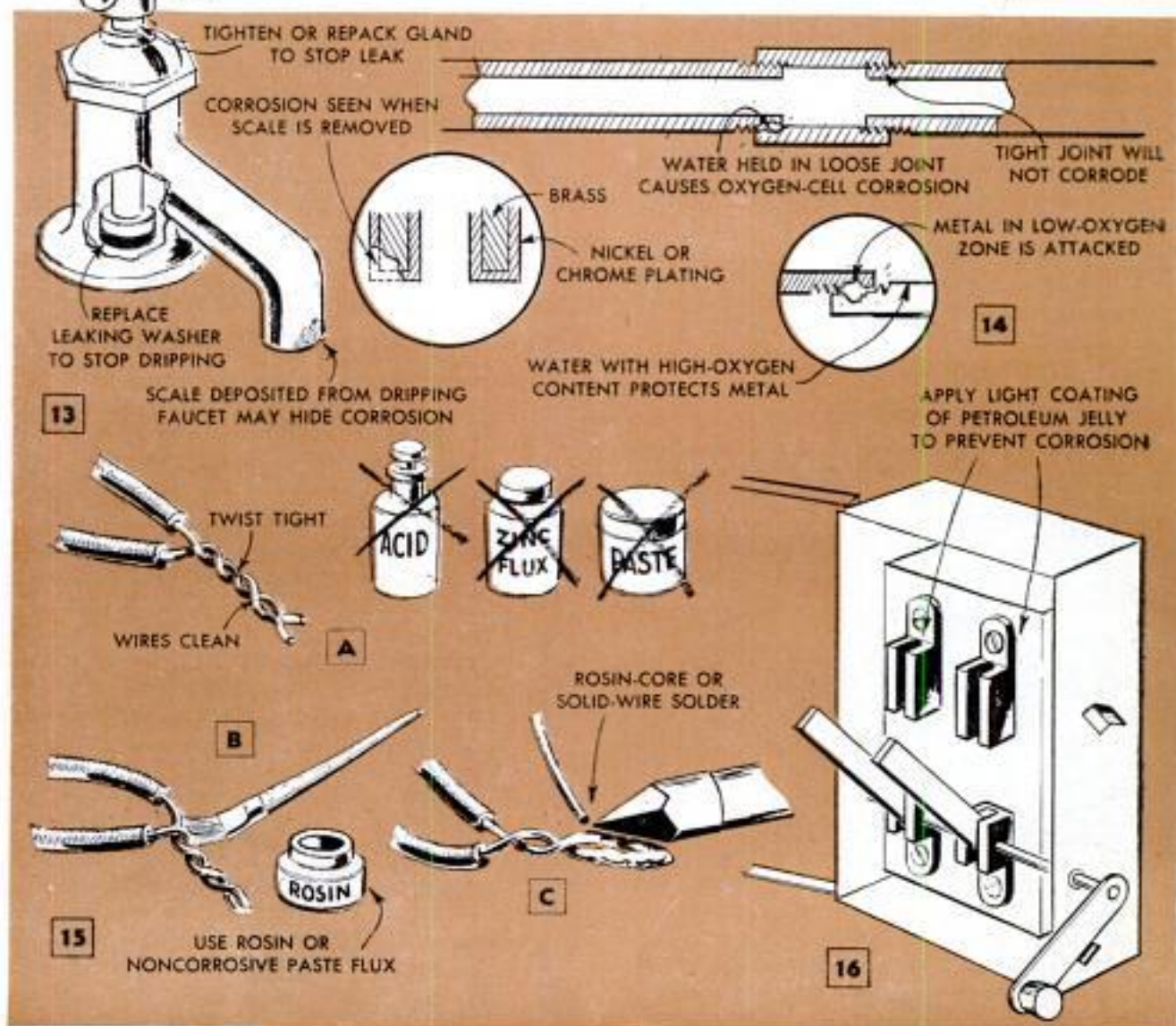

Two-Way Gate Kept Closed By Screen-Door Springs

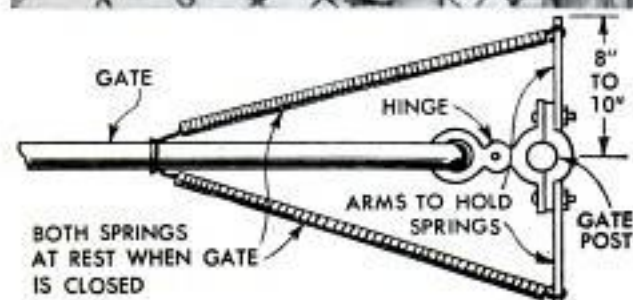

A gate that opens toward either side can be kept closed automatically by means of two screen-door springs. Each spring is fastened to a $\frac{1}{4}$ x 1-in. piece of flat steel that extends from 8 to 10 in. from the gate posts as shown in the illustration. On steel gates these pieces are bolted to the upper hinge clamps. To operate properly, both steel arms should be of the same length and both springs should be of equal length and tension. No matter which way the gate is opened, one of the springs will return it to the closed position.

Flow of Ink in Ruling Pen Started on Chamois

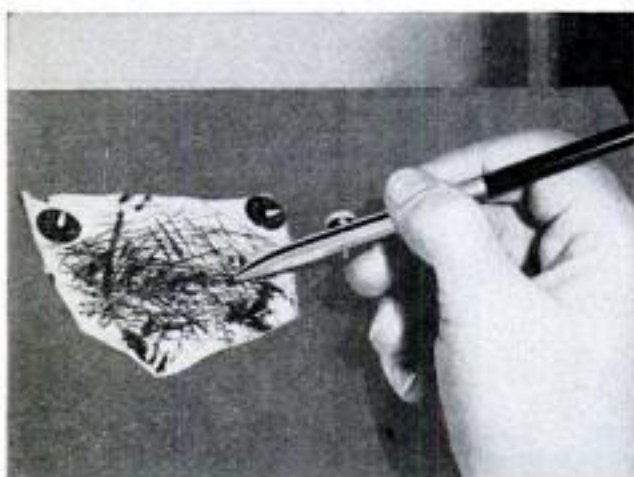

It is customary for most artists and draftsmen to start the flow of ink in a ruling pen by drawing it lightly across the back of the thumb or hand. To avoid soiling the hands, a small piece of clean chamois

should be tacked to one corner of the drawing board. When the pen is drawn across it, the flow of ink is started just as well as when touched to the flesh of the hand.



Adding Paste Coloring to Paint

A quick method of adding paste color to paint is to first mix the paste with solvent in a screw-top glass jar. Squeeze the tube of paste into the jar, add solvent and shake vigorously. Waste is kept to a minimum and the liquefied color mixes readily with the paint. When several cans of paint are to be matched, carefully measure the amount of solvent used per tube of paste coloring, then add precisely the same amount of the paste-solvent solution to each can.

Stove Grates on Garden Wall Serve as Flowerpot Shelves

One homeowner, when making a wall of natural stone blocks in his garden, used the grates from an old-style kerosene stove as shelves to hold flowerpots. As the wall was put up, the edges of the grates were stuck into the cement between the blocks. When the cement had set, the grates provided strong yet ornamental shelves.

Grover Brinkman, Okawville, Ill.



"Wagon Seat" Serving Tray

THE MULTIPLE USEFULNESS of the "wagon seat" type of tray, with one side open for convenient serving, was discovered long ago, and such trays have been popular ever since. One of these trays gives a real helping hand when serving guests in the living room or out on the lawn, and also serves as an extra sideboard in the dining room. Next to the bed in a sickroom, it provides ample space for medicines, drinking water, books and writing materials. Then, when not in use, it can be stored in a minimum of space.

A squared pattern for parts of the tray is shown below. After the parts are assembled with glue and screws, a good finish, consisting of several coats of varnish, should be applied. The folding stand for the tray is of simple construction and folds by pivoting on a steel rod. To keep the rod from slipping out of place,peen the ends over tight-fitting metal washers. A gay touch of color can be added if bright plastic webbing is used in place of the usual brown woven type. Wrap the webbing around the cross brace several times before tacking in place.

By
**Bertram
Brownold**

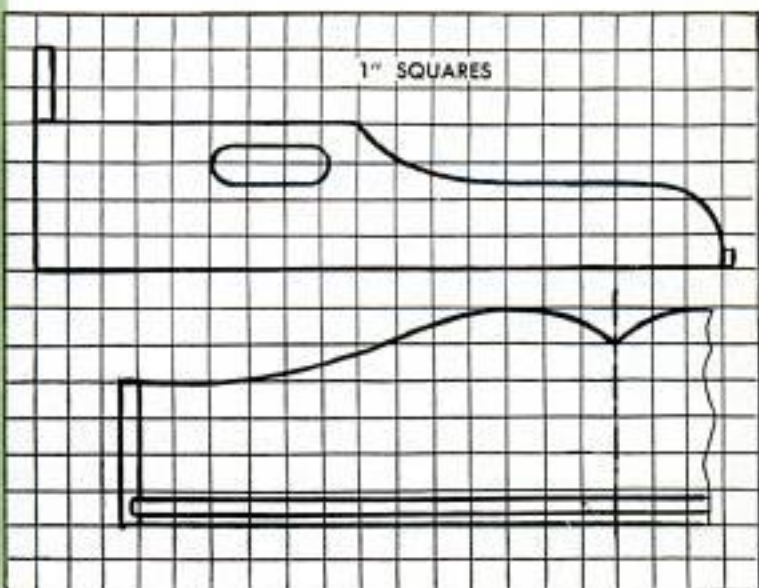
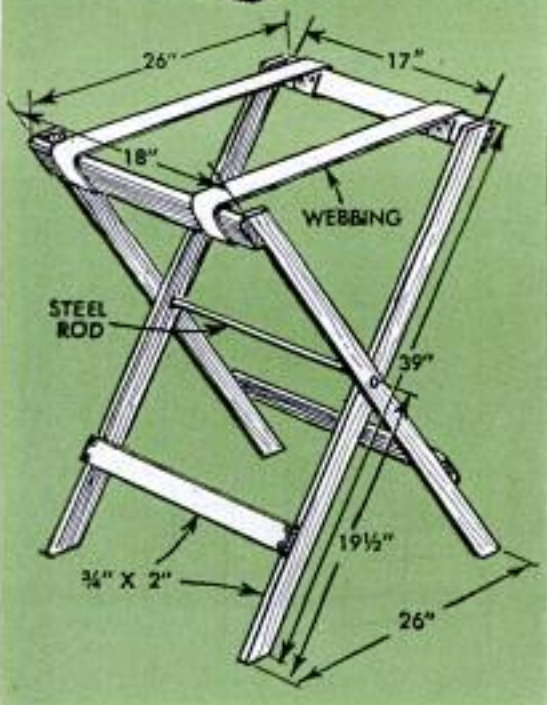
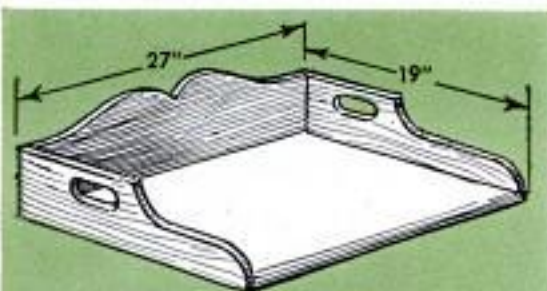
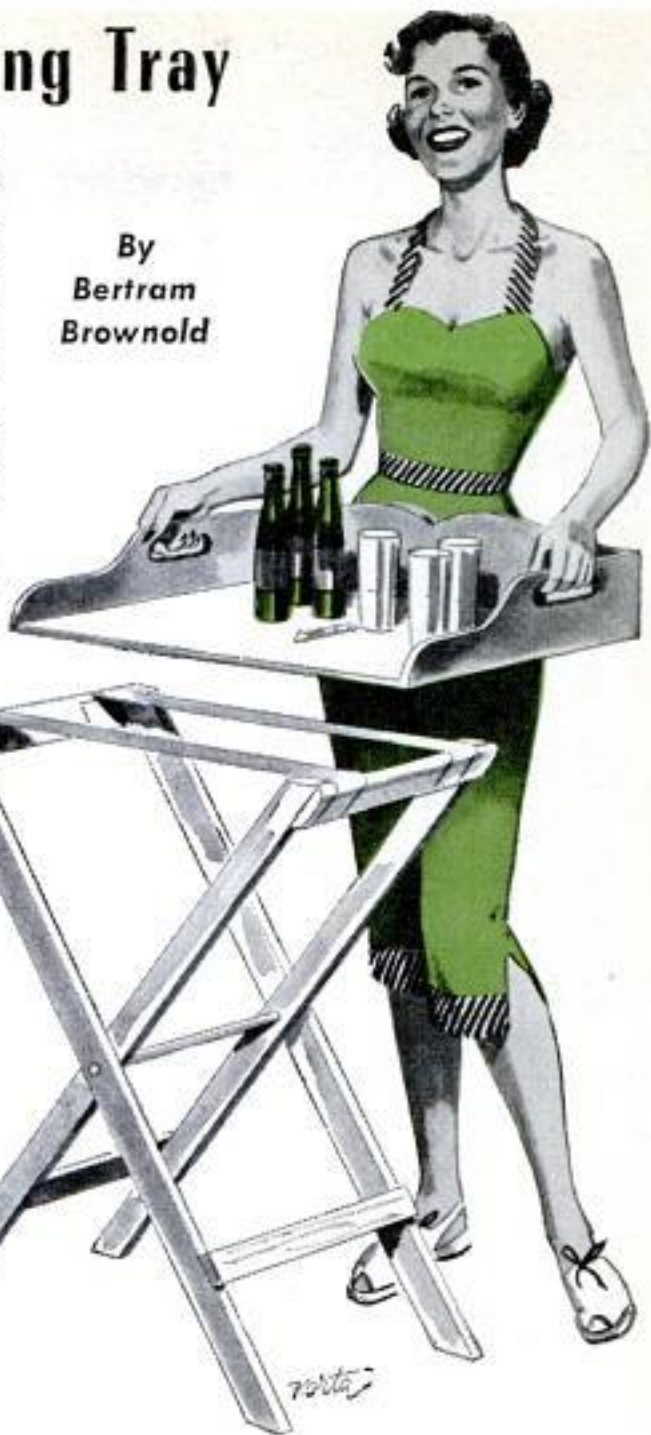



Good patching job depends on use of proper tools

HOW TO PATCH PLASTER

By V. Lee Oertle

EVERY HOME with plastered walls sooner or later needs minor plaster repairs to take care of cracks due to settling, dry-rot damage and accidental knock-outs. The average homeowner, by following the right methods and using the proper materials, can make them himself at very little cost. The right tools are important and should include a large, soft-bristled brush, a putty knife, a trowel, a chisel and a ham-

mer. If patches are to be made in a textured surface, a rubber float will be needed to give the finish a sandy appearance. For patching ordinary cracks and small holes, the best materials are Spackling compound and patching plaster. Spackling compound should not be used to patch large areas as it does not form a good bond to gypsum plaster and may peel away. If the repair is deep, extending all the way

1. The first step in repairing a damaged wall is to remove all loose and crumbling plaster with a chisel

2. Large holes usually are deep. Best material to use for patch is either molding or wood-fiber plaster





1. Use a chisel to open crack slightly, insuring good bonding surface, before applying Spackling compound

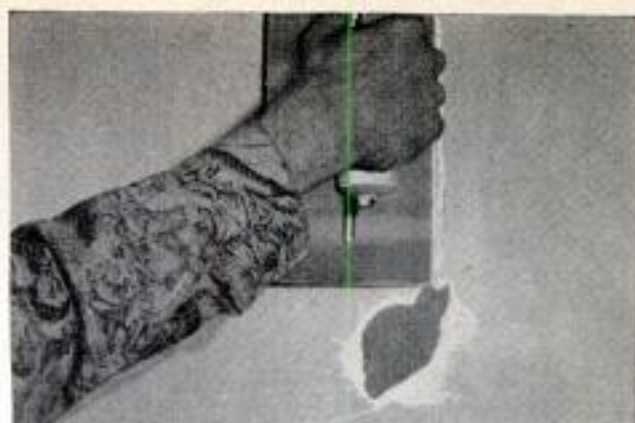

2. Dip edge of trowel into Spackling compound and fill crack in one motion, overlapping sides about 1 in.

3. Using the edge of the trowel, slice down across the crack to remove excess material. Allow 8 hr. to cure



4. After curing, remove burrs and rough spots with fine sandpaper, using a circular motion over crack

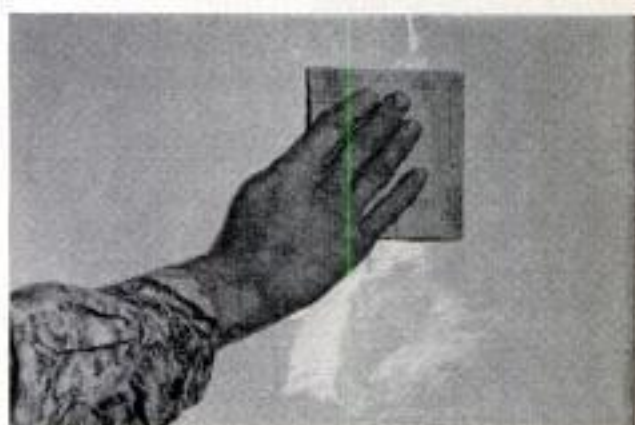

to the lath, it is best to use either wood-fiber plaster or molding plaster for the repair. The latter requires about 15 min. to set, but should be allowed to cure a day or so before sanding. To do a permanent repair job in areas where moisture has entered the wall and caused dry rot, as around sinks and bathtubs, portland cement plaster is recommended. Experts advise that the wood or gypsum lath in such areas be replaced with metal lath, as a help in preventing the dry rot from recurring.

For the final finish coat on large patches, the most commonly used materials are a lime and gauging-plaster mixture or a mill-mixed plaster (lightweight, premixed gypsum-and-aggregate mixture that produces an exceptionally hard surface). Molding plaster (plaster of paris) also can be used for this. The pictures on these pages show the proper methods to use in making plaster repairs around the home. Those above picture the four basic steps in patching a running crack. ★ ★ ★

3. To get smooth finish after patch has been made, wet spot with brush, followed closely by trowel

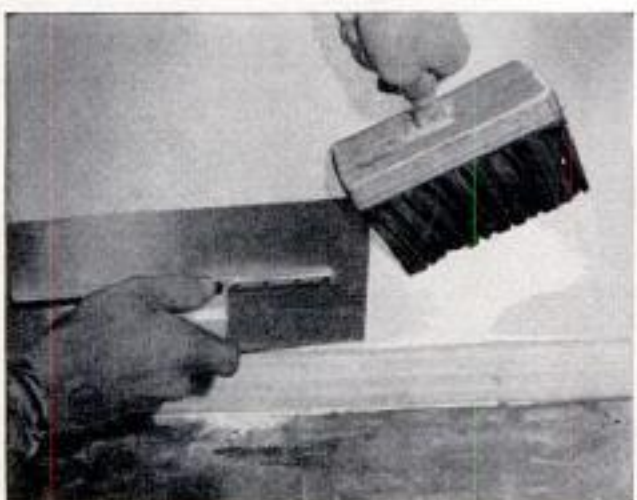

4. Make several passes with wet brush and trowel. Then sand smooth and feather edges after curing

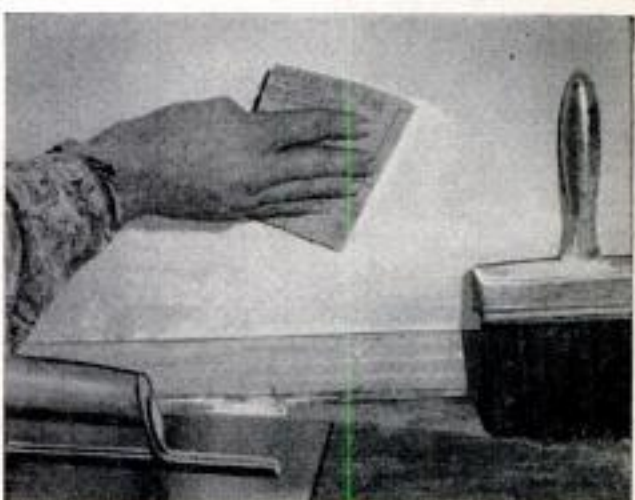

Corkscrew "Pegs" for Tent Driven Without Hammer



Tent pegs that do not require hammering into the ground can be made by bending lengths of $\frac{1}{4}$ -in. iron rod into the shape shown in the illustration. First, one end of the rod is ground to a point, after which it is heated and bent into a spiral shape with the upper end bent at a right angle to provide a driving crank. The pegs are driven by inserting the point into the ground and turning the crank in a clockwise direction.

Clean Molten Metal Under Dross Poured Through Hole in Ladle



size of the hole and its distance below the rim of the ladle will depend on the type and amount of metal being used and the amount of dross expected.

String Wound on Fishing Reel Prevents Usual Tangling

A discarded fishing reel can be used to store short lengths of string and twine without the usual problem of tangling. Fasten the reel in some convenient spot,

such as on the inside of a cupboard door or to a basement post. Additional lengths of string are simply tied to the end of the string already on the reel. If no discarded fishing reels are available, inexpensive ones can be purchased.

"Rolling Pin" Table Lamp

The column for this attractive table lamp requires no turning, being made from a wooden rolling pin. Both handles are cut off, then a spiral is marked around the pin by wrapping a strip of $\frac{1}{2}$ -in. tape around it. Use a fine-toothed saw and cut a groove along each edge of the tape $\frac{1}{4}$ in. deep. Remove the tape and cut out

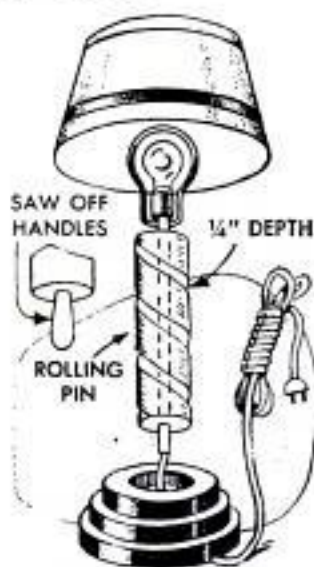

the wood between the saw cuts with a narrow wood chisel. Drill a hole through the center of the rolling pin with a sharp auger to accommodate a length of $\frac{1}{8}$ -in. electrical pipe. Three disks are used to make the lamp base, being $3\frac{1}{2}$, 4 and $4\frac{1}{2}$ in. in dia. respectively. The $3\frac{1}{2}$ -in. disk is bored out to receive the lower end of the rolling pin. Light sockets and lamp harps can be purchased at most appliance and hardware stores.—Joe Levigne, Chicago.

Gauge Clamped to Handsaw Assures Uniform Cut

A gauge consisting of two strips of wood clamped to the blade of a handsaw will assure uniform depth of cut when cutting grooves. The wood strips are screwed together at one end with a spacer between them the thickness of the saw blade. In use, the gauge is clamped on the blade, allowing the required depth of cut to project below it.

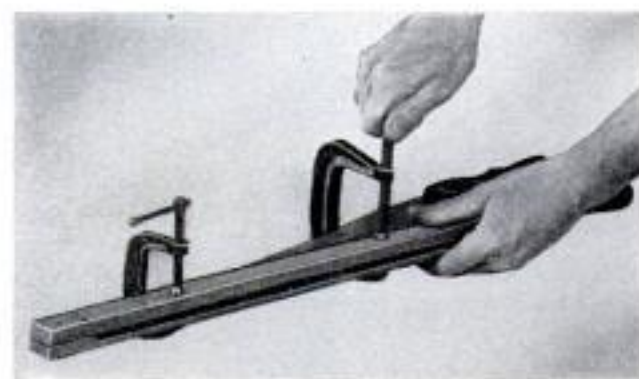

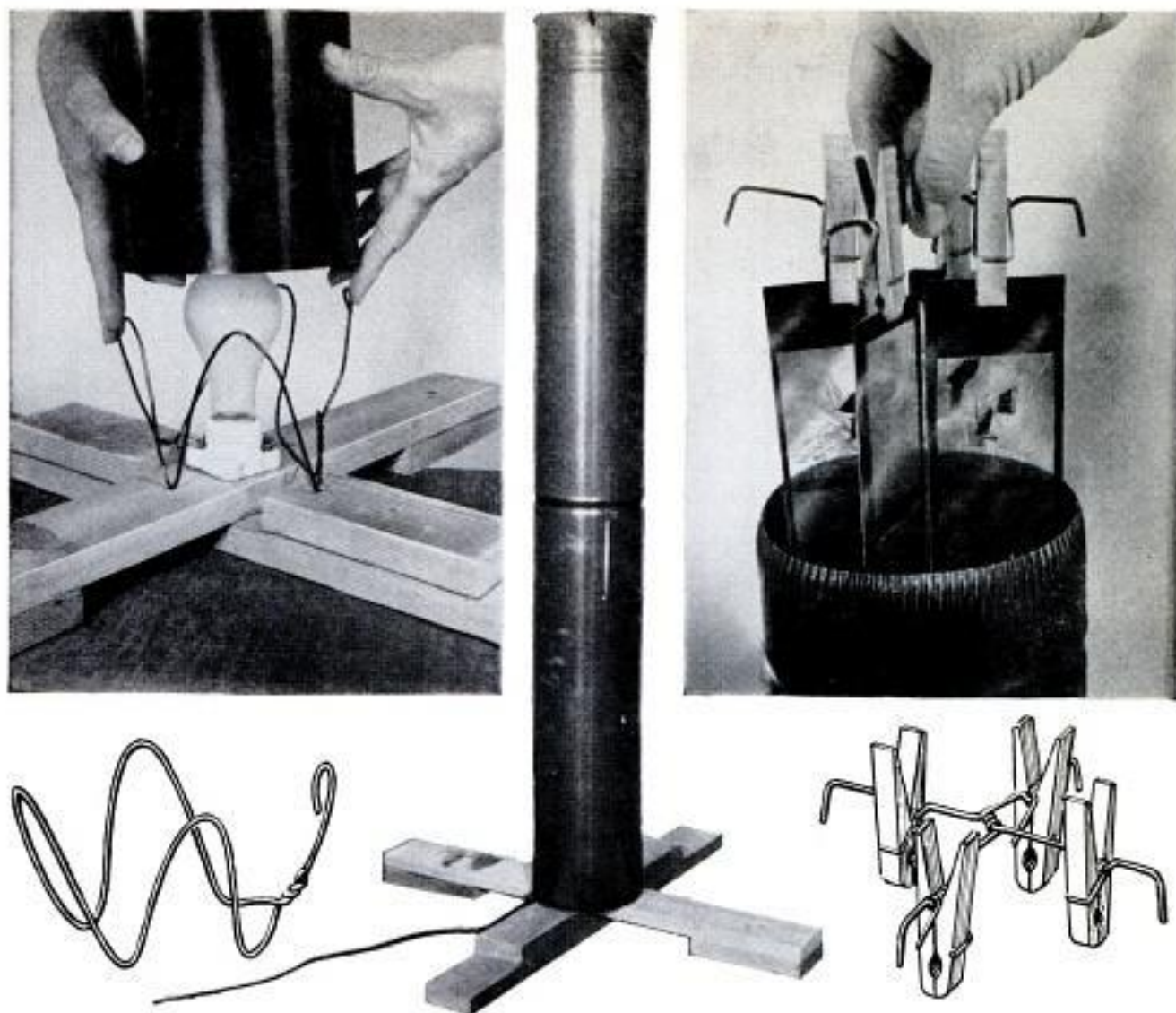

Bulb Provides Heat for Stovepipe Film Drier

An efficient convection-type drier for roll film is something any photographer can build for his darkroom at small cost. Made from 6-in. stovepipe, the drier protects film from dust and, because of the increased drying speed, results in negatives of a finer grain. Materials required include wood for the simple cross base, two or three lengths of stovepipe, an electric-

light socket and a 60-watt bulb. The rack from which the film is suspended and the spring clip which holds the pipe on the base are both bent from coat-hanger wire. To prevent curling, a clothespin is attached to the bottom of each film as a weight. Under ordinary conditions, four rolls of film will dry in less than an hour.

Eugene M. Hanson, Venice, Calif.

Set Plane Iron Quickly With Thickness Gauge



To set the iron of a hand plane uniformly and quickly, use a thickness gauge. First, lay a straightedge on the sole across the iron, slip the gauge under the raised end and adjust the iron to touch the gauge. If the setting is found right for soft wood, such as pine, it may be necessary to back off the plane iron a bit to take less "bite" when planing hardwood, such as maple.

Ken Murray, Colon, Mich.

☐ A little lipstick applied around the edges of a soldering job will act as a mask to keep the solder off adjacent areas.

Lightweight Utility Horses Made From Pipe and Lumber

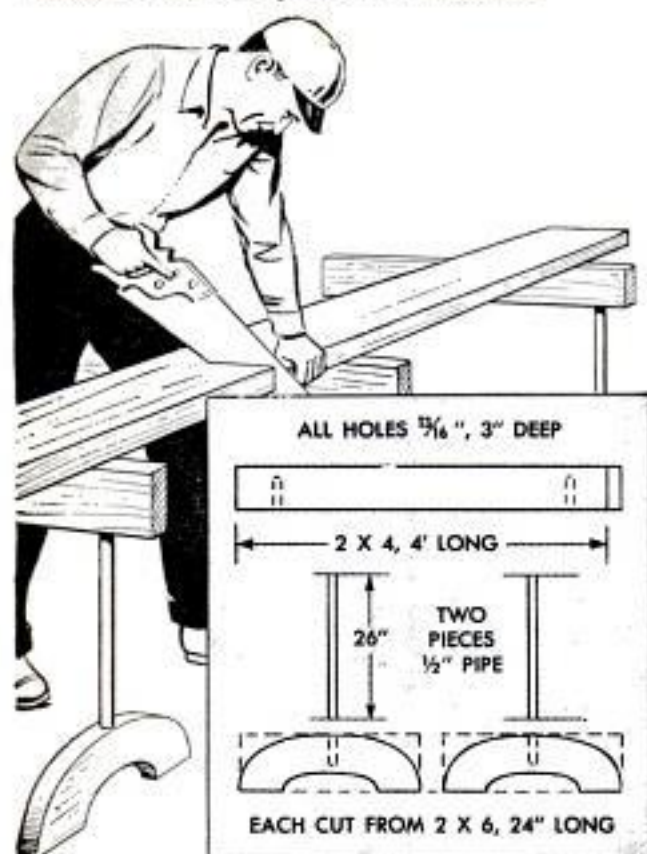

These sawhorses can be knocked down for transporting, or simply folded flat against a wall where they will project only 2 in. As shown in the detail, the top piece of the sawhorse is a 48-in. length of 2 x 4. The uprights are lengths of 1/2-in. pipe and the feet are cut from 24-in. lengths of 2 x 6 lumber. A sheet of plywood and two or three of the horses can be used to make a quickly knocked-down table for a backyard or for setting up a model train.

J. W. Welker, San Bernardino, Calif.

Chemically Softened Water Will Poison House Plants

Many makes of home water softeners replace the curd-forming calcium in hard water with sodium. This softened water is desirable for most uses around the home, but it should not be used to water house plants, since the sodium in the water is a poison to many plants. Thus, if you have a water softener and find that your plants

A Modern Kitchen . . .

decorated in cheerful colors and featuring well-lighted, step-saving work areas is the dream of every housewife. Old-fashioned kitchens can be made into dreams like this, as you will see in next month's story on modern kitchen design. It's packed with ideas and plans you'll want to copy

are droopy and sickly, stop watering them with the softened water. Instead, obtain water for them from the bypass valve, or use trapped rainwater.

Siding Gauge Uses Saw Blade For Quick Scoring

A siding gauge can be altered so that it will mark the cutoff point while held in one hand, leaving the other hand free to hold the siding in place. The alteration is made by screwing a hacksaw blade to the gauge. To permit proper operation, the opening between the legs of the gauge should be 1/2 to 1 in. greater than the width of the siding. In use, the gauge is set snugly against the corner boards, window or door frames and then moved up and down so that the teeth score the siding.

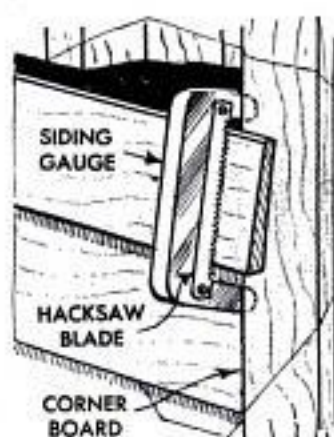

Telescope Support Improvised Utilizing Camera Tripod

A camera tripod can be used as a sturdy support for a telescope if a mounting block is made for attachment to the tripod. To do this, groove a wooden block, then drill and counterbore a hole at the bottom of the groove to accommodate the tripod screw and a nut. The telescope-retaining band is a strip of heavy sheet metal drilled and screwed to the sides of the block. A strip of felt inside the band will hold the telescope firmly without marring it.



SN 57



Winterize Your Car's ELECTRICAL SYSTEM

AS THE TEMPERATURE lowers with the approach of winter the efficiency of your car's electrical system lowers proportionally. This can be due to increased resistance within the various circuits and also in large part to the greater load imposed by cold-weather starting, prolonged use of accessories, moisture condensation and increased frictional drag in the engine and transmission during the longer warm-up period in cold weather.

Car electrical systems are made up of four circuits, the charging circuit, starting circuit, ignition circuit and accessory circuit. The accessory circuit varies greatly on different makes of cars and frequently requires highly specialized tools for proper checking and adjusting for cold-weather operation. The charging circuit includes the battery, generator, regulator and ammeter. The starting circuit is made up of the battery, starting motor and solenoid switch. The ignition circuit includes battery, distributor, ignition coil, ignition resistor (on new 12-volt systems), ignition switch, spark plugs and the distributor-to-plug wiring harness, or loom.

The battery, included in all the circuits, is the key unit of the system, and the one most likely to give trouble if the proper precautions are not taken. However, premature battery failure, or frequent dis-

charging of the battery, generally indicates a defect elsewhere. In a large percentage of such cases the cause may be traced to excessive resistance in the wiring due to defective leads and loose or corroded connections at terminals.

To locate such defects check the charging circuit, grounding the F-terminal of the regulator, Fig. 1, and operating the generator at a speed that will give approximately

To locate the causes of voltage drop in the charging circuit make the series of quick checks as indicated

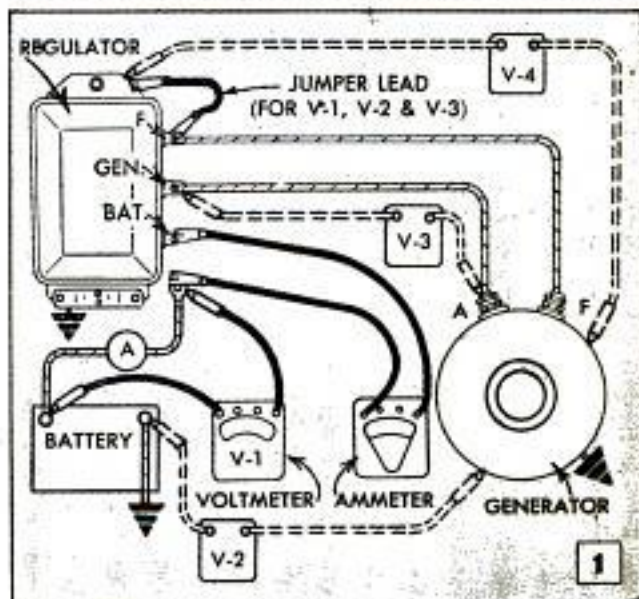

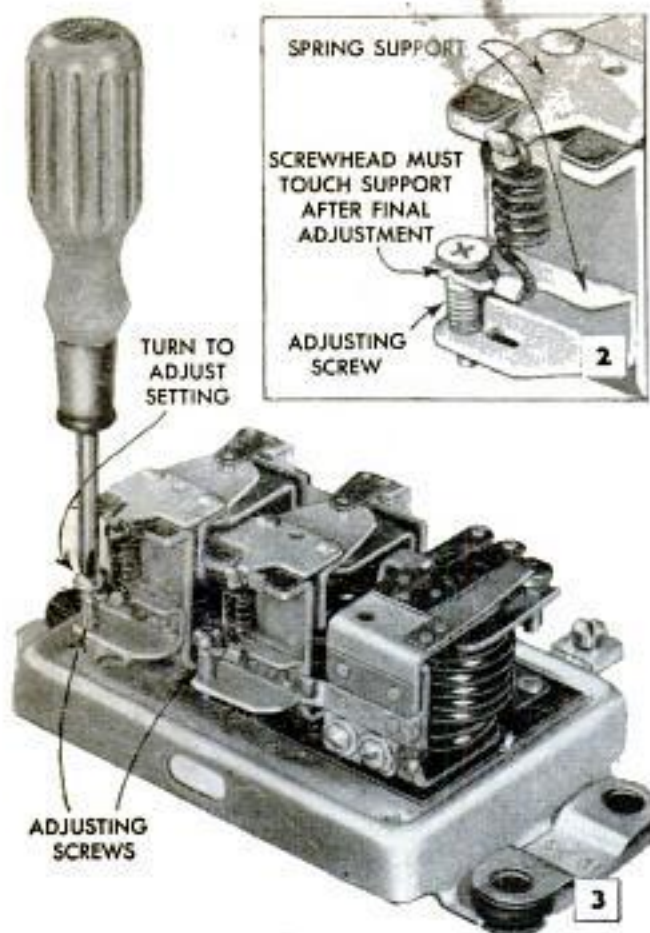

Two views above show how to adjust voltage regulator to keep battery charged under special conditions

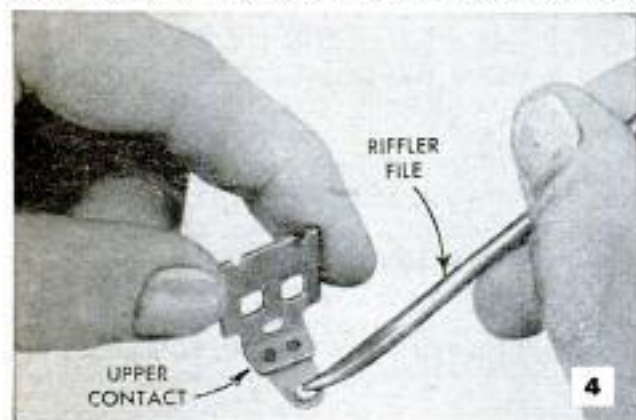

Above and below, always use a riffer file to clean the contact points of current and voltage-regulator units. Never use sandpaper or other type of abrasive



a 20-amp. charging rate. Then measure voltage drop at points V-1, V-2 and V-3. Reading at V-1, plus V-2, should not exceed 0.5 volt. The reading at V-3 should not exceed 0.3 volt. Readings above these figures indicate resistance in the circuit being checked. For the second check remove the ground lead at the F-terminal of the regulator. Stop the engine and switch on the full accessory load, including the lighting. This will approximate 20 amps. Now measure the voltage drop at V-4. If this is more than 0.1 volt, resistance is indicated in this portion of the charging circuit. Usually replacement of any defective wiring and cleaning and tightening connections will lower resistance to safe levels.

When checking the specific gravity of the battery electrolyte, always correct the reading for temperature. For example, if the electrolyte is above 80 deg. F. add 4 points (.004) for each 10 deg. above 80 deg. F. Subtract 4 points for each 10 deg. below 80 deg. F. When the specific gravity of each cell tests above the recommended minimum and the variation between cells is less than .025, check terminal voltage, using the starter as the load. The voltage drop should not exceed 9.0 volts (in a 12-volt battery). When using the starting motor for this purpose, be sure to ground the primary lead of the distributor to prevent the engine from firing. Also, don't operate the starter for more than 30 seconds continuously as otherwise it may be overheated and damaged. Keep the battery clean by coating it occasionally with a thick paste of baking soda and water. Leave the coating on for a minute or so, then wash off with clear water. Before flushing with water, cover the air vents in the caps with adhesive tape. Be sure the battery is anchored firmly in the carrier.

Figs. 2 to 5 inclusive show recommended methods of adjusting the voltage regulator and cleaning the contact points, should this be necessary. Voltage regulators usually are factory-set to limit current and voltage within a normal range. However, in extremely cold weather, or under special driving conditions, the normal range setting may not pass sufficient current to keep the battery fully charged. The correct setting of the regulator will keep the battery fully charged without excessive use of water. If the battery requires more than 1 oz. of water per cell per 1000 miles, the regulator setting may be too high. If you do the job of "tailoring" the regulator setting to suit your own driving requirements, two points of procedure are important. Before adjusting the regulator, bring it to operating temperature and after disconnecting and reconnecting regulator-generator leads for any purpose, be sure to polarize the

generator before starting the engine. This is done by momentarily connecting a jumper lead between the generator and battery terminals of the regulator.

Whenever the ignition system is serviced the distributor parts should have a quick check, especially the three pictured in Figs. 6, 7 and 8. There are various ways of checking the opening of the points, but the most accurate setting is obtained by using a dial indicator, Fig. 6. Be sure that the setting agrees with the manufacturer's instructions. It also is important that the tension of the breaker-arm spring be checked occasionally, using a spring scale like that pictured in Fig. 7. If the tension is over that specified for average operating conditions, rapid wear will result. If it is under the required amount, the arm may "bounce" at high speeds. Slight variations usually can be corrected with long-nose pliers, as in Fig. 8, without dismantling the unit. While you have the distributor cap off, examine it closely for any evidence of arcing. Clean the cap thoroughly and be sure the rotor is in proper operating condition. Then lubricate the unit in accordance with the manufacturer's instructions. It is necessary to make a careful check of the recommendations as these vary. Clean spark plugs and replace defective cables in the distributor-to-plug wiring harness.

In some cases, low generator output is caused by oxidized contact points in the voltage regulator. A quick check can be made as in Fig. 9 by turning on the headlights and operating the engine at a speed that will give a charging rate of about 5 amp. Then ground the F-terminal. If the generator output increases more than 2 amp. with the F-terminal grounded, oxidized points in the regulator are a possible cause. Another series of quick checks for resistance in the starting circuit is shown in Fig. 10, the three checks being made with the starting motor operating. If tests V-1, V-2 or V-3 exceed 0.2 volt, excessive resistance is indicated in that portion of the circuit being checked. ★ ★ ★



There are various methods of checking distributor-point opening, but a dial indicator is most accurate



Whenever a new breaker arm, or lever, is installed always check the spring tension with spring scale



Usually the spring tension can be altered slightly simply by bending the spring with long-nose pliers. Correct tension is important in high-speed operation

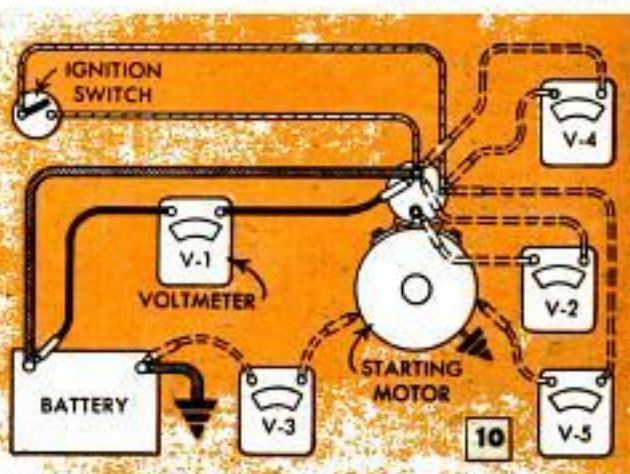
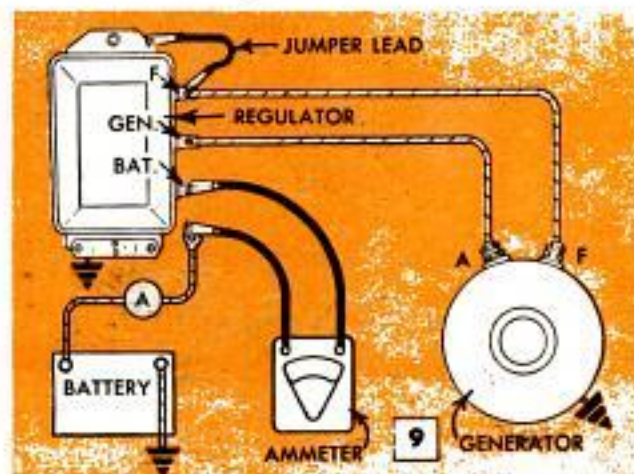



"Outrigger" Under Stepladder Prevents It From Tipping

An "outrigger" fitted across the lower ends of a stepladder will prevent it from tipping sideways. The outrigger is simply a length of 1-in. stock, long enough to project about 1 ft. or more on each side of the ladder. Two L-shaped brackets screwed to the outrigger provide grips for C-clamps which attach it to the ladder.

Postage-Stamp Holder



A convenient holder for rolled postage stamps is made easily from a can in which 27-ft. lengths of 35-mm. film are packed. Cut a slot $\frac{1}{16}$ in. wide from top to bottom in the side of the can

and feed the stamps through as shown. Replace the lid on the can and the holder is ready for use.

Small Magnet Holds Loose Papers Against Auto Instrument Panel

When you have several sheets of notes or other loose papers to carry with you in the car, you can hold them by placing them on the instrument panel and putting a small magnet over them. A number of

small sheets may be held in this manner. They are readily available and will not blow about in the wind.

Howard E. Moody, Upper Jay, N. Y.

Wedge Board in Sidewalk Form Eliminates Nails and Stakes

Instead of nailing or staking the movable endboard of a concrete-sidewalk form, use a wedge board that can be removed quickly when the concrete has set. A strip of 1 x 4, slightly longer than the 2 x 4 form

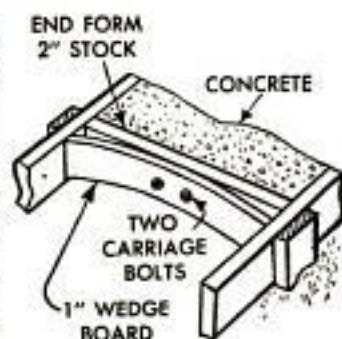

board is bolted to the center of the form board. The smooth heads of the bolts are located on the concrete side of the form board. Pressure of the wet concrete will force the form board back, tending to straighten the wedge board which is forced more tightly against the side forms. Stakes must be located on the outside of the side forms at the points where the wedge board is forced against them. The stakes prevent the side forms from bowing outward under the pressure of the wedge board.

Cut Lengths of Wire Duplicated By Stop Gauge on Pliers

Bent from a strip of sheet metal, a simple gauge speeds the job of cutting a number of identical lengths of wire with side-cutting pliers. One end of the metal strip is bent to a U-shape to fit snugly over one jaw of the pliers. The U-shape is offset so the extended portion of the strip aligns with the cutting edge of the jaw. The opposite end of the strip is bent up at right angles to provide a stop.



Musty odors in a basement or cellar can be eliminated by using chloride of lime on the floor. The powdered lime, which is obtainable at most drugstores, is sprinkled on the floor, allowed to remain until the odors are gone, swept up and discarded.

MAKE YOUR OWN ALUMINUM STORM SASH

SEE THESE WINDOWS BUILT
ON THE NBC-TV SHOW
DO-IT-YOURSELF,
SEPT. 18 AT 5:30 p. m.
CENTRAL STANDARD TIME

By Edward Mickley

IMAGINE making storm sash for all the windows of your home in a week end. It's been made that easy with the introduction of a special aluminum molding that fits over the edges of the glass and locks securely at the corners to produce a lightweight, durable storm sash.

Full-length or divided frames: If your windows are 9 sq. ft. or less, you may install a one-piece full-length sash. If they are over 9 sq. ft., it is best to fit them with two separate (divided) sash. In the latter case, the top section may be left permanently installed the year around and the bottom section replaced with an aluminum half screen during the summer.

Making the frame: First measure the width and height of the window opening. The completed frame should fit against the face

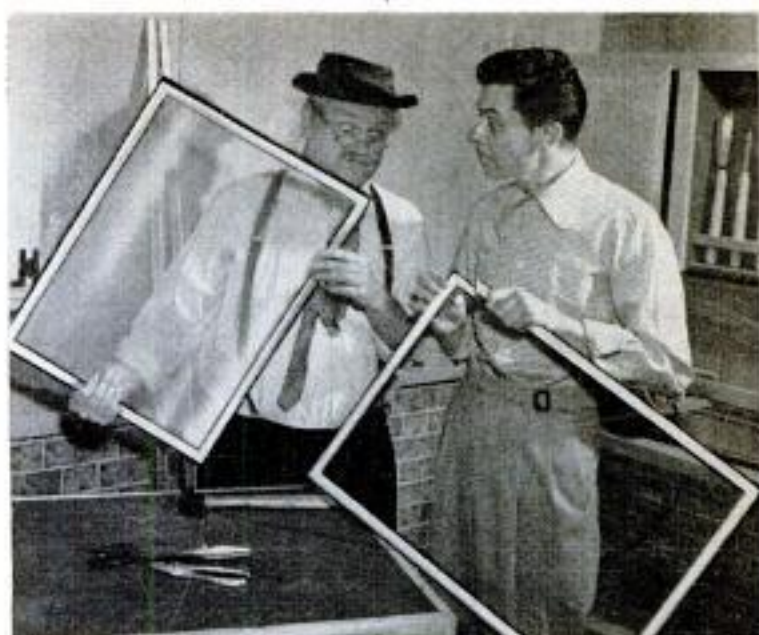

Dave Willock, right, shows Cliff Arquette how corners of frame are held securely with special aluminum corner-lock inserts

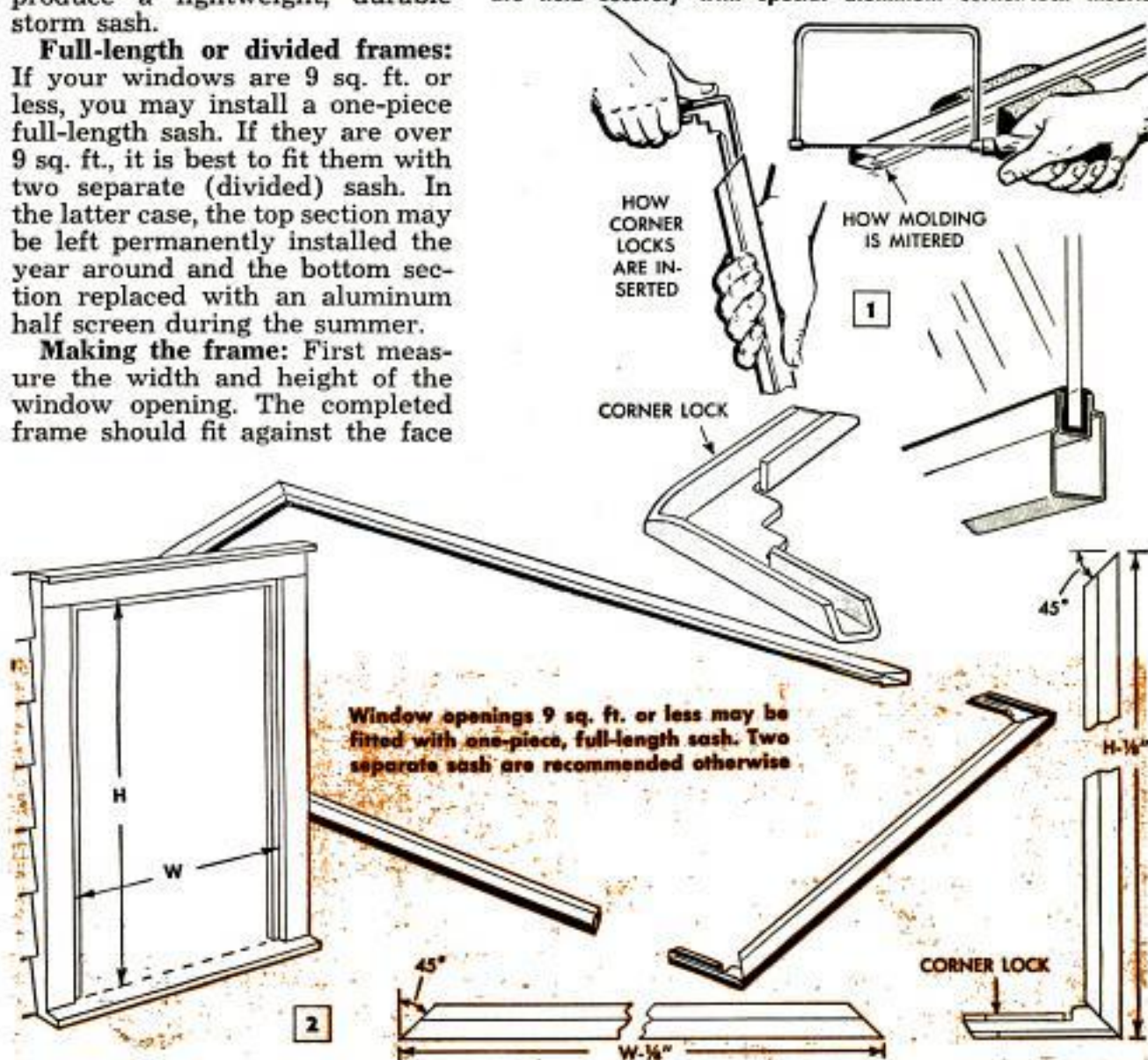

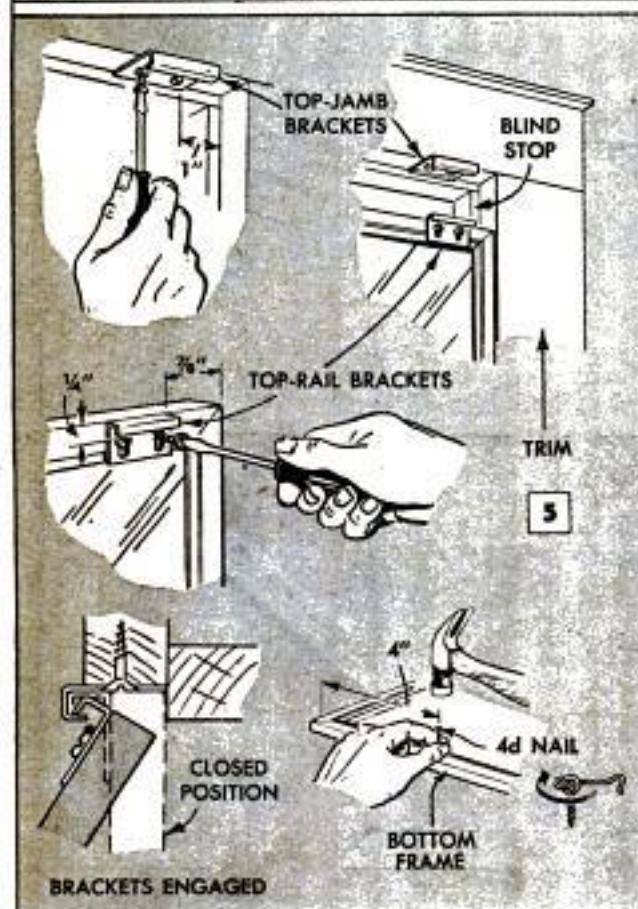
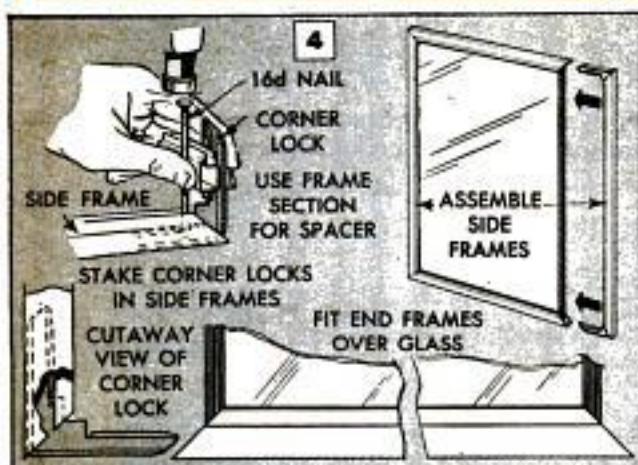
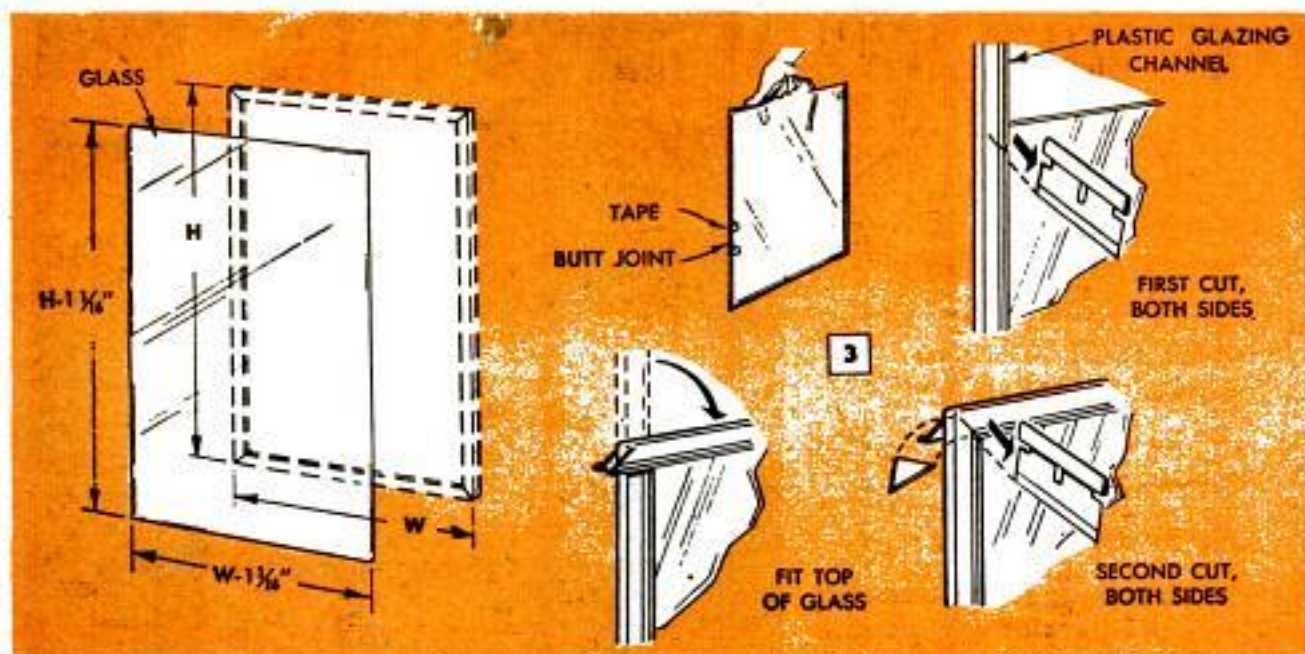

of the blind stop of the window casing, Fig. 2. When measuring for divided frames, you may divide the height equally or you may fit the sash so the dividing line comes even with the bottom edge of the upper sash.

Plastic glazing channels that seal the glass in the frame are furnished with the molding. These are pulled out of the molding and laid aside until later. After each piece of molding is marked for length, the ends are mitered. This is done with either a fine-tooth hacksaw or a coping saw as in Fig. 1. The ends are filed smooth.

Inserting the glass: Single-strength glass is okay for windows up to 6 sq. ft. but double-strength glass should be used for windows of greater area. The plastic glazing channel fits either glass thickness. In the case of a full-length frame, the glass should measure $1\frac{1}{16}$ in. less all around than the outside measurement of the frame.

In both full-length and divided sash, the frame should have a $\frac{1}{8}$ -in. clearance all around when installed. Basement sash screw directly to the edge of the window frame and, therefore, must be made to overlap the latter $\frac{3}{8}$ in. all around as in Fig. 6. Notice felt seal cemented to sash.

Assembling the frame: With the glass cut to size, start stretching the glazing channel over the edges, first mitering the end. Start at one corner and hold the chan-

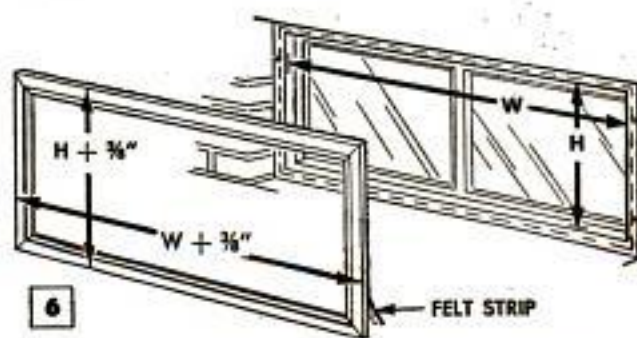

nel in position with tabs of cellulose tape placed about 1 in. down from the corner. The glazing channel is mitered as it rounds each corner of the glass, as shown in Fig. 3.

Now place the top and bottom frame members over the glazing channel, centering them so they will match properly with the mitered ends of the side molding. Each end of the side members is fitted with a special aluminum corner lock which is inserted as in Fig. 1 and anchored in place by piercing the metal with a nail as in Fig. 4. A scrap piece of molding held as shown will spot the nail at the right place. Finally, the side members are placed over the glazing channel, pressing the corner locks in the ends of the other members at the same time.

Hanging storm sash: Special metal hangers are available for hanging aluminum sash and Figs. 5 and 7 show how they are attached to both storm sash and window frame. Fig. 7 pertains to divided sash. Steps A, B and C in Fig. 8 show the method of attaching an aluminum channel to the lower edge of the upper sash to receive the lower sash and produce an airtight joint. It is perhaps best to add this channel before the glass is in place. ★ ★ ★

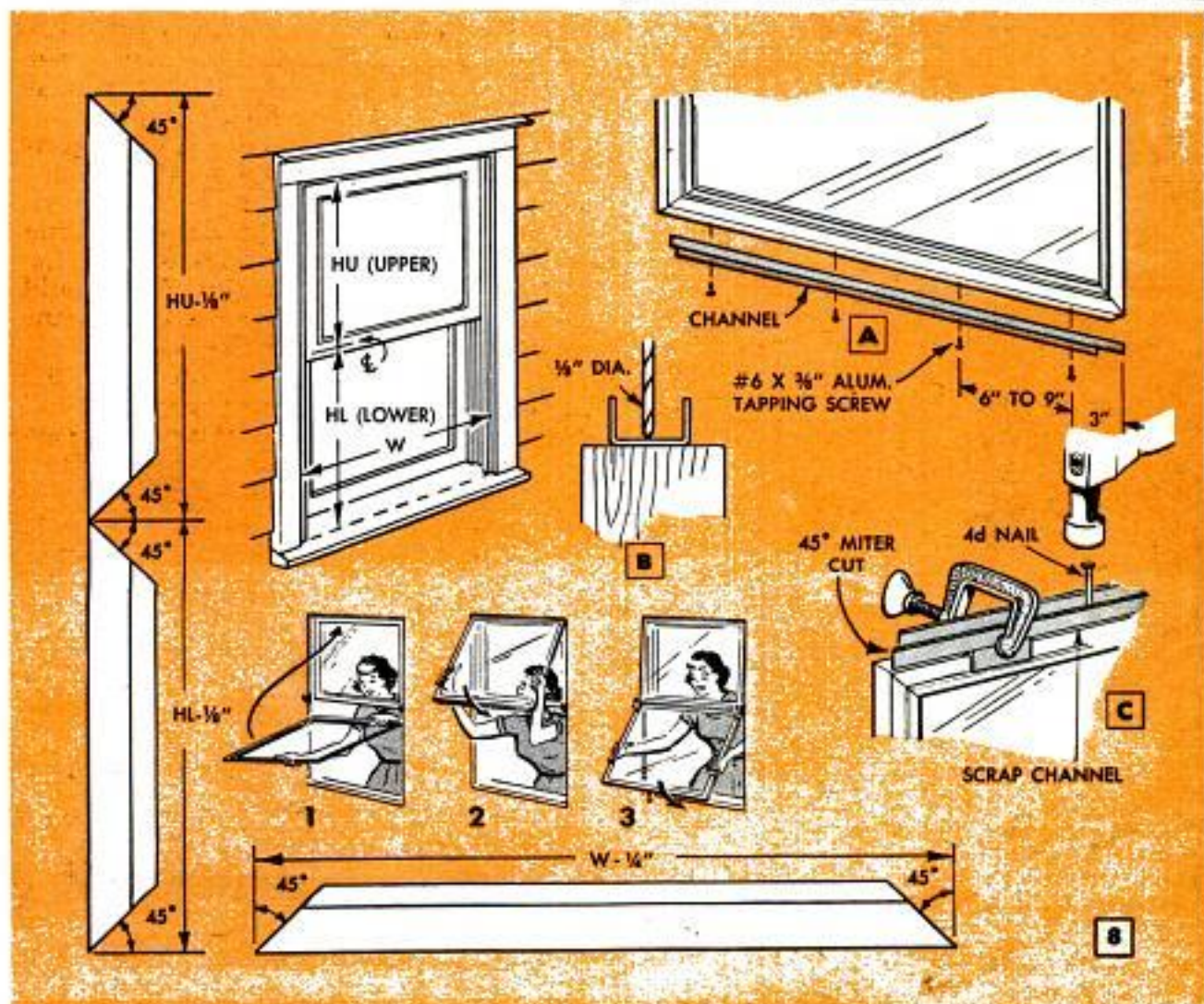
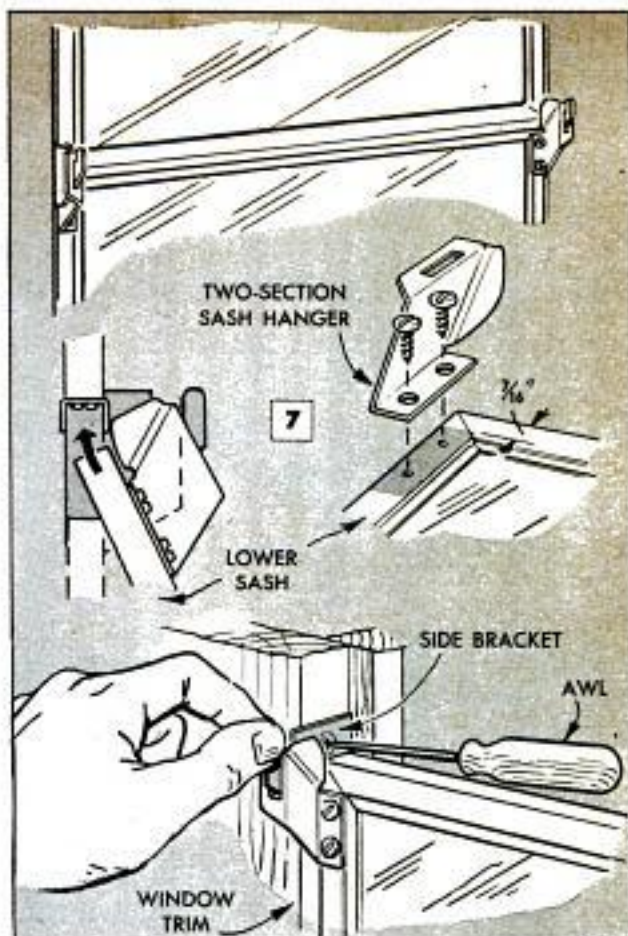

Strap Hinge Bent to Form Flexible Ladder Hook for Paint Pail



A hinged S-hook for hanging paint pails on ladders with either round rungs or flat steps can be made from an ordinary 4½ or 5-in. strap hinge. For round rungs, hooks are bent on the ends of the leaves as shown in the detail. When used on flat-

step rungs, one leaf of the hinge is bent to fit the step, with the hinge pin projecting beyond the edge of the step so the hinge leaf can swing freely.

Simple Flashlight Improvised From Dry Cell and Bulb

A quickly improvised flashlight can be made from a flashlight dry cell, a strip of tin and a one-cell flashlight bulb. Cut the tin strip to a point at one end and punch a hole near the opposite end into which the bulb can be



screwed. Bend the strip at right angles in the center and force the pointed end between the dry-cell case and the cardboard sleeve. Bending the tin strip so the bulb touches the dry-cell contact as shown, lights the bulb.

Beautiful, Useful Furniture YOU Can Build With FULL-SIZE PATTERNS

You can make sturdy, good-looking furniture, toys, valances, metal lamps—even a 12-foot utility outboard with *PM* Full-Size Patterns. They were all drawn by a professional designer and built in our shop to test correct fit of parts and construction details.

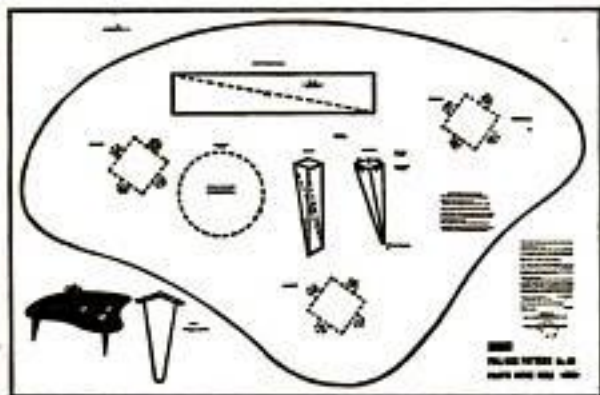

No. 116. Palette Coffee Table

Above is an actual photograph of Pattern No. 116, a Palette Coffee Table, which is 31½ x 47½ inches at its widest points. It can be made in one evening, if you have a bandsaw for making the curved cuts. The pattern includes complete construction and finishing details and costs 50c.

Modern Cocktail Table, No. 103. This table is 40 x 19 inches; 15½ inches high. With its metal grill inserts and plank top, it's modern in design and solid as a rock. One pattern—costs only 50 cents.



Love Seat, No. 114. Designed in the Lawson style, this love seat goes with either modern or traditional settings. Uses sagless type wire springs and foam rubber padding. Two patterns in the set: \$1.00.



Trundle Beds, No. 102. These beds save space and are safer for youngsters as there is no ladder to climb; have storage headboards; and use standard size mattresses. 3 patterns: \$1.50.



Order today! And ask about the other 14 patterns, all guaranteed to be good—or your money back!

POPULAR MECHANICS PATTERNCRAFT

200 E. ONTARIO STREET
CHICAGO 11, ILLINOIS



MAKE YOUR OWN ROUTER

By M. C. Anderson and J. W. Wilson

A SMALL ROUTER will handle some woodworking jobs no other power tool will do. It's also one of the simplest power tools to build in the shop, as the router bit is the only driven part. The power unit of the shop-made router pictured above is a vacuum-cleaner motor of the flange-mounted type designed for operation in a vertical position. When selecting a used motor of this type be sure that the bearings are in good condition. The

shaft diameter should be $\frac{3}{16}$ in. to take a standard chuck. *Deep - Best number*

Remove the motor brushes, keeping them in order so that they can be replaced in the same position as they were originally. Remove the armature and field coils. Cut away the flange at one end of the motor frame, using a hacksaw to cut off the waste and finishing with a file. If a metal-turning lathe is available, then the flange is easily turned down flush in the lathe. Slot the

187-0029

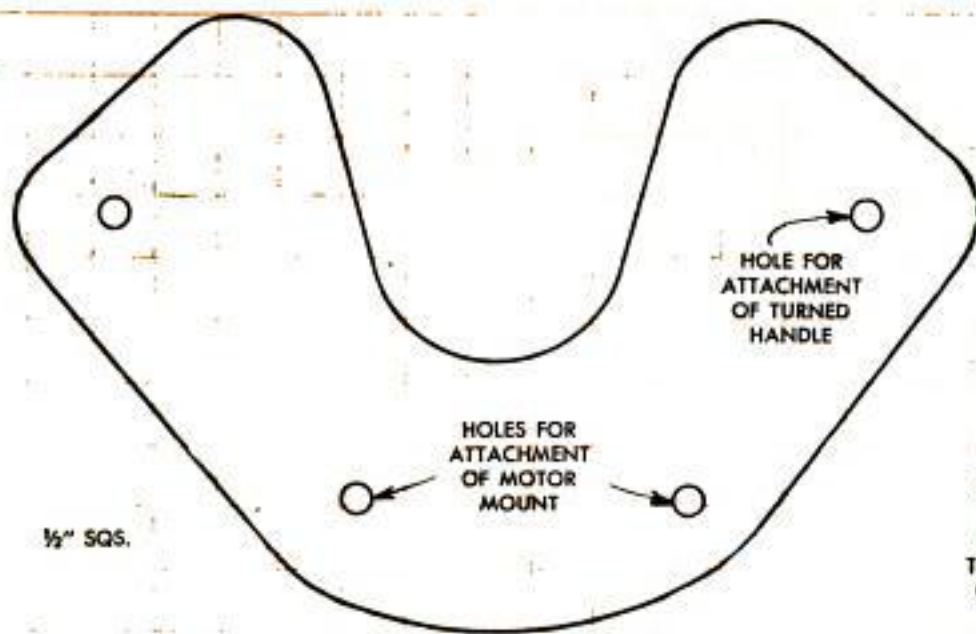

NOTE—SIZE AND SHAPE OF BASE PLATE MAY HAVE TO BE ALTERED TO SUIT VARIOUS TYPES OF VACUUM-CLEANER MOTORS



Motor housing is slotted to take two $\frac{1}{4}$ -in. bolts which permit vertical adjustment on mounting block

motor frame as shown in the upper left-hand photo on this page. The slot takes two $\frac{1}{4}$ -in. bolts, as pictured, which hold the motor in a vertical position on the mounting block and permit a vertical adjustment for depth of cut, as shown in the right-hand photo above.

The mounting block is made from hardwood and is attached to the base plate with bolts as in the details below. The base plate is sufficient for free-hand routing of recesses and also for straight work where the plate can be worked against a guide strip. For more exacting jobs the base plate is replaced by the edge guide detailed below. This unit works against either straight or curved edges. All parts should be made



Mounting block is of hardwood shaped to fit curve of motor housing. Block is bolted to the base plate

accurately of hardwood, smoothly finished.

When reassembling the motor, place the bolts in the slot in the frame before replacing the field coils. On some motors the slot can be cut without removing the coils. Be sure that the motor end plate fits true in the housing before tightening the bolts.

The chuck sleeve should fit snugly on the motor shaft. Remove any rust from the shaft by holding a piece of fine abrasive cloth in contact with it while the motor is running. Cut off a portion of the shaft, if necessary, so that the chuck fits as closely to the bearing as possible to reduce overhang and prevent vibration in heavy cuts. Follow the motor manufacturer's instructions for oiling the motor. ★ ★ ★

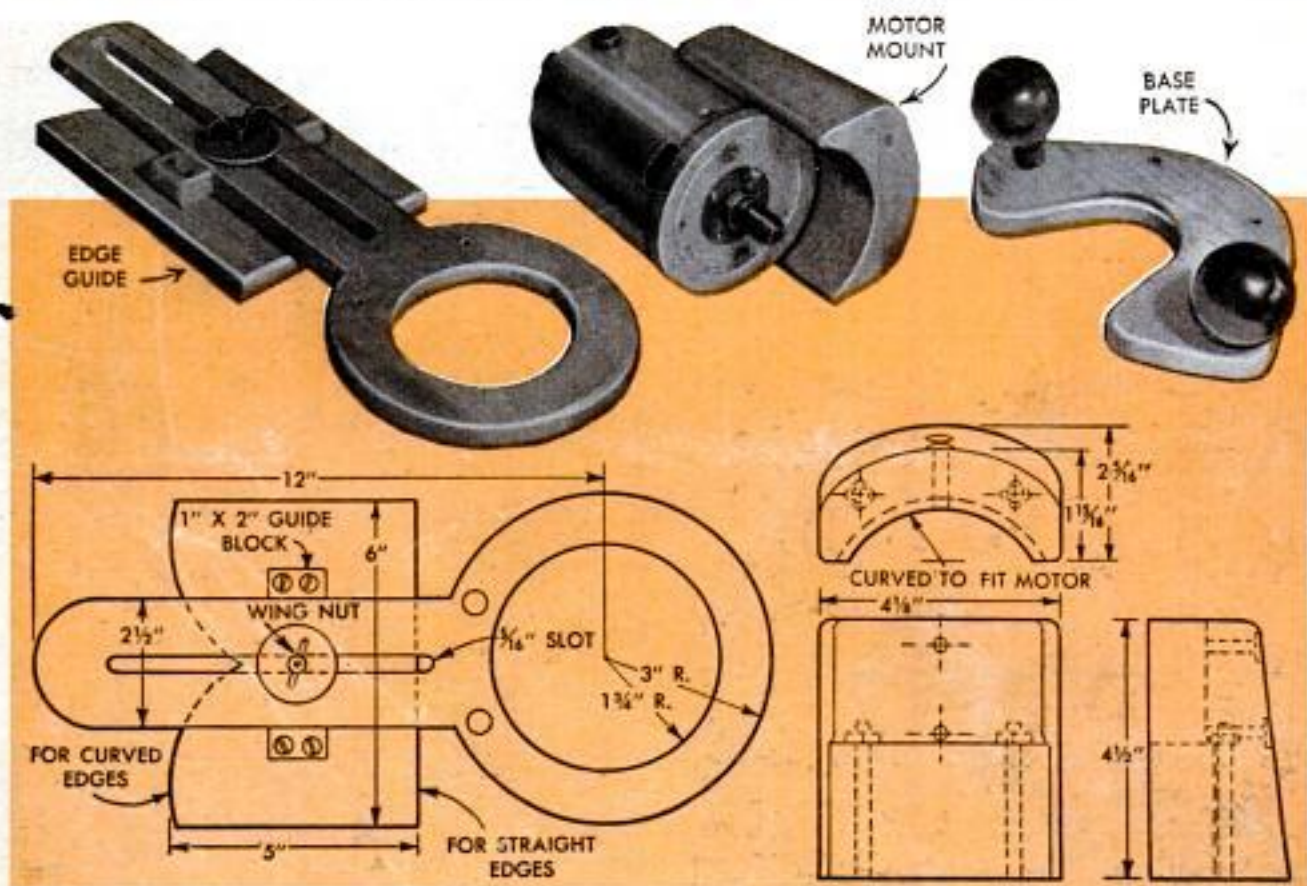

Setting Carburetor Float Level With Cylindrical Gauge



Accurate setting of a carburetor float level is more certain with a cylindrical gauge than with the usual flat type. The cylindrical gauge gives a constant measurement on

any diameter, avoiding inaccuracies which may result when a flat gauge is tipped slightly. Cylindrical gauges are made by turning short lengths of steel round to accurate diameters.

Charles Erwin Cohn, Chicago.

Remove All Wax and Polish Before Refinishing Floor

Unless all wax and oil polishes are removed from floors before they are revarnished, the new coat of varnish will not dry satisfactorily. The floor should be washed with turpentine and, while it is still wet, wiped dry with clean cloths. To make certain that all traces of polish are removed, the operation should be repeated.

Angled Feeler Gauges Speed Overhead-Valve Adjustment

Straight feeler gauges can be bent at an angle of about 30 deg. to permit more convenient use when setting tappets on an overhead-valve engine. Holder and blades are bent together. Fit a piece of sheet metal between the holder and blades on each side of the blades to protect them. Clamp the assembly in a vise with smooth or covered jaws and bend about $\frac{5}{8}$ in. from the end opposite the holder pin. Some of the blades may require a slight rebending to match the holder after removing from vise.

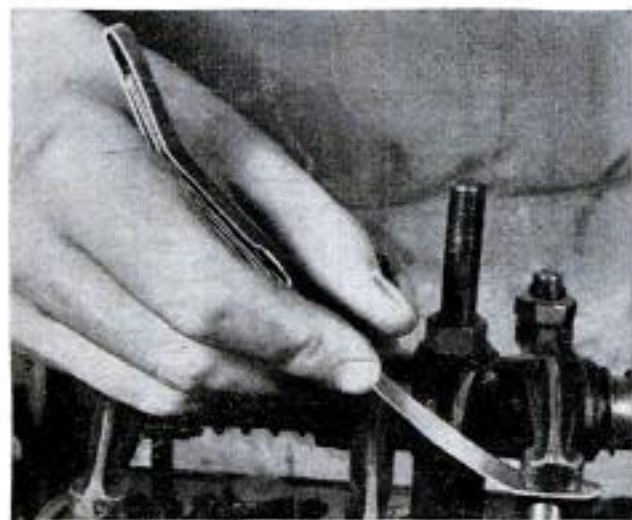

Drag Chain on Feed-Bunk Floor Aids Feeding Silage to Cattle

Feeding silage to 35 head of cattle, which once required 35 min., is now done in $2\frac{1}{2}$ min. by one farmer with the aid of a drag chain installed on the feed-bunk floor. Silage is forked from the silo, which is adjacent to the bunk, then rolled onto the drag as it runs by at 20 f.p.m. When the drag reaches the opposite end of the bunk it is shut off and the cows eat the feed in front of their stanchions. The drag chain is fitted with angle-steel flights 20 in. long, riveted to the chain at 20-in. intervals. The chain runs over sprockets at each end of the feed bunk and returns under the floor. A $\frac{3}{4}$ -hp. electric motor powers the unit.

George Laycock, Batavia, Ohio.

Removing Key Stuck in Keyway

A key that has become wedged in the keyway can be driven out by using a cape chisel and small steel blocks. The chisel is driven between the bearing housing and the key until the width of the chisel no longer is sufficient to bear against the key.

A steel block then is taped to the shaft as shown. Several blocks may be required, depending on the size of the chisel and the length of the keyway.



SN 57

CHECK UP ON

Saw Alignment

By
Sam Brown

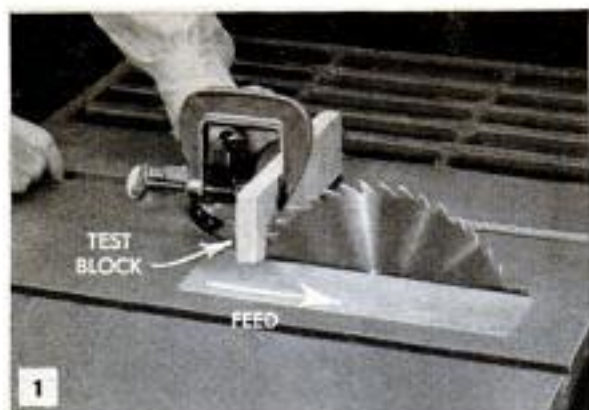

That the saw blade be parallel with the table is the basic rule in saw alignment. This can be determined by the reverse-cut method pictured below. Saw cuts line up when adjustment is okay

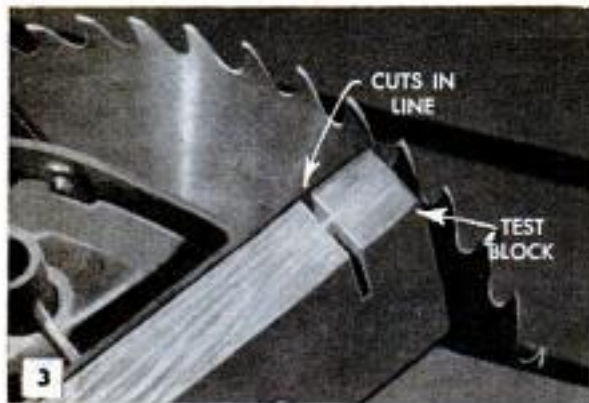

Sawing a test block in two also will check blade-table alignment. With power off, blade is rotated by hand until "high" tooth rubs against block. Back of blade is checked to note variation

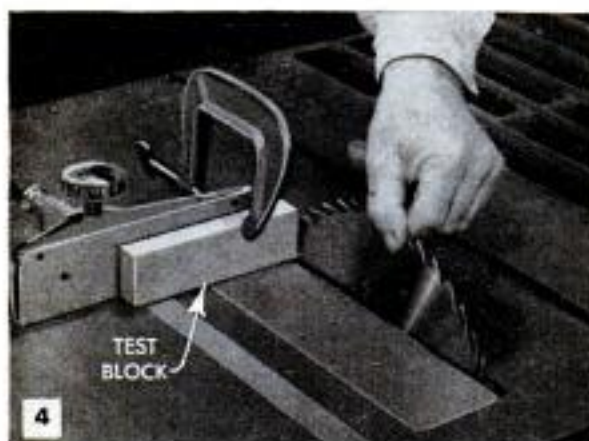

IF THE OLD faithful circular saw does not turn out the work the way it used to—if the work is out of square or tends to creep away or bind against the fence—it is time to check the alignment of the saw and make any necessary adjustments.

Table adjustment: The fact that the table must be parallel with the saw blade is the basic rule of saw alignment. With a tilt-table saw, a table error is likely to be in either direction. However, with a tilting-arbor saw, the shift of the blade usually is in a clockwise direction, due to motor drag, Fig. 5.

Table alignment may be tested by clamping a block of wood to the miter gauge, setting the blade at maximum height, and cutting halfway through the block with regular forward feed, Fig. 1. Then a similar cut is made with backward feed, Fig. 2. As this will tend to hog the work, hold the work firmly and feed slowly. When the block is turned over, Fig. 3, the saw cuts will line up if the table and blade are parallel.

For an alternate test, saw the block in two. Then, with the block still clamped to the miter gauge, rotate the blade by hand until the "high" area, or tooth, rubs against the block as in Fig. 4. Next, move the block to the back of the blade, rotate the blade backward and check the distance between the block and the same "high" tooth.

If either test discloses an open-back error

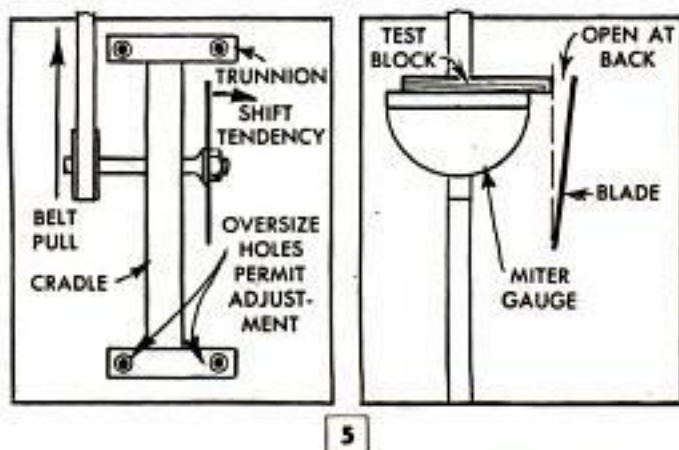



TEST CUTS SHOW FENCE OUT OF ADJUSTMENT

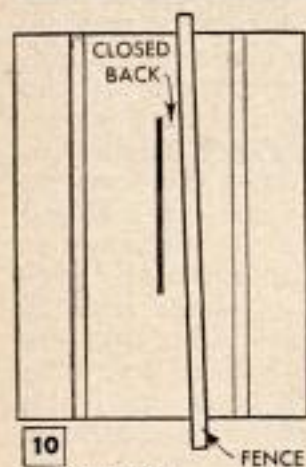

10 PREFERABLE ERROR IN FENCE POSITION

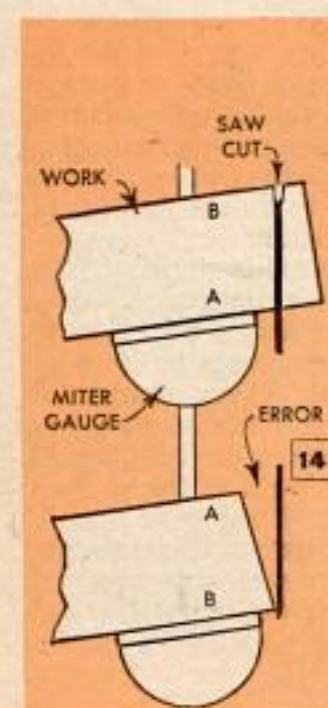
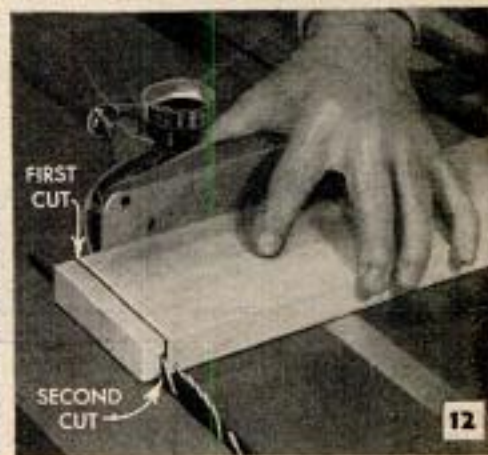

Miter gauge should permit an accurate 90-deg. cut. Cuts made halfway through test stock indicate error as above. Parallel cuts show that gauge is properly set. Miter gauge is reset by backing off screws holding index pin, right



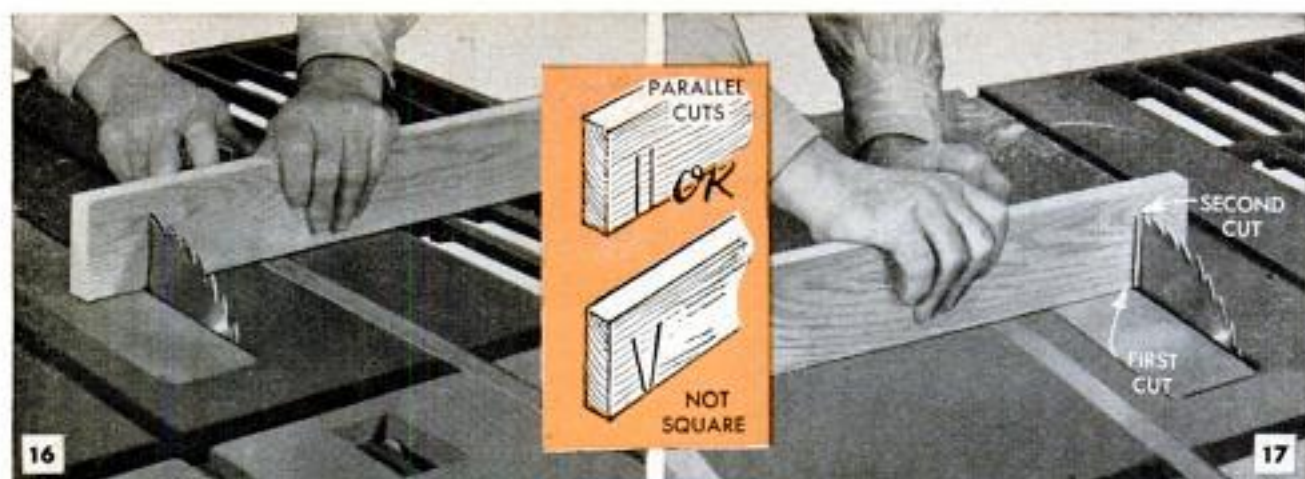

Vertical squareness is checked by the reverse-cut method as shown in the photos and detail above. If blade is not vertical, back off stop screw which controls blade or table tilt, adjust and then reset

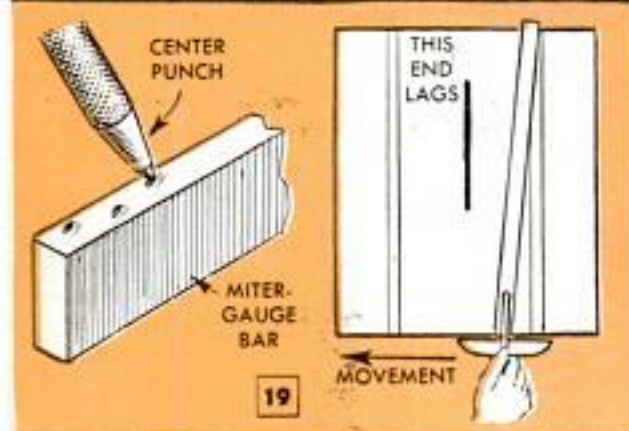
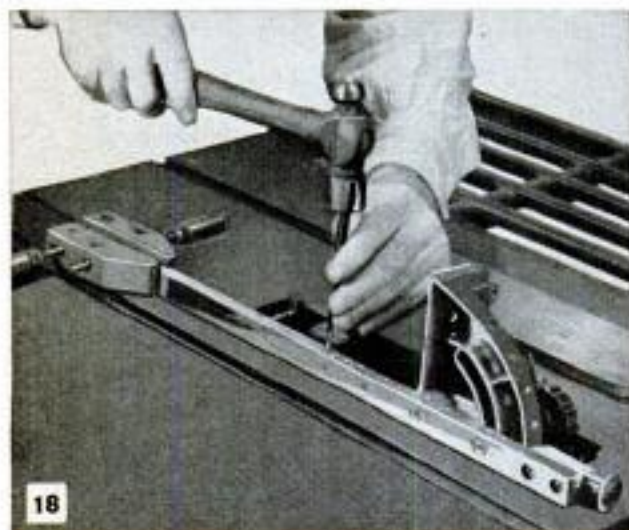

greater than $\frac{1}{64}$ in., or a closed-back error, adjustment is required. This is done by backing off the screws holding the trunnions, Fig. 5. Some saws have setover screws which then are turned as needed.

Fence alignment: After blade-table alignment is satisfactory, adjustment of the fence is simply a matter of setting it parallel with the table slot, Fig. 9. To do this, loosen the screws that hold the fence to the guide. The preferable error is a closed back, Fig. 10. Note that a slight amount of open back, as in Fig. 5, automatically provides the same amount of closed back in connection with the fence. Checking the fence setting can be done with reverse cuts, Figs. 6 and 7, which will be in line if the fence is parallel with the blade. Fig. 8 shows an obvious case of misalignment. If the fence is set parallel with a blade that is out of alignment, Fig. 23, the saw will rip satisfactorily but will not crosscut.

Adjusting miter gauge: The miter gauge is checked at the 90-deg. position with a test block having parallel edges. With the saw set at half work depth, cut one face of the block, Fig. 11. Then turn the work over and cut the other face, Fig. 12. As in Fig. 13, parallel cuts show a perfect setting, while a wedge shape indicates that the gauge is not set accurately. Another miter-gauge test made with a piece of stock having parallel edges is shown in Fig. 14. After crosscutting, turn the work over and note if the cut end remains parallel with the blade. To adjust the miter gauge, loosen the screws holding the index pin, Fig. 15, or back off whatever device is used to set the "square" position. Then, using the clamping screw only, adjust the gauge as needed. When a satisfactory cut is obtained, set the index pin and tighten the screws.

Vertical squareness: Whether or not the saw blade is perpendicular to the table can be checked by the reverse-cut method, Figs. 16 and 17. If the blade is not vertical, back off the stop screw which controls the table or blade tilt, adjust for a vertical cut and reset the screw. Repeat with the

blade or table set in the 45-deg. position.

Mechanical faults: Slight errors sometimes are caused by a loose miter-gauge bar. This can be corrected, at least temporarily, by making a number of punch marks on the side of the bar, Figs. 18 and 19, to raise the metal slightly. A pronounced error often is caused by shifting the fence with pressure applied at the extreme end, Fig. 19. The right way to shift the fence is by grasping it as in Fig. 20.

Six cases of misalignment: The six common cases of misalignment are shown in Figs. 21, 22 and 23. The identifying feature in all cases is whether the blade is "open" or "closed" in relation to the miter gauge and fence. If your saw has the usual error which is an open back when tested with the miter gauge, Fig. 22, right-hand detail, the resulting crosscut will be as shown in Fig. 24. If the fault is serious, making the cut will be impossible due to binding action. However, if the blade has a considerable amount of set or if the fault is slight, the cut may be satisfactory. Figs. 24 and 25 show what happens.

The open-back error has about the same effect on a ripping cut as on a crosscut. However, a slight error of this type is desirable in ripping, as it pushes the work against the fence. The opposite misalignment, left-hand detail of Fig. 22, leads the work away from the fence.

To summarize correct adjustment: The table and blade should be parallel, with a slight open back permissible. If the table and blade are parallel, the fence should be toed-in slightly to obtain good tracking. If the table-blade alignment is slightly off on the open-back side, the fence will have a corresponding closed back when adjusted parallel with the table slots. ★ ★ ★

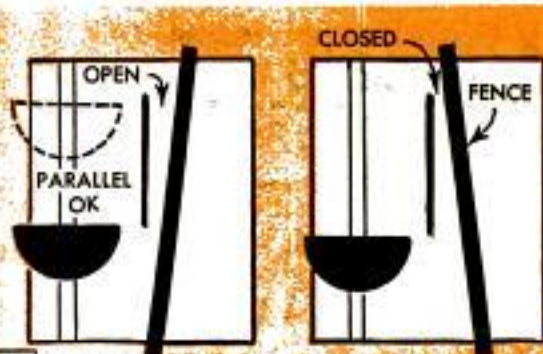

21 Fence not parallel with table is simple fault easily corrected. This error affects only ripping, not crosscutting

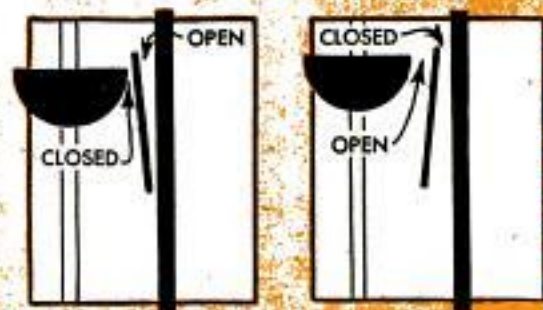

22 Blade not parallel with table is basic fault. If this error is excessive the saw neither rips nor crosscuts satisfactorily

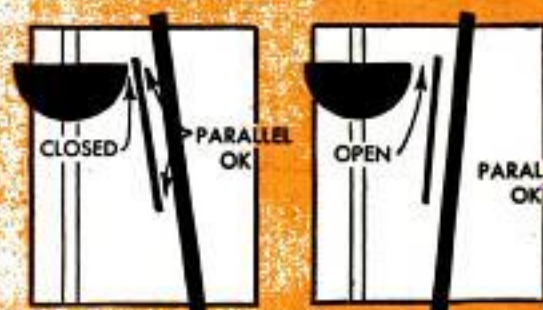

23 With blade and fence out of alignment, saw can produce suitable ripping cut. However, a clean crosscut is impossible

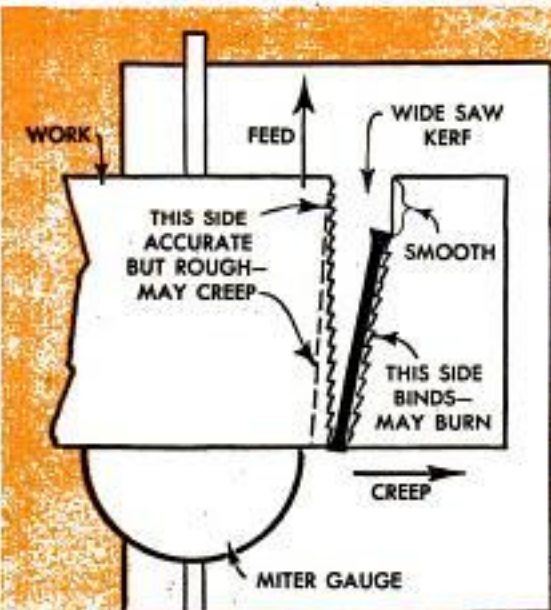

24 CROSSCUT WITH OPEN BACK

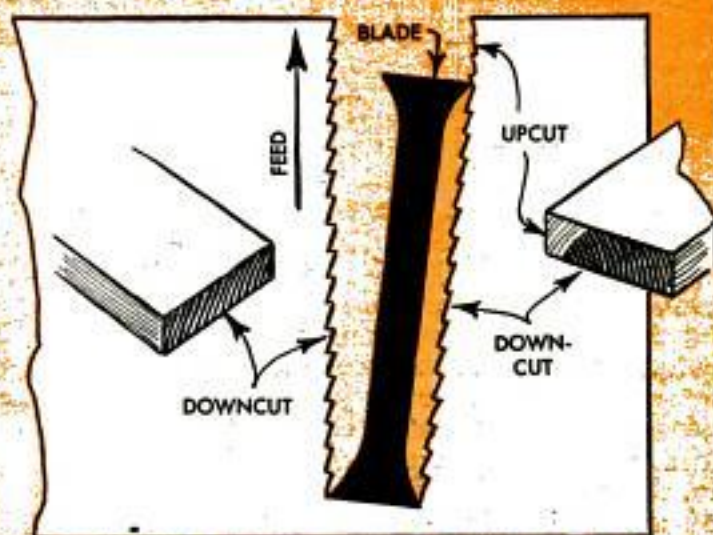

25 RIGHT SIDE WILL NOT BE SQUARE UNLESS WORK IS PUSHED ENTIRELY BEYOND BLADE

Swing Gate Keeps Hogs Clear Of Fence-Line Feed Trough



Cleaning and filling a hog trough is simplified on one farm by locating the trough on the center line of the hog-pen fence. A vertical-swinging wooden gate replaces a fence section above the trough. A slide, made as shown in the illustration, permits the gate to be locked on either side of the trough. When the trough is being cleaned or filled, the gate is swung inward and locked to keep the animals out of the way. To feed the animals, the slide is pulled up, then dropped inside the trough so the hogs cannot push it past the edge of the trough. Pipe stakes driven into the ground around the trough keep it from being pushed out of place.—Arthur A. Stevens, Canby, Ore.

Corn Planter Towed on Sled

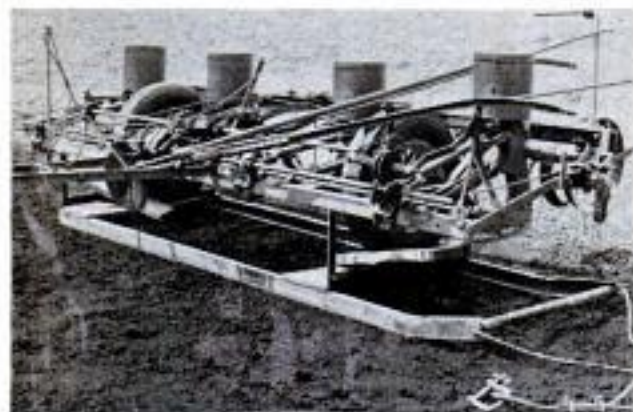

One farmer solved the problem of towing a four-row corn planter through narrow gates by building a welded-steel sled to carry the planter lengthwise. The runners of the sled are steel channels, 1½ in. x 3 in. x 10 ft. The runners are bent up 18 in. from the front end and a 3-ft. length of steel pipe is welded between them. Spaced the width of the planter's wheel tread, two 3-in. steel angles are welded between the runners at the rear of the

sled. A length of 1 x 12 plank is bolted to each angle and a wheel chock is spiked to the lumber. Two notched steel flats support the frame of the planter and keep it upright. A hole drilled near the front of each runner permits a towing cable to be passed through the pipe.

Wax Prevents File Clogging When Working Soft Metals



Candle wax will aid in preventing file teeth from clogging when working brass, aluminum or other soft metals. Clean the file thoroughly with a file card, then rub a candle stub over the full area of the teeth. After the job is done, the file can be warmed slightly to aid in brushing away the remaining wax. Use only enough heat to loosen the wax; excess heat will destroy the file temper.

Moistening Section-Box Blanks For Immediate Use in Beehive

Instead of dipping new section boxes in water before bending them to shape, one beekeeper uses a water pistol to moisten only the scored portions. The small amount of water used quickly dries out of the wood, permitting the boxes to be fitted with foundations and placed in the hive almost immediately.

Benjamin Nielsen, Aurora, Neb.

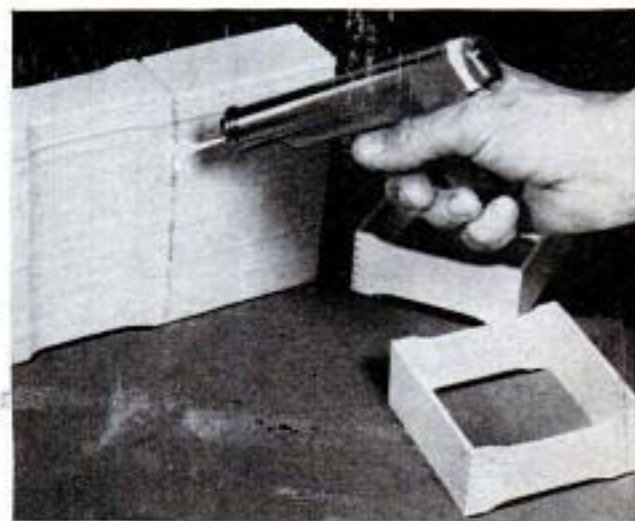

PERFECT OVALS

made with this scriber

This simple bench-made scriber was used by early woodworkers for scribing perfect ovals, or ellipses, when laying out exacting work. It consists of the parts A, B, C and D and a length of $\frac{7}{16}$ -in. dowel. All parts must be accurately made from hardwood. The parts A and B (part B is duplicated) are assembled on the dowel and adjusted to give the size ellipse desired. The swiveling guides on the parts B slide in the grooves cut in parts C and D. The setup is made as in the photo, pointed brads in part C being forced into the surface of the work. Adjust the scribing pencil. Then, with hands in position shown, swing arm right or left to scribe half the oval. Repeat the movement in the opposite direction.

Edw. Zitzman, Sr., Pacific, Mo.

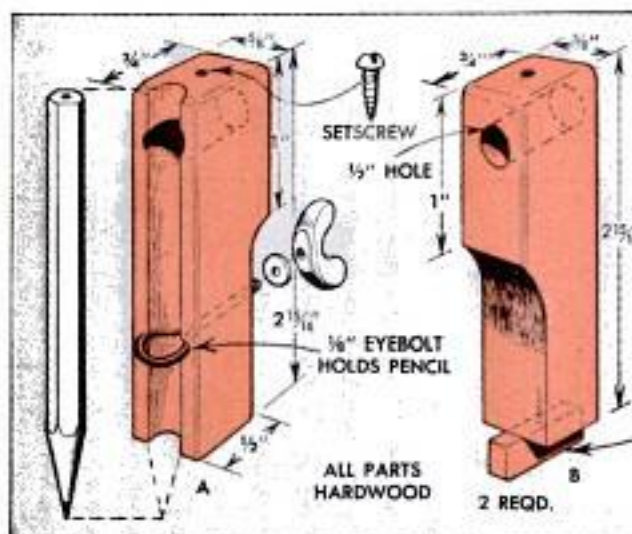
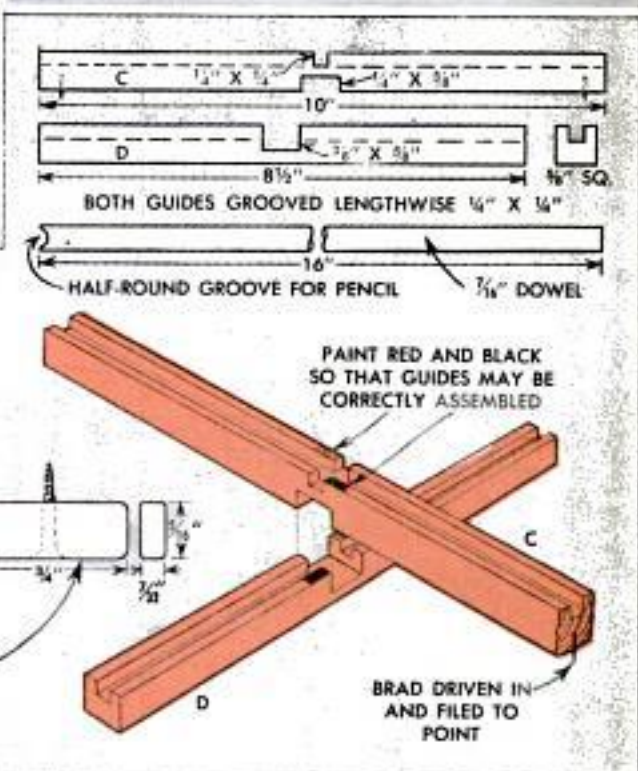
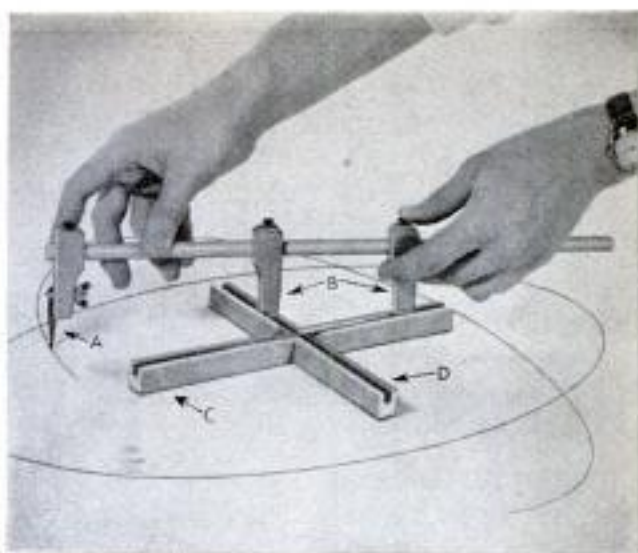

Orders Written on Blackboard Speed Farm Deliveries

Located on the side of a building adjacent to the farm driveway, this blackboard is used to leave delivery orders so drivers



SEPTEMBER 1955

can read them without leaving their trucks. The board is a timesaver for giving special chores or directions to the farm hands, and also serves as a handy "scratch pad" for figuring anything from dimensions to prices.

Garden-Hose Washers Improvised From Bottle-Cap Liners

In an emergency, when no regular washers are available, garden-hose connectors can be made watertight by using washers improvised from the cork liners of bottle caps. First, using a sharp knife, cut a disk from the center of the cork, leaving a ring about $\frac{1}{8}$ in. wide. Next, carefully pry out the ring. Because the cork is quite thin it usually will require two for each hose connection.—D. Gower, Guadalajara, Mex.

Copyrighted material 213



WTM 58

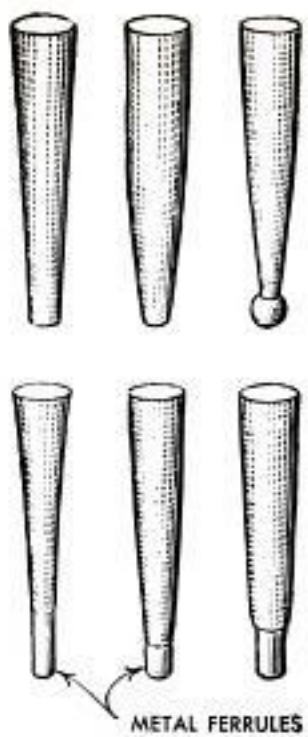

2 LEG STYLES

PLAIN TAPERED TURNINGS

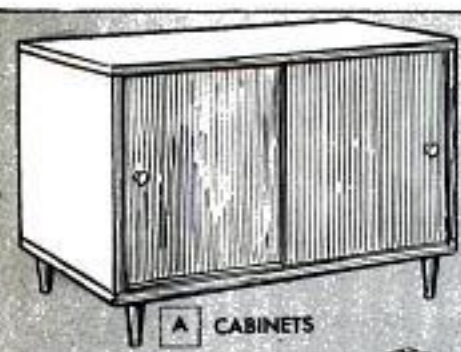

A CABINETS

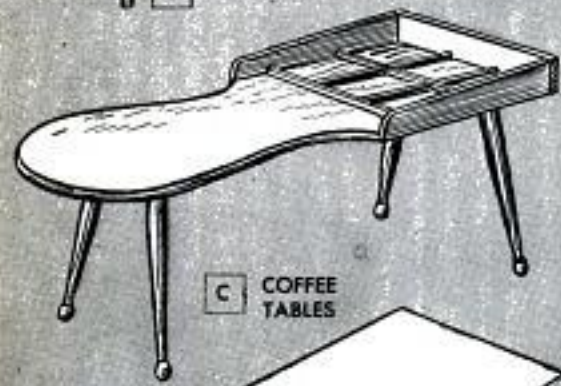

C COFFEE TABLES

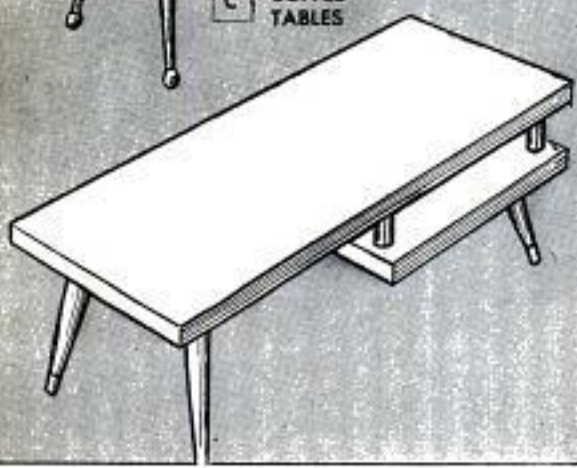

3

LEG IS
GLUED AND
SCREWED TO
FRAME

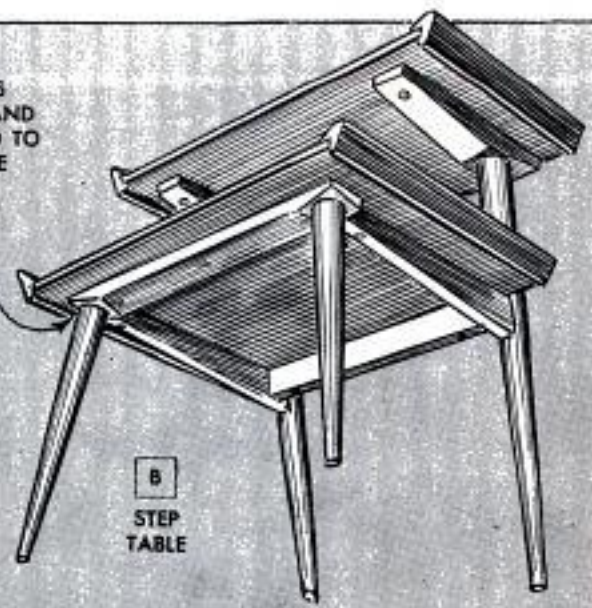

B
STEP
TABLE

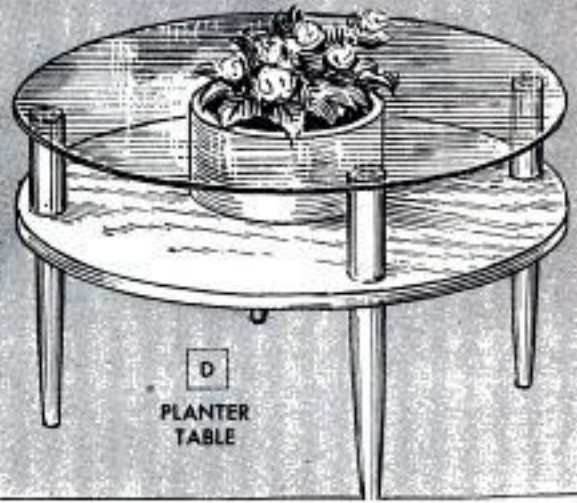

D
PLANTER
TABLE

MODERN DESIGN helps to reduce waste of material by the use of plain tapered turnings for cabinet, bench and table legs. Although there are allowable variations in styling, the plain turning has none of the intricate bead-and-cove combinations which are basic design features of earlier "spool" turnings.

The six styles detailed in Fig. 2 are those in common usage in modern furniture construction. Several applications are shown in Fig. 3, details A to D inclusive. The step table, B in Fig. 3, is pictured in Fig. 1. In any case, the hand-turning job begins with the square and you can save a lot of time and shavings if the taper is first ripped on the four sides of the square with a tapering jig as in Fig. 4. Set to the dimension required for the first two cuts on opposite sides of the square, then rip as in Fig. 5. Reset the jig to twice the first dimension and make the two final cuts. When determining the taper to be used, be sure to provide sufficient stock to allow for turning into round so that you end up with the leg size required.

Where there are no offset tenons or shoulders to cut in, turning the plain taper is a simple between-centers job in the wood lathe. Make sizing cuts at both ends with a parting tool as in Fig. 6, then rough-turn into

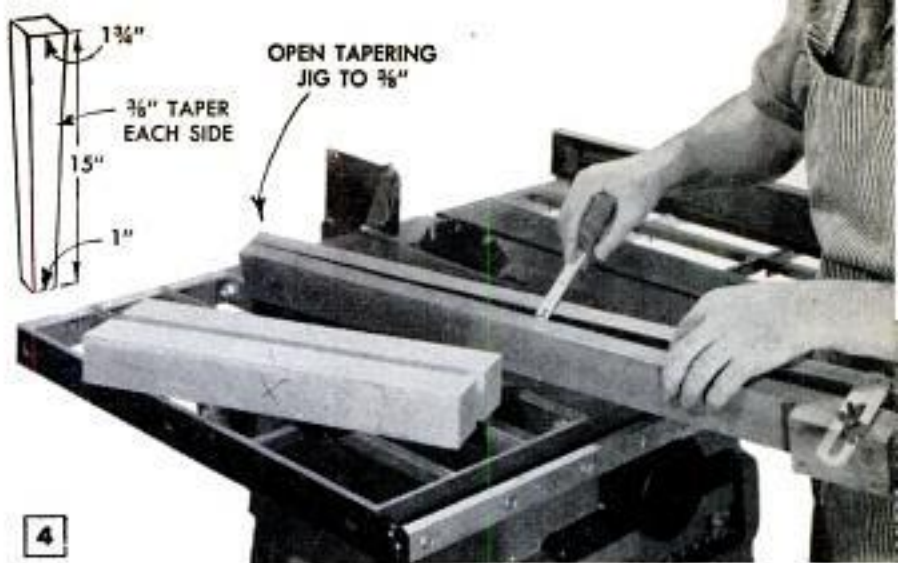

4

You can save a lot of lathe time by tapering the square from which turning is to be made. This is done as in photos above and below, using a tapering jig. When making taper cuts, be sure to allow sufficient stock for rough-turning into round. Plain, straight tapers are turned as in Figs. 6 to 9 inclusive

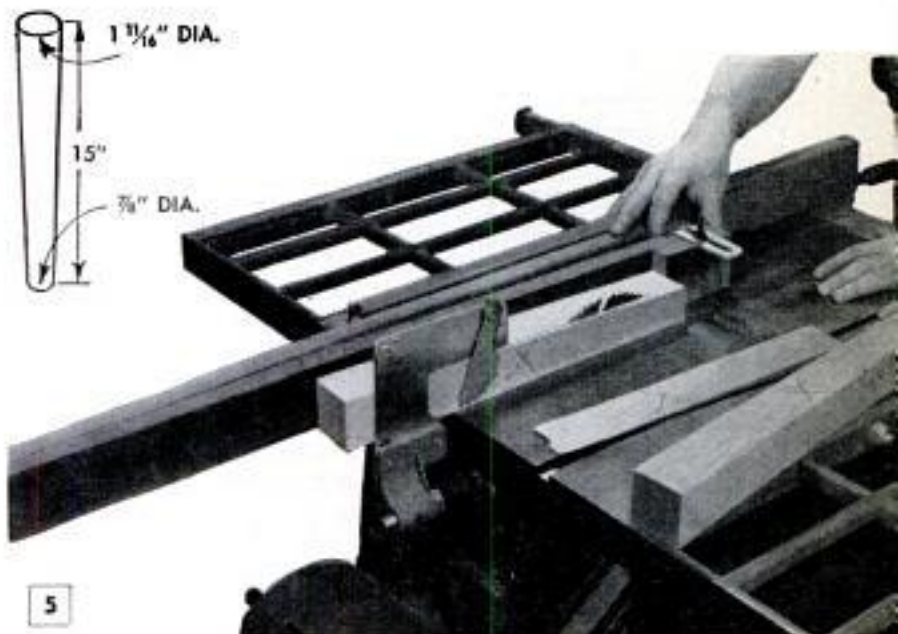

5

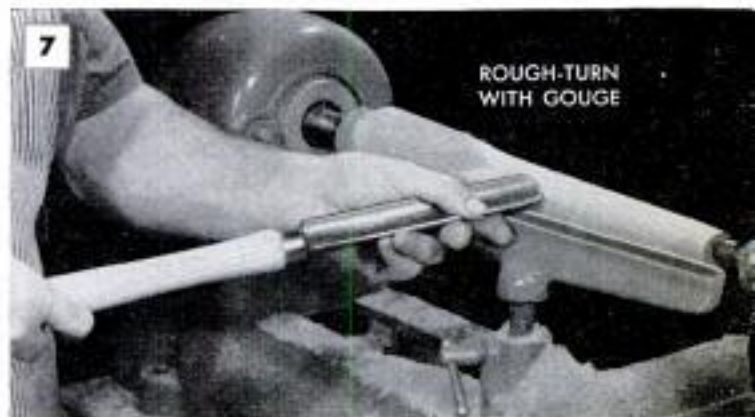
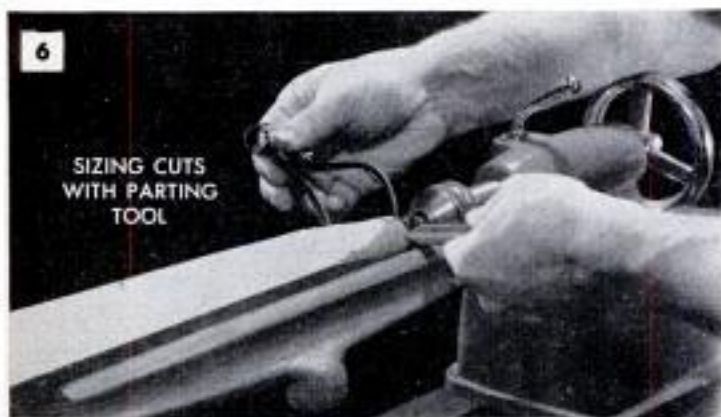

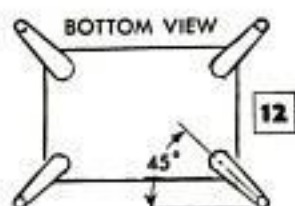
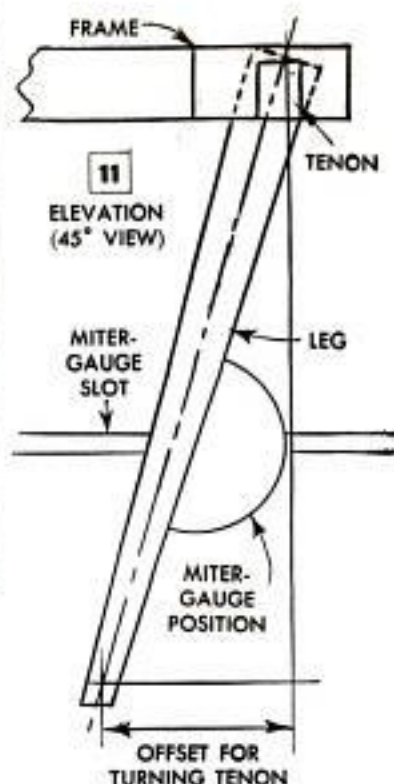
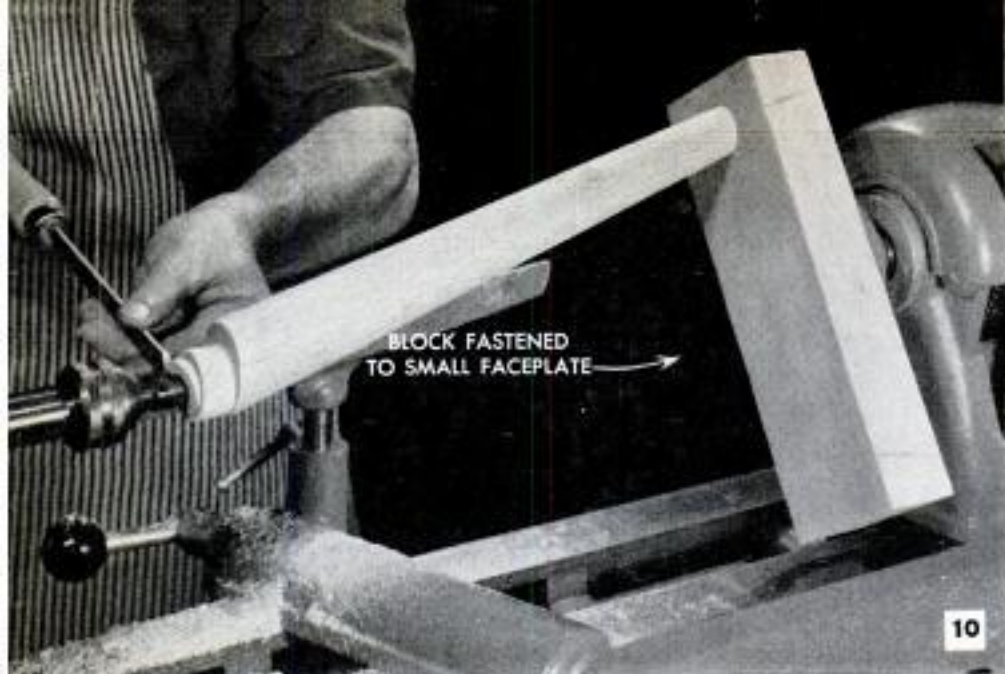

Turning a round tenon on a splayed leg is easy to work in lathe by offsetting as pictured above. By making a full-size drawing of that shown at right you can take off all measurements, also angle for trimming ends

round with the gouge as in Fig. 7. Finish with the skew chisel as in Fig. 8, and there you are. When finished work comes down to a small diameter in proportion to length, it may tend to vibrate under the turning tool when making cuts midway between the lathe centers. When this happens, some turners finish with a block plane as in Fig. 9. The plane must be razor-sharp and set to take a very light cut. In use the plane is held at an angle as pictured. This position gives a clean, shearing cut with the stroke of the plane made toward the tail center.

Where the frame, or base, of the project can be bevel-cut to take the upper end of the leg, the latter can be cut square across for fastening with a screw and glue. Or the leg can be turned with a concentric tenon. But in some cases the nature of the assembly will require the self-tenon to be turned by offsetting at an angle as in Figs. 10 and 11. To obtain accurate offset and angle it is helpful to draw a full-size elevation of the leg joint, Fig. 11. Then make the

Set miter gauge from a full-size detail made from Fig. 11. Then make first trimming cut as shown below

lathe setup in Fig. 10 and turn the self-tenon to the required size. Use calipers to assure a perfect fit as the degree of support afforded by the splayed leg is entirely dependent on an accurate fit of this joint, especially when no stretchers are used.

When metal ferrules are used, Fig. 2, care must be taken when turning the shoulder to obtain a precise fit, as otherwise a slight shrinkage of the wood will cause the ferrule to loosen. When locating splayed legs, with or without ferrules, be sure to place each one in the 45-deg. position in relation to the frame or base on which they are mounted, Fig. 12. If the upper ends of the legs are tenoned, either straight or offset, it is important to make sure that the tenon is cut to the right length, which is slightly less than the depth of the hole into which it is to be glued. When it is necessary to trim both ends of each leg, take the miter-gauge setting from the elevation drawing, then cut as in Figs. 13 and 14, shifting the miter gauge to the opposite groove in the saw table for the second cut. It is important to keep the same side of the turning up for both cuts. ★ ★ ★

Move the gauge to the opposite groove in the saw table and make second cut. Keep work same side up



Circular-Saw Blades Stored Between Cardboard Disks

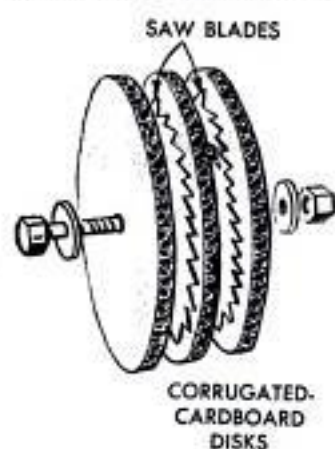

Spare circular-saw blades can be protected against damage by storing them between disks cut from heavy corrugated cardboard. Cut the disks slightly larger in diameter than the saw blades, then assemble disks and blades on a 1/2-in. bolt. Washers on

each side of the assembly help prevent bolt head and nut from crushing the cardboard. If the blades are stored in a box with other tools, hardboard disks offer greater protection.—George Kapitan, New York City.

Portable Stile Folds Flat For Easy Carrying



Instead of climbing over a woven-wire fence, which slackens the wire, one farmer uses a portable stile which is easily carried in a pickup truck. The stile folds flat and consists of two short ladders made of 2-in. stock hinged together at the top.

Bushing Removed From Blind Hole By Using Hydraulic Pressure

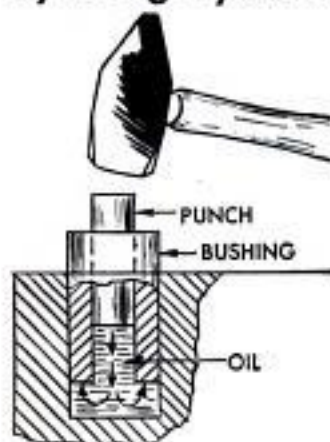

A "frozen" bushing that must be removed from a blind hole with minimum damage can be forced out by using hydraulic pressure. Fill the hole about half full of heavy oil and insert a close-fitting punch. Wrap a cloth around the punch and hold it down against the

bushing to shield against oil forced out past the punch. Strike the punch sharply with a hammer. The force of the hammer blow will be transmitted to the lower end of the bushing through the oil.



Cistern Cover Sealed to Rim With Auto-Tire "Gasket"

One Ohio farmer has made his cistern cover insect and dirt-tight by using an automobile tire as a gasket under the cover. A concrete rim around the cistern opening is shaped to hold the tire in place. The weight of the cover seals the cistern by forcing the tire tightly against the rim. Should the cover accidentally be dropped, the tire also provides protection against breakage.

Marks Painted on Monkey Wrench Permit Accurate Presetting

An adjustable wrench can be preset to the required-size opening if marks are painted on the shank, as shown in the photo. Use a rule to adjust the jaws and mark the 1/4, 1/2 and 1-in. measurements with a light-colored paint. Paint the 1-in. marks all the way across the shank, the 1/2-in. marks slightly shorter and the 1/4-in. marks shorter still.—R. Hanscom, Elmhurst, Ill.



SHOPPING FOR TOOLS



1

1. STRAPBREAKER provides a safe means of removing steel strapping used on shipping containers. Cuts steel straps to 2 in. wide. Has no moving parts. Head is heat-treated forging with two cutting edges. In use, cutting lip of slotted head is slipped under strap. A push or pull on handle severs strapping

Gustave Lidseen, Inc., 830 S. Central Ave., Chicago 44



2

2. COMBINATION DRILL countersinks and counterbores for common sizes of wood screws in one operation. Available in four screw sizes, Nos. 6, 8, 10 and 12, in lengths from 2 to 2 $\frac{7}{8}$ in. Can be adjusted to countersink screwhead flush or below surface. Adjustable to stop automatically at correct depth

Oswall Tool Co., Ltd., 928 Broadway, New York City

3. HIGH-SPEED CONVERTER multiplies drill-press spindle speeds through a 4-to-1 gear train. Fits any $\frac{1}{2}$ -in. drill-press chuck and high-speed converter chuck holds drill bits from 5/32 in. to No. 80, covering the range of small-hole drilling in cast-iron, brass, aluminum and plastics in the small job shop

Dinzus Machine Shop, 1423 S. 52nd Ave., Cicero 50, Ill.



3



4

4. HAND TAP cuts metric threads in standard sizes and pitches. Widely used in the repair and maintenance of foreign automobiles and machine tools. High-spiral flutes lower torque requirements and cut sharp, clean threads due to added chip clearance. Made from high-speed steel, specially hardened

Shearcut Tool Co., 7045 Durby Ave., Roseda, Calif.

5. SELF-POWERED JIGSAW has tilting frame that permits cutting at any angle up to 45 deg. in either direction, right or left. Built-in sawdust blower keeps working area clear. Has full 20-in. throat clearance. Blade turns 90 deg. right or left for ripping cuts. Machine is supplied complete with motor

Synco Corp., Oxford, Mich.

6. NONMARRING DOOR VISE holds a door in an edge-up position for boring lock mortises, installing hinges and cutting and fitting panels. Also holds a door in vertical position for glazing or painting. Door cannot slide or tilt while boring and planing operations are being carried out. Vise adjusts to 2 in.

E-Z Mark Tools, Los Angeles 16, Calif.



5

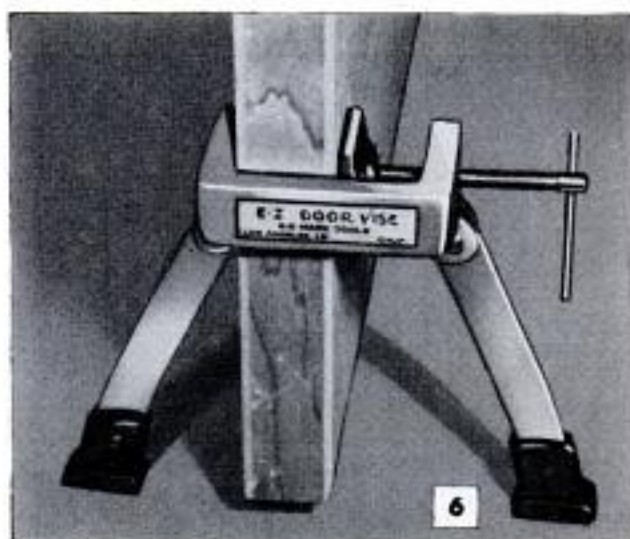

6

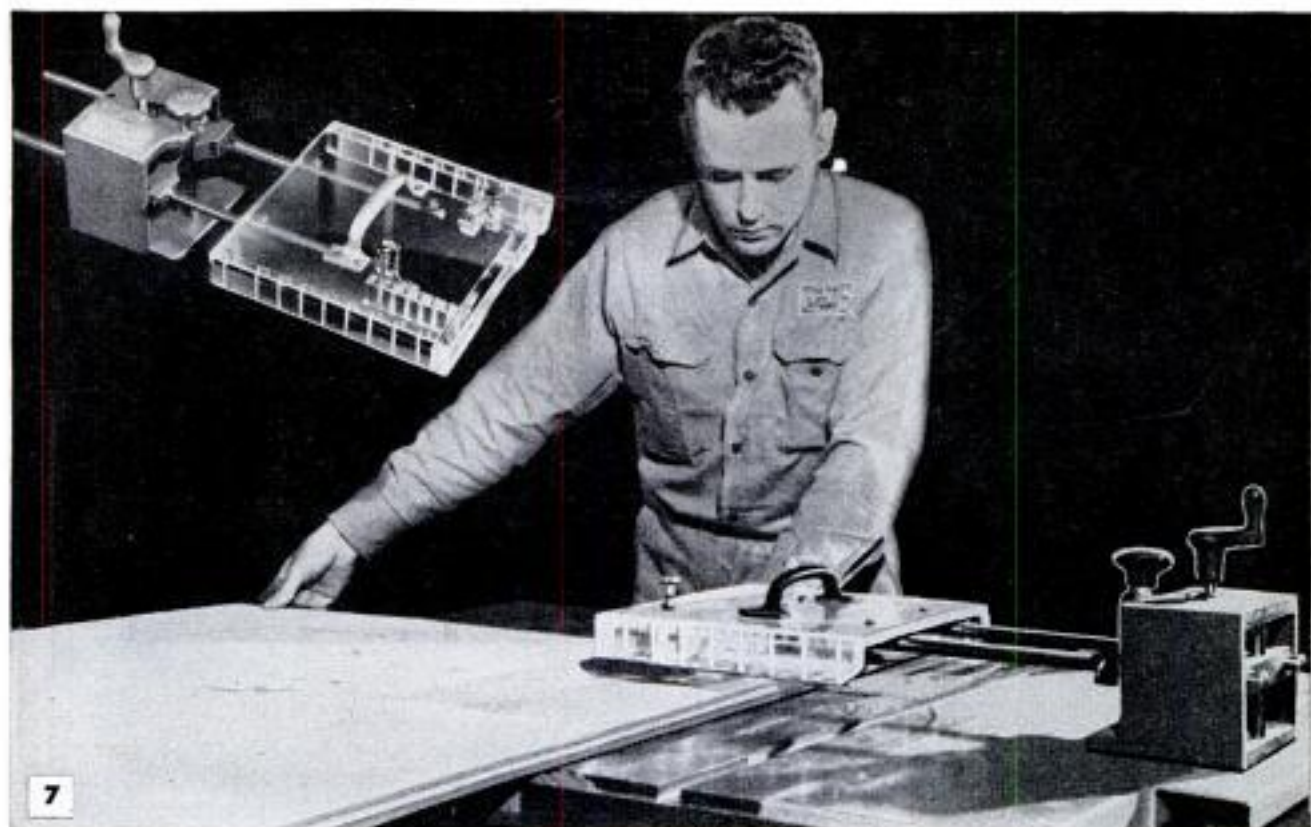

7. SAW GUARD gives full vision from any position for all cutting and grooving operations normally carried out on a circular saw. Unit has antikickback device which is spring-loaded to guard against binding of blade when ripping cross-grained wood. Guard is crystal-clear plastic, chip and break-resistant

Brett-Guard Co., Div. of Glenwood Industries, Inc., Englewood, N. J.

8. MIST COOLING SYSTEM applies coolant to cutting tools in the form of a fine mist that dissipates heat through evaporation of minute liquid particles. Nozzle holder is magnetic, can be attached to any metal part in most effective, convenient position. Eliminates coolant pumps, drip pans

Aetna Mfg. Co., Bensenville, Ill.

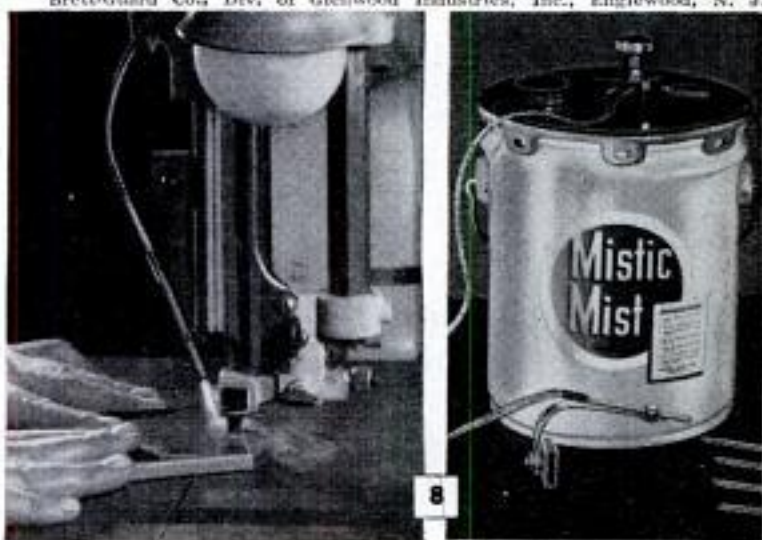

9. ELECTRIC KNIFE SHARPENER doubles as a light tool grinder for small chisels, carving tools and bladed instruments. When sharpening cutlery or instruments wheel guard serves as accurate guide for blade. Guard is removable for grinding small chisels and other edge tools on face of wheel

Burgess Vibrocrafters, Inc., Graylake, Ill.

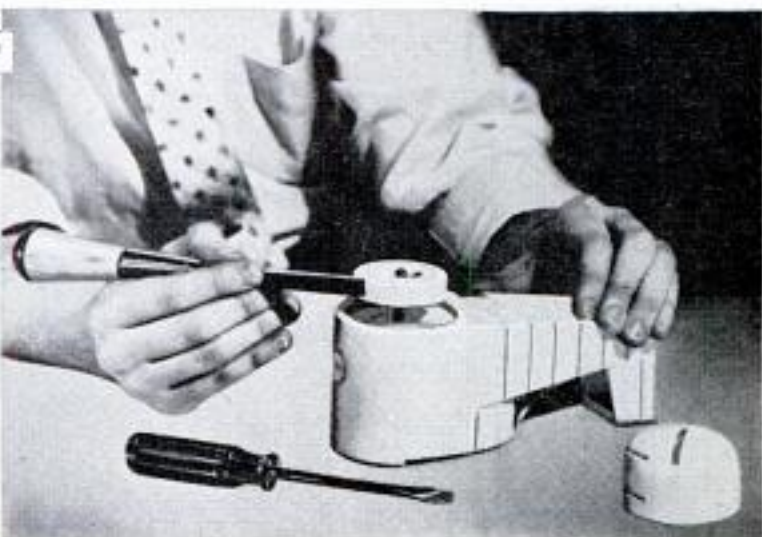
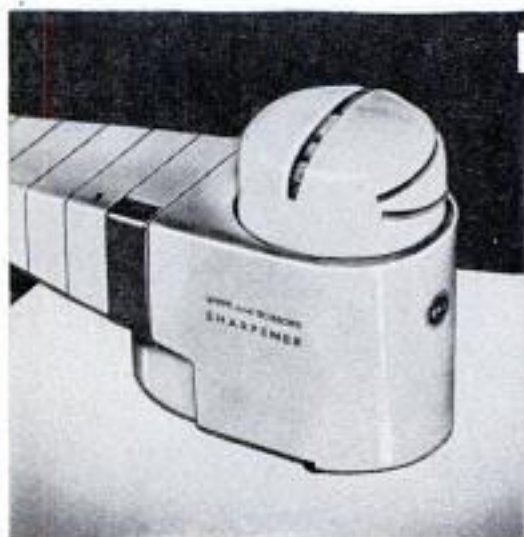

Putty Dam Around Drilling Job Supplies Oil to Bit



You can avoid repeated applications of oil to the bit when drilling metal in a drill press by using a putty dam to confine the oil around the bit. After setting the work, form the dam around the area to be drilled and apply the oil. Be sure the dam is high enough to prevent the bit from throwing out the oil.

Dim Car Lights Brightened With Aluminum Foil



Aluminum foil can be used to brighten taillights, turn-indicator and parking lights that have become dim because of rusted or tarnished reflectors. Press a

sheet of the foil around the bulb inside the light as shown. The lens will hold it in place. Lights not originally equipped with reflectors can be improved in the same manner.

"Trays" for Giant Ice Cubes Are Empty Milk Cartons

Giant ice cubes for quick cooling of hot-weather drinks, or for use in a portable icebox, can be made by filling empty milk cartons with water and placing them in the home freezer. If the cubes are to be used in

a beverage, wash under running water after the carton is stripped off. Washing will remove the wax particles from the waxed carton which freeze into the cube.

Joe Frisch, Cincinnati, Ohio.

Notch Filed in Tailstock Quill Locates Tool Bits on Center

A V-shaped notch filed in the quill of a lathe tailstock will provide a quick means of adjusting tool bits to on-center height. The notch is filed so its upper surface is horizontal and on the exact center-line height. Placing the top edge of a tool bit against the top surface of the notch, then tightening the tool-post screw, locates the cutting edge of the tool bit exactly on the center line.—C. W. Woodson, Chicago.



Insulation Stripped From Wire By Electric Brush

Stripping insulation from the ends of a number of pieces of wire is done quickly with a wire brush. The wire to be stripped is passed through a hole drilled or punched in a sheet-metal shield and held against a rotating wire brush. The length of the portion to be stripped is determined by the length of wire allowed to project through the shield. Light, multistrand wire will require the use of a softer wire brush than will solid wire.





"MISS MOPAR" SAYS:

get new-car
vitality

WITH

MOPAR

BATTERIES
SPARK PLUGS
CONDENSERS
POINT SETS
DISTRIBUTOR
CAPS

MOPAR

PARTS DIVISION • CHRYSLER CORPORATION
Get MoPar parts from your Plymouth,
Dodge, De Soto, or Chrysler dealer and
better general repair shops.

How to choose the right film for the right job



To suit the wide variety of picture-taking situations you may encounter—and to give you more control over the results—Kodak makes a number of different films. Each has its own special merits and applications. Below, we describe the most widely used Kodak black-and-white and color roll films. It will help you to know what each is especially made for.

One suggestion: learn about one film at a time by *using* it. Learn the proper ex-

posures for various lighting conditions. In other words, find out what the film can actually do for you before you tackle others. That way you'll get the most out of the special qualities built into each Kodak film. And it will show up in the quality of your pictures.

You can process all Kodak black-and-white films at home and make prints and enlargements yourself. Kodak's new Ektachrome Film can also be home-processed.

BLACK-AND-WHITE FILMS



Taken on Verichrome Film, 1/50 at f/8

KODAK VERICHROME FILM is a fairly fast all-purpose orthochromatic film for everyday snap shooting—using either daylight or flash. It will give good tone gradation and moderate grain. It has a wide exposure latitude and thus permits reasonable exposure errors. This saves many a picture when there's neither the time nor inclination to be very precise about exposure. It is ideal, of course, for fixed-shutter, fixed-aperture cameras. It is available in popular roll-film sizes—116, 120, 127, 616, 620.



Taken on Plus-X Film, 1/200 at f/16

KODAK PLUS-X FILM is a fast, fine-grain panchromatic film capable of excellent tone rendition, reproducing colors with the same degree of brightness as your eye sees them. It's the film to use for all indoor and outdoor work when enlargements are to be made from small or moderate-size negatives. It is desirable, too, when brightly colored objects are pictured, or where accurate rendering of delicate flesh tones is sought. Plus-X is available in roll-film sizes, including Nos. 135 and 828, and in film packs.



Taken on Tri-X Film, 1/100 at $f/3.5$, no flash

KODAK TRI-X FILM is a new, extremely fast panchromatic film of moderately fine grain. It is so sensitive that pictures may now be taken in light so subdued that good shots would hitherto not have been possible. Tri-X Film, in effect, gives the man with an $f/3.5$ lens an $f/2$ lens, and enables the man with an $f/2$ lens to get pictures impossible to get before. Because of its speed, Tri-X alternatively permits faster shutter speeds for action pictures or reducing the aperture for great depth of field. Tri-X produces superb pictures indoors with only the daylight that comes through the windows—and because deli-

cate tones are well rendered, the pictorial quality is high. Tri-X Film comes in roll film Nos. 120, 127, 620, 828, and 135. It is not recommended for fixed-aperture, fixed-shutter cameras unless the light level is quite low.

KODAK INFRARED FILM—a special-purpose film—produces unusual dramatic effects. Skies come out almost black, clouds fleecy white, and foliage very light. With this film and special infrared flash bulbs you can also make pictures in complete darkness. Kodak Infrared Film is available in 35mm magazines and in several sheet film sizes.



Taken on Infrared Film, 1/25 at $f/8$

COLOR FILMS

KODACHROME FILM gives you 2 x 2 slide transparencies in full, brilliant color. You can enjoy them in a hand viewer, project them on a large screen, and have them made into prints and enlargements. Kodachrome is available in miniature camera sizes Nos. 135 (20 or 36 exposures) and 828 (8 exposures) in both Daylight Type for outdoor shots, and Type A for use with flood or flash lamps.

KODAK EKTACHROME FILM is a new, fast color film in both roll and miniature sizes which provides excellent color transparencies comparable in quality to the Kodachrome type of film. But Ektachrome is three times as fast outdoors as Kodachrome. This makes it particularly valuable in situations where subjects are poorly lighted, or when faster shutter speeds to stop action are necessary. Ektachrome comes in Nos. 135 and 828 sizes, which give you 2 x 2 color slides for viewing in a hand viewer, projecting on a screen, or from which color prints can be made. The 120 and 620 roll-film sizes are generally used for making prints only, although there are projectors large enough to accommodate them in the

form of slides. Both Daylight Type and Type F (balanced for clear flash lamps) are available. Processing is done by local laboratories through your dealer. Or you can develop Ektachrome Film at home, if you wish, with the Kodak Ektachrome Processing Kit, Process E-2, \$1.80. Kit capacity is six 20-exposure 135 magazines or ten 828 rolls; for 120 and 620 film, four to five rolls.

KODACOLOR FILM, when developed, results in a "color negative" from which sparkling color prints are made. Kodacolor snapshots can be made with most any roll-film camera. It is fast enough to be used even in a simple-lens camera.

Kodacolor is available in Daylight Type or Type A for artificial light. It comes in popular roll-film sizes—116, 120, 127, 616, 620, 828.

Your Kodak dealer will help you select any Kodak film you need. He also has the Kodak Films Data Book which gives detailed information of these and other Kodak films—each designed for a particular purpose.

Prices subject to change without notice

Eastman Kodak Company, Rochester 4, N. Y.

Kodak
TRADE-MARK

Care and Feeding of Engines

BY
S. P. CORP



SEATING NEW RINGS

Even the best re-ring job depends, for enduring satisfaction, on how the engine is driven during break-in. When the engine is started for the first time with new rings, it should be accelerated quickly to an engine speed equal to 25 to 30 mph. This insures getting plenty of oil up onto cylinder walls and rings. Keep engine at this fast idle until it reaches normal operating temperature. Do not allow engine to idle at low speed during the warm-up period, and never run cold water through the radiator while seating new rings.

After engine is warmed up, drive car in low or second gear, to insure good lubrication and reduce load on compression rings. Accelerate in second gear to 35 mph, then drop back to 25 mph. Continue for 10 minutes. High idle speed with a light load as in second gear prevents overloading pistons and rings. Drive at 50 mph for first 200 miles.



TIMING WITH HIGH OCTANE

If the timing of your engine hasn't been checked lately, this should be done to make sure it is within manufacturers' specifications. With high octane gas, timing may be advanced, but only as specified. If you use high octane continuously, advance timing until a slight detonation is heard when you accelerate in high gear from 19 to 30 mph. Now retard timing just enough to eliminate the detonation, then idle and check for smooth operation. For economy, engine should be timed for the type of gasoline you use.



WRITE FOR FREE MANUAL

For professional suggestions on car care, send a postal card for your free copy of Sealed Power's new illustrated manual, "Care and Feeding of Engines." And when you re-ring, be sure to use Sealed Power KromeX Ring Sets—for fast break-in, for immediate oil economy, and for double ring life. They are the best ring sets built, proved in millions of road miles. Sealed Power, Dept. G-9, Muskegon, Mich.



Sealed Power

PISTON RINGS

Clinic for Homemakers



As a service to our readers in solving the hundreds of problems pertaining to a home—inside or out—the editors of *Popular Mechanics* invite you to present your problems to The Clinic Editor for help and advice. Address your questions to The Clinic Editor, *Popular Mechanics Magazine*, 200 East Ontario Street, Chicago 11, Ill.

Cold-Air Returns

Q—I have a hand-fired gravity heating system. Two rooms, one upstairs, one down, have never been comfortably warm. There are three cold-air registers, one in the hall, one in the living room and one in the kitchen. Is there any way to alter the installation to obtain uniform heating?—E. D., Mich.



A—Without a plan of the installation, we'll have to guess the cause and probable remedy. In this we are assuming that the cold rooms are not shut off from the rest of the house, that is, by a closed door, screen or drape. Usually the trouble in such cases is a lack of sufficient cold-air returns to maintain a proper circulation of air in all the rooms. Another possible reason is restriction of existing cold-air openings by placement of furniture, built-ins or rugs. You do not say whether the cold-air return in the hall is upstairs or down, but it is probable that its location would make little difference if the fault is a lack of adequate cold-air intake. However, if a new cold-air duct is installed the register should be upstairs, in the cold room if possible, if the cold-air register in the hall is downstairs. Conversely, if the existing cold-air register is upstairs then the new one should be placed downstairs. This arrangement is more likely to effect an equalization of air circulation. If it is possible, the new duct should be brought directly into the furnace jacket. It is likely that the installation of a new duct, with a cold-air intake located as suggested, will help correct the trouble.

Mildew in Closet

Q—We are troubled with mildew in clothes closets. It has damaged clothing, luggage and leather footwear, some items so badly that they had to be discarded. The two closets giving the greatest trouble have no windows. Would installation of windows help? Is there any other practical solution?—R. N., Ala.



A—It is probable that installing a window in each of the two closets would help, provided the sashes were adjusted to give some ventilation. Also there is the possibility that installing of louver

(Continued to page 226)

ALL ABOUT TOBACCO... INCLUDING SEVERAL REASONS WHY

Edgeworth Never Bites Your Tongue



Some brands give you shorts and bits which burn like tinder—fast and hot.



Others give you fine-cut shreds—good for cigarettes, but not so good for pipes.



Only Edgeworth gives you slow-burning "chunks" made for pipes and pipes alone.



Edgeworth's Way with White Burley Has Never Been Equalled

Tobacco experts know white burleys are the world's coolest smoking tobaccos. Edgeworth is a blend of aged burleys only. Other tobaccos use white burley too—but nobody yet has found how to process tobacco to give it the even-burning, cool-smoking character of Edgeworth "Ready-Rubbed".

What "Ready-Rubbed" Means to Your Smoking Pleasure

Old-Timers knew the secret of cool, even burning. They "hand-rubbed" their tobacco until it crumbled into chunks of just the right size. Now before Edgeworth is packed, an exclusive process "ready-rubs" it to give you a cool smoke with never a touch of tongue bite.

YOU'RE SMARTER SMOKING

Edgeworth

AMERICA'S FINEST PIPE TOBACCO FOR OVER HALF A CENTURY

This Amazing Pouch Means Cooler Smoking!



Edgeworth leaves our plant with just the right moisture content for a cool, no-bite smoke. Every pouch is that way when you open it, for only Edgeworth has the Seal-Pak pouch. Air-and-water tight, it promises you fresher tobacco than any other pocket pack.

Forgotten in Tackle Box—Edgeworth Still Fresh

A fisherman left an unopened Edgeworth pouch in his tackle box for a year. When found, the tobacco was still moist and cool smoking.



FOR A COOL MIXTURE TRY HOLIDAY

A blend of five tobaccos selected for mildness and aroma—in the Seal-Pak pouch.



AT YOUR DEALER'S

Get this guaranteed "Olde London" Pipe and two full-size pouches of Edgeworth tobacco for only \$1.00. The pipe is fine, hand-rubbed imported briar . . . with genuine hard rubber bit . . . carbonized bowl for cooler smoking. If your dealer is unable to supply you, use this handy order blank.

Name _____

Address _____

City _____ State _____

Mail with \$1.00 to "Olde London," Larus & Brother Company, Inc., Richmond, Va.
Offer Good Only in U. S. A. **PM-9**

STOP SAGGING REARS!



with
LOW-COST

AIR LIFT PNEUMATIC SPRING BOOSTERS

Car got that "middle age spread" look? Even new cars need help for overloads of luggage, equipment or extra passengers. AIR LIFTS fit between leaf springs and frame — inflate with air to support overloads up to 1000 lbs! Perfect for vacation trips, and so easy to install. See your dealer or write for his name.

Most
Models
\$20



FREE! . . . tip-packed literature on Air Lift remedies for sagging rears. Write Dept. 49.

AIR LIFT

AIR LIFT COMPANY,
LANSING, MICHIGAN

IT PAYS
TO BE
PARTICULAR
ABOUT
YOUR OIL

45¢
a quart



Modern, high compression engines need richer, tougher oil. Insist on WOLF'S HEAD:

100% Pure Pennsylvania . . . made from the best crude oil nature provides.

Refined three extra steps — stays rich, tough, full-bodied.

Scientifically Fortified — cleans as it lubricates.

With WOLF'S HEAD you'll get maximum power and you'll use less oil, too.

WOLF'S HEAD OIL REFINING CO., INC.
OIL CITY, PA.

(Continued from page 224)

doors in the closets would provide for sufficient air circulation. However, these alterations would be rather expensive to carry out. A cheaper way, and in most cases even more effective, is to install a receptacle near the baseboard for a 60-watt bulb. The receptacle should be of the flush type and wired into the lighting circuit so that it can be controlled by a wall switch. The bulb should be provided with a protective shield so that it cannot be broken by any object falling from above. The heat from a single 60-watt bulb will "dry" the air in the average-sized closet sufficiently to prevent the formation of mildew. Larger closets will require two bulbs, one at each end of the closet and located just above the baseboard. Also, there are special low-wattage electric heaters available which are designed to eliminate dampness and mildew in small enclosed areas such as clothes closets.



Curled Shingles

Q—The composition shingles on our new home seem to have curled so that the butts are raised noticeably. Near the ridge on one side the shingles appear to have buckled, resulting in a long, wavy ripple. What is causing this? Are there any preventive measures?—T. O., Neb.

A—Probably the most likely cause is shrinkage of the roof boards which, of course, is due to use of lumber not properly seasoned at the time of application. Insufficient nailing of the boards also can be a contributing factor. Adjacent boards, one or both of which shrink in varying degree, can set up a lateral pull on two or more courses of shingles and cause the buckling you describe. Boards insufficiently nailed may cup badly in drying. Shingle butts that come directly over cupped boards may be raised as much as 1/2 in. Adjacent rafters that bow upward in drying are also a contributing cause. Unfortunately, there isn't much you can do directly to remedy the defect. However, time is on your side as drying of the rafters and roof boards will cause them to stabilize at some point. As soon as stabilization occurs the shingle butts will gradually level sufficiently to correct the defect, or at least minimize it to such an extent that it is no longer objectionable. Buckling usually will correct itself in time, for the same reasons.

Wet Basement

Q—Water seeps into my basement every time there is a hard rainstorm. It seems to come in where the walls meet the floor and also around the footings of the center supports. There is never any great quantity of water, never more than an inch or so. It does not back through the drains. I'm told that the installation of vertical pipes, or stacks, in the drains will cure the trouble. The pipes are threaded to screw into special fittings installed in the drains. Will these help to cure my trouble?—R. O., N. J.

A—Ordinarily, we do not recommend the installation of the so-called "pressure" pipes to cure the trouble you describe as they do not relieve the pressure at the point of seepage in the average basement floor. There are several procedures, all of them comparatively expensive to carry out, but they do effect a permanent cure if the work is properly done. If the original floor is cracked or otherwise in bad condition, it's generally best to break it up and lay a new 4 to 6-in. reinforced floor over a tamped gravel fill. After the old floor has been removed and before the new floor is poured, it's a recommended procedure to cement-plaster the walls from the footings to the grade level, running in a well-rounded cove at the point where the wall meets the footing. When the new floor is poured, it is reinforced with 3/4-in. rods laid 8 in. on centers in two directions. Another method is pouring a new floor over the old where there is sufficient headroom. The surface of the old floor must be acid-etched, or scarified by chipping so that the new floor will bond to it.

- A. Ball-Race Steering gets a workout on the "skid pad" at General Motors Proving Grounds.
- B. The reduction in actual turning effort is measured by a recording wheel attached to the normal wheel.
- C. A Chevrolet's front wheels are turned—with velvety ease—by these 54 micro-polished steel balls.

"Here's why Chevrolet is easier to steer"

says Ed Cole, Chevrolet Chief Engineer

One thing that can rapidly turn driving fun into driving fatigue is heavy, stiff steering. This is a serious problem with modern cars, where so much of the weight is on the front wheels.

When we were designing the 1955 Chevrolet we attacked this problem in two ways: First, we moved the center of weight back to lighten the load on the front end. And then we incorporated Ball-Race steering, which substitutes the *rolling* friction of 54 micro-polished steel balls for the usual *sliding* friction.

If you imagine the steering column as a sort of giant bolt, the "threads" on this bolt are a closely packed spiral of those steel balls. When you spin the steering wheel the ball-bearing threads rotate inside a huge "nut" that is linked to the front wheels, pushing it down or up and thus turning the car.

That's how Ball-Race steering creates a manual system that comes awfully close to the ease of power steering—as you'll discover on your first demonstration drive. Why don't you sample it, soon, at your Chevrolet dealer's? . . . Chevrolet Division of General Motors, Detroit 2, Michigan.

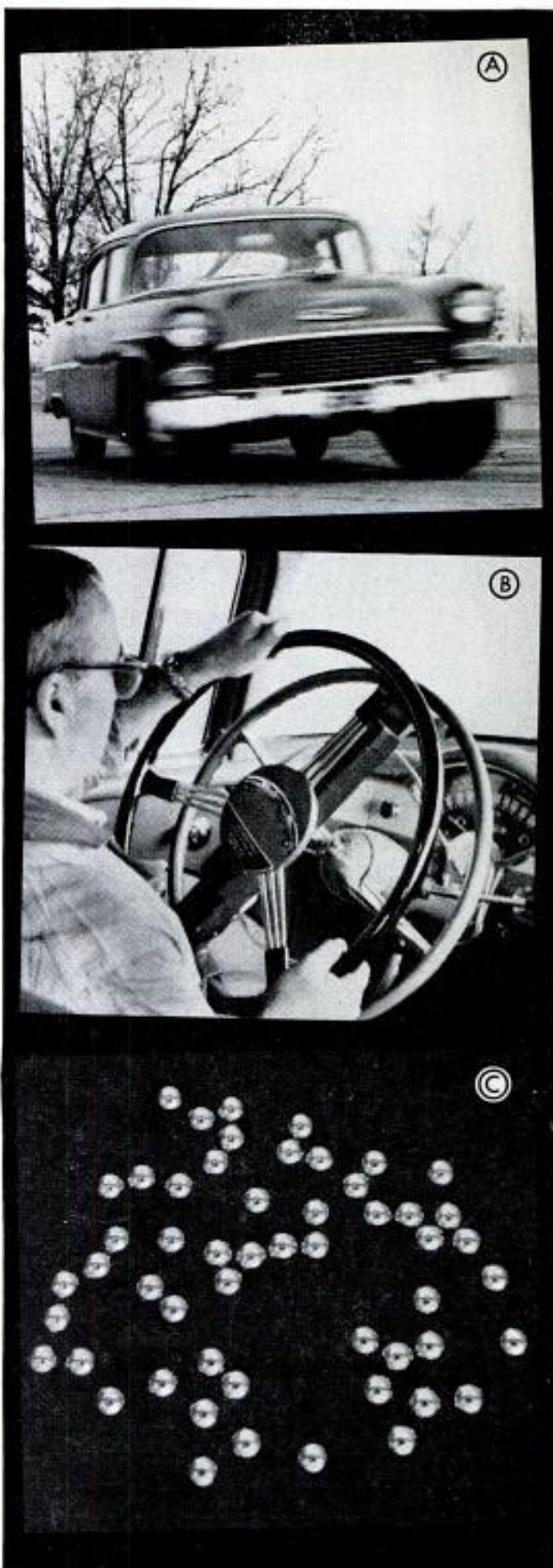



World's #1 Brush Gun . . .
MARLIN .35 CAL.

**Now Only
\$68.95***

**Regular and "Texan" Model
Carbines! \$10 Price Reduction Also
on Marlin .35 Cal. Rifles!**

HERE'S the only gun in this brush-blasting caliber that provides the split-second speed of lever action.

A terrific value . . . a tremendous favorite . . . at its original price of \$78.95! Practically a "steal" now—at only \$68.95*!

Available with regular pistol grip . . . or "Texan" style, with straight grip. All Marlin 336's are factory drilled and tapped for Weaver and other top mounts.

See your Marlin dealer now (name of one nearest you available on request). Many Marlin dealers have an installment finance plan for you.

Model 336—.35 Rem. Carbine—full magazine holding 6 shots. Reduced to **\$68.95***

**Prices slightly higher west of Rockies; and subject to change without notice.*

THE NAME
FOR GAME

Marlin

FINE GUNS
SINCE 1870

VALUABLE COUPON—MAIL TODAY!

The Marlin Firearms Co., Dept. PM-9, New Haven, Conn.

Please send me catalogue with information and photo-illustrations of Marlin Guns. Also send me a pack of (please check preference) single or double edge or injector type Marlin Razor Blades. I enclose 10¢ for handling.

Name _____

Street _____

City _____ Zone _____

County _____ State _____



Toy Helicopter

Unlike most toy helicopters, which merely look like the real thing, a tiny craft driven by electricity actually flies. The helicopter, which is maneuvered from a remote-control box, was developed by Jack Bennett, an American airplane pilot living in Bad Homburg, Germany. A German firm is planning to manufacture the toy.

Portable Camp Stove

It takes only seconds to set up a portable gas camp stove fueled with a disposable tank. The unit fits into a metal carrying case 11 inches long, 5½ inches deep and 5½ inches wide which also serves as an adjustable wind shield. The entire package weighs only six pounds. The burner lights instantly and can be regulated for varying cooking requirements. The unit's light weight, compactness and economy of operation make it ideal for camping, picnics and summer-cottage use.

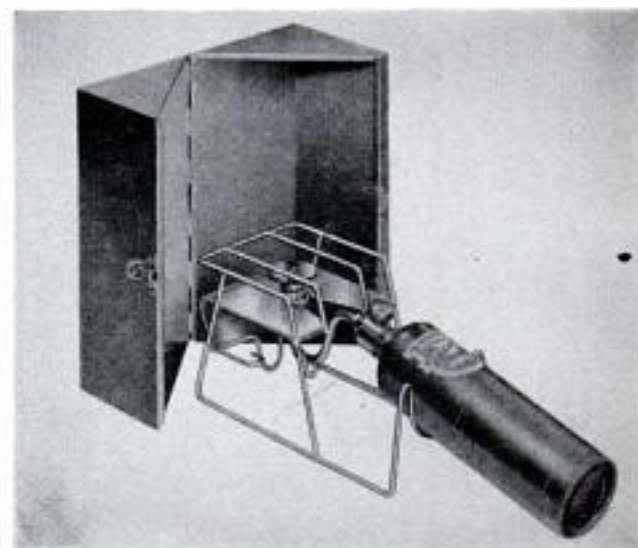

Put your electronic skills to work



Young men who are interested in electronics, mechanics, or other technical specialties have an interest in the U. S. Air Force. As an Airman, you may have an opportunity to develop your technical ability and learn an interesting, exciting, and good paying skill. Act today and put your skills to work tomorrow. Put them to work where they'll do the most good...put your skills to work in the U. S. Air Force.

You go places — faster in the U. S. Air Force

You may train with the U. S.
Air Force in one of these
interesting specialties

Radio and Radar Maintenance • Mis-
sile Guidance Systems • Armament
Systems • Weapons • Training Devices
Maintenance • Wire Maintenance

M-10-PM-2

AIRMAN INFORMATION BRANCH
Personnel Procurement Division
Box 2202, Wright-Patterson AFB
Dayton, Ohio

Please send me more information on my oppor-
tunity as an Airman in the U. S. Air Force.

Name _____ Age _____

Address _____

City _____ Zone _____ State _____



Take a tip
from
a rusty
bolt!

**Don't let harmful engine deposits
LOCK UP your car's horsepower!**

Just as rust binds a bolt, so deposits shackle your engine, stealing pep, wasting gasoline, causing excessive wear.

Pennzoil with Z-7 keeps vital parts free from all harmful contaminants. Allows the *Tough-Film*® to lubricate completely, *unlocking* horsepower for instant response, for better gasoline economy.

Next time, change to longer-lasting Pennzoil with Z-7. You'll *feel* the difference behind the wheel!

Sound your  for the
LONG QUART

NOW with
Z-7
the **POWER**
INGREDIENT



Switch now at this sign

**BETTER DEALERS
IN EVERY STATE FEATURE PENNZOIL® PRODUCTS**

© 1955, The Pennzoil Co., Oil City, Pa., Member Penn. Grade Crude Oil Assn., Permit No. 2

Clymer Tests the Clipper

(Continued from page 118)

The front end is designed for a soft ride. It is unusually soft for a torsion-bar system. In fact, I think it is too soft because at high speeds, while cresting the top of a sharp incline, I jumped the car at 60 miles per hour. The torsion system held the front end off the ground longer than it should and, in one instance at very high speed, the wheels actually left the ground. Heavier shocks to control the rebound would correct this situation.

There is a minimum of tire squeal on the corners. Due to the soft springing, there is considerable dip to the front end when the brakes are applied quickly. Packard engineers have tried to maintain the traditional American car soft front-end ride (desired by most buyers) and yet secure the advantages of the torsion-bar system with typical sports-car handling characteristics. It's a good trick if you can do it and Packard has succeeded to a certain extent. A switch under the dashboard disconnects the equalizer motor and this should be done when the car is left standing, as children and adults seem to find this device fascinating to watch in operation. An improvement over the manual switch control would be to have the switch turn off when the hand brake is applied with a flasher warning light attached, and to go on again when the brake is released, or, perhaps, to go off when the ignition is turned off.

The steering wheel, lock to lock, requires $3\frac{7}{8}$ turns, which is satisfactory (the $4\frac{3}{4}$ turns on cars without power steering seem excessive.) The turning diameter, curb to curb, is 41 feet with the power-steering car I drove—not bad for a 122-inch wheel-base automobile.

The Clipper brakes are better than on previous models, but I did find some fading while doing a lot of braking on descending hills and turning sharp corners. The pedal action requires a little more pressure than with other power brakes.

The Clipper Custom is one of the fastest stock cars in the United States today. The speedometer indicated over 116 miles per hour. The car operation is so smooth that it would creep up to 90 and 100 almost without effort on long, open stretches. It was so smooth and fast that I felt the speedometer must be much too fast, but, to my surprise, it was only about 7 percent fast at 100 miles per hour.

Economy was satisfactory, the consumption being perhaps a little on the high side, but I abused the car far more than the

(Continued to page 232)

"Pro" Glue Gives Hobbyists "Pro" Results!

For years Weldwood® Plastic Resin Glue has been the "Old Reliable" of professional cabinetmakers. Now, more and more hobbyists are using this "pro" glue. It's the best wood glue made! Makes glued joints stronger than the wood itself. The joints actually grow stronger with age. Weldwood Plastic Resin Glue is highly water-resistant too! Try it today.



YOU can machine Jobs 20 minutes after Gluing!

You save a lot of time when you can machine a job just 20 minutes after gluing! Hobbyists who use Weldwood Presto-Set® Glue often do just that! Presto-Set Glue is ready-to-use! Sets fast! Bonds like magic! It's the first white glue worthy of the Weldwood name. Bonds wood to wood, wood to cloth, cloth to paper, upholstery fabrics to wood, and many, many other combinations! Let this Wizard with Wood speed things up around your workshop!



Keep a Presto-Set Glue Squeezer at your bench!

It's a real shop tool. Runs glue into grooves, dowel holes, hard-to-reach-corners—quicker, cleaner. No waste. Get one today!



Weldwood Glues... Satinlac,® Firzite® are available at all hardware, lumber and paint dealers.

®Trademark



Painters' Secret Revealed!

Many hobbyists have been wondering how professional painters get those beautiful natural wood finishes. The magic word is Satinlac! Satinlac gives a handsome, satiny effect which wears well and is easy to maintain. Dries so quickly it's ready for the next coat in just 3 or 4 hours. In a jiffy you have a "custom-finished" job!



Clear Firzite tames Wild Wood Grain!

Now it's easy to give fir plywood the appearance of costlier woods. When staining, start with a coat of Clear Firzite. It soaks into the wood pores and subdues the wild grain. Practically eliminates grain raise and face checking. For oak, walnut and mahogany stains, add colors-in-oil.



Weldwood has a Right Glue

For... The job saves there n... of the glue maker and remember specially tackle. choice of s... cause they're the choice men who know glues best...

New Way to Bond Micarta without Clamps or Presses!

Now, it's really easy... even for an amateur... to apply plastic surfacing materials like Micarta to table tops, kitchen counters, bathroom and powder room surfaces. Sensational new Weldwood Contact Cement bonds instantly and permanently on contact—without clamps or presses. Has a thousand and one other uses around home, shop or garage. Also... it enables you to put up plywood without nails. This Wizard with Wood bonds all combinations of wood, cloth, leather, paper, glass and metal (including do-it-yourself aluminum).



Blond Finish on Furniture? Use White Firzite!

Now you can give furniture a blond woodsy finish without a "painty" or artificial look! Finish it yourself with White Firzite. This Wizard with Wood is equally wonderful for getting an eye-catching pickled finish. For tinted effects add colors-in-oil. (On soft wood or fir plywood paint jobs, White Firzite as an undercoater helps prevent grain raise and checking.)



UNITED STATES PLYWOOD CORPORATION

Dept. 62, 55 West 44th St.
New York 36, N. Y.

Send me leaflets on:

- Weldwood Plastic Resin Glue Satinlac
 Weldwood Presto-Set Glue Firzite
 Weldwood Contact Cement

NAME _____

ADDRESS _____

CITY _____ ZONE _____ STATE _____

**BIG
VALUE
TEAM!**

NEW! Two BY Four Saw Attachment works with Drill, Saw Table



"Gives you
all the features,
performance
of a
professional
power saw"



CUTS FULL 2" DRESSED LUMBER

Amazing new TWO BY FOUR Attachment makes all sawing easy! Cuts 1-11/16" at 90°, 1-3/8" at 45°. Professional power saw features, too; Telescope Guard, Rip Fence Guide, Bevel and Depth Adjustments. Easy-grip handle for one-hand perfectly balanced use. Any Cummins 1/4" pistol grip geared chuck drill runs it. At your Cummins Dealer—Now!

**ONLY
\$14.95**

New Saw Table has *Para-Lock* Rip Fence!

TWO BY FOUR Attachment hooks to new Saw Table in seconds. Table has exclusive *PARA-LOCK* Rip Fence Guide—automatically aligns guide with blade. Table top 14-3/4" x 15-1/2". Easy to add wood extension for 24" x 24" surface. Complete with 10" miter gauge \$12.95.



MODEL 624

get a *Cummins* Drill for better job results

Cummins Drills run quieter, smoother, longer. They're made better, with shock-proof gears, double-coil motors, dynamically balanced armatures—to give better job results. Cummins Model 304, shown, \$24.95 Others from \$19.95 to \$34.95



© J. O. M. C., 1955

**Get
FREE
Power
Tools
Book**

John Oster

MANUFACTURING CO.
Dept. CPT, 5055 N. Lydell
Milwaukee, Wis.

Please send full-color booklet showing 64 ways to use power tools, and where to buy them.

NAME _____

ADDRESS _____

CITY _____ STATE _____

average driver would. I added one quart of oil at about 500 miles.

Packard has improved their Ultramatic transmission which, as I have said before, was already the best automatic transmission offered in any car. The new Twin-Ultramatic combines all of the desirable features of the old Ultramatic and, in addition, offers dual speed ranges permitting the driver to select the range most desirable to satisfy driving tastes and conditions. One drive range is provided for normal forward driving. It reduces engine speed and provides smoother starting from the complete stop and is especially desirable when starting on snow, ice or wet pavement. A second range is provided for fast acceleration in traffic. This range is called "Dart." I found the normal driving range to be extremely smooth from a standstill to top speed. In the Dart range, the car has a terrific acceleration and very few production cars today can stay with the Clipper while accelerating from zero. With the throttle wide open, the upshifts are constant with no jerk. However, once in second gear, when the throttle is depressed at speeds below 25 miles per hour, the downshift is quite rough and acceleration is terrific. The car jumps away so fast it will spin the wheels on dry pavement. I don't like this leaping action below 25 or 30, but it smooths out above 35 miles per hour.

A two-stage torque converter with a direct-drive clutch is used, hence when the clutch is engaged by automatic action there is a positive drive with no possible slippage. It now also combines a two-speed automatic planetary train. Packard claims it gives the highest torque in the industry. It really gives the driver a choice of two automatic drives.

The best feature of the new Twin-Ultramatic is the fact that, in both of the driving positions, when the throttle is depressed about half way (instead of all the way down), the downshift takes place instantly and with excellent effect.

The shift-lever movement is smooth, but there is not enough space between the High and Low shift positions. The indicator selection is too precise and more movement of the lever should be required between these two positions. The indicator dial is mounted on the instrument panel. It should be closer to the steering wheel, as the steering hub partially obstructs the dial letters.

The driving position is comfortable and the seat is of chair height. This driving position, coupled with the torsion-bar suspension, gives the most relaxed ride that

(Continued to page 234)



All-chrome portable spotlight has powerful 4½" sealed beam unit. Perfect for night car repairs, spotting street signs, etc. Plugs into lighter socket. Pistol grip handle, with built-in on-off switch. 6 volts. 10-ft. cord included. (26414) **\$5.59**



It's easy to repair brakes with Wizard Master and Wheel Cylinder Kits. Includes live rubber cups, boots; precision made valves, springs. For most cars, trucks. Master Cylinder Kits, less piston (25820-48) from..... **69c**
Wheel Cyl. Kits (25905-28) from. **39c**



More pep and power! Marvel Mystery Oil lubricates top piston cylinder rings, hydraulic valve lifters of late model cars. Makes starting easier. For both crankcase, gasoline tank. Ideal year-around additive. 4 oz. (A1315) **30c**, Pt. (A1316) **85c**, Qt. (A1317) **\$1.35**

New Power...New Beauty... New Safety For Your Car At Western Auto

STORES AND ASSOCIATE STORES

NOTE: Western Auto Associate Dealers own their stores and set their own prices, terms and conditions. Prices may vary slightly due to differences in local conditions. (PA 51)



Guaranteed to fire in oil. Aldor Spark Plugs have bi-metallic thermostat control that keeps spark plug always at peak efficiency. Adjusts to any heat range requirement automatically. Special non-burning electrodes. In sets (118126-8) **95c ea.**

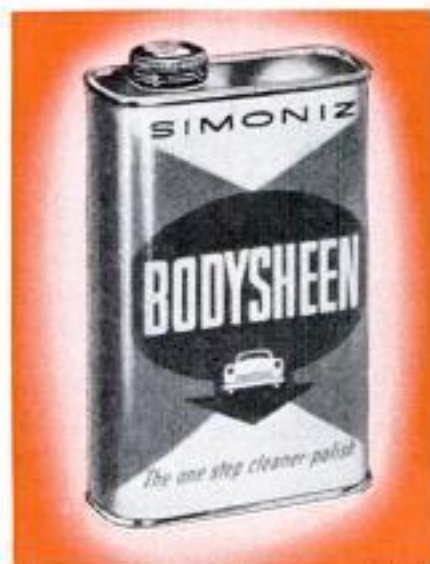

The one-step cleaner-polish! New Simoniz Bodysheen cleans and polishes, in one easy step. Just wipe on, then wipe it off! Brings out natural brilliance, enriches colors. Gives your car a long-lasting, weather-resistant finish. (27112)..... **98c**



Add new beauty and style to your car's interior, and protect your floor mat from wear with these handy rubber Utility Mats. Also has many uses around the house. Your choice of 5 colors. 17" x 17" (26102-09) **Ea. 95c**
17" x 20" (26110-14) **Ea. \$1.25**

FREE outdoor BOOK

Featuring

4 Coleman OUTING PALS

for More Fun on Every Outing



NEW Coleman Portable COOLER - Newest "Pal" for more fun on picnics, camping, outings of all kinds. Low "K" factor holds cold longer...keeps food, drinks cold, fresh. All inside corners rounded—easy to keep clean and odor-free. Soldered leak-proof. Exclusive latch opens with finger-touch. 3 sizes. Top quality at low price. See them today!

side corners rounded—easy to keep clean and odor-free. Soldered leak-proof. Exclusive latch opens with finger-touch. 3 sizes. Top quality at low price. See them today!

Coleman Floodlight Lantern means more hours of fun outdoors. Floodlights 100-ft. area. Lights instantly. Burns 8 to 10 hours on one filling. Safe; stormproof. Coleman Reflector makes it a powerful spotlight. Single, double mantle models.



Coleman Folding Camp Stove cooks like a gas range, any place, anytime. Lights instantly. Burns low cost fuel readily available. All the heat you want for any cooking—instantly regulated. Folds up and carries like a suitcase.* 2 and 3-burner models.

cost fuel readily available. All the heat you want for any cooking—instantly regulated. Folds up and carries like a suitcase.* 2 and 3-burner models.

Coleman Carrying Case-Camp Table dual purpose, roomy all-steel carrying case unfolds into a sturdy camp table. Table legs, 4 stools plus eating and cooking gear pack inside. Sets up in seconds.

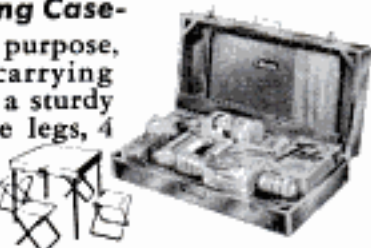

See Your Coleman Dealer's Display

MAIL COUPON TODAY

The Coleman Company, Inc.,
Wichita, Kansas Dept. 221-PM2
Please send me free copy of the new Coleman Book
"How to Have More Fun on Every Outing."

NAME _____

ADDRESS _____

CITY _____ STATE _____

I have ever experienced. I was less tired driving this Clipper Custom 769 miles than I would have been in any other car.

I found the body to be tight and no leaks or rattles developed, although there is considerable hood flutter on rough roads. Very little vibration was noticed, with the exception of a slight steering-wheel vibration at about 40 miles per hour while accelerating. This vibration diminishes as speed increases.

The interior of the car is nicely furnished and the instruments well arranged. There is an excellent view of all instruments and no upper half of the horn ring to obstruct vision. Temperature and fuel gauges have needle indicators, but Packard is using warning lights for generator and oil signals. I prefer needles.

The glove compartment is large and well located directly in the center. The starter is key-operated.

The windshield wipers are positive and efficient because an engine-driven rotary-type vacuum pump provides vacuum at all engine speeds. Smokers are going to enjoy the Clipper because it has two large ash trays, one on each side of the dash.

The windows open or close easily with $3\frac{1}{2}$ turns of the crank. The doors open easily from the inside and have a solid feel when closing. Door opening from outside is by push button and they are the easiest-opening doors of any car I have ever driven.

The foot throttle and brake pedal are very close to each other. In fact, they are a little too close. A wider brake pedal extending farther to the left would be desirable in this instance.

The left-hand-operated parking brake operates satisfactorily but is a rigid shaft. A hinged pivoted bracket would permit smoother operation. The T-handle should be mounted nearer the door because, when the brake is on, the handle extends too far back and too close to the driver's left leg.

Packard engineers, like too many others, have forgotten the need for practical bumpers. Two bulletlike extensions project from the front bumper. These projections may have eye appeal, but they are impractical as, when they strike the bumper of another car, they have no flat surface to match up with the car in front. As a result, these sharp bulletlike projections either go above or below the rear bumper of the other car. I can't understand the use of impractical bumper projections on any car.

There is an amazing amount of trunk space.

Packard has taken a few bold steps in 1955 and when such radical changes take place there are bound to be some "bugs." Most seem to have been corrected. ★ ★ ★

Good News for
budget-minded
HANDYMEN...



Complete
with **MOTOR**

NOW BUY THIS BASIC POWER TOOL WORKSHOP

by **SHOPMASTER**

for only

\$ 17.50
DOWN
and Small
monthly
payments

FROM YOUR

Shopmaster
HARDWARE & LUMBER DEALER

Just plug it in 
Flip the switch and operate

Now you can buy Shopmaster tools on the famous GECC Handyman payment plan. Pay only 10% down and balance in up to 18 months. Buy the Shopmaster Saw-Jointer combination or any Shopmaster tools totaling more than \$150 on this wonderful handyman payment plan. It's Shopmaster's way to give you tomorrow's power tools right now!



To Complete Your Workshop
Add These Other Quality
SHOPMASTER TOOLS
on easy **GECC** payment plan



10" Tilting Table
BAND SAW



12" Bench Model
DRILL PRESS



20" Jig Saw
Includes Motor

OTHER SHOPMASTER TOOLS



8" Tilting Arbor
Floor Model Saw



6" Ball Bearing
Jointer-Planer



12" Floor Model
Drill Press

Plus Complete Line of Accessories

Look at the features on this

Shopmaster Saw-Jointer Combination

- Ready to plug in and operate
- Comes complete with 1/2 HP motor
- Big husky 8" tilting arbor saw with 2 1/2" depth capacity, 13"x16" table size, mitre gauge and rip fence
- Rugged 4" jointer-planer with 3/4" cut, 4"x26" table and flexible guard
- All steel stand is 26" deep, 34" long and 36" high
- Handy switch is conveniently located in front
- Both tools have sealed-for-life ball bearings
- Saw-jointer combination, stand and motor sell for only \$174.50

It's America's Greatest Power Tool Value!
Write for **FREE** Catalog



Shopmaster

ROOM 10B, 1214 SOUTH THIRD ST., MINNEAPOLIS, MINN.

Modernize your kitchen the professional way...

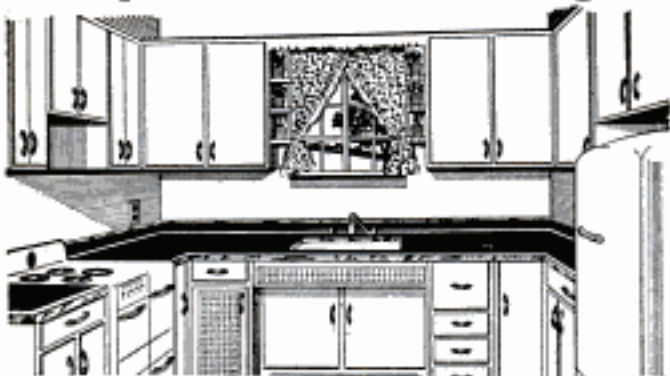

Full-Size EASI-BILD Pattern #201, Kitchen Base and Wall Cabinets, only \$1.00. Just trace, saw, assemble. Send \$1.00 in cash or stamps to Elmer's Pattern Dept., PM-95, P. O. Box 215, Pleasantville, N. Y.

with ELMER'S® GLUE-ALL and ELMER'S CONTACT CEMENT

Make your kitchen a joy to work in—a pleasure to live in—inexpensively! Do it yourself with these easy-to-follow patterns. Just be sure to glue cabinets and put on plastic laminate counter tops with materials the professionals use. ELMER'S® GLUE-ALL is the strong plastic glue that speeds assembly. It's quick-setting, won't stain. Comes in handy squeeze applicator. ELMER'S CONTACT CEMENT bonds plastic laminates to plywood. Never needs clamping... highly resistant to heat, water. Outperforms others in stress tests. The Borden Company, Chemical Division, Dept. PM-95, 350 Madison Ave., N. Y. 17, N. Y.



Available at better hardware, lumber, and paint stores.

BUILD FINE GRANDFATHER CLOCK NOW
The simple sensible Red-Kut way as thousands have—SAVE HALF. SHOP TESTED PLANS "SPIRIT OF THE CENTURY" Narrow waist 80" tall or stately straight side "SPIRIT OF AMERICA." EASY-TO-FOLLOW photopack plans tell all—plus BROCHURE of heavy brass weight Westminster, tube chime, movements, gorgeous dials, 3/4" solid mahogany case kits. Send \$1.00 today—Both plans \$1.50 NOW.
KUEMPEL CHIME CLOCK CO., 27 Kuempel Bldg., Minneapolis 16, Minn.

FREE CATALOG
NEW CHRYSLER BOAT KITS
BUY DIRECT—SAVE UP TO 2/3
FACTORY TO YOU!
No Dealers! You SAVE the BIG PROFIT!
12 MODELS—8 to 14 ft. —\$39 up
Finest quality Boat Kits at the lowest prices in history! Mahogany decks. Easy to build.
Also: FIBERGLAS—ACCESSORIES—TRAILERS
CHRYSLER-CRAFT (DEPT. 20) TONAWANDA, N. Y.

FIND URANIUM!!!
Prospecting made easy with Goldak's new U-238C triple-action geiger counter! Also famous line of metal locators, from \$49.50
Send 25c for radioactive uranium sample!
FREE DETAILS. Dealer Inquiries Welcome.

ANOTHER FIRST! → Goldak's "SCINTA-RAY"
compact, highly-sensitive scintillation counter
FIELD — VEHICLE — AIRBORNE
CHECK THESE FEATURES: size—4"x7"x5 1/2"; weight—4 1/2 lbs., including batteries; rugged aluminum case; long battery life; six sensitivity ranges; large 1"x1" NaI crystal

• **HIGH QUALITY** • **MODERATE PRICE**
Write for FREE details
GOLDAK COMPANY 1542PM W. GLENOAKS BLVD. GLENDALE, CALIF.

Packard Owners Like Torsion-Bar Suspension

(Continued from page 122)

Clipper owners engine trouble was more frequent as you will see by reading the percentage table on page 121.

The most-frequent engine troubles were oil consumption and noisy valves.

"Uses too much oil. Rings failing to seat. I am to get a new ring job."—Minnesota engineer and Clipper owner.

"Noisy. When cold, it sounds like a threshing machine at the start."—Florida sales manager and Clipper owner.

SPECIFICATIONS		
1955 PACKARD and CLIPPER		
ENGINE		
	Clipper Super Clipper Deluxe	Clipper Custom Packard
Type	OHV V8	OHV V8
Bore and stroke.....	3.8125 x 3.5 in.	4.0 x 3.5 in.
Piston displacement...	320 cu. in.	352 cu. in.
Brake horsepower.....	225 at 4600 r.p.m.	245 at 4600 r.p.m. (Custom) 260 at 4600 r.p.m. (Packard)
Compression ratio.....	8.0 to 1	8.5 to 1
Transmissions	3-speed conventional Ultramatic standard and Ultramatic	standard all Clippers; all Packards; Over- drive optional all Clippers
GENERAL		
Steering wheel turns, lock to lock.....	4 3/4	3 3/4 with power steering
Turn circle, curb to curb	43 ft.	45 ft.
with power steering..	41 ft.	43 ft.
Suspension	coil springs, front leaf springs, rear	torsion bars, front torsion bars, rear
BODY		
	All Clipper models	Packard models
Shipping weight.....	3700 lb. 3917 lb. (Custom)	4355 lb.
Wheelbase	122 in.	127 in.
Tread, front.....	59.8 in.	60.0 in.
Tread, rear.....	60.0 in.	60.9 in.
Height over-all.....	62.0 in.	62.3 in.
Width over-all.....	78.0 in.	78.0 in.
Length over-all.....	214.8 in.	218.5 in.
INTERIOR DIMENSIONS		
Front hiproom.....	62.8 in.	62.8 in.
Rear hiproom.....	62.0 in.	62.0 in.
Front headroom.....	36.2 in.	36.2 in.
Rear headroom.....	34.5 in.	34.9 in.
Front legroom.....	43.3 in.	43.0 in.
Rear legroom.....	43.8 in.	48.8 in.
CAPACITIES		
Oil	5 qt.	5 qt.
Water	26 qt.	26 qt.
Gasoline	20 gal.	20 gal.

Here are some more owner's quotations about engine troubles:

"Water leak in head."—Illinois township supervisor and Clipper owner.

"Tendency for oil to foul plugs. It is now remedied."—New York confidential investigator and Clipper owner.

"Had two head gaskets replaced."—Pennsylvania service-station operator and Clipper owner.

(Continued to page 238)

Special BLUEPRINT SALE 10 for \$1.00

A plan for every project—no matter what it is . . . modern home furniture, workshop bench, model ship, toy, ice yacht. We have a limited number of blueprints available at 10 for \$1.00, regularly 40c each! You can save dollars by buying now!



Easy to Follow

Beginner or craftsman, you will know exactly how to give your project that professional touch if you follow our plans. There will be no waste of materials—no extra cost. You choose from more than 70 different designs, including:

- 638 Flat Roof Arbor
- 764 12 Point Star Lamp
- 795 Two Cedar Chests
- 821 Entrance Unit
- 912 Folding Card Table and chairs
- 918 Martha Washington Sewing Cabinet
- 981 Colonial Coffee Table



- 985 Bent Metal Flower Stand
- 989 Speedy Motor Scooter
- 993 Twin Deck Beds
- 994 Console Table
- 996 Modern Table Lamps
- 997 Speedy Bobsled
- 1005 Six Towel Racks
- 1027 Hostess Tray



- 1030 Workshop Electromagnet
- 1043 Cricket Chair
- 1044 Chairside Magazine Case
- 1045 "Whizz" Fast Class E Ice Yacht
- 1049 Swedish Supper Cart

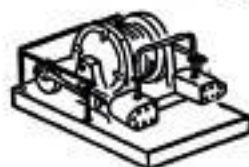

The biggest blueprint bargain in years. Any one of 70 designs may be yours. Don't miss this opportunity to buy your plans. BUY NOW from:

POPULAR MECHANICS PRESS
200 E. Ontario, Chicago 11, Illinois
Send 3c stamp for complete listing

Step into the BOOM
of Building, Remodeling!



**URGENT
NEED for
FLOOR
SURFACING
CONTRACTORS!**

Be Own Boss—BIG Earnings!

Look down any street at all the new homes going up, remodeling and construction of all kinds being done! All around you are new floors to be finished; old worn floors to be re-surfaced! Never before was the opportunity so great for you to quickly establish yourself in a fine business that pays you well . . . sanding floors with an easy-to-run American machine. Many earn \$50 a day and more. Age no barrier—men from 18 to 80, even with physical handicaps, enjoy this pleasant year 'round work. No schooling, no special talent or skills required. Only small investment in sander gets you started in a business that has brought financial security and happiness to thousands! Send today for "money-making booklet".

SEND
FOR . . .



THE **AMERICAN**
FLOOR SURFACING MACHINE CO.
ESTABLISHED 1922

The American Floor Surfacing Machine Co.
535 So. St. Clair St., Toledo 3, Ohio

Here is 25c in stamps or coin for booklet "Opportunities in Floor Surfacing", telling me how I can start my own floor sanding business.

Name.....
Street.....
City..... State.....

More Best-Liked Features

The following quotations describe other best-liked features of Packard and Clipper owners. They are arranged in order of frequency of mention.

"The car is very easy to handle on the road and it does not sway. It's easy to drive in the city and you can park it or put it in the garage easily."—Illinois refrigeration serviceman.

"I like the ease with which it handles. When you make a long trip, you are rested when you arrive instead of being beat up."—Florida minister.

"Styling is modern and up-to-date without being overdone."—New York wholesale grocer.

"Interior in excellent taste yet it is striking."—Connecticut research worker.

"Easy to see the road because of the height of the front seat and the large windshield."—Kentucky housewife.

"Plenty of room inside. Rich styling gives appearance of bigness and wealth."—Texas soldier.

"I like best the way it holds the road."—Illinois carpenter.

"I have had every type of transmission and this Twin-Ultramatic is the best automatic."—Michigan dentist.

"Dependable. As a Packard buyer since 1949 I find that I have had very little me-

chanical work done on any of them."—New York salesman.

And Some More Complaints

The following complaints are typical of those made by the owners and are arranged in order of frequency of mention.

"Ultramatic doesn't shift into direct until between 30 and 35. Our speed limit is 30 and that accounts for the high gas consumption."—Colorado bank teller.

"My chief complaint is poor gas economy."—Rhode Island illustrator.

"During break-in period, oil consumption was exceptionally high. Seems to have cleared up around 2800 miles."—Michigan trucker.

"Windshield leaks. Have tried to get it fixed but had little success as yet."—Pennsylvania construction man.

"Dust comes up into the trunk when driving on country roads. Company should take more pains in sealing body cracks."—Illinois merchant.

"Paint job was very poor. Had to have front fender repainted because spray gun missed it. Chrome is bad. Seams in back of rear fender rusted the first time it rained."—New Jersey salesman.

"Valves have a tendency to rattle when first started."—North Carolina supervisor.

(Continued to page 240)

NO. 286

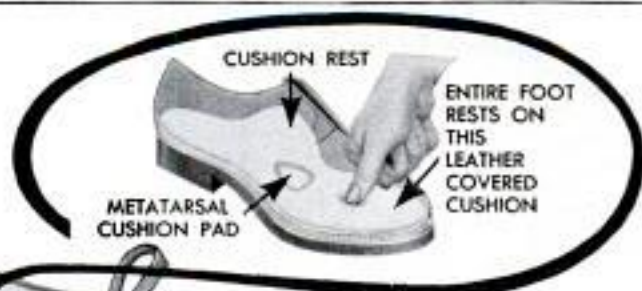

**Non-marking
Oil Resistant
corded soles and heels**

Full Cushion Foot Comfort

Amazing, the comfort you get from these Star Brand Work Shoes! Full cushion insole is soft, resilient, gives snug support, floating comfort, even as you work! And they feature: soft, pliable Burgundy leather uppers—solid leather counters—built in steel shank—yet they look like dress shoes. Try a pair on—soon.



Ask for

STAR BRAND

Cush-N-Bilt work shoes

For nearest dealer write:

ROBERTS, JOHNSON & RAND, Div. of International Shoe Co., St. Louis 3, Mo.

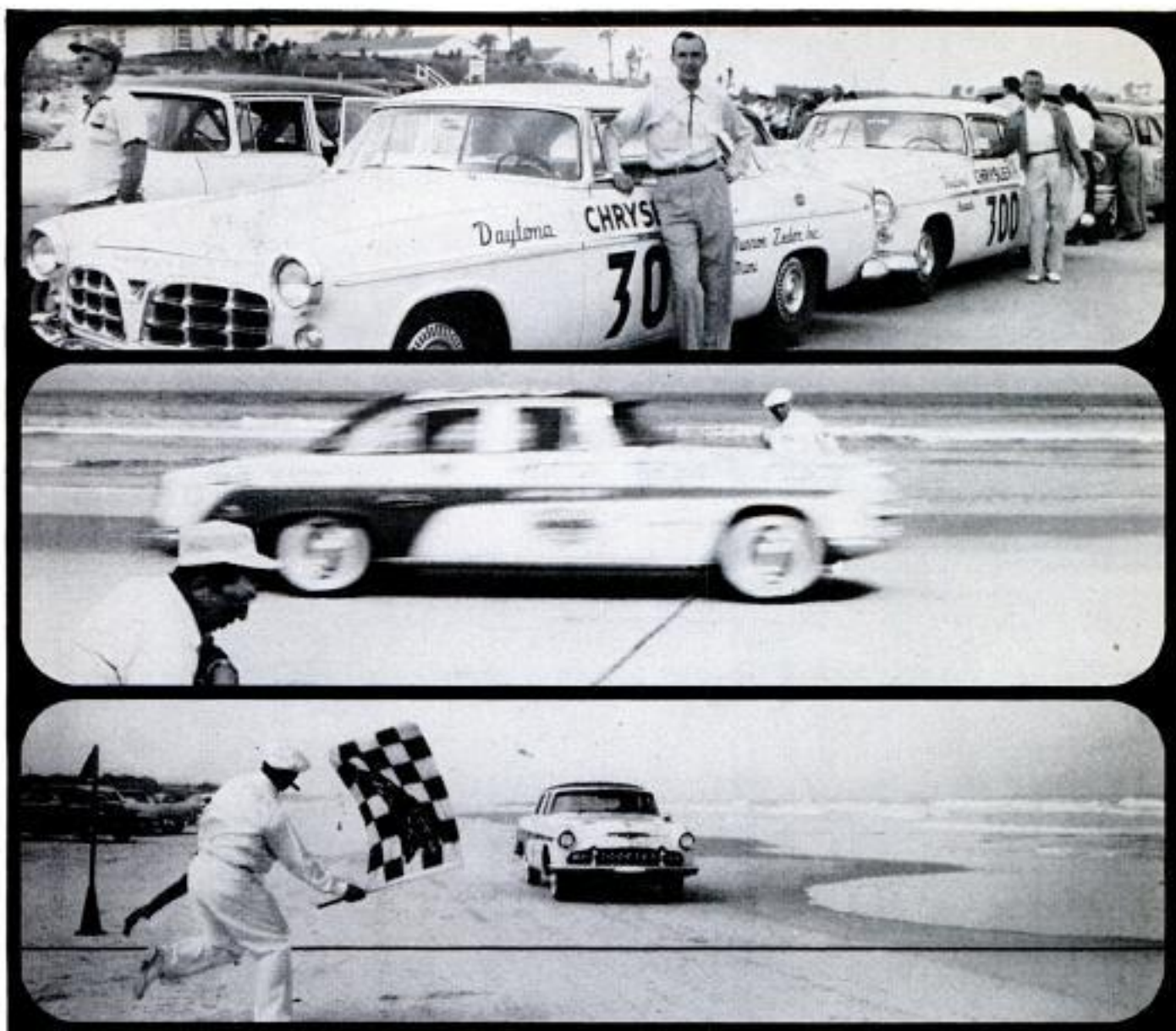

DAYTONA BEACH. Chrysler Corporation cars sweep first and second places in National Stock car races. Chrysler "300" (top picture) breaks record in "Flying Mile" (127.58 mph) and 160-mile Grand National (92.05 mph). De Soto (below) speeds to first place over all cars in its displacement class (112.29 mph).

This, Too, Is **THE FORWARD LOOK**

Another part of THE FORWARD LOOK at Chrysler Corporation is the *finest engines* America has yet produced. Of America's passenger-car manufacturers, only Chrysler Corporation harnesses the extra power and efficiency of the hemispherical combustion chamber used in modern airliner engines. It is not surprising that these V-8 engines break speed and endurance records.

Since the marks shown above were set, 17 more first place wins have been chalked up, plus the dra-

matic victory at the gruelling Mexican Road Race in which Dodge swept the first *four* places over 37 other cars in its class! All told, Chrysler Corporation cars have rolled up enough firsts at tracks across the nation to completely dominate both NASCAR and AAA-sanctioned stock car racing events.

This exceptional performance is another reason for the public's great acceptance of the beautiful cars of THE FORWARD LOOK.



CHRYSLER CORPORATION

PLYMOUTH • DODGE • DE SOTO • CHRYSLER • IMPERIAL

Copyright 1955 by Chrysler Corporation

Tops in TV drama—"CLIMAX"—CBS-TV, Thursdays.

SEPTEMBER 1955

Copyrighted material 239



Get Good Performance the Way Big Fleets Do...

East Texas Motor Freight, Dallas, Uses Federal-Mogul Engine Bearings

Some 500 communities between the Gulf of Mexico and the Great Lakes know East Texas Motor Freight's direct daily service.

ETMF keeps its modern equipment in top shape by careful maintenance work. For many years, ETMF has been a good user of Federal-Mogul engine bearings.

Federal-Mogul oil-control bearings have led in the replacement field for 30 years—because of *quality!* Get this quality, next time your car engine is overhauled. It costs no more to get the best—ask your mechanic!

for New
FEDERAL-MOGUL
Oil-Control
Bearings



RESEARCH • DESIGN • METALLURGY •
PRECISION MANUFACTURING • SERVICE

"Power brakes not as good as previous models. Too much pressure required. I understand this is being corrected."—Michigan salesman.

"Ash trays on dash are inaccessible. Take them out of those corners."—Florida owner.

"Poor visibility of Ultramatic quadrant."—Mississippi minister.

"Needs a full horn ring. Can't find it when I am turning corner."—New Jersey machinist.

"Glove compartment too small."—Michigan service-station operator.

"Buttons on the deluxe-upholstery seat backs are very uncomfortable."—Maine traveling salesman.

"While riding yesterday at 60 miles per hour the hood flew open without slightest warning. Only good luck and skillful driving of those behind me avoided a chain-reaction smashup."—New Jersey architect.

"Hood latch too well hidden and hard to operate."—Connecticut sales manager.

"Surge shock on quick acceleration at 20 to 30 miles per hour. Body should have more sound deadening."—Ohio owner.

What Changes Would You Make?

Because no piece of machinery is perfect we always ask the owners taking part in our surveys to list the one single change they would like to have made in their automobiles. We think that from this survey the manufacturers might learn something that will help them improve their products.

A large number of Packard and Clipper owners do seem to feel their cars are perfect and they are anxious to have no changes made. But there were a few with suggestions for the Packard Company to take seriously.

"I would like better coach work."—New Jersey executive.

"Move the parking-brake handle. It protrudes so far I hit my knee on it getting into the car."—Nebraska salesman.

"Move the brake pedal away from the accelerator."—Illinois engineer.

"All I want is more gas mileage."—South Carolina real-estate man.

"Left-handed ash tray is inconvenient on driver's side."—New Jersey bookkeeper.

"Go back to the pull-out glove compartment they had in 1953 models."—California foreman.

And that is the story of the 1955 Packard and Clipper as told by the persons who own them. These quotations point out the good and the bad, giving you a summary of the car's characteristics from which you can make up your mind. ★ ★ ★

To begin Floyd Clymer's road test of the 1955 Clipper Custom turn back to page 118.

"DO IT YOURSELF"
IT'S EASY WITH
KESTER SOLDER



Soldering's really a "cinch"... when you use time-tested, reliable KESTER... available everywhere.

FREE! "Soldering Simplified"... 16-page how-to-solder booklet. At your dealer or write direct.

KESTER SOLDER COMPANY
4251 Wrightwood Avenue Chicago 39, Illinois

WATCHMAKING

Learn at home • FREE sample lesson • Approved for Vets.
CHICAGO SCHOOL OF WATCHMAKING
2330 N. MILWAUKEE AVE., DEPT. 195-A, CHICAGO 47, ILL.

EARN GOOD MONEY
IN SPARE OR FULL TIME.

With a Universal Lawn Mower Grinder
Have a business of your own in your garage or basement, sharpening lawn mowers. Be your own boss. Small investment. We furnish everything you need to start. Write FREE Dept. M-95 today for complete details



ROGERS MANUFACTURING CO.
LINDSEY, OHIO

Print Your Own
Cards, stationery, circulars, tags, labels, photo and movie titles, advertising, etc. Save money. **Print for Others.** Good Profits! Prices sent. Raised Printing like Engraving, too. Sold direct from factory only. Write for free catalog of outfits and all details. **KELSEY PRESSES, M-37, Meriden, Conn.**

AGENTS — SELL TOOLS! GUNS! CAMERAS!

Buy tools, photo equipment, sporting goods, jewelry and thousand other nationally advertised products at big discounts. Big profits selling to others. Postcard brings free plan.

Get up to **40% off**

AMERICAN BUYERS SERVICE HERTEL STATION, DEPT. 15 BUFFALO 16, NEW YORK

FREE BOAT KIT CATALOG Write: **LUGER INDUSTRIES** DEPT. B 4452 NICOLLET AVE. MINNEAPOLIS 9, MINN.

8' to 14' Models from \$39.95 incl. freight

- Assemble your own boat
- No experience necessary
- Save 1/2 to 2/3 "factory built" prices

12 ft. Runabout Pictured.



KING MIDGET — WORLDS LOWEST PRICED CAR



Lower Priced, greater performance. Drive it for 75c per week. Also KING MIDGET JUNIOR, finely engineered, less than one-third cost of any comparable car, one twelfth cost of large cars. Agents wanted. **IT WILL PAY YOU TO GET THE FACTS.** Send 25c for literature and agents proposition on both cars, or \$1 (refunded first order) for this plus actual assembly book and service manual.

MIDGET MOTORS MFG. CO., Athens 1, Ohio

Shark Brand Swedish Chisels

Makes your job easier.
You'll do neater, more accurate woodworking with SHARK BRAND SWEDISH CHARCOAL STEEL paring chisels... holds its sharpness 3 times longer than ordinary chisels.

Write for Sandvik Folder. Dept. PM
Sandvik Saw & Tool
Division of Sandvik Steel, Inc.
1702 Nevins Road • Fair Lawn • N. J.

AMAZING NEW FORMULA SPRAY-O-NAMEL THE ORIGINAL BRUSHLESS PAINT!

EASIEST WAY TO PAINT LIKE A PROFESSIONAL!

Here's the handiest paint a handy-man can use for re-finishing or re-touching... indoors or out! No fuss, no mess, no brush — just press a lever and spray. **SPRAY-O-NAMEL**, the proven brushless paint, is foolproof. Won't run, won't bubble. Dries to a smooth, durable finish in 5 minutes. "Not an ounce of work in a 12-oz can!"

LARGEST SELECTION OF COLORS
Including: Chrome Aluminum, Golden Lustre, Coppertone, Battleship Grey, Garden Green, Canary Yellow, Medium Blue, Ivory, Pink, Chartreuse, Orchid, Sky Blue, Orange, Chinese Red, Wrought Iron Black, Dove or Maytag Grey, Dearborn Blue, Hollywood Tan, Burgundy Maroon, Ridge Green, Gloss White, Gloss Black, Appliance White, Flat White, Clear Plastic Zinc Chromate — and matched farm implement colors.

Special Introductory Offer to Popular Mechanics readers. Regular \$1.69 price at your dealer now only \$1.25 if you order from this ad. Limit: 1 per customer. Specify color. Order today from Dept. PM.
Send Check or M.O.

LOOK JOE!
NO BRUSH!
NO MESS!

ILLINOIS BRONZE POWDER CO., Inc.
2023 S. Clark St., Chicago 16, Ill.

HAVE FUN!

SAVE MONEY



TRY SUPERSHOP FREE
 Factory To You — \$79.95

Think of the fun you'll have and the money you'll save with your own big capacity workshop. Picture yourself sawing with the 8" ball bearing saw. Or drilling in steel with the vertical drill press. You bore with the horizontal drill—exclusive with SUPERSHOP. You sand with the 8" disc sander. You turn with the 30" lathe. You sharpen tools on the 5" grinder.

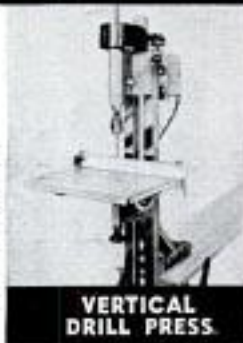

VERTICAL DRILL PRESS.

You are invited to TRY SUPERSHOP FREE. We will pay all shipping expense. Write for full details of this amazing FREE TRIAL PLAN. Mail postcard now.

POWER TOOLS INC.

175 Yates Ave.
 Beloit, Wis.

The easy way to paint!

Speedy Sprayer



Favorite of home owners and craftsmen for 20 years! SPEEDY SPRAYER gives your work that professional paint finish everyone admires. Sprays paint, enamel, varnish, lacquer, etc. . . . 4 to 7 times faster than hand brushing! Lightweight, portable, uses any 1/4 H.P. motor. Improved diaphragm principle assures clean, oil-free air. You'll find dozens of time and money saving uses for SPEEDY SPRAYER, including spraying insecticides 2-4-D and DDT. Complete outfit, without motor, only \$36.50.

At leading hardware, lumber, and auto supply dealers. FREE—write for handy booklet "How to Spray."

W. R. BROWN CORPORATION
 2635 N. Normandy • Chicago 35, Ill.

ONLY
\$36.50
 LESS
 MOTOR

Battery-Operated Intercom

(Continued from page 160)

drilling and reaming. If the unit is wired as shown in the diagrams no difficulty will be encountered in obtaining proper operation. It is suggested, however, that you recheck the wiring carefully before you connect the batteries to the chassis so as to avoid short-circuited batteries or burned-out tubes.

Testing:

When the wiring has been checked, the unit is tested by placing the substation next to the master station and turning on the monitor switch. This activates the amplifier

PARTS LIST

Battery-Operated Intercom System

- R1—25K ohm control #4 taper
- R2—10 meg. 1/2 watt
- R3—2.2 meg. 1/2 watt
- R4—1 meg. 1/2 watt
- R5—3.3 meg. 1/2 watt
- R6—330 ohm 1/2 watt
- C1—.005 mfd.
- C2—.05 mfd.
- C3—.005 mfd.
- T1—Stancor A4744 intercom transformer
- T2—Stancor A3879 output transformer
- S1—Amphenol 78-535 3-prong socket
- S2—Amphenol 78-535 3-prong socket
- P1—Amphenol 71-35 3-prong plug
- P2—Amphenol 71-35 3-prong plug
- Sw1—Switchcraft, type 1009, 3p.d.t. push-button switch
- Sw2—S.p.s.t. toggle switch
- Sw3—S.p.s.t. normally open push-button switch
- SP1, SP2—Jensen "Viking," type 3J6, 3" speakers
- A-Bat. Burgess 2D, 1 1/2 volts
- B-Bat. Burgess XX30, 45 volts (2 reqd.)
- Aluminum case, 3 1/2" x 6" x 8", ICA type 29444
- Speaker case for 3" speaker, ICA type 3987
- Cable, 3-conductor (as required)
- Chassis, 1 1/2" x 4 1/8" x 2 3/4", ICA type 29078
- 1U4 tube
- 3V4 tube
- Tube sockets, Amphenol 147-500 (2 reqd.)
- Knob Nuts
- Battery connectors Screws
- Terminal board Hookup wire
- Solder lugs Solder (rosin-core)

and should cause acoustical oscillations or howls through the speakers when the volume control is at maximum.

These oscillations will cease when the two units are separated by a reasonable distance.

Turn the monitor switch off and take the substation to another room. Have someone press the substation switch and talk into the speaker. The call should be heard clearly at the master station.

The final check involves pressing the press-to-talk switch of the master station to answer the call from the substation. If the operator at the substation can hear the reply, the system is performing properly and is ready for operation. ★ ★ ★



The Fremont
No. 521-S



Certainly
YOU CAN AFFORD TO OWN THIS HOME!

It's America's Most Complete House "Package" and LOOK...

Only \$2895

(WITHOUT BASEMENT)

COMPLETE with Utility Room (Home can be built with full basement if desired.)

Price subject to change without notice. Freight paid in 12 Midwest states.



If you've been putting it off because building costs are too high—PAGEMASTER has solved your problem! Never before have you been able to buy so much house at such low cost. What's more, you help plan it just the way you want it—you erect it the easy way and save even more dollars on construction costs.

No other builder manufactures and ships you a house "package" so complete. When it arrives, it is ready for you to erect it yourself, in just days! All exterior walls are panelized, all openings accurately cut in. Windows and doors are hung in frames, ready to insert into prepared openings. Roof trusses are manufactured in two sections, ready to be nailed

together. No other build-it-yourself house saves you so much construction time, or helps you avoid on-the-job mistakes.

You can't beat the price; you can't match the value! All PAGEMASTER Houses are eligible for VA or FHA financing. Why wish and wait any longer? Write TODAY and let us help you begin planning your PAGEMASTER Home just the way you want it!

Send 25c for our full-color catalog with many exciting new homes to choose from.

Pagemaster
HOMES

300 PIERCE STREET, SHAKOPEE, MINN.

"EXCLUSIVE NORTHWEST PRODUCER" of — "THE POPULAR MECHANICS PRECUT HOUSE" — "PANELIZED FOR EASY ERECTION"

Make your own Gems 29.50 f.o.b.

The Gem Maker comes complete with all necessary equipment, including a super-charged diamond blade for sawing, and all wheels for grinding, shaping and polishing; also complete instructions. The complete equipment as shown, less motor and belt, for only \$29.50, f.o.b., Burlington, Wisconsin. Write today for information and literature.

B & I MANUFACTURING CO.
Dept. 5 Burlington, Wis.

MENDS MOST ANYTHING

"HOLDS LIKE IRON"

Used by fine furniture makers. Ideal for home and office. In 3/4 oz. or 2 1/2 oz. sizes.

STRONG, ECONOMICAL TRAILER COUPLER

Tough, durable drop-forged steel socket keeps your trailer in tow no matter what! Model I-B, illustrated, hauls 2500 lbs., costs only \$4.66 (Fed. tax incl.). Other models to 10,000 lbs. capacity. Write for the dope on our complete line of trailer axles, couplers and parking jacks!

HAMMER BLOW TOOL CO.
WAUSAU 13-1, WISCONSIN

NOW! RCA GEIGER COUNTERS
for professional and amateur prospectors!

6 new models... \$119.50 to \$750*

Prospect With A Geiger Counter Backed By The Greatest Name In Electronics—RCA.

Full-vision easy-to-read meter • Rugged, durable construction • Complete with RCA long-life batteries • Factory-authorized service available • 6 models including super-sensitive units for aerial and car-borne surveys • All-weather metal case—easy to decontaminate.

Write Section I-63MM for illustrated folder.

RADIO CORPORATION OF AMERICA
Radiation Detection Equipment
Harrison, N. J.

*Suggested List Prices

B.F. Goodrich RUBBER FLOOR TILE



MAKE THE TOUCH TEST

Feel how *Super-Density* — found only in B. F. Goodrich Rubber Floor Tile — provides a smoother surface! This exclusive feature eliminates dirt-catching pores, makes floors easy to clean and keep clean!

AND YOU'LL DO THIS!



Install it yourself! Use the special 80-gage household thickness and the handy B. F. Goodrich Self-Installation Kit.



Send for **FREE** full color folder

B. F. GOODRICH Co., Dept. PM9
Flooring Div., Watertown 72, Mass.

Name.....

Address.....

City..... State.....



Garage-Door Sealer Strip

Overhead garage doors are sealed at the bottom by a flexible vinyl strip that is tacked on with a hammer and rustproof nails. The strip cushions the door when it closes and keeps out cold, dust, snow and driving rain. Molded on either side of the strip is a tube which acts as an air pocket. When the door is closed, this tubing presses down against the floor to form an effective seal. It not only keeps water from collecting under the door and freezing, but shatters any ice that has formed on it when the door is released and the vinyl springs back to its normal shape. The stripping, which is 1 $\frac{3}{8}$ inches wide, covers the entire edge of the door and protects it from damage.



Water-Repellent Shoes

Shoes that shed water and still "breathe" result when a silicone is tanned into the upper leather of the shoe. In a demonstration, a treated shoe and an untreated shoe were placed in a salt solution until one was shrunken and curled. The silicone-treated shoe remained straight, soft and flexible. The manufacturer says the treated leather permits the passage of air to maintain foot comfort, but stops water.



STANLEY PUTS SKILL IN YOUR HANDS



The "Yankee" Spiral Ratchet Screw Driver. This is a big, rugged, professional tool that takes the work out of screw driving. It drives and draws screws, and the spring-return handle is always ready *automatically* for the next stroke. Comes with three most wanted bits. No. 130A — \$7.70.



The "100 PLUS" Hammer. A 16 oz. beauty with a selected white hickory handle that *absorbs* impact shocks — doesn't carry it to your hand. All the hammer fine points carpenters look for — 2° toe-in, triple wedging, perfect balance, finely beveled claws. No. 11½ — \$3.75.

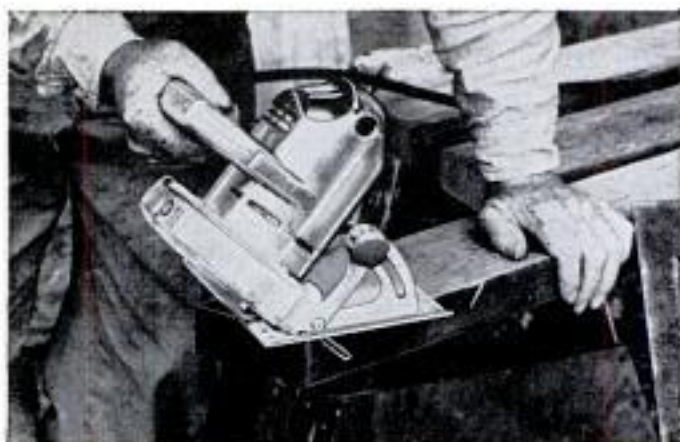

The 7" Builders Saw. This heavy duty, portable electric saw cuts 2 x 4's at 45°. It's a work-hungry tool, loaded with power and designed to make tough jobs easy. Exclusive Stanley "Motor Saver" protects motor from impact loads, as when striking a nail, etc. Multi-grip handle... convenient switch... automatic safety guard. No. H70 — \$77.50.

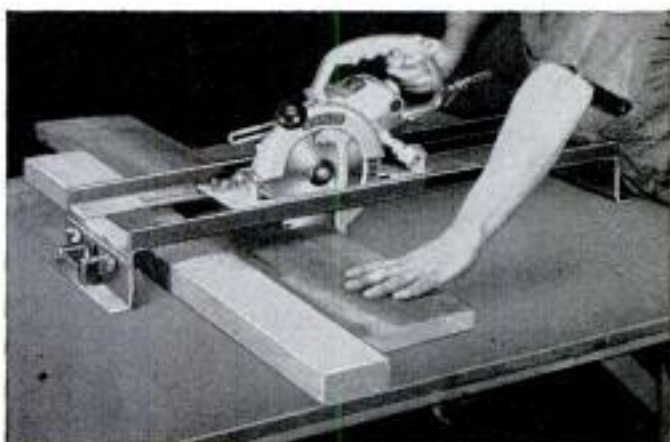

Saw Track for electric saw. This effective device is handy for many saw cuts where accuracy of angle is vital. It's virtually indispensable for production jobs like cutting rafters, fence pickets, etc. Recommended for cutting slate, marble, other stone with abrasive wheel on saw. No. H158 — \$25.75.

STANLEY

The Stanley Works • New Britain, Conn.

TOOLS • ELECTRIC TOOLS
HARDWARE • STEEL • STEEL STRAPPING

SEPTEMBER 1955

Department TE, The Stanley Works,
629 Elm St., New Britain, Conn.

- Gentlemen: Please send me
- free Tool Catalog 55
 - free Electric Tool Catalog EH15
 - 25¢ Pocketbook — "How to Work With Tools and Wood" — I enclose 25¢.

Name _____

Address _____

City _____ Zone _____ State _____

How to choose a paintbrush that does faster, streak-free work



Here's why it pays you to use a brush with Du Pont TYNEX nylon bristles



1. No break-in! You don't have to soak or flex a new brush . . . If it has "Tynex" nylon bristles.



2. Full paint pickup! Specially tipped and flagged "Tynex" bristles hold a full load of paint.



3. Smooth, even flow! Anyone can do streak-free work, because each tapered "Tynex" bristle provides better, more even flow.



4. Easier to clean! They're the easiest-to-clean bristles there are! Paint loosens quickly in any commercial cleaner, rinses out thoroughly.

FREE! 8-page booklet full of helpful painting tips. Write Du Pont Company, Polychemicals Dept. PM-9 Wilmington 98, Del.



"Tynex" is the registered trade-mark for Du Pont nylon bristles.

BETTER THINGS FOR BETTER LIVING . . . THROUGH CHEMISTRY

If I Were a Student Today

(Continued from page 106)

chemical laboratories for investigations of numerous kinds.

And away from the machines are the theoretical scientists, who are making calculations and theories about all the experimental results. They publish their ideas and experimental people are stimulated to try new experiments, and these in turn stimulate new theories.

These activities result in an understanding of the nucleus of the atom. This body occupies only about one millionth of a millionth of the volume of the atom itself. It consists of protons, the nuclei of hydrogen atoms, and neutrons, the neutral particles so important in the chain reaction of the atomic bomb, and they are held together in the nucleus by the most powerful forces that we know of. These studies enable us to know the processes that change elements into other elements and furnish the energy of the sun and stars, and they are leading us toward an understanding of possible processes that produced the atoms and perhaps the whole universe itself.

Our studies join with those of scientists working in other fields. We are learning the age of the earth and solar system; we are supplying materials for research in biochemistry and medicine and in industry.

On the purely human side there exists a fellowship among all true scientists that binds us together with an overwhelming devotion to learn the truth about these unknown things in nature. It is given to very few of us to make truly revolutionary discoveries, but it is given to many of us to contribute something and to be a part of the grand march of scientific knowledge.

All these things are mostly outside the classified activities of the Atomic Energy Commission. They are published in scientific journals and are freely discussed by scientists at their meetings. Most of the work is being done in our universities.

Of course these are not the things which young people who read this article will be doing. None of us knows what will be done some 10 years from now and this is the fascinating thing about science. The future always holds something new, something more fascinating, more unexpected, than the past or present. We are constantly opening new vistas and these you will explore. You will stand before the new machines, or write the new mathematical theories, or think of the new experiments, and ponder the behavior of the newly discovered radiations or particles or the great stellar explosions that originally produced

(Continued to page 248)

Get the oil filter element with the **ACCORDION FOLD**

Dirt particles, so tiny you couldn't feel them in your eye, can cause wear in your automobile's engine. Ford filter elements have an accordion-folded, superfine filter 13 feet long to trap dirt, keep cleansed oil flowing



Genuine Ford Oil Filters are designed with an extra large filtering area to cut engine wear by 60%

When it's time for a replacement in *your* Ford (about every 4000 miles) insist on a *Genuine Ford Oil Filter Element*. It's made to the exact specifications set up by the men who originally built your Ford — so you can be sure you're getting all the protection your Ford's engine is entitled to. What's more you also know that the element you're buying has passed all of Ford's own special endurance

tests before it was authorized for production.

Oil filters, spark plugs, fan belts, mufflers . . . remember *always* to specify *Genuine Ford Parts*. They're made right to fit right to last longer in your Ford!



Keep your Ford all Ford

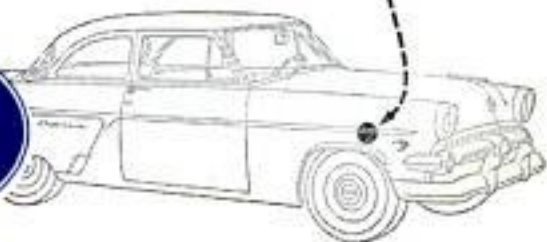

the elements. All of this is a challenge.

On the engineering side the purpose of scientific work is different, though the methods and often the actual experiments are the same. Applied science has for its objective the application of science to useful ends, while pure science seeks to understand natural phenomena.

There are many useful things which can be done with nuclear science, but let us discuss the problem of first importance, namely, economical peacetime use of atomic power. Many predictions have been made in regard to this question, some hopeful and some pessimistic. Of course no one can tell whether atomic energy will ever be economical until many men have really tried to make it so. And this illustrates the fascinating thing about engineering. Is it possible to devise nuclear-power plants such that the cost can be kept lower, say, than efficient coal-fired power plants or water power? The engineer tries his ideas by calculations and model experiments. He is part of a team that is batting ideas back and forth, criticizing, suggesting small or large modifications, or chucking the whole thing for a quite new line of approach.

It is my expectation that the development of atomic energy for power purposes will go forward in this way. We have the *Nautilus*, which is now in the Atlantic

under atomic power. It uses very expensive power, but atomic power nevertheless. Other experimental power plants are being run in the National Laboratories of the Atomic Energy Commission, but these are not economical either, and have been built to learn something about the problem. But before long, power plants capable of competing with other sources of power in special places, where fuel is difficult to secure, will be devised. These will be used in the arctic regions or in the tropics where coal and oil are not available.

The engineer starts with the scientific literature or data collected in industrial laboratories. He has an idea for producing some new product or power plant. He estimates by calculations as to whether it might be possible and economical. He convinces others as to its possibilities. Together they organize a group of engineers and workmen. They hold conferences of the most serious kind, making decisions involving millions of dollars. The plant is decided upon. It grows under the guidance of the construction engineers. In a year or two it is finished and begins operation. The "bugs" are slowly worked out of it. There stands a towering mass of concrete and steel with humming motors and pumps and a glistening control room of dials. It is

(Continued to page 250)

IT SMELLS GRAND



ONCE YOU CATCH
THAT THRILLING SCENT

IT PACKS RIGHT



LOAD UP QUICK -
YOU'LL SEE WHAT'S MEANT...

IT SMOKES SWEET



BY PLEASURE PLUS -
YOUR HEART'S CONTENT!

IT CAN'T BITE!

SIR WALTER RALEIGH'S BLEND OF CHOICE
KENTUCKY BURLEYS IS EXTRA-AGED
TO GUARD AGAINST TONGUE BITE.



FREE!

24-PAGE BOOKLET ON
PIPE CARE. JUST WRITE
TO: SIR WALTER RALEIGH
DEPT. G5, LOUISVILLE, KY.

**USE LUBRIPLATE
ON CATCHES AND HINGES
TO CHASE THE SQUEAKS
THE GREASEMAN MISSES**



TRY LUBRIPLATE! It's a new, white and clean, semi-fluid lubricant that stays put. Stops squeaks, prevents rust and corrosion. Works wonders on your car and around your home.

- In handy 35¢ and 95¢ tubes at hardware and auto supply stores.
- Dealers write to LUBRIPLATE DIVISION, Fiske Bros. Refining Co., Newark 5, N. J.

LUBRIPLATE
THE MODERN LUBRICANT



**NEW, IMPROVED CALCULATOR
FOR WOODWORKERS only 25¢**

Instantly gives information on lumber, nails, concrete mixes, painting materials, etc. Convenient, simple to read. Just set dial for nail specifications, to convert linear to board feet, find bit sizes for screws, compare characteristics of woods. 6" diameter heavily varnished cardboard. Send 25¢, no stamps, please to Greenlee Tool Co., 2109 Columbia Avenue, Rockford, Illinois.

10 New DELTA Hard Cover Books
"How To Get The Most Out Of" your Power Tools. Clearly written, illustrated. New projects, ideas. Write for FREE descriptive folder: Delta Power Tool Div., Rockwell Mfg. Co., 502-J Lexington Ave., Pgh. 8, Pa.



**COMPLETE SOLDERING KIT
only \$7.95**

Includes: Weller Soldering Gun, over 100 watts; supply of famous Kester Solder; Weller Soldering Aid; and Wire Brush. For hobbies and homecraft. Write for catalog.

WELLER ELECTRIC CORPORATION
816 Packer St., Easton, Pa.

**Need an extra \$1,000, \$2,000, or more? Make it with an
IDEAL LAWNMOWER
SHARPENER**



There are thousands of lawnmowers in your locality: Average \$1,000 profit per 250 mowers with customer satisfaction and repeat business assured. Provide this essential service with an Ideal® Lawnmower Sharpener, the only machine that grinds the reel to "fit" the bed knife. Compare by any standard. The Ideal, backed by 53 years of experience, costs no more. Write today for complete, free catalog.

THE FATE-ROOT-HEATH COMPANY
Dept. PM-9 Plymouth, Ohio

Building materials dealer says:

**"Don't just INSULATE—
TWINSULATE!"**



**"New aluminum TWINSULATION
gives you double action!"**

says Guy Mosteller, Rochelle, Ill., building materials dealer shown above installing Gold Bond TWINSULATION® in his own attic. "TWINSULATION is a double barrier against heat. The fireproof rock



wool blocks heat, and the aluminum surfaces reflect heat. Blankets are rugged and easy to install because the rock wool center is sealed to both sides of aluminum covering."

TWINSULATE your attic this weekend! Next winter, your heat bills will be up to 25% lower. In summer, your house will be up to 15° cooler. See your Gold Bond building supply dealer—or send coupon below for fact-filled "Home Insulation" booklet.

NATIONAL GYPSUM CO.
BUFFALO 2, N. Y.



NATIONAL GYPSUM COMPANY
Dept. PM-95, Buffalo 2, N. Y.

I enclose 10¢ for "Home Insulation" booklet.

Name.....

Address.....

City.....Zone.....County.....State.....



OWN YOUR BUSINESS

Start in Spare Time with a FOLEY SAW FILER

Here is a steady repeat CASH business you can start at home in your basement or garage, while you are working at your regular job. No experience is necessary to turn out perfect cutting saws—"the first saw I sharpened came out 100%. I think the Foley Saw Filer is a marvel of perfection," writes Clarence E. Parsons. Every saw you sharpen will bring you new customers. You will find you can make up to \$3 to \$5 an hour—\$20 to \$30 a week in your spare time as a starter. With a Foley Saw Filer you can file all hand saws, also band and cross-cut circular saws. It is easy to operate—simple adjustments—no eyestrain. Patented jointing principle evens up all irregular teeth and makes an old saw cut just like new.

This Free Book Shows How to Start

"MONEY MAKING FACTS" shows you how to get plenty of saws to file without canvassing, and how you can develop into a general repair shop that will be your own business. This is a helpful, practical book that tells just what to do—send for your free copy today. No salesman will call.



Send for **FREE BOOK**

FOLEY MFG. CO., 916-5 Foley Bldg.
Minneapolis 18, Minn.

Send me free book "MONEY MAKING FACTS"

Name _____

Address _____

successful, its power flows over wires, it lights our homes, runs our motors or its chemical product is sold in our markets. The engineer turns his back for he is now on another idea; but don't forget that the thrill that comes from an idea that has grown to a large plant of steel and concrete and many intricate new devices devised by him and others is his even though he laughs it off. Of course, only a few have the great ideas, but many of us are privileged to contribute.

Scientists are broadly educated. We have our specialties in which we spend most of our time and energies. But an ability to use our native tongue skillfully and effectively is important. We are citizens and take an interest in politics. We read the current literature of magazines, novels, serious books and—yes, alas—detective stories. We speak correct English and often a foreign language as well. We dance the "light fantastic" and could tell Milton that it becomes somewhat heavier with time. We accumulate libraries of technical books at the office and of literature and music at home. We travel at home and abroad for pleasure or on business or to give lectures in other universities in our own country and abroad. We belong to the "intellectuals" and are proud of it. Join us, young people, and live in a land of superb wonder, also in a land of work, work, work and in a land of comradeship with interesting people from the entire world.

But can you do this? It is my belief that many people do not have the particular capacities required to make scientists and engineers. However, more people have this capacity than we are accustomed to believe. Moreover, women have become outstanding scientists and the idea that women are inferior to men in this connection is not true. Two women at the Institute for Nuclear Studies at the University of Chicago are accepted on the same basis as men.

It takes many years of study to become a scientist, but all success of a real kind requires much work, study and years of application. Take the long look! Try to think what you may be at 30, 40, 50, not what you will be next year. The solid substantial esteem of your fellows is acquired only through persistence and effort in all fields.

We need scientists and engineers. We need scientists to learn to understand the facts of this universe, both physical and biological and to give us this magnificent understanding of our universe and our place in it. We need engineers and doctors to bring the practical applications of science to our daily lives. We all of us look to the new generation of young people for those who will continue our work. ★ ★ ★

Now! The Lowest Price Ever for a Quality Electric Drill New **SKIL** 1/4" Drill

with Jacobs
Keyless Chuck

only \$19⁹⁵

MODEL 535

No other drill on the market can match this combination of high quality, low price and famous name brand. Here is a SKIL Drill with *all* the features do-it-yourselfers want and need . . . priced for your budget workshop. Use it with accessories for literally hundreds of jobs at home, on the farm, on the job, or to add real pleasure to your own favorite workshop hobby.

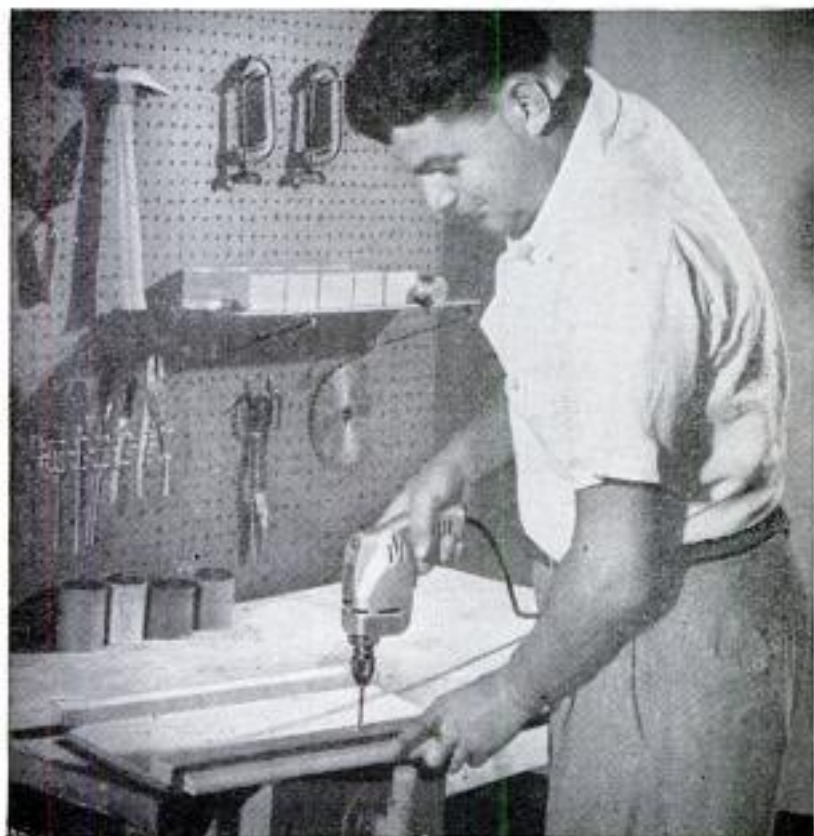

Compare These Features with Higher Priced Drills:

Keyless Chuck allows fast change of drill bits and accessories.

Self-Lubricated Bearings for years of dependable, trouble-free performance.

Hardened Steel Gears assure long life and maximum use of power.

Powerful Motor especially designed universal type for extra power and extra durability.

Pistol-Grip Handle gives greatest comfort and ease of handling.

Trigger-Type Switch with 100% overload capacity. Instant release. Simple locking device for continuous operation.

- 1/4" Capacity in steel, 1/2" Capacity in wood
- 2500 r.p.m. speed
- Only 3 1/2 lbs.

SKIL

BUILDERS TOOLS

Made only by the SKIL Corporation
formerly SKILSAW, Inc.
5033 Elston Avenue, Chicago 30, Illinois
3601 Dundas Street West, Toronto 9, Ontario
Factory Branches in All Leading Cities

**See and try the new Model 535 SKIL Drill at
your hardware, department or appliance store.**

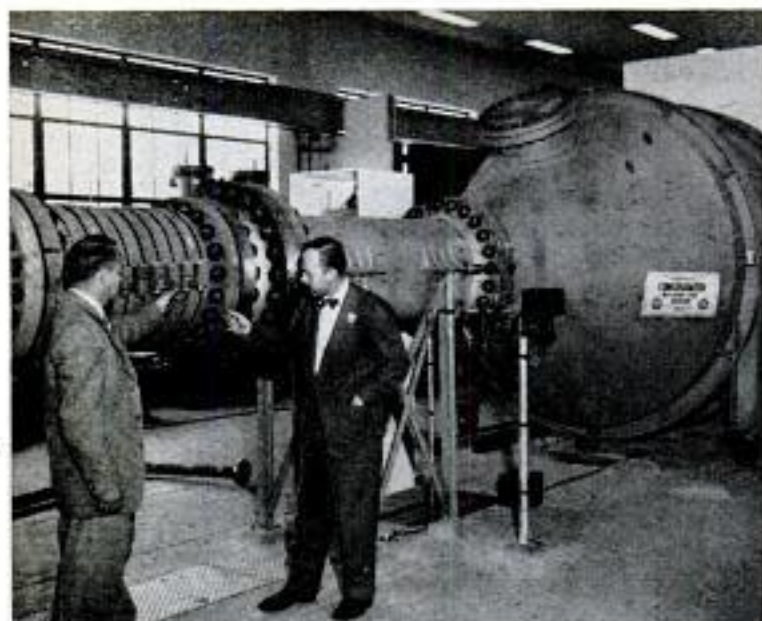

Test section of NACA "hot" tunnel grows four inches longer when heated. Expansion joint being examined here takes up growth

Jet Planes Head for Melting Point

(Continued from page 94)

Base where the Air Research and Development Command has placed special instruments on the Bell X-1B, a rocket plane that can travel at the rate of 1500 miles per hour for short periods of time. At Edwards, too, the NACA is making heat studies with the Douglas X-3, a plane that was designed from the start to beat the problems of speed and heat. The X-3 has been called the "Flying Stiletto" because it is almost 67 feet long but has only a 22-foot wingspan.

The X-3 was built overly strong to make up for the loss of strength that its aluminum and titanium structure would experience at high temperature. Thus each wing core began as a 2000-pound billet of solid

Missilelike probe is visible through double windows of inspection port in test section of NACA experimental hot tunnel



aluminum that was milled down to a grid weighing only 160 pounds. This grid was covered with an aluminum skin $\frac{1}{2}$ inch thick at the wing root and $\frac{1}{4}$ inch thick at the tip.

Instead of insulation, the X-3 depends on a 2500-horsepower refrigeration plant to keep its pilot and instruments cool. The fuel tanks, however, are insulated against aerodynamic heating and, as a final precaution, the plane's fuel is pumped through a precooler on the ground just before a flight. Otherwise the fuel might boil away.

The air that cools the interior of the plane goes through a wide range of temperature changes before it can be used. Air at 40,000 feet has an ordinary temperature of 65 degrees below zero and the temperature of this frigid air is

raised to 300 degrees by ram action (aerodynamic heat) when it enters the refrigeration compressor. Compression further heats the air to 700 degrees. Next an air-heat exchanger pulls the temperature down to 300 degrees again, after which a water evaporator cools the air to 145 degrees. Then, by expansion, it is dropped to 32 degrees, the freezing level.

The final step is to mix this air with warm air from inside the plane, bringing it to a comfortable 65 degrees. This is the temperature of the air that circulates around the pilot in the cockpit. From there the air is blown across the 1200 pounds of instruments on board and finally across the tires and landing gear.

Keeping the tires cool is extremely important in a "steady state" aircraft that is designed to fly at high speed long enough to heat up completely. Without special cooling the tires could cook during a long flight and become so weak they would blow up when landing, wrecking the plane.

Designwise, the X-3 already is a number of years old and now engineers are hoping that they can defeat the heat barrier by new methods. If possible they want to avoid the over-strength construction and the enormous refrigeration plant that are features of the X-3.

It may be, for instance, that an inch of polished glass fiber over a metal framework can be used as a self-insulating airframe. An even newer idea is to coat an aircraft with $\frac{1}{4}$ inch of magnesium-oxide insulation. Figures prepared

(Continued to page 254)

FUEL'S
GOLD...



why waste it!

Is your carburetor goldbricking? Well, you can strike it rich right now with a Rochester Carburetor, any fuel's best friend. You'll get more driving from every drop . . . more "go" from every gallon with a Rochester. Remember . . . Chevrolet, Pontiac, Oldsmobile, Buick and Cadillac *all* choose Rochester Carburetors as original equipment. Be sure to insist on a fuel-saving, penny-pinching Rochester Carburetor for your own car . . . for any car you service!

Insist on...

CARBURETORS BY  **ROCHESTER**
PRODUCTS

ROCHESTER
PRODUCTS
DIVISION OF
GENERAL MOTORS
CORPORATION
ROCHESTER N.Y.

TIME SAVING TIPS

FOR HOBBYISTS WITH

DU PONT DU CO CEMENT

REG. U.S. PAT. OFF.



STRONG

Put tool handles back on to stay—tough, durable "Duco" Cement will hold.



Attach sandpaper to sanding disc face with tight-gripping "Duco" Cement.



CLEAR

Build model airplanes neatly with transparent "Duco" Cement. It's almost invisible and extra-strong.



Upholster a model car—clear "Duco" Cement can't stain the fabric, holds tight even when wet.



FLEXIBLE

Mount arrowheads to file cards with flexible, tight-gripping "Duco" Cement—permits easy cataloging.



Join leather in contrasting colors for novel effects—"Duco" Cement is strong and flexible.



WATERPROOF

Hold radio coil windings tight with "Duco" Cement—it won't absorb moisture.



To make working-model boats really strong and seaworthy, fasten them together with waterproof "Duco" Cement.



A household favorite for 25 years



BETTER THINGS FOR BETTER LIVING
... THROUGH CHEMISTRY

by H. W. Adams, chief design engineer of Douglas, show that the skin of an uninsulated airplane takes on the temperature of the boundary layer in about one minute but that when protected with magnesium oxide the time lag is nearly 10 minutes. When protected with glass fiber the skin never gets as hot as the boundary layer.

Film cooling has been proposed, in which water flowing out of many tiny orifices in the leading edge is converted into steam by the heat, carrying the heat away with it. One difficulty is that a great deal of water would be required.

An intriguing possibility advanced by M. A. Sulkin, North American thermodynamicist, is to manufacture cold air on board a supersonic plane instead of carrying heavy, bulky refrigeration equipment. Tanks of liquid oxygen and liquid nitrogen plus a mixing valve would be enough.

Sulkin points out that the whole problem would be simpler if the pilot could be left on the ground. Still, it's difficult to design untenanted aircraft "because the pilot is an extremely light piece of equipment for the things he can do."

But no one has a good answer for what happens to a pilot who must leave a plane while traveling at a high Mach number. He would be immediately subjected to a hot blast of aerodynamic heat. Even at 1000 miles per hour this would amount to more than 150 degrees the instant he is ejected, though the heat would diminish as he slows down.

Escape capsules seem to be the best answer for bailing out of supersonic aircraft; now it appears they will need to be refrigerated as well as pressurized.

Many of the problems that confront the designers of fast aircraft are even worse in the guided-missile field, for here the speeds are much higher. A nose cone may become incandescent from aerodynamic heat, turning the rocket into a manmade meteor. The rocket might blow up if the heat penetrated into the warhead. One promising suggestion is to use a very thick nose cone of a metal having a low melting point. Its surface would continually melt away and the sloughing metal would carry much of the heat away with it.

Ideas like that, and brand new "cermet" materials that are partly ceramic and partly metallic, are under study. Convair, with a contract to design a ballistic missile that would fly far out into space and then plunge back down through the atmosphere again, has converted war-surplus searchlights into solar furnaces that can produce heats as high as 7000 degrees. The newest materials are being tested at temperatures approaching this heat. ★ ★ ★

BURGESS
flashlight
BATTERIES

BURGESS
CHROME
PROTECTED
FOR
LONGER LIFE
GUARANTEED
BURGESS
CHROME
PROTECTED
FOR
LONGER LIFE
GUARANTEED

BURGESS
PORTABLE RADIO
BATTERIES
LONGER
LISTENING PLEASURE

"A TROPICAL PARADISE
... THANKS TO BURGESS BATTERIES"

A QUALITY DRY BATTERY
FOR EVERY PURPOSE
ASK FOR THEM AT
YOUR FAVORITE STORE

Be Your Own Boss in the Profitable Excavating Business!

**CUSTOM OPERATORS OF
SHERMAN POWER DIGGERS EARN
UP TO \$1,000 AND MORE PER MONTH!**

Wherever you live, you'll find plenty of profitable work the whole year 'round for this versatile outfit . . . not just a "trencher" but an all-purpose excavating machine! Custom operators everywhere are making big money with Sherman Power Diggers. One bought a farm with just 3 years' profits! Work for builders, contractors, utilities, and municipalities on such jobs as • SEPTIC TANKS and DRAINFIELDS • SEWER LINES • FUEL TANK INSTALLATIONS • FOUNDATIONS and FOOTINGS • GAS and WATER LINES • FIELD TILING and many others. The Sherman Power Digger travels quickly from job to job, digs at a fraction of the cost of manual labor. It's simple to operate, easy to maintain, built to last . . . and, complete with tractor, actually costs less than many new cars! Send now for complete information about the easy-to-get jobs for your Sherman Power Digger. No obligation.

SHERMAN PRODUCTS, Inc.
Dept. 1720 Royal Oak, Michigan
SEPTEMBER 1955

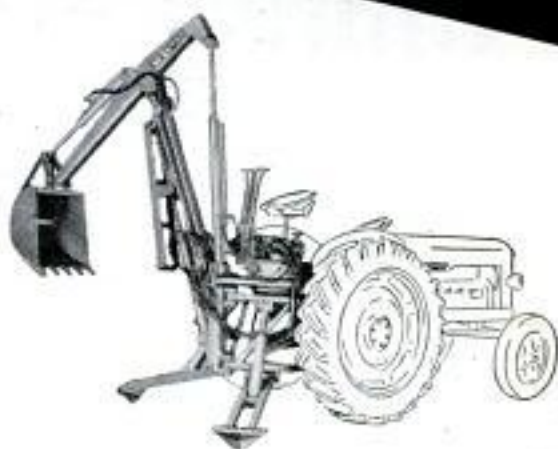

Send Now for FREE LITERATURE!

SHERMAN PRODUCTS, Inc.
Dept. 1720 Royal Oak, Michigan

Please send me complete information on the Sherman Power Digger

NAME _____

ADDRESS _____

CITY _____ STATE _____



It's the
Pacemaker
GRAPHIC® 45

for

BIG NEGATIVES!

A Pacemaker Graphic 45 gives you top quality 4 x 5 negatives using sheet film available in 44 different emulsions to meet any photo requirement. (You can also use economical roll film, film packs or Polaroid film in accessory film adapters.) To correct optical distortion the Graphic 45 has a rising-shifting-tilting front. For 1-to-1 copy or table-top photography use the double extension bellows. No miniature, folding or reflex camera can offer you *all* of these advantages. Ask your dealer for a demonstration or write: Dept. PM-95, Graflex, Inc., Rochester 8, N. Y.

GRAFLEX® *Price-Winning Camera*

Get This **NEW**
Catalog of
WOOD
AND
WOODWORKING
MATERIALS



World's Largest Selection of Finest Domestic and Imported Woods... Mouldings, Hardware, Tools, — ALL AT LOW MONEY SAVING PRICES! Your complete wood buying guide and project book. Craftsman is your best, most complete source of finest kiln-dried domestic and rare imported woods, beautiful wood inlays, colorful bandings, matched plywoods, embossed mouldings, carved ornaments, newest woodworking tools, "hard to find" cabinet hardware and fittings... more than 1,500 items! Packed with newest scroll saw patterns, project ideas & money making plans. Enclose 25c (refunded with first order) to help pay mailing, handling cost. Write now! **Craftsman Wood Service Co., Dept. A-9 2729 S. Mary Street - Chicago 8, Ill.**

148 PAGES
Many in full color
packed with rare, fancy & imported woods... veneers, plywoods, patterns, tools, ornaments, hardware... everything for the woodworker.
MAIL COUPON NOW!

CRAFTSMAN WOOD SERVICE CO.
Dept. A-9, 2729 S. Mary St., Chicago 8, Ill.

Enclosed find 25c. Rush me new Woodworkers' Catalog Handbook.

NAME _____

ADDRESS _____

CITY _____ ZONE _____ STATE _____

Ten Buses Grow Into a Train

(Continued from page 86)

that 400-passenger trains can be turned out for something around \$400,000 to \$500,000 apiece, provided they are ordered in sufficient numbers. This actually is less than the cost of one of the more luxurious dome cars! It's a mighty cheap initial cost, and would put the train right down to where it could be purchased even for suburban service for which it is ideally suited.

If it penetrated the light-train field, Electro-Motive would be bucking some stiff competition. All the major manufacturers are making the rounds like old-time railroad butchers hawking their wares. In this case they're selling lightweight trains. This is the biggest trend in passenger service since the first streamliner appeared in 1934.

For years engineers have been working on the highly publicized Train X, and two of these trains are now under construction, one for the New York Central and the other for the New Haven. The Talgo-style train, originally built by American Car & Foundry for the Spanish National Railways, will appear in an Americanized version this fall. P. B. McGinnis, president of the New Haven Railroad, has stated that he is interested in buying from 20 to 30 of the Talgo-type trains if other railroads will join him with similar orders so the initial cost can be reduced. Actually the Rock Island will be the first road in this country to own a Talgo, which will be delivered this fall. The Rock Island train will consist of four cars, each of them about 109 feet long. Each car really is made up of three articulated subcars. The center section has wheels at each end, while the two outer sections have wheels at their outer ends only, and ride piggyback on the center section. The three-unit car is completely reversible, whereas the original Talgo cars could be operated only in one direction.

One of the big advantages claimed for the Talgo type is that each car actually is steered around a corner. Ordinary rail cars have trucks that are free to pivot on curves. This makes the wheels tend to fight the rails and accounts, in some cases, for the screech as a high-speed train rounds a bend. The Talgo has a linkage system that actually steers each car around curves so the wheels are always tangential to the rails.

Rail-equipment manufacturers aren't just blowing smoke when they point out certain advantages of the lightweight trains. The Talgo, Train X, Budd's new lightweight tubular train built for the Pennsylvania, and the new Electro-Motive bus-train all are built of lightweight materials, have a

(Continued to page 258)

for glass-hard showroom beauty plus protection....
use

a new concept in car polishing
All done with the impregnated

HI-GLOSS TURKISH TOWEL

SO EASY... NOTHING TO IT!... POLISHES THE CAR IN LESS THAN 1/2 HOUR — Just Like a "\$25.00" Professional Job! TESTS PROVE HI-SPEED "HI-GLOSS" FINISHES WAY AHEAD! Beats All Other Methods of Beautifying and Protecting Car Surface! HARDER-SMOOTHER with no hard rubbing

HI-GLOSS Cleaner Polish....	\$1.45
HI-GLOSS Finish Process....	\$2.89
Regularly....	\$4.34
Special Combination Offer Only....	\$3.89



the trick is in the towel!

PROVE IT YOURSELF — GET HI-SPEED "HI-GLOSS FINISH"

If Your Favorite Store, Car Dealer or Service Station cannot supply you — Order Direct From Factory

Chisholm Industries Inc.

LYNN, MASSACHUSETTS

Big Money in AUTOMATIC PARKING

Earn from \$50.00 to \$100.00 or More a Day

OPERATE YOUR OWN PARKING LOT WITH WRRS ELECTRIC PARKING LOT GATES

1. Earns big return on investment.
2. Eliminates all labor costs.
3. Operates with coins, tokens or keys.

You can now earn big money in America's fastest growing industry—the operation of self-parking, off-the-street parking lots—with WRRS Electric Parking Lot Gates. Many WRRS lots now in operation are netting \$75 to \$100 a day, and more. Just think—a hundred-car lot... priced at 50c a car... and turning over just twice a day... grosses \$100 a day or \$30,000 a year. You can easily operate one or more WRRS lots in your spare time and earn that much money.

Yes, these big, easy profits are possible because WRRS Electric Parking Lot Gates eliminate the biggest single cost of a parking lot operation—attendants. Weekly wages range depending on locality. By eliminating this cost, the operator of a self-parking lot can able parking fee and insure heavy

profits. Any industry is a gold mine if it can be operated with no labor. Operation of WRRS Gates is made easy by the use of Remote Controls. They can be operated with coins, keys, tokens, or a combination of two or three of these methods. Here's how they operate! 1. The driver stops at the gate... and without leaving his car, deposits his coin or token or turns his key. 2. The gate arm raises to permit the car to enter. 3. The gate resumes its horizontal position immediately after the car has passed through. It's that simple!

profits. Any industry is a gold mine if it can be operated with no labor.

Operation of WRRS Gates is made easy by the use of Remote Controls. They can be operated with coins, keys, tokens, or a combination of two or three of these methods. Here's how they operate! 1. The driver stops at the gate... and without leaving his car, deposits his coin or token or turns his key. 2. The gate arm raises to permit the car to enter. 3. The gate resumes its horizontal position immediately after the car has passed through. It's that simple!

WRRS Gates are safe, dependable, and built to last many years. They operate in all types of weather. Made by the firm which has built over 10,000 railroad crossing gates, WRRS Electric Parking Lot Gates are sold with our regular railroad guarantee.

Free folder including installation diagram, revenue chart and detailed information sent on request. Get full facts on automatic parking lots—America's fastest growing industry. No charge... no obligation.



WESTERN RAILROAD SUPPLY CO.

2436 S. Ashland Avenue, Chicago 8, Illinois

Gentlemen: Please send me complete information on WRRS Electric Parking Lot Gates.

Name _____

Address _____

Canadian Distributor: Cameron, Grant Inc., 5002 Park Ave., Montreal 8, Quebec, Canada.

TWO NEW **LUFKIN** FEATURES



YOU'LL "MIKE RIGHT" EVERY TIME

With a new Lufkin Big Barrel Micrometer equipped with a friction thimble and a cam lock you can be sure of an exact measurement every time.

First, the new friction thimble automatically stops further pressure on the measuring faces when the correct reading is obtained.

Second, the exclusive new cam lock provides a secure and positive lock with a flick of the thumb. Time-consuming "two handed" locking and the danger of errors through movement while locking are eliminated.

Friction thimble and cam lock are but two of the many features and options on Lufkin's new Big Barrel Micrometers. Send the coupon below for full information—you're sure to find the mike that will please you every time!

BUY **LUFKIN** TAPES • RULES • PRECISION TOOLS
AT YOUR HARDWARE OR TOOL STORE
THE LUFKIN RULE CO., Saginaw, Mich.

MAIL
TODAY

THE LUFKIN RULE CO., Dept. PM, Saginaw, Mich.
Please send me full information on Lufkin Big Barrel Mi-
croimeters.

NAME _____

ADDRESS _____

CITY _____ STATE _____

very low center of gravity and achieve high speeds at low cost.

But some experienced railroaders express precisely the opposite philosophy. They say that passengers who want to get there in a hurry will continue to hop on planes, and that passengers who want to get there at the lowest-possible cost will continue to ride buses. This leaves only one type of passenger for the railroad—the man who wants luxurious travel. These railroaders believe that only special, heavy equipment with all the built-in comforts of a deluxe hotel will attract the traveler. Only time will tell whether they are right.

There's another difference of opinion as to where you will sit when you ride. One idea, expressed in most of the lightweight trains, is to drop the center of gravity and put you as close to the rails as possible. This means, of course, low seats and low windows. Others, particularly those connected with scenic roads, are convinced you'll want to ride high where you can enjoy the view. They're carrying the dome-car trend even farther. Santa Fe, for example, has announced that by the middle of next year its crack chair-car train, the El Capitan, will be completely equipped with ultramodern "Hi-Level" cars. These cars, in effect, are all domes. They are 15½ feet high, about two feet higher than conventional cars. The seats are eight feet above the rails, or four feet higher than the floor of a regular coach. The double-level arrangement eliminates vestibules, thereby adding 28 revenue-producing seats to each car. Doors are located in the center of the car, and luggage is carried on shelves in the lower level. A double-level diner built along the same lines has tables throughout the top level, with the kitchen below. Two elevators carry up your food.

At no time in recent history has railroad travel been in such a state of flux. Most of the railroads are now committed to new equipment of one type or another, with at least half a dozen orders placed for new lightweight, low-slung trains. Actually these are test orders to see how you, the passengers, will like the new equipment. You are the big question mark. Does high-speed, low-cost transportation appeal to you, or do you prefer luxurious travel? Will you continue to desert trains for planes and buses?

Only time will tell, but meanwhile a good deal of radical new equipment will start rolling along the rails. It may set the pattern for rail travel in the future. The streamliner that was such a fascinating sight in the '30s may be destined to join the steam locomotive and old wooden trestle in the railroad's nostalgic past. ★ ★ ★

SHOP BY MAIL and SAVE at GROBAN'S

SURPLUS & NEW MANUFACTURE EQUIPMENT FOR HOME, FARM & FACTORY ALL ITEMS UNCONDITIONALLY GUARANTEED!

A. C. ELECTRIC GENERATOR

ITEM #75-D 7 1/2 K.W. (7500 WATTS) single phase, 110/220 volt output. 3 wire system, 2 bearing construction. 5 groove 6" V belt pulley included. Self-excited. Foot mounted. Drive generator from tractor or stand by engine. Ample power for 6 room house. Dimensions: 34" x 11 1/2". Shipping Wt. 420 lbs. F.O.B. Chicago . . . **295.00**

Complete control box for these generators includes A.C. rheostat, automatic voltage regulator, field rheostat, and voltmeter, already wired and ready to connect to generator. List price \$187.00. Our Price **56.45**

PESCO GEAR TYPE HYDRAULIC PUMP

Compact — Powerful — Reliable

ITEM #160—Especially designed for belt drive from fan belt, power take-off, drive pulley, electric motor or small gas engine. Equally suitable for direct coupling.

Pedestal type mounting with two bolt holes for 3/4" hold-down bolts. Standard 1/2" pipe thread inlet and outlet ports. Delivers 4.5 GPM at 1000 PSI at 2800 RPM with 3 HP. Hardened steel gears turn in dense oilite bronze bearings. Rotation—clockwise facing shaft. Guaranteed trouble-free service. Ship. wt. 6 lbs. F.O.B. Chicago **22.50**

GROBAN FOUR-WAY OPEN CENTER HYDRAULIC CONTROL VALVE

ITEM #126—Four-way open center control valve, with built-in adjustable relief valve factory set at 1000 P.S.I. Spring loaded neutral position. For use with one double acting cylinder. In neutral position cylinder is locked and pump unloaded. Can be used as single unit or mounted in series. Has 3/4" pipe thread inlet and outlet. 1/2" pipe thread cylinder ports. Finger grip handle. Ship. wt. 10 1/2 lbs.

AN OUTSTANDING BUY! F.O.B. Chicago **21.50**

FACTORY-TO-YOU-VALUE PORTABLE ELECTRIC LIGHT PLANTS

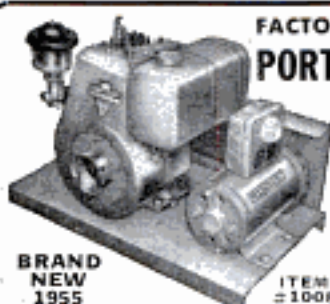

BRAND NEW 1955

POWER TO OPERATE:
 • Electric Saw, Electric Drills, Pipe Bender.
 • Refrigerator, Deep Freezer, Incubator.
 • Water Pump, Radio, Lights, Air-conditioner.

COMPACT — FITS IN THE TRUNK OF YOUR CAR
1000 WATTS OUTPUT, continuous duty. 115 Volts A.C. 60 cycles. 9 amps. Powered by husky, easy starting Clinton engine. Engine and generator operate at 3600 R.P.M. for maximum efficiency at minimum weight. Both units are mounted on steel base, with heavy sheet metal belt guard. Generator is self regulating, and is equipped with outlet box containing fuse and 2 A.C. convenience receptacles. Cost only 5c an hour to operate. Dimensions: Length 20 1/2", Width 12", Height 16". Shipping wt. 100 lbs. F.O.B. Chicago . . . **149.50**

700 WATT-GENERATOR SET—same as above, slightly smaller—with Briggs-Stratton Engine—Model 708—F.O.B. Chicago . . . **129.50**

1500 WATT-GENERATOR SET—50% more capacity—with husky Clinton 3.8 H.P. Engine, \$100 below usual price—Model 1508—F.O.B. Chicago . . . **199.50**

GROBAN HYDRAULIC SPEED REDUCER

with **FINGERTIP CONTROL**
USE FOR: Reamer Drives • Midget Cars • Feed Mills • Ginning Machines • Conveyors • Lathes • Milling Machines • Motor Boats • Cream Separators • Garden Tractors • Pumps.
 Variable output speeds from 0 to input speed available by moving control handle. Locking handle maintains setting. Use input power of 3/4 to 1 1/2 H.P. Shafts 5/8" diam. Input rotation counter-clockwise facing shaft. Input speed 750 R.P.M. 7 1/2" x 3 1/2" x 11 1/2". Gov't acquisition cost \$428.00. Ship. wt. 31 lbs. Complete with 2 qts. of oil and full instructions. F.O.B. Chicago . . . **54.50**

U. S. NAVY ALL BRONZE CENTRIFUGAL PUMP

These all bronze Centrifugal Pumps are ideal for use as marine bilge pumps, circulating pumps, fire protection or irrigation, car-washing, dewatering, basement sump pumping, lawn sprinkling. Will pump water, oil, kerosene, gasoline, DDT and sulphur compounds. Equipped with 6" adjustable V pulley, 2" dia. inlet and outlet, 180 GPM capacity. Inlet and outlet take hose with 2 1/4" inside diameter. Dimensions 11"x8"x11".

Total head-feet	Speed	H.P.	GPM
25	3600 RPM	3	180
35	3000 RPM	1 1/2	90
20	2400 RPM	1 1/2	75

Back plate may be rotated for most convenient inlet position. Shipping weight 31 lbs. Gov't cost \$6.00. F.O.B. Chicago . . . **29.50**

To place phone orders call Webster 9-3793

GROBAN SUPPLY CO. Dept. PM-9
 1139 S. WABASH AVE., CHICAGO 5, ILL.

BELT DRIVEN A. C. GENERATORS

Ideal for powering electric tools, oil burner, refrigerator, lights, or other appliances requiring up to 700 watts of power. **700 WATTS**, 115 Volts, 60 cycles A.C. 3600 R.P.M. Compact, self-regulating generator with V Belt pulley and double outlet receptacle. Rotation counterclockwise. May be driven by tractor or auxiliary gasoline engine. Requires 2 HP minimum. Dimensions: 10" long x 8" high x 6" wide. Shipping wt. 27 lbs. F.O.B. Chicago . . . **59.50**



Model 1010 — 1000 WATTS (Same as above) F.O.B. Chicago . . . **79.50**

RUGGED!! 20 TON MASSIVE!! CAPACITY HYDRAULIC CYLINDER

• ALL STEEL CONSTRUCTION
 • 7 1/4" BORE—15" STROKE
 • DOUBLE ACTION



ITEM #1715
 • 41,300 LBS. PRESSURE WITH 1000 P.S.I. PUMP OUTPUT.
 • UP TO 70,000 LBS.—CAPACITY ON INTERMITTENT SERVICE.
 • SOLID STEEL 2 1/2" PISTON ROD
 • 1" PORTS
 • OVERALL DIAMETER—10 1/4"
 • DISTANCE BETWEEN CENTERS—28 1/4" CLOSED—43 1/4" OPEN.

IDEAL FOR:
 • HYDRAULIC PRESSES • DUMP TRUCK HOISTS • TD-18, TD-24 INTERNATIONAL HARVESTER DOZERS AND GRADERS • LEVELING RAMPS • INDUSTRIAL MACHINERY • ROAD MACHINERY • FARM MACHINERY • HYDRAULIC TAIL GATES
 Replacement cost—\$260.00, Shipping Wt.—155 lbs.
SPECIAL PRICE 80.00
 F.O.B. Chicago . . .

ORDER DIRECT FROM AD SATISFACTION GUARANTEED
 Send Payment Or Purchase Order Today

FREE FALL-WINTER EDITION
 1955 CATALOG, 52 PAGES, chock-full of unsurpassed War Surplus Equipment Bargains for farm, home, factory, workshop. Write letter today.

ACE TOOLS
 No. 8-A SET

Be permanently tool-ed-up for every operation on your Metal Cutting Lathe.

No. 8-A Ace Tool Set for 9" and 10" Swing Lathes—fits shank size 3/4" x 3/4". Includes Turning, Cutting-off, Boring, Knurling and Threading Tools with high speed cutters, blades and wrenches. 8 complete tools in fitted steel case—nothing else to buy. See your local dealer or order direct.

ARMSTRONG BROS. TOOL CO.
 5268 W. Armstrong Ave., Chicago 30, Ill. **\$26.35**

MAGNETS 225 lb. PULL
 GENUINE ALNICO—NEVER WEAKENS

AMAZING, PERMANENT MAGNETS—WILL NOT WEAKEN NON-ELECTRIC
 Retrieve guns, tackle, tools and other steel items from lake, river, plating tanks, drains or other hard-to-reach spots. Recover drills, taps, etc. from sweepings. Clear alley of harmful tacks, nails. Many other uses. Pays for itself quickly. **GUARANTEED**. Try any magnet one week. Money refunded if you are not well pleased.

No. M-725 (Weights 54 oz.) Has pull of 225 lbs. on steel block. **\$15.00**
 No. M-625 (Weights 70 oz.) Has pull of 125 lbs. on steel block. **\$ 8.50**
 No. M-575 (Weights 18 oz.) Has pull of 75 lbs. on steel block. **\$ 6.00**
 No. M-500 (Weights 13 oz.) Has pull of 50 lbs. on steel block. **\$ 4.00**
 No. M-101 U-shaped Magnet (Wt. 2 1/4 oz.) Pull of 6 1/2 lbs. 2 for **\$ 1.50**
 No. M-291 Pocket Magnet (Wt. 1 1/2 oz.) Pull of 4 lbs. 2 for **\$ 1.15**
 No. M-35 Hobbyist assortment of eight small magnets. . . . **\$ 1.50**
 No. M-48 Powerful Hot Pad Magnets. 8 for \$1.00. 30 for **\$ 3.00**
 Send Money Order or Check. We pay postage. No C.O.D.'s.
MIAMI MAGNET COMPANY, 3240 N. W. 27th Ave., Miami 42, Fla.

SAVE on air conditioning



with RED TOP Insulating Wool

It pays for itself. You can save on air conditioning costs two big ways by insulating walls and ceiling with RED TOP WOOL:

1. A smaller, less expensive central or room air conditioning unit will do the job (saving you *hundreds* of dollars, in the case of a central unit).
2. Operating costs drop sharply (cutting them in half is not unusual).

Add to this the saving in winter heating costs, and RED TOP becomes a long-term investment that soon pays for itself.

Fireproof RED TOP mineral wool is tops in heat-stopping, heat-saving ability. Preformed batts and blankets for installing between open studs, joists or rafters. Nodulated for pouring or pneumatic blowing. For details, write Dept. PM-4, 300 W. Adams St., Chicago 6. *T.M. Reg. U.S. Pat. Off.



UNITED STATES GYPSUM
the greatest name in building

Only HOLD-E-ZEE The Original AUTOMATIC GRIP SCREWDRIVERS

PROVIDE THESE FEATURES:

- LOK-BLOK that makes blade twist and impact proof.
- GRIPPER that snaps back—recedes deep into handle, giving full blade use.
- HAND GROUND BITS—chrome vanadium, chrome plated blades.

YET COST NO MORE THAN
ORDINARY SCREWDRIVERS

UPSON BROS., INC., ROCHESTER 14 N. Y.



At Leading Dealers
Everywhere!



\$5 CASH AN HOUR!



Write today for
FREE BOOK

sharpening circular saws, planer and jointer knives in your home or garage... spare time. No experience needed. Hundreds of jobs in your neighborhood... no canvassing... no selling. Only \$15 down brings you this money-maker. Write today to:

BELSAW MACHINERY CO, 1646 Field Bldg., Kansas City 11, Mo.



Find URANIUM!!

GEIGER COUNTERS for uranium detection. All models and sizes— from low-cost, portable to super-sensitive airborne units. Prices start at \$37.50. Also TREASURE DETECTORS and MINERALITES. • **FREE INFORMATION** •

Detectron CORP.
5528 Vineland, North Hollywood, Calif.



Do-it-yourself Furniture for Small Fry

16 pieces made of selected hardwood, factory sanded, ready to paint, for children from 2 to 7 so you can now furnish "the most important room in the house" on a budget. Write

First Furniture

LANCASTER 2, MASSACHUSETTS



DRAINS cellars, cisterns, wash tubs; \$6.95 IRRIGATES - CIRCULATES - SPRAYS

Type P Pump has 1,001 uses. Up to 3000 GPH; 450 GPH 80" high; or 1800 GPH from 25' well. Use 1/8" 2" HP motor. Coupling included free. 1" inlet; 3/4" outlet. Stainless shaft. Won't rust or clog! Postpaid if cash with order. (West of Miss. add 50¢)

MONEY BACK GUARANTEE
Centrifugal and Gear Pumps in All Sizes
LABAWCO PUMPS, Belle Meade 7A, N. J.

FREE AMAZING NEW BOOK "HOW TO ANSWER ADS"



Never before have you seen anything like this. Tells you in simple language the correct way to answer ads. Gets you quicker replies—better results, and greater satisfaction. Will save you time and money and it's ABSOLUTELY FREE. No obligation whatever. Every reader of advertising should have this booklet. Send a postcard for your copy NOW. F. W. JOHNSON, Popular Mechanics Magazine, Room 600-A, 204 East Ontario Street, Chicago 11, Ill.



YOU CAN BUILD A VIOLIN FOR PLEASURE OR PROFIT

Now you can build a rich toned mellow violin modeled after a famous "Strad." YOU CAN MAKE A STRADIVARIUS VIOLIN contains 8 full scale plans plus complete instructions. You work directly from the plans with no confusing scale of dimensions to translate. Detailed instructions for each step including varnishing and stringing—even shows how to build your own tools. Cloth bound. Order today from:

POPULAR MECHANICS PRESS . . . \$3.50
200 EAST ONTARIO STREET, CHICAGO 11, ILLINOIS

**GIGANTIC
SAVE-TO-70%**

MAIL SALE

**WAR SURPLUS
EXCESS INVENTORY
BANKRUPT STOCK**

A-C TRANSFORMER

• Finest new Govt. transformer, step 115-v. up to 230-v. or 230-v. down to 115-v. 60-c.
• Rated at 3,000-w. Many uses home and business. Govt. Cost \$50.00. **SALE, PREPAID, \$29.35**



ARMY POWER PLANTS

• Marvelous buys in new condition Govt. surplus plants and generators. We pay freight!
• 1000-w, 115-v, 60-c, \$149.50
• 2000-w, 115-v, 60-c, \$289.50
• 3000-w, 115-v, 60-c, \$349.50
• 7500-w, 115-v, 60-c, \$570.00
• 3000-w, DC generator \$58.75
Send for free bulletin



AIR COMPRESSORS—TANKS, Etc.

Save to 70% on air fittings, tanks, compressors, etc. See our catalog.
• Piston Air Compressor, 150 lb. \$18.91
• Air Corp 300-lb. Pressure Tank \$6.79
• Auto Pressure Switch for Motor \$4.95
• Professional Paint Spray Gun \$9.95
• DeLuxe Air Kit complete \$45.49

SPECIAL LISTINGS

• We list below some really super pre-paid-to-you bargains available in limited quantities. Order promptly to avoid losing out on these fine buys.
• \$3,000 Giant Searchlight (FOB) \$159.50
• 30" Window Fan Kit \$15.95
• \$380 Adv. Air Corp Light Set \$19.81
• \$65 Centrifugal 1 1/2" Pump \$24.61
• \$98 Centrifugal 2 1/2" Pump \$44.37
• \$150 Experimental Amplifier \$6.97
• \$135 AC-DC Power Rectifier \$19.61
• 115-v AC Electric Chain Saw \$89.25
• \$175 5-row Weed Spray Outfit \$97.65
• Genuine Eastman Film and Paper 70% discount
• \$87 Hydraulic Cylinders \$3.89
• Also Hydraulic Pumps, Valves, etc. Save 60%
• Navy Steel Letter Dies \$6.91

ARMY SLEEPING BAG

• Finest wool O.D. color, very warm. Zipper closer. Fraction original cost. Only \$4.29 Prepaid
• Water proof cover \$1.45 Extra



SPECIAL OF THE MONTH!

GIANT FRESNEL FLOODLIGHT
over 2,000,000 candlepower!!!

• Marvelous light for advertisers, contractors, parking lots, merchants, night clubs, etc.
• Consists of immense "light house" type multi-element optical lens that focuses and multiplies light into wide high intensity beam.
• Complete with colored clamp on filter (for special color effect) also two 115-v, 1000-w, Mazda bulbs.
• Lamp has hi-speed powerful 115-v, 60-c, motor fan in base for cooling high intensity bulbs. New and perfect.
Govt. Cost \$860.
SALE, PREPAID \$44.50



SPECIALS FROM PREVIOUS ADS

• 6-v, Hydraulic Pumps 2500 Lbs. \$45.40
• Precision Surveyors Tripod Level \$37.95
• Automatic Remote Control Switch \$13.85
• Army Tool and Parts Cabinet \$7.99
• Selsyn Motors, 110-v, 60-c, Pair \$12.97
• Electrical Experimental Kit \$4.99

We pay transportation except where FOB. Write for large FREE Catalog. 100s items.

BURDEN SALES COMPANY
811 O St., LINCOLN, NEBR.

SEAW PLOW, CULTIVATE, MOW, RAKE
BULLDOZE, SNOWPLOW
SAW WOOD

TRACTORS

Just steer it with power turn. Several walking & riding models up to 14 H.P. Low price! Write for FREE literature.

SHAW Manufacturing Co.
Front St., Galesburg, Kansas
668-G N. 4th St., Columbus, Ohio

HELPFUL BOOKS

Send post card asking for FREE catalog

Popular Mechanics Press, 200 E. Ontario, Dept. 601, Chicago 11

Do it Yourself and SAVE!

**MOULDING, PLANING,
EDGING, SANDING,
JOINTING**

On the Job!

Std. Model ES-1
no blower or
fiber
hold-downs

Only
\$66.50

Model ED-1 \$88.50
Deluxe with blower
and fiber hold-downs

Head-Feed Drive
Bench Model (in
draw) 12"x4" Bed
Heavy cast, precision
ground. Shipping wt.
712.

Here is the low-cost, hand-feed bench model Moulder-Planer you have been waiting for! Especially designed for the home workshop, hobbyist or specialty woodworking shop, this rugged machine produces fine finishes in equal stock capacities as larger, more expensive models. Selected moulding patterns can be produced in widths up to 3 3/4". Planing capacity 4"x6" or 11" wide on second pass. Dealer franchises available. Territories open for factory reps.

SEND FOR FREE BROCHURE

of Complete Information

**EASTMAN FOUNDRY
& Machine Co., Inc.**

Dept. FW-953 113 Fair Street, Lenoir, N. H.
Division of HERBERT MFG. CO., Inc. 1912



PREVENTS RUST!

3-IN-ONE, unlike most ordinary household oils, actually prevents rust. No wonder 3-IN-ONE outsells all other home lubricants!



"3-IN-ONE" OIL

THE NEW DALTON Model D-500 ELECTRIC PORTABLE JIG SAW

7 SAWS IN ONE!

does the work of a RIP...
CROSS CUT... COPING...
JIG... SCROLL... BAND
and KEYHOLE SAW
CUTS ANY MATERIAL!
SAWS ANY SHAPE!

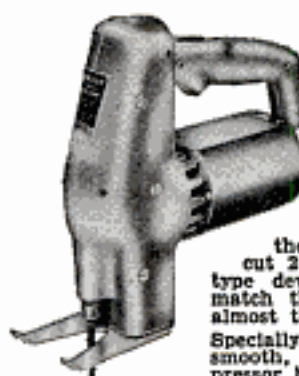

RIPS and CROSS CUTS 2x4's

Makes fast, smooth cuts... no jumping or chattering. Has the capacity to rip and cross cut 2 x 4's. The only other similar type device on the market that can match this amazing performance costs almost three times as much!

Specially built Dayton motor assures smooth, steady cutting. A built-in compressor blows sawdust away from guide line.

SPECIFICATIONS

• 4 to 1 gear reduction. • All gears hardened steel.
• Motor exposed for cool running. • Oilite bronze bearings.
• Air is pumped from top down through the center section, cooling unit as well as blowing sawdust from line.

IT CUTS wood — plastics — metals — composition boards — hard rubber and others.

IT SAWS circles — curves — straight lines — intricate designs.

Complete with 5 different blades
\$48.00

**SHIPPED ON APPROVAL
NO MONEY WITH ORDER — NO C. O. D.**

Try it ten days before you buy. If completely satisfied then send \$15.00 and pay balance at rate of \$11.00 per month for 3 months — No interest or Carrying Charges Added. If not completely satisfied, return to us, no explanation necessary.

KAPNER HARDWARE, INC. Dept. A-144
452 E. Tremont Ave., New York 57, N.Y.
Please rush one D-500 Jig Saw. I agree to pay \$15.00 within 10 days after receipt and \$11 per month thereafter.

Name _____
Address _____
City _____ State _____



**BETTER PERFORMANCE
IN ALL KINDS OF WEATHER**

Whether it is 100 in the shade or 30 below zero, your car will start quicker and run better with a Bendix* Electric Fuel Pump. It's easy to install and costs less per mile of operation than any electric fuel pump on the market. Sold by independent garages and service stations.

*REG. U. S. PAT. OFF.



FREE: A descriptive folder is yours for the asking. Write today.

Bendix

ELECTRIC FUEL PUMP

Grand Prix Winner

ECLIPSE MACHINE DIVISION, BENDIX AVIATION CORP.
ELMIRA, N. Y.

STANSTRIP* seals out
water, snow,
dust and drafts
—seals in heat



For the bottom
of overhead-type
garage doors

**DO IT YOURSELF
QUICKLY
...EASILY**

StanStrip is a Do-It-Yourself product, easily installed... a durable, live rubber weatherstrip that seals out weather and cushions door closing. Lasts for years. Pays for itself quickly. Available at leading hardware and lumber dealers.

*Trade-Mark



The Standard Products Co.
BUILDING PRODUCTS DIVISION
Port Clinton, Ohio

HOME PAINTING TIP NO. 8

SEPARATE COLORS the professional way when painting. "SCOTCH" Brand Masking Tape makes a neat, clean edge. Sticks tight to prevent "bleeding", but strips off easily. Flexible backing stretches to conform with irregular surfaces. Get "SCOTCH" Masking Tape in the convenient dispenser box—35¢, 69¢, 98¢ or \$1.69—wherever paint is sold. Minnesota Mining and Mfg. Co., St. Paul 6, Minn.



1956 CATALOG—Send 35c

70 Models for 1956! See the world's finest line before you buy. Rated tops in design, styling, performance by the experts. 1956 catalog plus booklet "Boat Selection, Operation, Maintenance" \$1.00

Custom-Craft
THE ORIGINAL "PACKAGED"
BOAT KITS

**BOAT PLANS
AND FULL-SIZE:
PATTERNS**

Over 100 Modern plans and full size patterns. Racing classes, cruisers, inboards, outboards, sail boats. By famous designers. 6' to 30' DESIGN CATALOG only 35c. For Design Catalog plus boat building handbook send \$1.00.

CUSTOM-CRAFT (DEPT. A) BUFFALO 7, N. Y.

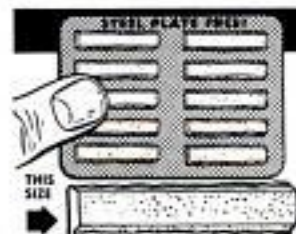

10 ALNICO V MAGNETS \$1.00

Powerful, permanent, rust-proof Alnico V magnets have 1000 uses in home, workshop, drafting room, plant. Hold notes, lists, prints, maps, work sheets. Magnetize pot holders, towels—perfect for cupboard door closures. Postpaid, no C.O.D.'s. Fun for all! Order today.

Dept. P1, MAGNEX, Inc., 851 Broadway, Denver 3, Colorado.

**THE BEST
IN PLIERS?**

CHAN NEL LOCK

CHAMPION D'ARMENT TOOL CO., MEADVILLE, PA.



AIRWAY COMPASS fits all autos boats, planes

SELF-LIGHTED, INSTANTLY INSTALLED no wires to hook up—no holes to drill. Same guaranteed performance that won Sherrill Compasses the ARMY-NAVY award for dependable service all over the world. 7 pastel colors—blue, green, white, gray, yellow, tan, coral. Complete, only \$3.98.

At dealers, or write SHERRILL PRODUCTS CO., MEXICO, IND.

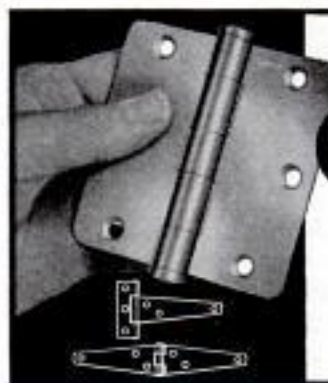

best hardware..
for hard wear

**GRIFFIN
HINGES**

at your hardware or
building supply store

GRIFFIN MFG. CO., ERIE, PA.



BUILT-IN BUNK BEDS
save space in small rooms; drawers store sheets, blankets, pillowcases.



IRONING BOARD
swings out from recess in counter top; it saves space and it's always handy.

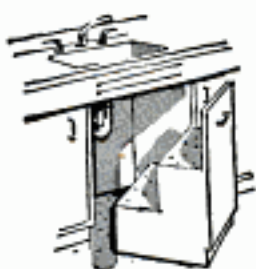

KITCHEN STEP STOOL
looks like under-sink cabinets, helps reach high shelves.

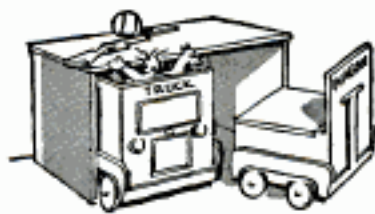

TOY CHEST
has roll-out drawers and seat painted like fire truck, moving van or rocket ship.

Built-ins are easy to plan, easy to make with superior Weldwood Fir Plywood

Built-ins teach an old house new tricks—make even a new house more livable with Weldwood Plywood.

Built-ins can save Mom hours in "picking-up" time around the house. When there's a place for everything, she'll be amazed at how much less housework there is to do. Rooms actually look larger, too!

See your lumber dealer this weekend; he'll be glad to help you plan your built-ins. And insist on the best—Weldwood Fir Plywood—for an easier, finer job.

ASK YOUR LUMBER DEALER FOR **Weldwood®** DOUGLAS FIR PLYWOOD

A product of UNITED STATES PLYWOOD CORPORATION
World's Largest Plywood Organization

New Do-It-Yourself Book!

Brand-new 40-Page Weldwood booklet shows you how to make plywood joints, how to wood panel a room, discusses glues and how to use them, has dozens of pictures of finished projects. Send for your copy!

PM 9-8

United States Plywood Corporation
Box 61, New York 46, N. Y.



Enclosed is 25¢ . . . please rush "Do-It-Yourself" book.

Name.....
Address.....
City.....State.....

Also Adult Eshelman 2 Passenger Sport Cars
1/5 The Price of any other Auto
70 Miles Per Gal.
Free Catalog.

MAKES FLOWS CULTIVATES HARROWS HAULS SPRAYS SAWS DOZER MOWS CUTS ROLLS TILLS SNOW FLOW

ESHELMAN

FOR Better LAWNS And GARDENS



Rotary Tillers Riding Mowers Tractors Low As **\$69**

Women can operate it. 1 to 8 H.P.

Shipping Points: BALTIMORE, CHICAGO, RENO
Free Catalog Write: ESHELMAN CO., Dept. R-58
109 Light St., Balto. 2, Md.

START YOUR HOME WORKSHOP WITH THIS BASIC POWER TOOL

Mall

Model 149B Improved
1/4" Electric Drill



- More Speed
- Greater Power
- Ball Bearing Construction

\$23.95
with Geared Chuck

Start with the versatile Model 149B. It drills in wood, metal, plastics, and ceramics. Then add low cost Mall attachments to do other shop jobs. The drill makes every attachment a power tool . . . at a fraction of the cost of buying special power tools for every job. It's the money-saving way to build a home workshop.



SEE YOUR MALL DEALER TODAY FOR THE BEST POWER TOOLS—AT LOW PRICES

MALL TOOL CO. PORTABLE POWER TOOLS
GASOLINE • ELECTRIC • AIR
7805 South Chicago Avenue, Chicago 19, Ill.

Send me your FREE Do-It-Yourself Booklet.

Name.....
Address.....

HU-188

make those "HIGH, HARD ONES"

... with the new

CARLSON

12 FT. BIG CHIEF

3/4" Wide White Blade

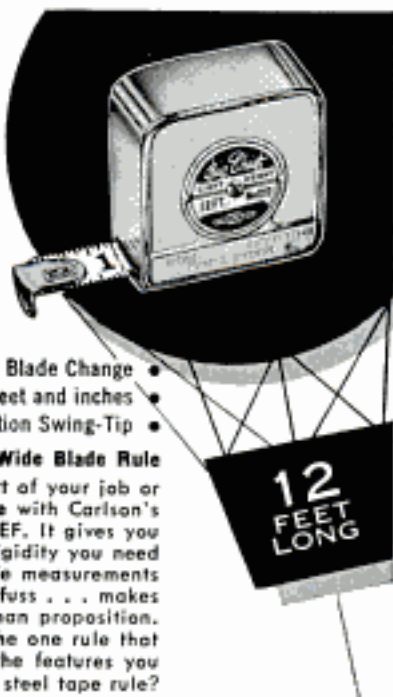

12 FEET LONG

- Handy 10-second Blade Change
- Double graduations—feet and inches
- Easy action Swing-Tip

By the Originators of the Wide Blade Rule

If measuring is a part of your job or hobby, make it a pleasure with Carlson's new, longer BIG CHIEF. It gives you the extra length and rigidity you need to make those high, inside measurements without strain or fuss . . . makes measuring a one-man proposition. Why put off owning the one rule that gives you all the features you need in a steel tape rule?

PRODUCED UNDER PATENTS 2089209, 2810939, 2629180 AND PAT. PENDING
CARLSON & SULLIVAN, INC. MONROVIA, CALIFORNIA

How \$19.95 can save your family, your home...



You're asleep. A fire starts. Every second is vital.

Automatically, a loud clear alarm sounds. Gives you precious extra time that can save your life, your family's, your home.

Only \$19.95, the Edwards Home Fire Alarm stands guard . . . watches over your loved ones every minute of every day and night. Gives added assurance too when there's a baby sitter that your children will be safe.

Easy to install. Run bell wire to heat-sensitive Edwards detectors. Fasten them to ceiling in furnace room, storage area. Mount signal unit in or near bedrooms. Connect the two detectors, plug in. That's all. (For protection in every room, use additional detectors, \$3.50 each.) Signal unit is only 5"x7". UL listed, 2" detectors operate at 140°.

At electrical or hardware dealers. Automatic, electric, fool-proof, Edwards Home Fire Alarm gives permanent peace of mind, freedom from fear of fire . . . for only \$19.95. Act now.



Available in flush and plug-in models.

So sensitive a lighted match sets off alarm!



EDWARDS HOME FIRE ALARM

Fire alarm systems for schools, hospitals, industries, offices . . . since 1872.

MAILING THIS TODAY MAY ONE DAY SAVE YOUR LIFE

EDWARDS CO., INC., Dept. PM-9, Norwalk, Conn.

Please send further information on the Home Fire Alarm.

(In Canada: Address Owen Sound, Ontario)

Name _____

Address _____

City _____ State _____

101 FREE TIPS

For the Handyman who works with wood

SEND for this informative booklet ON

WOODLIFE
The Original WATER REPELLENT PRESERVATIVE



Anything made of wood — and this folder illustrates 101 items — should have the water repellency, resistance against warping, swelling and shrinking — and immunity against termites and decay — made possible with Woodlife.

Woodlife is the original water repellent wood preservative containing PENTACHLOROPHENOL that should be on every handyman's work shelf — along with this folder which shows how to apply Woodlife to 101 household wood-working projects.

Woodlife is made by the makers of P.A.R., the water repellent, glossless finish that protects and restores the natural beauty of Redwood and Red Cedar.

Send for the "101 TIPS" Booklet, TODAY!

Protection Products MANUFACTURING COMPANY
Dept. Q Kalamazoo, Michigan

When you repair, remodel or build, always ask for Woodlife-treated lumber!



REPLACEMENT TOOL HANDLES

5 SIZES Your tools work easier, more comfortably— with new AB Long-Life Replacement Handles. Only \$1 FIVE sizes, 3/4" to 6". Fit most tools—rasps, files, chisels, awls, screw drivers. Lead alloy ferrule holds tool secure. Just press it on! A B MFG. CO., Dept. P, 1168 N. 50th Place Milwaukee 8, Wisconsin

WELD BRAZE
SOLDER CUT



4WAY
ONLY \$14.75
f.o.b. factory

WELDER
Complete with Twin Carbon Arc Torch and accessories . . . to handle all metal-craft work.

Acclaimed by thousands of Homeowners, Mechanics and Hobbyists as the welder of 1001 uses. Easily operated from properly wired 110 volt AC or DC line. The ideal gift with a life-long use. . . Order today on 10 day money back guarantee.

FOUR-WAY WELDER CO., Dept. F2-J
1810 S. Federal St. • Chicago 16, Ill.

Protect your home against power interruptions with an . . .

ONAN Emergency ELECTRIC PLANT

Provides dependable standby electricity for heating system, pumps, freezer, lights, appliances. Keeps home safe, livable. Automatic start and stop. Find out how little it costs!

Write for Folder!

D. W. ONAN & SONS, INC.
3311 University Ave. S. E. • Minneapolis 14, Minnesota

A SIZE FOR EVERY NEED
400 to 75,000 watts. Compact, quiet-running, easy to install. Gasoline engine powered.

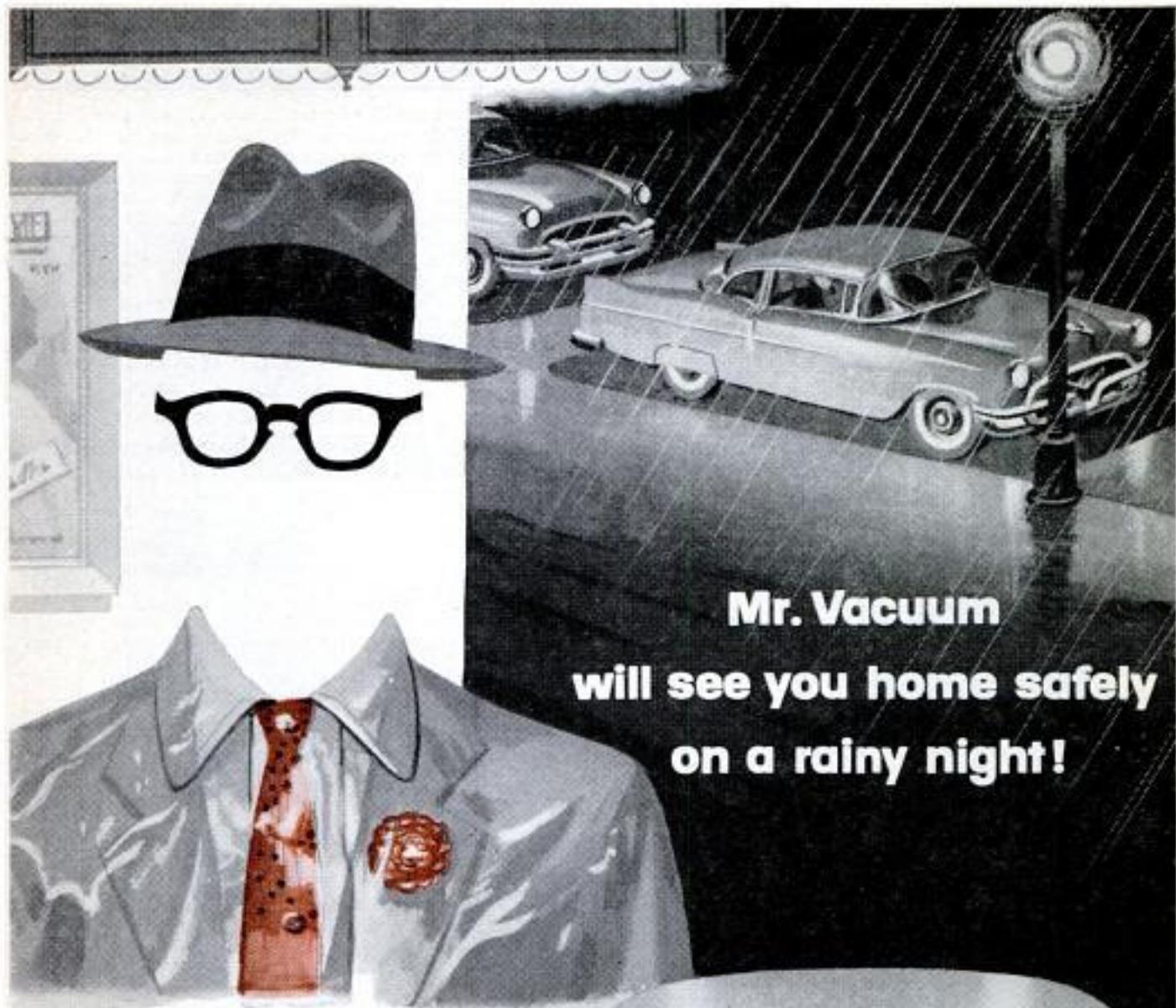

**Mr. Vacuum
will see you home safely
on a rainy night!**

It's dark—it's rainy—there's heavy traffic—visibility is poor! Safe vision at such times depends upon strong, steady windshield wiper action to keep the obscuring rain cleared from the glass. That's when you need the help of Mr. Vacuum!

That's what an AC Combination Fuel and Vacuum Booster Pump provides. Perhaps your car has one—many cars do. If not—your AC dealer can easily replace your present fuel pump with this double-value, double-purpose AC product.

Safety is everybody's business. You'll drive under trying conditions more safely, more comfortably, and with less fatigue if you ride with Mr. Vacuum. It's the extra vacuum power that insures safer vision.



DEPENDABLE FUEL SUPPLY PLUS
DEPENDABLE WIPER ACTION—
EVEN WHEN YOU SPEED UP

AC SPARK PLUG DIVISION • GENERAL MOTORS CORPORATION
FLINT, MICHIGAN

AC FUEL PUMPS ARE STANDARD FACTORY EQUIPMENT ON 9 OUT OF 10 CARS AND TRUCKS ON THE ROAD TODAY!



TIME-SAVING *Snap-on* FERRET SET

Here is one of the most useful of wrench sets... Snap-on's Ferret General Set 272-F.B. This carefully selected assortment provides the basic handle equipment and 59 sockets needed to handle a majority of nut turning jobs in automotive, aviation, refrigeration, and other service fields. Within its size range, no other set of wrenches can equal it for convenience and dependability. Set includes specially designed Metal Box with Tote-tray. HANDLES: Ratchet, Ratchet Adaptor, Speeder, Sliding Bar, Nut Spinner, Extension Bars, Flex-tension, Universal Joint. SOCKETS: Wide assortment, 1/4" to 3/8". Single and Double Hex Sockets, Double Square, Flexockets, Drivers, etc. Order direct from factory. For free catalog of Snap-on tools, write

SNAP-ON TOOLS CORPORATION

8062-l 28th Avenue

Kenosha, Wisconsin

*Snap-on is the trademark of Snap-on Tools Corporation

\$35,000 REWARD

FOR URANIUM



Here's your chance to "cash in!" Over \$3,750,000 in Government Bonuses have been paid for URANIUM discoveries in the past 2 years. Currently \$175,000 a month is paid to people like you.

Precision Geiger Counters and Scintillators are the finest instruments made for URANIUM prospecting. These highly sensitive instruments are compact, lightweight and ruggedly built for field use. Prices start at \$29.95.

CONTACT YOUR NEAREST DEALER

or write direct to factory for FREE 12-PAGE CATALOG and our 24-PAGE BOOKLET with "64 QUESTIONS AND ANSWERS ON GEIGER COUNTERS AND SCINTILLATORS."

PROSPECTORS RELY ON...



MAIL TODAY FOR FREE INFORMATION

Name _____ Title _____
 Company _____
 Address _____ City _____ State _____

PRECISION RADIATION INSTRUMENTS, INC.
 4223 PM W. Jefferson Blvd., Los Angeles 16, Calif.
 World's Largest Manufacturer of Radiation Instruments

SHEET METAL BRAKES

Forms Angles, locks, pans, etc. Quick clamp. All steel.
 15"—18 ga. steel, \$21.50;
 36"—22 ga., \$33.00; 48"—
 24 ga., \$48.00.
 Stand, \$7.00



Foot Power Squaring Shear, 30"—24 gauge.
 Bench Shear 7"—24 ga., 3 adj. gauges, \$16.50.
 Sheet Metal Folders 15"—1/4 to 1"—24 ga. \$16.50.

ORDER DIRECT OR SEND FOR CATALOG
 VYKE MFG. CO., 2435 15th St., Denver 2, Colo.

24-Page Illustrated

DO-IT-YOURSELF PROJECTS BOOK

Describes attic finishing, built-in cabinets, add-a-room, recreation room, kitchen remodeling, summer cottage and farm projects. Contains helpful information on how to get started, planning, cost estimating, materials purchasing, and proper procedures, also nail charts, moulding designs, etc. Send only 25c and also receive FREE 52-PAGE POWER TOOL CATALOG.

BOICE-CRANE COMPANY, 943 Central Avenue, Toledo 6, Ohio

MAGNETS

ASSORTED MAGNETS with big list of handy uses..... 5 for \$1
 POWERFUL POCKET MAGNET ideal for testing metals..... \$1
 RETRIEVING MAGNET pulls tools, etc., from tank or lake..... \$4
 HOT PAD MAGNETS to insert in your own hot pads..... 8 for \$1
 BULLETIN BOARD MAGNETS to "pin-up" memos, etc..... 8 for \$1
 ZERO-ZONE sensational new ice box, freezer thermometer..... \$1
 Write for free booklet including heavy retrieving magnets, also rods, bars, discs, sizes. 100% satisfaction guaranteed..... POSTPAID
 PARK MAGNETS, 259, 1557 GREENBAY RD., HIGHLAND PARK, ILL.

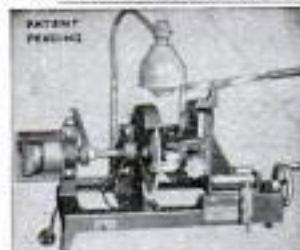

Start a NEW BUSINESS!

or Add to your present Repair Business
SHARPEN DULL PIPE WRENCHES
 PIPE TAPS & DIES
 "GUM" CIRCULAR SAWS
 Also MOTOR DRIVEN ROTARY HONE
 Write for Information

J. C. MOORE INDUSTRIES
 BOX # 276 FREDONIA, PA.



The Modern PLASTIC for lasting Home Repairs

PERMANENTLY mends cracks or holes in wood, tile, stone or plaster. Sticks and stays put—Does not chip, shrink or fall out. Easy to use. Economical. Mold it, chisel it, polish or paint it. The big 4-lb. can is obtainable from your lumber, paint or hardware dealer at \$1.25; or will be shipped direct postpaid (in U. S.) for \$1.50. Complete satisfaction guaranteed or your money refunded.

DONALD DURHAM CO.
 Box 804-T Des Moines, Iowa

POPULAR MECHANICS

THE SURE
WAY TO
KNOW

YOU ARE
BUYING A FINE
POWER DRILL

For top performance, choose the power drill equipped with a Supreme Chuck. The finest in quality and precision. Or replace your old style chuck with a Supreme. See your hardware dealer.

Supreme Chucks
BRAND



SUPREME PRODUCTS, INC., 2222 S. CALUMET, CHICAGO 16



URANIUM AND METALS

Easily located with the new M-Scope Detector. Superior Performance. Prices \$35.00 up. Monthly payment plan. Booklets "How to be a Successful Uranium Prospector" — "For Fun and Profit" free upon request.

FISHER RESEARCH LABORATORY, INC.
PALO ALTO CALIF.

McKENDREE DUCK PICKER



Pick ducks with power!

Attachment for 1/4-inch or larger electric drill...picks a duck clean in four minutes. Won't bruise the skin or scatter feathers. Send cash, check or M.O. now.

U.S.A. AND CANADA \$6.00 PPD.
All other countries \$8.50 ppd.
(Air mail extra—shipping weight 8 oz.)

McKENDREE PRODUCTS CO.

DEPT. PM
1893 Del Moro • Klamath Falls, Oregon

Arc Welding Pays Big

with these low cost welders

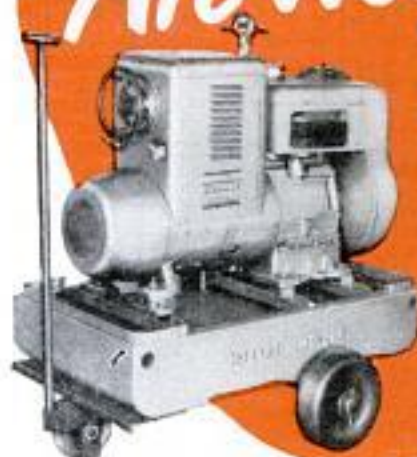

200 amp. aircooled "Husky Boy" gasoline engine driven welder

Earn hundreds of extra dollars. Set up your own full or part time welding shop. Cash in on the big demand for emergency repair work... a Hobart quickly pays for itself out of extra profits.

"HUSKY BOY" welds anywhere! In or out of the shop the "Husky Boy" can earn big profits for you. Light weight makes it ideal for using on small service truck for emergency calls, or for use in the shop. Wheels and handle available at a slight additional cost.

200 AMP. ELECTRIC DRIVE (Bantam Champ) Specially built for smaller shops requiring lighter weight and low investment. Gives full 200 amp. capacity. Lets you do production and repair work right in your own shop.

AC POWER—AC WELDER. An excellent dual purpose combination. Welds or runs lights, tools, motors independent of power lines. Can be belted or coupled direct to your own gasoline engine.

CONTRACTOR SPECIAL for all types of construction and outside repair welding. This 250 amp. welder is perfect on jobs where speed and quality are a must. Has 1 KW DC auxiliary power for operating lights, tools, etc. Portable mountings are available.



200 Ampere Electric Drive



AC Power—AC Welding



Contractor Special

It's easy to learn Arc Welding

Hobart School of Arc Welding
Learn profitable arc welding at the non-profit Hobart Trade School. Skilled instructors. G. I. approved. Best equipment. Low cost.

Modern Welding Lessons

Complete operator's training course. 200 fully illustrated pages. Only \$1.00

Mail the coupon!

HOBART BROS. CO., BOX M-95, TROY, OHIO, U. S. A., Phone 21223

"One of the world's largest builders of arc welders"

HOBART BROTHERS CO., BOX M-95, TROY, OHIO

Without obligation, please send me complete information on the items checked below:

Husky Boy Electric Drive
 AC Power—AC Welder Contractor Special

NAME _____
ADDRESS _____
CITY _____ STATE _____

Send Lessons Book Cash herewith Send C.O.D.

Welder's Vest Pocket Guide free!

SHELDON PRECISION LATHES

CHICAGO U.S.A.

Bench, cabinet, and pedestal base type lathes — swings from 10" to 15" each with its complement of accessories and attachments.

In a SHELDON Precision Lathe you have extreme accuracy without high cost, rigidity without excessive bulk, extra collet capacity for swing, and more power at the spindle than is ordinarily obtainable in lathes of this size.

Headstocks, carriages and tailstocks are hand scraped to beds. Large "Zero Precision" tapered roller spindle bearings hold extreme accuracy and permit modern operating speeds. Other quality features include: Full quick change gear boxes, full double walled aprons, tapered take-up gibs, and efficient underneath motor drives with larger motors and double V-belts to the spindle.

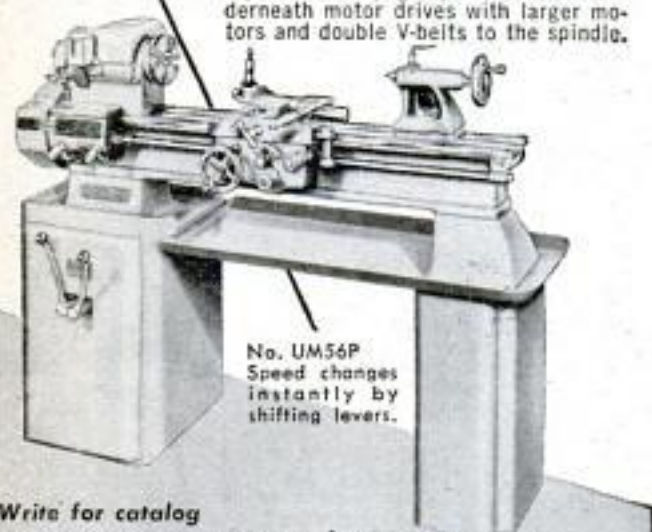

No. UM56P
Speed changes instantly by shifting levers.

Write for catalog

SHELDON MACHINE CO., Inc.

4268 N. Knox Ave., Chicago 41, Ill.



which sample* has the URANIUM?

All that "clicks" on the Geiger is not Uranium... other minerals are radioactive too, but not valuable. To tell if it's "pay dirt," you need SHERWIN's PORTABLE URANIUM ANALYSIS FIELD KIT—Model UA-12. Confirms PRESENCE and determines QUANTITY of URANIUM. For on-the-spot, accurate, reliable field tests, this is a must! Saves time, costly assays. No chemical training needed — Model UA-12 includes illus. instruction manual and all equipment necessary — in rugged, compact carrying case (18"x14"x10"—closed; 26 lbs.). Money Back Guarantee—send check or money order.



\$89.50

I.o.b., N. Y. C.

SHERWIN INSTRUMENT CO., Inc. *Center sample has URANIUM
2875-A Broadway, N. Y. 25, N. Y.

MONEY FOR MEN ALL FREE

THE PLASTEX Industry needs manufacturers on small scale and for big production of Lamp and Clock Stands, Art Goods and Novelties in Plastic and Marble imitation. Experience unnecessary. Raw material makes regular 10¢ store sellers. Rubber moulds furnished for speed production. Small investment brings good returns. We are now placing big Chain Store Orders with manufacturers. Ambitious men have chance for real prosperity. Our Free booklet will interest and benefit you.

PLASTEX INDUSTRIES, Dept. A

3400 Third Ave. New York 56, N. Y.

VARIABLE SPEED HYDRAULIC POWER TRANSMISSION



It has Infinite Speeds 0 to 550. Reverse, Automatic Overload Protection, Adjustable Torque up to 180 inch pounds. 3/4" Input and Output Shafts. It will handle 1/2" to 1 1/2" H.P. Motor. Case measures 7 1/2" long, 7" high, 6 1/2" wide. VALUE OVER \$300. Shipping Wt. 25 lbs. On C.O.D. Orders we require a 10% deposit.

\$54.50

Fob. Chicago

DIRZIUS MACHINE SHOP "F" 1423-25 So. 52nd Ave., Cicero 50, Ill.

SAVE MONEY on SURPLUS PARTS for MILITARY TYPE TRUCKS & JEEPS

4 & 6 wheel drive. FREE catalog to Jeep owners. State make truck or Jeep. (New Jeep Tops, steel or canvas all models). **AMERICAN AUTO PARTS CO., Inc.**, 1830 Locust, Kansas City, Mo.

WORLD'S BEST SMALL TRENCHERS



Portable DITCH-WITCH digs 2" to 6" clean, even ditches to 36" depth in all types of soil. Complete unit—self propelled—outdigs 8 men. Four rugged models.

Write for illustrated literature. **THE CHARLES MACHINE WORKS**
620 B Street Perry, Oklahoma

GET THIS STRAIGHT you can't beat an EMPIRE LEVEL



For improved accuracy, better visibility, less breakage, use the new Empire 9" aluminum Torpedo pocket level with machined bottom groove and protected, easy-reading vials. See your dealer today for all-purpose Empire Levels.

EMPIRE LEVEL MFG. CO. | 10930 W. Potter Rd., Dept. PM
Milwaukee 13, Wisconsin

Red Devil WOOD SCRAPERS



High carbon steel replaceable blades. Hardwood enamelled handles designed for easy holding. Scrapes clean in seconds. A model for every job (blade widths of 2 1/2", 1 1/2" and 1") priced to suit your budget.



FREE

#10 How to Prepare Surfaces for Finishing. Illustrated instructions on preparing masonry, wood and metal surfaces for painting.

Red Devil Tools. Dept. 148
130 Colt Street, Irvington, N. J.

Please send FREE copy of "HOW TO PREPARE SURFACES FOR FINISHING."

NAME _____
ADDRESS _____
CITY _____ ZONE _____ STATE _____

1615

MODERN**LAWN MOWER SHARPENER****COMPARE
BEFORE YOU BUY**Write for
free
booklet
10EOil remains in engine
while sharpening. Bed
knife sharpened in same
centers — no attachments
needed.**Start your own
business—increase
your income**Sharpens any mower in
ten to twenty minutes.
Handles complete assem-
bly of all reel types in-
cluding 36 in. power
mowers. Handle, wheels,
roller, and engine are
not removed.**\$26300****MODERN MFG. CO.**

F.O.B. PASADENA

160 N. FAIR OAKS, PASADENA, CALIF.

**DRIVE
ANYWHERE—****with CONFIDENCE!**These modern, fully jeweled compasses
show you the right way—the short cuts.
Save time and money! Surpasses rigid auto
makers' tests. Send for
Free Folder—"Parts—
Knives and Compasses."ONLY COMPASS
APPROVED BY
AUTO MAKERS!**DINSMORE INSTRUMENT CO.**
1802-37 KELSO ST., FLINT 1, MICHIGAN**DINSMORE
AUTO
COMPASS****TRAVELITE \$5.95**
(ILLUMINATED)**GUIDEWAY \$4.95**
(NON-ILLUMINATED)**DO IT YOURSELF!****Save Time and Money with the
"NEW HOME SERVICE TESTER"**No more waiting for TV and Radio
service . . . eliminate electrical and
other repair bills . . . Now you can test
all radio and TV tubes . . . Now you
can check home appliance shorts and
broken wires . . . Now you can test
light bulbs and fuses.You do all this yourself with
the "NEW HOME SERVICE
TESTER." Complete with
easy instructions — SAVE
MONEY—AND, have fun, too.
ORDER TODAY!

SATISFACTION GUARANTEED or your money back.

\$4.95
EA.
POSTPAID**Lindaily Products**2626 W. 103rd Pl.,
Chicago 43, Ill.Dept.
MP-9**INTERNATIONAL DRILL-SAW****HI-SPEED COPE SAW DRILL BIT****NEW LOW PRICE****REAM • CUT**DRILL, SAW, REAM . . . metal, pipe, wood,
plastic, Transite, etc. Use with electric drill,
slow drill press, lathe, milling machine.
Drills own starting hole, upper part of bit
is used to cut, saw, ream circles, ovals,
squares, scrolls. Easy to use. Ideal for car-
penters, mechanics, electricians, plumbers,
hobbyists, etc. Abrasive resistant, high
speed steel. Flutes ground from solid. Withstands severe con-
tinuous use without breaking. Resharpens free. Takes place
of up to \$50.00 in tools. 1" diameter, 2" cutting sections, total
length 8 3/4". Three types—All purpose, Wood, Heavy Metal.
Specify type needed. Set of three \$8.50. Details on request.
Shipped same day. Money-back guarantee. Dealer inquiries
invited. Order Now. Send Cash, Check or Money Order to**INTERNATIONAL TWIST DRILL CORP.** 418 Wyandotte, Rm. 636
Kansas City 6, Mo.**\$2.95**
POST
PAID
3 for \$8.50**Power Fade****shows here!****Slow pickup when you step on the gas
shows your power is fading . . . and it's
time to replace your Piston Rings!**Having to buy too much oil and gas, and
slow pickup reveal POWER FADE! Your rings
are badly worn—you're wasting money on
lost power.Top performance is gone. And despite
the extra oil used, vital engine parts remain
starved for oil. This is not only costly and
wasteful, but is a warning of expensive re-
pairs to come later.See your motor specialist for a ring check-
up. If he recommends a ring change, it will
pay you to install Hastings replacement
rings. They're engineered exclusively for
worn engines to quickly stop power fade,
oil-pumping and gasoline waste.All the safety and driving enjoyment of
full-powered performance are yours again
with Hastings Rings . . . it's the best money
you can spend on your car.**HASTINGS MANUFACTURING CO., HASTINGS, MICHIGAN**
HASTINGS LTD., TORONTO*Piston Rings, Casite, Oil Filters, Spark Plugs**** TOUGH but oh so gentle****HASTINGS****STEEL-VENT PISTON RINGS***Regular or Chrome-Faced**** TOUGH on oil-pumping • GENTLE on cylinder Walls**

SEPTEMBER 1955

269

Copyrighted material

3 KLEINS EVERYONE NEEDS

201-NE
Side Cutting
Plier



301
Long Nose
Plier



202
Oblique Cutting
Plier

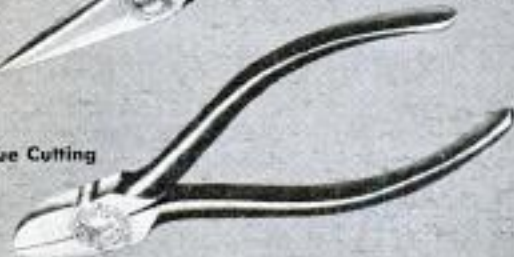

Here are three pliers everyone needs. With these Kleins on your workbench or in your tool kit you are equipped for any job where pliers can assist you.

And, of course, you have pride of ownership too, for as everyone knows, Kleins are the standard of quality in pliers—have been "since 1857."

201-NE—The famous side cutter originated by Klein. In 6", 7", 8" or 9" sizes.

301—You will be amazed at how many times a day you will use this handy long nose plier. Ideal for reaching into confined places, holding small parts, etc. In 5", 6" or 7" sizes.

202—This Klein oblique cutter is a tool that good workmen can't do without. Cuts close and clean and the knives stay sharp for years. In 5" and 6" sizes.

Good hardware dealers everywhere carry Kleins.

FREE KLEIN BULLETIN
Send for FREE Bulletin 455.
It shows all the most popular Klein Pliers.



Mathias KLEIN & Sons
Established 1857 Chicago, Ill., U.S.A.
7200 McCORMICK ROAD • CHICAGO 45, ILLINOIS

BUILD YOUR OWN POWER TOOLS— WITH GIL-BILT PARTS KITS

TILT/ARBOR SAW



- 27x28 in. table.
 - 13 1/2 in. capacity in front of blade
 - 10 in. blade cuts 3 1/4 in. deep, tilts full 45 degrees
 - Floor model 34" high, table always stays level
 - New Departure ball bearing arbor, 3/4" precision shaft turned down for 5/8" bore blades, alum. housing, shipped ready to run
 - Jackscrew and 4 1/2 in. dia. handwheel lowers and raises blade
 - Cast aluminum miter gauge and self-aligning rip fence guide
- GIL-BILT Metal Parts Kit includes Plans, ball bearing arbor, miter gauge and bar, rip fence guide, dado insert, lock knobs, jackscrew mechanism and handwheel, and all other metal parts (less blade) \$22.95
Same Kit with 10" Combination Blade . . . \$25.90
Same Kit with 8" Combination Blade . . . \$24.90

GIL-BILT 12-INCH BAND SAW

Ball bearing drive, rigid cast aluminum wheels, rubber tires. Handles stock up to 8 inches thick. Cuts to counter of 24" circle. 18 x 18 inch tilt table. Capacity and performance of band saws setting for \$80 and up. Plans and all metal parts in kit with 1/4" blade \$23.95
Return Kits in 10 days for refund if not satisfied.
For shipments up to 600 miles, add 2% over 600 add 10%. Amount in excess of actual postage will be refunded.



PLANS ONLY \$1.00 EACH POSTPAID

Order Kit now, or order Plans at \$1.00 each and Kit later less cost of plans.

Write for FREE Catalog.

Also Available: Plans & Parts Kits for 18" Band Saw, Belt Sander, Spindle Shaper, 8" Tilt-Table Saw

GILLIOM POWER TOOLS

Dept. 80-J, Lambert Field
St. Louis 21, Missouri

MAKE EXTRA MONEY

Start Your Own Business

Sell tools part time, full time. Save money for your industrial and institutional use. **A MILLION DOLLAR INVENTORY AT YOUR FINGERTIPS.**

Buy **NATIONALLY ADVERTISED** hand tools, hardware, fans, motors, power tools, paints, etc. **NO INVESTMENT REQUIRED.** Buy as you need it. Up to 50% **DEALERS DISCOUNT.**

Send \$1 Deposit for Dealers Card and mammoth dealers catalog. \$1 refunded on first purchase or returned if you are not 100% satisfied.

SILVO HARDWARE CO., Dept. PM-9, 108 Market St., Phila. 6, Pa.

FREE FOLDER "HOW TO SAND"

ADDRESS "Handy" SANDY
CARBORUNDUM®
Niagara Falls, New York

DO MORE PLANING JOBS WITH LOW COST BELSAW

LOW DOWN PAYMENT EASY TERMS

Exclusive **MONEY-MAKING** Features: • Full 12 1/2" x 6" capacity • Power feeds at 24" a minute • Provides for Grinding Knives in the Cutterhead • Attachments for Jointing, Rabbeting, Trough, Groove, Matching. Convert low cost rough lumber into high priced cabinet finished stock... Easy to make flooring and popular patterns. Send today for free literature and prices.

Belsaw Machinery Co., 2056 Field Bldg., Kansas City 11, Mo

How to Build Your Own GARAGE

Save as Much as 50%
of Usual Construction Costs

Get Popular Mechanics' brand new book **How to Build Your Own Garage** by Wayne Leckey, Assistant Shop Notes Editor, and find out how you can build your own garage at savings of 50% of usual cost. Leckey tells in famous step-by-step instructions and shows in big, clear photos, drawings and diagrams how to perform every building operation from laying the concrete to installing the final trim. There are 25 designs. Brick, frame, and concrete block fully covered. Send \$3.50 for your copy. 7-day money back guarantee.

POPULAR MECHANICS PRESS, 200 E. Ontario, Chicago 11, Ill.

MARLITE-IT-YOURSELF



You can afford beautiful ideas with economical MARLITE walls



A few days ago this was an unused porch! But a little imagination and Marlite Plank and Block made the difference. So easy to install you can do it yourself, this beautiful paneling has a tongue and groove joint. Fitting is easy. All fastenings are concealed. And Marlite's soilproof melamine plastic finish cleans with a damp cloth; never needs painting.

See your lumber dealer for distinctive wood and marble patterns, plus 10 "Companion Colors" styled by Raymond Loewy Associates. For FREE REMODELING FOLDER write Marsh Wall Products, Inc., Dept. 942, Dover, Ohio.

made with genuine Masonite®
Tempered Dualux®

Marlite
plastic-finished
WALL and CEILING PANELING

HAND HYDRAULIC PUMP

Single or double designs to 20,000 PSI



With or without reservoir. Standard reservoirs 70, 160, 910 cu. in. capacity. Interchangeable pistons 3/8 - 1/2 - 3/4 inch. 1 inch piston (special) 1/4" N.P.T. Pipe connection. 18" handle. Unit can be bolted or welded in position.

Can be used on hydraulic test stand, to actuate hydraulic cylinders, jigs, fixtures, as booster in hydraulic system. All pumps have release screw to relieve system. All steel construction.

SEND TODAY FOR FREE DESCRIPTIVE LITERATURE AND PRICE LIST.

WILLIAM S. PINE

1635 E. 22nd St.

Los Angeles 11, Calif.

THEY'RE **NEW!**



FASTEST-CUTTING JIG SAW MADE! This powerful new Millers Falls tool is a jig saw, hack saw, coping saw, rip saw, crosscut and keyhole saw all in one. Makes curved, straight or irregular cuts in wood, metal, all kinds of material—in places often inaccessible to other saws! Exclusive design features and special blades result in far greater cutting speed than any similar saw.

No. 480 Dyno-Mite Electric Jig Saw — \$44.95

THEY'RE **DYNO-MITE**



FOR THAT PROFESSIONAL FINISH! This new Millers Falls Orbital Sander finish-sands furniture, cabinets, interior trim . . . removes paint, varnish or surface imperfections . . . all without tracking, scoring or burning surface. High-speed orbital action permits sanding with or across the grain. Light weight makes it easy to use on overhead and vertical as well as horizontal surfaces.

No. 580 Dyno-Mite Orbital Sander — \$44.95

THEY'RE

Millers Falls

Finest Power Tools Made



FREE AT YOUR HARDWARE DEALER'S Ask for these folders on the whole power-packed line of Millers Falls Dyno-Mite electric tools including the remarkable new Dyno-Mite Power Workshop, or write direct.

MILLERS FALLS CO. • Dept. PM-9 • Greenfield, Mass.

free

GET THE WORLD'S LEADING
TV & RADIO PARTS AND
EQUIPMENT CATALOG

ALLIED'S 1956 ELECTRONIC SUPPLY GUIDE

324
VALUE-
PACKED
PAGES



Save on
Everything
in
Electronics

WORLD'S
LARGEST
STOCKS

Everything for Experimenters,
Builders, Amateurs, Servicemen,
Engineers and Hi-Fi Experts

Send for ALLIED's big 324-page Catalog, offering the world's largest selection of latest top-quality electronic equipment at lowest, money-saving prices. Features High Fidelity systems and components; recorders and phono equipment; TV tubes, antennas and accessories; Amateur station equipment; P.A. systems; test instruments; latest build-your-own kits; industrial electronic supplies—plus thousands of parts, tubes, transistors, tools and books. Get everything, get more for your money—send today for your FREE 1956 ALLIED Catalog!



ALLIED RADIO

Send for
FREE
CATALOG

ALLIED RADIO CORP., Dept.
100 N. Western Ave., Chicago 80, Ill.

Rush FREE 1956 ALLIED 324-Page Catalog

Name _____

Address _____

City _____ Zone _____ State _____

"ARCO JIG-SAW"



NOW
REDUCED TO
only \$8⁹⁵

First to fit 1/4" drills, this rugged portable jig-saw attachment has same capacity & precision as \$55 saws. Does work of jig, keyhole, coping, crosscut, rip, band & hacksaw! Built-in "Air-Jet" blows away sawdust. Guaranteed to cut intricate patterns—however large—in plywood, plastics, metals—even cuts 2x4's! Starts inside holes. Includes blade. Converts to Table Model with "ARCO STAND" Sturdy Casting. .52.75 6 Extra Blades. .51.95

SOLD AT BETTER HOME STORES. If not available, try this amazing tool on our UNCONDITIONAL 10-DAY MONEY BACK GUARANTEE. Send check or M.O. (ppd.) C.O.D.'s—plus post.

ARROW METAL PRODUCTS CO.

Dept. PM-9, 140 West Broadway, New York 13, N. Y.

695 HEAVY OIL-PH-BALL BEARINGS PUMPS MILLIONS OF GALS.

IRRIGATE, SPRAY, DRAIN OR FILL ANYTHING—ANYWHERE! Will not Rust—Clog—or Leak. Patented Seal. Pumps 2800 gph, 420 gph. at 75' high or 1600 gph from 25' well. Six blade impeller. Threaded for pipe. 3/4" inlet, 1/2" outlet. Use 1/4 to 3/4 hp motor. 7500 gph 9.99
Heavier 2800 gph. 8.95 Heavier 11.95
Check MO or COD—Money Back Guarantee
FREE Literature—Comparison Charts

U. A. T. ENG. & MFG. CO. HICKSVILLE 273, NEW YORK

MACHINE TOOL RECONDITIONING

& THE ART OF HAND SCRAPING
—USEFUL FOR DESIGN, SHOP & INSPECTION WORK—
SEND FOR FOLDER DESCRIBING ILLUSTRATED BOOK
MACHINE TOOL PUBLICATIONS, 382 Holly Ave., St. Paul 2, Minn.

Do It Yourself with DREMEL Straight-Line-Action SANDERS!



Send for free catalog
of Dremel power tools.

DREMEL MFG. CO., Dept. 116-H, Racine, Wis.

\$5000
PER DAY
AND MORE

SHARPENING
AND SERRATING
TABLE KNIVES

SAW-KEEN PORTABLE, ELECTRIC,
EASY - TO - OPERATE

Be your own boss, work anywhere, full or part time. Every restaurant, hotel, drive-in, etc., repeat customers. Serrated (saw-edged) table and steak knives in great demand. \$98.50 investment returns big profit daily. Guaranteed. Write today.

CUTTER-CRAFT 58-K SOUTH RAYMOND
PASADENA 1, CALIF.

BUILD WELDER OR LIGHT PLANT

Mfg.	TYPE	AMPS	VOLTS	PRICE
Westinghouse	P1	300	24	\$15.50
J. & Heinz	R-1	300	24	\$25.50
Gl.	160-250 amps, 30V.			\$19.50
D.C. Rheostats, or Volt. Regulators.				\$6.95 Ea.
G.E. #511	AC-DC	300	80 D.C.	\$17.50
A 115V. 1250 Watts	800 cy. A.C.			\$27.50 (new)

Instructions incl. with all generators

BRASS HAND FIRE EXTINGUISHER. quart \$4.95 postpaid. 4 GALLON, F. EXT. & INSECTICIDE PUMP, nozzle & hose, Wt. 15 lbs. \$2.95 (add postage).

(5) **SENSATIONAL SELSYNS.** For controlling distance operations, etc. \$9.95 per pair. (6) **Solenoid VALVES.** Bendix #81500 for hydraulics, distance operation, etc. Up to 1500 P.S.I. \$7.50 per pair. (7) **BEAM ROTATOR MOTOR** #103 for TV, HAM, FM, reversible, 2 H.P.M. for D.C. or 110V. A.C. Gov't. cost \$150.00. \$9.95. (8) **SOLENOID** #804 gives 1/2" or 1 1/4" travel, powerful for locks, switches, etc. \$4.95 per pair postpaid. INSTRUCTIONS incl. with all items No. 5, 6, 7, 8, (for D.C. & Appl. for 110V. A.C.)

(9) **CUNO OIL FILTER** for autos, filters without cartridge replacements. 3/4" ports or **PUROLATOR FILTER** #255 for trucks & tractors, 1" ports. \$4.95 Ea. postpaid.

General WAR SURPLUS SALE

MAKES IDEAL WINCH HOIST. Aircraft starter motor for 12 to 24V. D.C., belt or direct drive \$9.95

(1) **BLACK & DECKER MOTOR & PUMP.** 2 G.P.H. 1200 R.P.M. 1/2" ports \$8.95. (3) **THOMPSON CENTRIFUGAL PUMP & MOTOR** for fuel, hot water, etc. 300 G.P.H. \$7.50. Instruction incl. for Items 1 & 3. (for 24V. D.C. & appl. for 110V. A.C.)

(2) **THOMPSON LARGE VOLUME PUMP** for water, oil & insecticide, 400 G.P.H. 1" ports. \$7.50. (4) **ROTARY GEAR PUMP** #101 for hydraulic, water, or vacuum, 180 G.P.H. 200 P.S.I., 2 1/2" (mercury) \$6.95

(5) **VOLTMETER D.C.** 30 Volts, zero center, 300 ohms. \$4.95. **TACHOMETER INDICATOR.** 0 to 10,000 R.P.M. \$4.95. **HYDRAULIC PRESSURE GAUGE.** 0 to 2000 P.S.I. 1/4" ports. \$4.95. **VACUUM GAUGE,** range 0 to 10 inches Mercury, \$3.50

(6) **GLIDER TOW BAR.** Rated 100,000 lbs. & release load when lever is pulled, 14"x31 1/2". Wt. 10 lbs. \$7.50. **ELECTRIC ACTUATOR** with 1/2 H.P. motor, 24 V. D.C. & appl. for 110 V. A.C. Rated 2800 lbs. \$7.50

NEW HYDRAULIC CYLINDERS

AIR OR HYDRAULIC	DOUBLE ACTION	Stock	Bore	Stroke	Price
#11	1 1/2"	X	6"		\$7.50
#70	4"	X	10"		\$17.50 (s.a.)
#111	3"	X	24"		\$27.50
#24	3 1/2"	X	22"		\$32.50
#18	2 1/2"	X	8"		\$8.50 (s.a.)
#511	3 1/2"	X	21"		\$29.50

Adell FOUR WAY HYD. CONTROL VALVES for 1 D.A. cyl. 3/4" ports. #27. \$7.95; for 2 D.A. cyl. 1/2" ports. #620. \$9.95; for 1 to 4 D.A. cyl. 3/4" ports. #10060. \$12.95.

HYDRAULIC PUMP BARGAINS
Mfg. P.S.I. R.P.M. G.P.H. #
(5) Pesco 1500 1500 138 \$9.95
(8) Pesco 1500 4300 350 \$12.95
(7) Stratopower 1500 3750 400 \$17.50

BARGAINS FROM PREVIOUS ADS
(write for details if necessary)
• **PUMP & MOTOR.** 12-32V, 400 G.P.H. \$9.95
• **MOTOR & GEAR** for garage door... \$12.50
• **EMULSION GEM.** (m. light plants) \$8.95
• **ACCUMULATORS** 5" dia. \$8.50, 7" dia. \$7.50
• **HYDRAULIC FLOW EQUALIZER**... \$9.95
• **HYD. HAND PUMP,** 2000 P.S.I. ... \$9.95

Check or M.O. F.O.B. K.C., Mo.
GENERAL SALVAGE CO.,
2922 E. 27 St., Dept. 79, Kansas City, Mo.

Also Adult Size Cars for
• **GOLFERS**
• **AIRPORTS**
• **INDUSTRY**
• **LIGHT DELIVERY**

EDMELMAN 70 MILES PER GAL. GAS CHILD'S AUTO WITH MOTOR

STURDY, SAFE FOR KIDS

Comended by "Parent's Mag."

SHIPPING POINTS: BALTO, CHICAGO, RENO.
For Free Catalog Write Esbelmas, Dept. MC-39 109 Light St., Balto. 2, Md.



Pat. Pend.

INSTALL YOUR OWN ELECTRIC GARAGE DOOR OPERATOR

ORDER DIRECT AT FACTORY PRICE — SELLS REGULARLY AT \$169.

Complete with remote control. Sold on money back guarantee. Simple installation instructions included. Write for details. No obligation.

Linco Distributing Co.
R #4, Sidney, Ohio



YOUR PRICE \$115.00

BUILD D.C. WELDER!

WE SHOW YOU HOW to build this powerful welder without rewinding. Uses most any surplus aircraft generator. Produces 75-350 amps. Easy to build. **PLANS 35c** includes **NEW** booklet "HOW TO WELD," and **FREE WAR SURPLUS AND ELECTRICAL CATALOG.**

LEJAY MFG. CO., 1247 LeJay Bldg., Minneapolis 8, Minn.



GOVT. SURPLUS 60 PC. DRILL SET

Made by CLEVELAND TWIST DRILL CO. Army surplus in original packing never used. Wire gage sizes No's. 1-60. Made of the finest carbon steel to army specifications by one of the largest drill manufacturers in the U.S. Full jobbers lengths, precision ground and will easily cut through wood, plastic, steel, aluminum, and other metals. Supply limited. Reg. price \$14.95. Money back if not delighted. Add 40c for PP & Handling. Our low price. \$6.95

MATTHEW DAY CO., Inc. Dept. P. 12 E. Madison Ave., Dumont, N. J.



BETTER WORKMANSHIP IS EASY

- with **NICHOLLS TOOLS**
- It's easier to do a better job with Nicholls quality **TROWELS, FLOATS, CEMENT TOOLS, DARBIES and HAWKS.**

NICHOLLS CARPENTER SQUARE
... the leader since 1896!

ASK YOUR DEALER FOR **NICHOLLS NCTOOLS**

You Can't Buy a Better Tool

NICHOLLS MANUFACTURING CO. OTTUMWA IOWA



LAWN LIKE A GOLF GREEN! AERATE! Get A Reviva-Turf

File any reel-type hand or power mower. Moisture, seed, fertilizer goes down. Get a healthier lawn—fewer weeds.

REPLACES LAWN MOWER ROLLER

Deep Root Growth. Aerate as You Mow!
Order by size: 16", \$4.95; 18" \$7.95; 20", \$9.95; 21", \$10.95; 24" \$11.95. Special Sizes on Request. Add \$1.50 for postage, packaging.

ENGMAN MANUFACTURING CO.
1317 Locust Street Des Moines 9, Iowa



AMERICAN MACHINE & TOOL CO. MODEL CHANGEOVER SALE SAVE \$800 ON THIS TILT ARBOR SAW

All year a great buy at regular price of \$24.95—this 8-inch Plana Centric Tilt Arbor Power Saw is a spectacular bargain at \$16.95 during model changeover period. This big saving is possible by our patented construction, our manufacturing facilities, and our distribution methods. Top-quality saw features the original Plana Centric Patented Ball-Bearing Floating Drive, Patented Plana Centric Cradle Suspension, and Plana Centric Patented Rip Fence that locks front and rear against the table surface. Every part in this fine saw is manufactured in our own factories. All cast iron and steel construction. Crosscuts, rips, bevels, mitres, dados, cuts compound angles. Massive cast mitre gauge. Heavy steel base fastens to any workbench. Uses any standard 1/4 or 1/2 h.p. motor. **INCLUDED:** 8" Simonds Combination Blade at no extra charge. We start soon on 1956 models. During model changeover you can have this fine 1955 at a saving of \$8.00. Send check, M.O. or sent C.O.D.

LOOK AT ALL THESE SPECIAL FEATURES:

- Blade tilts, table stays level. Blade adjusts to any angle up to 50°.
- Single Hand Wheel Control. Tilts and tightens blade with a twist of the wrist. Blade rises and lowers; cuts from 0" to 2 1/4".
- Precision-ground cast iron table. Perfect flatness resists nicking and wear.
- Self-aligning rip fence. Adjustable to lie parallel to blade or give clearance either way.
- Patented Motor Mount takes any standard 1/4 or 1/2 h.p. motor. Motor rides on ball bearing rollers. Keeps belt tight, transmits full power.
- Heavy long-lasting, all-metal construction. Built for a lifetime. Shipping weight 25 lbs.

FAMOUS AMERICAN IRONCLAD GUARANTEE
Try any Plana Centric power tool for ten days. If, for any reason, you are dissatisfied, return the merchandise for full and complete refund—no questions asked. This famous guarantee has been offered on sales of more than 3 1/2 million power tools, and it has never been violated.

WRITE FOR FREE CATALOG
Big bargains in home workshop power tools

All power tools sent express collect

AMERICAN MACHINE & TOOL COMPANY
ROYERSFORD 14, PA.



ANNUAL INVENTORY CLEARANCE SALE

Now! During September only, unbelievable values on top quality Precision Optical microscopes and equipment. We've a limited number of clearance prices, so hurry! You can't make better microscopes buys! Every instrument with regular 10-day money-back guarantee.



MODEL 800 (75-150-300-600 power)

Quadruple revolving turret—prismatic consultation swivel head (360 degree)—achromatic condenser and iris—2-sides professional mirror for natural and artificial light—hardwood carrying case—slides and instruction booklet. Our regular list price \$39.95. Inventory sale price \$29.95. (only 125 for this clearance price).



MODEL 635 (150-300-600 power)

Equipped with 15X eyepiece (see free catalog for additional eyepieces)—achromatic built-in condenser—6-aperture disc diaphragm—all

metal construction—hardwood carrying case—12 page instruction booklet. Our regular price \$29.95. Inventory sale price \$19.95. (only 175 for this clearance price).

SEND CHECK OR MONEY ORDER to deposit on COD. Calif. add 3% state tax. Return any item within 10 days for full refund. Items manufactured to our rigid specifications by selected Japanese firms. Electronics are standard U.S. manufacture.

PRECISION OPTICAL COMPANY, 24 Precision Bldg.
4379 Sunset Boulevard, Los Angeles 29, California

MODEL 500K—21 PIECE HOME LABORATORY—If sold separately \$26.80, our regular list price \$19.95. Inventory sale price



\$14.95 ppd.
(only 350 sets at clearance price)

Including: Model 500 microscope (50-100-300-500 power)—quadruple turret—4-compartment cabinet—professional, light—magnifying glass—

scalpel—spatula—dissecting needle—tweezers—eye dropper—12 slides (3 prepared).

FREE WITH EVERY ORDER: Big 44 page catalog of microscopes from \$7.95 to \$319 including accessories, telescopes, binoculars.

UNMATCHED



Gerstner Chests are unequalled in quality and performance. Free Catalog.

GERSTNER TOOL CHESTS
455 Columbia St., Dayton 7, Ohio

FREE AMAZING NEW BOOK "HOW TO ANSWER ADS"



Never before have you seen anything like this. Tells you in simple language the correct way to answer ads. Gets you quicker replies—better results and greater satisfaction. Will save you time and money and it's ABSOLUTELY FREE. No obligation whatever. Every reader of advertising should have this booklet. Send a postcard for your copy NOW. F. W. Johnson, Popular Mechanics Magazine, Room 600-A, 204 East Ontario Street, Chicago 11, Illinois.

NOW—SHOPSMITH® for as little as \$3 per week

Start enjoying SHOPSMITH now for only \$29 down, \$3 weekly. Start saving now! Savings on projects and home repairs can more than equal weekly payments. See your hardware dealer or Montgomery Ward store. Write for 2 big, free, illustrated books.

SHOPSMITH, Dept. 303-B, Menlo Park, California



ELECTRIC WELDER

AC or DC
110 Volts

The "Little Marrel" all-metal welder, 5-year written guarantee. Welds 1/4" metal or money back. Repairs tanks, tools, fenders, machine parts, etc. Complete with everything—rods, unit, eye shield, directions. \$6.45 plus 50c postage. Flame torch accessory for soldering, cutting, brazing \$3.95 complete with carbons, brass rods, flux. \$2.00 Deposit on C.O.D. 1/4 inch Transformer Welder \$19.95 F.O.B.

ESSAY MFG. CO., Dept. 51, Quincy 69, Mass.

\$6.45
Complete



Ideal gift for your do-it-yourself friends. ACE SUPER SET, 39 pieces, best quality taps and adjustable dies in 17 popular sizes and threads. Complete with wrenches and accessories in unbreakable plastic box. Price \$18.95 postpaid. Write to:

TAILORED TOOLS, INC.
Sharon, Mass.

WAR SURPLUS ANOTHER BARGAIN SAVE UP TO 90%



"HELIOS" ORIGINAL TOOLMAKERS

VERNIER CALIPERS

ULTRAPRECISION—Imported. Used by machinists at Lockheed, Douglas, Bendix, GM, RCA, GE. Model 51/2E. Genuine Helios. Hardened lapped precision surfaces. 1/1000" and 1/128" graduations. Handy slide rule and thumb lock. Quick, accurate depth. A \$35 value. Satin finish. ALL NEW, just \$6.95. Leather carrying case, \$1 extra.



MICROMETER DEPTH GAUGE

With 3 rods to measure all depths from 0 to 3 inches by thousandths. Hardened tool steel lead screw has full 1 inch run. Base is 2 1/2" long, hardened ground and hand lapped. Accuracy guaranteed. Mfd. by Millers Falls Co. GOVT COST approx. \$10. NEW—\$10.95 ppd. USA. In velvet case.

MICROMETERS Chrome plated, precision engineered, carefully tooling to give long life. All new 0-1" cap. \$2.25 ea., 1-2" cap. \$3.95.



SENSATIONAL GENERATOR BUY!!

Famous Navy NEA-5 Generator.

Combination AC-DC Type. AC voltage—115 V. DC voltage—24 V. 200 Amp. 2 complete generators in 1... 2 separate fields and 2 separate armatures on same shaft yet no larger than regular aircraft generator. Ideal for home, farm and shop lighting plants by hooking wires to AC side. DC side can be used for welding and operating war surplus low voltage hobby motors and equipment. Weight 54 lbs. NEW. Approx. GOVT. COST \$350. NEW \$27.95 used perfect \$18.00



SPECIAL CARBON PILE TYPE VOLTAGE REGULATOR

To go with above generator. Incl. mounting base and completely enclosed in steel-mesh box. Helios maintain constant current and prevents pulsation. Ideal for installation with above generator for lighting plant. Wt. 5 lbs. Complete NEW. Approx. GOVT. COST \$90. Now only \$7.95

BUY 'EM BOTH SAVE \$5.45! Generator & Regulator together \$33

SENSITIVE ALTIMETER in 10 Ft. Increments.

Famous Pioneer! 0 to 35,000 ft. inches of Mercury. Tested and inspected in our own instrument lab. Guaranteed perfect. Approx. Govt. Cost \$150. NOW ONLY \$13.95 Ppd. U.S.A.

NEW 1955 CATALOG

Biggest ever... new low prices... send 25c for your copy today. Prices F.O.B. Culver City unless otherwise stated. Check, money order or cash, 25% deposit for C.O.D.

AIRBORNE SALES CO., INC. DEPT. PM 955
8501 Stellar Drive, Culver City, Calif.



Want a
bookcase?

(Pattern No. 42
Modern Four Piece
Bookcase Ensemble)

It's easy to build your own. No skill needed to use Easi-Bild* Patterns. Trace "simplified" pattern on wood; saw, and assemble. Patterns list materials and show each step. For a catalog of 200 Easi-Bild Patterns—send 35¢ to EASI-BILD, Pleasantville, New York.

*T.M. Reg. Easi-Bild Pattern Company

EASI-BILD PATTERNS



Easi-Bild Patterns specify PLASTIC WOOD for a real professional job. Handles like putty—hardens into wood.

"PLASTIC WOOD"



NO. 82
KNIFE SET
\$4.20

X-ACTO, INC.
13-45 Van Dam St.
Long Island City,
N. Y.

Send 25¢ for 28-page Catalog

FREE TOOL OFFER!

Send postcard today for complete information on how you can get your FREE TOOLS. No obligations but don't delay; write today!
POWER PRODUCTS, INC., Division 9-A
175 East 87th Street New York 28, New York

Say You Saw It in Popular Mechanics

do it faster...better!



PLIERS,
CHISELS,
PUNCHES,
SNIPS,
ADJUSTABLE
WRENCHES

Buy wherever
fine tools are
sold in U. S.
and Canada.

KRAEUTER

SEPTEMBER 1955

* Multi-Motion

*Almost all wood grain is naturally crooked, irregular. Only Syncro patented "Multi-Motion" sanding pad action can sand with such grain and completely finish the whole surface. AND—built-in Syncro motors are guaranteed against burn-out all during your ownership!



No. 900
HEAVY DUTY SANDER

Outlasts, outsands all other portables! No "jumping". So easy to use with patented "Multi-Motion" action!

Sanders

SANDING
HANDBOOK,
CATALOG
FREE!



No. 504

AMERICA'S
FINEST
FINISH
SANDER

Light, powerful. Easiest for vertical use. In metal case, sandpapers, polish pad.

No. 900-D

DELUXE
HEAVY
DUTY SANDER KIT

The ultimate in sanding! Kit contains sander with work light, metal case, 48 assorted sandpapers, polish pad.

SYNCRO CORP.,
Dept. 1-65, OXFORD, MICH.

By **SYNCRO**
MULTI-MOTION SANDER

275

Copyrighted material

GRAVELY

makes Leaves
VANISH!

Rotary Mower and
Leaf Mulcher



Powerful! **5-HP**

23 DIFFERENT TOOLS

- Mulches 30" width! . . . Twice the power of the usual Rotary Mower-Leaf Mulcher . . . Gravelly gets rid of leaves fast! — no raking or burning.
- One of 23 year-round attachments. For Winter: Snowblower, 48" Snow Plow, Chain and Circular Saws. New, improved Electric Starter optional. *Easy Pay Plan.*

Write today for FREE 24-page "Power vs Drudgery" Booklet.



GRAVELY TRACTORS, INC.
BOX 963 DUNBAR, W. VA.

FIELD-TESTED FOR 34 YEARS

KEEP ALL SAWS SHARP

SUPER FILER No. 9



USED AS JOINTER

SO EASY: With this new filing jig and jointer anyone can now sharpen any hand saw like new! When file hits hardened steel rollers teeth are finished and EXACTLY SAME HEIGHT. All teeth cut and saw runs true and smooth. Jig and instructions \$2.95 postpaid. Free literature. **SAVE TIME AND \$\$\$**

JOINT & SHARPEN CIRCULAR SAWS

Sensational new Super Filer No. 11 jointer and sharpens both hand and circular saws 6" to 10" with all teeth the correct height, depth, pitch and bevel. Easy to use—when file hits hardened steel roller, teeth are finished. Saw runs true and smooth with no side pull. Complete with special 8" file \$9.95 postpaid. "TRU-CIRCLE" saw set automatically sets teeth at 10° or more \$2.95.

SUPER SAW FILER No. 6
Automatically controls

SUPER DRILL GRINDER
Sharpens round shank drills from 3/32" to 3/8" in diameter, up to 6" long. Grinds old drills like new in 4 different point angles, using hand or power grinding wheels . . . \$2.95

DEPTH ANGLE PITCH
Automatic DEPTH CONTROL Rollers

IT'S NEW!
Perfect level and angle maintained, and fool-proof depth control for all Hip, Crosscut and Handsaws. Precision made and calibrated for instant setting at desired angle. Can be used in any vise or clamp. Complete with file, only \$6.50 postpaid. **SEND FOR FREE CATALOG**

A. D. McBURNEY, 5908 Hollywood Blvd., Hollywood 28, Cal., Dept. A-95

NEW MODERN FURNITURE PROJECT BOOK

16 complete, easy-to-follow plans for beautiful modern furniture . . . chairs, lamps, couches, tables. Build your own . . . have fun and SAVE! At 50c

all ATLAS dealers or write direct. ONLY 165c outside U.S.]

ATLAS PRESS COMPANY
92 N. Picher St., Kalamazoo, Mich.

CRESCENT TOOLS — ASK YOUR HARDWARE DEALER

Give Wings to Work

STOP Radio and TV Noises

with NEW, IMPROVED **FILTER PLUG**



BALANCED CIRCUIT eliminates power line interference from household appliances, fluorescent lights, motors, oil burners, autos, etc. Simple to use. Don't despair if you've tried other filters without success. THIS ONE WORKS. 5 day trial period. Money back guarantee. (No Ppd. COD's please.) We pay postage.

ONLY \$1.00

SCOPE MFG. CO. Dept. PM-2, Box 23, Knickerbocker Bldg., NYC 2, N.Y.

\$1.35 VALUE for only 89¢

Here's a bargain you shouldn't miss! A few copies of HOME KINKS '52 and '53 and USEFUL IDEAS '54 are still available. The combined value of these three money-saving books is \$1.35—but, if you act now, you can have all three to round out your files of P.M. annuals for only 89c postpaid! Mail your check or money order today to:

Popular Mechanics Press
200 E. Ontario St., Chicago 11, Ill.



CLIP THIS TO GET

NEW! DELCO LOW PRICE WATER

WELLMASTER JUNIOR JET SHALLOW WELL PUMP



Precision-Engineered and Quality-Built By . . . **GENERAL MOTORS DELCO**

Only **\$89.95** i.e.b. Rochester (Suggested List Price Model 53372 as illustrated)

- No other pump can match this new Delco Jet for PRICE . . . and QUALITY . . . in 1/2 HP class!
- New simplicity . . . only ONE moving part . . . New compactness . . . Self-adjusting capacity . . . New durability . . . All at new Low Price!

WRITE! for Full Information or Call Your Delco Water Pump Dealer Today!

DELCO APPLIANCE DIVISION
GENERAL MOTORS CORPORATION
Dept. PM3, Rochester 1, New York

SAVE ON PALLEY SPECIAL VALUES

BUILD YOUR OWN DIVING LUNG

As seen in Popular Science. Save up to \$100. Our fully illustrated instructions show how. Kit includes:
2 Air Bottles (1 hour air supply), pressure regulator, Hose, Shoulder Harness, Safety Belt, Clamps, Mesh Piece, Valves, etc. **45.95**

PALLEY BARGAINS IN DIVING EQUIPMENT

GENUINE
AIR-6004-1 Type
DILUTOR
DEMAND
PRESSURE REGULATOR
Recommended type. Gives proper regulation of air on demand. Used, Tested & guaranteed serviceable. **10.95**

COMPRESSED AIR TANKS
I.C.C. approved and tested. Will stand pressure of 1800 PSI.
22 cu. ft. cap. (30 min. time limit) - No valves. **9.75**
38 cu. ft. cap. (45 min. time limit) - No valves. **12.75**

NEW DEMAND REGULATORS . . . \$19.95
NEW FROGMAN SUITS
Of finest quality tearless Latex rubber. Two piece type. Factory seconds with minor imperfections, but guaranteed. With either long or short arms and legs. **24.95**
Please specify, \$54.95 vol.

48 cu. ft. cap. (1 hour time limit, without valve, ONLY **15.95**
CONTROL VALVE for above bottles. \$1.00
TWO-TANK CONNECTOR - **4.95**
SINGLE TANK CONNECTORS - \$3.95

FREE CATALOG ON DIVING EQUIPMENT

Send TODAY for your copy of this Fully ILLUSTRATED Catalog. Contains the latest information on Diving Equipment and related items. Also has an illustrated and described article "How to Build Your Own Diving Lung". See for Yourself - Order NOW!

AIR CORPS RUBBER BOATS

Ideal for Fishing and Hunting. Made to top Gov't Specs. Reconditioned & ready to use. Order Today!
MAN **22.50** 7 MAN **69.50** 10 MAN **115.00**
COLLAPSIBLE OARS **1.25 EA.**
LARGE Volume HAND AIR PUMP **5.49**

WATERPROOF BEDROLLS
Large 30"x96" heavy duty deck canvas bedroll. Has many pockets in each end to hold extra gear. An ideal enclosed ground cloth for a sleeping bag or air mattress. **4.95**
With (3) Str. straps & buckles.

ARMY SKI TROOPER STEEL FRAME RUCKSACK
Has large main compartment and 3 smaller pockets. Entire Pack mounted on light, comfortable, all-steel tube frame. With adjustable straps. A \$12.95 VALUE **8.95**

NEW IMPORTED, SELF-GENERATING CAMP STOVE

Smallest, most compact, yet entirely practical cooking stove you've ever seen. NO PUMPING - NO PRIMING necessary - entirely self-generating. Has collapsible grill for frying pan or coffee pot. Burns 2-1/2 hours on one filling of regular gas. ALL BRASS construction. Weighs 12ozs. Ideal for Besspector, Camper, Hiker, Picnic, etc. Guaranteed 1 year. **3.98**



NEW 4-SPEED HOBBY MOTOR
110 VOLT - 60 CYCLE
A rugged, precision built motor. Originally built for Navy - Now converted for You. . . Turns at 5, 25, 150 and 4000 RPM. Ideal for Barbecue, hobbies, etc. **9.95**
Cost Gov't approx. \$35.00 NOW!

NEW! JACK & HEINTZ 2-SPEED ENERGIZER
Used as auxiliary power source to actuate aircraft starters. Has 2-speed control for 200 RPM low or 275 RPM high. Heavy duty gear box gives extremely high torque. Power 110-115V AC. Easy to convert to many power uses. **27.50**

STEEL BARBECUE SPIT
Has 4 adjustable prongs. Complete with coupling to fit above motor. **3.50**

ONLY \$166 For This Extra Quality Hand Filed, Patent Ground, Saw Made For U. S. Ord. Dept.

Saw will not whip or bind in cut; handle is adjustable within 45° for easy, tireless sawing. Blade is 18" long, just right for tool box. Saw is made to rigid U. S. Ordnance Department specifications. No finer saw is available at twice the price. Ideal for professional carpenter, handyman or beginner! Quantity limited. One to a customer. Order now! Only \$1.66 postpaid.
EDEN-SCOTT & CO., 1725 Doan Ave., Cleveland 12, Ohio.



SAVE UP TO 50% BUY FROM IMPORTER

Genuine Select PHILIPPINE MAHOGANY LUAN PLYWOOD

Ideal For Fine CABINET WORK, FURNITURE, Paneling DENS, OFFICES, HOTELS, etc.

Our prices are LESS THAN DOMESTIC PLYWOOD at WHOLE-SALE. This selected LUAN MAHOGANY meets the most rigid specifications. It is WEATHER and WATER RESISTANT. You'll be amazed at the beauty of this fine wood. Its rich golden elegance will thrill you. Rotary cut for beauty of grain. Both sides sanded and ready to use. Bonded with finest resin adhesive. Face side unjointed.

See for YOURSELF FREE SAMPLE on request!

Available in three thicknesses - 3mm (approx. 1/8"), 4mm (approx. 3/16") and 1/4". All orders shipped by Special Truck for lowest rates. No order accepted for less than 100 lbs. - equal to (8) 3mm sheets, (5) 4mm sheets or (4) 1/4" sheets.

3mm (1/8") x 3ft. x 6ft. **55.00 VALUE**
1.79 PER SHEET
Minimum order 8 sheets

4mm x 4ft. x 6ft. **57.50 VALUE**
3.89 PER SHEET
Min. order 6 sheets

1/4" x 4ft. x 8ft. **59.50 VALUE**
4.99 PER SHEET
Min. order 2 sheets



TRANSLUCENT FIBERGLASS PANELS
Special purchase of 500,000 sq. ft. SAVE 40%. Finest Quality. In all lengths and widths. Full range of colors. As described in Oct., '54 issue of Popular Mechanics. **49¢ PER SHEET**
Write for FREE Booklet and Sample. 85¢ sq. ft. value.



3400 RPM 1/2 HP POWER SAW
compared to saws selling up to \$6.99
Ideal for HOME or SHOP
19.98 Complete with 5 1/2" Blade
RIPS - CROSSCUTS
CUTS A FINISHED 2x6 LIKE A KNIFE THROUGH HOT BUTTER!
A rugged, professional type, adjustable saw. Cut any angle, 0 to 45°. Has adjustable (0 to 6") rip fence. Safety trigger switch on handle. Full 1/2 HP Universal AC DC, 110-120 Volt, 60 cycle motor. Weighs 6 1/2 lbs.

EXTRA SAW BLADES - Available in Rip, Crosscut or Combination. Please specify . . . price per each **2.95**

SPORTSMAN'S 12 Pc. IMPORTED COMBINATION KNIFE

Eliminates 12 individual items from your Pack or Tool Kit!
(A \$12.95 VALUE) **4.95**
COMPLETE CAMPKIT
Here is the Perfect Combination Knife-Tool for every Outdoor Sportsman, Hunter, Camper, Fisherman, Boy Scout, Ranger, Roaster, etc. Think of it! 11, Fine quality Steel Tools, precision made to fold easily into the heavy bone covered body. In one neat, compact unit you have: (1) a regular knife; (2) a fork; (3) a spoon; (4) a draw knife; (5) a bone-saw and fish-scaler; (6) scissors; (7) a can and bottle opener; (8) a cork-screw; (9) a nail punch; (10) a screwdriver and (11) a metal file. All this PLUS a genuine leather, belt holster.
ORDER NOW While We Can Guarantee Delivery at this Special Low Price

ORDER FROM THIS AD - Pay by Money Order or Check. Purchase Orders accepted from D&B firms. 50% dep. with C.O.D. - Prices F.O.B. our store!!

PALLEY SUPPLY CO 2263 E. VERNON AVE., DEPT. PM-9 LOS ANGELES 58, CALIF.

Now HULL AUTO COMPASSES IN NEW CAR TONES

You can now select a Hull Auto Compass that matches or blends with the sparkling, bright pastel color of almost any new car! Most beautiful and useful accessory on the market. Guaranteed. At better dealers everywhere. Write for literature.

THE FAMOUS NAME IN AUTO COMPASSES
HULL MFG. CO. P. O. Box 246, D-9 WARREN, OHIO



Beaconlite[®] ILLUMINATED **3.65**
STREAMLINE NON-ILLUMINATED **2.45**

SCHALK'S WOOD PUTTY



Recommended
by Peter Putter

Not a plastic—
contains real hard wood

Here's the Wood Putty that won't shrink; can be stained with regular wood stains, and so can be used on any kind or color of wood; fills nail holes, cracks in floor, furniture, plywood; sets door pulls. And, when mixed with varnish instead of water, it becomes a waterproof material for boat repairs or exterior use. All you need for 101 odd jobs around home, farm and workshop—Schalk's Wood Putty!

At paint, hardware, building supply stores.
Made by Schalk Chemical Co., Los Angeles, Chicago

INSTALL
YOURSELF

IT'S
SO
EASY



SHUTTERS and DOORS, too!

You can order de'cor shutters and doors by mail; tailor made for the many decorative and practical uses in your home or office. The smartest, newest idea for new and old homes. Easily installed yourself. Satisfaction guaranteed.

SEND 25¢ for new illustrated brochure, "101 Uses for Shutters"—together with full information on how easy you can order by mail.

Write **de'cor**
OF GRAND RAPIDS, INC.
1609 EASTERN AVE., S.E.
GRAND RAPIDS, MICHIGAN

PROTO Low-Cost ADDA-UNIT TOOLS



No. 9950

marked molded openings for each size, keeps every tool in proper place.

No. 9950: 1/2" Drive Socket Set — \$15.00 (incl. holder 1.5" hinge handle, ten 1/2" drive, 12 pt. sockets 3/4"-1")

No. 9931: Open End Wrenches \$6.14 (incl. holder, 5 wrenches 3/4"-3/4")

No. 9953: Pliers — \$7.00 (incl. holder, 6" thin nose plier, 4 1/2" midjet plier, 8" multi-plier, 9 1/2" utility plier)

No. 9937: Comb. box & open End Wrenches — \$8.40 (incl. holder, 6 wrenches 3/4"-3/4")

No. 9942: Adjust. & Pipe Wrenches — \$9.64 (incl. holder, 2 adj. wrenches, 6" & 10", 2 pipe wrenches 8" & 14")

SAVE TIME AND EXPENSE!

Get Your Genuine PROTO TOOLS Prepaid

For prompt PREPAID (in U.S.) delivery send check or money order to



No. 9931



No. 9953



No. 9937



No. 9942

JAY-DEE SALES CO. 3304 N. SAN FERNANDO BLVD. BURBANK, CALIF.

FREE! 68 page PROTO Tool Catalog with Order — or send 10¢



OVERLOAD SPRINGS

\$9.95 Per Pair
Postpaid
2,000 lb. Size \$11.95

For cars and trucks. Front and rear. Gives 2,000 lbs. extra capacity for all 1/2, 3/4, and 1 ton trucks, 500 or 1,000 lbs. extra for all cars. Easily installed. Guaranteed. State make, model, Dealers wanted.

BRINKMAN MFG. CO.
2315 CLAY, DEPT. 15-S, TOPEKA, KAN.

BRONZE FOUNDRY Schools and Home Workshops

Make your own castings of aluminum, copper, bronze, silver. Foundry sets are available in three sizes including 2400 Deg. F. blast furnaces. See advertisements in March or Apr. issues, free Circular.

KANSAS CITY SPECIALTIES CO.
P.O. Box 6022 Dept. P-9 Marysville, Kan.

BIG DO-IT-YOURSELF PAINT SAVINGS

LEAD TO HIGH EXTRA MONEY PROFITS for YOU

Now! Buy finest Quality Paints at true low wholesale **FACTORY PRICES** direct from one of leading Paint Companies in U. S. Sell to your friends, neighbors, relatives etc. We show you how to cash in on tremendous profits brought on by **DO IT YOURSELF BOOM!** We furnish **EVERYTHING**—color cards, **DO IT YOURSELF** Plan, samples at low cost, etc. Start NOW! Write for **FREE** details. No obligation. No one will call on you.

STALEY PAINT MFG. CO.
5239 MANCHESTER, ST. LOUIS, MO.



FACTORY WHOLESALE PRICES

Put Up This APPROVED Fireplace and Chimney YOURSELF in 4 Hours NO MORTAR.. NO MASONRY



For 1, 1 1/2 or 2-story houses

Save more than half! Full-sized wood-burning fireplace and chimney. Safety clearances built in. Labeled by Underwriters Laboratories Inc. Sets right against wood floors, walls, studs, joists. Fully engineered, tested, proved — won't smoke. Triple-wall chimney of stainless steel and aluminum. Realistic brick-finish aluminum top. Write for



FREE details!

Add any mantel design

Majestic THULMAN FIREPLACE

The Majestic Co., Inc., 456 Erie St., Huntington, Ind.

PORTABLE LIGHT PLANTS

GIANT 2000-2500

WATT PLANT

110-120 v. 60 cyc. AC. absolutely the best made — exclusive dynamically balanced armature; heavy windings develop up to 5000 watt overload for motor starting. Skid mounted — portable. Powered by an easy starting Briggs or Wisconsin 6 HP engine—complete with all accessories; engine easily disconnected for other uses. Big outlet box, voltmeter, no wiring necessary. Ample current for all purposes. Factory warranty. (Item 31) Wt. 210 lb.

Reg. price \$595. Special at.....

Same plant with electric self starter (Item 31a).....

Generator only and control box.....

DUAL VOLTAGE 110-220 available on any of above models for \$28.00 additional.

\$299.50

\$359.50

\$169.50



TERRIFIC SAVINGS at MASTER MECHANIC'S bedrock factory prices!



600-700 WATT PUSH BUTTON START

115 v. 60 cyc. AC. Powered by a rugged 2 HP easy starting Briggs engine. No wiring necessary; just plug in and operate. Plenty of current for any oil burner, freezer, brooder, emergency lights, etc. which require

up to 700 watts. Ideal for television and radios. Complete with Voltmeter and built-in winding to charge 6 v. auto batteries. (Item 24.) Wt. 75 lbs. Easily fits in car trunk. Be prepared if storm knocks out.....

\$143.50

1000-1200 Watt Plant (Item 45) same as Item 24 but larger generator and engine with 50% greater output.....

\$199.50

1300-1500 WATT PLANT

115v. 60 cyc. AC. Push Button Start. Powered by a 3 1/2 HP Clinton engine. Combines big output with easy portability. Provides emergency power for operating any oil burner, sump pump, freezer, television, lights, communications systems, etc. which require up to 1500 watts. (Item 22.) Wt. 110 lbs. Reg. \$475 value, Factory price.....

\$239.50

1750 Watt Plant Powered by 4.5 Briggs engine. Electric starting & battery charging built-in. Factory price.....

\$279.50

2500 WATT PLANT—Push Button Start (Item 21) 110/120 v. 60 cyc. A.C. A rugged, long-lived powerful plant. Reg. \$645. Special.....

\$329.50

3500 Watt Plant Push Button Start (Item 23) 115 v. 60 cyc. AC. Similar to above, but larger and 33% more capacity. Wt. 270 lbs. Reg. \$760. Factory Price.....

\$379.50

Dual Voltage 110/220 available for above plants for \$30.00 additional.

LESS THAN WHOLESALE

(Item 162)

HI-LINE 6000 WATT PLANT Push Button Start 115-230 v. 60 cyc. A.C. A brute of a power plant with a rugged 14.6 hp. Wisconsin engine. Plenty of electricity for ranges, water heaters, freezers, pumps, machinery, etc. Affords both 110 and 220 volts. Ideal where heavy current is needed. Wt. 590 lbs. Easily worth \$995. With crank start.....

Factory price.....

\$585.50

Same plant, but with self-starter.....

\$645.50

KEEP CLOSE-TOLERANCE MACHINING EFFICIENT!



South Bend PRECISION TURRET LATHES

South Bend 2-H Precision Turret Lathe—1" collet capacity, 16 1/4" swing, 96 power turret feeds, 48 cross slide feeds, 48 carriage feeds, 48 thread cutting feeds.

• Base Price \$3190

South Bend Precision Turret Lathes keep efficient the machining of small duplicate parts. Their remarkable accuracy and positive controls simplify the holding of close tolerances with only normal machine handling care. Finishes are commonly produced that otherwise would require additional operations. Simplicity of tooling makes job changes quick and economical. Wide ranges of power feeds and thread cutting feeds assure maximum efficiency on every job. They are particularly suited for second operations. Available in 3 sizes: 1" collet—16" swing; 1" collet—10" swing; 1/2" collet—9" swing. Priced from \$211. Time payment terms can be arranged. Only 3 1/4% annual interest on original unpaid balance.



TURRET ATTACHMENTS

South Bend Turret Attachments are available for tooling 9", 10", 13" and 16" swing South Bend Lathes for repetitive operations. Precision built for precision work, their rigidity and accuracy permit maximum feeds and speeds. Prices of hexagon bed turrets range from \$273.00 to \$698.00. Square Turret Tool Blocks are priced from \$41.50 to \$91.00. Write for Attachment Catalog giving full information on South Bend Turrets and the complete line of South Bend Attachments and Accessories.

Compared with our costs
OUR PRICES ARE LOWER
than they were back in 1941



Prices are closely tied to costs. Costs are still rising. Buy now before increased costs necessitate higher prices.

SEND INFORMATION CHECKED:



9" and 10" BENCH LATHES



10" to 16-24" FLOOR LATHES



DRILL PRESSES



TOOL GRINDERS



1/2" & 1" Collet TURRET LATHES



7" BENCH SHAPERS

Name _____ Street _____

City _____ State _____

Building Better Tools Since 1906 • SOUTH BEND LATHE • South Bend 22, Indiana



How Handy is Your Family Handyman?

Many Formica do-it-yourself surfacing projects are easy enough for ladies or ten thumb husbands. But as a challenge to the real hammer and saw hobbyist we present this Formica remodeled bathroom done by a husband like the ones wives always point out to the fishermen and golfers.

(He is: Wm. "Bud" Meyers, Power Transmission Dept., Cincinnati Gas & Electric Co.)

Find It Fast
In The
'Yellow Pages'

or see your lumber, hardware or flooring dealer.



DEMAND THIS CERTIFICATION

This mark certifies genuine
REMOVE WITH SOAP AND WATER

*Seeing is believing. If this wash-off identification
is not on the sheet, it's not FORMICA.*



FREE! Formica samples and complete step-by-step do-it-yourself instructions on home use of Formica with simple tools and Formica Contact Bond Cement. Write

FORMICA 4596 Spring Grove Ave.,
Cincinnati 32, Ohio

In Canada: Arnold Bentfield & Co., Ltd., Oakville, Ontario

IT'S A PSYCHOLOGICAL FACT: PLEASURE HELPS YOUR DISPOSITION

How's your disposition today?

EVER FEEL TOUCHY AS A TIGRESS? It's only natural, when little annoyances irk you. But here's a psychological fact: pleasure helps your disposition. That's why everyday pleasures, like smoking for instance, are important. If you're a smoker, it's so sensible to choose your cigarette for utmost pleasure. What else but Camel!



For more pure
pleasure _ have a
Camel

*"I've tried 'em all...I'd walk
a mile for Camels' pleasure!"
Brian Keith*

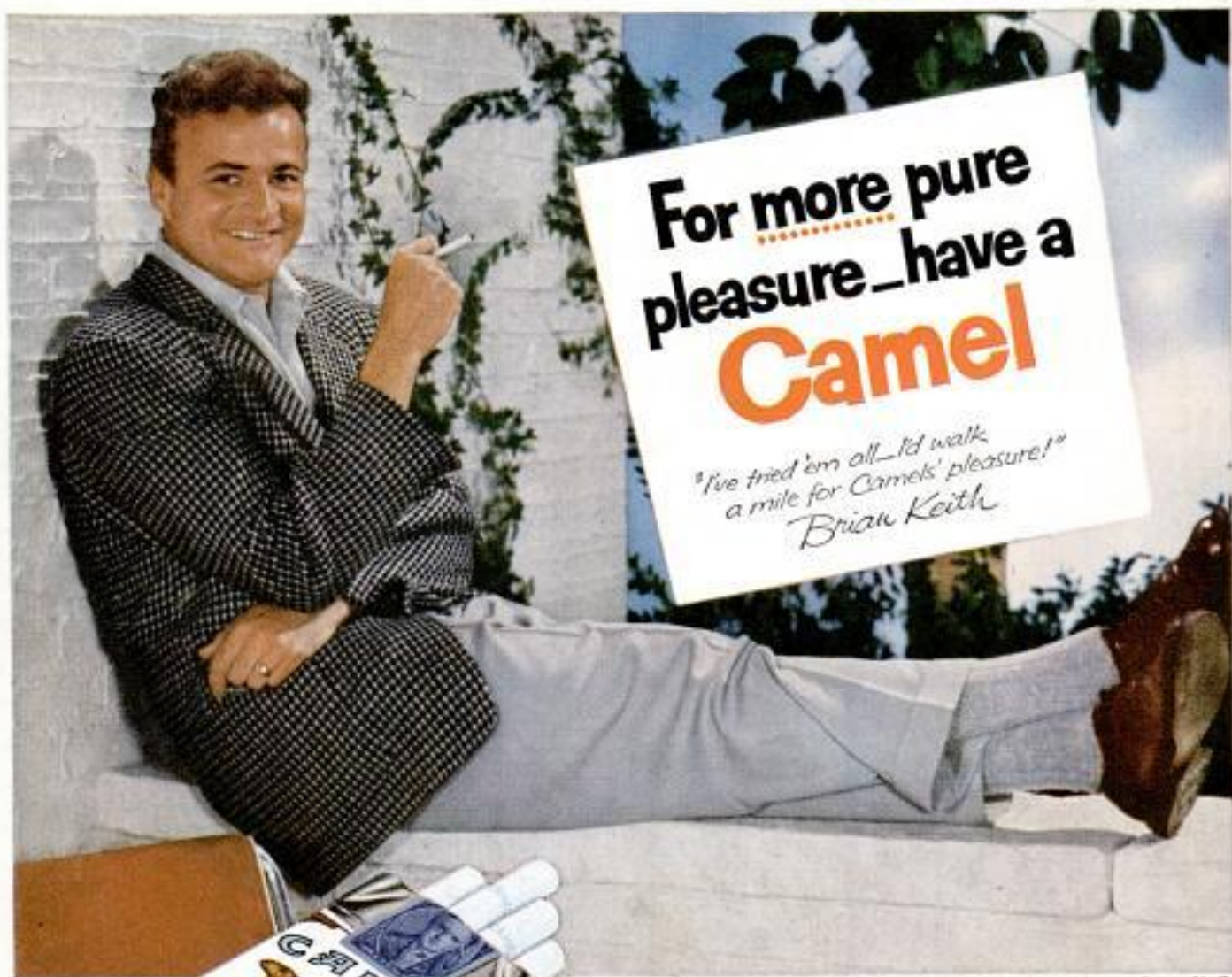

R. J. Reynolds Tobacco Co., Winston-Salem, N. C.



Hollywood's **BRIAN KEITH**, sensational star of TV's dynamic new "Crusader", agrees that pleasure helps one's disposition. And Camels give *more pure pleasure* — more flavor, reliable mildness, smoke after smoke. Good reasons for *you* to try Camels. See why today their richer blend agrees with more smokers than any other brand!

No other cigarette is so rich-tasting, yet so mild!

Copyrighted material