

POPULAR MECHANICS

MAGAZINE

WRITTEN BY MEN WHO CAN UNDERSTAND IT

REG. U.S. PAT. OFF.

NO. 1

NO. 1

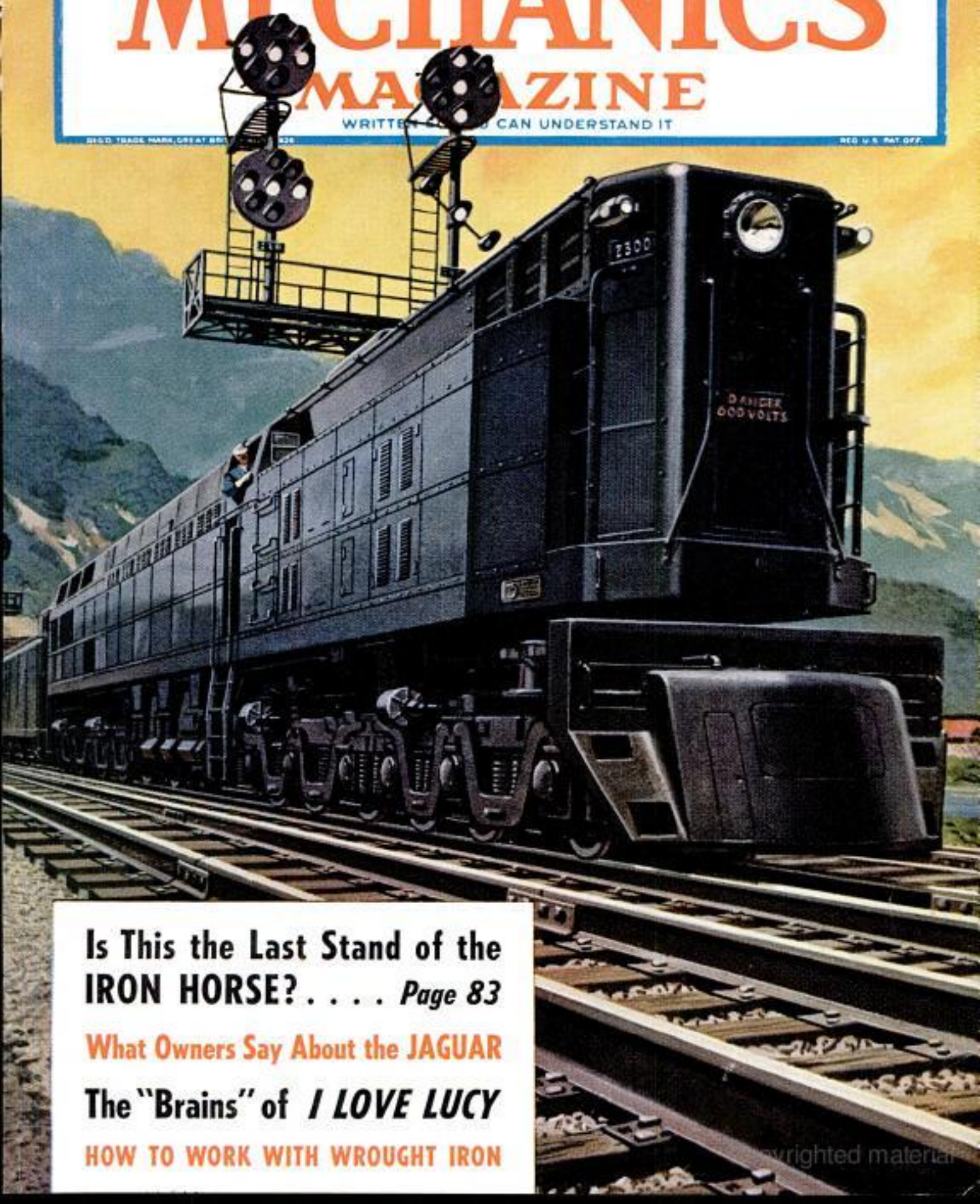

**Is This the Last Stand of the
IRON HORSE? Page 83**

What Owners Say About the JAGUAR

The "Brains" of I LOVE LUCY

HOW TO WORK WITH WROUGHT IRON

Copyrighted material

This is the kitchen →

My name is Saturday (mechanic)

I'm a husband

The sink top is rotted

My job.....



FIX IT !



- 9:01 A.M. I ripped off the old surface.
- 9:57 A.M. Scraped the plywood core of the sink top clean of old mastic.
- 10:32 A.M. Went to my lumber dealer to buy Formica.
- 10:33 A.M. Looked for the Formica Trade-Mark on the sheets to be sure it was genuine--It was.
- 11:05 A.M. Marked and sawed Formica to size for new top and backsplash. Used carpenter's saw--worked fine.
- 12:15 P.M. Spread Formica Contact Bond Cement on back of Formica and on plywood core.
- 12:44 P.M. Knocked off for lunch while cement was drying.
- 1:30 P.M. Applied cemented back of Formica to cemented top of cabinets. Used ordinary rolling pin.
- 1:51 P.M. Filed edges of Formica, applied metal moldings.
- 2:30 P.M. Had a beer. Accepted kiss from lady of the house. **CASE SOLVED.**

Formica samples and complete illustrated instructions for doing-it-yourself with Formica. Write to The Formica Company, 4596 Spring Grove Ave., Cincinnati 32, O.

DEMAND THIS CERTIFICATION

This mark certifies genuine
REMOVE WITH SOAP AND WATER

Seeing is believing. If this wash-off identification is not on the sheet, it's not FORMICA.





"We got a big kick out of designing this new Chevrolet, and you'll get an even bigger one out of driving it."

— says Ed Cole, Chevrolet Chief Engineer

IT ONLY happens once in an engineer's life-time—when a company like Chevrolet hands you a blank sheet of paper and says: "Design us a car—from scratch." But what a wonderful sensation it is to plan a car from the very beginnings, so that it is *right*, all down the line.

That's the chance we were given with the 1955 Chevrolet . . . and we started right from fundamentals with a new frame (*lighter but 50 per cent more rigid*), new bodies (*quieter, bigger inside, with 18 per cent more glass all around*), new spherical-joint front suspension (*softer flexing and uniquely self-adjusting*), outrigger rear springs (*for greater stability on curves*), even an Anti-Dive braking control (*to check that "nosing-down" in front when you apply the brakes suddenly*).

We came up with three new engines—two new versions of the "Blue-Flame" 6's and a 162-h.p.

"Turbo-Fire V8" that has the shortest stroke in its field and an 8 to 1 compression ratio. We added a Touch-Down Overdrive transmission, and a smoother Powerglide as extra-cost options, and a sturdier standard shift—even provided a 12-volt electrical system for more reserve power and a High-Level ventilation system that draws in cleaner, fresher air.

We made so many improvements they can't even be *listed* here—and we got a big kick out of it. But I know you'll get an even bigger kick when you slide behind the wheel of a car that is blue-print-new—from the tubeless tires right on up.

You can't know how advanced the '55 Chevrolet is until you drive it, so why not call your Chevrolet dealer today and have him set up a ride for you? . . . Chevrolet Division of General Motors, Detroit 2, Michigan.

MOTORAMIC



More than a new car . . . a new CONCEPT of low-cost motoring!

JANUARY 1955

Copyrighted material

FOR TV...IT DODGES

TROUBLE YOU CAN'T STOP

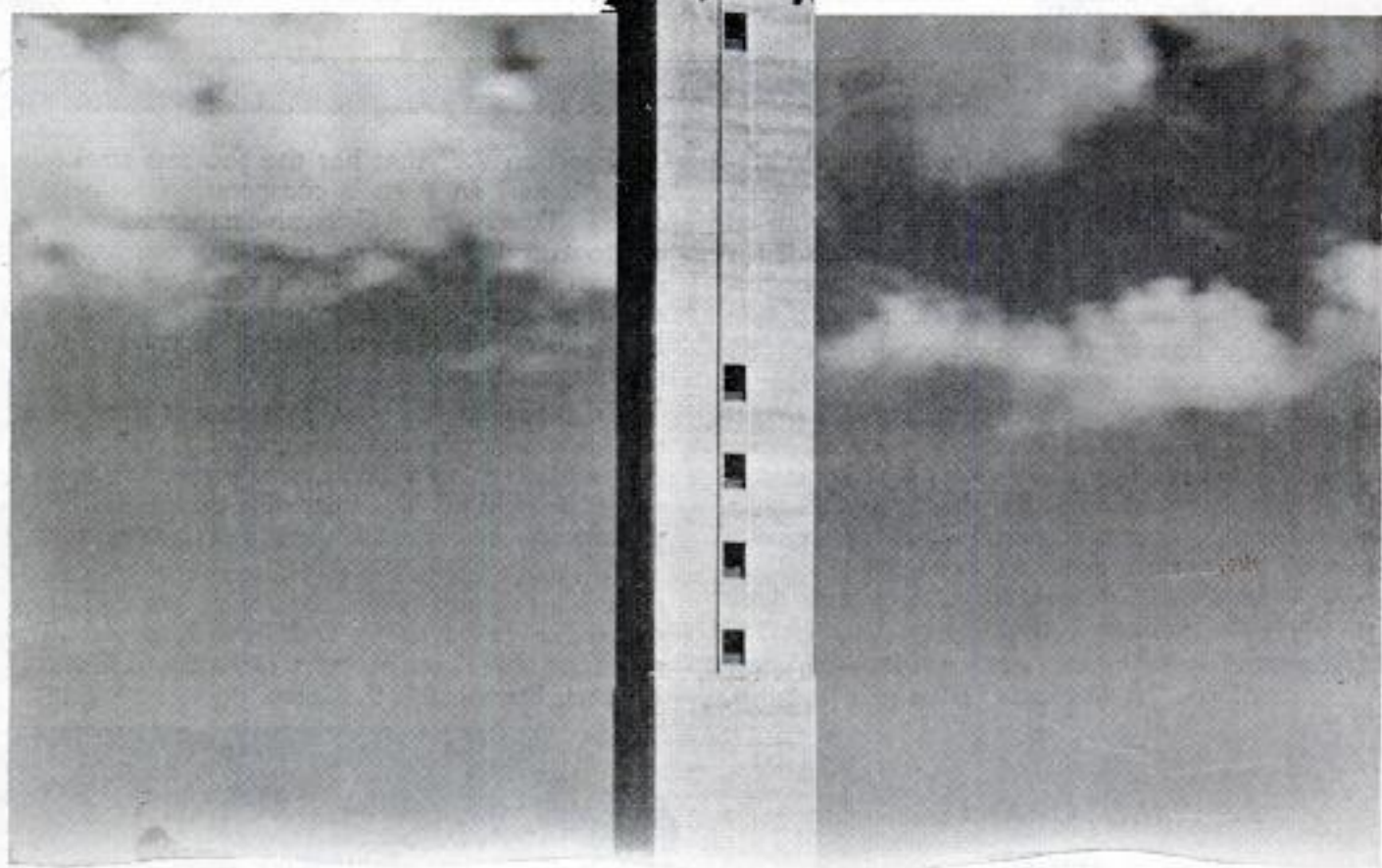

Radio Relay station on route between Chicago, Ill., and Des Moines, Iowa. Every fifth or sixth relaying tower is a control station, where high-speed

switching equipment enables a TV picture to skip out of a troubled channel and into a stand-by protection channel faster than the eye can wink.

There's no way to stop atmospheric changes that threaten television with "fade." But, for TV that travels over Bell's Radio Relay System, Bell Laboratories engineers have devised a way to sidestep Nature's interference.

When a fade threatens—usually before the viewer is aware—an electronic watchman sends a warning signal back by wire to a control station perhaps 200 miles away. An automatic switching mechanism promptly transfers the picture to a clear channel. The entire

operation takes 1/500 of a second. When the fade ends, the picture is switched back to the original channel.

This is an important addition to the automatic alarm and maintenance system that guards Bell's Long Distance network for television and telephone calls. It marks a new advance in Bell Telephone Laboratories' microwave art, developed to make your Long Distance telephone service, and your TV pictures, better each year.

BELL TELEPHONE LABORATORIES

Improving telephone service for America provides careers for creative men in scientific and technical fields.



Popular Mechanics Magazine

Registered in U. S. Patent Office and Canada

H. H. WINDSOR, Founder

H. H. WINDSOR, JR., Editor and Publisher



Next Month

AN AIRPLANE is missing and presumably down, and the Civil Air Patrol swings into action. Crews of an Air Force Rescue Service helicopter and a CAP light plane coordinate their search plans before taking off. With 7000 aircraft registered, the CAP stands ready 24 hours a day, 365 days a year, to undertake any mission—search, rescue or mercy flight. The dramatic story of the USAF's volunteer auxiliary appears next month under the title "CAP to the Rescue." The February *Popular Mechanics* also carries the big 48-page auto section, with specifications and pictures of all 1955 models, and a full-color feature on motorcar styling

Information not listed on articles in the index, starting on page 12, frequently is listed in the WHERE-TO-FIND-IT LIST, which is available to readers without charge. A copy may be obtained by writing to the Bureau of Information, *Popular Mechanics*, 200 E. Ontario, Chicago 11, Ill.

Published monthly by Popular Mechanics Company, 200 E. Ontario St., Chicago 11, Ill. H. H. Windsor, Jr., president; Wm. Harrison Petridge, exec. vice-pres.; D. F. Windsor, vice-president and secretary-treasurer; H. H. Windsor III, vice-president; Clover L. Perkins, advertising manager; Alan M. Devos, circulation manager. Single copy in the United States and Canada, 35 cents; subscription rates in the United States and possessions, Canada, Philippines and countries of the Pan-American Postal Union, 1 year \$3.50; 2 years, \$6.00; 3 years \$8.00. To all other countries add \$1.00 a year over United States prices for overseas postage. If you plan to move, notify us at least 30 days in advance so you will not miss an issue. Give both your old and new addresses. Entered as Second Class Matter, September 15, 1903, at the Post Office at Chicago, Illinois, under Act of March 3, 1879. Entered as Second Class Matter at Post Office Dept., Canada. Registered as Second Class Matter at the Post Office at Mexico, D. F., Mexico, June 20, 1950. Copyright 1955 by Popular Mechanics Company. Copyright under International Copyright Union. Copyright in France. All rights reserved under Pan-American Copyright Union. Printed in the United States of America.

Volume 103

JANUARY 1955

Number 1

Address all communications to: 200 E. Ontario St., Chicago 11, Ill.

Managing Editor.....	Roderick M. Grant
Assistant Managing Editor.....	Wayne Whittaker
Shop Notes and Crafts Editor.....	James R. Ward
Radio-Television, Electronics Editor.....	Frank L. Brittin
Associate Editor.....	Clifford B. Hicks
Associate Editor, Automotive.....	Arthur R. Railton
Associate Editor.....	George E. Moise
Associate Editor, Shop Notes and Crafts.....	Wayne C. Leckey
Assistant Editor, Shop Notes.....	W. Clyde Lammy
Assistant Editor, Crafts.....	Frank N. Stephany
Assistant Editor, Makeup.....	John C. Dalen
Automotive Correspondent.....	Leo Donovan
Art Director.....	Frank Beatty

Assistant Editors

Leonard F. Hiltz, Jay W. Hedden, Elliott H. McCleary, Emily Mullaney	
Eastern Editor.....	Richard F. Dempewolf
Empire State Bldg., Room 2906, New York City 1	
Western Editor.....	Thomas E. Stimson, Jr.
Suite 1010, 3460 Wilshire Blvd., Los Angeles 5, Calif.	
London Manager.....	Douglas W. Wedderspoon
Eagle House, Jermyn St., London S. W. 1, England	
Director, Bureau of Information.....	Allan Carpenter
200 E. Ontario St., Chicago 11	

In This Issue . . .

Is This the Last Stand of the Iron Horse? - - - - -	83
American Stylist at Paris Auto Show - - - - -	90
Even the Stagehands Have to Swim - - - - -	93
Listen—It's the Wail of the Turboprops - - - - -	105
They Photograph Engine Wear - - - - -	116
Let's Import Rain for the Dust Bowl - - - - -	119
He's "The Brains" of <i>I Love Lucy</i> - - - - -	127
What's New for Your Home - - - - -	136
The Owners Report on the Jaguar - - - - -	140
An Old Mill Grinds Again - - - - -	148
Taking That Spot-News Picture - - - - -	153
Radio, TV and Electronics - - - - -	159

For the Craftsman . . .

Railroad in a Suitcase - - - - -	163
Solving Home Problems - - - - -	170
Unusual Small Boat - - - - -	174
Plan of the Month—Corner Table - - - - -	182
How to Treat Plywood Edges - - - - -	186
An Introduction to Wrought Iron - - - - -	192
Weaving Revived by Table-Top Loom - - - - -	197
Restoring Ignition System - - - - -	204
How to Turn a Ball - - - - -	207
All About Glue and Gluing - - - - -	215
Shopping for Tools - - - - -	220

Other items, and manufacturers of available products described, are listed on pages 12, 14 and 16

JANUARY 1955

Copyrighted material

AC HOT TIP

-greatest spark plug achievement
in high-compression history!



Ten years ago, AC increased "Scavenging" action as one step in meeting high-compression demands!

Engineers depend on scavenging action, as they term the high-velocity swirling of combustion chamber gases, to carry away the combustion left-overs that cause plug fouling. Years ago, 1944 in fact, AC Spark Plug engineers put this principle to work by increasing clearance between the plug shell and the insulator tip in the AC Type 48 plug. This extra "Scavenge" area alone did not satisfy AC.

An amazing thin-tip, fast-heating insulator added even more — and is still an AC exclusive!

AC developed the insulator material that has completely outmoded porcelain. And AC soon found a way to form this material into long, thin insulator tips that could be recessed around the center wire. These thin tips heat fast, burn away harmful combustion deposits, stay clean longer. No one else has yet been able to duplicate this design.

Proved by millions of miles of driving in every make of high-compression engine built in America!

Of course everyone expects AC to be in the forefront of research to improve ignition for high-compression engines. The important thing to remember is that these benefits of AC Spark Plug design have been available since the first high-compression engine came off a production line. *Today's AC Hot Tip Spark Plugs fit every American make of car!* They are the *only* plugs designed with double cleaning action. No other spark plugs offer anything like AC's thin, hot tip features.

AC Spark Plug engineers with GM resources can be depended upon to LEAD the ignition parade!



AC SPARK PLUG DIVISION SPARK PLUGS GENERAL MOTORS CORPORATION

Watch BIG TOWN on NBC-TV



-another AC feature story that can't be topped!

**Man with
stapler beats
man with
glue 10 to 1**



...and cuts fastening costs 70%!
This carton-sealing race took place in a rubber products plant—the man at left using glue, his companion sealing 10 times faster with a Bostitch Autoclencch Stapler.

Gone are the gluepots, dripping brushes, spattered aprons. No more “glue-cake” on floor or hand truck. No “weighting” of sticky carton flaps. Cartons go off faster, cleaner, and can be re-used. And because the men are paid on piecework, take-home pay is bigger.

The Autoclencch is just one of 800 kinds of Bostitch staplers that trim time and costs on

thousands of different fastening jobs in factory and office. To fit the right stapler to the job, Bostitch has a staff of 300 Economy Men working out of 123 U. S. and Canadian cities.

If you are responsible for buying equipment, call the Economy Man nearest you. If not, tear out this page and take it or route it to the man who is. Every day's delay may mean more money down the drain.

The Bostitch Economy Man will tell you honestly whether stapling can save you time and money. Look for “Bostitch” in your phone directory, or write us.

Fasten it better and faster with



BOSTITCH, 541 Mechanic St., Westerly, R. I.

- Would like an Economy Man to analyze our fastening problems.
- Would like to have FREE BULLETIN telling how stapling can cut costs on fastening jobs checked below.

I want to fasten:

- | | | | |
|----------------------------------|---------------------------------------|---------------------------------|----------------------------------|
| <input type="checkbox"/> cartons | <input type="checkbox"/> plastics | <input type="checkbox"/> wood | <input type="checkbox"/> leather |
| <input type="checkbox"/> rubber | <input type="checkbox"/> light metals | <input type="checkbox"/> fabric | <input type="checkbox"/> roofing |

Name _____

Company address _____

City _____ Zone _____ State _____

This One



HDE6-SZW-BEQ9

LONG-PLAYING 33 $\frac{1}{3}$ R. P. M. HIGH-FIDELITY

8 MASTERPIECES

COMPLETE TO THE LAST NOTE!
NOT \$1 EACH, BUT \$1 FOR ALL 8!

\$1⁰⁰

Long
Playing

NOW you can get a real start on a complete record collection. Yes, you get ALL EIGHT of these great masterpieces — complete to the last note — for only \$1.00!

Why We Make this Amazing Offer

We were FORCED to make this "give-away" offer — for only by putting our records in your hands can we demonstrate their wonderful quality and extreme value. Performed by internationally renowned orchestras and artists. Custom-pressed on purest vinyl plastic. Reproduced with a tone fidelity encompassing the entire range of human hearing... 50 to 15,000 cycles!

Mail Coupon Now

As a Trial Member of the Musical Masterpiece Society, you are not obligated to ever buy another record from us. You do have the right to try — free of charge — any of the Society's monthly selections you wish. You receive prior notice of these and pay nothing in advance. Those you want are sent to you for FREE trial. After 5 days, the records you decide to keep are billed you at the low Membership Price of only \$1.50 per disc (average playing time 40 minutes). You save 2/3 the usual retail price! And, on this sensational demonstration offer, you start your collection with these EIGHT masterpieces for only \$1. But production capacity limits our membership rolls; when they are filled this offer must be withdrawn. Avoid disappointment. Rush coupon with a dollar today!

Musical Masterpiece Society, Dept. 701
43 West 61st St., New York 23, N. Y.

ALL 8 MASTERPIECES—\$1.00

I enclose \$1.00 as complete payment. Please send me ALL 8 of the masterpieces listed above and enroll me as a Trial Member.

I will receive advance descriptions of future monthly selections. I may try any of these — free of charge — without paying a penny in advance. I may reject any recording before or after I receive it, and may cancel my trial membership at any time.

In the future, for each selection I decide to keep, I will pay special Member's Price of only \$1.50 plus a few cents for shipping... saving 2/3 off the usual retail price!

Name

Address 701

City State

In Canada, address: 686 Bathurst St., Toronto 4, Ont.

SCHUBERT

Symphony No. 8
("Unfinished")
Zurich Tonhalle Orch.
Otto Ackermann, Cond.

BEETHOVEN

The Ruins of Athens
(March and Choir)
Netherlands Phil.
Walter Goehr, Cond.

BRAHMS

Academic Festival
Overture
Utrecht Symphony
Paul Hupperts, Cond.

MOZART

Piano Concerto in E Flat
Artur Balsam, piano
Winterthur Symphony
Otto Ackermann, Cond.

BACH

Toccatto and Fugue in
D Minor
A. Schreiner; Organ of
the Tabernacle,
Salt Lake City

WAGNER

Die Meistersinger,
Prelude, Act 1
Zurich Tonhalle Orch.
Otto Ackermann, Cond.

DUKAS

Sorcerer's Apprentice
Utrecht Symphony
Paul Hupperts, Cond.

MUSSORGSKY

Night on Bald Mountain
Netherlands Phil.
Walter Goehr, Cond.

in this corner..... THE EDITORS



Another Life Saved

Future, the magazine of the U.S. Junior Chamber of Commerce, reports another life has been saved by the use of the wooden lung which was a joint project of *Popular Mechanics* (Craftsman Section, Jan. 1952) and the Junior Chamber. Shortly after one of the lungs was built by the East St. Louis, Ill., Chamber and donated to St. Mary's Hospital, a patient's life was saved by its use.

Bulletin Boards on the Autobahnen

Blackboards along the West German Autobahnen keep motorists in touch with family and office, reports Joseph C. Scott of Kittery Point, Me. A phone call to the nearest highway office is relayed to service



stations in the estimated area of the traveling motorist, and attendants post the license number of the wanted car on the blackboard between the two strips of pavement. The boards are called "fernruftafeln," or long-distance-call boards.

To the Editor:

I have been a reader of your magazine for more years than I can remember and have always considered it a must on my list. I hope you keep printing your wonderful articles on homes

I have to do quite a bit of walking about the ship and yesterday, just for the heck of it, I kept track of how many times I was asked for your magazine. You can feel proud that it was 23 times in one hour.

L. Ohl,
USS *Shadwell* (LSD-15),
Fleet Post Office,
New York City.

(Continued to page 8)

5 reasons why ACCOUNTANCY



offers you



MORE MONEY and SUCCESS

**SEND FOR FREE
SAMPLE LESSON**

REASON #1. If you were an expert accountant right now, chances are you would find yourself among the highest-paid of all professional men and women. Even back in "depression years," surveys showed that accountants earned more on the average than men in other major professions.

REASON #2. The demand for accountants is great—everywhere. All businesses must have trained accountants to cope with ever-growing requirements. It's a profession offering wide opportunity—always—to the man who knows.

REASON #3. You can fit into any business, anywhere in the country—because accounting principles are universal. Think what this means in terms of security and independence!

REASON #4. Accountancy is open to all. Any man or woman of good intelligence, who enjoys figure work and is willing to follow LaSalle's systematic "problem method" plan, can rapidly qualify for a highly profitable, enjoyable

**LASALLE EXTENSION
UNIVERSITY**
A Correspondence Institution
417 S. Dearborn St., Chicago 5



lifetime career . . . and he doesn't have to finish his training before beginning to "cash in."

REASON #5. Without losing a day from your present work, you can prepare in spare hours at home, at low cost, under LaSalle's step-by-step "Problem Method" of "learning by doing." This famous plan accounts for LaSalle's remarkable record of having trained over 4,000 of all Certified Public Accountants and of having put many thousands of others into high-paying careers.

Send today for Free Sample Lesson and "Accountancy, the Profession That Pays." Learn about the five great fields of opportunity . . . and LaSalle's time-tested plan for helping men and women to rapid advancement, higher income, greater prestige and professional standing. The coupon below will bring this information to you—without cost or obligation.

MAIL THE COUPON NOW

LaSalle Extension University
A Correspondence Institution

Dept. 164-H 417 S. Dearborn St., Chicago 5, Ill.

Please send me, free of all cost or obligation, your Free Sample Lesson and 48-page illustrated book "Accountancy, the Profession That Pays."

Name.....Age.....

Address.....

City, Zone, State.....

WHAT ALL AUTO MECHANICS WANT TO KNOW

1664 PAGES



This Big Practical Book gives full information with working diagrams covering the principles, construction, ignition, service and repair of modern cars, trucks and buses.

Diesel Engines, Hydramatic & Fluid Drives Fully Explained.

A complete Guide of 1664 pages, with over 1500 illustrations showing inside views of working parts, with instructions for service jobs.

IT PAYS TO KNOW

How to fit pistons—How to locate engine knocks. How to fit connecting rod bearings—How to service main bearings—How to recondition valves—How to time valves—How to adjust fan belts—How to adjust carburetors and chokes. How to rebuild a clutch—How to service automatic transmissions—How to service brakes—How to adjust steering gear—How to cope with ignition troubles—How to service distributors—How to time ignition—How to "tune up" an engine.



\$4 COMPLETE • PAY \$1 A MO. TO GET THIS ASSISTANCE FOR YOURSELF SIMPLY FILL IN AND MAIL COUPON TODAY.

Step up your own skill with the facts and figures of your trade. Au-del Mechanics Guides contain Practical Inside Trade Information in a Handy Form. Fully illustrated and Easy to Understand. Highly Endorsed. Check the book you want for 7 DAYS FREE EXAMINATION. Send No Money. Nothing to pay postman.

MAIL ORDER



AUDEL, Publishers, 49 W. 23 St., NEW YORK 10, N. Y.

Please send me postpaid for FREE EXAMINATION books marked (x) below. If I decide to keep them I agree to mail \$1 in 7 Days on each book or set ordered and further mail \$1 monthly on each book or set until I have paid price, otherwise I will return them.

- AUTOMOBILE MECHANICS GUIDE, 1664 Pages. \$4
- TRUCK & TRACTOR GUIDE, 1299 Pages. 4
- DIESEL ENGINE MANUAL, 575 Pages. 2
- MACHINISTS HANDY BOOK, 1650 Pages. 4
- WELDERS GUIDE, 400 Pages. 1
- BLUE PRINT READING, 416 Pages. 2
- MATHEMATICS & CALCULATIONS, 700 Pages. 2
- SHEET METAL PATTERN LAYOUTS, 1100 Pages. 4
- SHEET METAL WORKERS HANDY BOOK, 388 Pgs. 1
- MECHANICAL DRAWING GUIDE, 160 Pages. 1
- MECHANICAL DRAWING & DESIGN, 480 Pages. 2
- AIRCRAFT WORKER, 240 Pages. 1
- TELEVISION SERVICE MANUAL, 434 Pages. 2
- RADIO MANS GUIDE, 1040 Pages. 4
- ELECTRONIC DEVICES, 216 Pages. 2
- ELECTRIC MOTOR GUIDE, 1000 Pages. 4
- WIRING DIAGRAMS (Light & Power), 272 Pgs. 1
- ELECTRICIANS EXAMINATIONS, 250 Pages. 1
- ELECTRIC POWER CALCULATIONS, 425 Pages. 2
- HANDY BOOK OF ELECTRICITY, 1440 Pages. 4
- ELECTRIC DICTIONARY, 9000 Terms. 2
- ELECTRIC LIBRARY, 7000 Pages (12 Book Set) 18
- SHIPFITTERS HANDY BOOK, 250 Pages. 1
- REFRIGERATION & Air Conditioning, 1280 Pgs. 4
- MILLWRIGHTS & MECHANICS GUIDE, 1200 Pgs. 4
- POWER PLANT ENGINEERS GUIDE, 1500 Pages. 4
- ENGINEERS & FIREMANS EXAMS, 525 Pages. 4
- PUMPS, Hydraulics & Air Compressors, 1658 Pgs. 4
- OPERATING ENGINEERS LIBRARY (3 Books). 9
- MECHANICAL DICTIONARY, 950 Pages. 4
- GARDENERS & GROWERS GUIDES (4 Book Set) 6
- CARPENTERS & BUILDERS GUIDES (4 Book Set) 6
- PLUMBERS & Steamfitters Guides (4 Book Set) 6
- MASONS AND BUILDERS GUIDES (4 Book Set) 6
- PAINTERS & DECORATORS MANUAL, 450 Pgs. 2
- HOUSE HEATING GUIDE, 1000 Pages. 4
- OIL BURNER GUIDE, 384 Pages. 1
- HOME APPLIANCE SERVICE GUIDE, 800 Pages. 4

Check NOW!

You Can Look Over Any Guide In Your Own Home — Start the Easy Payments If Satisfied

MAIL THIS TODAY



Name _____
 Address _____
 Occupation _____
 Employed by _____

(Continued from page 6)

Three Eras of Traffic

Kenneth R. Imig of Watseka, Ill., sends us this photo of a farmer's display showing three modes of travel of the last 150 years.

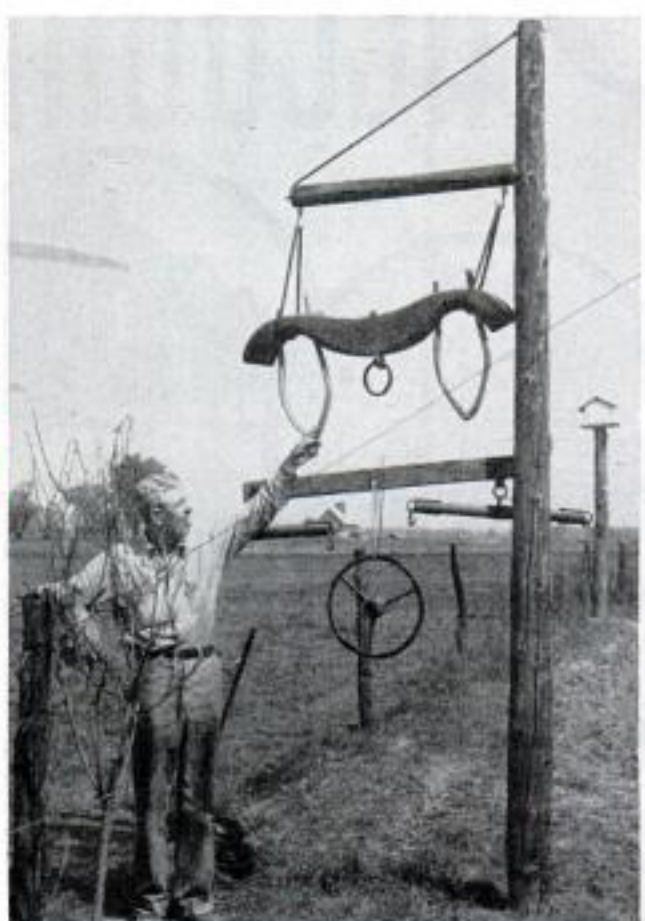

Harold Hartman, a farmer near Milford, Ill., mounted on a post a sturdy ox yoke, and below it a doubletree of the horsepower era. From this was suspended an automobile steering wheel of today's gas-buggy and farm-tractor era.

To the Editor:

On page 113 of your November 1954 issue, you make claims about a product we manufacture that are somewhat erroneous.

At no time, to my knowledge, did we ever say that our cleaner was good for "wallpaper." We did say "painted walls."

Norman Bassett, President,
 Demco Library Supplies,
 Box 1070,
 Madison 1, Wis.

To the Editor:

Enclosed is a picture of a boat that I built from plans I read in the May 1954 issue of *Popular Mechanics*. The plans called for 11-foot 11-inch length and 56-inch beam; I

(Continued to page 10)

How I foxed the Navy

by Arthur Godfrey



The Navy almost scuttled me. I shudder to think of it. My crazy career could have ended right there.

To be scuttled by the Navy you've either got to do something wrong or neglect to do something right. They've got you both ways. For my part, I neglected to finish high school.

Ordinarily, a man can get along without a high school diploma. Plenty of men have. But not in the Navy. At least not in the U. S. Navy Materiel School at Bellevue, D. C., back in 1929. In those days a bluejacket had to have a mind like Einstein's. And I didn't.

"Godfrey," said the lieutenant a few days after I'd checked in, "either you learn mathematics and learn it *fast* or out you go. I'll give you six weeks." This, I figured, was it. For a guy who had to take off his shoes to count

above ten, it was an impossible assignment.

I was ready to turn in my bell-bottoms. But an ad in a magazine stopped me. Here, it said, is your chance to get special training in almost any subject—mathematics included. I hopped on it. Within a week I was enrolled with the International Correspondence Schools studying algebra, geometry and trig for all I was worth.

Came week-end liberty, I studied. Came a holiday, I studied. Came the end of the six weeks, I was top man in the class. Within six weeks I had mastered two years of high school math, thanks to the training I'd gotten.

I. C. S. made the impossible—easy!

GET EXPERT GUIDANCE 3 FREE BOOKS Free, illustrated catalog on career that interests you. Also 36-page, pocket-size guide to advancement, "How to Succeed." Free sample lesson.

For Real Job Security—Get an I. C. S. Diploma!

I. C. S., Scranton 9, Penna.

INTERNATIONAL CORRESPONDENCE SCHOOLS

ICS

BOX 82299A, SCRANTON 9, PENNA.

(Partial list of 277 courses)

Without cost or obligation, send me "HOW TO SUCCEED" and the opportunity booklet about the field BEFORE which I have marked X (plus sample lesson):

ARCHITECTURE and BUILDING CONSTRUCTION

- Air Conditioning—Refrig.
- Architecture
- Architectural Interior
- Building Contractor
- Building Maintenance
- Carpenter and Mill Work
- Estimating
- Heating
- Painting Contractor
- Plumbing
- Reading Arch. Blueprints

ART

- Cartooning
- Commercial Art
- Fashion Illustrating
- Magazine Illustrating
- Show Card and Sign Lettering
- Sketching and Painting

AUTOMOTIVE

- Auto Body Rebuilding
- Auto Elec. Technician
- Auto-Engine Tune Up
- Automobile Mechanic

AVIATION

- Aeronautical Engineering Jr.
- Aircraft & Engine Mechanic

BUSINESS

- Advertising
- Bookkeeping and Accounting
- Business Administration
- Business Correspondence
- Public Accounting
- Creative Salesmanship
- Federal Tax
- Letter-writing Improvement
- Office Management
- Professional Secretary
- Retail Business Management
- Sales Management
- Stereographic-Secretarial
- Traffic Management

CHEMISTRY

- Analytical Chemistry
- Chemical Engineering
- Chem. Lab. Technician
- General Chemistry
- Natural Gas Prod. & Trans.
- Petroleum Engineering
- Plastics
- Pulp and Paper Making

CIVIL, STRUCTURAL ENGINEERING

- Civil Engineering
- Construction Engineering
- Highway Engineering
- Reading Struct. Blueprints
- Sanitary Engineering
- Structural Engineering
- Surveying and Mapping

DRAFTING

- Aircraft Drafting
- Architectural Drafting
- Electrical Drafting
- Mechanical Drafting
- Mine Surveying and Mapping
- Plumbing Drawing and Estimating
- Structural Drafting

ELECTRICAL

- Electrical Engineering
- Electrical Maintenance
- Electrician Contracting
- Lineman

HIGH SCHOOL

- Commercial Good English
- High School Subjects
- Mathematics

LEADERSHIP

- Foremanship
- Industrial Supervision
- Leadership and Organization
- Personnel-Labor Relations

MECHANICAL AND SHOP

- Gas—Electric Welding
- Heat Treatment Metallurgy
- Industrial Engineering
- Industrial Instrumentation
- Industrial Supervision
- Internal Combustion Engines
- Machine Design-Drafting
- Machine Shop Inspection
- Machine Shop Practice
- Mechanical Engineering
- Quality Control
- Reading Shop Blueprints
- Refrigeration
- Sheet Metal Worker
- Tool Design Toolmaking

RADIO, TELEVISION

- Industrial Electronics
- Practical Radio TV Eng'ing
- Radio and TV Servicing
- Radio Operating

TELEVISION Technician

- RAILROAD
- Air Brakes Car Inspector
- Diesel Locomotive
- Locomotive Engineer
- Section Foreman

STEAM AND DIESEL POWER

- Combustion Engineering
- Diesel—Elec. Diesel Eng's
- Electric Light and Power
- Stationary Fireman
- Stationary Steam Engineering

TEXTILE

- Carding and Spinning
- Cotton, Rayon, Woolen Mfg.
- Finishing and Dyeing
- Loom Fix'g Textile Des'ing
- Textile Eng'g Throwing
- Warping and Weaving

MISCELLANEOUS

- Domestic Refrigeration
- Marine Engineering
- Ocean Navigation
- Professional Engineering
- Short Story Writing
- Telephony

Name _____ Age _____ Home Address _____

City _____ Zone _____ State _____ Working Hours _____ A.M. to P.M. _____

Occupation _____

Canadian residents send coupon to International Correspondence Schools, Canadian, Ltd., Montreal, Canada. . . . Special tuition rates to members of the U. S. Armed Forces.

(Continued from page 8)

altered the plans to 13-foot 4-inch length and 60-inch beam and the freeboard is 2 inches higher all around. The boat has



been launched in the Delaware Bay and has proven very seaworthy.

William C. Price,
7223 Bradford St.,
Philadelphia, Pa.

Era of the Turboprops

The jet airliner is already in the skies, yet suddenly a new breed of transports swarms onto the scene. Pictured here is one of the biggest of the new turboprop family—Britain's Bristol Britannia, a giant driven by turbines harnessed to four propellers, and capable of flying 100 passengers between New York and London. It is

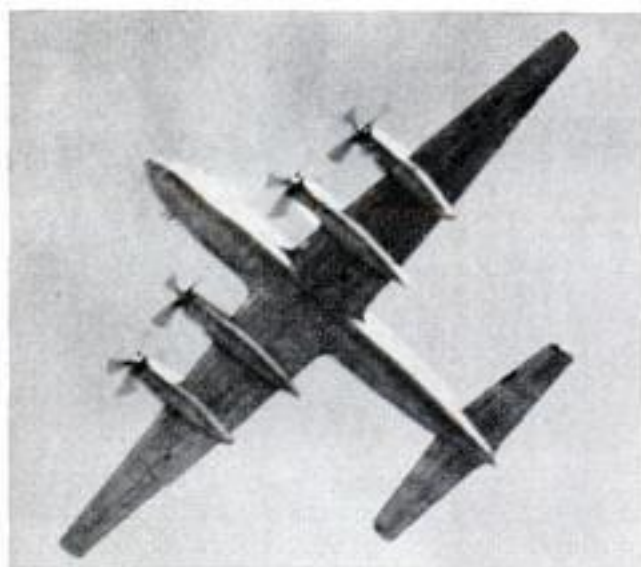

due to fly the international routes in 1955. For the story of this new development in aviation, read "Listen—It's the Wail of the Turboprops" beginning on page 105.

Correction

The microfilm camera shown on page 148 of our November issue is not, as indicated in the heading, of German make but is manufactured by an American firm and was exhibited at Dusseldorf. The maker: Diebold, Inc., Flofilm Division, Norwalk, Conn. The price, \$3500.

NEW GREASELESS WAY TO KEEP YOUR HAIR NEAT ALL DAY



New Vitalis with V-7 makes even dry, unruly hair easy to manage

V-7, the *greaseless* grooming discovery now in Vitalis, outdates messy oils. Keeps your hair neat, yet you never have an over-slick, plastered-down look.

What's more, Vitalis gives you wonderful protection from dry, brittle hair and parched scalp—even after a shampoo. Try it—you'll like it!

VITALIS®
HAIR TONIC
WITH V-7®



PRODUCT OF BRISTOL-MYERS



For Good Pay, Interesting Work, Security

Learn Electric Appliance Repair

AT HOME IN SPARE TIME

Build a better future. Get into a field where there is important work and the security that comes from knowing a good trade. The electrical appliance repair business offers OPPORTUNITY FOR YOU. Every wired home today has an average of 8 electrical appliances. Up to 10 million new appliances are sold every year. Owners pay well to keep them in repair and enjoy the convenience they provide. That means there's a fast growing need for trained men.

Opportunities Increasing For Men Who Know This Profitable Trade

You may want to be your own boss so you can enjoy the profits of your business. Or you may want to qualify for the better job of Service Manager or Supervisor in an Appliance Servicenter. Or perhaps you want to supplement your income doing electrical appliance repairs in your spare time. Opportunity in this growing field is great. Send for free book and see what the Electrical Appliance field offers you!

Pick up \$3, \$4, \$5 an Hour in Spare Time Starting Soon

Start soon to fix electric toasters, clocks, fans, vacuum cleaners, etc. for neighbors and friends. Spare time work done in your basement, garage, or spare room can earn you \$3 to \$5 an hour. See how easy it is to increase your earning power—how you can pay for this training many times over with spare time earnings.

Learn and Earn With This Appliance Tester You Get

This course includes the parts to build this sturdy portable appliance tester that helps you find electrical defects quickly and easily. You use it to learn and do actual electrical and appliance repair jobs. This multi-use tester helps you start making money soon after your training starts.

Train Now for Greater Security Low Price—Easy Terms

Today's automatic electrical appliances need expert servicing. The man who knows a good trade like appliance repair has a secure future. Put your spare time to good use. Invest \$2.50 down and \$5.00 a month in a better future. Write Electrical Appliance Training, National Radio Institute, Dept. AA5, Washington 9, D. C.



ACT NOW! Get Free Book And Sample Lesson

Actual lesson proves our method is clear, practical. Book gives facts about Electric Appliance opportunities and details of our training. Act now to make your future more secure.

MAIL COUPON TODAY

NATIONAL RADIO INSTITUTE

Dept. AA5, Washington 9, D. C.

Please send me Electrical Appliance Training Lesson and Book Free. (No salesman will call.)

Name _____ Age _____

Address _____

City _____ Zone _____ State _____

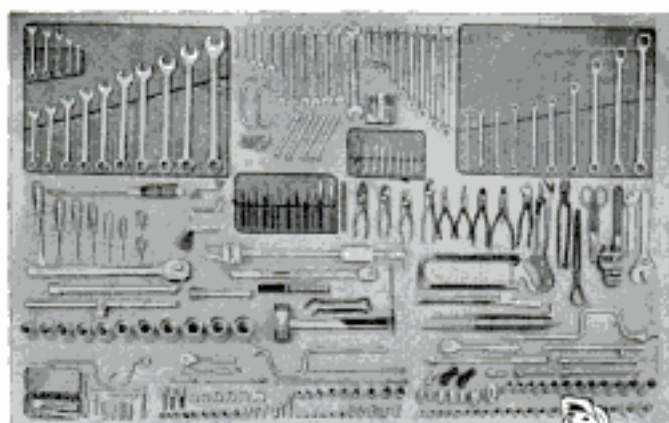

**Meet the
PROTO
"Maintenance
Master"
...the Tool Set
Users Designed!**



Extensive field research among maintenance men in all industries has resulted in the new PROTO "Maintenance Master," designed to the specifications of the men who use it. You will appreciate the great efficiency possible with this set because each tool was selected for its ability to perform on many jobs. The 9901, with its famous PROTO *Professional Quality*, is a set you will be proud to own. The tools are properly forged and heat treated for safety and long life. Their advanced designs are real time savers and their guarantee protects your investment. It will pay you to compare the completeness of the No. 9901 with your present tools or buy one from your PROTO dealer. Send 10¢ for 68-page catalog to

PLOMB TOOL COMPANY
2255Y Santa Fe Ave., Los Angeles 54, Calif.

No. 9901 "Maintenance Master"—Contents: 5 socket sets and attachments, wrenches, pliers, screwdrivers, torque wrench, gauge sets, snips, puller, hacksaws, soft hammer, bars, screw extractors, special tools. No. 9902 has chest; No. 9903 has a "Toolmobile" cabinet.

5494



Eastern Factory—Jamestown, N.Y.
Canadian Factory—London, Ont.

WHERE-TO-BUY-IT INDEX

Source of supply appears after items commercially available

AUTOMOTIVE

Old-car trailer gives safe ride.....115
Dolly eases tire changing (Clark-Feather Mfg. Co., Box 577, Fort Morgan, Colo.).....138
Gauge measures brake drums (Ammco Tools, Inc., Commonwealth Ave., North Chicago, Ill.).....138
Double-purpose tire tool acts as dolly and wrench (G & S Mfg. Co., Inc., 2834 E. Washington St., Phoenix, Ariz.)....145
Hose flushes auto radiator (Pat-Lo Enterprises, 228-86 Mentone Ave., Laurelton 13, N. Y.).....145
Motorcycle racing on ice is rugged Swedish sport.....147
Reverse pickaback157
Rear-seat table (Honorof Specialty Co., 1450 S. Michigan Ave., Chicago)157
"Car"-pentry shop158

CONSTRUCTION

Towering excavator moves along as it scrapes clay from bank.118
Crane attachment pounds deep hole.....124
Art of carpentry taught by kits.....133

FARM

Hay compressed into spool-size pellets seems to please cows..115
Mouth prop protects hands.....135
Chopper shreds bales (L. Pasching, Winsted Mfg. Co., Winsted, Minn.)150

HOUSE AND HOME

What's New for Your Home—
Nozzle for tank-type vacuum cleaner cleans rugs (Perry Industries, P.O. Box 411, Stamford, Conn.).....136
Potato slicer produces latticed wafers (Chester Archer, Box 207, Nashville 2, Tenn.).....136
Steaming basket with collapsible sides (Damar Products, Inc., Newark 5, N. J.).....136
Beverage dispenser (Jasper Rubber Products, Inc., Box 168, Jasper, Ind.)136
Adjustable mattress (United States Rubber Co., Rockefeller Center, New York City 20).....137
Revolving tray (Ett-Barr Co., 2251 Lincoln Ave., Altadena, Calif.)137
Fire alarm (Columbia Chemical Co., Inc., 154 E. Erie St., Chicago 11)137
Fireplace screen (H. T. Nelson Co., 1045 Foothill Blvd., La Canada, Calif.).....137
Fowl feathers removed by dip in solution.....138
Fan in place of light bulb makes lamp produce breeze.....139
Motorized cherry pitter speeds fruit preparation.....145
Temperature alarm (Custom Mfg. Co., 4105 W. Pullerton Ave., Chicago 39)147

INDUSTRY

Lifesaving bellows powered by crank.....115
Tri-duty inspection tool casts light in right spot.....118
Australians mine brown coal for gas.....132
Metal stitching saves British industry millions of pounds....152

MISCELLANEOUS

"Octopus" melts ice on ship.....124
Push buttons ease hospital work.....125
Carrier hooks over door (Chicago Precision Machine Co., 831 S. Wabash, Chicago 5).....134
Droplight hook clamps in position (L. O. Ramsey & Assoc., 15763 Meyers Rd., Detroit 27, Mich.).....134
Six shooter of frontiersmen stages comeback.....134
Dual-purpose fishing vest becomes life preserver (Charlie Buoy Corp., 2022 Second Ave., Seattle 1, Wash.).....135
Turbine fan blows in or out (A. J. Dobro, 1215 S. Laramie, Chicago 50)138
Uplifted airplane cockpit protects pilots while dusting crops..139
Device allows musicians to turn music with their feet.....145

(Continued to page 14)

INVENTORS

Learn how to protect your invention. The U. S. Patent Laws provide that any new and useful art, machine, article of manufacture, or composition of matter, or any new and useful improvement thereof, may be patented if the act of invention is involved. Therefore, every inventor with a valuable invention should take advantage of the Patent Laws and proceed for patent protection in order to safeguard his rights.

A patent gives the inventor the exclusive right to prevent others from making, using, or selling the invention claimed in the patent for a period of seventeen years.

The Patent Laws were enacted for the benefit of the inventor to give him protection for the features of his invention which are patentable. These features must be properly and concisely set forth and claimed in a formal application for patent, in order to comply with the requirements of the Patent Laws. For that reason, unless the inventor is familiar with patent matters, he should engage a competent registered patent attorney or agent to represent him. We are registered to practice before the U. S. Patent Office and are prepared to serve you in the handling of your patent matters.

A specially prepared booklet entitled "Patent Guide for the Inventor", containing detailed information with respect to patent protection and procedure, together with a "Record of Invention" form will be promptly forwarded to you without obligation upon request.

CLARENCE A. O'BRIEN & HARVEY JACOBSON

Registered Patent Attorneys

51-A DISTRICT NATIONAL BUILDING

WASHINGTON 5, D. C.

I SHOW YOU HOW TO

1 MAKE MONEY AT ONCE

2 START YOUR OWN BUSINESS

IN 2 WEEKS—
AT HOME
IN SPARE TIME



Permanently
METALIZE
Baby
Shoes
BRONZE,
SILVER,
GOLD

MILLIONS OF
NEW PROSPECTS
EVERY YEAR

Now is the time to cash in on this big-paying, easy-to-operate, year-round business and you need no experience. MATERIALS COST YOU ONLY 50c—YOU GET \$6.00! With many actual "show-how" illustrations and step-by-step instructions, YOU can start earning money at once in one week. Working only a few hours you can make more money than many people make working an entire week.

- Big Income
- Huge Demand
- Sales Plan
- Future Security
- Your Own Business

IMMEDIATE RESULTS

We will send you full details absolutely free.

FREE!
MONEY
MAKING
PLAN

Full Details
Without
Obligation

**MAIL COUPON
TODAY!**

KIKTAVI COMPANY, Dept. PM-551
11029 S. Vermont, Los Angeles 44, Calif.

KIKTAVI COMPANY, Dept. PM-551
11029 S. Vermont, Los Angeles 44, Calif.

Send me FREE details of your MONEY MAKING PLAN, without obligation.

NAME _____

STREET _____

CITY _____ ZONE _____ STATE _____

(Continued from page 12)

Huge rolling dry dock repairs small boats.....	146
Homemade power mower built from scrap parts.....	146
Thick rims protect records (Radio Corp. of America, New York City 20).....	147
An old mill grinds again.....	148
Combination boat and sled travels over water or ice.....	150
Coast Guard buoy carrier made from surplus parts.....	150
Make-it-yourself carving material.....	151
Largest "quiet" room to test transformer noises.....	152
Italian design borrowed for American executive amphibian.....	157
Model of rail auto built for assembly by HO enthusiast (Kemtron Products Co., 750 Fulton St., Fresno, Calif.).....	158
Sliding-roof cars loaded from above.....	158

PHOTOGRAPHY

Most powerful British X ray.....	138
Stroboscopic-flash unit fits miniature cameras (Strobo Research, 4551 N. 35th St., Milwaukee 16, Wis.).....	139

Radio-Television, Electronics

Transistor pocket radio (Regency, a Division of I.D.E.A., 7900 Pendleton Pike, Indianapolis 26, Ind.).....	159
How to operate your color-TV receiver (Color-TV set—Motorola Inc., 4545 Augusta Blvd., Chicago 51).....	160

Craftsman and Shop Notes Index

AUTOMOTIVE

Child's broom used to clean snow off auto windshield.....	167
Prevent battery shorting.....	203
Pliers support flashlight when changing flat tire.....	206
Automatic release for trip rope protects driver of tractor.....	211

FARM

Reversible poultry-feed trough easily cleared of rain or snow.....	210
Sickle bar raised hydraulically on converted mower.....	210
Welded clamp on tractor lift pulls pipe out of well.....	213
Discarded steel truck bed converted to portable granary.....	214
Oil drum on elevated platform fuels brooder-house stove.....	214
Chicken-wire fencing spliced with sections of tubing.....	219
Tanks set in concrete floor furnish water for hog lot.....	219
Vertical-sliding haymow door is counterbalanced.....	219
Poultry fountains suspended from pivoted supply lines.....	222

HOUSE AND HOME

Condensation inside metal window prevented by extra storm sash.....	168
Toast rack with a cozy.....	169
Solving Home Problems—	
Child can operate light.....	170
Egg carton for baby's socks.....	170
Rubber ball prevents overflowing of funnel.....	170
Door bumpers on table prevent wall scratches.....	170
Space-saver for lawn-mower storage.....	171
Repair dented kitchen pots and pans.....	171
Glass jar holds ball of twine and scissors.....	171
Bars on windows prevent children from falling.....	171
Hinge modified as spring latch locks window in open position.....	172
Alarm warns of sump-pump failure to prevent basement flooding.....	173
Shellac sizes plaster patches.....	173
Simple bed tray you can make in one evening.....	173
Holes drilled in trowel blade remove excess plaster.....	178
Auxiliary cabinet shelves permit additional storage.....	180
Fold-away drawing table.....	181
Cabinet under open lavatory stores bathroom supplies.....	184
Cardboard trough taped to wall catches plaster dust.....	184
Floor of insulated hardboard can be installed quickly.....	184
Clothespins utilized as "staples" to make temporary fence.....	189
Miniature wardrobe closet stores child's dresses.....	190
Scratched floors rejuvenated.....	190
Lawn mower stored close to wall by using storm-sash hanger.....	191
Pipe fittings form sturdy closet clothes pole.....	191
Refrigerator recess decorated with valance hung on hooks.....	191
Trap for night-flying insects uses light as bait.....	196

(Continued to page 16)

FOR REAL JOB SECURITY -GET AN I.C.S. DIPLOMA



"You can stop worrying, Jane. My job's secure now! And here's the insurance policy to prove it—my I.C.S. diploma!"

This feeling of security is probably typical of every I.C.S. graduate. Because—as the job situation gets tighter, the man with I.C.S. training has the advantage.

Why? Your I.C.S. diploma tells your present employer three important things: (1) You want to make the most of your present job.

For Real Job Security — Get an I. C. S. Diploma!

(2) You have the training you need for advancement. (3) You look for better ways of doing things *on your own*.

What you do about your future is up to *you*. Do nothing and stay at your present job at the same old pay. Or earn an I.C.S. diploma in your spare time for *security, promotions, more pay!* Your first step is to mark the course that interests you in the coupon below, and mail it to us.

Free books

We'll send you two interesting books. The first, "How to Succeed," is a gold mine of helpful tips. Points out many small things in your personality and behavior that can make the difference between success and failure. The second book tells you about the opportunities in the field of your choice. Plus sample lesson.

Costs pennies a day

Many an I.C.S. student has made up the cost of his course in one month with the salary increase his I.C.S. training earned for him. By studying at home in your spare time, you pay yourself many times an hour more than you're now making. (One student reports—"My I.C.S. course was worth \$95 an hour to me.")

The security of your present job—or the success in finding the new job you've always wanted—is in *your hands*. Move ahead with I. C. S. training while others stay behind on the routine, small-pay jobs. Remember, your first step to security and success is to mail this coupon. Take a few minutes and do it *now*. If you put it off, it can cost you your future.

I. C. S., Scranton 9, Penna.

INTERNATIONAL CORRESPONDENCE SCHOOLS

ICS

BOX 81299A, SCRANTON 9, PENNA.

(Partial list of 277 courses)

Without cost or obligation, send me "HOW TO SUCCEED" and the opportunity booklet about the field BEFORE which I have marked X (plus sample lesson):

- | | | | | |
|---|---|--|---|--|
| <p>ARCHITECTURE and BUILDING CONSTRUCTION</p> <ul style="list-style-type: none"> <input type="checkbox"/> Air Conditioning—Refrig. <input type="checkbox"/> Architecture <input type="checkbox"/> Architectural Interior <input type="checkbox"/> Building Contractor <input type="checkbox"/> Building Maintenance <input type="checkbox"/> Carpenter and Mill Work <input type="checkbox"/> Estimating <input type="checkbox"/> Heating <input type="checkbox"/> Painting Contractor <input type="checkbox"/> Plumbing <input type="checkbox"/> Reading Arch. Blueprints <p>ART</p> <ul style="list-style-type: none"> <input type="checkbox"/> Cartooning <input type="checkbox"/> Commercial Art <input type="checkbox"/> Fashion Illustrating <input type="checkbox"/> Magazine Illustrating <input type="checkbox"/> Show Card and Sign Lettering <input type="checkbox"/> Sketching and Painting <p>AUTOMOTIVE</p> <ul style="list-style-type: none"> <input type="checkbox"/> Auto Body Rebuilding <input type="checkbox"/> Auto Elec. Technician <input type="checkbox"/> Auto-Engine Tune Up <input type="checkbox"/> Automobile Mechanic | <p>AVIATION</p> <ul style="list-style-type: none"> <input type="checkbox"/> Aeronautical Engineering Jr. <input type="checkbox"/> Aircraft & Engine Mechanic <p>BUSINESS</p> <ul style="list-style-type: none"> <input type="checkbox"/> Advertising <input type="checkbox"/> Bookkeeping and Accounting <input type="checkbox"/> Business Administration <input type="checkbox"/> Business Correspondence <input type="checkbox"/> Public Accounting <input type="checkbox"/> Creative Salesmanship <input type="checkbox"/> Federal Tax <input type="checkbox"/> Letter-writing Improvement <input type="checkbox"/> Office Management <input type="checkbox"/> Professional Secretary <input type="checkbox"/> Retail Business Management <input type="checkbox"/> Sales Management <input type="checkbox"/> Stenographic-Secretarial <input type="checkbox"/> Traffic Management <p>CHEMISTRY</p> <ul style="list-style-type: none"> <input type="checkbox"/> Analytical Chemistry <input type="checkbox"/> Chemical Engineering <input type="checkbox"/> Chem. Lab. Technician <input type="checkbox"/> General Chemistry <input type="checkbox"/> Natural Gas Prod. & Trans. <input type="checkbox"/> Petroleum Engineering <input type="checkbox"/> Plastics <input type="checkbox"/> Pulp and Paper Making | <p>CIVIL, STRUCTURAL ENGINEERING</p> <ul style="list-style-type: none"> <input type="checkbox"/> Civil Engineering <input type="checkbox"/> Construction Engineering <input type="checkbox"/> Highway Engineering <input type="checkbox"/> Reading Struct. Blueprints <input type="checkbox"/> Sanitary Engineering <input type="checkbox"/> Structural Engineering <input type="checkbox"/> Surveying and Mapping <p>DRAFTING</p> <ul style="list-style-type: none"> <input type="checkbox"/> Aircraft Drafting <input type="checkbox"/> Architectural Drafting <input type="checkbox"/> Electrical Drafting <input type="checkbox"/> Mechanical Drafting <input type="checkbox"/> Mine Surveying and Mapping <input type="checkbox"/> Plumbing Drawing and Estimating <input type="checkbox"/> Structural Drafting <p>ELECTRICAL</p> <ul style="list-style-type: none"> <input type="checkbox"/> Electrical Engineering <input type="checkbox"/> Electrical Maintenance <input type="checkbox"/> Electrician <input type="checkbox"/> Contracting <input type="checkbox"/> Lineman <p>HIGH SCHOOL</p> <ul style="list-style-type: none"> <input type="checkbox"/> Commercial <input type="checkbox"/> Good English <input type="checkbox"/> High School Subjects <input type="checkbox"/> Mathematics | <p>LEADERSHIP</p> <ul style="list-style-type: none"> <input type="checkbox"/> Foremanship <input type="checkbox"/> Industrial Supervision <input type="checkbox"/> Leadership and Organization <input type="checkbox"/> Personnel-Labor Relations <p>MECHANICAL AND SHOP</p> <ul style="list-style-type: none"> <input type="checkbox"/> Gas—Electric Welding <input type="checkbox"/> Heat Treatment <input type="checkbox"/> Metallurgy <input type="checkbox"/> Industrial Engineering <input type="checkbox"/> Industrial Instrumentation <input type="checkbox"/> Industrial Supervision <input type="checkbox"/> Internal Combustion Engines <input type="checkbox"/> Machine Design-Drafting <input type="checkbox"/> Machine Shop Inspection <input type="checkbox"/> Machine Shop Practice <input type="checkbox"/> Mechanical Engineering <input type="checkbox"/> Quality Control <input type="checkbox"/> Reading Shop Blueprints <input type="checkbox"/> Refrigeration <input type="checkbox"/> Sheet Metal Worker <input type="checkbox"/> Tool Design <input type="checkbox"/> Toolmaking <p>RADIO, TELEVISION</p> <ul style="list-style-type: none"> <input type="checkbox"/> Industrial Electronics <input type="checkbox"/> Practical Radio TV Eng'ng <input type="checkbox"/> Radio and TV Servicing <input type="checkbox"/> Radio Operating | <ul style="list-style-type: none"> <input type="checkbox"/> Television Technician <p>RAILROAD</p> <ul style="list-style-type: none"> <input type="checkbox"/> Air Brakes <input type="checkbox"/> Car Inspector <input type="checkbox"/> Diesel Locomotive <input type="checkbox"/> Locomotive Engineer <input type="checkbox"/> Section Foreman <p>STEAM AND DIESEL POWER</p> <ul style="list-style-type: none"> <input type="checkbox"/> Combustion Engineering <input type="checkbox"/> Diesel—Elec. <input type="checkbox"/> Diesel Eng's <input type="checkbox"/> Electric Light and Power <input type="checkbox"/> Stationary Fireman <input type="checkbox"/> Stationary Steam Engineering <p>TEXTILE</p> <ul style="list-style-type: none"> <input type="checkbox"/> Carding and Spinning <input type="checkbox"/> Cotton, Rayon, Woolen Mig. <input type="checkbox"/> Finishing and Dyeing <input type="checkbox"/> Loom Fix'g <input type="checkbox"/> Textile Des'ing <input type="checkbox"/> Textile Eng'g <input type="checkbox"/> Throwing <input type="checkbox"/> Warping and Weaving <p>MISCELLANEOUS</p> <ul style="list-style-type: none"> <input type="checkbox"/> Domestic Refrigeration <input type="checkbox"/> Marine Engineering <input type="checkbox"/> Ocean Navigation <input type="checkbox"/> Professional Engineering <input type="checkbox"/> Short Story Writing <input type="checkbox"/> Telephony |
|---|---|--|---|--|

Name _____ Age _____ Home Address _____

City _____ Zone _____ State _____ Working Hours _____ A.M. to P.M. _____

Occupation _____

Canadian residents send coupon to International Correspondence Schools, Canadian, Ltd., Montreal, Canada. . . . Special tuition rates to members of the U. S. Armed Forces.

SELL NOTHING YET MAKE OVER \$132 WEEKLY!

Fantastic NEW way to make money! You sell nothing, so it won't make any difference whether you are a crackerjack salesman or just a beginner. All you do is offer any woman a set of stainless steel tableware FREE if she sells two sets to her friends! YOU make \$22.05 profit on each transaction. Just ONE a day means over \$132 weekly for you!

This is only one of the many ways you can make money in full or spare time. You can get catalogues with only YOUR name and address and get orders by mail or through agents. You can take orders on commission and we'll deliver and collect. We can also ship direct to your customers under YOUR label. There is a plan "custom-made" to suit YOU. Line includes open stock, choice of patterns etc.



"CAREER"
30 PIECE SET
Retail \$19.95

YOUR COST
\$5.95

PREPAID
WITHOUT CHEST

★
CLOTH LINED
CHEST RETAIL
\$2.95

YOUR COST
\$1.50
PREPAID

Solid stainless steel tableware is all the rage today. It is as beautiful as Sterling, yet will never rust, stain, tarnish or corrode. Never needs polishing. Changes eating to dining. Many sets sell over \$50. Today, Topval's popular prices create market of almost 50 million families.

FREE MONEY-MAKING OUTFIT!

Rush coupon for complete money-making plans, catalogue etc. FREE. No obligation. If you want to save time, order popular 30 piece set (retail \$19.95) at \$5.95 wholesale prepaid. Money back if you return set within 30 days.

TOPVAL CORP., Lindenhurst 12, N. Y.

Topval Corporation
Lindenhurst 12, New York

Date.....

- Rush complete money-making outfit free.
 Inclosed \$5.95 (NO C.O.D.) Send 30 piece set prepaid. I can return it within 30 days for refund. (Send \$7.45 if you wish chest included).

Name.....

Address.....

(Continued from page 14)

HOUSEHOLD HINTS

Cork inserted in vacuum bottle with aid of toothpick.....	167
Cleaning soiled holiday candles	180
Freeing stuck drinking glasses	184
Tubing keeps towels on rack	184
Rubber bands stored on card permit quick selection	203

INDUSTRY

Plier wrench on hoist rope lifts sheets of metal	168
Single-leg steel welding table provides foot clearance	210
Magnet removes drill chips from blind hole in steel	214

MISCELLANEOUS

Five dulled phonograph needles provide music-staff scribe.....	172
Plastic cable shaped as guide for drawing irregular curves.....	180
Stacked cans resist toppling when held with paper	189
Face painted on split rubber ball "talks" when squeezed.....	196
Lanterns to light skating pond held by tree-branch supports.....	201
Clothespin provides handle when carrying rubber boots	203
Fresh water for camping trip supplied by gravity-feed can.....	203
Thickness of acoustic tiles varied to eliminate harmonics.....	206
Rubber band on ball of twine prevents unwinding.....	213
Handy water bucket improvised from automobile inner tube.....	214
Razor blade attached to block provides cardboard cutter.....	219
Safety guard on tether stake also aids removal	222

PHOTOGRAPHY

Inexpensive negative file utilizes cigar box	167
Containers for lens filters, from fishhook boxes	168
Photographs in mail protected with corrugated cardboard.....	168
Photo-developing time reduced by utilizing washer agitator.....	172
Clothespins provide holder for darkroom thermometer.....	190
Floodlight clamp bolted to stand	196
Negative-retouching viewer made from picture frame	196
Handy hints for the photographer	202
Plastic-backed print smoothed on ferrotype tin with alcohol.....	206

TOOLS

Electric motor and tools carried in bucket	206
Electric drill powers garden cultivator	211
Arrow-fletching jig made quickly utilizing short dowel.....	213
Notch ground in claw of hammer provides tool for pulling tacks	214
Shopping for Tools—	
Sheet-metal brake (Television Accessories Co., Box 6001, Arlington 6, Va.)	220
Vacuum lifter (Littell Mach. Co., Air Div., 4555 Ravenswood Ave., Chicago 40)	220
Joint trowel (Mudmaster Co., 2927 Richmond, El Paso, Tex.)	220
Shaper spindle (Biddle Mfg. Co., Racine, Wis.)	220
Flexible sleeve (Pilot Tools, Inc., 225 Lafayette St., New York City 12)	220
Portable-drill guide (High Standard Mfg. Corp., Hamden, Conn.)	221
Paintbrush holder (Rirossa Products, Inc., P. O. Box 224, Lansing, Ill.)	221
Hand-plane guide (Perrine Co., Harrison, N. Y.)	221
Magnetic brad driver (Phillip Unsinger & Son, 637 Ohio Ave., Fremont, Ohio)	221
Template (Badoo Sales, Box 1, Station A, St. Petersburg, Fla.)	221

WORKSHOP HINTS

Graduate for home workshop improvised from fruit jar.....	167
Plywood supported on saw table by pipe-and-caster assembly.....	167
Wall hanger for rope coil cut from radiator hose.....	172
Notebook lists home repairs	178
Dowels chucked in drill press sandpapered to point	180
Fastener provides planing stop	180
Diameter of sphere measured by using wooden blocks	189
Waxed sheet under plywood speeds jigsaw operation	189
Tray on stepladder tread holds small parts	190
Wood-screw lubricant kept in cosmetic jar	190
Safety pin used as cotter to provide quick release	201
Dowels protected from vise jaws with spring-type clothespin.....	203
Banded surface can be simulated with half-round molding	210
Cut bolt to take off rusted nut	213
Repairing threads over keyways	214
Ends of cut hose join tightly when hacksawed together.....	222
Wax for ferrotype plates	222
Wheelbarrow hand guards prevent skinned knuckles	222

IMPORTANT NOTICE—It is the intention of this magazine to provide its readers with information regarding the latest developments in the mechanical arts. We take no responsibility as to whether the disclosures contained in our articles are covered by patents and advise readers to investigate this subject before making, using, or selling any of the products, machines, or processes described in order to avoid possible liability for patent infringements.



I WILL TRAIN YOU AT HOME FOR GOOD PAY JOBS IN RADIO-TELEVISION

J. E. SMITH has trained more men for Radio-Television than any other man. OUR 40th YEAR.

Fast Growing Industry Offers You Good Pay-Security-Bright Future

I Trained These Men

 "Repaired Radios six months after enrolling. Earned \$10 to \$15 a week, spare time." **ADAM KRAMLIK, JR.**, Sunburytown, Pa.

 "Am transmitter operator at KPAT. Most important day of my life was when I enrolled." **ELMER FREWALT**, Madison, S. Dakota.

 "Am employed by TV Clinic, handling the tough jobs that cannot be fixed in the home." **BERNARD SIERS**, Cleveland, Ohio.

 "I've come a long way since graduating. Have my own business on Main Street." **JOE TRAVERS**, Asbury Park, New Jersey.

AVAILABLE TO VETERANS UNDER GI BILLS

Do you want a good pay job, a bright future, security? Or your own profitable business? Then get into the fast-growing RADIO-TELEVISION industry. Keep your job while training at home. Thousands I've trained are successful RADIO-TELEVISION TECHNICIANS. Most had no previous experience, many no more than grammar school education. Learn Radio-Television principles from my easy to understand, illustrated lessons; get practical experience on actual equipment I furnish.

A Tested Way to Better Pay

Radio, even without Television, is bigger than ever. 115 million home and auto Radios create steady demand for service; 3000 Radio stations give interesting, good pay jobs to operators, technicians . . . provide good pay now, bright future later for men who qualify.

Men of Action Are Needed Mail Postage-Free Card

Act now to enjoy more good things of life. Take NRI training for as little as \$5 a month. Many NRI graduates make more in two weeks than the total cost of training. Mail card below today. J. E. SMITH, President, National Radio Institute, Washington 9, D. C.

2 FREE BOOKS SHOW HOW MAIL CARD



Television Is Making Good Jobs—Prosperity

Think of the opportunities in Television. Over 25,000,000 Television homes now and the total growing rapidly. 200 Television stations on the air and hundreds more under construction. Color Television is here. This means more operators, installation and service technicians will be needed. Now is the time to get ready for a successful career in Radio-Television. Mail the postage-free card today.



SEE OTHER SIDE

My Training Leads to Jobs Like These



BROADCASTING: Chief Technician, Chief Operator, Power Monitor, Recording Operator, Remote Control Operator. **SERVICING:** Home and Auto Radios, Television Receivers, FM Radios, P. A. Systems. **IN RADIO PLANTS:** Design Assistant, Technician, Tester, Serviceman, Service Manager. **GOVERNMENT RADIO:** Operator in Army, Navy, Marine Corps, Forestry Service Dispatcher, Airways Radio Operator. **AVIATION RADIO:** Transmitter Technician, Receiver Technician, Airport Transmitter Operator. **TELEVISION:** Pick-up Operator, Television Technician, Remote Control Operator.

CUT OUT AND MAIL THIS CARD NOW

Sample Lesson and 64-Page Book

Both FREE

Act now! Send for my DOUBLE FREE OFFER. Card entitles you to Actual Lesson on Servicing, plus my 64-page book.

NO STAMP NEEDED—WE PAY POSTAGE

Mr. J. E. Smith, President, National Radio Institute, Washington 9, D. C. Mail me Lesson and Book, "How to be a Success in Radio-Television." (No salesman will call. Please write plainly.)

NAME _____ AGE _____

ADDRESS _____

CITY _____ ZONE _____ STATE _____

VETS write in date of discharge _____



Train ^{AT} HOME to Jump Your Pay

Practice Broadcasting with Parts I Send



As part of my Communications Course I send you parts to build low-power Broadcasting Transmitter at left. Use it to get practical experience. You put this station "on the air..." perform procedures demanded of broadcasting station operators. An FCC Commercial Operator's License can be your ticket to a bright future. My Communications Course trains you to get your license. Mail card. Book shows other equipment you build.

Practice Servicing with Parts I send

Nothing takes the place of PRACTICAL EXPERIENCE. That's why NRI training is based on LEARNING BY DOING. You use parts I send to build many circuits common to Radio and Television. With my Servicing Course you build the modern Radio shown at right. You build a Multitester and use it to help make \$10, \$15 a week fixing sets in spare time while training. All equipment yours to keep. Card below will bring book showing other equipment you build.



Be a Radio-Television Technician



J. E. Smith, President
National Radio
Institute
Washington, D. C.
40 years of success
training men at home

Training PLUS opportunity is the PERFECT COMBINATION for job security, good pay, advancement. When times are good, the trained man makes the BETTER PAY, gets PROMOTED. When jobs are scarce, the trained man enjoys GREATER SECURITY. NRI training can help assure you and your family more of the better things of life. Even without Television, Radio is bigger than ever. Television is moving ahead fast and color Television will create more jobs, more opportunity. New uses for Radio-Television principles are coming in Industry, Government, Communications.

Television Making New Jobs, Prosperity

Naturally, my training includes Television. I have, over the years, added more and more Television information to my course and the equipment I furnish students gives



experience on circuits common to BOTH Radio and Television. Get the benefit of our 40 years' experience training men. My well-illustrated lessons give you basic principles you must have to assure continued progress. Read at the left how skillfully developed kits of parts I furnish "bring to life" things you learn from my lessons.

Find Out About Tested Way to Better Pay

Act now to get the better things of life. Take your first step—cut out and mail the card below. Doing so involves no obligation. I even pay postage. I want to put an Actual Lesson in your hands to prove NRI home training is practical, thorough. I want you to see my 64-page book, "How to be a Success in Radio-Television," because it tells you about my 40 years of training men and important facts about present and future Radio-Television job opportunities. You can take NRI training for as little as \$5 a month. Many graduates make more than the total cost of my training in two weeks. Mailing postage-free card can be an important step in making your future successful. J. E. Smith, President, National Radio Institute, Washington 9, D. C. 40 YEARS OF SUCCESS TRAINING MEN AT HOME.

SEE
OTHER
SIDE

CUT OUT AND
MAIL POSTAGE-
FREE CARD

FIRST CLASS
PERMIT NO. 20-R
(Sec. 34.9, P.L.&R.)
WASHINGTON, D. C.

Start Soon to Make
\$10, \$15 a Week
Extra Fixing Sets



Keep your job while training. Many NRI students make \$10, \$15 a week fixing neighbors' sets in spare time starting a few months after enrolling. E. J. STREITENBERGER, a graduate of New Boston, Ohio, writes, "By the time I graduated had paid for my course, a car and testing equipment." Mail postage-free card now.

BUSINESS REPLY CARD

NO POSTAGE STAMP NECESSARY IF MAILED IN THE UNITED STATES

POSTAGE WILL BE PAID BY

NATIONAL RADIO INSTITUTE

16th and U Sts., N.W.

Washington 9, D. C.

INVENTORS

If you believe that you have an invention, you should find out how to protect it. The first step is to have a search made of the prior pertinent U. S. patents. If a report on this search indicates that the invention appears patentable you can apply for a patent, and the specifications and claims should be prepared.

The firm of McMorrow, Berman & Davidson, with offices in Washington, D. C., is qualified to take the necessary steps for you. We can make a preliminary search on your invention, advise you whether we think it can be patented, and prepare your application for patent.

Unless you are fully familiar with the U. S. Patent Laws, we recommend that you engage the services of a Registered Patent Attorney to protect your interests. The patent laws are *your* laws. A patent gives you the right to prevent others from making, using or selling the invention claimed in your patent for a period of 17 years.

Use these patent laws for your protection. Investigate whether your invention can be patented. If you have what you believe to be an invention, we suggest that you have this firm make a search for you.

Send for a copy of our Patent Booklet entitled "How To Protect Your Invention," containing information about patent protection and patent procedure. Along with this we will also send you an "Invention Record" form, for your use in writing down and sketching details of your invention. We will mail them promptly. No obligation. They are yours for the asking.

McMORROW, BERMAN & DAVIDSON

Registered Patent Attorneys

PATENTS • COPYRIGHTS • PATENTS

135-A VICTOR BUILDING, WASHINGTON 1, D. C.

Start a profitable manufacturing business in spare time

with your own home as your headquarters



RIGHT at this moment there is a tremendous demand for new business enterprises in a branch of the plastics industry. Fortunately, this is a type of manufacturing business that does not require heavy or expensive machinery, rented space for storage, production or sales. A portable hand machine does the work wherever electric current is available, and the working area can be in almost any part of your home.

The opportunity that is open to you today, is to meet this growing demand in a new industry by establishing yourself as the manufacturing agent in your own trading area. Several hundred of our machines are already in use in both large and small communities. Some are even being operated successfully by women whose family duties make it necessary for them to be at home during the day, but whose family income is not enough to meet rising expenses. Most are being operated by men. Many started in spare time just to pick up an extra five or ten dollars for an evening's work. They found the work so profitable that some have now given up former jobs to devote full time to a business of their own.

One of our manufacturers gets all of his business by mail. Orders and money come to him in envelopes and he sends his products out the same way. Another delivers his entire output to stores in the vicinity. An-

other does a wholesale business supplying other manufacturers who do the selling. Still another works with advertisers in the manufacture of plastic advertising novelties and specialties.

The operation of the machine is simple and easy for anyone to learn. It does not require any knowledge of chemistry, mechanics, or electricity. And what some say is best of all, a manufacturing business like this enables a person to make good money without any house to house canvassing. The machine turns out from \$5.00 to \$15.00 worth of work per hour and it can be operated for as short or long a time as you wish.

We have prepared a simple step by step instruction manual that not only tells how to operate the machine, but also tells how to get the business coming in at a profitable clip right from the start. We will lend a copy of this book to any serious minded man or woman with the

understanding that a copy will be given them free if and when they purchase a machine—or the copy we lend can be returned if you decide not to go into the business. Reading it will not cost you anything.

If you are interested in a nice little home business that can bring in an extra \$60 or more for ten or twelve hours work in spare time, send your name. All information on the book and machine will be sent free, postage prepaid and no salesman will call to bother you. You read about it in the privacy of your own home without outside pressure and then decide whether you'd like to take the next step. Address your envelope to me in person. Send me the coupon below. Or, if you prefer send your name on a post card and ask for "Free information on starting a manufacturing business at home." Either way, send your name today and find out about this wonderful new fast growing money-making business.

RAYMOND E. BRANDELL

1512 Jarvis Ave., Dept. L-10-A, Chicago 26, Ill.

Raymond E. Brandell, 1512 Jarvis Ave., Dept. L-10-A, Chicago 26, Ill.

Dear Mr. Brandell: Please send information showing how I can start a profitable manufacturing business in my home in spare time. All the information you send will be mailed to me free of charge and no salesman is to call on me. I am not under any obligation to go ahead with the business and there is no charge for this information now or any other time.

Name _____

Address _____

City _____ Zone _____ State _____

POPULAR MECHANICS

Copyrighted material

THESE MEN ARE GETTING PRACTICAL TRAINING IN **ELECTRICITY**

—ELECTRONICS

On Real:



**A.C. and D.C. MOTORS
GENERATORS
SWITCHBOARDS
CONTROLLERS
WIRING JOBS
APPLIANCES
ELECTRONIC UNITS**

(Shown at left—Instructor explaining operation and testing of a large Motor Generator in our A.C. Department.)

AND **TELEVISION-RADIO**

On Real:

**TELEVISION SETS
RADIO RECEIVERS
F.M.
(Frequency Modulation)
ELECTRONICS
RECORD CHANGERS
AUTO RADIOS
PUBLIC ADDRESS Systems**

(Right—Instructor helping students check the wiring and trace circuits of television receivers.)



Train in the great SHOPS of COYNE

Largest, Oldest, Best Equipped School Of Its Kind In The U. S.

Whether 17 or up to 45 years of age, prepare for your future now. Don't be satisfied with a "No Future" job. Train the Coyne way for a better job in a field that offers a world of opportunities in the years ahead.

FINANCE PLAN Enroll now, pay most of tuition later. Part-time employment service while training, if needed.

WE TRAIN YOU IN CHICAGO. At Coyne you learn on real, full-size equipment. Trained instructors show you how, then you do practical jobs yourself. No previous experience or advanced education needed.

CLIP COUPON NOW for big new illustrated Coyne book "Guide to Careers in ELECTRICITY and TELEVISION-RADIO". No obligation; no salesman will call. Get vital facts now!



*Mail Coupon for
Big Free Book*

**APPROVED
FOR
VETERANS**

**B. W. COOKE, President
COYNE ELECTRICAL SCHOOL
500 S. Paulina St., Chicago 12, Ill. Dept. 15-72H**

Send **BIG FREE** book and details of your training offer. This does not obligate me and no salesman will call. I am interested in:

ELECTRICITY **TELEVISION-RADIO**

NAME

ADDRESS

CITY.....STATE.....

B. W. COOKE, Pres. **COYNE** FOUNDED 1899
ELECTRICAL SCHOOL

**A TECHNICAL TRADE INSTITUTE CHARTERED NOT FOR PROFIT
500 S. PAULINA ST., CHICAGO, Dept. 15-72H
ELECTRICITY ★ RADIO ★ TELEVISION ★ REFRIGERATION ★ ELECTRONICS**

Inventors

If you consider your invention valuable, take these necessary preliminary steps promptly to protect it by applying for a United States patent.

Sketch and describe your invention. (For convenience in starting action on your invention, use "Evidence of Invention" form offered below.)

Sign, date and have this invention disclosure witnessed by two people capable of understanding your invention.

Have us make a preliminary search among U. S. patents already granted for similar types of invention.

We then prepare a report for you on the probable patentability of your invention and recommend your further course of action.

This firm is registered to practice before the U. S. Patent Office. We are available to assist you in the preparation and prosecution of your application for patent.

We shall be glad to send you promptly and without obligation, an instructive booklet—"Patent Protection for Inventors"—and our convenient "Evidence of Invention" form.

VICTOR J. EVANS & Co. *Merlin M. Evans*
REGISTERED PATENT ATTORNEY
130-A MERLIN BUILDING, WASHINGTON 6, D. C.

INVISIBLE REWEAVING

Make Big Money at Home!

BEFORE



AFTER



WOMEN (AND MEN, TOO) FIND FINANCIAL SECURITY—AT HOME!

The demand is endless. Laundries, cleaners, tailors, department stores, homes—everybody needs professional reweaving service sooner or later. And skilled craftsmen are scarce! Learn to make cuts, moth holes, burns, tears **DISAPPEAR** from coats, suits, dresses, all fabrics almost like magic! **AND EARN UP TO \$10 IN AN HOUR AT HOME!**

The ORIGINAL, Complete Professional Course . . .

You need no special education, experience or ability. Age doesn't matter. Learn all the secrets of this fascinating profession in a few short weeks—start earning at once!

FREE GET THRILLING DETAILS NOW! This is a complete, professional course . . . with professional equipment, written by experts. Not a gadget. Not a condensed, unsatisfactory short-cut. **FABRICON** offers the **ORIGINAL** home-study course . . . first, best, most-complete in the field. It prepares you for professional work, and for professional earnings. Write **TODAY** for complete details **FREE**. **FABRICON CO., Dept. 321, 8342 S. Prairie Ave., Chicago 19, Ill.**

MEN!

Invisible Reweaving offers as much promise for profit to men . . . as it does to women. A great number of our successful students are men. Men can learn to do the work as well and as quickly as women. Actually, Invisible Reweaving is the perfect "lean" business—for man and wife . . . or even the entire family! Write!

SHINE WITHOUT 'POLISH'



Cars Glean Like Mirror

MEN! WOMEN! So easy a child can do it! Amazing "Dry" Polisher puts mirror-like shine on car **WITHOUT 'POLISH'**. No messy pastes, Equids, sprays. Simply glide over car. **PRESTO!** Leaves hard, lustrous, long-lasting protective Wax Coating. *Tube orders! Earn money!*

SAMPLES FOR TRIAL

Sample offer sent immediately to all who send name at once. Just a postcard will do. **SEND NO MONEY—just your name.**

KRISTEE CO., Dept. 681, Akron 6, Ohio



MECHANICAL DENTISTRY

A profession offering unlimited opportunities. Most modern and complete course embracing every branch from Plate to Porcelain Work, which prepares you to work for Dentists or start your own business. Individual instruction—practical training in day or night school. No books—no classes. Catalog upon request.

MCCARRIE SCHOOL OF MECHANICAL DENTISTRY
207 N. Broad Street Dept. 37 Philadelphia 7, Penna.

REAL ESTATE

BE A BROKER

PAYS BIG! SEND FOR FREE, BIG, ILLUSTRATED CATALOG NOW! Graduates report making substantial incomes. Start and run your own business quickly. Men, women of all ages, learn easily. Course covers Sales, Property Management, Appraising, Loans, Mortgages, and related subjects. **STUDY AT HOME** or in classrooms in leading cities. Diploma awarded. Write **TODAY** for free book! No obligation.

FREE BOOK TELLS HOW

Approved for World War II and Korean Veterans
WEAVER SCHOOL OF REAL ESTATE (Est. 1936)
2020 Grand Dept. PM Kansas City, Mo.



EXTRA MONEY
Selling **EXCLUSIVE**
PARAGON Cushion Shoes

Even If Now Employed

Enjoy your own lifetime, independent shoe business without investment. Steady repeats. To \$4.00 pair advance commissions. Big bonus. Make \$50 and more a week in full or spare time. 115 latest smart styles. Magic cushion. Easy to start. Write for **FREE OUTFIT** today!

No. 574
Lo-Line
2 Eyelet
Crushed
Grain

PARAGON SHOE COMPANY
79 Sudbury St., Dept. 20, Boston 14, Mass.

All Electronic Parts
YOURS TO KEEP!

NOW! WORK OVER 300 PRACTICAL PROJECTS with THESE PARTS AT HOME

to help You learn

TELEVISION RADIO-ELECTRONICS

Now . . . at home in spare time you can get BOTH the very training and subsequent Employment Service you need to help you start earning real money in America's thrilling, multi-billion dollar opportunity field of Television-Radio-Electronics. Now that Television is coming to almost every community, here is a chance of a lifetime to prepare to cash in on one of Television's great expansions.

D.T.I.'s amazingly practical home method enables you to set up your own HOME LABORATORY. You get many Electronic parts which you mount on individual bases with spring clip connectors. Tops for experimenting! Add or remove parts in a jiffy. No wasted hours of soldering and unsoldering for each project. You spend minimum time to get maximum knowledge of important circuits that really work. In fact, you get exactly the same type of basic training equipment used in our Chicago training laboratory—one of the nation's finest.

Build and KEEP This VALUABLE TEST EQUIPMENT

Your home laboratory projects also include building and keeping a versatile 5-inch Oscilloscope and precision Jewel Bearing Multi-Meter. These quality commercial test instruments help you EARN WHILE YOU LEARN and will prove mighty valuable, should you later decide to start your own full time TV-Radio service business. You also build and keep a quality 21-inch TV SET.

D. T. I. Provides EVERYTHING YOU NEED to master TELEVISION

In addition to your home laboratory and easy-to-read lessons, you even use HOME MOVIES—a wonderfully effective and exclusive D.T.I. training advantage. You watch hidden actions . . . see electrons on the march. Important fundamentals become "movie clear," helping you learn faster . . . easier . . . better.

LABORATORY TRAINING

Full time Residential training in D.T.I.'s great Chicago laboratories also available. MAIL COUPON TODAY for all facts. (If subject to MILITARY SERVICE you'll especially welcome the information we have for you.)

HOME MOVIES



Get This Information-
Packed Publication
FREE!

**89 WAYS
TO
EARN
MONEY
IN TELEVISION
RADIO
ELECTRONICS**



MULTIMETER

OSCILLOSCOPE



21 INCH

Build and keep this BIG DTI Engineered TV set—easily converted to U.H.F. (DTI offers another home training, but without the TV set.)

"ONE OF AMERICA'S
FOREMOST TELEVISION
TRAINING CENTERS"



DEVRY TECHNICAL INSTITUTE
AFFILIATED WITH
DEFORST'S TRAINING, INC.
CHICAGO 41, ILLINOIS

MAIL COUPON TODAY!

DEVRY TECHNICAL INSTITUTE

4141 BELMONT AVE., CHICAGO 41, ILL., Dept. PM-1-L

I would like your valuable information-packed publication showing how I can get started toward a good job or my own business in Television-Radio-Electronics.

Name _____ Age _____

Street _____ Apt. _____

City _____ Zone _____ State _____

D. T. I.'s Training is Available in Canada

TRY CORTINA'S SHORT-CUT TO



MORE MONEY NEW CAREER CULTURAL ENJOYMENT TRAVEL FUN

MAIL COUPON FOR

FREE RECORD

START SPEAKING

SPANISH

OR

FRENCH



ALMOST OVERNIGHT!

MAIL coupon for double-sided, non-breakable record and sample lesson. BOTH FREE! Listen as native instructor speaks to you on record. Let your eyes follow words in sample lesson at same time. Before you realize it, you'll be "chatting" easily in your new language—with a perfect accent!

Now's the time to learn a new language. It gives you such an advantage in business, social life. And here's the easiest way to learn—by listening! You gain a perfect accent (that's all you hear!) You don't learn grammar the "hard way"; you pick it up in CONVERSATION.

MAIL COUPON NOW

There are no "strings" to this offer. But it may end soon. Hurry! Rush coupon with 25c to help cover cost of special packing, shipping. We'll also send FREE book describing full Cortina course. No obligation.

Also:
GERMAN
ITALIAN
RUSSIAN
JAPANESE
BRAZILIAN

CORTINA ACADEMY

(Originators of Phonograph Method)

Dept. 641, 136 W. 52nd Street, New York 19, N. Y.

MAIL AT ONCE FOR *Free* RECORD

CORTINA ACADEMY, Dept. 641, (Est. 1882)
136 W. 52nd Street, New York 19, N. Y.

Please send me a FREE sample lesson in (check one)

SPANISH FRENCH RUSSIAN GERMAN
 ITALIAN JAPANESE BRAZILIAN

and information about full Cortina course. Enclosed is 25c (stamps or coin) to help cover the cost of special packaging, shipping.

Name _____
Address _____
City _____ Zone _____ State _____

more jobs than graduates

ENGINEERS
An interesting opportunity! If you pay you to write Box D, you'll receive a complete history of engineering and education.

Demand for our engineering graduates exceeds supply. Effective placement! Study in this world-famed college... established 1884. New term starts quarterly. Approved for Korean Vets.

Bach. Sc. degree in 27 months

Bachelor of Science in Mechanical, Civil, Electrical, Chemical, Aeronautical, Radio (Television), Administrative Engineering; Business Administration and Accounting. Also 36-weeks certificate course in Drafting. Intensive program: technical fundamentals accented; comprehensive courses.

Small classes; personalized instruction. For earnest, mature students whose time and budget require accelerated courses and modest costs. Preparatory courses.

Beautiful campus in friendly college town. Well-equipped, new and modernized buildings and labs. Enter March, June, Sept., Jan. Write Jean McCarthy, Director Admissions, for Catalog and View Book.



TRI-STATE COLLEGE

415 College Avenue

Angola, Indiana



GIANT BALLOONS

They're really BIG—surplus U. S. Govt. (new overage) Neoprene weather, target balloons. GREAT FUN in the backyard; at parties, picnics, dances, fairs, TERRIFIC for high school and college PHOMS. They attract BIG crowds to BUSINESS openings, civic events, conventions, exhibitions, trade shows. ORDER TODAY! Approx. inflated sizes:

3 ft. dia., 49c — 6 ft. dia., 99c
13 ft. dia., \$1.59 — 20 ft. dia., \$1.95

Postage paid on prepaid orders.
Calif. residents please add sales tax.

VOLUME SALES CO., War Assets Division

Dept. M-155 3930 Sunset Blvd. Los Angeles 29, Calif.

Secrets of VENTRILOQUISM Now Revealed!



Easy to learn in 60 to 90 days with our Home Study Course. RESULTS GUARANTEED. Make Money! Be Popular! Have Fun! Big Opportunity! Radio, Television, Stage Appearances! For FREE information regarding price and terms, WRITE: You must state your age. Dummy Catalog 25c.

FRED MAHER SCHOOL OF VENTRILOQUISM
Box 36, Studio PM-1, Kensington Station
Detroit 24, Michigan

TASOPE PHOTO-ENGRAVING PLANTS



Material Cost of This Cut 3/4c
Selling Price \$1.00 And Up

Establish your own profitable PHOTO-ENGRAVING business. Make cuts for newspapers, printers, and advertisers. Make etched name plates, plaques etc. Instructions furnished, no experience necessary. Sold direct from factory since 1931. First five hundred cuts sold locally or by mail will pay for plant and pay you well for your time. Write for FREE catalog.

TASOPE, DEPT. PM-1, AURORA, MO.

Ball-Bearing SPEED WHEELS

JUVENILE WHEELS (No bearing, solid tires)

5" 45c 6" 65c

7" 75c

(Semi-pneumatic tire, ball bearing)

8x1.25 \$1.85 10x1.25 \$2.20

8x1.75 1.95 10x1.75 2.30

8x2 2.20 10x2 2.65

12x1.75 3.45

INDUSTRIAL WHEELS

(Lug Base, Semi-Pneumatic tire)

6x2 SW \$3.45 10x2.00 \$6.10

6x2.00 4.00 10x2.75 5.15

8x2.00 5.20 10x2.75Pneu. 6.90

8x2.50 5.40 12x2.00 6.90

16x4.00 15.15 12x3.00 9.20

(Smooth Base, Pneumatic tire and tube)

8x3 2 ply \$10.00

10x3.50 2 ply 10.55

12x4 2 ply 14.41

4.00x8 2 ply 13.10

14x4.50 2 ply 15.96



CASTERS—Now Available

No c.o.d. orders. Prices F.O.B. our plant.

JIM BROWN TOY COMPANY

1095 HOME AVENUE

PM-155

AKRON 10, OHIO

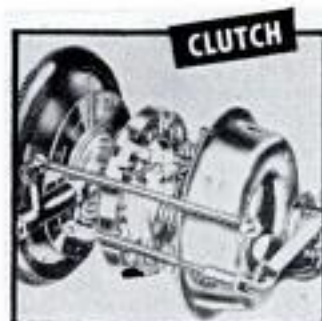

2950 photos and diagrams, plus crystal-clear directions, make every operation easy as A-B-C.

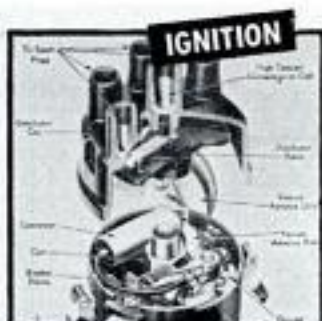

Diagrams, tables and text take the "mystery" out of all ignition systems.

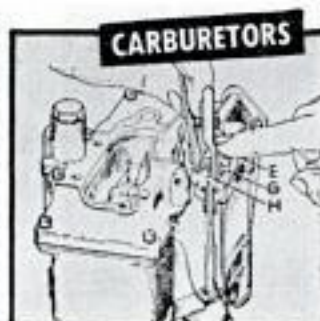

You get illustrated repair procedures for all types of carburetors.

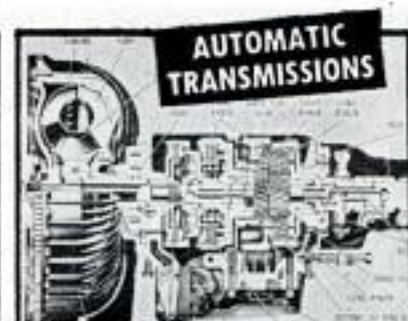

ALL AUTOMATIC TRANSMISSIONS are fully covered in special big section. (NOTE: All pictures shown here are greatly reduced in size. Actually, this giant book is almost a foot high!)

Here's the EASY Step-by-Step Way to FIX ANY PART OF ANY CAR



Fuel pumps can cause trouble. Pictures show exactly how to take them apart, fix them.

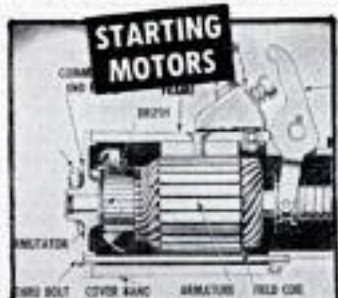

No guesswork. Clear pictures show how to fix starting motor, generator, brakes, etc.

Just 2 of the Many Letters of Praise
Does Every Job. "My MOTOR Manual is a wonderful help. It has a position to do every job."—S. L. Sharpless, Los Angeles, Calif.
Amazed Self and Friends. "I amazed myself and my friends, too. Now do jobs that stumped me before."—Michael Ballosky, Newark, N. J.

Now—Whether You're a Beginner or Expert Mechanic—You Can "Lick" Any Auto Repair Job On Any Car Built from 1940 Through 1954!

in a jiffy!

Now you can tackle any repair job, and do it quickly, easily, right—the first time! MOTOR'S BRAND-NEW AUTO REPAIR MANUAL shows you how—with crystal-clear pictures and step-by-step directions you can easily follow.

No guesswork. This giant guide tells you where to start; what tools to use. Leads you easily and quickly through the entire operation. Covers everything from a simple carburetor adjustment to a complete overhaul.

Everything You Need to Know

BIG, NEW REVISED Edition has MORE REPAIR INFORMATION THAN EVER! ONE THOUSAND giant pages, 2,950 "This-Is-How" pictures—clear drawings, diagrams, cutaway photos—make every step EASY. Over 290 "Quick Check" charts—more than 22,598 essential repair specifications. Over 225,000 service and repair facts. Instructions and pictures so COMPLETE, so CLEAR—you CAN'T go wrong!

Even a green beginner can do a good job. And top mechanics will be amazed at the time-saving procedures.

The "Meat" of Over 140 Official Shop Manuals

The editors have put together the "Know-How" from over 140 Official Shop Manuals; "bottled it down" into one handy indexed book.

Includes ALL Automatic Transmissions (including new Power-Flite). Covers the newest Carburetors, Engines (including new Buick, Ford, and Mercury V-8s) . . . Chokes . . . Fuel Pumps . . . Oil Filters . . . Starting Motors . . . Generators . . . Dis-

tributors . . . Clutches . . . Universals . . . Axles . . . Brakes . . . Power Steering . . . Shock Absorbers, etc.

Factory Specifications and Adjustment Tables. Tune-up Charts. Table of Measurements and Clearances. Overhauling, Replacement Facts—AND MUCH MORE. Used by Armed Forces, hundreds of thousands of auto service men! Now try it on this GUARANTEE:

Try Book for a Week FREE

SEND NO MONEY

Pay nothing to postman. Test book in your own garage or shop, It's GUARANTEED to pay for itself in 7 days. If it doesn't just return the book, and owe nothing. Rush coupon for your free-trial copy of this great money-saving Manual. MOTOR Book Dept., Desk 11, 250 West 55th St., New York 19, N. Y.

BRAND-NEW EDITION!



SEND NO MONEY! TRY BOOK FREE!

USED BY U.S. ARMY NAVY MARINES

Same FREE 7-Day Offer on MOTOR'S TRUCK and TRACTOR REPAIR MANUAL
Covers EVERY job on EVERY gasoline-powered truck and farm tractor made from 1946 thru 1954. 2200 pictures, 250 big 8 1/2 x 11 inch pages. \$3.00 parts. Check box proper in coupon for free trial.

COVERS 685 MODELS—ALL THESE MAKES

Buick	Ford	Nash
Cadillac	Frazer	Oldsmobile
Chevrolet	Henry J	Packard
Chrysler	Hudson	Plymouth
Crosley	Kaiser	Pontiac
De Soto	Lincoln	Studebaker
Dodge	Mercury	Willis

1,886,000 COPIES SOLD!

MAIL COUPON NOW FOR 7-DAY FREE TRIAL

MOTOR Book Dept., Desk 11, 250 West 55th Street, New York 19, N. Y.

Rush to me at once: (Check box opposite book you want.)

MOTOR'S New AUTO REPAIR MANUAL. If okay, I'll remit just \$2.00 in seven days, then \$2.00 monthly for two months and a final payment of 95c (plus 35c delivery charges) one month after that. Otherwise, I'll return the book postpaid in seven days. (Foreign price: Remit \$9.00 cash with order.)

MOTOR'S New TRUCK and TRACTOR REPAIR MANUAL. (Described at left.) If okay I will remit \$2.00 in seven days, and \$2.00 monthly for three months, plus 35c delivery charge with final payment. Otherwise I will return book promptly. (Foreign price: Remit \$10.00 cash with order.)

Print Name.....Age.....

Print Address.....

City & Zone No.....State.....

SAVE 35c delivery charge by enclosing WITH COUPON check or money order for full payment of \$6.95 for Auto Repair Manual (or \$8.00 for Truck and Tractor Manual). Same 7-day return-for-refund privilege applies.

These great minds were Rosicrucians . . .



Francis Bacon Benjamin Franklin Isaac Newton

WHAT SECRET POWER DID THEY POSSESS?

Why were these men great?

How does anyone—man or woman—achieve greatness? Is it not by mastery of the powers within ourselves?

Know the mysterious world within you! Attune yourself to the wisdom of the ages! Grasp the inner power of your mind! Learn the secrets of a full and peaceful life!

Benjamin Franklin, statesman and inventor . . . Isaac Newton, discoverer of the Law of Gravitation . . . Francis Bacon, philosopher and scientist . . . like many other learned and great men and women . . . were Rosicrucians. The Rosicrucians (NOT a religious organization) have been in existence for centuries. Today, headquarters of the Rosicrucians send over seven million pieces of mail annually to all parts of the world. Address: Scribe K.N.Z.

THIS BOOK FREE



The ROSICRUCIANS

San Jose (AMORC) California, U.S.A.

SEND THIS COUPON

Scribe K.N.Z.
The ROSICRUCIANS
(AMORC)
San Jose, California, U.S.A.

Please send me the free book, *The Mastery of Life*, which explains how I may learn to use my faculties and powers of mind.

Name _____
Address _____
City _____
State _____

INSURED TIRE SERVICE POPULAR BRANDS



FREE INSURANCE POLICY given with each used tire sold. We guarantee the amount of service you pay for.
Tube Given Free with Each Used Passenger Tire Upon Request

SPECIAL!
Deduct 10% on orders for two or more used tires

YOU CAN'T LOSE!!

GOODYEAR SUBURBANITE TYPE SNOW TIRES
New Tire Guarantee—Factory Rebuilt
BEST WINTER TRACTION OF ALL!

670x15	\$8.95	710x15	650x16	\$9.90
600x16		760x15	650x15	

Super Quality — Rugged Performance — 15 Months Insured Service

600x16	\$3.65	670x15	\$3.95	700x16	\$4.45	760x16	\$4.75
650x15	3.85	670x16	4.05	710x15	4.35	820x15	4.95
650x16	4.25	700x15	3.95	760x15	4.45	550x17	4.65

Supreme Quality — Nothing Finer — 30 Months Insured Service

600x16	\$5.25	475x19	\$5.45	700x15(6)	\$10.45	700x20	\$12.50
600x16(6)	6.75	640x15	4.95	750x16(8)	15.95	750x20(8)	15.50
650x16	5.75	670x15	5.35	700x17	11.95	750x20(10)	17.50
650x16(6)	7.25	710x15	5.45	750x17	16.45	825x20	21.50
700x16	6.35	760x15	5.95	750x15	10.95	900x20	19.95
750x16(8)	8.45	800x15	6.35	30x5	11.25	1000x20	20.45
550x18	4.95	820x15	6.35	600x20	10.95	1100x20	21.25
550x17	4.75	550x15	5.35	650x20	11.75	1000x22	21.95
650x15	5.25	670x16	5.15	32x6(8)	11.95	1100x22	22.75
700x15	5.35	700x16(6)	10.25	32x6(10)	12.75	1100x24	25.95

Whitewalls \$1.00 extra.

MIDLAND TIRE SALES
Speedy shipments on Mail Orders. F.O.B. Chicago. Insurance policy sent with each order. Deduct 10% on orders for 2 or more used tires. Send CHECK or MONEY ORDER.—No COD's.
3701 S. Normal, Dept. PM-30, Chicago 9, Ill.

BE A LEADER IN AVIATION

Parks graduates are known worldwide as leaders in aviation — their education is the finest offered. Advance faster . . . earn more in less time! Become a Parksman!

B.S. degree in 3 yrs. from Saint Louis University — Aero. Eng., Aero. Adm., Maint. Eng.

Non-degree courses — A & E Mechanics, Private, Commercial, Instrument, Flight Instructor and Multi-engine Ratings . . . CAA-Approved.

All Parks schooling approved for Veterans. Write for full information.

PARKS COLLEGE

ARNOLD HALL
EAST ST. LOUIS, ILL.

Do You Make These Mistakes in English?

MANY persons say "between you and I"—use "who" for "whom"—don't know whether to use one or two "e's" or "m's" or "r's." Every time you speak or write you show what you are. A command of effective English brings you added advantages, better opportunities.

You can improve your English through Sherwin Cody's 100% self-correcting invention. If you are ever embarrassed by mistakes in grammar, spelling, punctuation, or pronunciation, write for FREE book "How You Can Master Good English in 15 Minutes a Day." No obligation. SHERWIN CODY COURSE IN ENGLISH, 581 Central Drive, Port Washington, N. Y.

Learn CARTOONING

at home in spare time . . . the quick easy Landon Picture Chart way. Teaches how to originate—today's big need. Score of successes. Send 10c for Picture Chart (no test ability) and full details. Please state age.

Landon School of Cartooning, 5501 CTS Bldg., Cleveland 14, O.



OWN a BUSINESS without INVESTMENT



There's big money in your community taking easy orders from garages, service stations, lumber yards for Work Uniforms that advertise! Easy sales, big profits. Repeat business insures future. Represent finest, latest line in the field. Show huge selection of styles, embroidery fabrics, including miracle "wash and wear" Dacron, Orlon, etc. Everything you need to get started sent FREE.

TOPPS, Dept. 611. Rochester, Ind.

FALSE TEETH

KLUTCH holds them tighter

KLUTCH forms a comfort cushion; holds dental plates so much firmer and snuggler that one can eat and talk with greater comfort and security; in many cases almost as well as with natural teeth. Klutch lessens the constant fear of a dropping, rocking, chafing plate. 35c and 60c at druggists . . . If your druggist hasn't it, don't waste money on substitutes, but send us 10c and we will mail you a generous trial box.

KLUTCH CO. Box 5593-A ELMIRA, N. Y.



**IF YOU "EAT, SLEEP
AND LIVE" CARS...**

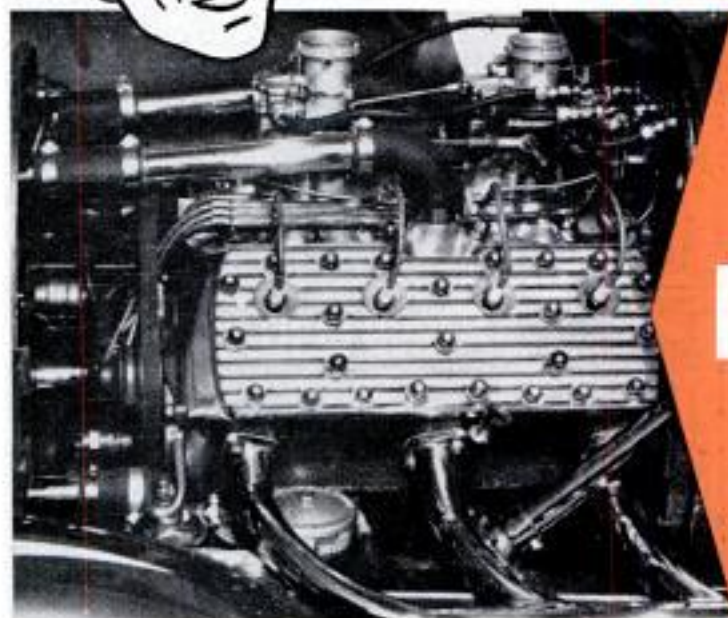

**TURN YOUR
HOBBY INTO
A CAREER!**

Get America's Big-time, Big-future

**AUTO MECHANICS & DIESEL
COURSE**

at Home in Your Spare Time!

Los Angeles' National Schools, America's automotive Technical Trade School since 1905, now brings its famous resident Shops and Faculty direct to you at home—to prepare you to earn more money, with job security, in today's fast-moving, opportunity-filled Auto Mechanics Industry!

Get your home training from the "Car Capital of The World"—America's most auto-minded city, center of Hot Rod and Sports Car activity! Mail the coupon below right now!



HERE'S THE GOOD WORD ON OUR "SHOP-METHOD" HOME TRAINING! You master all phases, including Diesel! Every step fully explained. All lessons fully illustrated. Latest equipment and techniques. You complete your training in short time... age and previous experience no obstacle!

EARN WHILE YOU LEARN! You can start Spare Time Earnings in Auto Mechanics soon after enrollment. Many students pay for their training and more this way.

THIS SET OF LIFETIME TOOLS—YOURS plus all-metal tool box, and other equipment. All part of your course, yours to keep.

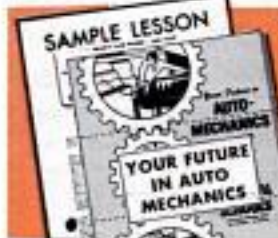

Send for FREE FACT-BOOK AND SAMPLE LESSON!

NOW! 2 offices to serve you faster! Mail coupon today to one nearest you!

YOU RECEIVE FRIENDLY GUIDANCE both as student and graduate. Our graduate department is always at your service to help you with personal and technical problems. We give you free Job Placement Service, too!

ATTENTION MEN OF DRAFT AGE. Many students have achieved higher rating, prestige, service branch they want, and higher pay due to this training. Mail coupon at once.

APPROVED FOR G.I. TRAINING

Both Home Study & Resident Courses Offered

**NATIONAL SCHOOLS
TECHNICAL TRADE TRAINING SINCE 1905**

**LOS ANGELES 37, California · CHICAGO: 323 West Polk St.
IN CANADA: 811 West Hastings Street, Vancouver, B. C.**

MAIL NOW TO OFFICE NEAREST YOU!

(mail in envelope or paste on postal card)

NATIONAL SCHOOLS, Dept. DB-15

4000 S. FIGUEROA STREET LOS ANGELES 37, CALIF. OR 323 WEST POLK STREET CHICAGO 7, ILLINOIS

Send **FREE** Auto-Mechanics Book and Sample Lesson. No obligation, no salesman will call.

NAME _____ BIRTHDAY _____ 19 _____

ADDRESS _____

CITY _____ ZONE _____ STATE _____

Check if interested **ONLY** in Resident Training at Los Angeles

VETERANS: Give Date of Discharge _____

DRAFTSMEN



**CASH BIG
PAY CHECKS!**

Train Now for
more success,
greater security

**LEARN AT HOME IN SPARE TIME
(or at college in Chicago)**

Check the want ads in any newspaper—SEE the big-pay opportunities open to you as a draftsman. What's more, you can learn this well-paid, prestige profession at home—quickly, easily! No special talent needed. Get complete, step-by-step Chicago Tech lessons in the mail, spend a few pleasant hours studying each week. In a short time you'll be a well-trained draftsman, ready to take your pick of many good jobs. Act now!



Free Information—Mail Coupon Today!

Get **FREE TRIAL LESSON** plus information about C.T.C. practical training. Learn what successful Chicago Tech graduates say about high pay and opportunities in drafting. No charge, or obligation.

CHICAGO TECHNICAL COLLEGE

A-253 Tech Bldg., 2000 So. Michigan Ave.
Chicago 16, Illinois

Mail me **FREE** lesson with facts about big opportunities in **DRAFTING**.

Name _____ Age _____
Address _____
City _____ Zone _____ State _____

Start Your Own Money-Making Business

Clean rugs on customers' floors—upholstery in their homes—even painted walls—with highly efficient electric machines which are making big money for others and giving them independence. Write today for complete information. It's **FREE!**

VON SCHRADER MFG. CO., 110 "R" PL., RACINE, WIS.

I'll Send You This Handsome SAMPLE CASE—FREE



**and Show You How to Make
Up to \$30.00 in a Day**

Mail coupon for this Free Tailoring Sample Case packed with 150 beautiful, big-value suit and overcoat fabrics. Take orders from friends, fellow-workers, others, for fine quality, made-to-measure clothes. Pocket big cash profits in advance. Because wearing our suits and overcoats brings more orders, we make it easy for you to get your own clothes without 1c cost. No experience is needed. **SATISFACTION GUARANTEED. SEND NO MONY.** Just fill out and mail coupon—today!

**J. C. FIELD & SON, Harrison & Throop Streets
DEPT. W-1716 - CHICAGO 7, ILLINOIS**

**J. C. FIELD & SON, Dept. W-1716
Harrison & Throop Sts., Chicago 7, Ill.**

Dear Sir: I WANT A MADE-TO-MEASURE SUIT TO WEAR AND SHOW, without paying 1c for it. Rush details and Sample Kit of actual fabrics, **ABSOLUTELY FREE.**

NAME _____ AGE _____
ADDRESS _____
CITY _____ STATE _____

WHAT TREASURES WILL YOU FIND?

Exciting Treasure Hunt! This big cloth bag contains over 1,000 genuine foreign postage stamps from more than 30 foreign countries in Asia, Europe, Africa, the South Seas, etc. Stamps are mostly still on paper, unpicked, unsorted, weighed out in bulk, just as received from foreign missionaries, banks, etc. Nobody knows what's inside! Worth \$10.00 or more at STANDARD Catalog prices. **FREE!** Valuable booklet "How to Collect Stamps", if you order Now. Money back guarantee.

ONLY \$1.00

H. E. HARRIS & CO.
1540 Transit Bldg., Boston 17, Mass.

WHILE THEY LAST! 107 "IRON CURTAIN" Stamps

Sensational Stalin stamp plus 106 others, all different, from Russia, Bulgaria, Rumania, Czechoslovakia, Ukraine, etc. Hard-to-get, smuggled from behind the infamous Iron Curtain! Guaranteed worth nearly \$2.50 at Standard Catalog prices! ALSO valuable booklet "How to Recognize Rare Stamps" and other fascinating offers. All for only 10c covering postage and handling. **Send Today!**

KENMORE STAMP CO., Millard 08-511 N.H.

EARN WHILE YOU LEARN AT HOME

How to Make Money in PHOTOGRAPHY

If you are OVER 17—good pay, fascinating work await you in photography! Start making money quickly—in sparetime—step into your own studio or exciting job. **LEARN-BY-DOING** method trains you at home! Write TODAY for **FREE** catalog. Also Resident Training, 45th Year! GI Approved.

NEW YORK INSTITUTE OF PHOTOGRAPHY
Dept. 49, 10 W. 33 St., New York 1, N.Y.

Send for **FREE BOOK**

HOW TO BREAK AND TRAIN HORSES

SEND FOR THIS FREE!

Make money. Know how to break and train horses. Write today for this book **FREE**, together with special offer of a course in Animal Breeding. If you are interested in Gaiting and Riding the saddle horse, check here () **Do it today—now.**

BEERY SCHOOL OF HORSEMANSHIP
Dept. 1101 Pleasant Hill, Ohio

RAISE GIANT FROGS **BIG DEMAND**

MILLIONS USED YEARLY!

Nation-wide markets waiting for all you can ship. Good prices year round. Breeder lays up to 20,000 eggs yearly. Season just starting! Men and women get ready now for this year's eggs. Small pond starts you. New book tells how! Send for my illustrated **FREE** folder today. Write now!

ALBERT BROEL-7
P.O. Box 506 New Orleans 1, La.

Broken or Loose FALSE PLATE?

Fix it Yourself EASILY in a Few Minutes

Your plates may become broken or loose just when you need them most. With **FIX-IT-KIT** you can repair your own broken plates. Also tightens loose fitting plates, easily. Get permanent comfort with professional material. Complete instructions. Satisfaction guaranteed or your money refunded. **Order Now** at a new low price only **\$2.98** postpaid—or sent C.O.D.

DENT-FIX DENTAL PRODUCTS, Box 674, Dept. PM-1, Kansas City 41, Mo.

Learn BAKING At Home

Baking is one of America's high industries in wages. Nearly **DEPRESSION-PROOF**. Thorough basic home course lays sound foundation. If you have aptitude, write for **FREE** Booklet, "Opportunities in Commercial Baking."

NATIONAL BAKING SCHOOL
835 Diversey Parkway Dept. 1351 Chicago 14.

It's New! 3 Years in Development
-NOW READY FOR YOU!



This is the new Sprayberry Training Television Receiver.

You build the new Sprayberry Tester... 18-range Volt-Ohm-Milliammeter readings.

17" to 24"
PICTURE TUBE

New Equipment! New Lessons! Enlarged Course!
SPRAYBERRY PRACTICAL TRAINING IN

RADIO-TELEVISION

3 NO OBLIGATION TRAINING PLANS



You will build this powerful short wave and broadcast superhet radio receiver.

You have NO MONTHLY PAYMENT CONTRACT to sign
... pay for this outstanding training as you learn!



F. L. SPRAYBERRY
 Pres.

Mail the coupon at once for my big all-new 56 page **FREE CATALOG** and **FREE Sample Lesson**. Get the full story of this remarkable new Training Plan. Read about my 3 **NO OBLIGATION PLANS** of "packaged unit" instruction. I can prepare you in as little as 10 MONTHS to take your place as a **Trained Radio-Television Technician**. You take no risk in enrolling for my Training because you **DO NOT SIGN A BINDING TIME PAYMENT CONTRACT**. I have been training successful Radio-TV technicians for 22 years...I can prepare you, too, to get into your own profitable Service Shop or a good paying job. Full information **FREE** and without any obligation. No salesman will call.

NEWEST DEVELOPMENTS

Your training covers U H F, Color Television, F.M., Oscilloscope Servicing, High Fidelity Sound and Transistors.

PRACTICE AND TRAIN AT HOME WITH 25 NEW KITS of EQUIPMENT

You get valuable practical experience in construction, testing and shop practice. You build a powerful 2 band superhet radio, the all-new 18 range Sprayberry multimeter, the new Sprayberry Training Television receiver, signal tracer and many other projects. All equipment is yours to use and keep. All your training is **IN YOUR HOME** in spare hours. I help you earn extra spare time money while you learn. Rush coupon below for all the facts—**FREE!**

SPRAYBERRY ACADEMY OF RADIO

111 NORTH CANAL STREET, DEPT. 10-T
CHICAGO 6, ILLINOIS



FREE CATALOG AND SAMPLE LESSON

Rush coupon for my catalog "How to Make Money in Radio-Television". **PLUS** an actual sample Sprayberry Lesson without obligation—**ALL FREE**. Mail coupon **NOW!**

SPRAYBERRY ACADEMY OF RADIO MAIL THIS COUPON FOR FREE Dept. 10-T, 111 N. Canal St., Chicago 6, Ill. **FACTS AND SAMPLE LESSON**
 Please rush New Catalog and Sample Lesson **FREE**. I understand that no salesman will call.

Name _____ Age _____

Address _____

City _____ Zone _____ State _____

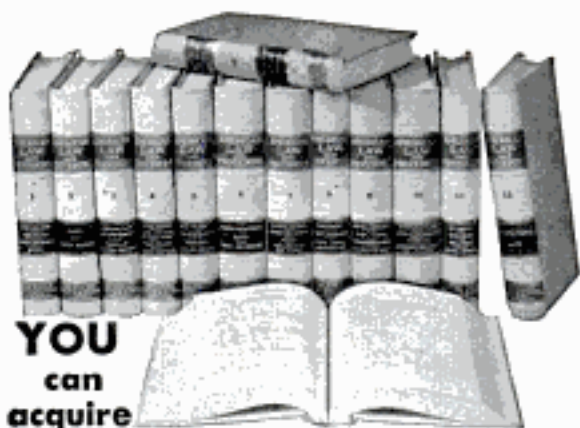

**YOU
can
acquire**

**LAW NIGHTS AT HOME!
L. B. DEGREE**

LaSalle's famous Law Library—used as reference in many Law libraries and Law offices—has enabled thousands to master Law surprisingly fast, in spare hours at home, for business and professional advancement.

These 14 remarkable volumes, compiled by leading professors and lawyers, cover the whole basic field of Law in condensed, orderly, simplified manner.

You advance rapidly with this great library, plus special lectures furnished. We guide you step-by-step with personalized Problem Method of instruction . . . you learn by doing—handling legal problems—not by memorizing rules.

Send for two FREE 48-page booklets, "Law Training for Leadership," and "Evidence," answering questions about Law and its value to you, and telling how LaSalle Law graduates are winning rapid advancement in business and public life. Mail coupon below. No obligation.

**LA SALLE EXTENSION UNIVERSITY
A Correspondence Institution**

417 S. Dearborn St. Dept. 164L Chicago 5, ILL.

Send me your two FREE booklets described above, without obligation.

Name.....Age.....

Street.....

City, Zone & State.....

LEARN LOCKSMITHING
Learn this fascinating, profitable trade from experts in your spare time at home! Age or physical handicap no disadvantage. Year around, steady income. Full or part time. Practical, illustrated lessons. You can make money even while learning! All materials and special tools supplied without extra charge.

INSTITUTE OF LOCKSMITHING, Dept. P-62
15 PARK AVENUE RUTHERFORD, N. J.
Lic. by N.J. State Board of Education
Approved for Veterans

send for **FREE BOOKLET**

**High School
at Home**

MANY FINISH IN 2 YEARS

No classes. No time wasted going to and from school. Progress as fast as your time and abilities permit. Standard H. S. texts supplied. Thousands enroll each year in this 58-year-old school. Send for FREE descriptive booklet.

AMERICAN SCHOOL, Dept. H145
Drexel at 58th St., Chicago 37, Ill.

Without obligation, please send FREE descriptive booklet.

Name.....

Address.....

Canadian Residents: Complete Canadian Course Available.
Write American School, 1610 Sherbrooke St., West, Montreal.

**Sensational Price Reductions
ON BRAND NEW—WORLD FAMOUS
Firestone TIRES**



**LESS
THAN
WHOLESALE**

SEND FOR
FREE CATALOG

**BRAND NEW — FIRST QUALITY
FIRESTONE PASSENGER TIRES**

All Tires Carry Famous Firestone Unconditional Guarantee	BLACK WALL TIRES 4 PLY FULL PRICE
640x15	11.78
650x15	14.22
670x15	11.88
710x15	13.11
760x15	15.05
800x16	10.56
850x16	14.01

**BRAND NEW — FIRST QUALITY —
Heavy Duty Firestone TRUCK TIRES**

Size	Full Price	Size	Full Price
700x15 6 ply	21.04	850x20 8 ply	24.96
700x15 8 ply	23.12	700x20 8 ply	28.01
600x16 6 ply	14.60	700x20 10 ply	34.95
650x16 6 ply	17.63	750x20 8 ply	36.31
700x16 6 ply	21.02	750x20 10 ply	40.28
750x16 8 ply	27.43	825x20 10 ply	49.70
700x17 6 ply	24.26	900x20 10 ply	61.11
700x17 8 ply	28.76	1000x20 12 ply	77.62
750x17 8 ply	31.25	1000x22 12 ply	81.90

**SPECIAL! BRAND NEW
WHITEWALL TIRES**

First Line 4 Ply Pass.	
600 x 16	12.69
670 x 15	14.30
710 x 15	15.82
760 x 15*	18.41
800 x 15*	20.23
820 x 15*	21.04

(Order by Mail—Send check or M.O.) • (All prices f.o.b. plant)
Farmers—Full line of tractor tires—Also complete stock of Mud & Snow Tires—Write for Prices.

**S & S TIRE CO. 1400 HADDON AVE.
CAMDEN 3, N. J.**



**WORLD'S LOWEST PRICED
ADDING MACHINE**

IDEAL FOR BUSINESS AND PERSONAL USE—GUARANTEED ACCURATE.
Not a toy. Operates with only a finger flick. Adds, subtracts, multiplies, divides. Counts up to one billion. Pays for itself over and over. Ideal Gift—for Business, Income Tax and School use. MONEY BACK GUARANTEE. Send name and address. Pay postman only \$2.95 plus postage. (Send full cash if outside U.S.) Beautiful rich-looking Leatherette Case included at no extra cost. Money back in 10 days if not delighted. AGENTS WANTED.

Calculator Machine Co., (Mfrs.)
Box 35 Glenview, Illinois

Vest Pocket Size
\$2.95
FREE TRIAL
only
TOTAL COST
SEND NO MONEY

**BUILD LUGGAGE AT HOME
WE SELL YOUR PRODUCTS!**

ONLY NEW HOME MONEY-MAKING PLAN IN YEARS!
Make Luggage and cases for traveling, photographers, musicians, salesmen, electronics, tools, portables, 1001 other items. Also repair Luggage. No special equipment needed. BIG Profits. We supply complete instructions, materials—everything. Write for free details and Business Plan. ABARSI CASECRAFT, Dept. G-1, 805 W. Sunset Blvd., Los Angeles 12, Calif.

BUY IT WHOLESALE!

GET UP TO 40% OFF
Start a Buying Service at Home.
SPARETIME, GET BIG-NAME MERCHANDISE FOR SELF AND CLIENTS UP TO 40% LESS THAN REG. PRICE. SALES EASY, AS YOU CAN GIVE SIZEABLE DISCOUNTS, STILL MAKE FAT COMMISSIONS. Post Card brings FREE COPY "The Wholesale Plan".
American Buyers Service
FREE! "THE WHOLESALE PLAN"

• 631-R Linden Ave., Buffalo 16, N. Y. •

**REPRODUCE ANY OBJECT
QUICKLY, EASILY**

Now you can easily and quickly make reproductions of any object in any quantity, right at home, overnight. Make perfect copies of anything of wood, metal, clay, plastic, glass, with new RUBBER MOLD method. No tools or special skills needed. Send for complete kit \$10.00 only \$2.95 postpaid. Brochure M1 gives complete, easy step-by-step instructions only 10c.
SCULPTURE HOUSE, 304 W. 42nd St., New York 36, N. Y.

**RUPTURED
BE FREE FROM TRUSS SLAVERY**

NOW there is a new modern Non-Surgical treatment that permanently corrects rupture. These Non-Surgical treatments are so certain, that a Lifetime Certificate of Assurance is given. Write today for our New FREE Book that gives facts that may save you painful and expensive surgery, and tells how non-surgically you may again work, live, play and love and enjoy life in the manner you desire. There is no obligation.
Excelsior Hernia Clinic Dept. 8305 Excelsior Springs, Mo.

START YOUR OWN BUSINESS!

ELECTRICAL APPLIANCE REPAIRING

SECURITY — INDEPENDENCE
WORK SHORT HOURS

There are millions of electrical equipment units in daily use . . . in factories, homes, office buildings and on farms. Skilled electrical technicians are needed to keep this equipment in good running condition. Learn at home in spare time.

You can now BE TRAINED to fill this BIG NEED . . . a need that grows day by day because of new electrical inventions for home and factory.

If you are mechanically inclined, can hold and use tools, we can give you the training and time-saving kits that will enable you to . . . Command More Money at Work . . . A Better Paying Job Elsewhere . . . Or A Business Of Your Own!

The ELECTRONIC KIT, a multi-purpose trouble detector, and other valuable Shop Method Training is sent to you! All instruction material is written in simple, easy-to-understand language, chock full of hundreds of detailed photos and drawings. Used by servicemen the country over.

We show you how to quickly locate the trouble, how to fix it and what to charge. ALSO, how to solicit business and keep business coming to you.

Get Full Facts on how you can get this training at home in your spare time and pay for it out of your earnings while learning!

IN YOUR OWN KITCHEN, BASEMENT, OR GARAGE

You don't need elaborate fixtures or expensive equipment to be a successful repairman. Work as many hours as you wish. The Electrical Appliance Technician is his own boss!

\$5.00 - \$6.00 HOUR

often charged for making ordinary repairs. We show you how to repair refrigerators, vacuum cleaners, washing machines, motors, etc., etc.

AGE IS NO BARRIER

Nor is a minor physical handicap. Work is light, pleasant and PROFITABLE.

FREE BOOK

On America's fastest growing industry

CHRISTY TRADES SCHOOL, Dept. D-3803, 4804 N. Kedzie, Chicago 25

CHRISTY TRADES SCHOOL, Dept. D-3803
4804 N. Kedzie Ave., Chicago 25, Ill.

Gentlemen:
Please rush me your FREE ILLUSTRATED BOOK about Electrical Appliance Servicing, facts on your Electronic Kit and Special form for paying later from earnings while learning.

NAME _____ Age _____

ADDRESS _____

CITY _____ Zone _____ State _____



EARN WHILE YOU LEARN!

Only had your course a few short weeks and have already made \$800.00. Going to quit my job paying \$250.00 straight salary to operate my own business.—J. D. S., St. Louis, Mo.
I work day times at the shipyard and after 4:00 P. M. I operate from my cellar and garage. I average \$10.00 to \$15.00 clear every day.—Walter Hasky, Brockton, Mass.



SEND COUPON TODAY



FREE
100
STAMPS
 ALL VALUABLE—ALL DIFFERENT
 Plus This Famous
RUSSIAN BEAR STAMP!

WHAT A GIFT! 100 stamps from all over the world... all different... all valuable! Total Standard Catalog Price guaranteed to be AT LEAST \$2! These stamps have NOT been sorted, so there's no telling what valuable stamps you'll find among them. **ALL YOURS FREE—PLUS** the famous BERLIN BEAR STAMP, issued by Russians as propaganda to show Russian Bear rebuilding Berlin. We'll also include a FREE copy of our "How to Collect Stamps," plus other interesting offers for your inspection. But hurry! Offer may have to be withdrawn soon. Rush coupon with 10c to help cover postage and handling to: LITTLETON STAMP CO., Dept. 1-PM, Littleton, N. H.

Guaranteed
 Catalog Value
 At Least **\$2.00**

LITTLETON STAMP CO., Dept. 1-PM, Littleton, N. H.
 Send—FREE—100 DIFFERENT STAMPS from all over the world, PLUS Russian Bear Stamp, and exciting, "How to Collect Stamps." I enclose 10c to help cover actual postage and handling costs.
 Name _____ (Please, PRINT)
 Address _____
 City _____ State _____

MEN! TRAIN NOW FOR A BIG PAY FUTURE IN DIESEL & SCIENTIFIC MOTOR TUNE-UP

- Diesel Construction
- Diesel Engine Repairman
- Diesel Operator
- Industrial Maintenance
- Auto Engine Rebuilding
- Bus & Truck Maintenance

Be a Trained Diesel Man
 Go places with DIESEL! Farms, factories and power plants, trains, ships, trucks, buses all use DIESEL POWER... all need DIESEL-trained men! You can start your DIESEL training at home, in spare time, with tested, proved U E I training. Course includes practical work on Diesel engines under skilled instructors. You learn the operation, maintenance, servicing of all types of Diesel engines, PLUS Scientific Motor Tune-up.
ACT NOW! If you have mechanical ability, you'll like Diesel! High School diploma not necessary. Write now for FREE book, "EARNING POWER IN DIESEL." Act Today!

MAIL NOW FOR FREE BOOK!

UTILITIES ENGINEERING INSTITUTE, Dept. DC-42
 2521 Sheffield Ave., Chicago 14, Ill. (Founded 1927)
 O. K.! Rush, without obligation, FREE Book on DIESEL.

NAME _____
 ADDRESS _____
 CITY _____ ZONE _____ STATE _____
 Check here for information if under 17.

MIRACLE TOMATO
 Yields **2** BUSHELS
 To a Vine



Now—You can grow the world's most amazing Tomato right in your own garden and get from 2 to 3 bushels of delicious, ripe tomatoes from every vine.
BURGESS CLIMBING TRIP-L-CROP
 TOMATO grows 16 to 20 feet high. Huge, meaty, solid fruit, wonderful flavor. Some weigh as much as 2 pounds each. Unsurpassed for canning and slicing. Blight free—drought and disease-resistant. Grows in any garden. Outyields all other varieties.
TRIAL PACKET 10c
 Postpaid. Order Today
3 Packets for 25c
 Write for FREE complete Catalog listing many unusual Seeds, Plants and Bulbs.
BURGESS SEED & PLANT CO.
 117 B. Galesburg, Mich.

Learn ACCOUNTING
 Business Administration
 Bookkeeping, secretarial and allied subjects at home in your spare time or attend nationally approved resident school. Write for FREE Success Book giving complete details on courses, plans, rates and employment opportunities. O.I. approved.

Hills BUSINESS UNIVERSITY AND EXTENSION SCHOOL
 629 W. MAIN ST. OKLAHOMA CITY 2, OKLAHOMA

MONEY in DONUTS
 Make new greaseless donuts. Start in kitchen. No smoke. Sell stores. Cash daily. No experience necessary. Free recipes. No obligation. Write!
MARTIN RAY CO., 3405 SO. 15th AVENUE, MINNEAPOLIS 7, MINN.

Build your own JET ENGINE!
 Order these plans today

1. JET PROPELLED BICYCLE. Assemble your own. Photo and instructions, \$1.00.
2. HOW TO MAKE EXPERIMENTAL JET ENGINES. Seven sheets drawings with information and instructions \$2.95.
3. BOTH OF ABOVE in one order \$3.75. SEND NO MONEY. Order both at once \$3.75 C.O.D. in USA plus c.o.d. postage. Send check or money order and we pay postage. Get other information too. Rush Order.

J. HOUSTON MAUPIN, Dept. 55, Tipp City, Ohio

OWN Your OWN Radiator Repair Business...

\$995
 Starts You Equips You

Earn \$6.75 per hour—\$8,000 to \$12,000 a year—servicing auto-truck-tractor radiators! New modern equipment makes work easy, fascinating, insures finest professional workmanship. Only \$995 starts you—\$100 training course included free by world's largest radiator equipment manufacturer. "Pays-for-itself" financing available.
WRITE for free folder "Want a business of your own?"
INLAND MFG. COMPANY Dept. PM-1
 1108 Jackson St., Omaha 8, Nebr.
 P.S. — Training alone also available—only \$150. Ask for training school literature.

"OWN a Business" Coupon**Start Now . . .
while employed****DURACLEAN CO., 5-161 Duraclean Bldg., Deerfield, Ill., U.S.A.**

Without obligation to me, send booklet and letter giving full details. Tell me how I may OWN a growing business of my own built upon satisfied customers.

Name _____

Address _____

City _____ Zone _____ State _____

**Are You The Man?**

If you have longed for the prestige and financial independence of YOUR OWN business, you can now realize this desire . . . if you can qualify for a Duraclean dealership. We are now enlarging this 25-year-old chain of independently-owned service dealerships which has rapidly grown to a world-wide service.

You must however be reliable, honest, diligent, and able to make a small investment in a business of your own . . . a profession for which we will personally and quickly train you. If needed, we will help finance you.

**You are Trained in a
New Profession . . . to Revive, Clean,
Protect Home Furnishings**

You have the opportunity to steadily increase the income for your family month after month and year after year without waiting for a raise. Duraclean dealers enjoy unusual profit on both materials and labor . . . after paying servicemen or salesmen. Service is rendered IN the home. Some have shops or offices . . . others operate from their home with no overhead expense. No experience is needed. We show you 27 ways to bring customers to you.

Our **MUTUAL COOPERATION** program gives you many unique and continuous advantages: National Advertising in Life, McCall's, House & Garden, Maclean's (Canada) and a dozen others. Copyright and trademark protection. Certificate approves equipment and materials. Products Insurance. Six-year Warranty. Pocket Demonstrators. Sales Book. Advertising Folders & Cards. Tested Ads. Ad Cuts & Mats. Store Display Cards. Radio & TV Musical Commercials. Home Show Booth Display. Publicity Program gets Free local newspaper stories. Prizes. Laboratory research and development. Duragram bulletins. Resale Service. Annual Conventions. Behind all this is a headquarters interested in YOUR personal success.

Almost every building houses a customer needing one or both services. Furniture stores, department stores, interior decorators, upholsterers and carpet stores, develop Duracleaning and Duraproofing jobs from their customers. Auto dealers take orders and have used cars Duracleaned. You have a high hourly income from the day you start . . . even while still employed.

Duraclean Revolutionizes Old Methods

Duraclean's growth to a world-wide service resulted from customer convenience plus its many superiorities over ordinary cleaning. Housewives, clubs, hotels, offices and institutions deeply appreciate not having furnishings out of use for days and weeks.

They are thrilled to see their upholstery and floor coverings cleaned and revived with a new consideration for its life and beauty. Duraclean doesn't merely clean . . . it restores natural lubrication to wool and other fibers. Colors revive. The re-enlivened rug and carpet pile unmat and rises.

Aerated foam created by the electric Foamovator (right) banishes dirt, grease and many unsightly spots without scrubbing. Customers tell friends how Duraclean has eliminated customary soaking, shrinking and breaking of fibers from scrubbing . . . how the mild quick action foam, lightly applied, provides safety from color runs and roughened fabric they have previously experienced . . . how fabrics look fresher, brighter, cleaner . . . how convenient it is not to have furnishings gone.

They appreciate the courteous, personalized service of Duraclean craftsmen. Such service is NEWS . . . it spreads to friends and neighbors. Customers become your best salesmen.

The companion Duraproof service not only kills moths and carpet beetles . . . it is WARRANTED to make fabric repellent to both. Damage to household goods and wearing apparel is greater from moths than fire. This modern treatment (illustrated above) PROTECTS rugs, carpets, upholstery, furs, clothing, blankets, piano-felts, auto-interiors, etc.

EASY TERMS: A modest payment establishes your business pay balance from sales. We furnish everything from electric machines to introduction slips including enough materials to return TOTAL investment.

FREE Booklet . . . Send for it NOW

Our first letter and illustrated booklet will explain everything . . . modern services, waiting market, how business grows, your large profit and PROTECTED territory. You can have your business operating in a very few days. Mail above coupon today while you can still get a dealership in YOUR location.

DURACLEAN CO., 5-161 Duraclean Bldg., Deerfield, Illinois

JANUARY 1955

We want to assure your success. A Duraclean dealer will train and assist you. He'll reveal his successful plan of building customers. He will work with you. This business is easy to learn . . . quickly established.

This is a sound, lifetime business that grows from REPEAT ORDERS and customer RECOMMENDATIONS. Alert dealers can gross an hourly profit of \$5.00 on own service plus \$3.00 on EACH service man at National Price Guide charges. Mail coupon today for full details.

What Dealers Say

Fuller Munroe: "I give full time to estimating and supervising. We average \$9 hourly income per service man but one man today produced \$118.00."

T. Komari (Japan): "Have 1,000,000 Yen contract Duracleaning for U.S. Army."

W. Lookiebill: "We've had 20 years of pleasant dealings. I'm 65 but am setting my sights for 20 more years."

P. Freidinger: "Had a big moth-proof business last year; one job was \$322.25."

R. Kimbrough: "Finished First White House of Confederacy and am to Duraclean the Governor's Mansion."

H. Satterfield: "Duracleaned chair for largest department store and got order for 60 to 75 chairs, couches and davenportes."

E. Schenk: "The customers I had on House and Garden ads were very pleased. Their furnishings came out beautiful."

A. Ullman: "It is very encouraging that every demonstration has been a sale."

L. Johnson: "Each customer leads to 3 or 4 more. One job two of us cleaned \$125 worth in 5 hours."

More quotations in our literature.

**OWN
a Growing
BUSINESS****FREE
Booklet
tells
how!**Mail
Coupon
TODAYA Duraclean dealer will
work with you in your town.

... TURN CONCRETE INTO GOLD!



MAKE UP TO \$75 A DAY IN YOUR OWN BUSINESS

If you want to have your own business — to start a business on your own — here's your big opportunity! New high speed, low cost General block machine produces up to 1,000 concrete blocks a day. Sell all you make to builders, supply houses, and others for homes, factories, buildings, garages. Cash in on the building boom! You can make profits of 100% to 150% — up to \$75. a day! General block machine equipped with 1/2 h.p. electric motor — or can be supplied with gasoline engine — works anywhere, in little space, indoors or out. Operates from ordinary house light socket. Simple, foolproof 3 step operation — so easy a child can do it. Makes superior 3 core blocks any size from 4" to 12". Also makes chimney, ash, corner and other types. Blocks meet any building code anywhere in the country. Materials — sand, water, cement, available anywhere. Simple illustrated operating instructions and mixing formulae for cement and cinder blocks supplied with each machine. Write for FREE folder with full information.

MOTOR DRIVEN

R. L. T. of New York City reports: "MY GENERAL BLOCK MACHINE PAID FOR ITSELF IN FIRST 2 WEEKS!" Hundreds now in use the world over! Write for FREE details today!

EXTRA

Amazing illustrated book gives floor plans for 6 sensational concrete block bungalows. Tells how to lay blocks, lay out building lines, mix concrete, build steps, porch and concrete floors all at great savings. Written by experts. Can save many times the cost of the machine! Get it now! No strings attached. Send \$1.

BOOK SENT FREE IF YOU BUY MACHINE. \$1 REFUNDED IF YOU BUY LATER.



GENERAL ENGINES CO.

DEPT. M-15, 307 HUNTER STREET, GLOUCESTER, N. J.

Learn to MOUNT Birds and Animals



To All Men & Boys!

Here is FUN and PROFIT!

Send Coupon for Free Book

Tells all about Taxidermy, and how you can learn at home to mount life-like Birds, Animals, Game-Heads, Fish. Save your valuable trophies. Decorate your home and den. Learn genuine Chrome Tanning for harness and sole leather buckskin and fine furs. Mount Common specimens, squirrels, rabbits, owls, even frogs, into marvelous craft-work groups, both useful, humorous. Wild game not necessary. Marvellous hobby. Fascinating.

BIG PROFITS Turn your spare time to cash. Have a sideline profitable business. Mount game trophies for sportsmen; sell your own mounts; save money and **Make Money** with expert tanning. Learn by mail from old reliable school with 400,000 graduates. **Investigate Now.** Send coupon or letter or post card **Right Now** for this marvelous **FREE BOOK.** There is no cost or obligation. Please state your **AGE.**

FREE BOOK



Northwestern School of Taxidermy, 2501 Elwood Bldg., Omaha, Neb.

Gentlemen—Please send me your FREE 48-page booklet explaining Taxidermy. (Please print plainly, and state age. Use postal card if more convenient.)

Name _____ Age _____

Address _____

Shrinks Hemorrhoids New Way Without Surgery

Science Finds Healing Substance That Relieves Pain—Shrinks Hemorrhoids

For the first time science has found a new healing substance with the astonishing ability to shrink hemorrhoids and to relieve pain — without surgery.

In case after case, while gently relieving pain, actual reduction (shrinkage) took place.

Most amazing of all — results were so thorough that sufferers made astonishing statements like "Piles have ceased to be a problem!"

The secret is a new healing substance (Bio-Dyne*)—discovery of a world-famous research institute.

Now this new healing substance is offered in ointment form under the name of Preparation H.* Ask for it at all drug stores — money back guarantee. *Reg. U. S. Pat. Off.



BIG DEMAND FOR ANIMATORS!

LEARN **ANIMATED CARTOONING**

EARN \$15,000 YEARLY!

Like to draw? Jobs open in TV cities nationwide! Home study courses: Basic and advanced. Tuition: \$10 monthly. Enroll now and get FREE \$35 Animation Drawing Board! Write TODAY FOR FREE BOOKLET.

ANIMATED CARTOONING SCHOOL OF AMERICA
STUDIO M-1 BOX 2109 HOLLYWOOD 28, CALIF.

ENGINEERING DEGREE IN 27 MONTHS

INDIANA TECHNICAL COLLEGE

B. S. DEGREE, Aeronautical, Chemical, Civil, Electrical, Mechanical and Radio Engineering (inc. TV and Electronics). Drafting, 1-yr. G.I. Gov't. approved. Low rate. Earn board. Large industrial center. Students from 48 states, 21 countries. Demand for graduates. Enter March, June, September, December. Write for catalog. 1615 E. Washington Boulevard, Fort Wayne 2, Indiana.

LEARN WATCH REPAIRING

AT HOME Modern, original instruction. Prepare for a position or start in business after completing our course. Write Today! **WISCONSIN SCHOOL OF WATCH REPAIRING**
2908 N. 44th St. Dept. M Milwaukee 10, Wis.

OIL FILTER REFILLS . . . 10c

Here's News! Ordinary toilet paper makes an ideal oil filter. Laboratory tests prove it cleans oil faster and better than popular makes of filter elements. All you need is a simple set of Retlif Adapter Plates . . . and you can start using toilet paper rolls (costing about 10c) in your present oil filter. For proof and descriptive literature, send name and address to:

RETLIF CORP., Dept. 138, 915 No. Highland Ave., Los Angeles 38, Calif.

Now Many Wear FALSE TEETH With More Comfort

FASTEETH, a pleasant alkaline (non-acid) powder, holds false teeth more firmly. To eat and talk in more comfort, just sprinkle a little **FASTEETH** on your plates. No gummy, gooey, pasty taste or feeling. Checks "plate odor" (denture breath). Get **FASTEETH** at any drug counter.

NOW... Start Fixing TV and Radio Sets RIGHT AWAY

TRY IT
FREE

FOR 10 DAYS IN
YOUR OWN HOME

JOHN
MARKUS

TELEVISION AND RADIO REPAIRING

McGraw-Hill's Amazing New Low-Cost Instruction Manual Skips "Theories" and "Formulas", Tells How-to-do-it in PLAIN ENGLISH!



Prove It on Your Own Set

Save up to \$50 a year just by installing, repairing, and servicing your own TV set. Book tells which controls to adjust or tubes to replace if picture is entirely dark — blurred — split — distorted — off center — tilted — wiggles and weaves — too pale — too black — jitters — snows — drifts — etc., etc.

PARTIAL CONTENTS

Tools Needed • How TV and Radio Sets Work • How to Remove and Re-place Tubes • Testing Tubes without Power-Supply • Using a Tube Tester to Test and Replace Tubes • How to Switches, Condensers, Coils, Transformers • Tuning Devices • Loudspeakers • Phone Pickups and Needles • How to Install and Repair Antennas — and MUCH MORE

TELLS HOW TO "Cash In" ON THE BIG DEMAND FOR RADIO-TV REPAIRMEN

Over 25 million TV sets over 100 million radios in this country! Shortage of skilled repairmen! You can make nice extra money and fixing sets for spare time neighbors in your spare time... or start your own full-time repair business, with steady profits. Book tells exactly how to get started; which tubes to stock; where to get information; how to make a service call. You can start fixing sets and making money before you're halfway through the book. Author tells how tough jobs can be done so you STILL make money.



... even if you have never fixed a LAMP or DOOR BELL before!

"Why hasn't somebody done this BEFORE?" That's what you'll say when you start browsing through this new and complete one-volume instruction-manual in radio and TV repairs.

For here at last a well-known EXPERT has found a way to tell you in PLAIN ENGLISH how to fix almost ANY radio or television set. (And he even tells you where you can go to have the extra-tough jobs done FOR you... at professional rates.) Right from the very first chapters you can start doing simple repairs... and before you're HALF way through the book, you can fix HALF the television and radio sets that you encounter. Surprisingly quickly you can fix your own and friends' sets... get a service shop job... even start your own money-making business right in your own home.

Why It's So EASY to Understand

No electronic formulas... no algebra... no laboratory experiments. Instead you deal only with the things that go wrong in sets—how to recognize and spot the trouble—and what to do about it. "Easy as A-B-C" directions and 700 clear photos, diagrams, and drawings show you exactly WHAT and HOW to fix, step-by-step.

The author is Associate Editor of *Electronics Magazine*. He's a long-recognized expert—not only on radio and TV—but also on making technical subjects easily understood by the average reader. He has spent FOUR years making this one-volume instruction manual so practical and easy-to-understand that even a man who never fixed a door bell before will have no trouble.

Here's everything you need to know about where and how to buy tubes and parts, where and how to get a circuit diagram for any receiver; how to choose and use basic tools; how to test tubes WITHOUT a tube tester; how to adjust 58 common TV controls; how to "diagnose" and "cure" common radio and TV troubles; how to fix or replace loudspeakers, phono pickups; how to install and check antennas; and much, much more.

SEND NO MONEY

Examine this big 556-page book for 10 days BEFORE you decide if you wish to own it. Try it out FREE on your own set. See how easy it makes your handling of repairs. Take 10 days to prove it PAYS FOR ITSELF, or don't keep it. Just mail coupon to: McGraw-Hill Book Co., Inc., Dept. PM-1, 327 West 41st St., New York 36, N. Y.

FREE 10-DAY TRIAL COUPON

McGraw-Hill Book Co., Inc., Dept. PM-1
327 West 41st St., New York 36, N. Y.

Please send me, for 10 days' FREE EXAMINATION, your one-volume "Television and Radio Repairing," by John Markus. If not delighted with it, I may return book, pay nothing. Otherwise, I will keep book and send only \$1.95 plus postage; followed by 3 monthly installments of \$2.00 each.

Name _____

Address _____ PM-1

City _____ Zone _____ State _____

SAVE MONEY. Check here if enclosing full price of \$7.95 WITH this coupon. Then WE will pay delivery. Same 10-day return privilege—full refund guaranteed.

Trouble-Shooting Chart Tells Where to Look for Bad Tube If:

No picture; no raster; no sound.
No picture; raster OK; no sound.
No picture; no raster; sound OK.
No picture; raster OK; sound OK.
Picture wiggles and weaves, licks blacks, or is very black; raster OK; sound OK.
Picture jittery, double image; raster OK; sound OK.
Snow on all channels; raster OK; sound weak.

Snow on all channels, raster OK; sound OK.
Picture and raster do not fill screen; sound OK.
Picture drifts up and down but not sideways; raster OK; sound OK.
Picture muddy and gray; raster OK; sound OK.
PLUS 29 OTHER COMMON TV TROUBLES.

BECOME A Mechanical Engineer

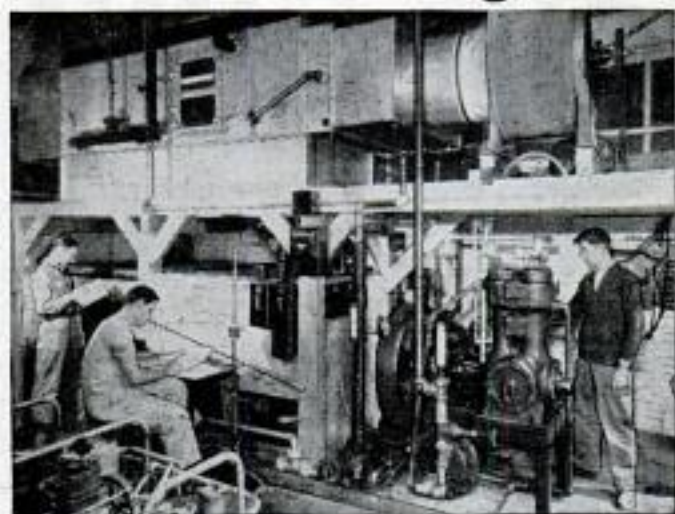

B. S. Degree in 36 months



Mechanical Engineers hold respected, well-paying, and highly interesting jobs in many fields of industry. You can prepare now . . .

for a secure future and a well-paid career as an engineer or engineering technician at the Milwaukee School of Engineering.

Choose from these courses at the Milwaukee School of Engineering

ENGINEERING 36 months, Bachelor of Science Degree

- Mechanical Engineering with a major in Design, Metal Fabrication or Plant Engineering.
- Electrical Engineering with a major in Electronics or Power.

SERVICE 6 to 12 months

- Electricity ● Heating
- Refrigeration ● Welding

TECHNICIAN 12 to 18 months

- Radio and Television
- Electronics
- Electrical Power
- Mechanical Technician
- Air Conditioning
- Welding

General preparatory course — 3 months.

TERMS OPEN APRIL, JULY, SEPTEMBER, JANUARY

Faculty of specialists. Over 50,000 former students. Annual enrollment from 48 states and 23 overseas countries. *Non-profit*. 52nd year. Military, Practical or Academic training evaluated for advanced credit. Approved for Veterans Training. Write for details today.

MILWAUKEE SCHOOL OF ENGINEERING

MS-BA

MILWAUKEE SCHOOL OF ENGINEERING
Dept. PM 155, 1025 N. Milwaukee
Milwaukee 1, Wisconsin

Send free illustrated career booklets Radio-TV
 Mechanical Technology Electrical Technology

I am interested in _____
(name of course)

Name _____ Age _____

Address _____

City _____ Zone _____ State _____

If veteran, indicate date of discharge _____

TUBE FREE WITH EVERY TIRE AT NO EXTRA COST



EXPERIENCE IS THE BEST TEACHER. OUR MANY YEARS PROVES YOU CAN'T GET MORE. WHY PAY MORE? LOW OVERHEAD—LARGE VOLUME SALES & SMALL PROFITS BRING YOU THESE "LOWEST PRICES."



WHAT GOOD IS A TIRE WITHOUT A TUBE? 21 YEARS AT THIS ADDRESS. FREE TUBES. AN ESTABLISHED POLICY OF CAREFUL SELECTION ASSURES YOU MANY HAPPY MILES. BE WISE — TRY ONE — YOU'LL BUY MORE! WE WELCOME COMPETITION. NO ONE CAN TOUCH OUR QUALITY & PRICE!



GOOD USED TIRES — NOT RECAPS

FREE If you buy 2 or 3 PASS, 4 PLY, 32 mos. guarantee tires, We GIVE ONE tire FREE. FREE

Specialists in Truck Tires—Selected for Toughest Jobs—Tops in Value		32 MOS. WRITTEN GUARANTEE		34 MOS. WRITTEN GUARANTEE	
600-16	\$4.42	475-19	\$4.82	700-16(6)	\$7.22
600-16(G)	5.32	640-18	4.22	750-20(10)	18.72
650-16	4.82	670-15	4.52	700-17	7.92
650-16(G)	6.82	710-15	4.52	750-17	10.02
700-16	5.32	760-15	4.82	825-20	10.82
700-16(G)	7.32	800-15	5.22	900-20	19.82
550-16	3.72	820-15	5.42	650-20	8.02
550-17	3.72	670-16	5.02	32x6(10)	11.72
650-15	4.82	760-16	7.02	32x6(10)	12.62
700-15	4.62	700-16(G)	7.22	750-15	10.72

Thousands of tires shipped all over the U.S.A. All tires shipped F.O.B. Phila. Send Check or M.O. with this ad. Dept. 2. No C.O.D.

STANDARD 834 N. Broad St., Philadelphia 30, Pa.

A "GOOD HAND" HELPS YOU SUCCEED!

Your Name
beautifully written, plus special pen-point for shaded writing.
Only 10¢

LEARN TO WRITE WELL

Handwriting quickly improves with our easy-to-understand picture lessons! Put your spare time to good use; send today for **FREE BOOKLET**, "How to Become a Good Penman," or check volumes wanted below at 51¢ each: Business Writing Artistic Writing Card Writing Bird & Design Flourishing Engraving Alphabets. COMPLETE SET \$4.50. Ask for price list of penman's supplies.

TAMBLYN SCHOOL of PENMANSHIP
S.A. Ziller, Pres., 442 Ridge Bldg., Kansas City, Mo., USA

Send for **FREE** 112 page Illustrated Catalog of Farm, Home, and Workshop Bargains.

Write to **WELLWORTH TRADING COMPANY**
Dept. E-1

1832 S. WABASH AVE. CHICAGO 16, ILL.

Finish **HIGH SCHOOL** AT HOME

Complete 4 Yrs. in 12 Months

Learn More! Earn More! Enter professional or technical schools. Advance Socially. Live a Happier, Fuller Life. Individual Courses or complete schedule. **WRITE FOR SCHOOL BULLETIN.**

ACADEMY FOR ADULTS
30 W. Washington, Dept. PM-105, Chicago, Ill.

LEATHERCRAFT

The "HE-MAN" Hobby

Make Leather Items for Gifts, to Sell, or for Your Own Use

START NOW making billfolds, belts, gloves, handbags, woolskin animals, etc. No tools or experience needed with Larson ready-cut Beginners' Kits. Instructions included. Also, carefully graded tooling and carving leathers, fine calfskins, supplies, projects for Crafts Classes, professionals. Quality **GUARANTEED**. Send 10¢ NOW for big, new illustrated Leathercraft Catalog and Guide for Beginners and Advanced Leathercrafters.

J. C. LARSON CO., INC.
820 S. Tripp Ave., Dept. 4027, Chicago 24, Illinois

Tune Up, Pep Up, Fix Up ANY CAR!

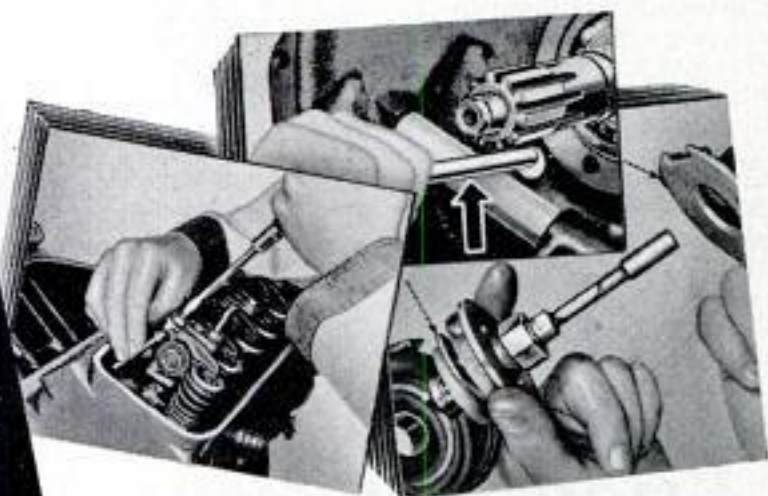

**YOU WON'T "MISS" WITH
HOW-TO-FIX-IT DATA LIKE THIS TO GUIDE YOU**

**New
Enlarged
Edition
BY THE
WORLD'S
LARGEST
AUTOMOTIVE
PUBLISHERS
Covers every
model**

of these 20 makes
from 1940 through
June 1954:

BUICK
CADILLAC
CHEVROLET
CHRYSLER
DE SOTO
DODGE
FORD
FRAZER
HENRY J.
HUDSON
KAISER
LINCOLN
MERCURY
NASH
OLDSMOBILE
PACKARD
PLYMOUTH
PONTIAC
STUDEBAKER
WILLYS

Let 19 famous auto repair experts show you how to handle practically any job on any car easier than you may have thought possible.

Using this giant, 43½-pound Chilton "ALL CARS" Service Manual is like having the 19 Chilton specialists who prepared it standing by your side guiding you every step of the way.

First they show you how to locate troubles. Then they show you exactly how to fix them.

No guesswork! No lost time! Backed by their clear instructions, even beginners can easily handle jobs they might not have dreamed of tackling.

FIX ANY MAKE, MODEL OR PART

Chilton covers every model of the leading 20 car makes from 1940 through June 1954 . . . over 600 models in all.

Gives how-to-fix-it data on specific jobs—NOT general theory.

Simply look up the make, model and part you want to fix. The Manual shows exactly what to do

. . . what work-saving shortcuts to take . . . what adjustments to make . . . what parts to replace . . . what tools to use . . . what mistakes to avoid.

Everything is made crystal clear. "Minor" details often so puzzling to beginners are fully explained.



Ask the best auto mechanics you know! They use the Chilton Manual, too — because it helps them work easier, better and faster. And it's "tops" for training beginners!

NOT a "Study" Book!

**JUST LOOK UP THE JOB YOU
WANT TO DO**

Use your Chilton Manual right at the bench when you've got a car to fix!

From tune-ups to complete overhauls . . . from "simple" repairs like windshield wipers to the most complicated automatic transmissions, it is a complete, easily understood service guide.

Published each year by the world's largest automotive publishers, home of Motor Age, Automotive Industries and Commercial Car Journal magazines, the Flat Rate Book, etc.

Contains 864 big pages; 58 Troubleshooting Charts; 353 Quick Check Data Tables. Almost 3,000 pictures make every step doubly clear.

PRACTICE 10 DAYS FREE!

The Chilton Co., Dept. PM-15
56th & Chestnut Sts., Philadelphia 39, Pa.

Send the big 864-page Chilton "ALL CARS" REPAIR MANUAL (Price \$6.95) for 10-day FREE EXAMINATION. If I like it, I will then promptly remit \$1.95 (plus 35c postage); then send \$2.50 monthly for 2 months. Otherwise, I will return manual postpaid in 10 days and owe you nothing.

(OUTSIDE U.S.A.—Cash only, price \$7.95. Same 10 day return privilege with money refunded.)

Name _____

Address _____

City, Zone, State _____

SHORTHAND IN 6 WEEKS

WRITE 120 WORDS PER MINUTE
Age No Obstacle — Lowest Cost

Famous SPEEDWRITING shorthand. No symbols, no machines. Uses ABC's. Easiest to learn and use. Qualify at home in spare time or through classroom instruction. Fast preparation for a better position and a sound, substantial future. Nationally used in leading offices and Civil Service; also by engineers, executives, students, etc. 120 words per minute—50% FASTER than Civil Service requirements. Over 250,000 graduates. Typing available.



Age No Obstacle
in Learning
SPEEDWRITING
Shorthand

"Because of my age, I was discouraged from studying shorthand. However, I completed SPEEDWRITING shorthand in about 5 weeks. SPEEDWRITING shorthand can be learned by anybody of sound mind regardless of age."—Otto Lehwald, Minneapolis, Minn.

The very low cost will surprise you
32nd Year

Schools in over 400 cities in U. S., Canada,
Cuba and Hawaii.

Write for FREE Booklet to: SCHOOL OF

Speedwriting
Dept. 1501-S, 55 W. 42 St., N. Y. 36

Hundreds of Companies Want
Advertising Work Uniforms
LIKE THESE!



We need men to
take their orders

Perhaps you have wondered where gas station attendants get the uniforms they wear—the ones with company names embroidered above the pocket and on the back. Geo. Master originated the idea of advertising work uniforms 25 years ago. Giant companies use them, "little fellows" buy them too. We have so many customers, we need more men to take orders.

If you qualify, we will set you up in business FREE. We give you everything you need to operate right from your own home—plus year-round advertising to pre-sell prospects.

One of our men, on his first call, took an order from a small dairy. His profit—\$758. He is almost sure to get repeat business automatically.

Master uniforms and work garments are sold and serviced all over the world. We ship direct to the customer from our factory. You work with one of the most complete kits ever devised. It's an expensive kit to prepare, but it costs you nothing.

Try our method for 10 days. Then, if you don't like the business, simply return the kit and forget the entire matter. This could well be the BIG OPPORTUNITY you have been looking for. Certainly, you have nothing to lose by trying it out. So fill out and mail coupon below today.

The Geo. MASTER GARMENT DIV.
307 WATER STREET - LIGONIER, INDIANA

Del V. Bergstrom, President
The Geo. MASTER GARMENT DIV.
307 Water Street, Ligonier, Indiana

Dear Mr. Bergstrom: Please send me a Complete Order Kit, with instructions, so I can make a 10-Day Test. I understand everything you send is FREE. If, after 10 days, I'm not delighted with the money I've made, I'll send the kit back.

NAME _____
ADDRESS _____
CITY _____ ZONE _____ STATE _____

INVENTORS

PROTECT YOUR INVENTION BY A
U. S. PATENT. SEND FOR FREE
"INVENTION RECORD" FORM AND
"PATENT INFORMATION
EVERY INVENTOR SHOULD HAVE".

CARL MILLER
REGISTERED PATENT ATTORNEY
WOOLWORTH BLDG., 35th FLOOR, 15A
NEW YORK CITY

PATENTS
C. A. SNOW & CO.
REGISTERED PATENT ATTORNEYS
WRITE FOR INFORMATION TO
428 SNOW BUILDING, WASHINGTON 1, D. C.

INVENTORS

Send for
PATENT INFORMATION REGISTERED PATENT
Book and ATTORNEY
INVENTOR'S RECORD ASSOCIATE EXAMINER
without obligation U. S. PAT. OFF. 1922-1929
GUSTAVE MILLER Patent Attorney & Advisor
15-PM WARNER BUILDING U. S. NAVY DEPT. 1930-1947
WASHINGTON 4, D. C. PATENT LAWYER

INVENTIONS WANTED

If you want to market, or sell, your invention for cash or royalties. Write for our Free Booklet. Send no drawings. We also welcome hearing from firms, or private capital, wishing to review inventions in any field. We will be glad to send notice of our clients' inventions.

GLOBAL MARKETING SERVICE
1404 Mitchell Street Dept. PD Oakland 1, Calif.

HELPFUL BOOKS

Send post card asking for FREE catalog
Popular Mechanics Press, 200 E. Ontario, Dept. 601, Chicago 11

INVENTORS

Whether an invention is patentable can be substantially determined by a search of the U. S. Patent records. Without obligation, write for information explaining the steps you should take to secure a patent.

JOHN N. RANDOLPH
Registered Patent Attorney
201 Columbian Building, Washington 1, D. C.

INVENTORS

I shall be pleased to furnish you, upon request, with full information relative to patent procedure—without any obligation on your part.

PATRICK D. BEAVERS
Registered Patent Attorney
934 Columbian Building Washington 1, D. C.



Get more money!
More security! More out of life!



Learn
**TELEVISION
• RADIO •
ELECTRONICS**

Get the best!

Get National Schools' SHOP-METHOD HOME TRAINING!

Start now! Why wait around for that raise or promotion that may never come? Get started now in high-paying TV-Radio-Electronics! National Schools' SHOP METHOD Home Training prepares you for success in a top-salary job or in your own business. You learn *all three*... Television, Radio, Electronics... in one complete course. Our Shop-Tested lessons and manuals help you master all phases in shortest possible time! Send coupon, find out today!

WHY NATIONAL SCHOOLS LEADS THE FIELD

Located in the "Television Center" of the world, our staff is in close touch with latest developments and opportunities. We give you personalized job placement assistance. We also give you confidential help with both technical and personal problems relating to your training. We show you how to make Part Time Earnings as you progress. Whether you live 30 miles away, or 3,000, you will always be pleased with our prompt, friendly service!

DRAFT AGE? Our home training helps you achieve specialized ratings and higher pay grades if you go in service.

30 MILLION TV SETS

need regular repair! Color TV means more sets than ever before. NOW is the golden opportunity to cash in on this multi-billion-dollar industry. Or "write your own ticket" in broadcasting, manufacturing, and other specialized phases!

**YOUR AGE
IS NO
OBSTACLE!**



Send for
FREE LESSON!
FREE BOOK & SAMPLE LESSON
will convince you!
SEND COUPON TODAY!

We send you this precision-tested Multitester! Plus parts to build Oscillators, Receivers, Signal Generator, Continuity Checker, Combination Short Wave and Standard

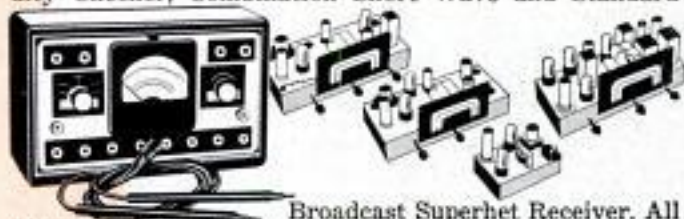

Broadcast Superhet Receiver. All this equipment is part of your National Schools course. **NO EXTRA CHARGES!** Send coupon for free books!

NATIONAL SCHOOLS, world-famous technical trade school. Now in our 50th year!



NATIONAL SCHOOLS

TECHNICAL TRADE TRAINING SINCE 1905
LOS ANGELES 37, California - CHICAGO: 323 West Polk St.
IN CANADA: 811 West Hastings Street, Vancouver, B. C.

- APPROVED FOR G. I. TRAINING
- BOTH HOME STUDY AND RESIDENT COURSES OFFERED

MAIL NOW TO OFFICE NEAREST YOU!

(mail in envelope or paste on postal card)
NATIONAL SCHOOLS, Dept. RB-15

4000 SOUTH FIGUEROA STREET
LOS ANGELES 37, CALIFORNIA OR 323 WEST POLK STREET
CHICAGO 7, ILLINOIS

Please rush FREE BOOK, "My Future in Radio-Television-Electronics," and FREE LESSON at once. I understand there is no obligation, and no salesman will call.

NAME _____ BIRTHDAY _____ 19__

ADDRESS _____

CITY _____ ZONE _____ STATE _____

Check if interested ONLY in Resident Training at Los Angeles.

VETERANS: Give date of discharge _____

**"I DOUBLED MY INCOME—
Am My Own Boss—
in CUSTOM
UPHOLSTERY"**



**Leonard Schroeder, Former Low Paid
Accountant—Increases Earnings 110%**

"I was an accountant earning a meager salary before getting UTS training in upholstery. As soon as I graduated, I got a much bigger paying job with a firm specializing in custom upholstery work. Now I've better than doubled my income operating my own business and have an ever-growing number of new and satisfied customers."

WHAT DO YOU WANT?

**Your Own Business? — Substantial Sparetime Earnings?
A Steady Job? — A Profitable Homecraft?
They're All Waiting for You in the
Big-Opportunity Field of
CUSTOM UPHOLSTERY**

Right AT HOME in your sparetime you can do what thousands of other UTS graduates have done—easily—enjoyably—PROFITABLY. The fact is . . . unlike other important industries where there are too many trained men—in the booming field of custom upholstery there's a growing, nationwide shortage of expert upholsterers—with well paid jobs waiting everywhere. Or, if you're tired working for bosses—sick of worrying about money, layoffs and slack seasons—then custom furniture upholstery offers you a golden opportunity to build a business at home, open your own shop, be your own boss, do clean, fascinating work, earn a good comfortable living all year 'round.

YOU EARN WHILE YOU LEARN RIGHT OFF

Best of all you can earn good money in your sparetime, at the same time that you learn this fascinating trade. No need to leave your job till you're ready.

At last the practical UTS course is available to you right at home. You learn to be a skilled professional craftsman under the personal supervision of topnotch upholsterers. Your course INCLUDES FREE Complete Set of upholstery tools, all frames, materials and fabrics you use to make beautiful custom upholstered furniture and slipcovers—you can sell or use yourself.

You start making furniture almost AT ONCE! Many UTS graduates earn enough doing sparetime upholstery to end their money worries. What they have done—YOU CAN DO! Course teaches you professional custom furniture upholstery, reupholstering, furniture finishing and repairs—slip cover, window cornice, cushion and drapery-making.

YOU MAKE

SLIPPER CHAIR
CLUB CHAIR
OTTOMAN
PLUS
SLIP COVERS
Yours to keep or sell

**Free Illustrated Book With Sample
Lessons Shows You How!**

Our FREE book, "Your New Way to a Successful Career," with sample lessons, shows you how! Tells all about this ever-growing trade and the many men and women who are finding happiness and success the UTS way. Training in N. Y. School also available. Licensed by N. Y. State. Upholstery Trades School, Dept. DA-305, 721 Broadway, New York 3, N. Y.

FREE ILLUSTRATED BOOK **FREE SAMPLE LESSONS**

UPHOLSTERY TRADES SCHOOL
Dept. DA-305, 721 Broadway, New York 3, N. Y.

Send me FREE book with sample lessons. No obligation—no salesman will call. I am interested in

Home Study In N. Y. School Training

Name _____

Address _____

City _____ Zone _____ State _____

APPROVED FOR KOREAN VETERAN TRAINING. Check here if Korean Veteran.

BETTER THAN EVER

IN COLD RELIEF

New

Tabcin

BRAND

MILES LABORATORIES, INC., Elkhart, Indiana

TELEPHONES



Desk Stand Style
Slightly used but in excellent condition

Many Valuable Uses
Inter-House Phones House to Barn, etc.
Loud Speakers Microphones
Educational Purposes, Toys, etc.

Come complete, ready to use with wiring diagrams included. **\$2.75** Postpaid in U.S.A.
Two complete for only **\$5.00**
TELEPHONE LAMP KIT—with illustrated instructions for making Desk Telephone Lamp including all parts (lamp, nipples, push switch, cord, plug, etc.) . . . **\$6.50** Post. (Shade is not included).

MICROPHONE, Dept. X-2102, 1760 W. Lunt Ave., Chicago 26, Ill.

RUPTURE



RELIEF...OR YOUR MONEY BACK
Original, patented Web, copied but never matched. Users say it's best ever. Relief or no cost to you. Write:

WEB TRUSS CO., Dept. M-1, Hagerstown, Md.

SOCK-O World's Most Powerful

SUPER SLINGSHOT
SILENT • RIFLE FAST • POWERFUL • ACCURATE
Great for small game, targets. 45 lb. pull. BIG sturdy Sock. Lively, Raw rubber. Sweet shooting! FREE! 100 steel balls, rubber and target. FREE!!! Thrilling SURPRISE PACKAGE with Two slings at \$2.95. Hurry, get 2! Guaranteed. Approved by American Small Game Sling-shot Assoc.

SOCK-O, 4860 W. 137 St., Hawthorne, Calif.

\$1.50 Wholesale
No C.O.D.

YOU CAN GET IT... WHOLESALE!

SAVE UP TO 60% ON THOUSANDS OF FAMOUS PRODUCTS. OPPORTUNITY TO START YOUR OWN HIGHLY PROFITABLE MAIL ORDER BUSINESS, WORK AT HOME, SPARE-TIME. NO MERCHANDISE TO BUY OR HANDLE. NO EXPERIENCE OR CAPITAL REQUIRED. EVERYTHING SUPPLIED. SEND POST-CARD TODAY FOR YOUR COPY OF

BUY DIRECT SAVE UP TO 60% **FREE "WHOLESALE TRADE SECRETS"**

CONSOLIDATED DISTRIBUTORS
21-03 LAFAYETTE, PATERSON 15, NEW JERSEY

FREE AMAZING NEW BOOK "HOW TO ANSWER ADS"



Never before have you seen anything like this. Tells you in simple language the correct way to answer ads. Gets you quicker replies—better results, and greater satisfaction. Will save you time and money and it's ABSOLUTELY FREE. No obligation whatever. Every reader of advertising should have this booklet. Send a postcard for your copy NOW. F. W. Johnson, Popular Mechanics Magazine, Room 600-A, 204 East Ontario Street, Chicago 11, Illinois.

THESE 3 FREE BOOKS

help you uncover
**YOUR HIDDEN
 MONEY-MAKING
 TALENTS!**

Worth more than any treasure are the abilities lying undeveloped within you: Your ability to learn, to direct others, to master the latest developments in any field of business or industry!

THESE three books have started thousands on the road to bigger incomes, better jobs, *immediate rewards!* They have been proved and improved, printed and reprinted, and now they are offered to you FREE as a service of International Correspondence Schools.

One is the 32-page gold mine of career tips, "How to Succeed." Another is the big I. C. S. catalog outlining opportunities in your field of interest (see list of subjects in coupon). The third is a sample I. C. S. lesson showing you the famous method of spare-time instruction that has brought success to so many.

"X" MARKS THE SPOT! It takes only a few minutes to mark and mail the coupon. It takes

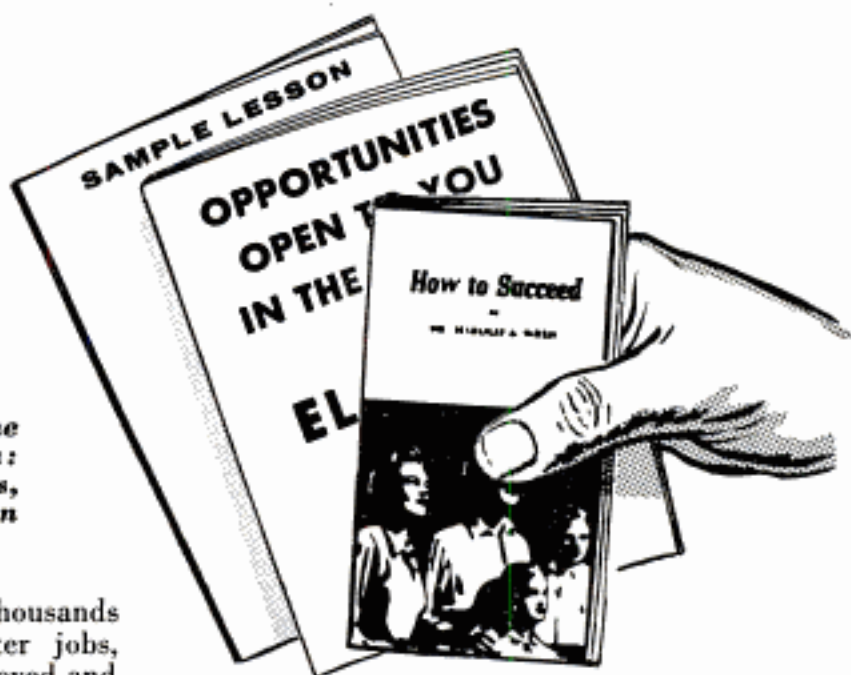

only a few days for these valuable free books to be delivered to you. It would take you years to progress as far in your job as I. C. S. can help you progress in months!

WARNING! These three books are costly. They will be valuable to you *only if you are seriously interested in devoting time, effort and money toward improving yourself!* There is no free and easy short cut to success! I. C. S. offers you a sound, practical method for training yourself at low cost. 277 courses. Complete, personalized lesson and answer service. No scrimping. Bedrock facts and theory plus on-the-job application. Diploma to graduates.

For Real Job Security — Get an I. C. S. Diploma!

I. C. S., Scranton 9, Penna.

INTERNATIONAL CORRESPONDENCE SCHOOLS

ICS

BOX 01299A, SCRANTON 9, PENNA.

(Partial list of 277 courses)

Without cost or obligation, send me "HOW TO SUCCEED" and the opportunity booklet about the field BEFORE which I have marked X (plus sample lesson):

ARCHITECTURE and BUILDING CONSTRUCTION

- Air Conditioning—Refrig.
- Architecture
- Architectural Interior
- Building Contractor
- Building Maintenance
- Carpenter and Mill Work
- Estimating
- Heating
- Painting Contractor
- Plumbing
- Reading Arch. Blueprints

ART

- Cartooning
- Commercial Art
- Fashion Illustrating
- Magazine Illustrating
- Show Card and Sign Lettering
- Sketching and Painting

AUTOMOTIVE

- Auto Body Rebuilding
- Auto Elec. Technician
- Auto-Engine Tune Up
- Automobile Mechanic

AVIATION

- Aeronautical Engineering Jr.
 - Aircraft & Engine Mechanic
- ### BUSINESS
- Advertising
 - Bookkeeping and Accounting
 - Business Administration
 - Business Correspondence
 - Public Accounting
 - Creative Salesmanship
 - Federal Tax
 - Letter-writing Improvement
 - Office Management
 - Professional Secretary
 - Retail Business Management
 - Sales Management
 - Stenographic-Secretarial
 - Traffic Management

CHEMISTRY

- Analytical Chemistry
- Chemical Engineering
- Chem. Lab. Technician
- General Chemistry
- Natural Gas Prod. & Trans.
- Petroleum Engineering
- Plastics
- Pulp and Paper Making

CIVIL, STRUCTURAL ENGINEERING

- Civil Engineering
- Construction Engineering
- Highway Engineering
- Reading Struct. Blueprints
- Sanitary Engineering
- Structural Engineering
- Surveying and Mapping

DRAFTING

- Aircraft Drafting
- Architectural Drafting
- Electrical Drafting
- Mechanical Drafting
- Mine Surveying and Mapping
- Plumbing Drawing and Estimating
- Structural Drafting

ELECTRICAL

- Electrical Engineering
- Electrical Maintenance
- Electrician Contracting
- Lineman

HIGH SCHOOL

- Commercial Good English
- High School Subjects
- Mathematics

LEADERSHIP

- Foremanship
- Industrial Supervision
- Leadership and Organization
- Personnel-Labor Relations

MECHANICAL AND SHOP

- Gas—Electric Welding
- Heat Treatment Metallurgy
- Industrial Engineering
- Industrial Instrumentation
- Industrial Supervision
- Internal Combustion Engines
- Machine Design-Drafting
- Machine Shop Inspection
- Machine Shop Practice
- Mechanical Engineering
- Quality Control
- Reading Shop Blueprints
- Refrigeration
- Sheet Metal Worker
- Tool Design Toolmaking

RADIO, TELEVISION

- Industrial Electronics
- Practical Radio TV Eng'ng
- Radio and TV Servicing
- Radio Operating

TELEVISION Technician

- RAILROAD
- Air Brakes Car Inspector
- Diesel Locomotive
- Locomotive Engineer
- Section Foreman
- STEAM AND DIESEL POWER
- Combustion Engineering
- Diesel—Elec. Diesel Eng's
- Electric Light and Power
- Stationary Fireman
- Stationary Steam Engineering
- TEXTILE
- Carding and Spinning
- Cotton, Rayon, Woolen Mfg.
- Finishing and Dyeing
- Loom Fix'g Textile Des'ing
- Textile Eng'g Throwing
- Warping and Weaving

MISCELLANEOUS

- Marine Engineering
- Ocean Navigation
- Professional Engineering
- Short Story Writing
- Telephony

Name _____ Age _____ Home Address _____

City _____ Zone _____ State _____ Working Hours _____ A.M. to P.M. _____

Occupation _____ Canadian residents send coupon to International Correspondence Schools, Canadian, Ltd., Montreal, Canada. . . . Special tuition rates to members of the U. S. Armed Forces.

PRINT postcards like MAGIC

5 in up to COLORS AT ONCE



without
inks
or
stencils

Yes it's true! With the new Post Master Spirit Postcard Printer, you can reproduce anything you can write, type, or draw in up to 5 colors—at a small fraction of normal printing costs!

It's fast, it's clean and so easy to use. Prints with Spirit Solution from carbon masters. Uses no messy inks or stencils—Prints with no waste—you get bright, clear copies every time. Ideal for postcard advertising, church or club mailings, printing labels, tags, and many other uses.

Order yours today from your office supply dealer. If he can't supply you, we'll ship direct on a money-back guarantee.

Master Addresser COMPANY

6500-P West Lake Street
Minneapolis 16, Minnesota

\$11.95
INCLUDING
MASTER UNITS, COLORED
CARBONS, FLUID AND
STORAGE CASE
\$12.95
Denver, Colo.
and West

AUDELS HOME APPLIANCE SERVICE GUIDE

This HANDY, Practical "How to Do It" book for Electric & Gas Home Appliance Servicemen, Mechanics & Dealers covers Basic Principles, Servicing, Operation & Repairs of Home Appliances. Tells How to Locate Troubles, How to take Appliances Apart, How to Make Repairs, How to Assemble and Connect. Gives up to date testing methods, wiring diagrams and complete data on each appliance.



**IT PAYS TO KNOW
HOW TO FIX**

Toasters—Pressing Irons—Waffle Bakers—Casseroles—Roasters—Broilers—Coffee Makers—Space Heaters—Water Heaters—Ranges—Home Wiring—Shop Work—Appliance Testing—Fundamental Electricity—Fractional H.P. Motors—Food Mixers—Fans & Blowers—Vacuum Cleaners—Washing Machines—Clothes Dryers

—Ironers—Dishwashers—Garbage Disposers—Refrigeration—Window Air Conditioners—Oil Burners—Drainage Pumps—Gas Ranges, Furnaces & Water Heaters—Bottled Gas Appliances. A SHOP COMPANION THAT ANSWERS YOUR QUESTIONS. Easy to read and understand—over 800 pages fully illustrated—with 500 photos and diagrams—1001 Facts. A ready reference.

\$4 COMPLETE • PAY \$1 A MONTH
TO GET THIS SERVICE INFORMATION FOR YOURSELF—FILL IN AND MAIL 7 DAY TRIAL COUPON TODAY.

AUDELS, Publishers, 49 W. 23rd St., New York 10, N. Y. Mail AUDELS HOME APPLIANCE SERVICE GUIDE (\$4) for free examination. If O. K. I will send you \$1 in 7 days; then remit \$1 monthly until \$4 is paid. Otherwise, I will return book promptly.

Name _____
Address _____
Occupation _____
Employed by _____

Earn \$217 a Month EXTRA With My FREE SHOE OUTFIT!

Just
2 Sales
a Day
Does It!

Rush a postcard today for my powerful FREE Shoe Selling Outfit. It contains everything you need to start a steady profit, repeat-order shoe business! Just 2 sales a day earns you up to \$217 a month EXTRA! It's amazingly easy! Just show friends, relatives Mason's famous shoes with comfortable Air-Cushion innersoles. People like buying the Mason way because they choose from over 160 dress, sport, work styles for men and women—including Nylon mesh, Cush-N-Crepe and Safety Toe work shoe styles. Because you draw from stock of 200,000 pairs, in an amazing range of sizes and widths—customers get the exact size, width and style they order! Our shoes are not sold in stores... people must buy from YOU! Start making BIG MONEY now... send for your FREE Special Outfit TODAY!



Write
TODAY!
MASON SHOE MFG. CO.
DEPT. MA537
CHIPPEWA FALLS, WIS.

"How to Make Money with Simple Cartoons"



A book everyone who likes to draw should have. It is free; no obligation. Simply address

FREE
BOOK

CARTOONISTS' EXCHANGE
Dept. 91D Pleasant Hill, Ohio

DEUTSCHES REICH



205 GERMANY only 25¢

This fabulous collection contains Scarce Stamps nearly 100 years old; giant and midget stamps; Hitler & blood-red swastikas; battle scenes; inflation issues with pre-war face of millions of dollars; Peace, Music & Religious stamps; birds, animals, sports, airmails—205 all different, worth \$4.22 at Catalog prices! PLUS free booklet, bargain lists and other offers for your free consideration. All for only 25¢. Send TODAY!
FALCON STAMP CO., Dept. 123, Falconer, N.Y.



500 TRICKS MAGIC TRICKS IT'S FUN TO DO MAGIC

Be popular! Amaze—mystify—entertain! For 30 years Douglas has satisfied customers all over the world. Now, you can enjoy this fascinating hobby. Only 10¢ brings our Catalog 500 Tricks, containing brand new tricks for pocket, parlor, stage. Join in the fun—send 10¢ today!
Douglas Magicland, Dept. A, Dallas, Texas

EARN \$25 TO \$75 A WEEK IN SPARE TIME ... No Selling To Do!



With Guaranteed JETMATIC Venetian Blind Laundry

No Experience Necessary. Start your own business part time in basement or garage. In a short time, when your profits exceed your job salary, you will make it your FULL-TIME business, as hundreds of others have done. Tremendous demand from homes, offices, factories, for this low-cost service. JETMATIC, made by world's largest manufacturer of professional Venetian blind laundries, guarantees perfect results without taking blinds apart, without hand rubbing. WRITE TODAY for complete details.

L. C. ROBINSON MANUFACTURING CO.
522 North Rural St. DEPT. MB Indianapolis 1, Ind.

THOUSANDS NOW PLAY

who never thought they could!



"Opened Door to Popularity"

"I was able to play many pieces in a short time. Family and friends certainly surprised. Course opened door to popularity, wider circle of friends. Recently I entered amateur contest—won First Prize."—Peter H. Kosyra, Manitoba, Canada.



Course Inspires Music Circle

Shown above is Miss Mildred Cade, of Houston, Texas. She and a number of her friends are so enthusiastic about the U. S. School of Music's quick easy way of learning that they've ALL taken it up.



Plays Banjo in a Short Time

"Enjoy your lessons for the Tenor Banjo; am progressing rapidly. Lessons are so simple, anyone can understand; yet so thorough I have learned to play by note in little more than a month!" — Andrew Schneider, Hanna, Wyoming.



"Can't Thank Your School Enough"

"Never studied music before. Your method is easy; being your own teacher is best. After 4 lessons, I could play a few pieces. Now play any piece I like. Can't thank you enough." — Rose Boyer, Blackwell, Mo.



Learns Faster Without Teacher

"I have no special talent — but thanks to you I play my guitar better than many who have taken lessons from teachers longer, and naturally at higher cost." — Myrella-Musquette Saint Andre, Montreal, Canada.

You, too, can play any instrument— By this EASY A-B-C Method

You think it's difficult to learn music? That's what thousands of others have thought! Just like you, they long to play some instrument — the piano, accordion, violin, guitar, saxophone or some other favorite. But they denied themselves the pleasure — because they thought it took months and years of tedious study to learn!

Learn in Spare Time at Home

And then they made an amazing discovery! They learned about a wonderful way to learn music at home — without a private teacher — without tedious study — and in a surprisingly short time. They wrote to the U. S. School of Music for the facts about this remarkable short-cut method. And the facts opened their eyes! They were amazed to find how easy it was to learn!

900,000 Students!

The result? Over 900,000 men and women have taken up music at home this simple, A-B-C way. Now, all over the world, enthusiastic music-lovers are enjoying the thrilling satisfaction of creating their own music. They have found the key to good times, and popularity.



Now a Famous Orchestra Leader

"I got my start in music with a U.S. School Course. How easy it is to learn to read notes, play an instrument, this 'teach-yourself' way! I've enrolled my two daughters." — Lawrence Weik.

**Costs Only Few Cents
a Lesson**

And that's what you can do, right now. NO TEDIOUS PRACTICING OF BORING SCALES AND EXERCISES! Even if you don't know a single note now, you'll "start right in on pieces." This builds up your skill and confidence so rapidly that soon you'll be able to play ALL your favorite songs and compositions by note. It's all so clearly explained—so EASY to understand—that even children "catch on" at once.

Get the proof that you, too, can learn to play your favorite instrument — quickly, easily, in spare time at home for only a few cents a lesson!

MAIL COUPON FOR FREE BOOK

Never mind if you have no musical knowledge, training or special "talent." Just read the fascinating FREE BOOK that fully explains all about the famous U. S. School method. (Instruments supplied when needed, cash or credit.) If interested tear out the coupon now, before you turn the page. U. S. SCHOOL OF MUSIC, Studio A301, Port Washington, N. Y. (57th Successful Year.)



U. S. SCHOOL OF MUSIC
Studio A301, Port Washington, N. Y.

Send me your 36-page illustrated FREE BOOK. No obligation — and no salesman is to call upon me. I'm interested in playing (name instrument) _____

I do I do NOT — have instrument now.

Name _____ (please print)

Address _____

CHOOSE YOUR FAVORITE INSTRUMENT

Piano, Guitar, Piano Accordion, Violin, Haw. Guitar, Mandolin, Trumpet, Cornet, Saxophone, Tenor Banjo, Organ, Ukulele, Clarinet, Trombone, Flute, Piccolo. Write your choice in coupon.

NEW! BIG MONEY MAKER—Works DAY and NIGHT You Can Make \$150.00 or \$300.00 a week

**THIS IS A REAL OPPORTUNITY FOR A MAN and WIFE
INVESTMENT FOR THE FUTURE . . . YEAR 'ROUND PROFITS**

IF YOU ARE AMBITIOUS and want Income and Stability; YOU will be interested in This Modern Way to Operate a Popcorn Route. Every man, woman and child loves popcorn, but when they taste **HOT, CRISPY and DELICIOUS French-Boy Pop Corn** they keep coming back for more. This develops into **Big Business**. You loan the **LITTLE GIANT DISPENSER** to your customers and keep supplying them with French-Boy Pop Corn. Simply deliver the popcorn and collect your money; he collects the coins as they buy. No Coin Box and No Service. Bags in 3 sizes: 5c, 10c and 25c. **ONLY 25 Dispensers can NET YOU over \$150 a week regularly. ONLY 50 Dispensers can NET YOU over \$300 a week.** The investment is well within the reach of the average couple but the **PROFITS** and the **FUTURE** are great.

Prepped Corn Shipped Anywhere in U.S.A. in Moisture-Proof Bags

Manufactured by:

Write or wire for **FREE Particulars NOW—TODAY!**

A.B.C. POPCORN CO., 3441 West North Ave., Dept. P-1, CHICAGO 47, (Wholesale Popcorn and Supplies)

No mechanical parts to get out of order

Economical to operate

For—
TAVERNS
THEATRES
DRUG STORES
CANDY STORES
BOWLING ALLEYS
RECREATION HALLS
CARNIVALS
FOOD SHOPS
LIQUOR STORES
5 & 10c STORES
COCKTAIL LOUNGES
AMUSEMENT PARKS
Etc., Etc.



**DELIVERS—
HOT Popcorn INSTANTLY**
(Wholesale Popcorn and Supplies)

SCIENTIFIC CRIME DETECTION



There's a Thrill in Bringing a Crook to Justice.

**A Steady Pay Profession
Good Times or Bad.**

We have taught thousands this exciting, profitable, pleasant profession. Let us teach you, too, in your own home. Learn Finger Printing, Firearms Identification, Police Photography and Criminal Investigation thoroughly, quickly and at small cost.

Over 800 of All U. S. Bureaus

of Identification employ students or graduates of I. A. S. You, too, can fit yourself to fill a responsible crime detection job with good pay and steady employment. But don't delay—get the details now. Let us show you how easily and completely I can prepare you for this fascinating work, during spare time, in your own home. You may pay as you learn. Write today, stating age. No salesman will call.

(A Correspondence School Since 1916)

INSTITUTE OF APPLIED SCIENCE

1920 Sunnyside Ave., Dept. 1351, Chicago 40, Ill.

Be A
**FINGER
PRINT
Expert**

FREE!!!
Send for Thrilling
**BLUE BOOK
OF CRIME**

MANUFACTURE THIS BEAUTIFUL CONCRETE OUTDOOR FIREPLACE

Right In Your
Own Backyard

**\$4.00 Worth of
Sand & Cement
produces this
Attractive
Fireplace.**

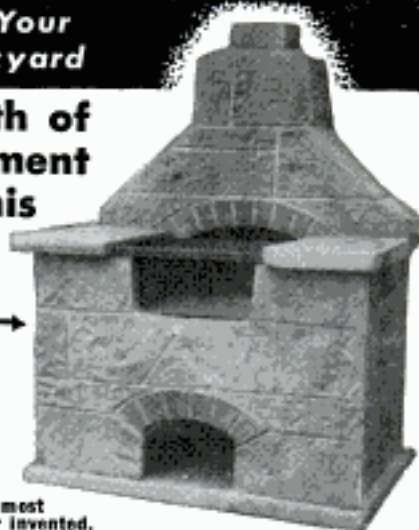

**Sells on Sight
from \$60. to \$80.
Easy to start your
own Profitable
Business.**

The General Fireplace Molds and Process are the most amazing and foolproof ever invented. Simple to operate. Two men can produce five fireplaces a day.

BIG DEMAND!!

Sell all you produce to Department Stores, Homeowners, Parks, Nurseries and Picnic Groves. Fireplaces sell on sight. No experience necessary. We supply full operating instructions and equipment plus the know-how that spells **BIG PROFITS**. This is an outstanding opportunity for men of vision and small capital to get into a busy rich paying field. Don't delay, be the only exclusive manufacturer in your own home town. Mail coupon at once for full details as to how you can reserve your territory. Molds sold only on exclusive franchise.

GENERAL ENGINES CO., Inc., Dept. MF-15
307 HUNTER ST. • GLOUCESTER CITY, N. J.

Mr. Tor of Philadelphia writes:
Sold 250 in first 4 months. Selling to Sears Roebuck, John Wanamaker, and Gimbel Bros. in Philadelphia area.

Name
Address
City Zone
State

CASTING SECRETS REVEALED

Big money! Cast 1000's of plaques, figurines, etc. with X.L. rubber molds. No exper., little capital req. X.L. rubber pts. \$2.50, qts. \$4 (postage extra). Models, rubber for 3 molds, \$1.50 ppd. U. S. only. Send 25c (refundable) for 40 pp fact catalog.

**HUGE PROFITS!
MORE MONEY!**

**PLASTIC ARTS STUDIO, Dept. PM2,
3403 S. Madison St., Muncie, Ind.**

60 POWER TELESCOPE \$3.98

VARIABLE EYEPIECE 20X-40X-60X — BRASS BOUND

NEW! Three telescopes in one. 3 different magnifications. 20 power for ultra-bright images with 40 and 60 power for extra long range. Guaranteed to bring distant objects, people, sports events, ships, moon, stars, etc. 60 times as close.

Most powerful for anywhere near the moon. ex. 5 sections. Closes to 1 ft. long. Contains 4 ground and polished lenses. Also used as a powerful compound microscope. Directions included. Mass production enables us to offer this instrument at amazing price of \$3.98 complete. Money back guarantee. We pay postage. Get yours now **CRITERION CO., 331 Church St., Hartford, Conn., Dept. PMB 26**



Make BIG MONEY!

RAISE CHINCHILLA RABBITS!

Cash Markets Supplied for Year Production
FREE - Illustrated Booklet - WRITE TODAY!
ROCK HILL RANCH, SELLERSVILLE 36, PA.

World's Largest Breeder of Chinchilla Rabbits



FREE OPPORTUNITY BOOK

- Have a business of your own! Make \$100.00 a week with no investment, no stock to carry.
- Thousands now earning lifetime incomes!
- Send for FREE Opportunity Book at no obligation.

HARRY COHON & SONS, Inc.
1067A Utica Ave., Brooklyn, N. Y.

"TRADE WITH THE HOUSE THAT HELPS YOU SUCCEED"

LAW FREE BOOK

Write today for FREE book, "THE LAW-TRAINED MAN," which shows how to learn law in spare time through the famous Blackstone home-study course in business and professional law. All instruction material furnished including big 16-vol. law library. Bachelor of Laws (LL.B.) degree awarded. Moderate cost; easy terms. Write today.

Blackstone School of Law, 225 North Michigan Ave. Dept. 51, Chicago 1, Ill.
Founded 1890

FREE - Amazing Book on RHEUMATISM, ARTHRITIS

If you suffer the aches, pains and discomforts of Rheumatism, as manifested in ARTHRITIS, NEURITIS, SCIATICA or LUMBAGO, send today for the FREE Book. It reveals important facts about why drugs and medicine give only temporary relief without removing cause. Explains fully a proven, specialized system of treatment that may save you years of distress. No obligation. Write for this FREE Book today!

BALL CLINIC, Dept. 756, Excelsior Springs, Mo.

What about YOUR Future?



"What can be in it for me?"

PLENTY! Better Job!—
Bigger Pay!—Brighter Future!

"How can I be so lucky?"

EASY! On the coupon check the subject that
interests you most, then—sign and mail it.



"Then What?"

FACTS! We will send facts which
show Your Big Opportunities
can be closer than you think!

FULL INFORMATION...NO COST...NO OBLIGATION

Yes, what about your future? Do you look forward into a rather hazy and distant time that you hope will bring you big job promotions, much higher pay, and lasting security? Or are you a realist and know that you are standing at the gateway to your *real* future right now, and that what's ahead for you depends on what you *do today*?

TODAY you can make the *big* decision of your life. You can make the choice that can start you toward richer goals. From the list in the coupon below, choose the career you want and decide to find out

how you can prepare for progress in it, in spare time, at home. Or if you are now in the work you like best, learn how you can start training for quicker promotion and higher earnings. Just *mark* and *mail* the coupon without delay.

American School, since 1897 an educational institution *not for profit*, has enabled others to *earn* more while they *learned* more. That opportunity is offered to you *now*. Learn *all* about it by sending the coupon immediately.

AMERICAN SCHOOL, Dept. G145, Drexel at 58th, Chicago 37, Ill.

Canadian Residents: Write to American School, 1610 Sherbrooke St. West, Montreal

AMERICAN SCHOOL, Dept. G-145, Drexel at 58th, Chicago 37, Ill.

Without obligation, please send FREE and postpaid, full particulars about the subject checked below.

- | | | |
|--|---|---|
| <input type="checkbox"/> Accounting | <input type="checkbox"/> Diesel Technician | <input type="checkbox"/> Mechanical Engineering |
| <input type="checkbox"/> Apprenticeship Courses | <input type="checkbox"/> Drafting—Building Trades | <input type="checkbox"/> Plastics Engineering |
| <input type="checkbox"/> Architecture & Building | <input type="checkbox"/> Drafting—Machine Trades | <input type="checkbox"/> Plumbing—Practical |
| <input type="checkbox"/> Automotive Technician | <input type="checkbox"/> Electrical Engineering | <input type="checkbox"/> Private Secretary |
| <input type="checkbox"/> Better Foremanship | <input type="checkbox"/> Electricity—Practical | <input type="checkbox"/> Retail Merchandising |
| <input type="checkbox"/> Bookkeeping | <input type="checkbox"/> Electronics—Industrial | <input type="checkbox"/> Salesmanship—Outside |
| <input type="checkbox"/> Business Management | <input type="checkbox"/> High School Courses | <input type="checkbox"/> Sheet Metal Work |
| <input type="checkbox"/> Civil Engineering | <input type="checkbox"/> Machine Shop Operations | <input type="checkbox"/> Tool Making |
| <input type="checkbox"/> Contracting | <input type="checkbox"/> Mathematics & Slide Rule | |

NAME _____ OCCUPATION _____

HOME ADDRESS _____ AGE _____

CITY _____ STATE _____

The sooner
you **ACT**,
the sooner
YOUR GOAL
can be
REACHED

Be Independent!

"The World's Best Motorcycle"



WRITE for FREE catalog and name of Triumph dealer nearest you. Dept. P.

NEW! Unlike clumsy, heavy types. Has no "junk" or useless accessories. Is functional and all motorcycle from head to foot. Beautifully engineered. Triumphs are leading America's trend to two-wheeled transportation. Used by air line pilots, sportsmen, policemen, farmers, business men, service men, etc. Solves traffic problems—easy to ride, safe, maneuverable.

TWELVE MODELS from
\$449.00

West
JOHNSON MOTORS, INC.
267 W. Colorado St.
Pasadena 1, Calif.

TRIUMPH

East
THE TRIUMPH CORPORATION
1727 E. Joppa Rd.
Towson, Baltimore 4, Md.

- "jet wing" double seat
- sparkling colors, with chrome finish
- front and rear springing
- gear position indicator



Free! 75 ORIENTALS

Brought to you from the farthest ends of the earth—these exotic valuable genuine STAMPS of the Orient! 75 all-different from Borneo, Siam, China, Japan, Hong Kong, Malaya, Sarawak, Singapore—and other exciting mysterious lands of the Far East. **EXTRA!** Free booklet, bargain lists, fascinating offers for your free examination. Send 10c for mailing expenses.

JAMESTOWN STAMP CO., Dept. 121 Jamestown, N.Y.

Free! 153 GERMANY

Giant and midget-sized STAMPS; hated Hitler heads; blood-red swastikas; inflation issues with pre-war face of millions of dollars; Allied and Russian Occupation issues; birds, animals, air-mail stamps—153 all-different, guaranteed worth \$2.46 at Catalog prices. **EXTRA!** Free booklet, bargain lists, and other fascinating offers for your free consideration. Send 10c for mailing expenses.

Jamestown Stamp Co., Dept. 122 Jamestown, N.Y.



Free! 129 NEW FULL SIZE PATTERNS \$1.00

EASY-TO-USE PATTERNS—just trace on wood, cut out, paint on 129 Unusual Novelties, Gifts, Lawn Figures up to 22 in., Action (memory-go-rounds, Windmill, Toys, Useful Gadgets, etc. Artist drawn. Money Back Guarantee. Clip this ad and mail with \$1 bill TODAY.

CRAFTPLANS, Dept. A-254, 1321 S. Michigan, Chicago 5

KEEP OFF

BECOME AN EXPERT IN TRAFFIC

The Traffic Executive today is one of the most important and well paid positions in industry and transportation. Thousands of firms need experts on rates, tariffs, regulations, etc.

We train you thoroughly at home in spare time thru the famous LaSalle Problem Method under the guidance of expert traffic authorities.

For nearly 50 years LaSalle has been helping ambitious men get ahead in this interesting and profitable field. Course compiled and reviewed by 175 of the country's leading traffic executives.

Get the facts. Mail coupon today for FREE 48-page book, "Traffic Management—the Fast Growing Profession" and learn of the opportunities in Traffic, and how you can become expert in this field.

LASALLE EXTENSION UNIVERSITY
A Correspondence Institution

417 S. Dearborn St., Dept. 164T, Chicago 5, Ill.

Name.....

Address.....

City..... Zone..... State.....

STUDY AT HOME

WITH AN EDUCATIONAL INSTITUTION

Courses in ARTS AND SCIENCES: Philosophy; Education; Letters; Public Health; Medical Jurisprudence; Psychology; Sociology; Physics; Chemistry; Geology; Pol. Science; Theology; Law; Business and Commerce; Accounting; Mathematics; Statistics; Agriculture. **ENGINEERING:** Electrical, Civil, Mechanical, Drafting, Architectural, Steam, Diesel, Aeronautical, Radio, Structural, Mining, Industrial, Petroleum, Refrigeration, Chemical. Send for free catalog. McKinley-Roosevelt Incorporated, 4610-K32, Sheridan Rd., Chicago 40, Illinois

BREED New Plant Varieties

Win up to \$10,000

THOUSANDS are paid every year by growers, seedsmen, etc. for new varieties. Learn Luther Burbank's secrets, also latest methods. Pave the way to a fascinating, profitable hobby. No experience or costly equipment needed. Let us show you in concise, non-technical form, how to produce "sports", giant forms, doubling, etc., without poisons, in a fraction of former time required.

FREE! Write now for FREE Folder and Facts. The Ascher Co., Dept. 98-1, 200 Detroit Ave., Concord, Calif.

RADIO

Engineering. All phases radio & electronics theory & practice; television; FM; broadcasting; servicing; aviation, marine & police radio. Prepare for good pay; 18-month course. Graduates in demand by major companies. Enter Jan., March, June, Sept. Regular campus life. Write for catalog. **VALPARAISO TECHNICAL INSTITUTE, Dept. D, Valparaiso, Ind.**



Ask Dealers for "Stemmler's"

FINE BOWS and ARROWS
SELECTED RAW MATERIALS

Catalog 5c; HAND BOOK

—Illustrated on Making and Shooting Archery—75c

L. E. STEMMLER CO.

Manorville (Box 3) L. I. N. Y.

ESSENTIAL FOR AMERICAN FLYER TRACK!

MODEL RAILROAD

R. R. SPIKE SETTER

Complete with Nail Spikes

Aligns and sets spikes; eliminates track distortion due to direct hammer blows; pulls up track in a jiffy—allows even a child to change layout or add track safely and quickly.

HAYDEN INDUSTRIES,
Box 239, Norwood, Mass.



\$1 POST PAID COMPLETE! MONEY BACK GUARANTEE

\$750 BUILDS 4 ROOMS & BATH! WHY PAY RENT?



For Seven Hundred Fifty Dollars and 30 days of your spare time, you can build yourself this Beautiful Home. Living Room 11x15, Front bedroom 9x11, Back bedroom 10x12, Kitchen 9x11, Bath 5x8, Hall 3x4. Wind out steel casement windows, Concrete block, stuccoed. Step-by-step illustrated instructions, blue-print and material list \$1.00 ppd. No COD. Moneyback guarantee. Economy Home, Dept. C, Box 645 Columbus 16, Ohio

I Dare You To Read My Mail!

THEN YOU'D BE CONVINCED THAT I CAN MAKE YOU THE KIND OF REAL HE-MAN YOU'D LIKE TO BE!

My Secret Method Has Worked Wonders For Thousands of Other Fellows — Here's What I'll Prove It Can Do For You In Just 15 Minutes a Day — At Home!

"Dynamic Tension Has Them All Beat!"

"After one week, I can see a difference in my chest and shoulder muscles, DYNAMIC-TENSION has 'em all beat a hundred ways!"

—Lee Jones, Texas

Course Works Wonders

"Your course works wonders for me. I am gaining friends, health, happiness."

—Joseph Chrabacz, Mass.



5 in. of Muscle in SEVEN DAYS!

"Here are the results at the end of a WEEK! Arm relaxed, 1 1/2 in. more, forearm 7/8 in., wrist 1/2 in., chest normal 2 1/2 in.; weight 4 pounds increase."

—C. S. Withrow, W. Va.

I COULD fill page after page of this magazine with enthusiastic letters from fellows who traded in skinny, peppy bodies for real HE-MAN STRENGTH and VITALITY. But what you want to know is— "What can Atlas do for ME?"

Just give me 15 minutes a day of your spare time—right in the privacy of your own home. I'll show you RESULTS that you can see, feel, and measure with a tape. I don't care how young or old you are or what your physical condition may be. If you can raise your arm and flex it, I can add SOLID MUSCLE to your biceps—in double-quick time.

I can broaden your shoulders, strengthen your back, develop your whole muscular system INSIDE and OUTSIDE! I can add inches to your chest, give you a vise-like grip, make those legs of yours lithe and powerful. I can shoot new strength into your old backbone, exercise those inner organs, help you cram your body full of pep, vigor and red-blooded vitality!



"Wonderful Progress!"

"I am sending you this snapshot showing my wonderful progress."

—W. G., N. J.

"You Sure Knew Your Stuff!"

"My chest muscles are really gaining in size. You sure know your stuff."

—C. R. Williams, Cal.



Increases Chest 3 1/2"

"Have put 3 1/2 inches on my chest (normal) and 2 1/2 inches expanded."

—F. S., New York.

SILVER CUP GIVEN AWAY



This handsome cup, over a foot high, will be given to the pupil who makes the greatest physical improvement in the next 3 months.

"After Only ONE WEEK—Oh Boy!"

"The muscles of my chest are beginning to 'stand out.' My arms are getting stronger. The muscles are bigger and harder. I have only been with you a week."

—C. Kraus, Ill.

"Feel Better, Stronger!"

"I feel better, and stronger. My muscles are surely coming out fast."

—James Parohman, Texas

Proud of his Muscles

"Just a note to tell you how proud I am of my beautiful Atlas medal—prouder, in that when I display it, I can also display my muscles for which the emblem stands."

—Jack Griggs, Tex.

Wonderful Results "I have gained unusual physical development through your methods. Am getting wonderful results."

—R. F., South Africa



Gains 29 Pounds

"Gained 29 pounds. When I started your course I weighed only 141. Now I weigh 170."

—T. K., New York



Charles Atlas

Awarded the title of "The World's Most Perfectly Developed Man" in an international contest.

FREE Illustrated 32-page Book. Just Mail the Coupon.

SEND NOW for my famous book, "Everlasting Health and Strength," 32 pages, packed with actual photographs and valuable advice. Shows what "Dynamic Tension" has done for others, answers many vital questions.

This book is a real prize for any fellow who wants a better build. Yet I'll send you a copy absolutely FREE. Rush the coupon to me personally: CHARLES ATLAS, Dept. 8N, 115 East 23rd St., New York 10, N. Y.



ARE YOU
Skinny, Weak and run down?
Tired, Nervous?
Lacking in Confidence?
Constipated?
Suffering from bad breath?
Fat and Flabby?
WHAT TO DO ABOUT IT is told in my FREE BOOK

WHAT'S MY SECRET?

"DYNAMIC TENSION"! That's the ticket! The natural method that I myself developed to change my body from the scrawny skinny-chested weakling I was at 17 to my present superman physique! Thousands of other fellows are becoming marvelous physical specimens—my way. I give you no gadgets or contraptions. You simply utilize the DORMANT muscle-power in your own God-given body—watch it increase and multiply double-quick into real solid LIVE MUSCLE.

My method—"Dynamic Tension" will turn the trick for you. No theory—so easy! Spend only 15 minutes a day in your own home. And you'll be using the method which many great athletes use for keeping in condition—prize fighters, wrestlers, baseball and football players, etc.

CHARLES ATLAS, Dept. 8N, 115 East 23rd St., New York 10, N. Y.

Send me—absolutely FREE—a copy of your famous book, "Everlasting Health and Strength"—32 pages, crammed with photographs, answers to vital health questions, and valuable advice. I understand this book is mine to keep and sending for it does not obligate me in any way.

Name _____ Age _____
(Please print or write plainly)

Address _____

City _____ State _____

"Building Beautifiers" Can Earn High Incomes

Colorcrete, a cementitious plastic, gives lifetime beauty and protection to drab, dirty masonry — concrete, stucco, etc. — on all kinds of buildings. Tough, tenacious, enduring. Easily cleaned. Helps to daylight dark interiors. Choice of gleaming white or 30 colors. Applied under pneumatic pressure to form an inseparable bond.



More Colorcreters are needed to supply the ever-increasing demand. Low investment appeals to men of limited capital. Work is easy, fascinating, highly profitable. Broad opportunity to develop a lifetime business. No special ability or experience needed because we supply full instructions and sales co-operation. Colorcrete machine is simple to operate, easy to move around. Write today for Opportunity Book.

Colorcrete Industries, Inc. **COLORCRETE** Co.
570 Ottawa Av., Holland, Mich.
IN CANADA: DUNN MASONRY MACHINERY LIMITED
1020 Dundas Highway, Cooksville, Ont.

PRINTS POST CARDS

Learn how both large and small businesses are boosting sales with new advertising machine. Write today for **FREE** illustrated BOOK of unique advertising plans, money-making ideas for your business. **Cardmaster**, 1920 Sunnyside, Dept. 12-A, Chicago 40, Ill.



MECHANICS

—EARN BIG PAY—

Industry needs skilled mechanics. GREER, leader for more than 50 years in the Trade School field, can train you quickly—You "learn by doing," using the finest equipment, under the supervision of expert technicians.

APPROVED FOR CIVILIANS OR GI'S

—CHOOSE YOUR TRADE—

- DIESEL MECHANICS 20 Weeks
- AUTOMOTIVE MECHANICS 20 Weeks
- BODY & FENDER REPAIR 16 1/2 Weeks
- GAS ARC WELDING 4 to 12 Weeks
- REFRIGERATION 13 1/2 Weeks
- AIR-CONDITIONING 8 1/2 Weeks
- MACHINIST TRADE 30 Weeks
- ADVANCED MACHINIST
(includes tool & die) 32 1/2 Weeks
- PIANO TUNING & REPAIR 36 Weeks

CHOOSE YOUR ENGINEERING COURSE

- DIESEL AUTOMOTIVE ENGINEERING 2 Years
- REFRIGERATION & AIR COND. ENGINEERING 18 Months

FREE EMPLOYMENT HELP.

Start your career with Greer by checking your interest above and mail coupon for complete information at no obligation.

NAME _____ AGE _____

STREET _____

TOWN _____ ZONE _____ STATE _____

Established 1902 — Over 50,000 Graduates.

GREER SHOP TRAINING
2236 S. Michigan Ave.
Chicago 16, Illinois

Super All Channel TV RECEPTION Powerful IN ALL DIRECTIONS

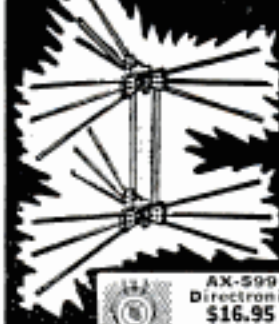

Rocket DIRECTRONIC MOTORLESS TV ANTENNA

- 360° Electronically Switched Beam
- No Motors
- No Roof
- Orientation
- No Electric Power
- No Ghosts
- Flick of Switch Clears Picture Instantly

In the city or in an ultra-fringe area, the Directronic will outperform ordinary antennas. Only the Motorless 360° Directronic TV Antenna offers "around the compass" reception WITHOUT Rotors. Clarity of picture will amaze, it's so bright, so sharply defined. AX-599 "Serviceman's Army" contains Hi-Pac molded insulator of extremely high tensile strength, 16 hi-tensile aluminum alloy elements, 1 set of connecting stabs (3), Universal U-Clamps for masts to 1 1/2", Directronic Beam Selector, 75 feet of Tri-X Cable.

Do not remit more than complete purchase price. 25% deposit on C.O.D. orders, please. Money-back guarantee.
NATIONAL ELECTRONICS OF CLEVELAND
6608 EUCLID AVENUE Dept. P-1 CLEVELAND, OHIO

"How to Make Money with Simple Cartoons"



A book everyone who likes to draw should have. It is free; no obligation. Simply address **FREE BOOK**

CARTOONISTS' EXCHANGE
Dept. 91A Pleasant Hill, Ohio

STUDY INDUSTRIAL DESIGN

You can train at Art Center School in California with practicing-professionals for upper-level jobs in INDUSTRIAL DESIGN. Recent graduates have been added to the staff at General Motors, Chrysler, Raymond Loewy, Henry Dreyfuss, etc. Majors in transportation, general product design, structures, community development, furniture design, packaging, display, 4-year degree courses. Learn to combine imaginative design with technical proficiency, coordinate utility and beauty. Stimulating environment. Field trips. Advantages of mild Southern California climate and nearby holiday spots. Coed. Placement service. Established 24 years. New term begins February 7. Write for catalog.

ART CENTER SCHOOL, Edward M. Adams, Director
5353 WEST THIRD STREET, LOS ANGELES 5, CALIFORNIA

PLEASE
SEND ME



for the
time checked.
I am enclosing . . .

- 1 year \$3.50
- 2 years \$6.00

name _____
address _____
city _____ zone _____ state _____

Hand this order to your newsdealer or send it to
POPULAR MECHANICS
200 East Ontario St. Chicago 11, Ill.

\$15²⁰ an hour!

This is the average earning reported by Presto salesman WILLIAM F. WYDALLIS. "The sky's the limit" on Presto profits because of America's serious need for this new fire extinguishing discovery.



WILLIAM F. WYDALLIS

"Most specialty salesmen are always on the lookout for a 'natural.' The 'natural' of this decade is the PRESTO FIRE EXTINGUISHER... because it is handy in size, simple to operate, and in the right price range.

"For every hour I have devoted to the Presto, I find that I have earned an average of \$15.20 an hour. I am now convinced that extraordinary money can be made in this safety field. I am devoting more of my time to this product now since I have discovered that the earnings on this item are greater than any item I have handled in the past."

William F. Wydallis
Van Wert, Ohio

Folks Are Amazed when you Tell Them This New Kind of Protection Costs Only **\$3.98**

WOULDN'T YOU like to be making the kind of money William F. Wydallis is making? His story (printed at right) is just one example of the brilliant success that Presto salesmen are meeting everywhere! A Florida salesman earned \$600 in one month. An Ohio man earned \$2100 in 2 months. A New York salesman earned \$1500 in one month. A New Hampshire salesman added the Presto as a *sideline* and picked up an extra \$1800 in 20 months.

Over Two Million Sold!

PRESTO contains an amazing new chemical "Chlorobromomethane" or "C.B." developed as a secret defense against fire during the war.

In comparing the effectiveness of "C.B." in fighting various kinds of fires an authoritative testing laboratory states: "It has been proved that 'C.B.' is about 1.5 to 6 times as effective as other common extinguishing agents on an equal weight basis."

This extra effectiveness of "C.B." means that Presto can be made light and handy enough for even a woman or child to use. Just a twist of the knob... and flames disappear! "Sells on sight" to civil defense workers, owners of homes, cars, stores, farms, service stations, boats, motorcycles, factories, offices and to stores for re-sale.

Why Large Presto Profits Are So Easy

Everyone is terrified at the very thought of FIRE! Every year fire kills more than 11,000 people. Most people who see Presto in action want one or more — ESPECIALLY WHEN THE PRICE IS ONLY \$3.98 EACH!

You can demonstrate Presto in a few minutes, and every sale will net you \$1 or more. We refill your demonstrator free... and we give you dramatically powerful printed sales material to "talk from"... free certificates testifying that Presto is GUARANTEED FOR 20 YEARS.

YOU DON'T NEED TO INVEST A PENNY. Just collect and keep \$1 or more every time you write an order—we collect the balance and deliver the extinguisher. (Or if you wish, you can buy from us at extra-low wholesale prices and then make up to \$2.18 profit per unit supplying both dealers and retail customers — we'll send you free details.)

Start Now — Mail Coupon

Get started in this rich new field now. Don't "put it off"! Every day you hesitate may cost you \$10, \$15, or even \$50 you could otherwise be making. Mail the coupon at right NOW for everything you need to get started right away!

MERLITE INDUSTRIES, Dept. 51, 114 East 32 Street, New York 16, N. Y.

Best Selling Months Just Ahead! Don't Delay—Mail Coupon Now!

MERLITE INDUSTRIES, Dept. 51, 114 East 32 Street, New York 16, N. Y.

Please send me illustrated sales literature, liberal profit plan, order blanks—everything I need to get started making good money introducing the Presto Fire Extinguisher in my locality.

- Check here if you wish to order a regular Presto to be used as a demonstrator (\$2.50).
- Check here if you wish to order a double capacity Presto to be used as a demonstrator (\$3.75).

Pay for themselves many times in increased sales. Can be returned as often as necessary for FREE refills. Send no money—we'll mail C.O.D. (Or enclose check or m.o. and WE will pay postage. Money back, if not delighted.)

Name.....

Address.....

City..... State..... Zone No. (if any).....

IN CANADA: Mopa Co., Ltd., 371 Bowd St., Montreal 1, P.Q.



- Only Presto Has All These Features!**
- Ends Fire as Fast as 2 Seconds
 - Chemical Contents 1.5 to 6 Times More Effective than Others on an Equal Weight Basis
 - Weights Less Than 1 Lb.
 - Easily Held in One Hand—Even by a Child
 - Needs No Inspection or Re-Charging — Does Not Corrode or Deteriorate
 - Costs Only \$3.98—Yet Out-Performs Bulky Extinguishers Costing Several Times as Much
 - Automatic Pressure — No Pumping
 - Guaranteed for 20 Years — Certificate is Packed with Every Presto

CHARLES KAMA
This Presto salesman from Texas was featured as "Salesman of the Month" on the front cover of a sales magazine. He told the magazine's reporter:
"I think I've succeeded pretty well. I'm making more than a thousand dollars a month—and I haven't touched bottom yet."



THIS GUIDE
120 PAGE
FOR AMBITIOUS MEN
FREE!



Have you had your copy?

120 pages of guidance to best-paid positions. Up-to-the-minute information for men who want to climb to the top. Tells how to get promotion, security and better pay through home study courses. This handbook "Engineering Opportunities" is free and entirely without obligation. Send the coupon. Make this your big year! Describes over ninety courses including:

Mechanical	Electrical	A.F.R.Ae.S.
Aeronautical	Radio	A.M.I.C.E.
Television	Automobile	B.S. (Pure
Building	A.M.I.Mech.E.	Science)

--- SEND COUPON TODAY ---

Canadian Institute of Science & Technology Limited, 572 Century Building, 412, 5th Street, N.W., Washington, D.C.

Please forward free of cost or obligation your handbook, "ENGINEERING OPPORTUNITIES".

Name

Address

Course interested in..... Age.....

Canadian Address: Canadian Institute of Science 572 Garden Building, 263 Adelaide St. W., Toronto, Ont.



Start As High As
\$4,205.00 A YEAR

Prepare NOW For 1955 Examinations

MEN—WOMEN

Postoffice Clerks-Carriers
 Railway Postal Clerks
 Stenographers
 Accountants
 Immigrant Inspectors
 Typists
 Customs Inspectors
 Many Other Early Jobs

Veterans Get Preference

MAIL COUPON TODAY SURE

FRANKLIN INSTITUTE

(Not Government Controlled)

Dept. Y-83

Rochester 4, N. Y.

Gentlemen: Rush to me, FREE of charge, list of U. S. Government big pay jobs. Send FREE 38-page book describing salaries, vacations, hours, work, etc. Tell me how to qualify for one of these jobs.

Name

Street

City..... Age?.....

WOODWORKING
Low Cost Home Craft Courses Now Available

LEARN The Easy Way!

Make money. Become a skilled woodworker. Interstate's new woodworking course tells and shows how to turn out hundreds of professionally constructed and finished wood projects with hand and power tools. Twenty-two profusely illustrated manuals. Over 1,000 pages. Over 75 projects. Written by expert instructors. The only complete course available today! Get full information without obligation... today.

HOW TO BE A SKILLED WOOD WORKER

Write for FREE Booklet

INTERSTATE TRAINING SERVICE

SCHOOL OF WOODWORKING
 DEPT. F-3-A, PORTLAND 13, OREGON

LOOK! **A MILLION THRILLS!**
 High Power **BINOCULARS**
30 DAY FREE TRIAL
 Finest Precision Optics
 Money Back Guarantee
 Easy Pay Plan
 Free! Catalog & Book "How to Select Binoculars"
 Dept M1 43 E. Green Pasadena, Calif.

33 Models
\$9.95 UP
BUSHNELL Binoculars

DAN LURIE
 "America's Most Muscular Man"
 —on television's "Big Top"

FAMOUS DAN LURIE

BARBELLS



with 4 courses—low factory prices
 50 lb. set...\$ 8.48 | 150 lb. set...\$20.48
 100 lb. set... 13.98 | 200 lb. set... 25.98

Write for Order by Mail; 50% with order, bal. C.O.D. Free Catalog Extra wts. 13c per lb., F.O.B. plant.

DAN LURIE BARBELL CO.

52-M-1 Bristol St. Dept. 559A Brooklyn, N. Y.

Write Like This
 YOUR penmanship can be improved in 3 hours or corrected to your satisfaction in 10 hours' practice with my **DEFINITE HAND CONTROLS**. New way!
WRITE OZMENT BOX 665 34-N, ST. LOUIS, MISSOURI

Complete OUTLINE FREE!

AUTO RACING BOOKS AT NEW LOW PRICE

Automobile Racing — Fifth Edition by Ray F. Kuns.

This is a book for auto racing fans. It covers construction and specifications of racing cars and tells and shows how you can build your own. It also contains regulations for midget auto racing and describes roadster racing in California. A number of Indianapolis races are described and pictured. Formerly \$1.00 per copy. Now just..... **50¢**

Automobile Racing — Fourth Edition by Ray F. Kuns.

Includes eight working drawings and complete building instructions for standard midget racers as well as drawings for midget road cars. Miller Ford V8 front-drive racers are illustrated and described and other big-time data given. Large, clear pictures give inside information. Was \$1.00—Now only **50¢**

POPULAR MECHANICS PRESS

200 E. Ontario St. Chicago 11, Ill.

QUIZ ABOUT YOURSELF

(You may be finding out things you never even suspected)

- Like to study car designs? Or the designs of airplanes?
- Do you have favorite colors? Color combinations?
- Do you admire creative individuals?
- Are you interested in people?
- Like to create arrangements of furniture in your own home?
- Do you have favorite pictures?
- Is money important (but not everything) to you?
- Like to try new things, and new ideas?
- Ever "doodle" on scraps of paper? Sketch cartoon characters? Anything!
- Do you ever think, "If only I could draw a picture of that!"

If you answered "yes" to more than half the questions above, it's a hint you may really have art talent!

Many do, and never suspect it. In fact, we've developed these surprising statistics about people:

5 out of 10 have some talent for art.

3 out of 10 have talent worth training.

But here's the sad fact:

Only 1 in 50 does anything about it!

You may be that one person in fifty. If you are, you're lucky, because the rewards

in art are boundless. As an artist you get more out of life—you see so much that other people miss. You're admired, and looked up to. You have the satisfaction of doing work you enjoy. And you're well paid.

For men and women with art talent and training there are many opportunities. Artists are wanted by the thousands to illustrate ads in magazines and newspapers. Also posters, greeting cards, books, movies, television. This is fascinating work. And a successful artist makes big money!

If you're not sure whether you have art ability, you can now find out—free!

A simple Talent Test has been developed by an amazing school in Minneapolis. This is the world's biggest art school, yet it has no classrooms. It teaches only by mail. Its graduates include many famous artists. You may never have heard of it—yet for 40 years Art Instruction, Inc. has been quietly discovering and training people with art ability.

You take this simple Talent Test at home alone, in your spare moments. Mail your test back and art teachers study it for signs of beginner-talent—then send you a free private analysis of your art ability.

Why don't you take this test, too? It has helped thousands get started towards a successful career in art. I'll be glad to mail your Talent Test to you free. Just send your name, address, age and occupation (student or other) to me, John Griffin, Studio 1135, Art Instruction, Inc., Minneapolis 15, Minnesota.



By John Griffin,

Minneapolis

Choose
Your
New
Home
from



Garlinghouse HOME PLANS

Choose from Hundreds of
Plans in These Beautiful
PLAN BOOKS
All Styles — 1 to 4 Bedrooms

- **"NEW SMALL HOMES"**
Over 80 new plans in popular new sizes—650 to 1175 sq. ft. floor space, 1, 2 and 3 bedrooms50c
- **"RANCH AND SUBURBAN"**
128 ranch plans most practical for town and country.50c
- **"DELUXE SMALL HOMES"**
Our largest selection—155 modern, time-tested designs. \$1.00
- **"HOMES IN BRICK"**
Many of these 115 tested designs of medium and large homes are in color. \$1.00
- **"BLUE RIBBON HOMES"**
2nd Edition, 63 pages of homes proved popular by actual sales. Many in color.50c
- All 5 above books for \$3.00 Postpaid—
- Our Complete Home Plan Library—18 books and over 1,250 Home Designs—Only \$8.00, a \$2.50 Saving.

Complete Plans for
"Do It Yourself" or
Contracting Part or All

These beautiful books contain hundreds of photographs, colored drawings, floor plans and descriptions—making it easy and economical to select the home you desire to build. Complete working plans, specifications, lumber and mill lists available for each design at Low Cost—enabling you to get contractor bids quickly—or to figure doing part or all the work yourself.

The moderate price of these plans is your best investment when building, since you know in advance what you are getting, thus avoiding misunderstandings. 24 hour service on plans with a money-back guarantee if unused plans are returned in five days. Our plan service used by builders and lumber dealers for over 40 years—America's largest.

**ORDER TODAY — All
Books Mailed Postpaid**

L. F. GARLINGHOUSE CO., INC., Box PM-22 TOPEKA, KANSAS

TRAINED MEN NEEDED

BIG PAY—GOOD FUTURE

- | | |
|-------------------------------------|--------------------------------------|
| <input type="checkbox"/> TELEVISION | <input type="checkbox"/> ELECTRONICS |
| <input type="checkbox"/> DIESEL | <input type="checkbox"/> AUTO |

WHY WORK FOR LOW PAY or risk being out of a job??? Usually the properly trained man has a steady job . . . through good times or bad. Even back during DEPRESSION there was a big demand for Bailey Trained men.

In only 5½ to 6 months we can train YOU to enter one of the big pay fields!

No previous experience or special education necessary. With our method of training you do not spend years pouring over books, figures, charts and graphs. You learn by rebuilding, repairing, testing and operating the most modern equipment, under the guidance of experienced, courteous and friendly instructors. This method of training gives you the experience and confidence required to step right into the big pay jobs without spending years as a mechanic's helper.

It's EASIER and COSTS LESS than you may think to get this residence shop training . . . we help you find part-time jobs while in school—full-time jobs after graduation. Check subject above in which you are interested and mail for complete information.

BAILEY Technical SCHOOLS

Veteran Approved

1634 S. Grand St. Louis 4, Mo.

NAME.....AGE.....
STREET.....
TOWN.....ZONE.....STATE.....

AUTHENTIC "WESTERN" BRANDING IRON

A Collector's Item—Useful Show Piece



Now—your own, personal branding iron for everlasting identification of personal articles. Not a toy, but a real he-man iron (18" long) hand-forged from finest steel. Will last a lifetime. Be different. Use it to "brand" steaks and chops for your barbecue or to decorate your game or rumpus room. A perfect gift for your outdoor friends. Personalized with two initials. Can be painted to match any color scheme. Satisfaction guaranteed or money back. Price in U.S.A. only \$3.98, ppd. Send name, address and initials (2) with remittance to:

EL RANCHO FORGE, 2300 N. Plum, Hutchinson, Kansas.

PROTECT YOUR EYES! NEW GOGGLES



Now, for new low price, shield precious eyes against flying particles from lathes, grinders, etc. This fine one-piece, full-view goggle—beautifully moulded of plastic—yours for only \$1.95 postpaid. Provides complete visibility & perfect protection in workshop, machine shop, on farm. Adjustable headband holds form-fitting goggles comfortably for hours. In clear plastic for shop wear, green-tint for outdoors (skiers, cyclists, etc.). State which. Order today! Money-back guarantee. Free folder on this, other unusual items.



ONLY \$1.95 Ppd.

CRAFTLINE, P.O. Box 9197-M, Richmond 27, Va.

BENJAMIN SUPER CO₂ GAS CARBINE—\$16.50

NEWEST TARGET
RIFLE—22
IDEAL
FOR
SMALL
GAME



ECONOMICAL
SAFE—NON-TOXIC

ACCURATE—CONVENIENT

PRACTICAL. Easy to operate—No spring recoil—No pumping. Uses low cost Soda Cartridges Cal. 22 Benjamin H-C Pellets and Darts.

Benjamin CO₂
Gas Pistols
Also Available

WRITE FOR FREE ILLUSTRATED FOLDER OF ALL MODELS
BENJAMIN AIR RIFLES AND BENJAMIN AIR PISTOLS
BENJAMIN AIR RIFLE CO.
896 MARION ST., ST. LOUIS 4, MO. U.S.A.

BE A DETECTIVE

WORK HOME or TRAVEL. Experience unnecessary.
DETECTIVE Particulars FREE. Write to
GEO. P. M. WAGNER, 125 W. 86th St., N. Y.

TRADE MAGAZINES

Business, Vocational, Professional, Hobbies, Agricultural, Educational, Sports. Single current copies. Special get acquainted service. Choose from 4,387—all fields. Current list FREE.

COMMERCIAL ENGRAVING PUBLISHING CO.
34AB North Ritter Indianapolis 19, Ind.

STAMP COLLECTORS 308 DIFFERENT STAMPS 25¢

Including scarce Trieste collection! United Nations Issue, Olympic, Latest wild animal set—in gorgeous multi-color showing the Lynx, Bear, Chimpanzee, Deer, etc. Stamps from riot-torn Trieste are becoming very scarce. These are only part of the big collection of 308 all different foreign stamps Cataloging \$7.00 that you get for only 25¢ to introduce our approval.



IDEAL STAMP CO., Dept. 3A, P. O. Box 64
West Farms Station, New York 60, N. Y.

POWER MOWERS & KITS

FREE
PLANS

LOW FACTORY
PRICES DIRECT
TO YOU

Build your own quality mower with our LOW COST KITS, Parts, Engines. Free Plans guide you. 3 and 4 Wheel Kits, complete. Parts precision finished, ready to use. Write TODAY for Free Plans, Low Prices, Parts List and Guarantee.



3-WHEEL KIT NO. T-800

America's Finest Power Mowers completely assembled in 3 and 4 wheel models. Belt or direct drive, 18" and 20" sizes. Nationally known make engine. Latest improved features, sturdy construction and money back guarantee fully described in color folder. Write today.



▲ TRIANGLE MANUFACTURING CO., Dept. M-1, Fort Scott, Kansas

**Yours for the asking—
No charge—no obligation**

"How to Become a Mail Order Millionaire"

Read how Gilbert on a "peanut" investment built up to \$350.00 A DAY. Learn how Zimmerman started a mail order business on a buck private's pay and spiraled \$16.80 into a big yearly income. See how a Chicago clerk quit a \$75.00 job and now makes \$22,000 a year in his own Mail Order business. Read how a southern boy made a fortune selling war-surplus parachutes which he bought as he went along. All Free! Send name on coupon for a copy of this fascinating reprint of "How to Become a Mail Order Millionaire" from *Mechanix Illustrated* plus details on the L.W. Mail Order Survey.



Start on a SHOESTRING!

The real-life stories of success in Mail Order read like fairy tales. If I had not personally known these people their stories would be hard to believe. Yet they are not only true, but they represent just a few of the hundreds of "little operators" who have been swept into big money by Mail Order.

GAINES. I personally guided his start when he invented an automatic pants presser. He started with one little ad in one magazine. Four years later he retired — with enough real estate to keep him in cash income the rest of his life.

VAN MARK. I worked with him for six years. I met him when he was a wagon man for a tea and coffee house, knocking on doors. He went into Mail Order on nothing—made money from the start—ended up six years later with savings of \$50,000 and an income of \$5000.00 a year for life without further work.

DUGGAN. A few years ago he was a truck driver. Started fooling with Mail Order in a spare room in his spare time. Last year he said, "I don't know how much I'm worth—after you get the first million you quit keeping track."

MRS. NIXON. Started a small Mail Order business at home—just to keep occupied. It looked good and she came to me for advice. I showed her how to expand. In two years the business got so big her husband resigned his job to help manage it.

FOXMAN. Foxman worked as a hack writer at \$70 a week. He had idle time in the evenings—ran an ad offering something he didn't have—got so many orders he had to find a source of supply. He made \$18,000 the first year. He gives me credit for "showing the way."

JORGENSEN. Consulted me about a specialty product. On my advice he ran one ad to "test" its saleability. That ad brought sales of \$50,000. In his first year he did a business of nearly a half million dollars. His original investment was less than a thousand.

These things I have seen. These people I have helped to the realization of their dreams — these and hundreds of others. My own fortune was made in Mail Order. And now my secrets can be yours.

L. W.

Have you ever thought of running a profitable little sideline right from your home? Has it occurred to you that you are just as capable as anyone else of making money on a product or service that can be sold by mail? Have you ever looked into the Mail Order business as it's run (on tiny investments) by innumerable small operators?

Forget about Sears and Ward's! Read about the "little fellows" . . . clerks, teachers, vets, mechanics, salesmen and others . . . who are packing Mail Order items in bedrooms, spare rooms, attics, garages, cellars . . . dumping them in the Post Office . . . and quietly banking the fistful of Money Orders, cash and checks delivered to them daily by the mailman.

An annual business of almost a billion dollars is done by "little fellows" who advertise and sell just one item! The Department of Commerce of the United States says, "A number of the most successful obtain incomes as high as \$40,000 to \$50,000.00."

It's an incredible story . . . a story of a business that's wide-open for newcomers . . . with opportunities for income far-and-away greater than you can ordinarily hope to attain by holding down a job. And in Mail Order you can stay as small as you wish—run your deal as a \$50 or \$75 weekly sideline—or consider jacking it up into really big figures as a full time operation.

Glance at the examples at left. These true stories are far from unusual. Multiply them by the hundreds and you begin to get an idea of what can be done . . . what is being done . . . in the phenomenal Mail Order field.

Yet, if you were to jump blindly into Mail Order your chances would be slim. A peculiar brand of "know-how" is vital in this little-known, little-understood business. This is fortunate for you. If any Tom, Dick, or Harry would "click" in Mail Order, the field would have been overloaded years ago.

But now you have the opportunity to learn the authentic secrets of successful Mail Order operation. They are revealed for the first time, step by step, in an extraordinary new Survey . . . the L.W. Confidential Mail Order Letters.

This Survey is not a course—not a book—not a group of lessons. It is a simple guide that anyone can follow. It shows you how to pick the right product for Mail Order. It shows you exactly how to start a profitable business fast, with cash or Money Orders in the envelopes you receive. It shows how to buy your product out of the very money you get in the mail, so you don't have to tie up cash in large supplies of your product. It gives you actual examples of ads and letters, analyzed to show how and why they make money. It demonstrates the months to start, the time to expand, the best way to get prospects' names. It reveals from A to Z the confidential facts that have made fortunes for Mail Order operators who use them.

Mail the coupon today, or simply send your name and address on a postcard. No salesman will call. We will mail, postage prepaid, a Free copy of "How to Become a Mail Order Millionaire" and along with it will give you complete facts about the L.W. Mail Order Survey. Read the facts. Then decide whether you would like to spend spare time or full time in a profitable, fascinating Mail Order enterprise. If you think you would like to follow the footsteps of hundreds of others who are now making good money in this way, you can get your L.W. Survey and begin at once.

Please don't decide to write us "a little later." Send your name now, before you forget. This one little act might be the first step to a future of independence and wealth.

**The L. W. MAIL ORDER SURVEY, Dept. 11
805 LARRABEE ST., LOS ANGELES 46, CALIF.**

**The L. W. MAIL ORDER SURVEY, Dept. 11
805 Larrabee St., Los Angeles 46, Calif.**
Mail me a free copy of "How to Become a Mail Order Millionaire" and details about the L. W. SURVEY. It is understood there is no charge at any time, and that I am not under the slightest obligation. After reading, I will decide whether I want to use the L. W. Confidential Letters to help me start a Mail Order business at home.

NAME _____
ADDRESS _____
CITY _____ Zone _____ STATE _____

You Can Be a Manufacturer of BRIKCRETE



"The World's Most Modern Masonry" is produced in a chain of independently owned local plants. That's why such low prices go along with such high quality without sacrifice of manufacturing profits. Local materials and local labor cut freight and distribution. Brikcrete brings a super-masonry down to price levels of frame. Gives owners incentive to buy.

Brikcrete has design, size, and color in keeping with the modes of today. Self-contained insulation values—12" long—8" or 4" thick—range of 14 colors. Suited to every kind of construction—residential, commercial, industrial.

Many territories are open for additional local plants. Franchise protection. Equipment available on easy terms, or basic machine can be leased to responsible operators. Write today for interesting Brikcrete Book No. 2.

Brikcrete Associates, Inc.
402 W. 25th Street
Holland, Mich.



The World's Most Modern Masonry

IN CANADA: DUNN MASONRY MACHINERY LIMITED
800 Dundas Highway, Cooksville, Ont.

PUMP WATER FAST!



Drains Wash Tubs, Cellars, Cisterns. Famous #7 pumps 2800 gph. 420 gph. at 75' high or 1600 gph. from 25' well. Sturdy rustproof alloy metal. Six blade impeller. 3/4" inlet, 1/2" outlet. Standard pipe threaded. Uses any 1/4 to 1/2 H. P. Motor. Will not leak or clog. Iron clad guarantee. Send check, M.O., or sent C.O.D. **\$895** M.F.T.

Irrigate, Fill Tanks, Draw Well Water. Heavy duty #8 pumps 7000 gph. 1000 gph. 75' high 3000 gph. from 25' well. Rustproof alloy metal. 8 blade impeller. 1" inlet, 1" outlet. Standard pipe threaded. Will not leak or clog. Iron clad guarantee. Send check, M.O., or sent C.O.D. **\$1195** M.F.T.

Free Catalogue—Gear Pumps, Large Centrifugal Pumps, Deep and Shallow Well Pumps, Sump Pumps.

MOORE MANUFACTURING CO.
SWEDESBORO 1, NEW JERSEY

SAY YOU SAW IT IN POPULAR MECHANICS

ENGINEERING DEGREE IN 27 MONTHS

Big Demand for Graduates

Aeronautical, Chemical, Civil, Electrical, Mechanical and Radio Engineering (inc. TV and Electronics)

Hundreds of young men are earning B. S. ENGINEERING DEGREES annually in this recognized institution — year around operation. New terms start quarterly. Many students earn a major part of their college expenses in this large industrial center.

Low tuition. Competent instruction. Thorough, intense, practical program. Modern, well-equipped laboratories including new physics laboratory and modern wind tunnel. Individualized instruction emphasized.

Government approved for G.I.'s. Engineering preparatory courses. Students from 48 states and 21 foreign countries. Enter March, June, September and December. Send coupon for free catalog and full information. Enroll now.

SEND COUPON TODAY

INDIANA TECHNICAL COLLEGE

515 E. Washington Boulevard
Fort Wayne 2, Indiana

Please send me free information on B.S. Engineering Degree in 27 months as checked.

- Aeronautical, Chemical, Civil, Electrical,
 Mechanical, Radio-Television

Name _____

Address _____

FOR BIG MEN ONLY!



SIZES 10 to 16 WIDTHS AAA to EEE

WE SPECIALIZE in large sizes only— sizes 10 to 16; widths AAA to EEE. Low-Tops; Wing Tips; Hand-Sewn Mocca-sins; Cordovans; Dress Oxfords; Work Shoes; Sox; Slippers; Rubbers. Enjoy the finest in fit, comfort, style at amazingly low cost. Mail only. Write for FREE Style Book TODAY!

SEND FOR FREE CATALOG

KING-SIZE, INC., 526, Brockton, Mass.

HIGH BLOOD PRESSURE?



A home Blood Pressure Gauge now tests your pressure at home as often as you wish! That's how to avoid unexpected strokes, heart and kidney damage, insomnia, headaches, etc. Full particulars on how to test pressure and what to do for your condition are included with this dependable mercury gauge. It is simply constructed so it can be operated alone and it actually pays for itself in less than a week. Free descriptive circular sent on request.

THE STANDARD UNIT \$5.98 postpaid
Or C.O.D. plus postage. Contains everything that is needed, including functional stethoscope.

THE DELUXE UNIT \$9.23 postpaid
Or C.O.D. plus postage. Same outfit as stand-ard unit, but includes genuine professional stethoscope.

JOY SPECIALTY COMPANY Scientific Instrument Dept.
2320-A W. Hubbard Street Chicago 12, Illinois

YOUR OWN BUSINESS EARN \$25 DAY SPARE TIME

Operate your OWN profitable Venetian Blind Laundry business. Earn \$25 day—spare time! . . . and build a permanent, lifetime full-time business. Clean Venetian Blinds from Homes, Offices, Institutions, etc. Easy to learn and operate. New, uncrowded field. Previous experience unnecessary.

Write NOW for full information—No obligation.
A. A. LAUNDRY CO. 101 So. 44th St., Philadelphia 4, Penna.



SEND ME



every month so I am sure to see each new issue. Here's

- \$3.50 for 1 year
 \$8.00 for 3 years

name _____

address _____

city _____ zone _____ state _____

Hand this order to your newsdealer or send it to

POPULAR MECHANICS
200 East Ontario St. Chicago 11, Ill.

MAKE UP TO \$10 AN HOUR AT HOME WITH 50¢ WORTH OF MICRO-FLUFF

HIGH COST OF LIVING GETTING YOU DOWN

Want to add an extra \$100 or more to your regular monthly pay check in a few **SPARE TIME** hours of pleasant occupation **AT HOME**? That's just the position I was in a few years ago when I ran across an Old-World formula for applying short cotton fibers to practically any surface, in such a manner that it looked and felt just like costly velvet or velour.

THIS PROCESS AMAZED ME

I spent several years experimenting until I developed what I now call the **FLOK-KRAFT MICRO-FLUFF** method. This **NEW METHOD** is far removed from the Old-World way of applying these short fibers. Also it permits the use of tiny fibers of **RAYON** and other modern materials in **MANY COLORS** in addition to cotton.

NO OVERHEAD—NO EXPENSIVE EQUIPMENT

Start in your basement, garage, attic, service porch, or even on a card table in your bedroom. With an hour's practice you can apply a few pennies worth of **FLOK-KRAFT MICRO FLUFF** to a yard or two of butcher paper, and make it look like \$15-a-yard velvet for window displays in the finest jewelry, gift, or department stores, etc. Takes only a few minutes and practically no effort.

MICRO-FLUFF IS BEAUTIFUL AND LONG WEARING

Truly the most amazing material you ever saw, **MICRO-FLUFF** comes in every color of the rainbow, is long lasting, has the **TOUCH** appeal of luxurious velvet or suede, and goes on practically any surface—paper, metal, wood, glass, plastic, plaster, rubber, even sponge-rubber. It is wonderful to line silverware or hosiery drawers, cover and line jewelry boxes, decorate lamps and lamp shades, finish the inside of auto trunks or glove compartments (to protect luggage and accessories from scratching) re-cover women's party shoes, phonograph turntables, etc. Apply to toys, figurines, wall plaques, signs, store displays and a thousand-and-one other items, new or old. **FLOK-KRAFT MICRO-FLUFF** makes old objects beautiful and salable — increases value of many new products by 500%.

Read What Others Say . . .

"Received the outfit and everyone that saw it is very enthused. I only had it about thirty minutes and got an order for a \$100 job."
Mr. C. H., Maryland

"Got \$52.50 for those 7 trunk interiors for about 4 hours work. \$7.50 per trunk."
J. O., Mo.

"... I have received my order and believe me, I'm very pleased and happy as I've made myself MORE than the cost of my supplies already, and I've still got more jobs to do."
Cpl. G. W., S. Carolina

"... pleased with your course and I'm being swamped with work to do."
W. F., Penn.



BIG-PROFIT ORDERS COME FROM NEIGHBORS, GIFT SHOPS, STORES—ALSO MAIL-ORDER

Every household has one or more items that can be saved from discard by a **FLOK-KRAFT** job. Decorate store display cases and windows (jewelers love this) and also supply them with fast-selling **FLOK-KRAFTED** gift items and other merchandise. Manufacturers are prospects for contracts to apply **FLOK-KRAFT** to furniture, instrument cases, luggage, and hundreds of other products. Every neighborhood needs a **FLOK-KRAFTER**. **HELP US FILL A HUGE DEMAND.** Since succeeding beyond my wildest dreams in my own **FLOK-KRAFT** business, I have concentrated on helping ambitious men get started in the same way to build a successful future, free of time clocks and nagging bosses. My plan is designed to help you start at home in spare time, and build gradually toward a full-time business with employees working for you. And you can start **RIGHT NOW. DON'T SEND ME ANY MONEY**, just your name and address on a postcard, and I'll rush you a **FREE SAMPLE OF FLOK-KRAFT MICRO-FLUFF**, the **FLOK-KRAFT PLAN** and full **FREE** details. I'll also arrange to send you the complete **FLOK-KRAFT MICRO-FLUFF** outfit to try out right in your home, before you agree to buy anything at all. The outfit includes detailed instructions with hundreds of show-how photographs and drawings that make everything simple, right from the start. Also included is our specially designed, high-velocity Applicator and a generous supply of **FLOK-KRAFT MICRO-FLUFF**—everything you need to get going right away. You owe it to yourself to investigate. Rush me your name and address today by Airmail, and I'll show you how to start making money at once!

NELS IRWIN, Coast Industries, Dept. 21,
Los Angeles 61, California

SEND NO MONEY—MAIL COUPON NOW!

Nels Irwin—COAST INDUSTRIES, Dept. 21,
Los Angeles 61, California

Please rush me **FREE** sample, details, etc. I understand that everything you send is free and that I'll be under no obligation now or ever.

NAME _____

STREET _____

CITY _____ STATE _____

MAKE EXTRA MONEY **PLASTICS** **LEARN AT HOME**

There are RICH OPPORTUNITIES for MEN and WOMEN with "know-how" in Plastics. Interstate's new Plastics course tells and shows how to make hundreds of fast selling items out of Plastics. Gives complete training in fabrication, casting, lamination, molding, internal carving, etc., in simple, easy, step-by-step language and pictures. Plastics and Fabricating Kits for 23 valuable Plastic items come with training at no extra cost. **START A PLASTICS BUSINESS OF YOUR OWN.** No other industry holds such promise for the future. You can make big money manufacturing novelties, toys, signs, etc., in your own home in spare or full time. Don't wait! Learn NOW how Interstate's Plastics Training qualifies you for success in the Plastics field.

PLASTICS AND SUPPLIES FURNISHED FOR 23 VALUABLE PROJECTS

INTERSTATE TRAINING SERVICE
Dept. C-3-A Portland 13, Oregon

LEARN HOW TO MAKE fast-selling PLASTIC NOVELTIES FURNITURE JEWELRY SIGNS TOYS LAMPS WRITE TODAY!

MAKE MONEY WRITING
.. short paragraphs!

You don't have to be a trained author to make money writing. Hundreds now making money every day on short paragraphs. I tell you what to write, where and how to sell; and supply big list of editors who buy from beginners. Lots of small checks in a hurry bring cash that adds up quickly. No tedious study. Write to sell, right away. Send for free facts. **BENSON BARRETT, 1751 Morse Ave., Dept. 27-A, Chicago 26, Ill.**

Learn REFRIGERATION AND AIR CONDITIONING
FREE! PLAN FOR YOUR SUCCESS

EXTRA CASH NOW - Spare time at home - Earn while you learn by doing with Easy Home Course. **START YOUR OWN BUSINESS** - No Experience Needed. Special tools & equipment furnished. Send for **FREE BOOK** - TODAY!

MECHANICS TRAINING SCHOOL-Dept. P-551
11029 S. Vermont • Los Angeles 44, California

FREE BOOK

STAMMER?

Get your copy of the new 18th edition of my book, "Stammering: Its Cause and Correction," which describes the Bogue Unit Method for scientific correction of stammering and stuttering. Ask, also, for free **SPEECH CHART!** 54th year. Benjamin N. Bogue, Dept. 553, Circle Tower, Indianapolis 4, Indiana.

GET THIS FREE BOOK!

BUY DIRECT...TV TUBES
50% OFF LIST PRICE!

ALL TUBES UNCONDITIONALLY GUARANTEED ONE YEAR
Send for complete list of tubes and prices

NEW JERSEY RADIO & TELEVISION TUBE CO.
906F Westfield Ave. Elizabeth, N. J.

AIRPLANE ENGINES

Lycoming 190 horsepower, 6 cylinder, aircooled Model O-435-1, opposed type engines. Ideal for

AIR DRIVE BOATS & SLEDS

Rush name for **FREE** brochure and full facts.

AERO PARTS SUPPLY, Municipal Airport, Houston 17, Texas

250 POWER

Complete Telescope Lens Kit **only \$3.49** postpaid

Conquer Space, Explore the Universe, Planets, Moon Craters, New Stars, etc. Complete Lens Kit consists of 80 inch focal length ground and polished objective lens, eyepiece lenses for 50 POWER, 100 POWER, 150 POWER, 200 POWER, 250 POWER, and all necessary lens fittings. Easy to make from simple step by step instructions. (Triod and mount not included.) Money back guarantee.

BUSSE SALES CO., Hartford 1, Conn., Dept. PM 29

"Man alive! You sure found the reason for that engine knock quick!"

"And I'll fix it quick, too. This new manual shows me just where to look and what to do."

NOW YOU CAN Find the trouble and FIX IT FAST on any car!

As valuable to car owners as to expert mechanics—this book tells how to find the trouble in one or two quick steps, and correct it at once!

FREE 10-DAY TRIAL
Return book, pay nothing if not satisfied

Almost any auto fix-it job can be a "snap" with this manual. First, you find the trouble right away. Misfires, weak spark, engine knocks, whatever the complaint—you can find the cause in one or two quick steps with this book.

If the car is burning too much gas, for example, turn to section on Fuel systems. You'll find 23 causes listed. Book tells you what to check first, where to look, what tools you need, how to repair the trouble. Every job is explained step-by-step in easy-to-read language. And more than 250 pictures, charts and tables show you how to do it.

This book offers much more than the standard auto manufacturer's service manuals. It explains the "Why" of every job as well as how to do it. Engineers from the "Big 3", the independents, the parts-makers like AC, Auto-Lite, Stewart-Warner, Zenith Carburetor, and many others helped to produce this amazing book. Mechanics tell us that using this book is as good as having an expert working right along side.

SEND NO MONEY. Be you beginner or expert, this book is yours to try **FREE** for 10 Days! Prove its worth to yourself without spending a penny. Just fill out and mail coupon. When postman delivers book, pay nothing. Then, after 10 days, if you are not satisfied that this is one of the greatest time and money savers you've ever seen, return it, and pay nothing.

AMERICAN TECHNICAL SOCIETY
848 East 58th Street Dept. C-119 Chicago 37, Illinois

AMERICAN TECHNICAL SOCIETY (Publishers since 1898)
848 East 58th St., Dept. C-119, Chicago 37, Illinois

Please send me at once **AUTOMOTIVE MAINTENANCE AND TROUBLE SHOOTING** for **FREE** 10-day examination. If I am not convinced that this book is a real time and money saver, I can return it and pay nothing. If I keep book, I will send check or money order for \$5.95 plus few cents postage.

NAME _____

ADDRESS _____

CITY _____ STATE _____

Check here if sending full payment to save postage. You may return book any time within 10 days for full refund if not delighted.

HOW TO FIND AND FIX TROUBLES WITH:

Battery, generator, starting motor, horn, headlights. How to tune-up engine, carburetor, spark plugs, coil and points; How to test magneto, condenser, cooling system, thermostat, and electrical system; How to adjust power brakes, power steering, and wheels; How to service power accessories, air conditioning, etc.

Paint STRIPES with New "PAINT PEN"!

Makes Straight, Curved or Parallel Lines!

Just fill glass vial with any color paint. Use like a fountain pen to stripe furniture, bikes, autos, model planes, toys, linoleum, wall board. Beautiful, clean, crisp results every time, like professional painters. No experience needed to draw straight, curved, circular or evenly spaced parallel lines. Can't clog or smear. May also be used with glue, tempera, textile paint, or ceramic underglazes. Paints on wood, glass, plastics, metal, fabrics and paper. Lasts a lifetime. Only \$1 postpaid, complete with tip for 1/16 inch stripe. C.O.D.'s plus postage. Used by industry. Order your Paint Stripping Tool TODAY!

New! "DOUBLE-STRIP" MODEL Only \$2.95

Newest paint stripping invention. Makes DOUBLE stripes—one wide and one narrow or two wide or two narrow at the same time. Or adapt quickly for wide or narrow single stripe. Makes 5 combinations. FREE—Send postcard for complete information... or order now... \$2.95.



\$1.00 DEALERS

Master Paint Stripping Tool packed in Display Cartons of 1 dozen. Fast, profitable seller. Write for discounts. Attention All Home Craftsmen! New Paint Stripping Tool gives "professional" results every time, yet simple, easy to use. Send \$1 now.

ATTENTION—MANUFACTURERS! Write today for information about our industrial and production stripping tools. **WENDELL MFG. CO., Dept. 31** 4234 Lincoln Ave., Chicago 18, Illinois

6 Other Complete Tools Complete tools for 1/64, 1/32, 3/64, 1/64, 5/32 or 1/8 inch stripes. \$1.50 each. Extra tips 75c ea. **COMPLETE KIT with ALL 7 TIPS, \$5.00.** (Also 1/4" tip, only \$1.00). All tips interchangeable.

MAKE YOUR ART TALENT PAY

Learn fundamentals of COMMERCIAL ART at home!



If you are seeking extra income, or a new career, investigate the possibilities of commercial art! The Washington School of Art, with 40 years of experience teaching "Art for Pleasure and Profit" at home, offers professional guidance in this highly-paid field. Start commercial art, designing, cartooning, illustrating, lettering—all in one complete home study course. Low tuition, easy terms: trial plan. Full details upon request. No salesmen. Use coupon.

Washington School of Art
Studio 121 N
Washington 5, D.C.

Name _____
Address _____ Age _____
City, Zone, State _____

SAY YOU SAW IT IN POPULAR MECHANICS

LEARN TV in KC

FAMOUS FOR 24 YEARS

1,000's OF SUCCESSFUL GRADS COAST TO COAST



Easy, quick, fascinating. Learn TELEVISION in 36 short weeks of enjoyable companionship in shop training. Wonderful job opportunities. Graduates have choice of many jobs or can establish their own TV repair shop. **YOU CAN START EARNING AS MUCH AS \$150 PER WEEK.** NO limit as time goes on. U.T.S. is an old established school (TV exclusive for 24 years) staffed by expert instructors, headed by one of America's first TV broadcasters. Costs so little to prepare yourself for life. No previous experience needed. Fully approved for Korean Veterans. Also fully approved course in color TV (first in U.S.A.). Get the full story today.

FREE CATALOG

FILL OUT COUPON—
UNIVERSAL TV SCHOOL
1228B Admiral Boulevard, Kansas City, Missouri
PLEASE SEND ME INFORMATION FREE

Name _____ Age _____
Address _____
City _____ State _____
 Check here if Korean Veteran

Lt. Wt. Aluminum PIANO HINGE

Length 72 inches, thickness .040—width 1 1/4"—

Operating radius 275 degrees. Made of aluminum alloy, and in 8 foot lengths only— \$1.15

HEAVY DUTY STEEL PIANO HINGE

Length 56"—Thickness 3/32"—Width (open) 3-5/16"—Operating radius 330 degrees—Made of heavy duty steel—Drilled ready for use. Ideal for drop tables, heavy tool boxes, heavy doors, and many other uses where heavy hinges are required. Sold in 56" lengths only. Ship. Wt. 7 lbs. At a fraction of original cost **\$1.45**

LIVE RUBBER SHOCK CORD



Made in accordance with rigid army specifications. Clean fresh stock. 3/4" contains approx. 40 strands of live rubber. 3/8" approx. 100 strands. 3/4" approx. 300 strands, etc. Sold in 25 ft. lengths or more. At about 20% of original cost. Excellent for marine and boat supplies, for trampolines, for tying down tarps, etc.

DIA.	PRICE (per 25')	SHIP.	WT.
3/4"	\$2.00		2 lbs.
3/8"	\$2.75		3 lbs.
3/4"	\$3.25		4 lbs.
5/8"	\$4.50		5 lbs.
3/4"	\$5.75		6 lbs.

Quantity price on application.

Prices F.O.B. Chicago. Include approx. postage on orders paid for in advance. C.O.D. orders enclose 25%, balance sent C.O.D.

U. A. S. Corp. Dept. PM-1 5637 W. 63rd Pl. Chicago, Ill.

CARBURETOR SAVES GAS VACUATING OVERRICH MIXTURES



Car owners who are getting poor gas mileage, and wasting money due to overrich mixtures, will be pleased to learn how to save gas. Easily installed Vacu-matic invention is **Automatic** and operates on the supercharge principle. For cars, trucks, tractors.

SALESMEN WANTED! Big Profits! FOR FREE PARTICULARS, HOW YOU CAN GET ONE ON YOUR OWN CAR FOR INTRODUCING, just send your name and address on a post card to—**VACU-MATIC, 7617-2098 W. State St., Wauwatosa, Wis.**

WHOLESALE Electric Guitars - Parts - Build Your Own

Accordions, amplifiers, double-necks, triple-necks, pickup mikes, mandolins, non-electric instruments, etc. 1955 Models wholesale. Free Catalog. Free home study course with instruments. Parts and plans available to build your own 6 or 8 string or multi-neck electric guitar. Martin and Fender available at list price. **CARVIN CO., Box 28 PM1, Baldwin Park, Calif.**

RUPTURED?

Something different. Light. Cool. No leg straps. No elastic. No pressure on hips or spine. Inexpensive. Worn by Mechanics, Farmers, Doctors, etc., everywhere. Guaranteed. Write **EST. 1893 DEPT. PM, PRESTON, ONT., CAN.**

HAND-LOCK PRODUCTS

Guide to HOME REPAIRS



Pays for Itself 100 Times Over

Beat the high cost of home upkeep. Save hundreds of dollars every year on carpentry, electrical, painting, plumbing and other jobs around the house with **Popular Mechanics GUIDE TO HOME REPAIRS**. Simplified how-to-do-it instruction and 646 pictures make all jobs, inside and out, easy. Covers construction, remodeling, modernizing, repairing that you can do yourself at small cost. 192 page cloth bound book only \$2.50 postpaid. Order today under our money back guarantee.

POPULAR MECHANICS PRESS, Dept. PM16
200 EAST ONTARIO STREET CHICAGO 11, ILLINOIS

Enjoy the Fascinating Story of the Horseless Carriage in



Popular Mechanics

AUTO ALBUM

166 Illustrations

The most intriguing book about the automobile ever printed. It's thrilling, fascinating and informative. From the very first gasoline-propelled buggy to the cars of today and the atomic auto of the future. The first cars—the men who made them—the scrambled start and the development of the fabulous auto industry—the story of auto racing—the growth of the Nation's highways. 116 thrilling action pictures—old-time cars—racing cars—early auto advertising—automotive oddities. Roll call of names of more than 2000 autos made in the U.S. included. Ideal gift book. Cloth bound, only \$3.00 by mail. Money back if not pleased. Paper covered edition \$1.00 at newsstands.

POPULAR MECHANICS PRESS, Dept. PM14
200 East Ontario Street Chicago 11, Illinois



WOULD YOU LIKE TO RECEIVE STACKS OF LETTERS LIKE THESE EACH WITH MONEY FOR YOU?

I have found a proven formula for quick success in making money. Others I've shared it with also have been successful. Would you like to know about it?

It's simpler than you might think — just buying good imports at next-to-nothing foreign prices and selling them in the U.S. by mail order or at wholesale to stores.

To most people, importing smacks of mystery, romance — and "costly" things for collectors. Actually, any capable and ambitious man or woman should learn import-export quickly. And, there are thousands of beautifully made imports obtainable at trifling cost abroad to sell in the U.S. by mail order. There are also great opportunities in exporting U.S. products.

Native villages in Africa, romantic Vienna, bustling Copenhagen, mysterious Hong Kong — yes, countryside hamlets and great cities all over the world produce fascinating products.

Using my plan, you don't have to travel abroad unless you want to. You don't even have to know a foreign language. And, there is no face-to-face selling in mail order.

I have proven this plan with 103 imports — and the opportunities for the sale by mail of thousands more are breathtaking in their possibilities. Hunting knives and binoculars from Germany, silverware from Sheffield, England — hand-carved art objects from Africa — all costing less than \$1 abroad have values up to \$5 or more here and are big sellers by mail order.

Monthly bulletins sent free to those who follow my plan show suppliers of new and desirable imports.

As I write this, I am receiving as many as 1,000 cash orders a day for imported clocks — all by mail order. They cost me only 63¢ and I sell them far below the U.S. market — a terrific bargain and a wonderful seller. And, I don't stock them as they are shipped direct to the buyers from abroad, *after I receive the cash.*

So you see, it is even possible to conduct a business of this kind without investing in merchandise.

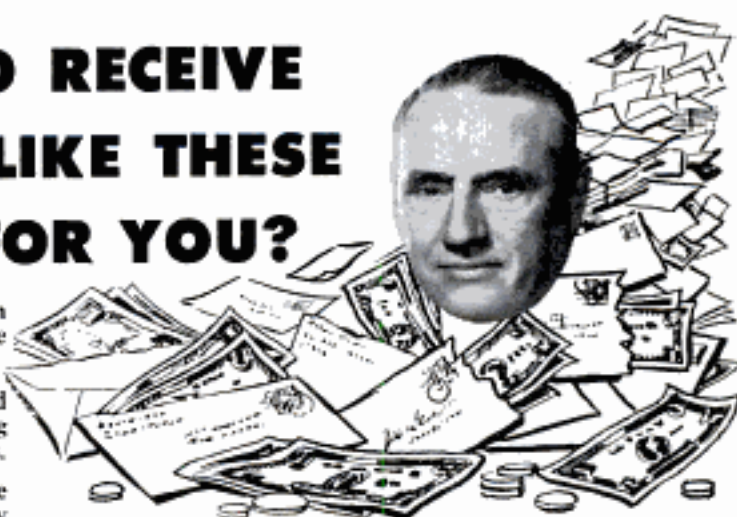

Mrs. McGinn, one of my students in Illinois, operates a gift shop and sells Arabian perfume by mail order. F. Basler, N. J., sells Aztec bird feather pictures from Mexico to stores and by mail order.

You might ask, "Why do you let others in on your plan? Why don't you keep it all for yourself?" The answer is that items for import are countless. No one person could possibly handle even a small proportion of them. There's plenty of business in import-export for you and me and many others.

If you are sincere and really open-minded to a new and different opportunity — one which may change your whole idea of the kind of money you can make in your own full or part time business — write today for full details. Air mail reaches me overnight.

B. L. Mellinger, Director, Dept. E251
1717 Westwood, Los Angeles 24, Calif.

— — — AIR MAIL THIS COUPON NOW — — —

B. L. Mellinger, The Mellinger Co., Dept. E251
1717 Westwood, Los Angeles 24, Calif.

Mr. Mellinger: Without obligation, show me the big profits to be made through World Trade, especially in mail order from my own home.

Print Name.....

Address.....

Town & Zone.....State.....

Say You Saw It in
POPULAR MECHANICS



DEVELOP A HE-MAN VOICE!

Write for FREE book "How to Strengthen Your Voice for Greater Success" by Eugene Feuchtinger. No obligation. Book will be mailed at once in plain wrapper, postpaid. Just send your name and address. State age. **PREFECT VOICE INSTITUTE, 210 S. Clinton St., Studio AV-2, Chicago 6, Ill.**



Catalog of 3200 Novelties, Gadgets, Jokes & Tricks

Send 10c for amazing catalog of novelties, joke articles, funmakers, tricks, gadgets, live animals, scientific supplies, hobbies, planes & boats, unusual seeds, time-savers, cameras, optical goods, projectors, movies, lucky jewelry, religious goods, disguises, masks, musical instruments, stamps, coins, puzzles, fortune tellers, radios, auto & bike accessories, telescopes, magnifiers, compasses, banks, smokers' items, artist supplies, printing sets, engines, motors, shockers, knives, billfolds, guns, rifles, sports, books, games, plants, pennants, emblems, etc. Send name, address and 10c to:

JOHNSON SMITH & CO.
Dept. 935 Detroit 7, Mich.

Here's 10c. Rush me New Catalog!

Johnson Smith & Co., Dept. 935, Detroit 7, Mich.

Name.....

Address.....

FREE! ELIZABETH II EMPIRE STAMPS



Rush coupon below at once! We'll send you one of the most exciting offers ever made! Think of it! . . . from the far corners of the British Empire — Falkland Islands, Ceylon, Seychelles, South Africa, Tristan da Cunha, to name just a few — this generous collection of hard-to-get (mint and used) Elizabeth II stamps, Coronation and others. They're all genuine, all different! Also a FREE copy of our helpful illustrated "Stamp Collector's Guide"! PLUS! in handsome color, a reproduction and story of the World's Rarest Stamp! Other valuable offers included for your free inspection. Don't delay — this rare offer may be withdrawn soon! If coupon has been clipped, send direct to: GARCELON STAMP CO., Dept. PMIE, Calais, Maine.

GARCELON STAMP CO., Dept. PMIE, Calais, Maine.
Rush FREE Empire Stamps and other offers.
(PLEASE PRINT)
NAME _____
ADDRESS _____
CITY _____ ZONE _____ STATE _____

PREPARE FOR THE BEST JOBS IN INDUSTRY

**TRAIN
at HOME**
IN YOUR SPARE TIME
or at
ALLIED INSTITUTE
in Chicago

- MECH. ENGINEER
- DRAFTSMAN
- TOOL DESIGNER
- TOOL ENGINEER
- TOOL & DIE MAKER
- MASTER MACHINIST

NO RECESSION FOR ALLIED TRAINED MEN

MORE JOBS THAN GRADUATES Shortages of Draftsmen, Designers, Tool Engineers, Machinists, Tool & Die Makers are so widespread that you can pick a highly paid key job and look forward to Achievement and Security.

You can begin your training in Short Courses and continue progressively to a Bachelor Degree in 26 months.

Allied is approved by Industry, Dept. of Education, Office of Public Instruction, State of Illinois, U. S. Veterans Admin., U. S. Dept. of Justice. Accredited: C. S. A.



ALLIED SCHOOL of MECHANICAL TRADES

1338-42 South Michigan Ave. Dept. PM-1 Chicago 5, Illinois

SEND ME WITHOUT OBLIGATION INFO. ON YOUR COURSES:
 HOME STUDY RESIDENT VETERAN NON VETERAN
 NAME _____
 ADDRESS _____ AGE _____
 CITY _____ STATE _____

FOOLISH TO PAY MORE, DANGEROUS TO PAY LESS!



TUBE FREE WITH EACH TIRE!
FREE This Pictured Tire Ash Tray Included With 2 or More Tires!
 If you buy a PAIR, you get a SPARE FREE
 If you buy THREE, you get a 4th tire
 Does Not include W.I.V. - Snow-tires or truck tires

GOODYEAR, GOODRICH, FIRESTONE, U.S. and others. Partially used tires. "family-safe," not recaps, not retreads. Top grade. Our prices are about 65% off new tire prices. Any defective tire replaced FREE of charge. 34 months written guar. bond.

600-16	\$4.52	670-15	\$4.52	850-15	\$4.62	800-15	\$5.22
650-16	5.02	710-15	4.52	700-15	4.72	820-15	5.42
700-16	5.42	740-15	4.82	850-17	3.92	850-15	4.52
640-15	4.32	WHITEWALL TIRES \$1 EXTRA		590-15	4.52		

FLEETOWNERS—get the right tire for the right job. Include truck model, make & tire size with order. My "Sure-Footed" traction tires are recappable later. They're worth the slight difference.

600-16 (D)	\$6.42	700-17	\$8.42	750-20	\$10.92
650-16 (D)	6.92	750-17	10.92	825-20	17.92
700-16 (D)	7.72	800-20	7.92	900-20	17.92
700-15 (D)	7.92	650-20	9.32	1000-20	17.92
750-16 (D)	8.92	700-20	10.22	1100-20	18.42

SNOW-TIRES Goodyear Suburbanite type or "Snow-Grip" traction. \$7
 Factory rebuilt, any car, guaranteed 26 months

MARVIN BLATT 6th & Spring Garden Sts. Philadelphia, Pa.
 MILITARY MUD-GRIP TIRES
 AA Guar. 20 Mos. AAA 36 Months
 900-16 \$10.22 900-16 \$13.92
 750-20 9.72 750-20 13.52
 Send Check or M.O. & this ad to save C.O.D. Coll. Charges
 "Sincerity that was born 27 years ago"

Watch Repairing Pays Big Money Learn at home



Watch repairers in great demand. Train step-by-step in 10 easy lessons. We furnish all tools and 15 jewel watch and practice movement. Turn spare time into cash. A licensed school. Low cost. Send for FREE book today.

ILLINOIS SCHOOL OF WATCH REPAIRING

2870 Elston Ave., Dept. PM-15, Chicago 18, Ill.



Blast off with DUAL vacuum AIR HORNS!

ONLY \$9.95
 *POSTPAID
 Money-back Guarantee

The voice of authority and commanding warning for safer highway driving. One BLAST and those "Road Hogs" really move over. Installed under the hood or on the front fender. Beautiful Incooper finish. Operates from intake manifold. No tank needed. Only \$9.95 complete with cylinder head bracket, steering column lever, hose, fittings, etc. Send check or money order today. We pay postage. \$1.00 deposit required on all C.O.D. orders.

Compare with \$25 to \$100 Air Horns

THE PROTECTUDOD CO.
 Dept. 402, 716 N. E. 17th Rd., Fort Lauderdale, Florida

YES! SEND



directly
to my door
every month

I am enclosing
 \$3.50 for 1 year
 \$8.00 for 3 years

name _____
 address _____
 city _____ zone _____ state _____

Hand this order to your newsdealer or send it to
POPULAR MECHANICS
 200 East Ontario St. Chicago 11, Ill.

New **PROFIT-PROVEN*** Home-Business!

"I make \$400⁰⁰ a week!"



SCREEN PRINT CO.
Dept. 21
15127 S. Broadway, Los Angeles 61, Calif.
Gentlemen: Please mail me Free Revealing Details, samples, Opportunity Plan, etc.—All this is sent absolutely Free and sent to me by return mail. I am under no obligation now or ever.

NAME _____
ADDRESS _____
CITY _____ ZONE _____ STATE _____



free!
Complete REVEALING DETAILS, Authentic SAMPLES, Proven Big-Money OPPORTUNITY PLAN, "HOW-TO" BOOKLET. Learn the secrets. Rush this coupon TODAY!

*Proves MR. J. T. ANDERSON, Inglewood, Calif.
(Notarized statement on file in our office and open to inspection)

Big Money?—sure it is—because Huge Profits are waiting to be "tapped" with this **MIRACLE NEW PRINTING METHOD**. Now, you may share the exciting secrets and build a big-paying **FULL OR SPARE TIME** Screen Printing Business right **IN YOUR OWN HOME**. Yes, we'll teach you, too, how to turn pennies into dollars in this newest, most sensational printing method ever invented. **WHAT IS SCREEN-PRINT?** It's an exciting new printing technique—amazingly simple and fascinating. (It may soon revolutionize the entire printing industry) **NO EXPENSIVE EQUIPMENT**, no printing press, no "cuts," no art ability, no experience is necessary—yet you can print beautiful professional jobs on **PAPER, GLASS, LEATHER, CLOTH—ANYTHING!** You print in all colors—even new "glowing" **FLUORESCENT**

COLORS. It's amazing—but true! **EARN PROFITS IMMEDIATELY—IN YOUR OWN HOME!** Start in your garage, basement, kitchen, spare room—anywhere! It's much easier than you think. Then expand as this new printing industry grows. **300% PROFIT** on some jobs—earn up to \$12.50 per hr. **HELP FILL THE HUGE GROWING DEMAND**. No selling because every business in your area needs Screen-Printing. You can save them up to 50% on printing, too. **WE SUPPLY EVERYTHING YOU NEED**. Never before has such a profitability been offered to anyone wishing to start a full-time or spare-time "business of his own." Don't Hesitate! All the **CONFIDENTIAL FACTS** are yours if you **MAIL COUPON TODAY**—before it's too late.

READ WHAT OTHERS ARE SAYING—Investigate! "Would not take \$1000.00 for secret...just what I have been searching the world over for." C.S., Nev.; "Making 75% of living expenses already in spare time." E.L., Ontario; "Made \$80 first week—terrific opportunity"—W.S., Iowa.

Mail Coupon and Learn Secrets Too!

Print colorful **ADVERTISING DISPLAYS, SIGNS, BANNERS, POSTERS, LABELS, WALLPAPER, NOVELTIES, INSTRUMENTS, ETC. ETC.**

HELPFUL BOOKS

Send post card asking for **FREE** catalog

Popular Mechanics Press, 200 E. Ontario, Dept. 601, Chicago 11

LOCKSMITHING & Key Making

PRACTICAL UP-TO-DATE COURSE—ONLY \$4.95

Easy-to-learn modern information for self-instruction. How to work on locks, de-code, make master-keys, repair, install, service, etc. For every handyman, home owner, carpenter, mechanic, service station operator, fix-it shop, hardware dealer, locksmith, 53 plain illustrated lessons. **FULL PRICE ONLY \$4.95. SEND NO MONEY.**

Just pay postman plus C.O.D. postage. Or send \$4.95 with order. We'll ship postpaid. Satisfaction guaranteed or refund. **NELSON-HALL CO., 210 S. Clinton St., Dept. AV-2, Chicago 6, Ill.**



I MADE **\$14 PER DAY**
While still learning!

T. C. H.—WEST VIRGINIA



I MADE **\$800 IN 3 MONTHS**
While taking your course!

F. V.—NEW YORK

Get into the

ELECTRIC APPLIANCE REPAIR & SERVICE BUSINESS



OPEN YOUR OWN SHOP

As soon as you enroll, I send you my New Book "How to Open Your Own Business" at no extra cost. PTS training is more than a home study course in electric appliance repair and service. It gives you the "know how" on the operation of your shop from a business standpoint: What to charge, how to get customers. Everything possible is done to start you on the road to success.

WE TEACH YOU:

Electric motors, house wiring, refrigerator, auto ignition, automatic washers, garbage disposals, fluorescent lights, irons, cleaners, etc., at home.

FULL OR SPARE TIME

SEND FOR THIS **FREE BOOK**



SPARE OR FULL TIME

You can actually increase your income while still learning—spare or full time

ACT NOW

Want a good-paying business—a job in a fast-growing industry? Send now for your **BIG FREE BOOK—"My Plan for your Success."** Get started **NOW**

EASY TO LEARN

Men of all ages, yes, even the man of 69 can get into this expanding field. A **REAL OPPORTUNITY** for the practical man who wants the **BETTER THINGS IN LIFE**. The easy PTS Home Study Plan prepares you for greater earnings **NOW!**

I SEND YOU A

BIG KIT of TOOLS at No Extra Cost



MAIL THIS COUPON TODAY

PACIFIC TRAINING SCHOOL H. T. ARMSTRONG
11029 S. Vermont Dept. P-551 Los Angeles 44, Calif.
Please send me, without obligation, your free booklet and details.

Name _____

Address _____

City _____ Zone _____ State _____

New Amazing Invention — "Magic Art Reproducer"

DRAW

Anyone Can Draw
With This Amazing
New Invention —
Instantly!



Complete
For Only **\$1.98**
De Luxe
Model

ANY PERSON IN ONE MINUTE

**NO LESSONS!
NO TALENT!**

You Can Draw Your Family, Friends, Anything
From REAL LIFE—Like An Artist Even if
You CAN'T DRAW A Straight Line!

Yes, anyone from 5 to 80 can draw or sketch or paint anything now . . . the very first time you use the "Magic Art Reproducer" like a professional artist—no matter how "hopeless" you think you are! Anything you want to draw is automatically seen on any sheet of paper instantly! Then easily and quickly follow the lines of the "picture image" with your pencil . . . and you have an accurate original drawing that anyone would think an artist had done. Also make drawings larger or smaller as you wish. Anyone can use it on any desk, table, board, etc.—indoors or outdoors! No other lessons or practice or talent needed!

HAVE FUN! BE POPULAR! Everyone will ask you to draw them. You'll be in demand! After a short time you may find you can draw well without the "Magic Art Reproducer" because you have developed a "knack" and feeling artists have—which may lead to a good paying art career.

Also Excellent for
Every Other Type
of Drawing!

- Human Figures •
- Outdoor Scenes, landscapes, buildings •
- Still life, vases, bowls of fruit, lamps, furniture, all objects •
- Copy photos, other pictures, portraits, etc. •
- Copy blueprints, designs, decorations, for woodwork, machines, for needlework, crocheting, knitting •
- Copy all cartoons.



FREE! "How to Easily Draw Artists' Models"

This valuable illustrated guide is yours free with order of "Magic Art Reproducer." Packed with pictures showing all the basic poses of artists' models with simple instruction for beginners of art. Includes guidance on anatomy, techniques and figure action.

Create Your Own Designs for All Hobbies! Reproduce on anything.



Outdoor Scenes, landscapes, buildings.



**SEND NO MONEY!
Free 10-Day Trial!**

Just send name and address. Pay postman on delivery \$1.98 plus postage. Or send only \$1.98 with order and we pay postage. You must be convinced that you can draw anything like an artist, or return merchandise after 10-day trial and your money will be refunded.

NORTON PRODUCTS, Dept. 5801T, 296 Broadway, New York 7, N. Y.

WHEELS WHEELS WHEELS

7" Disc Wheel 3/8" Tire 3/8" sleeve	45c ea.
8" Disc Wheel 1 1/8" Tire 1/2" sleeve	70c ea.
7" Disc Wheel 1" Tire 1/2" ball bearing	80c ea.
8" Disc Wheel 1 1/8" Tire 1/2" ball bearing	\$1.00 ea.
8" Disc Wheel 1.50 semi-pneum. Tire 1/2" B.B.	\$1.35 ea.
8" Disc Wheel 2" semi-pneum. T. 1/2" B.B.	\$1.50 ea.
10" Disc Wheel 1.75 semi-pneum. T. 1/2" B.B.	\$1.50 ea.
10" Disc Wheel 2.75 semi-pneum. Tire 3/4" B.B.	\$3.50 ea.
12" Disc Wheel 1.75 semi-pneum. T. 1/2" B.B.	\$1.85 ea.

Above wheel prices includes hub cap. Plus Postage, C.O.D.'s accepted. AXLES—Sizes 5/16 in., 3/8 in., 1/2 in.—Cut to size—End holes drilled.

UNITED WHEEL STAMPING CO.

12131 S. PEORIA STREET PM-1 CHICAGO 43, ILLINOIS

SAY YOU SAW IT IN
POPULAR MECHANICS

**SELL JUST ONE
SENTRY SAFE A DAY
AND YOU CAN EARN
\$8,000 A YEAR!**

Only 5% of the people own a personal safe to protect their valuables from fire, theft and loss! Cash in on this untapped market with **SENTRY**—the world's finest small safe. New mahogany cabinet model makes everyone a prospect—householders, professional men, farmers, small businessmen. Set your own price, take a big mark-up, and still under-sell all competition. Just one **SENTRY** sale a day can bring you \$8,000 a year. Choice, exclusive territory. Drop shipment if desired. Send for full details, giving address including county.



BRUSH-PUNNETT CO., 575 West Ave., Rochester 11, N.Y.

Save Hundreds of Dollars Yearly With Guide to Home Repairs

**Home Repairs, Modernizing Jobs Made Easy
for Home Owners**

Beat the high cost of home upkeep. Stop staggering labor costs. Save hundreds of dollars every year on carpentry, electrical, painting, plumbing and other jobs around the house with **POPULAR MECHANICS GUIDE TO HOME REPAIRS**. Simplified how-to-do-it instructions and 648 pictures make all jobs, inside and out, easy. Covers construction, remodeling, modernizing, repairing, that you can do yourself at small cost. Repair leaky faucets for pennies; save \$10 to \$15 on new electrical outlets; save hundreds of dollars on new floors, porch repairs, back painting, gutter replacements and other improvements. 192 page cloth bound book only \$2.50 postpaid. Get **GUIDE TO HOME REPAIRS** today under our money back guarantee.

POPULAR MECHANICS PRESS, Dept. PM1, 200 E. Ontario St., Chicago 11



ELECTRIFY your SEWING MACHINE

NEW LOW PRICE! \$9.95 90 DAY GUARANTEE

Buy direct from manufacturer and save! Kit comes fully wired, installed in a jiffy. Fits all machines! You get **ALL-NEW PARTS**

- Motor & Bracket
- AC-DC 115/60c
- Multi-speed foot control
- Cord set & block
- Easy instructions
- Steel pulley & belt

FREE . . . reg. \$2.95 chrome SEW-LITE given with every kit.

10 DAY FREE TRIAL—ORDER NOW!

Send no money, pay COD or send money order and we'll pay postage. Please state whether wheel on your machine turns toward you or away from you. Shipping wt. 6 lbs.

SENIOR SEWING MACHINE CO.
Box 147 Dept. PM63 Brooklyn 6, N. Y.

I will show you how to start your own

BIG PAY BUSINESS IN YOUR LIVING ROOM...

Breed RARE Tropical Fish!

Nature Multiplies Your Profits Up To 1000%

Species of Tropical Fish	Average No. Eggs Each Birth	Approx. Retail Price, Full Grown Fish
Jewel Fish	50 to 100	\$ 4.00 to \$ 6.00 pr.
Kissing Gourami	Over 200	\$ 2.00 to \$ 15.00 pr.
Pompadour Fish	10 to 50	\$50.00 to \$100.00 pr.
Angel Fish	80 to 150	\$ 1.00 to \$ 10.00 pr.



LEARN THE SECRETS—

Breed **TETRAS** that light-up like neon signs; **GOURAMI** (Kissing Fish) that smooch-away like newlyweds; **FIGHTING FISH** that duel to the death; **ANGEL FISH** that are breathtakingly beautiful, hundreds of other rare, valuable varieties. I'll furnish everything you need to start breeding Tropicals immediately!



SEA HORSE. Shown giving birth to 350 young. Retail for \$4 to \$15 pair.



FIGHTING FISH. Lays about 500 eggs each birth. Retail about \$4.50 per pair.



ANGEL FISH. Graceful, exotic. Lays about 250 eggs each time. Popular, big profit maker.

"We were successful—you can be, too. It's easy, it's fun!" Say Mr. & Mrs. C. F. Collins, owners of famous Collins Aquarium, Conn.

HERE'S WHAT OTHERS SAY—

"Already have back orders for twenty 10 gallon tanks stocked with fish!" *F.H.S., Kans.*

"Business prospect in this area is tremendous!" *J.E., Ga.*

"These fish have a great market potential, believe it will pay anyone to breed them!" *D.G., Calif.*



E. Edward Fisher

SPARE TIME OR FULL TIME!

MAIL COUPON TODAY

TROPICAL FISH BREEDERS OF AMERICA, Dept. D1
15121 So. Broadway,
Los Angeles 61, California

Rush everything free, without obligation, to—

Name _____

Address _____

City _____ State _____

© 1955

FREE!

Complete, lavishly illustrated "Success Folder," Home-Business Plan, Color Breeding Brochure, Reprints, all details. No obligation. **WRITE TODAY!**



Here's the one home business that's unbelievably easy and inexpensive to start, yet is so NEW it offers unlimited profit opportunity! NATURE does the work, YOU make the money—up to \$75 per pair. Breed Exotic Tropicals in your LIVING ROOM, garage, spare room, anywhere. Spend only minutes a day. NO EXPERIENCE, NO BIG INVESTMENT necessary. I'll give you all the secrets, everything you need to make BIG MONEY, TOO!

GET INTO PARTNERSHIP WITH NATURE! Tropicals lay 300-600 eggs per birth, many times a year! No other business offers such valuable, sought-after "merchandise" for so little time, effort, expense. You may raise enough in your LIVING ROOM alone to make \$7.50 per hour—gain financial independence!

HELP FILL HUGE DEMAND in your area from fanciers, stores, businesses, restaurants, etc. No compe-

tion from big business. Breeder shortage now forces many buyers to purchase OUT OF STATE.

IT'S FUN—FASCINATING! These beautiful "water jewels" delight the senses... provide endless relaxation, and PROFIT! Make big MONEY at a job you'll enjoy!

ACT NOW! Be first in your area to capitalize on this Once In A Lifetime Opportunity!

Can A Man My Age Become a Hotel Executive

"How I Stepped Into a BIG PAY Hotel Job"



Even Though He Has No Previous Hotel Experience?

W. Bradley Hall Becomes Hotel Manager Although Without Experience

"When I enrolled in the Lewis School, I was a Railroad Conductor. Shortly afterwards, I went to work in a Chicago hotel. Within a year I was earning 50% more than in my previous position. Recently, I took over the 'Y' cafe and am my own boss."

Don E. Ulmer Becomes Hotel Manager As A Result of Lewis Training



"After I received my Lewis diploma, I accepted a position at a resort hotel. This position was obtained for me by the Lewis Placement Service. At the end of the season, I was appointed Manager of another hotel. Thanks to Lewis Training."

STEP INTO A WELL-PAID HOTEL POSITION

COURSE APPROVED FOR ALL VETERAN TRAINING

LEWIS HOTEL TRAINING SCHOOL, Room AA-317, Washington 7, D. C.

39th SUCCESSFUL YEAR

Send me, without obligation, the Free Book, "Your Big Opportunity." I want to know how to qualify for a well-paid position.

Home Study Resident Training

Name _____ (Print Name & Address)

Address _____

City _____ Zone No. _____ State _____

Check here if eligible for Veteran Training

Important positions, ever-increasing opportunities await trained men and women in essential hotels, motels, clubs, apartment house projects. Lewis graduates are "making good" as managers, assistant managers, stewards, social directors, hostesses and in 55 other types of well-paid positions. Previous experience proved unnecessary in this business, where you're not dropped because you are over 40. Lewis Training qualifies you at home, in spare time or through resident classes in Washington.

FREE book describes this fascinating field. It tells how you are registered FREE in Lewis National-Placement Service. Mail coupon today! Lewis Hotel Training School, Room AA-317, Washington 7, D.C.

GROW MIDGET TREES

\$1000 worth on your window sill!

EARN MONEY SPARE TIME!

Learn the ancient Oriental Technique. Grow Ming Trees—perfect, living specimens—BUT ONLY INCHES HIGH! Elm, Cypress, Oak...any kind. All BLOOM, even BEAR tiny, delicious fruit. New "Miracle Growing Method"—NO WAITING! Takes only minutes a week... sell for up to \$25, \$50, even \$250 each! FABULOUS \$\$\$ OPPORTUNITY! Everyone wants one. It's easy, fun. NO EXPERIENCE NEEDED. We supply everything. Write today—we'll send you:

FREE! Genuine Seeds & Plan

NATIONAL NURSERIES, Dept. M-1, 8463 S. Van Ness Ave., Inglewood 4, Calif.

SAVE \$65 on this LUXURIOUS \$100 CONTOUR CHAIR

Scientifically correct design for restful, healthful, relaxing. Adjusts for perfect sitting or reclining comfort. Proved beneficial to heart, nerves... most popular chair in every home. Firestone foam rubber and washable, pliable genuine Duran upholstery. Would cost \$100 or more in any store. Shipped all ready to put together in less than one evening. No cutting, no drilling, no skill needed. A woman can do it. Order now! Everything needed for only \$34.95, f.o.b. Balto. State color wanted: forest green, royal blue, ruby red, walnut brown. Enclose \$5 deposit, pay balance on arrival. Money back if not satisfied.

\$34.95 For Everything Needed Complete

Put It Together in 1 Evening



GENUINE FOAM RUBBER

BESTECRAFT, Dept. 95
Matheson Bldg., Baltimore 2, Md.
Make Money Selling and Assembling Contour Chairs For Friends.

AMAZING NEW TINY RADIO

Really Works—Small as a Pack of Cigarettes!



GETS LOCAL RADIO STATIONS WITH CLEAR BELL-LIKE TONE—NO STATIC OR INTERFERENCE NEEDS NO TUBES, BATTERIES OR COMPLICATED WIRING! NO AC PLUG INS! Nothing to wear out. Thousands of users—early report years of service. Uses new crystal diode and HI-Q coil. SELF-CONTAINED SPEAKER PHONE. Just the tiny radio to take with you ANYWHERE YOU GO—ON TRIPS, VISITING, ETC.—for real fun and enjoyment—ANYTIME. Merely hook to anything that can act as an antenna for local reception. Free DX antenna kit included. **SEND ONLY \$1.00** (bill, ch., mo.) and pay postman \$3.99 C.O.D. postage or send \$4.99 for p.p. delivery. COMPLETE READY TO LISTEN. MIDWAY CO., Dept. PPM-1, Kearney, Nebr.



OWN YOUR OWN BUSINESS

Free folder tells how! Build and operate this profitable roadside stand—seasonal or year 'round. Mail coupon now.



RICHARDSON Corporation
Dept. PM-1, P.O. Box 790, Rochester 3, N.Y.
Please send me FREE folder on your tested, franchised refreshment stand.

Name.....
Address.....
Place.....

New! Ultra Powerful

7X, 35

LIGHTWEIGHT BINOCULARS & LEATHER CASE



\$34.95

F.T.L.

DON'T CONFUSE THIS 7X, 35 BINOCULAR WITH ORDINARY ONES! This is the **NEWEST, MOST IMPROVED MODEL!** Super-powerful, yet compact—only 5 inches high and **SO** light! Prismatic lens system gives needle-sharp definition. Genuine Kiaroptar **COATED** lenses. Synchronized center focusing. Wide field, 375 ft. at 1,000 yds. Weighs only 1/2 of reg. 7X binoculars. Slips easily into coat pocket. Pigskin leather case & straps included. We've sold hundreds at such **HIGHER** prices. Special to Popular Mechanics readers—Binoculars, pigskin case & straps—only **34.95**, tax incl. Send orders to:

THORESEN'S

DEPT. 6-A-170, 352 FOURTH AVE., NEW YORK 10, N. Y.

Electric Motor Kit 35c



Real Electric Motor in kit form. Fun to build, fun to run. All parts furnished. Build in 15 minutes, without tools. Over 1,000,000 sold for home and classroom use. Practical and simple way to learn principles of electricity, magnetism, how a motor operates and how electricity is generated. 6,000 rpm. Every part precision finished. Schools, clubs, camps, Army & Navy programs use them. 35c each, 10 or more 28c ea., 100 or more 25c, ea.

World of Adventure, Department 129, Ann Arbor, Michigan
New World Adventure Catalog FREE
Packed with over 1,200 self-help, home educational items. Make your life more fun, more profitable, and more interesting. Covers hobbies, vocational guidance, aptitude tests, wall charts and maps. Consumer guidance, travel, foreign languages, public affairs, slides, records, science materials, pocket books on everything from Art to Zoology, etc. Send name & address with 6c for mailing to:
World of Adventure, Department 129, Ann Arbor, Michigan

HELPFUL BOOKS

Send post card asking for **FREE catalog**
Popular Mechanics Press, 200 E. Ontario, Dept. 601, Chicago 11

MECHANICAL ADDRESSER COMPLETE

30 DAY TRIAL OFFER \$10⁹⁵



Addresses anything mailable—easily, quickly, professionally. Thousands in use. Complete with supplies for 250 names. Money-back guarantee. Send check or money order to:
THE HEYER CORP. Dept. 155
1856 S. Kostner, Chicago 23, Illinois

CHANGE TV STATIONS FROM YOUR CHAIR



DO-IT-YOURSELF "TV REMOTE CONTROL KIT" \$14.95 EACH

ALL YOU NEED IS A SCREW-DRIVER! Fits any TV set—No drilling—Won't mar or scratch—Clamps on clean—Kit contains everything you need for installation.
SATISFACTION GUARANTEED
REMOTE CONTROL CO. DEPT. P-1, 2418 W. NORTH AVE. CHICAGO 47, ILL.

FREE—TO MEN WHO WEIGH 200 LBS. OR MORE

New Burns Martin Spring Catalog shows America's biggest stock of large-size clothing—sizes 44 to 72. First quality apparel, designed to make you look slimmer and trimmer. Money-back guarantee with every item. Send for **FREE Catalog, NOW!**
BURNS MARTIN Dept. 654, 121 Summer St. Boston 10, Mass.

Courtesy Maxwell Offset



“WE’RE LOOKING FOR PEOPLE WHO LIKE TO DRAW”... say America’s 12 Most Famous Artists. Many men and women have hidden art talent they never dreamed of. They could be trained for success and security in the field of art if they only knew their own ability. We artists will help you discover your art talent free! Send for our **FREE ART TALENT TEST.**



Thousands paid \$1 to take this revealing 8-page test. It’s yours FREE if you act at once. Mail the coupon NOW!

<p>America’s 12 Most Famous Artists NORMAN ROCKWELL JON WHITCOMB AL PARKER STEVAN DOHANOS HAROLD VON SCHMIDT PETER HELCK FRED LUDEKENS BEN STAHL ROBERT FAWCETT AUSTIN BRIGGS DONG KINGMAN ALBERT DORNE</p>	<p>FAMOUS ARTISTS SCHOOLS Studio G-O Westport, Conn.</p> <p>Send me without obligation your Famous Artists Talent Test.</p> <p>Mr. _____ Age _____ Mrs. _____ Miss _____ (PLEASE PRINT)</p> <p>Address _____</p> <p>City _____ Zone _____ State _____</p>
--	---

HELPFUL BOOKS

Send post card asking for FREE catalog

Popular Mechanics Press, 200 E. Ontario, Dept. 601, Chicago 11

100 BEST Woodworking Projects



SELECTED FOR YOU BY POPULAR MECHANICS EDITORS
 Enjoy the fun — the pride — of making things. Get 100 BEST WOODWORKING PROJECTS, complete with simplified instruction, plans, diagrams and more than 400 how-to-do-it pictures. Make all kinds of furniture, baby carriages, clocks, lamps, book shelves, fireplaces and other useful articles at little or no cost. Send only \$2.00 with name and address. Money back if not pleased.

POPULAR MECHANICS PRESS, Dept. PM6, 200 E. Ontario St., Chicago 11

LEARN MEAT CUTTING AT NATIONAL

Pay After Graduation



The steady dependable trade of Meat Cutting taught easily in 8 short weeks. YOU LEARN BY DOING under actual meat market conditions in big modern school at Toledo.

For beginners or men with experience. Get a profitable store of your own. Remember, PEOPLE MUST EAT! Big pay jobs. Free employment help. Thousands of successful graduates.

Buying, cutting, percentage, pricing, advertising, selling, etc. A complete retail meat education. National School established over 30 years. Get National training NOW. Pay your tuition in easy weekly payments

after you graduate. Send coupon for FREE 52 page school catalog — TODAY. G.I. approved.

National School of Meat Cutting, Inc., Dept. 50-N, Toledo 4, Ohio	
Send me your FREE school catalog on National Training at Toledo in Meat Cutting, Meat Merchandising and Self Service Meats. No obligation. No salesman will call.	
Name _____	Age _____
Address _____	
City _____	State _____
Approved for training Korean Veterans	



**RAKE IN A GOOD YEAR'S PAY
IN SIX MONTHS'
SPARE TIME!**

**COLLECT
\$3.00 TO \$5.00 FOR EVERY HOUR!**

Take full advantage of the opportunities offered ambitious men by my sensational Seasonal Money - Making Plan, and you can loaf the rest of the year! Here's all you do to start:

Send the coupon below for my FREE Book "Run a Profitable Business". I'll rush it to you without cost or obligation. And in one of the most exciting half hours of your life, you'll see how you can:

- 1 Make every lawn mower in your area worth \$3.00 to \$16.50 to you each season.
- 2 Own an amazingly simple Automatic machine which will do the vitally necessary work of sharpening these mowers for you.
- 3 Pay for the machine with the PROFITS you should earn your very first month.
- 4 Avoid all risk, because you can follow in the footsteps of hundreds of smart, ambitious fellows like yourself, in many parts of America, who use the Foley Seasonal Money-Making Plan for SUCCESS, PROSPERITY, and SECURITY.

5 Add profits from a score of EXTRA products and services, to the money your Foley Electra-keen Lawn Mower Sharpener pours into your pockets. For instance, you can make profits sharpening and re-toothed saws, making keys, sharpening scissors, knives and skates — an almost endless variety.

6 Cash in now on the Building Boom, starting on a "shoe string", and rapidly developing your own important, big-money business.

7 Enjoy the personal cooperation of experts representing the largest company in its field, with a 54-year reputation for fair dealing.

8 If you want to work all year, see how you can DOUBLE or TRIPLE your present income.

**OWN THIS MAGIC
MONEY-MAKING
MACHINE!**



The Foley Electra-keen Lawn Mower Sharpener puts a perfect cutting edge on both hand and power mowers—2 to 3 times faster than any other method. It sharpens all blades and cutter bar together just like lawn mower manufacturers do it. (No need to take mowers apart!) Costs less than 1c per mower for electricity and material. Handles up to 3 or 4 mowers per hour. Prices for sharpening run from \$1.50 to \$3 for hand mowers—\$5 to \$8 for power mowers. You make 99% profit! Start this fascinating business in your basement, garage or work shed. You'll be excited as the work and PROFITS pile up, assuring you a rich spare-time income!!

**\$2,600
IN ONE SEASON!**

"Last year I had a net profit of \$2,600." E. G.

**PAID FOR
ITSELF IN
30 DAYS!**

"I'm well pleased with our Foley." G. Springer

**1,000
MOWERS A YEAR!**

"I sharpen 800-1,000 mowers a year." J. P. Howell

FREE! This valuable book "Run a Profitable Business" will be sent to you free and postpaid. It shows how to start your own money-making business and make \$3.00 to \$5.00 for every hour. Rush coupon NOW, to start making money right away!



SEND FOR FREE BOOK!

Mr. W. M. Ringer, Jr., President
Foley Mfg. Co., 107-5 Foley Bldg.
Minneapolis, Minnesota

Yes, I sure would like to rake in a good YEAR'S PAY in just 6 months' spare time! Please rush FREE and postpaid your valuable book "Run a Profitable Business" showing how I can make money in my own lawn mower sharpening business.

NAME.....
ADDRESS.....
TOWN.....STATE.....

RUSH THE COUPON TODAY!

FOLEY MFG. CO. 107-5 Foley Building
Minneapolis, Minnesota

WORLD'S
BEST
WANT-AD
MEDIUM

CLASSIFIED ADVERTISEMENTS



Advertisements in this section \$1.00 per word, each insertion, minimum 10 words, payable in advance.
To be inserted under proper classification, copy must be in our office the
20th of the second month preceding date of issue
F. W. Johnson, Manager, Classified Advertising
Popular Mechanics Magazine, 200 East Ontario Street, Chicago 11, Illinois

YOU'LL PROFIT

By reading and answering the classified ads in this section. Hundreds of opportunities for you to make and save money

AUTOMOBILES. MIDGET CARS

CLYMER'S New books. Just published! Indianapolis 1934 Race Yearbook \$1.50. Number 7 Historical Motor Scrapbook, 250 historical automobiles illustrated, described \$2.00. Scrapbook Early Auto Supplies and Equipment, corny, educational, laugh on each page, 1000 illustrations, \$1.00. Scrapbook Model "T" Ford includes Clymer experiences with model "T" \$2.00. Cars of Stars and Movie Memories, 400 photographs early stars, movie sets, cars, a knockout \$2.50. 1954 Mobilgas Economy Run \$1.50. Book of Car-Toons, laugh on every page \$1.00. Motor Memories, wonderful clothbound antique car book \$2.50. Ford Speed Manual \$2.00. Chevrolet Speed Manual \$2.00. Souping the Stock Engine \$2.00. World's Famous Racing Aircraft \$1.50. Chevrolet Owner's Handbook \$1.50. Ford Owner's Handbook \$1.50. Plymouth Owner's Handbook \$2.00. All postpaid. Write free catalog 125 automotive books. Ployd Clymer, Dept. E, 1268 S. Alvarado, Los Angeles, Calif.

ANTIQUÉ Automobile color slides, 2x2. Illustrated catalog free. Universal, Box 779A, Beverly Hills, Calif.

WORLD'S Largest supplier hi-mileage speed equipment. Thousands of items to help double the power, mileage, speed of your car. Amazing fuel savers. Complete customizing parts. Thick photo-catalogue 25c. (Literature free.) Write today. Newhouse Automotive Stores, Los Angeles 22.

HI-Compression copper gaskets, \$6.45 postpaid. Speed Shangri-La, 64 Afton PM-201, Rochester 12, N. Y.

FREE Motor magazines; automobile literature, old, new and foreign; glossy photos, dealer books, service manuals, offered with non-profit organization. Write today; get on free mailing list. Auto Maniacs, Stockbridge, Mich.

1955 **SUPERIGNITIONITER**, Starting, pep, mileage, \$4.50. Dealers. Barbells course \$35.00. EG, Elmsford, N. Y.

AUTO SUPPLIES AND EQUIPMENT

SEAL Your automobile cooling system. No water or antifreeze lost. Fill and forget. Free information. Jos. Dunnigan, 401 S. Central Ave., Baltimore 2, Maryland.

BUY Wholesale nationally advertised auto supply, thousands other products at big discount. Free "Wholesale Plan." American Buyers', 629-D Linden, Buffalo 16, New York.

LACHAPELLE'S Treatment. (Patented.) Makes any car better, even a brand new one. Free data. Ferns Products, Box 71827-B, Los Angeles 1, Calif.

FORD-T parts. Most complete stock in U. S. for all old cars. Try to stump us. B. S. Wisneski, Milwaukee 7, Wisconsin.

SAFETY Belts for automobiles, \$5.95. Several types, colors. Guaranteed. Literature. Box 1142, Poughkeepsie, N. Y.

RADIATORS Repaired \$10, f.o.b. Chicago. New and reconditioned radiators. Reconditioning and specials to order. Kale, 2250 Milwaukee, Chicago 47.

BIG All-new 1955 speed-sport-chrome and custom hot-rod catalog. Entirely new and different. Illustrating thousands nationally known products at tremendous discounts! Send 25c (refundable). Gotham, 1155 Broadway, New York 1, N. Y.

LATEST Automobile accessories for your driving comfort and safety; car's beauty and preservation! Catalogue free. Bonn, Box 62-D, New York 68, N. Y.

BRUSH Plating outfits connect to a battery. No tanks or shop required. Free particulars. Gunmetal Co., Ave. J., Decatur, Ill.

PROTECTO Rod stops rust; removes car radiator scale. Write Godfrey, 1108 Jefferson, Boise 1, Idaho.

WILLYS Owners—Install Ford V8 engine in station wagons, Jeeps, trucks. Conversion kit \$43.25. Send check or m.o. for prepaid delivery. Free details. Hoosier Machine Products Co., 313 S.E. 6th St., Pendleton, Oregon.

BLACK Top dressing for convertible tops. Gives that new look. Contains silicone for durability. Spray or brush on. Will not stiffen, crack or peel. Full instruction included. \$3.00 postpaid. Nutop, Box 757, Hendersonville, N. C.

GENUINE Motor treatment, Lachapelle's, (patented). Only \$3.00 delivered. Increases compression, power. Saves gas, oil, repairs. Money back guarantee. You can't lose. Free circular. Write Joe Dillon, Authorized Warehouse and Agents Distributor, Box 323-4 Bridgeport, Ohio. Exclusive distributorships, agencies open.

THIEF Chaser—Stops tire, gasoline, and auto thieves. 20 year guarantee. Salesmen wanted. Unique sample offer. Novak Company, 3131 West 13th, Gary 11, Ind.

YOUR Name engraved on distinctive lifetime key tag. \$1.00. Esch Enterprises, Box 322, Alhambra, California.

CRANKSHAFT Grinder, hand operated. Makes bearings fit without taking engine apart. \$3.75. Literature. L. D. McGee, 719 Cascade St., Wenatchee, Wash.

BACK-Seat driver's license! Send 25c. Toots, 2045-P Morse, Chicago 45.

CAR Burning oil? Losing compression? Try Clifford's Compression Seal. \$2 postpaid. Clifford's Engineering, 1329 Seventh, Aurora, Illinois.

NEW And used parts at savings. Complete guaranteed parts service for all models cars and trucks—1924 and later. Largest in the West. Army parts specialists. No catalog, write for quotations. Fast mail order service. Pioneer Auto and Truck Parts Co., 734 W. 13th Avenue, Denver, Colorado.

TAPPET Noises in Fords, Chevrolets and Mercurys stopped with Kaye Tappet Silencers. Free literature. Kaye Products, 2067B S. Layton Blvd., Milwaukee 15, Wis.

END Oil changing! Refine your oil as you drive! Refinol antiquates all other oil filters. Free booklet on saving your car or tractor motor. International Refinol Company, 8948 W. 47th, Brookfield, Ill. "Chicago's technical suburb."

AUTO Accessory and parts catalog, 1955 edition—all new! 148 pages. Save up to 50%, over 50,000 items, including Hollywood accessories, hi-speed equipment, rebuilt engines, all parts and accessories for all cars and trucks! Hard-to-get parts! Send 25c (refundable). J. C. Whitney, 1919-PM Archer, Chicago 16, Illinois.

SPEED Equipment. Any car. Send year, make, and \$1.00 for full particulars. Refundable with purchase. Power, 327 West 117th, Hawthorne, California.

ELECTROPLATE Auto parts, novelties, mirrors. Easy, inexpensive home processes. Free booklet. Tyco Metals, Box 1331-BG, Houston 19, Texas.

LATEST Custom accessories. Items not in stores. New low prices. Push button doors, trunks, windows, etc. New illustrated catalog, biggest ever. 25c. Eastern Auto, 3319-A, South Grand, Los Angeles 7, California.

THUNDERBOLT Ignition unit boosts motor power, saves gas. Slips on distributor in 10 seconds. \$2.98 postpaid. Money-back guarantee. Free literature. Auto Products, 722 W. North Avenue, Baltimore 17, Maryland.

KWIK-Start Co. system starts cars fast. 6000 No. Menard, Chicago 30, Ill.

AUTO TRAILERS

ALUMINUM Camp trailer kit—Vacationists, hunters, fisherman, folding, 560 lbs., sleeps five. Literature. Sample materials 20c. Master Camper, West Sayville, N. Y.

TRAILER Building. Illustrated circulars 20c. Craftsman Books, Box 1153, Milwaukee 1, Wis.

AIRPLANE Wheels, tires, tubes; new, used. Write for free list and prices. Chris Stoltzfus, Box 470, Coatesville, Penna.

TRAILER Manual. Over 200 pages, 250 pictures. Tells how to: buy, tow, travel, build, live-in, repair. \$1.98. Trail-R-Club of America, Dept. PM-1, Box 1376, Beverly Hills, California.

ASSEMBLE Yourself kit. Slip-on cabin coach for pickups. Trailer blueprints. Literature 10c. Comstock Trailers, 585-P, Parsons, Kansas.

EXCEPTIONAL Expanding eight foot trailer. Accommodates family of five. Build yourself. Literature 10c. Pramcar Company, Wilmington, Mass.

BUILD Your own trailer! Plans for all kinds. Illustrated catalog 10c. Jim Dandy, 125-M, Wausau, Wisconsin.

MOTORCYCLES, BICYCLES, MOTORSCOOTERS AND SUPPLIES

WHIZZER Motors \$20.00; midget car \$15.00; motorscooter \$6.00; Cushman two-speed \$20.00. Send 25c (35c first class mail) for catalog #28 jammed with sensational bargains in wheels, motors, motor-scooters, midget cars, motorbikes, construction plans, etc. Gail, 1313 Jefferson, Toledo, Ohio.

NEW! "Cycle Silencer." Engineered exhaust tailpipe replaces muffler; pounds lighter, eliminates backpressure. Guaranteed to make your motorcycle go miles faster. Neat styling; legal. \$9.95 postpaid. Free literature. Write Turnkey Products, 623 20th Avenue, San Francisco 21, Calif.

MIDGET Auto \$10. James motorcycle \$15. Cushman motorscooter \$10, less engines; Clinton engine \$4. Whizzer \$15. Four airplane tires \$3, (mailorder only). Send 25c (35c first class mailing) for latest Directory Catalogue Number 63, just out, listing these and hundreds of other bargains in new and used midget cars, motor-scooters, homebuilders parts, plans, etc. Midget Motors Directory, Athens 1, Ohio.

REBUILT Bicycle or motorscooter engines. \$17.00 up. Cauffiel Motors, Temperance, Michigan.

RECONDITIONED Motorcycles and motors. Chromium accessories. Complete stock Indian parts. Expert rebuilding. Fast service. Indian Motorcycle Sales, Kansas City 27, Mo.

"BUZZZZZ" The motorcycle magazine. International coverage. Thoroughly illustrated. Yearly \$2.00. Sample 25c. 5424-A Sawyer, Chicago 25.

HARLEY-Davidsons — America's best used buys! We pay shipping on motorcycles. Genuine new, used, parts, accessories for current and obsolete models. Send 25c for bulletin, catalog. Knuth's (Harley-Davidson factory dealer). 2491 Pond du Lac, Milwaukee, Wis.

AVIATION

CONFIDENTIAL Reports on best paying jobs and careers with airlines, feederlines, aircraft factories, corporations, cropdusters, etc. Pilots, mechanics, all aviation specialties. Experienced and unskilled. Foreign and American. Complete satisfaction guaranteed. Only \$2.00. (Airmail \$2.25). Research Services, Box 2904-PMB, St. Louis 17, Missouri.

LIGHTPLANE Building. Illustrated circulars 20c. Craftsman Books, Box 1153, Milwaukee 1, Wis.

FREE: Monthly aircraft, electronic, gadget list. Dick Rose, Everett, Wash.

BUILD A man carrying helicopter jet engine yourself! "Practical Ram Jet Design"—\$1.00. "Practical Pulse Jet Design"—\$1.00. Decker Engine Works, Plasterco, Va.

PROPELLERS. Plans, supplies for air boats, snow sleds. Catalog 10c. Gano Propellers, Box 3384-A, Ft. Worth, Texas.

PROPELLERS. Plans, kits for snow sleds, air boats. Immediate delivery, satisfaction guaranteed. Catalog 25c. Banks-Maxwell, Box 3301E, Ft. Worth, Texas.

NEW And used headquarters for automotive and airplane parts and accessories. Our prices are low prices. Dee Jon's Sales Co., 2826 Kelton Avenue, West Los Angeles, California.

BATTERIES, GENERATORS

AMAZING Battery charger—Gives more power to lights, radio; faster starting even in cold weather. Batteries last up to one year longer. Only \$1.00 ppd., 2 for \$1.60. Batteries, 174 S. Perry, Spokane, Wash.

LONG Life battery—Make your own. Details free. Marbill Products, Elkcoot City 3, Md.

EDISON Nickel storage batteries. Any voltage, any amperage. Unconditionally guaranteed. Power plants, generators, motors. Literature, Hawley Smith Co., Croton Falls 1, N. Y.

ELECTRICAL SUPPLIES

STOP Power loss and save money. This triple wall receptacle has beryllium copper coil springs that hold plugs tight. \$2.00 postpaid. U.L. approved, guaranteed. Miles, 7655-A West Myrtle, Chicago 31.

COPPER Wire specialists. Bare, tinned, magnet, cords, cables and lead wire. Mohawk, 3021 W. Armitage, Chicago 47, Illinois.

OHMMETER. For motor and appliance service, \$7.55 prepaid. Motor Industries, Quincy, Illinois.

ELECTRIC Pencil: Engraves all metals \$1.50. Beyer Mfg., 10311-H Springfield, Chicago 43.

LAMPS—25c Brings bargain catalog showing all parts for repairing, building. Contains instructions for electrifying vases, oil lamps, etc. Gyro Lamps, 5402P Clark, Chicago 40.

LEARN Appliance service. Motors, washers, refrigeration, everything. Booklet. Manager, Box 73136, Los Angeles 3.

LAMP Supplies — Wholesale. Any amounts. All parts for repairing and building lamps. Catalogue 15c. Brown Lamp Co., Box 501-Wellston Sta., St. Louis 12, Mo.

AIR CONDITIONING

AIR Conditioning systems cleaned—vacuum and steam method—commercial and industrial contracting anywhere in U.S.A. A Ventilation Cleaning Service, 469 West Willis, Detroit 1, Michigan.

WELDING, SOLDERING, PLATING

BUILD-UP-OWN a.c. welder and a.c. power plant with a good used engine and low cost Hobart generator. Welds anywhere and supplies 5kw stand-by power for any emergency. Write Hobartweld, Box M-153, Troy, Ohio.

PERFECT Soldering now possible. New amazing tinning compound does wonders. Failureproof. For steel, cast iron, copper, lead, etc. Smooth jobs guaranteed. 4 oz. tin \$1.00. 1 lb. \$2.50. Canadian Powdered Metals, R. #1, Hamilton, Ontario, Canada.

100 AMP. A.C. welder \$50. 220 volts, single phase, G.E. transformer. DuPont Smith, 106 Verbena, Oak Ridge, Tenn.

BUILD Arc welder the easy way using aircraft generator. Plan 10c including catalog welder-kits, hydraulic-kits, etc. Dunbar Mfg., Box 12206-B4, Houston 17, Texas.

ACETYLENE Welding outfits new \$49.00; used \$29.00; arcwelders \$49.50. Eagle Welding, Dept. P.M., 5085 Broadway, Chicago 40, Ill.

A.C. Welders. 4 sizes. Lowest prices. Free literature. Holgeron's Serv., Canton, Kan.

ELECTROPLATING Equipment, anodes and solutions for all types of plating. Instructions. Assemble your own plater and save. Free catalog. Ramyr, Dept. E-4, 1624 East First Street, Los Angeles 33, California.

SELF-Training System. Radiator repairing, cleaning, recoring. How to equip small shop at low cost. Supply sources, trade secrets, instructions. Radiator Service, East Jordan, Mich.

MACHINERY, TOOLS, SUPPLIES

USE On drill press or lathe, fast low cost thread tapping attachment, other uses. Free literature by return mail. H. & T. Manufacturing Company, Spirit Lake, Iowa.

NEW Electric drills and saws. $\frac{1}{4}$ " \$11.75 and \$15.75; $\frac{1}{2}$ " \$30.75; 6 $\frac{1}{4}$ " tilting arbor \$39.95. Prepaid. Wilt Surplus, 7829 Racine, Chicago 20.

FREE Details. Clear \$75 weekly in spare time installing garage door openers. No investment, experience or equipment necessary. Best Tools Inc., Box 92, Berwyn, Ill.

ALLEN Two ton power bench type punch press. \$97.50. Circular. Allen, Dept. PMB, Clinton, Missouri.

BIG Factory catalog! Buy direct—Save middleman's profits; hundreds of labor saving tools and equipment; tremendous savings. Send 10c. Master Mechanic Mfg., Dept. CL-64, Burlington, Wis.

NEW All-purpose speed changer. Circular. Multispeed Company, 3420 Meadowbridge, Richmond 22, Va.

MAKE It yourself at Zelf, the rental machine shop. Lathes, millers, grinders, drills, welders, etc., with accessories. Low hourly rates. For your use in the Zelf Shop only. 121 W. 64th St., New York. SU7-8353.

HAMMER-Guard is a new tool made of rubber to slip on your 16 oz. hammer to stop those hammer tracks. You can pull nails without damage too. Just out. Send \$1.00. Postpaid. Highland Industries, Greenville, Maine.

PRECISION Hand tapping on your drill press. Tappo Chuck Wrench, fits keystone chucks, size 6A 33 0- $\frac{1}{2}$ inch. \$3.75 postpaid. Money back guarantee. Free details. Gilbert Manufacturing Co., 139-J Riverview Ave., Elkhart, Indiana.

SNOWTRACTORS! Army Weasel parts. World's largest supplier. Symington of Seattle, Union Bay Place, Seattle 5, Wash.

AIRCRAFT Generators: L-3, 24V, 25A, \$9.95; ETA, 12V, 50A, \$14.95; P-1, 24V, 200A, \$14.95. Homelite plant, 3hp engine, 25V, 2000W, 70A, \$47.50. Build welders, platers, lighting, F.O.B., Aero Parts Supply, Municipal Airport, Houston, Texas.

SHEBEL Saw filer files all saws. Circular. A. P. Shebel, 730 So. 2nd St., Milwaukee 4, Wis.

ALL Steel woodworking lathe, 5 x 12, \$9.95 prepaid. Circular. Sypher Co., 210 Cherry, Toledo, Ohio.

\$16.50 PRECISION 2" Three jaw universal chuck with #2 Morse taper arbor, key \$8.95 prepaid. Ideal for turning-headstock, tallstock, turrets. For button dies. Guaranteed. Prehler Company, 1625 Milwaukee, Chicago 47.

ENGINES, MOTORS, DYNAMOS

REWIND Motors yourself. Complete instructions \$1.00. Lewis Mfg., Howell 10, Michigan.

ENGINES—Marine, industrial, Helwege Co., 741 S. Ocean, Freeport, N. Y.

REBUILT $\frac{1}{2}$ to 3 h.p. engines \$17.00 to \$37.00. Cauffiel Motors, Temperance, Michigan.

WINDING Data. 225 motors, single and three phase, \$1.00. Data Company, Box 7631, Kansas City 28, Mo.

BOATS, OUTBOARD MOTORS

SAVE On marine supplies. Propellers, engine conversion kits, engines, boat kits. No catalog. Submit requirements for quotation. Discounts from 20% to 40%. Marine Discount Corp., P.O. Box 12, Rockville Center, N. Y.

REDUCE Breakage. Plexiglas windshields, side panels. Clear or colored. Cut to size. Send 25c for complete catalogue and prices. Direct factory distributor. Delta Products, 1400 Henderson, Fort Worth, Texas.

JOHNSON Outboard specialists. Used parts for all models at substantial savings. Prompt quotations. Specify model serial. Crandall-Hicks, 910 Commonwealth, Boston, Mass.

BOAT Owners: Send \$1.00 for liberal sample kit fiber-glass process with instructions for low cost everlasting waterproofing, reinforcing, repairing. Glass-Weld, 578 Hamilton Ave., Waterbury, Conn.

MARINE Conversions—Willys to Cadillac. Catalogue and conversion hints free. Barr Marine Products, 2706 Castor Avenue, Philadelphia 34, Penna.

BUY Wholesale nationally advertised outboards, thousands other products at big discount. Free "Wholesale Plan." American Buyers, 628-D Linden, Buffalo 26, New York.

68 DESIGNS, Catalog 25c. Kit, hardware catalog, 15c. Marincrafts, 55-M Sorrento, Allston, Mass.

SIMPLIFIED. Modern boat plans and patterns. Inboards and outboards 12'-22'. Please state type. Glen Designs, Box 568, Compton, California.

FULL Size, cut-to-shape boat patterns, blueprints, 7 $\frac{1}{2}$ -38 feet. New 1955 illustrated "Build a Boat" catalog of 50 nautical architect-designed cruisers, runabouts, sloops, skiffs, outboard boats, sailing, racing, houseboats, 50c. Marine hardware catalog, \$1.50. Bigger, better 1955 "How to Build Boats" book, \$2.50. PolyWog Houseboat Plans, \$12. Cleveland Boat Blueprint Co., Dept. A-66, 9400 Steinway, Cleveland 4, Ohio.

AIRPLANE Engines, all makes 65 to 300 hp., for air boats, snow sleds; complete power package, test run, ready to install. Write for descriptive list and prices. Chris Stoltzfus, Box 470, Coatesville, Penna.

MARINE Conversions, Willys to Cadillac, engines, kits and parts. Catalogue and conversion hints free. Barr Marine, 2706 Castor Avenue, Philadelphia 34, Penna.

FIBERGLAS Permanent boat waterproofing. Lowest wholesale prices. Guaranteed materials. Easy application. Full instructions. Complete kits, \$12.60 up. Free literature. Ajax Plastics, Dept. PM, P.O. Box 1323, Fort Worth, Texas.

FREE Booklet on famous Plycraft prams and boats—\$79.50 and up! Not kits! Sturdy fiberglass, reinforced waterproof plywood, riveted construction. Light-weight. Fully painted, inside and out. Mahogany seats, rails, knees. Write today for full details and name of nearest dealer. Lawrence Plycraft, Dept. PM, South Canal Street, Lawrence, Mass.

FREE Catalog! Boat kits, trailers, fiber-glass, marine hardware. Luger Industries, Dept. M, 4452 Nicollet, Minneapolis, Minn.

BOAT Patterns. Literature and illustrated boat construction book \$1.00. German Boat Company, West Saginaw, Mich.

MARINE Conversions for Ford and Jeep engines. Catalog 10c. Lehman Manufacturing Company, 972D Broad Street, Newark 2, New Jersey.

NEW, Used, rebuilt marine motors. Marine conversions, fittings. Free catalog. Stokes Marine Supply, Dept. 24, Coldwater, Michigan.

CONVERT Fords and Jeeps to 100% marine engines with Osco's world famous Convo-Kits. Deluxe catalogue 25c (coin). Oscomotors, 3627B Lawrence, Philadelphia 40, Penna.

AIR Boat plans, supplies, catalog 25c. Banks-Maxwell, Box 3301F, Ft. Worth, Texas.

BOAT Covers, custom and ready made. Also tarpaulins, canvas yard goods, life preservers. Free boat cover catalogue. Morsan, 10-46R 50th Avenue, Long Island City 1, N. Y.

ATHLETIC EQUIPMENT, BODY BUILDING COURSES

FREE Catalogue. 10c for postage appreciated. Dr. Thompson, 919 Fourth, Manhattan 30, Kansas.

PUSHED Around? Why take nonsense from bullies, wise guys, other pests. Give them the surprise of their lives. Easy when you know police Jiu Jitsu. Complete fully illustrated course comes in one volume, same as taught police and members of armed forces. Send \$1 now, we will send police Jiu Jitsu postpaid by return mail. Satisfaction guaranteed. Books Publishing Co., Amityville 3, N. Y.

BARBELLS. Exercise equipment. Courses. Free booklet. Good Barbell Co., Reading, Penna.

SPORTING GOODS, GUNS, FISHING TACKLE, ARCHERY, TRAPPING

GUN Parts for obsolete firearms. Mausers, Laggers, Walthers, firing pins, springs, extractors, barrels, magazines. Order today No. 9 illustrated parts list 25c. Western Gun Exchange, Box 619, Whittier, Calif.

BUY Wholesale nationally advertised sporting goods, thousands other products at big discount. Free "Wholesale Plan." American Buyers', 627-D Linden, Buffalo 16, N. Y.

ELIMINATE Backlash with lifetime "Automatic Thumper." Guaranteed, \$2.00 postpaid. Windsor Sales, Windsor 2, Mo.

LEARN Gun repairing at home. Profitable business. Details 10c. Modern Gun Repair School, Box 430-P, Marshfield, Wis.

FREE Fishing catalog—132 pages. Over 3000 hard to find fishing specialties. Netcraft Company, Dept. PM1, Toledo 13, Ohio.

FLY Tying time: Select fly materials at reasonable prices. Hooks 50c/100 and up. Free illustrated catalog. Wholesale to manufacturers. Fly kits: with vise. Beginners \$3.95, amateurs \$5.20, select \$7.95, deluxe \$9.95. Spinning kit: \$7.95 postpaid. No c.o.d.'s. Shoff's, Dept. B, Kent, Wash.

GUNS! Free list. Owens Sporting Goods, 2142 E. Tenth, Long Beach 4, Calif.

TENTS, Camping equipment. Send 10c for 100 page tent, camping equipment catalogue-handbook. Morsan, 10-21R 50th Avenue, Long Island City 1, New York.

SAVE 50% Finest archery equipment. Revealing "How to Bow-fish, Bow-hunt, Make Own Tackle, Improve Accuracy" booklet plus catalog. Send 25c for handling. Malibu Archery, 3156RJ Eighth, Los Angeles 5, California.

HOLLOWGLASS Fishing rod kits. Assemble yourself. Save over half. Casting, spinning, fly and boat, \$4.95 up. Full instructions. Free literature. Makit Rod Co., 429 1/2 Fulton, Fort Worth, Texas.

TUBULAR Glass rod kits—Casting, spinning and boat, fresh and saltwater. Build custom rods at home for profit. Free listing of blanks, guides, handles and accessories. Fishermen's novelty key chain 25c. Rodman, Box 41, Wauwatosa, Wisconsin.

SPORTSMEN! Camp fire grill, slides up, down. Holds pots, pans. Grill right on surface! Picture, details. Westminster, Montpelier, Ohio.

KNOTTY Pine gun racks. Low prices. Details free. Lodgepole Pines, Bettendorf, Iowa.

ATTENTION! Colt collectors. Complete your collection of rare gun replicas for your den, office, or lodge. Free information. Woolslair, 645-D 30th, Hermosa Beach, Calif.

2000 GUNS! Guns! Happy New Year! Hunters, shooters, collectors. All guns and accessories. Bargain catalog 50c. Agramonte, 201 Warburton, Yonkers 2G, N. Y.

SWIMMERS! Send \$3.95 for imported French mask. Catalog of skin divers' equipment and books 25c. Aquafun PM, Davenport, Iowa.

MOLDS—For making fishermen's sinkers. Free illustrated booklet. Reading Instrument Co., Box 78, Reading, Penna.

DELUXE Cleaning service on suede and leather jackets. Expert repairing. Free price list. Write Ed Roper, New Idea Cleaners, Coatesville, Penna.

100 GOOD Fishing spots in Canada. \$1.00. Box 247, Terminal A, Toronto, Canada.

OLD Guns. Current prices. Free catalog. Pioneer Books, Harriman, Tennessee.

5000 BARGAINS. Firearms, binoculars, war relics. Catalog 50c. Smith Firearms, Runnemeade, N. J.

180 PROFUSELY Illustrated pages antique pistols, swords, daggers, armor, etc. 50c. Robert Abels, M860 Lexington Ave., New York 21.

MANY Modern, antique guns. List 10c coin. Ed Howe, 52 Main, Coopers Mills, Maine.

JAP Rifle altering to 30-06, \$6.00. Jap-shells, \$3.75. Catalog 5c. T. P. Shop, West Branch 11, Mich.

PORTABLE Blinds: For duck, crow, goose shooting. Very light 4 x 5 ft. woven natural Tule mats. Strong. Excellent on duck boats and permanent blinds too! \$3.00 delivered. Peacock Broom Co., 915 Bryant St., San Francisco, Calif.

IMPORTED, Daggers, stilettos, throwing, pocket, hunting knives, etc. Free catalog. J. D. Clinton, 94 Church, Mt. Clemens 2, Michigan.

CALL Elk, deer, coyotes, foxes, etc. Original Animal Calls, Burley, Idaho.

TAXIDERMY

MODERN Taxidermist magazine. Greenfield Center 2, N. Y. Devoted entirely to taxidermy, methods, photos. Trial year's subscription, \$1.00.

BINOCULARS, TELESCOPES, MICROSCOPES, MAGNIFIERS

DYNASCOPE—New sensational reflector telescope 65X-130X-167X-4 power finder fully achromatic. Hardwood folding tripod, completely ready for use. Send for details. Criterion Manufacturing, Dept. DP8, Hartford, Conn.

SAVE 25%! Get interesting facts. Free 52 page binocular, telescope catalog. \$3.95 to \$250.00! United, 9043 S. Western, A-8608, Chicago 20. Dealers wanted.

400X TELESCOPE Makers kit contains focusing tube, erector, 5 lenses and instructions, \$3.75. Giant 100X astronomical telescope complete with tripod, \$15.00. Free information. Suffolk Science, Mattituck 3, N. Y.

SPECIALISTS. Used microscopes and accessories. Unusual selection prepared slides. Microscopy supplies. Scientific oddities. Telescopes and equipment. Many more interesting items. See them in our 1955 illustrated catalog, free. Research Scientific Supplies Inc., 60 Wall Street, New York 5, N. Y.

REFLECTOR Telescope kits from \$6.25. Mirrors and mirror cells, diagonals, focusing mounts, tripods, tubing oculars. Fully guaranteed. Free illustrated catalog. Visit our store 166 Church St., New York, N. Y. Send orders and inquiries to Esco Products, Dept. PM-1, 1428 Willow Avenue, Hoboken, N. J.

WAR Surplus bargains! Millions of lenses, instruments, telescopes, binoculars, components and complete line of astronomical telescope items. World's greatest optical market place! Send only \$1.00 for beginner's 10-lens kit and big instruction booklet Stock CH. Write for catalog CH free! Edmund Scientific Corp., Barrington, New Jersey

FREE Literature. 400X day and night telescope easily made. 5 lenses, erector, focusing tube, instructions \$6.00 postpaid. Established 25 years. We originate. Others copy. Carl Jamer, Manorville, N. Y.

IMPORTERS' Amazing prices, precision binoculars, 22 models. Free trial. Folder, "Binocular Selecting," catalog free. Dealers wanted. Prentiss Importers, Mercury Bldg., West Los Angeles 25, Calif.

BINOCULARS, Telescopes, microscopes, terrific values \$3.98 up. Request free money saving catalog. Criterion, Dept. P26, Hartford, Conn.

MICROSCOPES. Prepared slides, biological stains, oculars, illuminators, mechanical stages, objectives, mounting media, parts, specialized equipment. Premium quality merchandise, lowest prices anywhere. Write for free illustrated microscope catalog and price list. Benjamin Miller, 134 W. 32nd St., Rm. 204-A, New York 1, N. Y.

REFLECTING Telescopes, 60X, completely assembled \$29.75. Guaranteed observatory clearness. Free information. Skyscope, 475 Fifth Avenue, New York 17.

PETS—DOGS, BIRDS, RABBITS, HAMSTERS, ETC.

CHINCHILLAS—10 Animals, equipment. H. Johnson, Pocono Road, Danbury, Conn.

CHINCHILLAS, Registered, low prices. Kray, 1600M West Goodhope, Milwaukee 9, Wisconsin.

CHINCHILLAS: Top-quality N.C.B.A. registered breeders. Mature, guaranteed bred pairs or sturdy young stock. Terms. C & B Chinchillas, Wycocena, Wis.

RACCOONS, Minks—Bred females, Baby skunks. Catalog 25c. Shady Fur Farm, Springfield, Minnesota.

HAMSTERS—Golden; young, \$4.00 pair, fully developed, \$5.00 pair. Adirondack Hamstery, Prospect 58, New York.

RABBITS. Best home moneymaker. Booklet free. Tayco Rabbitry, Hapeville, Georgia.

RAISE "Wil" strain rabbits. Free catalog. Wilson's Rabbitry, Greer, S. C.

HUNTERS! Raccoon Mountain and Short Creek Kennels now combined. Large number of coonhounds, foxhounds, rabbit-hounds, beaglehounds, bird-dogs, puppies. Free literature and pictures. Trial, Dures Thomas, Owner, Box 464, Boaz, Alabama.

HAMSTERS—Special January sale. Write for details. Anderson's Hamstery, 35 Oneida, Pontiac, Michigan.

GUINEA Pigs. Wonderful enterprise. Booklet free. Taylors Company, Hapeville, Georgia.

CHINCHILLAS—Big profits, send 25c for literature to Tom McGowan, 170 Horton Ave., Valley Stream, L. I., N. Y.

START Right by knowing facts about rabbit raising. Illustrated booklet describing all breeds, housing, feeding, breeding, marketing. 48 pages 10 cents. American Rabbit Breeders Association, 36 Arba Building, Pittsburgh, Penna.

MAKE Money raising chinchillas, mink, pigeons, rabbits, cavies for us. Free catalog. Keeney Brothers, New Freedom 2, Penna.

RAISE Mink: Free booklet, pen plans, inside secrets, feed care. Mink are money makers. Investigate today. Lawrence Mouldard, Brigham City 12, Utah.

RAISE Moneymaking Angora, New Zealand rabbits. Particulars free. White's Rabbitry, Jackson, Mich.

MAKE Big money! Raise Chinchilla rabbits. Cash markets supplied. Write today! Rockhill Ranch, Sellersville 15, Penna.

STANDARD Rabbit Journal, Milton 3, Penna. Year \$1.00. Sample dime. Beginners manual 25c.

GROW Mushrooms. Cellar, shed, and outdoors. Spare, full time, year round. We pay \$3.50 lb. We paid Babbitt \$4,165.00 in few weeks. Free book. Washington Mushroom Ind., Dept. 171, 2954 Admiral Way, Seattle, Washington.

MINK Raising information free. Complete. Lake Superior Mink Farm, Superior, E11, Wisconsin.

CHINCHILLAS—Big profits. Free literature. Tom McGowan, 170 Horton Ave., Valley Stream, L.I., N. Y.

FARMS, FARM LANDS, REAL ESTATE

\$5.00 MONTHLY Buys 40 acres productive land; near town; price \$240.00; free list. Box 425-P, Carthage, Mo.

CALIFORNIA Home and ranch sites \$395. 100% oil rights. Terms. 10c brings catalog. Pacific Tax Sales, 1621-A Cahuenga, Hollywood 28, Calif.

FLORIDA—5 Acres high dry land near beaches, have homestead and garden. Only \$595.00, \$10.00 down, \$10.00 month. Information write O. B. Potterfield, Owner, Union Building, Department W, Charleston, West Virginia.

BUY Safely: Farm, home, business. Write Jenkins, B236, Doniphan, Mo.

STROUT Catalog—Mailed free. Farms, homes, businesses, 35 states, coast-to-coast, 3357 bargains described. World's largest; 55 years service. Strout Realty, 7-M So. Dearborn St., Chicago 3, Ill.

CANADIAN Tax sale lands for three dollars an acre and up. Small monthly payments. Farms, timber, hunting and fishing camps, minerals. Limited number of properties. Write at once for free catalogue. Tax Sale Service, Room 105, 120 Bloor St., West, Toronto 5, Canada.

FLORIDA. Lakefront homesites near Ocala Forest and Saint John's River. Excellent fishing-hunting. \$10.00 monthly without interest. \$295.00-\$895.00. Literature. Write, Parker, Paisley, Florida.

PARM And business catalogs free! 4 big editions. Florida, Northeastern states. West's. M-1, Pittsburgh 17, Penna.

HOUSTON Money-maker. Buy beautiful guaranteed homesites in popular southside addition, for \$345. Payable \$15 monthly. America's fastest growing city. Second largest seaport. Folders free. Preston Wood, Box 413, Houston, Texas.

ADDRESS—Armstrong, Shook, Missouri. Giant listings, inexpensive lands, mailed free.

FLORIDA Winter garden farms. Beautifully wooded 10-acres for \$995, payable \$25 monthly. Near famous Panama City pleasure resort. World's finest beaches. Lovely lakes. Wonderful fishing, hunting. Guaranteed most desirable homesites in Florida. Fine investment. Information free. Wendell Wood, Fountain, Fla.

RETIREMENT Homes, gardens, nothing down. List free. Perrys, Brier Hill, Penna.

ONLY \$5.00 Down! Full price \$89.50 on easy terms buys big 5000 square foot home-site at Bandera, Texas. Heart of "dude ranch country." Electricity, telephone. 1300 feet above sea level. Warm days and cool summer nights make vacation paradise. Hunting, fishing, golfing, swimming, horseback riding. Write for free photographs and details. Bandera Pass Ranch, Dept. 201, Bandera, Texas.

FLORIDA—Nice homesites near Ocala national forest in Lake county. Best fishing, hunting. Low prices, easy payments. Folder free. Howard Vernor, DeLand, Florida.

FLORIDA—Beautiful retirement homesites near gulf coast. Excellent hunting, fishing in 9 fresh and salt water rivers. 11 bays and gulf. \$250 at \$10 monthly. Free literature. V. M. Matthews, Box 1406, Asheville, N. C.

HOMESITES \$400—Convenient payments. California's finest garden section. On Morro Bay's scenic shores. Wonderful fishing, boating, bathing. Fertile soil, softest water, temperate climate, congenial community. Free literature. Richard Otto, Department M, San Luis Obispo, Calif.

FLORIDA Or California bound? We can help you solve your housing problems. Mail 50c for your copy Guide to Easy Living, Retirement and Travel. Sellhorn's, Box 1950, Sarasota, Fla.

PLANTS, SEEDS, NURSERY AND GARDEN SUPPLIES

CASH, Retirement income, grow flowers, retail, wholesale, mailorder, spare-time. Ten professional programs \$1.00. Box 135, Berea, Ohio.

TREES And shrubs. Raise your own from seed for shade, windbreak, snow fence, ornament, erosion control, etc. For free planting guide, price list, write Woodlot Seed Company, Norway 9, Michigan.

INSTRUCTIONS For dwarfing plants and trees. Send \$1.00 to Trees, Box 5368, Detroit 11, Michigan.

EVERGREENS: Seedlings. Transplants. For growing ornamental landscape. Christmas trees. Quality stock at low prices direct from growers. Write for price list and planting guide. Suncrest Evergreen Nurseries, Dept. PM, Homer City, Penna.

POULTRY, FARM SUPPLIES

POULTRY Farmers, broiler growers, turkey raisers, read the new American Poultry Journal for latest ideas and greater profits. 12 months, 50c. Special offer, 4 years \$1.00. American Poultry Journal, 182 North Wabash, Chicago.

RAISE Turkeys the new way. Write for free information explaining how to make up to \$3000 in your own backyard. Address—National Turkey Institute, Dept. 3, Columbus, Kansas.

PROFITABLE OCCUPATIONS

WANT A diesel job? New opportunities to increase income. Higher pay. More money. We can help you qualify. Tools. Shop method home training. Write today! Diesel, Tractor, Heavy Equipment Division, Interstate Training Service, Dept. B-3-A, Portland 13, Oregon.

MAILORDER Beginners instruction manual, sources, methods, opportunities, 25c. Carnahan Bros., 5580 Nelson, Cypress, Calif.

START Your own home mail order business. Beginners instruction booklet 25c. Savaglio, 5646 W. 57th St., Chicago 38, Ill.

SELL Stamps. I guarantee profit. Fairbrook, 133-21 Blossom, Flushing, N. Y.

LOS Angeles help wanted ads airmailed \$1.00. Woods, 12442 E. Sproul, Norwalk, California.

FREE! "301 Profitable Small Businesses!" Amazing shoestring plans! Work home! Start sparetime! Deumant Surveys, Kenmore 23-PM, N. Y.

"HOW To Make Money With Simple Cartoons"—A book everyone who likes to draw should have. It is free; no obligation. Simply address Cartoonists' Exchange, Dept. 91CP, Pleasant Hill, Ohio.

LABOR Union leaders needed. Opportunities for well paid, satisfying positions. Home or travel expense paid. Book giving full instructions, guidance, \$1.00. Union Job Guidance Bureau, 103-PMB Erie St., Salamanca, N. Y.

\$10,800 PROFITS! Your own mailorder business! No risk! Success plan free! Treasury, 709 Webster, New Rochelle L-27, N. Y.

BUY Wholesale thousands nationally advertised products at big discount. Free "Wholesale Plan." American Buyers', 628-P Linden, Buffalo, N. Y.

WELDING Pays big money. Learn easily at best equipped school in country. Non-profit school with low cost training. G.I. approved. Write Hobart Trade School, Box M-152, Troy, Ohio.

ALASKA! Last American frontier. \$1.00 brings 1955 business directory and government map. Military and civilian construction, homestead and highway facts, mining, aviation, fur-farming, grazing, timber, travel directions. Hot list of firms hiring. How-when-where to apply. Alaska Opportunists, Box 92-P, Hollywood 28, Calif.

FOREIGN U.S. jobs to \$18,000. Many overseas countries, fare paid. Skilled-unskilled trades, office. Stamped self-addressed env. brings reply. Job Opportunities, Waseca, I.J. Minn.

OVERSEAS, Latin American, Alaska, Canada employment. Originator 1955 "Foreign Service Directory" up-to-minute report on military and civilian construction; oil companies; aviation; transportation; steamship; mining; government job info. How-when-where to apply. Listing firms hiring. \$1.00. Global Reports, Box 883-P, Hollywood 28, Calif.

\$1300.00 MONTHLY For truck drivers, \$1400 monthly for carpenters, electricians, plumbers, mechanics, \$1200.00 for clerks and laborers. Full information and complete foreign listings, with current information on Spain, Korea, Australia, Alaska and Canada, \$1.00. Current information on stateside projects, \$1.00. Dept. 3-A, Opportunities Unlimited, 1110 Commerce Bldg., St. Paul, Minn.

ST. Lawrence Seaway started. Latest information, application form, \$1.00. Trans-Canada construction opportunities, \$1.00, cash or moneyorder. Both airmailed \$2.25. Allied Opportunities, Dept. PM-1, Box 10, Station B, Hamilton, Ontario, Canada.

MAKE Money writing short paragraphs! No tedious study. I tell you what to write, where and how to sell; and supply list of editors buying from beginners. Many small checks add up quickly. Write to sell, right away. Send for free facts. Benson Barrett, 1751 Morse, Dept. C-27-A, Chicago 26.

MAN Wanted—Are you dissatisfied with your work? Would you like a business of your own? If so, write Rawleigh's, Dept. A-GG-PPM, Freeport, Ill.

ATTENTION Construction men! Laborers, trades, truck drivers, clerical, engineers, supervisory, many others. Latest copyrighted reports! Who to contact for highest paying jobs. To \$1500.00 monthly. Over 52 countries, including U.S., St. Lawrence Project, Spain, South America, Alaska, Europe. Year registration and advisory service. Application forms. Best oil, aviation opportunities. Unconditional guarantee of satisfaction. Write or wire today! \$2.00. Airmailed \$2.25. (C.O.D.'s accepted.) International Reporter, Box 1047-PK, St. Louis 1, Missouri.

300 DOMESTICATED Earthworm eggs (hatch 1,200) \$2. Advance instructions sent! Detailed book 10c. Avery, 112-S Elizabeth, Wichita 13, Kansas.

FREE Information available about foreign and U.S.A. job opportunities paying to \$1500 monthly. Write immediately. Dept. 76G, National Employment Info. Serv., 1020 Broad, Newark, N. J.

AMAZING Booklet, "How To Build Your Own Mailorder Business," 23c. Continental Publishers, 216 W. Jackson, Chicago 6, Illinois.

MUSHROOMS Grown boxes, barrels. Manureless process 50c. Spawn \$1.00. Gordons, 553 William, Winnipeg, Manitoba.

AUCTIONEERING. Home study course. Diploma granted. Auction School, Ft. Smith, Ark.

FREE Information. Construction projects require all trades. Ellis, PM-1, Box 207, Westmount, Quebec.

EVERYBODY Likes candy. Learn to make professionally. Our 44th year. Ragsdale Candies, D6, East Orange, New Jersey.

WE Get \$150 daily in the mail, live as we please. You can too. Write: Clifton, 105 F. St. N.E., Ephrata 20, Wash.

I Average \$125 weekly selling books by mail! So can you! Start sparetime! Work home! Cooper, 247-R Taunton, Buffalo, N. Y.

TYPISTS—Profitable home business. Complete copyrighted information, \$1.00. Gaunt, 827-A Irving, Chicago 13.

SELL Swanky personalized all occasion gifts. \$2.00 investment. Our "free stock" plan carries you. 100% profit. Details 25c. Weigand, 3914 Carondelet, New Orleans 15.

RICH Industrial city needs workers. Send \$1.00 for jobs available now! Hulbert, 167 Beech, Paterson 3, New Jersey.

PAINT Signs. Have your own profitable business. Biggest complete course with 324 illustrations, 18 in colors, \$5 postpaid. Free circular. E. C. Matthews, 2325 Cass, St. Louis 6, Missouri.

WHOLESALE! 8000 Nationally famous products. 30-80% discounts! Large catalog. Sensational business plans included. Consolidated Distributors, 21-20 Lafayette, Paterson 15, New Jersey.

SECRET Investigation. Experience unnecessary. Investigators particulars free. George Wagoner, 123 M West 86th, New York 24.

FOREIGN Employment construction work. If interested in foreign projects with high pay write Foreign Service Bureau, Dept. PM, Metuchen, New Jersey.

HOME Workers needed! Spare time, full time. Assemble luggage and cases with our complete illustrated step-by-step instructions. We sell your product—Supply everything. Manufacturing representative needed in your area immediately. Unlimited profits possible. Investigate at our risk. Free details. Cascraft, 807-G10 Sunset, Los Angeles 12, Calif.

MAKE Flexible molds. Cast figurines, plaques. Free sample. Tooker, 630-M Chestnut, Hamilton, Ohio.

GROW Mushrooms. Cellar, shed, and outdoors. Spare, full time, year round. We pay \$2.50 lb. We paid Babbitt \$4,165 in few weeks. Free book. Washington Mushroom Ind., Dept. 99, 2954 Admiral Way, Seattle, Wash.

FREE Book "505 Odd, Successful Businesses." Work home. Expect something odd! Pacific, Oceanside, Calif.

MAKE New greaseless doughnuts in kitchen. Sell stores. Free recipes. Michael Ray, 3605 South 15th Ave., Minneapolis 7, Minnesota.

RAISE Pheasants on \$100 week plan. Little capital and space can make you independent. Free details. Great Central System, Columbus 20, Kansas.

BE The Popular Mechanics representative in your neighborhood and earn big profits in your spare time. Write Popular Mechanics Magazine, Room 408M, 200 E. Ontario St., Chicago, Ill.

FREE Folio "Up to \$45,000; Unlimited Vacations." No merchandise, equipment. Unknown! Works itself, home! Hayling, Carlsbad, Calif.

BOOKS, PERIODICALS, PICTURES, POSTCARDS

GUATEMALAN Postcards: Twelve different views. One dollar postpaid. Send money order. Mapillon, Box 268, Guatemala, C.A.

INTERESTING Books in English printed in France. Bookfinder, Box 3498, Havana, Cuba.

SPARETIME Profits taking subscriptions all magazines. Wholesale catalog free. Cassell Publishers, Westfield, New Jersey.

MAGAZINE Subscriptions. Largest commissions. Bonus. Qualified Publications, 451ML Kingston, Brooklyn 25, N. Y.

BOOKS Wanted! Hard cash paid. Books found, no obligation. J. Williams, Box 673, Hoboken, N. J.

BOOKFINDING Service. Old and new books. List free. Mail Order Bookstore, 1336-P Southwest Hall, Portland 1, Oregon.

USED Pocket novels, 8 for \$1.00. List for stamp. Trunket, Glenshaw, Penna.

POSITIVE Success. Secrets free! Write today. Success School, Sparta 7, Michigan.

BOOKHUNTERS! All subjects. Send wants! Jaher Book Service, 630-P East 178 Street, New York 57.

PUBLICATIONS By internationally famed physician-psychologist-author C. Franklin Leavitt. Your Personal Problems and How to Solve Them; Self Mastery Through Understanding; How to Plan Your Life. Free descriptive literature. The Leavitt Science, Clinton, Illinois.

CATALOG, 1200 Popular educational, self-help materials, pocket books, etc. 10c. World Adventure, D-239, Ann Arbor, Mich.

100,000 SPORTS Publications—For sale. 1860 to date. List wants. Adco, Briggs Station, Los Angeles 48, California.

POCKET Novel books, 10 for \$1.25. Mixed selection, \$3.00 value. Box 3717, Baltimore 17, Md.

FREE Information. Falk's sensational handbook gives instant solutions to 100,000 practical problems. Columbia Graphs, Columbia, Conn.

BOOK Catalogue, 1000 bargains. send 10c. Book Publishers, Amityville 3, N. Y.

MAKE Money from suggestion plans. Learn methods to find suggestions. Over 100 general tested suggestions that can pay you money. 15 common principles of suggestions. 15 tips based on experience. One suggestion could pay you hundreds of dollars. \$2.00. Mail Sales, Gen. Del., Detroit 3, Michigan.

"SCIENCE Milestones." Records march of science starting 400 years before Christ, right up to date. Amazing facts revealed. 312 pages packed with startling information that will thrill you. A real history of science. \$5.00. Literature free. Popular Mechanics Press, 200-SM East Ontario St., Chicago 11, Ill.

STAG Cartoon booklets! Laughs galore! 24 vest pocket size adult collectors items \$1.00. All different. Free gift with order. Terry Thorne, Dept. PM, Box 8335 Crenshaw Sta., Los Angeles 8, Calif.

BOOKHUNTERS! Scarce, unusual, miscellaneous books supplied. Atlantic Book Service, Cedar Street, Charlestown 29, Massachusetts.

NATIONAL Geographic Magazines. 1833-1952. Periodical Service, Box 465-PM, Wilmington, Delaware.

BOOKS Found! Any author, old or new. Rush titles wanted; no obligation. International Bookfinders, Box 3003-PM, Beverly Hills, California.

BOOKHUNTERS! All subjects. Send wants! College Book Service, 52 W. Kingsbridge Rd., New York 68, N. Y.

ALL Sports bookfinder! Any sport subject. Send wants. Osmo Tuiskula, Box 482, Worcester 1, Mass.

FREE: Exciting catalog packed with books covering most everything. Think of it—From cover to cover you will find described and illustrated hundreds of books telling how to fix and how to build almost anything. How to remodel your home; do your own decorating, plumbing, electrical work. Simplified books covering concrete work, carpentry, painting, furniture making and refinishing. How to build your own boat, home workshop tools. Best books on photography, welding, hobbies, homecraft. How to make a home freezer. Send for your free copy now. Popular Mechanics Press, 200-BC East Ontario St., Chicago 11, Ill.

MAGIC TRICKS, PUZZLES, JOKER NOVELTIES

ILLUSTRATED Catalogue 25c, mimeographed catalogue 10c, joke list 5c. Eagle Magic, Minneapolis 2, Minn.

3100 NOVELTIES, Tricks, jokes, gadgets, funmakers, hobbies. Catalog 10c. Johnson-Smith, D853, Detroit 7.

VENTRILOQUISM Taught quickly! Home study! Results guaranteed! Information free! Write, giving age. Dummy catalog 25c. Fred Maher School, Box 36, Kensington Station, Detroit 24, Michigan, Studio P.M.-A.

BE A magician. Large professional magic catalog of latest tricks. 35c. Ireland, C-109 North Dearborn, Chicago 2.

THRILLING—224 Page catalog, magician's tricks, sensational Houdini escapes, handcuffs, amusement goods together with "Mystery Review Book," prepaid. Send one dollar. Magician Heaney Co., Oshkosh, Wisconsin.

VENTRILOQUISM Selftaught. Quick, easy lessons, 25c. Dummies. Ventriloquist, CalAllen, Texas.

ZANTO'S Free trick. Write Zanto, Waverly, Ohio.

"WHAT I Know About Women"—Pocket size booklet packed with fun. It's a scream. You'll love it. Fun every time you show it. Order yours today. \$1. Postpaid. Ranney, 315 East Commerce, San Antonio, Texas.

BECOME Second person living to blow tobacco from kingsize cigarette. \$1.00. Box 117, Omaha, Neb.

WE Supply every noted magician. Large professional catalog \$1.25. Holden's, 120 Boylston Street, Boston, Mass.

PROFESSIONAL Catalog, 175 pages, 25c. Williams, 900 Plymouth, Ellwood City, Penna.

SENSATIONAL Magician's wand 25c. (Vanishes handkerchief!) Catalog included. Box 1352-PM, Philadelphia 5.

40 JUGGLING Stunts. Easily learned. \$1.00. J. R. Bates, Riverton, Ky.

WOODEN Nickel, catalog, trick, 10c. Fun'n Magic, 423-P North St. Marys, San Antonio 5, Texas.

BEST Magic. Joker's novelties. Lower prices. Catalog 10c. Top Hat, Evanston 12, Ill.

MAGIC Course. 10 professional lessons in pocket, parlor, and club magic. Easy to do. No special apparatus. \$2.00. Yohe, 101 Criss St., Pittsburgh 34, Penna.

\$3.00 VALUE Superb magic tricks only 25c to new acquaintances. Magic offers and instructive bulletins mailed frequently. Southeast Magic Studio, Box 15-W, Eutawville, S.C.

500 TRICKS, Douglas famous 120-page catalog, only 10c. Fastest service to magicians for 30 years. Send 10c today. Douglas Magicland, Dept. 1, Dallas, Texas.

2500 TRICK Catalogue (512-pages), pocket, parlor, stage. World's finest magic. Catalogue \$2.00 (dollar trick included free). Kanter's, M-1311 Walnut, Philadelphia 7.

COINS, TOKENS, CURRENCY

\$10.00 FOR Certain Lincoln pennies, Indianheads \$50.00. Booklet showing prices paid. 10c. Lincoln Coins, D-229, Glendale, Arizona.

FIFTY Indian cents \$2.00, twenty different dates \$1.00. Sayers, 1000 East Unaka, Johnson City, Tennessee.

GET Profit and pleasure in collecting old coins. Send 10c for 56-page illustrated coin catalog. You'll be delighted with it. Send for it now. B. Max Mehl, 370 Mehl Building, Fort Worth, Texas. Largest rare coin establishment in U. S. Established 55 years.

COIN Collector's Magazine. Over 1000 pages per year. Sample copy 30c; \$3.00 per year. Hewitt, 7320-J Milwaukee, Chicago 31.

1863 ALABAMA \$1 Note, uncirculated, 75c; 1955 coin handbook, 127 pages, 380 illustrations, clothbound, \$1.25. Cook Coins, Jackson 5, Mississippi.

OLD Money wanted. Will pay fifty dollars for nickel of 1913 with Liberty head (no buffalo). We pay cash premiums for all rare coins. Send 4c for large coin folder. May mean much profit to you. Numismatic Co., Dept. 20, Fort Worth, Texas.

TAHITI Set (4) \$1.00; 15 different Indian cents \$1.00. Buying Handbook \$1.00; Retail Guidebook \$1.75; 64-page bargain catalogue 35c. Bebee's, 4514 North 30th Street, Omaha 11, Nebraska.

WANTED—1894-S dime pay \$1,000.00. Certain 1913 nickel \$1,500.00. 1901-S quarter \$30.00 to \$250.00. Hundreds of others. Know their true value. Complete illustrated catalogue 50c. Three \$1.00. Catalogue money refundable. Worthycoin Corporation (D-524), Boston 8, Massachusetts.

FIVE Indianhead cents, five page bargain list, 25c. Economy Sales, 160 Dean, Mansfield, Mass.

20 FOREIGN Bills 25c. Lists included. Dwight Musser, Dunbar, West Virginia.

40 COINS, \$1.00. 60 Bills, \$1.00. 50 coins and bills, \$1.00. Oddehon, Box 482, St. Louis, Mo.

FOREIGN Coins, 25 different \$1.00. Webb, 2200 Quintara, San Francisco 16, Calif.

SAVE Bargains. Coins, stamps. Hubers, 210 South Sixth Street, Minneapolis.

APPRAISALS, Certified by expert. Minimum \$1.00 per coin. Special collection fees arranged. Numismatic Appraisal Service, Box 456-P, Encino, California.

30 FOREIGN Coins \$1.00. 10 Indianhead pennies \$1.00. Valley Coinco, Box 66, McAllen, Texas.

JAPANESE Invasion notes 1c to \$1000.00 set \$1.00. 100pp, illustrated coin catalogue, 25c. Shultz, Salt Lake City 10, Utah.

FREE! Foreign coin, banknote and coin collectors illustrated catalog to approval service applicants. Send 3c postage. Tatham Coinco, Springfield 30, Mass.

INDIAN Cent with bargain lists 10c. Hutchinson, 3463 'T' Street, Philadelphia 34, Penna.

CONFEDERATE And Southern bank notes. 3 different, \$2.00. 50 mixed Indian pennies, \$2.00. Ben's Coin Shop, 31 N. Clark, Chicago 2.

WORLD'S Greatest magazine for coin collector's and wooden nickel 10c. Lawrence Brothers, Anamosa, Iowa.

STAMP COLLECTING

UNMATCHED Offer: 100 different world stamps—20c; 500, 75c; 1000, \$1.50; 25 nudes, \$1.00; 50 birds, \$1.00; 100 pictorials, 75c; 25 triangles, \$1.00; 100 ships, \$1.00. Limited supply. Thompson, 906-22 Ave. N.E., Minneapolis, Minn.

ANIMALS: Lion, leopard, antelope giraffe, elephant and numerous others. Everything 10c to approval applicants. Crystal Stamps, 3540 Regent No., Minneapolis, Minn.

14,000 DIFFERENT—Yours on our streamlined systematic club plan for only 50c weekly. Big shipment every two weeks. Details free. Sjoquist, Box 217, Valley Stream 75, New York.

FREE U.S. 72 page catalogue. Contains almost 1000 illustrations; over 10,000 delightful bargains, plus "How to Collect." Stone's, 192 Washington, Boston 8, Mass.

AMAZING Sort and save mixtures. Beautiful pictorials, all large stamps. 2c each regardless of catalog. Postpaid both ways. Dusty Farnam, Box 2278, Van Nuys, Calif.

101 DIFFERENT Worldwide: Triangles, commemoratives, pictorials. 10c. Approvals. Free \$5.00 U.S. stamp. V-Ann, G.P.O. 671M, Brooklyn 1, New York.

FINE Approvals. Fast, personal service. What countries do you prefer? I'll send their stamps. Skinner, 438 Locust, Long Beach 12, California.

SWITZERLAND Prize package, 50 different—Trains, bridges, castles, commemoratives, bi-colors, pictorials. Unusual cancellations too! Only 10c with approvals. Molzan, 720 Pomona, El Cerrito 8, California.

ILLUSTRATED United States catalog 10c deductible on \$1.00 order. Unused flag set 55c. Standard, 10840E Woodview, Parma Hts. 30, Ohio.

WASHINGTON Bicentennial set, used, complete only 15c to applicants for our medium priced United States and Canada approvals. NACO, 682 Pearl, Benton Harbor, Michigan.

200 BEAUTIFUL Assorted Latin American stamps. Send \$2 to Horst, Cas. 84-D, Santiago, Chile.

20,000 DIFFERENT World \$175.00; 10,000, \$47.00; 5000, \$13.00; 3000, \$6.50. Gould's, Box 631, San Francisco 1, Calif.

PENNY Approvals that satisfy. Robert Moed, 245 Kosciusko St., Brooklyn 21, N. Y.

FORTY Canadian and Newfoundland stamps including commemoratives 10c to approval applicants. Union Subway Stamp Company, 198 Bay Street, Toronto.

FREE 105 British colonials, pictorials, Mauritius, Tanganyika, Pakistan, Nigeria, Rhodesia, Singapore. Fascinating story approvals. Send 10c handling, please. Canada Stamp Company, 19218 Main St., Niagara Falls, New York.

100 JAPAN 10c. All different, with approvals. Gould's Stamps, Box 631, San Francisco 1, California.

ADULT Collectors approval selections Hawaii, Canada, commemoratives, Philippines, general foreign. Reasonable. Montalto, New Church, Virginia.

PARAGUAY 27 Different mint 20c. approvals. Excello Stamp Company, Box 469, Red Bank, New Jersey.

DEALERS—Wholesale list. Postage 3c. Frank, 5031 Queensberry, Baltimore 15, Maryland.

1000 STAMPS For you to look at—Big, attractive approval books of beautiful stamps. Pick and choose to suit yourself, at 1c and 5c each! Let us show you the economical way to a large, worthwhile collection. Wolverine Stamp Service, Dept. A-24, Fruitport, Mich.

OLD Stamps wanted. I will pay \$100.00 each for 1924 green Franklin stamps, rotary perforated eleven (up to \$1000.00 each unused). Send 10c for large illustrated folders showing amazing prices paid for old stamps and coins. Baker-Stamps, (PM-51), Elyria, Ohio.

WORLD'S Largest stamp (7½ x 14 inches). A real curiosity! Retail for 50c, only 3c to approval applicants. Tatham Stamp Co., Springfield 30, Mass.

ZOO Parade—10 different bi-colored stamps depicting queer civet from Liberia, bay-thighed Diana monkey, Sudan camel, hedge-hog, rabbit, squirrel, fox, finch, golly, gullpen including big triangles. Regular \$1.00 value only 10c to approval applicants. Roseland Stamp Co., Dept. A-34, Spring Lake, Mich.

WEIRD Diamond shape coffee stamp! Lovely flower triangle! First American big commemorative. Greenland, idol dancer, etc. Free with approvals. Capital Stamp Co., Little Rock 2, Ark.

FREE! Monaco Holy Year set 3, Sanmarino discus thrower and tennis stamps, Guinea beetle, Sarawak butterfly, Tonga shield. Offer includes 3 triangles, premium coupon. All to new approval applicants. Moulblow, 304H Lynn, East Northport, New York.

325 DIFFERENT Worldwide collection; includes everything. Airmails; complete sets; triangles; bi-colors; birds; flowers; animals. Everything (catalogs over \$6.00) 25c to approval applicants. Century Stamps, Dept. PM, 111 West 94th Street, New York 25, New York.

FREE Russia mint set with our beautiful pictorial worldwide approvals. Oak Stamps, 1007-V, Cedarhill, Royal Oak, Mich.

MINT U.S. at face! Send 25c for a surprise packet of all different commemoratives. Sent with U.S. approvals. Western, Box 1689P, Salinas, California.

UNITED States—58 different including 8 airmails, 15 commemoratives, 10c. Approvals. Sunset, Box 47, South Gate, Calif.

SUPERIOR Worldwide mission mixture. Amazing variety! Half pound \$1.50. Bay Nielsen, 4407B St. Catherine, Montreal 6, Canada.

LEOPARD, Antelope, eland, plus worldwide packet, free to approval buyers. Conquistador, 2627C Troy Road, Schenectady 9, N. Y.

126 DIFFERENT, Includes triangle, diamond, airmails, old United States, British Colonies, animals, others; 10c with approvals. Cactus Stamps, Desert Springs 2, Calif.

FREE: Mint British Colonies from Brunel, Papua, New Guinea, Caymans Gilbert Ellice, Seychelles, Sarawak, Dominica. Free with approvals. Viking, 11-2 Northern Blvd., Great Neck, N. Y.

SOMETHING New, something different, something terrific. Try our books of 1000 different and see for yourself. Mostly 1c and 2c but Scott's catalog number and price under each stamp. Big discounts. Modern Stamp Co., Dept. A-5, Ferrysburg, Mich.

FREE Complete set of famous Americans, flags, parks and presidentials to approval buyers. Send 5c for 15 of the above stamps plus full particulars. Triboro Stamp Company, 145 Nassau Street, Dept. 101, New York 38, N. Y.

LOOKING For bargains? Try our 1c and 2c approvals mounted in books of 1000. We believe in both quantity and quality. First try will satisfy. Clark Stamp Co., Dept. A-44, Muskegon Heights, Mich.

100 CANADIAN And Newfoundland stamps including early issues, commemoratives, large size pictorials. Free for 5c postage. Empire Stamp Company, Dept. PMM, Toronto, Canada.

FREE British Colonial stamps, 107 different including free stamp magazine. From far flung British outposts, Africa, Asia, Caribbean. Send 10c handling charge. Approvals. Niagara Stamp Company, St. Catharines 41, Ontario, Canada.

CONGO Flowers free with our attractive pictorial approvals. Johns Stamps, Box 3735-N, Kercheval Station, Detroit 15, Mich.

FREE Stalin, Hitler, Mussolini stamps with our beautiful approvals. Karrys Stamps, 870-M Seward, Detroit 2, Mich.

AMERICAN Stamps! Coins! Bargains! Sullivan, 127-F E. 4th, St. Paul 1, Minn.

50 FOREIGN 10c With approvals. McLendon Stamp Co., 1830 West Fifth St., Montgomery, Ala.

U.S. 40 different 10c. 40 different commemoratives 25c. Both 30c. Seidenberg, Appleton, Wis.

100 USED Foreign plus German Colony, 10c. approvals. Album Service, Soledad 6, Calif.

LAVISHLY Illustrated stamp magazine, yours for asking. Randall, 1517 So. Michigan, Chicago 5, Ill.

135 DIFFERENT U.S. commemoratives \$1.00. Request approvals. Harold Holub, 18 East 196th Street, New York 68, N. Y.

ZEPPELIN Set free, with approvals. Variety Stamps, 57-P Circuit, Newton Highlands 61, Mass.

55 FOREIGN Free approvals. Collier, 215 12th St. N.E., Atlanta 5, Ga.

20 U.S. Commemoratives, 100 world, 10c. approvals. Weckerling, Box 442B, La Feria, Texas.

FREE. Scott's International Album. Other premiums. Particulars with approvals. Raymax, 35-Z Maiden Lane, New York City 38.

FIRST U.N. set. Among world's prettiest. Only 10c. Approvals. Welles, Box 1246-R, New York City 8.

TOPS! Free book, "How to Collect Stamps." Send for your copy today! Approvals. Littleton Stamp Co., Littleton 61, N. H.

25 DIFFERENT Luxembourg 10 cents. approvals. Waha Company, 178 No. 17th Street, East Orange, N. J.

BARGAINS Galore! Ask for Stamps of Quality price list today. Elholms, 821 Hayes, Racine, Wis.

U.S. plate number blocks. Stamp scholars say scant supply shoves scores skyward! Don't delay longer. Starter six commemorative collection \$1.00 with approvals, details. Wm. Kuehl, 3125 East K. Tacoma 4, Wash.

QUEEN Elizabeth unused coronations 10c. Dolinco, 31 Parkrow, New York City 38, N. Y.

FREE! 202 Different, including Elizabeth coronation. Popular set approvals accompany. Send 10c for mailing. Pirland Stamp Co., Box 493, Seattle 11, Wash.

FREE! Obsolete U.S. occupation set with most interesting approvals. Airmails, colonials, pictorials, topicals, commemoratives. Lowest prices. Riedell, Greensburg, Penna.

50 DIFF. Finland, 10c with approvals. Carroll's, W. 310-A Sprague, Spokane, Wash.

PHILIPPINE Set free with our bargain approvals. Name the country you save and we do the rest. Blanc Stamps, A-25625 Koontz, Roseville, Mich.

100 OLD United States between 1861 and 1935, \$1.00. Roush Stamps, 51 Chestnut, Mansfield, Ohio.

1500 MIXED Foreign stamps \$1.00. No approvals. Aaron, 789 Valencia, San Francisco 10, Calif.

SAVE Money on these bargain lots of early mint U.S. commemoratives. 60 different 1935-1944, \$3.00. 50 different 1909-1934 including Lincoln, Pilgrim, Wallow, Lexington \$5.00. Free lists. Philip Mantius, Setauket, N. Y.

PARAGUAY Heroes set. Three values free with our worldwide books on approval. Henry Stamps, 8075-A Hildale, Detroit 34, Mich.

FREE! Big United States catalog. Valuable guide and check list. Hundreds of illustrations. Approvals. Harrisco, 1010 Transit Building, Boston 17, Mass.

FREE! 82 Flags of the world in full color, with purchases from low-cost packet lists and approvals. Write for samples today. Myers, Box 327P, Williamsport, Penna.

10 DIFFERENT Early mint commemorative plate blocks 1935-1937, \$2.00; 20 different 1933-1939, \$5.00. Free lists. Philip Mantius, Setauket, N. Y.

BEAUTIFUL French Colony approvals. Jungle scenes, warriors, animals. Thousands at 1c and 2c. Grove Stamp Service, Box 183, Garden Grove, Calif.

FREE United States illustrated catalog. Bailey, 44 Bromfield, Boston, Mass.

BRITISH Empire: 107 all different, 10c. Leslie Anderson, Seaside Heights, N. J.

ILLUSTRATED Album, hinges, gauge, detector, fifty stamps, two sets—all 10c. Approvals. Cornett, 228 West 25th, New York 1.

12,000 PENNY Approvals waiting for you. Many from exotic countries, pictorials, airmails, new issues. Tilbury, Box 862, Newark 1, New Jersey.

\$3 PACKET (Scott's catalogue value) all different stamps. Free to approval applicants. R. Bernier, 555 Markham Street, Toronto 4, Canada.

100 PICTORIALS, Giant and triangle stamps, 15c with approvals. Bilislands, Box 1101P, Spokane 10, Wash.

EXCHANGE. Send 100-200 different stamps with 15c. Receive different. Patterson, Lancaster 10, New York.

MINT U.S. approvals. Russell Patrick, 5550 East 42nd, Indianapolis 26, Indiana.

125 UNITED States different commemoratives, etc., 25c. C. P. Steger, Steger, Ill.

BEAUTIFUL Multi-colored Indonesia sets 10c. Approvals. World, Box 815, San Francisco.

U.S. commemoratives, 33 different 10c. Approvals. White, 516A Avenue L, Brooklyn 30, N. Y.

VENEZUELA—9 Different postage, 15 different airmails, 25c. Free lists. Hugh Watchorn, Box 310, Middlebury, Vermont.

MONACO Nudes complete 10c. Approvals. Royal Stamp Company, Tamaqua, Penna.

CAMEROON Set 6c. Approvals. Mrs. Van Housen, R.F.D. 1, Highland Mills, N. Y.

FREE! 25 Different Switzerland with swell approvals. Kardell, Box 2058-M, Santa Fe, New Mexico.

FREE U.S. 35 different with superior approvals. Sparta, Box 1082, Rochester 3, N. Y.

BARGAIN Disposal list 3c. Accumulations wanted. Samples 30c. Approvals. Bristol Stamps, Collinsville, Conn.

30 U.S. commemoratives 25c with approvals. Brown, 1704, Ft. Myers, Fla.

FREE Animals, birds, triangles, flowers, ships, locomotives, kings, dictators, multi-colored, historical, geographical, musical, battles, giants, midgets and over 100 others. Fascinating story approvals. Send 10c handling, please. Canada Stamp Company, 19318 Main St., Niagara Falls, New York.

LOOK! Your choice: 75 all-different U.S. or 10 complete foreign sets, 10c. Approvals. Farmer, 4913 Rosewood, Los Angeles 4, Calif.

SPECTACULAR Mint collection—Bi-colors, tri-colors, diamonds, triangles, airmails, sports, silver jubilees, commemoratives, memorials, including 10 complete sets, 25c with custom-line approvals. Boulder Stamp Company, Box 578-M, La Mesa, California.

5000 DIFFERENT 1c Approvals sent in books of 1000; adults only. Allen Stamp Co., Box 1109A, Lanikai, Hawaii.

12 DIFFERENT Triangles 5c with penny-provals. Penny-proval Company, 29-5 New York Building, Saint Paul, Minnesota.

FREE! Giant foreign packet. Stam, Malay, pictorials, triangles, etc. for 3c. Approvals. Kensington Stamp Co., Buffalo 15, New York.

TRY A selection of our low priced approvals. J & G Stamp Service, 332P East 149 St., Bronx 51, N. Y.

FREE Mint set with approvals. Laurentian, PM-1, Box 298, Station-H, Montreal 25.

SAVE! Buy stamp packets. Free list. Box 1782, Los Angeles 53, Calif.

BARGAINS Galore. Low priced approvals. Schur, Box 117, Williamsville 21, N. Y.

TRIANGLES, Bi-colors and large pictorials. Worldwide, on approval! Cole, 43-A Rinewalt, Buffalo 21, N. Y.

CEYLON, 300 Mixed including flowers, animals, pictorials—\$1.00. Approvals. Pacific Stamp Sales, Box 1865, San Diego 12, California.

RUSSIAN Medals complete, catalogue value \$1.60, 10c with approvals. Golden's, 6721 Eastwood, Philadelphia 49, Penna.

1000 DIFFERENT \$1.00 With approvals. Jacobsen, 4395-C Broadway, New York 40, N. Y.

POCKET Stock book full of popular stamps. Value \$1.00, only 10c with approvals. Pot-'O-Gold Stamps, Litchfield, Conn.

EXCITING New book, "How to Collect Stamps, Coins, Paper Money." Packed with amazing facts; information worth dollars. Fully illustrated, 160 pages. 75c. Popular Mechanics Press, 200-ST E. Ontario St., Chicago 11, Ill.

27 DIFFERENT Hitler heads and particulars on how to obtain complete set United States Columbian issue. 10c. Tri-stamps, Demarest 4, N. J.

BARGAIN Hunters attention! Free stamp magazine. 1000 interesting stamps for your approval inspection. Completely catalogued, substantially reduced. Free tongs and hinges with purchase. Niagara Stamp Company, St. Catharines 31, Ontario, Can.

WHOLESALE Price lists for dealers. Progressive, 2700 Burkhardt, Cincinnati 15, Ohio.

DIFFERENT, 500, 50c; 1000, \$1.25; 2000, \$2.75; 5000, \$11.00. Approvals. K. S. Holmes, London, Canada.

5 MINT Blocks free to approval applicants. A. H., 1207 Northland Ave., Buffalo 15, N. Y.

MACAO Flower set, 10c with approvals. Seminole Stamps, Box 1138-P, Coral Gables 34, Florida.

WONDERFUL Offer. 7 complete mint sets only 10c with approvals. Reich (M26), 1033 Lawrence, Chicago 40.

ALBUM! 32 Pages! Only 10c! Approvals. Hartford Stampmart, Hartford 1, Conn.

UNITED Nations cover free to applicants of U.S. or British Colonial approvals. A. Taylor, Skyland, N. C.

WORLDWIDE, 50 All different, absolutely free, just to introduce our incomparable approvals. Kent Stamp Company, OPO Box 87, Brooklyn, N. Y.

FREE U.S. illustrated bargain catalogue. Rothberg's, 53 Bromfield, Boston 8, Mass.

TWO \$5.00 U. S. stamps plus 20 different, 10c with U. S. approvals. Irwin Stamp Co., Box 1105, Brooklyn 30, N. Y.

100 DIFFERENT U. S., 40c with U. S. approvals. Faith, 1339½ Westminster, Alhambra, California.

ECONOMICAL ½c-1c-2c-Approvals, 22,000 varieties available. Dresel, Box 270-n, New York 25, N. Y.

50 DIFFERENT Bulgaria 10c! Approvals. Ensign Stamp Company, Dept. M, Berdan Avenue, Paterson 2, New Jersey.

NUDES Set: Colorful approvals 10c. Atlas, 2830-M, Eisenhower, Racine, Wis.

25 STAMPS For only 10c! This mammoth value includes airmails, pictorials; stamps from strange countries cataloguing up to 25c each! Also approvals. Mystic Stamp Company, Camden 80, New York

50 DIFF. U. S. commemoratives 25c. Mammoth packet list free. Econopackets, Box 168, Riverside 9, Calif.

WOW! 153 All different Germany, 10c. Zeppelins, semi-postals, airmails, high values, big bargain lists and approvals included. Jamestown Stamp, Jamestown 512, New York.

STAMPS Wanted. Misc and used, collections, accumulations. Good grades only. Buy outright if bargain. What have you? Write, give details. Vanroy Shirk, Lebanon, Penna.

300 DIFFERENT, Triangle, airmail, pictorials, etc. 25c. 500 mixed U. S. 25c. Carlton's, Tujunga, Calif.

200 DIFFERENT, Including Roosevelt triangle, 10c to approval applicants. M. Avalon Stamp Company, Springfield, Mass.

50 DIFFERENT Argentine 10c. Approvals. Reuter, 611 W. 40th Pl., Los Angeles 37.

AMAZING Offer! 200 United States stamps—including commemoratives, airmails, high denominations to \$1.00. Only 10c to approval applicants! Illustrated bargain lists free. Mystic Stamp Co., Dept. 80, Camden, New York.

100 DIFFERENT Spain 25c. Penny approvals included. Reed, Box 980, Chicago 90, Ill.

OLD Scarce U.S. seconds on approvals. Slight imperfections, lowest prices. Herfield, Clintonhill Sta., Newark 8, N. J.

SPEND Pennies! Not dollars! Thousands of fascinating stamps to choose from our 1c and 2c approvals. No premiums. Just honest value. Pat F. Knowles, Box 2247, Van Nuys, Calif.

OLD U.S. approvals. Low prices. MacG., 2905 Observatory, Cincinnati 8, Ohio.

50 DIFFERENT United States 5c with bargain approvals, lists. Bookman, Manatee 1, Florida.

U.S. Mint 797 SPA sheet, 10c to U.S. approval applicants. M. Haycock, 153M 74th St., Brooklyn 9, N. Y.

850 MIXED U.S. old-new 25c. Lists. Weatherby, Medina, Ohio.

25 FRENCH Colonies 5c; approvals sent. Adlex, 367-M Park Ave., Newark 7, New Jersey.

200 DIFFERENT! Plus Macau, Rhodesia, Mauritius, etc. Only 10c to approval applicants. Evden, Box 128, Valley Stream 50, New York.

GIANT Approvals, thousands different, one cent each. Wahl's Stamp Exchange, 7008P Farragut, Chicago 31, Ill.

FREE Sample! Interesting, illustrated, informative! National Stamp News, Anderson, South Carolina.

65 ALL Different U. S. stamps. Includes 50 year olds, commemoratives, airmails and \$5.00 stamp. Only 15c. Approvals. Willett Co., Box 511-L, Port Chester, New York.

PACKETS—World, different, 3,000, \$7.00; 5,000, \$19.00; 10,000, \$60.00; 20,000, \$256.00! 30,000, \$600.00. Russell, Box 2011D, Natural Bridge Station, St. Louis 15, Mo.

WORLDWIDE, Variety packets 100, 10c; 500, 75c; 1000, \$1.75; 5000, \$13.75. Philatelic House, Rockville Centre, N. Y.

50 DIFF. Uruguay 10c to approval applicants. Elco Stamp Co., 682 Pearl, Benton Harbor, Mich.

FREE Lavishly illustrated U.S. catalog. Ace, 1431 Grace, Cleveland 7, Ohio.

BEAUTIFUL Sets. Packets. Approvals. Free album to beginners. Freeman, 18 Main, Peterborough, N. H.

U.S. Mint Tipex-Cipex souvenir sheets 60c. Free price list. Brooks, 2352A East 23rd Street, Brooklyn 29, New York.

100 DIFFERENT Worldwide stamps 10c to approval applicants. Ladue Stamp Co., 9815 Clayton, St. Louis 17, Mo.

ESTONIA Carrier pigeon set free. Approvals. Canyon Stamps, Box 808, San Fernando, California.

CIPEX Souvenir sheet plus 25 different U.S. 10c. Approvals accompany. Village Stamps, 90-39P 214 St., Queens Village 28, N. Y.

25 DIFFERENT Ships, trains, flowers, animals 25c. Approvals. Hayek, 396 Mountainview Road, Englewood, N. J.

FREE—British, Spanish, French Colonial collection. Approvals. Pleasure Stamps, 1865P—52nd, Brooklyn 4, New York.

FREE French West Africa pictorials, approvals. Eagle, 6916 Roosevelt Boulevard, Philadelphia 49, Penna.

ANTIQUES, RELICS, INDIAN GOODS, CURIOS

THREE Triangular warpoints or six arrowheads \$1.00. Charles Palmer, RD, McKeesport, Penna.

DARK Africa genuine native handmade ivory ebony carvings. Marvelous gifts. Particulars 25 cent stamp. Vessiere, O. O. B. 2482, Leopoldville, Belgian Congo.

4 FINE Arrowheads \$1.00. 6 gem arrowheads \$2.00. List free. Lear's, Glenwood, Arkansas.

EXAMINE Genuine hand printed Indian art at our risk. Illustrated list free. Tewa, 724 Canyon, Santa Fe, New Mexico.

UNITED States silver dollars \$1.75 each postpaid. Fred Birch, Box 634, Deer Lodge, Montana.

4 SELECTED Arrowheads \$1.00. List 5c. H. Talburt, Calico Rock, Ark.

QWUITschuerrbelluuischen. Crowded for space. Selling 600 historical firearms, 30,000 prehistorical, stone age Indian relics, collectors cartridges, coins, Confederate money, Revolutionary, civil, Indian wars, flintlocks, muskets, revolvers, swords, bayonets, bullet molds, powder flasks, Blunderbusses, pepperboxes, stage coach, Winchester, buffalo carbines, Kentucky rifles, Derringers, frontiers. Arrowheads, tomahawks, gempoints, steer-deer-buffalo horns, eagle feathers, bo-wood, violin wood, mounted pheasants, quail, squirrels, deerheads, owls. Agates, fossils, mineral. Daguerrotypes, gold dollars, duelling pistols. Send 35c for profusely illustrated catalog. Heicke, Wenona, Ill.

PRECIOUS STONES, MINERALS

16 PRECIOUS Gems, beautifully mounted; with descriptions. \$4.00 prepaid. Eckert Mineral Research, Florence, Colo.

GEMCUTTING, Silvercraft authority. Illustrated magazine tells how. Cut rocks, make jewelry. 150 ads illustrating equipment, offering gems for collectors, cutters. Postal brings literature. Lapidary Journal, Drawer B, Del Mar, Calif.

DIAMONDS Are missing in most mineral collections. Guaranteed genuine rough diamond one carat \$18.00, sample \$2.00. Cresco Trading, 522B Fifth Avenue, New York.

FOOL'S Gold from famous gold camp 25c; nuggets, delicate dendrites, magnetite, uranium 75c. Martin's, Leadville, Colo.

EARTH Science, the Rockhounds' national magazine. Subscription \$2.00, sample 25c. Box 1357, Chicago 90.

TEN Beautiful highly polished genuine gems. Only \$1.00. Baroque shapes. O'Brien's, 1116-M Wilcox, Hollywood 38, Calif.

GEMSTONES, Mineral specimens. Every variety. Lowest prices. Free booklet. Plummer's, 4720 Point Loma Ave., San Diego 7, Calif.

SAPPHIRE, Topaz, tourmaline, garnet, peridot. 5 uncut gem specimens. \$1.00. O'Brien's, 1116M Wilcox, Hollywood 38, Calif.

HOBBIES AND COLLECTIONS

CHRISTMAS And charity seals. Approvals. Eckert, 5043 Warwick, Chicago 41, Illinois.

HOBBYISTS, Viewcard collectors, worldwide membership lists, one issue 25c, three issues 50c, year \$1.50. Postcard Exchange, Box 4473-A, Dallas, Texas.

100 DIFFERENT Military patches. Colorful, authentic. Free album. \$5.00. Wolf Appleton, Inc., 566-D Broadway, New York City 12.

MATCHBOOK Collectors—Latest set and lists 25c. Yeingst, Parkway Road, Harrisburg, Penna.

NAZI Medals, ribbons, souvenirs. Big packet \$1.00. Illustrated lists. Medcrafts, 1923 34th St. S.W., Calgary, Canada

RAISE Miniature 18 inch tall trees in your home. Nature's masterpieces! Fascinating, profitable hobby. Details free. Miniature Forests, 325 Bankers Trust Bldg., Indianapolis 4, Indiana.

UNUSED Matchbook covers. 100 different \$1.00. 36 page catalog 25c. Matchcover album \$3.00. Charles Edelman, 1311C East 84, Cleveland 3, Ohio.

NEW—15 Different match covers 10c. Box 202, Rochester 1, N. Y.

MILITARY Miniatures; U. S. Marines, American Revolution, Civil War, Custer's Cavalry. Illustrated catalog 25c. Bussler Miniatures, 59 Russell Park, Quincy 69, Mass. Dept. B.

FREE Leathercraft catalog, Do-It-Yourself. Write Tandy Leather, Box 397-AH, Tulsa, Oklahoma.

INVENTING Can be an interesting and profitable hobby. Write for complete particulars. Institute of American Inventors, Dept. 40-E 631-E St., N.W., Washington 4, D. C.

CAMERAS, PHOTO SUPPLIES

BUY Wholesale nationally advertised cameras, photo supplies, thousands other products at big discount. Free "Wholesale Plan." American Buyers, 629-PP Linden, Buffalo 16, N. Y.

20 TO 50% Discount everything photographic, giftware. Free catalogue. Dart, 3812 E. Atlantic Avenue, Brooklyn 24, New York.

PHOTOGRAPHY For pleasure or profit. Learn at home. Practical basic training. Long established school. Free booklet. American School of Photography, 835 Diversey Parkway, Dept. 3431, Chicago 14.

CAMERA Repairmen greatly needed! You can learn manufacturers' service methods at home, in your spare time! Free, big illustrated book tells how: Write today. National Camera Repair School, Dept. PM11, Englewood, Colorado.

OIL Coloring photographs—A fascinating hobby or profitable sideline for those with artistic talent. Learn at home. Easy simplified method. Free booklet. National Photo Coloring School, 835 Diversey Parkway, Dept. 3431, Chicago 14.

MONEY For you—New 1955 market guide. Send \$2.00. Richard & Co., 1618 Linwood, Kansas City, Missouri.

JUMBO Prints, 8-exposure roll 30c; 12 exposure, 45c; 16 exposure 55c. Reprints, oversize 4c. Guaranteed quality. Mail Order Photo Service, Box 297, Watertown, Wisconsin.

PHOTO Lampshades, reproducing your cherished photographs. Free brochure. Coast O'Maine Studio, Boothbay Harbor 2, Maine.

NEW DeJur "750" projector with beaded 30x40 screen \$112.95 (regularly \$173.25). Photo equipment, appliances, typewriters, terrific savings. Free catalog. Camera Shoppe, Box 601-Y, Mount Vernon, N. Y.

BASS Says: Quality cameras since 1910. When in Chicago visit the camera cross roads of the world, or write us for your favorite equipment, new or used. Satisfaction guaranteed. Bass Camera Co., Dept. AG, 179 W. Madison St., Chicago 2, Ill.

DISCOUNTS To 40%—Cameras, projectors, tape recorders, lenses. Write for individual quotations, no catalogs. Classified Camera D, 2375 E. 65 St., Brooklyn, N. Y.

PHOTO FINISHING

SPECIAL Offer—8 Jumbos 25c; 12, 35c, with this ad. Western Photo, PM15, Box 298, San Francisco 1, Calif.

PHOTOS Copied. Cent each. Details, samples, 10c. Rapco, 113 Oregon, Fall River, Mass.

TRIAL Offer—Good with ad only. One roll film developed, 8 exposures 25c, 12 exposures 35c. King sized, dated prints from roll only. Don't send negatives. Sir Walter Photo, Raleigh, N. C.

ENLARGEMENTS! Eight 5x7's or five 8x10's, \$1.00. Wilart Enlargers, Box 967, Little Rock, Ark.

12 EXPOSURE Rolls 39c, jumbo prints. Guaranteed work, one day service. Lincoln Studios, Dept. K, Box 13, Lincoln, Nebraska.

PARTICULAR? Custom finishing guaranteed. 8 Jumbos 35c, 12—50c. Special! 35mm. 36 exposures \$1.10. Free mailer. Flash-Photo, Box 36G, Brooklyn 4, N. Y.

GUARANTEED Quality. Fast service. Eight jumbos in beautiful super pak plastic ring binder albums only 35c. Send for free mailers and particulars of our complete photo finishing service. Grand Fotos, G.P.O. Box 1410, New York 1, N. Y.

TWO Beautiful prints from each picture on roll, 8 exposure 35c, 12 exposure 45c. Thirty-three years of satisfied customers. Quick service. Lens Photos, Dept. J-4, Janesville, Wis.

ROLL Developed and 16 prints 40c. Free mailers. Fast service. Mayfair Photos, Box 617-K, Toledo 1, Ohio.

BEAUTIFUL Enlargement from each picture on roll, 8 exposure 35c; 12 exposure 45c. Cut Rate Photos, Dept. B-4, Janesville, Wis.

TOP Quality. Fast service. 8 jumbos 35c in beautiful super pak album, 16 contacts 40c. Reprints—Jumbos 4c; contacts 3c. Satisfaction guaranteed. Write for free mailers and circulars. Fast-X-Photo, Box A, Jersey City, N. J.

6 OR 8 Picture roll 35c. 12 or 16 picture roll 55c. Each roll developed and printed in handy album pack. Send coin with roll. No c.o.d.'s. Mailing containers sent free. Deluxe Film Service, Box 1263-A, Shreveport, Louisiana.

12 JUMBOS From any size roll developed 25c with this ad only. S. Skrudland, Lake Geneva, Wis.

MOTION PICTURES AND SOUND EQUIPMENT

8 OR 16MM. films \$2.98 each. Free list. Specify sound or silent. Corey-m, 556 Aldine, Chicago 13.

RECORDING Tape, new, sold below wholesale. Box 1404-A, San Francisco 1, Calif.

RENT 16MM. sound feature pictures—\$3.95, three days, including delivery, return postage. 23-minute short subject programs, \$2.49. Big catalog free. Eastin Pictures, 136 Eastin Bldg., Davenport, Iowa.

TAPE Recorders, accessories. Best buys. Boynton Studio, 10 Pennsylvania, Tuckahoe, New York.

REVERSE P85 deluxe projector, case, latest, spotless, \$88.38. DeJur 750 projector, case, \$112.80. Free catalogue. 1001 bargains. Dealer's Mart, 54 Beverly Road, New Rochelle, N. Y.

FREE! Blackhawk's fall sale catalog new and used 16mm., 8mm. films, used 16mm. sound projectors, new 2"x2" color slides. Blackhawk Films, 1083 Eastin, Davenport, Iowa.

16 MM. Sound-used projectors and films. Rental, sale, exchange, bargain prices. Free lists. National Cinema, 71 Dey Street, New York City.

SALE. Rent, 8-16 sound, silent films, equipment. Mogul's, 112 W. 48, New York 36.

TAPE Recorders, tapes, accessories. Unusual values. Dressner, Box 66M, Peter Stuyvesant Station, New York City 9.

5,000 8-16MM. Silent-sound films. International, 2129 Strauss, Brooklyn 12.

MOVIE Camera film: 8mm. roll \$1.50, 16mm. 100' \$3.00. Free processing. Better Films, 742 New Lots, Brooklyn, N. Y.

8 & 16MM. Professional national parks movies in Kodachrome. list 10c Ideal, 4644 W. Geary, San Francisco 18, California.

SAVE 50%! Guaranteed-fresh color, b.&w. movie film! 8mm., 16mm. Free catalog! Eso-R, 47th Holly, Kansas City 12, Missouri.

WILD Animal and bird movies, 8 mm. or 16 mm. beautiful color or B&W. Also 2x2 color slides. Send for free catalog. Wild Life Films, 5151-A Strohm Ave., N. Hollywood, Calif.

MUSIC AND MUSICAL INSTRUMENTS

PLAY Piano the first day! Copyrighted secret. Details free. Miracle Method, Box 5203P, Phoenix, Arizona.

MUSICAL Instruments, supplies. Save up to 50%. Free wholesale catalog. Musicians Service, Box 711, Wilkes-Barre, Penna.

LP Records—10" 69c, 12" 89c. Guaranteed new. Catalogue 20c. Records, 4710 Caroline, Houston 4, Texas.

PHONOGRAPH Records 5c per record. Low as wholesale. A. Porsch, Hinton, Iowa. Information 25c.

SONGWRITERS: Large recording company may record your song. National sales and promotion if selected. No charge for melodies. Send song material to Music Makers, Dept. E-5, Box 2507, Hollywood, California.

ELECTRIC Guitars, amplifiers. Wholesale. Free catalog. Carvin, PM, Baldwin Park, California.

POPULAR Songs. How to write and sell them. Write for free booklet Successful Songwriting. Gateway Songs, Box 2470, Hollywood 28, Calif.

ACCORDIONS—World's largest selection of famous makes. Direct-from-importer-to-you at lowest wholesale prices. Trade-ins accepted. Free color catalogs. Write today. Chicago Accordion Center, Inc., Dept. M, 754 North Damen, Chicago 22, Ill.

SWISS Musical movements. Finest. \$2.50. Spielman, 131 West 42nd, New York 36.

1954 ACCORDIONS—Wholesale. Free catalog. American Accordion Center, PM-8, 5329 Belmont, Chicago.

WANTED! Poems for musical settings. Write Songwriters' Service, Clifton, N. J.

ACCORDIONS. Wholesale to everyone. Save up to 60%. All national known brands. Free catalogue. Del Principe, 29 South Cicero, Chicago 44.

SONGPOEMS Wanted. Mail to: Tin Pan Alley, Inc., 1650 Broadway, New York 19, N. Y.

FREE Record of your song. Your words, my melody. Free information. Johnny Mack's Melody Mart, 1094 West 39th Street, Dept. A, Los Angeles 37.

SONGWRITERS! Protect your ideas! Hold all songs, poems! Write for safe correct procedure first! Song Service, Dept. P, 333 W. 56th St., New York 19, N. Y.

POEMS Wanted for musical setting. Send poems. Free examination. Five Star Music Masters, 630 Beacon Bldg., Boston, Mass.

WRITE Songs. Big money and reputation. Write for information. J. Gordon Pub. Co., 4700 South California Avenue, Chicago.

SONGWRITERS! Send poems, songs. Music Service, 243 West 72nd St., PM, New York 23.

POEMS Wanted for musical setting. Send poems. Free examination. Crown Music Company, 1476 Broadway, New York City 36.

SWISS Musical movements \$1.90. Helax, 218 West 72nd Street, New York 23.

SONGWRITERS—Success, fame, fortune if talented. Songs revised, composed, published, promoted by largest firm. Free appraisal. Since 1943. Postcard to Nordyke Publishing Co., 7070 Hollywood Blvd., Hollywood 28, PM, Calif.

RADIO, TELEVISION AND ELECTRONICS

FREE Radio tester, soldering iron. Build and keep 15 high quality radios—Only \$19.95 complete. No experience required. Enclose 25c for valuable Radio-TV Repair Guide and kit catalog. Progressive Edu-Kits Inc., 497 Union Ave., Dept. PM25, Brooklyn 11, N. Y.

HIGH Powered T.V. antennas for less than \$2.00. For plans, plus tips to improve reception, send \$1.00. T.V., Box 217, Longview, Wash.

FIFTEEN Assorted—Resistors, condensers, knobs, 30c. Trowbridge, 312 West 75th, Chicago 21.

MAKE Simple, tubeless, batteryless, distance-getting radio. Genuine Melomite crystal, detector. Illustrated instructions. 50c postpaid. Allen, 427-PM5, Clinton, Missouri.

FREE 308 Page 1955 television-radio-electronics catalog! World's largest stocks, lowest prices. Complete supplies for builders, experimenters, amateurs, servicemen. Latest builders' kits. TV, Hi-Fi, phonos, records. P.A. Thousands of parts, tubes, test instruments, books, diagrams. Top quality money-saving values. Get your copy now! Allied Radio Corp., 100 N. West-corn Ave., Dept. 34-A-5, Chicago 80, Ill.

EDUCATIONAL 3-Speed portable phonograph kit. Beam power amplifier \$15.95 prepaid. Fidelity Unlimited, 6303 39th Ave., Woodside 77, N. Y.

SIMPLIFIED Radio Builder's Handbook plus latest "Electronic Experimenter" issue—25c. Alena, 286 East Broadway, New York 2.

CRYSTAL Radio. Wired loud. Guaranteed, 75c. Cozzo, 1080 Ovington, Brooklyn 19, N. Y.

LOUD Crystal, latest "transistorized" radio plans: 50c. Amorose, Route Four, Richmond, Virginia.

WEBCOR #2010 Recorder, \$139.50. Wilcox 211a, \$84.50. TDC Stereotone recorder, \$169.00. All like new. Free catalogue. 1001 bargains. Dealer's Mart, 54 Beverly Rd., New Rochelle, N. Y.

ATTENTION Dealers. New variety three-speed full fidelity portable phonograph \$19.90 f.o.b. factory. Halas Electronics, 5123 Cermak, Cicero 50, Illinois.

TRANSISTOR Portable radio. World's first offered. Weighs three ounces complete. For amazing details rush postal to Trans-Mite Labs., Mantoloking, N. C.

CRYSTAL Radio experimenters. Write Leslie Hulet, 305 Hope, Lakewood, N. J.

REPAIR Your TV. Prepared exclusively for you. Plus additional service. Make, model, \$2.00. Personal TV, Box 66A, Little Neck, N. Y.

TV Trade-in sets, Philco, Emerson, G.E., Admiral, Motorola, Tele-King, others. List available. 10"—\$17, 12"—\$20 up. Washtek Service Co., 1501 Boston Rd., Bronx, N. Y. DA 3-9281.

COLOR Television! Enjoy 3 color screen now. Easily attached. Details free. Zingo Products, Johnstown 77, New York.

BUSINESS OPPORTUNITIES

DOLLARS In personalized baby record books. Sell by mail. Eleven thousand new prospects daily. Use same literature we do. No-Co-Ro, Oakland 6, California.

NEW! Make money at home. Build and sell modern lamp, lampshade kits. Guaranteed to sell on sight. Fabulous profits. Free facts. Scott Studio, 746-B Howard Ave., Brooklyn 12, New York.

FREE! Private labels! Exclusive sales! Own a business! Sell radio PI, stores, mailorder. We supply product, plan, literature; you furnish executive management and employ salesmen. VitaMins, 2908PMA Beverly, Los Angeles 57.

LEARN Sewing machine repair, electrify, trade, sell. How to make big money at home sparetime. New zigzag machines, parts, etc., wholesale. Free details. Taylor Service, Hamilton PM-1, Ohio.

GROW Orchids at home—Profitable, fascinating. Year 'round, Maine to California. No greenhouse. Gorgeous cactileyas, cymbidiums, etc. Successful home grower shows you how. Full details free. Flowerland, 4622-PK Wilshire, Los Angeles 5.

BECOME A game warden, or join forestry, park, lookout, wildlife conservation services. Enjoy outdoor work, good pay, real security. Complete information free! Write Home-Study Institute, 3156JY West Eighth, Los Angeles 5, California.

PUBLISH Your own mail order magazine. Sample 10c. Decco Company, Portland 7, Oregon.

START A buying service, buy wholesale thousands nationally advertised products. Make big profits selling at sizable discounts. Postcard brings details. American Buyers, 627-P Linden, Buffalo, N. Y.

MEN Wanted—Build luggage and cases at home. We sell your products, supply complete instructions, materials, everything. No special equipment needed. Free details. Casecraft, 805-G13 Sunset, Los Angeles 12, Calif.

FREE! "301 Profitable Small Businesses!" Amazing shoestring plans! Work home! Start sparetime! Deumant Surveys, Kenmore 23-PM, N. Y.

OPERATE Your own cafe, diner. My guide reveals ways to start on only minor investment. I did it, so can you when you know how. Write Restaurant Arts, BU11, Fremont, Ohio.

ADVERTISING Book matches—Cash in on big demand; sell union label matches. Cuts for all businesses and political parties. Free powerhouse selling kit, low prices, protection guaranteed on repeat orders. Cash commissions. Superior Match Co., Dept. MX-155, 7530 Greenwood, Chicago.

YOUR Own mail-order business. Free counsel. La Roche, Merritt Island 3, Fla.

START Own mail business on small capital. Supply information on fast-growing plastics industry to others. Offer limited. Write Rockaway-Hall Company, Rockaway 3, Oregon.

STARTING? Inexperienced? "Which Home Business?" sent free. Farr, Garnerville, N. Y.

I want to send you proof of the wonderful pulling power of Popular Mechanics classified pages. What's your proposition? Write me today. Include literature if possible. P. W. Johnson, Manager Classified Advertising, Popular Mechanics Magazine, 200 E. Ontario St., Chicago 11, Ill.

MONEY In sparetime fixit shop at home. Repeat cash business. Experience unnecessary. No selling. Free booklet explains. Victor Foley Company, Columbia Heights, Minnesota.

HUSBAND-Wife team wanted to own-operate retail store—Staple year around products. Experience unnecessary. Work with million dollar manufacturer under whose proven plan you can make up to \$12,000 yearly. Exclusive franchises available good middle size towns in Iowa, Nebraska, Missouri, Kansas, Oklahoma, Arkansas, Texas, Illinois, Ohio. \$5,000 investment required, fully secured. Investigate this opportunity for independence in permanent respected business. Write Manufacturer, Box 7366, Kansas City, Missouri.

\$20.00 DAILY Possible. Sharpening barber, beauticians scissors. Details free. Wayne Zell, Summitville-2, Indiana.

START Home business—Make gold plated costume jewelry. Beginners kit \$1.00. Completed sells for \$3.00. Catalog 25c. Don-Bar Novelty, Dept. E-81, 3511 Armitage, Chicago 47.

MAIL Order plan, proved winner, practical, workable, profitable. Send now for copyrighted fact-packed booklet and complete plan, both for only 25c postpaid. Satisfaction guaranteed. Maine Industries, 22 Dartmouth, Bangor, Maine.

START Your own business on credit. Your own boss. 1661 of our dealers sold \$5,000 to \$28,500 in 1953. We supply stocks, equipment on credit. 200 home necessities. Sales experience unnecessary. Pleasant profitable business backed by world-wide industry. Write Rawleigh's, Dept. A-U-PPM, Freeport, Ill.

OWN, Operate route Wishing Wells. Place these new \$8.50 skill games on counters in cafes, luncheonettes, clubs, etc. Collect coins weekly. Write, Legalsharr, Box 929, Long Beach 1, California.

UNUSUAL Invention, earn \$500 month up. National company, full or part time. Automatic fire extinguisher exclusive. Big rural market. \$11 sales earns \$6. Sample outfit furnished. Write: Superior Products, Inc., Dept. 203, 4215 Michigan, Kansas City, Missouri.

OPPORTUNITY Seekers names, none over 60 days. From advertising in magazines. All seeking ways to make money at home. 500, \$5.00; 1000, \$8.00. Typed on gummed labels. Try 1000, you will be back for more. Ken-West, 7-K South Harlem St., Worcester 4, Mass.

BOOKKEEPERS, Increase earnings operating Kensington bookkeeping service. Kern, 5632 Lankershim, North Hollywood, California.

MAKE Money at home as renewal headquarters for all magazines. Liberal commissions. No experience—no capital needed. Supplies furnished. Write for free catalog. McGregor Magazine Agency, Dept. 500B, Mount Morris, Ill.

NEW Plastic mending tape. Just press on! Repairs clothing instantly. Lightning seller. Samples sent on trial. Kristee 108, Akron, Ohio.

FISHWORM Breeder's book—\$1.00. Postpaid. Literature free. Dixdok, Kent, Ohio.

PROFITS Up to \$600.00 mailing 100 catalogs. Write: Your Best Distributors, 200 West 34th, New York 1.

MAIL Order and direct sales. Small cash outlay. Everything furnished. Dyer Co., Windsor 2, Mo.

START Spare-time mailorder business. Gedgard, Box 798-D, New York 1, N. Y.

FINANCIAL Independence by mail order. Details free. Opportunities Unlimited, Dept. 6, Box 1576, Boston, Mass.

\$1000 MONTHLY Possible in collection agency business. Free details. Write Cole Associates, Syracuse 2, N. Y.

IMPORT-Export opportunity, profitable, world-wide, mail-order business from home, without capital; or travel abroad. Established world trader ships instructions for no-risk examination. Experience unnecessary. Free details. Mellinger E701, Los Angeles 24.

METALLIZED Baby shoe mountings, supplies. Instructions. Foster, 1520 Ardmore, Chicago 26.

MAKE Perfumes, other products. Sell mailorder. Formula catalogue free. International, 6347 Parnell PM-1, Chicago 21, Illinois.

PRINT Without a printing press! Amazing new method! Print colorful signs, banners, cards, posters, glasswear; anything at home. Big profits. Moneymaking opportunity! We supply everything. Beautiful sample, home-business plan free! Write Screen-Print Company, Los Angeles 61, California.

FREE—Everything you need to make big money. World's famous French-type perfumes. Tremendous profits. "Husk" O'Hare, 5732 North Kenmore, Chicago 40, Illinois.

OWN A business without investment! Write for free display. America's finest work uniforms embroidered to advertise. Prospects, profits unlimited. Topps, Dept. 531, Rochester, Indiana.

TRADE Magazines. Business, vocational, professional, hobbies. Single current copies. Special get acquainted service. Choose from 4,387—all fields. Current list free. Commercial Engraving Publishing Company, 34C North Kitter, Indianapolis 19, Indiana.

WORK At home—No mail order, no selling; several ideas to choose from. Folder free. Greenplay, 541 West Third, Reno, Nevada.

MAIL Circulars, 100% commission. Free details. Fisher's, Dept. M1, 4750 So. Central, Los Angeles 11, California.

MAKE Big Money at home! Invisible reweaving pays up to \$10.00 profit in an hour. Make tears, holes disappear from fabrics. Constant demand from laundries, cleaners, home brings steady earnings. Details free. Fabricon, Dept. AE, 8342 S. Prairie, Chicago 19, Illinois.

FREE New 280-page book. 2000 businesses, farms, income properties for sale throughout America. Specify type of business desired, and general location. Book No. 76, 5400 Wilshire, Los Angeles, Calif.

MAKE Durable building plastic, easily, beautiful, tough. Any color. 101 uses. Exclusive district. 800% profit. Bays Laboratories, Oklahoma City 9.

IT'S Here! 1200% profit! Machineless laminating photos, documents, licenses, etc. in clear, self-sealing, plastic. Lifetime protection. No equipment needed! Also, sell through agents, homeworkers, etc., or cash in selling home laminating kits, local, by mail. Everybody a prospect. \$1 brings complete laminating kit (seals 10 articles) wholesale prices, all details, postpaid. Satisfaction guaranteed. Garen Sales, 1321-M3 Stanberry, Zanesville, Ohio.

WE Love our mailman—He leaves over \$1000.00 monthly in our rural mailbox. My college professor husband drafted a scientific home mailorder method. We bought a Texas ranch, live as we always wanted. Now we sell the Ranch Mailorder Method. Operates anywhere. Inquire: Eveningshade Ranch, Helotes, Texas.

PHOTOGRAPHIC Silk screen printing. Improved process, easily understood instructions \$2.50. Two important materials free to first 1000. Remie, 2946 Tyburn, Los Angeles 39, Calif.

YOUR Own established shoe polish business without investment if good salesmen. Write for details. Johnson, 1737 No. Campbell, Chicago 47, Ill.

EARN Money at home! Homeworker Magazine tells how. Sample 25c. Sizemore, 20-H East Delaware, Chicago 11.

COMMISSION Circulars—Offering real merchandise. Send 10c for samples and details. Products, Box 23, Boston 17, Mass.

EARN \$2.00 Hour! I do—Making sandals. Youngs, 1308-PM, South First, Arcadia, California.

\$70 WEEKLY Guaranteed—Potential, home, spare time. \$6.47 hourly full time. Shortcut public bookkeeping. Immediate income, easy! Revolutionary simplifications. Client producers. Auditax, 34651AF, Los Angeles 34.

ESTABLISH Chicago address. Mail forwarded daily. Continental, 20D West Jackson, Chicago 4.

OWN A mail-order paper products business. Sell envelopes, tags, bags, boxes, wholesale. Tremendous demand. Steady profits. No capital necessary. Omaha Envelope Service, Dept. 20, 4721 California, Omaha 3, Neb.

TIN-Cans. Turn them into cash. Nine methods. Instructions 50c. Charles Company, 12-DCK, Norwood, Ohio.

EXPORT Business made easy! Substantial income, home operated, low overhead, no merchandise buying. Complete setup service. Hermes Exports, 152 West 42, New York 18.

SELL Popular Mechanics and all other magazine subscriptions. Free catalog, supplies. Subscription Service Company, Dept. A, P.O. Box 2070, Birmingham, Ala.

WANTED! Home producers, by manufacturers in our clearing house service. Become subcontractor, casting plastic products for these companies. Thousands of easy-to-make items required for consumer-industrial use. Cash in at home, without previous experience. Plastic Service Associates, Dept. 1-PM, East Boston 28, Mass.

WRITERS! Authors! Columnists! Get endless supply ideas. Instructions 50c. Charles Company, 12-DCM, Norwood, Ohio.

CHINCHILLA Dealership available for local representation of large western ranch. Huge profits made from fascinating business operated from home. Andes Chinchillas, Paramus, N. J.

INVESTIGATE Earthworm breeding! Pleasant, profitable home industry! Part; full time! Free revealing facts, information! Write Earthmaster System, 45D, El Monte, Calif.

OPERATE Your own mail order business! At home in spare time. Start right. Avoid costly mistakes. "Mail Order Business Manual" shows you how! Details free. Bud E. Hine, Box 93, Battle Creek, Michigan.

ENJOY Benefits and profits from co-publishing "Progressive Mail Trade" magazine. Sample copy and details 25c. Bud E. Hine, Box 93, Battle Creek, Michigan.

UNUSUAL Home mailorder business. Fascinating, clean, profitable. Ready to operate. Angora House, PM2, Springfield, Illinois.

GOOD Paying business silvering mirrors, plating autoproducts, reflectors, bicycles, bathroom fixtures, etc., by late method. No tanks or shop required. Outfit furnished. Free booklet. Gunmetal Co., Ave. H., Decatur, Illinois.

NEED Money? Raise earthworms. Write for easy plan. Earthworm Gardens, 104 Peacock Building, El Monte, Calif.

MAKE Money in landscaping—Start your own business, part or full time. Many good paying positions open. Earn while learning. Send for free book. National Landscape Institute, Dept. M-15, 310 S. Robertson Blvd., Los Angeles 48.

BUY Wholesale. Thousands items. Start home mailorder business. Literature free. Russell, Box 481, Roseburg, Ore.

HOME-Operated mail-order business. Everything supplied. Sensational plan for lifetime repeat orders. Literature free. Consumer Service, 1073 Piedmont, Atlanta, Georgia.

BE Listed! Receive latest-best low-cost starting book-merchandise mail selling offers. National, Box 88A, Dorchester 22, Mass.

BIG Mail 10c. Maxwell, 2938-Oak, Bettendorf, Iowa.

45 MONEYMAKERS 10c. Literature describing mailorder included. Service Bureau, Box 596, Toronto, Canada.

POPCORN And potato chip equipment. Eakins, Box 933-A5, Springfield, Ohio.

NEWEST Home business opportunities. Request free bulletin. Falcon, Winnebago 2, Ill.

FOR The best mail order deal in America write Modern Enterprises, Cynthia, Kentucky.

EXTRA Income. Do leathercraft easy way. Free information. Tandy Leather Company, Box 791-Q8, Fort Worth, Texas.

START Your own business at home. Sell subscriptions for popular magazines. Liberal commissions. Send for supplies, etc. DeSales Magazine Service, 60 East 42nd St., New York 17, N. Y.

I Average \$125 weekly selling books by mail! So can you! Start sparetime! Work home! Cooper, 246-R Taunton, Buffalo, N. Y.

PARTNERSHIPS. How to start. Withdraw. Oust undesirable partner. Particulars free. Reynard, Box 1265-A, Peoria, Ill.

OPERATE Profitable independent business. Sell lumber, wood products by mail. No investment. Chas. Webster, Guttenberg, Iowa.

WANT Up to \$100.00 weekly deposited in your mail box? Details free! Inquire Aldensmith, 2708 Ladera, San Bernardino, Calif.

CASH Now and year 'round from your home. No magic. Booklet 24 exact proven steps of mailorder business success. \$2.00 or c.o.d. Mailtest Research, P.O. Box 2, Little River Sta., Miami 38, Fla.

WANTED: 500 Mail order dealers! Literature 25c. Steinberger Press, 1274-C Stebbins, New York City 59.

MAKE Money! Start a mailorder business. Copyrighted instructions \$1.00. Home Enterprises, 817-C Park S.W., Canton, Ohio.

\$150 WEEK—Easy! Start home Venetian blind laundry. Revealing book free. AT Co., 101 S. 44th, Philadelphia 4, Penna.

LIQUID Rubber. Make flexible molds. Free sample. Chaney, 1130 E. 16th St., Jacksonville 6, Fla.

MEN—Income from local information. No selling. Neherco, LaVerne, California.

WINNING Mail order plans. Merchandise, books. Details free. Mid-State, Box 214, Syracuse 1, N. Y.

RUBBER Molds for casting plaques, figurines, novelties. Catalog illustrating over 100 fast sellers, 10c. Castcraft Studios, 508-PM Marion Street, Brooklyn 33, N. Y.

INCREASE Your income. Build your own mail order business. Copyrighted booklet tells how. Only 25c postpaid. Satisfaction guaranteed. The Gerwigs, 366 South Huron, Columbus 4, Ohio.

BUY Wholesale thousand items. Lists free. Triple J. Industries, 132 Berkshire, Bridgeport 8, Conn.

NEWEST Spare, full-time home business. \$5 to \$10 hour possible. Paint with suede—The finish with touch and eye-appeal. Beautify auto dashboards, signs, radios, toys, figurines, lamps—1001 others. Complete, step-by-step instructions sent for no-risk examination. Free details. Coast, Los Angeles 61.

FREE Wholesale kit guarantees you 33% to 60% profit on cameras, appliances, typewriters, etc. Arrow Distributing, 154F Nassau St., New York 38.

FREE Folio "Up to \$45,000; Unlimited Vacations." No merchandise, equipment. Unknown! Works itself, home! Hayling, Carlbad, Calif.

FINANCIAL Security and success in business can be yours! Make us prove it. Write to Success Unlimited, Box 1945, Solvang, Calif.

\$500 MONTHLY Possible raising earthworms. My "senior kit" best yet for beginners. Complete, nothing else to buy. Get facts with raising instructions. Send 25c (refundable). Multiple Cabin Services, Kalkaska 1, Michigan.

START Home manufacturing business. Make cleaners, soaps, polishes, cosmetics. Free literature. Kemix, Park Ridge, Ill.

IMPORT-Export mailorder opportunities! Details. Warner, Box 6, Port Scott, Kansas.

PART Time or full time. Your own business, selling name brands. No inventory required. Manhattan-W, 225 W. 57 St., New York City.

MAKE Flexible molds. Cast figurines, plaques. Free sample. Tooker, 630-R Chestnut, Hamilton, Ohio.

FORTUNES Made raising crickets and fishworms. Guaranteed raising and marketing instructions, \$1.00. Carter Farms, Plains, Georgia.

NEW-Different home business opportunity! Address-mail literature featuring real merchandise. Everything furnished. Mills, 1752-A, Garden Ave., Lorain, Ohio.

METALIZE Baby shoes, jewelry, gifts. Bronze, gold, silver. Free bulletin. Kiktavi, 7217-PY South Broadway, Los Angeles 3.

HAVE Home business mailing postcards offering real merchandise. Big earnings. Write: Mednis, 10 Port Norfolk, Boston 22, Massachusetts.

NATURAL Molding rubber, extra thick. Free sample. Flock, W. Wooley, 115-A Donald, Peoria, Ill.

ELECTROPLATE Auto parts, novelties, mirrors, baby shoes. Easy, inexpensive home processes. Free booklet. Tyco Metals, Box 13231-MM, Houston 19, Texas.

BOOKKEEPERS. Keep books, small firms spare time. Manual latest technique by C.P.A., \$3.00. Modern Business, Box 406, Youngstown 1, Ohio.

MAKE Money at home—Mail cards, circulars feature real merchandise. Everything furnished. Big earnings. Philip's, Box 3-P, Boston 22, Mass.

RECAST Old batteries into new. Latest achievements. Battery Laboratories, Minneapolis.

MAKE Rubber stamps, repair dolls; learn silk screen printing. Catalogue (60 ideas) free. Universal, Box 1076-A, Peoria, Ill.

TO \$40.00 Weekly. Sparetime, home operated mailorder business. Successful beginner's plan. Everything supplied. Lynn, 10420-M National, Los Angeles 34, Calif.

COPUBLISH Mail Sale Advertiser, leading mail order paper. Details, latest copy, dime. Vanroy Shirk, Lebanon, Penna.

SCHEMER Magazine, Canfield 1, Ohio, monthly mailorder ideas, plans. Year \$1.00. Sample 20c.

PLASTERCRAFT Molds, liquid rubber, plasters, flocks, candle supplies. Catalog and manual free. Blue Rapids Supply, Blue Rapids, Kansas.

BUY It wholesale! Manufacturers, distributors offer \$50,000 items. Literature free. Olsen, 1231-A East Third St., Duluth 5, Minn.

\$25 WEEKLY Working two hours daily at home. Lycke, Box 2471-A, Cleveland 12, Ohio.

GROW Mushrooms, Cellar, shed, and outdoors. Spare, full time, year round. We pay \$3.50 lb. We paid Babbitt \$4,165.00 in few weeks. Free book. Washington Mushroom Ind., Dept. 172, 2954 Admiral Way, Seattle, Washington.

\$46 FROD square foot plywood; jigsaw necessary. Write: Woodarts, Bridgewater, Mass.

BREED Rare tropical fish at home. Earn big money! Learn secrets! Help fill huge demand. Amazing opportunity! Free plan. Tropicals, 1008-F Los Angeles St., Los Angeles 15.

RESILVERING Mirrors, formula 50c; two-way lookout mirrors, (No one sees you), 50c; coppered mirrors, 50c. All \$1.00. Nelko-Mir, Box 3462-J, Chicago 54.

LIVING Miniature ("Ming") trees only 10 to 20 inches tall. Grow at home. Big profits! Spare time opportunity. Fascinating! Amazing! Write for free seed and plan. National Nursery, Dept. FC, Inglewood 4, California.

MAKE Money spare or full time, casting metal toys and novelties. Big wholesale and chain store demand for autos, soldiers, ashtrays, banks, etc., keeps manufacturers busy. Production moulds furnished for up to 100 and more castings per hour. No experience or special place necessary. Write for information and illustrations of patterns needed. Metal Cast Products Co., Dept. A, 1696 Boston Road, New York 60, N. Y.

OPERATE Profitable mail order business. Write Walter Service, 4159-A East 112th, Cleveland 5, Ohio.

MINK Raising information free. Complete. Lake Superior Mink Farm, Superior, EEL, Wisconsin.

COLORGLAZED Concrete pottery made without molds. Patented method. Cemetery products, novelties, tiles. Basement leak-sealing. Money-making projects. Booklet, details free. Men only. National Potteries Company, Orand Rapids, Minnesota.

FREE Book "505 Odd, Successful Businesses." Work home. Expect something odd! Pacific, Oceanide, Calif.

FIX Typewriters. Free booklet describes our modern, inexpensive home-study course. Factory methods taught. Write Typewriter, Building 1, Tarentum, Penna.

MONEY In new greaseless doughnuts. Start in kitchen. No smoke. Sell stores. Free recipes. M. Ray Company, 3605 South 15th Ave., Minneapolis 7, Minn.

BRONZED Baby shoe supplies, instructions, mountings. Metal bookends, \$1.50 pair. Free catalog. National Bronze Supply, Box 56, Los Angeles 32, Calif.

MAILORDER Home business! Details stamp. Shirley, 20-Raspeburg, Baltimore 6, Maryland.

VENDING Machines—No selling. Operate a route of coin machines and earn amazing profits. 32-page catalog free. Parkway Machine Corporation, Dept. 72, 715 Ensor St., Baltimore 2, Md.

BRONZE Baby shoes. Instructions, equipment and mountings for genuine electroplated process. Free catalog. Hollywood Bronze Supply, Dept. B-3, 1624 East First Street, Los Angeles 33, Calif.

FLEXIBLE Rubber molds for plaster and Marble figurines. Sample and large illustrated catalog 25c, refunded on first order. K-C Novelties, Dept. 74, Easthampton, Mass.

NEW Exceptionally profitable plans. Ideas for home operated mail business. Rush name. Miller, 1881-P Roxbury Road, East Cleveland 12, Ohio.

START Venetian blind laundry, patented machine. Free information. Jet Company, 522 N. Rural, Indianapolis 1, Indiana.

ELECTROPLATING Turns spare time into dollars. "Professional Electroplating Technique." Information free. Plater C. Hyde, 327 West 120th Street, Los Angeles 61, California.

BUY Wholesale thousands items. Lists free. Cottage Industries, Omaha 12, Nebr.

FREE New 280-page book. 2000 businesses, farms, income properties for sale throughout America. Specify type of business desired, and general location. Book No. 76, 9400 Wilshire, Los Angeles, Calif.

WHOLESALE! 8,000 Nationally famous products. 30-80% discounts! Large catalog. Sensational business plans included. Consolidated Distributors, 21-11 Lafayette, Paterson 15, New Jersey.

INFORMATION Worth dollars. Free details. Wolfe, 8106 So. Park Ave., Chicago 19.

MAILORDER—Operate profitable home business using free advertising method. Revealing information free. Seidel, 6000-HF Sunset, Los Angeles 28.

MONEYMAKING OPPORTUNITIES

ACME Saw sharpeners are the finest you can own. Don't be satisfied with less. Send for free literature. Max Mfg. Co., 138 Stockton Ave., San Jose 26, California.

START A buying service, buy wholesale thousands nationally advertised products. Make big profits selling at sizable discounts. Postcard brings details. American Buyers, 630-P Linden, Buffalo, N. Y.

OPERATE Your own cafe, diner. Only minor investment needed. Guide reveals how. Write Restaurant Arts, MO11, Fremont, Ohio.

"HOW To Make Money With Simple Cartoons"—A book everyone who likes to draw should have. It is free; no obligation. Simply address Cartoonists' Exchange, Dept. 91-CM, Pleasant Hill, Ohio.

FREE! "301 Profitable Small Businesses!" Amazing abstracting plans! Work home! Start sparetime. Deumant Surveys, Kenmore 23-PM, N. Y.

LEARN Technical Metaphysics and insure your future. Easy, inexpensive correspondence course. Simplest method known. Diploma. Write: Premier College of Technical Metaphysics, 2332, McKenzie St., Vancouver, B. C., Canada.

OPERATE "Escalator" mailorder system, selling our products or any products. Most revolutionary mailorder system known. Write: Selbyco, Decatur 162, Ill.

FORTUNE Positively offers wealth and power to any man with sufficient courage and tenacity to employ the same simple method that actually produced every single one of the world's great fortunes. Your acceptance of this real challenge could be your life's upward turning point. "Beckoning Fortune" tells you how. \$2.00 postpaid. Phillips Company, Box 6817, Towson 4, Md.

SPARETIME Profits taking subscriptions all magazines. Wholesale catalog free. Cassell Publishers, Westfield, New Jersey.

OPERATE Profitable mail order business. Robin Sales, 1001 Curtiss, Downers Grove, Ill.

OUR Book "Home Factory" tells how to make 101 products and articles used daily. Tells where to buy materials you need wholesale. 50c. Money back if dissatisfied. Ken-West Distributors, 7-K South Harlem St., Worcester 4, Mass.

PACIFIC Northwest job opportunities \$1.00. Baker, 1412 Jefferson Ave., Yakima, Wash.

COST Of things going up faster than your income? You can make more full or part time as a Rawleigh dealer. Write for full particulars. Rawleigh's, Dept. A-RR-PPM, Preepert, Ill.

CHINCHILLAS, Unusual terms, three years to pay, no interest or carrying charges. Box 348, Manhattan Beach, Calif.

EARTHWORMS: Raise for profit, bait. El Sobrante Earthworm Farm, 749 Rincon, El Sobrante 11, California.

PAST Selling engraved colorful plastic desk name plates. Send \$3.00 for samples, plus plate with your name. Refundable. Good mailorder item. Nemo Plastics, Wold-Chamberlain Field, Minneapolis, Minn.

MAKE Money at home as renewal headquarters for all magazines. Liberal commissions. No experience—no capital needed. Supplies furnished. Write for free catalog. McGregor Magazine Agency, Dept. 500C, Mount Morris, Ill.

GIANT Mails—Moneymaking offers. Send 25c today! Wrede, Atkinson 1, N. C.

MEXICAN Featherbird pictures. Enormous profits. Sample picture 25c. Mexican Importing, Northern Pacific 1190, Albany, Oregon.

SELL Merchandise by mail to women. We furnish everything. Big earnings. Tamolane, Box 244, Denver 1, Colorado.

MAKE To \$4.50 hour doing common pen lettering. National Artists, 801 1/2-A North Marsalis, Dallas 3, Texas.

INCREASE Your income, turn your spare time into cash—Making quick-selling, highly profitable lamps and fiber glass shades. Every home a prospect for one or more. Hundreds already doing it, so can you. No experience needed. No special tools required. Gearon's big, new 72 page 1955 illustrated Catalog No. 8 will show you how, quickly. One special 8-page section shows 6 beautiful lamps in kit form, ready for you to assemble. Another 12-page section shows you how to make stunning, ultra-modern fiber glass shades. Page after page filled with wide variety of other attractive shades, shade frames, figurines, and lamp bases. Also oil lamp converters, boring compound, and all kinds of cords, sockets, pipes, harps, finials, bases, and hundreds of other parts. Everything you need. And you can buy everything wholesale, sell at retail, make big profits, fast. Send only 25c right now for Gearon's big 1955 catalog and wholesale price list. Like hundreds of others, you'll be glad you did. Gearon Co., Dept. 503-B1, 27 S. Desplaines, Chicago 6, Ill.

YOU Can succeed using ten simple words. Amazing results. Details free. Litho Publishing Company, 1627 Belmont Avenue, Seattle 22, Wash.

LEARN Home mail order business. Actual proven plan 25c. Fisher Specialty Co., 716 West Hazel, Corning, Ark.

WHOLESALE! 16-80% Discounts. Appliances, tools, etc. Catalog 50c. Levesque Supply, Atlanta, New York.

YOU Can earn home profits. Write Lombard, 296 West 5th, South Boston 27, Mass.

LET Us sell your crafts. Home Enterprises-C. R-3, Box 94, Bend, Oregon.

\$200 MONTHLY Possible raising earthworms! Backyard, garage, basement. Complete illustrated booklet explains raising, feeding, packing, marketing. 25c postpaid! Ozark Worm Farm-J, Willow Springs, Missouri.

MAGIC Money independence and security guaranteed for you at home. Send postal for full information. Granite Traders, Wolfboro, New Hampshire.

FREE Catalog: Selected home-moneymaking, craft, hobby, retirement-project books. Shields, Box 358-E, Mountain Home, Arkansas.

LEARN Directing money-raising campaigns for churches, hospitals, institutions. Earned \$3085 in six weeks on my first campaign on \$50 investment. Unlimited field. Course backed by 34 years experience. William Arbogast, 229 East Mason Avenue, Alexandria, Virginia.

NEW "x111" Ultra-blue signs. 7c, retail 50c. Sample free! Lowy, 812 Broadway, Dept. 834, New York 3.

GET \$10 Merchandise orders by mail! Keep \$5.00. Supplies furnished. Orders filled. Genmerco, Box 142, Dorchester 24 J, Mass.

HOMEWORKERS Profitivity packet 10c. O'Dell's, 33401 So. 6th St. Road, Springfield, Illinois.

JOHNSON'S Emergency cleaning kit, America's hottest money-maker. Cleans suit 3c. Dress 2c. Necktie 1c. \$25 daily. Free kit deal. Johnson Company, Box 944, Ashland, Ky.

EARN \$50.00 Daily making mats, shoes and mud guards from old tires. S and S Patents Inc., 1307 North Clark St., Chicago 10, Ill.

\$100 WEEK Possible; spare, full time; different, proven, successful plan. Herco, 319-B Sea Street, Quincy 69, Mass.

BIG Mails! Many offers, samples, etc. Get listed, 25c. Don Bates, Oakland, Iowa.

WHOLESALE! 8000 Nationally famous products. 30-80% discounts! Large catalog. Sensational business plans included. Consolidated Distributors, 21-12 Lafayette, Paterson 15, New Jersey.

JIGSAW Bandsaw owners, let your machine bring extra profits, fun. Free details. Nu-Art, Dept. B, Box 2235, Boston, Mass.

SELL Religious mottoes—Send no money. We trust you. Crystalglo, Box 96, Sidney, Ohio.

15 MILLION Dollars paid in '53 for suggestions! If your company has a system you can earn regularly. It's easy! Send \$1.00 for booklet, "Dollars for Ideas" and year's membership, in Suggesters Club, Box 227, Harvey, Ill.

START A profitable subscription business in spare time! We need men and women (young or old) as representatives for all leading national magazines. Liberal commissions paid for new and renewal subscriptions. Start earning money in this pleasant work at once! Clip this ad and send with your name and address to: Agency Bureau, Dept. PM, Hearst Magazines, 250 West 55th St., New York 19, N. Y.

PROFIT! Prestige! Publish a magazine under your own name! Only \$3 per month! Sample, details 3c! Filmer, 910 Marion, Pharr 22, Texas.

RECEIVE Latest book selling and money-making opportunities. Write: Tradewinds, Box 82-8, Chattanooga, Tennessee.

FREE Folio "Up to \$45,000; Unlimited Vacations." No merchandise, equipment. Unknown! Works itself, home! Hayling, Carlsbad, Calif.

EARN At home. Several ideas to choose from. No mail order. No selling. Folder free. Todaro, 433-A Motheral, Monessen, Penna.

FREE Leathercraft catalog, Do-It-Yourself. Write Tandy Leather, Box 397 AM, Tulsa, Oklahoma.

BOOKKEEPERS! Forget debits, credits, double entry! Govt. investigators want records, not systems. More firms use our simple, inexpensive method than any other. Popular demand. Unlimited earnings. Age no barrier. Live anywhere. Amazing details free. Penna. Business Service, Box 923, York 3, Penna.

FOREIGN Employment construction work. If interested in foreign projects with high pay write Foreign Service Bureau, Dept. P.M., Metuchen, New Jersey.

PRINTING And office supplies wholesale. 20,000 items. Literature free. Royal, Box 368-A, Cleveland 27, Ohio.

ATTENTION! Typewriter owners. Make handsome profits. Write today. Groves Company, 682, Hastings 8, Nebraska.

GENERAL Contest Bulletin. Issued monthly. Sample, 25c. 1609 1/2 East 5th, Duluth, Minn.

GROW Mushrooms. Cellar, shed, and outdoors. Spare, full time, year round. We pay \$3.50 lb. We paid Babbitt \$4,165.00 in few weeks. Free book. Washington Mushroom Ind., Dept. 173, 2954 Admiral Way, Seattle, Washington.

50,000 ARTICLES Wholesale. Source directory dime. Nelko, Box 3462-DR, Chicago 54.

READ Progressive Mailtrade, the magazine that tells how to make money by mail. Dime brings sample and special offer. Progressive Mailtrade, Box 357, Sheboygan, Wisconsin.

WINNING Prize contests is fabulous, confidential, home opportunity! Send stamp! National Contest Bulletin, Box 2685-P, Miami 16, Florida.

FREE Book "505 Odd, Successful Businesses." Work home. Expect something odd! Pacific, Oceanside, Calif.

BUILD Sales by recruiting productive distributors selling direct or to retail outlets. Secure most concentrated circulation through classified columns of Salesman's Opportunity. Write for facts. Gilbert, Salesman's Opportunity, Room 1700, 28 East Jackson, Chicago 4.

SELL—Buy Titania gems. More brilliant than diamonds. \$9.75 carat wholesale. Free catalogue. Diamonite, 1404-M Mitchell, Oakland 1, California.

SCHOOL Seniors—Sell classmates America's most beautiful graduation name cards. Largest selection. Highest commission. Outsell all others. Free sample kit. Printcraft, Dept. M, 1509 Maple Street, Scranton 5, Penna.

FORMULAS, PLANS, ETC.

300 YEAR Calendar in your head. Know day of week when dates known. (Good business astrologers.) Code \$1.00. Krystop, Felton, Calif.

EXPERIENCED Druggist offers ten profitable formulas for 50c, coin or stamps. Read, 3140 View, Fort Worth, Texas.

NEW Formulas, free literature. Hertzstein, 511 Thomas, Grand Rapids, Mich.

CHEMICAL Product analysis. Moderate fees. Northwestern Laboratories, 2316 Brown, Evanston, Illinois.

TESTED Formulas. Catalog free. Pont Laboratories, 2625 South Eighth, Terre Haute, Indiana.

FREE Formula catalog. Anything analyzed \$35.00. Western Chemical, Salem, Oregon.

FORMULAS, 10,000 for \$5.00. Authentic, reliable, practical. Brockway, 1145 High, Topeka 1, Kansas.

FOR Proof of what you can do in specialty manufacturing get our literature. It's free! Miller, Chemist, 1517-P, Tampa, Florida.

ANY Formula \$3.00. Catalog—Mfg. Treatise 10c. J. Belfort, 192 N. Clark, Chicago 1.

FORMULAS; All kinds. Latest, best. Literature free. Kemikal, Park Ridge, Ill.

REAL Manufacturing formulas. Lists free. Cummings, Chemist, Gordon Ave., Syracuse 4, N. Y.

PRODUCT Analysis, manufacturing formulas, processes developed. Moderate fees. Plastics, Box 1574, Boston 4, Mass.

PLASTICS

PLASTICS, All types. Plexiglas, vinyl, acetate, teflon, nylon, polyethylene. Rods, sheets, tubing, film. Send 25c for complete catalogue and prices. Direct factory distributor. Delta Products, 1400 Henderson, Fort Worth, Texas.

PLASTICS Home-craft course for men and women. Tells and shows how to make hundreds of fast selling plastics products. All plastics and materials for 23 projects included in course. No special tools needed. Course pays for itself. Write for free booklet. Interstate Training Service, Dept. D-3-A, Portland 13, Oregon.

LAMINATING Supplies. Free price list. Solomonson, 46 Cornhill, Boston 8, Mass.

NEW Liquid casting plastic. Clear, colors. Embed flowers, insects, coins. Saw, drill, carve. Send 25c for "How to Cast With Liquid Plastic" and proved success plan showing how to make money at home. Castolite, Dept. A-101, Woodstock, Illinois.

PLEXIGLAS, Lucite. Square foot cost, 1/16", \$1.10; 1/8", \$1.45; 3/16", \$1.75; 1/4", \$2.15; 3/8", \$3.28; 1/2", \$4.38. Colors add 10%. Send 15c for postage. Aristocrat Plastics, Inc., 55 Clarkson St., New York City.

PLASTIC, Sheets, rods, tubes, etc. Free list. Plastic Supply Co., 2901 N. Grand Blvd., St. Louis 7, Mo.

PLEXIGLAS, Lucite sq. ft. (12"x12") cost 1/16" \$1.14, 1/8" \$1.50, 3/16" \$1.85, 1/4" \$2.20. Add 10% for postage. Almac Plastics, 600 Broadway, New York 13, N. Y.

MONEYMAKING Liquid casting plastic. Complete kit \$3.00. Handbook only 50c. Kennitz Corporation, 2755 N. 5, Milwaukee, Wisconsin.

PLEXIGLAS Sheets—Cut to size. Clear. All thicknesses. Standard outdoor translucent colors. McClarin Plastics, P.O. Box 168H, Hanover, Penna.

CHEMISTRY

CHEMICALS, Supplies. Catalog 20c. Laboratory Sales, Box 161-A, Brighton, Mass.

ION Exchange chromatography chemistry set \$4.00. Free literature. Chemlab, 800 Delaware, Berkeley, Calif.

AMAZING New book of science. Experiments, formulas and catalogue of laboratory supplies. Only 25c. National Scientific Co., Dept. PM-1, 2204 W. North Ave., Chicago 47, Illinois.

GEIGER And scintillation counters. \$29.95 up. Catalog 10c. Atomic Laboratories, Box 343, Berkeley, Calif.

NEW Idea chemical and apparatus outfits for home experimenting, photo-scales, microscopes, chemicals, biologicals and laboratory supplies in small quantities. Catalog 25c. Established 1931. John H. Winn, 1244 West 23rd St., New York, N. Y.

CHEMICALS And apparatus for industrial, analytical, and private laboratories. Catalog 25c. Dept. M-50, Biological Supply Co., 1176 Mt. Hope Ave., Rochester 20, N. Y.

ILLUSTRATED Catalog: Chemistry, mineralogy, biology 20c. Tracey Laboratories, Evanston, Illinois.

BUY IT WHOLESALE

WHOLESALE Prices—Drafting equipment, artists' supplies. Catalogue. Gordon's, 219-M Madison, Chicago 6.

BUY Radios, watches, appliances at wholesale prices. Rush 50c for catalog to Edward Clemens, 318 W. Bridge St., Morrisville, Penna.

WE Sell anything wholesale. Huge savings. Wholesale, 1600A West Goodhope, Milwaukee 9, Wisconsin.

BUY Wholesale. Catalog 35c (refundable). Carlton, 3007 Wharton, Philadelphia 46, Penna.

ONE Million articles wholesale. Directory \$1.00. Johnson's, 3262-P Medina, Fort Worth, Texas.

BUY Surplus wholesale. Catalogue 25c (refundable). Ort, Dept. PMI, Thomasville, Penna.

WHOLESALE! 8000 Nationally famous products. 20-80% discounts! Large catalog. Sensational business plans included. Consolidated Distributors, 21-14 Lafayette, Paterson 15, New Jersey.

AGENTS WANTED

AGENTS-Salesmen: Sell beautiful hand-colored plastic enlargements and sensational new personalized photo compacts, rings, bracelets, lockets, etc. Experience unnecessary. 40% advance commissions. We deliver, collect. Wonderful sideline. Better full time. Free sample outfit. Novel Portrait Co., 3343 North Ave., Chicago, Ill.

GOLD Letters. \$1.00. Signs painted. Frank Watkins Signs, 1241 Overton Park, Memphis, Tennessee.

BUY Wholesale thousands nationally advertised products at big discount. Free "Wholesale Plan." American Buyers, 629-P Linden, Buffalo, N. Y.

HIGH Profits in amazing unbreakable plastic housewares, tablecloths, drapes, utility covers. Free catalog PM51. Acclaim, Box 4, New York 40, N. Y.

ASTOUNDING Demand. Plastic article. Every adult a potential sale. Free details. Sunny Crystal, Box 6, Harper Station, Detroit 13, Michigan.

BUY Wholesale—25,000 items. Catalog 25c. Matthews, 1472-B4 Broadway, New York City 36.

BE First to sell famous automatic fire extinguishers with amazing new CM-7. Replaces carbon tetrachloride. Top commissions. Thousands of new prospects. Free use of samples. Write Red Comet Inc., Dept. 397-N, Littleton, Colo.

APPLIANCES, Cameras, watches! Large wholesale catalogue! Cam Company, 6806PM—20th Ave., Brooklyn 4, N. Y.

MAKE Money giving away free hosiery! Introduce amazing nylon stockings (guaranteed against runs and snags) and men's-children's hosiery (guaranteed one year) by giving away free trial pairs regardless whether or not final purchase is made! Earn up to \$3 hour spare time. Mail postcard today for free samples men's and women's hosiery with complete money-making outfits. Nothing to pay now or later. Absolutely no obligation. Kendex, Babylon 13, N. Y.

HAVANA Sales hit! "Coffe Flower Perfume." Sample free. Manufacturing, Box 3300, Habana, Cuba.

I Average \$125 weekly selling books by mail! So can you! Start sparetime! Work home! Cooper, 245-R Taunton, Buffalo, N. Y.

STRANGE Dry window cleaner. Sells like wild. Replaces messy rags, liquids. Simply glide over glass. Samples sent on trial. Kristee 66, Akron, Ohio.

PROFITABLE Deal available selling magnetic pencils to waitresses, nurses. Sample \$1.00. Nicholson Corporation, 3402 Cahuenga, Los Angeles 28, Calif.

AT Last! Something new and sensational in everyday cards, 21 for \$1. Make extra money fast! Show satin, velvet, metallic cards. Get orders easy. Big line \$1 assortments scented stationery, personalized napkins, gift items. Imprints free. Several \$1 boxes on approval. Puro Co., 2801 Locust, Dept. 540-A, St. Louis 3, Mo.

NEED More money to live on? Increase your weekly income \$20 to \$25 or more in spare time. Supply Rawleigh products to consumers. Also openings for full time dealers. Write Rawleigh's, Dept. A-DD-PPM, Freeport, Ill.

THOUSANDS Articles wholesale. Supply source directory 10c. Idealer, Park Ridge, Illinois.

SELL New automatic floor waxer. Trigger on handle. Retail \$2.95. Your profit 125%. Write Smith, Inc., Greenfield 18, Mass.

FREE Box of all occasion greeting cards just for sending your name and address. Permit us to tell how you too can make big money during your spare time showing friends, neighbors Elmira's sparkling line of all occasion greeting cards. No obligation to buy. To receive your gift box with details and samples on approval, send post card today to Elmira Greeting Card Co., Dept. 197, Elmira, N. Y.

MAKE Big money selling Sunshine's exclusive everyday cards. Nationally famous assortment sells on sight for \$1.00. Many others. Beautiful stationery, gift wraps, novelties, deluxe 21 card assortment, etc. Send postcard today for sample kit on approval. Sunshine Art Studios, Inc., Dept. PM-1, Springfield 1, Mass.; Pasadena 3, California. (East of Rockies address Springfield office.)

SELL Amazing value 21 for \$1.00 all occasion greeting card assortment. New type wrappings, home and gift items. Big profits, plus extra cash bonus. Write for feature assortments on approval, free samples exclusive personal stationery, free illustrated catalog, selling guide. New England Art Publishers, North Abington 133G, Mass.

MAKE \$25-\$100 Fast for yourself or organization. Sell friends big value \$1.00 and \$1.25 all-occasion greeting card assortments, Valentine, Easter boxes. Gift wrappings, gifts, 200 items! Experience unnecessary. Samples on approval. Free unprinted stationery samples. Free \$1.00 gift for promptness. Hedenkamp, 361 Broadway, Dept. PM-36, New York.

FOG-Stop windshield cloth. Instantly removes blurry mist, frost, sleet, snow. Stops windshield fogging. Samples sent on trial. Kristee 66, Akron, Ohio.

CASH In on tremendous demand for new cheap burglar alarm for automobiles, homes, stores, auto service stations and other property. 286% profit. Unique sample offer. Northwest Electric Co., 132-A Main, Mitchell, S. Dak.

COMIC And laff books. Back numbers \$25.00 thousand f.o.b. Samples \$5.00 hundred. Arista Comics, 194 No. Columbus Ave., Mt. Vernon, N. Y.

CALIFORNIA Sweet smelling beads. Sensational sellers. Particulars free. Mission, 2328 FR, W. Pico, Los Angeles 6, Calif.

SPARE Or full time profitably spent selling reproductions of customers' snap shots on lamp shades, tiles, brooches, plaques. Pleasant and interesting for buyer and seller. Wells Studio, 14040 Euclid Avenue, Cleveland, Ohio.

PROFITS To 150% selling finest everyday greeting cards. New 21-card \$1.00 assortments, unusual gifts, 100 fast-sellers. Valuable gift bonuses. Assortments on approval, stationery samples free. \$1.00 gift free for prompt action! Creative Cards, 4401 Cermak, Dept. 525-A, Chicago 23.

MAKE Easy money. Sell famous \$3 CO-2 fire extinguisher. Wholesale or direct. Fast sales, liberal profits. Fire Killer Mfg. Co., Dept. E, 115 W. 17th Street, Hazleton, Penna.

SEND Postcard for free money-making kit guaranteed direct-from-mill nylons, lingerie, blouses, men's and children's wear. American Mills, Dept. 441, Indianapolis.

BEAUTIFUL Feather pictures. 200% profit! Free sample. Apartado 9036, Mexico 1, D.F.

\$30-\$75 PER Sale. Power mowers. Chain saws. Easy terms. Farmco-51, Excelsior Springs, Mo.

MAKE Money introducing world's cutest children's dresses. Big selection, adorable styles. Low prices. Complete display free. Rush name. Harford, Dept. N-2341, Cincinnati 25, Ohio.

BIG Profits selling ties (\$2.00 value) \$6.50 dozen. Free catalog. Empire Cravata, 611C Broadway, New York 12.

TAKE Rubber stamp orders. Free details. Stamps, Box 2326, Denver, Colo.

60% PROFIT On cosmetics—Famous nationally advertised Hollywood Cosmetics pay 60%! Make \$35 day up! Hire others. For free samples, details, write Studio Girl, Glendale, Calif., Dept. PM-124.

TREMENDOUSLY Profitable. Sell religious articles. Different. New. Write J. Cross Company, North Attleboro, Mass.

BONUS Plan! Bonus given for every order you send in from our wholesale catalog. Free details. Pette Company, 1554-PM West 11 St., Brooklyn 4, New York City.

FREE Wholesale kit guarantees you 33% to 60% profit on cameras, appliances, typewriters, etc. Arrow Distributing, 1540 Nassau St., New York 38.

EASY Handwork makes fast-selling useful articles. Sample free. Sunmade Company, Brockton 64, Massachusetts.

EASY Extra income—Sell sensational new silicone scorch resistant ironing board cover. Good Housekeeping approved. Terrific \$1.98 seller! Send for free complete selling kit. Sample cover \$1.10. Menell Products, Dept. R—P.O. Box 431, Midtown Station, New York 18, N. Y.

HAVE A complete store in your pocket. Buy wholesale and make big profits. Send for free general merchandise catalog now. Jay Norris, Dept. P, 445 Broome St., New York City.

PRINTING. Advertising salesmen—Excellent money-making sideline selling decalcomania name plates, small quantities. Automobile initials, sign letters. Free samples. Ralco, XL, Boston 19, Mass.

GOLD or silver letters, numbers. Windows, doors, trucks. 1" to 6". 500% profits. Free samples. Atlas-T, 544 West 79th, Chicago 20.

\$1.00 PROFIT Selling \$2.95 photo enlargement deal. Allen Studio, Riegler Bldg., Little Rock, Ark.

MAKE Extra money. Sell front door name plates to friends, neighbors. Retail \$1.98; you make \$1.00! Free selling kit. Modern Engraving Co., P.O. Box 194, Boston 14, Mass.

AGENTS—300% Profit selling genuine gold window letters; stores and offices. Free samples. Metallic Sign Letter Co., 431-D North Clark, Chicago.

YOUR Own business—Used suits \$1.50, overcoats 65c, mackinaws 35c, shoes 12½c, ladies coats 30c, dresses 15c. Enormous profits. Catalog free. Moro, 1218AA South Jefferson, Chicago 7.

SCHOOL Seniors—Be popular with classmates. Have spending money galore. Details free. Craftcards, Box 235-L, Pittsburgh 19, Pennsylvania.

INCREASE Your income—Personal initialed buckles, belts, cap badges. Free information. Hook-Fast, Box 480 (PM), Roanoke, Va.

NEW Push button salt-pepper dispenser. Sprays it out! Can't clog. Can't spill. King, 55-P Oleander, West Springfield, Mass.

WHOLESALE! 5000 Nationally famous products. 30-80% discounts! Large catalog. Sensational business plans included. Consolidated Distributors, 21-10 Lafayette, Paterson 15, New Jersey.

JUST Take orders. We deliver. Gadgets. Send 25c. Miss Ann, Jackson Heights 72, New York.

SALESMEN—DISTRIBUTORS

ADVERTISING Book matches—Cash in on big demand; sell union label matches. Cuts for all businesses and political parties. Free powerhouse selling kit, low prices, protection guaranteed on repeat orders. Cash commissions. Superior Match Co., Dept. M-155, 7530 Greenwood, Chicago.

CALENDARS, Advertising novelties, matches. All styles, including religious, varnished, 12 sheet, girls. Hundreds of advertising novelties, books matches, etc. Fleming Calendar Co., Sales Division, 6539 Cottage Grove, Chicago 37, Ill.

100% PROFIT. Fast money for you! Take orders for Sweet Georgia Brown cosmetics. Colored people buy quick. Free sample. Write Valmor, 2451-LZ Michigan, Chicago 16.

MONEY Making opportunity! Take big profit orders for world famous patented varieties fruit trees. Also flowering shrubs, roses, vines. Big sales outfit free. Stark Bro's, Desk 30115, Louisiana, Mo.

BIG Money-making opportunity. Exclusive line work uniforms. Jackets, pants, shirts, coveralls. Advertising embroidered. Every business prospect. Outfit free. Master Div., 311 Water, Ligonier, Ind.

AD Matches! Sell amazing designs—10, 20, 30, 40 and 240-light book matches. Bigger spot cash commissions; every business a prospect. Low prices for high quality. Repeats. Start without experience; men, women; full, part time. Buy nothing! Sales kit furnished. Match Corp., Dept. PM-61, Chicago 32, Illinois.

BE Independent. Sell Rawleigh products. Good nearby locality open. Write today. Rawleigh's, Dept. A-D-PPM, Freeport, Ill.

BUY Wholesale thousands nationally advertised products at big discount. Free "Wholesale Plan." American Buyers, 630-D Linden, Buffalo, N. Y.

SALESMEN: Over \$50.00 daily. New colossal industrial and store deal. Samples furnished. Durawear, 53 W. Jackson, PM-1, Chicago, Illinois.

30,000,000 WOMEN Want amazing new automatic refrigerator defroster. You sell 8 out of 10 on sure-fire free trial. \$250.00 weekly profit not uncommon. Rush postcard for guaranteed plan. D-Frost-O-Matic, Dept. D-102, 173 W. Madison St., Chicago 3, Illinois.

RICH Opportunity for men in their 50's. Healthful, pleasant occupation. No investment needed. 150 of our men made \$500 to \$3000 in one month; many just beginners. Heckman made \$104 first 2 hours; Crowley made \$224 first day; exceptional earnings. Openings available. (If you live in Canada write President, Dept. PM, 25 Industrial St., Leaside, Ontario.) In U.S., President, Dept. PM, Box 711, Fort Worth 1, Texas.

LOOK! 10 Blades give year shaving. Details, blades—25c. Smithco, NE, 6618, Kansas City 23, Mo.

45,000,000 PROSPECTS For red hot 98c item! Openings for salesmen from coast to coast on terrific repeater that sells to service stations in case lots. King, 1609 Cochran, Dallas, Texas.

GET New shirt outfit free; make \$90.00 weekly on 5 average orders a day. Famous quality made-to-measure dress and sport shirts at \$3.95 up sell fast to all men. No experience needed. Full or part time. Write: Packard Shirt Co., Dept. 828, Terre Haute, Ind.

GOLDMINE Of 600 money-makers. Copy free. Specialty Salesman Magazine, Desk 5, 307 N. Michigan, Chicago 1.

QUALITY Ties—Your profit 189%. Catalog free. Loren Specialties, 4351-A-1 Flournoy, Chicago 24.

75c PROFIT On each dollar! Luxurious stainless steel tableware, guaranteed 50 years. Can't rust, tarnish or stain. Looks like sterling silver. 30, 50 and 75 piece sets, open stock, attractive chests. Write orders on commission or go in business for yourself. Use our catalogues with only your name. Have agents, others sell for you. Offer women set free for every two sets they sell to friends. Many other money-making plans. We can also ship under your label. Rush postcard for free catalogue, plans, etc. No obligation. Topval Corp., Lindenhurst 41, New York.

DISILLUSIONED? We hit something anyone really can sell easily spare time, no gadgets. \$1.00 required to cover publication costs, refunded first order. Southern Office Supply, 919 NE 1st Ave., Miami, Florida.

DISTRIBUTORS—Salesmen wanted. Very good profits. Steady repeat business. Write Favorite Records Company, Box 841, Chicago 90, Ill.

SERVICE Station lubrication items. Easy sales, 90% buy. No foolin'. R. L. Meyer Sales, 1401 W. 113th St., Los Angeles 47, Calif.

SPRAY—Can fire extinguisher. Sell \$2.00, you make \$1.50. Eleven other profitable pressurized spray can products. Amazing sellers, repeaters. Free literature. Strobel Aerosol Co., 2412A Market, Louisville, Ky.

ANYONE Can sell famous Hoover uniforms for beauty shops, waitresses, nurses, doctors, others. All popular miracle fabrics, nylon, dacron, orlon. Exclusive styles, top quality. Big cash income now, real future. Equipment free. Hoover, Dept. K-100, New York 11, N. Y.

SELL "Dandy"—Fast moving automotive accessory. Dandy, Box 5, Columbus, Ind.

NEW Jobs open in selling! Send name, address for five free issues of Opportunity Magazine's money-making guide, listing hundreds of companies who'll pay you well, full or part-time. No experience needed. Opportunity, 28 E. Jackson, Dept. 17, Chicago 4, Ill.

BIG Money as landscape advisor! Opening up new areas and need several good men. Must be aggressive, over 30 years and have car. Previous sales experience valuable but not required—as you will be trained by our own successful company representative using new unique method. Men with ability and desire to get ahead can make \$100 weekly. If successful you will be considered for district manager. Franklin, Box 202, Newark, New York State.

DISTRIBUTORS. Large profits. Terrific repeat orders. Unique Italian brooms. Write Peacock, 400 Montgomery Street, San Francisco, California.

SELL Book repair shop service. National chain. Your own business. Professor Martin, Aisen, North Dakota.

EDUCATIONAL AND INSTRUCTION

WANT A diesel job? New opportunities to increase income. Higher pay. More money. We can help you qualify. Tools, Shop method home training. Write today! Diesel, Tractor, Heavy Equipment Division, Interstate Training Service, Dept. B-3-A, Portland 13, Oregon.

INVESTIGATE Accidents—Thousands of insurance companies, airlines, and steamship lines use claim investigators. Learn this fascinating work, easily, quickly. Free book now! Universal Schools, Dept. 101, Box 8202, Dallas 5, Texas.

EARN College degree, remain employed. Write: Brentwood College, Box 19-721, Los Angeles 19, California.

BLUEPRINT Reading for machine and building trades. Train at home. Learn to read blueprints with confidence in 10 easy lessons. Literature free. Belton School, 1059K North Lawndale, Chicago 51, Ill.

FINGERPRINTING Course \$12.00. Diplomas awarded, details free. Alabama School of Fingerprinting, Box 185, Fairfield, Alabama.

CLERGYMEN'S, Laymen's courses. Free bulletin! Midwestern Bible School, 517 Merchants Bank Building, Indianapolis.

AUCTIONEERING Taught by mail. Free sample. Colonel Nelson, Renville, Minn.

FREE Sample lesson shows how easy accountancy is to master. Low cost, easy terms. Send today—We'll include catalog describing opportunities in this field. La Salle Extension University, A Correspondence Institution, Dept. H 841, 417 South Dearborn St., Chicago 5, Illinois.

AVOID Failure! Six lessons small business management. Auditor-business advisor established 1929. Text distributed nationally. Write! Wm. Grosnick, 115 State, Springfield 3, Mass.

COMPLETE Your high school at home in spare time with 58 year old school. Texts furnished. No classes. Diploma. Information booklet free. American School, Dept. X145, Drexel at 58th, Chicago 37, Illinois.

BOOKLET By C.P.A. Taxes and record keeping for hobbyists and small businesses. \$1.00. Stafford Press, Box 456, Madison, N. J.

BECOME A doctor of psychology or metaphysics. Learn secret of contentment, happiness. Win degree of Ps.D. or MsD. Solve mental worries. Free book. College of Universal Truth, 5038-C Broadway, Chicago.

HIGH School—No classes. Study at home. Spare time. Diploma awarded. Write for free catalog HF-50, Wayne School, 2527 N. Sheffield, Chicago 14, Ill.

IT'S Fun learning a language by Linguaphone, world's standard conversational method. At home easily master French, Spanish, German, Modern Greek—29 languages available. It's like living in another land, you listen, you hear men and women speak, you understand, you speak. Save time, money. Gain job, school, travel, cultural opportunities. Write for free book. Linguaphone Institute, 83015 Radio City, New York 20.

WELDING Training pays at Hobart Welding School, Box M-151, Troy, Ohio. VA contract. Best equipment. Catalog free.

SQUARE Peg in round hole? Dissatisfied? Restless? Unhappy? Do psychological tests at home. Uncover true abilities, aptitudes. First time available. Low cost. Details free. Write Psychologic Testing Institute, Dept. 234, 201 N. Wells, Chicago 6, Ill.

BOOKS—Government surplus. Free catalog listing fifty other free catalogs on instructional, text and vocational subjects. Three million volumes, new and used. Bargain prices. Long's College Book Co., Dept. PM, Columbus 1, Ohio.

DRAFTSMEN—Urgent demand. Train now. Pay later. Free details. Industrial Training, 1704-A Frederick, Fort Worth 7, Texas.

CATALOG, 1200 Popular educational, self-help materials, pocket books, etc. 10c. World Adventure, D 254, Ann Arbor, Mich.

APPLIED Success dynamics. Free details. A-D Psychology Ctr., Box 847, Ocean Park, Calif.

USED Correspondence courses bought, sold, rented. Catalog free. Educational Exchange, Summerville, Ga.

POSITIVE Success. Secrets free! Write today. Success School, Sparta 7, Michigan.

CORRESPONDENCE Course. Overcome self-consciousness. Personal. Confidential. Rise above fear and handicaps. Learn how to direct your powers creatively. For free information write The Leavitt Science, Clinton, Illinois.

FREE Bible correspondence course. Worldwide. Harmer, Missionary Institute, Bonita Springs, Florida.

SMASH Worries, fears, problems! Enjoy life, success. Request free positive thought motivation plan. Easy, quick results. Write: Applied Christian Psychology, Inc., Box 1924-G, Louisville 1, Ky.

1955 U.S. Gov't. jobs! Men-women, 18-55. Start as high as \$80.00 week. Qualify now! 23,000 jobs open. Experience often unnecessary. Get free 36-page book showing jobs, salaries, requirements, sample tests. Write: Franklin Institute, Dept. Z-24, Rochester, N. Y.

SUCCESS in business, social life—Strengthen your voice! Free booklet. State age. Prefect Voice Institute, 210 South Clinton, Studio 2AV-2, Chicago 6.

CORRESPONDENCE Courses, bought, sold, rented. Catalog free. Courses, Box 1272-P, Burbank, Calif.

INCREDIBLE! Become mental superman overnight! Free booklet! Bijou, Box 1727-MT, Hollywood 28, California.

LEARN X-ray by home study and practical experience. Fascinating work. Good pay. Free catalog. National Institute, Desk 7, 4868½ Sheridan, Chicago 40, Ill.

INVESTIGATOR Training. Phillips Secret Service System, 1917-B North Kenneth, Chicago 39.

ENGINEERING Diploma correspondence courses. Other graduating opportunities. Aureas, 156 West 73rd Street, New York City.

ARTISTS Make money. Booklet free. Drawing, painting, advertising art, cartooning; one enjoyable course; start at home. Write for free illustrated book, "Art For Pleasure And Profit." Our 40th year. Washington School of Art, Studio 421R, Washington 5, D. C.

GOVERNMENT Positions pay well. Home training for exam, \$9.95, entire cost. Refunded if don't pass, 47 years training experience. Order, or write immediately. Ozment Instruction, Box 665-34CS, St. Louis, Mo.

LEARN Auctioneering. Term soon. Write for catalog. Missouri Auction School, Box 8425G1, Kansas City, Missouri.

AUCTIONEERING. Be an auctioneer. Earn big money. Term soon. Write for catalog. Kansas City Auction School, Suite 307, Shankman Building, 3119 Troost, Kansas City, Missouri.

BE A real estate broker. Study at home. Write for free book today. GI approved. Weaver School of Real Estate, 2020C Grand, Kansas City, Missouri.

LEARN Appliance service. Motors, washers, refrigeration, everything. Booklet. President. Box 73136, Los Angeles 3.

NEW. Uncrowded profession, part, full time. Know people. Analyze handwriting, earn big fees. Business men, housewives, doctors, attorneys, teachers use and report success from radio, writing, lecturing, teaching, consultation, court work. Trial lesson free. Give age. Igas, Inc., 414 Wilhoit Building, Springfield, Missouri.

STUDY by correspondence for Doctor's degree in Psychology, Metaphysics and Divinity. College of Divine Metaphysics, Dept. P-M, 2811 North Illinois St., Indianapolis 8, Indiana.

MIDLAND Linotype School. Charles City, Iowa. Civilian and Veteran Courses. Free placement. Established 1909.

HIGH School diploma at home. Licensed teachers—Approved materials. Southern States Academy, Box 144-MX, Station E, Atlanta, Georgia.

SECRET Investigation. Experience unnecessary. Investigators particulars free. George Wagner, M125 West 86th, New York 24.

PHYSICAL Therapy and massage. We train you at home. Earn big profits from your own private practice or work with hospitals and doctors. Free catalog. National Institute, Desk 4, 4868½ Sheridan Road, Chicago 40, Illinois.

GROW Mushrooms. Cellar, shed, and outdoors. Spare, full time, year round. We pay \$3.50 lb. We paid Babbitt \$4,165.00 in few weeks. Free book. Washington Mushroom Ind., Dept. 174, 2954 Admiral Way, Seattle, Washington.

EARN While you learn. Auto and diesel mechanics master this top paying trade. Many graduates earn \$100 a week and up. Approved for Korean veterans. For free information write Dept. No. 256, Nashville Auto-Diesel College, Nashville 3, Tenn.

BOOKKEEPERS! Increase your earnings! Operate your own simplified "Dollar-A-Week" bookkeeping and tax service. Full or spare time. Details free. No obligation. Ellis, Box 200, Cedar Grove, North Carolina.

MEDICAL Laboratory technicians in great demand. We train you in your own home. Catalogue free. Imperial Technical Institute, Box 973-J, Austin, Texas.

USED Correspondence courses and books sold and rented. Money back guarantee. Catalog free. (Courses bought.) Lee Mountain, Pisgah, Alabama.

PIANO Tuning pays. Learn this profitable profession at home easily with patented Tunometer and mechanical aids. No knowledge music necessary. Diploma granted. Write for booklet. Niles Bryant School, 3731 Stockton Blvd., Dept. P, Sacramento 20, California.

PLAYS, STORIES, MANUSCRIPTS

WRITE For pay, new easy way. Based on your daily experiences, thoughts. Free information. Creative Ability Developer, 1819 Gilpin, Denver 18, Colorado.

NO Luck finding a book publisher? Write for free Booklet PM. Vantage Press, 120 W. 31, New York.

BUSINESS SERVICE

NEW Advertising machine prints and illustrates government postal cards. Write for free book of unique advertising plans, money-making ideas for your business. Cardmaster, Dept. A, Chicago 40.

ZINC Engravings. From any photograph or drawing. 5 inches, only \$1.60. Free price list. Miller-Hoiles, 437 E. Market, Alliance, Ohio.

SPECIAL SERVICES

MIAMI Business opportunity, help wanted columns. Airmailed \$1.00. Moss, 800 N.E. 163 St., N. Miami Beach, Fla.

INFORMATION On anything. Ferguson Research Specialists, 116-14 141 St., South Ozone Park 36, N. Y.

CARTOONING, COMMERCIAL ART, SHOWCARD & SIGN PAINTING, TATTOOING

"HOW To Make Money With Simple Cartoons"—A book everyone who likes to draw should have. It is free; no obligation. Simply address Cartoonists' Exchange, Dept. 91C, Pleasant Hill, Ohio.

COMMERCIAL Artists, cartoonists courses \$1.98. Fogel's, 172 Bay 28th Street, Brooklyn, N. Y.

ENGINEERING Difficulties solved—Fifth year pregraduate mechanical engineers. Inquire Deltoid, Box 3055, University Station, Columbus, Ohio.

FREE Trial cartooning lesson. No obligation. Write V. Vande Linde, Madison, W. Va.

LEARN Lettering at home. Fascinating, high-paying profession. Clarence Donigan Associates, 2712 N. Vermont, Royal Oak, Michigan.

CARTOONISTS: Amateur, professional. Prepare for animation with Max Fleischer's plan. Write Vera Coleman, Lincoln Building, New York, N. Y.

ATTENTION—Sign painters-hobbyists. 14 sets alphabet, monogram, numeral patterns. ½"-4" high, \$1.00 postpaid. Walker Studio, 21-A, 4343 Lindell, St. Louis 8, Mo.

ARTISTS Make money—Booklet free. Drawing, painting, advertising art, cartooning; one enjoyable course; start at home. Write for free illustrated book, "Art for Pleasure and Profit." Our 40th year. Washington School of Art, Studio 421-R, Washington 5, D. C.

CHALK Talks. Laugh producing program \$1.00. Catalog 10c. Balda The Cartoonist, Oshkosh, Wisconsin.

TATTOOING Course, supply brochures 25c. Zeiss, 728 Lesley, Rockford, Illinois.

LEARN Sign painting at home. Test lesson free. Ben Kerns, Box 812-PM, Greenville, S. C.

PAINT Signs with master patterns. Set 1½" to 12" high \$1.00; sample 3c. Eyerly, B-583, Newton, Iowa.

9 ALPHABET, 3 Numeral pattern sets and raised wood letter catalog, \$1.00. Sign Letter Distributors, P.O. Box 101, Mineola, N. Y.

ADVERTISING AGENCIES, LETTER WRITERS, FOR ADVERTISERS

CANADIAN Mailing lists. All classifications. 1000 names \$2.00. Payne's, 162 McKittrick, Kentville, N. S., Canada.

FREE Copy, layout service. Mailorder ad, 1,600,000 nationwide circulation, \$28.70 inch. 24-word classified, 20 big Sunday newspapers, \$30. Advertising ratebook free. Chicago Advertising Agency (Established 1900), Chicago 4.

MAILING Lists. Canadian agents. Free details! Elliott's, 252 Gainsborough, Toronto 8.

EXPORTERS: Increase sales in Central America. Mailing list any classification. Mapilon, Box 268, Guatemala, C.A.

SALES Letter showmanship. We write sales letters and sales bulletins that get results. Tell us what you have in mind. Ad-Creators, Hutchinson, Kansas.

FREE! 1955 Advertisers Rate and Data Directory. 52 pages! E. H. Brown Advertising Agency, 20 N. Wacker, Chicago 6.

500 RECENT Cash buyers \$2.00. McQuillan, Box 471, Baton Rouge, La.

ADVERTISING—Display, classified. Experts since 1893. Interesting budget brochure free. Newmark's Agency, 217-7th Ave., New York.

MAILING Lists, most any classification. 1000 names \$5.00, 1000 your circulars mailed with ours \$4.00, 5000 your circulars printed and mailed \$12.95. Write Dixie Mailers, King, North Carolina.

ADS Placed in out of town newspapers and magazines. Low rates. Catalogue free. Ideas that pay. Baker Advertising Agency, Successors Ankrum Agency, 189 W. Madison, Chicago 2.

ADVERTISE: 24 Words, 100 Canadian newspapers \$5.50. Lists free. Advertising Bureau, 10511-C Springfield, Chicago 43.

RUBBER STAMPS AND OFFICE SUPPLIES

BARGAIN Catalogue—Office supplies and equipment free. 1000 embossed business cards \$3.75. Guild, 2702 Georgia Avenue, Washington, D. C.

RUBBER Stamps 30c up. Complete service. Unconditional guarantee. Catalog 10c refundable. None free. Esco-115-Print, 8 Holt, Dayton 7, Ohio.

3 LINES, Pocket or cushion \$1.00. Hansen, 4908-P Ohio, Chicago 44.

3 LINES, \$1.00. Fast service. Quality printing, reasonable. Samples. Johnson Press, 443 MacDonough, Brooklyn 33, N. Y.

FREE Style list stock stamps. Criterion, Box 2326, Denver 25, Colo.

LINE 25c; 2-45c! 3-65c. Stamp Works, Auburn, Nebraska.

RUBBER Stamps by professional craftsmen. 3 lines \$1.00. Price list. South Coast Press, P.O. Box 2074, San Bernardino, Calif.

TYPEWRITERS, DUPLICATORS, OFFICE DEVICES

RECONDITIONED Typewriters. All makes, list free. Typewriter Exchange, Bedford, Penna.

TYPEWRITERS—Govt. surplus, office size typewriters from \$20.00, free list. Meshna, 378 Lynn, Malden 48, Mass.

WRITE Your business letters longhand 2c each. Use new copyrighted form. 100 forms \$2.00. Planforms, Box 533, Elmhurst, Ill.

RECONDITIONED Typewriters, duplicating, printing devices. \$25.00 up. Supplies. Appliances. DixieGraph, King, N. C.

PRINTING, MULTIGRAPHING, MIMEOGRAPHING GUMMED LABELS

BETTER Printing — Reasonable prices. Free estimates. Samples. Reporter, Chelsea, Oklahoma.

15-35% DISCOUNT On raised printing. Samples. Lédfin, 3813-J Winslow, Ft. Worth 9, Texas.

1000 THERMOGRAPHED Business cards. \$4.44 postpaid. Type chart, sample free. Luis Embossed Cards, Box 423, Lansing 2, Michigan.

10,000 ATTRACTIVE Circulars \$10.00 up. Samples. Fame, 291 Ellis, San Francisco 2, Calif.

QUALITY That pays off for you! Send for price list. Corliss Print, 354 Essex, Whitman, Mass.

1000 EMBOSSED Cards, \$3.95. 4-line stamp, choice of 800 emblems, \$2.00 postpaid! Accuracy guaranteed. Samples. Parr, 426-J Ontario, Burbank, Calif.

OFFSET Printing \$6.50—1000, 8½x11, 16 lb. National Letter, 1463 Broadway, New York 36.

QUALITY Printing. Booklets, publication, catalogs, stationery. Free catalog. Adams Printers, 30 W. Washington, Chicago 2, Illinois.

BUSINESS Stationery. Letterheads, envelopes, cards, invoices, statements, office forms. Samples free. Oren, Printer, Valiant, Okla.

FREE Catalog. Business, personal printing. 1000 embossed cards \$2.80 postpaid. D M Sales Co., Sebastopol, Calif.

CIRCULARS Designed, and offset printed with illustrations by leading artists. Vartyper composed. Send your copy for free estimates. Ferguson Printing, 214 S. Grant, Indianapolis 1, Indiana.

1000 EMBOSSED Business cards, \$2.95 postpaid; maximum six lines. John Peper, Box 822, Chattanooga 1, Tenn.

1000 EMBOSSED Cards \$4.00. Samples. Simon, 1566A Hoe Avenue, New York 60.

PRINTING By Ace. Samples, catalog free. 518 Ridge Road, Lyndhurst, N. J.

SALESBOOKS, 25, \$2.85 Postpaid. Gropp, 466 Harman St., Brooklyn 37, N. Y.

1000 BEAUTIFULLY Embossed business cards \$3.55 prepaid. McClellan, 112-S Elizabeth, Wichita 13, Kans.

100 LETTERHEADS (8½x11) Printed carefully \$1.00 postpaid. Envelopes same. Race Printers, Hudson, New York.

1000 EMBOSSED Business cards, \$2.95 postpaid. Samples free. Jaynar, Box 723, Oak Lawn, Illinois.

1000 #6¾ ENVELOPES \$4.99; #10, \$6.84; statements \$4.74, postpaid. Erco Printing, Bronx 72, N. Y. Free catalog.

BUSINESS Cards \$2.95 — 1000. Apco, 207 E. 3rd, Peru, Ind.

MIMEOGRAPHING — Reasonable. Any copy. Mailers Service, Box 606-A, Chicago 90, Ill.

100 LETTERHEADS Or envelopes \$1.00. Two colors \$1.50. Broadbrook, Botsford, Connecticut.

100 ENVELOPES. Printed 2-colors \$1.25. Box 523, Rochester 2, N. Y.

MIMEOGRAPHING — Letters, pricelists, formulas, instructions. Lowest prices. Lem's Letter Shop, 5710 Stanton, Detroit 8.

500 ¾x2¼ FOUR Line gummed stickers 50c. Red border \$1.00. Moritz Printery, Saginaw, Mich.

TWO Color 8½x11 letterheads, 500, \$4.00. Samples. D'Yarmett Printing, Newark, Ohio.

PRINTING, Offset, mimeographing — Samples, prices, free. Mimeo-Press, Madison, Tennessee.

ILLUSTRATED Business letterheads; catalog 10c. Howprint, 723-G Eunice, Webster Groves 19, Missouri.

PRINTING—Office supply catalog 25c. Refundable. Wallace, 1072 Tower Grove, Saint Louis 10, Missouri.

PRINTING OUTFITS AND SUPPLIES

MAKE Your own cuts. Free literature. Plasti-Rubber, Box 4308, Mobile, Alabama.

MAKE Your own self-molding rubber stamps and printing cuts. Plexirubber, Argyle 1, Wisconsin.

NEW Type 69c up. New cuts 10c. Stamp. John Ryan, 275 Lamartine St., Jamaica Plain 30, Mass.

PRESSES, Type cabinets, supplies. List for stamp. Lincoln Press Company, 220-A Hartwell, Fall River, Mass.

DO Your own printing. Save money. Simple rules. We supply everything. Print for others; good profit. Raised printing like engraving too. Have home shop. Details free. Kelsey Presses, V-11, Meriden, Connecticut.

PRINTING Presses, type, supplies. Lists 3c. Turnbaugh Service, Loyalville, Penna.

PRESSES, Supplies, paper. Catalog 10c. Custom, Box 211-P, Springfield, Missouri.

PATENT ATTORNEYS

CANADA—Ramsay Company Registered, 273 Bank Street, Ottawa, Canada.

INVENTION Record form free and "Patent Information Every Inventor Should Have." Carl Miller, Registered Patent Attorney, Woolworth Building, New York.

REGISTERED Patent attorney offers services. Sanders, 6430 Evans, Chicago 37, Illinois.

"INVENTOR'S Guide" and "Record of Invention" free on request. Frank P. Ledermann, Registered Patent Attorney, 154 Nassau Street, New York City.

PATENTS — Irving L. McCathran, 315 McLauchlin Bldg., Washington 1, D. C. Registered Patent Attorney.

PATENTS. "Proof of Invention" free. E. E. Vrooman, Registered Patent Attorney, 507 McKim Building, Washington 5, D. C.

INVENTORS: When you are satisfied that you have invented something of value write me, without obligation, for information as to what steps you should take to secure a patent. Write Patrick D. Beavers, Registered Patent Atty., 935 Columbian Bldg., Washington 1, D. C.

C. A. Snow & Co.—M427, Snow Building, Washington 1, D. C. Registered Patent Attorneys. Write for information.

INVENTORS: Without obligation, write for information explaining the steps you should take to secure a patent. John Randolph, Registered Patent Attorney, 203 Columbian Bldg., Washington 1, D. C.

INVENTORS—If you believe you have an invention, you should find out how to protect it. The firm of McMorro, Berman & Davidson with offices in Washington, D. C., is qualified to take the necessary steps for you. Send for copy of our patent booklet "How to Protect Your Invention." We will also send you an "Invention Record" form. No obligation. They are yours for the asking. McMorro, Berman & Davidson, Registered Patent Attorneys, 134-X, Victor Building, Washington 1, D. C.

INVENTORS—Take these preliminary steps toward patent protection. Sketch and describe your invention. Sign, date and have this disclosure witnessed by two people who understand your invention. Have us make a preliminary search among U.S. patents already granted for similar types of invention. We report on the probable patentability of your invention and recommend your further course of action. Write for our instructive booklet, "Patent Protection for Inventors" and convenient "Evidence of Invention" disclosure form. Victor J. Evans & Co., 131-A Merlin Building, Washington 6, D. C.

INVENTORS. Learn how to protect your invention. Unless the inventor is familiar with patent matters, he should engage a competent registered patent attorney or agent to represent him. We are registered to practice before the U.S. Patent Office and prepared to serve you in handling your patent matters. "Patent Guide for the Inventor" containing detailed information concerning patent protection and procedure with "Record of Invention" form will be forwarded to you upon request—without obligation. Clarence A. O'Brien & Harvey Jacobson, Registered Patent Attorneys, 51B-A District National Building, Washington, D. C.

FOR INVENTORS

INVENTORS. A booklet telling you how and where to find out what I have learned in 11 years as an inventor. \$1.00. Mark Smith, Box 29, Glen Ridge, N. J.

INVENTORS: Profit from "One Inventor's Experience" or money back! Avoid costly mistakes! Get facts I learned in obtaining and promoting 30 U.S. patents. Send \$1 today. R. E. McLean, 5703 South Benton, Kansas City 30, Missouri.

43 FACTS Successful inventors know before applying for patents. Fred Roth, 14623 Dickens St., Sherman Oaks, Calif.

INVENTION promotion specialist, patented, unpatented. Inventors Promotion Service, 152 West 42nd, New York 18, N. Y.

INVENTIONS Wanted. Patent pending only. Stark Corporation, Cedarburg 1, Wisconsin.

INVENTORS, Manufacturers: Make profitable business contracts through Inventor's Mart, Esperson Bldg., Houston, Texas.

PATENT Searches, including copies of nearest patents, \$5.00. Reports airmailed within 48 hours. More than 100 registered patent attorneys use my service. For free invention protection forms, write Miss Ann Hastings, P.O. Box 176, Washington 4, D. C.

INVENTORS! Ask how our products procurement program expedites patent placements with national manufacturers. Willard Industries, Box 2106, San Francisco 26, Calif.

INVENTORS—Send for free patent information book and inventor's record. Registered Patent Attorney, Associate Examiner, Patent Office 1922-29; Patent Attorney & Advisor, Navy Department 1930-47. Gustave Miller, 15A Warner Building, Washington 4, D. C.

INVENTORS. Learn how to protect your invention. Unless the inventor is familiar with patent matters, he should engage a competent registered patent attorney or agent to represent him. We are registered to practice before the U.S. Patent Office and prepared to serve you in handling your patent matters. "Patent Guide for the Inventor" containing detailed information concerning patent protection and procedure with "Record of Invention" form will be forwarded to you upon request—without obligation. Clarence A. O'Brien & Harvey Jacobson, Registered Patent Attorneys, 51A-A District National Building, Washington, D. C.

INVENTION Record form free and "Patent Information Every Inventor Should Have." Carl Miller, Registered Patent Attorney, Woolworth Building, New York.

SEARCHES—Put your patent searches in the hands of a registered patent attorney or agent, as he qualifies to give a worthwhile patentability report. Record of invention form upon request and information on patent protection. Patrick D. Beavers, Registered Patent Attorney, 935 Columbian Bldg., Washington 1, D. C.

INVENTORS: Information on patent procedure furnished on request, without obligation. John Randolph, Registered Patent Attorney, 202 Columbian Building, Washington 1, D. C.

INVENTORS: If you have an invention for sale, patented or unpatented, write Institute of American Inventors, Dept. 40A, 631-E St. N.W., Washington 4, D. C.

"INVENTOR'S Guide" and "Record of Invention" free on request. Frank P. Ledermann, 154 Nassau Street, New York 38, N. Y.

"HOW To Apply for Patent by yourself" instruction booklet by Z. deSauvan, engineer-inventor, not an att. \$2.00, Box 687, Alhambra, Calif.

\$500 AWARD For usable idea! Established manufacturer with reasonable plastic slush and dip molding products needs item for summer season. You will be fully protected. Write Edwards Agency, 435 S. LaCienega, Los Angeles, Calif.

INVENTORS—This firm is registered to practice before the United States Patent Office and available to assist you in the preparation and prosecution of your patent application. "Patent Protection for Inventors" booklet containing detailed information and steps to take toward patent protection sent promptly upon request. No obligation. Victor J. Evans & Co., 132-A Merlin Building, Washington 6, D. C.

PATENT Searches \$5.00. 48-hour airmail service. Invention protection forms free. Write Patent Engineering Service, 711 14th Street N. W., Washington 5, D. C.

INVENTORS—If you believe you have an invention, you should find out how to protect it. The firm of McMorrow, Berman & Davidson with offices in Washington, D. C., is qualified to take the necessary steps for you. Send for copy of our patent booklet "How to Protect Your Invention." We will also send you an "Invention Record" form. No obligation. They are yours for the asking. McMorrow, Berman & Davidson, Registered Patent Attorneys, 134-W Victor Building, Washington 1, D. C.

CASH For your idea. 280 manufacturers need inventions, patented or unpatented. List free. Invention Bureau, 208M Clinton, Oak Park, Ill.

COMPLETE Services for inventors. "Record of Invention" form free. Write National Inventors Institute, 4097 East 131st St., Cleveland 5, Ohio.

PATENT Searches, \$5.00, including patent copies. Same reliable search as conducted for patent attorneys. Free protection forms. Fast, accurate service. Patent Service Institute, 945-A Pennsylvania Avenue, Washington 4, D. C.

PATENT Searches \$5.00. 48-hour service. Free invention protection forms. Write Raymond L. Smith, Patent Searcher, 622 Sheraton Building, Washington 5, D. C.

PATENTS FOR SALE

STEAM Bath, shower, and sun bath. All in one cabinet. Can be used in every home. Electrically operated. John Ruth, P.O. Box 72, North Madison, Ohio.

MANUFACTURER-Distributor for two patented products, royalty basis: (1) electronic item for office and light industry; (2) cleaning device for service stations and janitors' supply. Shreve, Box 1583, Charlotte 1, N. C.

INVENTORS: Test the commercial value of your patented or unpatented inventions, quickly and inexpensively. Write for free information. Institute of American Inventors, Dept. 40-B, 631-E St. N.W., Washington 4, D. C.

INVENTIONS WANTED

INVENTORS Don't sell your invention, patented or unpatented, until you receive our offer. Write Cowgill, Box 298, Marion, Ohio.

INVENTIONS Wanted. Patented, pending only. Inventors Patent Exchange, Hartford 1, Conn.

INVENTIONS Wanted. Patented; unpatented. Tremendous manufacturers lists. Global Marketing Service, 1404 Mitchell, Oakland 1, California.

INVENTORS: Hundreds of manufacturers have requested our assistance in locating marketable new products. Complete information free. Institute of American Inventors, Dept. 40-D, 631-E St. N.W., Washington 4, D. C.

CASH Buyers for ideas and inventions. Write National Inventors Institute, 4097 East 131st St., Cleveland 5, Ohio.

FROM Center American industry. National Research & Development Corporation seeks patented or unpatented inventions for development or sale. Write for booklet A. Room 324, 11 West 42 Street, New York, N. Y.

INVENTIONS Wanted, to manufacture on national royalty. Patented or patented pending. Con-Mar Manufacturing Company, 1137 N. W. 47th, Oklahoma City 6, Oklahoma.

INVENTORS: If your invention is adaptable to our business we will contract on cash or royalty. If not, we will try to place. Free booklet. Kessler Corporation, 51X, Fremont, Ohio.

PATENTED: Unpatented. Write for latest inventions wanted list, 12-point guaranteed promotion plan, inventors' guide, etc. Superior, 338-344 North Rodeo, Beverly Hills, Calif.

NEW Products wanted: Patented or unpatented, royalty or purchase; reliable manufacturer; send general description only; details required after acceptance. Box 176, Roslyn, New York.

INVENTIONS Promoted. Patented or unpatented. A-1 service for inventors since 1911. Write Adam Fisher Co., 5418 Idaho, St. Louis, Mo.

INVENTIONS Wanted. State whether patented, unpatented. M. Martin, P.O. Box 593-D, Healdsburg, Calif.

INVENTIONS Wanted. Patented or patent pending. 24 years experience promoting inventions. National Service Bureau, 3120 Meramec, St. Louis 18, Mo.

WANT Patented products to manufacture and distribute nationally. Rubber, metal, plastic or wood. Will buy outright or manufacture on royalty basis. Fargo Rubber Corporation, 137 E. 58th St., Los Angeles 11, Calif.

SALES And promotion. Patented or unpatented inventions. Canadian, U.S. service. Free particulars. Canadian Patent Enterprises, 31 Leighland East, Burlington, Ont., Canada.

INVENTIONS Of 6 types wanted by large midwestern manufacturer. For full details see ad by J. Walter Thompson on page 78 of this issue.

INVENTIONS. We have time, money, and know how needed to develop and promote them. Inventors Research, 1154 North Western, Hollywood 29, Calif.

MANUFACTURING

STAMPING Dies, stamping, metal products made to your specifications. Inventions developed and produced in metal. Any quantity. Send drawing for free estimate. Walwood Products, Doster, Mich.

BIGGEST. Most complete illustrated model railroad catalog. 600 cast items. HO and O. 10c. Selley, 744 Clay, Winter Park 3, Fla.

COMPLETE Working drawings and patterns for heavy duty electric router thoroughly tested in production. Woodwork, Box 292, Hartsdale, N. Y.

DESIGNING. Manufacturing. Machinery, inventions, models. Henry, Engineer, 2136 E. Monmouth, Philadelphia, Penna.

MODELS — Small lot manufacturing. Metals, plastics, etc. Milburn, Burlington, Kentucky.

MODELS. MODEL SUPPLIES

FLEISCHMANN Famous German steam engines \$4.95 to \$85.00 and mechanical ships 79c to \$45.00 postpaid. Catalog 50c. Merlo, 30-18 94 St., Elmhurst 73, N. Y.

1955 CAR Models, 1/25 scale, all metal, chrome trim. Send for catalog! Cars & Hobbies, Dept. PM-22, 2333 Haddon, Chicago.

POWER Models. Unusual steam, gasoline and traction engines, fittings, metals. Anniversary catalog 50c. Chas. Cole, Ventura, Calif.

BUILD Miniature passenger hauling live steam locomotive with file and drillpress. We do machine work, you bolt it together. Catalog 50c. Little Engines, Wilmington, California.

SHIP And yacht model fittings; blueprints. Send 25c for illustrated catalog listing hundreds of items. A. J. Fisher, 1002-1 Etowah Ave., Royal Oak, Mich.

SHIP And other scale models. Most complete line in New England. Kits, fittings, plans, books, tools, engines, motors. Illustrated catalog 25c. James Bliss & Co., Inc., Dept. 5M, 342 Atlantic Ave., Boston 10, Mass.

BALSA Wood. Grade AAA. Free sample, price list. Sig Mfg. Co., Montezuma, Iowa.

SHIP Models and yacht supplies. Complete, large 68 page catalogue 50c. Bill Wild's, 510 East 11 St., New York City 9.

HOME CRAFTSMEN

89 FULL Size jig saw patterns of beautiful shelves, ornaments, toys, novelties. Plus "How, Where to Sell." Only \$1.00. Mastercraft 14M, 7041 Olcott, Chicago 31, Illinois.

FREE Make-it-yourself craft catalog, low-cost kits and supplies. American Handicrafts, Box 1479-AQ, Fort Worth, Texas.

WOODWORKING Course for home craftsmen. Twenty-two manuals. Over 1,000 pages. 75 training projects. Only complete home training program available today. Carefully written, profusely illustrated. Covers everything from wood selection to final finishing. Complete instruction in care and use of all hand and power tools. Prepared by expert manual training instructors. Write for free booklet. Interstate Training Service, Dept. G-3-A, Portland 13, Oregon.

LEATHERCRAFT Items at big savings. Make billfolds, belts, gloves, handbags, moccasins, woolskin animals, etc. Sell, use or give as wanted gifts. Start now making quality leather specialties with Larson easy-to-assemble beginners kits. No tools or experience needed. Illustrated instructions. Attention professionals, hobbyists and crafts classes! Careful grading assures a uniform selection of tooling and carving leathers, fine calfskins, kits and projects. Quality guaranteed. Complete stock of accessories, tools, supplies. Orders shipped same day received. Send 10c today for big, new illustrated catalog for beginners and advanced hobbyists. J. C. Larson Co., 820 S. Tripp, Dept. 4850, Chicago 24.

BUY Wholesale nationally advertised power, hand tools, thousands other products at big discounts. Free "Wholesale Plan." American Buyers', 628-PP Linden, Buffalo 16, N. Y.

LEATHERCRAFT. Tremendous stock of leather, tools, supplies, and kits. In leather business over forty years. Send 10c for big catalog. Sax Bros., 1111 No. 3rd, Dept. PM-13, Milwaukee 3, Wisconsin.

101 FULL Size patterns. Smart, new, gifts, novelties, lawn figures, shelves, action windmills, alphabets. Plus "Make Money Jig Sawing." Only \$1.00. Mastercraft 15M, 7041 Olcott, Chicago 31, Illinois.

16 NEW Lawn chairs, 22 picnic tables, benches, trellises, etc. All 38 plans with necessary full size patterns, \$1.00. Mastercraft 13M, 7041 Olcott, Chicago 31, Ill.

MAHOGANY Mitre boxes. Sixteen inch, \$3.50; twenty inch, \$3.95; post paid cash with orders. Send fifteen cents for folders many other homecraft items. Eastern Hills Lumber Company, Station M, Cincinnati 27, Ohio.

LEATHERCRAFT, Metal tooling, textile painting, beadcraft, shellcraft, many other crafts. Fun, easy, profitable! Free, big, illustrated catalog. Write today. Kit Kraft, Dept. 221, Box 1086, Studio City 1, Calif.

JIGSAW Owners attention! Start earning money at home cutting out wooden novelties and souvenirs. Write H. Cook, Dept. A, 4407 S. Normal Ave., Chicago 9, Ill.

PLASTICS Home-craft course for men and women. Tells and shows how to make hundreds of fast selling plastics products. All plastics and materials for 23 projects included in course. No special tools needed. Course pays for itself. Write for free booklet. Interstate Training Service, Dept. D-3-A, Portland 13, Oregon.

VIOLINMAKERS, Repairers, amateurs, professionals. Fine tone European wood. Materials, tools, patterns, instructions. Illustrated catalogue 10c. Premier Violin Supplies, Division PVM, 430 South Broadway, Los Angeles 13, California.

35 FULL-Size lawn and animated weathervane patterns \$1.00 postpaid. Lincoln Studio, Columbia, Conn.

MAKE Perfect circle with simple jig attached to band saw. Plan 50c. Henkemeyer, Box 36, St. Cloud, Minn.

MAKE A million lamps, no two alike, complete information. 25c. Cy Products, Dept. 2B, Lafayette, La.

200 PATTERNS For woodworkers, illustrated literature 20c. Bell Plans, RD #6, 362 East 59th St., Brooklyn 3, New York.

CARTOONS For your home shop. Free sample. Bill Bazik, Box 4774-M, Cleveland 26, Ohio.

ALPHABET Patterns. Monograms, numerals. 14 sets 1 1/2" x 4" high, \$1.00 postpaid. Walker Studio, A-21, 4343 Lindell, St. Louis 8, Mo.

MODERN Furniture do-it-yourself plans. Free literature. McAleer Hardwood Products, Box 645, Bensenville, Ill.

LEATHERCRAFT For pleasure and profit. Big new illustrated catalog of leathers, easy-to-make projects, tools accessories, supplies. Send 10c today. Tanart Leathercraft Co., Dept. PM, 149 N. 3rd Street, Philadelphia 6, Penna.

FREE "Do-it-yourself" leathercraft catalog. Tandy Leather Company, Box 791-H8, Fort Worth, Texas.

MAKE And sell home shoe shine kit. Information write C. Parsons, 417 Stahl Ave., New Castle, Delaware.

BEAUTIFUL Inlaid boxes are easy for power saw owners. Materials for three exquisite boxes, instructions, \$3.95. Veneer, inlay catalog, "veneering tips" 10c. Southern Craftsmen, Box 1844-C, Louisville 1, Ky.

MONEY From scrapwood. Patterns and instructions \$1.00. Jigsaw necessary. Lynda, Medway 9, Mass.

BIG Savings leather—Now, for first time, you can buy full sides of top grain cowhide at our special, amazingly low "tannery-to-you" prices. For details, write Dept. 1, W. D. Byron & Sons, Williamsport, Md. Fine cowhide tanners since 1832.

LEATHERCRAFT Supplies at lowest prices. "Craftool" stamps. Catalog 10c. Crown Leather, 22 Spruce Street, New York 38.

LEATHER, Tools, lacings, supplies. Free catalog. National Handicraft, 199 William St., New York 7.

STYLECRAFT Sure fire hits. "Pre-traced" leather kits. Handbags, billfolds, filigree belts, over fifty other projects. Patterns on leather. Why trace? Just carve, assemble and lace. Large assortment "precarved" kits also available. Send 25c for catalog, free folder. Refunded first order. Apache Leather Company, 2804 E. Washington St., Phoenix, Arizona.

KNOCKDOWN Cedar chests. Lumber and veneers. Free price list. Oles & Kendall Company, Huntsville, Ala.

FREE Information. Money-making full size patterns. Professional designs. Furniture, gift shop items. Write Jigsaws, 117 Worth, New York 13.

KNOCKDOWN Cedar chests and lumber. Free price list. Bedford Lumber Company, Shelbyville, Tennessee.

FIGURINE Catalog, 1955 edition. 800 illustrated items including Mrs. Helm's paints, enamels; Helen's water color paints, etc., only 35c. Klosterman, Dept. K, 954 Arcade, St. Paul 6, Minnesota.

FREE Leathercraft catalog, Do-It-Yourself. Write Tandy Leather, Box 397AC, Tulsa, Oklahoma.

DO IT YOURSELF

EASILY Built basement window greenhouse. Details free. Jays, 2112 Portland, Minneapolis 4.

SAVE Money! Make your own cornices. Instructive booklet illustrating construction, upholstery and design. Only \$1. Flexo, 5306 Church Avenue, Brooklyn 3, New York.

BUILD Streamlined plywood kitchen cabinets. Plans, photos, instructions, \$1.00. Playnecabinets, 4617 Johnson, Western Springs, Illinois.

TV Trouble? Fix it yourself. Be ready for trouble. Our TV trouble shooting guide shows you how in easy, fast, safe steps. 80% cases guaranteed. No experience necessary. Send \$1.00 now. Sentinel Electric Company, Box 2693, Kansas City 42, Missouri.

BUILD 10 Amazing machinist tools that can't be bought anywhere! Save \$100. Free literature. Progressive Tool Designers, 2161R So. 76th Street, Milwaukee 14, Wisconsin.

SAVE 50-75%. Build it yourself, tools, household appliances. Wholesale catalog. Nueblings-M. Sicklerville, N. J.

ELECTRO-Pen, writes permanently any metal. Operates on transformer, car battery. Build yourself, simple plans \$1.25. Remler, 2946 Tyburn, Los Angeles 39, Calif.

GENUINE Tooling leather "do it yourself billfold kit" only \$1.00 postpaid. First 500 customers receive free gift. Miles Crafts, 3220-P Fish Avenue, New York 69.

WATER Softener tanks, zeolite, parts to make your own unit. McCarthy Company, 2930 W. Burlington, Milwaukee 10, Wis.

CLOCK Movements — Gorgeous dials, plans, kits. See ad page 233.

DO IT yourself. What? Repair TV, build furniture, make barbecue, plumbing repairs, build boats, do house wiring, remodel home, lay tile, modernize kitchen, repair home, and scores of other things you can do yourself. Books covering each subject, only 25c. Send for descriptive list. It's free. Popular Mechanics Press, 200-LB East Ontario St., Chicago 11, Ill.

FURNITURE — Wrought iron legs and frames! You assemble. Free catalogue. Phillips Furniture, East Peoria 8, Illinois.

GEIGER Counter and metal detector kits. Inexpensive, educational. Free literature. Electronic Applications, 5024 Lee Highway, Arlington 7, Va.

BUILD Inexpensive concrete blockmaker. Motor-hand. Also mixer. (Both for less than \$10.) Then make blocks for 5 room house for \$95. Write. C. Lee, Mountain View, Oklahoma.

DO-It-Yourself. Build a power mower with Handy-Dandy conversion kit. \$19.50, prepaid in U.S.A. Fits 16" to 20" mower. LeClaire Mfg. Co., LeClaire, P. M., Iowa.

LEATHERCRAFT Supplies. Handbag, billfold kits. Catalog 25c, refundable. Free advice. Folders. Phil Thiel, 306 Broadway, Seaside, Oregon.

3-D Projector, thrilling performance, takes Stereo Realist slides. Nineteen detailed full size drawings \$5.00. Illustrated circular 10c. Victor Specialties, 775 D Main Street, New Rochelle, N. Y.

HOW To paint. Do it yourself. Illustrated instructive book, 25c. Catalog free. Popular Mechanics Press, 200-HP E. Ontario St., Chicago 11, Ill.

BE Your own plumber. You can. Few inexpensive tools and our instructive book, "Home Plumbing Guide," shows and tells you how. Hundreds of photographs and diagrams. Easy to follow. 160 pages. \$3.50. Catalog free. Popular Mechanics Press, 200PG East Ontario St., Chicago 11, Ill.

WATCHES, OLD GOLD, JEWELRY

HIGHEST Cash for old gold, broken jewelry, gold teeth, watches, diamonds, silverware, spectacles, platinum. Free information. Satisfaction guaranteed. Rose Refiners, Heyworth Bldg., Chicago 2.

WATCHMAKERS' Tools, materials, supplies, watches. Catalog. Gales, Box 1000, Chicago 90, Ill.

AMATEUR - Professional watchmakers' supplies; correspondence instructions; repairing. Bengale Company, Culver City, California.

RHINESTONES, Jewelry settings, cameo, sequins, beads, hobby kits. Catalog free. J & M Novelties, Dept. CA-3, Griffith, Indiana.

WATCH And clock repairing books for hobbyists. Free information. North American, Dept. 15-A, 2320 N. Milwaukee, Chicago 47, Illinois.

\$8.50 RONSON Whirlwind lighter free with every watch purchased. Catalog 25c. James, Box 1161, Miami 7, Florida.

MAKE Costume jewelry for fun and profit. Catalog 25c. Bergen Arts, 128M Main, Hackensack, N. J.

JANUARY Clearance sale. Costume jewelry findings, rhinestones. Discounts 25% to 50%. Free catalog, bargain list. Ebert, Box P183, East Orange, New Jersey.

USED Watches \$1. Name brand. Free list. Southern Watches, Gray 14, Georgia.

WATCHES Overhauled \$4.50. One year's guarantee. Berkowitz, 1150 Castlehill, New York 62.

COSTUME Jewelry supplies. Catalog and samples. 35c. Largest line in America. Milady-Fair Co., G.P.O. Box 1328, New York City 1.

FREE Sample pair of earrings shows you how easy it is to make beautiful costume jewelry. Over 5000 styles listed in new catalog, 25c. Barry's, 188 Ardsley Court, Newark, N. J.

TOBACCO, SMOKERS' SUPPLIES

INVENTED Wilson pipe reamers for myself. Pipe smokers ran me wild! Result—Three sizes handsome brass reamers \$2. Satisfaction guaranteed. Folder. Hy Wilson, Reamers, Hudson, Indiana.

PIPE Smokers! Write today for free eye-opening facts about smoking. A surprise awaits you. E. A. Carey, Dept. Y, Chicago 40.

FOR THE HOME

FOAM Rubber furniture cushions. Factory seconds, 50% discount. Free catalog. Perma-Foam, 140-C Main Street, East Orange, New Jersey.

RAZORS, BLADES, SHARPENING

100 DOUBLE Edge blades \$1.00. Order today from Paul Jacobs, 3527 N. Cramer, Milwaukee 11, Wisconsin.

FREE Package famous razor blades, quality Swedish stainless imports. Fit any double-edge razor. Enjoy among the best shaves ever, and join Gay Blades Mail Order club, too. Rush us (1) Your name and address; (2) Number of days present blade lasts you. Send no money but act now. Gay Blades, Dept. PM1, Box 1464, Palo Alto, California.

METHOD Safety razor blade sharpener. \$1.00. Box 213EE, East Hartford 8, Conn.

BEAUTIFUL Guaranteed electric shavers, limited time, \$4.00. Berco Company, 1802 Cherry, Toledo 8, Ohio.

OF INTEREST TO WOMEN

A Dress shop in your home. No investment. Liberal sales commissions. Write Bellecraft Fashions, 111 YS Eighth Ave., New York.

EMBROIDER Stamped linens. Buy direct from manufacturer and save. Send for free catalog. Merrilee, Dept. 702, 22 West 21st Street, New York 10, N. Y.

MAKE Big money at home! Invisible reweaving pays up to \$10.00 profit in an hour. Make tears, holes disappear from fabrics. Constant demand from laundries, cleaners, homes brings steady earnings. Details free. Fabricon, Dept. C, 8542 S. Prairie, Chicago 19, Illinois.

BIG Money and independence for you at home. Write Granite Traders, Wolfeboro, New Hampshire.

DRESSES 24c; Shoes 39c; men's suits \$4.95; trousers \$1.20. Better used clothing, free cat. Transworld, 164-AH Christopher, Brooklyn 12, N. Y.

PROFITABLE Hobby—Addressing and mailing advertising postcards. Write for free folder. Fowico Distributors, Muncie, Indiana.

DRESSMAKERS. Sewers, wholesale lists. Dress, suitings, formal fabrics. Box 863, Norwalk, Conn.

PROFITABLE Home business. Make fast-seller chenille monkey trees, dolls, flowers. Terrific holiday demand. Information free. Velva, Bohemia 16, N. Y.

GROW Mushrooms. Cellar, shed, and outdoors. Spare, full time, year round. We pay \$3.50 lb. We paid Babbitt \$4,165.00 in few weeks. Free book. Washington Mushroom Ind., Dept. 176, 2954 Admiral Way, Seattle, Washington.

FOR SALE—MISCELLANEOUS

GENUINE Bull-whips, hickory cattle canes, cowboy boots, cow-bells. Write for free list. Stock Yards Market, 6001 Benore Road, Toledo, Ohio.

HEARING Aid batteries, wholesale. Free list. Habs, Box 51, York, Penna.

BUY Surplus boat, jeep, truck, airplane, machinery tools, photographic, radio equipment direct from government. Save. List \$1.00. Box US213, East Hartford 8, Conn.

OLD Wall telephones. Working order, oak cabinets, hand crank for ringing. \$5.00 each. Telephone Co., Turtle Lake, Wis.

"SCIENCE Milestones": New, thrilling history of science, and the men who made it. More fascinating than fiction. 300 pages, 8 1/2 x 11. Packed with pictures. \$5.00. Descriptive literature free. Windsor Press, Book Dept., 200 E. Ontario St., Chicago 11, Ill.

WANTED—MISCELLANEOUS

SCRAP Plastic to produce 1" x 5" x 1/4" pieces. Nemo Plastics, Wold-Chamberlain Field, Minneapolis, Minn.

PRODUCTS Wanted to sell auto, variety, chain stores. Established 1919. Salespower, Box 818, Cleveland 22, Ohio.

WANTED—Documents, autographs, valentines, correspondence, envelopes, other Americana before 1900. Stine, Kingshighway, Edwardsville, Illinois.

QUICKSILVER. Sterling, silver solders, precious metals. Wholesale Terminal, Norwood, Massachusetts.

SCRAP Mercury (quicksilver) containers supplied—Tantalum, bismuth, tungsten. Metallurgical Products Company, Established 1909, 35th and Moore Sts., Philadelphia 45, Penna.

PERSONAL

BORROW By mail from Postal Finance Co. Employed men and women can easily obtain \$50 to \$600 fast, entirely by mail. Repay in small monthly payments. Friends, relatives, employer tradespeople will not know you are applying for loan. Advise occupation, amount wanted. Postal Finance Co., 200 Keeline Bldg., Dept. 7A, Omaha, Nebraska.

ENTERTAINERS: Win popularity! Spark your speech with fresh, amusing anecdotes. Folio of forty, \$1.00. Forrest Miller, 522 Raub, Easton, Penna.

LETTERS Remailed from Kansas City 25c; receiving, forwarding address, \$5 monthly. Confidential. Sterling Services, P.O. Box 505, Kansas City 41, Mo.

OIL Portrait. Likeness. Send photo. \$40.00. Berglund, 4449 So. Lacrosc, Chicago.

TORONTO, Ontario. Letters remailed. 25c—one, 6 for \$1.00. Burney, Scarborough, Ont., Canada.

LETTERS Remailed 25c. Write for first class personal mailing address rates. McLaughlin, 800 Stewart, Columbus 6, Ohio.

LONDON, Finland, reairmail \$1.00. B.C.M. Lonsdale, Monomark House, London, W.C.I.

UNCLAIMED Stocks, bonds and bank accounts. Information and registration papers \$1.00. Institute of American Inheritance Research, Box 5340-A, Chicago 80, Ill.

RESURRECTION On earth—Not heaven. Free! Write: Harvest, Jefferson City, Mo.

LETTERS Remailed 25c. Los Angeles, San Francisco, Portland, Ore. Return address furnished, \$2.00 monthly. Pearl, 1358 6th Ave., San Francisco.

REMAIS 25c. Help wanted column airmailed \$1.00. Rema, 2223 Valentine NE, Grand Rapids, Michigan.

BOSTON Remailing 25c. Hanley, Box 155, Sta. A, Boston 18, Mass.

WORLD Traveler guides small group through Sweden, Norway, Denmark, Holland, Belgium, France, Britain, 32 days, July-August 1955. Transatlantic transportation from New York and return; transportation and sightseeing in Europe mostly by private cars; three meals daily; first-class hotels. Total price only \$1345 if reservation now. For program mail stamp. Dr. Kauffmann-Grinstead, 401 Mountain Valley, Hot Springs, Arkansas.

SAN FRANCISCO reliable, confidential remail letter 25c, additional 15c each, 4 scenic postcards 50c. Big complete Sunday classified ads airmailed \$1.00. Your errands, San Francisco or any nearby cities \$1.00 up. Boulton, Box 1342, San Francisco 1, Calif.

PALM Beach, Ft. Lauderdale, Hollywood, or Miami Beach letters and cards remailed, 25c, 5 for \$1.00. Post cards for sale, 10 for \$1.00, Box 1828, Pompano Beach, Florida.

SAN FRANCISCO help wanted Sunday section \$1.00 airmail. Pearl, 1358 6th Ave.

MEXICAN Law, General Practice Attorney, 1203 Arizona St., El Paso, Texas.

REMAIS 25c. Confidential forwarding service. Voight, Dept. 8, 4742 N. Damen, Chicago 25, Illinois.

LETTERS Reairmailed from Tokyo \$1.00. C. Hatch, CPO Box 280, Tokyo, Japan.

LETTERS Remailed 25c. L.A. or S.F. help ads airmailed \$1.00. Servisenders, 4448 Fairmont, Fresno, California.

FROM Canada's largest city. Help wanted ads airmailed \$1.00; Remails 25c. Marc's, Box 758, Station B, Montreal, Canada.

LETTERS Remailed 25c, information Vancouver area \$2.00. Source supply 50c. Alec Tanasec, 8570 Cartier St., Vancouver 14, B. C., Canada.

REMAIS 50c. Receiving-forwarding \$3. Hedgpath, Box 830, Alhambra 21, Calif.

T. W.—How can you get help needed? Best is here. Marks cleared up. Phone or wire collect. Your plan not bad, but means further loss and serious illness here. O.K.? F. W.

HOW Can I get out of debt? Stop that garnishment? Save my job? You can! Free confidential details. E. Borum, 411 West Walnut Street, Kalamazoo, Mich.

"HOW Can I find out?" You can! Information confidentially developed. Any matter, person, problem. Worldwide. Officially licensed. Established 1923. William Herman, 170 Broadway, New York City.

LETTERS Remailed 25c. Personal forwarding address. Monthly rates. Hicks Service, Box 1547, Washington 13, D. C.

MEXICAN Law office, Bank references, P.O. Box 41, Juarez, Chih., Mexico.

PORTRAIT In oils. Modern-impressionistic, by the renowned E. John Shay, see Fate magazine advertisement for particulars. Send any photograph. \$25.00 prepaid. P. O. Box 4102, Panorama City, California.

LOVELAND Remail 25c. B. A. Ogden, P.O. Box 86, Loveland, Ohio.

BIG Mail! Attractive offers! Magazines, etc. 6c! Filmer, 9101 Marion, Pharr, Texas.

SAN Francisco postmark! Letters remailed, 25c. Private receiving-forwarding address available. Monthly rates. Memo-Mart, Box 3244, San Francisco 19, Calif.

MISCELLANEOUS

BUMPER Strips—Advertise fairs, rodeos, sports, political, religious events, etc. by fluorescent bumper strips. Free price list and sample on request. Emroy Displays, Inc., 5111 W. 25th Street, Cicero 50, Illinois.

NEW Amazing Raysol shaving cream, eight months shaving pleasure. One dollar. Ten super keen blades free. Raysol, 464M Poplar Bluff, Missouri.

BOOKKEEPING—Tax record simplified for beginners. \$1.50, details free. Hoover Business Service, New Madison 4, Ohio.

COMPLETE Geiger kit \$10.00. Free details. Devine, 3594 Los Flores, Lynwood, Calif.

BUY Wholesale thousands nationally advertised products at big discount. Free "Wholesale Plan." American Buyers, 631-D Linden, Buffalo, N. Y.

GUATEMALAN Hand made products: leather bags, belts, skirts. Free catalog. Mapilon, Box 268, Guatemala, C.A.

HAIRCUT As you like it. Booklet 25c. Mastrolia, 32-20CC 89th Street, Jackson Heights 69, New York.

PORTABLE Drafting machines. Illustrated folder. Drafting Equipment Co., 504 Randolph, Meadville, Penna.

LEATHERCRAFT For pleasure or profit. Make easy-to-assemble purses, belts, gloves, woolskin toys, 100 other items for gifts or to sell. Send 10c today for big catalog. Largest leathercraft stock in U.S. J. C. Larson Co., 830 S. Tripp, Dept. 4351, Chicago 24.

EARN Money evenings, copying and duplicating comic cartoons for advertisers. Adservice, Argyle 1-A, Wisconsin.

BRAZILIAN Orchids. Information free. Catalog \$1.00. Orquideario, Corupa, Santa Catarina, Brazil.

"8 MISTAKES Parents Make." Every parent should have this new book about child training. It is free; no obligation. Simply address Parents Association, Dept. 671, Pleasant Hill, Ohio.

GERMAN Manufacturer directory! 800 pages, English-Spanish index. \$9.00 postpaid insured. Burke Associates, Manchester, Mass.

SEPTIC Tanks, cesspools, toilets, cleaned, deodorized with Tru-Septic. No mixing, no bother. Guaranteed. 4 treatments cost only \$1.75 at your dealer, or order direct. Earl Young Co., Encino, California.

GEIGER Counters, kits and assembled models. All include radioactive sample. Send for details. Geiger Counters, Box 111, Sta. A., Hartford 6, Conn.

CATALOG, 1200 Popular educational, self-help materials, pocket books, etc. 10c. World Adventure, D 244, Ann Arbor, Mich.

LEARN How to ripen fruits, nuts, blown prematurely from trees. How frozen chicks came to life again. 800 catalogued, copyrighted problems, answers, including above, for only 25c. "Doc" Hartmann, Southold, L. I., N. Y.

3400-YEAR Perpetual calendar. From 46 B.C. to 2400 A.D. Send 50 cents to Franklin Calendar Co., 1129 South Illinois Street, Indianapolis 25, Ind.

PHOTO Lampshades. Your negatives or pictures. For information write Conaways, Box 7261, San Antonio 10, Texas.

BE Somebody! Get somewhere! Request free positive thought motivation plan. Easy, quick results. Write: Applied Christian Psychology, Inc., Box 1924-O, Louisville 1, Ky.

VIGOROUS Health. Amazing solar health system. Inquire. Box 1061-S7, Escondido, Calif.

MAGNETS—Permanent Alnico. Never loses magnetism. Many uses. Excellent for map, bulletin work. No. 3, 12 for \$1.00. No. 5 stronger (magnetic pot holder magnets) 6 for \$1.00. Quantity prices. Pritt Co., Dept. MA-1, 12 West 27th, New York City.

ALLERGIC To eggs or wheat? Have developed recipe for luscious steamed pudding using neither. Keeps like fruit cake. Recipe \$1.00 with variations. Alma Wootan, Willcox, Arizona.

DUPONTS 100% Nylons, 51-15, full fashioned, ravel-stop seam, three pairs \$2.50. Electric A.C. Taylor made razor, year guarantee \$4.75, both together \$7.00. Wholesale catalog included, separate 25c. Hartmann, Southold, N. Y.

CLOGGED Drains opened by new powerful chemical called Sursolvent. Removes grease, soap, tree roots, etc., without expensive digging and electric rodding machines. Simple to use. Mix with water and pour down sink. Postal brings free details. Electric Sewer Cleaning Co., Allston 34, Mass.

CLEAN That cesspool, septic tank or drain! No pumping, no digging, no odor. Nothing to mix. Just pour into drain. Full charge \$3.00. Guaranteed. Send cash, check or money order for Quik-Kleen to Monsey Products Co., Dept. 44, Philadelphia 29, Penna.

"VENTRILLOQUISM Selftaught"—Complete book 25c. Greenview, Box 61-BY, Whitestone 57, New York.

COLT Gun replicas for your home, lodge, club, or office. Free facts. Woolslair, 645-G 30th, Hermosa Beach, Calif.

INCREDIBLE! Become mental superman overnight! Free booklet! Bijou, Box 1727-MT, Hollywood 28, California.

300 BIG Mails guaranteed. Samples, plans, offers, propositions, 12 months listing, \$1.00 refundable. Wright Publications, 2270 Hubbard, Memphis 8, Tenn.

FOOD Problems? Dietitian answers any three questions \$1.00. Write: Food, 1217 Alameda, Tucson, Arizona.

70 BIBLE Lessons, 25c. Bulletin, Box 87, Cathedral Sta., New York 25.

I Average \$125 weekly selling books by mail! So can you! Start sparetime! Work home! Cooper, 348-R Taunton, Buffalo, N. Y.

MARBELCRETE—Stops all dusting and wearing away of cement floors. Permanent treatment. Information free. Becker Paint & Varnish Co., Bay City, Michigan.

RUSTOFF Removes rust from guns, tools and power machines. \$1.00 for quart. Rust-off Company, 650 46th St., Des Moines, Iowa.

SUGGESTION Handbook helps you win suggestion awards. \$1.00. Almar, Box 141, Miamisburg, Ohio.

RECEIVE Magazines, samples, catalogues. Mails from everywhere. Offers, hundreds. Get listed 25c. Rorick, Box 86, Cincinnati 26, Ohio.

GOLD, Silver, metal detectors. Geiger counters for uranium. Mineralights. Sensational new fully guaranteed models. None finer. Information free. Detectron Corp., 5420 Vineland Ave., North Hollywood, California.

TREASURE Finders for gold, silver and minerals. Money back guarantee, best available. Also Geiger counters for uranium prospectors, free information. Write Goldak Company, 1541 West Glenoaks, Glendale 1, Calif.

GROW Mushrooms. Cellar, shed, and outdoors. Spare, full time, year round. We pay \$3.50 lb. We paid Babbitt \$4.165.00 in few weeks. Free book. Washington Mushroom Ind., Dept. 175, 2954 Admiral Way, Seattle, Washington.

PANNING Gold—Free lesson; catalogue of mining, mineral books, supplies. Old Prospector, Box 729D1, Lodi, Calif.

TREASURE—M-Scope Geiger counters, mineral locators. Why buy something inferior when you can buy the best at a lower price? Backed by years of experience. Fully guaranteed by factory. Detects minerals, metals, gold, silver, coins. Payment plan available. Proven superior performance. Free 16 page illustrated booklet. Fisher Research Lab., Inc., Palo Alto, California.

URANIUM. Gold, silver, treasure. New power-packed, highly sensitive metal detectors and Geiger counters. Kit and factory assembled models from \$34.50. Lightest weight, guaranteed. Free literature. Electronic Applications, 5024 Lee Highway, Arlington 7, Va.

WHOLESALE! 8000 Nationally famous products. 30-80% discounts! Large catalog. Sensational business plans included. Consolidated Distributors, 21-13 Lafayette, Paterson 15, New Jersey.

SNOOPER Geiger counter. Only \$29.95 complete. Super-sensitive. Pocket size. Find a fortune in uranium. Order now. Send \$5.00, balance C.O.D. Money back guarantee. Free catalog, scintillator and larger uranium and metal detectors. Precision Radiation Instruments, 2235 CPM So. LaBrea, Los Angeles 16, Calif.

1000 GOLDEN OPPORTUNITIES

For years we have been teaching and guiding ambitious people how to acquire profitable and fascinating occupations, starting at home or shop with only a few dollars investment, and how to make more money than ever before! We now offer **YOU** the same unlimited opportunities! On this page are briefly described only 4 out of **HUNDREDS** of similar products and processes waiting for you in Catalogs Nos. 19 and 20. Wonderful ideas for turning your **TIME** into **MONEY!**

The Wonders of Liquid Plastics

Manufacture Without Tools or Machinery

No previous experience or special ability required! **NO TOOLS OR MACHINERY** required. The entire process is about as easy as pouring water out of a glass! The **WONDERS OF LIQUID PLASTICS** make all this possible! Many of the products made with our liquid plastics serve so many diverse and useful functions, many can so easily be converted into beautiful and attractive products that thousands of our customers are now actively engaged in a wide variety of proud and profitable businesses established with the aid of our products and instructions!

UNLIMITED OPPORTUNITIES

Work with **LIQUID IVORY, LIQUID GLASS, LIQUID MARBLE, LIQUID EBONY, LIQUID PORCELAIN, LIQUID WOOD, LIQUID GEMSTONE**, and many other **LIQUID PLASTICS** and in a matter of minutes turn them into an endless and valuable procession of beautiful imbedded jewelry, novelties, ornaments, statuettes, bookends, lamps, pensets, lighters, ashtrays, keychains, figurines, curios, **SOUVENIRS**, art and gift products, fishing lures, **BOATS, GADGETS** galore, exquisite **GEMS!** Make gears, tools, dies, forms, handles, dials, knobs, **MACHINE PARTS**, models of inventions, pistol grips. The list is endless! The only **LIMITATION** is your **IMAGINATION!** Liquid Plastics are the blessing of every creative and ambitious person... with these materials **ANYONE** can create and manufacture by the **THOUSANDS** and at a tiny fraction of what it would cost by any other method! Just send 25c and we will send you our big combination instruction-catalog No. 19, describing all of the products mentioned above and the methods of use! You'll readily admit it's the most fascinating book of its kind as far as opening new worlds of activity and opportunities for you!

FREE Catalog #19 is devoted exclusively (64 pages) to the art of manufacturing **EVERYTHING** without tools or machinery! Send for it today! We will include valuable book, **THE WONDERS OF LIQUID PLASTICS** absolutely free! Catalog No. 19, 25c.



PLASTIC LAMINATING

We manufacture new-process Laminating Machines from \$35.00 and up! Here is a wonderful business you can operate right from home! Make \$10.00 an hour easily! Laminate photos, cards of all kinds (identification, Social Security, business, credit, membership, etc.), newspaper clippings, etc. Send us any card or photo (not over 2" x 3") and 50c and we will laminate it for you to demonstrate the fine quality of work performed by our laminating machines! For more details, see Catalog No. 20.



FREE KIT!

CATALOG #20 is filled with fascinating occupations that can be turned into extremely **PROFITABLE** home and shop businesses! **UNLIMITED POSSIBILITIES UNLIMITED PROFITS!** No previous skill required. Learn Jewellery, Wirecraft, Photocraft, Woodcraft, Machine Shop Practice, Marbleizing, Ceramic Craft, Bell Making, Mold Making, Model Making, Metalcraft, Metal Enameling, General Craft, Plastic Laminating, Book Binding, Leathercraft, Embossing, Lampcraft, Feathercraft, Internal Carving, Extruding, Etching, Plating and dozens of other unique and fascinating occupations that can lead to riches! Send only 25c for CATALOG #20 and receive one outfit mentioned above (our choice) **ABSOLUTELY FREE!**



THE UNIMAT & PRECISION TOOLS IN ONE

A high precision, powerful variable speed **LATHE** for metal, wood, plastics, etc. Sturdily built, compact micro-controls! Ideal for machinists, model and tool makers, jewelers, hobbyists. Attachments quickly convert the **UNIMAT** into a **TABLE SAW** in less than a minute. Also, **DRILL PRESS** (with Jacobs-like chuck), **SURFACE GRINDER, MILL, SANDER, SCREW CUTTER** and **PORTABLE HAND DRILL** can be set up with the **UNIMAT** in a matter of minutes and each conversion is a precision tool with variable speed adjustment. Comes in handsome wood chest. **UNIMAT** is a terrific tool at a very low price. Easy terms. Literature and valuable **MACHINIST'S GUIDE** free. Be sure to mention **UNIMAT**.

FREE! Valuable set of 3 **CARVING TOOLS** (Value \$2.98) and remarkable \$2 book **"THE JOB FOR YOU AND HOW TO GET IT"** Also, all Plastic **RAINCOAT** All these valuable items are **FREE**. See Catalog #19 for details.

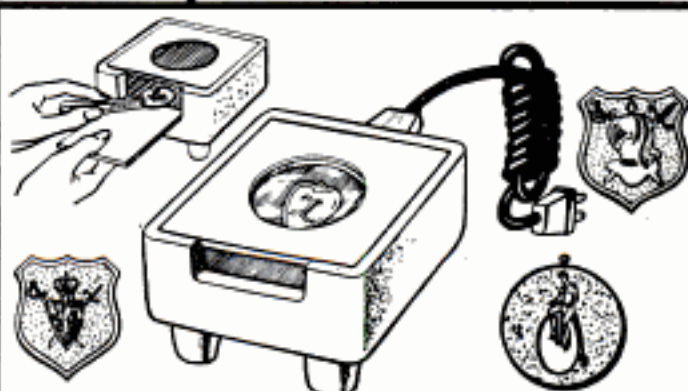

VITRO-NAMEL

Here is a wonderful opportunity to manufacture **LIFETIME ENAMELED JEWELRY** at home with our complete **VITRO-NAMEL OUTFIT!** High-temperature Kiln, glazes and all accessories (ready to operate) included at this unbelievably low price of only \$8.50 postpaid! Over 60 exquisite pre-stamped designs to choose from resulting in magnificent work with a minimum of labor or skill! Nothing else like **VITRO-NAMEL** anywhere... only \$8.50 complete and postpaid. See Catalog No. 20 above.

P. O. BOX 6737
CHICAGO 80, ILL.

PLASTICAST CO., Dept. C

P. O. BOX 987
PALO ALTO, CALIF.

(Write to either address)

6 kinds of inventions wanted immediately!

This may be just the opportunity you have been looking for

• A famous manufacturer, one of our important clients, is presently seeking patented inventions and developments in the fields of hydraulics, automobiles, aircraft, agricultural implements, and construction and materials handling equipment.

Your patent, if usable, will be bought outright or a licensing agreement arranged.

Simply send us a letter explaining the nature of your invention. You will receive an immediate reply direct from the manufacturer. Any and all negotiations will give your patent full consideration and protection.

Address Department X

J. WALTER THOMPSON COMPANY
410 N. Michigan Ave. Chicago 11, Ill.

HELPFUL BOOKS

Send post card asking for FREE catalog
Popular Mechanics Press, 200 E. Ontario, Dept. 601, Chicago 11

start a big profit business with a small investment
EARN UP TO \$200 a DAY

Manufacturing Exciting New

RAINBOW ROCK

Concrete Slump Brick in your back yard

Earn big building boom profits with Rainbow Rock, the colorful new building brick that's taking the country by storm. Sell all you can make to contractors, builders, building supply houses. **RAINBOW ROCK CUTS LABOR COSTS BY 1/3!** Amazing low cost machine makes modern slump brick 24" long (3 times the length of ordinary brick) in a variety of widths and pastel colors . . . up to 1500 bricks a day! **NEEDS NO SPECIAL SKILL.** Operates indoors or out. Full instructions and valuable mixing formulae supplied. **YOU CAN START EARNING BIG MONEY NOW. PAY AS YOU PROFIT!** A limited number of machines available on easy payment terms. **NOW** is the time to start. Write today for free literature and full information.

GENERAL ENGINES CO., INC.
Dept. MR-15—307 Hunter Street
Gloucester, N.J. - Gloucester 6-1337



STEEL PIER SENSATION
Luxurious RAINBOW ROCK fireplace wall in living room of the "Home of the Century" in Atlantic City, N. J.'s Steel Pier . . . acclaimed by over 300,000 Summer, 1953 visitors as the most beautiful they'd ever seen! Endorsed by the Pier's famous architect, Wilton F. B. Koelle.



Makes beautiful, decorative fences, garden walls, garages, outside walk, room separators, etc.

Enjoy Modern Living • Make Your Home Worth More With This Popular Mechanics Book . . .



759 PICTURES

Above: How to lay a new roof over the old.

Right: New walls over the tired old walls. A few of the 83 modern kitchen ideas.

Below: Modern ceilings for old basements.

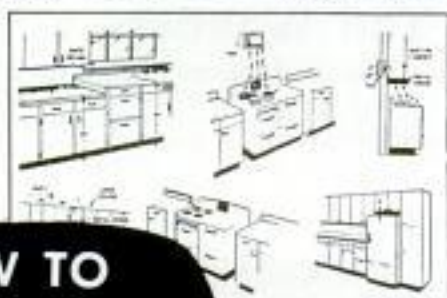

HOW TO Remodel Your Home

With Data on New Materials and Products Available to Home Owners

Here are hundreds of ways you can make a modern home out of an old house, make the house worth more and save money while doing it. If you own an old house or intend to buy one, get "How to Remodel Your Home" by E. R. Haan, formerly technical editor for Popular Mechanics. You can do the modernizing yourself or have it done for this vital book contains 547 methods and 759 illustrations covering complete modernization, adding rooms and living space, installing new kitchens and baths, adding closets, wardrobes, rumpus rooms. Complete face-lifting jobs for the outside and morale building jobs for the inside. Learn the joys and conveniences of modern living with this vital book prepared especially for the home owner. Mail coupon for your copy today

Money Back if You Want It.

Get the book now. Check it for information that will help you improve your home for appearance, convenience and value. If not fully pleased return the book in 7 days and Popular Mechanics will refund every penny you have paid.

Big Book.
Same Size as
This Magazine.



What to Do!
How to Do It!
How to Cut Costs
and Save

In this book — 17 big helpful sections. They are:

- From old to new—Your modern kitchen
- Better bathrooms
- Basement rumpus rooms
- Curing wet basements
- Attic space and dormers
- Adding rooms to the outside—Porches and breezeways
- Utilizing idle space—New look for outside walls
- Modern interior walls—Heat-loss and humidity controls
- Roof framing and covering
- Windows that modernize
- Entrances and doors
- Variety in floors
- Wiring, plumbing heating. In all—547 money-saving articles you can use.

Use Coupon to Get Remodeling Book

POPULAR MECHANICS PRESS, 200 E. Ontario St., Chicago 11

Send at once "How to Remodel Your Home," postpaid for \$2.95. I understand I may return the book in 7 days for full refund.

- Remittance for \$2.95 enclosed. Send book postpaid.
 Send COD. I will pay postman.

Name _____

Address _____

City _____ State _____

315 Different STAMPS — 25¢

SPAIN Lindbergh Air Mail

Also Stamps From:

- INDIA
- GREECE
- ISRAEL
- SOUTHERN RHODESIA



Valuable Spanish Airmail pictures Lindbergh, his plane and the Statue of Liberty! Giant imported collection also includes: **FAR EASTERN REPUBLIC**—complete set of 5—imperforates from hard-to-get dead country (value 50c); **GREECE AIRS**—stunning set of 2 (value 30c); **SO. RHODESIA**—Cecil Rhodes Commem; **INDIA**—Victory pair; **U.S.A.**—\$5 1931 issue; **ISRAEL**—Jumping Stag; plus hundreds of other fascinating stamps and sets from all over the world. Grand total of 315 all-different stamps—regular \$6.50 value—yours for only 25¢ to introduce our Bargain Approvals. Money back if not delighted. Included, **FREE**—"Midget Encyclopedia of Stamps"—plus Stamp Dictionary & Identifier.

SEND 25¢ TODAY ASK FOR LOT FO-20
ZENITH CO., 81 Willoughby St., Brooklyn 1, N.Y.

PLASTICS CATALOG

POLYESTER-FIBERGLAS BOAT AND CAR MATERIALS • PLEXIGLAS
• VINYLITE • ACETATE • WHOLESALE-RETAIL PRICES

Our 14 years experience in plastics plus our continuing interest in the fast developing plastics field enables us to supply you with the best plastics materials and advise you on how to use them and get the most for your money. Polyester and Fiberglass for permanent boat coatings and car bodies; Plexiglas, clear and colored, sheets, rods and tubes; Acetate and Vinylite sheet; cements, supplies, metal findings, books, including the best book of its kind, "Polyester and Fiberglass" by Maurice Lannon. Our new catalog is crammed with information and facts. It lists prices and tells how to order and how to use all kinds of plastics and materials. We'll mail it first class for 15¢—you'll get it in less than a week—send 25¢ if you want it airmailed. Remember, quality and fast service is our stock in trade. Send for the new catalog today.

GEM-O-LITE PLASTICS COMPANY

5350-D RIVERTON AVENUE NORTH HOLLYWOOD, CALIFORNIA

LEVEL SIGHTS for WATER SURFACE



PRECISE GUN-SIGHT PRINCIPLE!

Set-up and sight LEVEL in seconds.—with or without a tripod (fits camera tripod). All directions, any distance—at once—no adjusting! 4 oz., compact C-LEVEL is accurate for contouring, forming, framing, drainage, walks, landscaping, etc. \$4.95 check or M.O. or pay postman \$4.95 plus C.O.D. charge.

SATISFACTION OR MONEY-BACK.

C-LEVEL, Box 101, Orland Pk., Illinois



Have a Motorized Shop at Low Cost

Make
Your Own

POWER TOOLS

Popular Mechanics Book Shows How to Make 60 Machines from Scrap and Discarded Materials

Get SIXTY POWER TOOLS AND HOW TO BUILD THEM, the sensational new Popular Mechanics book. Build your own lathe, drill press, sander, circular and band saw and other power tools at a cost of only a few dollars each. Use old auto parts, pipe and wood and odds and ends that cost little or nothing. Every detail of construction is given in plain language you can understand and follow. Hundreds of pictures and plans show every step to follow in making the power tools you want. Clip this ad and mail with name, address and only \$2.50, or we will send C.O.D. (U.S.A.). You'll be amazed with the fine, practical tools you can make and how little they cost. Your money back if you return the book in 7 days. Order today.



Over 250 Pictures

POPULAR MECHANICS PRESS, Dept. PT-1, 200 E. Ontario St., Chicago 11

FREE 1955 ALLIED TV & RADIO CATALOG

THE COMPLETE ELECTRONIC SUPPLY GUIDE



**308
VALUE-
PACKED
PAGES**

Save on
Everything
in
Electronics

WORLD'S
LARGEST
STOCKS

Everything for Experimenters,
Builders, Amateurs,
Servicemen, Engineers and
Hi-Fi Specialists

Send for ALLIED's big 308-page value-packed buying guide to everything in TV, Radio and Electronics! Largest selections of custom TV chassis, antennas and accessories; FM and AM tuners; High Fidelity systems and components; recorders and phono equipment; Amateur supplies; test instruments; builders' kits; industrial electronic supplies —plus the world's largest stocks of electronic parts, tubes, tools and books. Save on everything in Electronics —send today for your FREE 1955 ALLIED Catalog.



ultra-modern facilities to SERVE YOU BEST



Send for
FREE
Catalog

ALLIED RADIO

ALLIED RADIO CORP., Dept. 5-A-5
100 N. Western Ave., Chicago 80, Ill.

Rush FREE 1955 ALLIED 308-Page Catalog

Name _____

Address _____

City _____ Zone _____ State _____

Completed Popular Mechanics Ranch Type House and exact scale pictorial room and suggested furnishing layout. To right of dotted line is BASIC HOUSE. Expansion to the left. Designed for easy building in two convenient steps.



Basic house includes living room, dining area, two bedrooms, kitchen, bath, utility room and car port. Can be built for about \$5000.

More than 100,000 families have built their own homes in the past few years, doing all of the work, or most of it themselves. Right now, one of every five homes being built is at least partially owner-built. This proves that you too, if you can use hammer and saw, can build your own home and save more than one-half of the cost.



Build the Basic House First

Add When You Need More Room

When expanding you add garage and breezeway, and car port becomes third bedroom. About \$2500.

Get this Newest Popular Mechanics "Build-It-Yourself" Book and Building Plans and Save Many Thousands of Dollars

Book gives complete step by step instruction in simple language. Hundreds of pictures, actual photos and diagrams, showing every phase of construction, guide you from start to finish. Ten working size blueprints give floor plans, elevations, notes on construction, framing, lumber list, specifications, plumbing and wiring diagrams.

Read How and See How — Simplified Instruction

You read "how-to-do-it" in the book. You see how it looks in actual pictures. You follow the plans for dimensions and details. You make use of labor-saving kinks and special methods developed especially for the project.

No Previous Building Experience Required

Any ordinary handy man, using only simple tools, can build this house with little or no assistance and enjoy every

part of it. And at the same time, save in labor costs, more than he spends for material.

Order Book and Plans Now

Use the handy coupon below to order your copy of the RANCH-TYPE HOUSE BOOK AND PLANS. Read the book; study the plans and then you will be prepared to go right ahead when you are ready to build. Even if you have the house mainly built by others, you can still enjoy a tremendous savings by using the instructions and blueprints from Popular Mechanics.



Use This Handy Order Coupon

POPULAR MECHANICS PRESS
200 E. Ontario St., Chicago 11, Ill.

Send at once my copy of the Ranch-Type House Book and Plans as checked below:

- | | |
|--|--|
| <input type="checkbox"/> Remittance enclosed | <input type="checkbox"/> Send C.O.D. (postage extra) |
| <input type="checkbox"/> Ranch Type House Book | \$ 3.50 |
| <input type="checkbox"/> Set of 10 Blueprints | 13.50 |
| <input type="checkbox"/> Book and Blueprints | 15.00 |
| <input type="checkbox"/> Duplicate Set of Blueprints | 5.00 |

Name _____

Address _____

City _____ Zone _____ State _____

Beat the High Cost of Home Owning It's Easier Than You Think

Here is a dream home that can become a reality without too much worry about money. Build this beautiful Ranch Type Home yourself. Simply follow the Popular Mechanics RANCH TYPE HOUSE BOOK AND PLANS. You can save \$7,000 to \$10,000 and have one of the most desired homes of these times. You can build it all now—or part of it—and add garage, breezeway and another bedroom later on without affecting the basic house.

Modern Design • Fully Finished • All-Season
Build this Home Anywhere and Save

Designed for Popular Mechanics by John F. Whelan, famous West Coast architect and designer of homes and entire villages. It's a year 'round house. 81 feet long and 29 feet wide. Fully insulated. Finished outside and inside with durable plywood and requires no plastering. Brick "island wall" and big fireplace in living room. Heating, unique ventilating system and latest development in electric wiring included. A dream home that can easily come true and a home that can grow with the family.

Reduced size illustrations from book. Building roof truss on floor for easy construction. Mrs. Tom Riley, Portland, Oregon, singles the roof on her Popular Mechanics Ranch Type House



**LOOK BETTER!
FEEL BETTER!**

USE A
Vibrosage

ELECTRIC MASSAGER

- Professional-Type
- 4 Scientifically Designed Applicators
- Sanitary

A few minutes daily use of VIBROSAGE gives that stimulating, healthful aid to circulation . . . relief from aches and pains. Four applicators assure maximum effectiveness for scalp, face and body. Operates on 110 volt, 60 cycle A.C. Five day trial—money-back guarantee! If your dealer cannot supply you, send \$8.95 check or money order, for pre-paid shipment. Or, send \$2; pay postman balance plus postage and C.O.D. charges.

BEAUTY APPLIANCE CORP., Dept. V525-A, RACINE, WIS.



BOAT KIT SAVES

UP TO

\$200⁰⁰

12 ft.—\$97
14 ft.—\$129

Freight incl.

Build your own boat like thousands have done! No skill needed with Taft "Picture Method." Own the boat you want and save up to \$200.00 while building it. All materials provided to complete boat shown. Order today. We pay freight. Satisfaction guaranteed. Free folder shows models priced from \$39.00.



MARINE 636 39th Ave. N.E., Dept. PM-1
WOODCRAFT Minneapolis 21, Minnesota

FREE CATALOG

Over 300 books on Fishing, Hunting, Home Repairs and Improvements, Bricklaying, Welding, Home Workshop, Power Tools, Hobbies, Crafts, Home Building, Trades, Making Money at Home, Furniture Making, Woodworking, Carving, Photography, Art, Drawing, Mechanisms, Engineering, Refrigeration, Plumbing, Radio-TV, Electricity, Automobiles, Farming, Livestock, Gardening, Decorating, Painting, many, many more. Send for yours today.

POPULAR MECHANICS PRESS, 200 E. Ontario St., Chicago 11

Guaranteed for Life of your car

The **NEW Metalloy Grid Batteries**

Custom Built
for Today's
Driving
Conditions



Electomic Plates and Cells

REGISTERED U.S. PATENT OFFICE
MILLING PATENT TYPE

ELECTOMIC Lifetime Battery . . . \$19.95

\$34.95 VALUE ONLY \$19.95 IF YOU INSTALL IT YOURSELF. FACTORY DIRECT TO YOU. THE WORLD'S GREATEST BATTERY IMPROVEMENT IN OVER 40 YEARS.

GUARANTEED FOR THE LIFE OF YOUR CAR—AS LONG AS YOU OWN IT.

"METALLOY" GRIDS (SILVER-NICKEL-TELLURIUM) PLUS ACTIVATED OXIDES PRODUCE ELECTOMIC PLATES AND CELLS GIVING INSTANTANEOUS STARTING POWER—FAR GREATER CAPACITY EVEN AT FRIGID TEMPERATURES—WITHSTANDS TERRIFIC VIBRATION. ELECTOMIC LIFETIME BATTERIES OUT-PERFORM ALL OTHER BATTERIES—EXCEED GOVERNMENT SPECIFICATIONS . . . ORDER YOURS TODAY. MAKE EXTRA MONEY—BE THE FIRST IN YOUR AREA TO INSTALL FOR OTHER CAR OWNERS. ACT QUICKLY—DON'T MISS THE OPPORTUNITY OF A LIFETIME. FILL IN ORDER FORM BELOW AND AIR MAIL TODAY.

ELECTOMIC LIFETIME BATTERIES, DEPT. PM 114
601-85th Ave., Oakland 21, California

Please Ship (Cash, Check, Money Order Enclosed)

- 6 volt Pass. Car Electomic Lifetime Batteries @ \$19.95 (inc. tax)
- 12 volt Pass. Car Electomic Lifetime Batteries @ \$24.95 (inc. tax)

**BUY DIRECT and
SAVE UP TO 1/2**
on ITALIAN ACCORIONS
EASY TERMS

Act NOW!



Accordions of famous makes and breath-taking beauty now can be yours! Mail coupon for FREE Color Catalog and amazing Wholesale Prices.

5 DAYS
FREE
TRIAL

MONEY
BACK
GUARANTEE

MAIL
COUPON
NOW

TRY BEFORE YOU BUY

World's largest selection direct from Importer to you! 30 models to choose from. SATISFACTION GUARANTEED or your money back. Trade-ins accepted. Terms as low as \$10 monthly. Write today!

**Big
Color
Catalog
FREE!**

Send me Free Color Catalog—full details.

Name _____

Address _____

City _____ State _____

ACCORDION MANUFACTURERS & WHOLESALE OUTLET

2003 West Chicago Ave., Dept. R-15 Chicago 22, Ill.

15 X 65 "SUPER VISION"

Enjoy tremendous power, wide field of view, brilliant illumination. Streamlined designing, using lighter, stronger metals, make this 15 power binocular easier to hold and use than many glasses half its power! Water-dust resistant. Objective lenses almost 3" across! \$15 x 65! 1 1/2" interior sides of VITAL prisms and front and rear Acromatics COATED with magnesium fluoride for sharp, crisp images—made in Japan by skilled optical craftsmen. **30 DAY NO RISK TRIAL.** Return for refund if dissatisfied. Cash orders postpaid. C.O.D.'s require \$2.00 deposit. AIR MAIL SHIPMENT \$4.00 extra! Leather case, straps included! Add 10% Federal tax. **UNITED BINOCULAR CO., 9043 S. Western, Dept. ARF-8808, Chicago 20. DEALERS WANTED.**



CENTER
FOCUS

FOR _____
Make and Model, Year of Car

NAME _____

ADDRESS _____

CITY _____ ZONE _____ STATE _____

Learn how homeowners everywhere save money by installing their own

MATICO TILE FLOORING



*MATICO's New Improved
Install-It-Yourself System
Makes It Easy!*



1—Mark straight lines through the center of the room in both directions, using a chalk and line.

2—With a notched trowel, spread adhesive evenly over floor and allow to "set."

3—Press tiles into position. You can walk on MATICO as soon as floor is in place.



Yes, you can enjoy colorful, durable MATICO Asphalt Tile Flooring in your home at amazing low cost by installing MATICO yourself. You can't buy a more economical type of luxury flooring than MATICO. It lasts for years... is easy to keep sparkling clean and comes in 32 striking decorator colors that can't wear off because colors and marbling go clear through the tile.

It's a cinch to install, too, with MATICO's tested install-it-yourself instruction booklet... tile calculator... and special tool kit. Why, you can finish a room in just a few hours.

Why put up with a dingy, worn-out floor when it costs so little to install a MATICO tile floor yourself.

See your classified telephone directory for the name of your MATICO dealer.



MASTIC TILE CORPORATION OF AMERICA

Joliet, Ill. • Long Beach, Calif. • Newburgh, N. Y.

Manufacturers of:

Aristoflex • Confetti • Parquetry • Asphalt Tile • Cork Tile • Plastic Wall Tile

MASTIC TILE CORPORATION OF AMERICA
Dep't. M2-1, P. O. Box 986, Newburgh, N. Y.
Please send me MATICO's money-saving install-it-yourself instruction kit and complete color chart.

Name

Address

City..... Zone..... State.....

44-173

IS THIS THE LAST STAND OF THE IRON HORSE?

POPULAR JANUARY 1955
MECHANICS

WRITTEN SO YOU CAN UNDERSTAND IT
VOL. 103 NO. 1

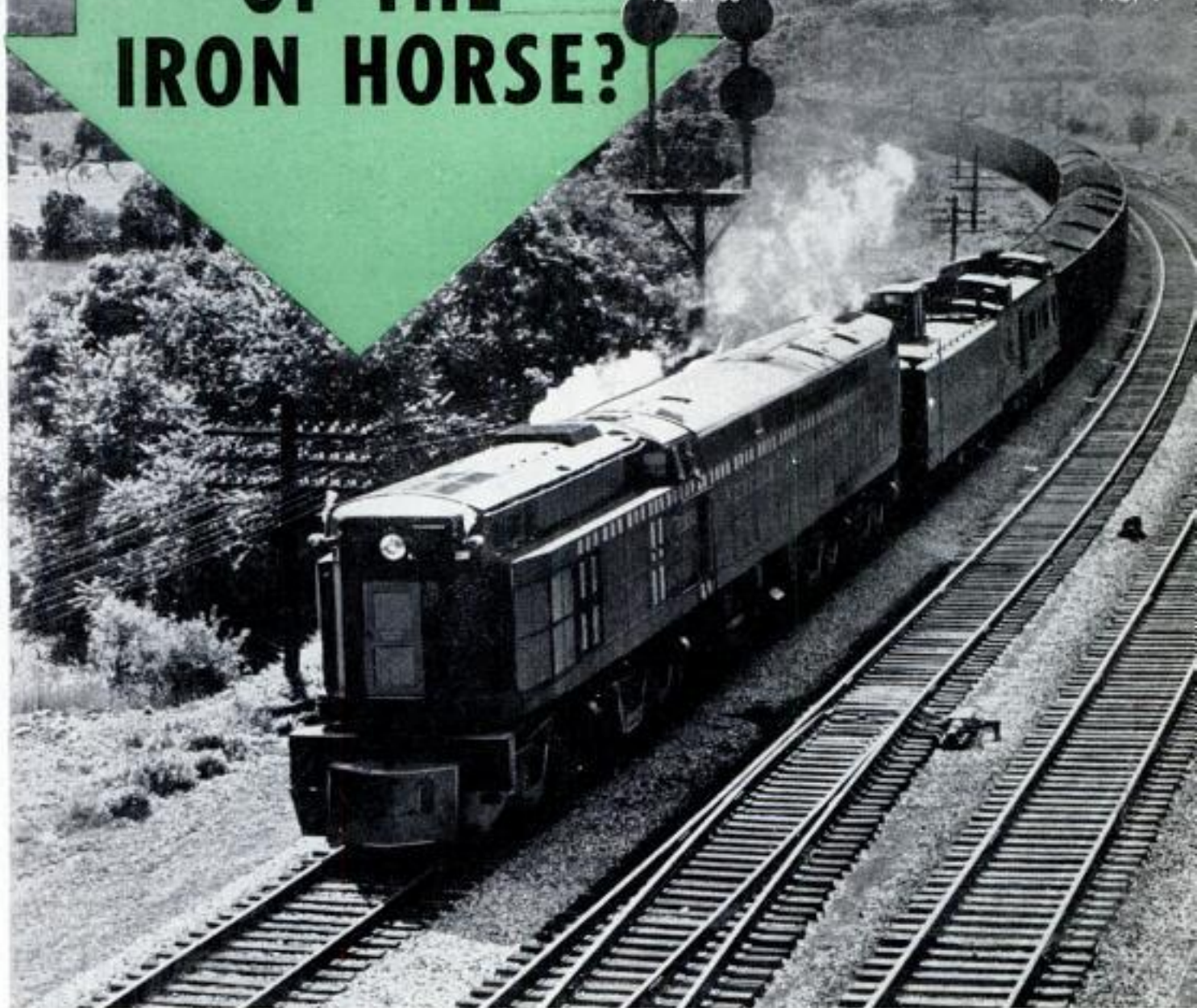

By Walton M. Rock

A BIG, BLACK monster of a locomotive is growling up and down the boiler-busting grades of the southern Appalachians these days, pulsing a defiant challenge to the sleek diesels so rapidly replacing its coal-burning brothers.

This new power plant on wheels burns coal, too, like all the other engines operated by the Norfolk and Western Railway. But the resemblance ends right there.

For this hulking brute is a coal-fired, steam-turbine-electric locomotive. Steam generated in the boiler at high pressure drives a turbine which develops 4500 horse-

power at an electric generator supplying power to 12 traction motors, one for each axle.

But though this is a steam locomotive, the legendary Casey Jones and his mates of a bygone day would never recognize it as such.

In size alone, it beats anything Casey ever saw. Together with its tender, it is a little over 161 feet long and weighs 586 tons.

The black giant is so long that, with its tender, it cannot be handled on existing turntables. When it is necessary to turn it around, the tender is uncoupled, the huge



Norfolk and Western had some pretty-good-sized steam locomotives pounding its high iron before No. 2300 came along. But the big steam-turbo-electric job, with its 586-ton weight and 161-foot, 1½-inch length, puts them in the little-brother category. Former record-holders in the weight and length divisions were these articulated giants. The 2-8-8-2 Class Y6 (above) weighed 495 tons, while Class A 2-6-6-4 locomotives (below) were the road's longest, 121 feet, 9¼ inches. Both were made in N&W's own Roanoke shop





Designed for the heavy work of hauling coal over Appalachian grades, giant "Jawn Henry" is big and black and powerful, dwarfing sleek No. 600, a bullet-nosed, streamlined passenger locomotive. The Norfolk and Western is the only major railroad in the United States that has stuck to steam for all freight and passenger operations. With the great part of its revenue coming from haulage of coal, the road uses coal-fired steam for motive power. No. 2300 is the latest N&W effort to prove the diesel experts wrong

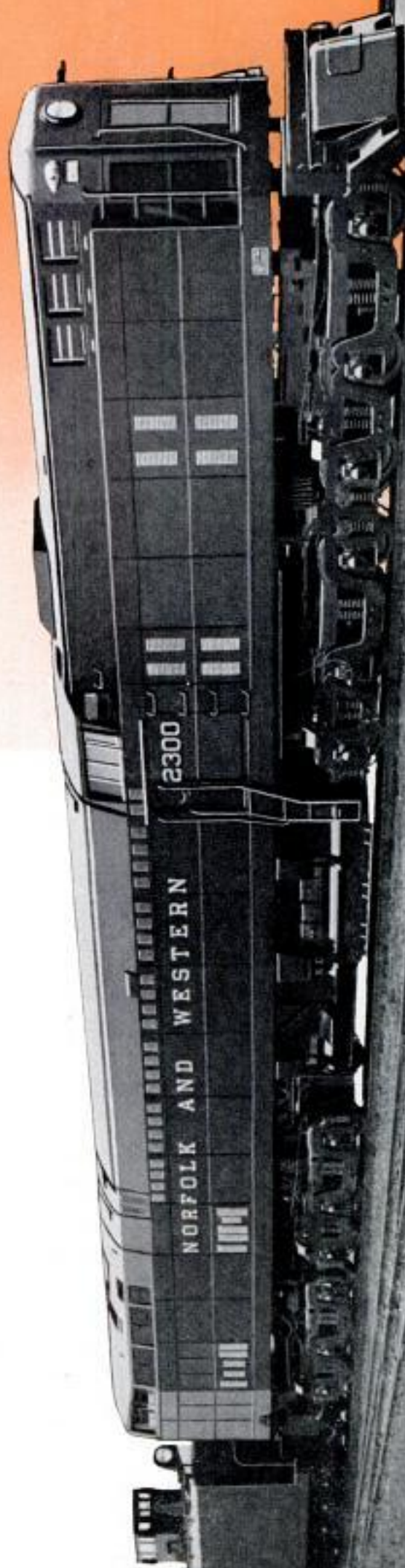



Automatic stoking in this coal burner takes the sweat out of the fireman's job. His cab has a minimum of simple controls

locomotive is turned, and the tender hitched onto the other end. It is nearly 40 feet longer than the N&W's longest conventional engine.

Casey and his friends would find a few other items turned around, too. Coal, 20 tons of it, is in a compartment of the engine itself, in front of the cab. The boiler is behind the cab, along with the turbine and generators. The tender contains only water (22,000 gallons) and a special water softener, with a brakeman's cupola perched jauntily on top.

Coal is fed from bunker to boiler by an automatic stoker. The softened, de-aerated, preheated water, preheated air for combustion and steam pressure all are fed and maintained at the proper levels by automatic controls. Even the ashes are removed automatically. The grate travels like an endless belt, depositing the ashes as it makes its turn.

Incidentally, one glance at the steam-pressure indicator would have sent Casey and his fireman jumping from the cab for their lives. The needle holds at 600 pounds per square inch, twice that of a conventional steam locomotive.

Locomotive 2300, the official designation given the engine by the N&W, is many things to many people.

To the mountaineer watching from his lonely shack, or the town dweller along the right of way, it is a long (the engine itself is nearly 112 feet), angular "shoebbox" on wheels that can haul a mile-long string of coal cars past his place at 60 miles per hour. Such smoke as there is comes from a stack that is little more than a hole in the roof, and there is no puffing. The sound that comes from No. 2300 could best be described as a dull roar.

Coal men look on it hopefully as a

development that may restore to them a once-great market that has been shrinking steadily since the advent of the diesel.

The N&W people see it as the answer—maybe—to the diesel power they have so far scorned. The N&W, alone among major railroads, has stuck to the steam engine for both freight and passenger use.

A quick glance at the railroad's operations shows the reasoning behind the N&W's position. Economically, Norfolk and Western makes a major portion of its living hauling coal out of the rich southern Appalachian field, and is not disposed to slap its best customer by using diesel power.

Moreover, it's good coal. And, by virtue of its availability, it's the cheapest fuel the railroad could burn.

Technically, N&W motive-power men believe they have developed the steam locomotive to the highest possible degree of efficiency. The railroad builds many of its own in the huge shops near Roanoke, Va., to fit the road's requirements. It has developed servicing facilities designed to get the best out of the huge locomotives. And aside from the lower initial cost of the steam engine as compared with the diesel, there remains the fact that, as one N&W motive-power man put it, "a steam engine is just getting broken in good when it's 30 years old."

So efficient are the N&W's giant "A" class (12 drivers) and "Y-6" class (16 drivers) locomotives that the road long ago tore down 208 miles of overhead wire and scrapped an entire fleet of electric locomotives once used to haul the long coal trains over some of the toughest trackage in the nation.

Nevertheless, N&W engineers recognize along with railroad men everywhere that electric drive is the best way to deliver power to the wheels of a locomotive. Electric drive means smoother operation and higher tractive effort. There are no reciprocating parts to eat up the power. It is easy

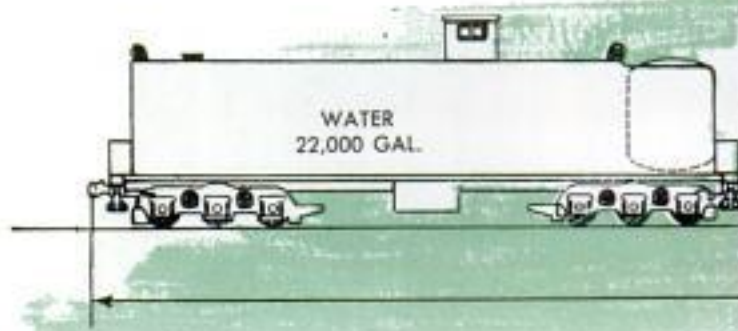

N&W's 600 series are big passenger haulers, but one is small when alongside No. 2300. Despite lack of rods, stack and cylinders, the giant is a steam locomotive



on the rails. Its light, standardized running gear means easier work for shop crews.

The most direct answer to this, of course, was the old electric locomotive. But the cost of stringing overhead wire or laying third rails over miles of track was prohibitive in most instances.

Then came the diesel-electric. To many railroads, this self-propelled power plant with its relatively high efficiency and low-cost operation was the answer to the rising coal cost and increasing obsolescence of the old steam locomotive.

But not to the N&W. It stuck to coal and made the best of it.

Electric drive was still in the back of the minds of the N&W

(Continued to page 256)

Steam-turbine pressure, generator output and power delivered to each of 12 axle motors, are all controlled by one throttle lever

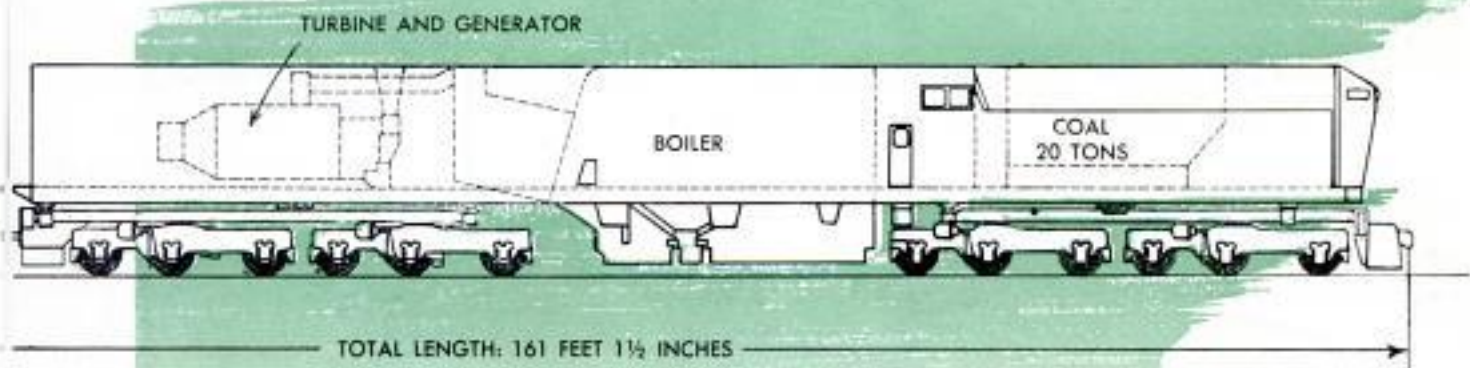
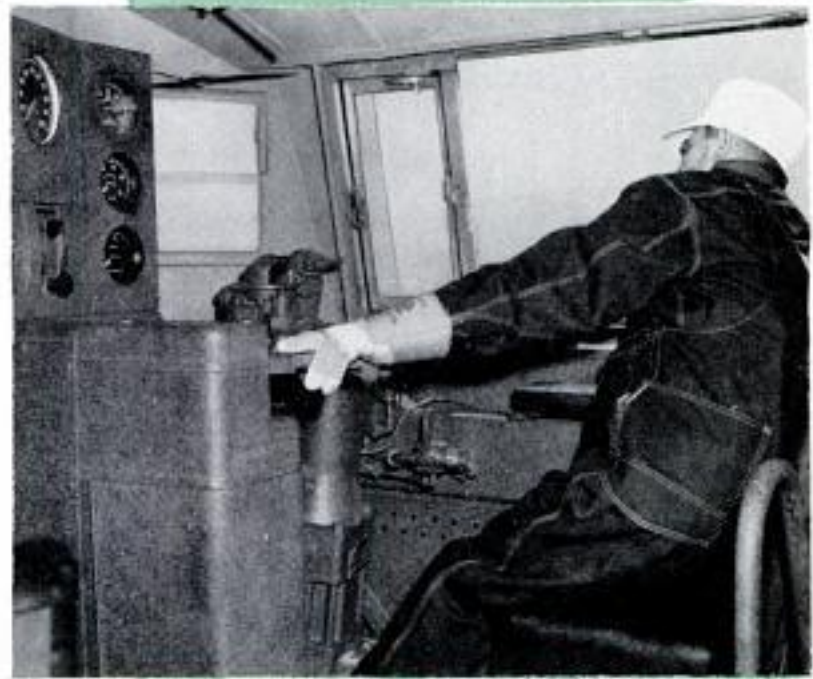

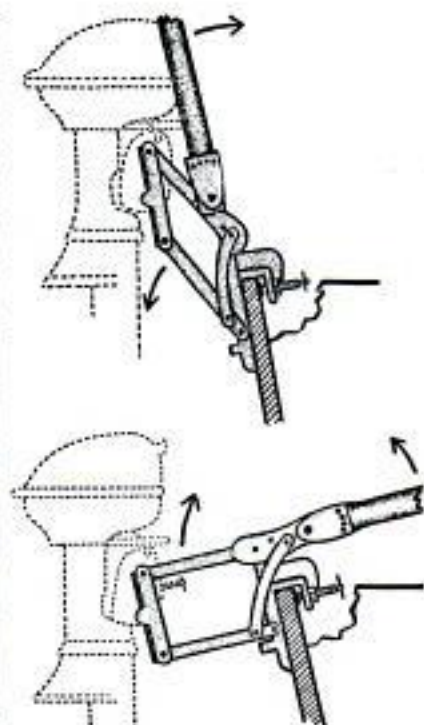

Handle on New Mount Lifts or Lowers Outboard Motor

You can raise or lower an outboard motor merely by moving a handle if the motor is clamped to a new mount. Raising the long handle lifts the motor in relation to the boat. Most outboards require 18 inches or more of water, but the new mount makes

it possible to use the motor in water only six inches deep. The mount is especially effective in turbulent water filled with rocks and shallows, as it gives the operator instant control over the depth of the propeller.

Wind Gauge for Home Use

Operating on the same principle as an aircraft air-speed indicator, a simple wind gauge has been developed by a Chicago manufacturer. Pressure derived from the wind entering a calibrated opening mounted on a weather vane is transmitted by flexible tubing to the indicator tube, which can be mounted any place inside a building. The indicator is calibrated in both miles per hour and the Beaufort scale, whose top reading is 12.

Bricklaying Made Easy

Designed to aid the novice bricklayer, a sheet-steel spacer automatically corrects mortar thickness and spacing. The spacer is placed under and at the end of each brick laid in a course, assuring uniformity for the amateur bricklayer. The spacer also serves as a wall tie.





Install-It-Yourself Door Jackknives Above Car Inside Garage

Easily installed by the homeowner, a new aluminum garage door jackknives inside the building. As a result of its folding action, the door requires only six inches of overhead space and only six inches of clearance from the door to the car's rear bumper. The door is lifted by a torsion

spring and a spiral cable drum. The operator just unlatches the door and gives it a gentle push and the mechanism lifts it to the overhead position. The door is made in leather-grain embossed aluminum. It comes in the standard dimensions of seven feet high and eight feet wide.

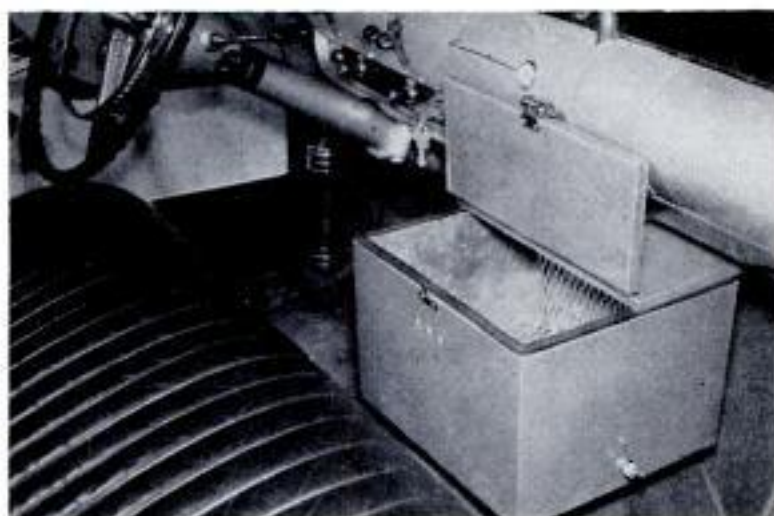

Automobile Refrigerator Hooks to Air Conditioner

You can munch popsicles while driving through the desert if your car is equipped with a new auto refrigerator. The unit connects to any refrigerated, automobile air-conditioning system and can be installed in an hour. It mounts on the floor in front of the instrument panel, behind the front seat or in the trunk compartment. Its capacity is 960 cubic inches which is large enough for 18 bottled drinks or two dozen 12-ounce cans.

Coin-Operated Recorder Allows Dictation on Trip

Businessmen on trips can dictate letters to a new coin-operated recorder and mail one transcript home. A quarter buys a 15-minute recording belt and a stamped mailing envelope. Another quarter activates the recording machine for 10 minutes. The unit is housed in a soundproof booth and provided with a comfortable chair. It is being installed in hotels, airports and railroad stations throughout the country.

☛ There are 80,000 species of snails in the world, according to the Smithsonian Institution.





UNNOTICED AMONG the 1,000,000 Frenchmen who crowd into the Paris Auto Show each year are the world's most influential stylemakers: The men who style America's cars.

These stylists make an annual pilgrimage across the Atlantic to see what Europe has that is fresh, that might perhaps be adapted to American designs. Rarely do they find something they can pick up intact. More often, there is a suggestion, a hint, that can be reworked to fit American tastes.

Cars from all over the world are shown at Paris, but those that the American stylists linger around longest and sketch most carefully are invariably Italian. In Italy, automobile styling has become a fine art.

Representing the Packard Motor Car Company at Paris this winter were Edward Macauley, director of styling, and Richard Teague, chief stylist (shown at left).

Popular Mechanics asked Mr. Teague to sketch the show's high lights for its readers. Quotations are also by Mr. Teague. ★ ★ ★

An American Stylist at the Paris Auto Show

" . . . Most original was the Farina coupe on a 4½-litre Ferrari chassis . . . It has double rear-roof fins with a window overhang similar to that on our Balboa show car . . . and a long, low drop-off hood ending in a Venturi opening containing an egg-crate grille . . . Headlights are retractable. Two driving lights are set in the grille."

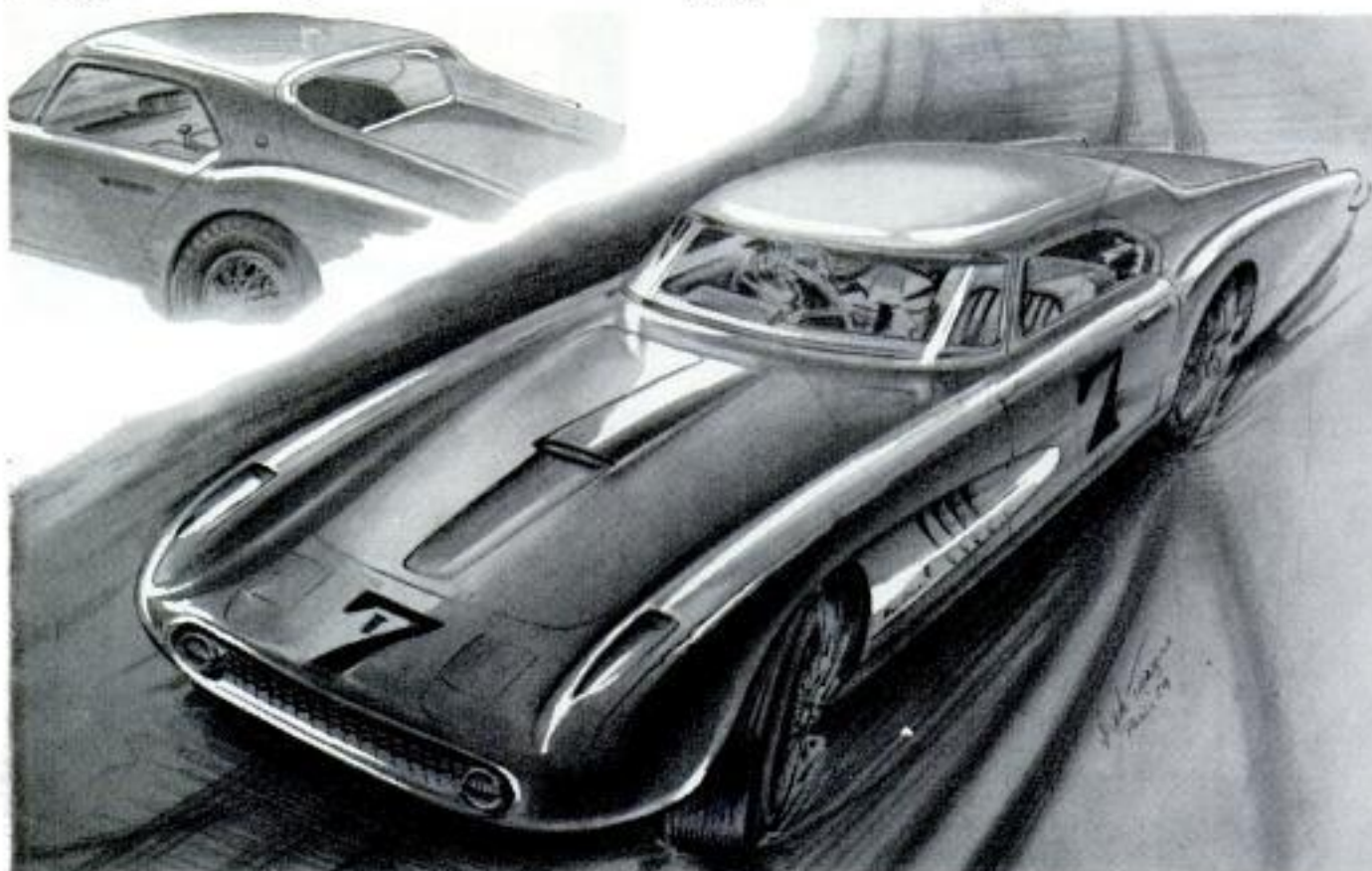

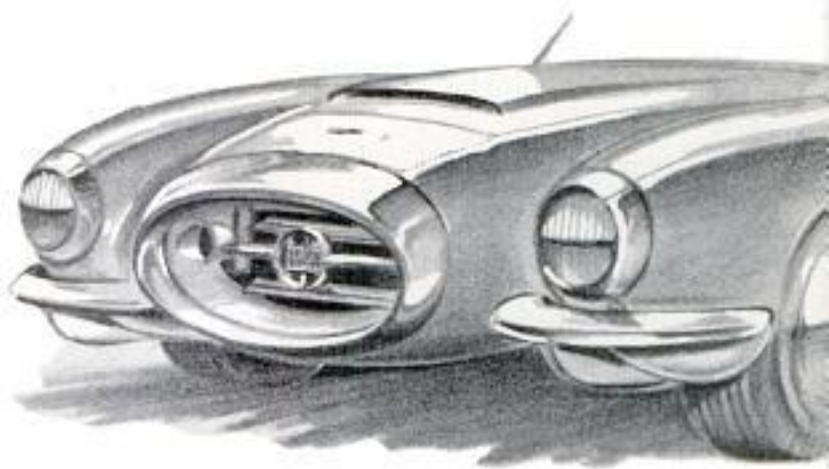
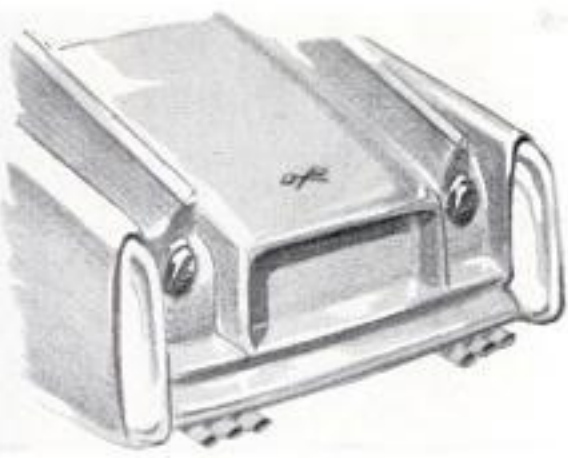

" . . . Second most interesting was also a Farina . . . this one on a V6 Lancia chassis. It has similar roof fins in the rear—watch for these on some of Detroit's cars of tomorrow. Front end is a large oval with horizontal louvers. I didn't think the styling work-out was as well done in the rear (left) as in the front. The recessed front grille is another styling trick that Detroit stylists may be using very shortly."

" . . . This year the foreign trend is toward the Venturi front grille . . . an excellent example is the Simca, right. It has its grille mesh recessed inside a single heavy blade. Headlights are set into the outer ends of the long oval."

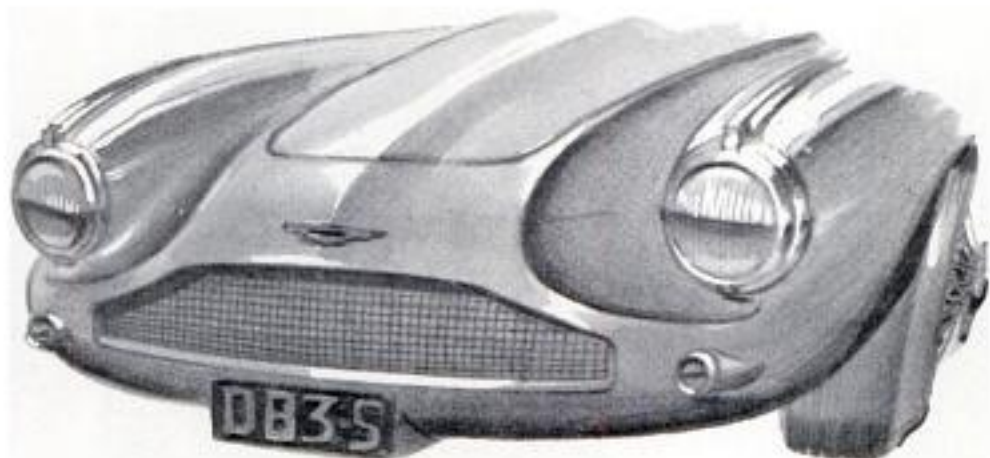

" . . . On the way home from Paris I stopped in London at the Earls Court show. British are best in competition styling. Passenger-car styling is behind the trend. An excellent example of competition styling is the Aston Martin (left). It has a hood design using scallops like on our '51 Packard."

" . . . Ghia's body on an Alfa Romeo chassis is original in its front-end styling. Bumpers wrap around the base of the headlights, which are actually suspended in large fender openings, supported by three spokes. Air is taken in around the headlights, ducted down to cool the brakes."

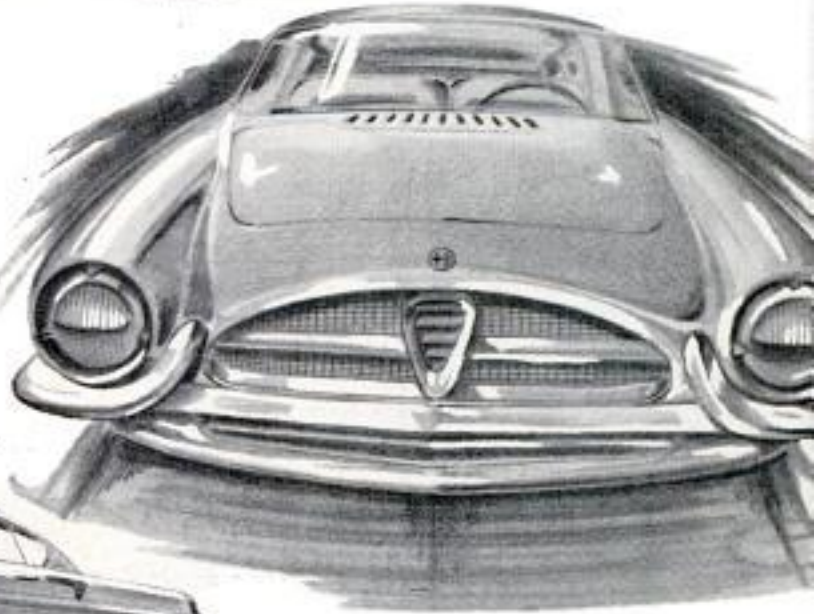



Railroad Tosses "Passengers" Over Cliff at Supersonic Speed

SURPASSING the fevered imaginations of children's TV scripters or comic-book artists is a new 12,000-foot railroad under construction near Utah's Zion National Park. Cars on this railroad toss "passengers" off the top of a 1500-foot cliff at supersonic speeds. Parachutes and other deceleration devices then are supposed to float them gently to the floor of the desert a mile or so away.

Fortunately the passengers will be mechanical dummies studded with recording instruments. They are the Air Force's robots testing bail-outs from supersonic

planes—bail-outs that might kill human pilots.

The trains on the railroad consist of two cars, a rocket pusher and a test sled. The latter carries the dummy or test ejection seat or capsule. The former provides the power and is halted by a water brake before it also plunges over the edge of the cliff. The facility is being built because the Air Force found that full-scale testing of ejection methods from high-speed aircraft was too expensive, and that tests from missiles were impractical. Scheduled completion date of the center is 1956.

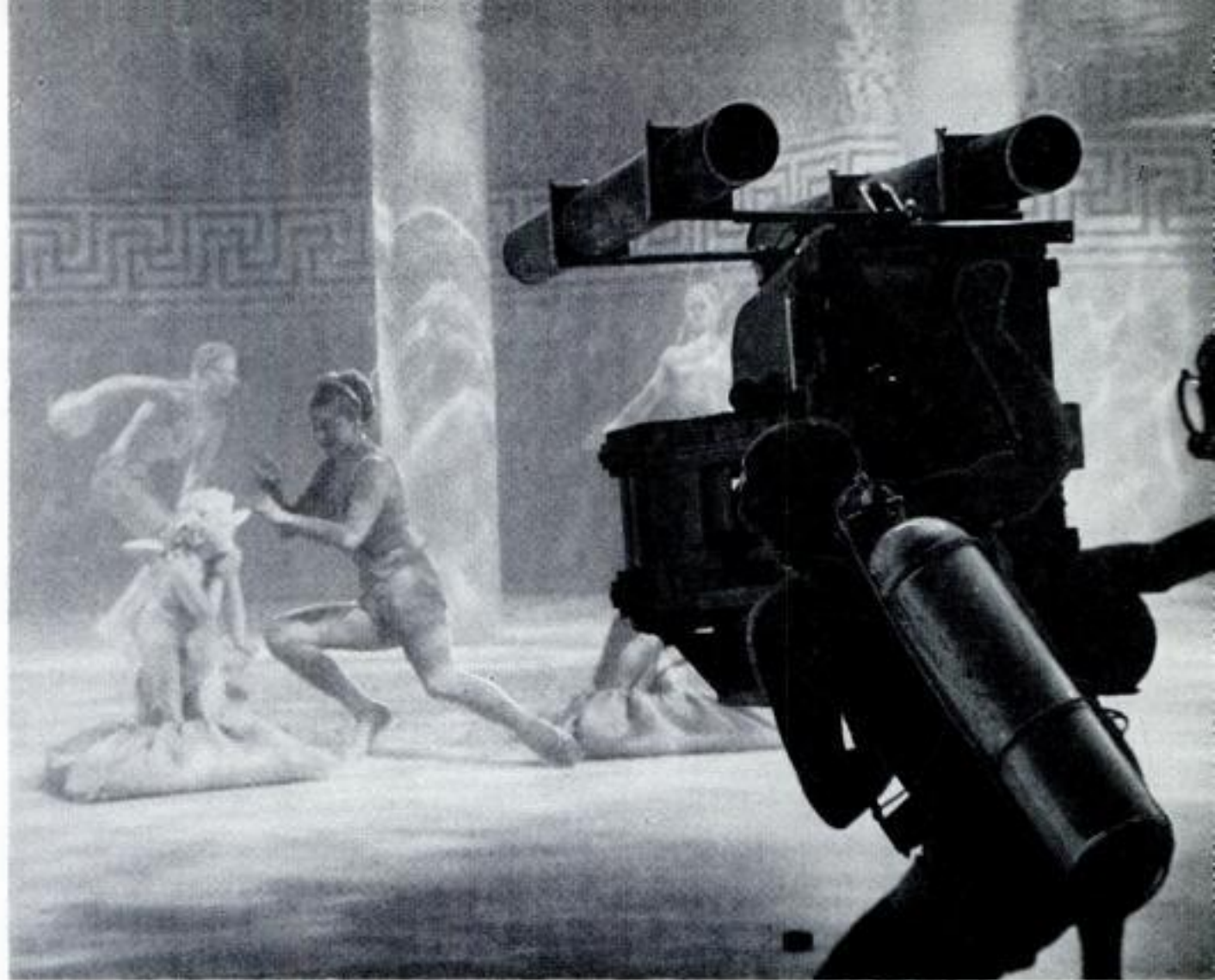

Special free-floating underwater movie camera manned by aqua-lung crew follows action of Esther Williams

Even the Stagehands Have to Swim

THE BEST WAY to make a good underwater movie is to take the entire motion-picture company below the surface. That's what director George Sidney did when he filmed the underwater scenes for Esther Williams' forthcoming Metro-Goldwyn-Mayer picture, *Jupiter's Darling*.

The entire company, sometimes as many as 25 persons, went underwater and stayed there. Camera crews, property men and electricians for handling the lights wore aqua lungs that allowed them to stay down for two hours at a time. Part of the time Sidney directed the picture from the bottom, sometimes he observed the action from a glass-walled chamber built into the hull of a boat on the surface.

Even the actors, who wore no breathing apparatus, stayed under water

for half an hour or so. Between camera "takes" they gulped air from compressed-air hoses that were held by safety men who were out of camera range.

About the only members of the company who stayed on the surface were a pair of property men in a rowboat who looked

Stage crew on headquarters boat at Silver Springs, Fla., awaits orders
Eben Henson photo



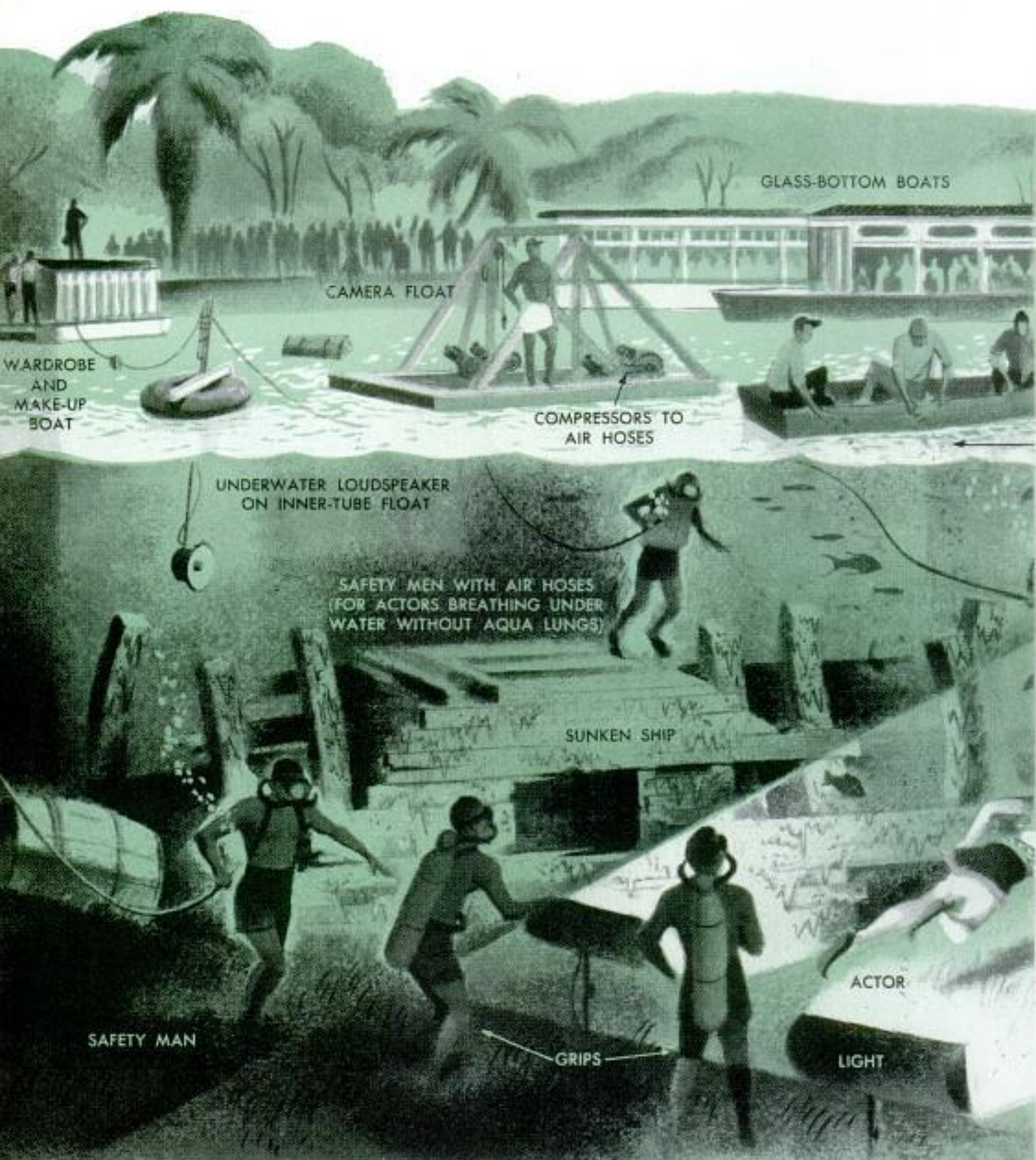

This is the scene above and below water during the filming of *Jupiter's Darling* at Silver Springs, Fla.

down on the action below them and released schools of fish into the scene when they saw Sidney wave his hand in their direction.

The picture tells the story of Hannibal's march on Rome and its underwater scenes are part of the story. The movie is said to include the longest underwater footage ever shot in color by a Hollywood studio. Some of the scenes were made in 20 to 50 feet of water at Silver Springs, Fla.,

and other sequences were made in a huge tank on the MGM lot in California.

Part of the action at Silver Springs called for an underwater chase in which actors dressed as gladiators swim in pursuit of Esther Williams. The chase occurs in and around the sunken wreck of an ancient Roman galley.

This set was built at the studio and is a replica of a galley's ribs and broken planking and is complete to such details as moss,

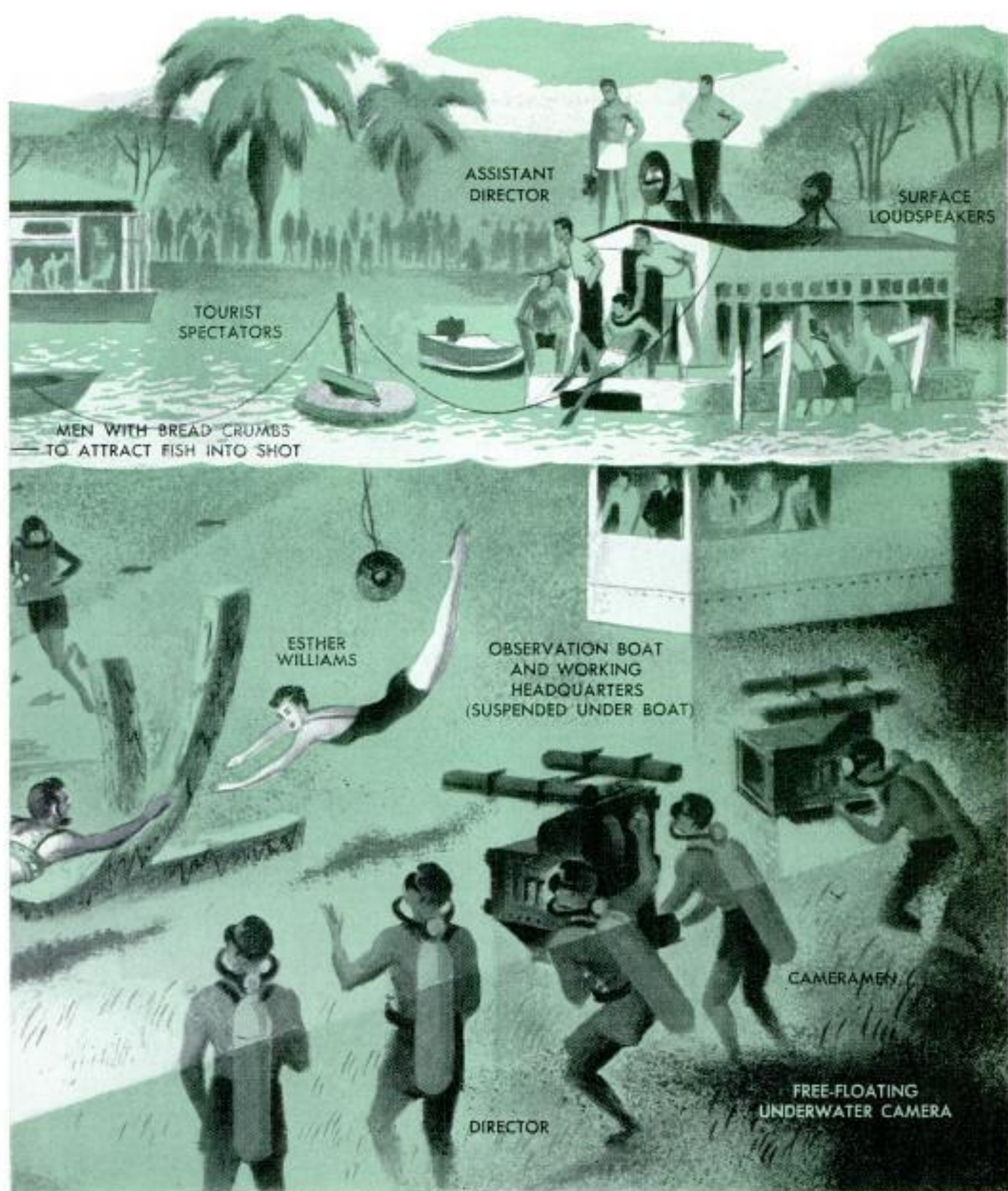

Assistants watch filming of scene from glass-walled observation booth suspended under headquarters boat

seaweed and barnacles, the last of which were made of rubber so that actors who brushed against them wouldn't be cut. Visible inside the wrecked part of the galley were urns and chests typical of the period. The set was taken apart after construction and shipped to Silver Springs, then re-assembled and sunk below the surface.

The big technical achievement that made it practical to film long scenes under water was the invention of a neutral-buoyancy

camera that neither sinks to the bottom, nor floats to the surface. It stays just where the cameraman puts it, at any depth down to 90 feet. The camera and its waterproof blimp and attachments weigh 510 pounds on dry land, yet below the surface it is literally weightless. In spite of its great bulk an underwater cameraman can point or pan with it as easily as you operate a small, lightweight, amateur-movie camera.

Pushing the unit in front of him, a

cameraman would swim down to the desired location, turn the camera in the right direction, tip it to the correct angle and then take his hands away. Unless there are currents in the water the camera remains motionless until it is purposely moved again.

The neutral-buoyancy housing, or blimp, was perfected by John Arnold, head of the MGM camera department. The camera was to be entirely self-contained with its own power so that there would be no trailing wires or connections to the surface. It was to be held by hand instead of operated from a tripod. It was to carry 1000 feet of film so that as much as an entire day's shooting could be recorded.

Arnold designed and built two outfits, one containing a standard motion-picture camera fitted with a CinemaScope lens, the other having a different kind of wide-screen lens. The waterproof blimp enclosing each camera is made of aluminum sections bolted together and having rubber gaskets in

(Continued to page 264)



Inventor Arnold and director Sidney inspect underwater camera. The parts labeled are: 1. Stabilizer tubes; 2. Film magazine; 3. Focusing knobs; 4. Different lenses; 5. Wide-screen lens; 6. View-finder lens; 7. Camera's own aqua lung; 8. Compressed-air tank; 9. Self-contained batteries; 10. Front cover of waterproof blimp; 11. Tripod used only when on dry land.

Eben Henson photo

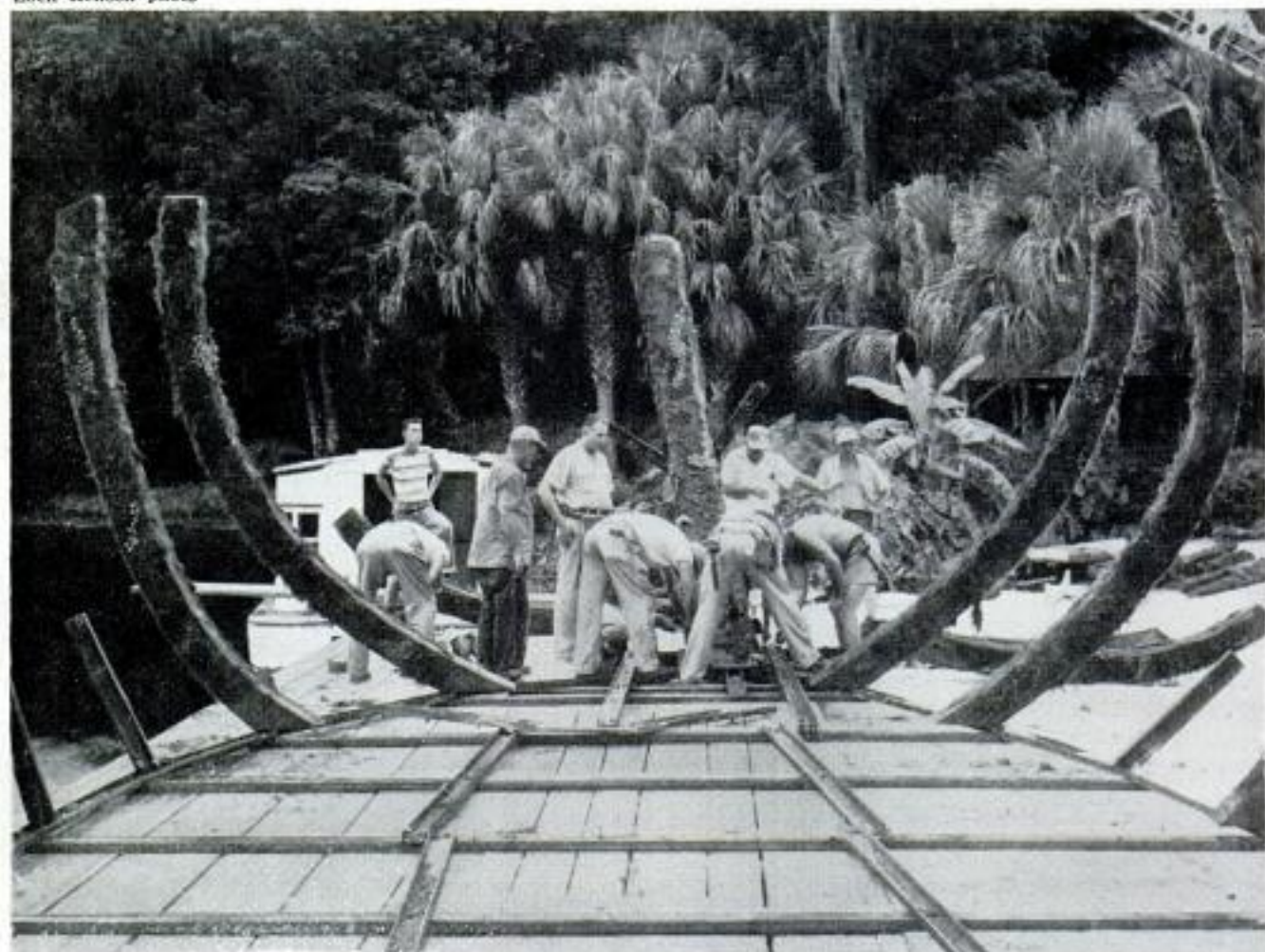

READ ABOUT
THE '55 CARS

BOOKS

Cadillac

CHEVROLET

Chrysler

DeSoto

DODGE

FORD

HUDSON

Imperial

KAISER

Lincoln

Mercury

Nash

OLDSMOBILE

Packard

Plymouth

Pontiac

Studebaker

Willys

IN

February

**YOU'LL SEE OUR
BIG 1955 ANNUAL
SECTION ON**

AUTOMOBILES

including

- 48 pages all about automobiles
- All the '55 models on parade
- 8 color pages—A new car from stylist to assembly line
- What does it cost to drive a car?—A survey of owners
- Floyd Clymer recalls the "flops" of yesteryear
- Are European engineers better than ours?
- Specifications of all the '55 cars
- How to break in a new automobile
- Automatic transmissions made understandable

On the newsstands January 27th

JANUARY 1955

97

Copyrighted material



House Trailer Mounted on Pontoons Becomes Comfortable Barge

SOMETHING NEW in a boat with all the comforts of home is *Dumbo*, an ordinary house trailer mounted on pontoons. The craft is designed to meet the needs of confirmed landlubbers who want a comfortable home for fishing or just nosing around the inland waters. The barge measures 40 by 15 feet, and is mounted on 47 pontoons.

Secured to the deck is a standard house trailer minus its undercarriage. The craft is complete with a pressure water system, a generating plant (along with plugs for shore tie-in to 110-volt current), four bunks and a butane stove and refrigerator. Two 12-horsepower outboard motors push the barge along at about five knots.

Wheel is mounted on platform above the trailer to give pilot a good view. Beneath deck are 47 pontoons

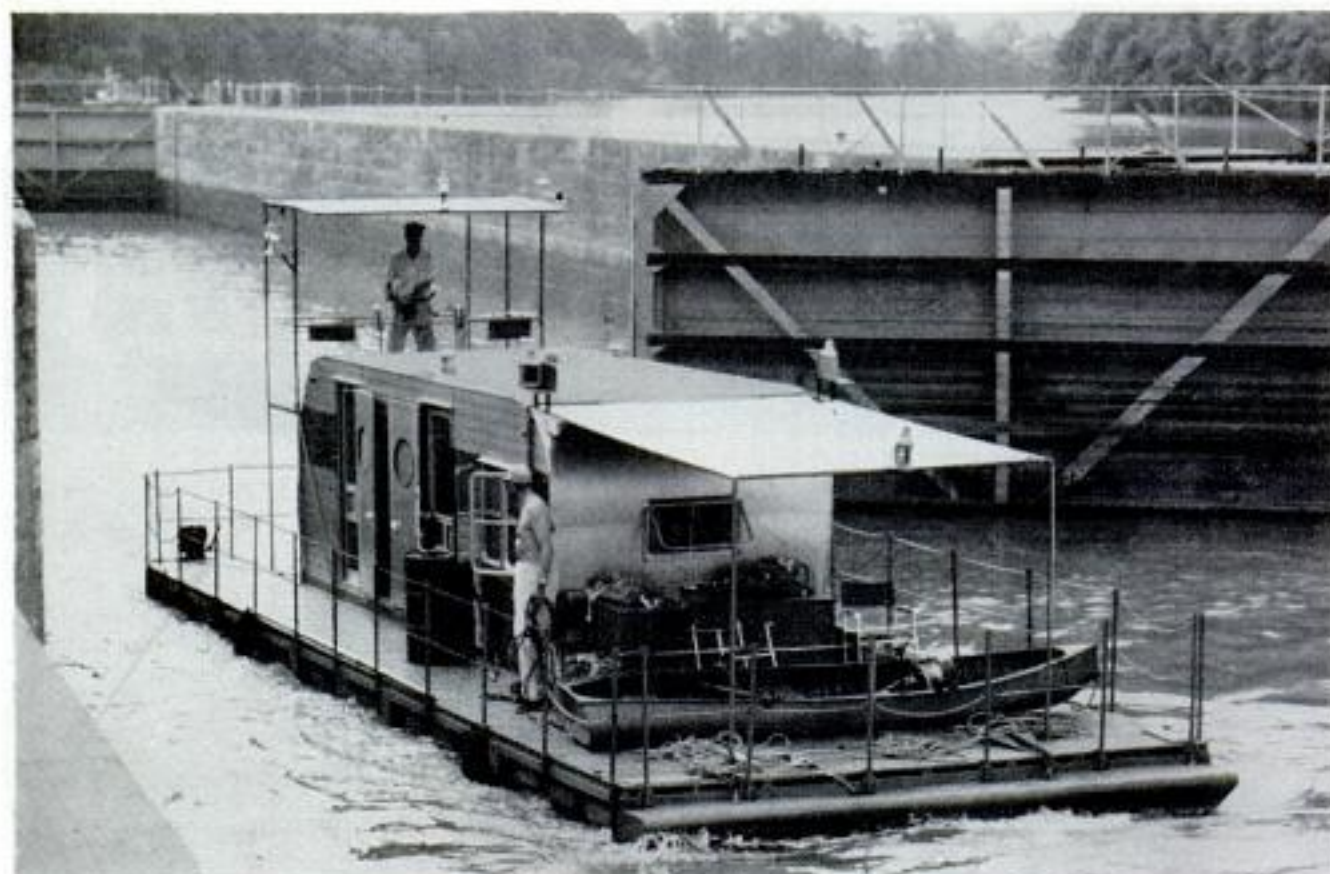

Steel pipes form the columns, asbestos-cement panels form the walls of a new California house built for our Western Editor, Thomas E. Stimson, Jr., who is holding "open house" until March 1 at 1436 Allenford Ave., Los Angeles

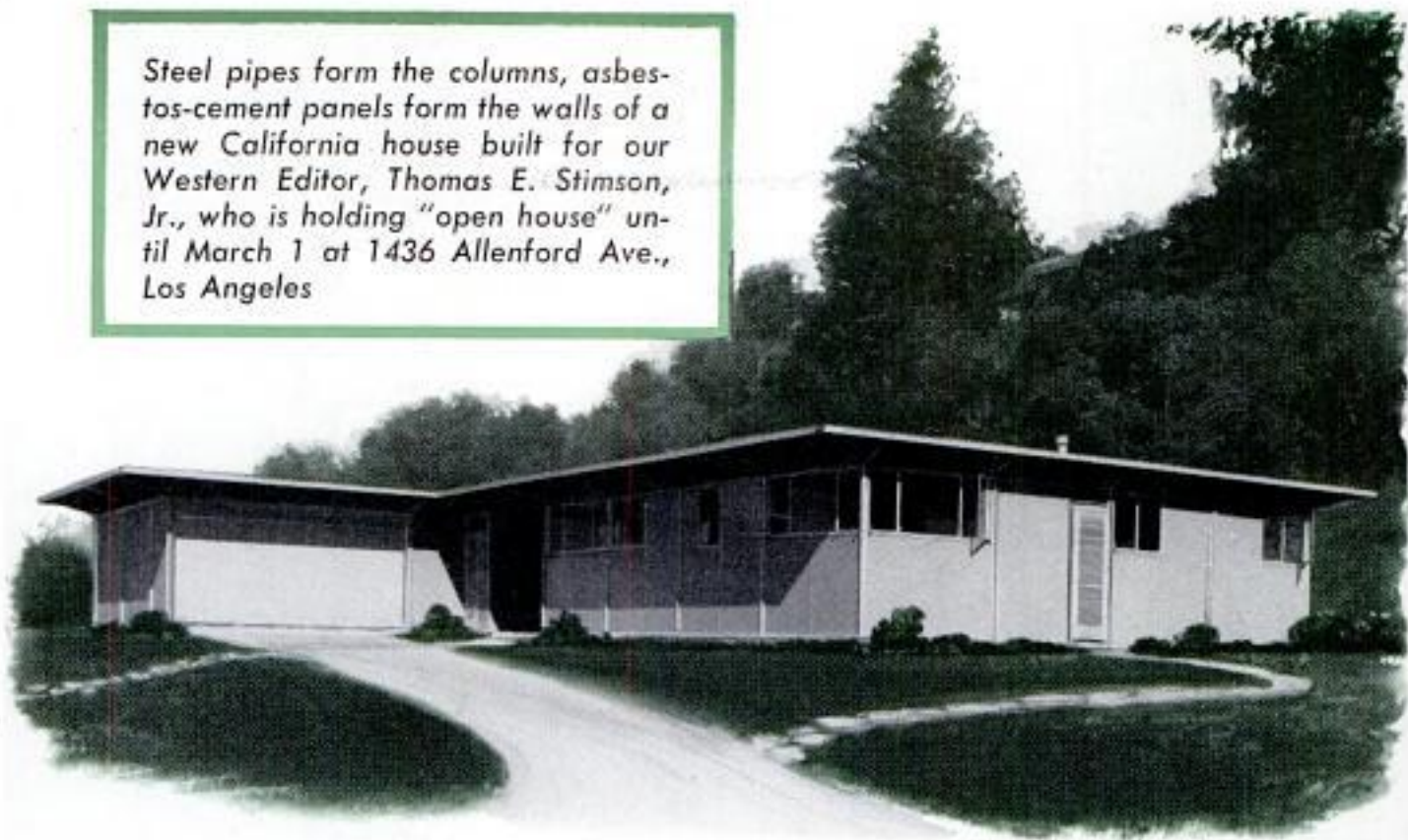

I Chose a Steel-Frame House

By Thomas E. Stimson, Jr.

I'M JUST COMPLETING a new house that is a mechanical masterpiece. It was designed for comfort and easy maintenance and was built through a new construction system. It contains striking innovations for efficient living.

The house has a steel frame like an office building. To a large extent it was put together with a welding torch instead of hammer and nails. It has built-in sound insulation and is considered proof against fire, earthquake, windstorm, insects and extremes in temperature. Yet it cost no more than standard high-quality construction. It should last for a couple of centuries.

About the only addition it may require in the next 50 years or so would be a solar battery to provide all light, heat and power. When perfected, this battery could be placed on the roof adjacent to the space reserved for the future heliport.

I can open or close the aluminum garage door from my car from as far as 100 feet away, using a new magnetic-impulse transmitter that is keyed to my garage door alone. From a master panel in the bedroom I can control prowler lights outside the house as well as the principal lights inside. One button on the panel turns on the coffeemaker in the kitchen. Also, from the



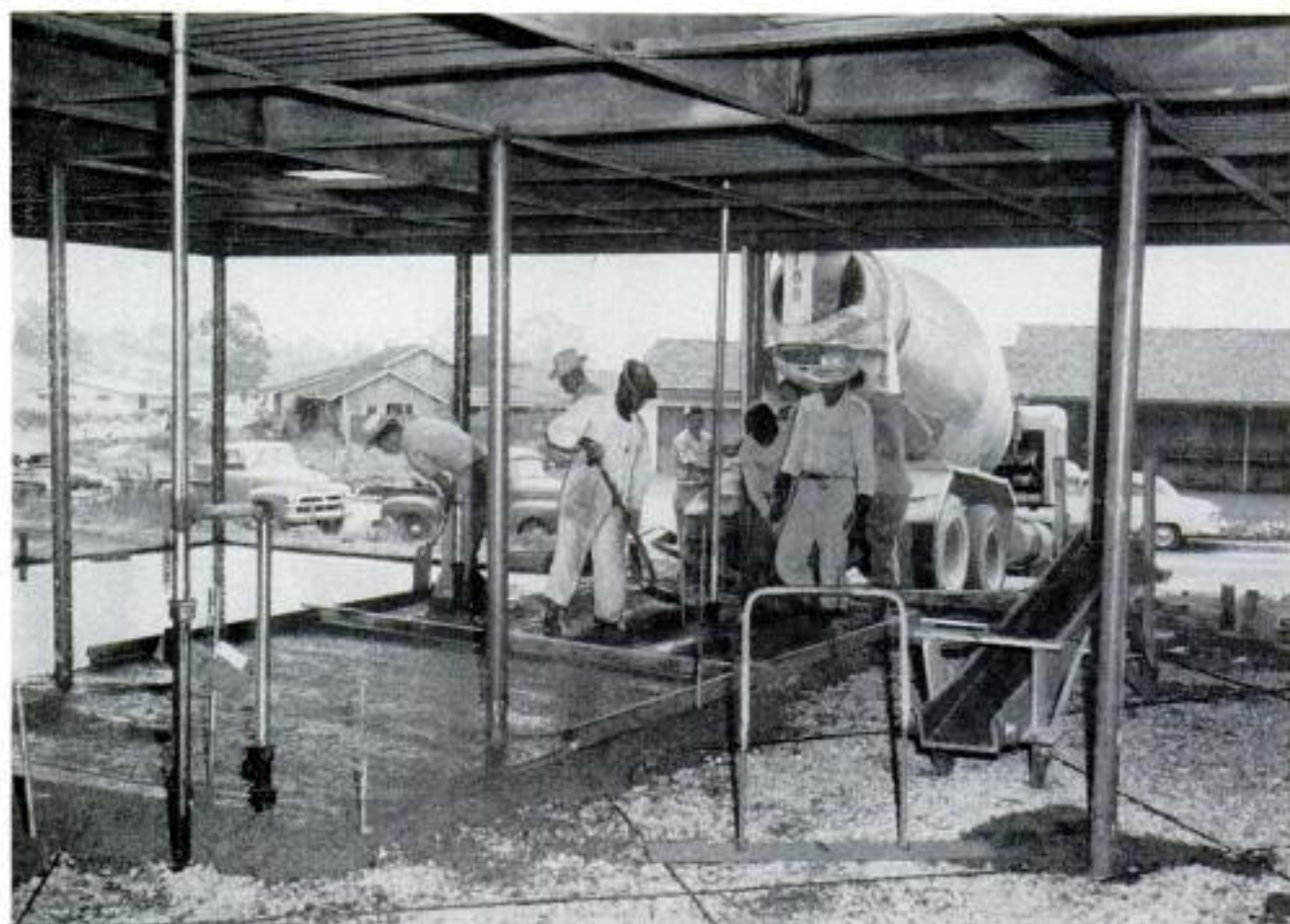

Footings and floors are poured in one operation. Reinforcing rods buried in slab tie columns together

bedroom, I can talk over a built-in intercom system to the kitchen or to visitors at the front door.

Although the exterior of the house is plain in appearance, the inside is a dream. The house has three bedrooms, a study,

two bathrooms, a living room and entry, dining room, kitchen, a breakfast nook and laundry area. There's a lanai or semi-enclosed porch off the living room, along with some sliding glass doors. The two-car garage is in the front of the house where it

Bedroom area is separated from rest of house by entry. Garage, kitchen and laundry are at front of the house

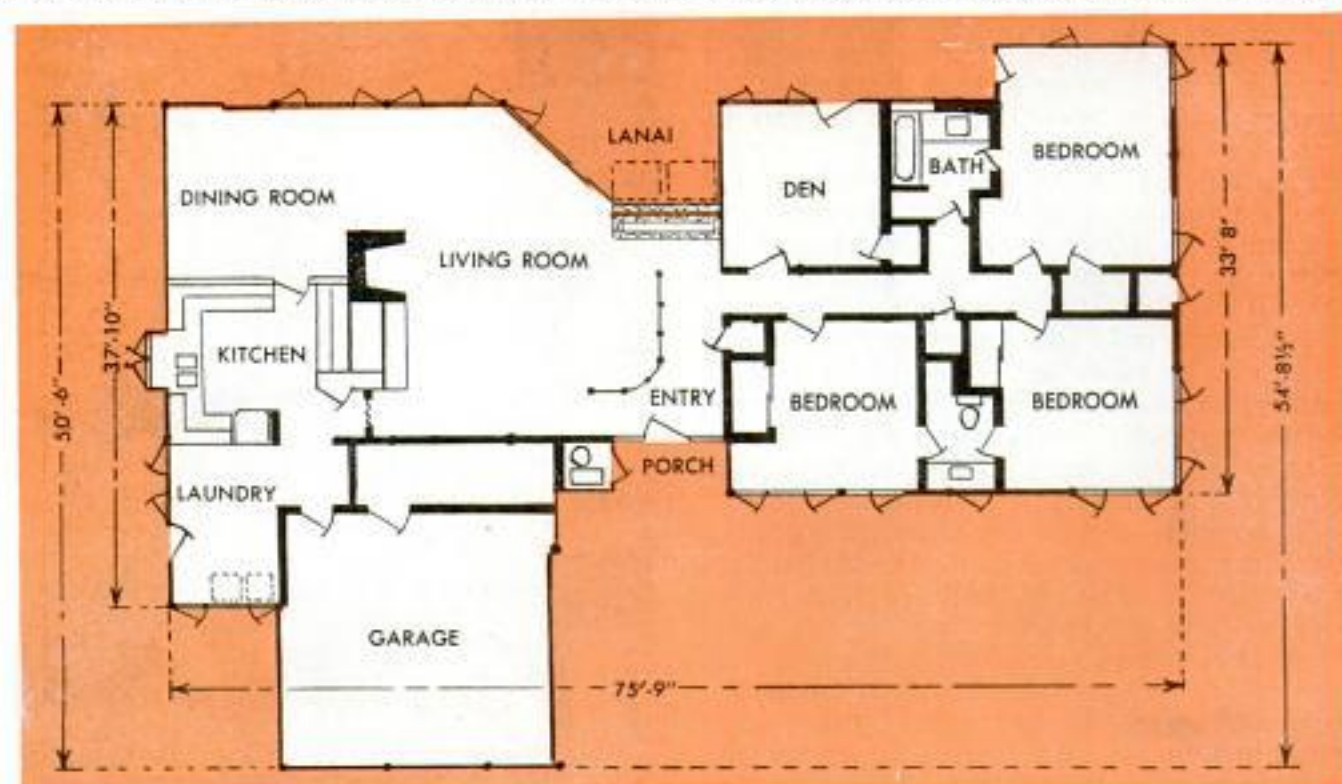

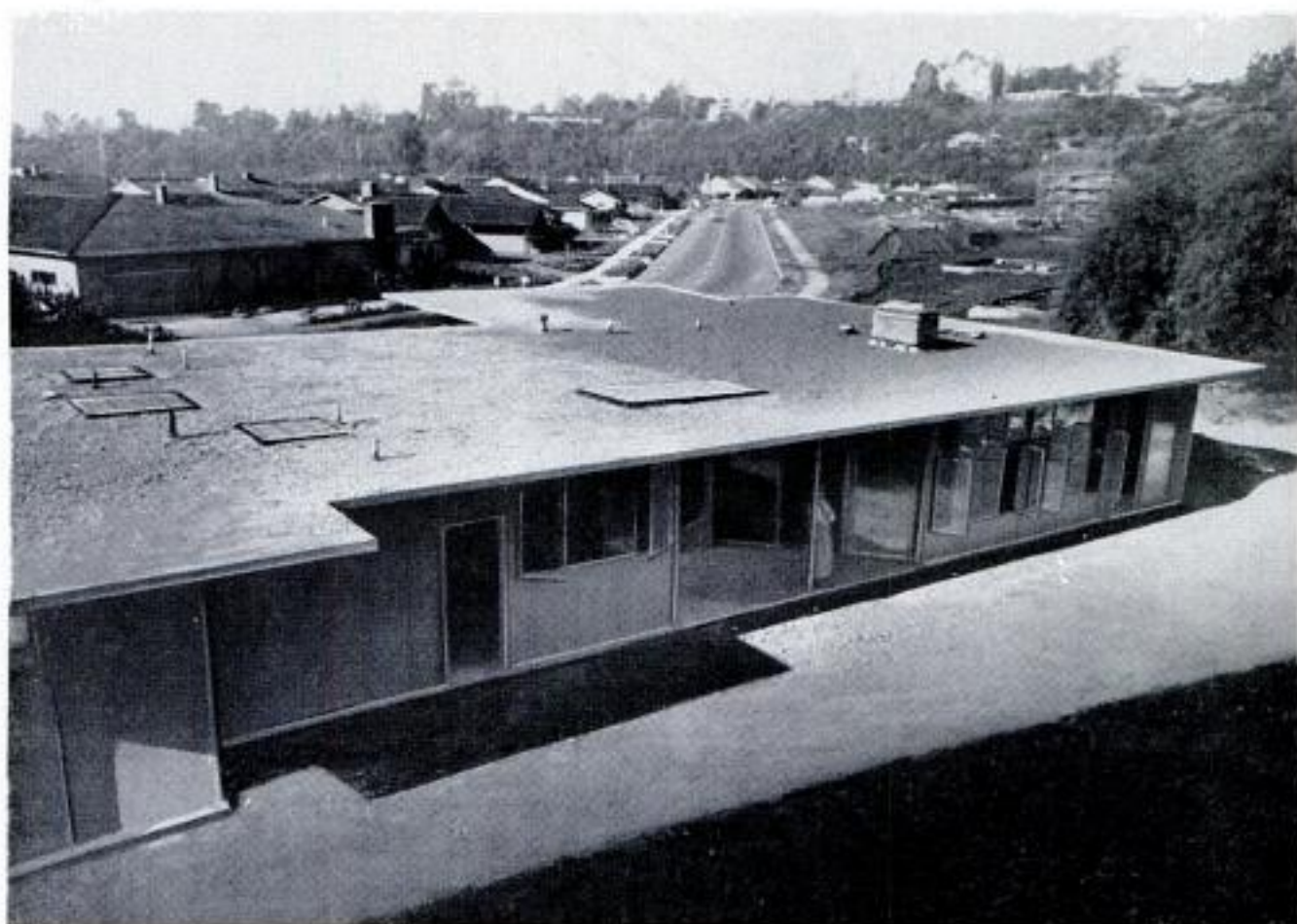

Flat roof lowers construction costs. Nonglare skylights are placed strategically to illuminate rooms below

belongs, avoiding a long driveway to the rear on which unseen children might be playing. You can step directly from the garage to the kitchen with your bundles, a convenience housewives appreciate.

The steel-frame construction system that I used is the invention of Eugene Memmler of Glendale, Calif. Several years ago Memmler asked himself: "With all the new building materials and construction methods, why do people keep on building frame houses that constructionwise are about the same as they were a century ago?"

He evolved a new technique using steel, concrete, asbestos-cement panels and wood, and employed each material where it contributed most efficiently to the structure. Then he built a residence for himself as a test structure. He figured that the materials would cost a lot more than a conventional wood frame but that erection costs would be less, so he would come out even.

His system works so well that I used it, with his help and that of MackIntosh and MackIntosh, engineers, and architect Adrian Wilson, A.I.A. My contractors were Luther, Dahlin and Rogers.

In addition, a number of national companies lent some of their best engineering talent to help me put the house together. If you happen to be in Los Angeles you are invited for a visit any time up to March 1.

Columns are bolted to concrete piers. Later, footings will be poured around columns up to metal bar





Wall panels only 1½ inches thick have insulating value of 25 inches of masonry. Below, ceiling panels rest on metal straps



The address is 1436 Allenford Avenue.

The frame is made of 3½-inch vertical pipe columns spaced eight feet apart. Across the tops are welded 12-inch junior I-beams that support the flat steel-roof deck. The bases of the vertical columns are anchored in concrete and, in addition, are joined together by tightly stretched reinforcing rods. After the concrete floor slab was poured, these embedded rods provided a kind of prestressing to the floor that made other reinforcing unnecessary.

The roof consists of a half inch of insulation on top of the steel deck, with three plies of roofing paper mopped with hot asphalt and finished with a layer of light-weight crushed volcanic rock. The flat roof has several advantages. It is architecturally modern, costs less than a pitched roof and allowed me to install a new kind of nonglare skylighting that helps illuminate some of the rooms below.

The steel frame supports the entire weight of the roof, so all the walls are non-load-bearing. Exterior walls are only 1½ inches thick yet have the same insulating value as 25 inches of solid masonry. They consist of fabricated panels faced on each side with a layer of asbestos and cement. After the steel frame was erected, these panels were shoved into place and bolted to the frame, their edges sealed with calking compound.

Inside the house I used conventional wood-stud and plaster partitions because this type of wall is the most practical for concealing the necessary water pipes, plumbing stacks and wiring. After these partitions were set in place they were anchored permanently to the floor and the overhead beams by means of steel fasteners shot from a gun.

Where electric switches and outlets were required on the outside wall of a room, they were built into the sheet-metal covers that conceal the interior exposures of the steel columns of the house frame. The electric outlets, incidentally, have spaces for three plugs instead of the usual two. In some rooms I connected one set of contacts in an outlet to a handy wall switch at the

(Continued to page 260)



Converted Model A with vertical exhaust and oversize tires tows sledder. Handrails at right protect rumble-seat riders

Beach Buggies Tow Sand Sleds

FOLLOWERS of a new sport around Southampton, L. I., area, hitch homemade sleds to hopped-up, stripped-down Model As and ride the sand instead of the waves. A short rope gripped with both hands maintains the rider's balance as the towing car picks up speed, and a well in the rear of the sled furnishes a secure foothold as the device whips along the beach. A steel plate on the bottom protects the sled from the sharp sand.

Sand-sledding really got started when a group of enthusiasts formed the Southampton Beach Buggy Association, bought six Model A Fords and stripped them down. Most of the cars weigh only about 900 pounds. Each car was hopped up and equipped with oversize tires to give traction in soft sand.

When all is ready, the sled is hitched to the back of the beach buggy and the car starts out slowly, gathering speed as it goes. The sledders scoot along at 25 to 35 miles per hour on the dry sand.

Towing cars pull sleds at speeds up to 35 miles per hour. Sledders' club has six stripped-down Model As



Sand-sled ride offers thrills of water sport. Well in rear of sled provides firm foothold on curves





Drill With Cylindrical Bit Cuts Concrete and Stone

Like a mole tunneling through dirt, a new machine cuts its way through concrete, reinforcing bars or stone. It is equipped with diamond-embedded bits which are cylindrical in shape and which cut out a solid core of the material. Depending upon the bit used, the resulting hole is $\frac{1}{4}$ inch to six inches in diameter. The drill will cut a six-inch-diameter hole through a foot of concrete in less than two minutes. An extension arm can be used if the hole is to be more than 18 inches deep. It is quiet, dustless and electrically powered. It's portable, lightweight and will drill vertically or horizontally.

Rain Detector Buzzes Alarm

You're warned of the first few splatters of rain by a moisture detector that sounds a buzzer. This allows time before the storm to close windows, bring in laundry from the line and call in pets and children. A moisture-sensitive grid, placed outdoors, is connected by a long cord to the buzzer unit that is plugged into a standard electrical outlet. The detector is like units which raise convertible tops when it rains.



Tractor-Driven Pile Driver Tamps Soil and Digs Wells

Tractor engines can be made to do the hard farm work of driving fence posts, tamping soil or breaking up stone or concrete with a driver and breaker attached to a Ford tractor. Designed for one-man operation, the unit is operated by a single lever. A 200-pound drive weight is actuated by the tractor's power take-off, and attachments adapt the implement to post-driving, tamping or well drilling.

Corner Tape for Dry Walls

Packaged in 100-foot rolls and as easy to handle as ordinary paper tape, a new steel corner tape for sealing dry-wall joints has been marketed. The tape consists of two thin strips of steel mounted on paper, and can be shaped easily into the joints between wall and ceiling. It is applied with wallboard-joint cement and smoothed over.

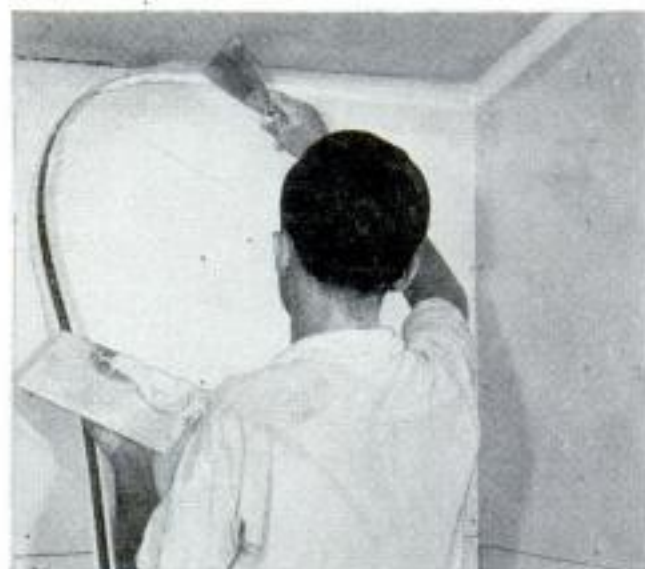

LISTEN - - -

It's the Wail of the Turboprops

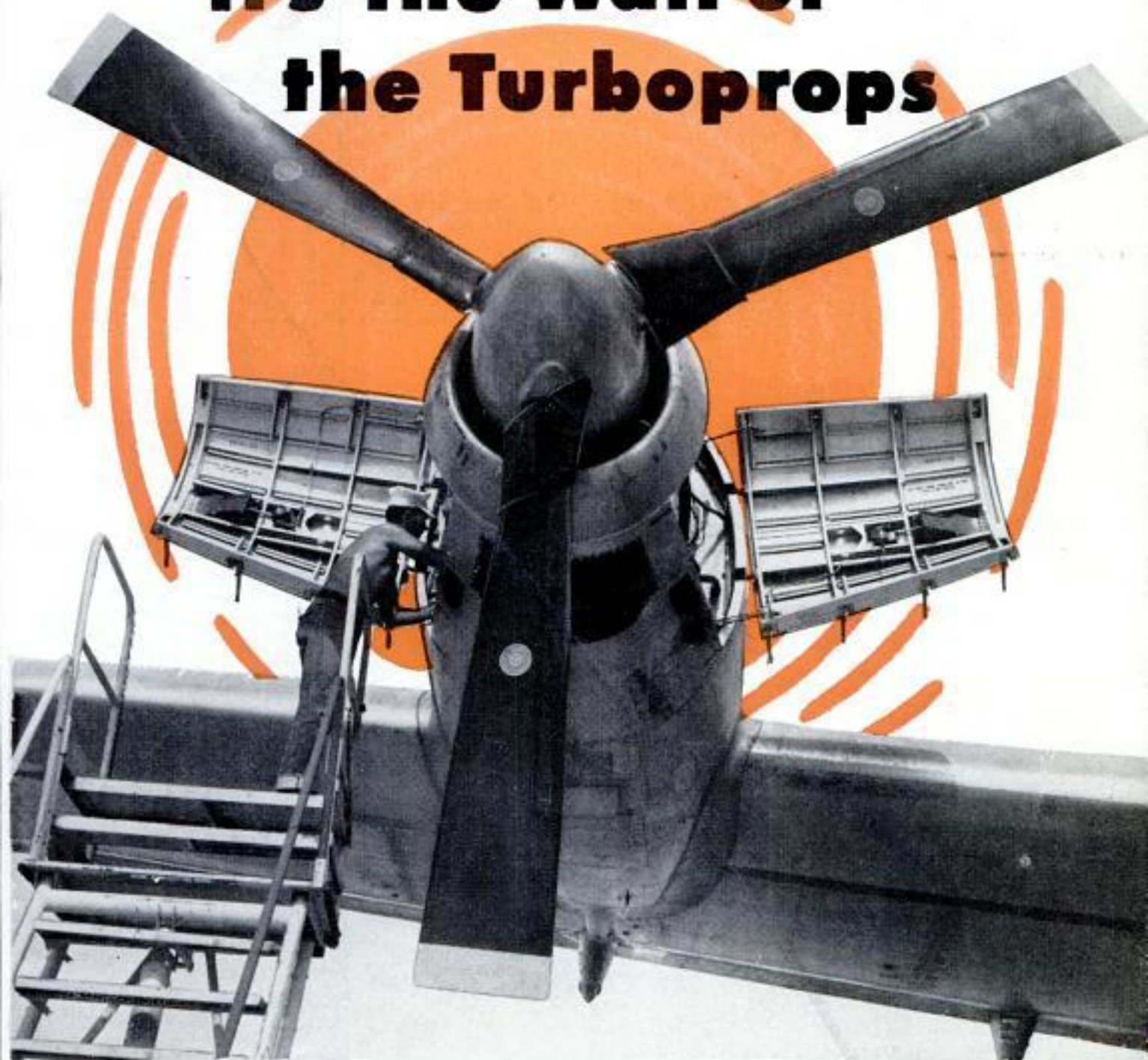

By Ewart Thomas

THERE'S A NEW SOUND in America's skies today, the eerie wail of the turboprops.

The distinctive sound comes from the whine of the propeller tips, the scream of the turbine and the roar of the jet exhaust. That's what you hear from the ground. Inside the plane there's often so little noise that one new turboprop transport has been dubbed the "hushliner."

There's a big surge to this kind of aerial

propulsion because the turboprop looks like the champion power plant for hauling heavy cargoes over long distances. It permits higher speeds than are practical with piston engines and is more economical than the jets.

Lockheed added 100 miles per hour to the speed of a Navy Super Constellation when it converted the plane to turboprop power, yet kept much of the economy that had been obtained with piston engines.



Capital Airlines' British Vickers Viscounts will be the first turboprop airliners operated in the U. S. (above)

An Allison turboprop drives the contrarotating propellers of Convair's experimental vertical-take-off fighter (left)



Cruise speed of Lockheed's Super Constellation increases 100 miles per hour with Pratt & Whitney turboprops (below)



Built for the Air Force, the Lockheed C-130 is the first U. S. transport plane specifically designed for turboprop power



Turboprops have greatly improved the performance of the giant Douglas C-124 Globemaster transport



The new turboprop "Super Connie" can fly 16-ton loads across the United States in less than six hours, a good two hours under present airline schedules.

Convair has converted some of its Model 340 piston airliners to turboprops for the Air Force; Douglas is testing a big C-124 military transport on turboprops instead of the original piston engines; Martin has some conversions under way, and Boeing has been modifying some of its Strato-freighters for turboprop power.

Recently Lockheed flew its new YC-130, the first cargo transport designed from the ground up for turboprop engines. The plane has a wingspan of 132 feet and a fat fuselage that sits close to the ground for truck-level loading through a huge door under the upswept tail. Douglas has under construction a similar and even larger transport that is designed to carry 25 tons of payload a distance of 3500 miles at better than 400 miles per hour. Both the Lockheed and Douglas turboprop transports might be able, as civilian transports, to haul cargo at five cents per ton mile, from one half to one third of today's costs with piston-engine transports.

Turboprops are used on the big Convair XP5Y flying boats, on Allison's demonstration Turbo-Liner and have been tested by North American and Douglas for carrier-based aircraft. The new engines power the vertical-take-off fighters built by Lockheed and Convair.

With the exception of Allison's Turbo-Liner, all American turboprop development so far has been for the armed forces. Meanwhile, English builders of turboprop engines have been busy in the civil as well as military field. Their turboprop-powered passenger transports have been used in Europe for several years. In the United States, Capital Airlines has ordered 40 of the English transports and begins using some of them on its routes this spring. The new Capital airliners are Vickers Viscounts that are powered by four Rolls-Royce turboprop "Dart" engines. The Viscount carries 40 or more passengers, has a normal range of 1000 miles and flies in excess of 300 miles per hour. Trans-Canada Air Lines also has ordered Viscounts for early delivery.

Basically, the turboprop has the same kind of gas turbine that is used to drive a jet aircraft. As a turbojet, all the thrust from the turbine is used as jet drive, out the tail pipe. When redesigned as a turbine-propeller power plant, more wheels are added to the turbine and these additional blades absorb most of the jet thrust. The main shaft now has enough torque to drive a set of propellers through a 10-to-1-reduction gearbox. Only about 10 percent of the

power goes out the tailpipe as jet thrust.

From the standpoint of fuel economy the turboprop is almost as good as a piston engine. A typical turboprop consumes .42 pounds of fuel per hour per horsepower at 460 miles per hour as compared to the .40 pounds of fuel per hour per horsepower required by a piston engine at only 345 miles per hour. A pure jet uses more than twice as much fuel.

The turboprop has other advantages. Compared to a piston engine it weighs approximately half as much for the power developed. It has about half the frontal area and thus less drag. Compared to a jet, its propellers allow it to take off with much less runway and then to climb at a greater angle. It lands more slowly and comes to a stop much sooner. Engineers say that aircraft piston engines developing more than 4000 horsepower don't appear practical, yet turboprops developing 5500 horsepower already are in use. Ultimately the engines may be designed to produce as much as 15,000 horsepower.

The turboprop is a constant-speed engine that runs continually at high revolutions per minute. The pilot doesn't change his power settings for climb, cruise or descent. His throttle simply changes the pitch of the propeller blades.

The controls in the cockpit are about the same as ever, the chief difference being that the engine throttle lever has two quadrants, one for ground operation and the other for take-off and flight. The throttle is moved through a gate to go from one range to the other.

Starting a turboprop engine is somewhat different from starting a jet because of the great drag of the propellers. A compressed-air starter rotates the gas turbine's shaft up to some 2000 revolutions per minute, at which point the burners "light off" and begin to produce power. But drag is so great that the engine would simply quit if left alone at this point, so the starter continues to boost it along until 6000 revolutions per minute are attained. At this speed the

Turboprops fly higher and climb faster. Solid line diagrams turboprop flight; dotted line the piston ship

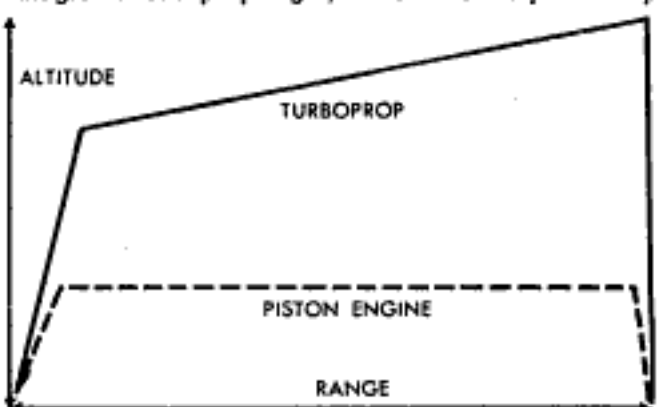

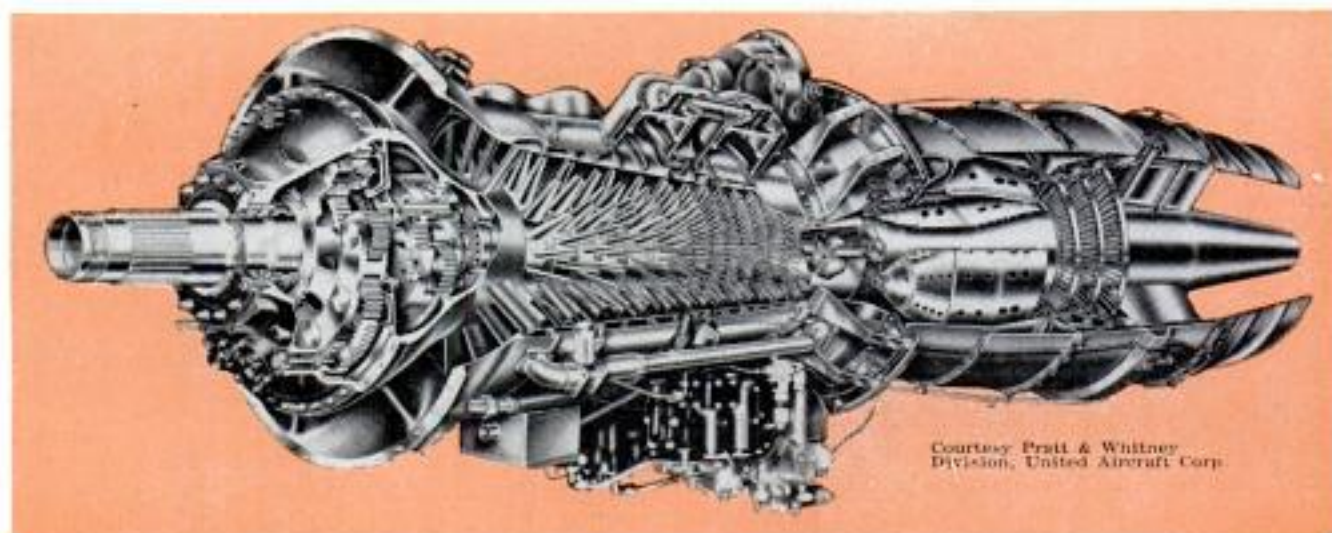

Courtesy Pratt & Whitney Division, United Aircraft Corp.

The simple principle of the turboprop is illustrated below, while complexity of the actual engine is evident in the cutaway above. Exhaust blast from combustion chamber drives turbine shaft, geared to prop

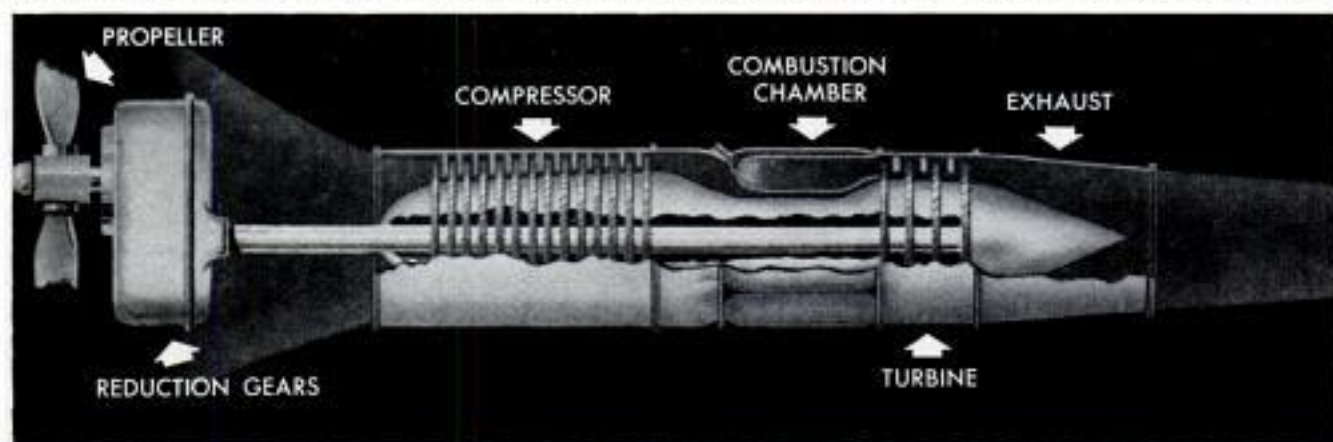

Courtesy Allison Division, General Motors Corp.

starter shuts off and the engine slowly accelerates up to "idle" at 13,000 revolutions per minute. At idle the propeller blades are turned to exert a slight negative thrust to counteract the slight positive thrust from the tail pipe.

Now the pilot can operate his throttle, pushing it ahead in ground range to taxi slowly ahead, or pulling it back to reverse the propeller pitch to make the plane move backward.

When he moves the throttle into flight range for take-off the propellers change their angle of attack to take deeper bites of air. In the meantime, more fuel automatically flows to the burners so that engine revolutions per minute remain unchanged under the heavier load. In a broad sense the propeller blades know only one speed and operate at that speed continuously. The blades merely change their angle of attack in response to movements of the throttle.

When flying a turboprop transport, the pilot doesn't climb at a rather flat angle until he reaches cruising altitude and then fly straight and level, as he would do in a piston-engine plane. Instead, he climbs at a very steep angle to the initial cruising altitude and then continues to climb gradually for most of the distance to his desti-

nation This is because the turboprop gains in efficiency with altitude, and the pilot can climb to greater altitudes as the plane's weight is reduced by the consumption of fuel.

Most turboprops built so far are of the simple direct-coupled type in which additional turbine wheels are added to a standard gas turbine. More complicated to build and much simpler to operate is the so-called free turbine. This is a standard gas turbine with a hollow main shaft having a second shaft contained inside the hollow shaft. This shaft contains the additional turbine wheels at one end, and is connected to the propeller gearbox at its other end. It is this shaft that rotates the propellers. The British "Proteus" is of this type.

Another kind, the dual-spool turboprop, is similar to the free turbine and has an additional compressor stage at its front, directly behind the gearbox. This also is called the "supercharged" turboprop engine. It is the most complicated of all to design and build, but is less affected by high ground temperatures (which can reduce take-off payload) and maintains full power to high altitudes. It can be designed for a fuel consumption so low that it is said to compete with a diesel in economy.

Still another turboprop engine consists of two gas turbines placed side by side and feeding into a common gearbox. One turbine can be shut down for economical operation at low altitude, both of them can be used for climbing and for high speed at high altitude.

Another design of gas turbine is the so-called bypass or ducted-fan engine. This would be a gas turbine with some extra-large compressor blades at its forward end. Much of the compressed air would travel through the turbine as usual, with the balance of the air being ducted along the outside of the engine casing to join the hot jet exhaust. On paper this engine is quite efficient although it has not yet been built.

Now that Capital Airlines is testing turboprop Viscounts, other airlines will be watching to see how the new power plants operate. Until now most airlines have had a wait-and-see attitude because the turboprops have not been entirely reliable in the past. In fact, various military turboprop aircraft have spent most of their lives on the ground waiting for replacement parts to be designed and built. The basic turboprop engine is pretty rugged, to be sure;

and the difficulties have had to do with propeller-pitch controls and with the safety controls that must function if an engine happens to overheat or overspeed.

Among the most important safety features recently developed is a negative-thrust-control system that detaches the propeller assembly from the engine immediately in case of power-plant failure, even before the feathering device that weathercocks the blades into the wind has time to operate. Without such a system, the drag from one propeller of a multi-engined plane could be so great when a power plant failed that the plane could go out of control or even whip around so rapidly that it would break up.

Now that this and other safety controls have been proven, various air-transport manufacturers are expected to develop turboprop airliners within the next couple of years.

Turboprop airliners are the next step, and even when the pure-jet airliners begin to flash past them they won't go out of the picture. For short passenger hauls and for flying cargo they will still be unsurpassed.

★ ★ ★

Unnecessary with piston engines, propeller-pitch controls are added to turboprop flight engineer's board

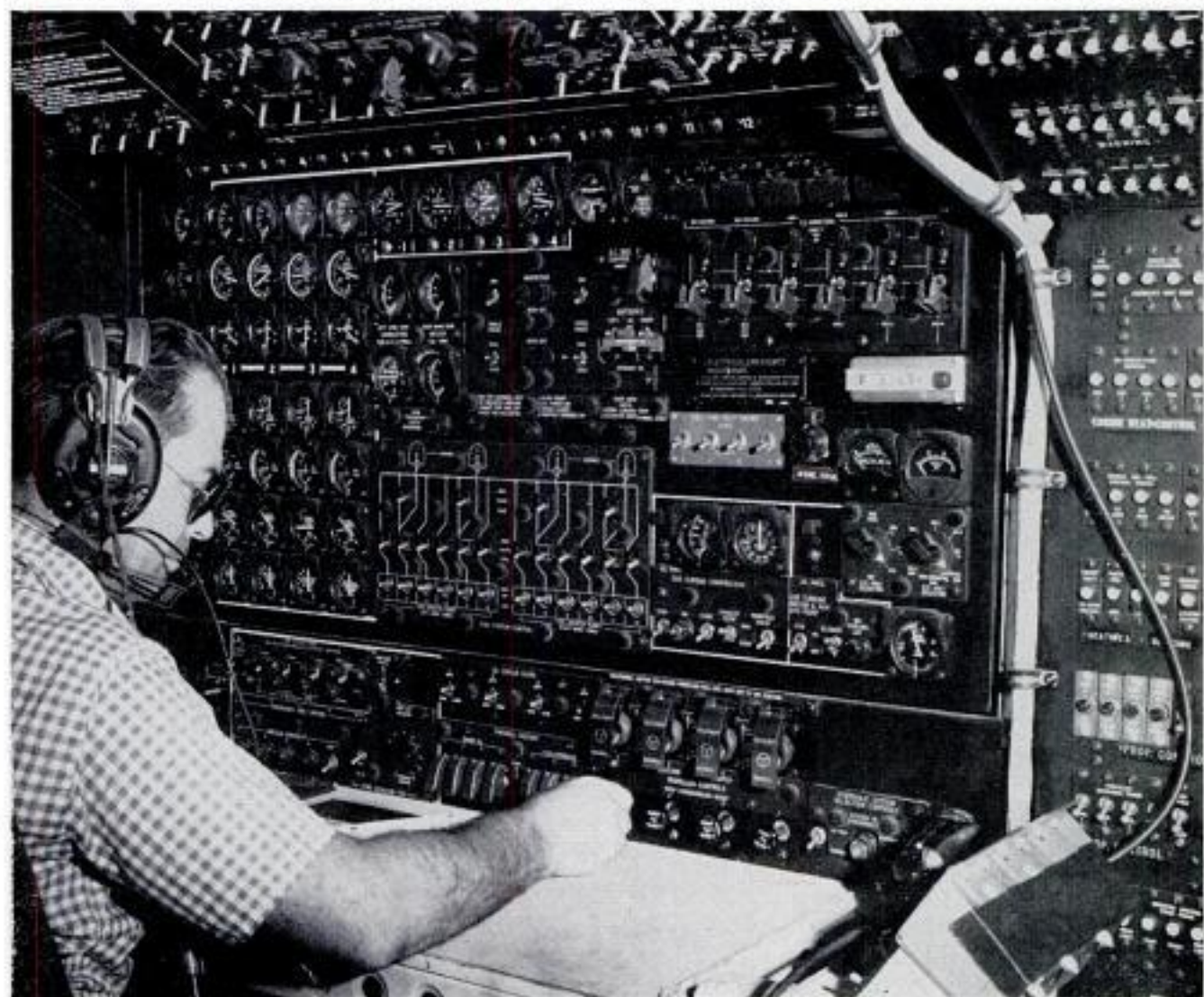

Detroit Listening Post



By Leo Donovan

ABOUT TWO YEARS AGO, a Jaguar sports car set a record of 100.65 miles per hour for 10,000 miles. It was the first production car to average more than 100 miles per hour for 10,000 miles.

Now a 1955 Packard with its new V8 engine has averaged 104.74 miles per hour for 25,000 miles! The car was a Patrician four-door sedan with the new torsion-bar suspension. The 104.74-mile-per-hour average is figured on elapsed time—actual running time had to be several miles per hour faster to allow for pit stops. The top lap speed (2½-mile track) was 114 miles per hour.

Packard is bragging about the engine (and well it should) and the fact that oil consumption was the same at the finish of the 25,000-mile grind as at the start—a quart every 845 miles. But there will be little bragging about gasoline economy! It averaged about 7 miles per gallon! Let that be a lesson to you. If you want economical driving, don't average 104 miles per hour!

Twelve Drivers Used

Twelve drivers took part in the test. They were relieved every hour at refueling stops. The run would have been uneventful, says Packard, except for the weather. There was considerable rain during the period and driving at 110 miles per hour in rain is not exactly relaxing.

The unbelievable part of the feat is the fact that only one car was available for it. In most runs of this type, several cars are started with the hope that at least one will finish successfully. Packard's limited budget meant that only one 1955 car could be made ready for the run.

As it happened, there was a breakdown at just over 10,000 miles and the whole thing had to be restarted. A hydraulic valve lifter failed—something that could happen to anybody, as they say. The average speed at that point was 105.859 miles per hour—a new record itself.

But Packard decided to go for the 25,000 as planned so a new engine was installed

in the same car and the run restarted. This time the engine didn't miss a beat.

Most-Powerful Engine

Incidentally, the 1955 Packard engine has a 352-cubic-inch displacement and a reported 260 horsepower with one four-barrel carburetor. The Caribbean convertible will have two four-barrel carburetors and its horsepower, probably the highest in the industry, is still secret.

Besides Packard, the only 1955 cars still waiting to be unveiled are Hudson, Nash, Kaiser and Willys. Kaiser is still an unknown quantity. Willys will have a major styling change, say informed sources.

Hudson and Nash are now twins under the skin, but outwardly there is considerable difference. In fact, George Romney, president of American Motors, reports that the two cars share only one exterior body panel. The basic body shell is identical, however. You'll be amazed at what can be done with the same "skeleton"—both have the unitized, frameless construction.

The 1955 Nash offers a unique fender treatment. Front fenders no longer house the headlamps. The lights are now inset in the oval front grille, similar to those on the Nash-Healey sports car. The front fenders come to a graceful curve with small parking lamps set into the lower halves.

Buick will spark the midseason sales period with its four-door hardtop sedan. This company is the one that set the trend when it brought out the two-door hardtop several years ago. It is expected (by Buick, at least) that the four-door hardtop will have a similar effect. The absence of any center post in the four-door sedan will make the traditional family car as sleek as a convertible. Whether the leak and rattle problems have been solved for four doors remains to be seen—these are still problems in some two-door hardtops!

Air-Cooled Engines

Chrysler Corporation has developed a 200-horsepower air-cooled engine for an experimental airborne military truck. It has six cylinders and a fuel-injection system instead of a carburetor. The truck body, wheels and axles are made of aluminum. Each wheel has independent torsion-bar suspension. The 2½-ton truck weighs only 9000 pounds, compared with 14,000 for a conventional model.

American Motors has bought the rights to the Mighty Mite, the midget more compact than the Jeep that will run on three wheels if necessary. Engineers at American Motors have developed an air-cooled, lightweight engine for the tiny vehicle. This may be a hint of future plans for the small, basic car so dear to Nash.

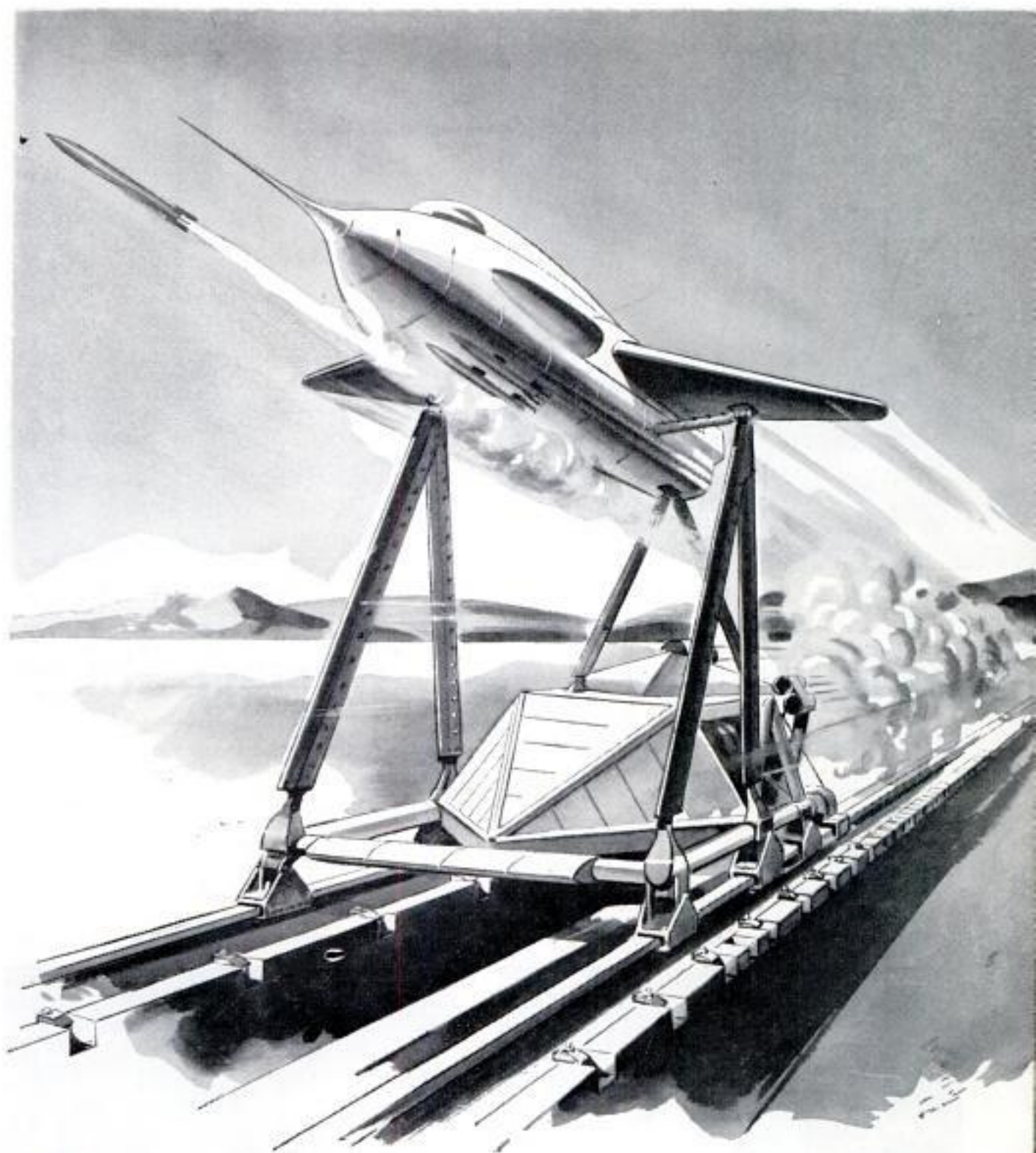

"Snort" Makes Supersonic Tests for Navy

CAPTIVE TESTS of guided missiles, rockets, model or full-size airplanes and assorted parts are being made at supersonic speeds at the Navy's new research track at China Lake, Calif. The track has been dubbed the "Snort" due to the sound from its powerful rocket motors. The Snort is 4.1 miles long and was designed to bridge the gap between wind-tunnel and free-flight testing. Among its many advantages are the recovery of test objects intact and instrument (including photographic) recordings of all phases of the tests. The

Snort affords accurate measurements of thrust, acceleration, velocity, lift, drag, vibration, shock-wave effects, flutter and many other factors. Measuring instruments include magnetic-pickup track coils, a telemetering system and cameras stationed every 500 feet along the track. Test items can be mounted on either monorail or dual-rail carriages which ride on metal shoes. The Snort's supporting facilities at the station consist of a test-control building, an assembly building, a blockhouse and a magazine for storing explosives.



This Panagra pilot (top left) can see a radar "map" of the weather ahead in the hooded scope at his left

Airborne Radar Sees Through Storms

NORTHBOUND over the Caribbean in a flight from Panama to Miami, the pilot of a Panagra DC-6 saw the sky ahead of him illuminated by lightning flashes from horizon to horizon. Normally this would call for greatly reduced speed to meet expected thunderstorm turbulence,

or a lengthy, schedule-destroying detour. The pilot neither reduced speed nor did he detour markedly from his course. He arrived in Miami on schedule and with no discomfort to his passengers.

At North Platte, Neb., airport a DC-3 took off directly into a front 152 miles long,

Dark storm centers, invisible on ordinary circuit (left), stand out with special weather wiring (right)

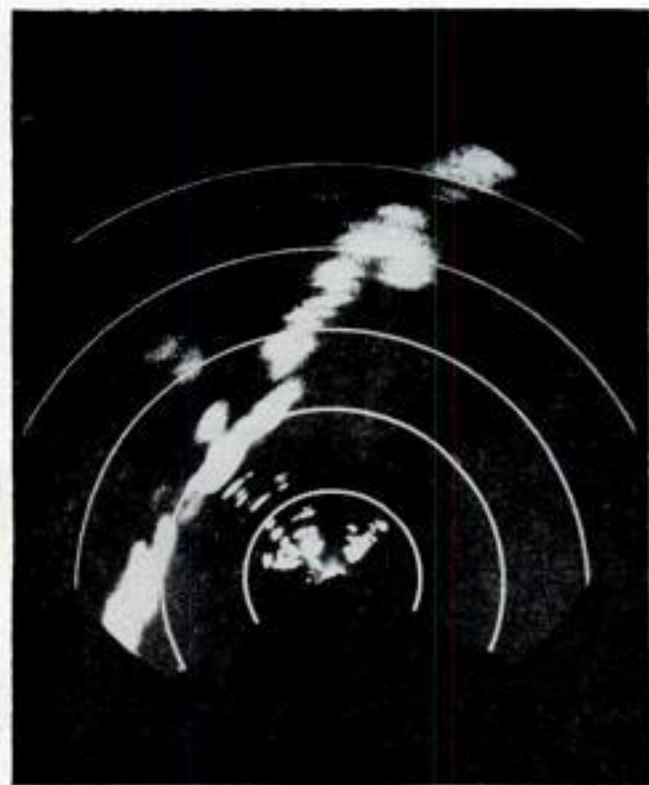



The United DC-3 at left above took off and flew directly into this threatening front, detoured by other aircraft. Actual danger in the storm was in three centers spotted on scope of same front, right

with clouds 40,000 feet high. Three scheduled flights in the vicinity prudently detoured widely, but the DC-3, a United Air Lines cargo plane, flew right into the front and 20 to 30 miles through it. Only "mild choppiness" was experienced.

Neither pilot unduly endangered lives, cargo or aircraft. Each was able to "see" the storm centers hidden in the cloud masses and widespread lightning flashes with one of electronics' greatest contributions to safety on schedule for the airlines—airborne weather radar.

The storm centers appeared to them as "doughnuts" of light surrounding dark spots on hooded radarscopes in their cockpits. The dark holes in the doughnuts—the cores of the storms—were clearly visible because of isoecho contour circuits in the radar sets.

These formidable-sounding circuits actually have the simple function of eliminating return signals, or echoes, of greatest intensity from the scopes. Thus very heavy rain at the storm center appears as a black spot surrounded by reflections of lesser precipitation.

Airborne weather radar can probe storms as far as 200 miles ahead and report them faithfully on the scope in the cockpit.

It enables a pilot to determine whether a threatening sky is truly dangerous or whether slight detours around storm centers can carry him ahead on his course. It also can help him to spot prominent terrain features in heavy weather. ★ ★ ★



The black plastic radome on the nose of this DC-6 conceals and streamlines the weather-radar antenna





Long-Range "Voodoo" Fighter

Powered by two 10,000-pound-thrust Pratt and Whitney J-57 turbojet engines, the McDonnell F-101A "Voodoo" fighter is one of the most powerful fighter planes ever built. Performance figures are secret, but the aircraft is in the supersonic class and can carry atomic weapons. It is ca-

pable of in-flight refueling. A long-range fighter, the Voodoo will be assigned to the Strategic Air Command. Dimensions are: 39-foot, 7-inch wingspan, 67-foot, 4-inch length and 18-foot height. Wings and stabilizers are swept back 35 degrees. The wing skin is of heavy, preformed sections.

Dry-Ice Balloon

Dry Ice has been adopted to time the release of anti-Communist leaflets from Free Europe balloons wafted over Hungary. A frame carried beneath the plastic balloon is fitted with two cardboard boxes, one at each end of a free-swinging rod. The Dry Ice evaporates, allowing the upper box to tip and spill its load of leaflets.

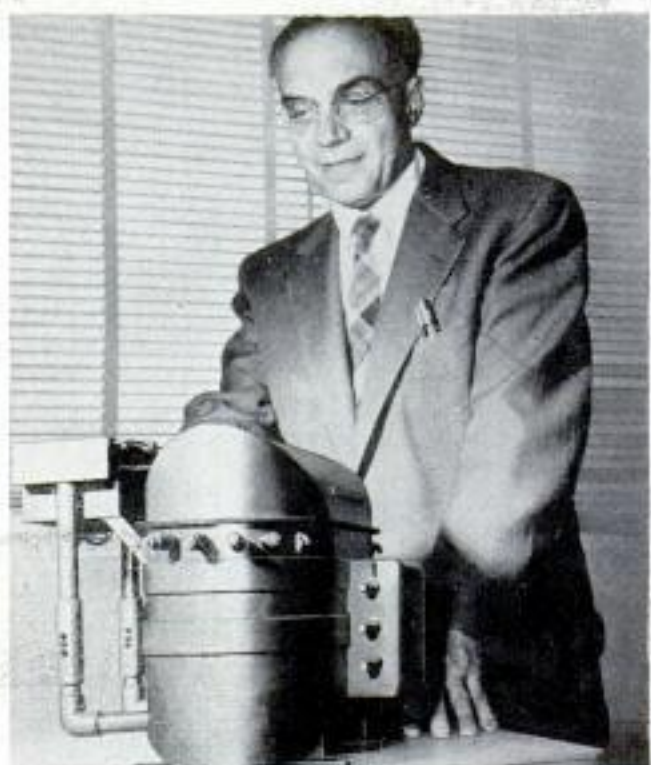
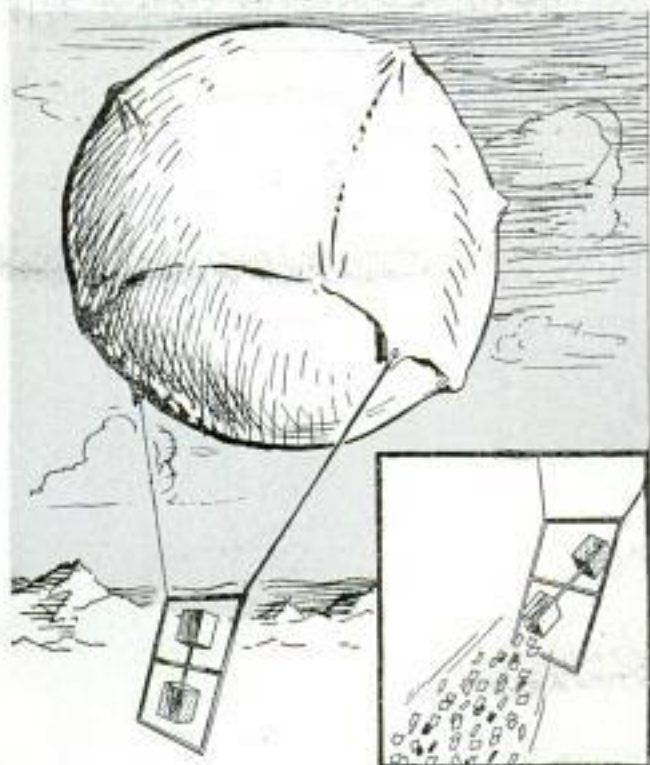

Gas Insulates New Transformer

Gas, rather than liquid, insulates and cools new transformers under development by General Electric Co. Sulphur hexafluoride, a heavier-than-air gas, is the agent used in this first application of a gaseous insulation to high-voltage power transformers. The new insulator allows design of transformers rated at 69,000 volts.

Hay Compressed Into Spool-Size Pellets Seems to Please Cows

Hay is compressed into pellets about the size of large spools at the University of Wisconsin. H. D. Bruhn, agricultural engineer, began experimenting with hay in pellet form in the hope of finding a way to reduce the labor of haymaking. He has developed an experimental machine that forms the pellets in a tube under hydraulic pressure. Both long and chopped hay have been pelleted successfully. Bruhn believes the farmer may some day pellet the hay in the field, drop it into a wagon, dump it from the wagon into an elevator and run it into a bin. The pellets are about two



University of Wisconsin Electric Farm photos

inches in diameter and 1½ inches high—too large for a cow to swallow whole. How do the cows like the pellets? They simply picked them up and began chewing them.



Old-Car Trailer Gives Safe Ride

Antique-car restorer Eldon Neibling, of Topeka, Kans., hauls his "classic cars" safely in a custom trailer that is only eight inches above the ground. Slung beneath two axles, the four-wheel trailer is so low it is easy to jack up the front end to bring the back end level with the ground.

Lifesaving Bellows Powered by Crank

Breathing is restored by a hand-operated bellows connected by flexible hose to a face mask. Developed in Sweden, the respiratory apparatus weighs less than six pounds and costs around \$140. Designed for emergency use, it was recently tested at the Epidemic Hospital of Gothenburg, Stockholm.

☐ Latest thing in door mats is a rubber mat with luminous "hello" at its center to greet visitors night or day.



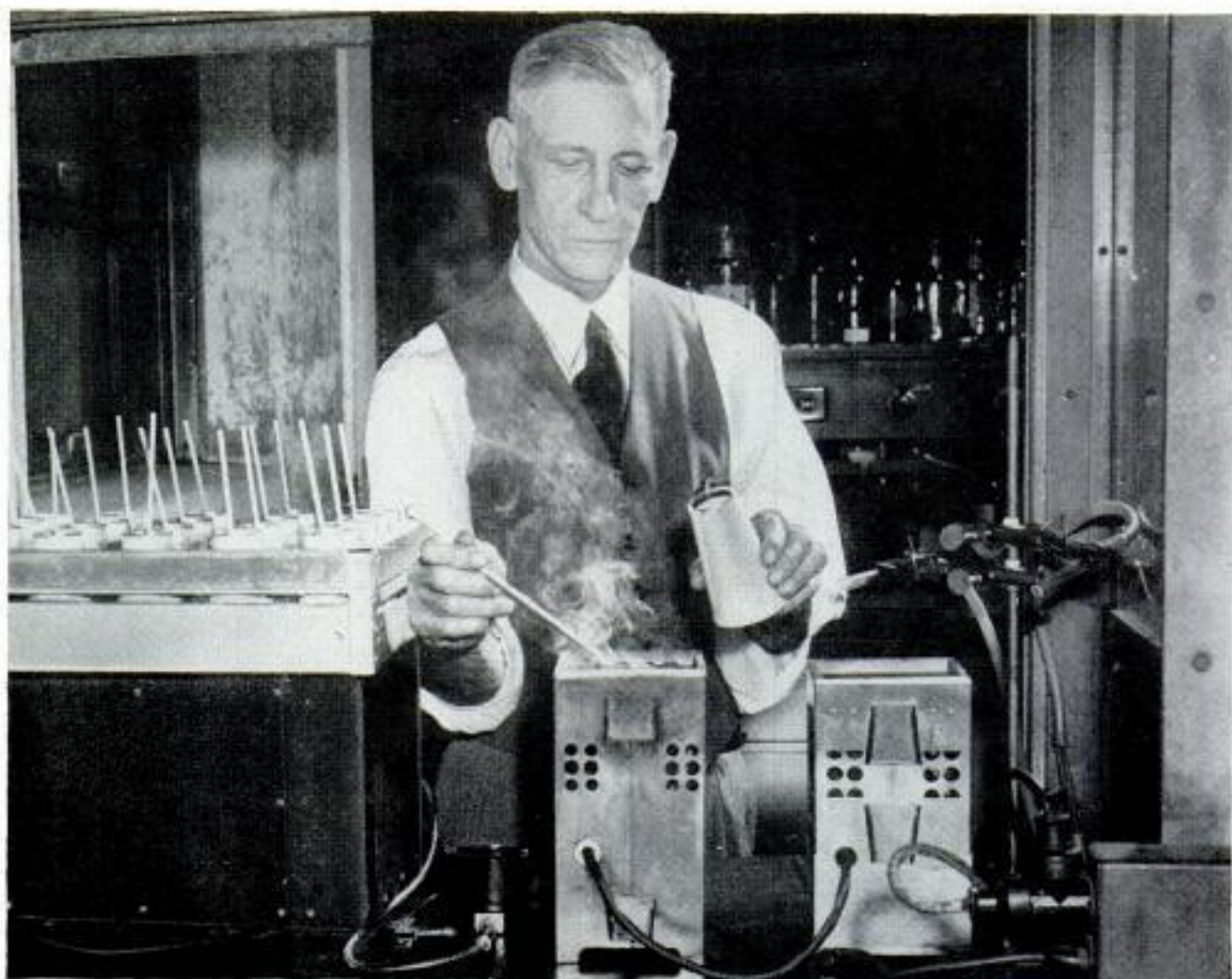

Testing process starts when sample of oil from locomotive is carefully dropped onto pellet warmed by hot plate

They Photograph Engine Wear

By Phil Hirsch

IF YOU'VE ever missed railroad connections because your train fell behind schedule, you'll be glad to know that something is being done to prevent such mishaps in the future.

The "cure" depends upon an instrument known as an emission spectrograph, which looks a little like a fugitive from a comic strip. The complete system requires, among other things, milk bottles, fountain straws and an electric hot plate. Recently, several railways each invested \$25,000 in such contrivances to make their trains run on time.

The machine "photographs" wear and tear inside a diesel engine. It sees the same things a mechanic would if he could crawl under a cylinder head or perch on top of a bearing and stay there during every mile the engine was in operation. Thanks to the emission spectrograph, late arrivals due to mechanical failures have dwindled to the vanishing point on many

of the railroad lines in this country.

Briefly, this is how the emission spectrograph works: Pulling freight and passengers back and forth causes two major kinds of wear inside a diesel engine. One is leakage—gaskets and piston rings loosen, and water or fuel oil gets into the lubricating system. Also, air filters begin to let in dirt, as well as air, after a while. This dirt is the villain primarily responsible for the second type of wear—erosion. Just as sand kicked up in a storm will chip paint off a building, these small dirt particles will chip tiny bits of metal off engine parts which, in turn, means overhauling more often.

Now, if you had a method of measuring the amount of water and fuel oil leaking into the lubricating system, and a method of measuring the dirt and other foreign bodies, you would know when the engine had to be pulled in for an overhaul and what parts had to be replaced.

You can obtain both measurements from

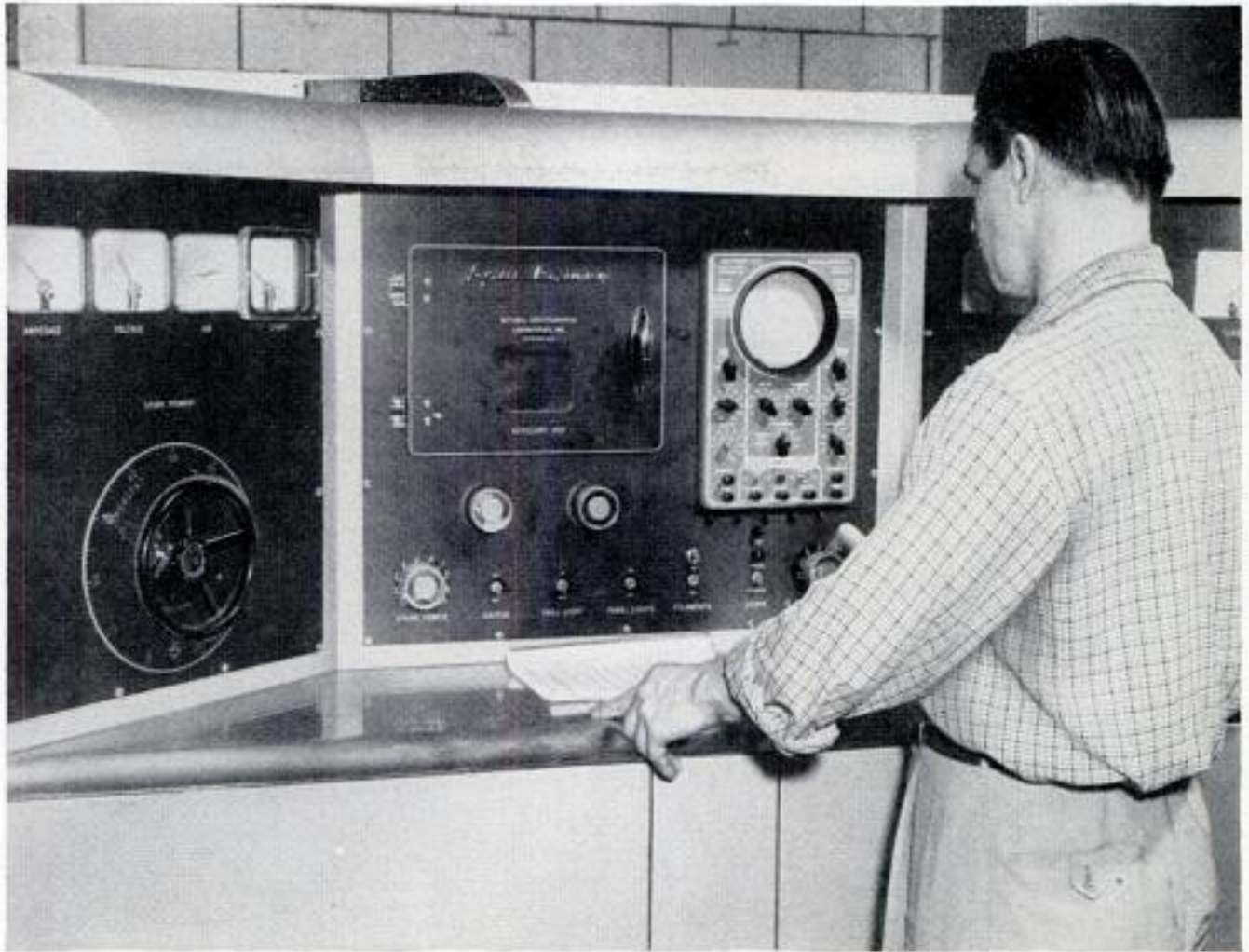

Meters and dials stud control board of emission spectrograph which measures foreign elements in oil sample

the emission spectrograph. And, by analyzing lube-oil samples at periodic intervals, the gadget accurately produces a continuous diesel-engine history covering every operating mile.

The machine supplies engine data in the form of numbers. Each number represents the concentration of a particular foreign element in the lubricating oil. A high silicon concentration, for example, means a lot of dirt is getting in (since silicon is the chief chemical element in airborne dirt), and the engine's air filters should be checked. A high concentration of boron (one of the elements in radiator water) means there is a leak in the cooling system. Similarly, a large quantity of copper, lead, silver or other metal in the lubricating oil indicates which parts should be checked for wear.

Recently, I saw the instrument put through its paces at the Rock Island Lines' Chicago research laboratory. The Rock Island's emission spectrograph keeps tab, not on one engine, but on 600, which operate along 6000 miles of track between Memphis and Denver, Minneapolis and Houston.

Rock Island's chief chemist, J. T. Rudd, showed me one engine-history report that described what was going on outside the engine, as well as inside. He pulled a card out of a file and pointed to a column headed "silicon," which contained the numbers

(Continued to page 230)

Pellet coated with oil residue is placed in spark-gap chamber with tweezers. Current is turned on, and light from the spark indicates the type and amount of each foreign element in oil



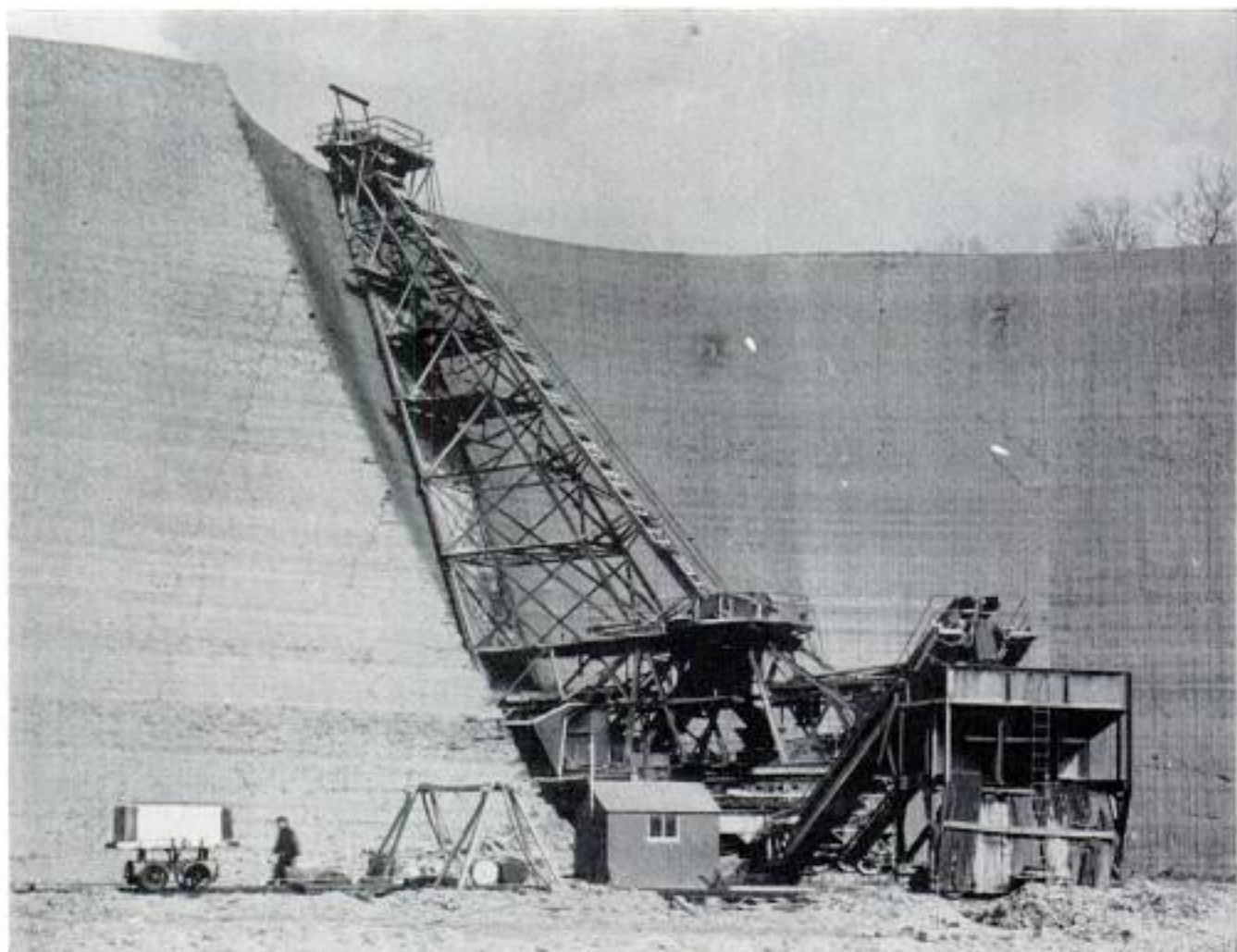

London Times photo

Towering Excavator Moves Along As It Scrapes Clay From Bank

Clay for bricks is planed from the sides of deep pits with a slanting excavator. The 92-foot-high tower of the machine rests against the face of the clay bank. Cutters and scrapers mounted on an endless chain travel from top to bottom of the bank and carry the cut clay into a chute feeding a central hopper. From the hopper the clay is carried by conveyor to an outside hopper where wagons transport the clay to the

brickyard. The machine moves along the clay face at six inches per minute. The tower can be adjusted to various angles and also turns about its axis. When digging, it swings back and forth to make a semi-circular cut. The design of the English machine permits a safe angle of digging and a smooth, stable face. The clay is delivered in small, workable lumps. It can dig a clay face 90 feet deep at the rate of 110 tons per hour.

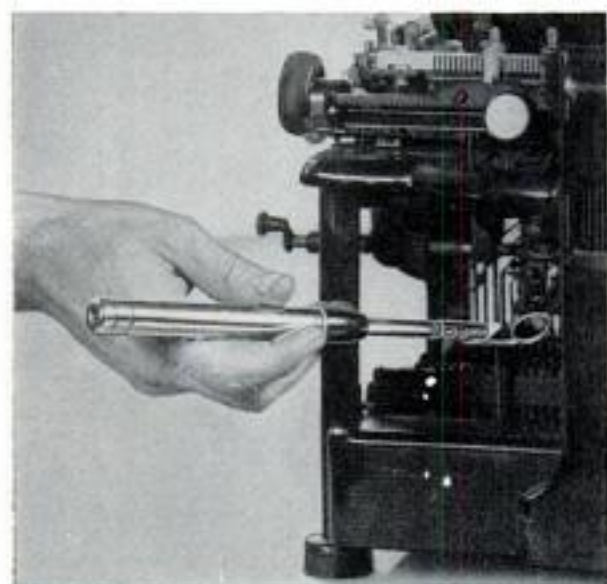

Tri-Duty Inspection Tool Casts Light in Right Spot

Inspection of tight wiring or close machine areas is easy with a three-way tool. Essentially, it is a flashlight powered by miniature batteries. When a plastic probe is inserted in its nose, light is beamed to the tip of the probe and given off in a flood of illumination. A small round mirror that is clipped to the probe permits inspection of tight areas. The compact probe is designed for engineers, machine and TV technicians, dentists and repairmen. It offers the proper illumination at the spot desired.





Radar truck tracks cloud formations and radio direction-finding truck records lightning 1000 miles away

Let's Import Rain for the Dust Bowl

New Mexico scientists pursuing the rain-making project turn up a strange discovery: Water changing into ice generates electricity

By Thomas E. Stimson, Jr.

YUCATAN? This is Dust Bowl. We'd like about 800,000,000 tons of rain next week. Start your ground generators!"

Fantastic instructions like this may not seem farfetched a few years from now. There's a possibility that dry Texas and much of the drought area can be changed into a vast garden spot simply by seeding rain clouds over the Yucatan peninsula in Mexico.

The idea of controlling the weather from a distance stems in part from a striking relationship that has been observed between periodic cloud-seeding activities in New Mexico and subsequent heavy rainstorms as far away as the Ohio valley. The air masses that were seeded in New Mexico were on their way east toward the Ohio.

To test the long-range idea, a proposal to seed the Yucatan clouds is advanced by

Two thunderstorm scientists, Doctors Workman and Reynolds, diagram some electric fields inside a cloud

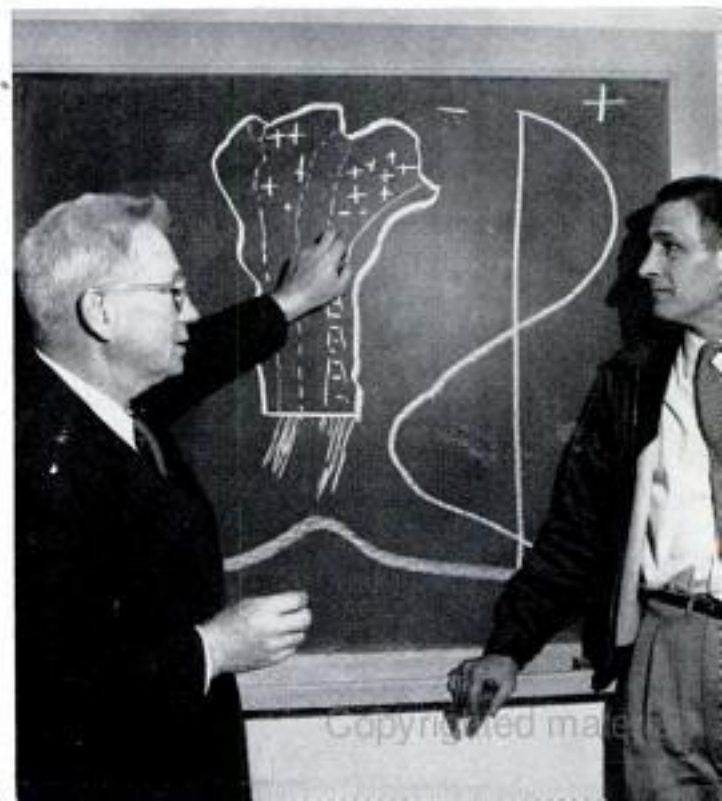

RADIATION FROM RADIO EQUIPMENT USED TO MEASURE LIGHTNING UP TO SEVERAL THOUSAND MILES AWAY

FAN CONTROLS UPDRAFT VELOCITIES

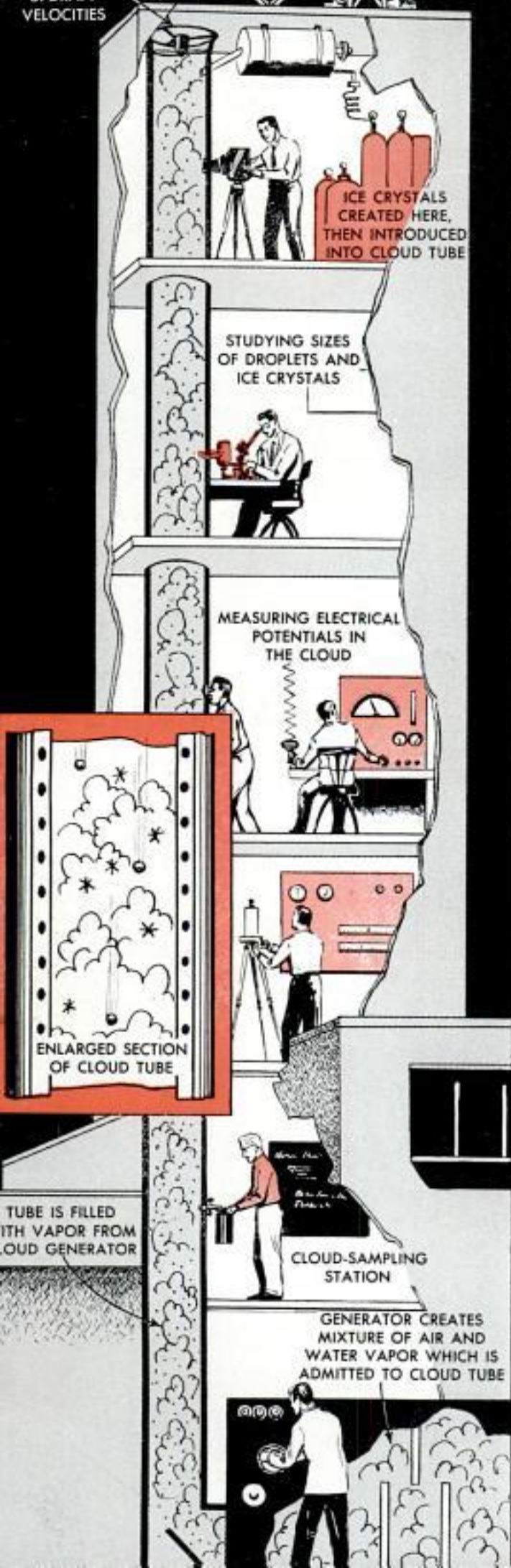

Dr. E. J. Workman, president of the New Mexico Institute of Mining and Technology. The Socorro campus of the institute has been headquarters for much of the rain-making research conducted in the United States.

"Summer winds frequently sweep north from the Gulf of Mexico after leaving much moisture in the Yucatan area," Doctor Workman states. "It would be a worthwhile experiment to seed the Yucatan area in an effort to reduce rainfall in that wet region and thus force the air masses to transport their moisture farther north.

"Quite possibly all of northeastern Mexico, Texas and parts of New Mexico and Oklahoma would benefit.

"Usually when you seed clouds with silver iodide or other nuclei you are trying to increase the rainfall in the immediate area. But the same method can actually reduce precipitation. If an immature cloud is seeded, for instance, the cloud-building mechanism is disrupted and the cloud vanishes.

"Similarly, overseeding can put a mature cloud right down on the ground and end its life, bringing a relatively quick end to its rain production.

"Either or both of these methods should be tried off Yucatan in efforts to increase the rainfall where we need it."

Modern research on rain making (actually rain augmentation) has been going on continuously ever since Dr. Irving Langmuir and Dr. Vincent J. Schaefer of General Electric developed their seeding techniques in 1946. Yet the subject is so broad that it is still far from being an exact science, although about a dozen groups in the United States and abroad are actively studying it.

To learn more about how to make it rain, the cloud physicists at the New Mexico institute go aloft in aircraft studded with research instruments. They bore through thunderstorms, tag air masses with fluorescent aerosols and then trace the air masses for hundreds of miles to observe the mixing of the atmosphere. Today they

Thunderstorm laboratory, below, has tower in which scientists can simulate most cloud conditions. Drawing shows cloud formed in big tube for close study



are preparing to create artificial thunderstorms and other rain clouds inside a huge test tube at Socorro, and to use radio direction-finding apparatus on a continental scale (with stations in Minnesota, Florida and New Mexico) for tracing thunderstorms by their electrical discharges.

Already, working with zero-freeze boxes and other apparatus in their thunderstorm laboratory, the Socorro scientists have learned a number of brand-new facts about nature. One of their milestones was the discovery of what probably causes lightning. Doctors Workman and S. E. Reynolds found that an electric charge is created when water freezes into the solid state, no matter whether the freezing occurs in a cloud or in your refrigerator at home.

A sample no larger than an ordinary ice cube, they discovered, may generate as much as 250 volts while changing from water to ice. The amperage is extremely small, usually less than 100 microamperes, but enough to be significant in thunderstorm electrification.

At Socorro this Workman-Reynolds effect is demonstrated by inserting one lead from an electrostatic voltmeter into water contained in a plastic cup with a platinum base placed on a freezing unit. The base of the cup is grounded to the unit. The voltmeter needle remains at zero until freezing begins, then slowly swings over to 40, 50 or 150 volts, depending on the impurities in the water. The voltmeter needle returns to zero when all the water has frozen.

In a thunderstorm, Doctor Workman theorizes, water that is shed from growing ice generates enough voltage to produce a lightning stroke, apparently a logical theory.

The step-by-step sequence is something like this: The thunderstorm has its beginning as an updraft of air from the heated surface of the ground, or as a breeze that is deflected upward by a mountainside. In either event, the warm air travels upward until it encounters sub-zero temperatures.

The moisture in the air freezes into ice crystals and becomes electrified in doing so. Soon the ice crystals become heavy enough to begin falling through the ascending column of air or in the region alongside it, and it is at this point that the separation of the electric charges begins. Water droplets in the ascending air column rob the ice and



Doctor Reynolds measures the time that water, freezing in cup, generates electricity as indicated on the dial of the voltmeter



Generator on car creates clouds of silver-iodide smoke, seeding cloud formations in experiments to increase the rainfall

hail pellets of their positive charge and thus a region of positive charge is built up high in the cloud.

As the pellets continue to fall, they encounter warmer temperatures and begin to melt, yielding their negative charge to the water vapor low in the cloud.

The result of this process, extremely simplified here, is that a region of positive charge builds up high in the cloud and a negatively charged center gathers in the lower portion of the cloud. These centers may discharge together as sheet lightning, or the discharge may occur between the ground and the low negative center in the

Spectacular lightning discharge, according to the thunderstorm scientists, may result from electrical fields caused by moisture freezing in the cloud

Numbers on diagram show the sequence as freezing moisture produces electrical fields in clouds. These discharge as sheet lightning or lightning strokes

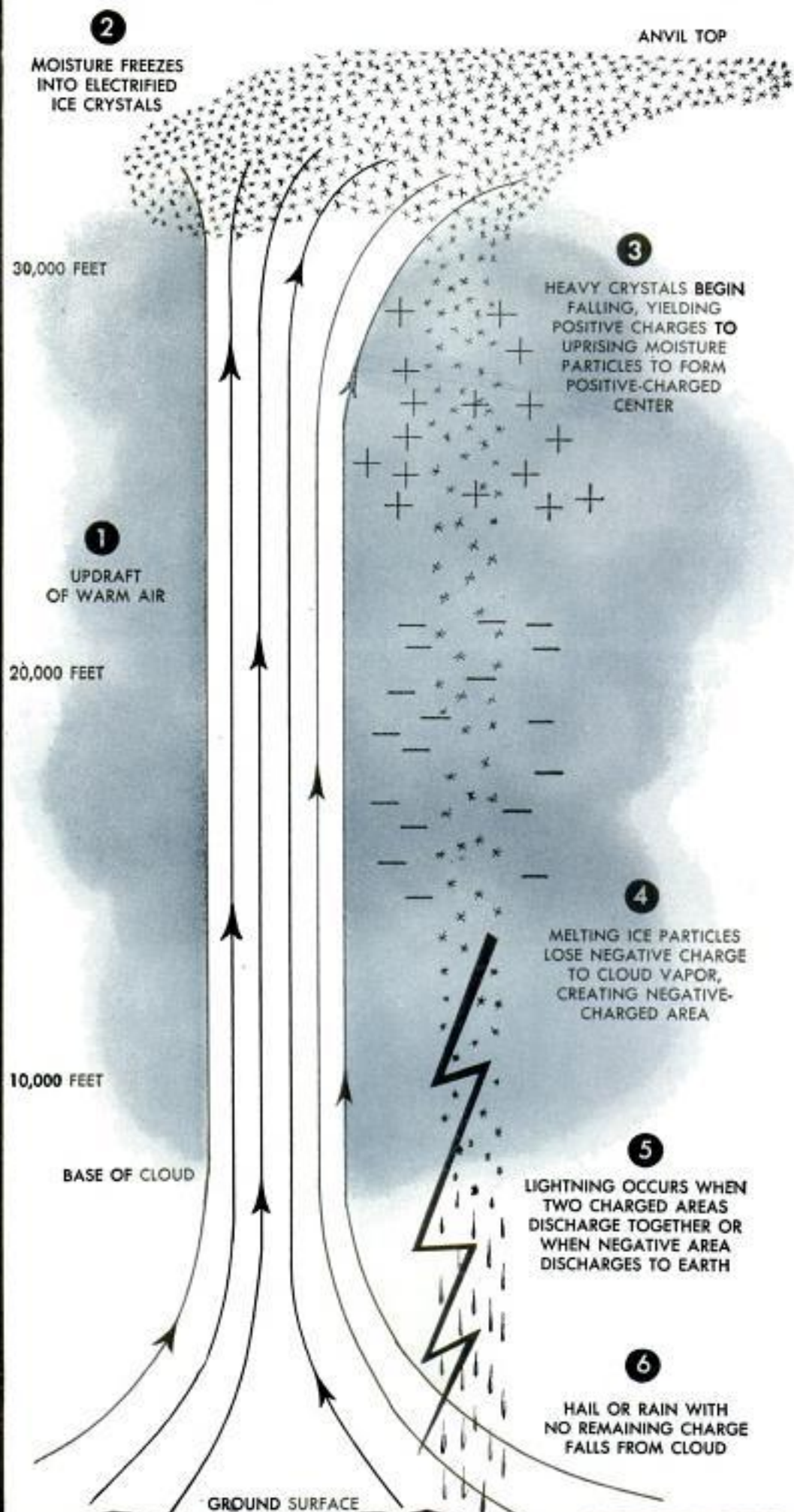



Floating copper screen measures voltage and amperage of freezing water. Metal sheet tests electrolytic action

form of a lightning stroke. This last event leaves the cloud with a net positive charge, something that explains the "fair-weather positive field" that surrounds the earth.

A thunderstorm goes through its whole complicated life in about half an hour. It begins with an updraft, then precipitation drags the air downward and creates a downdraft, killing the system. But this action in turn generates a second cell. This is the explanation of why a weather pilot flying through a line of thunderheads may find an updraft in one, a downdraft in the next.

The same electrical phenomenon that causes lightning and thunder may be the key to other natural conditions that have puzzled scientists in the past.

"For instance," Doctor Workman suggests, "every lake and pond apparently produces current during winter freezing. Some electrolysis takes place, converting small amount of water into free oxygen and free hydrogen. This has been demonstrated in the laboratory. Thus the freezing of water can account for the constant trace of hydrogen in the atmosphere, something that has been difficult to explain in the past."

This winter a reservoir on the Socorro campus is being used in large-scale tests of the Workman-Reynolds effect. The electric potential between the ice and water will be measured during the time the reservoir is freezing. Amperage likewise will be

measured and it may be that the reservoir will be found to be producing several amperes of current. Copper and tin electrodes will be placed in shore waters to learn whether the "freeze" electricity can perform an electroplating action. If it does, this could be an explanation of how, in quite a few instances, some natural deposits of pure metals were created.

Other research at the institute has shown that ice can be an efficient conductor of

(Continued to page 234)

Cross section shows how one type of portable generator produces silver-iodide cloud through combustion

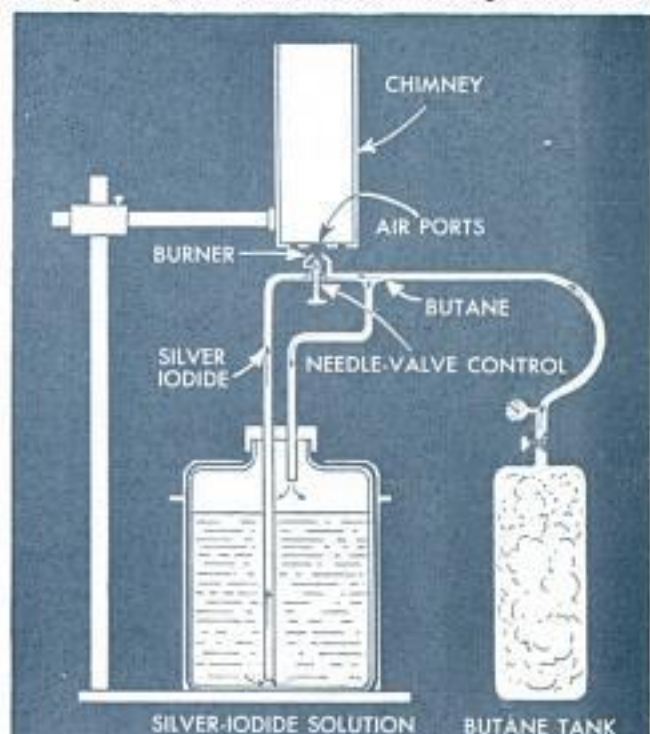

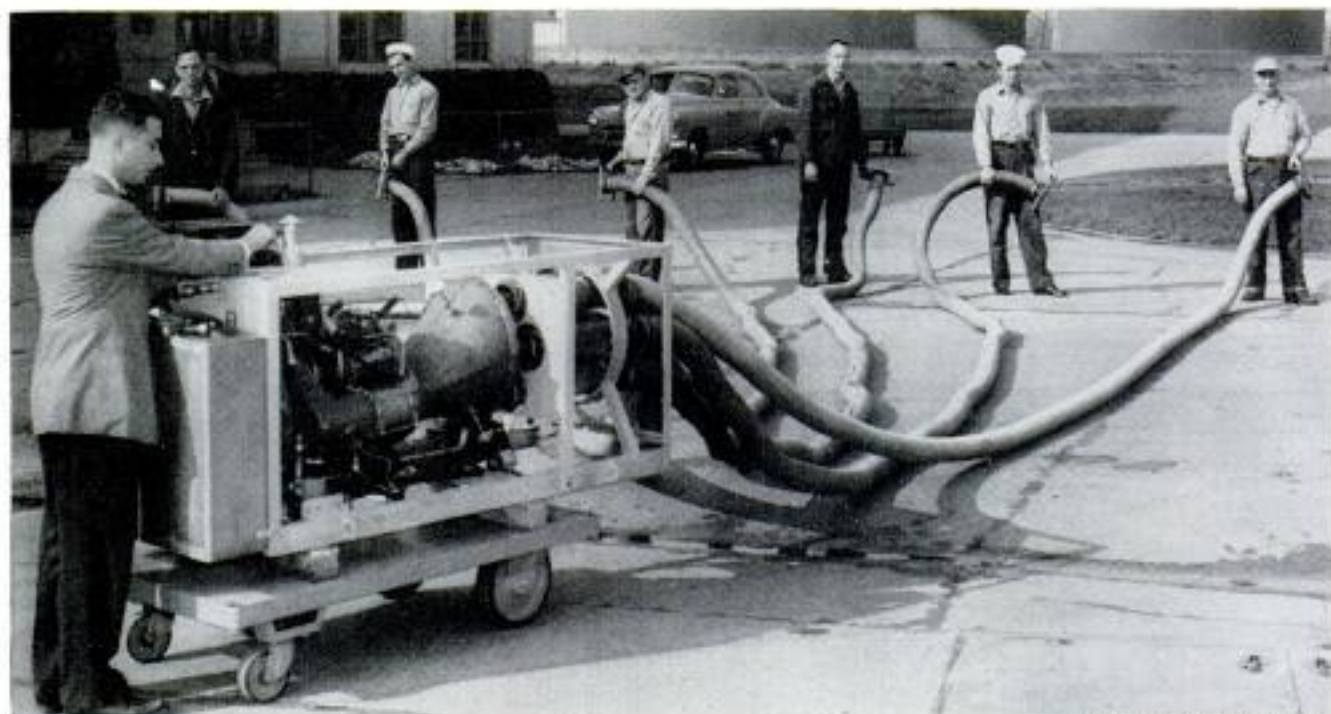

Official U. S. Navy photo

"Octopus" Melts Ice on Ship

Hot exhaust gases from an airplane gas-turbine engine may be used by the Navy to melt ice on ships in arctic waters. The engine, a Boeing Model 502, would supplant the axes and steam now used to clear masts and deck gear. Six flexible reinforced-rubber hoses are connected to extensions on the engine's exhaust pipes. The extensions, four inches in diameter, overlap the two-inch exhaust outlets. Cold air rushes in around the two-inch pipes, mixing with the 1200-degree-

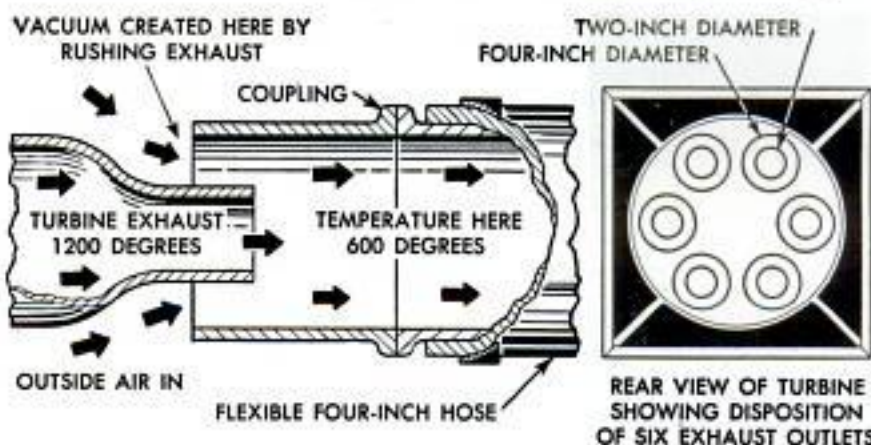

Fahrenheit exhaust gases and lowering their temperature to 600 degrees. Two of the modified engines are being tested on icebreakers in arctic regions.

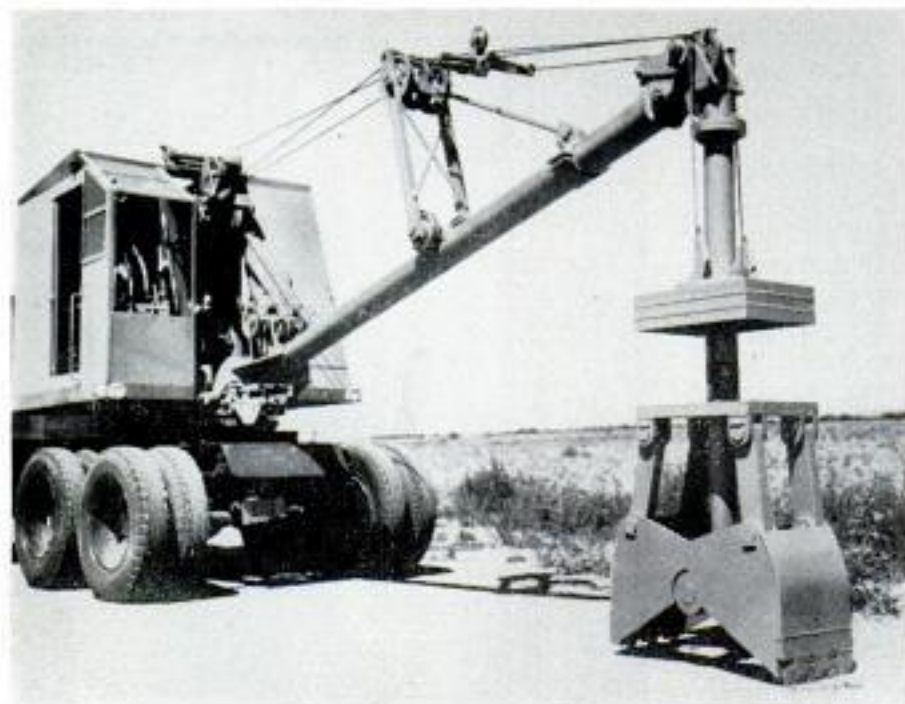

Crane Attachment Pounds Deep Hole

Deep holes for cisterns, wells and for drainage are dug rapidly with an attachment for a crane. With powerful pile-driver strokes, the unit eats through dirt or asphalt street. Essential features of the unit are a grapple, a bucket with sharp digging teeth and a hammer. The hammer smashes down on a metal frame connected to the coupling arms of the open bucket. The bucket opens to dig a rectangular hole, closes to lift the material and deposit it.



Minneapolis-Honeywell Co. photos

Monitor on bedsprings signals nurse if the patient becomes restless

Push Buttons Ease Hospital Work

STAFF WORKERS at the new Long Island Jewish Hospital, in Floral Park, N. Y., have an army of electronic aids ready to assist them at the push of a button. These include a two-way communication system between patient and nurses, vest-pocket portable receivers carried by doctors to pick up messages from a high-frequency-radio paging system, and units outside operating rooms to test doctors and nurses for static electricity. Another innovation is an electronic bed monitor attached to the springs that relays a signal to the nurses' station if a patient tosses about more than usual. The hospital also has a cooling system which uses water from a deep well.



Nurse stands on tester for static electricity outside the operating-room door

Conveyor belt from central supply room carries medical supplies quickly to the operating room above

"Patient to nurse. Over." Two-way communication to nurses' station will save thousands of steps



Farmer Relaxes in Swivel Chair of Milk Plant



Without leaving his swivel chair in the pit, farmer can milk from 25 to 30 cows per hour. Below, the little steel building, measuring 11 by 26 feet, can be attached to an existing barn



IN A NEW milk plant, the dairy farmer does all his work from a swivel chair. The "packaged plant" includes the prefabricated building and most of its equipment, right down to the cushioned swivel chair itself. The steel building measures 11 by 26 feet and is divided into two rooms. The milking room contains the milk-handling equipment. The remainder of the building is the milking room, which has a pit in the center. From his swivel chair in the pit the farmer pulls a cord, which opens a sliding door to admit a cow from the holding area. The cow is stopped in the first stall for cleaning and then moves on to the next stall for milking. The arrangement of the stalls permits two cows to be milked simultaneously while a third cow is being prepared for milking. From his comfortable chair the farmer can twist a crank, dropping mixed grain and feed supplement into two mangers from an overhead hopper, permitting the cows to feed while they are being milked. The walls and ceiling of the building are insulated and the inside walls are lined with easily cleaned plastic. The stalls, mangers, swivel chair and even a towel dispenser are provided. Only the milking equipment, plumbing and wiring are not included since each farmer has his own preferences.

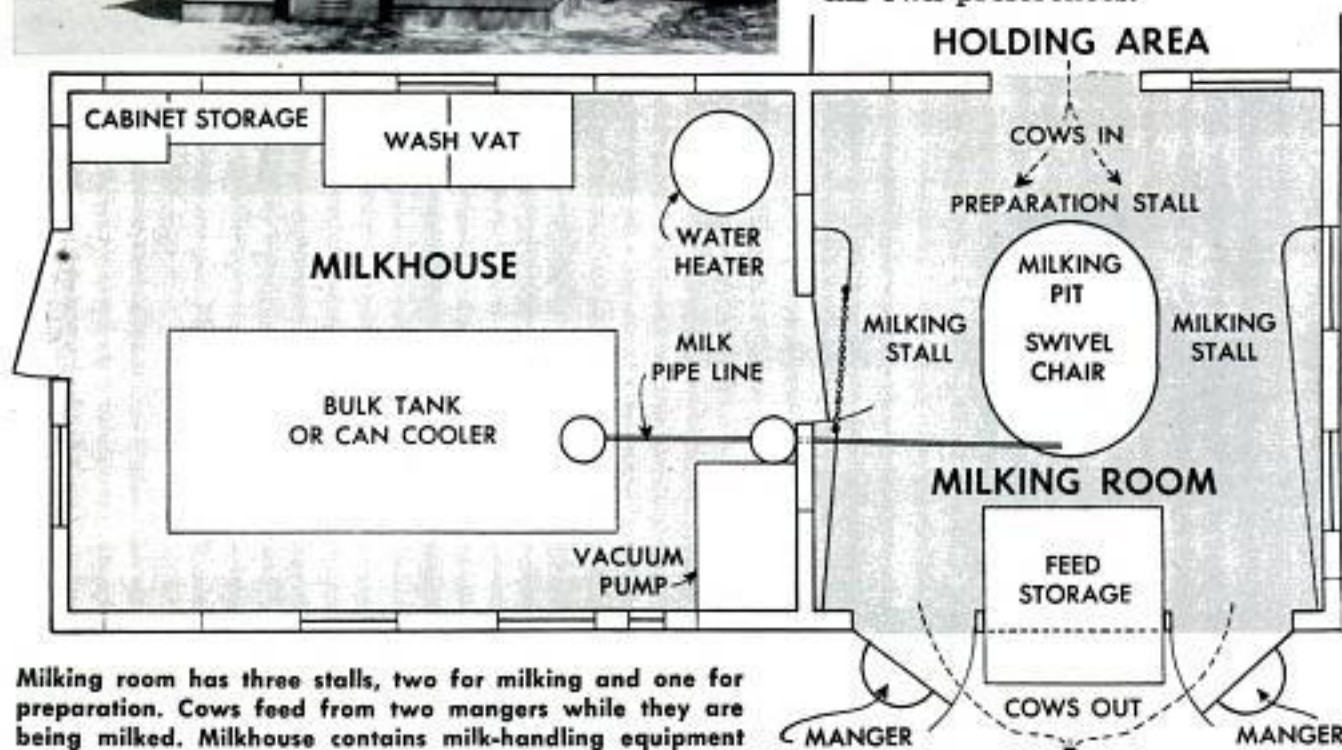

Milking room has three stalls, two for milking and one for preparation. Cows feed from two mangers while they are being milked. Milkhouse contains milk-handling equipment



Lucille Ball helps producer-inventor Oppenheimer cut birthday cake



By
Bill Tusher

He's "The Brains" of *I LOVE LUCY*

AT LUNCHEON recently on the Hollywood set where *I Love Lucy* is filmed for TV, Lucille Ball said to me: "By the way, if you ever want anything invented, see 'The Brains.'"

The name of Jess Oppenheimer, head writer and producer of *I Love Lucy*, had come up during our discussion, and it was to this one-man "idea factory" that Lucy was referring when she spoke of The Brains.

Oppenheimer came by the appellation of The Brains because of an amazing penchant for inventing mechanical devices at the drop of a problem. He dreams them up—

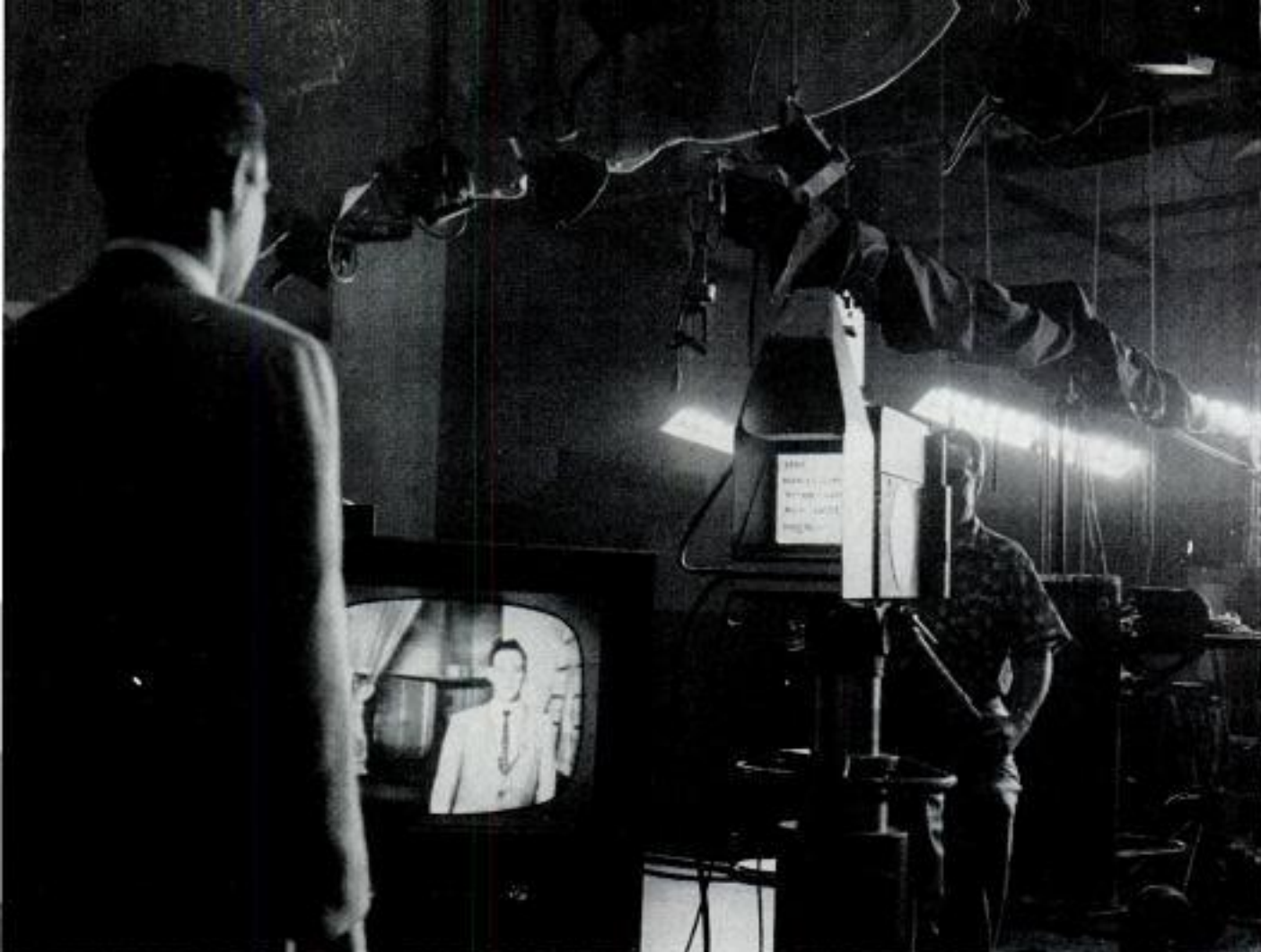

Oppenheimer's tricky viewer for commentators permits them to look directly into TV camera and read script

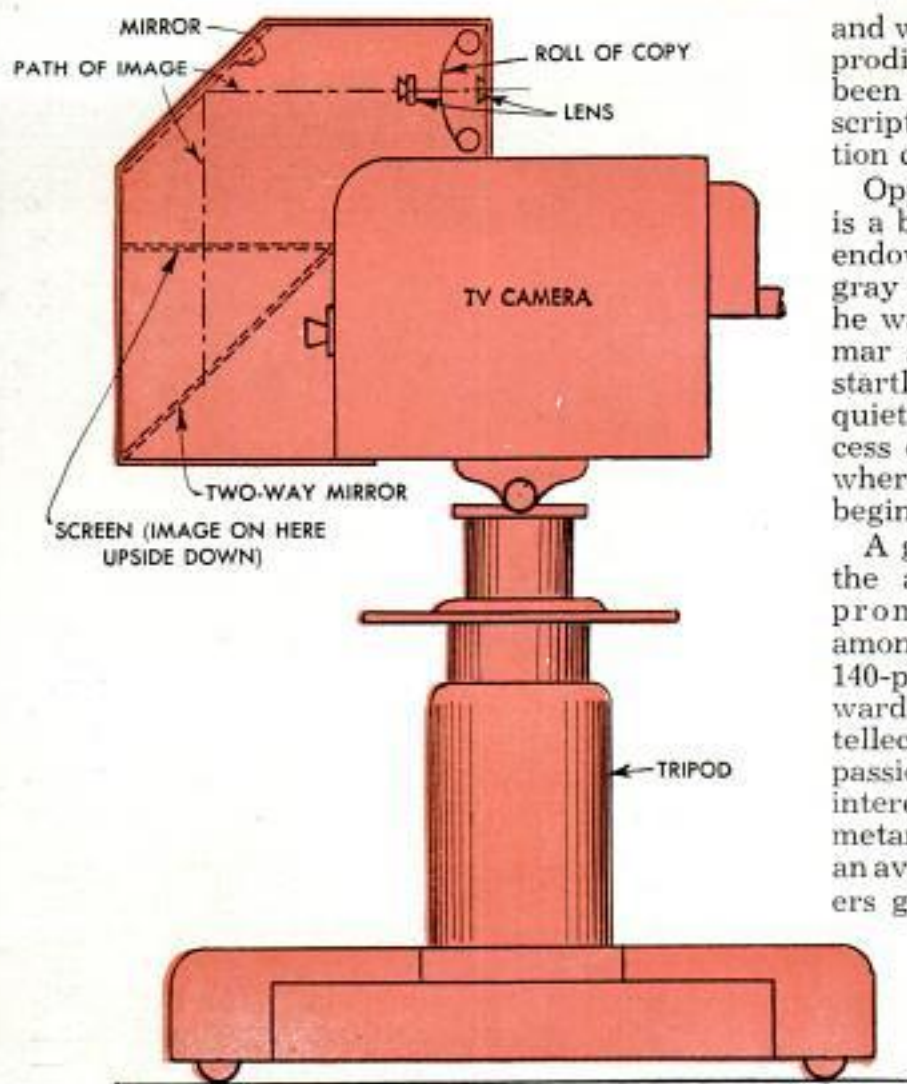

and works them out—with the same prodigiousness and facility that he's been turning out award-winning scripts for the most popular situation comedy on television.

Oppenheimer's associates say he is a bona fide genius who has been endowed with a surplus supply of gray matter from childhood. When he was in the third grade of grammar school, his teachers made the startling discovery that he was quietly toting around an IQ in excess of 140, that mental borderline where normalcy ends and genius begins.

A group of college savants under the aegis of Stanford University promptly included young Jess among the 1000 gifted children of 140-plus IQ, and from that day forward Oppenheimer has been an intellectual guinea pig followed with passionate interest by psychologists interested in the social and economic metamorphosis of the genius. On an average of once a year, fieldworkers go forth and check on what is happening to these human brain trusters. It is obvious that Jess Oppenheimer has been no disappointment at all to Prof. Lewis Terman,

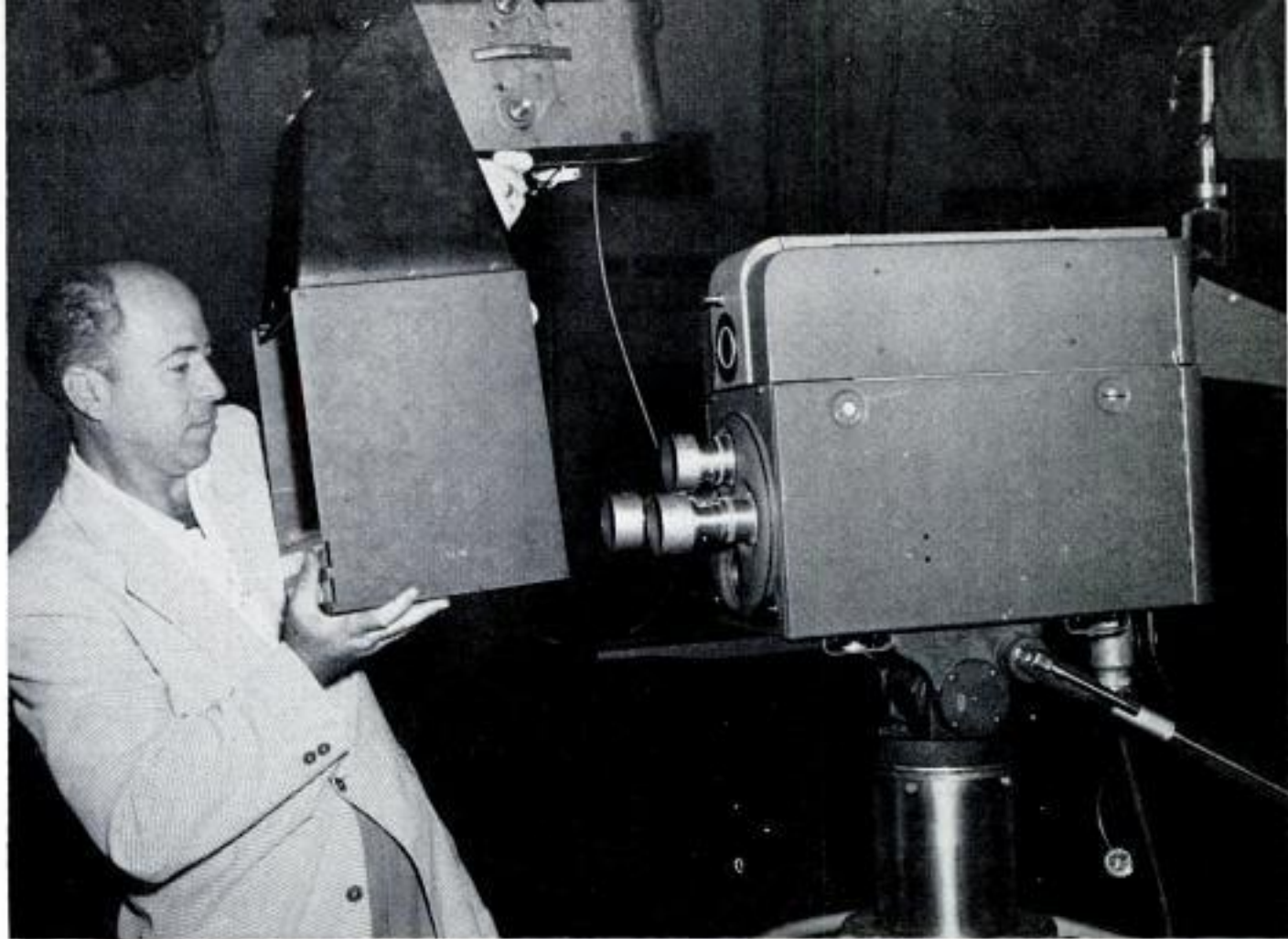

The inventor prepares to mount his Jayo Viewer in front of TV camera. It does not interfere with the lens

head of the test-study group and dean emeritus of the psychology department at Stanford.

For years before the advent of TV, Oppenheimer was a top radio writer, and he made the transition to the new medium as the head writer and producer of *I Love Lucy*, having been the chief scribe of Lucille Ball's kilocycle forerunner, *My Favorite Husband*.

So far in his inventive binge, Oppenheimer has come up with the following:

1. The Jayo Viewer—a device which makes it possible for a television commentator or actor to look directly into the camera while reading his lines, rather than to the side or below the camera.

2. An ingenious push-button system for authentic audience reaction on filmed TV shows, which does away with actual audiences, stops actors in their verbal tracks and answers all the criticisms hurled, he feels justly, at phony laugh tracks.

3. A directional-control ball caster which provides flexibility and speed of movement not possible with conventional camera dollies.

4. An inexpensive system for synchronizing series-wound motors.

5. Special glasses designed to take the headache out of third-dimension films by permitting the viewer to watch 3D in 2D!

6. Safe home electrical outlets from

Viewer not only provides clear view of script for commentator or actor, but also cues from director



which children cannot receive a shock even if they insert a screwdriver.

There will be more on the way. Oppenheimer is thinking all the time. Almost all his inventions have materialized after he explained his idea, and his wife, Estelle, scoffed, "That's impossible!"

The first time this happened was when their 5½-year-old daughter, Joanne, was one. Just because children from time immemorial had been given to spilling their food over themselves was no valid reason, in Oppenheimer's opinion, why he should put up with that nuisance.

He went to the nearest machine shop with the baby's spoon, had them put a swivel on it, and from then on, no matter how precariously Joanne conveyed the spoon to her mouth, the swivel connecting the handle and the bowl prevented the spoon from turning over.

Since then someone has come out with the same idea commercially. That was before Oppenheimer was impressed with the profit-making potentialities of his inventions. Patents have been applied for and granted on all his subsequent inventions. Oppenheimer has formed his own corporation, and invested thousands of dollars in working models of his viewer and directional-control ball caster with the intention of bringing them promptly to a waiting market.

Oppenheimer's associates at Desilu Productions, the organization which handles the filming of *I Love Lucy* and four other major television shows, got their first indication of his

inventive genius when they came to him with a problem involving the splicing of film. They found that every time they used a paper clip to splice two sections of film, the clip made a click on the magnetic sound track. They tried using tape, but this was unsatisfactory, too, because the tape was sticky and gathered dust.

"The answer," smiled Oppenheimer, "is simple. All you need is aluminum paper clips."

He ordered a supply manufactured by a company in the East, and they have been filling the bill perfectly ever since.

From that time on, it became the standard procedure on the TV movie lot, when thrown by a problem, to implore Oppenheimer to invent a way out. Having been dubbed *The Brains*, Oppenheimer good-humoredly accepted his new extra-curricular position in the Desilu kingdom.

It had been a continuing source of annoyance for Oppenheimer to watch television newscasters surreptitiously looking beside or below the camera to read their scripts. Oppenheimer kept saying, "If only there was something they could put in front of the lens to do away with that."

One night while the Oppenheims were watching a TV news show in the den of their

Brentwood home, the drapes happened to be pulled back, and Oppenheimer happened to look at the window. He saw a reflection of the room in the window, jumped up excitedly and cried: "That's it!"

"Dear," his wife asked quietly, "what is it?"

Oppenheimer (standing) inspects a new film for the *I Love Lucy* show



Oppenheimer jubilantly explained that because it was dark outside and the lights were on in the room, it was possible to see the reflection in the window. Yet, he pointed out, if he were outside in the dark, looking inside, he wouldn't see any reflection at all in the window.

"Well," he concluded triumphantly, "there's no reason why I can't apply the same principle to the television lens and figure out a way of looking directly into the camera to read the script without interfering with the picture."

Oppenheimer promptly built a working model of the Jayo Viewer. It works so well that he stands to make a young, or even a more substantial, fortune renting the viewers to television stations which have been praying for just such a miracle.

His viewer projects a reflection of the script—in letters that are $\frac{5}{8}$ inch high—onto a two-way mirror placed in front of the lens at a 45-degree angle. The commentator or actor can't even see the lens. He merely sees the script going by. Conversely, the lens penetrates the antireflective coating on the rear of the mirror and photographs the performer without picking up any of the light illuminating the script. The effect is that the commentator may relax, and in fact give the impression that he is thinking up his lines as he goes along.

Oppenheimer's viewer not only achieves the illusion of spontaneity in newscasts, but it effects other improvements and short cuts which the industry is expected to welcome.

For purposes of visibility, it previously had been necessary to develop a special typewriter with letters $\frac{1}{2}$ inch high. Special paper—usually teletypewriter paper 12 or 13 inches wide—was required. This



By flicking tiny rod on one lens of Oppenheimer's 3D glasses, the image is converted to restful 2D

paper had to be placed before the performer in sections or panels.

With the Jayo Viewer, any conventional typewriter may be used. A roll of carbonized acetate is fed into the typewriter, and wherever the surface is struck by a typewriter key the carbon is removed, leaving a transparent film—or white letter—against a black background. When this film is projected onto the beam splitter—the Oppenheimer two-way mirror chemically treated with 25-percent-transmission and

(Continued to page 238)

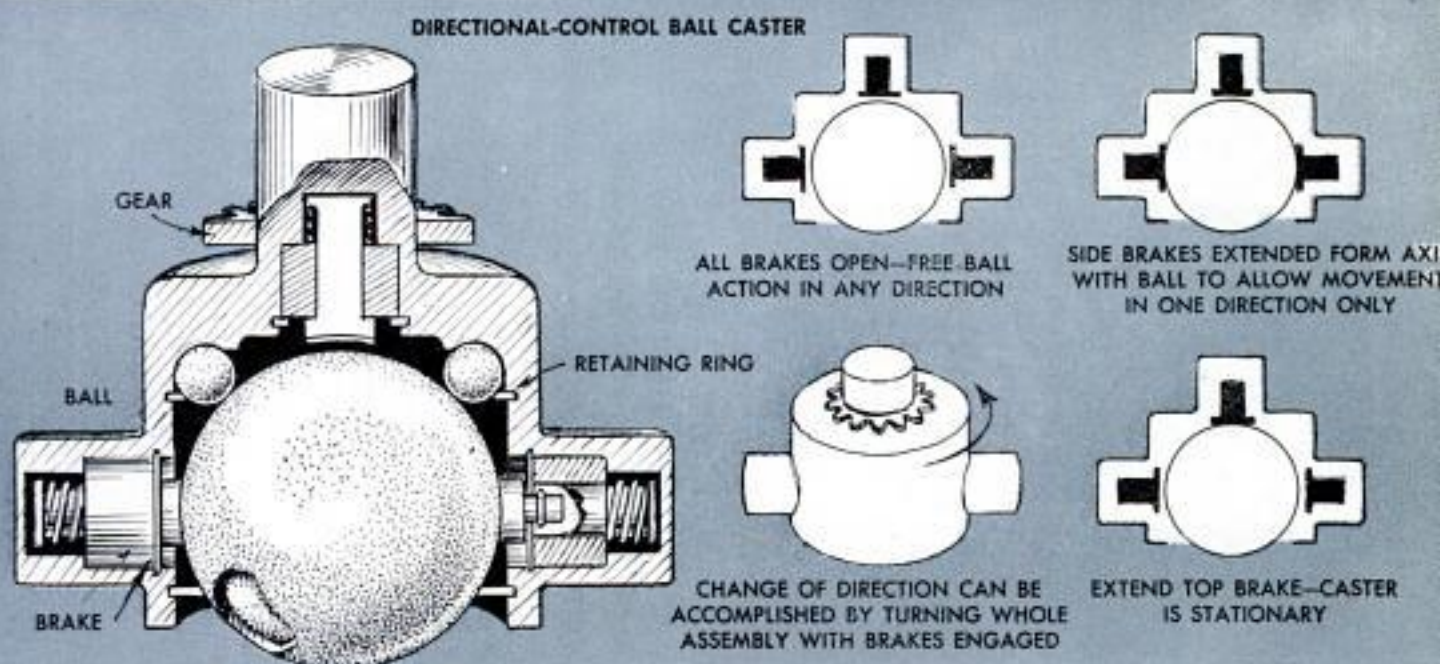

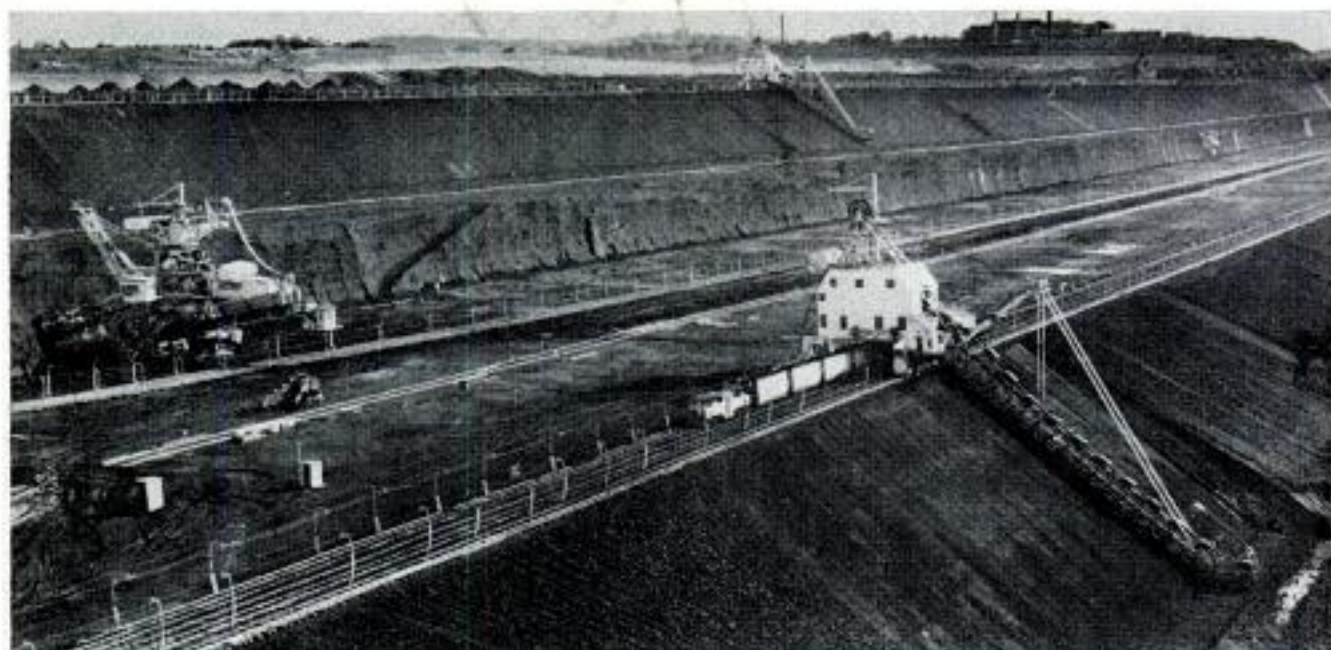

Three giant dredgers in brown-coal open cut at Yallourn, Australia, produce 20,000 tons of coal daily

Australians Mine Brown Coal for Gas

BROWN COAL, which lies untouched in many countries, will be turned into gas for commercial and household use by a new plant near Melbourne, Australia. The fourth of its kind in the world, it will be similar to three plants built in Germany and now behind the Iron Curtain.

Earthy brown and crumbly, brown coal is much different from black coal and has a high moisture content, low heating value, deteriorates rapidly in storage and often ignites spontaneously. Although unmined in the United States, it comprises almost one third of our total coal resources. In

Dredger's endless chain of buckets digs 550 tons of coal hourly

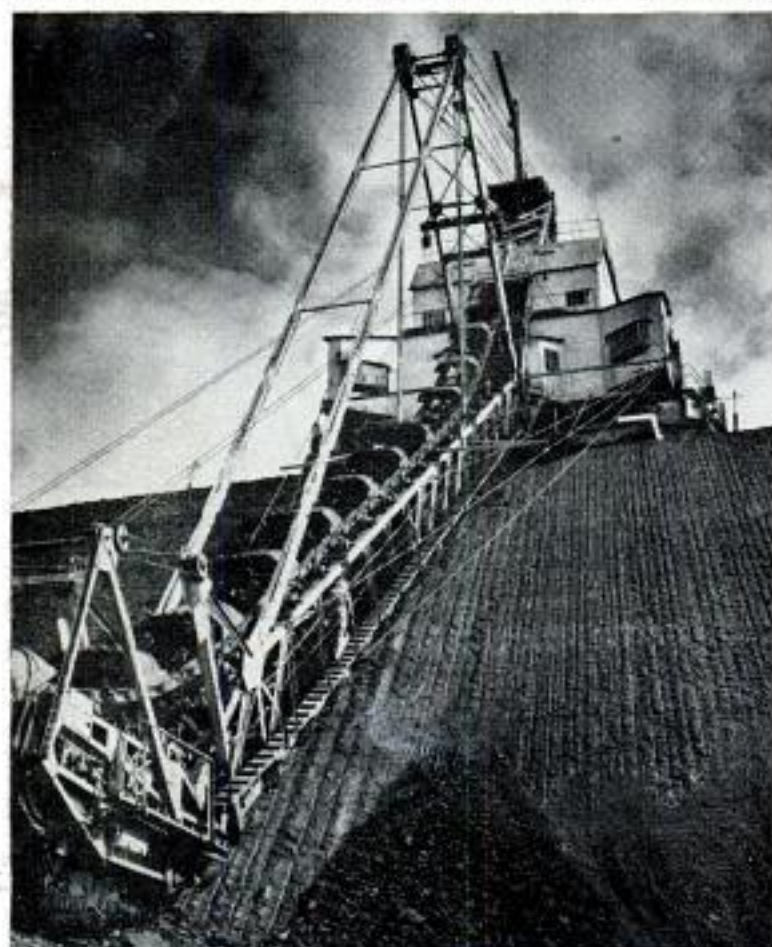

Australia, brown-coal reserves outnumber black-coal reserves. Nearly 7,000,000 tons of brown coal are taken each year from the great open-cut mine at Yallourn.

The Melbourne plant, due for completion in 1956, will use a mixture of one third raw coal and two thirds dried briquettes. Oxygen and superheated steam are mixed outside the generator and fed into it through the grate. They come in contact with the carbon derived from brown coal to produce a mixture of hydrogen and carbon monoxide known as "water gas." As this rises through the bed, its temperature falls and methane formation takes place, increasing the heating value of the gas. The gas is then washed and precooled in a spray cooler and further cooled under pressure in tubular coolers, where tar and oil by-products are condensed and recovered. It is stripped of the benzol it contains, dried, and piped into town mains.

It is expected that within 30 years all of the gas used in Victoria will come from brown coal. Gasoline, diesel oil and tar will be among the valuable by-products.

Art of Carpentry Taught by Kits

A SCALE-MODEL method of teaching carpentry is being used with great success in a number of high schools and colleges. Each student is furnished with a complete kit of miniature lumber for building a cutaway model of a house, barn, church or some other structure. Called Minimalic Construction, the method was developed by O. G. Hughson of Portland, Ore., 89-year-old philanthropist and educator, who has spent 20 years perfecting this means of giving boys a trade know-how along with the fun of a hobby.

Each Mini kit contains a full stack of lumber (230 pieces) plus blueprints, nails and instructions. Because a complete model house would be immensely complicated, these are of cutaway plan. The building's framework is completed; enough of the siding, roof, doorways and so forth is installed to give the principles involved. The models are of good size, scaled $1\frac{1}{2}$ inch to the foot, so they can be assembled by standard methods. Regular carpentry tools are used and each board

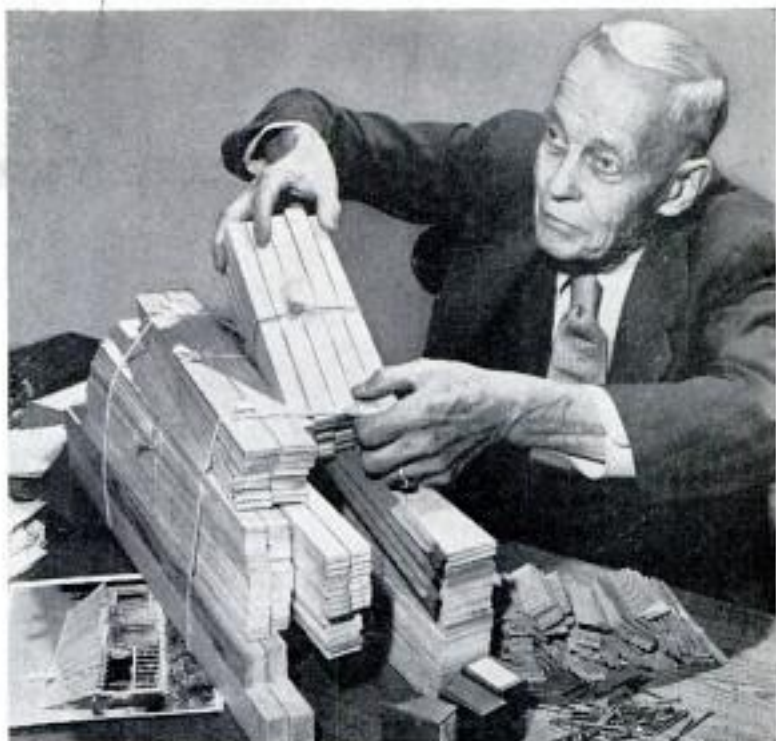

O. G. Hughson inspects a kit of miniature lumber for building a cutaway model house. Even the nails are scaled to size

is fitted and assembled with small nails just as if it were on a real house. The student learns how to use a carpenter's square, to read blueprints, methods for putting in a foundation and framing, then finishing with siding and window frames. Kits are available only to schools and most of the cost is absorbed by West Coast lumber companies.

Houses, barns and even churches are constructed in cutaway design by students learning building principles

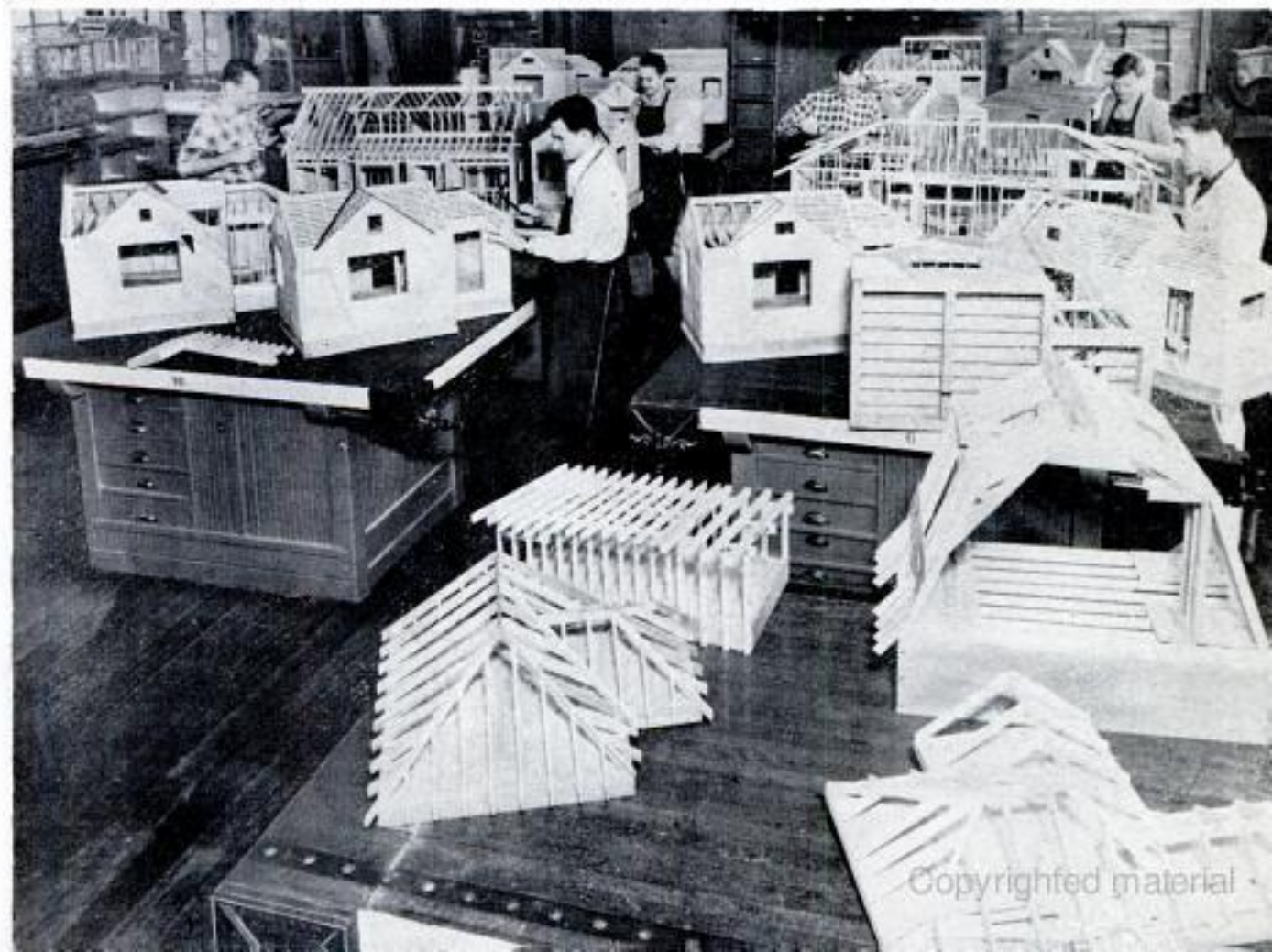



Six-Shooter of Frontiersmen Stages Comeback

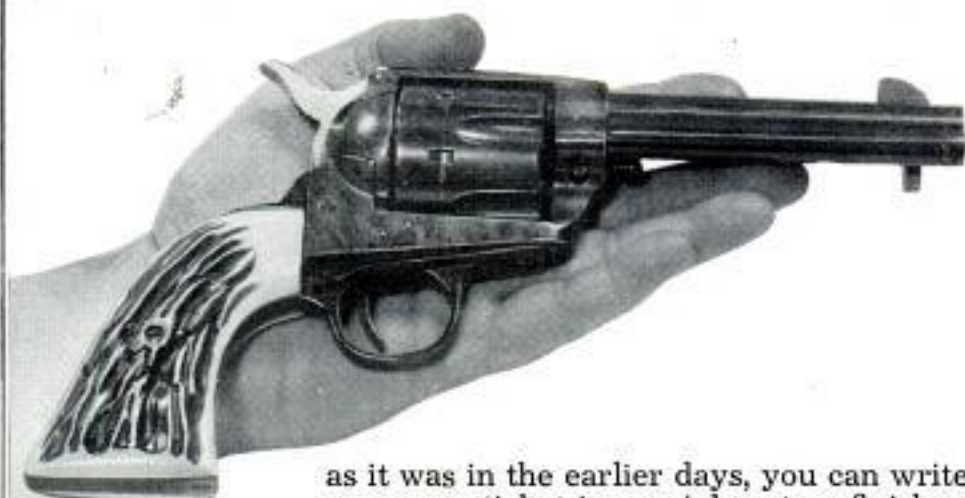

Expert handgunners, collectors and gun fanciers generally agree that among heavy handguns the Colt Single-Action Frontier Revolver is a natural, one of the finest ever designed. It was made by the originators for nearly 70 years, but was discontinued prior to World War II. An exact duplication is now offered by another manufacturer, with modern steels and new calibers. Just

as it was in the earlier days, you can write your own ticket in special custom finishes, nickel, chrome, silver, gold, both plate and inlay. The engraving ranges from the simplest scrolls to full presentation. With only a few minor exceptions, involving changes in screw threads and firing-pin assembly, the new gun is a perfect reproduction of the old Frontier Model. It has the same weights, lines and barrel lengths. To the eye, it is the same handgun that recalls so vividly the stories, legends and personalities of the frontiersmen who many years ago made it famous.

Droplight Hook Clamps in Position

Droplights with reflectors stay put when a new plate with an attached hook replaces the existing hook. The replacement is made after removing the old hook and drilling or punching two holes. Strong spring tension holds the light in any of six positions. The position of the light can be easily changed by rotating the hook.

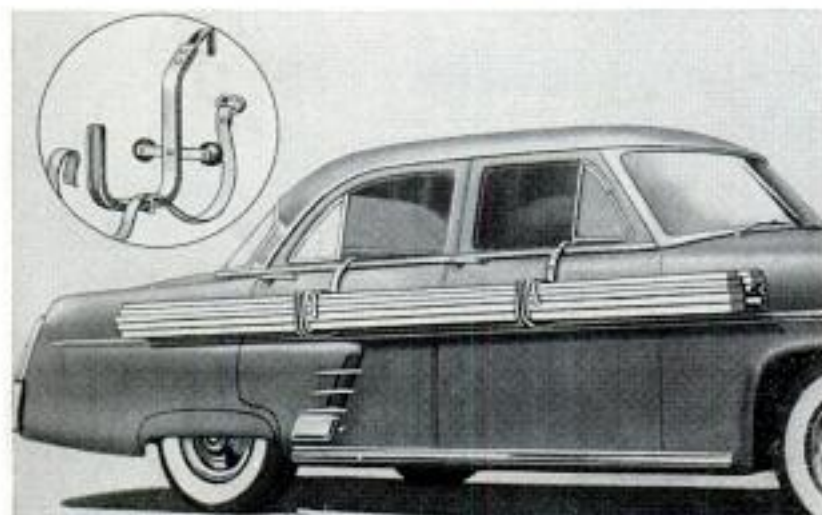
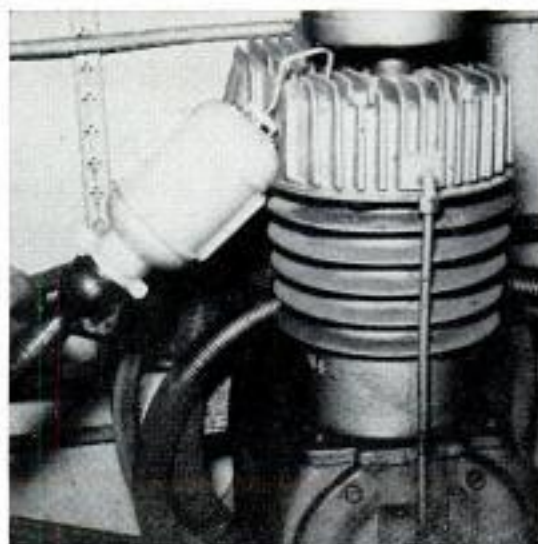

Car Carrier Goes on Or off in Seconds

Ideal for carrying pipe, lumber, poles or other long, narrow items, a hook-type car carrier simply slips between the window glass and the door. There are no clamps to apply or screws to tighten. Suction cups protect the finish of the car door. The load is tied down and held in place by straps. With a pair of the carriers, 12-foot lengths of lumber can be carried easily and safely.

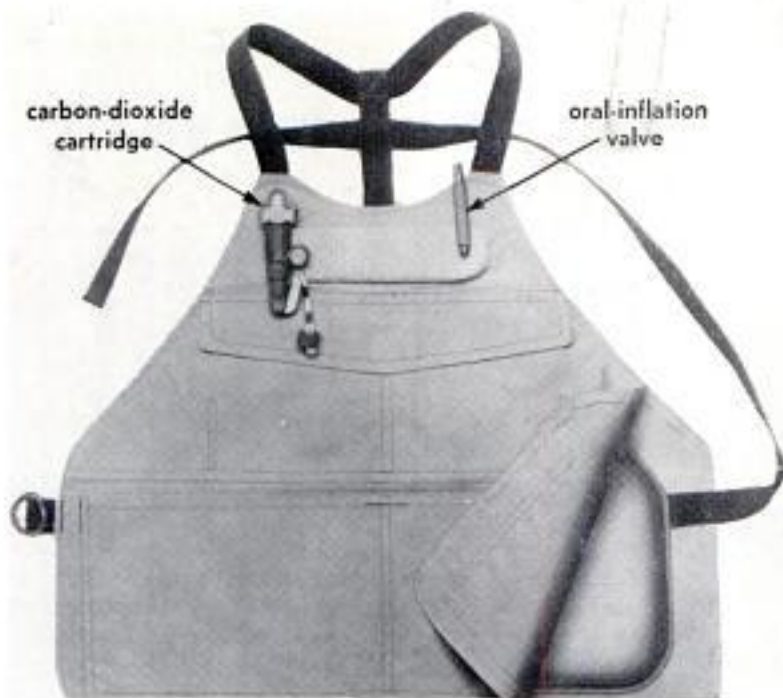

Bladder inside vest is inflated by carbon-dioxide cartridge or lung power. Vest has pockets for equipment

Dual-Purpose Fishing Vest Becomes Life Preserver

Fishermen need not fear deep water when they're wearing a new inflatable vest. Inside it is a detachable, rubberized cloth bladder that is blown up by a cartridge of carbon dioxide when a plunger cord is pulled. There is also a valve for deflation and for oral inflation. A main advantage of the garment is the fact that it doesn't have the appearance or bulk of a conventional life preserver. On the poplin vest is a pad for hooking flies and spoons for ready access or drying. Six pockets hold a variety of articles. The harness is of heavy web straps that are adjustable to fit any person. The wearer can swim easily or simply float on his back.

Vest easily supports man with hip boots and heavy clothing. User always floats in a face-up position

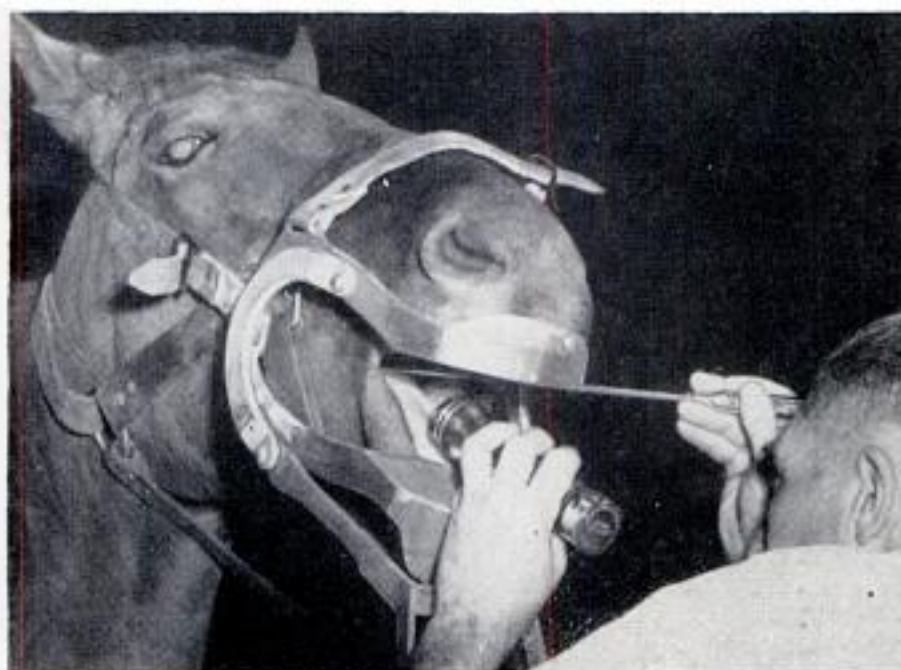

Mouth Prop Protects Hands

Veterinarians at their recent national convention got a peek at a handy device for propping open a horse's mouth. The sturdy metal unit allows a doctor to inspect throat, tongue and teeth without danger to hands or equipment, and without loss of time.

Composed of fly ash, lime and coal slag, a new runway material has been developed that resists the terrific heat of jet-engine exhausts.

WHAT'S NEW FOR Your Home



1. NOZZLE for tank-type vacuum cleaners is made to clean cotton, shag, hooked, loop and rag rugs. Bottom surface of nozzle is a gridded plate which glides smoothly over stringy carpet. Fluffy nap or strings are lifted and vibrated to loosen the dirt, but plate prevents nap from being sucked into nozzle

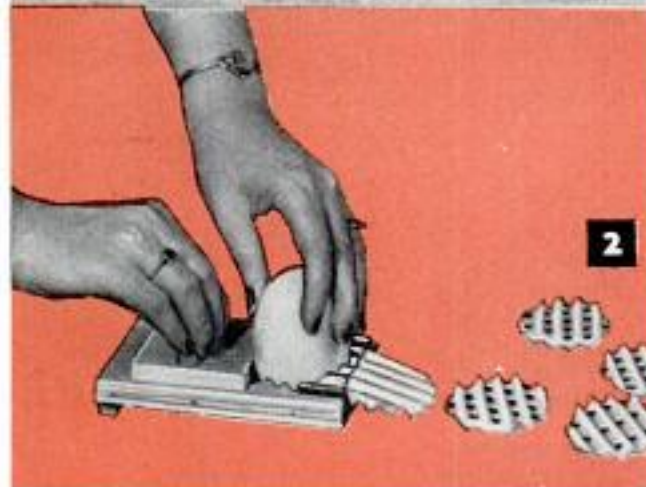

2. POTATO SLICER produces latticed wafers for frying. The unit consists of a cleated wooden block and stainless-steel cutters, and cuts crisscross strips and holes in the slices by a push-pull motion. The slices are uniform and are cut without waste. Diamond-shaped or square holes can be cut in wafer



3. STEAMING BASKET with collapsible sides adjusts to fit any cooking pot, transforms it into a steam cooker. It can be used for warming bread and leftovers, to defrost frozen foods, as well as for cooking. Telescopic fold-in legs keep basket from touching water. Handles protect hands from steam



4. BEVERAGE DISPENSER mounts rubber bulb which is pressed when a glassful of liquid is wanted. Spillage and breakage are eliminated because the container remains in the refrigerator until empty. The gallon unit, when filled with milk, encourages children to serve themselves

5. ADJUSTABLE MATTRESS is inflated or deflated to regulate firmness. Sleeping surface is of foam rubber and foundation consists of air cylinders. Each half of the double mattress can be inflated independently. The one-piece mattress foundation rests on a wooden platform



6. REVOLVING TRAY equipped with ball bearings turns at light touch even with a heavy load. Tray can be used by Scrabble players, or by an amateur chef to hold sauces and spices. Placed on refrigerator or cabinet shelves, the tray turns to bring foods "front and center"

5

7. FIRE ALARM consists of a gas-filled pressure can that sounds a shrill, five-minute warning and releases a sharp odor when room temperature reaches 135 degrees. The self-contained unit requires no maintenance, and is designed to supplement sprinkler systems and serve as a low-cost home fire detector



6

8. FIREPLACE SCREEN rolls up with the press of a foot lever, rolls down with the touch of a hand lever. A durable ball-bearing roller operates a cable to raise and lower the brass screen. The fine-mesh screen does not obscure the fire and allows heat to pass through easily. Finish is baked enamel

7



8





Turbine Fan Blows In or Out

Air is forced in or out of a room by a turbine-type fan that fits in the window like an air conditioner. Filters fitted in the ends of the cylindrical unit clean the air of dust and pollen. Air is supplied at the rate of 540 cubic feet per minute.

Fowl Feathers Removed By Dip in Solution

All feathers, even the pinfeathers, can be removed easily from ducks and other fowl with a new powder which is dissolved in water. The bird is dipped in the solution and, the manufacturer says, the feathers wipe off easily. The product also deodorizes the birds.

Most Powerful British X Ray

Reported to be the most powerful instrument of its type in the world, a 15,000,000-volt linear accelerator for research and treatment of cancer has been perfected in England. The machine will be installed in St. Bartholomew's Hospital in London. It first will be used for research, and later for high-voltage cancer therapy.

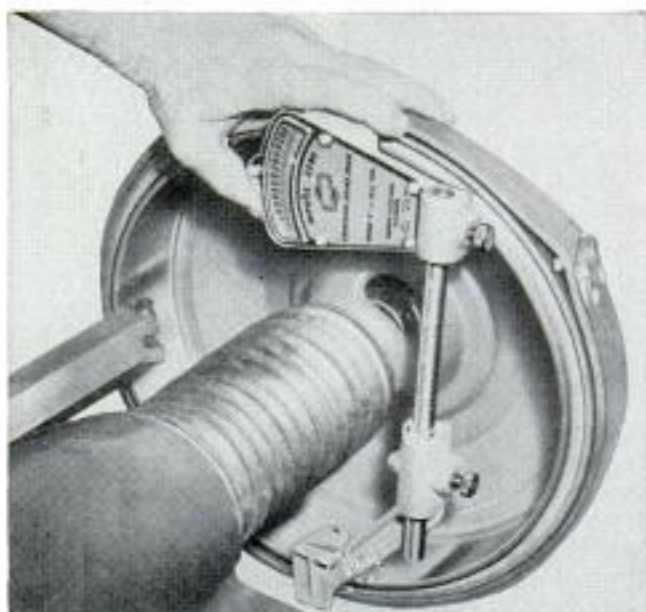

Gauge Measures Brake Drums

Featuring micrometer accuracy, a gauge for brake drums checks diameters to determine if the drums are round and safe enough for continued use. Measuring drums from 8 to 18 $\frac{3}{8}$ inches in diameter, the gauge can be used on drums on or off the lathe. Readings are seen on a large, direct-reading scale. By establishing diameter, the mechanic can match the lining to the drum for 100-percent contact.

Dolly Eases Tire Changing

One man can change truck tires weighing from 30 to 300 pounds with a lightweight dolly. The tool aids in pulling off the wheel and transporting it over floors, soft or hard dirt or over graveled terrain. It weighs less than seven pounds.





Fan in Place of Light Bulb Makes Lamp Produce Breeze

You can turn a desk lamp into a ventilating unit with a recent German invention. It's a compact fan that screws into any light-bulb socket. The three propeller blades are plastic and the device comes in a variety of colors.



Stroboscopic-Flash Unit Fits Miniature Cameras

Designed especially for miniature and candid-camera work, a lightweight stroboscopic-flash unit will provide 1000 flashes on one set of dry cells. The unit weighs only 50 ounces and comes in a case slung on a shoulder strap. Duration of the flash is about $\frac{1}{14}$ second, with three to four seconds required for the unit to build up power between shutter openings.

Uplifted Airplane Cockpit Protects Pilots While Dusting Crops

Perched several feet higher than they customarily are, pilots in a newly designed crop-dusting airplane are less likely to be crushed between the engine and the cargo in the event of an accident. Most dusters now in use are converted trainers in which the pilot sits directly ahead of hundreds of pounds of chemical. The new airplane also has sharp steel blades on the leading edges

of the landing gear to cut any wires it might accidentally strike while flying low. It weighs 886 pounds empty and carries an 800-pound load of chemicals. When it has been certified by the Civil Aeronautics Administration, the plane's builders, Charles Kellenbarger and the Ohio Aviation Research and Development Foundation, plan to make the blueprints available.



OWNERS REPORT:

No other car in its field is as famous as the Jaguar XK 120. To learn its good and bad qualities, we polled owners from coast to coast. Here is what they wrote

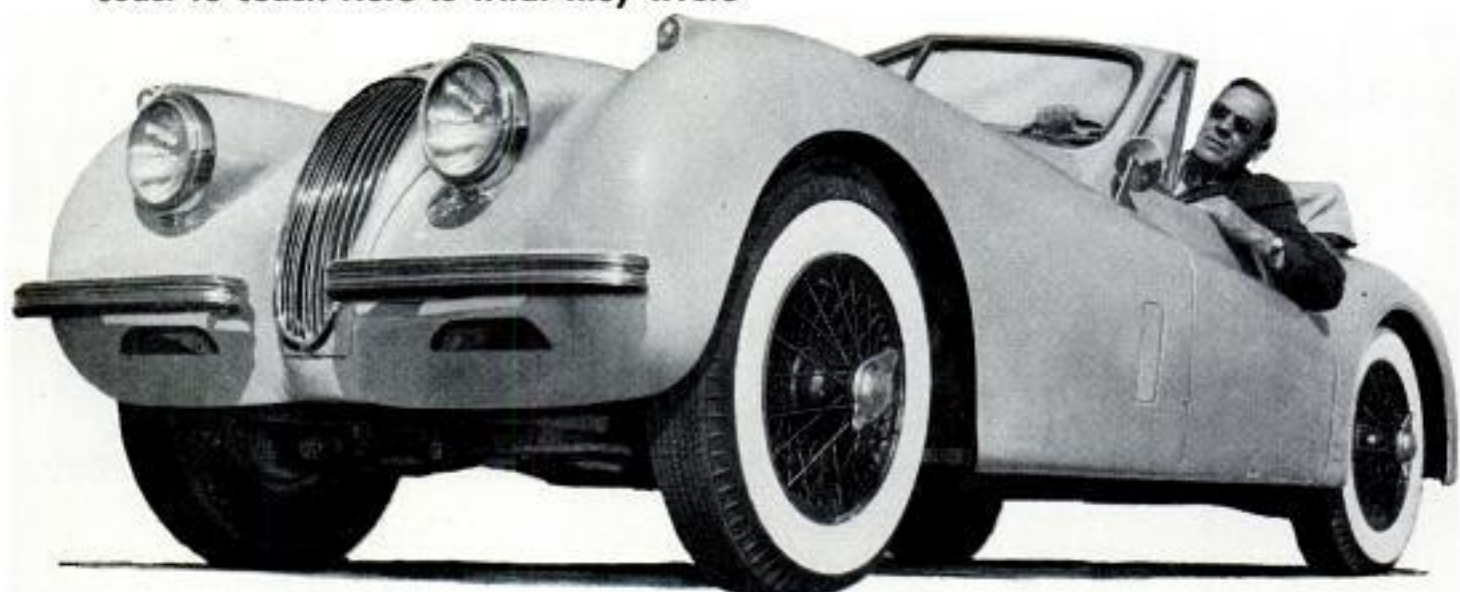

Owners Praise:

Roadability

"A pleasure to drive on a twisting road."

Oklahoma retailer

Performance

"Very fast acceleration. Eats up the miles on long trips."

New York actor

Handling

"Gives a feeling of security at fast speeds."

Oklahoma produce dealer

Owners Dislike:

Leaks

"Terrible dust leaks. Doors not tight. Water comes in."

Iowa farmer

Brakes

"Brakes not easily adjusted. Still do not work properly."

Ohio physician

Ventilation

"After the first hot, rainy day with the side curtains up I was ready to sell the car."

New York executive

ROADSTER



HARDTOP



CONVERTIBLE



Jaguar Owners Rate Performance And Roadability As Top Features

By Jaguar Owners

PARKED IN FRONT of a banker's home or in the pits at Watkins Glen, the Jaguar looks as though it belongs! Performance or prestige—the Jag has it. Conservative businessmen and radical sports-car fanatics all share this attitude—they all love their Jaguars. Why?

To find out why, *Popular Mechanics* polled Jaguar owners from coast to coast.

As you might have guessed, the best-liked features of the Jaguar XK 120 are its performance and roadability.

"I like best the high-speed performance. This car can cruise all day at 100 m.p.h. and still have sufficient reserve power. Good gas mileage at high speeds also."—Ohio mechanical engineer.

"Has quick response. Seems to be alive."—Iowa cattle feeder.

"It's willing to go under all conditions. Top speed is 138 miles per hour when tuned to perfection."—New Jersey pharmacist.

Not far behind performance was roadability in the owners' list of best-liked

features. (Roadability is a car's ability to hold its course on any type of road at all speeds. It is a characteristic that any successful sports car must have.)

"Flat cornering and a feeling of security at fast speeds."—Oklahoma produce dealer.

"Its roadability will tolerate many mistakes on the part of the driver, even at high speed."—New York technician.

"There is nothing that can compare with it as a very fast touring car."—New York engineer.

"Roadability excellent except on wet pavements where it is very skiddish."—Ohio business executive.

"A pleasure to drive on a twisting road. Cornering among the best. Rear end hard to make break loose."—Oklahoma retailer.

Owners Do Have Complaints

Although owners are almost unanimously enthusiastic about their Jaguars, there are some complaints. Roadster owners

(Continued to page 142)

CLYMER ROAD TESTS THE JAGUAR

By Floyd Clymer

FOR ANYONE who wants to drive a different kind of automobile, one that packs a terrific punch and handles unlike any American car, the Jaguar XK 120 is his dish.

I drove the test Jaguar XK 120 M (modified) in California, to Santa Maria, to Bakersfield, over the hot Mojave Desert, over winding mountain roads of the Lake Arrowhead region, returning over the Angeles Crest mountain highway to Los Angeles, a distance of 512 miles. The test was over all types of roads, including some off-highway roads that were no more than trails.

Outside of a lot of necessary gearshifting



in city traffic and on hills, the car is easily controlled and flexible in performance. Handling on corners is excellent, due to the combination of a short wheelbase, narrow tread, excellent power and suspension and its light weight that is well-balanced with 1500 pounds on front and 1610 pounds on rear wheels.

The six-cylinder engine develops 190 horsepower at 5400 revolutions per minute, with a compression ratio of 8:1. With 210-cubic-inch displacement, the engine size is smaller than either a Ford Six (223.0 cubic inches) or a Chevrolet Six (235.5 cubic inches). This engine provides high power

(Continued to page 248)

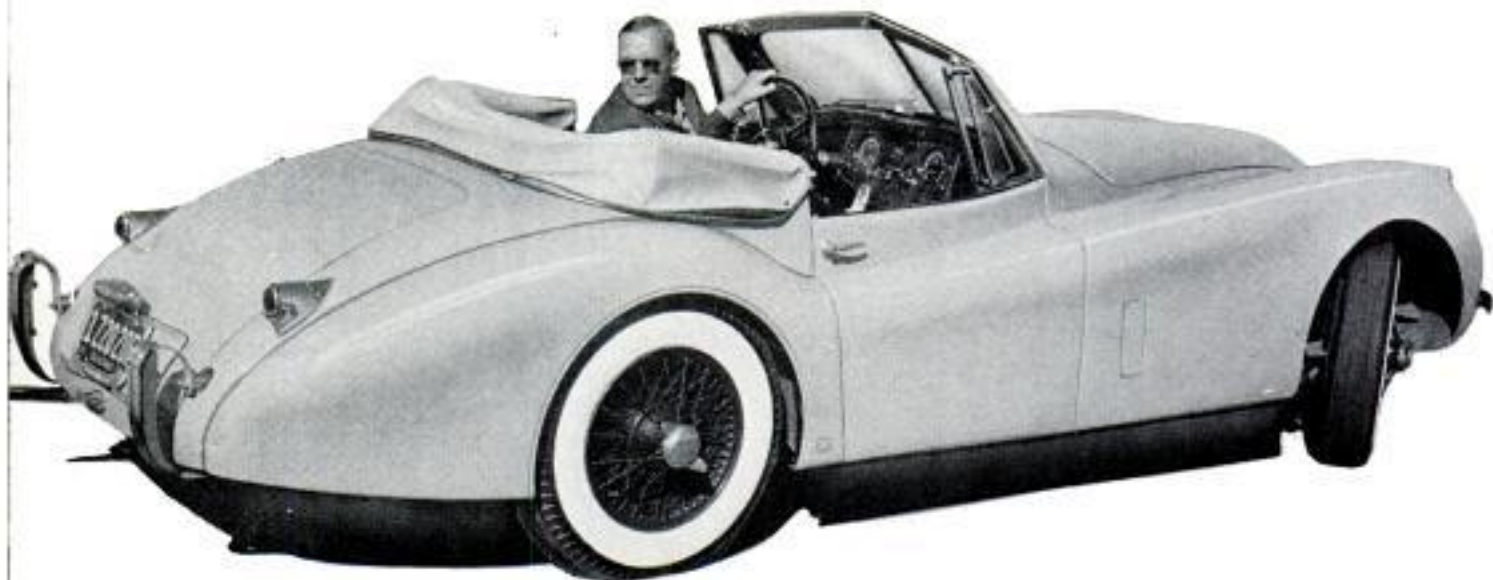

With its small turn-circle diameter (31 feet), narrow tread and short length, the Jaguar is easy to park



Telescopic column enables the driver to adjust steering-wheel position to suit himself. Instrument panel is made of hardwood

Luggage space in trunk is inadequate, say some owners. The spare tire fits in separate compartment under luggage space

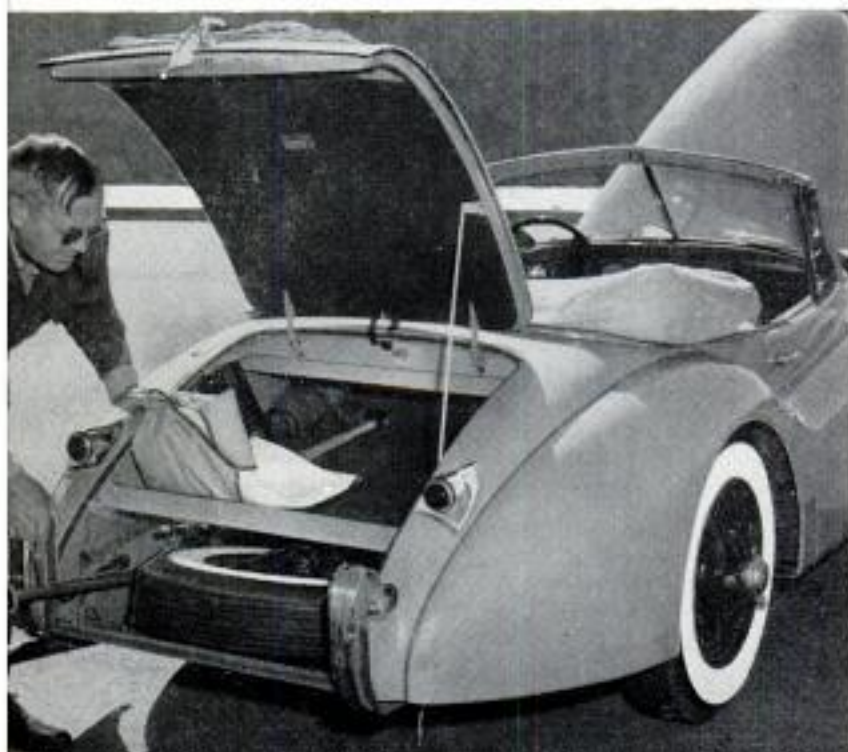

complain principally of annoying rain and dust leaks in passenger compartment and trunk. Owners of the other two models, convertible and hardtop, made no such complaints.

"Roadster top leaks."—New York realtor.

"Canvas top could be better designed to prevent leaks and avoid scratching body."—Illinois broker.

"Too many openings on roadster for water to be blown in during rain."—New York businessman.

"Not very happy with side curtains. Rain leaks in through them and also into trunk."—Indiana beautician.

"Side curtains leave drafts."—New York accountant.

"Top on my convertible does not leak and I put it up and down with one hand."—New York model.

"Rain does leak in some, but amount is insignificant."—Ohio physician.

Second on the list of complaints was that old bugaboo—poor dealer service.

"I have had trouble with my dealer. It seems to me that he has dollar signs in his eyes."—New York serviceman.

"I am trading my Jaguar in on a regular American car. Why? I can't afford two cars and you must have two if you own a sports car so you will be able to get around when the dealer is working on yours—that is if you're lucky enough to get to leave it at his exalted location!"—Ohio salesman.

"Dealer service in this area is very poor. Car was taken to garage with complaint of missing at high

Percentages From PM Poll of Jaguar Owners

Average mileage reported
by Jaguar owners...5204 miles

Average miles per gallon:

On trips.....17.2 m.p.g.
In traffic.....14.6 m.p.g.

Owners having:

Roadster model.....63%
Convertible coupe.....11%
Hardtop coupe.....26%

Handling:

Excellent.....88%
Good.....10%
Poor.....2%

Roadability:

Excellent.....82%
Good.....18%
Poor.....0%

Structural rigidity:

Excellent.....69%
Good.....27%
Poor.....4%

Acceleration:

Excellent.....88%
Good.....12%
Poor.....0%

Average time from 0-60

m.p.h.....8.5 sec.

Average top speed.....120 m.p.h.

Engine:

Excellent.....89%
Good.....11%
Poor.....0%
Prefer some other kind.....0%

Over-all rating of Jaguar:

Excellent.....78%
Good.....19%
Fair.....3%
Poor.....0%

Transmission:

Excellent.....70%
Good.....26%
Poor.....4%
Prefer automatic.....4%

Body styling:

Excellent.....87%
Good.....13%
Poor.....0%
Would prefer roll-up windows.....62%
Would not prefer roll-up windows.....38%

Canvas top:

Easy to operate.....49%
Difficult to operate.....51%
Owners reporting rain leaks into body.....73%
Owners reporting no rain leaks into body.....27%
Prefer additional passenger space.....23%
Would not prefer additional passenger space.....77%

Brakes:

Excellent.....67%
Good.....27%
Poor.....6%

Steering:

Excellent.....88%
Good.....8%
Poor.....4%

Riding comfort:

Excellent.....50%
Good.....50%
Poor.....0%

Have previously owned another sports car.....59%

Haven't owned another sports car.....41%

Own another car in addition to Jaguar.....70%

Would buy another Jaguar:

Yes.....81%
Might.....5%
No.....14%

Owner's rating of dealer service:

Excellent.....27%
Good.....27%
Fair.....17%
Poor.....29%

Owners belonging to a sports-car club or group.....21%

Owners using Jaguar in races, rallies or other competition.....20%

Best-liked features:

Performance.....64%
Roadability.....44%
Handling.....35%
Styling.....32%
Engine.....10%

Most frequent complaints:

Leaks.....21%
Poor service.....14%
Spark-plug fouling.....9%
Brakes pull when wet.....8%
Heats up in traffic.....8%

speed. A new set of plugs (the third in 4500 miles) and a sport coil were installed. A bill of \$30 was submitted for this service.” —New York physician.

“The car cannot be beaten. The dealer service, however, stinks. Dealer acts as if he is doing you a favor to sell you parts. Parts are slow coming and handled with an extreme lack of courtesy.”—Ohio student.

This complaint of poor dealer service was made by 29 percent of the owners. For

other percentages see chart on this page.

There were many owners (21 percent of them) who said they had absolutely no complaints to make about their Jaguars.

Why Own a Sports Car?

Anyone who has never driven a sports car always asks why would anybody buy such a small car? In quantity alone (how much per passenger) the sports car is certainly expensive. What, then, makes it

Cutaway shows location of chain-driven twin overhead camshafts, outstanding feature of the Jaguar engine

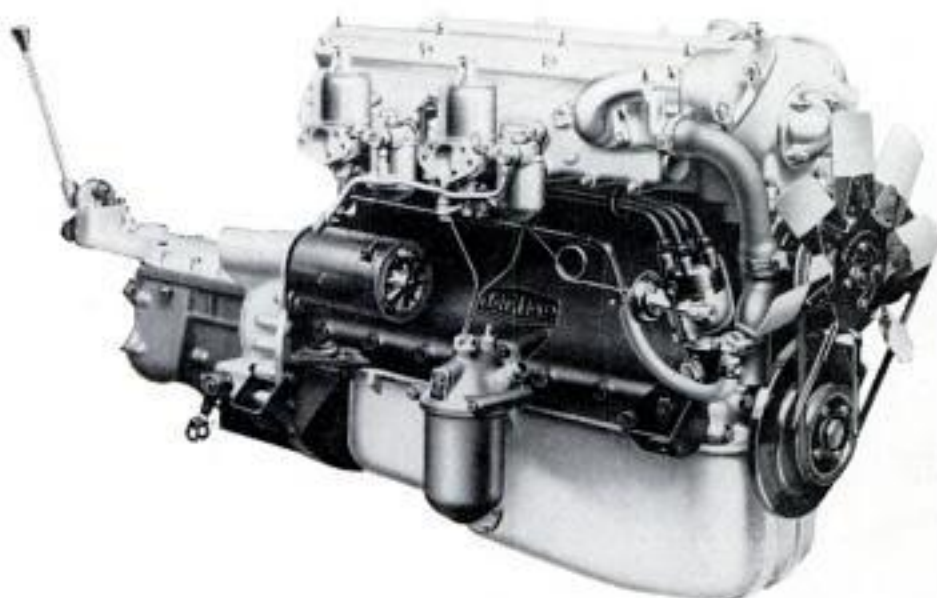
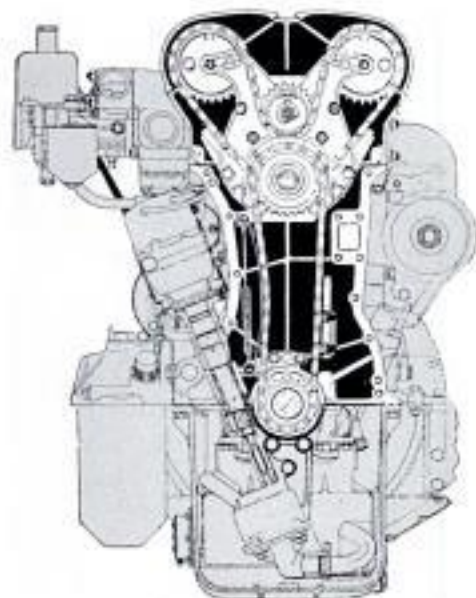

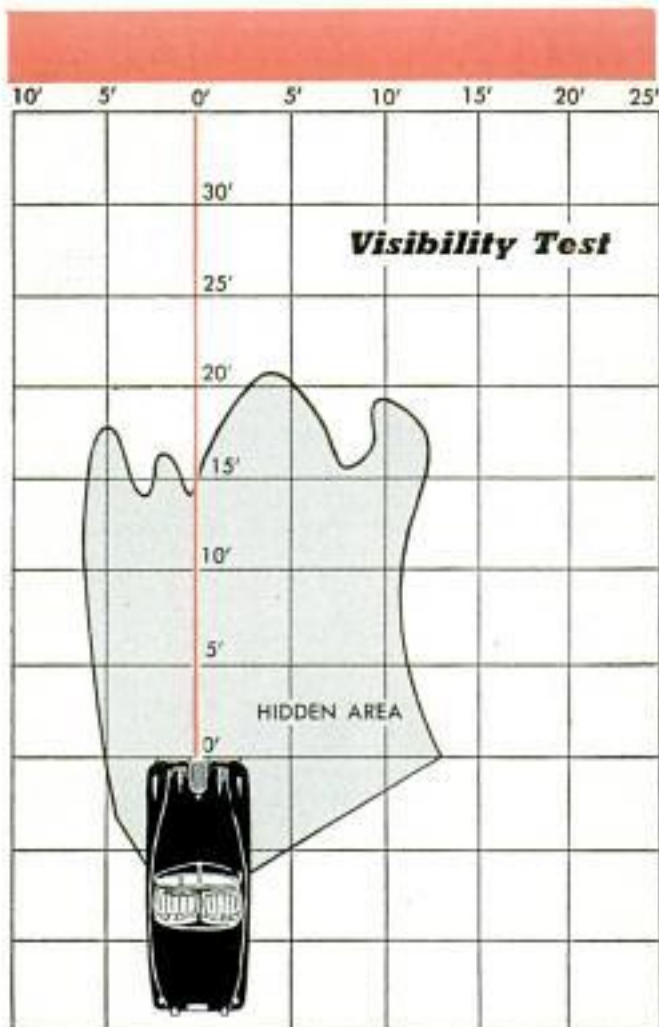

Acceleration Test

JAGUAR XK120M CONVERTIBLE

¼ mile from zero	16.9 seconds
½ mile from zero	26.5 seconds
0 to 30 miles per hour	3.6 seconds
0 to 60 miles per hour	8.7 seconds
Top speed by speedometer	132 miles per hour
Actual top speed about 120 miles per hour	

Economy Test

Constant-Speed Mileage

At constant 30 miles per hour	21.4 miles per gallon
At constant 50 miles per hour	19.2 miles per gallon
At constant 60 miles per hour	16.4 miles per gallon
At constant 75 miles per hour	13.1 miles per gallon

Cross-Country Mileage

Los Angeles to Santa Maria (moderate traffic)	17.4 miles per gallon
Santa Maria to Lake Arrowhead	16.1 miles per gallon
Lake Arrowhead to Los Angeles (Premium gasoline used)	17.2 miles per gallon

To provide a complete report on each automobile, PM combines two separate tests. One is written by the owners themselves and is the result of a coast-to-coast mail survey of owners selected from the registration lists. The other is a road test by auto writer, Floyd Clymer

as popular as it is both here and abroad?

"An excellent buy for the money. It puts the fun back in driving."—Iowa musician.

"The best method of getting from Point A to Point B with the least fuss and time and in a comfortable and enjoyable manner."—New York rocket engineer.

"An almost instantaneous response to steering. A fine car for the money. However, you must like fine cars and be willing to learn how to maintain and service them yourself."—New York embalmer.

"I drive it, it doesn't drive me. Most Detroit products feel like juggernauts."—New York automotive-parts jobber.

"This car is for those who enjoy being a factor in the operation of an automobile."—Illinois salesman.

"When I drive it, I feel we (the car and I) are one—a team. It steers so beautifully it almost anticipates. You own a sports car for individual pleasure. It's like owning a bike when you were a small boy."—New York manufacturer.

Other Best-Liked Features

Handling characteristics are third on the list of best-liked features.

"Superb handling at all speeds. Also superior acceleration."—New York mechanical engineer.

But there were a few who disagreed.

"Need too much strength to steer at low speeds and when parking."—New York construction superintendent.

"Superior in everything but downtown driving and parking."—Oklahoma adjuster.

The Jaguar's low, alert lines appeal to just about every car lover. It looks like its name—like a huge, powerful cat ready to pounce. It is not surprising then that the owners rated styling high on their list of best-liked features.

"A car that I am proud to drive. It is admired by all who appreciate fine cars. Its sleek lines and furnishings are outstanding."—New Jersey housewife.

But here again some disagreement.

"I like its appearance, but should have a better-looking top for the roadster."—Ohio photographer.

Farther down on the list of complaints were a few of a mechanical nature.

Spark-plug fouling was complained of by 9 percent of the owners. Brakes pulling when wet was a complaint of 8 percent. Tendency of the engine to heat up in traffic was also mentioned by 8 percent.

"Spark plugs foul up every 200 or 300 miles. I have used 3 or 4 different sets in 6000 miles."—New York executive.

(Jaguar now recommends the installation of N8B spark plugs during break-in period to prevent fouling.—Editor)

(Continued to page 246)



Double-Purpose Tire Tool Acts as Dolly and Wrench

Tires are changed quickly and safely with a tool that keeps you out of danger should the jack fail. One end of the tool serves as a cradle for the tire so that it can be lifted, lowered or spun around to match up with the studs. The tire rests on rollers which permit easy rotation. The other end of the tool contains a socket for tightening nuts. The rollers on the cradle serve as the handles of the wrench to permit fast tightening.

Hose Flushes Auto Radiator

To simplify flushing of automobile radiators, a radiator cap has been developed with a coupling for an ordinary garden hose. This enables the automobile owner or service-station attendant to flush out radiators and engine blocks simply by attaching a hose to the cap, opening the drain cocks on the block, the radiator or both and turning on the water at moderate pressure. Caps are made to fit all cars.



JANUARY 1955



Device Allows Musicians to Turn Music With Their Feet

Teutonic inventiveness and love of music merge in a German device that allows musicians playing string, wind or reed instruments to turn sheet music without using their hands. Operated by a pedal, the page turner moves only one sheet at a time —by reaching behind the pages. The music stand and turner can be folded for carrying without removal of the score.

Motorized Cherry Pitter Speeds Fruit Preparation

Designed primarily for the housewife, an electric cherry pitter perfected in Germany should also prove a boon to small canners. The pitter takes cherries from a hopper, slits them, pits them and drops them into a waiting dish in one operation. Pits drop into another container and juice is diverted to a glass.





Huge Rolling Dry Dock Repairs Small Boats

Designed by the Army Transportation Corps to speed repair of landing barges and other small craft where permanent facilities are not available, a rolling dry dock mounted on huge, tubeless, pneumatic tires is undergoing tests at Fort Eustis, Va. The dry dock will pick up vessels 60 feet long and weighing 75 tons. It is not powered, but is hauled ashore by Caterpillar tractors. Mounted on 36 by 41-inch tires with a 9½-foot inflated diameter, the dry dock is 42 feet long and 32 feet wide.



Homemade Power Mower Built From Scrap Parts

Fred Dunham of Nashville, Tenn., used parts from a Crosley, a Cushman scooter, a sewing machine and an airplane to make a homemade power mower. The job took up his spare time for a month, but he has what he wanted—power, maneuverability and economy. A Crosley engine does the work. A chain-and-sprocket assembly provides drive through the Crosley transmission. A belt assembly pulls the two 25-inch rotary blades which cut a 50-inch swath. He gets about “two acres per gallon” of gasoline.

☐ Natives of the Bocas del Toro province of Panama get their houses screened by spiders that spin their golden, lacy webs around entire huts.



Cycle Magazine photos

Heavy padding protects the driver's left knee as it rides along the ice when he cuts sharply around corner

Motorcycle Racing on Ice Is Rugged Swedish Sport

Motorcycle racing on ice is one of the most spectacular of Sweden's many winter sports. The motorcycles speed in tight circles around small tracks on ice, depending for traction on scores of spikes embedded in the tires. Sturdy guards are installed over the wheels to minimize chances of injury to riders in case of collisions. The riders wear heavy knee pads on one leg because in cornering they drag their inside knees on the ice to maintain balance.

Thick Rims Protect Records

Thick rims on some of the new long-playing phonograph records protect the grooves from nicks and scratches during storage. Because the outer rims are slightly higher than the rest of the records, there is no contact between playing areas when the disks are stacked atop each other. RCA developed the feature and is making it available to other manufacturers.

Closeup shows the spike-studded front tire and the metal guard that reduces danger to driver in crash



Temperature Alarm

Now you can leave your home untended without worrying about a breakdown of the heating system. A compact device flashes a warning red light if the temperature drops below 50 degrees. A neighbor can check your house daily by glancing in the window.



An Old Mill Grinds Again

ONE OF THE few remaining gristmills in the Midwest now is grinding corn meal for the market again, thanks to a group of Muskogee, Okla., citizens and some modern engineering equipment. The mill has been a landmark at Bitting Springs, Okla., for four generations. A few years ago the group of citizens bought the old mill and put it back into operation so they would have a source of whole-grain corn meal. Since then they have added modern equipment to condition the grain so it will not become rancid and are packaging it for shipment to market. An electric motor whirls the extractor to remove moisture from the grain, which then is dried under infrared lamps. But the 20-foot water wheel still turns the stone burrs which grind the grain, and the romantic building looks much as it did a century ago. ★ ★ ★

To clean the grain, it is placed in a container and lowered by hand into a tank of running spring water





Grain flows from container into moisture extractor



Electric motor whirls extractor to remove the water



Infrared lamps around belt continue drying process
Corn trickles slowly between stone grinding burrs



Grain is cured in ventilating racks before milling
Old-fashioned ground corn meal is packaged for sale





Combination Boat and Sled Travels Over Water or Ice

Specially designed for travel over water or ice, a combination boat and sled now links Frauenchiemsee Island off Germany with the mainland all year around. Winter ice that blocked boat travel had previously

isolated the island for lengthy periods. The new boat-sled navigates easily over mixed stretches of ice and open water. It is poled over ice and rowed or poled through water, slush or splinter ice.

Chopper Shreds Bales

Farmers can "unbale" hay or straw with a shredder that chops, loosens, fluffs up the tightly packed material and blows it into a pile. It eliminates the job of shaking bales and slabs apart by hand. Baled straw torn apart by the shredder and used for bedding covers a larger area because it can be spread evenly. Hard-packed hay is made palatable by shredding. The machine is powered by a $\frac{1}{2}$ to $\frac{3}{4}$ -horsepower motor.

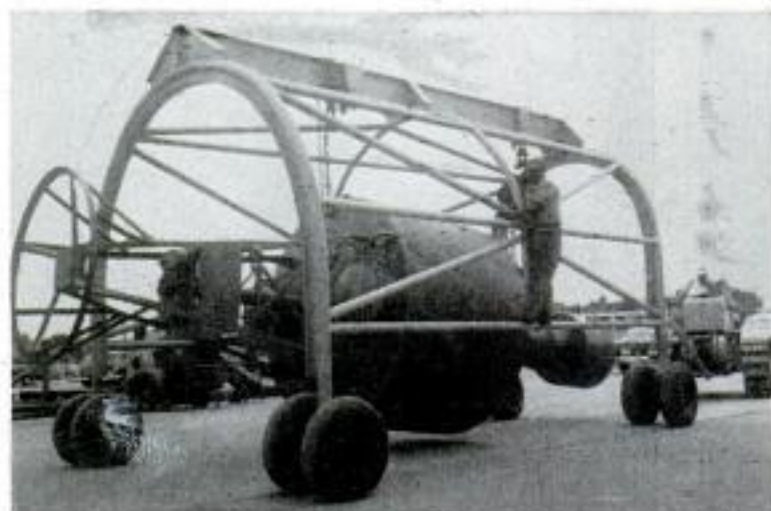

Coast Guard Buoy Carrier Made From Surplus Parts

Buoys, like icebergs, have most of their bulk beneath water. On dry land the bottom-heavy giants are awkward to handle. But Coast Guard engineers at Portsmouth, Va., have built a carrier that easily handles the largest, 12-ton buoy. They put it together with four-inch steel pipe, a metal center brace, surplus airplane wheels and two chain hoists, at a cost of \$1200. It is pulled from place to place by a crawler-type tractor.

Make-It-Yourself Carving Material

LOOKING for a new craft material? Then try your hand at Girostone, a homemade material that looks like granite, yet is almost as light as balsa. Larry Argiro, associate professor of art at State University Teachers College, New Paltz, N. Y., discovered Girostone by accident. It is a mixture of vermiculite aggregate, cement and sand. You can make it hard or soft by varying the amount of vermiculite. Argiro recommends starting with a soft mix of four parts vermiculite to one part cement, with a little sand. Add enough water to form a thick paste and pour into a shoebox or other container. In two or three days knock it out of the container and it's ready for your knife. The soft varieties can even be carved with a spoon, making them ideal for children, while harder types may require a hammer, chisel and coping saw. You can carve anything from Girostone that you can carve from other materials, so projects are limited only by imagination.



Plaque takes shape as youngster wields a paring knife. Girostone can be cast in any thickness and as soft as desired



Coping saw cuts Girostone easily and rasp quickly gives form to a carving. The soft carving material makes a hit with children because it can be easily worked by them

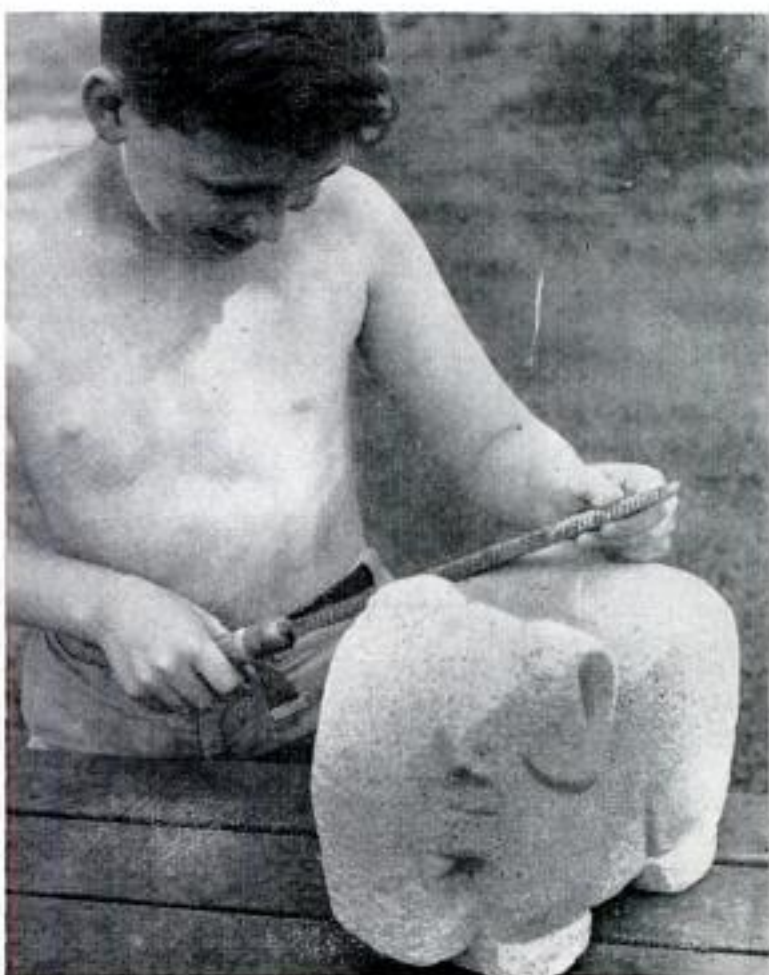

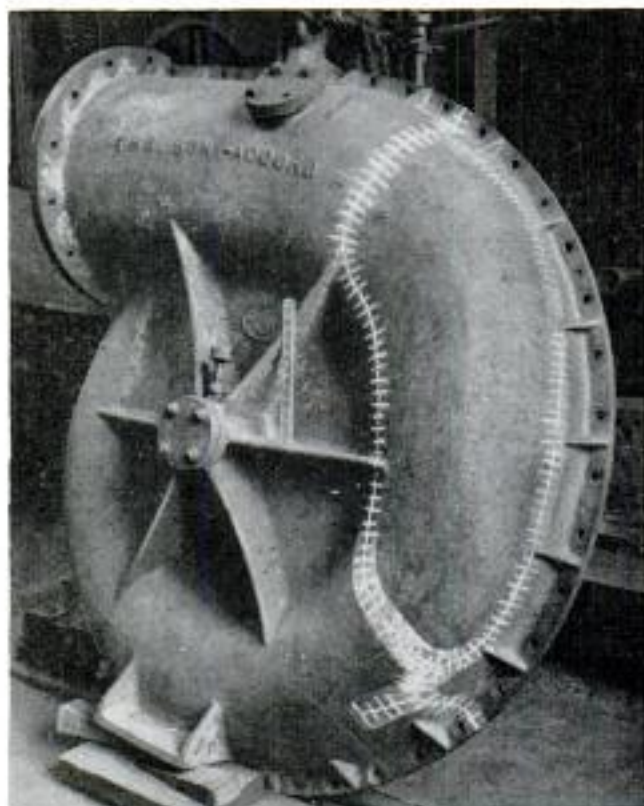

Metallock "stitches" cracks in heavy metal, such as the turbine casing above and the tool frame, right

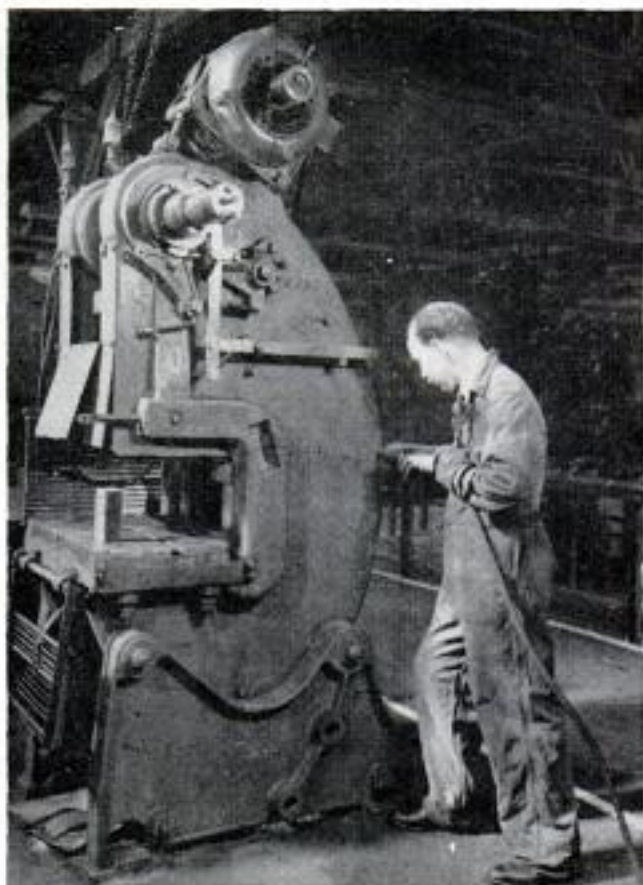

Metal Stitching Saves British Industry Millions of Pounds

American ingenuity in applying the principle of ordinary corrugated fasteners, or "wobble nails," to metal has saved British industry millions of pounds in the past few years. The process, called Metallock, consists of inserting a series of metal locks, or stitches, across a fracture line in a casting or forging, and then crossing them with a line of interlocking studs forced into the fracture itself. Perfected in the Texas oil fields where repair of metal without weld-

ing heat is often necessary, the process was adopted by the Navy during the war, but was not widely used in England or on the Continent until 1946. Scarcity of replacement parts in war-damaged countries boomed the business. Metallock has been used in Britain for speedy repair of such irreplaceable items as steam cylinder heads of foreign or obsolete design, for pump and turbine casings, generator frames and winding drums.

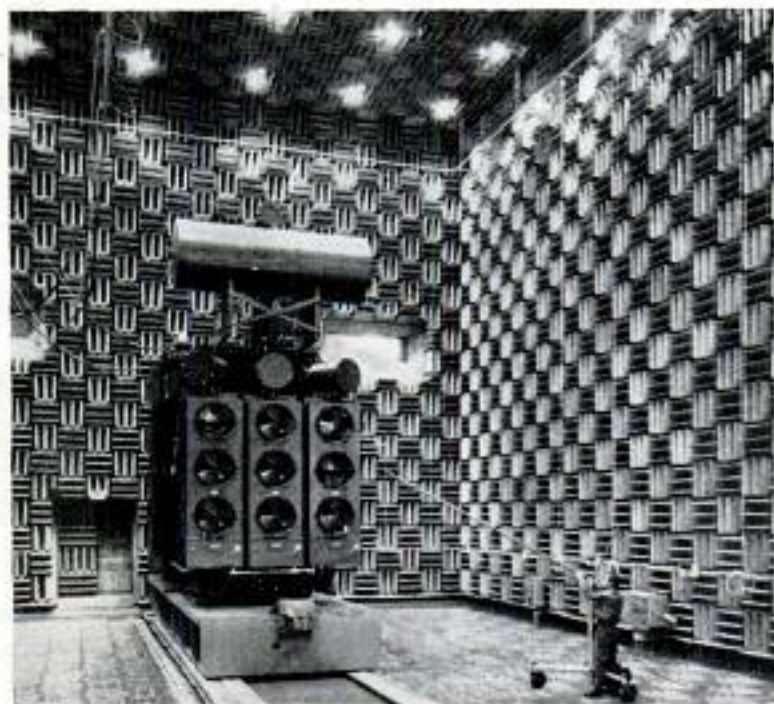

Largest "Quiet" Room To Test Transformer Noises

You might hear a pin drop, but you couldn't get an echo with a cannon cracker in the world's largest anechoic chamber, or "quiet" room. Anechoic means "without echo," and a room without echoes was precisely what General Electric had in mind when the immense chamber was constructed. The walls are completely lined with glass-fiber wedges arranged in a pattern that absorbs all sound. The chamber is 43 feet high, 58 feet long and 48 feet wide and has walls 5 feet thick. It was built to aid engineers attempting to reduce the hum and sound-reproducing qualities of electrical transformers of all sizes.

Taking That Spot-News Picture

By Richard W. Emery

IT'S A COMMON THING in a newspaper photo lab to hear someone complain: "Too late! Some amateur beat me to it!"

That means that once again the nonprofessional who just happened to be on the spot in time got a "spot news" picture the press cameraman didn't get.

Nobody doubts that the most essential single thing about getting that "big picture" is being *there* while the picture can be shot. Newsmen go to great pains to "be there." Their employers at great expense set up

news-gathering organizations backed up by telephones, radios, automobiles, planes—everything possible to aid the day-and-night vigil for spot-news breaks and coverage by photography.

But the unexpected happening has a way of popping up at unlikely times and places. Press cameramen can't always clip off the miles in time. That's when the photographic honors may go to someone else who has a camera and uses it well.

There's no love lost between the working

Firemen run as burning bridge collapses. This picture was cropped; photographer was not in danger area

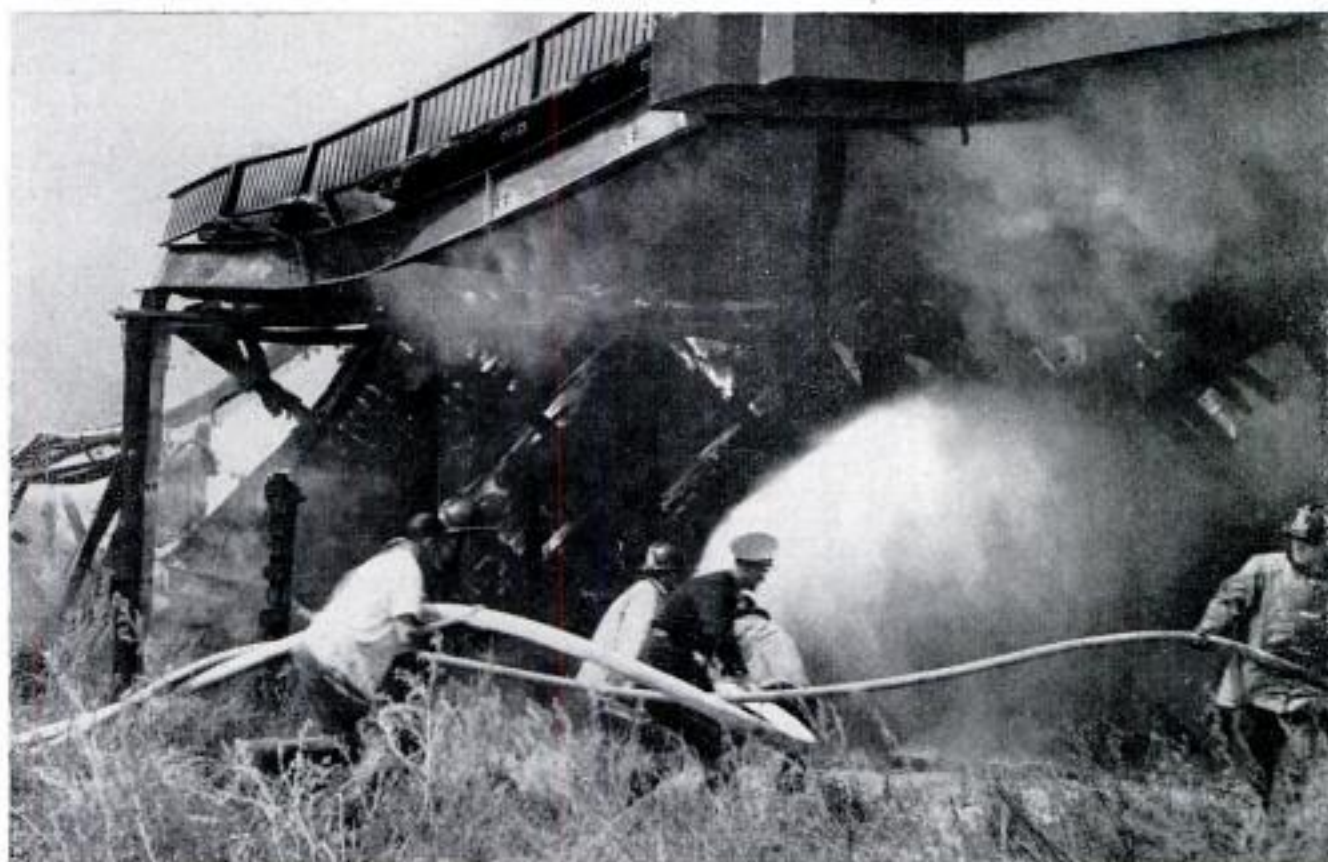



Ben Heddick photo (above)



Earth-shaking, roaring "gasser" could be heard for miles. Loud sounds may so distract photographer that he makes mistakes

press photographers and the "amateurs" who often beat them to the punch. Press management, however, usually looks with friendly eyes on the amateur photographers.

"Amateur" photos many a time have saved the day for a newspaper. Most newspapers and news-photo services have a standing offer for good photos of spot news, and members of their staffs have been warned against "growling" or "biting in clinches" with amateur competitors.

Sometimes the newsman and the amateur break even on arrival time, prowl their respective paths around the big event and come up with pictures in which the newsman is grievously outpointed. The disgruntled newsman may then see the amateur's pictures replace his in his own newspaper. That's when you'll hear another old complaint in the news-photo lab: "These amateurs have a million dollars to spend on equipment. They have the best cameras and every gadget money can buy. They're walking dictionaries on photography. They aren't amateurs! They're real experts!"

But a modest housewife with an inexpensive camera won the Pulitzer Award for Press Photography for 1953. Her "li'l old beat-up 15-year-old" camera took a sharp, clear picture of a truck and its driver hanging perilously from a high bridge.

"Just happened to be

Camera far back of fire lines caught this shot of hotel fire. Closer view would have cost the picture its foreground of people



Ocean waves make news sometimes—but may damage your camera. Fast “grab shots” need high shutter speeds

there,” said the press experts, enviously. “Just luck. Anybody there could easily have shot the same thing!”

The lamenting press cameraman, however, knows better than that. Through his own wide experience he realizes that luck alone won't get the picture for you, or deliver it to a picture editor. He knows that there are 10 *musts* in spot-news photography.

The 10 *musts* apply equally to professional news cameramen and their amateur opponents.

1. You must have your camera with you in working order.

2. It must be properly loaded with good film.

3. You must know your camera is focused sharply on the subject in regard to distance.

4. You must expose the

Pictures like this rescue of a young swimmer are not often secured by press photographers. Amateur must be ready for emergencies





Rescue workers in dory search for flood victims. Shot was taken at dusk with 1/10-second, wide-open exposure



H. S. Melvin photo

Dramatic evidence of earthquake damage makes good material for the amateur's camera. Below, a mother thrown to the street by a traffic accident tries to console her weeping youngsters. Certain types of pictures won't wait for the press photographer



film to enough light to completely register a picture-image while also stopping action.

5. You must aim the camera at the subject.

6. Your camera must be motionless while its shutter is open.

7. You must avoid accidents and oversights.

8. You must get enough facts about your picture to identify it—accurately and as fully as possible.

9. Your picture must be transported from the scene to the outlet which will use it.

10. Your negative must be properly developed and printed.

Each one of those 10 points is full of possibilities for *not* coming up with a spot-news picture on the editor's desk. To take a closer look:

You must have your camera with you in working order. If you don't habitually keep a camera near you, you won't have it in an emergency. Provide a dust-tight, insulated case to carry your camera in, in your automobile. If you have a large camera, too big to be handily carried, get a small, spare one which will slip into a pocket. Use your camera often enough to keep acquainted with it. Keep it in repair, ready for quick use.

It must be properly loaded with good film. Film past its expiration date (printed on the package) may still be good, but fresh film is a safer bet. Load film into your camera very carefully, in subdued light. If you don't, you may light-streak the film before you have taken a picture on it. There are fast films and slow films, black-and-white and color. You must know what kind of film you are

(Continued to page 242)



Italian Design Borrowed for American Executive Amphibian

Taking a leaf from the sports-car makers' book, a newly formed Milwaukee aircraft company plans to market a gull-wing amphibian combining Italian-made air frame and wings, American engines and other components. The plane, known as the Royal Gull, is a five-place, executive-type

amphibian. Wings and air frame are made by Italy's Piaggio & Co., while power comes from two 260-horsepower Lycoming engines turning pusher-type three-bladed Hartzell propellers. The aircraft is in the 180-mile-per-hour class and can cruise seven hours. It carries a 1940-pound load.

Rear-Seat Table

Metal straps suspend a sturdy table from the back of an automobile front seat, giving back-seat riders a chance to play cards, type, sew or otherwise amuse themselves. The 12 by 30-inch table top is resin-treated hardwood fiberboard finished in enamel. Hangers, legs and supports are sturdily made of steel. The table top can be folded down or the entire unit removed and stored in the trunk.

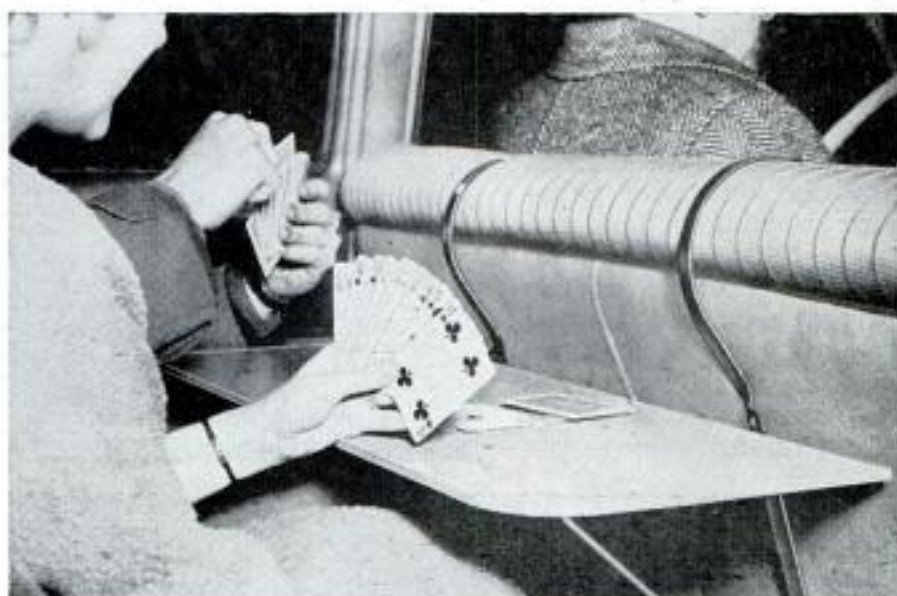

Reverse Pickaback

Semitrailers on flatcars are becoming common sights in the United States as more and more railroads adopt the pickaback method of moving less than carload freight, but in Germany the situation is reversed, and freight cars are mounted on trailers for movement through city streets. Lack of sidings hampered West German railroads until this method was devised.

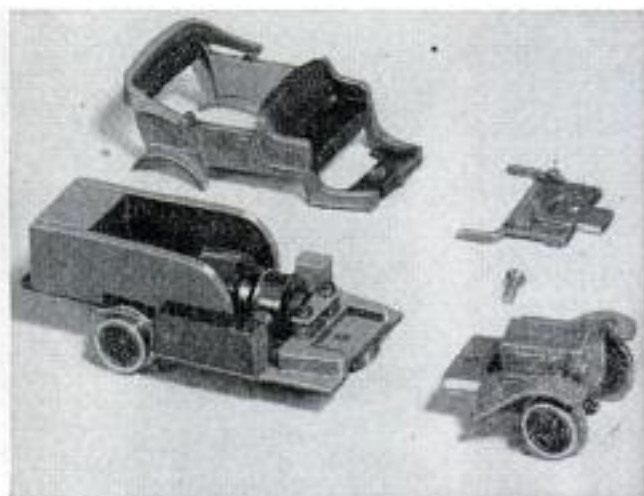
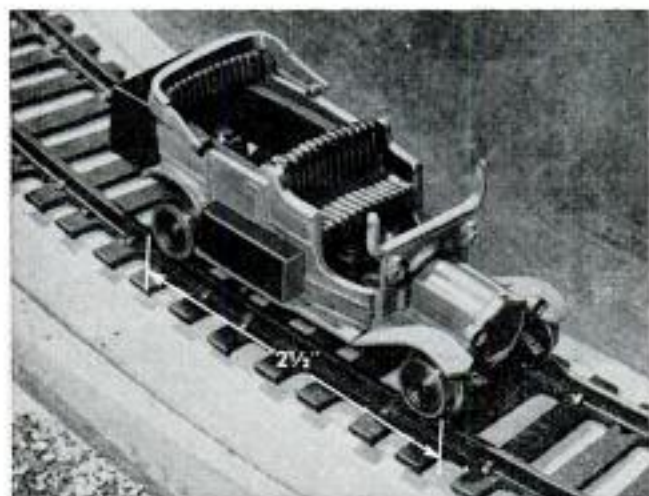

Model of Rail Auto Built for Assembly by HO Enthusiasts

Model-railroad fans can now obtain an authentic HO model of a rail automobile in kit form. The all-brass model is a copy of a 1907 Thomas Flyer once used on the

Diamond & Calder Railroad near Diamond Springs, Calif. It is powered by an electric motor and is quickly assembled by the purchaser from a few basic sections.

Sliding-Roof Cars Loaded From Above

Freight cars built in Germany have sliding roofs so large loads can be dropped into place from above. The roof is built in two sections which operate like sliding doors. Mounted on roller bearings, the roof sections can easily be moved by one man. The ends of the freight cars are hinged like the gate of a dump truck so the freight cars can be unloaded faster by tilting them.

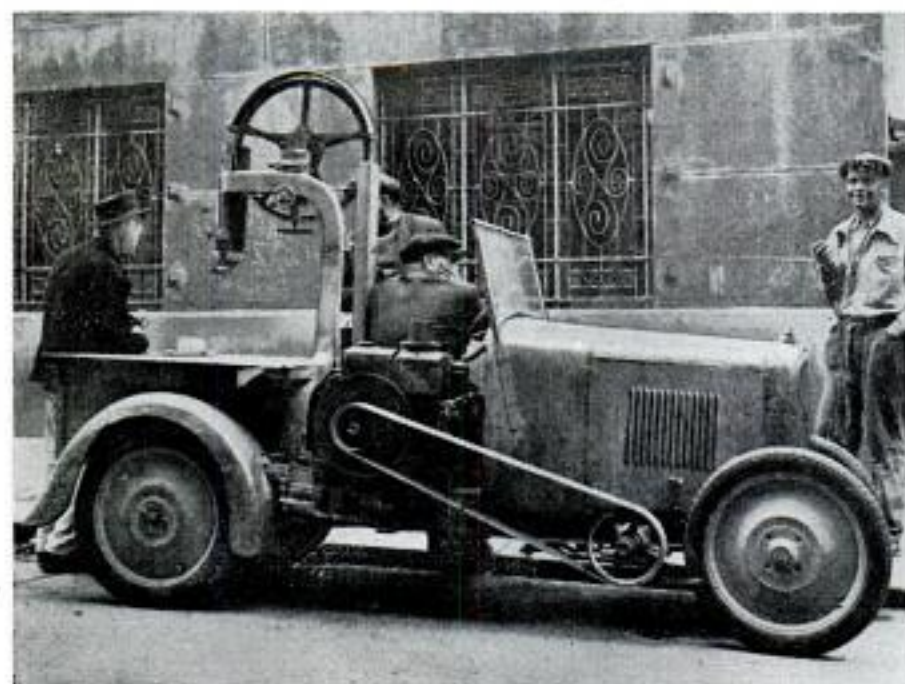
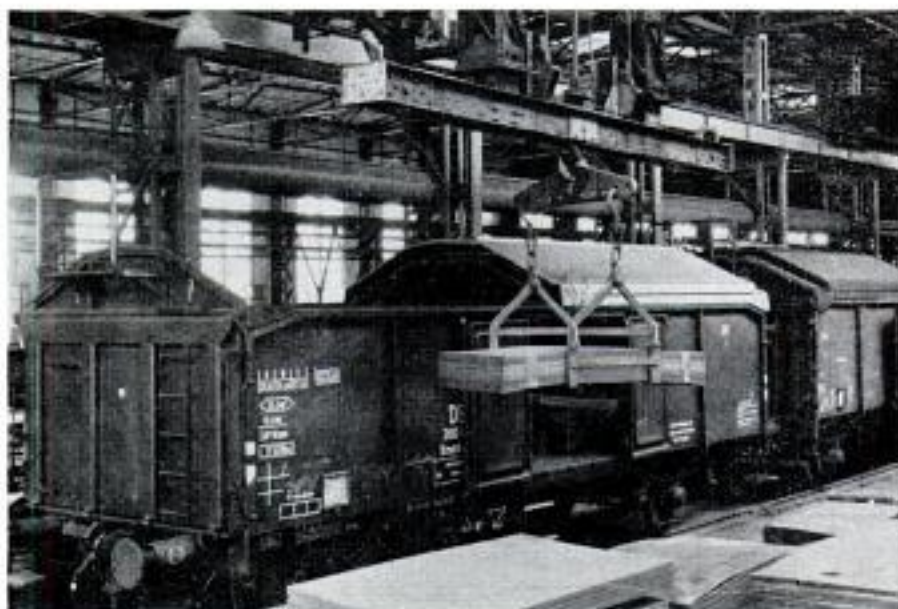

"Car"-pentry Shop

Itinerant carpenters in Yugoslavia have used their ingenuity to build a traveling workshop. They mounted saws and drills on an old automobile and devised a system of gears and belts from an engine to power the tools. Now they can move their shop from door to door and even town to town in search of customers.

☐ Test pilots at a major aircraft plant flew 3,700,000 miles in 1953 to check new production models as well as for engineering test purposes.

HOW TO OPERATE YOUR

By Frank L. Brittin, W9DCX



COLOR-TELEVISION receivers have been simplified in circuitry and the number of controls reduced to a practical minimum. Only two added controls need be adjusted by anyone, in the Motorola receiver illustrated, to turn a good monochrome (black-and-white) picture into beautiful "live" color provided that the program is being telecast in both mediums.

More than 75 percent of the nation's 30,000,000 TV households are now within the areas receiving color broadcasts. Live-color programming averages about 10 to 15 hours per week with several added hours of selected films in color. Tricolor-picture tubes with large screens have been perfected to a point where manufacturers no longer hesitate to get into full production. These tubes are now made in the popular 19 and 21-inch sizes. The Model 19CT1 Motorola color-TV set shown in photos A and C employs a 19-in. Hytron "205" tricolor-picture tube.

Many years of experimenting and field testing, by this manufacturer and several others, have gone into the development of color-TV receivers. Today the results are highly satisfactory when the programming is good and the telecasting meets the technical requirements. In this writer's opinion both CBS and NBC engineers have done, and are doing, an excellent job.

Early color telecasts leaned heavily on vivid greens, blues and reds. This distracted from story continuity as such emphasis on

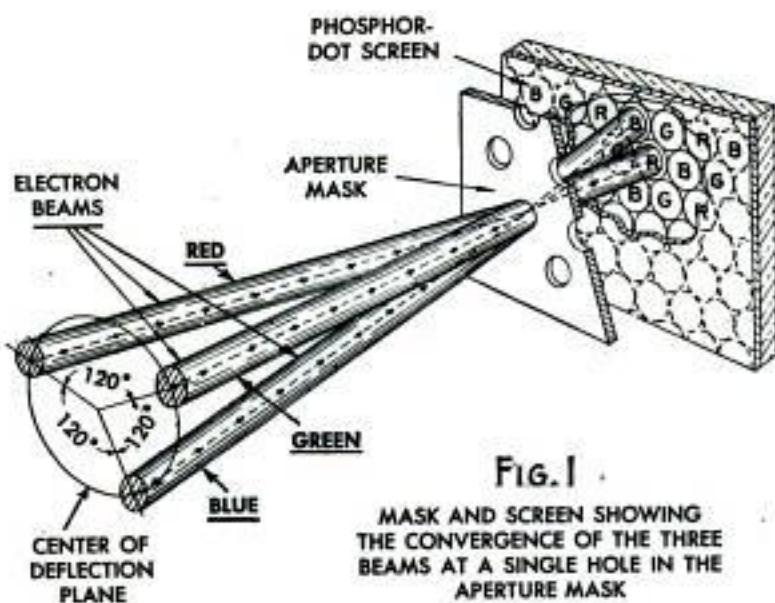

VHF OPERATION (CHANNELS 2 THROUGH 13)

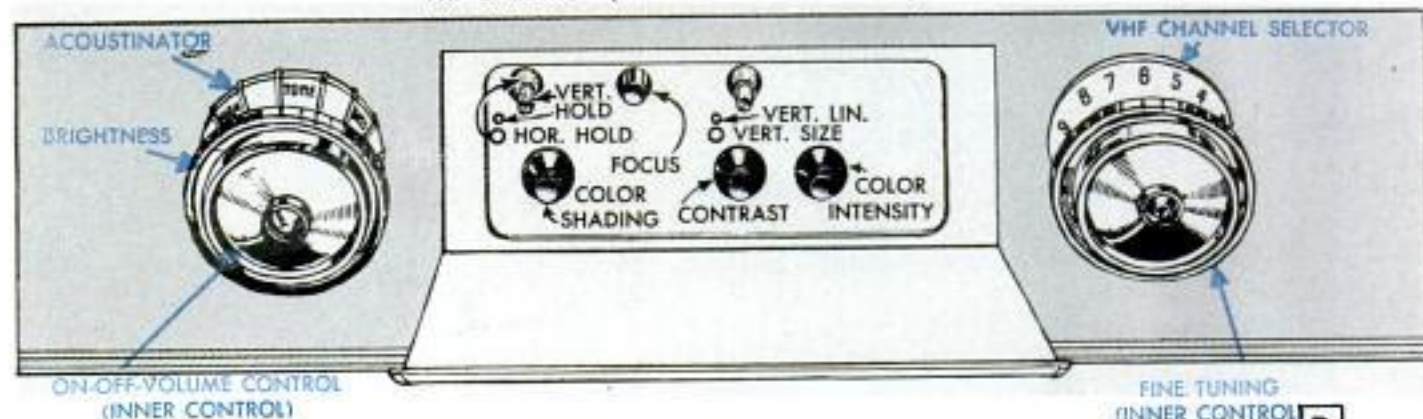

CONTROLS FOR MONOCHROME (BLACK & WHITE) RECEPTION

POPULAR MECHANICS

NEW COLOR-TV RECEIVER

color was not natural or pleasing to the average viewer. Early color movies went through the same growing-up period. Today programming has been greatly improved and there are fewer complaints of "forced" color in either system. In other words: a poor program is not improved by receiving it in color.

It has been estimated that color-TV production for 1955 will be about 150,000 sets. In 1957 it should reach 3,500,000 and 4,500,000 by 1958.

As comparatively few color-TV sets are now in homes, you probably do not have yours as yet. However, as a reader of *Popular Mechanics Magazine*, you are interested in what they look like and what they do. Operation is easy and no technical knowledge is necessary. Sketch B shows all of the controls that are located on the front of the receiver. You will note that with two important exceptions they are no different from those found on most modern black-and-white-TV sets.

A color-television picture screen is composed of extremely tiny phosphor dots of three different colors, arranged in a regular sequence and the different dot colors are red, green and blue when lighted. An exploded view of the tricolor-picture tube is shown in Fig. 2, and a diagrammatic illustration of the mask and screen appears in Fig. 1. The screen dots are of such minute size that it is very difficult to see the individual dot colors even when viewed closely and the final result is a blending of the three colors to form a lighted screen of a particular tint. Note in Fig. 1 that the converging beams from the three electron guns, sketch G, pass through the hole in the aperture mask and strike their respective phosphor dots.

When the blue, green and red dots of the picture screen are mixed in the proper intensities, the screen will appear white to the viewer. It is on such a white screen, made up of these three different colors, that a black-and-white picture may be constructed. It is easy to see that a black-and-white picture is actually being formed on a colored screen, also that there is actually no black or white area on the screen. To

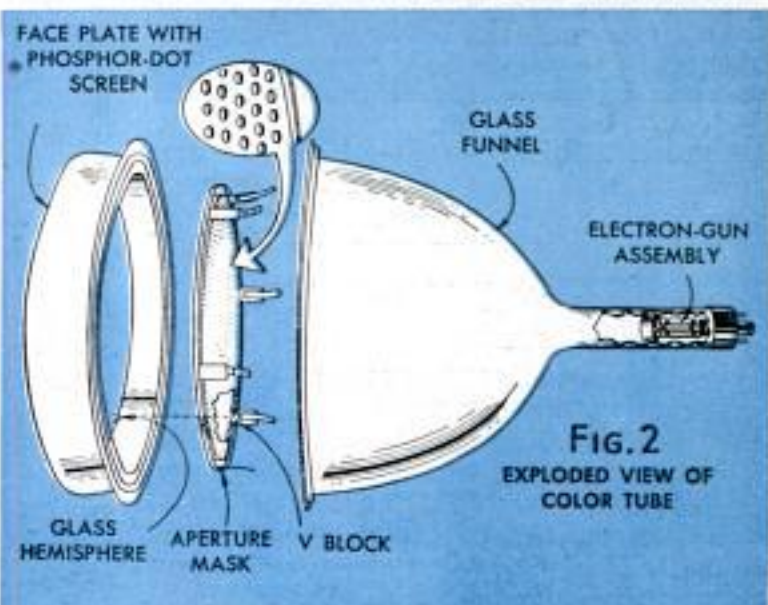

RECEIVING COLOR PROGRAMS

COLOR-INTENSITY CONTROL

Advance this control slowly to the right until color begins to appear in the picture. Continue to adjust the control until the desired strength of color is obtained. In some color-TV sets this is called the Chroma control.

COLOR-SHADING CONTROL

This really is a master control and is only operative when the color picture is on the screen. Adjust this control next for the most-pleasing and natural flesh tones or for some object having familiar coloring. The final touching up for best picture detail and most-satisfactory color reproduction is done with the usual fine-tuning dial at far right. If the fine-tuning control is not adjusted correctly the color may be removed from the picture.

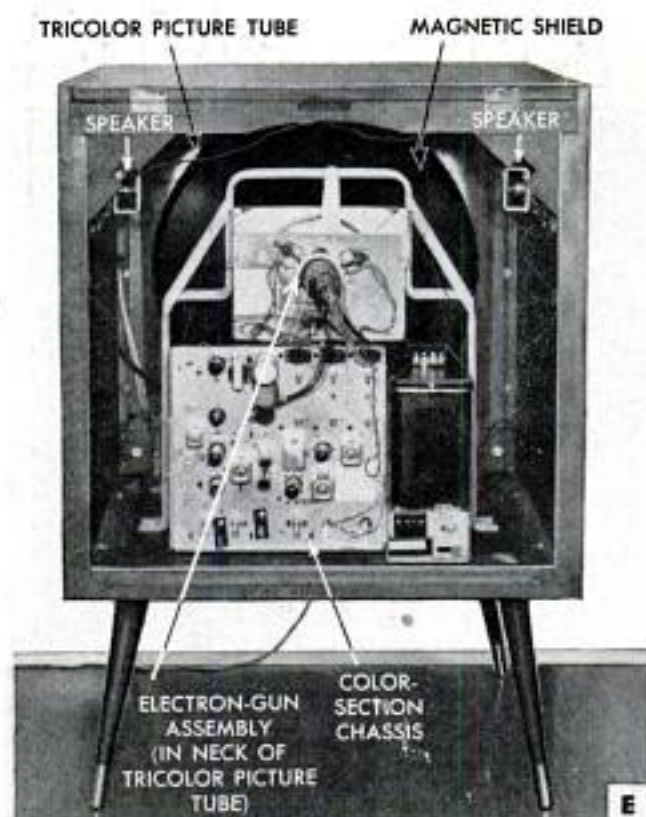

distinguish a black-and-white picture formed on a three-color screen from one formed on a regular white screen, TV engineers use the word "monochrome." This word will be used from now on to describe a black-and-white picture on the screen of a color-television receiver. The basic color adjustments are all made at the factory but it is necessary that the dealer's serviceman make the final convergence-coil adjustment and check the supplementary controls on the rear panel, sketch F, to correct any misadjustment caused by rough handling in shipment. This job is done by the serviceman who uses a color-dot generator which produces a pattern of small dots on the face of the color tube and provides a quick and easy method for making accurate convergence adjustments.

The first operating step on front panel B is to turn the receiver on by rotating the on-off-volume control to the right until a click is heard. Now, before advancing this

control, let the circuitry warm up for two or three minutes. In a color receiver this warm-up period is necessary in order to produce a good picture either in color or in monochrome. The three color channels require slightly different warm-up periods. After warm-up, advance this control for medium volume. Always adjust the receiver for a good monochrome picture first with color-intensity control turned off by counterclockwise rotation until stop is reached. Turn the contrast control to about the middle of its range; then adjust the brightness control until the picture screen is well-lighted. Now turn the channel selector to the desired channel number and adjust the fine-tuning control for best picture detail. Then readjust contrast control for most-pleasing picture. Adjust the acousticator (tone control) for tone desired. None of the other controls need be touched. The small undercover combination controls at top center are the conventional-TV picture-adjustment controls to be found on any television receiver and are seldom used. Now, if the program is being telecast in color on that channel, and you are getting a good monochrome picture on the screen, refer to the color-receiving controls in sketch D and follow the simple steps for receiving color programs. Any member of the family who can tune your present black-and-white-TV set, can operate this color set and get satisfactory results. Just remember to warm up the set first; adjust for the desired strength of color and then use the color-shading control for the most natural and pleasing flesh tones. After the color program is off, turn the color-intensity control completely off and you are all set for monochrome programs. These have an interesting background-lighting effect not found in regular black-and-white sets. The blacks are soft and velvety and the whites are pleasingly clean and clear.

Photo E shows a rear view of this Model 19CT1 color-TV receiver with the back cover removed. Note that the color-section chassis is mounted in a vertical position for

(Continued to page 258)

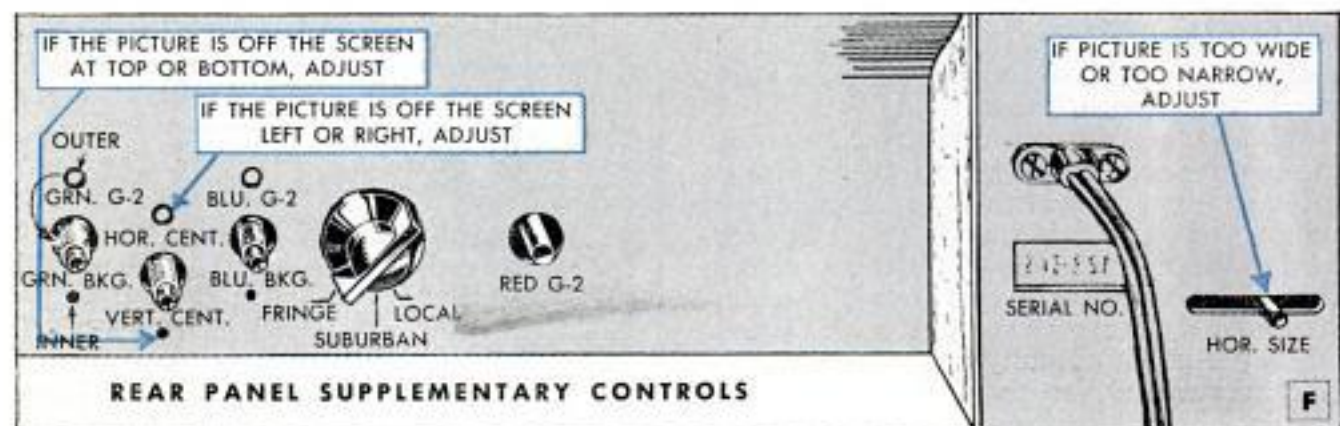

the POPULAR MECHANICS CRAFTSMAN



RAILROAD *in a* SUITCASE

WHEN FRANK BEATTY, *Popular Mechanics* art director, craves a bit of diversion, he dons his cap and bandana and loses himself in the operation of his Lilliputian railroad. Frank refers to his HO system as his "railroad in a suitcase" for he designed it so it can be folded in a compact case for easy carrying and storing.

Covering an area only 4-ft. sq., Frank's layout takes his fast freights through villages, mountain gaps and countryside in remarkable realism, as everything is in Tom Thumb scale. Every inch of space is put to use; even the top of a mountain lifts off to provide storage for some of the rolling stock. Except for the transformer, which is carried separately along with the rolling stock, all the scenery and parts of the layout are integral, with ample clearance being provided for the tiny buildings when the unit is folded.

Color photos by Don Honick, staff photographer

Right, storage for several pieces of rolling stock is provided inside corner mountain. Spackle-covered mountain top is held in place with two wood screws





Above, separate cover board fitted with handle (shown on floor) is used to hold two halves of folded unit together. Below, HO freight on elevated siding



Frank's railroad is supported at chair height by four detachable pipe legs which are turned into pipe flanges screwed to blocks attached to the corners. Detached, the legs are stored on top of a cover board and held with either spring clips or short straps.

The general layout is shown in the diagram on the opposite page which also spots the location of the various buildings, mountains, shrubbery, etc. The curve sections of the track are laid out on a 20-in. radius, using standard wooden roadbed which is sold in hobby shops. The pull-apart drawing on page 166 shows how the "suitcase" is made. The bottom consists of



LUMBER OFFICE

WATCHMAN'S TOWER

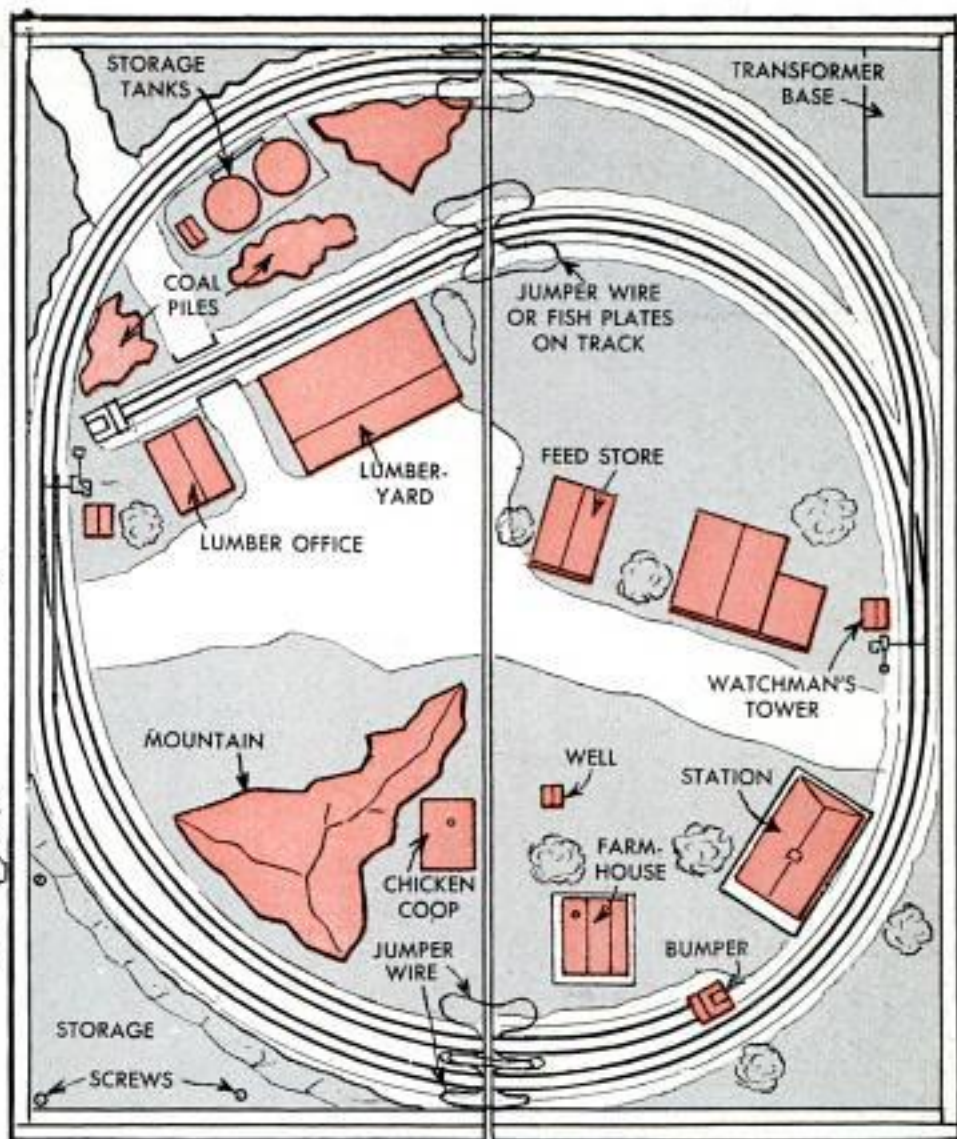
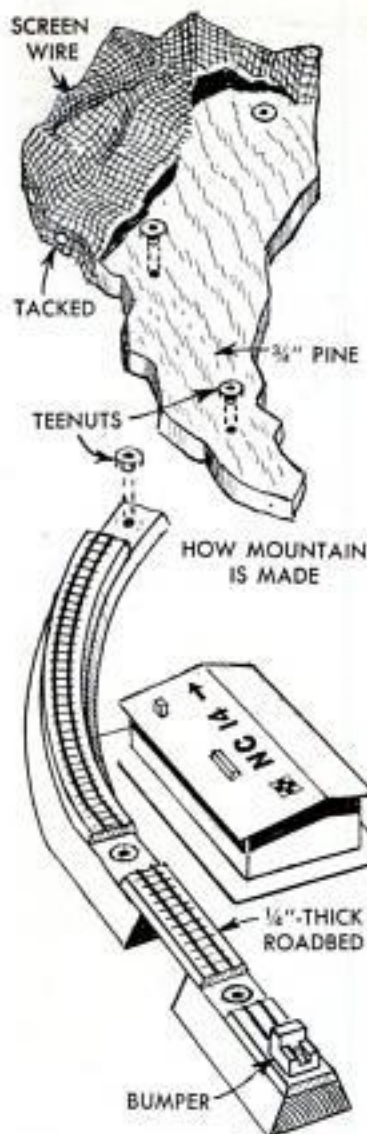

two sections of $\frac{1}{4}$ -in. plywood which are spaced $\frac{1}{16}$ in. apart with two sheet-metal straps held with screws. The straps are removed for folding. A strip of cloth tape, tacked to one side only, is placed over the joint. One section of plywood is framed on three sides with pieces of 1 x 4, while the other section is framed with pieces of 1 x 2. Both sections are held together with 1 x 2 cleats, bolted across the ends. These cleats are made removable and are bolted to a cover board during storage. Teenuts have been used for all bolts as they permit flush mounting. Reinforcing cleats, $\frac{1}{2} \times \frac{3}{4}$ in., are glued and nailed to the bottom of the plywood sections along the outer edges.

The cover board, which is fitted with a suitcase handle and a sheet-metal bracket at each end, holds the two sections together when they are dismantled. Registering holes to match those in the brackets are made in both sections for bolts and Teenuts. Two cleats on the underside of the cover board provide extra rigidity.

The mountain storage compartment is formed in one corner of the layout with plywood and fitted with a triangular wooden cover held with two screws. Then regular plaster-patching compound called Spackle is applied with a spatula to simulate rocks and typical mountain terrain. The other mountain in the foreground is

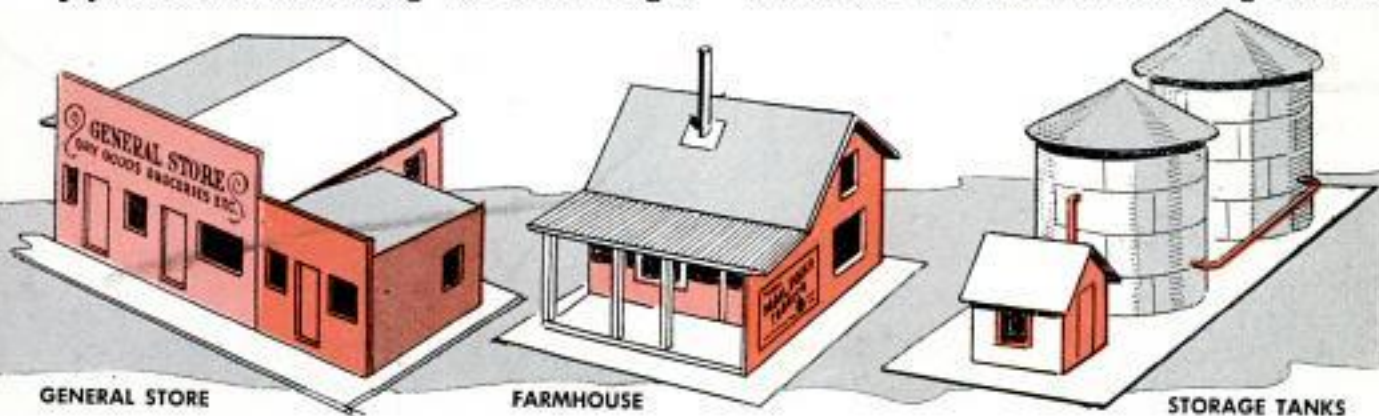

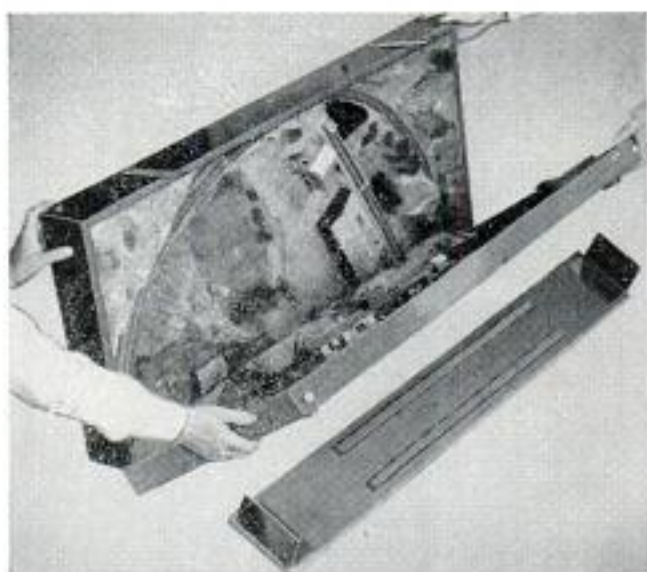

Flat-iron straps hold both halves together on one side while a cover board bolts to the opposite side

formed by tacking screen wire to an irregular wooden base, forming the wire into peaks and plastering it with Spackle.

The track roadbed is elevated 1 in. from front to rear of the layout to provide a gradual grade and allow underpasses to be formed under the raised portion as well as the lumberyard siding. Spackle is applied to the sloping sides of the roadbed, after which it is painted appropriately and finally coated with varnish and sprinkled with sand when tacky. The road through the town is treated similarly, and "grass" is planted by sprinkling packaged hobby-store grass in wet shellac or varnish. The various buildings are glued permanently in place. Where the track layout crosses the joint in the plywood, regular fish plates or jumper wires may be used to wire the abutting ends of the track. A wooden block, located in one corner of the layout, serves as a base for the transformer. ★★★

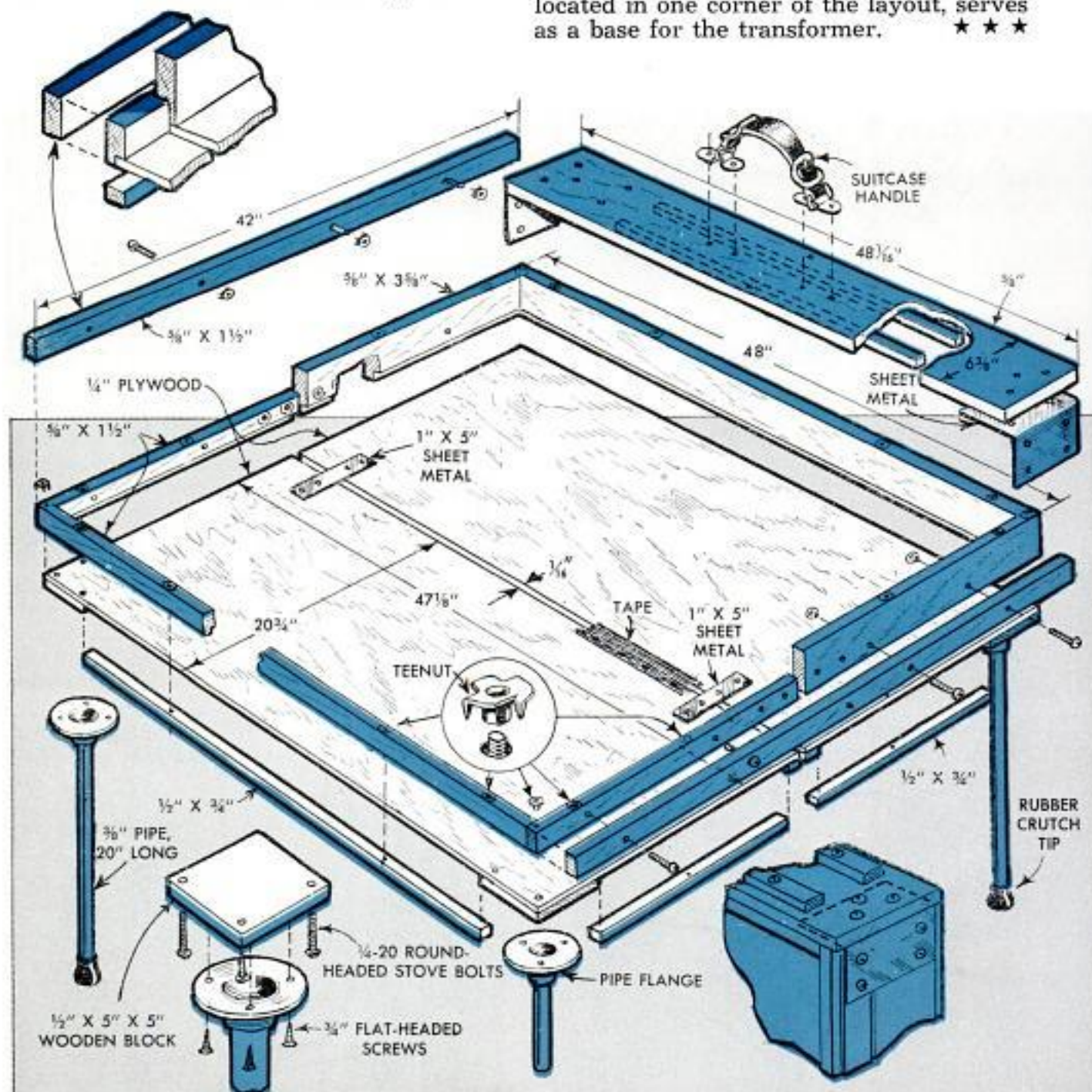

Cork Inserted in Vacuum Bottle With Aid of Toothpick



An ordinary wooden or plastic toothpick can be used to relieve the vapor pressure which makes it difficult to insert the cork in a vacuum bottle filled with hot liquid. The toothpick is held alongside the cork as it is pushed into the bottle and allows the excess pressure to escape.

The toothpick is removed when the cork is in place. The cork should be moistened before it is inserted in the bottle.

Henrietta Muller, Danboro, Pa.

Child's Broom Used to Clean Snow Off Auto Windshield

A child's toy broom carried in your car during winter is handy for cleaning snow from the hood, windshield and rear window. The long handle enables you to clear away the snow without getting it on your clothes. It is also useful for sweeping out snow which has been tracked onto the floor of the car.—R. M. Woodbury, Natick, Mass.

Inexpensive Negative File Utilizes Cigar Box

An ordinary cigar box, similar in size to the one shown, will provide an inexpensive, durable file for storing negatives up to 116 in size. Cataloguing of the negatives, which should be kept in kraft-paper or glassine envelopes, will be simpler if cardboard dividers having appropriate data written across the top edge are used to keep the negatives separated.



JANUARY 1955

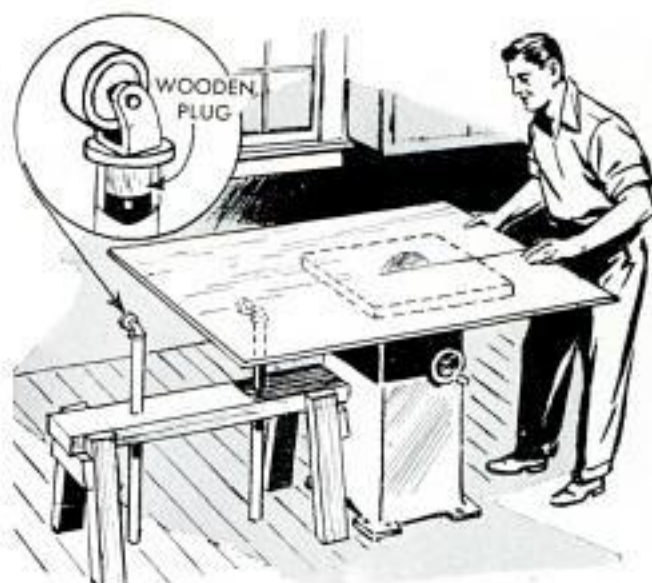

Plywood Supported on Saw Table By Pipe-and-Caster Assembly

When ripping plywood on a bench saw, additional support for the plywood sheet can be provided by a pipe-and-caster assembly, as shown. Wooden plugs are driven into the ends of two lengths of pipe and then drilled to take casters. Holes are drilled in the cross member of a sawhorse in which the pipes are inserted. In use, when the plywood extends beyond the saw, the work rolls across the casters. For extra-wide work, two of these assemblies could be used side by side, or a single one can be turned parallel to the saw table.

Graduate for Home Workshop Improvised From Fruit Jar

A graduate for mixing various solutions needed around the home workshop can be improvised from a glass fruit jar. Attach a strip of waterproof adhesive tape vertically to the jar and mark it with waterproof ink. To accurately mark the volumes, use a kitchen measuring cup to pour water into the jar in measured amounts. For a quart jar, every 4 oz. would be precise enough. For 1-oz. measures, use a smaller container, such as a small mayonnaise jar.

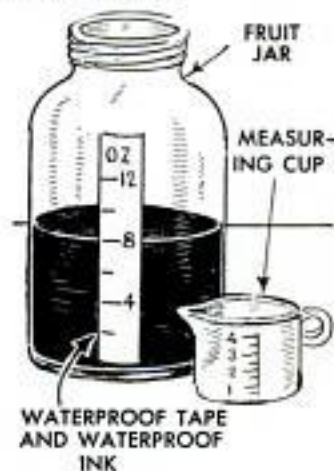

Hugh Lineback, Stillwater, Okla.

When the color cakes of a child's water-color set come loose from their backing, they can be stuck in place again with clear nail polish.

167

Condensation Inside Metal Window Prevented by Extra Storm Sash



Condensation appears on the frames of some metal casement windows, even when the regular metal-framed storm sash is installed, because the window frame is not completely covered. One way to overcome this problem is to install an inside storm sash which covers the entire window, and is spaced 1 or 2 in. away from it. The storm sash should fit the window opening snugly and be provided with felt or rubber gaskets on all four edges. The sash is kept in place by screws which pass through it and into tapped holes in the metal frame of the window. Sleeves fitted over the screws hold the storm sash the proper distance from the window.

Photographs in Mail Protected With Corrugated Cardboard

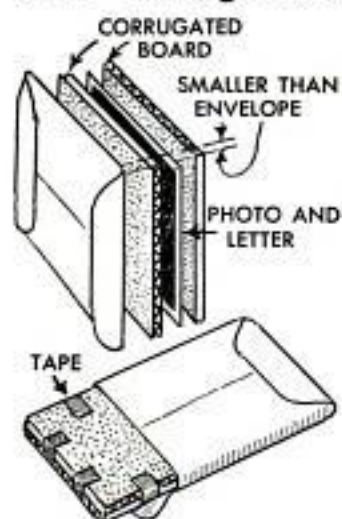

When mailing photographs or artwork, use corrugated cardboard instead of flat cardboard. The corrugated material is not only stronger, but lighter, so it will save on postage. Cut the pieces slightly smaller than the size of the envelope, and also cut them so that they can be inserted in the envelope

work between the sheets of cardboard, fasten strips of tape over the edges to keep them together and to prevent the work from slipping past the edge where it would be damaged.

Plier Wrench on Hoist Rope Lifts Sheets of Metal

When hoisting flat or corrugated sheets of metal or other material to the roof of a building, a plier wrench will provide a quick and convenient way of attaching the sheets to the hoist rope. One end of a length of strong wire is twisted tightly around the adjusting screw on the plier, then the other end is formed into a loop through which the hoist rope is tied.—Howard R. Clark, Springdale, Ark.

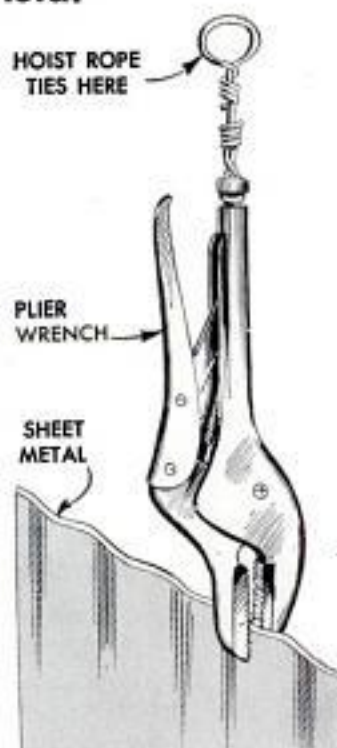

Containers for Lens Filters From Fishhook Boxes

Small round boxes of the type in which fishhooks are sold will come in handy for storing and carrying lens filters. Transparent tops set in plastic slip-on covers make it possible to identify the filters without removing the covers. For added convenience, cement one of the boxes to the camera, so a filter is carried with the camera.

Eugene Lee Burner, Morgantown, W. Va.





TOAST RACK with a COZY

FOR PRACTICAL as well as decorative reasons this toast rack, which is a replica of an old English toast cozy, is a fine project for the craftsman. It will keep toast warm for quite a while and, at the same time, prevent it from becoming soggy. The cover is made of sheet metal cut from ordinary cans and then peened and burnished. It is assembled with rivets. The arches for the rack are of heavy wire bent to a uniform curve by means of the simple bending jig shown in the photo. The base and handle should be made of hardwood for durability.

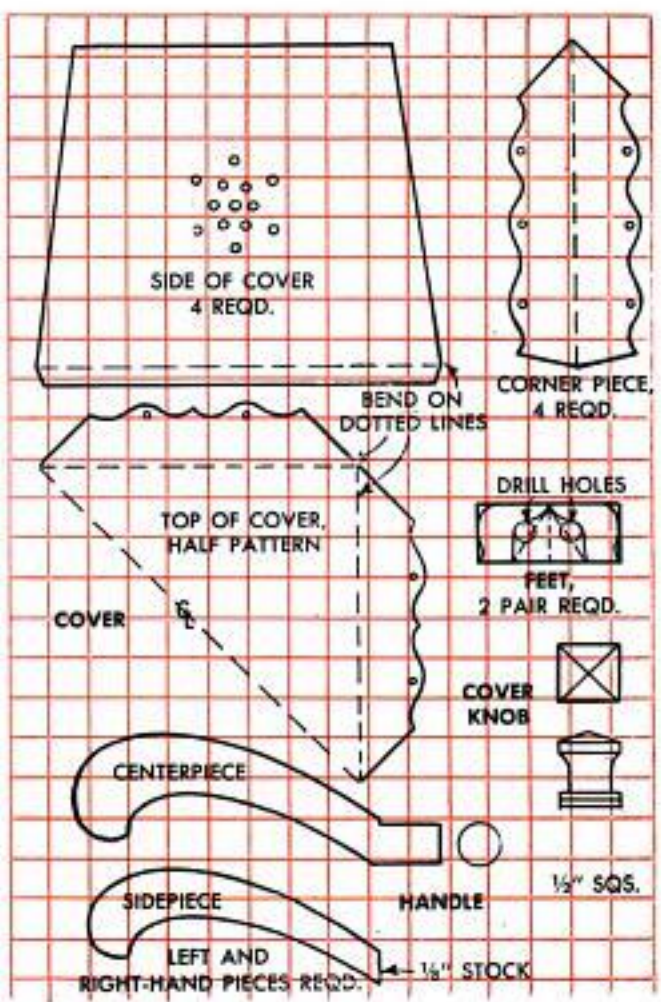
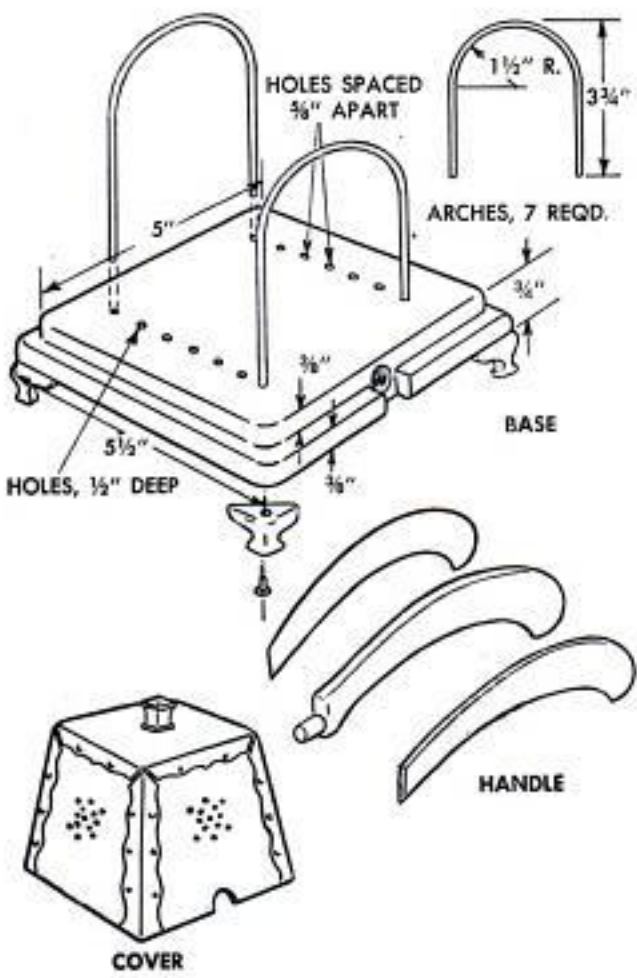
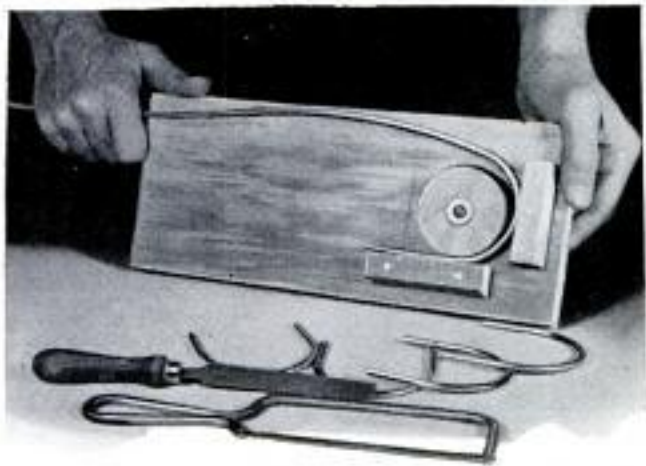

Solving Home Problems

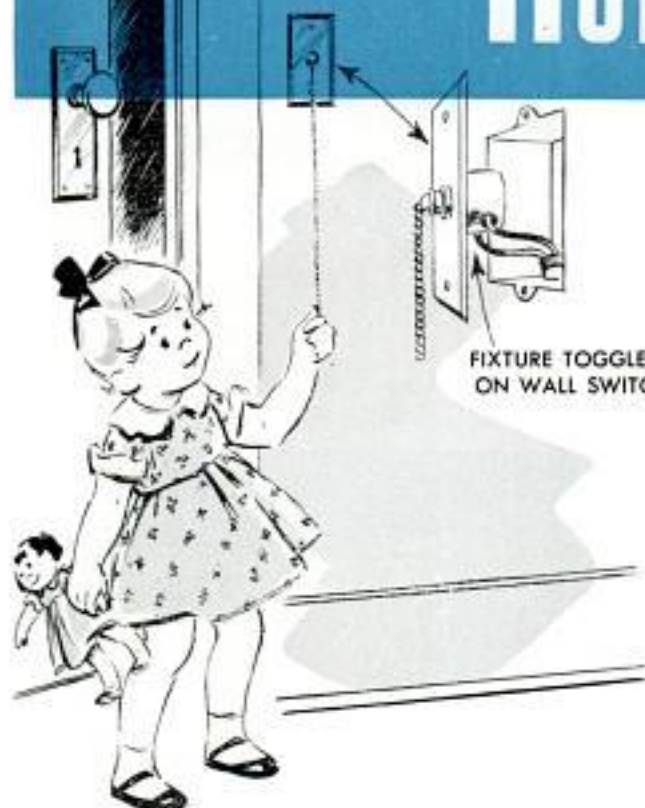

YOUR CHILD can operate the light in his room without the need of climbing on a chair if you replace the regular push-button wall switch with a fixture-type toggle switch. Simply connect the wires to the toggle switch and attach it to the old switch plate

WHEN USING A FUNNEL to fill narrow-necked bottles, you can avoid overflowing of the liquid with this stopper. It is made by inserting a length of stiff wire in a small rubber ball. The ball is pushed down to stop the flow of water when the bottle becomes full

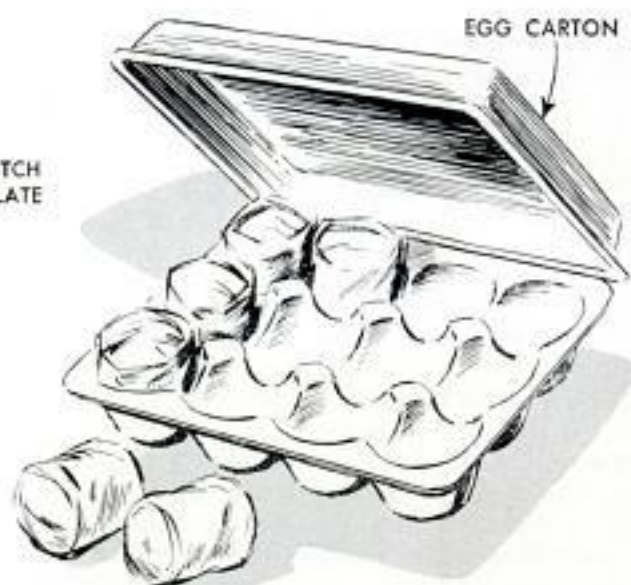

BABY'S SOCKS won't be lost among the clothes in the drawer where they are kept if you use an egg carton as a sock tray. Give it a coat of shellac, then one of enamel and, finally, another coat of shellac. Roll each pair of socks tightly for storage

SCRATCHES on a kitchen wall, caused by a table being pushed against it, won't be a problem anymore if large rubber-headed tacks or door bumpers are fitted to the table. Attached to top of legs or to apron, they extend far enough to prevent contact

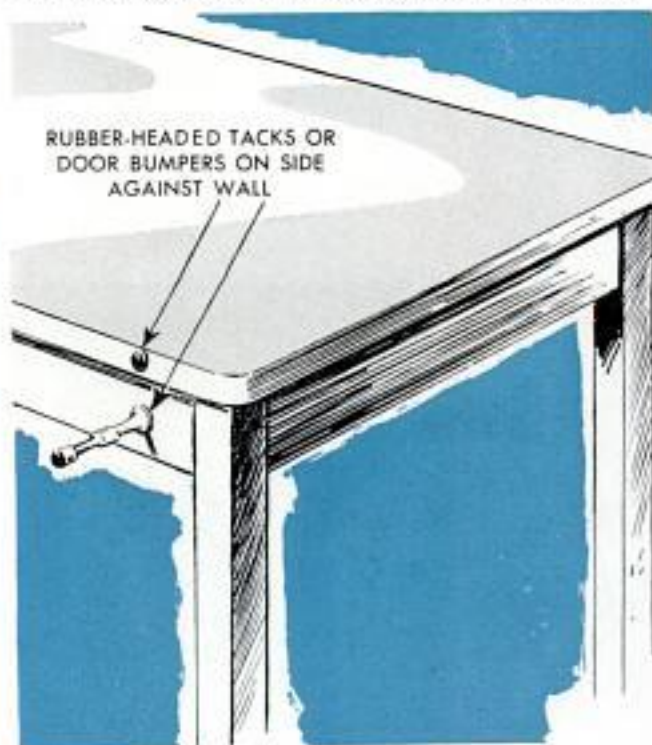

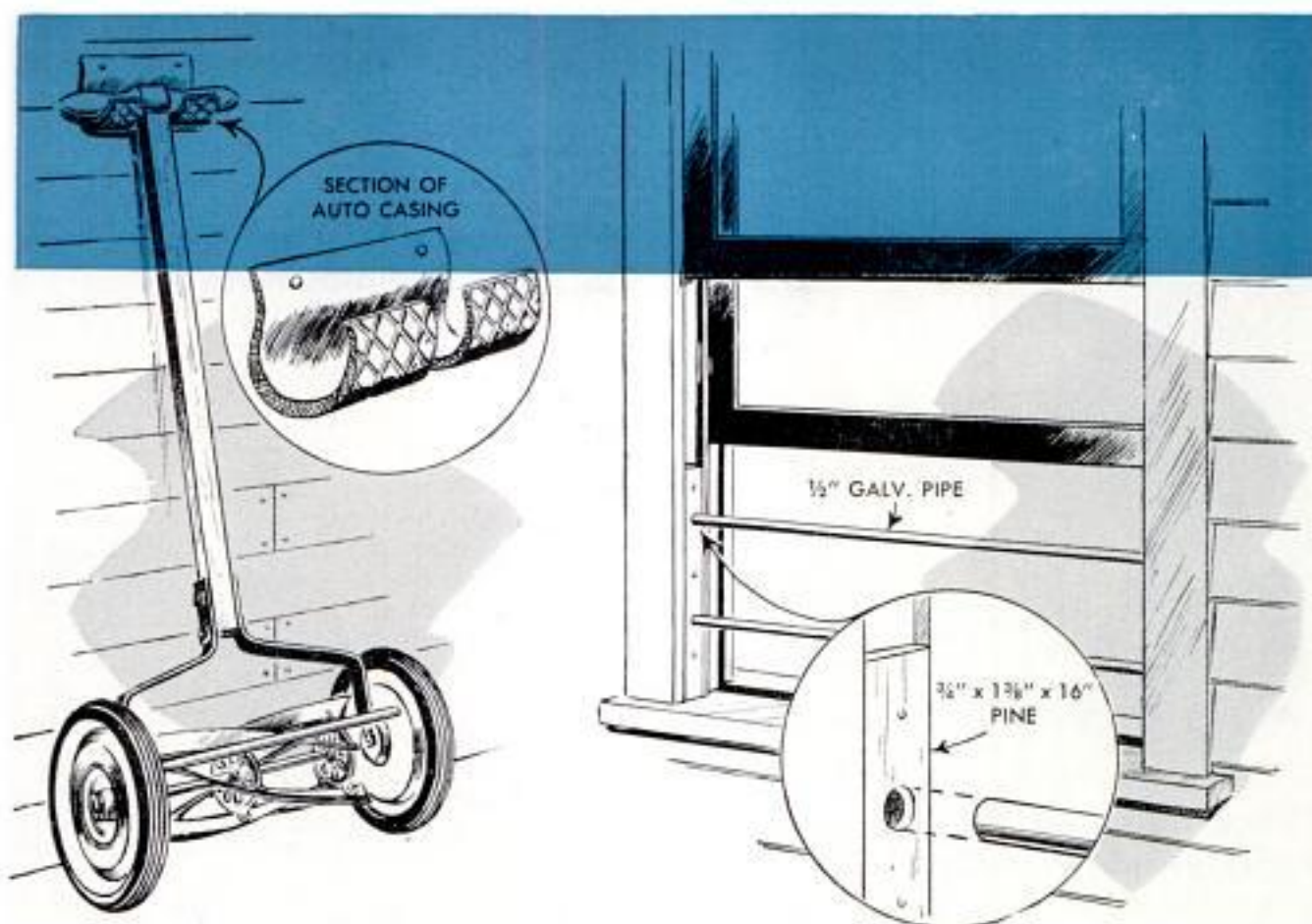

THE LAWN MOWER will occupy less space if stored against the garage or shed wall with the handle supported vertically. To hold it in this position, cut a section of auto-tire casing and notch it as shown. Nail it to the wall at the height of the handle

TO PREVENT the possibility of small children falling from second-story windows, one homeowner installed protective bars. The bars are lengths of $\frac{1}{2}$ -in. pipe cut to the window width and set in holes drilled in pine spacers attached inside the upper sash track

DENTED KITCHEN POTS and pans can be restored easily. First, fill a small sack with sand. Next, slip a rubber crutch tip over your hammer head. Finally, hammer the dents out from the inside of the utensil while dented portion rests firmly against the sandbag

A GLASS JAR having a metal or plastic screw cap can be converted into a handy holder for a ball of twine and a pair of scissors. Cut a slot near one side of the cap to hold the scissors and punch a hole in the center of the cap for dispensing the twine

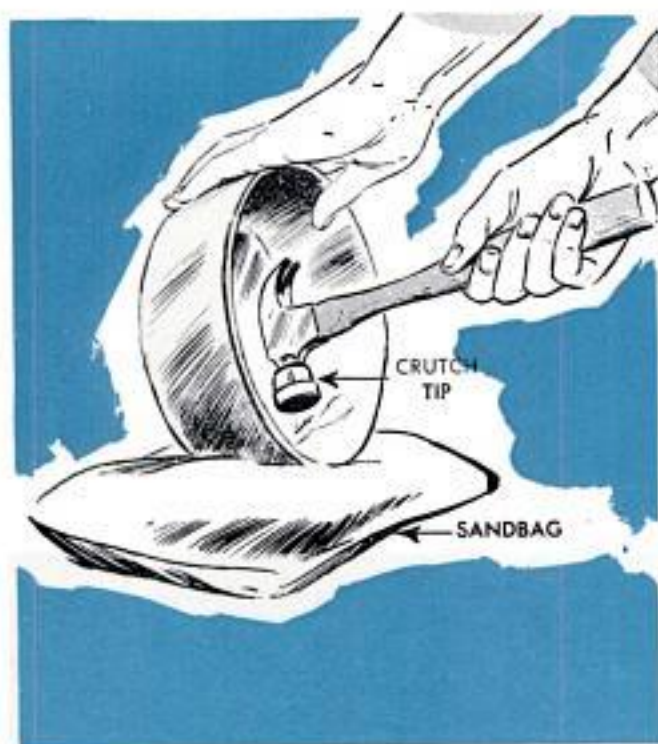



Hinge Modified as Spring Latch Locks Window in Open Position

A double-hung window sash cannot be opened from the outside when it is held by a lock made from a T-hinge and a length of flat steel. The short leaf of the hinge is screwed to the top edge of the lower sash so the long leaf will contact a length of flat steel screwed to the side member of the upper sash. The hinge then is fitted with a flat spring, as shown in the detail. The top end of the long leaf is filed to a narrow width and bent at right angles to fit into holes drilled in the flat steel. Positions of the holes in the flat can be varied to suit individual requirements. When the window is opened from either top or bottom, the spring-loaded leaf is pulled back, then released to fit into the hole corresponding to the opening of the window. The lock also can be used on horizontal-sliding windows.

Five Dulled Phonograph Needles Provide Music-Staff Scriber

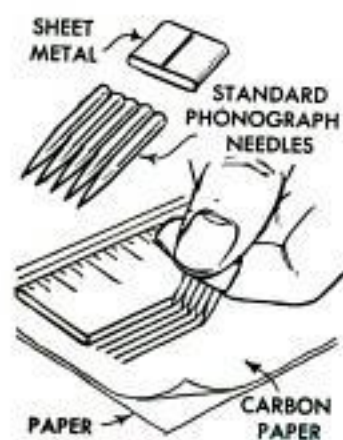

Music students and musicians who have frequent occasion to copy or transpose music can make a simple staff scriber by soldering five phonograph needles in a sheet-metal holder. When the assembly is soldered, rub the points of the needles against

a piece of emery cloth to dull them. This prevents the needles from cutting through the carbon paper over which they are drawn to produce carbon lines on blank paper underneath.

Wall Hanger for Rope Coil Cut From Radiator Hose

A short length of automobile-radiator hose can be utilized as a handy wall hanger for a coil of rope or line. Slit the hose lengthwise and round off the corners at the ends of the cut to permit easy insertion and removal of the rope. Punch two holes in the hose and screw it to the wall, using washers under the screwheads.

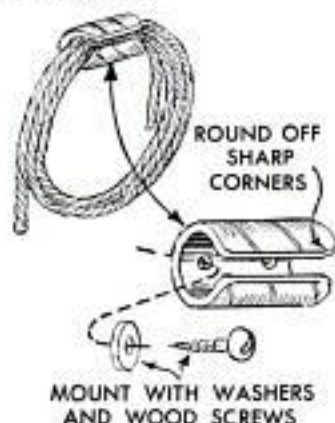

Norm Jacky, Fond du Lac, Wis.

Photo-Developing Time Reduced By Utilizing Washer Agitator

The job of agitating a film tank during lengthy fine-grain processing can be simplified by utilizing the agitator of a washing machine. A bolt that fits the threaded hole in the agitator shaft is used to bolt a block of wood to the shaft. The tank is held on the block with clips shaped from coat-hanger wire. Development is so efficient that the time can be reduced approximately 10 percent. In the case of Microdol, for example, developing time can be cut from 16 to 13 min.—Turk Smith, Phoenix, Ariz.



Simple Bed Tray You Can Make in One Evening

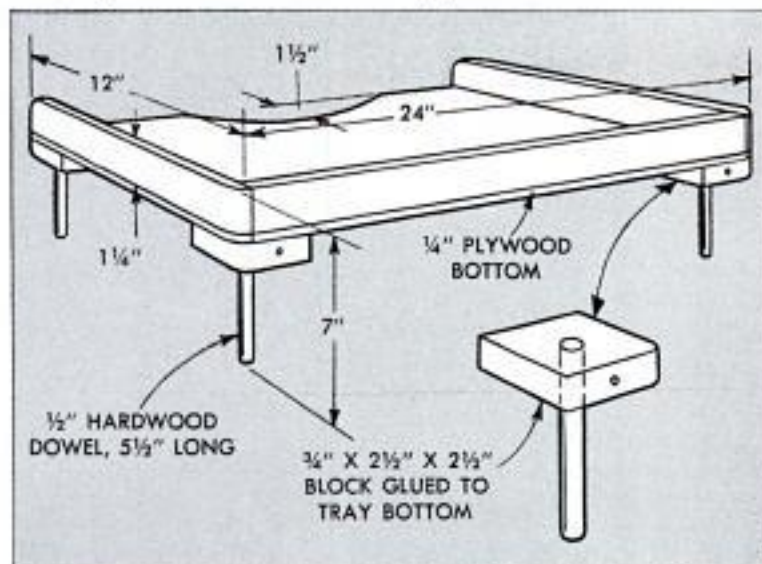

This simple and attractive lap tray will help mother in a dozen ways around the house to save time and eliminate extra cleaning, especially in the sickroom. Complete meals can be placed on the tray and carried to a bedridden child or adult, then placed on the bed over the patient's lap. Between meals, the cleared tray can be used as a play surface for a youngster or as a card or writing table for an adult.

The suggested dimensions for the tray

can be varied to suit the individual needs, but care should be taken to see that it is not so large as to be awkward to handle the tray nor so small that it is impractical. The cutout at the back of the table top, which allows the tray to fit closer to the person using it, was cut with 1 1/2-in. radius on the original. This size is all right for a child, but might have to be increased for an adult. For purposes of storage, the dowel legs of the tray could be removable.

Alarm Warns of Sump-Pump Failure to Prevent Basement Flooding

A flooded basement may be prevented by this alarm installed in the sump tank to give warning if the pump fails to operate because of some minor defect. The alarm system is actuated when the water level in the sump reaches a predetermined height, which raises the float so the copper

plate on top of the float rod contacts the plate fixed to the wooden support. This connection closes the circuit which causes the doorbell to ring. The doorbell may be powered by a 6-volt battery or other 6-volt supply source. The wooden support for the alarm is simply a 2 x 4 with two long screw eyes set in it so they align vertically to assure free motion of the float rod. A stop pin keeps the rod from dropping too far. A pump that seldom runs may become inoperative because the float rod has become corroded so it cannot raise with the float and close the switch, or the electric motor itself may become "frozen." A preventive measure to assure that the pump will operate properly when necessary is to fill the sump with water every couple of months and allow the pump to empty it.

George P. Schmid, Deerfield, Ill.

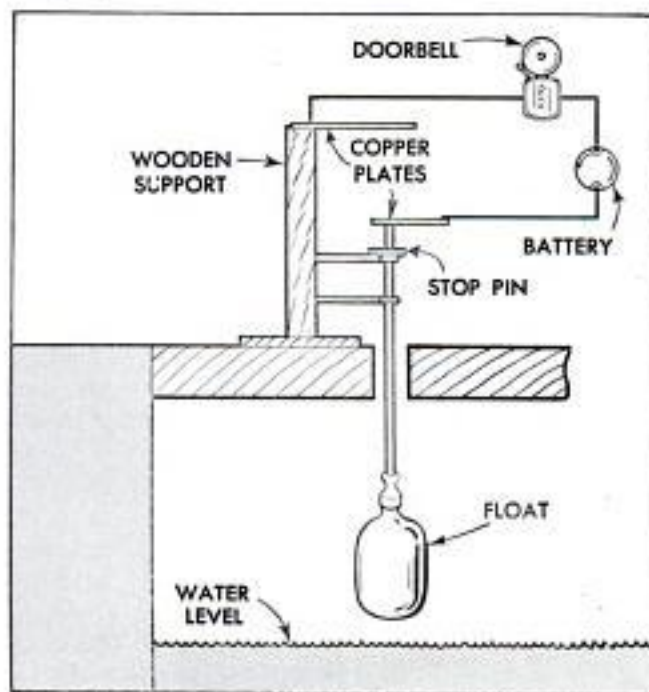

Shellac Sizes Plaster Patches

To do a finished job of painting over patched plaster surfaces, sandpaper the patched areas when completely dry and then apply a coat of shellac. The shellac will size the porous plaster and prevent absorption of the fresh paint.

I. M. Fenn, Chicago.

UNUSUAL SMALL BOAT



Above, this little boat is seven feet of safe water fun for children. It's good looking and easy to use



The boat has many uses; among other things it can serve as a picnic table, as above. Below, with the three sections nested, it makes a compact package that is lightweight and fits into most car trunks



By H. W. Bull

HERE IS A SMALL BOAT, which divides into three sections, that is designed primarily for children's fun. It is safe, lightweight and, in addition to boating, can be used as a picnic table or as a back-yard wading pool. For ease of handling and carrying, the three sections of the boat nest one inside the other, making a compact package small enough to fit into the trunk of a car. The boat has unusually good stability, provided by a flat bottom and very wide beam. The heaviest section weighs only 32 lb., and the total weight of all three sections is only 76 lb., all of which make for easy handling and transporting.

The boat is constructed of $\frac{1}{4}$ -in. exterior plywood throughout. Every effort was made to be economical in the use of this material, and all of the plywood parts can be cut from one 4 x 16-ft. sheet if desired, as shown in Fig. 4. Note dotted lines on ends of sidepieces in pattern. This indicates waste material which should be cut off after each side is in place on the boat. The frame is made from hardwood. On the original model, the chine molding and cross members were cut from white-oak flooring and the uprights were cut from beech. The dimensions of the chine, frame and upright members are given in Fig. 3.

The first step in the assembly of the boat is to cut out all of the plywood pieces. Check over-all dimensions in plan view,

WTM 56

Fig. 2. Next the $\frac{3}{4}$ x 1-in. cross members are installed. They are glued to the bottom sheets and held by $\frac{3}{4}$ -in. No. 7 flatheaded brass screws driven in every 2 in. Note that cross members are set in $\frac{5}{16}$ in. from the ends to provide a seal for the partitions to be installed later. Now the chine pieces are cut to size. To make them easy to bend to the shape of the plywood bottom, rip each of these lengthwise vertically through the center. The outer half of each chine is then glued and screwed in place, being bent as you go. The inner half is then placed against the outer piece and fastened to it and to the bottom with glue and screws.

The bulkheads, bow and stern pieces can now be installed. They are attached to the bottom frame and the upright members of the frame are attached to them and to the bottom frame. Then temporary braces are used to hold the endpieces at the proper angle, as shown in the photo on page 177. With this much of the three sections of the boat complete, they are placed on the floor and, with cardboard between them to provide $\frac{1}{8}$ in. of spacing, they are clamped together while the sides are put on.

The sides are temporarily positioned on the boat. They are held in place by drilling holes through the excess material at the ends of the sidepieces and running wires through them. The wires are drawn taut between the two sides until the sidepieces are drawn snugly against the uprights. Once they are in position, they are care-



When you can't take the boat to the water, bring water to the boat and you have a little wading pool

fully marked and removed. Along the top and bottom edges, the sides are cut to within $\frac{1}{16}$ in. of the marked line. The ends are not cut, since they must be used to hold the sides in place as the glue sets. Once the sides are trimmed, they are replaced on the boat, held once again by the wire. All joints are flooded with glue, and then screws are driven 2 in. apart into all of the upright members and into the chine molding.

The outside molding is now put on. The bow and stern moldings, see Fig. 3, are installed first. The side moldings are ripped in half lengthwise so as to be easier to bend around the curve and held with screws driven from the inside of the boat. Note

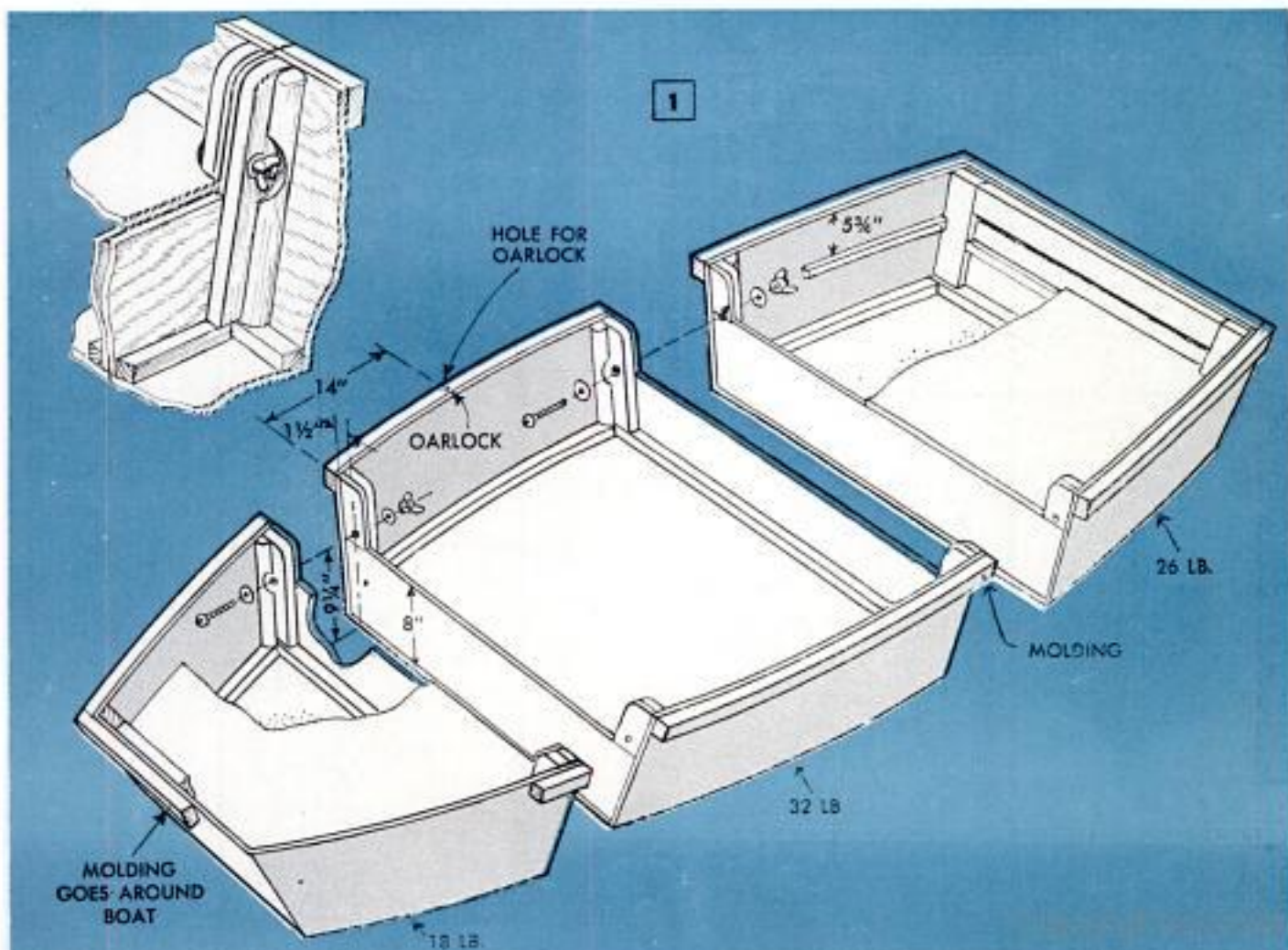

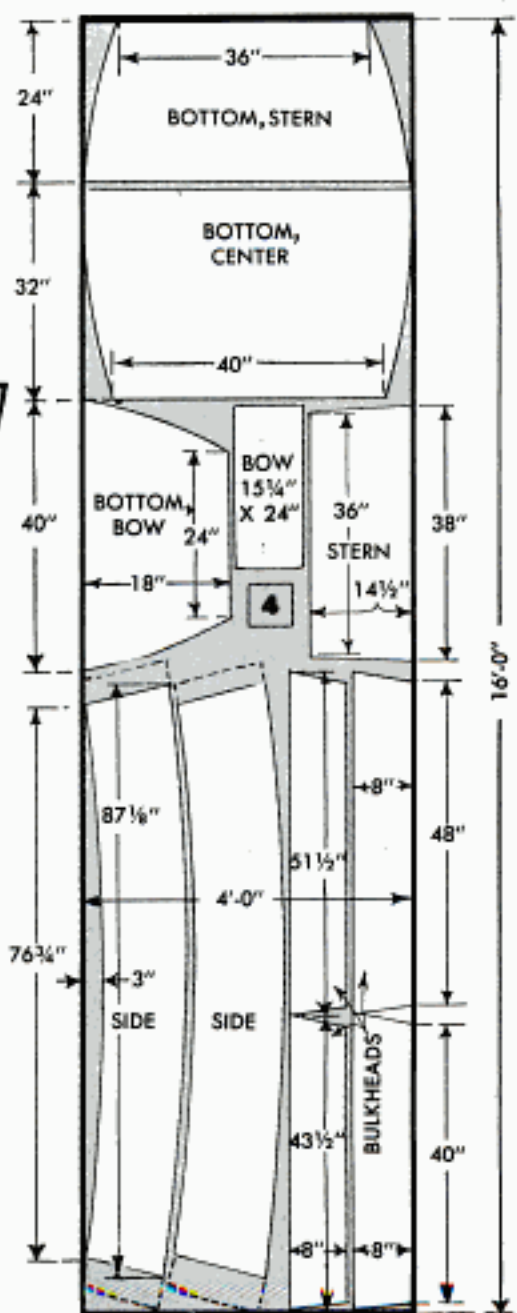
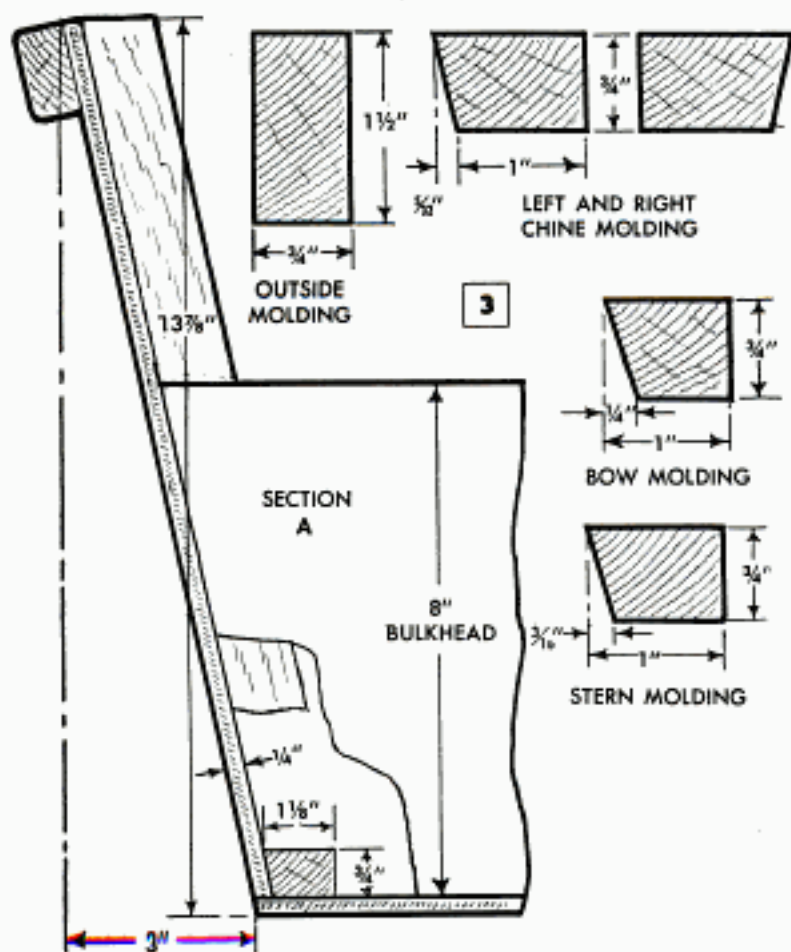
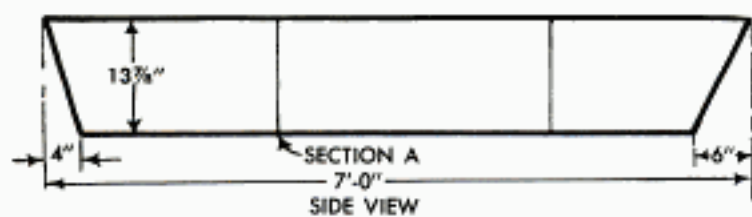
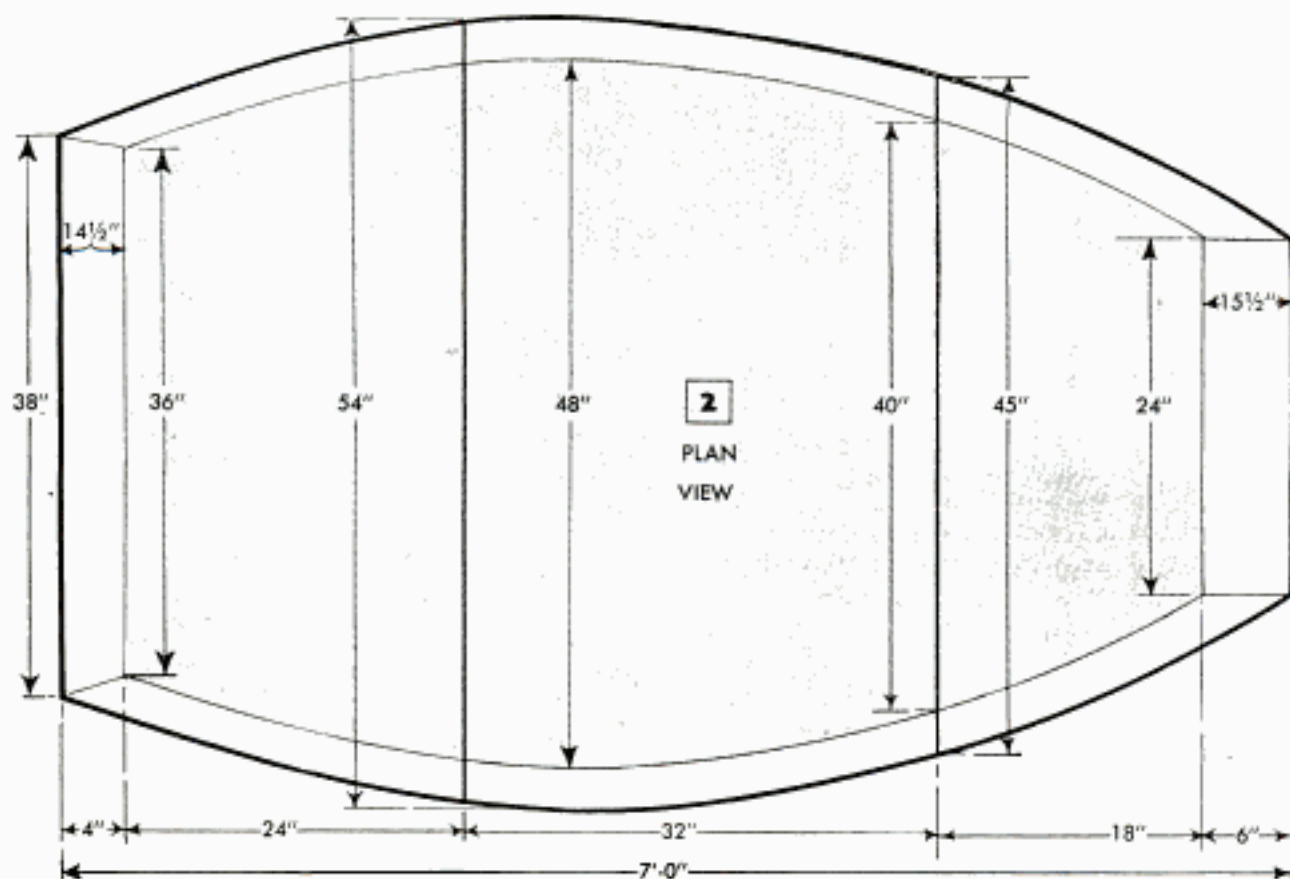

that the stern molding is made wider so that it will support an outboard motor.

When all the glue has dried thoroughly, the three sections of the boat are cut apart by sawing the sides through at the junction points. The excess material is trimmed off the ends and all edges are sanded smooth. The three sections are held together with clamps while holes are drilled for the bolts and wing nuts which hold the sections together. The holes are $\frac{9}{16}$ in. in dia., and into these are fitted $\frac{1}{2}$ -in. cap screws, 2 $\frac{1}{2}$ in. long. The screws are fitted with standard wing nuts and washers.

The seat rails are $\frac{3}{4}$ -in. quarter round, and 1 $\frac{1}{4}$ -in. quarter round is installed to strengthen upright members and notched to clear the wing nuts. The seats are cut from ordinary $\frac{1}{4}$ -in. plywood, and another section of floor is cut for the center section of the boat from the same material. See details in Fig. 6. This floor is glued in the bottom of this section because of the hard wear it gets. To prevent excessive wear on the underside of the bottom, two strips of $\frac{5}{16}$ x 1 $\frac{1}{2}$ -in. white oak were run the length of the bottom, spaced 24 $\frac{1}{2}$ in. apart. The boat was finished by sanding it completely and staining a deep red mahogany. The molding was painted green. Several coats of spar varnish completed the boat.

Collapsible oars are made by sawing 7-ft. softwood oars in half and fitting them with aluminum ferrules as shown in Fig. 5. Small tubing fitted to the end of one oar section fits into larger tubing fitted to the other oar end. The two are held together by a cap screw. The position of the oarlocks is given in Fig. 1. ★ ★ ★



Above, the three sections are nested. Below, the boat is ready to have sides put on. Note that bow and stern are held at proper angle by temporary braces. Next step is to clamp sections together

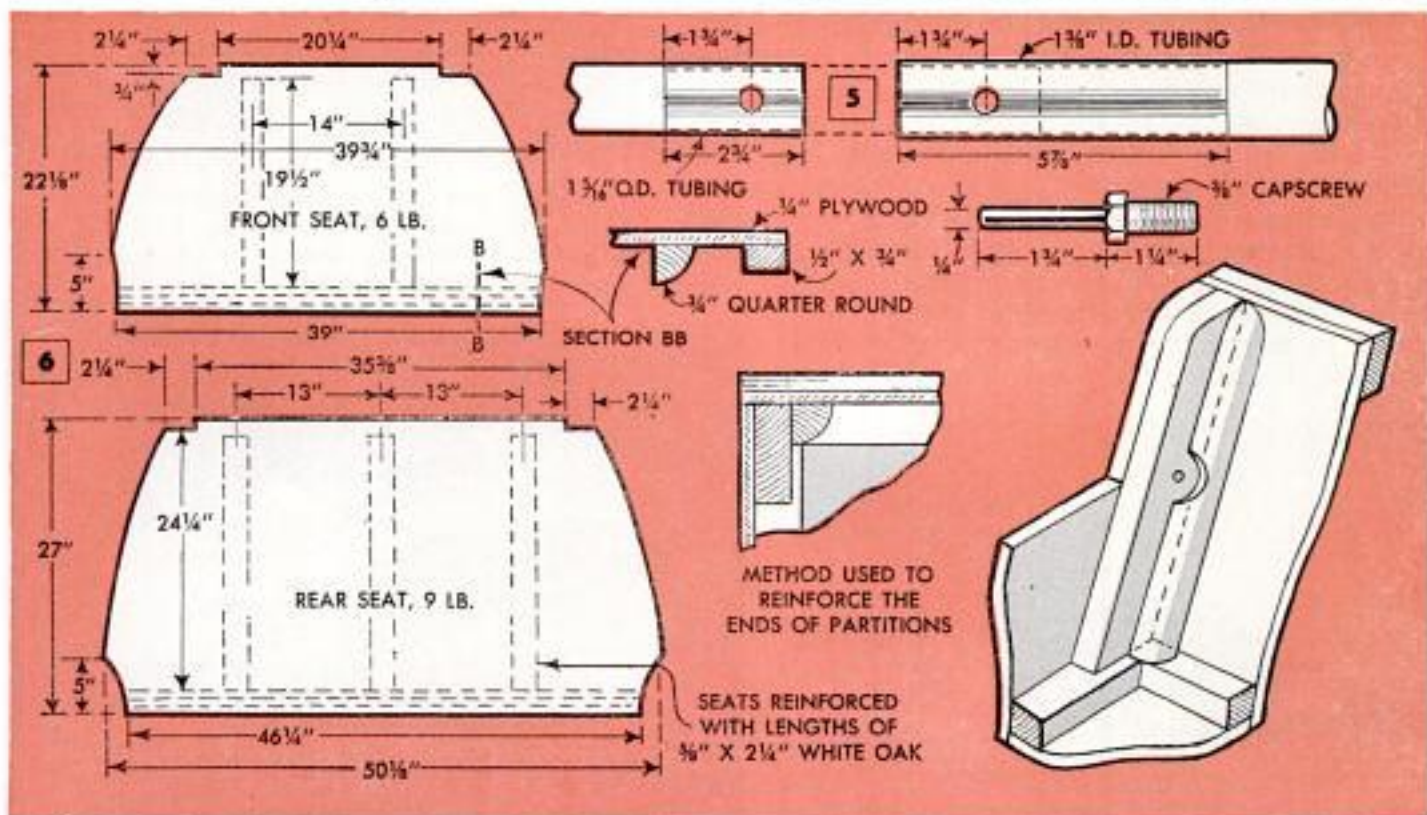
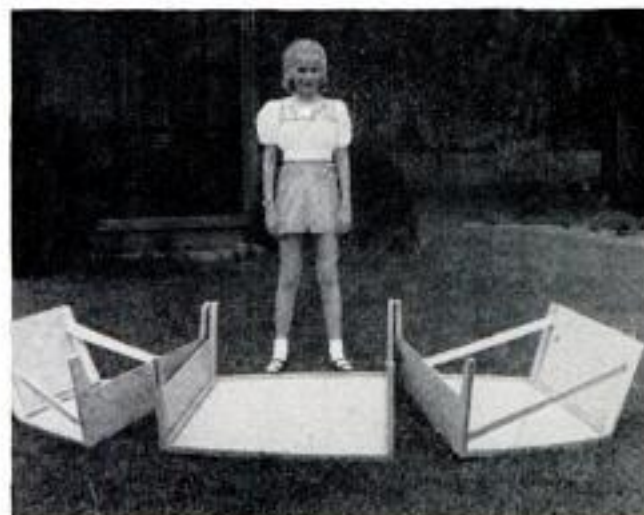



Notebook Lists Home Repairs

A small notebook and pencil tied to strings and hung on a nail next to the workbench are used by one family to keep Dad aware of needed home repairs. Whenever a member of the family notices a needed repair he drops by the workshop and jots it down in the book. Checking through the book also gives Dad the chance to order needed parts and supplies, such as hinges and brackets, ahead of the time he will use them.—B. Ainslie, Ottawa, Can.

Holes Drilled in Trowel Blade Remove Excess Plaster

Amateur plasterers often have difficulty in removing excess plaster from a patching job without gouging out too much and breaking the key to the laths. A number of $\frac{1}{4}$ -in. holes drilled in the trowel, as shown in the photograph, will allow the excess plaster to be forced through the trowel as the plaster is leveled, thus maintaining a smooth surface. A regular trowel should be used for the finish troweling of the whole patch to assure a smooth surface that will align with the wall.

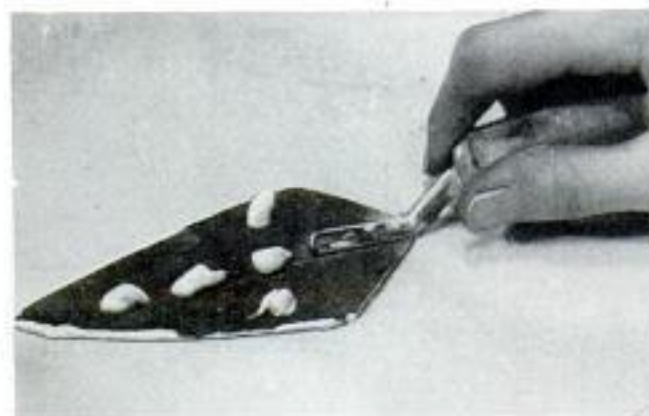

FLAT-FOLDING

By Bertram Brownold

DESIGNED to fold flat like a cigarette case, this unusual sewing caddy with its drop-leaf shelf can be stood open beside an easy chair to make sewing a real pleasure. Closed, it is flat enough to be stored behind a door or hung in a closet.

Each half is made exactly like the other and both are surface-hinged together along one edge to swing open. In addition to the drop shelf, one half is fitted with a spool rack, swing-out button drawers and a trough for odds and ends. The other half has an elastic-top cloth storage pocket tacked to the inside. A row of hooks at the top holds such items as scissors, darning egg, tape measure and pincushion. The two plywood handles are jigsawed at one time and are set flush in each half of the stand. The outside of the stand is faced with plywood panels that are first covered with gay cretonne or chintz and then tacked to the legs. Sheet-brass catch completes the stand.

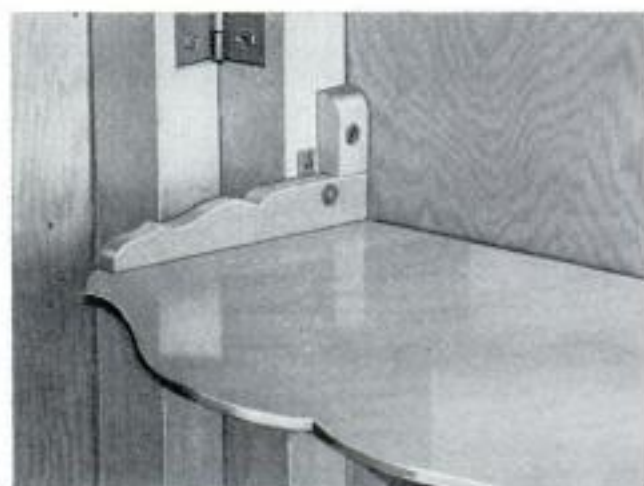

Above, stop blocks, one on each side, support the tilting shelf at right angles when lowered. Below, the outside panels are covered with cloth which is wrapped around the plywood and tacked to rear side

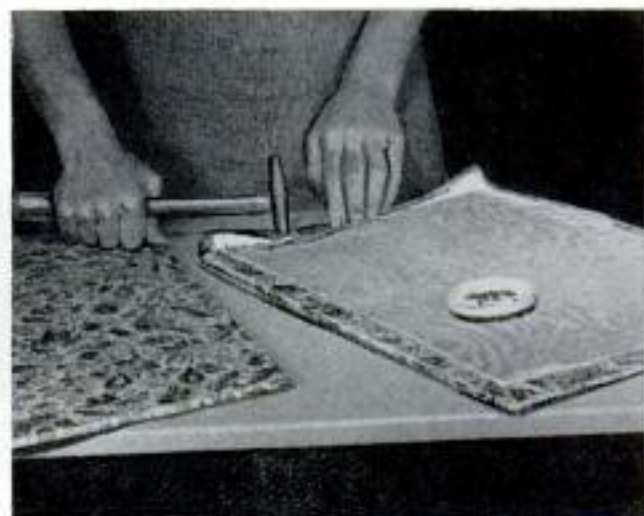

Auxiliary Cabinet Shelves Permit Additional Storage



When kitchen cabinets become overcrowded, it often is possible to gain additional narrow auxiliary shelves at the back of the cabinets. Dishes, plates and bowls usually are stacked only 4 to 6 in. high and the space above, while necessary at the front, is wasted at the back. This space generally will allow the installation of shelves about 3 in. deep. If the original cabinet shelves fit on brackets which are adjustable in holes drilled in the cabinet ends, the auxiliary shelves can be installed in the same manner. Cut the auxiliary shelves $1\frac{1}{2}$ in. shorter than the regular shelves and nail $\frac{3}{4} \times \frac{3}{4}$ -in. cleats across the ends. The cleats should be as long as the regular shelves are deep.

Fastener Provides Planing Stop

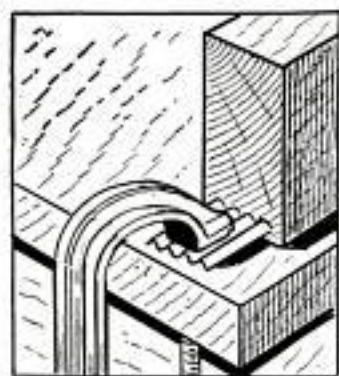

Instead of driving a nail into the top of the workbench to serve as a temporary bench stop, use a corrugated corner fastener held with a C-clamp. Face the sharp edge of the fastener toward the work.

Cleaning Soiled Holiday Candles

To make soiled holiday candles look like new again, wipe them with a soft cloth dipped in kerosene and then wrung out. Do this quickly, using a smooth up and down motion. Then, using the same motion, reharden the wax with a cloth dipped

in cold water. To polish the candles and restore their original luster, simply rub briskly a few times with a crumpled sheet of tissue paper.

La Verne Howell, San Diego, Calif.

Dowels Chucked in Drill Press Sandpapered to Point

A number of wooden dowels or metal rods can be shaped to an identical point by chucking them in a drill press and using the tool illustrated, which is a beveled wooden block screwed to a base plate. The angle side of the block is covered with sandpaper to shape wooden dowels and a file is held against it when shaping metal rods. In use, the block is moved slowly back and forth to prevent the sandpaper or file from becoming clogged in one spot.

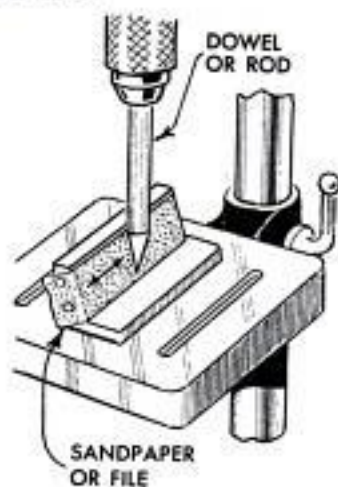

Plastic Cable Shaped as Guide For Drawing Irregular Curves

Draftsmen, and others who have occasion to draw irregular curves, will find that a length of flat, plastic wiring cable can be shaped to almost any desired curvature. It has a smooth edge for use with either a pencil or ruling pen, and permits a line to be drawn in one continuous sweep rather than in short segments as is the case when standard fixed curves are used. Once the cable is bent, it will retain its shape until it is deliberately rebent.



WTM 56

FOLD-AWAY DRAWING TABLE



By C. D. Macy

IF YOU HAVE only an occasional need for a regular drawing table but are faced with the problem of where to put it, this compact, disappearing unit may be the answer. Opening out from a shallow wall cabinet, $4\frac{3}{4}$ in. wide, the table actually takes no floor space at all. The novel way that it folds is shown in the sectional view. A standard-size drawing board, 31×42 in., provides the table top. This is fitted with wooden rollers which operate in channel tracks

formed by the sides of the cabinet. The drawing board is faced on the underside with two paneled frames, a short upper one being permanently screwed to the board itself while a lower frame is hinged to the upper one and to the cabinet at the bottom. The hinged panel provides the supporting brace for the drawing board. The cabinet is mounted at the top of the baseboard and securely screwed to wall studs through the mounting cleats.

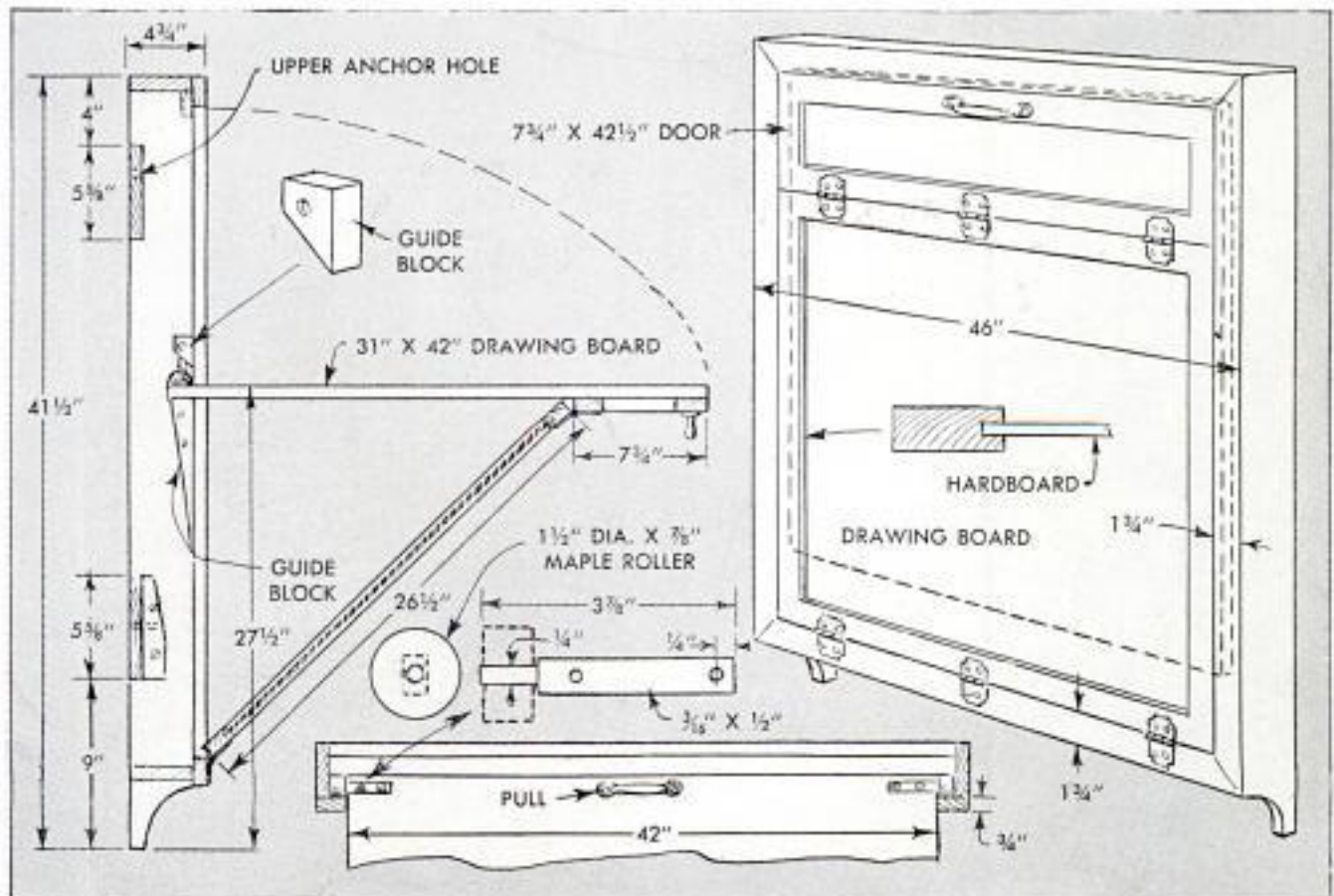

PLAN of the MONTH...

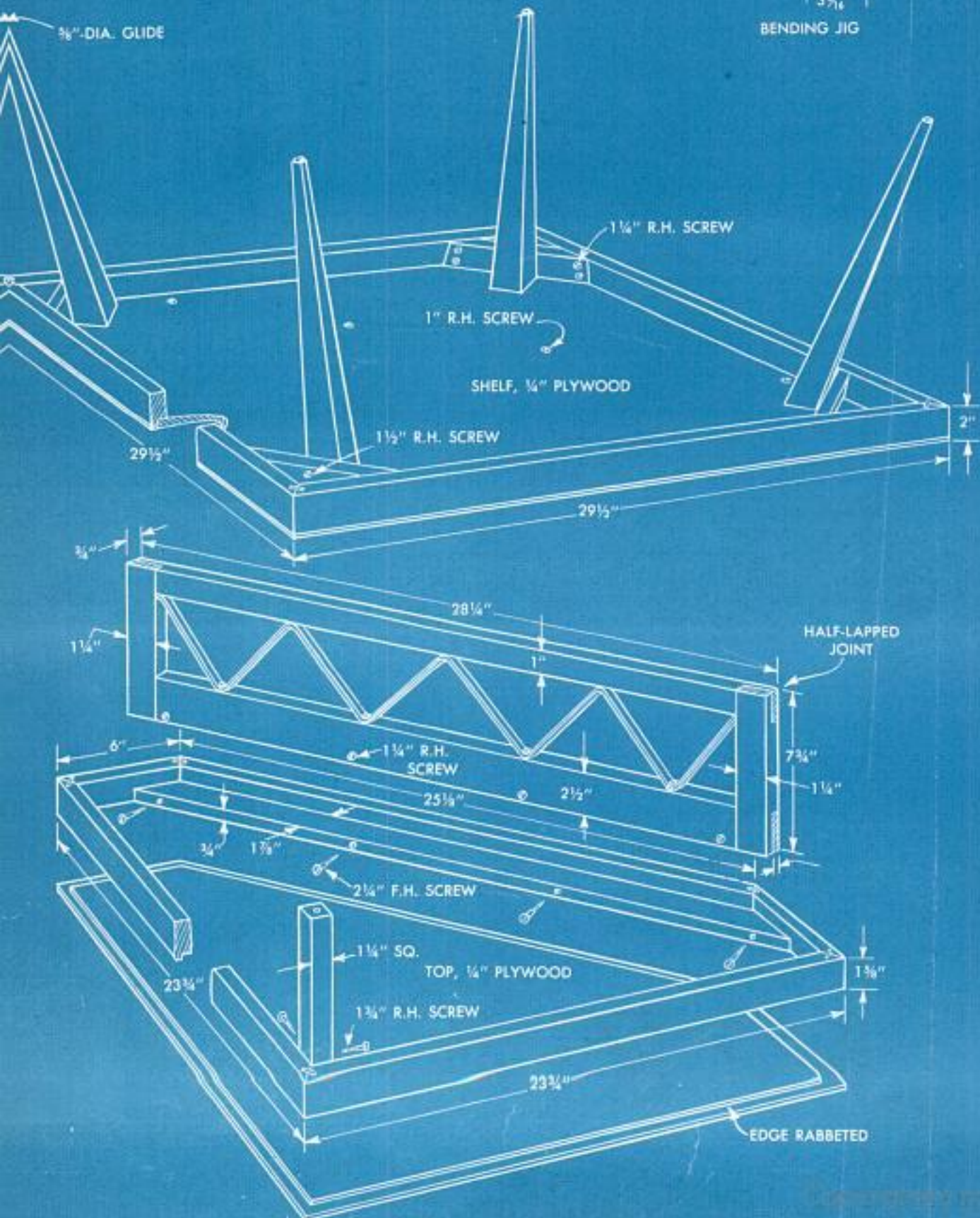
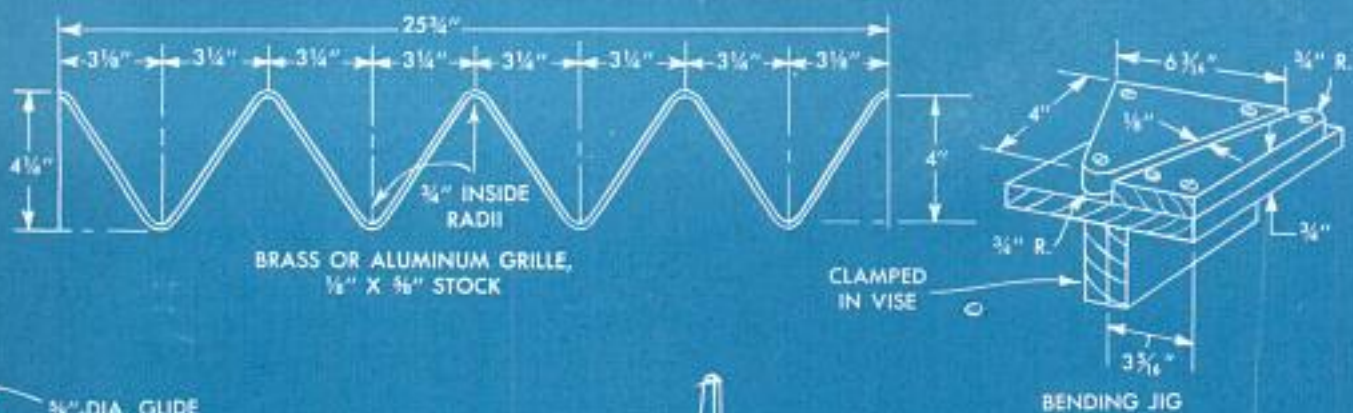

... Corner Table

W T M 56
Modern Furniture

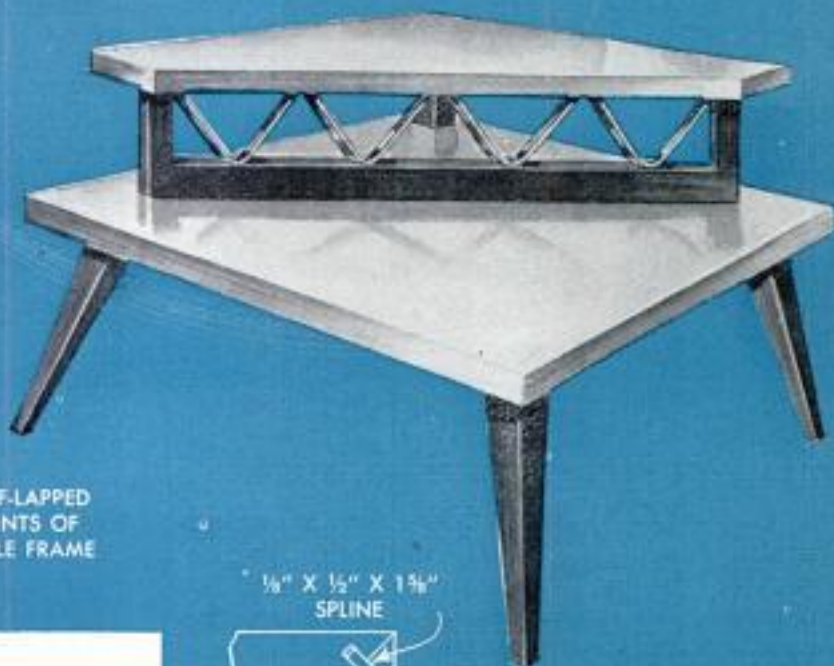
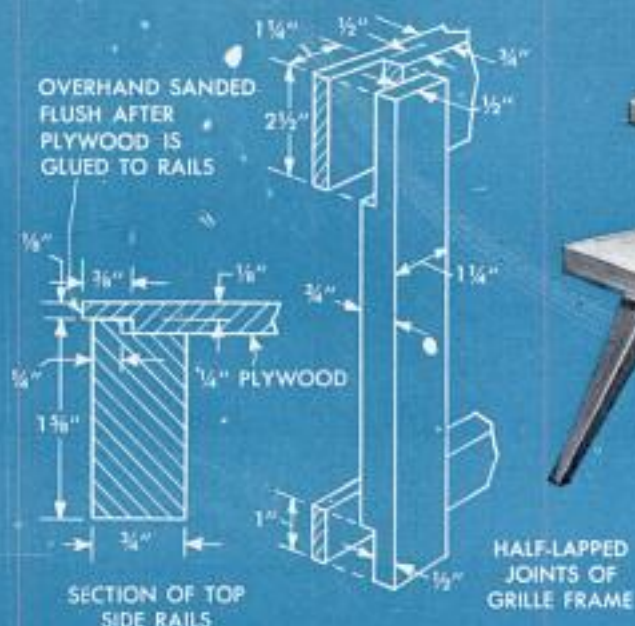

While designed as a companion piece to the coffee and step tables presented in the October 1954 Plan of the Month, this attractive corner table can be used alone with any grouping of contemporary furniture. The same matching brass grillwork used in the previous designs is incorporated here and general construction closely follows that of the other tables. Both the square and triangular table tops are made up separately by first assembling an outside frame of rabbeted pieces and then covering with plywood. You'll note in the details that the plywood also is rabbeted and allowed to overhang the edges of the frame so it later can be sanded flush with the face of the frame. Canted corner cleats provide a means of attaching the tapered table legs with screws from the inside. The triangular top is supported with a simple rectangular frame, plus a post at the back

MATERIAL LIST

Plywood

- 1 pc. — $\frac{1}{4}$ " x $23\frac{7}{8}$ " x $23\frac{7}{8}$ " — Top
- 1 pc. — $\frac{1}{4}$ " x $29\frac{5}{8}$ " x $29\frac{5}{8}$ " — Shelf

Lumber

- 2 pcs. — $3\frac{1}{2}$ " x $1\frac{1}{8}$ " x $29\frac{1}{2}$ " — Top back rails
- 2 pcs. — $3\frac{1}{4}$ " x $1\frac{5}{8}$ " x 6" — Top end rails
- 1 pc. — $3\frac{1}{4}$ " x $1\frac{5}{8}$ " x $25\frac{1}{8}$ " — Front top rail
- 4 pcs. — $3\frac{1}{4}$ " x $1\frac{5}{8}$ " x $29\frac{1}{2}$ " — Shelf rails
- 1 pc. — $3\frac{1}{4}$ " x $2\frac{1}{2}$ " x $28\frac{1}{4}$ " — Top frame rail
- 1 pc. — $3\frac{1}{4}$ " x 1" x $28\frac{3}{4}$ " — Bottom frame rail
- 2 pcs. — $3\frac{1}{4}$ " x $1\frac{1}{4}$ " x $7\frac{3}{4}$ " — Frame posts
- 1 pc. — $3\frac{1}{4}$ " x $1\frac{7}{8}$ " x $28\frac{1}{4}$ " — Frame cleat
- 1 pc. — $1\frac{1}{4}$ " x $1\frac{1}{4}$ " x $7\frac{3}{4}$ " — Back post
- 4 pcs. — $1\frac{3}{4}$ " x $1\frac{3}{4}$ " x $16\frac{7}{8}$ " — Legs
- 9 pcs. — $\frac{1}{8}$ " x $\frac{1}{2}$ " x $1\frac{1}{2}$ " — Splines
- 4 pcs. — $3\frac{1}{4}$ " x $1\frac{13}{16}$ " x $7\frac{5}{8}$ " — Leg cleats

Hardware

- 8 — No. 14 x $1\frac{1}{2}$ " Roundheaded wood screws
- 20 — No. 10 x $1\frac{1}{4}$ " Roundheaded wood screws
- 4 — No. 10 x 1" Roundheaded wood screws
- 4 — No. 10 x $2\frac{1}{4}$ " Flatheaded wood screws
- 1 — $\frac{1}{8}$ " x $5\frac{1}{2}$ " x $\phi 2$ " — Flat brass
- 4 — $\frac{5}{8}$ " Dia. — Furniture glides
- 9 — No. 14 x $\frac{1}{2}$ " Escutcheon pins

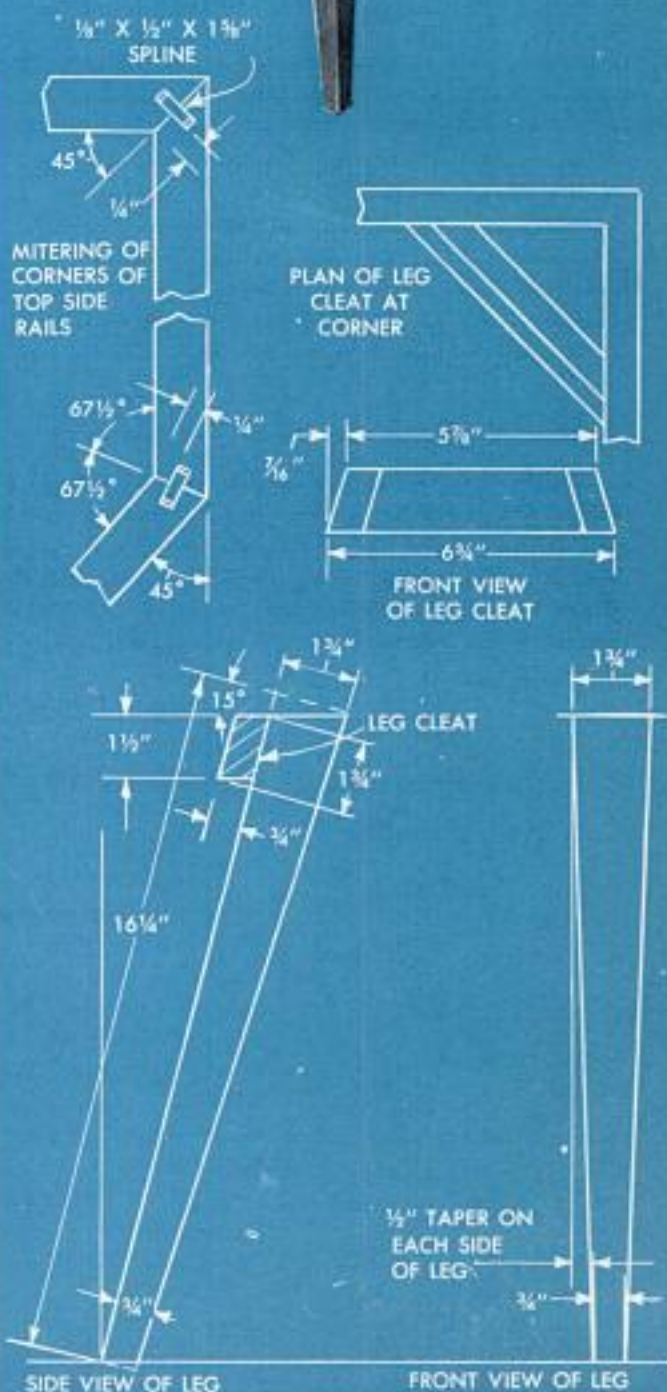

Floor of Insulated Hardboard Can Be Installed Quickly



Photo courtesy Insulite Div., Minnesota and Ontario Paper Co.

One method of installing a floor quickly when finishing an attic or other space to provide living quarters, is to use 4 x 4-ft. sheets of $\frac{1}{4}$ -in. tempered hardboard. Because the floor will be smooth and have relatively few joints, tile can be installed with a minimum of labor. To provide sound insulation against the noise of footsteps, the hardboard should be nailed over an underlayment of $\frac{1}{2}$ -in. insulation board. When nailing the hardboard over the insulation, draw lines on the hardboard to show the locations of the floor joists, and use 9d nails.

Freeing Stuck Drinking Glasses

If two drinking glasses stick together, separate them by pouring cold water in the top one and setting the bottom one in warm water. The cold water will cause the top glass to contract slightly, while the warm water will make the bottom glass expand sufficiently to free them easily.

Sam Fenn, Chicago.

Cardboard Trough Taped to Wall Catches Plaster Dust

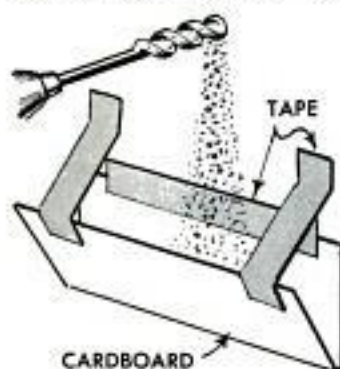

Positioned just beneath the work, a trough made of light cardboard or heavy paper will catch most of the plaster dust and shavings caused by drilling into a plastered wall. The trough is held against the wall

with a strip of masking tape along the back edge and two tape "braces" which lead from the front edge of the trough to the wall. When pulled from the wall after the

job is done, the tape will leave only faint marks that can be removed. The trough is useful when installing wall switches and outlets, and larger versions can be made for use under more extensive repair jobs.

Rex W. Logan, Kansas City, Mo.

Tubing Keeps Towels on Rack

If you have trouble keeping towels from sliding off smooth towel rods, a few short lengths of rubber tubing slipped over the rods will overcome the problem. If the rod is clamped at both ends, slit the tubing lengthwise.

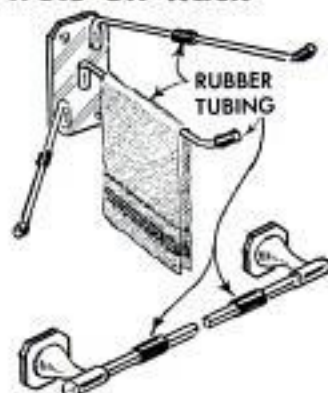

Cabinet Under Open Lavatory Stores Bathroom Supplies

Soap, scouring powder and other frequently used bathroom supplies can be stored neatly out of sight in a simple cabinet built under an open lavatory. The base of the cabinet is a platform made of 1-in. stock and is set back about 4 in. from the front edge of the lavatory to provide toe space. The door and side panels of the cabinet consist of a frame of 1 x 2s covered with hardboard. Shelves fitted with rails may be attached to the inside of the door to store small items. In the cabinet shown in the photo, time and materials were saved by eliminating the side not usually visible.

Photo courtesy Crane Co.



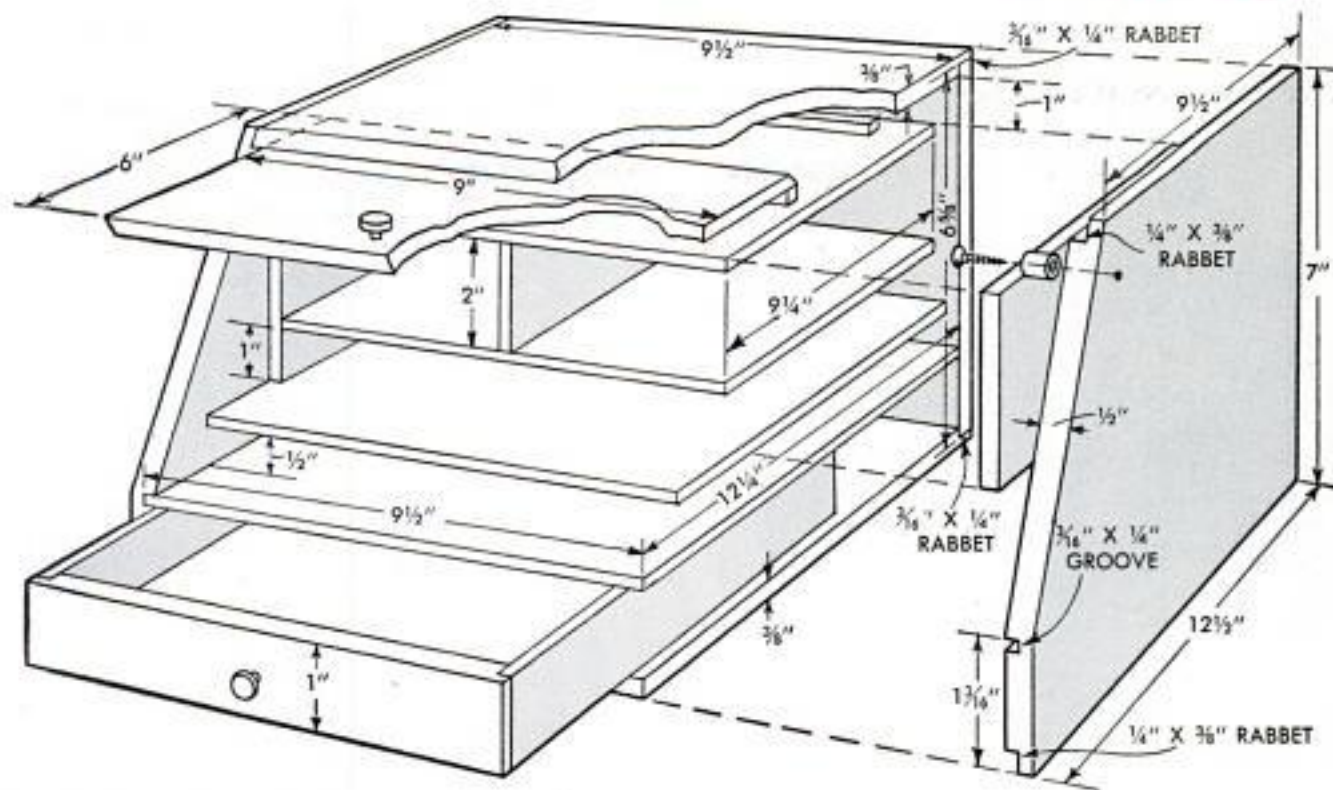

A ONE-EVENING PROJECT ★ STATIONERY CABINET

By I. M. Fenn

LETTER WRITING becomes twice the pleasure when your stationery is stored near at hand in a convenient little cabinet such as this one. There are separate compartments for both writing paper and envelopes and a shallow drawer for pen, pencils and stamps. It may be made from common fir plywood and painted, or from fancy hardwood-faced plywood and varnished. You'll need pieces of $\frac{1}{2}$, $\frac{3}{8}$ and $\frac{1}{4}$ -in. stock. The sides are cut out first, a rabbet being run along the top, rear and bottom edges, and a $\frac{1}{4}$ -in. groove made $1\frac{3}{16}$ in. up from the bottom. The back, top, bottom and pull-out lid are cut from $\frac{3}{8}$ -in. stock. With the exception of the lid, all three members are glued in the rabbeted edges of the side pieces. The lid rides on two $\frac{3}{8}$ -in.-dowel rollers, and a stop cleat across the rear edge of the lid prevents pulling it all the way out. Obviously, the lid must be in place before the separate paper-and-envelope compartment is installed. The drawer is made to fit the opening.

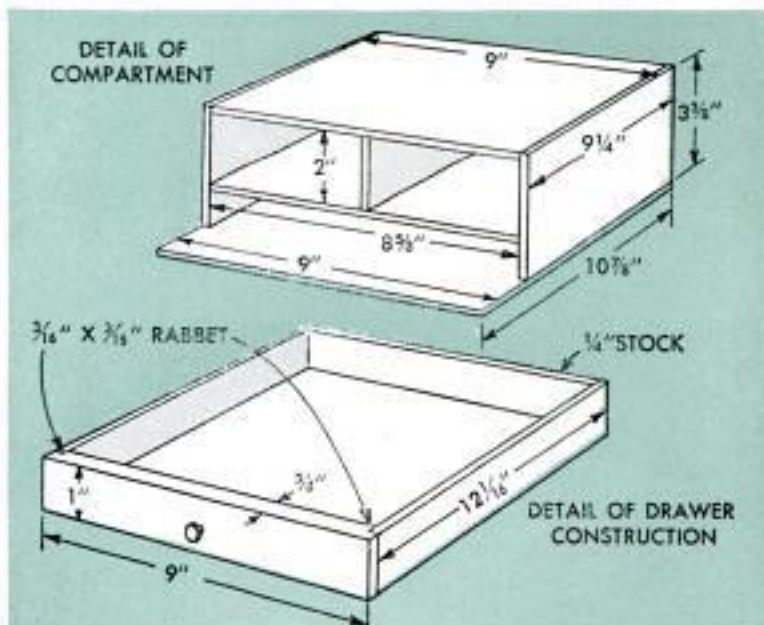

SN 56

HOW TO TREAT PLYWOOD EDGES

By William B. Eagan

WHILE THE USE of plywood has become universal in both the building and furniture industries, its use in the home shop has always confronted the craftsman with the problem of how to conceal or treat the exposed laminations of the material. The drawings on this and the following two pages illustrate a number of ways that the edges can be covered. Some of the methods are comparatively simple while others are more involved.

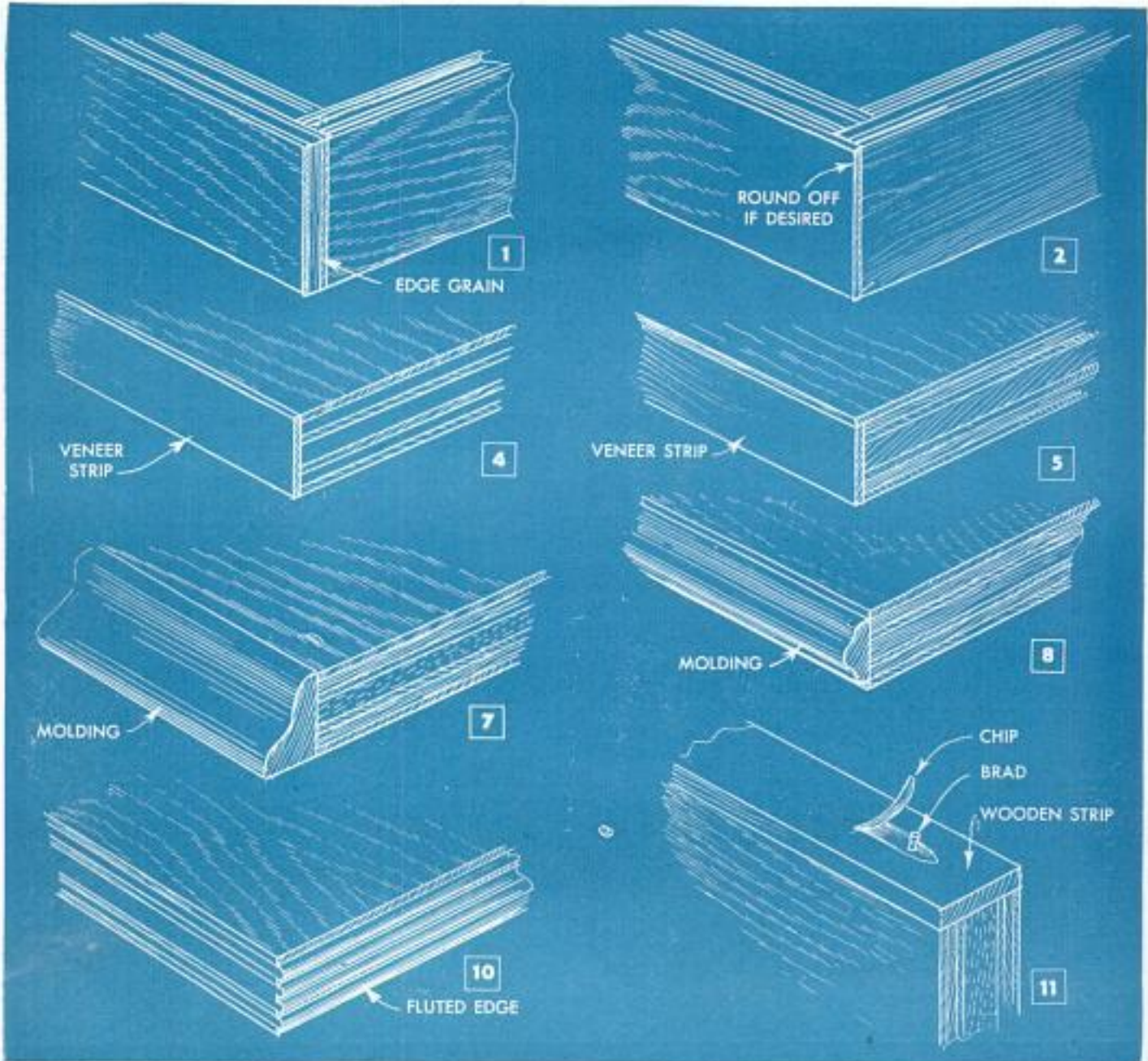

The most common type of drawer joint is shown in Fig. 1, but here the edge grain is exposed and conspicuous. Figs. 2 and 3 show how the same drawer joint can be made so very little or no edge grain is exposed. The amount of edge grain exposed in Fig. 2 may be further reduced and even camouflaged by rounding the corner.

You also have the problem of what to do with plywood edges when the material is used for the shelves in a bookcase or for a table top. The easiest solution is to hide the exposed plies with strips of veneer as shown in Fig. 4. Usually the grain of the veneer is placed lengthwise, but a pleasing variation is had by letting the grain run vertically. In this treatment, often referred to as crossbanding, two plies of veneer produce the best job. This consists of gluing two sheets of veneer together with the grain at right angles and then cutting the edging strips from it. Here, the veneer is brought flush with the top surface of the

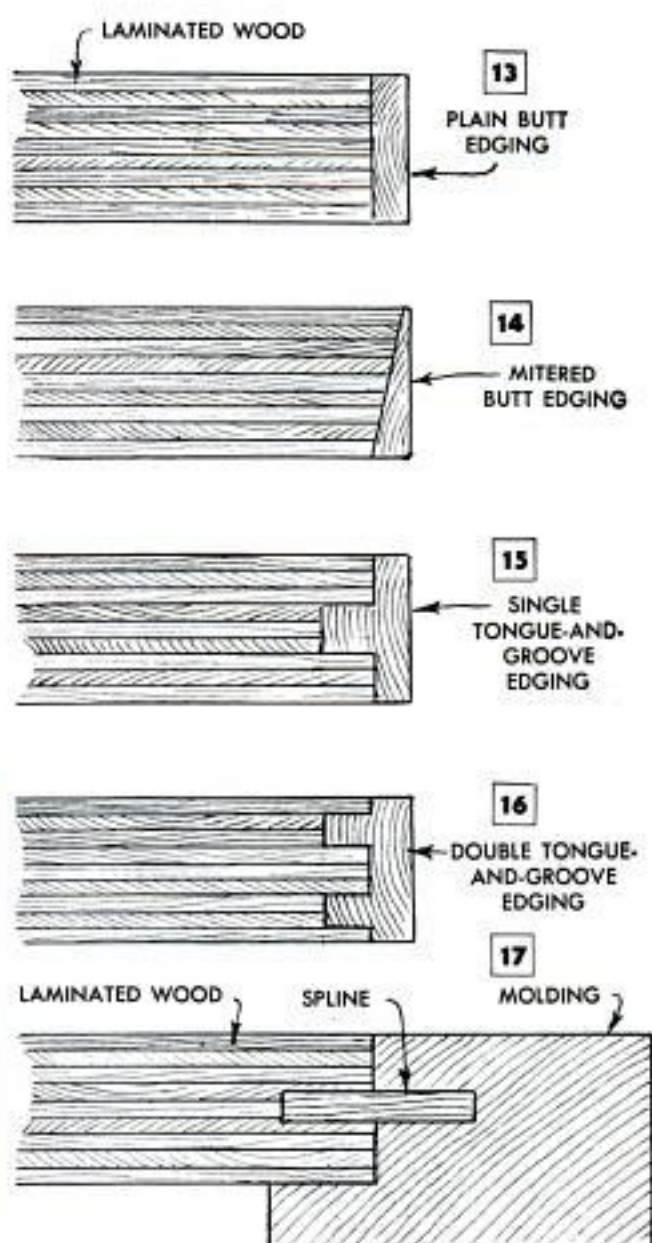
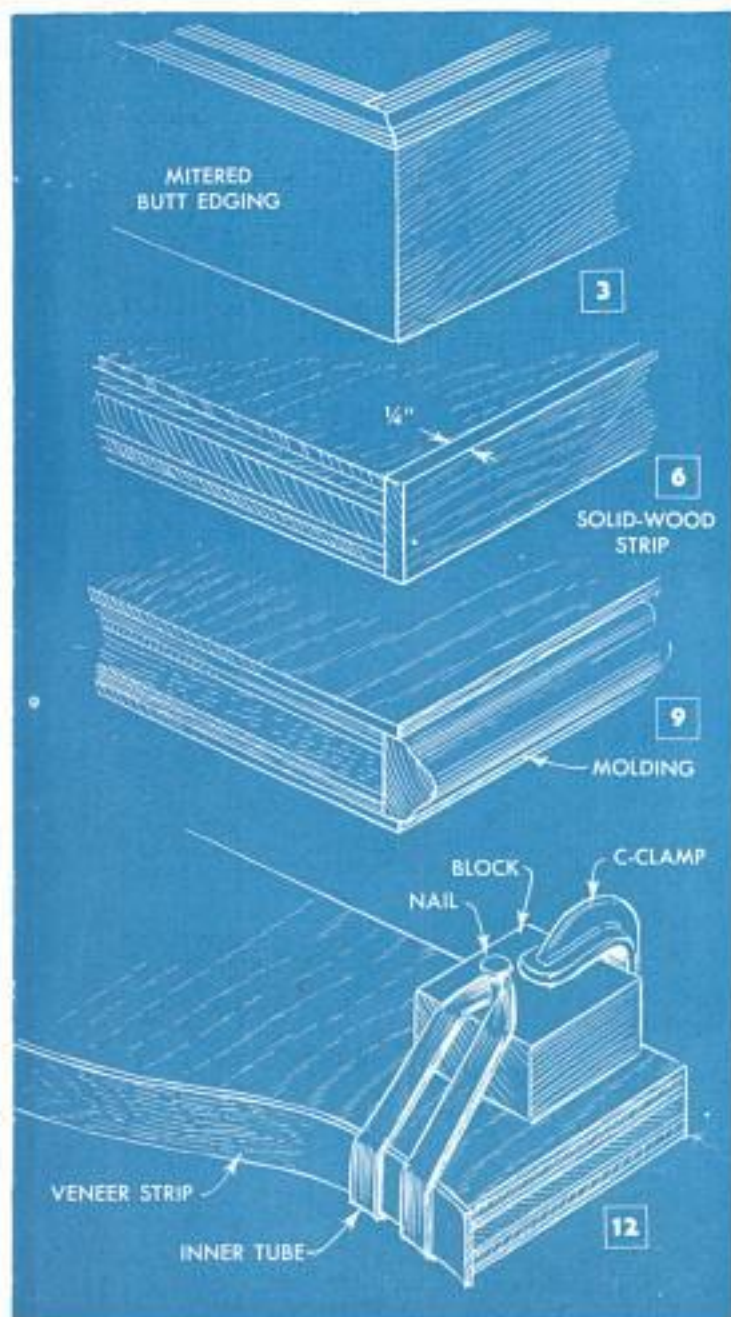

Below, left, simple fixture for holding veneer to curved edge while glue dries consists of rubber band hooked over nails in two blocks clamped to each side of work. Strong band is cut from inner tube



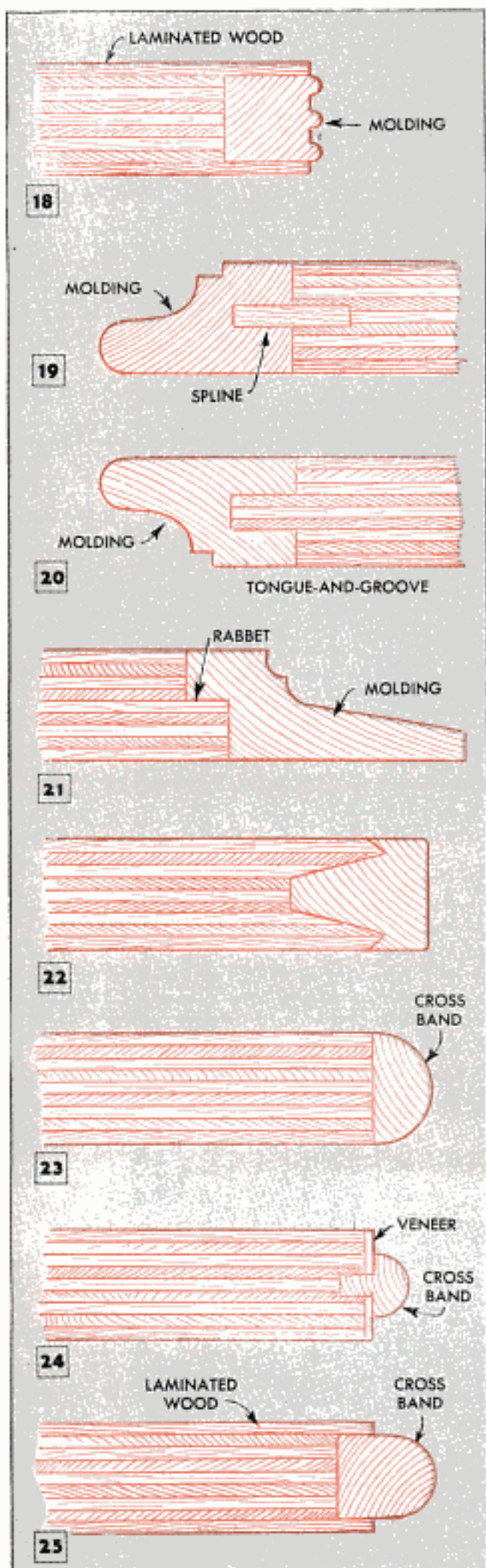

plywood. The objection to having the edge of the veneer show can be overcome by first rabbeting the laminated edge of the plywood as shown in Fig. 5 and letting the top ply overhang the edge of the veneer banding. This latter method also tends to protect the edge of the veneer from wear and damage.

Instead of using thin veneer as in Fig. 4, a 1/4-in. strip of matching solid stock may be glued to the edge to hide the plies, Fig. 6. Similar treatment is shown in Figs. 7 and 8 except that stock molding is used. By running a groove in the center of the plywood edge to receive a molding which is narrower than the thickness of the plywood, a variation can be had resulting in a stronger joint, Fig. 9. There are cases where the objectionable plies can be "concealed" without actually adding anything to the edges. Such is the case when a piece of furniture is given a two-tone treatment by painting or staining the plywood edges, or when design permits the edges to be beaded or fluted on a shaper as shown in Fig. 10. Beading should be limited to furniture such as Duncan Phyfe.

In facing the edges with banding or molding, glue alone is not relied on. The striping is nailed also. Fig. 11 shows how the nailheads are concealed by first lifting a chip with a narrow gouge, driving the brad and then gluing the chip down again. Done properly, the chip seldom can be detected when the final finish is applied to the wood. When veneer is to be applied to a curved plywood edge, Fig. 12 shows a simple method for holding the work until the glue sets.

Figs. 13 to 25 inclusive show additional ways that molding of one kind or another can be used to dress off the edges of plywood. Plain butt edging, Fig. 13, in which

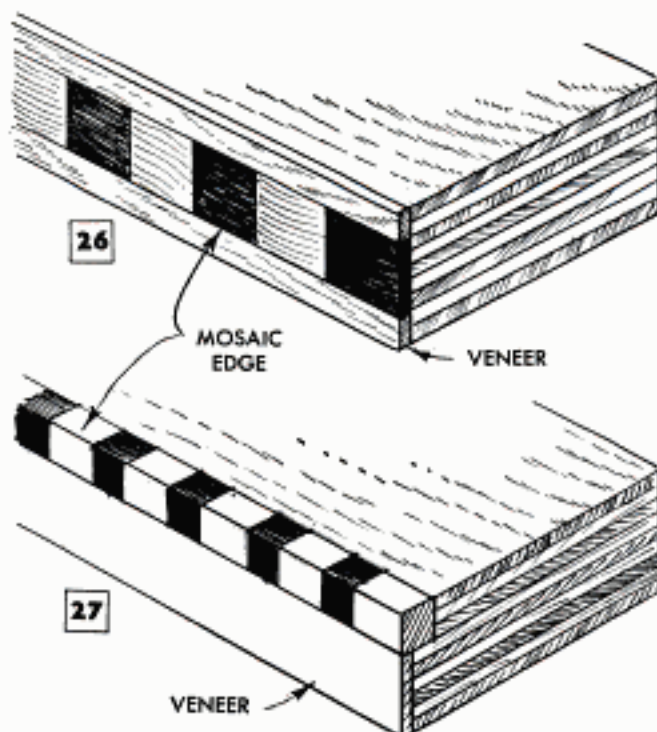

the strip is surface-glued, is the easiest of all to apply. Where it is desirable to reduce the visible thickness of the strip, the mitered butt joint can be used, Fig. 14. Here, the strip is dressed at an angle to match a similar bevel cut in the plywood and simply surface-glued and nailed in place. Splines, Figs. 17 and 19, often are used to give a stronger joint when applying edge moldings. The use of a spline is especially recommended where a wide molding is involved. If molding equipment is available, plain solid stock may be applied to the edges and shaped afterward. The home craftsman will find many stock moldings adaptable. Fig. 22 pictures a joint that perhaps is the strongest of all but one that requires a complicated cut made by a special machine.

A bold treatment of the plain cross-banded edge is shown in Figs. 26 and 27. Here, inlaid banding is used. A strong contrast is obtained by using rare woods, such as ebony, holly, ivory or boxwood. In Fig. 27, a rabbet is cut along the upper edge of the plywood to take a built-up mosaic strip and veneer covers the rest of the exposed laminations. ★ ★ ★

Clothespins Utilized as "Staples" To Make Temporary Fence



A neat temporary fence, such as the kind needed to protect a newly seeded lawn, can be made quickly and easily by using wooden clothespins to "staple" a wire or rope to lengths of $\frac{3}{4}$ -in. pipe. The pipes first are

driven very firmly into the ground and spaced around the area to be protected. Then the clothespins are fitted over a length of wire or light rope and slipped into the ends of the pipes. Tie the line to the first pipe, keep it fairly taut all the way around the fence and tie it to the last pipe. *Caution:* An extremely low fence is hazardous for adults and running children.

Waxed Sheet Under Plywood Speeds Jigsaw Operation

To simplify moving and turning small pieces of thin plywood on a jigsaw table, place the work on top of a sheet of wax paper. This also is helpful if the stock is of resinous quality, as the wax paper "lubricates" the saw blade.

Stacked Cans Resist Toppling When Held With Paper



To aid in keeping stacks of boxes or cans in a warehouse or store from being knocked over easily, place a sheet of wrapping paper between the tiers. A stack so arranged will resist considerable impact because only the top layer of cans or boxes is loose. The paper "binds" the units in each layer together so that the full weight of one or more layers must be overcome before the stack will topple.

Diameter of Sphere Measured By Using Wooden Blocks

The diameter of spheres, disks or round stock can be determined quickly by using two wooden blocks and a straightedge. The sphere or other object to be measured is placed between the blocks—which should have parallel sides and a squared end—and a straightedge rule is held against them. The distance between the blocks is the diameter of the object. Various types of flat-jaw clamps can be used in a similar manner for this kind of measuring.

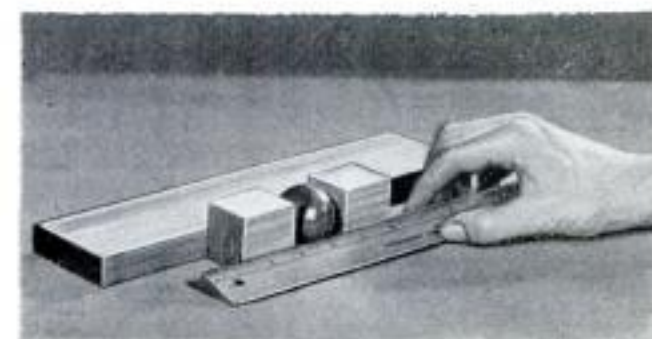

Miniature Wardrobe Closet Stores Child's Dresses



With only limited closet space in the house, one handyman provided hanging storage for his small daughter's dresses by building a miniature wardrobe closet to sit on top of a chest of drawers. Plywood was used in the construction of the closet which is a simple box fitted with a hinged door. The box is 12 in. deep x 24 in. high and can be made any convenient length. The exterior is painted to match the chest on which it sits and decal decorations may be applied to the door. The inside can be covered with a dainty wallpaper or painted. A 1-in. dowel, set in brackets, supports the hangers for the dresses.—Maurine M. Remenih, Arlington Heights, Ill.

Tray on Stepladder Tread Holds Small Parts



When using a stepladder on a job where small parts are involved, a tray made from a pie tin can be clipped to the top tread to hold the parts. A sheet-metal or spring-steel clip is soldered to the bottom of the tin as illustrated.

Scratched Floors Rejuvenated

Wood putty can be used effectively to fill unsightly scratches and gouges in hardwood floors. Apply the putty with your fingers or a putty knife and work it into

the scratch, building it up a little higher than the board surface. When the putty has hardened, sand it flush with the floor, using a medium-fine sandpaper. Then finish with shellac. If the floor is light colored, the putty may be used as it comes from the can. However, if the floor has darkened, the putty should be stained to match before it is applied, or stain can be applied to it after it has been sanded smooth.—Bureau of Industrial Service, Inc., New York City.

Wood-Screw Lubricant Kept in Cosmetic Jar

To be sure of always having a supply of lubricant for use with wood screws, fill a small cosmetic jar with cotton and saturate it with linseed oil or liquid soap. The wood screws then can be wiped across the cotton to pick up oil without the problem of having an excess that will drip from the screws. Be sure the jar has an airtight lid to prevent evaporation or hardening of the liquid when not in use.



Clothespins Provide Holder For Darkroom Thermometer

Two plastic clothespins, of the type shown in the photograph, can be used to provide a simple and convenient holder for a photographic stirring-rod thermometer. The light spring action of the clothespins holds the thermometer firmly, yet allows it to be picked up easily. The clothespins are fastened to the edge of a table or shelf with small staples.

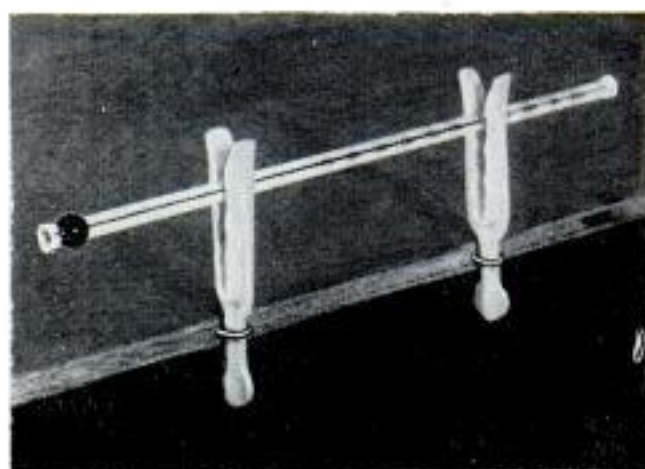

Pipe Fittings Form Sturdy Closet Clothes Pole

Unlike the wooden clothes pole that bends and creaks under the weight of winter garments, this pipe rack will handle your heaviest garments safely. Its strength is limited only by that of the shelf to which it is attached. The original rack was made up of 1-in. pipe and fittings, although $\frac{1}{2}$ or $\frac{3}{4}$ -in. pipe can be used. As shown in the drawing, the lengths of pipe which form the clothes pole are suspended from the underside of the closet shelf with floor flanges and nipples, the latter being about $2\frac{1}{2}$ in. long. The nipples are turned into an elbow at each end of the clothes pole and into one or more pipe tees



used to join the pipe sections. The rack is completely assembled before the flanges are screwed to the underside of the shelf.

Thomas P. Ramirez, Fond du Lac, Wis.

Refrigerator Recess Decorated With Valance Hung on Hooks

Because his wife was dissatisfied with the blank, unfinished look of the refrigerator recess in the kitchen, one home handy man installed a deep valance in which is mounted a clock. The valance is jigsawed from plywood and the clock is fastened to the back so the face shows through a framed opening. Artificial ivy, purchased at the 10-cent store, is used for decoration. The installation of the valance was simplified by hanging it on hooks and eyes, which also permits easy removal for cleaning.

John Krill, North Lima, Ohio.



Lawn Mower Stored Close to Wall By Using Storm-Sash Hanger

A lawn mower can be stored to occupy a minimum of floor space by using either a storm-sash hanger or a long hook and screw eye to hold it close to a wall. When using the sash hanger on wooden handles, the eye, usually screwed to the sash, is fastened to the mower handle near the top and the tongue is screwed to the wall. When using a hook and eye, the hook is screwed to the wall and the eye is driven into the mower handle near the bottom. Either method can also be used on metal-handled mowers, machine screws being substituted for the wood screws.

☐ When sending clothes to the cleaner, outline bad spots in white thread and, if you know what caused the spot, tag it so the spotter can use the correct cleaning fluid.

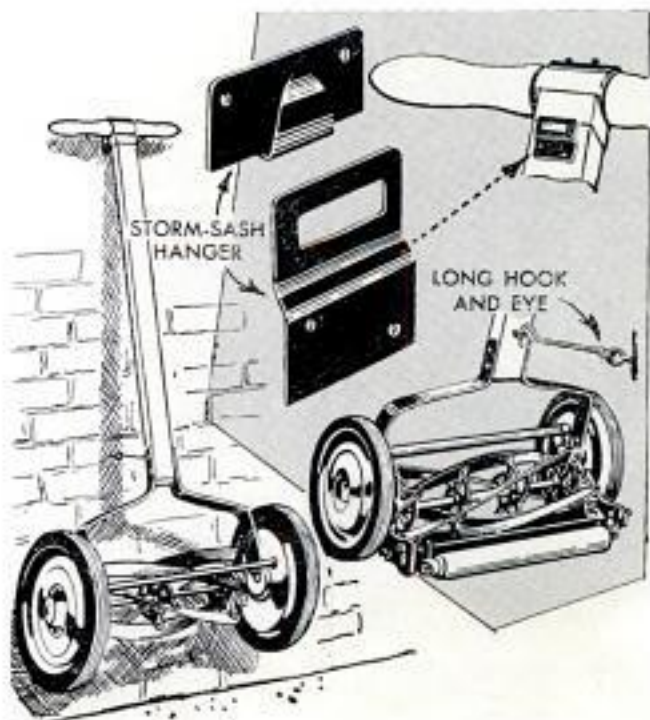

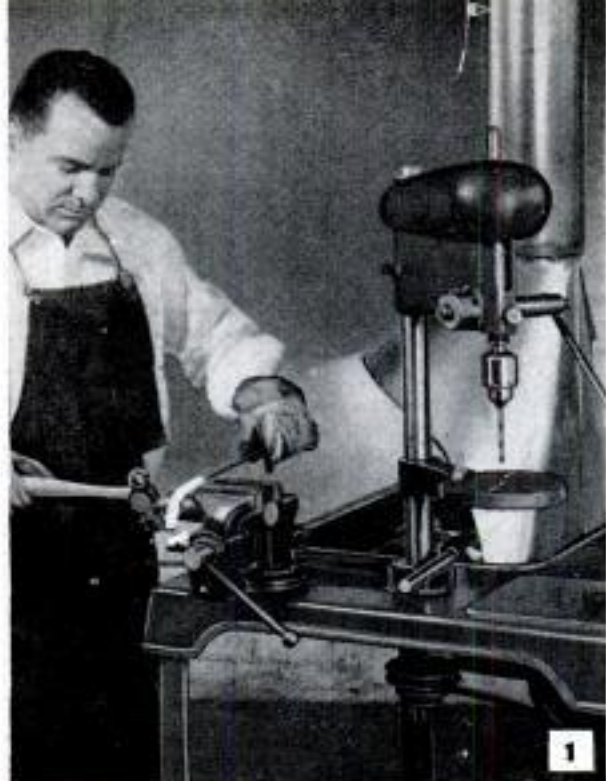

Photo courtesy Champion Blower and Forge Co.

By Sam Brown

AN INTRODUCTION TO

WROUGHT IRON

X808

SN 56

FIRE IS THE SECRET of working ornamental wrought iron—a red-hot piece of iron can be bent easily to almost any shape. While the traditional heat source for iron working is the open forge, excellent results can be achieved with an ordinary liquid-fuel hand torch. A torch, a hammer, a drill and some rivets are all the basic equipment needed. Figs. 2, 3, 4 and 5 show a few examples of the type of work that can be done either with the torch or a small forge.

The metal: Old-fashioned wrought or puddled iron is no longer manufactured to any great extent because mild steel is nearly identical to it and much less expensive to make. The main feature of wrought iron or mild steel is that they contain only a trace of silicon and carbon. Such a material is tough, malleable, bends easily and welds beautifully. Unlike carbon steel, it does not harden when heated red-hot and plunged into water. Some of the many stock shapes available in mild steel are shown in Fig. 6. The rectangular shape with rounded edges, usually called band iron or strap iron, can be purchased at many hardware and farm stores, while complete iron stocks for craftwork are available from

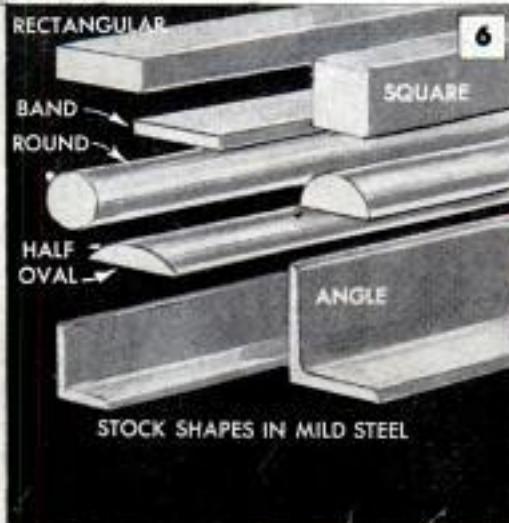

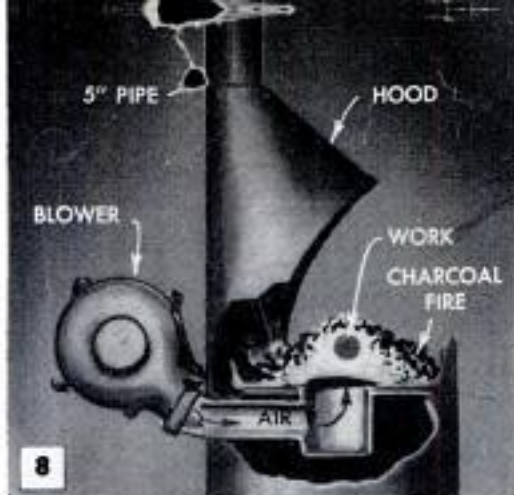

8

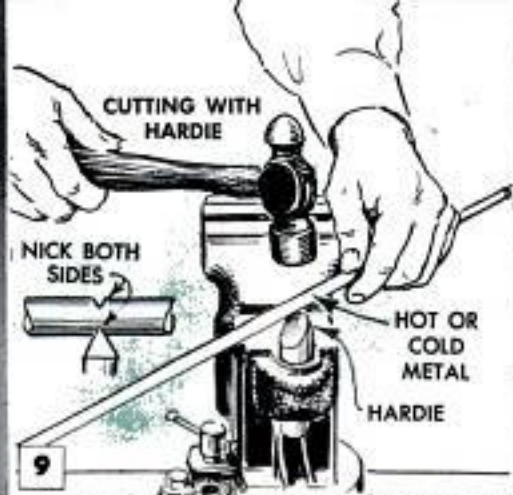

9



10

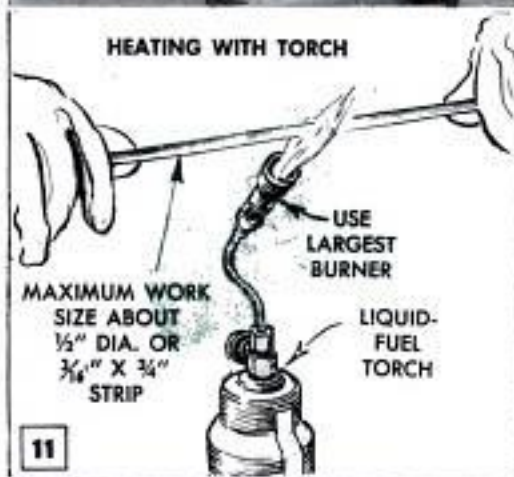

11



12



13

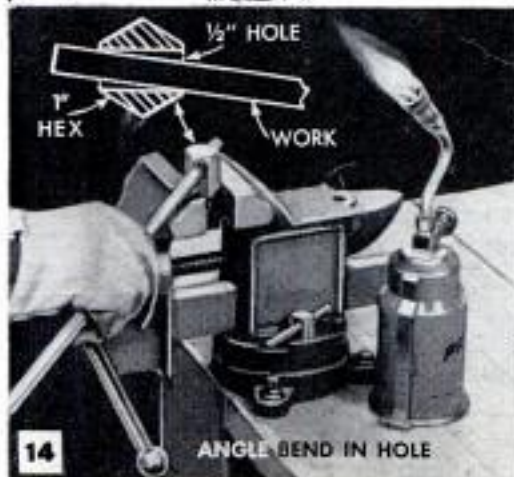

14

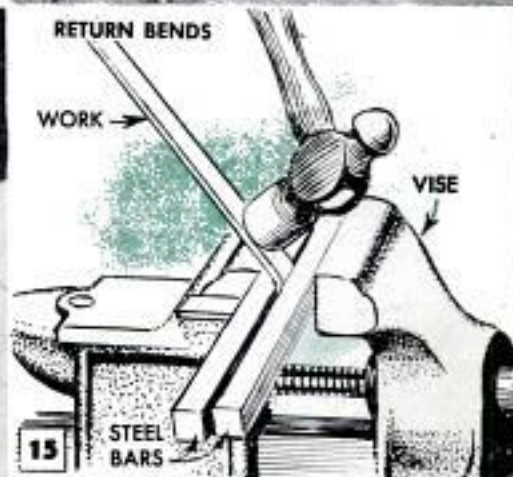

15



16

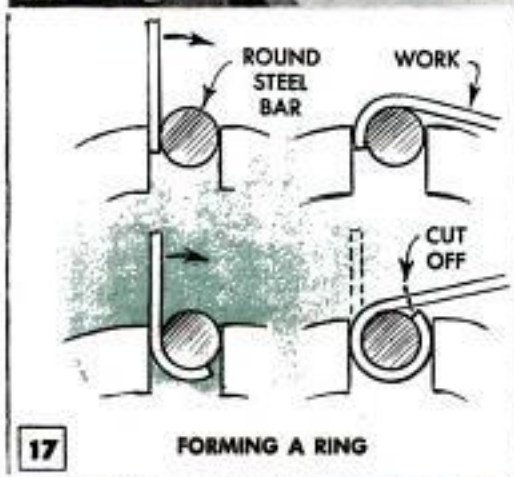

17



18

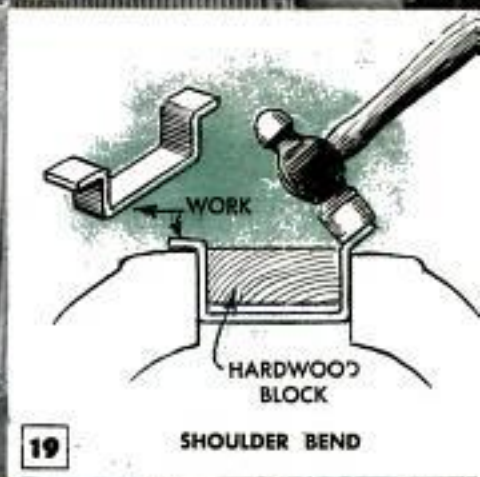

19



20

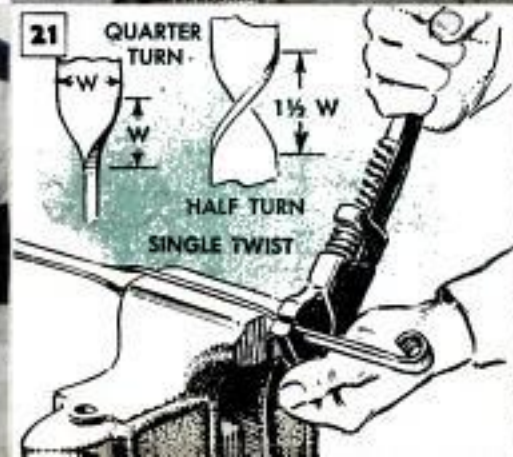

21



22



23

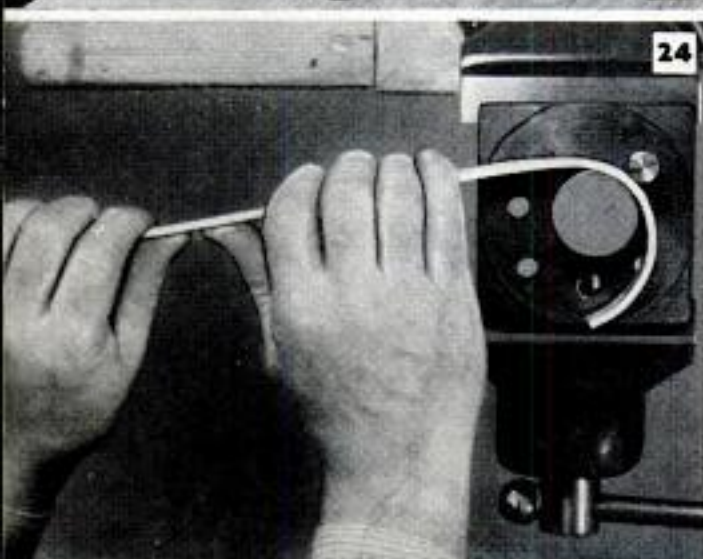

24

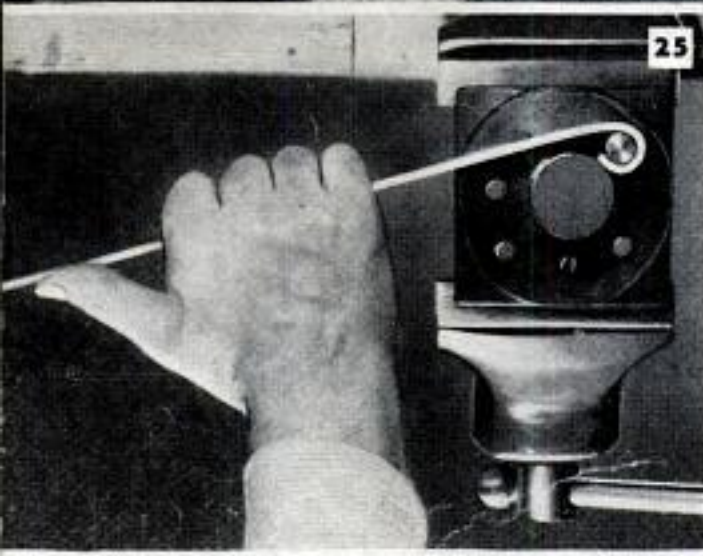

25

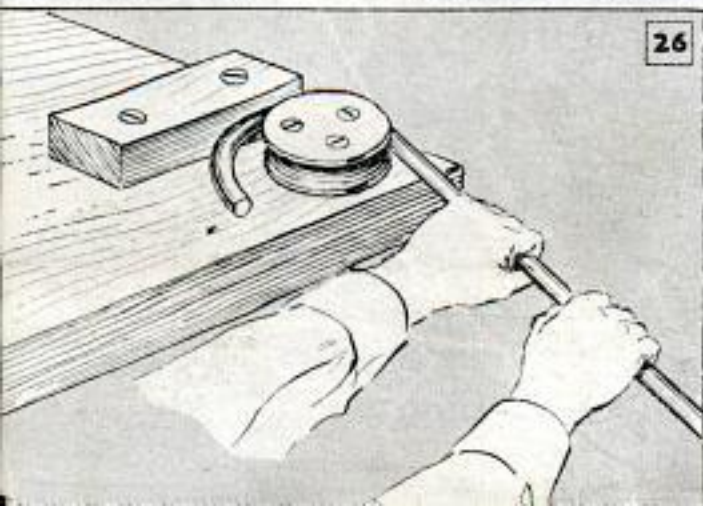

26

craft and metal-supply houses. The material usually is available in 10-ft. lengths for craft use.

Heating equipment: Many projects in wrought iron can be worked cold. However, band iron over $\frac{1}{8}$ in. thick and rounds over $\frac{1}{4}$ in. in dia. become increasingly more difficult to bend. An inexpensive liquid-fuel torch is the least expensive and simplest solution. This type of torch will put a red heat on band iron up to about $\frac{3}{16}$ x $\frac{3}{4}$ in. and rounds to a $\frac{3}{8}$ -in. dia. The localized nature of the heat, Fig. 11, makes the torch ideal for angular bending. As in Fig. 12, rod stock can be bent with hand pressure alone.

One of the hottest heat sources is the twin-carbon arc torch, Fig. 29. An obvious disadvantage of the arc torch is that you have to wear a helmet and gloves for protection against the ultraviolet and infrared rays. A small arc torch, working on 110 volts, will heat rounds up to about $\frac{3}{4}$ in. in dia. for angular bending. Like all torches, however, it is generally unsatisfactory for heating a long length of rod.

Most fascinating and satisfying of the heat sources is the time-honored forge, Fig. 1. This is the most flexible, most economical heat source for regular work. And, if you burn smithing charcoal, the fire will be clean and smokeless—practical for use in the basement workshop. A draft connection should be made to a chimney or to a basement window, in the latter case using a low-speed exhaust blower. A typical home-shop forge is shown in Fig. 7. The fire itself should be deep enough to bury the work yet protect it from direct air from the blower, Fig. 8. The forge will put a red heat on 2-in.-dia. bar stock in about 5 min. With the forge fire, a large area or a long length of work can be heated uniformly, this being especially important for such jobs as making a long twist, Fig. 22.

Basic operations: The basic operations in working with wrought iron are cutting and bending. Cutting is done with a hacksaw or with a chisel or hardie, Fig. 9. A 3-in. bench shear, Fig. 10, is ideal for cutting light stock.

Most of the basic bends are shown in Figs. 12 to 22. One of the most useful bending devices is a bar or a block of metal having one or more holes bored through it. This is used in the same way as the hex bar pictured in Fig. 14. An eye is formed by first making a ring, Fig. 17, and then bending the standing metal with the aid of a vise, Fig. 18. Gradual bends of all kinds can be hammered hot or cold on any type of round anvil or bar, Fig. 20. Single twists of a quarter or half turn are made with a wrench, Fig. 21. In the details, W equals the width of the stock.

Scroll bends: Gradual curves or scrolls

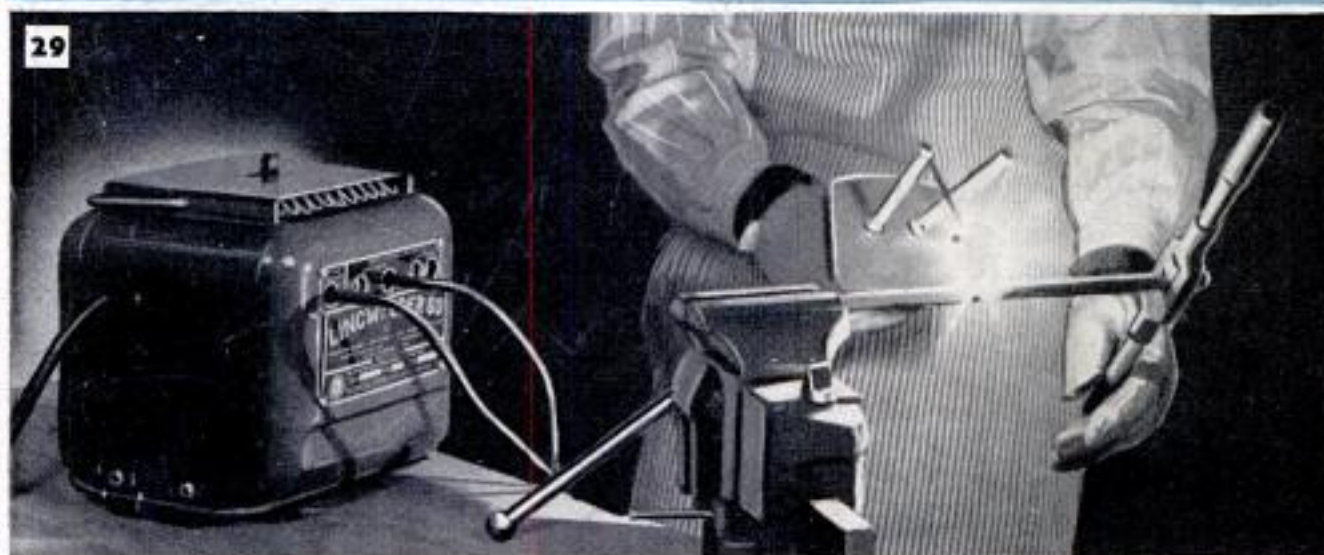
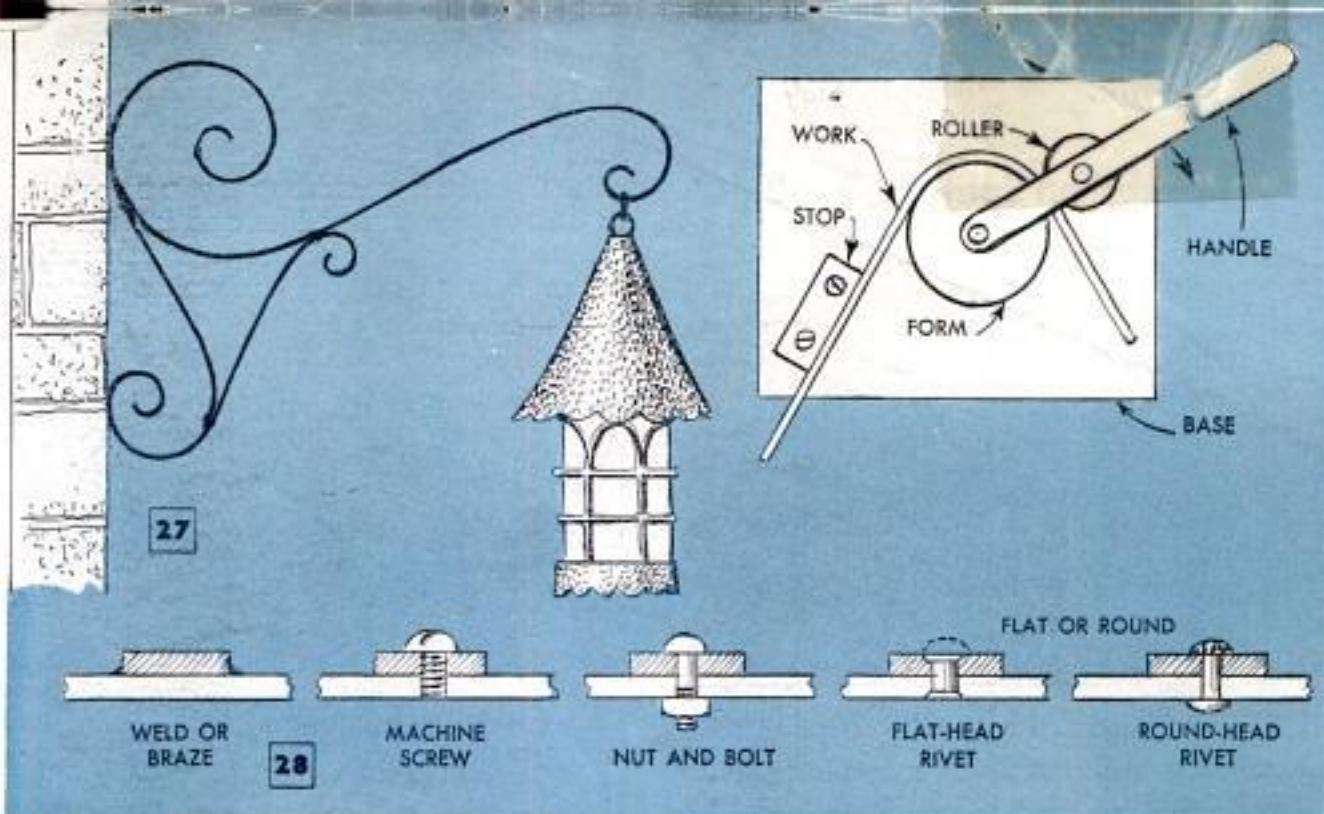

predominate all period designs in wrought iron. These curves are made on a bending jig. The jig consists of a purchased or home-made setup of two metal pins around which the work is bent, Figs. 23 to 25. Eye bends can be made directly around the smaller pin, Fig. 25, while large bends are worked gradually with a series of bends, Fig. 24. Large work also can be bent over wooden forms, Fig. 26, a method which is used widely for bending tubing. When a number of pieces are to be bent to the same curve, a handle-and-roller setup, Fig. 27, saves time and assures perfect work.

Fastenings: Ironwork is assembled by welding or brazing, or with machine screws, bolts or rivets, as in Fig. 28. Riveting is the most popular home-shop method, and most riveting jobs can be done with the simplest of equipment, as in Fig. 30.

Finishing: The most popular finish for all ironwork is flat or satin-black paint. A protective or rust-inhibiting undercoat should be applied on all ironwork used outdoors. This also is desirable on indoor ironwork to secure better finish adhesion. ★ ★ ★



Face Painted on Split Rubber Ball "Talks" When Squeezed

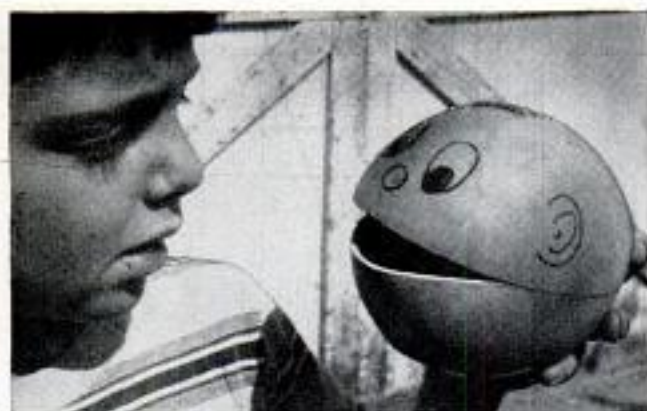

A child's rubber ball, when split as in the photo, can be painted to resemble a doll's face. The split section will then serve as the doll's mouth, which can be made to open or close by pressure on the side of the ball. Children can have hours of fun practicing to be ventriloquists with such a doll.

Trap for Night-Flying Insects Uses Light As Bait

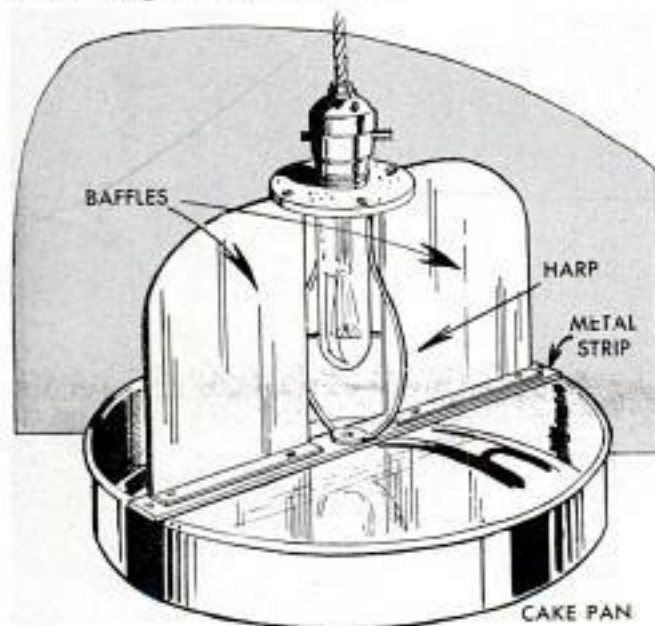

A screened-in porch or enclosed patio will be a pleasanter place if this simple trap for night-flying insects is hung near the outside entrance. The trap consists of two baffles of bright sheet metal which are flanged and screwed to a strip of metal. The strip is fitted on the diameter of a cake or pie pan and the ends then are screwed to the rim of the pan. A lamp harp, of the type with a threaded base that screws onto a lamp socket, is inverted and screwed to the center of the strip between the baffles. The bulb is a special type that gives little visible light, but is highly attractive to insects. Such bulbs are available at most appliance stores. The insects are attracted

to the light, and when they try to fly around the bulb, strike the baffles and fall into the pan. A thin layer of kerosene or insecticide in the bottom of the pan takes care of the rest.

Floodlight Clamp Bolted to Stand

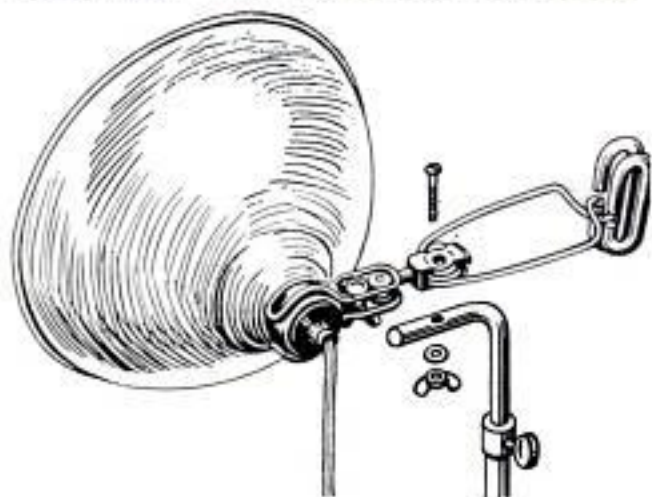

The problem of attaching spring-clamp type photo-floodlamp reflectors to portable light stands so the floodlamp does not "drop" can be solved by drilling a small hole in the horizontal section of the light standard. A machine screw then is passed through the clamp fixture and through the hole in the standard and held with a wing nut. The spring clamp of the reflector now can be utilized to store the cord when the light is not in use.

Jack Wilson, Los Angeles, Calif.

Negative-Retouching Viewer Made From Picture Frame

One photography enthusiast made his own negative-retouching stand by utilizing an old deepset picture frame. The clear glass was removed from the frame, which then was inverted and fastened to a gooseneck lamp by a simple bracket, as shown in the photograph. A piece of frosted glass, cut to fit the recess in the frame, completed the viewer.—H. Leeper, Canton, Ohio.





Just compare this modern aluminum loom with the old-fashioned treadle variety pictured below. The warp, the threading of which was the difficult part of weaving, is supplied by maker

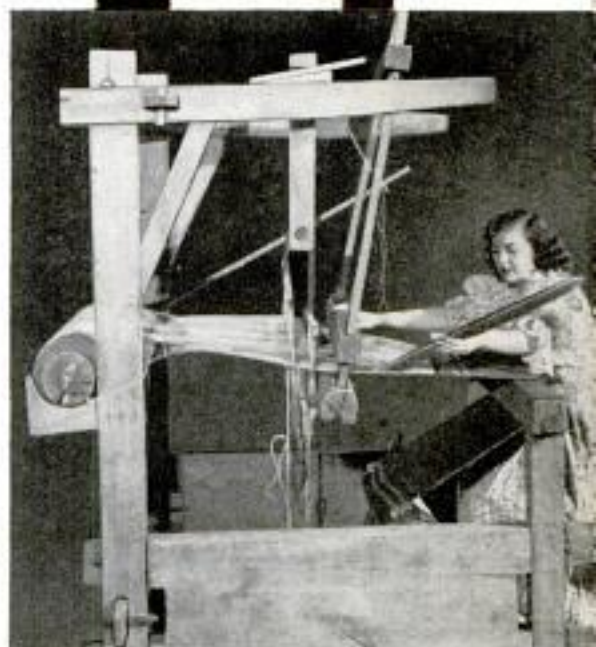

WEAVING REVIVED BY TABLE-TOP LOOM

By Norb Hildebrand

HAND-WEAVING, once a necessary skill in every American household, is again entering the home. But this time it comes as a creative and extremely practical hobby for those looking for an outlet for artistic expression or just a relaxing kind of do-it-yourself fun. It's fun that can pay off in a well-dressed look, too. For example, you can weave material for a suit or coat of the finest imported wool, hand-spun if you like, in the color you prefer and according to your own choice of pattern. This can be done for around 10 dollars. Even after you have paid a tailor to

Photos by Vories Fisher





Photo above shows chair seat being fitted with cover of hand-woven material. Bedspread pictured below is another example of what can be done with hand-weaving



Comparing pattern of weave below with that of the colorful tartan shown at the right will give you some idea of the versatility of the modern hand loom



The unique screen, pictured above, was made by weaving thin strips of bamboo into coarsely woven cloth

make the suit or coat for you, it will still cost only about half the retail price of a similar garment.

Unlike the old-fashioned treadle loom, today's loom is as modern and practical as the power saw or sewing machine. There is a portable, lightweight model made of tubular aluminum that is set on a table top and can be stored in a closet. And you can make anything on it that grandmother made on her cumbersome treadle loom. In fact, the weavers of today can do things that grandmother never dreamed of because of the synthetic yarns at their disposal. If you like to experiment, you can combine things like split bamboo, leather and plastic. This can be easily done without any prior training. A half-hour practice session to learn the operation of a modern loom and how to throw a shuttle is all it takes.



In the past, the only stumbling block to learning to weave had been the problem of making warps. But now the manufacturer of the loom does this for you. The warp is the yarn which runs horizontally from the back of the loom to the front, the woof, or weft, being passed through it at right angles during the weaving operation. At least one manufacturer provides a warping, or threading-in, service for his customers who send him the detachable parts involved in dressing the loom. For a nominal fee he puts on the warp and threads it properly, using whatever materials the customer specifies or supplies. In this way, it takes you only a few minutes to set up the loom, compared to hours of tedious work formerly required.

Such a service simplifies hand-weaving to the point where even a 10-year-old child can weave. You can buy a loom or rent one on a monthly basis. The only other costs, in addition to the warping service, are those of the materials used. These will vary with the size of the project and the selection of yarns.

Regardless of the type of loom, weaving is accomplished by raising a certain number of threads in the warp so that the weaver may pass the weft through at right angles and thus make the web. The harness raises the threads in the warp by means of heddles, each of which controls a single thread or a group of threads. The manner in which the warp threads are strung through the heddles is determined by the pattern desired by the weaver. Thus, a

PARTS OF THE LOOM

A—WARP BEAM: Cylinder of wood or metal at back of loom around which warp is wound.

B—HARNESS: Frame of wood or metal holding heddles which permits weaver to raise a selection of warp threads. Harnesses of treadle loom are foot-operated while harnesses of some modern looms are operated by levers or a cylinder-and-pin arrangement at top of loom.

C—HEDDLE: Device of string or flat metal having an eye through which warp is threaded according to pattern. Each heddle may control single thread or combination of warp threads.

D—BEATER: Heavy wooden or metal frame swung against woven material between each row of weft yarn. Amount of beating varies with type of yarn and desired tightness of material. Rhythm is most important in beating. The reed is a comblike device held in the beater through which the warp is threaded. Reed serves to keep warp threads properly spaced. Individual teeth in reed are known as "dents." Number of dents per inch designates the kind of reed.

E—BREAST BEAM: Cylinder of wood or metal at front of loom over which web is held taut.

F—CLOTH BEAM: Wooden or metal roller at front of loom and below breast beam on which finished cloth is wound.

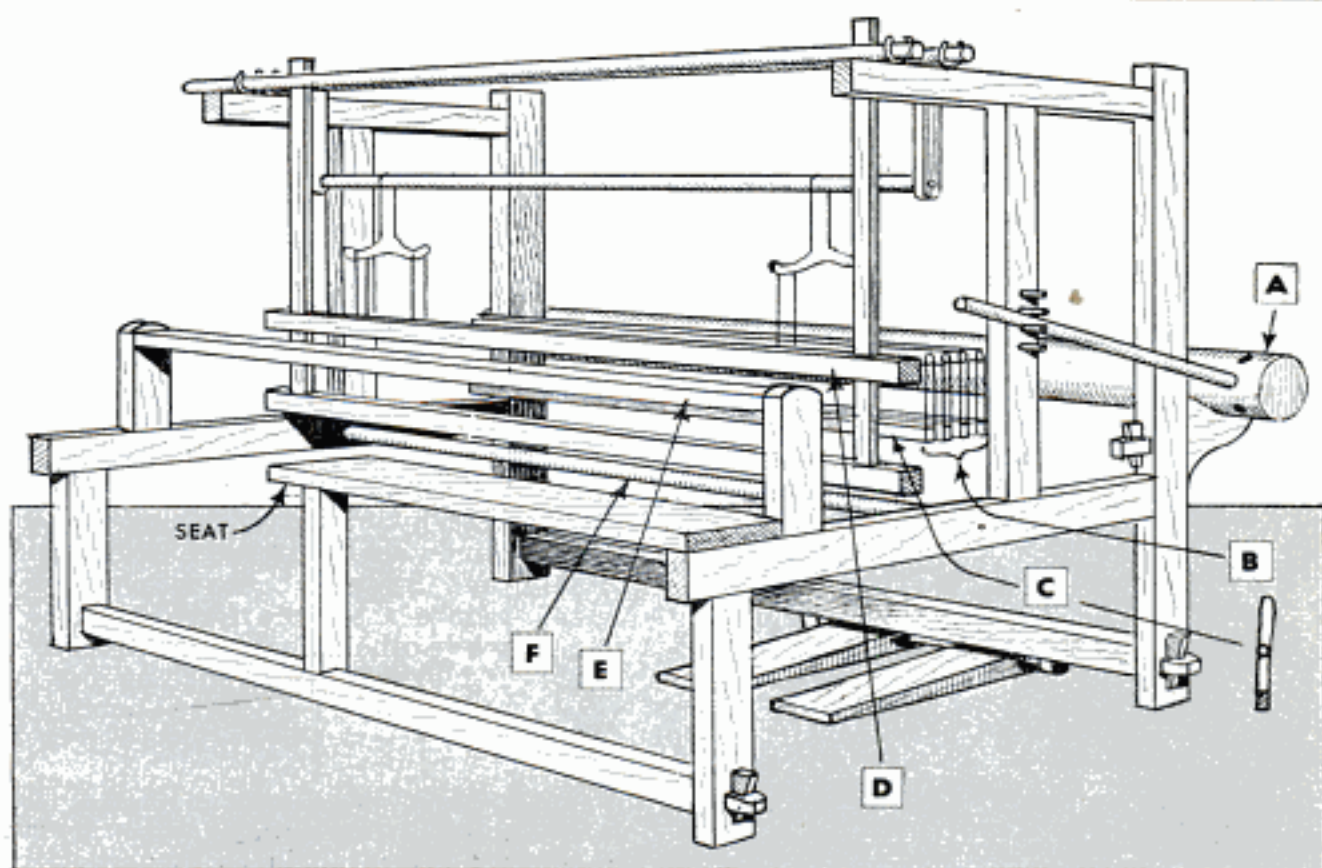



Here the boat-shaped shuttle is being thrown through the shed. Weft yarn unwinds from shuttle as it is moved

single harness may control every other thread, every two threads, every three, four or whatever the desired combination may be. By adding harnesses, the weaver adds the variety of control. For the beginner, the four-harness loom is adequate since, coupled with the variations of warping and the variety possible in the weft, there are hundreds of possible patterns from which to choose.

The foot-operated treadles, or the hand-

operated wheel, raise the harness which in turn raises a specific number of warp threads. This forms a V-shaped opening between the warp threads known as the shed, and it is through this opening that the yarn for the weft is passed. As the weaver throws the shuttle through the shed, the yarn unwinds.

After each "throw" the harnesses are shifted, interlocking each thread in the weft with the threads in the warp. Then the weft is beaten, or pressed firmly together, according to the tightness desired in the finished material. Getting a rhythmic beat assures uniformity in the woven fabric. That is all there is to the weaving operation; raise the harness by means of the treadle or handwheel, throw the shuttle and beat the weft. Some weavers beat before they change harnesses while others beat before and after. It makes no difference as long as the beat is consistent and rhythmic. ★ ★ ★

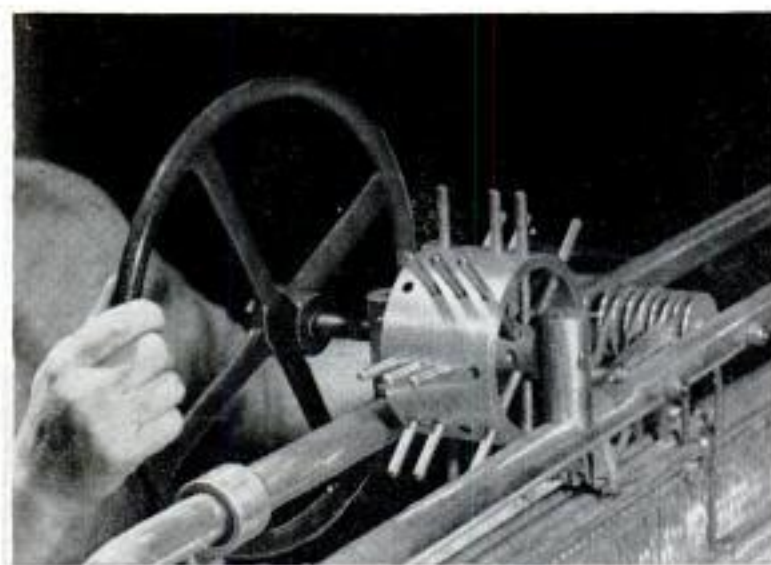

Cylinder-and-pin setup of modern loom raises harness according to pattern. Pins are relocated in holes as desired

WEAVING TERMS

THREAD: A length of tightly spun or twisted filaments which produce a smooth, fine strand. Warp material usually is called a warp thread.

YARN: A length of loosely twisted filaments in a single strand. Weft material usually is called weft yarn.

WARP: Threads running lengthwise in loom.

WEFT: Yarn woven crosswise in the warp.

SHUTTLE: A device, usually of wood, for holding weft yarn. There are two basic types: A "stick shuttle" for holding heavier materials which are pushed through the warp threads. A "throw shuttle" which is a boat-shaped and hollowed-out block holding weft yarn wound on a quill. As the shuttle is thrown through the warp threads, the weft material unwinds.

SHED: A V-shaped opening, as seen from the side, in the warp threads. This is produced when certain warp threads are raised by the harness. The shuttle is pushed or thrown from side to side through the shed, bringing the weft over and under a combination of warp threads.

PICK SHOT OR THROW: A single traverse of the warp threads by the weft yarn.

BEAT: After each throw of the shuttle, the beater is swung against the woven material, or web. The beat must be rhythmic and of the same force each time in order to produce evenly woven material. Force of beat is varied depending on the material used and the desired tightness.

SELVAGE: The edges of the woven material running parallel to the warp threads.

WEAVE PATTERNS

TABBY OR PLAIN WEAVE: Alternate warp threads—one thread up, one thread down (1-2, 1-2, 1-2, 1-2). This results in a fifty-fifty arrangement of the warp and weft color and the material is the same on both sides.

TWILL: Progressive alternation of warp threads (1-2, 2-3, 3-4, 4-1). By coming back on the next four warp threads in reverse order (4-3, 3-2, 2-1, 1-4) a herringbone results. When the material is turned over, the pattern will be the same on both sides but the colors will be reversed.

BASKET: Two sets of alternate warp threads are raised in opposition (1-2, 3-4, 1-2, 3-4). As with the twill, the pattern will remain the same, but the colors will be reversed on opposite sides of the material.

Lanterns to Light Skating Pond Held by Tree-Branch Supports



To support several lanterns above the ice for illuminating large areas of a skating pond, one sportsman hit upon the idea of using forked branches and discarded implement wheels for the purpose. Each branch was inserted in the hub of a wheel as shown, thus providing a base for holding it in an upright position. Then a lantern was hung from the forked end of each limb at the height desired, providing not only light but a rustic decoration.

Safety Pin Used as Cotter To Provide Quick Release

To prevent the wing nuts on the clamps of his boat trailer from working loose when the trailer was towed over rough roads, one man drilled holes in the bolts just above the nuts and installed large safety pins. Safety pins were used, rather than cotter pins, to provide quick release when it was necessary to loosen the wing nuts.

Grover Brinkman, Okawville, Ill.

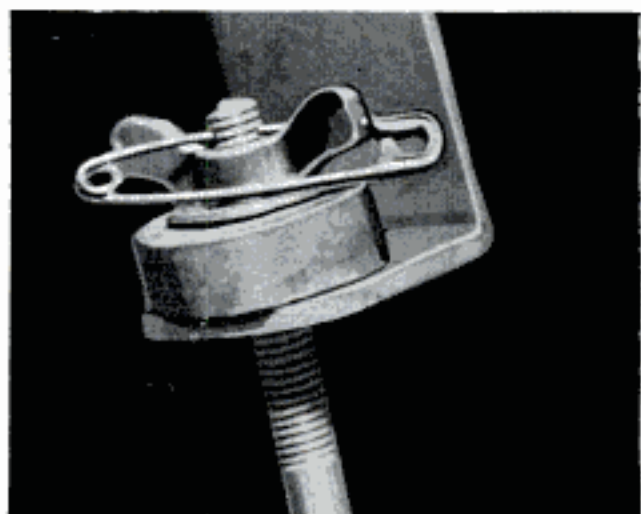



Handy Hints for the PHOTOGRAPHER

MOVIE MAKING, still close-ups and developing all can be done more easily by adapting one or more of the five hints illustrated on this page. Left, home-movie title fade-ins and fade-outs are made by using a sheet of cellulose-acetate tracing film cemented to a cardboard frame. In use, the title card is held against the back of the film. Then with the camera running, title card is slowly tipped backward to produce a "dissolve." Fade-ins of titles are accomplished by reversing the procedure. Titles can be filmed in color or black and white.

Below, to combine rigidity with freedom of camera movement when photographing small objects at short range on a table top, clamp a pan head to the table with a C-clamp. A single C-clamp will do for most small cameras, while the larger ones may require two clamps to hold the pan head rigidly in place

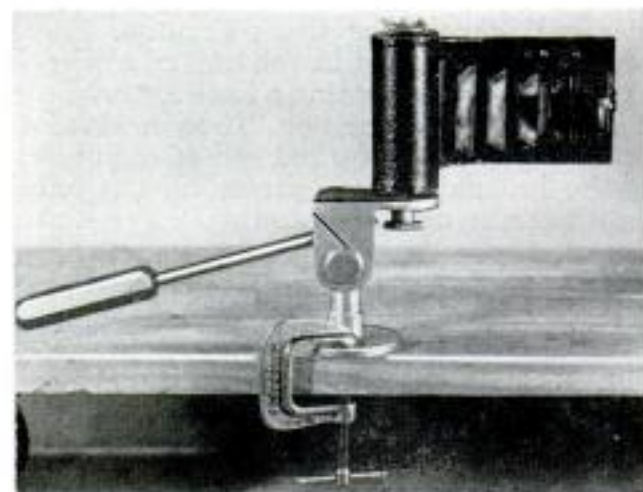

Below, when feeding film into the reel of a plastic film-developing tank, the film will stick and buckle if perspiration on the hands dampens the edges which contact the reel. To prevent this, dry the hands carefully, make sure the reel is completely dry and handle the film only by the edges, as shown in photo



Below, when using a slow, fine-grain developing solution, fit the 5 x 7-in. developing tray inside a war-surplus .30-cal. ammunition box. The clamps on the lid hold it tightly in place so the box is completely light-tight. With the developer inside the box, dark-room lights can be left on during the developing time



Below, empty filter boxes can be utilized in a number of ways for use with camera equipment. Fastened to the top of the camera, the box provides an excellent way of carrying a pair of filters right with you on a field trip. The bottom half of the box, fitted with a felt strip inside the rim, can be used as a lens cap

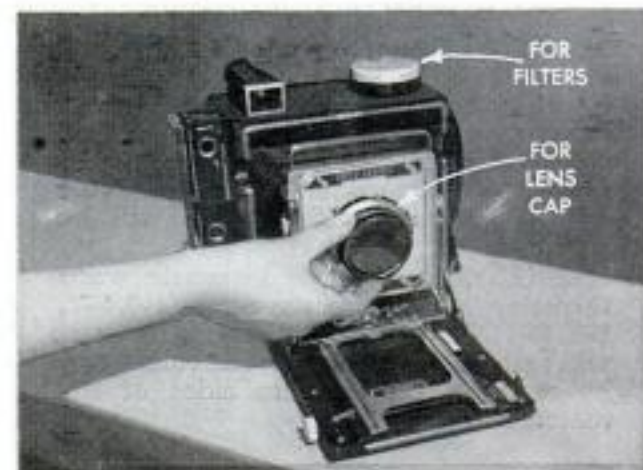

Rubber Bands Stored on Card Permit Quick Selection

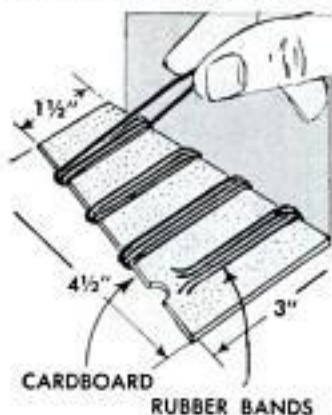

A notched card, cut from heavy cardboard, provides a convenient method of storing various sizes and lengths of rubber bands. The size of the card can be varied to take a variety of sizes.—H. M. Suttle, Dayton, Ohio.

Prevent Battery Shorting

Accidental shorting of the battery connectors by tools when making repairs around the car can be avoided if both connectors are painted with undercoating material. A small spot on the top of each connector can be left uncovered so that testing equipment can be used.—Henry Hanscom, Elmhurst, Ill.

Dowels Protected From Vise Jaws With Spring-Type Clothespins

Small wooden dowels may be held in a regular vise without being damaged by the jaws if a spring-type wooden clothespin is used. The clothespin is clipped around the dowel and both then are slipped into the vise jaws. When the jaws close, the dowel is held firmly and the clothespin absorbs any damage from the jaws.—Gilbert C. Close, Hawthorne, Calif.



JANUARY 1955



Fresh Water for Camping Trip Supplied by Gravity-Feed Can

To carry a supply of fresh water on automobile and small-boat camping trips, one outdoorsman has made a gravity-feed storage container from a new 5-gal. kerosene can. When stored in the trunk of the car, the can eliminates the necessity of pouring water, allowing it to be drawn from the supply without disturbing the luggage you have so carefully packed. The container is made by soldering a hose connection to the side of the can near the bottom and attaching a 5-ft. length of plastic hose to it. To the other end of the hose, a standard faucet is attached. An air vent is provided by soldering a copper tube over a small hole in the spout cap.—George Brook Taylor, Daytona Beach, Fla.

Clothespin Provides Handle When Carrying Rubber Boots

When obliged to carry heavy rubber boots by the small finger loops, sportsmen and hunters will find that a common clothespin can be used as a comfortable handle. The clothespin is inserted through the loops, as shown in the illustration, and distributes the weight evenly across the palm of the hand. When on a trip or in the field, a short length of a small-diameter twig, or even a pocketknife can be used.



203

Copyrighted material



RESTORING IGNITION SYSTEM

By Ed Packer

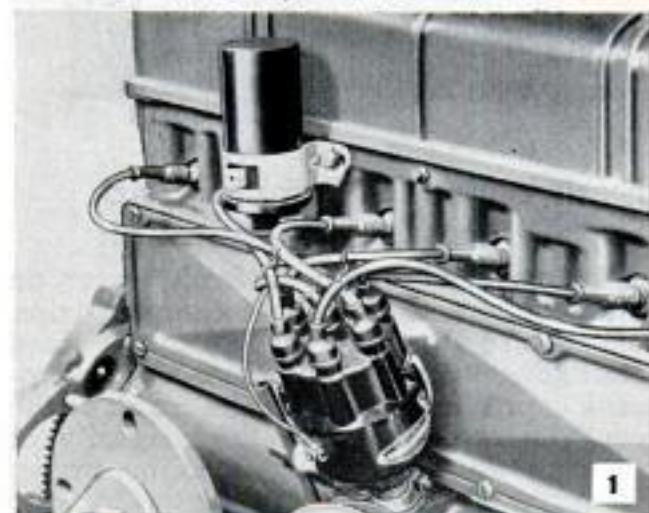

GENERALLY, the job of reclaiming an old car, truck or tractor engine includes an overhaul of the ignition system, as many of its parts frequently require rebuilding or replacing. First, the parts must be checked for electrical and mechanical defects. To do a thorough job, the distributor, Fig. 1, should be removed from the engine. Before removing the unit be sure to note the position of the distributor arm. Some mechanics mark its position relative to the housing so that there can be no error in replacing the unit in precisely the same position. Also, the engine crankshaft must not be moved until the distributor, Figs. 1 and 2, has been replaced. These precautions make it unnecessary to retune the engine after assembly.

One of the important electrical checks is for a grounded terminal, Fig. 3. Using test prods, place one on the terminal and one on the metal distributor housing with the breaker points open. The test bulb will light if the terminal is grounded. Another fairly reliable test for grounded terminal, when the system is complete with battery, is to remove the wire from the terminal, turn on the ignition switch and then flash the wire to the terminal with the points closed. Normally there will be a spark. But if there also is a spark when the points are open, it generally indicates a loose terminal or defective terminal bushings. There also is the possibility of a shorted condenser or a grounded contact-arm spring. If the tests turn up none of these common defects the unit probably is still in serviceable condition electrically.

One of the most important mechanical checks is to determine the amount of side play in the distributor shaft. If this is excessive, above .005 or .006, new bushings are needed. Also it should be remembered that normally the distributor cam rides freely on the distributor shaft. If it is frozen on the shaft, due to rust or other causes, the automatic spark advance will be rendered inoperative. If the cam does

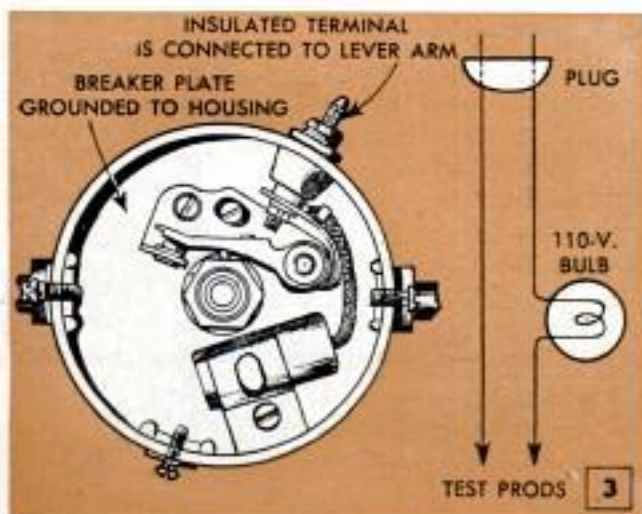
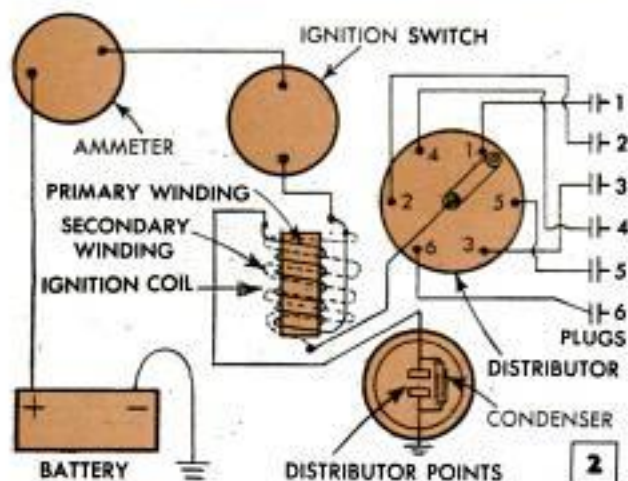

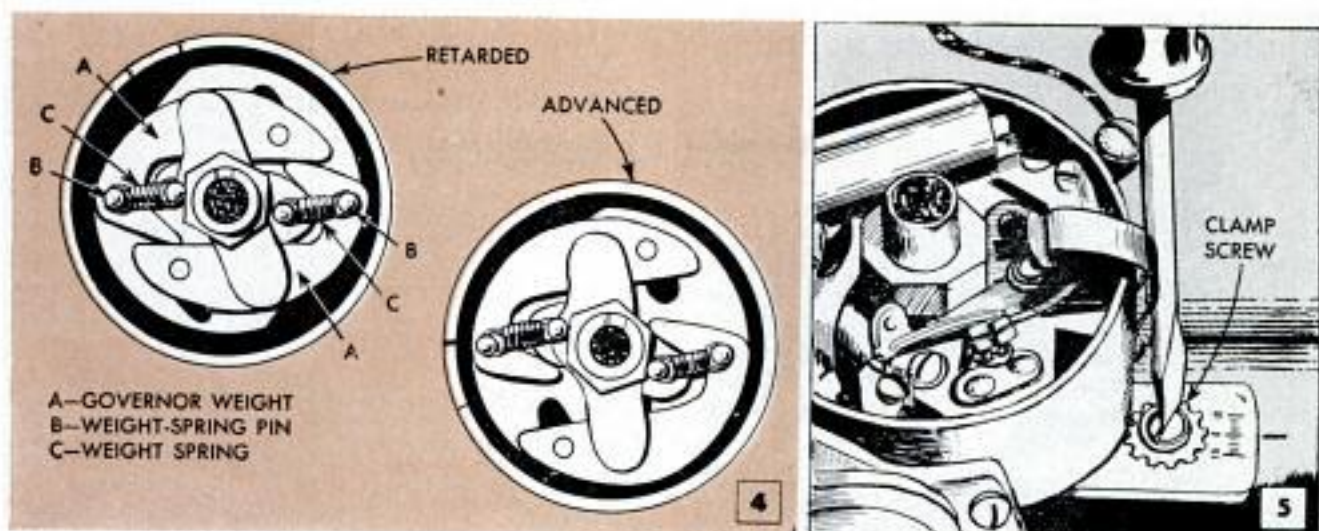

not move freely under finger pressure, then dismantle the unit by removing the breaker plate and the insulated terminal. This will expose the centrifugal governor weights which are driven by the distributor shaft. These weights rotate the breaker cam on the shaft to advance or retard the spark according to engine speed. The cam can be freed and lifted off the end of the shaft by removing the governor-weight springs, Fig. 4, and then working it off the end of the shaft. Clean the parts in a solvent, polish the shaft and cam with crocus cloth and oil and then examine the weight springs carefully for spots of rust. If the springs show any sign of rust, they should be replaced. Be sure that the weights move freely from the retarded to the advanced positions. These movements involve the three parts A, B and C in Fig. 4.

Nearly all distributors are equipped with a vacuum advance. The weights (centrifugal advance) control spark advance in relation to engine speed while the vacuum unit controls spark according to engine load. When overhauling old engines most mechanics replace the vacuum unit as, in most cases, it is not practical to attempt a repair.

When assembling and replacing the distributor on the engine, check to see that the timing-adjustment screw is tight. Fig. 5 shows one type. Also check the breaker-point gap with a feeler gauge as in Fig. 6. If necessary, reset according to the manufacturer's instructions. Be sure that the wear surfaces of the cam are smooth. Also, it's a good idea to check the tension of the breaker-arm spring as in Fig. 7. Lubricate the parts as they are assembled.

To prevent the possibility of explosion shattering the distributor cap, a comparatively rare occurrence and due to a fuel-air mixture entering the distributor through the vacuum unit, mechanics vent the unit by drilling a $\frac{5}{16}$ -in. hole in the bottom of the bracket, Fig. 8. This prevents the fuel mixture reaching the distributor. ★ ★ ★

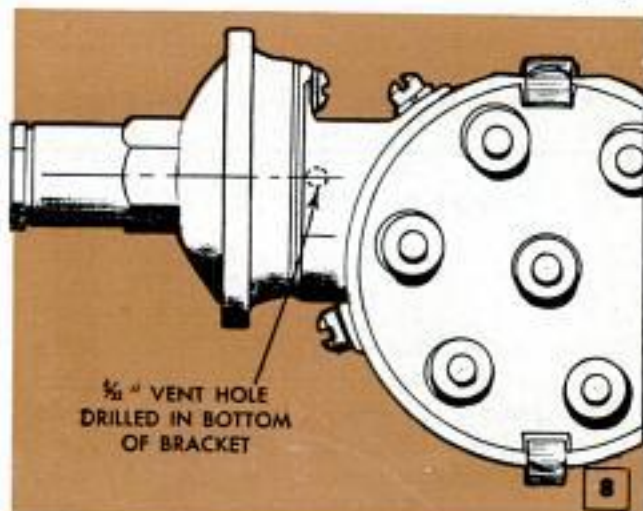
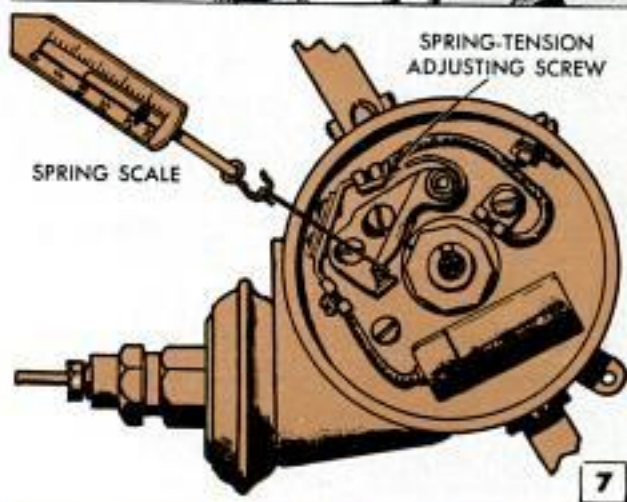
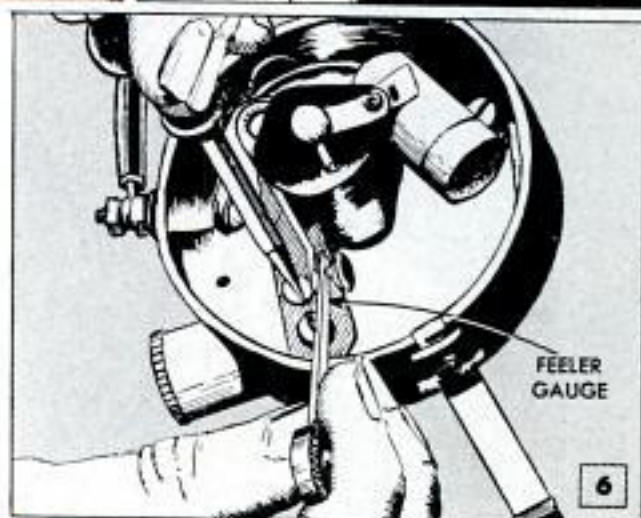

Pliers Provide Flashlight Support When Changing Flat Tire

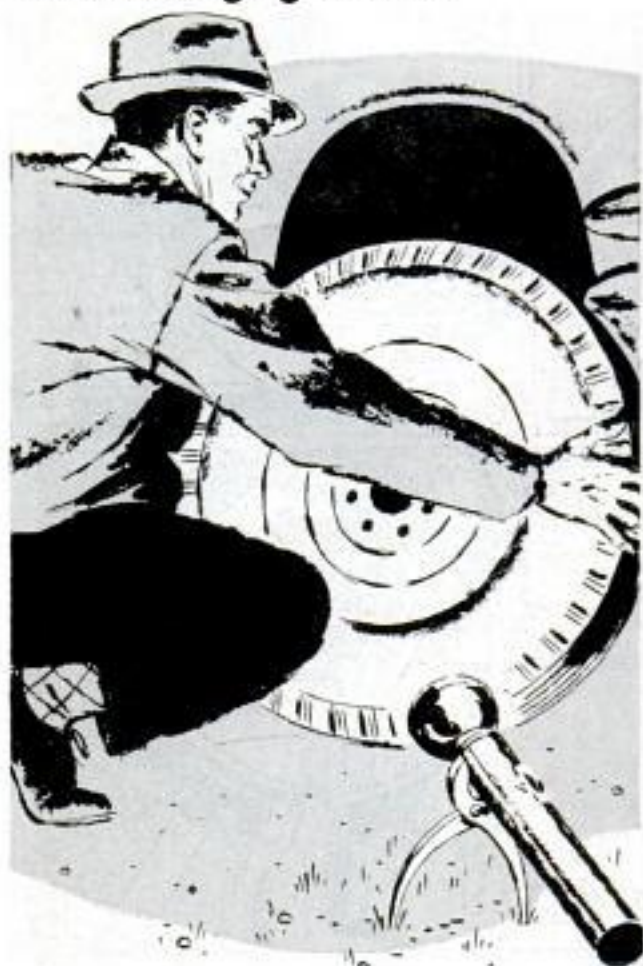

When he had to change a flat tire at night with only an ordinary flashlight for illumination, one motorist used a pair of pliers to support the light. The ends of the handles are forced into the ground and the barrel of the light rests in the open jaws of the pliers.—L. W. Mitchell, Carrsville, Ky.

Thickness of Acoustic Tiles Varied To Eliminate Harmonics

The sound-absorbing qualities of acoustic materials applied to closely spaced parallel surfaces sometimes can be cancelled because of the short distance between the surfaces. In one case involving soundproofing a double door joining two rooms in a motel, $\frac{1}{2}$ -in. acoustic tile had been applied

to both doors. Noise from one room was still clearly audible in the other, even though the walls also were soundproofed. The solution to this particular problem was to apply $\frac{3}{4}$ -in. tile to the face of one door, leaving the $\frac{1}{2}$ -in. tile on the other. The different thicknesses of tile on each surface cancelled out the harmonics which had been responsible for the transference of sound.—Robert F. Welch, Venice, Calif.

Electric Motor and Tools Carried in Bucket

A fractional-hp. electric motor, which is difficult to carry because of its shape, can be transported easily from one job or building to another by placing it in a bucket. Wrenches, V-belts and other necessary accessories for the motor can



be carried in the bucket at the same time. Because of the extra weight, the handle of the bucket should be provided with a grip made from a section of rubber hose to make it easier to carry.

Plastic-Backed Print Smoothed On Ferrotypc Tin With Alcohol

Photo paper which has a plasticized or water-resistant back sometimes is difficult to roll smoothly onto a ferrotypc tin. To overcome this, squeegee the excess water from the print, then moisten the back with denatured alcohol. When the alcohol has softened the material on the back, force the paper into smooth contact with the ferrotypc tin with a roller or squeegee.

Walter E. Burton, Akron, Ohio.



Keep Your Tools Sharp . . .

To get the most out of your workshop tools and bits, keep them sharp, for even the best quality tools, when dull, can't do a good job. Sharpening tools isn't difficult, but there is a right way and a wrong way for each edge, and there are tricks that make the job easy. All the information you need to do a professional job on your tools is in next month's big story on tool sharpening



SHOP NOTES

How to TURN A BALL

TURNING A wooden ball, or sphere, in your wood lathe is easier than it looks. The trick is in following through with all details of a step-by-step procedure. Follow the proper sequence and you end up with a perfect ball on the first try. Ordinarily, it is best to use hardwoods of dense grain such as birch and maple.

Figs. 1 to 5, inclusive, picture the several steps in turning a ball on the screw center where the diameter of the finished ball does not exceed 4 in. When mounted on the screw center as shown, only one separate step, that of mounting in a cup chuck as in Fig. 5, is required to finish the ball completely. The first step is to turn the stock to the cylindrical form and to the exact diameter of the ball as in Fig. 1. The table, Fig. 8, gives the length of the octagon side for balls ranging from 1½ to 6-in. dia. Note how the measurement is made in Fig. 1, also the upper detail in Fig. 8, the latter showing the work mounted between centers. Rough-turn to the octagonal shape as in Fig. 2. Then make a template of ¼-in. plywood, bandsawing the end to the same radius as that of the ball. Taper the radius end of the template to a width a trifle more than one fourth the diameter of the ball, lower detail, Fig. 8. Wrap a piece of fine sandpaper around the partially turned ball and sand the curved end of the template. Now turn the ball shape by working the tool directly over the template as in Fig. 3.

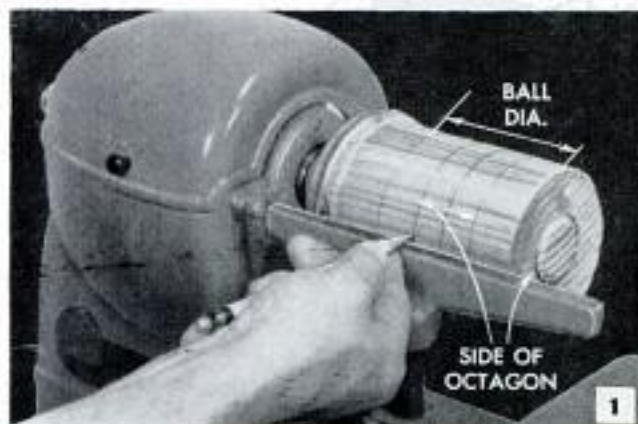

MARK LINES FOR OCTAGON

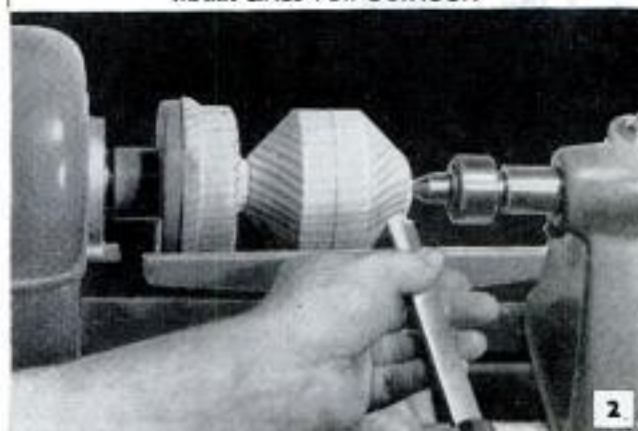

ROUGH-TURN TO OCTAGON SHAPE

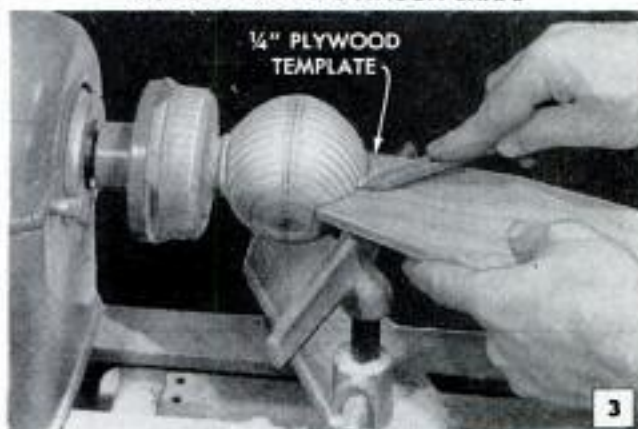

TURN BALL SHAPE

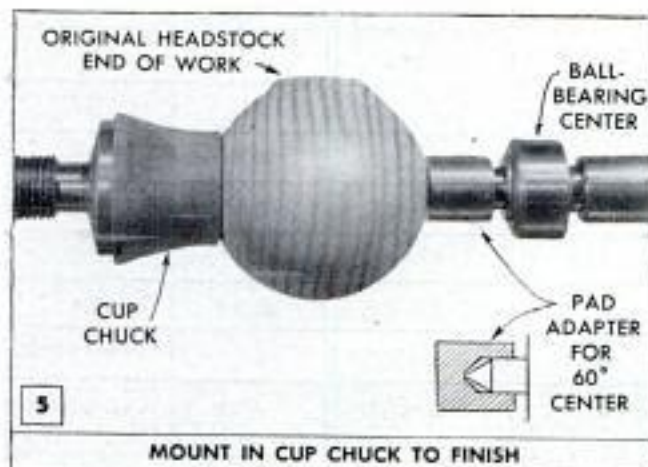

MOUNT IN CUP CHUCK TO FINISH



SAND BALL WITH TEMPLATE

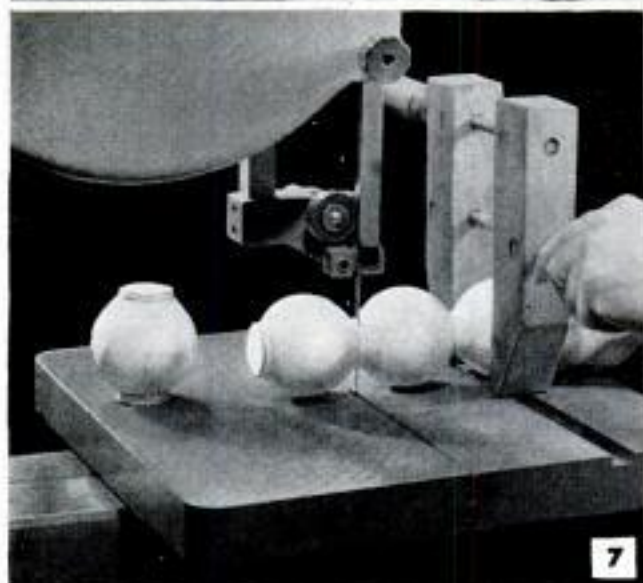
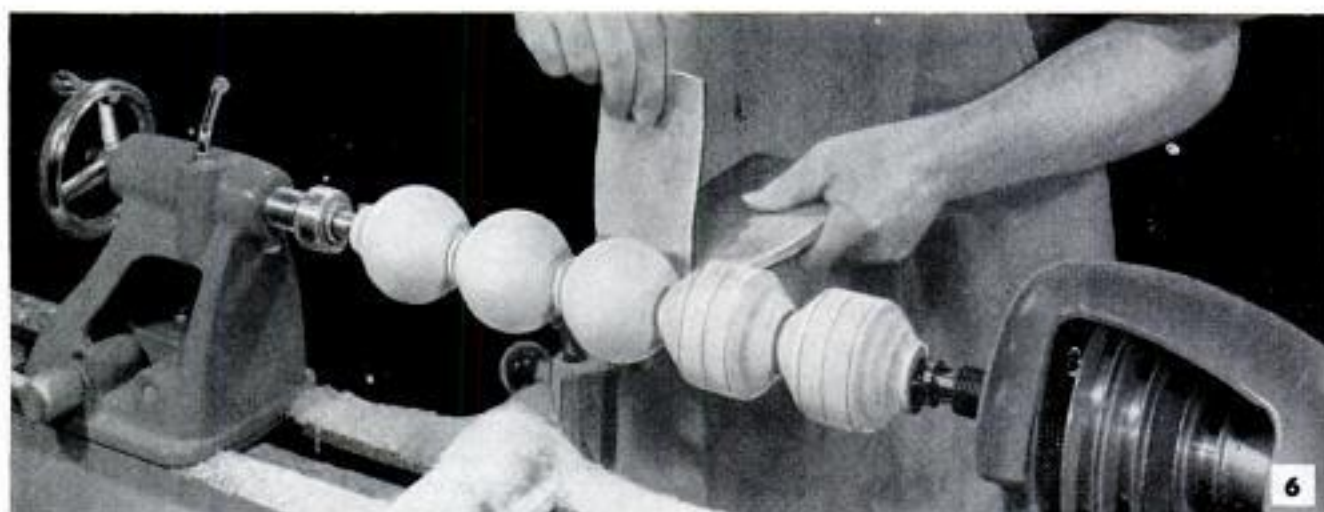

Then sand as in Fig. 4. Keep the paper and template moving uniformly over the surface, as otherwise a flat or groove may be produced. If the ball is to be center-drilled this operation can be carried out before removing the turning from the screw center. Lathe speed used in these operations should be about 2400 r.p.m.

There are several precautions to be taken when sanding the ball shape. The first thing of importance is the choice of a sandpaper grade to suit the type of wood. As a rule you can use a grade-coarser paper on softwood than on the average piece of hardwood and get a smoother job without scratching or burning. When sanding a ball, select a grade of paper that will work

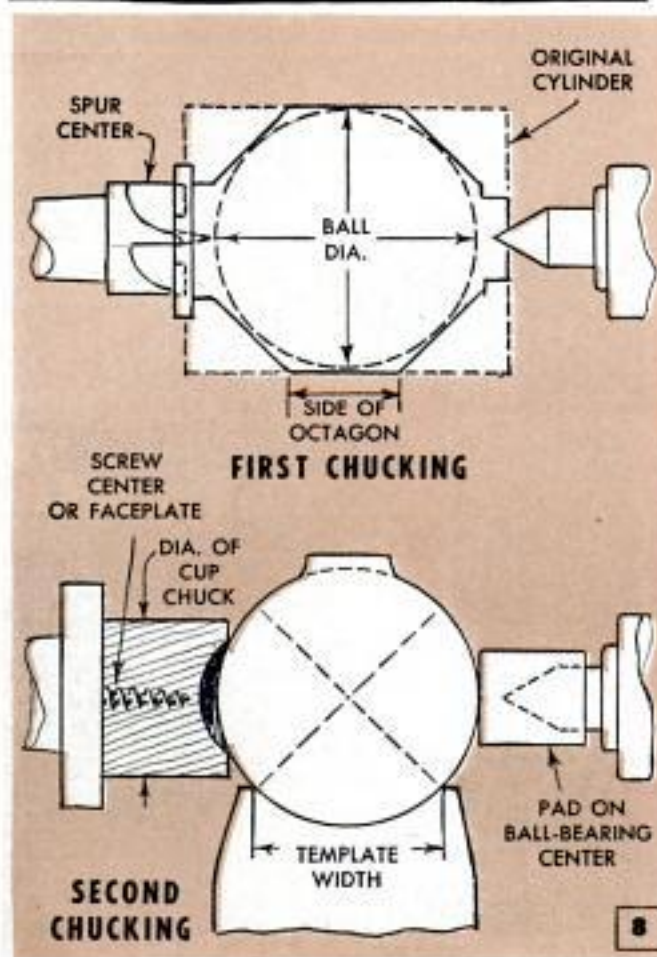

Data - TURNED BALLS

BALL DIAMETER	SIDE OF OCTAGON	TEMPLATE WIDTH	CUP CHUCK DIAMETER
1½"	¾"	1¾"	¾"
1¾"	¾" - ⅜"	1¾"	1"
2"	1⅛" + ¼"	1¾"	1½"
2¼"	1⅝"	1¾"	1¾"
2½"	1⅝" - ¼"	1⅝"	1¾"
2¾"	1⅞" + ¼"	2½"	1¾"
3"	1¾"	2⅝"	1¾"
3¼"	1¾" - ¼"	2½"	1¾"
3½"	1⅞" + ¼"	2⅝"	2½"
3¾"	1⅞"	2⅞"	2¼"
4"	1⅞" + ½"	3⅝"	2½"
4½"	1⅞"	3½"	2¾"
5"	2⅛" + ¼"	3¾"	3½"
5½"	2¼" + ¼"	4⅝"	3½"
6"	2½" - ¼"	4½"	3¾"

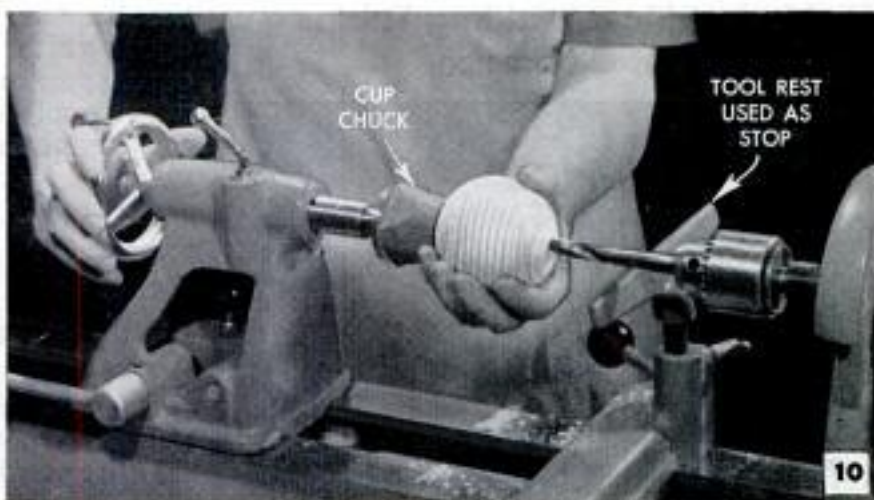
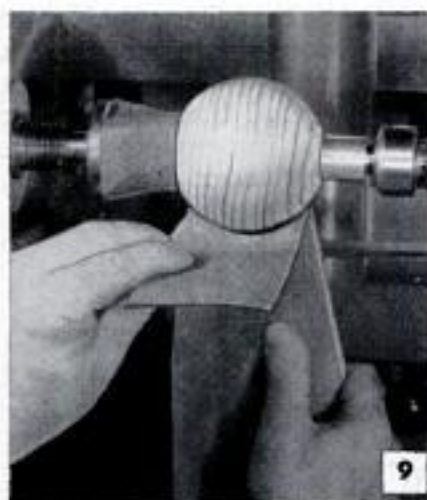

on the flat grain of a piece of waste of the same kind of wood without leaving scratches. Touch this to the rotating ball with the template as in Fig. 4, then stop the lathe and observe the results carefully. If there are no pronounced scratches on the surface, it probably is safe to proceed. The reason for this precaution is that the purpose of sanding is only to smooth the ball, not to shape it. Also, before sanding, be sure that the paper used is not creased. A crease in the sandpaper will leave a scratch, or groove, that is difficult to remove without reducing the diameter of the ball.

The final step is to cut the ball from the waste and mount it in a cup chuck as in Figs. 5 and 8. Then turn off the hub, or boss, remaining after sawing the ball from the waste. This must be done with special care as the interrupted cut may cause the turning chisel to dig in and spoil the work.

When a number of balls of the same diameter are required, turn a spindle to the ball diameter, then remove the waste and partially turn each ball individually as in Fig. 6. Cut them apart with a bandsaw as in Fig. 7, or with a handsaw, then mount in the cup chuck as in Fig. 8 and finish each one separately. If the balls turned between centers require center holes, they may be

accurately drilled with the setup pictured in Fig. 10, using the cup chuck on the tail center. Ordinarily, the diameter of the cup chuck should be slightly less than one fourth the diameter of the ball. Note also that the ball-bearing lathe center in the tailstock is fitted with a pad as in Fig. 5.

Where the ball is to be 4 in. or more in diameter it is best to remove a portion of the waste by compound bandsawing, the layout on the rough block being made on all four sides, as in Fig. 11. Then bandsaw the block to the shape shown in Fig. 12 and blacken one face with a soft-lead pencil. The blackened strip should be about $\frac{1}{2}$ to $\frac{3}{4}$ in. wide so that it is readily seen while the work is rotating. After the ball has been partially finished between centers, be especially careful when turning down center projections, or bosses, to prevent over-cutting. Have lathe in a good light so that you can see the double image of the ball as it rotates. The double image will gradually fade out as the work comes to a spherical shape. Then sand with the template as in Fig. 9, stopping the lathe frequently to note the progress of the work. When the fine sanding marks begin to criss-cross those made in the first sanding operation the curve is uniform. ★ ★ ★

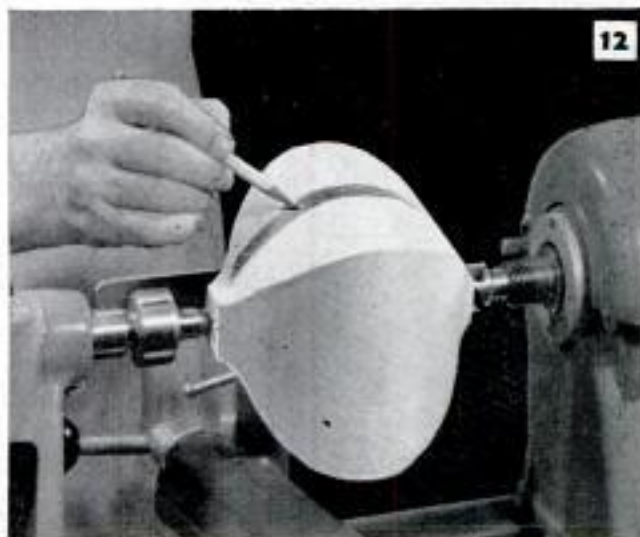
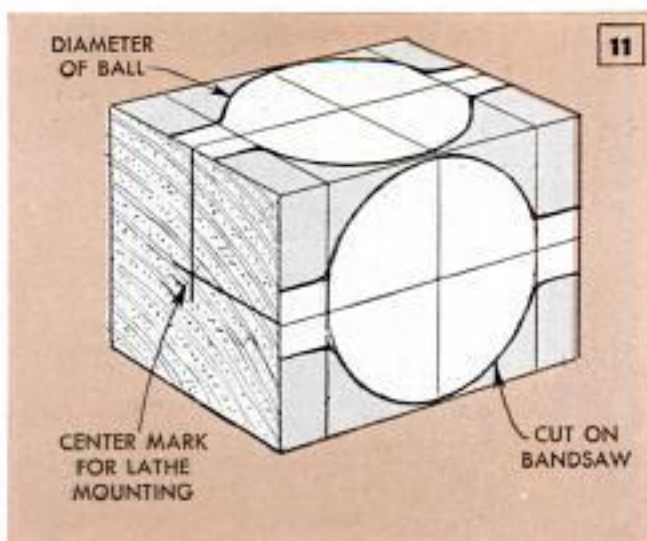

Single-Leg Steel Welding Table Provides Foot Clearance



Because its top is supported on a single center leg, the heavy-duty welding table, shown in the photograph, eliminates the problem of foot clearance when working around it. The table top is a 36 x 36-in. piece of 1½-in. steel plate welded to the leg, which is a length of 5-in.-dia. steel pipe set in the concrete floor. The lower shelf on which the tools are stored is 29 in. square and is a light steel plate. A steel flat welded to the edge provides a flange. The table is used both for welding and cutting and its extra-strong construction will absorb the heavy hammering required when fabricating or straightening metal shapes.—Leland Elam, Sacramento, Calif.

Beaded Surface Can be Simulated With Half-Round Molding

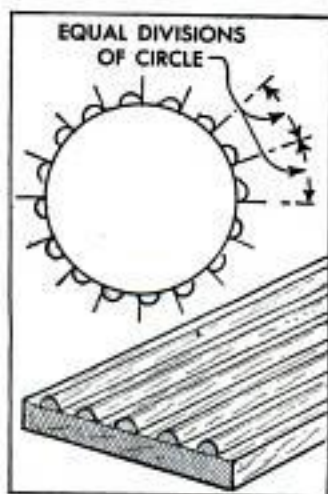

The easiest way to simulate a beaded surface on either flat or curved work is to apply half-round molding as shown in the illustration. For round work, the periphery must be divided accurately for the strips and spaces between them. The spacing between the strips can be varied for

best appearance, but all spaces must be of equal width. The easiest way to obtain this equal spacing is to use a spacing block when applying the strips. Unusual effects can be obtained by using spacing strips made of a darker wood than the molding strips, or by staining them beforehand.

Reversible Poultry-Feed Trough Easily Cleared of Rain or Snow

Rain or snow, which often fills outside poultry-feed troughs, is merely dumped out by inverting a two-way trough made from two sections of eaves trough riveted together. Turned up, the trough can be filled with feed immediately while the lower trough drains and dries.



Sickle Bar Raised Hydraulically On Converted Mower

To avoid having to raise the sickle bar manually on a horse-drawn mower adapted for use with a tractor, one farmer mounted a hydraulic cylinder on the mower tongue to operate off the tractor hydraulic unit. In mounting the cylinder, the upper end was pivot-bolted to the sickle-bar lifting lever. The lower end pivots on a bolt in a bracket formed by welding square pieces of flat steel to a triangular-shaped piece. The bracket then is bolted to the tongue.



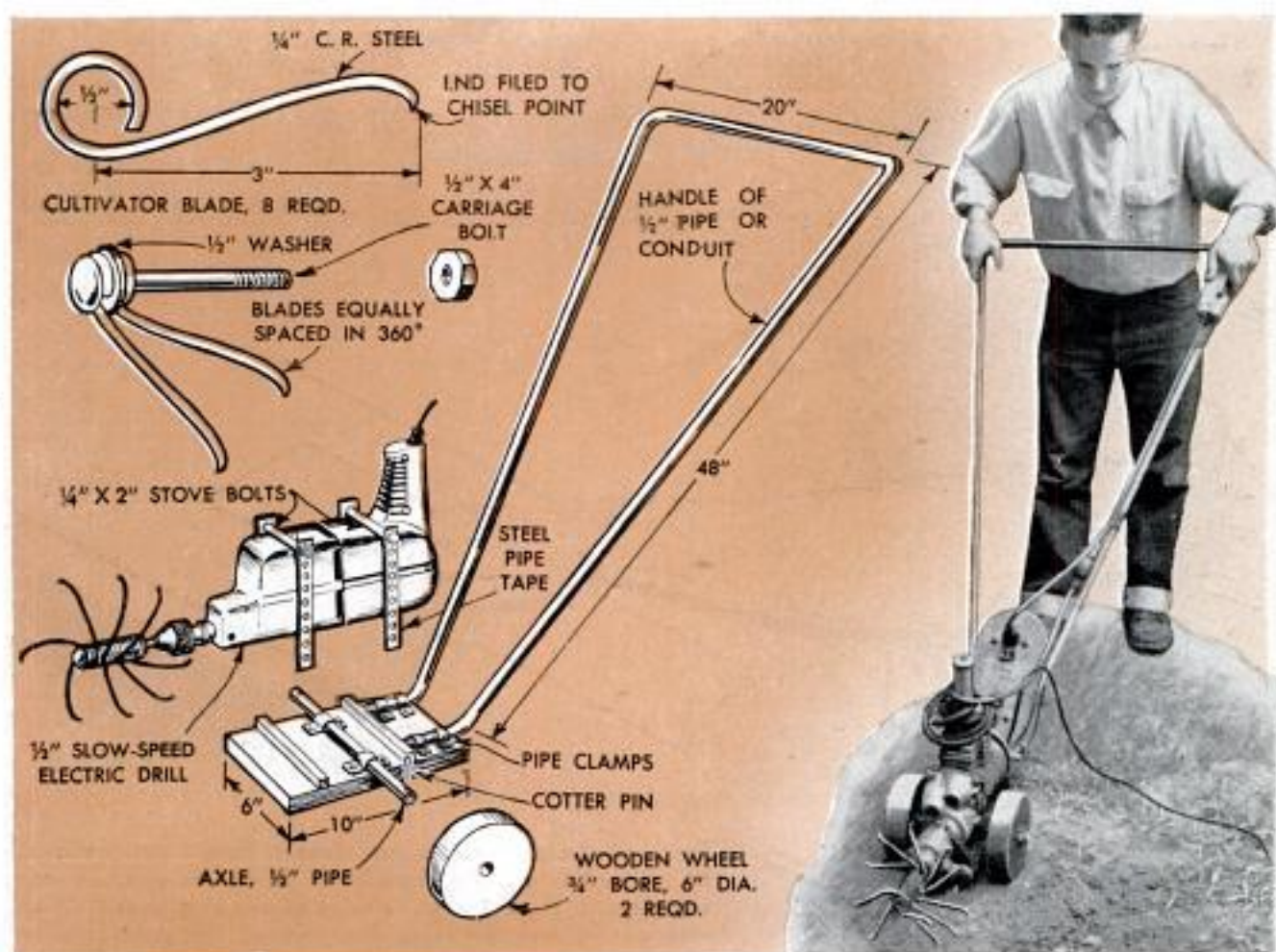

Portable Electric Drill Powers Garden Cultivator

For surface cultivation of garden row crops this improvised unit, powered by a portable electric drill of $\frac{1}{2}$ -in. capacity, has all the principal advantages of a rotary cultivator. It's especially handy in small gardens because of its light weight and maneuverability. The drill, which should be of the slow-speed type, is mounted in the inverted position on a wooden platform supported by two wooden wheels. Small rubber-tired wheels can be substituted. The handle is formed by bending $\frac{1}{2}$ -in. pipe

or conduit and the ends are attached to the platform, or base, by means of pipe clamps. The axle is attached in the same manner. The cultivator blades, or teeth, are bent to the shape indicated and placed side-by-side on a $\frac{1}{2}$ -in. bolt with spacer washers between. After spacing the blades the nut is drawn tight to hold them in position. The switch on the drill is locked in the on position and a separate two-pole switch is located on the handle to provide more convenient control of the drill motor.

Automatic Release for Trip Rope Protects Driver of Tractor

The danger of the seat being pulled off a tractor by a trip rope tied to the seat, when an implement accidentally becomes unhooked, can be eliminated by using a "slip fitting" to hold the end of the rope. The fitting is a short length of auto-radiator hose slit down one side and attached to the tractor seat with a wire loop. The trip rope is passed through the hose, then a metal ring, length of dowel or just a large knot is tied in the end so the hanging weight of the rope will not pull it through. A heavy pull on the rope will cause it to slip through the slit in the hose, thus preventing it from pulling on the seat.

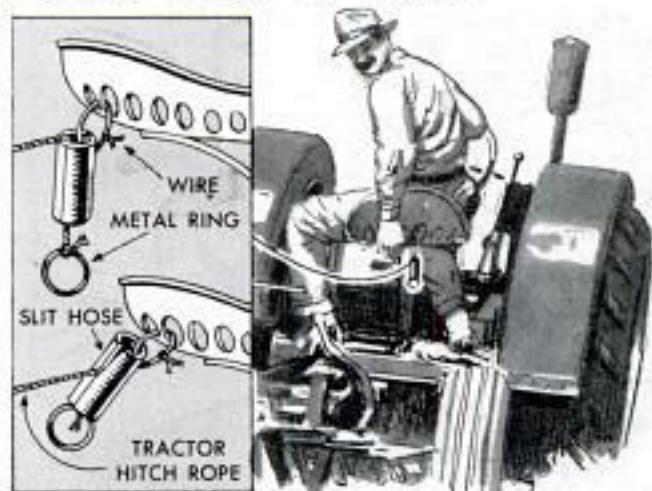

SN 56

SHOP USES FOR EMERY BOARDS

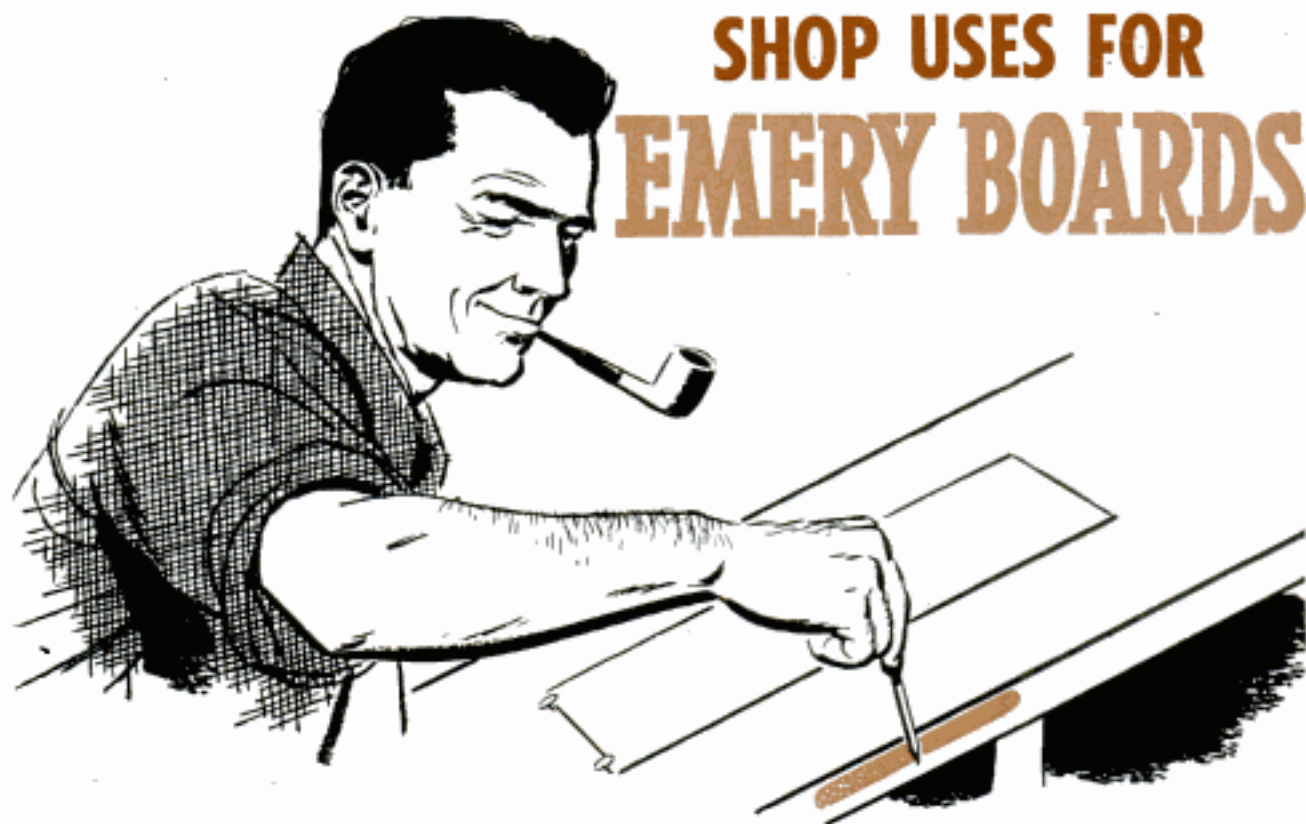

Every good artist has his own ideas of how a pencil should be pointed to suit the work he is doing. An emery board cemented or thumbtacked to edge of drawing board, either side out, is just the thing for pointing the pencil. For a sharp, flat point it's usually best to use fine side of board

Lower left, small parts gripped in the vise may suddenly slip sidewise if a little too much pressure is applied when driving a screw or drilling a hole. To prevent this mishap, place an emery board on either side of work before tightening vise jaws. Friction surface of boards holds securely

Flexibility of a large emery board makes it especially useful for finishing small metal parts. It is better and smoother than an ordinary file for this purpose and also much easier to control when the dimension is close to the required size. Both sides can be used

Below, right, when laying out work to close dimensions, a carpenter needs a fine, flat point on the pencil so that the dimension line is not over or under when marked along the blade of the square. An emery board cemented to the handle of the try square is handy for pointing the pencil

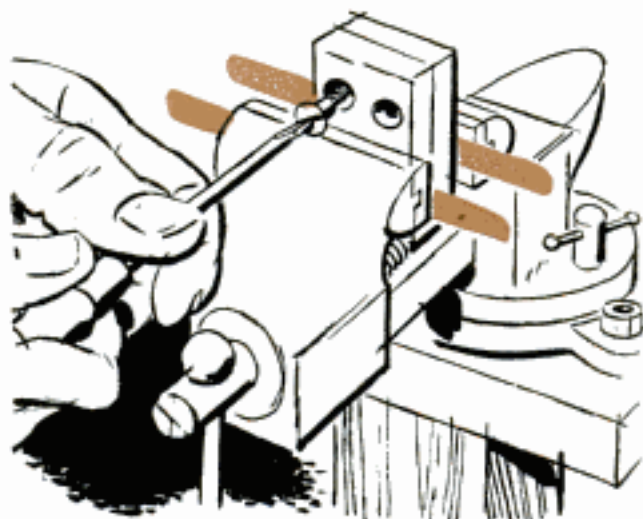

Arrow-Fletching Jig Made Quickly Utilizing Short Dowel

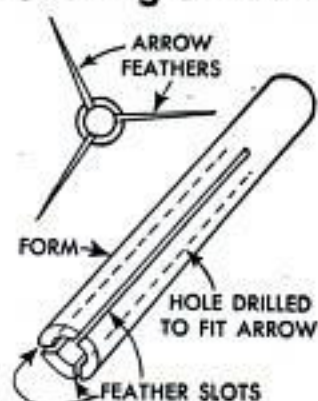

When gluing new feathers on an arrow, the problem of holding them in position until the glue has dried can be solved by using a jig made from a short length of dowel. The dowel is drilled lengthwise to fit over the end of the arrow and three equally spaced slots are cut to hold the feathers. The jig should be coated with paraffin to prevent the glue from adhering to it. In use, the jig is slipped over the end of the arrow, and the feathers, their one edge dipped in glue, are inserted in the slots. When the glue is dry, the jig is removed from the arrow, leaving the feathers in the required position.

Rubber Band on Ball of Twine Prevents Unwinding



One method of assuring that a ball of twine will not become unwound when it is dropped is to use a wide rubber band with a hole punched in it. The band is snapped around the ball and the loose end of the twine is pulled through the hole, as shown. If the ball of twine unwinds from the inside, the rubber band need not be removed to use the twine.

Cut Bolt to Take Off Rusted Nut

When a bolt on which a nut has rusted fast is in a restricted location that prevents gripping the head with a wrench, and a hammer and chisel cannot be used, split the bolt lengthwise with a hacksaw. Cut down through the bolt until the nut also is cut in half, then drive out the bolt with hammer and punch.—Hugh Lineback, Stillwater, Okla.

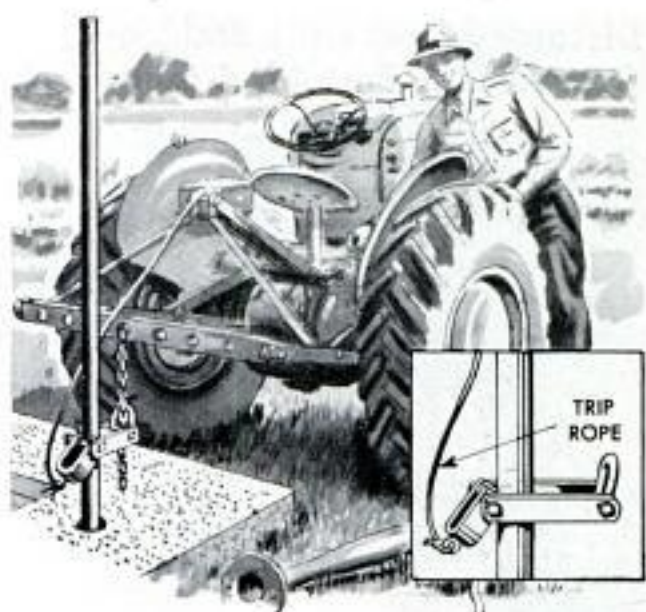
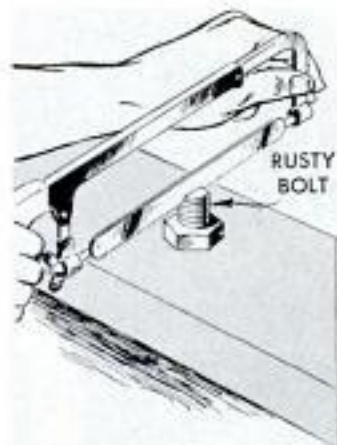

Welded Clamp on Tractor Lift Pulls Pipe Out of Well

Tractor power and a welded clamp have replaced muscle power on one farm for pulling the pump pipe from a well. Consisting of two $\frac{3}{8}$ x 2 x 9-in. flat-steel sides with a steel block welded between them near the center, the clamp has a clevis fitted at each end. One clevis is used to suspend the clamp from the hydraulic lift of a tractor. Shaped from flat steel, the clevis at the opposite end has squared ends which aid the clamp to grip the pipe. A trip rope, passed through an eye welded on this clevis, is used to release the grip of the clamp. To use the clamp, the pump must first be jacked up from the platform and unscrewed from the pipe which is held with a regular alligator-jaw clamp. The welded clamp then is fitted over the pipe and it is raised the limit of the hydraulic lift. The clamp then is released with the trip rope and the clamp lowered. The process is repeated until all the pipe is pulled.

A. M. Wettach, Mt. Pleasant, Iowa.

Magnet Removes Drill Chips From Blind Hole in Steel

Chips caused by drilling or tapping a blind hole in iron or steel can be removed by using a soft iron or steel rod and a strong magnet. The rod should be long enough to reach the bottom of the hole, and small enough in diameter to enter the hole freely. Drop the rod to the bottom of the hole and place the magnet on the end. When magnet and rod are removed from the hole, some of the chips will cling to the bottom of the rod. Pull the magnet away from the rod to clean it of chips, then repeat the complete operation until all the chips are removed from the hole.

Charles R. Haynes, Vestal, N. Y.

Discarded Steel Truck Bed Converted to Portable Granary



Using a steel truck bed as the bottom half, one farmer constructed this ratproof granary. It has a capacity of 200 bu. and can be set on blocks, as shown, or mounted on skids so that it is easily moved with the tractor from place to place on the farm.

George Laycock, Batavia, Ohio.

Notch Ground in Claw of Hammer Provides Tool for Pulling Tacks



When working with old lumber, you often find tacks and brads that are driven so far into the wood that the claw of a regular hammer cannot be slipped under the heads. To overcome this problem, and eliminate the need for a second tool, file or grind a V-notch

in the end of one claw. The sharp-edged notch can be used to pull most tacks and brads and will not hinder the use of the hammer claw for pulling nails.

William B. Eagan, Louisville, Ky.

Repairing Threads Over Keyways

When chasing worn threads on slotted keyways, chipping sometimes occurs, since the thread die may jump or chatter during

the cutting of the first few threads. However, if a small spot is welded or brazed at the very end of the keyway—just enough to fill the tip of the slot—the die won't chatter as it is started for the chasing process.—Harry J. Miller, Philadelphia, Pa.

Handy Water Bucket Improvised From Automobile Inner Tube

An excellent emergency water bucket that can be carried in the car and will take up little storage space, can be improvised from a sound, but discarded auto inner tube. Cut the tube in two, as shown, then cut oval handholes for carrying. For added strength,

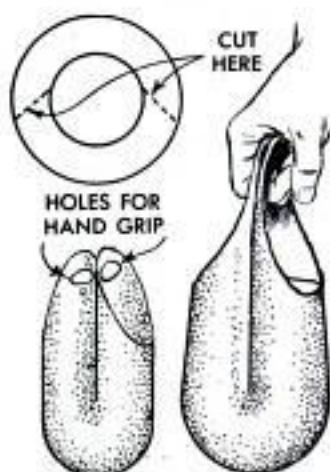

cement a piece of inner-tube rubber on both sides of each end of the tube around the handholes. The bucket also would be handy on an outing or camping trip.

Oil Drum on Elevated Platform Fuels Brooder-House Stove

To eliminate frequent filling of the oil stove in the brooder house, one farmer installed a 55-gal. oil drum on a raised platform outside the house. The bung on one end of the drum is pushed down to receive a small-size supply line. The bung on the top is left open to provide a supply of air and is covered to keep out the rain.

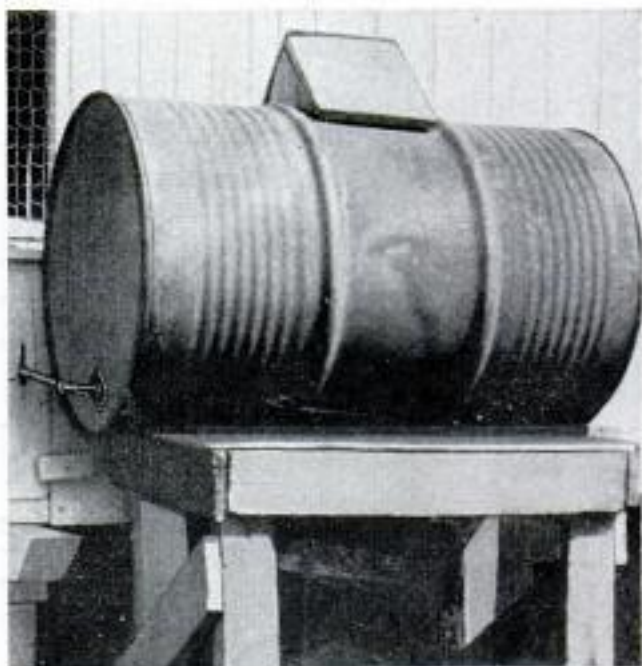

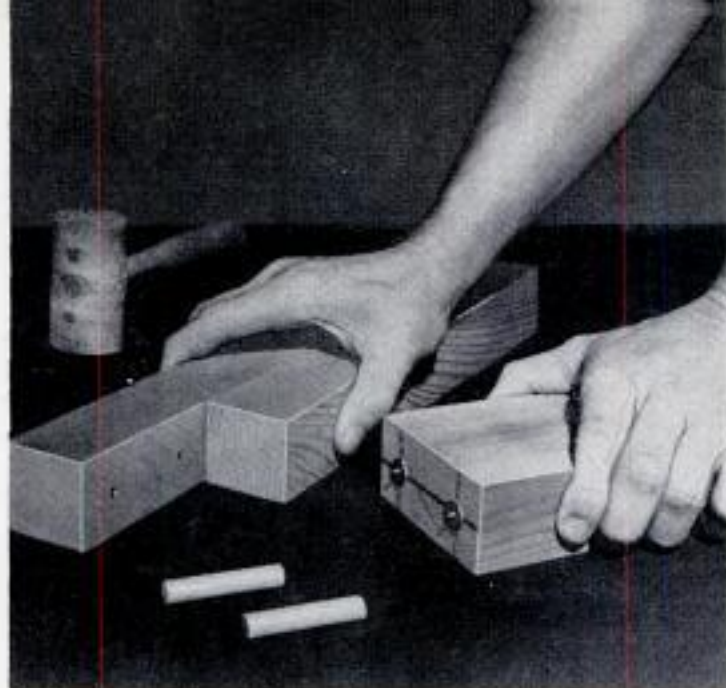

In this doweled joint, end grain is joined to flat grain. End grain should have two coats of glue before joining. Dowel locators assure perfect alignment

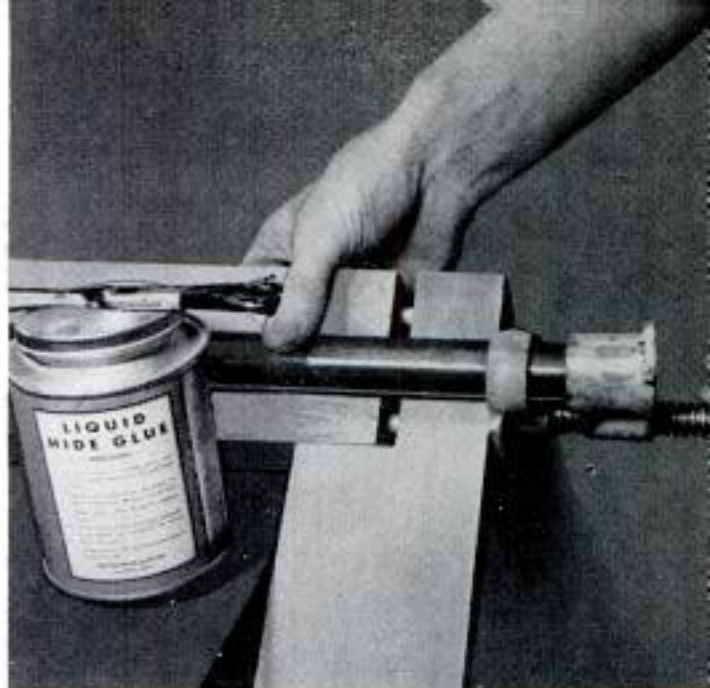

A bar clamp is used to draw the joint tight after application of the glue. Care should be taken to assure a perfect fit between all meeting surfaces



A tub filled with water makes a good "clamp" for flat work such as veneering a small surface. Place a piece of plywood under the tub to distribute pressure

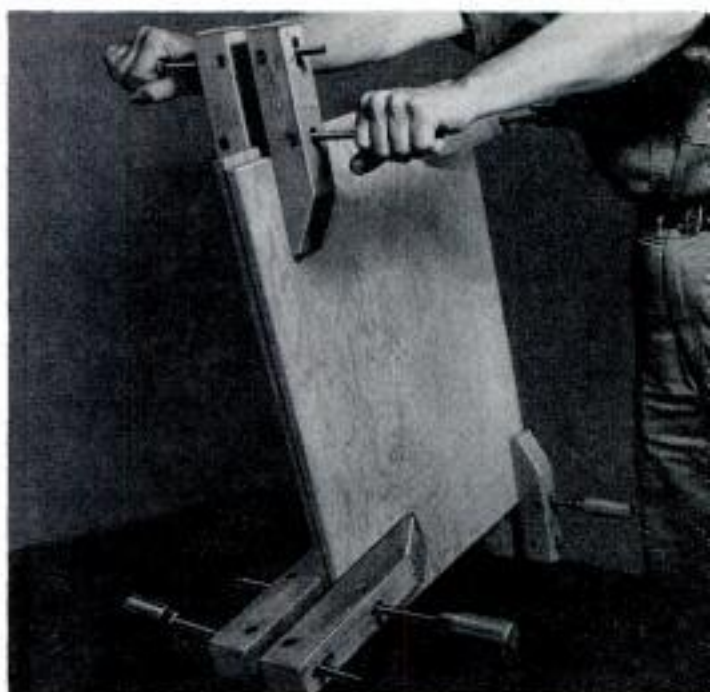

Laminating and veneering can be carried out with hand screws, using four or eight screws, depending on size of work. Adjust hand screws for uniform pressure

By Jerry Parker

~~20-58~~
SN 58

GLUE KNOW-HOW has been simplified by the ready-to-mix and ready-to-apply cold adhesives which eliminate heating and the temperature problem at the time of application. Liquid hide glues have supplanted the older hide glues that were supplied in the flake form and required heating for a period of time to reduce them to a usable consistency. Although the older glues were highly effective in durability and holding power, they are not so suitable for use in small manufacturing plants and home shops due to the special equipment required for preparation and application. Both the liquid hide glues and the newer resin glues, the latter having the appearance and consistency of thick cream, are especially useful in home-shop joinery. Both these glues, also the

All About
GLUE
and
GLUING

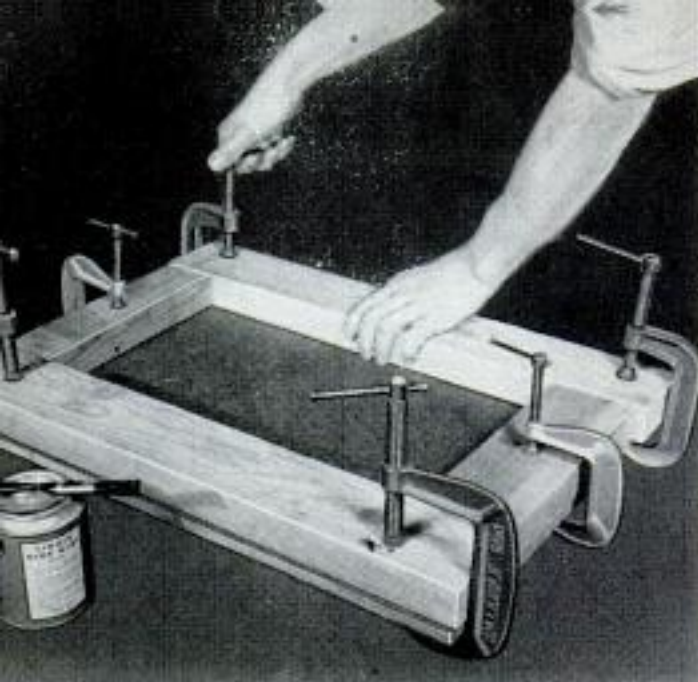

Laminating hardboard to wood is easy with the setup pictured. C-clamps should be equally spaced to distribute pressure uniformly. Wipe away excess glue

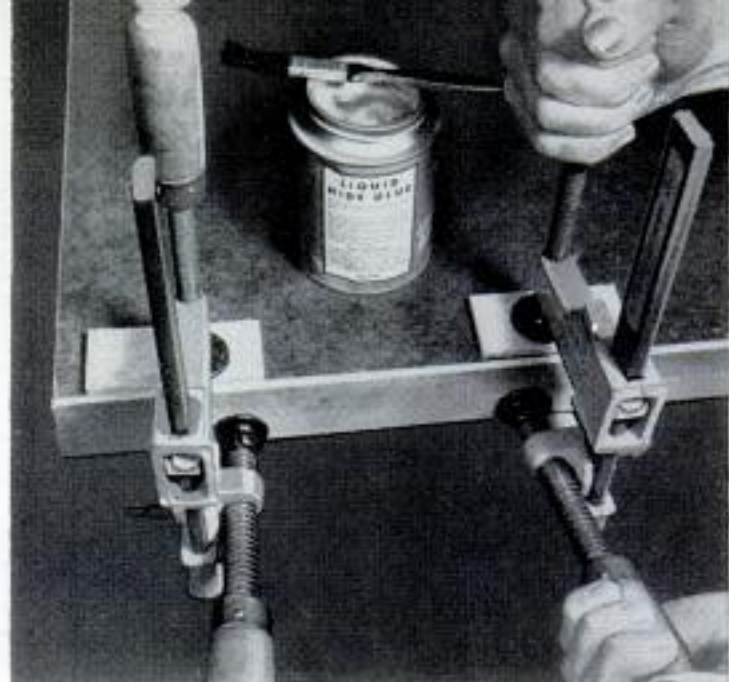

Edge clamps are large C-clamps with a sliding fixture that permits applying pressure in two directions. They are especially useful for gluing strips to edges

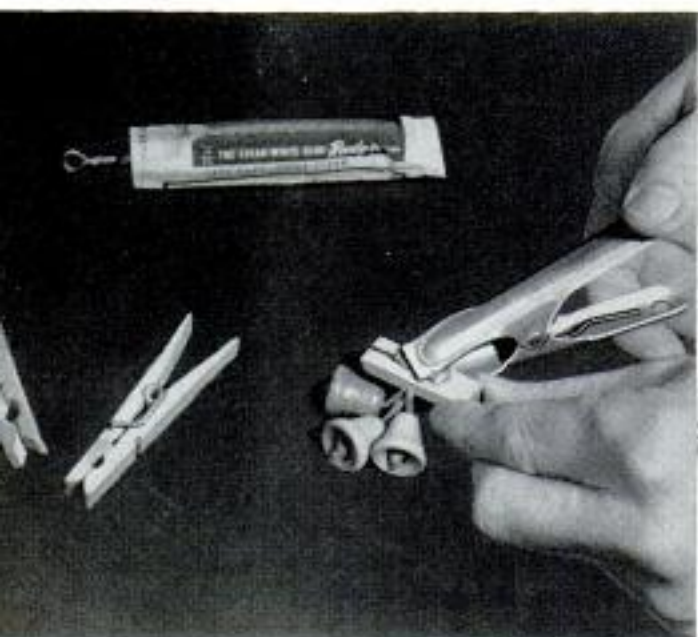

Spring clamps and clothespins of the spring type are used for joining small parts, border inlay and assembly of models. Spring clamps come in several sizes

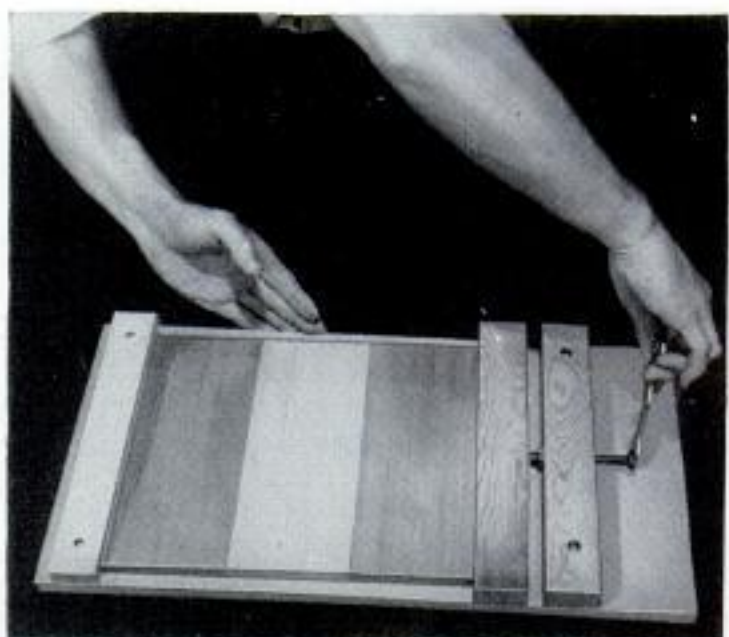

Improved clamps for edge-gluing can substitute for bar clamps. The simple unit pictured is very effective. Bolt forces the movable jaw against the edge of work

ready-to-mix type supplied in the powder form, require only the simplest clamping equipment. All are water-resistant in the sense that holding power is affected little, if any, by ordinary dampness. When a completely waterproof glue is required, the craftsman uses a resorcinol glue supplied in a two-part container, one part of which contains a dry powder, the other a catalyst in liquid form. When the powder and liquid are mixed in accordance with instructions they form a waterproof glue of great holding power. When gluing woods which contain natural oils such as rosewood, teak, lemon and yew wood, the craftsman uses a casein glue, which comes as a powder and is mixed with water to form a fairly heavy liquid.

Edge-gluing and joint-gluing of frames

and cabinet parts require not only the use of the correct glue, but a careful trial fitting of the parts to insure full contact over the whole area of the meeting surfaces. When edge-gluing a number of strips to form a wide panel, the edges of the strips must be jointed true, either by machine or by hand-planing. Craftsmen make a trial assembly of cabinet frames before applying glue to the joints. This will assure a perfect fit of the parts when they are glued and clamped. When gluing cabinet-frame members where end grain is joined to flat grain, it is important to apply two coats of glue to the end grain. Allow the first coat to become tacky, then apply a second coat and join. When joining flat grain, as in edge-to-edge work, the important thing is to apply the glue in a uniform coating. This can be done

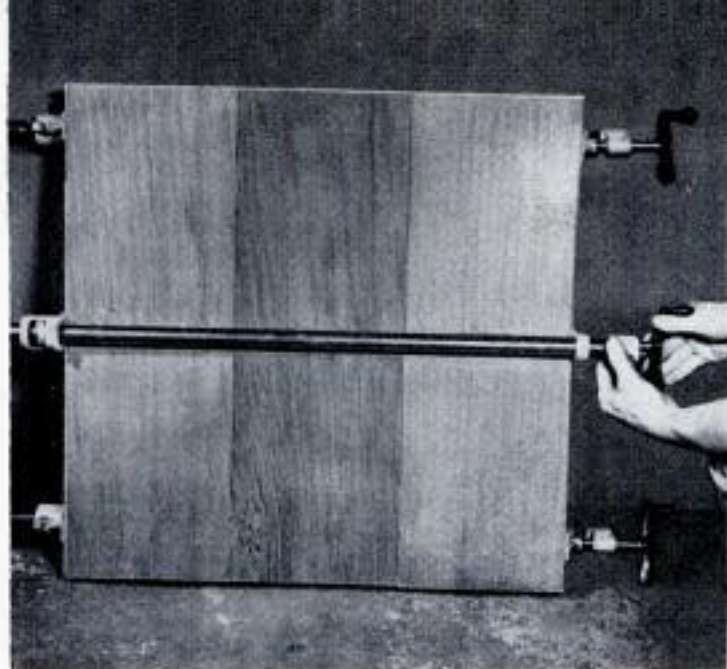

Bar clamps, or carpenter's clamps, are best for edge-gluing a number of strips to form a wide panel or top. Note spacing and alternate position of center clamp

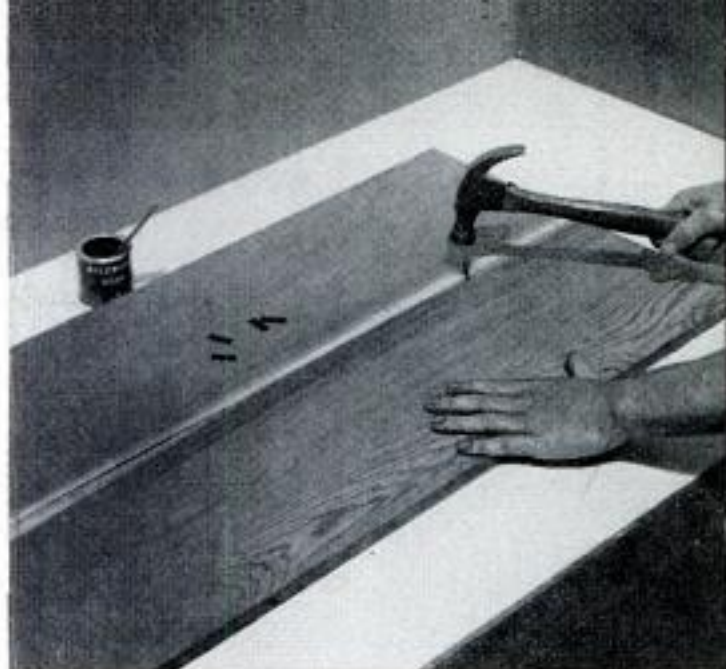

On work where exposed metal is not objectionable, corrugated fasteners are suitable "clamps" for edge-gluing. Usually they are driven into both sides of joint

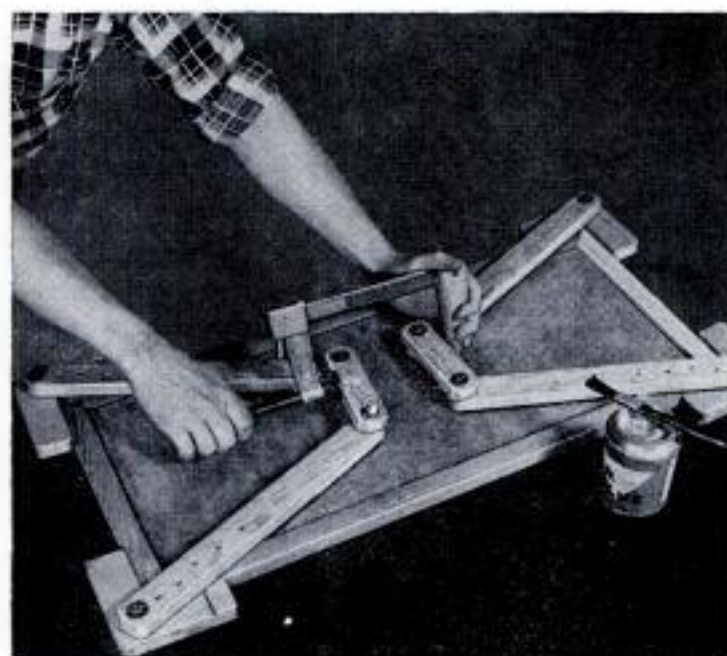

A self-adjusting miter clamp is handy in the home shop. You can make one like this in a few minutes. Note how two members are drawn tight with C-clamp

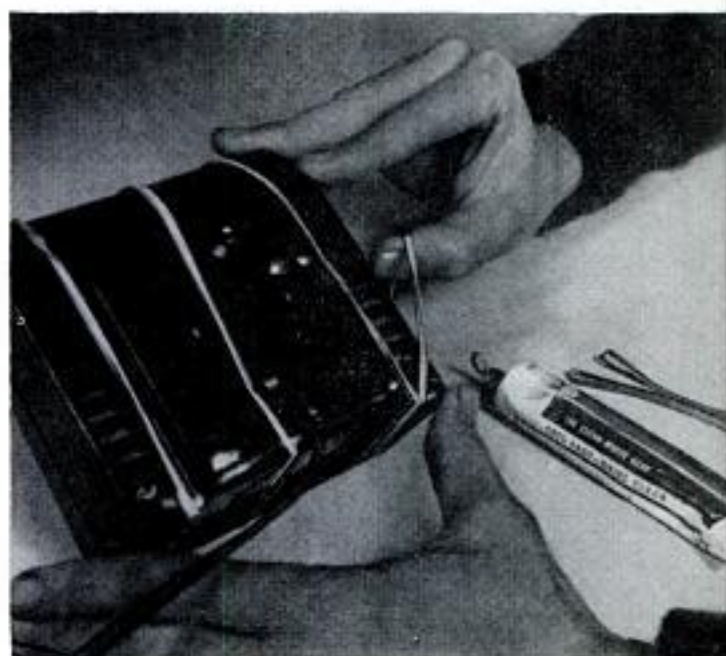

Ordinary rubber bands of various sizes are just the thing where it is necessary to apply a light, uniform pressure when gluing or cementing small parts

For certain clamping operations requiring light pressure, cellulose tape is useful. Simply spread glue on joining faces, locate parts and wrap with tape

Craftsmen often improvise bar clamps when building or repairing chairs. This simple, two-part clamp is especially effective for this type of parts assembly



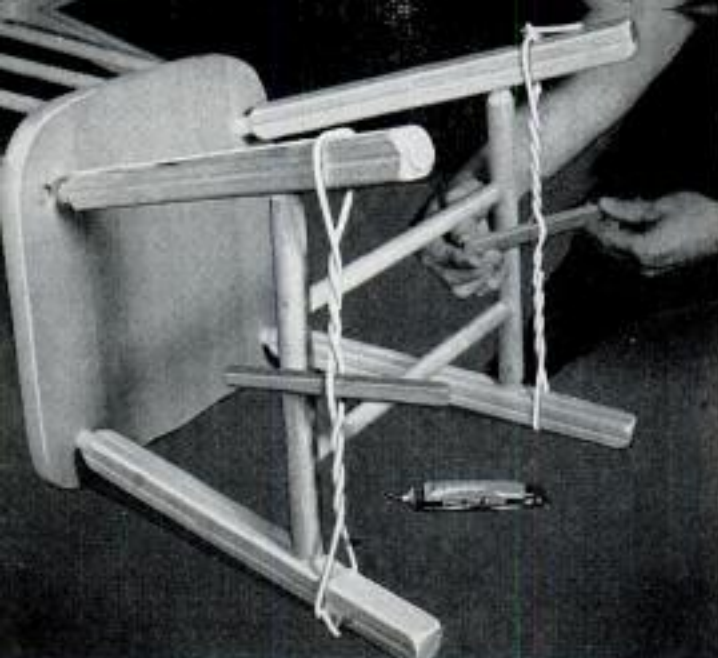

For repairing a single chair, twisted cords can be used to apply pressure until glue sets. Cord clamp is quickly improvised from a length of clothesline

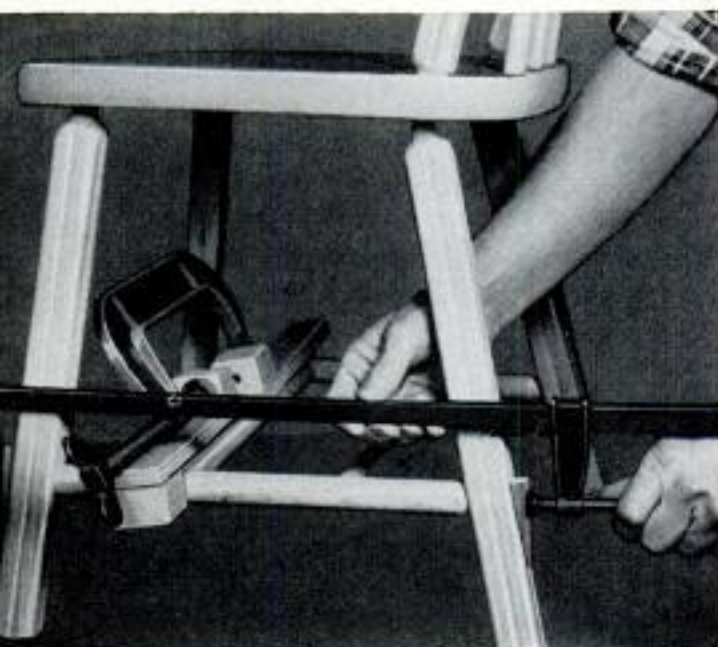

In some cases, chair assembly can be speeded up by applying pressure in two directions simultaneously. Here three bar clamps will be placed at right angles

When the amount of work to be done justifies its purchase, the band clamp is best for chair work. Here the lower assembly is clamped in one operation

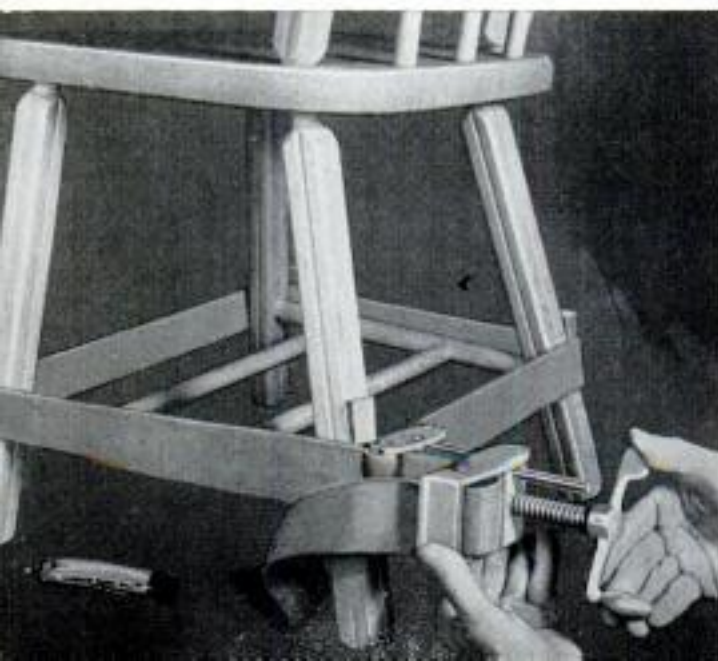

with a thin wooden paddle, a brush, or best of all, a glue applicator of the roller type. This applicator operates in a manner similar to a wheel-type paint striper.

Beginning with the two right-hand photos on page 215, various methods of clamping are pictured. Correct application of the clamps and the amount of pressure applied are the two most important points about clamping. Bar clamps, C-clamps and wooden hand screws, or adjustable clamps, are the most commonly used in the small shop. Bar clamps, or carpenter's clamps, are used chiefly in edge-gluing several strips of stock, also in cabinet-frame assembly. It is important that bar clamps be located square with the work so that pressure is exerted uniformly. Also, when more than two bar clamps must be used, locate the center clamp, or clamps as the case may be, equidistant from those near the ends of the work. The upper left-hand photo on page 217 is a good example of correct bar-clamping. Note that the center clamp is placed with the bar across the opposite face of the work. This position of the third clamp helps to equalize the pressure and also prevents any tendency of the work to buckle. If the work has been cut to the finish size before clamping it will be necessary to protect the edges at the point where the metal clamp jaws engage. This is done by placing small pine blocks between the edge of the stock and the jaws, or by cementing pieces of leather to the face of the jaws. You also can improvise a good substitute for bar clamps, the clamp in the lower right-hand photo on page 216 being a good example.

C-clamps and edge clamps, upper left and upper right-hand photos on page 216, are used when it is necessary to apply pressure near the edges of the work, as in gluing on an edging strip, or in veneering. Edging clamps, upper right-hand photo, page 216, are provided with a sliding bracket, or jaw, which makes it possible to apply equal pressure in two directions. Another clamp which belongs in this classification is the simple spring clamp shown in the lower left-hand photo, page 216. This clamp works in a manner similar to pliers, the spring acting to close the pivoted jaws. Spring-type clothespins also can be used in the same manner.

Improvised miter clamps, rubber bands, cellulose tape, corrugated fasteners, "chevron type" fasteners, all these can be made to serve as clamps in certain gluing operations. In building or repairing chairs, the band clamp, lower photo at the left, is universally useful. It consists of a length of canvas or other tough fabric attached to a special fixture having a snubbing device which permits adjustment of the fabric band to any required length. ★ ★ ★

Razor Blade Attached to Block Provides Cardboard Cutter

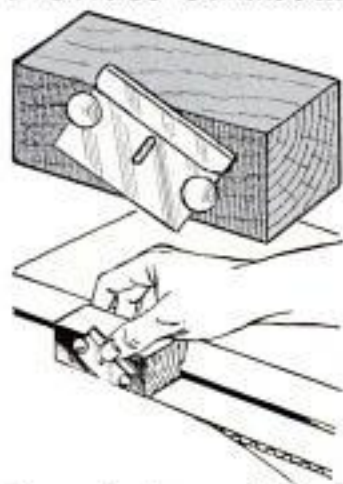

One man who had frequent need to cut corrugated cardboard for packing inserts, mailing photos and other purposes, made a simple and efficient cutter by thumbtacking a single-edge razor blade to one side of a small wooden block. The blade is set to just cut

through the cardboard. When one corner of the blade is dulled, the blade is easily changed end for end. A double-edge blade also could be used for this purpose, but the upper edge of the blade should be covered with cellulose or adhesive tape to prevent injury to the fingers.

Vertical-Sliding Haymow Door Is Counterbalanced

The time and labor involved in closing a conventional hinged-type haymow door can be reduced considerably by using this counterbalanced door that slides vertically. Tracks for the door are provided by first nailing 2 x 4s to the outside surface of the barn, then nailing 1 x 6s on top of them and allowing one edge to project. Ropes tied to each side of the door lead up over pulleys and down to free-hanging weights which counterbalance the door so it can be operated with a minimum of effort.



JANUARY 1955



Tanks Set in Concrete Floor Furnish Water for Hog Lot

The waterers in the hog lot of one farm are buried 5 ft. in the ground to aid in keeping the water at a constant temperature and to prevent winter freezing. The waterers are discarded hot-water tanks, each having one end removed. The tanks are set in the ground at such a depth that when the concrete floor is poured around them, 3 in. of the tank projects above the surface. The water line that supplies the tank is run underground from a boxed-in pan and float just outside the fence. A 12-quart bucket, with holes punched around the sides, fits in the top of each tank, to prevent feed and dirt from dropping into the tanks. The buckets are cleaned simply by lifting them and pouring their contents on the ground.—G. Laycock, Batavia, Ohio.

Chicken-Wire Fencing Spliced With Sections of Tubing

Splicing together two lengths of chicken-wire fencing, which usually is done by sewing with wire or by twisting the strands together, can be accomplished more easily with diagonal sections cut from a length of copper tubing. Cut the tubing as indicated by the dotted lines in the detail then spread the points of the resulting rings with a screwdriver. Use a pair of pliers to pinch the rings onto the chicken wire, as shown in the illustration. The rings should be spaced every 5 in. along the splice.

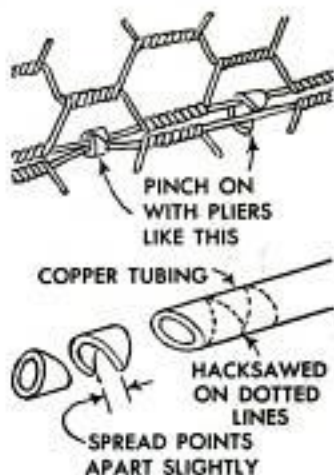

219

SHOPPING



1

1. SHEET-METAL BRAKE for bench-vise mounting forms angles, brackets and channels. Box-bending and end-folding attachments are available. Handles 18-ga. metal in sheets up to 24 in. wide. Assembled, ready for use. Easily adjusted for various bends

Television Accessories Co., Box 6001, Arlington 6, Va.



2

2. VACUUM LIFTER is connected to an air line to provide a powerful hand lift for sheet metal, glass, hardboard and other materials having flat surfaces on which a vacuum can be maintained. Saves time, labor in warehousing and production operations

Littell Mach. Co., Air Div.,
4555 Ravenswood Ave., Chicago 40

3. JOINT TROWEL for dry-wall finishing has a wide, replaceable steel blade which produces a perfect cemented joint in two strokes, one to apply cement and one to feather edges. Eliminates cement waste, cuts finishing time in half. Comes with special cement pan

Mudmaster Co., 2927 Richmond, El Paso, Tex.



3

4. SHAPER SPINDLE with integral cutter comes in a variety of sizes and shapes. Can be driven by electric drill, drill press or flexible shaft. Adjustable ball-bearing guides assure consistently accurate work. Kit includes handle, guides and three cutters

Biddle Mfg. Co., Racine, Wis.

5. FLEXIBLE SLEEVE permits continued use of taper-shank twist drills, reamers and end mills having worn or damaged shanks. Sleeve consists of a tapered coil spring wound from square-section spring steel. Spring grips shank securely. Runs true in spindle

Pilot Tools, Inc., 225 Lafayette Street, New York 12, N. Y.

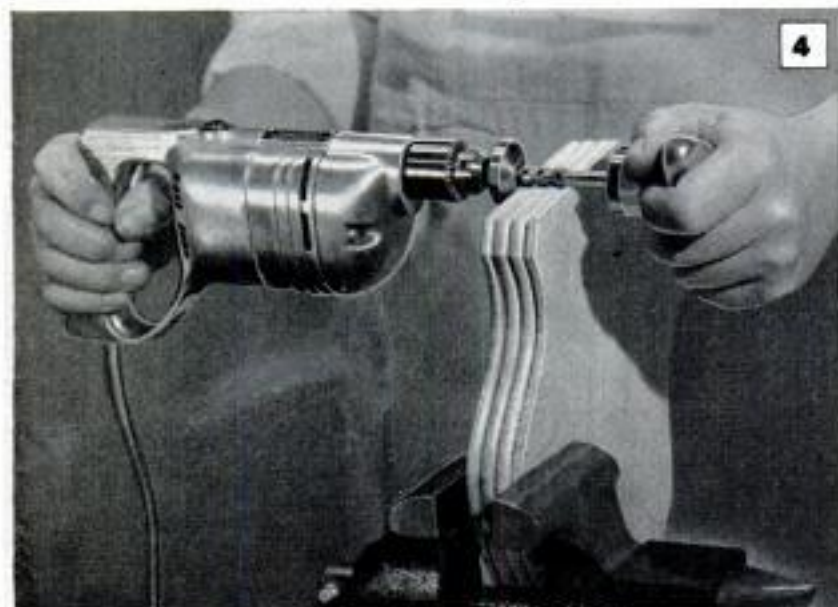

4



5

FOR TOOLS

6. PORTABLE-DRILL GUIDE makes it easy to drill true holes vertically, horizontally or at any angle with a portable electric drill. Unit adjusts mechanically to different positions by means of a scale and pointer, no spirit level being used. Can be removed from drill and replaced without altering adjustment. Easy to attach and has an accurate built-in depth gauge

High Standard Mfg. Corp., Hamden, Conn.

7. PAINTBRUSH HOLDER clamps securely to the edge of paint bucket, or can, and holds brush in position pictured. Bottom of holder forms a shallow receptacle which catches and retains drippings from brush so that they may be returned to container. Holds any regular-size brush, the handle always projecting within easy reach. Made from heavy sheet metal

Hirosa Products, Inc., P.O. Box 224, Lansing, Ill.

8. HAND-PLANE GUIDE enables user to joint edges of boards at right angles with the face, plane accurate bevels to any angle up to 45 deg. and true irregular edges of rough-sawed stock. Clamps to any standard hand plane and consists of a fixed bracket and a pivoted wing which swings and locks at any angle. Unit can be clamped to either side of plane

Perrine Company, Harrison, N. Y.

9. MAGNETIC BRAD DRIVER picks up and drives small brads without any possibility of damage to the work or injury to the fingers, which so often happens when attempting to drive brads with a hammer. Magnetic plunger picks up the brad and withdraws it into a guide with the point protruding. Pressure on handle forces plunger forward, driving the brad

Phillip Unsinger & Son, 607 Ohio Ave., Fremont, Ohio

10. TEMPLATE for setting of friction door catches, without the necessity of making individual measurements, is adaptable to cupboard doors of the flush and lipped, or rabbeted, types. Screw holes for catches are accurately located and punched as in the three photos below. In the final step, lower photo at left, door is closed against pins to locate catch

Badeo Sales, Box 1, Station A, St. Petersburg, Fla.



6

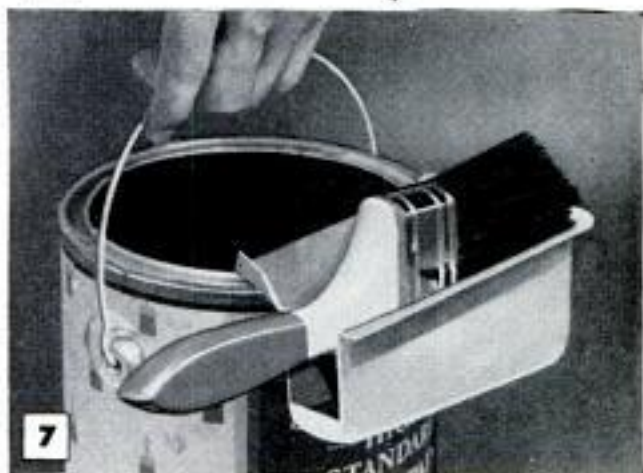

7

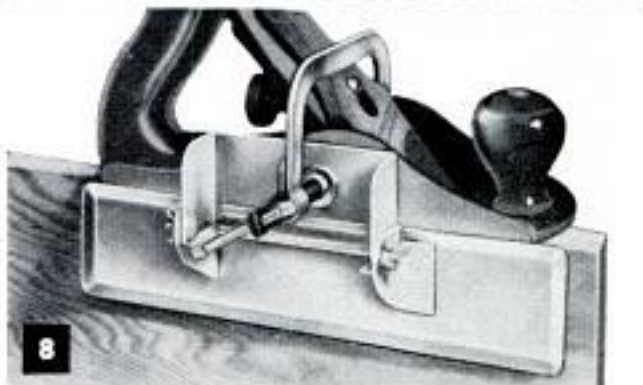

8

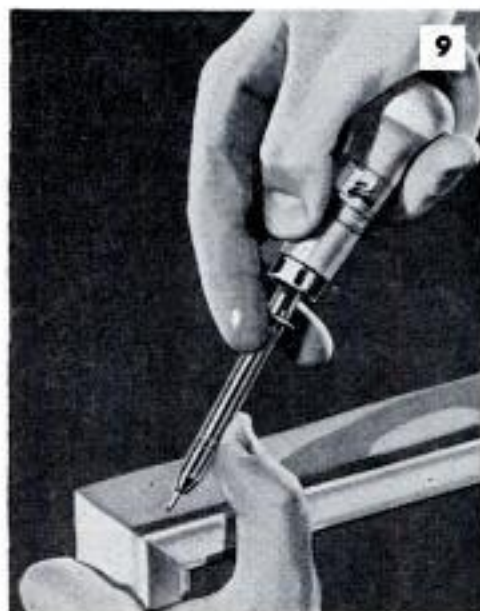

9



10

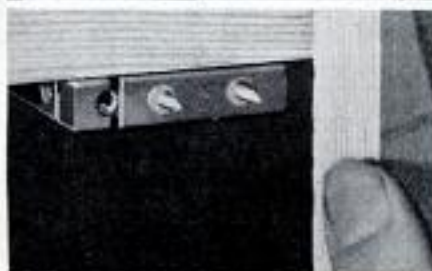

Wheelbarrow Hand Guards Prevent Skinned Knuckles



Skinned or bruised knuckles, caused by striking your hand against a wall or other object when pushing a wheelbarrow, can be prevented by installing hand guards on the handles. Sections of auto tire can be used as guards on steel-pipe handles by cutting holes in the sections and slipping them over the pipe. The casing sections are screwed to wooden handles with washers under the screwheads. When an extremely heavy wheelbarrow is used in a confined area, steel barn-door handles bolted to the wheelbarrow handles will provide maximum protection.

Wax for Ferrotypes Plates

Paraffin dissolved in lighter fluid makes an excellent solution for waxing ferrotypes plates. The fluid evaporates quickly, leaving a thin wax coat. A lighter-fluid can provides a handy dispenser.

Ends of Cut Hose Join Tightly When Hacksawed Together

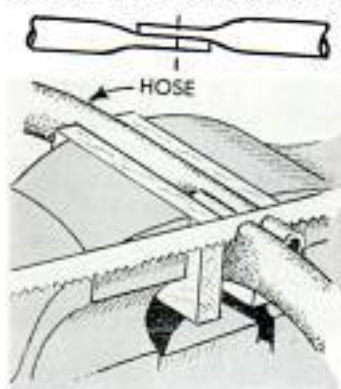

It is a fairly simple job to repair a leaking rubber garden hose by cutting out the damaged section and splicing the ends together on a pipe nipple; the difficulty lies in making the cut ends meet exactly.

After removing the damaged section, clamp the severed ends in a vise and hacksaw through both pieces at the same time. The ends will now meet exactly when slipped over the pipe nipple and clamped.

George Eyck, Redlands, Calif.

Safety Guard on Tether Stake Also Aids Removal

A length of pipe slipped over a much-used steel tether stake will protect the tethered animal against injury from the jagged edges of the battered top. Besides protecting the animal, the pipe provides a handy means of loosening the stake when it is to be removed.

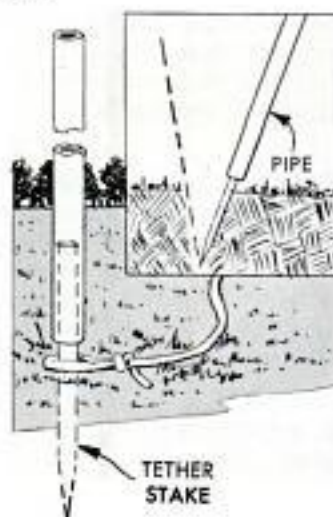

Poultry Fountains Suspended From Pivoted Supply Lines

As an aid in keeping the litter dry and water fountains clean, one poultry raiser suspends the fountains with the water-supply pipes. A swing joint, provided by two pipe elbows connected directly to each fountain, permits the fountain to be gradually raised and kept level as the chicks grow. Also, the fountains can be lifted out of the way when the floor is cleaned. Under ordinary pressure the elbows will not leak when used in this manner. However, for use over a period of years, a regular swing-joint fitting in place of the elbows would assure complete watertightness.

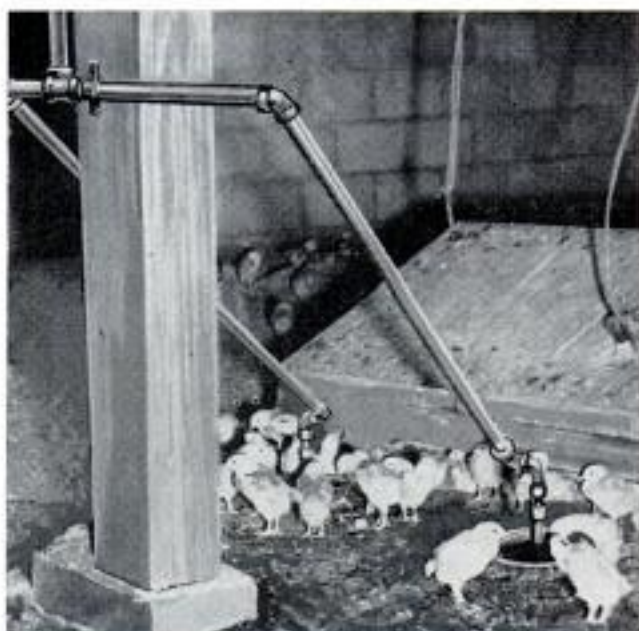

You can train with the U. S. Air Force

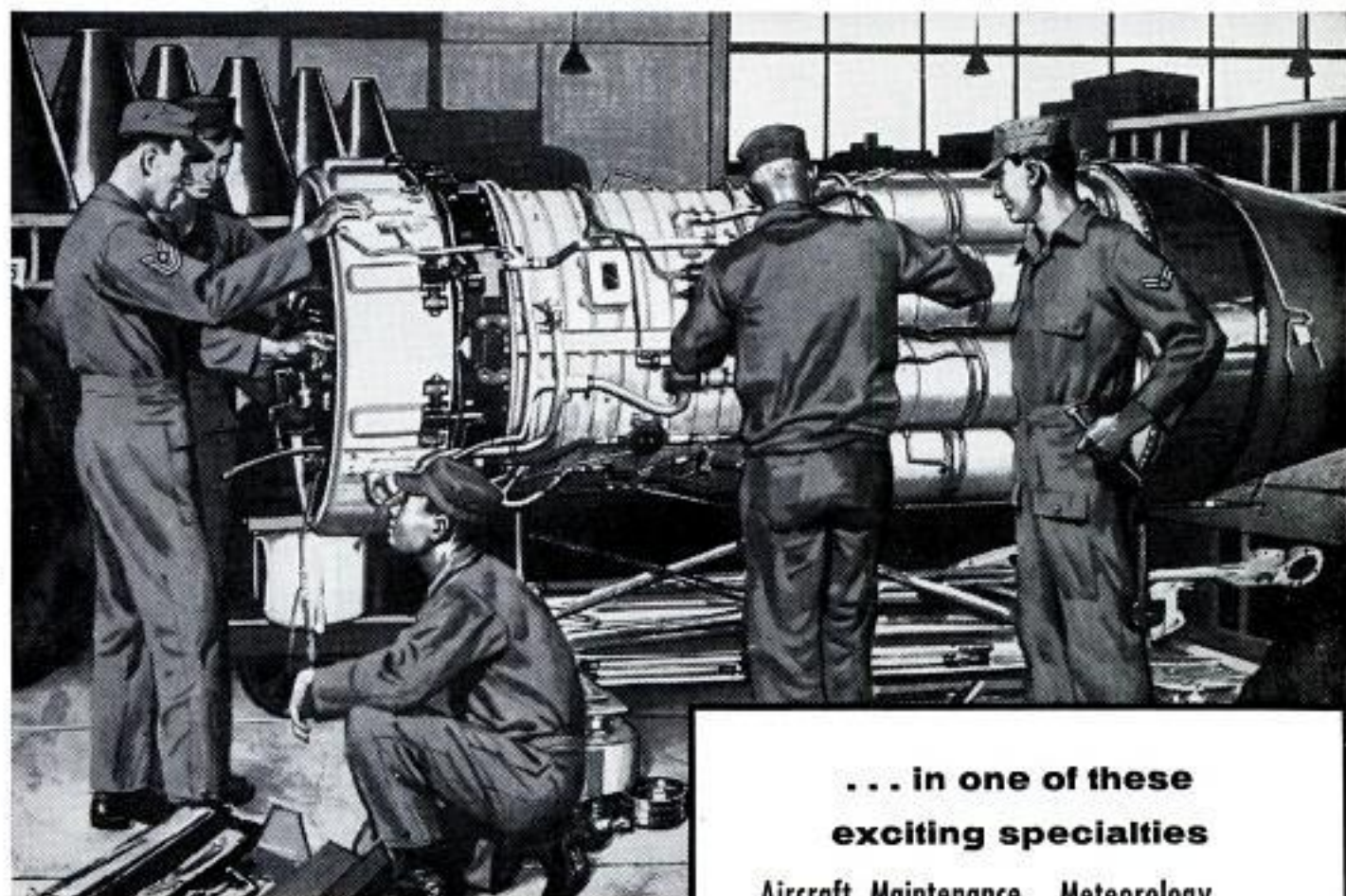

Are you interested in engines, electronics, radio, or other technical specialties? If so, you belong in the U. S. Air Force! As an Airman, you may have the opportunity to learn from the ground up, and become a specialist in anything from Turbo-jet mechanics to Radar or Electronics. You'll train with young men, men who will be quick to appreciate your skills and aptitudes.

You'll earn good pay and have unlimited opportunities for adventure and travel. What's more, you'll be assuring yourself of a good future . . . a future in which the training you may receive in the U. S. Air Force will pay you huge dividends for the rest of your life.

**You'll go places—faster
on the young man's team**

. . . in one of these exciting specialties

Aircraft Maintenance	Meteorology
Air Traffic Control	Photography
Atomic Weapons	Photomapping
Communications	Radar
Construction	Rocket Propulsion
Guided Missiles	Supply
	Transportation



**STUDENTS! Graduate
before you enlist**

Personnel Procurement Division M-2-PM
AFPTR-P-4, U. S. Air Force,
Washington 25, D. C.

Please send me more information on my opportunity as an Airman in the U. S. Air Force

Name.....Age.....

Address

City.....Zone.....State.....



Portrait of you with your family—and nobody at the camera! It's simply and easily done by tripping camera shutter with a Kodak Ektalux Remote Release and solenoid. An Ektalux Extension Unit (on left) provides dramatic side-lighting.

This FLASH makes pictures with a difference

You can make new, exciting flash pictures when you use equipment with versatility designed into it! Read all about it—

The Kodak Ektalux Flash system makes possible a whole new range of lighting effects. It will give you ideas for pictures which never occurred to you before. These two pages show examples. Your photo dealer most likely can demonstrate others.

Kodak Ektalux is the most dependable kind of flash system, too. It uses the B-C (battery-condenser) circuit. The condenser acts as a storage reservoir. It builds up an electrical charge, fires the flashbulb with a full surge every time. You never "miss" a picture because of a weak battery firing the flashbulb late. And you can use six or more extension units for lighting big areas.

Your photo dealer will be glad to demonstrate the Ektalux Flashholder on your camera. Then you can see for yourself how many things it can do!



Kodak Ektalux Flashholder—B-C powered, fires 6 or more extension units, each unit having 20-foot cable. Features pistol-grip handle; removable, easy-to-pack reflector; quick load-eject sockets for midget and medium-base bulbs; durable, lightweight. Now only \$19.75*. Extension Units, each \$9.75. Addition of solenoid trips shutter from Flashholder; Remote Release with solenoid permits exposure control up to 20 feet from camera; Synchro-Switch permits external synchronization if needed.

LOOK WHAT YOU CAN DO WITH THE KODAK EKTALUX FLASH SYSTEM

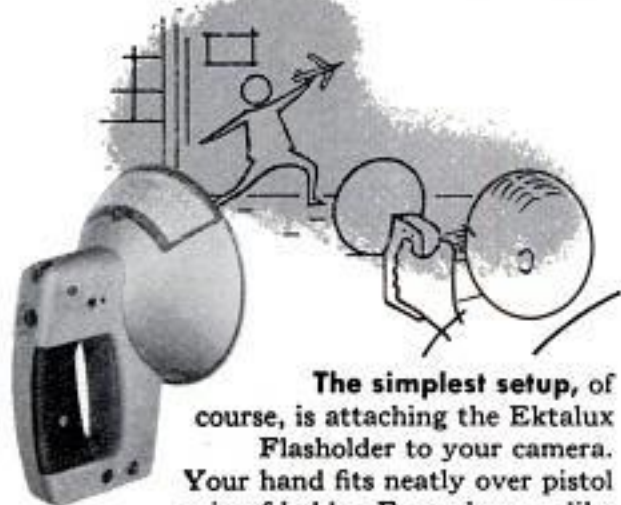

The simplest setup, of course, is attaching the Ektalux Flashholder to your camera. Your hand fits neatly over pistol grip of holder. For a close-up like this, you can use any midget flashbulb (also has socket for medium screw-base bulbs).

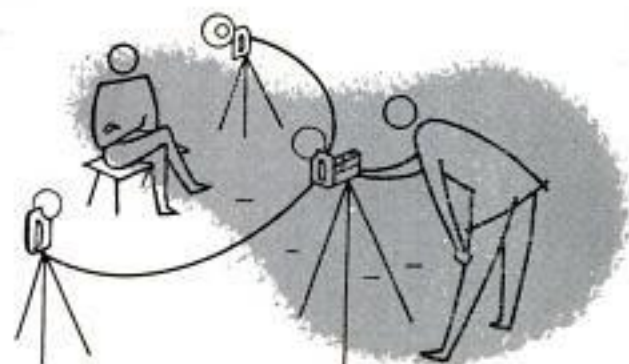

For a pleasing portrait, you can attach two Ektalux Extension Units to your Ektalux Flashholder—and fire *all* simultaneously from the camera, exactly timed for perfect results. The Extension Units use the dependable B-C power of the Flashholder. 20-ft. cords allow freedom in placing units.



Cute pictures of babies are easy when you divert their attention *from* the camera. Simply hold Ektalux Flashholder away from camera, trip shutter solenoid from Flashholder. You'll catch a more natural pose.



Here's a hobby shot you'll find most useful. Set up the Ektalux Flashholder away from the camera for side-lighting. 20-ft. cord gives great freedom of movement. Fire bulb from camera as you trip shutter.

Other Kodak Flash Equipment for Round-the-Clock Pictures



Kodak B-C Flashholder—Offers dependable B-C power at low cost—only \$9.95*. Highly efficient Lumaclad reflector, exposure guide, Flashguard.



Kodak Extension Unit, Model 1—Makes multiple-flash shots easy. 20-ft. cord, support clamp, Lumaclad reflector, Flashguard \$11.00 each



Kodalite Midget Flashholder—Uses new low-cost M2 bulbs. For Brownie Hawkeye, Bull's-Eye and Holiday Flash Cameras. Lumaclad reflector. \$3.20*



Kodak Standard Flashholder—Same size and design as B-C Flashholder but without B-C feature. \$7.95*



Kodak B-C Flashpack—Converts two-cell flashholders to B-C power. Uses 22½-volt photoflash battery. \$2.95* *Batteries extra

Prices subject to change without notice

Eastman Kodak Company Rochester 4, N. Y.

Kodak
TRADE-MARK

Care and Feeding of Engines

BY
S. P. CORP



FACTS ABOUT ANTI-FREEZE

Before adding anti-freeze, your cooling system should be flushed with clear water and allowed to drain. After adding anti-freeze, run engine till solution is thoroughly mixed, leaving radiator cap off so air can escape. Then stop engine and check level of solution in radiator, being sure hydrometer is clean and bulb is free to move. Fill and empty hydrometer several times to get a correct reading, as all hydrometer tests are calibrated for the temperature of the solution.

ANTI-FREEZE SOLUTIONS PROTECTING TO -20°F



Never mix glycol-type anti-freeze with alcohol-type, as freezing points vary widely and accurate testing would be impossible. Do not mix different brands of alcohol-type anti-freeze, as rust-inhibitors may cause a chemical reaction that would reduce anti-rust effect. Do not use anti-freeze from one year to the next unless you add new rust-inhibitor. Rust-inhibitor will lose its effectiveness after one year.

Always tighten hose clamps or replace hose when adding anti-freeze. Anti-freeze will seep through places where water will not pass. Be careful with stop-leak compounds; don't use them to stop a hose-leak.

WHEN ENGINE CUTS OUT

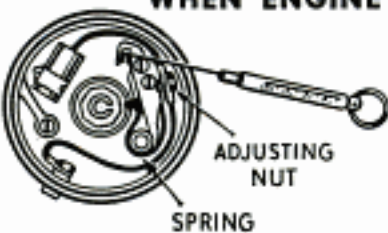

If your engine cuts out at speeds over 50 mph, here are two of several possible causes: **SPARK PLUGS** may be of too hot a type, missing fire under extreme heat, and should be replaced. Or

SPRING TENSION in distributor may need adjusting. This tension should be 17 to 20 ounces. Measure with an ounce scale as shown, then loosen adjusting screw and move spring in or out till correct tension is reached.

ASK FOR NEW FREE BOOKLET

Sealed Power has just published a brand new manual, "Care and Feeding of Engines," made up from these helpful columns which have appeared in leading magazines. Handy cross-index makes it easy to find the answer to almost any engine problem. A postal card to Sealed Power, Dept. G-1, Muskegon, Michigan, will bring your free copy promptly. When you re-ring, get the best—Sealed Power KromeX Ring Sets.

Sealed Power

PISTON RINGS

Clinic for Homemakers



As a service to our readers in solving the hundreds of problems pertaining to a home—inside or out—the editors of *Popular Mechanics* invite you to present your problems to The Clinic Editor for help and advice. Address your questions to The Clinic Editor, *Popular Mechanics Magazine*, 200 East Ontario Street, Chicago 11, Ill.



Ice Dams

Q—Last winter ice formed near the eaves along the north side of the roof on my ranch-type home. Several leaks developed just above the cornice. Water has damaged the plaster. After ice melted in the spring the shingles appeared to be in good condition. The roof did not leak during the spring, summer or fall. What was the cause?

—N.R., Conn.

A—Snow on the lower edge of the roof melts during warmer weather and then freezes during a cold snap, forming a dam which retains much of the water running down from a higher level as the snow melts during a warm day. The water held above the ice dam thus formed seeps under the tabs of the shingles and leaks into the attic, usually at a point just above the plate. You did not say, but apparently the shingles were laid directly on the roof boards without an underroofing of smooth roll roofing or asphalt-coated paper made for this purpose. Many homeowners experiencing this trouble have installed lead-coated electric heating cable, looping the cable across the width of the roof in vertical loops extending from 15 to 30 in. above the eaves. The cable must be properly connected to the power line and a switch provided for turning the current off and on. Such units are said to be quite effective when correctly installed.

Snow Mold



Q—When my lawn started last spring I noticed that in several small patches there was no new growth, the plants apparently having been killed. However, the grass near these spots seemed entirely unaffected. I raked the soil in the bare spots and reseeded, using the best seed and a fertilizer of recommended proportions. The new seeding caught immediately and made a good growth. What was the cause?

—O.H., Neb.

A—Did you spill oil, dry-cleaning fluid or any other root-destroying chemical on the areas affected? If not, then the description would indicate that the bare spots in the lawn resulted from what is known as snow mold. The fact that the new

(Continued to page 228)

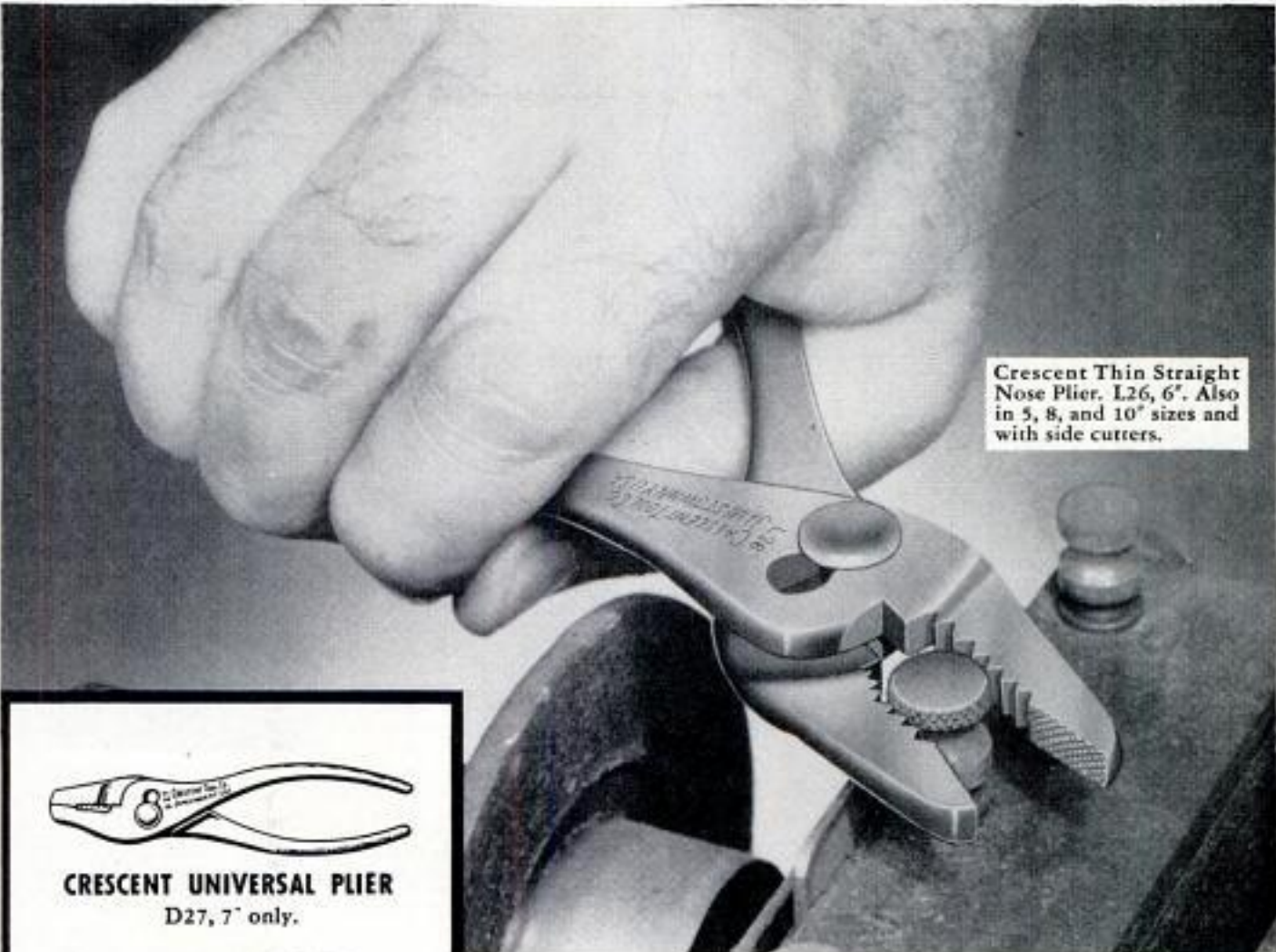

Crescent Thin Straight
Nose Plier. L26, 6". Also
in 5, 8, and 10" sizes and
with side cutters.



CRESCENT UNIVERSAL PLIER
D27, 7" only.



MoToR Kit COMBINATION PLIER
G25, 5". Also in 6, 8, and 10" sizes.



CEETEECO COMBINATION PLIER
H25, 5". Also in 6, 8, and 10" sizes.



CRESCENT THIN BENT NOSE PLIER
J26, 6" only.

CRESCENT SLIP JOINT PLIERS

Crescent offers a wide selection of styles and sizes in this widely used plier type. All are drop-forged from special analysis steel and finished in bright plate. They have sharply milled teeth, comfortable handles and smooth working joints. The joint bolt and nut are turned from solid bar steel and case hardened. Sold by Industrial Distributors and Hardware Dealers everywhere.

CRESCENT TOOLS

Give Wings to Work

*Sign of the Artisan
Symbol of Excellence*



Crescent is our trade-mark, registered in the United States and abroad, for wrenches and other tools. Sold by leading distributors and retailers everywhere and made only by
CRESCENT TOOL COMPANY, JAMESTOWN, NEW YORK

YOU NEED THIS POWERFUL NEW JIG-SAW.

for
DO-IT-YOURSELF JOBS
Valances, Lawn Furniture,
Intricate Designs, Toys



**SAFE
FOR ALL
AGES**

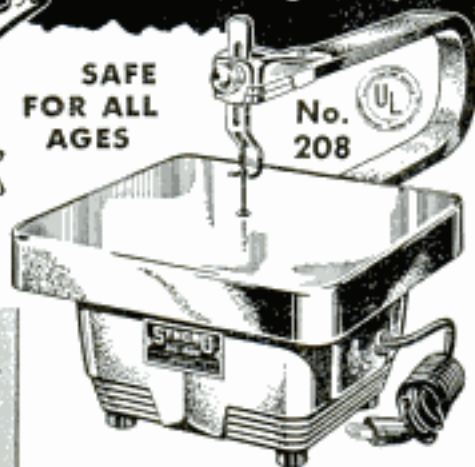

No. 208



HOME REPAIRS



VALANCES



LAWN FURNITURE



**TOYS
INTRICATE DESIGNS**

Yes ...it cuts 2x4's

New Syncro No. 208 is the only self-powered jig saw to offer you ALL these important features:

1. Cuts 1 3/4" wood
2. Cuts to center of 30" circle.
3. 100 square inches of working surface.
4. Adjustable arm permits cutting any length.
5. Safe for every member of the family.
6. Motor guaranteed against burn-out during ownership.
7. Cuts smooth edge—no splintering—no sanding needed.
8. Cuts with same blade: wood, plastic, metal (ALUMINUM, etc.), linoleum, leather, etc. Send coupon for FREE Catalog. Remember:

More Syncro-Made Jig Saws Have
Been Sold Than Any Other
Self-Powered Make!

**NEW 208 CUTS MORE
MATERIALS FASTER
THAN ANY OTHER
Self-Powered JIG SAW!**

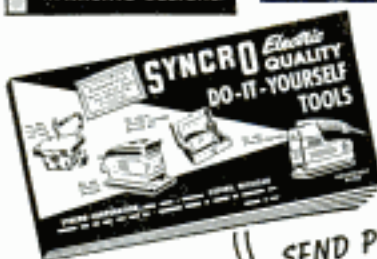

SYNCR0
QUALITY TOOLS

**SEND POSTAL NOW
FOR LOW PRICE AND
FREE CATALOG!**

SYNCR0 CORPORATION
Dept. 1-15
Oxford, Michigan, U.S.A.

Send Free Syncro Catalog of Jig Saws, Sanders and Free 8-page "Sanding Handbook".

Name _____

St. & No. _____

City _____ State _____

(Continued from page 226)

seeding germinated and grew readily would tend to bear out this conclusion. What is called snow mold on lawns generally results when the area is covered for long periods with drifted snow or ice to a considerable depth. As a preventive it might be practical to level small snowdrifts and it is said that recurrence can be prevented to some extent by treating the soil with mercuric chloride at the rate of about 3 oz. per 1000 sq. ft. However, in your own experience this would appear to be unnecessary. Piles of leaves, grass clippings and newspapers also can damage grass in the manner you describe if covered with snow during the winter. However, the damage is seldom as extensive and complete as that caused by the so-called snow mold.

Winter House Plants

Q—What varieties of house plants can I grow in a large old-fashioned bay window located on the north side of the house? If possible I would like to grow plants in the bay the year around. During the summer months plants would get some direct sunlight during the morning and evening hours, but how about the winter months? Storm sash are used all during the winter, but the bay is directly exposed.—R. H., Mo.



A—Nearly all potted plants should do reasonably well during the summer months, but only certain ones can be expected to thrive during winter in a north window. Ordinarily the common ferns, ivies and variegated-foilage plants do best, especially during the cold months. There are others, of course, but these seem to be the most consistently successful. Start them in large pots that provide plenty of space for rich soil. Place gravel and a small amount of sand in the bottom of each pot to provide aeration and ample drainage. Water on a regular schedule. Most careful indoor gardeners place the pot in a shallow container which can be filled with water at regular intervals. Liquid plant food should be supplied frequently. When nights are severely cold, tender plants should be moved away from the window or may be protected by covering the lower half of the sash with heavy corrugated cardboard held in place with cellulose tape. On more moderate days when the sunshine is bright, move the plants close to the window. In some cases indoor gardeners build a removable flat of metal, or wood with a metal lining, in which the potted plants can be arranged attractively.

Noise Problem

Q—We moved into our new home three years ago. It is of frame construction, 1 1/2-story with brick veneer across the front and on one side, full basement and hardwood floors. Walls are plasterboard, dry-wall construction throughout. Ever since we moved in we have been puzzled by unusual snapping, or creaking, sounds which seem to originate in the attic space, but also are sometimes heard in the walls in different locations and at different times, but more particularly at night. This has become so objectionable that we are thinking seriously of selling, but have hesitated to do so because we like the location. What is the cause of the objectionable noise?—C. M., Wash.

A—We wouldn't sell for the reason given. There are several possible causes of the phenomenon you describe, but the most likely one is a slow shrinkage of the framing materials. This can take place over a considerable period of time, especially in a humid climate where dry-out of the housed frame members of the structure is impeded by the comparatively high moisture content of the air. As the materials dry they contract slightly along the length. Wherever framing parts are joined, any contraction of the members causes meeting surfaces to slip past one another, resulting in the squeaks, or creaking sounds. The movements are so very slight that as a rule no damage results and in time the wood will stabilize at some point.

See How Little It Costs
to Build a Ready-Cut

Liberty Home

Ranch - type home,
64 feet wide, with
three bedrooms



\$3128

Freight-Paid
Prices
As Low
As
\$2608



Save 30% to 40%

You can save several thousand dollars when you build a Liberty Home! Buy direct from our mill at our low, factory, freight-paid price. We ship you the lumber cut-to-fit, ready to erect. Doors, windows, roofing, paint, glass, hardware, nails, etc., all included in the price. Plans furnished—also complete building instructions. No wonder our customers write us that we saved them 30% to 40%. Easy terms—monthly payments. Architecturally approved construction. (Not prefabricated.)

What "Liberty" Owners Say

Ahead \$2,000 to \$3,000

"We have moved into our 'Liberty' home and are more pleased with it every day. I think I would be safe in saying we are ahead \$2,000 to \$3,000 by buying your Liberty Home and doing the work ourselves."

Saved \$4,000 to \$6,000

"Compared to a local contractor's price to build a home equal to my 'Liberty,' I will be saving \$4,000 to \$6,000; so you can see why I have such enthusiasm for Liberty Homes."

Visit a Liberty Home!

Many thousands of Liberty Homes have been built in all parts of the country. If you would like to visit and inspect the model that suits you best, write us and we will give you its location.

Handsome Big CATALOGUE

Pictures wonderful homes in colors at money-saving prices. Write for FREE catalogue today. (WEST OF MISSISSIPPI, 35c)

BIG BOOK
of
House Plans
in Colors
FREE

LEWIS MANUFACTURING CO.

1251 Lafayette

Bay City, Mich.

FIND \$\$\$\$

NEW U-238 geiger counter—world's smallest, most sensitive uranium locator. Ideal for prospecting even on hunting, fishing trips! (Full line of mineral and metal locators, too.)



FREE
booklets on
request. (Dealer
inquiries welcome.)

GOLDAK COMPANY 1542 W. Glenoaks Blvd., Glendale, Calif.

SET-UP - KNOCKDOWN SAWHORSE with Jiffy BRACKETS



No nails or bolts... use 2x4's for legs. 2x4 or wider for crossbar. Rugged, sturdy, easy to move, saves storage space. Sold by hardware and building material dealers, or order direct.

GRAND HAVEN STAMPED PRODUCTS CO., Grand Haven, Mich.

TIME TO TURN



BUT
WHICH
WAY?



• Driving by route number may be all right, until you reach the inevitable double-arrow intersection. This and many other common situations make the HULL AUTO COMPASS your ONE UNFAILING means of eliminating guesswork and confusion—on the open road or strange city streets. There are more HULLS in use than all others combined—your inspection will tell you why.

Beaconlite \$6.95
ILLUMINATED
STREAMLINE \$4.95
NON-ILLUMINATED

WRITE FOR LOCAL DEALER'S NAME • FREE LITERATURE

HULL MFG. CO. P. O. Box 246, D-1 WARREN, OHIO

Get this New 1955 Catalog
- Saves You ^{up} to 50% _{to}
on AUTO PARTS
and ACCESSORIES



156
PAGES
50,000
ITEMS

All New Edition
Just off the PRESS—
RUSH
Coupon!

JUST A FEW OF THE 50,000 ITEMS LISTED IN THIS BIG NEW CATALOG

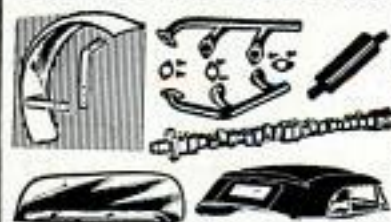

- Auto radios
- Hi-Speed Equipment
- Mufflers, pipes
- Engines, parts
- Transmissions
- Custom Style Acces.
- Tires, Tubes
- Tools
- Springs, Shocks
- Ignition Parts

World's Largest Selection... Everything for Your Car, Truck, Custom-styled Car, Hot Rod

It's ready now . . . the only *complete buying guide* to everything you need for your car, truck, custom-styled car, or hot rod . . . at *rock-bottom prices!* Thousands of hard-to-find parts . . . equipment and replacement parts for cars from 1920 to brand new 1955 models! New *Hollywood accessories* not offered in stores; *high-speed parts* to soup up your engine; *custom-styling equipment* to give your car that "expensive" look. Speedy shipment, guaranteed satisfaction, and *money-saving prices!* Mail coupon now!

FREE . . . valuable Safety Chart showing how you can know if your car is safe—sent free if you mail coupon for catalog TODAY with 25¢ to help pay postage and handling. We credit the 25¢ on your first \$5-or-more order, so Catalog will then be **FREE TO YOU.** Fill in and mail Coupon NOW!

J. C. WHITNEY & CO., 1917 P1 Archer Ave., Chicago 16, Illinois

MAIL THIS COUPON TODAY!

J. C. WHITNEY & CO.
 1917 P1 Archer Avenue, Chicago 16, Illinois

Rush giant 1955 catalog of auto parts and accessories at sale prices. I enclose 25¢ to cover part of cost, which will be credited to me on my first \$5.00-or-more order.

Name.....

Address.....

City..... State.....

They Photograph Engine Wear

(Continued from page 117)

"14," "175," and "12.3." These numbers represented the amount of silicon found by the emission spectrograph in successive samples of lubricating oil taken from one engine during a three-week period.

"The second sample, registering 175, was taken right after the unit finished a run through the Texas Panhandle during the height of the dust storms there early this year," Rudd explained. "So much dirt was in the air that the engine filter couldn't handle it. Notice also that the copper and lead counts went up, too. That represents the damage to engine parts caused by the dirt. You can see from this report what kind of a job the emission spectrograph is doing for us."

Rudd then showed me an empty milk bottle. "This is where the analysis begins," he explained. The bottle was made of cardboard, in the shape of a cone. After a lubricating-oil sample comes in, 30 grams are poured into one of these cardboard bottles.

Rudd walked over to a laboratory bench with a small box on it. This was an electric hot plate.

He opened a drawer and brought out a black pellet about the size of an aspirin tablet. He put this on the hot plate and turned on the juice, first setting the dial at 700 degrees Fahrenheit. While the pellet was "cooking," he used a fountain straw to remove 10 drops of oil from the milk bottle containing the sample. He let this oil fall on the pellet, one drop at a time. As each drop hit, it burned. The residue, consisting of a tarry coating on the top of the pellet, contained the contaminants that were in the oil.

After Rudd had prepared the pellet, we walked into a small room near by. Inside, and taking up most of the space, was the emission spectrograph and a related piece of equipment known as a "densitometer." The important parts of the emission spectrograph include: A spark gap, like those on the spark plugs in your car; a prism; a camera and enough controls to keep my two-year-old son happy for a century.

The pellet was placed on a small platform, only a little larger than the pellet itself. This platform is actually one of the two electrodes that form the spark gap. A small motor turns the pellet, much like a midget phonograph record. Meanwhile, high-frequency electric current arcs across the spark gap. Color of the spark is determined by impurities coating the pellet.

You may remember, if you took high-school chemistry, that every chemical

(Continued to page 232)



CULTIVATE



MOW WEEDS



MOW LAWNS, WEEDS, MULCH LEAVES



BLOW SNOW



GRAVELLY

**More
for your
Money!**

5-HP GRAVELLY Makes Tough Jobs EASY!

Gravelly does jobs other tractors won't . . . because Gravelly has *extra* power for tough mowing, gardening, field, farm jobs.

And you get *more* when you get Gravelly: All-gear drive, power reverse, simple, easy operation, power attachments *securely* mounted, quickly interchanged by only four bolts!

PLUS . . . 21 JOB-RIGHT TOOLS!

Your choice of 21 tools . . . used with one versatile tractor that saves you time, work and worry *all year long*.

"Power vs. Drudgery" booklet shows how Gravelly solves your upkeep and gardening problems.

FREE



HAUL

WRITE TODAY

GRAVELLY TRACTORS, INC.
BOX 163 DUNBAR, W. VA.

'55 FORD

... the fine car
of its field!

NEW, IMPROVED CALCULATOR FOR WOODWORKERS only 25c

Instantly gives information on lumber, nails, concrete mixes, painting materials, etc. Convenient, simple to read. Just set dial for nail specifications, to convert linear to board feet, find bit sizes for screws, compare characteristics of woods. 6" diameter heavily varnished cardboard. Send 25c, no stamps, please to Greenlee Tool Co., 2101 Columbia Avenue, Rockford, Illinois.



Protect your home against
power interruptions
with an...

ONAN Emergency ELECTRIC PLANT

Provides dependable stand-by electricity for heating system, pumps, freezer, lights, appliances. Keeps home safe, livable. Automatic start and stop. Find out how little it costs!

Write for Folder!

D. W. ONAN & SONS, INC.
8585 University Ave. S. E. • Minneapolis 14, Minnesota

A SIZE FOR EVERY NEED

1,000 to 50,000 watts.
Compact, quiet-running,
easy to install. Gasoline
engine powered.



DO-IT-YOURSELF!



Modernize with prefinished MARLITE PLANK & BLOCK

A hammer, saw, and level are all you need for beautiful walls, quickly installed. Planks (16" x 8") and Blocks (16" square) with exclusive tongue and groove joint are easily applied over old or new walls. Soilproof baked finish fused to a tempered hardboard never needs painting, cleans with a damp cloth. Ten "Companion Colors," plus 4 distinctive wood patterns, practical for every home interior.

Write for free folder and do-it-yourself instructions, or see your lumber dealer. Marsh Wall Products, Inc., Dept. 142, Dover, Ohio. Subsidiary of Masonite Corp.

Marlite Plank and Block
Patent Applied For

Marlite

PREFINISHED
WALL and CEILING PANELING

Made with genuine Masonite® Tempered Duolux®

JANUARY 1955

231

Copyrighted material

free

GET THE WORLD'S LEADING TV & RADIO CATALOG

ALLIED'S 1955 ELECTRONIC BUYING GUIDE



**308
VALUE-
PACKED
PAGES**

Save on
Everything
in
Electronics

**World's Largest Stocks... for Builders,
Experimenters, Amateurs, Servicemen,
Engineers and Hi-Fi Specialists**

Get ALLIED's big 308-page Catalog featuring the world's largest selections of latest top-quality electronic equipment at lowest, money-saving prices. See the newest in custom TV chassis, antennas and accessories; FM and AM Tuners; High Fidelity systems and components; recorders and phonograph equipment; Amateur receivers and supplies; builders' kits; test instruments; industrial electronic supplies—plus thousands of parts, tubes, tools and books. Get *everything*, get *more* for your money—send today for your FREE 1955 ALLIED Catalog!



Send
for
FREE
Catalog

ultra-modern facilities to Serve You Best

ALLIED RADIO

ALLIED RADIO CORP., Dept. 5-AA-5
100 N. Western Ave., Chicago 80, Ill.

Rush FREE 1955 ALLIED 308-Page Catalog

Name _____

Address _____

City _____ Zone _____ State _____

element gives off a light of a certain color when it burns. Thus, if you can separate the colors in the spark, you can identify the elements coating the pellet.

That is what the prism is for. It separates the light from the spark into its component colors. These colors are then "painted" on a photographic plate.

The actual colors don't show up in the picture; rather, each color is designated in terms of its wavelength. What you get in the photo is a line about 1/4-inch thick and just about six or seven inches long. There are dark and light places along this line which correspond, respectively, to large and small quantities of a particular color in the spark. Since the colors designate particular contaminants, these dark and light points along the line represent large and small concentrations of contaminants in the lubricating oil. In other words, as the concentration of each contaminant varies, so does the shading along the line in the emission-spectrograph photo.

To find out the exact concentration, you need some means of measuring this shading. The densitometer handles this job. It rates the darkness or density of any point along the line in terms of a number. A dark point might receive a rating of 2, and a lighter portion a rating of 20. The scale ranges from 0 (black) to 100 (white).

The final step in the process is to convert the densitometer reading, with the aid of a standard formula, into figures which represent the concentration of each contaminant per million parts of oil. This is done on a glorified slide rule which was developed by Rock Island chemists.

Although the Rock Island paid \$25,000 for its emission spectrograph, "the money was well-spent even if we have saved only one crankshaft," explained J. E. Tiedt, supervisor of operations at the Chicago lab. Fortunately, crankshaft failures are almost as rare today as a snowstorm on the Sahara. But, as Tiedt pointed out, when a crankshaft does burn out, the cost of replacing it, including labor and engine down time, is well above \$25,000.

Actually, of course, the emission spectrograph is saving more than engine crankshafts. For it is able to spot troubles that can affect every part in the engine.

The new method is much speedier and far more thorough than the technique it replaced. Railroad chemists formerly checked engine wear by burning a few drops of an oil sample and then mixing the ash with various acids to find the contaminants. It took three men about a week to process 30 engine samples. With the emission spectrograph, three men can process over 50 samples a day.

 **NO MORE
BLOWN OUT FUSES!**

Here's Mini-Breaker®... the lifetime replacement for old-fashioned fuses



- Fits like a fuse in any standard fuse socket.
- Just press the shockproof Mini-Breaker button to restore service.
- Built-in timelag handles starting loads of major appliances.
- Protects against all overloads and short circuits.
- Lifetime protection against electrical fire hazards.

In 10, 15, 20, 30 amps. AC only, 125 volts max. Listed by Underwriters' Laboratories, Inc.

MINI-BREAKER®

Ask for it at your favorite store or write Mechanical Products, Inc., Jackson, Michigan

DRILL and TAP with EASE



New miracle sulphur-suspended threading compound for drilling, tapping, threading, boring, broaching. Apply direct from tube before starting job—no further lubrication needed. Rushes quickly to the "hot" area—and stays there! Save money too—1½ oz. tube approx. 1 pint of threading oil!

At your favorite hardware store or order direct: 50¢ per tube, postpaid, inc. handling & postage.

PAKET INC., Dept. PM1, 8039 S. Exchange, Chicago, Ill.



BUILD FINE GRANDFATHER CLOCK NOW

The simple sensible Red-i-Kal way as thousands have — SAVE HALF SHOP TESTED PLANS "SPIRIT OF THE CENTURY" Narrow waist 83" tall or stately straight side "SPIRIT OF AMERICA." EASY-TO-FOLLOW pictorial PLANS tell all—plus BROCHURE of heavy brass weight Westminster, tube chime, movements, porcelain dials, 3½" solid mahogany case kits. Send \$1.00 today — Both plans \$1.50 NOW.

KUEMPEL CHINE CLOCK CO., #7 Kuempel Bldg., Minneapolis 16, Minn.

NEW SHOP SMITH has capacity-PLUS!

• Beats any power tool at any price. Powerful ¾-hp. motor. Big all-purpose 9" circular saw. Lathe 16½" swing. 12" sanding disc with 14" x 18½" table. Drill press to center of 16½" circle. Horizontal drilling unlimited. Price complete, \$269.50. Write for catalog. MAGNA ENGINEERING CORP., Dept. 279-B, 12819 Coit Rd., Cleveland 8, Ohio, or Menlo Park, Calif.

MAGNETS 225 lb. PULL
GENUINE ALNICO—NEVER WEAKENS

AMAZING, PERMANENT MAGNETS—WILL NOT WEAKEN! NON-ELECTRIC Retrieve guns, tackle, tools and other steel items from lake, river, plating tanks, drains or other hard-to-reach spots. Recover drills, taps, etc. from sweeping. Clear alley of harmful tacks, nails. Many other uses. Pays for itself quickly. GUARANTEED. Try any magnet one week. Money refunded if you are not well pleased.

No. M-725 (Weights 54 oz.) Has pull of 225 lbs. on steel block. \$15.00
 No. M-625 (Weights 70 oz.) Has pull of 125 lbs. on steel block. \$ 8.50
 No. M-575 (Weights 18 oz.) Has pull of 75 lbs. on steel block. \$ 6.00
 No. M-500 (Weights 15 oz.) Has pull of 50 lbs. on steel block. \$ 4.00
 No. M-30 Hobbyist assortment of six small magnets. \$ 1.50

Send Money Order or Check. We pay postage. No C.O.D.'s.
 MIAMI MAGNET COMPANY, 3240 N. W. 27th Ave., Miami 42, Fla.

Floor Surfacing Contractors NEEDED!



- ★ BIG PAY
- ★ FULL or PART TIME
- ★ AGE No Barrier
- ★ Minimum Investment

Highly Respected Profession Offers You Unusual Opportunity to BE YOUR OWN BOSS

Thousands of men of all ages have found financial security and happiness in a phase of the building and remodeling industry that has become as necessary as the hammer and nails. The pay scale is high for those who are willing to work; many earn \$50 a day and more. No great physical stamina required—men from 18 to 80, even with physical handicaps, enjoy this pleasant year 'round indoor work where earnings are limited only by the amount of time you devote to it. The American Floor Surfacing Machine Co., a 50-year-old pioneer firm and leader in the industry, shows you how to quickly make good in this stable business. No schooling, no special talent or skills required. Only small investment in sander gets you started. Send coupon for "money-making booklet" entitled "Opportunities in Floor Surfacing"—enclose 25c in coin or stamps to cover handling.



AMERICAN FLOOR MACHINES

SEND ↓

The American Floor Surfacing Machine Co.
 535 So. St. Clair St.
 Toledo 3, Ohio

Here is 25c in stamps or coin for booklet "Opportunities in Floor Surfacing", telling me how I can start my own floor sanding business.

Name.....

Street.....

City..... State.....

Get This NEW 1955
Craftsman Catalog of
WOOD
AND WOODWORKING
TOOLS AND EQUIPMENT

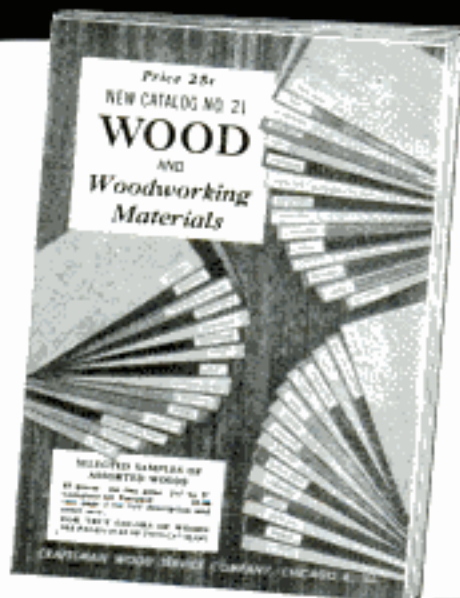

Everything
 for the
 Woodworker
 and His
 Shop!

**World's Largest Selection of
 Finest Domestic and Imported
 Woods . . . Mouldings, Hard-
 ware, Tools . . . ALL AT LOW
 MONEY SAVING PRICES! . . .**

Your complete wood buying guide and project book. Craftsman is your best, most complete source of finest kiln-dried domestic and rare imported woods, beautiful wood inlays, colorful bandings, matched plywoods, embossed mouldings, carved ornaments, newest woodworking tools, "hard to find" cabinet hardware and fittings . . . more than 1,500 items! Packed with newest scroll saw patterns, project ideas and money making plans. Enclose 25c (refunded with first order) to help pay mailing and handling cost. **WRITE TODAY!**

Craftsman Wood Service Co., Dept. A-51
 2729 S. Mary Street • Chicago 8, Ill.

CRAFTSMAN WOOD SERVICE CO., Dept. A-51
 2729 S. Mary St., Chicago 8, Ill.

Enclosed find 25c. Rush me new **WOODWORKERS' CATALOG HANDBOOK.**

NAME _____
 ADDRESS _____
 CITY _____ ZONE _____ STATE _____

**148
 PAGES**
 Many in
 Full Color
 packed with
 rare, fancy &
 imported
 woods . . .
 veneers, ply-
 woods, pat-
 terns, tools,
 ornaments,
 hardware . . .
 everything
 for the wood-
 worker.

**MAIL
 COUPON
 NOW!**

Let's Import Rain for the Dust Bowl

(Continued from page 123)

electricity in one direction and an almost perfect insulator when the current is reversed. The flow of electrons is always toward the surface at which freezing began, and the ice must "grow" in one direction so that all its crystals adhere together evenly. The discovery that ice can behave something like a vacuum tube or transistor eventually may contribute toward a more scientific understanding of electricity and its conductors.

Their studies of thunderstorm electrification have led the Socorro scientists to suggest an intriguing possibility: Why not convert thunderstorms into mild rainstorms that would deliver plenty of rain and yet produce no lightning? Drawing the fangs of thunderstorms could reduce huge timber losses caused by lightning fires, as well as prevent disastrous lightning strikes in inhabited areas.

The scientists learned in the laboratory that the electrical effects caused by freezing become neutralized in the presence of ammonia; now they propose to infuse ammonia into a thunderstorm from ground generators or from aircraft. If the idea works, the storm will produce a soaking rain without any lightning.

Cloud physicists think that every drop of rain begins with a nucleus of some sort on which cloud moisture gathers, eventually building up to a raindrop. About a million particles of cloud moisture must be collected to make up a drop of rain. The ice crystals that serve as nuclei in thunderstorms don't exist in relatively warm clouds at low altitudes, and one of the present problems is to learn what kind of nuclei, if any, induces precipitation from such clouds.

Dust particles and pollen are pretty well distributed in the atmosphere, but these don't attract or absorb moisture and so don't appear to be good condensation nuclei. Salt particles drawn up into the air during ocean storms could be ideal nuclei, and physicists from Socorro have flown over many parts of the country seeking these particles. So-called "chloride clouds" have been found in the atmosphere along the Pacific and as far inland as Utah, but east of the Rockies the particles are relatively scarce. So far, the scientists haven't been able to pin-point definitely any kind of particle as the one that brings on rain from warm clouds.

In the hope of finding out, and also to learn more about thunderstorms, the New Mexico institute is completing a six-floor tower on top of its Socorro Thunderstorm

(Continued to page 236)

SHOP by MAIL and SAVE at GROBAN'S

SURPLUS SALE

ALL ITEMS Brand New!

GROBAN FOUR-WAY OPEN CENTER HYDRAULIC CONTROL VALVE

ITEM #126—Four-way open center control valve, with built-in adjustable relief valve factory set at 1000 P.S.I. Spring loaded neutral position. For use with one double acting cylinder. In neutral position cylinder is locked and pump unloaded. Can be used as single unit or mounted in series. Has 3/4" pipe thread inlet and outlet, 1/2" pipe thread cylinder ports. Finger grip handle. Ship. wt. 10 1/2 lbs.

AN OUTSTANDING BUY!
P.O.B. Chicago **21.50**

CENTRIFUGAL PUMP

Brand New **GENERAL MOTORS —ALLISON**
200 GALLONS Per Minute

- For Draining Basements
- Fire Fighting
- Irrigation
- Fuel Transfer
- Swimming Pools
- Home Water Systems
- Dewatering

For high volume commercial, home and industrial use. Standard 2 1/2" pipe thread inlet, twin 1 1/4" pipe thread outlets. Ball bearing supported 3/4" shaft. Easy priming. Rotation, counter-clockwise facing shaft. Gov't. acq. cost \$145.00. Complete with full instructions. Ship. wt. 35 lbs. P.O.B. Chicago. **39.50**

Will deliver 200 gals. per min. against 45 ft. head using 3.2 H.P. at 3500 R.P.M.

BERRY — HEAVY DUTY HYDRAULIC PUMP or MOTOR

ITEM #166—Use on road machinery, vibrators, paper mills, wire reels, hydraulic presses, speed control units. Ball bearing construction, balanced cam design assures high efficiency performance. When used as a pump: delivers 8 G.P.M., 1000 P.S.I., 8 H.P. At 1200 R.P.M. as a HYDRAULIC MOTOR: Rated up to 12 H.P. up to 2400 R.P.M. Standard 3/4" pipe thread ports, 3/4" shaft with keyway. Dimensions: 14 1/2" x 8" x 7". Weight 43 lbs. Regularly \$212.00. **OUR SPECIAL PRICE**—ea. **59.50** P.O.B. Chicago 2 for 110.00

A. C. ELECTRIC GENERATOR

7 1/2 K.W. (7500 WATTS) single phase, 110/220 volt output. 3 wire system. 2 bearing construction. 5 groove 6" V belt pulley included. Self-excited. Foot mounted. Drive generator from tractor or stand by engine. Ample power for 6 room house. Dimensions: 34" x 11 1/2". Shipping Wt. 420 lbs. P.O.B. Chicago. **295.00**



GROBAN HYDRAULIC SPEED REDUCER

with FINGERTIP CONTROL

USE FOR: Reamer Drives • Midget Cars • Feed Mills • Canning Machines • Conveyors • Lathes • Milling Machines • Motor Boats • Cream Separators • Garden Tractors • Pumps.

Variable output speeds from 0 to input speed available by moving control handle. Locking handle maintains setting. Use input power of 1/4 to 1 1/2 H.P. Shafts 5/8" diam. Input rotation counter-clockwise facing shaft. Input speed 750 R.P.M. 7 1/2" x 7 1/2" x 11 1/2". Gov't acquisition cost \$428.00. Ship. wt. 31 lbs. Complete with 2 qts. of oil and full instructions. P.O.B. Chicago. **54.50**

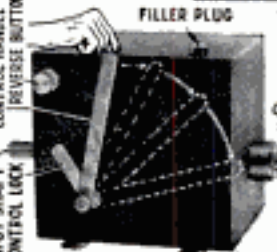

Brand New! 5-TON BLACKHAWK HYDRAULIC LIFT KIT

The Complete Kit **NOW ONLY 44.45 complete**

For — Dumping farm wagons • Adjusting depth of plows • Hydraulic press • Hydraulic Jack • Snow plows.

KIT CONSISTS OF:

- 1—Brand new Blackhawk Model P-151—Hydraulic hand pump with built-in oil tank and release valve. Rated from 1200 P.S.I.—to 8400 P.S.I. 26" handle. Dim. 8" x 6" x 6" **Item #82**..... **22.50**
- 1—6 Ft. length double wire braided rubber covered hydraulic hose—tested to 20,000 lbs. **Item #2784**..... **3.95**
- 1—Hydraulic cylinder, 2 1/2" bore, 7 1/2" stroke, 1 1/2" stainless steel shaft, with lift 10,000 lbs. using pump pressure. Standard clevis mounting. May also be used for double action service. **Item #355A**..... **17.00**
- 2—Qts. non-foaming hydraulic fluid..... **1.00**

All necessary hydraulic fittings. Total ship. wt.—40 lbs. **\$44.45**

COMPLETE KIT PRICE..... **\$44.45**
ALL OF ABOVE INCLUDED P.O.B. Chicago



HEAVY DUTY 12 VOLT D. C. GENERATORS

ITEM #99—For trucks, autos, marine equipment, construction machinery. 12 Volt—50 amps.—6 bolt mounting flange spline shaft—life time grease—sealed ball bearings. Mfgd. by Leeco-Neville. Acq. cost \$165.00. **NOW ONLY**... P.O.B. Chicago **16.50**



RUGGED! 25 TON MASSIVE!! CAPACITY

HYDRAULIC CYLINDER

- ALL STEEL CONSTRUCTION
- 8" BORE—15" STROKE
- DOUBLE ACTION

ITEM #1815

- 50,000 LBS. PRESSURE WITH 1000 P.S.I. PUMP OUTPUT.
- UP TO 70,000 LBS.—CAPACITY ON INTERMITTENT SERVICE.
- SOLID STEEL 2 1/2" PISTON ROD
- 1" PORTS
- OVERALL DIAMETER—10 1/2"
- DISTANCE BETWEEN CENTERS—28 1/4" CLOSED—43 1/4" OPEN.



IDEAL FOR:

- HYDRAULIC PRESSES
- DUMP TRUCK HOISTS
- TD-18, TD-24 INTERNATIONAL HARVESTER DOZERS AND GRADERS
- LEVELING RAMPS
- INDUSTRIAL MACHINERY
- ROAD MACHINERY
- FARM MACHINERY
- HYDRAULIC TAIL GATES

Replacement cost—\$300.00. Shipping Wt.—135 lbs. **SPECIAL PRICE**..... **95.00**
P.O.B. Chicago.....

ITEM #1715

- 7 1/4" BORE—15 1/2" STROKE
- 41,300 LBS. PRESSURE WITH 1000 P.S.I. PUMP OUTPUT

OTHER FEATURES SAME AS ABOVE
Replacement cost—\$260.00. Shipping wt.—155 lbs. **SPECIAL PRICE**..... **80.00**
P.O.B. Chicago.....

ROTARY VANE FUEL PUMP

ITEM #104A—A fine reversible utility unit for gasoline or fuel oil pumping, etc. Capacity, 400 gallons per hour. 3/4" pipe thread inlet and outlet. Has built-in, adjustable relief valve, set at 30 P.S.I. Adjustable to 100 P.S.I. Rotation in either direction; 1/2" standard shaft, ball-bearing supported. Dimensions: 5 1/2" x 3 1/2" x 10". Shipping weight 8 lbs. **A \$55.00 VALUE**..... **16.50**
P.O.B. Chicago.....

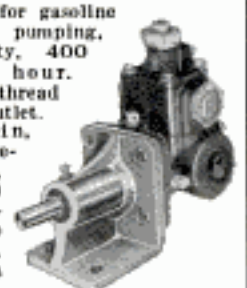

ORDER DIRECT FROM AD SATISFACTION GUARANTEED
Send Payment Or Purchase Order Today

FREE WINTER EDITION
1955 CATALOG, 52 PAGES, check-full of unsurpassed War Surplus Equipment Bargains for farm, home, factory, workshop. Write letter today.

BATTERIES!—START

—a factory at home and re-cast junk batteries into new; latest achievement. We supply complete instructions and everything needed. Large daily profits!

BATTERY LABORATORIES, Dept. PM, Minneapolis 4, Minn.

MORE For Your Money in a SHAW "DU-ALL"

Improved design, better value in 1 1/4, 2 1/4, 3.5 H.P. walking tractors. New, low cost, streamlined 2 1/4, 5, 8 H.P. riding tractor. Expensive, new 1 1/4 H.P. tiller that pulverizes up to 12 inch swath 6 inches deep, and less. Automotive gears on heavier models. Prices will please you. **FREE CATALOG**. Write today.

SHAW MFG. CO. 4501 Front St., Galesburg, Kans. 6686 N. 4th St., Columbus, Ohio

AT ALL HARDWARE STORES

FULLER'S "SCREW HOLDER" SCREW DRIVERS

NOW! do the job at HALF THE COST!

- Spring Clip holds and sets screws tightly!
- Reaches those "out of the way" spots!
- In 3 1/2", 4 1/2", 6" and 8" lengths — ONLY **30c** (3 1/2" x 1/8" blade)
- Hi Carbon Blades! • Unbreakable Amber Handles!

FULLER TOOL CO., Inc. 3522 Webster Ave., N. Y. 67
Export Sales Dept., John H. Graham Co., 105 Duane St. • New York, U. S. A.

EASY

DOES IT WITH

USG DURON*

the hardboard of 1001 uses



TOOL CHEST



DOG BED



CLOTHES HAMPER



MAGAZINE RACK



You can build it yourself easier, faster—and the job comes out *right* with DURON because *this* hardboard is made for easy sawing, bending, nailing, laminating, drilling. Smooth on both sides, responds well to edge treatment—the finished job actually *looks professional*. You needn't paint the rich brown surface of DURON—but if you want to, it takes paint beautifully! Try this practical hardboard in your home workshop!

FREE PLAN BOOK

12 pages of easy-to-follow plans for making useful things. Ask your dealer or write Dept. PM-1, 300 W. Adams, Chicago 6.



UNITED STATES GYPSUM

The Greatest Name in Building

Laboratory. Cloud vapors will be generated in a chamber at the bottom of the tower, then conducted to the "cloud tube" that will extend to the tower's top. Ice crystals, salt particles and all other likely nuclei will be introduced into the artificial cloud in attempts to coalesce the vapor particles into actual raindrops. The cloud tube is insulated and portions of it may be refrigerated to temperatures as low as 20 degrees below zero F., thus duplicating the low temperatures found inside the tops of thunderclouds. Updrafts and downdrafts can be created in simulation of the air currents inside actual clouds.

If, as is hoped, studies with the cloud tube lead to the discovery of the mechanism by which warm clouds produce rain, then attempts will be made to increase artificially the amounts of that rainfall. The big goal of the Socorro scientists is to find ways of producing valuable amounts of rain in the areas where it is needed and at the times it is needed most. ★★★

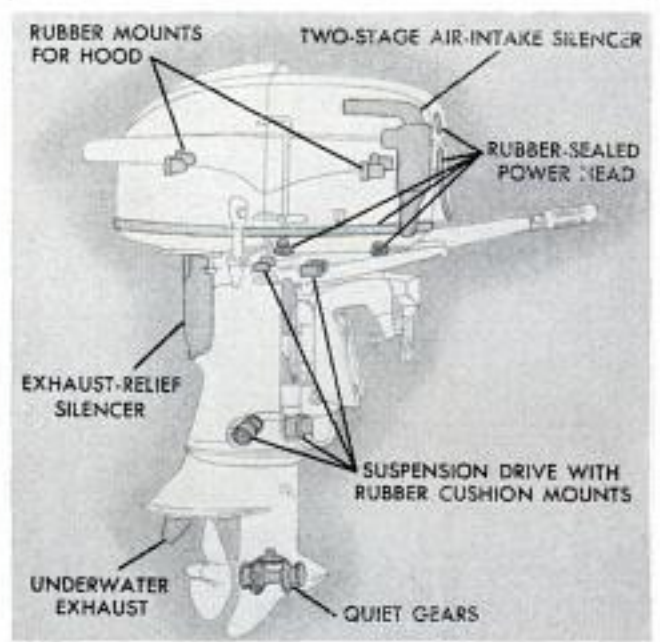

No More Roar in Big Outboards

Last year the major outboard-motor manufacturers vied in quieting their smaller motors. This year the main emphasis is on eliminating the roar of the bigger outboards. Several silencing devices have been added to the 10 and 25-horsepower Johnson models and the 7½, 15 and 25-horsepower Evinrude models. A rubber-cushion mounting system isolates the motor from the boat and prevents the boat from becoming a sounding board for the motor's vibration. The powerhead and hood are also mounted in rubber. A new two-stage air-intake silencer cuts down high and low frequencies, and an exhaust-relief silencer minimizes the noise behind the motor.

fully assembled real 1/7 HP. DIESEL ENGINE

OVER 100,000 SOLD AT HIGHER PRICE. NOT A TOY!

DEEZIL is a perfect power plant for planes, boats, race cars and experimenters. (Runs at 7500 R.P.M. Produces 1/7 HP. Weighs only 5 oz.)

DEEZIL is an ultra precision engine as carefully machine-tooled as Giant army engines. Cylinder is honed to .0001 inch and hand fitted to its individual pistons.

DEEZIL is compact, rugged, streamlined. Starts quickly. Simple to install. You get it fully assembled.

DEEZIL is test run at the factory to assure perfection. Operating instructions included.

Send \$1.95 plus 5c postage today.



196 Page Book on Model Engines... \$1.00 Postpaid
(GIANT HOBBY CATALOG INCLUDED)

GOTHAM HOBBY CORP., DEPT. P, 107 EAST 126 ST., NEW YORK 35, N. Y.

NOW
\$1.95
Plus 5¢ Postage



ACTUAL SIZE

VARIABLE SPEED HYDRAULIC POWER TRANSMISSION



It has Infinite Speeds 0 to 550. Reverse, Automatic Overload Protection; Adjustable Torque up to 180 inch pounds. 3/8" Input and Output Shafts. It will handle 1/2 to 1 1/2 H.P. Motor. Case measures 7 1/2" long, 7" high, 6 1/2" wide, VALUE OVER \$300. Shipping Wt. 25#. On C.O.D. Orders we require a 10% only Dep. Chicago

\$54.50

DIRZIUS MACHINE SHOP "J" 1423-25 So. 52nd Ave., Cicero 50, Ill.



GEARS

In Stock - Immediate Delivery
Gears, speed reducers, sprockets, thrust bearings, flexible couplings, pulleys, etc. A complete line is carried in our Chicago stock. Can also quote on special gears of any kind. Send in your blueprints and inquiries.

Send for Complete Catalog No. 10
CHICAGO GEAR WORKS
440-50 N. Oakley Blvd., CHICAGO 12, ILL.

FISHERMEN

SEND FOR
FREE CATALOGUE TODAY!
FULLY ILLUSTRATED
FULLY DESCRIPTIVE
ALL PRICES LISTED

Make Your Own SINKERS! JIGS! SQUIDS! CASTING AND SPINNING LURES!

It's fun, it's easy with Sweet's
ALUMINUM MOLDS

Molds for fresh and salt water fishermen. Handled and hinged for easy, fast operation. Over 100 types, 500 sizes. Write for free catalogue.

AS LOW AS
\$2.95
PER MOLD



SWEET'S MOLDS
Tonawanda 16, N. Y.



STOP
sway, sag and dip!



No more dangerous swaying on curves or deep dipping on hard stops. No more unsightly sagging due to weakened springs. Amazing, low cost AIR LIFT units make old springs ride like new — smooth bumps, cushion spring action against curves and stops, ease steering, save tires and avoid repairs. Super-simple to install and factory guaranteed. At car dealers and repair shops or write direct. Be sure to specify make and model of your car. Write Department 41.



FREE — Send for HOW TO STOP FRONT END TROUBLES booklet, Dept. 41.

AIR LIFT COMPANY
2330 W. Main Street, Lansing, Michigan

for
Saws that Cut

TODAY...
TOMORROW...
ALWAYS...

it's SANDVIK!

Made of genuine Swedish Charcoal Steel... hardened, tempered and filed to produce the finest, sharpest, longest lasting cutting edges you've ever seen. Extra high crown, perfect balance, easy-grip handle. Compare a Sandvik saw with any ordinary make. The difference in the way it cuts will convince you that there's no finer handsaw made.

Be sure to look for the Sandvik "Fish & Hook" trade mark. See your hardware dealer or write us for handsaw folder. Dept. PM-1

"Fish & Hook"
Brand of Quality



Sandvik Saw & Tool

47 WARREN ST., NEW YORK 7

DIVISION OF SANDVIK STEEL INC.
SANDVIK SAWS SERVE THE WORLD

He's "The Brains" of I Love Lucy

(Continued from page 131)

75-percent-reflective coating—the letters are magnified to 5/8 inch.

It does away completely with the need for uniform or special equipment. And as a bonus feature, Oppenheimer's invention has standard cues boxed on the top and bottom of each page. They are printed instructions such as "Speed Up," "Slow Down," "One Minute to Go," etc. The director merely has to push a button to light up the particular instruction he wishes his performer to follow.

Another use to which the Jayo Viewer lends itself, although this is not its primary purpose, is that of an off-camera prompter. By being placed at strategic positions during a performance, it can make fluffing a thing of the past.

If Oppenheimer was annoyed by newscasters who did not look him squarely in the eye from his TV screen, he has been no less put out with filmed comedy shows which resort to canned laughter. Probably the seed for this particular public service was planted when Oppenheimer was a boy in San Francisco. He and his pals used to patronize a movie house which had a special section equipped with earphones for the hard of hearing. Whenever there was a comedy, Oppenheimer and his cronies would sit in that section and use the earphones so they could hear the dialogue which otherwise would have been drowned out by audience laughter.

Oppenheimer worked out two intricate methods for getting authentic laugh tracks on filmed TV comedies. One system delays the actors on the set by means of a silent signaling system which suspends the dialogue for the predetermined duration of the laugh. During this lull in the conversation, the performers fill the breach with pantomime action known in the trade as pieces of business. If the line is considered to warrant a seven-second laugh, a nudge of the push button puts the light on for seven seconds. If the actor is supposed to come in after one or two seconds, the signal lasts that long. Laughs are recorded later, and in that way there is adequate audience reaction and no conflict with the movement of the story.

The second system plotted out by Hollywood's "Leonardo da Vinci" is the one that renders audiences superfluous. It provides, through the use of tape recording, a method of playing the laughs on the set while the performance is in progress. This is another multiple push-button device which operates a complete catalogue of laughs

(Continued to page 240)

IF YOU LIKE TO BUILD THINGS
that are different...



Swing-up Garage Door



Valance Bookcase



Storage Chest

...these plans were designed with you in mind. Here are only a few of the many interesting indoor and outdoor projects we have for you. You build them without blueprints! Our Simplified Easi-Build* Patterns take out

the guesswork—specify all materials required.

*T.M. Reg. Easi-Build Pattern Co.

You build primarily with weatherproof, crackproof Homasote — insulating-building boards available (throughout the U.S. and in Canada) in many sizes, thicknesses and densities. Homasote works easier than wood — takes any wallpaper, paint or stain.

NEW! Three illustrated folders—suggesting 18 practical make-it-at-home projects — ranging from the attic to the cellar. Mail the coupon today for patterns and/or folders.



18 new ideas

MAKE IT AT HOME — WITH HOMASOTE

HOMASOTE CO.,
Dept. A-6, Trenton 3, N. J.

I enclose \$_____ for patterns or literature as checked:
 3 Make-it-at-Home folders (10¢) Garage Door Pattern #86 (50¢) Bookcase Pattern #271 (50¢)
 Storage Chest Pattern #269 (50¢)

NAME.....
ADDRESS.....
CITY.....ZONE.....STATE.....
My lumber dealer is:.....

EXCITING NEW PERFORMANCE! SLEEK NEW STYLING! NEW LOW PRICES!

Chris-Craft Boat Kits for 1955



Popular 8-ft. Pram is fun to row; takes small outboards. Kit \$49



Fast 12-ft. Vagabond is car-top-size sportsman's boat! Kit \$117



Trim 14-ft. Dolphin—flashing performance, budget price! Kit \$139



Smart, swift 14-ft. Barracuda with walk-thru center deck! Kit \$225



Speedy—16-ft. Express Cruiser has big cockpit; sleeps 2. Kit \$335



Luxury—18-ft. Fiesta; room for 2 berths, galley, toilet. Kit \$645

... as little as **\$49 full price**

Now! Command a new 1955 Chris-Craft Kit Boat! Assembly is easy and fun—and you save up to 50% or more! Kits include precut Philippine Mahogany or Fir parts and Fir marine-plywood panels; brass fastenings; seam compound; decals. Stem, frames, transom come fully machined—assembled in most kits! Illustrated instructions show, step by step, how to assemble your kit. *Start today!* See your Chris-Craft Dealer, or send for folder! Many models to choose from!

(Prices f. o. b. factory, subject to change.)

BOAT KIT DIVISION
CHRIS-CRAFT CORPORATION
ALGONAC, MICH.

Send Chris-Craft Boat Kit folder to:

Name _____

Address _____

City _____ State _____

WORLD'S LARGEST BUILDERS OF MOTOR BOATS

\$6⁹⁵ **DRAINS** cellars, cisterns, wash tubs; **IRRIGATES - CIRCULATES - SPRAYS**

1,001 USES—HOUSE, GARDEN, FARM
Original All-Purpose Pump has 2400 GPH capacity, 380 GPH 75' high; or 1500 GPH from 25' well. Use any 1/6 to 3/4 HP motor. Stainless steel shaft, 1" inlet, 3/4" outlet. Motor coupling included.

DOES NOT CLOG OR RUST!
Postpaid if cash with order. (West of Miss. add 50c.) **MONEY BACK GUARANTEE.** Larger Centrifugal Pumps, and Gear Pumps in all sizes. **LABAWCO PUMPS, Belle Mead 7, N. J.**

NEW 12-FT. POCKET TAPE
MAKES L-O-N-G MEASUREMENTS EASY
made only by **EVANS**

Only **\$1.89**



No longer need you make two measurements for 12-ft. jobs as you must do with shorter tapes. Chrome-plated case is no larger. Each EVANS Tape packed in FREE transparent Tenite utility case.

Marked So You Don't Have To Figure
No Other Tape Is Marked This EVANS Way



King-Size 10-Ft. White-Tape

STANDS UP STRAIGHT

For Upright Measurements!

Wider (3/4") heavy-duty blade makes those long upright measurements easy and accurate. Exclusive EVANS double markings, same as 12-ft. pocket tape. FREE belt clip and Tenite utility case with every EVANS King-Size.



Only **\$2.39**

At hardware stores everywhere in the U.S.A.

Evans & Co., Elizabeth, N. J.

Makers Of Evans "Long Tapes"—25-50-75-100 Ft.

2642



\$35,000 REWARD FOR URANIUM

Here's your chance to "cash in!" Over \$2,500,000 in Government Bonuses have been paid for URANIUM discoveries in the past 2 years. Currently \$150,000 a month is paid to people just like you.

Precision Geiger Counters and Scintillators are the finest instruments made for URANIUM prospecting. These highly sensitive instruments are compact, lightweight and ruggedly built for field use. Prices start at \$29.95.

CONTACT YOUR NEAREST DEALER or write direct to factory for FREE 12-PAGE CATALOG, describing URANIUM and Metal detectors.

DEALERS WANTED



PRECISION RADIATION INSTRUMENTS, INC.
2235PM S. La Brea, Los Angeles 16, California

WORLD'S LARGEST MANUFACTURER OF PORTABLE RADIATION INSTRUMENTS

WORKSHOP WONDERS

with
WISE-GRIP

**YOU'LL FIND
NEW USES
EVERY DAY!**

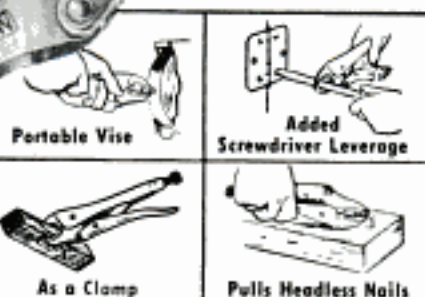

**10W, 10"
with Cutter
Only \$2.60**

So powerful, so handy, no one person could list all the uses for amazing, all-purpose Wise-Grip! Locks onto work with terrific non-slip grip. Turns, twists, pulls, ratchets, cuts, holds. A super-pliers, locking wrench, portable vise, clamp—in one trim tool! 7" and 10", with or without cutter. Only \$1.85 to \$2.60. At your dealer!

Made only by PETERSEN MFG. CO., Dept. M1, DeWitt, Nebr.



how to
build
"open-wide"
closets
with

Fashionfold

Doors

send for new
illustrated folder

Change waste space into handy wall-to-wall wardrobes, corner and hallway storage closets. You'll add beauty yet save dollars with Ra-Tox FASHIONFOLD DOORS. Woven of sturdy Northern Basswood in colors or rich natural wood. Supplied complete... installed in minutes. No fitting, trimming or finishing.

**Write
today!**

for new closet idea folder with easy-to-follow designs. Send 10c in coin to cover handling.



THE HOUGH SHADE CORPORATION
1066 Jackson • Janesville, Wisconsin
IN CANADA: Canadian Ventilating Shaded Ltd., Peterborough, Ont.

SOLD BY LUMBER AND BUILDING MATERIALS DEALERS

differing in length and quality to meet the needs of the story.

This system offers the director a choice between a tape with preselected laughs which may be integrated chronologically with the dialogue, or a multiple tape in which the director may push the various buttons for a guffaw, a giggle, hearty laughter or whatever the script may justify.

As soon as the button is pushed, laughter rises just as it would with a live audience, and fades in the same manner. The machine stops automatically at the conclusion of one laugh, and is ready to launch the next laugh instantly at the push of a button.

As producer of *I Love Lucy*, Oppenheimer was concerned with the limitations of the conventional camera dolly inherited by TV from the movie sound stages. He realized that it was impossible to set up certain camera shots with existing dollies, so he invented the Jayo directional-control ball caster. It operates on giant balls instead of the wheels on which the conventional dolly moves. This ball-caster principle permits his dolly to move in any direction, yet keeps it susceptible to control when desired. When the brake assembly is applied, it converts the balls into wheels and allows the dolly to be steered in any direction. At the same time the assembly facilitates prompt change of direction whenever required.

It was while perfecting the Jayo Viewer that Oppenheimer developed his low-cost method for synchronizing series-wound motors. He came up with an idea, for which some of his patents now are pending, which synchronized three motors at a cost of \$40, supplanting the established method requiring a master motor costing \$250.

Oppenheimer and his wife were seeing a 3D picture, *The House of Wax*, when he got the inspiration for glasses that permit a person to see 3D in 2D. He noticed people holding their hands over one eye because of eyestrain and headache.

He solved this problem by inventing a pair of polarized glasses in which one lens is variable. This permits the viewer, by flicking a tiny rod extending from the circular eyepiece, to switch the variable lens to an opposite plane from the fixed lens. Presto! This converts the 3D image to 2D.

Mrs. Oppenheimer sometimes questions the wisdom of putting so much money in inventions. Oppenheimer insists the expenditure is justified.

"Aside from the fact that business investments are deductible," he smiles, "I don't think I've ever had any experience which I haven't sooner or later incorporated into a radio or TV show. So, one way or another, it can't help but pay for itself." ★ ★ ★

SAWING IS EASY WITH THESE TWO FAMOUS "DO-IT-YOURSELF" POWER TOOLS



"ARCO-SAW" the only 5" circular saw attachment guaranteed to whiz thru 2x4's in one cut. Has right angle gear drive (no clumsy, dangerous direct drive with drill sideways). No need to pay 3 to 5 times as much for saws that do the same work. Accurate, fast adjusting Depth, Bevel, Rip Gages are foolproof. Convert your basement or attic 8-times faster than hand sawing — build kitchen cabinets, book-cases — and save plenty! Simply attach "ARCO-SAW" to any 1/4" electric drill by tightening strong Safety-Yoke & Clamp around drill and run this powerful saw with one hand. New 5" Safecut Blade zips thru heavy lumber. You'll find "ARCO-SAW" with its tough BLADES—5" Safecut, Rip, Crosscut, or Comb...\$1.75

ARCO SAW
No. 455
"ARCO-SAW"
\$12.50
with Blade

90-DAY FACTORY GUARANTEE

"ARCO JIG-SAW"

Does work of Jig, Keyhole, Coping, Rip, Band and Macksaw! EXCLUSIVE "AIR-JET" BLOWS AWAY SAWDUST. You would expect to pay \$50 or more for a portable jig saw that has the same capacity, cutting speed & precision as "ARCO JIG-SAW." But here, for the first time, is a versatile, rugged saw that attaches in 1 minute to any 1/4" electric drill — eliminates expensive built-in motor — saves you the difference! Guaranteed to cut intricate patterns, intricate — no matter how large — in eels — plywood, wallboard, plastics, metals — even lumber up to 2x4's! Cuts openings without starting hole. Safety-Yoke & Clamps give you a vibration-free unit. Has wide Shoe-Plate. Converts to Table Model with
No. 401 "ARCO STAND" \$2.75
6 Blades for wood, metals, etc. . . . \$1.95



No. 500
"ARCO JIG-SAW"
\$10.95
with blade.

AT BETTER
HARDWARE STORES
EVERYWHERE

BUY THE BEST—see your hardware dealer now! If not available, try "ARCO" Tools on our 10-DAY MONEY BACK GUARANTEE. Send us check or M.O. (Postpaid). C.O.D.'s—postage extra.

ARROW METAL PRODUCTS CO. Dept. PM-1, 140 WEST BROADWAY, NEW YORK 13, N. Y.



BRONZE FOUNDRY

Schools and Home Workshops
Make your own castings of aluminum, copper, bronze, silver. Foundry sets are available in three sizes including 2400 Deg. F. blast Furnaces. \$22.50; \$29.50; and \$42.00. f.o.b. Kansas City. Free Circular.

KANSAS CITY SPECIALTIES CO. P. O. Box 6022, Dept. P-1 KANSAS CITY, MO.

SPRINGFIELD TILLER

Big 2 h.p. Springfield SPRINGTIL model. Tines guaranteed for life. Non-winding. Easy to control. 7 1/2" to 21 1/2" tilling widths. Converts to roller, aerating tool, edger, and furrower.



SEND FOR FREE 1955 CATALOG
Quick Mfg. Inc., 3257 E. Main St.,
Springfield, Ohio

Find HIDDEN TREASURES
GEIGER COUNTERS (as shown) for Uranium Detection, TREASURE DETECTORS for gold, silver, etc. Lightweight, ultra sensitive. None finer. Also Mineralights for Tungsten.
• INFORMATION FREE •
Detectron Co.
5420 Vineland, North Hollywood, Calif

Wholesale! TOOLS! GUNS! CAMERAS!
BUY TOOLS, PHOTO EQUIPMENT, SPORTING GOODS, JEWELRY AND THOUSANDS OTHER NATIONALLY ADVERTISED PRODUCTS AT BIG DISCOUNTS. SAVE ON OWN PURCHASES. BIG PROFITS SELLING TO OTHERS. POSTCARD BRINGS FREE COPY "THE WHOLESALE PLAN".
Get up to 40% off
AMERICAN BUYERS SERVICE
629 Linden Ave., Dept. 15, Buffalo 16, N.Y.

KING MIDGET AUTOMOBILE

WORLD'S LOWEST PRICED AUTOMOBILE. Drive it for 75c per week. Amazing performance, comfort. Full accessories, doors and heater. Ready to run or assemble it with our bolt together parts. Rider agents wanted, earn car free. Send 25c for detailed literature, or \$1 (refund first order) for this plus assembly book and service manual filled with photos, drawings, specifications.
MIDGET MOTORS MFG. CO., ATHENS 1, OHIO

YOU CAN START A \$40 A DAY BUSINESS IN YOUR SPARE TIME



Andy Phillips says:
"MyBELSAW Sharp Smith gives me big profits at low expense — I can run 35 to 40 circular saws in an 8-hour day — that makes me \$40 cash."

"I also get BIG EXTRA PROFITS... up to \$4 an hour... by grinding planer and jointer knives — there's always a demand for this kind of work."

You can start this REPEAT CASH business in your own home or garage while you are working at your regular job. Easy to operate, no experience needed. "Pays for itself from just 65 jobs." — *Harvey Jensen*

For as little as \$15 down payment, you can get your BELSAW SHARP SMITH rushed to you.

FREE book tells how
YOU can start making money the very day your BELSAW SHARP SMITH arrives. Earns \$4 to \$5 an hour in your SPARE TIME sharpening and setting circular saws for builders, lumber yards, factories... Plus BIG EXTRA CASH, precision grinding planer and jointer knives, plane irons, wood chisels and drill bits. Hundreds of jobs in your own neighborhood. No extra equipment needed, no canvassing. Send today for your Free copy of "Life-Time Security."



BELSAW MACHINERY CO
3706 Field Building Kansas City 11, Mo.

**RELIEVES
HEADACHE
NEURALGIA
NEURITIS PAIN**

FAST



Here's Why...

Anacin® is like a doctor's prescription. That is, Anacin contains not one but a combination of medically proved active ingredients. Anacin is specially compounded to give FAST, LONG LASTING relief. Don't wait. Buy Anacin today.

Say You Saw It in
POPULAR MECHANICS

**Do-It-Yourself
Upholstering
new and old
Now Possible**

with NO-SAG SPRING KITS



CHAIRS



SOFAS

- EASY TO INSTALL
- COMPLETE INSTRUCTIONS FURNISHED

USE POPULAR MECHANICS DESIGNS
IDEAL FOR BUILT-IN FURNITURE

12 Ft. NO-SAG SPRINGS and Fastenings, Hardware in Separate Kits:

For Seats 9 ga. \$1.95
For Backs 11 ga. \$1.85

Available at Upholstery Supply Houses or send check or money order direct to

DISTRIBUTORSHIPS AVAILABLE

NO-SAG SPRING COMPANY
21590 HOOVER RD. • DETROIT, MICH.



Taking That Spot-News Picture

(Continued from page 156)

using and, in a general way at least, know how to use it in your particular camera. Fast black-and-white film is best for press use. When you unload exposed film from your camera, again take great care to protect the film from strong light, especially direct sunshine.

You must know your camera is focused sharply on the subject in regard to distance. If you are shooting a simple box camera, which has fixed focus, you have no worries here. Other cameras must be focused upon the picture-to-be. Focusing is easy enough; the problem is to remember to do it. If you make camera adjustments in the same order each time you take pictures, you'll be less likely to forget an essential step in an emergency.

You must expose the film to enough light to register the picture-image while also stopping action. Many camera users shy from the job of trying to understand what "exposure" means. Exposure is putting enough light on the film to burn the picture-image completely into the film's sensitized surface. If exposure is too "thin" you lose all shadowy areas of the picture. If exposure is too "heavy" the picture is muddy.

Your judgment is required in choosing a shutter speed and an aperture (size of opening in lens; also called diaphragm opening or iris; this is the f-stop shown on the dial) which together will admit the right total quantity of light.

The shutter regulates how long the light enters the camera.

The aperture regulates how fast the light comes in.

The total amount of light needed is determined by the speed rating of the kind of film you are using.

You must measure (with a light meter) or estimate the brightness of light illuminating the subject.

You must choose a shutter speed fast enough, if possible, to stop action in the scene you are shooting. If you intend to hold the camera in your hands for shooting, the shutter speed shouldn't be less than $\frac{1}{50}$ second; $\frac{1}{100}$ would be better.

Your choice of aperture depends on what shutter speed is required and on intensity of light on the subject. By buying and using a good light meter you can save yourself years of photographic aches and pains. You'll educate your eye to light values, and you'll take a short cut to understanding and applying the ABCs of exposure. The meter does its service by eliminating one big "guess" from your photography; the meter

(Continued to page 244)

STICK WITH
LEPAGE'S
GLUE

REGULMENT OF A HUNDRED OF MONEY
 Guaranteed by
 Good Housekeeping
 IF NOT AS ADVERTISED THEREIN

GLOUCESTER, MASS.

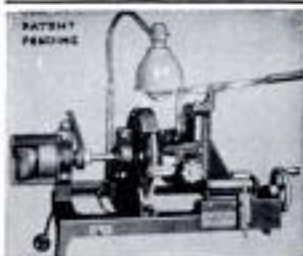

Start a NEW BUSINESS!

or Add to your present
 Repair Business
SHARPEN DULL PIPE WRENCHES
 PIPE TAPS & DIES
 "GUM" CIRCULAR SAWS
 Also MOTOR DRIVEN ROTARY HONE
 Write for Information
J. C. MOORE INDUSTRIES
 BOX M 276 FREDONIA, PA.

WORLD'S BEST SMALL TRENCHERS



Portable DITCH-WITCH digs
 2" to 6" deep, even ditches to
 36" depth in all types of
 soil. Complete unit—self prop-
 elled—outdigs 8 men. Four
 rugged models.
 Write for illustrated literature.
THE CHARLES MACHINE WORKS
 620 B Street Parry, Oklahoma

STATICmaster
 ELIMINATES SURFACE STATIC ELECTRICITY
 Removes Objectionable Dust and Lint
 For use in hobbies where static
 makes fine craftsmanship difficult ...
 Photographic and Model work of all kinds.
 Buy Staticmasters at your local photographic store
 or order direct ... sent postpaid if cash with order

The Pelonium Strip Does The Trick
\$4.95

NUCLEAR PRODUCTS CO.
 Dept. 65-10175 E. RUSH ST., EL MONTE, CALIF.

AUTOMATIC LOCKING PLIERS

No adjusting . . . Just grip on any size work
 within the 2-wide range made possible
 by the slip-joint . . . pressure remains
 locked. Finger-operated release
 trigger provides instant one-hand
 plier, wrench or clamp
 action. Forged-heat treat-
 ed durable 7 1/2" tool.
 Money-Back Guarantee

SARVIE TOOL CO.
 Dept. P-61, Box 164,
 Alexandria, Minn.

ONLY \$2.25
 at dealers or postpaid in U.S.A.

STEP UP PERFORMANCE OF YOUR OUTBOARD

WRITE FOR OUTBOARDER'S BIBLE—
 our 1955 catalog. It's FREE! Contains
 much valuable information on how
 to get MORE SPEED, for racing or
 pleasure, from motors of 5 HP to 50
 HP; better performance and load car-
 rying capacity from any motor old or
 new. Easily understood recommendations enable
 you to choose a propeller virtually custom-built
 for your motor and boat combination—much more
 rugged and damage resistant than the original.
 Write NOW, Michigan Wheel Co., Dept. P-61,
 Grand Rapids 3, Mich.

Made
\$900
IN SPARE TIME

*Trade Mark
 Reg. U.S.
 Pat. Off.*

with
FOLEY* automatic SAW FILER

"I did very well last year with my Foley equipment, sharpening about 950 saws in my spare time. About \$900 for me."
 Leo H. Mix

"I have done 4 or 5 thousand saws in my spare time in the 4 1/2 years since I got the outfit, and they are all coming back with repeat orders."
 Len Crego

Make up to \$3 or \$5 an hour in Spare Time

With the high prices of food, clothing and everything else, just think what you could do with extra money every week! With a Foley Automatic Saw Filer you can file hand, band and circular saws better than the most expert hand filer. "The first saw I sharpened with my Foley Filer came out 100%" — writes Clarence E. Parsons. Cash business, no canvassing. No eyestrain — no experience needed.

FREE BOOK Shows How to Start

"**MONEY MAKING FACTS**" tells just what to do to start your own spare time business in your basement or garage. Just think — with a small investment, no overhead, no stock of goods to carry, you can get right into a cash business. Send coupon today — no salesman will call.



Send for FREE BOOK

FOLEY MFG. CO.,
 116-5 Foley Bldg., Minneapolis 18, Minn.
 Send FREE BOOK — "Money Making Facts"

Name _____
 Address _____

DO MORE PLANING JOBS WITH LOW COST BELSAW

Exclusive MONEY-MAKING features:

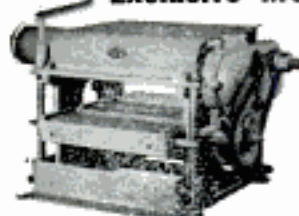

- Full 12 1/4 in. x 6 in. capacity
- Power feeds at 24 ft. a minute. (Easily adjusted for lower feed rate)
- Machined cast iron bed; adjustable rolls, total bed length 42 in.
- Provides for Grinding Knives in the Cutterhead.
- Attachments for Jointing, Rabbeting, Tongue, Groove, Matching.

Belsaw Multi-Duty Planer for cabinet shops, builders, lumber yards, woodworking plants and spare time work shops... Now you can convert low cost rough and random size lumber into high priced cabinet finished stock... Easy to make flooring and popular patterns. Belsaw quickly returns cost with savings on raw material... profits on finished stock.

Send Today for FREE literature on Belsaw, the LOW COST, high speed production planer.

BELSAW MACHINERY CO

1010 Field Bldg. ● Kansas City 11, Missouri

LOW DOWN
PAYMENT
EASY
TERMS

Extra money for you with IDEAL LAWNMOWER SHARPENER

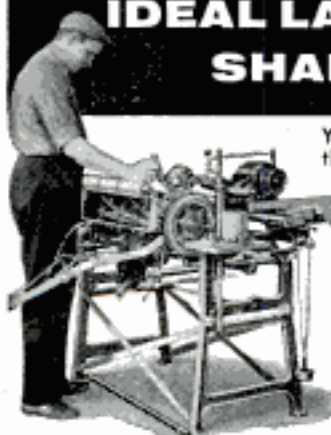

You can earn extra money with the Model 300 Ideal Lawnmower Sharpener. No experience needed, easy to operate. Grinds and reconditions reel and bed knife. Customer satisfaction guarantees repeat business. Complete shop in one machine. Spare time or full time, it's the IDEAL way to extra profits for you. Write for catalog today. The Fate-Root-Heath Co. Dept. PM-1, Plymouth, Ohio

RADIO CONTROL YOUR MODEL

"CUSTOM MIDGET" RADIO

ONLY \$9.98

LICENSE FREE BAND
OPERATES SAME AS \$50.00 SETS, INCLUDES LONG RANGE TRANSMITTER RADIO, RECEIVER RADIO AND CONTROL ACTUATOR ALL 3 EAST ASSEMBLY WITH OUR PARTS AND PLANS \$9.98. PLANS ALONE \$1.

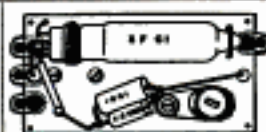

PLANES
BOATS
CARS

DETAILED INFORMATION & RADIO CATALOGUE 25c

SPECIAL "SUPPLY SOURCE" DIRECTORY & \$7.00 SUPPLY COUPON... \$1.00

BOOK "RADIO CONTROL OF MODEL AIRCRAFT" CONTAINS 14 PLANS \$3.98

RADIO CONTROL GARAGE DOOR DETAILS... \$1.00

RADIOMODELS BOX 34 DEPT. PM BALTIMORE 6, MARYLAND

takes a look at what you're going to shoot and tells you how bright the light is.

Lacking a meter at the time of your big picture, you make your best guess at light intensity. For protection against error you can bracket your shots. Give one shot much heavier exposure, and one shot much thinner exposure, than your best guess; of the three exposures, one should be close enough to give you a printable negative.

You must aim the camera at the subject. This sounds like an only too obvious rule, but many a news photo has been lost because the camera lopped off somebody's head, or because the camera was too close to take in the essential parts of the picture.

Your camera must be motionless while its shutter is open. Camera movement spoils more pictures than any other error. High shutter speed reduces the bad effect of camera movement; shutter speed alone won't eliminate it. Only immobilizing the camera solves the problem. The trouble here is that you probably won't have a tripod handy at the time and place of the unexpected big picture. You may be able to improvise a roosting place for your camera where it will cover the subject.

You must avoid accidents and oversights. There's an endless list of things which can defeat the camera user on the threshold of glory. The usual hullabaloo around the scene of a spot-news event raises the hazard level photographically and otherwise.

Do your picture-taking from a place where you won't get hurt. Camera and picture alike may be lost if the camera gets smashed, dropped or drenched. Trying to take pictures from a dangerous place raises mental hazards; you are much more likely to forget some step in camera mechanics—focusing, for example. Find a safer spot and shoot with care!

You must identify the picture. What happened? Who are the people? Where did it happen? When? What other essential facts must be known to describe the picture? So far as possible you must get those facts for a spot-news picture.

Your picture must be transported to the news channel. Time counts in news photography. Instead of taking time to go home and develop your films, telephone newspapers that might want your pictures.

Your negative must be properly developed and printed. News-photo labs like to do their own developing and printing. They have cut the time of such processing to the minimum and they have their own ideas about contrast, cropping and size of prints. Their lab men are wizards at making the most out of a negative. Hand your exposed films over to them and hope for the best!

★ ★ ★

Cut glass easily
ask your dealer for
Red Devil
glass cutters



Red Devil Tools.

Get your FREE copy of "HOW TO CUT GLASS."

MAIL COUPON TODAY

Red Devil Tools. Dept. 152
130 Coit Street, Irvington, N. J.

NAME _____

ADDRESS _____

CITY _____ ZONE _____ STATE _____

2813

CUT-TO-FIT HOMES CUT BUILDING COSTS

CHOICE OF 57 DESIGNS

ORDER NOW

SAVE UP TO 1/3

Build your own home and save the builders' profit—plus savings in lumber and labor with Sterling Ready-Cut-Homes. Anyone can assemble with simple, easy to follow plans furnished. Every house complete with all lumber roofing, nails, glass, hardware paint, doors and windows marked ready to erect. Freight paid. Complete building plans ready for filing at low cost. Sold separately if desired. Write today!

PRICED FROM \$2150 up

Five Easy Payment Plans

Send 25c for NEW COLOR CATALOG

INTERNATIONAL MILL AND TIMBER CO.
DEPT. PM 15 BAY CITY, MICHIGAN

DELCO MOTOR

You can't beat this sensational buy! Triple Rubber Mounted Motor for fans, refrigeration, air-conditioning units, etc. 1 7/8 H.P., 115 Volt, 50-60-Cy., A.C. 1500 R.P.M., Over-all Ht. 7 3/4". Tested! Powerful! Quiet! Immediate delivery. ORDER NOW! Weight, 5 lbs. complete with blade.

\$6.95*

FREE! Send for large Electrical, Plumbing & Motor Catalogue.

*Plus postage, send check or money order 3740 N.W. 27th Ave. **NATIONWIDE SUPPLIES INC.** Miami 42, Florida



NO. 21D HAND DRILL & PIN VISE \$1.00

x-acto

KNIVES • TOOLS
HANDICRAFT KITS



X-ACTO, INC.
48-41 Van Dam St.
Long Island City, N. Y.

Send 20c for 28-page Catalog

200 ONE-EVENING PROJECTS

Start and Finish Any One of These Projects in One Evening!

The editors of Popular Mechanics have assembled 200 projects, any one of which you can start and complete in a single evening. In a few hours' time, using only simple hand tools, you can build a coffee table, magazine rack, end table or scores of other useful projects. There are projects for the entire family. Best of all, any one may be built in just a few hours. No special skills are needed. Even if you have never built anything before, you can build the 200 projects in this big new book!

Step-by-Step Instructions, Show-How Photos, Drawings

First you read how to do it in famous Popular Mechanics step-by-step instructions and then actual photos, drawings and diagrams show you how it is done.

Each Project Costs Just 1c

Just imagine! Each project costs you only 1c. Where else today can you get so much for so little? Pull out and mail the coupon now. Pull money-back guarantee, of course.



POPULAR MECHANICS PRESS, Dept. EP-1
200 E. Ontario St., Chicago 11, Ill.

Gentlemen: Remittance for \$2.00 enclosed. Rush postpaid my copy of 200 ONE-EVENING PROJECTS. Unless it is entirely satisfactory I may return it in seven days for a full refund.

NAME _____

ADDRESS _____

CITY _____ ZONE _____ STATE _____

Send C.O.D. (U.S.A. only). Postage extra.

PUMP WATER FAST!



Drains Wash Tubs, Cellars, Cisterns. Famous #7 pumps 2800 gph. 420 gph. at 75' high or 1600 gph. from 25' well. Sturdy rustproof alloy metal. Six blade impeller. 3/4" inlet, 1/2" outlet. Standard pipe threaded. Uses any 1/2 to 1 1/2 H.P. Motor. Will not leak or clog. Ironclad guarantee. Send check, M.O., or sent C.O.D. **\$8.95**



Irrigate, Fill Tanks, Draw Well Water. Heavy duty #8 pumps 7000 gph. —1000 gph. 75' high 3000 gph. from 25' well. Rustproof alloy metal. 8 blade impeller. 1" inlet, 1" outlet. Standard pipe threaded. Will not leak or clog. Iron clad guarantee. Send check, M.O., or sent C.O.D. **\$11.95**

Free Catalogue—Gear Pumps, Large Centrifugal Pumps, Deep and Shallow Well Pumps, Sump Pumps.

MOORE MANUFACTURING CO.
SWEDSBORO 1, NEW JERSEY

Say You Saw It in Popular Mechanics

THE NEW DALTON Model D-500 ELECTRIC PORTABLE JIG SAW

7 SAWS IN ONE!

does the work of a RIP...
CROSS CUT... COPING...
JIG... SCROLL... BAND
and KEYHOLE SAW
CUTS ANY MATERIAL!
SAWS ANY SHAPE!

RIPS and CROSS CUTS 2x4's

Makes fast, smooth cuts... no jumping or chattering. Has the capacity to rip and cross cut 2 x 4's. The only other similar type device on the market that can match this amazing performance costs almost three times as much!

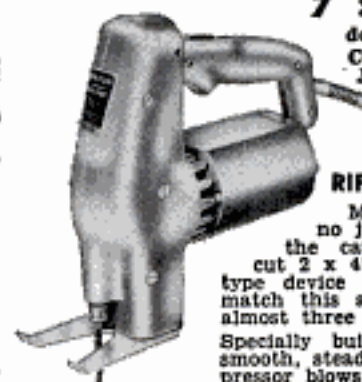

Specially built Dayton motor assures smooth, steady cutting. A built-in compressor blows sawdust away from guide line.

SPECIFICATIONS

- 4 to 1 gear reduction. • All gears hardened steel.
- Motor exposed for cool running. • Oilite bronze bearings.
- Air is pumped from top down through the center section, cooling unit as well as blowing sawdust from line.

IT CUTS wood — plastics — metals — composition boards — hard rubber and others.

IT SAWS circles — curves — straight lines — intricate designs.

Complete with 5 different blades

\$48.00

**SHIPPED ON APPROVAL
NO MONEY WITH ORDER — NO C. O. D.**

Try it ten days before you buy. If completely satisfied then send \$15.00 and pay balance at rate of \$11.00 per month for 3 months — No Interest or Finance Charges Added. If not completely satisfied, return to us, no explanation necessary.

KAPNER HARDWARE, INC.
Dept. A-124, 2348 Second Ave., N. Y. 29, N. Y.

Please rush one D-500 Jig Saw, I agree to pay \$15.00 within 10 days after receipt and \$11 per month thereafter.

Name _____

Address _____

City _____ Zone _____ State _____



**QUALITY UNSURPASSED—
PERFORMANCE UNEQUALLED**

**Yet Cost No More Than
Ordinary Screwdrivers!**

HOLD-E-ZEE

**The Original AUTOMATIC GRIP
SCREWDRIVERS**

*Much Wanted
Special Features*

UPSON BROS., INC., ROCHESTER 14, N. Y.



**EXCLUSIVE
LOK-
BLOK®**
Makes Blade
Twist & Impact
Proof
**AT ALL
LEADING
DEALERS**



Explosion-Proof, Portable

**ACETYLENE
GENERATOR**

PORT-A-MATIC

New, portable acetylene gas generator. Solder, heat, braze—or weld and cut with addition of oxygen. 3 models: Approximately 5 cu. ft., 12½ cu. ft., 25 cu. ft. gas capacities, weighing 30, 50, and 80 lbs. loaded, respectively. For repair shops, plumbers, electricians, construction men, and hobbyists.

Write for information and prices.

SAFE!
even upside down

**PORT-A-MATIC, INC. | HILLSBORO,
1665 North Connell | OREGON**

**A
NEW
YEAR**



This year and every year is a New Year of satisfaction when you use a Gerstner Chest. Free catalog.

GERSTNER TOOL CHESTS

455 COLUMBIA ST., DAYTON 7, OHIO

SMALL! POWERFUL!

**ECONOMY
TRACTOR**



Unequaled value! Low price!

America's finest tractor. Ruggedly built. Easy to operate. 700 lbs. Borg-Warner clutch, trans. and diff 10 to 1 reduction. 40% more drawbar pull than ordinary tractors 8-1/4 H. P. engine. 20 quick change implements. HOOD, FENDERS.

Thousands
In Use

Write for
complete
details.

Engineering Products Co.
915 N 1 Niagara Ct.
Waukesha, Wisconsin



**CONFIDENTIAL
MAP
FILE**

Easiest way to file and find maps, blue prints, tracings. Metal cabinet file with locking doors. 112 tilting tubes handle 60" prints. Tubes are indexed for quick location.

Patents Pending

#MT-4 Only \$187.50

Write for Illustrated Folder

SCOTT-RICE CO. 612 S. Main. Tulsa 3, Okla.

Owners Rate Features of Jaguar

(Continued from page 144)

"Motor difficult to keep in tune. Spark plugs foul out."—Illinois restaurateur.

"Brakes are excellent except in rain when they grab unevenly."—Maine professor.

"Brakes should be fixed so they don't get wet."—Ohio radio announcer.

"Brakes are apparently not easily adjusted."—Ohio surgeon.

"Overheats in traffic. No ash tray. Have to clean and change spark plugs too often."—New York manufacturer.

"Compared with American cars, the water temperature zooms sharply in traffic."—Connecticut musician.

But many owners wrote that they expected some minor disadvantages when they bought the Jaguar because it is, after all, a sports car.

"Don't let petty gripes mislead you. I'm wild about the car. You can't come near it without paying a few thousand dollars more."—New York actor.

Here are some complaints taken at random from the owners' replies.

"Lack of foot space brings cramps on long trips."—Oklahoma student.

"Needs larger rear window in roadster and a more adequate rear-view mirror."—New York artist.

"Side curtains are bothersome. Visibility with top up is very poor."—West Virginia accountant.

"Only complaint is that the doors hit the curb when parked close. Tail pipes hit road when going up into my garage."—New York production manager.

"Latest model has very poor seats."—New York executive.

"Insufficient knee room."—Ohio retail merchant.

"Have to have tires aired every week. The natural-rubber tubes leak air."—Indiana businessman.

"Aluminum doors get dented easily by careless parkers."—New York manufacturer's field representative.

"Would appreciate a bend in oil dipstick to keep from getting burned on the manifold."—Oklahoma student.

"Steering wheel could be a little lower. Short person has to look through wheel."—New York farmer.

"Should enlarge rear deck for more luggage room."—Ohio broker.

"Takes 10 minutes to put up top on roadster."—New York restaurateur.

"Needs more bumper protection."—Oklahoma oilman.

(Continued to page 248)

**BE YOUR OWN BOSS
WORK AT HOME
IN SPARE
OR FULL TIME**

**THERE'S BIG
MONEY IN THIS
FINE BUSINESS**

**SHARPENING
LAWN MOWERS...**

**ONLY THE NEW MODEL "B"
UNIVERSAL GRINDER
ALLOWS YOU TO GRIND
POWER AND HAND MOWERS
BETTER, FASTER, AND EASIER**

**... AND GIVES YOU
ALL THESE ADVANTAGES**

- **SMALL INVESTMENT**
- **EASE OF OPERATION**
- **NO REMOVAL OF ENGINE,
BED-KNIFE, HANDLE, OR ROLLER**
- **EASE OF MOWER ADJUSTMENT**
- **LESS TIME PER MOWER**
- **MORE SATISFIED CUSTOMERS**

**Read What These
Universal Owners Say:**

J.S. of Michigan writes:
*"I figure my profits
(last season) at over
\$1,000.00."*

Mr. C. H. R. of Ohio,
says, *"This season, I
have taken in \$3,688.20."*

Another Universal own-
er from Pennsylvania
tells us: *"I spent only
40c for a newspaper ad
and have done nearly
\$500.00 worth of busi-
ness."*

Mr. B. of California
writes: *"The lawn mow-
er grinding business,
with my Universal
Grinder, has been a
gold mine these last two
years."*

G. E. of Arkansas says:
*"I have had my Univer-
sal Grinder two months
and made a net profit of
\$227.00 in spare time."*

● Thousands of men have started this profit-
able business of their own with a small invest-
ment. The Universal is low in price and high
in value. You can start in your garage or base-
ment; and, by following our simple instructions,
the Universal Lawn Mower Grinder will put
you on the road to profit.

The Universal Lawn Mower Grinder is a
simplified design built to sharpen power and
hand mowers with a minimum of effort. Any-
one having a little mechanical ability can do
a good job, without previous experience. The
Universal is the only lawn mower sharpener in
the world that enables you to grind both bed-
knife and reel blades in one set-up, without
removing them from the mower. No extra at-
tachments or equipment necessary to do a
complete job. Just follow a few simple in-
structions and you can turn out a perfect job
on your very first mower.

If you are now working, you can start this
fine business and still keep your present job.
It takes only 20 to 30 minutes to grind a
mower and, by using just a few evenings a
week, you can earn a substantial spare-time
income to develop a full-time business of your
own and buy all those extra things for yourself
and family that help make this a better world
to live in.

There are probably 50,000,000 hand and power
lawn mowers in America that should be
sharpened every year. A good number of these
are in your very community. Commercial
mowers at golf courses, cemeteries, hospitals,

parks, schools, etc. bring even larger fees; and,
with the speed, ease, and accuracy of opera-
tion the Universal provides, you can build a
business that will provide a lifetime future. It's
a business that no one is too young to earn a
good living in; and, likewise, one that you
never grow too old to operate at a good profit.
(Some of our most successful users are re-
tired). You can shape your own future, make
your business as modest or as large as you
wish. You are your own boss, to come, go, and
do as you like.

As long as grass continues to grow, mowers
will have to be sharpened in order to cut it.
Having a Universal Lawn Mower Grinder will
enable you to get your share of this profitable
business.

You can operate your business from home—no
trudging to the job; fighting crowds; no more
dissatisfaction with job or boss in this good
business. It's easy, profitable work; so easy a
boy can do it. It's pleasant, convenient, and,
best of all... it's highly profitable. Others
are enjoying the happy, carefree life of being
their own boss—why not you? Whether you
want the security and independence of a full-
time business of your own, or the extra living
comforts spare time profits can bring, you
owe it to yourself and family to send the
coupon today. Now don't put it off. Investi-
gate our proved success plan now. We furnish
complete instructions, everything you need to
start and develop a good profitable business.
Just fill in and mail the coupon now.



**ONLY ON UNIVERSAL
CAN BOTH BED-KNIFE
AND REEL BLADES BE
SHARPENED IN ONE
EASY SET-UP, WITHOUT
REMOVING BLADES
FROM MOWER.**

**ROGERS
MANUFACTURING CO.
LINDSEY,
OHIO**

**ROGERS MANUFACTURING CO.
Dept. M-15, Lindsey, Ohio**

Gentlemen: Please rush me details about the
profit possibilities of the Universal Lawn Mower
Grinder.

NAME _____

STREET _____

CITY _____ STATE _____



Piston rings wear out, too!

You can't see the wear on your piston rings. But you can feel it—in your engine's loss of power—and in your pocketbook.

At the first symptom of power drop-off or oil-pumping, you should go to your motor specialist for a ring check-up.

Wasted oil costs money. Needless repairs cost more. Both can be avoided by replacing the piston rings at the first symptom of ring wear.

Hastings rings are especially designed for replacement service. They deliver the lubrication that older motors must have—but always with complete oil control.

Don't gamble with the power that is built into your engine. Restore it, keep it, enjoy it.

If your motor specialist recommends new rings, ask him to install a Hastings Steel-Vent replacement set. Truly the best money you can spend on your car!

HASTINGS MANUFACTURING CO. • HASTINGS, MICHIGAN
HASTINGS LTD., TORONTO
Piston Rings, Casite, Oil Filters, Spark Plugs

HASTINGS

STEEL-VENT PISTON RINGS

Regular or Chrome



TOUGH on Oil-Pumping
GENTLE on Cylinder walls

"Poor license-plate arrangement in rear. Too close to trunk handle."—New York farmer.

"Carbon throw-out bearing on clutch has no life at all."—New York executive.

Owners Praise Engine

The twin overhead-camshaft six in the Jaguar is recognized as one of the world's finest engines. And the owners agree, although some complained that it was so fine it had to have frequent tuning.

"One of the smoothest engines I know."—Ohio miller.

"Overhead-cam engine hard to work on."—Massachusetts machinist.

Almost all owners praised the hand-shift four-speed transmission.

"I like to downshift for passing and for fast cornering."—Iowa butcher.

"Wouldn't under any conditions have an automatic transmission on my Jaguar."—New York television performer.

"I like best the lack of automatic gadgets."—Illinois diemaker.

Typical of the owner devotion to the Jaguar is the following quotation from the questionnaire of a Oklahoma chemist:

"Altogether we love our Jaguar although we have had it only three months. We are only sorry we didn't get one several years ago so we could have enjoyed it more."

★ ★ ★

For the report on Floyd Clymer's road test of the Jaguar XK 120 turn back to page 141.

Clymer Tests the Jaguar XK 120

(Continued from page 141)

output by means of dual overhead camshafts, mounted at a 70-degree angle, which operate the overhead valves by a two-stage duplex roller chain. Because of its relatively small displacement, compared with American cars of similar output, the Jaguar uses dual carburetors, extra-large intake valves and header-type exhaust scavenging for maximum breathing. Naturally, these high-performance practices step up the engine revolutions for brake-horsepower rating, but likewise make this engine very effective in the lightweight Jaguar. Best performance is obtainable in the range above 4000 revolutions per minute, about where maximum torque occurs, whereas most American cars develop maximum torque in the 2000-2500 range.

Even though the Jaguar engine attains its best performance with high revolutions, it is interesting to note that, unlike the present engine trend (large bore and short

(Continued to page 250)

CUT PERFECT GROOVES WITH *Warren* WASHERS ON YOUR SAW BLADE!

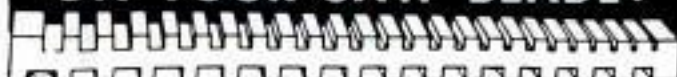

**NOT ONE — NOT TWELVE — BUT
40 DIFFERENT CUTS**

Engineered to cut clean, accurate, parallel grooves—just dial the desired width—40 micromatic adjustments—leave on saw for straight cuts. **GUARANTEED.** At your dealers or order direct. Arbor sizes $\frac{1}{2}$ " $\frac{3}{4}$ " 1 ". Send for free booklet



ONLY
\$4.95
per
100

WARREN WASHERS COMPANY
Dept. 21, Box 98, North End Station, Detroit, Michigan

MONEY for MEN ALL DATA FREE

THE PLASTEX Industry needs manufacturers on small scale and for big production of Lamp and Clock Stands, Art Goods and Novelties in Plaster and Marble imitation. Experience unnecessary. Eye material makes regular 10c store sellers. Rubber moulds furnished for speed production. Small investment brings good returns. We are now placing big Chain Store Orders with manufacturers. Ambitious men have chance for real prosperity. Our Free booklet will interest and benefit you.

PLASTEX INDUSTRIES, Dept. A
3400 Third Ave. New York 36, N. Y.

20 UNUSUAL, PRACTICAL, DO-IT-YOURSELF FURNITURE PLANS

Build distinctive furniture of custom quality. ATLAS Plan Book No. 1 shows exactly what to do... large diagrams, clear instructions 20 projects by top designers. Send 50c (65c outside U.S.A.) to: **ATLAS PRESS CO.**, 1-24 N. Pitcher St., Kalamazoo, Mich.



BUILD YOUR OWN

LAWN AND GARDEN TRACTOR

USE ONLY WRENCH AND SCREWDRIVER. Complete kit with all parts fitted and finished. Requires less than three hours assembly time. ACCESSORY KITS for Lawn Mower, Roller, Dump Cart, Hay Mower, Rotary Tiller, Snow Plow, Circular Saw, Emergency Light Plant.

UNITED STATES FORGE & FOUNDRY CO.
CONSTRUCTION EQUIPMENT DIV. PULASKI, NEW YORK



POWER HACKSAW \$55.75

LESS MOTOR
F.O.B. Benton Harbor

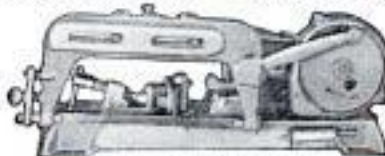

Send for full details and name of nearest dealer.

● Rugged cast iron construction. Wt. 56 lbs. bronze bearings. Draw cut. Auto. return lift. Auto. shut-off. Vise swivels 45°. Cap. 4"x4".

EXCEL MACHINE TOOLS Dept. PM-15 BENTON HARBOR, MICHIGAN

DON'T DIG 'TIL YOU KNOW WHERE

The most amazing instrument you've ever seen! New **MAGNA PROBE** traces water, gas, and metal or tile sewer lines. Saves hours of unnecessary digging. Finds hidden springs and underground streams. Just as efficient over concrete as bare ground. Sensitive to depth of 30 ft. Works indoors or outdoors. **MAGNA PROBE** works by scientific principle of dissimilar metals and elements attracting and opposing one another like magnetic electricity. So simple—a child can use it. **GUARANTEED TO WORK!**

ONLY
\$2.98

Post-Paid

Complete with easy-to-use instructions TODAY! Send check or money order (no C.O.D.'s) to:

THE MAGNA PROBE CO.
6022 Mayfield Road Cleveland 24, Ohio



SURFWOOD comes in 4' x 8' panels, $\frac{5}{16}$ " thick. Open and sound knotholes add to its picturesque, weathered appearance.

Beautiful new wall paneling looks like weathered driftwood— install it yourself at low cost*!



PANEL YOUR DEN with the clean-swept look of the sea! With Surfwood, you can transform a whole room or make a good-looking hobby nook in your living room or bedroom. Surfwood's large panels go up easily right over existing walls. Nail holes are hidden by Surfwood's irregular surface.

SURFWOOD texture is produced by special process that etches away the soft wood tissues between the hard grain.

SURFWOOD can be finished to give a wonderful variety of effects: it can be stained any color, finished natural with Satinlac, pickled with white Firzite, or even rubbed with dry pigment to give a modern two-tone look.

SEE SURFWOOD at your lumber dealer's or at any one of the 73 United States Plywood or U.S.-Mengel Plywoods showrooms located in principal cities.

*An 8' x 12' wall costs only \$23; prices vary slightly in different areas.

SEE YOUR LUMBER DEALER



Weldwood®

REAL WOOD PANELING

United States Plywood Corporation

WORLD'S LARGEST PLYWOOD ORGANIZATION

Weldwood Building, 55 W. 44th St., New York 36, N. Y.
and U. S.-Mengel Plywoods, Inc., Louisville, Kentucky

The easy way to paint!

Speedy Sprayer

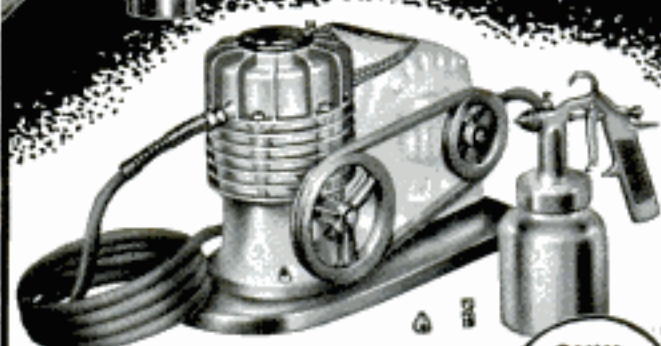

Favorite of home owners and craftsmen for 20 years! SPEEDY SPRAYER gives your work that professional paint finish everyone admires. Sprays paint, enamel, varnish, lacquer, etc. . . . 4 to 7 times faster than hand brushing! Lightweight, portable, uses any 1/2 H.P. motor. Improved diaphragm principle assures clean, oil-free air. You'll find dozens of time and money saving uses for SPEEDY SPRAYER, including spraying insecticides 2-4-D and DDT. Complete outfit, without motor, only \$36.50.

At leading hardware, lumber, and auto supply dealers. FREE—write for handy booklet "How to Spray."

W. R. BROWN CORPORATION
2635 N. Normandy • Chicago 35, Ill.

ONLY
\$36.50
LESS
MOTOR

WANT TO MAKE GARDEN, YARD AND LAWN CARE EASY? SAVE WORK WITH

Ariens
*Yardster**

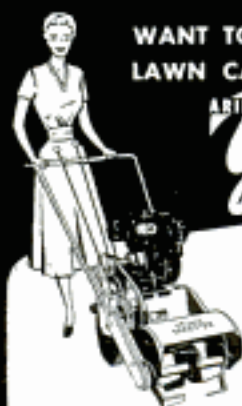

* interchangeable attachments for preparing and cultivating garden . . . mowing lawns, cutting weeds . . . spraying trees and plants . . . clearing snow from walks, drives.

Prepare garden without spading . . . cultivate all season without hoeing using the famous Ariens Yardster rotary tiller — now at a new low price — only \$166.50. Self-propelled with 2-speed wheel drive — merely guide it! With mower, sprayer and sno-thru attachments it's unequalled for construction, looks, performance and price. See it soon!

LOOK! Only \$129.75 for the amazing

Ariens
Jr

rotary tiller with "paring knife" tines. See it! Try it! And you'll buy it! Visit your dealer or write:

Ariens

ARIENS COMPANY • 159 Calumet St. • Brillion, Wis.

stroke), it has a comparatively long stroke (4.173 inches) and a smaller bore (3.268 inches). Long-stroke engines usually are not considered ideal for extreme high speed but Jaguar seems to be the exception and the long stroke does permit the handling of a high gear ratio with ease. The cylinder head is aluminum alloy with hemispherical combustion chambers. Twin S.U. horizontal carburetors are used with an electrically controlled automatic choke. Seven large steel-backed bearings carry the 2 $\frac{3}{4}$ -inch-diameter crankshaft and the engine has minimum vibration.

At high and low speeds and around sharp corners the fast steering enables one to

SPECIFICATIONS
Jaguar XK 120M

ENGINE

Type 6 cyl., in-line, OHV, twin overhead camshafts
Displacement 210 cu. in.
Bore and stroke 3.268x4.173 in.
Brake horsepower 180 at 5300 r.p.m.
Compression ratio 8:1
Carburetors Two S.U. horizontal
Transmission Four-speed

GENERAL

Wheelbase 102 in.
Tread, front 51 in.
Tread, rear 50 in.
Tire size 6.00x16
Weight 3110 lb.
Turning circle 31 ft.
Steering wheel turns lock to lock 2 $\frac{3}{4}$
Front suspension Independent front suspension with wishbones and long torsion bars
Rear suspension Semielliptic springs
Brakes Lockheed hydraulic, 12-in. drums with cooling ducts on front drums
Electric equipment Two 12-volt batteries, 64-amp. capacity
Gasoline capacity 15 gal.

correct skids quickly. From lock to lock only 2 $\frac{3}{4}$ turns of the wheel are required. This is a good safety feature, even though more effort is necessary to turn the wheels. Turn circle is small (31-foot diameter).

The four-speed gearbox is synchromesh in second, third and fourth speeds, with a fourth-gear ratio of 1:1 which, with the rear-axle ratio of 3.54:1, enables the Jag to cruise at high speeds with little effort or strain. I found the best maximum speeds on level ground for shifting up are as follows: From first, 30 miles per hour; from second, 63 miles per hour; and from third to fourth, 85 miles per hour.

The short, stubby gearshift lever is handy for top performance in traffic or on winding roads where quick shifting is often desired. A hand shift is a "must" for every true sports-car driver.

It is definitely a high-performance car

(Continued to page 252)

FOR ASSEMBLY · REPAIR and INSTALLATION WORK

ELIMINATE DROPPING AND FUMBLING HEX HOLLOW-HEAD SET SCREWS and CAP SCREWS

WITH THE **NEW**



OVER 200 TYPES AND SIZES IN STOCK

WALDEN

in-a-grip

TRADE MARK WRENCHES PATENTS PENDING

WRITE FOR CATALOGUE

MANUFACTURED EXCLUSIVELY BY

STEVENS WALDEN Inc.
480 SHREWSBURY STREET
WORCESTER, MASSACHUSETTS

FOR OVER 50 YEARS MAKERS OF SPINTITES, GRIP SPINTITES, FORCE-FORMED SOCKET WRENCHES — AND ALL TYPES OF MECHANICS' HAND TOOLS

ALSO CHILD'S 2 PASS. MOTOR CAR

Write For Free CATALOG

ESHELMAN HOLDS 1 ADULT

AUTO WITH MOTOR

LOWEST PRICE
70 Miles Per Gal. Gas
25 Miles Per Hour

Eshelman

DEPT. MC-51
109 Light St.
Baltimore, Md.
333 N. Michigan Ave.
Chicago 1, Ill.
7070 Hollywood Blvd., L. A. 28, Calif.



Adults Write for Free Catalog

For Best Results! Use

a white glue — invisible when dry
DAMP-PROOF HARMLESS

WILHOLD GLUE

Finest Quality with Oxidant

PLASTIC APPLICATORS Always Dependable



WILHOLD PRODUCTS CO., Los Angeles 31 · Chicago 44

JOINT AND SHARPEN ALL SAWS

SAVE TIME AND \$\$\$



Sensational new Super Filer No. 11 joints and sharpens both hand and circular saws 6" to 10" with all teeth the correct height, depth, pitch and bevel. Easy to use—when file hits hardened steel roller, teeth are finished. Saw runs true and smooth with no side pull. Complete with special 8" file \$9.95 ppd. **FREE FOLDER.**

"TRU-CIRCLE" saw set. Automatically sets teeth at 10° or more \$2.95. **FILE SAWS THE RIGHT WAY**

Guaranteed



SO EASY with this new filing jig and jointer anyone can now sharpen any handsaw like new! When file hits hardened steel rollers teeth are finished and EXACTLY THE SAME HEIGHT. All teeth cut and saw runs true and smooth. Jig and instructions \$2.95 postpaid. Free Folder. A. D. MCBURNEY, 5908 Hollywood Blvd., Hollywood 28, Calif., Dept. A-15

BUY



...and save!

Save up to 20% on fuel by weather-stripping with INNER-SEAL! Tough, flexible INNER-SEAL seals heat IN, seals cold OUT. INNER-SEAL is neoprene-coated, waterproof, abrasive-resistant. It fits perfectly even on warped frames ... lasts for years.

INNER-SEAL is available in handy "do-it-yourself" Queen B and B Paks — in the exact lengths you need to weather-strip doors, windows and storm windows. Complete instructions on how to weather-strip printed inside every pak.

Protect your overhead garage doors! Heavy-duty INNER-SEAL Garage Door Cushion prevents splintering, keeps out dirt, moisture, cold.

FREE! "Why & How To Weather-Strip" booklet — available where you buy your hardware or building supplies.

OR. WRITE: DEPT. PM1,



BRIDGEPORT FABRICS, INC., BRIDGEPORT 1, CONN.



New Mending Tool

Build and repair with this handy workshop helper. New polyvinyl acetate adhesive is ready to use, forms strong, long-lasting bond on wood and other porous materials. Sets fast. Dries clear. New squeeze bottle makes gluing faster, cleaner, easier. Get the large 8-oz. workshop size. \$1.00 at leading hardware stores. Write for folder. The Borden Company, Chemical Division, Dept. PM-15, 350 Madison Avenue, New York 17, N. Y.



© T. B. C.

ELMER'S[®] GLUE-ALL

FINISH BRASS CASTINGS YOURSELF!

SAVE \$10⁰⁰

on this solid brass
CANDLESTICK SET!

Save up to 1/2 on 24 brass items!

Exciting new craft for all home craftsmen. Finish beautiful, heavy weight brass items for home, gifts or big profits. No experience required. Save up to 1/2 by finishing candlesticks, trivets, doorknockers, picture frames, etc., from castings produced by one of America's leading quality brass foundries.



WOODWARD BRASS FINISHING KIT

\$9.25

**PAYS FOR ITSELF IN A
FEW HOURS OF USE!**

WRITE TODAY for free wall chart showing all 24 items, plus instructions, prices and full information on finishing kits. No obligation.

Kit shown is for 3/4" drill

**WOODWARD Finish-It-Yourself BRASS
READING, PENNSYLVANIA**

and the Jaguar's makers claim it to be the fastest stock-production car in the world. It will loaf along at 100 miles per hour and, by speedometer, will hit 130-132 but, like American speedometers, a check showed the British Smith speedometer to be about 8 percent fast at top speed.

The ride is not soft and springy by American standards, but the independent front suspension, using wishbones and long torsion bars coupled with a rear suspension of semielliptic springs controlled by Girling hydraulic shocks, makes the car hold the road with little bounce, float or sponginess. The low-slung body and chassis still boasts a 7 1/8-inch ground clearance, comparable to American cars.

Lockheed hydraulic brakes with 12-inch drums are used. Front drums are fitted with air-cooling ducts. Jaguar brakes are definitely improved over earlier models and at all speeds the car could be brought to a straight-line stop without side pull in either direction, although the pedal pressure is harder than is necessary for braking most American cars.

The gasoline economy, for a high-performance sports car, is good.

Jaguar certainly offers many different features as compared to our cars. The driving position is excellent and one feels as though he is a "part of" and master of the car, due to the low center of gravity and the seating position. Like most other sports cars, entering or getting out of a Jag takes a little body "English" or twisting, but practice soon makes the entry a simple routine matter.

The Bluemel telescopic steering wheel can be moved in or out about three inches so that the driver may select the driving position that suits him best. Once a position is selected a large nut locks the wheel in one position. If desired, the wheel position can be changed while driving.

The divided bucket-type seats are finished in good-quality leather but, by American standards, they are rigid and without much spring—but a sports-car driver likes them that way. They can be individually adjusted. The body has a rigid feel and the doors open and close easily. The British must like to turn cranks for, unlike the quick-action steering wheel, it takes 3 1/2 turns of the short crank to lower or raise the window of the convertible.

The clutch pedal requires considerable pressure, as does the brake pedal, and the foot must be lifted 4 1/2 inches from the throttle pedal to reach the brake pedal—which is too much. The hand-brake lever, located alongside the shift lever is locked instead of released by pushing down on the

(Continued to page 254)

SKYMASTER PALM SIZE RADIO

A real electron tube radio... no toy! Reception clear as a bell up to 1000 miles. Covers broadcast band 540-1600 KC. Sold worldwide except behind Iron Curtain. All parts, hearing aid batteries, fit in case. Parts precision-built, fully guaranteed. KIT includes tube and photodiagram for easy assembling. Batteries \$1.15 per set. Reg. \$2.50 ALNICO MAGNET EARPHONE only \$1.45 or 1900-ohm Hearing Aid Earset (\$10 value) only \$4.95. C.O.D. orders accepted with \$1 deposit. Canadian orders please remit in full.



\$5.95 KIT

POSTPAID
FACTORY ASSEMBLED
(set only) \$8.95

PRECISION ELECTRONICS, Placerville, Calif.

Treasure - Minerals - COINS
Easily located with new Light-weight M-Scope Detector. Superior performance, lowest price, monthly payment plan.
FREE LITERATURE
FISHER RESEARCH LAB., INC.
PALO ALTO CALIF.

FREE BOAT KIT CATALOG
8' to 14' Models from \$39.95 incl. freight

- Assemble your own boat
- No experience necessary
- Save 1/3 to 2/3 "factory built" prices

Write: Marine Hardware, Fiberglass, & Trailers
DEPT. D 4452 NICOLET AVE. MINNEAPOLIS 9, MINN.

HYDRAULICS
Build-Up-Own Dozer, Hay-Fork, Loader, Hoist, etc. 25c brings PLAN with essential hydraulic information & big Catalog of Hydraulic-kits, Arc Welder-kits, Surplus items, etc. Send today.
DUNBAR MFG., Box 12206-8B Houston 17, Texas

"Do-it-Yourself" Begins With How
"How to Work With Tools and Wood" makes the basic do-it-yourself skill easy for handyman or homeowner. Fully illustrated, only \$2.00 postpaid. Order from Stanley Tools, 62 Elm Street, New Britain, Conn. In Canada, write to Stanley Tool Co. of Canada 62 Stanley Street, Roxton Pond, Quebec.

THE TOOL BOX OF THE WORLD
Hardware • Electric Tools • Steel Strapping • Steel

GET THIS STRAIGHT you can't beat an EMPIRE LEVEL

For improved accuracy, better visibility, less breakage, use the new Empire 9" aluminum Torpedo pocket level with machined bottom groove and protected, easy-reading vials. See your dealer today for all-purpose Empire Levels.

EMPIRE LEVEL MFG. CO. | 10930 W. Potter Rd., Dept. PM Milwaukee 13, Wisconsin

Make BIG MONEY with this combination a.c. welder - a.c. power

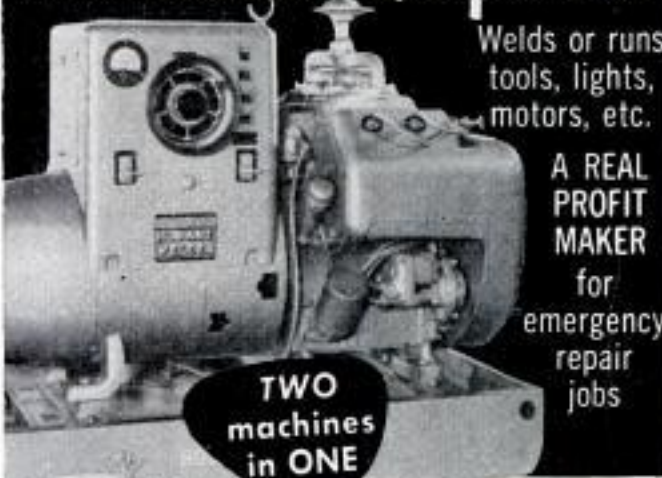

Welds or runs tools, lights, motors, etc.

A REAL PROFIT MAKER for emergency repair jobs

TWO machines in ONE



200 Amp. AC Welder-AC Power Combination, four cylinder air-cooled engine. Furnishes 200 amperes of welding current and 5,000 watts of AC power alternately. Easily mounted on your truck or trailer for quickly getting to where it's needed on a moment's notice.



"Husky Boy" 200 amp. welder driven by a 2 cylinder air-cooled engine. Perfect for outside or around the shop welding. Handles the big pay jobs.

AC Power or AC Welder. An excellent dual purpose combination available in 200 and 300 amp. welding sizes. Can be belted or coupled direct to your own gas engine.

Transformer Type AC Welder 250 amp. A real welder for production and repair work in shops that have only single phase power available.

"Bantam Champ" 250 amp. electric motor driven welder for general shop use. Ideal where compactness and low investment are prime considerations.



Investigate these BIG MONEY MAKERS today



Hobart School of Arc Welding
Learn arc welding quickly by actual on the job experience at the non-profit Hobart Trade School. Complete or partial courses.

Modern Arc Welding Lessons 200 pages. Fully illustrated. Learn practical arc welding in your spare time. Only \$1.00.

Clip this COUPON and mail today
HOBART BROTHERS CO., BOX M-15 TROY, OHIO, Phone 21223
"One of the world's largest builders of arc welding equipment."

Please send additional data on items checked:

"Husky Boy" AC Power-AC Welding **free!**

AC Transformer "Bantam Champ"

Hobart Welding School Welding Lessons, Welder's Vest Pocket Guide \$1.00

NAME _____

ADDRESS _____

CITY _____ STATE _____

BUILD YOUR OWN POWER TOOLS - WITH GIL-BILT PARTS KITS

Exclusive GIL-BILT Build-It-Yourself Features

- No machining—build easily with hand tools only
- No blueprint reading—step-by-step pictorial plans, full scale patterns, actual photographs
- Sturdy wood, aluminum and steel construction
- Capacity and performance of commercial saws selling from \$60 to \$250.
- Proved performance. Nationally advertised and sold for 7 years. Satisfied customers around the world.

GIL-BILT 10-in. TILT/ARBOR SAW



- 27x28 in. table, 13 1/2 in. capacity in front of blade
- 10 in. blade cuts 3 1/4 in. deep, tilts full 45 degrees
- Floor model 34" high, table always stays level

- New Departure ball bearing arbor, 3/4" precision shaft turned down for 3/8" bore blades, alum. housing, shipped ready to run
- Jackscrew and 4 1/2 in. dia. handwheel lowers and raises blade
- Cast aluminum miter gauge and self-aligning rip fence guide

GIL-BILT Metal Parts Kit includes Plans, ball bearing arbor, miter gauge and bar, rip fence guide, dado insert, lock knobs, jackscrew mechanism and handwheel, and all other metal parts (less blade) \$22.95
 Same Kit with 10" Combination Blade \$26.90
 Same Kit with 8" Combination Blade \$24.90

GIL-BILT 12-INCH BAND SAW

- Cuts to center of 24 inch circle
- Handles stock up to 6 inches thick
- 18x18 inch table tilts 45 degrees
- Lower wheel and drive pulley runs on sealed New Departure Ball Bearings! Upper wheel runs on two 3/4" bore Oilite Bronze bearings
- Upper wheel tension and tilt mechanism of cast aluminum, completely assembled
- Upper and lower blade guides, Each has ball thrust bearing, self-lub bronze jaws
- Rigid cast aluminum wheels fully machined ready-to-install. Heavy rubber tires
- Uses standard 78 inch blades up to 3 1/2 in. wide
- Fully enclosed mechanism for utmost safety



GIL-BILT Metal Parts Kit includes Plans, rubber tires, aluminum wheels, 1/4 in. blade, ball bearing spindle, tilt mechanism, blade guides, table tilt segments and all other metal parts. \$23.95

ALSO AVAILABLE
 Plans & Parts
 Kits for 18-in.
 Band Saw, Belt
 Sander, Spindle
 Shaper, 8-in.
 Tilt/Table Saw

Return kits in 10 days for refund if not satisfied.
 For shipments up to 600 miles, add 5%; over 600 add 10%.
 Amount in excess of actual postage will be refunded.
 Order kit now, or order Plans at \$1.00 each and kit later less cost of plans. Write for FREE Catalog.
 Dept. 80-A, Lambert Field
 St. Louis 21, Missouri

GILLIOM POWER TOOLS

Warm, Dry Floors

With Amazing **ZONOLITE**[®] INSULATING CONCRETE

IDEAL FOR

- Basementless Houses
- Garages
- Farm Buildings

Blocks Condensation, Prevents Heat Loss!

Building or remodeling a house, garage or farm structure? Here's a way to be sure of warm, dry floors all year 'round! One inch of Zonolite concrete insulates as well as 12 to 16 inches of ordinary concrete! **LIGHTWEIGHT... easy to mix. You can do it yourself!** A good investment in any building for comfort, fuel savings; for increased profits from farm stock.

See your building supply dealer for FREE estimate on how much Zonolite Concrete Aggregate you'll need for your job.

Zonolite Company, Dept. PM-15
 135 S. LaSalle St., Chicago 3, Ill.
 Please rush free "How-to-do-it" manual. No obligation.

Name.....
 Address.....
 City.....Zone....State.....



button on top. Jag calls it a "fly off" type. It is handy for quickly applying and releasing the hand brake in an emergency or in cornering because it will fly back to the off position automatically. It is also excellent for use in starting up on a hill.

The horn will not blow unless the ignition switch is on. A directional-signal lever is located directly above the horn button, with a warning light working when the lever is set for a turn in either direction. Twin electric windshield wipers operate satisfactorily. The instruments are well-located in a walnut-wood instrument panel which appears expensive but old-fashioned.

Of course, no true sports-car enthusiast would be found dead without a tachometer on his car. Many drivers shift and drive by the "tach" to indicate when gears should be shifted for best performance.

Mounted within the Smith's tachometer dial is an electric clock with very small but readable dial. One unusual feature is part of the gasoline gauge. When the gasoline supply is almost exhausted, a small warning light flashes—a good idea. Oil and temperature gauges are mounted under a single glass dial.

As in most sports cars, rear vision in the convertible is not good because the tiny cowl mirror has small scope and the rear window glass is very small. The side-mounted mirror is more useful. Front vision, however, is excellent and little red guide lights appear at each front-fender tip. There were no sun visors on the convertible, but the chaps with the long-visored caps may not need them for, like golfers, fishermen and other outdoor sportsmen, they like the sun, front or rear.

One thing the foreigners do supply is an excellent set of tools, as does Jaguar. Many sports-car owners like to tinker with their cars. A central jack operates amidships to lift both wheels on one side of the car at the same time in case of a tire change.

The bumpers should be deeper and should afford more protection for use in traffic and parking. They are definitely too narrow and many cars with massive bumpers do not match up with the bumper positions of the Jag. Sometimes this causes damage to body, grille or trunk-lid handle and lock.

The acceleration of the Jaguar is great. Its excellent road-holding qualities, low road position of the car and its unique suspension make it fun to drive. Its performance came up to my expectations. It isn't exactly the type of car that every John Doe would enjoy for driving through traffic or for use as a family car, but it definitely offers something that cannot be had in any mass-produced American car. ★ ★ ★

MODERN**LAWN MOWER SHARPENER****COMPARE
BEFORE YOU BUY**

Write for
free
booklet
10E

Oil remains in engine while sharpening. Bed knife sharpened in same centers — no attachments needed.

Start your own
business—increase
your income

Sharpens any mower in ten to twenty minutes. Handles complete assembly of all reel types including 36 in. power mowers. Handle, wheels, roller, and engine are not removed.

\$26300**MODERN MFG. CO.**

F.O.B. PASADENA

160 N. FAIR OAKS, PASADENA, CALIF.

**ELECTRIC WELDER**AC or DC
110 Volts

The "Little Marvel" all-metal welder. 5-year written guarantee. Welds 1/4" metal or money back. Repairs tanks, tools, fenders, machine parts, etc. Complete with everything — rods, unit, eye shield, directions. \$6.45 plus 50c postage. Flame torch accessory for soldering, cutting, brazing \$3.95 complete with carbons, brass rods, flux. \$2.00 Deposit on C.O.D. 1/4 inch Transformer Welder \$19.95 F.O.B.

\$645
Complete

ESSAY MFG. CO., Dept. 51, Quincy 69, Mass.

**FREE FOLDER "HOW TO SAND"**

ADDRESS "Handy" SANDY

CARBORUNDUM®

Niagara Falls, New York

SHOPMASTER'S

NEWEST SENSATION

**COMBINATION
POWER TOOL**

It's... Cuts Saw
Drill Press, Sander,
Router, Shaper, Lathe
All in One

For Complete Information Write Dept. 10U
1214 S. 3rd St., Minneapolis, Minn.

SHOPMASTER, INC.**ONE-MAN SAWMILL** LOW AS **\$50.00** DOWN

Take BELSAW Portable Sawmill right to the trees — turn out valuable lumber for home and farm — sell to local yards — make up to \$50 a day custom sawing for neighbors. BELSAW lasts a lifetime. No crew needed. Power with tractor or auto engine. Beginners get excellent results. Send today for **FREE BOOK**.

BELSAW MACHINERY CO.
8119 Field Bldg. Kansas City 11, Missouri

BUILD HELICOPTER GLIDER

The famous new GYRO-GLIDER, world's simplest and safest aircraft, is now available to amateur builders in plans and kits. Send **\$1.00** now for three-view drawings with specifications and ask about kits and detailed building and flying instructions.

BENSEN AIRCRAFT CORP., Dept. PM-1
P.O. Box 2621 Raleigh, N. C.

ONLY **\$1** Name _____ Address _____
City _____ State _____

Greatest Thrill in Flying!

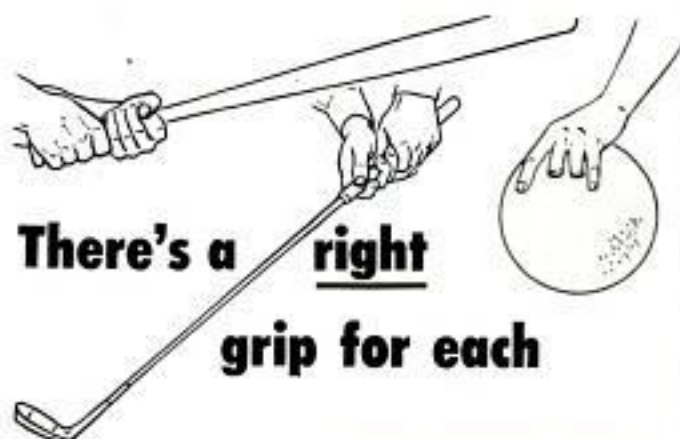

There's a right
grip for each

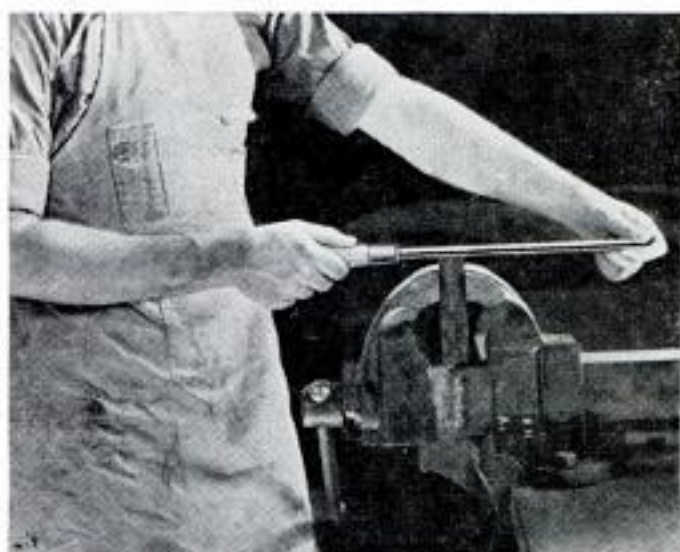

IN FACT, there's usually a right grip for each situation you face and each result you want to achieve. In filing both the right type of file and the right grip, stroke or touch are necessary—(a) for the kind of metal you are filing; (b) for the roughing, finishing, smoothing or sharpening the job calls for.

Nicholson's famous 52-page book, "File Philosophy" (in a new edition just off the press), is rich in information on the subject.



It also illustrates and describes a comprehensive assortment of Regular, Special Purpose, Curved Tooth, Swiss Pattern and Rotary files every skilled homemaker or professional mechanic will be proud to own. The book is **FREE—send for it.**

Nicholson and Black Diamond file brands have no superior anywhere in the world. Good hardware stores pride themselves in selling them.

NICHOLSON
U.S.A.

NICHOLSON FILE COMPANY

22 Acorn St., Providence 1, R. I.

(In Canada: Nicholson File Company
of Canada Ltd., Port Hope, Ontario)

BLACK DIAMOND
U.S.A.

NICHOLSON
FILES FOR EVERY PURPOSE

INCOME TAX MONEY SAVER pay only your fair share!

There's no question of what you owe when you keep an **INDIVIDUAL TAX SAVER** record. Complete instructions included. Order today!

VAN LOON BROS. Dept. PM-1
Box 8758 University Park Station
Denver 10, Colorado

ENCLOSE

50c



Paramount AIR COMPRESSOR

COMPARE Price — Features — Savings!

Reg. \$24.95. Ball bearing piston-type compressor of revolutionary new design. Can't be matched as an all-purpose, low cost unit. New principle operates it on conventional $\frac{1}{2}$ HP—BUT delivers MORE air than ordinary $\frac{1}{2}$ HP unit. For professional paint spraying, tire inflating, insecticiding and hundreds other uses in shop, farm, home! Delivers 2 $\frac{1}{2}$ cu. ft. air per minute. Includes Tank—Air Gauge and Air Regulator for adjusting pressure from 0 to 100 lbs. Order now and SAVE! Satisfaction guaranteed or money back. We pay postage.

\$12.95

FREE Catalog of ELECTRICAL EQUIPMENT VALUES
ROBERTS ELECTRIC CO., 849 W. Grand, Dept. P-244, Chicago 22, Ill.

Print Your Own

Cards, stationery, circulars, tags, labels, photo and movie titles, advertising, etc. Save money. **Print for Others, Good Profits!**—rules sent. Raised Pricing like Engraving, too. Sold direct from factory only. Write for free catalog of outfits and all details. **KELSEY PRESSES, M-37, Meriden, Conn.**

Join the
**MARCH
OF DIMES**

in

January



Is This the Last Stand Of the Iron Horse?

(Continued from page 87)

motive-power men, however. And more than five years ago they got together with Baldwin-Lima-Hamilton, Westinghouse and the Babcock and Wilcox Company.

The problem they faced was the development of a heavy-duty locomotive that had the flexibility of electric drive, but which burned coal for its fuel.

Actually, the idea of a steam-turbine-electric locomotive was not new. Other locomotives, embodying similar features, had been built, operated—then scrapped.

The fault, engineers felt, lay in the boiler design. Previous steam turbines had used low-pressure boilers that gave poor fuel results. At least one ran into continual boiler trouble because of the stresses resulting from rapid drops of pressure every time the train was started.

So Babcock and Wilcox came up with a water-tube boiler in which a 600-pound pressure is maintained over the entire operating range by automatic controls.

N&W men say any crew on the board can take the 2300 up over the mountains after only a short period of instruction. C. E. Pond, the general superintendent of motive power, says it's even easier to operate than a conventional steam locomotive.

How is it working? The higher-ups in the N&W motive-power department won't talk—yet. Although 2300 has been in regular service since May 31, with a dynamometer car loaded with testing gear hitched right behind the tender, performance data has been kept a deep, dark secret pending completion of exhaustive tests.

But around the shops and among the men who have worked with the big boy since its inception, you sense a feeling of optimism and accomplishment.

"It's doing everything we thought it would, and then some," one young engineer said in an unguarded moment of enthusiasm.

The locomotive hasn't been given a formal name yet, although one imaginative writer dubbed it "Jawn Henry" after another legendary railroad figure and publicity men have fallen in line. Around the shops, though, it's more often referred to as "the big one."

Anyway, you come from the roundhouse with the feeling that the Norfolk and Western has got something.

Some of those concerned are already worrying about what will happen to the 2300s when the atomic-powered loco comes on the scene.

★ ★ ★



INTERNATIONAL
HIGH SPEED STEEL SAW DRILL BIT

Insist on the genuine original

DRILL, SAW, REAM . . . metal, pipe, wood, plastic, Transite, etc. Use with electric drill, slow drill press, lathe, milling machine. Drills own starting hole, upper part of bit is used to cut, saw, ream circles, ovals, squares, scrolls. Easy to use. Ideal for carpenters, mechanics, electricians, plumbers, hobbyists, etc. Abrasive resistant, high speed steel. Flutes ground from solid. Withstands severe continuous use without breaking. Resharpens free. Takes place of up to \$50 in tools. 1" diameter, 2" cutting sections, total length 31". Three types—All Purpose, Wood, Heavy Metal. Specify type needed. Set of three \$11.50. Details on request. Shipped same day. Money-back guarantee. Dealer inquiries invited.

Order Now Send Cash, Check or Money Order to
INTERNATIONAL TWIST DRILL CORP.
618 Wyandotte, Rm. 632, KANSAS CITY, MO.

Only \$395
POST PAID

Viking TRACTORS & TILLERS



\$89.50
and up

1 and 2-wheel
Terms as low as \$10 per month

Write for free catalog today!

American Farm Mach. Co., Dept. J-204
1061-33rd Ave. S.E., Minneapolis, Minn.
43 Church St., Pawtucket, R.I.

Porter-Cable

Homemaster Tools

MAKE A "Stradivarius"
VIOLIN

—For Pleasure
—For Profit
—For Your Own Use

BOOK AND PLANS ALL YOU NEED



**You Can Do It at Little Cost!
It's Easy! It's Fun!**

Here is the "tops" of all home crafts projects. Make a violin—a replica of a famous "Strad"—the original of which sold for \$80,000.00. Joe Reid who has made hundreds of fine violins makes the job so easy—so inexpensive—in his new book "You Can Make a 'Stradivarius' Violin." You don't need any tools. Reid shows you how to make all the tools you need from old table knives, worn out files, sheet metal, etc. Eight full-size plans, 14x21 inches folded into the book give you every detail in actual size.

Violins Bring High Prices

Make a violin and you probably will never want to sell it. But good tone modern violins bring terrific prices, yet the materials cost comparatively little. With Reid's plans and step-by-step instructions you can make such a violin for yourself. 15 chapters guide you in selection of wood, fashioning the belly, back, sides, mold, lining, neck, scroll, purfling. Other chapters cover varnishing, finishing, stringing. Others show how to make tools and clamps at little or no cost.

Order Book Today. Money Back if Not Satisfied.

Make your own violin for pleasure or profit. Get book and plans now. Clip this ad and mail with check, money order or cash for only \$3.50 or we will ship C.O.D. Money back in 7 days if not satisfied.

FULL SCALE PLANS INCLUDED
Working plans, drawn to full scale, are included in a special pocket inside the book where they may be withdrawn for quick and easy reference.



Complete Instructions
8 Actual Size Plans
How to Make the Tools You Need
Where to Get the Materials

You trace or work direct from actual size plans. No measurements to translate or confuse you. You see the entire violin in the plans. You read the how-to-do-it instructions in the book.

\$3.50 Cloth Bound
ORDER FORM IN BACK

POPULAR MECHANICS PRESS

Dept. 30
200 E. Ontario St., Chicago

INSTALL YOUR YOUNGSTOWN KITCHEN NOW—AND SAVE!



You'll have a lot of fun installing your own Youngstown Kitchen. You'll save money. And it's easy. Steel Youngstown Kitchens units are precision built, to go together perfectly.

WE SHOW YOU HOW



"Do It Yourself" book, loaded with easy-to-follow illustrations, shows how to install your own Youngstown Kitchen. See how easily and quickly you can do it, using only a few simple everyday tools.

FREE DECORATING ADVICE

"Answer Book" shows Youngstown Kitchens units, illustrated suggestions for floor coverings, drapery fabrics, enamels, wall coverings, base cabinet-top colors.



STEEL Youngstown Kitchens
SEND COUPON NOW

Youngstown Kitchens, Dept. PM-155
Mullins Manufacturing Corporation, Warren, Ohio

Please send 16-page, fully illustrated "Do It Yourself" book, 12-page full-color "Answer Book," and big 32-page "Installation Manual." I enclose 10c for mailing (no stamps, please).

NAME (Please print) _____

ADDRESS _____

CITY _____ ZONE _____

COUNTY _____ STATE _____

© 1955 Mullins Manufacturing Corporation

Get FASTER STARTING NO VIBRATION MORE MILEAGE



from
**AMERICAN
EAGLE**

PERMA-GAP
PATENTED
SPARK PLUG

**NO FOULING
NO BURNING
NO CLEANING
NO ADJUSTMENT**

The only spark plug to receive the
MERIT AWARD from the AMERICAN
SOCIETY OF INDUSTRIAL ENGINEERS

**FASTER, SURER STARTING EVEN IN SUB-
ZERO TEMPERATURES — LAST LONGER**

Reason: RADIAL CATHODE gives a 360° Foolproof Arc of fire area — HOTTER — STRONGER spark — will not foul with oil, gas, or water. Radial Cathode acts as a baffle which prevents carbon and fouling inside of spark plug. Radial Cathode transfers heat faster, prevents burning of spark plug — lasts longer. Try them on your car — Truck, Tractor, etc. and see the difference.

ASK YOUR DEALER or
ORDER TODAY — Costs no more
for better, longer performance.

Introductory Price

Send check or money order — C.O.D.'s
accepted — DISTRIBUTORSHIPS OPEN

\$1.00

Postpaid

AMERICAN EAGLE Perma-Gap SPARK PLUG CO.
8655 Military Ave. Detroit 4, Mich.

MILLING MACHINE

COMPLETE WITH MOTOR, CHIP PAN & VISE

6" long.—1½" trans.—4" vert. **\$149.50**

MONEY-BACK GUARANTEE

DESIGNED BY CHILDS
Heavy duty Machine Tool. Suggested cast-iron const. Precision ball-bearing spindle. Dovetail ways. For do-it-yourself or small mach. shop. Wt. 50 lbs. Order now for prompt delivery.

Southern Machine Tool Co., Coners, Ga.



find URANIUM with ATOMS



Gun Type

SCINTILLATION COUNTERS
100-times more sensitive than a Geiger Counter. Currently used by Atomic Energy Commission for Uranium prospecting. Excellent for airborne, mobile or foot prospecting. From \$299.50 up.



Prospector

\$84.50

The "PROSPECTOR", Model GC-228—a portable, light (2½ lbs.) ultra-sensitive Geiger Counter for radio-active ore prospecting. The first to utilize a patented Printed Circuit. Uses low voltage batteries. 3 methods of indication—flashing neon light, earphone & meter with 3 ranges of sensitivity. \$84.50 complete. **RADIAC CO., INC., 489 Fifth Ave., Dept. PM-1, N.Y. 17, N.Y.**

How to Operate Your New Color-TV Receiver

(Continued from page 162)

easy servicing and that two speakers are employed for high-quality sound distribution. See sketch G for further details of the electron-gun assembly that is installed in the neck of the tricolor-picture tube.

When the back cover is in place, the rear-panel supplementary controls appear as in sketch F. The average color-TV-set owner will leave these to his serviceman. Students and experimenters will find interesting data on the adjustment of these supplementary controls in the manual. These supplementary controls need adjustment so infrequently as to be negligible. The three-position area-selector switch allows you to adapt the receiver to your location.

A color, as compared to monochrome, signal contains a number of additional signals which must reach the receiver for

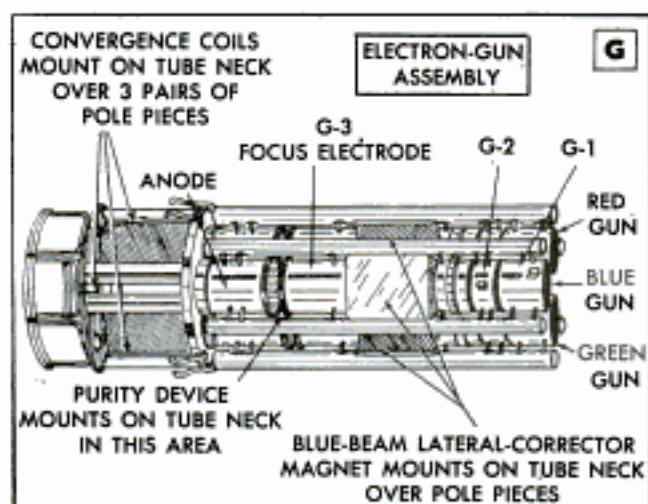

good color reproduction. Color reception requires a broad-band type of antenna. Narrow-band, single-channel antennas are unsatisfactory. In strong-signal areas, indoor antennas often give good color reception; however outdoor broad-band types are best. Colored room lights and colored lamp shades should be avoided as they can change the color rendition. Sketch H shows a tuning dial arranged for the UHF stations, to include channels 14 to 83. ★ ★ ★

(ONLY FOR SETS EQUIPPED FOR UHF CHANNELS 14-83)

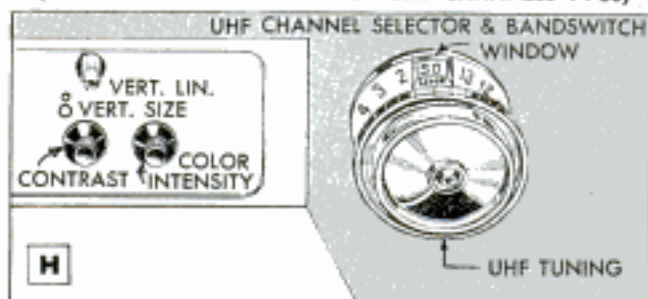

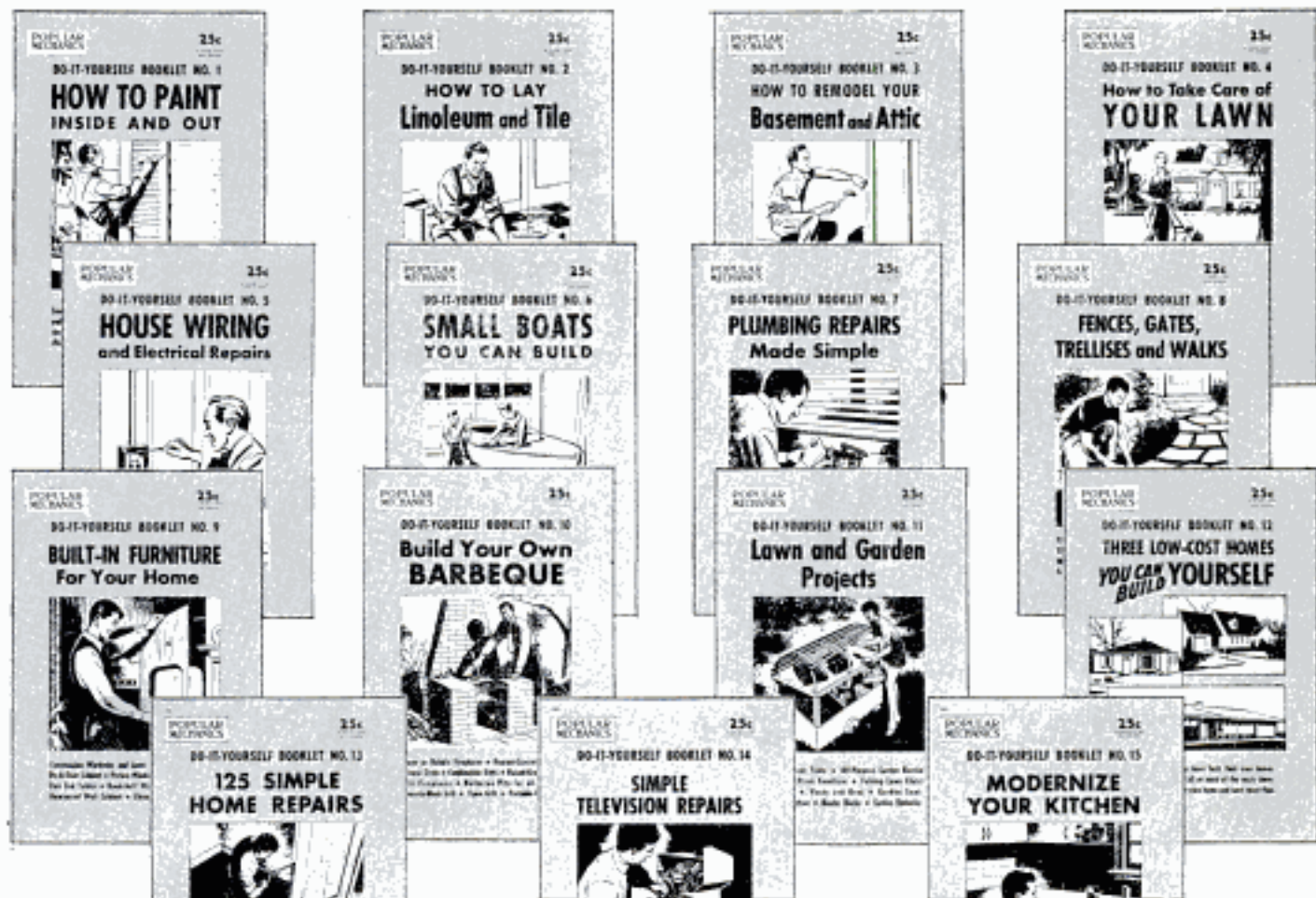

NOW — MAKE DO-IT-YOURSELF PROJECTS EASY

GET THESE NEW POPULAR MECHANICS DO-IT-YOURSELF BOOKS

- 1. HOW TO PAINT INSIDE AND OUT.** Complete guide to home painting. Covers both interior and exterior work as well as surface preparation, types of paint and necessary equipment.
- 2. HOW TO LAY LINOLEUM AND TILE.** It's easy to do a professional floor or wall tiling job with this book to tell and show you how. Simply follow step-by-step directions and photos.
- 3. HOW TO REMODEL YOUR BASEMENT AND ATTIC.** Convert your damp basement or unused attic into usable living space. Includes construction details and finishing suggestions.
- 4. HOW TO TAKE CARE OF YOUR LAWN.** A finer, greener lawn can be yours. Instructions cover preparation, fertilization, seeding, watering, mowing, etc.
- 5. HOUSE WIRING AND ELECTRICAL REPAIRS.** If you wish to add a few new outlets, or do a complete re-wiring job you'll find step-by-step instructions in this book.
- 6. SMALL BOATS YOU CAN BUILD.** Take your choice from several sturdy seaworthy rowboats, runabouts and sailboats. All are completely detailed to make actual construction easy.
- 7. PLUMBING REPAIRS MADE SIMPLE.** Save money by making the majority of your plumbing repairs yourself. Covers leaking valves and faucets, clogged drains, and many other repairs.
- 8. FENCES, GATES, TRELLISES AND WALKS.** Beautify your

- home with these attractive, easy-to-build garden ornaments. Several designs of each are included with building details.
- 9. BUILT-IN FURNITURE FOR YOUR HOME.** Make your home more livable and efficient with well-designed built-in furniture. Includes built-in television, bookshelves, etc.
- 10. BUILD YOUR OWN BARBECUE.** Hours of summer-time fun are yours with a sturdy attractive outdoor barbecue. Includes several designs each with detailed plans and instructions.
- 11. LAWN AND GARDEN PROJECTS.** Make your garden your restful summer-time living room. Build chaise longue, attractive comfortable lawn chairs and other garden furniture.
- 12. THREE LOW-COST HOMES YOU CAN BUILD.** Includes a concrete block house you can build for less than \$4500; a story and one-half modified Cape Cod and an 81-ft. ranch for \$7450.
- 13. 125 SIMPLE HOME REPAIRS.** Save hundreds of dollars on home repairs. Includes complete directions for correcting sticking doors, squeaking floors, gutter maintenance and more.
- 14. SIMPLE TV REPAIRS.** Make many television repairs yourself. Tells how you can correct most television defects; how to change tubes and make adjustments for improved reception.
- 15. HOW TO MODERNIZE YOUR KITCHEN.** Now—have a modern kitchen with up-to-date conveniences. Includes layouts, cabinet construction details and all necessary information.

**ONLY
25¢
EACH**

6 FOR
\$1.25

15 FOR
\$2.75

USE HANDY ORDER COUPON BELOW

POPULAR MECHANICS PRESS, 200 E. Ontario, Chicago 11

Gentlemen: Please send copies of book nos.: 1: 2: 3: 4: 5: 6: 7: 8: 9: 10: 11: 12: 13: 14: 15: (circle numbers desired)

Remittance enclosed

Send C.O.D.

I enclose \$ _____

Name _____

Address _____

City _____ Zone _____ State _____

TAKE PICTURES LIKE THE PROFESSIONALS

WITH A

Graphic[®]
23



**1 SCARCELY BIGGER THAN
YOUR HAND**

2 UNMATCHED VERSATILITY



CENTURY GRAPHIC[®]



CROWN GRAPHIC[®] 23



SPEED GRAPHIC[®] 23

The Graphic 23's are true professional, press-type cameras. They have everything you need to take almost any kind of picture, day or night. Though small and light, they give you rugged dependability available in no other camera! No other 2¼ x 3¼ camera can do so much so perfectly. Step up to a Graphic. See the complete line at your Graflex dealer's. You can own one for as little as \$24 down!

For your nearest Graflex dealer, consult your classified telephone directory.

GRAFLEX[®]

PRIZE-WINNING CAMERAS

Write for information: Dept. PM-15,

GRAFLEX INC., ROCHESTER 8, N. Y.

I Chose a Steel-Frame House

(Continued from page 102)

doorway so that from the door I can switch on a table lamp. The other contacts in the outlet remain "hot" at all times.

Other lighting is provided by incandescent lamps or fluorescent tubes recessed above ceiling panels of corrugated plastic.

My ceiling consists of four-by-four-foot panels of glass-fiber insulating material spray-painted a pleasing light shade. These rest on the lower flanges of the I-beams and on steel straps that divide the areas between the I-beams into appropriate spaces.

There is a 12-inch space above the ceiling which represents the depth of the I-beams. All the wiring for the house as well as the gas pipes for heating and cooking run in this space through small holes cut in the beams. All hot and cold-water piping may also be placed above the ceiling. If one of the overhead utilities ever requires service you can reach it simply by lifting out one of the ceiling panels.

For heating I used counterflow forced-draft gas-fired heating furnaces at two locations. Hot air from the furnaces circulates through large perimeter ducts along the outside edges of the floor slab.

The exterior of the house is painted with a plastic coating that was developed to stand up under severe industrial and chemical conditions. It is expected to last several times longer than most ordinary house paints. For the interior I selected a vinyl-resin coating that is available in numerous decorators' colors.

I used cork tile on much of the concrete floor slab, vinyl-tile flooring in the kitchen and bathroom areas and carpets in the bedrooms. Wall paneling in the dining area is another new product. It consists of wide, thin strips of walnut veneer woven together in a diamond pattern and then compressed flat in a press.

Other features of the house include clothes hampers that are built into the walls and that have enough room for large amounts of soiled clothes, gas-stove and oven-broiler units that are built right into the kitchen cabinets with an automatic timer for the oven, sliding wardrobe doors that extend all the way up to the ceiling and a front-door peephole with a swivel eyepiece so that all parts of the front entrance can be viewed.

Kitchen and bathroom tile has striking designs that were created by the silk-screen process, then baked in permanently by firing in a kiln. Another attraction is a rotating platform in the cabinets alongside the fireplace. A table-top television set on

(Continued to page 262)

for flawless, scratch-free finishes . . .

Insist on DREMEL

STRAIGHT LINE ACTION SANDERS

Did you know there are 4 different sanding actions? In choosing a power sander, it's the kind of sanding action that counts. To do the job right, you must sand with the grain. Sanding across the grain with a circular or orbital motion leaves scratches and swirl marks which scar the finish and show up after varnishing. Only DREMEL STRAIGHT-LINE ACTION sands with the grain, guarantees flawless, scratch-free finishes. Choose from 3 sizes. Hobbyist, craftsman, housewife—there's a DREMEL sander to fit your need.



EXCLUSIVE!

Quick-action detachable pad. Extra pad free.



MODEL 2000

Sander-polisher, 14,400 strokes per min.; wt. 5 lb.; 21 sq. in. surface. Steel carrying case, pad, 25 abrasives.

\$24.50

MODEL A

Sander-polisher-massager, wt. 2 1/2 lbs.; 12 sq. in. surface. Polish pad, massage pad 6 abrasives.

\$14.85

NEW MODEL "53". Here's a real powerhouse, driven by a ROTARY MOTOR. Weighs only 5 1/4 lbs., has 24 sq. in. sanding surface. Out-performs others costing much more. Positively the best heavy-duty sander buy on the market. Complete with 2 detachable sanding pads. **\$34.85**

STUDY THIS CHART!

Of the four common sanding actions, only Dremel sands 100% with the grain—the only guaranteed scratch-free action approved by finishing experts.



SEND FOR FREE CATALOG OF DREMEL TOOLS—SEE YOUR DEALER: If he cannot supply order direct on 5-day trial, money-back guarantee. Remit in full for postpd. shipment; or send \$2, pay postman balance plus postage and COD.

DREMEL MFG. CO., Dept. 115-A, Racine, Wis.

Build Your Own Walks,
Driveway, Outdoor
Fireplace, Steps, Etc.

What to Make With CONCRETE



The terrific high costs of even little concrete jobs are mostly for labor. Get Popular Mechanics **WHAT TO MAKE WITH CONCRETE** and save all the labor costs while making your home or farm ship-shape. You can lay foundations, sidewalks and driveways; build steps, outdoor fireplaces, sandboxes, tennis courts, garden and swimming pools and other installations at very little cost. Book shows all — tells all — how to make the right mixture, plan, apply and gives 50 professional short cuts. Hundreds of pictures. Only \$2.00 postpaid. Order today. Money back if not pleased.

POPULAR MECHANICS
PRESS

Dept. PM17, 200 E. Ontario
Chicago 11, Ill.



HOW TO BUILD Your Own GARAGE

Save Up to 50% of Usual Cost!

Get Popular Mechanics' brand new book **How to Build Your Own Garage** by Wayne Leckey, Assistant Shop Notes Editor, and find out how you can build your own garage at savings of 50% of usual cost. Leckey tells in clear step-by-step instructions and shows in big, clear photos, drawings and diagrams how to perform every building operation from laying the concrete to installing the final trim. There are 25 designs. Brick, frame, and concrete block fully covered. Send \$3.50 for your copy. 7-day money back guarantee.

POPULAR MECHANICS PRESS, 200 E. Ontario, Chicago 11, Ill.

ARE YOU DRIVING Holes IN YOUR CAR?



A cupful of anti-freeze escaping into your engine can cause serious damage. Don't let this happen to you! Bar's Leaks, containing Rhizex, will STOP WATER LOSS AND DANGEROUS ANTI-FREEZE SEEPAGE!

Bar's Leaks contains tiny soft particles which fill any minute holes or cracks and anneal in the heat of the engine, thus forming a permanent seal. A combination of oil and fine non-abrasive particles, resists rust chemically and inhibits scale mechanically. Bar's Leaks scrubs away damaging deposits and maintains a stable lubricative coolant which prolongs the life of your water pump.

Your car needs a Bar's Leaks PREVENTATIVE MAINTENANCE TREATMENT every 5000 miles.

Approved and used by world's largest automobile manufacturers

\$1.00 IN U.S.A.
and CANADA

FREE: Write for new brochure, "Truth and Consequences"

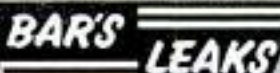

BAR'S PRODUCTS SUPPLY, INC.
5871 S. Telegraph Rd., Dearborn, Mich.

send for **FREE CATALOG**

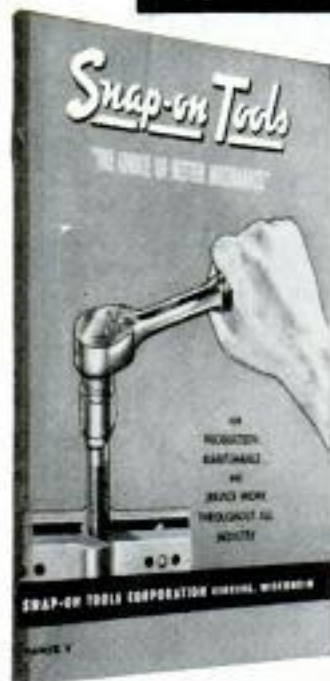

America's Foremost
money-making
MECHANICS'
TOOLS

It's easy to own the same "pay-off" tools used and endorsed by America's top-earning mechanics throughout the automotive, aviation and industrial fields! Snap-on tools help you handle every repair job faster, easier, better. And they LAST... pay for themselves over and over again! Start building your own tool set now with basic Snap-on units—add others any time. Genuine Snap-on tools are never sold in stores—direct to users only. Mail coupon for free catalog.



Snap-on Tools Corporation
8062-A 28th Ave., Kenosha, Wis.

Send me free catalog. Occupation _____

Name _____

Address _____

City _____ Zone _____ State _____

Also Eshelman SPORT CARS LOWEST PRICE 70 Miles Per Gal. Holds 1 Adult. Free Catalog

ESHELMAN CAR SNOW PLOW
CLEARS ROADS & DRIVEWAYS

Attached to car or truck in 2 minutes without tools. Clears snow 24" deep and full width of car. Lightweight, sturdy. Order Now. Enclose \$10.00 deposit. We pay freight. Balance C.O.D.

ESHELMAN, Dept. SP-51
109 Light St., Baltimore 2, Md.
333 N. Michigan Ave., Chicago 1, Ill.
7070 Hollywood Blvd., Los Angeles 28, Calif.
(Or write for Free catalog)

\$39.95 COMPLETE

FIRM FOUNDATION for HOME-MADE TRAILERS

Utility Axle
Assemblies

Model 1-UCO, shown, features 1 1/2" solid steel axle, loads 2500 lbs. Comes completely equipped, except for tires. \$65.29 postpaid (when paid in advance). Many other models. We manufacture a complete line of trailer axles, couplers and jacks... tell us what you need!

HAMMER BLOW TOOL CO.
WAUSAU 13-A, WISCONSIN

this platform can be turned so it can be seen from the living room, from out-of-doors or from the dining area.

The house has some 2250 square feet of heated living area. When an additional 265 square feet are added (half the area of the garage and porches) for estimating purposes, the house cost \$14 per square foot to build. This figure includes all normal profits for the contractors, but does not include the price of the land or the cost of architects' plans or financing.

By eliminating the remote-control garage-door operator, the budget set aside for landscaping and for draperies and by other economies, this house could be built for \$12.50 per square foot. Construction-wise it would be no different.

The steel-pipe columns, I-beams and the other materials are available in all parts of the United States, so a house like this can be built anywhere. In extremely rigorous climates the cost might rise a few cents a square foot because of extra floor insulation and a larger-capacity heating plant.

You can build as large a house or as small a house as you want with this construction system. Practically any floor plan can be adapted to it. Its basic principle is a four-foot module (the width of the exterior wall panels) and costs are kept down when this module is followed. Unless you have had considerable experience in steel fabrication and erection this is not the kind of building that the average "do it yourself" home builder can put together. It calls for a portable welding and cutting outfit and the knowledge of how to use these tools.

There's one thing about a house like this that's an actual handicap: It is so novel in appearance, especially when the steel frame is standing by itself, that people passing by just can't help stopping in to ask questions. Time is money and that runs up the costs. And some craftsmen and subcontractors are lost at first. Plumbing drains, for instance, have to be laid out with care ahead of time, before the floor is poured or the partitions are erected.

Too, carpenters and electricians find that they can't nail into the overhead beams as usual. Then they learn that wonders can be done with a welding torch. With the portable electric-welding outfit you not only weld the house frame together, you tack onto it all the brackets and clamps that the subcontractors require. With the same torch you cut holes through the steel just where they are needed.

Memmler spent a couple of years working out all these details and the final result is a house that's a masterpiece of construction. ★ ★ ★

GIGANTIC
SAVE-TO-70%

MAIL SALE

WAR SURPLUS
EXCESS INVENTORY
BANKRUPT STOCK

GIANT FRESNEL LIGHT

● Amazing 110-V with intensifier fresnel, 12 ft. adj. tripod, spare bulbs, expensive case, etc.
Cost over \$200.00.....\$49.50

AC PLANTS GENERATORS

● Army's finest plant, 115-V, 60c. 3000-4000 watt, 4 cyl. water cooled. Only...\$349.50
● Also many other buys plants and generators all sizes.

SURVEYORS LEVEL

● Leading make complete with rod, tripod, case, instructions...\$37.95
● Level-transits...\$77.50
also at.....\$77.50

ARMY PARTS CLEANER

● Air turbo solvent cleaner. Makes dirty, greasy parts shiny bright. 25"x20"x20"....\$29.95

FIRST AID CHEST

● Expensive Army complete metal 10" x 10" x 3" case full essential items, with instructions.....\$6.95

DELUXE ARMY TOOL CHEST

● Finest wood cabinet design. 19" x 38" x 20". Lift out drawers. Cost over \$50.00.....\$21.95

**SELSYN
ROBOT MOTORS**

● Marvelous units. Permit transmission mechanical motion over wires. Make weather units, burglar, etc. Cost over \$82.50, two for...\$12.97

AUTOMOTIVE TESTER

● Tests starters, generators, ignition all cars. Full instructions. Made for U. S. Army.
Cost over \$70.00.....\$14.67

GOV'T. AIR TANK

● Portable 300 lb. unit, fill at filling station, holds air indefinitely. Complete as shown, only...\$15.95
● Also values in compressors, valves, gauges, hose, etc.

BOMB HOIST

● Great unit. 1500 ± cap. 21 to 1 ratio, 12 ft. lift. Ready to use. Cost over \$125.00.
Special.....\$27.49

EXT. TELEPHONE

● Wall phone same used on city systems. Use as extension, inter comm, etc.....\$4.99
● Also farm phones, desk phones, etc.

ELECTRONIC MISCELLANEOUS

- W. E. Photo Cells.....49c
- Tetratron Trigger Tube.....98c
- Ultra-Black Life Tube.....48c
- Generator 30-V, 200-A, 110-V AC...\$29.00
- Fire Burglar Alarm Unit.....99c
- Farm Wall Telephone.....\$9.95
- Desk Phone.....\$1.99
- Remote Automatic Switch \$13.95

SPECIAL OF MONTH

● Genuine Garwood worm drive ball bearing powerful Power Winch. 12,000 lb. cap. Complete with clutch.
● Drum size 14" wide x 12" long.
● Overall size 27" x 16" x 16".
● Shaft 1 1/2" in diameter. Extends 2" out from case.
● Exceptionally fine unit for trucks, tractors, dozers, etc.
Orig. cost over \$275.00.
Prepaid.....**\$169.50**

HYDRAULIC CYLINDER

● Expensive precision 1 1/2" bore 4" stroke, 2-way cyl. use for steering boats, remote control, lifting, pushing, etc.
Cost \$87.50.....\$3.89 each.
● Many other hydraulic items in catalog.

HYDRAULIC FARM CYLINDER

● Leading make, 3 1/2" bore, 8" stroke.
Fine for plow lifts, etc. List \$25.00.
Special.....\$11.95
● Also pumps, valves, hose, etc.

We Pay All Freight and Postage!

ORDER FROM AD or write us for big **FREE CATALOG!** 1000s of items! Motors, sporting goods, hand and electric tools, watches, tarps, etc., etc. We pay all freight.

BURDEN SALES COMPANY
803 "O" Street LINCOLN, NEBRASKA

OWN A...

PLYMOUTH?

FIX IT YOURSELF!

Popular Mechanics Magazine has published an Owners Manual covering all 1941 to 1952 models of Plymouth cars. So accurate mechanics use it... so simple a woman can understand it.

Save money on your Plymouth repairs. Prevent trouble. Enjoy care-free driving. Increase trade-in value. Avoid major repairs by fixing minor troubles before they get serious. Get sparkling performance at all times. Has 272 pages, more than 350 photos, diagrams, tables, charts, breakdown drawings, plus clear, non-technical directions that make all repairs simple as ABC. Written by Ed Packer with assistance of Chrysler Corporation. Shows you how to diagnose Plymouth troubles by feel, sound, sight, smell and performance. Simple trouble shooting. Permanent repairs. Emergency repairs. Plus, "How to get value from garages."



MONEY BACK IF IT DOESN'T SAVE MORE THAN IT COSTS!

One minor repair will save the cost ten times over. Read it. Then you decide. If you don't see that you'll save more than the cost, send it back for refund. SEND NO MONEY. Send postcard. Ask for PLYMOUTH Manual. Postman will deliver C.O.D. for \$3.50 plus postage. Or, save postage by sending \$3.50 with order. Send today. Save its cost on your next repair.

POPULAR MECHANICS PRESS

200 E. ONTARIO DEPT. 18 CHICAGO 11, ILLINOIS

8-INCH TILT ARBOR SAW

\$19.95

Factory to You

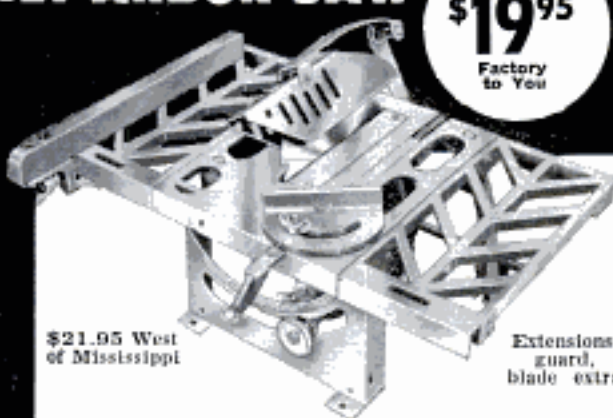

\$21.95 West of Mississippi

Extensions, guard, blade extra

PRECISION GROUND CAST IRON TABLE

Miter Gauge and rip fence included — standard equipment.

Rips, Miters, Bevels, Dadoes, Makes Mouldings.

Patented blade tilt mechanism and patented ball bearing motor mount.

BIG CAPACITY — CUTS 2 x 4's AT 45°

TIME PAY PLAN

YOURS FREE for the asking—amazing free trial plan and full information. Send postcard.

15 DAY FREE TRIAL

POWER TOOLS INC.

167A Yates Ave. Beloit, Wisconsin

Get Our Big Manual of "HARD-TO-GET" ITEMS

For home craftsmen, wood workers, industrial art departments, furniture repair men, hobbyists, cabinet makers, etc. Send only 50c today for your copy.

A few of the items we sell: Inlays, fancy cabinet wood, lumber, Ebony, Holly, Dimension cut lumber, lignum vitae, Carving Blocks, Turning Squares, 120 kinds of veneers, Abrasive papers, archery woods, bill-board clamps, binswings, bed fasteners, blueprints. Chair braces, brass chain, brass fencing. Craftsmen books, candlestick holders, candlestick sockets, card table hardware, casters. Chair cane, ceramic tiles, clamp nails, crib hardware, Dowels and dowel pins, dovetail centers, drawer rollers, felt, Flock finishes, foam rubber, furniture clamps, composite professional finishing materials, Folding tables, hand tools, Furniture pulls, modern and period, chest and ornamental hardware, all types of hinges and locks, small box hardware, Inlaid picture kits, Inlaid card table legs, leather working tools, Micarta, revolving Lazy Susans, musical movements, moulded wood carvings, Metalcraft material, Moto sander, nut bowl hardware, Picture frame moldings, Pee Cut Wood Pix, perforated steel panels, pilaster standards, plastics and plexiglass, internal carving bits, plastic polishing compounds, Electric routers, sanders, foot rheostats, hand drills, sprayers, revolving fixtures for television tables, chairs, etc. Fibre rush, screw hole buttons, spiral saw blades, sliding door track, sharpening stones, home owners specialties, 100 woods, oak woods, platform rocker springs, Table leaf supports, tack rags, thermometer cards, turned furniture legs, typewriter fixtures. Complete upholstery supplies. Veneer presses, wood burning pens, wood working instructions, black and copper wrought iron hardware, zigzag wire.

Send fifty cents today (refunded on 1st order) for your copy of the Country's leading Catalog, "Constantine Manual for Craftsmen" to:

ALBERT CONSTANTINE & SON, Inc.
Dept. PM-1 797 East 135th St. New York 54, N. Y.

Also
Eshelman
Sport
CARS.
LOWEST PRICE
70 Miles
Per Gal.
Holds
1 Adult.
Free Catalog.



Women can operate it.
Free Catalog. Write
**ESHELMAN, Dept. R-51, 109 Light St.,
Baltimore 2, Md., 333 N. Michigan Ave., Chicago 1, Ill., 7070 Hollywood Blvd., Los Angeles 28, Calif.**



Esther Williams swims toward the realistic-looking sunken wreck covered with moss and rubber barnacles

Even the Stagehands Have to Swim

(Continued from page 96)

the seams. The front of the blimp contains a large faceplate of half-inch optical glass, and that serves as a window for the lens. Behind the camera another port in the blimp allows the cameraman to read the footage indicator on the camera.

By means of remote controls on the outside of the blimp, the cameraman can start and stop the camera, change focus and diaphragm setting, adjust his view-finder lens and make all the other changes required.

The neutral-buoyancy feature is provided by a complete aqua-lung unit similar to those worn by the cameramen and technicians. Operated by water pressure, a valve automatically admits air into the blimp from a compressed-air storage cylinder when the camera is moved downward in the water.

Four hollow buoyancy tubes on top of the CinemaScope camera (two for the lighter, wide-screen camera) are used as stabilizers that normally keep the camera upright when under water. Arnold provided each unit with a battery-powered propeller so it could move along under its own power while the cameraman swam or walked beside it.

Complete with its cameras and lenses, each neutral-buoyancy blimp cost \$22,000. Both have performed so well that MGM is thinking about making more underwater movies, some of which may be filmed below the surface in their entirety. ★ ★ ★

PUNCH PRESS

2 Ton Power Bench Type
Make Your Shop Complete
Powerful — Dependable — Economical

Easily make your own dies for light stampings, forming, riveting etc. Ideal for production or experimental work. Replaces more expensive presses. Requires only 1/2 H.P. motor. Weight 105 lbs. Fully guaranteed. Only \$97.50 less motor. Write for free circular. Dealer inquiry invited

ALVA F. ALLEN, Dept. PM, Clinton, Missouri

SHEET METAL BRAKES

New eccentric clamps. Forms angles, locks, pans, etc. Mount on bench, truck or floor stand. All steel construction. Size 15"x16 gauge, 40 lbs. \$21.50; 30"x20 ga., 65 lbs. \$28.50; 30"x22 Ga., 80 lbs. \$33.00; 48"x24 ga., 110 lbs. \$48.00; 72"x24" ga., 140 lbs., \$90.00. Floor



stand, 22 lbs., \$7.00. Shipped Collect. 24" Squaring and slitting shear cuts sheet metal, plastic and wire. For bench mounting \$38.00. Floor stands \$7.00. Express Collect. Shears 7" by 16 gauge, straight or curved, any length cuts 1/8" aluminum bars. \$12.50 collect.

ORDER DIRECT. OR SEND FOR CATALOGUE.
VYKE MFG. CO., P-2439 15th St., Denver 2, Colo.

**PLANNING TO
BUY OR BUILD
A BOAT?
LOOK FOR THIS
WELDWOOD® TAG**

IT'S YOUR GUARANTEE
that the plywood used in
the boat won't delaminate,
is the best made!



UNITED STATES PLYWOOD CORPORATION
World's Largest Plywood Organization
55 West 44th Street, New York 36, N. Y.

Build a Better Garage for One Half the Cost!

Get New Popular
Mechanics Book Be-
fore You Build, Buy
or Plan Any Garage

How to Build Your Own GARAGE

25 beautiful designs
Save half the cost!
Over 200 illustrations,
plans, and drawings
show you how to build
a frame, brick or block
garage, etc.

Build It Yourself or
Have it Built—Either
Way You Save and
Get a Better Garage

Over
500
Pictures

The Answer to All Garage Problems

Here is the answer to every garage problem. If you can use a hammer and saw, you can save hundreds of dollars on a fine new, modern garage. Get "How to Build Your Own Garage," Popular Mechanics' simplified How-to-Do-It book for the amateur builder and follow the pictures and instructions. If you prefer to have your garage built by others, get this book first for it can solve any garage problem you may have.

Prepared especially for the inexperienced builder by Wayne C. Leckey, associate crafts editor of Popular Mechanics, with the assistance of many builders, manufacturers and associations in the building, lumber and hardware fields. It TELLS HOW in simplified, step-by-step instructions—SHOWS HOW with hundreds of plans, diagrams and actual photographs.

Money Back Guarantee

Mail the coupon for "How to Build Your Own Garage" today. Use the book for 7 days and return it for full refund if it does not please you. You can't lose under the P. M. guarantee of satisfaction or your money back.

25 Designs to Choose From

Every type—every style—every size. All shown in actual photographs to help you make your own choice. Actual building plans available for many of the garages shown.



Two-car frame garage amateur can build and getting garage under cover with large sheets of plywood. Both illustrations from the book.

Use This Money Back Coupon

POPULAR MECHANICS PRESS, Dept. GB-2
200 E. Ontario St., Chicago 11, Ill.

Send at once, "How to Build Your Own Garage" under your 7 day trial, money-back guarantee. Remittance for \$3.50 enclosed. Send postpaid. Send C.O.D. (U.S.A. only). I will pay postman \$3.50 plus charges.

Name _____

Address _____

City _____ Zone _____ State _____

new!

Starrett STEEL RULES with no-glare Satin Chrome finish

All the advantages of *Satin Chrome Finish*, pioneered by Starrett, are now available on two new Starrett steel rules.

No-glare, hard wearing, multi-plate *Satin Chrome Finish* makes it easy to read the rule at any angle, in any light; speeds up readings; eliminates eyestrain; helps avoid errors. It also resists moisture, acids, perspiration, rust and stains.

Available through your Starrett distributor in two types — *full flexible* and *spring tempered*. Write for descriptive folder No. 322. Address Dept. AP

No. C604RE
6" and 12"
SPRING
TEMPERED
with 8ths and
16ths on face,
Quick Reading
32nds and
64ths on
reverse, 1/32"
and
graduations.

No. C309R
6" FULL FLEXIBLE with
16ths and Quick Reading
32nds on face, Quick
Reading 64ths on reverse.

SEND FOR IT — ONLY 10¢
Starrett "Tools and Rules" Book
50 page booklet shows the right tools
for any precision measuring job. 100 pic-
tures plus helpful reference tables. Send
only one dime. Address Dept. SP.



THE L. S. STARRETT COMPANY · ATHOL, MASS., U.S.A.



MECHANICS' HAND MEASURING TOOLS AND PRECISION INSTRUMENTS
DIAL INDICATORS • STEEL TAPES • PRECISION GROUND FLAT STOCK
HACKSAWS, BAND SAWS and BAND KNIVES

Build it Yourself! Furniture • Furnishings • Work Benches • Children's Toys • Shelves • Boat • Cupola • Weathervane • With

Popular Mechanics
NEW

FULL SIZE PATTERNS

Authentic Designs by Professional Designer
Trace Patterns on Wood and Follow Simple Guides
Every Step Made Easy for Building at Home.

Now you can make modern furniture, a fine work bench, toys for the children, fancy shelves, even a 12-foot motor boat and other things you want and need. But best of all, you can save money and turn out articles with that sought-after professional look. Popular Mechanics presents the first group of many new full size patterns for home craftsmen. They are the designs of John Bergen, noted furniture designer, working with the craft editors of Popular Mechanics—the big name in home shop and craft projects.

So easy to use, these full size patterns make play of most wood-working jobs.



Modern Step Table

No. 104. New and original design to match cocktail table Number 103. 28 x 18 inches. Upper step 24 inches high. A modern and stylish addition to any living room. 1 pattern. 50 cents



Decorative Wall Shelves

No. 110. Two attractive, distinctive wall shelves you can build to beautify your home. You can choose either modern or traditional styling. Modern shelf with metal trim is 28 x 16 x 8 inches. Traditional design is 29 1/2 x 16 x 8 inches and includes attractive fret work. Drawers can be eliminated if desired. 2 shelves in one pattern. 50 cents



Modern Cocktail Table

No. 103. Beautiful new and original design with plank top and metal grill inserts in sides. 40 x 19 inches, 15 1/2 inches high. Fun to make and a joy to own. 1 pattern. 50 cents



Modern Tub Chair

TV Chair



No. 112. A real all-out lounging chair in attractive modern design. Seat is 22 inches deep, 24 inches wide. Overall, 28 x 27 inches, 27 inches high. Simple foam rubber upholstery over Sagless type wire springs. Your choice of cover. 2 plans. \$1.00



Personal Work Bench

No. 108. Here's a compact, sturdy workbench designed to stand up under frequent use and provide a maximum amount of work space in a small area. Top is 44 x 20 inches, 35 inches high. Drawer and sliding doors. Completely enclosed, it provides a large amount of storage space for tools, materials, etc. 2 patterns. \$1.00

Juvenile Chest Robe



No. 106. A good-to-look-at and convenient-to-use wardrobe for the little folks room. 30 inches wide, 16 inches deep, 39 inches high. Has two drawers, shelf and hanging storage space. Cabinet and drawer construction simplified. 2 patterns. \$1.00

No. 111. Beauty and comfort are well combined in this TV Chair. Seat 22 inches deep, 24 inches wide. Overall, 27 1/2 x 32 1/2 inches, 26 1/2 inches high. Uses simple Sagless type wire springs. Instructions included for easy-to-do upholstery with new foam rubber method. 2 patterns. \$1.00



Trundle Beds

No. 102. Space-saving, safer beds for young people. No ladder to climb. Easier to make up. One bed tucks away under the other. Size 90 x 45 1/2 inches. Top bed 40 inches high. Lower bed 23 inches high. Storage cabinet in head. Springs included in patterns. Uses standard size mattress. 3 patterns in set. \$1.50

POPULAR MECHANICS NEW FULL SIZE PATTERNS

Each pattern lists the materials needed and shows you what type and size of lumber to choose. Then you lay the patterns on this lumber, trace, saw, smooth edges and put the pieces together. It's as easy as that, for every nail, screw, bolt, dowel and joint to be glued, is located for you on the pattern. You can't go wrong. You can't make a mistake.

If you can use a hammer and a saw and other simple tools, you can do a genuine professional-like job with any pattern you choose. What's more you'll get a lot of fun and personal satisfaction making good-to-look-at and useful things and save more money than you spend.



Love Seat

No. 114. Beautify your home with this smartly designed, comfortable love seat. A truly fine piece of furniture you can be proud to own. Modernized Lawson style goes well with either modern or traditional furnishings. 48 inches between arms. 21 inches deep. Overall, 55½ x 29 inches. Upholstery is new Sagless type wire springs with foam rubber padding. Your choice of covering material. 2 patterns in set. \$1.00

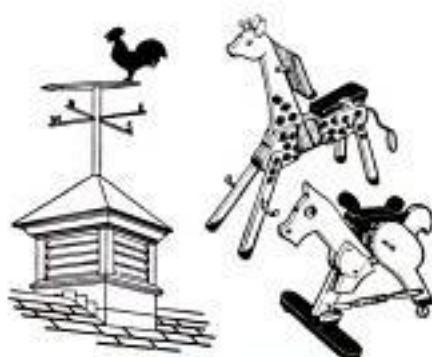

Cupola and Weathervane

No. 107. Design and style that invites use on home in town, on farm, or on garage or other smaller building. Cupola is 24 x 24 inches. 34 inches high plus height of weathervane, which can be made of metal or tempered hardboard. 1 pattern. 50 cents



Sofa Bed

No. 113. A full size sofa by day and a comfortable bed for one by night. Sagless type wire springs built-in. Uses standard size 4½ inch, foam rubber or other mattress. Removable bolster. Overall size 78¾ x 29¾ inches. Height 33 inches. 2 patterns in set. \$1.00



Valances and Trims

No. 109. Add charm and beauty to your home quickly and inexpensively with these drapery valance designs and other attractive designs for interior use around windows, cabinets, between wall cabinets in kitchen, etc. and for exterior use on porches, gables, etc. Merely trace patterns on the wood, saw to traced lines and then assemble. Finishing suggestions are included. Adjustable for various widths and lengths. 12 designs on 1 pattern. 50 cents

Toys for the Children

No. 105. The "Giraffe Drawing Board" with board mounted on the long neck and adjustable seat. "Backing Bronco" the riding toy with delightful action. Patterns include assembly instructions and painting suggestions. Both on one pattern. Build these for your children today. 50 cents

Order by Number or Use the Coupon

Select from this listing of the first 14 sets of Popular Mechanics full size patterns. Every article shown has actually been built from one of the patterns. Every pattern has been proven for design, correct fit of parts and construction details and is guaranteed to please you or the full purchase price will be refunded. Order on handy coupon.

Order Blank for Popular Mechanics Patterns

Popular Mechanics Press • 200 E. Ontario St. • Chicago 11 MS-1

Send at once. Popular Mechanics Full Size Patterns as indicated below. Remittance for \$_____ enclosed. Send postpaid. I understand that any pattern which does not please me may be returned within 7 days for full refund of purchase price.

—Crusette. Utility Outboard (101)	\$2.00	—Personal Work Bench (108)	\$1.00
—Trundle Beds (102)	1.50	—Valances and Trims (109)	50c
—Modern Cocktail Table (103)	50c	—Decorative Wall Shelves (110)	50c
—Modern Step Table (104)	50c	—TV Chair (111)	1.00
—Toys for Children (105)	50c	—Modern Tub Chair (112)	1.00
—Juvenile Chest Robe (106)	1.00	—Sofa Bed (113)	1.00
—Cupola and Weathervane (107)	50c	—Love Seat (114)	1.00



CRUSETTE 12 Foot Utility Outboard

No. 101. Build this sturdy 12-foot utility outboard at amazing savings using only ordinary hand tools. Previous experience is not necessary. A fine seaworthy craft, ideal for fishing, family outings and other general utility uses. Length 12 feet. Beams 4½ foot. Complete material list and step-by-step instructions included. 4 patterns in set. \$2.00

Name _____

Address _____

City _____ State _____

SURE THEY'RE GOOD!

...you set
the standards
yourself



Products with brand names that you call for again and again are literally just what you order, because you yourself are constantly dictating their quality standards.

Your approval is the measuring stick that manufacturers go by. *You* decree how a seam will be sewn, an edge ground, a design balanced. *You* say if a flavor will be sharpened, a fragrance tempered, an angle softened, a color heightened. Products stand or fall on your acceptance . . . so their makers keep quality up, UP to the point that keeps you buying.

Man, you're the boss. And lady, you couldn't be closer to quality control if you sat in the manufacturers' collective lap.

*Guide to good buying: the ads
in this magazine.*

BRAND NAMES FOUNDATION INCORPORATED

A NON-PROFIT EDUCATIONAL FOUNDATION
37 WEST 57 STREET, NEW YORK 19, N. Y.

**WANT QUALITY? PATRONIZE THE DEALER
WHO PROVIDES YOUR FAVORITE BRANDS**



How to save money on all plumbing jobs — using approved methods.

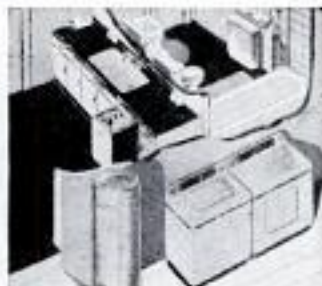

How to select materials and fixtures.

Save on Plumbing Costs

When You Build · When Making Improvements · Repairs · Maintenance

Do All Kinds of Jobs Yourself With Home Plumbing Guide

Got a leaky faucet; a clogged drain; a noisy hammering water pipe? Want to add a bathroom to your home, install a new kitchen, or even build a home? Then you need Popular Mechanics' HOME PLUMBING GUIDE. It shows how you can do every kind of plumbing job yourself and can easily save you hundreds of dollars. Savings on even a small job will pay for this practical book many times over. It covers plans and layouts, installation, maintenance and repair of all home plumbing systems; tells you what materials to get and use and how to do a proper job with approved methods.

Over 500 Pictures and Diagrams and Hundreds of Money-Making Tips

Simple everyday jobs, bigger remodeling and improvement jobs and complete installations are made clear and simple and easy to follow. Few, other than the simplest tools are required and some of these can be rented. Pipe, materials and fixtures are available from mail order houses, hardware dealers and supply houses. Don't pay high prices for work you can do yourself. Get the HOME PLUMBING GUIDE. You will be amazed how the practical, text and hundreds of how-to-do-it pictures simplify jobs you thought might be difficult.

Mail Coupon. Money Back if You Want It

Get the HOME PLUMBING GUIDE today. Only \$3.50. Read it. Study it. Put the vital information it contains into practice. Then if you are not satisfied return the book for a complete refund of your money. Order today.



Mail Coupon Today for Money Back Home Trial

POPULAR MECHANICS PRESS, Dept. HPG-1
200 East Ontario Street, Chicago 11, Ill.

Send Popular Mechanics HOME PLUMBING GUIDE in cloth binding at once. I understand I may return the book in 7 days for full refund of my money.

- Remittance for \$3.50 enclosed. Send postpaid.
 Send C.O.D. (U.S.A. only) I will pay postman plus charges.

Name _____

Address _____

City _____ Zone _____ State _____

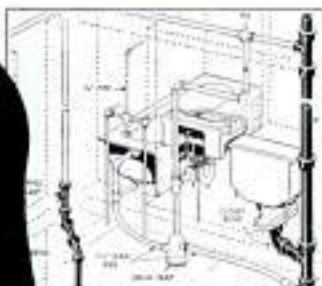

How to plan and lay out plumbing installations.

15 Ways to Save Money in Your Own Home

- All about modern home plumbing
- How to use plumbing tools in your home
- Getting acquainted with pipe
- Pointers on planning home plumbing systems
- Installing and maintaining the home drainage system
- Your own private sewage disposal system
- The causes of drainage troubles and how to cure them
- Home water lines and how to install them
- Valves and faucets and what to do with them for best and most economical service
- Your own private water supply system
- All about water heaters and automatic supply
- Methods and advantages of water conditioning
- Water system troubles and how to prevent and cure them
- How to install plumbing fixtures and take care of them for longer life

BOAT KITS

OVER 60 MODELS for 1955

Inboard or outboard—Dinghies to cruisers—8-21'—World's most complete line of real performance boats. Advanced design—modern styling—finest materials—easier to assemble! \$49.50 up.

SEND 35c for 1955 CATALOG

40 pages — includes hardware, paint, fittings, trailers, Armor-Glass, etc. SPECIAL OFFER: Catalog plus valuable book "Boat Selection, Operation, Maintenance" \$1.00. (DEALER INQUIRIES INVITED)



ARMOR GLASS

NEW SUPER-XXX FIBERGLAS

Permanently leak-proof your boat! End annual painting and calking forever! Easy to apply on any boat. Hundreds of uses. SEND 10c for FOLDER and measuring chart or send \$1.00 for folder, chart and TWO valuable booklets: "How to Use Armor-Glass" and "How to Build Fiberglass Boat or Auto." PATCH-REPAIR KIT: \$5—includes generous supply Fiberglass plus plan for tool or tackle box. (DEALER INQUIRIES INVITED)

BOAT PLANS

OVER 150 MODERN PLANS with FULL-SIZE PAPER PATTERNS

Build your boat the modern way—the easy way, with Custom-Craft patterns. Save time-money. Material lists, building procedure included. Racing classes—cruisers—inboards — outboards — sailboats, etc. 6-38'—plywood or planked. SEND 35c for DESIGN CATALOG or send \$1.00 for design catalog plus boat building handbook... explains the A-B-C's of boat construction.



BOAT HARDWARE FITTINGS

1955 MARINE BUYER'S GUIDE

Over 2000 items. World's largest, most complete catalog of full racing and speedboat accessories, general boat hardware, fittings, paints, marine engines, conversions, conversion kits and hundreds of other bargains! Big savings on nationally famous marine items! SEND 35c for CATALOG or send \$1.00 for catalog plus valuable booklet "How to Paint, Outfit and Care for Your Boat". Every boat builder or boat owner should have a copy!

CUSTOM-CRAFT · DEPT. 7 · BUFFALO 7, N. Y.

MACHINE TOOL RECONDITIONING

& THE ART OF HAND SCRAPING

— ILLUSTRATED —

SEND TODAY FOR FOLDER DESCRIBING BOOK

MACHINE TOOL PUBLICATIONS, 382 Holly Ave., St. Paul 2, Minn.



The CRANESCRIBER with plastic attachments replaces clumsy instruments. 18" RULE changes to 3' BEAM COMPASS or 18" CALIPER. ELLIPTICAL LAYOUTS up to 3' easily formed. RAISED STRIPING EDGE plus ADJUSTABLE 'T' SQUARE also provided. Ideal for homecraft or professional use. \$5.95 ppd., fully guaranteed. No C.O.D.s. CRANECRAFT, Box 76-PM Mamaroneck, New York.



Covers All Models 1940 to 1952
— All Features — Including
Powerglide
Transmission

Get Popular Mechanics Owner's Manual

If you drive a Chevrolet—any model—1940 to 1952—get this owner's manual today. It will save you money on repairs and service; give you safe, economical and trouble-free motoring and protect your investment in your Chevrolet by keeping it constantly at top value. Can easily be worth hundreds of dollars to you in a single year.

Learn All About Chevrolet's Powerglide Automatic Transmission

Know Your Chevrolet Valve-in-Head Engine and How It Operates

Understand Chevrolet's Center Point Steering and Unitized Knee-Action.

Protect Your Investment. Know Your Chevrolet.

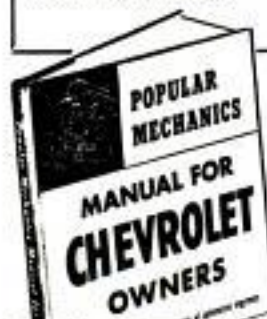

Chevrolet Owners

Spend Less to Own
and Drive Your Car

Official, Authoritative Bumper to Bumper Information

Prepared by a noted automotive authority and Popular Mechanics editors with the full cooperation of Chevrolet engineers and service specialists. Covers all phases of Chevrolet operation, service and maintenance. 304 pages of practical information and hundreds of photos, diagrams, charts, and sectional views, make every part, every operation, easy to understand. Complete index enables you to put your finger on the information you want instantly.

Prevents Costly Repairs

Explains everything about your car; what can go wrong; how proper adjustment and servicing should be done; how to prevent major troubles and costly repairs later on. Even if you don't service your car at home the manual will save you important money on every day operation.

Mail Coupon Today

Mail coupon now. Send only \$3.50 for prepaid delivery or you can pay postman, plus charges. See money back guarantee in coupon.

POPULAR MECHANICS PRESS
200 East Ontario St., Chicago

Send Manual for Chevrolet Owners at once. If not satisfactory I will return it within 5 days and you will refund full purchase price.

Remittance for \$3.50 enclosed. Send C.O.D.

Name _____

Address _____

City _____ State _____



Motorized Snow Shovel

Shoveling snow is almost fun when you use a motorized snow shovel. The unit is equipped with a $\frac{3}{4}$ -horsepower electric motor that uses household current and travels at the rate of 24 feet per minute. The 36-pound unit is given the necessary traction by the operator, who steps on a foot plate each time a "bite" is taken. Tilting the handle regulates the distance between blade and sidewalk. Heavy snow and ice are easily broken up and pushed away by the machine, according to the manufacturer, who also recommends its use in cleaning industrial waste from factory floors. Attachments for edging and cultivating soon will be manufactured.

Fishing-Rod Kits

Anglers can make their own fishing rods with kits that contain all the necessary parts including tubular glass-fiber shafts. Several different models of casting, spinning and fly rods are available. The angler assembles the parts, wrapping the guides and cementing the ferrules and rod tip in place.

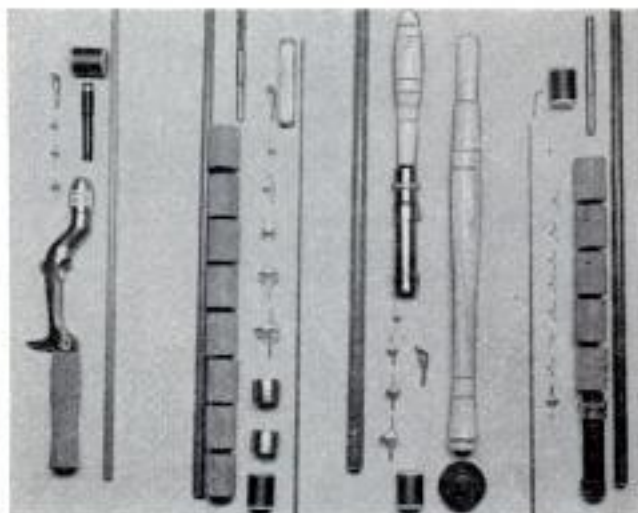

DRILL • SAW • REAM • CUT
ALL WITH ONE BIT!
BEAVER SPEED SAW DRILL BIT



ONLY \$2.45 each
3 for \$7.00
POSTPAID

Beaver's new improved high speed side cutting drill bit can be used on any electric drill, drill press, lathe or milling machine. Made from the finest American high speed steel. 3 1/2" long, 2" side cutting section, 1/4" diameter. Designed to cut steel, wood, plastic, aluminum, etc. A versatile time-saving tool for EVERYONE. Money back guarantee! Three types available: All-Purpose, Wood and Heavy Metal—specify type desired. Buy them from your dealer today! Or send cash, check or money order NOW.

Distributor inquiries invited.

BEAVER DRILL & TOOL COMPANY, Div. PM-1
 701 East 5th Street • Kansas City 5, Missouri

WELD **BRAZE**
SOLDER **CUT**



4WAY
ONLY \$14.75
 f.o.b. factory
WELDER
 Complete with
 Twin Carbon Arc
 Torch and ac-
 cessories... to
 handle all metal-
 craft work.

Acclaimed by thousands of Homeowners, Mechanics and Hobbyists as the welder of 1001 uses. Easily operated from properly wired 110 volt AC or DC line. The ideal gift with a life-long use... Order today on 10 day money back guarantee.

FOUR-WAY WELDER CO., Dept. F2-A
 1810 S. Federal St. • Chicago 16, Ill.

SAVE MONEY on SURPLUS PARTS for MILITARY TYPE TRUCKS & JEEPS

4 & 6 wheel drive. FREE catalog. State make of truck or Jeep. (New Jeep Tops, steel or canvas for all models). **AMERICAN AUTO PARTS CO., Inc., 1830 Locust, Kansas City, Mo.**

BUILD Your Own GARAGE

Save Up to 50% of Usual Cost!
 Build your own garage and save! Wayne Leckey, Popular Mechanics Assistant Shop Notes Editor, tells and shows how in his new book *How to Build Your Own Garage*.

No Previous Building Experience Required
 If you can use a hammer and a saw you can build your own garage. Leckey tells how in simple step-by-step instructions and shows how in big, clear photos, drawings and diagrams. Everything is covered from the laying of the foundation right up to and including applying the final trim.

25 Designs—Brick, Frame and Concrete Block Construction. Complete Building Data

There are 25 different designs from which you may choose. Brick, frame and concrete block construction is fully covered. Leckey tells and shows how to pour the foundation, erect the framework, erect the roof, apply insulation and shingles, lay the driveway, install trim, flower boxes, etc. It's all there for you to read and see.

7-Day Money Back Guarantee
 Get your copy of this valuable book today. Read and use it for seven days and if it isn't entirely satisfactory return it for a full refund. Send only \$3.50 for your copy to Dept. 90

POPULAR MECHANICS PRESS
 200 E. Ontario, Chicago 11, Ill.

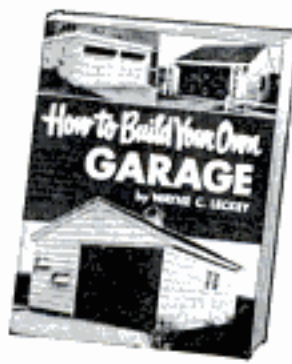

WAR SURPLUS AND OTHER BARGAINS SAVE UP TO 90%

GEAR HEAD MOTOR
 Use to turn antenna, open or close doors and windows, barbecue, displays, etc. Approx. 1 RPM. Set for 140° turning with limit switches that can be removed for full 360° turning. Operates on 24 Volt DC. 1/2" shaft dia. 3" wide, 10" long. Wt. 4 lbs. High speed 7000 RPM, 1/10 HP motor, micro-switches, reduction gears, mounting brackets—a bonanza for hobbyists. Approx. Govt. Cost \$90. In perfect condition, now just \$3.50. Mfd. by Barber-Colman Company.

SENSITIVE ALTIMETER in 10 Ft. Increments. NEW! Famous Pioneer! 0 to 35,000 ft. finches of Mercury! Tested and inspected in our own instrument lab. Guaranteed perfect. Approx. Govt. Cost \$150. NOW ONLY \$12.95 PREPAID!

NEW PUMP AND MOTOR
 Pump has 1" connections, built-in relief valve, adjustable up to 1500 lbs. Max. capacity 6 GPM. 1 1/2 H.P., 24-volt motor, 4000 RPM. Can be used on 12 or 36 volts. Govt. cost approx. \$350 — our price — NEW — \$9.95.

EXCELLENT—FIRST QUALITY "High-Test" SPEED DRILLS
 Complete set of 29 drills from 1/16" to 1/2" by 64ths. Full jobber's length. Wt. 2-1/2 lbs. A \$24.95 value. New. With 1/4" shank — \$9.95. With straight shank — \$8.95. Complete with case and size markings. Order now!

NEW IMPROVED MODEL MAUSER-TYPE PRECISION 1/1000" VERNIER CALIPERS
 Quick, handy, accurate. 6" Vernier Calipers. Glass hardened, lapped measuring surfaces. Fine engraved scales—1/1000" & 1/10 mm for inside, outside & depth measurements. Friction thumb release. Larger capacity. 2 gib adjustments. Reg. \$25. Now only \$6.95. Leather case \$1 extra.

SENSATIONAL GENERATOR BUY!! Famous Navy AC-DC Generator Combination AC-DC Type. AC voltage—115 V. 10.5 Amps. 1200 Watt. DC voltage—24 V. 200 Amps. 2 complete generators in 1... 2 separate fields and 2 separate armatures on same shaft yet no larger than regular aircraft generator. Ideal for home, farm and shop lighting plants by hooking wires to AC side. DC side can be used for welding and operating war surplus low voltage hobby motors and equipment. Weight 54 lbs. NEW. Approx. GOVT. COST \$350. NEW \$27.50. Used Perfect \$18.00.

SPECIAL CARBON PILE TYPE VOLTAGE REGULATOR to go with above generator. Incl. mounting base and completely enclosed in steel-mesh box. Helix maintain constant current and prevents pulsation. Ideal for installation with above generator for lighting plant. Wt. 5 lbs. Complete NEW. Approx. GOVT. COST \$90. Now only \$7.95

BUY 'EM BOTH - SAVE \$5.45! Generator & Regulator together \$30

P1 GENERATORS
 Electric. Auto-Lite, 200 Amps, 24 Volt, 4500 RPM. Dandy arc welder. Wt. 53 lbs. Approx. GOVT cost \$450. Like NEW. \$11.50 incl. easy diagram.

MICROMETERS Chrome plated, precision engineered, carefully tooling to give long life. All new 0-1" cap. \$2.25 ea., 1-2" cap. \$3.50.

NEW 1955 CATALOG Biggest ever... new low prices... Send 25c for your copy today. Prices otherwise stated. Check, money order or cash. 25% deposit for C.O.D.

AIRBORNE SALES CO., INC. DEPT. PM155
 8501 Stellar Drive, Culver City, Calif.

Say You Saw It in POPULAR MECHANICS



CUT BUILDING COSTS 2/3! Make Your Own Concrete BLOCKS and BRICKS To Use or Sell

New superior moulds make absolutely square, true, easy-to-lay blocks which will pass any building code. Production is fast... easy. One durable \$30 machine will make four 5"x8"x12" blocks per minute—1,000 a day. Pays for itself in one day! Sell blocks for big profit... or save 2/3 building cost for yourself. POST CARD BRINGS FREE FOLDER.

ECONOMY MFG. CO.
 DEPT. P STONE MOUNTAIN, GA.

A NEW LINE OF STARLITE ALUMINUM boats



STURDY... LIGHT... LOW COST

Six new STARLITE Aluminum Boats for '55... tops in safety, maneuverability, and beauty—yet surprisingly low in cost! Ruggedly constructed—no flimsy hulls—no maintenance worries. Good marine design assures seaworthiness, lightness, and perfect balance... feather-touch performance with oars or out-boards, and graceful planing action with even the smaller motors. Full-length spray rails and Styrofoam floats. Easy to lift and carry. Fifteen types to fill every boating need.

WRITE FOR FREE 1955 CATALOG

YOUR BEST BUY

STARCRAFT METAL BOATS

Dept. Q-1 Goshen, Ind.

BARGAIN: 1/3 H.P. Dual Purpose Portable Sprayer

3. CFM QUINCY X2 COMPRESSOR \$57.50

Low 35-45 lbs. pressure for paint spraying. High 75-100 lbs. pressure for tires, tools, etc. Portable sprayer handles any paint spraying job. Also gives high pressures for tire inflation, etc. 1/3 H.P. Westinghouse super induction 115 V. 60 cy. AC Motor. 1725 RPM. Positive Piston Type Quincy Compressor 2 x 1 3/4 in. bore & stroke. Speedy 1 Qt. Pressure Type Spray Gun, handles any type liquids. Unit complete as illustrated: Tank with wheels, 1/2 H.P. Motor, Quincy Comp., all accessories, tire chuck, cord and plug, belt & pulley, hose & Qt. Gun. Knocked Down—KD... only \$57.50
SAME UNIT AS ABOVE fully assembled—AS-3... only \$67.50

Regular Value \$95. Fob.



FREE 1 Qt. Spray Gun \$10.00 Value
complete as illustrated K.D.

Write For FREE Catalog: Listing Motors, Compressors: ALL SIZES.
C. MARSHALL SALES, 3546 W. Fullerton Av., Dept. P-1, CHICAGO 47

500 POWER! 50 — 100 — 300 — 500X

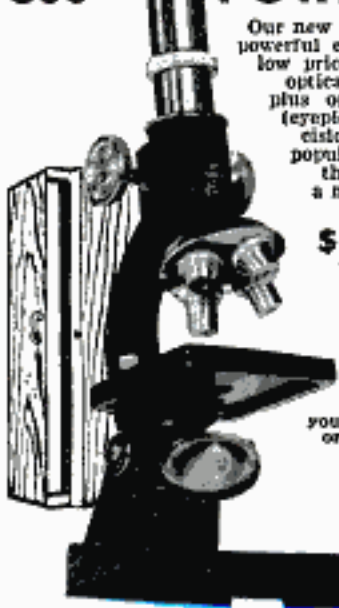

Our new quad turret microscope is the most powerful ever placed on the market at this low price. Brilliant optics, four precision optically-ground glass objective lenses, plus optically-ground glass ocular lens (eyepiece). An amazingly versatile, precision-built instrument, it is already a popular favorite in schools and colleges throughout the country. Covered by a money-back guarantee, it is shipped to you postpaid with slides, fitted hardwood cabinet and manual...

\$14.95 postpaid

FREE

Just published! The new '55 catalog of the most outstanding microscopes and accessories ever offered anywhere at such low factory-to-you prices. Included with your order or — write for your free copy today!

10-Day Money-Back Guarantee
Send check or money order, 1/3 deposit on C.O.D. California residents add 3% state tax.

the AKRON

21 Akron Bldg., 4378 Sunset Blvd., Los Angeles 29, Calif.



FREE! INFORMATION YOU SHOULD KNOW NOW ABOUT

URANIUM PROSPECTING

Uranium is making fortunes overnight. The Government pays up to \$35,000 bonus for uranium finds. But, there is information you should know about uranium prospecting. Get it FREE in a valuable booklet by Dr. Benjamin Schloss, well known scientist who worked on the original wartime atomic bomb project. "How To Make Money Prospecting for Uranium", how to find; how to sell; legal aspects, etc. We'll send this booklet, along with a Geiger Comparator Chart: "How to Select a Geiger Counter" FREE—write today. NUCLEONIC CO. OF AMERICA, 196 DeGraw St., Brooklyn 31, N. Y.

MAKE UP TO \$5 AN HOUR WITH

EASISHARP



MONEY MAKING SALES PLAN FREE

Big profits in your spare time sharpening jobs. We show you how to start making money immediately. This is your chance now to have your own business and a steady income. Sharpen a pair of scissors in less than two minutes! A child can operate it. Weighs only 10 lbs. Every house, barber, tailor, dressmaker—everyone uses sharpeners and all need sharpening two to four times a year. Don't let some one else beat you to this opportunity. Write immediately to

SERR-EDGE MACHINE CO., 9731 Lorain Ave., Cleveland, Ohio

FURNITURE FOR YOUR BEDROOM

YOU'LL BE THE ENVY of your neighbors with this beautiful bedroom suite in honey maple, oak or walnut! Here's a bed with storage space... a three-piece vanity with cosmetic compartment and makeup mirror... a Mr. and Mrs. dresser... twin night stands with drawers!



Send for Complete PLANS Only \$2.00

YOU MAKE IT YOURSELF! Only two power tools, a saw and a jointer, are needed to turn out this modern bedroom furniture. No other project of Popular Mechanics Magazine in recent years has captured the fancy of home craftsmen as has this easy-to-build suite. Letters demanding detailed plans poured in after the suite was pictured in Popular Mechanics. And now the plans are ready! They're detailed scaled drawings—a complete set of 4. Send for them today!

POPULAR MECHANICS PRESS, Dept. 26
200 East Ontario Street, Chicago 11, Illinois

I enclose _____ for a complete set of plans for making the modern bedroom suite illustrated above.

Name _____

Address _____

City _____ Zone _____ State _____

PAGE Garden Tractors

1955 MODELS More Work! Less Cost!



• 2 to 6 HP walking and riding machines • Over 60 attachments available! • All enclosed gear with reverse. No belts—no chains!

NEW "PAGE-BOY" TILLER
Ask for Details!
25 years' experience behind every PAGE—fully guaranteed!

Plows, discs, tillis, seeds, cuts grass and weeds, and many other jobs!

Shows over 60 attachments!

PAGE 1804 S. 81st St. Milwaukee, Wis.

Free Catalog

ENJOY TRAVELING WITH AMERICA'S FINEST AUTO COMPASSES



GUIDEWAY
Only \$4.49

TRAVELITE
Illuminated
Only \$5.49

DINSMORE

Shows you the right way—the short cuts. Always accurate and dependable anywhere. Fits all cars. Send for free folder—"Pants, Knives and Compasses" and name of nearest dealer.

DINSMORE INSTRUMENT CO., 1802-21 Remell St., Flint 1, Mich.

METAL WORKERS 4 TOOLS IN 1



"4 in 1" PUNCHES, FORMS, SHEARS, RIVETS metals up to 16 ga., 1" width, 5 sizes round punches included. Model #10—\$9.95, postpaid. Hex, square, rectangular punches—40c each. BRAKES—up to 90° Bends—16 ga., 12" and 18" widths. Unique feature permits forming of Boxes, Trays, Covers with up to 1" flange edge. 12" Model #12—\$9.95, 18" Model #18—\$14.95, F.O.B. Buffalo. NOTCHING & NIBBLING UNITS—Model N2 "V" Notch 1"x1" and Model N2N 1"x3/4"—\$9.95 each, F.O.B. Buffalo. THREADING DIE—Thread rod stock for 1/8", 5/32" and 3/16" standard nuts \$1.00 postpaid.

ALBERT J. TATU, INC.
85 Columbia Dr., Dept. PM-1, Williamsville 21, N. Y.

THE BEST IN PLIERS? CHAN NEL LOCK

TRADE MARK REG. U.S. PATENT OFFICE

CHAMPION DeARMENT TOOL CO., MEADVILLE, PA.

BUILD YOUR OWN ARC-WELDER



We show you how to build NEW powerful welder. No rewinding. Uses most any surplus aircraft generator. Easy to build. 75-300 amps. Complete PLANS 35c. Send today and we'll include FREE our Big War Surplus & Electrical Catalog.

LEJAY MFG. CO., 1247 LEJAY BLDG., MINNEAPOLIS 8, MINN.

Opportunity for Men with Automotive Background and Executive Ability

Manufacturer and marketer of nationally-advertised line of automotive products now expanding operation here and abroad. Distributors needed to warehouse and administrate to growing dealer network. If you have organizational ability and are financially responsible, write for details.

Your inquiry held in confidence; Write: Box P.M.-1, 10418 Venice Blvd., Culver City, Calif.

How YOU can

SAW DRILL GRIND TURN SAND



with **SUPERSHOP**

5 BIG POWER TOOLS IN 1

- 8" TILTING TABLE SAW
- 1/2" DRILL PRESS
- 8" SANDER
- 30" LATHE
- 5" GRINDER

When you DO-IT-YOUR-SELF with SUPERSHOP you save money and you have fun. You can build a house or a garage—handle BIG jobs. The 8 inch saw cuts 2 1/2 inches deep. Heavy tubular steel frame. 100% Ball Bearing. Lifetime accuracy. Save \$65.05—buy direct from factory. Take advantage of our FREE trial plan.



DRILL PRESS



SANDER



LATHE



GRINDER

FACTORY TO YOU **\$79.95**
EASY PAY PLAN

POWER TOOLS INC. 167 Yates Ave. Beloit, Wisconsin

Please send me your FREE How-To-Do-It Catalog.

NAME _____

ADDRESS _____ STATE _____

BARRON Drill Press TOOLS



ROTARY PLANER

Planes • Rabbits
Tenons • Panels
Routs • Bevels

Only \$8.50 COMPLETE

BARRON TOOL CO. INC.
364 Architects Bldg., Detroit 1, Mich.

FOR WORKSHOP AND INDUSTRIAL USES...

Over 40 precision built woodworking tools and accessories... Hi-Speed Router Bits—Rotary Surface Sanders & Drum Sanders—Safety Shaper Cutters—Dovetail Cutters—Large Auxiliary Metal Tables—All Metal Shaper Fences—Spindle Adapters—Handy Bench Vises. Many other items indispensable for accurate, useful, versatile workshop use. Every tool sold on complete satisfaction or your money back. See your Barron Dealer. Ask for special folder — "24 Extra Uses for Your Drill Press."

FREE
Workshop
Guide &
Catalog

"DO IT YOURSELF" IT'S EASY WITH KESTER SOLDER



Soldering's really a "cinch"... when you use time-tested, reliable KESTER... available everywhere.

FREE! "Soldering Simplified"... 16-page how-to-solder booklet. At your dealer or write direct.

KESTER SOLDER COMPANY
4251 Wrightwood Avenue Chicago 39, Illinois

"TOOL SHADOWS" show where your tools belong



"TOOL SHADOWS" are die-cut shadows of your tools with pressure-adhesive on the back, so they stick to any surface. They dress up your workshop, make it look neat and organized. Send \$1 for complete set of 42 basic "Tool Shadows" to: TOOL SHADOWS, Duplex P, 109 East 81st St., New York 28, N. Y.

make your own Gems 29.50 F.O.B.

The Gem Maker comes complete with all necessary equipment, including a super-charged diamond blade for sawing, and all wheels for grinding, shaping and polishing; also complete instructions. The complete equipment as shown, less motor and belt, for only \$29.50, f.o.b., Burlington, Wisconsin. Write today for information and literature.

B&I MANUFACTURING CO.
Dept. 5 Burlington, Wis.

BENCH ANVIL

FOR HOME WORKSHOPS. Hundreds of uses in home workshop, machine shop, garage, etc. Ideal for home craftsmen and model makers. Makes it easy to hammer, flatten, straighten, bend, shape or pattern, seat rivets. Hi-carbon RR Track steel, prime coated. Complete with lag screws ready to mount. Sizes: 3" length—\$2.95, 6"—\$3.95, 12"—\$5.95. Prices FOB Phila. Send check or M.O. Money Back Guarantee!

O'HARA BROS. MACHINE CO.
Dept. 5, 6526 Upland St., Phila. 42, Pa. 3" length

\$2.95

ASSEMBLE YOUR OWN TILLER... SAVE!

We supply all parts except engine, already painted, plus full instructions. Tackle 8-in. teeth, 12" wide housing and shaft, sprockets, chains, belts, wheels and handles. Only \$59.00 f.a.b. No field. Send check or money order today!

RED-E TRACTOR CO. SHEFFIELD 0 WISCONSIN

FREE CATALOG

NEW CHRYSLER BOAT KITS

BUY DIRECT—SAVE UP TO 2/3

FACTORY TO YOU!
No Dealers!
You SAVE the BIG PROFIT!

12 MODELS—8 to 14 ft. —\$39 up
Finest quality Boat Kits at the lowest prices in history! Mahogany decks. Easy to build.
Also: FIBERGLAS—ACCESSORIES—TRAILERS

CHRYSLER-CRAFT (DEPT. 20) TONAWANDA, N.Y.

KEEP YOUR CAR BATTERY FULLY CHARGED AT HOME!

With a SCHAUER CHARGER, you charge your battery at home—overnight—without disconnecting cables or removing battery from car. And you get better service—much longer life—from a battery kept fully charged.

Priced as low as \$13.95

A dependable SCHAUER CHARGER is the handiest automotive device you'll ever own. Quickly pays for itself. Operates from 110-volt home power. Compact, lightweight; sets on floor or shelf or hangs from wall. Models for 6 and 12-volt batteries. Sold by most auto stores.

If your dealer can't supply, send for FREE catalog. Many thousands of wise motorists own SCHAUER CHARGERS. Get yours now.

SCHAUER MANUFACTURING CORP.
4532 Alpine Ave. Cincinnati 36, Ohio

OWN A... FORD?

FIX IT YOURSELF!

Popular Mechanics Magazine has published an Owners Manual covering all 1941 to 1952 models of Ford cars... So accurate mechanics use it... so simple a woman can understand it.



Save money on your Ford car repairs. Prevent trouble. Enjoy care-free driving. Increase trade-in value. Avoid major repairs by fixing minor troubles before they get serious. Get sparkling performance at all times. Has 272 pages, more than 350 photos, diagrams, tables, charts, breakdown drawings, plus clear, non-technical directions that make all repairs simple as A B C. Written by Ed Paeker with the assistance of the Ford Motor Company. Shows you how to diagnose all Ford troubles by feel, sound, sight, smell and performance. Simple trouble shooting. Permanent repairs. Emergency repairs. Plus, "How to get value from garages."

MONEY BACK IF IT DOESN'T SAVE MORE THAN IT COSTS!

One minor repair will save the cost ten times over. Read it. Then you decide. If you don't see that you'll save more than the cost, send it back for refund. SEND NO MONEY. Send postcard. Ask for the Ford Manual. Postman will deliver U.O.D. for \$3.50 plus postage. Or, save postage by sending \$3.50 with order. Send today. Save its cost on your next repair.

POPULAR MECHANICS PRESS
200 E. Ontario, Dept. 90, Chicago 11, Illinois

SAVE UP TO 85% ON SPECIAL PALLEY BARGAINS



GIVE THE KIDS A THRILL WITH THIS AMAZING RADIO RECEIVER

Here's a COMPLETE RADIO RECEIVER that picks up STANDARD BROADCAST STATIONS without using batteries or electricity! Just plug in the headset, antenna and ground wires and tune in your favorite program. You'll be amazed at the STRONG, CLEAR SIGNAL. Has a 100KC tuning range. Comes complete with Receiver, Antenna and Ground wires plus a Headset with two 2000 Ohm ear phones. NOT A TOY - A Genuine Crystal Receiver!

WITH HEADSET ONLY **3.95**



NEW 7x50 BINOCULAR

Ideal for Boatsman, Hunter, etc. All lenses & prisms are made from the finest precision components to give you true image clarity. Air-to-glass optical surfaces are hard coated for increased brilliance and clarity. Lenses are Achromatic, optically ground and color corrected. Made by finest Japanese Optical Works.

7 power 50mm BINOCULARS - Individual focus. Field of view 375 ft. at 1000 yards. \$40.00 value plus 10% fed. tax **24.95**

WITH PIGSKIN CASE & STRAPS



30-45-60 POWER POCKET MICROSCOPE

For Prospector, Mineralogist, Rockhound, Botanist, etc. Specially made for and imported by us. Has precision ground and polished lenses. Moisture and dust proof body. Magnification of 30, 45, and 60 power. **3.75**



AMAZING NEW MICROSCOPE TELESCOPE

A new optical development. A pocket size Microscope-Telescope. When closed it serves as a 50 POWER Microscope, when opened out it acts as a full 10 POWER Telescope. Only inexpensive Japanese labor can make this price possible. **4.39**



AVIATORS (AM-6330) WINDPROOF & DUSTPROOF GOGGLES

Chamels lined, rubber covered frames. Has REPLACEABLE GROUND LENSES in either clear, amber or green. Frames have special non-fogging breather slits. Nose bar is adjustable. Specify lens color. **ONLY 2.49** ~~5.99~~ VALUE

EXTRA LENSES—Choice of colors listed above. Price per pair . . . **1.00**

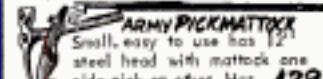

ARMY PICKMATTOCK

Small, easy to use has 12" steel head with mattock on one side pick on other. Has hardwood handle & case. **1.29**



PORTABLE SHOVEL

New G.I. Surplus. 20" hardwood handle. Blade folds. NEW **1.29**



BOLO KNIFE AND CASE

Made of top quality steel. 15" long. Ideal for clearing brush, etc. Comes complete with sturdy belt sheath. **1.98**



NAVY SEALED BEAM LIGHT

U.S. Navy Portable Search Spotlight. Has pistol grip & aiming sight. Makes ideal search, signal, spot or an emergency light for boat, car, camp, etc. 12 volt light—4" lens . . . **4.29**

24 volt light—5" lens . . . **4.79**

320 PAGE CATALOG

Packed with Bargains in GOVERNMENT SURPLUS FACTORY CLOSE-OUTS & GEN. MERCHANDISE - Fully Illustrated. Items for Hobbyist, Mechanic, Godgeener, Sportsman, etc. Send 50¢ TODAY to cover cost of handling & mailing - this 50¢ credited to YOUR FIRST ORDER. . . .

Order from This Ad. Pay by M.O. or check. P.O.'s excepted. From D&B firms. 1/2 deposit with C.O.D.'s. All Prices FOB Los Angeles.

DO IT YOURSELF! IT'S FUN! IT'S PROFITABLE!



GENUINE SELECT PHILIPPINE MAHOGANY LUAN PLYWOOD

Our prices are LESS THAN DOMESTIC PLYWOOD at WHOLESALE. Due to the terrific demand generated by our national advertising and the amazing acceptance by the American public, we are importing this beautiful Luan Mahogany in BOAT LOADS - making possible further huge savings to you.

This selected LUAN MAHOGANY meets rigid Gov't Specifications. It is WEATHER and WATER RESISTANT. You'll be amazed at the beauty of this fine wood. Its rich golden elegance will thrill you. Rotary cut for beauty and grain. Both sides sanded and ready to use. Bonded with finest resin adhesive. Face side unjoined. Ideal for paneling DENS, OFFICES, HOTELS, CABINETS, etc.

31" x 6 ft. x 3/8" approx. 1/8" 18 sq. ft. A \$5.00 VALUE FULL SHEET Min. order 8 sheets

See for YOURSELF FREE SAMPLE on request! All orders shipped by special truck for LOWEST rates. No order accepted for less than 100 lbs. . . . (4) 1/4" sheets (8) 1/2" sheets

4 ft. x 8 ft. x 1/4" 32 sq. ft. A \$9.50 VALUE FULL SHEET Min. order 4 sheets

WORLD'S GREATEST DO-IT-YOURSELF TOOL BARGAINS

3400 RPM 1/2 HP POWER SAW

Compare to steel mill up to \$9.50 Ideal for HOME SHOP

19.98 Complete with 5 3/4" Blade

CUTS THROUGH A 2x4 LIKE A KNIFE THROUGH BUTTER RIPS - CROSSCUTS

A rugged, professional type, adjustable saw. Cut any angle, 0 to 45°. Has adjustable (8 to 6") rip fence. Safety-trigger switch on handle. Full 1/2 HP Universal AC-DC, 110-120 Volt, 60 cycle motor. Weighs only 6 1/2 lbs. A sensational Value - We sold over 700 Saws in Los Angeles in one

NEVER BEFORE AT OUR LOW PRICE!

34 Pc. HOME WORKSHOP COMPLETE

DRILL • SAND • BUFF GRIND POLISH • MIX PAINT

Famous Make 1/4" ELECT. DRILL WITH JACOBS CHUCK

Another Palley exclusive. A sturdy, all-purpose drill for all home work-shop and "DO-IT-YOURSELF JOBS." 1800 RPM AC-DC motor. Automatic trigger with lock action.

Kit contains: 1/4" Drill with Jacobs chuck, 7 carbon steel drills; 6-piece spindle adaptor; polishing bonnet, sanding discs, grinding & buffing discs, drill stand, etc. Complete in metal case.

24.95 VALUE **\$16.88** COMPLETE KIT

12 Pc. IMPORTED COMBINATION KNIFE

Eliminates 12 Individual Items from your Pack or Tool Kit! (A \$12.95 VALUE) **4.95**

Here is the Perfect, Combination Knife-Tool for every Outdoor Sportsman, Hunter, Camper, Fisherman, Boy Scout, Ranger, Rancher, etc. Think of it! 11, Fine quality Steel Tools, precision made to fold easily into the heavy bone covered body. In one neat, compact unit you have (1) a regular knife, (2) a fork, (3) a spoon, (4) a draw-knife, (5) a bone saw and fish-scaler, (6) scissors, (7) a can and bottle opener, (8) a cork screw, (9) awl punch, (10) a screwdriver and (11) a metal file. All this PLUS a genuine leather, belt holster.

ORDER NOW While We Can Guarantee Delivery at this Special Low Price

PALLEY SUPPLY CO 2263 F. VERNON AVE., DEPT PM-1 105 ANGELES ST., CALIF.

Schupack's Amazing Tool Bargains! All Brand New! Save up to 100%!

75 MOUNTED WHEELS AND MINIATURE CUTTERS



Regular Value \$11.00
\$4.50 Post-Paid

For cutting and grinding on wood, metal or plastic. Includes 26 mtd. wheels and points on 3/32" shanks; 24 miniature cutters on 3/32" shanks; 25 short shank min. cutters. Will fit all electric drills and hand grinders.

FLEXIBLE SHAFT - ONLY \$4.95 Post-Paid



Fits all electric drills & hand power tools. 38 1/2" long. Oilite bearings. Core of specially wound, high carbon steel wire in flexible steel casing. Will accommodate tool shafts up to 1/4" dia. For lathes, electric drills, etc.

2 DRUM SANDERS \$1.50 Post-Paid



With 12 Bands in Assorted Grits. 1 1/2" dia. x 1" long on 1/4" arbor with 12 bands

ONE DRUM. 1" DIA. x 1" LONG ON 1/4" ARBOR WITH 6 EXTRA SLEEVES \$1.00 Post-Paid

NEW ILLUSTRATED CATALOG 10c

10 Hi-Speed Steel & Carbon Drills \$1.95

30 for \$2.75

Most popular sizes up to 1/4"

5 Hi-Speed Steel Drills \$1.95

1/4" to 1/2" Dia. \$1.95

15 Assorted Drills \$3.95

From 1/16" to 1/2" high speed steel and carbon.

12 Assorted Drills \$3.60

High speed & carbon steel, from 1/8" to 1/2". Ppd.

5 Woodworkers Drills \$2.95

From 1/4" to 3/4" on 1/4" shank.

6 HI-SPEED STEEL ROTARY FILES \$4.50 P.P.

Various shapes on 1/4" shanks. For grinding, deburring.

12 MOUNTED WHEELS and points on 1/8" Shank \$2.95 Post-Paid



36 for \$7.50

For grinding on plastic wood, soft and hard metals. Regular List Value \$8.40.

18 MOUNTED POINTS ON 3/32" SHANK \$2.50

12 MTD. WHEELS ON 1/4" SHANK \$3.60

18 ROTARY CUTTERS \$5.85 Post-Paid



Value \$13.50

Illustrated 1/2" size

Assorted sizes cutter on 1/4" or 3/32" shank. Will fit all hand grinders. Ideal for cutting wood, metal, or plastic. Brand new.

ADAPTER CHUCK \$1.50 Post-Paid



With 2 interchangeable collets, opening from 3/32" to 1/2" on 3/32" shank. Price each only.

ADAPTER CHUCK, 60 to 80 on 3/32" Mandrel \$1.00

SCHUPACK SUPPLY CO., 7331 COTTAGE GROVE AVE., DEPT. M-63 CHICAGO 19, ILL. SEND CHECKS OR M. O. NO COD'S PLEASE

GET LONGER LIFE - Better Performance from Your Machinery with Alemite GREASE GUNS WAR SURPLUS

EVERY SHOP NEEDS ONE



Shop owners, machinery owners, auto hobbyists, mechanics... get better service and longer life from your machinery by using this heavy-duty 16-oz. GREASE GUN. Made by the Alemite Corp. and Ballrank. Like-new condition. 2 1/2" overall length - 2 1/4" dia. cylinder. **ONLY \$2.95** Postpaid

SAVE! This GREASE GUN listed today at \$11.75. We ship anywhere, postpaid. No COD's. Special price to dealers in dozen lots.

ORDER NOW WHILE THEY LAST. FULTON AUTO EXCHANGE 2235 Stewart Ave., S.W., Atlanta, Georgia. FAIRfax 8606

SEND ONLY \$1 for next 6 issues of famous DELTA-GRAM, best home woodworking magazine you ever saw. Packed with shop-tested ideas—12 to 15 in each issue. Send \$1 (no stamps) to: Delta Power Tool Division, Rockwell Mfg. Co., 502A N. Lexington Ave., Pittsburgh 8, Pa.

AUTOMATIC RETOOTHER for HAND SAWS

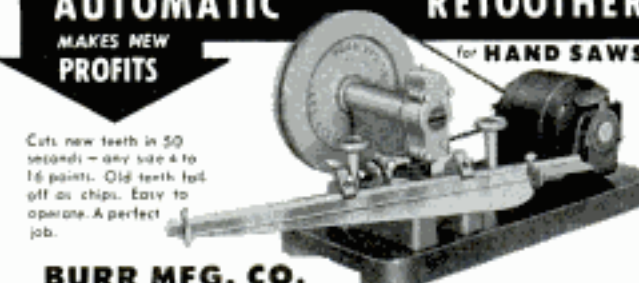

MAKES NEW PROFITS

Cuts new teeth in 50 seconds - only sets 4 to 16 points. Old teeth fall off as chips. Easy to operate. A perfect job.

BURR MFG. CO. 8933-C VENICE BLVD. LOS ANGELES 34, CALIFORNIA

BUILD 15 RADIOS AT HOME WITH THE NEW IMPROVED 1955 PROGRESSIVE RADIO "EDU-KIT"

ONLY \$19.95 COMPLETE



Now Includes High Fidelity Signal Tracer & Code Oscillator

All Parts, Instructions, Soldering Iron, Tester included. Money Back Guarantee.

PROGRESSIVE "EDU-KITS" INC. 497 Union Ave. Bklyn. 11, N. Y.

PROGRESSIVE "EDU-KITS" INC. Dept. PM-525, 497 Union Ave., Brooklyn 11, N. Y.

RUSH ME THE FOLLOWING:

Free Descriptive Literature—No Obligation.

Free Valuable Radio and TV Guides—No Obligation.

Name _____

Address _____

City _____ Zone _____ State _____

Steel Shelving at Factory Prices!

for CARPENTERS, MECHANICS, HOBBYISTS, SHOP AND HOME OWNERS

Unit 12"x36"x6'1" with 6 shelves—200 lb. capacity ea.—adjustable 1 1/2". Complete with nuts, bolts, braces.

SEND FOR FREE CATALOG **\$15.95 K.D.** plus freight

Send Check or Money Order to: **WILLIAM PHILLIPS CO., 429 4th Ave., Pittsburgh, Pa.**

MAGNETS

ASSORTED MAGNETS with big list of handy uses.....5 for \$1

POWERFUL POCKET MAGNET ideal for testing metals.....\$1

RETRIEVING MAGNET pulls tools, etc., from tank or lake.....\$3

HOT PAD MAGNETS to insert in your own hot pads.....8 for \$1

BULLETIN BOARD MAGNETS to "pin-up" memos, etc.....8 for \$1

SLENDER MAGNETS remove chips from drill holes.....2 for \$1

Write for free booklet. 100% satisfaction guaranteed.....POSTPAID

PARK MAGNETS, PM-1, 1557 GREENBAY RD., HIGHLAND PARK, ILL.

FREE AMAZING NEW BOOK "HOW TO ANSWER ADS"



Never before have you seen anything like this. Tells you in simple language the correct way to answer ads. Gets you quicker replies—better results, and greater satisfaction. Will save you time and money and it's ABSOLUTELY FREE. No obligation whatever. Every reader of advertising should have this booklet. Send a postcard for your copy NOW. F. W. JOHNSON, Popular Mechanics Magazine, Room 600-A, 204 East Ontario Street, Chicago 11, Ill.

AUTOMATIC BOOSTER FAN WARMS HARD-TO-HEAT ROOMS SAVES HEATING DOLLARS



Designed for Gravity Type Hot Air Furnaces, this Alien Booster Fan works AUTOMATICALLY. Quiet and efficient, you can install it in a few minutes. Set the thermostat and it works AUTOMATICALLY spring, fall, and winter. Fan will not operate if furnace is not on or if air temperature in duct is below automatic setting. 750 CFM. Guaranteed. Prepaid when check accompanies order.

\$19.95 COMPLETE **PARK HEATING SPECIALTIES** 6212 Goodrich Avenue, Minneapolis 16, Minn.

NOW! USE YOUR WILLYS OR DODGE AS BOTH A 2 and 4 WHEEL DRIVE



Enjoy 2-wheel drive pep, speed, extra mileage, performance—keep 4-wheel drive power and traction with **WARN HUBS**. Change 4-wheel to 2-wheel or back in seconds with fingertip control. Front end assembly stands still in 2-wheel drive—ends drag, stops shimmy, cuts front tire wear, increases gas mileage. Willys factory approved. For Willys \$70.60; Willys Automatic \$122.83 pr. — both sold exclusively by Willys dealers everywhere. Dodge Locking Hub \$74.00. Standard Hub \$25.00 pr., ppd. direct or at Dodge dealers. All hubs guaranteed. Write for literature.

WARN MFG. CO., RIVERTON Box 6064-A4, Seattle 88, Wash.

power...



instantly, where you need it!



STANDBY or CONTINUOUS DUTY
by **MASTER MECHANIC**
at bedrock
factory prices!

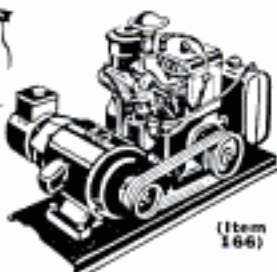

(Item 166)

HI LINE 6000 WATT PLANT

HEAVY DUTY—110/220 v. 60 cyc. AC. A brute of a power plant with a rugged 14.6 hp. Wisconsin engine. Affords both 110 & 220 volts. Ideal where heavy current is needed. Wt. 500 lbs. Item 166. Easily worth \$995. With crank start **\$585.00**
Same plant, but with Generator & control box only, self-starter **\$645.00** (Item 162)
Belt driven. Wt. 240 lbs. Item 163 **\$345.00**

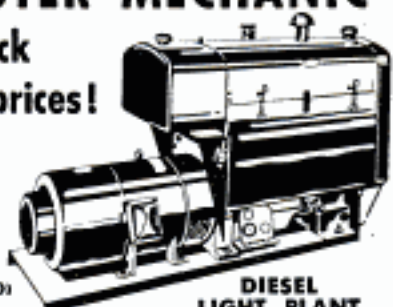

(Item 1680)

DIESEL LIGHT PLANT

11-12 KW (Item 1680) Diesel Master 110/220 v. AC single or 3 phase, 1800 rpm direct connected. Electric self-starting. Engineered for permanent power where continuous low-cost heavy duty service is important. Wt. 1350 lb. Reg. **\$1895.00** list \$3650.00. Factory price...
GAS DRIVEN PLANT 10-11 kw. 110/220 v. 60 cyc. AC single or 3 phase, powered by a 4 cyl. Wisconsin air cooled engine. Belt driven—simple reliable 5 V-belt drive. Mounted on rugged steel skid. (Item 217) with crank start) Wt. 900 lbs. **\$1075.00** Factory price...
Same plant with self-starter... **\$1145.00**

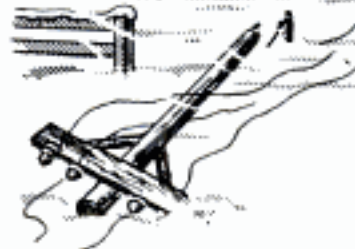

Operate Heating Plants



Keep Freezers Going



Run Milking Machines

Power failure need not be a disaster!
Instant starting MASTER MECHANIC light plants provide electricity immediately... keep oil burners, water pumps, milking machines and food freezers in operation. Don't risk costly freeze-ups, meat spoilage, blackouts and other vital machinery stoppages. Master Mechanic's direct from factory prices make it possible for every one to have the insurance of uninterrupted electric power, regardless of storm, tornado or hurricane!

And you can have power wherever you want it! Master Mechanic's portable plants can be taken anywhere... to provide standard 115 volt, AC power to operate saws, drills, chain saws, floodlights, etc... on building construction, road work or in the woods!



(Item 31)

GIANT 2000-2500 WATT PLANT

110/120 v. 60 cyc. AC. Exclusive dynamically balanced armature; heavy windings develop up to 5000 watt overload for motor starting. Skid mounted—portable. Powered by an easy starting Briggs or Wisconsin 6 hp engine—easily disconnected for other uses. Bag outlet box, voltmeter, no wiring necessary. Item 31. Wt. 210 lbs. Reg. \$345. Special... **\$299.50**
Same plant with electric self-starter. Item 31a **\$329.50**
Generator only and control box... **\$169.50**
DUAL VOLTAGE—110/220 available on any of the above models for \$20.00 additional.



(Item 23)

DYNA POWER 3500 WATT PLANT

Push Button Start. 115 v. 60 cyc. AC. Built-in battery charging. Powered by a sturdy 8 hp air-cooled Wisconsin engine. Built for continuous duty, yet compact and portable. Integral positive drive—an exclusive Master Mechanic feature. Includes control box, plug-in power receptacle and voltmeter. Item 23. Wt. 370 lb. **\$379.50** Factory price...
DUAL VOLTAGE—110/220 available for \$20.00 additional.

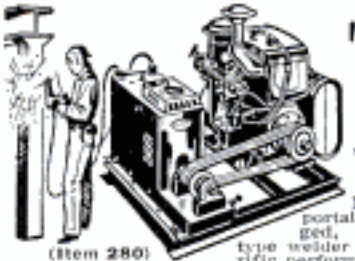

(Item 280)

MASTER DC ARC WELDERS

Now! a portable, rugged, industrial type welder with terrific performance, yet at a price hundreds of dollars less than you'd expect. Senior model made for years of trouble-free, continuous service. High capacity DC welding unit enables you to tackle any job with confidence—easily welds anything up to 2" plate using from 1/16" to 1/2" rods. Built-in stabilizer and cooling system makes easy to strike and hold. Dual control rheostat provides low heat soldering, brazing and welding from 10 to 300 amps. Complete with instructions, guarantee and triple V-belt or flat pulley. You can pay more, but you can't buy a better welder.
WELDER ONLY—DUAL CONTROL MODEL. Same as above, but drive with your tractor, jeep or gas engine of 14 HP or more. (Item 280) **\$119.50** Wt. 110 lbs. \$450 value.
WELDER ONLY—STANDARD MODEL. Same as above but with single rheostat for heavy metal welding only. (Item 38.) **\$99.75** Wt. 110 lbs. \$450 value. Special...
COMPLETE POWER MASTER (Illustrated above) powered by a 14.6 hp., air cooled Wisconsin engine. Wt. 480 lbs. (Item 280) Complete with welder costing \$1200. Special for January only... **\$399.50**
WELDING KIT. Two 10 ft. leads, welding helmet, electrode holder, ground clamp. Sold only with welder... **\$10.50**

Any of our plants may be equipped to operate automatically if desired
WRITE FOR DETAILS!

MASTER PORTABLE LIGHT PLANTS

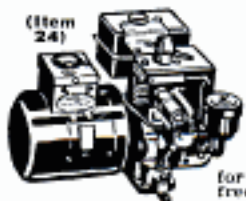

(Item 24)

ELECTRA LITE 600-700 WATT

Push Button Start 115 v. 60 cyc. AC. Powered by a rugged 2 HP easy starting Briggs engine. No wiring necessary; just plug in and operate. Plenty of current for any oil burner, freezer, brooder, emergency lights, etc. Which require up to 700 watts. Ideal for television and radios. Complete with voltmeter and built-in winding to charge 6 v. auto batteries. (Item 24) Wt. 75 lbs. Easily fits in car trunk. Be prepared if storm knocks out power lines. Reg. \$275. value. **\$143.50**
1000-1200 Watt Plant (Item 45) same as Item 24 but larger generator and engine with 50% greater output **\$199.50**
Little Giant 350 Watt Plant
Imagine—65 compact pounds of portable power that goes with you anywhere—easier to carry than an outboard motor. Provides plenty of current for lights, radios, small power tools, electric shavers, etc. Perfect for hunters, campers, contractor's service trucks, etc. 220 watts, 115 v. DC. Ruggedly constructed with 1 1/2 HP Briggs engine. List price \$224.75. Item 27a. **\$99.75** Spec. factory price.



(Item 20)

PORTO POWER 1500-1750 WATT

115 v. 60 cyc. AC. Push button start. Powered by a 4.5 HP Briggs engine. Combines compactness and easy portability with higher output for handling heavier starting loads. Built-in winding for charging 12 v. batteries. An ideal standby power plant for operating oil burners, sump pumps, freezers, television, lights, communication systems, etc. Perfect for contractor's power tools. Item 20. Reg. \$429.50. Wt. 146 lbs. Factory Special. **\$279.50**

Send check or M.O. Prices f.o.b. Factory. 10 day Money back guarantee. SEND 10c for... **BIG 1955 Catalog**
MASTER MECHANIC MFG. CO., DEPT. 55-1 **Burlington, Wis.**

WE MAKE ALL SIZES UP TO 25,000 WATTS

More for Your Money

If there is any one reason why South Bend Lathes are so popular it is because they represent the maximum value per dollar of cost. We invite comparison feature-by-feature with any other make, and are confident you will find South Bend gives you more for your money. Send coupon for catalog.



How to Run a Lathe

Every lathe operator needs this helpful handbook on lathe operation and care. Exceptionally complete. 128 pages — 365 illustrations. Price 50¢ postpaid.

TIME PAYMENTS
only 3¼% interest

Yes, only 3¼% interest on original unpaid balance. Low down payment and balance in up to 24 equal monthly payments.

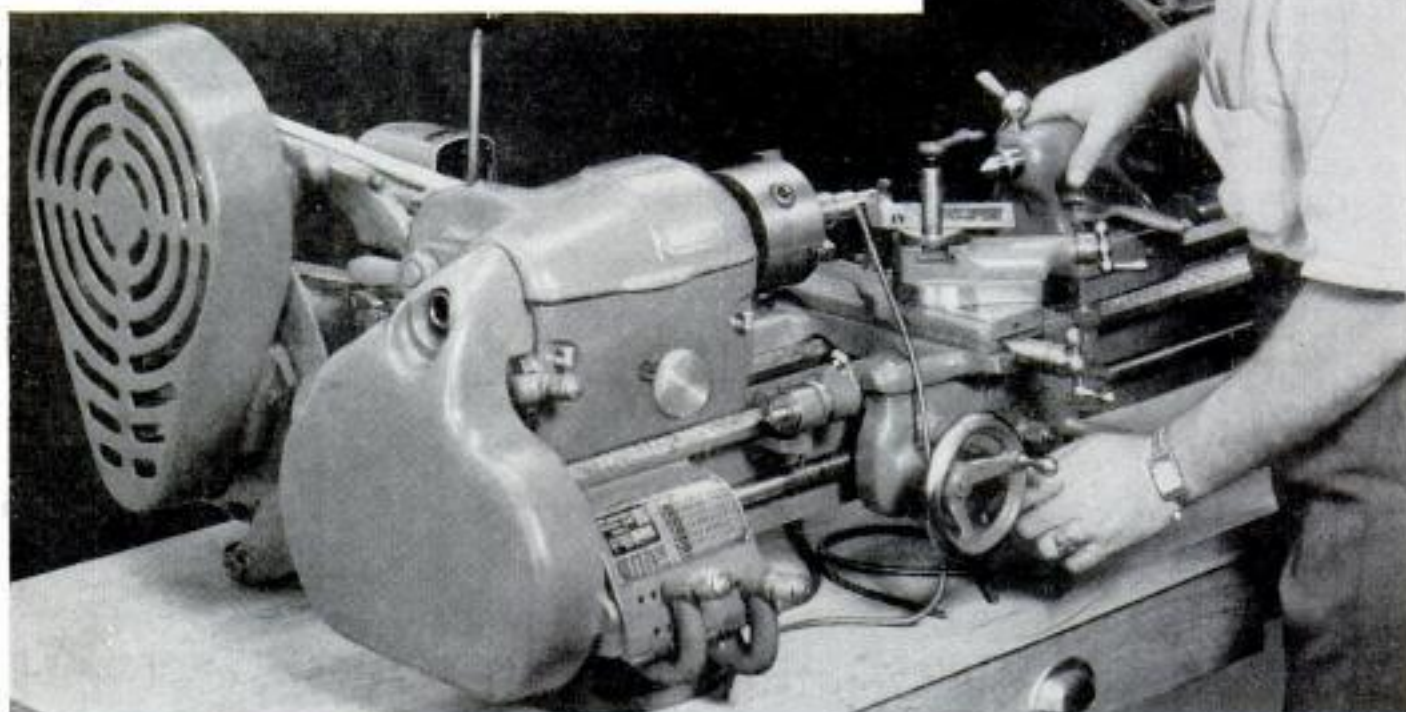

Compared with our costs
OUR PRICES ARE LOWER
than they were back in 1941

WAGES UP 155%	MATERIALS UP 131%	PRICES UP ONLY 49%
41 55	41 55	41 55

Prices are closely tied to costs. Costs are still rising. Buy now before increased costs necessitate higher prices.

SEND INFORMATION CHECKED:

<input type="checkbox"/> 9" and 10" BENCH LATHES	<input type="checkbox"/> 10" to 16-24" FLOOR LATHES	<input type="checkbox"/> DRILL PRESSES	<input type="checkbox"/> TOOL GRINDERS	<input type="checkbox"/> 3/8" & 1" Collet TURRET LATHES	<input type="checkbox"/> 7" BENCH SHAPERS
--	---	--	--	---	---

Name _____

Street _____ City & State _____

Building Better Tools Since 1906 • SOUTH BEND LATHE • South Bend 22, Indiana

11 makes of **passenger cars set** **Champion SPARK PLUG** **performance record!**

All 52 entries in the Darlington, S. C. 500-Mile Grand National Stock Car Race used **Champion Spark Plugs** and not a single **Champion** was replaced during the entire race! The cars competing were: **Buick, Cadillac, Chrysler, Dodge, Ford, Hudson, Mercury, Nash, Oldsmobile, Plymouth, and Studebaker.**



WESTERN UNION
CHAMPION SPARK PLUG CO. SEPT. 7, 1954
TOLEDO, OHIO
ALL 52 CARS ENTERED IN THE 1954
NASCAR SANCTION 500 MILE GRAND
NATIONAL RACE AT DARLINGTON, S. C.
USED CHAMPION SPARK PLUGS EXCLUSIVELY
AND NO SPARK PLUGS REQUIRED
REPLACEMENT.
BILL FRANCE, PRESIDENT
NATIONAL ASSOCIATION FOR
STOCK CAR AUTO RACING.

Big-time stock car racing is a brutal test of spark plugs . . . they must stand up and deliver under punishment equal to many thousands of miles of normal driving. Only the best spark plugs can meet this challenge.

That's why professional drivers turn to Champions regardless of the make of car when the chips are down and performance is the payoff!

You, too, certainly want top performance from your car. But you won't get it with weak, inefficient spark plugs. Give your engine a fair chance to show what it can do. Have your Champion dealer install full-firing, five-rib Champions—the perfect partners for today's modern gasoline. You'll feel the difference immediately!

CHAMPION SPARK PLUG COMPANY, TOLEDO 1, OHIO



The New, Mighty **REO V-8**

195 H.P.—220 H.P.

GOLD COMET

weight, with accessories, 1211 LBS.

ONLY 39½" LONG

- Output is a startling ½ h.p. per cu. in. of displacement (35% more than the average of all other gasoline engines

- of 360 cu. in. and larger).
- Shorter than other 170-225 h.p. truck engines by 5⅛" to 19¾".

- Delivers from 18% to 60% more h.p. per pound than other 170-225 h.p. truck engines. What power!

MOST POWERFUL V-8 TRUCK ENGINE EVER BUILT

REO MOTORS, INC. Lansing 20, Michigan

Copyrighted material 50th ANNIVERSARY

"Engine" is our middle name!

REO