

# POPULAR MECHANICS

## MAGAZINE

WRITTEN SO YOU CAN UNDERSTAND IT

REG. U.S. PAT. OFF.

*See page 88*

*In This Issue*  
The story of your Navy recruit—  
**FROM BOOT TO  
ELECTRONIC WHIZ-KID**

*For the Craftsman*  
**Stop Those Roof Leaks**



# IT'S AMERICA'S LARGEST SELLING OUTBOARD MOTOR

## *Johnson Sea-Horse 5*

### Ask Commercial Users— They Know!

This brilliant outboard motor does so much so well, it outsells *any* model of *any* make. It is by far the leader in the popular size range (from 4.0 to 7.5 hp. inclusive). Yachtsmen favor it. Fishermen love it. Commercial users, who run their motors more in a single day than many sportsmen do in a full season, choose it for economical, **DEPENDABLE** water transportation in rugged going everywhere. Ask your Johnson Dealer. Look for his name under "Outboard Motors" in your classified phone book.

#### **FOR 1952 -4 Great Alternate Firing Twins**

- SEA-HORSE 3—3 hp. . . . \$145.00\*
- SEA-HORSE 5—5 hp. . . . \$187.50\*
- SEA-HORSE 10—10 hp. . . . \$295.00\*
- SEA-HORSE 25—25 hp. . . . \$390.00\*

OBC certified brake hp. at 4000 rpm. \*All prices f.o.b. factory, subject to change.

**FREE!** New Sea-Horse Handy Chart describes all the motors in detail. Write today.

#### JOHNSON MOTORS

400 Pershing Rd., Waukegan, Illinois  
*Johnson Motors of Canada, Peterborough*



5 HP... ALTERNATE FIRING TWIN... FAMOUS FOR DEPENDABILITY...  
NEUTRAL CLUTCH... FULL PIVOT REVERSE... NO SHEAR PIN WORRY  
SYNCHRO-CONTROL... AND MORE... ONLY \$187.50\*





# here's why...it's so reliable!

**THE**  
**TIMKEN**  
*Silent Automatic*  
**WALL-FLAME**  
**OIL BURNER**  
*has only one*  
*moving part!*

You are assured of maximum reliability when you install a Timken Silent Automatic Wall-Flame Oil Burner! The one moving part—with its integral oil distributing tubes and fans—does all the work. Nothing else moves. Nothing else wears. Actuated by an electric motor, the mono-rotor rests on a steel ball pressed into the bottom end of the shaft, with the result that the rotor spins like a top—freely, easily and with little wear. The basically different, basically better wall-flame burner is the heart of every Timken Silent Automatic oil heating unit—conversion burners, furnaces and boilers. See your Timken Silent Automatic Dealer or mail the coupon below.

**no pressure!**  
**no blowtorch roar!**

No complicated pressure pump is required to force the fuel oil through a pin-point atomizing nozzle. No blower is required to send a blast of air into the ashpit. It's whisper-quiet!



**NO "OIL CAN" LUBRICATION!** The shaft of the mono-rotor is lubricated by the fuel oil flowing through the burner, eliminating the need for "oil can" lubrication—at any time!

**TIMKEN**  
*Silent Automatic*  
**HEAT**

**OIL • GAS • COAL**  
 TIMKEN SILENT AUTOMATIC DIVISION  
 The Timken-Detroit Axle Company • Jackson, Michigan  
 The Timken-Detroit Axle Company of Canada, Ltd., Toronto, Ont.



MAIL THIS COUPON TODAY FOR ILLUSTRATED LITERATURE!

Timken Silent Automatic, Jackson, Michigan  
 Please mail illustrated literature. I am interested in:



NAME \_\_\_\_\_  
 STREET ADDRESS \_\_\_\_\_  
 CITY and STATE \_\_\_\_\_  
 If you are a stud

This One



NETA-JBC-JA22





↑ Front of the new frequency-time standard at Bell Telephone Laboratories. In the rear there are 600 electron tubes and 25,000 soldered connections. Room temperature is maintained within two degrees.

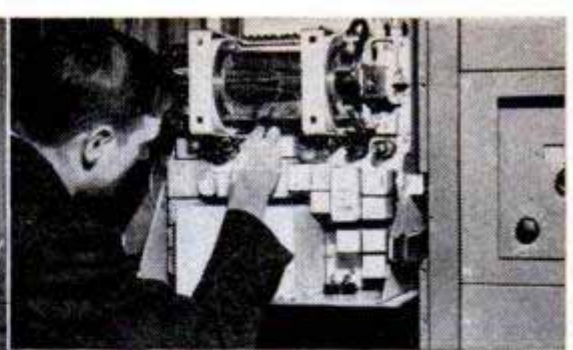

Each crystal is enclosed in a cylindrical oven which holds the crystal temperature to within 1/100 of a degree.

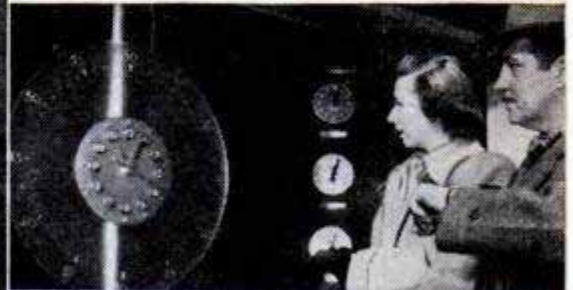

At the A. T. & T. building at 195 Broadway, New York, passersby set watches by the world's most accurate public clock, which is controlled by the master standard.

## A vibrating crystal keeps master time



The controlling quartz crystal vibrates in vacuum at 100,000 cycles per second. The standard is powered by storage batteries, with steam turbo-generator standing by, just in case of emergency.

Ever since Galileo watched a lamp swinging in Pisa Cathedral, steady vibration has measured time. In the 1920s Bell Laboratories physicists proved that quartz crystal oscillators they developed to control electrical vibration frequency in the telephone system paced out time more accurately than ever.

Bell's latest master standard keeps an electric current vibrating at a frequency that varies only one part in a billion, keeping time to one ten-thousandth second a day.

A master oscillator governs carrier frequencies of the Bell

ship-to-shore, overseas and mobile radiotelephone services, the coaxial and *Radio-Relay* systems which carry hundreds of simultaneous conversations, or television. In northeastern states, it helps keep electric clocks on time.

The new standard also provides an independent reference for time measurements made by the U. S. Naval Observatory and the National Bureau of Standards. Thus, world science benefits from a Laboratories development originally aimed at producing more and better telephone service.

### BELL TELEPHONE LABORATORIES



Improving telephone service for America provides careers for creative men in scientific and technical fields.



# Popular Mechanics Magazine

Registered in U. S. Patent Office and Canada

H. H. WINDSOR, Founder

H. H. WINDSOR, JR., Editor and Publisher



## This month's cover

HOSE DANCING DERVISHES, the helicopters, seem to be whirling the jet planes and guided missiles right out of the spotlight these days. Time was when man dreamed he could fly like a bird. Now, thanks to the "eggbeaters," he's beaten the bird at its own game, for he can zoom straight up or down and hover motionless in the air. Recently the copter has toted thousands of casualties from danger in Korea and has air lifted Marines behind enemy lines. On page 88, noted British artist G. H. Davis presents "Helicopter Forecast From England," with complete details on big and little eggbeaters now under construction or on the drawing board. Our cover shows the huge W-85, which can carry 100 troops and has a 15-ton pay load. It very likely will be powered by twin-jet engines on each blade of a three-blade rotor. Mr. Davis also forecasts three other unique craft now in the design stage in England

Published monthly by Popular Mechanics Company, 200 E. Ontario St., Chicago 11, Ill. H. H. Windsor, Jr., president; William Harrison Fetridge, vice president; D. F. Windsor, vice president and secretary-treasurer; H. H. Windsor III, vice president; Clover L. Perkins, advertising manager; Alan M. Deyoe, circulation manager. Single copy in the United States and Canada, 15 cents; subscription rates in United States and possessions, Canada, Philippines and countries of the Pan-American Postal Union, 1 year \$3.50; 2 years, \$6.00; 3 years \$8.00. To all other countries add \$1.00 a year over United States prices for overseas postage. If you plan to move, notify us at least 30 days in advance so you will not miss an issue. Give both your old and new addresses. Entered as Second Class Matter, September 15, 1903, at the Post Office at Chicago, Illinois, under Act of March 3, 1879. Entered as Second Class Matter at Post Office Dept., Canada. Registered as Second Class Matter at the Post Office at Mexico, D. F., Mexico, June 20, 1950. Copyright 1952 by Popular Mechanics Company, Copyright under International Copyright Union. Copyright in France. All rights reserved under Pan-American Copyright Union. Printed in the United States of America.

Volume 97 MARCH 1952 Number 3

Managing Editor.....Roderick M. Grant  
 Assistant Managing Editor.....Wayne Whittaker  
 Shop Notes and Crafts Editor.....James R. Ward  
 Radio-Television, Electronics Editor.....Frank L. Brittin  
 Associate Editor, Aviation.....Aubrey O. Cookman, Jr.  
 Associate Editor.....Clifford B. Hicks  
 Assistant Shop Notes and Crafts Editor.....Wayne C. Leckey  
 Automotive Editor.....Siler Freeman  
 Art Director.....Frank Beatty

Assistant Editors  
 W. Clyde Lamme Theodore A. Daum Frank N. Stephany  
 Arthur R. Railton Elsie L. Domin Carlton H. Ihde  
 Eastern Editor.....Richard F. Dempewolff  
 Empire State Bldg., Room 2906, New York 1, N. Y.  
 Western Editor.....Thomas E. Stimson, Jr.  
 302 23rd St., Santa Monica, Calif.  
 London Manager.....Douglas W. Wedderspoon  
 77 Baker St., London W. 1, England  
 Director, Bureau of Information.....Allan Carpenter  
 200 E. Ontario St., Chicago 11

## IN THIS ISSUE

Wanted: Jobs for a Trillion New Chemicals -	81
Science Tackles the "Sixth Sense" - - - -	91
Treasure Hunting Is Good Business - - - -	97
The '52 Ford Rolls Out - - - - -	102
Report on the Foreign Cars (Part I) - - - -	106
The Bottom of the Barrel - - - - -	112
Army Meets the Big "A" - - - - -	119
From Boot to Electronic Whiz-Kid - - - -	123
I Was the Gadgeteer for a TV Madhouse - -	134
What's New for Your Home - - - - -	140
Mexican Safari - - - - -	144
Sports Cars Take Over the Town - - - -	152

## For the Craftsman

Adding the Final Touch - - - - -	165
Build a Desk for Your Typewriter - - - -	168
Cookie—15" Model Hydroplane - - - -	179
Combination Bed-Tent Fits on Car Top - -	187
Finding and Stopping Roof Leaks - - - -	194
Know Your Car's Nervous System - - - -	201
Servicing Geared Drill Chucks - - - -	211
Better Metal Drilling - - - - -	216
Shopping for Tools - - - - -	224
Radio, TV and Electronics - - - - -	227
Clinic for Homemakers - - - - -	238

Other items, and manufacturers of available products described, are listed on pages 14, 16 and 18



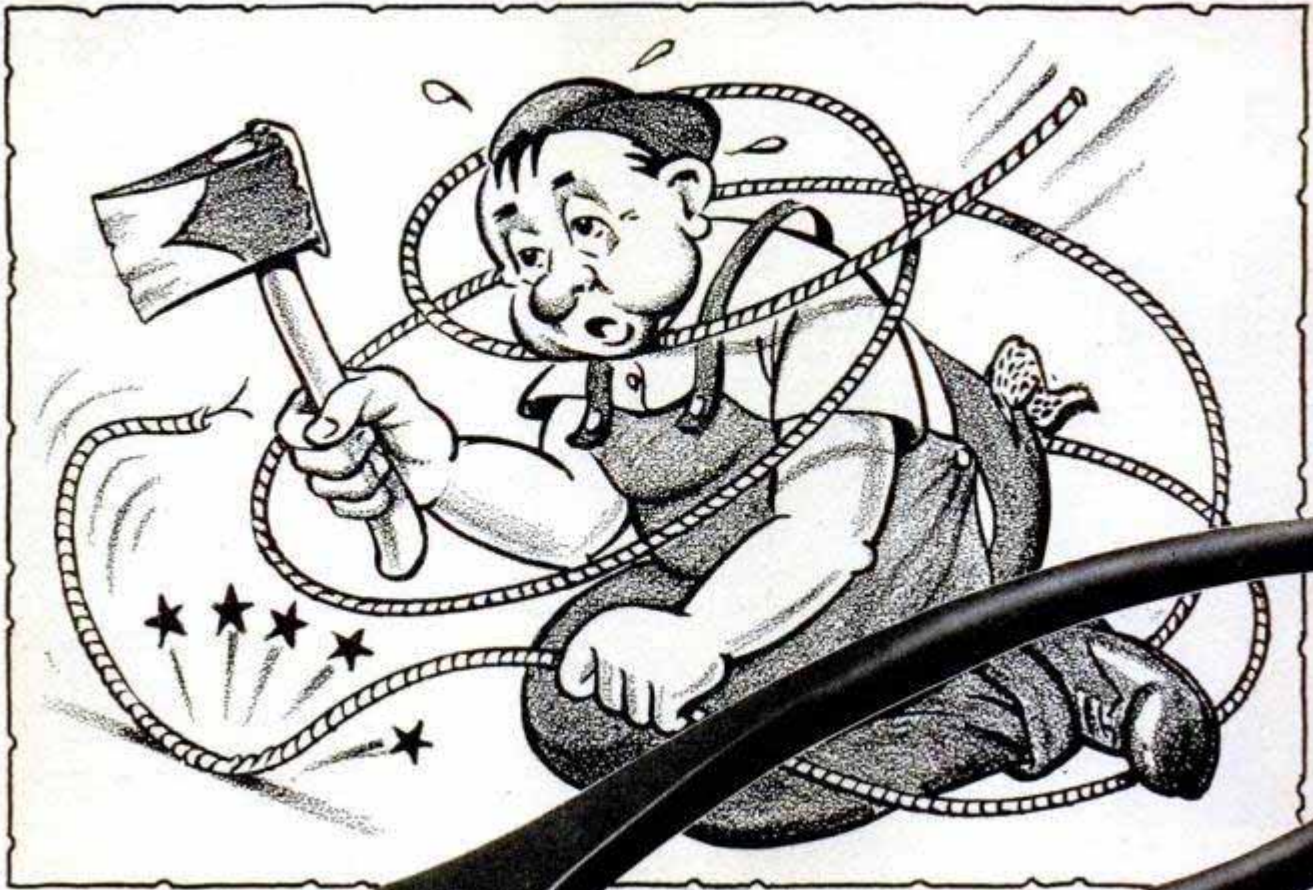

## There's a CRESTOLOY PLIER for EVERY JOB

Apparently Buster has never studied the Crescent Plier display board at his hardware dealer's. If he had, or had read the Crescent book—"How to Use Hand Tools"—he would know that the right tool for this job is a pair of CRESTOLOY Heavy Diagonal Pliers. They're made of special steel, streamlined, with the right feel and cutting leverage for tough jobs. ♦ See your Hardware Dealer NOW

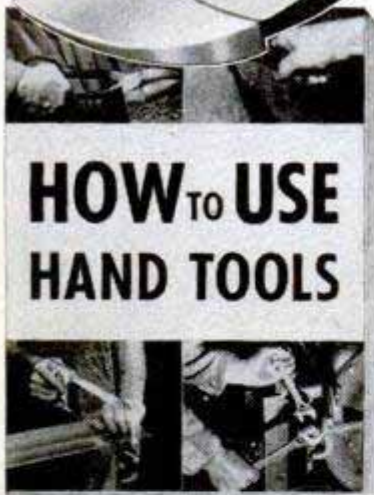

### HOW TO USE HAND TOOLS

### FREE BOOK!

Has all the answers. It tells what tools to use and how to use them. Fully illustrated. A postcard will bring it to you. Send today.



**CRESCENT TOOLS**

*Give Wings to Work*

*Sign of the Artisan  
Symbol of Excellence*

Crescent is our trade-mark, registered in the United States and abroad, for wrenches and other tools. Sold by leading distributors and retailers everywhere and made only by CRESCENT TOOL COMPANY, JAMESTOWN, NEW YORK



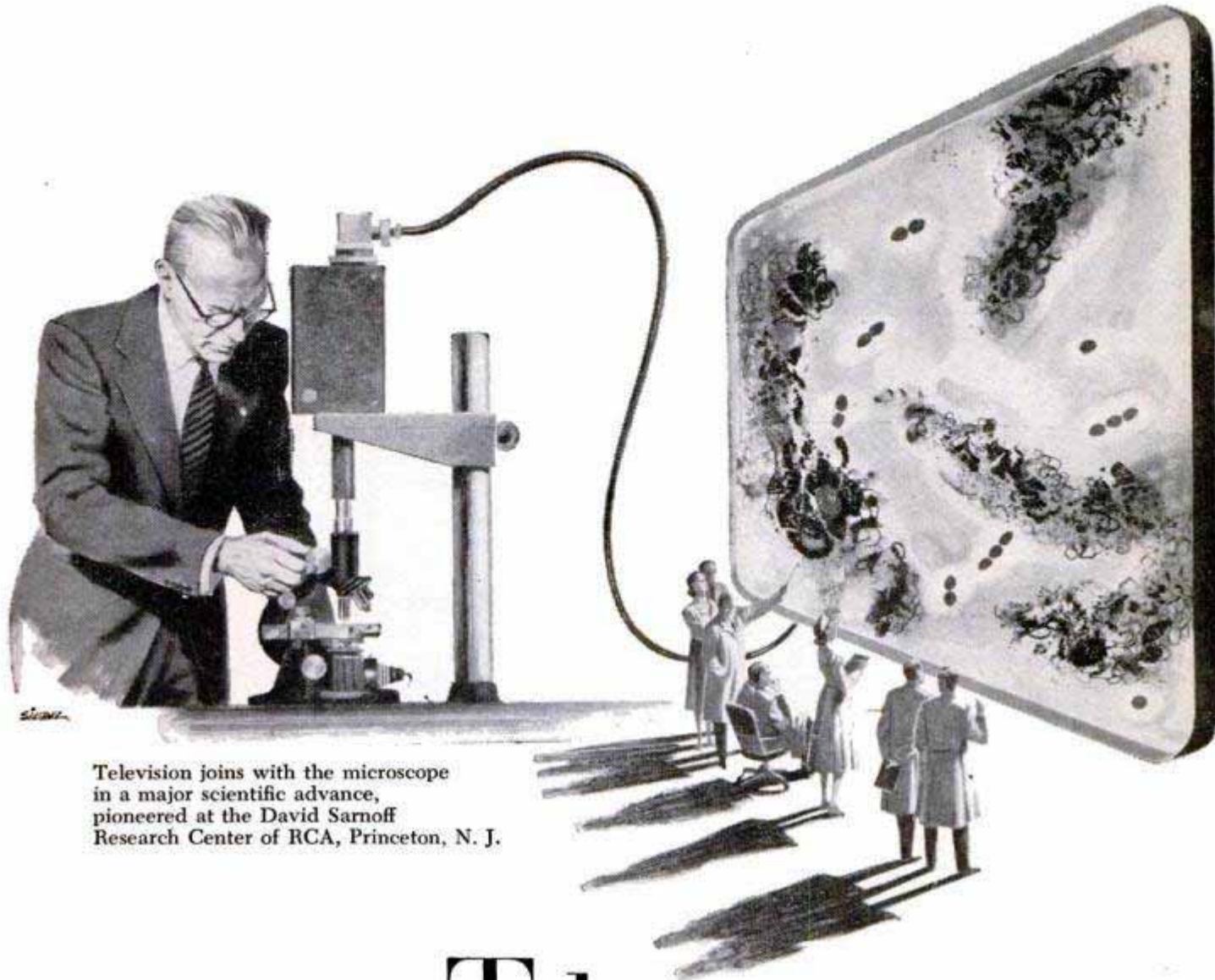

Television joins with the microscope in a major scientific advance, pioneered at the David Sarnoff Research Center of RCA, Princeton, N. J.

# Microbes star on Television

## in war against disease!

Until very recently, scientists found it difficult to keep microbes alive for study—at high magnification—in light microscopes. Dyes used to make the microbes visible killed some. Others were destroyed by the intense light.

RCA scientists have solved this problem by making television a working partner of the microscope. “Eye” of their new system is a tiny industrial television camera built around RCA’s sensitive *vidicon* tube. No intense light is needed, since this electron tube “sees” at low light levels. And by making the tube sensitive to the red or violet bands of the spectrum, dyes and stains are eliminated.

With RCA’s new system, research men can now watch living germs or cells—immensely magnified—on the screen of a television set. Many are able to watch at a time. Students can be more easily trained. And science *learns more* about disease by watching *live* micro-organisms move about.

### How RCA Research benefits you:

Improving the microscope by teaming it with television is an example of the many paths explored by RCA Research. You benefit directly by better performance from any instrument or service trademarked RCA or RCA Victor.

\* \* \*

See the latest in radio, television, and electronics at RCA Exhibition Hall, 36 West 49th Street, New York. Admission is free. Radio Corporation of America, RCA Building, New York 20, N. Y.

**RADIO CORPORATION OF AMERICA**

*World Leader in Radio—First in Television*





# More and more car owners have the Pyroil habit

The Pyroil habit is so good for your car, and so easy on your budget. That's why more and more drivers ask for Pyroil when they "fill-er-up" at their favorite gas stations.

A few ounces of Pyroil in the gas tank, a pint in the crankcase with every oil change—that's the simple Pyroil habit. Then when you step on the gas, you'll start easily and smoothly with no drain on the battery. There'll be no wear-and-tear on pistons and cylinder walls due to friction. Pyroil cleans your motor and keeps it clean. Because Pyroil causes oil to cling to metal surfaces, those expensive engine parts are coated night and day with a cushion of protective lubrication.

The Pyroil habit pays off. Keep up the Pyroil habit—keep on adding miles to your car.

## Pyroil for Aircraft Engines

Use Aircraft Pyroil B for lubricating oil, Aircraft Pyroil A for gasoline.

**GIVEN!** An attractive Pyroil metal savings bank—takes coins up to 50¢ pieces. **MOTORISTS**, it's yours for the asking — sent postage paid.



Manufactured and Guaranteed by Pyroil Company, 125 Pyroil Bldg., La Crosse, Wisconsin

Canadian Distributors: Central Purchasing Agencies, Ltd., Toronto, Ontario

### PYROIL COMPANY

125 Pyroil Bldg., La Crosse, Wisconsin

I want my car to last and run properly. Please tell me more about Pyroil and how it can accomplish this for me.

Name \_\_\_\_\_

Address \_\_\_\_\_

City or Town \_\_\_\_\_ State \_\_\_\_\_



in this corner.....

## THE EDITORS



FLOYD CLYMER writes about automobiles, as every reader knows, but he is partial to airplanes when he travels to far places. On a recent flying trip to Europe to cover the foreign-car situation, he made Jules Verne look like a piker. From Milan, Italy, where he visited the Alfa-Romeo factory, Clymer made a quick side trip to Barcelona, then to Italy and to Vienna, where he landed—to his surprise—in the Russian zone. Floyd brought back scores of photographs of those fascinating European cars, and we have culled the best of them to illustrate his two-part article which begins on page 106 and will be continued in the April issue.

### Letter to the Editor

The enclosed picture entitled "Leap to Doom" was taken recently on a commercial tuna-fishing boat off the west coast of Mexico, just as the voracious 750-pound shark crashed against the boat's rail after leaping for a tuna being landed.

Sharks are a headache to commercial fishermen, as they molest and are very destructive to other fish. To get rid of them, they are, wherever possible, shot. Fishing is normally done from the suspended rack shown, but when a shark is known to be

(Continued to page 8)

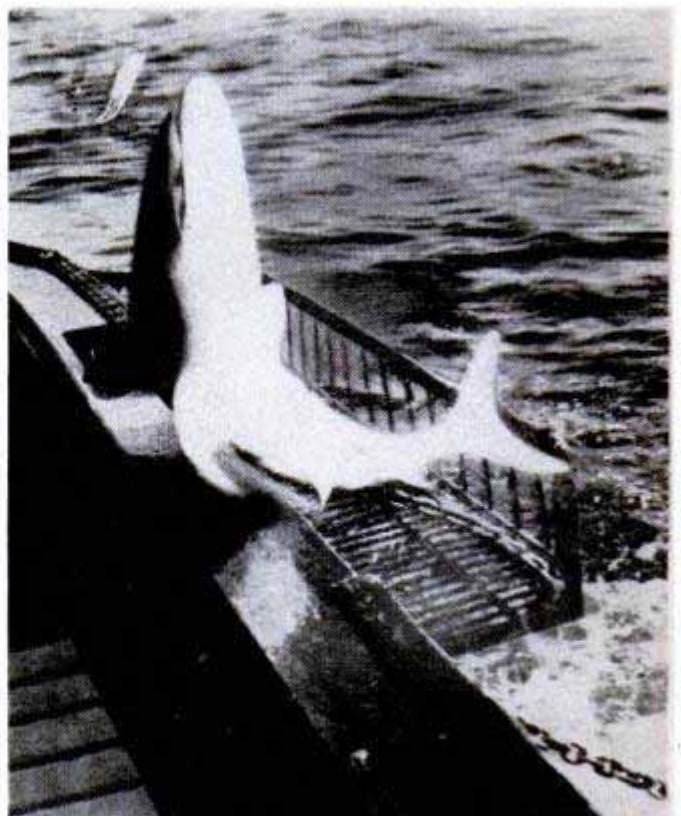





How these 18 Experts can help you

# Get into a High Pay ACCOUNTING CAREER

LaSalle's famous staff of Accounting authorities are helping thousands prepare for fast promotions and bigger pay. They can do the same for you!

If your heart is set on a larger income and all that it means . . . better home—fine car—larger bank account—more of the good things of life. . . .

If that's your ambition and you are really serious about it, then you owe it to yourself to get the REAL FACTS about Accountancy, and the many good-pay opportunities that can be YOURS through LaSalle's famous Problem Method plan.

It matters not whether you've had a single day of experience in this field—or whether you have already started but want to climb higher. LaSalle's expert training is designed to take you from where you are . . . to where you want to be . . . in higher positions and a lifetime career of security and good income.

## WHY YOU CAN'T FAIL TO GAIN

You see on this page a panel of experts who know Accounting from A to Z . . . all the way from simple bookkeeping, on up through advanced accounting, cost accounting, auditing, income tax, and coaching for the C.P.A. degree. These are only part of LaSalle's instruction staff. But what is most important to you . . .

... THESE C.P.A. EXPERTS KNOW HOW TO IMPART THEIR KNOWLEDGE TO OTHERS... HOW TO HELP YOU PREPARE QUICKLY YET THOROUGHLY FOR SUCCESS IN THIS VERY LUCRATIVE FIELD

The proof? What stronger proof could there be than

more than 3,500 Certified Public Accountants (approximately 10% of the U.S. total) who have trained with LaSalle? Or the hundreds of thousands of men and women whom LaSalle has helped qualify rapidly for more money, a brighter future, in a high-pay-lifetime career? These thousands came to us with different backgrounds of experience and varying degrees of ambition. Many have reported raises and promotions after only a few weeks of training. Thousands of them have written to say they are now earning 50% more—even *double* their former incomes—often in less than a year. These letters are published in book form for your inspection. They were written by real people, with real income, problems and ambitions—people who might be your next-door neighbor.

Yes, if you are really sincere in wanting to better your position—start your income climbing—enjoy a lifetime career of high standing and high reward—this friendly staff of experts can help you.

## SEND FOR FREE SAMPLE LESSON... ALSO BIG 48-PAGE BOOK OF LATEST INFORMATION ABOUT CAREER OPPORTUNITIES

You don't have to wonder what LaSalle's Accountancy plan is like. You will be sent a free sample lesson, which does not obligate you in any way. Study it—keep it—see for yourself how simple, clear, and easy it is to master. This is an actual lesson right out of the regular training—to show you exactly how LaSalle's Problem Method has trained more than 1,275,000 men and women from all walks of life.

Also . . . the 48-page book, "Accountancy, the Profession That Pays," gives all the latest facts about the new and growing opportunities in five different fields of profitable employment.

This can be an important day in your life. A coupon like the one below has started hundreds of thousands of men and women toward a bigger job, a larger income. It can do the same for you.

Mail the Coupon Today!

FREE 48-PAGE CATALOG

LA SALLE

FREE SAMPLE LESSON

EXTENSION UNIVERSITY

A Correspondence Institution

417 S. Dearborn St., Dept. 364H, Chicago 5, Ill.

Send free Sample Lesson in Accounting—also, 48-page free book, "Accountancy, the Profession That Pays" . . . all without cost or obligation.

Name.....Age.....

Address.....

City & Zone.....State.....

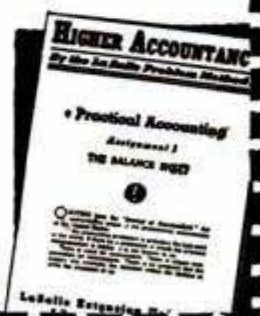



# Easy, low-cost way to have 3-way indirect lighting in your old table lamps

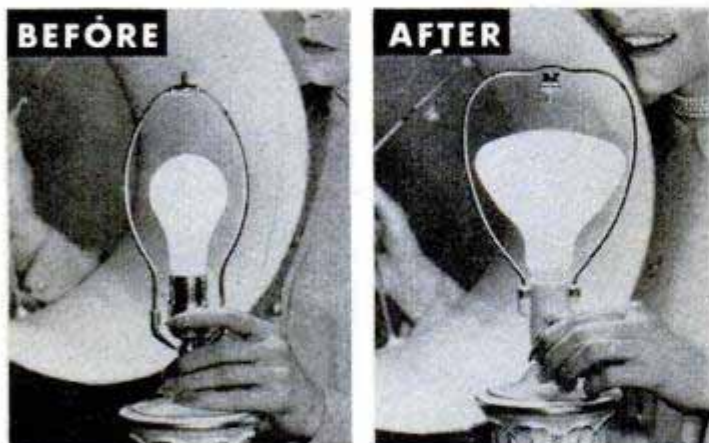

In just minutes, you can convert your old table lamps to give you indirect lighting with three brightness levels! General Electric's new R-40 3-lite bulb, plus Monowatt adaptor kit, transforms your lamps as shown above—gives pleasing diffused light and choice of 150, 100, and 50-watts at the flick of a switch.

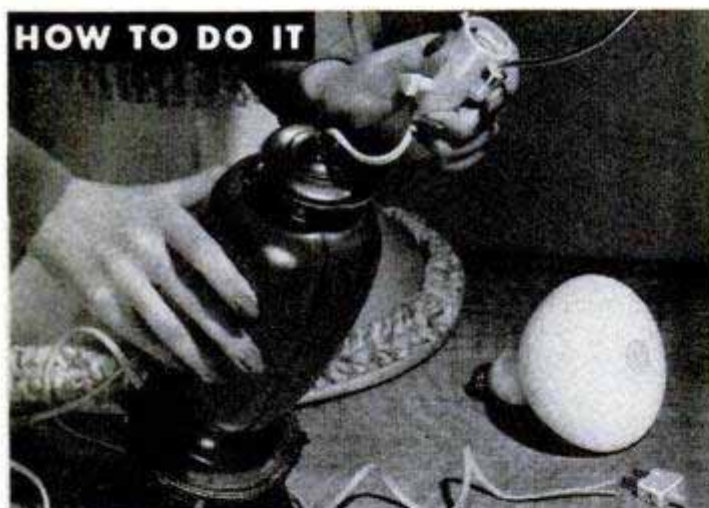

Using the special new Monowatt "Improv-a-lite" unit, you simply remove socket and wire, pull new wire through lamp, and screw on 3-lite socket. Then slide wire into plug, press down on lever, and it's ready for use!

To learn where you can buy "Improv-a-lite" units and R-40 bulbs, if not yet available where you shop, write Monowatt Dept. PM3, General Electric, 95 Hathaway Street, Providence, R. I.

**FREE BOOKLET**—gives tips on modernizing table lamps. For your copy of "How to Wire Lamps", write to address above.



You can put your confidence in—

**GENERAL  ELECTRIC**

(Continued from page 6)

about, the crew move back on deck so the riflemen have a clear range for shooting. This had been done when this picture was taken.

Hoping to get a picture of the shooting of a shark, I was standing close to one rifleman, when suddenly the water just off the side of the boat boiled up, and this shark leaped into the air after the fish. The action was so swift and close and unexpected that I was not sure where the shark was at the time of tripping the shutter. The shark, after crashing against the rail, was carried by its momentum onto the boat's deck, with the crew scrambling for safety, and thrashed around and died—obligingly saving us the time and trouble of trying to shoot it.

Roy Whitehouse,  
San Marcos, Calif.

## Letter to the Editor

This will acknowledge the safe arrival of the citation announcing my election to *Popular Mechanics'* Half Century Hall of Fame. You know already of my appreciation of this election and this citation will serve as a continuing and visual reminder of the honor that has been accorded me.

Vannevar Bush,  
Washington, D. C.

## Letter to the Editor

I thank you very much for your kind letter and the citation [Hall of Fame]. I admired greatly the fine taste and workmanship of the script. . . .

Albert Einstein,  
Princeton, N. J.

## Letter to the Editor

The heavy pressure of work toward the close of the year, together with the holiday season, has delayed my acknowledgment of your courtesy informing me of election to the *Popular Mechanics'* Hall of Fame. To be included in the group you have selected is truly an honor. . . .

Igor I. Sikorsky,  
Bridgeport, Conn.

## Letter to the Editor

The very attractive citation in its frame came through in good shape, and I wish again to express appreciation of the honor of election to the Half Century Hall of Fame which *Popular Mechanics* has set up. You have handled the affair very graciously.

Karl T. Compton,  
Cambridge, Mass.

(Continued to page 10)



**GOING UP?**

AGE 45  
\$8500

AGE 55  
\$10,000

AGE 35  
\$6000

**OR DOWN?**

AGE 35  
\$3250

AGE 45  
\$3250

AGE 25  
\$2500

AGE 55  
\$2250

You're looking at *your* future. With the right training you can go *up* — steadily up to management level. You'll make more money — live better as the years go by.

*Without* that training there's a ceiling on what you can earn. By the time you're middle-aged you'll be on the way down, into the ranks of the poorly paid.

It's up to you to choose. You can make or break your future. And *now* is the time to decide. Not next year, or next month, but

*now*. You can get the training that will command a trained man's salary. The International Correspondence Schools have helped hundreds of thousands of men to qualify for advancement. And those men had no more at the start than you've got right now. Find out how *you* can prepare yourself — at home and in your own spare time — for the position you want in the work you like best. Don't put it off. Mark this coupon and get it in the mail today.

## INTERNATIONAL CORRESPONDENCE SCHOOLS



BOX 5522-L, SCRANTON 9, PENNA.

Without cost or obligation, please send me full particulars about the course BEFORE which I have marked X:

- Air Conditioning and Plumbing Courses**
  - Air Conditioning
  - Heating
  - Plumbing
  - Refrigeration
  - Refrigeration, Domestic
  - Refrigeration & Air Conditioning
  - Steam Fitting
- Aeronautics Courses**
  - Aeronautical Engineer's, Jr.
  - Aircraft Drafting & Design
  - Aircraft Mechanic
  - Engine Mechanic
- Automotive Courses**
  - Automobile
  - Auto Technician
  - Auto Electric Technician
  - Auto Body Rebuilding & Refinishing
- Chemical Courses**
  - Chemical Engineering
  - Chemistry, Analytical
  - Chemistry, Industrial
  - Food-Plant Sanitation
  - Petroleum Refining
  - Plastics
  - Pulp and Paper Making
- Civil Engineering and Architectural Courses**
  - Architecture
  - Architectural Drafting
  - Bridge and Building Foreman

- Building Estimating
- Civil Engineering
- Contracting and Building
- Highway Engineering
- Reading Structural Blueprints
- Sanitary Engineering
- Structural Drafting
- Structural Engineering
- Surveying and Mapping
- Communications Courses**
  - Electronics
  - Practical Telephony
  - Radio, General
  - Radio Operating
  - Radio Servicing
  - Television
  - Telegraph Engineering
- Electrical Courses**
  - Electrical Drafting
  - Electrical Engineering
  - Electric Light and Power
  - Lighting Technician
  - Practical Electrician
- Diesel Engines Courses**
  - Diesel Engines
  - Internal Combustion Engines
- Mechanical Courses**
  - Forging
  - Foundry Work
  - Heat Treatment of Metals

- Industrial Engineering
- Industrial Instrumentation
- Industrial Metallurgy
- Machine Shop
- Mechanical Drafting
- Mechanical Engineering
- Mold-Loft Work
- Patternmaking—Wood, Metal
- Reading Shop Blueprints
- Sheet-Metal Drafting
- Sheet-Metal Worker
- Ship Drafting
- Ship Fitting
- Tool Designing
- Toolmaking
- Welding—Gas and Electric
- Railroad Courses**
  - Air Brake
  - Car Inspector
  - Diesel Locomotive
  - Locomotive Engineer
  - Locomotive Fireman
  - Locomotive Machinist
  - Railroad Section Foreman
  - Steam-Diesel Locomotive Eng.
- Stationary Engineering Courses**
  - Power Plant Engineering
  - Stationary Fireman
  - Stationary Steam Engineering

- Textile Courses**
  - Cotton Manufacturing
  - Loom Fixing
  - Textile Engineering
  - Woolen Manufacturing
  - Rayon Mfg.
- Business and Academic Courses**
  - Accounting
  - Advertising
  - Bookkeeping
  - Business Administration
  - Business Correspondence
  - Business Law
  - Cartooning
  - Certified Public Accounting
  - Commercial
  - Commercial Art
  - Cost Accounting
  - Fashion & Book Illustration
  - Federal Tax
  - First Year College
  - Foremanship
  - Good English
  - High School
  - Higher Mathematics
  - Industrial Supervision
  - Motor Traffic
  - Personnel—Labor Relations
  - Postal Civil Service
  - Retailing
  - Retail Business Management
  - Salesmanship
  - Secretarial
  - Sign Lettering
  - Stenography
  - Traffic Management

Name \_\_\_\_\_ Age \_\_\_\_\_ Home Address \_\_\_\_\_  
 City \_\_\_\_\_ State \_\_\_\_\_ Working Hours \_\_\_\_\_ A.M. to \_\_\_\_\_ P.M.  
 Present Position \_\_\_\_\_ Employed by \_\_\_\_\_

Special tuition rates to members of the Armed Forces. Canadian residents send coupon to International Correspondence Schools Canadian, Ltd., Montreal, Canada.



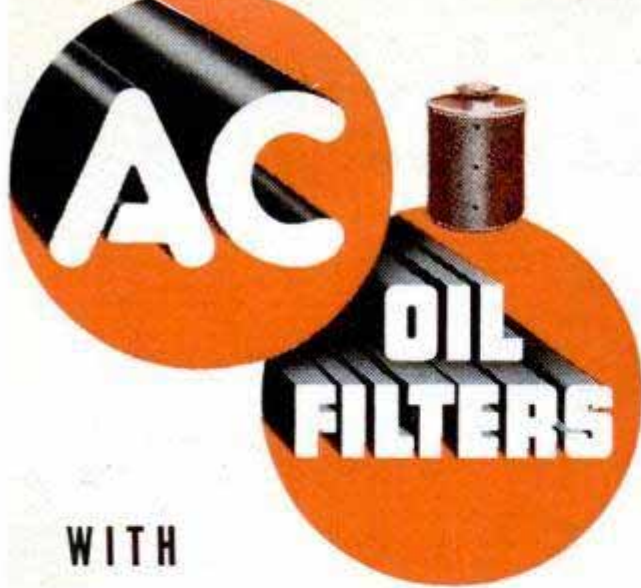

WITH

**ALUVAC**

**ELEMENTS**

**ESPECIALLY ENGINEERED  
FOR CHEVROLET**



**TRAPS ENGINE OIL DIRT AS  
SMALL AS 1/100,000 OF AN INCH**

AC Oil Filters with *Aluvac* Elements are designed to help preserve and protect engine power and lengthen the life of moving parts. They provide the finest filtration money can buy, removing particles as fine as 1/100,000 of an inch. Whenever you need a new oil filter element—regardless of the make of car you drive, or the make of filter you are using—install an AC *Aluvac* Element.

AC SPARK PLUG DIVISION  GENERAL MOTORS CORPORATION

**Letter to the Editor**

Next month I expect to see . . . an apology to the automobile industry for the entirely erroneous figures quoted by Floyd Clymer [Clymer's report on the Hudson, December 1951] on his stockcar records. He must have been looking at the wrong book because, according to my records, he was not quoting Hudson stockcar records but records set by a supercharged 1937 Cord Super Eight. . . . No Hudson has been built yet that will clock 100 miles per hour. I'll take my "Cad" and outperform a Hornet any day of the week. . . . A 1939 Hudson Eight does hold the record for stockcars of less than 305 cubic inches at 93.88 miles per hour.

Maj. Elden D. Jones,  
Hdqrs., 15th Air Force  
March A.F.B., Calif.

Dear Major Jones:

You must have an eagle eye to have detected the error, as you are the only one who has written about it. Actually, my information came out of the A.A.A. official record book. . . . I unintentionally picked the figures from the Cord records instead of the ones from the Hudson, which were printed alongside. Therefore, the records that I mentioned in my *Popular Mechanics* article actually were the ones made by the supercharged Cord. The speeds given for Hudson, which previously had held the record, should have read as follows:

- 90.15 m.p.h. for 500 miles,
- 89.00 m.p.h. for 1000 miles,
- 87.78 m.p.h. for 2000 miles.

The Class C closed record held by the Hudson Eight for one mile is 93.88 miles per hour, and the Hudson Six made the record in Class D of 81.19 miles per hour for one mile in 1939.

Floyd Clymer.

(The editors join Floyd Clymer in apologies to Major Jones, Hudson and Cord for the error.)

**Letter to the Editor**

I've been getting *Popular Mechanics* since September 1906. . . . In the 20s I was in Troy, Mont., four miles from the village. Every month I walked the distance, both ways, to get my magazine . . . in a hurry. Could have waited for it in the mail two or more days later. Not for me. When I want something, it's now! After 45 years I'm still a more-than-satisfied customer.

Dan Dann, the Fixit Man,  
Kingston, N. Y.



# WHAT Every AUTO MECHANIC Wants to Know

A motor vehicle is a machine of many parts, each part designed and constructed for its own special function.

All good mechanics, like good doctors, should know the working theory and operation of each part and understand what causes trouble and how to remedy it.

## LET AUDELS AUTO GUIDE SOLVE YOUR PROBLEMS

Every auto mechanic, helper, serviceman and operator can use a copy of AUDELS AUTOMOBILE GUIDE. The information it gives saves time, money and worry. Highly indorsed by all users. It presents the whole subject of auto mechanics from A to Z in plain language and simple terms.

This Big Practical Book gives full information with working diagrams covering the principles, construction, ignition, service and repair of modern cars, trucks and buses.

A complete Guide of 1800 pages, with over 1500 illustrations showing inside views of the working parts, with instructions for service jobs. Diesel engines, Fluid and Hydra-matic drives fully explained.

### IT PAYS TO KNOW HOW TO

How to fit pistons—How to locate engine knocks—How to fit connecting rod bearings—How to service main bearings—How to re-condition valves—How to time valves—How to adjust fan belts—How to adjust carburetors & chokes—How to rebuild a clutch—How to service automatic transmissions—How to service brakes—How to adjust steering gear—How to cope with ignition troubles—How to service distributors—How to time ignition—How to "tune up" an engine.

### INFORMATION IN A HANDY FORM

73 INTERESTING CHAPTERS—Read this partial list of subjects on which practical information is fully given for quick reference under the headings as shown below. Ready Reference Index.

All Parts of an Automobile—Automotive Physics—The Gas Engine—Gas Engine Principles—Multi-Cylinder Engines—Horse Power—Automobile Engines—Stationary Parts—Moving Parts—Pistons—Piston Rings—Connecting Rods—Crank Shafts—Valves—Valve Gear—Cams and Cam Action—Valve Timing—Cooling Systems—Fuel Feed Systems—Dual Fuel Feed—Mixture—Carburetors—Carburetor Service—Automatic Choke—Super-Chargers—Transmissions—Special Transmissions—Fluid and Hydra-matic Drives—Clutches—Universals and Propeller Shafts

A Ready Reference

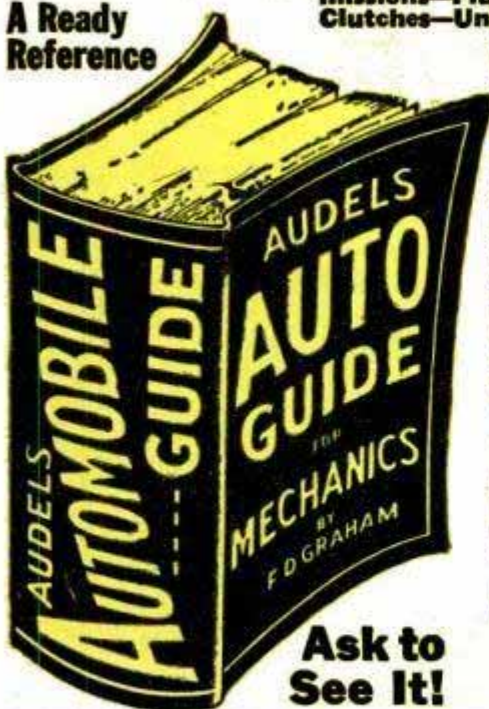

Ask to See It!

—The Differential—Rear Axles—Rear and Front Suspension—Running Gear—Brakes—Wheel Alignment—Knee Action—Steering Gear—Tires—Lubricants and Lubrication—Automotive Electricity—Ignition Systems—Magneto Ignition—Spark Plugs—Ignition Coils—Distributors—Automatic Spark Control—Ignition Timing—Generators—Starters—Generator and Starter Testing—Lighting Systems—Storage Batteries—Charging and Testing—Diesel Engines and Trouble Shooting.

**7 DAYS' FREE TRIAL TO GET THIS ASSISTANCE FOR YOURSELF SIMPLY FILL IN AND MAIL COUPON TODAY.**

**\$4 COMPLETE PAY \$1 A ONLY 1 MO.**



### Sent on 7 Days Approval

Step up your own skill with the facts and figures of your trade. Audels Mechanics Guides contain Practical Inside Trade Information in a handy form. Fully illustrated and Easy to Understand. Highly Endorsed. Check the book you want for 7 DAYS FREE EXAMINATION. Send No Money. Nothing to pay postman.

## ---CUT HERE--- MAIL ORDER

AUDEL, Publishers, 49 W. 23 St., NEW YORK 10, N. Y.

Please send me postpaid for FREE EXAMINATION books marked (X) below. If I decide to keep them I agree to mail \$1 in 7 Days on each book or set ordered and further mail \$1 monthly on each book or set until I have paid price, otherwise I will return them.

- TRUCK & TRACTOR GUIDE, 1299 Pages . . . \$ 4
- AUTOMOBILE MECHANICS GUIDE, 1800 Pages . . . 4
- DIESEL ENGINE MANUAL, 575 Pages . . . 2
- MACHINISTS HANDY BOOK, 1650 Pages . . . 4
- WELDERS GUIDE, 400 Pages . . . 1
- BLUE PRINT READING, 416 Pages . . . 2
- MATHEMATICS & CALCULATIONS, 700 Pages . . . 2
- SHEET METAL PATTERN LAYOUTS, 1100 Pages . . . 4
- SHEET METAL WORKERS HANDY BOOK, 388 Pgs. . . 1
- MECHANICAL DRAWING GUIDE, 160 Pages . . . 1
- MECHANICAL DRAWING & DESIGN, 480 Pages . . . 2
- AIRCRAFT WORKER, 240 Pages . . . 1
- TELEVISION SERVICE MANUAL, 384 Pages . . . 2
- RADIOMANS GUIDE, 914 Pages . . . 4
- ELECTRONIC DEVICES, 216 Pages . . . 2
- ELECTRIC MOTOR GUIDE, 1000 Pages . . . 4
- ELECTRIC WIRING DIAGRAMS, 272 Pages . . . 1
- ELECTRICIANS EXAMINATIONS, 250 Pages . . . 1
- ELECTRIC POWER CALCULATIONS, 425 Pages . . . 2
- HANDY BOOK OF ELECTRICITY, 1440 Pages . . . 4
- ELECTRIC DICTIONARY, 9000 Terms . . . 2
- ELECTRIC LIBRARY, 7000 Pages (12 Book Set) . . . 18
- MARINE ENGINEERS HANDY BOOK, 1258 Pgs. . . 4
- SHIPFITTERS HANDY BOOK, 250 Pages . . . 1
- REFRIGERATION & Air Conditioning, 1280 Pgs. . . 4
- MILLWRIGHTS & MECHANICS GUIDE, 1200 Pgs. . . 4
- POWER PLANT ENGINEERS GUIDE, 1500 Pages . . . 4
- ENGINEERS & FIREMANS EXAMS, 525 Pages . . . 1
- PUMPS, Hydraulics & Air Compressors, 1658 Pgs. . . 4
- ENGINEERS LIBRARY (3 Book Set) . . . 9
- MECHANICAL DICTIONARY, 950 Pages . . . 4
- GARDENERS & GROWERS GUIDES (4 Book Set) . . . 6
- CARPENTERS & BUILDERS GUIDES (4 Book Set) . . . 6
- PLUMBERS & Steamfitters Guides (4 Book Set) . . . 6
- MASONS AND BUILDERS GUIDES (4 Book Set) . . . 6
- PAINTERS & DECORATORS MANUAL, 450 Pgs. . . 2
- HOUSE HEATING GUIDE, 1000 Pages . . . 4
- OIL BURNER GUIDE, 384 Pages . . . 1

Name \_\_\_\_\_  
 Address \_\_\_\_\_  
 Occupation \_\_\_\_\_  
 Employed by \_\_\_\_\_

AUDEL, Publishers, 49 W. 23 St., New York 10, N. Y.





Makes \$10

Shop Specializes in Television

ized service-manufacturing for an enviable in Television Miller, Maumee, O.



\$5 to \$8 Week In Spare Time

"When halfway through the course, made \$5 to \$8 a week fixing sets. Now sell and install Television sets." — E. J. Streitenberger, New Boston, O.



Calls N.R.I. His "Stepping Stone"

"N.R.I. has been my stepping stone from a few hundred dollars to over \$4,000 a year as a Radio Engineer. Make extra money servicing Radios." — Alton B. Michaels, Trenton, Ga.

# BE A SUCCESS IN RADIO- Learn by Practicing

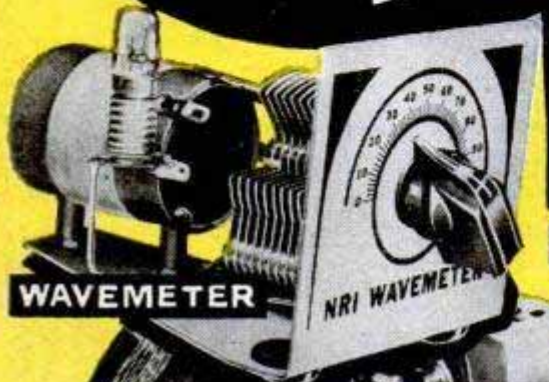

WAVEMETER



MODERN RADIO

Build Equipment Like This With Kits I Send You

I give you PRACTICAL EXPERIENCE with many valuable Kits I send that "bring to life" my illustrated texts. In my Servicing Course, you build a modern Radio, Multitester, AM Signal Generator, etc. In my Communications Course, you assemble a low-power Broadcasting Transmitter, Wavemeter, Electronic Multitester, etc. Some equipment from both these courses is shown on this page.

All of the equipment that you build is yours to keep.



**NEW! Advanced Television Practice!**

New, special TV kits furnished to build high-definition SCOPE . . . RF OSCILLATOR with flyback power supply . . . complete TV SET . . . many other units. You see pulse, trapezoidal, saw-tooth wave forms. Get valuable PRACTICAL EXPERIENCE locating and correcting TV troubles. Mail coupon for facts, pictures and prices!

**MAKE EXTRA MONEY WHILE LEARNING**

I show you how to earn \$5, \$10 a week or more, fixing Radios in spare time while training. I send you parts to build the multitester (shown at right) that helps you do it. You get practical experience. I send you Special Booklets that tell you how to get and do these profitable spare time jobs.



TRANSMITTER

MULTITESTER





**NRI-Graduate Doubles Salary**

"I am employed by Station WKBO as transmitter operator. Have more than doubled my salary since starting in Radio full time." — A. Herr, New Cumberland, Pa.



**Manager Radio and Television Dept.**

"From Radio and Television Technician . . . was promoted to Manager of Television Service and Installation. Thanks to N. R.I." — L. Hauger, San Bruno, Calif.



**Gets First Job Through N.R.I.**

"My first job was operator with KDLR, obtained for me by your Graduate Service Dept. Am now Chief Engineer Police Radio Station WQOX." — T. S. Morton, Hamilton, Ohio.

**I TRAINED THESE MEN**



# TELEVISION

## at Home in Spare Time

**Get a Good Job--Have a Bright Future in America's Fast Growing Industry**

Do you want good pay, a job with a bright future and security? Would you like a profitable shop of your own? The fast growing, prosperous RADIO-TELEVISION industry is making these opportunities for you. Radio alone is bigger than ever. 90 million home and auto Radios, 3100 Broadcasting Stations, expanding use of Aviation and Police Radio, Micro-Wave Relay, Two-Way Radio for buses, taxis, etc., are making opportunities for Servicing and Communications Technicians and FCC-Licensed Operators.

**Television is TODAY'S Good Job Maker**

In 1946 only 6,000 TV sets sold. In 1950 over 5,000,000. By 1954, 25,000,000 TV sets will be in use, according to estimates. Over 100 TV Stations are operating in 35 states. Authorities predict there will be 1,000 TV Stations. This means new jobs, more jobs, good pay for qualified men.



**WANT A BUSINESS OF YOUR OWN?**

Let me show you how to have a good, steady income from your own Radio-Television shop. Many N.R.I.-trained men each year start without capital, like Robert Dohmen, New Prague, Minn., above. He writes, "Am now tied in with two television outfits."



**EXTRA PAY IN ARMY,**

**NAVY, AIR FORCE**

Knowing Radio, TV, Electronics can help you get extra rank, extra prestige, more interesting duty at pay up to several times a private's base pay. You are also prepared for good Radio-TV jobs upon leaving service. Mail Coupon TODAY.

**Many Soon Make \$10 A Week Extra in Spare Time**

Keep your job while training at home. Hundreds I've trained are successful RADIO-TELEVISION TECHNICIANS. Most had no previous experience; many no more than grammar school education. Learn Radio-Television principles from illustrated lessons. Get PRACTICAL EXPERIENCE—build valuable multimeter for conducting tests; also practice servicing Radios or operating transmitters—experiment with circuits common to Radio and Television. You keep all equipment. Many students make \$5, \$10 a week extra fixing neighbors' Radios in spare time. SPECIAL BOOKLETS start teaching you the day you enroll.

**The ABC's of SERVICING**

**How to Be a Success in RADIO-TELEVISION**

**FREE ACTUAL LESSON AND 64 PAGE BOOK**

Act Now! Send for my FREE DOUBLE OFFER. Coupon entitles you to actual lesson on Servicing; shows how you learn Radio-Television at home. You'll also receive my 64-page book, "How to Be a Success in Radio-Television." You'll read what my graduates are doing, earning; see photos of equipment you practice with at home. Send coupon in envelope or paste on postal. J. E. SMITH, President, Dept. 2CA, National Radio Institute, Washington 9, D.C. OUR 39th YEAR.

**MAIL THIS NOW**

**Good For 2 Books FREE**

**MR. J. E. SMITH, President, Dept. 2CA National Radio Institute, Washington 9, D. C.**

Mail me Sample Lesson and 64-page Book "How to Be a Success in RADIO-TELEVISION." Both FREE. (No salesman will call. Please write plainly.)

NAME.....AGE.....

ADDRESS.....

CITY.....ZONE.....STATE.....

Approved Under G. I. Bill.



Source of supply appears after items commercially available



This Haul Beats All  
of Madame's Jewels... 'Cause  
**PROTO** means  
**PRO**fessional  
**TO**ols!



You get true professional quality in PROTO tools, because they are designed and built to meet the exacting requirement of tool experts. Modern user-tested designs, PROTO-specified alloy steels, proper forging and heat treating, and extreme care in all manufacturing steps result in tools that are extra strong, accurate, easy to handle and long-lived.

The PROTO Line Includes Wrenches of All Types, Pliers, Screwdrivers, Punches, Chisels, Sockets & Handles, Pullers, Tool Boxes, Industrial Tools and Many Others.

Make your PROTO dealer's store your professional tool headquarters. Send 10¢ for 68-page catalog to

**PLOMB TOOL COMPANY**  
2255P Santa Fe Ave., Los Angeles 54, Calif.

5281



Eastern Factory—Jamestown, N.Y.

**ATOMIC RESEARCH**

Science manufactures two heaviest atoms..... 86  
Atomic reactor makes electricity.....105  
Atomic "race track" boosts electron speed.....150

**AUTOMOTIVE**

Trailer bed folds out of way..... 86  
Detroit listening post.....101  
1952 Plymouth .....128  
"Level load" trailer axle (American Steel Foundries, 410 N. Michigan Ave., Chicago).....150

**AVIATION**

Helicopter forecast from England..... 88  
Turborotor helicopter (Kaman Aircraft Corp., Bradley Field, Windsor Locks, Conn.).....121  
Biggest-known jet bomber (Boeing Aircraft Co., Seattle 14, Wash.) .....121  
Flying flashlight pinpoints targets.....122  
Portable elevator .....133  
Ten-jet troop carrier.....138  
Speedy refueling of jets.....147

**FARM AND GARDEN**

Pills for plants..... 86  
Chemical prevents elm-tree disease.....122  
Water heater floats in stock tank (Richards Products Mfg. Co., Arapahoe, Neb.).....129  
Beetle fights a battle.....148  
Brush cutter .....163

**HOBBIES AND NOVELTIES**

Nylon trappings for cowboy trade (Hope Hunter, High River, Alta., Can.) .....111  
Chains for shoe soles.....121  
Reclining bicycles .....133  
Chalk sculptor .....139  
Child's jet airplane powered by vacuum cleaner.....163

**HOUSE AND HOME**

Stick-on ruler (Stick-E-Ruler, Watkins Glen, N. Y.).....140  
Shelf unit (Wellfleet Sales Co., P. O. Box 218, Newark 1, N. J.) .....141  
Freezer thermometer (Fee and Stenwedel, Inc., 2210 W. Wabansia, Chicago) .....141  
Canned-milk dispenser (Mastercraft Products, 212 Summer St., Boston 10, Mass.).....141  
Venetian blind cleaner (New England Associates, 486 Broad St., Providence, R. I.).....141  
Curved toothbrush (Brittain Products Co., 380 E. Exchange St., Akron 4, Ohio).....141  
Dish rack (Kitch'N-Handy Products, Tacoma 2, Wash.).....141  
Pan gripper (Weaver Sales Co., P. O. Box 2441, Salt Lake City, Utah) .....141

**INDUSTRY**

Robot machinist (Daco Machine and Tool Co., Tillary and Prince Sts., Brooklyn 1, N. Y.).....128  
Automatic paint system uses electrostatic "spray".....142  
Tin-can compressor .....142  
Explosion test chamber.....143  
"Pipe organ" oil driller (Emsco Derrick and Equipment Co., 6811 S. Alameda, Los Angeles, Calif.).....160

**MILITARY**

Army unwraps improved rifles.....129  
Test gun fires tiny missiles.....151  
Altimeter is supersensitive (Wallace and Tiernan Products, Inc., Belleville, N. J.).....159

**PHOTOGRAPHY**

Lens test bench produces parallel rays (Grover Photo Co., 201½ E. Broadway, Glendale, Calif.)..... 87  
"Inside the camera" view..... 87  
Tougher base for movie film.....270

(Continued to page 16)



# INVENTORS

**L**earn how to protect your invention. The U. S. Patent Laws provide that any new and useful art, machine, article of manufacture, or composition of matter, or any new and useful improvement thereof, may be patented if the act of invention is involved. Therefore, every inventor with a valuable invention should take advantage of the Patent Laws and proceed for patent protection in order to safeguard his rights.

A patent gives the inventor the exclusive right to prevent others from making, using, or selling the invention claimed in the patent for a period of seventeen years.

The Patent Laws were enacted for the benefit of the inventor to give him protection for the features of his invention which are patentable. These features must be properly and concisely set forth and claimed in a formal application for patent, in order to comply with the requirements of the Patent Laws. For that reason, unless the inventor is familiar with patent matters, he should engage a competent registered patent attorney or agent to represent him. We are registered to practice before the U. S. Patent Office and are prepared to serve you in the handling of your patent matters.

A specially prepared booklet entitled "Patent Guide for the Inventor", containing detailed information with respect to patent protection and procedure, together with a "Record of Invention" form will be promptly forwarded to you without obligation upon request.

---

**CLARENCE A. O'BRIEN & HARVEY JACOBSON**

*Registered Patent Attorneys*

21-C DISTRICT NATIONAL BUILDING

WASHINGTON 5, D. C.



GET THE WORLD'S LEADING

**RADIO & TV CATALOG**

★  
**FREE**

★  
**1952**

★  
**212-Page  
Edition**

★  
**ALLIED'S**

**BIG COMPLETE  
BUYING GUIDE**

*Save on Everything  
in Radio and TV*

**Everything for Experimenters,  
Builders, Amateurs, Service-  
men, Engineers and Soundmen**

Send for ALLIED'S 212-page 1952 Catalog, the value-packed guide to *everything* in Radio and Television! Latest home radios, TV equipment, Amateur supplies, P.A. Systems, Hi-Fidelity Sound, recorders, test instruments, builders' kits—plus the world's largest stocks of electronic parts, tubes, tools, books and diagrams. Get more for your money—send today for your FREE 1952 ALLIED Catalog!

**Get Radio's Leading  
Buying Guide Today**

**FREE!**

**ALLIED RADIO**

ALLIED RADIO CORP., Dept. 5-C-2  
833 W. Jackson Blvd., Chicago 7, Ill.

Rush FREE 1952 ALLIED 212-Page Catalog.

Name \_\_\_\_\_

Address \_\_\_\_\_

City \_\_\_\_\_ Zone \_\_\_\_\_ State \_\_\_\_\_



**NEW  
UP-TO-DATE  
SEND FOR IT NOW**



(Continued from page 14)

**MISCELLANEOUS**

Aerial cable car pulls itself along..... 90  
Machine replaces heart or lung..... 122  
North America abounds in harmful insect pests..... 129  
Spider-leg catamaran ..... 130  
One-piece hooks attached by feel (Brummel Hook Co., 1619 W. Winona Ave., Chicago 40)..... 143  
Hot-air radiant heat in catacombed floor (Airfloor of America, Culver City, Calif.)..... 147  
Model tames raging river..... 158  
Plastic tie plates for rails..... 158  
"Yacht of future" is enclosed from deck to trim superstructure ..... 159  
London's post-office railway..... 164

**Craftsman and Shop Notes Index**

**AUTOMOTIVE**

Soiled sun visors renovated by reversing positions..... 175  
Tire talcum dusted on tube lessens pinching tendencies..... 215  
Matchbox abrasive used as file for breaker points..... 215

**FARM**

Pig creep built from gates..... 213  
Adjustable outboard ground shoe protects combine in rough fields ..... 226  
Tractor-tire valve stems protected with sheet-metal guards... 226

**HOUSE AND HOME**

Newspaper guide helps position pictures when hanging..... 174  
Decals conceal chipped porcelain..... 175  
Cleanout pipe set in ground simplifies cleaning of sewer..... 175  
Solving home problems..... 176  
Locating a short circuit in home appliances..... 178  
Trapped water in steam radiator siphoned with syringe..... 186  
Placing spring on bed frame..... 192  
How to build a flower box..... 193  
Corner rack for bath towels..... 200  
Rubber tubing connected to faucet secured with waterproof tape ..... 208

**METALWORKING**

"Tooled" pictures in metal foil simulate hammered designs.. 183  
Porch lantern ..... 191  
Dial indicator from an old watch..... 214

**NOVELTIES AND TOYS**

Candle placed inside flowerpot produces novel "hurricane" lamp ..... 175  
Inexpensive Easter baskets from berry boxes..... 186  
Clock with works removed makes inconspicuous "piggy" bank. 190

**PAINT AND PAINTING**

Tips on enameling woodwork..... 190  
Painting outdoor furniture..... 200  
Spray-gun water trap..... 223

**PHOTOGRAPHY**

Synchronized flash with a studio shutter..... 205  
Storage cabinet for hobby photos..... 206  
Roll-film tank emptied quickly by blowing into filler hole... 208  
Bobby pin suspends thermometer to check bottled solution... 209  
Flashlight fitted with filter for darkroom use..... 209  
Rubber bands on lightstand arm improve gripping surface... 209  
Packing cut-film holders in carrying case..... 209  
Flood-reflector ventilation holes indicate if lamp is turned on. 209  
Auxiliary strap added to camera case used for carrying by hand ..... 210

**TOOLS**

Wire stand attached to electric-drill housing protects bit cutting edges ..... 174  
Miter box adjustable for wear..... 178  
Improved grip on drill chuck..... 183  
Plumb bob for emergency use..... 186  
Beam compass improvised from dowel rod..... 200

(Continued to page 18)



# INVENTORS

If you believe that you have an invention, you should find out how to protect it. The first step is to have a search made of the prior pertinent U. S. patents. If a report on this search indicates that the invention appears patentable you can apply for a patent, and the specifications and claims should be prepared.

The firm of McMorrow, Berman & Davidson, with offices in Washington, D. C., is qualified to take the necessary steps for you. We can make a preliminary search on your invention, advise you whether we think it can be patented, and prepare your application for patent.

Unless you are fully familiar with the U. S. Patent Laws, we recommend that you engage the services of a Registered Patent Attorney to protect your interests. The patent laws are *your* laws. A patent gives you the right to prevent others from making, using or selling the invention claimed in your patent for a period of 17 years.

Use these patent laws for your protection. Investigate whether your invention can be patented. If you have what you believe to be an invention, we suggest that you have this firm make a search for you.

*Send for a copy of our Patent Booklet entitled "How To Protect Your Invention," containing information about patent protection and patent procedure. Along with this we will also send you an "Invention Record" form, for your use in writing down and sketching details of your invention. We will mail them promptly. No obligation. They are yours for the asking.*

**McMORROW, BERMAN & DAVIDSON**

*Registered Patent Attorneys*

**PATENTS • COPYRIGHTS • PATENTS**

**1355 VICTOR BUILDING, WASHINGTON 1, D. C.**



# HE Mailed This Coupon

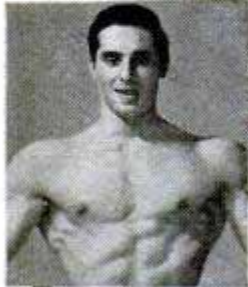

**CHARLES ATLAS**  
115 East 23rd St., New York 10, N. Y.  
I want the proof that your system of "Dynamic Tension" will help make a New Man of me—gives me a healthy, husky body and big muscle development. Send me your free book, "Everlasting Health and Strength."  
Name **THOMAS MANFRE**  
(Please print plainly)  
Address **87th St. - 45 St.**  
City **BROOKLYN** State **N.Y.**

...and Here's the Handsome Prize-Winning Body I Gave Him!

Thomas Manfre of New York mailed my coupon. Got my free book. Won my Atlas-Champion, Sterling Silver Cup. He says: "Look at me NOW! 'Dynamic Tension' WORKS! I'm proud of the natural, easy way you made me an 'Atlas Champion!'"

## Let Me Prove I Can Make You a New Man!

Would you like greater development—a muscular body? Then listen: I was once a 97 lb. weakling. Afraid to fight, ashamed to be seen in a swimming suit. Then I discovered the secret that changed me into "World's Most Perfectly Developed Man." My secret is "Dynamic Tension." Its purpose is to give you powerful rippling muscles you like to see in your mirror. And for those with systems sluggish from lack of exercise — to help them tone up their entire body, inside and out.

## Only 15 Minutes a Day

My method—"Dynamic Tension"—will turn the trick for you. No theory — every exercise is practical. And man, so easy! Spend only 15 minutes a day in your own home. From the very start, you'll be using my method of "Dynamic Tension" almost unconsciously every minute of the day—walking, bending over, etc.—to BUILD MUSCLE and VITALITY. And you'll be using the method which many great athletes use for keeping in condition—prize fighters, wrestlers, baseball and football players, etc.

**FREE My 32-Page Illustrated Book Yours—Not \$1. or 10c—But FREE!**  
Send for my book, "Everlasting Health and Strength." 32 pages, packed with actual photos, valuable advice. A real prize for any fellow who wants a better build... but yours FREE! Rush coupon to me personally:

**CHARLES ATLAS**  
Dept. 8Q, 115 E. 23 Street,  
New York 10, N. Y.

**CHARLES ATLAS, Dept. 8Q**  
115 East 23 Street, New York 10, N. Y.

I want the proof that your system of "Dynamic Tension" will help make a New Man of me—gives me a healthy, husky body and big muscle development. Send me your free book, "Everlasting Health and Strength."

Name \_\_\_\_\_ Age \_\_\_\_\_  
(Please print or write plainly)  
Address \_\_\_\_\_  
City \_\_\_\_\_ State \_\_\_\_\_

## CHARLES ATLAS

Twice winner and holder of the title "The World's Most Perfectly Developed Man."

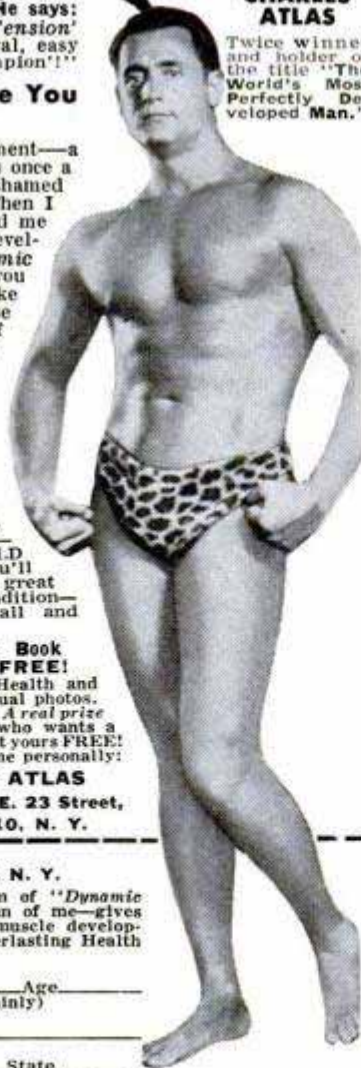

(Continued from page 16)

Using C-clamp on pipe.....	213
Hose washer protects lathe center.....	215
Converting lathe dog to safety type.....	215
Graphite lubricates drafting tools.....	215
Wing-type bit (Westinghouse Electric Corp., Pittsburgh, Pa.).....	224
Chisel-tooth circular saw blade (Skillsaw, Inc., 5033 Elston Ave., Chicago).....	224
Combination wrench (H. D. Hunter Co., 3499 E. 14th St., Los Angeles 23, Calif.).....	224
Shaper head (Photo Research Corp., 127-129 W. Alameda Ave., Burbank, Calif.).....	224
Voltage calculator (L. E. Van Halst, P. O. Box 317, Wolcottville, Ind.).....	224
Twist drills for portable electric drills (Standard Tool Co., 3950 Chester Ave., Cleveland 14, Ohio).....	225
Claw-hammer attachment (Amsco Co., Le Center, Minn.).....	225
Earth-auger accessory (Mall Tool Co., 7725 South Chicago Ave., Chicago).....	225
Parrot-head pruner (Sargent and Company, New Haven, Conn.).....	225
Sharpening jig (PTI Incorporated, 401 Broadway, New York City).....	225
Auxiliary clamp on lathe chuck increases capacity.....	226

## WOODWORKING

Plan of the month . . . Extension dining table.....	184
Wrench aids in driving screw eyes.....	192
Out-of-reach nail started easily when held by hammer claws.....	204

## MISCELLANEOUS

Sponge rubber protects fingers while starting small nails.....	174
Boat trailer has fenders made from old tires.....	178
Clothespin serves as clamp to hold end of steel tape.....	183
Paper-bag "mittens" aid dressing child.....	183
Alarm-clock movement cleaned without disassembling.....	186
Tracing legibly onto copper.....	189
Method for determining location of concealed leak in vertical run of pipe.....	190
Sponge-rubber "ball" provides realistic drive during golf practice.....	190
Heat from light-bulb clusters speeds seedling growth.....	192
Swinging shelf at top of ladder provides extra tool space.....	192
Plastic scraps clean files.....	192
Campfires started quickly with waterproof igniters.....	200
Bar clamp made like sawhorse.....	200
Cushion holds phonograph needles.....	204
Sections of car inner tube make bins for small parts.....	204
Paper coated with lighter fluid made temporarily transparent.....	204
Drawer pull on glue-can lid facilitates opening.....	204
Plastic jig holds ribbon taut for hand-lettering.....	213
One man is able to load this mixer onto truck or trailer.....	213
Section of eave gutter shields mouse trap.....	215
Test shows polarity of electric wires.....	226
Holder for job tickets.....	226

## Radio-Television, Electronics

TV-set data for servicemen (Howard W. Sams Co., 2201 E. 46th St., Indianapolis 5, Ind.).....	227
Putting movies on tape (Bing Crosby Enterprises, Los Angeles, Calif.).....	231
Electronic range (Raytheon Mfg. Co., Waltham, Mass.).....	231
Plastic lens for big screen TV (Polaroid Corp., Cambridge 38, Mass.).....	231
Portable TV-set has big screen (Motorola Inc., 4545 Augusta Blvd., Chicago).....	231
Spacemaker record storage unit (Wellfleet Sales Co., P. O. Box 218, Newark, N. J.).....	231
Metal detector (Gardiner Electronics Co., 2018 N. Dayton St., Phoenix, Ariz.).....	232
Pack set power unit (Motorola Co., 4545 W. Augusta Blvd., Chicago).....	232
Vari-typer branding machine (Ralph C. Coxhead Corp., Newark 5, N. J.).....	232
Scotch electrical tape (Minnesota Mining and Mfg. Co., 900 Fauquier Ave., St. Paul, Minn.).....	232
Modular radio cabinet (General Electric Co., Chemical Div., Pittsfield, Mass.).....	232

**IMPORTANT NOTICE**—It is the intention of this magazine to provide its readers with information regarding the latest developments in the mechanical arts. We take no responsibility as to whether the disclosures contained in our articles are covered by patents and advise readers to investigate this subject before making, using, or selling any of the products, machines, or processes described in order to avoid possible liability for patent infringements.



# HOW TO IMPRESS THE BOSS



Suppose you do prepare for advancement in your spare time. Can you be sure news of it will reach the right ears? Will your boss be impressed?

I. C. S. regularly reports the progress of its students to their employers, regularly receives letters expressing appreciation of this service.

Typical of the many letters is one from an executive of a well-known oil company: "We want to thank you for your progress report on the above-named employee. It may interest you to know that he is being promoted, effective immediately."\*

YOU want your employer to know that you are ready for promotion. YOU want your training recognized and rewarded. Then act now to obtain that training. Sound, practical I. C. S. Courses cover more than 400 business and technical subjects. The coupon brings full information.

\*Name furnished on request.

## INTERNATIONAL CORRESPONDENCE SCHOOLS



BOX 5523-L, SCRANTON 9, PENNA.

Without cost or obligation, please send me full particulars about the course BEFORE which I have marked X:

- |   |   |   |  |
|---|---|---|--|
| <p><b>Business and Academic Courses</b></p> <ul style="list-style-type: none"> <li><input type="checkbox"/> Accounting <input type="checkbox"/> Advertising</li> <li><input type="checkbox"/> Bookkeeping</li> <li><input type="checkbox"/> Business Administration</li> <li><input type="checkbox"/> Business Correspondence</li> <li><input type="checkbox"/> Business Law</li> <li><input type="checkbox"/> Cartooning</li> <li><input type="checkbox"/> Certified Public Accounting</li> <li><input type="checkbox"/> Commercial <input type="checkbox"/> Commercial Art</li> <li><input type="checkbox"/> Cost Accounting</li> <li><input type="checkbox"/> Fashion and Book Illustration</li> <li><input type="checkbox"/> Federal Tax <input type="checkbox"/> First Year College</li> <li><input type="checkbox"/> Foremanship</li> <li><input type="checkbox"/> Good English <input type="checkbox"/> High School</li> <li><input type="checkbox"/> Higher Mathematics</li> <li><input type="checkbox"/> Industrial Supervision</li> <li><input type="checkbox"/> Motor Traffic</li> <li><input type="checkbox"/> Personnel—Labor Relations</li> <li><input type="checkbox"/> Postal Civil Service <input type="checkbox"/> Retailing</li> <li><input type="checkbox"/> Retail Business Management</li> <li><input type="checkbox"/> Salesmanship <input type="checkbox"/> Secretarial</li> <li><input type="checkbox"/> Sign Lettering</li> <li><input type="checkbox"/> Stenography <input type="checkbox"/> Traffic Management</li> <li><b>Aeronautics Courses</b></li> <li><input type="checkbox"/> Aeronautical Engineer's, Jr.</li> <li><input type="checkbox"/> Aircraft Drafting and Design</li> </ul> | <ul style="list-style-type: none"> <li><input type="checkbox"/> Aircraft Mechanic</li> <li><input type="checkbox"/> Engine Mechanic</li> <li><b>Air Conditioning and Plumbing Courses</b></li> <li><input type="checkbox"/> Air Conditioning <input type="checkbox"/> Heating</li> <li><input type="checkbox"/> Plumbing</li> <li><input type="checkbox"/> Refrigeration</li> <li><input type="checkbox"/> Refrigeration, Domestic</li> <li><input type="checkbox"/> Refrigeration &amp; Air Conditioning</li> <li><input type="checkbox"/> Steam Fitting</li> <li><b>Chemical Courses</b></li> <li><input type="checkbox"/> Chemical Engineering</li> <li><input type="checkbox"/> Chemistry, Analytical</li> <li><input type="checkbox"/> Chemistry, Industrial</li> <li><input type="checkbox"/> Food-Plant Sanitation</li> <li><input type="checkbox"/> Petroleum Production &amp; Refining</li> <li><input type="checkbox"/> Plastics <input type="checkbox"/> Pulp and Paper Making</li> <li><b>Civil Engineering and Architectural Courses</b></li> <li><input type="checkbox"/> Architecture <input type="checkbox"/> Architectural Drafting</li> <li><input type="checkbox"/> Bridge and Building Foreman</li> <li><input type="checkbox"/> Building Estimating</li> <li><input type="checkbox"/> Civil Engineering</li> <li><input type="checkbox"/> Contracting and Building</li> <li><input type="checkbox"/> Highway Engineering</li> <li><input type="checkbox"/> Reading Structural Blueprints</li> <li><input type="checkbox"/> Sanitary Engineering</li> </ul> | <ul style="list-style-type: none"> <li><input type="checkbox"/> Structural Drafting</li> <li><input type="checkbox"/> Structural Engineering</li> <li><input type="checkbox"/> Surveying and Mapping</li> <li><b>Communications Courses</b></li> <li><input type="checkbox"/> Electronics <input type="checkbox"/> Practical Telephony</li> <li><input type="checkbox"/> Radio, General <input type="checkbox"/> Radio Operating</li> <li><input type="checkbox"/> Radio Servicing</li> <li><input type="checkbox"/> Television</li> <li><input type="checkbox"/> Telegraph Engineering</li> <li><b>Electrical Courses</b></li> <li><input type="checkbox"/> Electrical Drafting</li> <li><input type="checkbox"/> Electrical Engineering</li> <li><input type="checkbox"/> Electric Light and Power</li> <li><input type="checkbox"/> Lighting Technician</li> <li><input type="checkbox"/> Practical Electrician</li> <li><input type="checkbox"/> Power House Electric</li> <li><input type="checkbox"/> Ship Electrician</li> <li><b>Diesel Engines Courses</b></li> <li><input type="checkbox"/> Diesel Engines</li> <li><input type="checkbox"/> Internal Combustion Engines</li> <li><b>Mechanical Courses</b></li> <li><input type="checkbox"/> Forging <input type="checkbox"/> Foundry Work</li> <li><input type="checkbox"/> Heat Treatment of Metals</li> <li><input type="checkbox"/> Industrial Engineering</li> <li><input type="checkbox"/> Industrial Instrumentation</li> <li><input type="checkbox"/> Industrial Metallurgy</li> <li><input type="checkbox"/> Machine Shop <input type="checkbox"/> Mechanical Drafting</li> </ul> | <ul style="list-style-type: none"> <li><input type="checkbox"/> Mechanical Engineering</li> <li><input type="checkbox"/> Mold-Loft Work</li> <li><input type="checkbox"/> Patternmaking—Wood, Metal</li> <li><input type="checkbox"/> Reading Shop Blueprints</li> <li><input type="checkbox"/> Sheet-Metal Drafting</li> <li><input type="checkbox"/> Sheet-Metal Worker</li> <li><input type="checkbox"/> Ship Drafting <input type="checkbox"/> Ship Fitting</li> <li><input type="checkbox"/> Tool Designing <input type="checkbox"/> Toolmaking</li> <li><input type="checkbox"/> Welding—Gas and Electric</li> <li><b>Railroad Courses</b></li> <li><input type="checkbox"/> Air Brake <input type="checkbox"/> Car Inspector</li> <li><input type="checkbox"/> Diesel Locomotive</li> <li><input type="checkbox"/> Locomotive Engineer</li> <li><input type="checkbox"/> Locomotive Fireman</li> <li><input type="checkbox"/> Locomotive Machinist</li> <li><input type="checkbox"/> Railroad Section Foreman</li> <li><input type="checkbox"/> Steam-Diesel Locomotive Engineer</li> <li><b>Stationary Engineering Courses</b></li> <li><input type="checkbox"/> Power Plant Engineering</li> <li><input type="checkbox"/> Stationary Fireman</li> <li><input type="checkbox"/> Stationary Steam Engineering</li> <li><b>Textile Courses</b></li> <li><input type="checkbox"/> Cotton Manufacturing</li> <li><input type="checkbox"/> Loom Fixing <input type="checkbox"/> Rayon Manufacturing</li> <li><input type="checkbox"/> Textile Engineering</li> <li><input type="checkbox"/> Woolen Manufacturing</li> </ul> |
|---|---|---|--|

Name \_\_\_\_\_ Age \_\_\_\_\_ Home Address \_\_\_\_\_

City \_\_\_\_\_ State \_\_\_\_\_ Working Hours \_\_\_\_\_ A. M. to \_\_\_\_\_ P. M.

Present Position \_\_\_\_\_ Employed by \_\_\_\_\_

Special tuition rates to members of the Armed Forces. Canadian residents send coupon to International Correspondence Schools Canadian, Ltd., Montreal, Canada.



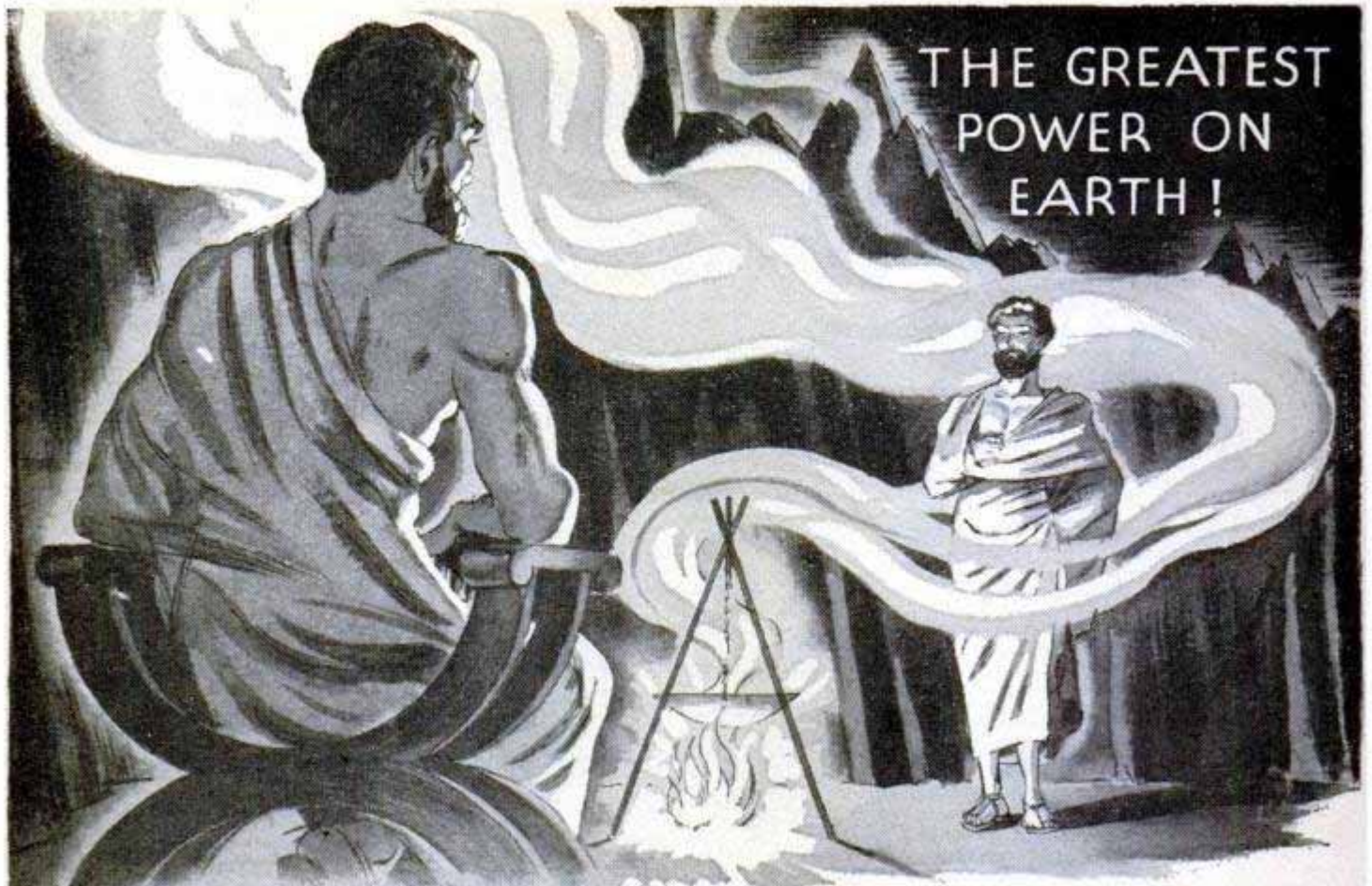

# The Magic of Mind

**W**ERE the great personages of the past victims of a stupendous hoax? Could such eminent men of the ancient world as Socrates, Pericles and Alexander the Great have been deluded and cast under the spell of witchcraft—or did the oracles whom they consulted actually possess a mysterious faculty of foresight? That the human mind can truly exert an influence over things and conditions was not a credulous belief of the ancients, but a known and demonstrable fact to them. That there exists a wealth of infinite knowledge just beyond the border of our daily thoughts, which can be aroused and commanded at will, was not a fantasy of these sages of antiquity, but a dependable aid to which they turned in time of need.

It is time you realized that the rites, rituals and practices of the ancients were not superstitions, but super-fuges to conceal the marvelous workings of natural law from those who would have misused them. Telepathy, projection of thought, the materializing of ideas into helpful realities, are no longer thought by intelligent persons to be impossible practices, but instead, *demonstrable sciences*, by which a greater life of happiness may be had.

One of America's foremost psychologists and university instructors, says of his experiments with thought transference and the powers of mind—"The successes were much too numerous to be merely lucky hits and one can see no way for guessing to have accounted for the results." *Have you* that open-minded attitude of today which warrants a clear, positive revelation of the

facts of mind which intolerance and bigotry have suppressed for years? *Advance with the times*; learn the truth about your inherited powers.

*Let this free book explain*

The Rosicrucians (NOT a religious organization) have been leaders in introducing the ancient wisdom of mental phenomena. Established throughout the world for centuries, they have for ages expounded these truths to those thinking men and women who sought to make the utmost of their natural faculties. Use the coupon below—avail yourself of a pleasing book of interesting information which explains how you may acquire this most *unusual* and *helpful knowledge*.

## The ROSICRUCIANS (A M O R C)

USE THIS COUPON

Scribe: D.R.Y.  
The Rosicrucians, AMORC  
San Jose, California

I am sincerely interested in knowing more about this unseen, vital power which can be used in acquiring the fullness and happiness of life. Please send me, without cost, the book, "THE MASTERY OF LIFE," which tells me how to receive this information.

Name \_\_\_\_\_

Address \_\_\_\_\_ State \_\_\_\_\_



train for  
**ELECTRICITY**  
**TELEVISION-RADIO**  
**REFRIGERATION-ELECTRONICS**



on real equipment in the great shops of  
**Coyne**

- good job opportunities now
- interesting work
- better future

Be a success! PREPARE yourself—the easier way at COYNE. Whether 16 or 50, start training now for a job with a real future in ELECTRICITY, TELEVISION-RADIO, ELECTRONICS or REFRIGERATION. Learn from State-approved instructors—who have worked on the job themselves. Train where thousands of successful men have been trained for over half a century. Established in 1899. Get a Coyne diploma when you graduate... a sign of recognition.

**NOT "HOME-STUDY" COURSES**

You learn quickly, the most practical way at Coyne... on real equipment. Experienced instructors show you how. No advanced education or previous experience needed.

**Start Now—Pay Later**—Small down payment starts you—balance in easy payments later. If you need part-time work to help meet living expenses while at Coyne, we'll help you get it. *Courses approved for qualified veterans.*



*Get Big Free Book Today*

If you want to get ahead... learn either of these two vital fields... be a success — **SEND THE COUPON BELOW**, for big, illustrated Coyne book. Mail it today—facts by return mail. *No salesman will call.*



**TRAIN NOW FOR A VITAL JOB IN INDUSTRY OR HIGHER RATING AND BETTER PAY IF DRAFTED**

ELECTRICITY, TELEVISION, RADIO, ELECTRONICS and REFRIGERATION play a vital role in Nation's Defense program. Uncle Sam needs thousands of men in and out of uniform who are trained in their fields. So does Industry. And these jobs are just as necessary after the present emergency. Electricity, Electronics and Refrigeration are

big opportunity fields under all conditions. Television-Radio is a newer field that is growing like wild fire. Government is about to authorize hundreds of new TV stations. **Send for Big Free Book** and facts about how you can prepare quickly for these great opportunity fields. **Send coupon today.**

B. W. COOKE, President

**COYNE** [SCHOOL]  
**A TECHNICAL TRADE INSTITUTE**  
**CHARTERED NOT FOR PROFIT**  
 Established 1899  
 500 S. Paulina Dept. 32-72H, Chicago 12  
**ELECTRICITY \* TELEVISION \* RADIO \* REFRIGERATION \* ELECTRONICS**

B. W. Cooke, President  
 COYNE School  
 500 S. Paulina St., Chicago 12  
 Dept. 32-72H

Send your **BIG FREE BOOK** and details of your training offer. I am interested in  
 ELECTRICITY  TELEVISION-RADIO

NAME .....

ADDRESS.....

CITY..... STATE.....





SEND  
NO MONEY  
•  
MORE THAN  
4000 PAGES  
•  
2750  
PICTURES

On  
Approval

## 9 BIG COMPLETE BOOKS BUILDING, ESTIMATING, CONTRACTING

Examine this Up-to-Date Edition for 10 days. See how these nine books supply easily understood training that will help you to get a better job and make more money, or start a profitable business for yourself. Think what a BIG help it will be to have them handy for use in solving all sorts of building problems.

Learn to draw plans, estimate, do all-new construction and modern remodeling to meet fast growing demand. More than 4000 pages of practical, pay-raising information with 2750 helpful illustrations, on such subjects as blueprint reading, concrete forms, masonry, carpentry, steel square, electrical wiring, plumbing, heating, painting, and hundreds more.

In our more than 50 years we have never offered more complete building information. Send the coupon TODAY.

(A year's consulting privileges with our engineers now given with these books without extra cost.)

AMERICAN TECHNICAL SOCIETY—Publishers Since 1898  
Dept. G319, Drexel Ave., at 58th St., Chicago 37, Ill.

I would like to examine your 9-Volume Set of Building, Estimating, Contracting Books. I will pay the delivery charges only, but if I choose I may return them express collect. If after 10 days' use I prefer to keep them, I will send you \$3 and pay the balance at the rate of only \$4 a month until \$34.80 has been paid. Include consulting service as offered above.

Name \_\_\_\_\_

Address \_\_\_\_\_

City \_\_\_\_\_ State \_\_\_\_\_

Please attach letter giving employer's name and address (if self-employed give business man reference). Men in service please give home address.

## Learn this Profitable Profession

IN 90 DAYS  
AT HOME

## Money-Making Career Open to Men and Women, 18 to 60

Hundreds of men and women between 18 and 60 make \$10 to \$20 in a single day giving scientific Swedish Massage and Hydro-Therapy treatments. There is big demand from doctors, hospitals, sanatoriums and clubs. Graduates earn large full time income from these or in private practice in their own offices. Others make good money from home treatments given in spare time. Learn this interesting money-making profession in your own home, through our home study course. Same instructors as in our nationally known resident school. You can win independence and prepare for future security by qualifying for your Graduation Certificate. Course can be completed in 3 to 4 months. Many earn while they learn. Begin your training at once.



### NEW 32-PAGE BOOKLET FREE

Fill in the coupon below (please print name and address) and mail it for your FREE copy of 32-page Information Booklet. If you act at once we will include Anatomy Charts and Success Booklet which supply additional information you should have. All will be sent postage paid.

THE COLLEGE OF SWEDISH MASSAGE  
Dept. 264C, 41 E. Pearson St., Chicago 11, Illinois

Please send me FREE and postpaid New 32-Page Illustrated Booklet, Anatomy Charts and Success Booklet at once.

Name \_\_\_\_\_ Age \_\_\_\_\_

Address \_\_\_\_\_

City \_\_\_\_\_ State \_\_\_\_\_

## No Experience Needed To PRINT YOUR OWN POST CARDS

The GEM STENCIL DUPLICATOR saves money... gets results quickly! Hundreds of uses for every type of business and organization. We ship the GEM complete with all supplies, Guide Board for accurate printing and 60-page Book of Ideas at the special low price of only \$8.50 (a \$15 value).

### FREE TRIAL OFFER

Use the GEM FREE at our expense! SEND NO MONEY. Write and complete GEM outfit will be sent you postpaid. After ten days, send us only \$8.50 or return the GEM. You must be satisfied!

BOND EQUIPMENT CO. Dept. 48  
6633 Enright • St. Louis 5, Mo.



Our  
21st Year

## LEARN CARTOONING Get in the BIG MONEY

Former Landon students are really cleaning up. Creators of "Steve Canyon", "Freckles", "Out Our Way", "Winnie Winkle", "Regular Fellers", "The Neighbors", "Strange as it Seems" are just a few of them. Simplified Landon Picture Chart method makes progress quick, exciting, easy. Earn while learning. Rush 10c for Picture Chart (to test your ability) and full details. Please state age.



Landon School of Cartooning, 5203 CTS Bldg., Cleveland, O.

## FREE CATALOG

All The Best and Latest  
Garden and Farm Books, Bulletins

A wealth of up-to-the-minute expert advice on how to do wonders on a little land or a thousand acres... wonders with flowers, vegetables, fruits, landscaping, poultry, livestock, woodlands, fishponds, composing, soil improvement, etc. etc. Just send name and address for this fascinating FREE catalog by return mail.

### COUNTRY BOOKSTORE

Box 2703 Noroton, Conn. Estab. 1943

## Learn ACCOUNTING BOOKKEEPING

This nationally renowned school has demand for graduates in good salary positions thru Nationwide recognition and placement service. Write Department PMH today for Big 32 page Success Book to be sent to you FREE



Hills BUSINESS UNIVERSITY AND  
EXTENSION SCHOOL  
619 W. MAIN ST. OKLAHOMA CITY 2, OKLAHOMA



## AUTO WASHER

Your car sparkling clean—in a jiffy—magic "sponge" cleaning-cloth. Simply glide over car. PRESTO! Dust, grease, dirt, grime disappear like magic. Your car gleams like a mirror. Take orders! Make money!

### SAMPLES for TRIAL

Sample offer sent immediately to all who send name at once. Hurry, postal will do. SEND NO MONEY—just your name. KRISTEE CO., Dept. 690, Akron 8, Ohio

## RUPTURED?

### Get Relief This Proven Way

Why try to worry along with trusses that gouge your flesh—press heavily on hips and spine—enlarge opening—fail to hold rupture? You need the Cluthe. No leg-straps or cutting belts. Automatic adjustable pad holds at real opening—follows every body movement with instant increased support in case of strain. Cannot slip whether at work or play. Light. Waterproof. Can be worn in bath. Send for amazing FREE book, "Advice To Ruptured" and details of liberal truthful 60-day trial offer. Also endorsements from grateful users in your neighborhood. Write:

CLUTHE SONS, Dept. 31, Bloomfield, New Jersey.



# GET THE MONEY AND SECURITY YOU'VE ALWAYS WANTED!



**L. J. ROSENKRANZ, President,** National Schools, the man who has trained many, many men like YOU. Men who now own successful, respected businesses of their own. Men who hold important, high-paying positions in famous companies. You CAN be a success. Mail coupon for more details.

## Let Me Show You How! Mail the Coupon for My FREE Books!

Each book has page after page in color. Gives you the complete story about my proved training method...tells how quickly it can train you for a secure, high-paying job. Don't wait. Get the facts. Send today for my valuable books on Radio-Television or Automotive-Diesel. Check the coupon at right and mail it to me today. Absolutely no obligation.

### NO SALESMAN WILL CALL!

I'll send you a FREE SAMPLE LESSON TOO, if you act fast! Shows how easy it is to learn with National Schools Home Training.



NATIONAL SCHOOLS, Dept. B-32  
4000 South Figueroa Street  
Los Angeles 37, California

Mail in envelope  
or paste on  
penny postal card

Send me Free the book checked below and the sample lesson. I understand no salesman will call on me.

- "MY FUTURE IN RADIO-TELEVISION & ELECTRONICS" OR  
 "MY FUTURE IN DIESEL-AUTOMOTIVE & ALLIED MECHANICS."

NAME \_\_\_\_\_ AGE \_\_\_\_\_

ADDRESS \_\_\_\_\_

CITY \_\_\_\_\_ ZONE \_\_\_\_\_ STATE \_\_\_\_\_

Check here if you were released from the service less than 4 years ago.

Let National Schools - a resident-training school for nearly 50 years-train you at home for today's unlimited opportunities in Radio-TV or Automotive-Diesel. National Schools is one of the largest schools of its kind in the world. It has 4 big buildings of modern shops and labs. Its faculty is considered tops. You learn fast from easy lessons - all perfected under actual shop conditions. Approved for eligible vets.



**Earn Extra Money while you're learning! I'll show you how!**  
**EASY TERMS • FREE GRADUATE SERVICE**  
**Mail coupon today-find out more!**

# WHICH HIGH-PAYING FIELD DO YOU WANT?

**TODAY'S SHORTAGE OF TRAINED TECHNICIANS CREATES CHANCE OF A LIFETIME FOR YOU...IN EITHER FIELD!**

## RADIO-TELEVISION & ELECTRONICS

OR

## AUTOMOTIVE-DIESEL AND ALLIED MECHANICS

### JOB SECURITY! BIG MONEY! FOR YOU IN TODAY'S EXPANDING INDUSTRIES!

Think of it! With guided missiles, radar and other electronic devices so important to national defense. With big, new developments in color TV. With over 90,000,000 home and auto radios, over 12,000,000 TV sets. With more than 3100 radio stations...over 100 TV stations-and more building every day-imagine the terrific opportunity you have!

#### You Train at Home-In Your Spare Time

With National Schools Master Shop Home Training, you master all phases of Radio-Television-Electronics. You learn fast from hundreds of pictures and diagrams. All lessons have been developed and tested in National Schools famous shops and labs. No wonder your National Schools training is so up-to-date, practical, interesting. And so easy!

### LOOK! WE SEND YOU ALL THESE PARTS! -and you keep them!



We send you lots of standard professional parts. You do lots of practical experiments. You learn step by step. Until you can build the big Superheterodyne Receiver you see above-and other important test units. Mail the coupon-today.

#### I TRAIN YOU FOR GOOD-PAYING JOBS LIKE THESE

Radio Station Engineer; District Service Manager; Aircraft Radio Inspector; Inspector Technician; Own your own repair shop; Service Specialist; Special Civil Service Positions; Sound Truck Operator; Complete Television Service and many others. Thousands of National Schools graduates have jobs like these. Why not you? Start your career-be sure to mail the coupon today.

Only National Schools Gives You This Professional Multi-Tester



You get this factory-made new Multi-Tester...an important instrument every Radio-TV man must have.

### GREATEST DEMAND FOR TRAINED MEN IN HISTORY! NOW IS YOUR CHANCE!

What an opportunity! With over 8 million older cars needing big service and repair jobs. With defense industry having more high-paying jobs than they can fill. With the Armed Forces offering quick advancement to trained mechanics. YOU ARE NEEDED as never before! Now you can get the good pay, security, the satisfaction of doing what you want to do! Don't delay-mail the coupon NOW!

#### Right in Your Own Home!

You learn all about Gasoline Engines, Diesel and Special-Fuel Engines, Automotive Tune Up, General Garage Mechanics, Auto Electrical Service. You get complete training for this great, growing industry.

Yet National Schools Home Training is easy! Because it's based on actual shop methods in National Schools big resident school. Mail the coupon for more details-NOW.

#### National Schools Gives You All These Tools

You start out owning the tools of your trade. A kit of standard, professional tools and equipment. They're all part of your course! -And you keep them-they're yours!



#### I Offer You All These!

Basic Lesson Texts. Diesel Installation & Maintenance Instructions. Spare Time Lessons. Engine Service Manuals. Engine Repair Drive Systems. Diesel Electric Power Texts. Special Thermodynamic Instruction.

### Attention: Men Going into the Service Soon!

With National Schools training in Radio-Television or Automotive-Diesel, you have the opportunity to get into special service classifications. That means higher pay and grade, more prestige-right away! This is important-so be sure to mail the coupon today without fail.

### WHICH OF THESE HIGH-PAYING JOBS WOULD YOU LIKE?

- MOTOR TUNE UP SPECIALIST
- DIESEL ENGINE SPECIALIST
- FARM EQUIPMENT MECHANIC
- YOUR OWN GARAGE OR REPAIR SHOP
- GENERAL GARAGE MECHANIC
- PARTS DEALER
- AUTO ENGINE REBUILDING
- FUEL INJECTION SPECIALIST

You can have secure jobs like these. Just mail the coupon-and find out!

**NATIONAL SCHOOLS**

TECHNICAL TRADE TRAINING SINCE 1905  
LOS ANGELES 37, CALIFORNIA



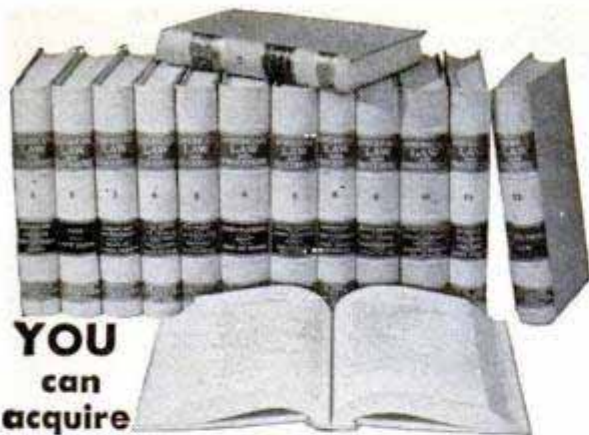

**YOU**  
can  
acquire

## LAW NIGHTS AT HOME! L. L. B. DEGREE

LaSalle's famous Law Library—used as reference in many Law libraries and Law offices—has enabled thousands to master Law surprisingly fast, in spare hours at home, for business and professional advancement.

These 14 remarkable volumes, compiled by leading professors and lawyers, cover the whole basic field of Law in condensed, orderly, simplified manner.

You advance rapidly with this great library, plus special lectures furnished. We guide you step-by-step with personalized Problem Method of instruction . . . you learn by doing—handling legal problems—not by memorizing rules.

Send for two FREE 48-page booklets, "Law Training for Leadership," and "Evidence," answering questions about Law and its value to you, and telling how LaSalle Law graduates are winning rapid advancement in business and public life. Mail coupon below. No obligation.

### LA SALLE EXTENSION UNIVERSITY A Correspondence Institution

417 S. Dearborn St., Dept. 364L, Chicago 5, Ill.

Send me your two FREE booklets described above, without obligation.

Name.....Age.....

Street.....

City, Zone & State.....

## ENGINEERING DEGREE IN 27 MONTHS

### Big Demand for Graduates

**Aeronautical, Chemical, Civil, Electrical, Mechanical and Radio Engineering (including Television)**

Hundreds of young men are earning engineering degrees in this recognized institution each year—continuous operation. New terms start quarterly. Many students earn a major part of their college expenses in this large industrial center.

Low tuition. Competent instruction. Thorough, intense, practical program. Modern laboratory facilities including new physics lab. and modernized wind tunnel. Individualized instruction emphasized.

Approved for Veterans. Engineering preparatory courses. Students from 48 states and 21 foreign countries. Enter March, June, September or December. Send coupon for free catalog and full information. Enroll now.

SEND COUPON TODAY

## INDIANA TECHNICAL COLLEGE

532 E. Washington Boulevard  
Fort Wayne 2, Indiana

Please send me free information on B.S. Engineering Degree in 27 months as checked.

Aeronautical,  Chemical,  Civil,  Electrical,  
 Mechanical,  Radio-Television

Name.....

Address.....

# EAT ANYTHING WITH FALSE TEETH

If you have trouble with plates that slip, rock and cause sore gums—try Brimms Plasti-Liner. One application makes plates fit snugly without powder or paste, because Brimms Plasti-Liner hardens permanently to your plate. It relines and refits loose plates in a way no powder or paste can do. Even on old rubber plates you get good results six months to a year or longer **YOU CAN EAT ANYTHING!** Simply lay soft strip of Plasti-Liner on troublesome upper or lower. Bite and it molds perfectly. Easy to use, tasteless, odorless, harmless to you and your plates. Removable as directed. Money back if not completely satisfied. **SEND NO MONEY.** Order a \$1.25 package to reline one plate. Pay your postman when he delivers. Or send money now and save C. O. D. charges. Sample of plate cleaner FREE. Also available at leading drug stores. **PLASTI-LINER COMPANY, Buffalo 11, N. Y., Dept. 43-R.**



## BRIMMS PLASTI-LINER THE PERMANENT DENTURE RELINER



**7 X 50 COATED  
\$36.00**

COATED! Lightweight. Moisture-Dust proofed. INDIVIDUAL FOCUSING. ACHROMATIC! LARGE 50mm Objective Lens (2 inches across!) BRIGHTER images, sharper and clearer. Undistorted field of 375 feet at 1000 yards. Featherweight! Weighs 31 oz.! Carry UNITED Seal of Quality. UNCONDITIONALLY GUARANTEED. Try for 30 days at our risk. Refund in full if not completely satisfied. Price includes genuine plush lined leather case and straps. Cash orders prepaid. C. O. D.'s Western Ave., Dept. ARF-4008, Chicago 20. DISPLAY SALES ROOMS open 9:30-3:30 MON. thru Fri. Dealers Wanted.

plus postage. Add Federal tax. UNITED SINGULAR CO., 9043 S. Western Ave., Dept. ARF-4008, Chicago 20. DISPLAY SALES ROOMS open 9:30-3:30 MON. thru Fri. Dealers Wanted.

## LEARN WATCH REPAIRING



**AT HOME.** By our modern and original system of instruction you can learn every part of the **WATCH REPAIRING TRADE AT HOME.** Prepare yourself for a well-paying position or start in business after completing our course of instruction. Good watch repairers are in demand and generally earn very good salaries. For particulars apply to the

**WISCONSIN SCHOOL OF WATCH REPAIRING**  
759 N. Milwaukee, Dept. 3, Milwaukee 2, Wis.

## ILLUSTRATED COMIC BOOKLETS

Sell our **ILLUSTRATED COMIC BOOKLETS** and other **NOVELTIES.** Each booklet size 4 1/2 x 2 1/2 AND IS FULLY ILLUSTRATED. We will send 24 assorted booklets prepaid upon receipt of \$1 or 60 assorted booklets sent prepaid upon receipt of \$2. Wholesale novelty price list sent with order only. No orders sent C.O.D. Send Cash or Money-order.

**REPSAC SALES CO., 1 Orchard St. Dept. 39C, New York 2, N.Y.**



### FOR BETTER HOMES AT LESS COST

Start planning your home now with America's largest, oldest, and most complete home plan service. Hundreds of home plans to fit every purse. Modern, Ranch, Period and many other styles—pictures of homes already built. Sizes from 2 to 4 bedrooms. Many expandable.

**3 Beautiful Plan Books only 50c each. Postpaid.**

- 1. Choice Selected Homes.** Over 75 selected designs. 32 in color.
- 2. Ranch & Suburban.** 158 designs ideal for town and country.
- 3. Blue Ribbon Homes.** 128 most popular designs. 32 in color.

Blue Prints, Mill Lists, and Complete Specifications available for each design at **LOW COST.**

**L. F. GARLINGHOUSE CO., INC., Box PM-16 TOPEKA, KANSAS**



**NOW... GET EVERYTHING YOU  
NEED TO LEARN AND MASTER**

# TELEVISION

**RADIO-ELECTRONICS  
...AT HOME!**

Use REAL commercial-type equip-  
ment to get practical experience

Your future deserves and needs every advantage you can give it! That's why you owe it to yourself to find out about one of the most COMPLETE, practical and effective ways now available to prepare AT HOME for America's billion dollar opportunity field of TELEVISION-RADIO-ELECTRONICS. See how you may get and keep the same type of basic training equipment used in one of the nation's finest training laboratories... how you may get real STARTING HELP toward a good job or your own business in Television-Radio-Electronics. Mail the coupon today for complete facts — including 89 ways to earn money in this thrilling, newer field.

**D.T.I., ALONE, INCLUDES BOTH MOVIES and HOME LABORATORY**  
In addition to easy-to-read lessons, you get the use of HOME MOVIES — an outstanding training advantage — plus 16 big shipments of Electronic parts. Perform over 300 fascinating experiments for practical experience. Build and keep real commercial-type test equipment shown at right

**Get BOTH of these  
information packed  
publications FREE!**

**89 WAYS  
TO  
EARN  
MONEY  
IN TELEVISION  
RADIO ELECTRONICS**

**YOU GET  
ALL 6**

**MODERN LABORATORIES**

If you prefer, get all your preparation in our new Chicago Training Laboratories—one of the finest of its kind. Ample instructors, modern equipment. Write for details!

**MILITARY SERVICE!**

If you're subject to military service, the information we have for you should prove very helpful. Mail coupon today.

**ACT NOW! MAIL COUPON TODAY!**

DE FOREST'S TRAINING, INC. DEPT. PM-3-1  
2533 N. Ashland Ave., Chicago 14, Ill.

Without obligation, I would like your Opportunity News Bulletin showing "89 Ways to Earn Money in Television-Radio-Electronics"; also, the folder showing how I may prepare to get started in this thrilling field.

Name.....Age.....  
Address.....Apt.....  
City.....Zone.....State.....

ABOVE: Build and keep a real 17 INCH commercial TV receiver. Optional after completing regular training at moderate added cost.



**Here's the  
REAL THING!**

**SET UP YOUR OWN  
HOME LABORATORY**



R-F Signal Generator



Oscilloscope



6-Tube  
Radio



Multimeter

Home  
Movies

**"ONE OF AMERICA'S FOREMOST  
TELEVISION TRAINING CENTERS"**

**De FOREST'S TRAINING, INC.**  
CHICAGO 14, ILLINOIS  
A DeVRY INSTITUTION



# \$175<sup>00</sup> PROFIT IN MY FIRST FIVE DAYS!

With PRESTO, Science's New  
Midget Miracle Fire Extinguisher



"Easiest Money I Ever Made," says  
C. S. Melious. Many others "cleaning  
up" — so can YOU!



Science's New  
Midget Miracle  
"PRESTO"

AMAZING new kind  
of fire extinguisher. Tiny "Presto"  
(about size of a flashlight!) does job of  
bulky extinguishers that cost 4 times as  
much, are 8 times as heavy. Ends fires  
fast as 2 seconds. Fits in palm of hand.  
Never corrodes. *Guaranteed for 20 years!*  
Sells for only \$3.98!

Show it to civil defense workers, own-  
ers of homes, cars, boats, farms, etc. —  
make good income. H. J. Kerr reports \$20  
a day. C. Kama, \$1,000 a month. Write  
for FREE Sales Kit. No obligation. MER-  
LYTE INDUSTRIES, Inc., Dept. 53, 201  
East 16th St., New York 3, N. Y. In Can-  
ada: Mopa, Co., Ltd., 371 Dowd St., Mon-  
treal 1, P. Q. (If you want a regular Presto  
to use as a demonstrator, send \$2.50.  
Money back if you wish.)

C. S. Melious

## TRAVEL for ★ "UNCLE SAM"



Start  
as high as  
\$3,795.00 Year

Prepare NOW For  
Next Examinations

VETERANS GET  
SPECIAL PREFERENCE  
Many examinations  
expected soon  
City Mail Carriers  
City Postoffice Clerks  
Stenographers-Typists  
Messengers,  
Customs Inspectors—  
and many others.  
32-Page Book  
on Civil Service  
FREE  
Mail Coupon  
today—  
SURE

### FRANKLIN INSTITUTE

(Not Government Controlled)

Dept. F-83

Rochester 4, N. Y.

Rush to me, entirely free of  
charge, 32-page book with:  
(1) A full description of U. S.  
Government jobs; (2) A list of  
U. S. Government jobs; (3) Tell  
me how to qualify for a job.

Name.....

Address.....

City.....Age.....

COUPON

MAKE EXTRA  
MONEY

## PLASTICS

LEARN  
AT HOME

LEARN HOW  
TO MAKE  
fast selling  
PLASTIC  
NOVELTIES  
FURNITURE  
JEWELRY  
SIGNS  
TOYS  
LAMPS



There are RICH OPPORTUNITIES for MEN and  
WOMEN with "know-how" in Plastics. Interstate's  
amazing new Plastics course tells and shows how to  
make hundreds of fast selling items out of Plastics.  
Gives complete training in fabrication, casting, lam-  
ination, molding, etc., in simple, easy, step-by-step  
language and pictures.

START A PLASTICS BUSINESS OF YOUR  
OWN. No other industry holds such promise for  
the future. You can make big money manufactur-  
ing novelties, toys, signs, etc., in your own home  
in spare or full time. Don't wait! Learn NOW  
how Interstate's Plastics Training qualifies you  
for success in the plastics field.

Write for FREE Information Today!

### INTERSTATE TRAINING SERVICE

School of Plastics, Dept. C-3C  
PORTLAND 13, OREGON

HICKORY ACRES  
6-WKS. OLD  
STARTED

## CAPONS

### Easy, Profitable to Raise

Wonderful, tender capon meat brings top  
prices — makes finest eating. Easy to raise  
in back yard, on farm, or with other chicks.  
Hickory Acres 6-Wks. Old Capons are your  
best buy. Cost less than day old turkeys —  
easier to raise. Write for prices, information.

HICKORY ACRES CAPON FARM  
BOX PM. WINDSOR, MISSOURI

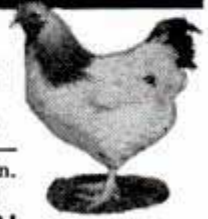

## GOLD-SILVER-COINS

Easily located with new  
Lightweight M-Scope Detec-  
tor. Superior performance,  
lowest price, monthly pay-  
ment plan.

FREE LITERATURE  
FISHER RESEARCH LAB., INC.  
PALO ALTO CALIF.

## ENGINEERING DEGREE IN 27 MONTHS

### INDIANA TECHNICAL COLLEGE

B. S. DEGREE, Aeronautical, Chemical,  
Civil, Electrical, Mechanical and Radio  
Engineering (inc. television), Drafting,  
1-yr. Government approved for G.I.'s,  
Low rate. Earn board. Large industrial  
center. Students from 48 states, 21  
countries. Demand for graduates. Enter  
March, June, September, December.  
Write for catalog, 1632 E. Washington  
Boulevard, Fort Wayne 2, Indiana.

## BECOME AN EXPERT IN

# TRAFFIC

Traffic men earn \$4,000 to \$10,000 and up. Thousands of firms need  
experts on rates, tariffs, regulations. We train you thoroughly in spare  
time at home for executive traffic jobs. Personal training under traffic  
authorities. Placement counsel and help. Write for free 48-page book  
"Traffic Management—the Fast Growing Profession."

LASALLE Extension University, 417 So. Dearborn St.  
A Correspondence Institution Dept. 364T Chicago 5, Ill.

Now  
**MIRACLE**

QUICK  
EASY

**WALL  
CLEANER**

Saves Costly Redecorating

AMAZING INVENTION. Banishes old-  
style housecleaning mess and muss. No  
rags—no sticky "dough"—no red, swollen hands. No  
more dangerous stepladders. Literally erases dirt like  
magic from Wallpaper, Painted Walls, Ceilings, Window  
Shades. Take orders from friends! Earn money! Act now!

**SAMPLES FOR TRIAL** Sample offer sent im-  
mediately to all who  
send name at once. Hurry. Postcard will do. SEND NO MONEY—  
just your name. KRISTEE CO., Dept. 692, AKRON 8, OHIO



# Learn RADIO TELEVISION

—New Package Unit Plan—**PAY AS YOU LEARN**  
**NO MONTHLY PAYMENT CONTRACT TO SIGN!**



**I Send You  
 18 BIG  
 KITS  
 OF RADIO-  
 TELEVISION  
 EQUIPMENT**



**Approved for  
 Veterans  
 Under the  
 G. I. Bill**

**IF YOU ARE  
 EXPERIENCED IN RADIO**

Men already in Radio who seek a short intensive 100% TELEVISION Training with FULL EQUIPMENT INCLUDED are invited to check and mail the coupon at the right.

**Train in 10 Months OR LESS  
 At Home In Spare Hours**

Now . . . be ready for Radio-Television's big pay opportunities in a few short MONTHS! Frank L. Sprayberry's completely new "Package" training unit plan prepares you in just 10 MONTHS . . . or even less! There is NO monthly payment contract to sign . . . thus NO RISK to you! This is America's finest, most complete, practical training—gets you ready to handle any practical job in the booming Radio-Television industry. In just 10 months you may start your own profitable Radio-Television shop . . . or accept a good paying job. Mr. Sprayberry has trained hundreds of successful Radio-Television technicians—and stands ready to train you in less than one year, even if you have no previous experience!

**Valuable Equipment Included With Training**

The new Sprayberry "package" plan includes many big kits of genuine, professional Radio-Television equipment. While training, you perform over 300 demonstrations, experiments and construction projects. In addition, you build a powerful 6-tube standard and short wave radio set, a multi-range test meter, a signal generator, signal tracer, many other projects. All equipment is yours to keep . . . you have practically everything you need to set up your own service shop. The Sprayberry book-bound lessons and other training materials . . . all are yours to keep.

**Earn Extra Money While You Learn!**

All your 10 months of training is AT YOUR HOME in spare hours. Keep on with your present job and income while learning . . . and earn EXTRA CASH in addition. With each training "package" unit, you receive extra plans and ideas for spare time Radio-Television jobs. Many students pay for their entire training this way. If you expect to be in the armed forces later, there is no better preparation than good Radio-Television training.

**FREE 3 BIG RADIO-TELEVISION BOOKS**

I want you to have ALL the facts about my new 10-MONTH Radio-Television Training—without cost! Rush coupon for my three big Radio-Television books: "How to Make Money in Radio-Television," PLUS my new illustrated Television Bulletin PLUS an actual sample Sprayberry Lesson—all FREE. No obligation and no salesman will call. Mail coupon NOW! I will rush all three books at once!

Sprayberry Academy of Radio, Dept. 10-G  
 111 North Canal St., Chicago 6, Ill.

**Mail  
 Coupon  
 Today!**

**SPRAYBERRY ACADEMY OF RADIO, Dept. 10-G  
 111 North Canal St., Chicago 6, Ill.**

Please rush to me all information on your 10-MONTH Radio-Television Training Plan. I understand this does not obligate me and that no salesman will call upon me.

Name . . . . . Age . . . . .  
 Address . . . . .  
 City . . . . . Zone . . . . . State . . . . .

Please Check Below About Your Experience  
 Are You Experienced?  No Experience

**NO OBLIGATION  
 No Salesman  
 Will Call**



# FREE! 10 HITLER STAMPS!



## 10 SCARCE STAMPS—ALL DIFFERENT SENT FREE TO SECURE NAMES FOR OUR MAILING LIST

MAIL coupon at once. We'll send you this fascinating set of 10 Hitler stamps. Different sizes, colors, values. **NO COST TO YOU.** Stamps were issued by short-lived nation of Bohemia-Moravia. Much sought after. Now becoming **SCARCE.** Our supply is limited. Don't ask for more than one set. We'll also include other interesting offers for your inspection—**PLUS** a **FREE** copy of our helpful, informative book, "How to Collect Stamps."

This special offer may have to be withdrawn soon—so rush coupon NOW to: Littleton Stamp Co., Dept. PM-3, Littleton, N. H.

LITTLETON STAMP CO.

Dept. PM-3, Littleton, N. H.

Send—**AT NO COST TO ME**—the ten Hitler stamps and informative booklet, "How To Collect Stamps."

Name \_\_\_\_\_  
 Address \_\_\_\_\_  
 City \_\_\_\_\_ State \_\_\_\_\_

## FIND OUT FREE!

**HAVE YOU GOT WHAT IT TAKES?**

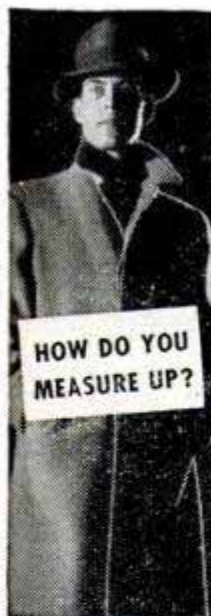

SUCCESS  
HOME STUDY  
WILL TO WIN  
CHARACTER  
HEALTH

to be a **FINGER PRINT EXPERT or TRAINED INVESTIGATOR?**

Send for free IAS Qualification Questionnaire. If in our opinion your answers indicate that you "have what it takes," then you will receive absolutely free the famous "Blue Book of Crime" . . . plus full details on how to train at home in Crime Detection and Finger Printing! IAS graduates are key men in over 800 Police Bureaus. See if YOU can train for this exciting, steady, "good pay" work! No obligation. No salesman will call. Write today, stating age.

**INSTITUTE OF APPLIED SCIENCE**  
 1920 Sunnyside Ave., Dept. 1353, Chicago 40, Ill.

**INSTITUTE OF APPLIED SCIENCE**  
 1920 Sunnyside Ave., Dept. 1353, Chicago 40, Ill. \*

Gentlemen: Without obligation or expense on my part, send me your qualification questionnaire. I understand that upon receipt of my answers you will immediately advise me if you think they indicate that I have a chance to succeed in criminal investigation or finger print work. Then I will receive FREE the "Blue Book of Crime," and information on your course and the 800 American Identification Bureaus employing your students or graduates.

Name \_\_\_\_\_  
 Address \_\_\_\_\_ RFD or Zone \_\_\_\_\_  
 City \_\_\_\_\_ State \_\_\_\_\_ Age \_\_\_\_\_

## TOOLS AT WHOLESALE

**DIRECT FROM FACTORY**

Full line of top quality, fully guaranteed, chrome, factory-new mechanics hand tools. You save **HALF REGULAR PRICE** for tools of this quality.

Pay **EASY MONTHLY TERMS**

**WRITE TODAY FOR FREE CATALOG**



## MECHANICS CO-OP

Dept. A OAKLAND 8, CALIFORNIA



## Money In Hamsters

The new wonder animals from Syria. Often called Toy Bears. Delightful pets. Everyone wants them. Laboratories use thousands. Clean, odorless. Raise anywhere. NOW, spotted and golden breeds. We furnish breeders, equipment and manual of instruction. Write today for free illustrated literature.

**GULF HAMSTERY** 1536 BASIL ST., MOBILE 17, ALA.



## LEARN MEAT CUTTING At Home—In Spare Time

Get into the vital meat industry. Concise, practical Home Training based on 25 years proven instruction methods used at National's famous resident school. Prepares you for bigger pay as Meat Cutter, Supervisor, market manager or more money in your own store. Go as rapidly as your spare time permits. Diploma. Start NOW to turn your spare hours into money. Send for FREE bulletin today. No obligation.

**NATIONAL SCHOOL OF MEAT CUTTING, INC.,** Div. U-138, Toledo 4, Ohio

**A "GOOD HAND" HELPS YOU SUCCEED!**  
**LEARN TO WRITE WELL**

Handwriting quickly improves with our easy-to-understand picture lessons! Put your spare time to good use; send today for **FREE BOOKLET**, "How to Become a Good Penman," or check volumes wanted below at \$1 each:  Business Writing  Artistic Writing  Card Writing  Bird & Design Flourishing  Engraving Alphabets. **COMPLETE SET \$4.50.** Ask for price list of penman's supplies.

**OUR 53rd YEAR**  
**TAMBLYN SCHOOL of PENMANSHIP**  
 S. A. Ziller, Pres., 442 Ridge Bldg., Kansas City, Mo., USA

Only 10¢ writing.



## CARTOONING

**HAVE FUN! MAKE MONEY!** Cash in on your sense of humor **AT HOME—BY MAIL!** No experience needed to start. Write today for **FREE TRIAL LESSON** and full particulars.  
**Moon Gag Cartoon School, Dept. M, Fall Creek, Wis.**

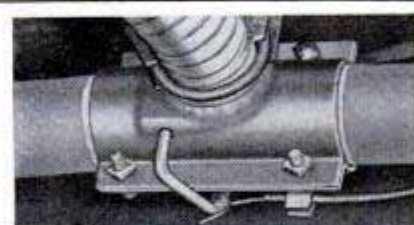

## HURRICANE EXHAUST CUT-OUT

This specially engineered cut-out enables you to install special pipes and mufflers without removing the original muffler.

Now control your exhaust tone from a dash control button. Cut back into your original muffler in restricted areas at will. Fits all exhaust pipes from 1 3/4" to 2 1/4" size. This cut-out is well constructed; actually strengthens exhaust pipe; made of heavy plate steel, designed for easy installation—no special tools required. Sent post-paid for only \$6.95 check or money order. Satisfaction guaranteed or your money back.

**ST. LOUIS PRODUCTS CO.,** Box 24-A, Normandy 21, Mo.



# Mr. CAR OWNER! — Brand New Book SHOWS YOU HOW TO REPAIR YOUR OWN CAR!

Brand New Book  
128 pages  
500 illustrations,  
photos and diagrams.

Covers all Cars —  
up to and including  
1951  
Models!

## Takes the Mystery Out of the OPERATION and General Repairs of Any Make or Year Car

How much will you spend on car repairs this year? How much uncertainty, aggravation and trouble will you be bothered with because of motor noises, faulty operation and even breakdowns? I'll bet you have no idea how *easy* it is to make your own repairs—even if you've never poured a quart of oil into your car yourself!

You've watched a car mechanic adjust a carburetor—there's nothing to it! The same with most of the adjustments and repairs on a car. This book shows you—in *easy-to-follow drawings and photographs*—just how to locate and fix practically any car trouble! Such as how to fix a leaky radiator and save \$10. How to change a fan belt—and a complete set of brake linings. How to put in a new set of spark plugs—and how to align your wheels. How to tighten your steering wheel—and how to put in a new set of shock absorbers. How to clean your fuel system—and how to lubricate your car. In brief, this book is so thorough, it will show you how to do any fix-it job from adjusting your window wiper to making a complete overhaul!

### SAVE MONEY—

Perhaps Hundreds of Dollars Depending on the Actual Troubles of Your Car

The complete price of this book will be saved the first time you may straighten a dent in your fender—or put in your own anti-freeze. There is no measuring the total money you will save—and there is no measuring your feeling of self-confidence and security in knowing what is wrong—and what has to be done.

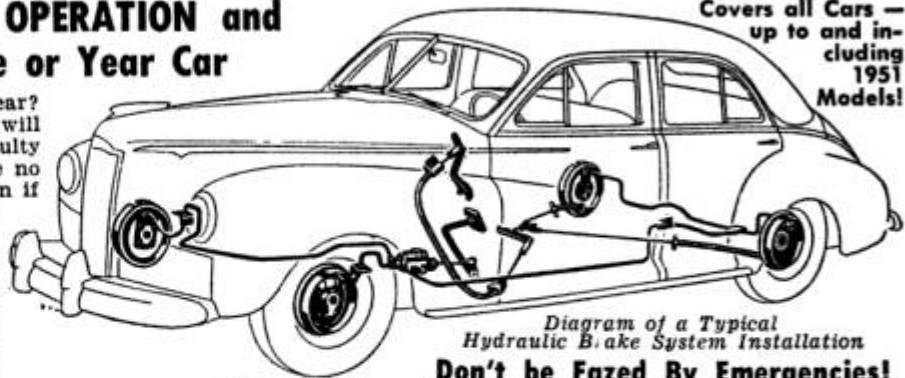

Diagram of a Typical Hydraulic Brake System Installation

only **\$2.00** complete price  
and sold with a full YEAR'S MONEY BACK GUARANTEE!

### Don't be Fazed by Emergencies!

It happens with every driver—especially with an older car,—that an engine will suddenly GO DEAD! And it usually happens in the middle of nowhere. With this book (in the first place, you'll be warned beforehand, and it won't happen to you) if it does, you will know how to locate and take care of any emergency trouble that may occur!

### TRY THIS BOOK FOR A WHOLE YEAR!

See how valuable it will be to you—in actual service! You don't have to be an expert to understand automobiles! You can easily get to know the basic principles of how an automobile runs—you can lengthen the life of your car for years—you can save money and be sure of the condition of any used car you may buy—you can make all adjustments and repairs on your car and save lots of money. And we will let the BOOK PROVE ITSELF TO YOU. Just mail the coupon now. When the book arrives—go through it. See how every page shows you something of help. Use the information at any time and all through the year. If you feel that the book hasn't helped you—RETURN IT FOR FULL REFUND. Send for THE AUTOMOBILE HANDBOOK—by Simon Palestrant now—to really enjoy your car.

### Take the "Guesswork" Out of Buying a Used Car

Don't let anybody sucker you into buying a "lemon". Know what you are buying before you put your money down. With a few simple tests and an examination and knowing what to look out for—just as explained in this book—you'll be able to KNOW the honest, actual condition and value of any used car you are thinking of buying!

## How to Build FIREPLACES AND BARBECUES

by Barbara Baer



There are few things that the craftsman can build that will bring him and his family as much pleasure over the years as a fireplace or barbecue. This new book is thorough and painstaking in its directions. It starts with the basic "plan" and then explains just what has to be done and how to do it. It presents a choice of different types of fireplaces, as to period—Early American, Colonial, Federal, Rustic, Dutch, English, Modern, etc.—as to cost, from \$12 up to \$150—as to type, from center, corner, two-way, hooded, etc. There is an equal selection of barbecue designs, for every need from portable models to designs to serve spacious grounds and large gatherings. There is a plan for a barbecue which can be built for 40¢, and one with dozens of in-betweens. The

three cooking units, plus book also includes tips on fire building and even how to cook, broil or barbecue.  
Brand New Book and only

**\$1.50**

## LAMPS AND LAMP SHADE MAKING

by S. Palestrant



To brighten a corner or room, figuratively and literally, there is nothing like a beautiful, original lamp. This book makes it very easy for even the "all-thumbs" man or woman to design (or copy) and construct charming, simple or even decorator type lamps. It includes over fifty original lamp and lampshade designs from which the reader can select his favorite to make. Modern lamps! Antique style lamps! Period lamps! This book starts at the very beginning, taking you step-by-step with picture directions through every phase of making complete lamps, including the wiring. The book also covers the history, development and aesthetics of lamps and lighting—includes a full explanation of incandescent, fluorescent and other types of lighting. Every type of lamp—floor, table, wall; ceramic, wooden, metal, plastic bases, and lampshades of all materials and types are thoroughly covered. Contains a listing of sources of supply. Convert your favorite vase, statue or ornamental object into a lamp—you'll find it easy now. Brand New Book. Price

**\$2.50**

## TOY MAKING—200 PROJECTS FOR FUN AND PROFIT

by S. Palestrant

A vast Encyclopedia of profitable, fascinating fun! Here is a volume that shows even the "fumble-fingered" beginner how to turn out wondrous toys to make those small faces sparkle! You will be making a set of jiggling acrobats, a balancing circus cat, a happy prancing horse or those lovable pecking pigeons. Then you can make old Noah's Ark, complete with all his animals! Sets of model trains, ships, planes... manikin dolls, ceramic,

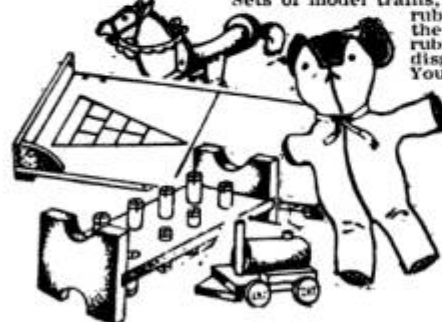

rubber, wooden or stuffed dolls to delight the heart of any little girl. You can make rubber or waxed masks, complete make-up disguises for those Halloween escapades. You can even create a puppet theatre, complete with stage, settings, and real animated puppets to put on home shows. This big, complete book covers toys of all types, of all materials, for children from 1 to 100! Construction Toys—Push-Pull & Knock-Down Toys—Mechanical & Electrical Toys—Scientific & Educational Toys—Dolls, Puppets, Masks, Games, Trick Toys & Novelties, Soldiers, Garden & Seashore Toys, and many more! Complete step-by-step instructions, photographs, diagrams and complete plans make these projects so simple to turn out. Also sources of supply for anything and everything you might want.  
Just published. Only

**\$2.50**

Homecrafts, Dept. 744, 799 Broadway, New York 3, N.Y.

HOME CRAFTS, Dept. 744  
799 Broadway, New York 3, N. Y.

Please send me the book or books I have checked below. It is understood that if I am not satisfied, I can return them and get my money back.

I am enclosing \$\_\_\_\_\_ in full payment.

Send order postage paid.

Send order C.O.D. for \$\_\_\_\_\_ plus shipping charges.

The Automobile Handbook . . . . . \$2.00

How to Build Fireplaces & Barbecues . . . . . 1.50

Lamps and Lampshade Making . . . . . 2.50

Toy Making—200 Projects to Make . . . . . 2.50

Name \_\_\_\_\_

Address \_\_\_\_\_

City & Zone \_\_\_\_\_ State \_\_\_\_\_



# FIX SAGGING FLOORS YOURSELF with TEL-O-POST



Save big repair bills for fixing sagging floors — which cause cracking plaster, sticking doors, open joints. Install Tel-O-Post yourself for only \$10.

Tel-O-Post is the original adjustable steel post with a built-in jack. Used in cellars, under porches, in garages, barns, etc. Only 20 minutes to make installation. . . patented locking pin assures safety.

Ask for Tel-O-Post at your building supply, lumber or hardware dealer . . . or send coupon and \$10 check.

**BRAINARD STEEL COMPANY, Dept. C-3**  
Griswold Street, Warren, Ohio



- Send illustrated booklet on Tel-O-Post installation.
- My dealer does not stock. Enclosed is check for \$10 (\$15 West of Kansas City). Ship via express prepaid one No. 1 Tel-O-Post, adjustable from 5' to 8'4".

Name \_\_\_\_\_  
Address \_\_\_\_\_  
City \_\_\_\_\_ State \_\_\_\_\_

**MONEY-BACK GUARANTEE IF NOT SATISFIED**

# PORTABLE GARAGE

**\$1095**

(Extra Heavy Gauge)

**\$895**

(Heavy Gauge)



FLEXTON  
Approved by  
Good Housekeeping

**USE IT ANYWHERE!**

- Goes wherever your car goes ● Folds compactly ● Keeps rain, snow, dust, salt air, sun or sleet away ● Will withstand Extreme cold without cracking and protects your car's finish ● Perfect for storage of Cars, Furniture, Machinery Equipment ● Durably constructed of clear transparent—heavy gauge vinyl plastic that is long wearing and tough ● Nylon threads and grommets for extra security and wear ● Spring-tite elasticized bottom, holds securely in all kinds of weather ● Fits all makes and models ● Direct from manufacturer ● FREE: Carrying case! Enclose check or money order, or sent C.O.D.

**MARDO SALES CORP., Dept. B-567**

480 Lexington Ave.

New York 17, N. Y.

## BOYS-IT'S FREE!

### "THE WONDERS OF CHEMISTRY"

This exciting new book shows how to amaze your friends with chemical magic, describes many fascinating home experiments, tells of fun, thrills and big future opportunities for boys who know chemistry. Special atomic energy feature. Send today!

**THE PORTER CHEMICAL COMPANY**  
46 Prospect Avenue, Hagerstown, Maryland



## Do You Make These Mistakes in English?

MANY persons say "between you and I"—use "who" for "whom"—don't know whether to use one or two "e's" or "m's" or "r's." Every time you speak or write you show what you are. A command of effective English brings you added advantages, better opportunities.

You can improve your English through Sherwin Cody's 100% self-correcting invention. If you are ever embarrassed by mistakes in grammar, spelling, punctuation, or pronunciation, write for FREE book "How You Can Master Good English in 15 Minutes a Day." No obligation. SHERWIN CODY COURSE IN ENGLISH, 53 B & O Bldg., Rochester 14, N. Y.

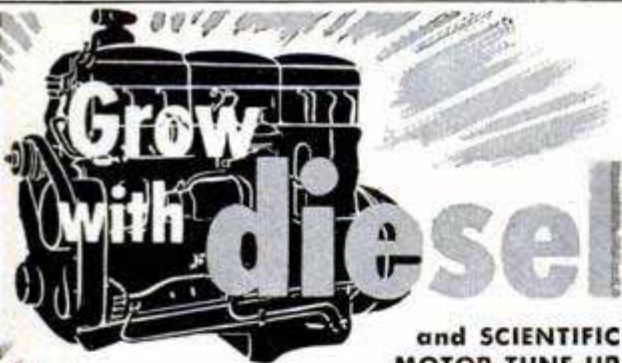

and SCIENTIFIC MOTOR TUNE-UP  
—One of America's Fastest-Growing Big-Pay Industries!

Get ready now . . . Make a place for yourself in the mighty Diesel industry. Be there to take advantage of the opportunities ahead. The U.E.I. Plan for learning Diesel is simple, practical and is based upon the principle of learning-to-do-by-doing. Includes Auto Engine Tune-Up. You get fundamentals through spare-time home-study, followed by actual shop practice on modern Diesel engines. Experienced instructors guide you step-by-step—you learn the HOW and WHY of Diesel operation, service and maintenance.

Get all the facts—mail the coupon and we'll send you a free copy of "Earning Power in Diesel." Mail coupon today!

### UTILITIES ENGINEERING INSTITUTE

Dept. DC-18 (Founded 1927) Chicago 14, Ill.

UTILITIES ENGINEERING INSTITUTE, Dept. DC-18  
2521 Sheffield Ave., Chicago 14, Illinois

Please send me, without obligation, your free book, "Earning Power in Diesel."

NAME (print).....AGE.....  
ADDRESS .....

CITY..... Zone..... State.....  
 Check here for information if you are under 17

### TASOPE PHOTO-ENGRAVING PLANTS

Establish your own profitable PHOTO-ENGRAVING business. Make cuts for newspapers, printers, and advertisers. Make etched name plates, plaques etc. Instructions furnished, no experience necessary. Sold direct from factory since 1931. First five hundred cuts sold locally or by mail will pay for plant and pay you well for your time. Write for FREE catalog. TASOPE DEPT. PM3, AURORA, MO.



**Reduce RADIO NOISES**  
SIMPLY PLUG Radio or Appliance cord into Noise Eliminator and plug into wall socket. Enjoy reception FREE from many distracting noises. Send No Money, pay postman \$1.25 each (2 for \$2.00) plus postage or send cash and we'll mail postpaid. Try 5 days, money back if not delighted. Many hundreds of satisfied users. Send for yours today. 2 for \$2.00  
MERIT SALES, Dept. C-30, 4225 Eldone Dr., Baltimore 29, Md. \$2.00

## FALSE TEETH

### KLUTCH holds them tighter

KLUTCH forms a comfort cushion; holds dental plates so much firmer and snugger that one can eat and talk with greater comfort and security; in many cases almost as well as with natural teeth. Klutch lessens the constant fear of a dropping, rocking, chafing plate. 25c and 50c at druggists . . . If your druggist hasn't it, don't waste money on substitutes, but send us 10c and we will mail you a generous trial box.

KLUTCH CO. Box 5293C ELMIRA, N. Y.



# VOTE TODAY

FOR THE FUTURE  
YOU WANT!

AMERICAN SCHOOL, Dept. G345, Drexel at 58th, Chicago 37, Ill.  
Without obligation, please send FREE and postpaid, full particulars about  
the subject checked below.

- Accounting
- Air Conditioning
- Architecture & Building
- Automotive Technician
- Better Foremanship
- Bookkeeping
- Business Management
- Contracting
- Diesel Technician

- Drafting—Building Trades
- Drafting—Machine Trades
- Electrical Engineering
- Electricity—Practical
- Electronics—Industrial
- High School Courses
- Machine Shop Operations
- Mathematics & Slide Rule
- Mechanical Engineering

- Plastics Engineering
- Plumbing—Practical
- Private Secretary
- Refrigeration
- Retail Merchandising
- Salesmanship—Outside
- Sheet Metal Work
- Tool Making

NAME .....

HOME ADDRESS .....

CITY .....

OCCUPATION .....

AGE .....

STATE .....

THIS IS YOUR BALLOT

Check the career that interests you most,  
Fill in spaces and mail at once—no obligation

● Today, choose the job you want — and prepare for it in spare time at home. Or if you are already engaged in the work you like best, start training now for quicker promotion. In hours you might otherwise waste, gain the knowledge and skill that can help you to get ahead faster, make more money, and have greater security.

Thousands before you have followed this plan and were able to step out ahead of others who didn't fit themselves for advancement or who seemed willing to trust to luck.

### Training Backed by 55 Years of Experience

For over half a century American School has helped ambitious men and women

toward success by providing specialized training for commercial and technical advancement. At a cost you can afford you can prepare at home to climb in the kind of work you prefer. American School's study program for you has been planned by experts with years of experience in the subject you select and they will give you needed guidance every step of the way.

### Don't Delay Your Start

Give serious thought to the list of training courses listed above. Pick the opportunity that interests you, check it and add your name and address. (Check more than one if you are undecided as to which appeals most.) Finally clip out and mail the "ballot" and full information will be supplied, without cost or obligation.

PRACTICAL, EFFECTIVE HOME STUDY TRAINING SINCE 1897

AMERICAN SCHOOL, Dept. G345, Drexel at 58th, Chicago 37, Ill.

THE SOONER YOU START, THE SOONER YOUR GOAL CAN BE REACHED



IF ELECTRIC SHAVERS  
CAN'T TOUCH YOUR BEARD  
YOU NEED A



THE SHAVER  
THAT SHAVES  
ANY BEARD

Whisker's clipper-type .002" thin blade shaves any length beard, even to 7 days' growth, without pulling or stalling. 110v AC model; no TV or radio interference! See your barber or dealer. If he cannot supply you, send \$15.95—we pay postage; or send \$2, you pay balance plus postage and C.O.D. 10-day money-back guarantee.



**CADET ELECTRIC HAIR CLIPPER**  
Cuts hair, removes superfluous hair from legs and under arms. The same fine quality clipper used and sold in many beauty shops. See your shop, or dealer. If you prefer, send \$10.95—we pay postage; or \$2, you pay post-man balance, postage and C.O.D.

ELECTRO TOOL CORP., Dept. W522-C, Racine, Wis.

CORTINAPHONE  
makes it FUN to



# SPEAK FRENCH-SPANISH

RUSSIAN-GERMAN  
ITALIAN-BRAZILIAN-JAPANESE  
"Learn by Listening" to CORTINA RECORDS, at home, the NATURAL way — quickly, easily, cheaply.

**Only 15 Minutes a Day!**

The Cortina method, famous for 70 years, teaches you to speak like a native. THOUSANDS have found it the most fascinating, most effective way to learn languages for Pleasure, Business, Travel, Culture. INVESTIGATE!

**Send For FREE BOOK!**

Illustrated 32-page book, "The Cortinaphone Short-Cut" sent FREE. No obligation. Tells just what you want to know. Interesting. Get it!

ALL NEW RECORDINGS ON UNBREAKABLE RECORDS WRITE TODAY

CORTINA ACADEMY (Est. 1882)  
Suite 643, 105 W. 40 St., N. Y. 18, N. Y.  
Please send me—without obligation—your free book. I am interested in (check)  
 French  Spanish  German  Italian  Brazilian  
 Russian  Japanese

Name \_\_\_\_\_

Address \_\_\_\_\_

City \_\_\_\_\_ State \_\_\_\_\_

VETS! Check if NOW eligible under G. I. Bill.

# PRESTO! ANYONE CAN MASTER GLAZE



Car Owners! Meet Master Glaze—the sensationally different luster for new and used cars! Not a wax—not an oil polish—not a paint!—nothing that "smears" over the surface.

**MASTER GLAZE** is a unique discovery—a creamy liquid—quick and easy to apply! Gives a hard, glass-like surface. Even gasoline cannot dull it! Lasts six months to a year! Amazing luster—beautiful, sparkling clean and brilliant! Doesn't finger-mark—doesn't smear! A match box full glazes an entire car. Seals the pores—protects! NOTHING LIKE IT!

## FREE SAMPLE

Just send your name and address to  
**MASTER GLAZE CO., 7720-728 W. Harwood Ave., Milwaukee, Wis.**

## "How to Make Money with Simple Cartoons"



A book everyone who likes to draw should have. It is free; no obligation. Simply address

FREE BOOK

**CARTOONISTS' EXCHANGE**

Dept. 93A Pleasant Hill, Ohio

## RUPTURE!

An amazing Air-Cushion Invention allows body freedom at work or play. Light, neat, cool, sanitary. Durable, cheap. Day and night protection helps Nature support weakened muscles gently but surely. No risk. **Sent on Trial!** Write NOW for free Booklet and **Proof of Results.** All correspondence confidential.  
**Brooks Company, 373 State St., Marshall, Mich.**



## World's Fastest Boats!



Build your own high speed racing boat from a Champion plan! Send 25c for catalogue containing pictures and description of 18 models. Hydroplanes, Utilities and 3 Points. 6 to 20 ft. lengths. **CHAMPION BOATS, 1524 W. 15th St., Long Beach 13, Calif. Dept. 15 O.**

## WEATHER-PROOF YOUR CAR...



LIKE THE NEW

CADILLAC, FORD, HUDSON, CHRYSLER, etc.

Drive thru rain, snow, puddles, protected by **SEALTIGHTS** — the original ignition weather-proofing insulators.

## SEALTIGHT IGNITION INSULATORS

AMERICA'S FINEST INSULATORS!

Weatherproof, short-proof all cars, trucks, tractors, gas motors with Sealtights on spark plugs, distributor, coil, magneto. **ASK YOUR GARAGE or SERVICE STATION,** or write us for details, giving make and model of car.

**SEALTIGHT CORP., Dept. PM32, Cedar Rapids, Ia.**





not everyone does as well, but E. O. Lockin, who started a business of his own, reports...

for 12 months I've averaged  
**\$800 PER MONTH INCOME**

—most of it clear profit for me!



You, too, can start your own business. No special skill, no large investment required. Costs nothing to find out—no obligation. Mail coupon today for interesting **FREE** book.

• Mr. Lockin expresses his grateful thanks for the opportunity to make a decent living on his own. Many men have discovered how to be independent, to be freed of bosses and layoffs—to build their own future on a steady, dependable foundation. L. A. Eagles grossed more than \$200 his first week. R. E. Traynor says, "I made \$62 gross in one day." Others report gross from \$100 per week to \$12,000 per year.

How much you make depends largely on you. You need no special skill, no large investment to start.

**No shop necessary.** Our **ELECTRIC RUG WASHER** cleans rugs and carpets like new right on the floor... removes dirt and grime and helps to show their natural color and beauty. So efficient and safe for carpets, it is used by largest hotels and railroads.

You take no risk. Machines fully guaranteed. Mail coupon today for complete information including how to start making big profits quickly in YOUR OWN business. **BIG** opportunity. Send coupon now.

**VON SCHRADER MFG. CO., RACINE, WIS.**

**VON SCHRADER MFG. CO.,**  
 1330 "R" PL, Racine, Wisconsin

Send at once (no obligation) your **FREE** booklet containing information about your **ELECTRIC RUG WASHER** and how I can start my own permanent, profitable business.

Name \_\_\_\_\_  
 Address \_\_\_\_\_  
 City \_\_\_\_\_ Zone \_\_\_\_\_ State \_\_\_\_\_

**MILLIONS OF APPLIANCES NEED REPAIR!**

**EARN BIG MONEY.. WORK PART OR FULL TIME IN ELECTRIC APPLIANCE REPAIRING!**

- ELECTRIC REFRIGERATORS
- WASHING MACHINES
- VACUUM CLEANERS
- ELECTRIC RANGES
- MOTORS
- SEWING MACHINES
- TOASTERS
- WAFFLE IRONS
- MANGLES
- HEATING PADS
- FREEZERS
- ELECTRIC FANS
- ELECTRIC IRONS
- LAMPS
- ETC., ETC.



**ELECTRONIC KIT TROUBLE DETECTOR**  
 (Checks shorts, wattage, continuity, etc.)  
 is sent to all students

**MAIL COUPON for FREE BOOK**

Learn this fascinating big money paying profession at home in your spare time. Learn by doing, by working with your hands building, testing, repairing electrical appliances of all kinds. Electrical appliance repairmen are needed everywhere — wherever electricity is used. You need no special previous training or experience. Age is no handicap. **CHRISTY** has trained over 33,000 men in all parts of the world. Men who today command big wages or own profitable businesses of their own.

**PAY LATER FROM EARNINGS WHILE LEARNING**

**CHRISTY** shows you how to make money while still learning, what to charge, how to set up your own shop, how to build power tools from spare parts, etc. It will pay you to write today.

**CHRISTY TRADES SCHOOL, Dept. D-403**  
 4432 N. Kedzie Ave., Chicago 25, Ill.

Send me your **FREE** book on Electrical Appliance Repairing and special form for "paying later from earnings made while learning."

NAME \_\_\_\_\_ AGE \_\_\_\_\_  
 ADDRESS \_\_\_\_\_  
 CITY \_\_\_\_\_ STATE \_\_\_\_\_



# IMAGINE THEIR JOY

when they found they could play this easy-as-ABC way!



### Learned Quickly at Home

"I didn't dream I could actually learn to play without a teacher. Now, when I play for people they hardly believe that I learned to play so well in so short a time."

\*H.C.S., Calif.



### Plays at Dances

"Your lessons have been most satisfactory. I can play all of the popular songs. I have earned money playing at dances."

\*E.N.J., New York

## What Instrument Would You Like to Play?

JUST name your instrument and we'll show you how you can learn to play it—quickly, easily, in spare time at home. Never mind if you don't know one note of music from another—don't worry about "special talent." And forget all you've ever heard about music being hard to learn.

The truth of the matter is that thousands now play who never thought they could! Yes, men and women everywhere have discovered this amazingly easy way to learn music at home. Now they are enjoying the thrilling satisfaction of playing the piano, violin, guitar, saxophone or other favorite instruments. Some of them are playing in orchestras and over the radio; others are teaching music, making money in spare or full time. And thousands are having the time of their lives playing for their own enjoyment and the entertainment of their friends.

No tedious study and practice, no tiresome exercises. You learn to play by playing—start right in with the melody of a simple tune! It takes only a few minutes a day; the cost is trifling. Does it sound too good to be true? Mail the coupon and get the FREE PROOF!

### Easy as A-B-C



### SEND FOR FREE PROOF

Fascinating illustrated booklet answers all your questions; free Print and Picture Sample shows how method works. If interested, just mail coupon to U. S. School of Music, Studio B303, Port Washington, N.Y. (850,000 Students—Our 54th Successful Year.)

\*Actual pupils' names on request. Pictures by professional models.

### FREE! Print and Picture Sample

U. S. School of Music, Studio B303, Port Washington, N. Y.

Send me Free Book and free Lesson-Sample. No salesman is to call upon me. I'm interested in playing (name instrument).....

I do  I do not—have instrument now.

Name.....  
(please print)

Address.....



### Plays on Radio

"I can't keep from telling you that I have a good position playing from KTHS, Hot Springs, Ark., every morning."

\*J. S., Okla.

## DRY OUT DAMP WORKSHOPS!



Amazing little Fedders Electric Dehumidifier dries damp rooms without messy chemicals! Plugs in like a radio, removes up to 3 gals. of moisture from the air every 24 hours. Stops damage from rust, mildew, rot, warp. Protects tools, wood, guns, luggage, furniture, linens. Compact and portable. No service worries. Runs for a few pennies a day. Write today for details on 5-day FREE home trial offer. Fedders-Quigan Corp., Dept. PM-1, Buffalo 7, New York.

**fedders**

A GREAT NAME  
IN COMFORT

## RUPTURE



RELIEF...OR YOUR MONEY BACK Original, patented Web, copied but never matched. Users say it's best ever. Relief or no cost to you. Write:

WEB TRUSS CO., Dept. M-3, Hagerstown, Md.

## GROW MINIATURE TREES

FOR PROFIT & PLEASURE



Fabulous Money—Real Fun! Grow genuine live dwarf (Ming) trees. A terrific new business and hobby. Astounding details Free. Write —

DWARF TREES, Dept. 28  
P. O. Box 355, Briggs Station  
Los Angeles 48, Calif.

## REAL ESTATE

BE A BROKER

PAYS BIG! SEND FOR FREE, BIG, ILLUSTRATED CATALOG NOW! No obligation. Graduates report making substantial incomes. Start and run your own business quickly. Men, women of all ages, learn easily. Course covers Sales, Property Management, Appraising, Loans, Mortgages, and related subjects. STUDY AT HOME or in our classrooms in big cities. Diploma awarded. G.I. approved. Nationally known.

WEAVER SCHOOL OF REAL ESTATE (Est. 1936)  
Suite 300 Law Bldg., Dept. PM, Kansas City, Mo.

FREE BOOK TELLS HOW

## WEATHER DAMP—Car Won't Start?

### SHORTSTOP

starts damp motors quick

Just press button on handy aerosol can and spray plugs and wires. New, improved formula contains silicone. One treatment protects for months.

Get Shortstop at your service station, garage or auto supplies store.

ZACO LABS • 1360 W. 9th, Cleveland, O.



# NOW you can learn TV-RADIO servicing at Home

in your  
spare time!

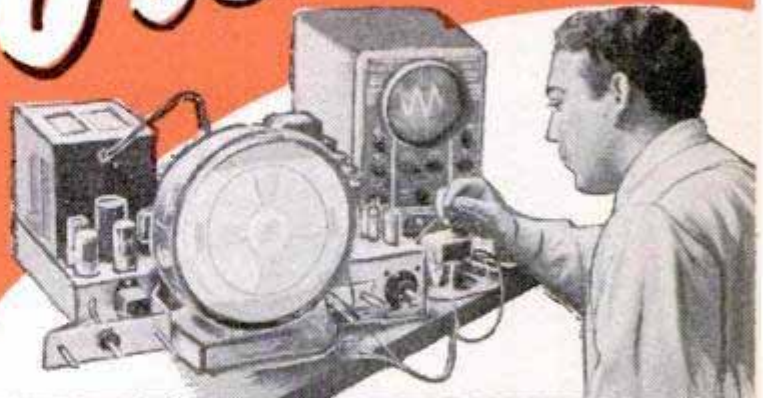

## BIG DEMAND FOR TRAINED MEN!

Famous CRESCENT SCHOOL of Radio & Television now offers a *complete* HOME STUDY COURSE for those unable to attend classes! CRESCENT SCHOOL's experience of millions of training hours assures you of the finest training available. New simplified lessons and illustrations — *no previous training needed!* Parts-kit included.

Get into this high-paying field with a future! Many students start to earn extra cash while learning. Complete the course as quickly as you can learn. Certificate awarded upon completion of course. CRESCENT SCHOOL's free placement service is available to you!



INCREASED EARNINGS



INTERESTING WORK



AN UNLIMITED  
FUTURE

# FREE!

Send TODAY for FREE illustrated, interesting booklet & complete details about the HOME STUDY COURSE!

PAY AS LITTLE AS  
**\$5** MONTHLY

Total cost for complete course  
as little as **\$100**

Crescent School — one of the largest of its kind! Multi-million-dollar plant in its own 6-story building.



## SEND COUPON TODAY!

CRESCENT SCHOOL Dept. B-3  
500 Pacific St., B'klyn 17, N. Y.

Sirs: Rush free booklet & complete details about your HOME STUDY COURSE . . . at no obligation to me.

NAME .....

ADDRESS .....

CITY.....ZONE.....STATE.....



# NOW, EVERYONE CAN BUILD WITH CONCRETE BLOCKS

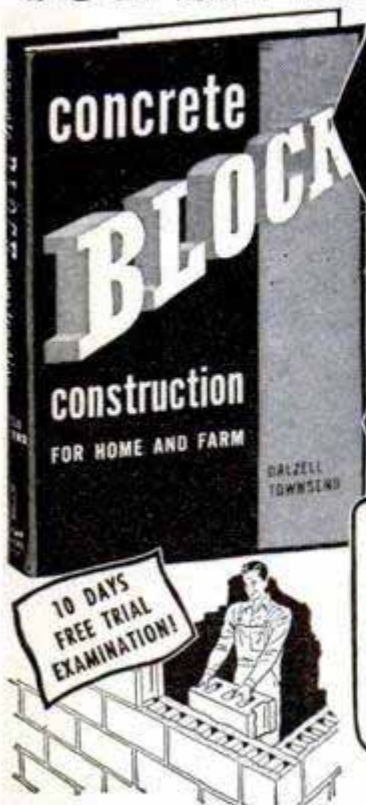

For speed and economy use concrete blocks!

You can build a garage or addition to your home!

Save thousands of dollars by doing it yourself!

Partial list of contents: Kinds of mortar and cement, Foundations, Sidewalks, Drives, Planning of framework, How to pour footings, How to waterproof, Barns and small farm structures, Walls, Windows, Chimneys, Homemade concrete and cinder blocks.

YOURS FOR ONLY \$2.75

Brand new, just off the press, packed with pages of step-by-step plans, simple, easy-to-follow instructions, *Concrete Block Construction* will show you how to build a garage, summer home, expand and modernize farm buildings—all at a fraction of the cost you would expect to pay.

Use of concrete blocks has greatly increased in recent years in building an enormous variety of structures. Everyone deserves a chance to make the greatest use of this low-cost and readily-available material. As for speed in construction, concrete block building can't be licked!

Think of saving thousands of dollars for only a \$2.75 investment. That's what this important book will mean to you. Written and illustrated so that practically anyone can build a structure from concrete blocks, every page is filled with the experience of authorities who know how to instruct and guide others with simple, concise language.

You do not have to accept our word about the importance and value of this book. In fact, we insist that you must be completely satisfied, that everything is as we say it is or you may return the book and owe us nothing. But don't delay. The first printing is large enough to take care of only the current demand. So don't risk having to wait for the second edition. Mail coupon now!

**THIS COUPON IS GOOD FOR 10 DAYS TRIAL!**

American Technical Society (Publishers since 1898)  
Dept. C-419, 848 East 58th St., Chicago 37, Illinois  
Please ship me at once CONCRETE BLOCK CONSTRUCTION for free 10-day examination. If I keep book, I will pay \$2.75 plus a few cents postage, otherwise I will return books and owe nothing.

Examine  
Free  
at Home

No  
obligation

- Concrete Block Construction for Home and Farm.....\$2.75
- How to Design and Install Plumbing.... 3.50
- How to get the Most House for your Money 2.50
- Carpentry..... 2.50
- Interior Electric Wiring and Estimating —Residential and Farm..... 3.95
- Steel Square..... 2.25
- How to Estimate for the Building Trades 5.50
- Practical Mathematics..... 2.75
- Building Insulation..... 4.95
- Stair Building..... 2.50
- Brick Laying Skill and Practice..... 3.00

Print Name \_\_\_\_\_

Street or RFD \_\_\_\_\_

City \_\_\_\_\_ State \_\_\_\_\_

To save postage I am enclosing payment.

## INVENTORS

Before you make any effort to market your invention, you should take the first steps toward proceeding for patent protection.

I shall be pleased to furnish you with information relative to patent procedure, upon request from you, and this will be without any obligation on your part.

**PATRICK D. BEAVERS**

Registered Patent Attorney

934 Columbian Building Washington 1, D. C.

## PATENTS

### C. A. SNOW & CO.

REGISTERED PATENT ATTORNEYS  
WRITE FOR INFORMATION TO  
428 SNOW BUILDING, WASHINGTON 1, D. C.

## INVENTORS

Whether an invention is patentable can be substantially determined by a search of the U. S. Patent records. Without obligation, write for information explaining the steps you should take to secure a patent.

**JOHN N. RANDOLPH**

Registered Patent Attorney

201 Columbian Building, Washington 1, D. C.

## INVENTORS

Send today for "Patent Protection for Inventors" outlining preliminary steps to take toward patent protection, also convenient "Evidence of Invention" Form.

**VICTOR J. EVANS & CO.**

730-C Merlin Building • Washington 6, D. C.

## INVENTORS

Send for **PATENT INFORMATION** Book and **INVENTOR'S RECORD** without obligation

**GUSTAVE MILLER**  
32-PM WARNER BUILDING  
WASHINGTON 4, D. C.

**REGISTERED PATENT ATTORNEY**  
Patent Attorney & Advisor  
U.S. NAVY DEPT. 1930-'47  
ASSOCIATE EXAMINER  
U.S. PAT. OFF. 1922-1929  
**PATENT LAWYER**

## INVENTORS

IF YOU WISH TO PROTECT YOUR INVENTION, You should take steps to protect it by a U. S. Patent. Write me for "INVENTION RECORD" form

**CARL MILLER**

REGISTERED PATENT ATTORNEY

WOOLWORTH BLDG., 35th FLOOR, 32A  
NEW YORK CITY





# I'll show you how to EARN BIG MONEY IN PLASTICS without tools or machinery!

## A NEW HOME INDUSTRY

NEVER BEFORE has such a GREAT OPPORTUNITY like this been offered! The CHANCE OF A LIFETIME! The chance to learn and START a new, fascinating and HIGHLY PROFITABLE business of your own! We have started THOUSANDS of ambitious people in this wonderful and thrilling new business because the work is so easy and pleasant (many turn it into a profitable hobby), requires only a FEW dollars investment, can be started ANYWHERE by ANYONE . . . at home, garage, basement, den, shop, etc. and most important, WITHOUT TOOLS OR MACHINERY you can produce in QUANTITY exceptionally attractive and desirable plastic things of such great variety and usefulness beyond your imagination! All this valuable knowledge and instruction is yours FREE . . . we teach you, help you get started and buy part of your production! We also help you obtain DEFENSE WORK!

## MAKE ANYTHING

This new method of creating unlimited quantities of useful things without machinery is CASTING . . . the extremely simple process of pouring liquid plastics into molds; the entire method is as easy as pouring water out of a glass! No machinery or tools required! In a few minutes the liquid turns into a beautiful solid; hard, durable, colorful or transparent plastic in the form of Jewelry, Novelties, Gadgets of every shape and form, Machine Parts, Fishing Lures, Bookends, Cig. Lighters, Tools, Dies, Handles, Knobs, Pensets, Figurines, Souvenirs, Toys, Dolls, Baby Shoes . . . A THOUSAND USEFUL THINGS! Some of our plastics are transparent and sparkling clear, ideal for imbedding flowers, photos, curios, etc. Others are like beautiful Ivory, Ebony, Marble, Ce-

ramics, Etc. The field is really UNLIMITED. Practically anything your imagination can create can be CAST with our plastics, one or a thousand!

## BILLIONS FOR DEFENSE

The government has started the greatest defense program in history! BILLIONS are being spent! Our liquid plastics can be used in THOUSANDS of vital defense applications. With our catalog we will include instructions how YOU can obtain defense work, how YOU can take part in this tremendous program to insure the future of America! A grand opportunity to combine patriotism and profit! A grand opportunity of obtaining THOUSANDS OF DOLLARS of defense work!

## 1000 OPPORTUNITIES

Regardless what you are doing now you can get into the CASTING BUSINESS in your spare time or evenings; we assure you, once you do, you will be eagerly devoting all of your time to this very easy, fascinating and HIGHLY PROFITABLE business. Countless letters from enthusiastic busy PLASTICAST users testify to successful businesses developed as a result of answering this ad! BUT LET US PROVE IT: send only 25¢ for our big 48 page catalog of Casting Materials, Molds, etc. We will also send you, absolutely FREE, an attractive CASTING to show you what can be done with our plastics in a few minutes! IN ADDITION, we will also send you a valuable instruction book giving details on the ART & BUSINESS OF CASTING! Yes, all this for only 25¢, but write for it today . . . this may be the lucky coin that will start the most fascinating and profitable phase of your life! Don't delay anything that can mean so much to your future—write today.

## PLASTICAST CO. (Dept. "C")

P. O. BOX 6737 (Write to) P. O. BOX 987  
CHICAGO 80, ILL. nearest address) PALO ALTO, CALIF.

CANADIAN CUSTOMERS: Send 35¢ for catalog to Canadian Ind. Plastics, 1056½ W. Pender St., Vancouver, B.C.



# LEARN MEAT CUTTING AT NATIONAL

Pay After Graduation

NOW—train in JUST 8 WEEKS at famous National School for a big-pay job with a SECURE future in the dependable trade of Meat Cutting, Meat Merchandising and Self Service Meats.

Be an expert Meat Cutter, Market Manager, Supervisor and make an expert's pay. Get a profitable market OF YOUR OWN. Unlimited opportunities in this vital, nationwide field.

You learn easily, quickly the National Way. You have your own tools and meat to work with. Expert instructors show you how. You get actual, practical experience right here in our big, modern school where we have been training top meat men for nearly 30 years.

Cutting, percentage, pricing, advertising, selling, buying, A COMPLETE RETAIL MEAT EDUCATION. Diploma. FREE employment help. Thousands of successful graduates.

## TRAIN NOW — PAY LATER

Get your training NOW. Pay tuition in easy installments after you graduate. We'll get you a job, if you need it, to PAY ALL YOUR EXPENSES while at school. If you want to BE A SUCCESS—have a secure future—send coupon AT ONCE for our big 52-page school catalog showing students in training and telling about our LEARN BY DOING method. Read letters from graduates. GET ALL THE FACTS. No obligation. You have



everything to gain. Paste coupon on postcard or mail in envelope TODAY.

**National School of Meat Cutting, Inc., Dept. 50-C, Toledo 4, Ohio**

Send me your FREE school catalog on National Training at Toledo in Meat Cutting, Meat Merchandising and Self Service Meats. No obligation. No salesman will call.

Name \_\_\_\_\_

Address \_\_\_\_\_

City \_\_\_\_\_ Zone \_\_\_\_\_ State \_\_\_\_\_



# Amazing New Auto "Trouble-Shooter"

## Spots ANY Car Troubles- In a Jiffy!

MOTOR's Handy, Pocket-Size Manual Enables You To  
"Find What's Wrong" Quickly and Easily!

NO more guessing or groping for causes of car ailments! Now you can put your finger on every possible cause of car trouble — by turning to indexed check-list in MOTOR's amazing NEW "TROUBLE-SHOOTER"!

For example, if car has Fan Belt Noise, just turn to that section and you find SEVEN specific things that can cause it. In this same way, no matter what is wrong, this handy manual checks through 2000 possible causes in a jiffy! Covers engines, clutches, brakes, ignition, axles, battery, starting motor, springs, shock absorbers, steering wheels, tires, transmissions, etc. Section on automatic transmissions alone is worth price of book. Saves time, work, headaches. A "must" for beginner or veteran mechanic. Handy spiral binding; stays open while you work.

### SEND NO MONEY

Pay postman \$1 on delivery, plus C.O.D. charges. If not satisfied, return book in 7 days for refund. Or SAVE C.O.D. charges by sending only \$1 NOW. Same return privilege.



MOTOR Book Dept. Box CM1  
250 West 55th St., New York 19, N. Y.

Rush me on approval, MOTOR's TROUBLE-SHOOTER. I will pay postman \$1 plus 43 cents shipping and C.O.D. charges. Unless satisfied, I may return book in 7 days for refund.

Name.....

Address.....

City..... Zone..... State.....

SAVE MONEY!—Check box and save 43c shipping charges by enclosing \$1 WITH coupon. Same refund privilege.

# AUDELS Carpenters and Builders Guides 4 vols. \$6

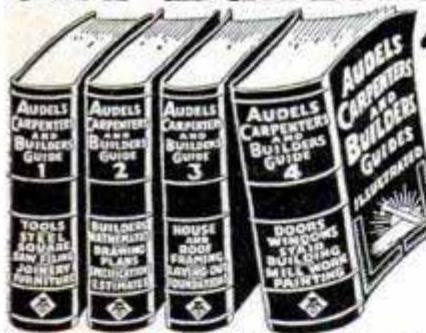

### Inside Trade Information On:

How to use the steel square—How to file and set saws—How to build furniture—How to use a mitre box—How to use the chalk line—How to use rules and scales—How to make joints—Carpenters arithmetic—Solving mensuration problems—Estimating strength of timbers—How to set girders and sills—How to frame houses and roofs—How to estimate costs—How to build houses, barns, garages, bungalows, etc.—How to read and draw plans—Drawing up specifications—How to excavate—How to use settings 12, 13 and 17 on the steel square—How to build hoists and scaffolds—skylights—How to build stairs—How to put on interior trim—How to hang doors—How to lay floor—How to paint

Inside Trade Information for Carpenters, Builders, Joiners, Building Mechanics and all Woodworkers. These Guides give you the short-cut instructions that you want—including new methods, ideas, solutions, plans, systems and money saving suggestions. An easy progressive course for the apprentice and student. A practical daily helper and Quick Reference for the master worker. Carpenters everywhere are using these Guides as a Helping Hand to Easier Work, Better Work and Better Pay. To get this assistance for yourself, simply fill in and mail the FREE COUPON below.



AUDEL, Publishers, 49 W. 23rd St., New York 10, N. Y.

Mail Audels Carpenters and Builders Guides, 4 vols., on 7 days free trial. If OK I will remit \$1 in 7 days and \$1 monthly until \$6 is paid. Otherwise I will return them. No obligation unless I am satisfied.

Name.....

Address.....

Occupation.....

Employed by..... PM

# PREVENT

STEAMED-UP, FOGGED AUTO WINDOWS and WINDSHIELDS, KITCHEN WINDOWS, EYE-GLASSES, BATHROOM MIRRORS, etc.

Amazing New, Steam-Proof Miracle Ever-Clear Cloth

Only 50c  
Just one rub over ANY glass surface does the complete job and prevents future fogging for many months.

Keeps any glass sparkling, crystal-clear under all conditions. Works just like magic! Just rub the scientific, chemically treated Ever-Clear Cloth on any glass or mirror and steam won't form on its surface FOR MONTHS. Assures clear windows that are never foggy. Reduces tension of winter driving—no blind driving—prevents accidents, saves lives. AUTO WINDOWS WON'T BLUR, CLOUD UP or "SWEAT" . . . even with all the windows shut.

Now, even cooking or baking won't steam up windows

No more steam to block your vision! It's quick and easy to use. Fine for eye-glasses too; they'll remain clear when entering a warm room from the cold outdoors . . . or while enjoying hot drinks.

Satisfaction Guaranteed or Money Back!

Keep one Ever-Clear Cloth in your car and one in the house. We know you'll be pleased. Not more than 2 to a customer. Add 15c to each Ever-Clear Cloth ordered for postage, handling. No C.O.D.

GREAT AMERICAN SALES CO.

900 W. Lake St., Dept. 995, Chicago 7, Illinois

# PHOTOGRAPHY

EARN BIG MONEY! PERSONAL ATTENDANCE TRAINING in News-Magazine-Fashion-Portrait-Advertising-Natural Color Photography. Splendid equipment, glamorous models. Or—our COMPLETE HOME STUDY COURSE provides you with a spare time short-cut to success.

Our 42nd year. Write immediately for BIG FREE BOOK!

NEW YORK INSTITUTE OF PHOTOGRAPHY  
Dept. 49, 10 West 33 St., New York 1, N. Y.

# ITALIAN ACCORDIONS

Hand Made. Very Best. Buy Direct from Factory Representative at lowest wholesale prices and Save Money. Send Name and Address for FREE catalog.

ITALIAN ACCORDION MFG. CO.

7600 Cottage Grove Ave., Dept. PM-3, Chicago 19, Ill.

# BE A LOCKSMITH



Learn Locksmithing and Keymaking from Experts in Your Spare Time at Home! Locksmiths in big demand! No layoffs, no slow seasons! Age no disadvantage. Year-round, steady income in this permanent, respected field. Full or part time. Practical illustrated lessons show how to make money even while learning! All materials, special tools supplied. FREE BOOKLET.

INSTITUTE OF LOCKSMITHING, Dept. P-28, 15 PARK AVE. RUTHERFORD, N. J. Lic. & Approved State of N.J. VA Approved

# DEPENDABLE CRAFT SUPPLIES



LEATHER CRAFT • PLASTICS • POTTERY CRAFT • BLOCK PRINTING • BELT CRAFT • TEXTILE COLORS • POWER TOOLS • WOOD BURNING • INSTRUCTION BOOKS • ETC.

DWINNELL CRAFT SHOP  
Dept. PM-352—Wheeling, W. Va.



Give the handicapped a chance. Use Easter Seals

# FALSE TEETH

That Loosen  
Need Not Embarrass

Many wearers of false teeth have suffered real embarrassment because their plate dropped, slipped or wobbled at just the wrong time. Do not live in fear of this happening to you. Just sprinkle a little FAS-TEETH, the alkaline (non-acid) powder, on your plates. Holds false teeth more firmly, so they feel more comfortable. Does not sour. Checks "plate odor" (denture breath). Get FAS-TEETH at any drug store.



New Amazing Invention — "Magic Art Reproducer"

# DRAW—The First Day **NO LESSONS! NO TALENT!**

Anyone Can Draw With This Amazing New Invention—Instantly!



Complete For Only

**\$198**

You Can Draw Your Family, Friends, Anything From REAL LIFE—Like An Artist Even if You CAN'T DRAW A Straight Line!

Yes, anyone from 5 to 80 can draw or sketch or paint anything now . . . the very first time you use the "Magic Art Reproducer" like a professional artist — no matter how "hopeless" you think you are! Anything you want to draw is automatically seen on any sheet of paper instantly! Then easily and quickly follow the lines of the "picture image" with your pencil . . . and you have an accurate original drawing that anyone would think an artist had done. Also makes drawing larger or smaller as you wish. Anyone can use it on any desk, table, board, etc.—indoors or outdoors! No other lessons or practice or talent needed! **HAVE FUN! BE POPULAR!** Everyone will ask you to draw them. You'll be in demand! After a short time you may find you can draw well without the "Magic Art Reproducer" because you have developed a "knack" and feeling artists have — which may lead to a good paying art career.

Also Excellent for Every Other Type of Drawing!

- Human Figures
- Outdoor Scenes, landscapes, buildings
- Still life, vases, bowls of fruit, lamps, furniture, all objects
- Copy photos, other pictures, portraits, etc.
- Copy blueprints, designs, decorations, for woodwork, machines, for needlework, crocheting, knitting
- Copy all cartoons.

- Outdoor Scenes, landscapes, buildings



- Still life, vases, bowls of fruit, lamps, furniture, all objects



- Copy designs, blueprints, decorations, etc. for woodwork, machine, for needlework, crocheting, knitting



**FREE! "SIMPLE SECRETS OF ART TRICKS OF THE TRADE"**

This valuable illustrated guide is yours FREE with order of "Magic Art Reproducer." Easy ABC art tricks that anyone can follow on different techniques, effects, proportions, perspectives, shading, color, animated cartoons, human figures to use with "Magic Art Reproducer" for added touches to your drawings.

**SEND NO MONEY!**

Free 10-Day Trial! Just send name and address. Pay postman on delivery \$1.98 plus postage. Or send only \$1.98 with order and we pay postage. You must be convinced that you can draw anything like an artist, or return merchandise after 10-day trial and your money will be refunded.

**NORTON PRODUCTS, Dept. 5803, 296 Broadway, New York 7, N. Y.**

## NEW LOW PRICED CAR WASHER

**CLEANS YOUR CAR IN 12 MINUTES!**

Imagine! Only \$3.95 washes your car for years—and saves you up to \$50 every year! "Wonder Wand" is easy to operate—just attach it to garden hose—watch it scrub, rinse, flush away dirt and grime like magic! Ideal for cleaning windows, walls, screens, etc. No ladder, no soap, no pail, 3 ft. Aluminum alloy handle, unbreakable super Duroplas head has softly bristled fountain brush. Only \$3.95 postpaid. Try it! Your money back if not delighted. Order No. G-1117.

**UNBREAKABLE SUPER DUROPLAS HEAD**  
Softly bristled fountain brush

only **\$3.95** postpaid

Or — DELUXE MODEL with 4 ft. jointed handle, duroplene bristles, water-control valve in handle. Only \$4.95, postpaid. Order No. G-1130.

A boon for washing cars, windows, walls, garages, porches, etc. SEND FOR FREE CATALOG OF OTHER BRECK MERCHANDISE

**496 Breck Building, Boston 10, Mass.**

- PAYS FOR ITSELF IN 2 OR 3 CAR WASHINGS
- SOFT BRISTLES
- NON-RUST ALUMINUM HANDLE!
- NO SPONGE, PAIL, CLOTH NEEDED!

Home and Garden Gifts  
**BRECK'S**  
RELIABLE SINCE 1818

## 'Amazing Attachment MAKES OLD REFRIGERATORS INTO MODERN Automatic Defrosters!

Thirty Million Prospects. Sell without "selling pressure" on sensational Free Trial Plan. Just plug it in and leave it. Frees women from drudgery and mess of defrosting. Saves electricity. Keeps food longer, better. Gives longer life to refrigerator. Secret "follow-up" Plan often brings five additional sales by making every user your agent. Big season now on! **SENT FREE ... JUST SEND NAME!** Don't send a cent—just your name on penny postcard. We'll send you the biggest money-maker you ever got your hands on and guarantee your sales at profits as high as \$5.00 on each sale. Rush your name!

**Women buying by the thousands!**  
Salesmen Cleaning up on "Free Trial" Sales Plan Sent Free with Instructions. Make as high as \$5 on Every Sale!



**MAXILUME COMPANY, 125 West Hubbard Street, Dept. D-8-C, Chicago 10, Illinois**



# C. T. C. TRAINING IN DRAFTING

PREPARES FOR  
PROMOTION  
MORE MONEY  
SUCCESS

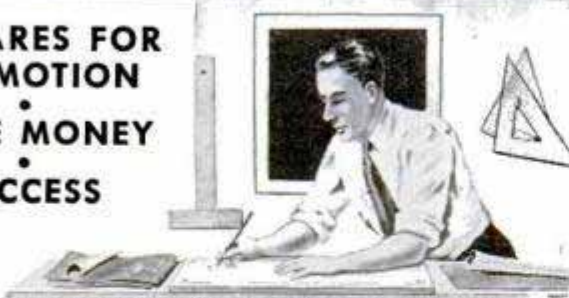

"Here I am at work making good money as a draftsman. I'm glad I sent the coupon to Chicago Tech for that Free Trial Lesson and found out how easy it is to learn Drafting in spare time at home. Today, I feel secure in my job. What's more, I feel I'm slated for promotion and more pay."

## LEARN IN SPARE TIME—AT HOME!

(or at the College in Chicago)

A few hours of pleasant home study every week—that's all. All the tools you need; drawing outfit included. This tested method—developed over 47 years of C.T.C. progress—prepares men quickly for good positions in industry.



### FREE INFORMATION—SEND COUPON

To prove to you how easy it is to learn Drafting at home, we will send you this FREE TRIAL LESSON. Mail coupon or send post card today.

## CHICAGO TECHNICAL COLLEGE

C-250 Tech Bldg., 2000 So. Michigan Ave.  
Chicago 16, Illinois

Mail me FREE Lesson with information about big opportunities in DRAFTING.

Name \_\_\_\_\_ Age \_\_\_\_\_

Address \_\_\_\_\_

City \_\_\_\_\_ Zone \_\_\_\_\_ State \_\_\_\_\_



Aren't YOU as SICK and Tired as I was of being SKINNY-

Then DO as I did. Mail Coupon below I gained 53 lbs. of Mighty Muscle I added 6½ inches to my CHEST 3 inches to each ARM by using the JOWETT SYSTEM

That's what Roger Hirsch a 112 lb. 6 ft. weakling did—Look at him NOW in a few short weeks.

In 10 pleasant minutes a day in your own home—Let me make you a winner at anything you tackle with progressive power. I'll give you a NEW HE-MAN Body for your OLD SKELETON FRAME.

Send me only **10c**

And Get All 5 Picture-Packed HE-MAN BUILDING COURSES and also get

JOWETT Builder of HE-MEN



## FREE PHOTO BOOK of Strong Men and a MUSCLE METER

JOWETT INSTITUTE, Dept. PM-23  
230 Fifth Avenue, New York 1, N.Y.

Dear George: Please mail to me prepaid FREE Jowett's Photo Book of Strong Men, a Muscle Meter, plus all 5 Muscle Building Courses. "How to Become a Mighty He-Man." ENCLOSED FIND 10c in complete payment for EVERYTHING.

NAME \_\_\_\_\_ AGE \_\_\_\_\_

(Please print plainly, include Zone Number)

ADDRESS \_\_\_\_\_ No C.O.D.'s

CITY \_\_\_\_\_ ZONE & STATE \_\_\_\_\_

## How to Always Have HOT WATER

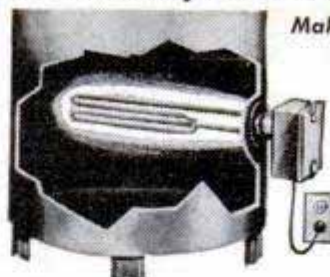

Make Your Own Automatic Electric Water Heater **\$19.95** now for only

INSTALL IN 5 MIN.

No disturbing or draining of tank or pipes

Why suffer without hot water? Enjoy lots of it to wash, bathe, shave. Heater keeps water HOT in your present tank. Turns ON when needed—shuts OFF when water is heated. No flue, dirt, fire!

ONE YEAR GUARANTEE  
U. L. Approved Heater

Ideal for 30-gal. tanks! Heater screws into any size boiler tap as shown. Plugs into outlet . . . 1320 w. 110 v. AC. (Also 2000 w. 220 v. model for BX cable \$19.95) . . . works automatically thereafter. Temperature adjustable between 120 to 180 degrees. Replaces coal, oil, gas in home, store, summer cottage, green house, farm, barn, stock tank, poultry scalding, factory. Uses only ¼ to ½¢ electricity per gallon hot water. Why burn expensive main furnace unit for hot water? Send check or M. O. NOW; save postage, shipping charges. ORDER NOW . . . TODAY. Money back in 10 days if not delighted.

COLLOID EQUIPMENT CO., INC. Dept. PM3, 50 Church Street, New York 7, N. Y.

## Run the Best "Shoe Store Business" in Town!

SHOE BUSINESS

I'll put a "Shoe Store Business" right in your hands. You don't invest a cent—make profits from \$10 to \$75, as much as \$200 monthly in spare time. No store overhead. Exclusive comfort features build quick profits and repeat business. Sell amazing line of Air-Cushion comfort shoes to friends, neighbors, fellow workers. Dress, sport, work, safety shoes for men, women. Send postcard today for FREE SALES OUTFIT!

CONSOLIDATED SHOE SYSTEM, Box C1-108, Chippewa Falls, Wisc.

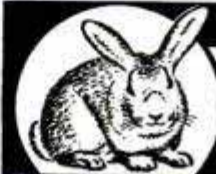

## Make BIG MONEY!

RAISE CHINCHILLA RABBITS!

Cash Markets Supplied for Your Production

FREE - Illustrated Booklet - WRITE TODAY!

ROCK HILL RANCH, SELLERSVILLE 36, PA.

World's Largest Breeder of Chinchilla Rabbits



## 1952 EDITION

It's New! It's Different! Get world's largest Auto Accessory & Parts Catalog and save money. Over 50,000 items, including Hollywood Accessories, Hi-Speed Equipment, Rebuilt Engines, all parts & accessories for all cars & trucks. We have that Hard-To-Get part! Jam packed with bargains. Completely illustrated. (100 pages) Send 25c (refundable).

J. C. WHITNEY & CO., 1917-XP Archer Ave., Chicago 16, Ill.



## BOYS! MAKE YOUR OWN RADIO

Make your own simple, tubeless, batteryless Crystal Radio. SEND 25c for a GENUINE MELOMITE CRYSTAL with complete illustrated instructions for making your own set. Crystal sent postpaid with instructions and our own publication, "THE MAGIC CRYSTAL" which is full of news, diagrams, questions and answers of interest.

SEND 25c FOR YOUR CRYSTAL TODAY!

ALVA ALLEN RADIO Dept. PM-3 Clinton, Mo.

USE EASTER SEALS. HELP CRIPPLED CHILDREN

## MY FALSE TEETH STAY TIGHT EVEN AFTER DRINKING HOT COFFEE!

● Mrs. J. P. writes: "I was delighted to find Staze held my teeth tight even after hot coffee!"

Staze is fluid-resistant . . . contains "aqua-trol," which holds back moisture penetration. Thus, it holds false teeth tighter, longer. With Staze, thousands now bite into corn and steak—enjoy all the hot coffee they want.

Even if plates are old and loose, Staze holds them tighter. Many denture wearers say that with Staze old plates seem to hold better than when new. At drugstores, or write STAZE, Box PM-2, Stamford, Conn., for free tube.



**Leonard C. Lane, B.S., M.A.,** Exec. Dir. of Pierce School of Radio and Television. Licensed by the State of N. Y. President of Radio-Television Training Association. Approved as a Correspondence School under the Laws of the State of N. Y.



**I GIVE YOU A ROUND TRIP TO NEW YORK CITY**

from wherever you live in the U. S. or Canada. Yes, I pay your way. After you finish your home-study course, you can study with me, here, in the heart of the radio and television world. Two weeks, 50 hours, advanced instruction using the most modern electronic equipment at world-famous Pierce School of Radio & Television, PLUS operating Pierce Radio Station and Pierce TV Station (both operated by students), PLUS Code Machine Set Up. I take you behind the scenes of New York's Radio-TV stations—to study first hand!

You learn BEST with the BEST!

**15 SECONDS**  
**THAT CAN CHANGE YOUR WHOLE LIFE**  
**CASH IN ON TV**

**I GIVE YOU 15 BIG TV-RADIO KITS**  
 To BUILD and KEEP including this Giant-Screen TV Set and illustrated units.  
 Everything furnished including all tubes and batteries.  
 Plus Telephone Transmitter, CW Power Supply Units, P.A. Amplifier

R.F. Signal Generator



Supr. Heterodyne Radio Receiver



Multitester

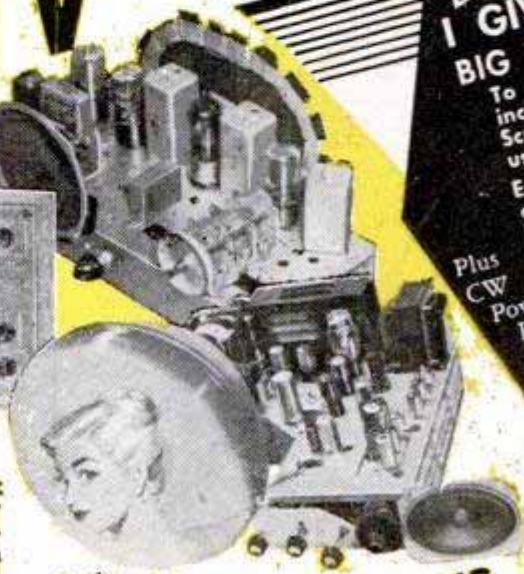

Giant-Screen TV Set

**BE A SUCCESS IN A BILLION DOLLAR INDUSTRY**  
 Television is spreading fast throughout the country. Get in on the ground floor of America's fastest growing industry... Now! Don't let this chance pass you by. Today's big demand for trained radio-TV men will be even greater in coming years! Make your future secure in a well-paying field!

**EARN EXTRA MONEY IN YOUR SPARE TIME**  
 Keep your job. I TRAIN YOU IN YOUR SPARE TIME. Make money while learning. Repair neighbors' and friends' radios and TV sets. I show you how. Many students pay for entire training out of spare time earnings!

**BECOME A CERTIFIED TV TECHNICIAN**  
 RTTA Shop-Methods are widely acclaimed because they're so practical. Step by step you learn how by doing. You set up and use the equipment with RTTA'S simple instructions. It's easy! You learn fast and before you know it you're an expert technician.

**EARN GOOD PAY — OR START YOUR OWN BUSINESS**

My trained graduates are holding good jobs at NBC-TV, CBS-TV, RCA, DUMONT, EMERSON, PHILCO, ADMIRAL, HUGHES AIRCRAFT — and many more radio and TV stations & electronic firms. If you prefer, get a good job installing and servicing radio-TV sets — or start your own business. You can write your own ticket in this big industry. Be independent. Well-trained technicians earn respect.

12/13/51 "I hold an interesting job with good pay. Anyone who wants lifetime security should take your practical training course." — Howard Relyea

12/12/51 "As Radio Officer of a merchant ship I received \$867.45 for a 40 day trip. The training at your school helped me get this very good position." — Stanley Nawrocki

11/14/51 "Before completing your course I earned more than enough in my spare time to pay for your course. I now hold a good job." — William D. Mullen

FREE PLACEMENT SERVICE

**PLUS "EXTRAS"**

- Only RTTA gives you a home study course in RADAR at no extra cost! Learn the secrets of "the Electronic Miracle" — RADAR!
- RTTA helps you prepare for your FCC license with FCC STUDY AIDS, which are provided as part of this course... at no extra cost.

No previous training needed!

\* 15 seconds — that's all it takes to fill out and clip this coupon. Mail it right away. Find out for yourself how easy it is to become a certified TV technician — earn good pay and future security!



ONLY RTTA is at Times Square, Radio City, "Heart of the TV World." You get "up-to-the-minute information from the place where Radio-TV news is made!"



**GOING INTO UNIFORM?**  
 Qualify for military specialist ratings, higher pay! Learn how!

**I TRAINED THESE MEN FOR SUCCESS**

I have trained hundreds for Radio-TV jobs.



**SEND NO MONEY. BOTH BOOKS FREE!**

Mr. Leonard C. Lane, President Dept. 31  
 RADIO-TELEVISION TRAINING ASSOCIATION  
 1629 Broadway, Radio City Station  
 New York 19, N. Y.

Dear Mr. Lane:  
 Show me how I can make BIG MONEY IN TELEVISION within MONTHS! Rush by return mail my FREE Sample Lesson and BIG FREE Manual.

Name .....  
 Address .....  
 City ..... Zone ..... State .....  
 (PLEASE PRINT PLAINLY) Age: .....

**RADIO TELEVISION TRAINING ASSOCIATION**  
 1629 BROADWAY — RADIO CITY STATION  
 NEW YORK CITY 19, NEW YORK

FREE SAMPLE LESSON - BIG FREE MANUAL



Hydro-drive Champion  
your best companion!



Hydro-drive  
**Champion**

Independent Propeller Control Hydraulic Clutch

**OUTBOARD MOTORS**  
FORWARD • NEUTRAL • REVERSE  
without shifting gears!

CHAMPION MOTORS CO., MINNEAPOLIS, MINN.

**High School**  
at Home

**Many Finish in 2 Years**

No classes. No time wasted going to and from school. Progress as fast as your time and abilities permit. Standard H. S. texts supplied. Thousands enroll each year in this 55-year-old school. Send for FREE descriptive booklet.

**AMERICAN SCHOOL.** Dept. H345  
Drexel at 58th St., Chicago 37, Ill.

Without obligation, please send FREE descriptive booklet.

Name \_\_\_\_\_

Address \_\_\_\_\_



THE MOST AMAZING OFFER IN USED  
TIRE HISTORY. EVERY PASSENGER TIRE  
**UNCONDITIONALLY  
GUARANTEED**  
plus TIRE INSURANCE FREE

**10% OFF** ON ORDERS FOR TWO OR MORE TIRES

**TRIPLE INSPECTED PASSENGER TIRES**

Unconditional	One Year Guarantee plus Tire Insurance Free		
600-16 \$5.59	700-16 \$7.59	700-15 \$5.59	550-16 \$5.95
600-16(6) 6.50	600-15 5.59	750-16 12.25	550-17 5.75
750-16 5.79	650-15 5.59	550-15 5.59	475-19 5.75

**LO-PRESSURE TIRES FOR EASY RIDING**

Unconditional	One Year Guarantee plus Tire Insurance Free		
640-15 \$5.75	710-15 \$6.50	820-15 \$7.50	760-16 \$7.50
670-15 5.95	760-15 6.75	670-16 6.95	

**MUD AND SNOW TIRES**  
2 YEAR WRITTEN GUARANTEE

600-16 \$6.95	900-16 \$12.95	750-20 Regular \$12.50	Special \$15.95
---------------	----------------	------------------------	-----------------

**EXTRA VALUE TRUCK TIRES**  
ONE YEAR WRITTEN GUARANTEE

600-20 \$10.75	750-20 \$14.50	825-20 \$21.50	1100-20 \$26.95
650-20 11.75	32x6(R) 11.75	900-20 19.50	1100-22 24.50
700-20 12.50	32x6(10) 12.50	1000-20 20.00	750-20(10) 18.00

TRACTOR TIRES available in all sizes. Complete line of High Mileage Tires in stock. Write for price list for sizes not listed. Take off 10% on orders for two or more tires. Prices subject to change.

MAIL ORDERS PROMPTLY FILLED. Send check or money order with this ad. **THE SAFETY CO.** "FOR THAT SAFE TIRE" Dept. PM, 920 W. CARY ST., PO BOX 2254, RICHMOND, VA.

**MAKE MORE MONEY IN  
MANAGEMENT  
PRODUCTION**

Great opportunities today for men skilled in Production Management. In spare time at home add to your present ability the knowledge which can prepare you for a better job and more money. Training built by experienced factory men and taught by management experts. Placement counsel and help. Write today for FREE book "Industrial Management" showing how you can climb higher—faster.

LASALLE Extension University, 417 So. Dearborn St.  
A Correspondence Institution, Dept. 364-IM Chicago 5, Ill.

**FREE BERRY'S NEW POULTRY BOOK**

Gorgeously illustrated, describing DAY-OLD and 4-WEEK CHICKS. 50 varieties, sexed or unsexed. AMERICA'S FINEST; also Ducks, Geese, Guinea. ORIGINAL BERRY'S FARM, for over 50 years. Beautiful book and LOW PRICE LIST FREE, stamps appreciated. BERRY'S POULTRY FARM, Box 29, Clarinda, Iowa

**PLASTICS CATALOG**

Small Quantities — SPECIAL PRICES — Large Quantities  
There's more information and tricks-of-the-trade and a larger variety of plastics materials listings packed into this catalog than you've ever seen before. Sheets, rods, tubes, casting, draping, molding plastics, supplies, findings, etc. We make our own Carving Dyes. "Gem-Coat" Fiberglass and Polyester coating. For fast, courteous, personalized service. TRY US. CATALOG 10c, — or Airmailed for 25c in U.S.

**GEM-O-LITE PLASTICS CO.**  
5350B Riverton Ave., North Hollywood, Calif.

**TAKE THE STEPS NOW THAT WILL GIVE YOU LIFETIME SECURITY IN AVIATION!**

**NOW IS THE TIME**

Booming aviation industry urgently needs properly trained young men! Big paying jobs are open right now, with more to come! Embry-Riddle offers maximum training in minimum time. Fully accredited 8-mo. to 26-mo. courses in all aeronautical phases. Job-fitting instruction backed by 25 yrs. experience training today's aviation leaders. Be prepared. Enroll now! Illustrated catalog, address:  
REGISTRAR, EMBRY-RIDDLE, DEPT. 99, MIAMI 30, FLA.



Don't Renew Your TV Service Contract! ... Don't Buy A TV Set!

UNTIL YOU READ THIS!

SAVE up to \$100 a Year  
on Your TV REPAIRS!

SAVE UP TO \$150 ON A NEW TV SET!

NOW! You Can Fix Your Own TV Set  
Easily • Safely • Quickly with  
Sensational NEW TV OWNER'S Guide  
... Just Published!

**GUARANTEE**  
Save \$65 to \$200 This Year Alone  
OR YOUR MONEY BACK!

Fix Any Set—Any Make

The Biggest, Most Complete TV Owner's Handbook Ever Published!  
All The Money Saving Information You Want—Easy To Follow—  
No Experience Needed—Easy as A-B-C Picture Instructions  
Show You How To Improve Reception, Make 90% Of Your TV  
Repairs In 1 to 5 Minutes—Only Tool Needed Is Screwdriver!

AT LAST, James Contos, Chief Engineer of a leading electronics corporation, for years in charge of servicing N. Y. department store TV sets, has just published his BRAND NEW TV OWNER'S GUIDE—the book that saves you money every time you open it!

YES! We Will Send You This Amazing New Money-Saving Book For A Full Year! We Guarantee Whether You Now Own A TV Set, Or Plan To Buy One, You Will Save \$65 to \$200 This Year!—or it won't cost you a penny!

**IF YOU NOW OWN A TV SET**

This Book Shows You How To:  
... Fix Your Own Television Set—In 1 to 5 Minutes!  
... Build Your Own Color Converter—In 1 Weekend!  
... Install Your Own Special Antennas—Filters—Boosters!  
... Double and Triple Reception In Bad Or Fringe Areas!

**IF YOU PLAN TO BUY A TV SET**

This Book Shows You How To:  
... Save Up To Half The Price When You Buy!  
... Get The Best Possible Set For Your Area!  
... What To Watch For When Buying!—Don't Be Cheated!  
... Get The Top Trade-In Value On Your Old Set!

**Tells You Everything You Have To Know**

Are you one of the thousands needlessly plagued by troubles and distortions on your set? Are you still throwing out \$5—\$10—\$20 every time a service man twists a knob on your set, or turns the same screw you can turn with your thumbnail? Isn't it foolish to spend \$65 or \$100 for a service contract, and then wait 3 or 4 days for repairs? ... when it's so easy to fix your set yourself, AND SAVE! Save up to \$75 on special antennas, color converters, filters—SAVE \$65 to \$200 IN 1 YEAR!

Clear—Simple—You Can't Go Wrong!  
No Technical Diagrams—Easy as A-B-C,  
with Hundreds of "Show-How" Pictures

This new TELEVISION OWNER'S GUIDE is so complete, so easy to follow, so FOOL-PROOF, it's like having a top-notch television engineer right at your elbow! Regardless of the make or year of your set, HUNDREDS OF

**BEDFORD COMPANY**  
Dept. PM3, 699 Madison Ave., New York 21, N.Y.

Only \$1.98  
FULL YEAR MONEY BACK GUARANTEE

Send No Money

"HOW-TO" PICTURE INSTRUCTIONS track any trouble right to its source, show you exactly what to do, and then lead you step-by-step through the entire repair! It's so easy, and there's absolutely no danger when you do it our way. In less than 5 minutes you'll be fixing those jumpy or distorted pictures, cutting out static, ghosts, snow, herring-bone effects, lines,—making major repairs such as burnt out tubes, blurred pictures, shorted picture tubes, even if you've never seen the inside of a set before! ... and without spending one cent for special equipment!

**1001 Money-Saving Tricks**

Learn the 1001 money-saving shortcuts and professional tricks that take all the expensive "hocus-pocus" out of television. Learn how to save up to 50% when buying your set, installing your set, adding accessories. Know when you need a serviceman, and when you don't: what has to be done, how much it should cost, how to adjust rear set controls or best reception. Even includes a chapter on Radio Repairs! It's the most complete, authoritative, up-to-the-minute volume on television ever published, and it's yours to use for an entire year at our risk if you send today!

**Amazing Full Year's GUARANTEE**  
Read this daring introductory guarantee! TV OWNER'S GUIDE must save you \$65 to \$200 this year alone, whether you now own a TV set or plan to buy one in the future, or you may return the book even a year from today for full money back.  
Signed  
BEDFORD COMPANY

**ACT NOW!**  
Special Offer Gives You Magic Trouble Spotter FREE!  
Send TODAY and get Magic Trouble Spotter FREE, with your TV OWNER'S GUIDE. Examine up to a full year. If not convinced book will pay for itself in 1 day—if it doesn't save you \$65 to \$200 in 1 year, return for money back, keep Magic Trouble Spotter as FREE Gift!

**FREE!**  
(Yours to keep even if you return book!)  
**MAGIC "TROUBLE SPOTTER"**  
Now! Spot Your TV Trouble at a Glance... and see how to fix it, fast.  
Big 11 by 44 inch chart pictures 90% of TV troubles! You instantly spot your problem, and see exactly what to do to fix it! Here are just a few samples of the many repairs you'll be making yourself, in 1 to 5 minutes, and saving \$5 to \$20 every time!

- If Set Suddenly Goes Black**  
No waiting 3 or 4 days for service or getting "soaked" by independent repair man. Magic Trouble Spotter tells what's wrong, and shows what to do!
- If Picture Tube Starts Out**  
Why throw away \$25 for repair? Magic Trouble Spotter and screwdriver give you miracle repair in 4 minutes!
- No Picture, No Sound**  
No need to run to neighbor's house for favorite program! Magic Trouble Spotter has set operating again before commercial is over!
- Picture Blurred? Stretched?**  
Magic Trouble Spotter gives you movie-clear picture in 30 seconds, easy as A-B-C!

**SAVES You MONEY 24 Ways!**  
This Book Shows You:

- How To save up to \$150 when buying your set.
- How To get the best set for your viewing area.
- How To buy a "top brand" set for up to 50% less.
- How To avoid hidden installment payments.
- How To get the top trade in on your old set.
- How To avoid being gyped.
- What to watch for when buying your new set.
- What you must know about your warranty, and service contract.
- How To double and triple fringe or bad area reception without a special antenna.
- How To bring in weak channels clearly with only 5 minutes work.
- How To install your set.
- How To install your own antenna—built in, indoor, or outdoor.
- How To be sure you are getting an honest repairman.
- How To repair your own set, on the spot, with no special equipment, no experience.
- How To avoid repair racket.
- How To know what the repair should cost, and avoid overcharges.
- How To avoid long waits when you give your set to a repairman.
- How To light your room correctly to avoid television eyestrain.
- How To correct minor defects and avoid major breakdowns.
- How To buy at auction sales—discount houses—second hand shops.
- How To know your legal rights with your landlord, repair man, service contract.
- How television can benefit your child.
- How To get more enjoyment from your TV set.
- How Your television set really works.

... and so much more!

**SEND NO MONEY! Mail Free Gift Coupon NOW!**

Bedford Co., Dept PM3, 699 Madison Ave., N. Y. 21

Gentlemen: Without obligation, please rush me the new TV OWNER'S GUIDE for no risk examination and trial. I agree to pay postman on arrival \$1.98 plus postage. If I am not satisfied I may return at any time within a year for full money back.

Also send me ABSOLUTELY FREE, the Magic Trouble Spotter chart, mine to keep as a FREE GIFT whether or not I keep the TV OWNER'S GUIDE.

NAME .....

ADDRESS .....

CITY ..... ZONE ..... STATE .....

SAVE MORE! If you send \$1.98 with coupon, we pay all postage charges. Same money back guarantee.



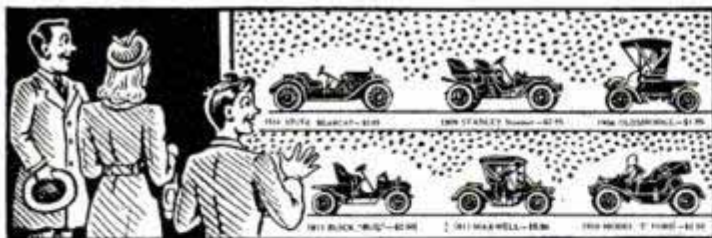

So Authentic --- They're On Display In National Museums!

## ANTIQUE AUTO SETS

HOBBYISTS call these miniatures collector's items! You'll agree when you build your set of these fascinating antique autos — each so realistic they bring the early days of the automobile back to life! Length 6" to 10 1/2" when completed. They come pre-fabricated with all ready-shaped parts, plastic cast-wheels, lamps, radiator, horn, etc. Authentic history with each car; also step-by-step instructions that a 10-year old can follow with ease! At toy, hobby and department stores. Nationally known; guaranteed money back if not satisfied. A grand hobby for all from the age of 9 to 90; wonderful for shut-ins and convalescents. Start NOW — order a complete set! Other models not shown are:



1904 Olds—\$1.95



1911 Maxwell—\$2.50



1914 Stutz Bearcat—\$3.95



1909 Stanley Steamer—\$2.95



1903 Model "A" Ford—\$2.50

- |   |            |   |            |
|---|------------|---|------------|
| <input type="checkbox"/> 1902 Franklin                | ... \$2.50 | <input type="checkbox"/> 1910 "T" Ford            | ... \$2.50 |
| <input type="checkbox"/> 1906 Columbia Electric       | ... \$2.50 | <input type="checkbox"/> 1909 "T" Ford            | ... \$2.95 |
| <input type="checkbox"/> 1910 International Harvester | ... \$2.95 | <input type="checkbox"/> 1903 Rambler             | ... \$2.50 |
| <input type="checkbox"/> 1900 Packard                 | ... \$2.50 | <input type="checkbox"/> 1913 Mercer Raceabout    | ... \$3.95 |
| <input type="checkbox"/> 1903 Cadillac                | ... \$2.50 | <input type="checkbox"/> 1906 "Old 16" Locomobile | ... \$3.95 |
| <input type="checkbox"/> 1911 Buick "Bug"             | ... \$2.50 |   |            |

Write to us — Add 25c for postage and handling. No C. O. D.'s please.

**HUDSON MINIATURES OLD-TIMERS**  
 "Originators of Antique Autos in Miniature"  
 SCRANTON HOBBY CENTER, Dept. 14, Scranton 10, Pa.

# BOOKS that tell HOW and show you

- PRACTICAL CARPENTRY**. Here at last is a really modern easy-to-understand cyclopedia of building data... all the information you need to learn carpentry trade, remodel or build home of your own. Over 1,100 illus. \$5.00
- AUTOMATIC TRANSMISSIONS SIMPLIFIED**. Learn all about: Foromatic, Hydramatic, Dynaflo, Powerglide... all other transmissions both new and old. How transmissions are constructed, how they operate, how to service... \$4.00
- AUTO REPAIR KINKS**. Hundreds of kinks (unusual time and money-saving shortcuts) that have helped mechanics out of tough spots. Tuneup specifications on all popular cars. Combined experience and KNOW HOW of World's best Auto Mechanics. \$3.00
- AUTO MECHANICS MANUAL ON BRAKES & STEERING (Including Wheel Alignment)**. Brand New. Takes mystery out of servicing auto brakes (all passenger cars, trucks) wheel alignment... Technical terms eliminated... the real "gospel" by an expert, in handy, usable form... \$3.50
- AUTO BODY & FENDER REPAIRS**. Gives approved methods for doing professional job. Use book to help get a good job or start business of your own... \$3.50
- DYKE'S AUTO ENCYCLOPEDIA**. Complete course in auto mechanics with special emphasis on fundamentals... trouble shooting, testing, adjusting and repairing. New 22nd ed. 1491 pages, 4800 illus... \$7.50
- Check books you want, clip this ad and mail with check, money order or U. S. currency, carefully wrapped. PROMPT REFUND if not completely satisfied.
- MODERN ELECTRIC & GAS REFRIGERATION**. Covers repairs, adjustments, overhauling every type of domestic, commercial equipment. Non-technical. Most helpful and biggest selling book on refrigeration. Used by U. S. Army, 984 pages... \$5.00
- FIX YOUR FORD**. New manual covering servicing and repairing of V-8's and 6's from 1932 up to and including current series. Based on experience of leading Ford mechanics... \$2.50
- AUTO SERVICE MANAGEMENT**. How to start and operate profitable auto business... \$5.00
- MERRY OLD MOBILES ON PARADE**. History of early automotive industry in picture form. Every page is crammed with interest \$2.50
- MODERN WELDING PRACTICE**. Up-to-date encyclopedia of welding information. Covers all types of gas, electric welding, heat treating, metal cutting... including submerged arc, inert gas welding, arc-oxygen cutting, sprayed hard surfacing, powder cutting, etc. \$5.00
- DYKE'S CARBURETOR BOOK**... \$3.50
- PLUMBING AND PIPE-FITTING LAYOUT**... \$2.50
- A. C. POWER WIRING** \$4.00
- D. C. POWER WIRING** \$4.00
- BAILEY'S HANDBOOK**. Questions and answers for stationary, marine, diesel engineers and firemen \$2.00
- HOUSE WIRING**. Information on all phases. \$3.00
- AIRPLANE WELDING** \$3.50
- SHEET METAL DIE DESIGN**... \$2.25
- STORAGE BATTERY SIMPLIFIED**... \$3.00

## GOODHEART-WILCOX CO.

Dept. 176 1321 S. Michigan Ave. Chicago 5, Ill.

# Watch Repairing Pays Big Money Learn at home

## Free Literature Tells How

Watch repairers in big demand. You train step-by-step in 10 easy lessons. You learn to take a watch apart—repair and put in perfect working order. We furnish all tools, and a 15 jeweled watch. Practice movement with first lesson.



Turn spare time into cash—perhaps a business of your own. A licensed school. Students 18 to 65 have profited by our training. Low cost.

Write Today for All the Facts—No Obligation

**ILLINOIS SCHOOL OF WATCH REPAIRING**  
 2870 Elston Ave., Dept. PM-3, Chicago 18, Ill.

**Big Profit CHINCHILLAS Fun Educational**

Breed Chinchillas for the fur market. Chinchilla garments sell from \$8,000—\$35,000! Establish your own "gold chip" business. Clean, tame, easy to raise. Write experts. Chapman Chinchilla Farms, originators of Chinchilla breeding farms in America. Send for illustrated folder full of pictures and information today. P. O. Box 221. 4957-P West 104th Street, Inglewood, Calif.

**CHAPMAN CHINCHILLAS**

**ORIGINAL FACTORY COLOR AUTO TOUCH-UP KIT**

All Mars, Nicks, Scratches, Scrapes disappear like magic — Easy! \$1.98 post paid

Duplicate the exact paint color of your car... apply this special process, and the mars and nicks are impossible to detect! Kit contains Wax remover—Cleaner; Primer sealer undercoat; IDENTICAL FACTORY PAINT; Thinner (keeps paint for years); sand paper; Easy instructions. Give car name, year, and color code number under the hood. Satisfaction guaranteed. Nothing like it. Immediately pays for itself.

**FREE Touch-up PAINT BRUSH with prompt orders.**

**PRIOR PRODUCTS, 1417 W. 63rd St., Chicago, Illinois**

## STUDY TO BE A DOCTOR of Psychology or Metaphysics

Obtain a Ps.D., Ms.D., D.D., or Ph.D. degree. Be a Teacher, Lecturer or Accredited Practitioner. Teach others how to achieve Health, Happiness and Contentment. Chartered by State. Write for FREE book telling how.

**THE NEOTARIAN COLLEGE OF PHILOSOPHY**  
 Desk 8, Pickwick Building Kansas City 6, Missouri

## SENSATIONAL \$1 SALE

### 563 DIFFERENT GENUINE STAMPS

- 1 ROOSEVELT issues from many nations. 31 scarce historic stamps.
- 2 MAMMOTH collection of 500 all different stamps including War issues, commems, airmails, etc. Catalog value over \$15.00.
- 3 EXOTIC collection — African Natives, Sport Games, Military issues, Indonesia, Angola birds, Vatican City, Israel, early classic from the Kingdom of Nepal, etc.
- 4 SCARCE 1904 Nicaragua issue with inverted surcharge. ALL FOUR LOTS—563 different genuine stamps—(Reg. value \$14.75) for only \$1.00. Approvals included.

**NATIONAL STAMP SALES, Dept. 300, 832 Eighth Ave., New York 19, N. Y.**

## REMODEL YOUR FALSE TEETH AT HOME

Easy to do

**Make life EASIER with a snug, comfortable FIT**

Just squeeze strip of Dr. Day's Dental Plate Liner out of tube and mold to plates like modeling clay. It sets OVERNIGHT to shape of your gums. Forms firm LONG LASTING elastic CUSHION for tender gums. REALLY different! Self-fitting, tasteless, odorless plastic. Sticks to plates, but can be removed harmlessly. ENJOY EATING, talk, smile, without need for powder or paste. One tube - plenty for at least 2 remodeling jobs - only \$2. More COMFORT than ever, or MONEY BACK, without question. Try at our risk. Sold only by mail. \$2. C.O.D., cash, check or Money Order.

**Dr. Day's** Just spread it on

**DAYLOR LABORATORIES, 551 S. Oxford, Los Angeles 5, Calif., Dept. 29**



**World's Greatest Hobby  
For Men and Boys!  
Get This Free Book. It  
Tells How You Can Learn to**



**Learn At Home**  
Men, Boys, Hunters, Fishermen, mount and save your lovely wild-game trophies. Be a Taxidermist. Mount Birds, Animals, Heads, Fish, Tan skins. YOU learn easily, quickly in spare time. Have a grand home-museum. The finest and the greatest hobby known, for sportsmen. Fun, real profits.

**FREE BOOK**

Yes, FREE. Beautiful strange, valuable Book, telling all about Taxidermy. Contains over 100 beautiful game-pictures. And it's yours FREE, if you rush your request. You can mount all kinds of wild-game, and common specimens too. We can positively TEACH YOU. So GRASP this opportunity. RUSH letter or postal for this amazing FREE BOOK. Don't delay. State your AGE. N.W. SCHOOL OF TAXIDERM, 2503 Elwood Bldg., Omaha 2, Neb.

**GET THIS FREE BOOK!**

**LAW FREE BOOK**

Your FREE copy of "The Law-Trained Man" shows how to gain prestige and greater earnings through Blackstone home law study. All instruction material furnished including 17-volume Law Library written by 65 well-known law authorities. Lawyers, judges among our graduates. LL.B. degree. Low cost; easy terms. Write today.

**BLACKSTONE COLLEGE OF LAW** 225 N. Michigan Ave. Dept. 53, Chicago 1, Ill.  
A Correspondence Institution Founded in 1890

**SHORTHAND IN 6 WEEKS AT HOME**

Famous Speedwriting Shorthand system. No symbols; no machines. Uses ABC's. Easy to learn, write, transcribe. Low cost. 100,000 taught by mail. Also typing. 29th year. Write for FREE booklet to:

**Speedwriting**  
Dept. 1503-2,  
55 W. 42 St., N. Y. 18, N. Y.

**GREAT PROFITS**  
MAKE YOUR OWN RUBBER MOLDS

Make your own rubber molds quickly, cheaply with X.L. RUBBER. Cast thousands of perfect figurines, book ends, plaques, ornaments, ash trays, etc. **GREAT PROFITS!** Write for NEW Catalog.

X.L. Rubber, Pts. \$2.50; Qts. \$4.00 (postage extra). Models and enough for 3 molds \$1.50 prepaid.

**SEND FOR FREE FACTS**

**PLASTIC ARTS STUDIO** Dept. 2, 3403 S. MADISON ST., Muncie, Ind.

**BE A DRAFTSMAN for BIG PAY!**

**LEARN AT HOME IN SPARE TIME**

Drafting offers trained men excellent starting salaries, unlimited advancement opportunities with big earnings. Machines will never replace the draftsman. Before any production starts plans must be drawn and Draftsmen are the first to be hired. Drafting is light, pleasant work, in pleasant surroundings and leads to top managerial positions.

**CTS OFFERS NEW TRAINING PROGRAM**

You learn the hows and whys of successful production planning by studying at home. You learn by making actual drawings. CTS gives you professional drafting instruments, a drafting table, drafting supplies, everything you need at no extra cost. For Free catalogue write

**CHRISTY TRADES SCHOOL, Dept. DB-1403**  
4432 N. Kedzie Ave., Chicago 25

**MEN - WOMEN!**

# Paint it with Suede

**SPRAY ON RAINBOW COLORS**

**for PROFIT and Pleasure..**



**A SENSATIONAL NEW HOME BUSINESS!**  
**A NEW INDUSTRY...**  
**A NEW MIRACLE FINISH!!**  
**MAKE \$500 to \$1000 PER HOUR and more!**

**Read What Others Say About Flok-Kraft**

"... pleased with your course and I'm being swamped with work to do." W.F., Pa.

"Got \$52.50 for those 7 trunk interiors for about 4 hours work. \$7.50 per trunk." J.O., Mo.

"Received the flok-kraft outfit and everyone that saw it is very enthused. I only had it about thirty minutes and got an order for a hundred dollar job." Mr. C. H. Maryland.

**PROFESSIONAL SECRETS CAN BE YOURS**

At last, secrets of this amazing miracle finish can be yours! Huge profits waiting to be tapped in tremendous new field. Flok-Kraft gives a velvety, luxurious surface to radios, lamps, toys, signs, store displays, figurines, auto dash boards—a thousand and one items to be seen on every hand easily and quickly beautified, enriched, increased in value with Flok-Kraft. Make old objects beautiful—saleable, make new things worth much more with this soft, rich covering that can be applied to any surface, even if old or worn.

**YOU CAN LEARN IN A FEW DAYS**

Make to \$5.00—yes! even \$10.00 and more per hour. Fully detailed Flok-Kraft instructions—complete and easy to understand—every point explained—shows you how to start on the road to big money, full or spare time.

**WE FURNISH EVERYTHING YOU NEED TO START**

You also get complete Flok-Kraft kit of materials and equipment that enables you to start at once. Add to your income from your regular job or begin to build a successful business of your own and do it all, right in a corner of your basement, garage, service porch, kitchen or living-room.

**GRASP THIS LIFETIME OPPORTUNITY TODAY**

I'll arrange to send you the complete outfit—everything you need to start—for leisurely, no-risk examination right in your own home. You owe it to yourself to investigate. Fill out and mail the coupon below for FREE details, Sample, Plan, etc. Do it today! Everything I send you now is FREE of charge and post-paid. Airmail is faster.

**YOURS TO EXAMINE WITHOUT RISK!!**

Complete instructions, starting kit of materials, equipment—complete, full details on how you can start your own business, spare or full time—EVERYTHING sent you to EXAMINE AT OUR RISK!

**FLOK-KRAFT and DEFENSE**

Flok-Kraft offers a way to big extra money, assisting defense manufacturers in many lines as well as filling a big demand on the home front.



NELS IRWIN  
Director of Instruction

**FREE! Booklet, Sample, Plan!**

**SEND NO MONEY! JUST YOUR NAME AND ADDRESS**

COAST INDUSTRIES, Dept. 23  
1004 S. Los Angeles St.  
Los Angeles 15, Calif.

Genlmen: Please rush me FREE details, sample, etc. I understand that everything you send is free and that I'll be under no obligation now or ever.

NAME \_\_\_\_\_ STREET \_\_\_\_\_ CITY \_\_\_\_\_ STATE \_\_\_\_\_



PICTURE BOOKLET  SENT FREE

# CONVAIR

in Sunny San Diego  
has a **JOB** for you:

**OPPORTUNITIES NOW OPEN:**



1. TOOL DESIGNERS
2. TOOL PLANNERS
3. PATTERN MAKERS
4. TOOL & DIE MAKERS
5. JIG & FIXTURE BUILDERS
6. MACHINISTS
7. LOFTSMEN

San Diego offers you California living at its best — and Convaair gives you the top working conditions. Employee Retirement Plan. Group Insurance. Two weeks vacation. Eight holidays annually. Free Housing Office and much more — plus that wonderful San Diego climate.

Send this coupon now for booklet, details and Application Blank.

Employment Office  
Consolidated Vultee Aircraft Corporation  
3302 Pacific Hiway  
San Diego, California Dept. 700

NAME \_\_\_\_\_  
OCCUPATION \_\_\_\_\_  
ADDRESS \_\_\_\_\_  
CITY \_\_\_\_\_ STATE \_\_\_\_\_

## SAVE 50% - THOUSANDS HAVE ASSEMBLED \$42<sup>UP</sup> PACKAGED BOAT KITS



**27 MODELS**

Dinghies, skiffs, racers, inboards, outboards and cruisers. Assemble your own boat, it's easy, it's fun!

All parts pre-cut or pre-fabricated from finest materials. Get all the facts from our big 24 page catalog. See how Packaged Boats are built, how they perform, how exclusive construction features make assembly easy. Includes specifications, performance data plus hardware and paints.

**SEND 25¢ for NEW 24 PAGE CATALOG**  
CUSTOM-CRAFT - DEPT. 7 - BUFFALO 7, N. Y.

**BOAT PLANS PATTERNS** Over 50 modern plans and full size patterns. Racing classes, cruisers, inboards, outboards, sail boats. By famous designers. 6' to 30'. DESIGN CATALOG 35¢. Design Catalog and boat building handbook, \$1.00

MARINE MART - DEPT 7 - BUFFALO 7, N. Y.

**BRAND NEW** **30 DAY FREE TRIAL**  
**High Power BINOCULARS**  
Finest Precision Optics  
Featherlight  
Money Back Guarantee  
Easy Pay Plan  
Leather Case Incl'd.  
**Free! Catalog & Book**  
"How to Select Binoculars"  
Dealer Inquiries Invited  
Bushnell Bldg., Dept. M43  
Pasadena 1, Calif.



33 MODELS  
**\$14<sup>95</sup> up**  
**BUSHNELL Binoculars**

**New CHRONOGRAPH Wrist Watch**

A "Once In A Blue Moon" Value—  
with an unlimited **GUARANTEE!**  
(Exclusive of Parts)

Fine Timekeeper PLUS precision-stop-watch with sweep second hand to time races, operations, moving objects, etc. Perfect for time-study work. Rugged movement in handsome, non-magnetic, shock-resistant stainless steel case. "SOLD EVERYWHERE AS HIGH AS \$17.00" Our Price \$7.75 plus 10% tax (Total \$8.63). Send check or money order now and we will pay postage. Or we will send C.O.D., plus charges. Act Quickly.

**\$7.75**  
Plus Tax 480 Lexington Ave., New York 17, N. Y.  
**MARDO SALES CORP., Dept. 593**



**BECOME AN EXPERT IN ELECTRICAL CONTROL**

Earn up to \$700/mo. Only basic knowledge of electricity needed. Home course.

**ELECTRICAL INSTRUCTIONS, DEPT. PM-3**  
AUDUBON STA., BATON ROUGE, LA.

**EASY TO LEARN CODE**

Learn or increase speed with an Instructograph—the Radio-Telegraph Code Teacher that takes the place of an operator-instructor and enables anyone to master code without further assistance. Available tapes from beginners' alphabet to typical messages on all subjects. Speed range 5 to 40 WPM. Always ready—no QRM. Thousands have "acquired the code" with the Instructograph System. Write today for convenient rental and purchase plans.

**INSTRUCTOGRAPH COMPANY**  
4701-V Sheridan Road, Chicago 40, Illinois



**'How to Make Money with Simple Cartoons'**

A book everyone who likes to draw should have. It is free; no obligation. Simply address **FREE BOOK**

**CARTOONISTS' EXCHANGE**  
Dept. 93D Pleasant Hill, Ohio



**ROLL-O-KITE**

Thrill to this revolutionary spool-type kite and its amazing spinning action.

**\$1.00 POSTPAID**

Kit contains durable ready-cut balsa, brightly colored discs, easy-to-follow assembly and flying instructions. Measures 15x6 in.

**ROLL-O-KITE, Box 182C, Lomita, Calif.**



**Learn BAKING At Home**

Baking is one of America's high industries in wages. Nearly depression-proof. Thorough basic home course lays sound foundation. If you have aptitude, write for **FREE BOOKLET: "Opportunities in Commercial Baking."**

**NATIONAL BAKING SCHOOL**  
835 Diversey Pkwy. Dept. 1353 Chicago 14





# new, easy way to.. STRIPE with PAINT



**\$1  
ONLY**

**POSTPAID  
ATTENTION  
Home Craftsmen  
and Hobbyists**

**Do Perfect Paint Striping  
at Home with New Kind of  
PAINT STRIPING TOOL**

This Master Painters' Striping Tool makes it easy to do expert striping on furniture, bikes, model planes, autos, signs, toys, linoleum, wall board, etc. Makes plain, painted walls look like tile. Paint straight lines... curved... circular or evenly spaced parallel lines the same way a professional painter does. Simply fill Tubular-Glass Paint Fountain with any color paint and wheel tip feeds paint evenly. Tips interchangeable—jaws split apart for easy cleaning. Tool complete with tips for 1-16 in. stripe only \$1.00 postpaid. Other complete tools with 1-64, 1-32, 3-64, 5-64, 3-32, 1-8 inch tips, \$1.50 ea. Extra tips — 75c each.

**DEALERS  
Paint  
Striping Tool**  
packed in attractive display cartons of 1 doz. Fast, profitable seller. Write for illus., circular, discounts.

Just the tool you've been waiting for! New PAINT STRIPING tool gives "professional" results every time, yet simple and easy to use as a fountain pen. Adjustable guide keeps lines straight as an arrow. Just as easy to make curves or free hand designs. Adds new beauty and finished look to everything you paint. Send dollar today.

**WENDELL MFG. CO., 4234 N. Lincoln Ave., Dept. 3-C, Chicago 18, Ill.**



## REAL PANSY COASTERS Make Them at Home

**EASY — FUN  
PROFITABLE**

Now create new and truly different gift articles like the beautiful pansy coaster shown—made by embedding real pansies in Castolite—the "magic" liquid casting plastic. With our



simple step-by-step method you can make hundreds of valuable articles, including smart costume jewelry, chic Hi-Style buttons, colorful key tags, tie-clasps, cuff links, plaques, tiles, many other things. Send 25c for Big Castolite Creations Manual. FREE with Manual, inspiring New Home-Success Plan. Write:

**CASTOLITE CO., Dept. C-1, Woodstock, Ill.**

## Develop Hidden Earning Power

# STUDY LAW

**at home! LL.B. Degree**

Qualify yourself in spare time for advancement, greater earnings, business success. Now, more than ever, legal ability is in demand! Easy-to-understand step-by-step lessons and text material furnished — invaluable for permanent reference. Over 40 years expert instruction. 114,000 students enrolled. Easy payments. Find out now, at no cost, how study of law can help you. Write today for FREE Book "Law and Executive Guidance."

### AMERICAN EXTENSION SCHOOL OF LAW

**Dept. 1353, 646 N. Michigan Ave., Chicago, Ill.**

## When You Can Earn More in WATCHMAKING LEARN By KCSW's Outstanding Method

**WRITE TO**

High-paying jobs now open. Pleasant work. Or build a business for yourself right in your own home, repairing clocks and watches. Inquire today about the opportunities in this high-paying trade, through the latest HOME STUDY TRAINING. Also Resident School.

**KANSAS CITY SCHOOL OF WATCHMAKING**  
1218 Admiral Blvd. Kansas City 6, Missouri

## BECOME AN

# Electrical Engineer



- Major in Electronics or Power
- B.S. Degree in 36 months
- Technician Certificates in 12 to 18 months

### FOLLOW THIS PLAN

By 1954 there will be at least two positions for every engineering and technician graduate. Enter these opportunities early... earn your B.S. Degree in 36 months through optional year 'round study.

### RADIO-TELEVISION TECHNICIANS are needed throughout America's fastest growing industry.

You become a Radio Technician in 12 months. In 6 additional months become a Radio-Television Technician. These Technician Courses are complete in themselves and can be applied as one-third of the B. S. Degree program.

Choose from these courses:  
**SPECIAL!** One-month Television Service Clinics on latest field problems

- SERVICE 6 months**
- Electricity • Welding
  - Refrigeration • Heating
  - Preparatory

- TECHNICIAN 12 to 18 months**
- Radio and Television
  - Electronics
  - Electrotechnics (Power)
  - Welding
  - Air Conditioning

- ENGINEERING 36 months**
- Electrical Engineering — B. S. Degree. Major in Electronics or Power.

Military, Practical, or Academic training evaluated for advanced credit. Faculty of specialists. Over 48,000 former students from all states and 23 overseas countries. Nonprofit.

## MILWAUKEE

### SCHOOL OF ENGINEERING

TERMS OPEN APRIL, JULY, OCTOBER, JANUARY  
Founded 1903. Milwaukee, Wis.

Write for free 110-page catalog, 48-page pictorial booklet "Your Career" and "Occupational Guidance Bulletins."

**MILWAUKEE SCHOOL OF ENGINEERING**  
Dept. PM-352, 1025 N. Milwaukee,  
Milwaukee, Wisconsin

Without obligation send Catalog for Electrical Engineering, B. S. Degree, major in  Electronics;  Power;  "Your Career"; Occupational Guidance Bulletin on:  Radio-TV  Electrical Power  Welding  Heating, Refrigeration, Air Conditioning;  TV Clinic.

Name.....Age.....

Address.....

City.....Zone.....State.....

If veteran, indicate date of discharge.....





Get into...

# PLASTIC LAMINATING AT HOME!

Sensational New  
**"ONE MAN  
BUSINESS"**  
..pays \$10 to \$20 profit  
for each dollar of cost.

Make \$20 to \$30 a day by our  
**MAGIC MAIL PLAN**... get  
orders and cash from your mailman!

Here's the newest and most fascinating of all home-operated businesses. For the first time, a simplified machine brings the fabulous profits of Plastic Sealing and Plastic Laminating within the reach of the small operator. Can be

operated in a corner of the kitchen, basement, or garage. And any man or woman, regardless of age, education, or experience—can learn this interesting work in a few minutes of reading—can turn out professional jobs after one hour's practice.



## TWO EXCITING FIELDS FOR BIG PROFITS!

No house-to-house canvassing. No face-to-face selling. We not only supply the equipment you need for the work, but also show you exactly how to cash in big daily profits from two big demand fields.

### A FORTUNE IN PLASTIC SEALING

Millions of people want to protect valuable cards, photographs, documents and papers against wear, soil, and damage. By our MAGIC MAIL Plan you get this business through the mails. Open envelopes and take out money and orders. Details of this plan will amaze you. It will be sent free. Just mail coupon.

### ENORMOUS PROFITS IN LAMINATING

A creative, artistic business. Gift shops sell your entire output. Just a few of thousands of giftwares illustrated on this page. Beautiful colors. Endless designs. Exclusive "one of a kind" appeal brings sales at ten to twenty times the cost of materials. Beautiful illustrations and instructions for making these artistic novelties sent free.

The opportunities in Plastic Laminating are so big that space here does not permit even skimming the surface. To get any idea

# FREE

at all of the size of these markets and your place in this sensational business you must read the details. See for yourself how easy it is to do the work—how you can put plastic sheets into your machine and take out a fortune—how money and orders come to you in the mail—how gift shops clamor to get more and more of your creations—how you can start with one machine and build up a big production plant with others doing the work—how you can get money and business from every State in the Union—how you can achieve independence without study or experience.

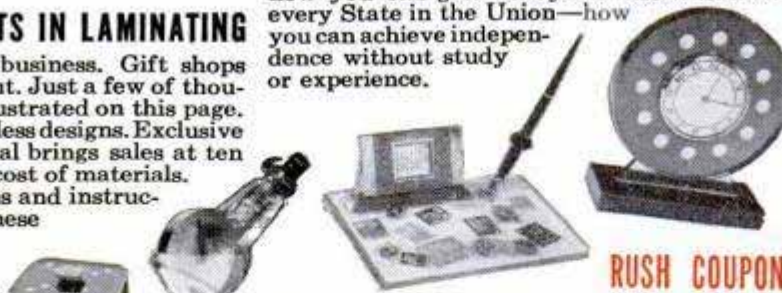

RUSH COUPON

Never before has such an opportunity been offered the small, home-operator—an opportunity to gain complete personal independence in a big money business of your own. Don't lose a minute. Get the facts at once. All information, fully illustrated with pictures, is free. Send the coupon—or send your name on a penny postcard. There is no charge now, or at any other time. We may be limited in the number of Warner Laminators that can be made up, so don't put this off. Send for the information on this exciting opportunity today.

**WARNER ELECTRIC CO.,**

1512 Jarvis, Dept. 3-C, Chicago 26, Illinois

**WARNER ELECTRIC CO. Dept. 3-C**

1512 Jarvis, Chicago 26, Illinois

Rush complete information with illustrations showing the things I can make and the money possibilities in Plastic Laminating. All this is free. I do not pay a penny now or at any other time. No salesman is to call. Send all facts by prepaid mail. Be sure to tell me how I get orders and money from my Postman by your MAGIC MAIL Plan.

NAME \_\_\_\_\_  
ADDRESS \_\_\_\_\_  
CITY \_\_\_\_\_ ZONE \_\_\_\_\_ STATE \_\_\_\_\_

## \$5-\$10-and \$20 BILLS COME TO YOU IN THE MAIL

By our MAGIC MAIL Plan you sit at home, send out mail, and get back money and orders. Additional profits in supplying local people with lifetime protection for

**SNAPSHOTS—IDENTIFICATION CARDS—DISCHARGE PAPERS—DRIVERS' LICENSES—SOCIAL SECURITY CARDS—VOTERS REG. CARDS—MENUS—BIRTH CERTIFICATES—CREDIT CARDS—BIRTH AND WEDDING ANNOUNCEMENTS—RAILROAD PASSES—IMPORTANT DOCUMENTS OF ALL KINDS.**

Lifetime protection. See how laminating protects against wear, soiling, and moisture damage with its smooth, flexible, plastic covering on each side. **LIFE-TIME PROTECTION** needed for valuable or sentimental objects of all kinds—even a priceless whisp of hair can be laminated. Think of the countless thousands of profit items for your Laminating Press.

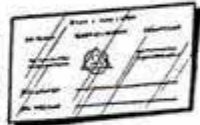

## Thousands of Beautiful Art Creations

No one yet has been able to list the thousands of gorgeous articles that can be made by Laminating as explained in our Free Information. Just a few are

- COSTUME JEWELRY—CIGARETTE BOXES—JEWEL CASES—GLOVE AND HANDKERCHIEF BOXES—CUFF LINKS—NOVELTY BUTTONS—TRAY—CANDLESTICKS—COASTERS—CLOCK CASES—LAMP BASES—PICTURE FRAMES—BOOK ENDS—PAPER KNIVES—KEY CHAIN CHARMS—CHECKERS—CHESSMEN—ADVERTISING SIGNS—NAME PLATES—BOOKMARKS—BELT BUCKLES—TIE RACKS—KEEPSAKES OF ALL KINDS.



**WORLD'S  
BEST  
WANT AD  
MEDIUM**

# CLASSIFIED Advertisements



Advertisements in this section 85 cents per word, each insertion, minimum 10 words, payable in advance. To be inserted under proper classification, copy must be in our office the 20th of the second month preceding date of issue  
F. W. Johnson, Manager, Classified Advertising  
Popular Mechanics Magazine, 200 East Ontario Street, Chicago 11, Illinois

## YOU'LL PROFIT

By reading and answering the classified ads in this section. Hundreds of opportunities for you to make and save money

### AUTOMOBILES, MIDGET CARS

**AUTOMOBILE** Topics, established 1900, oldest automobile magazine in America, now owned and published by Floyd Clymer. More interesting than ever. Clymer's foreign car and auto show survey, French, German, Swedish, Italian, English, Russian cars. (Clymer's report behind the Iron Curtain). Feature articles, technical information. U. S. production figures and news direct from world's motor capital—Detroit. Custom, racing, production news. Now revised for the automotive industry and car owners. Limited time offer \$5.00 per year. \$8.00 two years. Includes free \$2.00 Clymer Motorbook as gift. Floyd Clymer Publications, 1268 S. Alvarado—P.M., Los Angeles, Calif.

**FLY** To Marion without cost for your new Jaguar, M.G., Morris or Crosley car. Bank rate financing. Walraven Motors, Marion, Ohio. Phone 2-4135.

**MAKE** Ford use diesel fuel. \$2.00 for plans. Refiner, Box 292, Columbus, Nebr.

**SENSATIONAL Power!** Flashing speed! Amazing economy for your car! Easily installed high compression aluminum heads and dual carburetors increase horsepower 25%. Low prices! Catalog 10c. Honsaker's, Mansontown, Penna.

**FREE** Motor magazines; also old, new and foreign automobile literature; shop manuals, engineering papers, data books, glossy photos. Contact auto nuts everywhere. Write today; get name on free mailing list. Auto Maniacs, Stockbridge, Mich.

**SURPRISE** Package "on approval." Send only name and address (without money). Pay \$1.00 later, if delighted. Octa-Gane, San Gabriel 8, California.

**1952 SUPERIGNITIONITER:** Starting; pep; mileage. \$4.50. EG Mfg., Elmsford, N. Y.

**BIGGEST** "Speed equipment catalog" in world! Save, order direct—Hollywood mufflers \$4.95, dual mufflers \$18.95, cut outs \$6.95, dual intake manifolds \$12.95, racing cams \$29, hi-compression heads \$26.95, water injectors \$6.95, customizing kits \$1.98, chrome accessories at discounts! Catalog plus "Hot Rod Handbook"—25c. Almqvist Engineering, Milford 34P, Pennsylvania. (Dealers wanted.)

**PFOHL** Engineered racing motors. Hot rod camshafts, average \$23.50 exchange. One day service. Auto Electric Service, Box 54, Anderson, Ind.

**FROM** Speedway to roadway! Track-proved hi-speed heads and manifolds for your passenger car! No special tools needed! Increase horsepower 30%! Astounding getaway! Free illustrated catalog. (Dealers wanted.) Speedsport, 4866-D Milwaukee, Chicago 30.

**BUY** Racing heads, dual manifolds. Hot coils, etc., without money. Information free. Newhouse Automotive Industries, Los Angeles 22.

**WATER** Injection. Also economy, power, methods. Free illustrated information. Neher Industries, La Verne, California.

**LATEST** 1952 Edition! Just out—100 new pages! Get world's largest auto accessory and parts catalog and save money. Over 50,000 items, including Hollywood accessories, hi-speed equipment, rebuilt engines, all parts and accessories for all cars and trucks. We have that hard-to-get part! Jam packed with bargains. Completely illustrated. Send 25c (refundable). J. C. Whitney, 1919 Archer, Chicago 16.

**SAVE**—California custom accessories headquarters. Buy direct from original designers. Chrome dash panels, electric push button door-trunk conversions, fender skirts, dual mufflers, lowering kits, speed-dress up equipment. 40 page catalog, hundreds of photos—25c. Eastern Auto, 3319A South Grand, Los Angeles 7, Calif.

### AUTO SUPPLIES AND EQUIPMENT

**FIBERGLAS** And plastics for custom bodies and hard tops. Instructions and complete supplies. Industrial Plastics, 4425 Linden St., Oakland 8, California.

**REMANUFACTURE** Your automobile or truck engine for less than one-half new engine cost. One year or twelve thousand mile guarantee. Factory direct to you. Write today, information by return air mail. Skaggs Brothers, Dept. C, 5425 So. Vermont, Los Angeles 37, California.

**MOTORISTS** Are reporting three to five more miles per gallon. Guaranteed, gasoline vaporizer, increases power; easier starting. \$3.50. Turb-O-Vane, Stockton, California.

**SIRENS.** Air horns! Bermuda bells. Free accessory catalog. McCanna Company, 148-PM East 40th, New York 16.

**MOTORIST** Save gasoline by Vacu-mating overrich mixtures. Fits all cars. For free particulars write Vacuumatic, Dept. 1867, Wauwatosa, Wis.

**YES,** It puts bearings on the pistons. Lachapelle's Treatment. Patented. \$3.00. Your dealer or postpaid. Ferns Products, 8120-B Walnut Dr., Los Angeles 1, Calif. Data on request. Cuba, Luis Izaguirre, San Carlos 178, Cienfuegos. Wanted, Canadian manufacturer distributor for Lachapelle's Treatment. Canadian patent No. 459,592, royalty.

**INCREASE!** Gasoline mileage three to five miles per gallon; guaranteed gasoline vaporizer increases power on cars, trucks and tractors. Reduces carbon, easier starting, perfect idling, higher top speed. Install in five minutes. \$2.00 prepaid. Jim Dandy Vaporizer, P.O. Box 3557 McKellar Sta., Memphis 6, Tennessee.

**NEVER** Change your oil! Full details free. Thousands of users. New oil filter. Dept. TI, Henderize, Inc., 5667 Freeport Blvd., Sacramento, California.

**FORD** And Mercury users '35-'48. Weak springs? Get a better than new ride, increased stability, and easier "handling" with a coil "Spring Booster Stabilizer." (Fits front or rear spring.) Guaranteed. \$11.50 ea. postpaid. C.O.D. orders accepted. P & S Co., Burr, Nebr.

**CHEVROLET** Owners—Stop tappet noise with Kaye Tappet Silencers. Quality product. Easy to install. Money back guarantee. Complete set \$5.95 postpaid. Kaye Products, P.O. Box 1423P.M., Milwaukee, Wisconsin.

**ELECTROPLATE** Autoparts, accessories, etc. Portable Tyco Electro-Plater \$5.95, including plating salts, formulas, instruction manual. Tyco Metals, Box 13231-BD, Houston 19, Texas.

**NEW** Garden hose, any length 7c foot. Hose for every purpose. Air welding, etc. C.O.D. Bate's Rubber, Box 501, Wildwood, New Jersey.

**BE** Independent, save money. Grind crankshafts without disassembling engine. New hand operated tool \$3.75. Literature. D. McGee, 719 Cascade, Wenatchee, Wash.

**HYDRAULIC** Jack repair kits. Repair your own. Send for prices. Jack Parts Company, 2000 South Claiborne, New Orleans, La.

**25% DISCOUNT.** New auto, truck, tractor tires. C. Page, Franklinville, N. Y.

**"HOW To Soup-Up Your Car."** Hot rod handbook plus equipment catalog—25c postpaid. Almqvist Engineering, Milford 36P, Pennsylvania.

**BRUSH** Plating outfits connect to a battery. No tanks or shop required. Free particulars. Gunmetal Co., Ave. J., Decatur, Ill.

**SPEED** Equipment. Edelbrock, Offenhauser, Navarro heads, manifolds, Winfield cams, dual ignition points. Chev. 37-51, Ford 49-51. Deeptone mufflers, headers, dual muffler sets, Mallory coils, distributors. Speed catalogue 25c. Urzi's Auto Supply, San Jose, California.

**AUTOMOBILE** Seat cover bargain. See page 71. Young Products.

**OVERDRIVE** Sig-Na-Lite flasher fits all cars with overdrive. Saves gas, no forgetting. \$2.95 complete. Quality Products, 5227 Parker Ave., Chicago, Ill.

**STOP** Worrying about fires. Install a Zak Auto Fireman in your car. This safety gadget quickly releases battery cable from battery terminal, stopping electrical fires. Replaces terminal clamp bolt. \$1.00 postpaid. Park Sales, P.O. Box 73, Forest Park, Illinois.

**WATERPROOF** Your car ignition, latex rubber insulation. Guaranteed starting with motor wet. Big supply \$1.00. Sure Start, Box 94, Union City, N. J.

**LIGHT** Your Powerglide dial. Free information. Gaiser, Box 25, Kokomo, Ind.

**FOR** Economical operation of cars, trucks, tractors install Octa-Gane Alcohol-Water injector. Write Shade, Webster 1, N. Y.

**AUTO** Parts and accessories. Briggs Automotive Engineering of Chicago, P.O. Box 3454 Merchandise Mart, Chicago 54, Ill.

**HOW** To buy speed equipment without money. No selling. Information free. Newhouse Automotive Industries, Los Angeles 22.

**NEW** And used guaranteed parts for civilian and army cars and trucks. Largest stock in America. Mail orders. Pioneer Auto Wrecking Co., 734 W. 13th Ave., Denver, Colorado.

**NEW** Government surplus. Low voltage circuit tester in steel box cost \$202. Our price \$27.50. Will test batteries, starters, generators, voltage regulators, grounds, short circuits. Wilt Electrical Company, 7829 S. Racine Ave., Chicago 20, Ill.

**SEND** For free life membership card. "Water Burners" of America, La Verne, California.

### AUTO TRAILERS

**BUILD** Your own trailer! Plans for all kinds. Illustrated catalog 10c. Jim Dandy, 125-M, Wausau, Wisconsin.

**BUILD** Streamlined house trailer, telescopes small for towing. Not canvas. Complete blueprints, pictures and instructions \$2.00. Thomas Comstock, 585, Parsons, Kansas.



## MOTORCYCLES, BICYCLES, MOTORSCOOTERS AND SUPPLIES

**CATERPILLAR** Junior crawler tractor—Electric motor driven! Rugged full-track pulls loads easily over lawns, fields, pavements. Most sensational child's vehicle made! Catalog free. Mystic River Sales Co., Box 312-P, Mystic, Conn.

**AMERICAN** Motorscooter \$20, Cushman \$35, Comet \$35. Others as low as \$12.50 less engines, engines \$5 up. British MG, less running gear \$75. (Mailorder only.) Send 2c for catalogue 46, just out, listing these and hundreds of other bargains in new and used midget cars, motorscooters, parts for homebuilders, plans, etc. (35c by first class mail). Midget Motors Directory, Athens, Ohio.

**PARTS**, Pistons, new, used, cheap, Harley, Indian, Henderson. List 10c. Ballak, 811 N. 9th. St. Louis 1, Missouri.

**HARLEY-Davidson** parts, accessories, repair manuals. Bargains on parts and tires for models earlier than 1942. Philadelphia Harley-Davidson Company, 857 North Broad Street, Philadelphia 23, Penna.

**RECONDITIONED** Motorcycles and motors. Chromium accessories. Complete stock Indian parts. Expert rebuilding. Fast service. Indian Motorcycle Sales, Kansas City 1, Mo.

**HARLEY-Davidson**—All models and prices. Genuine late and old model supplies. Expert service. Send 25c for bulletin. Knuth's, 1753 Muskego, Milwaukee, Wis.

**GOOD** Whizzer \$20; motorscooter (twist grips) \$22.50; midget car \$15; Shaw bicycle motor \$15. Send 25c (35c first class mail) for catalog #20 jammed with sensational bargains in wheels, motors, clutches, motorscooters, midget cars, motorettes, motorbikes, etc. Gail, 538 Erie, Toledo, Ohio.

**U. S. Govt. surplus** "45" Harley Davidson motors, complete with carburetor and generator, in running condition—\$69.50 f.o.b. Chicago. 25% deposit with order. Parts and accessory catalog 25c. Triangle, 2157 Harrison, Chicago.

**MOTORCYCLE** Magazine—Worldwide coverage. Yearly subscription \$2.00. Sample 20c. Motorcycle News, 5424-A Sawyer, Chicago 25.

**REBUILT** Gasoline engines \$17.00 to \$37.00. Cauffiel Motor Industries, Temperance, Michigan.

**WHIZZER** Motor \$5; Cushman motorscooter \$15; Indian motorcycle \$30; Engines \$3 up; motorbike frame \$3. Rush 25c (35c first class mail) for catalog #950 listing many other amazing bargains in motors, midget cars, motorscooters, motorbikes, etc. Associated, Box 1764-CS, Toledo, Ohio.

## AVIATION

"1947" **CESSNA** 120, Starter, electric system, metal propeller. Extra nice. \$1395. \$795 down, \$66.24 monthly. Walraven Motors, Marion, Ohio. 2-4135.

**LIGHTPLANE** Circular, illustrated, 20c. Craftsmann Books, Box 1153, Milwaukee 1, Wis.

**JET** Engine plans \$1.00. Very simple—make own. J. Symonds, 500 N. Tamarind, Fontana, Calif.

**PROPELLERS**: For snowsleds, boats. Literature. Standard Aircraft, Box 387, Ft. Worth, Texas.

## BATTERIES, GENERATORS

**GENERATOR**, 1000 Watt, 110 volt, a.c. built from 12 volt Dodge generator. Volt regulator. Constant voltage, variable speed. Instructions guaranteed. \$3.00. Allen's Service, 1432 Del Valle Station, Los Angeles 15, Calif.

**EDISON** Non-acid storage batteries. Amazing long life. Any voltage. 37 to 600 ampere hour sizes. Lighting plants, generators, motors. Literature. Hawley Smith Co., Croton Falls 1, N. Y.

## ELECTRICAL SUPPLIES

**LAMP** Supplies—Wholesale. Any amounts. Prompt shipment on all parts for repairing and building lamps. Illustrated catalog 15c. Brown Lamp Co., Box 501—Wellston Sta., St. Louis 12, Missouri.

**ELECTRIC** Pencil—Writes, engraves all metals. \$2.95. Reb Industries, 265-DAA, Elmhurst, Illinois.

**AC** Watthour meters, \$5.00. Miller, 1011 W. 16th St., Davenport, Iowa.

**10 WATT** All triode high fidelity audio amplifiers. Built-in preamplifier, separate tone controls, seven tubes. \$67.50. Send for particulars. Electronic Wiring, Selden, L.I., N. Y.

**ASTONISHING!** Plastic magnets, Pair 25c. 2442 Miller Road, Flint, Michigan.

**BE** Independent, be secure, have your own profitable business—Earn \$20.00 and more a day making beautiful, fast-selling lamps at home. No equipment needed. Illustrated course teaches you quickly. Course, parts catalog, wholesale price list—only \$2. Gearon Co., Dept. 200-B3, 27 S. Desplains, Chicago 6, Ill.

**FREE**—War surplus catalog. Bargains galore. Welders, motors, generators, hydraulics, pumps, kits for assembling your own, other items. Save. LeJay Company, Minneapolis, Minnesota.

**BIG** Profits rebuilding automobile generators. Introductory manual \$1. Modern, Box 4704, Kansas City, Mo.

**ELECTRIC** Pencil: Engraves all metals \$1.50. Beyer Mfg., 10511-H Springfield, Chicago 43.

**LAMPS**—Had trouble finding repair parts? Your search is ended. 25c brings 64 page illustrated catalog also containing wiring charts. Gyro Lamps, 5402P Clark, Chicago 40.

## WELDING, SOLDERING, PLATING

**ELECTRO** Plating equipment—New and used. Complete assemblies. All sizes for all types of plating. Baby shoe metallizing sets. Mounts, supplies. Free catalog. Hollywood Bronze Supply, Dept. 2, 1624 E. First Street, Los Angeles 33, California.

**ACETYLENE** Welding outfits. New \$49.00, used \$29.00; arcwelders \$49.00. Eagle Welding, Dept. PM, 5085 Broadway, Chicago 40, Illinois.

**200 AMP.** Welding generators. Brand new. \$25.00. Free literature. Thorndyke Mfg. Co., Pipestone, Minn.

**A.C. Welders**, 4 sizes, lowest prices. Free literature. Holgerson's Service, Canton 1, Kans.

## MACHINERY, TOOLS, SUPPLIES

**FLEXIBLE** Shaft tool by Fairchild for grinding, polishing, sanding, buffing, carving. Original price \$19.95—While they last! Special price \$12.95. Public Sport Shops, 11 S. 16th Street, Philadelphia 2, Penna.

**SCREW** Drivers. Shock resistant handles. Only \$3.00 for big 8 assortment of Phillips, regulars, stubbies. Free list of other tool bargains. Raymond Talbot, School Road, Perkasio, Penna.

**FREE!** Complete catalog of precision tools for any job. Big stocks—famous brands: Lufkin, Starrett, Brown & Sharpe. Immediate delivery. Wide selection. Write for your copy today! Mid-City Hardware & Supply Company, 318 South Halsted Street, Chicago 6, Illinois.

**BUILD** Concrete walls without laying blocks or constructing forms with Dudley Wall Builder. Free literature. Carl Dudley, Doniphan, Mo.

**WATCHMAKERS** Lathe by Marshall, complete with motor, foot pedal and two chucks, value \$250.00, condition like new, \$95.00. Public Sport Shops, 11 S. 16th Street, Philadelphia 2, Penna.

**HIGH** Speed drills, carbide tipped lathe tools, boring tools, carbide cement drills, grinding wheels, free list. Tool Supply, 3370—No. 53 St., Milwaukee 16, Wis.

**REBUILT** Drill presses \$14.00 to \$75.00. Cauffiel Motor Industries, Temperance, Michigan.

**ONLY** \$3.95. 2" Universal lathe chuck, \$14.00 value. Har-Mur, 2349 Devon Ave., Chicago 45, Ill.

**CONCRETE** Block machine. Standard sizes. \$39.50. Average 400 daily. Free catalog. Concrete Machine Company, 5129 South Compton, St. Louis 11, Mo.

**SAVE 90%** On power tools. Handbook 25c. Robert Fellows, Caledonia 4, N. Y.

## BOATS, OUTBOARD MOTORS

**FASTEST** Boats in the world—Build now. Complete plans available for sleek three point racing hydroplanes, runabout and others. Send 25c immediately for illustrated catalogue. Champion Boats, 1524 W. 15th St., Dept. 22-O, Long Beach 13, Calif.

**FULL** Size, cut to shape boat patterns, blueprints, 7½-38 feet. Illustrated "Build a Boat" catalog, 25c (coin). "How to Build Boats" book, \$1.00. PolyWog houseboat plans \$10. Marine catalog \$1.00. Cleveland Boat Blueprint Co., 3107 Detroit Ave., Cleveland 13, Ohio.

**MAHOAGNY**, Fir, marine plywood. All lengths. Huebly Boats, LeSueur, Minn.

**SAVE ¾** Cost. Assemble your own boat. We furnish parts. No experience necessary. Rowboats, cruisers. Illustrated catalog 25c. Midwest Boat Company, Menomonee Falls, Wisconsin.

**BOAT** Patterns, kits. Thirty designs. Descriptive literature and illustrated boat construction book 40c postpaid. Germain Boat Company, West Saginaw 3, Michigan.

**GET** Our big 228-page 1952 marine hardware, boat and equipment catalog. Send \$1.00 for packing and mailing, refunded with first order. Garland Frasher Marine Sales, 540-J 31st Street, Huntington, W. Va.

**OUTBOARD** Motor parts—New, used for all makes. Send stamp for price quotation. Outboard Motor Mart, Inc., 309-A Atlantic Avenue, Boston 10, Massachusetts.

**MARINE** Conversions for Ford and Jeep engines. Catalog 10c. Lehman Manufacturing Company, 972D Broad Street, Newark 2, New Jersey.

"P38 Belly tanks," steel, \$9.95. Free picture. Bucks Auto Parts, Box 89, Merced, Calif.

**NEW**, Used, rebuilt marine motors. Marine conversions, fittings. Free catalog. Stokes Marine Supply, Dept. 24, Coldwater, Michigan.

**SAVE** Money, have fun—Build your own boat. Popular Mechanics "23 Boats You Can Build" tells and shows you how. 192 pages, 500 illus., detailed diagrams and material lists. Everything from 10 ft. dinghy to 25 ft. cabin cruiser. Only \$2.00. Order today from Popular Mechanics Press, Dept. 107, 200 E. Ontario, Chicago 11, Ill.

**CONVERT** Fords and Jeep to 100% marine engines with Osco's world famous Convo-Kits. Deluxe catalogue 25c (coin). Oscomotors, 3627B Lawrence, Philadelphia 40, Penna.

**ARE** You interested in boats? Write for free copy The Rudder, a magazine on boats and boating. 15 Murray St., New York 7.

## ENGINES, MOTORS, DYNAMOS

**REBUILT** Gasoline engines \$17.00 to \$37.00. Cauffiel Motor Industries, Temperance, Michigan.

**WINDING** Data, listing 225 motors, single and three phase, \$1.00. Motor Data Co., Box 7631, Kansas City 3, Mo.

## ATHLETIC EQUIPMENT, BODY BUILDING COURSES

**BARBELLS**. Exercise equipment. Courses. Free booklet. Good Barbell Co., Reading, Penna.

**MASSIVE** Proportions quickly. Barbells wholesale catalog \$1.00. Barbells, Elmsford, N. Y.

"**POLICE** Jiu Jitsu." Authentic, illustrated \$1 postpaid. Satisfaction or money back. Books Publishing Co., 56-C W 24th St., New York 10.

**DEADLY** Judo—Fiercest fighting technique. Trick knockouts. (Over 200 illustrated pictures.) Expert instructions; three volumes. Complete \$2.25. Variety House, Box 46-B Wall Station, New York 5.

**GAIN** Weight! 4 exercises will increase weight. Complete \$1.00. Body Builders, 36 Nevada Street, Winthrop, Mass.

## SPORTING GOODS, GUNS, FISHING TACKLE, ARCHERY, TRAPPING

**FISHWORM** Culture—This booklet "Raising Worms for Pleasure or Profit" tells how to fix beds, indoors, outdoors; small or commercial scale; what, when, how to feed; how to keep worms from crawling out; how and where to sell. \$1.00 postpaid. Tennessee Worm Hatchery, Box 265-C4, Nashville 2, Tennessee.

**FISHING** Tips galore, only 10c. Pledger, Box 984, Memphis, Tennessee.

**TENTS**, Canvas; direct from manufacturer. Also war surplus. Camping equipment, sleeping bags. Tremendous selections. Free catalogue. Low prices. Mor-san Sales, Dept. PM-1, 10-15<sup>th</sup> 50th Avenue, Long Island City 1, New York.



120 PROFUSELY Illustrated pages antique pistols, swords, daggers, armor, etc. 50c. Robert Abels, M860 Lexington Ave., New York 21.

**SPECTACULAR** Lure for fish. Two samples 50c. Ward, Westbrook 12, Connecticut.

**CATCH** Fish by the hundreds. Guaranteed method never fails. Details free. Specialty Products, Box 345-P, Wilkes-Barre, Penna.

.32 PISTOL \$5; .22 Rifle \$10; 1824 musket \$8; double-barrel 12 gauge \$10; arrow-head collection 70c. Rush 25c (35c first class mail) for catalog #510 listing other bargains in guns (new and old), swords, relics, etc. Jefsco, Box 1682-CS, Toledo, Ohio.

**GUNNERS!** Don't be "skunked" again! Put more game on your table! Our free booklet, "Straight from the Shoulder" is full of wing-shooting facts. Write the Poly-Choke Co., 812 Tunxis St., Hartford, Conn.

**FISHWORMS** At wholesale. Send 3c stamp. Alton Tozier, Macon, Georgia.

**SHOTGUNS, Rifles, Revolvers, 500 modern, obsolete. Also cartridges. Each list 10c coin. Ed Howe, 52 Main, Coopers Mills, Maine.**

**CAST Iron molds—For casting your own sinkers. Free booklet. Reading Instrument Co., Box 78, Reading, Penna.**

**5000 BARGAINS, Firearms, binoculars, war relics. Catalog 50c. Smith Firearms, Runnemeade, N. J.**

**MOLDS, (For fisherman's sinkers, squids, jigs and lures.) Handled and hinged. Quality fishing tackle. Free catalogue. E. L. Sweet & Son, Tonawanda, New York.**

### TAXIDERMISTRY

**MODERN Taxidermist Magazine, Greenfield Center 2, N. Y. Devoted entirely to taxidermy, photos, articles, methods. Trial year's subscription, \$1.00.**

### BINOCULARS, TELESCOPES, MICROSCOPES, MAGNIFIERS

**SAVE 50% On new binoculars! Free catalog. Free book, "How to Select Binoculars." Write today! Bushnell's, 43-M-33 Green, Pasadena 1, California.**

**SAVE!** Free 20-page, 3 color binocular catalog. 60 different models. United Binoculars, A-3908, 9043 S. Western, Chicago 20.

**TELESCOPIC Cameras** easily made. Telephoto lens and instructions \$5.00. Instructions alone 10c. Telescopic Cameras, Manorville, N. Y.

**BARGAINS Jewelers' 4X magnifier \$2.50 value \$1.00. Anelag, Rochester, Wisconsin.**

**REFLECTING Telescopes, 60X, completely assembled \$29.75. Guaranteed observatory clearness. Free information. Skyscope, 475 Fifth Avenue, New York 17.**

**AMAZING Prices, imported precision binoculars. Free trial. Pricelist, folder "Selecting Binoculars" free. Prentiss Importers, Mercury Bldg., Los Angeles 25, Calif.**

**BINOCULARS, Telescopes, microscopes. Our 20th year of leadership in optical values. Bargain catalog free. Brownscope Co., 24 West 45th Street, New York.**

**WAR Surplus bargains, binoculars, telescopes, sextants, millions of lenses, prisms, reticles, eyepieces, objectives, etc. Mail 10c for Big "Catalog CH." Send \$1.00 for Stock CH-10-piece lens kit and big instruction booklet. Edmund Scientific Corp., Barrington, N. J.**

**POWERFUL Astronomical telescopes** easily made. Perfect lenses and instructions; 100X \$3.00; 100X and 200X \$4.00; 100X, 200X and 400X \$6.00. Full power, clear vision guaranteed. Instructions alone 10c. Suffolk Science Service, Riverhead, N. Y.

**MAKE Your 6" telescope reflector. Glass, abrasives, instructions—\$8.50. F. Cameron, Box 65, Inwood, N. Y.**

**REFLECTOR Telescope kits, refractors. Free illustrated bulletin. Esco Products, 911 Willow Ave., Hoboken, N. J.**

**GIANT Astronomical telescope with 6 ft. tripod \$15.00. f.o.b. factory. 100 power. (10,000 area magnification). Clear vision, full power guaranteed. Ready for use. Suffolk Science Service, Dept. BT, Riverhead, N. Y.**

### PETS—DOGS, BIRDS, RABBITS, HAMSTERS, ETC.

**DAIRYMEN:** Why pay more? Buy direct. Quality dairy calves—Cows, T.B. and Bangs free. Cattle shipped on order. R. H. Walter, Lannon, Wis. Phone 26M13 or 28M5.

**ANGORAS, Giant chinchillas. Finest heavy-producing, prize-winners. Catalog free. P. M. Grinsteads, Edwardsville, Ill.**

**GUN** Shy dogs broken in 3 days. Secret revealed—Booklet only \$1.00. R. J. Armstrong, 1305 Armour, Kansas City, Mo.

**GOOD Profits—Raise rabbits. Profitable business. Free booklet. Tayco Rabbitry, Hapeville, Georgia.**

**MAKE Extra cash. Raise Giant Chinchilla rabbits. Waters Rabbit Farm, Glennville, Ga.**

**BIG Profits. Raise guinea pigs. Free booklet. Taylors, B426A, Hapeville, Ga.**

**500 BRED Mink. Booklet, pen plans 20c. Lake Ontario Mink Ranch, Gravel Road, Webster, N. Y.**

**BEAUTIFUL Pure white pedigreed police puppies. Ansonia Kennels, Mose, N. Dak.**

**EXCELLENT Opportunity raising Angora rabbits. Big money. Free illustrated information. Ohioland Rabbitry, Box 4756, Cleveland 26, Ohio.**

**HAMSTERS—Golden or spotted. Cages and equipment. Free illustrated details. Lakeview Hamster Colony, Newfield, New Jersey.**

**BOOKLET "Treatise on Breeding and Raising Canaries"—\$1.00. Audubon Publishing Co., 3449-PM N. Western, Chicago 18, Illinois.**

**RAISE Mink; Free booklet, pen plans, inside "secrets", feed, care. Mink are money makers. Investigate today. Lawrence Molgard, Brigham City 12, Utah.**

**MAKE Big money! Raise Chinchilla rabbits. Cash markets supplied. Write today! Rockhill Ranch, Sellersville 15, Penna.**

**EARN Up to \$400 monthly raising Angora or New Zealand rabbits. Plenty markets. Particulars free. White's Rabbitry, Newark 38, Ohio.**

**MINK Raising information free. Complete. Lake Superior Mink Farm, Superior, Eel, Wisconsin.**

**A Practical beginning to successful rabbit raising. 48 page illustrated booklet. Dime. American Rabbit Breeders Association. 36 AR & CBA Bldg., Pittsburgh, Penna.**

### PLANTS, SEEDS, NURSERY AND GARDEN SUPPLIES

**STRAWBERRY Plants** retailed, wholesale prices. Write Specialty Farm, Rockford, Minn.

**GINSENG, Goldenseal. Hundred seeds \$1.50; thousand \$5.00. Dozen plants \$1.50; hundred \$9. Growing-selling instructions included. F. M. Collins, Viola, Iowa.**

**TREES And shrubs. Raise your own from seed for ornament, windbreak, snow fence, erosion control. Christmas trees, spruce, firs, pines, others. Free planting guide, price list. Woodlot Seed Company, Norway 4, Michigan.**

**RAYNER'S Special berry garden. Luscious, fresh fruit grown in your own garden. Strawberries: 100 early, 100 mid-season. 100 late top quality plants for \$6.99. Blueberries: 4 early, 4 mid-season, 4 late giant cultivated bearing age plants \$7.69. Nationwide shipments. Also fruit trees, ornamentals. Catalog free. Rayner Brothers, Salisbury 99, Maryland.**

### FARMS, FARM LANDS, REAL ESTATE

**SPRING List select stock farms, central Arkansas. Owen Farm Agency, Conway, Arkansas.**

**FLORIDA—Hunting, fishing, fruit growing, 5 acres, \$245.00, \$10.00 down, \$10.00 month. G. B. Potterfield, Union Building, Charleston, W. Va.**

**UNITED Farm Agency's big free spring catalog of farm and country real estate bargains can help you plan soundly for your future security in the country. Good pictures, many states, easy terms, many equipped, growing crops included. For special service, state requirements, desired location. Write for your catalog today. It's free! United Farm Agency, 220-PM South State St., Chicago 4, Ill.**

**FARM And business catalog free! Big 1952 edition. Over 1000 bargains from \$1000 up. Maine to Florida. West's, M-3, Pittsburgh 17, Penna.**

**\$145 FLORIDA Homesites. Pay \$10 monthly. Large, beautifully wooded tracts, high and dry, in famous Panama City pleasure resort area. World's finest beaches. Lovely lakes. Wonderful fishing, hunting. Grow fruits, berries, nuts, vegetables, poultry. Low taxes. Electricity. Build your retirement home in this desirable community and enjoy our glorious year-round climate. Write today for full information. Wendell Wood, Box 873, Houston, Texas.**

**FLORIDA. New Lake County development adjoining Ocala National Forest. Best fishing, hunting. Safe from bombs. Nice homesites \$245 at \$10 monthly. Fold-over free. Howard Vernor, DeLand, Florida.**

**CANADA—Hunting, fishing lodge. Dollar for details. Box 248, Whalley, B. C., Canada.**

**CALIFORNIA, Oregon, Washington land. Acres and acres of virgin soil. Ideal for farming, ranching, resorts, etc. Sacrificed for delinquent county taxes. Your opportunity to buy now from \$5 to \$10 per acre full price, including 100% oil and mineral rights. Send 10c (coin) for full details, catalog, photos. Pacific Lands, Box 2350 BW, Hollywood 28, California.**

**CANADIAN Tax sale lands for two dollars an acre and up. Small monthly payments. Farms, timber, hunting and fishing camps, minerals. Limited number of properties. Write at once for free catalogue. Tax Sale Service, Room 105, 120 Bloor St., W., Toronto 5, Canada.**

**TWO Strout catalogs. East and mid-west red cover; west coast edition blue. Farms, homes, businesses, bargains galore. Either mailed free. Strout Realty, 7 So. Dearborn St., Chicago 3, Ill.**

**\$5.00 MONTHLY Buys 40 acres near town; price \$200.00. Free list. Box 425-P, Carthage, Missouri.**

**FARM-Ranch opportunities. Favorable conditions. Washington, Minnesota, Montana, Idaho, Oregon, North Dakota. Literature, farm descriptions. Specify which state. J. W. Haw, 119 Northern Pacific Ry., St. Paul 1, Minn.**

**HOMESITES \$300—Convenient payments. California's finest garden section. On Morro Bay's scenic shores. Wonderful fishing, boating, bathing. Fertile soil, softest water, temperate climate, congenial community. Free literature. Richard Otto, Department M, San Luis Obispo, Calif.**

### POULTRY, FARM SUPPLIES

**KNOW How to raise poultry for profit. Read Poultry Industry. Every issue packed with helpful hints and practical suggestions. Latest articles on breeding, feeding and management. Subscribe now, 1 year 50c, 3 years \$1.00. U. S. funds or checks payable at a New York or Boston bank. Poultry Industry, Dept. PM, 376 Boylston St., Boston 16, Mass.**

**BABY Chicks, America's finest, 50 varieties, 8 crossbreeds, bloodtested, sexed or unsexed, low prices. Gorgeous poultry book free. Berry's Farm, Route 12, Clarinda, Iowa.**

**RAISE Turkeys the new way. Write for free information explaining how to make up to \$3000 in your own backyard. Address National Turkey Institute, Dept. 3, Columbus, Kansas.**

### PROFITABLE OCCUPATIONS

**MAKE Money at home with Larson leathercraft. No experience needed. Easy-to-assemble belts, purses, gloves, etc. Send 10c for big catalog of 100 ideas. Largest stock in U. S. J. C. Larson Co., 820 S. Tripp Ave., Dept. C75, Chicago 24.**

**WANT A diesel job? Our approved, up-to-the-minute diesel training program can help you qualify for steady, big pay jobs or specialized military training. Covers diesel, tractor, heavy equipment repair, service, operation. Easy to master. High grade mechanics tools, worth \$50 come with course. No loss of present income. Job placement advisory service. Investigate! We invite comparison of material and service. Write for information today. Interstate Training Service, Dept. 3C, Portland 13, Oregon.**

**MAKE Flexible molds! Cast plaques, bookends, figurines! Free sample! H. Tooker, 630-M Chestnut, Hamilton, Ohio.**



**TURN** Your spare time into cash. Make quick-selling, highly profitable lamps — every home a prospect. No experience or special tools required. New 1952 56-page illustrated catalog shows shades, shade frames, figurines and bases, oil lamp converters, boring compounds, and dozens of similar items. Also all kinds of sockets, cords, pipes, harps, finials, bases, and hundreds of other parts—everything you need. Special 8-page section shows 6 beautiful lamps in kit form ready to assemble. You buy wholesale, sell at retail—make big profits. Hundreds doing it. You can, too. Send 25c today for catalog and wholesale price list. Refundable first order. Gearon Co., Dept. 500-B3, 27 S. Desplaines, Chicago 6, Ill.

**"HOW To Make Money With Simple Cartoons"**—A book everyone who likes to draw should have. It is free; no obligation. Simply address Cartoonists' Exchange, Dept. 93-CP, Pleasant Hill, Ohio.

**CONSTRUCTION Job list.** Published monthly. \$1.00. Dempster's Construction Scout News, Dept. 268-JD, Bridgeport, Ill.

**FOREIGN Employment construction men,** building trades, helpers, office men, others, interested in foreign projects. High wages, quarters, transportation. Send \$1 for foreign construction compendium and application forms. Foreign Service Bureau, Dept. PM-3, Metuchen, New Jersey. (Not an employment agency—No fees.)

**START Profitable mailorder business.** Everything supplied at low cost. For details write Galle's, Box 326, Station A, Atlanta, Georgia.

**RAISE Earthworms.** Outstanding opportunities. \$200 monthly possible! Book, complete instructions, \$1.00. Free details. Ozark Worm Farm-J, Willow Springs, Mo.

**RAISE Earthworms for profit.** Folder, "David's Folly." Earthworm Farm, Westbrookville, Maine.

**JUMBO Frog raising profitable.** Information 10c. Vol Brashears, Berryville, Ark.

**YOU Can raise domesticated earthworms.** Sensational profits. Instructions free. Midwest Earthworm Farms, Box 999E, Wichita 1, Kansas.

**FOREIGN Jobs.** Contracts underway and soon starting in Africa, South America, Canada, England, Europe, South Pacific, Middle East, Mexico and Alaska. Send \$1.00 for foreign job news, information, application forms, etc. DCS Foreign Job News, Dept. 268-JE, Bridgeport, Ill.

**BUSINESS Without investment!** No selling. No manufacturing. No merchandise inventory. No technical experience required. \$200 weekly possible. Details free! Lurene Business Plans, P.O. Box 4692, Dept. PM, San Francisco, Calif.

**MUSHROOMS Grown.** Boxes, Barrels. Instructions 50c. Spawn \$1.00. Manureless process. \$2.00. Gordons, 328 Bannerman, Winnipeg, Manitoba.

**\$100-\$200 WEEKENDS.** No selling or manufacturing. Mahaffey, 3032-W Weldon, Los Angeles 65.

**PRINT Without a printing press.** Big profits! See page 74.

**\$4 TO \$10 Hour spare time,** billion-dollar adjustment field. Free book—Now! Universal Schools, M-54, Box 8202, Dallas 5, Texas.

**HONEST Information!** Pictures. Leading rabbit farming magazine. Not hobby. Sample dime. Box 5142, Miami 29, Florida.

**ALASKA!** Just released! Over 50 gigantic new construction contracts! Names, addresses, companies hiring, \$1.00 complete. Alaskan Opportunities, (PM) Box 362, Kenmore, Wash.

**ALASKA—Last American frontier.** \$1.00 brings 1952 business directory, government map, construction projects military and civilian, homestead and highway facts, hunting-fishing-game rules, mining, aviation. List of firms hiring. How-when-where to apply. Alaska Opportunist, P.O. Box 883-P, Hollywood 28, California.

**FOREIGN And Latin American employment.** 1952 "Foreign Service Directory" gives up-to-minute facts on military and civilian construction, government jobs, major oil listings, aviation, transportation, steamship lines, mining, importers, exporters, how-when-where to apply, application forms, hot list firms hiring. \$1.00 postpaid. Global Reports, P.O. Box 883-P, Hollywood 28, Calif.

**FREE Book "505 Odd, Successful Businesses."** Work home. Expect something odd! Pacific, Oceanside, Calif.

**OWN A printing business.** Good profits printing cards, stationery, etc., in spare time. Easy rules furnished. Have home shop. Send dime for illustrated printer's supply book and samples. Kelsey, Inc., I-24, Meriden, Conn.

**"EVERYBODY Likes candy"**—Learn to make professionally. (Our 40th year.) Ragsdale Candies, D6, East Orange, New Jersey.

**EARN Up to \$400 monthly** raising Angora or New Zealand rabbits. Plenty markets. Particulars free. White's Rabbitry, Newark 61, Ohio.

**RAISE Pheasants on the \$100 week plan.** Little capital and space can make you independent. Free details. Great Central Game Management System, Columbus 1, Kansas.

**\$40.00 WEEKLY Made** growing mushrooms, fresh, dried. Dominion patent 331583. Free spawn. North American, 169P Yonge, Toronto, Canada.

**BE The Popular Mechanics representative** in your neighborhood and earn big profits in your spare time. Write Popular Mechanics Magazine, Room 408M, 200 E. Ontario St., Chicago, Ill.

## BOOKS, PERIODICALS, PICTURES POSTCARDS

**25c IN Coin** brings 5 Kodachrome reproductions Michigan copper country postpaid. Goodman Photo, Houghton, Mich.

**BOOKS—Government surplus.** Textbooks, including International Correspondence Schools Home Study Pamphlets. On half million volumes. Bargain prices. Free catalog. Long's College Book Co., Dept. PM, Columbus 1, Ohio.

**"BOARD"** Baseball game. Different, exciting. \$1.00. Smitty, 132 Bartley, Mansfield, Ohio.

**MAGAZINE Subscriptions** taken for technical and business magazines. Educational Aids, Dept. 1, Box 248, Temple City, California.

**500,000 MAGAZINES** And books of every description. Back dates and current. Wholesale and retail. C. W. Bookstore, 38 Myrtle Avenue, Brooklyn 1, N. Y.

**OUT Of print books!** Send wants. Book Finder, Cincinnati 30, Ohio.

**10 SCENIC Postcards of Paducah,** the Atomic City. 35c. Jerry Toof, 3939 Sunset Ave., Paducah, Ky.

**MORE Amazing and startling than Science-fiction.** "The Complete Prophecies of Nostradamus." Contains over 1000 astounding prophecies from 1555 to the present, which have proven themselves with uncanny accuracy—and beyond until 3797. Contains old French text and exact English translation, in plain language easy to understand. Translated, edited and interpreted by Henry C. Roberts. 350 pages, handsomely bound 6"x8". \$3 postpaid. Nostradamus, PM, 380 Canal St., New York City 13.

**MAGAZINE Subscriptions wholesale!** Bedard Publications, Dept. PM, Box 637, Detroit 31, Michigan.

**CATALOG 400 Popular books.** Bargain prices, 10c. Books Publishing Co., 56-F W. 24th St., New York 10.

**MAGAZINES (Back dated)—Foreign, domestic — Arts, books, booklets, subscriptions, etc.** Catalog 10c (refunded). Cicerone's, 86-22 Northern Blvd., Jackson Heights, N. Y.

**BOOKHUNTERS!** All subjects. Send wants! Jaher Book Service, 620-P East 178 Street, New York 57.

**BOOK "Breeding of Parakeets" and cage-bird magazine—\$1.00.** Audubon Publishing Co., 3449-PM N. Western, Chicago 18, Illinois.

**BOOKHUNTERS!** Scarce, unusual, miscellaneous books supplied. Atlantic Book Service, Lawrence Avenue, Charlestown 29, Massachusetts.

## GAMES AND ENTERTAINMENT

**MARIONETTES,** Taught, easy. Particulars 3c. Finis Magis Co., 1214 Randolph, Waterloo, Iowa.

## MAGIC TRICKS, PUZZLES, JOKER NOVELTIES

**MAGIC Trick,** genuine wooden nickels and magic catalog, all for 35c. Fun'n Magic, 511 N. St. Marys, San Antonio, Texas.

**MINDREADING.** Mysterious yet simple trick. Send dollar to Andrew Snyder, 169 Norfolk St., New York 2, N. Y.

**GREATEST Book on card tricks—"Expert Card Technique"** (cloth, 500 pages, 352 illustrations), \$6.00. Other magic books, \$1.00 up. List free. Fleming Book Company, 728 Madison, York, Penna.

**FREE Trick with 1952 illustrated catalogue 10c.** Maj Magic Products, 23-P Friends Lane, Westbury, N. Y.

**VENTRILOQUISM Taught,** 3c stamp brings particulars. Smith, 801 Bigelow, Peoria 5, Ill.

**MAGIC Monthly,** year 25c. New 1952 magic catalogue 10c. New joke lists 5c. Magic Factory, Minneapolis 2, Minn.

**HAVE Fun** telling fortunes with cards. New system. Experience unnecessary. Send \$1.00 for detailed instructions, card meaning chart, and six mystifying card tricks. Fortune Teller, Box 1421, Ogden, Utah.

**"DUNNINGER'S Tricks."** Not a catalog! 125 mystifying tricks you can easily perform. Illustrated. Explained. Get your money's worth! Send only \$1.00 for your copy now! Loyal, 4014-C Amundson Avenue, New York 66.

**PROFESSIONAL Catalog and free trick 35c.** Terry's Magic Studio, 6606 Duryea Court, Brooklyn 19, New York.

**WORLD'S Largest professional magic shop,** keeps you in touch with latest tricks. To receive mailings, send \$1.00 for new catalog. Holden's, M220 West 42nd St., New York.

**BIG Fun kit!** Tricks, jokes, novelties, books. Real clever stuff. Howls galore, \$1.00. Johnson, 414 McRae, Wilmington, N. C.

**16 CARD Tricks and catalog 25c.** Sterling Magic, Royal Oak, Mich.

**FREE Trick and large illustrated catalogue, 35c.** Lerro Magic, 509 80th Street, Brooklyn 9, N. Y.

**LATEST Magic for pocket, parlor, stage.** Catalog 500 tricks, only 10c. Unequaled magic service for 30 years. Douglas Magieland, Dept. 1, Dallas, Texas.

**512-PAGE Catalogue of 2500 tricks,** pocket, parlor, stage. World's finest magic. Send \$1.50 for catalogue (refunded first \$6.00 order). Kanter's, M-1311 Walnut, Philadelphia 7.

**PROFESSIONAL Catalog,** 124 pages, 25c. Williams, 900 Plymouth, Ellwood City, Penna.

**BE A magician.** Large professional magic catalog of latest tricks, 35c. Ireland, C-109 North Dearborn, Chicago 2.

## COINS, TOKENS, CURRENCY

**WE Pay \$5 to \$500 each** for hundreds of old or odd U. S. and foreign coins. Keep all until posted. Send 20 cents for illustrated coin value book, with bargain lists free. 45 years in business. Coin Exchange, Le Roy 7, N. Y.

**OLD Money wanted.** Will pay \$100 for 1894 dime, S. mint. \$50 for liberty head nickel (not buffalo). Big premiums paid for all rare coins. Send 4c for large coin folder. May mean much profit to you. Numismatic Co., Dept. 20, Fort Worth, Texas.

**UNITED States coins bought, sold.** Johnson, 644 E. Valerio, Santa Barbara 3, Calif.

**MORGAN Series:** 10 different halves \$8.75; quarters \$5; dimes \$3; 20 Indian-heads \$1; 4 large cents \$1; sensational 100-coin grab-bag \$6.50. List 10c. Nelson, Box 346, Rye, N. Y.

**COMMEMORATIVE \$1½ — Columbus,** Stone Mountain, Oregon, Pilgrim, Texas, Ky., Washington, Cleveland, \$2.00 ea. Coin catalogue, thousands of coins, 25c. Shultz, Salt Lake 10, Utah.

**BARGAINS!** Rare collection contains United States cent before 1815, 1851 cent, colonial coin before 1790, half cent, flying eagle cent, 1863 cent, 1865 cent, uncirculated 1909 VDB cent, 1923-S cent, 2c pieces, 3c silver, 3c nickel, half dimes, shield nickel, 1883 nickel, 1913 nickel, Liberty seated dimes, Columbus 50c, old \$1.00 bill, Civil War cent, Jackson cent, Confederate money, foreign coin, foreign bill, ancient coin 1500 years old, complete buying-selling catalogue everything \$5.00, 20 different Indian cents \$1.00, 10 different Liberty nickels \$1.00, 10 different large cents \$2.00, 1864L cent \$2. Everything \$10.00, catalogue 25c. Worthycoin Corporation, (D-420), Boston 8, Massachusetts.

**FREE!** Foreign coin, banknote and coin collectors illustrated catalog to approval service applicants. Send 3c postage. Tatham Coinco, Springfield 30, Mass.

**40 DIFFERENT Coins.** \$1.00. 100 different bills, \$1.00. Oddehon, Box 482, St. Louis, Mo.



**FIFTY** Assorted Indian cents, \$1.50. Rare 1931-S cents, \$1.00. Giant fifty-two page illustrated bargain catalog, 10c. Ben's PM Department, 31 North Clark, Chicago 2.

**COIN** Collector's Magazine. Largest independent, over 1000 pages per year. Sample copy 30c; \$3.00 per year. Hewitt, 5450-J Clark, Chicago 40.

**FOREIGN** Money, wooden nickels, and "coin collector's" big new magazine 10c. Lawrence Brothers, Anamosa, Iowa.

**GET** Profit and pleasure in collecting old coins. Send 10c for 56 page illustrated coin catalog. You'll be delighted with it. Send for it now. B. Max Mehl, 370 Mehl Bldg., Fort Worth Texas. Largest rare coin establishment in U. S. Established 52 years.

### OLD STAMPS WANTED

I Will pay \$100.00 each for 1924 1c green Franklin stamps, rotary perforated eleven (up to \$1,000 each unused). Send 10c for large illustrated folders showing amazing prices paid for old stamps, coins and collections. Vernon Baker, PM-23, Elyria, Ohio.

### STAMP COLLECTING

**COLLECTION** At a standstill? Let us show you our top quality 1c to 5c approvals. Many satisfied customers. Write today. References appreciated. Roseland Stamp Co., Dept. 10-D, Spring Lake, Michigan.

**FREE** Complete set of famous Americans, flags, parks and presidentials to approval buyers. Send 3c for 15 of the above stamps plus full particulars. Triboro Stamp Company, 145 Nassau Street, Dept. 102, New York 38, N. Y.

**IS** Your hobby expensive? Are high prices keeping your collection on the shelf? Try our 1c and 2c foreign approvals in books of 1000, or U. S. at bargain prices. Clark, Box 544P5, Muskegon, Michigan.

**FREE!** Monaco nude set 3. This popular set being offered new approval applicants. M. Moubliow, 740 Hegney, Bronx 56, N. Y.

**FINE** Approvals. Fast, personal service. What countries do you prefer? I'll send their stamps. Skinner, 438 Locust, Long Beach 12, California.

**500 MIXED** U. S. commems, airs, coils, etc. 20c. Sibley, Mendon, Mass.

**FREE** 50 Different stamps only to serious approval applicants. Stanley Zajac, 710 Shaw St., Toronto, Canada.

**COMMEMORATIVE** Mints wholesale, sheets, fours, singles. Write Stamps & Buttons, Rockford, Minn.

**55 DIFFERENT** United States, including airmails, presidentials, commemoratives, revenues, etc. Only 5c. Approvals. Free big lists. Bookman, Maplewood, N. J.

**CANADIAN** Collection free—Includes early Victorian issues, jubilees, high values, commemoratives, special issues, Newfoundland, pictorials, etc., etc., together with Philatopic Magazine all free. Send 5c postage. Empire Stamp Company, Dept. PM, Toronto, Canada.

**POUND** Stamps containing thousands \$1.00. Longacre Shop, 581 Sixth Ave., New York 11.

**GIANT** Approvals. Thousands different at 1c and 2c. Wahl's Stamp Exchange, 7008 Farragut, Chicago 31, Ill.

**UNITED** States all different. 8 airmails plus 50 others. Including commemoratives for 10c to approval applicants. Sunset, Dept. 99, Box 47, South Gate, Calif.

**FREE** Mint British Colonies from Niue, Gilbert Ellice, Nauru, Turks Caicos, Brunel, Caymans, Tonga, Pitcairns, Sarawak. Free with approvals. Viking, 130-Z, Clinton St., Brooklyn, N. Y.

**GORGEOUS** Angolas, dime with approvals. Harris, Box 4, Tomkins Cove, N. Y.

**DEALERS**—Wholesale list. Postage 3c. Frank, 5031 Queensberry, Baltimore 15, Maryland.

**FREE** Illustrated catalog. U. S., foreign. Hurt and Fosse, Blue Ridge, Virginia.

**100 NETHERLANDS.** All different. Beautiful assortment. 10c with approvals. Thomson's, Box 4074-P, Miami, Florida.

**STAMPS, Albums, packets!** Big 1952 44 page illustrated catalog free! "Stamps By Mail," 2133 Lunt, Chicago 45.

**OUTSTANDING** Offers galore. The Stamp World 10c. Sibley, Mendon, Mass.

**100 SOUTH** American stamps, souvenir 10c, approvals. Austin, 2917p Grand Concourse, New York 68.

**FREE**—Bahrain! Double bonus approvals. Stampmart, Box 28A, Rutherford, N. J.

**ITALY**—100 Different 5c with approvals. DeRespinis, G.P.O. Box 771P, New York 1.

**UNITED** States. 10 large commemorative 3c, approvals. Winehold, Woodbine, Penna.

**100,000 STAMPSATIONAL** Grabbags, 25c each! Niagara Stamp Company, 15 Queensway, Niagara-on-the-Lake, Canada.

**200 DIFFERENT**, Triangle, airmail, pictorials, etc., 10c. Carlton's, Tujunga, Calif.

**FREE!** Your choice! 25 different from penny approvals. Hanlon, Box 407-M, Upper Darby, Pennsylvania.

**FLAG** Stamp—Free with hygrade U. S. approvals. Wenigman, 1933 Patterson, Chicago 13.

**GERMANY** B218-229, "Nazi army" war-planes, submarines; free to approval buyers. William Deems, Ravenswood, West Virginia.

**ILLUSTRATED**, Complete U. S. list—6c postage. Hantak, 1030 Euclid, Cleveland 15, Ohio.

**GRABBAG**—Sets and singles from 57 different countries, 10c! Approvals. Billingslea's, Gilmer, Tex.

**FREE**—50 Mint. Including San Marino St. Marinus set, approval applicants. Broadmoor Stamp Co., Pittsburgh 34, Penna.

**ALBUM!** Holds over 1000 stamps! Only 10c! Stampmart, Hartford 1, Conn.

**FREE!** 50 Japanese stamps (all different). Approvals. Star Stamps, 225 Willard, Jamestown, New York.

**1000 NICE** Stamps, plus packet cataloging \$5.00, both \$1.00. Orin Brown, 3309 11th S.W., Canton 10, Ohio.

**SCANDINAVIA**—100 Different, 20c! Netherlands, 100 different, 20c! Free lists. Hantak, 1030 Euclid, Cleveland 15, Ohio.

**FINEST** Quality stamps. Low prices. Free catalog. Excello, Box 500, Shreveport, Louisiana.

**FREE!** Large pictorials from medieval Malta! With temptingly-priced approvals. "PG," 195 Park, Lewiston, Maine.

**SERIOUS** Collectors! Custom-made approvals to your requirements. State your needs. Brooks, 2352W East 23rd Street, Brooklyn 29, New York.

**STAMPS**—World different; 1000, \$1.00; 2000, \$2.25; 3000 \$5.00; 5000, \$13.00. Mounted. Russell, Box 2011-D, Natural Bridge, St. Louis 15, Mo.

**FREE** Monaco holy year short set, including two triangles. Sent to approval applicants. Pegasus Stamp Company, 716-M DeKalb Ave., Brooklyn 16, N. Y.

**FREE** Sample—Interesting, informative, illustrated! National Stamp News, Anderson, South Carolina.

**POLAR** Bear triangle, giant George Washington, six colored Ecuador, Arctic triangle, first American commemorative, Corsica, Devils Island, others. Everything free with approvals. Capital Stamps, Little Rock 2, Ark.

**SCARCE** Nicaragua Roosevelt, Madagascar, Turkey, Martinique, Ecuador, Somali Coast, Cuba, Mints. Send 3c. Silas Stamps, Box 55-X, Triborough, New York 35, N. Y.

**NUDES** Set and colorful approvals—10c! Atlas, 2830-a Eisenhower, Racine, Wis.

**FIVE** Mint plate box \$1. Guaranteed preferences. Tunstall Stampex, Greenville, N. C.

**FREE** 10 Japan war stamps. Approvals. Schroeder, 1486 1/2 Sherburne, St. Paul 4, Minn.

**200 UNIVERSAL** Different stamps, 10c. Charlie Seifert, Box 1672, Reading, Penna.

**U.S. And Confederate** states catalogue free. Stone, 45 Bromfield, Boston 8, Mass.

**FREE!** Pictorials—Penny approvals. Pegrum, Box 785, Huntington Park, Calif.

**BOOKS** Of 1000 selected stamps, 1c—2c each! Niagara Stamp Company, 11 Queensway, Niagara-on-the-Lake, Canada.

**"GOYA** Nude" 3c with approvals. Royal Stamp Company, Tamaqua, Penna.

**BEAT** This if you can! Over 520 different stamps, catalog over \$11, for only 25c to serious adult approval applicants. Free illustrated price list. Cosmophilatelist, Andover, N. J.

**310 BRITISH** North America early issues, airmails, commemoratives, all off paper, catalog value over \$7.00 with Canadian price list and Emco Journal included. Send only 25c. Marks Stamp Company, Dept. PM, 92 Adelaide St. W., Toronto, Canada.

**1/2—1—2c APPROVALS.** Bargains galore! Cole, 43 Rinewalt, Buffalo 21, N. Y.

**UNITED** States stamps nearly 100 years old, Roosevelt set, others, 40c value—only 5c to applicants United States approvals. Wakonda, Box 272K, Jackson Heights, N. Y.

**BAHAWALPUR** Silver jubilee mint set, free to applicants of United States or British Colonial approvals. Alan Taylor, Box 735, Winter Park 2, Florida.

**5 POUND** Transvaal (cataloging \$2.00). Goya nude, Indonesia blockade issue, Russia rubles, triangle, diamond. Everything 25c, including approvals. Stampex, 116-T Nassau, New York City.

**GERMANY**—Colonies, offices, states. Most 1/2-1/5 catalogue. Approvals—list 3c. Myers, VanZandt Ave., Little Neck, N. Y.

**LIBERIA** Colorful animal set only 20c. Approvals. Herman Wolfel, 135 Glenwood, Manchester, New Hampshire.

**FIRST** U. S. (1847) government reissues 5c, 10c, plus giant bargain U. S. collection—only 5c to applicants U. S. approvals. Metropolitan, Box 312G, Jackson Heights, N. Y.

**BEAUTIFUL** N.Z. semipostal triangles picturing British Princesses only 10c with worthwhile approvals. George Richie, 1539 Sixth, Alameda, California.

**FREE**—Illustrated catalog! Kenmore, Milford, C-57, N. H.

**U. S.** Illustrated price list free. Lush, 9627 Martindale, Detroit 4, Michigan.

**GET** This! Airmail book, plus over 100 airmail stamps—only 15c. Thrilling stories, valuable information on beautiful airmails from the world over including \$10,000 airmail—all for 15c! Big bargain lists and approvals. Jamestown Stamp Co., Jamestown 708, N. Y.

**50 DIFFERENT** Latin American airmail stamps 30c. Approvals. Johnson, Box 367, Morgan Hill, Calif.

**PENNY** Approvals by country. M. H. Hoerning, 15, Farmington, Ark.

**"HOW** To Recognize Rare Stamps." Free book illustrated! Kenmore, Milford, H-57, N. H.

**U. S.** Illustrated price list free. DeLisle, 154 S. 2nd St., San Jose, Calif.

**FREE!** Spanish Guinea #305-7 with foreign approvals. Sharp, Temple 1, Penna.

**RUSSIAN** 250,000 Ruble stamp plus 311 others 10c. Goliath, Bethlehem 2, N. H.

**PENNY** Approvals and specialties. Lush, 9627 N. Martindale, Detroit 4, Mich.

**FREE.** Scott's International Album. Other big premiums. Full particulars with approvals. Raymax, 68-Z Nassau St., New York 38.

**500 EXOTIC** Japan stamps—10c. Kenmore, Milford, J-57, N. H.

**WONDERFUL** Offer. 7 complete mint sets Manchukuo, Bohemia, etc., only 10c with approvals. Reich Stamp Co., 4647 Kenmore, Chicago 40, Dept. M23.

**TALKING** Drums (Gold Coast); 2 Nicaragua triangles, 55 other beauties, total catalogue \$2, all only 2 dimes. Approvals. Reuter, 611 W. 40th Pl., Los Angeles 37.

**DIFFERENT** 500, 35c; 1000, \$1.00; 2000, \$2.00; 5000, \$10.00 with approvals at wholesale to clear. K. S. Holmes, London, Can.

**U. S. Army and Navy** heroes on stamps; 10c with United States approvals. Locust, Box 305-T, Harmon-on-Hudson, New York.

**500 MIXED** Stamps and surprise packet for 10c, with approvals. Fahsing, Dept. PM, Atascadero, California.

**COMPLETE** New issue free to new approval applicants. Paul Seaman, Box 176, Langhorne, Penna.

**POUND** Mixtures. U. S. or foreign, \$1.00. Book Nook, Willmar 61, Minnesota.

**FREE!** Big United States catalog! Invaluable guide and check list. Hundreds of illustrations. Harris & Co., Boston 17, W—Mass.

**110 DIFFERENT** Hitlers, Roosevelt, Liberia, Haiti, etc. with approvals 10c. Buckley, 208 Ludlow Bldg., Dayton 2, Ohio.

**U. S. Specialists!** Stamps, coins. Write 210 South Sixth Street, Minneapolis.

**FREE** Packet with introductory approvals. Luther Chick, 436 No. Main, Brewer, Maine.

**U. S.** Price list free. P. Wetterquist, 1635—13th Avenue, Rockford, Illinois.

**100 DIFFERENT** Spain 25c. Penny approvals included. Reed, Box 980, Chicago 90, Ill.



**FREE!** Big illustrated catalog! "Everything for the stamp collector." Harrisco, 202 Transit Bldg., Boston 17, Mass.

50,000 STAMP Grabbags 25c each. Anderson, 630B Bingham, Reading, Penna.

**FREE.** 750 Mixed U. S. for dime postage. Weatherby, Medina, Ohio.

10,000 PENNY Approvals waiting for you. Many from exotic countries, pictorials, airmails, new issues. Tilbury, Box 862, Newark 1, N. J.

**FREE.** 25 Different U.S., approvals accompany. Village Stamps, 90-39P 214 St., Queens Village 28, N. Y.

**FREE** Collection — Over 100 different stamps of world; commemoratives, animals, natives, ships, famous men, others all to approval buyers; also Scott albums, catalogs. Bell Stamp Service, Dept. S-2, Bell, Calif.

**START** Your own stamp business. Send for free circular. Donald Shepard, Box 1147, Chicago.

**ZOUNDS!** Amazing "queer countries," savage and exotic lands packet. Absolutely free with approvals! Saxon, Vista, Calif.

205 AUSTRIA—All different only 10c. Beautiful commemoratives, pictorials, airmails, high values. Catalog price nearly \$6! Approvals. Garcelon, Calais 111, Maine.

NICARAGUA Sports, Costa Rica agriculture sets 10c with approvals. Seminole Stamps, Box 1138-P, Coral Gables 34, Fla.

UNITED States approvals—Select, used, mint. Kingsbury, South Woodbury 2, Vt.

10,000 DIFFERENT 1c Each! Gordon Davison, Box 1019S, Manchester, N. H.

312 MIXED U.S. only 10c to "gold nugget" approval applicants! Nothing like them. Kessel's, Folsom, California.

OLD Scarce U. S. seconds on approval. Slightly defective. Bargain prices. Herfield, Clintonhill Station, Newark 8, N. J.

50%-75% DISCOUNTS! Approvals from 33,000 collection—1/2c up! Schur, Box 235, Buffalo 12, N. Y.

750 FRANCE And colonies stamps 10c. Littleton Stamp Co., Littleton 25, N. H.

300 DIFFERENT Given free with approvals. Postage 3c. Windsor Stamps, 1435 East 67th Place, Chicago 37.

50 DIFFERENT U. S. 10c. No approvals. Seidenberg, 944, Appleton, Wis.

STAMPS Wanted. Collections, duplicates, surplus stock, mint and used. Buy outright if bargain. What have you? Vanroy Shirk, Lebanon, Penna.

77 DIFFERENT United States—25c. Approvals. Utechts, 1143-D North Keeler, Chicago 51.

307 ALL Different—Only 15c! Beautiful collection: commemoratives, triangles, high values, bicolored stamps, etc. Garcelon, Calais 400, Maine.

NOTHING Free. Just good stamps reasonable. Send dime for seventy-four page catalog. Ben's Stamp Shop, 31 N. Clark, Chicago 2.

FREE U. S. price list, postage 3c. Mark Hanna, 335 5th Ave., Pittsburgh 22, Penna.

**AMAZING Offer!** 500 United States stamps—including commemoratives, airmails, high values to \$5.00. Only 10c to approval applicants! Illustrated bargain lists free. Mystic Stamp Co., Dept. 80, Camden, New York.

**FREE "Stamp Finder."** Tells instantly country to which any stamp belongs. 32 pages profusely illustrated. Garcelon, Calais 17, Maine.

**WOW!** 203 All different Germany 10c! Zeppelins, semipostals, airmails, high values, etc. to new customers. Jamestown Stamp, Jamestown 512, New York.

**WORLD'S Largest stamp** (7 1/2 x 14 inches). A real curiosity! Retail for 50c, only 3c to approval applicants. Tatham Stamp Co., Springfield 30, Mass.

500 STAMPS For only 10c! This mammoth value includes airmails, pictorials; stamps from strange countries, cataloging up to 25c each! Also approvals. Mystic Stamp Company, Camden 80, New York.

**COLUMBIANS.** Trans-Mississippi, Pan Americans, Pan Pacific, ten other different commemoratives. All 10c with your request for U. S. approvals. Moda Stamps, Box 261-X, C.S.A., New York 8.

**FREE!** Powerful magnifying glass. Jamestown Stamp, Jamestown 202, New York.

200 DIFFERENT Including Roosevelt triangle, 5c to approval applicants. M. Avalon Stamp Company, Springfield, Mass.

### ANTIQUES, RELICS, INDIAN GOODS, CURIOS

4 ANCIENT Perfect arrowheads \$1.00. Grooved stone tomahawk \$3.00. Perfect peace pipe \$5.00. List free. Lear's, Glenwood, Arkansas.

### PRECIOUS STONES, MINERALS

GRADUATE Geologist ships mineral suites (collections), amateur, professional. \$2.00 up. Moffet, 11303-75 Avenue, Edmonton, Canada.

"JUDGING Gems" \$1. Free list unusual handicraft manuals. Technicraft Publishers, 3207 Winnie Drive, Hollywood 28, Calif.

MINERALOGY Course \$5.00. Western School of Mineralogy and Mining, Inc., Box 1130, Longbeach, Calif. Inquiries appreciated.

GEMS, Precious and semi-precious, genuine, from world-wide sources. Deal direct, no overhead, save money. Catalog 10c. Hill Co., 5450-G Portland Rd., Salem, Oregon.

FIND Tungsten, mercury, uranium with mineralight. Free brochure. Write Dept. PM8 Ultra-Violet Products, South Pasadena, California.

GEMCUTTING, Silvercraft authority. Illustrated magazine tells how. Cut rocks, make jewelry. 150 ads illustrating equipment, offering gems for collectors, cutters. Postal brings literature. Lapidary Journal, Drawer B, Palm Desert, Calif.

GEMSTONES, Mineral specimens. Every variety. Lowest prices. Postcard brings free booklet. Plummer's, 2183C Bacon, San Diego 7, California.

### HOBBIES AND COLLECTIONS

GET Acquainted offer. 50 different matchbook covers 25c. Free lists. Yeingst, 502 Parkway, Harrisburg, Penna.

HOLLYWOOD Famous nite spot souvenirs, menus, book matches, etc. Big assortment \$1.00. James Hackney, Box 9222, Station S, Los Angeles, Calif.

GENUINE Airline baggage stickers! Foreign and domestic. Twenty different \$1.00. Hester, 114 Franklin Street, (3-H), Morristown, N. J.

COLLECT Cartophilic cards! New fascinating hobby. Interesting packet containing birds, butterflies, aeroplanes, flowers, trains and other rare cards. Plus big illustrated catalogue. All for 10c. International Cartophilic Co., Dept. PM, 1152 Yonge Street, Toronto, Ontario.

UNUSED Matchbook covers—100 different \$1.00 36-page catalog 25c. Charles Edelman, 1311C East 84, Cleveland 3, Ohio.

INVENTING Can be an interesting and profitable hobby. Write for complete particulars. Institute of American Inventors, Dept. 40-E 831-E St. N.W., Washington 4, D. C.

FREE Blueprint Catalog! Hundreds of projects—motor scooter, furniture, toys, birdhouses, radios, garden furniture, power tools, boats, workbenches, home freezer, many more! Send postcard to Popular Mechanics Press, Dept. 103, 200 E. Ontario, Chicago 11, Ill.

### CAMERAS, PHOTO SUPPLIES

PUT Better titles into your home movies. Free catalogue. Elite, Box 526M, Minneapolis.

TELEPHOTO Cameras easily made. Telephoto lens and instructions \$5.00. Instructions alone 10c. Telescopic Cameras, Man-orville, N. Y.

BIGGEST Camera bargains and best place to sell is in the Phototrader. Send for free copy. Box 630, Westport 1, Conn.

BUY Photographic supplies wholesale. Cameras, films, projectors. Expert camera repairing. Free catalog. Capitol Photo Supplies, 2428 Guadalupe, Austin, Texas.

BASS Says: Trading cameras a national habit since 1910. Write to Bass the old "horse trader." A postcard will do. Simply say: "Bass, I have and I want. How much will you allow me?" It's fun to trade with Bass. Satisfaction guaranteed. Bass buys, sells, and trades. Bass Camera Company, Dept. AG., 179 W. Madison St., Chicago 2.

MAKE Half-tone and line negatives for offset or photoengraving with your photo enlarger. 32-page manual tells you how. Price \$3.50. Cliff Edom, 117-M Stewart Road, Columbia, Missouri.

ADD "Spice" to home projection shows with colorful old-time Nickelodeon slides. 2x2. Write for free list. Nickelodeon Co., New Fleidner Bldg., Portland 5, Oregon.

FREE Photographic bargain book packed with hundreds of sensational values in still and movie cameras, lenses and latest accessories. Super savings for you in new and used equipment. Liberal trade-in allowances, too, on your equipment. Write now for your free copy to Central Camera Company, Dept. 9L, 230 S. Wabash Ave., Chicago 4. (Photographic headquarters since 1899.)

PHOTOMURALS. Your negative or ours. Catalogue 25c. Photomammoth Murals, Dept. M, 12048 Vanowen Street, North Hollywood, California.

### PHOTO FINISHING

CUSTOM Photo finishing guaranteed. 8 exposures 35c; 12, 50c; 16, 70c. Bound in beautiful plastic ringed album. Special! 35mm., 36 exposures \$1.00. Free mailer. Flash-Foto, Parkville Station, Box 36, Brooklyn 4, N. Y.

TWO 8x10 Enlargements 50c. Five for \$1.00. Send negatives and coins to Wilart Enlargers, Box 967, Little Rock, Ark.

ENLARGEMENTS—5x7, 25c; 8x10, 40c; New negative 45c; minimum \$1.00. Lawson, 1505 Southern Blvd., Bronx 60, N. Y.

8 CONTACTS 30c, Jumbos 40c, 12-45c, jumbos 55c, reprints 4c, jumbos 5c. Western Photo, Dept. PM252, Box 298, San Francisco 1, Calif.

MAIL Us your films. Prompt service. 8 exposures developed and printed 30c. Foto Art Studio, Box 406, San Francisco, Calif.

16 PRINTS Or 8 jumbos from roll, 25c with this ad. S. Skrudland, Lake Geneva, Wis.

6 OR 8 Picture roll 35c, 12 or 16 picture roll 55c. Each roll printed and developed. Handy album pack. If you fail to get pictures on your film a new roll will be sent you without extra cost. Send coin with roll. No c.o.d.'s. Mailing containers sent free. DeLuxe Film Service, Box 1268-A, Shreveport, Louisiana.

NEW-16 Oversize contact prints, or 8 jumbos in album 25c. (Trial.) Album Studios, Weatherford, Okla.

8-EXPOSURE Roll developed and printed, jumbo size, 40c; 12-60c, 16-80c. All prints in attractive memory albums. Free mailers. Crown Photo Service, Box 392B, Augusta, Ga.

### MOTION PICTURES AND SOUND EQUIPMENT

WORLD'S Biggest selection of new and used 16mm. sound, 16mm. silent and 8mm. films—over 100,000 prints on hand! Everything at bargain prices. Savings of 50% and more are commonplace! Good used 16mm. sound projectors—Ampros, Bell and Howells, Victors are often available for as little as \$129.95. Reels, cans, supplies at bargain prices! Write today for your free copy of Blackhawk's big current catalog. "Sixteen's Super Market." Blackhawk Films Inc., 1208 Putnam Building, Davenport, Iowa.

BARGAINS 16MM. sound films. Also for exchange. Bedner, 5300 So. Talman, Chicago.

RARE Old time movies, 16mm., 8mm. Send for list. Film Classics, 1645 N. LaBrea Ave., Hollywood 28, Calif.

FREE Movies. Thousands of subjects. Interesting. Entertaining. Fascinating. New directory, only 50c. National Cine, 126 Lexington, New York 16, N. Y.

CLEARANCE Sale of 16mm. films. Want a real buy in 16mm. sound films? Take advantage of the I.C.S. 1952 clearance sale of 16mm. sound features, comedies, cartoons, novelties, musicals. New, used. Send for our giant list "A" today stating machine you own (make and model). Institutional Cinema Service, Inc., 1560-PM Broadway, New York 19, N. Y.

THE World's greatest story. "Entire Life of Christ;" 8 mm., 16mm. Sound and silent. Rent or purchase. Hemenway Film, 33 F Melrose Street, Boston 16, Mass.

LEARN Free lance, educational, Hollywood, and television film technique at home. State licensed. Write for free catalog. Motion Picture Institute, Birmingham 4, Michigan.



## RADIO AND TELEVISION

5000 NEW-Used 8-16mm. silent-sound films. International, 2120 Strauss, Brooklyn 12.

UNUSUAL 8-16MM. movies. Full-color projection length sample, \$1.00. Color Tru-Art slides, three samples \$1.00. Big catalog, 25c (refundable). National Film Supply, Toledo 9-H, Ohio.

8-16MM. Silent-sound films. Complete rental library. All latest subjects. Free catalogue, sample film 10c. Garden Film, 317 West 50th, New York 19.

BASS Says: Leadership since 1910 guarantees satisfaction. Finest Cine equipment: 8mm., 16mm., and 35mm., silent and sound. Write the old "horse trader." Satisfaction or your money back always! Bass Camera Company, Dept. A, 179 W. Madison St., Chicago 2.

RENT 16MM. sound films, 50c reel. Large selection; free catalog. Film Service, 128 Chestnut St., Roselle Park, N. J.

GUARANTEED Fresh 8mm. roll, magazine; 16mm. roll, magazine movie films. Color, b&w. Free catalog. ESO-S, 47th Holly, Kansas City 2, Missouri.

MOVIE Camera film: 8mm. roll \$1.50, 16mm. 100' \$3.00. Free processing. Better Films, 742 New Lots, Brooklyn, N. Y.

## MUSIC AND MUSICAL INSTRUMENTS

SONGWRITERS! Outstanding, ethical offer. Hibbeler, C-5, 2157 N. Avers, Chicago 47.

SHEET Music 10c; 12 for \$1.00. Irving Siegel, Marshfield, Wis.

LATEST Popular sheet music 40c each. 30 famous hits \$1.50 (\$15 value). Stuart, Box 442, Union, New Jersey.

NAME Your instrument! Lowest prices. Kaye Music, 103B St. Marks Place, New York City.

YOUR Words and our music—A winning combination. Send poems. Free examination. Song Promotion Guild, 350 Broadway, New York 13.

RECORDS. Package ten latest records, popular, hillbilly, blues, \$4.00. Life-time needle \$1.00. Sy's, 1 Ann St., New York 38, N. Y.

MUSIC Arranged. Songs printed. Frank Wildt, Music Publisher, Lancaster, Penna.

POPULAR Songs. How to write and sell them. Write for free booklet Successful Songwriting. Gateway Songs, Box 2470, Hollywood 28, Calif.

SONGPOEMS And lyrics wanted with new and clever ideas to be set to music. Tin Pan Alley, Inc., 1650 Broadway, New York 19, N. Y.

HAWAIIAN Ukulele course. 288 chords, 96 strokes, 12 songs. Send \$1.00 or c.o.d. plus postage. Ukulele, 1411 Irving Park, Chicago 13, Ill.

POEMS Wanted for musical setting. Send poems for free examination. Five Star Music Masters, 630 Beacon Bldg., Boston, Mass.

GUITAR. Master only 12 chords, play hundreds of songs. \$1. Money back guarantee. Bennett, 629 N. St. Andrews Place, Hollywood 4, Calif.

SEND For free booklet, How To Write and Sell Songs. Get the facts first. Poems examined free. Reliable Music Service, Box 430-P, Hollywood 28, California.

SONGWRITERS! Protect your ideas! Hold all songs; poems! Write for Safe Correct Procedure first! Song Service, Dept. P, 333 W. 56th St., New York 19, N. Y.

POEMS Wanted. Broadcast consideration. Sooner Song Co., 22PM North West 8th, Oklahoma City 2.

SONGWRITERS! Send poems, songs. Music Service, 243 West 72nd St., PM, New York 23.

SWING Piano—By mail. 30 self-teaching lessons \$3. (Samples.) Phil Breton Publications, P.O. Box 1402, Omaha 8, Nebr.

POEMS Wanted to be set to music. Free examination. Send poems. McNeil, Master of Music, 510-PM S. Alexandria, Los Angeles, California.

WRITE Songs. Big money and reputation. Write for information. J. Gordon Pub. Co., 4700 South California Avenue, Chicago.

WANTED! Poems for musical settings. Write Songwriters' Service, Clifton, N. J.

ACCORDIONS—Save 50% and up. Cash or terms. New and used. All brands. Wholesale to every one. Free catalogue. Del Principe, 307 South Wabash, Chicago, Ill.

MUSICAL Instruments, accordions, guitars, 10-day trial, 10c for catalog. Meyers, 454-A Michigan, Detroit 26, Michigan.

BUILD 15 Radios—Only \$1.30 each. Experience unnecessary. Home Radio & T.V. Course, includes trouble-shooting and servicing lessons, radio principles, code instructions, practical radio building and repairs. You build and keep receivers, transmitters, amplifiers, test equipment, code oscillator. All parts, tools, instructions supplied including radio tester and electric soldering iron. Write for full particulars and receive absolutely free your copy of "Radio & TV Repair Guide." No obligation. Progressive Electronics Co., 497 Union Ave., Dept. PM-16, Brooklyn 11, N. Y.

MAKE Simple, tubeless, batteryless, distance-getting crystal radios. Crystal and illustrated instructions 25c postpaid. Allen, 427-P, Clinton, Mo.

FREE Electric soldering iron, every serviceman needs one! Get full information. Rose Co., 98S Park Place, New York 7, N. Y.

BUILD A 25c tester—Test your tubes, test others. Diagram, instructions \$1. Alexander, 780 E. 214th, New York 67.

FREE! 212 Page Radio-Television-Electronic Catalog! World's largest stocks, lowest prices. Complete supplies for builders, experimenters, amateurs, servicemen. Latest radios, phonos, television, recorders, sound equipment. Thousands of parts, tubes, test instruments, books, diagrams. Top quality money saving values. Get yours now! Allied Radio Corp., 833 W. Jackson Blvd., Dept. 45, Chicago 7, Ill.

TV And FM antennas. Yagi, conical, bow-tie, mounts, accessories. Lowest prices. Wholesale Supply Co., Lunenburg 1, Mass.

## BUSINESS OPPORTUNITIES

TIN-Cans. Turn them into cash. Nine methods. Instructions 50c. Charles Company, 12-CTG, Norwood, Ohio.

EARN Money at home with your typewriter! Spare time! Details free. Edwards, Publisher, 3915-PM, 12th, Des Moines 13, Iowa.

START Mail order bookshop—Profits to 70%. Profitable future. 25c brings booklet, samples, exciting ideas. General Publications, Ossining, N. Y.

CASH Income from your backyard! Unusual businesses! Pickett's, Florence, Kentucky.

EARTHWORM Business. Raise, sell for gardens, tropical fish food, fishing. Wisconsin Earthworm Farm, Oshkosh, Wis.

NEW Exceptionally profitable plans, ideas for home operated mail business. Rush name. Miller, 1772-P Carlyon Road, East Cleveland 12, Ohio.

FISHWORM Breeding. Profitable. Easy methods. Free literature. Haase, Kent 10, Ohio.

RESILVERING Mirrors, formula 50c; two-way lookout mirrors, (No one sees you), 50c; coppered mirrors, 50c. All \$1.00. Nelko-Mir, Box 3462, Chicago 54.

SAWDUST. Turn it into cash. Twenty methods. Instructions 50c. Charles Company, 12-CTF, Norwood, Ohio.

LIQUID Marble—Colorful, glossy! Molded, brushed, sprayed! Cast novelties, statuary, colored tiles. Flexible molds. Composition floors. Particulars free. Marbleizing Service, Edwardsville, Illinois.

OPERATE Mail order business. Small capital. Free details. Main Service, 157 Britannia, Hamilton, Canada.

START Profitable home business. 101 ideas tells how. Free with year's subscription to Progressive Mail Trade. Maxted Book Agency, Western Springs 4, Ill.

OPERATE Profitable mailorder business. Particulars free. George Lenhoff, Lincoln 8, Nebraska.

FREE Catalogue. Sell jewelry. Bulova. Elgin. Electric appliances. Post, Waynesboro 54, Penna.

VITAMIN Sales business \$50! Includes packaged vitamins worth \$126.00. Labels printed with buyers name, prepared literature, automatic selling plan. Terrific local, national, foreign mail sales. Immense profits. Man or woman can operate anywhere. \$3.00 full size sample \$1.50. Durkin, 410-S West 9th St., Los Angeles 15, California.

MAKE Money with Merritt. Sell men's Davis air cushioned shoes, dress, work, heavy duty. Popular priced. Advance commissions. Cash bonuses. Experience unnecessary. Write to Geo. Merritt Shoe Co., C-103, Brockton, Mass.

DISTRIBUTORS Wanted. Aluminum awnings. Big profits. Big demand. Make your own. Everything supplied. Details free. Kramer Industries, 321 S. Anita, Los Angeles 49, Calif.

START Home mailorder business. Sell books, folios, merchandise. Circulars furnished. Sample folio, 20 imprints, dime. Siegel, Box 84, New York 12, N. Y.

START Your own mail order business with hundreds of live repeat hobbycraft items. No stock to carry. We pack and ship for you. Free details. Write Dept. A3, Mail Order Service, 845 S. Wabash, Chicago 5.

LEARN Sewing machine repair. Electrify, rent, trade, sell. Make "big money" at home, spare time. New motors, machines, etc. wholesale. Details free. Taylor Service Co., Hamilton PM-3, Ohio.

INVISIBLE Reweaving. Men-women. Instructions shipped for no-risk examination. \$5.00 hour possible spare-full time. Reweave burns, tears, moth-holes like new at home. Free details. Skillweave, 1717-BB Westwood, Los Angeles 24.

OPERATE "ESCO"—Fastest, simplest, easiest, most revolutionary mailorder plan known—Selling highly useful, needed merchandise. Write, Selbyco, Decatur 154, Ill.

INVISIBLE Reweaving — Big profit, big demand, easy-to-learn with low-cost complete course—nothing else to buy, ever. Details free, write today: Fabricon, Dept. N-2, 8342 S. Prairie Ave., Chicago 19, Ill.

MAKE Tough, durable plastic—1c pound. Makes attractive floors, walls, built-ins, roofs. Build good home, \$150 room. Bays Laboratory, Oklahoma City 9.

FREE Big mail. Send name. Publisher-33, 4121 Wyoming, St. Louis 16.

LEARN Professional candy making, profitable home business. Details free. Fate, Kissimmee, Florida.

WANTED! At once! Home producers by manufacturers in our clearing house service. Become a sub-contractor casting plaster and plastic products for these companies. Thousands of easy-to-make items required. Cash in at home without previous experience. For details write Plastic Service Guild, Dept. PM, East Boston 28, Mass.

WHOLESALE Sources. Big mailorder profits. Ferguson, 521 Midland, Little Rock, Arkansas.

SEND 25c For book "Planned Mail-Selling Pays." Tells how to get money daily by mail. Refundable first order. Esco Print, 2538 Holt St., Dayton 7, Ohio.

VEND 5c Hersheys, cookies, with low cost machines. Know-how supplied. Goodman Vending Service, Lebanon, Penna.

MAKE Perfumes at home. Write, "Carey Laboratories," 1914 Chouteau PM-3, St. Louis 3, Missouri.

MAKE Flexible molds! Cast plaques, bookends, figurines! Free sample! H. Tooker, 630-R Chestnut, Hamilton, Ohio.

MAKE Big money at home with magic pearl finish. Free plan. Pearl-Art, 7216 Bear, Bell, Calif.

YOUR Name and address on postal will bring many local and mail business opportunities. Apex Supply, Box 165, New York 18, N. Y.

QUICK Money! "Repairing car batteries!" At home! Easy too! Batteryman, Grand Junction, Colo.

\$10 HOUR! Possible! At home! Invisible reweave cuts, tears, moth holes, snags, burns in clothing, 28 samples, automatic latch steel tool, including material for life and instructions. \$3.00 completely guaranteed. Literature free. Walsh, 894 Main, Buffalo 2, N. Y.

\$200 WEEKLY Reported! No selling. Free booklet. T. J. Surface, Roanoke 4, Virginia.

WHERE To buy at wholesale 100,000 articles. Free list. Also extra-income information. Maywoode, 1133 Broadway, New York.

EARN Extra money operating mailing-addressing service. Also type manuscripts for authors. Particulars free! Vernon Torrey, Melrose 76, Mass.

"MAKE Perfume." Profitable mailorder business. Catalogue free. "International," 6347 Parnell-PM-3, Chicago 21, Illinois.

MAIL Selling opportunities galore! Free! Wehner, Box 142-A-1, Roxbury 19, Mass.

DO It yourself—Refinish your own furniture. We tell you how. For new or old furniture, it's easy and saves money too. Send 25c coin for instructions to Refinishing, Box 156, Rosemead, Calif.



**TRADE Magazines** help you to success. Get latest cop.es through our easy-to-get-acquainted service. Hundreds of business, professional, craft, fashion, feed, fertilizer, finger printing, firearms, fire prevention, fish, florist, food, foreign trade, fraternal, fruit, funeral directors, fur farming and others covering all interests. Send for list today. It's free. Commercial Engraving Publishing Company, 34C North Ritter, Indianapolis 19, Indiana.

**MAKE \$6.73** Every time you sell one—and they're amazingly easy to sell! We have new adding machines in original factory cartons you can sell for only \$14.95 and you make 45%. They're executive model portables, precision built with automatic clearance, direct subtraction, fully guaranteed. Send for life size color photo with full details. Write today to Lightning Adding Machine Co., Inc., Dept. P-15, 1260 West Second Street, Los Angeles 26, Calif.

**YOUR Own business** with a minimum investment. A national organization offers you this opportunity in the fast growing soft ice cream business with possible profits from \$8000 to \$15,000 per season. For full particulars write to: Dari-Delite, 1524 Fourth Avenue, Rock Island, Illinois.

**BIG Money!** Spare or full time in your home. No selling! Spray new miracle finishes, plush and suede, on signs, radios, automobiles, figurines, lamps, toys, etc. Our business is booming. Help us fill huge demand. New easy Flok-Kraft methods. Material costs few pennies. You get dollars. Free samples, complete powerful money-making plan free. Write now! Coast, 1002D S. Los Angeles St., Los Angeles 15, Calif.

**START Your own business** on credit. Always your own boss. 1437 dealers sold \$5,000 to \$28,500 in 1950; their average \$6,704. We supply stocks, equipment on credit, 200 home necessities. Selling experience unnecessary to start. Wonderful opportunity to own pleasant, profitable business backed by world-wide industry. Write Rawleigh's, Dept. C-U-PPM, Freeport, Ill.

**MAKE Money** at home doing light-easy mailing work. Everything furnished—Orders filled for you. Charles, Box 63-P, New York 63, N. Y.

**QUICK Sign painting.** Use letter patterns, avoid sloppy work, wasted time. Write for sample. John Rahn, A1330 Central, Chicago 51.

**LEARN Moldmaking, plaster casting.** Profitable home business. Details free. Hobby Shop, 410 S. Detroit, Toledo, Ohio.

**IMPORT-Export!** Men—women. Instructions from established world trader shipped for no-risk examination. Opportunity profitable world-wide mail-order business from home without capital; or travel abroad. Experience unnecessary. Free details. Melinger, 1715-BB Los Angeles 24.

**MONEY** will be rolling in. Send for our book on how to earn your living at home. \$2.00 postpaid. Graybill Publications, RD 4-M, Lancaster, Penna.

**21 POPCORN, Candy apple formulas,** proven money-makers. Send \$1 today for formulas, catalog of money-making ideas. Concession Supply, 3916 Secor, Toledo, Ohio.

**FIX Typewriters.** Free booklet describes our modern, inexpensive home-study course. Factory methods taught. Write: Typewriter, 3915 Corbet, Tarentum, Penna.

**PUBLISH Own newspaper.** Sample copy, details 10c. Denton Press, Elizabethtown, New York.

**SELL Your products by radio!** No risk! Pay commission. 400 nationwide broadcasters! Simon-P6, 59 Park Avenue, New York City 16.

**FREE Booklet "50 Ways to Make Money by Mail."** Every single one a "dream" job! Norman Ford, Box 413, Pittsfield, Massachusetts.

**PROFITABLE Home business.** Electroplate novelties, autoparts, mirrors, baby shoes, etc. Portable Tyco electro-plater \$5.95, including plating salts, formulas, instruction manual. Tyco Metals, Box 13231-ME, Houston 19, Texas.

**RUBBER Molds!** New catalog illustrating over 100 professional molds, 10c. Castcraft Studios, 508-P Marion St., Brooklyn 33, N. Y.

**OUTSTANDING "Home business" opportunities!** Complete literature sent free! Midwest Industries, Box 615, Enid, Okla.

**RECAST Old batteries** into new. Latest achievements. Battery Laboratories, Minneapolis.

**MAKE-Sell quality perfumes.** Easy, pleasant. Very profitable. All supplies furnished. Genmerco, Box 142-C, Dorchester 24, Mass.

**MASTER Electroplating!** Lucrative field. Licensed correspondence course. Stamp brings details. Kushner Electroplating School, Stroudsburg 230m, Pennsylvania.

**FREE Folder—"100 Ways to Make Money in Silk Screen Printing."** Write: National, Box 88-PM, Dorchester 22, Mass.

**MAKE Money** in your own home the way we do—Selling by mail. Interesting, profitable. Smith, Box 1427-PM, Burlington, N. C.

**PRINT Without a printing press.** Big profits! See page 74.

**READ "Advance"**—The voice of mail order. Offers money-making opportunities, sources of supply, personal guidance, etc. Issued monthly. Sample copy 35c. Yearly subscription \$2.00. Advance Publishing Company, 313 East 21st Street, Suite 450, New York 10, N. Y.

**WANT To make a lot of money,** want that new home or a fine new automobile? A famous American philosopher has written a "Magic Formula for Personal Accomplishment" which clearly shows you the way, perhaps to the uppermost height of success. Try it at our risk. Write for free details. Ben Sweetland Foundation, Suite 229, 960 Harrison St., San Francisco 7, California.

**HOTEL Managers** applications now being accepted. Hotel experience not necessary. Salary and living quarters while training. Advancement opportunities. National organization. Write, Personnel Manager, 3500 Book Tower, Detroit 26, Michigan.

**MAKE Money** sharpening saws and lawnmowers. Start at home. Free book, "Money Making Facts," tells how. Victor Foley Company, Columbia Heights, Minn.

**COLOR Concrete** with chemicals. Marble-glaze cement benches, pottery, garden ornaments. Home-shop. 10c brings sample, pictures. Hollywood Cementcraft, 8527-R Wonderland, Hollywood 46, Calif.

**THERE'S Big money** servicing a route of waterless hand cleaner dispensers, full or spare time! No other like ours! Western B Aircraft, Los Angeles 19.

**URANIUM Enterprise** possessing unlimited potentialities requires several associates to participate in development of this "world's most sought for" material. Write Johnston, Box 142D, North Battleford, Saskatchewan, Canada.

**TO \$35.00 Weekly.** Spare time, home operated mail order business. Successful small "beginner's" plan. Everything supplied. Lynn, 10420-M National, Los Angeles 34, California.

**GROW Laboratory animals** for fun and profit. Teach children food values. See food promote growth and health, or stunt growth, destroy health. Wonderful hobby, educational, entertaining. Sell animals for profit. Use in schools, clubs, demonstrations. We furnish animals, instructions, cages, supplies. Information free. Cage Supply, 121 East Fifth Street, Bonham, Texas.

**BOOKKEEPERS—Earn \$5000 yearly part time.** Sell, operate new sensational CPA bookkeeping service. Kern, 4942 Vineland, North Hollywood, Calif.

**EARN Extra money, spare time.** Write, Chamberlain, Box 894, Manchester, New Hampshire.

**CHINCHILLAS (No rabbit).** Raise anywhere. Pleasant, profitable. Information. Chinchillas, Ithaca, Michigan.

**GOOD Paying business** silvering mirrors, plating autoparts, reflectors, bicycles, bathroom fixtures, etc., by late method. No tanks or shop required. Outfit furnished. Free booklet. Gunmetal Co., Ave. H, Decatur, Illinois.

**137 WAYS To make money,** in home or office, business of your own. Full particulars free. Elite Co., 220 Grand St., New York 13.

**START A venetian blind laundry.** Profit opportunity for lifetime business. New machine method. Free booklet on request. F. C. Co., 442 N. Seneca, Wichita 12, Kans.

**MAKE Money** at home as renewal headquarters for all magazines. Liberal commissions. No experience, no capital needed. Supplies furnished. Write for free catalog. McGregor Magazine Agency, Dept. 500B, Mount Morris, Ill.

**SELL By mail, free details:** instructive booklet 25c. Manhattan House, Box 51-M, St. Albans 12, New York.

**1001 OPPORTUNITIES Club,** 1495 Westchester Ave., New York 72, offers real money making ideas. Free information.

**MAKE GIFTS, novelties, jewelry,** from sea shells, fish scales, plastics. No tools needed! Learn secret methods of bronzing, pearlizing, gilding, silvering, metalizing, luminizing, dyeing. Write: Giftcrafts, Box 4550-PM, Coral Gables, Florida.

**POPCORN** and potato chip equipment. Long Eakins Company, 5260 High, Springfield 99, Ohio.

**FREE Particulars "Profitable Home Business Products"** plus wholesale sources 740,000 items. Cottage Industries, Omaha 12, Nebr.

**BUY Wholesale.** Thousands articles. Supply directory, 10c. Idealco, Park Ridge, Illinois.

**ESCAPE Wage slavery.** Easily. Operate your own profitable lifetime business. Free literature. Corley, H285 Carlton, East Rutherford, New Jersey.

**LEARN Silk screen printing;** invisible reweaving; repair dolls; make rubber stamps; repair sewing machines. Natural Rubber for molds. Free sample. Universal, Box 1076-a, Peoria, Ill.

**SAVE. Profit—Buy thousands** nationally advertised articles direct from manufacturers. Literature free. E. L. Gray, Box 456, Tombstone, Arizona.

**EARN Extra Money!** "Homeworker Magazine" tells how. Sample 25c. Size-more, Box 7, 4917 Kostner, Chicago 30.

**VENDING Machines** earn big money! An investment as low as \$10.50 will start you in this fascinating, profitable business that can lead you to the road of success and independence. Routes can be established and operated in either full or spare time with no experience needed. Write for full details and our free catalog illustrating our nut, candy, gum and stamp vendors; also pin ball machines, music boxes, etc. Write immediately to Parkway Machine Corporation, Dept. 7, 715 Ensor Street, Baltimore 2, Maryland.

**EARN Money** mailing dollar-pulling circulars—Keep 90c. Everything furnished. Genmerco, Box 142-P, Dorchester 24, Mass.

**BE Listed** to receive latest mail order offers, samples, propositions. National, Box 88-P, Dorchester 22, Mass.

**BOOKKEEPERS.** Keep books, small firms spare time. Manual latest technique by C.P.A., \$3.00. Modern Business, Box 406, Youngstown 1, Ohio.

**FREE Book "505 Odd, Successful Businesses."** Work home! Expect something odd! Pacific, Oceanside, Calif.

**NATURAL Molding Latex.** Extra thick. Free sample. W. Wooley, 115-A Donald, Peoria, Ill.

**\$46 FROM Square foot plywood;** jigsaw necessary. Write: Woodarts, Bridgewater, Mass.

**MAKE Money** spare or full time, casting metal toys and novelties. Big 1952 wholesale and chain store orders for cast metal autos, soldiers, ashtrays, banks, etc., keep manufacturers busy. Production molds furnished for up to 100 and more castings per hour. No experience or special place necessary. Write for information and illustrations of patterns needed. Metal Cast Products Co., Dept. A, 1696 Boston Road, New York 60, N. Y.

**EXTRA Money—No selling, operate vendors.** Amazing profits, details free. Silver King, Suite 220, 622 Diversey, Chicago 14.

**BIG Money** and fun growing live miniature Ming trees on your window sill. Write for free rare tree seed and plan. National Nurseries, 8620A Ruthelen, Los Angeles 47, California.

**BUY It wholesale!** Manufacturers, distributors offer 850,000 items. Literature free. Olsen, 1231-A East Third St., Duluth 5, Minn.

**FIGURINE Molds** and many others, liquid rubber, statuary plasters, flock finishes, etc. Illustrated catalog and "Plastercraft" manual free. Blue Rapids Supply, Blue Rapids, Kansas.

**\$25 WEEKLY** Working two hours daily. No canvassing. No manufacturing. Lycke, Box 2471-A, Cleveland 12, Ohio.

**MOLDING Rubber** \$2.95 quart, \$9.95 gallon prepaid! Plastercraft Supply Company, 3051 St. Clair Avenue, Cleveland 14, Ohio.

**HOW And where to obtain capital,** details free. Star Service, Wapakoneta, Ohio.

**EARTHWORK Breeding?** First, get unusual story. "An Earthworm Turned His Life." Free. Earthmaster, Dept. 14, El Monte, Calif.

**MONEY** in new greaseless doughnuts. Start in kitchen. No smoke. Sell stores. Free recipes. M. Ray Company, 3605 South 15 Ave., Minneapolis 7, Minnesota.



**INCOME** From local information. No selling. Write Neherco, La Verne, Calif.

**NEW Profitable home business** repairing zippers. Thousands of customers waiting. No experience required. We furnish everything. Write Texas Specialty Company, 204-B Texas, Texarkana, Texas.

**UNPAINTED** Bookends, plaques, statues, figurines. List. Haverty Products, 822-17th St., Altoona, Penna.

**OPERATE Profitable mail order business.** Write Walter Service, 4159-A East 112th, Cleveland 5, Ohio.

**DOLLARS** In personalized baby record books. Sell by mail. Use same literature we do. No-Co-Ro, Oakland 6, Calif.

**FABULOUS Earnings**—Fascinating pastime. Growing genuine, living miniature (mung) tree. New sensational business or hobby. Astounding information free. Dwarf Gardens, Box 355B, Briggs Station, Los Angeles 48, Calif.

**MADE \$24,500** Using money making plans from Schemer Magazine, world's oldest mailorder publication. Box 275M, Canfield, Ohio. Year \$2.00. Sample 20c.

**MINK Raising** information free. Complete. Lake Superior Mink Farm, Superior, EE1, Wisconsin.

**COPUBLISH** Leading m.o. paper. Latest copy Mail Sale Advertiser, details, dime. Vanroy Shirk, Lebanon, Penna.

**COLORGLAZED** Concrete pottery made without molds. Patented method. Cemetery products, novelties, tiles. Basement leak-sealing. Money-making projects. Booklet, details free. Men only. National Pottery Company, Grand Rapids, Minnesota.

**LIQUID Rubber.** Make flexible molds. Free sample. Chaney, 1130 E. 16th St., Jacksonville 6, Fla.

**MEN—Women.** Everybody likes candy. Learn to make professionally. Our 40th year. Ragsdale Candies, D5, East Orange, New Jersey.

### MONEYMAKING OPPORTUNITIES

**WILL Manufacture, sell, pay you royalty** for clever wood toys. Box 498, Gainesville, Texas.

**"HOW To Make Money With Simple Cartoons"**—A book everyone who likes to draw should have. It is free; no obligation. Simply address Cartoonists' Exchange, Dept. 93-CM, Pleasant Hill, Ohio.

**MAILORDER** Selling pays off, when you know how. Several worthwhile opportunities available. Variety, 57-H Circuit Avenue, Newton Highlands 61, Massachusetts.

**RESULT** Getting "moneymaking" opportunities. Information 10c. Cashbox Ideas, Mar Vista 10, California.

**PRODUCE** Cheap houses, flowers, concrete ornaments. Shiffers, Box 129, Millersburg, Penna.

**GROW** Miniature dwarfed trees. Full particulars \$1.00. Bridges, 2759 Primrose, Ft. Worth, Texas.

**OPERATE Profitable mail order business.** Mail order manual, \$1.00. Free circular. Sheldon Mail Order, Sheldon 1, Iowa.

**UNPAINTED Plaques, bookends, novelties.** Stamp brings list. Umlauf, 239 So. Luther, Detroit 25, Michigan.

**\$35 WEEKLY!** Possible! Home! Spare time! 27 unusual projects! Literature free. Walsh, 894 Main, Buffalo 2, N. Y.

**WIN** Contest money. General Contest Bulletin gives hundreds of tips. Lists current contests and rules. Sample 25c. General Contests, 1609½ East 5th, Duluth, Minn.

**MAKE \$10.00** Or more an hour at home, spare time or your own business. Apply metal Name-ies initials to rubber footwear, leather goods, apparel, sports gear, hundreds of other uses. Foolproof, easy-to-apply. Write Rub-R-Nam Mfg. Co., 263 Sexton Bldg., Minneapolis 15, Minn.

**EARN** Money evenings, copying and duplicating comic cartoons for advertisers. Adservice, Argyle 1, Wisconsin.

**FREE** Nationwide advertising, publicity! Advertise your products to 51 million readers thru 77 national magazines, free of charge! Broadcast on 400 radio stations without risking a penny! Send 25c (refundable) for details today! Treasury, 149 Storer, New Rochelle 4-L, New York.

**CONCRETE** Septic tanks, illustrated circular, descriptive instructions, \$2.00. One man job, no machinery, failure impossible. Sanitarian, 169 Pawtuxet Ave., Edgewood, R. I.

**STOP!** Write here. Cash opportunities. Green, 13 Earl, Red Bank, N. J.

**EARN** While learning to hand-paint textiles. No canvassing. Screen-Art Service, Stillwater 7, Minnesota.

**SEVERAL** Mailorder magazines and homework offers 10c. William Woodrow Jenkins, Lucasville, Ohio.

**\$100-\$200 WEEKENDS.** No selling or manufacturing. Mahaffey, 3032-B Weldon, Los Angeles 65.

**MAKE** Money by telephone. Brand new friendly home enterprise. Beats mail order. No investment. No office. Instructions 25c. National, Box 381, San Bernardino, Calif.

**MAKE** And sell waterless hand cleaner. Formula \$1.00. Formco, Box 265, Cedar Rapids, Iowa.

**FREE** Ads brought Abbeon \$8,000. Sensational mailorder plan free. Publicity, 1501K Trailsend, Kalamazoo, Mich.

**FREE** Folder "Your Happiness;" extra income, health, success! Adolph Menzel, Oshkosh 13, Wis.

**GET** Several plans for home business, 25 cents. Box 165, Brooklyn 17, N. Y.

**50,000 ARTICLES** Wholesale. Source directory dime. Nelko, Box 3462-DR, Chicago 54.

**FREE** Book "505 Odd, Successful Businesses." Work home. Expect something odd! Pacific, Oceanside, Calif.

**BE** Appointed State Notary Public now! Details: Stationers, Helotes, Texas.

**PUBLISH** Your own magazine. Hand-some 52 page format, well edited, illustrated. Cost low as \$1.00 month. Brings you prestige, profits. 25c brings sample, details. National, Ord, Nebr.

**READ** Progressive Mailtrade, the magazine that tells how to make money by mail. Dime brings sample and special offer. Progressive Mailtrade, Box 357, Sheboygan, Wisconsin.

### FORMULAS, PLANS, ETC.

**LATEST** Manufacturing formulas, for profitable, easy to make chemical specialties. Lists free. Automotive Chemical Laboratories, Box 393-A, Hicksville, N. Y.

**HOT** Tamale making for profit. Particulars. Write F. E. Skinner, 419 W. Live Oak, Altus, Okla.

**FREE** Formula catalog. Anything analyzed \$25.00. Western Chemical, Salem, Oregon.

**FORMULAS;** All kinds. Latest, best. Literature free. Kemixal, Park Ridge, Ill.

**TESTED** Formulas. Interesting descriptive booklet free. Pont, Box 635-PM, Terre Haute, Indiana.

**ANY** Formula \$2.00. Satisfaction guaranteed. Jack, Chemist, 4292 Parkside, Philadelphia 4.

**REAL** Manufacturing formulas. Lists free. Cummings, Chemist, Gordon Ave., Syracuse 4, N. Y.

### PLASTICS

**NEW** Liquid casting plastic. Clear, colors. Embed flowers, insects, coins. Saw, drill, carve. Send 25c for wholesale catalog and new sales manual showing how to make money at home. Castolite, Dept. C-101, Woodstock, Illinois.

**PROTECT** Your identification, social security, driver's license cards, wallet size photos; sealed in transparent plastic. 50c each; 3 for \$1.25; 6 for \$2.00. Satisfaction guaranteed. Keeler Products, 1703-PB North Albany, Chicago 47.

**MANUFACTURERS** Of a complete line of internal carvings. Crystal Floral Company, Bound Brook, New Jersey.

**INTERNAL** Carvers—Now you can get our plastic coloring secrets and basic dye kit. \$1.00. Zenith Plastics Co., Box 464, Ypsilanti, Michigan.

**LEARN** Plastics at home. Small cost—Spare time. Dime brings sample plastic, three experiments, full details. Plastic Projects, Box 5151, Detroit 35, Mich.

**LUCITE** Plexiglas. Any size sheets, masked. Square foot (12 x 12) cost, 1/16", \$1.20; 1/8", \$1.40; 3/16", \$1.75; 1/4", \$2.08. Include 10% postage. Almac Plastics, 230 Fifth Ave., New York 1, N. Y.

**PLASTIC**, Sheets, rods, tubes, etc. Free list. Plastic Supply Co., 2901 N. Grand Blvd., St. Louis 7, Mo.

### CHEMISTRY

**CHEMICALS** And apparatus for industrial, analytical, and private laboratories. Catalog 20c. Dept. M-50, Biological Supply Co., 1176 Mt. Hope Ave., Rochester 20, N. Y.

**SPECTROSCOPE** For quick chemical analysis \$3.00. Book 200 electric stunts \$1.00. Kutting Sons, Los Altos, Calif.

**SAVE** Money! Supplies catalog 15c, refundable. Laboratory Sales, Box 161-A, Brighton, Mass.

**LABORATORY** Apparatus, chemicals, microscopes, complete chemistry sets, minerals, uranium ore. 10c brings catalog. Porter Chemical Company, Hagerstown 1, Maryland.

**NEW** Idea chemical and apparatus outfits for home experimenting. Photo-scales, microscopes, chemicals, biological and laboratory supplies in small quantities. Catalog 25c. Established 1931. John H. Winn, 124A West 23rd Street, New York, N. Y.

**ILLUSTRATED** Catalog: Chemistry, mineralogy, biology. 10c. Tracey Laboratories, Evanston, Illinois.

### AGENTS WANTED

**CALENDARS**, Advertising novelties, matches. All styles, including religious, varnished, 12 sheet, girls. Hundreds of advertising novelties, book matches, etc. Fleming Calendar Co., 6539 Cottage Grove, Chicago 37, Ill.

**DO** You need money? \$40.00 is yours for selling only 50 boxes of our 300 greeting card line. And this can be done in a single day. Free samples. Other leading boxes on approval. Many surprise items. Experience unnecessary. Free samples personalized stationery, napkins. Write today. It costs you nothing to try. Cheerful Card Co., 505 White Plains, New York.

**PHOTO-Salesmen**, agents. Sell beautiful hand colored plastic enlargements and sensational new photo compacts, rings, bracelets, lockets, etc. Collect deposit, we deliver. Profitable sideline. Send card, for free sample kit. Novel Portrait Co., 3343 North Ave., Chicago, Ill.

**ABSOLUTELY** Free! Big package actual sample fabrics and style presentation of dresses, lingerie, hosiery, etc. Take orders. Commissions big. Send no money. Melville Co., Dept. 6769, Cincinnati 25, Ohio.

**YOUR** Own business—Used suits \$1.50; topcoats 50c; shoes 12½; ladies' coats 30c; dresses 10c. Enormous profits. Catalog free. Moro, 558-AA Roosevelt, Chicago 7.

**MAKE** Money fast—Sell big value greeting cards. Four new 21 card \$1.00 all-occasion assortments. Birthday, Easter, novelty cards. Gift wrappings, stationery, notes. Unusual gift items. Over 100 fast-sellers. Amazing profits. Write for samples on approval and "get-started" plan. Hedenkamp, 361 Broadway, Dept. PM-19, New York.

**MAKE** Wedding profits. Sell invitations, napkins, matches. Samples free. Dunbar's, Middlebush 3, N. J.

**ALL-Occasion** greeting cards that are such terrific sellers all you have to do is show them. 21 boxed sell for \$1.00. Over 100 other wonderful boxes including birthday, get-well, etc. Profits to 100% plus bonus. Write for free samples. Kit on approval. Regal Greeting Card Co., Dept. 138, Ferndale, Michigan.

**\$200 WEEKLY.** Sell outstanding silver-plate, flatwear. Murphy-Yale, Meriden, Conn.

**SELL** Sunshine exclusive everyday cards and make big money the easy friendly Sunshine way. Complete selection greeting cards, stationery, gift wraps, novelties, etc. 21 deluxe miniature everyday cards—75c. Many others. Send postcard today for your Sunshine sample kit on approval to: Sunshine Art Studios, Dept. PM-3, 115 Fulton St., New York 38, New York.

**MAKE** Money calling on friends. Show nationally advertised greeting cards—New all-occasion assortment and laugh-packed barrel-of-fun. Also sensational pinafores and parasols personal notes. All three dollar sellers. Up to 50c profit for you. Big line, includes gift wrappings, stationery, gift items, etc. Get three assortments on approval. Write Wallace Brown, 225 Fifth Ave., Dept. J-4, New York 10.

**STRANGE** "Dry" window cleaner. Sells like wild. Replaces messy rags, liquids. Simply glide over glass. Samples sent on trial. Kristee, 145, Akron, Ohio.

**BUY** Wholesale — 25,000 items. Catalogue 25c. Matthews, 1472-B8 Broadway, New York City.

**MORE** Money in closeouts. Pricelist free. Metro, 60 South Street, Boston 11, Mass.



**MAGIC** Words give you daily cash! "Kendex nylons are free unless satisfactory." New style 300 only 98c including your commission, bonus and postage. If these wonderful sheer DuPont nylon stockings run, snag or are not satisfactory within 1½ months of receipt, we refund the full 98c so they will cost nothing! What woman will hesitate to wear fine nylons at our risk? Just write orders. We deliver and collect. Advance cash plus huge bonus. Spare or full time. No experience necessary. Postcard brings you sample stocking and money-making outfit free and prepaid. No obligation. Kendex Corporation, Babylon 63, N. Y.

**NEED Money?** \$50-\$100 and more is yours—easily, pleasantly, quickly. In spare time just show friends irresistible Elmira assortments of all-occasion greeting cards, wrappings, personalized stationery, napkins, matches, many other exclusive, profitable specialties. No investment. No experience. Success assured. Bonus. Special prizes. Promptest service. Write today. Free samples, assortments on approval. Elmira Greeting Card Co., Elmira 111, N. Y.

**AT Last!** Something new and sensational in everyday cards, 21 for \$1. Make extra money fast! Show satin, velour, metallic cards. Get orders easy. Big line \$1 assortments, scented stationery, personal matches, kiddie books. Imprints free. Two \$1 boxes on approval. Puro Co., 2801 Locust, Dept. 240-C, St. Louis 3, Mo.

**FREE Samples**, and amazing plan, giving you gorgeous dress without penny cost. Rush name today with dress size. Harford, Dept. G-435, Cincinnati 25, Ohio.

**MEXICAN Feather pictures.** High profit! Fast sellers! Adelphi, Box 57-B, Bellerose 6, N. Y.

**NEW "Sponge"** wall cleaner. Erases dirt like magic. Wallpaper, painted walls, ceilings. Saves redecorating. Lightning seller. Samples sent on trial. Kristee, 144, Akron, Ohio.

**BIG Profits**, fast sales with 7 sensational new items! Free samples! Durever, 2781-D Atlantic Ave., Brooklyn, N. Y.

**BIG Profits** in spare time! I'll send free assortment full-size samples fine foods, household necessities to ambitious men—women who need money. Friends, neighbors buy eagerly. Send no money. Just write Blair, Dept. 31HC, Lynchburg, Va.

**MAKE Tremendous profits** with fast-selling costume jewelry! Buy direct! Sell your friends, neighbors and customers at big savings to them! Write for our free catalog! Penn Jewelry, Dept. P, 826 W. Lacka., Scranton, Penna.

**HOTTEST 39c Item** on the market. National Sales & Service, Greenville, Penna.

**BRAND New invention**, stops backache. Sensational offer to agents. Dr. Latham Belt Company, Box 961, Lakeland, Florida.

**MEXICAN Feather pictures**, unusual novelty. \$1.00 (stamps) brings \$2.00 worth samples, refunded if unsatisfied. Aztec Art, Apartado 762, Mexico City.

**PART Time salespeople**—Men and women. Daily cash returns showing Artmoore Products, three "in demand" items. No investment in stock. Liberal no risk starting offer. Write Dept. P-3, Artmoore, 1319 North Third, Milwaukee, Wisconsin.

**ULTRA-Blue stock signs**—7c, sell 50c. 2000 slogans, 7" x 11", comedy, religious, general. 15 samples, \$1.00. Lowy, 812 Broadway, Dept. 658, New York 3.

**CALIFORNIA Sweet smelling beads**. Sensational sellers. Free particulars. Mission, 2328PM West Pico, Los Angeles 6, Calif.

**GET On bandwagon** and help popularize new business method needed by every large, small industrial, commercial concern. Profits quick and tremendous. Investment small. Write for free brochure telling entire story. Kemble & Mills, Inc., 317 Third Ave., Pittsburgh 22, Penna., Dept. ACM.

**AGENTS; Salesmen; extremely large profits** selling complete line colored granite memorials. Artcraft Memorials, St. Cloud, Minnesota.

**READY To pay you biggest cutlery profits** ever known. Exclusive line made for the masses. Rush inquiry. James Industries, 25 Municipal Bldg., Skaneateles, N. Y.

**WHOLESALE Catalog appliances**, toys, watches, etc. 25c (refunded first order). Cam Company, 1717-58th, Brooklyn 4, N. Y.

**BIG Profits selling ties**. (\$2.00 values) \$6.50 dozen. Free catalog. Empire Cravats, 648 Broadway, New York 12.

**LOOK**—Big profits, free samples. Greeting cards, personalized napkins, personalized stationery and gift items. G. M. Dunn Co., 484 Broadway, Newark, N. J.

**MEN, Women** make \$5.00, 15 min. New patent. Get protected agency your territory. Carter, 443 Seaman, Akron, Ohio.

**MEXICAN Feather pictures.** Sell on sight; 200% profit! Free details; sample 10c stamps. Sylvia PV, Apartado 9036, Mexico City.

**PRINTING**—Salesbooks, envelopes, tags. Free illustrated catalog. Ersco, Bronx 72, N. Y.

**FAST-Selling product**, earn money! Velazquez, 696-P Elton Ave., New York 55.

**WALKER'S Tooth powder**, users' favorite, can multiply your profits. Write J. Walker, 633 Plymouth Ct., Dept. 3, Chicago 5.

**BUY Wholesale** thousands nationally advertised products at big discount. Sent free "The Wholesale Plan." American Buyers' Service, 629-P Linden, Buffalo, N. Y.

**POWER Lawn mower**—\$45.00. Prepaid. Sensation. Exclusive deal. Rotacut-RP, Excelsior Springs, Mo.

**BARGAINS**—Terrific savings, job lots, close-outs! Also save up to 50% on complete lines of drygoods, clothing, hosiery, notions, drug sundries, toiletries, novelties, gifts, jewelry, television, etc. 2000 items. Send 25c for illustrated wholesale bargain catalog, closeout flyers, and special "get acquainted" offer. Valuable merchandise certificate (worth many times 25c) included free. Reliable Jobbers, 311-B N. Desplaines, Chicago 6.

**BE A money maker.** Use your home as magazine headquarters. Liberal commissions. No experience—No capital needed. Everything furnished. Write for free catalog. McGregor Magazine Agency, Dept. 500A, Mount Morris, Ill.

**\$50 WEEKLY** Selling finest razor blades, other items. Free details. Edisans, Box 274, Far Rockaway, N. Y.

**GUARANTEED 200,000 Mile ring, valve job!** Restores compression! Stops oil pumping! Send \$3.00 for \$6.00 package and sales offer! Nerlino, Box 7, Inglewood 5, Calif.

**SCHOOL Seniors!** A postal will bring you our wonder, Kwick-Sell Cardalog of popular graduation name cards. Biggest profits! Only firm giving free Golden Memory Book and Souvenir Chest. Don't miss out. Hurry that postal! Craftcards, Box 235L, Pittsburgh 30, Penna.

**NEED Extra cash?** Take orders for personal initialed belts and buckles, cap badges, tie holders, etc. Choice of 3000 emblems. Free sales kit. Hook-Fast, Box 1425PM, Providence, R. I.

**SCHOOL Seniors**—Earn sensational profits selling classmates America's most beautiful graduation name cards. Largest selection. Outsell all others. Free sample kit. Printcraft, Dept. M, 1425 E. Elm St., Scranton 5, Penna.

**EXCELLENT Sideline** for printing and advertising salesmen. Decalomania name plates in small quantities. Great demand. Also, make money with our line of automobile initials and sign letters. Free samples. "Ralco" XL-Roxbury, Boston 19, Mass.

**AGENTS; Stamping names** on key protectors. Sample 25c. Stamping outfits, checks, social security and name plates. Hart Mfg. Co., 303 Degraw St., Brooklyn, N. Y.

**AGENTS**—300% Profit selling genuine gold window letters; stores and offices. Free samples. Metallic Letter Co., 438-B North Clark, Chicago.

**SELL Big money-maker** to men and women. Easy handwork makes fast-selling useful articles. Sunmade Company, Brockton 64, Mass.

**GOLD Lacquered and silver sign letters**, Windows, doors, trucks. Standard sizes. Penny each. Free samples. Atlas-P, 544 West 79th, Chicago 20.

**SALESMEN, Distributors**, fast selling costume jewelry direct from factory. Big picture catalog, free. Pickcraft, M19 Bank, Attleboro, Massachusetts.

#### HIGH-GRADE SALESMEN

**BIG Money fast.** Sell printing, office supplies, advertising specialties. Experience unnecessary. Every business buys. Lowest price. Full-part time. 1000 products. Permanent. Samples free. Kaeser-Blair, Dept. 33, Cincinnati, Ohio.

**FLUOR-O-Signs** sell fast. Top commissions. Write Fluor-O-Signs, 106 Forsyth, New York 2, N. Y.

**PAINTS, Varnishes, roof coatings, flooring, automobile undercoating.** Sell ready-made accounts. Earn up to 30% commissions—Time, territory your own. Big season ahead. Scott Paint Co., 2948 E. 81, Cleveland, Ohio.

**BRAND-New sport shirts 50c each** and amazing money-making opportunity for you! Take orders for world's finest uniforms and work clothes. Sell to garages, service stations, factories! Earn huge profits, get new sport shirts at 50c! Write for thrilling details, free outfit. Topps, Dept. 533, Rochester, Indiana.

**MAN To earn \$90 week up.** Long needed invention. Advertiser Saturday Evening Post, Colliers. Prospects everywhere. Full or part time. Exclusive. No investment. Free samples. Write Red Comet, Inc., Dept. 31-B, Littleton, Colorado.

**WANT To make real money?** You can positively make \$50.00 a day and up selling a brand new item going to every type of food and beverage store, factories, laboratories, hospitals, etc. First time advertised. Samples furnished. Utility Dura-wear, 53 West Jackson Blvd., Dept. PM-03, Chicago, Illinois.

**I'LL Put a "shoe store business"** in your pocket! Nation's leader trains you to make big money! Fit men, women. Free sample outfit. Write today! Consolidated Shoe System, Dept. CI-100, Chippewa Falls, Wis.

**ANYONE Can sell Hoover DuPont nylon uniforms** for beauty shops, waitresses, doctors, nurses, others. In white and colors. Exclusive styles. Top quality. Low priced. Exceptional income. Real future. Equipment free. Write fully. Hoover, Dept. C-100, New York 11, N. Y.

**WRITE 3 Words**—Collect \$7.65 on 10-second demonstration to merchants. Write on glass with amazing magic crayon—Presto! 5 color advertising message takes fire, glows like brilliant neon. Three sales daily bring \$22.95 profit. Rush postcard for details. Complete sales kit, free! Maxilume Co., 125 W. Hubbard, Dept. CL-8-C, Chicago 10, Illinois.

**AMAZING Discovery**, Master Glaze, puts brilliant glass-like surface on cars. Free sample, information. Big commissions. Master Glaze, Dept. 734, 7720 Harwood, Milwaukee, Wis.

**ADVERTISING Book matches**—Cash in on big demand; sell union label matches. Cuts for all businesses and political parties. Free powerhouse selling kit, low prices, protection guaranteed on repeat orders. Cash commissions. Superior Match Co., Dept. M-352, 7530 Greenwood, Chicago.

**REPRESENT America's largest factory** selling advertising pencils. High commissions. Attractive line. Send \$1.00 for pencil kit (refundable). Union Pencil Company, 389 Broadway, New York City.

**SUCCESS Opportunity**—Sell famous Spring-Step shoes. Earn up to \$25 daily plus cash and shoe bonus. Write PM-3, Ortho-Vent Shoe Co., Salem, Va.

**MAKE Big money**—Season starting. Sell 1953 calendars, advertising specialties and executive gift line. Experience unnecessary. Commissions advanced. Outfit free. North American Calendar, 605-AA Washington, Chicago 6.

**A Fine income**, your own nylons free! Show nylons, lingerie, men's socks with amazing free replacement guarantee against runs, snags, tears. Write for free sales kit. Group organizers invited. Rosalee Hosiery Co., Clifton 58, N. J.

**AD Matches!** Sell amazing designs—20, 30, 40 and 240-light book matches. Bigger spot cash commissions; every business a prospect. Low prices for high quality. Repeats. Start without experience; men, women; full, part time. Buy nothing! Sales kit furnished. Match Corp., Dept. PM-27, Chicago 32, Illinois.

**SALESMEN**—Get happy! Hundreds different things to sell; all details free! Write what you sell now; what you'd like to sell. Your mail box will run over! Salesmen's Service, Drawer 8711, Fort Worth 12, Tex.

**BEST Source** for nylons. Rich Co., 215 W. 98, New York 25.

**MAKE Money** with fast-selling Bostonian shirts. Blouses too. Spare time, full time. Sales kit free. Bostonian, 89 Bickford, Dept. M-10, Boston 30, Mass.

**NEW Jobs open in selling!** Send name, address for five free issues of Opportunity Magazine's money-making guide, listing hundreds of companies who'll pay you well, full or part-time. No experience needed. Opportunity, 28 E. Jackson, Dept. 17, Chicago 4, Ill.



## EDUCATIONAL AND INSTRUCTION

**LISTEN**—Learn a language by linguaphone. At home, quickly, easily, correctly master Spanish, French, German, Russian, Chinese—any of 29 languages through Linguaphone Conversational Method. Add to service, job, travel opportunities. Send for free book. Approved for Veterans' Training, Linguaphone Institute, 8303 Radio City, New York City.

**MAKE UP** to \$45-\$55 week as a trained practical nurse! Learn quickly at home. Booklet free. Chicago School of Nursing, Dept. M-3, Chicago.

**"HOW To Break and Train Horses"**—A book every farmer and horseman should have. It is free; no obligation. Simply address Beery School of Horsemanship, Dept. 1103, Pleasant Hill, Ohio.

**BOOKKEEPERS!** Increase your earnings! Operate your own simplified "Dollar-A-Week" bookkeeping and tax service. Full or spare time. Details free. No obligation. Ellis, Box 200-C, Cedar Grove, North Carolina.

**BE A real estate broker** through home study or classroom instruction. Write for free book. Approved for Veterans. Weaver School of Real Estate, Suite 300 Law Bldg., Box CP-2, Kansas City, Mo.

**FAST Writing.** Easy lesson 10c. Elliott, 4426 S. Carrollton, New Orleans.

**WELDING** Training pays at Hobart Welding School, Box M-322, Troy, Ohio. VA contract. Best equipment. Catalog free.

**STUDY** For game warden, park, forestry and patrol service. Write Delmar Institute, D11, Whittier, Calif.

**LEARN** Priceless secrets of technical metaphysics. Easy, simple. Write Canada School of Technical Metaphysics, 2532 McKenzie Street, Vancouver, B. C. Canada, for amazing information.

**USED** Correspondence courses bought and sold. Literature free. Walsh, 894 Main, Buffalo 2, N. Y.

**3800 LATEST** Used correspondence courses catalog \$1.00. EG, Elmsford, N. Y.

**WORK** For U. S. gov't! Start high as \$73.00 week. Men-women. 95,000 jobs open each month. Experience usually unnecessary. Qualify now! Write for free 32-page book showing jobs, salaries, sample tests. Franklin Institute, Dept. G-24, Rochester, N. Y.

**PRACTICAL Nursing**—Learn easily at home, spare time. Big demand, good earnings. High school not necessary. Write for free facts. Wayne School, Dept. FG-8, 2525 Sheffield, Chicago 14, Ill.

**INCREDIBLE!** Unprecedented! Look under "Miscellaneous!" Bijou, Box 1727-MO, Hollywood 28, California.

**FREE** Details. Secrets of Successful Salesmen, \$1.00. Wye Co., 636 Dorchester Ave., Boston 27, Mass.

**BECOME A Doctor** of Psychology or Metaphysics. Teach secret of contentment, happiness. Win degree of Ps.D or Ms.D. Solve mental worries. Free book. College of Universal Truth, 5153-C North Clark, Chicago.

**HIGH School**—No classes. Study at home. Spare time. Diploma awarded. Write for free catalog HF-18, Wayne School, 2527 N. Sheffield, Chicago 14, Ill.

**WHY Die?** Look under "Miscellaneous!" Bijou, Box M2-1727, Hollywood 28, Calif.

**LEARN** To write music! New, easy instructions remove the mystery! Learn how to put your melodies on paper! Make money—set your own and others' song poems to music, prepare "lead sheets" to send publishers, etc. Previous musical training unnecessary! Get facts free—write today to Meadowlark Music School, 11-123 Sumner Road, Colorado Springs, Colo.

**FREE Folder**—Make \$10,000 yearly in public adjusting. No experience needed. Sterling, Great Neck 14, N. Y.

**A College degree** by home study. B.A., M.A., Ph.B., degrees by home study. Previous credits recognized. Remain employed and still attain a college education. No residence requirements. State chartered. Fremont College, Santa Fe 19, New Mexico.

**SMASH Worries,** fears and problems. Wake up your mind with our home-study behavior control plan. Many helped. Rush request for amazing free lecture. Educational Psychology, Inc., Box 1924-N, Louisville 1, Kentucky.

**INVESTIGATE**—Missing persons! Be a skip tracer or credit investigator! Home study! Write Pacific Institute, 492 44th Street, Oakland 9, Calif.

**DRAFTING**—Learn easily at home. Monroe Institute, PM-3, Alton, Illinois.

**START A** collection agency business. Very profitable. Quickly learned. Write Cole & Associates, Syracuse 2, N. Y.

**\$8-15,000 YEARLY** Not unusual for Acme-trained tool and die designers! Industry desperately needs competent men. You can learn quickly by easy home study. No art ability required. Acme graduates go farther faster in tool and die designing. Famous "Cope" system includes same methods and texts used by our resident schools to train tool and die designers. Write today for free literature. Acme School of Die Design, 8 N. Jefferson Street, Dayton 2, Ohio.

**GUNSMITHING.** Learn now! Start earning good income. Our residence course is thorough, practical! Approved for qualifying veterans; easy-pay plan for non-vets. Part-time work arranged. Write: Pennsylvania Gunsmith School, 1000M Western, Pittsburgh.

**MEDICAL** Laboratory technicians in great demand. We train you in your own home. Catalogue free. Imperial Technical Institute, Box 973-J, Austin, Texas.

**USED** Correspondence courses and books sold and rented. Money back guarantee. Catalog free. Courses bought. Lee Mountain, Pisgah, Alabama.

**"BRIDGE To Knowledge"** bestirs new heart in you to succeed. \$1.00. Ingraham, Box 9025, Los Angeles 5, Calif.

**PIANO** Tuning pays. Learn this profitable profession at home. Our Tonometer and mechanical aids make learning easy. No knowledge music necessary. Diploma granted. Largest and oldest school—53rd year. G.I. approved. Write for booklet. Niles Bryant School, 78 Bryant Bldg., Washington 16, D. C.

**SECRET** Investigation. Experience unnecessary. Investigators particulars free. George Wagner, M125 West 86th, New York 24.

**USED** Correspondence courses and educational books bought, sold, rented. Catalog free. Educational Exchange, Summer-ville, Ga.

**INVESTIGATOR** Training. Phillips Secret Service System, 1917-B North Ken-neth, Chicago 39.

## PLAYS, STORIES, MANUSCRIPTS

**LOOKING** For a book publisher? Write for free booklet PM2. Vantage Press, 230 West 41, New York.

**MUSICAL** Comedy plays. Dorby Publications, P.O. Box 131, Brier Hill, New York.

I want new writers to cash checks of \$1 to \$100 offered daily. The easiest way to write for pay. No previous experience necessary. Free details. Saunders M. Cummings, 468-11 Independence Bldg., Colorado Springs, Colo.

## BUSINESS SERVICE

**BUSINESS** Prestige—Have a New Orleans mailing address. Gateway to Central and South America. 25c each, or \$4.00 monthly. Strictly in advance. Sinclair Advertising Service, Box 762, New Orleans, La.

**INCORPORATE** Your business. Many advantages. Delaware laws free detail. Tax Research Bureau, Inc., Box 710, Wilmington, Delaware.

## SPECIAL SERVICES

**FLORIDA.** Remail your letters 20c each. 12 beautiful Florida postcards mailed, \$1.00. Send addresses. Kinsella, 2626—22 Street South, St. Petersburg, Florida.

**LETTERS** Remailed 25c each. Norton, Box 634, Rockland, Maine.

**LETTERS.** Poems composed on any subject. Send information. One dollar. Typing of any kind. Retired school teacher. Kinsella, 2626—22 Street South, St. Petersburg, Florida.

**SEATTLE** Remail service 25c. Cards 12½c. C. W. Jensen, 605 Yesler Way, Seattle 4, Wash.

**LETTERS,** Remailed Chicago 25c; other states 30c; other countries \$1.00. Valuable Chicago address \$5.00. Storage, road, salesman's letter service. C. Mack Mail Order, 5656 N. Hermitage, Chicago 26, Ill.

**LETTERS,** Cards remailed 25c each. 8 scenic postcards \$1.00. Mailing address \$3.00 monthly. Stadler, Box 2335, Hollywood 28, California.

**LETTERS** Remailed 25c. Help wanted. Business opportunities Seattle, Tacoma, \$1.00. Porter, Box 422, Tacoma 9, Wash.

## CARTOONING, COMMERCIAL ART, SHOWCARD WRITING, SIGN PAINTING

**"HOW To Make Money With Simple Cartoons"**—A book everyone who likes to draw should have. It is free; no obligation. Simply address Cartoonists' Exchange, Dept. 93-C, Pleasant Hill, Ohio.

**3 CARTOONING** Course \$3.95. Photo cartooned \$2.50. Art, Elmsford, N. Y.

**LEARN** Cartooning, illustrating, portrait drawing, showcard writing, etc., quickly with our new, easy methods. Catalog free. National Artists, 801 North Mar-salis, A-2, Dallas 3, Texas.

**BE Smart.** Get in art. Let me start you free. 25 years experience. Nick Nichols Arts, 39 W. Adams, Chicago 3, Ill.

**RAISED** Wood letters for signs. Send 10c for catalog. Sign Letter Distributors, P.O. Box 101, Mineola, N. Y.

**LEARN** Sign painting at home. Test lesson free. Ben Kerns, Box 812-P.M., Greenville, S. C.

**SEND \$1.00** For six test art lessons, questions, art opportunities, answers. American, Box 8066, Dallas 5, Texas.

**CHALK** Talks. Laugh producing program, \$1.00. Catalog 10c. Balda The Car-toonist, Oshkosh, Wisconsin.

## ADVERTISING AGENCIES, LETTER WRITERS, FOR ADVERTISERS

**ADVERTISERS**—Sell your product nationally, regionally. We show you how. Martin Advertising Agency, 15AR East 40 St., New York.

**1000 OPPORTUNITY** Seekers names \$1.00. Foster's, Box 6142, Oklahoma City 11.

**MID-Winter** and June high school graduates \$18.00M. National coverage. Box 72, Burlington, Wisconsin.

**FREE!** 1952 Advertisers Rate and Data Directory. 52 pages! E. H. Brown Advertising Agency, 20 N. Wacker, Chicago 6.

**BIRTH** Lists nationally by states monthly \$15.00M. Q Service, Burlington, Wisconsin.

**FREE** Copy, layout service. Mailorder ad, 1,700,000 nationwide circulation, \$25.90 inch. 24-word classified, 20 big Sunday newspapers, \$30.00. Advertising ratebook free. Chicago Advertising Agency (established 1900), Chicago 4.

**ADS** Placed in out of town newspapers and magazines. Low rates. Catalogue free. Ideas that pay. Baker Advertising Agency, Successors Ankrum Agency, 189 W. Madison, Chicago 2.

**ADVERTISERS!** Reach nearly 18,000,000 readers. 25 Sunday national key newspapers, 18 words, \$59.00. "Terrific pullers." 20 popular newspapers, \$11.50. Free booklet. Special—One inch display 2-821,198 circulation, \$51.10. Newmark's Advertising Agency, (Established 1893), 217-7th Ave., New York 11.

**MAILING** Lists; \$5.00-1000 up. Write Dixie Service, King, N. C.

**24 WORDS** in 50 weeklies, \$4.96. J. Dar-nell, 730 Hays, Jackson, Tenn.

**ADVERTISE:** 24 Words, 40 newspapers \$3.50. Lists free. Advertising Bureau, 10511-C Springfield, Chicago 43.

## TYPEWRITERS, DUPLICATORS, OFFICE SUPPLIES

**NEW** Typewriter ribbon does not dry out or clog type. \$1.25 each. General Typing Service, 921 Seward, Hollywood, Calif.

**RECONDITIONED** Typewriters, printing devices, office machines, equipment. DixieGraph, King, N. Car.

## RUBBER STAMPS AND OFFICE SUPPLIES

**BETTER** Quality! 3 lines, \$1.00; one, 40c. Fast service, printing, etc. Catalogue. Johnson Press, Box 6-A, New York City 29.

**SPEED-Mo** rubber stamp pads. Sample 55c. Ford's Stamps, Bristol 9, Conn.

**3 LINE;** Self-inking pocket stamp. \$1. Bauer-Lee, Sierra Madre 5, California.

**3 LINES** 50c; Pads 35c; signature \$2.35. Stamp-Right, Wauwatosa, Wis.

**LINE** 25c; 2-45c; 3-65c. Stamp Works, Auburn, Nebraska.



## PRINTING, MULTIGRAPHING, MIMEOGRAPHING GUMMED LABELS

SATISFIED Customers from coast to coast say we do better printing for less money. Free samples, prices. Sutton Printing, Box 853-M, Waycross, Georgia.

100 EACH 8 1/2x11 Letterheads, 6 3/4 envelopes, 4 lines, \$1.80 postpaid. Kautz Printers, Cuero, Texas.

1000 ADDRESS Stickers \$1.00, three lines. Orwat, 1243 South 54th Street, Philadelphia 43.

LETTERHEADS, Envelopes, business cards, 100, \$1.00. Trace Printers, Hudson, New York.

NEED Printing? Request samples, prices. Gooch, 202PM, Hernando, Miss.

1000 EMBOSSED Business cards (raised letters) \$3.95 postpaid. 2 color cards \$4.45. Samples free. All-Trades, 304 Chestnut Street, West Hempstead, N. Y.

100 8 1/2x11 HAMMERMILL Letterheads and 100 envelopes \$1.95. H. Hudson, Centredale, R. I.

5000 #6 3/4 ENVELOPES Printed \$3.10 per thousand. 1000 embossed business cards \$4.25. Free samples. Michel, Box 76, New York 16.

EMBOSSED Business cards. Free samples. Vine Ad Press, 582A Courtland Avenue, New York 51, New York.

PHOTO Offset printing! No cuts, no typesetting. Astoundingly low prices. Quality work guaranteed. Get catalog. Thomason, 3316-ms, Purington, Fort Worth 3, Texas.

PROMPT Delivery—500 business cards, \$3.75 postpaid. Edgar Wilson, 1539 Coolidge, Portsmouth, Ohio.

BUSINESS Stationery. Lowest prices. 500 8 1/2x11 letterheads \$3.55, 500 6 3/4 envelopes \$3.30, plus postage. Send 10c for ready-made samples and price list. Centro Products, LeCenter, Minn.

PRINTING—Offset, 8 1/2x11, \$6.95 thousand. Send stamp for offset copy instructions. Price list. Kale Brothers, 2250 Milwaukee, Chicago 47.

PENCILS—Your name. 20-\$1.00. Agents wanted. Warpress, Warwick, R. I.

OFFSET Plates. Send original copy. Lewis Graphic, N. Tonawanda, N. Y.

QUALITY Printing. Stationery, circulars, booklets, publications. Free catalog. Adams, 30 West Washington, Chicago 2, Ill.

200 LETTERS Mimeographed on printed letterheads 8 1/2x11 only \$2.00; 500, \$4.25; 1,000, \$6.10. Ross S. Weygandt, Box 313P, Wooster, Ohio.

MIMEOGRAPHING — Reasonable. Any copy. Mailers Service, Box 606-F, Chicago 90, Ill.

SPECIAL Discount price list on political, commercial printing. Dornfeld, Iron Ridge 14, Wis.

JOB Printing. Free estimates. H. L. Wilson Press, New Germantown, Penna.

MIMEOGRAPHING — Letters, pricelists, formulas, instructions. Lowest prices. Lem's Letter Shop, 5710 Stanton, Detroit 8.

BUSINESS Printing. Samples, prices free. Howprint, 723-M Eunice, Webster Groves 19, Missouri.

125 8 1/2x11 LETTERHEADS And 125 6 3/4 envelopes \$2.00, postpaid. 250 of each \$3.50. Going Print Shop, Box 1544A, Muskogee, Oklahoma.

1000 BUSINESS Cards \$2.50 prepaid. Samples free. Reliable Print Shop, 907 East Jefferson, Louisville 6, Ky.

500 3/4x2 1/4 FOUR Line gummed stickers 50c. Red border \$1.00. Moritz Printery, Saginaw, Mich.

## PRINTING OUTFITS AND SUPPLIES

MAKE Your own, self-molding, rubber printing cuts. Plexirubber, Argyle 1, Wis.

PRESSES, Type, cabinets, supplies. List for stamp. Lincoln Press Company, 220-F Hartwell, Fall River, Mass.

PRESSES, Supplies, paper. Catalog 10c. Custom, Box 211-P, Springfield, Missouri.

PRINT Your own cards, stationery, circulars, advertising. Save money. Simple rules. Print for others, nice profit. Raised printing like engraving too. Have home shop. Details free. Kelsey Presses, L-11, Meriden, Conn.

PRINTING Presses, type, supplies. Lists 3c. Turnbaugh Service, Loysville, Penna.

## PATENT ATTORNEYS

INVENTORS—If you consider your invention to be something of importance, take steps to protect it with a United States Patent which gives you the right to exclude others from making, using and selling your invention as claimed. "Patent Protection for Inventors" outlines steps to take to secure patent protection. Mailed promptly without obligation. Victor J. Evans & Co., Merlin M. Evans, Registered Patent Attorney, 731-C Merlin Building, Washington 6, D. C.

"INVENTOR'S Guide" free. Frank P. Ledermann, Registered Patent Attorney, 154 Nassau Street, New York.

REGISTERED Patent attorney offers services. Sanders, 6430 Evans, Chicago 37, Ill.

PATENTS. "Proof of Invention" free. E. E. Vrooman, Registered Patent Attorney, 507 McKim Building, Washington 5, D. C.

INVENTORS—If you believe you have an invention, you should find out how to protect it. The firm of McMorrow, Berman & Davidson with offices in Washington, D. C., is qualified to take the necessary steps for you. Send for copy of our patent booklet "How to Protect Your Invention." We will also send you an "Invention Record" form. No obligation. They are yours for the asking. McMorrow, Berman & Davidson, Registered Patent Attorneys, 134-H Victor Building, Washington 1, D. C.

INVENTORS — For "Invention Record" form, contact Carl Miller, Registered Patent Attorney, Woolworth Building, New York.

INVENTORS: Learn how to protect your invention. Unless the inventor is familiar with patent matters, he should engage a competent registered patent attorney or agent to represent him. We are registered to practice before the U.S. Patent Office and prepared to serve you in handling your patent matters. "Patent Guide for the Inventor" containing detailed information concerning patent protection and procedure with "Record of Invention" form will be forwarded to you upon request; without obligation. Clarence A. O'Brien & Harvey Jacobson, Registered Patent Attorneys, 21B-A District National Building, Washington, D.C.

INVENTORS: When you are satisfied that you have invented something of value write me, without obligation, for information as to what steps you should take to secure a patent. Write Patrick D. Beavers, Registered Patent Atty., 935 Columbian Bldg., Washington 1, D. C.

INVENTORS: Write for free brochure "Evidence of Invention." Labiner, World Building, New York 38.

C. A. Snow & Co.—M-427, Snow Building, Washington 1, D. C. Registered Patent Attorneys. Write for information.

INVENTORS: Without obligation, write for information explaining the steps you should take to secure a patent. John N. Randolph, Registered Patent Attorney, 203 Columbian Bldg., Washington 1, D. C.

CANADA—Ramsay Company Registered, 273 Bank Street, Ottawa, Canada.

## FOR INVENTORS

INVENTORS—If you believe you have an invention, you should find out how to protect it. The firm of McMorrow, Berman & Davidson with offices in Washington, D. C., is qualified to take the necessary steps for you. Send for copy of our patent booklet "How to Protect Your Invention." We will also send you an "Invention Record" form. No obligation. They are yours for the asking. McMorrow, Berman & Davidson, Registered Patent Attorneys, 134-G Victor Building, Washington 1, D. C.

INVENTORS—If you have a valuable invention, you are advised to authorize a preliminary search through appropriate classes of United States patents. This firm is registered to practice before the Patent Office and is available to make such search and report to you concerning the probable patentability of your invention. Instructive booklet with "Evidence of Invention" form sent upon request. Victor J. Evans & Co., 732-C Merlin Building, Washington 6, D. C.

DRAFTING, Designing, developing, engineering, patent drawing service. Inquiries confidential. Rejo Engineering, 24A Chiswick Rd., Brighton, Mass.

PATENT Searches, \$5.00, including patent copies. Same reliable search as conducted for patent attorneys. Free protection forms, 48 hour services. Patent Service Institute, 945-A Pennsylvania Avenue, Washington 4, D. C.

COPYRIGHT, Design and patent guide on request. Patent Attorney Metzler, 11 West 42nd, New York 18.

INVENTORS—Develop and market your invention through unique plan. Free literature. Inventors' Intermediaries, Inc., 11 West 42nd St., New York 18, N. Y.

PATENT Searches \$5.00. Record of invention forms free. 48-hour service. Write Miss Ann Hastings, P. O. Box 176, Washington 4, D. C.

SELL Your unpatented invention yourself. Read how, \$2.00. James R. Garcia, "A" Street Station, Clearwater, Florida.

PATENT Searches \$5.00. 48-hour service. Protection forms free. Write Raymond L. Smith, Patent Searcher, 410 Bond Building, Washington 5, D. C.

INVENTIONS, Sold, leased, complete services. M. Joyce Humphries, 1425 Landtitle, Philadelphia 10.

PATENT Searches \$5.00. Protection forms free. Patent drawings prepared. Write Patent Engineering Service, 1404 New York Avenue, Washington 5, D. C.

INVENTORS: Learn how to protect your invention. Unless the inventor is familiar with patent matters, he should engage a competent registered patent attorney or agent to represent him. We are registered to practice before the U.S. Patent Office and prepared to serve you in handling your patent matters. "Patent Guide for the Inventor" containing detailed information concerning patent protection and procedure with "Record of Invention" form will be forwarded to you upon request; without obligation. Clarence A. O'Brien & Harvey Jacobson, Registered Patent Attorneys, 21A-A District National Building, Washington, D.C.

INVENTORS: Without obligation, write for information explaining the steps you should take to secure a patent on your invention. John N. Randolph, Registered Patent Attorney, 202 Columbian Bldg., Washington 1, D. C.

SEARCHES—Put your patent searches in the hands of a registered patent attorney or agent, as he qualifies to give a worthwhile patentability report. Record of invention form upon request and information on patent protection. Patrick D. Beavers, Registered Patent Attorney, 936 Columbian Bldg., Washington 1, D. C.

SEARCHES \$5.00. Reliable reports airmailed within 48 hours. "Record of Invention" free. Capitol Patent Service, Box 664-P, Washington 4, D. C.

INVENTORS — For "Invention Record" form, contact Carl Miller, Registered Patent Attorney, Woolworth Building, New York.

CASH For your idea, 280 manufacturers need inventions, patented or unpatented. List free. Invention Bureau, 208M Clinton, Oak Park, Ill.

PATENT Owner representative. Years of experience. Can I help you? Charles A. Scott, 773PM Garson Avenue, Rochester 9, N. Y.

INVENTORS: If you have an invention for sale, patented or unpatented, write Institute of American Inventors, Dept. 40A, 631-E St. N.W., Washington 4, D. C.

SELL Ideas direct to manufacturers. Kit \$2. Inventors' Supply House, Box 1118B, Newark, N. J.

## INVENTIONS WANTED

IF You have a useful gadget to manufacture write J. Lenarwick, 160 Pastoria St., Sunnyvale, Calif.

INVENTORS! Sell that idea for cash to manufacturers. Patented or pending. For information write Inventors' Service Bureau, 847F Roscoe St., Chicago 13, Ill.

WANTED—Patented, unpatented items cast aluminum. K & M Foundry, 3116 W. Lake Street, Chicago 12.

INVENTIONS Wanted. Patented or patent pending. 21 years experience promoting inventions. National Service Bureau, 3120 Meramec, St. Louis 18, Mo.

INVENTORS — Good patented, patent pending inventions wanted by manufacturers. Booklet free. Market Contacts, 719-A2 Magnolia, Tupelo, Miss.

INVENTIONS Wanted by manufacturers. Patented-pending only. Free details. Inventors Exchange, Dept. B, Hartford 1, Conn.



**INVENTIONS** Promoted. Patented or unpatented. Est. established 1911. Write Adam Fisher Company, 61 Enright, St. Louis, Mo.

**INVENTORS:** Hundreds of manufacturers have requested our assistance in locating marketable new products. Complete information free. Institute of American Inventors, Dept. 40-D, 631-E St. N.W., Washington 4, D. C.

### PATENTS FOR SALE

**TWO** Patented wonder toys, lathe accessory, other ideas for cash or royalty. Inventor, 415 James S.E., Grand Rapids, Michigan.

**NOVEL** Selfclosing safety pin protected by two "patents pending." Write Room 342, 88 6th St., San Francisco 3, Calif.

**FOR** Sale patent convertible and folding baby seat. Write E. J. Quiggle, Shelby Inn, Shelby 17, Ohio.

**INVENTORS:** Test the commercial value of your patented or unpatented inventions, quickly and inexpensively. Write for free information. Institute of American Inventors, Dept. 40-B, 631-E St. N.W., Washington 4, D. C.

### MANUFACTURING

**WOOD** Turnings—Handles, toys, foot-stool legs. Robens, Buena Vista, Virginia.

**MODELS**—Small lot manufacturing. Metals, plastics, etc. Milburn, Burlington, Kentucky.

### MODELS, MODEL SUPPLIES

**BUILD** Historic ships, vehicles. 50c to \$9.00 kits. Illustrated catalog 10c. Ideal Models, 19 West 18th Street, New York 11.

**IMMEDIATE** Delivery on big 60 page 1952 "HO" model railway catalog of parts, car kits, locomotives, diesels, etc. Listing thousands of items in stock. Price 35c. 1952 "O" gauge catalog, 40 pages scale and toy trains. Price 25c. Dept. W, All-Nation Hobby Shop, 182 North LaSalle St., Chicago 1, Ill.

**HOME** Models and doll houses are fun to build, profitable to sell, with our accurately scaled, pre-fabricated materials. Send 10c for samples and booklet, "How You Can Build Model Homes." Architectural Model Materials, Inc., Dept. M32, 4208 Armitage Ave., Chicago 39.

**BRASS** Gears and model supplies for the inventor. Send 10c for catalog. Pierce Model Works, Tinley Park, Ill.

**PRECISION** Engineered model steam plants built to your specifications. We specialize in model boilers and turbines. Send 5c for folder describing ready-built models, steam plants, reduction gears, etc. Address replies to: Russell L. Hutchens, Box 14, Peak Island, Maine.

**SHIP** And yacht model fittings; blueprints. Send 25c for illustrated catalog No. 27—listing hundreds of items. A. J. Fisher, 1002-I Etowah Ave., Royal Oak, Mich.

**SHIP** Models—Most complete line in New England. Kits, fittings, plans, books, tools, engines, motors. Illustrated catalog 25c. James Bliss & Co., Inc., Dept. SM, 220 State St., Boston, Mass.

**LIONEL**, American Flyer, illustrated catalog free. Ben's PM Department, 134 North Dearborn, Chicago 2.

**BUILD** Historic ship models, complete kits 50c to \$9.00. Catalog 15c. Ideal Models, 19 W. 18th, New York 11, N. Y.

**SHIP** Models and yacht supplies complete. Large 64 page catalogue 30c. Bill Wild's, 510 East 11 St., New York City 9.

**STEAM** Locomotives, 1½", 1", ¾", ½", ¼" scales. Castings, rail, steam fittings! Thorough drawings with instructions. Catalog 50c. Little Engines, Wilmington, California.

### HOME CRAFTSMEN

**NEW** Shellcraft instruction book just completed. Diagrams and photos show how to use cut shells, fish scales, glitter, night-glow; design jewelry, novelties, plaques, centerpieces, etc. Clearest instructions anywhere. 35c postpaid; our giant catalog 25c. Shellart Studios, St. Petersburg, Fla.

**89** FULL Size jig saw patterns of beautiful shelves, ornaments, toys, novelties. Plus "How, Where to Sell." Only \$1.00. Mastercraft 34M, 7041 Olcott, Chicago 31, Illinois.

**OUR** Biggest leather and craft catalog yet! 1000's of items. Send 25c (refunded with first order). Russo Handicraft Supplies, Dept. 3-C, 245 S. Spring, Los Angeles, California.

**LEATHERCRAFT** For pleasure or profit. Make easy-to-assemble purses, belts, gloves, woolskin toys, 100 other items for gifts or to sell. Send 10c today for big catalog. Largest leathercraft stock in U.S. J. C. Larson Co., 820 S. Tripp, Dept. 1775, Chicago 24.

**90** ALL New, full size lawn ornament and novelty patterns, up to 20" high. Only \$1.00. Mastercraft 32M, 7041 Olcott, Chicago 31, Illinois.

**WOOD** Carvings make wood projects beautiful and valuable. Illustrations and prices free. Hasse Carvings, 35 S. Oxford St., Indianapolis 1, Ind.

**LEMON**-Orange skins make simple unusual attractive oddities, novelties, flowers, dolls, ornaments, etc. Illustrated copy "Citrus Skin Art" plus free gift attractive golden kangaroo lapel pin. \$1 bill. Ranaid's Representatives, Box 49, P.O. Broadway, Queensland, Australia.

**REMODEL** Kitchen cabinets. Postcard brings price list of slab doors, drawers, hardware and accessories. Thombert Company, Newton 16, Iowa.

**JIGSAW** Owners attention! Start earning money at home cutting out wooden novelties and souvenirs. Write H. Cook, Dept. A, 4407 S. Normal Ave., Chicago 9, Illinois.

**16** NEW Lawn chairs, 22 picnic tables, benches, trellises, etc. All 38 plans with necessary full size patterns, \$1.00. Mastercraft 33M, 7041 Olcott, Chicago 31, Ill.

**MINIATURE** Furniture kits. Solid cherry. Easily assembled. Large selection. Catalog 20c. Culver Miniatures, 194 Sixty First St., Dept. A, Niagara Falls, N. Y.

**NATIONALLY** Advertised finishing materials wholesale. Lacquers, abrasives, glues, etc. Catalogue 25c. Finishers Products Co., Box 8647, Dept. C, Dallas, Texas.

**HOME** Building or remodeling? Need help how-to-do-it? Send questions. \$1.00 to P.O. Box 342, San Leandro, Calif.

**WOODWORKING** Patterns, full size. Large assortment \$1.00. Sample 25c. Duty free. Mosbro Patterns, 44-M Victor, Mimico, Ontario.

**LEATHERCRAFT** Kits, wholesale, that you finish. Sell retail on sight, at a handsome profit. Catalog 25c (refunded on ordering). Wholesale Leathercraft Company, District 763 Box 165, Milwaukee 14, Wis.

**SWISS** Music movements, finest make, lowest price. Ask for leaflet. Helaxe Company, 233 West 72nd Street, New York.

**POTTERY** Wheel sets \$3.75-\$6.95 postpaid. Free circular. Putter-Potter, Saranac Lake, N. Y.

**METAL** Spinning. Everything in spinning lathes, tools and accessories. Send 20c in stamps for metal spinning instruction book and big catalog on woodworking tools. Boice-Crane Company, 943 Central Avenue, Toledo 6, Ohio.

**LEATHERCRAFT** Bargains! Lacing. Francis Byrd, 3406 Montrose Ave., Richmond, Va.

**80** FULL Sized patterns, lawn ornaments, toys, novelties, \$1.00. Modern Woodcraft, Saginaw, Mich.

**VIOLINMAKERS**, Amateurs, professionals. Fine tone European wood, materials, supplies, instructions, patterns. Illustrated catalogue 10c, refunded. Premier Violin Supplies, Dept. VZ, 430 South Broadway, Los Angeles 13, California.

**JIGSAW**, Bandsaw owners, let your machine bring extra profits, fun. Free details. Nu-Art, Dept. B, Box 2235, Boston, Mass.

**"TOPS"** In everything for leathercraft. Low priced kits, leathers, tools, lacing. Catalog 10c. Crown Leathers, 22 Spruce Street, New York 38.

**FREE** Information. How to make money with jig saw. Write Jigsawers, 117-M Worth, New York 13.

**WOODCRAFT** Patterns—Large what-nots, lawn ornaments, toys, novelties, large assortment \$1.00. Joanness, Box 141-E, Omaha 7, Nebr.

**WHOLESALE** Shellcraft book 15c. Large shellcraft kit \$1.85 postpaid. Shell-Art Novelty, 5th and Moore, Philadelphia 48, Penna.

**\$46** FROM Square foot plywood; jigsaw necessary. Write: Woodarts, Bridgewater, Mass.

**KNOCKDOWN** Cedar chests. Lumber and veneers. Free price list. Giles & Kendall Company, Huntsville, Ala.

**30** LAWN Ornament patterns. Ready cut. Full size. Color indicated. \$1.00 postpaid. Lincoln Craft Studio, Columbia, Conn.

**HAVE** Fun! Make money! "Working With Leather." 64-page booklet tells how. Send 25c for copy. Free gift if you mention this magazine. Valuable information included. No foreign orders. Wilder & Company, 1039 Crosby, Chicago 10.

**100** FULL Size jig saw patterns up to 20" high, only \$1.00. Pattern Service, Medway 9, Mass.

**LEATHERCRAFT**, Copper tooling, textile painting, many other crafts. Big free catalog shows everything you need. Kit Kraft, 7377 Melrose, Hollywood 46, Calif.

**LEATHERCRAFT** Supplies catalog. Pleasure and profit. New style handbag patterns, belts. Leathercraft school G.I. approved. 25c for catalog (refund 1st order). Dept. PM, Apache Leather Co., 2004 E. Washington St., Phoenix, Arizona.

**LEATHER**, Tools, lacings, supplies. Free catalog. National Handicraft, 199 William St., New York 7.

### MAKE IT YOURSELF

**BUILD** Home freezer, complete step by step illustrated plan \$1.00. Use discarded parts found in every home. Details free. Clarke Refrigeration Co., 2571 43rd Ave., San Francisco, Calif.

**BUILD** Electric lantern. Simplified instructions. Information, photographs free. Conti Supply Co., 92-A Columbia St., Wood-Ridge, N. J.

**STREAMLINED**, Built-in kitchen cabinets to fit any kitchen. Illustrated manual describes designing and construction. All for \$1.00. Thombert Company, Newton, Iowa.

**MAKE** Your own "Stone-Veneer." Economical. Easily made, quickly applied. Looks like genuine stone. Transforms any home into one of excellent beauty. Formulas, illustrations, patterns. Alburg, Box 17, Carrollton, Mich.

**\$750** BUILDS Cozy 4 rooms and bath; concrete block, stuccoed. Instructions and blueprint \$1.00. Farrow, G83, Box 645, Columbus 16, Ohio.

**BUILD** Over 100 machines with Kimo Plans, Box 307-P, New York 19. Satisfaction guaranteed. Catalog 25c (refundable).

**GRANDFATHER** Clock easily built. Big savings. See ad on page 295.

**CONSTRUCTION** Blueprints for lovely low cost, two bedroom, basementless home. Sample construction contract free. Send \$1.00. Plans, Box 1007, St. Clair Station, St. Paul 5, Minn.

**FREE** Handbook, build sawmills, block machines, freezers, tractors, scooters, 250 shop, farm, home machines. Nichols Co., Dept. C-1801, Purvis, Mississippi.

**SEND** 25c Today for new large catalogue of supplies for 21 popular crafts. Dept. D-11. Dearborn Leather Company, 8625 Linwood Avenue, Detroit 6, Michigan.

**BUILD** Your own "tractor." Free information. Eltraco, D-I, Camptonville, California.

**"CONCRETE** Block Homes." 32 page booklet on how to build. \$1.00. H. C. Lightfoot, Civil Engineer, Richboro 1, Penna.

### WATCHES, OLD GOLD, JEWELRY

**WRIST** Watches, U. S. Air Corps, Waltham, 16 jewel, water and shock proof, stainless steel case, reconditioned. Value \$35.00—Special \$15.00. Public Sport Shops, 11 S. 16th Street, Philadelphia 2, Penna.

**"THE** Modern Clock." All about clock repair. 502 pages. 173 illustrations. \$4.95, postpaid, 10-day return privilege. North American, Dept. 12-C, 2018 North Avenue, Chicago 47, Illinois.

**RHINESTONES**, Jewelry settings, cameo, sequins, beads. Send 10c for illustrated catalog. J & M Novelties, Dept. CC-3, Griffith, Ind.

**5** ELGIN, Waltham, Illinois, Hampden gents' wristwatches needing minor repairs, \$18.00. Write for prices. B. Lowe, Holland Bldg., St. Louis 1, Mo.

**WATCHMAKERS'** Tools, materials, supplies, repairs, catalog. Gales, Box 1000, Chicago 90, Ill.

**WATCHMAKERS** Staking set, 50 punches, 6 stumps, \$39.50. Larger set 100 punches, 20 stumps, \$49.50. Public Sport Shops, 11 S. 16th Street, Philadelphia 2, Penna.

**WATCHMAKERS'** Journal contains helpful hints on watch repairing. \$1.00 year. Sample copy 20c. Dean Co., Box 3218, Daytona Beach, Fla.



**SWISS Wrist watches.** New guaranteed, tax included specials. Shock, water resistant, radium hands, dial, formerly \$8.95, now \$6.55; 7 jewel service calendar, formerly \$17.95 now \$10.95; 17 jewel Incabloc service watch, formerly \$65.00 now \$27.94; 17 jewel waterproof Incabloc automatic (self-winding) anti-magnetic, formerly \$85.00 now \$39.88. Rebuilt, guaranteed like new, 17 jewel Gruen, Bulova, Benrus, Elgin, gents, ladies wrist watches, new cases, \$24.95. All watches carry 10 day money back guarantee. Write, Dutz Enterprises, Box 284, Lincoln, Ill.

**WATCHMAKERS' Hobbyists' complete informative catalog 20c.** Bengal Company, Culver City, Calif.

**HIGHEST Cash paid for old, broken jewelry, gold teeth, watches, silverware, diamonds, spectacles, platinum.** Free information. Satisfaction guaranteed. Rose Smelting Company, 29-A East Madison, Chicago.

#### TOBACCO, SMOKERS' SUPPLIES

**PIPES, Pipemaking instructions 10c.** Kits \$1.00. 2829-L Dixie, Hamilton, Ohio.

**CIGARETTES—Roll 200 mild-tasty for 75c.** Particulars free. Also factory-fresh pipe tobaccos. Pete Moberly, Box 850, Owensboro, Kentucky.

**WANTED—Cigarette, tobacco cards.** Write Charles Bray, East Bangor, Penna.

**AROMATIC Agents increase smoking pleasure.** Information free. Cozza, Pharmacist, Pequannock, N. J.

#### OF INTEREST TO WOMEN

**HOME Sewers—Send 10c for folders and profitable working details.** Baby Gay, Beaver Dam 6, Wisconsin.

**PLASTICS Pay big profits in spare time.** Show America's finest, largest line of colorful, latest styled curtains, drapes, tablecloths, unbreakable dishes to friends and neighbors. Take easy orders. Earn big profits and your own plastics free of extra cost. Up to \$10.00 in a day profit! No experience, investment necessary! Gorgeous 36 page style book in color, actual samples, complete details free! Write Lorraine Products, 844 W. Adams, Dept. C-19, Chicago, Ill.

#### FOR SALE—MISCELLANEOUS

**HANDSIGHTING Levels, improved, new model, used for grading land, contouring and laying out fences, piers, roads and gardens, price \$2.50 postpaid.** Public Sport Shops, 11 S. 16th Street, Philadelphia 2, Penna.

**USED Vending machines, Route operation.** Vassar, 3500 14th, Washington 10, D. C.

**SAMPLE Mail Order World magazine combined with Opportunities Preferred and large nationally advertised merchandise whole sale catalog, 50c.** Double money back guaranteed. Daurio Enterprises, Teaneck 8, New Jersey.

**SAVE Money on chrome cabinet hardware.** Write Box 89, Troy, Ohio.

**SAVE Money on army, navy and factory surplus.** Write today for new 60-page illustrated catalog. Tennusa Sales Co., Dept. AN, 1451 Market, Chattanooga, Tenn.

#### WANTED—MISCELLANEOUS

**NEW Items wanted—From manufacturers or inventors for manufacture new, unusual items suitable for mail order, promotion or general distribution.** Send samples or details. H. D. Campbell Co., Rochelle 27, Illinois.

**TELETYPE Machines, parts, any condition.** Manhattan Electronics, 219 1/2 South Sepulveda, Manhattan Beach, Calif.

**QUICKSILVER, Platinum, gold, diamonds, sterling, dental-jewelry-optometrist scrap.** Ship or write. Wholesale Terminal, Norwood, Massachusetts.

**SCRAP Mercury (quicksilver) tantalum, bismuth, tungsten, Metallurgical Products Company, Established 1909.** 35th & Moore Sts., Philadelphia 45, Penna.

#### PERSONAL

**COLUMBUS, Ohio, your address.** Letters remailed, replies forwarded. \$2.00 month. McLaughlin, 369 Welch, Columbus 7, Ohio.

**EARN Sparetime money.** Literature free. Booklet 30c. Box 48, Brooklyn 25, N. Y.

**BORROW By mail. Loans \$50 to \$600 to employed men and women.** Easy, quick. Completely confidential. No endorsers. Repay in convenient monthly payments. Details free in plain envelope. Give occupation. State Finance Co., 323 Securities Bldg., Dept. J-14, Omaha 2, Nebr.

**PAPERHANGERS: Mix Mannatex compound with paste, keeps wall paper from cracking.** Information free. Guaranteed trial size \$1.00. Write, Paperhangers Supply, P.O. Box 37, Louisville 1, Ky.

**PERFUME: Wholesale! Earn \$4.00 hour! 60% off!** Guaranteed highest quality. Rush \$1.00 for regular \$4.50 purse flacon and catalog! Stuart, 4616-P Hollywood, Hollywood 27, Calif.

**BITE Fingernails? Order J.M.J. today.** For men and women. Mail \$1.00 to The Jamarr Co., 3909 Dismount St., Dallas 11, Texas.

**A \$2.00 Swindle.** Cut your own hair forever. Bok Haircutter, Box 1691, Miami 10, Fla.

**MEXICAN Law. General Practice Attorney.** 1203 Arizona St., El Paso, Texas.

**PRINT Without a printing press.** Big profits! See page 74.

**MEXICAN Law practice reliably conducted.** Box 1736, El Paso, Texas.

**"HOW Can I find out?" You can! Information discreetly developed.** Any matter, person, problem, anywhere. Worldwide. Officially licensed, bonded service. Established 1922. Reasonable. Confidential. William Herman, 170 Broadway, New York.

**HERE'S How and where to borrow \$50.00 to \$300.00 by mail.** Confidential. Free particulars. Postal Finance Company, Dept. 45, Sioux City, Iowa.

#### MISCELLANEOUS

**LUMINOUS Paint—Glow in the dark.** Sky blue, yellow, green, green-blue. Indoor and outdoor. Waterproof. Weatherproof. 2 oz. jar \$1.00 postpaid. Nite Glo, Box 49, New Haven 5, Conn.

**MAILING List, 300 names, \$1.00; thousand \$4.00.** We can supply you with jewelry and novelties. Mardel J. Company, 23 Aborn Street, Providence, R. I.

**MAGNETSTIK Cements everything, wood, celluloid, glass, metals, china, bakelite, marble, plastic.** Sample 15c. Rosenblum, 267 Canal St., New York 13.

**300 BIG Mails guaranteed, samples, offers, propositions, 12 months listing, \$1.00.** Wright Publications, 2270-M Hubbard, Memphis 8, Tenn.

**PRINCESS Garters—Comfort and beauty.** Send 50c for sample pair. Excelsior Pro. Co., Box 4644, Detroit 34, Mich.

**CLOTHING—Alterations, remodeling and repairs by experienced tailors.** Reasonable prices. Free estimates. Berman's, 30-A North Wells, Chicago 6, Illinois.

**100 TOYS, Novelties—\$3.50, 100 army patches \$5.00.** Lassen, 588 S. Washington, Falls Church, Va.

**HAIRCUT As you like it.** Free circular. Booklet 25c. Mastrolia, 5 1/2 BP Jane, New York City 14.

**MAKE Own treasure locator.** Positively works up to several hundred yards. Instructions \$5. Clifton, Box 56, Wellington, Colo.

**WHY Die? Know latest medical discoveries and live!** "Your Medical Scrapbook" tells everything! Wonder drugs! Atomic treatments! Miraculous cures! Free literature. Bijou, Box M2-1727, Hollywood 28, California.

**INCREDIBLE! Unprecedented!** Become a mental superman overnight! Floor everybody! No studying! "Memoprop" does all your thinking! It's uncanny! Revolutionary! Write: Bijou, Box 1727-MO, Hollywood 28, California.

**EARN Up to \$200 month, inventing toys, games, gadgets.** Write Hendrickson, Argyle 1-A, Wisconsin.

**INTERESTING Mails.** 25c keeps name on mailing list three months. Bentz, (Desk E/59), Chatawa, Mississippi.

**70 BIBLE Lessons, 25c.** Bulletin, Box 87, Cathedral Station, New York 25.

**SEPTIC Tanks, cesspools, outdoor toilets cleaned by patented formula.** Send \$1.00 to Septifed Corporation, Chambersburg, Penna.

**MEN—Thrilling new experience awaits you in effortless shaving.** Nothing like it! Exciting details free. Write: Kenmore Distributors, 3819-M Kenmore, Chicago 13.

**RAISE Ginseng.** Seeds ready cir. free. Fazler Seeds, Patchogue, N. Y.

**FREE Catalog! War surplus clothing.** Amazing bargains. N. Y. Clothing Co., New York 29A.

**SAVE Money on everything you buy in 1952—From cigarettes to a new home.** Send 50c cash for list or postcard for details. Write King Lusk, Dept. 3, 65 Jackson Street, Aurora, Illinois.

**TIE Your tie like I tie mine—A perfect knot everytime.** Instructions, simple accessories, 50c. Ti-Neat, Box 128, Marion, Ohio.

**SEPTIC Tank care and ideas.** Send \$1.00 to Sani-Septi Corporation, Fayetteville, Penna.

**YOUR Name embroidered, fast color 10 silk identification tapes \$1.00.** American Embroidery Co., 1103 E. Colorado St., Glendale, California.

**URANIUM Prospecting information free.** Prospector, Box 142-I, North Battleford, Saskatchewan, Canada.

**CESSPOOL Trouble? Use Peps-It.** Rejuvenates fermentation action, saves pumping costs, deodorizes, reduces masses. Costs only \$2.50. Safe. Sanitary. Free descriptive literature. Chemical Cesspool Cleaning Co., Boston 34, Mass.

**SQUARE Dance instructions, thirty dances, \$1.00.** Wesley Rader, 3926 Alcott, Denver 11, Colorado.

**RECEIVE Giant mails, magazines, catalogs! Three months 25c, year 50c.** Waddell's Directory, 341B East 76th, New York 21.

**AMAZING Plastic air cushion \$1.00.** Wenogart, Box 1495, Philadelphia 5, Penna.

**DRESSES 24c; Shoes 39c; men's suits \$4.95; trousers \$1.20.** Better used clothing. Free cat. Transworld, 164-AD Christopher, Brooklyn 12, N. Y.

**LAWN Mowers.** Hand and power sharpening, adjusting and engine care. Easily done by yourself. Knowledge 22 years experience yours for \$1.00 postpaid. Wirt's, 2419 Gnahn, Burlington, Iowa.

**VITAMINS.** Special two weeks trial supply of potent Multi-Vims only \$1.00. Satisfaction guaranteed. Vigor Vitamins Company, Box 5, Cedar Rapids, Iowa.

**BIG Mails, mail order magazine opportunities 25c.** Harvey Teeple, Decatur, Indiana.

**OUTDOOR Toilets cleaned, deodorized! Cut digging, pumping, moving costs.** Safe, economical. Details free. Wilmette Farm Supply, Dept. 90, Wilmette, Ill.

**GOLD, Silver, metal detectors.** Geiger counters for uranium. Mineralights. Sensational new fully guaranteed models. None finer. Information free. Detlectron Co., 5631 Cahuenga Blvd., North Hollywood, California.

**LEATHER Jackets repaired.** New knit, zippers or relined. Work fully guaranteed. Jackets made to order. Free circular. Taubers, 689 Mission, San Francisco 5, Calif.

**MEDICAL Laboratory Technicians in great demand.** We train you in your own home. Catalogue free. Imperial Technical Institute, Box 973-J, Austin, Texas.

**NEW! "100 Best Woodworking Projects"**—144 page Popular Mechanics book with 100 special projects for every member of the family. Furniture, toys, novelties, many more. Send \$2.00 to Popular Mechanics Press, Dept. 105, 200 E. Ontario, Chicago 11, Ill.

**OUTDOOR Toilets, cesspools, septic tanks cleaned, deodorized with amazing new product.** Just mix dry powder with water; pour into toilet. Safe, no poisons. Save digging, pumping costs. Postcard brings free details. Burson Laboratories, Dept. C-36, Chicago 22, Illinois.

**YOUR Leather jacket renovated expertly.** Free circular. Berlew Mfg. Co., Dept. 8, Freeport, N. Y.

**TREASURE Finders for gold, silver and minerals.** Money back guarantee, best available. Also Geiger counters for uranium prospectors, free information. Write Goldak Company, 1541 West Glenoaks, Glendale 1, Calif.

**PANNING Gold lesson and catalogue.** Beginners supplies, books, "maps where to go" free. Old Prospector, Box 729DI, Lodi, Calif.

**TREASURE—M-Scope Geiger counters, mineral locators.** Why buy something inferior when you can buy the best at a lower price? Backed by years of experience. Fully guaranteed by factory. Detects minerals, metals, gold, silver, coins. Payment plan available. Proven superior performance. Free 16 page illustrated booklet. Fisher Research Lab., Inc., Palo Alto, California.



**New Advertising Machine**



**Prints & Illustrates Gov't Post Cards**

**FREE** Learn how thousands of business men, in every line, are boosting sales in spite of conditions—with ad messages—printed and illustrated in a few minutes on gov't post cards—with amazing new patented **CARDMASTER**. Your "today's" ideas, read by your prospects next morning. Not a toy, but a sturdy advertising machine, built to last for years. Low price, sold direct. Guaranteed for five years. Send name today.

**SEND NAME** We'll send **FREE** illustrated book of money-making **IDEAS** for your business and complete, unique advertising plans. **RUSH YOUR NAME TODAY.**  
**CARDMASTER COMPANY**  
 1920 SUNNYSIDE, Dept. 133, CHICAGO 40, ILL.

**MEN - WOMEN, LEARN**

# Skil-Weaving

**MAKE GOOD MONEY AT HOME**

**SECRETS OF FRENCH INVISIBLE REWEAVING**

Now, learn invisible reweaving at home. Repair burns, tears and moth holes in suits, dresses, coats, etc., like new, at big profit. No previous experience needed. Big profit orders come from Homes, Cleaners, Dept. Stores—also mail orders. Up to \$5 an hour possible, spare or full time without overhead or expense for materials. Complete Skil-weave Instructions yours to examine at home, without risk. **FREE** details—write **NOW**. Airmail reaches us overnight.  
**SKIL-WEAVE, 1715-JB Westwood, Los Angeles 24, California.**

**SILVER SOLDER TORCH & KIT \$7.50**

**JOINS ALL METALS PERMANENTLY**

Do your own repairing. KIT includes one tube silver solder "XCEL-FLUX" paste and 10 5-in. lengths silver solder alloy. Hottest ALCOHOL TORCH known. 2700° F. flame. Operates in any position, indoors or out. Pint of special fuel included. TORCH alone with pint of special fuel \$6.50. K-T alone \$1.50. Add 35c on each order towards shipping charges.  
**AMERICAN PRODUCTS CORP., 422 S. Dearborn, Dept. 3-C, Chicago**

# STUDY AT HOME

**WITH AN EDUCATIONAL INSTITUTION**

Courses in **ARTS AND SCIENCES**: Philosophy; Education; Letters; Public Health; Medical Jurisprudence; Psychology; Sociology; Physics; Chemistry; Geology; Pol. Science; Theology; Law; Business and Commerce; Accounting; Mathematics; Statistics; Agriculture. Courses in **ENGINEERING**: Electrical, Civil, Mechanical, Drafting, Architectural, Automotive, Steam, Diesel, Aeronautical, Radio, Structural, Mining, Industrial, Petroleum, Marine, Refrigeration, Air Conditioning, Chemical. Send for free catalog.  
**McKinley-Roosevelt Incorporated, 4610-K32, Sheridan Rd., Chicago 40, Illinois**

**USE EASTER SEALS. HELP CRIPPLED CHILDREN**

# FOR BIG MEN ONLY!

**SIZES 10 to 16 WIDTHS AAA to EEE**

We SPECIALIZE in large sizes only—sizes 10 to 16; widths AAA to EEE. Loungers: Nylon Mesh; Dress Oxfords; Moccasins: High and Low Work Shoes; Slippers; Rubbers; Overshoes; Sox. Enjoy the finest in fit, comfort, style at amazingly low cost. Sold by mail only. Write for **FREE** Style Book **TODAY!**  
**KING-SIZE, Inc., 831, Brockton, Mass.**

**SEND FOR FREE CATALOG**

**I'LL PAY YOU TO WRITE ORDERS FOR**

# KENDEX NYLONS

**THAT ARE FREE**

**UNLESS SATISFACTORY!**

Amazing, but true! The most sensational offer ever made!



Can you imagine how much money you could make writing orders for wonderful nylons that actually cost nothing unless satisfactory? Our leading Style 300 de luxe, first quality, full fashioned sheer nylons now reduced to only 98c a pair **INCLUDING** your commission, bonus and even postage. This stocking is so finely made — gives so much wear, that **KENDEX** will refund the full 98c purchase price if the hose runs, snags or shows undue wear within **ONE AND A HALF MONTHS!** Should that happen, the hose will cost the customer **NOTHING!**

This isn't selling. It's like giving something away! What woman could refuse to wear nylons at **OUR** risk? There's nothing for you to buy or deliver. You get advance cash on every order plus a huge bonus that increases your earnings by 40%!

## FREE SAMPLE STOCKING!

I'm so positive you can make money that I'm willing to give you a sample stocking, color card and all sales materials absolutely free! I'll even pay the postage. What's more, you need promise nothing. The whole outfit is yours and if you don't make enough money, just throw it away!

I don't care if you are 18 or 80 — whether you can spare one hour or fifty hours a week. Man or woman — young or old — spare or full time — experienced or not, this can be the opportunity you have been hoping for.

If you write me quick, I'll also include complete money-making outfit of a wonderful line of men's hosiery actually guaranteed **ONE FULL YEAR** or replaced free without question!

## MAIL THIS COUPON NOW!

Date.....

Michael H. Kent, President  
 Kendex Corporation  
 Babylon, 246, N. Y.

Send me, absolutely free and postage prepaid, your complete money-making outfits including free sample stocking. It is understood I am under no obligation and if I am not satisfied with the money I make, I will throw away the outfits.

Name.....  
 Address.....  
 City..... Zone..... State.....



# THIS HANDBOOK FOR AMBITIOUS MEN FREE!



Have you had your copy?

150 pages of guidance to best-paid positions. Up-to-the-minute information for men who want to climb to the top. Tells how to get promotion, security and better pay through home study courses. This handbook "Engineering Opportunities" is free and entirely without obligation. Send the coupon. Make this your big year! Describes over ninety courses including:

- |                 |               |             |
|-----------------|---------------|-------------|
| Mechanical Eng. | Electrical    | A.F.R.Ae.S. |
| Aeronautical    | Radio         | A.M.I.C.E.  |
| Television      | Automobile    | B.S. (Pure  |
| Building        | A.M.I.Mech.E. | Science)    |

--- SEND COUPON TODAY ---

Canadian Institute of Science & Technology Limited, 536 Century Building, 412, 5th Street, N.W., Washington, D.C.

Please forward free of cost or obligation your handbook, "ENGINEERING OPPORTUNITIES".

Name.....

Address.....

Course interested in..... Age.....

Canadian Address: Canadian Institute of Science 536 Garden Bldg., 263 Adelaide Street, W., Toronto 1

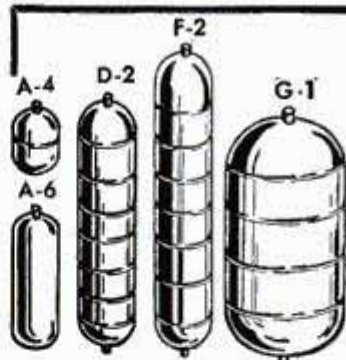

## STEEL AIR TANKS

Steel pressure tanks suitable for compressors, pneumatic units, gases, hydraulics, and liquids. Rated at 500 lbs. per square inch pressure. 1/4" standard pipe thread openings on tank ends as shown.

		Size	Wt. Lbs.	Internal Volume	Price
A-4	Stainless Steel—New	7 1/2"x5 1/4"	1 1/2	104 cu. in.	\$1.50
A-6	Carbon Steel—New	14 1/2"x5 1/2"	3 1/4	280 cu. in.	3.50
D-2	Stainless Steel—New	24"x6"	5	500 cu. in.	5.50
D-2A	Carbon Steel—New	24"x6"	5	500 cu. in.	4.50
F-2	Stainless Steel—New	45"x6"	11	1000 cu. in.	9.50
F-2A	Carbon Steel—New	45"x6"	11	1000 cu. in.	5.50
G-1	Stainless Steel—New	24"x12"	18	2100 cu. in.	11.50
G-1A	Stainless Steel—Used	24"x12"	18	2100 cu. in.	9.50

Prices F.O.B. Chicago. Include approx. postage on orders paid for in advance. C.O.D. orders enclose 25% balance sent C.O.D.

**U. A. S. Corp.** Dept. PM3, 5637 W. 63rd Pl. Chicago, Illinois

## CARBURETOR TOO RICH MAKES MOTORIST TOO POOR



Car owners who are wasting money and not getting proper gas mileage due to over-rich mixtures will be pleased to learn how to save gasoline by VACU-MATING over-rich mixtures. VACU-MATIC fits all cars, trucks and tractors. It is automatic and operates on the supercharge principle. Easily installed in a few minutes.

**SALESMEN WANTED!** Big Profits! Send name, address on a postcard for free particulars and how to get yours for introducing.

VACU-MATIC CO., 7617-1866 W. State St., WAUWATOSA, WIS.

## Have an OFFICE of YOUR OWN!

LEARN NEW PROFITABLE PROFESSION  
At Home in 60 Days, Men & Women, 18 to 70!

Be Your Own Boss and the Boss of Others. Be Respected. Meet Interesting People.

Earnings of men and women in this profession run as high as \$5,000-\$15,000 yearly. Others make good money in spare time. Little money needed to start. A business where your earnings begin sooner. Easy to learn. No selling or goods to buy. No experience necessary. A depression-proof business. A course of action to guide you step by step as you earn. All 53 lessons sent at once to use as operating manuals. Easy terms. Diploma. Money-back agreement. Write for FREE BULLETIN.



**FRANKLIN CREDIT SCHOOL**  
Dept. 71-M ROANOKE 7, VIRGINIA

BY MAIL in  
Easy Lessons



**WHY SUFFER TONGUE BITE?**  
Cost 3 times as much to build as the best of old-fashioned pipes. But **KILL TONGUE BITE, STOP DRINK.** FREE circular tells WHY. Write:

**KLENSMOK PIPES**  
P.O. No. M597,  
Johnson City, Tenn.  
R-Reg. U.S. Pat. Off. Pat's. and Pat's. Pend.

## TELEVISION

**LEARN AT HOME!** America's newest and most sensational method of home training in television maintenance and repair. Low cost; easy terms. Act now! Write...

**TELEVISION TRAINING** 531 S.W. 12th AVENUE  
PORTLAND 5, OREGON

## HELPFUL BOOKS

Send post card asking for FREE catalog  
Popular Mechanics Press, 200 E. Ontario, Dept. 601, Chicago 11

## Learn PHOTOGRAPHY at Home

Splendid opportunities. Prepare in spare time. Practical basic training. Long-established school. Send for free book, "Opportunities in Photography." No obligation.  
American School of Photography, 835 Diversey Parkway, Dept. 1353, Chicago 14, Ill.

### GREER SHOP TRAINING

2230 So. Michigan Blvd.  
Chicago 16, Illinois

## Leader in Practical Training for 50 years

Gain success by learning a trade offering security and high pay—go into business for yourself.  
**Get the "Know-how" at Greer**

You learn in our new, large, modern shops by working with latest tools and equipment of the trade — tear down, inspect, repair and rebuild... under supervision of experts. Greer founded 1902. Over 51,000 successful grads. Part time, full time, day and evening. E-Z terms. Mail coupon today.

CLIP COUPON . . . MAIL TODAY

Greer Shop Training—2230 South Michigan Chicago 16, Illinois Desk 213

Please send information about trade checked:

<input type="checkbox"/> Body, Fender Repair	<input type="checkbox"/> Auto Mechanics
<input type="checkbox"/> Welding—Arc, gas	<input type="checkbox"/> Diesel Mechanics
<input type="checkbox"/> Refrigeration & Air-conditioning	<input type="checkbox"/> Tool & Die
<input type="checkbox"/> Machine Shop	<input type="checkbox"/> Piano tuning

G.I. approved discharged Vets disch. after July 25, 1947

Or learn at home—extension courses:

<input type="checkbox"/> Diesel	<input type="checkbox"/> Refrigeration	<input type="checkbox"/> Plastics
---------------------------------	--	-----------------------------------

Name \_\_\_\_\_

Address \_\_\_\_\_

City \_\_\_\_\_

State \_\_\_\_\_

Age \_\_\_\_\_



# DRAW for MONEY

# BE AN ARTIST

## YOU CAN LEARN AT HOME IN YOUR SPARE TIME

Enjoy this fascinating hobby — Train for a profitable career

Trained artists are capable of earning \$75, \$100 and more a week. No previous Art experience necessary. We teach you step by step. Only WSA offers you this proven method famous since 1914. COMMERCIAL ART, DESIGNING, CARTOONING all in one up-to-date, complete course. You even can earn in spare time while learning. Qualify for good art jobs in Advertising, Television, Newspapers, Magazines, Studios, etc. For 38 years WSA graduates have been "making good"—WHY NOT YOU?

**TRIAL PLAN REVEALS YOUR TALENT.**

**TWO BIG ARTISTS OUTFITS GIVEN.** When you enroll you receive your first complete set with all the materials you need to start. Mail coupon for **FREE BOOK**, "Art for Pleasure and Profit,"—it fully describes course and commercial opportunities for you in art. Low cost—easy terms. (No salesman will call)

**FREE BOOK gives details!**

WASHINGTON SCHOOL OF ART, Studio 123F  
Washington 5, D. C.

Please send me full information and your Free Book, "Art for Pleasure and Profit." (please print)

Name \_\_\_\_\_ Age \_\_\_\_\_  
Street \_\_\_\_\_  
City \_\_\_\_\_ Zone \_\_\_\_\_ State \_\_\_\_\_



## Build the Best! EASY TO ASSEMBLE BOAT KITS

### NEW CATALOG

- OVER 40 PAGES, INCLUDES ALL YOU NEED TO BUILD YOUR OWN
- 1 - BOAT KITS—30 MODELS
  - 2 - MARINE HARDWARE
  - 3 - MARINE ENGINES
  - 4 - MARINE CONVERSIONS
  - 5 - PAINTS & COLOR CHARTS

All For Only 35c,  
SEND COIN TODAY

### ROWBOATS

8-10-12-14 FT.

\$39 up



### OUTBOARDS

8 Models 12 to 18 FT.



### INBOARDS & CABIN CRUISERS

16 TO 23 FT.



## NEW 18 FT. OUTBOARD CABIN CRUISER

FAST VEE BOTTOM HULL SPEEDS UP TO 25 M.P.H. — ROOMY CABIN, WITH TOILET, SLEEPS TWO —

### U-MAK-IT PRODUCTS

703P-WHITTIER ST., Bronx 59, N. Y. City



## HAVE FUN MAKING MONEY

Fill Your Spare Time with Pleasure, Creating Objects of Art at Home by "Ceramizing." Turn 56c Worth of Material into Profits as high as \$5.00 for One Hour's Work

LEARN—in less than an hour—how to turn twigs, leaves, flowers, into gorgeous costume jewelry—how to transform inexpensive articles into valuable objects of art. Amaze your friends with your overnight success as a creative artist—without learning to draw or design. Send your name—no money. We will mail, postage paid, a big tabloid newspaper size book printed in all the colors of the rainbow—showing the endless variety of beautiful giftwares and exclusive jewelry you can make in your home.

Explains entire "Ceramizing" process and shows steps necessary to get started. Delightful as a hobby. Exciting as a source of ready money for spare hours at home.

### FREE!—Just Send Name

Put your name and address on a penny postcard and mail it to us. We will mail the book on "Ceramizing" at once. No salesman will call. And there is no charge now or at any other time. See what fun it is to make money in this new home art—"Ceramizing."

**WARNER SHOPS, 1512 Jarvis Ave., Dept. C-3-C, Chicago 26, Ill.**





No Shop  
Needed

# Operate YOUR OWN Business



## Clean & Mothproof rugs, upholstery

**If now employed:** You can operate in spare time and build up a permanent profitable full-time business

Can you qualify? . . . If you are dependable, honest and willing to work, send for FREE Booklet explaining how you can become "your own boss" in a growing business of your own. You'll use proven successful methods of established DURACLEAN Dealers. Service rendered "in the home," offices and public buildings. Easy to learn.

**DURACLEAN** cleans by absorption! No scrubbing. No soaking or shrinkage. Fabrics dry in just a few hours. Dirt, grease and many unsightly spots vanish as if by magic . . . colors revive. Upholstery and floor covering last longer. Results often almost unbelievable.

**DURAPROOF** kills moths and carpet beetles. Makes material resistant to both! Another year 'round service. **DURAPROOF** to our knowledge, is the only mothproof service backed by a National Money Back, 4 YEAR WARRANTY for your customer's protection.

These services are Nationally Advertised! Leading furniture and department stores recommend **DURACLEAN** Dealer's service. Almost every building in your territory houses a potential customer. Even auto dealers buy your service to revive upholstery in used cars.

Some dealers establish a shop or an office after business has grown. Others continue to operate from their own home. Alert dealers can average \$4.50 hourly gross profit on service they render and \$3 on EACH of their servicemen at National Price Guide charges.

Territories are limited! Write immediately for FREE 16-page illustrated Booklet. Easy Terms. No obligation. Write TODAY!

### Duraclean Co.,

Duraclean Bldg. Dept. 2-163 Deerfield, Illinois



### REALIZES SECRET AMBITION THROUGH N. I. A.

"Writing has been my secret ambition. Though I have only completed five N.I.A. assignments, I write a weekly column in our Base paper. Thanks to N.I.A. training."—Cpl. Paul M. Walker, Army Air Base, Alomogordo, N.M.

## To People who want to write but can't get started

DO YOU have that constant urge to write but fear that a beginner hasn't a chance? Here is what the former editor of Liberty said:—"There is more room for newcomers in writing than ever before."

### A Chance to Test Yourself — FREE

The Newspaper Institute of America offers a FREE Writing Aptitude Test. Its object is to discover more men and women who can add to their income by fiction and article writing. The Writing Aptitude Test is a simple but expert analysis of your latent ability, your powers of imagination, logic, etc. Those who pass this test are qualified to take the famous N.I.A. course based on the practical New York Copy Desk Method which teaches you to write by writing! You work at home, in leisure time, constantly guided by experienced writers. Soon you acquire the coveted "professional" touch. Then you are ready to market your stories, articles and news items.

### Mail the Coupon Now

Taking the FREE Writing Aptitude Test requires but a few minutes and costs nothing. So mail the coupon now. Take the first step towards the most enjoyable and profitable occupation—writing for publication! Newspaper Institute of America. One Park Ave., New York 16, N.Y. (Founded 1925)

**FREE** Newspaper Institute of America  
One Park Avenue, New York 16, N. Y.

Send me, without cost or obligation, your Writing Aptitude Test and further information about writing for profit as promised in Popular Mechanics, March.

Miss \_\_\_\_\_  
Mrs. \_\_\_\_\_  
Mr. \_\_\_\_\_

Address \_\_\_\_\_  
(All correspondence confidential. No salesman will call on you.) 55-C-782

Copyright 1951 Newspaper Institute of America

**LEOPARD** **COWHIDE** **REVERSIBLE AUTO SEAT COVERS**

\$2.98 **FITS ALL CARS**

Made of FLEXTON  
Approved by Good Housekeeping

- Order direct from manufacturer and save!
- **LEOPARD SKIN** on one side
  - **COWHIDE** on the other. Made of Heavy Gauge plastic for long wear
  - **WATERPROOF** and **STAINPROOF** • Simple to attach—with **REINFORCED OVERLAP** side grip elastics that hold securely • **PERFECT FIT COVERS** are made roomy and dress up your car's interior
  - **PATENTED SHRINKING** holds seat and back neatly. Sewn with **NYLON THREAD** for long wear. **LONG WEARING-DOUBLE DUTY**
  - **5 DAY MONEY-BACK GUARANTEE!**
  - **CHOICE OF SPLIT OR FULL FRONT SEAT STYLES** only \$2.98. Complete set for front and rear seats only \$5.00. When ordering specify make of car and style of seat. Order NOW. Enclose payment and save shipping charges. C.O.D. orders sent collect plus postage.
  - **MARDO SALES CORP., Dept. 920**  
480 Lexington Avenue New York 17, N. Y.

**\$5000.00 in PRIZES**

**DRAW MY HEAD**

OPEN TO AMATEUR ARTISTS ONLY!

1st & 2nd Prizes Complete \$130.00 ART COURSES

80 other VALUABLE PRIZES

Take this test and try for a thrilling prize. Discover if you have profitable Art talent. You may gain a lifetime of happiness and high earnings if you mail your drawing today. Amateurs only. Our present students not eligible. Copy this girl 4" to 6" high in pen or pencil, and mail to us. None returned. Winners notified. New \$5000 contest each month. Send your drawing now and include your name, address, age and occupation. Enter today.

**WALLER ART EXCHANGE, Studio 70, 1000 N. CHARLES ST. BALTIMORE-1, MD.**

**NEW PENN YAN BOAT CATALOG**

40 PAGES • NEARLY 100 MODELS

**FREE!** Get yours today. Catalog describing nearly 100 models, including Cartops®, Trailboats, other outboards, rowboats, canoes and sailers. Describes amazing new no-soak, no-leak, All-Wood *Striptites*. 40 pages. Penn Yan Boats, Inc., 34th St., Penn Yan, N. Y.

**ANALYZE HANDWRITING**

**MORE INCOME, Prestige, Success, Fascinating uncrowded profession-business, full or spare time. FREE illustrated lesson & Year Book shows how men and women in home, business and professions analyze handwriting to understand people. MAKE MONEY. FREE lesson and information about unusual opportunities if over 21.**

**I. G. A. S., Inc., 716 Wilhoit Bldg., Springfield, Mo.**

**LEARN PHOTOGRAPHY**

Famous Low Cost 16 Wk. Home-Study Course. A fascinating Hobby or Money-Making Career can be yours in Portrait — Advertising — News — Magazine — Fashion — Landscape — Photography.

Write for particulars today!

**APPLIED PHOTOGRAPHY ACADEMY**

910 North Main St. Akron, Ohio



# DOUBLE YOUR PAY BY USING THIS BOOK EVERY DAY

The future is unlimited for the man in the shop who has the answers to problems that cause delays and slow production. "UNIVERSAL MACHINISTS' HANDBOOK" has helped thousands of shop workers, all over the country, climb to BIGGER PAY. You get the answers to any mathematical problem on diesel repair and welding operations — the proper use and care of lathes, milling machines, drills, and gears. Plus scores of other job hints based on actual working experience! You'll be on the road to a better job within seven days after receiving the 15th edition of "UNIVERSAL MACHINISTS' HANDBOOK", or we'll refund your money. Start to the top NOW by sending your name, address, and only \$2.00 to: SHIELDS PUBLISHING CO., 3031 N. Broadway, Desk M-2, St. Louis, Mo., USA



## LOCKSMITHING & Key Making

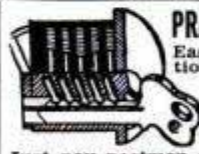

### PRACTICAL UP-TO-DATE COURSE—ONLY \$4.95

Easy-to-learn modern information for self-instruction. How to work on locks, de-code, make master-keys, repair, install, service, etc. For every handyman, home owner, carpenter, mechanic, service station operator, fix-it shop, hardware dealer, gunsmith. 53 plain illustrated lessons. FULL PRICE ONLY \$4.95. SEND NO MONEY.

Just pay postman plus C.O.D. postage. Or send \$4.95 with order, we'll ship postpaid. Satisfaction guaranteed or refund. NELSON-HALL CO., 210 S. Clinton St., Dept. C-2, Chicago 6, Ill.

**FREE  
MONEY-  
SAVING  
CATALOG**

EVERYTHING IN RADIO,  
TV, ELECTRONICS

Leading makes. Parts, hi-fi, sets, ham gear, P.A. systems, tools, test equipment, etc. For your free copy mail postcard now to:

LAFAYETTE RADIO 100 6th Ave., Dept. 1C, N. Y. 13



## Bar Bells

Buy Direct From Factory Approved and Recommended by Karl Koberle (Foremost Ex-Army Instructor on Weight Training) **\$895** up

Write for free booklet and price list. **INDEPENDENT IRON WORKS**  
2416 East 23rd Street, Dept. B  
Los Angeles 58, Calif.

## Secrets of VENTRILOQUISM Now Revealed!



Easy to learn in 60 to 90 days with our Home Study Course. RESULTS GUARANTEED. Make Money! Be Popular! Have Fun! Big Opportunity! Radio, Television, Stage Appearances! For FREE information regarding price and terms, WRITE. You must state your age. Dummy Catalog 25c. **FRED MAHER SCHOOL OF VENTRILOQUISM**  
Box 36, Studio C Kensington Station  
Detroit 24, Michigan

# RUPTURED?

**DON'T SUFFER TORTURE, IDLENESS and DISCOMFORT with an old-fashioned TRUSS**

Get back to normal living with this new appliance innovation that lets you run, play, work, lift, stoop or squat like any normal person. This radically new appliance is as supple as a rubber-band—flexes with every body movement, yet gives positive 3-point support. Won't slip, shift, gouge, rub or chafe. Gives you a new lease on life—new freedom of movement—and a degree of comfort you never thought possible. See for yourself. There is no obligation. A penny postcard brings details. Don't delay. Write today.

**ACTIVE MAN APP.** Dept. MP-3, 549 W. RANDOLPH CHICAGO 6, ILLINOIS

# GROW Living MIDGET TREES!

EARN \$10.00  
PER HOUR!

- AT HOME
- IN SPARE TIME
- NO EXPERIENCE NEEDED



It's new! Amazing! At last, the secret of growing miniature (MING) trees can be yours. FULL GROWN, dwarf trees—only a few inches high. Beautiful miniature fir, orange, oak, Chinese elm, peach, pine, cypress—any kind! ALL BLOOM and even BEAR FRUIT. All perfect healthy specimens—but miniature in size! Make costly home decorations and expensive centerpieces. (SOLD FOR OVER \$1,500 EACH) Big demand. Costs only pennies—takes only minutes per week. IT'S EASY! Fun! A new fascinating hobby—a new fabulous \$\$\$\$ business.

Send for free secret plan details.

### HELP US FILL HUGE DEMAND!

These trees are being demanded by STORES CLUBS • HOTELS • FLORISTS • HOUSEWIVES • INTERIOR DECORATORS • COLLECTORS • HOBBYISTS — A Big Money Opportunity FOR YOU.

**FREE! FASCINATING PROFIT PLAN**



NATIONAL NURSERY SUPPLY CO., Dept. M3  
8463 South Van Ness,  
Inglewood 4, Calif.

Rush me FREE plan IMMEDIATELY!

Name \_\_\_\_\_  
Address \_\_\_\_\_ Zone \_\_\_\_\_  
City \_\_\_\_\_ State \_\_\_\_\_

## AUTO MECHANICS! BOOST YOUR EARNINGS

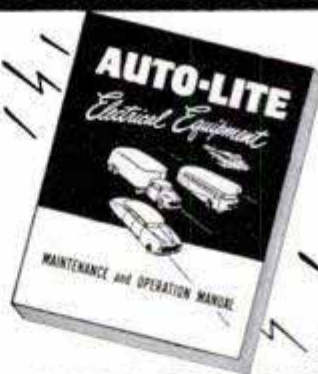

# AUTO ELECTRICAL SERVICE

*made easy!*

JUST OFF THE PRESS

Contains technical information

Only \$2.00

Price in Canada \$2.25 postpaid. Send cash, check or money order to Electric Auto-Lite Company, Limited, Sarnia, Ontario

The finest, most completely illustrated full color book on the complete automotive electrical system. Includes full information on the seven basic electrical circuits built by Auto-Lite . . . Starting—Charging—Ignition—Horns—Windshield Wipers—Instruments—Lighting. Plus Trouble Shooting Charts worth many times the price of the book. Gives you the answer every time.

### SPECIAL! NO MONEY COUPON

THE ELECTRIC AUTO-LITE COMPANY—Toledo 1, Ohio  
Yes, send me your "Maintenance and Operation Manual" by return mail. I will pay the postman when he delivers my copy \$2.00 plus postage. (If \$2.00 is enclosed with this coupon, the book will be sent postpaid.) If after 10 days I am not satisfied I may return the book and my money will be refunded.

NAME \_\_\_\_\_  
ADDRESS \_\_\_\_\_



# BIG OPPORTUNITIES OPEN IN THE METAL TRADES



- \* Drafting
  - \* Tool & Die Designing
  - \* Tool & Die Making
  - \* Machinist Trade
- Only 60 school days - 360 Hours - of practical Shop Training or Mechanical Structural or Aircraft Drafting*



Allied will train you easily and quickly for these Important Trades and place you on a Good Paying Job.

Inquire about our **PAY AFTER GRADUATION PLAN**

Write for **Free Books** a 1¢ postcard will do!

INDICATE PREFERENCE - RESIDENT or HOME STUDY

**ALLIED SCHOOL of MECH. TRADES**  
403 ALLIED BLDG. 1338 S. Michigan Ave. Chicago, Ill.

# UNLIMITED OPPORTUNITIES IN ENGINEERING

DEGREE IN 27 MONTHS

**Study Engineering** in this world-famed school, established 1884. Demand for our graduates exceeds supply. Growing shortage of engineers. No field offers greater opportunities for responsible, lucrative positions.

**Bachelor of Science Degree** in Mechanical, Civil, Electrical, Chemical, Aeronautical, Radio (Television) Engineering; Business Administration and Accounting. Also 36-weeks certificate course in Surveying and Drafting.

**Personalized Instruction.** Accelerated courses. Non-essentials eliminated. For ambitious, earnest students. Earn your degree in the shortest possible time. Preparatory courses. Placement service.

**Extensive Campus.** Well equipped, new and modernized buildings; up-to-date labs. Low cost. New terms start quarterly. Enter September, January, March, June.

Write today for free catalog and special information.



**TRI-STATE COLLEGE**

422 College Ave. ANGOLA, INDIANA

# AERONAUTICAL ENGINEERING

Design Aircraft & Components—Study with Jets & Rockets—Great Future—Advanced Aeronautical Subjects—World-Wide Enrollment—Fully Accredited—Established 1929—Approved for Vets—CAL-AERO grads in heavy demand.

WRITE TODAY for Special Information. P.M.-3

NAME \_\_\_\_\_ AGE \_\_\_\_\_  
ADDRESS \_\_\_\_\_  
CITY \_\_\_\_\_ ZONE \_\_\_\_\_ STATE \_\_\_\_\_

**CAL-AERO TECHNICAL INSTITUTE**  
GRAND CENTRAL AIR TERMINAL • GLENDALE 1, CALIFORNIA

# PORTABLE GARAGE

Try 10 Days at OUR risk!



DELIVERED \$10

*Goes wherever your car goes*

**HEAVY DUTY PLASTIC LOW COST MODEL \$869**  
Compare with \$9.95 and \$10.95 Plastic models.

Insured delivery right up to your age or cartage. C.O.D.'s cost 25 cents more. **TRY 10 DAYS AT OUR RISK!** Your \$10 back QUICK if not fully satisfied! Mention car make, year and model!

**THORESEN DIRECT SALES, Dept. 6C-140**  
131 West 33rd St., New York 1, N. Y.

# MODERNIZE YOUR GUN WITH Franzite GRIPS

IMPROVE YOUR SCORE

Franzite Grips are positively unbreakable — most durable made. Offered for Colt, Smith & Wesson, Hi-Standard, Ortgies, Luger, Mauser, other domestic and imported guns. Wide choice of smart designs in Ivory, pearl, walnut, onyx, agate, black and a few target, staghorn and carved grips. Low prices! **FREE NEW CATALOG.** Dealers wanted.



**SPORTS, INC. (MFRS.)** 5501 Broadway, Dept. BH-3, Chicago 40, Ill.

Our 463rd Advertisement

# REAL DIESEL ENGINE

**\$2.95**

- for planes, boats, midget cars
- 7500 RPM; 1/7 HP; ht. 3 1/2"; wt. 5 oz.
- precision machined for smooth operation

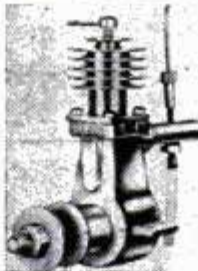

You just can't beat this price for a precision diesel engine! Streamlined, compact, easy to install. Thousands of satisfied users all over the world. Fast delivery if you **ORDER TODAY!** Send \$2.95 plus 25c postage.

**GOTHAM HOBBY CORP.** Dept. P. 107 E. 126th St. New York 35, N. Y.

# 100 POWER... Telescope Lens Kit COMPLETE ONLY \$3.00

See The Wonders Of The Sky.—Explore planets, island universes, new stars and million other phenomena. Lens kit consists of a 47 M.M. dia. 52 in. focal length ground and polished objective lens and a 100 power astronomical eyepiece lens. Simple to follow directions for assembling in one or two evenings. Mounting and tripod not included but easy to make from directions. Money back guarantee.

**LE MAR SCIENTIFIC CORP., Dept. D, 3412 W. Jackson Blvd., Chicago 24**

USE EASTER SEALS. HELP CRIPPLED CHILDREN

# WIN BETS AND FRIENDS!

**\$100**

Postpaid No GOD's



*Baffle 'em*

*at Bars and Parties.*

This merry little drunken Fall Guy—a sturdy, precision-made pocket novelty—will have your friends, guests, and strangers flock around you with his antics. Every clever raggster will be impressed and puzzled. Instructions tell how only you can make him stand up on his shakey legs or command him to topple over. Will challenge all who see it done. Based on new scientific principles.

If not available in your community, write direct. DEALER INQUIRIES INVITED

**FOUR GUYS PRODUCTS**  
DEPT. P-3, 601 W. 26TH STREET, N.Y.C.





Let Us Put This Magnificent New 1952

# MIDWEST TELEVISION

CONSOLE With Its MAMMOTH

# 20-Inch

PICTURE TUBE

IN YOUR HOME ON

# 30 DAYS TRIAL

## FACTORY-TO-YOU

You be the judge! See and hear Mammoth-Picture Midwest Television right in your own home for 30 days. If you are not 100% satisfied, any money you have paid will be promptly refunded. Send today for the new 1952 catalog of the finest Midwest line in 32 years.



We Pay Transportation Charges

LOW FACTORY PRICES

### Special Bonus



## GIFT!

Illuminated

### TELEVISION CLOCK

Given With Every Purchase of a MIDWEST RADIO or TELEVISION LIMITED TIME ONLY!

### MIDWEST 20-Inch TELEVISION CHASSIS

Ready for easy installation in your own cabinet.

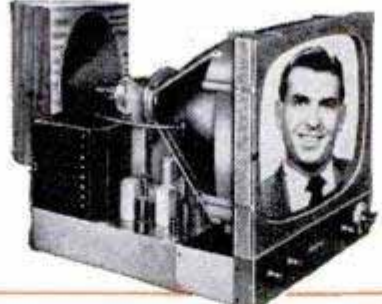

## EASY TERMS

WRITE or PHONE

For This NEW 1952

# FREE MIDWEST RADIO CATALOG

If You Live In One of These Cities Phone and Ask for Your Catalog

- NEW YORK MURRAY Hill 2-6810
- CHICAGO State 2-5600
- PITTSBURGH Grant 1-0609
- CLEVELAND Prospect 1-7450
- DETROIT Woodward 3-1233
- ST. LOUIS Grand 1161
- PHILADELPHIA Locust 4-1035



or Send Coupon Below

WRITE IN NAME AND ADDRESS (PLEASE PRINT) ON COUPON OR POSTCARD

MIDWEST RADIO & TELEVISION CORP. Dept. 258, 909 BROADWAY • CINCINNATI 2, OHIO

Please send me your new FREE 1952 Catalog.

NAME \_\_\_\_\_

ADDRESS \_\_\_\_\_

CITY \_\_\_\_\_ ZONE \_\_\_\_\_ STATE \_\_\_\_\_

## Also—Powerful New 1952 World-Ranging MIDWEST Series of RADIOS

For Beautiful Consoles and Complete Chassis

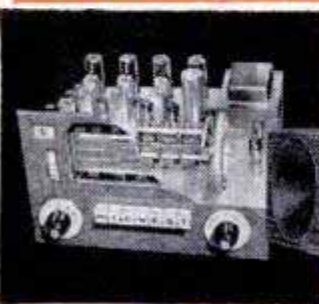

An entirely new line of radios featuring the powerful Series 16 five wave band AM-FM Radio Chassis and the magnificent Symphony Grand Radio-Phonograph with 3-Speed Automatic Intermix Record Player.

*Easy Terms*



MIDWEST RADIO & TELEVISION CORP. DEPT. 258, 909 BROADWAY, CINCINNATI 2, OHIO



**America's Most Helpful Books and the Biggest of all Book Values!**

*get these* **POPULAR MECHANICS BOOKS**  
from your **NEWS DEALER**

1952  
1953  
Issues

50¢

50¢



\$1.00



\$1.00

Get these famous PM Annuals at your neighborhood news dealer. Every year, hundreds of thousands of home owners, craftsmen, hobbyists, shop men and others use these famous how-to-do-it books — to make money — to save money — in hundreds of different ways. Pick up YOUR copies in economical paper covers at a handy news stand. They are the world's biggest book values.

**HOME KINKS** Newest 1953 edition. Just published. Packed with ideas, hints, kinks, for every home owner. Practical information that will make your home more livable and more valuable and save you money. Hundreds of photos and drawings. Only 50¢

**USEFUL IDEAS** 1953 edition. Ready in May. Remember to get yours. Things to do and make for the home; for recreation; for fun and profit — tips and ideas that have made and saved hundreds of dollars for others. Fully illustrated. Only 50¢

**SHOP NOTES** Now 240 pages. Latest 1952 edition. Most popular annual ever published and a must for every man who uses tools. More than 200 articles on tools and their uses, workshop information, kinks, ideas, money-saving repairs, etc. Elaborately illustrated. Only \$1.00

**WHAT TO MAKE** New 1952 volume. More than 200 projects—things to make at home from toys to beautiful furniture — from gadgets to household appliances. Step by step instruction and hundreds of photos and drawings. Many 4-color illustrations. Only \$1.00

Published by Popular Mechanics Press.  
Get them from your news dealer.

## How to **Tempt a Fish** Complete Fisherman's Guide

Here is fascinating information and practical help that would take the average fisherman a lifetime to pick up by himself. It is a book for the casual angler . . . and the veteran fisherman too . . . who dares anyone to tell him something new.

Included is expert advice by Joe Godfrey, Jr., world famous fishing authority and founder of the Fishing Hall of Fame, on fly casting, bait casting and salt water fishing. This is accompanied by 20 pages in actual colors showing the best lures for game fish of every type and in every locality.

### Informative • Fascinating • Helpful

Presented in Popular Mechanics famous easy-to-understand style and illustrated with hundreds of photographs and diagrams. HOW TO TEMPT A FISH tells you the secrets of flycasting . . . bait casting . . . salt water fishing . . . how to gather and use live bait . . . how to care for and repair your rods, reels, lines and other tackle . . . how to tie knots and splices . . . when and where to fish . . . how to fish through the ice . . . spearing fish . . . how to mount your own prize catches like a professional . . . how to stock a fish pond . . . what footgear to wear when fishing . . . how to cook in camp . . . what kind of boat to buy or build. Completely indexed so every tip and kink is easy to find.

128 PAGES

**\$2.00**

525 ILLUSTRATIONS

Order from

Popular Mechanics Press, 200 E. Ontario, Chicago 11

**BEST FISH LURES.** 20 Pages in Full Brilliant Color.

Where To Fish and When.

Tried and True Tips on Tackle.

Mount Your Catch Like the Experts.





# AUTO SEAT COVER BARGAINS!

Special Offer

**COLORFUL PLASTIC**  
FRONT ONLY \$1.98  
COMPLETE SETS \$3.89

Red, Blue, or Green

**"SCOTCH" PLAIDS**  
FRONT ONLY \$2.98  
COMPLETE SETS \$5

Simulated **LEOPARD**  
FRONT ONLY \$2.98  
COMPLETE SETS \$5

Lifelike **ZEBRA**  
FRONT ONLY \$3.69  
COMPLETE SETS \$6

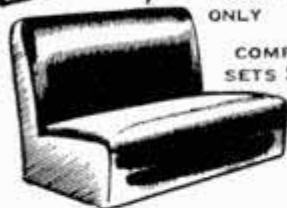

**WHAT A BUY!** Now at last you can have smart seat covers that will protect your upholstery and add distinction to your car at amazingly low cost. These remarkable seat covers are tailored of miracle plastic in rich, lustrous colors. New snap-on action holds them tight! **FITS ALL CARS!** Colorfast. Will not fade... will not shrink. Waterproof, stainproof, greaseproof. Will resist burns. Easily cleaned with damp cloth when necessary.

**SEND NO MONEY.** Just send name, complete address, seat covers desired and your color choice. (Also second color choice.) We'll ship immediately. Pay postman plus postage when your order arrives. Or, enclose cash, check or money order, and We Pay Postage. **FREE TEN DAY TRIAL!** If after using them 10 days in your own car you're not 100% satisfied, return for full refund of purchase price. Order TODAY at our risk!

**YOUNG PRODUCTS**

DEPARTMENT 194

2605 ELMHURST, DETROIT 6, MICH.

# POWERFUL MOTOR

ONLY \$2.98

DRIVES MODEL PLANES, BOATS, CONSTRUCTION SETS, Etc. WITH AMAZING SPEED! RUNS ON FLASHLIGHT BATTERIES!

**BOYS! MODEL-MAKERS!** Get this new MIGHTY MIDGET D. C. Electric motor. It's a honey! Looks and runs just like a big one. Motor is powerful yet measures only 1 x 1 x 1 1/4 inches; weighs one ounce! Turns up 6,800 r.p.m.'s. REVERSES instantly. Motor is in durable black plastic housing. Comes complete with two 1 1/2 volt batteries in clip holder, transparent plastic gear-box—PLUS ten extra gears and pulleys for working out your own ratios. No shocks, sparks or shorts. Endless hours of fun. Educational, too! 10 Day Money back guarantee! Send no money. Order today. Pay postman only \$2.98 plus postage when delivered. Or send \$2.98 with order and we will pay postage.

NO TRANSFORMER NEEDED

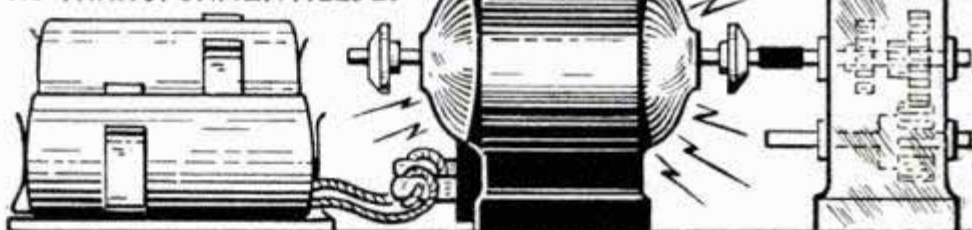

IMPERIAL SALES CO., Dept. 785  
114 East 47 St., New York 17, N. Y.

## LEARN THE VITAL ELECTRIC EQUIPMENT and APPLIANCE SERVICE and REPAIR BUSINESS



I made \$800 in three months while still taking your course.  
F. V., New York



I made \$14 per day while still learning.  
T. E. H. West Virginia

### BIG MONEY—INDEPENDENCE

Here is the ideal business for the man who is happiest when working with tools. Wide open opportunities in every city, town, village. Everyone a customer for the man trained to service and repair electrical equipment and appliances.

### NO PREVIOUS EXPERIENCE NEEDED

New visual method of instruction teaches you how to repair electric motors, house wiring, refrigerators, auto ignitions, automatic washers, garbage disposals, fluorescent lights, irons, cleaners, etc. **NO PREVIOUS EXPERIENCE NEEDED.** Almost before you know it you will have the knowledge to help you make **BIG, EASY PROFITS** at home in this highly respected and growing field.

**Yours!**

**Big Kit Tools**  
Does not cost you one cent extra.

### AGE NO HANDICAP

Young men, older men, even the man of 69, can find a place in this expanding big-money field. Grasp this opportunity for better things today

### Your Own Business—Spare or Full Time

Your own business—your own shop. Complete step-by-step instructions include our book, "HOW TO OPEN YOUR OWN BUSINESS." Costs nothing extra. PTS training more than a home-study course—gives you the "know-how"—all the professional secrets of electrical equipment and appliance repair and service—the operation of your own shop from a business standpoint—what to charge—how to bring your customers to you—everything to start you on the road to success and future security. I'll send you my complete plan that shows you how to learn the electrical equipment and appliance service business. **SEND NO MONEY—WRITE TODAY!**



**FREE!**

Book that tells you how to learn to repair and service electrical equipment and appliances.

### MAIL COUPON NOW

**PACIFIC TRAINING SCHOOL, Dept. P-523**  
7217 S. Broadway, Los Angeles 3, Calif.

Send me your **FREE** book that tells me what electrical appliance repair and service can mean to me. Remember I am under no obligation

Name \_\_\_\_\_  
Address \_\_\_\_\_  
City \_\_\_\_\_ Zone \_\_\_\_\_ State \_\_\_\_\_



# INSTALL A "MILE-O-METER"

LEARN HOW TO SAVE GAS AND TUNE YOUR OWN MOTOR . . .

"Mile-O-Meter" on the dashboard registers miles per gallon faithfully at all speeds, under every driving condition . . . Will show what speed your engine delivers its maximum power. Can save you many gallons of gas . . . Provides constant check on engine condition — Warns you of operating imperfections for 31 different motor adjustments . . . Nationally advertised in leading magazines and newspapers . . . Can be installed in a few minutes . . . transferred from old to new car. Fine watch precision . . . Order yours today!



STD. Model  
**\$9.75**  
2 3/4" Dia. Ppd.  
Fed. Tax Incl.

## HUGE 24 PAGE INSTRUCTION MANUAL AND MILEAGE CALCULATOR INCLUDED FREE!



Installation requires no experience . . . becomes a constant companion on every trip. Saves cost in a short time. This professional gauge is a must!

**\$14.95** DELUXE MODEL with Chrome Ring  
3 3/8" Dia. Ppd. Fed. Tax. Incl.

**GALE HALL ENGINEERING Dept. 141**

BOSTON 18, MASS.

DELUXE MODEL NOW ILLUMINATED

# ELECTRIFY your SEWING MACHINE

BE AN AGENT!

**\$9.50** NEW LOW PRICE!



Re-sell at a PROFIT! You make as high as \$9 with each sale. Kit comes fully wired, installed in a jiffy. Fits all machines!

You get ALL NEW PARTS:  
● Motor & Bracket  
● AC-DC 115v 60c  
● Multi-speed foot control  
● Cord set & block  
● Easy instructions  
● Steel pulley & belt

FREE . . . reg. \$2.95 chrome SEWLITE given with every kit.

10 DAY FREE TRIAL — MONEY BACK GUARANTEE!  
Send \$5 deposit, pay postman balance plus postage. Please state whether wheel on your machine turns toward you or away from you. Shipping wt. 6 lbs. Write for free sewing machine accessory catalogue. No obligation.

**SENIOR SEWING MACHINE CO.**

1046 BEDFORD AVENUE Dept. PM-35 Brooklyn 5, N.Y.



# HE-MAN VOICE!

STRENGTHEN your voice this tested scientific way. Yes—you may now be able to improve the POWER of your speaking and singing voice . . . in the privacy of your own room! Self-training lessons, mostly silent. No music required.

**FREE BOOK** Write TODAY for Eugene Feuchtinger's great booklet "How to Develop a Successful Voice." It's absolutely FREE! You must state your age. Booklet mailed postpaid in plain wrapper. No salesman will call. Send your name and age RIGHT NOW! Prefect Voice Institute, 210 S. Clinton St., Studio C-2, Chicago 6, Ill.

# 117 MILES PER GALLON

RIDE TO WORK—TAKE TRIPS

A REAL MOTORCYCLE —NOT A MOTOR BIKE!



TWIN-PISTON

World Renowned Motorcycles since 1903. Over 100,000 in use.

Made by Triumph Works, Germany (U. S. Zone)

4-SPEED, TWIN-PISTON; Foot Shift; Front and rear springing; beautiful chrome finish, precision built; easy to operate. Reasonably priced—orders filled promptly.

WRITE FOR FREE CIRCULAR  
TWN MOTORCYCLE Co. of AMERICA, 15 Park Row, Dept. M, New York 38, N.Y.

# ● ANNOYED BY TV "COMMERCIALS"?

Attach a TVX Com-muter ("commercial" muter) to your set and obtain blessed relief from yakity-yak announcers. When a commercial comes on you can instantly turn the sound off without leaving your seat! Result: the "commercial" is in pantomime and fun to watch! Doubles your TV enjoyment!

Easily attached to any TV set in a few minutes. No special tools required. Complete with 20' cord and hook-up instructions. Money back guarantee.

The TVX Co., Dept. P,

Send only \$1.98, check or M.O. 217 Riverdale Ave., Yonkers, N. Y.

# GET BETTER PAINT RESULTS



WITH A SINGLE COAT . . . New free illustrated 24-page book tells right kind of aluminum paint to use. We don't make paint, but have prepared this fact-packed book to help you get best results with aluminum paint.

Write for free copy of "Paint it Bright".  
**ALUMINUM COMPANY OF AMERICA,**  
1718C Gulf Building, Pittsburgh 19, Pa.

# WANT TO Write Stories

**FREE BOOK** Articles & Mysteries? tells how you learn at home



Would you be willing to spend a few hours a week learning to write so you may earn \$300-\$1200 a year part-time? Or many thousands full-time? FREE book, "Art of Writing Salable Stories" tells how to get started writing short stories, radio-TV scripts, articles, business items. Many students earn while learning (A.B. Aretz sold first 2 stories for \$255). Endorsed by famous authors, scores of successful graduates; approved for veterans. Send today for FREE book (no salesman will call).

**PALMER INSTITUTE OF AUTHORSHIP, Founded 1917**  
1680 N. Sycamore Hollywood 28, Calif. Desk T-32

# Wheels Wheels



- 5" Disc Wheel 3/8" Tire 5/16" or 3/8" Sleeve . . . . .30c ea.
- 6" Disc Wheel 3/8" Tire 5/16" or 3/8" sleeve . . . . .35c ea.
- 7" Disc Wheel 3/4" Tire 3/8" sleeve . . . . .45c ea.
- 8" Disc Wheel 1 1/8" Tire 1/2" sleeve . . . . .70c ea.
- 7" Disc Wheel 1" Tire 1/2" ball bearing . . . . .80c ea.
- 8" Disc Wheel 1 1/8" Tire 1/2" ball bearing . . . . . \$1.00 ea.
- 8" Disc Wheel 2" semi-pneum. T. 1/2" B.B. . . . . \$1.35 ea.
- 10" Disc Wheel 1.75 semi-pneum. T. 1/2" B.B. . . . . \$1.50 ea.
- 12" Disc Wheel 1.75 semi-pneum. T. 1/2" B.B. . . . . \$1.85 ea.

Above wheel prices includes hub cap.  
AXLES AVAILABLE — Sizes 5/16 in., 3/8 in., 1/2 in.  
Cut to size — End holes drilled

## UNITED OFFICIAL SOAP BOX DERBY WHEELS

Model 110

Model 111

Steel Disc Wheel  
10 1/2 in. O.D.  
1/2 in. ball bearing  
1 3/4 in. hub thickness  
1 in. extruded tiring  
Painted Red  
With hub cap. Each . . . **\$1.35**  
Plus postage. C.O.D.'s accepted.

Steel Disc Wheel  
11 in. O.D.  
1/2 in. ball bearing  
1 3/4 in. hub thickness  
1.50 in. semi-pneumatic tire  
Painted Red  
With hub cap. Each . . . **\$1.75**

## UNITED WHEEL STAMPING CO.

12131 S. PEORIA STREET PM-3 CHICAGO 43, ILLINOIS

# FREE! 60-PAGE BOOK ON

## Job Opportunities in 14 Great Industries



If you want a better job with more pay, read this valuable book. It describes thousands of good jobs—waiting in 14 industries. It explains how you can get ready for success—at home in spare time. No high-pressure—just plain facts. Mail coupon for your free copy!

**MAIL THIS NOW!**

**COMMERCIAL TRADES INSTITUTE**  
1400 Greenleaf Ave., Chicago 26 Dept. B2-3  
Send 60-page book, Bulletin 1952.

Name \_\_\_\_\_ Age \_\_\_\_\_  
Address \_\_\_\_\_  
City \_\_\_\_\_ State \_\_\_\_\_



NEEDLESS TO PAY MORE RISKY TO PAY LESS

TUBE GIVEN WITH EVERY TIRE

28 MOS. GUARANTEE SENT WITH EVERY TIRE YOU BUY



GOOD USED TIRES

A TRIAL OF ONE TIRE WILL CONVINCE YOU.

No extra charge for tubes—Tube given with every pass. and truck tire purchased

18 YEARS AT THIS ADDRESS

600x16	\$5.39	670x15	\$6.20
650x15	5.75	700x15	6.50
650x16	5.84	700x16	5.75

710x15	\$6.32	760x16	\$7.95
750x15	6.86	820x15	6.95
760x15	6.42	550x18	5.02

600x20	\$9.75	32x6(10)	\$14.02	1070x20	\$18.35
650x20	9.95	750x16(8)	8.95	1100x20	18.35
700x20	11.75	825x20	21.00	1000x22	17.38
750x20	12.75	900x20	18.50	1100x22	18.35

Thousands of tires shipped all over U.S.A. All tires shipped F.O.B. Phila. Send Check or M.O. with this ad. Dept. 2.

STANDARD 834 N. Broad St., Philadelphia 30, Pa.

## FOAM RUBBER CUT SHAPES

Select from this—one of the largest Foam Rubber stocks—whatever shape or thickness you want—Cut circles or squares for upholstering or padding chairs, mattresses or pads for twin or regular beds, auto seat cushion tops—auto wedges—all new fresh stock—expertly cut to exact size. Lowest prices—satisfaction guaranteed. One day delivery.

Uncovered Foam Pads 1 1/2" thick	Auto Seat Pads 24" X 60"
12" X 14".....\$1.25	1 1/2" thick.....\$6.45
16" X 16".....1.35	2" thick.....7.95
16" X 22".....1.75	Mattress Pads
18" X 24".....2.00	Twin Size.....\$19.55
22" X 24".....2.95	Full Size.....23.95

Add 10% to these prices for postage and packing.  
NO C.O.D. PLEASE — PLEASE PRINT NAME  
Ask for catalog No. 201

RUBBER COMPANY, Dept. 201-B 50 E. CERMAK RD. CHICAGO 16, ILL.

Give the handicapped a chance. Use Easter Seals

## POWERFUL-LONG RANGE



MADE IN U.S. ZONE  
GERMANY

AMAZING VALUE!

Compare with domestic binoculars selling up to \$9.95, for clarity, light weight, rugged construction! GERMAN KLAROVIS ground lenses give terrific magnification, wide field of view, and sharp, brilliant detail! Smooth, SYNCHRONOUS centre focusing mechanism, 4.2 mm objectives. NEW! Different! CAUTION! Do not confuse with crudely made binoculars claiming 18 mile ranges! You can depend on GUARANTEED KLAROVIS QUALITY! Manufactured by German artisans.

TRY AT OUR RISK!

SEND NO MONEY! Pay only 2.95, plus postage on arrival! (Or send only 2.95 and save postage!) Try 10 days at our risk! Thrilling satisfaction GUARANTEED or money back!

THORESEN DIRECT SALES, Dept. 6C-134  
131 West 33rd Street, New York 1, N. Y.

NOT \$9.95  
2.95

KLAROVIS

## FURNITURE for YOUR BEDROOM



SAVE MONEY, be the envy of your neighbors by making this beautiful bedroom suite yourself! Only a power saw and jointer are needed to turn out this smart suite, featuring bed with storage space, three-piece vanity with cosmetic compartment and makeup mirror, Mr. and Mrs. dresser, and twin night stands with drawers. Letters demanding detailed plans poured in after this furniture was pictured in Popular Mechanics Magazine. Now the 4 plans are ready—easy-to-follow scale drawings—and they're yours for only \$2.00! Send for a complete set today.

POPULAR MECHANICS PRESS  
200 EAST ONTARIO STREET, CHICAGO 11, ILL.

Start a Business in Your Backyard



Earn BIG MONEY MAKING BUILDING BLOCKS

General Concrete Vibrator  
BLOCK MACHINE

CAPACITY 1000 BLOCKS A DAY

only \$218 LESS MOTOR F.O.B. PLANT

SHIPPING WEIGHT 400 LBS.



Here is a business you can start on small capital—in your own backyard—that earns 100 to 150% profit, with unlimited opportunities. Make concrete or cinder blocks. Millions used for homes, factories, public buildings, garages. Sell all you make to building trade. Do it with a General—and you're headed for success.

1000 BLOCKS A DAY

The General is a high speed, power-driven block machine at amazingly low cost. Rugged all-steel construction. Simple to operate indoors or outdoors. Makes superior 3 core type block meeting all code requirements. Produces up to 1000 blocks per day. Full operating instructions and mixing formulas supplied. Write for FREE details.

Wonderful Book Written & Illustrated by Experts

HOW TO BUILD YOUR OWN CONCRETE BLOCK HOME Only 1/2 Prepaid

## GENERAL ENGINES CO.

DEPT. M-32 • 307 HUNTER ST. • GLOUCESTER, N. J.

Includes floor plans for 6 beautiful, easy to build concrete block bungalows. Shows ways to save money. How to lay blocks, lay out building lines, mix concrete, build steps, porches and concrete floors. Mail coupon at once with \$1.

Name.....  
Address.....  
City..... Zone... State.....



Build it Yourself!

## TRAILER COACHES

Complete Trailer Book and Construction Data for 10, 16 and 22 Foot Trailers — Only \$1.50

Here's everything you want to know about trailers, with plenty of pictures and plans and instructions for building three different types. Covers also, history of trailers, trailer parks, camps and overnight-stops information, furniture, furnishings, materials and engineering data. If you want to build a trailer, live in a trailer, or just want to know more about trailers, get this book. Only \$1.50 postpaid. Rush order to:

Partial Contents

Trailer Parks—Living in a Trailer—Towing a Trailer—Floor Plans—Service—Classifications—Balance—Dollies—Jacks—Weight Distribution—Construction—Working Drawings for a Two-Place, Standard Travel and Standard Dwelling Trailers. Size 8 1/2 x 11 1/4 inches.

POPULAR MECHANICS PRESS • Dept. 350, 200 E. Ontario St., Chicago

## TRY HOME STUDY WATCHMAKING

Turn dull spare hours to pleasure and profit. Master watch repairing the thrifty home study way. An exciting hobby or fascinating career. No experience needed. Send coupon today!

## FREE Sample Lesson

CHICAGO SCHOOL OF WATCHMAKING

1608 N. MILWAUKEE AVE., DEPT. 132, CHICAGO 47, ILL.

SEND FREE SAMPLE HOME STUDY LESSON

Name.....  
Address.....  
City..... Zone... State.....



# FREE BOOK AND ACTUAL SAMPLE

Screen Print, Dept. 23  
1010 So. Los Angeles St.  
Los Angeles 15, California  
Dear Mr. Nowak: Please rush me FREE BOOK, ACTUAL SAMPLES, and your amazing new PRINTING PLAN

Name \_\_\_\_\_  
Address \_\_\_\_\_  
City \_\_\_\_\_ State \_\_\_\_\_

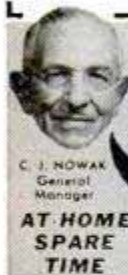

IT'S AMAZING! I'll show you how to make up to \$12.50 per hour

## PRINTING WITHOUT A PRINTING PRESS

**AMAZING NEW COLOR PRINTING METHOD**  
A fascinating new miracle-way to print—a secret method that lets you print colorful signs, posters, banners, drapes, wallpaper, flags, glass, fabrics—ANYTHING without an expensive printing press or costly equipment. This new process is revolutionizing the entire printing industry—it's one of America's fastest-growing businesses—it's your "chance of a lifetime" to make Big Money Now! Be the FIRST in your area to profit. The secret can be yours—just mail the coupon above today!

**EASY TO LEARN! NO EXPERIENCE NECESSARY!**  
Simple fascinating method! No artistic ability needed. It's possible for anyone (young or old) to make up to \$50 PER WEEK printing in SPARE TIME alone—AT HOME!

**START YOUR OWN BUSINESS—BE YOUR OWN BOSS**  
Wouldn't you be happy if you could take only one hour of your time and \$1.00 worth of materials—and sell your printing for \$15 or more. It's that easy! It's amazing! Your home can be your office—No selling because there's a huge demand everywhere. GOVERNMENT CONTRACTS AVAILABLE TO BID. Biggest opportunity in America—costs you nothing to receive all CONFIDENTIAL FACTS—Mail coupon today!

SCREEN-PRINT  
1010 S. Los Angeles St., Los Angeles 15, California



Print paper of all kinds

PRINT BANNERS

PRINT FABRICS

PRINT INSTRUMENTS

PRINT SIGNS

FOR SALE

YOU CAN PRINT ANYTHING WITH



MONTH AFTER MONTH, YEAR AFTER YEAR, YOU SEE OUR AD. REMEMBER IT'S DANGEROUS to pay less if you want the finest (nonskid) USED tires.

## GOOD YEAR Firestone

GOODRICH, UNITED STATES, GENERAL & OTHERS, NOT RECAPS

Our policy is to select your tires so carefully, as if our very future depended on the service given by that particular tire.

FREE TUBE WITH "ALL" BLATT'S GOOD GRADE TIRES		GOLDEN RULE GUARANTEE BOND.	
GOOD GRADE 16 MONTHS	600-16 \$4.14	700-15 \$4.54	825-20 \$7.94
650-16 5.42	670-15 4.74	700-20 8.54	32x6(8) \$8.64
700-16 5.04	710-15 4.94	750-20 8.64	32x6(10) 9.94
650-15 4.44	550-17 4.64	825-20 15.92	1000-20 13.94

FINEST GRADE 26 MONTHS		GOLDEN RULE GUARANTEE BOND	
THIS GRADE MADE THE BLATT NAME "WORLD FAMOUS"	450-20 \$6.00	450-21 \$6.00	700-15(6) \$10
600-16 5.49	650-15 5.94	600-20 9.94	900-20 18.54
650-16 6.42	670-15 6.24	650-20 9.94	1000-20 18.54
700-16 5.94	700-15 6.54	700-20 11.94	1100-20 18.54
750-16 7.94	710-15 6.34	32x6(8) 10.54	1000-22 17.54
550-17 5.94	760-15 6.50	32x6(10) 13.92	1100-22 18.54
525-18 5.54	820-15 7.04	750-20 12.54	700-17 12.00
650-19 9.00	475-19 5.94	825-20 19.84	1100-24 21.54

Buy Our "Right" TRUCK TIRES  
Std. Guar. 16 Mos. Rugged Guar. 30 Mos.  
MILITARY MUD-SNO TREAD

750-20Std. \$10.75	750-20Rg. \$19.95
750-16 Rg. 18.95	900-16 Rg. 11.95
8-10-12-14-Ply 600-16 Rg. 9.95	900-16 Rg. 18.95

**BLATT** BLATT BLDG., GIRARD & LANCASTER AVES., DEPT. PM., PHILADELPHIA 31, PA.  
Send check or money order and this ad for rush shipment. We won't ship a tire we wouldn't use. The name to trust in rubber. PRICES SUBJECT TO CHANGE  
Shipments RUSHED Down South, Up North and Far West

## Learn TATTOOING At Home

Earn extra MONEY—Tattoo blood types and designs in your community. Splendid opportunity in every town. Prepare in spare time. Practical instructions. Send 25c for details and list of Tattoo Supplies. No obligations. ZEIS SCHOOL OF TATTOOING • 728 Leslie, Rockford, Ill.



## MASTER MIND!

Learn Short-Cut Mathematics  
Juggle figures, do baffling number tricks. Make people gasp at your marvelous lightning-quick mind. Multiply 4 figures by 4 figures without using old-fashioned multiplication! Big cloth-bound volume; fully illustrated course.  
Sharpen up Your Brain Power  
Includes worked-out problems, answers, etc. Sensational bargain, only \$1.95, postpaid or COD plus postage. Satisfaction guaranteed or refund. Order this amazing "Short-Cut Mathematics" today!  
**NELSON-HALL CO., 210 S. Clinton St. CHICAGO 6, ILL. \$1.95 Complete**

## WHERE TO SEARCH FOR BURIED TREASURE

(with Maps & Pictures). Thrilling new volume packed with actual details of gold, bejeweled lost treasures in U.S., Mexico, etc. Lost Dutchman, Montezuma's Treasure, Spanish Main, Villa's Gold Bars, Golden Cargo, & more than 100 others. Just published. Send \$2 today.  
TREASURE PRESS, Dept. E, Crown Point, Indiana

# FREE CATALOG

Over 300 books on Fishing, Hunting, Home Repairs and Improvements, Bricklaying, Welding, Home Workshop, Power Tools, Hobbies, Crafts, Home Building, Trades, Making Money at Home, Furniture Making, Woodworking, Carving, Photography, Art, Drawing, Mechanics, Engineering, Refrigeration, Plumbing, Radio-TV, Electricity, Automobiles, Farming, Livestock, Gardening, Decorating, Painting, many, many more. Send for yours today.

POPULAR MECHANICS PRESS, 200 E. Ontario St., Chicago 11

## Everybody's Wild About 'Em! SPEEDEE-BILT flying models

27 Other Thrilling Models Including Ships and Jet Race Cars. ONLY 85c



Here's thrilling fun for kids—8 to 80 years old. Genuine SPEEDEE-BILT flying models, including the hard-hitting Sabre-Jet shown above. Easiest models to build. Build one complete and fly it in an evening. Kits contain built-up Monofoil wing, pre-fab fuselage, finished metal and wood parts, plastic 2-3-4-bladed props, pilots, canopies, cannon, rockets, bombs and other plastic parts. Complete catalog of 18 planes, including jets, 5 jet power race cars and 5 U.S. Fighting ships free in every kit. Be sure you get Monogram Models.  
**At All Hobby Shops or Sent by Mail**  
If no store near you send 85 cents, plus 25 cents for postage and packing, to address below. Delivery guaranteed.

MONOGRAM MODELS, Dept. 13, 225 N. Racine Ave., Chicago 7

The Cleanest, Coolest Shaves of Your Life!  
Brand-New, Precision-Made A.C.

## ELECTRIC RAZOR



Only \$4.95

DOUBLY GUARANTEED!

TRY IT—without risking 1c—  
for 30 DAYS ON YOUR OWN BEARD!

Say "goodbye and good riddance" to old-fashioned shaving methods! Start shaving the STERLING ELECTRIC way and enjoy the cleanest, coolest, smoothest, most-comfortable shaves of your life. Toughest whiskers come off clean as a whistle . . . and FAST! The STERLING mows 'em down like magic! Yes, here's every advantage of electric shaving at an incredible low price . . . only \$4.95 complete. You'll save the entire low cost in a few months in blades and shaving cream you don't buy! Not a toy, not a gadget. Far from it! Precision-made. Looks, handles, performs like razors costing 3, 4 and 5 times more! Look at these "expensive razor" features:

- 4 precision shaving heads!
- Automatic safety guide-bar.
- Hollow-ground cutting blades
- Powerful 60-cycle motor.
- Blades honed in special
- Cutting blades chrome plated diamond-honing compound!
- for lifetime service.
- AND MORE! Handsome white plastic case, 6 ft. extension cord, self-starting, self-sharpening, self-lubricating . . . all for the incredible low \$4.95 price . . . and DOUBLY GUARANTEED!

### YOU DON'T RISK A PENNY TO TRY IT!

Make us prove it! Send for the Sterling today. When it arrives use it on your own beard for 30 days. If you don't agree that the Sterling is the shaving value of all time, return it for an immediate, no-questions-asked refund. If you keep it, you're protected for ONE YEAR by our written guarantee against mechanical defect. Rush your order. Quantities limited. Send only \$1.00. Pay postman \$3.95 plus 70c postage on delivery. Or send \$4.95 with order and we ship postage paid! LADIES—NOTE: the Sterling shaves underarms, legs smooth and fast. You'll love it!

### MODERN MERCHANDISE CO.

169 W. Madison St., Dept. 556, Chicago 2, Ill.



# WAR SURPLUS OPTICAL BARGAINS

## 35 POWER ERECTING MICROSCOPE

Amazing clarity. "All-Position" Universal mount. 3" of working space from objective to platform. Prism Erectors give you an erect image—exactly as your eye sees it. Ramsden Eyepiece permits fine precision focusing. 3-Element color corrected objective—1" diameter. Microscope body is of brass with black crackle finish. 6 1/2" long with base 7"x9". Easily worth \$75.00.



Stock No. 970-H.....\$29.50 Postpaid

## SLIDE PROJECTOR SETS

Consists of all unmounted lenses you need to make the following size projectors:

Stock #4029-H—35 mm.....\$2.85 Postpaid

Stock #4038-H—2 1/4"x2 1/4".....\$3.35 Postpaid

Stock #4039H—2 1/2"x3 1/2".....\$3.35 Postpaid

## SIMPLE LENS KITS

—Include plainly written, illustrated booklet showing how you can build lots of optical items. Use these lenses in photography and for dozens of other uses in experimental optics, building TELESCOPES, low power Microscopes, etc.

Stock #2-H—10 lenses.....\$ 1.00 Postpaid

Stock #5-H—45 lenses.....5.00 Postpaid

Stock #10-H—80 lenses.....10.00 Postpaid

We Have Literally Millions of War Surplus Lenses and Prisms for Sale at Bargain Prices. Numerous Types of Instruments. Tool

Write for FREE CATALOG-H

EDMUND SCIENTIFIC CORP., Barrington, N. J.

## TOOTHACHE?

Ask your Druggist for **DENT'S**

TOOTH GUM  
TOOTH DROPS  
POULTICE

## NEW TINYTONE RADIO

Really Works — World's Smallest. New Preset Crystal eliminates All Tubes, Batteries or Electric "Plug-ins" Forever! Sweep hand dial—Beautiful Red Plastic case.

**GUARANTEED TO WORK** on local stations if used as directed or money refunded—use most anywhere—**SEND ONLY \$1.00** (bill, ck., m.o.) and pay postman \$3.99 C.O.D., postage or send \$4.99 for P.P. delivery. **COMPLETE WITH EXTRA LONG DISTANCE AERIAL KIT AND PHONE.**

LIMITED SUPPLY — SO ORDER NOW!  
MIDWAY CO., Dept. BPM-3, KEARNEY, NEBRASKA

## BIG DEMAND DRAFTSMEN, DESIGNERS, ENGINEERS, MATHEMATICIANS

DRAFTING-DESIGN, Aircraft, Mechanical, Electrical, Architectural, Structural, Building Estimating, Surveying, Blueprint Reading, Algebra, Geometry, Trigonometry, Calculus, Physics. **PREPARE LICENSES.** Professional Engineer, Architect, Stationary Refrigeration, Electrician, Plumber, Civil Service Engineer Exams. Days, Evs., **VETERANS ACCEPTED.**

MONDELL INSTITUTE, 230 W. 41st ST., N. Y., N. Y., State Licensed. Established 1910

## RADIO

Engineering. All phases radio & electronics theory & practice; television; FM; broadcasting; servicing; aviation, marine & police radio. Prepare for high pay: 18-month course equal in radio content to 4 yrs. college. Enter Jan., March, June, Sept. Regular campus life. Catalog.

VALPARAISO TECHNICAL INSTITUTE, Dept. D, Valparaiso, Ind.

## EXTRA INCOME THE YEAR 'ROUND

Earn additional income and have fun at the same time! Popular Mechanics MONEY MAKING HOBBIES shows you how to make 132 different projects at home in your spare time! Complete instructions with over 600 illustrations, photographs, drawings and diagrams. Projects for everyone regardless of experience. Excellent resale value. Start making your hobby pay a profit by ordering a copy of MONEY MAKING HOBBIES today from

POPULAR MECHANICS PRESS \$2.00  
200 E. Ontario Street Chicago 11

## LEOPARD 295

SATIN-LIKE "RICH-TONE" DESIGN EACH

### Auto Seat Covers

**TERRIFIC VALUE!** New, deluxe RICH-TONE material looks like LEOPARD FUR, gives beauty and distinction to your car. Adds new life to old, worn interiors. Protects new car upholstery against wear, dust, grime, stains, grease, bad weather. Tough, durable, resists cracking! Handsome tailored makes and models. **NO pins! No tacks! No sewing!** Ingenious SNAP-TITE feature. Just SNAP on or off in a JIFFY! Best of all; they're only 2.95 for front or rear seat.

**SPECIAL!** Pair for front and rear, only 4.95. Send no money. Pay price plus postage on delivery or send check or money order for free delivery and **SAVE!** Mention car make, model & year; also if front seat is full front or SPLIT coupe front. Try 10 days at our risk! Guaranteed to satisfy or money back! **RUSH!**

CONSUMERS MART, Dept. 6C-150  
131 West 33rd St., New York 1, N. Y.

# NO MORE "Bay Window!"

## Boy! I Feel GREAT!



Say, is a bulging belly making you look and feel "all-in"—like an "old timer"? Just put on a "Chevalier" Health-Supporter Belt and presto! that "bay-window" looks smooth and sleek... like a real Beau Brummel figure! You'll say, "Boy, I look and feel great!"

Look! IT FITS YOU JUST RIGHT!

only \$3.98 POSTPAID

## The "CHEVALIER" HEALTH SUPPORTER BELT

Amazing "wrap around" band adjusts to EXACT SIZE you want! YOU APPEAR SLIMMER INSTANTLY!

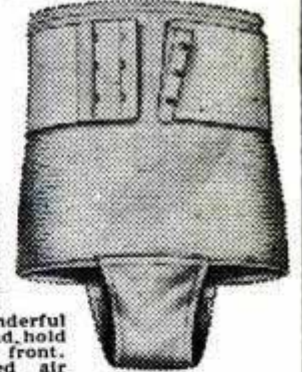

YOU SEE A CHANGE in your appearance the very instant you put on a "Chevalier"! That's because you can adjust it instantly for a perfect fit with perfect comfort—you streamline your abdomen the way you want it, right away! Chevalier is scientifically made of fine quality natural elastic s-t-r-e-t-c-h cloth that will give wonderful support to the small of your back and hold in your dragging belly paunch in the front. Comes with scientifically designed air cooled pouch (detachable) for masculine support and protection.

Wear a "Chevalier" Health Supporter Belt and see what an amazing difference it makes in the way you look and feel! That's our guarantee. You can try a "Chevalier" on FREE TRIAL at our risk. Only \$3.98—if you keep it! See our absolute no-risk offer below. Mail coupon today!

**FREE Extra Pouch.** The Chevalier has a removable pouch made of a soft, comfortable fabric that absorbs perspiration. So that you can change it regularly we include an extra pouch. Limited offer. Order yours today.



SEND NO MONEY - YOU TRY IT BEFORE YOU BUY IT

RONNIE SALES, INC., Dept. 6915-E  
487 Broadway, New York 13, N. Y.

Send me for 10 days' FREE TRIAL a CHEVALIER HEALTH-SUPPORTER-BELT. I will pay postman \$3.98 (plus postage) with the understanding that includes my FREE pouch. In 10 days, I will either return CHEVALIER to you and you will return my money, or otherwise my payment will be a full and final purchase price.

My waist measure is \_\_\_\_\_ (Send string the size of your waist if no tape measure is handy)

Name \_\_\_\_\_

Address \_\_\_\_\_

City \_\_\_\_\_ Zone \_\_\_\_\_ State \_\_\_\_\_

SAVE up to 60c. We pay postage if you enclose payment now. Same Free Trial and refund privilege.

Enclose payment on Canadian or Foreign \_\_\_\_\_



**Now!**  
**Be a Well-Paid Expert**  
**ON ALL ELECTRICAL**  
**REPAIRS and MAINTENANCE**

Defense Program Means  
 Bigger Pay in Essential Field for  
 Top Electrical Repair Men

Prepare NOW for a good-paying, ESSENTIAL job. Defense plants need expert electrical repair, maintenance men. Get the "know-how" from this Electrical Maintenance and Repair Library.

5 Volumes; 2072 Pages; 1834 Pictures  
 Starts at beginning, takes you step by step through every phase of connecting, altering, testing, repairing all types of equipment. How to install motors, generators, rewind motors; inspect, repair starters; locate trouble; test induction motors, and MUCH MORE! One entire volume crammed with trouble-shooting charts. Simple diagrams make everything crystal-clear. Gives best on-the-job practices of experts. Will



**FREE**  
**10-DAY**  
**TRIAL**

help to put you in big-pay class and to rate as an ESSENTIAL worker.  
 Send no money. Mail coupon for FREE 10-DAY TRIAL. Note special price, easy payments.

McGraw-Hill Book Co., Dept. PM-3-52  
 327 West 41st St., New York 18, N. Y.  
 Send me for FREE 10 days' examination the Electrical Maintenance and Repair Library. If not satisfied I will return books. Otherwise I will send \$2.50, plus postage, then and \$4 a month for 5 months (a saving of \$4.50 under regular price of \$26.).

Name \_\_\_\_\_  
 Home Address \_\_\_\_\_  
 City & State \_\_\_\_\_ PM-3-52

WE PAY POSTAGE if you enclose \$2.50 first payment WITH coupon. Same return privilege for full refund.

**PICK ARCHER**  
**Pol-mer-ik**  
 for BETTER PAINTING  
 POLISHING, REFINISHING

**FREE BOOK!**

"101" handy hints, valuable shortcuts and worthwhile savings. Write Archer-Daniels-Midland Co., 603 Roanoke Building, Minneapolis, Minnesota.

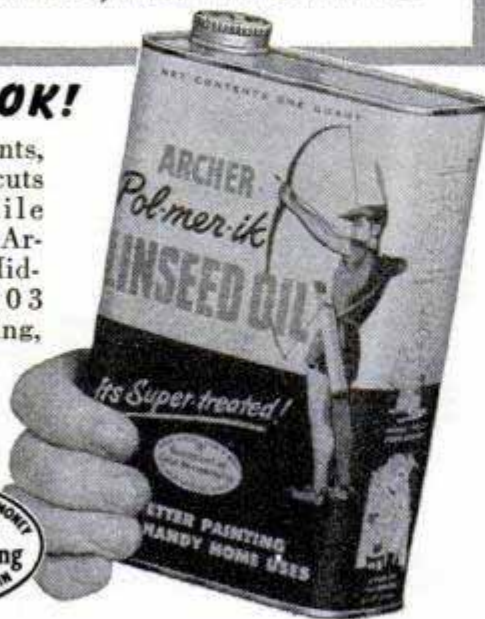

REPLACEMENT OR A REFUND OF MONEY  
 Guaranteed by  
 Good Housekeeping  
 IF NOT AS ADVERTISED THEREIN

**Super-treated LINSEED OIL**

**FURNITURE**  
**FOR YOUR**  
**BEDROOM**

YOU'LL BE THE ENVY of your neighbors with this beautiful bedroom suite in honey maple, oak or walnut! Here's a bed with storage space... a three-piece vanity with cosmetic compartment and makeup mirror... a Mr. and Mrs. dresser... twin night stands with drawers!



Send for Complete PLANS Only \$2.00

YOU MAKE IT YOURSELF! Only two power tools, a saw and a jointer, are needed to turn out this modern bedroom furniture. No other project of Popular Mechanics Magazine in recent years has captured the fancy of home craftsmen as has this easy-to-build suite. Letters demanding detailed plans poured in after the suite was pictured in Popular Mechanics. And now the plans are ready! They're detailed scaled drawings—a complete set of 4. Send for them today!

POPULAR MECHANICS PRESS, Dept. 26  
 200 East Ontario Street, Chicago 11, Illinois

I enclose \_\_\_\_\_ for a complete set of plans for making the modern bedroom suite illustrated above.

Name \_\_\_\_\_  
 Address \_\_\_\_\_  
 City \_\_\_\_\_ Zone \_\_\_\_\_ State \_\_\_\_\_

**PLEASE SEND ME**

for the  
 time checked.  
 I am enclosing . . .

1 year \$3.50  
 2 years \$6.00

name \_\_\_\_\_  
 address \_\_\_\_\_  
 city \_\_\_\_\_ zone \_\_\_\_\_ state \_\_\_\_\_ C-32

Hand this order to your newsdealer or send it to  
**POPULAR MECHANICS**  
 200 East Ontario St. Chicago 11, Ill.



*Build-it-yourself*

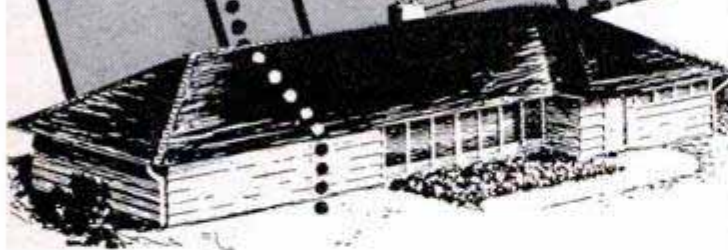

**Popular Mechanics Famous RANCH-TYPE HOUSE**

Save Thousands of Dollars by Building This Beautiful Home Yourself

Join the more than 100,000 families who have built their own homes in the past few years doing all or most of the work themselves and you can save more than 50% of usual building costs! Here is a dream home designed by the noted architect John J. Whelan, designer of the Drew Pearson home, especially for amateur home builders. You can build the basic five room unit for approximately \$5000. Carport may be converted into third bedroom and breezeway and garage added at your leisure. Basic house is to the right of the dotted line in the picture above; expansion is to the left. House fully expanded is 81 feet long and 29 feet wide.

**Order Book and Plans — Save \$7000 to \$10,000**

Book gives complete step by step instruction. Hundreds of pictures, photos and diagrams, showing every phase of construction, guide you from start to finish. Ten working size blueprints give floor plans, elevations, notes on construction, framing, lumber list, specifications, plumbing and wiring diagrams.

**Read How and See How —**

**Simplified Instruction**  
You read "how-to-do-it" in the book and see how it looks in actual pictures. You follow the plans for dimensions. You make use of labor-saving kinks, special methods.

**No Previous Building Experience Required**

Any ordinary handy man, using simple tools, can build this house with little or no assistance. And at the same time, save more

than he spends for material.

**Order Book, Plans Now**

Use the handy coupon below to order RANCH-TYPE HOUSE BOOK AND PLANS. Read the book; study the plans and then be prepared to go right ahead when you are ready to build. Even if you have the house mainly built by others you can enjoy a tremendous saving by using the instructions and blueprints.



*Order on this Handy Coupon*

**POPULAR MECHANICS PRESS, Dept. RH**  
200 East Ontario St., Chicago 11, Ill.

Send at once my copy of the Ranch-Type House Book and Plans as checked below:

- Remittance enclosed       Send C.O.D. (postage extra)
- |  |         |
|--|---------|
| <input type="checkbox"/> Ranch-Type House Book       | \$ 3.50 |
| <input type="checkbox"/> Set of 10 Blueprints        | 13.50   |
| <input type="checkbox"/> Book and Blueprints         | 15.00   |
| <input type="checkbox"/> Duplicate Set of Blueprints | 5.00    |

Name \_\_\_\_\_

Address \_\_\_\_\_

City \_\_\_\_\_ Zone \_\_\_\_\_ State \_\_\_\_\_

Give the handicapped a chance. Use Easter Seals

MARCH 1952

**MANUFACTURE THIS BEAUTIFUL CONCRETE OUTDOOR FIREPLACE**  
Right In Your Own Back Yard

**\$4.00 Worth of Sand & Cement produces this Attractive Fireplace.**

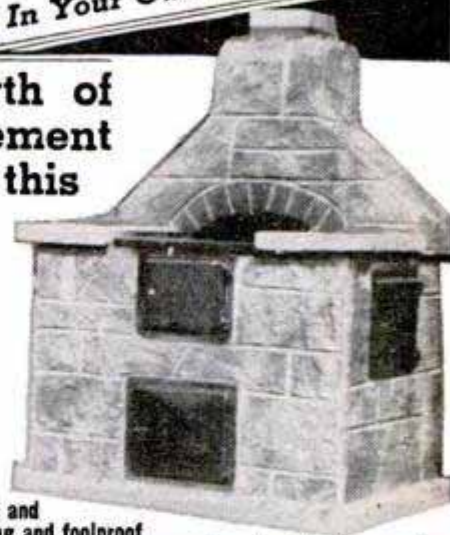

**Sells on Sight from \$60. to \$80. Easy to start your own Profitable Business.**

The General Fireplace Molds and Process are the most amazing and foolproof ever invented. Simple to operate, two men can produce five fireplaces a day.

**BIG DEMAND!!**

Sell all you produce to Department Stores, Homeowners, Parks, Nurseries and Picnic Groves. Fireplaces sell on sight. No experience necessary, we supply full operating instructions and equipment plus the know how that spells **BIG PROFITS**. This is an outstanding opportunity for men of vision and small capital to get into a busy rich paying field. Don't delay, be the only exclusive manufacturer in your own home town. Mail coupon at once for full details as to how you can reserve your territory.

Molds sold only on exclusive franchise.

**GENERAL ENGINES CO., Inc., Dept. MF-32**  
307 HUNTER ST. • GLOUCESTER CITY, N. J.

Mr. Tor of Phila. writes: Name \_\_\_\_\_  
Sold 250 in first 4 months. Selling to Address \_\_\_\_\_  
Sears Roebuck, John Wanamaker & City \_\_\_\_\_ Zone \_\_\_\_\_ State \_\_\_\_\_  
Gimbel Bros. in Phila. area.

*IT'S FUN TO FINISH FURNITURE WITH NEW—*



*Transvener*  
**PLASTIC FILM VENEER**

**REPRODUCTIONS OF BEAUTIFUL WOOD GRAINS**

Transvener makes any smooth surface look exactly like the most beautiful wood! Easily applied film-like sheets cover wood, metal, composition board, glass. Many patterns available. **SPECIAL TRIAL OFFER!** 16"x24" Transvener sheet in beautiful Mahogany grain, Welding Solution, Squeegee, full Instructions—all for only \$1.00 postpaid. Money back guarantee. Order today! Sorry, no C.O.D.'s.

**SPECIAL TRIAL OFFER!** Postpaid

**MAIL COUPON NOW!**

**TRANSVENER DIVISION, DI-NOC COMPANY**

Dept. A-2, Public Sq. Bldg., Cleveland 13, Ohio

Enclosed is \$1.00. Please send Transvener, Welding Solution, Squeegee and Instructions.

Name \_\_\_\_\_

Address \_\_\_\_\_

City \_\_\_\_\_ Zone \_\_\_\_\_ State \_\_\_\_\_

Offer good for limited time only. Offer good only in Continental U. S.



**FAMOUS 15 & 17 JEWEL BULOVA WRIST WATCH \$16.95 PLUS TAX**

**UNLIMITED WRITTEN GUARANTEE**

**SAVE \$44 ON THIS 17 JEWEL WRIST WATCH \$14.95 PLUS TAX**



**WERE UP TO \$59.50**  
Save \$42.55

Also Choice of  
● BENRUS  
● GRUEN  
● WALTHAM  
● ELGIN

You get these unredeemed **UNLIMITED GUARANTEED** famous Bulova and other movements in latest style Yellow Gold Cases at this sensationally low price because we bought out **SURPLUS STOCKS** of leading New York and Md. jewelers. Order now while they last. Specify make preferred and whether men's or ladies'! Only \$16.95, plus \$1.70 tax. Order right now!

**FREE 10 DAY TRIAL**

**FREE EXPANSION BAND WITH EACH ORDER**

**FORMERLY SOLD FOR \$59.00**  
**INCABLOC SHOCK PROTECTED WATER & DUST PROOF**  
Worn by **ARMY, NAVY & MARINES**

Luminous dial, sweep second hand. Super Accurate. Imported Swiss precision movement and case. You get these brand new **UNLIMITED GUARANTEED** watches now for a small fraction of the original price. You save \$44, because we bought out surplus stocks. Order men's style \$14.95 plus \$1.50 tax or ladies' and nurses' style, \$16.95, plus \$1.70 tax. Order now at this low price.



**NURSES' MODEL \$16.95 Plus tax**

**WEAR AT OUR RISK!**  
Money Back guarantee in 10 days if not delighted!

**SEND ONLY \$1 DOWN PAYMENT** with order. Pay balance to postman on arrival plus postage. Or we pay postage if you enclose full payment plus tax.

**MARYLAND DISTRIBUTORS, Dept. 356** 501 E. BALTIMORE ST. BALTIMORE-2, MARYLAND

**FREE!** Watch and Jewelry Catalog at Almost Wholesale Prices!

*Special Offer*

**WORK CLOTHES BARGAINS!**



**FREE 10 DAY TRIAL**

**WORK SHIRTS**  
**79c**  
3 for \$2.29

Blue, Tan, White  
Measure Neck & Arm

**WORK PANTS**  
**99c**  
3 for 2.69

Blue, Tan, White  
Measure Waist & Leg

**SHOP COATS**  
**\$1.79**  
3 for \$5

Blue, Tan, White  
Send Chest Measure

**COVER ALLS**  
**\$1.98**  
3 for \$5.49

Blue, Tan, White  
Send Chest Measure

**WHAT A BUY!** Surplus stock from a big midwest supply firm makes these gigantic savings available to you! Sturdy, serviceable work clothes, though used, have been washed, thoroughly sterilized and reconditioned. Every garment made of long-wearing wash materials, strongly sewn, with reinforced stitching at points of strain. When ordering please state measurements under item.

**SEND NO MONEY!** Just send name, complete address, clothing desired (state how many of each), and your color choice (also 2nd color choice). We will ship immediately. Pay postman, plus postage when your order arrives. Or, enclose cash, check or money order, and We Pay Postage. Keep 10 days. Return for full refund of purchase price if not completely satisfied. Order TODAY at our risk!

**YOUNG DISTRIBUTING CO. Dept. 246 2605 Elmhurst, Detroit 6, Mich.**

**New PRINTMASTER!**  
**PRINT YOUR OWN POSTCARDS**  
Advertise **ECONOMICALLY**. Use Postcard MESSAGES for **EFFECTIVE** Advertising! Ideal for Notices, Sales, Announcements, Forms, Labels, Etc., in every type of Business and Organization. Time and Money Saver! Send today for **FREE** Illustrated Information.  
**PRINTMASTER DUPLICATOR CO.** 655 S. WELLS ST., DEPT. PM-3 CHICAGO 7, ILL.



**... Works Wonders on FALSE TEETH**

● New, different acrylic **VELDENT** easily relines plates at home, makes false teeth fit tight. One application lasts for months, works wonders, saves time, bother and money. Send for **FREE FACTS** today on "The Secret of Correcting Loose Dental Plates."  
**VELDENT CO., BOX 96-3, LOS GATOS, CALIFORNIA**



**HELP CRIPPLED CHILDREN**

**1952**

The National Society for Crippled Children and Adults, Inc.  
11 S. LaSalle St., Chicago 3, Ill.  
The Easter Seal Agency

**Thrilling Work COLORING PHOTOS**  
Fascinating vocation learned at home by those with aptitude. Thrilling pastime. National method brings out life-like colors. Free booklet.  
**NATIONAL PHOTO COLORING SCHOOL**  
835 Diversey Pkwy., Dept. 1353, Chicago 14



**WALKIE TALKIES ONLY \$4.99** COMPLETE SET OF 2  
**POCKET SIZE** —ELECTRONIC VOICE POWERED  
No tubes, batteries, adjustments. Guaranteed to work anywhere up to 1/4 mile with extra wire. Swell for room to room—garage to house, etc. Your own private, talk-listen phone. Not war surplus. Brand new. Guaranteed. Two complete units with interconnecting wire — **READY TO USE!**  
**SEND \$1.00** deposit and pay postman \$3.00 plus postage charges or send \$4.99 for postpaid delivery. Available only by mail from **MIDWAY COMPANY, Dept. WPM-3, Kearney, Nebraska**





# Introducing the NEW 1952

*Lightning ⚡ Change*

## ROTOTILLER

Reg. U. S. Pat. Off.

SO LOW IN COST  
ALMOST ANYONE  
CAN AFFORD IT!

### Eight Wonderful Yard and Garden Machines — ALL-IN-ONE!

Just Look at Some of the Jobs This "Automatic Handyman" Can Do!

NOW you can have row upon row of crisp, fresh vegetables, berries, fruits—lovely clipped lawns—all kinds of flowers—without having to hire a single gardener! Now you can have the show place of your neighborhood, while others "break their backs" trying to match your garden and grounds.

The reason for this amazing revolution in suburban and country living is the New 1952 Lightning-Change ROTOTILLER. This astonishing, self-powered mechanical handy man makes all other yard and garden tractors virtually obsolete! The secret is in its ability to do so many different jobs

around the place so quickly — so easily! In just a few moments, and with only simple tools, you can convert it into a power cultivator, power pump, power lawn mower, power weed cutter and mulcher, power snowplow and light bulldozer, power wood saw or power composter. It can even generate emergency electricity, if the electricity goes off!

Whether you own a garden tractor or not, you owe it to yourself and your family to find out everything about this revolutionary new machine. Let us tell you the complete story, without any obligation on your part. Simply . . .

### MAIL COUPON NOW FOR *Free Book*

This big, FREE picture-packed Book, "A Little Power—A Lot of Living!" was written especially for you by Ed Robinson, author of the famous "Have-More" Plan. You will find in it a whole new work-saving, time-saving way to make country and suburban living the dream you have always longed for. We also send you actual low-cost, delivered prices, and the name of your nearest ROTOTILLER dealer.

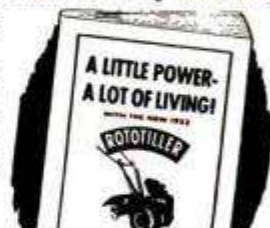

**ROTOTILLER, Inc.**  
Dept. 203, Troy, New York

Please send me FREE, a copy of your Illustrated BOOK, "A LITTLE POWER—A LOT OF LIVING," by Ed Robinson, author of the famous "Have-More" Plan.

Name.....  
(Please Print)

Address.....

City.....County.....State.....

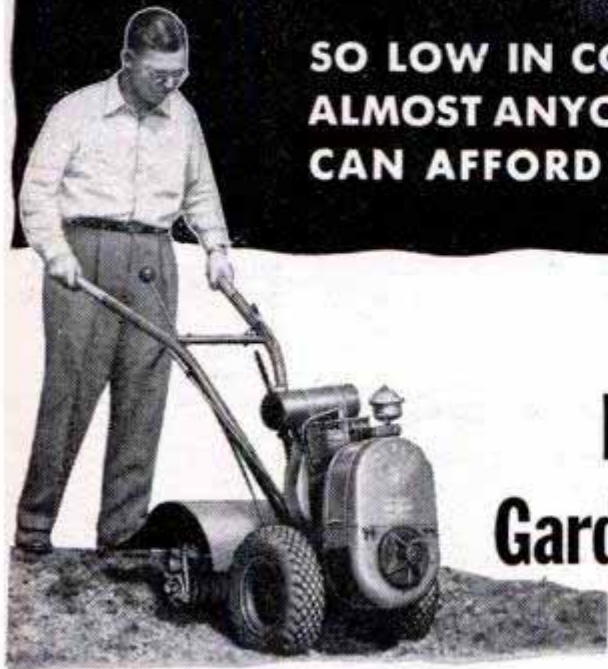

**1 As a Gardening Machine**—it does the work of plow, disc and harrow—all in one easy operation. Takes all the "back-breaking" work out of gardening. Now you can have bigger, better crops with less work!



**2 As a Cultivating Machine**—it weeds around even the most tender surface roots with almost no damage. Wonderful for cultivating grapes, corn, etc.—in fact, ANY crop! So simple a child can operate it!



**3 As a Composting Machine**—it composts right in the garden itself—producing miracles of soil improvement without special fertilizers. Enriches topsoil by mixing in leaves, weeds, any organic material.



**4 As a Lawn Mower**—it cuts a velvet-smooth 25-inch swath. No overhanging wheels. Leaves no untrimmed edges. In seconds your "automatic handyman" converts into the finest lawn mower you could ask for!



**5 As a Weed Mower and Mulcher**—it can swiftly cut down tall grass, brambles, even brush—reducing fire hazards. Also ideal for clipping poultry ranges, cleaning up vegetable and flower garden in the Fall.



**6 As a Snowplow or Light Bulldozer**—Keeps walks and roads clean. Will grade lawns and terraces. The 30-inch blade swivels to right or left.

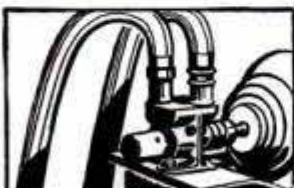

**7 As a Water Pump and Sprayer**—it offers fire protection, soil irrigation, water for livestock, insecticide spraying. Throws a 50-foot stream of water.



**8 As a Wood Saw**—it cuts logs up to 14 inches across like butter. But get FREE BOOK to read about many other uses of this versatile power machine.



# Save

as much as

**\$47.00**

with

# Nurlizing



### TYPICAL OVERHAUL COSTS FOR 1947 SIX-CYLINDER CAR WITH .007" CYLINDER TAPER

#### STANDARD OVERHAUL

Rebore 6 Cylinders.....	\$20.30
6 New Pistons...	35.70
1 Set PC 2-in-1 Chrome Rings..	19.00
1 Set Gaskets....	5.57
Labor (including grinding valves, fitting pins, installing main and rod inserts, etc.).....	56.40

Total Cost **\$136.97\***

#### NURLIZING OVERHAUL

Nurlizing 6 Pistons.....	\$ 4.50
Regrooving Top Piston Groove..	4.50
1 Set PC 2-in-1 Chrome Rings..	19.00
1 Set Gaskets....	5.57
Labor (including grinding valves, fitting pins, installing main and rod inserts, etc.).....	56.40

Total Cost **\$89.97\***

\*These prices are average. Costs may vary slightly in different parts of the country.

### Perfect Circle's proven method of resurfacing worn pistons!

IT'S TRUE! The \$47.00 saving shown here is typical of the amazing economy you can expect on engine overhauls, when you have your old pistons Nurlized!

Perfect Circle Nurlizing is an exclusive method of restoring worn pistons to their original fit, to save you the cost of new pistons. What's more, Nurlizing restores power, eliminates piston slap, and assures better lubrication at all times.

When your car is due for an engine overhaul, insist that your Doctor of Motors Nurlize your old pistons for thousands of money-saving miles of top performance! Perfect Circle Corporation, Hagerstown, Indiana.

# Perfect Circle

PISTON RINGS—NURLIZING

*The Standard of Comparison*





WITHIN THE PAST few months, chemistry—like a curious lad—has vaulted across the fence and started exploring a vast new field. Though the chemist knows little about this broad expanse, he's aware of its significance. He realizes he has leaped into a third dimension in chemistry and, dimly, he sees it's a dimension with truly staggering possibilities.

In the past the chemist's work has been divided into two broad fields—organic and inorganic chemistry. Traditionally, organic has been the more important and fascinating field, for it deals with hydrocarbons, the fuels and foods of our universe. Hydrogen and carbon eagerly combine with each other and with other elements to form a huge array of basic building blocks—from plywood and cold cuts to plastics and coal.

Invisible gas, five times heavier than air, is poured from beaker to beaker. Balloon floats in it

# POPULAR MECHANICS

MARCH  
1952

WRITTEN SO YOU CAN UNDERSTAND IT  
VOL. 97 NO. 3

By Clifford B. Hicks

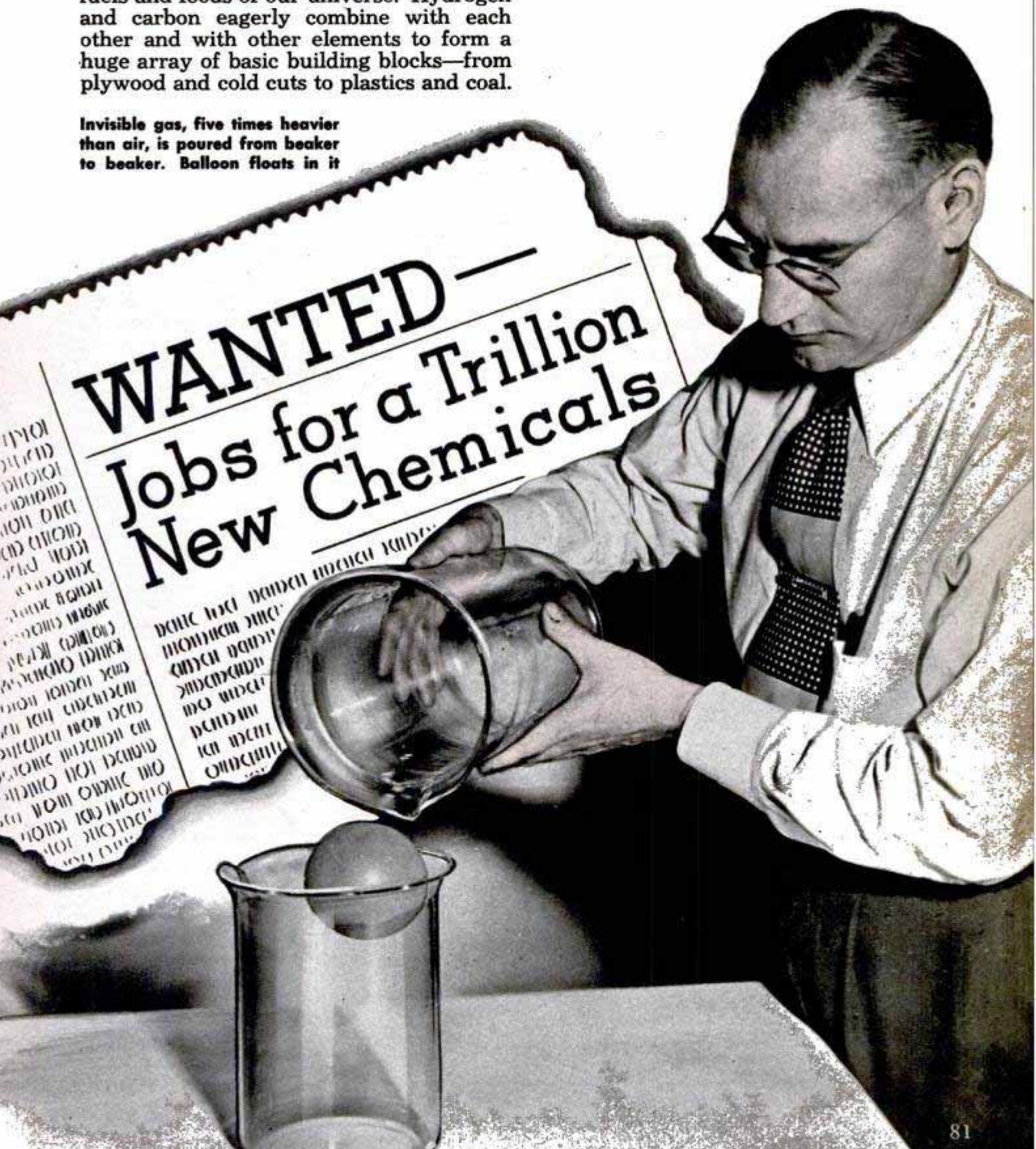



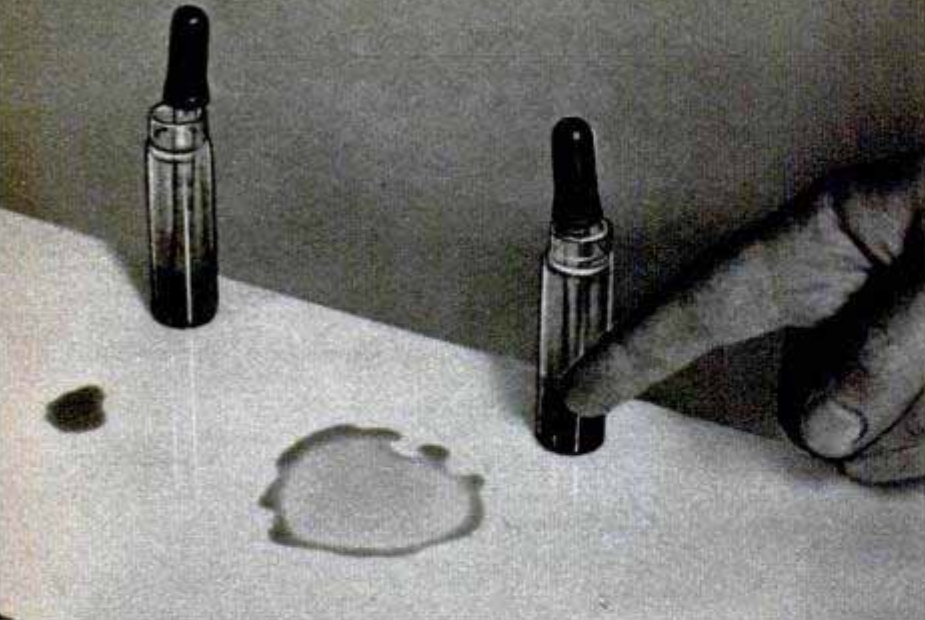

Common detergent, left, remains in drop form on smooth surface. New chemical keeps spreading until it evaporates

can bet your boots this new horde of chemical servants soon will play an important part in making your life safer and more enjoyable.

Consider, for example, the possibility of a lifetime lubricant sealed into your car engine; a house paint that just plain refuses to permit your home to burn down; pots and pans that literally push away scorched foods; detergents so effective a grease monkey's overalls will come clean in a

few swishes.

Conservative chemists remain silent when you start discussing such items, for they haven't yet been produced. But the same scientists will lecture in glowing terms on the strange and novel properties of fluorocarbons that very likely will make these products possible.

The basis of all this optimism is a single cast-iron pot, about as unimpressive as a washtub. It's virtually hidden away in one corner of a new building erected by Minnesota Mining & Manufacturing Company. This unpretentious tub, actually an electrolytic cell, is turning out an impressive array of fluorocarbon compounds, not just in test-tube lots, but by the ton.

The story of the chemicals actually is the story of reforming the most sinful of all

Now chemistry stands on the rim of a third basic field—the fluorocarbons. In a brick factory in southern Minnesota, fluorocarbons are pouring out by the ton. They promise to be every bit as versatile and useful as the vast number of hydrocarbons.

It's estimated there are about a million hydrocarbons, of which around 10,000 are available commercially. Beside the chemical symbol for each of these hydrocarbons the chemist now can insert the symbol of a corresponding fluorocarbon. But this is just the beginning. The derivatives of the new family are so numerous it's theoretically possible to produce around a trillion fluorocarbon compounds. So far only about 500 chemicals in this chain reaction have been turned out, but these show such strange and desirable personalities that you

Table shows relationship between hydrocarbons and new chemicals. Note how properties are almost opposites

	CHEMICAL COMPOUND	SYMBOL	PROPERTIES	USES AND POTENTIAL USES
HYDROCARBON	BUTANE	$C_4H_{10}$	HIGHLY COMBUSTIBLE GAS	FUEL GAS
FLUOROCARBON		$C_4F_{10}$	HEAVY, INVISIBLE, NON-FLAMMABLE GAS	FIREPROOF BLANKET FOR TANK FILLED WITH EXPLOSIVE GAS
HYDROCARBON	TRIBUTYLAMINE	$(C_4H_9)_3N$	LIQUID SOLUBLE IN WATER TO PRODUCE A COMPOUND WHICH CONDUCTS ELECTRICITY	USED AS A BASE IN MANUFACTURING OTHER COMPOUNDS
FLUOROCARBON		$(C_4F_9)_3N$	INERT FLUID, INSOLUBLE IN WATER, WHICH WON'T CONDUCT ELECTRICITY	ELECTRICAL INSULATION
HYDROCARBON	PROPANE	$C_3H_8$	HIGHLY COMBUSTIBLE GAS	FUEL
FLUOROCARBON		$C_3F_8$	NONFLAMMABLE, NONTOXIC GAS	REFRIGERANT
HYDROCARBON	ETHYL ETHER	$(C_2H_5)_2O$	HIGHLY VOLATILE AND COMBUSTIBLE LIQUID	ANESTHETIC AND SOLVENT
FLUOROCARBON		$(C_2F_5)_2O$	NONTOXIC, NONCOMBUSTIBLE GAS	FIREPROOF GAS BLANKET, GASEOUS INSULATION FOR RADAR AND TV TRANSMISSION CABLES

NOTE HOW SUBSTITUTION OF FLUORINE FOR HYDROGEN, IN THE CHEMICAL SYMBOL, COMPLETELY CHANGES THE PROPERTIES OF EACH COMPOUND



elements, fluorine. The history of this wayward gas is written in a series of violent explosions, blasts which have wrecked the few laboratories where men have been brave enough to try to tame the stuff. In pure form, fluorine is the most reactive element in nature. Metals burst into flame upon contact; glass vanishes in a puff of smoke, and asbestos melts into ashes.

The element is extremely plentiful in nature, but it's always combined with other elements. Fluorspar, the most important fluorine-containing material, occurs in big and widespread deposits. Phosphate rock also contains much fluorine. In these forms the element is as docile as a lamb.

Chemists hadn't even seen the pure gas until 1886, when a French scientist, Henri Moissan, tried twisting the tiger's tail. He electrolyzed a solution of hydrogen fluoride, obtained fluorine, and caught just a glimpse of the green gas before it exploded. The fluorine vapor almost killed Moissan, and nobody tried to pick a real argument with the tiger until the mid-30s, when it was tamed just enough to incorporate it into the Freon compounds.

The few scientists who experimented at all with fluorine became convinced that if it were combined with carbon the result would be a strange family of chemicals with properties just the opposite of the pure gas. Fluorocarbons promised to be the most stable compounds ever imagined. The problem was simply—and dangerously—to produce them.

Experimental laboratory cell, made of cast-iron pipe, can theoretically turn out a trillion new chemicals. Diagram shows simplicity of the process

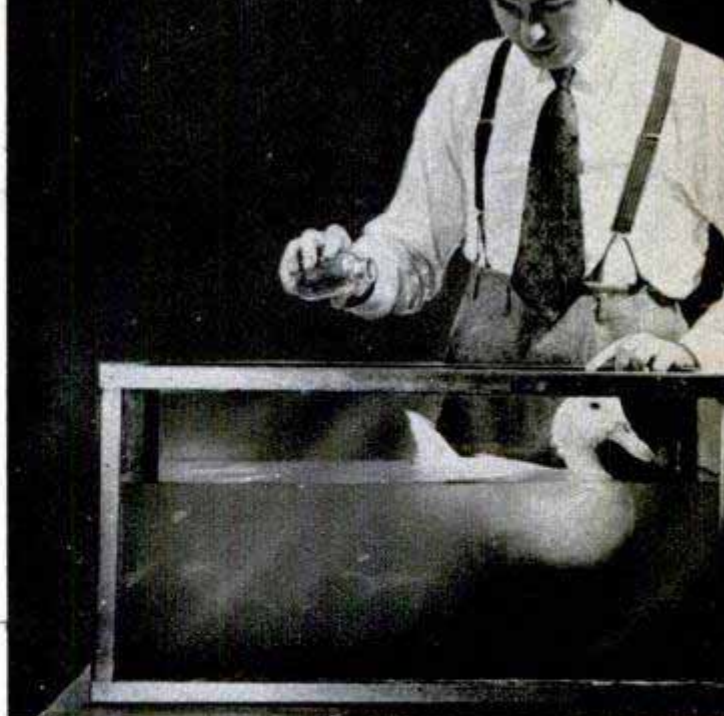
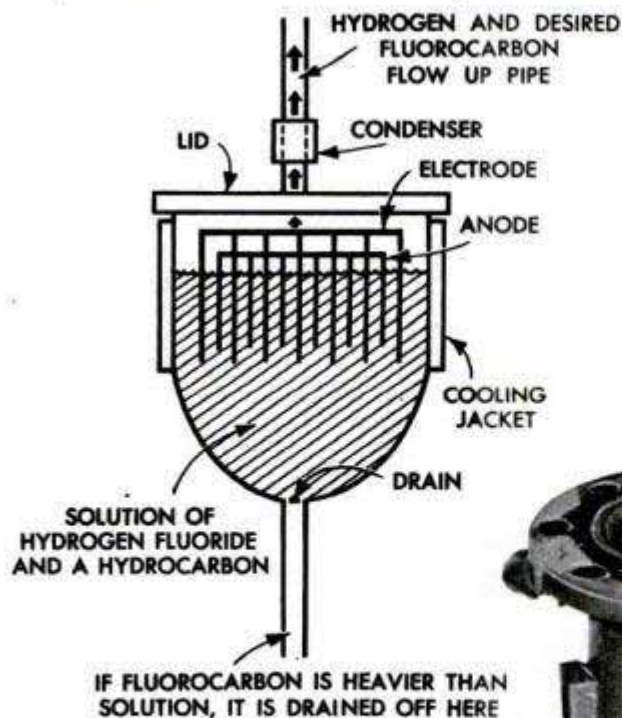

Man outsmarts duck: Drops of fluorocarbon in water make it so "wet" even a duck sinks slowly to bottom

One day in 1939 Prof. J. H. Simons of Pennsylvania State College mixed hydrogen fluoride (a derivative of one of the fluorine compounds found in nature) with one of the hydrocarbons. He passed a direct current through the mixture and presto—the result was a whiff of







FIRE



PAINT OXIDATION

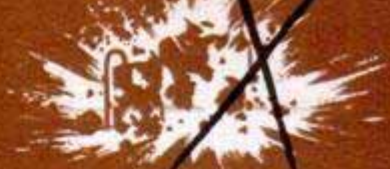

EXPLOSIONS



TOP SECTION MOVES DOWN AS EXPLOSIVE GAS IS DRAWN OFF BOTTOM

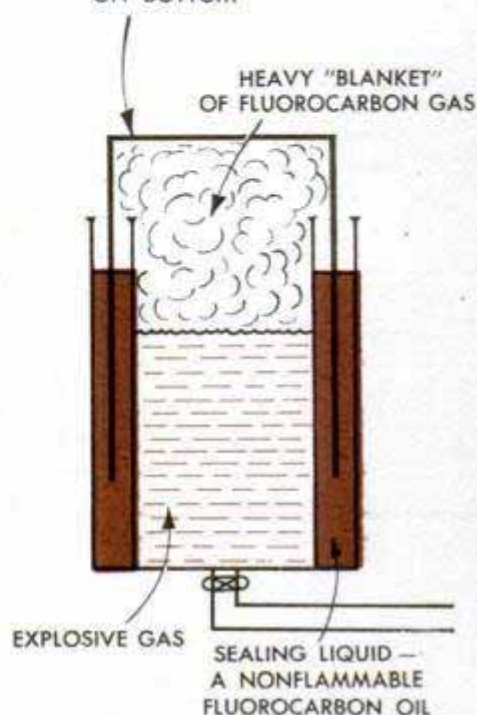

EXPLOSIVE-GAS TANK PROTECTED BY FLUOROCARBONS

Doctor Taylor, behind array of fluorochemicals, demonstrates that one liquid is much heavier than water. Diagram shows how storage tank filled with explosive gas could be protected by "blanket" of fluorocarbon gas

hydrogen gas and a few cubic centimeters of fluorocarbons.

A short time later, with war flaring through Europe, a couple of government officials asked a group of industrial chemists to produce pure fluorine, not just by ounces but "maybe a million pounds of it."

The flabbergasted chemists, sworn to secrecy, went to work. They came through with free fluorine all right. They probably didn't know the fluorine was needed to produce uranium hexafluoride, which in turn was converted into the stuffing of the atom bomb. Trouble was, the uranium-fluorine combination was so corrosive it reacted with anything and everything. Metal pipes and glass tubes, sealed with grease or rubber, just melted away when exposed to the stuff.

Simons, who was acquainted with the problem, submitted a few drops of the liquid he had produced in his electrolytic cell, and tests showed it resisted the ravages of even its parent, fluorine. Fluorocarbons

eventually were used as sealants and coolants in separating the uranium isotopes.

Simons had been working on other projects for Minnesota Mining & Manufacturing Company (popularly called 3M), and in 1944 the company started sponsoring his work in fluorocarbons. The immediate result was a series of tests with the experimental cells. The ultimate result was the first big cell, which went into operation last October and now is turning out a variety of fluorocarbons in quantities large enough for wide distribution for testing. The new chemicals are seeking steady employment.

Meanwhile seven years of unpublicized research and millions of dollars have gone into the project. Dr. Nelson W. Taylor, manager of the company's Fluorochemicals Department, has a research crew of 75 scientists, mostly eager young men who know they are stalking big game. In the company's St. Paul laboratories they are tracking down one fluorocarbon after another with deceptively simple experimental cells.





ROTOR



TERRITES

The beauty of the cell method is that it by-passes free fluorine. Another big advantage is that it is a continuous process. The 3M scientists have been working around the clock to find the limits of their process. So far they're stumped. Apparently you can produce virtually any imagined combination of fluorine, carbon and other elements in the cell.

The cell itself is as simple as an automobile storage battery, which it resembles in many ways. And turning out one of the fabulous new chemicals is as easy, in theory, as mixing a pot of stew and bringing it to a boil. The chef mixes a solution of hydrogen fluoride with an organic chemical in the vat. The particular chemical he uses depends upon the fluorocarbon he desires. He drops the cell lid into place and passes an electric current of five or six volts through the cell. The current causes the fluorine to replace the hydrogen in the chemical. The displaced hydrogen goes up

(Continued to page 252)

New gas snuffs out a blaze in a split second. Army says it's superior to all other fire extinguishers

At bottom of tube is a fluorocarbon. Next comes layer of water, and at top is a layer of a hydrocarbon, heptane. Three layers won't mix, each refracts light differently (note the "steps" in the hand-held thermometer). Better film may result from fluorocarbons' remarkable optical qualities







## Pills for Plants

Gardeners can feed vitamin B1 to their flowers and vegetables with a spray attachment for the hose. The attachment is a coupling which connects with the faucet. The hose then is screwed onto the coupling. From the attachment runs a small rubber tube which is dropped into a container of water. The gardener dissolves a number of

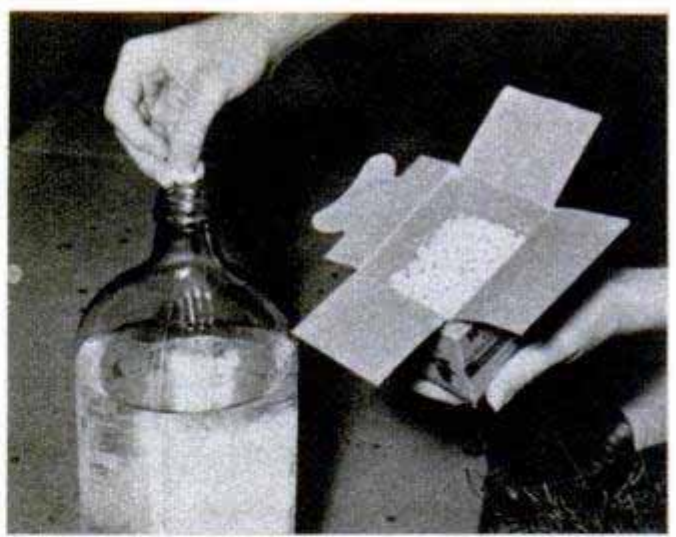

vitamin tablets in the water, then sprays his lawn. As the water comes through the hose, it draws with it a small amount of the vitamin-enriched water from the container. In planting or transplanting, a tablet can be dropped directly in with the seed or plant. It dissolves over a period of time to enrich the soil and aid the plant's growth. The vitamin complex designed for plants also is available in powdered form.

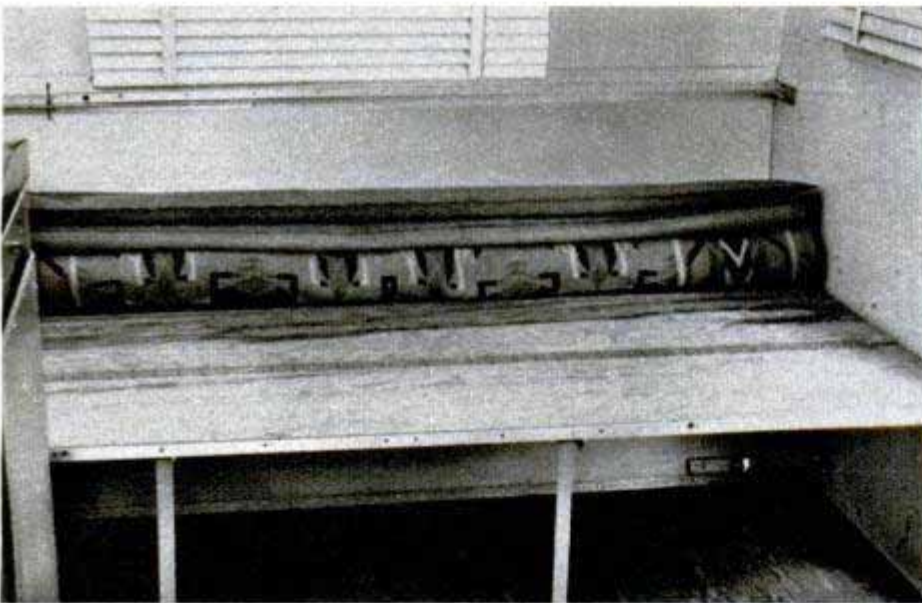

## Trailer Bed Folds Out of Way

Replacing the usual sofa bed, a compact shelf-type trailer bed folds against the wall to provide extra space for chairs and a table. Long piano hinges allow the bed to fold in two places to provide a locker compartment for the bedding. A pneumatic mattress is used with the bed, which is supported on each end by metal strips.



## Science Manufactures Two Heaviest Atoms

Two new isotopes, the heaviest atoms known, have been produced by atomic bombardment in the 60-inch cyclotron at the University of California. The isotopes, which are known as Berkelium-245 and Californium-246, provide two of the missing links in the pattern of radioactivity of the elements. They are new forms of elements which were discovered after World War II.





### "Inside the Camera" View

Sight-seers visiting a building high atop a cliff in San Francisco can virtually "walk inside a camera" and look at the view through the lens. Floyd Jennings devised the building to bring a magnified view of the surrounding area to several people at the same time. Visitors find themselves in a darkened, boxlike room. In the center of the room is a large oval viewing table. A turret overhead contains a 12-power lens which casts a view upon the table in brilliant natural colors. The turret moves in a 20-degree arc each minute to reveal a new view.

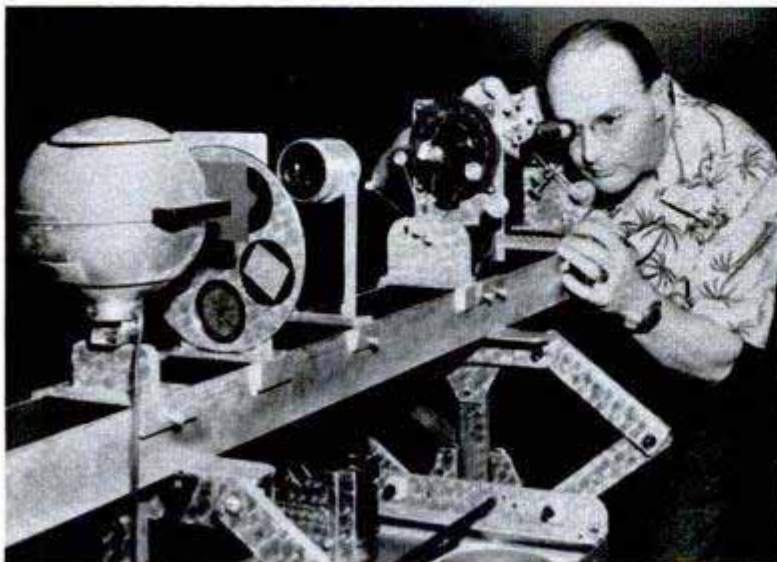

### Lens Test Bench Produces Parallel Rays

Producing parallel rays of light, a new optical bench accurately tests photographic lenses. Usually, parallel rays for testing are obtained from those distant light sources, the stars, but with the new instrument the technician can provide his own rays. Some of the tests made by the apparatus indicate the degree of resolution of a lens, coma, astigmatism, color aberration and spherical aberration. A lens' focal length may also be determined.



**W-80**  
20 TO 24 PASSENGERS

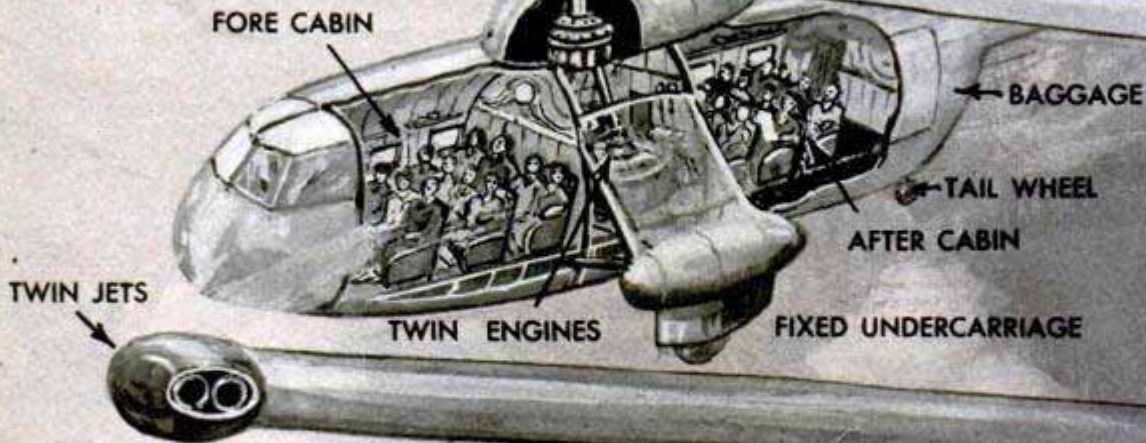

**W-85**

CARRIES 100 TROOPS  
OR 68 PASSENGERS  
15-TON PAYLOAD  
TYPE MAY MOUNT  
THREE-BLADE ROTOR  
WITH TWIN-JET ENGINES  
ON EACH BLADE OR  
SIX-BLADE ROTOR  
WITH SINGLE ENGINE  
ON EACH BLADE

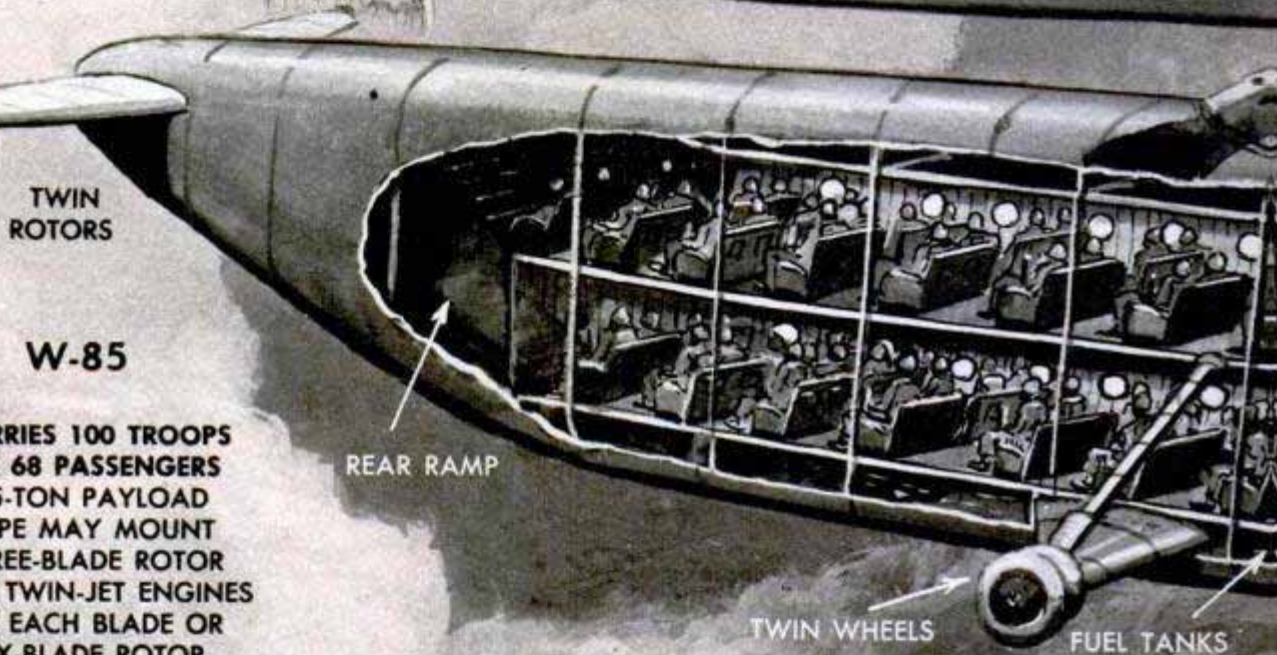

**W-81**

**W-81**



**W-81**  
32-SEATER  
SPEED 150 M.P.H.  
WITH TWIN-JET ENGINES



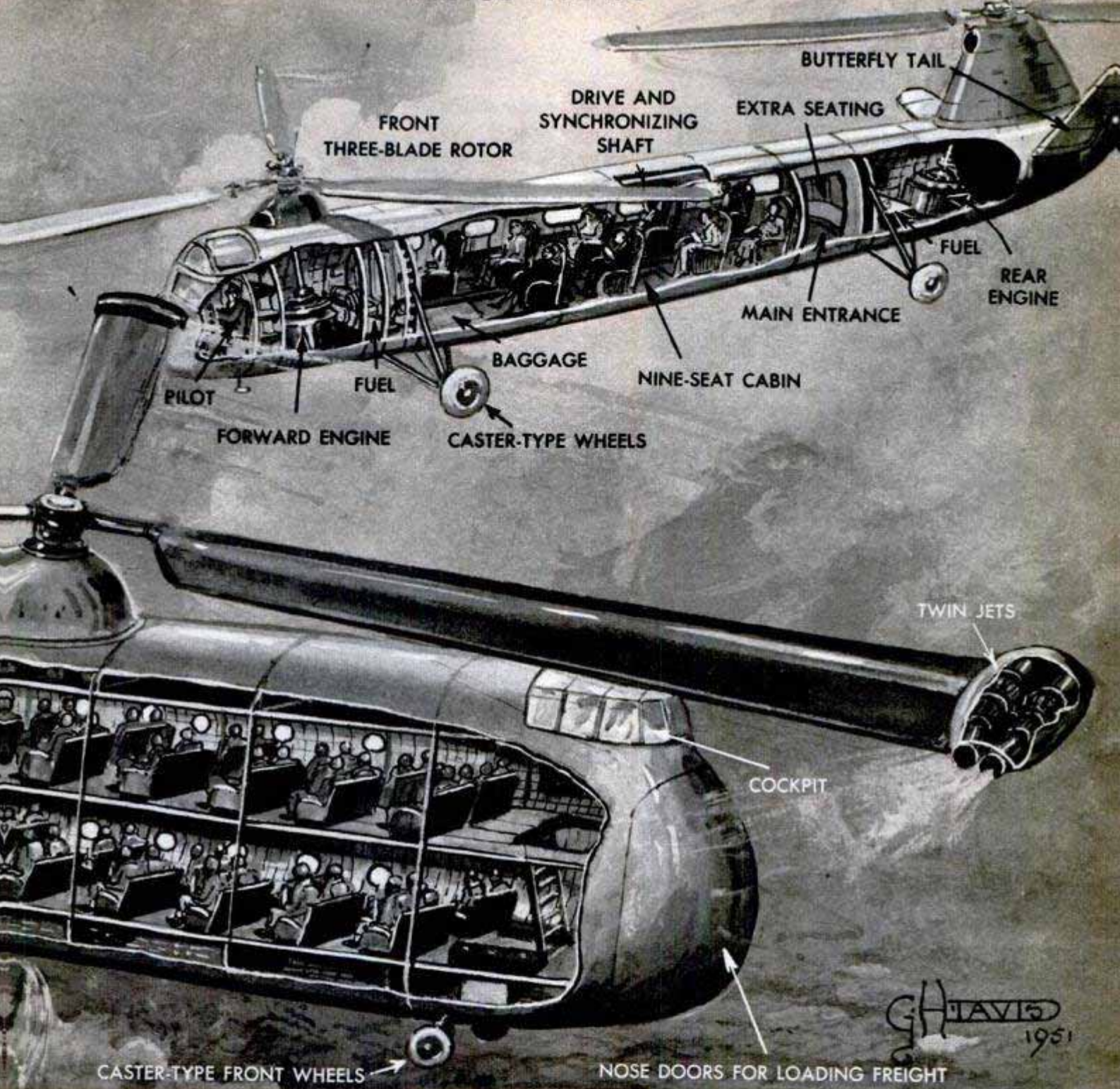

## Helicopter Forecast From England

Several experimental helicopters have been built in England or now are in the design stage. Type 173, shown at top of page, has two motors to power the two rotors. Should either motor fail, the other can be used to drive both rotors. The W-81, at left, has two turbojet units, placed side by side, which are expected to give the aircraft speeds up to 150 miles per hour. The huge W-85, above, is designed to airlift about 100 troops in military use

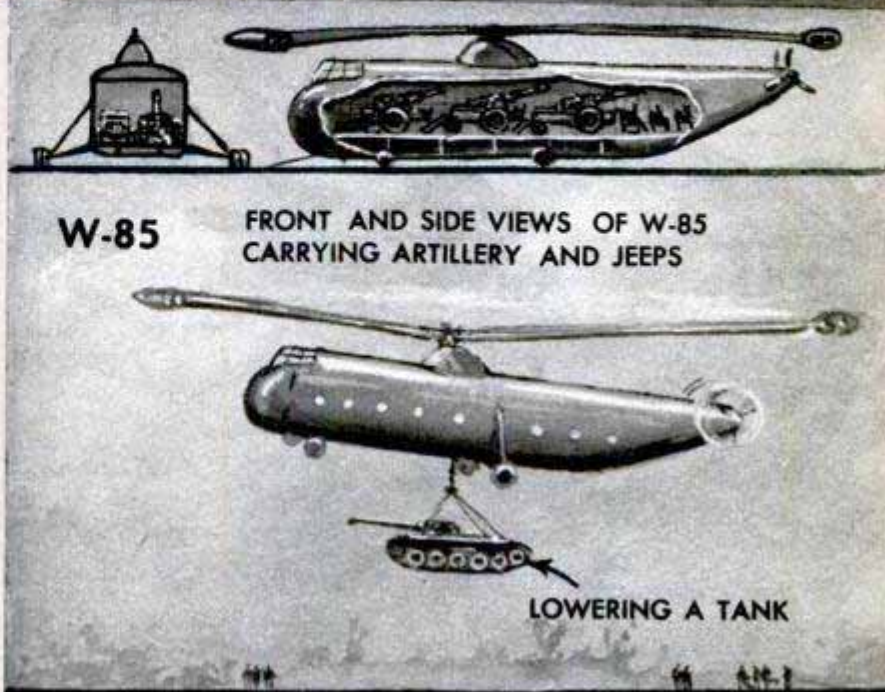

W-85

FRONT AND SIDE VIEWS OF W-85  
CARRYING ARTILLERY AND JEEPS

LOWERING A TANK



# AERIAL CABLE CAR PULLS ITSELF ALONG



PULLING itself 5000 feet up an Alaskan mountain by winding cables around its wheels, an aerial car uses the principle proved by inventor Phil Grabinski, former Washington logger, when he drove a Model-T Ford chassis over a house to convince government officials his theory was sound.

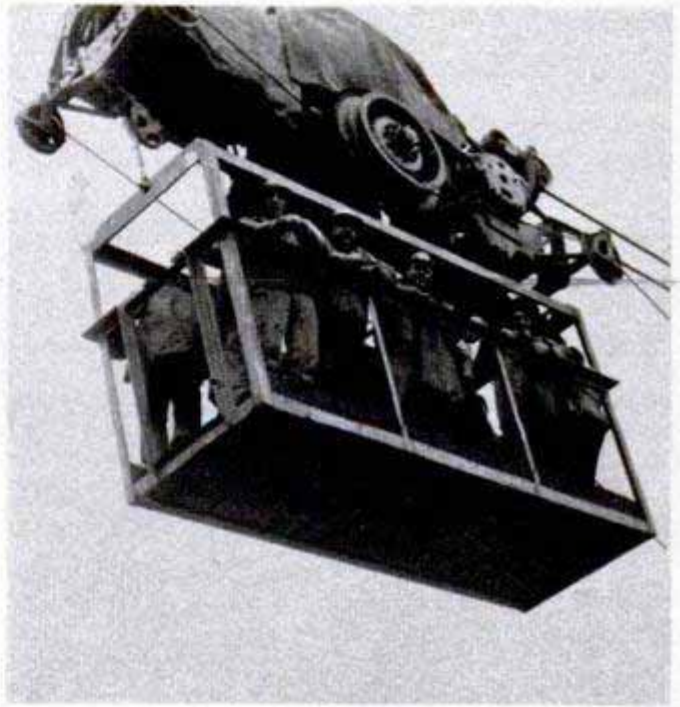

Above, its inventor sitting on the fuel tank, the aerial car (an ancient Ford) proved it could pull itself up and over a house "by its own bootstraps"

Right, using the principle proved with the Ford, a self-propelled car hauls men at an Alaskan project

Below, the tramway climbs 5000 feet of rugged mountainside. The operator sits in a cab above the cage

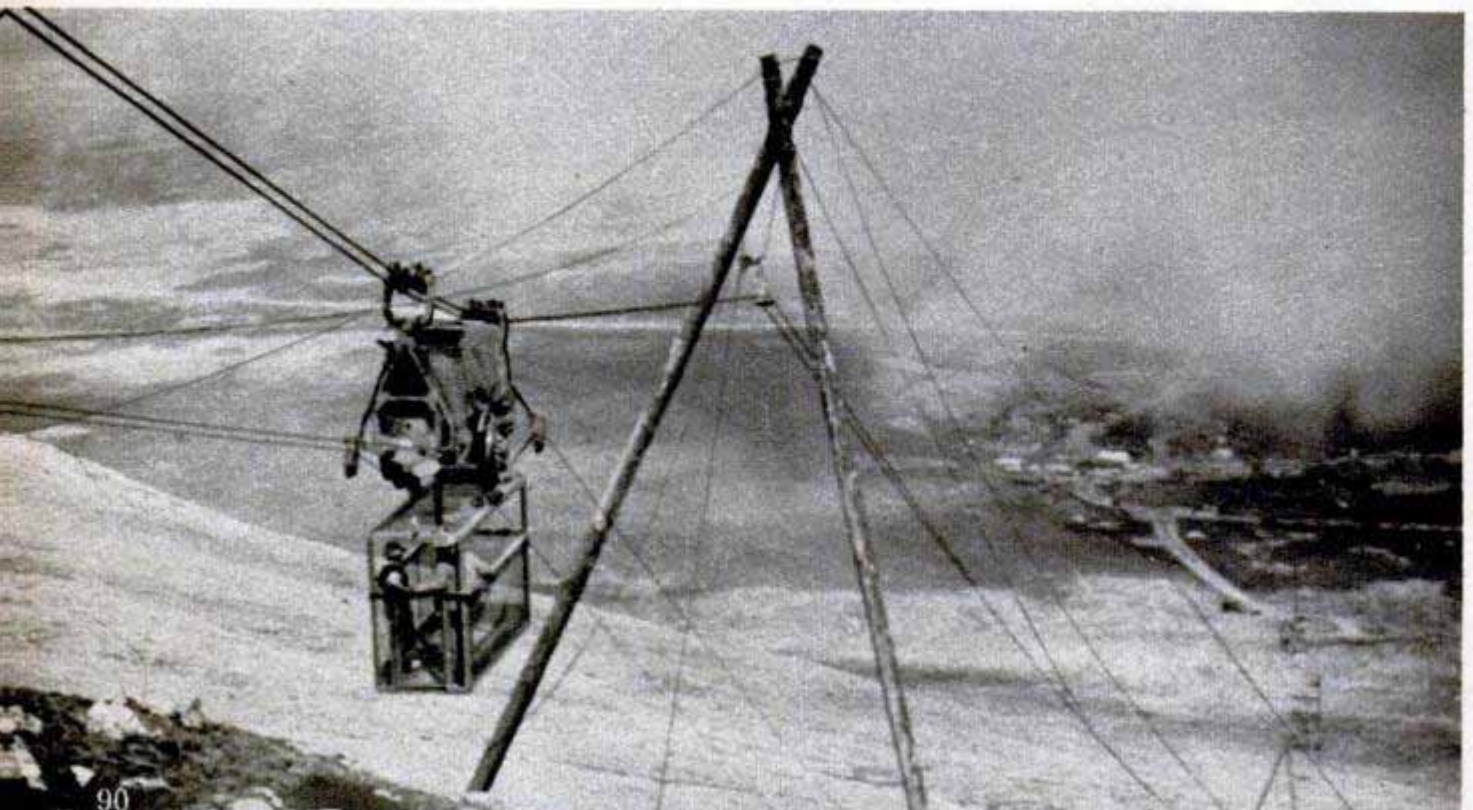



In a clairvoyance test, subject sketched a chemical flask while trying to "guess" unknown picture in sealed envelope. Original picture, shown directly above, has an identical chemical flask

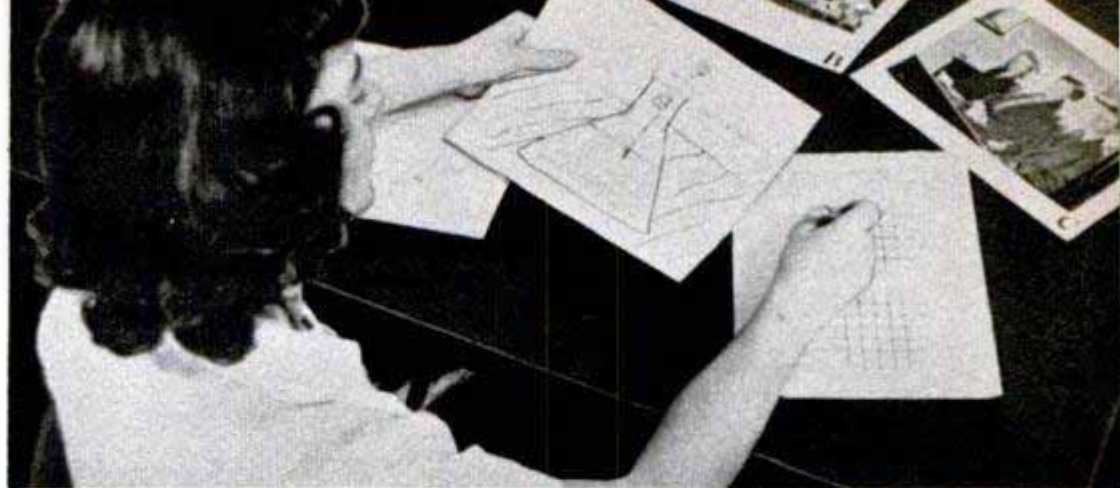

# Science Tackles the "SIXTH SENSE"

By Richard F. Dempewolff

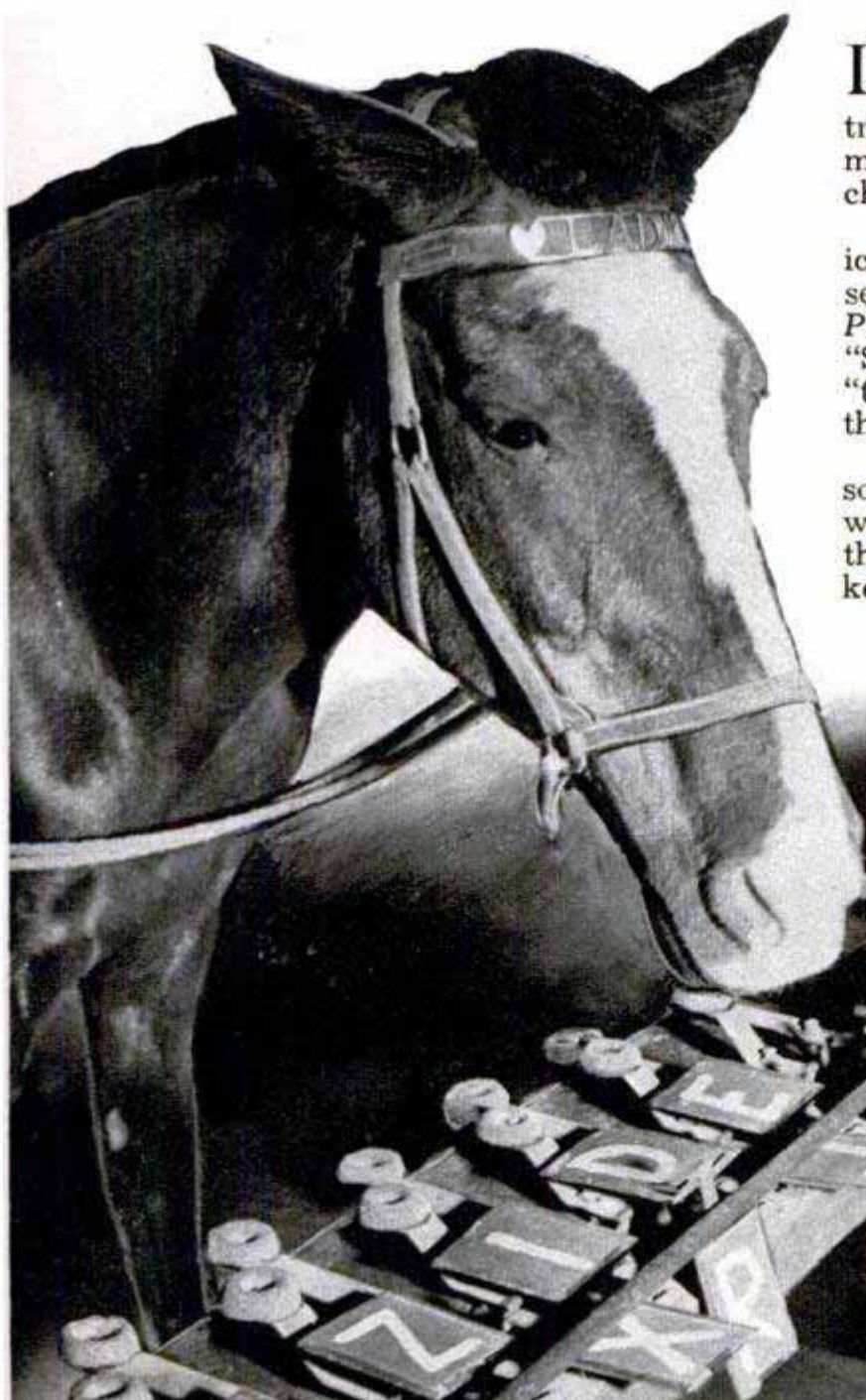

DO PEOPLE and animals have the power to peer into the future, read minds, transfer thoughts through space and even make things happen which all the laws of chance and physics say are impossible?

On my return from a recent South American article hunt, I stopped off in Florida to see Roderick Grant, my vacationing boss—*Popular Mechanics'* managing editor. "Some friends of mine," he informed me, "talked to a horse in Richmond, Va., on their way down here."

I felt his forehead, but there was no fever so I kept listening. "They asked the horse where they lived," he went on, "and it told them by spelling out letters on a sort of keyboard. The man asked what his mother's

Author asked Lady, the Talking Horse, for name of PM's managing editor. Without hesitation Lady spelled Grant by nuzzling special keyboard. Science is trying to unravel extrasensory ability of animals and humans



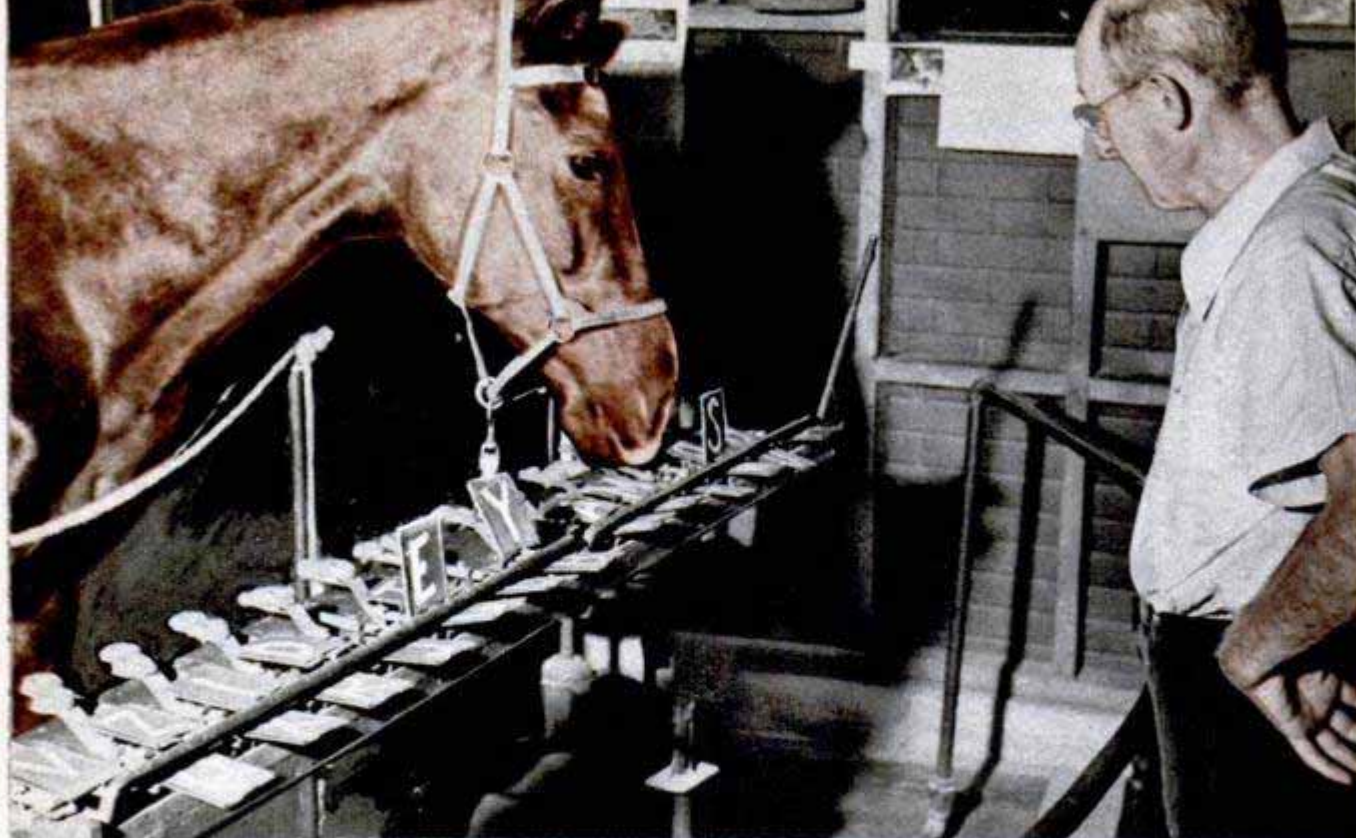

Lady spells "EYS" in reply to question about author's daughter, who was then about to undergo eye operation

maiden name was, and the horse got that, too. Neither the horse nor its owner had ever seen these people before. What's more, the horse also did arithmetic problems. I think you should investigate it for a story."

"It's a trick," I said. "But I'll tell you what. Get someone driving back that way to ask the horse: 'Who is the eastern editor of

*Popular Mechanics*?' If the horse spells 'Dempewolff,' I'll buy that story." I figured that was the last I'd hear of talking horses. Even people can't spell Dempewolff.

A month later I learned that the horse had done it. It took the humor out of the situation with a thud, but my curiosity zoomed and I left for Richmond.

The horse, I discovered, is a 26-year-old mare with a sleepy, faraway look. She's called Lady Wonder and is stabled on a tiny old farm off the main pike south of the city, where anyone can "chat" with her for a small fee. Her owner, Mrs. C. D. Fonda, didn't know me from Adam. We started warming up with simple arithmetic problems, which Lady solved perfectly.

Investigator signals readiness to subject in another room, who then tries sketching picture unknown to her

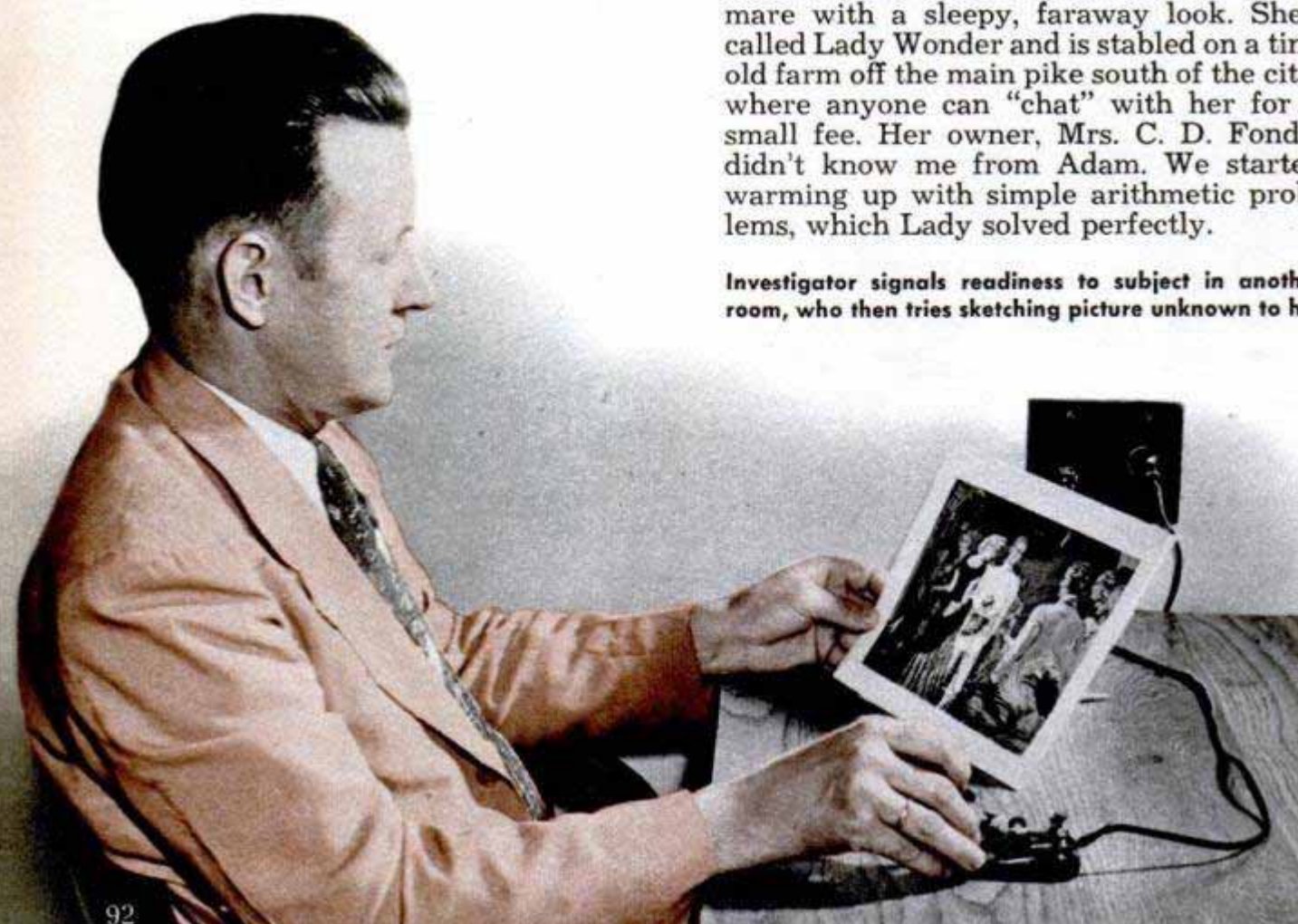



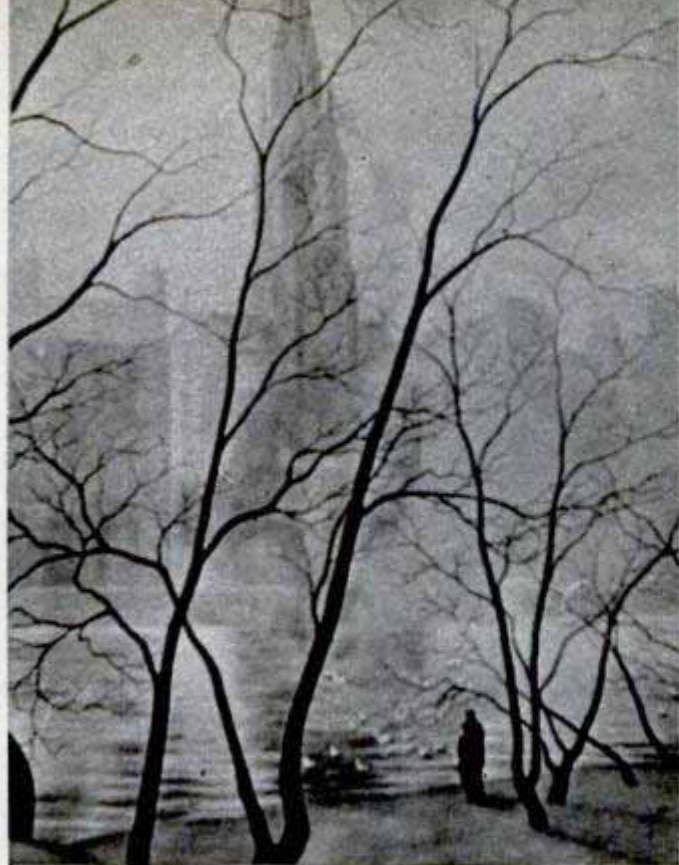

**TEST PICTURE**, never seen by subject, was sealed in opaque envelope and shuffled with other envelopes

In front of Lady is a row of levers with sponge-rubber tips. Each lever releases a catch, permitting a single metal plaque, bearing a letter on one side and a number on the other, to pop up. Lady nudges these with her chin, thus spelling out words or running up a row of figures. Mrs. Fonda announced that the horse had *not* memorized the keyboard. To prove it, she pulled the letter plaques from the holders, let me shuffle them and put them back in any order I wanted. "Lady knows the alphabet, so it doesn't matter," she said blandly.

I watched for signals between horse and

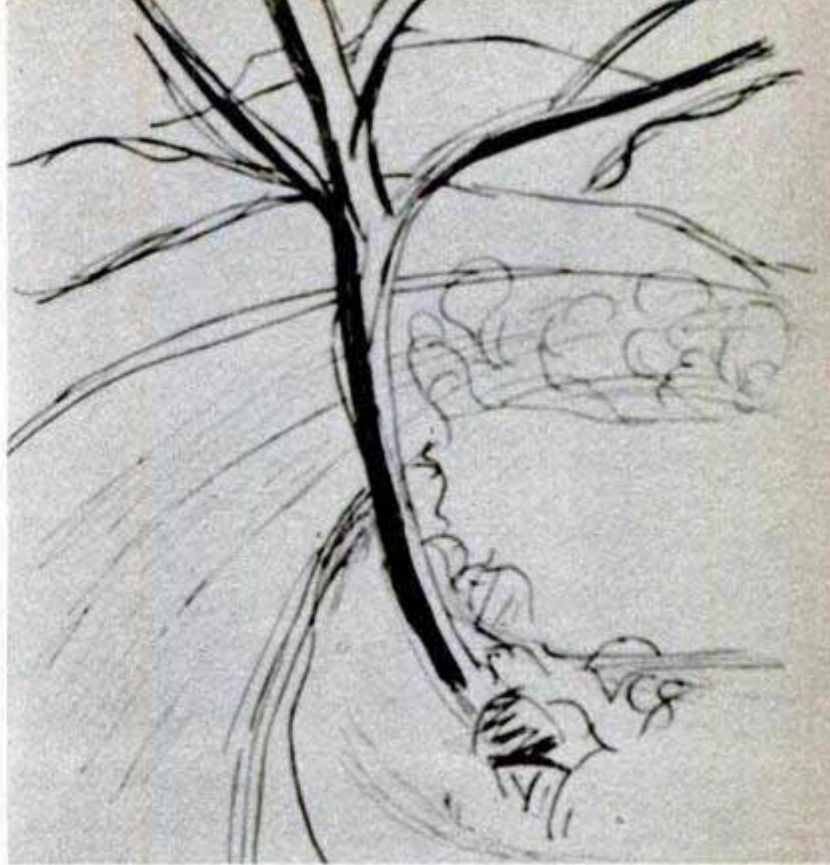

**SUBJECT'S SKETCH**, which was remarkably similar, shows a tree without leaves, outlined against sky

woman, but none was visible. Mrs. Fonda stood well behind and off to one side of the horse. "What's the name of my boss?" I asked. Lady, watching me with her sleepy brown eyes, fussed among the keys, then started nudging them. "G-R-A-N-T," she punched out.

I asked her the name of my six-year-old

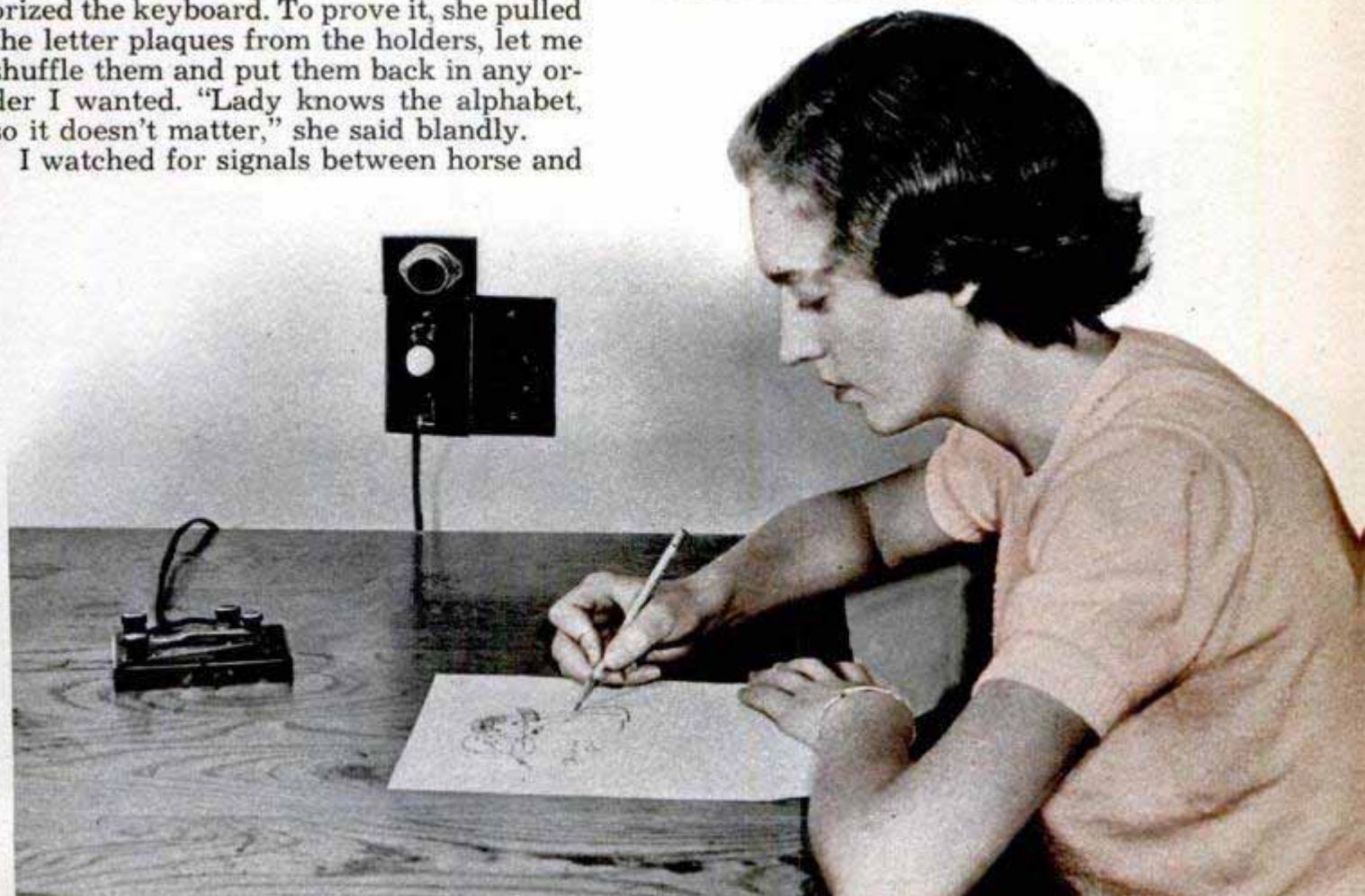





Colored marbles are placed at random in tray, which is covered. Subject tries duplicating pattern

According to Mrs. Fonda, she discovered the horse's talent shortly after her family bought it for a workhorse when it was a few months old. "I'd just *think* I should go feed Lady, head for the door and see her galloping in from the fields before I could call." She reports that she started teaching her to spell with wooden baby blocks. "It's hard to tell how Lady did it," says Mrs. Fonda. "I'd tell her a letter or number, and show her the right block. I taught her to nudge a

daughter, who was then scheduled to enter the hospital for an eye operation back in New York. The horse fumbled a long time and punched several wrong keys. I took a photograph of her anyway, and kept coaxing. Finally she spelled out "Judy," which is correct. Later, when the pictures were developed, I saw that the "wrong" letters she had first punched out spelled—"E-Y-S"! (The keyboard has only one E.)

Lady spelled the name of my home town, Chappaqua; told me where I worked, and my mother's maiden name. I asked her if there'd be another big war and she spelled out "Y-E-S." When? "1-9-5-2." Time will tell whether she got that right or not. Let's hope she missed.

few blocks together to spell words. We only did it a few months, a couple of hours every few days, when pretty soon Lady was spelling words I hadn't taught her."

The horse has pulled any number of uncanny tricks. Mrs. Fonda claims that in the middle of several "interviews," Lady has quit answering the customers' questions, and pegged out "Got to go." It was exactly her dinnertime on each occasion. Another time, according to the woman, Lady quit when a grocer's delivery truck came into the driveway. Even Mrs. Fonda didn't know what was being delivered, because her husband had done the ordering. But Lady, out in the barn, spelled out "bananas" on the keyboard, and wouldn't answer another

Investigator runs through deck of ESP cards, placing them in five stacks according to subject's pointer

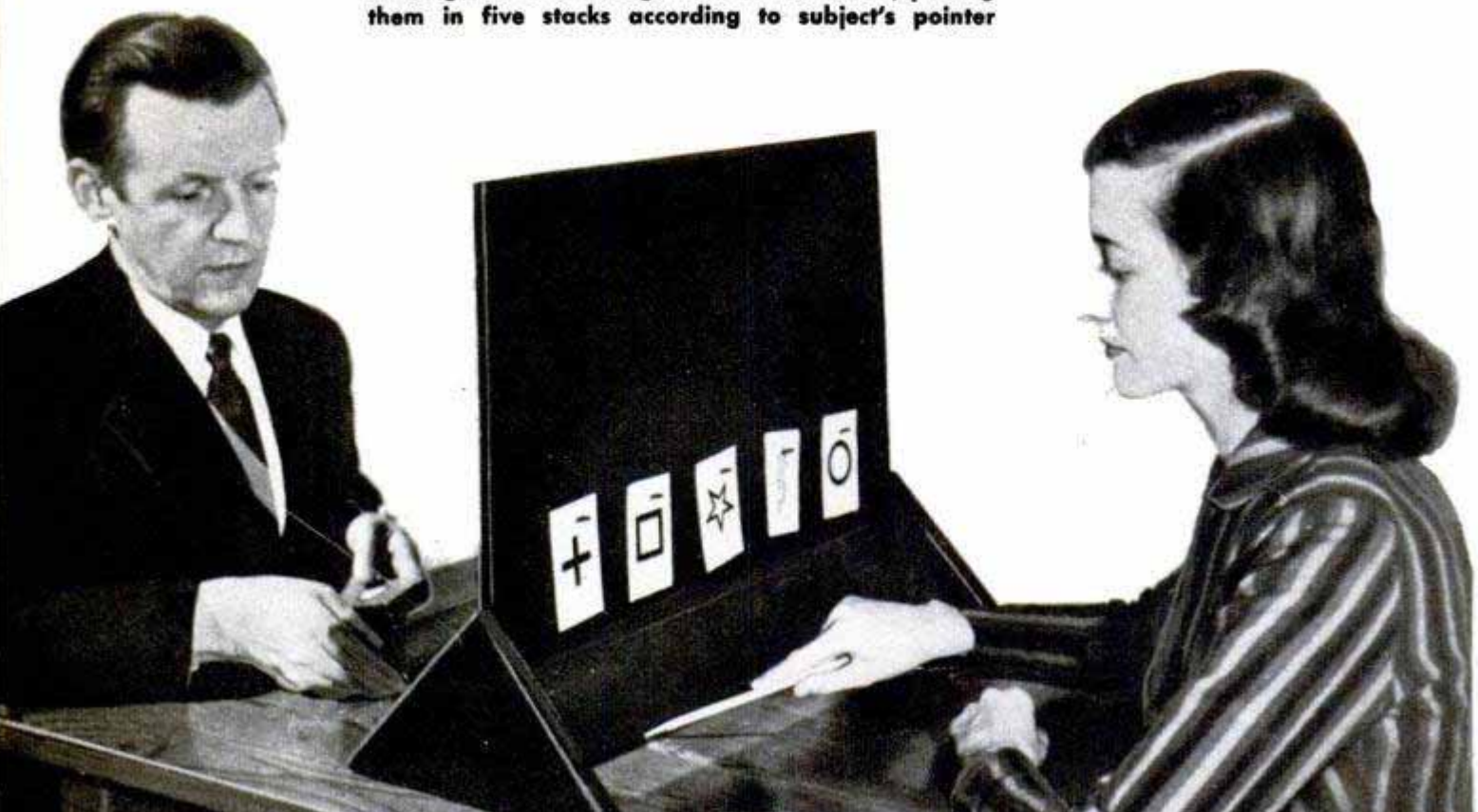



question. She loves bananas. On investigating, Mrs. Fonda discovered that her husband had ordered a dozen bananas and, at the moment, they were being unloaded from the truck.

What's the answer? Is the horse—or the woman—endowed with psychic powers, or is it all a clever trick?

When the filly was three years old, Dr. J. B. Rhine of Duke University, famous scientific investigator of extrasensory perception, and his wife spent six full days examining Lady. "We restricted the owner, asked her to stay motionless and as far away from the horse as possible," he reported. "This did not seem to interfere. She was blindfolded and turned away from the horse. The horse still succeeded. We screened them from each other and results still were good. Even with Mrs. Fonda out of the room some results were obtained, but the filly became unmanageable."

In more recent tests, Doctor Rhine got less conclusive results. But, he says, "that didn't alter our view that the horse formerly had been responding by extrasensory perception."

Animals, Doctor Rhine explains, seem to have some kind of ability which enables them to perform remarkable feats. Whether it is actually a "sixth" sense or an amazingly keen response stemming from a known sense organ, no one knows yet, he says.

There are scores of stories of animals wandering home from points hundreds of miles away. There are dogs and cats that seem to "sense" friendliness or antagonism in a person. Might this be evidence of some telepathic ability?

Scientists have snorted "superstitious

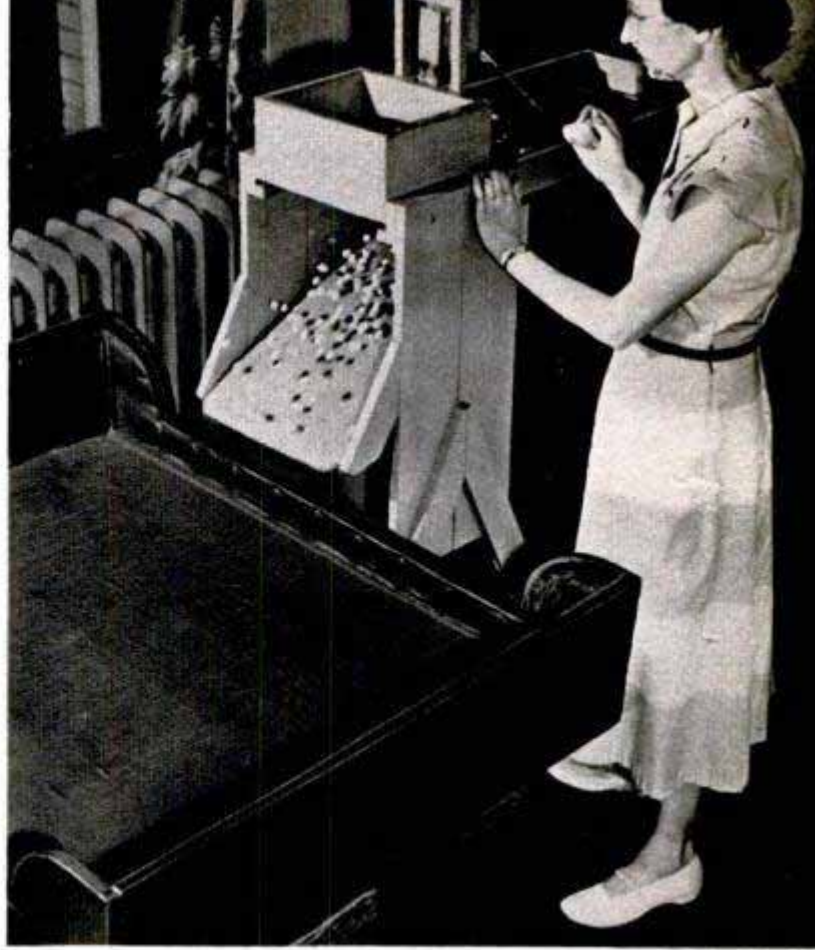

Box dumps dice on table while subject "wills" certain number to appear. Tests indicate some may control dice

After test on opposite page, cards are checked for accurate "guesses." One subject scored a perfect 25!





Machines such as this dice tumbler eliminate any physical skill on part of subject. Some subjects seem to have an uncanny ability to "will" certain numbers to appear

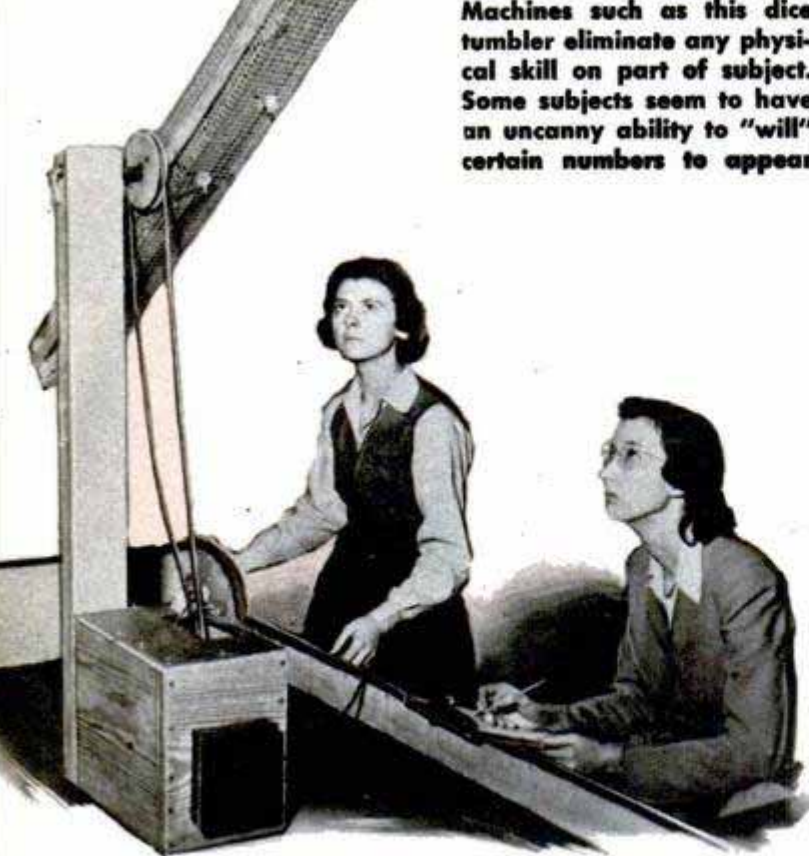

nonsense" at the mere mention of what today are called "psychic phenomena." Recently, however, many scientists not only have stopped sneering, but dozens of them are busy applying laboratory methods and mathematics to things such as telepathy, clairvoyance, premonition and other intangible mysteries.

By 1940, some 900,000 scientific tests of

Marked chips tumble down a snaky chute in another test to determine whether mind can influence matter



superphysical powers had been made with ordinary people like you and me. The results showed odds of billions upon billions to one better than the mathematical laws of chance that something beyond pure coincidence is at work in our "hunches" and "premonitions." Subsequent tests have sent those odds soaring to a figure so high you'd need some 500 zeros to express it.

Now, in Doctor Rhine's Parapsychology Laboratory at Duke University, Durham, N. C.—one of the best known of the psychical-research strongholds—scores of unique devices are helping to put our nebulous "sixth sense" under the microscope for study and observation. His famous, odd-looking "ESP" (extrasensory perception) playing cards swish back and forth in automatic shufflers, while ordinary subjects try to "foresee" the order in which they'll fall. Dice rattle in spinning cages or mechanical shakers and tumble down broad chutes to absolutely level table tops, where their faces are counted, recorded and compared with the "target" faces "willed" by student subjects. Lights flash, and telegraph keys tap out time signals as experimenters located in widely separated parts of the campus run telepathy and clairvoyance tests across space. Subjects play tricky "matching" games with colored marbles in a two-layered box, "copy" pictures they can't see, play a wide variety of card games, or watch a series of marked chips cascade down a long snaky runway, and "will" the tumbling

(Continued to page 262)

Subject tries to make chips land with a certain side up. Scores indicate that perhaps some people can do it!

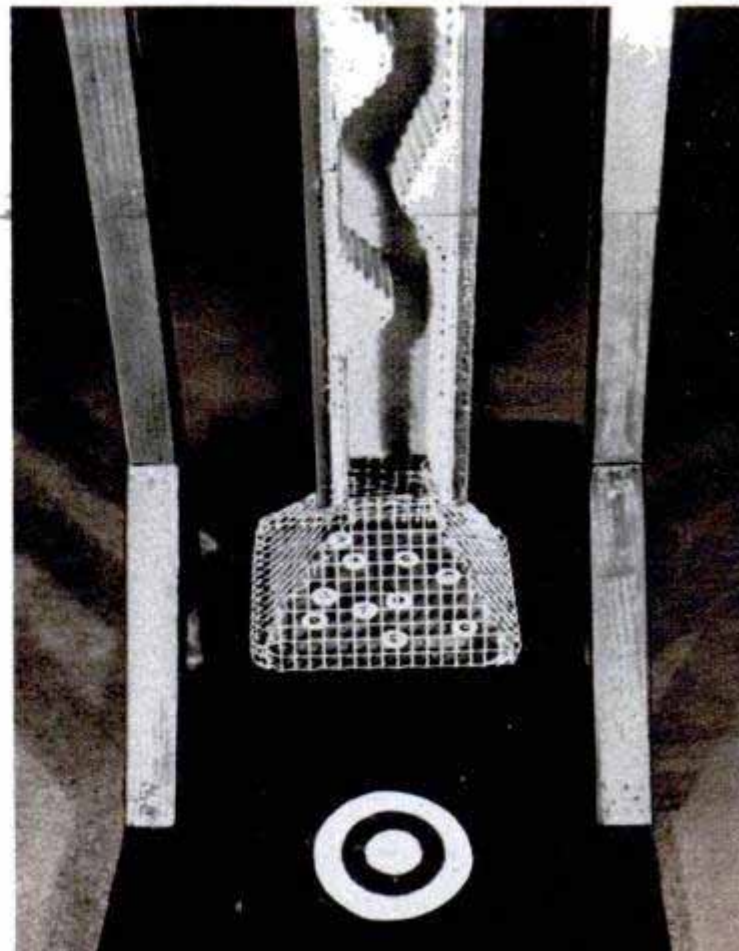



# TREASURE HUNTING is GOOD BUSINESS



Amateur treasure hunters may not be successful, but they are scientific, as the electronic detectors testify

**By George X. Sand**

*Photographs by  
Verne O. Williams*

**T**HERE'S NO QUICKER way to start an argument in Florida these days than to mention treasure hunting. It makes no difference which side you take—pro or con—you can find someone to disagree with you anywhere from Jacksonville to Miami to Pensacola. Treasure hunting is becoming a top attraction in the "Sunshine State" and a business as well.

Tourists and natives alike are seeking the pot o' gold. Secret maps, whispered locations and dusty books are as common as roadside stands. It's easy to find someone who "knows" where treasure is buried. Persons who have found treasure are much scarcer!

Florida's treasure hunters range from the beachcombers, whose eyes are their only equipment, to the big-time operators who hire boats and deep-sea divers to go after the loot. Successful or not, this treasure hunting makes good business for the boatmen, the map

makers, the gas stations and motel keepers.

There's no denying that hidden beneath the sands and waters around Florida is treasure worth millions. History bears this out. But little of this treasure involves the mysterious trappings of pirate maps and secret codes. Most of it is gold and silver that went to the bottom in shipwrecks. But it's treasure, nonetheless, and most "scientific" treasure hunters specialize in this variety, leaving the "oaken cask under the crooked oak tree" to the romanticists!

Waiting to be salvaged within a few miles of Miami are said to be sunken riches worth



Treasure hunters should study this photo carefully. These may be the only treasures they will find—and they're in a museum





Seaplanes aren't essential for treasure hunting, but if you can afford one, it will carry you to those remote Florida Keys where loot may be awaiting you

Here's the map that is a best seller in Florida. It is said to have been a major stimulant in the recent revival of interest in treasure hunts. At a dollar a copy, it has been a real treasure for its creator

at least \$64,000,000. More than 60 wrecked vessels, many of them pirate ships, are scattered around the ocean bottom near the vacation city.

Similarly, at least another \$300,000,000 lies elsewhere off Florida's sun-washed beaches. Such infamous characters as Gasparilla, Morgan and Billy Bowlegs supposedly hid untold wealth in silver, gold and jewels around the islands east of Pensacola. A British gunboat in 1840 sank a Billy Bowlegs privateer in Apalachee Bay with \$5,000,000 in bar silver aboard. Somewhere in the narrow mouth of the Steinhatchee River, a Confederate ship sank in 1862 with \$500,000 in silver. Near the mouth of the Suwanee River, a pirate ship shelled another craft until it sank, taking with it \$5,000,000 in gold and silver that was being shipped to Spain in partial payment for the purchase of Florida by the United States. A pirate ship was sent to the bottom by the British warship *Pegasus* at the entrance to Charlotte Harbor. Survivors described the cargo as including \$1,000,000 in gold and silver bars. There is no record of these riches ever having been recovered.

These are only a few of the historic "facts" that tempt the treasure hunter. Undoubtedly, they have some basis in truth. No doubt, there are other wrecks with similar treasures hidden by shifting sands and blue waters.

Seeking these rewards, the treasure hunter, like an inventor with his secret invention, moves quietly and furtively. He refuses to say where he is hunting or what he has found. He tries to act like an inno-

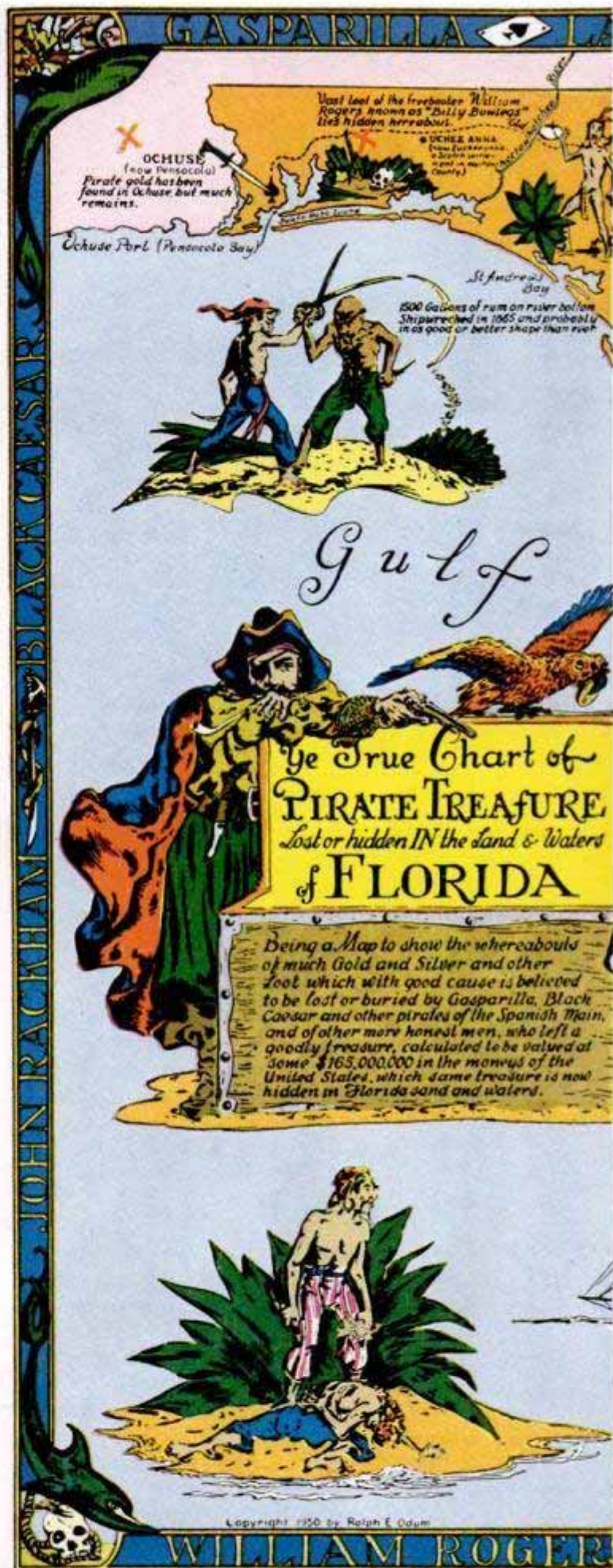

cent fisherman or vacationist. He may imply that he or somebody he knows has found treasure, but he won't be definite because, he says, "it's his own business."





Illustrated by Warner Saxford

Copyright R. E. Odum, 918 Tampa St., Tampa, Fla.

If you act impressed, he will, like a talkative fisherman, entertain you with stories of "big ones" that got away!  
 All the stories have one thing in common:

an utter vagueness about recovered treasure. Of course, there are a few exceptions. One such exception is a story about the treasure recovered by Arthur McKee of

MARCH 1952

See 236 SIS E. Call St. 99





Serious treasure hunters use diving helmets to explore a reef off Long Key where there are gold, silver and gems worth \$64,000,000

Thickly coated with sea growth, a large anchor was the clue that led to the discovery of three bars of pure silver on a coral reef



Homestead City. He was searching the water off Key Largo for old Spanish cannon in 1949. He spotted a wrecked Spanish ship on a coral reef in less than 60 feet of water. A diver himself, McKee went down to look for cannon. Among the ship's ballast he found three silver ingots, coated with thick layers of coral crust. The ingots were taken to Washington where the Smithsonian Institution bought one of them. It was identified as having come from an ancient and rich silver mine in Panama that was worked by the Spanish with Indian slaves.

McKee admits finding only three ingots. However, it is unlikely that the ship was carrying only a few of them. It is more probable that others are buried near the wreck. The one he sold to the Smithsonian weighed 70 pounds and was assayed at 99.36-percent-pure silver. The price: \$1000. McKee refused to sell the other two, one weighing 60 pounds, the other 75 pounds.

He's not at all secretive about the discovery and talks about it voluntarily. He even takes tourists out to the scene of the wreck and explains how he found the ingots. He does cash in on his find though by operating a tourist attraction, the Museum of Sunken Treasure, on Plantation Key, that draws a steady stream of tourists.

Another Floridian who has found a way to make treasure hunting pay is Ralph E. Odum of Lakeland, an assistant attorney general for the state. Odum found his treasure without going on a single expedition. He and his wife made extensive research into Florida history and compiled data on lost treasures. He drew up a rough sketch of the treasure locations and showed it to Warner Sanford, a map maker in the state highway department. Sanford painted a romantic-looking map ideal for framing, on which the various treasure points were marked. Appropriate sketches of pirates and privateers decorate the map, making it suitable for hanging in a game room or

(Continued to page 236)





# Detroit Listening Post

*By Siler Freeman*

**T**HE AUTOMOBILE INDUSTRY now has its 1952 models in the field and there may or may not be some to follow. It depends on the market, and the market is something which all the manufacturers face with a good deal more than the normal amount of uncertainty.

The Ford Motor Co. has brand-new cars in all three lines. Two of them have new engines of the type which are in demand, the overhead valve in the Ford Six and the overhead-valve V-8 in the Lincoln. Bodies are new. It is the biggest change the company has made since the 1949 model was brought out.

General Motors' cars show mechanical improvements, though not too many body changes. All engines in the higher-priced ranges have been stepped up in horsepower. Cadillac's is 190, at the top of all competition. Oldsmobile 98 has one rated at 160. Buick's and Pontiac's are more powerful. Olds has a new body on the 98. Cadillac, Olds and Buick offer power steering to meet Chrysler's challenge.

Studebaker has restyled its postwar design. Nash has the first Farini-designed car to intrigue the public, and is adding another Rambler to the list.

Hudson has added the Wasp to its Hornet line. They are working strenuously to bring out a lower-priced car. Packard, with power brakes and better interiors, is set to cash in on its flashy new models.

The over-all market will get a thorough test this year. With the conventional models placed before the public, the passenger-car manufacturers are also testing the custom sports-model possibilities. General Motors' experimental Le Sabre, Buick's XP-300 and Chrysler's K-310 have been joined by Ford's Continental X-100. This has the dual purpose of meeting the competitors' challenge in the field of

supercars, or "dream boats," and at the same time offering a pattern for former buyers of Continentals. Designed by George W. Walker, who also is responsible for the 1952 Ford, Mercury and Lincoln, it was built at the behest of Henry Ford II.

Ford has been toying with the idea of reviving the Continental line, discontinued several years ago, but until now little has been done. With the new 160-horsepower V-8 engine in production, the new styling of the X-100 may induce young Ford to re-enter this field.

Chrysler's K-310 is causing much comment. Chrysler officials say they have, without solicitation, many orders for this sports car. The chassis and engine are Chrysler's, and the body is styled by Ghia of Turin, Italy. It would not take much to put this into the "specially built" category for the few who have the necessary bundle to purchase it.

At the same time, the economy car is being tested on the uncertain market. Nash's Rambler has been established as a leading contender. When Hudson's low-priced car reaches the market and Kaiser-Frazer's redesigned Henry J is offered, it will be a battle worth watching. The ones which may be hurt are the medium-priced cars. Emphasis this year appears to be on the top and bottom.



**This 1952 Cadillac 60 Special sedan is powered by a new 190-horsepower, V-8 high-compression engine. It has the dual-range Hydra-Matic transmission**



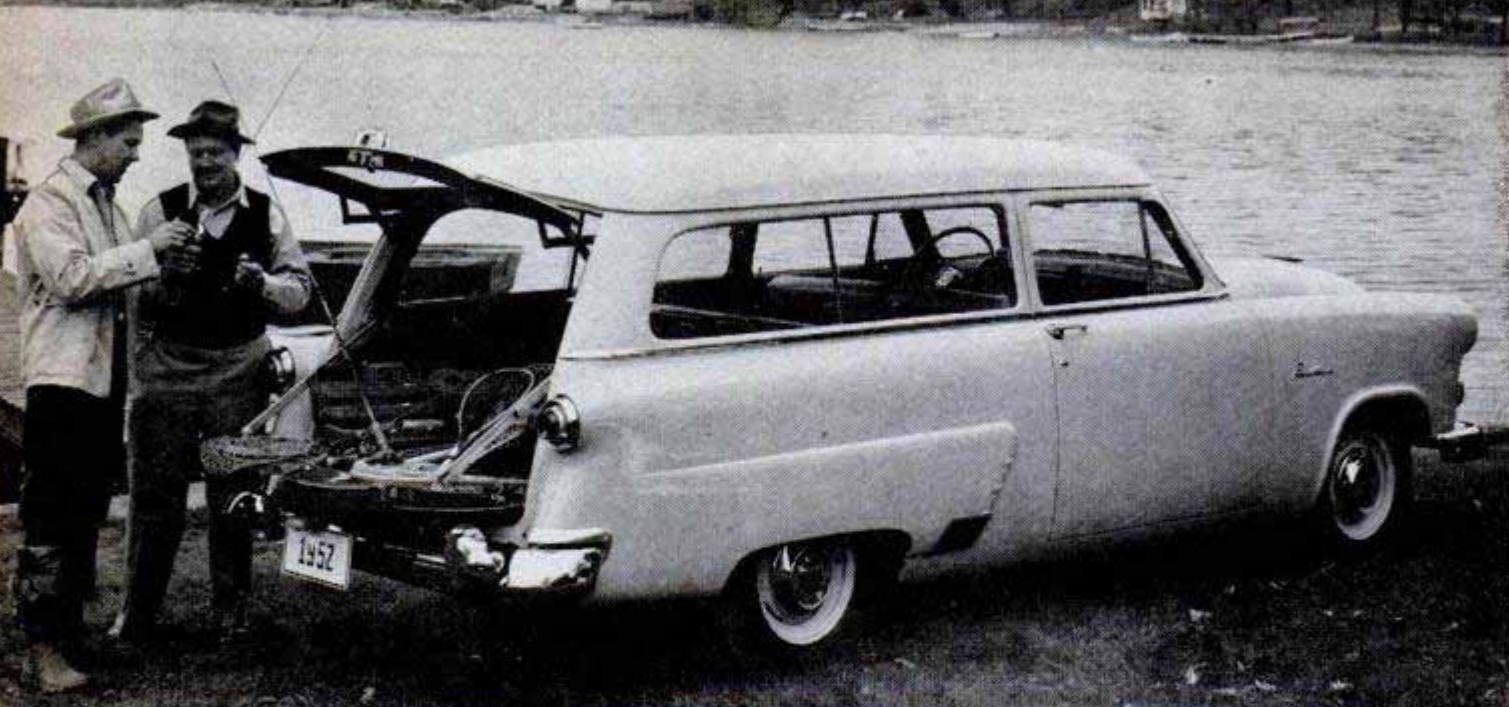

For business or pleasure, Ford's '52 utility car, the all-metal Mainline Ranch Wagon, seats six passengers

By  
Siler Freeman

## THE '52 FORD

THE 1952 FORD line shows a car longer and more streamlined and completely restyled. At least one model, the six cylinder, has a new engine, while the V-8 has been stepped up in horsepower, although it is still basically the same as last year's.

The wheelbase of the 1952 Ford is only an inch longer, but the car appears lower and longer because of its streamlining. The hood is low and wide and the front end centers around a triple-spinner air-scoop grille. The glass area is larger, both front

and rear, with a new curved windshield.

The Mainline is Ford's lowest-priced line. The higher-priced line is the Crestline, which includes for 1952 the Victoria, Country Squire station wagon and the Sunliner convertible.

Besides the new engine, Ford this year features a different type of brake suspension. Instead of going through the floor board, it is suspended from the top with a dash-mounted master brake cylinder, leaving the floor board clear.



Included in the Ford Crestline this year are the Sunliner convertible, Country Squire station wagon and shown below, the Victoria (hardtop)





Parked at left of the Victoria, Customline Fordor Sedan features new Ford body with curved one-piece windshield

## ROLLS OUT

Another Ford "first" is the gasoline-tank filler. Instead of coming through the fender, it is mounted under the trunk lid. The license-plate holder swings down to reveal the opening so that it can be filled easily from either side.

The trunk-lid hinges are side-mounted to prevent scuffing of luggage. Insulated body bolts dampen noises and vibrations.

The overhead-valve six is rated at 101 horsepower. It has a compression ratio of 7:1, which can be raised when higher-octane gasolines become available. The V-8 engine now offers 110-horsepower and has a compression ratio of 7.2:1. Both engines operate on standard gasolines.

The Mainline comes in the business

coupe, Tudor, Fordor and the new Ranch Wagon, a metal station wagon. The Customline includes the Tudor, Fordor, club coupe, and an eight-passenger, all metal Country Sedan station wagon.

Ford's big "surprise" of its 1952-model display is a car which is about 16 months away from becoming a finished product, but forecasts its thinking in the sports-car class. This is the "Car of Tomorrow" designed for Henry Ford's own use, but which will serve as a model for the Continental.

The Continental was discontinued from the Lincoln line in 1948. Henry Ford II said it will be revived when materials and machine tools become available.

The ultrastreamlined car shown was a

With a compression ratio of 7 to 1, new overhead-valve six-cylinder Ford engine is rated at 101 horsepower

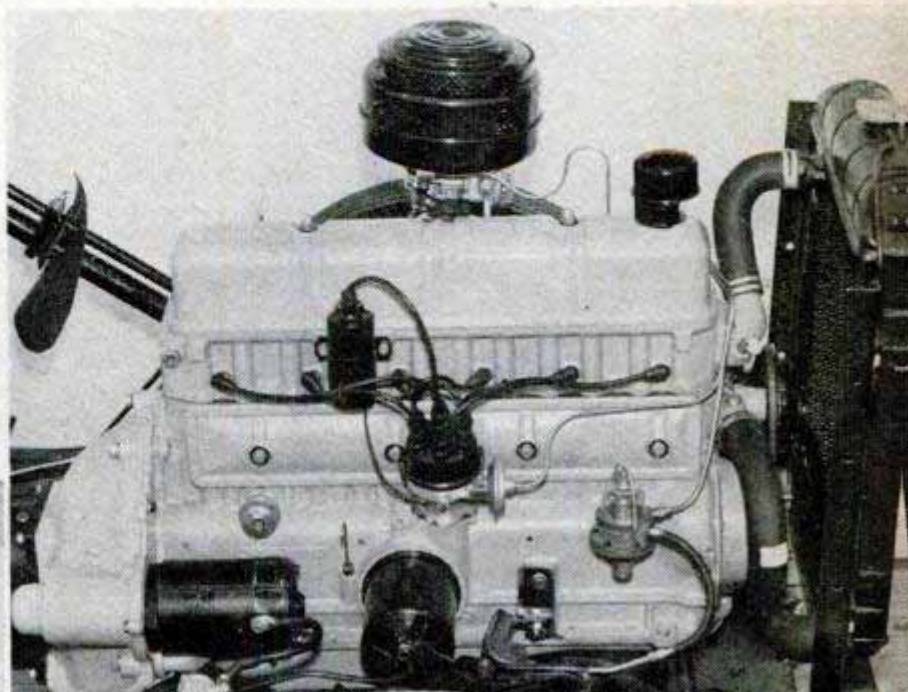
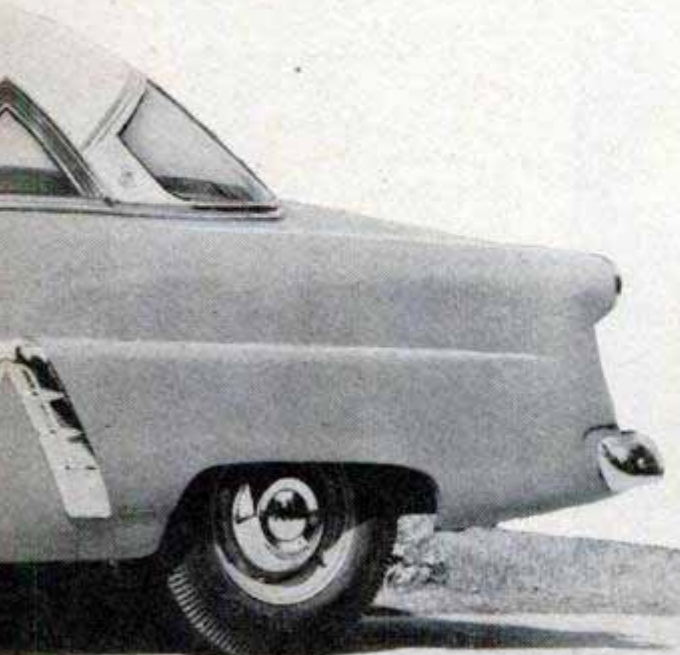



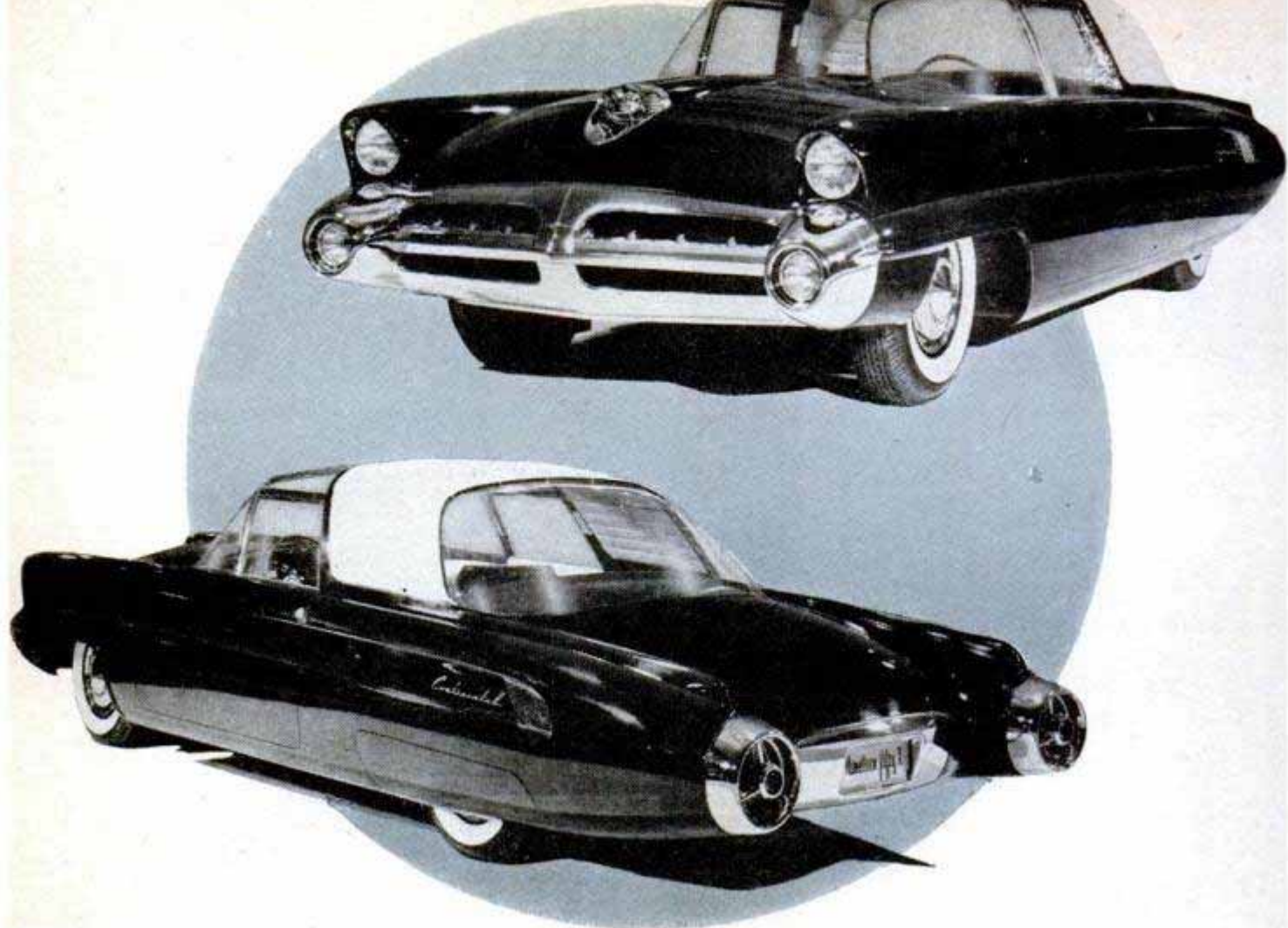

Reflecting Ford's thinking in the sports-car class is the Continental 1950-X, still in laboratory stage. Car has a curved windshield which meets a clear-domed top that retracts into a leather-covered canopy

clay mockup, done to a turn. It has new styling features and makes wide use of plastics in the top. The windshield is curved to meet the clear top, which is designed to roll back into the rear portion, made of leather.

It is Ford's answer to General Motor's Le Sabre and Buick's XP-300, as well as Chrysler's more utilitarian K-310. Unlike the first two, it is in the cabriolet styling rather than the convertible and shows an obvious European flare in design.

The car, when completed, will have the new Lincoln overhead-valve V-8 engine with 160 horsepower. Ford expects to use it as the highlight of the company's golden-anniversary celebration in June 1953.

The production Continental will probably not reach the market until 1955.

Mechanical man beside driver in test area records riding qualities of new Ford models with scientific precision

104 POPULAR MECHANICS





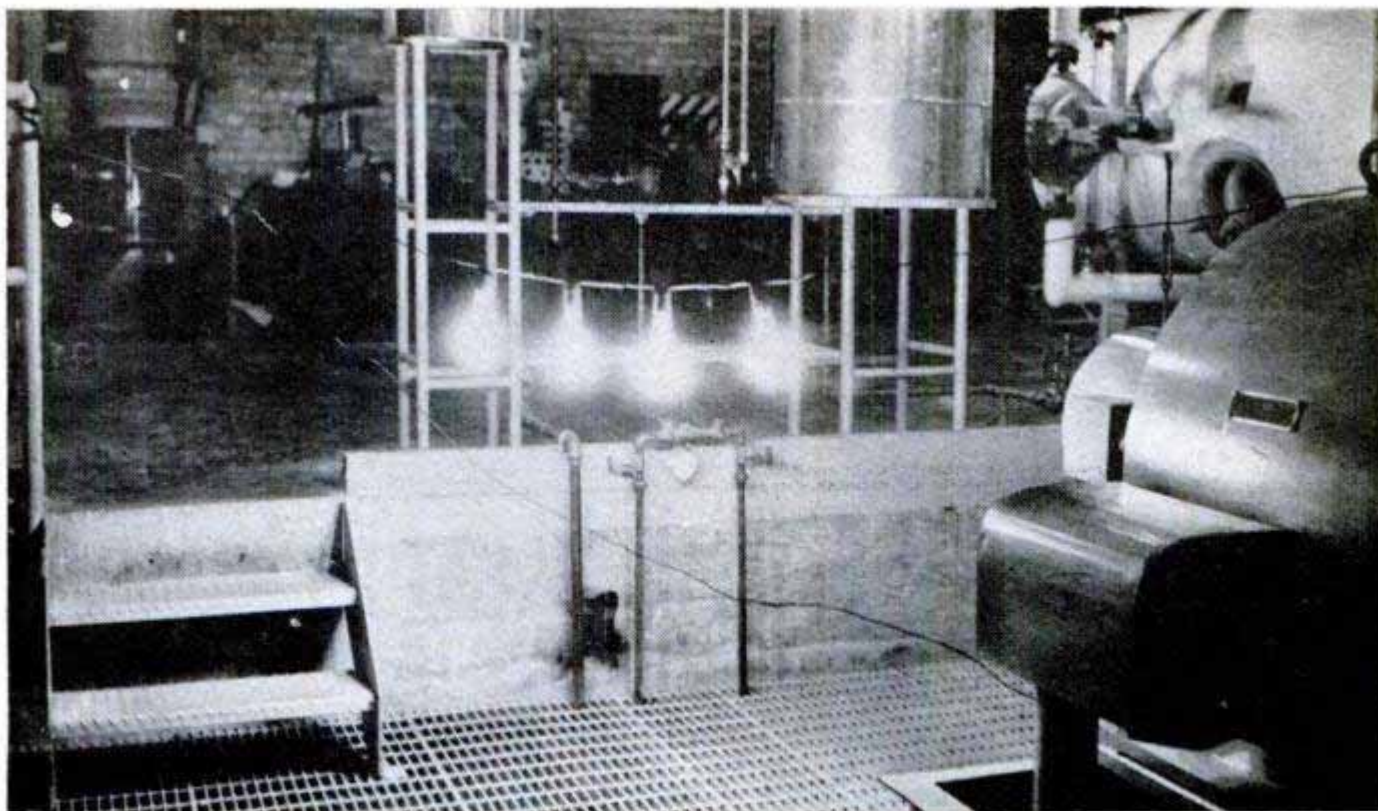

Making history are these four bulbs as they glow with the first electricity ever produced by atomic energy

## ATOMIC REACTOR MAKES ELECTRICITY

For the first time in history, useful amounts of electricity have been produced with atomic energy. The Atomic Energy Commission announced that although the power generated was only 100 kilowatts and the project was entirely experimental, the result is another milestone in the atomic age. Heat energy was removed from an experimental breeder reactor by a liquid metal of a type not revealed. Sufficient heat was transferred to generate steam for driving the turbine and generator. Power generation is an incidental part of the breeder-reactor experiments being conducted near Idaho Falls, Idaho, but it is providing data about the handling of liquid metals under radioactive conditions. The principal function of the breeder reactor is to convert nonfissionable material into fissionable material more rapidly than the nuclear fuel is consumed, a process that would contribute to expansion of our atomic program. It can never be used to generate large amounts of power, but it is providing information that will be valuable in designing atomic power plants of the future, say scientists at the Idaho laboratory.

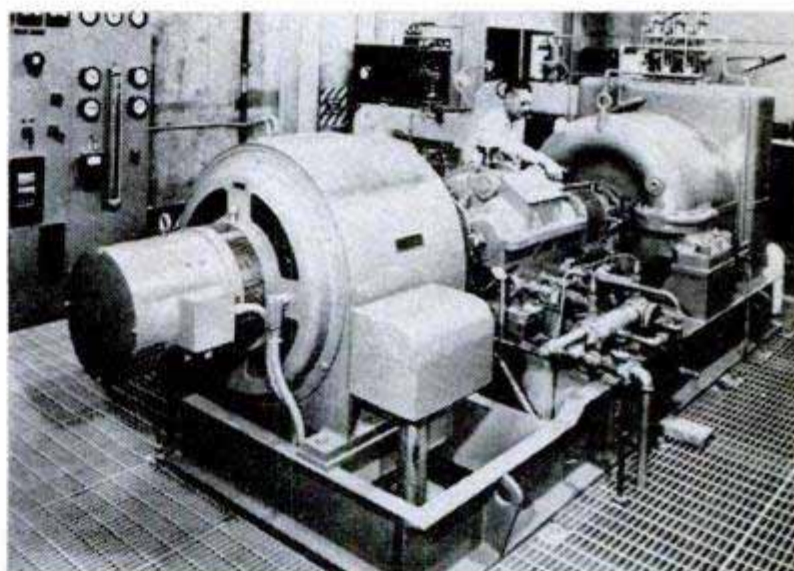

Heat from the atomic breeder reactor made the steam that spun the turbine and generator shown above. Below, the scientists and technicians recorded their feat on the power-plant wall

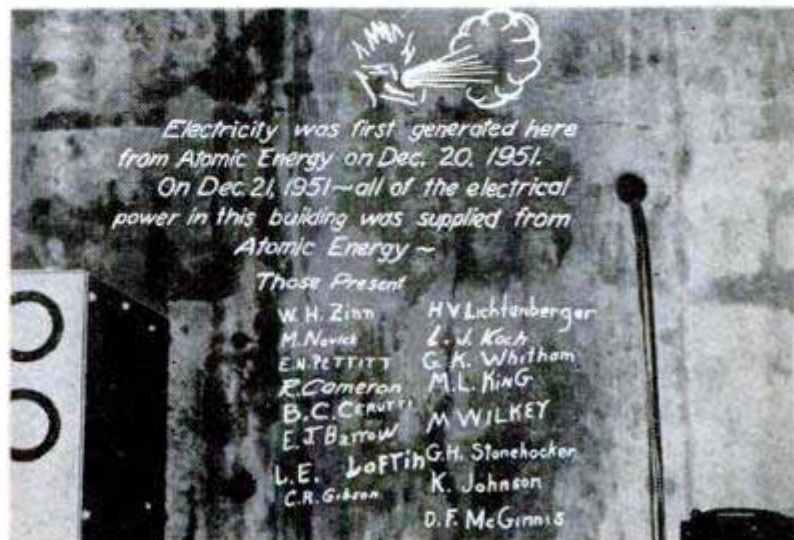



# REPORT on the FOREIGN CARS

By Floyd Clymer

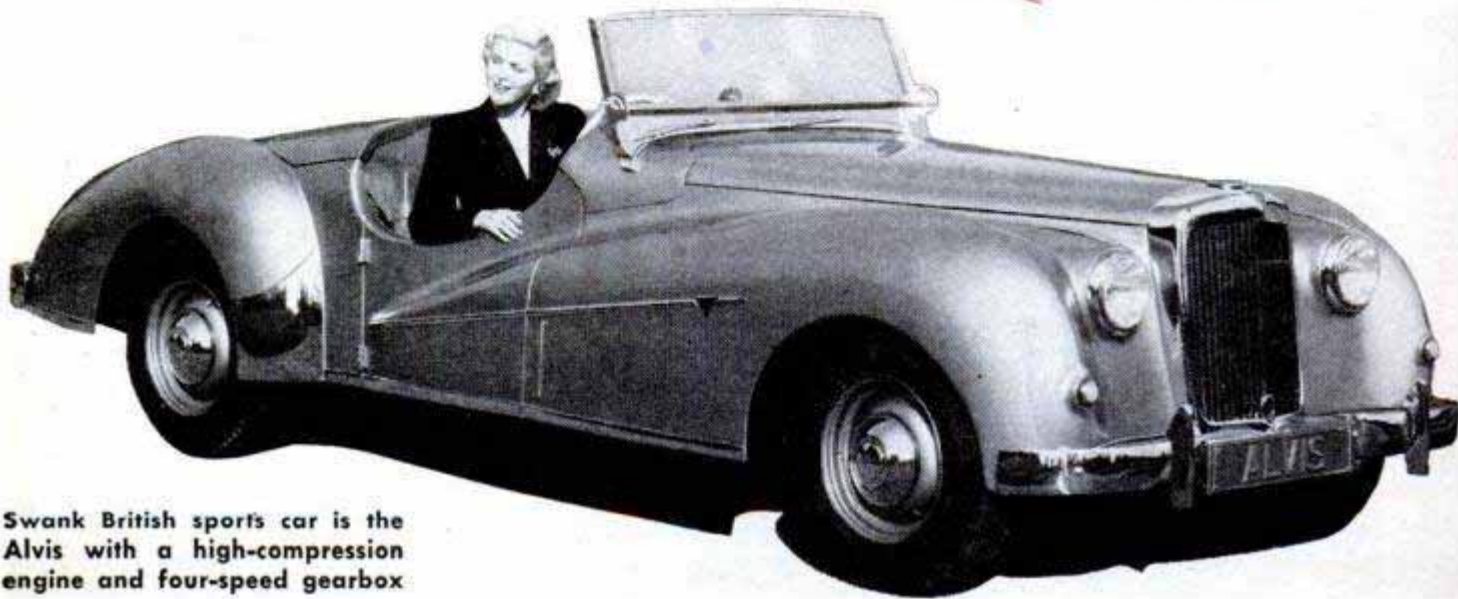
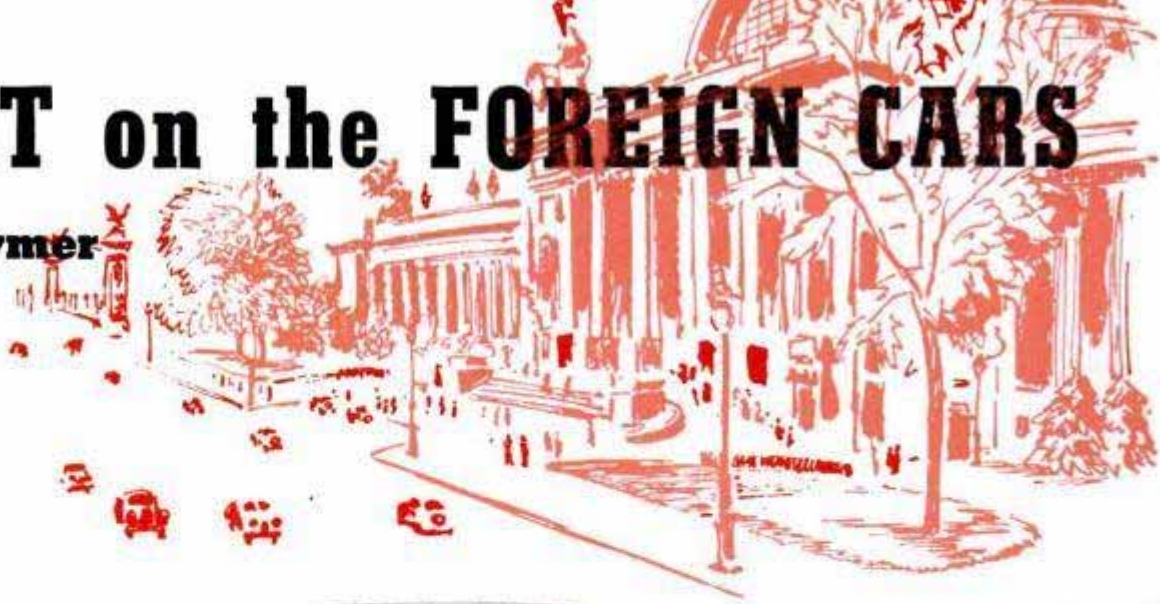

Swank British sports car is the Alvis with a high-compression engine and four-speed gearbox

In Germany Floyd Clymer inspects the new Mercedes-Benz 300, which retains more conservative styling



## Part I

**M**ANY CAR OWNERS often have wondered why cars built in Europe have such a fascination for a certain group of Americans. Hence this story is based on a 30-day air journey to make a survey and report the highlights of the foreign-motor-car industry to *Popular Mechanics* readers.

I first flew to Paris for the exhibition in the Grand Palais. Here most of the world's cars were on display, even prototypes that have no immediate chance of production. Special custom-built bodies on many of the cars are both beautiful and fantastic in design. The new Pegaso from Spain was the center of interest. It is a V-8 of overhead-camshaft design. Ricart, former Alfa-Romeo engineer, heads this Spanish firm which builds fine trucks and buses in what was a Hispano-Suiza factory. The first 200 Pegaso sports cars now are in production.

An old favorite, the Bugatti, made its appearance in a half modernistic, half prewar Bugatti design. Citroen, the second-largest car builder in France, with its front-wheel-driven cars in four and six-cylinder models, and a tiny air-cooled, two-cylinder job attracted much attention. This firm seems to



One of the big hits of the Paris show was the Pegaso, which is built in Barcelona. This fast car is powered with V-8 engine

get away with the same body lines year after year, and the French seem to like it. What these cars lack in style is made up in dependability and economy of operation.

Only Renault, with its popular four-cylinder, rear-engine job, exceeds Citroen in sales. Renault is a government-owned factory. The late Renault was accused by the French government of collaborating with the Nazis during the occupation and the plant was seized. It is the largest plant in France and is located in Billencourt, a suburb of Paris. It operates efficiently

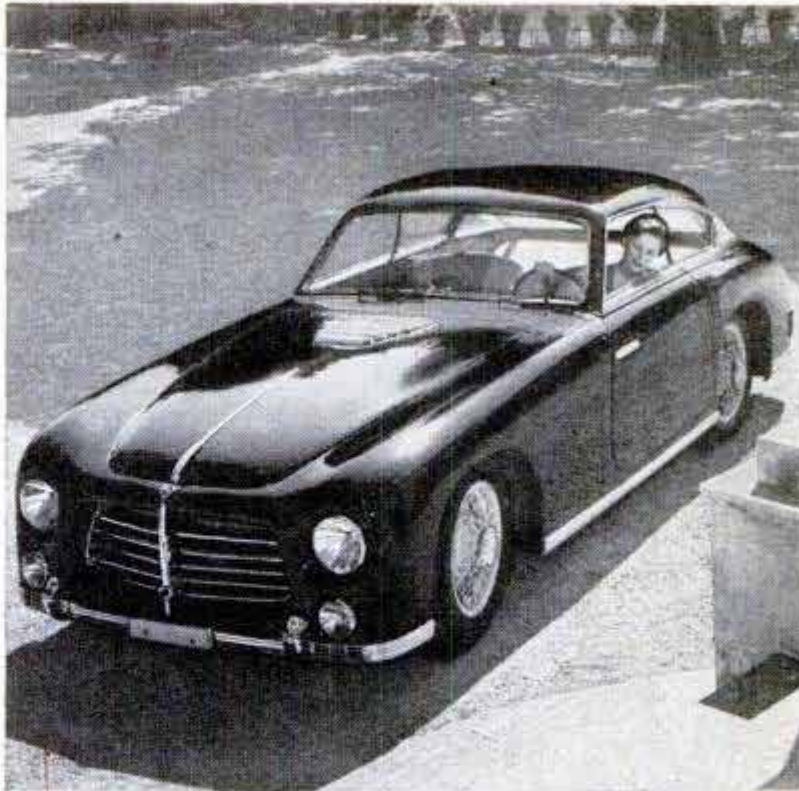

with 33,000 employees, of which 13 percent are women. Salaries average about 150 francs (about 52 cents) an hour. Production is about 450 units per day. I found the factory which I visited to be very modern. Detroit assembly-line methods are used. They even manufacture their own bolts, nuts and pistons.

Sketch at left was made at the Paris show for PM by L. Darrow. Below, Clymer on Paris street interviews owner of a French Ford, called Comete







Left, British three-wheel Reliant Regal is a four-seater powered by four-cylinder engine easy on gas

Below, British Allard sports two-seater hugs the ground, has overall length of 168 inches, high speed

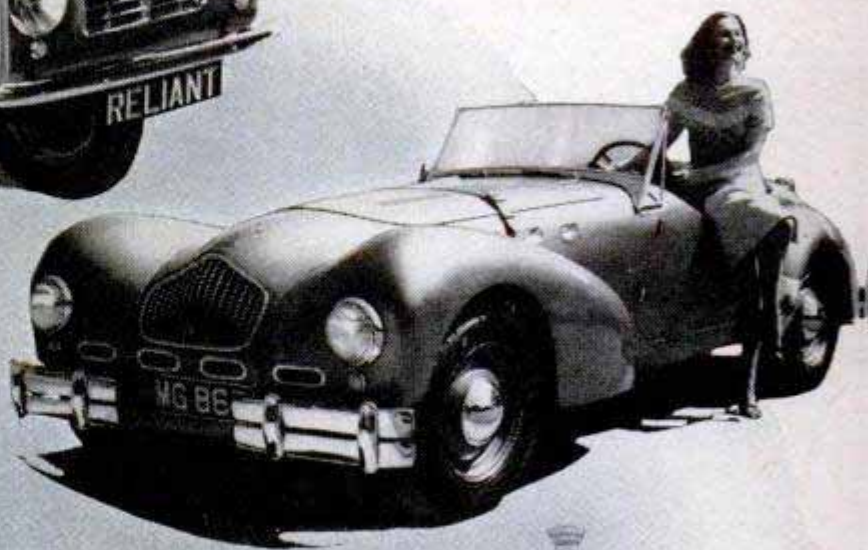

Above, British Healey has a four or six-cylinder engine, a top sports car

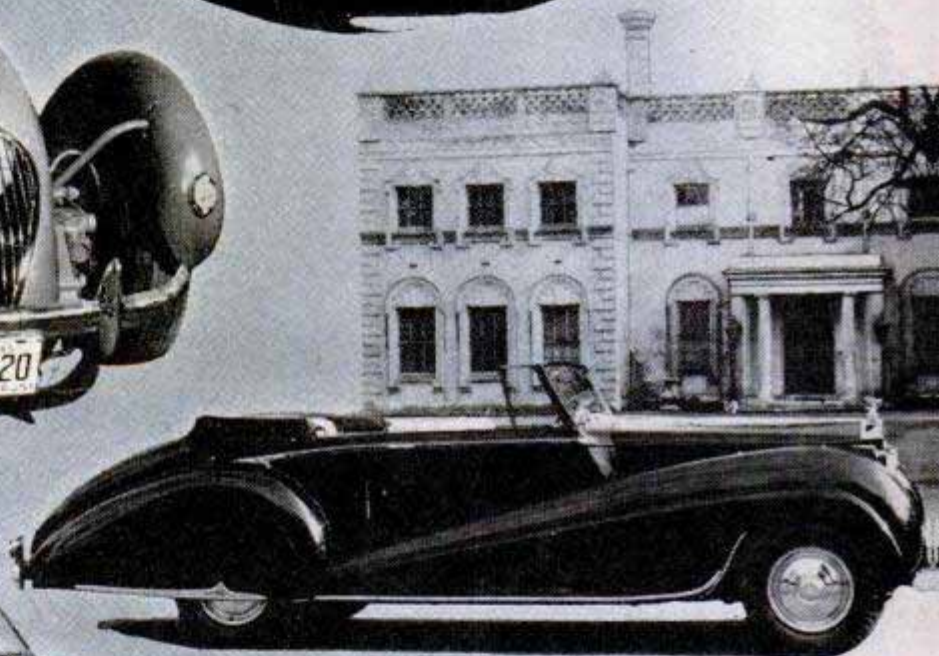

Above, Rolls Royce convertible coupe is made for export sales



Above, the six-cylinder Aston Martin convertible has a high compression ratio of 8.16 to 1

Clymer smiles from the Jaguar Mark VII sedan which he tested over Goodwood track in England







Volkswagen assembly line at Wolfsburg, Germany, is highly efficient and turns out 415 autos and 35 vans daily

and have their own make tires.

The third-largest builder in France is Peugeot. The fourth is Simca. My visit to the Simca factory in Paris was a revelation. Here is an extremely modern plant also using Detroit-type assembly methods. During the war, Simca repaired 75,000 Jeep engines for the Allies. Now it builds 300 Simcas a day in the popular Aronde model, a well-engineered, modernistic car somewhat along American lines in appearance. The price is 725,000 francs (about \$2000), quite high for a car of its size and out of the reach of most Frenchmen. Those who can afford it must wait eight to ten months for delivery. The chassis of the higher-priced sports model is built at the factory and the body is by Fastel-Metallo, famous body builders.

Simca workers average 180 francs an hour (approximately 63 cents), which is quite high for a French workman. About 7000 workers are employed here, includ-



ing 300 office workers. The plant is clean and well-managed. The factory serves food to the workers on a chain-line basis. For 50 francs (18 cents) each worker gets a piece of meat, bread and fruit, and wine or coffee. Simca has a large number of homes which it builds and rents to workers, and is now building more. About 70 percent of the machinery at Simca is from the U. S., having been procured through Marshall Plan aid.

From Simca I went to Ford of France at Poisy, 30 miles from Paris. Here is a miniature replica of U. S. Ford plants. I found a new, modern and exceptionally well-managed plant which, with its 5800 employees, is France's fifth-largest automobile factory.

In France the Ford is called the Vedette, and it is powered with a 60-horsepower V-8

Below, some details of foreign cars sketched by Darrow at the Paris exhibit show simplicity in the design

Below, famous French car, Bugatti, has wire wheels and a one-piece windshield—combining old and new

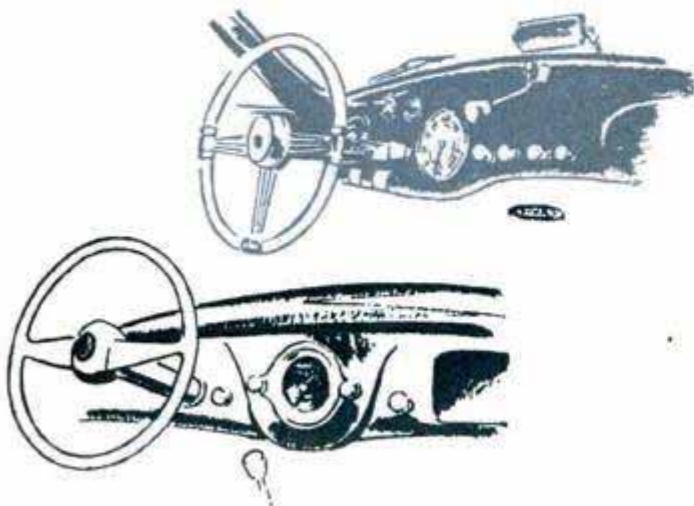





Left, one of France's smartest cars, the Delahaye, stopped traffic at the Paris show. Above, Clymer drove this Swedish Volvo, popular car in Sweden

imports. For that matter, the average Briton must wait from six months to three years to secure delivery even on a British make.

During show week, the Guild of Motoring Writers held a test day at Goodwood, a speedway 60 miles from London. Three laps of a winding course were allowed each driver in the cars he selected. Here I drove everything from a Morris Minor to a Rolls Royce.

Of the sports cars I drove, I was most impressed with the Aston Martin coupe with its 120-horsepower tuned engine of double-overhead-camshaft design. Top speed of 110 miles per hour is claimed, and its acceleration is terrific. It is the best-handling sports car I've ever driven. Performances by the Allard and the new Mark VII Jaguar saloon (sedan) were commendable. The new Jaguar is an outstanding example of fine British craftsmanship and is truly a wonderful car. The Rolls Royce, of course, is Britain's finest luxury car. Its little brother, the Bentley, is an excellent performer. Daimler, the highest-priced British car which is used by royalty and many government officials, also was there. I made the trip from London to Goodwood and return in a massive seven-passenger Daimler. It performed well, but I was disappointed in the rather rough ride for a car having Daimler's reputation.

The Hillman Minx and the Austin rode very nicely, as did the British Ford four-cylinder Consul and six-cylinder Zephyr. A fine small car is the Morris Minor, which really handled as well as many larger cars. The new Austin 7, a tiny economy car, created much interest at the show but was not at Goodwood. The Healey is a fine job of

(Continued to page 286)



engine such as Ford once built in this country. It's a cross between a prewar Ford and a postwar Mercury in appearance. The newest French model is the Comete, a beautiful job with the same engine as the Vedette, but with Continental lines that appear more Italian than French.

Next I flew to London, where the annual motor show at Earls Court was in progress with cars on display from nearly every country, including U. S. makes which cannot be sold in Great Britain because of the dollar shortage and British restrictions on

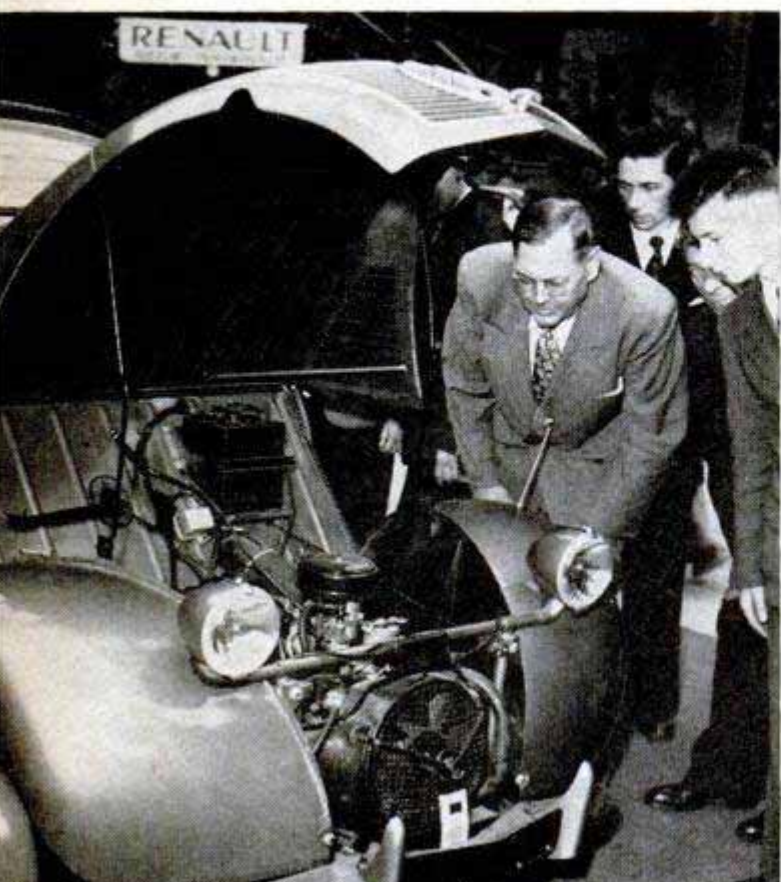

Clymer takes a peek at the small opposed air-cooled engine of a tiny French Dyna Panhard at Paris show





Western girl admires nylon lariats, belts, bridles and other items made from war-surplus parachute cord

## Nylon Trappings for Cowboy Trade

WHEN Hope Hunter of High River, Alta., ex-champion calf-roper, retired from ranching in 1946, he came across some war-surplus parachute cord. Figuring nylon would make a tough lariat with just the right "give," he braided a 40-foot rope and tried it out. It was a failure. Although strong enough to resist anything on four legs, it was too soft to fall where desired. Hunter

and his wife, after two years of experiment, hit upon a chemical solution which solved this problem, and today they're turning out nylon lariats, bridles, hackamores, cinches, browbands, halters and other items. Mrs. Hunter has branched off into braided belts, and Hunter now has a contract with the Royal Canadian Mounted Police to provide lanyards.

Mrs. Hunter braids nylon belts in rainbow colors to catch the eye of cowgirls and Western tourists

Husband and wife team up to make lanyards for the Mounties. Chemical solution stiffens the nylon cord







**50<sup>th</sup> ANNIVERSARY**  
FEATURE

WHAT IS HAPPENING TO OUR NATURAL RESOURCES? IN THIS TIMELY SPECIAL ARTICLE, THE U. S. SECRETARY OF THE INTERIOR TELLS HOW CLOSE WE ARE TO

# The Bottom of the Barrel



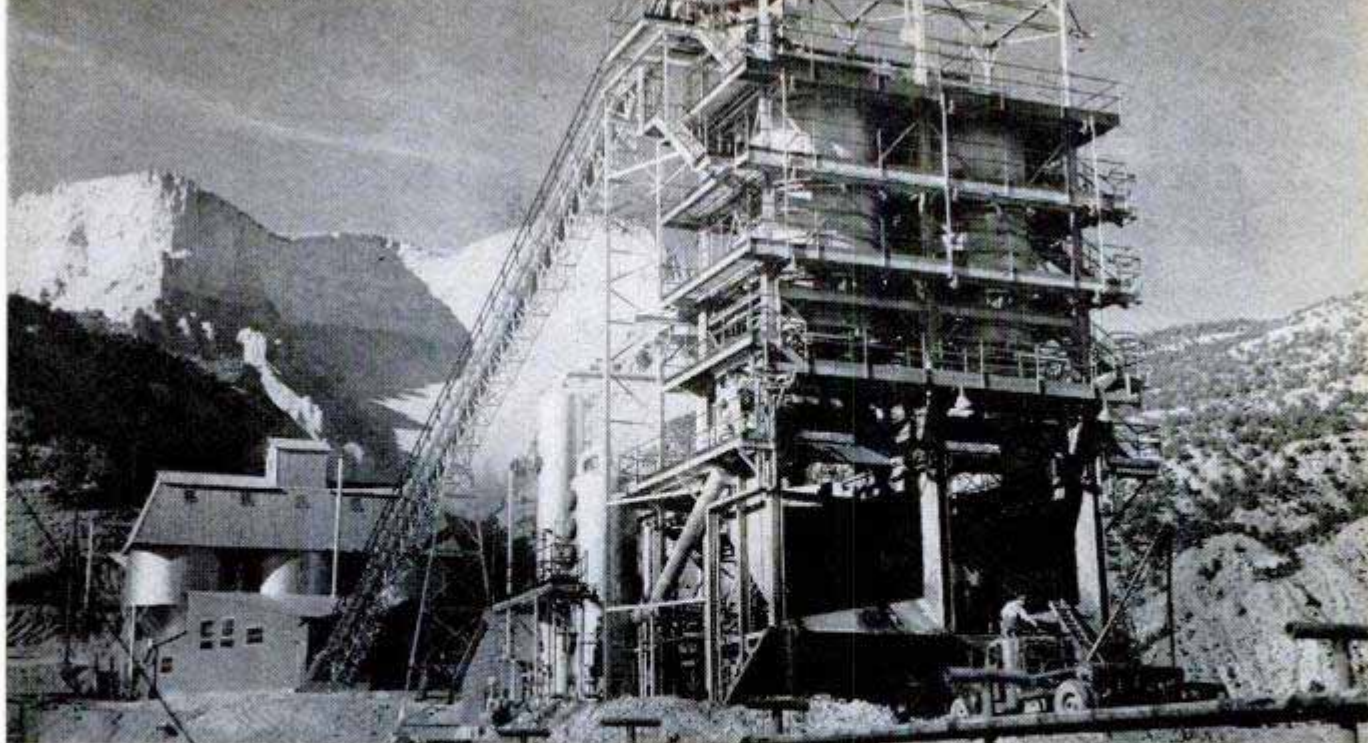

Cliffs of oil shale in background tower over the Bureau of Mines' oil-from-shale refinery at Rifle, Colo.

**FIFTY YEARS AGO**, most Americans spoke of their country as a land blessed with inexhaustible natural resources. They meant every word of it. Soil, water, timber, minerals—all seemed to be present in such abundance that the supply could never conceivably run short.

Yet even in 1902—the year *Popular Mechanics* was founded—thoughtful people could see a few danger signals. Here and there it was apparent that at least some of these resources could give out if the exploitation were ruthless enough. The idea

of conservation was beginning to take hold. Significantly, it was in 1902 that the great federal reclamation program was begun.

Looking back, we can see that this reclamation program, with its emphasis on the need for conserving our resources, came just in time.

The country was beginning an era of industrial development which was to make wholly unprecedented demands on its resources. Just when we were beginning to see that those resources were not really limitless, we entered a period in which we

Lighter tint in lines of chart below (representing manganese, etc.) indicate that U. S. production is far below present needs, which are met by imports

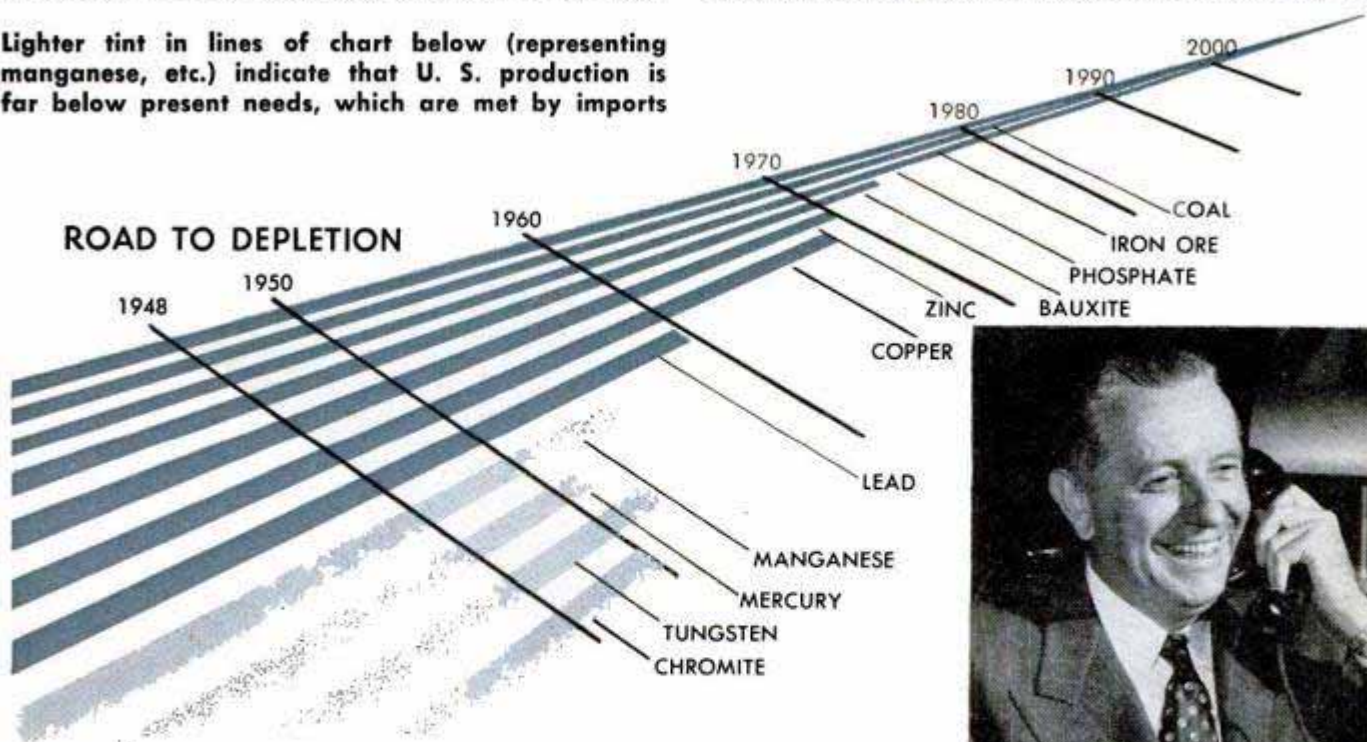

**By Oscar L. Chapman**  
**U. S. Secretary of the Interior**





Giant 25-foot pipe is used in Columbia irrigation project in Washington. Below, vast Mesabi iron-ore pit







had to draw upon them more extensively than ever before.

This called for a new mental attitude. We had to conserve the resources which had seemed so limitless, but we also had to get a much broader use out of them while we were conserving them. In plain English, we had to meet the rising needs of the present and at the same time to make certain that the needs of the future could also be met.

So as we look back over the past 50 years we are bound to do a certain amount of stock-taking. How well have we succeeded in this strange two-way job? Where do we stand? Have we met the challenge of the past half century at the expense of the next half century, or as we look to the future can we be reasonably satisfied that we can

**Big dams like Grand Coulee mean tremendous electric-generating capacity and, below, irrigation of crops**



**Coal flowing from Majestic Collieries in Kentucky represents one natural resource with reserves for years**







One of the big natural-resource quests of today is for oil. Here a drilling crew is working into night

continue to make some intelligent progress?

Broadly speaking, I think the answer is most encouraging. The job certainly is not nearly finished, but great progress has been made. If we go on as we have begun, we do not need to fear that our material development will presently be stopped by a failure of our natural resources.

It must be remembered, of course, that we have an extraordinarily complex society, and that some of its needs simply cannot be met from our own native resources. For some of the basic raw materials we are—in greater or lesser degree—dependent on supplies that come from beyond our shores, and as far as anyone can see that will always be the case.

But in the main, the record of the last 50 years is good; better, I suspect, than a well-informed American in 1902 might have felt entitled to anticipate. We have made tremendous use of our resources in those 50 years, but we are not becoming a "have not" nation. I do not think we are ever going to become one.

It would, of course, be a great exaggeration to say that our whole modern attitude toward the proper use of our resources came from the passage of the Reclamation Act in 1902. Much of it developed independently, both in and out of government. But passage of the Reclama-

**Wise forestry methods ended waste and ruin of woodlands and saved a natural resource**



A glance at chart shows why Secretary Chapman sees the making of oil from coal important in the future

tion Act at least symbolized the nation's growing awareness that the land's resources had to be conserved and not wasted. It wrote into law, so to speak, the decision that we would not buy today's prosperity at the expense of tomorrow's. Furthermore, it helped us to see that wise conservation does not merely mean saving natural resources, but involves a sustained effort to make all of America's basic resources continuously productive for the lasting benefit of the entire nation.

The Conservation Act, in effect, put the federal government in partnership with the West in developing land and water resources. First on the Salt River in Arizona, then on the Shoshone in Wyoming and later on many other streams in the 17 Western states, federal projects were built which turned raw desert into new farmlands.

In the very early stages of this program,





the builders of Roosevelt Dam on the Salt River had an idea which sparked a revolution in natural-resource conservation. In 1906 they installed a small generating plant in a cave in a canyon wall to provide hydroelectric power for construction work. From that moment, electricity became the paying partner of the irrigation farmer, and the true value of the potential represented by America's unharnessed streams began to be apparent.

Hence developed the idea of the multiple-purpose type of water-resource development—the project which would not only provide water for irrigation but which also would furnish hydroelectric power, flood and sedimentation control, protection for fish and wildlife and opportunities for recreational development.

Tangible results of all of this are now part of our permanent landscape all across the West. Intangible results are part of our steadily rising standard of living and our national well-being. All in all, more than a million people live on the six million acres of farms and in the scores of communities created by the 79 reclamation projects. These acres produce crops worth half a billion dollars a year, and the cumulative value of these crops is more than three times the 2½ billion dollars which have been invested in the federal reclamation program during the last 50 years. In addition, these dams have an electric-generating capacity of more than four million kilowatts.

Those figures indicate pretty clearly that the task of conserving and developing our land and water resources in the West has been pretty effectively tackled. It is, of course, far from complete. The best current estimate is that some 24,800,000 acres of land are now being irrigated, and it seems possible that as much more may eventually be reclaimed through techniques and developments similar to those now in use. Much remains to be done. But a great start has been made. The country is learning how to make the best use of its streams, and through that use is turning idle land into a productive asset.

Adequate water supply, incidentally, is not a problem for the West alone. Our use of water, in industries and in cities, has increased prodigiously in this past half century, and while the nation's water resources, all in all, appear to be remaining relatively constant, by 1950 water shortages of a local nature were appearing all over the country. It is easy to see why this has happened. Not only has our population greatly increased in the last 50 years, per capita use of water has soared from an average of something between 200 and 400 gallons per day, in 1900, to approximately 1100 gallons per day at present.

Knowledge and techniques pertaining to the nation's water resources have been developed largely in the past 50 years. Fundamental studies to determine ground-water conditions through the country have lagged. We need to continue and expand such studies, and we need also to experiment with such matters as the artificial precipitation of rainfall and the desalting of sea water. There appear to be substantial possibilities in these fields, and the pressure on our water resources is great enough now to indicate that we should find out exactly what those possibilities are and how they can be realized.

Soil and water, to be sure, are only two of our basic resources. Another resource, which is absolutely basic to our development as an industrialized nation, is our supply of minerals.

Current shortages sometimes color the view which we take of our position in regard to minerals. These shortages are perfectly genuine, but they by no means require us to don sackcloth and ashes. On the contrary, we have good reason for optimism—*provided* that we do our part properly.

Obviously, mineral deposits differ from renewable resources like forests, water and soil. They are wasting assets; there is only one crop, and when it is gone it will never be renewed. When we take a ton of ore or a barrel of oil out of the ground we cannot replace it. Clearly, the total volume of minerals in the American earth is smaller today than it was 50 years ago, and it will continue to decline as long as mining continues.

But that is only part of the story. We cannot increase our mineral deposits, but we can increase our mineral resources, and we have been doing it with a good deal of success for half a century; indeed, there is reason to believe that we have barely begun.

A mineral deposit does not become a mineral resource until it is possible to use it. To use it, we must first know how to find the deposit, then how to mine it, then how to get the element out of the waste material with which it is associated, then how to turn it into a usable raw material, and lastly how to fabricate the raw material. In addition, we must know how to do all of these things economically and with a minimum of waste.

The past half century has seen great advances in all of those steps. The search for ore bodies is now a highly organized scientific operation instead of the hit or miss venture of the lone prospector with his pick and his burro. Mining has become highly mechanized, both in open-pit mines and underground. Immense progress has been made in extracting needed minerals from complex ores, so that much that was waste rock 50 years ago is now commercial ore.

(Continued to page 282)





Above, a monitoring team checks radioactivity of a Jeep parked some distance from an atomic explosion

Left, testing radioactivity, monitor wears a skull-cap, respirator, coveralls, gloves and shoe wrappings



## THE ARMY

**... Front-line fighters team up with atomic experts on Nevada's "scorched earth" to learn how to fight with—and survive—the new "A" weapons**

**WHAT'S THE** best way to protect our own troops when we explode an atomic weapon on near-by enemy forces?

How can you warn pilots of radioactive clouds?

What should be done if the wind shifts and the fall-out from such a cloud drops on our own men?

These are some of the life-or-death questions that the armed forces are studying, to learn how to protect our forces not only from possible enemy A-bombs, but from our own as well.

A full-size A-bomb dropped deep in enemy territory is one thing; today's problems concern weapons of tactical size that would be used in a front-line battle area.







Troops watch the rising cloud from a tactical A-bomb at a safe distance several seconds after the explosion

# MEETS THE BIG "A"

By  
Thomas E. Stimson, Jr.

These have been tested already, according to Gen. J. Lawton Collins, Army chief of staff, and he adds that atomic-artillery and guided-missile battalions will replace some of the conventional heavy artillery "in the not too distant future."

Flash-blindness from one of these weapons could put a battalion out of the fight for 10 minutes or an hour, depending on proximity. From six miles away the flash can be 100 times more blinding than the sun.

The mushroom-shaped cloud produced by an atom bomb drifts away like any other cloud. Yet it remains a hazard for a long time. A pilot flying through the fresh cloud would die from the effects, and even hours later enough radioactivity would be present to deposit dangerous concentrations on leading edges and in air filters. Would a radiation meter in the plane warn the pilot of the hazard?

To learn the answers, the armed forces are taking part in the nuclear-testing program of the Atomic Energy Commission at the Yucca Flat test site in Nevada. The 640-

square-mile proving ground is in a wasteland northwest of Las Vegas and will be used for all ordinary experimental nuclear detonations in the future.

Here, it is understood, atomic bombs several times more powerful than those dropped on Japan are being tested, as well as baby bombs that represent only a part of that energy. Some of the dawn explosions have been photographed in Los Angeles, almost 300 miles away, while others were not seen, heard or felt even 70 miles from Yucca Flat.

Atomic explosions have certain characteristics in common. When a "nominal" bomb is exploded 2000 feet in the air, ignition immediately heats the surrounding atmosphere to incandescence. A luminous ball of fire 45 feet in diameter with a temperature of 300,000 degrees C. is produced. A shock wave slams out in all directions.

Within a second the ball of fire attains its maximum radius of 450 feet and its temperature falls rapidly. Nine seconds later the shock wave has radiated beyond two

RANGE: 1000 MILES PLUS

Chart shows the relative ranges of three principal types of atomic weapons, including the atomic shell

ATOMIC BOMB DELIVERED BY PLANE





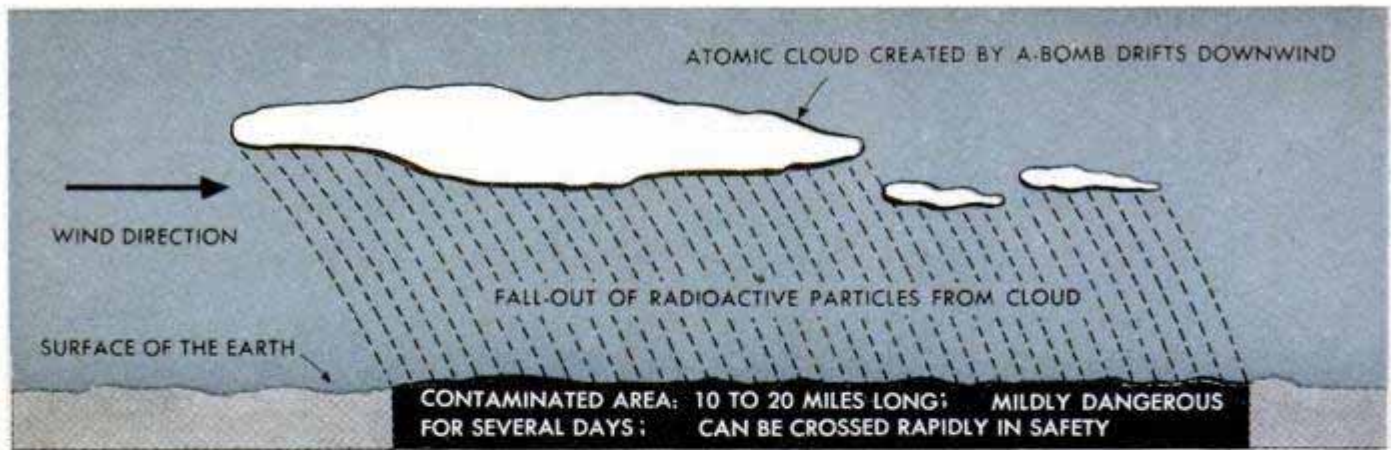

GENERALLY, THE CONTAMINATED GROUND AREA WOULD BE SHAPED LIKE THIS

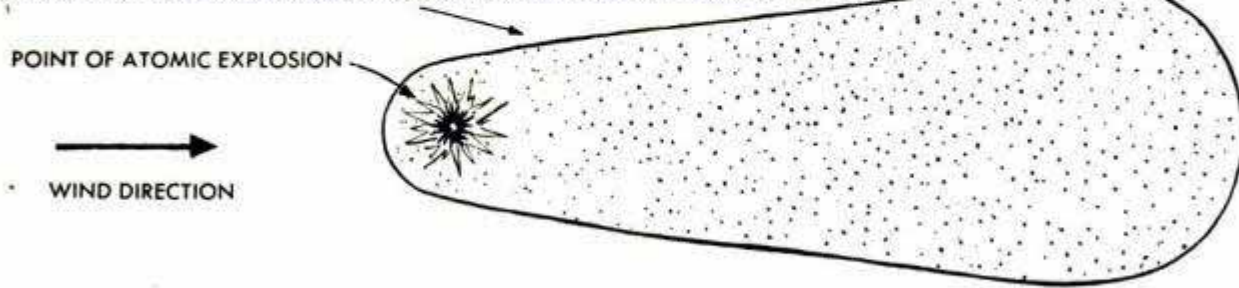

After an A-blast, radioactive clouds drop contaminated particles over area downwind, adding to the danger

miles and all immediate blast, heat and radiation damage is done. The ball of fire loses its luminosity.

The ignition space is now a huge bubble of hot gases and smoke that rises like a balloon. This movement contributes to the suction phase of the explosion, in which immense quantities of dust and surface debris may be drawn up into the cloud to become contaminated by fission products.

In the next several hours most of this dangerous radioactive dust settles back to

earth in a fall-out pattern determined by the height of the cloud, and the force and direction of the wind.

Cattle that were in the fall-out area of one of the first nuclear detonations developed blisterlike lesions and lost much hair though they were 10 to 15 miles away from ground zero. In the case of the plutonium bomb, the fall-out materials are likely to include plutonium particles that are poisonous in addition to being radioactive.

(Continued to page 302)

Hoses radiating from this instrument detect changes in barometric pressure when explosions take place



Recorder, being synchronized here, records changes in barometric pressure detected by device at left







U. S. Air Force photo

## Biggest-Known Jet Bomber

Bug-eyed and high-tailed, the U. S. Air Force's XB-52 is expected to be the largest jet bomber ever flown. After its engine run-up and taxiing period are concluded, the 175-ton airplane will probably fly through

the stratosphere at about 600 miles an hour. The long-range bomber, built by Boeing, has eight J-57 Pratt & Whitney jet engines and a tandem-wheeled landing gear. The only other information now approved for release about the aircraft is that its electrical system requires 200 kilowatts.

## Turborotor Helicopter

Being tested for the Navy, a new turborotor helicopter promises greater performance due to the saving in weight effected by use of the gas turbine. A normal piston-engine installation in the craft would weigh in excess of 500 pounds, whereas the turbine totals less than half that weight. Mechanical simplification and the ability to operate on low-grade fuel afford further advantages.



## Chains for Shoe Soles

During a severe winter storm two years ago, W. K. Young, a postman of Abilene, Tex., took a good many spills on the icy sidewalks. Young started working out a remedy for the problem. The result is a set of nonskid "foot chains" that slips over his shoes. Heel and sole plates are strapped to the shoes, and the chains, which are like those used for dog leashes, crisscross the plates. Now Young can walk safely on the most slippery sidewalks as the chains bite into the ice. The postman has applied for a patent on his shoe chains.

□ During 1951 the United States produced more than 100 million tons of steel, a production mark never before reached during a calendar year.





## Flying Flashlight Pinpoints Targets

Resembling a large bomb, a big flashlight beneath the wing of U. S. Air Force bombers lights the way to added destruction. Where vehicles and other objects are suspected but hidden by darkness, the carbon-arc lamp is flashed on and the entire target area is illuminated. Inside the lamp's glass dome nose is a large reflection disk that can be rotated to direct the beam.

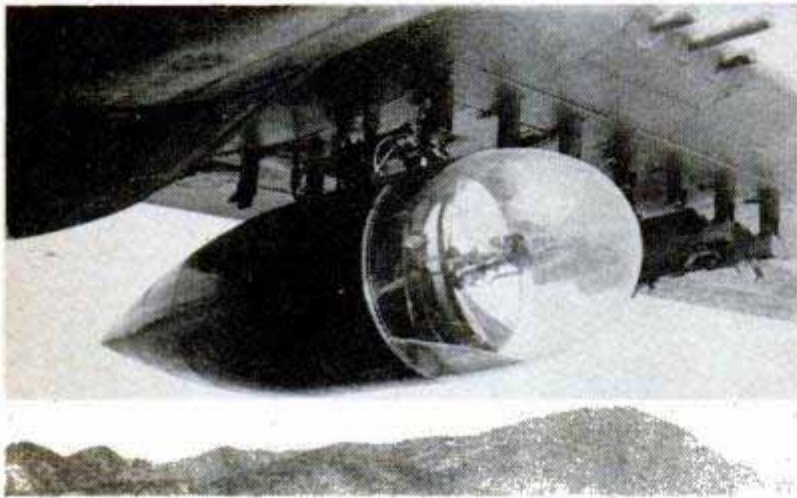

## Machine Replaces Heart or Lung

Surgeons convening at the Sorbonne in Paris were shown an intricate new machine that can take the place of a heart or lung during delicate operations. The apparatus was invented by Prof. J. Jongbloed of Holland.

## Chemical Prevents Elm-Tree Disease

Dutch elm disease, which has threatened to wipe out that popular shade tree, can be prevented in seedlings by a new chemical treatment. The treatment is effective in all but a few cases. Only five percent of the seedling elms treated with the chemical, then inoculated with the disease fungus, developed the disease. The chemical is absorbed into the tree to attack the fungus at its source. Other chemical treatments have been somewhat effective, but they had to be introduced through the soil around the tree. The new chemical can be

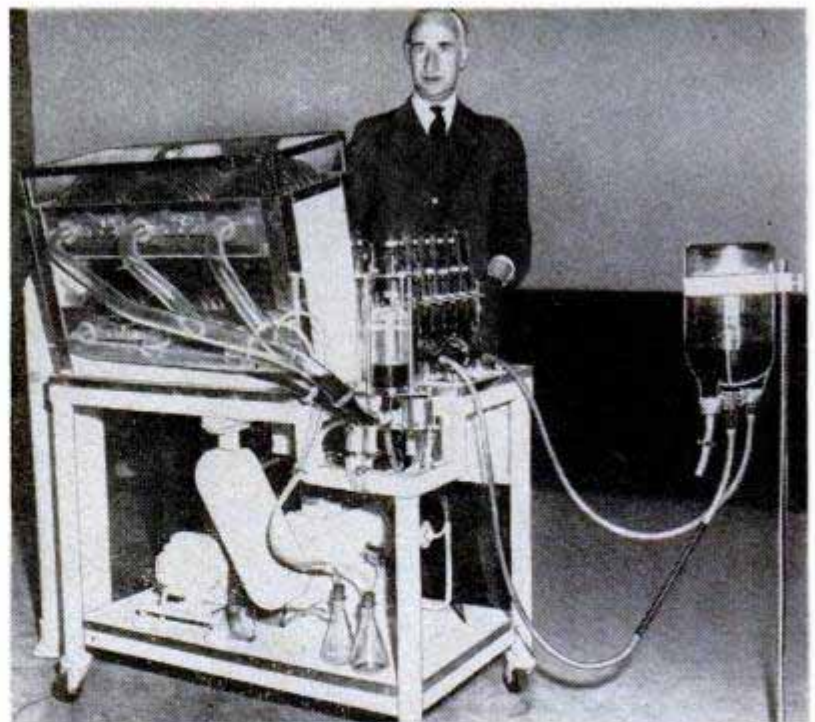

sprayed on the tree, a much less expensive method. Many city trees could not be given treatments through the soil because they were surrounded by pavement. The chemical is 2-methylcarboxymercaptobenzothiazole—a name to discourage any fungus.



# FROM BOOT TO ELECTRONIC WHIZ-KID

By Paul Lee

Technical trainees check  
a big gun director by  
tracking local aircraft

U. S. Navy photos



ONE DAY LAST WEEK a vaguely doubtful lad walked through the main gate at Great Lakes Naval Training Station and swapped his civvies for Navy dungarees. Though the youngster hadn't even finished high school, it's quite possible that barely a year from now he'll be responsible for servicing and repairing the most intricate electronic equipment in the U. S. Navy.

Within 14 or 15 months this same lad may be serving as father, mother, nursemaid and doctor to the Navy's gunfire-control systems, the miracle robots that can pinpoint a jet plane five miles away, train the swaying, dipping guns and blast the enemy

out of the sky. These electronic brains un-snarl complex problems in seconds.

It's high tribute to the Navy's training program that this inexperienced young man can learn in a few short months to diagnose and repair breakdowns in this fantastic array of tubes and gyroscopes, condensers and radar screens. If you told

**This is the third of four articles on the training of our recruits. Next month, "Here Come the Leathernecks!"**

Today they're rather bewildered landlubbers. A year from now they may be servicing the Navy's miracle robots





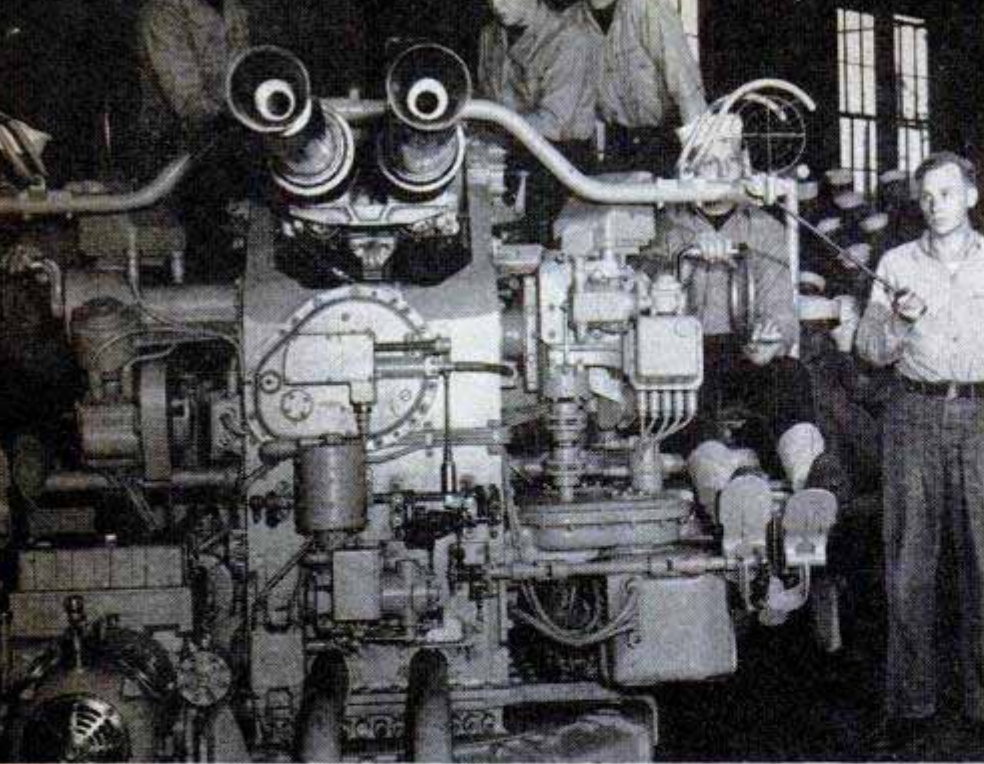

Boots learn gunnery by manning a real 40-mm. gun. Center, technical student gets close-up of instrument which sets time fuses as shells come up loader. Bottom, boots extinguish blazing oil in mockup of a ship's compartment

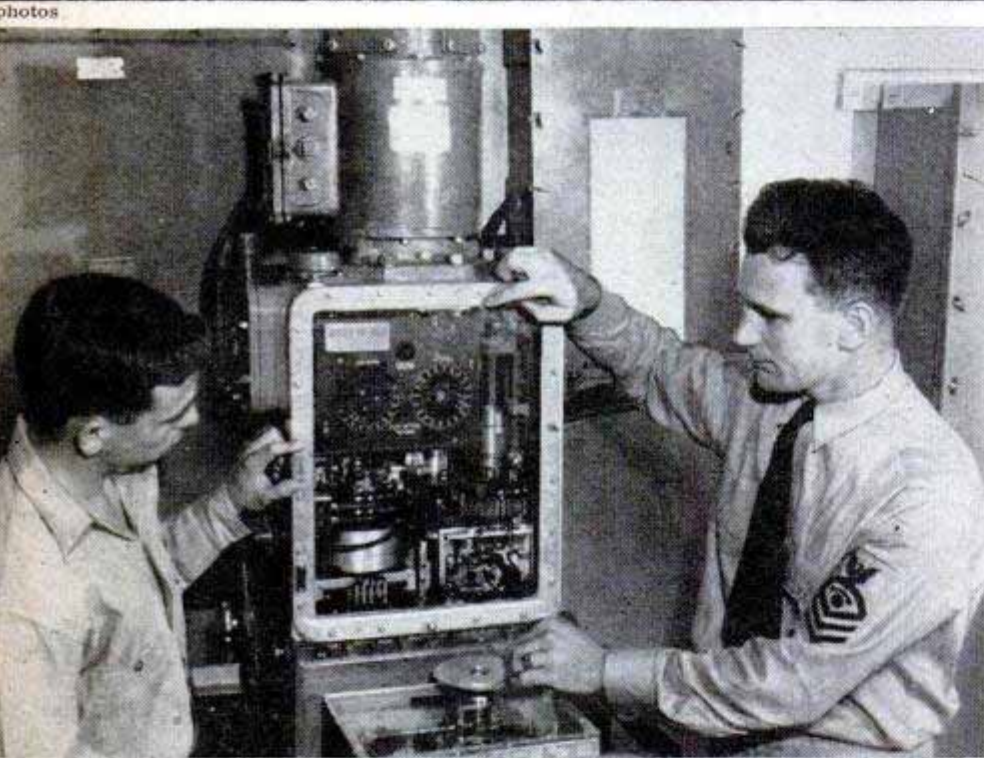

the lad what was in store for him he'd label it the wildest scuttlebutt he'd ever heard.

In learning to tend these split-second mathematicians, the young man will have to survive 11 crowded weeks of boot training, then struggle through 44 weeks of vastly more difficult training at the U. S. Naval School, Fire Control Technicians Class "A," near Washington, D. C. The technical school will make him a seagoing expert in electronics, but first Great Lakes must mold him into a sailor.

Today's rookie training is a far cry from the boot camp of the old-time Navy, or even the Navy of World War II.

"I took—or rather survived—boot training back in 1923," recalls a wrinkled chief petty officer, who now drums military subjects into the recruits. "In those days we drilled, ate, drilled, slept and drilled.

"Now it's different. The boot who wades through today's recruit training soaks up civics and history as well as seamanship. He hears lectures on everything from 'The Chemistry of Fire' to 'Marriage and Family Life.' He learns by doing. He learns fire fighting by fighting fire and cargo handling by swinging a nine-foot boom himself. We instructors use any item of equipment that can help us forge a seaman from an irresponsible kid in 11 short weeks: Movies, wire recorders, intricate ship models, a full-size mockup of a destroyer bow, electric eyes





for gunnery practice, overhead projectors. The chief adds with a smile, "And, of course, the rookie still lifts 'em up and puts 'em down on the drill field."

At Great Lakes the recruit hits the deck at 0530. In the next two hours he shaves, dresses, eats and swabs down his bunk bay. By 0745 he's off for his first class, which might be anything from a "drumfire" lecture on ship's nomenclature to a back-breaking session on the rifle range. Every minute of the morning instructors continue to pound the Navy into him. At 1135 there's a break for lunch, but by 1300 he's back in class for three more hours, sputtering through a dousing in the pool to learn sea survival, or listening to a technical lecture on the basic types of naval ammunition. At 1600 he either starts washing his clothes or takes some physical drill. By the time he's finished his evening chow he's breathed the Navy through a very long day.

Driving him through those crowded hours is the harsh, barking voice of the petty officer, ripe with sarcasm and sea lingo. Naval armament may change from rifles in the rigging to atom bombs, but the old-time petty officer remains as immutable as the sea itself.

Because fire is the biggest danger aboard ship, the boot absorbs a full measure of fire fighting. At the Great Lakes fire-fighting range, concrete structures have been built to the exact shape and size of ships' compartments. Instructors fill these buildings with oil, then touch off an inferno. The recruit, teamed with his mates, must fight his way toward the roaring fire armed with a 1½-inch hose equipped with a fog nozzle. By the time he actually reaches the hatch of the compartment and puts out the fire, he's sputtering and half blind. He's learned a healthy respect for fire, but he's also gained confidence that he can meet and conquer it.

During his training the rookie endures 10

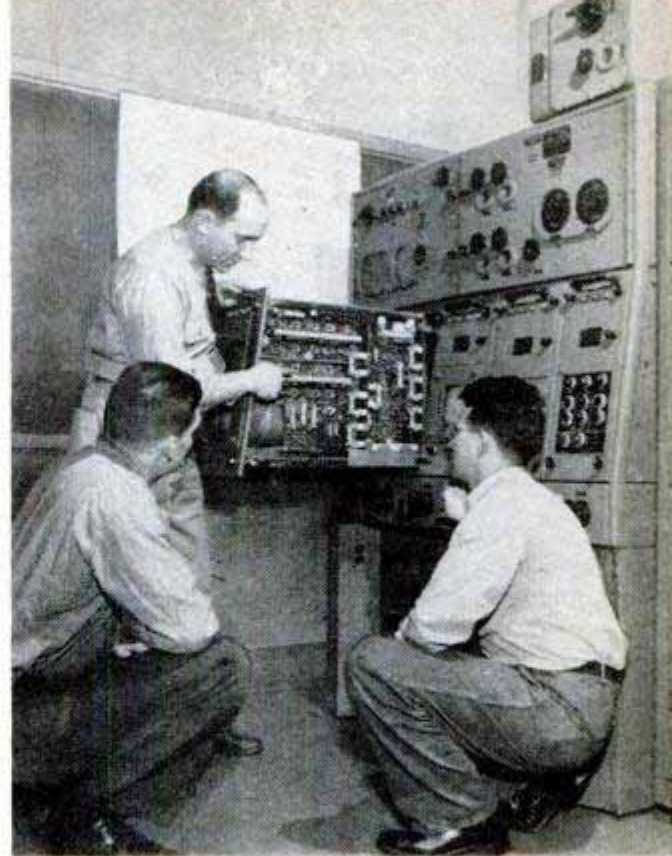

Maze of wires in pull-out drawer is traced by students learning to maintain radar of fire-control system

hours of swimming and sea survival, 28 hours of hammer-hard physical training including boxing, wrestling and an obstacle course that would appall an all-American halfback. Very likely, late in the training, he becomes cocky as an old "salt," and jeers at the landlubbers as they "come aboard" the base. Actually, he's only at the keel of the Navy and has a lot to learn before he'll climb into the superstructure.

When he finishes his boot training the proud new seaman can sign up for any one of 54 different service schools designed to make him a specialist in any field from lithography to photography, patternmaking to storekeeping. If he's interested in electronics, he may very well be shipped off

Diagram shows how various units of fire-control system are scattered above and below decks of typical warships

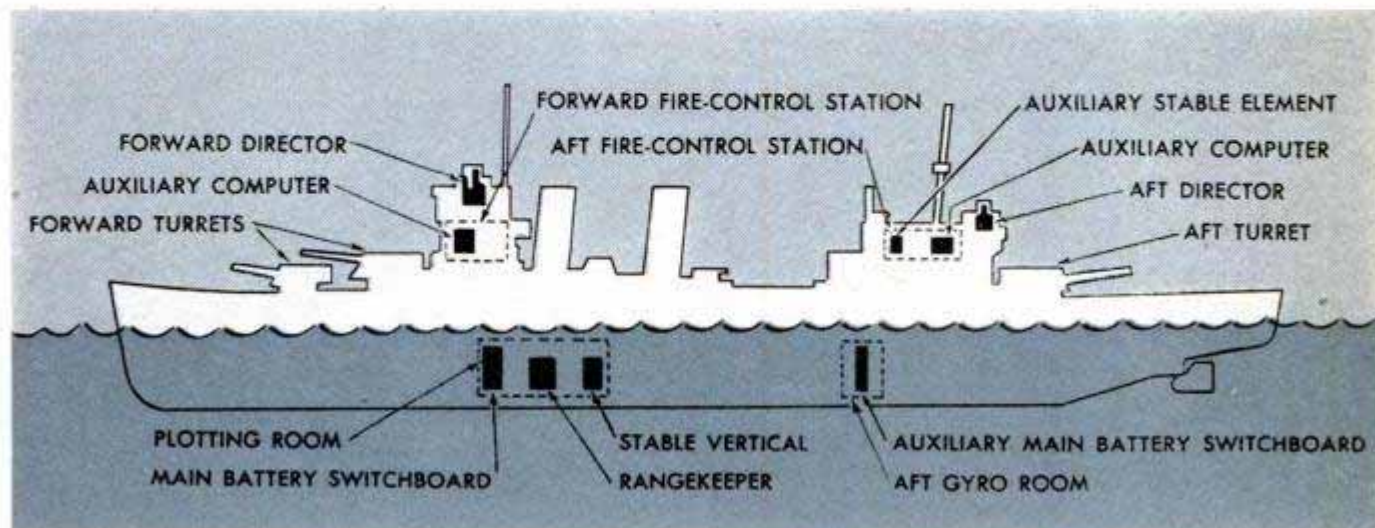



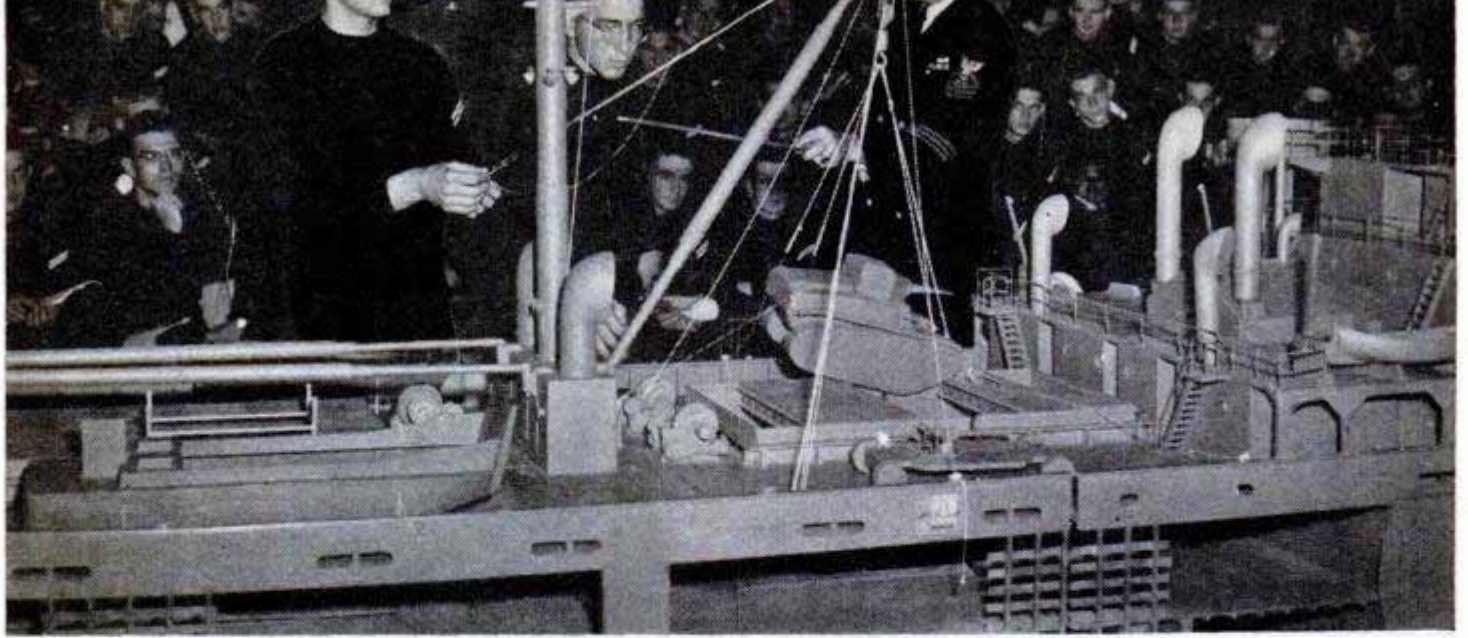

Boot learns principles of cargo loading by lowering miniature tanks and other gear into huge ship model

to the Fire Control Technicians School near Washington, one of the Advanced Technical Service Schools.

Officers at the school lament the confusion in an occasional seaman's mind over the name of the school. Sometimes a bewildered bluejacket, having tasted a whiff of smoke on the fire-fighting range, will show up at the Fire Control Technicians School expecting an easy berth while he soaks up some advance dope on fire fighting. Such a man becomes understandably perturbed when he embarks on a course in electronics tough enough to give an experienced TV serviceman the shakes.

Veteran Navy men, in true tradition, speak no word against their service to an outsider, but among themselves they'll grumble that the sailor's life isn't as simple as it was in the good old days. Most of this nostalgia stems from the fact that today's Navy couldn't exist without jet engines, radar beams and electronic calculators, which require the care of real specialists.

Consequently, today's bluejacket must be an expert on something more than swabbing decks and chipping paint. He must know how to service a jet plane, deactivate unexploded bombs or repair the brains of a fire-control system.

Gunfire-control system, seagoing cousins of the famous ENIAC, do the work of hundreds of mathematicians, literally in a split second. There are half a dozen dif-

ferent systems, but they perform essentially the same operations. Through radar they detect the approach of an enemy plane; locate it; estimate its range, altitude, approach angle and speed; calculate the rate of movement of the ship, and its course; learn the wind velocity. After obtaining this information they calculate when and where an antiaircraft shell of a certain velocity and trajectory will intersect the plane's course. Finally, they feed this information to the swaying guns and stabilize them in relation to the target. Theoretically, it's possible for a modern battlewagon to blast an enemy plane out of the sky without a single man above decks and without a single eye seeing the plane. Also, the fire-control system can line up and fire every battery aboard ship at the same target.

In Navy lingo, this problem of pointing a gun on a moving ship so the shell will intersect the course of a high-speed plane is known as the surface-to-air problem. A recent visitor at the Fire Control Technicians School asked an instructor if he'd solve a simple surface-to-air

(Continued to page 278)

Miracle gunfire-control system, in order to make shell intersect jet plane's course, must detect plane, estimate range, altitude, approach angle, speed; calculate movement of ship; learn wind velocity. In seconds it "solves" mathematical problem and feeds information to swaying guns, stabilized to blast the plane

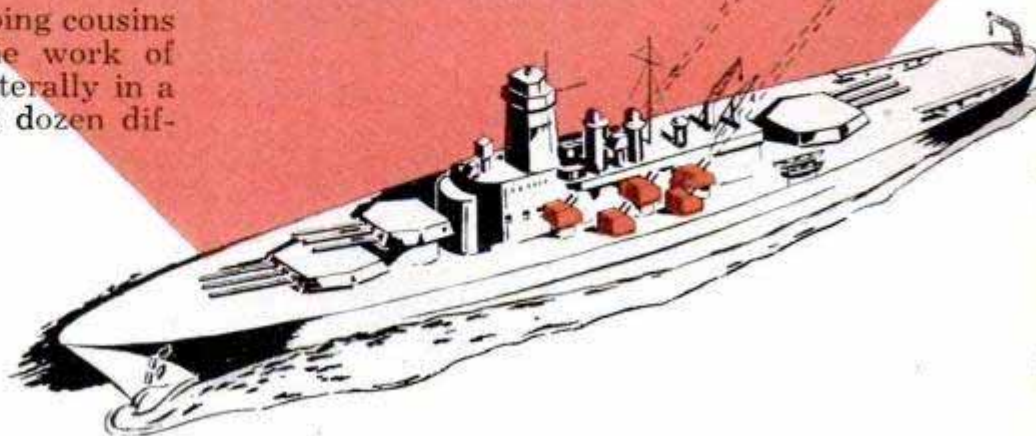





Top, roof of the school  
bristles with all kinds  
of radar antennas. Right,  
students who will service  
gear aboard ship check  
operation of gun director

Special Devices Center built this panel to demonstrate the basic laws of physics





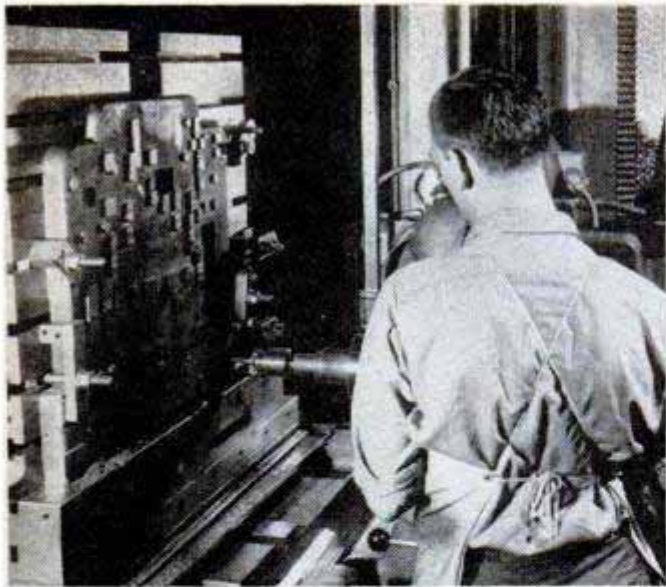

All the man does at this machine is load and unload the work. Tool is controlled by the perforated tape

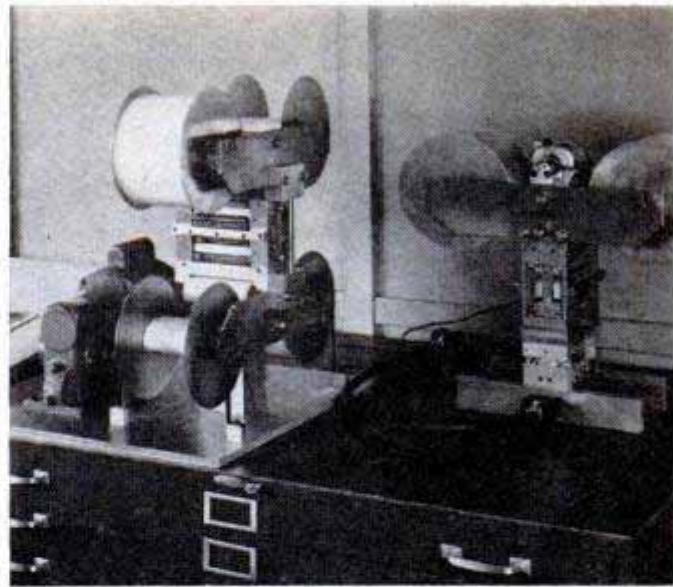

Control tape is perforated on machine, left, from blueprints. Tape then runs through "sensor," right

## Robot Machinist

Draftsmen can now "operate" lathes and other machine tools without leaving their drawing tables with a tape-operated control system that brings the day of the automatic factory much closer. Ideal for mass-production plants having repetitive runs of metal-cutting operations, the robot is controlled by a perforated tape that is cut directly from blueprints—an operation per-

formed on the drawing table. Perforations represent essential dimensions for the part to be machined. As the tape moves through the "sensor," a translating device, electrical contacts vary voltages that control movement of the tool and work. Virtually the only manpower needed is to load and unload the work at the machine. However, periodical inspections are made to be sure that tolerance limits are maintained, and to determine when tools need replacement.

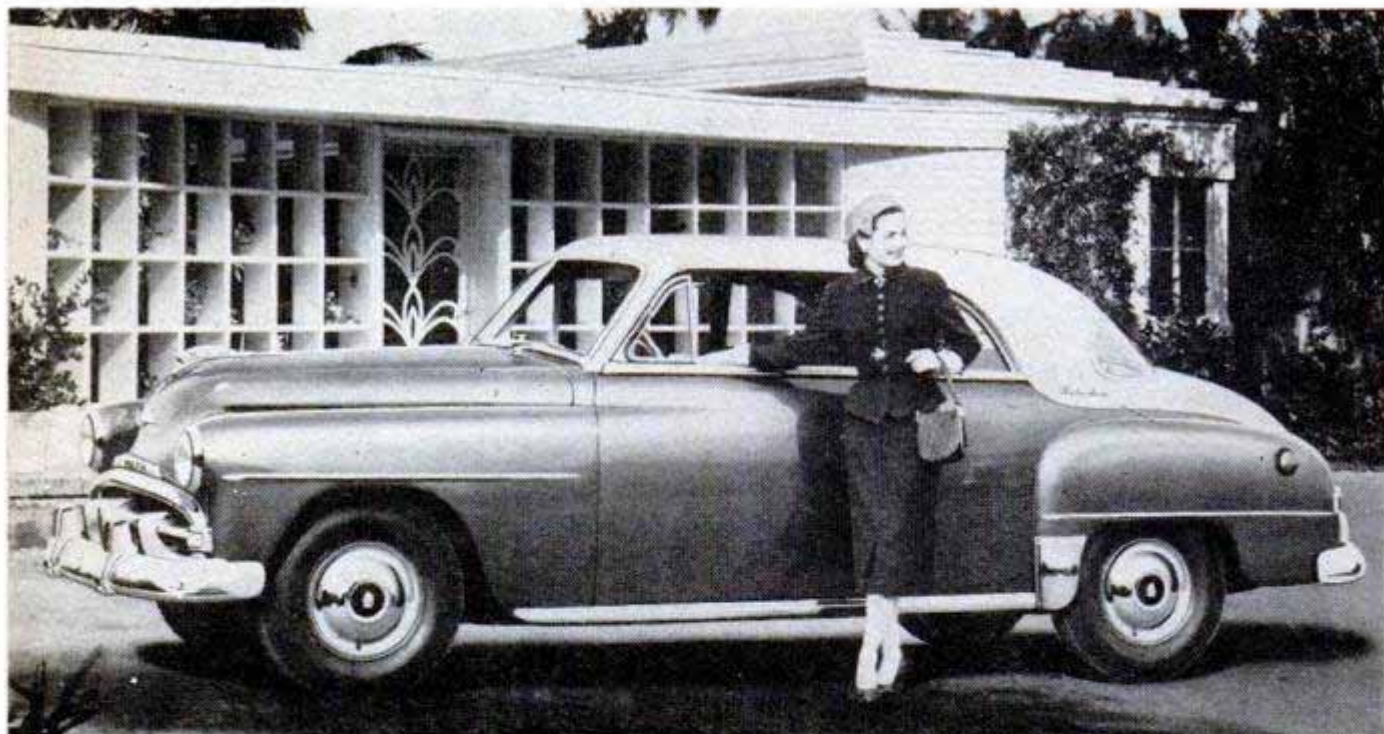

## 1952 Plymouth

Pace-setter for the '52 Plymouth line, which includes 10 body types, is the Belvedere hardtop club coupe, styled in an assortment of lively two-tone colors. The 97-horsepower floating-power engine, with a 7:1 compression ratio, has a newly de-

signed combustion chamber that produces a smoother flow of power. Plymouth's ride also has been made more comfortable by improvements in springing and the Oriflow shock absorbers. Tinted safety glass is available on all cars in the line as optional equipment. Speed of the electric windshield wipers has been increased 10 percent.





## Army Unwraps Improved Rifles

Two new weapons, one a gun that shoots around corners, have been unveiled by the Army. The idea of a gun that shoots around a corner is an old one, but such a weapon has never been perfected until now, according to Army spokesmen. The new curved barrel is an attachment for the M-3 submachine gun. It deflects the .45-caliber slug 90 degrees, and can be adjusted to fire to the left, right, up or down. Tank crews



in Korea had requested such a weapon to shoot enemy infantrymen who crawled on top of the tanks. The other new weapon is a lightweight .30-caliber rifle that can be fired in bursts like a machine gun. Still in the testing stage, the new rifle is  $1\frac{3}{4}$  pounds lighter than the  $9\frac{3}{4}$ -pound M-1 now used by the infantry. It has a magazine holding 20 rounds instead of the eight in the M-1, fires a cartridge  $\frac{1}{2}$  inch shorter than the one now in use and can be fired one shot at a time or as a fully automatic gun by holding the trigger open.

## Water Heater Floats in Stock Tank

Watering tanks for livestock are kept from freezing by a heater that floats on the surface. By preventing the surface from freezing, the heater prevents ice from forming anywhere in the tank. Either natural or bottled gas, fuels now available to most stockmen, can be burned as fuel in the heater. Three inches of glass fiber and a sheet of aluminum foil deflect the heat across the surface. A thermostat controls the burner, but it also may be adjusted manually.



## North America Abounds in Harmful Insect Pests

There are 80,000 varieties of insects in North America, and these pests do \$4,000,000,000 damage annually to agricultural crops, according to Dr. Francis F. Heyroth, assistant director, Kettering Laboratory, University of Cincinnati. Insecticides, in addition to increasing the food supply by destroying these insects, also prevent the spread of such diseases as typhus fever, plague and malaria. According to Doctor Heyroth, no accidental deaths ever have been recorded that can be clearly at-

tributed to the DDT insecticides, even though DDT has some toxicity for animals and man. But, he declares, the hazards associated with the use of insecticides are far outweighed by their public-health value.

If you do not find the information you need in the index on pages 14, 16 and 18, sources of further information are available without charge from *Popular Mechanics*. Write to the Bureau of Information, 200 East Ontario St., Chicago 11, Ill.



# SPIDER-LEG CATAMARAN



Inspired by a catamaran described in July 1948 *Popular Mechanics*, above, four New Englanders built this "cat" that the writer, a yachtsman for 50 years, says is the fastest boat under canvas





## To the Editor . . .

THE WRITER is so intrigued with the well-written and beautifully illustrated article about the catamaran in your November 1951 issue that he cannot resist telling of his experience with a similar craft.

My old friend, Arthur W. Stevens of Boston and Marblehead, returned from a trip to Hawaii in 1949 fairly bursting with enthusiasm over a catamaran he had seen at Waikiki Beach, a picture and write-up of which had appeared in *Popular Mechanics* (July 1948). All he needed was a slight nudge from me to call on one of our younger and successful naval architects, Ray Hunt. The result of that visit was an interview with Selman Graves of the Marblehead Yacht Yard. Between the two of them there was built a sailing vessel beyond our wildest dreams.

Her exact dimensions are not essential. The pontoons are 42 feet long with a maximum beam on deck of about 20 inches and set about 13 feet apart. They are beautifully designed and constructed sturdily of plywood and oak timbers. Each was fitted with a centerboard slot, a winch for handling same and a good pump. If I were to repeat the experience, I think I would substitute a few watertight compartments for the pumps. It's no great trick to construct a tight hull of this kind, but in the event of a collision resulting in a puncture it would be nice to stay afloat. In the second year, we compromised by stuffing plenty of Styrofoam into these hulls to provide buoyancy if they were punctured.

The original design called for a "cat" rig—true iceboat style. The 50-foot mast was a masterpiece, teardrop design about four inches thick (hollow, of course) and about 14 inches fore and aft. It was set on a swivel or rotating base and followed the angle of the boom. I went out with the designer and Mr. Stevens on the trial run. Fortunately, it was a light day with a smooth sea. At every movement that mast rattled around overhead like a veritable seagoing sword of Damocles. After about 10 minutes of it, I told brother Hunt that I was sure his rig was an aerodynamic achievement, but a poor shipmate and that I, for one, was ready to call it off. We did. That was all for the cat rig.

Next we installed a conventional mast from a Triangle Class boat, about 10 feet shorter and stepped in a fixed position about three feet farther aft, and a jib was added. The total sail spread was changed little. It was still about 600 square feet.

One bright Sunday morning it blew hard from the northwest (an offshore breeze at

Marblehead) and I hastened to Stevens' house to suggest that we put the catamaran over the jumps. He, being 70 years old, suggested that he'd rather watch the act than take part in it. Designer Hunt suggested that he take Stevens out in his power boat, which was tested to 20 knots, and they would time us. Well, I collected three Marbleheaders, two of them airline pilots with the day off, and we went aboard, hoisted all sail and let her go for the harbor entrance.

It was a crisp 30-knot northwester with the puffs coming out of Salem running well above that—probably at least 40. The few yachts out sailing were under shortened canvas. Heading down the North Shore we had the wind on the port quarter and even before we cleared the entrance and got out from under the shelter of Fort Sewell we had pulled by the power boat which was wide open and doing her scheduled 20 knots. When the first of the puffs hit us from Salem Harbor, that catamaran lifted her twin noses into a semiplaning position and flew. A twin-crew sport fisherman down to leeward tried to hold us, but we "walked" out from under him as though he were anchored. We couldn't have been doing less than 30 knots and probably, for a short distance during the height of each puff, more than that. We had no centerboards in her that day and she carried such a hard-weather helm with that quartering breeze that I had the eight-foot tiller right across her to hold her off and drive her. That dragged the twin rudders and set up a six-foot water plume at the stern of each pontoon like a destroyer at full speed. It was so thrilling that we four found ourselves yelling at the top of our lungs like kids on their first roller-coaster ride. The moldings that were on the bows for the first 10 feet to act as water breaks were really breaking water. They were practically atomizing it with the result that we seemed to be steaming up forward as we tore through the water. Finally, we decided to return to our waiting friends who had hove to far astern. Close hauled, she seemed to go about as fast as she had downhill. In the puffs you could feel her straining in her effort to pull her windward leg out of water. However, she maintained remarkably level keel. I don't think her windward waterline came up over 10 inches, if that. Just as we pulled up alongside our motor escort, one of the weather stainless-steel shrouds parted right at the fitting and over went the mast. Then the escort earned her keep by towing us back to the yard.





Close-up view of the catamaran shows the spider-leg design, a modification of the boat described in *Popular Mechanics*

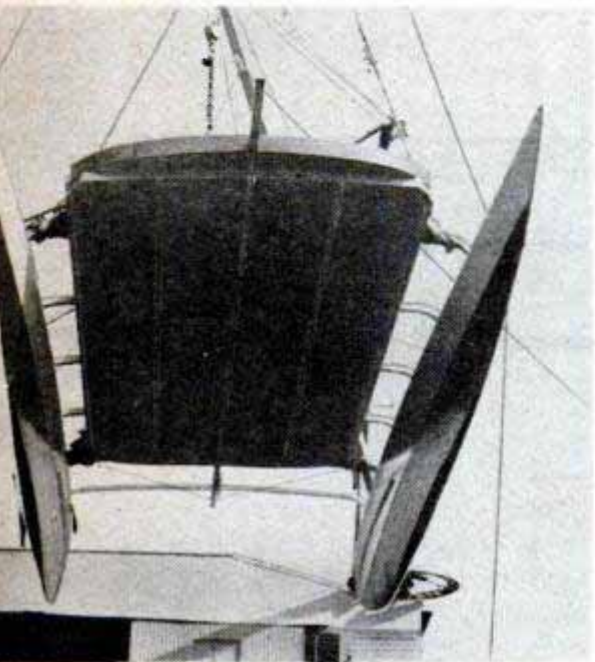

Buoyancy is provided by two slim pontoons that cut through the water with almost no resistance. Below, the broad, high deck forms a stable platform for day sailing

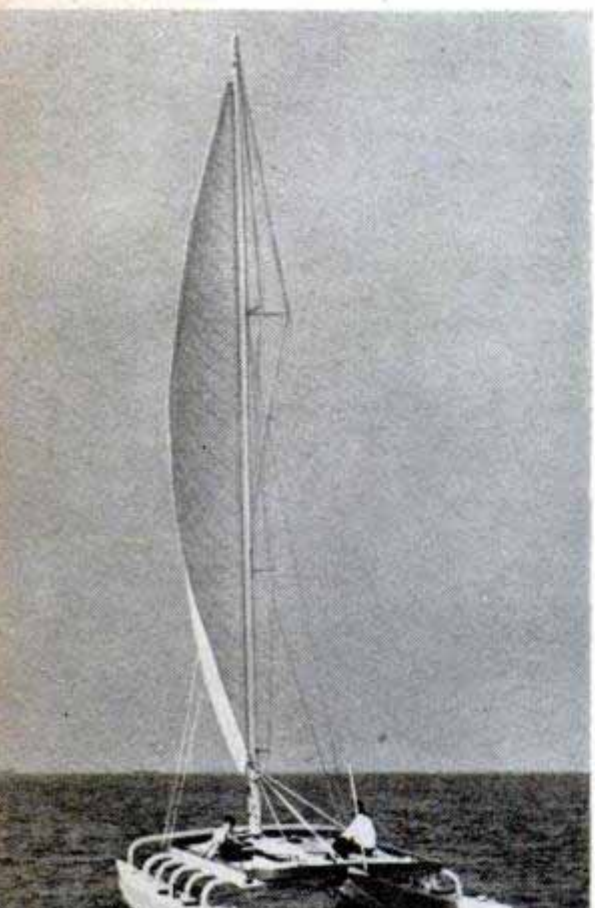

I am convinced that we attained and held a higher speed on the run than has ever been attained by a sailing vessel. That may sound like a ridiculous statement because of the utter impossibility of proving it, but I base it on 50 years of sailing experience.

Within a couple of weeks we were rerigged with a tailor-made spar a little on the heavy side and with heavier wire rigging. We substituted good old-fashioned splices in the place of fittings, added a second lower shroud and another jumper stay and were ready again. We put her into the Corinthian Yacht Club Chowder Race, a handicap affair, as scratch boat. The weather conditions were about as unfavorable as possible—a moderate to strong southeaster with a nasty, confused sea and ground swell. A four-mile beat saw those long narrow pontoons plowing through the steep seas and coming out the other side. The hull strain set up was terrific and I was fully prepared to see her break up. However, she reached the first mark and reaching for the second mark we passed half a dozen craft that had started ahead of us.

With the wind and sea abeam on the last leg, the strain on the hull grew worse. We were going great guns and passing boat after boat when, without warning, there was a crash and the whole ship seemed to crumple up. The starboard cross members broke right at the curve. The starboard pontoon drifted off to one side attached only by the steering cable. The deck fell down into the water on that side. We climbed on the other pontoon and sat like sea gulls until rescued. The Coast Guard towed in the wreckage and the season was over.

During the summer of 1950, I had the cat in my home waters of Hingham Bay, which were more favorable, and my kids had a lot of fun sailing her. I am entirely sold on the possibilities of catamaran design, even if Ray Hunt's first attempt proved too weak for rough going. During the winter of 1949, Selman Graves designed and fitted  $\frac{3}{16}$ -inch steel sleeves onto these spider legs and welded them to steel saddles bolted to the hulls at each station. This added about 600 pounds of weight and set her down a couple of inches in the water, but gave her a much greater margin of security and, I think, solved the problem of holding her together. We didn't have any opportunity of testing this new gear to anything like the limit, but I'm betting on it.

This vessel has changed hands. I hope the new owner will experiment by dropping the deck right onto the pontoons even if he has to pull them together a bit to do it. He can secure the whole contraption much better that way and still have plenty of clearance between pontoons. I'm satisfied that the hulls are very fast and that a wonderful day sailer can be made out of her. As a matter of fact, I think there is a definite place in day sailing for a smaller catamaran—about 20 feet. Such a little boat could be designed to be dry, stable, safe and very fast. It would be a great platform from which to watch conventional yacht races, ranging easily ahead of the racing fleet at all times and watching them round the marks and then beating them back to the finish line.

Harold P. Cooley, Boston, Mass.





## Reclining Bicycles

Two brothers from Copenhagen, Denmark, are pedaling their way around the world—while lying down! Their bicycles are built on long, horizontal frames which

permit them to pedal while reclining. Their heads are pillowed on convenient headrests, and the bicycle handle bars pass beneath their legs. The brothers expect to finance their three-year, round-the-world trip by selling picture postcards of the odd vehicles.



Lockheed Aircraft Corp. photos

## Portable Elevator

Air-freight handling is speeded by two new loading devices that are powered by the airplane's own electrical system. With them, one man in an emergency can load an entire transport. One is a knockdown elevator that lifts 10,000 pounds 12 feet and

has flexible ramps that permit carts and hand trucks easy access. It can be stowed in the plane. The other aid is a subfloor endless chain running the length of the cabin. A device hooked into the moving chain, through a floor slot, pushes or pulls loads of up to 10,000 pounds. The conveyor is controlled by a remote on-off switch.





Jim McNamara inspects a Rube Goldberg lie detector with a "mechanical brain" inside robot that blows talcum powder from eye if subject lies

# I WAS THE GADGETEER FOR A TV MADHOUSE

By James Deitch

Left, fly exterminator for persons filling out income tax is attached to pencil. The swatter is a decoy

Below, climax of McNamara's alarm clock which starts on page opposite is tipping can of water over sleeper

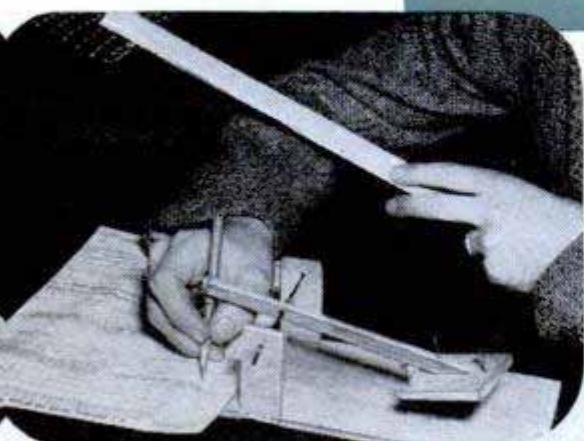



Automatic ash sifter and distributor sifts out big particles and spreads the ashes evenly over any rug

**I WANT YOU** to make an alarm clock 20 feet long that goes off when a magnifying glass lights a firecracker. Have it ready for tomorrow's show!"

That's the kind of assignments I have had from a television performer in Hollywood. The man's name is Jim McNamara and until Uncle Sam requested his services in Korea he entertained with a Rube Goldberg television stint. My job was building many of the insane inventions he demonstrated on TV. He called these "boons to humanity."

Take the alarm-clock gismo. McNamara had a particularly important show coming up and wanted something elaborate. He said that alarm clocks never went off on time, and that was why he was always late to the studio. So he wanted one that worked on something reliable—like the sun.

His idea was that the sun has always come up in the morning—as far as we know. Therefore, this useful source of illumination could be employed to set off a firecracker which in turn would start a chain of events that would eventually wake up *anybody*. Of course, as there wasn't any sunlight in the studio, he would have to



light the firecracker with a match, but the audience would get the idea.

I fastened a firecracker to a folding stand. Around the firecracker I wrapped a piece of string with a weight on the other end. When the firecracker went off, it broke the string and dropped the weight on a rocker arm, which in rocking released a piece of light rope.

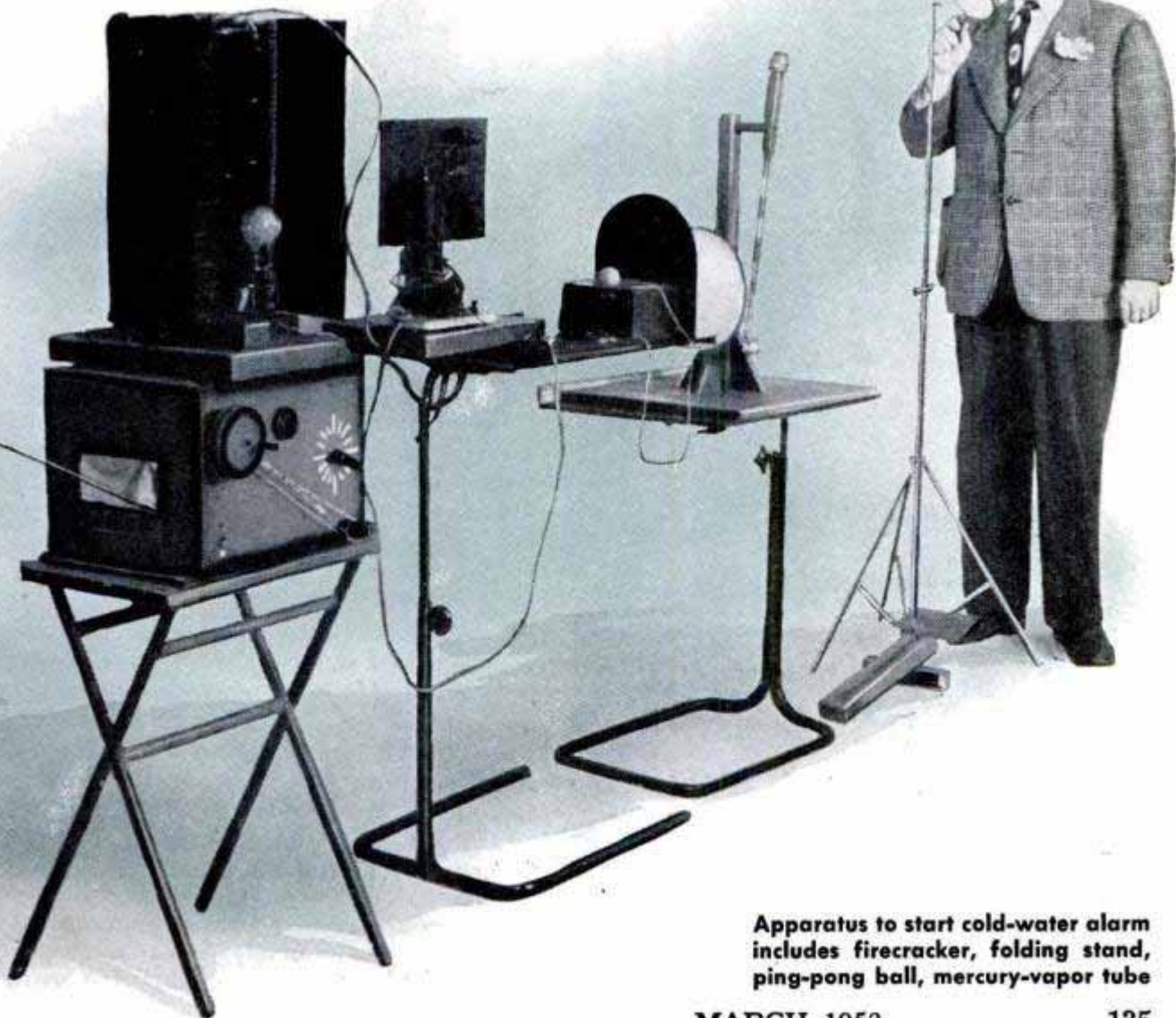

Apparatus to start cold-water alarm includes firecracker, folding stand, ping-pong ball, mercury-vapor tube



McNamara demonstrates his trick fish scaler, which has delighted TV audiences. After a fish is passed through the machine all that comes out is a skeleton. Electric motor in gadget operates two moving platforms



Here McNamara is shown placing simulated fish on intake platform. Switch starts wheels and dials turning. Water spigot is at end

This in turn released a swinging lever arm with a block of wood attached to one end. The block was studded with pins, points facing outward. These broke a balloon, which in exploding tripped a trigger mechanism, setting off a mousetrap. The mousetrap shot a ping-pong ball, attached to a string, three feet into the air. When the string jerked taut, it set off another mousetrap that acted as an electrical relay—and all sorts of things began to happen.

A gong rang. A flashbulb went off. A mercury-vapor tube began flashing. Next another relay tripped, starting a fractional-horsepower electric motor that turned a gear chain which caused a hand to revolve around a large dial, and at the same time turned a small drum which wound up a length of clothesline.

The other end of the clothesline ran over a pulley and was fastened to a tin can that was attached to a mike boom by a swivel arrangement. As the clothesline wound onto the drum, the can slowly tilted.

This can was filled with water, and I lay on a cot directly under it. For some reason I never clearly understood, McNamara insisted that I wear a flowing red beard and a top hat. He was always devising weird costumes for me, sometimes a Napoleon hat, occasionally a frock coat and a derby with a television aerial sticking out the top, and once a moth-eaten bearskin with a hole cut in the middle for my head.

Anyway, as the can tilted, a stream of wa-

Dark cloth draped over umbrella prevents friends of the owner from recognizing him and wanting to share shelter. The peephole is for observing pretty girls







The author tests McNamara's detector for locating any possible "square" electrons in faulty bowling balls

ter poured on my face, theoretically awakening me. McNamara liked the idea so well that he used it several times.

A typical example of McNamara's brain typhoons was the "soup cooler." The core of this monstrosity was an automobile fuel pump. This was powered by a six-volt dry battery, with a switch in the line. I constructed a radiator out of metal from two tin cans and some scraps of wood. The output side of the pump was connected to the radiator with a piece of rubber tubing, and another piece of tubing was fitted to the intake side. The whole contrivance was carried in a black medical bag that once belonged to my great-grandfather.

You simply carried the bag to the restaurant, and while waiting for the soup, unpacked the gear and placed it on the table. When the cup of boiling soup arrived, you placed it under the radiator, and dropped the loose end of the intake hose into the bubbling broth. I provided a screen across the intake to prevent alphabet noodles getting into the machinery.

At the flip of a switch the soup was sucked out of the cup and pumped into the top of the radiator. It then cascaded over the grid and back into the cup, being effectively cooled in the process. The thing worked perfectly.

One day McNamara came into my workshop sizzling with the idea that humanity could not continue to exist in peace and happiness unless an automatic fish scaler were instantly designed. He wanted a box that would automatically slurp up a fish, go through all kinds of weird motions, and then give forth a fish skeleton. He thought

(Continued to page 258)



Soup cooler pumps hot liquid from cup to top of the radiator where it drizzles over grid and back to the cup. Below, the "grumplatch" has no known use





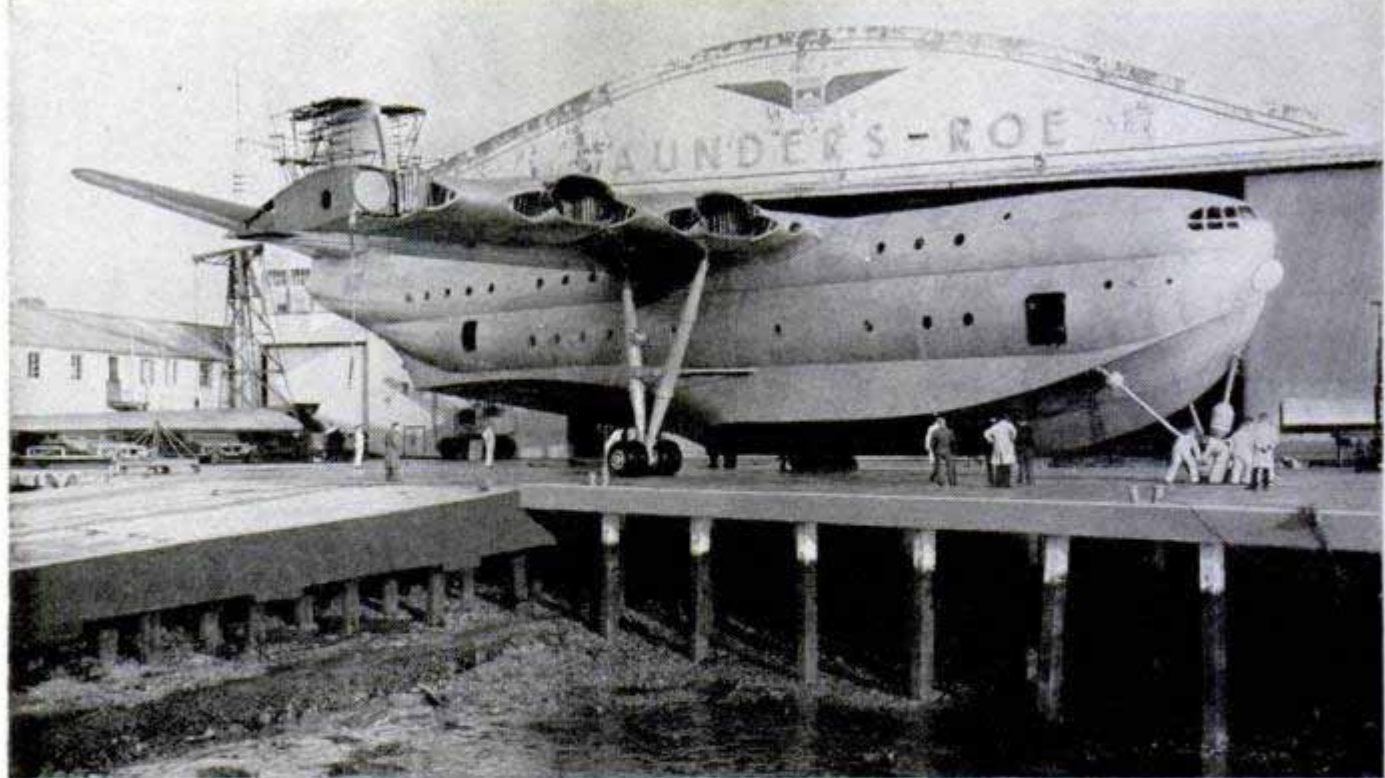

Great Britain's new 140-ton Princess flying boats will be the largest passenger-carrying aircraft in the world

## TEN-JET TROOP CARRIER

TWO HUNDRED MEN will be able to fly 3500 miles nonstop in the 10-jet, troop-carrier plane being readied for flight tests in Britain. The first of three being built in the Princess class, the 140-ton flying boat is expected to have a cruising speed of 330 knots (380 miles an hour). Her 10 Bristol Proteus turboprop engines will give an aggregate output of 35,000 horsepower. The wingspan of the giant craft, with floats down, is nearly 220 feet. Its over-all length is 148 feet. The hull is the largest metal structure ever built for an airplane. Four tanks in the wings, divided by baffle plates

to prevent sloshing, will carry a total of 14,500 gallons of fuel. Because of the plane's great weight and size, all the controls will be electric-hydraulic, with the pilot's movements actuating the power units. The double-bubble hull is pressurized to a differential of eight pounds per square inch at 40,000 feet. A pound compressor is located in each wing between the hull and the inboard engines. When all three Princess flying boats are in service, they will be able to carry in a year as many soldiers as would be carried by nine troopships of normal size.



Pivoted on the main landing wheels, the giant's nose is raised to lower tail enough to clear the hangar opening



# CHALK SCULPTOR



Carving and painting chalk figures like these take a sensitive touch. Resnick's large arms and hands make the tiny figures he carves appear even more delicate



**GIVE LEONARD RESNICK** a stick of chalk and an old crochet hook and in a few hours he'll sculpture a delicate figurine so tiny you'll need a magnifying glass to see the details.

Resnick, a young Baltimore engraver, has been making chalk miniatures ever since he was in grade school. His subjects range from Chinese figures to comic-strip characters. He does historical figures of Washington and Lincoln and also sculpts from live models (one of his best is a bust of his daughter).

The crochet hook, sharpened to a point, is the only tool he uses. He mounts the figurines on small bases and then paints them with water colors. A protective coating of clear lacquer is then applied.



Below left, Mrs. Resnick displays some of her husband's work. Right, he carves the chalk with a crochet hook





WHAT'S NEW FOR

# Your Home



**STICK-ON RULER** is printed on an adhesive tape that sticks to any surface without wetting. The tape is an acetate fiber and has yardstick markings printed on it. It is sold by the roll and can be attached anywhere by finger pressure

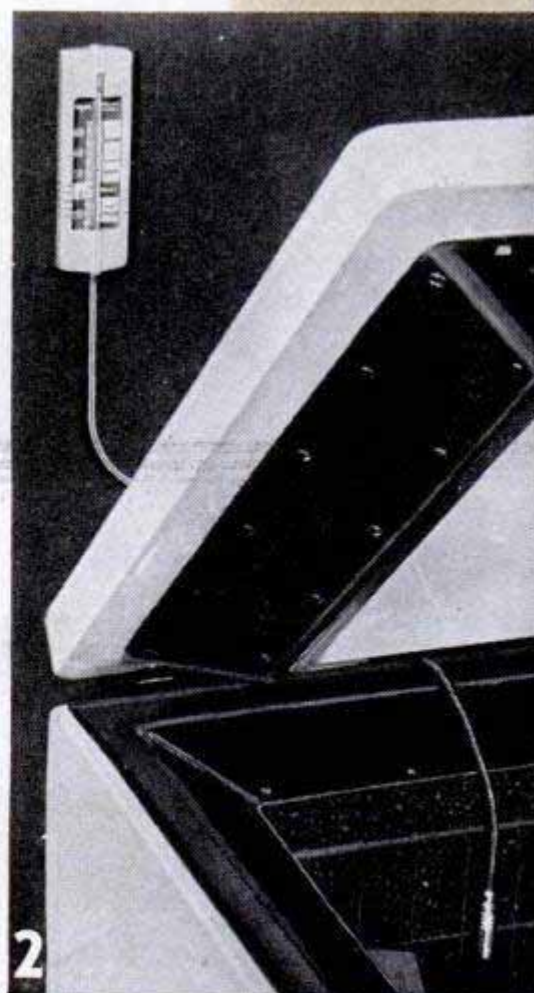
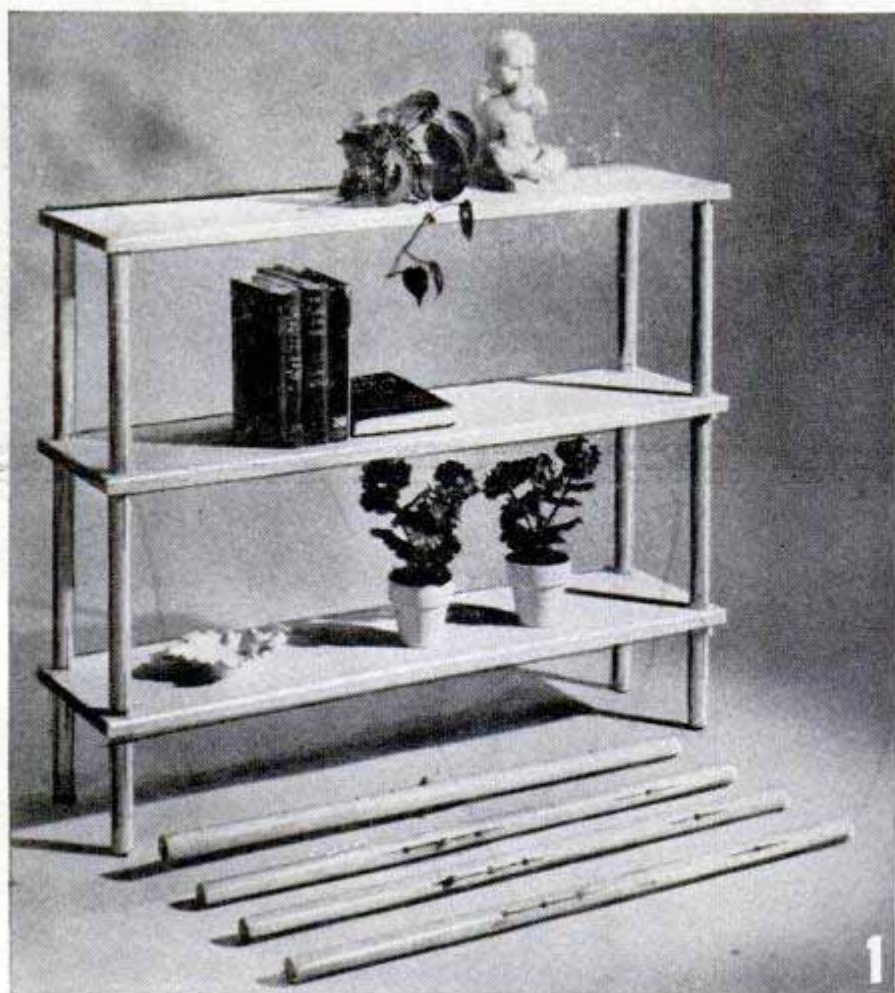



1. **SHELF UNIT** can be put together by a child. No nails, screws or hardware are used. Dowels serve as legs and they slip through holes in three knotty-pine shelves. Wooden pegs fit into holes in the dowels, expanding them to a snug fit in the shelf boards, which are supported by the same pegs. Available in 2 and 3-foot sizes, the unit is sold in kit form

2. **FREEZER THERMOMETER** provides a way to check inside temperature of a home freezer without opening the lid. It is mounted outside the freezer and gets its readings by means of a bulb hanging inside. Connecting the two is a slender capillary tube that does not interfere with lid closing. The thermometer scale is placed at eye level for easy reading

3. **CANNED-MILK DISPENSER** looks attractive on the table and conceals unsightly evaporated-milk cans. It is made of plastic and comes in a variety of colors. Inside the dispenser lid are two sharp metal points that automatically puncture the can when the lid is pressed down. The front point is formed of a tube through which the milk is poured

4. **VENETIAN BLINDS** are cleaned and polished in one quick operation with an applicator-paste combination sold as a kit. The applicator has felt pads which retain the paste, spreading it evenly over the slats. This cleans, waxes and polishes at the same time, according to the manufacturer. The applicators come flat or curved for wood or metal slats

5. **CURVED TOOTHBRUSH** reaches parts of your teeth inaccessible to a standard brush. The bristles are set in a spiral around a pliable wire which is bent to any angle to clean hard-to-reach spots. It is not intended to replace a regular brush, but to be used with it. Its handle is shaped so it can be attached to the regular brush handle with rubber bands

6. **DISH RACK** mounts on any cabinet, wood or metal. Its supporting post can be adjusted to various heights. Dishes are separated by sizes and each size is stacked on a separate rack that swings in and out for easy access. Use of the rack eliminates piling various sizes of dishes on top of each other and prevents the chipping that such stacking causes

7. **PAN GRIPPER** takes the place of the hot pad beside the kitchen range. It is an all-metal tong device that grips pans, lids and bottles between its jaws. Being metal, it is easy to keep clean. With it, you can carry heavy dishes from the oven shelf to the table using only one hand. The more you squeeze the two handles, the tighter the grip on the pan

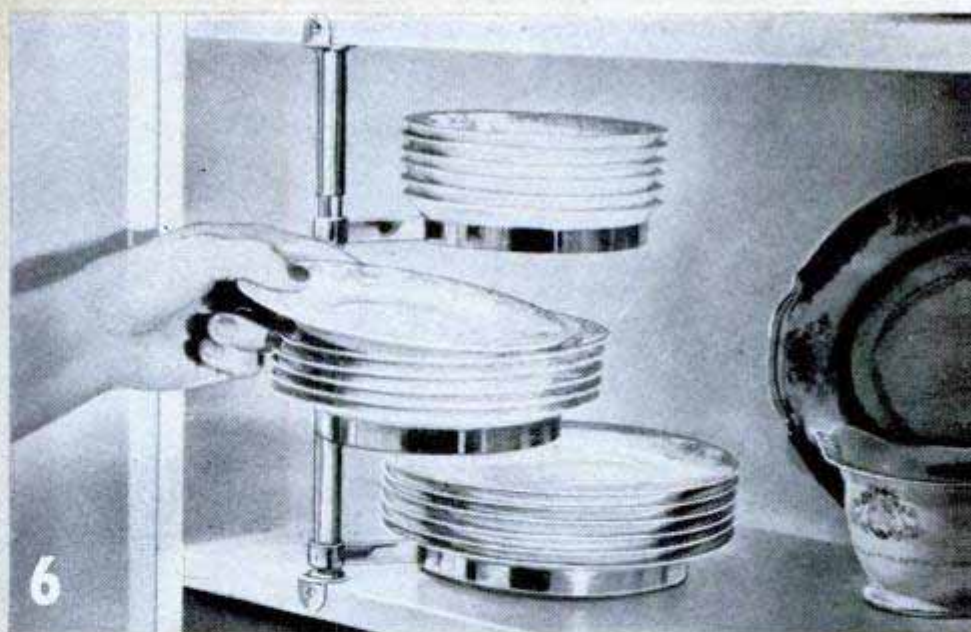
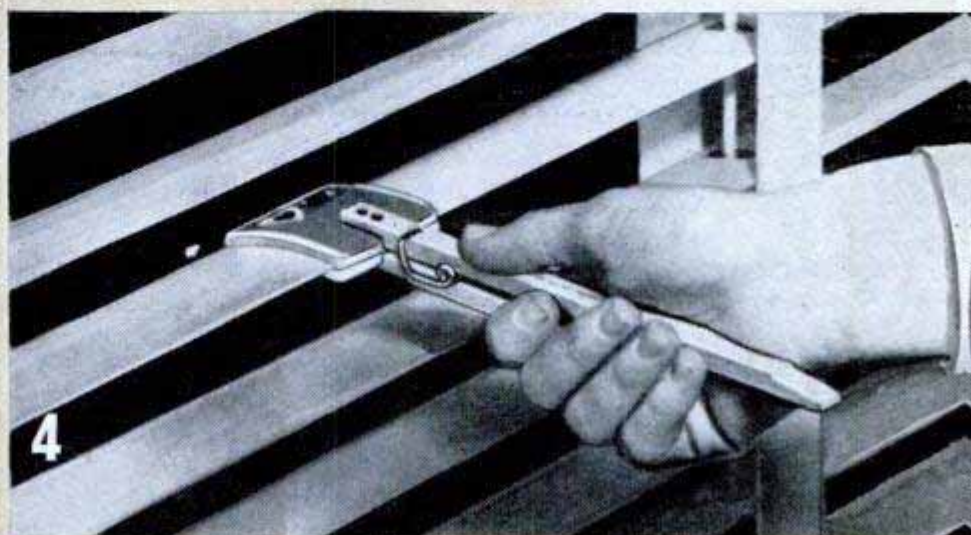



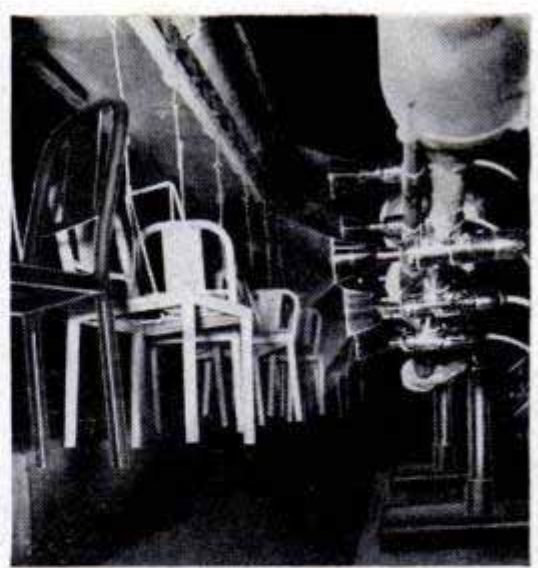
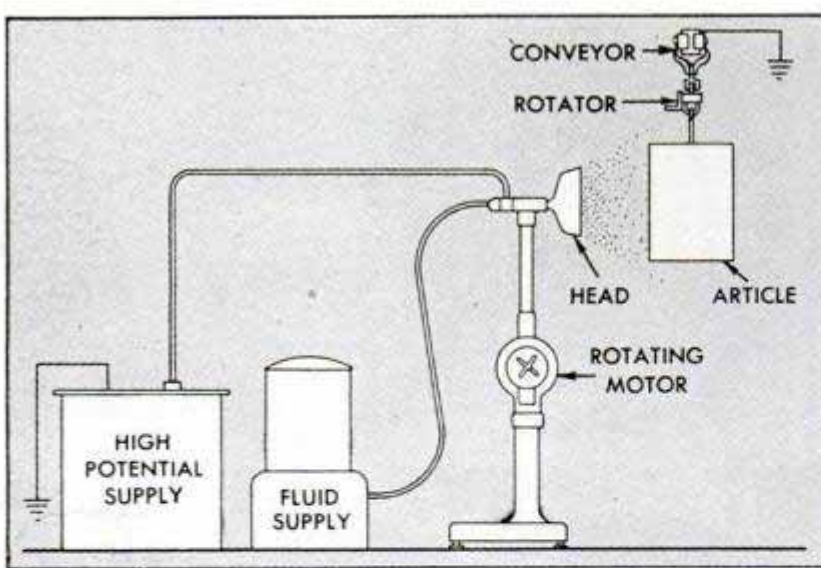

Paint is fed to a metering head, hooked to one terminal of an electrostatic potential, and attracted by the grounded article

All surfaces of these chairs are painted electrostatically as they pass the "guns"

## Automatic Paint System Uses Electrostatic "Spray"

All the paint goes on the article and none is lost in overspray with an electrostatic spray system that deposits paint electrically. The article to be coated is carried by conveyor past a cone-shaped "spray gun." Actually, it is not a gun at all, but instead is a metering device that feeds paint evenly over its rotating conical surface. A high electrostatic potential, having one terminal connected to the gun and the other ground-

ed to the article to be painted, creates a strong field between the article and the gun. The force of this field transforms the paint into a spray of fine, charged particles and creates an attraction that pulls the particles to the grounded article, coating it evenly and without waste. No compressed air is used, no waterwashed walls for overspray removal are needed and paint waste is eliminated by the process.

## Tin-Can Compressor

Used tin cans, which seem to add nothing to the economy except a disposal problem, can now be turned into something useful. A giant press, exerting a 2000-pound-per-square-inch punch, packs a hopper full of cans into a 30-pound block consisting of 95-percent reclaimable steel. The cans are dumped into the hopper by an electromagnet. The press squashes the cans into a uniform briquette ready for the blast furnace. The machine produces 6000 pounds of scrap steel an hour in briquette form. Impurities, including the small amount of tin in the cans, are removed during the reclamation process.

Used tin cans are smashed into the briquette, left, by press at right

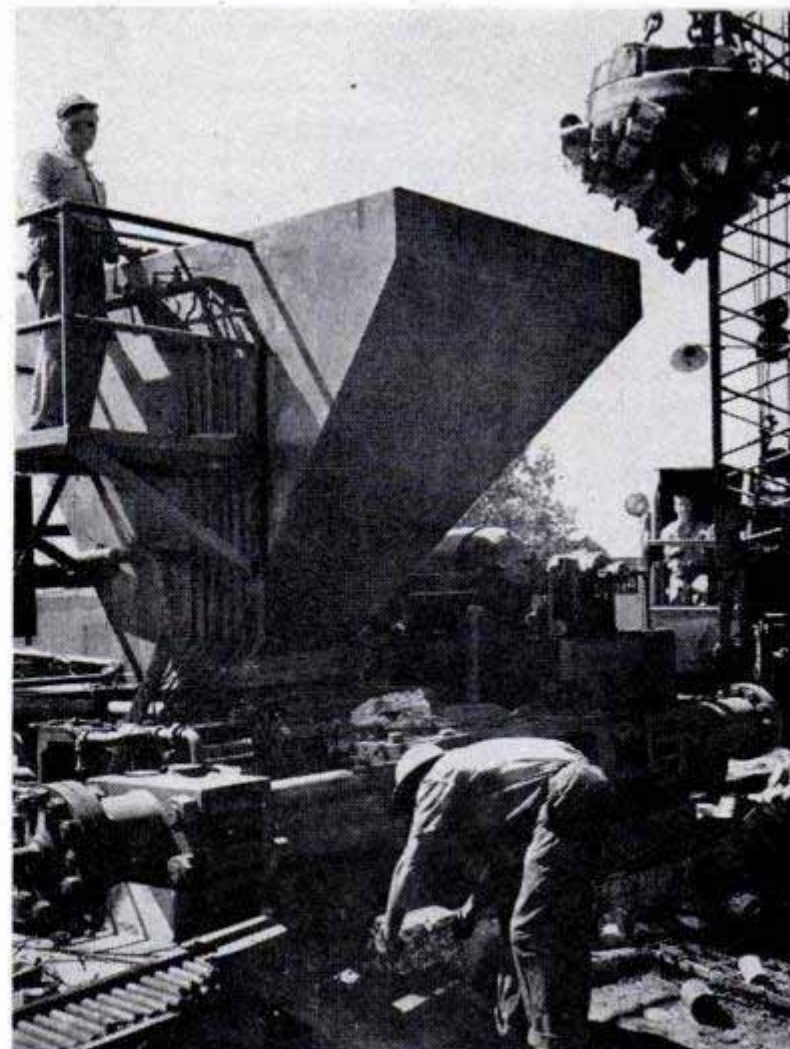



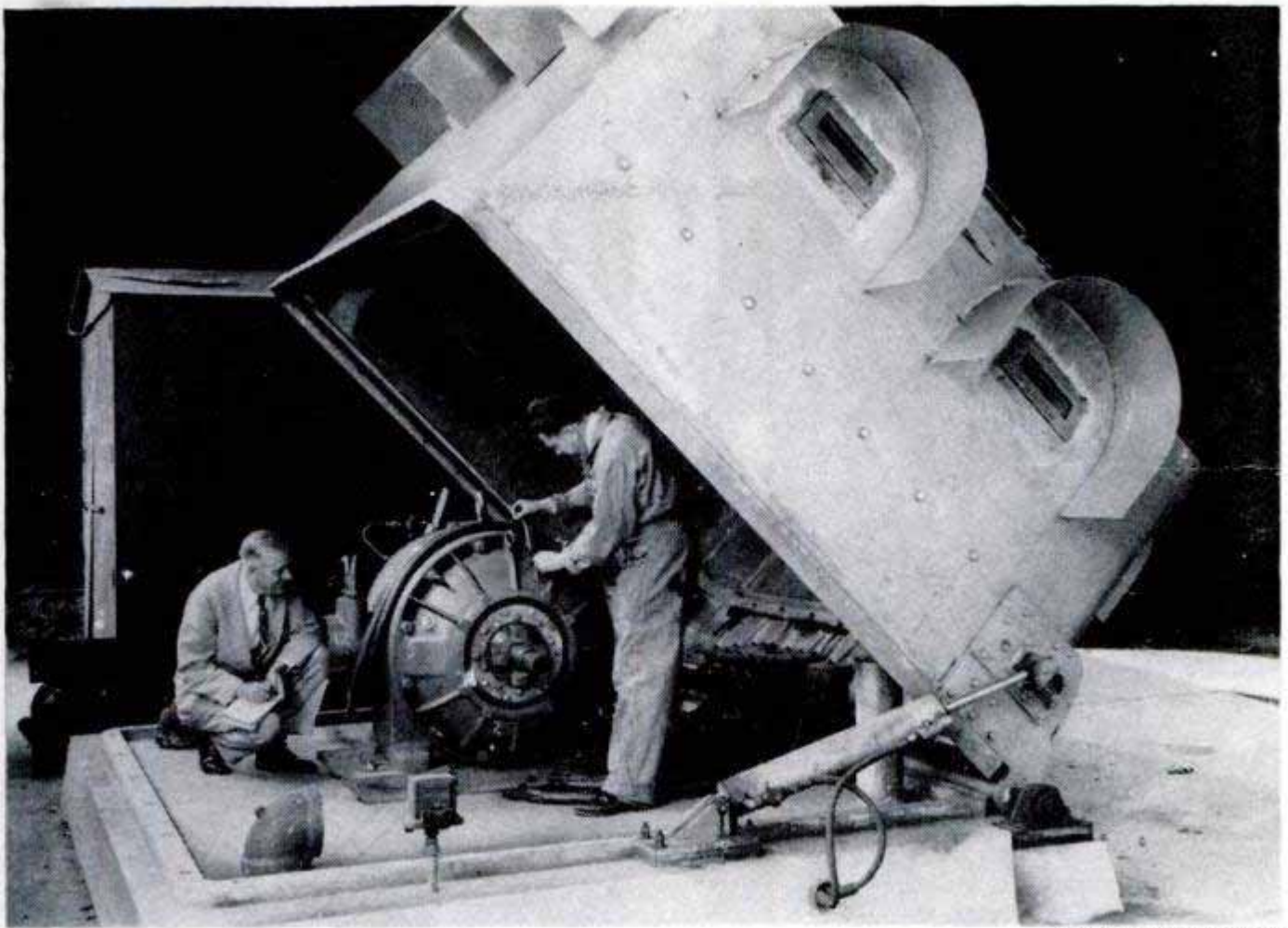

Bureau of Mines photos

## Explosion Test Chamber

Electrical equipment used in coal mines is tested for explosion hazards in a new chamber developed by the Bureau of Mines. The chamber, made of aluminum, can be tilted by hydraulic rams to permit access to the interior. The part to be tested is filled with a highly explosive mixture of gas and air. The chamber then is filled with a similar mixture, and the gas inside the test part is ignited with a spark plug. If the explosion inside the part touches off the mixture in the chamber, the part fails the test and is not given an explosionproof rating. Explosions occurring in the gas-filled cham-

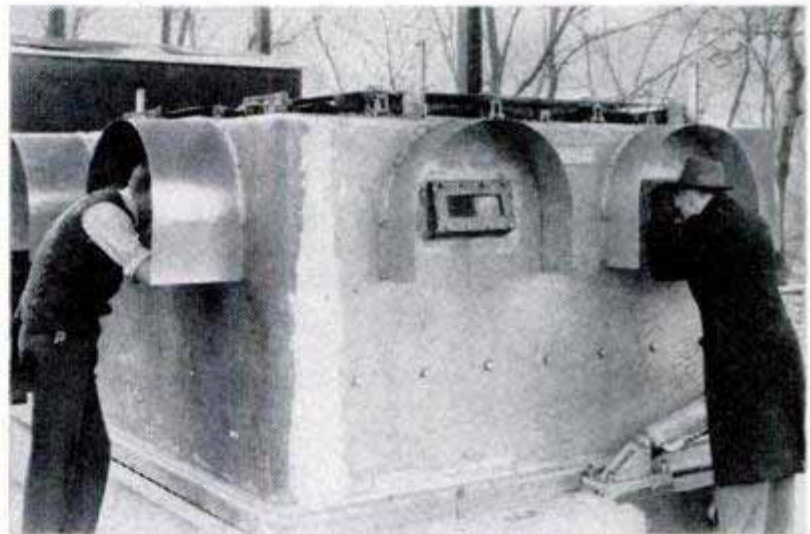

ber are released harmlessly through paper diaphragms atop the structure.



## One-Piece Hooks Attached by Feel

Quickly attached—even in the dark by touch—these handy hooks cannot come apart accidentally. Made in one solid piece with no moving parts, the hooks have thin, beveled openings. Suitable for use with wire, cable, chain or rope, the hooks are attached simply by turning them at right angles and slipping one through the other. The weight of the attached cable or rope keeps the hooks aligned in a locked position so that high winds cannot dislodge them.





Near the Guatemala border, the Russells encountered happy descendants of an abandoned Aztec garrison

### By S. Robert Russell

**G**REAT CIVILIZATIONS flourished in Mexico long before the Christian Era. Even the earliest of these ancients possessed an amazing knowledge of engineering, astronomy, weaving, stone carving and pottery making.

Strangely enough, nothing uncovered gives the slightest clue as to when or where they learned these things. Thousands of years must have elapsed as early cave dwellers struggled up toward the cultural level of Mexico's ruins. But nothing yet unearthed indicates that these first *Mexicanos* served their long appren-

ticeships in Mexico. Neither can their cultures be linked conclusively with those that flourished in other parts of the world.

It seems almost as though Mexico's first settlers dropped from the sky with their arts and crafts in a relatively advanced

The Russells' jungle car plowed through dense chaparral to reach remote rock ruins in southern Mexico

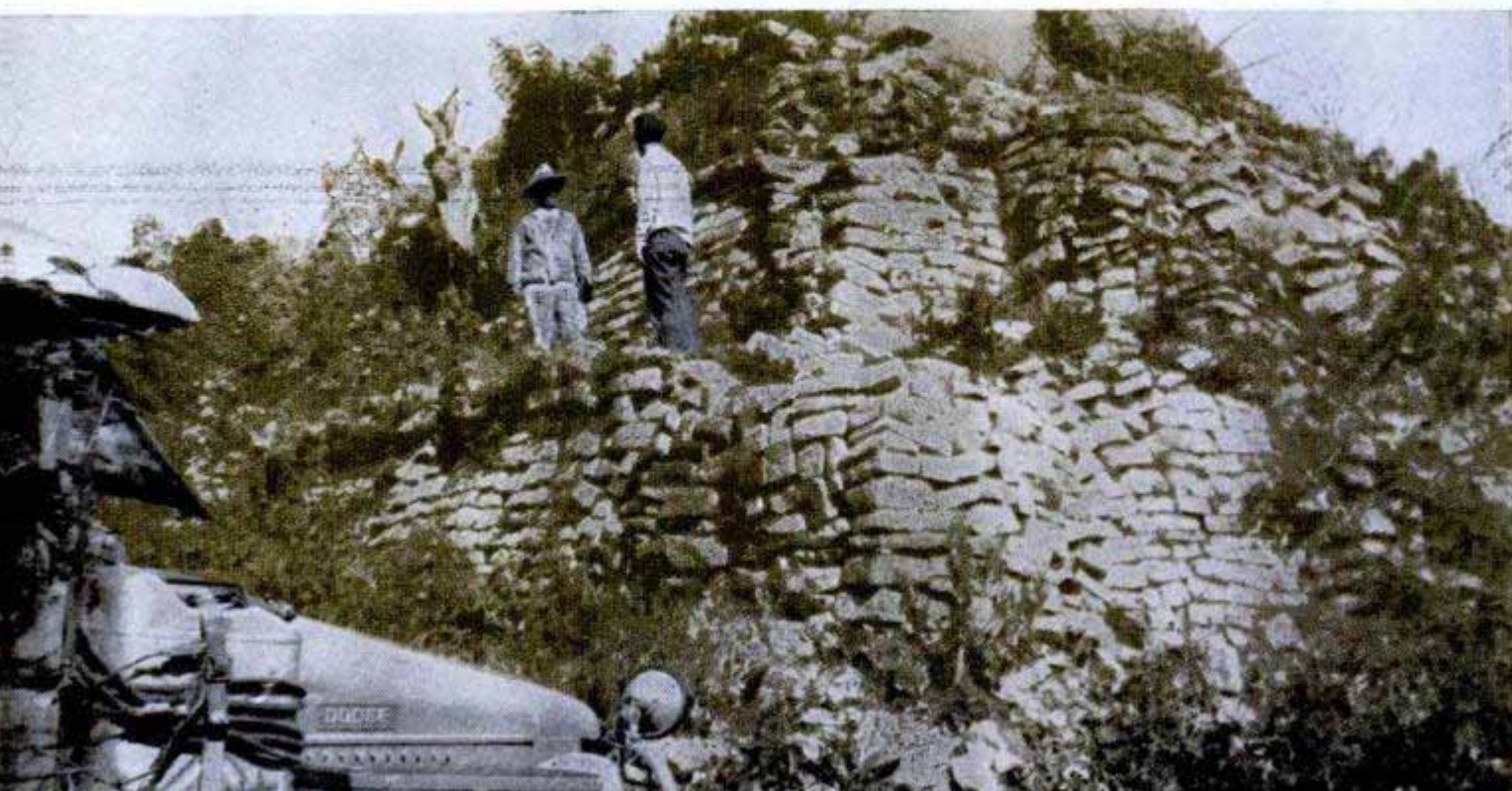



# MEXICAN SAFARI



It took six oxen and a power winch to pull the truck across the Grijalva River after being stuck 3½ hours

stage of development. This is one of the land's greatest mysteries.

On our 1950-51 expedition in our jungle truck, my wife and I searched for clues from a base in San Cristobal de Las Casas, in the state of Chiapas, about 100 miles from the Guatemala border. This city was built on the site of an ancient Indian town named Colet, in what was the heart of the early Mayan empire.

On its clean, paved streets can be seen Indians of more different tribes, each in his own colorful tribal costume, than can be found in any other settlement. They all speak Mayan dialects.

To us, the Zinacantecos are the most interesting. They are descendants of Aztec warriors stationed at a garrison in the area that was abandoned centuries ago.

We decided to drive to their village, Zinacantan. The road

was a narrow, rough oxcart trail that clung precariously to the sides of mountains. At one point we found a landslide had completely blocked the road with huge boulders. The thought of turning around was unattractive because the width of the road was only slightly greater than the truck's



Herminio, the guide, Mrs. Russell and native boys inspect rock with ancient markings found in Mexican cornfield





Jungle car meets with landslide on a narrow road with a drop of 200 feet on one side. It took Russell a half hour to turn back



Incense burner used by Lacandon Indians during tobacco-planting and harvest rituals has hole under head to support burning cigar

Military tread on tires was a boon to the Russells in traveling over jagged rocks which would have cut ordinary tires to shreds



wheelbase. A 200-foot drop on one side made backing up for a mile or so even less inviting. I chose turning around. It took me a half hour and required 26 cuts of the wheels before I made it.

Then there was the time we decided to ford the Grijalva River to reach the little town of Acala. The place was rumored to be the site of ruins left by a vanished and unidentified people.

We reached a point opposite the town after bouncing and grinding over 25 miles of the roughest trails. Once there, the people warned us that no truck could possibly ford the river. It had never been done. Ox carts could do it, they said, because their wheels stand very high and oxen can swim.

Our engine sat higher than that of a conventional truck, so we tried to follow an ox cart across. We would have made it, with water well up on the engine, if I hadn't dropped the front wheels into a hole.

We were stuck there for 3½ hours. The swift current undermined our tires and the heavy truck settled lower and lower. The hand crank on the truck's winch pulled the cable so tight that it sang like a fiddle string, but it could not break the wheels loose.

Our jungle home would probably be there yet if the friendly natives had not come to our rescue with oxen. It took six of the powerful beasts, plus the winch and cable, to pull us to dry land.

And so we finally drove into Acala, establishing a record as the first to do so. Once there, we found the ruins were no different from countless others of the early Mayan empire.

From a scientific viewpoint, however, this expedition was quite successful. In exploring a remote cave, we discovered a cache of hundreds of shallow mud bowls. They were extremely crude, obviously shaped by hand, and appeared to be sun-baked. Possibly they are the oldest pottery yet found in the country.

(Continued to page 250)





## Hot-Air Radiant Heat In Catacombed Floor

Sheet-metal forms, interconnected like miniature catacombs, make concrete floors for houses that are radiant-heated by forced hot air. The forms, flat on the bottom, are assembled directly on the subslab

and connected to a concrete supply duct from the heater. When the finished floor is poured over the forms, a series of "mushroom" columns is created to support the floor. Warm air, forced into the hollow space that honeycombs the floor, warms the concrete, creating a room-size, radiant-heat panel. The hollow space is also connected to registers which can be opened or closed to provide quicker heat when necessary. Once the floor has been heated, however, the registers are closed and the house heated entirely by radiation. The concrete supply ducts from the heat are buried below the subslab. Installation of this system is said to cost substantially less than for other types of radiant heat.

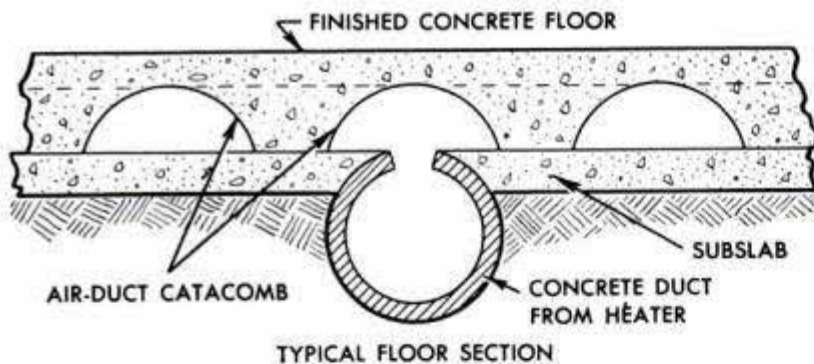

## Speedy Refueling of Jets

In 2½ minutes, a tank truck refuels a thirsty jet plane through two boom-supported hoses. The equipment, consisting of a semi-trailer tank truck with swinging fuel lines and special high-speed nozzles, was built in the Netherlands. It has been used by the R.A.F. in England. Tank capacity of the unit is 2650 gallons, and it can be driven 38 miles per hour.

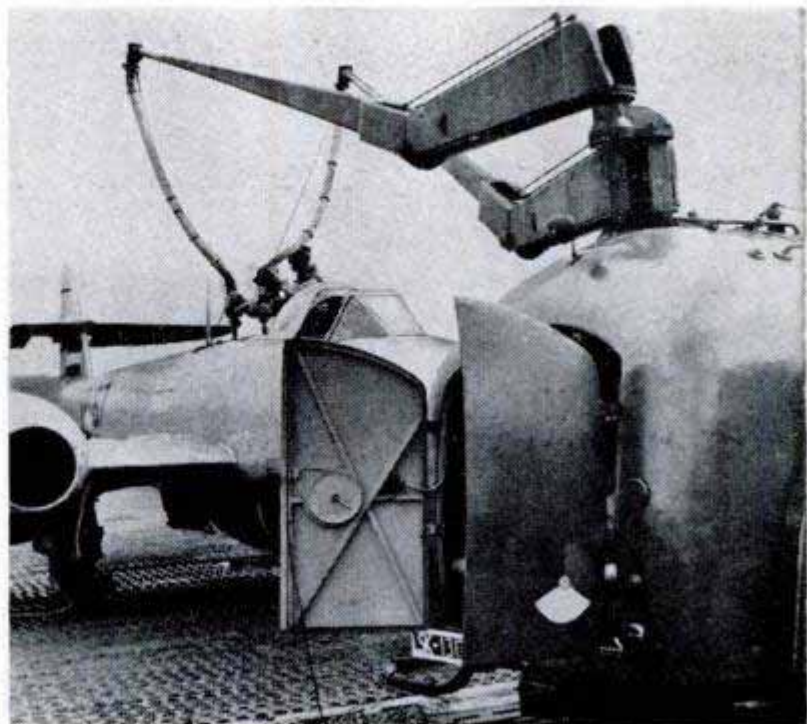

Sources of available products described in this issue are listed on pages 14, 16 and 18. Sources of further information on other articles are given in the WHERE-TO-FIND-IT LIST, available from Bureau of Information, *Popular Mechanics*, 200 East Ontario Street, Chicago 11



# A BEETLE FIGHTS A BATTLE

By O. A. Fitzgerald



SOME DAY a monument may rise to immortalize the goatweed beetle. It could be in California, or Oregon, or Washington, or Idaho, or Montana. In all those states, and a few others on the sundown side of the Rockies where stockmen have seen goatweed explode all over their ranges, this popular relative of the very unpopular Colorado potato beetle is chewing its way to fame.

In its quiet, persistent and dependable way the goatweed beetle is doing for present-day stockmen what the sea gulls did for the Mormon pioneers in Utah. Already the beetles have given back thousands of acres of range land to the stockmen, and the insects' real job—from the standpoint of the West's livestock industry—is just beginning.

This useful beetle looks very much like a ladybug, except for color. The goatweed eaters come in several metallic hues—dark blue, dark green, purple and greenish bronze.

Whether you want to call that weed goatweed, as is common in the Pacific Northwest; or St. Johnswort, the name the weed has carried in its westward migration across the United States; or Klamath weed, as it is known in California and Oregon, the weed has set something of a record for fast spread and destruction.

The weed's original home was somewhere around the Mediterranean. It was first reported in the eastern United States in 1600. First Pacific Coast appearance was along the Klamath river in Oregon. Ranges where goatweed was unknown 20 years ago are loaded with it today. The plants are prolific seed producers, and livestock scatter those seeds.

Some years ago a U. S. Department of Agriculture agronomist became curious to learn just how many of the tiny goatweed seeds it would take to weigh a pound. That agronomist, Clarence I. Seely, soon regretted his curiosity. After suffering eye-strain trying to count enough individual seeds to get a weighable quantity, he turned to very rough guessing. Now he is content to answer the question with a general "way up in the millions."

Dark spots are imported beetles working away at their favorite occupation—eating the destructive goatweed



Western ranges were strangling until a little bug from Australia with a voracious appetite for goatweed was imported and sent out to pasture . . .

Worst of all is that the seeds, despite their powdery fineness, have a high rate of germination. Almost every one that drops from the fleece of a migrating sheep can be expected to grow into a plant.

As the goatweed acreage zoomed, stockmen found themselves confronted with this dilemma: They couldn't afford to control the weed; yet if they expected to stay in the business of raising meat or wool they couldn't afford not to.

Goatweed goes for land that isn't worth much per acre. Several of today's chemical weed killers will knock out the weed easily but on \$1 land the expense is terrific. From the cost angle, this method of control hardly could be justified.

When the full impact of the weed was felt, many stockmen were ready to give the land back to the Indians. Then they heard about some bugs down in Australia that loved to eat goatweed, in fact wouldn't even look at anything else.

"Bring 'em up, we've got lots of goatweed," declared a Washington cowman.

The first colonies of those bugs were settled in California by the U. S. Department of Agriculture and the University of California. Getting Australian beetles to like their new home wasn't simple. For instance, Australia's winter rains were a signal to start laying eggs. Our scientists pulled a fast one by putting the bugs under light sprays every few days. Thinking it was the rainy season the beetles came across with the eggs.

Today, in California, billions of the beetles are chewing away on the goatweed on hundreds of thousands of acres of range land in 20 counties. Stockmen who once were worrying about the weed now are thinking about the best combinations of grasses they can use on the land the bugs are reclaiming for them.

Beetles from California have been flown by the hundreds of thousands to Oregon, Washington, Idaho and Montana to carry on the good work in northern ranges.

Typical of the way the beetles are handling this assignment is the story of one Idaho colony. In the spring of 1948, an entomologist from the University of Idaho dumped an ice-cream carton full of beetles—around 3000—on the ground in about a six-foot circle on a hillside in the Clearwater canyon.

"Those beetles have now increased and

(Continued to page 260)



Brought to Idaho by plane, about 3000 beetles are released to colonize a range blanketed with goatweed



Friendly Australian beetles are scooped into a paper sack to establish a new colony. Below, beetles cooperate with collectors, drop off plants at a touch





RADIO FREQUENCY  
ACCELERATING CAVITY

MAGNET

X-RAY BEAM

ELECTRON INJECTOR

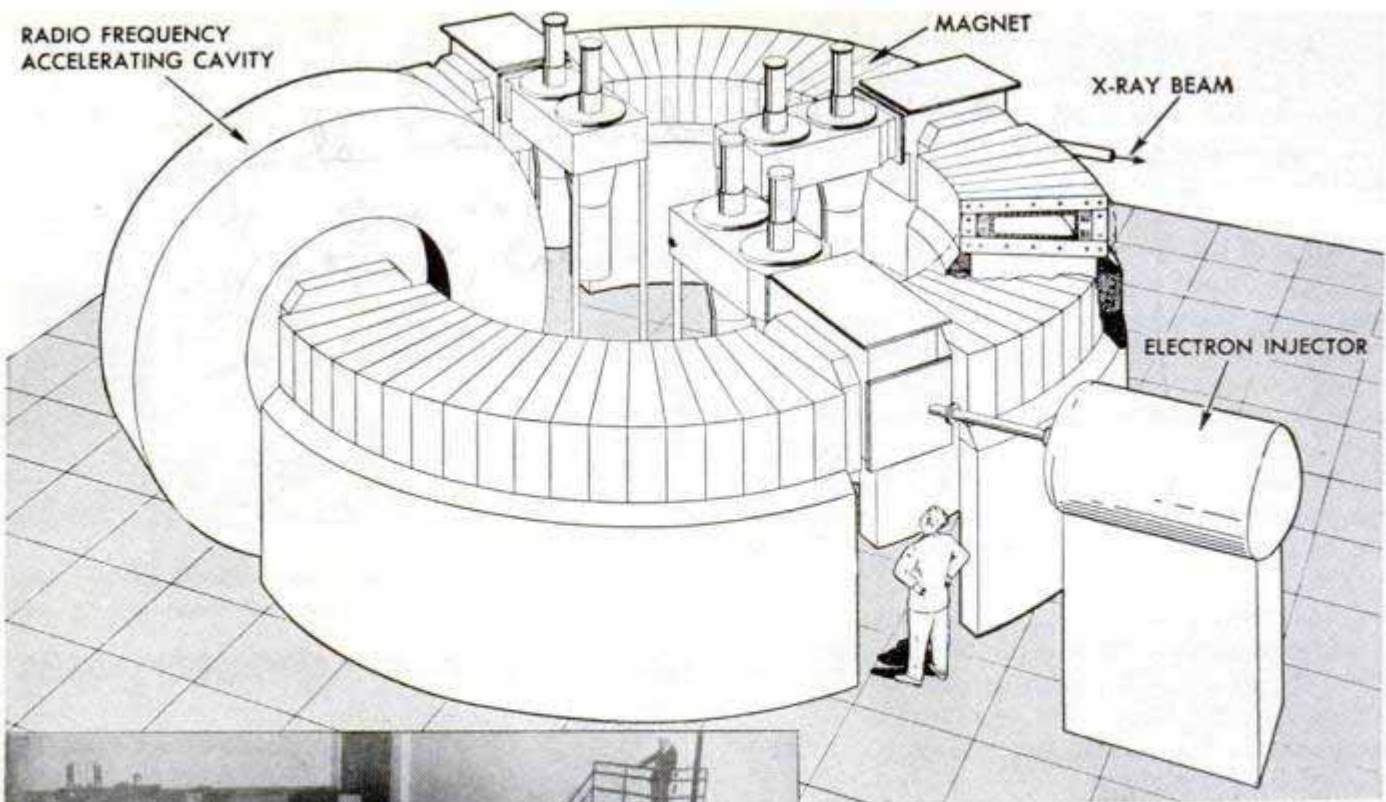

Electrons from injector move through vacuum tube inside circular magnet. Radio-frequency booster imparts speed to electrons

Magnet of big synchrotron is 36 feet in diameter. Nuclear instrument may help scientists solve mystery of atomic "glue"

## Atomic "Race Track" Boosts Electron Speed

Electrons will travel 50,000 miles in  $\frac{1}{4}$  second around an atomic "race track" which may help scientists solve the mystery of atomic "glue," the force which holds the nuclei of atoms together. The new nuclear-research machine, called an electron synchrotron, now is under test at the California Institute of Technology. Built at a cost of \$1,250,000 and financed by the Atomic Energy Commission, the synchrotron

consists of a ring magnet, 36 feet in diameter, and a radio-frequency booster. The booster imparts more speed to the electrons each time they whirl around the curved vacuum tube inside the magnet. In full operation the electrons will have a peak energy of a billion volts and will travel just under the speed of light. The instrument will create X rays, mesons and other particles for nuclear studies.

## "Level Load" Trailer Axle

Installed individually or in tandem, an axle now available for trailers has a very low center of gravity and is designed to keep trailer bodies level even when hauling off-center loads. The unit consists of two helical torsion springs around a steel axle member which has offset wheel spindles.

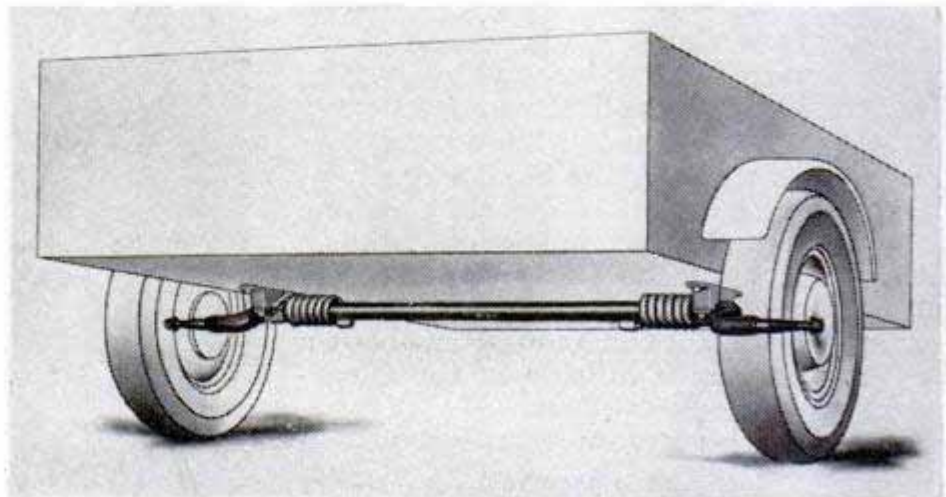



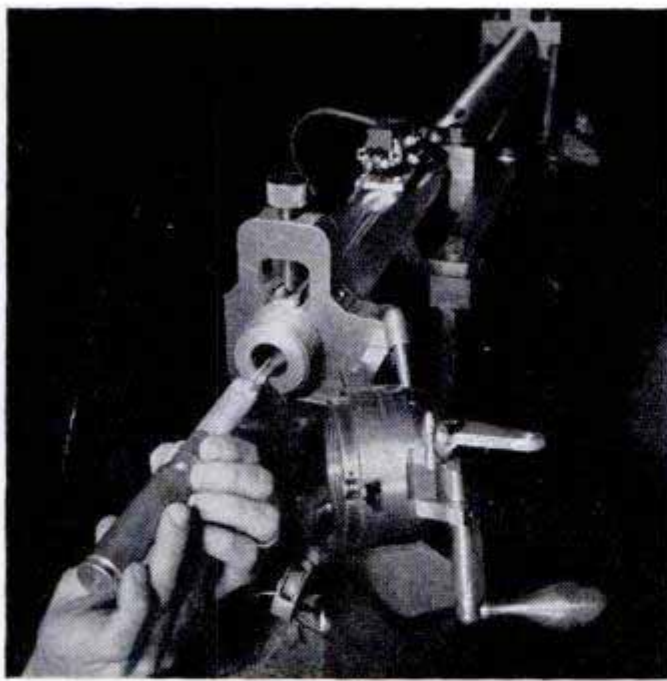

Missile when loaded is housed in a plastic carrier which breaks away as the model leaves the gun muzzle

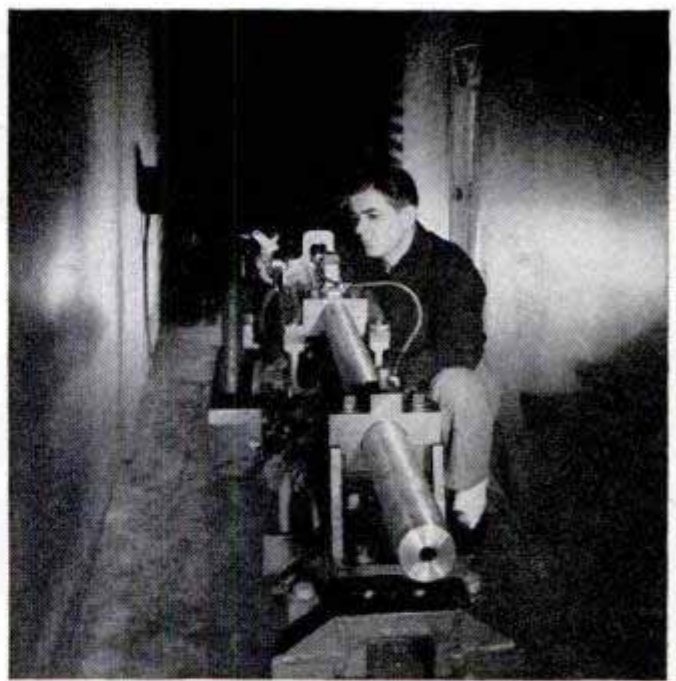

Guns of various calibers are used to fire test-shape models against supersonic air stream inside tunnel

## Test Gun Fires Tiny Missiles

To test missiles of various shapes, engineers at Moffett Field, Calif., are using a gun to fire tiny models through a free-flight tunnel. The models are launched against an air stream of from two to three times the speed of sound. This, plus the velocity of the missile, produces data on aerodynamics at eight times the speed of sound. Photoelectric cells time the model in flight. The missile crashes into cotton waste.

Cutaway of the tunnel shows how speed of the model is calculated by several photoelectric-cell recorders

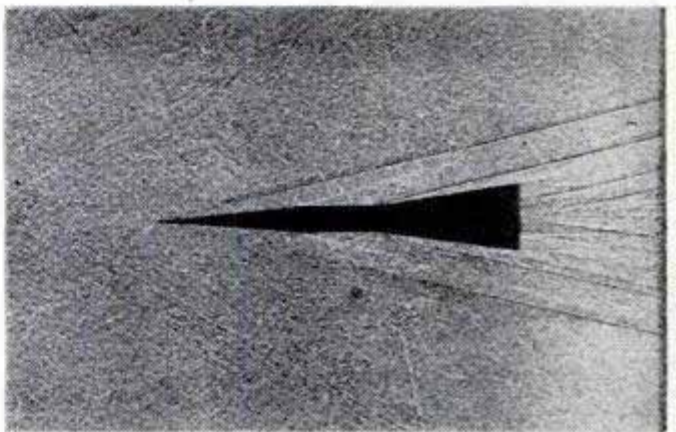

Shadowgraph of a missile model in flight reveals supersonic shock waves caused by the missile's shape

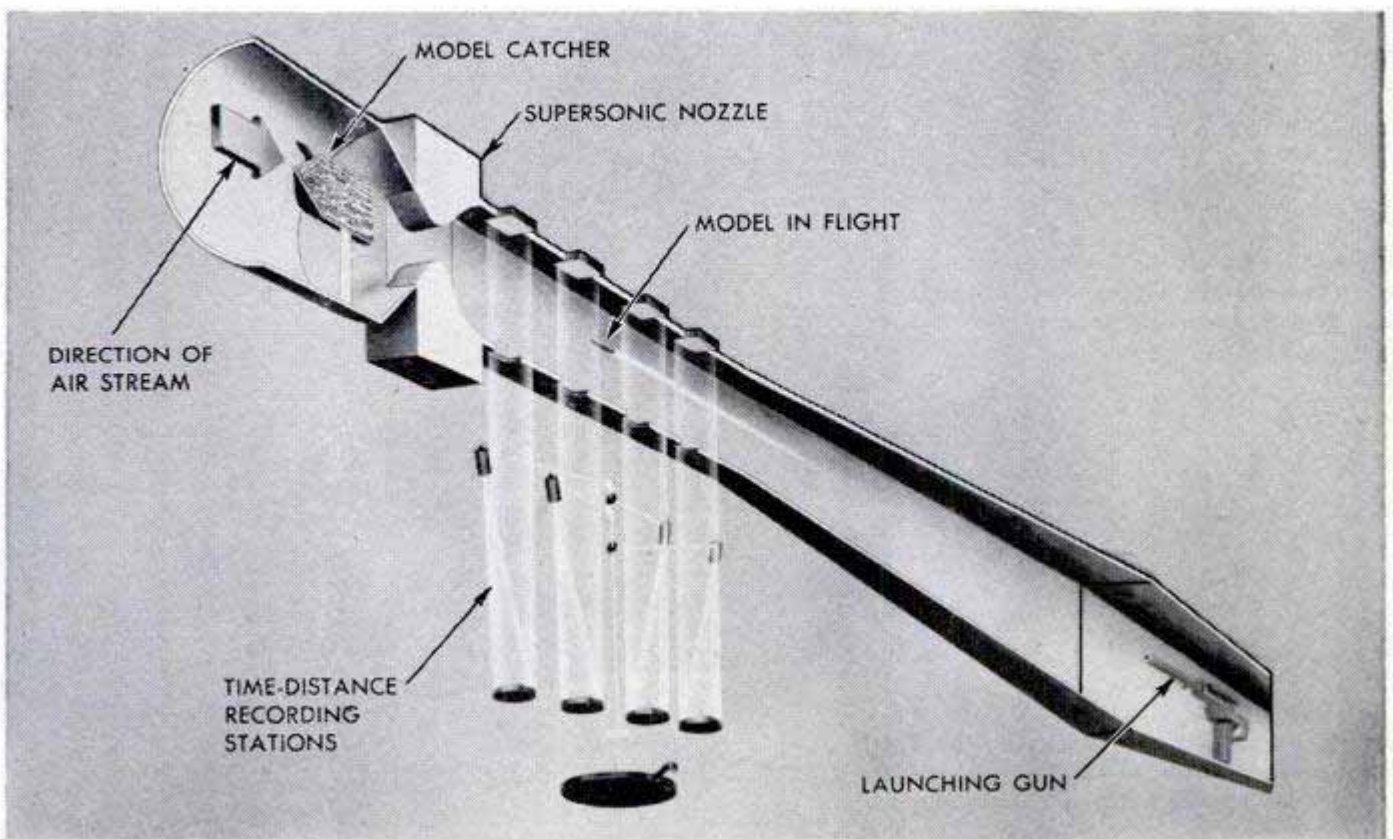



Novice drivers fight for position, right, as they head into bank turn at start of race at resort town of Elkhart Lake, Wis.

*Sports Car Club of America  
P.O. Box 508  
Westport, Conn.*

Taking time out from his work, machinist Richard Gent winds up his \$5000 Bandini Fiat for the first time on a closed course



# SPORTS

*By Donald R. Brooks*

A ROARING EXHAUST catches your ear at a stoplight, and you have to look down at the driver of a low-slung, power-packed sportster alongside.

He's the proud owner of a gleaming sports car, all wrapped up in his favorite hobby — tuning, polishing and driving his cherished, precision-made machine. A member of the regional Sports Car Club of America, this hobbyist carefully plans his holidays to participate in a sport that is fast growing in popularity in this country—road racing against competition at full speed on a closed course.

Next summer, from all over the United

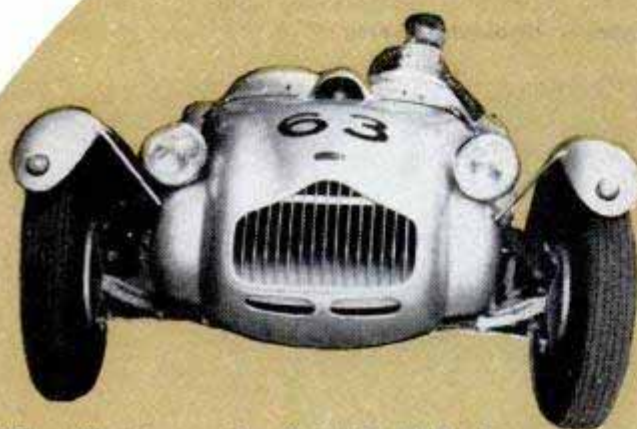

Cadillac-Allard, expertly piloted by Michael Graham, placed second in feature race



Argentine driver George Malbrandt is ready to send his Jaguar, No. 135, around the 6.75-mile town-and-country-road course



Turning up speeds of 100 m.p.h., the Fiat Siata uses 4.25 by 15 tires, weighs 850 pounds and is powered by a Crosley engine





## **CARS** Take Over the Town

States, hundreds of the shiny speedsters will show up at competition events staged solely for their own enjoyment. A typical example of the gala affairs was the one held at Elkhart Lake, Wis., last year.

What happens to a town of 571 population when a crowd of some 50,000 racing enthusiasts and spectators swarms into it for a day?

The quiet resort of Elkhart Lake found out one warm week end in late August as sports-car fans from all over the United States, and drivers from several foreign countries, wheeled their cars into the town for another "turn" at road racing.

After a "dress rehearsal" and attendance of 10,000 people the previous year without publicity, this was a full-scale parade of the country's most prized vehicles in the sports-car field.

A chamber of commerce official, anxious for the visitors to enjoy themselves and yet insure their safety, proudly spoke of national-guard units, local and near-by fire departments, ambulances, doctors and policemen in attendance, which were just a part of the planning that required seven

months. Even a crash boat had been ordered to stand by on the calm lake in case of an accident in that vicinity.

All anxious to do their bit for the colorful affair, the contented citizens of this little town graciously opened their homes to accommodate the tremendous overflow from the few hotels that were booked up months in advance of race day. As one local merchant put it, "Every citizen in the town except those on crutches has been assigned something to do."

The big holiday, planned by C. Bayard Sheldon, racing enthusiast and Chicago banker, was another activity of the S.C.C.A. Patterned after such successful events as the Watkins Glen Grand Prix, Bridgehampton and Pebble Beach races, this was a national 200-mile nonprofit affair.

According to Sheldon, 60 percent of the Chicago S.C.C.A. membership are tremendously interested sports-car owners who earn \$5000 per year or less.

Starting their parade to Elkhart Lake two days ahead of race time, upon arrival the carefully groomed mounts are wheeled into a test line where they are required to

**In a powerful blue-and-white Cunningham, John Fitch averaged 80.82 m.p.h. to win the 200-mile grind against top drivers**

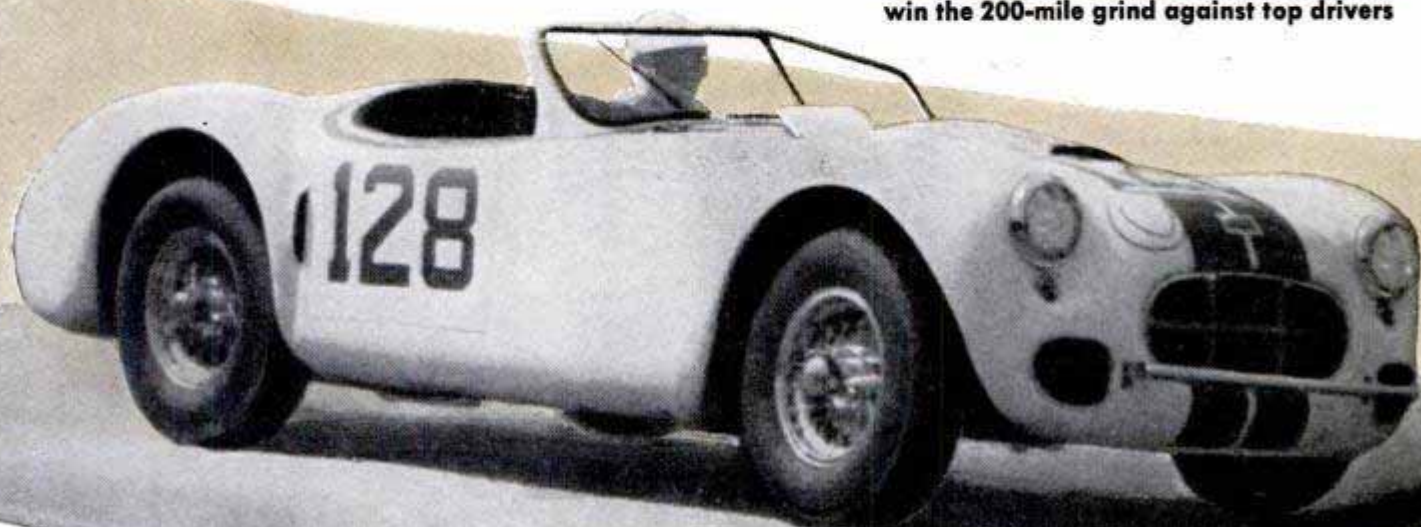



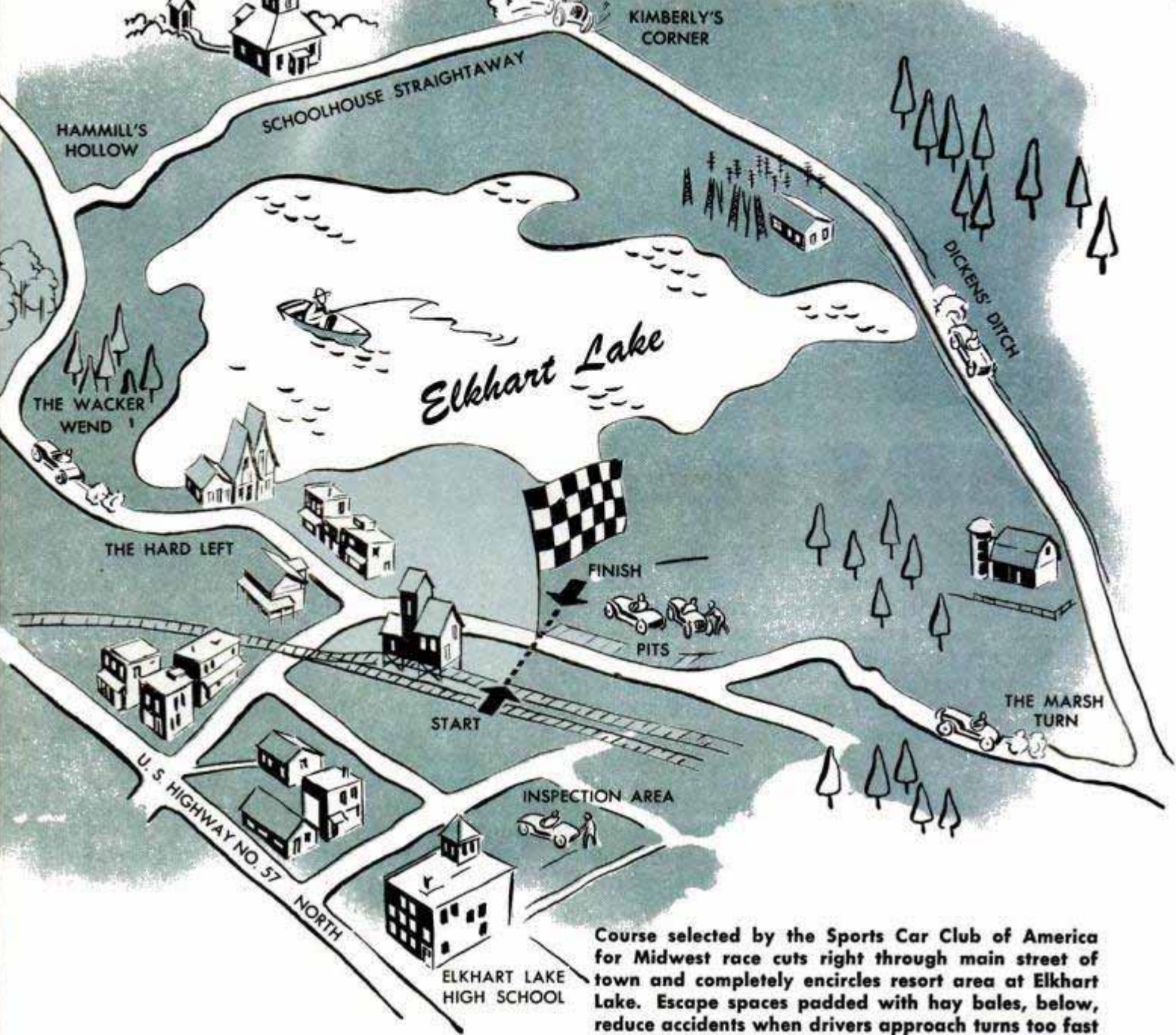

Course selected by the Sports Car Club of America for Midwest race cuts right through main street of town and completely encircles resort area at Elkhart Lake. Escape spaces padded with hay bales, below, reduce accidents when drivers approach turns too fast







Inspection of competitive cars includes a test to be sure the tank is filled with regular pump fuel

undergo examination by experts to insure proper conditioning and qualification for competition. Here the cars are checked for wheel balance and alignment, front end and steering, action of brakes, including emergency, and condition of brake lining, tires, wheel hubs, horn, mirror, headlights, taillight, stoplight, door locks, oil or gas leakage, windshield, spare tire, fenders, generator, starter, safety belt, crash helmet and goggles. A sample of fuel is taken from



Bad skid sends Bill Spear's Ferrari into the hay, off the road and almost through a barbed-wire fence

the tank and tested to be sure it's pump fuel—regulation for the race.

Drivers are also required to have an eye examination, take out necessary insurance to cover themselves and the pit crew and produce a competition license for S.C.C.A. road racing.

Entry fee for competition cars is \$10.00.

Necessary equipment for the pit crew of each competing driver includes a copy of road-racing regulations, fire extinguisher,

On one of the straightaways, Ted Boynton of Winnetka, Ill., uses all the power of his 1971-cc Frazer-Nash







Critical wheel alignment of cars is checked by experts in the inspection area before race day

first-aid kit, tools and an ample fuel supply.

Once through inspection, drivers are free to acquaint themselves with the course, abiding by local road regulations. They continually "wind" their highly tuned cars around the course into the night to become thoroughly familiar with every curve, hill and turn of the road. Every second is a valuable one during the race and taking maximum advantage of all opportunities

for acceleration may mean closing the gap behind the leader.

Selected for convenience of club members, because of its midway location between East and West Coasts, the 6.75-mile course at Elkhart completely encircles a lake, takes in the town's main street and a pleasing number of hills, curves and square corners. In mapping such a course for sports-car competition, every effort is made

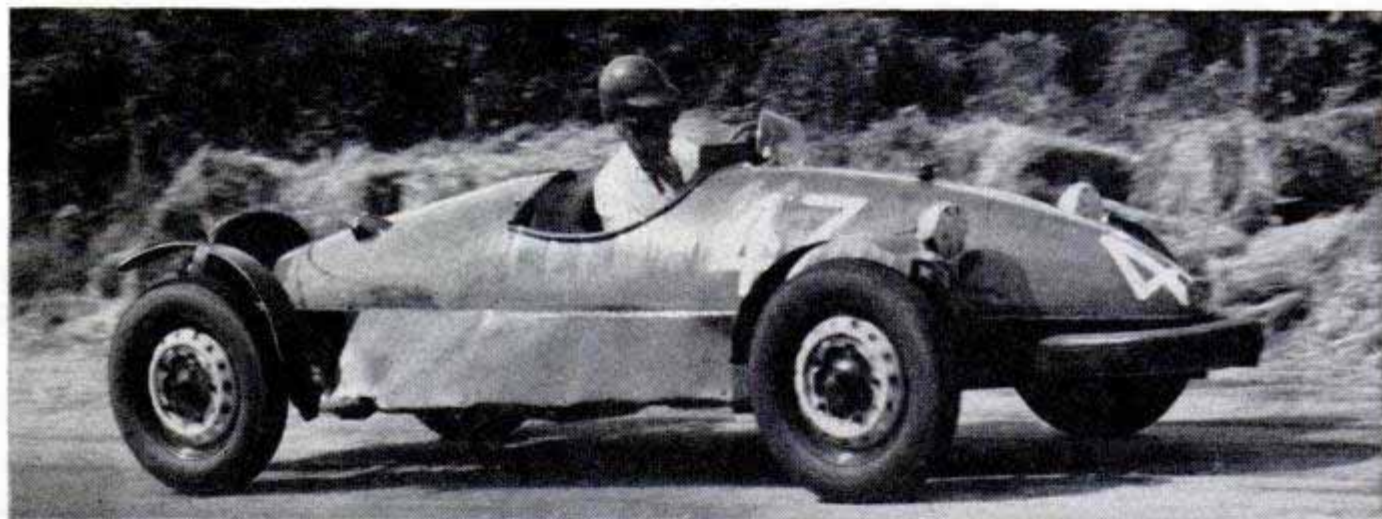

Kurt Hildebrand, above, gets lots of speed out of his German Volkswagen chassis fitted with a cut-down airplane belly-tank body. Below, Kurt quickly changes power plants in his rear-engine car along a quiet street





to keep an escape route open beyond sharp turns for use by drivers who may approach the turns too fast and feel they will be unable to bring their cars safely around them.

As time for the race approaches, cars are taken into their previously arranged and marked pit areas along the track. Here, pit crews take a last close look at the cars from grille to taillights, talk over last-minute strategy and carefully arrange equipment and tools in the pits to insure fast servicing of the cars should drivers find it necessary to pull in during the 200-mile grind.

Just as in the famed 500-mile Indianapolis classic, cars are wheeled to the starting line in rows abreast. When inspection tickets have been collected from drivers and the starter is informed that all cars in the field are in order, the anxiously awaited words, "Drivers, start your motors!" come from near-by loudspeakers.

A cloud of exhaust rises from the noisy sportsters and the green flag sends drivers into roaring action on their 200-mile clockwise dash for a prized trophy and the personal satisfaction of spinning their cars around a closed course against some of the country's best competition.

Regulation signals are manned at critical points on the course, which are connected by telephone to change pace of the race quickly in case of accident. Green flags indicate the road is clear, yellow is a caution to all

(Continued to page 246)



Low-slung German Veritas (1949 model) is taken through the inspection line by its owner, Ralph Knudsen. Car has only 3½-inch road clearance

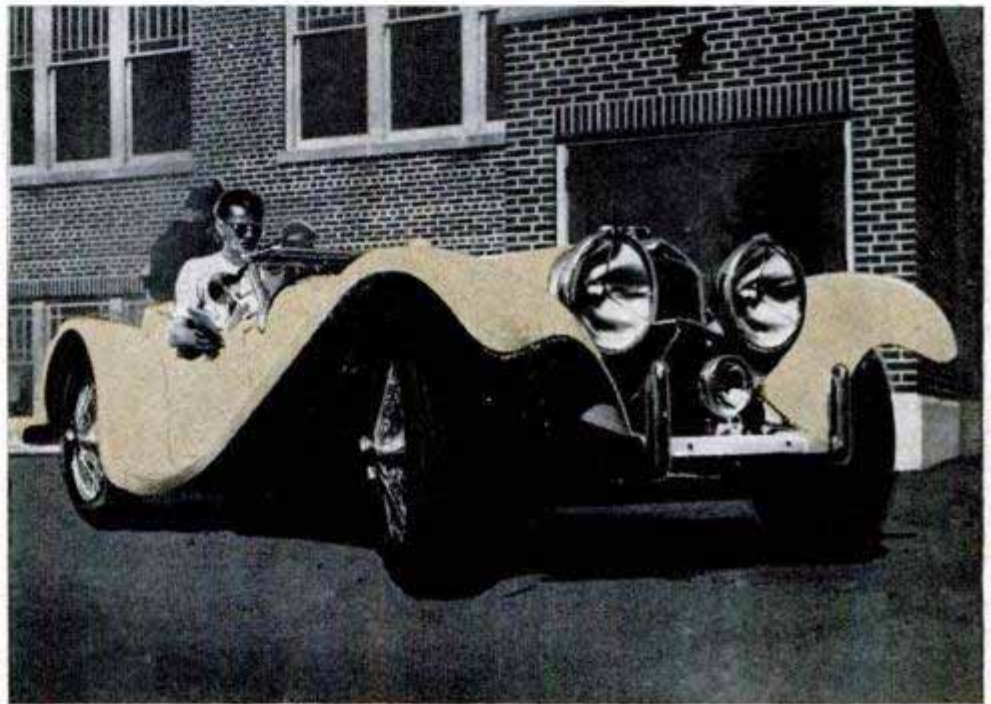

Before chauffeuring Dave Garroway's Jaguar 120 to victory in the novice race, Frank Bott submits the car for inspection. Below, Jim Kimberly's highly polished, 12-cylinder Ferrari is capable of 150-m.p.h. speeds on straightaways





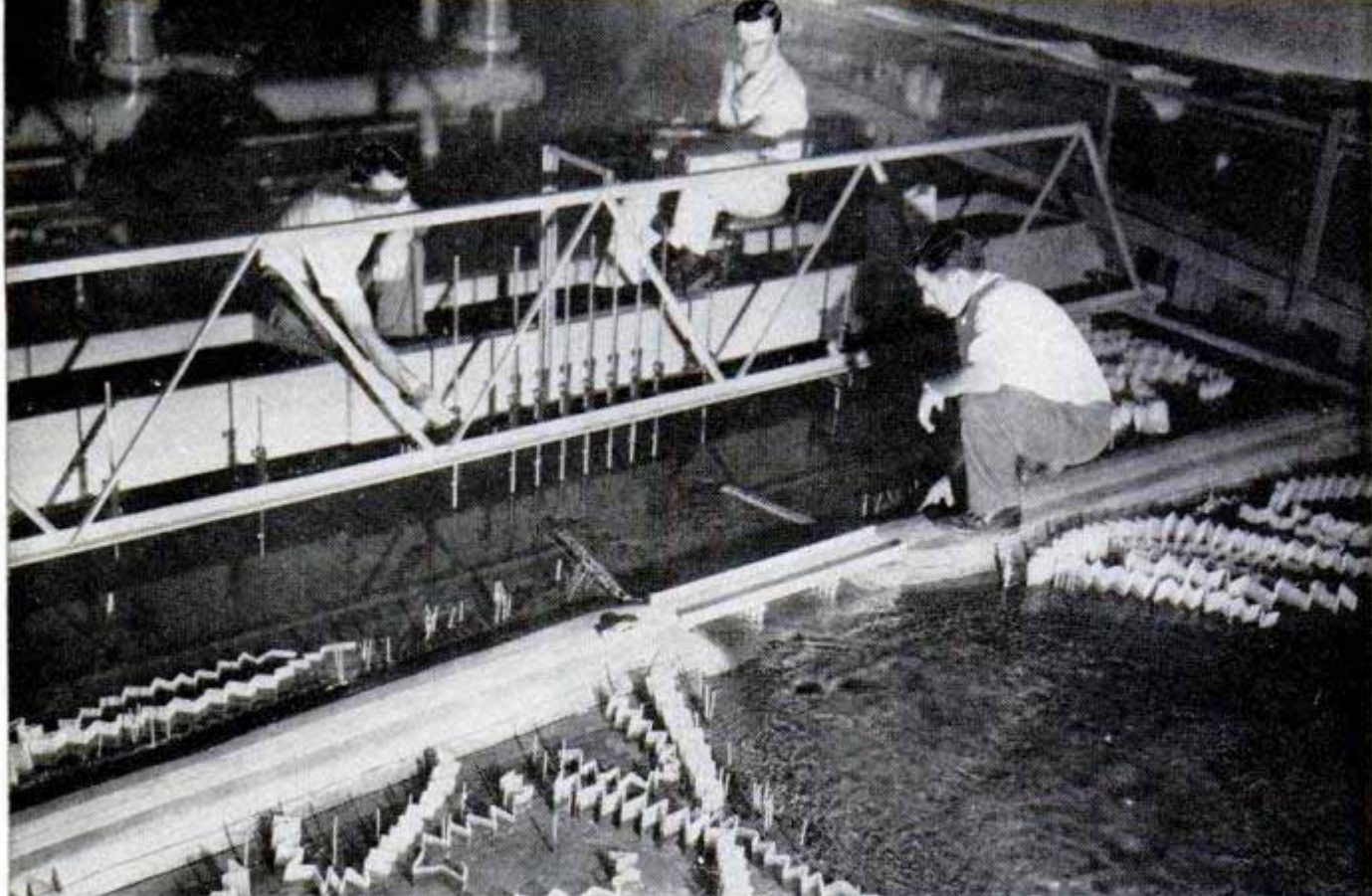

## Model Tames Raging River

Engineers at the University of Illinois are using a model to tame a raging river and save the state an estimated \$400,000. The Wabash River, at flood times, has cut a 40-foot hole in its channel adjacent to the piers of an important highway bridge. Though hundreds of tons of rubble have been dumped into the hole, the river continues to threaten the bridge. The engineers, in cooperation with the state's highway de-

partment, built a big model of the terrain and flowed water over it to discover what was happening. As a result of their studies, dikes will be built a distance of 100 feet upstream from the bridge, and the end of a near-by island will be cut away. The tests show that this will eliminate the big eddy causing the damage. The cost of the project will be far less than the cost of a new bridge. The model was built under the supervision of Prof. John C. Guillou over a period of two years.



## Plastic Tie Plates for Rails

Tie plates made of plastic now are supporting railroad rails at a switching yard in Cleveland. The inventor of the new plastic, called Dynakon, says it is three times as strong as steel. The tie plates, which weigh only one fifth as much as their metal counterparts, are under test as a substitute for steel, and are unaffected by the salt water dripping from refrigerator cars, which causes deterioration of steel plates.

Information not listed on articles in the index frequently can be found in the WHERE-TO-FIND-IT LIST, which is available to readers without charge from the Bureau of Information, *Popular Mechanics*, 200 E. Ontario St., Chicago 11, Ill.



## Altimeter Is Supersensitive

Developed by Army engineers, a new altimeter, operating on atmospheric pressure, is so sensitive it can measure the height of an ordinary table or record elevations 15,000 feet above sea level. The instrument will be used to measure ground elevations in building airfields and roads, and as an aid in photomapping work. It is equipped with a variable night light. A vacuum chamber expands or contracts in response to changes in atmospheric pressure. The instrument's mechanism, in turn, rotates the indicating hand on the dial. The instrument can be used from 1000 feet below sea level up to altitudes as high as 15,000 feet.

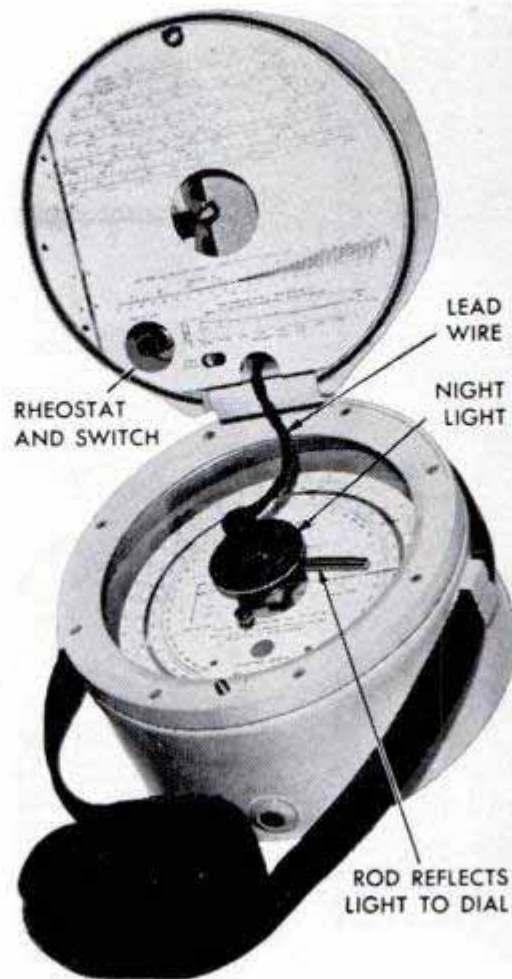

## "Yacht of Future" Is Enclosed From Deck to Trim Superstructure



Shaped with the lines of an airplane, a "yacht of the future" built in Scotland has a completely enclosed superstructure and deck. The rakish, 46-ton motor cruiser measures 81 feet long and is powered by two diesel engines. Underwater, the hull is of normal shape, but every line of the trim craft above water is a long curve. The wheelhouse is similar in appearance to the cockpit of a fighter plane. Stowed on deck is a 12-foot motor dinghy which can be hoisted by a derrick through an opening in the superstructure, normally covered by canvas. The craft has accommodations for two crew members and eight passengers. The facilities include two bathtubs with showers, a refrigerator and hot and cold water in every cabin. The futuristic yacht has a cruising range of 2000 miles.



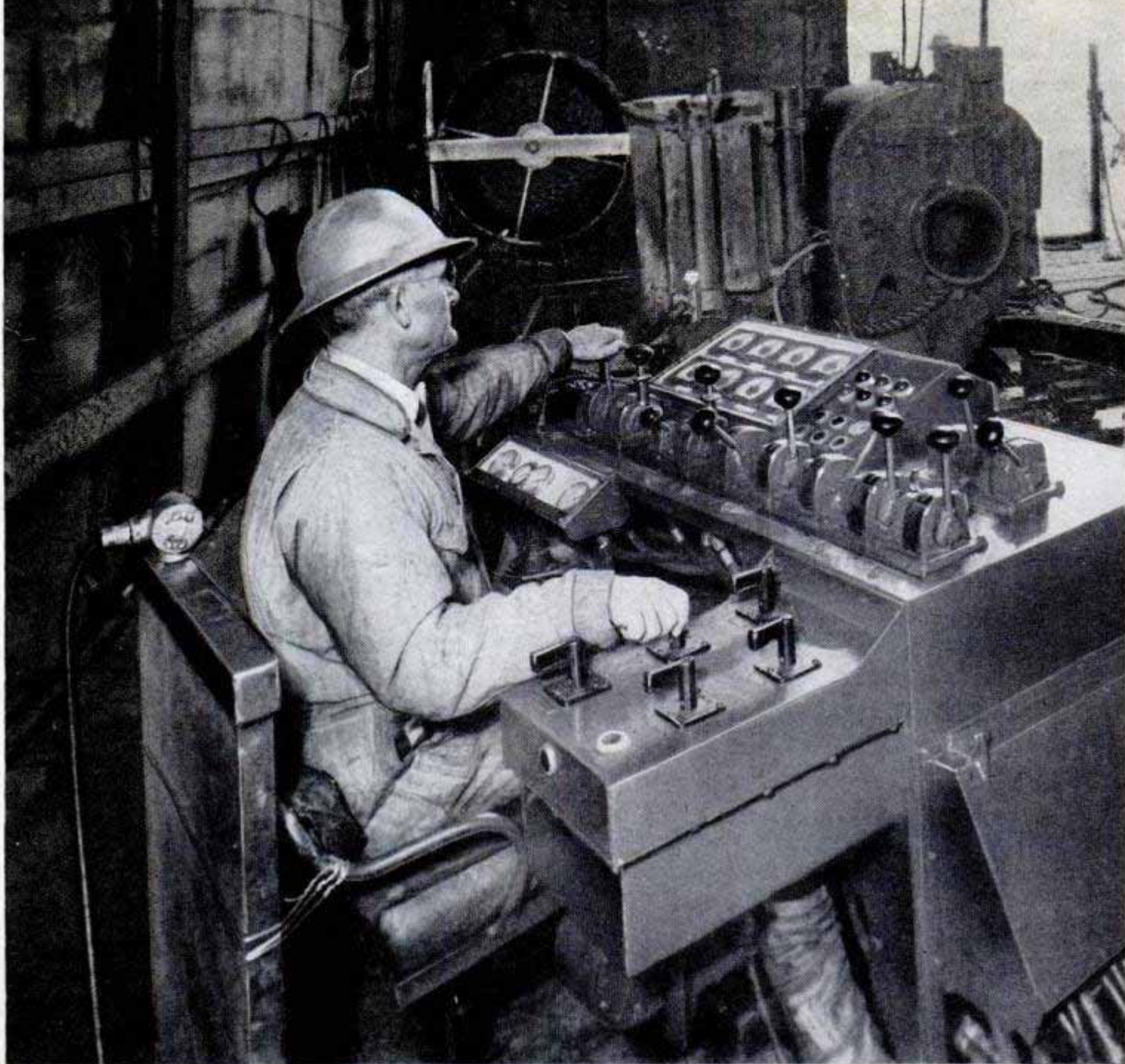

From his "pipe organ" console, the driller controls the lowering of sections of pipe into the well, on opposite page

# "Pipe Organ" OIL DRILLER

By Andrew Hamilton

**T**AKE TWO diesel engines salvaged from a couple of Navy LSTs, three electric submarine motors, the draw works from a steam rig, a 162-foot derrick and what do you have?

Answer: One of the largest and most unusual deep-test oil-well drilling rigs ever built—one that will probe for pools of black gold four miles or more below the earth's crust.

To operate the \$400,000 giant, a driller sits at a console and "plays" on a panel of

knobs, lights and switches like the organist at Radio City Music Hall!

This revolutionary drilling rig has been tested in two southern California oil fields—Baldwin Hills and Santa Fe Springs.

When the rig with its 162-foot derrick was tested in Baldwin Hills, a Los Angeles residential section, there were complaints about the noise from near-by homeowners. Officials of the movie studios in the vicinity were unhappy because drilling sounds were picked up by their sensitive microphones.





So engineers covered the tall tower with heavy quilted canvas, filled with sound-deadening material. High walls of the same stuff were erected between the engines and the generators. Then, thousands of horsepower went back to work with only a dull drone and an occasional muted clank.

"But that derrick—it was the craziest-looking thing you ever saw," commented a driller. "It reminded me of my long-legged Aunt Minnie in her quilted bathrobe!"

This radical drilling rig is a part of Standard Oil of California's long-range program to convert the conventional steam rigs into more economical, internal-combustion engine power.

"We were aiming at three targets," said a Standard engineer recently. "First, greater portability in equipment suitable for deeper holes; second, improved operating characteristics; third, lower maintenance costs.

"We hope to use rigs of this type in the future for deep tests from 15,000 to 20,000 feet, as well as for everyday drilling of 8000 to 10,000-foot holes."

The rig's 2400 horsepower is nearly half again as much as the average heavy drilling outfit. The power is supplied by two 1200-horsepower diesel engines, the port and starboard main propulsion engines of an LST. Three electric motors, originally built for Navy submarines, are also being used. Had this material been purchased brand new instead of being salvaged and reconditioned, the cost of the new rig would have run around \$700,000, or more, instead of \$400,000.

The diesel-electric setup requires no outside source of electric power. The two giant LST engines drive direct-current generators and provide electric power for the equipment. The use of electric power reduces vibration and wear, thus increasing operating efficiency and sensitivity over the conventional power rig or steam draw works.

From the beginning, the problem was to devise a rig that was both big and easy to move. In the oil business, the expense of rigging up, tearing down and moving eats up the bank roll.

The decision to use diesel-electric power was a major factor in shaving expenses. The power-generating and power-control units are self-contained so that it is unnecessary to dismantle them when moving time comes.

Sheathed in canvas padded with absorbent material to deaden the drilling noises, the 162-foot derrick towers above the two diesel-electric power plants, right

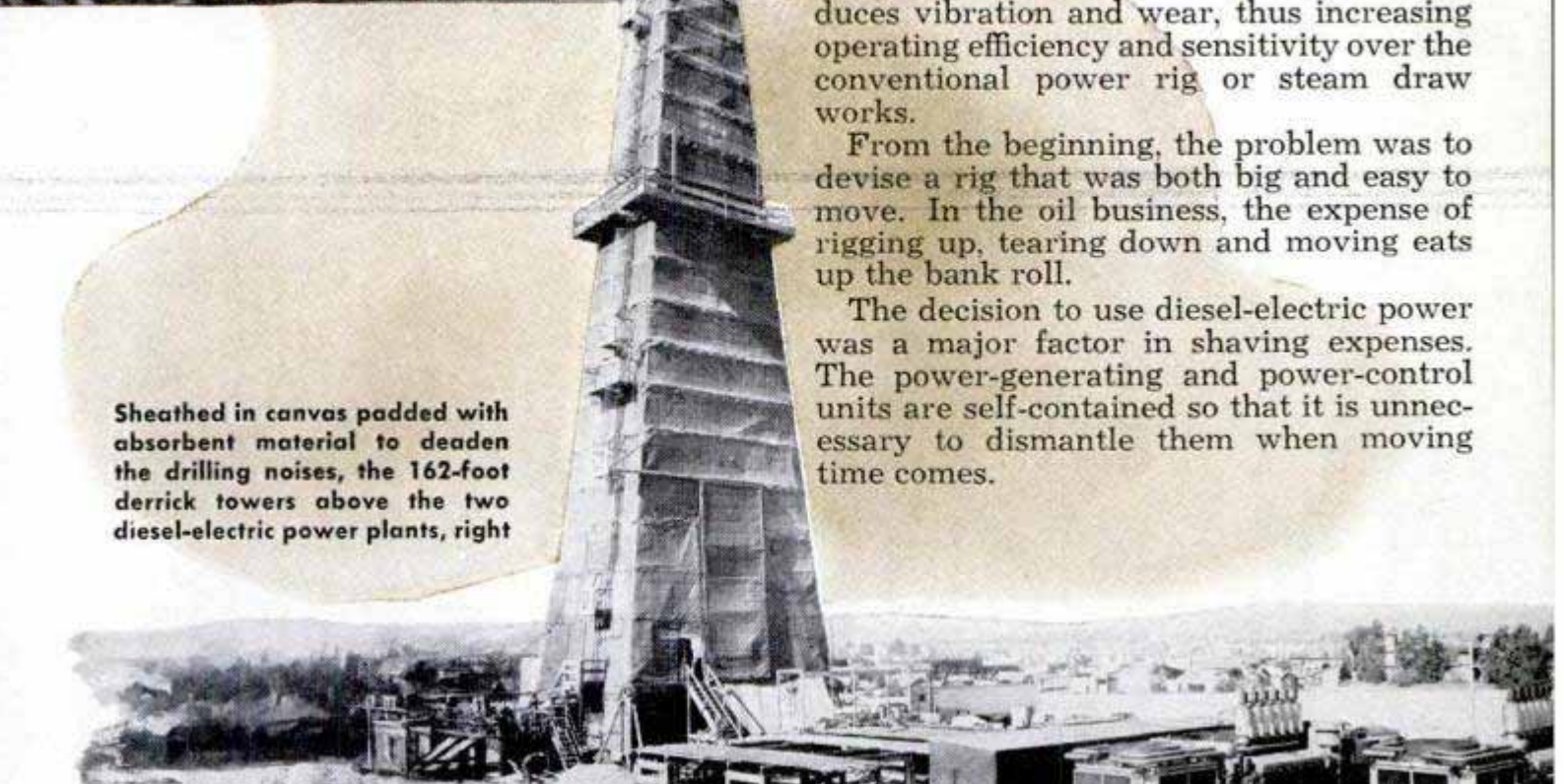
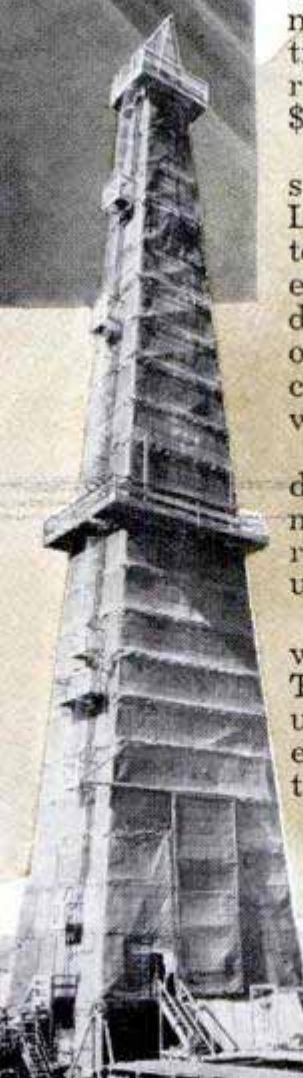



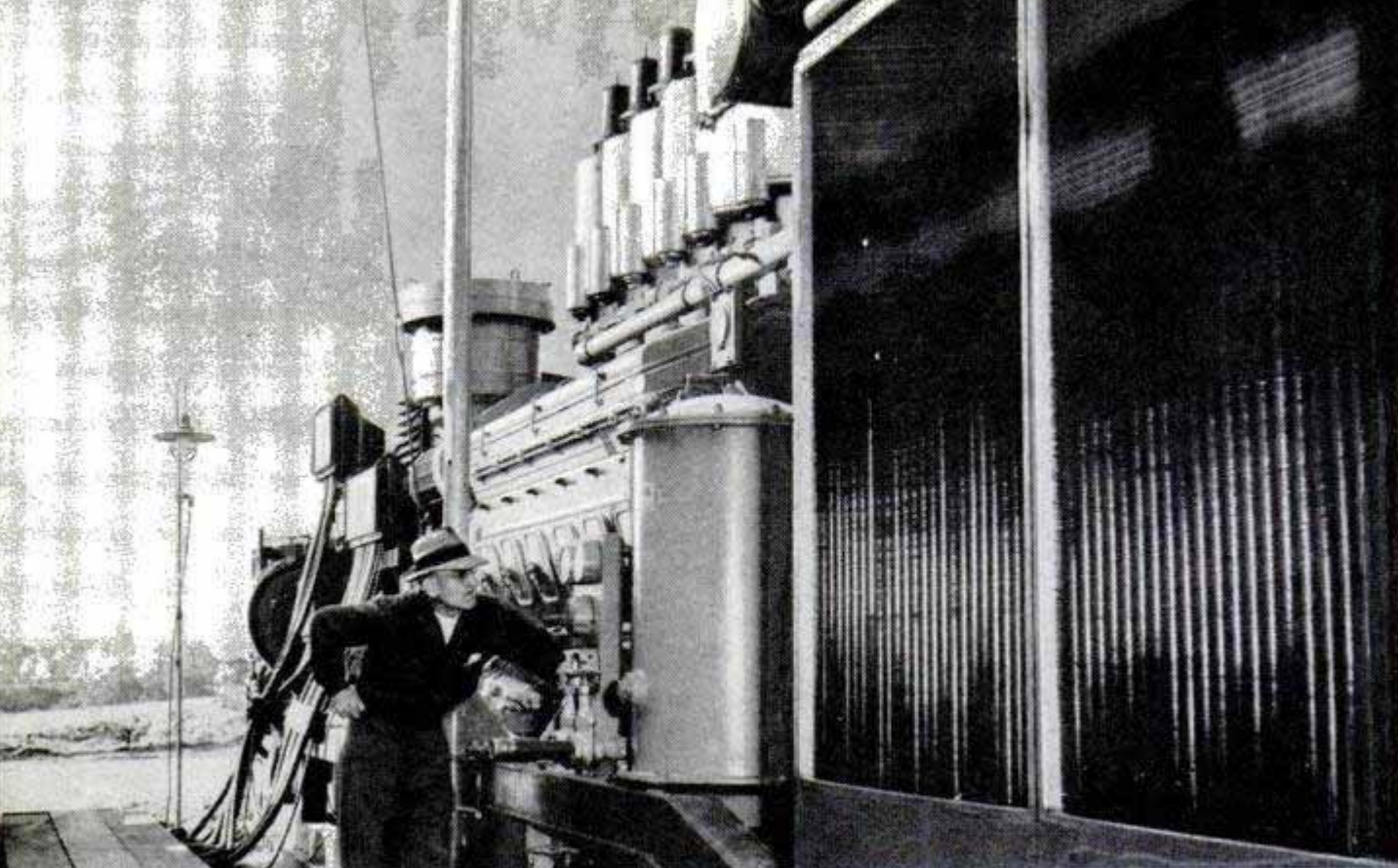

Formerly on an LST, this 1200-horsepower diesel now powers the drill rig. Object at right is a radiator

A large motor-driven reel is provided for transporting the more than 3500 feet of two-inch cable used for power connections between generators, motors and control points—representing a total weight of more than seven tons. All mechanical and electric units are mounted on skids to make them easy to move around or to mount on trucks for long hauls.

When shifted from one location to another in the oil fields, the engine-generator

set will be moved as one unit. Total weight: 96,000 pounds. But when the unit is trucked over the highways, the engine-generator set breaks down into two separate packages to meet California road-width, road-height and road-weight requirements.

The most unusual feature of the new diesel-electric experimental rig, however, is the system of "finger tip" control. No longer does the driller stand alongside the

(Continued to page 244)

Workmen make connections on the drill's two mud pumps, right. Each unit is mounted on skids for mobility





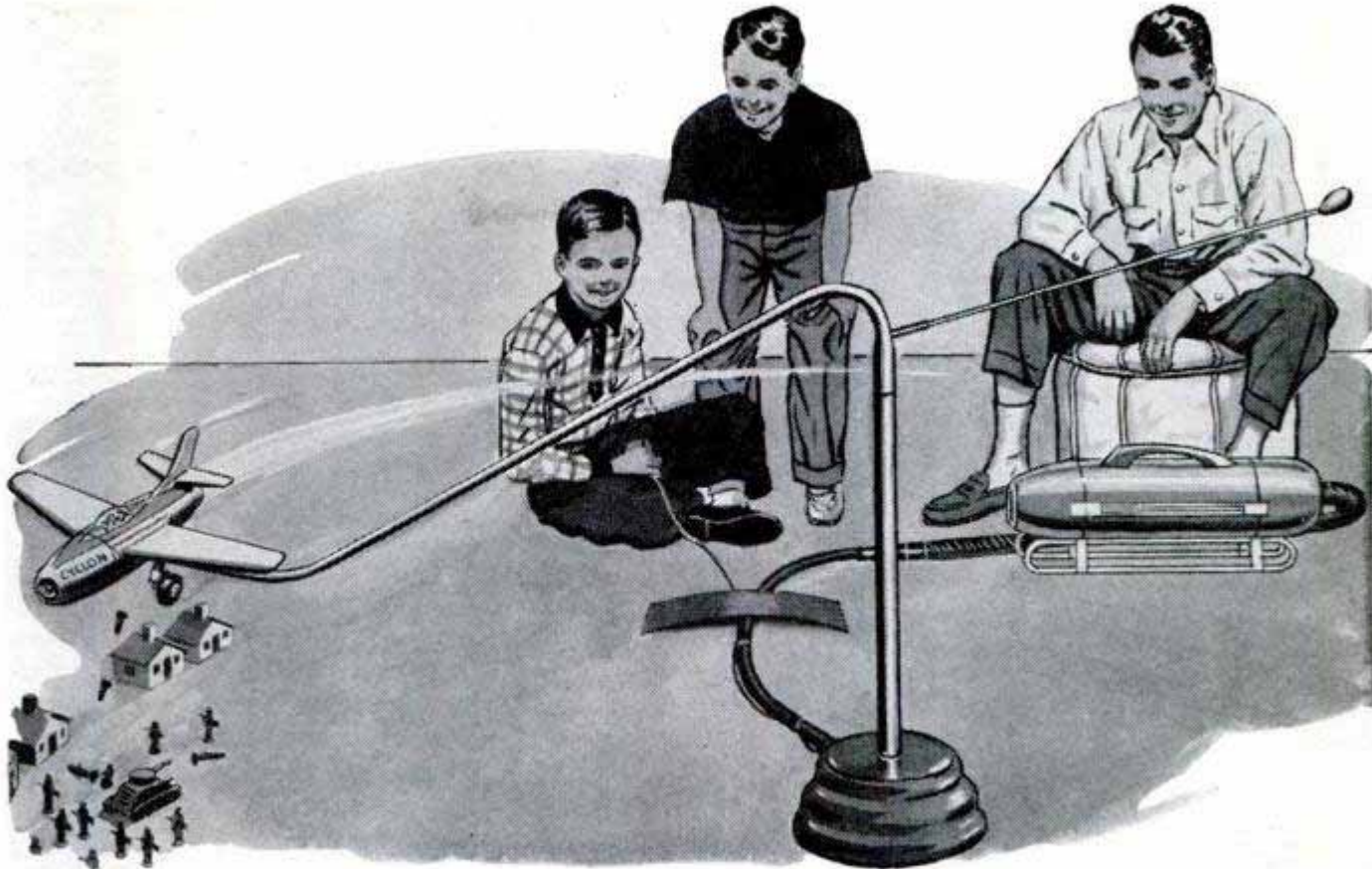

## Child's Jet Airplane Powered by Vacuum Cleaner

Mom's vacuum cleaner becomes one of the children's playthings, providing the thrust that keeps a toy plane in the air. Invented in Spain, the plane is a model of an American jet aircraft. Air is supplied to the jet "engine" of the plane through a tube that also supports the plane as it flies around a central pivot. The air is piped through a nozzle in the tail, causing the plane to fly at a height of about two feet. A small siren is built into the plane to imitate the sound of a real jet engine. Another feature of the toy is a remote-controlled bomb release. When a button is pressed, the plane drops 24 bombs in succession.

Bombs are released from the plane by remote control. The ramp over the sweeper hose allows the plane to taxi on the floor. Below, close-up of jet in flight

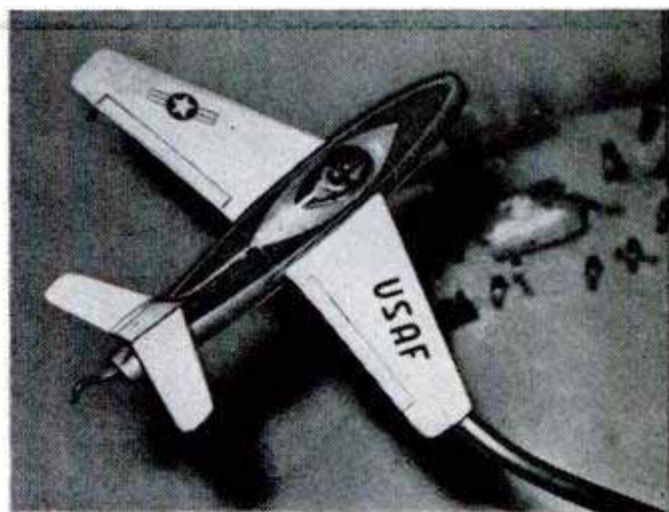

## Brush Cutter

Rotating like a giant egg beater, a tractor attachment driven by the power take-off clears brush up to six feet tall and three inches in diameter. A flat piece of steel, about eight inches long sharpened on the leading edge, is attached to the bottom of the rotating "gate." It cuts through the stalks and the ladderlike gate tosses the brush aside. The device was built by J. N. van Rhyn of Klapmuts, South Africa.



# LONDON'S POST-OFFICE RAILWAY



Photos courtesy Postmaster General, London

**Off-loading mail containers of London's post-office railway system, which operates 70 feet underground**

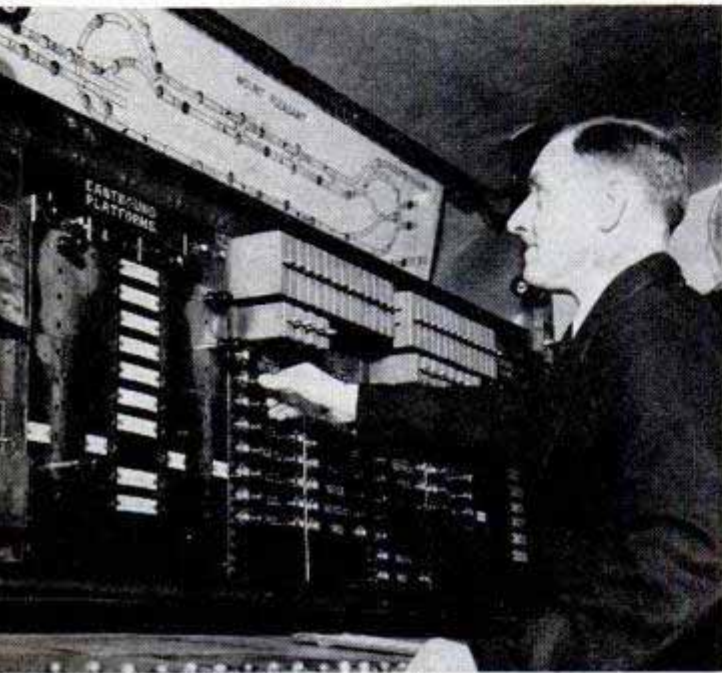

**Running at speeds up to 35 m.p.h. through 6½ miles of tunnels, driverless trains are controlled from the switch cabins, above**

**Fed by road routes, post-office stations along the underground railway move mailbags to trains by chutes and conveyors**

**PRINCIPAL ROAD ROUTES FEEDING RAILWAY LINES OPERATED**

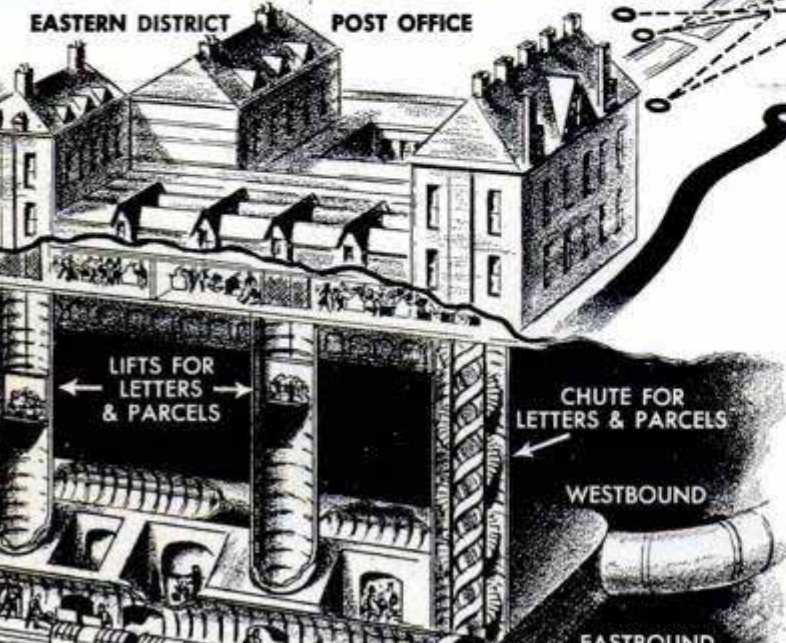

**STILL** in use after many years of successful operation, London's post-office underground railway—only one of its kind in the world—carries a total of 11½ million letters annually. It is similar to Chicago's freight-carrying tunnel system, which may sometime be used to help speed up mail deliveries in the Loop area. The London railway operates 70 feet underground through 6½ miles of tunnels. Except at station approaches, the electric trains run in a single tunnel, reaching speeds of 35 miles per hour between stations. The driverless trains carry four mailbag containers, holding an average of 15 letter bags each. Small battery-operated "locomotives" on short sidings along the line stand by as substitutes for faulty trains.

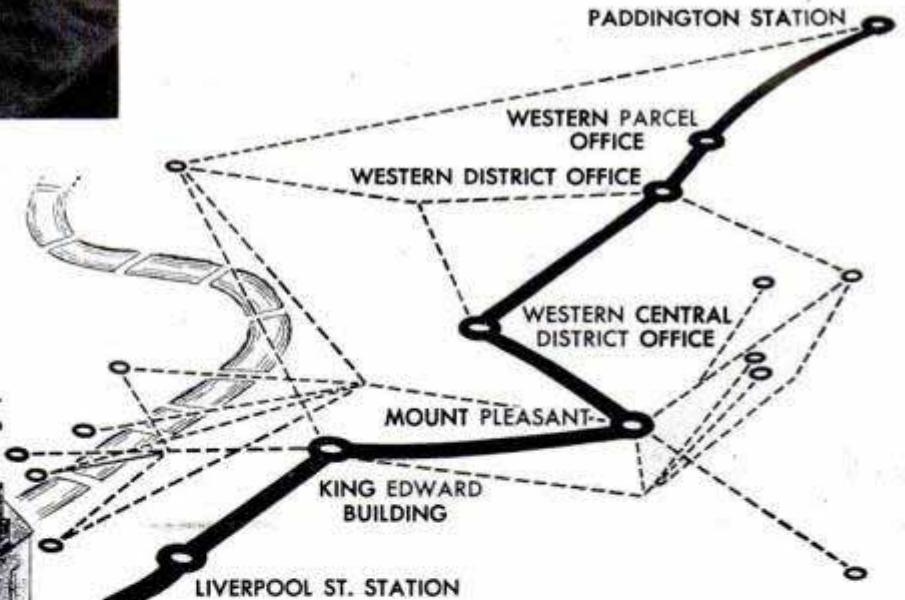



## ADDING THE FINAL TOUCH

Does your house have eye appeal? Often, the mere addition of colorful modern shutters, or a smart door motif, is all it takes to make "just another house" rate a second look

By **Wayne C. Leekey**

IT'S A BEAUTIFUL HOME but it seems "unfinished." Perhaps you've said that yourself when driving by a particular new home in your neighborhood. You may even have said it about your own house. True, while a house may be well designed and built, nicely landscaped and newly painted, it may still lack the final touch which gives it individuality and eye appeal. That touch might be the mere addition of colorful and modern-looking shutters. In other instances, a bright-colored door entrance offset with a smart abstract motif in white may do the trick. An uninteresting, commonplace garage door is made the focal

*PM color photos by Paul T. Hutchinson*



Above, three white frames contrasting against a maroon background lend a smart panel treatment to a front entrance. Below, good example of how plain-looking garage door can be treated for eye appeal







Nine "picture frames" add the final decorative touch to this plain one-piece, upward-acting, garage door

point and assumes a "belonging" look with bright paint and a few well-placed decorative overlays. And, finally, a tier of flower boxes mounted between supporting posts, as pictured on page 167, will complement a front entrance.

Whether the final touch is achieved with shutters or overlay door motifs, it's something that can be tackled by the average homeowner with a minimum of effort and tools, and the "lift" it will give a home will improve the appearance and increase the salability considerably. The suggestions pictured on these pages are but a few of the



Two vertical groupings of bevel-edge blocks provide another simple and attractive garage-door treatment

many possibilities. In most cases, the work of adding overlay motifs to shutters and doors entails nothing more than making simple "picture frames" of stock molding and nailing them in place in an interesting geometric pattern. For this you'll need only a common, wooden miter box to miter the corners of the frames. If a motif of wooden blocks is desired, as pictured above, you can cut them quickly to size from common lumberyard material. If you are not too adept at handling a handsaw, many lumberyards will gladly saw the blocks to your specifications, so that all you'll have to do

"Nested" paneling applied to daring Chinese-red door carries out striking modern design of this swank garage

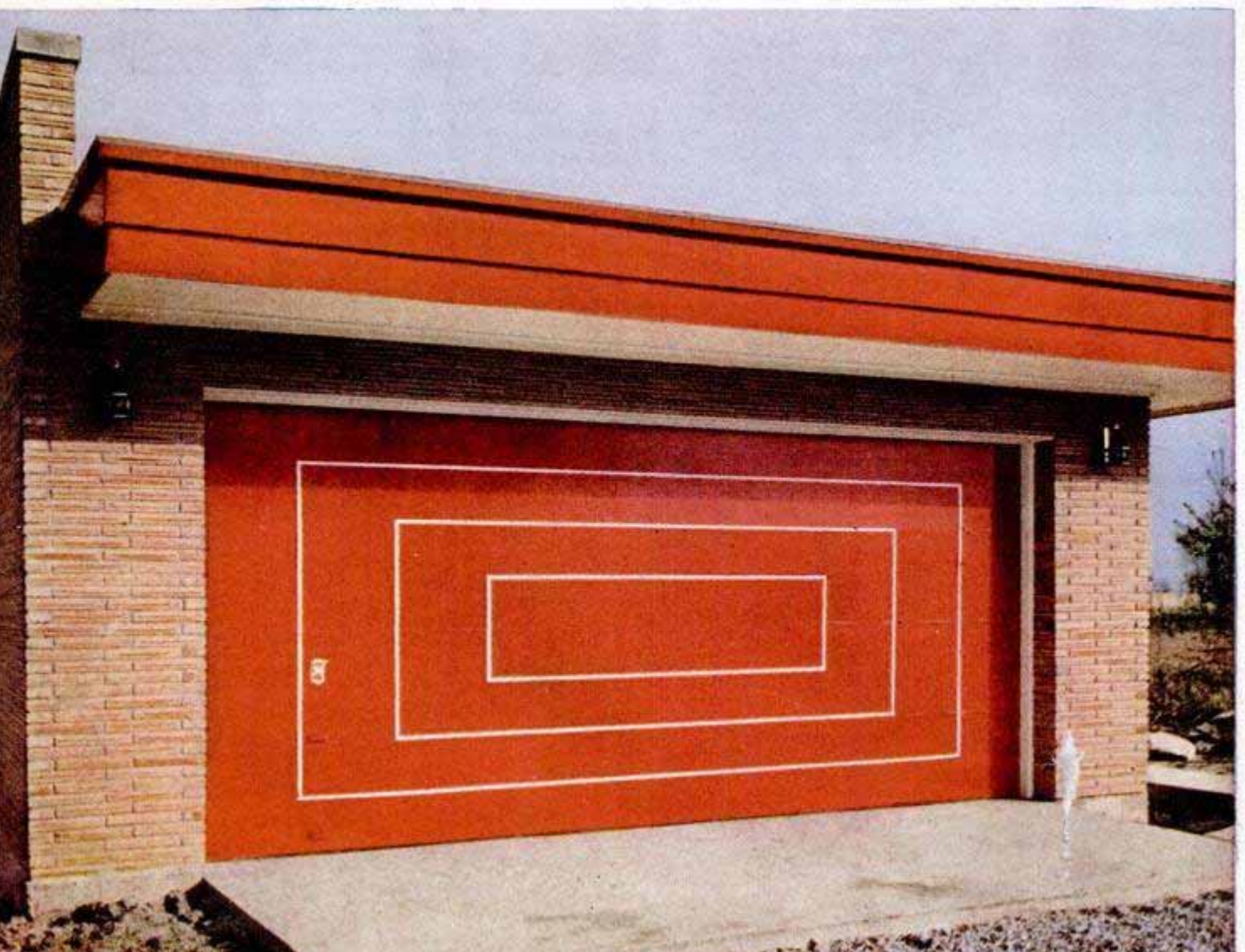



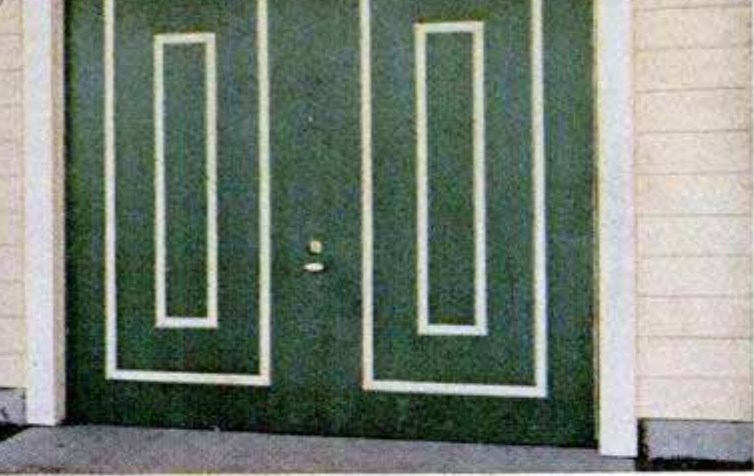

Frames within frames applied vertically provide a third effective treatment for decorating garage door

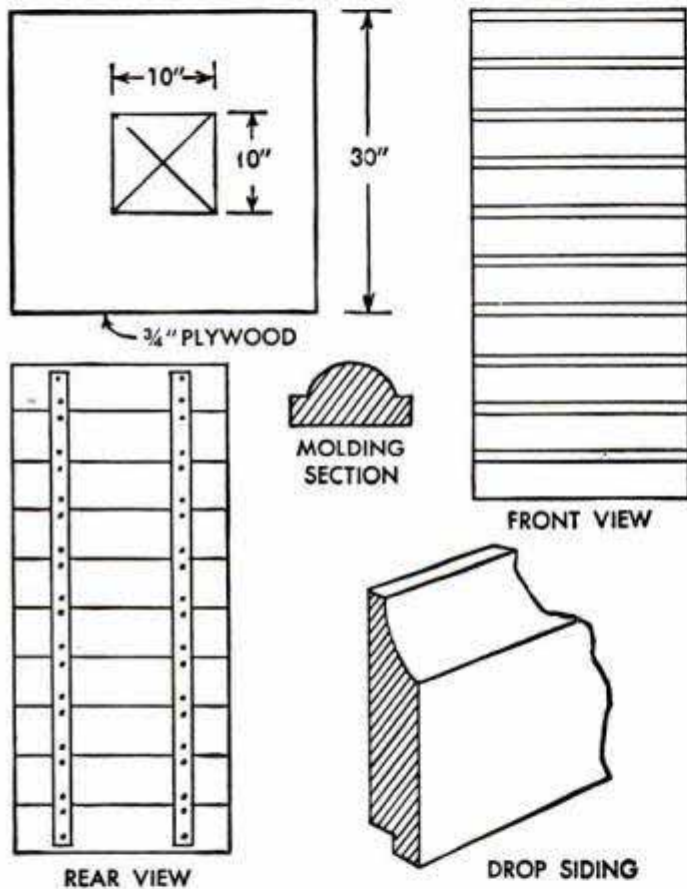

Tiered flower boxes of matching color complement a red entrance decorated with a Chinese motif. Below, same overlay design can be carried out on shutters

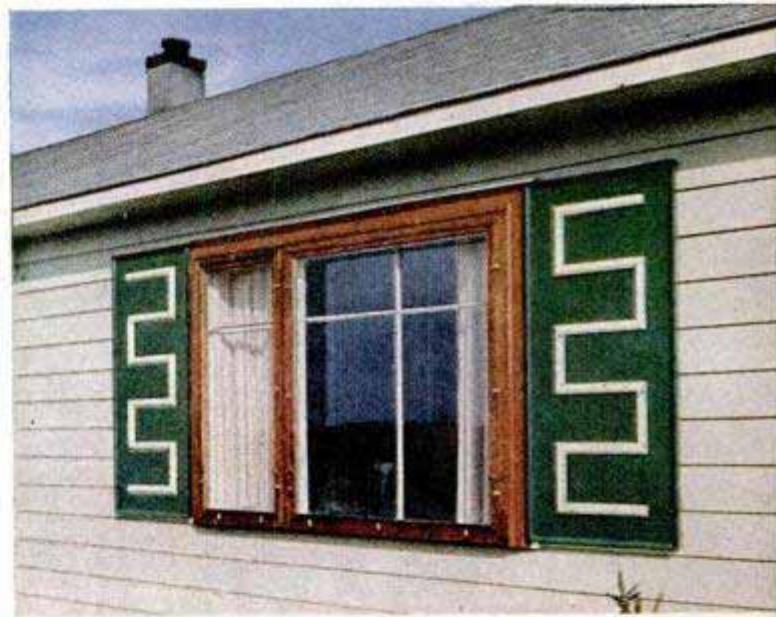

Below, this example shows how three white squares centered vertically on plain plywood shutters give smart eye appeal to this russet-colored brick home

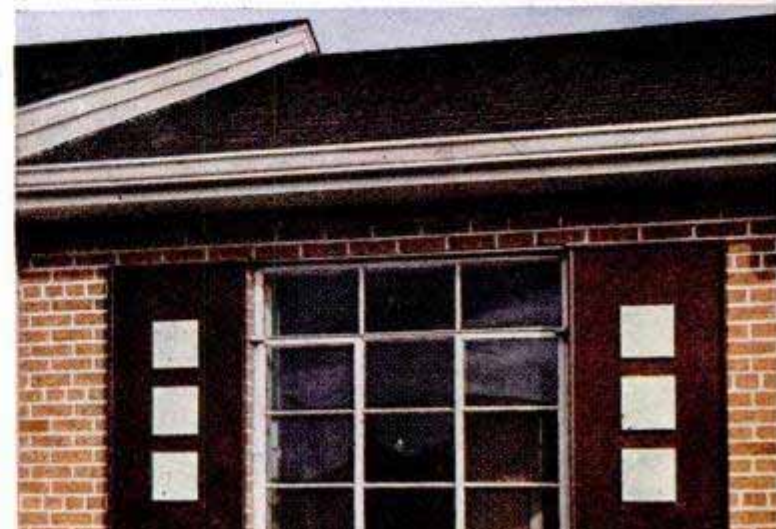

is screw them evenly and squarely in place. The most effective shutters, especially on a modern house, are plain simple ones. Rectangular panels of exterior-grade plywood make excellent shutters when well painted and decorated with a contrasting molding motif. For the popular "clerestory" window, or any other short, single-sash window, a square panel of plywood set off in the center with a pyramid-faced, contrasting square makes a most striking shutter for a modern home. Another simple way of making a good-looking shutter with little work is to use common drop siding. The siding is simply cut to the desired lengths and screwed to battens attached vertically to the rear side. The shadow lines formed by each section of the siding give a most striking effect when the shutters are exposed to strong sunlight.





Whether you work at home or just want a desk for personal correspondence and storing papers, you'll find these typewriter desks good-looking and easy to build

*Desks styled by John Bergen*

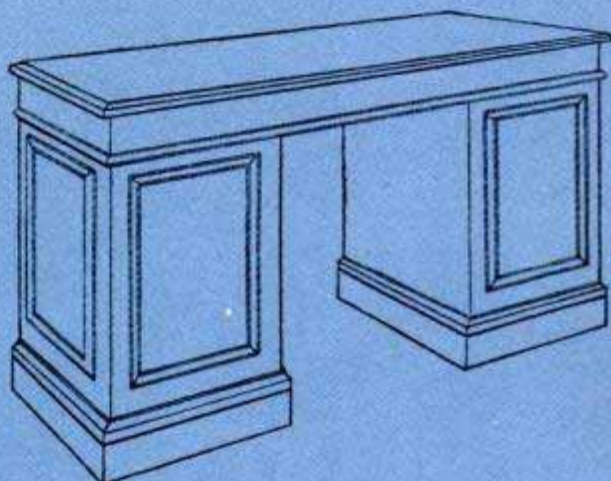

**BUILD A**





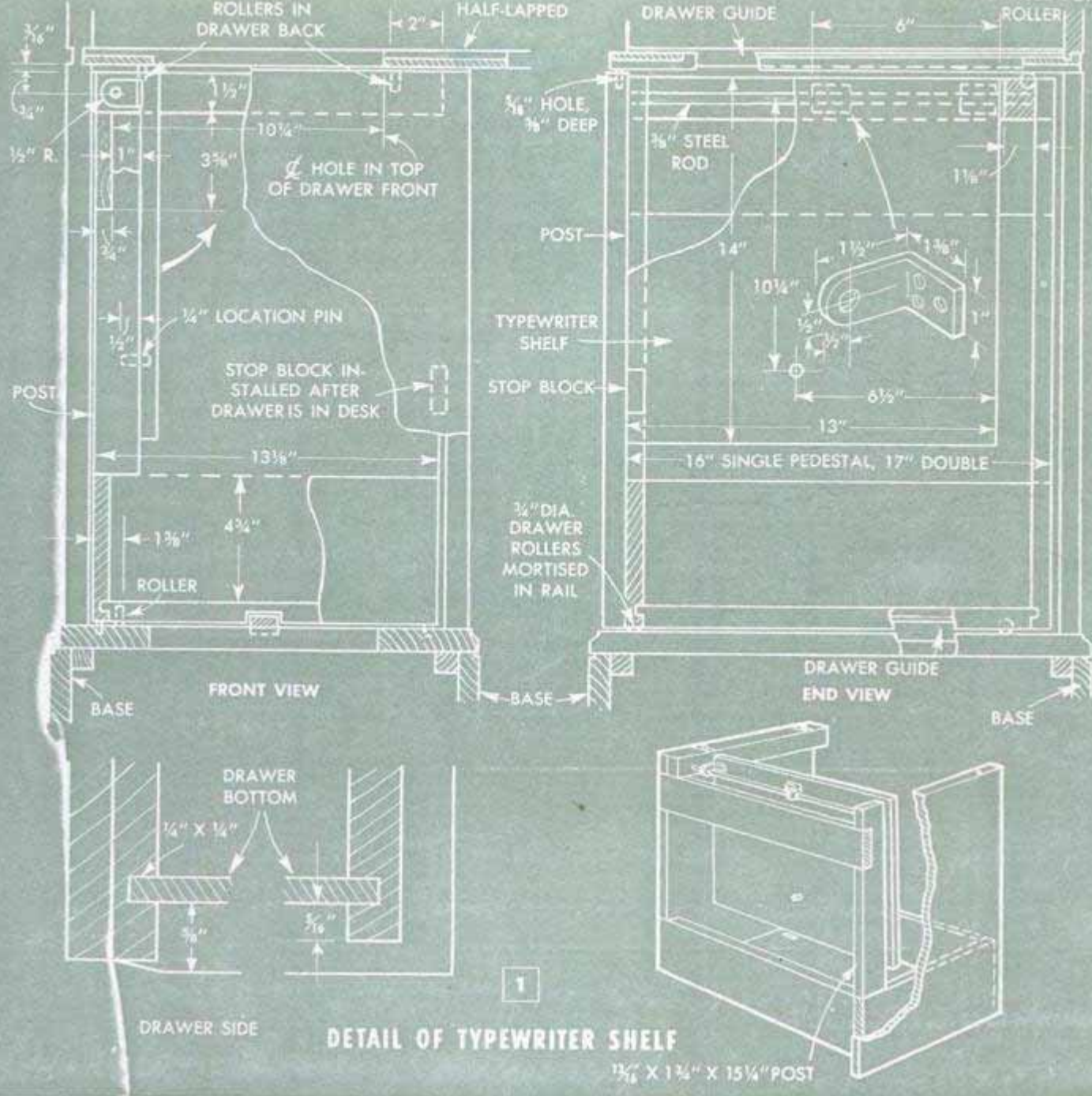

# DESK for your TYPEWRITER

THE TWO typewriter desks pictured on the opposite page are designed to fit in with your present furniture, whether period or modern. As illustrated, the desks will go well with traditional furniture—or, with the simple addition of modern drawer pulls and a finish in one of the popular gray or blonde tones, either desk will be right at home with your modern pieces. Both desks feature a simple pull-out typewriter shelf which is easy to build and operate, and the lower portion of the shelf frame is fitted with sides to form a utility drawer. The double-pedestal desk includes three drawers in the top section and two roomy drawers in the right-hand pedestal, the lower drawer being deep enough to serve

as a letter file. The single-pedestal desk has two top drawers in addition to the utility drawer under the typewriter shelf.

Except for mounting the pedestals on the base, the construction of both desks is much the same. The cabinets are made of  $1\frac{3}{16}$ -in. plywood, which is also used for the drawer fronts and typewriter shelf. Rails for the top section and drawers, trim moldings, etc., are made of hardwood while the drawer bottoms are of hardboard.

Construction of the double-pedestal desk is detailed in Fig. 3, and the single-pedestal unit is described in Fig. 4. Note in Fig. 3 that the side and back panels of the pedestals rest on a mitered frame which is screwed and glued to cleats fastened to the



inside of the base frame. The latter is mitered and supported by a glue block at each corner. The frame supporting the upper drawer in the right-hand pedestal is half-lapped and glued in grooves run in the plywood pedestal sides. Note in Fig. 3, section A-A, how the  $\frac{5}{8}$ -in. trim molding is fitted along the front and back of the desk. The molding on the sides of the pedestals is laid in  $\frac{1}{8}$  x  $\frac{5}{8}$ -in. grooves cut in the plywood panels, and the corners of the molding are mitered.

On the single-pedestal desk, a separate coved base molding is used. The sides and back panels of the typewriter pedestal rest directly on the mitered base members. The latter are rabbeted to form a shoulder for the ends of the panels, and cleats are glued and screwed to the base members to provide additional bearing surface. The post is made as in Fig. 4, section C-C. The base members and double panel are separated with spacers, as in the lower left-hand de-

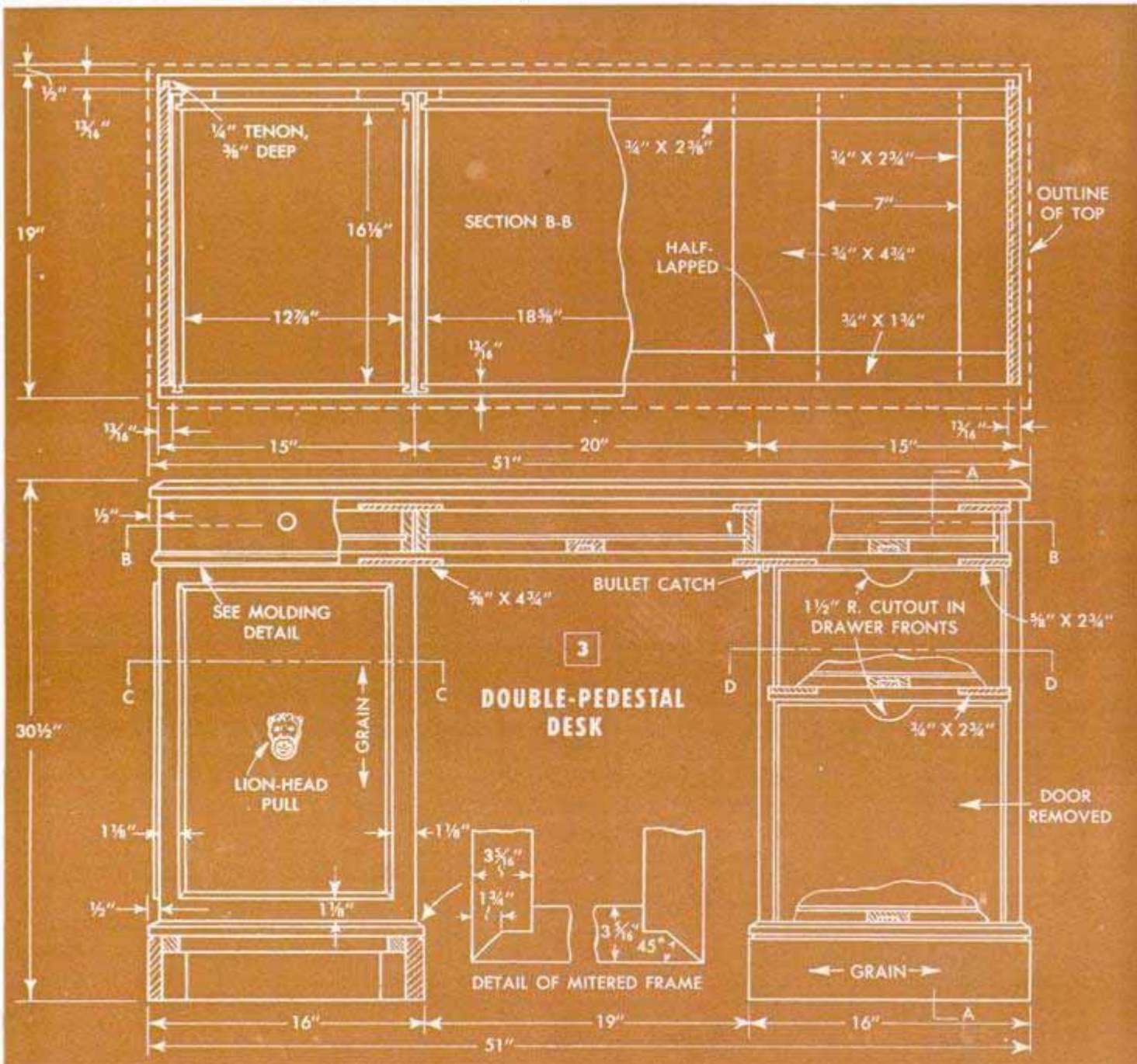
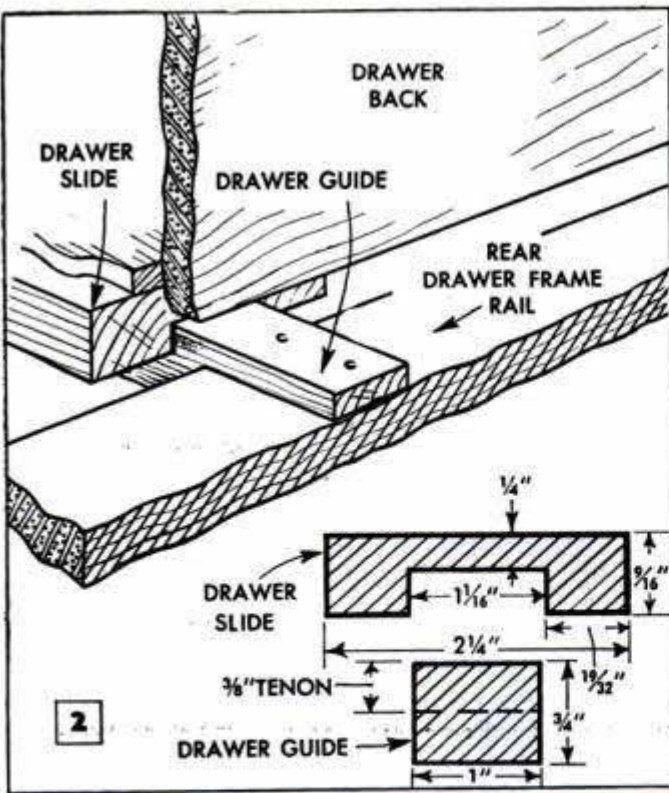



tail. The molding at the front of the post is made to fit flush with the inside of the base member.

Drawer construction is typical, with the plywood bottom being housed in grooves cut in the side, front and back members, as shown in the lower left-hand detail of Fig. 1. However, the drawer sides at the ends of the desks are joined to the fronts with a blind dovetail, as in Fig. 4, to allow the front to close flush with the side panel of the desk. Fig. 2 dimensions the drawer guide and slide, and pictures the method of installation.

The typewriter shelf and drawer are detailed in Figs. 1, 3 and 4. To use the typewriter, the drawer is pulled out far enough to allow the typewriter shelf to be swung upward. When the shelf is raised sufficiently high to clear the drawer front, it is pulled forward, sliding on the  $\frac{3}{8}$ -in. rod, until a locating pin on the underside of the shelf engages a hole in the top edge of the

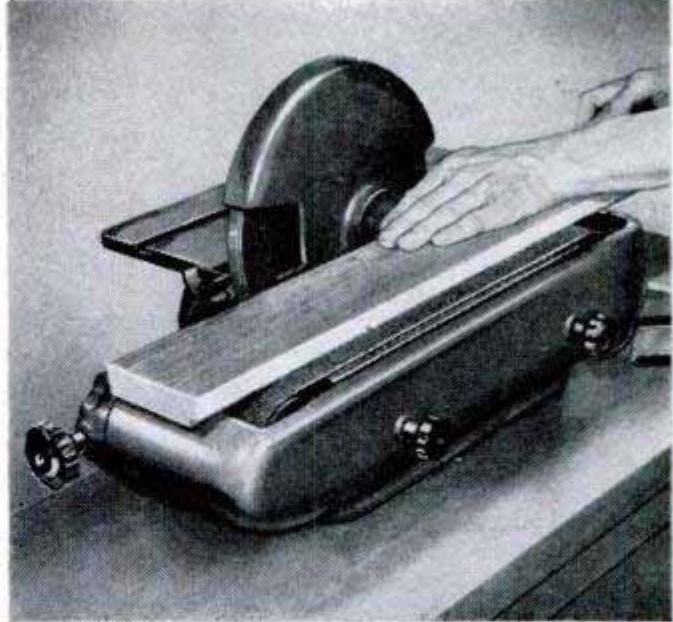
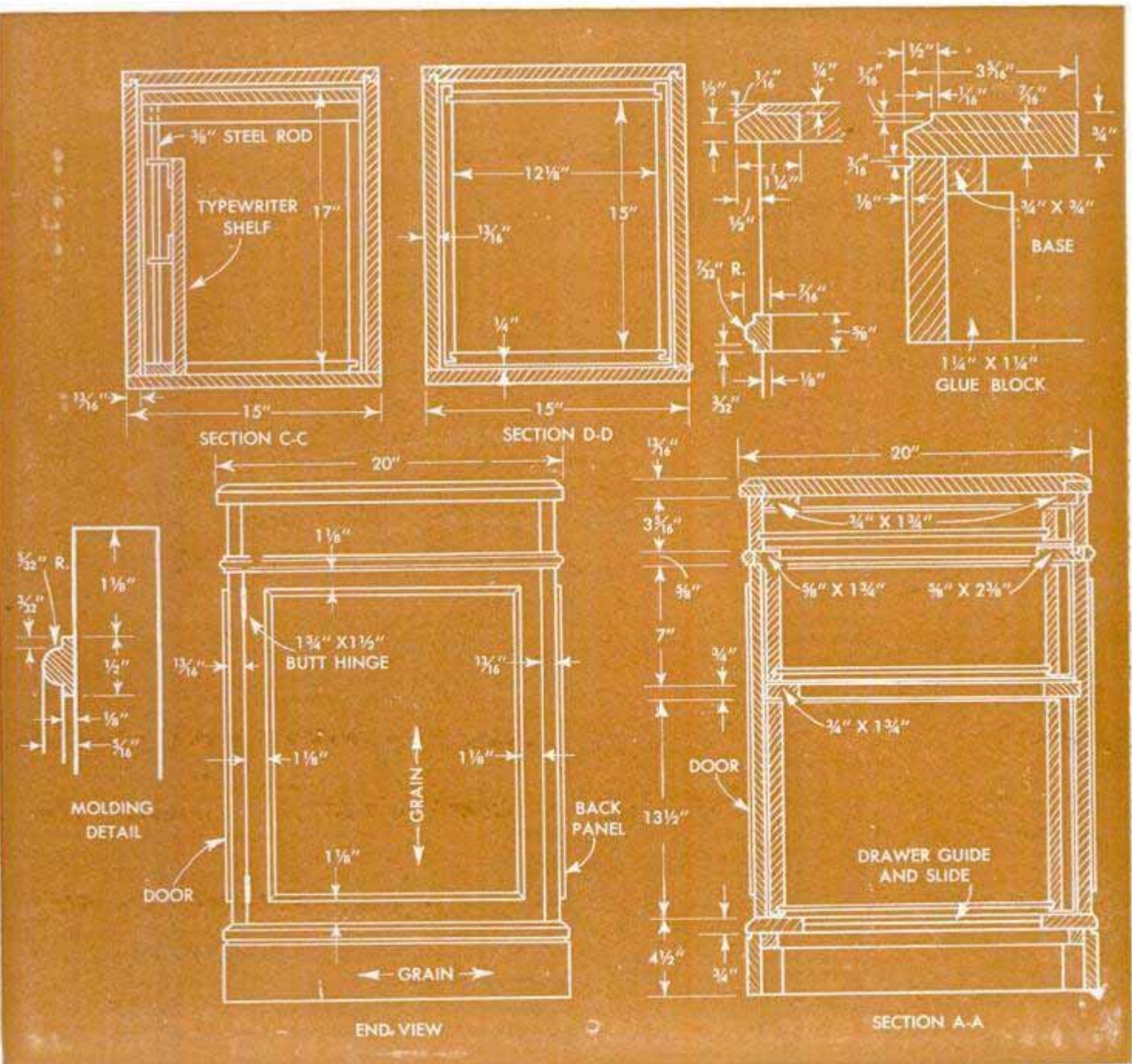

Photo above shows a combination sander being used to smooth the outer surface of one of the base members for the double-pedestal desk. Rabbet along top edge forms groove when mitered frame is assembled







## MATERIAL YOU WILL NEED

### DOUBLE-PEDESTAL DESK

#### MAHOGANY PLYWOOD

- 1 pc.  $1\frac{3}{16}$ " x 19" x 50"—Top
- 2 "  $1\frac{3}{16}$ " x  $17\frac{3}{4}$ " x  $25\frac{3}{16}$ "—Ends
- 2 "  $1\frac{3}{16}$ " x  $17\frac{3}{4}$ " x  $21\frac{1}{4}$ "—Ends
- 4 "  $1\frac{3}{16}$ " x 15" x  $21\frac{1}{4}$ "—Drawer front, door & backs
- 1 "  $1\frac{3}{16}$ " x  $3\frac{9}{16}$ " x 50"—Back
- 2 "  $1\frac{3}{16}$ " x  $3\frac{5}{16}$ " x 15"—Drawer fronts
- 1 "  $1\frac{3}{16}$ " x  $3\frac{5}{16}$ " x 20"—Drawer front
- 1 "  $1\frac{3}{16}$ " x 7" x  $14\frac{1}{8}$ "—Drawer front
- 1 "  $1\frac{3}{16}$ " x  $13\frac{1}{2}$ " x  $14\frac{1}{8}$ "—Drawer front
- 1 "  $1\frac{3}{16}$ " x 13" x 14"—Typewriter shelf

#### MAHOGANY

- 2 pc.  $\frac{3}{4}$ " x  $1\frac{1}{4}$ " x 51"—Top moldings
- 2 "  $\frac{3}{4}$ " x  $1\frac{1}{4}$ " x 20"—Top moldings
- 2 "  $\frac{7}{16}$ " x  $\frac{5}{8}$ " x  $19\frac{5}{8}$ "—Center moldings
- 2 "  $\frac{7}{16}$ " x  $\frac{5}{8}$ " x  $50\frac{5}{8}$ "—Center moldings
- 8 "  $\frac{5}{16}$ " x  $\frac{1}{2}$ " x 19"—Trim moldings
- 4 "  $\frac{5}{16}$ " x  $\frac{1}{2}$ " x  $12\frac{3}{4}$ "—Trim moldings
- 4 "  $\frac{5}{16}$ " x  $\frac{1}{2}$ " x  $15\frac{1}{8}$ "—Trim moldings
- 4 "  $\frac{3}{4}$ " x  $3\frac{5}{16}$ " x 16"—Base frame
- 4 "  $\frac{3}{4}$ " x  $3\frac{5}{16}$ " x 20"—Base frame
- 4 "  $\frac{3}{4}$ " x  $3\frac{3}{4}$ " x 16"—Base
- 4 "  $\frac{3}{4}$ " x  $3\frac{3}{4}$ " x 20"—Base

#### HARDWOOD

- 2 pc.  $\frac{3}{4}$ " x  $1\frac{3}{4}$ " x  $47\frac{7}{8}$ "—Top frame
- 2 "  $\frac{3}{4}$ " x  $2\frac{3}{4}$ " x  $17\frac{5}{8}$ "—Top frame
- 2 "  $\frac{3}{4}$ " x  $4\frac{3}{4}$ " x  $17\frac{5}{8}$ "—Top frame
- 2 "  $\frac{5}{8}$ " x  $2\frac{3}{4}$ " x  $18\frac{3}{4}$ "—Top drawer frame
- 2 "  $\frac{5}{8}$ " x  $4\frac{3}{4}$ " x  $18\frac{3}{4}$ "—Top drawer frame
- 1 "  $\frac{5}{8}$ " x  $1\frac{3}{4}$ " x  $47\frac{7}{8}$ "—Top drawer frame
- 1 "  $\frac{5}{8}$ " x  $2\frac{3}{8}$ " x  $47\frac{7}{8}$ "—Top drawer frame
- 2 "  $\frac{3}{4}$ " x  $1\frac{3}{4}$ " x  $13\frac{7}{8}$ "—Drawer frame
- 2 "  $\frac{3}{4}$ " x  $2\frac{3}{4}$ " x  $17\frac{3}{8}$ "—Drawer frame
- 6 "  $\frac{1}{2}$ " x  $2\frac{9}{16}$ " x  $17\frac{3}{8}$ "—Drawer sides
- 2 "  $\frac{1}{2}$ " x 7" x  $16\frac{3}{8}$ "—Drawer sides
- 2 "  $\frac{1}{2}$ " x  $13\frac{1}{2}$ " x  $16\frac{3}{8}$ "—Drawer sides
- 2 "  $\frac{1}{2}$ " x  $2\frac{3}{16}$ " x  $13\frac{3}{8}$ "—Drawer backs
- 1 "  $\frac{1}{2}$ " x  $2\frac{5}{16}$ " x 19"—Drawer back
- 1 "  $\frac{1}{2}$ " x  $6\frac{3}{4}$ " x  $12\frac{1}{2}$ "—Drawer back
- 1 "  $\frac{1}{2}$ " x  $13\frac{1}{4}$ " x  $12\frac{1}{2}$ "—Drawer back
- 4 "  $\frac{3}{4}$ " x 1" x  $17\frac{1}{4}$ "—Drawer guides
- 2 "  $\frac{3}{4}$ " x 1" x  $16\frac{1}{4}$ "—Drawer guides

- 3 "  $\frac{9}{16}$ " x  $2\frac{1}{4}$ " x  $16\frac{5}{8}$ "—Drawer slides
- 2 "  $\frac{9}{16}$ " x  $2\frac{1}{4}$ " x 16"—Drawer slides
- 4 "  $\frac{3}{4}$ " x  $\frac{3}{4}$ " x  $14\frac{1}{2}$ "—Base strips
- 4 "  $\frac{3}{4}$ " x  $\frac{3}{4}$ " x 17"—Base strips
- 8 "  $1\frac{1}{4}$ " x  $1\frac{1}{4}$ " x 3"—Base corner blocks
- 2 "  $\frac{3}{4}$ " x  $5\frac{1}{2}$ " x 17"—Typewriter-drawer sides
- 1 "  $\frac{3}{4}$ " x  $3\frac{5}{8}$ " x 17"—Typewriter-drawer sides
- 1 "  $\frac{3}{4}$ " x  $1\frac{3}{4}$ " x  $15\frac{1}{4}$ "—Typewriter-drawer post
- 1 "  $1\frac{1}{8}$ " x  $1\frac{1}{2}$ " x  $13\frac{1}{8}$ "—Back cleat

#### PLYWOOD

- 1 pc.  $\frac{3}{4}$ " x  $13\frac{1}{8}$ " x  $19\frac{7}{8}$ "—Typewriter-drawer back
- 1 "  $\frac{3}{4}$ " x  $12\frac{5}{8}$ " x  $16\frac{1}{4}$ "—Typewriter-drawer bottom

#### HARDBOARD

- 2 pc.  $\frac{1}{4}$ " x  $13\frac{3}{8}$ " x  $16\frac{5}{8}$ "—Drawer bottoms
- 2 "  $\frac{1}{4}$ " x  $12\frac{5}{8}$ " x  $15\frac{1}{2}$ "—Drawer bottoms
- 1 "  $\frac{1}{4}$ " x  $19\frac{1}{8}$ " x  $16\frac{5}{8}$ "—Drawer bottom

#### MISCELLANEOUS

- 3 - 1" dia. knobs
- 2 - 2 $\frac{5}{8}$ " lion-head pulls
- 1 - Bullet catch,  $\frac{3}{8}$ " dia.
- 6 - Drawer rollers,  $\frac{3}{4}$ " dia. wheels
- 1 -  $\frac{3}{8}$ " steel rod,  $16\frac{1}{4}$ " long
- 2 - Metal brackets

### SINGLE-PEDESTAL DESK

#### MAHOGANY PLYWOOD

- 1 pc.  $1\frac{3}{16}$ " x 18" x 39"—Top
- 2 "  $1\frac{3}{16}$ " x  $16\frac{3}{8}$ " x  $25\frac{15}{16}$ "—Ends
- 1 "  $1\frac{3}{16}$ " x  $16\frac{3}{8}$ " x 22"—End
- 1 "  $\frac{1}{4}$ " x  $16\frac{3}{8}$ " x 22"—End
- 1 "  $1\frac{3}{16}$ " x 15" x  $21\frac{1}{4}$ "—Drawer front
- 1 "  $1\frac{3}{16}$ " x  $3\frac{5}{16}$ " x 15"—Drawer front
- 1 "  $1\frac{3}{16}$ " x  $3\frac{5}{16}$ " x 24"—Drawer front
- 1 "  $1\frac{3}{16}$ " x  $3\frac{9}{16}$ " x 39"—Back
- 1 "  $1\frac{3}{16}$ " x 15" x 22"—Back
- 1 "  $1\frac{3}{16}$ " x 13" x 14"—Typewriter shelf

#### HARDWOOD

- 2 pc.  $\frac{3}{4}$ " x  $1\frac{3}{4}$ " x  $37\frac{7}{8}$ "—Top frame
- 1 "  $\frac{3}{4}$ " x  $1\frac{3}{4}$ " x  $16\frac{3}{8}$ "—Top frame
- 1 "  $\frac{3}{4}$ " x  $2\frac{3}{4}$ " x  $16\frac{3}{8}$ "—Top frame
- 1 "  $\frac{3}{4}$ " x  $4\frac{3}{4}$ " x  $16\frac{3}{8}$ "—Top frame
- 1 "  $\frac{5}{8}$ " x  $1\frac{3}{4}$ " x  $37\frac{7}{8}$ "—Center frame
- 1 "  $\frac{5}{8}$ " x  $2\frac{3}{8}$ " x  $37\frac{7}{8}$ "—Center frame
- 1 "  $\frac{5}{8}$ " x  $1\frac{3}{4}$ " x  $17\frac{3}{4}$ "—Center frame
- 1 "  $\frac{5}{8}$ " x  $2\frac{3}{4}$ " x  $17\frac{3}{4}$ "—Center frame
- 1 "  $\frac{5}{8}$ " x  $4\frac{3}{4}$ " x  $17\frac{3}{4}$ "—Center frame
- 2 "  $\frac{3}{4}$ " x  $5\frac{1}{2}$ " x 16"—Typewriter-drawer sides
- 1 "  $\frac{3}{4}$ " x  $3\frac{5}{8}$ " x 16"—Typewriter-drawer sides
- 1 "  $\frac{3}{4}$ " x  $1\frac{3}{4}$ " x  $15\frac{1}{4}$ "—Typewriter-drawer post
- 1 "  $1\frac{1}{8}$ " x  $1\frac{1}{2}$ " x  $13\frac{1}{8}$ "—Typewriter-drawer back cleat
- 4 "  $\frac{1}{2}$ " x  $2\frac{9}{16}$ " x  $16\frac{3}{8}$ "—Drawer sides
- 1 "  $\frac{1}{2}$ " x  $2\frac{5}{16}$ " x  $13\frac{9}{16}$ "—Drawer back
- 1 "  $\frac{1}{2}$ " x  $2\frac{5}{16}$ " x  $22\frac{9}{16}$ "—Drawer back
- 3 "  $\frac{3}{4}$ " x 1" x  $16\frac{3}{8}$ "—Drawer guides
- 2 "  $\frac{7}{16}$ " x  $2\frac{1}{4}$ " x  $15\frac{1}{2}$ "—Drawer slides
- 2 "  $\frac{3}{4}$ " x  $1\frac{5}{16}$ " x  $15\frac{1}{2}$ "—End cleats
- 1 "  $\frac{3}{4}$ " x  $1\frac{1}{2}$ " x  $17\frac{1}{2}$ "—End base cleat
- 2 "  $\frac{3}{4}$ " x  $2\frac{3}{4}$ " x  $17\frac{1}{16}$ "—Pedestal base rail
- 1 "  $\frac{3}{4}$ " x  $2\frac{3}{4}$ " x  $13\frac{3}{8}$ "—Pedestal base rail

#### MAHOGANY

- 1 pc.  $\frac{3}{4}$ " x  $2\frac{3}{4}$ " x  $13\frac{7}{8}$ "—Pedestal base rail
- 2 "  $\frac{3}{4}$ " x  $4\frac{1}{2}$ " x 16"—Base
- 2 "  $\frac{3}{4}$ " x  $4\frac{1}{4}$ " x 19"—Base
- 4 "  $\frac{3}{16}$ " x  $\frac{5}{16}$ " x  $13\frac{5}{8}$ "—Face molding
- 4 "  $\frac{3}{16}$ " x  $\frac{5}{16}$ " x  $4\frac{1}{8}$ "—Face molding
- 8 "  $\frac{3}{16}$ " x  $\frac{5}{16}$ " x  $12\frac{3}{4}$ "—Face molding
- 2 "  $\frac{1}{2}$ " x  $\frac{5}{8}$ " x  $18\frac{3}{4}$ "—Band molding
- 2 "  $\frac{1}{2}$ " x  $\frac{5}{8}$ " x  $39\frac{3}{4}$ "—Band molding
- 2 "  $\frac{3}{4}$ " x  $1\frac{1}{4}$ " x 40"—Top band molding
- 2 "  $\frac{3}{4}$ " x  $1\frac{1}{4}$ " x 19"—Top band molding
- 2 "  $1\frac{1}{4}$ " x 2" x  $22\frac{1}{8}$ "—Posts

#### HARDBOARD

- 1 pc.  $\frac{1}{4}$ " x  $13\frac{9}{16}$ " x  $15\frac{1}{2}$ "—Drawer bottom
- 1 "  $\frac{1}{4}$ " x  $15\frac{1}{2}$ " x  $22\frac{9}{16}$ "—Drawer bottom

#### PLYWOOD

- 1 pc.  $\frac{3}{4}$ " x  $12\frac{5}{8}$ " x  $15\frac{1}{4}$ "—Typewriter-drawer bottom
- 1 "  $\frac{3}{4}$ " x  $13\frac{1}{8}$ " x  $19\frac{7}{8}$ "—Typewriter-drawer back

#### MISCELLANEOUS

- 3 - Drawer pulls, 3" boring
- 1 -  $\frac{3}{8}$ " dia. steel rod,  $15\frac{1}{4}$ " long
- 2 - Metal brackets
- 6 - Drawer rollers,  $\frac{3}{4}$ " dia. wheels



drawer front. As this drawer is quite heavy when the typewriter is installed, three pairs of rollers are used to attain easy operation. One pair is mortised into the top cleat at the rear of the drawer to roll against the crossrails of the top-section frame. Then a second pair is mortised in the drawer bottom near the back panel, and the third pair is mortised in the front rail of the pedestal so each roller will be directly in line with one of the drawer sides and under the inner front member of the drawer when it is in the closed position. Note in the upper details, Fig. 1, how the  $\frac{3}{4}$ -in.-plywood drawer bottom is rabbeted all around to form a tenon which is glued in grooves cut in the sides, back and front of the drawer. The outer drawer front should be glued and screwed to both the vertical cleat and the inner front member.

Mahogany, walnut or oak lumber, along with plywood faced with a matching veneer may be used for the exposed portions of the desks. Less-expensive hardwood and plywood, of course, may be used for the concealed members. If desired, the entire desk can be made of poplar or gum and covered with plastic veneer.

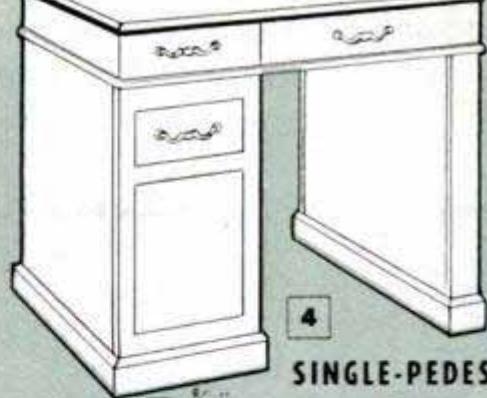

4 SINGLE-PEDESTAL DESK

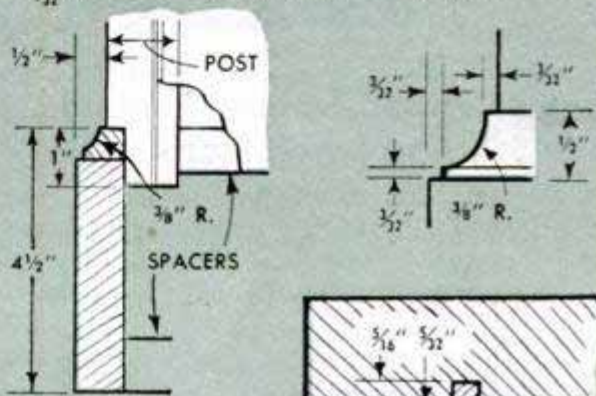
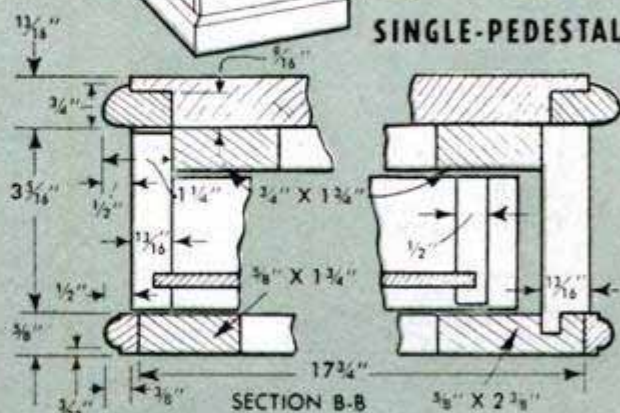

DETAIL OF BEAD ON TYPEWRITER DRAWER AND BACK

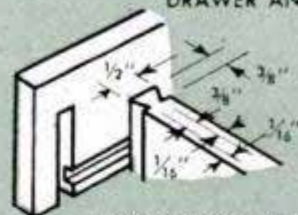

DRAWER SIDES AT ENDS OF DESK JOINED TO FRONTS WITH BLIND DOVETAIL

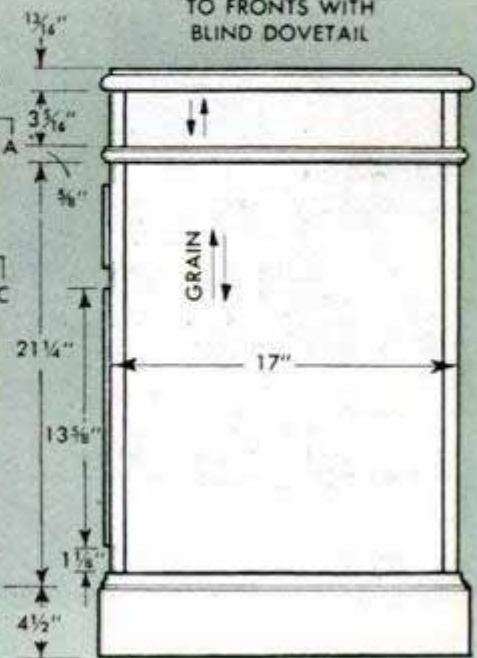
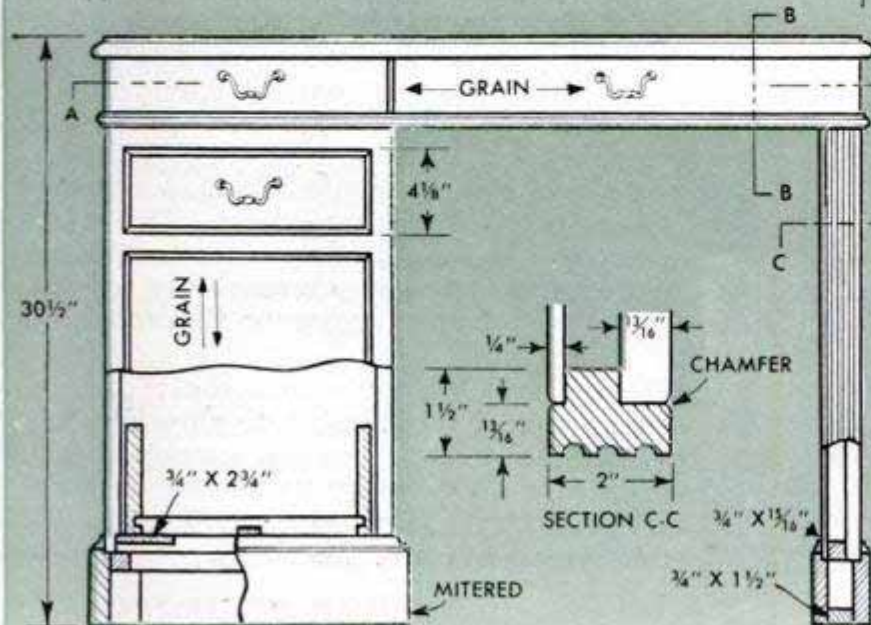
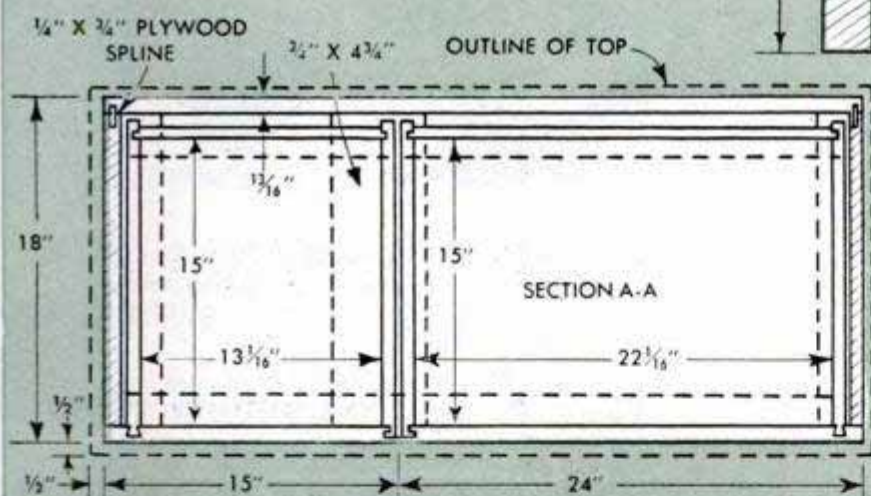

END VIEW



## Newspaper Guide Helps Position Pictures When Hanging Them in Pattern on Wall

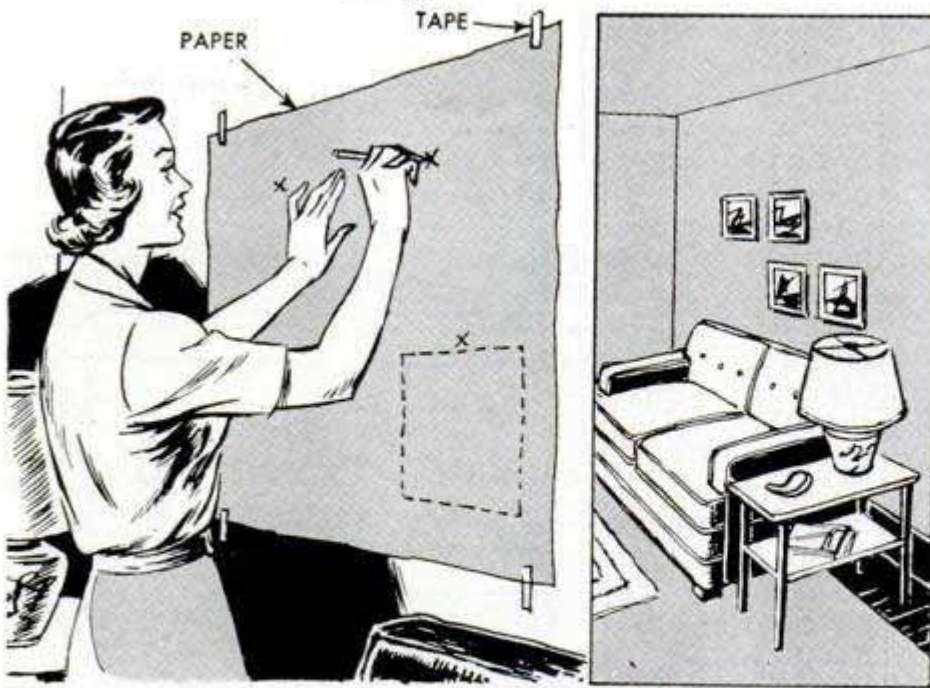

Here's one way of simplifying the job of hanging several small pictures in a pattern on a wall. First, place the pictures on a large piece of wrapping paper, or several sheets of newspaper that have been pasted together, and align them in the positions desired. This done, mark the paper where picture hangers are to be secured to the wall. Now, holding the marked paper against the wall, punch through the paper with the point of a pencil to mark the wall for later insertion of the hangers. If the guide paper is difficult to handle, try taping it to the wall as shown.

## Sponge Rubber Protects Fingers While Starting Small Nails

Of the various methods that have been found helpful in starting finishing nails and brads of a size difficult to hold with the fingers, one carpenter has found that a small pad of sponge rubber tops them all. Not only does the rubber serve to hold the nail for starting, but it provides a pad to protect the surface from hammer marks. The resilience and porous texture of the rubber allows the nail to be driven practically home and the pad to be lifted easily from the head of the nail before completing the nailing. In the case of a fine piece of cabinet work where it is important to avoid accidental hammer dents, it is always wise to



use a small nailset to finish driving the nail flush or below the surface of the work.

George Kapitan, Bronx, N. Y.

## Wire Stand Attached to Electric-Drill Housing Protects Bit Cutting Edges

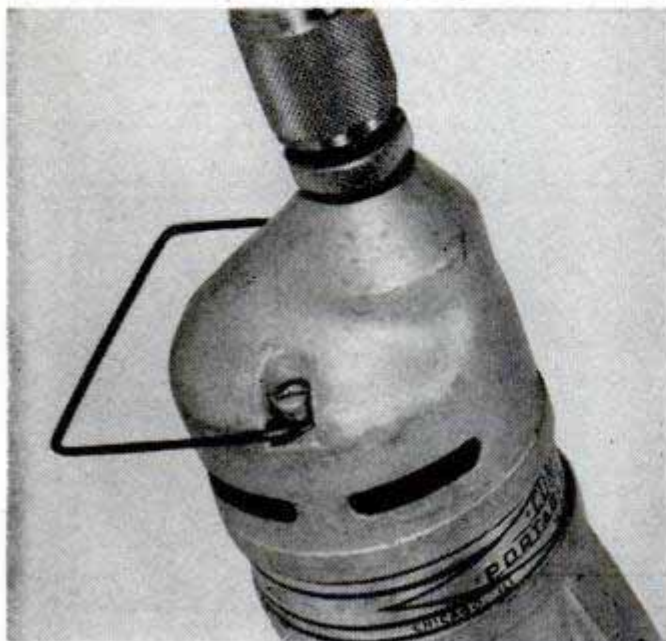

When an electric drill is laid down on a bench temporarily there is always a possibility of damaging the cutting edges of the drill bit or other tool being used in it. To avoid this possibility, one workman uses a wire stand which is clamped over two of the assembly bolts on the drill housing. The stand can be shaped from wire such as a piece of coat-hanger wire. The stand is bent to a U-shape and eyes are formed on each end to slip over the assembly screws.

Henry Hanscom, Elmhurst, Ill.

☛ If you have been unable to find a glue or cement that will hold glass to glass, leather to metal or other unusual combinations, ignite a small quantity of shellac to burn off the alcohol. The residue will be a very effective all-purpose glue.



After digging a ditch to clean the sewer from his house, a short distance from where it empties into the main sewer, one homeowner permanently embedded a cleanout pipe in the ground to facilitate future cleaning needs. A  $\frac{3}{4}$ -in. pipe was joined to the draintile, about 20 ft. from the main sewer, and set at an angle for easy manipulation of a cleaning cable. Concrete secures the pipe to the tile and anchors the upper end. The pipe is capped where it protrudes above the ground. Steel telephone cable, frayed at one end and handle-shaped at the other, is utilized for cleaning.—R. J. Carabin, San Antonio, Tex.

## Cleanout Pipe Permanently Set in Ground Simplifies Cleaning of Residential Sewer

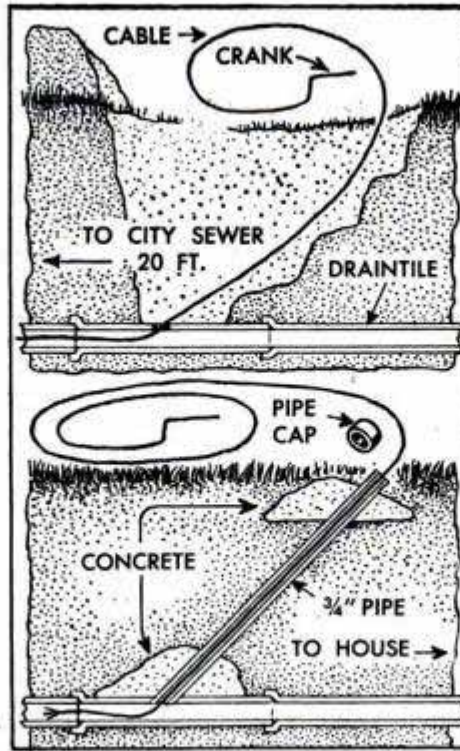

## Soiled Sun Visors Renovated by Reversing Positions

Usually identical in size and shape, stained and dirty sun visors in a car may be made to appear like new by simply interchanging them in the brackets. This will place the protected, upper side in full view on the bottom and, at the same time, place the soiled side on top, more or less hidden from view. Also, this operation usually

will check whatever drooping tendencies the visors have, because they will be made to function in the opposite direction. If they still droop, the condition may be remedied by wrapping a short strip of cellulose tape around the rods before inserting them in the brackets.

Charles P. Fitz Patrick, Philadelphia, Pa.

## Candle Placed Inside Flowerpot Produces Novel "Hurricane" Lamp

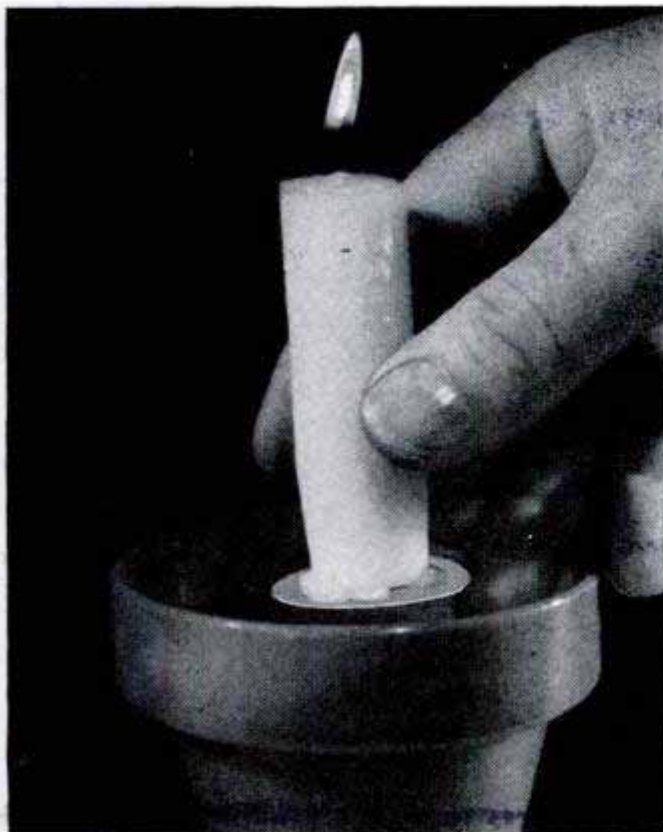

If you use lighted candles on festive occasions, a very novel and unusual effect can be produced by placing a short, lighted candle inside a plastic flowerpot. These are translucent and come in various colors. The candles can be mounted on lids cut from tin cans or any other base of suitable size. Another way of mounting a long-burning candle is to fill the pot about half full of melted wax and insert a wick in it while the wax is in the liquid form. The pot then becomes a candle in itself and still produces the same effect.

## Decals Conceal Chipped Porcelain

The appearance of a chipped porcelain cabinet or refrigerator can be improved by covering the marred spots with decalcomania transfers. In some cases, it may be desirable to apply one or two decals in addition to those covering chipped spots in order to balance the over-all effect. The decals are obtainable in numerous colors and designs.



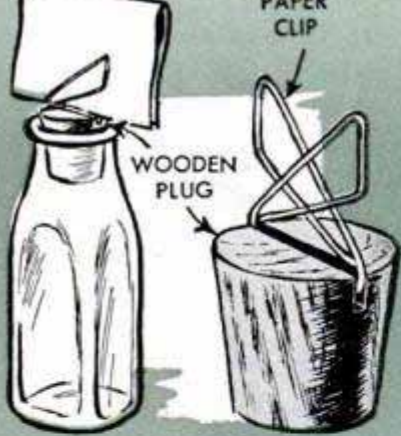

**NOTES FOR MILKMAN** are held safely on top of the bottle by a plug and paper clip set in the neck. Clip is pressed in a slot cut across top of tapered plug



**TAPE "FROG"** supports stems of cut flowers in vase having flared top. Cellulose tape, stretched crisscross over top of vase, is hidden by leaves of the flowers



**ASSORTED RUBBER BANDS** can be cut from worn-out rubber gloves. Strips from wrist portion provide larger bands, and smaller sizes are cut from the fingers

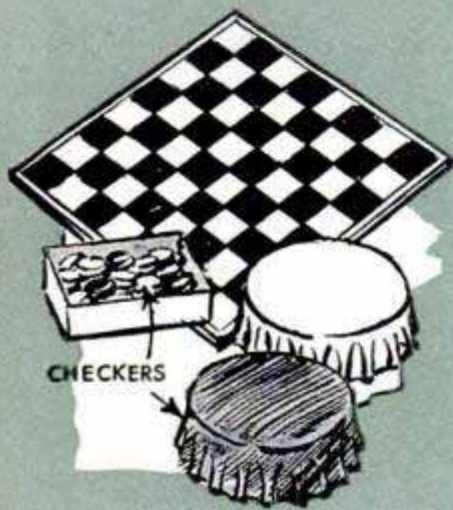

**INEXPENSIVE CHECKERS** to replace ones that are lost are improvised from beverage-bottle caps. Paint the caps red or black, or identify them by brand name

# Solving HOME PROBLEMS



**TO REMOVE LINT** from woolen garments, rub the surface with a rubber bath sponge. You will find this faster and more efficient than using a clothesbrush

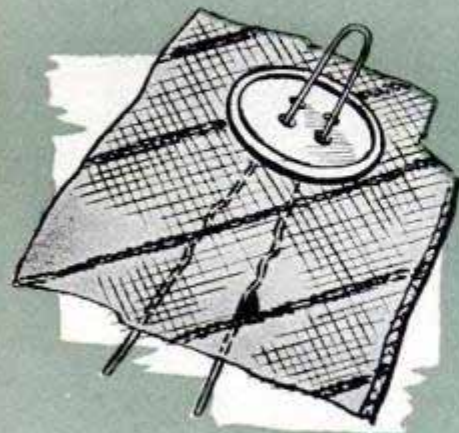

**USE A HAIRPIN** to locate a button before sewing it to the garment. Press the pin through the fabric to hold the button in place while testing for proper fit



**CRACKING OF CRYSTAL** cups when filled with hot coffee or tea can be prevented by placing a silver teaspoon in the cup and pouring beverage into the spoon



**A ZIPPER WILL WORK** easily if lubricated occasionally with graphite. Rubbing an ordinary lead pencil along the teeth of the zipper coats them with graphite



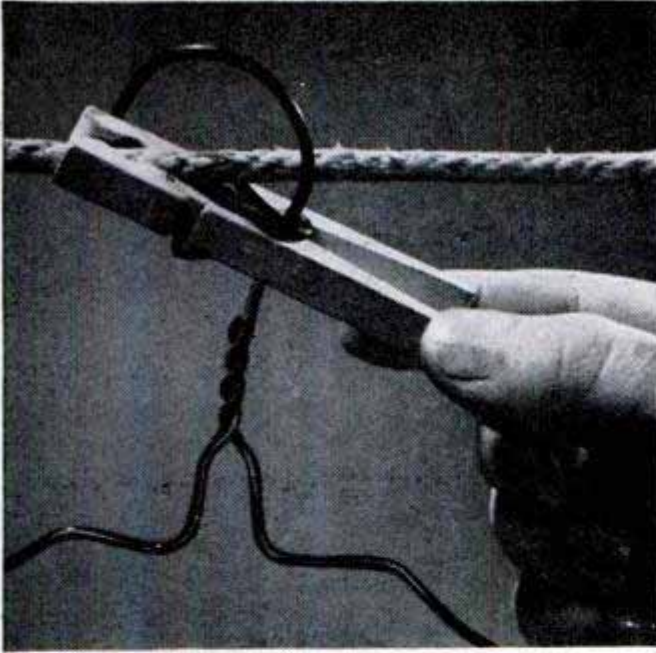

**WHEN GARMENTS ARE AIRED** on a clothesline, the coat hangers tend to slide toward the lowest part of the line. This will not happen if each hanger is clamped to the line with a spring-type clothespin



**DUSTING VENETIAN BLINDS** takes less time if a pair of socks is slipped over the hands. Less bulky than a dust cloth, socks also allow you to dust behind the tapes and under the slats with both hands

**HOLE DRILLED IN PAINT-CAN LID** permits use of artists' brush without removing lid. To seal can, cover hole with short bolt and washer or with piece of cellophane "cemented" to lid with a little paint

**SIMPLE WALL BRACKET** for flowerpot is made quickly from angle iron and bolt. Latter is inserted through hole in the bottom of the pot and the outer hole in bracket. Pot and bracket are painted the same color

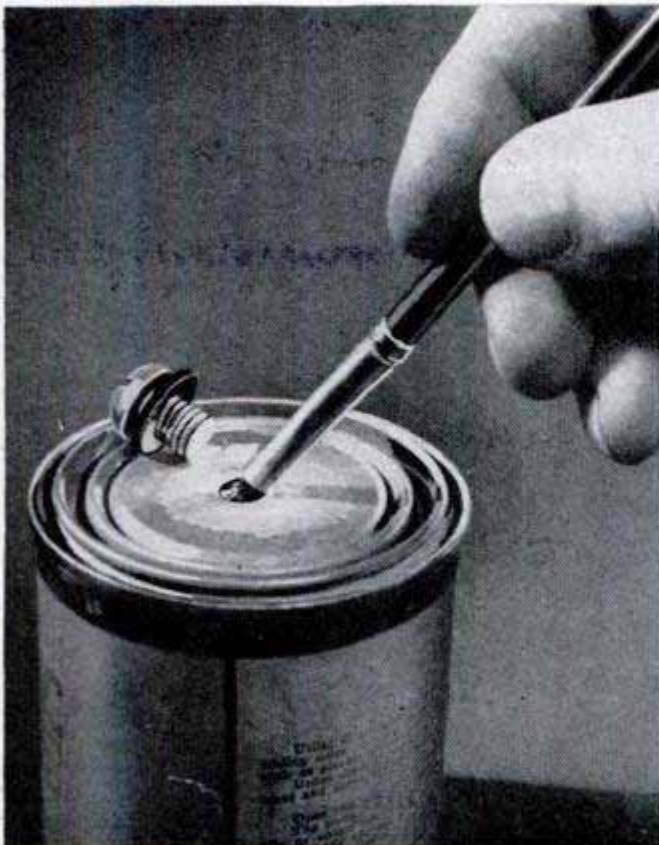



## Miter Box Adjustable for Wear

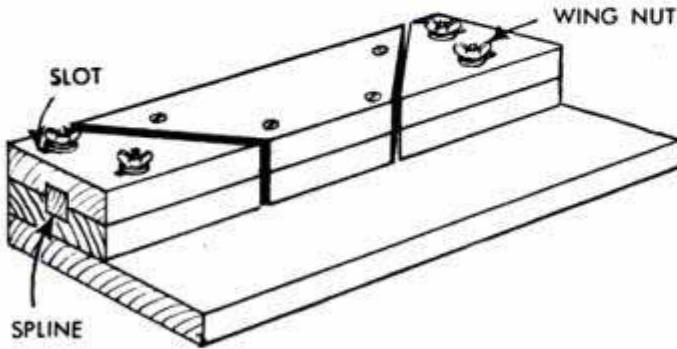

If you need a common wooden miter box for repairs around the home, here's a practical one that features adjustable endpieces to permit taking up play when the slots become worn. The box consists of three boards, two of which are narrower than the third and grooved to take a  $\frac{1}{2}$ -in.-square spline snugly. All three pieces are screwed together with the spline in place, using four flat-headed wood screws placed in the positions shown. Next, the 45-deg. slots are marked. However, before the slots are cut, two  $\frac{1}{4}$ -in. holes are drilled at each end through all three pieces to take flat-headed stove bolts. When the holes are drilled, the slots can be cut down to the baseboard. The bottom piece of each end block is screwed permanently to the baseboard and the spline is glued in the groove. Then holes in the top piece of each block are elongated to permit adjustment of the upper pieces. Washers and wing nuts are fitted to the stove bolts and the sliding pieces are backed away just enough to allow the saw blade to pass freely in the slots. The wing nuts are tightened to lock the sliding pieces in place.

R. E. Hancock, Portsmouth, Va.

## Locating a Short Circuit In Home Appliances

When electric fuses repeatedly blow out in the home and you suspect a short circuit in one of your lamps or appliances, try this test to locate the trouble. Turn off all wall and ceiling lights and pull the plugs of all lamps and appliances. Then, screw a 100-

watt light bulb into the socket where the fuses have blown. If the bulb lights immediately, it indicates a short somewhere in the house wiring, in which case the main switch should be thrown and an electrician called at once. However, if the bulb does not light, plug in the lamps and appliances one by one and watch the effect on the bulb. If, when a lamp is plugged in and turned on, the test bulb lights to its full brilliancy but the lamp bulb does not light at all, the short is in that lamp. If no short is present, both bulbs will light at half brilliancy. Only heavy-wattage heating units and motorized units free of shorts will become warm when subjected to this test, although the test bulb may light to full brilliancy as a result of the low resistance of the appliances.

W. H. McClay, Pasadena, Calif.

## Boat Trailer Has Fenders Made From Old Tires

A half section of an old tire casing makes an inexpensive fender for use on a boat trailer. Such fenders cost nothing and prevent the trailer wheels from throwing mud on the back end of the tow car. The tire

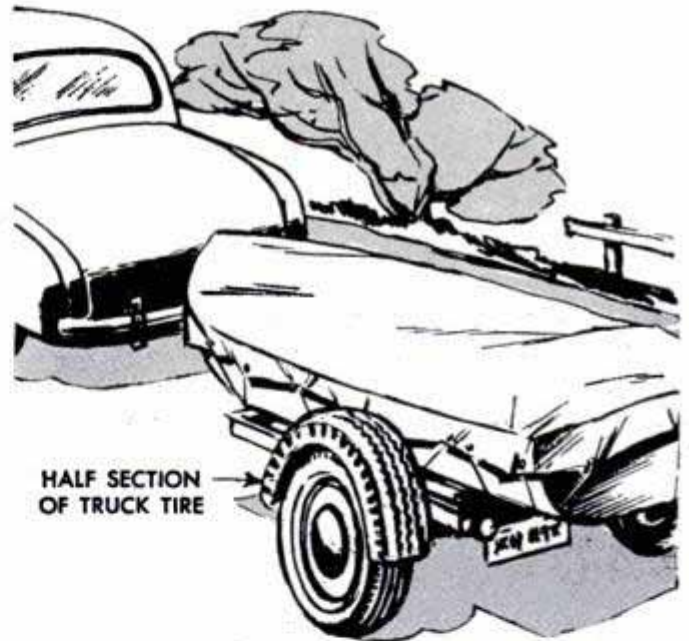

from which the sections are cut should be larger in diameter than the ones used on the trailer. A coat of aluminum paint will add to the appearance of the fenders and also help in making the trailer visible at night to approaching motorists. Mounting of the fenders will depend on your particular trailer. Suitable brackets can be shaped for this purpose or, in some cases, it may be possible to bolt the tire sections directly to the sides of the trailer.

Omer Dye, Columbia, Mo.

☞ Satisfactory remover for spots on plaster can be made by mixing a nonflammable cleaning fluid with powdered chalk.



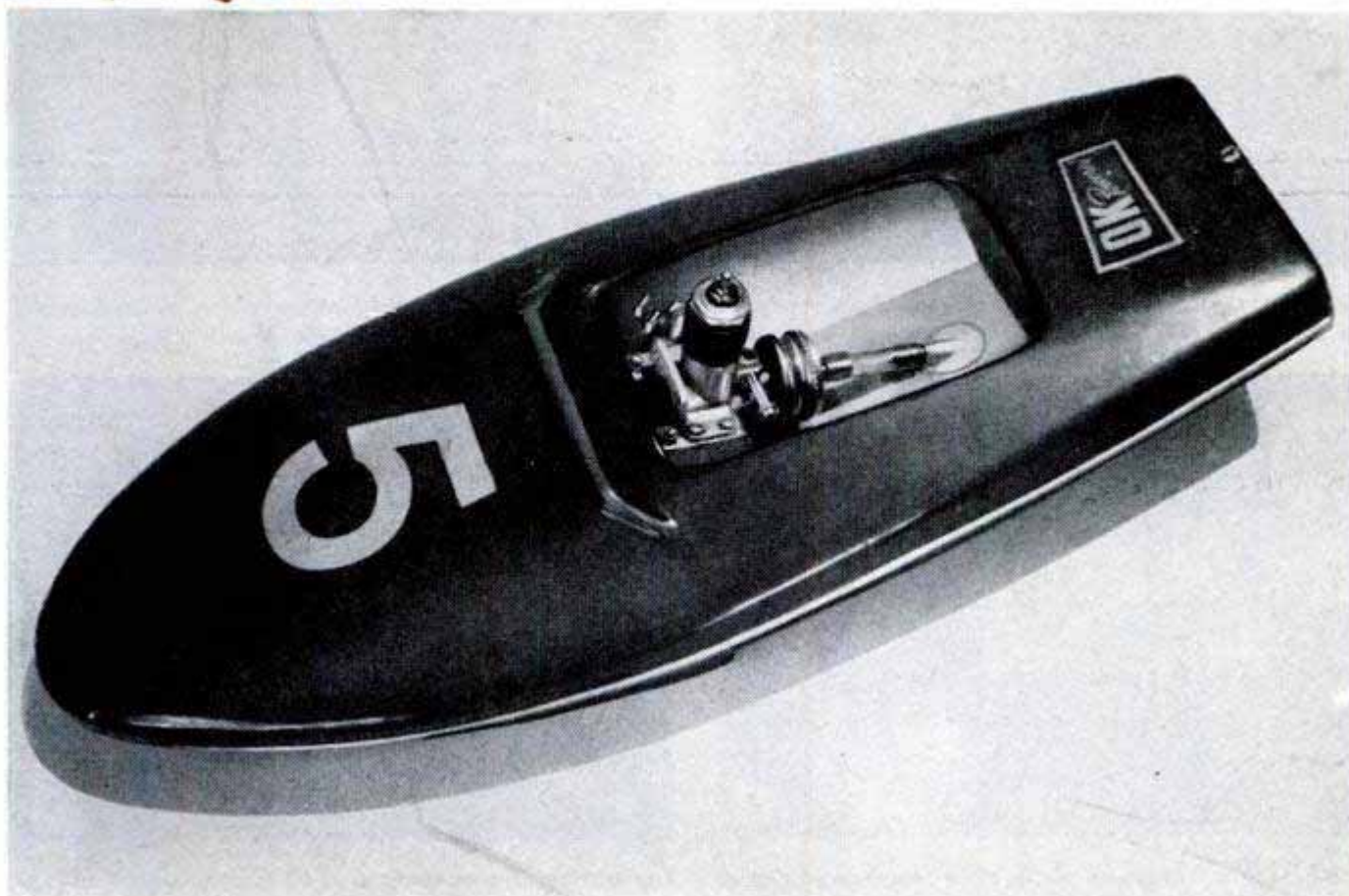

**By Jack Wilson**

**YOU'LL** get hours of fun in return for every minute spent in building Cookie. Greatly simplified methods of construction bring the assembly of its 15-in. hydroplane hull easily within the skill range and equipment of the most inexperienced modelmaker.

**Hull construction:** Proceed step by step as in Figs. 2 to 10 inclusive, beginning by cutting the bulkheads and keel from  $\frac{1}{8}$ -in. balsa wood, and assembling as in Fig. 2, using a fuel-resistant cement available from model-supply dealers. Fit hull planking as in Figs. 3 to 6 inclusive, then smooth the parts with fine sandpaper and round over the upper edges. Do not round edges of the bottom plank or the sponson projections. The sponsons are planked separately as in Fig. 7. Use rubber bands and pins to hold parts tightly together while the cement sets. In Fig. 4, clothespins serve as clamps. When planking the sponsons, Figs. 7, 8 and 10, it's important to trim off the bottom edges of the inside strips flush with the bulkheads before the bot-

tom pieces are cemented in place. Cement  $\frac{1}{16}$  x  $\frac{1}{16}$ -in. basswood moldings along the sides of the hull just below the gunwales. Cut the transom slightly oversize and glue to bulkhead No. 6 as in Fig. 9.

**Installing engine and propeller shaft:** On engines with beam-mounting lugs, install hardwood engine mounts against bulkhead No. 4. Engines of the radial-mounting type can be installed on a fire wall as in Fig. 14.

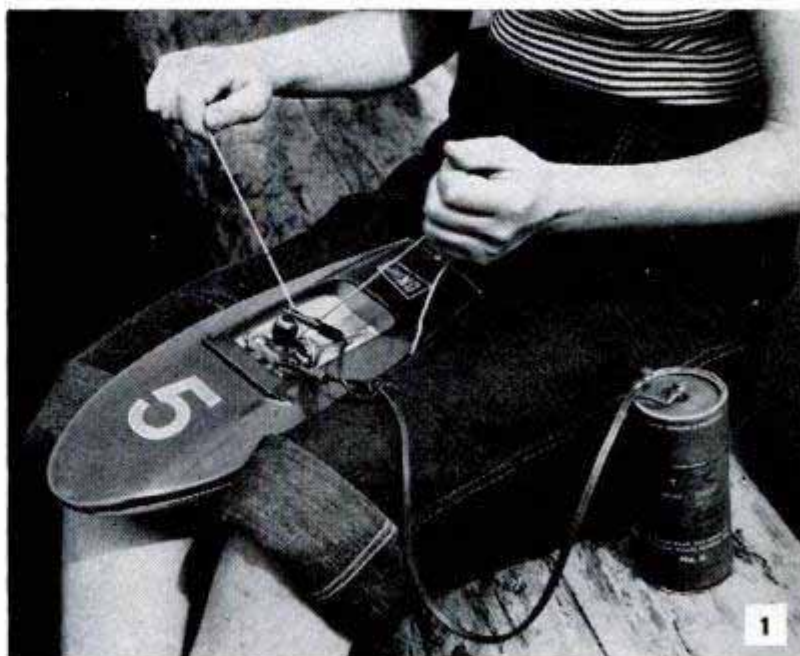





**2**  
Begin construction by cementing the bulkheads to the keel. Check alignment with a triangle or square

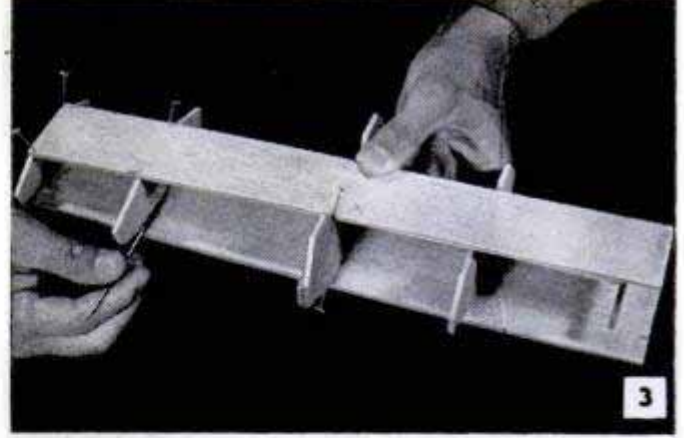

**3**  
Cement upper deck and bottom plank to bulkheads Nos. 3, 4, 5 and 6. Hold in place with pins as shown

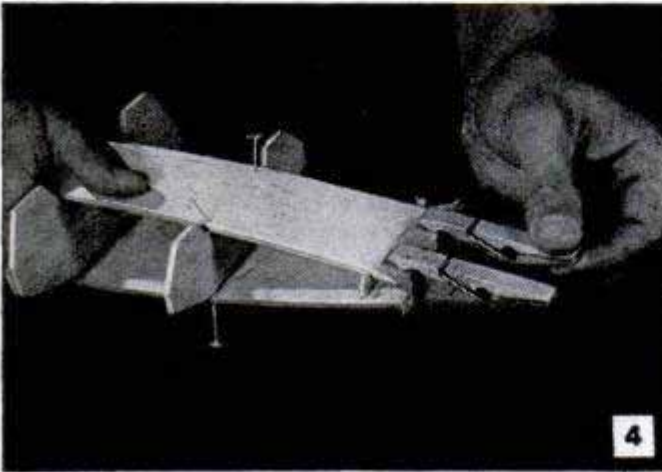

**4**  
Bevel front end of lower plank, then cement and clamp the two parts. Use balsa blocks and spring clothespins

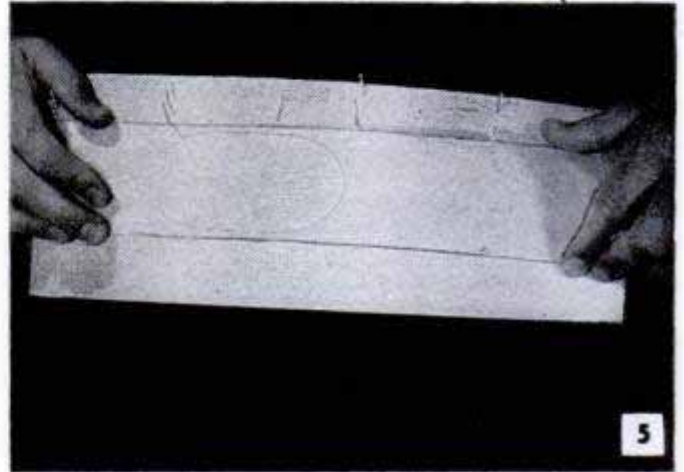

**5**  
Lay out cockpit opening and fit a coaming of balsa-wood after cutting out waste and sanding smooth

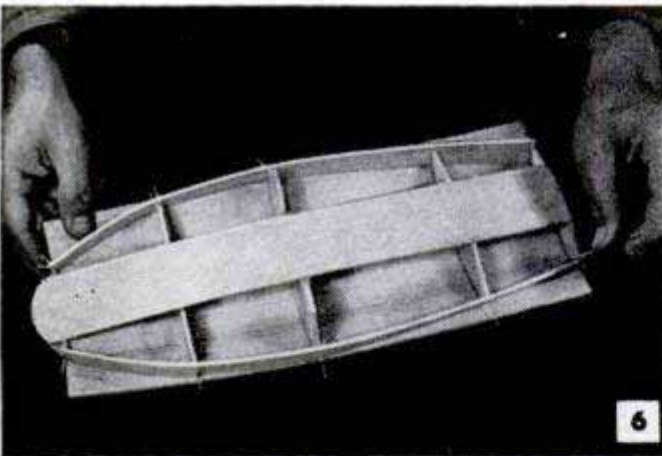

**6**  
Above, steam side planks to assure a clean bend at forward ends. Bevel edges of bulkheads for true fit. Below, trim bottom edges of sponson strips flush

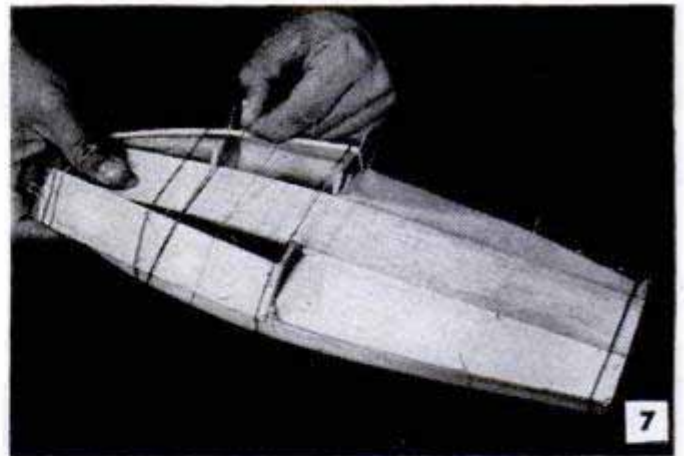

**7**  
Above, use rubber bands and pins to hold sponson strips until cement sets. Below, cut transom to fit over No. 6 bulkhead, coat with cement and pin until dry

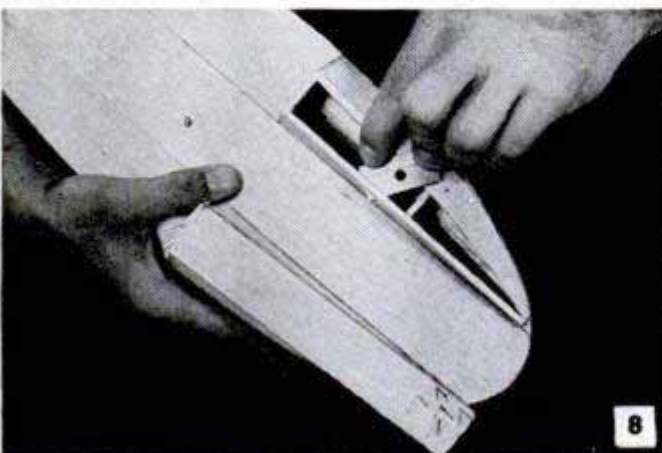









10 Fill all openings at seams with wood putty and sand entire hull, using special care to smooth the sponsons

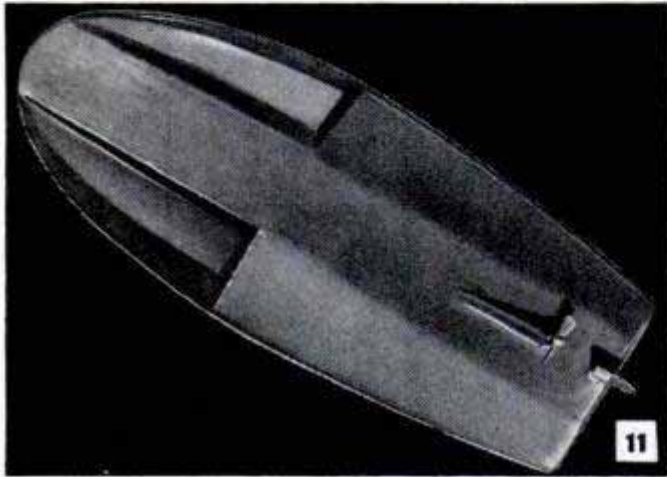

11 Bottom view of the finished hull showing the sponsons, the propeller housing and skag, and rudder in place

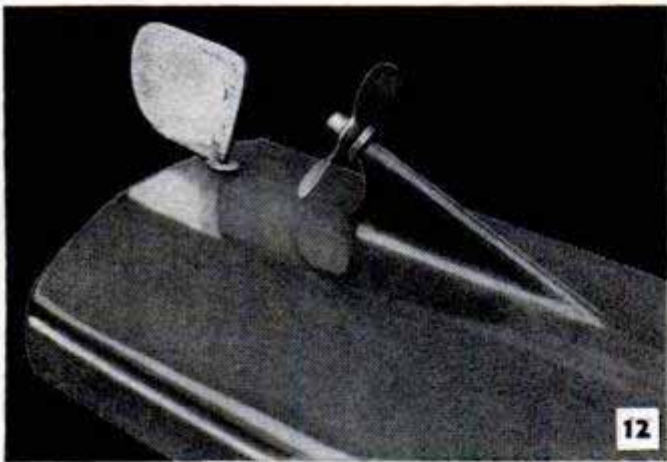

12 Above, special care is taken to fair the skag smoothly into the bottom lines to cut water friction to a minimum. Below, note grooved engine flywheel and tether

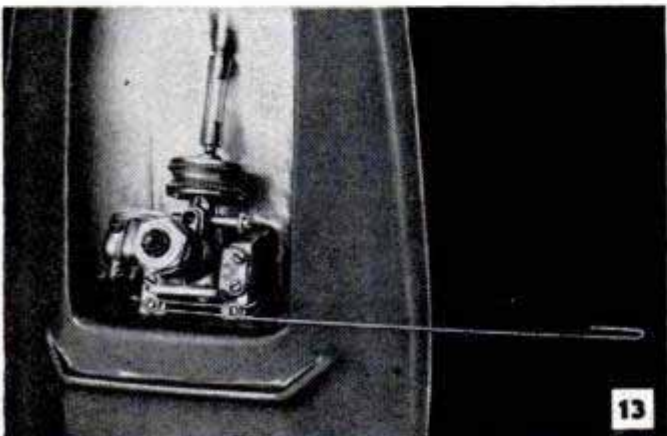

13

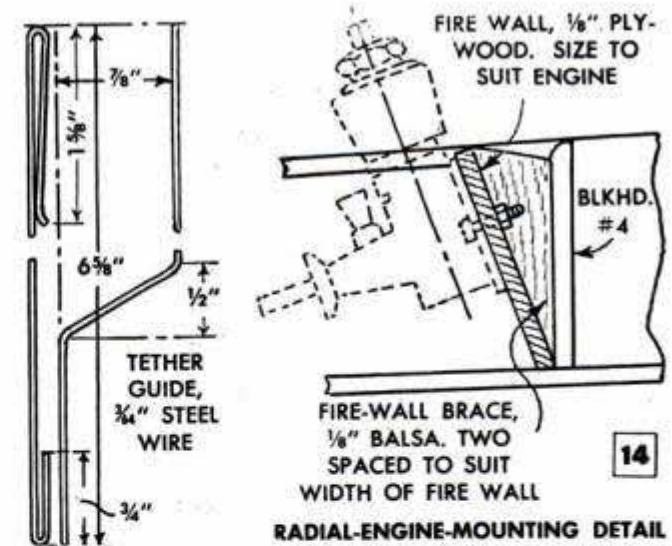

14 RADIAL-ENGINE-MOUNTING DETAIL

Before installing either type of engine, cut a hole through the bottom of the hull for the propeller-shaft housing. Mount the engine and use it as a guide to alignment of the propeller-shaft housing. When properly aligned with the engine shaft, cement the propeller-shaft housing and skag in place. Note in Fig. 13 that the engine has a grooved flywheel. The concave groove is filed or turned in the flywheel and is  $\frac{1}{4}$  in. wide and  $\frac{7}{64}$  in. deep. Thus the flywheel is made to serve as a winding drum for the starting cord, Fig. 1. As indicated on the construction details, the propeller shaft is cut from a heavy-duty bicycle spoke, utilizing the threaded end onto which the propeller hub is force-threaded. It will be necessary to extend the engine crankshaft in order to provide a projection beyond the wide-rimmed flywheel for placement of the flexible coupling. Use a 5-40 stud about 1 in. long for this purpose. In this case the extension shaft is screwed into the tapped end of the crankshaft and the flywheel is held in place with a 5-40 brass nut. A  $1\frac{1}{4}$ -in. length of clear-plastic fuel line serves as a flexible coupling from the engine to the propeller shaft, Fig. 13. The propeller and rudder are cut from 20-gauge sheet brass. The propeller blank is soldered to the hub, the blades are bent to the pitch angle given and the edges are filed sharp.

**Installing rudder post:** Drill a  $\frac{1}{8}$ -in. hole through the deck and bottom of the hull just forward of the No. 6 bulkhead, coat the holes with cement and insert the rudder-post tube. Solder a  $\frac{1}{4}$ -in. brass washer to each end of the tube. Cut the rudder post from a bicycle spoke, bend it as shown and solder the rudder in place. File the lower end of the post flat and very nearly flush with the sides of the rudder. The post is held in any desired position by means of a lock washer and nut. Figs. 11 and 12 picture the rudder and propeller in place. As final steps, provide a removable wire tether, Fig. 14, and a fuel tank of  $\frac{3}{8}$ -oz. capacity. Sand the hull ready for finishing.



## Clothespin Serves as Clamp To Hold End of Steel Tape

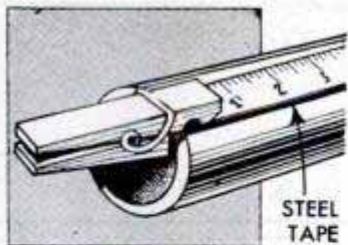

When using a steel tape to measure a long steel bar or length of pipe, the small hook usually provided on the end of the tape to anchor it is

likely to slip off. To avoid this, just use a spring-type clothespin to hold the clip in contact with the work.

Ronald Eyrich, Milwaukee, Wis.

## "Tooled" Pictures in Metal Foil Simulate Hammered Designs

Interesting pictures and unusual designs can be "tooled" in metal foil by using a newspaper mat as a pattern. The tooled foil simulates a skillfully hammered or routed metal relief when applied to a jewel-box top, wall plaque or other novelty. The mats, which are made of stiff paper, may be obtained from any newspaper printing plant. If a quantity of them is available, a suitable picture or design usually can be found. To tool the foil, place it over the mat and then press the metal into the depressions on the surface of the mat. Tool the metal with an orange stick or a stylus which is sufficiently blunt so that it will not break the foil. After the picture has been transferred, apply a heavy coat of casein glue or similar stiffening material to the foil while it is still in the mat so that it will retain its shape when removed. Use escutcheon pins or a suitable cement to mount the foil on the plaque or box top.

Ken Murray, Colon, Mich.



## Paper-Bag "Mittens" Aid Dressing Child

Every parent knows what an exasperating job it is to run the hands of a small child through a bulky coat or other outer garment. Invariably, the little tykes keep their fingers spread like a fan to make the job nearly impossible. This caused one impatient mother to resort to the use of small paper bags which she placed on each hand of the child. These serve as mittens to keep the outstretched fingers and thumbs from catching on the sleeve lining and make the job exceptionally easy, especially in the case of a heavy snow suit. As the bags provide gauntlets that cover the cuffs of a sweater, they also prevent the sweater sleeve from climbing up the arm of the child when running the hand through the sleeve of a coat.

## Improved Grip on Drill Chuck

A better grip on the chuck handle of a small hand drill is possible if a split section of rubber hose is slipped over it as shown. The section may be secured to the handle with rubber cement, if desired.



Waterproof adhesive tape can be used as an emergency repair for a leaky radiator hose. Wrapped tightly around the hose, it will stop the leak for several days.



# PLAN OF THE MONTH... *Extension*

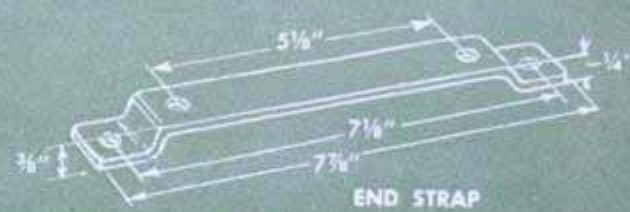
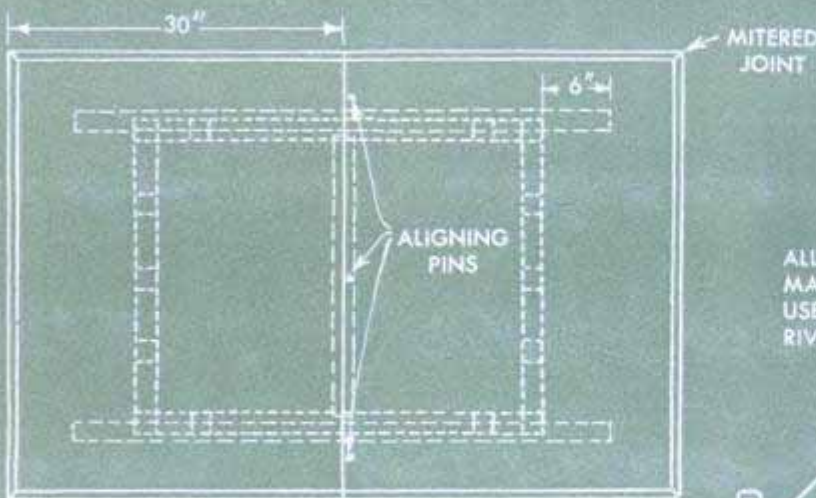
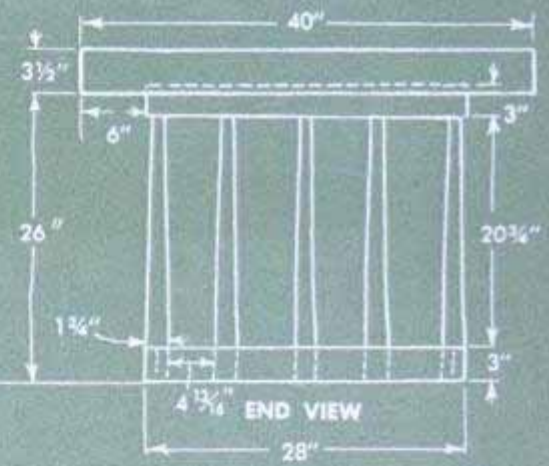
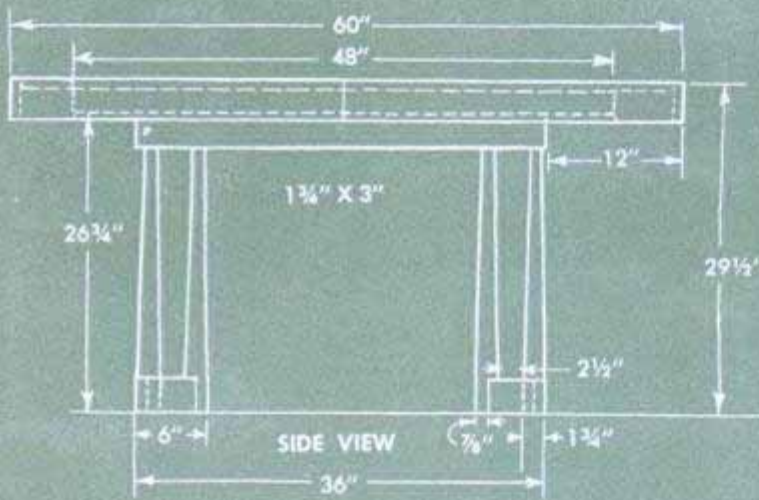
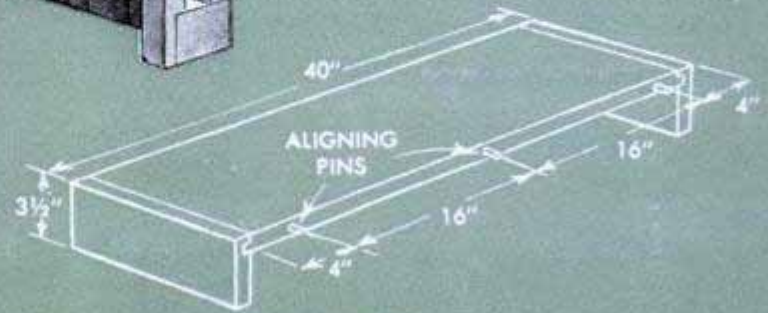
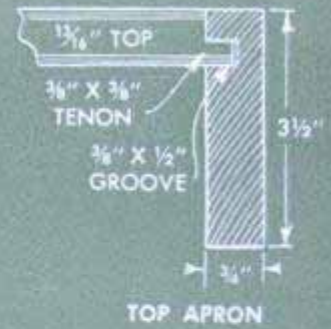
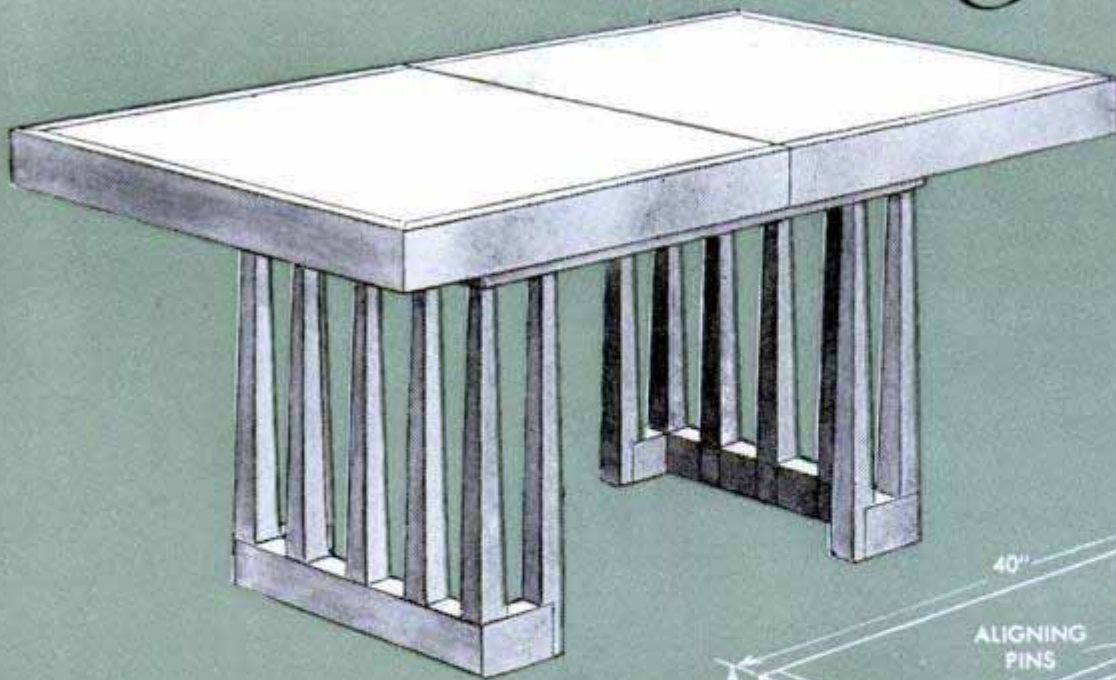

ALL PARTS OF EQUALIZER ARE MADE OF 1/4" X 3/4" FLAT STEEL. USE WASHERS AS SPACERS AT RIVETED JOINTS.

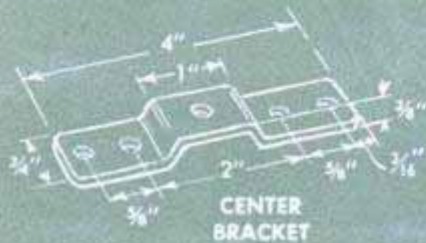
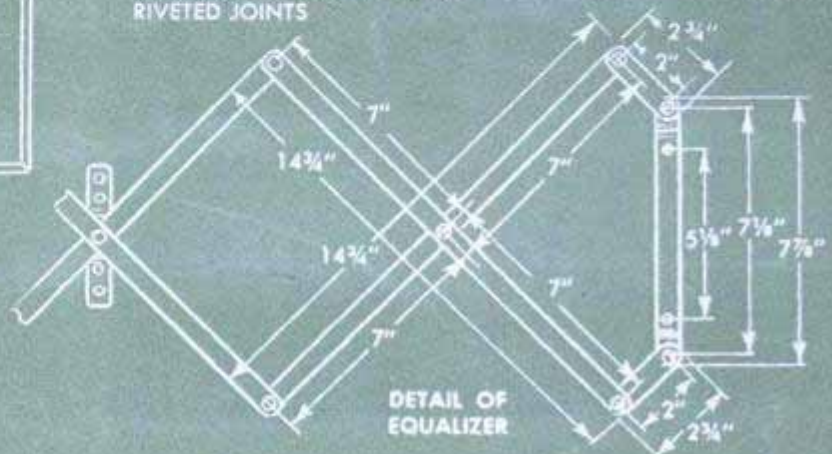



# Dining Table

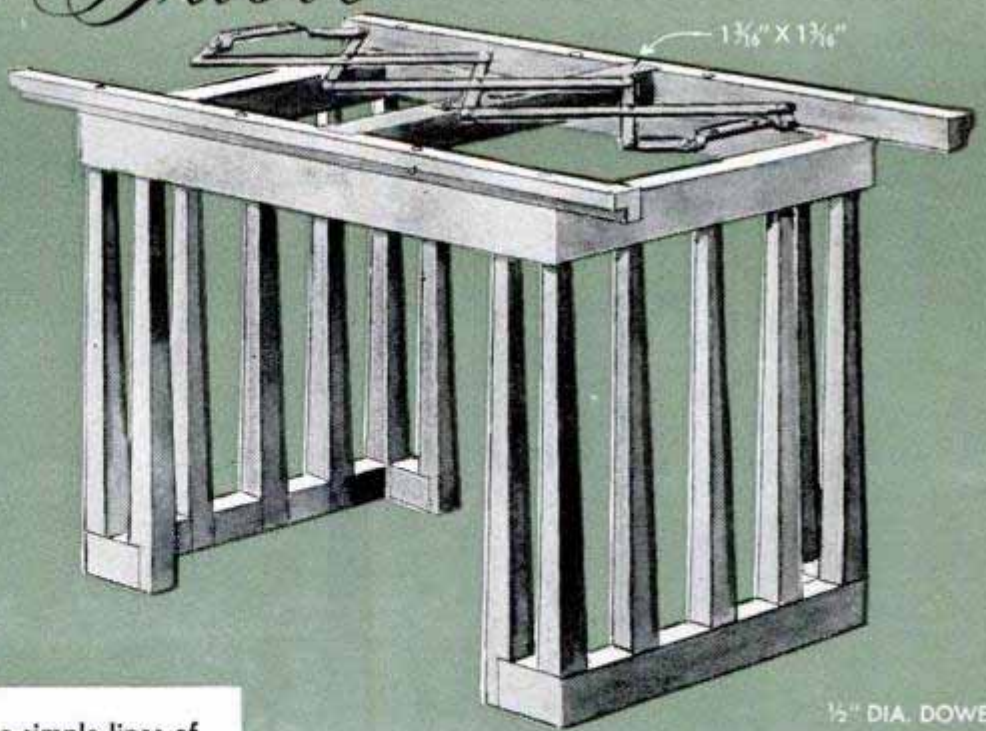
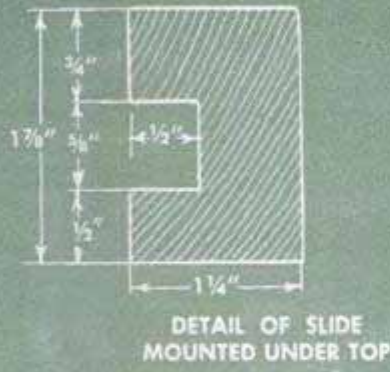

Designed to harmonize with the simple lines of modern home furnishings, this dining table has simplified construction features of special interest to craftsmen with limited equipment. Each pedestal is built up by joining seven tapered posts to a mitered base with half-lap joints. Top ends of posts are doweled to a subframe which supports the top. The latter is built up from two pieces of plywood, the aprons being strengthened by glue blocks as shown. Grooved members of the two-piece guide are attached to the underside of the top while the rabbeted members are screwed to the subframe. A parallel-arm equalizer prevents binding of the top extensions as they are opened or closed

## MATERIAL LIST

- 2 pcs.—1 3/16" x 29 5/8" x 39 1/4"—Top (plywood)
- 2 pcs.—1 3/16" x 14" x 39 1/4"—Leaves (plywood)
- 4 pcs.—3/4" x 3 1/2" x 30"—Side top rails
- 2 pcs.—3/4" x 3 1/2" x 40"—End top rails
- 4 pcs.—1 3/4" x 3" x 28"—Base end rails
- 4 pcs.—1 3/4" x 3" x 36"—Base side rails
- 2 pcs.—1 3/4" x 3" x 36"—Side base rails at top
- 14 pcs.—1 3/4" x 1 3/4" x 23 3/4"—Posts
- 4 pcs.—3/4" x 3 1/2" x 14"—Leaf aprons
- 4 pcs.—1 1/4" x 1 7/8" x 29 1/4"—Top slides (maple)
- 2 pcs.—1 3/16" x 1 7/16" x 48"—Guides (maple)
- 1 pc.—1 3/16" x 1 3/16" x 26 1/2"—Cross brace (maple)
- 10 ft.—3/4" x 1/8" flat steel for top equalizer

FASTEN EQUALIZER TO CENTER OF CROSS BRACE, WITH EQUALIZER IN CLOSED POSITION, END STRAPS ARE SCREWED TO UNDERSIDE OF TOP APPROX. 1/2" FROM INSIDE EDGE

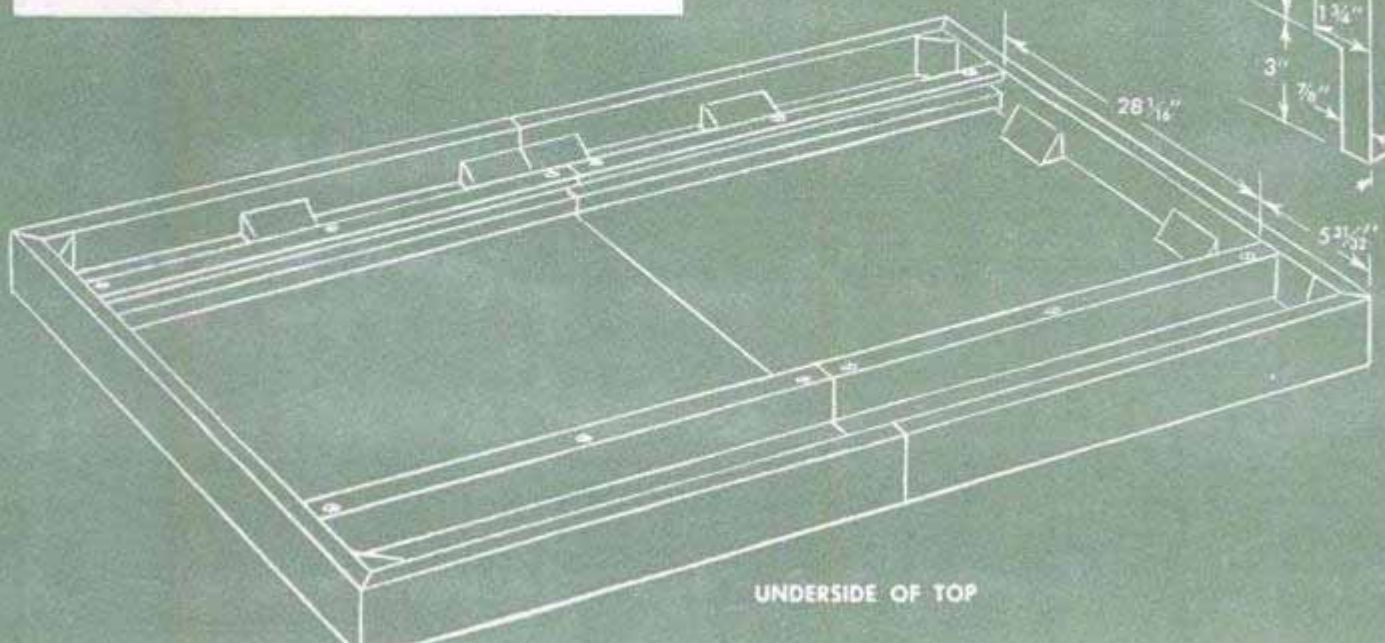
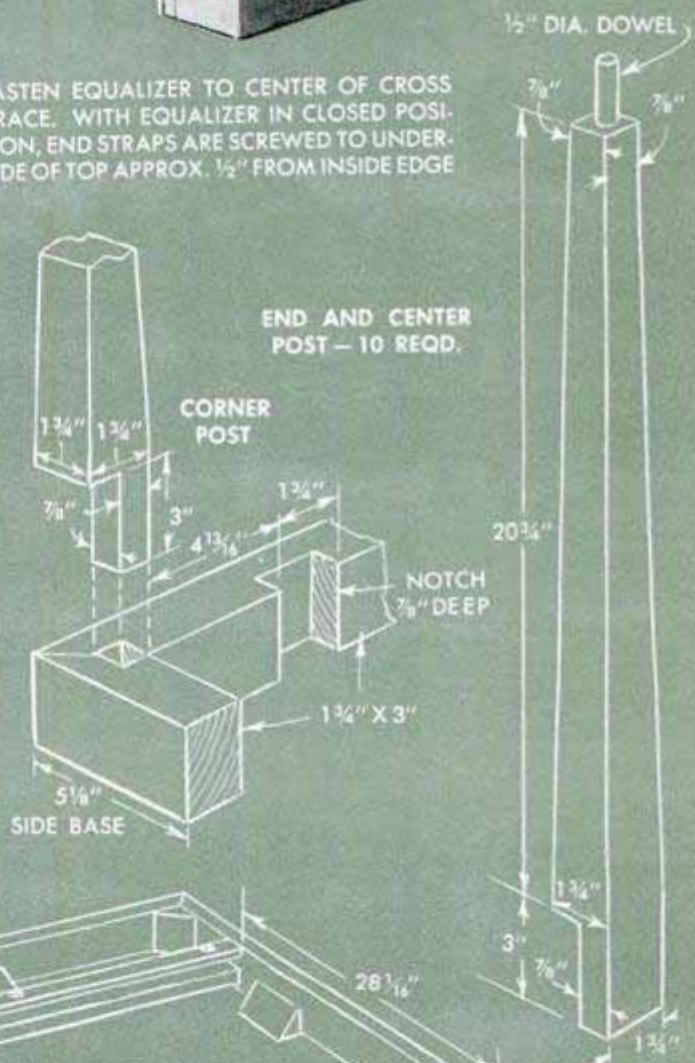



## Trapped Water in Steam Radiator Siphoned With Syringe



A minor disadvantage of the single-pipe steam-heating system is that a certain amount of steam condenses and leaves water in the bottom of the radiators. To maintain top heating efficiency, this trapped water must be removed. This is usually done by disconnecting the radiator, tipping it on end over a shallow pan and allowing it to drain. However, there is a much easier method of doing this by simply siphoning the water with a syringe and hose. You'll need about five or six feet of  $\frac{1}{4}$ -in. rubber hose and a bulb syringe with check valves, which can be purchased at most drug-stores. The hose is connected to the intake side of the bulb and, after removing the air valve at the top of the radiator, the end of the hose is inserted in the opening until it touches the bottom of the radiator sections. Siphoning action is produced by simply squeezing the bulb, remembering to keep the end of the outlet hose below the water level in the radiator.

Charles L. Funnell, Yonkers, N. Y.

## Alarm-Clock Movement Cleaned Without Disassembling

Before spending money for repairs on an alarm clock that has become undependable or stopped running altogether, try this method of cleaning it. First, take the movement out of the case and remove the hands, alarm indicator and face. Holding the movement with pliers, move it back and

forth in a quart of hot water in which a tablespoon of household lye has been dissolved. Continue for about five minutes, then rinse the movement thoroughly in clear water, after which it should be placed in a warm place to dry. To lubricate the movement, heat an ounce or two of light household oil in a container set in boiling water. Hold the movement over an empty dish and pour the oil into the wheels and bearings. Wind the springs and let the movement drain for 24 hrs. When reassembling, the proper location of the alarm indicator can be found by setting the alarm and then turning the hands of the clock slowly until it rings.

G. A. Alexander, El Cajon, Calif.

## Plumb Bob for Emergency Use

You will find that a nail set and a slip-on-type pencil eraser can be used to improvise a suitable plumb bob in an emergency. Punch a hole through the center of the eraser and run the cord through it, knotting it inside the eraser as detailed. Then just slip the eraser over the head of the set.

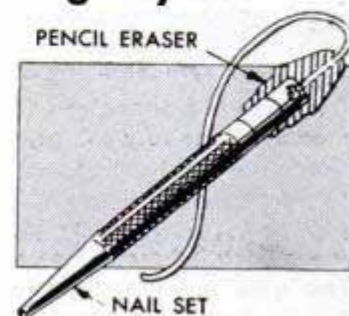

## Inexpensive Easter Baskets From Berry Boxes

Small boxes of the type in which fresh berries are sold can be adapted easily to make attractive Easter baskets. All that is necessary is to attach a cardboard handle, which then is wrapped with colored crepe paper. The main part of the box is decorated with ribbon and paper to harmonize.

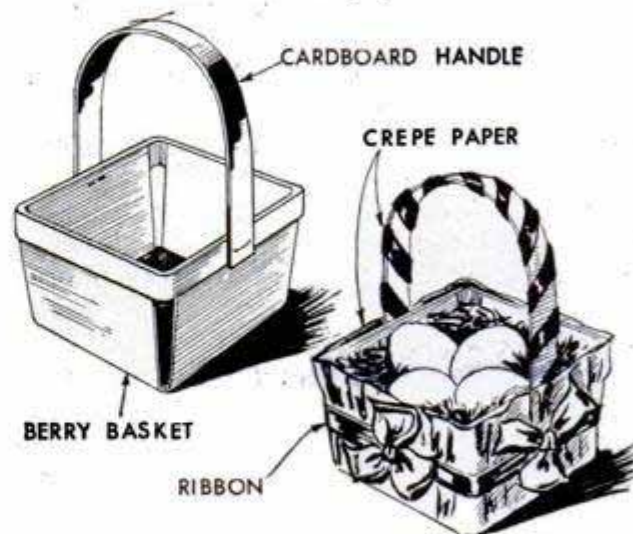

If desired, the interior of the box can be lined before filling it with the candy, eggs and other edibles.

Victor H. Lamoy, Upper Jay, N. Y.





# Combination **BED-TENT** fits on car top

By **Austin H. Phelps**

VACATION campers, hunters and others who prefer to "go light" on both long and short trips will appreciate the compact utility of this bed-tent. It combines the weather protection of a sturdy tent and the comfort of a four-poster bed in one unit which folds into a flat bundle easily transported on any car-top carrier. The mattress and all bedding remain inside when the unit is folded for transport. Although, as dimensioned, the bed frame will accommodate an innerspring mattress of three-quarter size, most campers will prefer an air mattress, as it is much lighter, more compact, and easier to keep clean. Other bedding in addition to the mattress can be whatever the climate and season require. It takes only a few moments to ready the unit for occupancy. There are no stakes to drive and no ridgepole to string. Merely unstrap the unit and slide it from the car carrier, open the folding legs, pull up the self-locking ridgepole and there you are.

The first step in the construction is to build the angle-steel frame shown in the plan detail below. Cut the side and end-pieces to length and square the ends with a file. Position the pieces and mark and center-punch for bolt holes at the corners. Note that the frame is assembled with the angle web up on both the sides and ends. Drill

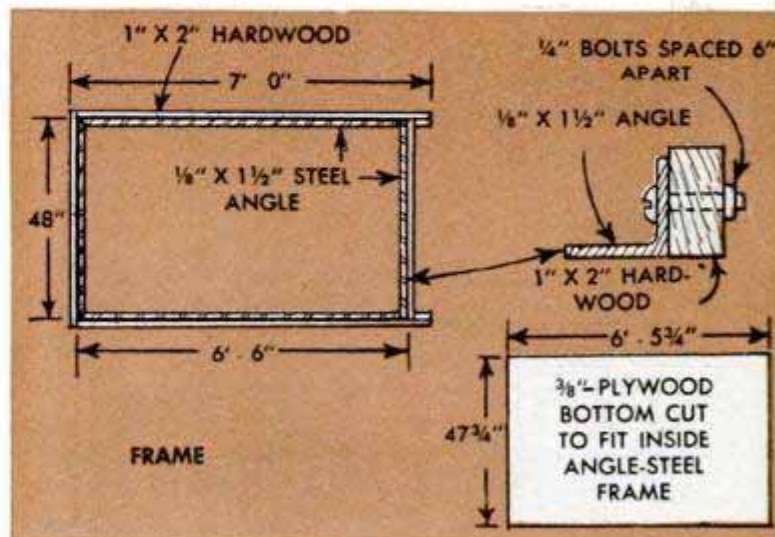



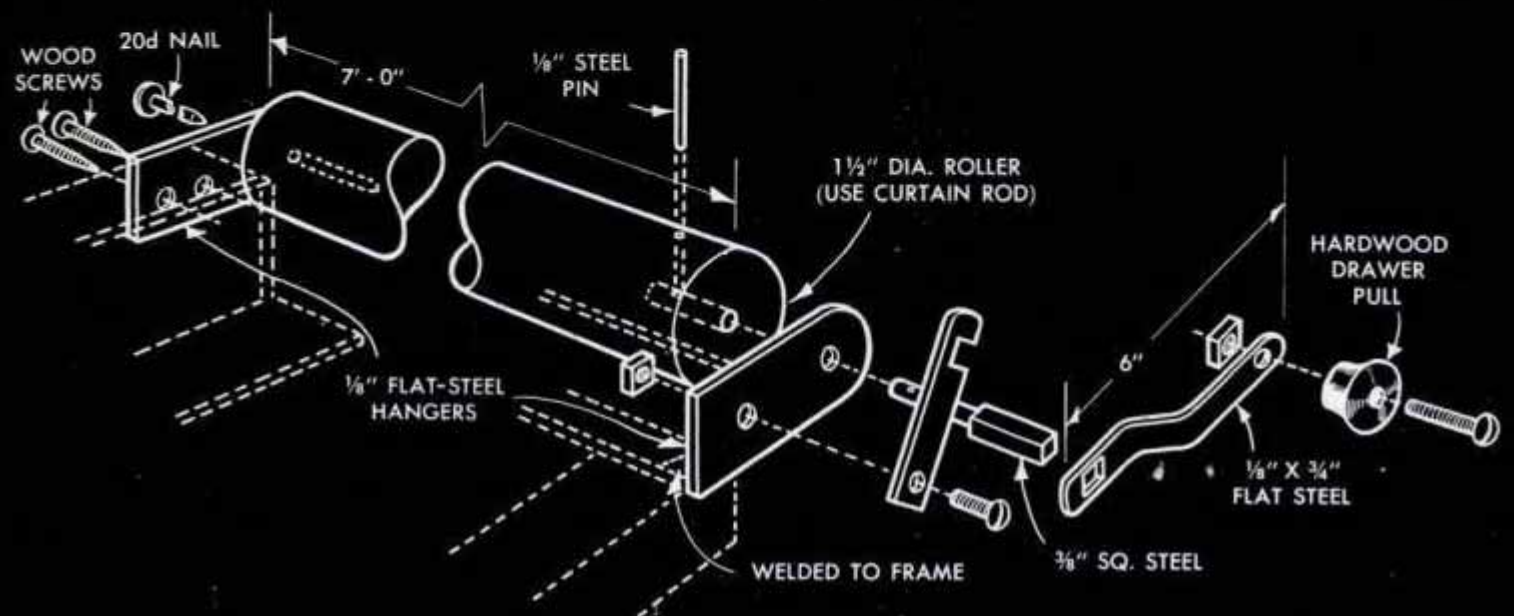
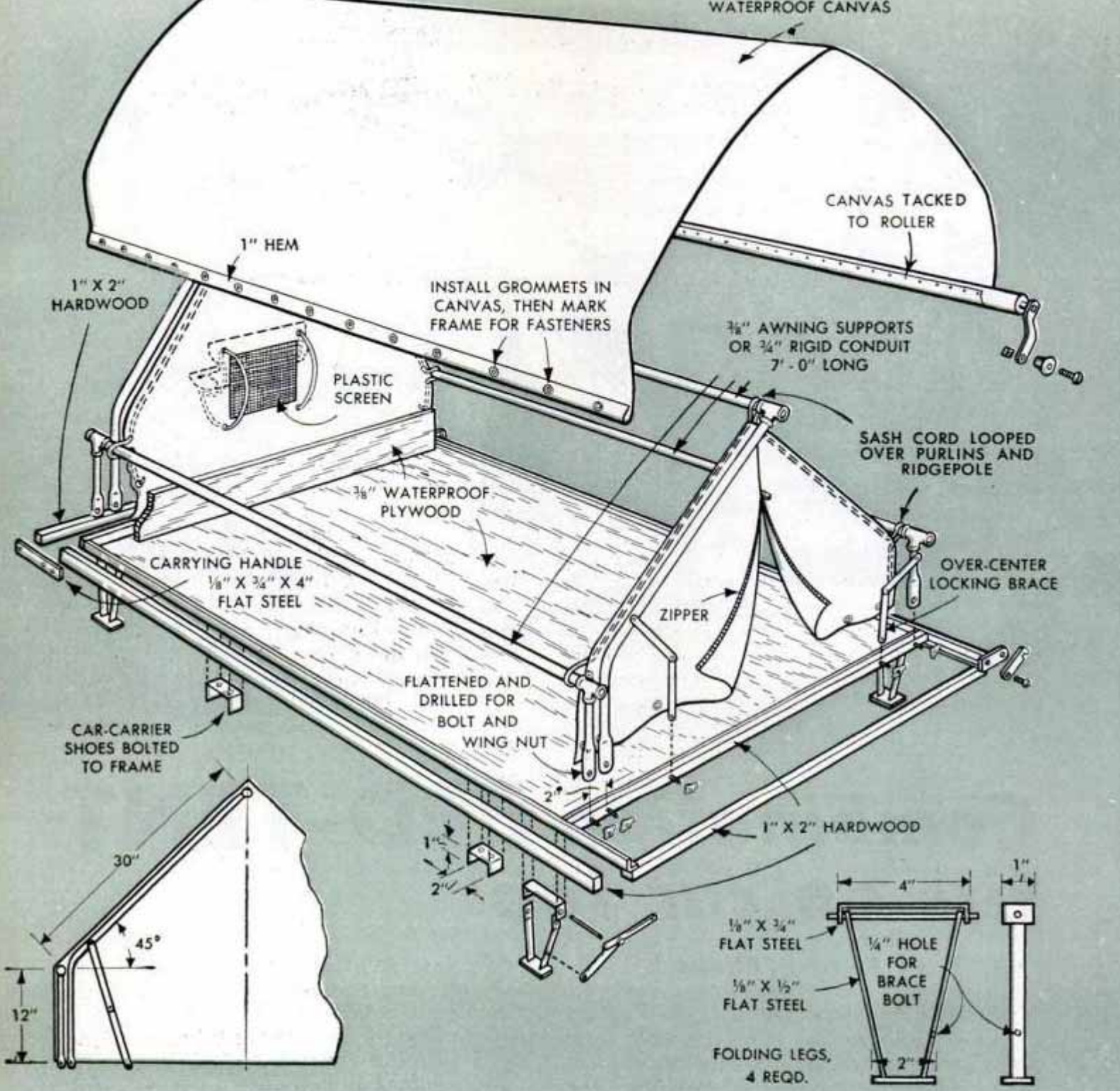



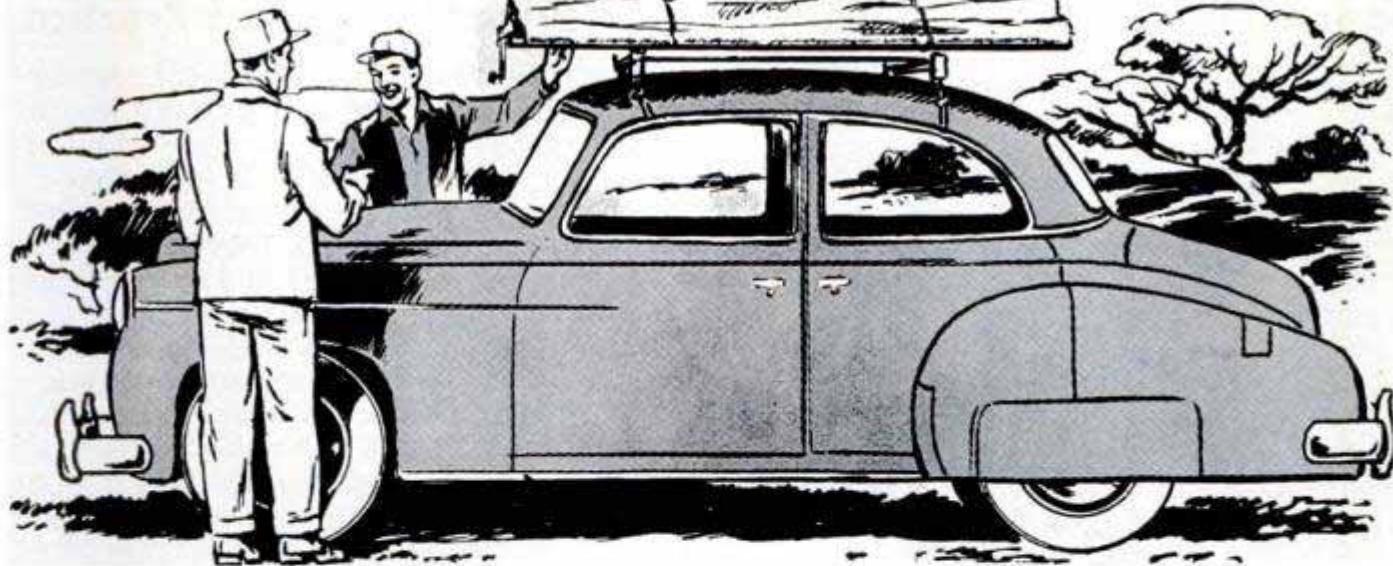

holes for the corner bolts and also drill holes in the vertical webs for screws which hold hardwood strips. The strips are attached to the angles as detailed, using short flat-headed screws. Next, cut the plywood bottom and headboard, but, before installing the bottom, make sure that the frame is square. Then attach the plywood bottom with  $\frac{1}{4}$ -in. flat-headed stove bolts with the heads countersunk in the wood and the nuts turned on from the bottom so that they bear against the steel angle.

Note in the details on the opposite page that there is a headboard cut from  $\frac{3}{8}$ -in. plywood and placed at the head of the bed inside the frame. Next, bolt on the wooden facing strips, noting that the carrying-handle brackets at the rear of the bed frame fit over the facing strips. Weld hanger brackets at the front and rear of the frame on the right-hand side to form bearing brackets for the roller as in the lower detail on the opposite page.

Note in the detail that the length of the ridgepole and the purlins is given as 7 ft., but, before cutting material, take careful measurements, as this dimension may vary. Flatten the ends of the conduit uprights in a vise, round the ends with a file and drill for  $\frac{1}{4}$ -in. bolts. Make the 45-deg. bends in the ridgepole supports. Then assemble the three units and clamp them in position on the frame so that you can locate the holes for the purlin frames, the ridgepole, and also the holes for the over-center braces. After these parts have been bolted in place—note that all bolts are provided with wing nuts—assemble the roller, or winding drum, as in the lower details on the opposite page. As will be seen from the detail, the roller is provided with a removable crank and a ratchet-type lock which permits tightening the canvas to a uniform tension and holding the adjustment.

Make four folding legs from flat steel as in the center right-hand detail on the oppo-

site page. The leg brackets are bolted to the underside of the angle-steel frame at the corners and are provided with folding braces. At this stage the bed is placed on a level floor and the purlins and ridgepole are raised so that accurate measurements can be taken for cutting the canvas covering to fit. Note that the covering is attached to the frame on the left side with grommets and fasteners and that the right-hand edge is tacked to the roller. When tacking the canvas to the roller, allowance must be made for shrinkage of the fabric. The canvas closure at the head of the bed is provided with a plastic-screened opening and a separate canvas closure which is opened and closed by means of a sash, or awning, cord as shown. A slide fastener provides a double fly for opening the front of the tent covering. Both canvas ends are fastened at the bottom with grommets and are held taut with cord looped over the purlins and ridgepole. Locate the car-carrier shoes by placing the folded unit on the car-top carrier and marking pencil lines to indicate the position of the shoes. After bending to the required size from  $\frac{1}{8}$  x 1-in. flat iron, the shoes are attached to the bottom of the bed with stove bolts. Apply two coats of spar varnish to the plywood bottom, headboard and wooden rails and enamel metal parts in whatever color desired.

### Tracing Legibly Onto Copper

Finding copper and brass too smooth to permit tracing legible designs onto them with carbon paper, one craftsman coats the metals with flat, white paint. Carbon transfers perfectly onto the paint, which is easily removed with turpentine after each design has been worked into the metal. Where a supply of such metals is kept in stock, time will be saved by coating a number of sheets in one operation, and storing them until used.



## Sponge-Rubber "Ball" Provides Realistic Drive During Golf Practice



When unable to locate any of his regular practice golf balls, one golfer found that a sponge-rubber cube will provide a more satisfactory practice "ball" than the common cotton, knitted or plastic variety. Not only are they inexpensive (several can be cut from a 10-cent sponge) and require less practice area, but it is not necessary to tee them up. The balls are cut in 1½-in. squares from a rubber bath sponge and are practically indestructible. Although square in shape, direction of flight still indicates if a ball is topped, hooked or sliced, and a well-hit ball will make a report like that of a pistol. A 9 x 9-in. rubber floor tile provides an excellent driving mat.

Edward Jenicke, Chicago.

## Tips on Enameling Woodwork

Before enameling new interior woodwork, brush on a liquid filler. Follow this with one or two coats of enamel undercoater tinted to the desired color. Then apply at least two coats of gloss or semi-gloss enamel, allowing 24 hrs. drying time between coats. Any rough spots that are found on the surface should be sanded smooth after each coat (except the final one) has dried thoroughly.

A. E. Fenn, Chicago.

## Method for Determining Location of Concealed Leak in Vertical Run of Pipe

If you are confronted with the task of locating a concealed leak in a vertical run of pipe, or a run in which the number of inches rise per lineal foot of pipe is as great or greater than the inside diameter of the pipe, try the following method: First, close a valve somewhere in the pipe line below the leak, and disconnect the pipe at a point above the leak. Completely fill the line with water and allow all of it above the leak to drain out. Then, proceed to fill the line again, this time noting the amount required. With this figure, you can determine the number of lineal feet from the disconnected end of the pipe to the leak

by figuring 1 pt. of water to the number of feet listed below for the corresponding size of pipe. If the inside diameter of the pipe is ½ in., 1 pt. of water will fill 7.9 ft. of it. If ¾ in., 4.5 ft.; 1 in., 2.78 ft.; 1¼ in., 1.6 ft.; 1½ in., 1.17 ft.; 2 in., .715 ft. or 2½ in., .5 ft. If the pipe is none of the sizes listed, multiply the inside diameter of the pipe by itself, and multiply the result by .7854. Then divide this result by the number of cubic inches of water required to refill the line and the quotient will be the distance in lineal inches from the upper end of the pipe to the leak.

W. F. Schaphorst, Newark, N. J.

## Clock With Works Removed Makes Inconspicuous "Piggy" Bank

The possibility of having a "piggy" bank stolen by petty thieves gave one housewife the idea of using a bank that would not be obviously a container of coins. The works from an old alarm clock are removed (leaving the face and hands in place) and a slot is cut in the back for inserting the coins.

G. E. Hendrickson, Argyle, Wis.

☐ Ceramic figurines are given an attractive glossy finish by coating with white shellac.

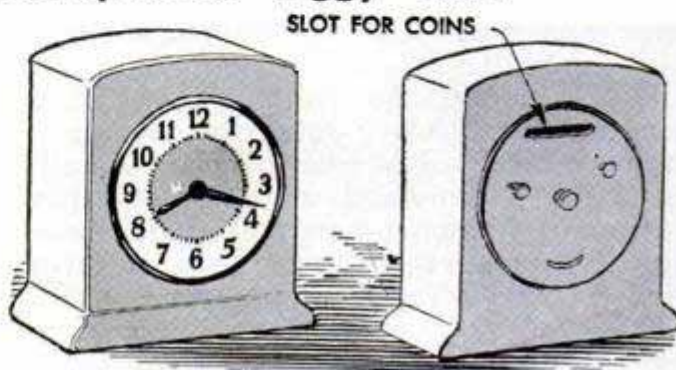



# PORCH LANTERN

By Dick Hutchinson

SUPPORTED by a wall bracket, this attractive porch lantern features an illuminated house number that is easily seen from the street at night. Lantern sections are cut from thin sheet copper and riveted together with  $\frac{1}{4}$ -in. brass escutcheon pins. Numerals and other openings are cut out with a cold chisel. An elbow and short pipe carry wires from a socket inside the lantern into the wall of the house. A ceiling canopy (shown in photo) is made by hammering out the center of a piece of copper and drilling a hole to take a brass fixture loop. Chain links are formed from  $\frac{1}{8}$ -in. copper wire.

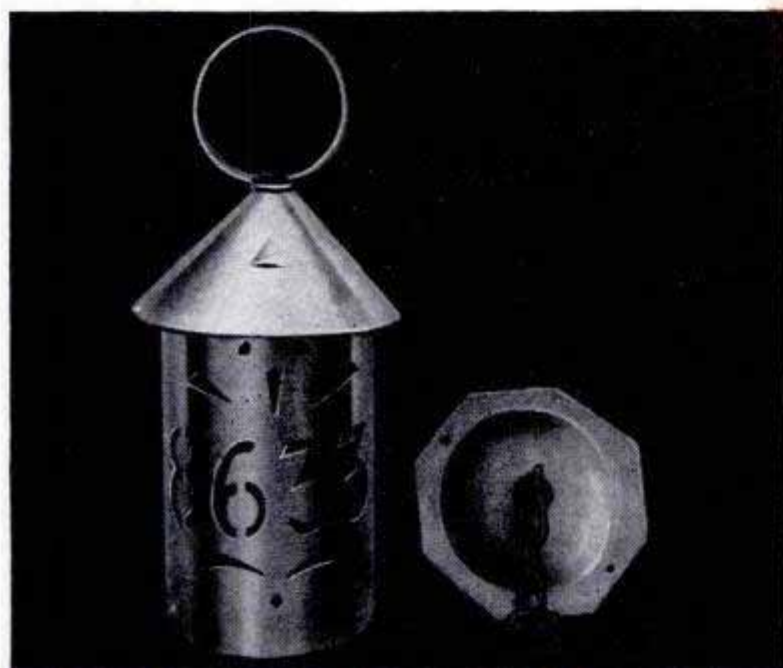
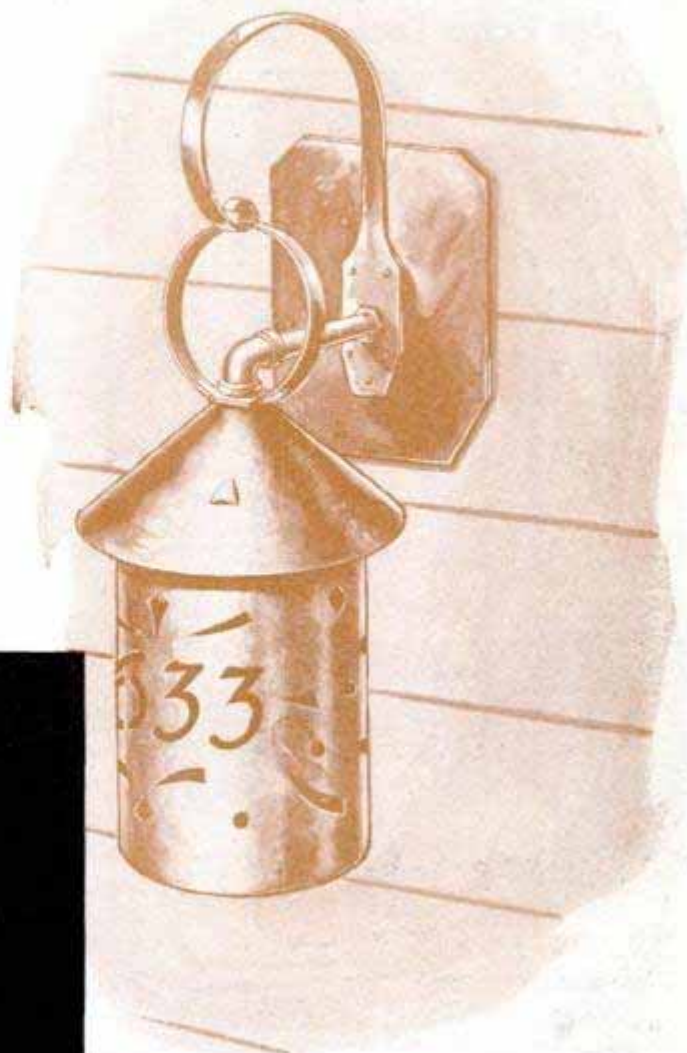

Above, lantern shown supported by wall bracket. Left, finished lantern and ceiling canopy with supporting chain attached. Chain links are formed by winding copper wire around rod or lathe mandrel and cutting into short lengths with chisel. Removed from rod, links are assembled and ends forced together

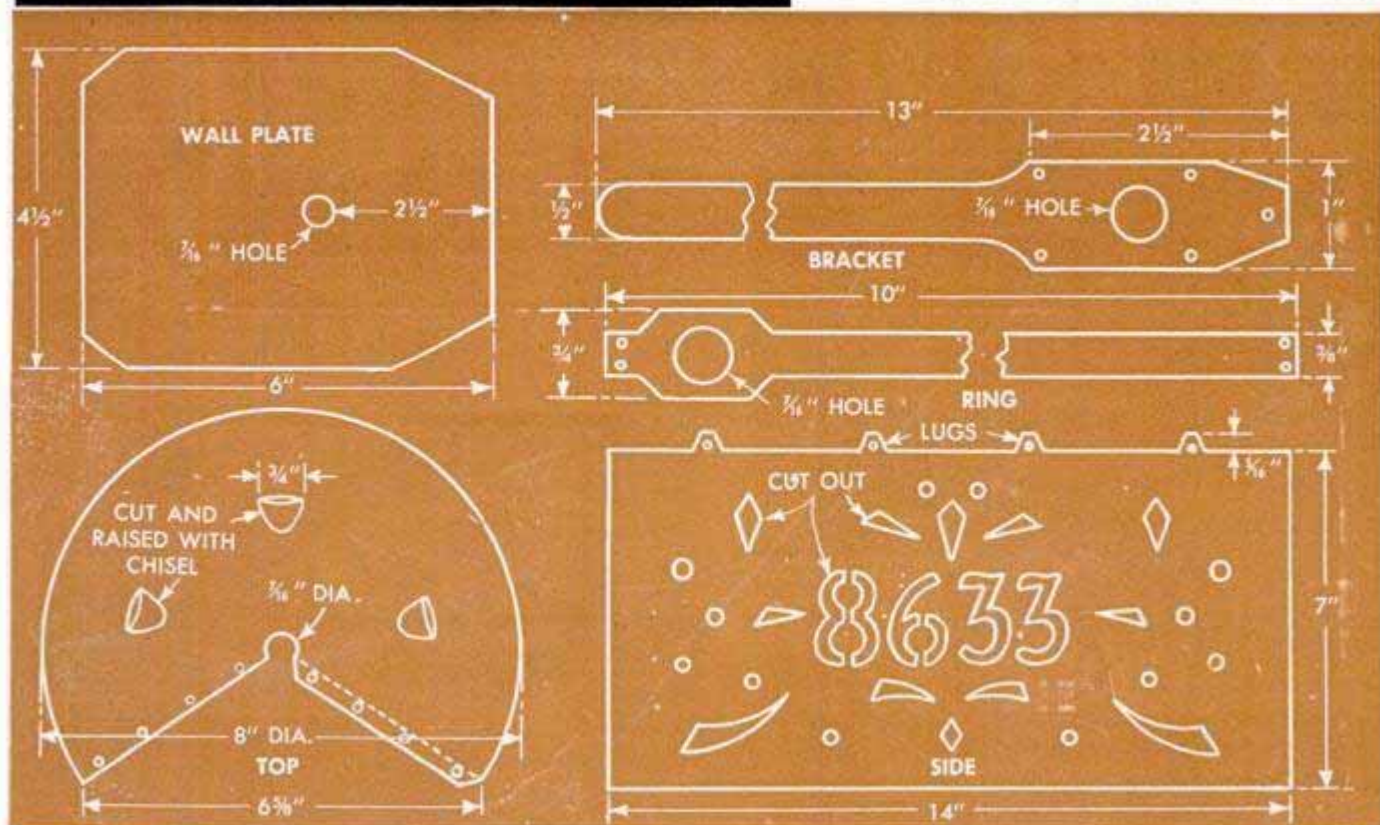



## Swinging Shelf at Top of Ladder Provides Extra Tool Space

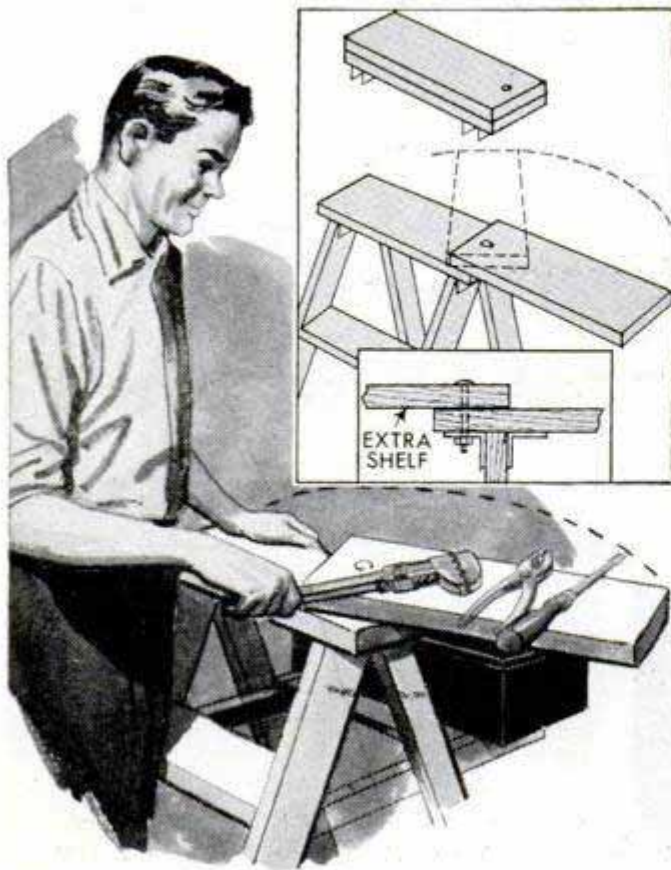

The space on top of a stepladder, handy for holding tools and supplies while working, may be doubled in size with the addition of this shelf, which swings out of the way when not in use. Cut from a board to the size of the ladder top, the shelf is pivoted with a bolt and nut, as well as two large washers. The washers are placed between the board and the ladder top to allow it to swing freely.

## Wrench Aids in Driving Screw Eyes

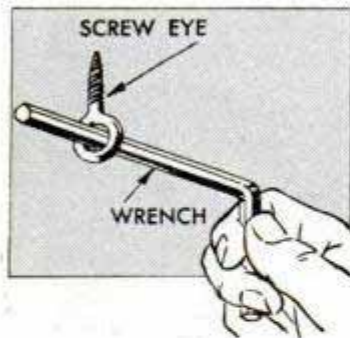

The next time you have a number of screw eyes or hooks to drive, try using a socket-head setscrew wrench to speed up the job. The end of the wrench that is bent at a right angle will

serve as an ideal handle for "cranking" the screw eyes in place.

Don Brooks, Lombard, Ill.

## Placing Spring on Bed Frame

Lowering a box spring on a metal double-bed frame of the type not having slats can be done easily by one man. Two boards are placed across the bed rails to keep the edge of the spring from slipping off the far rail

while it is being lowered into position. Then, the boards are carefully slipped from under the spring, one corner at a time, so that the spring comes to rest on the side rails.—Horace F. Goodwin, East Riverside, N. B., Can.

## Plastic Scraps Clean Files

Home craftsmen who work with sheet plastics will find that scraps of the material can be utilized for cleaning mill files. Broken or worn plastic objects, such as brush handles, dishes or toys, also can be used if cut into pieces of suitable size. The edge of the comparatively soft plastic quickly assumes the shape of the file teeth and cleans them thoroughly.

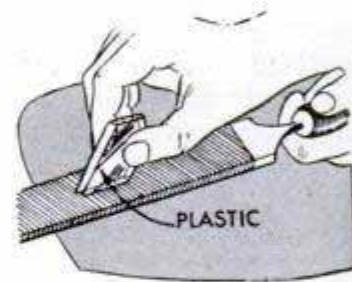

## Heat From Light-Bulb Clusters Speeds Seedling Growth

Hotbeds heated by clusters of 25-watt light bulbs hurry vegetables to your table 10 days to two weeks ahead of ordinary outdoor plantings, as vigorous seedlings from heated hotbeds are already well-rooted individual plants when transplanting time arrives. Using the same method of heating, certain flowering plants can be made to produce profuse blooms four weeks earlier than normal. Build the hotbed frame and the seedbed in the regular way, then construct individual heating units by attaching eight porcelain sockets to a length of 1 x 4 which will span the hotbed frame across its width. One heating unit is required for an area 3 x 6 ft. An average-size hotbed frame 6 x 6 ft. would require two units. The units are wired to a common outlet and are controlled by a bulb-type thermostat placed just below the surface of the soil. The thermostat is set to turn on the lights when the temperature in the hotbed falls below 50 deg. F.







# how to build a CONCRETE FLOWER BOX

*By Raymond Schuessler*

REQUIRING only inexpensive materials and easily constructed forms, this attractive concrete flower box will provide a distinctive and durable ornament for mounting beneath a window or along the porch railing of your house. Consisting of an inside and outside form, the forms are assembled from 1-in. stock, in any length or width desired. Both forms are sanded smooth and finished with two or three coats of shellac to prevent warping. The inside form, built to provide 1½-in.-thick concrete sides and bottom, is carefully centered when set in the outside form prior to the pouring of concrete. All surfaces that will come in contact with the concrete are oiled to pre-

vent concrete from sticking to the sides of the forms as they are being removed. During the pouring operation, concrete should be tamped into all corners, as well as around any strips of molding or blocks of wood mounted inside the forms to create various decorative effects. The concrete is allowed to harden for 24 hours before the forms are removed. Following this, all voids and other irregularities are filled with a thick, creamy mixture of portland cement and water. The entire box is then coated with this mixture. When this is done, the box is permitted to cure for one week, during which time it is given a thorough wetting each day.

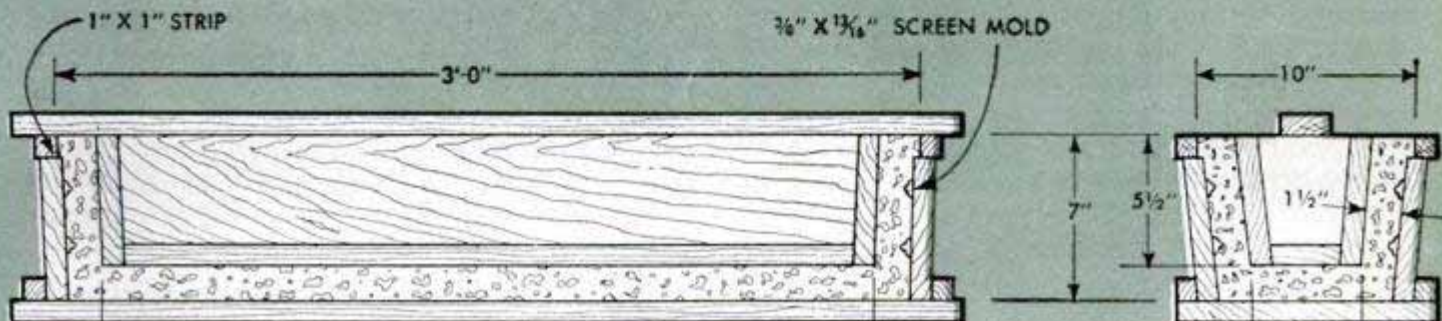
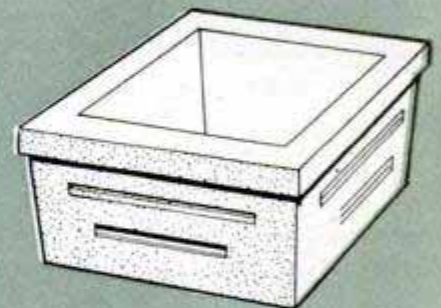
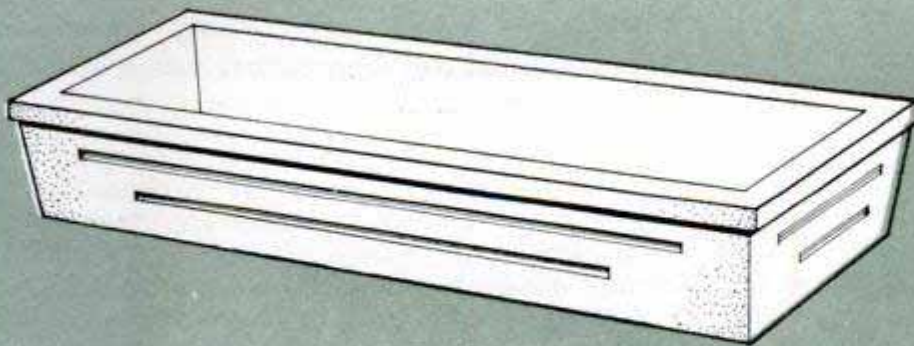



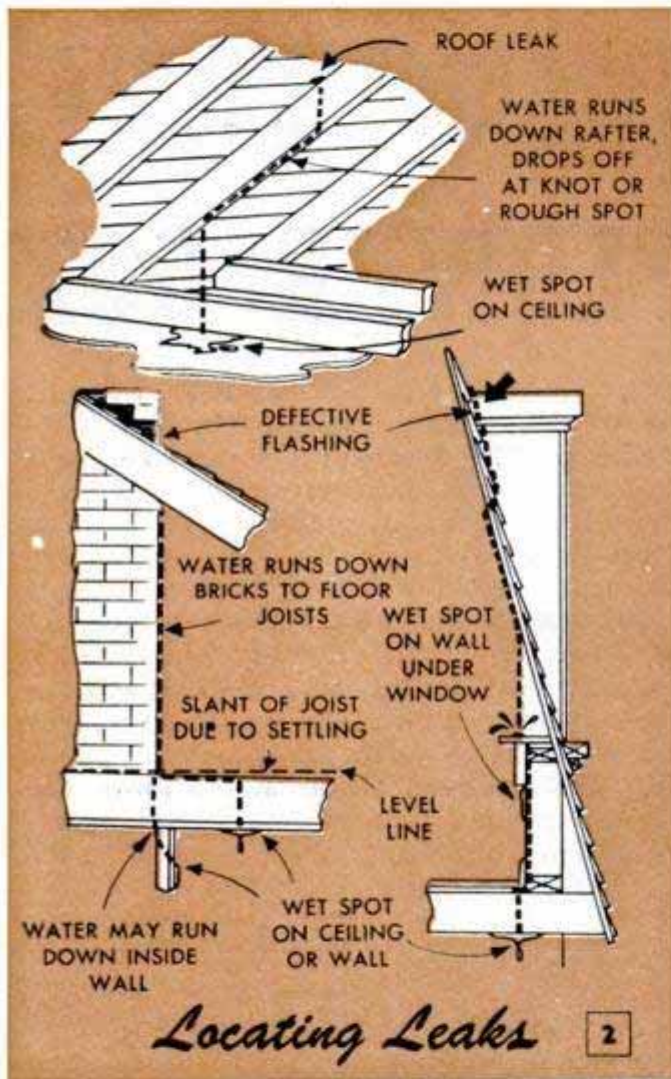
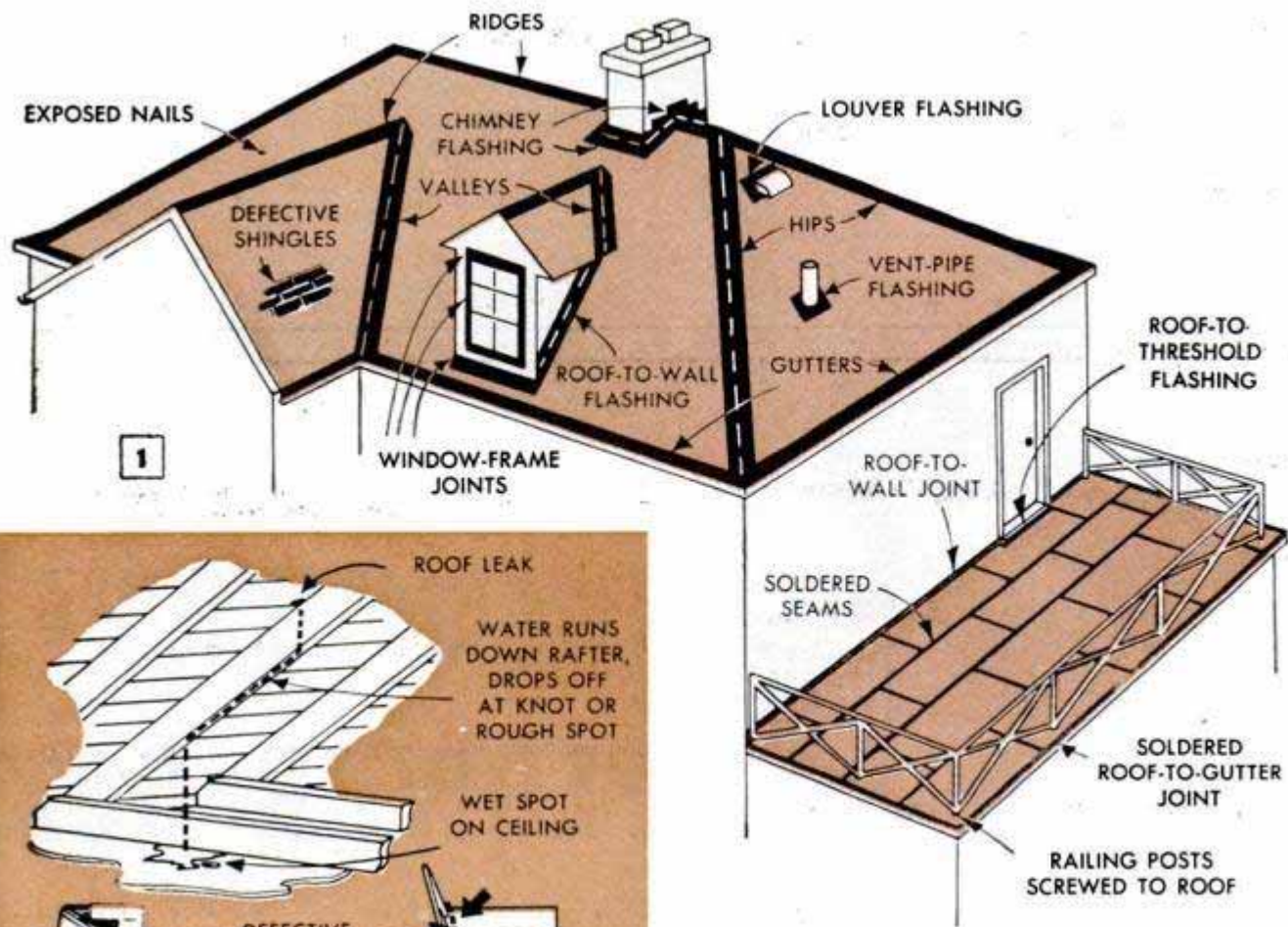

## FINDING and STOPPING ROOF LEAKS

To prevent serious damage and costly repairs to walls and ceilings, roof leaks should get immediate attention

By E. R. Haan

**H**AVE YOU lately noticed discolored spots on the wallpaper, which remain damp for some time after a rainstorm, or is the paint peeling from the plaster at one or more points on the ceiling? Often these are the first warning signs of roof leaks that can cause loosening of the plaster, rotted rafters and ceiling joists and in some cases even more extensive damage. Usually it's difficult to locate a leak at the precise time it first occurs, but periodic checks of the most likely locations may avoid an expensive repair.

Where leaks commonly occur: Fig. 1

shows points on a typical house roof where leaks are most likely to occur. Frequently they can be traced to defective flashing where the roof joins a chimney, wall or dormer, or to a break in the valley flashings. Poorly soldered seams in sheet-metal roof decks may pull apart, and serious damage result. Leaks often develop around rusty roofing nails or where wooden shingles are warped or split. Exposed nailheads are potential causes of leaks and for this reason gutter hangers should always be nailed under the shingles rather than over them. Leaks through walls and ceilings also can be caused by water overflowing clogged gutters or downspouts.



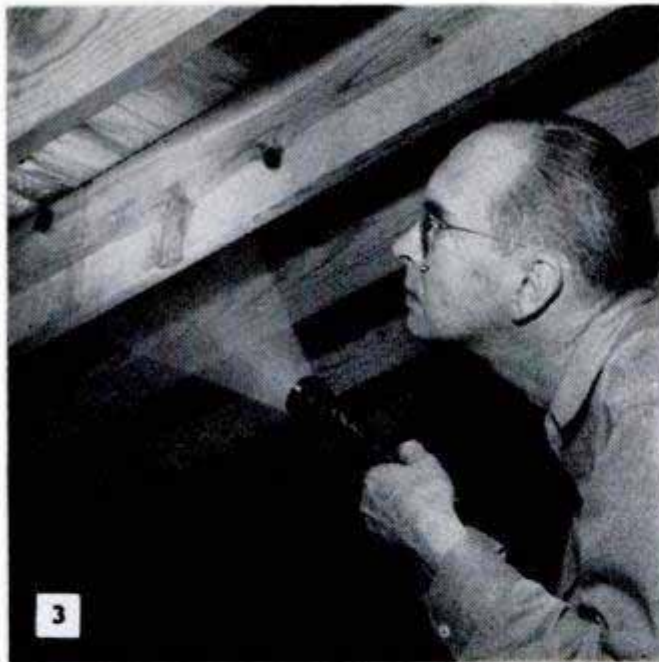

**Locating leaks:** A roof leak may be located some distance from the wet spot appearing inside the house on the wall or ceiling. Fig. 2 shows three examples. Water from the leak may run a long way down the rafter or along joists and partition plates, and even down the studs, before it soaks through the wall or ceiling. When the underside of the roof is exposed in the attic, inspection of the roof boards and rafters likely will turn up telltale discolorations of the wood caused by water. Often you can locate the leak during a heavy rainstorm. In closed attics you may be able to see pinholes in the roof by examining it carefully on a bright, sunny day. When such an opening is discovered, push a broomstraw or a length of fine wire up through the hole to serve as a marker. Where the underside of the roof is covered, carefully inspect the outside where leaks are most likely to occur, or the places which are closest to any wet spot that shows up inside the house.

**Temporary cures:** Usually you can stop leaks temporarily with an application of roofing cement or calking compound. Spread a coating of cement over defective flashing, as in Fig. 4, to seal small holes and cracks. Work cement over and around exposed nailheads and apply it over joints in metal roofs or gutters. A relatively large break in the roofing material can be cov-

ered with a patch, as in Fig. 5. First, coat the dry, clean surface with cement, press a piece of cloth down on the fresh cement and then apply another coat of cement over the cloth. Use calking compound around window and door frames and at points where wood joins shingles, Fig. 6.

**Leaks at chimney flashings:** Metal flashing that shows signs of rust should be cleaned thoroughly and protected by coating with roofing cement. Of course, if the metal is badly rusted it should be replaced. Fig. 7 details the usual practice in placing base and counter flashing around a chimney. Large chimneys projecting from steep roofs below the ridge generally are further guarded by a "cricket," or saddle, which sheds water freely and prevents snow accumulating above the chimney. In time, leaks may occur around the saddle, permitting water to run down the sides of the chimney and may loosen plaster in rooms below. Galvanized sheet metal generally is used for saddles and flashing. Flashings of copper, zinc or stainless steel will last almost indefinitely. Leaks sometimes develop at the chimney when the counter flashing is held only by mortar as in Fig. 10. Such leaks can be stopped permanently by thoroughly cleaning all loose mortar out of the joints and repointing with a mortar consisting of portland cement, 1 part, and clean, sharp

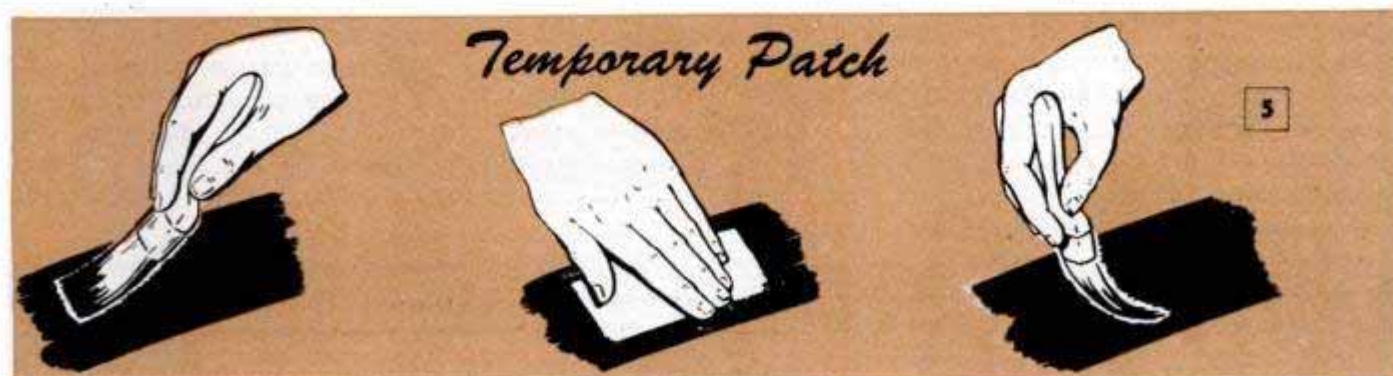



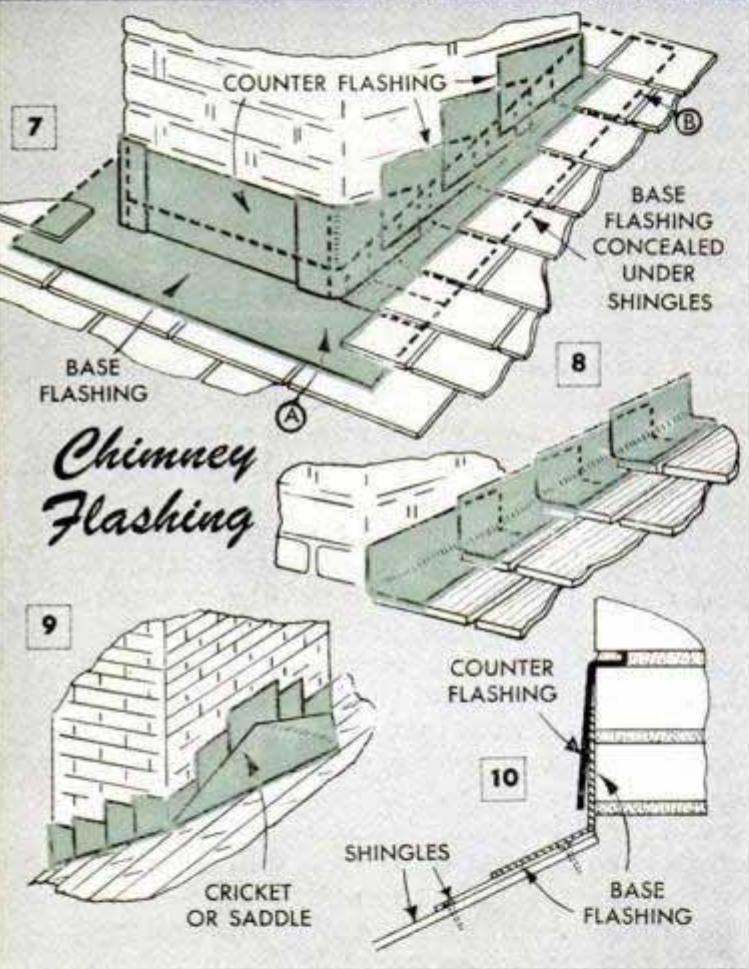

## Chimney Flashing

sand, 2 parts. If the counter flashing requires renewal, bend the sheets as in Fig. 10, making allowance for a 3-in. lap. In applying counter flashing, coat the surface of the base flashing with roofing cement before placing the counter flashing. It's also a good idea to spread cement on the lower side of the mortar joint where the flashing enters. Base flashing extends vertically on all sides of the chimney. The lower horizontal strip of the base flashing, indicated at A in Fig. 7, extends over the shingles about 4 in., while the strips on the other three sides extend under the shingles about the same distance, as indicated at B. Flashing

may be formed in one piece to fit around the chimney, all joints being soldered, or it may be made up of long horizontal strips and somewhat shorter strips that overlap at the sloping sides. Flashing strips also may be interleaved with the shingles as in Fig. 8. To replace base flashing, adjacent shingles must be loosened or removed and then replaced. This is done as in Figs. 25 to 28 inclusive.

**Repairing valley flashings:** In roof valleys the flashing generally extends about 8 in. each way from the center. Open-valley flashings usually consist of roll roofing or flashing felt, although sheet metal also is used. Roll roofing and flashing felt should be applied in two layers, the lower one 18 to 20 in. wide and the upper one 30 to 36 in. wide, Fig. 12. These layers may be continuous or in strips laid with a 24-in. lap. The bottom layer is cemented to the roof boards, the cement being spread a few inches beyond the edges on both sides. The second layer is cemented to the first, and cement also is applied to the top surface of the upper layer where the shingles overlap it. Valley flashing that leaks at several points along its length should always be completely replaced. If it leaks at the lower end only, replace as in Fig. 14. Open valleys on wood-shingled roofs require sheet-metal flashing which usually is obtained from a sheet-metal shop in 8-ft. lengths and bent to conform to the roof pitch at the valley. An overlap of 4 in. at the ends usually is sufficient. To install flashing, the overlapping shingles should be loosened, as explained later on. When replacing shingles over flashing, drive the nails about  $\frac{1}{2}$  in. in from the edge of the flashing strips.

Closed valleys may have continuous flashing, or may consist of overlapping strips under the shingles, or short pieces may be interleaved with the shingles as in Fig. 15. On asphalt roofs, pieces of roll roofing or sheet metal can be used under the shingles in closed valleys. Frequently, pieces of flashing felt are inserted between shingles on each side of the joint, or the shingles may continue past the joint. To stop leaks in closed valleys insert pieces of galvanized sheet metal between shingles as in Fig. 16. Push them between the shingles and the old flashing, beginning at the bottom and working up as in Fig. 11. The top edge of each piece should project about 3 in. above the butts of the shingles of the course above.

**Other flashing repairs:** Where roofs join brick walls, flashing repairs are made in the same way as around a chimney. Flashing on walls covered with wood siding, shingles, or stucco, is installed with a lap of 4 to 6 in. as in Figs. 17 and 18. Horizontal flashing projects over the top course of



shingles and beyond the nails that hold them. Metal flashing along a sloping edge may be continuous, may consist of overlapping strips, or it may be interleaved with the shingles. When roll roofing is used it should be protected from breaking at short bends by a beveled fillet as in Fig. 19. Continuous flashing should be used under a "Boston" ridge, Fig. 20, under wooden ridge boards, Fig. 21, and also under hip ridges, Fig. 22. Vent pipes from the plumbing generally are flashed with sheet lead and rarely require renewal unless damaged in some way. If there is leakage at the window sill joining a sloping roof, new flashing can be installed as in Fig. 23.

**Stopping shingle leaks:** Defective shingles often can be made leakproof simply by

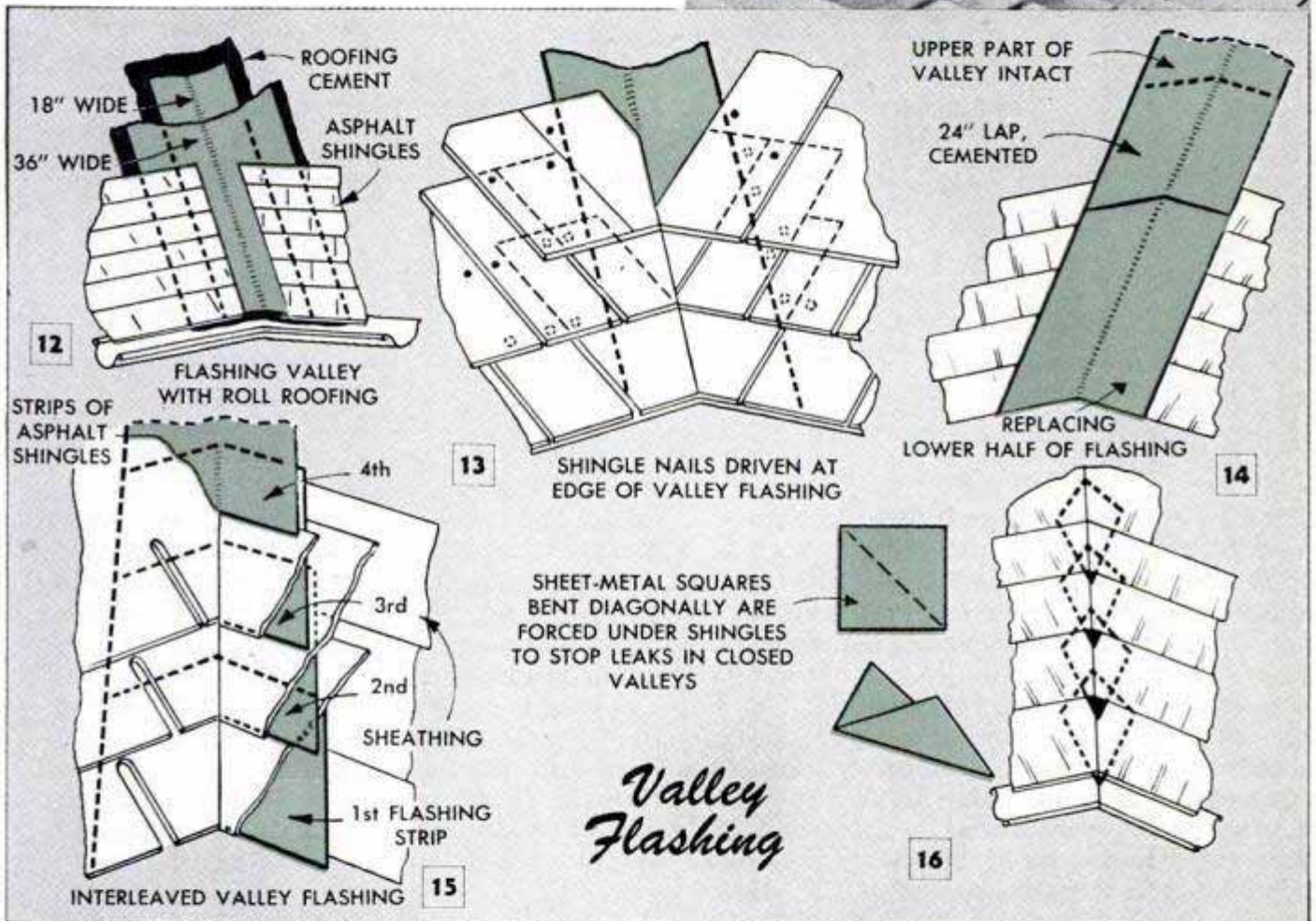

slipping a piece of galvanized sheet metal under them as in Fig. 24. However, an entire strip of asphalt shingles is not difficult to replace. Keep in mind that each strip extends about 2 in. above the exposed portion of the course above and usually is held by two rows of nails. These are removed by carefully prying them up with a screwdriver as in Fig. 28. To re nail, use new galvanized nails of the type made especially for asphalt shingles. Seal all old nail holes with roofing cement. Individual asphalt shingles are removed and replaced in the same manner. When wooden shingles require replacement, the nails are cut with

a chisel improvised by grinding a beveled V-notch in a discarded file, Fig. 25. Cutting the nails with this tool will release the defective shingle and permit it to be pulled out. Before tapping the replacement shingle into position, drive two shingle nails about  $\frac{3}{4}$  in. from the edges and far enough above the butt end so that the nails will be covered by the shingles in the course above when the replacement is in position. To admit the replacement shingle with its projecting nails, loosen several shingles in the course above as in Fig. 26. After slipping the shingle in place drive down the nails by placing the nail-cutting chisel over the heads



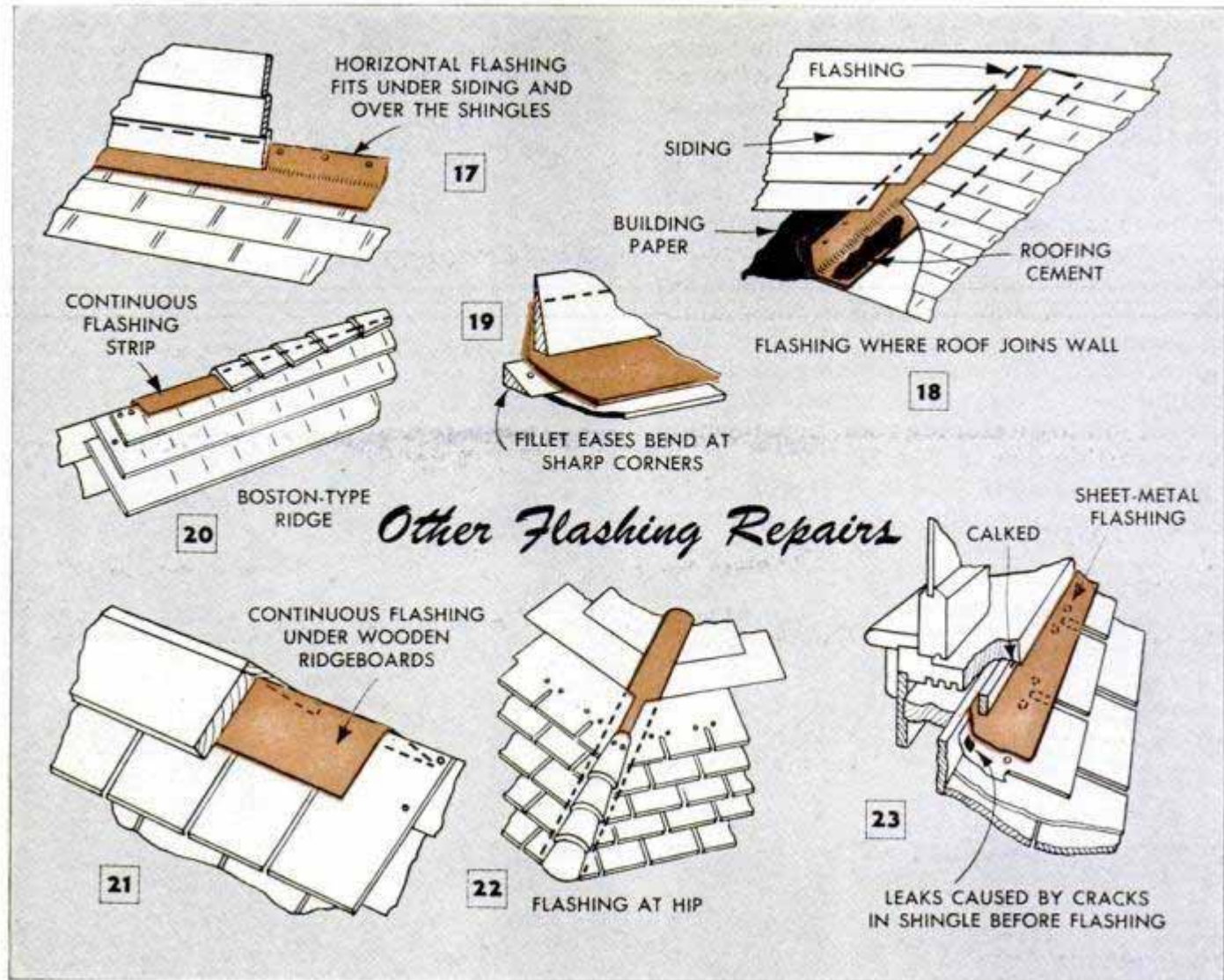

### Other Flashing Repairs

as in Fig. 27, then tapping lightly on a hardwood block held over the shingle and directly above the nails. Loosened nails of the shingles above are driven down in the same way. In all these steps, care is necessary to prevent splitting the shingle.

**Leaks in metal and roll roofing:** Small holes causing leaks in metal roofs can be repaired by soldering. Temporary patches cemented over large holes as in Fig. 5 are effective until permanent repairs can be made. The metal must be clean and dry and the patch must be nailed at the edges before applying cement. Defective sheet-metal roofs are sometimes repaired by covering with roofing felt and a specially made roll roofing having a selvage. First, the metal roofing is nailed securely, then asphalt lap cement is applied with a roof brush to the metal and over each piece of felt as it is applied. Finally lay the selvage roll roofing over the freshly applied cement.

**Repairing built-up flat roofs:** When leaks occur in built-up flat roofs, which consist of several layers of felt cemented together, the surest method of stopping the leak permanently is to cut out square sections from each layer as in Fig. 29. Dip the knife blade frequently in turpentine to assure that it cuts freely. The top square must be quite

large, the next one smaller to provide an 8 to 10-in. lap. Several squares are removed, each cut progressively smaller, care being taken to cut through only one layer at a time. Marking and cutting measured squares makes it easy to cut new ones to fit. These are cemented in place with lap cement, each square being tapped with a hammer and hardwood block to assure full contact. If the roof is already coated with gravel or slag, the final patch is coated liberally with cement before spreading the gravel.

**Safety precautions:** Don't take chances when working on a roof. Wear rubber-soled shoes. Never work on a roof wet by rain, dew, or frost. Tie a rope to a post, or other solid anchor, on the opposite side of the house, throw the free end over the ridge and tie it securely around your waist when you get into working position. Then you can work on a roof of moderately steep pitch in comparative safety. On extremely steep roofs use a ladder provided with a hook that fits over the ridge as in Fig. 30. The angle between the ladder and the hook should conform closely to the roof angle at the ridge. Metal ladder hooks which clamp onto the rungs also are available. When extensive roof repairs are to be made



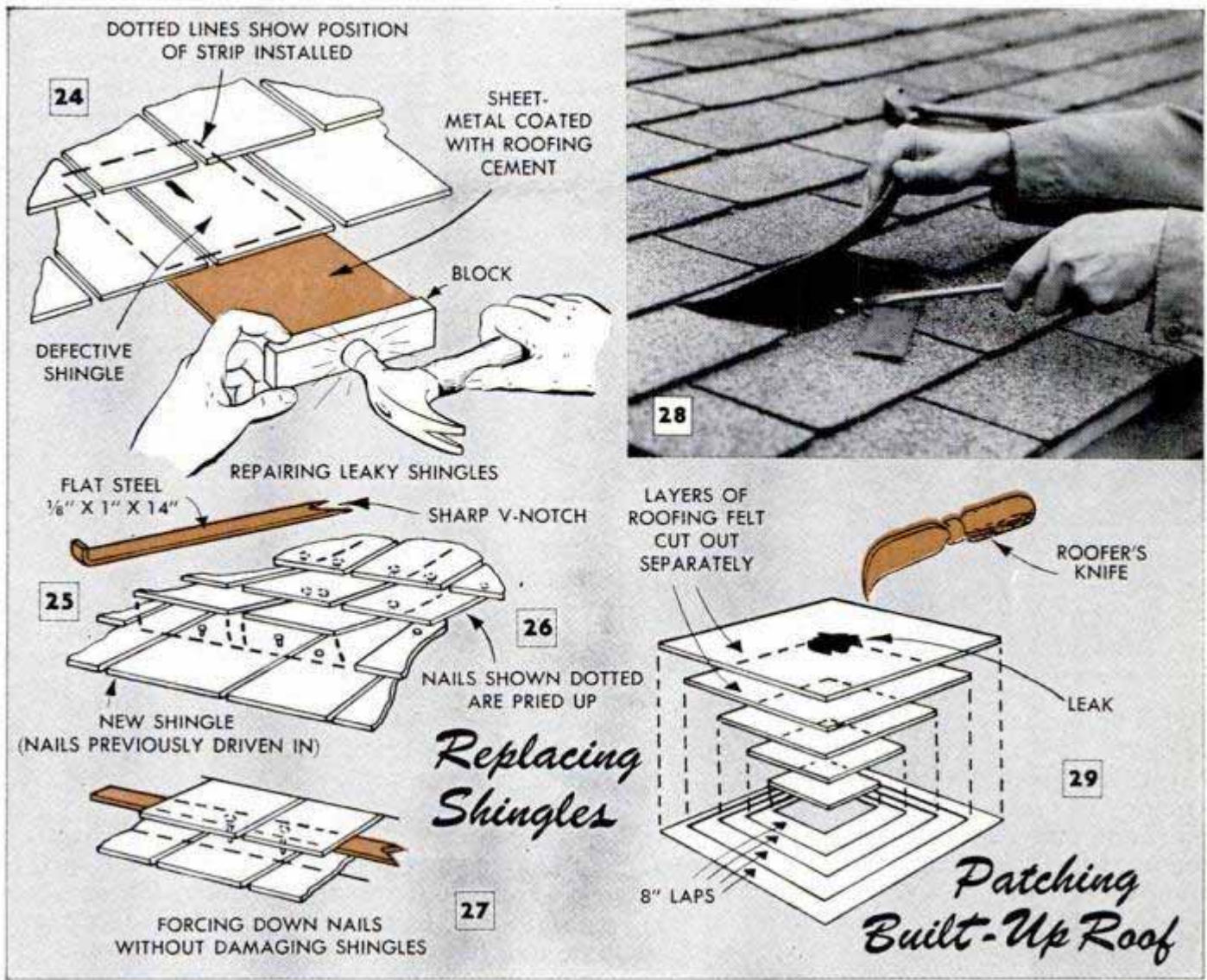

it's a good idea to build a scaffold of the type shown in Fig. 31. The side members have holes spaced 12 to 24 in. so that cross-pieces can be bolted at any convenient height.

**Ice dams:** On low-pitched roofs having overhanging cornices, leaks often are caused by ice dams which form over the cornice. Heat loss through the roof melts the snow at higher levels during the day and the water runs down and collects in considerable amount just above the dam, which remains frozen due to the lower temperature of that portion of the roof which extends over the walls. Water sometimes seeps under the shingles and drips onto the attic floor just inside the plate. The only way to stop such a leak at the time is to cut channels through the ice at several points along the cornice so that the water can drain away. It will be necessary to keep these channels open until the ice over the cornice melts. A good preventive measure on a roof already laid is to apply shingle-tab cement to all shingles in the first five to seven courses. The cement, properly applied, will help to prevent future leaks from this source. When laying a new roof, apply three to five widths of smooth roll roofing above the eaves, lap-

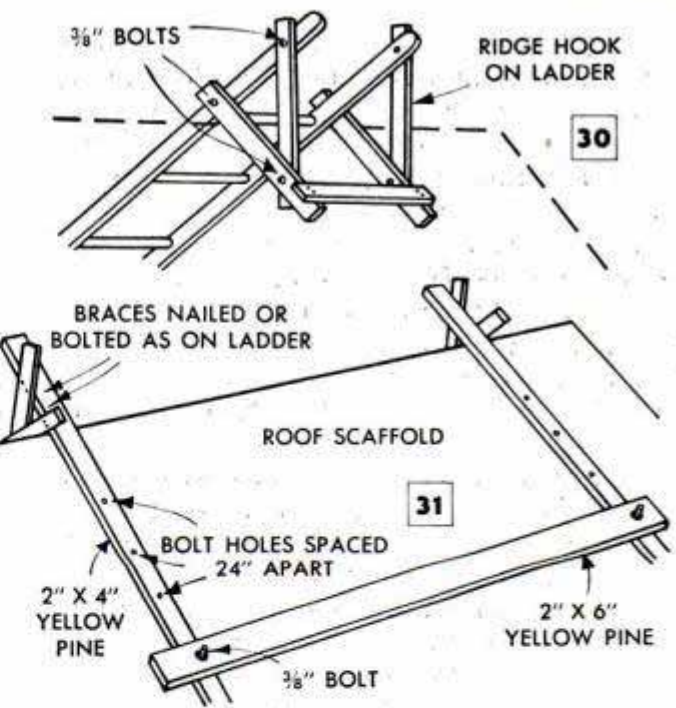

ping 5 in. and cementing the laps. In localities where the roof is exposed to high winds, leaks sometimes occur as a result of the lifting or curling of the shingle tabs by the wind. In this case the tabs should not be nailed down. Rather it is best to use a shingle-tab cement which is especially made for anchoring shingle tabs and preventing wind damage.



## Campfires Started Quickly With Waterproof Igniters



With an igniter such as the one shown in the detail, it is no trouble to start a campfire quickly even in a light rain. The igniter is made by placing bits of cloth or other absorbent material in a paper cup of the type used for baking small cakes and saturating them with melted paraffin. One igniter usually will start several fires.

## Bar Clamp Made Like Sawhorse

Designed by a woodworker for special work in assembling heavy doors, this sawhorse-clamp unit does double duty as a combined support and bar clamp when assembling and gluing other types of work. It is made in the same manner as an ordinary sawhorse, except that the bottom of the beam is notched, each notch having one straight and one slanting face to engage the ratchet ring attached to the sliding jaw. This permits moving the sliding jaw to any point along the beam to position it for clamping work of various widths. A hardwood block bolted to the top of the saw-

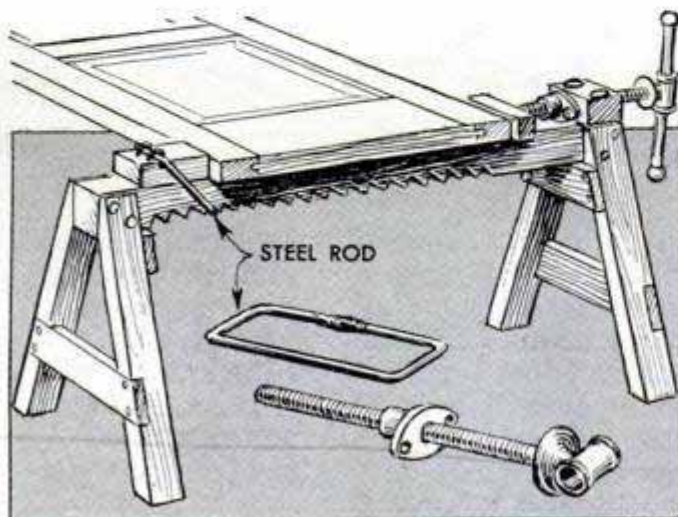

horse beam is drilled to take an ordinary vise screw in a loose fit. The threaded vise-screw pad is then bolted to the inside face of the block. The end of the vise screw is filed square so that a hardwood block placed between the end of the screw and the edge of the work will act as a jaw when tightening the clamp.

## Corner Rack for Bath Towels

Installing a towel rack in a corner of a bathroom not only creates a novel and pleasing effect but permits utilizing space which otherwise often is wasted. An ordinary towel rack can be used by just bending it at a right angle in the center and fastening it with screws to the two walls that form the corner as shown.

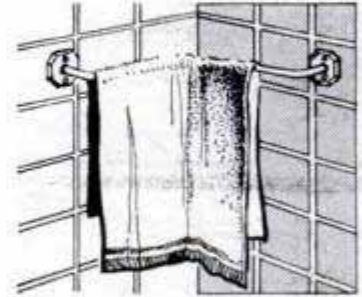

Arthur Trauffer, McClelland, Iowa.

## Painting Outdoor Furniture

Before painting outdoor furniture, apply a coat of shellac to the surface. This will keep the resin in the wood from bleeding through the paint, and the latter will retain its original color throughout the summer. If you apply weatherproofing compound to swings and lawn furniture, keep the weatherproofing from streaking or running by binding it to the wooden base with a thin undercoat of shellac.

## Beam Compass Improved From Dowel Rod

Home-workshop owners who have only occasional use for a beam compass can improvise one from a length of dowel as pictured. One end is drilled to take a lead pencil, which is held in place by means of a screw eye. The movable pivot for the compass is made from a small block of hardwood which is drilled to slide over the dowel. A wood screw driven into the underside of the block and filed to a point serves as the pivot, and a screw eye driven into the upper end locks the block into position on the dowel.

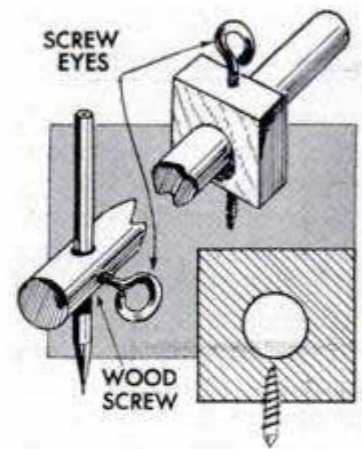

Hugh Lineback, Stillwater, Okla.



# KNOW YOUR CAR'S NERVOUS SYSTEM

## Care of the Battery

*'57 auto Repair  
Manual*

By W. K. Mitchell

**T**HE BASIC UNIT of the car electrical system, which was described last month, is the storage battery, which performs three vital functions. It supplies current for the cranking motor and ignition as the car is started. It also supplies current for lights, radio, heater and other accessories whenever the generator output drops below the demands of these devices. And, in addition, it serves as a voltage stabilizer in the electrical system. As the battery must perform each of these functions dependably, proper maintenance of the battery pays maximum dividends in carefree, economical driving.

Fig. 1 shows the various parts of a typical three-cell passenger-car battery. Each cell produces a potential of two volts and, as

the cells are connected in series, a total of six volts is available at the terminal posts. The internal assembly is illustrated in Fig. 2, the plates being made by application of special lead-oxide pastes to rectangular grids. These pastes become the active materials of the plates when the battery is complete.

Battery troubles usually signal their coming well in advance by unmistakable symptoms. One of the most common causes of premature battery failure is overcharging, and its warning is excessive use of water by the battery. Normally, a car battery will not require the addition of water more often than once a month or every 2000 miles. When ends of the cell covers

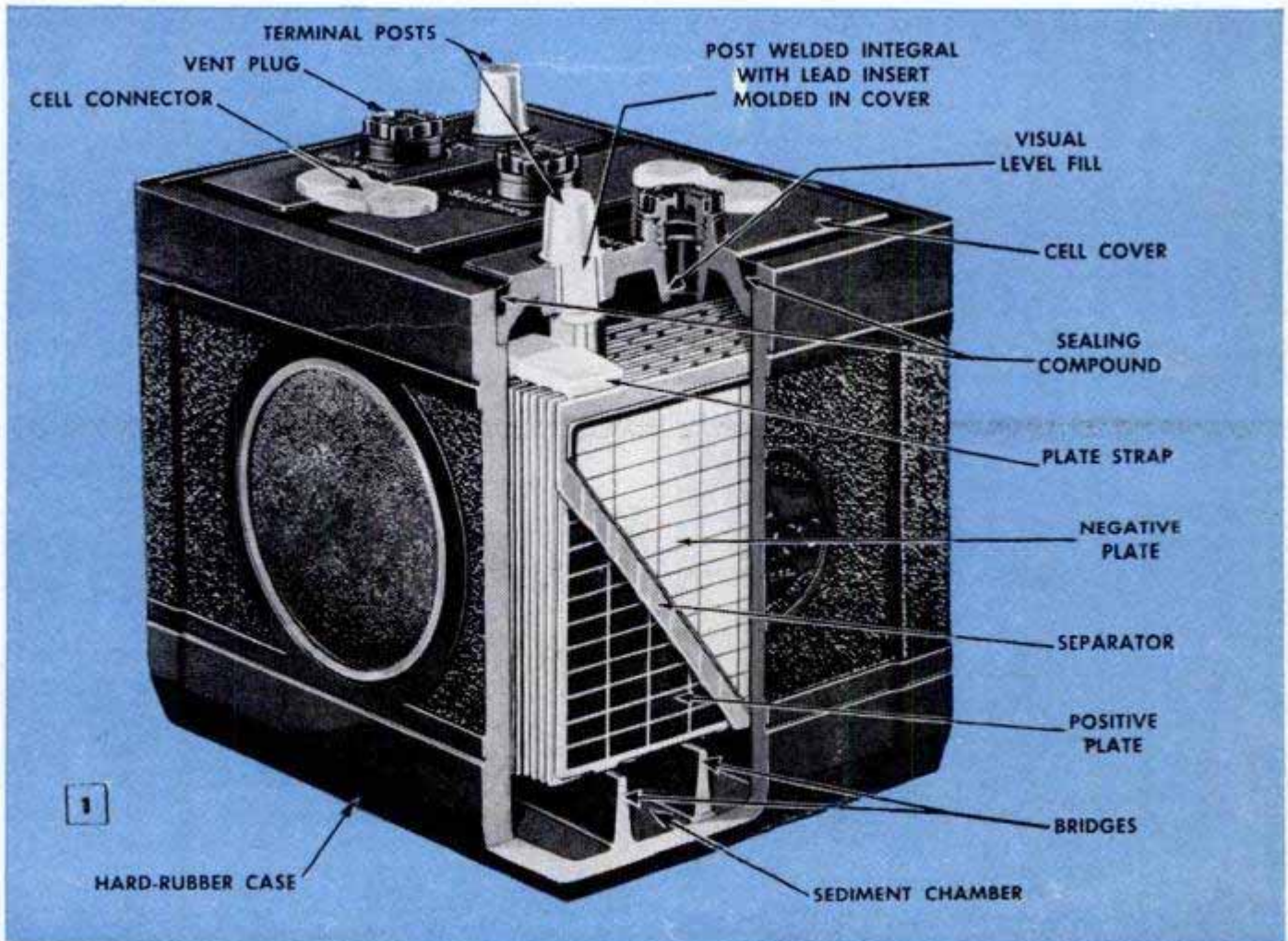





COMPLETE BATTERY ELEMENT



PLATE GRID



PLATE



PLATE STRAP

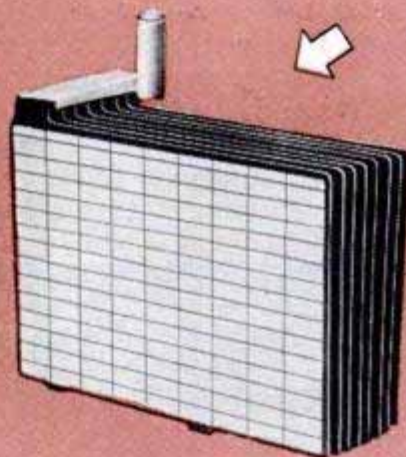
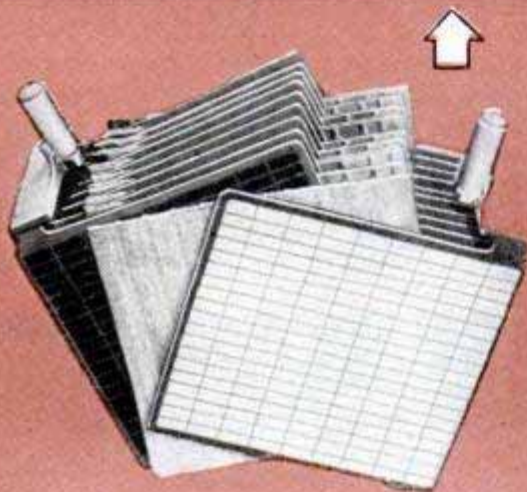

PLATE GROUP

2



POSITIVE AND NEGATIVE GROUPS WITH SEPARATORS

Battery pictured below has been damaged by overcharging. Arrows point to cell covers pushed upward



have been pushed up by the overcharging action as in the photo at the left, internal damage to the battery is well advanced. The most common causes of overcharging are too high a voltage-regulator setting or overheating of the battery because of poor ventilation, excessive engine heat or high road temperatures.

Overfilling the battery with water is a frequent cause of damage. When too much water is added to a cell, the electrolyte level is apt to reach a point where normal gas vents are closed off. This allows gas to accumulate under the cell cover until sufficient electrolyte is pushed out to uncover a vent. Not only is this electrolyte lost to the battery, but it causes excessive corrosion of the cables and carrier. Batteries overfilled repeatedly indicate their trouble by a constantly wet appearance, excessive cor-



rosion and second-rate performance. The remedy, of course, is more careful filling.

Though not so common as the first two battery troubles, excessive cycling can be equally ruinous. Cycling—repeated charging and discharging of the battery—is caused by intermittent driving, requiring an unusual number of starts per mile, or by excessive use of accessories when the generator is not charging. This action softens and loosens the positive active material in the plates, and it is washed free and circulates in the electrolyte, giving it a brownish color and weakening the battery. The cure for this trouble is to avoid long or frequent periods of battery discharge.

The hydrometer test, Fig. 3, and the cranking-load test, Fig. 4, are two simple methods of battery testing available to the home mechanic. The hydrometer test indicates the battery's state of charge by measuring the specific gravity of the electrolyte in each cell. All readings are based on a temperature of 90 deg. F., and temperature variations must be taken into consideration. Temperature corrections can be made by adding four gravity points (.004) to the reading for every 10 deg. the electrolyte is above 80 deg., and subtracting four points for every 10 deg. below. If a variation of more than .025 is noted between cells, further checking by means of the cranking-load test should be done. This test, which measures the current between cells, is taken with a simple voltmeter having two test prods. Turn off the ignition switch, and press the starter button, quickly checking the voltage of each battery cell as in Fig. 4, while the motor is being turned over. Do not operate the starting motor for more than 30 seconds without pausing to let it cool for two minutes or more. If the voltage of any of the cells falls below 1.5 during cranking, or if there is a difference of more than 0.2 volt between cells, serious trouble is indicated and the battery should be checked by a competent serviceman. In making the cranking-load test, the battery temperature should be between 70 and 90 deg. F. The specific gravity should not be less than 1.250 for batteries which are fully charged at 1.280 to 1.290. Other batteries should be proportionately charged.

In hot climates, it often is necessary to lower the setting of the generator regulator to prevent battery overcharge, while in cold weather the setting frequently must be adjusted to its maximum to obtain adequate charging. The effect of cold weather on a battery is shown by the diagrams at the right. The most important regular service a motorist can give his car battery is to see that the water level of each cell is maintained and the battery, hold-down clamps, cables and case kept clean.

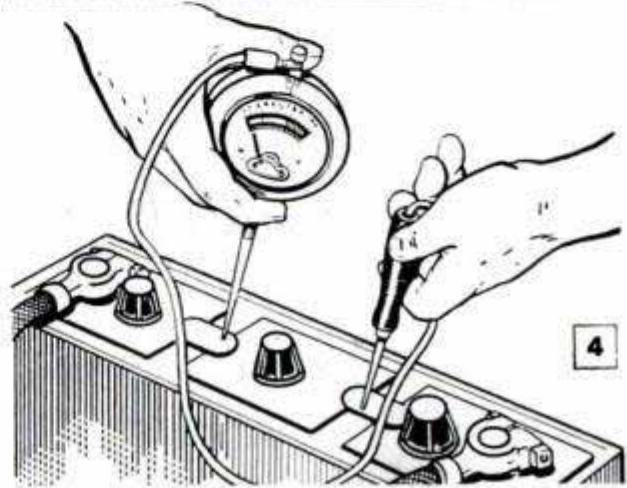
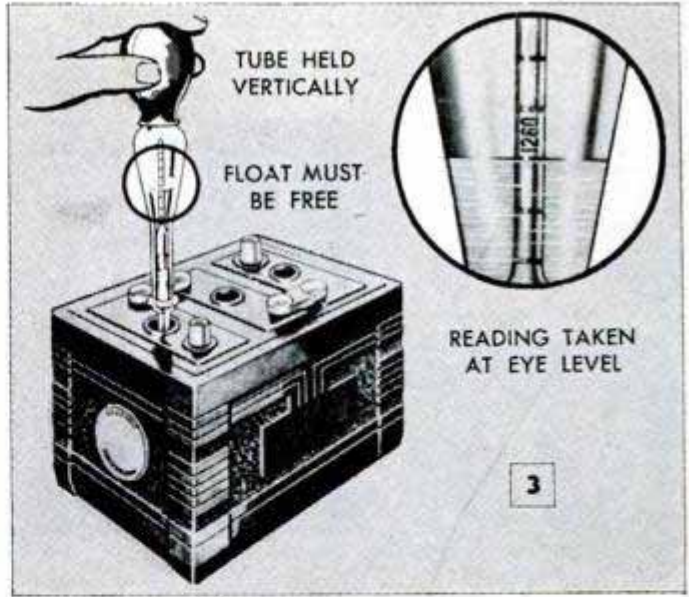

#### HOW TEMPERATURE AND STATE OF CHARGE AFFECT BATTERY CRANKING POWER

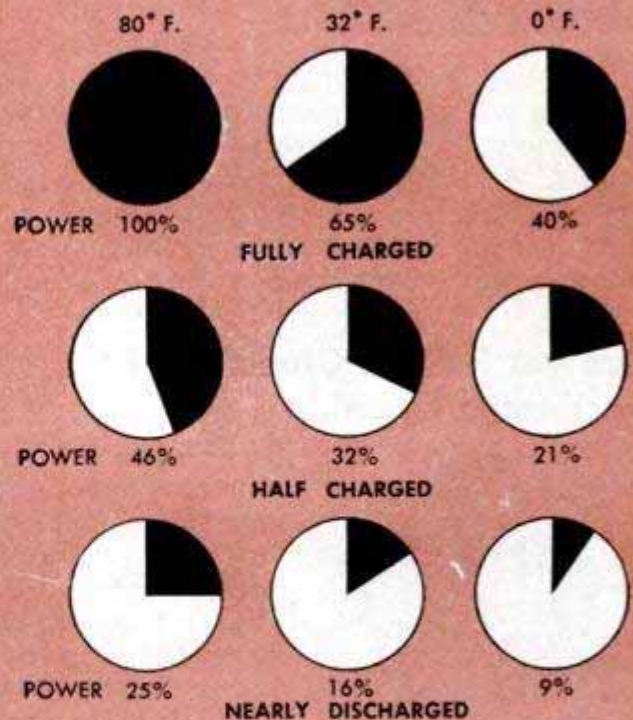

#### HOW ENGINE-OIL TEMPERATURE AFFECTS CRANKING LOAD





## Out-of-Reach Nail Started Easily When Held by Hammer Claws

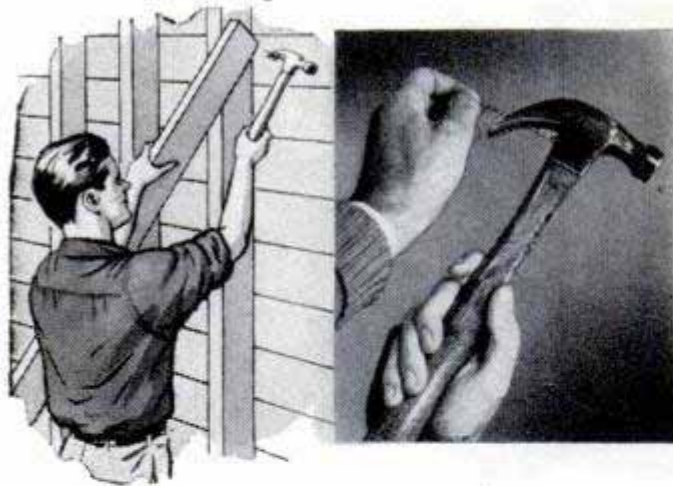

Where the nature of a job makes it necessary to start a nail with only one hand, wedge it between the claws of the hammer with the head against the body of the hammer head. Held in this manner, the nail can be started in the work with one light blow, after which the hammer is removed and the nail driven in the regular way.

Richard Hanscom, Elmhurst, Ill.

## Cushion Holds Phonograph Needles



Half of a sponge-rubber ball cemented to a convenient spot on the record changer provides a handy "pincushion" for storing phonograph needles. Cut

from a ball an inch or more in diameter, the cushion will hold a plentiful supply of needles, the soft rubber protecting the delicate points. As the balls are available in a variety of colors, one can be selected which will not detract from the appearance of the phonograph.—Don Nielsen, Aurora, Neb.

## Drawer Pull on Glue-Can Lid Facilitates Opening



Frequent opening of a can of glue by prying the lid up with a screwdriver bends the lid so that air enters the can and dries out the glue. This is prevented and the can opened easily if a wooden or plastic drawer knob is fastened to the lid. Punch the lid for the drawer-

knob bolt and place a large washer on the underside of the lid before inserting the bolt. The washer will help retain the original shape of the lid.

## Sections of Car Inner Tube Make Bins for Small Parts

Useful bins for small nails, screws and other parts can be made from sections of a car inner tube. Make each one by cutting away the side, as illustrated, to leave a flap at one end, and then tacking a wooden block in the other end to serve as a bottom.

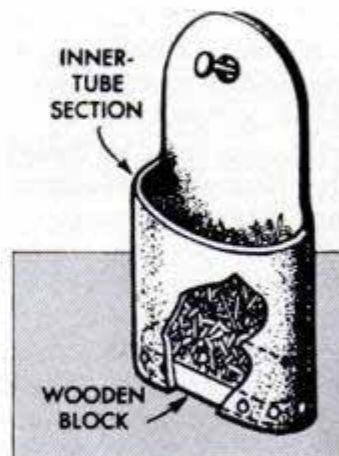

Punch a hole in the flap for hanging and, if desired, reinforce the hole by cementing a couple of rubber washers around it. When using a bin, parts can be poured out on the flap for easy accessibility, and can be replaced merely by tipping the bin back into a vertical position. Also, if you want to carry a bin in the tool kit or your pocket, the parts can be kept intact by folding the flap over the opening of the bin.

## Paper Coated With Lighter Fluid Made Temporarily Transparent

If you wish to trace drawings or lettering, a sheet of paper may be made temporarily transparent by sponging it with lighter fluid. Paper treated in this manner will remain transparent long enough for ordinary tracing jobs, but the fluid will eventually evaporate to leave the sheet as clean and opaque as before.

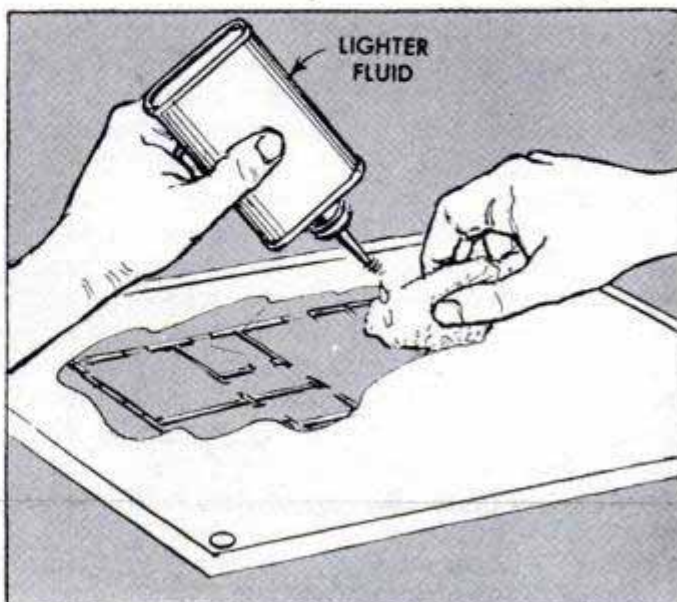



# SYNCHRONIZED FLASH

## With a Studio Shutter



By H. F. May

FOR PHOTOGRAPHING large groups with a view camera, where a satisfactory retake is seldom possible, I made this flash synchronizer for use on a bulb-operated shutter. The photo and wiring diagram below show how the unit is assembled and how it works. To operate the contacts I used the cylinder and piston from an old pneumatic shutter. This unit is fitted into the shutter hose as shown in the wiring diagram. Suitable contacts were salvaged from a discarded telephone relay, the arm of the movable contact having just the right amount of tension. The sequence of operation is quite simple and entirely automatic. When the bulb is pressed, air is forced

through the hose to the camera shutter which opens under pressure somewhat less than that required to close the contacts. After the shutter opens, pressure builds up in the hose to the point where the resistance of the movable contact to upward movement of the pneumatic-cylinder piston is overcome. Then the contacts close the circuit and fire the flash bulbs. For convenience of operation I mounted the electrical units on a plywood base about 4 in. square. Then I made a sheet-metal cover to fit snugly over the base. Slots cut in the cover permit the hose to pass through near one side as pictured. The resistor limits current build-up to 8 amps. and prevents blowing a fuse on the 110-v. line when the bulbs are fired. A safety switch installed in the line permits the shutter to be opened without firing the bulbs.

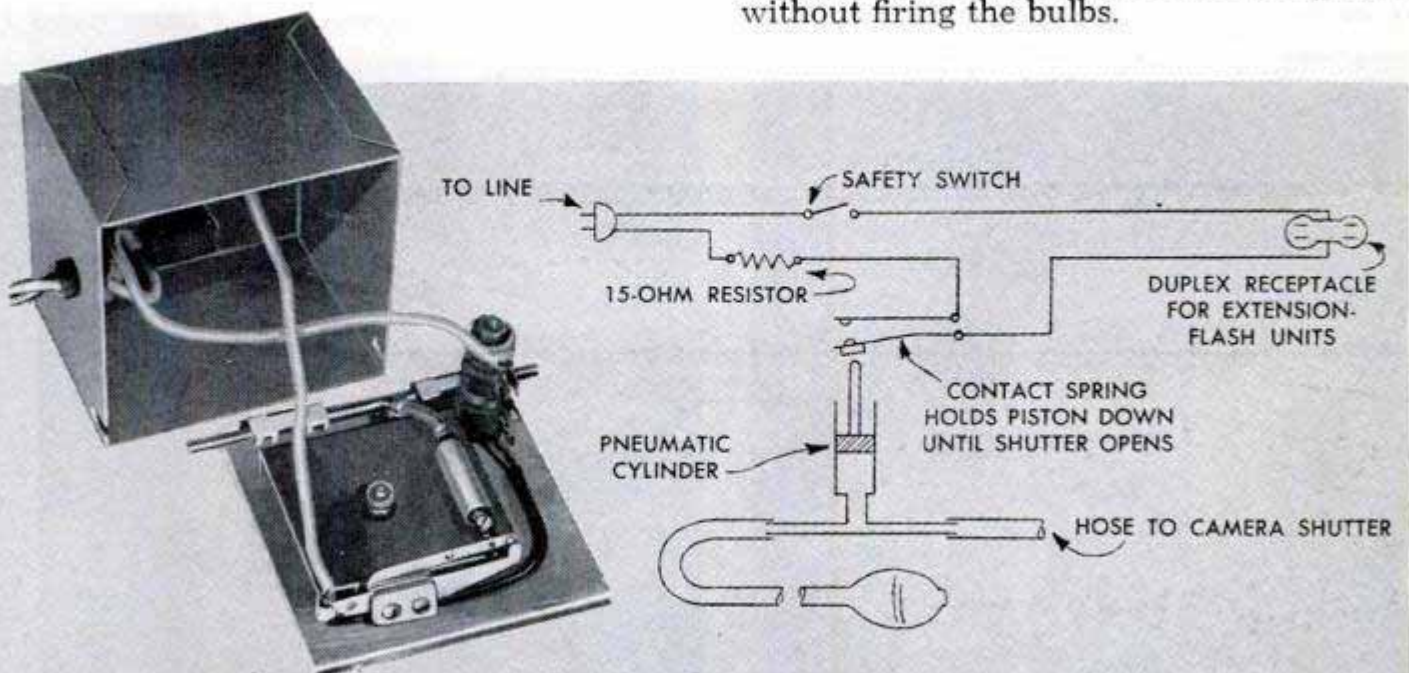



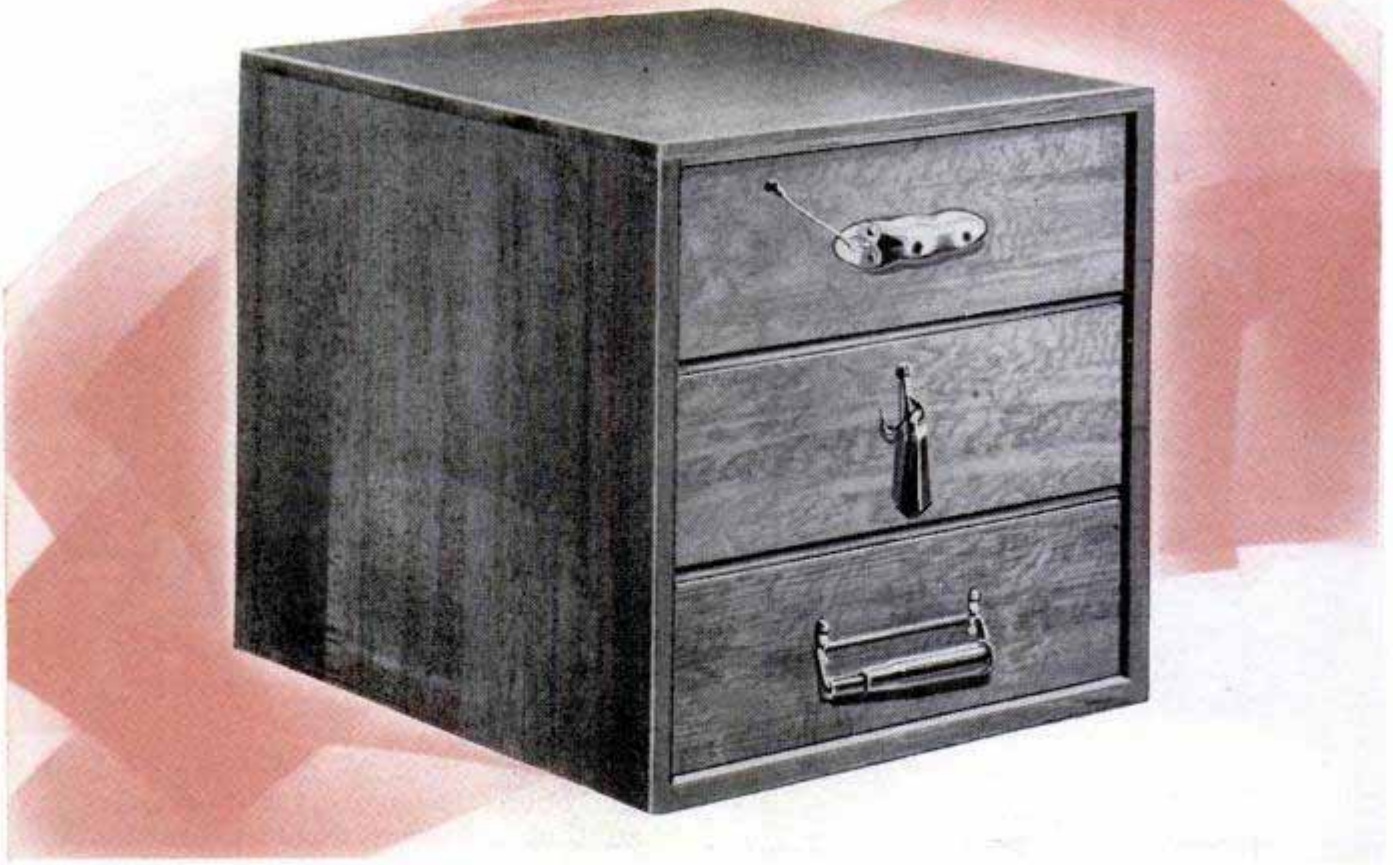

# STORAGE CABINET for Hobby Photos

By **Walter E. Burton**

**I**N TENDED primarily for storing prints and color slides, this hobby-photo cabinet keeps your prize shots right at your finger tips. With three roomy drawers, one for color slides, another for unmounted

prints up to 4 x 5 in., and a third for a large photo album, there will be no time wasted in trying to find the prints you want to show your friends. The hobby atmosphere is topped off by fitting the cabinet with appropriate drawer pulls, such as empty rifle shells, or prized fishing lures.

Photo album can be opened without removing it from special drawer. Note that sides of drawer are cut back so its depth approximates thickness of the album. Notch in drawer back facilitates turning album pages

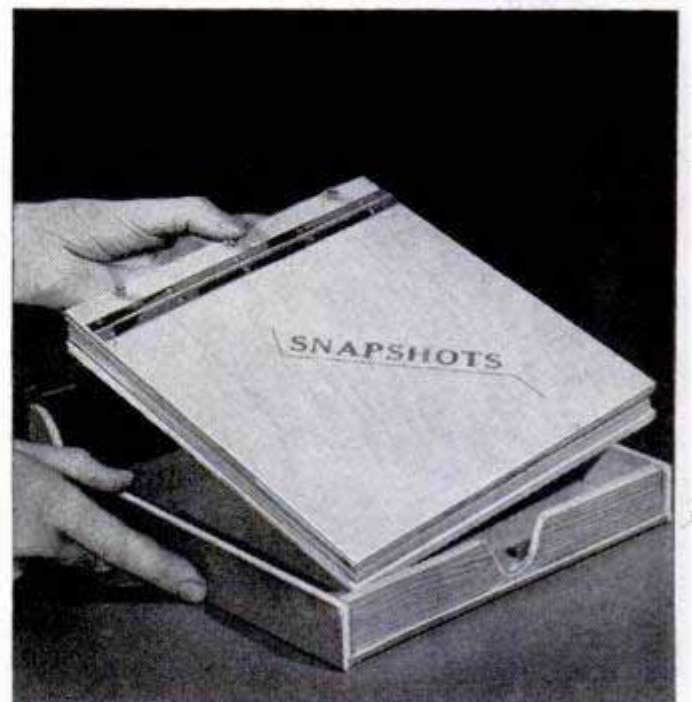
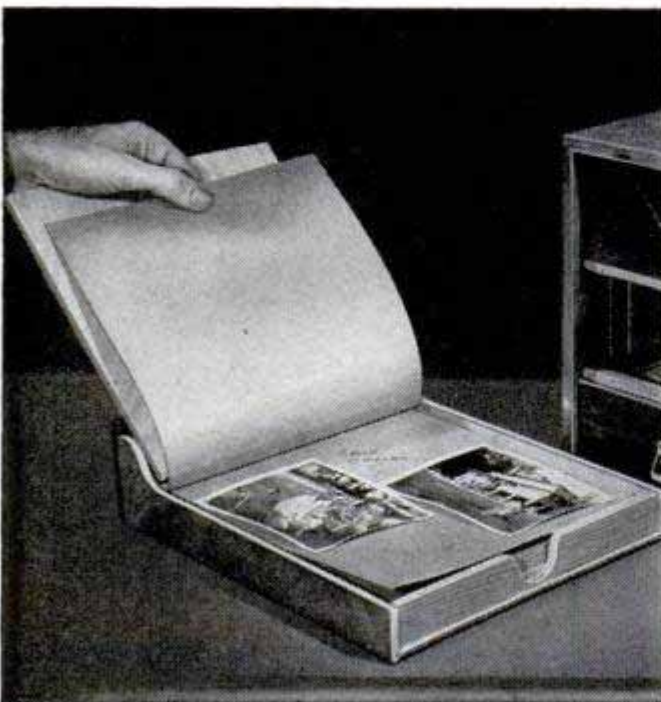



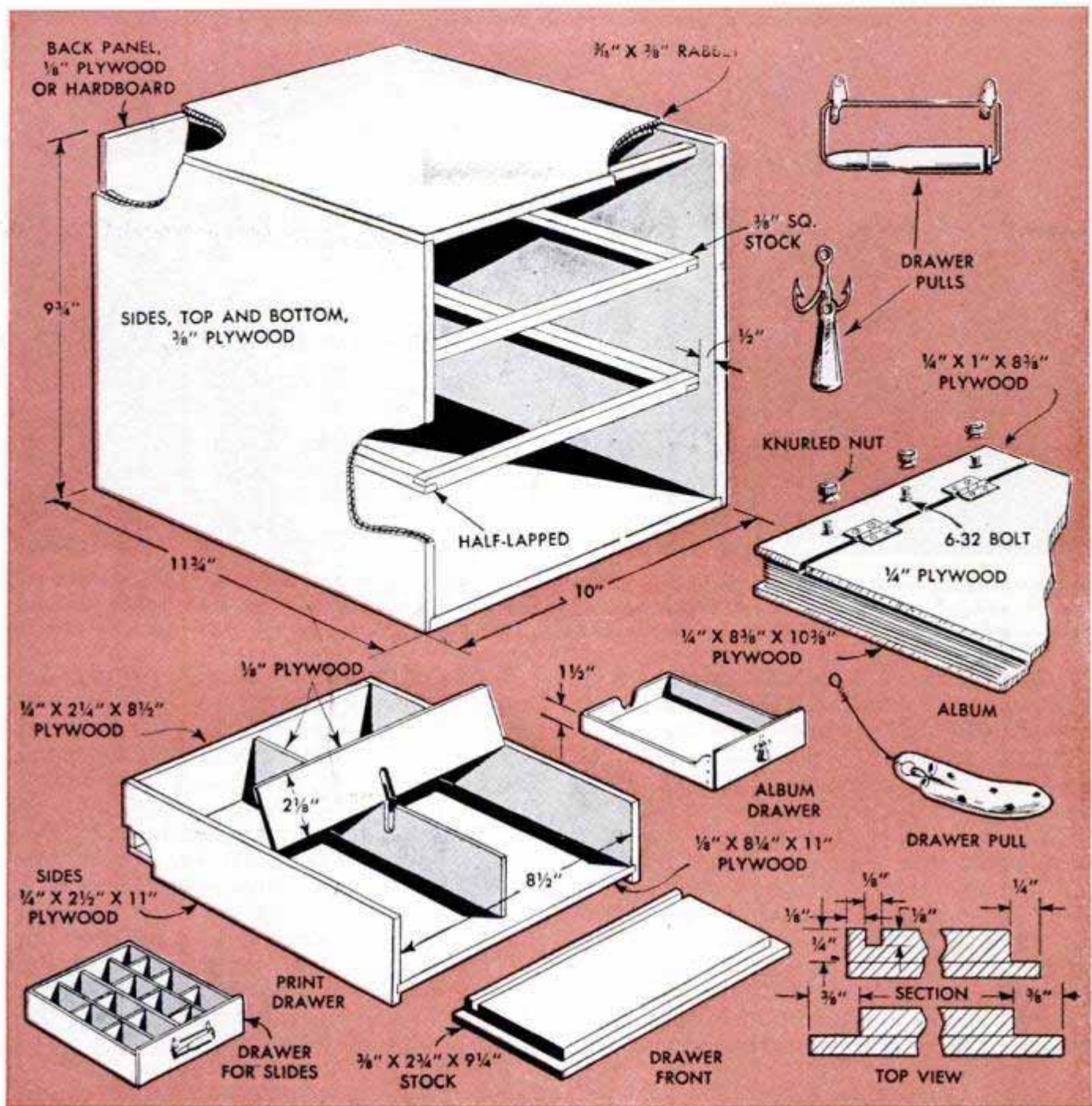
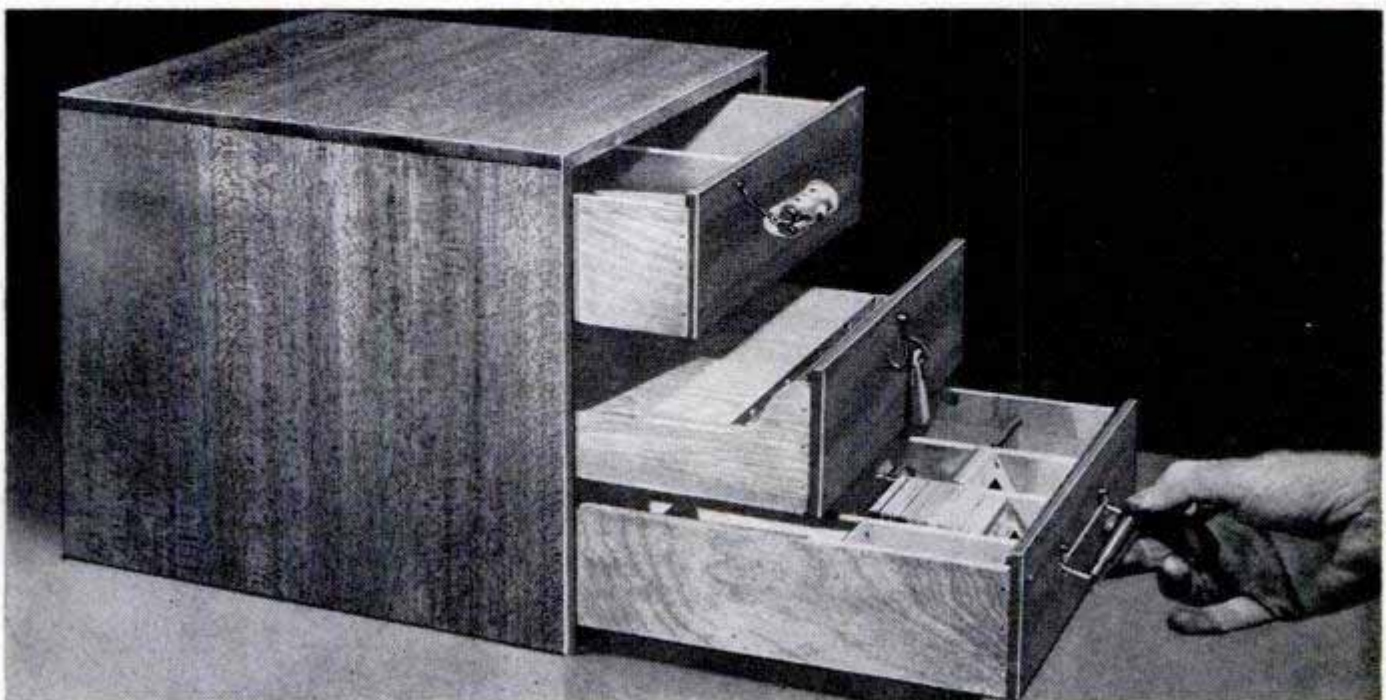
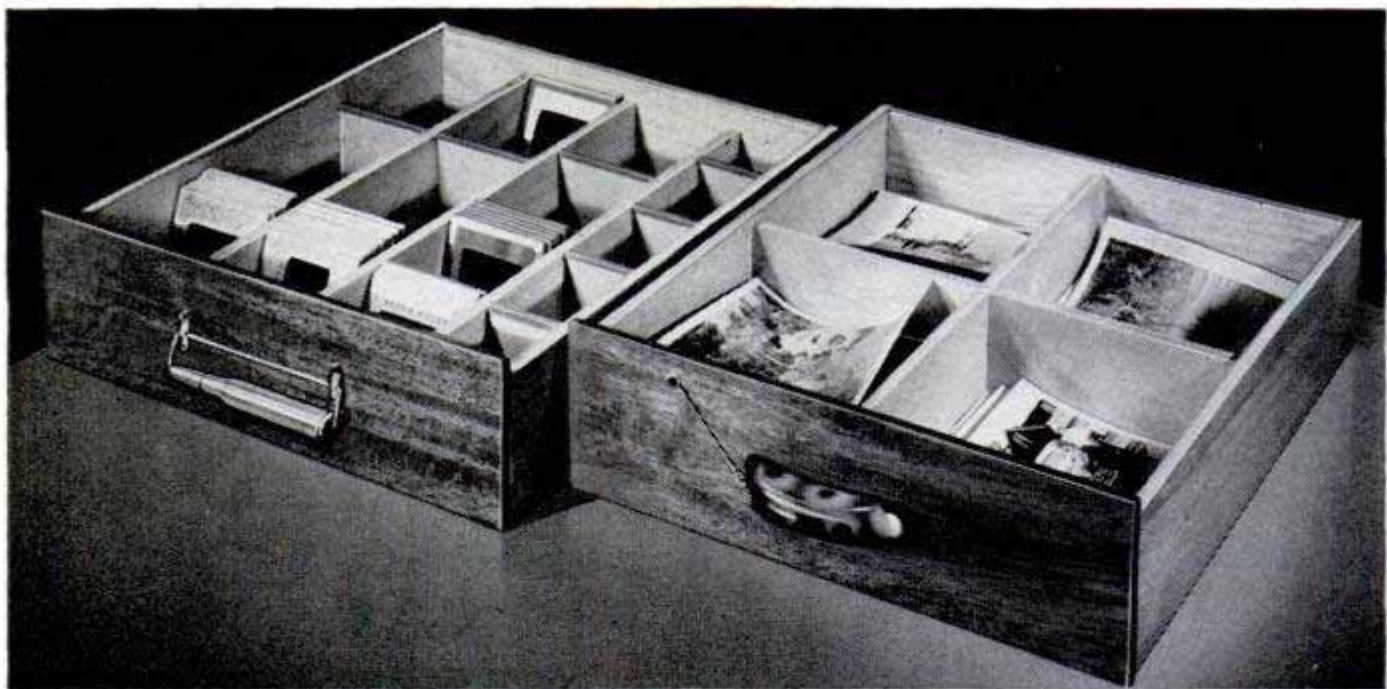

Photo below shows various drawers installed in cabinet. The drawer pulls are practical as well as novel







Empty-cartridge drawer pull on slide drawer is made by drilling the bullet and the base of the shell to receive the ends of a stiff-wire hanger. Primer cap, of course, must be removed from shell before drilling. Small sheet-metal clamps are used to fasten hanger to drawer front. Fishing lure is attached with screws

The cabinet is of simple box construction as shown in the detail on the opposite page. Note that the top is rabbeted for the edges of the side members and the sides are rabbeted to take the cabinet bottom. The rear edges of all four members are rabbeted to take the back panel. The drawers are built as indicated, the center and top drawers being supported by frames nailed and glued to the side and back panels. Note that the corners of the frames are half-lapped. The top, bottom and sides can be of  $\frac{3}{8}$  or  $\frac{1}{2}$ -in. plywood with the back of hardboard. The drawer bottoms and partitions also can be made of hardboard if preferred to plywood.

A photo album of suitable size may be purchased or, if desired, one may be custom-built from plywood, heavy paper and three brass bolts fitted with knurled nuts. The top is made in two sections which are hinged with a length of piano hinge or other small, surface-mounted hinges. The heavy-paper leaves used for the album should be folded double along the back edge and the bolts passed through both thicknesses. In addition to strengthening the leaves, this also spaces them so the book will fold flat when mounting corners are used to fasten the prints. Finish the plywood album cover with varnish.

## Roll-Film Tank Emptied Quickly by Blowing Into Filler Hole



When changing solutions in a plastic roll-film tank, you can speed up the removal of the used liquid by inserting one end of a rubber tube in the filler hole and then blowing through the other end. If the tube is too small to fit snugly in the hole, wrap it with a layer or two of adhesive tape.

## Rubber Tubing Connected to Faucet Secured With Waterproof Tape

In an emergency, rubber tubing can be connected to a faucet by wrapping several turns of waterproof tape around the tubing near the end to increase the diameter so the tube can be force fitted into the faucet. After inserting the tubing, use the tape or a length of cord to tie it to the faucet.

☐ Replace worn padding on the jaws of clamp-on photoflood lamps by wrapping the jaws with electrician's rubber tape.



## Bobby Pin Suspends Thermometer To Check Bottled Solution



Time can sometimes be saved by checking the temperature of photographic solution while in the bottle. To do this, clip a bobby pin onto the thermometer and hang it in the bottle as shown.—John J. Rea, Urbana, Ill.

## Flashlight Fitted With Filter For Darkroom Use

With its rays safely filtered by a piece of green cellophane fitted over the lens, a pocket-size flashlight may be used to locate



misplaced articles in a photo darkroom while film is being developed. If the only cellophane obtainable proves to be too thin, it may be folded into two or three thicknesses to cover the lens, after which it is attached to the flashlight barrel with cellulose tape. When searching for the missing articles, it should be remembered to keep the flashlight beam pointed downward at all times and always below the level of the table where film is being developed.—Robert Hertzberg, Jackson Heights, N. Y.

## Rubber Bands on Lightstand Arm Improve Gripping Surface



Inasmuch as the metal arm on his floodlamp stand is too smooth and narrow to permit getting a firm grip on it with a reflector clamp, one amateur photographer solves the difficulty by wrapping a couple of wide rubber bands around the arm to provide the needed friction. Rubber tape could be used for the same purpose, in which case it could be wrapped around the entire length of the arm to permit placing lights at any point desired.



## Packing Cut-Film Holders In Carrying Case

When packing cut-film holders in a camera carrying case, place each holder upside down in the case. In this way, there will be no chance of accidentally pulling the slide out of the holder when the latter is removed from the case.

## Flood-Reflector Ventilation Holes Indicate if Lamp Is Turned On



In addition to preventing a floodlamp reflector from overheating, tiny holes drilled around the socket opening will make it a simple matter to determine from a distance whether or not the lamp is turned on. This is especially helpful when using several lamps that are grouped together.



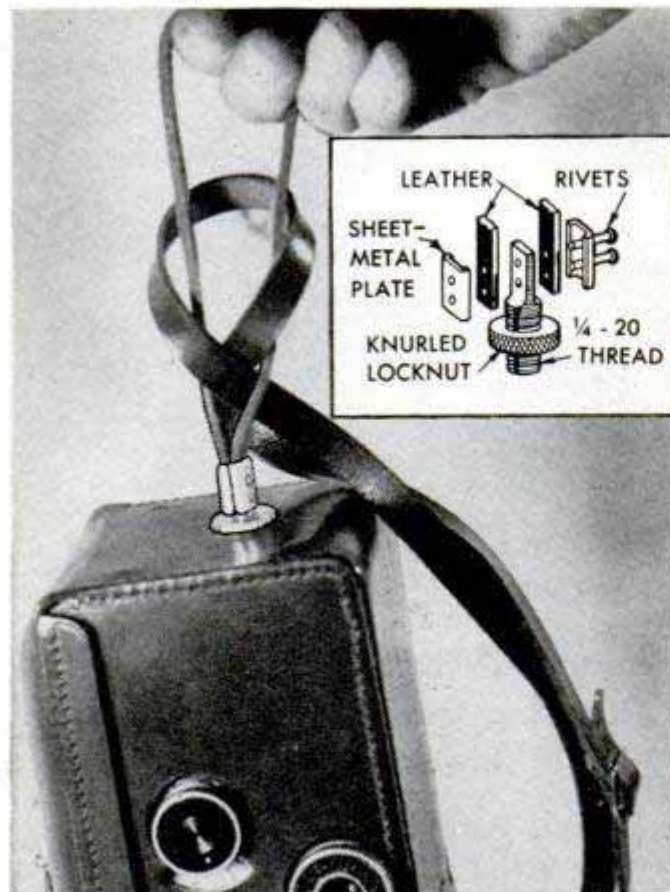

In addition to the usual shoulder strap on a camera case, provision for carrying the camera by hand, in the manner of a briefcase, is sometimes desirable. This detachable handle serves such a need and can be made at a minimum cost. Start by removing the head from a 1/4-20 brass machine screw, grinding one end flat and drilling it as shown. The detail shows the assembly in which the two ends of a short strap and two brass reinforcing plates are riveted to the screw. A hole is cut in the camera case to permit turning the screw into the tripod socket of the camera and a knurled nut is tightened against the case to prevent the handle from working loose. When carrying the camera by hand, slack in the shoulder strap can be taken up by looping it through the handle.

Walter E. Burton, Akron, Ohio.

☐ A unique way to get a child to pose for a picture is to stick a small piece of tape on his hand. The concentrated efforts of the child to remove the tape provide you with a variety of appealing poses.

## Some Time in Your Life

### You'll Need All Three of These . . .

**1. Motorist's Fix-It Book:** the most complete and compact guidebook for automobile upkeep you'll ever discover. Liberally illustrated with photographs and diagrams, it shows you how to perform every automotive job from changing a tire to servicing the generator regulator. There are chapters on motor tune-up, clutch care, brake servicing, trouble-shooting the starter and the cooling system. You'll save the price of this book many times over by following the chapters on "Getting Home on a Sick Engine," "Stretch Your Gasoline Dollar," and "Tire Care Means Long Wear." Whether you're a youngster just buying your first "jalopy" or a man with a dozen cars in your past, the "Motorist's Fix-It Book" is a year-around *must*. Garage mechanics use it, too!

**2. What to Make With Concrete.** There are two vital differences between hiring a concrete job done and doing it yourself . . . one is the price—and what a whale of a difference when you do it yourself! And the other is the satisfaction of seeing your own work take shape in concrete. Whether you're a beginner or an expert, this book has much to tell you. First of all, the fundamentals of mixing concrete that will endure, and how to use it properly. Then come detailed plans for making your own swimming pool or tennis court, concrete stairs, sidewalks, outdoor fireplace and garden pottery, and a whole section filled with uses of concrete on the farm. There's

even a chapter on building your own concrete mixer. And another tells how to make a machine to form 100 concrete building blocks per hour. Save yourself time and money by doing your own concrete work with the help of this *Popular Mechanics* book.

**3. How to Paint With Brush and Spray.** Time was when you just took a can of paint, plain oil paint, and slapped it on with a brush. Few crafts have changed as much and as rapidly as that of the modern painter. Here is a book that is up to the minute . . . packed with all the know-how you'll need, whether the job of the moment is refinishing old furniture, varnishing a floor, painting the house inside and out or laying on a new coat of stucco. One entire section is devoted to the use and care of the spray gun. There are articles, graphically illustrated, on crackle and marble finishes, on stains and varnishes and enamels, on lettering signs and silk-stenciling greeting cards, on painting Dresden figurines and painting automobiles. Whether painting is a hobby or a business with you, or there's a job to be done at home, you'd be smart to get this book!

These three books belong in your *Popular Mechanics* Craftsman Library. Order them by writing The Popular Mechanics Press, 200 E. Ontario Street, Chicago 11, Ill. Enclose money order or check. Motorist's Fix-It Book, \$2.00; What to Make With Concrete, \$2.00; How to Paint With Brush and Spray, \$2.50.



## SERVICING GEARED DRILL CHUCKS

By Harry L. Truchelut

**A**FTER long periods of hard service, geared chucks on all-purpose units, such as portable electric drills and small drill presses, become clogged with an accumulation of wood and metal chips, dust, and abrasive grit which impairs the accuracy of the chuck and may even cause serious damage. Often a thorough cleaning of the chuck will restore its accuracy and save the cost of replacement. Disassembly of a geared chuck is simple when you use a two-piece jig like that shown in Figs. 2 and 6. The jig consists of a pressure plate and cap and the two members are combined in the disassembly and reassembly of the chuck as in Fig. 2, using an ordinary bench vise as a means of applying pressure as in Figs. 3 and 7. The pressure plate and cap detailed in Fig. 6 are designed to accommodate several sizes of geared chucks, but

Disassembling jig consists of pressure plate and cap which are placed in vise with chuck between. Closing vise jaws forces the geared sleeve off the chuck body

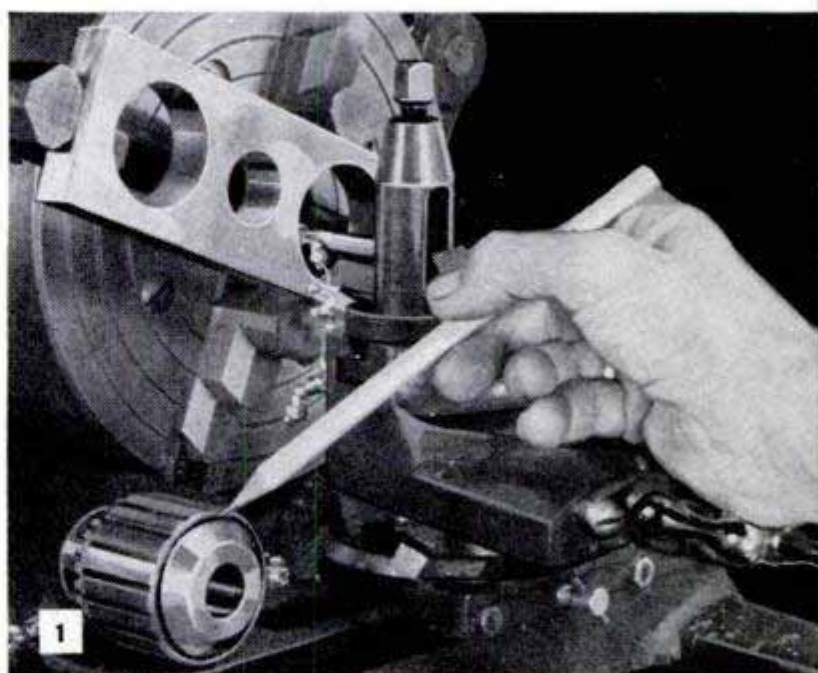

For disassembling and assembling geared drill chucks, a pressure plate, shown in lathe chuck, is necessary. Holes in plate are bored a little larger than chuck body

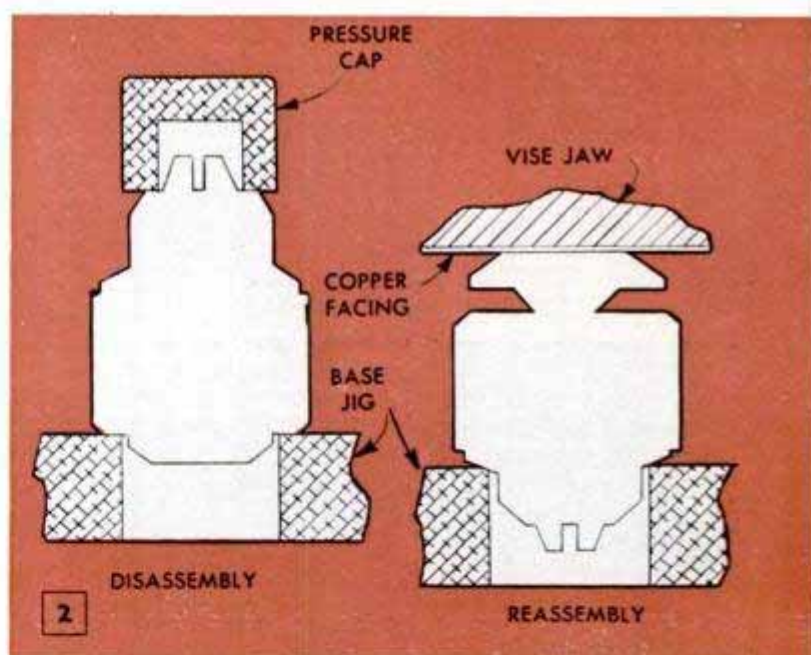

Clean all parts of the disassembled chuck in a clean solvent, using an old toothbrush to loosen accumulations of dirt and hardened grease from moving parts

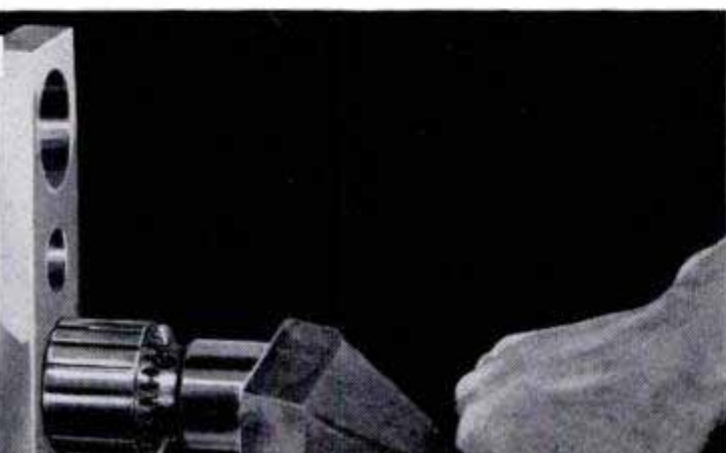



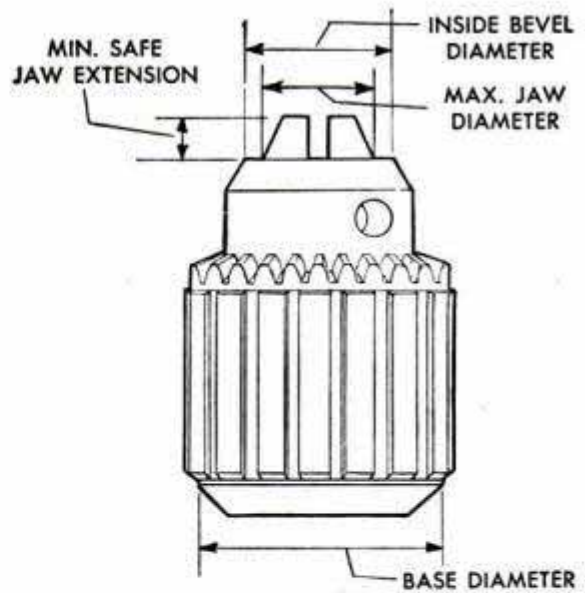

CHECK THESE DIM. BEFORE MAKING JIG

8

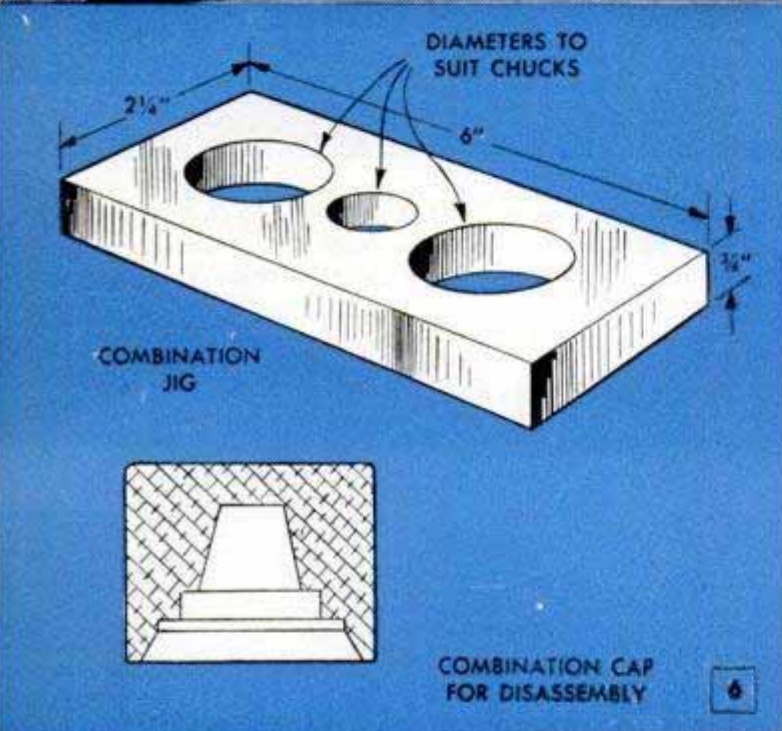

also can be made as separate units for each individual chuck, if desired. The units pictured were made from machining aluminum alloy, the pressure plate being set up in the lathe and bored as in Fig. 1. Before finishing the bores, check the measurements of the individual chucks at the points shown in Fig. 8, and then bore the plate and cap accordingly. Ordinarily, the holes bored in the plate should be about .005 in. larger than the diameter of the chuck body as measured just above the top end of the geared sleeve, Fig. 1.

To disassemble the chuck, first detach it from the tapered spindle and run the jaws either in or out so that they are just slightly more than half closed. This is important, as otherwise the teeth on the upper ends of the jaws may not fully clear the sleeve and damage can result when the sleeve is forced off. Now, set up the jig and chuck as in Fig. 3 and tighten the vise jaws slowly until the geared sleeve is released. This exposes the chuck body so that the hardened split ring and jaws may be removed. Wash all parts thoroughly in a clean solvent, using an old toothbrush to remove hardened grease and accumulations of dirt and grit. Handle all parts carefully and take special precautions to avoid dropping them on the floor. In reassembling, after cleaning and relubricating as in Fig. 5, be sure to replace all parts in the same order and in their proper positions. Then place the pressure plate and chuck in the vise as in Fig. 7 and force the sleeve slowly back into position on the chuck body. In this operation it is advisable to use a soft-metal facing on the vise jaws to avoid burring the tapered hole in the chuck body. It should be noted that some special types of geared chucks are fitted with ball bearings and it is not recommended that these be disassembled in the manner described.

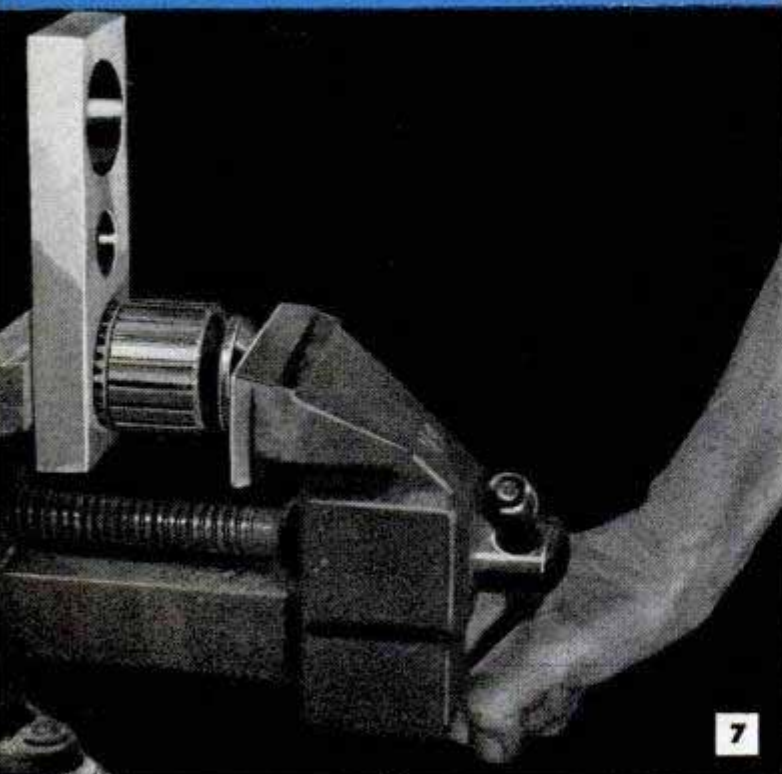



## Plastic Jig Holds Ribbon Taut For Hand-Lettering

Seeking a solution to the problem of holding narrow ribbon taut for hand-lettering with a brush, one artist came up with a simple jig, or holddown, made from thin sheet plastic, that did the trick. Two narrow slots are cut in the plastic, each one of a length slightly greater than the width of the ribbon. One slot is cut near the top edge of the plastic sheet, the other near the bottom as shown. Then the ribbon is passed through the upper slot from the underside of the sheet and pulled down through the lower slot to hold it flat and taut for lettering. After the ribbon has been inserted the plastic is fastened to the drawing board with thumbtacks.

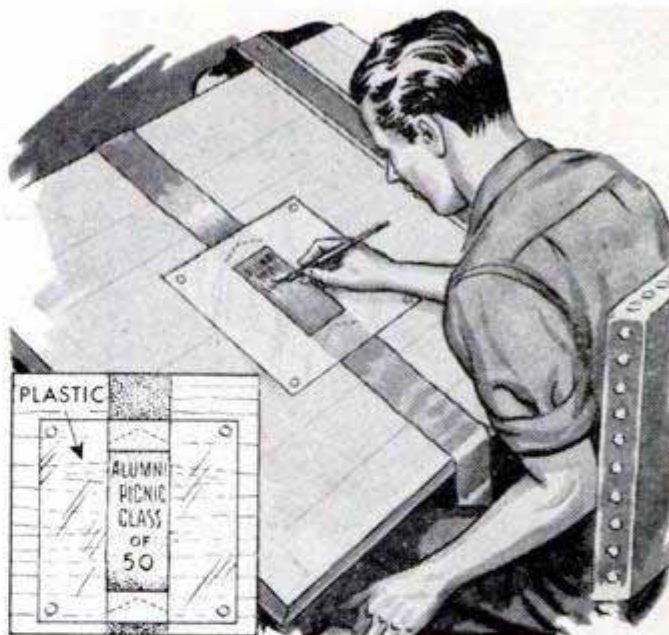

## One Man Is Able to Load This Mixer Onto Truck or Trailer

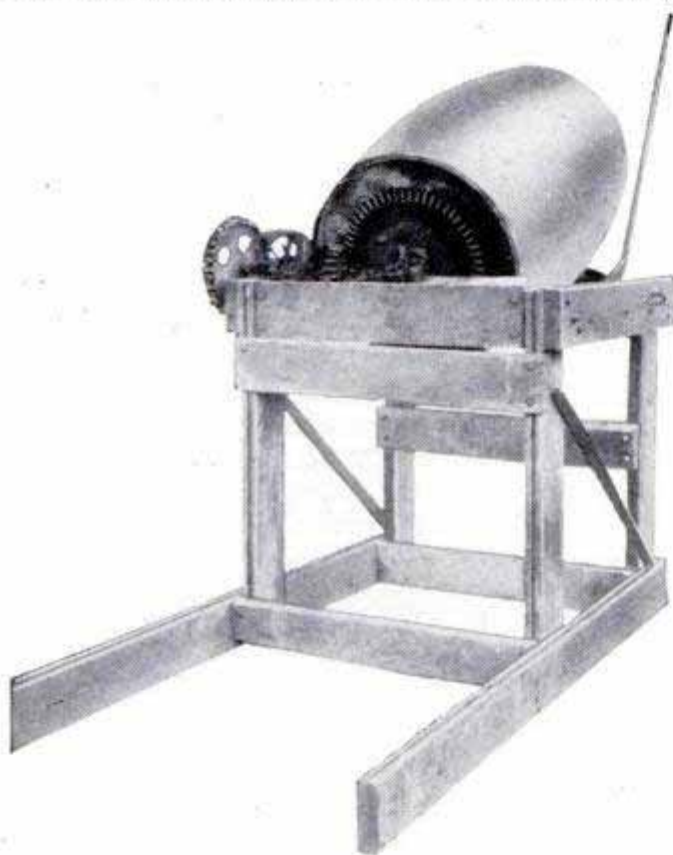

Tiring of the difficult job of loading a small concrete mixer onto a pickup truck, one contractor built a special frame for the mixer that made one-man handling simple and easy. In this case the builder used 2 x 5-in. tank staves for the frame, but any stock of similar sectional size will do. The frame is bolted together and braced for additional rigidity and is mounted on two long skids as shown. To load the unit, the truck or trailer is backed into position at the side of the mixer and the tailgate lowered. The mixer is tipped and turned so that the ends of the skids rest on the bottom of the truck bed. Then it is raised to the level position and slid forward into the truck or trailer.

## Pig Creep Built From Gates

Confronted with the problem of providing a temporary pig creep on open range without cutting new material for a permanent unit, one farmer utilized the line fence for one side and then set up three ordinary driveway gates to complete an enclosure around a conventional self-feeder. One of the gates is raised a short distance above the ground so that only the young pigs can pass underneath. Gates are wired to permanent fence posts and to heavy stakes driven into ground at corners.

## Using C-Clamp on Pipe

When clamping a piece of pipe or other round work to a flat surface, try using a C-clamp and a short length of angle steel having a flat filed on the upper edge to take the pad of the clamp screw, as shown. Considerable pressure can then be applied to the pipe without having the clamp slip out of position.

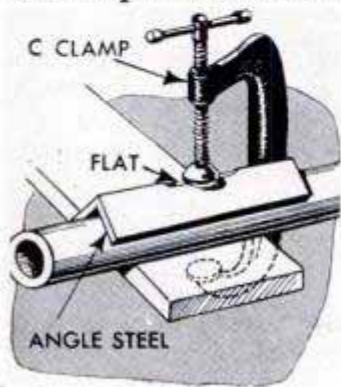



# DIAL INDICATOR

## from an old watch



Calibrate dial by clamping the instrument in tool post and setting plunger lightly against stock chucked in lathe. Move crossfeed .001 in. and mark hand movement on dial. Repeat until dial is calibrated. Hand movement can be varied by relocating pickup vane

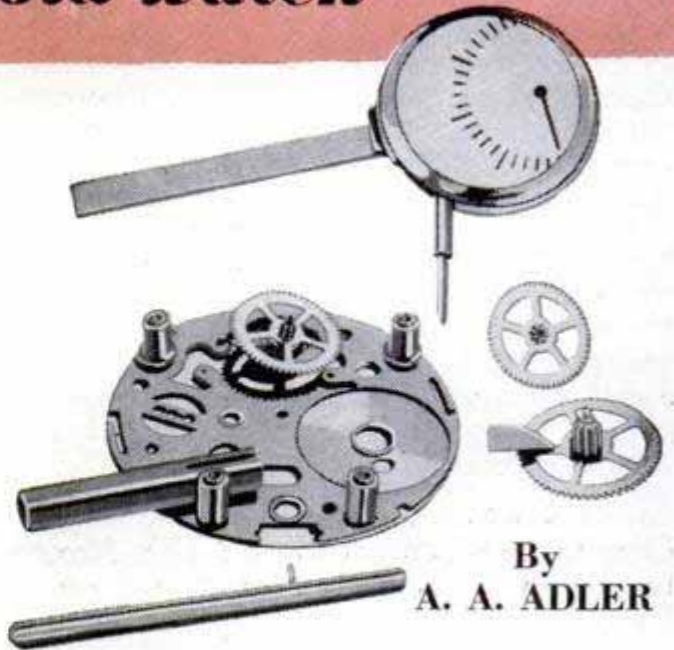

By  
A. A. ADLER

METALWORKING craftsmen who hesitate to stand the cost of a manufactured dial indicator can make an accurate indicator from an old wrist watch or pocket watch, and the cost is negligible. First, remove all the parts from the watch case, leaving the spacer bushings intact. Save the three larger gears, hairspring, frame and case, discarding the rest of the parts. Solder a small sheet-metal pickup vane to the largest gear, as in the detail, and make the plunger and guide. Assemble the parts, as shown, and solder a mounting arm to the case back.

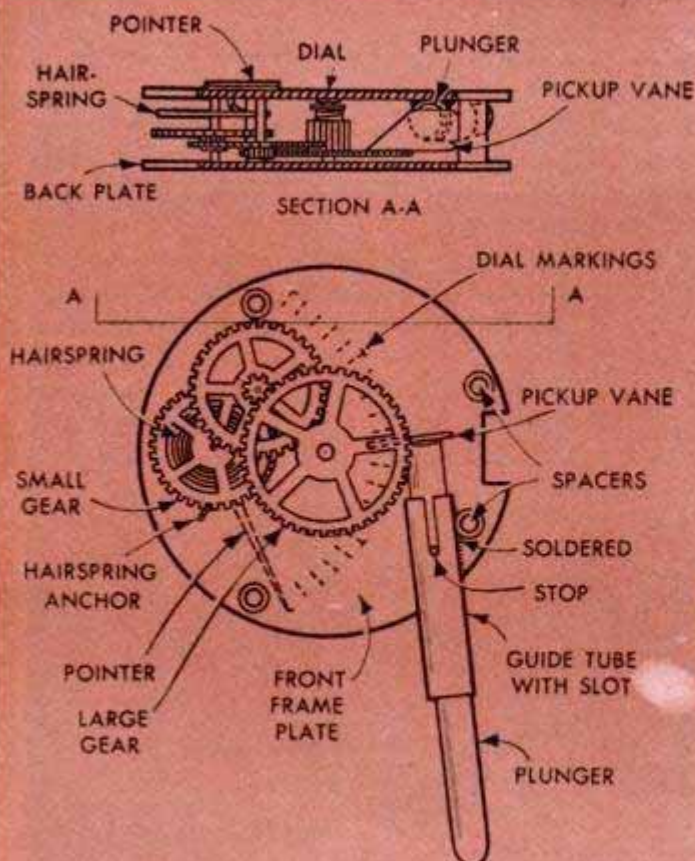
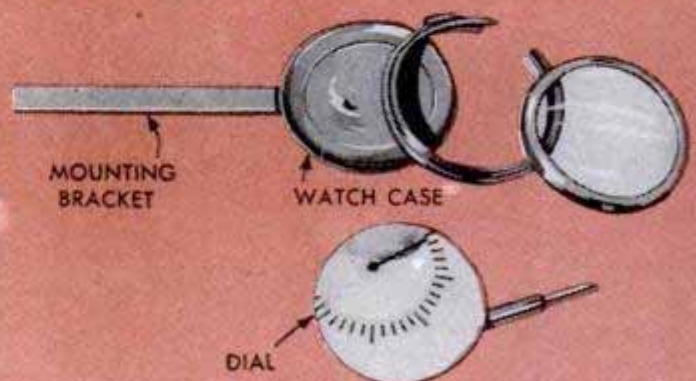
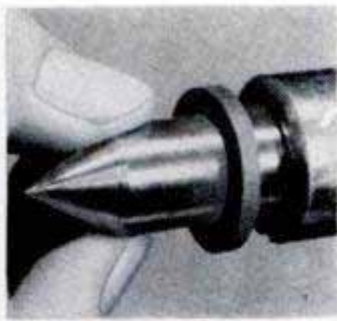

Photo above shows plunger of  $\frac{1}{8}$ -in. rod inserted in guide tube. Latter is slotted for wire stop on plunger and is soldered to plate so plunger presses against pickup vane. Dial is of heavy paper, and stiff-wire hand is soldered to shaft of small gear





## Hose Washer Protects Lathe Center



To keep the taper end of a dead center on a metal-turning lathe free of dust and grit, slip a hose washer over the center as shown and slide it against the tailstock. A guard of

this type will prove to be especially desirable when grinding or turning metal that creates a fine dust.

## Matchbox Abrasive Used as File

His car stalled, one motorist investigated and found the breaker points pitted and burned. Lacking a file of any sort, he eventually hit upon the idea of using the abrasive side of a matchbox. Just enough abrasive action was supplied to clean the points and get the car underway again.

Ed Packer, Chicago.

## Converting Lathe Dog To Safety Type

A standard lathe dog can be converted to one of the safety type by substituting a socket-head screw for the ordinary cap screw. Two screws of different lengths will furnish a choice of sizes which will permit clamping the work so that the screw will not project enough to catch in the operator's clothing.



## Tire Talcum Dusted on Tube Lessens Pinching Tendencies

The possibility of an inner tube being pinched will be reduced considerably by applying tire talcum to the tube instead of dusting the tire casing in the usual manner. Spreading talcum over the entire surface of the tube greatly lessens any chance of the tube creasing when installing it in the tire, especially at the point where it contacts the wheel rim and tire beads.

John D. Bell, Los Angeles, Calif.

## Section of Eave Gutter Shields Mouse Trap

When it is necessary to set a mouse trap where it endangers poultry or small pets, invert a short section of eave gutter over the trap as shown. This will allow

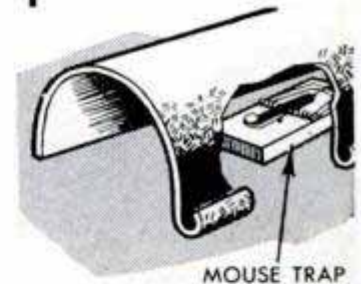

mice to get at the trap but will prevent other animals or poultry from being injured. Also, the shield will increase the possibility of trapping mice, because they usually prefer to move about underneath an object, if possible.

Benton Anderson, Royal Oak, Mich.

## Graphite Lubricates Drafting Tools

Applying graphite to threaded parts of drafting tools allows the adjusting nuts to spin more freely and prevents undue wear that may cause improper adjustment. The graphite can be applied simply by rubbing the threads with a pencil point. This is especially helpful in preventing "spot" wearing on the finely threaded adjustment rods of the instruments.



# Better METAL DRILLING

By Sam Brown

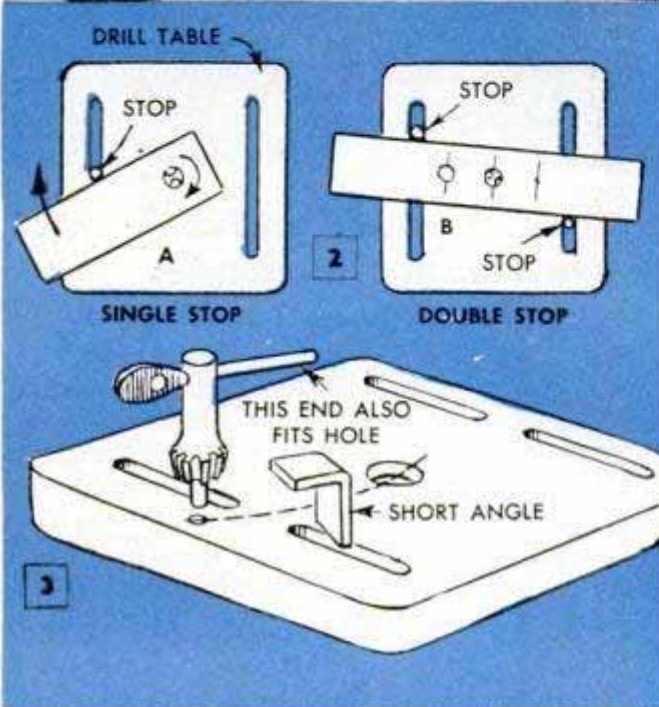
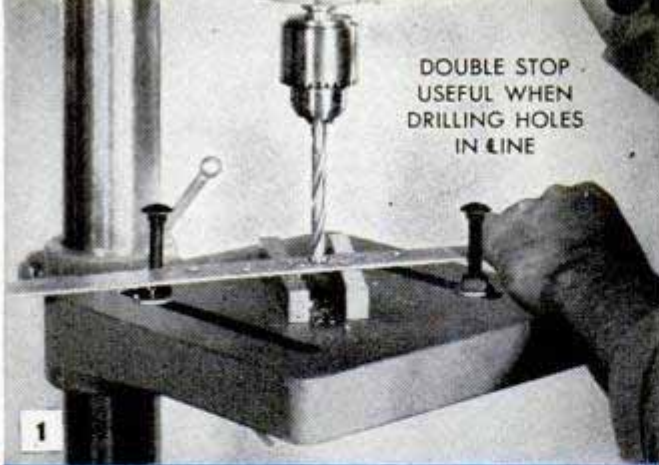

VERY LITTLE WORK can be done in metal without drilling holes. This basic operation calls for a good layout, proper mounting of the work and the use of the right drill, running at the right speed. With a knowledge of these fundamentals, you will be able to produce precision work and get the most from your drill press.

**Layout:** Drilling begins with a layout mark. A steel scriber is commonly used to draw lines marking the hole position, although a sharp pencil can be used for many jobs. The finer the scribed or penciled lines, the more accurate the layout will be. A center punch is positioned carefully at the intersection of the lines, Fig. 4, and the punch mark is then made with one hammer blow, as in Fig. 5. If a check shows the punch mark to be exactly on the intersection of the lines, it can be deepened as

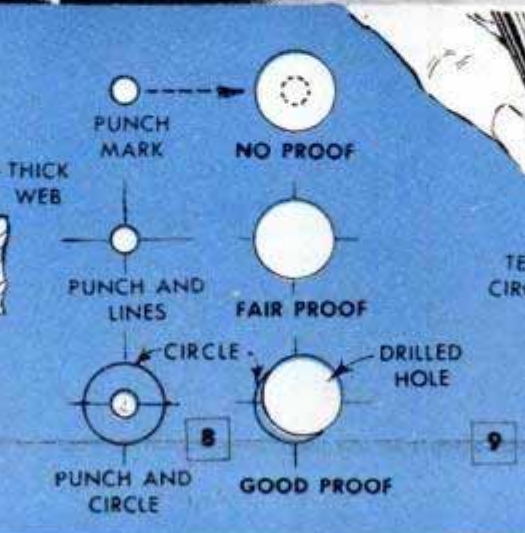
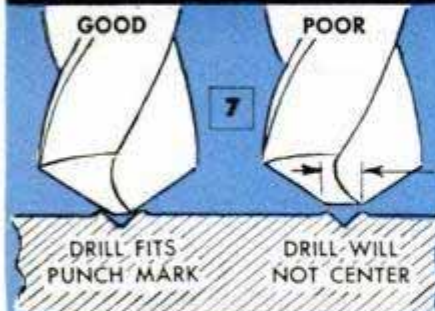
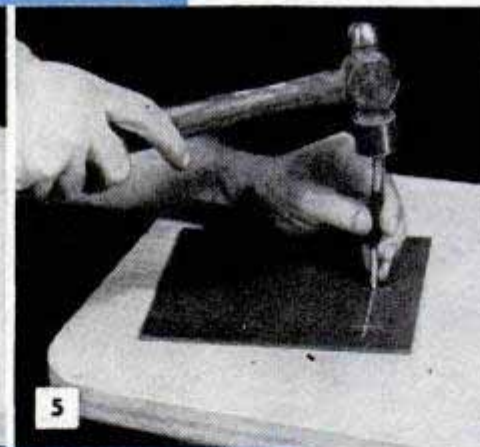
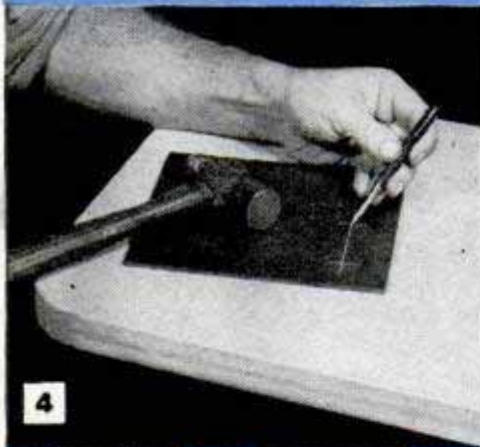

Layout is usually done with a scriber. Punch mark at intersection of scribe lines centers drill and prevents walking

DRIFTING A HOLE IS EASY TO DO WITH A COLD CHISEL



needed. If the mark is slightly off, it can be corrected by side punching, Fig. 6, finishing the job with the punch held vertically. For exacting work, a prick punch, having a 60-deg. point, is used to make the first indentation. This is followed by a center punch—one with a 90-deg. point. The punch mark must be a little larger than the web of the drill, Fig. 7, to center the drill properly and prevent walking.

Although drifting a hole is done after the drill has started to cut, it is usually considered as layout work. This is done with a cold chisel, making one or more marks in the conical recess made by the drill, as in Fig. 9. Drifting must be done before the drill starts cutting its full diameter. For accurate work, the hole diameter should be marked with dividers after prick punching, as this gives the best proof of accuracy, Fig. 8. Here you will note how easily any wander or drift can be determined merely by checking the hole with the scribed circle.

**Mounting:** The simplest mounting is the stop bolt, which has the primary function of keeping the work from rotating, Fig. 2, A. The stop is most useful when working flat bar stock. On long work, the drill column itself is often used as a stop. A double stop, Figs. 1 and 2, B, is useful for repeat work or drilling holes in line. Many gadgets are used for work stops, but nothing beats the chuck wrench itself, Fig. 3. Some drillers like a short length of angle iron, especially if the drill table has diagonal slots.

The most popular holding device is the drill-press vise. Fig. 10 and Figs. 14 to 23 show various setups for different types of work. When the work is too large for the vise, it can usually be mounted by clamping to the table. One clamp located near the drill, Fig. 11, will hold most work securely. Figs. 12 and 13 show how to attach clamps to the table for best results. Another handy device for general work is the hold-down shown in Figs. 24 and 25. The auxiliary

Note in photos below that clamp throat should be deep enough so jaw almost reaches center of table

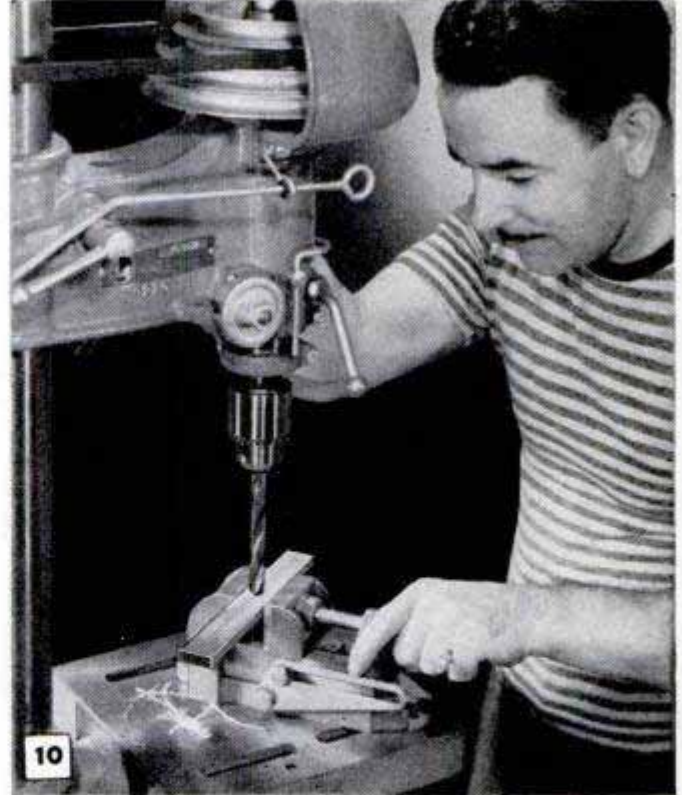

Vise is handiest of work-holding devices, as weight will usually control spin of the work without stops

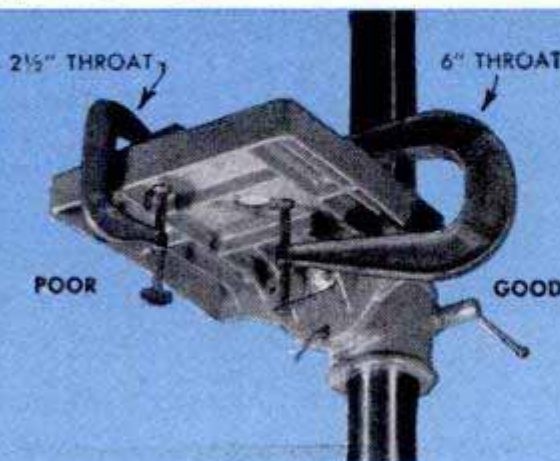
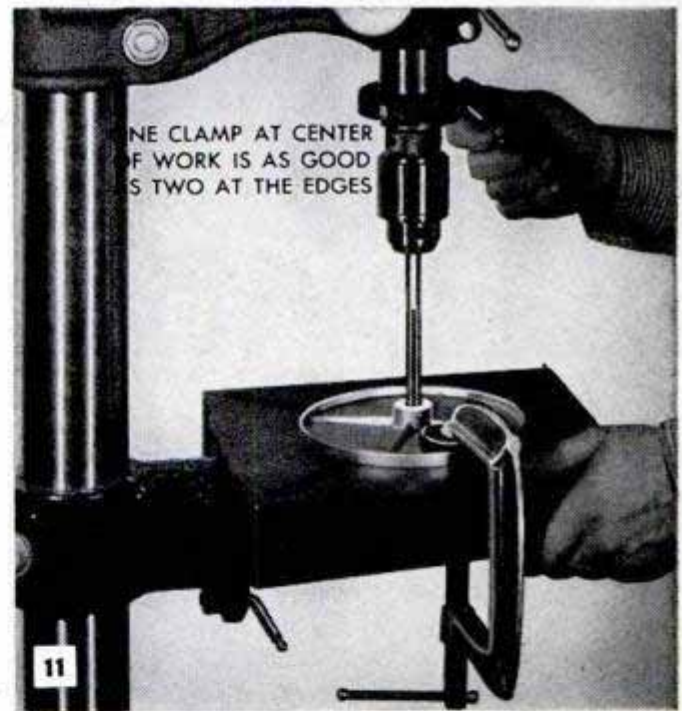

12

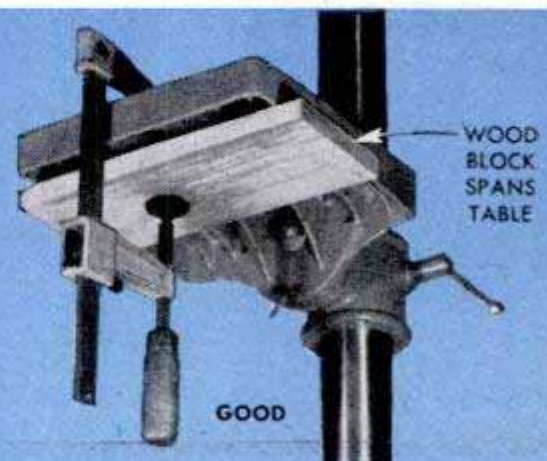

13



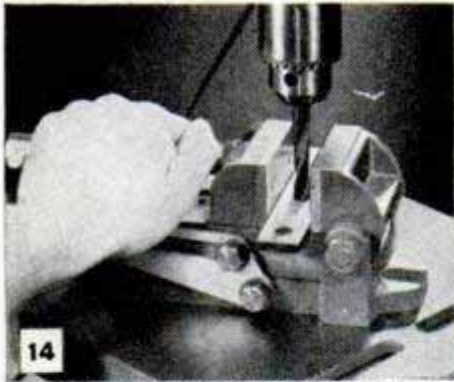

14 WORK PLACED AT BOTTOM OF VISE IS WELL SUPPORTED

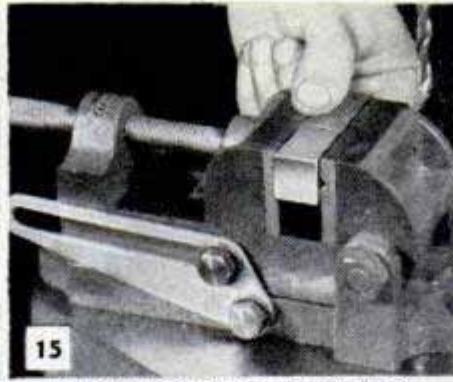

15 FLUSH MOUNTING IS EASY TO SEE—OFFERS FAIR SUPPORT

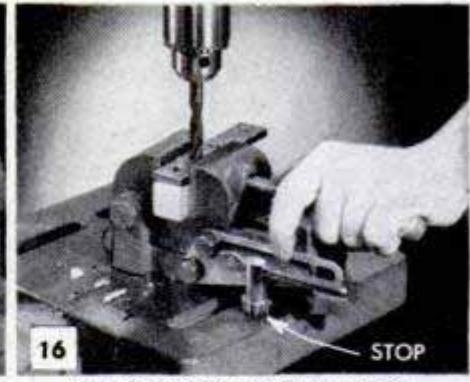

16 WOOD BLOCK PLACED UNDER WORK IS EXCELLENT SETUP

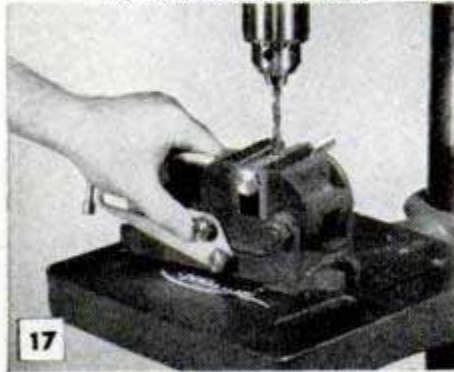

17 SMALL ROUNDS ARE GRIPPED RIGIDLY BY V IN VISE JAW

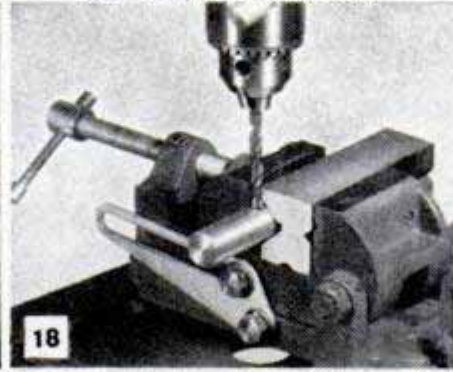

18 SEPARATE, LARGER V IN VISE IS NEEDED FOR BIG ROUNDS

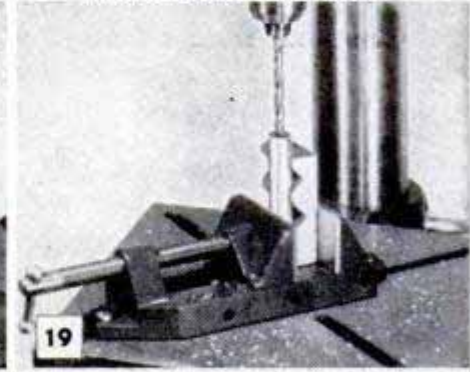

19 VISE V OR V-BLOCK IS USED FOR END DRILLING ROUND STOCK

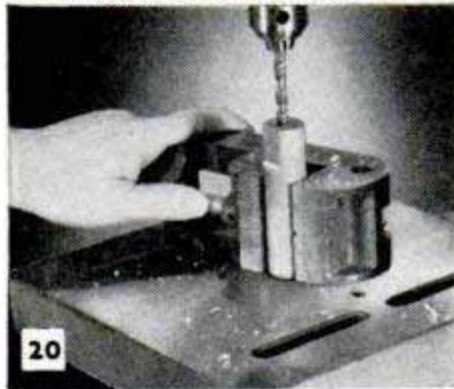

20 PLAIN VISE CAN BE USED ON SIDE FOR HOLDING LONG WORK

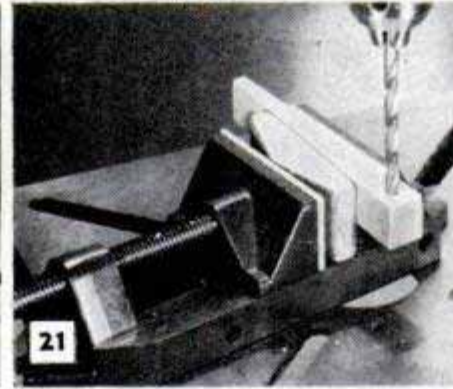

21 PIVOT JAW IS USEFUL WHEN DRILLING TAPERED OR ODD-SHAPED WORK

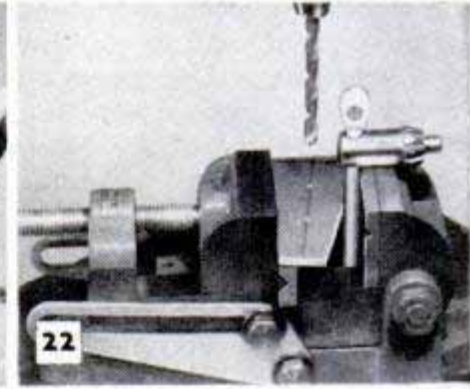

22 ROUND BAR IN VISE PROVIDES SAME ACTION AS PIVOT JAW

wooden table, which is favored by woodworkers, is also handy for mounting many drilling jobs in metal and, when used with a fence, as in Fig. 26, the combination is just the thing for drilling holes in line. The table is detailed in Figs. 27 and 28. Numerous other mounting methods are used, but the devices shown will handle 95 percent of all drilling jobs you are likely to encounter. With the exception of large, heavy work, which has enough weight to "stay put" by itself, every piece of metal drilled on the drill press should be held in some safe, practical manner to keep it from spinning. Never attempt to hold small work by hand. The emerging point of the bit is apt to catch suddenly and spin the work, causing painful injury. *Always clamp small work.*

**The right speed:** Use the table in Fig. 50

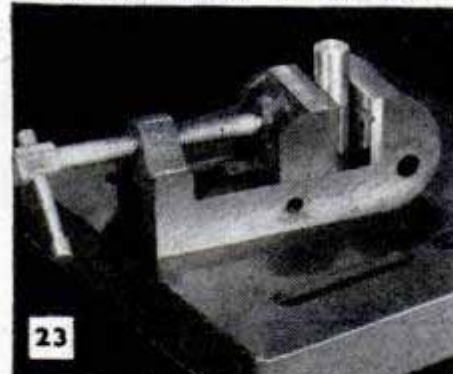

23 PLAIN VISE ALLOWS LONG WORK TO PASS THROUGH HOLE IN TABLE

to find the right speed for a particular job. The figures given are practical speeds, somewhat lower than those used in industrial practice. If you are drilling steel and do not know what type of steel it is, use the 60-f.p.m. speed listed for machine steel. This is also the best all-around drill speed for all materials. It is practical to use speeds lower than

listed, provided you do not combine them with excessive pressure. Beginners frequently use a very low speed to prevent burning the drill, but then make the more serious mistake of applying too much pressure. A maximum of about 25 lbs. should be used with lever feed, but 10 to 12 lbs. of pressure is sufficient for most jobs. A pressure of 10 lbs. at the feed lever means that you are applying about 200 lbs. on the drill point.

**Best drill point:** Most work can be done



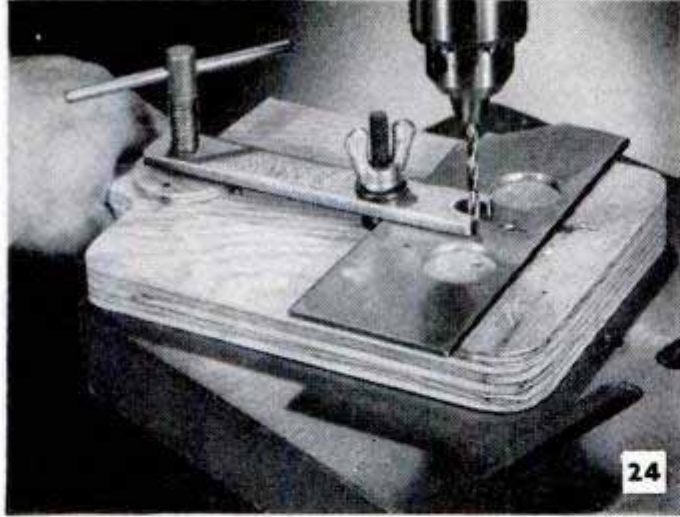

Universal hold-down, pictured above and detailed at right, takes wide variety of work. Table of  $\frac{1}{4}$ -in. plywood is pried off and replaced when worn

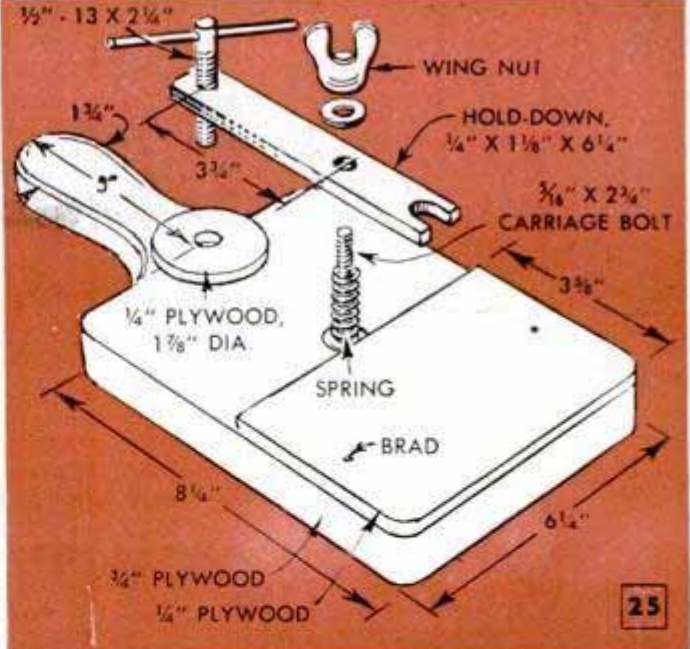

satisfactorily with the standard 118-deg. point, Fig. 51, upper left-hand detail. A noteworthy exception, however, is brass, which works better if the lips are ground to a zero rake so that they will scrape instead of cut. The other recommendations given in Fig. 51 can be used on occasion as desired. The most practical point for most sheet metal is the very blunt style shown. It results in a minimum burr on the underside of the work.

**Drilling a hole:** The actual drilling of the hole is done by one of three methods. The simplest is to go right ahead and drill with the work held freehand in some floating mount, such as a vise or a universal hold-down. A good light, preferably located behind the work, is a valuable aid. With this, you can see the drill point even when it is revolving at high speed, Fig. 52. This, of course, is of considerable help in bringing the drill and the punch mark as close together as possible. However, it is the sense of touch which actually guides the drill into the punch mark. The work should be held lightly, but allowed to float, or move freely, on the drill table until you can feel the drill enter the punch mark.

The second method is "float and clamp," as shown in Figs. 53 to 55. In this system the clamp is added after the hole has been spotted freehand by the floating method mentioned above. A third system is the pointer method, described in Figs. 29, 30 and 31. With an accurate pointer and properly ground drills, this system is very accurate.

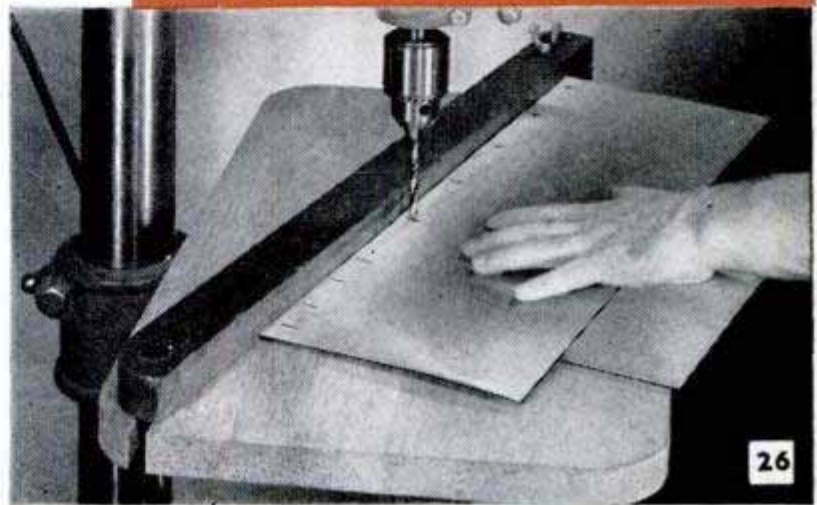

Wooden table provides a good mounting surface for many drilling jobs, as it allows support blocks to be nailed to table. Fence setup, above, is excellent for drilling holes in line

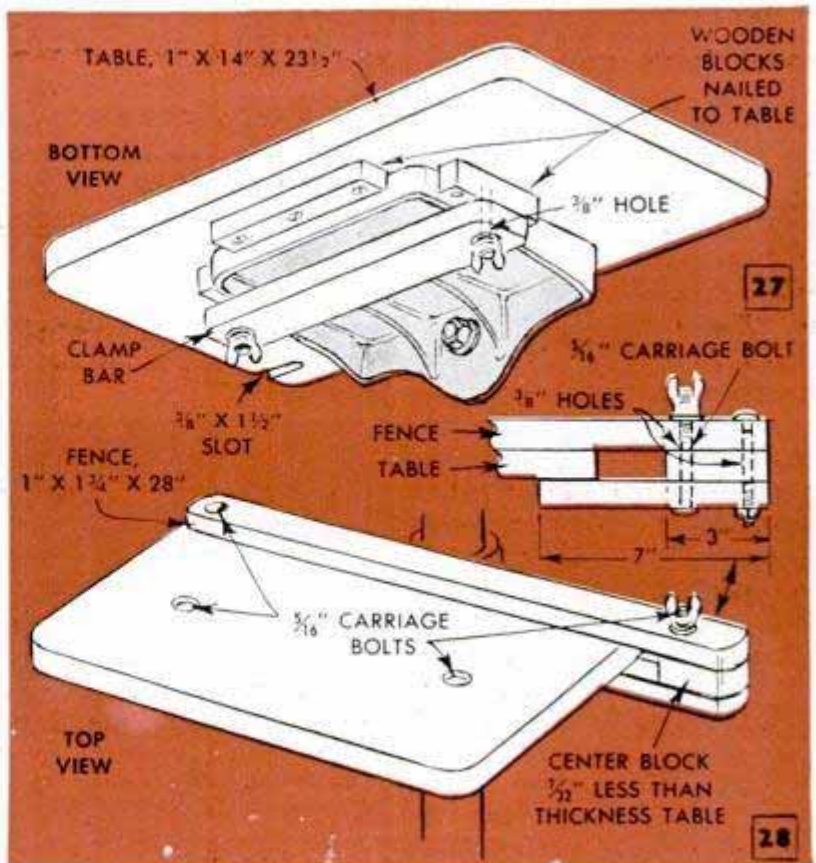



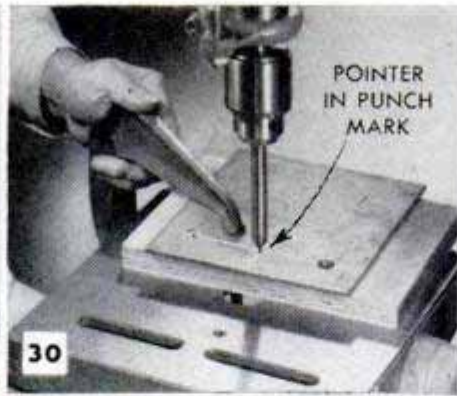
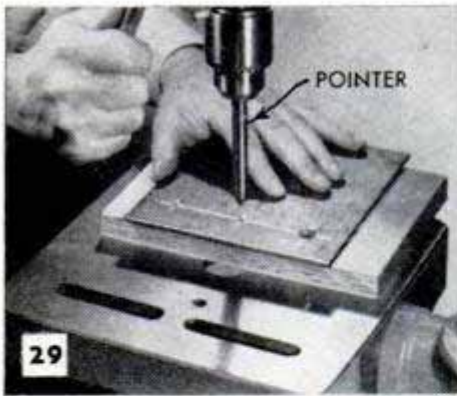

Locating bit with pointer method assures accurate work. Pointed rod is chucked in drill press, and work is positioned so point is centered in the punch mark. Work is clamped and point is replaced with bit

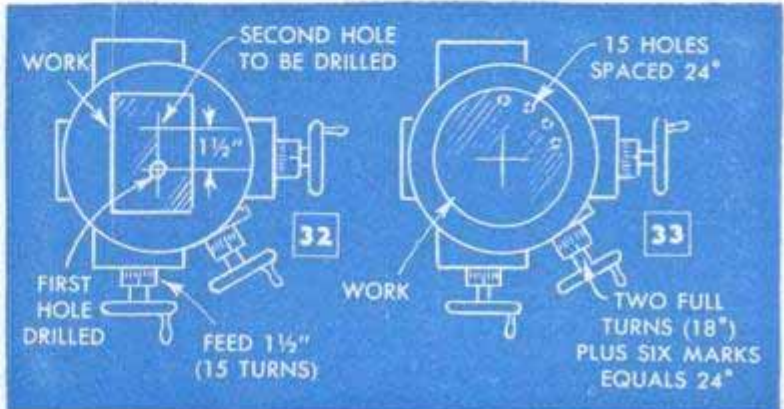
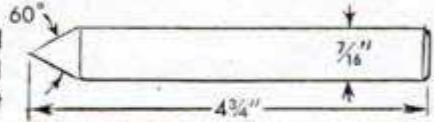

Bit is centered accurately to .001 in. if work is mounted on rotary table, utilizing micrometer feeds. Rotating table is especially handy for spacing series of holes on radius

**Job pointers:** The rotary table, Fig. 34, makes an excellent mount for accurate work. Unlike other mountings, it allows the work to be clamped first and then moved to the exact position for drilling by means of micrometer feeds, as shown in Figs. 32 and 33. The rotary feature is especially useful for drilling holes around a circle, Figs. 35 to 38, as well as for circular routing or light milling. The various job setups shown in Figs. 39 to 49 are typical drilling hints which the average driller will be able to use to good advantage. Probably the most widely used technique in home-shop drilling is the double-decking of parts to be joined, as pictured in Figs. 46 and 47. An alternate to this simultaneous-drilling technique is to drill the top part alone and then clamp it to the second piece

NUMBER OF HOLES	DEGREE SPACING
3	120
4	90
5	72
6	60
7	51.43
8	45
9	40
10	36
12	30
14	25.71
15	24
16	22.5
18	20
20	18
24	15
30	12
32	11.25
36	10
40	9
45	8
48	7.5
60	6

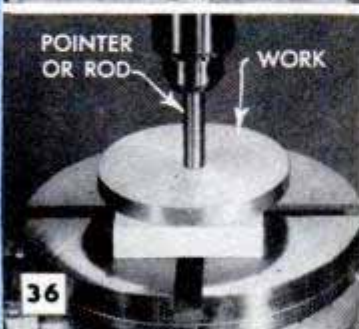
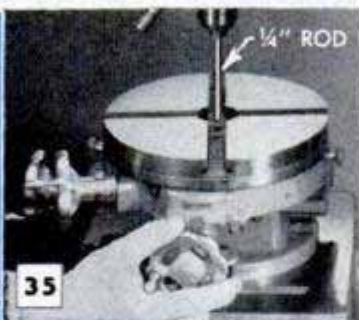

Centering work on rotary table is done by measuring from edge of table or by using pointer method. With latter method, first center table under spindle, Fig. 35. Then center work on table, using pointer or rod, Fig. 36. Clamp work, adjust table and drill



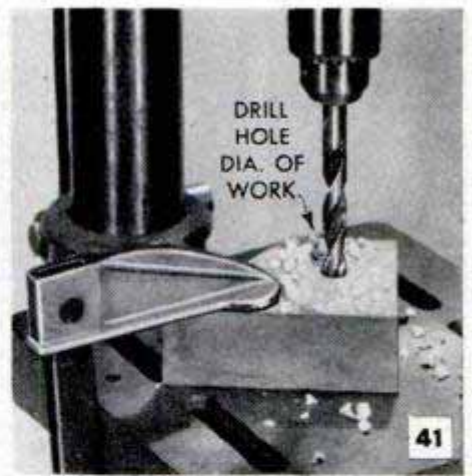
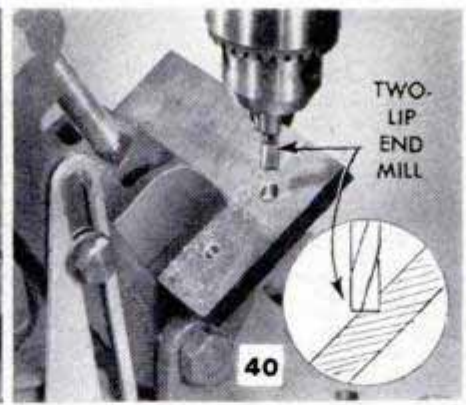
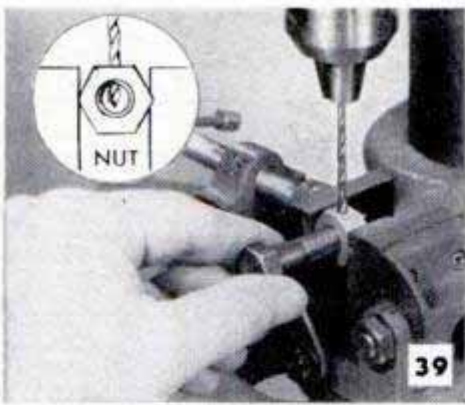

Cross drilling bolt is done easily, Fig. 39, by turning bolt into drilled nut which is clamped in vise. Bits can be started at angle without danger of runoff if a flat surface is milled on work, as in Fig. 40

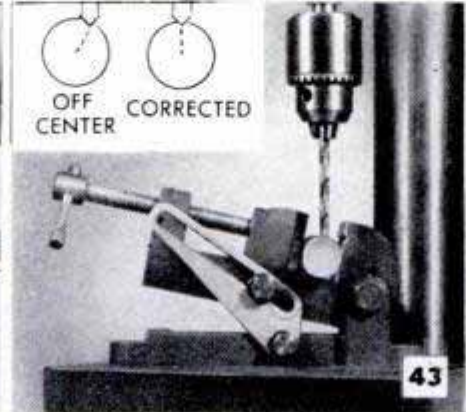

Center of round work is located by sliding work under bit so surface is just scratched, Fig. 42. If angle vise is tilted slightly before drilling, runoff can be corrected by changing of angle vise, Fig. 43. Hole in end of rod is located by drilling clamped block, Fig. 41, and pressing work upright in drilled block, Fig. 44

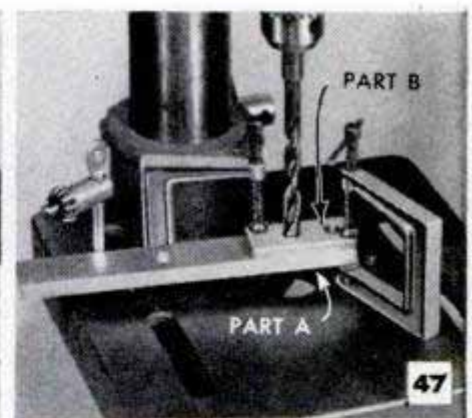
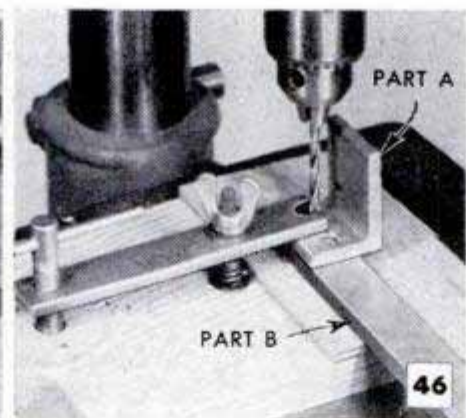
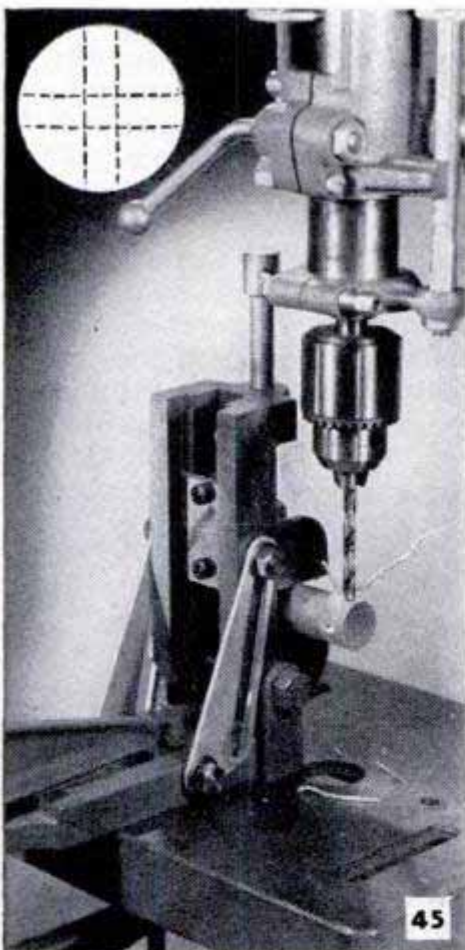

To assure accuracy, joined parts should be drilled simultaneously whenever possible. If desired, holes can be located and drilled in top part, which is then used as guide for drilling aligning holes in bottom part

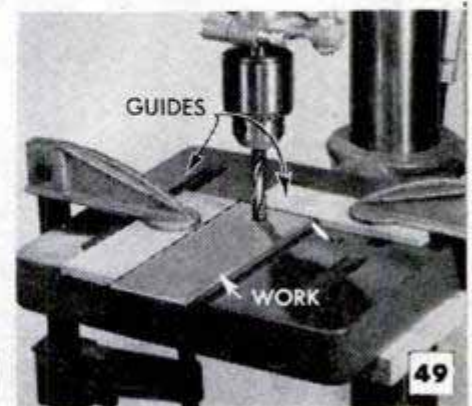
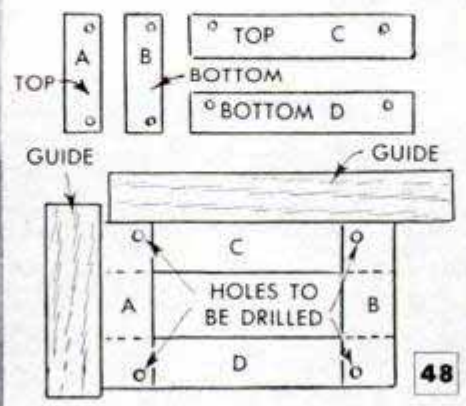

Transverse holes in round work are drilled at right angles, Fig. 45, by using scale on angle vise. Square assembly can be drilled without marking by using two guides clamped to table, Figs. 48 and 49. Parts A and B are drilled identically, as are C and D. Turning over parts B and D aligns holes for assembly



MATERIAL	FEET PER MIN.	DRILL DIAMETER											
		3/16"	1/8"	3/16"	1/4"	5/16"	3/8"	7/16"	1/2"	5/8"	3/4"	7/8"	1"
ALUMINUM	250	15000	7600	5000	3800	3000	2500	2100	1800	1500	1200	1100	900
BRASS	200	12000	6000	4000	3000	2400	2000	1700	1500	1200	1000	875	750
CAST IRON, SOFT	110	6700	3300	2200	1700	1300	1100	900	850	675	550	475	425
CAST IRON, HARD	80	4800	2400	1600	1200	1000	825	700	600	500	400	350	300
MALLEABLE IRON	70	4200	2100	1400	1000	850	700	600	525	425	350	300	250
PLASTICS, SET	140	8400	4200	2800	2100	1700	1400	1200	1000	850	700	600	525
PLASTICS (Heat Forming)	90	5500	2700	1800	1300	1100	900	800	700	550	450	400	350
STEEL, SOFT	80	4800	2400	1600	1200	1000	825	700	600	500	400	350	300
STEEL, MACHINE	60	3600	1800	1200	900	725	600	525	450	375	300	250	225
STEEL, TOOL	50	2700	1500	1000	700	600	500	425	375	300	250	225	200
STEEL (Hard Stainless)	30	1800	900	600	450	350	300	250	225	175	150	125	125
WOOD	300	18000	9000	6000	4500	3600	3000	2600	2200	1800	1500	1300	1200

USE ONE HALF SPEED GIVEN FOR CARBON DRILLS. WHEN A LUBRICANT IS USED, SPEEDS CAN BE INCREASED ABOUT 25 PERCENT. ALWAYS USE ACTUAL DRILL SPEED NEXT UNDER FIGURE GIVEN.

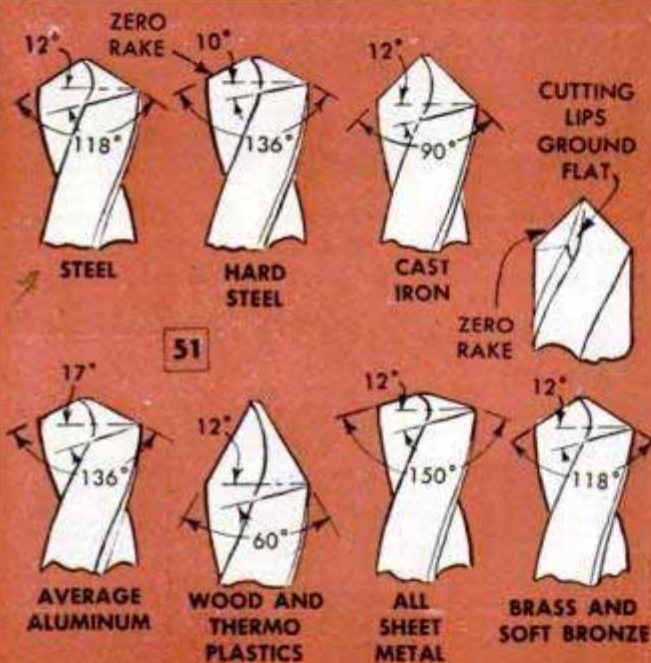

These are best points for various materials, 118-deg. point being suitable for most jobs

to serve as a guide. When clamping is not practical, one of the holes in the second piece should be carefully marked and drilled, after which the two parts can be bolted together for additional drilling. Note how the chuck wrench has been used to provide a stop to prevent the work from spinning when the bit breaks through.

The use of guide jigs is just the opposite of the technique of double-deck drilling. Work drilled with guides is done singly by the piece, the guides assuring proper hole location in each part. The most common example of this work is the right-angle joint or any combination of similar joints, such as a square frame, Fig. 48. In work of this kind, pieces A and B must be the same size and pieces C and D must be the same. Then, by turning the pieces over and end-for-end, all holes can be drilled with the same guides and will align perfectly when assembled.

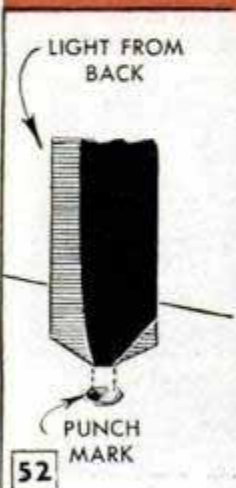

Float-and-clamp is common method of centering drill. Work is held lightly by hand, with press running, until bit finds center, Fig. 53, and then clamped to table for finish drilling, Figs. 54 and 55. Back-lighting drill aids in centering on punch mark



# SPRAY-GUN WATER TRAP

By E. J. Andrews

IF YOUR paint-spraying compressor does not include a built-in water trap, you can be sure of better finishing jobs by making this efficient water and oil extractor from odds and ends. Installed in the airline, the unit will not only trap droplets of water but the filter will condense any mist, keeping condensation in the gun to a minimum. For best results, the extractor should be installed as close to the gun as practical, as higher temperatures near the compressor will cause some water vapor to pass through the extractor and then condense in the line or gun. The extractor can be fitted with a pipe flange for convenient mounting on the shop wall, or mounted on an upright for use outdoors. The extractor consists of a head, filter and a brass case emptied by means of a drain cock at the bottom. The case can be made from a length of 1½-in. brass sink-trap tubing, which is already threaded and fitted with a compression collar and gasket, or ordinary brass tubing can be used and a collar turned to suit. Although parts of old radiator valves were used for the head of the original unit, this can be improvised from pipe fittings or turned from brass stock. Dimensions are not important, the only requirement being that the intake tube carry the air below the filter and that all joints are tight enough to prevent air leaks. The filter material is held in place around the intake tube with a perforated sheet-metal disk at each end. Brass or copper scouring pads provide excellent filters, as they do not become waterlogged and will not deteriorate. Worn nylon hosiery or cotton waste also can be used, but this material must be replaced periodically.

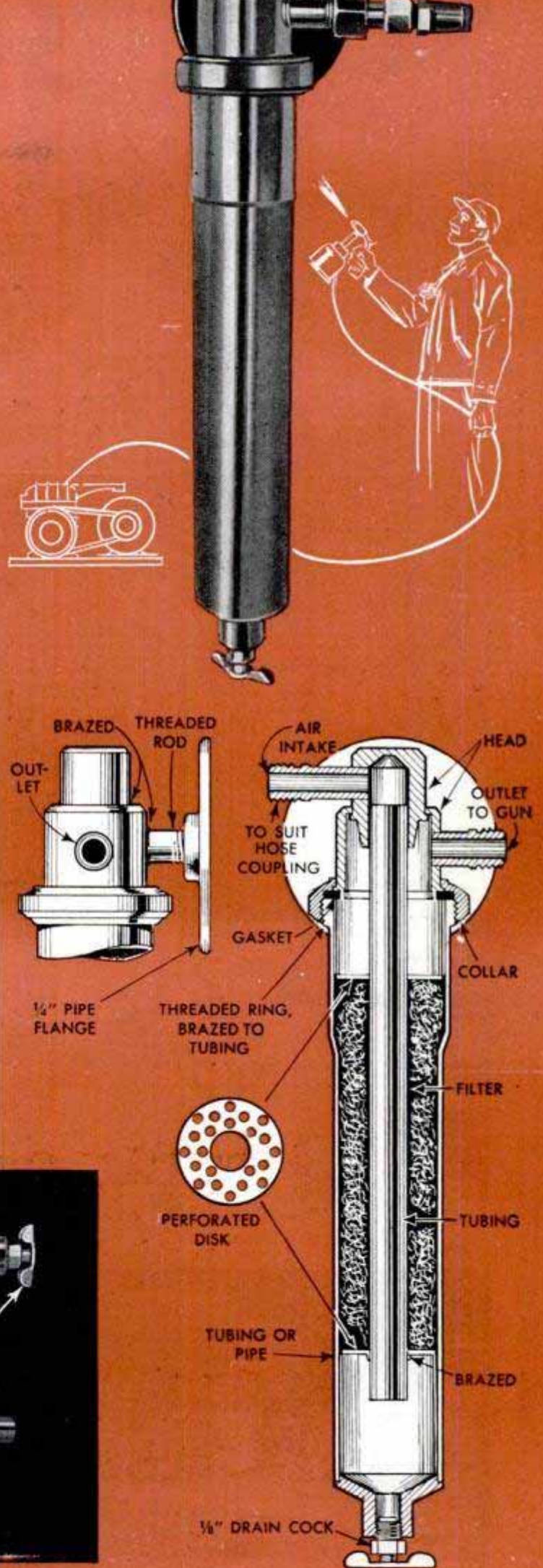
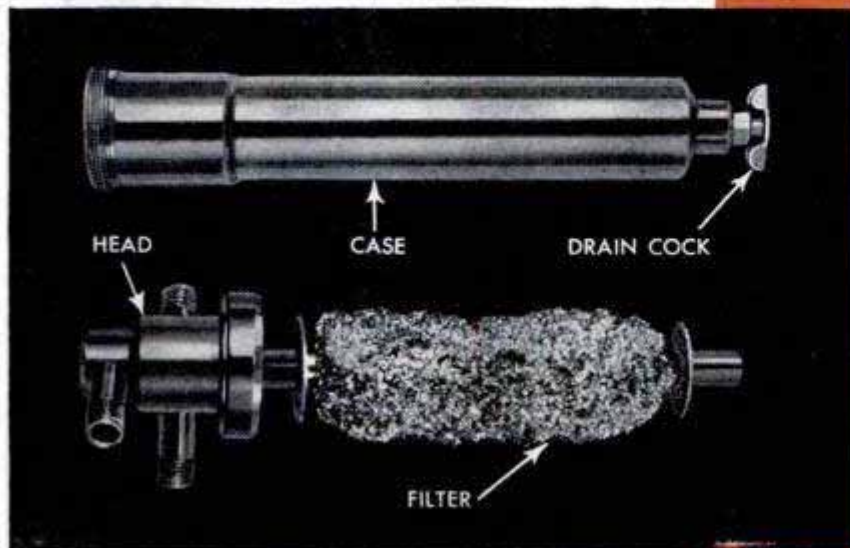



# SHOPPING



1

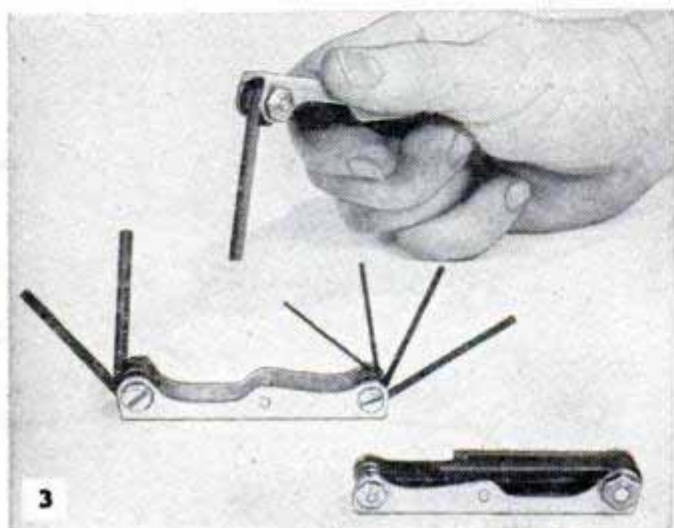

3

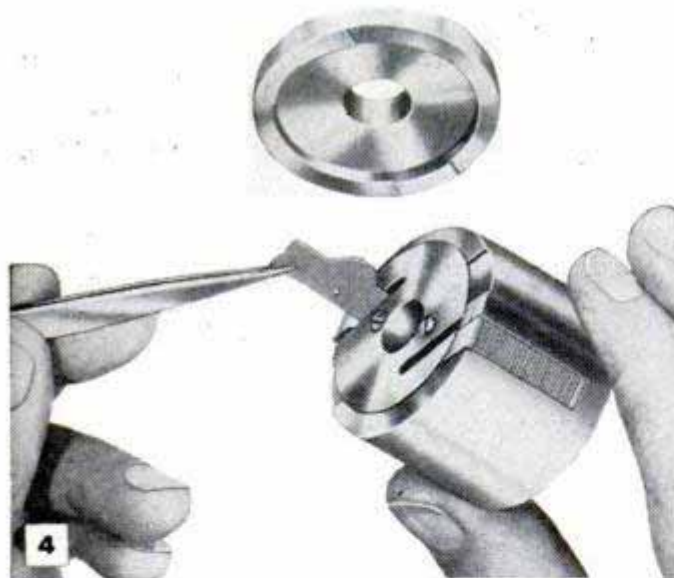

4

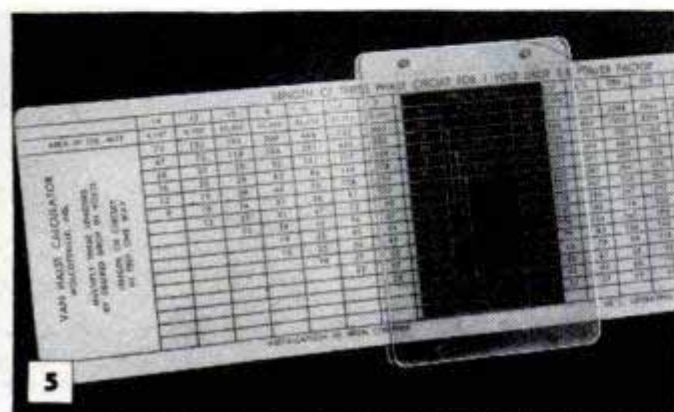

5

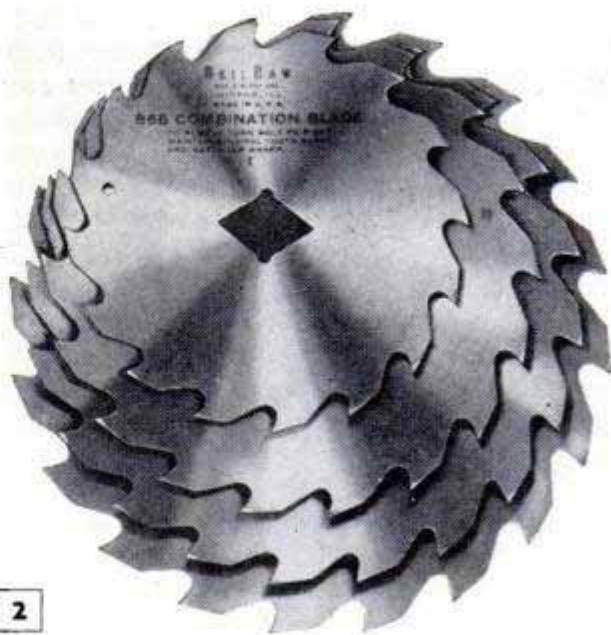

2

**WING-TYPE BIT** for drilling plastic at high speeds has recently been made available. Bit has a straight shank for use in drill press or portable drill. Round-bottomed grooves ground in each cutting edge break the chips uniformly, aid in quick dissipation of heat and prevent "creeping" of the cutting edges when drilling deep holes. Shallow holes are drilled with clean, sharp edges. The bit is available in a range of sizes

**CHISEL-TOOTH** circular-saw blades for use in portable electric handsaws cut clean and fast in both hard and soft woods. Special shape of the tooth gives the cutting edge sufficient backing to withstand the heaviest work and to hold a cutting edge over exceptionally long periods of time without sharpening. Blades are tensioned to stand up without danger of breakage under the heavy twisting strains of freehand operation

**COMBINATION WRENCH** for socket-head setscrews has the six most commonly used sizes nested in a convenient handle made sufficiently sturdy to withstand normal torque applied to the largest size wrench included in kit. As shown in the photo, the six separate wrenches are pivoted at the ends of the handle and fold down flush when not in use. Folding feature permits wrench to be used in close quarters

**SHAPER HEAD** is fitted with knives which are adjustable to conform to the desired molding contour. Each "knife" consists of a number of thin, chisel-edged cutters which are arranged side by side in a row in the special head. Each knife is set to contour of molding it is desired to duplicate and locked in head. Specially designed locking clips hold setting. After knives are locked in head, unit is placed on shaper spindle

**VOLTAGE CALCULATOR** that works in a manner similar to a slide rule has been made available by a well-known manufacturer of electrical equipment. Made pocket-size of durable materials, the calculator consists of a scale in tabular form over which a sliding plastic window may be moved to whatever position necessary in calculating values or electrical characteristics. Especially useful to electricians and assemblers



# FOR TOOLS

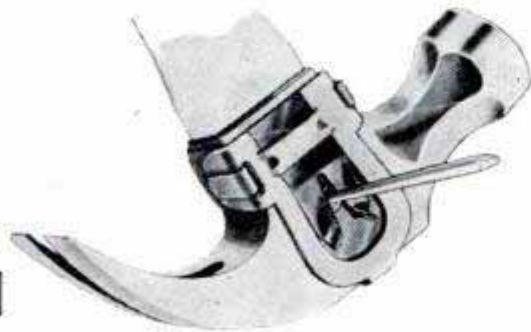
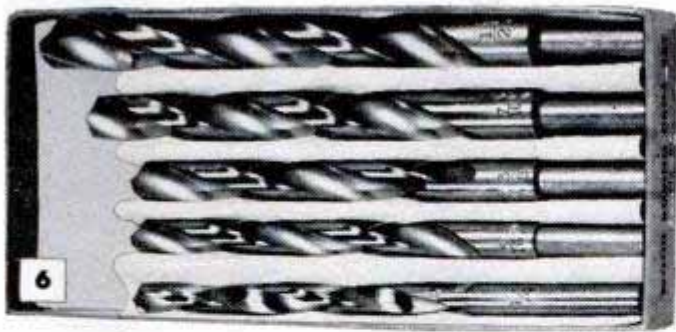

**TWIST DRILLS** made especially for use in small portable electric drills greatly extend the work range of the portable drill by making possible high-speed drilling in both hard and soft woods. Special shape of the flutes clears chips readily at high speeds and, in deep holes, eliminates tendency of ordinary drills to clog and burn wood. Supplied in kits containing five sizes ranging from  $\frac{1}{4}$  to  $\frac{1}{2}$  in. Drill sizes have  $\frac{1}{4}$ -in. shanks

**CLAW-HAMMER ATTACHMENT** permits one-hand starting of nails in hard-to-reach places. Unit is attached to the hammer eye by means of a metal strap. A V-notched spring clip holds the head of the nail firmly against the flat surface of the eye as the nail is started by a light, sidewise blow of the hammer. After the nail has been started, the hammer is detached from the nail by a slight downward movement

**EARTH-AUGER ACCESSORY** for a chain saw is now supplied as an attachment for the portable gasoline-driven units used by farmers, lumbermen and linemen. The auger comes complete with all parts necessary for bolting to the chain-saw power unit and is provided with handles for two-man operation. Forms a clean, round hole in the hardest earth in a few minutes' time. Quickly detachable from drive unit

**PARROT-HEAD PRUNER** gets its name from the unusual shape of the pruning head, which has been designed for easy operation in several positions. Angle of the cutting head with the plier-type handles gives a powerful leverage for clean cutting of large, tough twigs in dormant trees and shrubs. Lower handle is provided with curved finger stops and a return spring and lock for locking the handles in the closed position

**SHARPENING JIG** for the new "cut control" saw blades having widely spaced teeth is provided with special stops which permit accurate grinding of the blade rim to conform to the required depth below the cutting circle of the teeth. This is important as on smaller blades of this type points of the cutting teeth project only .020 in. above noncutting rim of the blade. Unit bolts to bench top at right of bench grinder

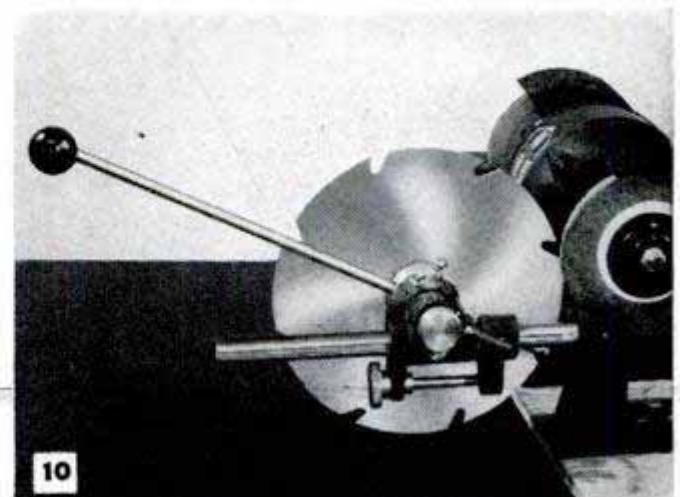
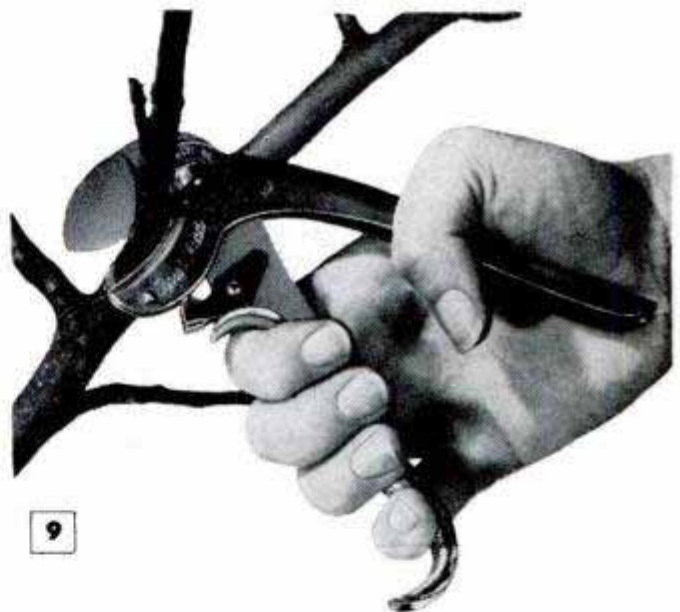





### Adjustable Outboard Ground Shoe Protects Combine in Rough Fields

To prevent damage to his combine when harvesting grain in terraced fields, one farmer fitted a wide, steel ground shoe directly under the outboard divider. Closely spaced holes in the supporting bracket permit the shoe to be adjusted for the correct height so that the sickle and divider will ride over terrace ridges and other obstructions without digging in and causing waste of grain and possible damage to the machine. The shoe is also an aid in maneuvering the machine about small fields and over grassed waterways.

### Tractor-Tire Valve Stems Protected With Sheet-Metal Guards



A sheet-metal guard, mounted on each wheel of a tractor or wagon, will keep the tire-valve stem from being chewed by hogs or knocked off in stubble. The removable guard is bent to fit over the valve stem, leaving enough room to insert the air-hose nozzle when inflating the tire. One end of the

guard is drilled so it can be held in place with a wheel lug, and the other end is bent to engage the wheel flange.

☐ To reflect light on a car motor for repairs, paint the underside of the hood white.

### Holder for Job Tickets

A suitable holder for job tickets in a garage or shop can be made by cutting a series of evenly spaced slits in a length of radiator hose. To make the holder easy to screw or nail on the wall, taper each end of the hose.

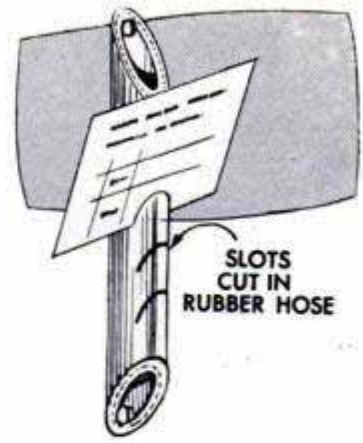

### Test Shows Polarity of Electric Wires

For determining the polarity of electric wires, stick the ends of the wires into the freshly cut side of a raw potato. Once inserted, the positive wire will have a purplish discoloration form around it, whereas clear, frothy bubbles will appear around the negative wire.

### Auxiliary Clamp on Lathe Chuck Increases Capacity

When having to face bar stock that is slightly greater in length than the capacity of a four-jaw lathe chuck, the chuck still can be used by mounting the work as

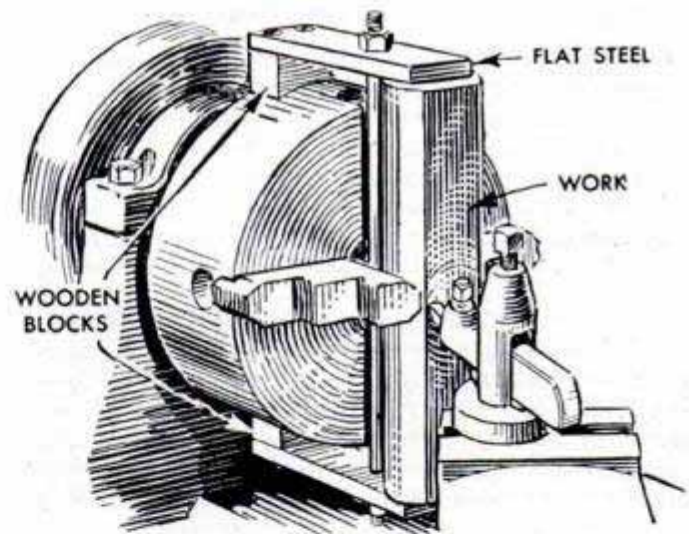

shown. Remove two opposite chuck jaws and cut two wooden blocks to fit the body of the chuck on which they rest. These blocks support two flat-steel pieces that serve as jaws to grip the work. Each jaw is drilled for a 1/4-in. clamping rod, threaded at each end to take a nut. The work is clamped in position by tightening one of the nuts, and the two chuck jaws are run in to center the work and give additional support. The maximum length of work that can be mounted in this manner is limited only by the clearance between the chuck and the lathe bed.

C. W. Woodson, Miami, Fla.



## TV-Set Data for Servicemen

KEEPING your television serviceman fully informed on TV receivers of all makes is a major operation. There are approximately 50,000 of the country's top television-service technicians who are responsible for the maintenance of the nation's millions of TV receivers. In a large measure, these technicians depend upon an organization of highly trained specialists equipped with unusual facilities to analyze electronic and electromechanical devices, such as radio and television receivers. They compile and collate their electrical and mechanical specifications, delineate the devices graphically, and finally publish complete technical information and instructional service data on each manufacturer's model. These individual "Photofact" folder sets are issued every month.

Large diagrams and pictures plus full voltage and resistance charts speed up work. Photo A shows a new TV-set model going through a thorough preliminary checking. This unique field service, that no manufacturer would care to attempt in such detail for each new model on his production line, helps him through his service organization, and independent servicemen, to keep his product in good working order.

Photos B and C show views of the laboratory and art sections of the organization which supplies this specialized data to the well-equipped TV serviceman such as the one shown in photo D.





# "LITTLE GIANT" RADIO-INTERCOM

By Lothar Stern



A

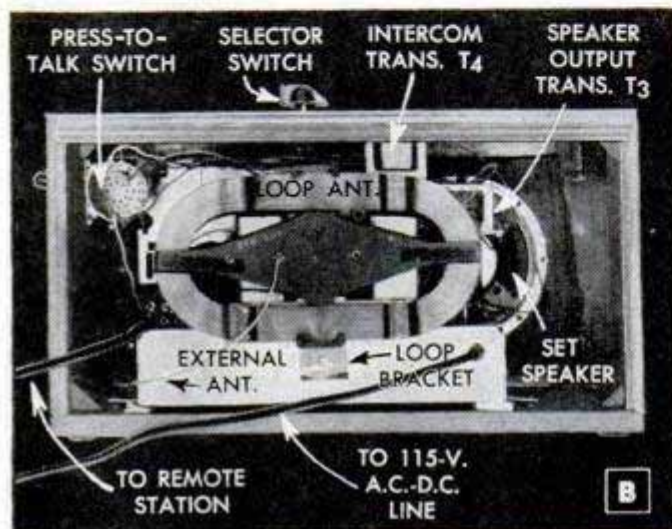

B

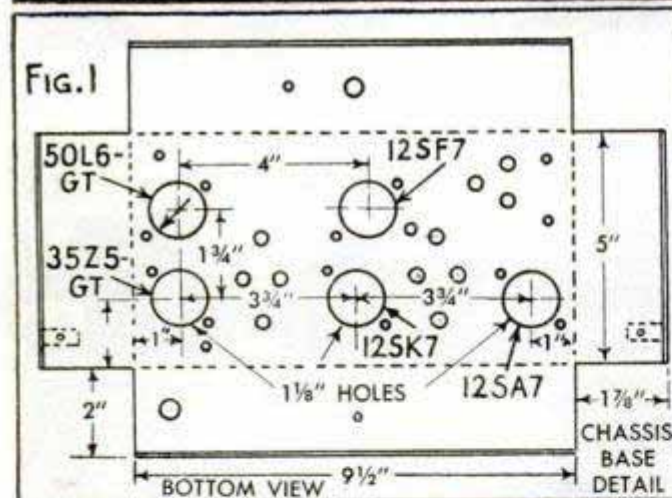

**B**EGINNING with the March 1934 issue, a special construction article for radio students and experimenters has been the popular annual "Little Giant." This home and classroom project for March 1952 is another in the popular series that is designed for advancing students and experimenters who are looking for an unusual circuit application that will serve a useful purpose and, at the same time, test the builder's ability. It is not intended for the beginner.

This new 1952 model combines an intercom system with a favorite a.c.-d.c. five-tube superheterodyne receiver circuit. The set circuit is the standard five-tube line-up with the exception of the 12SF7 which replaces the 12SQ7 usually employed. This change was made because the 12SF7, being a diode-pentode combination, provides greater gain than is obtainable from a diode-triode tube such as the 12SQ7. The added gain is needed because the voltage output of a speaker used as a microphone is much less than the output of a second detector in a radio, thus requiring more amplification. The volume of both the radio and intercom can be controlled with the regular set volume-control potentiometer.

When an intercom system is combined with a good radio receiver it becomes an instrument of pleasure as well as a utility. If you have ever wanted your radio in two places at once so that you could go about your work in other rooms and still listen to your favorite programs without turning up the volume of your set to a point where it would disturb the neighbors, this combination unit solves the problem. Mother can send children's programs to the nursery, or listen in on their activities. It becomes an electronic baby sitter at night when the parents are playing cards or viewing television downstairs. It also provides a private line from the living room to the basement workshop or the garage.

## RESISTORS

- R1=22,000-OHM, 1/2-WATT, CARBON
- R2=15 MEGOHMS, 1/2-WATT, CARBON
- R3=2.2 MEGOHMS, 1/2-WATT, CARBON
- R4=500,000-OHM VOL. CONTROL MALLORY U-48, TAPER No. 1 WITH S.P.S.T. SWITCH
- R5=3900-OHM, 1/2-WATT, CARBON
- R6=2.2 MEGOHMS, 1/2-WATT, CARBON
- R7=1-MEGOHM, 1/2-WATT, CARBON
- R8=470,000-OHM, 1/2-WATT, CARBON
- R9=470,000-OHM, 1/2-WATT, CARBON
- R10=150-OHM, 1/2-WATT, CARBON
- R11=100-OHM, 1/2-WATT, CARBON
- R12=1000-OHM, 1-WATT, CARBON
- R13=220,000-OHM, 1/2-WATT, CARBON



# SYSTEM FOR EXPERIMENTERS



**NOTE—**  
 C3=27-PLATE, 431 MMFD. R.F. SECTION  
 C4=19-PLATE, 170.7 MMFD. OSCILLATOR SECTION  
 TR=TRIMMERS 2-17 MMFD. (BUILT IN)  
 (THIS 2-GANG VARIABLE CONDENSER IS A STANDARD SUPERHET TYPE)  
 L2=MEISSNER OSC. COIL TYPE 14-1033  
 T1=MEISSNER INPUT I.F. TRANS. 16-5712  
 T2=MEISSNER OUTPUT I.F. TRANS. 16-5714  
 T3=STANCOR UNIVERSAL OUTPUT TRANS. A-3850  
 T4=STANCOR INTERCOM TRANS. A-4744  
 C1=10 MMFD. CERAMICON; C2=3 MMFD. CERAMICON (FOR SINGLE LOOP ANTENNA)—SEE TEXT

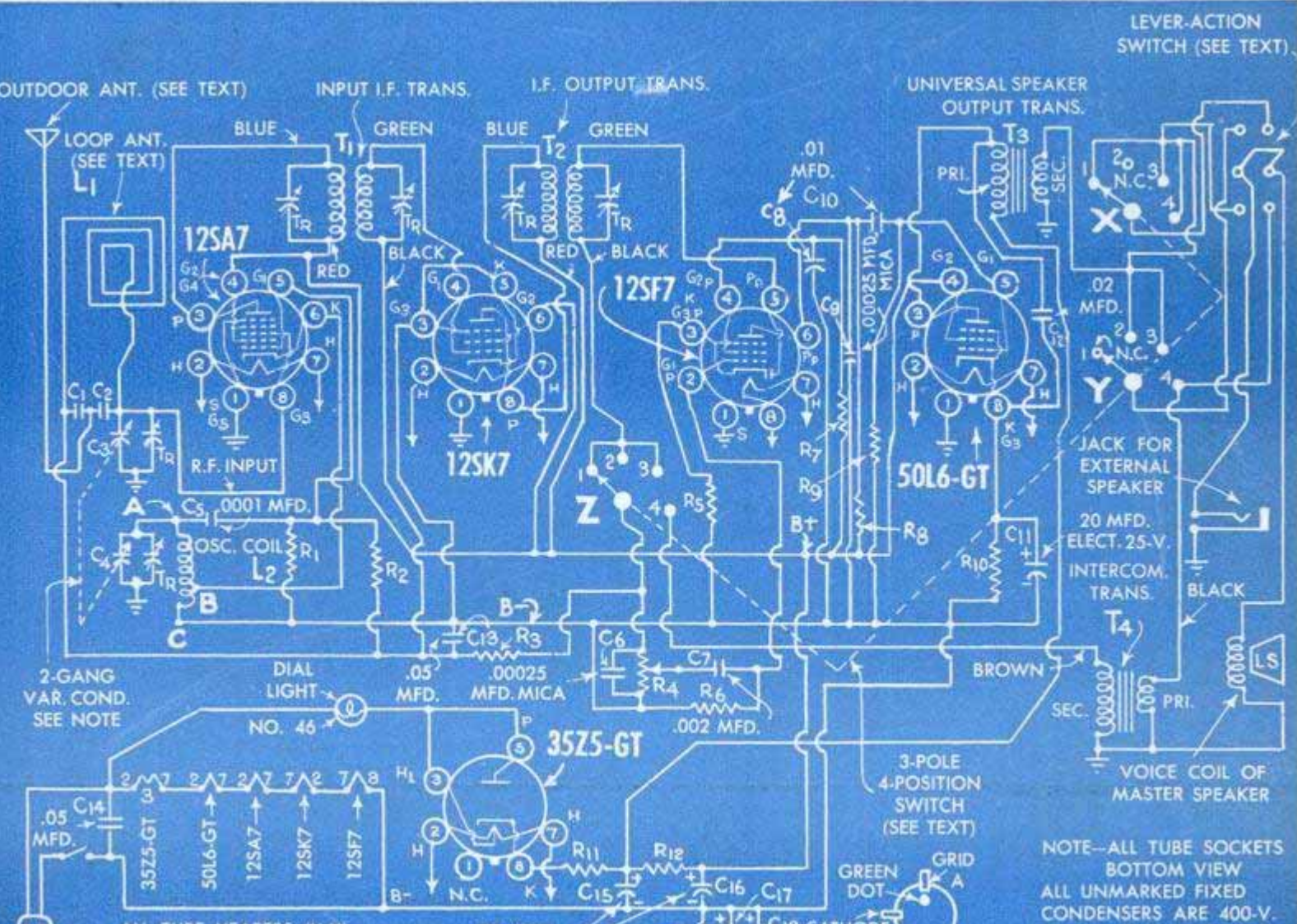



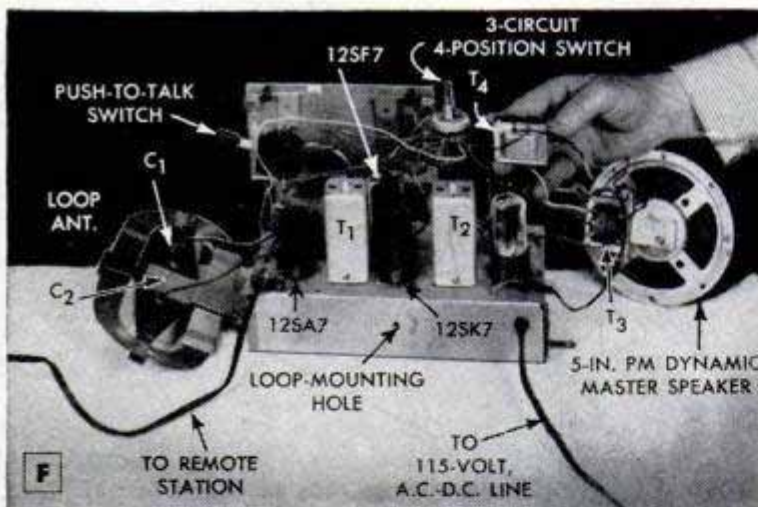
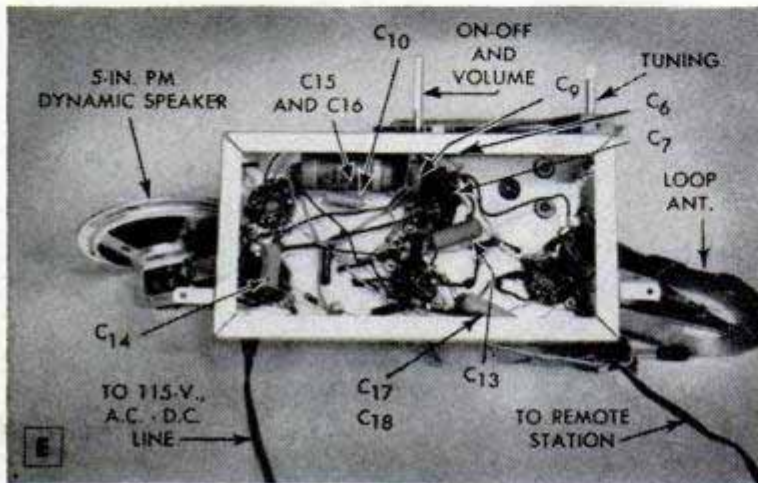
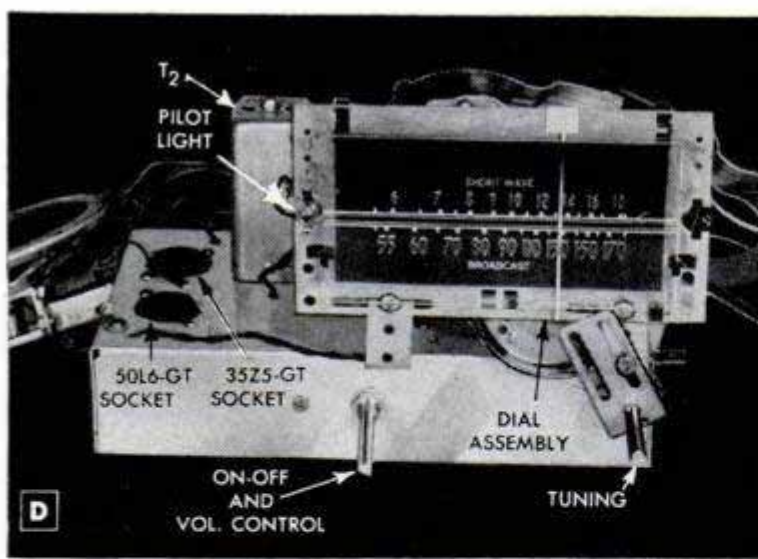

into a two-station intercom system, with the remote speaker acting as a microphone. By pressing the lever-action switch downward, the speaker in the set becomes a microphone and the person at the remote station can hear your voice. The speakers are both 5-in. PM dynamic types having 3.2-ohm voice coils. These list in parts-house catalogues for less than \$2.00 each. The connecting cord for the remote station is ordinary rubber-covered lamp cord, soldered to a two-lug terminal strip mounted on the rear of the set chassis, one lug being grounded on the set chassis. This grounded side of the connecting cord is common with the grounded side of the open-circuit jack mounted on the rear of the remote-station speaker case. The line, of course, terminates in an ordinary speaker plug that goes in the jack.

The complete circuit diagram appears in Fig. 2. All grounds indicated are chassis grounds. Use rosin-core wire solder for all circuit connections. Keep all grid and plate leads as short as possible and well separated to prevent feedback. The two-gang variable tuning condenser C3 and C4 is shock-mounted at three points by means of rubber grommets and fiber spacers as indicated in Fig. 4. The condenser is fastened to the chassis with 6-32 machine screws 1/2 in. long after a washer has been inserted between the head of the screw and the grommet. The frame of this variable condenser must be connected to the chassis base by means of a piece of flexible wire braid.

The loop antenna used in the model is a single loop with a condenser network so that an outdoor antenna can be attached for distant reception, if

(Continued to page 272)

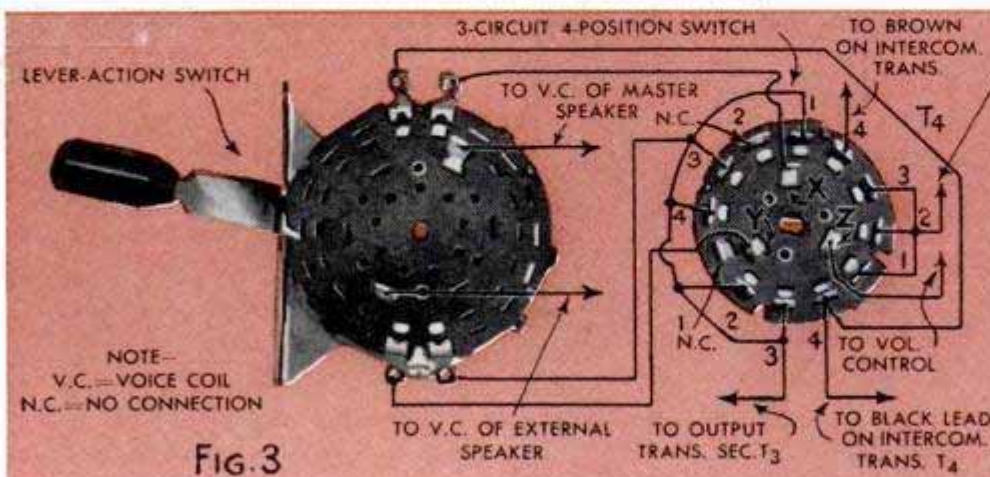

FIG. 3

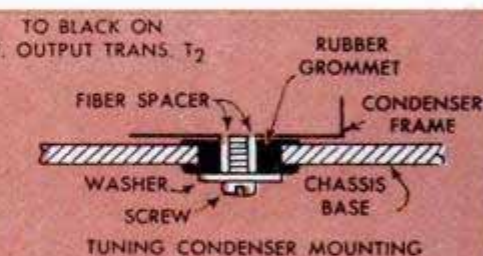

FIG. 4

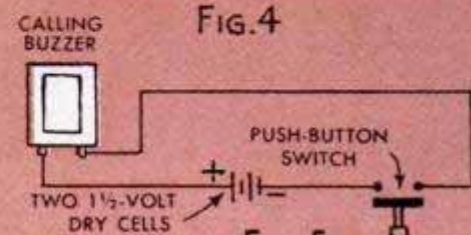

FIG. 5



# TV and Electronics Today

NOW THERE IS a device for putting moving pictures on a tape exactly like a sound recording. Wayne R. Johnson (left) and John T. Mullin, electronic engineers, photo A, are the codevelopers of this unit which is claimed to have important military applications. The inset photo shows the tiny "brain," or lens, of the device. With this new electronic marvel, air photography could be transferred directly to tape which can be instantly retransmitted to the ground and received on an ordinary TV receiver without costly delay of developing and processing film. The engineers claim that it will in time eliminate all film from the movie and television industry.

The nation's newest and largest ocean liner, the SS *United States*, will provide its passengers with meals cooked electronically by microwave energy through the use of two Radarange units in the ship's galley. One of the units is shown in photo B. Owners of record players, especially the small table types that do not provide record-storage compartments, can now assemble one of the Space-Maker record-storage units illustrated in photo C. Anyone can assemble it in about 15 minutes. The first big-screen portable television receiver employing a 14-in. picture tube to appear on the market is the Motorola 14P1. The new portable, shown in photo D, is housed in a wood cabinet covered with simulated leather, and employs either an indoor or outdoor antenna. Photo E shows a large Schmidt-type plastic lens, designed to make a giant television picture for a theater screen look as sharp as it would on a living-room TV set.

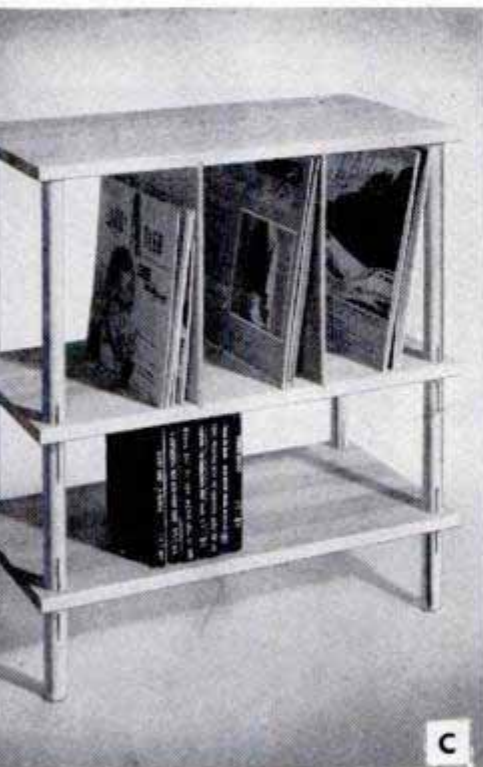
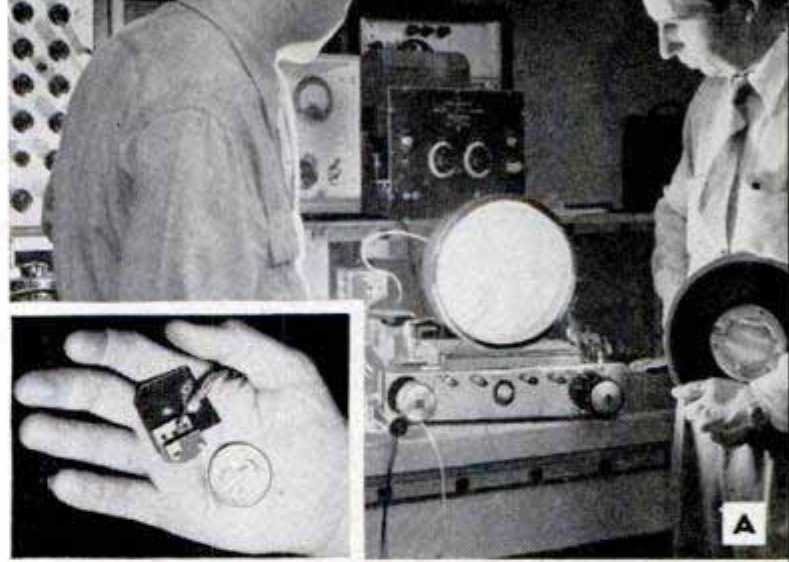



# HINTS FOR RADIO WORKERS



**A**

**A**—Civil-defense workers and others using FM two-way radiophone pack units have always faced the problem of conserving the dry batteries that are necessary for portable operation. A new flexible pack-set power-supply unit makes it possible to operate these radiophone units from either a 117-volt a.c. line, or a 6-volt d.c. primary power supply. The semifixed station application illustrated shows this compact power-supply unit mounted on the wall

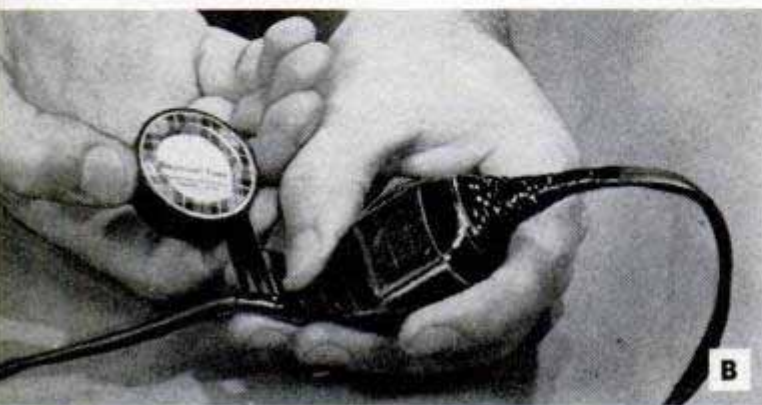

**B**

**B**—No. 33 Scotch electrical tape is an approved wrap for splices in electrical wiring. It is resistant to oil and water. Its stretchiness allows it to conform well in making extension-cord splices and for insulating wear spots on switches and plugs as illustrated

**C**—A new method for marking the identification on conductors of various electrical wiring systems does away with metal and fiber tags. The compact marking machine operates like a typewriter. An electric heating unit brands a deep, permanent imprint of the characters and symbols in either black or blue



**C**

**D**—Metal detector employs two search coils. Small coil is intended for detecting smaller metal objects while the larger coil shown has greater depth range for bulky objects or deposits. It is claimed to be free from false detection from various types of vegetation, certain changes in soil conditions, as well as moisture

**E**—Modular radio cabinet, used in the Chemical Division of the General Electric Company, has as its basic module a simple rectangular case. With a change of dial knobs or other extraneous parts, the appearance of several different plastic designs can be achieved. Eight different cabinet designs result

**F**—Improved vacuum-tube voltmeter now available in kit form for radio workers and experimenters. The compact cabinet is 4½ in. deep, 4-11/16 in. wide and 7¾ in. high. Top-quality precision resistors are employed in the multiplier circuit. The unit has extremely wide coverage and calibrates on both a.c. and d.c. Scales indicate ohms, volts, and DB. It also has a zero set mark for alignment of FM radio receivers



**D**



**E**



**F**





## PERFECTIONIST . . .

A real mechanic . . . a born mechanic. To you a job that is "all right" just isn't good enough. You demand perfect workmanship in materials and tools. And you are quick to recognize the work and products of other perfectionists.

Bonney wrenches are the work of such men. That is why mechanics call Bonney wrenches America's finest — unmatched for lightness, strength, balance, and precision.

Bonney wrenches are the pride of the men who make them . . . the pride of the men who use them.



The perfectionist is exemplified in the men who build and service the planes and engines that have made such names as Consolidated, Douglas, Lockheed . . . Pratt & Whitney Aircraft, Wright . . . United, Pan



HASTINGS PISTON RINGS

# Tough

BUT OH SO

# Gentle

**TOUGH** on oil-pumping  
**GENTLE** on cylinder walls

are *tough* on oil-pumping.

Want to stretch your engine's life? Then get the rings that are *gentle* on cylinder walls.

There's just one thing to do about worn-out piston rings and that's replace them—and the more you delay the more you'll pay.

You'll save money if you replace them with Hastings Piston Rings. They're engineered exclusively for replacement service. They *stop* oil-pumping, *check* cylinder wear, *restore* engine performance—for thousands of extra miles. It's the best money you can spend on your car.

HASTINGS MANUFACTURING CO., Hastings, Michigan  
HASTINGS LTD., Toronto

Piston Rings, Spark Plugs, Oil Filters, Cas.ite, Drout



# HASTINGS

## STEEL-VENT PISTON RINGS





# POPULAR MECHANICS

readers know that they get smoother performance and quick starts when worn-out spark plugs are replaced with

# AUTO-LITE SPARK PLUGS

THESE three world-famous Ignition Engineered Auto-Lite Spark Plugs have been selected as original factory equipment on millions of America's finest cars, trucks and tractors.

• **Auto-Lite Resistor Spark Plugs** offer greater gas savings plus benefits found only in automotive type spark plugs with built-in resistors.

• **Auto-Lite Standard Spark Plugs** offer unsurpassed quality and unbeatable performance.

• **Auto-Lite Transport Spark Plugs** are especially suited to rugged farm, truck, bus service and give lowest cost per mile of spark plug operation.

See your Auto-Lite Spark Plug Dealer today, because "You're Always Right With Auto-Lite."

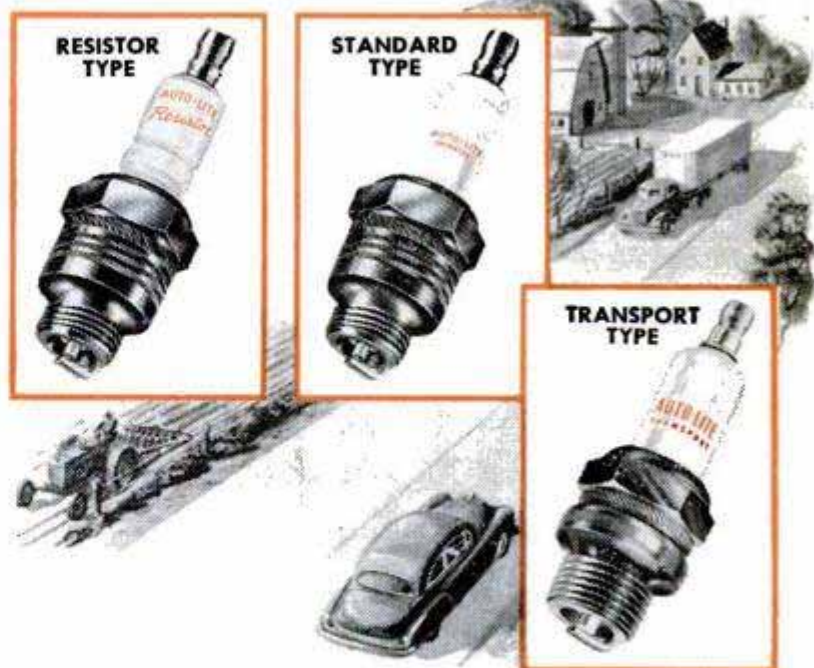

Auto-Lite Spark Plugs—Patented U.S.A.

TUNE IN "SUSPENSE!" . . . CBS RADIO MONDAYS . . . CBS TELEVISION TUESDAYS





**Modestly Priced Kodak Hobbyist Enlarger—\$44.00.** A good enlarger lets you accomplish much more than just make a big picture from a tiny negative. You can select the ideal portion of your picture . . . eliminate unwanted areas . . . make the enlargement even better than the original print. The "Hobbyist" uses "cold light" illumination—perfect protection for negatives. New integrating-sphere lamphouse assures even light distribution. Includes Kodak Enlarging Ektanon Lens, 89mm. *f*/6.3 (Lumenized), with click stops. For negatives through 2¼ x 3¼ inches.



**Easy to Set Up.** Rapid assembly of the Hobbyist Enlarger gets it into action fast. Disassembles with equal ease for convenient storage where space is limited.



**New Negative Carrier.** Greatly simplifies loading. Circular in shape, rotates easily. Sizes for 35mm. up through 2¼ x 3¼. One comes with each enlarger. Cups extra.

# HOW TO SET UP A DARKROOM

**Taking the picture** is only half the fun. Developing and printing—and making your own enlargements—can double your rewards in photography. You can set up a darkroom on a modest budget—for as little as the price of a Kodacraft outfit (see facing page). And, for less than \$50, you can add a fine enlarger complete

with lens. On these two pages you see a wide choice of equipment, all reasonably priced. How much you spend on your darkroom is just a matter of how far you want to pursue this fascinating hobby. Why not see your Kodak dealer about it? His professional advice will help you start off right and keep within your budget.

**New Kodak Enlarging Ektanon Lens, 50mm. *f*/4.5—\$14.00.** All elements are Lumenized. Iris-type diaphragm has click stops down to *f*/16. There are eight Kodak Ektanon and Ektar Enlarging Lenses for enlargers that take negatives up to 4 x 5 inches. They are all Lumenized (hard-coated) and designed for maximum correction at close working distances. Let your Kodak dealer help you select the one best suited for your needs with the Kodak Flurolite Enlarger (see at right).

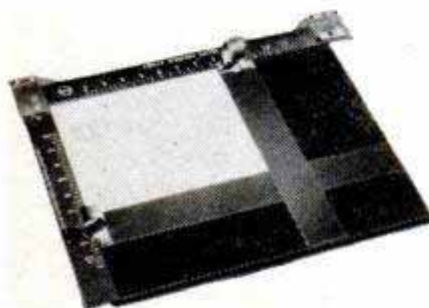
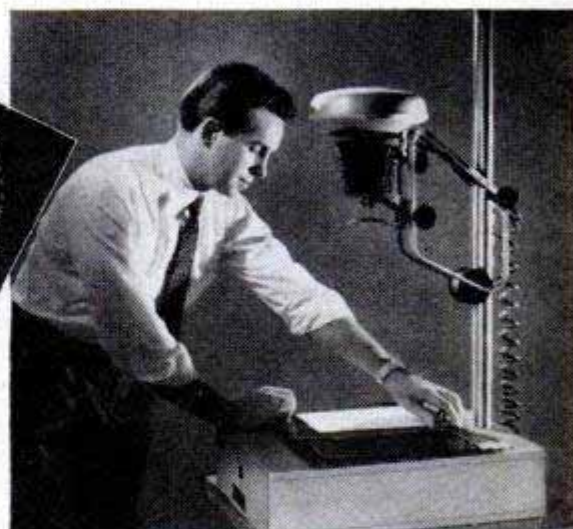
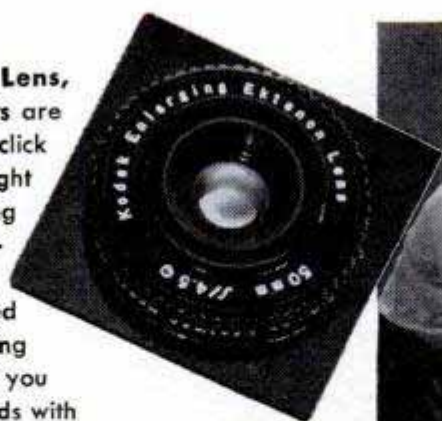

**Kodak Masking Easel, 11 x 14—\$9.60.** For use with any vertical enlarger. Will mask prints up to 11 x 14 inches. Can be adjusted for ¼- to ¾-inch margins. Spring-steel hinges facilitate adjusting print size.

**An Advanced Enlarger—The Kodak Flurolite—\$99.50** (without lens). Does much more than enlarging. With accessories the 2¼ x 3¼-inch "Flurolite" quickly converts for copying, cine-titling, slide-making, close-up photography, photomicrography, and for use as a view camera. "Cold light" protection for negatives.





**Free Your Hands with the Kodak Utility Footswitch—\$10.00.** Controls enlarger, printer, or safelight. Attaches to floor, or to vertical support for operation by knee pressure. Low-intensity neon light clearly marks its location.



**Save Paper and Time—Kodak Projection Print Scale—\$1.15.** This is a transparency divided into 10 sectors of varying density, each indicating a different printing time. Full instructions guide you in choosing best exposure time.



**For Precise Timing—Kodak Electric Time Control—\$13.50.** Plug printer or enlarger right into control for automatic timing from 1 to 57 seconds. Repeat timing possible. Continuous light for accurate focusing is provided for your convenience.



**Spring-Wound—Kodak Timer—\$6.75.** Has both minute and split-second hands. Covers all intervals from 1/2 second to 60 minutes. Can be stopped and restarted without resetting hands. An added feature is the handy tilting base.

## ON A MODEST BUDGET



**Inexpensive Printing Materials—Kodacraft Printing Kit—\$4.30.** Includes three 5 x 7 trays, printing frame, Kodak Velite Paper, graduate, Kodak Tri-Chem Pack, thermometer, stirring rod, book of instructions.



**For Developing and Printing—Kodacraft Photo-Lab Outfit—\$7.45.** Contains new Kodacraft Roll-Film Tank with 620-120, 616-116, and 127 roll-film aprons; Kodacraft Printing Frame; other accessories.



**Includes Printer—Kodacraft Advanced Photo-Lab—\$12.10.** The contents of this photo-lab can all be packed in the metal printer. The printer takes negatives up to 4 x 5 1/2 inches. Includes all other essentials.



**Washes Prints Automatically—Kodak Automatic Tray Siphon—\$4.50.** Washes films, too. Converts ordinary tray into effective washer. Attaches to water tap. Hypo-laden water is continuously siphoned off.



**You Need One of These—Kodak Darkroom Lamp—\$4.70.** Use in wall socket or from a drop cord. Includes a Kodak Safelight Filter and uses 15-watt bulb. Kodak safelight lamps screen out photographically dangerous white light and provide safe working illumination. There's a wide selection available, with prices as low as \$1.00 for the Brownie Darkroom Lamp, Model B. The Brownie Darkroom Lamp Kit, complete with Series 0, 2, and 3 safelight cups, only \$1.75.

*Prices subject to change without notice*

Your Kodak dealer will be glad to demonstrate this equipment for you. See him for all your photo needs.

EASTMAN KODAK COMPANY, ROCHESTER, N. Y.

# Kodak





# Care and Feeding of Engines

BY S. P. CORP

## ABOUT AUTOMATIC CHOKES

Whenever an engine stalls during the warm-up period in cold weather, here are the checks to be made with regard to the automatic choke:

1. Automatic choke should allow a very fast idle when first started in cold weather, usually 1000 rpm or more.
2. Use manufacturer's specifications to learn correct idling speed after warm-up, usually about 500 rpm. Carburetor choke linkage is out of adjustment if these speeds are not correct, and will cause trouble.
3. Faulty operation of water thermostat will cause engine to run too cool in cold weather, wasting gas. Dash heat indicator should show 160° while driving, unless a high-opening thermostat is used.

## TYPES OF AUTOMATIC CHOKES



One make of carburetor combines a climatic control with the automatic choke. This control is affected by different grades of fuel and can be adjusted for smooth operation during warm-up. Always make adjustment with carburetor on car and engine cold.

For average driving, Index (1) should be in center. Loosen clamp and move housing one notch at a time. If engine spits during warm-up, move one notch to RICH, tighten clamp, and check engine.

Where choke is mounted on exhaust manifold, test by removing air cleaner. Choke valve should be wide open. Have someone step on starter and watch valve. It should close and stay closed till engine starts, opening slowly as engine warms up. Remember, engine will run at a fast idle until warmed up.

## IF YOUR CAR LOAFS TOO MUCH

No pep on a hill? No pick-up on the level? Get new Sealed Power Piston Rings! If it's a late-model car or truck, get a Sealed Power KromeX Ring Set. The Sealed Power MD-50, best steel oil ring ever made, controls oil even in badly tapered and out-of-round bores. A postal to Sealed Power Corp., Dept. G-3, Muskegon, Mich., will bring you the new illustrated booklet, "More Power, Less Oil, Less Gas!" It can save you real money!



(Continued from page 100)

den. It was put on sale around the state at a dollar and soon became a best seller. So many requests for copies came in that Odum turned the sales job over to the Florida Council for the Blind. Some folks say that Odum's map is responsible for the rebirth of treasure hunting in the state. Whether this is true or not, there can be no doubt that it has stimulated a tremendous amount of interest.

In addition to these two stories, there are hundreds of treasure-find tales that are vague about results. This air of mystery and the suggestion of great wealth combine to convert new treasure hunters.

About 1935, so one story goes, a fisherman known around the waterfront as "Charlie" dozed off while sailing near Pigeon Key. His unguided boat ran onto a reef. Awakening, he stepped over the side into the shallow water to push his boat free and slipped on some hard objects. He discovered he was standing on what appeared to be several barnacle-encrusted pigs of metal.

Thinking them to be ballast from some wrecked ship, he worked several of them loose and heaved them into his boat, intending to use them as ballast himself.

Two years later, in Miami, he hauled his boat out for repairs. He tossed out the ballast and was surprised to hear that the bars, striking together, failed to sound as iron should. He cut into one and decided it must be lead. Somebody suggested that he have the metal analyzed. It was pure silver!

Although he searched long for it, the fisherman was never again able to locate the treasure site. He described the reef as littered for a distance of 300 feet with similar bars! A schooner was lost off Pigeon Key in 1820 with \$5,000,000 in bar silver aboard. These bars could have been its cargo, as they have never been located. Thus the story ends in the mystery characteristic of treasure tales. Hearing about a reef littered with solid-silver bars often makes sober folks pore over charts of Pigeon Key.

In 1925, Dewey Hulsebeck, who owns 80 acres on Little Torch Key, found a broken crock on his land near a newly dug hole. He also found two gold and five silver Spanish coins near by. Later investigation disclosed that a man in Key West had apparently become wealthy all of a sudden. Hulsebeck determined to his own satisfaction that the man had discovered the crock which had been filled with gold and silver coins. He was unable to recover any of the

(Continued to page 242)



you can GO PLACES  
...with an Evinrude!



Fact is, you can wander all over the chart... with speed, comfort, minimum cost... in a snug and able cruiser powered by Big Twin! Furthermore, you can "trailer" your boat *anywhere*, to waters of your choice. Your cruising horizons are *limitless!*

Big Twin is the motor outboard cruising had been waiting for. A motor with abundant power to reel off the knots on substantial cruising hulls. A motor with *Gearsift* for neutral starting and full maneuverability, and engineered for complete remote control.

Above all, a motor with *stamina* for trouble-free performance from shove-off to home-again!

In a single season, on coastal and inland waters everywhere, Big Twin has won its place as the motor for practical, low-cost cruising. If you'd like the whole story, see *your Evinrude dealer!* You'll find his name in your phone book under "Outboard Motors." For free catalog of the complete line of Evinrude models, write EVINRUDE MOTORS, 4765 N. 27th St., Milwaukee 16, Wisconsin.

In Canada: Evinrude Motors, Peterborough, Ontario



# EVINRUDE

FIRST IN OUTBOARDS... 43rd YEAR



# Here's how for home painters



Get rid of fresh paint smells—overnight! Pour a teaspoonful of ammonia into a bowl of water in center of fresh-painted room. Relax and go to bed. Next morning the smell is gone. Of course, you can save yourself all this trouble by using Devoe Wonder Tones—leave no

painty smell, dry in 20 minutes.

**Clean-up trick for roller coater containers!** Before you start, line bottom of paint tray with two layers of newspaper. Then bend over edges and tape them down. When painting's done, just throw papers away. Containers are as clean as when you started.



**Preventing paint skin—a two-edged trick!** To prevent skin from forming in partly used can, float a little turpentine on top of the paint. Pour just enough to cover surface. Because paint thickens when it stands for long, surface turpentine can be stirred in as thinner when you're ready to paint again.

**A tip for painting drawer knobs!** Here's a handy tip: before you start painting, screw the knobs part way into a piece of cardboard—like the top of a shoe box. You can hold the knob steady while painting—and it will sit still while drying. The perfect enamel for that knob, by the way, is Devoe Mirrolac—comes in many bright colors.



You can get all the painting accessories that you need—and many more helpful tips at the sign of the Devoe Diamond. Why not stop in and see your Devoe Dealer very soon? You'll find his name listed in the Classified Phone Book.



# Clinic for Homemakers

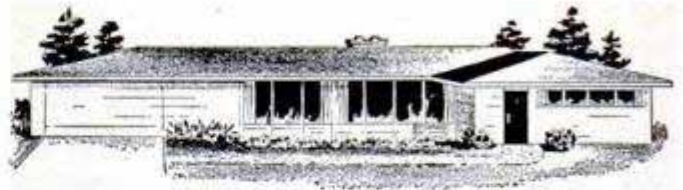

As a service to our readers in solving the hundreds of problems pertaining to a home—inside or out—the editors of *Popular Mechanics* invite you to present your problems to The Clinic Editor for help and advice. Address your questions to The Clinic Editor, *Popular Mechanics Magazine*, 200 East Ontario Street, Chicago 11, Ill.

**Dixie Lawn Supply Co.**  
922 BAYTER AVE  
LOUISVILLE, Ky.



## Aerifying Lawn

**Q**—I have recently heard of a new method of building a good and permanent lawn by a process which I believe is known as aerifying. How is this done? Is the procedure the same as that known as spiking? My lawn is on a heavy clay soil and the grass is thin, lacks color and withers during the drier summer months. Various lawn weeds are trou-

blesome. I kill them out during one season and they are back as thick as ever the next spring. What can I do about it?—A. S., Ind.

**A**—The process known as aerifying is not to be confused with spiking, although the procedures are quite similar. Aerifying is simply a form of subsurface cultivation which has been adapted to use on lawns with good results. Although the process is not new, it has come into more general use in the past five years. Implements for both hand and power operation are now available. Power-driven units are suitable only for use on large estates and golf greens, but hand-operated aerifiers in both the push and fork types are available for use on small lawns. All units work on much the same principle. Spoon-shaped blades are forced into the turf and as they are withdrawn they remove a small core of soil. The action of the blades beneath the surface leaves an open, loose-walled cavity through which both water and fertilizer can readily enter. The result of aerifying is to make plant food and water readily available at the lower root levels, which greatly stimulates both root and top development of individual plants. On sloping lawns this type of cultivation prevents washing. The vigorous turf resulting from this treatment effectively discourages growth of common lawn weeds.

## Installing Aluminum Gutters

**Q**—My home has a low-pitched roof and wide cornices. The gutters and downspouts have rusted out beyond repair and I plan to replace them with aluminum gutters. The advice I get is rather confusing. I'm told that aluminum gutter is not desirable, that is, it will not withstand the load of snow and ice that accumulates during the winter, and that it cannot be painted. Also, some say that only half-round gutter should be used, while others advise the box-type aluminum gutter. How should I proceed, and what type gutter should I use?—T. S., Mich.

**A**—Aluminum gutter in both the box and half-round types is extremely durable. It is not subject to damage by rust or corrosion. It does discolor

(Continued to page 240)



THE MOST *Versatile* TOOL  
ON YOUR BENCH...  
**CHANNELLOCK Pliers**

Made only by  
**CHAMPION DEARMENT!**

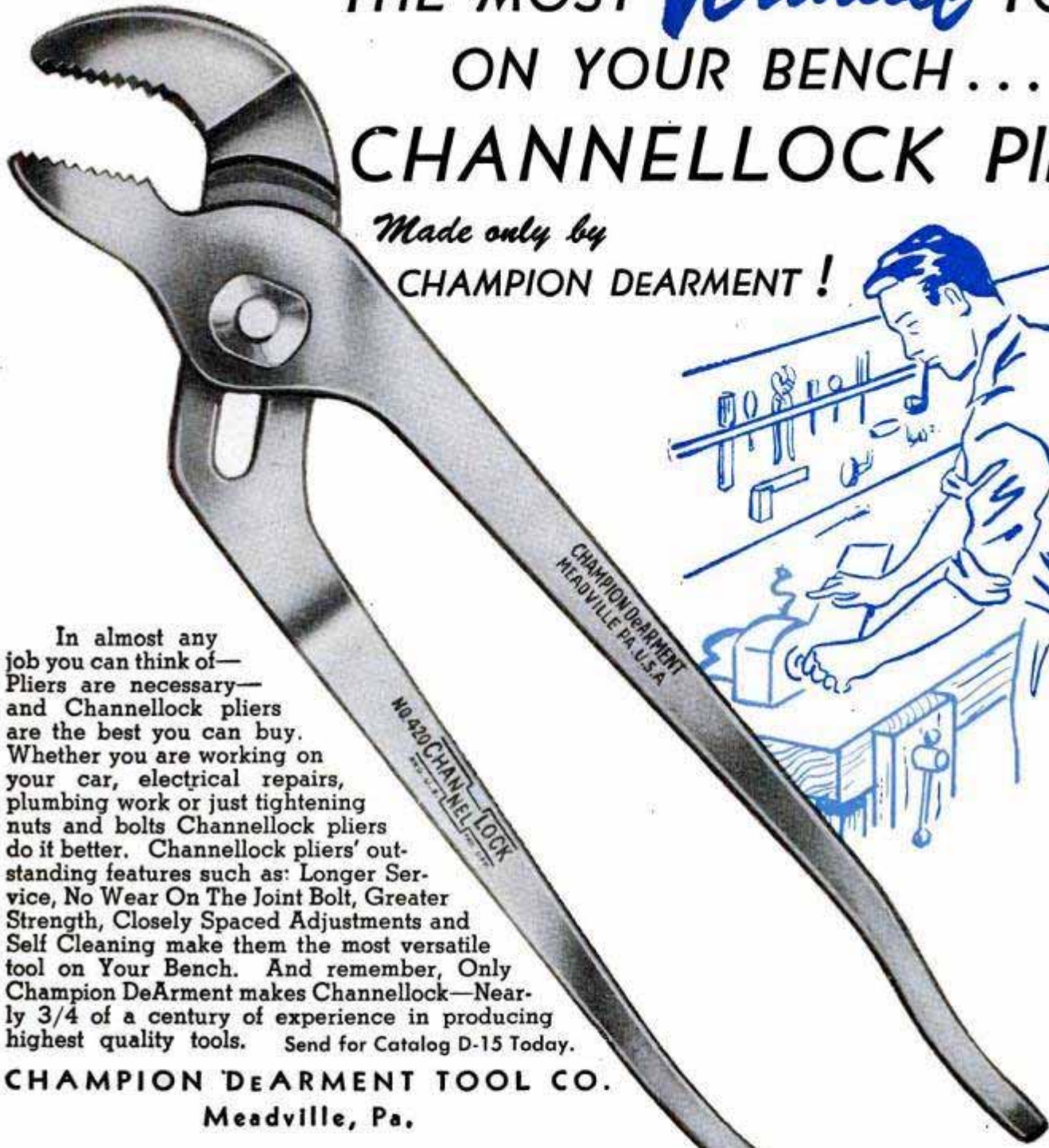

In almost any job you can think of—Pliers are necessary—and Channellock pliers are the best you can buy. Whether you are working on your car, electrical repairs, plumbing work or just tightening nuts and bolts Channellock pliers do it better. Channellock pliers' outstanding features such as: Longer Service, No Wear On The Joint Bolt, Greater Strength, Closely Spaced Adjustments and Self Cleaning make them the most versatile tool on Your Bench. And remember, Only Champion DeArment makes Channellock—Nearly 3/4 of a century of experience in producing highest quality tools. Send for Catalog D-15 Today.

**CHAMPION DEARMENT TOOL CO.**  
Meadville, Pa.

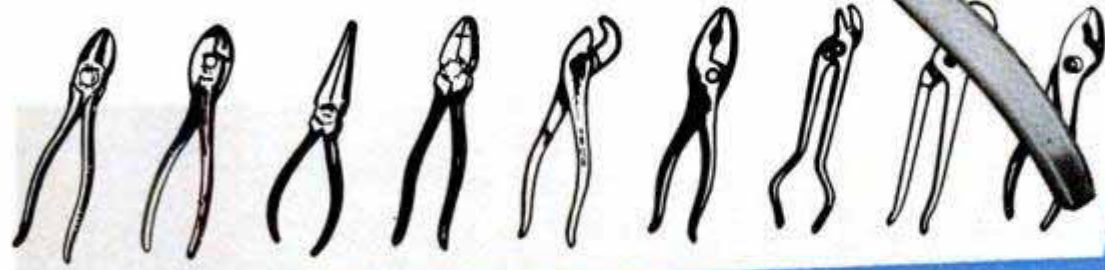

Channellock pliers are listed in the Yellow Pages of most Telephone Directories under "Tools"



*Only* **CHAMPION DEARMENT...**  
*makes* **CHAN NEL LOCK**  
TRADE MARK REG. U. S. PATENT OFFICE



# Pointers for home painters Walls:

When replastering small areas, cut out all loose plaster. Leave indentation (see insert). Wet new edges with warm water before applying fresh plaster.

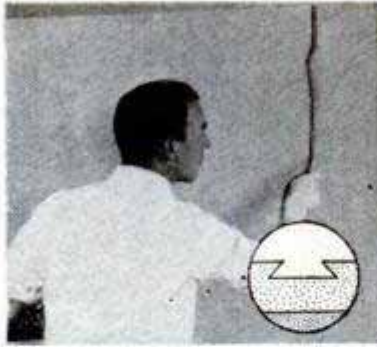

With the tip of brush, work paint up to molding. For best results use a nylon-bristled brush of the right size—one designed for the job.

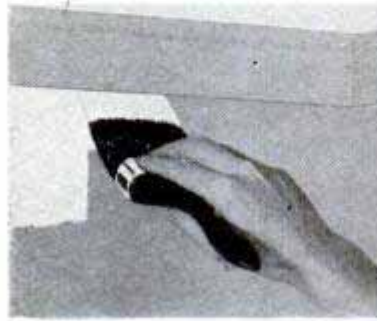

Start painting in corner at molding. Work down to baseboard. Cover a space about two feet wide. Paint last strokes into area just painted to avoid overlap marks.



For overnight cleaning, pour thinner on brush. Work out paint on newspaper using stick or paint scraper to squeeze out paint. Suspend brush in thinner.

**JOB AFTER JOB** you'll get best results with a well-tipped nylon paint brush. Durable Du Pont nylon bristles paint smoother . . . are clean and sanitary . . . never get brittle . . . don't break off even under the roughest treatment. And nylon bristles last from 3 to 5 times longer than ordinary bristles. Leading manufacturers make nylon paint brushes in all types and sizes. Look for the name **NYLON** on the handle. Be sure to pick the size brush designed for the job . . . and demand Du Pont nylon bristles.



Better Things for Better Living  
... through Chemistry

The best brushes have  
**DU PONT NYLON  
BRISTLES**

(Continued from page 238)  
somewhat with age because of the oxides which form on the surface of the metal. It can be painted at any time, although a general recommendation is that it be exposed to weathering for a period of three to six months before painting. When new, the metal is very smooth and does not provide a suitable surface, or "tooth," for foundation coats of paint. Generally, manufacturers' specifications for hanging aluminum gutters of either type will call for hangers to be spaced every 30 in. throughout the length. In new installations the hangers should be nailed directly to the roof boards before the shingles are laid. Otherwise, the shingles should be lifted at the eaves and the ends of the hangers inserted underneath the shingle butts and nailed. Always use aluminum nails for attaching aluminum hangers.

*See backy book*

## Shingle-Tab Cement

**Q**—The shingle butts on the roof of our new home have been turned up by high winds. So far they have not leveled again as I thought they would. The irregularly raised butts give the roof a very unsightly appearance and I'm afraid that leaks will develop during heavy rainstorms. Is there anything that can be done to remedy this condition?

—G. S., Neb.



**A**—If the tabs have been merely turned upward and have not been broken it is possible to repair the damage by use of a new product which has recently been made available and is known as shingle-tab cement. If it is applied in accordance with the manufacturer's instructions, it produces a fairly satisfactory and permanent job. However, in most cases it is advisable to make the repair only during warm weather when the temperature is 70 deg. F. or more. The higher the temperature the better, as then the shingle tabs can be bent back and flattened into their original position without danger of breakage or buckling. When making the repair, begin at the ridge and work down. Usually it is best to apply the cement to all the tabs in each shingle course, even though only a few of them may have been raised.

## Kick Plate Tarnishes

**Q**—I have a polished-brass kick plate on my front door and I find that it takes constant rubbing with a polishing compound to keep it smooth and bright. The metal seems to darken and discolor irregularly although it is protected during the winter months by a tight-fitting storm door. Isn't there some way of preventing the discoloration of the polished surface?

—B. M., N. Y.



**A**—Remove the plate from the door and polish it in the regular way. Then wash it thoroughly with a solvent to remove all traces of oil and polishing compound. Next, go over the surface lightly with fine steel wool (No. 000 or finer) rubbing in a straight back-and-forth stroke, rather than a curved or circular movement. Wash the plate again with a lacquer solvent and, when the solvent has evaporated, pick up all traces of dust and lint with a painter's tack rag. Now apply a coat of clear metal lacquer, following the directions on the container in all details. This lacquer dries quickly and forms a smooth film that prevents tarnishing of the metal for long periods of time. When renewal is necessary, wash off the old coating with lacquer solvent and apply a fresh coating of lacquer.



# On Every Oldsmobile for 40 years

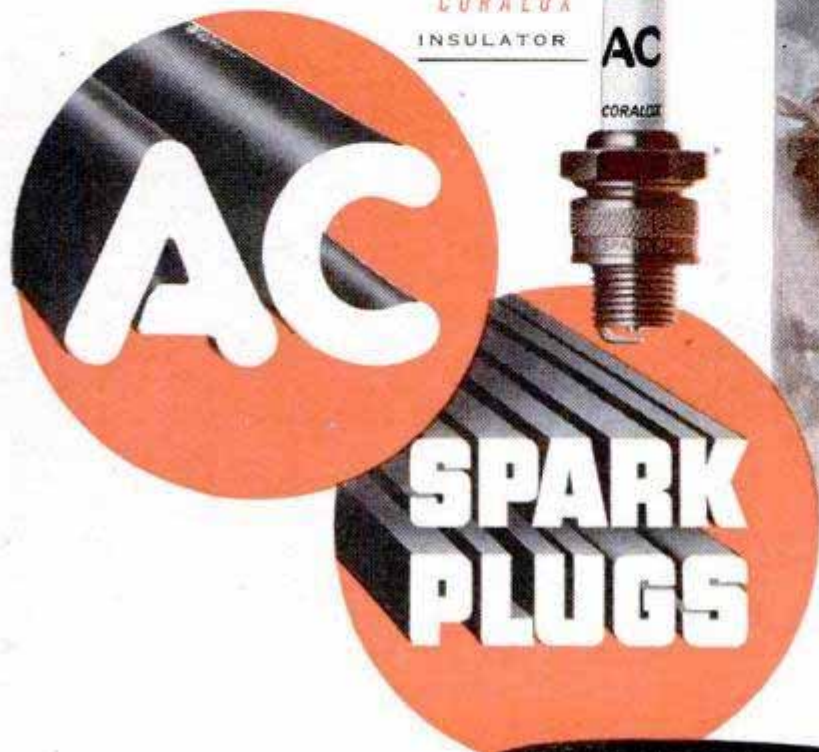

PATENTED  
CORALOX  
INSULATOR

AC

CORALOX



**FACTORY EQUIPMENT TODAY ON NEARLY AS  
MANY NEW CARS AS ALL OTHER SPARK PLUG MAKES COMBINED**

For over forty years—from the days of the famous Olds "Limited" to the flashing 1952 Olds "Rocket," AC Spark Plugs have been standard factory equipment on all Oldsmobile cars. As engines have increased in compression, power, and speed—AC has always been ready with engineering improvements that have conquered new and difficult operating conditions.

AC's patented *CORALOX* Insulator is one of the latest improvements. Its physical properties provide better insulator shapes—better heat conduction—better electrical insulation—greater resistance to fouling—surer firing.

You, too, can enjoy all these *CORALOX* advantages—no matter what make of car you drive—if you insist upon AC Spark Plugs.

AC SPARK PLUG DIVISION



GENERAL MOTORS CORPORATION



# Graduate to a GRAPHIC



for pictures  
with **PUNCH!**

● It costs no more to own a Pacemaker Graphic . . . and you save many times over in better pictures and fewer shots lost. First choice of press photographers because of its rugged dependability, versatility and ease of operation . . . it's the ideal camera for you too! You'll have more fun and get better results, regardless of conditions. Two models in three sizes meet every need. Prices start at \$174.15 . . . remarkable value when you consider the prize-winning features. See the Pacemakers at your Graflex dealer's, or mail coupon for information.

Graflex Inc., Dept. 87  
Rochester 8, New York

Please send me details on:  
Pacemaker Graphic and Accessories

Name \_\_\_\_\_

Street \_\_\_\_\_

City \_\_\_\_\_

County or Zone \_\_\_\_\_

State \_\_\_\_\_

**GRAFLEX**<sup>®</sup>  
Prize-Winning Cameras

money from the man, who denied finding it. On the beach at Naples, Fla., in 1945, a tourist couple is said to have found numerous stained doubloons. It is possible that these coins were washed ashore from a near-by wreck. However, nobody knows who the tourists were, nor does there seem to be any record of the discovery. John W. Prince of Naples says he has found gold and silver "nuggets" on the beach himself, as well as other treasure, but he would "prefer not to go into detail on this."

Hilsebeck also learned from an old Key resident, Leonard Lowe, that almost 100 years ago Lowe's father had seen a small boat come ashore from a sailing vessel. Two men carried a large chest from the boat into the woods. When they returned to the boat, they did not have the chest. Although many searches were made in the area, the box was not discovered until recently, says Hilsebeck. The persons who found the box are unknown, but Hilsebeck and others did find remains of the box in a deep hole that appeared to have been dug several years earlier. The box was constructed of heavy hardwood planks fastened together with handmade iron spikes.

But, as in most stories, nobody admits finding the loot.

Some stories are based on discoveries said to have been made years ago. W. T. Cash, state librarian of Florida, went on a treasure hunt near the mouth of the Steinhatchee River. He was seeking a treasure said to have been located by two young men shortly after the Civil War. These men were fishing in the river and noticed an iron chain extending into the water from the branch of an oak tree. They pulled on the chain until an iron chest came to the surface. The chain had almost rusted through, and the weight of the chest as it came out of water broke one weakened link. The chest sank in about 30 feet of water. They were unable to raise it again despite repeated attempts. When they returned with more equipment, they were unable to locate the chest at all.

Cash went looking for the spot, but he, too, was unable to find any sign of the chest, although he doesn't doubt that it is there waiting for some lucky discoverer.

Several hundred expeditions have gone to lonely Cocos Island off the coast of Panama, where the famous "Loot of Lima" is supposedly cached — untold millions in church treasure removed from the city before the advancing forces of Simon Bolivar in the 1820s. The government of Costa Rica, which owns the island, charges a fee for exploration. Thus far, it is the only agency to make any money from the treasure hunt!

(Continued to page 244)



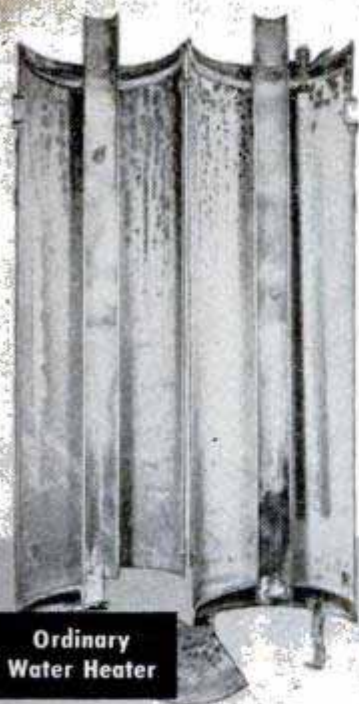

Ordinary  
Water Heater

← **ORDINARY** galvanized water heater tank interior after one year of service in a corrosive water area. The left half has deposits of water-borne minerals. The right half has been cleaned to reveal actual surface. **NOTE NUMEROUS DEEP RUST PITS**, indicating penetration of galvanized surface and rapid destruction of the water heater tank by corrosion.

**PERMAGLAS.** Glass-surfaced steel tank interior after the same year of service in the same city as the galvanized tank. The left half shows deposits of water-borne minerals. The right half has been cleaned. **NOTE ORIGINAL GLASS SURFACE**, still smooth and effective against corrosive attack . . . no rust . . . your assurance of many more years of service.

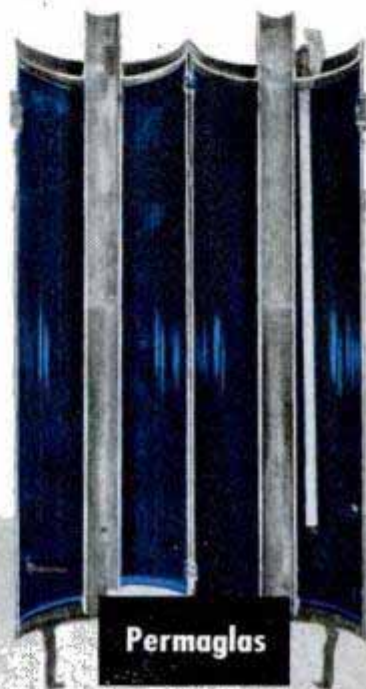

Permaglas

We cut  
water heaters in two  
to prove to you

## Permaglas is your best buy

**Permaglas** water heaters and galvanized water heaters of identical design, in service in twelve cities having widely divergent water conditions, were removed at the end of a year and cut in two, lengthwise, for critical inspection.

**Conclusive**, unmistakable proof of *Permaglas* superiority in resisting corrosion shows up for you to see!

**Exclusive** *Permaglas* features provide lasting service. They comprise: 1) glass-surfaced steel tank, 2) removal of dissimilar metals from contact with water, 3) shielding of

fittings from electrolytic action, and 4) "Neutrolizer" standby protection against attacks by corrosive waters.

**For complete** information on *Permaglas* water heaters, electric, gas or LP-gas, mail the coupon.



A. O. Smith Corporation  
Water Heater Division, Dept. PM-352  
Kankakee, Illinois



Send me, without obligation, your FREE booklet on the inside story of *Permaglas* water heater superiority. Please include information on

Gas  Electric  LP-Gas Water Heaters

Name \_\_\_\_\_

Address \_\_\_\_\_

City \_\_\_\_\_ Zone \_\_\_\_\_ State \_\_\_\_\_

# A.O. Smith

AUTOMATIC WATER HEATERS





# Aha! Help for the Hobbyists!

offered by these  
Wizards with Wood

Hobbyists delight in results made possible by Weldwood Glue, Firzite and Satinlac. Ask for these magic hobby-aids at hardware, paint and lumber dealers, or mail coupon below for free leaflets.

## Newer than Shellac or Varnish



Pints, Quarts,  
Gallons

For "natural wood" finishes on furniture, panelling or woodwork, there's nothing like Satinlac. Brings out natural grain and color beauty of any plywood or solid wood. Avoids that "built-up" look; will not turn yellow or darken with age. "Water-clear," easy to brush or spray, dries ready for next coat in 2 or 3 hours.

### SATINLAC\*

## Glue That's Stronger than Wood



To make things or fix things, use Weldwood Glue for all wood-to-wood bonds. Makes joints stronger than the wood itself. Mixes easily with water. Stain-free, rot-proof... highly water-resistant!

### WELDWOOD® PLASTIC RESIN GLUE

## A MUST for Finishing Fir Plywood



Tame that wild grain with FIRZITE. Virtually prevents grain raise or checking... readies the surface satin-smooth for paint, stain or enamel. (For blond, pickled, or tinted effects on soft or hard woods, use White Firzite).

### FIRZITE\*

\*Trade Marks

United States Plywood Corporation,  
Dept. 392, 55 West 44th St., New York 18, N.Y.  
Send me free leaflets on Weldwood Glue, Firzite  
and Satinlac.

NAME \_\_\_\_\_

ADDRESS \_\_\_\_\_

Some of the most exciting treasure stories come from people who sell detector equipment for locating treasure. Quite naturally, they are interested in making people treasure conscious.

If you decide to make a try at treasure hunting, it will be wise to remember that the odds are against you. Don't go all out for a story—others have, to their regret. Confine your activities to a small scale. Study the history of Florida, and become interested in tales of pirate days. Then, even if you never get any closer to a treasure chest than a story book, you'll at least enjoy the excitement of the chase.

If you keep your expenses light and don't lose your head, you'll have plenty of fun and get lots of fresh air and sunshine—both of which are real Florida treasures!

## "Pipe Organ" Oil Driller

(Continued from page 162)

draw works, hauling on long levers, stamping on foot pedals, getting dust in his eyes and a crick in his back. Now he sits comfortably on a foam-rubber chair at one corner of the drilling floor and operates a bank of knobbed levers in a console before him. Dials and winking lights give him instant information and warning on every drilling procedure.

Using levers alone or in combination, he applies power in any desired range—speeding up or slowing down the blocks, motors, pumps and generators. He can instantly summon hundreds of horsepower to brake the descent of tons of pipe into the hole or to control pressures and the flow of mud.

One of the drillers operating the new rig has been with Standard more than 40 years. He's worked with everything from the early rickety steam rigs to the latest experimental model.

When asked how he was getting along, he pushed back his hat, grinned and said:

"Well, I'll tell you. I can't even play a mouth organ—but here I am playing a pipe organ."

Since then, hard-boiled drilling crews have called the new console "the pipe organ." Compact and skid-mounted, the console can be moved to any convenient place on the derrick floor. Every one of the various controllers has an infinite number of speeds from zero to full both in forward and reverse.

Automatic devices, developed by General Electric and called amplidynes, give exact and instant response. They protect motors against power beyond their capacity or unevenly balanced loads on moving

(Continued to page 246)



# Belanger 99... 1951's "Winningest" Car Used Champions Exclusively!



Murrell Belanger with his Belanger Special and his pit crew of outstanding race car technicians.



Owner of 1951's "winningest" car, Mr. Murrell Belanger.

*"When Lee Wallard won the 1951 Indianapolis 500 mile race at the record speed of 126.244 M.P.H. average, it was the first time the race had been run under four hours. That's a terrific test of car, engine, tires, brakes and spark plugs. After Wallard's injury, Tony Bettenhausen took over, winning eight of the remaining races. This brought the total for the Belanger Special to nine wins out of fifteen AAA Championship events—a record for any one car in one season. Tony, my head mechanic and myself really know the meaning of that word dependability and in my book, it's a synonym for Champion Spark Plugs. They're built to live up to their name and they do."*

Murrell Belanger



Lee Wallard, winner of the 1951 Indianapolis Race at the record breaking speed of 126.244 m.p.h. average.



Tony Bettenhausen, 1951 AAA Champion Race Driver, with eight wins out of fifteen championship events.



**FOLLOW THE EXPERTS**

DEMAND CHAMPION SPARK PLUGS FOR YOUR CAR

CHAMPION SPARK PLUG COMPANY, TOLEDO 1, OHIO



**BEST  
INVESTMENT  
I EVER MADE!**



**You  
can really**

**take it easy** when there's a smooth-running Worcester Shear Master in the family. So effortless to operate that even the gals like to use it! Sharp-cutting "Sta-Temp" blades that stay sharp longer. Clutch and speed controls right at your finger tips. Totally enclosed chain and sprocket. Easy-to-get-at oil cups. Genuine Timken roller bearings. Big, traction-grip tires. And a dependable 1.6 h.p., 4-cycle Briggs & Stratton engine. You'll get years and years of faithful service out of this fine power mower, backed by Worcester's *half-century* reputation as makers of America's finest lawn mowers. Write today for illustrated literature.

# Worcester

## 21-INCH SHEAR MASTER

**FREE!** An attractive, fully illustrated folder describing in detail the many outstanding features of this great power mower and the other fine Worcester lawn mowers. Write today to Worcester Lawn Mower Co., Division of Savage Arms Corporation, 84 Broadway, Chicopee Falls, Mass.

**WORCESTER MAKES A MOWER  
FOR EVERY LAWN, EVERY BUDGET**

Ask your dealer to help you select the Worcester hand or power mower best suited to your needs.

parts or generators. Without such controls, operations would have to be slowed down considerably, lest engines, generators and moving parts wreck one another.

Although the new diesel-electric drilling rig is designed to bore 20,000 feet or more into the earth, it was not built with any thought of beating the world's record of 20,524 feet set by the Superior Oil Company in Wyoming's Green River basin two years ago.

Instead, Standard is more interested in having an efficient new tool to work with, one that will dig test holes speedily and cheaply—thus exploring new frontiers for oil in deep formations or in those that have been exhausted by shallow drilling.

## Sports Cars Take Over the Town

*(Continued from page 157)*

drivers to maintain position (no passing) and keep their cars under control at speeds not in excess of 50 miles per hour. A red flag means the race is halted and all cars must pull off to the side of the road.

Drawing by classes, with larger displacement classes in front, put Briggs Cunningham in the front-row, outside position. Piloting a sleek, powerful sports car of his own design, Cunningham was trailed by two more of his expertly assembled cars chauffeured by Phil Walters and John Fitch, well-known drivers in Eastern racing circles.

The Cunningham cars are composites of American auto parts from Fords, Dodges (truck), Chryslers, Cadillacs and Oldsmobiles. Powered by souped-up Chrysler Fire-Power engines capable of delivering 260 horsepower, the big cars are equipped with special Indianapolis-type racing wheels and tires, luxurious interiors and roomy aluminum racing bodies especially designed for the comfort and safety of drivers.

Now in limited production in a West Palm Beach, Fla., plant, the Cunningham sells for around \$12,000.

Also included in the lineup were several of the famous 12-cylinder Ferraris driven by Jim Kimberly of Chicago and Bill Spear of Southport, Conn. These 285-horsepower cars are capable of 150 miles per hour and consistently are strong competition in such races. Kimberly, unfortunately, was forced to retire his blue "power house" from the race because of clutch trouble, although mechanics had worked on it the night before.

Running strong at all times was a Cadillac-Allard, No. 63, owned by Jim Chapman of Los Angeles and expertly piloted by

*(Continued to page 248)*



# 1 ounce = 44 lbs!



THAT'S WHY FORD IS SO CAREFUL TO BUILD CLUTCHES IN PERFECT BALANCE—WHY YOU SHOULD NEVER SETTLE FOR LESS THAN A GENUINE FORD CLUTCH. ANOTHER FORD ADVANTAGE!



ONE OUNCE OF UNBALANCE IN YOUR CLUTCH BECOMES 18 POUNDS OF UNBALANCE AT 3000 RPM, 44 POUNDS AT 5000. THE RESULTING VIBRATION CAN MAKE A RATTLETRAP OUT OF A GOOD CAR.



THESE ARE BUT A FEW REASONS WHY THIS CLUTCH, LIKE ALL GENUINE FORD PARTS WORKS BETTER—WHY IT SAVES YOU DOLLARS THROUGH QUICKER INSTALLATION AND PROTECTION AGAINST SLIP.

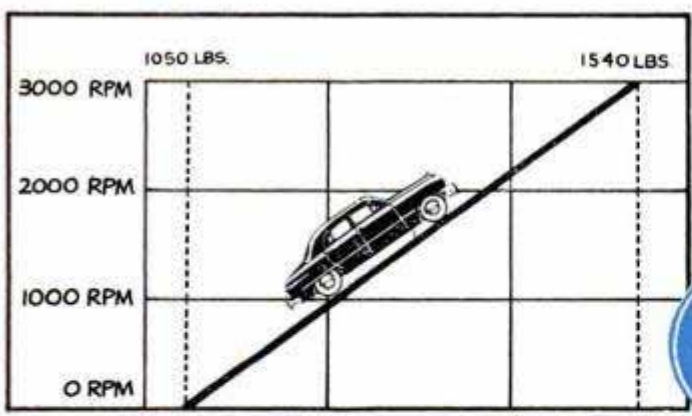

STANDING STILL, A GENUINE FORD CLUTCH GRIPS WITH 1050 POUNDS PRESSURE. AS THE ENGINE SPEEDS UP THE CLUTCH HOLDS TIGHTER. AT 3000 RPM THIS PRESSURE INCREASES TO 1540 LBS.



AVAILABLE WHERE YOU SEE THIS SIGN... AT ALL FORD DEALERS AND SELECTED INDEPENDENTS.

*ALWAYS INSIST ON THE PARTS THAT ARE MADE RIGHT TO FIT RIGHT TO LAST LONGER!*



## KEEP YOUR FORD ALL FORD!





# Stop RADIATOR TROUBLE Now!

★ Unless you are asking for trouble—your radiator deserves a *thorough* spring cleaning! Get rid of winter's accumulated rust and dirt the easy, effective way—with these three Bowes radiator conditioners. Then you can enjoy care-free spring and summer motoring.



## BOWES RADIATOR KLEN-ZUR

Quickly removes rust and scale . . . contains no harmful acid . . . makes cooling system like new.

## BOWES RADIATOR RUST-ROUT

Protects the cooling system, prevents accumulation of more rust . . . lubricates water pump, too.

## BOWES RADIATOR STOP-LEAK

Effectively seals any existing leaks and helps prevent new leaks.

**DRIVE IN WHERE YOU SEE THIS EMBLEM**



★ It takes so little time to condition your cooling system for spring and summer driving . . . yet it can be so costly and troublesome to neglect it. Don't delay—prepare NOW for spring and summer with Bowes Cooling System Chemicals.

BOWES "SEAL FAST" CORP., INDIANAPOLIS 7, INDIANA

horsepower Allard originally cost \$5000, but Chapman refuses to say how much more he has put into the car.

From his position in the pits, Chapman constantly flashed signals to Mike during the last laps to "Get 128"—a Cunningham driven by the pace-setting Fitch. Slowly closing the gap behind the leader, Graham was forced to make a brief pit stop for fuel, but managed a quick getaway and crossed the finish line in second place.

Studded with a good assortment of MGs and Jaguars, the colorful field of cars, which actually compete against their own class, also included a German Veritas, built especially for racing. Owned and driven by Ralph Knudsen, a Milwaukee development engineer, the high-powered car, made in 1949, has only 3½ inches of road clearance. According to Knudsen, this feature of the \$7500 car has caused him some trouble. Specifically, during competition at a Watkins Glen event when he ripped off the pan. Reported to be the only car of its kind in this country, the Veritas was also forced out of the race during early laps because of clutch trouble.

After driving his sleek little Bandini Fiat in a preliminary novice race, Richard Gent of Lindhurst, Ohio, turned the wheel of his No. 103 over to George Weaver. It was the first closed-course event for the four-cylinder, 65-horsepower car in this country, and Gent was well pleased with its performance and ability to turn up speeds in excess of 100 miles per hour. Being a machinist, he purchased the car in a run-down condition solely on the recommendation of a New York sports-car dealer who had seen it perform in Italy. After competitive driving in the car, which he has now put in top running condition, Gent is happy with his \$5000 bargain.

Taking time out from his routine as salesman for a Chicago auto firm, Kurt Hildebrand had his share of anxious moments with a car of his own design. A standard Volkswagen chassis was fitted with a special racing body fashioned from an aircraft belly tank. Equipped with spring-mounted fenders, the body design (with engine in rear) lends itself nicely to carrying a spare tire flat under the front of the car, ahead of the wheels.

After passing technical inspection the day before the race, Hildebrand headed for the course to "wind up." With only a few turns around the track, he threw a flywheel on the flat, four-cylinder Volkswagen engine, which he had specially tuned and fitted with two Amal (special motorcycle) carburetors. Working feverishly during the

(Continued to page 250)



Your entire foot  
**RESTS IN COMFORT**  
 while you work!

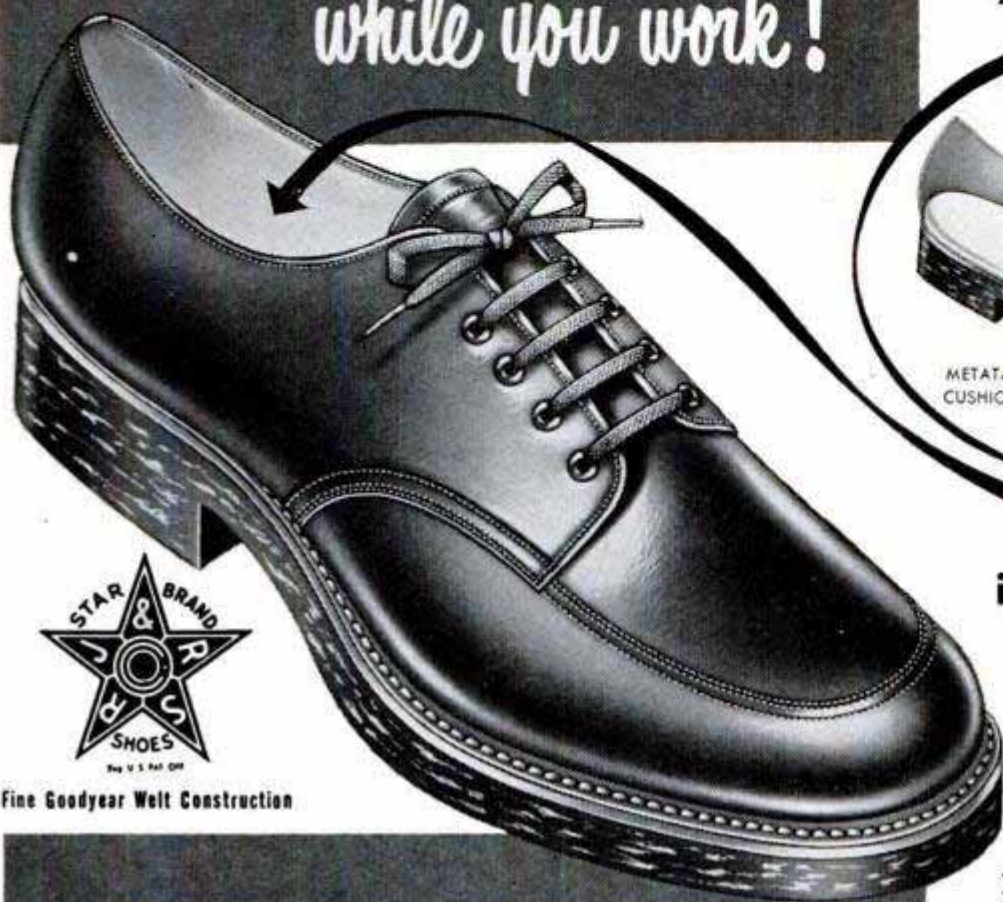

Fine Goodyear Welt Construction

**STAR BRAND**  
*Cush-N-Bilt*  
**WORK SHOE No. 286**

Here's how the  
*Cush-N-Bilt* innersole  
 rests your feet while you work

Resilient innersole, made of a molded cushion of extra soft sponge rubber is covered with a walking surface of genuine cowhide leather. It rises on the inside, gives snug support and comfort to the arch. Metatarsal pad massages and relaxes busy muscles. Your entire foot rests in comfort while you work!

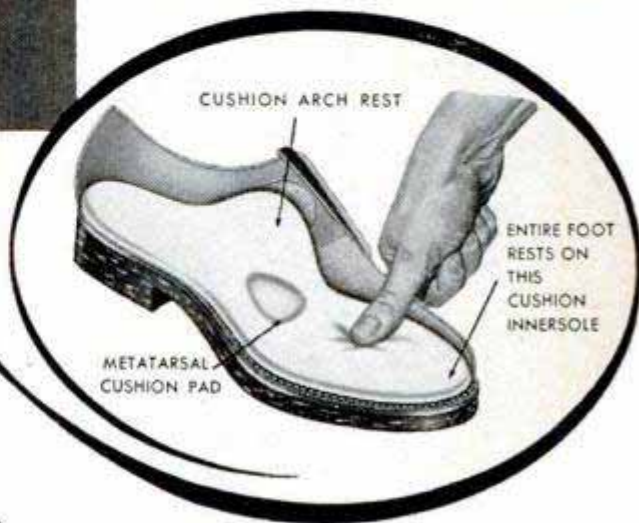

it's new! it's different!  
*cushion innersoles*  
*of sponge rubber*  
 absorb work shock  
 reduce foot-fatigue

If you do the kind of work that's hard on the feet . . . you'll really appreciate this amazing new shoe. Specially designed to reduce foot fatigue, it has extra-soft cushion innersoles that give you the feel of pillowed comfort! Its built-in steel shank, metatarsal and "cookie" arch pads both support and rest your feet while you work. Uppers are made of pliable genuine cowhide leather; corded soles and heels are non-slip and oil-resistant. Looks like a dress shoe . . . but it's specially constructed for rare comfort, extra duty and extra long wear!

EXPERTLY FITTED by your local Star Brand shoe dealer!

- ✓ **OIL-RESISTANT, NON-SKID CORDED SOLES AND HEELS**
- ✓ **GENUINE COWHIDE LEATHER UPPERS** (cordovan colored)
- ✓ **Built in STEEL SHANK ARCH SUPPORT** braces the arch, holds down foot-fatigue!

built for the man  
 who works on  
**HARD CONCRETE**  
**or OILY SURFACED**  
 floors, pavements, etc.

FOR DEALER NEAREST YOU, WRITE: Roberts, Johnson & Rand, DIV. OF INTERNATIONAL SHOE COMPANY - ST. LOUIS 3, MO.



# 3 Ways to Handsome Hair! *Right Now!*



*Fights  
Dandruff!*



*Relieves  
Dryness  
and Itching!*



*Grooms  
Hair  
Perfectly!*

Lucky Tiger grooms your hair perfectly. But it does a lot more besides. Lucky Tiger kills on contact the dandruff germ, *pytosporum ovale*, removes loose dandruff and gives your scalp a clean, wide-awake tingle. Treat your hair to all this, plus natural, greaseless grooming. Ask your barber, he knows.

## LUCKY TIGER 3-PURPOSE Hair Tonic



Sold at all toilet goods counters.

night to repair the damage without success, he finally removed the engine entirely and replaced it with a stock engine from a passenger car of the same make. Sliding into the lineup at the last minute, Kurt fanned his No. 47 around the grueling "200" without mishap.

Receiving much attention before and during the race was a shiny blue Fiat Siata, entered by Tony Pompeo of New York City. Weighing only 850 pounds, the well-polished little car, costing \$2500, is powered by a Crosley engine. Turning up speeds over 100 miles per hour, the Siata demonstrated outstanding road-holding ability for its weight.

Victorious in the race was John Fitch, chauffeuring the powerful white-and-blue Cunningham, No. 128. He set the pace all the way with the exception of two laps when his teammate, Walters, led the field. At an average speed of 80.82 miles per hour, Fitch completed the race in 2 hours and 30 minutes. During his run, Fitch turned one lap at an average speed of 101.2 miles an hour, and two other laps at over 100 miles per hour, three of the fastest road-racing laps on record, according to the S.C.C.A.

Come August this year, and time for the hundreds of S.C.C.A. members to stage another national competition in the Midwest, the residents of Elkhart Lake and their neighbors may have to take up positions a few hours earlier to get a clear view of America's top sports cars displaying their amazing speed and beauty.

## Mexican Safari

*(Continued from page 146)*

In another place we located what we believe are the ruins of a pre-Stone Age city. They cover some 20 to 30 acres, and once boasted roughly paved streets and crude rock buildings. Today the loftiest ruin is hardly over three feet high.

Days of painstaking search there failed to locate a single arrowhead or artifact of stone. The people who built that lost city had not mastered the art of carving or working rock. They were pre-Stone Age pottery makers, for the ground is carpeted with shards (fragments of earthen vessels).

Our discovery of cave dwellings and this ancient city may be the first proof that some of Mexico's earliest cultures evolved right in the land instead of dropping from the sky. Further research should clarify the picture and date the ruins. We suspect that they may be 10,000 years old.

Of the many improvements incorporated in the 1950 version of our jungle home,

*(Continued to page 252)*



# You Don't Have To Be A Tool Expert To See Why Experts Choose Guaranteed Westcraft Tools!

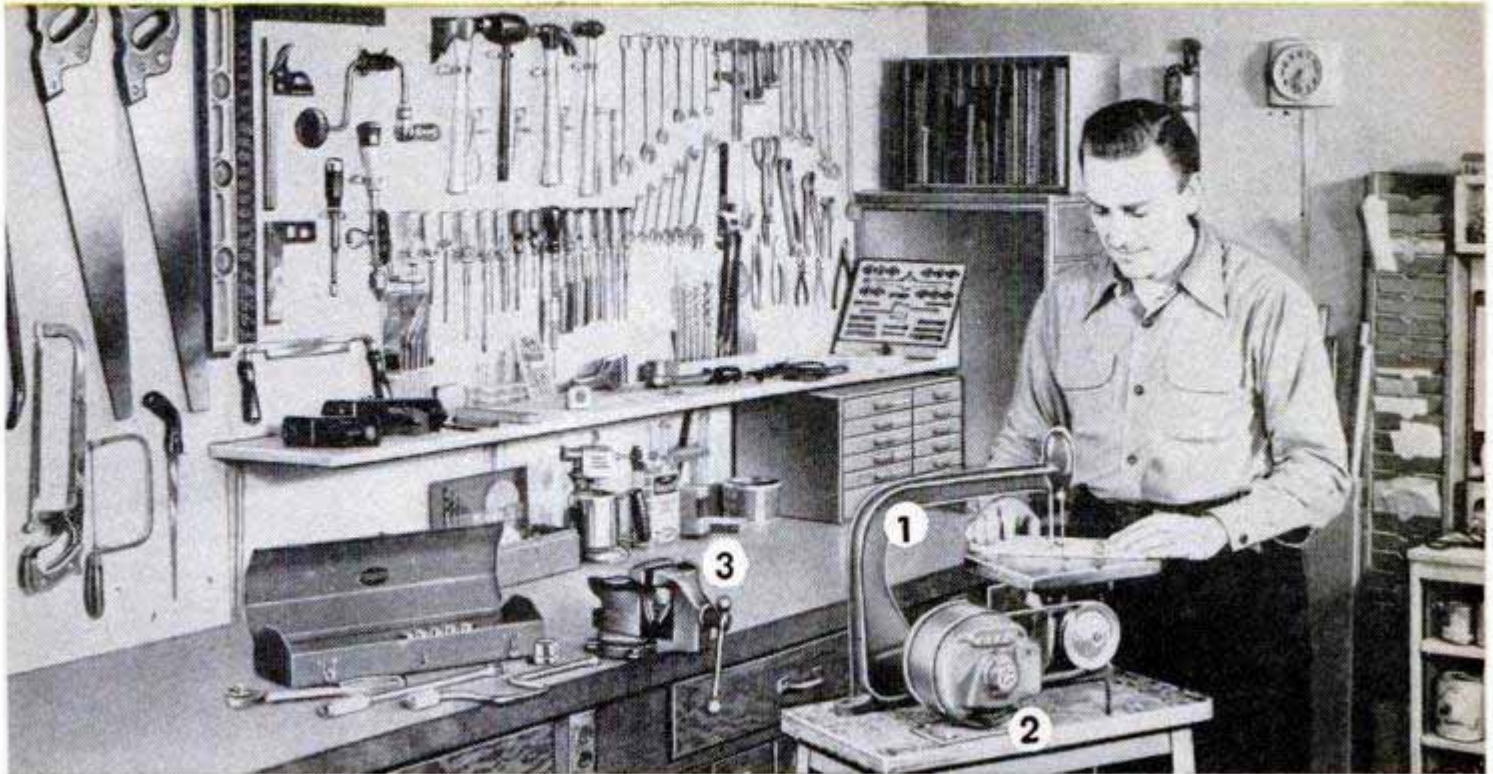

Just one visit to Western Auto will prove to you that famous, professional-quality Westcraft Tools give you the same lasting accuracy of other brands costing far more. Every West-

craft Tool is precision-built, fully-guaranteed . . . the kind of tool you'll be proud to own. And they're yours on easy Western Auto terms. See, try and compare Westcraft this week!

① **Tilt Table Jig Saw** does accurate jig, scroll, sabre sawing in wood and plastics to 1" thick. Scotch yoke, oil-lite bearings. 5" blade, adjustable guides. . . . (2H1102) **\$19<sup>35</sup>**

② **1/4 HP Electric Motor**, 1725 rpm, 115 volt, 60 cycle AC. Split phase. GE guaranteed for 1 year. Use with jig saw, washer, churn, paint sprayer, etc. . . . (2H1600) **\$17<sup>25</sup>**

③ **Mechanic's Vise**, 3 1/2" jaws open to 4 1/2". Removable pipe jaws and face plates. 180° swivel base. 5/8" acme threaded feed screw. Weighs 17 lbs. . . . (4HR4836) **\$6<sup>25</sup>**



**Soldering Iron**, 100 watt. Many home uses. Fast-heating nickel chrome sealed-in element lasts longer. 6-ft. heavy duty cord. Only. (4HR4816) **\$2<sup>00</sup>**



**"Loc-Grip" Plier**. 1500-lb. grip. Use with ratchet action or as lock-on handle. Narrow steel jaws, hardened and tempered. Only (HR1205) **\$1<sup>98</sup>**



**Screwdriver**, alloy steel, chrome-plated. 4" sq. blade. Extra long, positive-grip handle. Professional quality. Yours for (HR1361) **85¢**



**1/2" Electric Drill**, 115 volt. Alloy steel gears for greater power. Cutler-Hammer trigger switch. Polished aluminum alloy housing. . . . (2H1380) **\$33<sup>95</sup>**

Professional Quality—Wizards of Performance

## WESTCRAFT TOOLS

**WESTERN AUTO STORES & ASSOCIATE STORES**

Sold Only By

Sold by the largest group of associated tool departments in America

NOTE: Western Auto Associate dealers own their own stores and set their own prices, terms and conditions. Prices may vary due to differences in local conditions. If you do not know the location of your nearest Western Auto Store, write Western Auto Supply Co., 2107 Grand, Kansas City, Missouri © 1952 (PM32)



# Here's Money to Live On . . .

When You're Sick or Hurt  
and Can't Work



*Mutual of Omaha has  
Paid me over \$8000  
during the 3½ Years  
I've been Sick*

— HARRY F. HECK,  
101 Taylor St., California, Mo.

**UP TO \$300 A MONTH!** That's what your Mutual of Omaha Sickness and Accident Insurance can pay you whenever you are totally disabled by accident or confining sickness.

## HERE'S HOW IT WORKS:

- Pays up to \$300 a month
- Pays from the *first day* you see your doctor
- Pays as long as you are totally disabled, whether a few days, weeks, months, or even for *life*
- Pays you whether you're in the hospital or at home
- You use the benefit money for any purpose you like
- Liberal benefits for nonconfining sickness
- No medical examination required for membership
- Cost is amazingly low

**YOU CAN BE SURE** when you insure with Mutual of Omaha, *world's largest* exclusive health and accident company. It has paid more than \$400,000,000 in benefits. Licensed in all 48 states, District of Columbia, Canada, Alaska and Hawaii.

**SEND COUPON** TODAY FOR FULL INFORMATION  
NO COST . . . NO OBLIGATION

**JUST PASTE ON POSTCARD IF YOU LIKE**

Gentlemen:

I would like full information without cost or obligation on Mutual of Omaha Sickness and Accident Insurance which pays up to \$300 a month.

Name \_\_\_\_\_ Age \_\_\_\_\_

Address \_\_\_\_\_

City \_\_\_\_\_ State \_\_\_\_\_

**Mutual**  
**OF OMAHA**



**MUTUAL BENEFIT HEALTH & ACCIDENT ASSOCIATION**  
OMAHA, NEBRASKA

Dr. C. C. Criss, Chairman of the Board  
V. J. Skutt, President

Canadian Head Office: Toronto

PM 352

two proved outstanding. The power winch was invaluable in dragging the truck over oxcart trails so deeply rutted that both differentials went aground.

We were surprised when our military-tread tires paid off the best, not in mud, but on arid stretches solidly carpeted with sharp rocks. There the rubber knobs geared our wheels to the rocks. By using the extremely low gear ratio, available since we installed the two-speed transfer case taken from a half track, the truck literally crawled over obstructions. There was no wheel spinning which, on a knife-edge rock, can quickly cut a tire through to the fabric. We simply left the clutch engaged and regulated the "speed" from almost nothing with the engine idling to a top of three or four miles an hour.

It was rough on the tires, but we got through at the speed of a crippled snail. We were 6½ hours covering one five-mile stretch. On it a solid mat of brush and trees had grown up between the rocks. Indians told us it would stop a horseman. But a horse cannot push over trees. Our truck could, and did. "El Jeep Casita" performed to our complete satisfaction.

## Wanted: Jobs for a Trillion New Chemicals

(Continued from page 85)

an escape hatch, and the resulting fluorocarbon either moves through the hatch too, or simply is drained off the bottom, depending upon whether it is heavier or lighter than the solution in the tank. Fluorocarbons can be gases, liquids or solids.

The operation of the cell is as deceptive as it is simple. Why should five or six volts of electricity cause fluorine atoms to jump to attention, push hydrogen atoms out of the way and grab hold of the carbon atoms? It's a question even the experts can't answer, at least just now.

"Just how this process works is still a mystery," says Professor Simons, "but the important thing is that it does work, and in a highly efficient manner."

The chief value of the fluorocarbons lies in their stability, according to Dr. Hugh Bryce, the brilliant young scientist in charge of finding new fluorochemical applications. The carbon atoms form a skeleton inside the compound, and the fluorine atoms wrap themselves around carbon like a skin. They refuse to let anything penetrate to the skeleton.

Compared to hydrocarbons, the new chemicals are as hard as diamonds. Part of the value of the age-old hydrocarbons is

(Continued to page 254)



# MARFAK

# -S-T-R-E-T-C-H-E-S-

## -HOLDS TOGETHER

Big  
reason  
why  
MARFAK  
Chassis  
Lubrication  
lasts  
longer!



To prove how *Marfak* holds together, clings and stretches, this famous "Stretch Test" is the clincher. An ordinary lubricant would fall apart. This test shows that tough, tenacious *Marfak* won't work out of bearings. It stays put, protecting points of wear and friction far longer. As a result, *Marfak* chassis lubrication lasts for 1,000 miles or more — gives you "cushiony" driving from one lubrication job to the next. Drive in for *Marfak* lubrication today! See your Texaco Dealer, *the best friend your car ever had.*



## THE TEXAS COMPANY

### TEXACO DEALERS IN ALL 48 STATES

*Texaco Products are also distributed in Canada and in Latin America*



**TUNE IN . . . TEXACO STAR THEATER** starring MILTON BERLE on television every Tuesday night.  
**METROPOLITAN OPERA** radio broadcasts every Saturday afternoon. See newspaper for time and station.



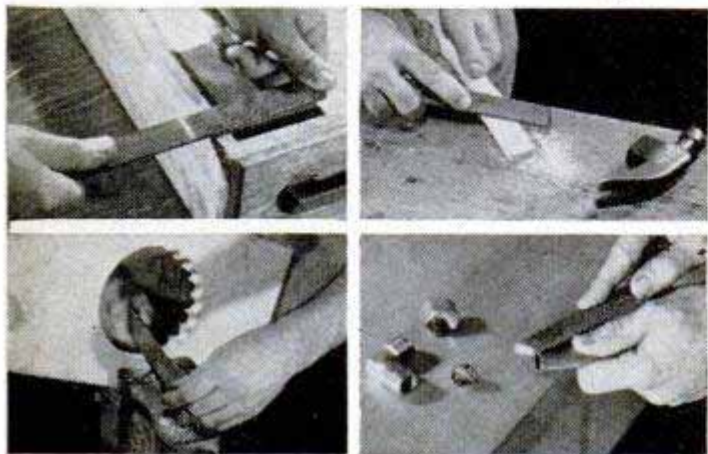

## The rasp that outgrew its name

It was originally designed for shoemakers. And it's still called a "Shoe" Rasp. But with its four types of cutting surfaces, users have found it "as versatile as a multi-blade jackknife." You can use it on hundreds of jobs—on wood, metal, plastics, leather, etc. On flat, concave, or convex surfaces. It's practically—

**FOUR FILES IN ONE.** . . . One side is half *Flat file*, half *Flat rasp*; other side is half *Round file*, half *Round rasp*. Just the thing for use around the house, farm, garage, workshop, or boat yard!

Ask your hardwareman for the handy Nicholson "Shoe" Rasp. Excellent, long-lasting quality. Also write us for **FREE BOOK**, "*File Philosophy*," showing this and many other Nicholson files—plus valuable information on use and care of files.



**NICHOLSON FILE COMPANY**  
22 Acorn Street, Providence 1, R. I.  
(In Canada, Port Hope, Ont.)



# NICHOLSON FILES

FOR EVERY PURPOSE

that they are "soft"—that is, they readily, often eagerly, react with oxygen, thus enabling us to burn food in our bodies, obtain heat from coal, rip the sky in jet planes and blast stumps with TNT. But the hydrocarbons also are our principal building materials, and here oxidation costs us billions of dollars each year.

If you painted your house last summer, chances are it will need another coat in about three years. Oxidation. The rubber sidewalls of your tires may be getting hard and crumbly. Oxidation. In 1950, fires cost this country an estimated \$649,000,000. Fire is oxidation at a rapid pace.

Most fluorocarbons, on the other hand, simply won't oxidize. You can't burn them, no matter how hot a flame you apply. A few are so stable they probably would be the hardest materials in the world to get rid of.

Take butane as an example of the relationship between the old and new compounds. Butane, a hydrocarbon with the chemical symbol  $C_4H_{10}$ , oxidizes so readily it is used as a fuel. Taylor and his staff have substituted fluorine for the hydrogen, making  $C_4F_{10}$ , which they call perfluorobutane. This strange gas is noncombustible and four times as heavy as butane. It would make an ideal fireproof, sparkproof blanket across the top of a gas tank.

The familiar hydrocarbons also can be attacked by decay and fungi. On the other hand, bacteria and insects can't use fluorocarbons for food, so substances made from these compounds—or protected by them—are completely free from decay and termite damage. This is big news in the field of paints, polishes and other coatings.

Other unique personalities show up among the offspring of the fluorine-carbon marriage. "Take N-octadecylheptafluorobutyramide or trifluorobromomethane, for example," says Doctor Taylor with a twinkle in his eye. "The latter chemical has some remarkable properties." He picks up an apparently empty beaker and very carefully pours nothing into another beaker. As you begin to think Doctor Taylor has been working too hard on N-octadecylheptafluorobutyramide, you notice something very perturbing. A small inflated balloon, which was resting on the bottom of the second beaker, slowly begins to rise. By the time Doctor Taylor has emptied the first beaker, the balloon floats atop the second, supported by several cubic inches of space.

"You probably have guessed the answer," says Doctor Taylor. "The first beaker was filled with trifluorobromomethane, a colorless, odorless gas. It's five times heavier than air, so you actually can pour it, and

(Continued to page 276)





OUR WALLS  
MADE ME  
WAIL!



UNTIL I  
DISCOVERED  
GOLD BOND  
COLOR  
TEXTURE!



YES, WE HAD DRAB,  
DULL, DINGY  
OLD WALLS!



I ASKED MY NEIGHBORHOOD DEALER  
WHAT TO DO. HE TOLD ME ABOUT  
AMAZING GOLD BOND COLOR  
TEXTURE...IN EIGHT NEW COLORS!



I JUST MIXED  
IT WITH TAP  
WATER...



... AND BRUSHED  
IT ON. IT DECORATES  
LIKE PAINT  
AND COVERS  
LIKE PLASTER



THEN I USED  
A SPONGE TO  
GET A DISTINC-  
TIVE SWIRL FINISH



OR A ROLLER  
DOES DOUBLE  
DUTY. COVERS  
AND TEXTURES IN  
ONE OPERATION.



YOU CAN GET ENOUGH COLOR  
TEXTURE FOR AN AVERAGE  
ROOM FOR ABOUT **\$4.85!**



AVAILABLE AT  
YOUR LOCAL  
GOLD BOND  
LUMBER AND  
BUILDING  
MATERIAL DEALER  
OR PAINT STORE

You'll build or  
remodel better with  
**Gold Bond**

NATIONAL GYPSUM COMPANY  
BUFFALO 2, NEW YORK



**"You can't beat SHOPSMITH**

*Kitchen designed and built by A. A. Myrus, Oneonta, N. Y.*



**1 "FULL-SIZE PLYWOOD PANELS** are hard to handle on the average table saw. But not on SHOPSMITH. The SHOPSMITH table extension gives you plenty of working surface — up to 48" between blade and fence. Not many saws can match that!"

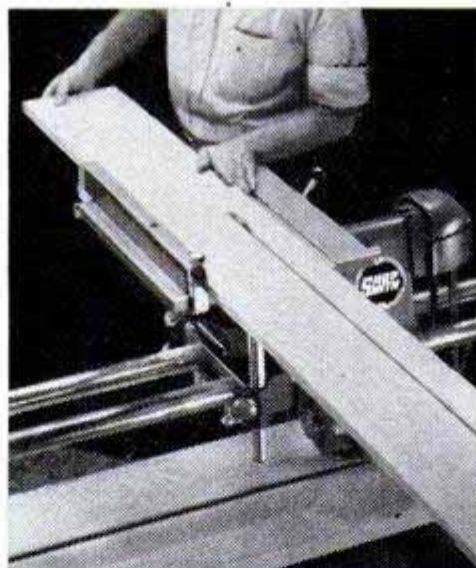

**2 "HAIRLINE CUTS.** Another thing I like about SHOPSMITH is its extremely accurate blade-to-fence setting. You make your fine adjustments by changing the position of the blade with the quill feed lever. It's faster and more accurate than shifting the fence."

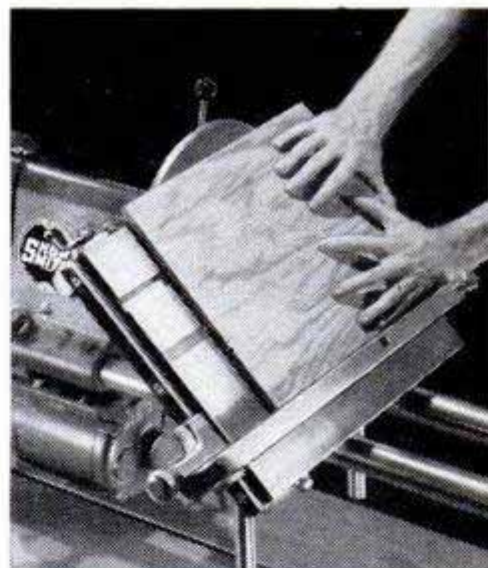

**3 "BEAUTIFUL BEVEL.** Plywood is difficult to bevel with a plane or shaper. It chips and splinters. But I was able to get perfect results with SHOPSMITH set up as a disc sander and the table tilted 45°. Sander was also used to butt-sand drawer fronts and framing members."

SEE SHOPSMITH DEMONSTRATED AT LEADING HARDWARE AND DEPARTMENT STORES OR ANY MONTGOMERY WARD STORE. WRITE FOR FREE CATALOG!

**SHOPSMITH is a complete power workshop . . .**

8" circular saw • 12" disc sander  
33" wood lathe • 15" drill press  
Horizontal drill

**SHOPSMITH complete except for \$189.50**

\*Special 1/2-hp., capacitor-type 120-volt, 60-cycle motor, \$34.50



## for cabinetwork!"

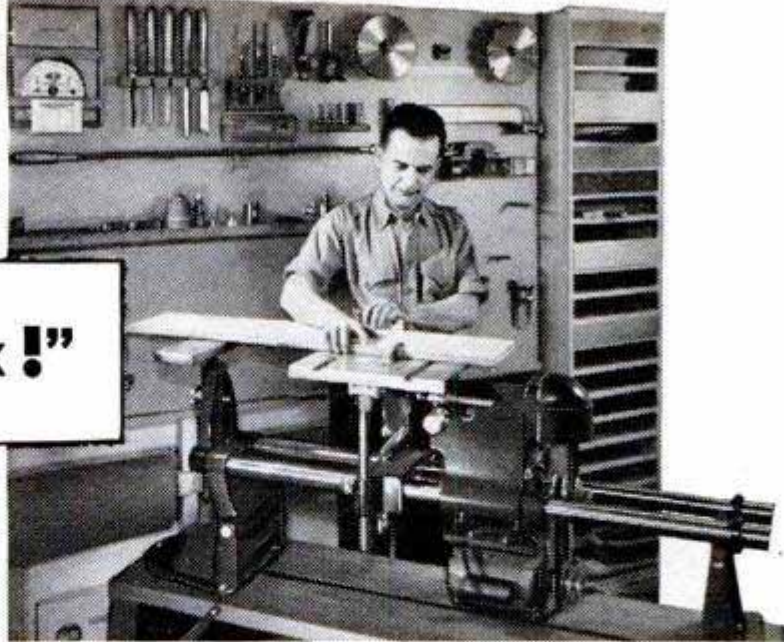

"I'm remodeling our entire kitchen. It's a big job. But, thanks to SHOPS MITH, I'm saving time and money and having the time of my life.

"Take the cabinetwork, for instance. There's where SHOPS MITH really showed me what it could do. I was able to cut 4' x 8' plywood panels easily and accurately. For 'right-on-the-button' saw blade to fence settings, I used the micro-quill adjustment—only SHOPS MITH has it. I beveled the edges of the cabinet doors with the disc sander. And I switched to the horizontal drill for doweling the maple chopping block.

"What especially impresses me is the accuracy of the work SHOPS MITH turns out. Every part fits perfectly. Corners are absolutely square. Dimensions check to the fraction of an inch. One reason for that is the fact that you can use the rip fence and miter gauge as jigs in almost every setup. Another reason is that SHOPS MITH is one integral unit. It can't get out of line.

"And when you add it all up—compactness, ruggedness, flexibility, extra features—it's easy to see why SHOPS MITH is America's most popular power tool."

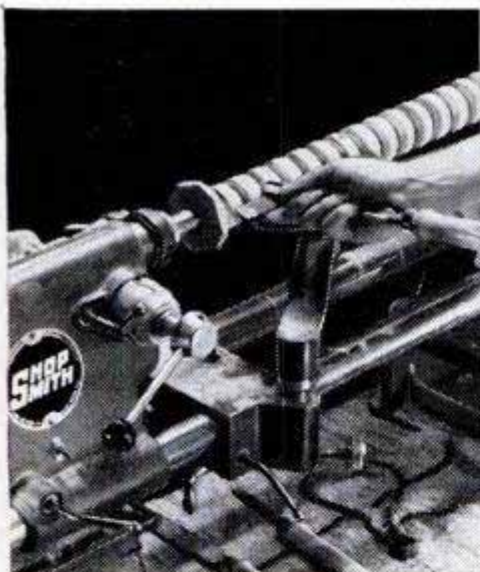

**4 "KNOBS** for the drawers and cupboard doors were turned fifteen at a time with SHOPS MITH in the lathe position. The SHOPS MITH tool rest slides parallel to work making it faster and easier to turn long pieces. Speeds can be varied from 800 to 3600 rpm."



**5 "HORIZONTAL DRILLING** surely saves time and headaches. I used it to drill maple boards for a doweled chopping block. Table and rip fence served as jigs, made it easier to position holes accurately. The SHOPS MITH spindle floats on four ball bearings, has a 4" quill feed."

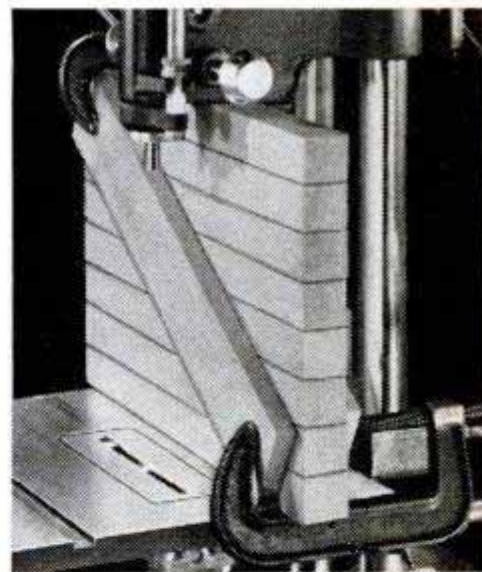

**6 "GLUE PRESS.** There's almost no limit to the things you can do with SHOPS MITH. After the maple chopping block was glued, I clamped it to the tubular steel ways of the SHOPS MITH, let the weight of the headstock (about 100 pounds) act as a press until glue was set."



**MAGNA ENGINEERING CORPORATION**  
Dept. 196-B  
at factory nearest you:  
12819 Coit Road, Cleveland 8, Ohio, OR  
Menlo Park, California

Please send me the free 16-page SHOPS MITH catalog.

Name \_\_\_\_\_

Address \_\_\_\_\_

City \_\_\_\_\_ State \_\_\_\_\_



# I Was the Gadgeteer for a TV Madhouse

(Continued from page 137)

that the fish coming out in skeleton form ought to get a laugh—which it did.

I sprayed a paper carton with gray lacquer until, as far as the television camera was concerned, it looked as swish as something out of Buck Rogers. Then I installed an electric motor inside the carton. The motor operated two moving platforms, one for the fish going in and one for the skeleton coming out. The motor also turned a number of wheels and dials. Finally, just to mystify everybody, I attached a hose bib to one side of the box and built a miniature television aerial which I fastened to the top.

The fish skeleton was the worst problem. I finally soldered together some lengths of brazing rod and cut a fish head and tail out of sheet copper. I sprayed the skeleton white; it was a complete success.

Sometimes McNamara built his own inventions. Once he constructed an automatic ash tray, sifter, dispenser and armrest which he was certain would revolutionize American smoking habits. He based the contrivance on the theory that ashes were good for the rugs, but if you merely flicked the ashes off the end of your cigar, the little piles of ash would make the rug bumpy.

So he built an elaborate affair, which he wore around his neck, that combined an armrest and an ash tray. When the tray became full, the contents were dumped through a screen, automatically straining the ashes and spreading them evenly over the floor.

Another of the gadgets he turned out was a device for killing flies that annoy you while making out your income-tax form. In one hand he held a fly swatter to baffle the flies, as it is well known to science that flies never go near a fly swatter. In the other hand he held a pen or pencil, using it to complete the income-tax blank.

But the pen or pencil was attached to a lever-arm arrangement through which he could instantly squash any fly which—lulled into security by the fly swatter—dared to nibble at the flybait which you had previously put out. All of this could be done without your looking up from the income tax form.

The last invention I built for McNamara was a little device which I think really has a future. It is an exploding-cigar detector. After long and involved research, I discovered that exploding cigars have gone through a process of radical evolution during the last 25 years. In the old days they were detonated by explosive caps buried

(Continued to page 260)



"Well... Claude has *one* good habit... he uses *non-alcoholic* Wildroot Cream-Oil!"



"Little dandruff, heh? Better try Wildroot Cream-Oil!"



"OK, OK! You're still *my* best friend... but Wildroot Cream-Oil is *my hair's* best friend!"

BEAMER KELLER

**YOUR HAIR'S  
BEST FRIEND**

America's  
Favorite  
Hair Tonic!





# Longest Lasting Screening You Can Buy!

Here's proof that  
**LUMITE\*** Screening  
outlasts all other kinds!

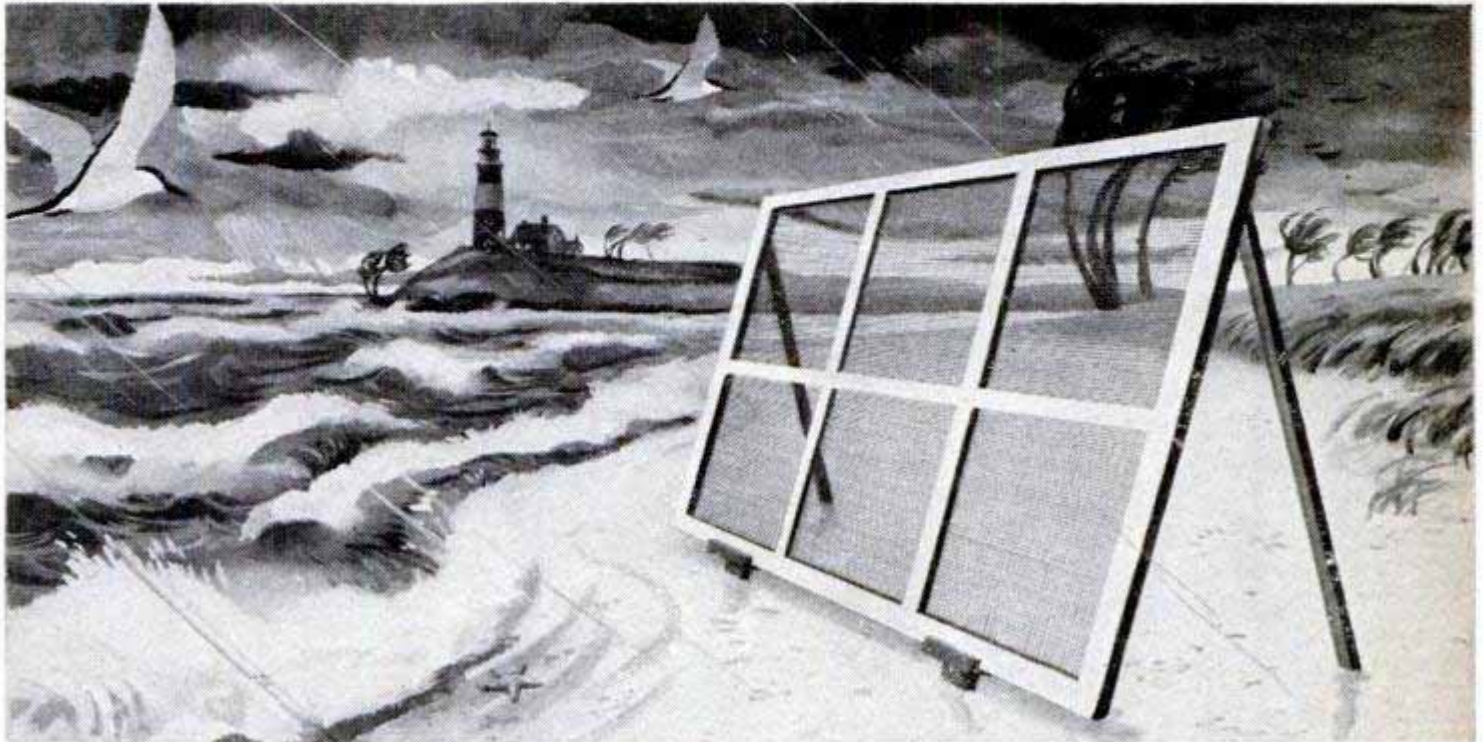

**Can't be beat for durability!** In actual comparison tests under the worst exposure conditions, LUMITE saran screening resisted the effects of weather outdoors *better than ALL other kinds of screening!* LUMITE is unharmed by salt air, humidity, city soot and acid smoke. Further tests proved LUMITE has the strength to take harder blows without bulging or breaking than ALL other kinds of screening!

**SAVE WORK,  
MONEY, THESE  
3 WAYS!**



**1. No painting or varnishing** needed to preserve LUMITE because weather outdoors has practically no effect on LUMITE. Ideal for every exterior use.



**2. No ugly stains** caused by screen rust or other corrosion because LUMITE screening is made, not of metal, but of rustproof, corrosion-proof saran.



**3. Fewer repairs, fewer replacements** over the years, because LUMITE lasts longer and is actually more resistant than ALL other kinds of screening.

**RUSTPROOF  
CORROSION-PROOF**



Free sample and folder. Write: Dept. PM-23, Lumite Division, Chicopee Mfg. Corp. of Georgia, 40 Worth St., N. Y. 13, N. Y.

# LUMITE\*

**SARAN SCREENING**

\*Registered trade-mark



# SELF-CONTROL STARTS HERE



in the stogies. Modern "exploding" cigars have a piece of spring steel buried in the cigar, kept under tension by a length of string. When the string burns through, the spring snaps open and rips the cigar apart.

I painted a short piece of  $\frac{3}{16}$ -inch dowel in bright colors and embedded a small Alnico 5 magnet in one end. When a friend hands you a cigar, you simply go over it carefully with the magnet end of the dowel. If the cigar sticks to the magnet, you know that there is steel in it. You then hand the cigar back to your friend, and, if possible, hold a gun on him and make *him* smoke it.

Building inventions for a TV madman may seem like a queer type of work, but I found it a lot of fun. It was a constant challenge and involved all sorts of interesting shopwork. Am I right, Mr. Goldberg?

## A Beetle Fights a Battle

(Continued from page 149)

spread  $\frac{3}{4}$  of a mile in all directions," reports Dr. William F. Barr of the university's entomology department. "A cleanup of goatweed from this area is well under way."

So far a general policy of secrecy has surrounded the location of the test colonies in the Pacific Northwest. California had plenty of trouble from beetle pirates. Stockmen who had lots of the weed slipped in and got themselves a few thousand. Snitching the beetles was bad enough. Trampling the colony area was worse, for more were killed than were carried away. The secrecy was to protect the beetles until a colony could hold its own against grazing and against thieving visitors.

But now the secrecy lid is being lifted. With beetles multiplying so rapidly, there's already a "come and get 'em" sign on some of the colonies in California. Free beetles are in prospect for Pacific Northwest ranchers.

"When our Idaho colonies reach the stage where they can provide surplus beetles for new plantings we will hold open houses at which ranchers and landowners with goatweed-covered ranges will be given an opportunity to bring their pots and pans and collect a few thousand beetles to take home," Doctor Barr explains. About 3000 beetles are sufficient for a foundation.

All that's needed in goatweed control with beetles, it seems, is to find the right species of beetle for the locality. Goatweed has a tremendous range of adaptability in elevation, soil and climatic conditions. But the beetle appears equal to this challenge. Somewhere in its lineup of species is one that can do well just about anywhere goatweed thrives.

(Continued to page 262)

and to restore

**CAR PERFORMANCE**

## OIL-CONTROL STARTS HERE

To stop oil-pumping, replace worn engine connecting rod bearings

Lost control usually spells trouble. This is especially true when applied to oil flow in your car, truck or tractor engine.

When the connecting rod and main bearings are worn, they lose control of oil flow. They no longer meter exact amounts of oil for proper engine lubrication. Excess oil reaches combustion chambers, burns to performance-stealing carbon on spark plugs, valves, pistons and rings. Performance goes up in smoke!

Give new piston rings a chance to do their own job—replace worn engine bearings, too! Genuine Federal-Mogul bearings are engineered for the job of oil control. Ask your mechanic!

**FEDERAL-MOGUL SERVICE**  
(Division of Federal-Mogul Corporation)  
DETROIT 13, MICHIGAN



CONTROL OIL-PUMPING

WHERE IT STARTS—REPLACE WITH

**FEDERAL-MOGUL**

**BEARINGS**

OIL CONTROL





**SEARS**  
ROEBUCK AND CO.

# DUNLAP 8-in. TILTING-ARBOR Bench Saw

REG. U.S. PAT. OFF.

## YOURS FOR ONLY



# \$46<sup>95</sup>

Cash

Complete with blade, miter gauge, rip fence, machine pulley, and V-belt.

ONLY \$5.00 DOWN

COMPLETE OUTFIT AS SHOWN

# \$110<sup>00</sup>

Cash

Complete Bench Saw with motor, motor pulley, two side table extensions, power tool bench, tool light, and Power Panel.

ONLY \$11.00 DOWN ON EASY TERMS



Table stays level, work lies flat at any angle of cut. Blade and guard tilt up to 45°



Double-row ball bearings form unit with arbor, prevent misalignment; need no oil



Floating motor mount makes tilting easier, keeps proper belt tension. Motor dismounts

These Accessories make your saw much more useful

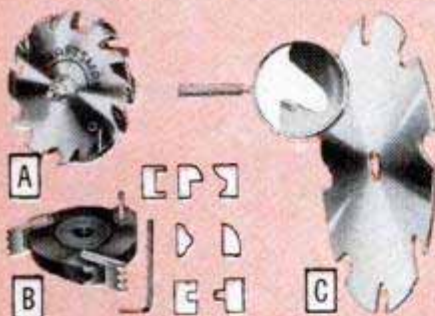

**A CRAFTSMAN 6-inch Dado Set.** Dados, rabbets, grooves, etc. with 1/2 or 3/8-inch-arbor bench saws. \$9.50 per set.

**B CRAFTSMAN Molding Cutter Head.** Fits most bench saws with 1/2 or 3/8-inch arbors. 4-inch diam. With Allen wrench. \$4.50. Cutter bits for above head. 1-in. wide bits cut styles as shown. Styles \$2.95 per set, and up.

**C CRAFTSMAN Carbide-tipped Saws.** New! Safer—8-tooth design eliminates kickback. Teeth project only .020 in. above non-cutting edge. Rips, crosscuts, miters—lasts 20 times longer than ordinary blades. 5/8 to 10-in. diameters, all arbor sizes. \$10.85 and up.

### Compare the features! Compare Price! One of our best power tool values . . . ever!

We compared this 8-inch DUNLAP to many other saws of the same type and price, and we know of *none* that equal it in work-saving features, performance, or price! *Only \$5.00 down puts this saw in your shop.*

**Tilting arbor** lets you cut any angle up to 45° while the work itself stays level. You can work faster, easier, and more accurately.

**Floating-drive motor mount** supports motor behind saw . . . smothers vibration . . . makes tilting easier . . . lets you remove motor for use with other tools.

**Super-lubricated precision ball bearings** NEVER need further lubrication, NEVER get out of line. (They form integral unit with arbor shaft.)

**Improved fence design** accurately squares fence directly against front of table. Can be used on either side of blade. Easily removed.

**17x14-in. table** of cast semi-steel; top and sides machined. 8-inch combination blade (1/2-in. bore) gives up to 2 1/4-in. depth of cut. (Use at least 1/2-H.P. motor: 3450 R.P.M., 2 1/2-in. pulley, 40-in. belt; or 1750 R.P.M., 5-in. pulley, 44-in. belt.)

**Complete outfit** (as shown) includes CRAFTSMAN 1/2-H.P. 3450 R.P.M. ball-bearing capacitor motor (110-120 volt, 60-cycle AC), 2 1/2-in. motor pulley, 2 side table extensions, 40-in. belt, adjustable steel power tool bench, tool light, and Power Panel (remote control for light, motor, etc.).

See this great DUNLAP saw value today at your nearest Sears Retail Store!

Your nearest Sears Retail Store will furnish you with exact selling prices which will not exceed ceiling prices under applicable price regulation of O. P. S.

## CRAFTSMAN and DUNLAP Tools by SEARS, ROEBUCK and CO.

REG. U.S. PAT. OFF.

REG. U.S. PAT. OFF.

### Famous for fine quality . . . precision performance . . . low price!



A few stockmen still shy at the idea of encouraging the propagation of bugs by the billions. Sure, they will eat the goatweed. But couldn't they prove to be a pest worse than the weed? Nothing to fear there, say the entomologists.

"The beetles eat only goatweed," Doctor Barr declares. "Not a thing else. If their food isn't available they will crawl or fly until they find some. Migrations up to five miles have been reported. If the beetles can't find goatweed anywhere they just give up and die."

## Science Tackles the "Sixth Sense"

(Continued from page 96)

chips to fall with a certain side uppermost.

Sitting in his laboratory, surrounded by dice cages, card shufflers and other mechanical devices, Doctor Rhine can relate stories of psychic phenomena until your hair stands on end.

He tells about one little boy who disappeared. Two days later a woman in the same village had a sort of daydream in which she visualized herself looking into a hole between some familiar rocks. She saw the legs and feet of a child half covered with dirt, wedged in the bottom. Frightened, she led some friends to the spot and they found the missing boy, dead. This, Rhine

points out, could have been a vivid case of clairvoyance.

Even more dramatic is the alleged clairvoyant experience of a 10-year-old girl who was walking down a road reading a book when, suddenly, her surroundings seemed to fade and she visualized her mother lying on the floor of an unused room at home, a lace handkerchief beside her. She ran to the near-by office of a doctor and sobbed her story. The doctor, more to allay her fears than anything else, took her home and was shocked to find the mother in the exact room described by the youngster, lying on the floor with the lace handkerchief beside her. She was suffering from a heart attack.

"Distance doesn't seem to matter in these cases," Doctor Rhine says. In one case, a man in Java said he dreamed in accurate detail about his mother's funeral at the time it was occurring in South Carolina. Even more significant is the account of a woman who was in Switzerland when her sister died in Chicago. Somehow, she knew it, and had her husband write down the date and hour when she first felt it. Later they learned that the sister died at the exact time they had marked down.

Psychic phenomena seem to have as little respect for time as for space, according to Doctor Rhine. When they leap the gap of

(Continued to page 264)

# DO IT TODAY! SWITCH TO

## MILD

# KENTUCKY CLUB

Notice how much better your pipe tastes—how much fresher your mouth feels when you switch to Kentucky Club.

Look for the blue tin with the picture of the red-coated rider. Send for free catalog showing fine pipes and how to get them at big savings. Mail Pouch Tobacco Co., Wheeling, West Va. Dept. 91



"Look! Another man switched to Kentucky Club—the thoroughbred of pipe tobaccos."



# IMPROVE YOUR WOODWORKING!

## with the NEW DURO 12" BAND SAW

The most practical power tool addition to your workshop. Enables you to "cut corners" on many woodworking operations! Versatile, convenient and dependable, will increase workshop efficiency and improve work quality. Has many features ordinarily found on higher priced tools: ball bearing blade guides above and below table keep blade running truer and smoother; double trunnion table supports; balanced disc wheels; roller type bearings. Work table tilts to 45°. One piece guard covers both wheels, has provision for built in light, unlocks easily, allows operator to check blade tension and tracking quickly, safely. Also permits easier blade changing. Can be used for metal cutting with special converter. There's a Duro Band Saw for every purpose in 10", 12", 15" and 16" models.

### A NEW KIND OF PROJECT MAGAZINE

A treasure of project ideas. Prepared by a practical craftsman. Refreshingly new material — with photographs, plan drawings, step by step instructions, that even a beginner can follow easily. Send 25c for sample copy, or you can save 1/3 and get 6 issues for \$1. Either way we'll refund your money if not delighted.



### Write Today!

For full details and specifications on the Duro 10", 12", 15" and 16" Band Saws and full story on the complete line of Duro power tools.

#### DURO METAL PRODUCTS CO.

2668 No. Kildare Ave., Chicago 39, Ill.

Please send me full details about the new Duro Band Saws.

I enclose 25c for sample copy of DURO CRAFTER Project Mag.

I enclose \$1 for 6 full issues of the DURO CRAFTER.

Name \_\_\_\_\_

Address \_\_\_\_\_

City \_\_\_\_\_

Zone \_\_\_\_\_ State \_\_\_\_\_

Dealer's Name \_\_\_\_\_



**DURO METAL PRODUCTS CO.**  
2668 N. KILDARE AVE. CHICAGO 39, ILL.  
Also Makers of Duro-Chrome Hand Tools

## WASH YOUR HOME!

### SUCCESSFUL HOUSE WASHER CLEANS

### LIKE NEW PAINT JOB!

### Cleans Porch and Basement Floors

### SAVES PAINT AND MONEY — EASY TO USE!

Seven foot light extension hose on handle attached to garden hose — valve controls soap, scrub and rinse operation. Has 3 ft. Telescope handle which opens to 6 ft. long. GUARANTEED not to leak.

Supplied complete with sufficient detergent tablets to wash average two story home at only \$14.95 POSTPAID. Short handle model pictured above, only \$11.95. Aluminum quota reduced 65%, making early orders advisable. ORDER DIRECT or write for details.

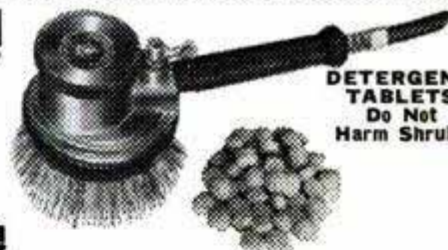

**DETERGENT TABLETS**  
Do Not Harm Shrubs

**TUCKER MFG. CO., Dept. PM-352, Cedar Rapids, Iowa**



### DRAINS Cellars, Wash Trays; CIRCULATES Oil; IRRIGATES Gardens!

ORIGINAL "Type P" Pump has 1,001 year "round uses — home, shop, garden, farm. DRAINS cellars, cisterns, wash tubs, ditches, pools. IRRIGATES gardens, lawns, truck patches. SPRAYS crops, orchards. CIRCULATES oil, coolant. SUPPLIES water to elevated tanks from wells as deep as 25 feet. 2400 gals. per hr. capacity. 360 GPH 75' high. 1500 GPH from 25' well. 1" suction and 3/4" discharge ports fitted for hose. Use 1/2 to 1-1/2 HP motor or engine. 1/2" Stainless Shaft. Oil-less Bearing. DOES NOT CLOG OR RUST!

ONLY \$6.95



## WHICH OF THESE 5 PUMPING UNITS DO YOU WANT?

Easy to Assemble!  
Easy to Use!



### TYPE C-4

Direct drive. Ideal for plumbing fixtures below sewer line. Complete with 1/2 HP motor, \$25.95. Without motor, only \$11.25.

**LITTLE GUSHER** Irrigates, drains, waters livestock, fights fires! Pumps 2000 GPH 25' high or 360 GPH 75' high. 2 HP engine with 3" power take-off V-pulley. Adjustable from 1700 to 4500 RPM. Portable. Dollar for dollar, pound for pound, the best pump. \$69.00 complete with valve at... 1 1/2" Bronze Foot Valve, 1 1/2" suction hose, \$1.25 per foot. 1 1/4" discharge hose, \$1.00 per foot.

**BIG GUSHER** Pumps 7000 GPH. Complete with 3' of 2" suction hose and 2" foot valve, only \$89.00. 1 1/2" suction hose, \$1.75 per foot. 1 1/2" discharge hose, \$1.25 per foot.

### Low-Cost Accessories

All Bronze Foot Valve for 1" hose, \$3.45  
1" Suction Hose, per foot, \$ .38  
3/4" Discharge Hose, per foot, \$ .22

### Money Back Guarantee

All prices POSTPAID if money order or check with order. West of Mississippi & Canada, add 50c for Type P; \$1.00 for other models.

**LABAWCO PUMPS, Belle Mead 22, New Jersey**



**TYPE D-3** Cleans 40' well or cesspool quickly! Drains. Irrigates, etc. Operates in any position. 400 GPH 40' high; 1400 GPH 20' high. Complete with 1/2 HP motor, \$32.95. Without motor, only \$12.85.

**TYPE D-4** Drains cellars, pools, boats. 1500 GPH 5' high; 600 GPH 13' high. Same as D-3 except with 1/4 HP motor \$27.45. Without motor, \$12.85.

**AUTOMATIC SWITCH** for 24" sump, fits D-3 and D-4. \$4.60.



# magic pivot DOES IT!

**\$ for \$ and lb. for lb.  
cuts deeper at 45°**

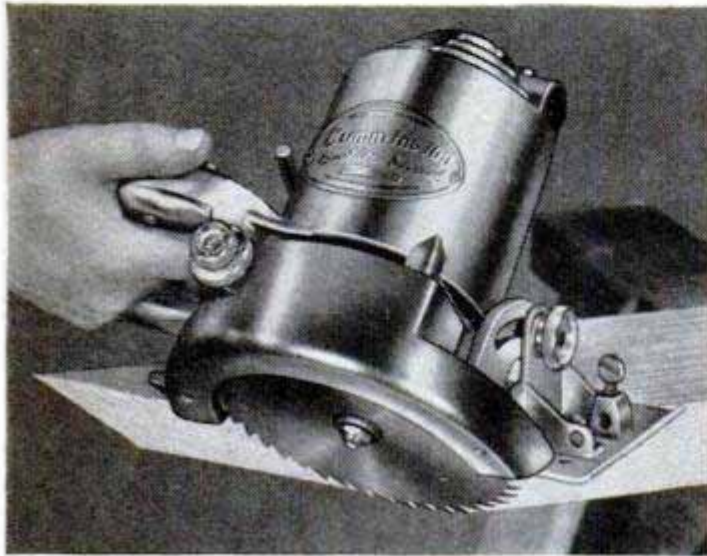

**Here's why you haven't seen the best 'till  
you see the CUMMINS 700**

**magic pivot** does it! Yes, with this amazing new exclusive CUMMINS feature, the CUMMINS 700 noses the blade down deeper into the work at 45°—where other saws lose cutting depth. The CUMMINS 700 actually cuts deeper at 45° with a 6 $\frac{3}{8}$  in. blade than any 7-in. saw and most 7 $\frac{1}{4}$ -in. saws that cost up to twice as much, weigh 15 to 20 lbs. The CUMMINS 700 weighs 10 lbs.—yet it puts more power at the cutting edge, cuts faster. It cuts full dressed 2-in. lumber at 45° with blade to spare—something no 7-in. saw will do.

The CUMMINS 700 with **magic pivot** is your king size saw buy! Price only \$69.50—yet it outperforms the field at lower cost, with more power, and a 50% savings in weight to save your muscles.

In addition, Cummins STUB RADIUS blades last twice as long. Because they have so much extra blade to spare at 45°, you get twice as many sharpenings and still hold full-through-cut at 45°. **magic pivot** is the first basic improvement in portable electric saws in almost 25 years! Don't buy any saw until you see the **magic pivot** CUMMINS 700—it is heavy duty, all-ball-bearing industrial quality—best there is! See it at your hardware store now.

Let us give you all the facts on this amazing development—send for Cummins Portable Power Saw Pamphlet today.

# Cummins

**PORTABLE TOOLS**

**Cummins-Chicago Corp.**

4740 N. Ravenswood Ave. Chicago 40

time, they become what he calls "precognitive" or prophetic. A specially strong hunch might be a mild form of precognition. One of the most striking examples is the famous case of John W. Dunne, brilliant engineer who designed England's first military airplane. In 1913, he dreamed he was on a railroad embankment near the Firth of Forth bridge in Scotland. Looking down, in his dream, he saw that a northbound train had just tumbled from the tracks, huge stones still rolling after it. Crushed, mangled cars lay in a smoking heap on a broad green field where people walked about. In his dream he knew this was happening in the spring of 1915. He told the dream to his sister, who recalled that he mentioned "probably March" as the time. On April 14, 1915, a crack train, *The Flying Scotsman*, leaped the tracks near the Firth of Forth bridge and crashed to a golf course 20 feet below the tracks.

Very often, when people report ESP cases to the Parapsychology Lab, they tell of physical effects that accompany them. "People tell of being near a dying friend and hearing loud knocks on a door when no one is near," Rhine reports. "I've heard of clocks that haven't worked for years suddenly striking; of piano keys being struck when no one is in a room. Such cases may be hallucination. They may not." He tells of one friend who reported that when his wife's father died of a sudden heart attack, a radio that had been blaring in the room suddenly stopped—and so did two others in the separate homes of the man's two daughters. None was in need of repair, nor was the program interrupted, it later turned out.

Doctor Rhine feels such occurrences might well be psychokinetic, or PK—the influence of mind over matter.

All these cases are exciting; some are highly documented. But to the scientist, no one's word is enough to prove that a thing as nebulous as telepathy or clairvoyance is a fact, rather than a coincidence, or even a lie from a fertile imagination.

At the Duke Parapsychology Laboratory, Drs. J. B. Rhine and Louisa Rhine (his wife) and their serious-minded assistants view the documented accounts as interesting historical data and that's all. To provide a scientific hook that will snag the intangible psychical phenomenon in action, and haul it in for study and mathematical analysis, they have devised unique instruments, games and techniques.

Students sit at tables separated from experimenters by plywood baffles, playing "guessing" games with Rhine's ESP cards. This is a deck of 25 cards, each marked with one of five vivid symbols—a cross, a star, a

(Continued to page 266)



SAVE AT GROBAN'S ON THESE BRAND NEW

# WAR SURPLUS Bargains

GUARANTEED UNCONDITIONALLY

## HEAVY DUTY AIRCRAFT QUALITY HYDRAULIC EQUIPMENT

Large supply of new labor-saving, economical hydraulic equipment in many types and sizes. Use these positive, highly efficient smooth pressure hydraulics on presses, arbors, lifts, loaders, power control, positioning, brakes, plastic dies, auto frame alignment, etc., etc.



**ITEM #29KJ**—Gear Type Hydraulic Pump. Ideal in industrial applications and for operating all hydraulically powered farm implements including loaders, stackers, swathers, plows, etc. Delivers 1000 PSI (may be set at lower PSI if desired), 12 GPM at 400 RPM. Maximum operating speed 800 RPM—rotation counter clockwise. Has built-in relief valve, permanent or torque bar mounting, 1" diameter shaft, 3/4" pipe tap inlet, 1/2" pipe tap outlet. Ship. wt. 22 lbs. **45.50** F.O.B. Chicago.

**ITEM #127**—Double acting hydraulic cylinder. 1" bore, 1" stroke, 1/2" diam. shaft, 1/4" tubing thread ports. Overall length closed—6 1/2". Clevis mounting at both ends. Perfect for clamping and feeding. **5.95** Postpaid



**ITEM #126**—Double acting hydraulic cylinder. 1 1/2" bore, 28" stroke. Will lift 1760 lbs. with 1000 PSI line pressure. Weight 8 lbs. A **\$55.00** value. Now only, **Postpaid 16.95**

**ITEM #126**—Four-way, open center control valve with built in adjustable relief valve. Factory set at 1000 P.S.I., spring loaded neutral position, for use with one double acting cylinder. Fully balanced plunger type, smooth, positive, easy operation, can be used as single unit or mounted in series of any combinations desired. Has 3/4" pipe thread inlet and outlet, 1/2" pipe thread cylinder ports. Newly manufactured to our specifications. Shipping weight 8 1/4 lbs. An outstanding buy! F.O.B. Chicago. **21.50**



**ITEM #103**—Double acting hydraulic cylinder. 2 1/2" bore, 17" stroke. Clevis mounting. Will lift 4900 lbs. with 1000 PSI line pressure. 1 1/4" diam. shaft, 3/8" tubing thread ports. Overall length closed 28". Ship. wt. 11 lbs. **21.50** F.O.B. Chicago.

**ITEM #6**—Double action hydraulic cylinder. 3" bore, 24" stroke, will lift 7070 lbs. with 1000 PSI line pressure. Steel barrel, 1 1/2" stainless steel shaft. Gov't. acq. cost \$176.00. Ship. **28.00** wt. 26 lbs. F.O.B. Chicago.

**ITEM #42**—Double action hydraulic cylinder. 4" bore, 18" stroke. Rated lift capacity with 1000 PSI line pressure is 12,500 lbs. Ship. wt. 30 lbs. F.O.B. Chicago. An Excellent Buy for **32.50**

## HYDRAULIC SPEED REDUCER WITH FINGERTIP CONTROL

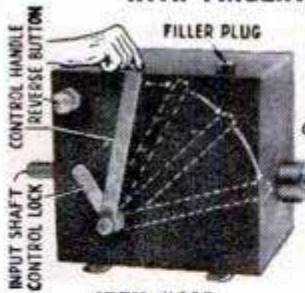

**USE FOR:** • Reamer Drives • Midget Cars • Feed Mills • Canning Machines • Conveyors • Lathes • Milling Machines • Motor Boats • Cream Separators • Garden Tractors • Pumps

Variable output speeds from 0 to input speed available by moving control handle. Locking handle maintains setting. Internal relief valves prevent overloading. Use input power of 1/4 to 1 1/2 H.P.

This Westinghouse-Oil Gear Unit converted to commercial use from 40 MM anti-aircraft traversing mechanism consists of a variable displacement hydraulic pump feeding a fixed displacement hydraulic motor. Adjustable relief valves set at factory for 100 inch pounds of torque may be reset up to 180 inch pounds. Independent reverse control allows full output power and speed selection in either direction of rotation.

Both input and output shafts measure 5/8" diam., include keyway. Input rotation is counter-clockwise facing shaft. Recommended input speed not to exceed 750 R.P.M. Over-all dimensions 7 1/2"x7 1/2"x11 1/2". Gov't acquisition cost, \$428.00. Shipping weight 31 lbs. Complete with 2 qts. of oil and full instructions. F.O.B. Chicago. **54.50**

**FREE: 1952, 48-PAGE CATALOG**

Loaded with unsurpassed War Surplus Bargains for the farm, home, factory and workshop. Write today! Write, Wire or Phone WEbster 9-3793

## IMMEDIATE DELIVERY. LARGE STOCK MANY SIZES BRAND NEW GENERATING PLANTS

PLENTY OF EMERGENCY STAND-BY OR GENERAL UTILITY POWER. FROM 350 WATTS TO 25 KVA.

**Item #183**—3000 to 4000 WATT GENERATOR SET  
**FEATURES**—Power for your home or business. Simply connect to power panel or house circuit. • Constant voltage regardless of load. • Push button start or stop. • Easily made full automatic start or stop. • Circuit breaker stops plant in event of short circuit. **SPECIFICATIONS**



—Sizes 19"x30"x48". Steel skids, weatherproof housing, requires no building. Wt. 725 lbs. • Hercules 4-cyl. 10 HP gasoline engine. Load governor. Oil filter. Quiet muffler. 6-volt starter generator. • Hobart 115 volt, 60 cycle, 3,000 to 4,000-watt generator. Furnishes either single or three-phase power, 2 or 3 wire. • Panel contains oil gauge, voltmeter, ammeter, circuit breaker, voltage regulator, start button. Today's Cost Over **\$1,200.00. SALE PRICE, F.O.B. Chicago... 465.00**

**Item #178**—350 watt—110 volt—60 cycle A.C. direct coupled to 1 cylinder Mideo engine. Shpg. Wt. 116 lbs. **125.00** F.O.B. Chicago.

**Item #182**—Onan Generator—5KW—120 volt—60 cycle A.C. single phase, direct coupled to Ford 4 cylinder water cooled engine with push button start, battery ignition. (Battery not included.) Shpg. wt. 1200 lbs. **795.00** F.O.B. Chicago.



**Item #199**—Power Unit PE-99—7.5 KW—120 Volt—Single and 3-Phase—60 Cycle A. C. Master generator driven by a 4 cylinder, V-type, air cooled, Wisconsin engine with magneto ignition, push button start. The self-excited, drip-proof generator is driven from 5 parallel V-belts. Control panel contains engine and generator instruments, including circuit breaker, emergency start-stop buttons, volt meter, ammeter. Complete semi-enclosed unit mounted on steel skid. Weight 1085 lbs. **945.00** F.O.B. Chicago.

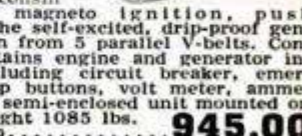

**Item #201**—PE 95-G—10 KW—110/120 Volt—60 Cycle A.C.—Single Phase. Totally enclosed. Onan generator direct coupled to Willys Jeep, 4 cylinder, water cooled engine, push button start. Instrument panel with engine and generator instruments, circuit breaker, controls, etc. Uses 6 volt car battery. Battery not incl.) Skid mounted. Ship. wt. **1295.00** 1500 lbs. F.O.B. Chicago.



**Item #180**—15 KW—127/220 volt—60 cycle AC—3 phase 1800 RPM. Brance & Krachy Generator direct coupled to International Harvester 4 cylinder, water cooled engine with magneto ignition—push button start. Panel has voltmeter, ammeter, 4-wire electrical system, belt driven excitor generator, rheostat voltage control. Engine and generator mounted on steel skids. Ship. wt. 2000 lbs. (Battery not included.) F.O.B. Chicago. **1650.00**

Write for free information on other generators from 350 watts to 25 KVA.

## BRAND NEW GENERAL MOTORS — ALLISON CENTRIFUGAL PUMP

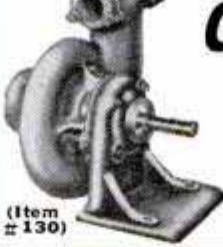

**200 GALLONS PER MINUTE**

- For Draining Basements • Fire-Fighting
- Irrigation • Fuel Transfer • Swimming Pools • Home Water Systems • Dewatering

This General Motors-Allison Centrifugal Pump—designed for use on U. S. Air Force Mustang fighters, now converted for commercial, home, and industrial high volume pumping applications. Inlet, 2 1/2" standard pipe thread, twin outlets with 1 1/2" pipe thread, ball bearing supported 3/4" shaft. Easy, fast simple priming. Rotation, counter-clockwise facing shaft. Shipping wt. 35 lbs. Gov't. acq. cost \$145.00. F.O.B. Chicago. **39.50** NOW ONLY

Suction Lift	Head Pressure	Gal. Per Min	H.P.	R.P.M.
10'	75'	260	6.0	3500
10'	65'	200	5.2	3500
10'	80'	40	1.5	2500
10'	50'	140	5.0	3500
10'	30'	100	3.0	2500

## NEW MODEL 353 D.C. ARC WELDER

— DUAL RANGE — For Stationary or Portable Use. HEAVY DUTY RANGE TO 250 AMPS. NEW 'MAGIC TERMINAL' FOR LOW CURRENT 30 TO 100 AMPS. IDEAL FOR • FARM • FACTORY • GARAGE • WORKSHOP

This precision engineered D.C. Arc Welders contain the highest quality War Surplus aircraft components built to exacting government specifications. They are light in weight, have oversized lifetime grease-sealed ball bearings, air cooled commutator, dial type rheostat for easy pin-point control, a high-low rheostat switch, reactor coil for even arc and the new 'MAGIC TERMINAL' low current welding range for welding lighter materials. Designed for many years of trouble-free service. Run welder from drive pulley or power take off of a tractor or Jeep. 7 1/2 HP electric motor or 10 HP gas engine at 2500 R.P.M. Uses two V belts or flat belt. Continuous output rating 200 amps. Intermittent welding rating 250 amps, 30 volts. This sensational price includes double V or flat belt pulley and complete operating instructions. Shipping weight 107 lbs. \$350.00 Value. Item #65. F.O.B. Chicago. Now Only **119.50**



Welds Anything From Auto Fenders To Tractor Frames **119.50**

**GROBAN SUPPLY CO. DEPT. PM-3**  
1139 SO. WABASH AVE., CHICAGO 5, ILL.  
ORDER DIRECT FROM AD—SEND PAYMENT OR PURCHASE ORDER TODAY SATISFACTION GUARANTEED



**Save Time, Save Work**

*Save Yourself*



**Do more work faster and easier with  
**BOLENS** garden tractors**

Save time and enjoy extra hours for relaxation. Make yard and garden jobs easier and more fun with a BOLENS garden tractor — proved best by impartial test. Only BOLENS offers: patented design features, finger-tip controls and perfect balance for easier handling . . . superb engineering, rugged construction for years of trouble-free service.

**PROVE to YOURSELF** that BOLENS tractors are superior — offer more for your money. See your dealer today.

*Models illustrated: A. 2.5 HP Power-Ho DeLuxe, B. 1.6 HP Handi-Ho, C. 6 HP Ridemaster. Others available. Complete line of attachments save you time and effort all year 'round.*



**BOLENS** Products Division

Food Machinery and Chemical Corporation  
265-3 S. Park St., Port Washington, Wis.

Please send free literature and name of nearest dealer.

Name.....

Address.....

City..... (.....) State.....

B-178

circle, a square, or three wavy lines. In clairvoyance tests, cards are spun in an automatic shuffler—a long black box lined with wavy walls and suspended on an axle—and then placed in a closed box. The subject tries to name the top card. Or perhaps he'll go right on down through the pack. Later the cards are removed and compared with his "guesses." Since no one knows the order of the cards, the subject could get consistently correct answers only through clairvoyance.

"Five out of 25 cards is what the mathematical laws of chance say should be predicted in such a game," Rhine explains. "When we come up with subjects who hit six and seven in thousands of runs, and consistently give scores with odds of 10,000 to one better than chance, which we do, we know that something more than pure chance is at work."

Any doubt that investigators were on the track of something startling vanished when one man named Lingmayer scored a succession of nine hits in a row, then named 15 cards right. Then another subject named Pearce called all 25 for a perfect score. The odds against such a performance occurring by pure chance are so astronomical that this page wouldn't be wide enough to accommodate the figures.

Other perfect scores have been made since then. Rhine tells about a nine-year-old orphan named Lillian, who made excellent scores. One day the experimenter promised her 50 cents if she got all the cards right. At the next test, Lillian said, "Don't say anything. I'm going to try something." She closed her eyes for a moment, went to the table and kept moving her lips all through the performance—"wishing all the while I would get 25," she told the experimenter later. And she did!

Rhine explains that the girl's attitude was ideal because of the promise of reward.

In telepathy, instead of using the cards themselves, the tester simply thinks of one of the symbols while the person being tested tries to match his thought. In precognition tests with the cards, the subject predicts in what order the cards will come from the automatic shuffler *before* they are shuffled. In one set of 4500 such tests at Duke, scores averaged 400,000 to one that something beyond mathematical chance was operating.

In one room, clairvoyance testers use a tray of 25 colored marbles in sockets. Another tray with empty sockets fits on top of it and locks in place. The subject, who has never seen the marble arrangement in the bottom tray, dips in a bag of marbles and tries to match colors with those under-

(Continued to page 268)



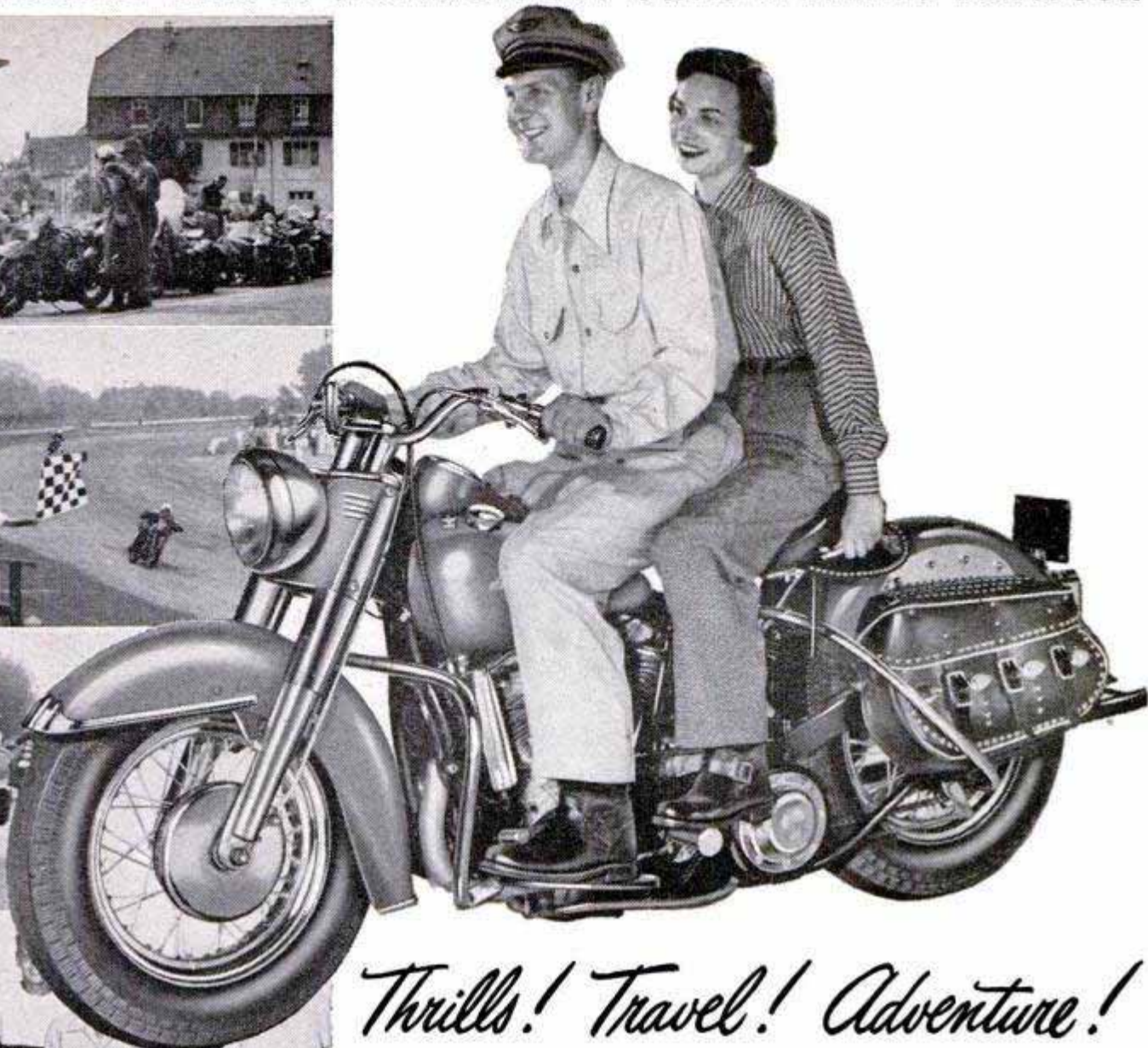

*Thrills! Travel! Adventure!*

WITH A  
**HARLEY-DAVIDSON**  
**HYDRA-GLIDE®**

All the country's scenic spots, historic places, natural wonders *are yours to enjoy* when you ride the ultrasmooth Harley-Davidson Hydra-Glide! It's your "magic carpet" that whisks you on a never-ending round of good times, takes you to exciting races, on sight-seeing trips, thrilling gypsy tours, and a host of other fun-packed motorcycling events! Easy to own on convenient terms, so why not join the pleasure parade? See your dealer today. Mail the coupon NOW!

HARLEY-DAVIDSON MOTOR CO., Dept. P, Milwaukee 1, Wis.

Enclosed is 25 cents for literature on the 1952 models, and a copy of the Enthusiast Magazine filled with motorcycle action pictures and stories.



Name.....

Address.....

City..... State.....



QUALITY PLUS  
PRECISION . . .

# Shopmaster

Tools and  
Accessories

for  
**BUDGET-MINDED  
Hobbyists**



8" Tilting Arbor Bench Saw \$76.95

7" Tilting Arbor Bench Saw \$47.95

8" Tilting Table Bench Saw \$51.50

10" Tilting Arbor Bench Saw \$86.95

10" Floor Model Tilting Arbor Saw \$105.00



12" Drill Press . . . \$47.95

12" Floor Model Drill Press . . \$54.00

6" Jointer-Planer . . \$79.95

4" Jointer-Planer . . \$47.95



15" Jig Saw (Tilting Table). \$27.95

Saber Saw \$17.95



12" Band Saw . . \$87.50

10" Band Saw . . \$46.45

Belt and Disc Sander . . . . \$51.50

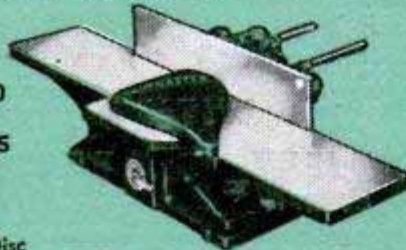

Spindle Shaper . . . . . \$45.95

10" Wood Turning Lathe \$45.95

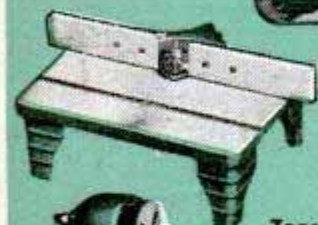

Zone 2 prices, slightly lower in zone 1.



WRITE TODAY FOR  
FULL COLOR CATALOG.



**SHOPMASTER, INC.**

1214 Third St. S., Minneapolis, Minn.

neath. Here again, the mathematical laws of chance call for five proper matches out of 25, yet at Duke the scores in hundreds of tries fell far above that chance average.

Most startling are the tests with pictures which the subject tries to "copy" without seeing what he's "copying." In GESP tests, which may involve either clairvoyance or telepathy or both, the experimenter in another room looks at the picture, signals the subject that he's ready by telegraph key, and the subject tries to draw what he thinks the other person is looking at. In clairvoyance tests, the pictures are put in sealed opaque envelopes, and shuffled so no one knows which is which. Then one envelope is picked out and the subject tries to draw what he thinks is inside. He has never seen any of the pictures before, of course.

Some results give you the cold shudders. One man drew a chemical flask and test tube on a laboratory table. The picture in the other room showed a doctor, with an identical flask in front of him, filling a hypodermic needle.

Such dramatic evidences of clairvoyance and telepathy occur frequently enough to go far beyond the realm of coincidence, Doctor Rhine has determined.

Toughest nut to crack scientifically was PK. Rhine had documented accounts of a famous professor of religion whose inkwell split in two with a sharp report when a student asked him for evidence of the spiritual world; of a wooden table top rent asunder with a loud crack when no one was near it. He has a photograph of the four pieces of a steel bread knife that shattered with very similar sound effects at the same time. How do you get at the strange force, if it exists at all in a person, that might make such things happen?

A young gambler provided the answer. Many people, he told Rhine, believed they could influence the roll of dice. Wasn't that the same thing? Rhine thought it might be. Today, in his laboratory, subjects roll dice under rigid controls on specially prepared surfaces. A target number is chosen and the thrower tries to make it come up as often as possible. He may use two dice, rolled from a cup, or turned in a cage by motor. In new and bigger apparatus, dozens of dice jiggle in automatic shakers, tumble down a perfect inclined plane and spread across a level table. Target hits are noted and recorded. Here's how it works. If the subject is throwing for single faces such as a "three," for instance, pure chance says that one "three" can be expected in every six die-throws.

Though there has never been anything to compare with the perfect scores in the

(Continued to page 270)



**DISSECTING KIT**



**\$4.95**  
postpaid  
**For Microscopic Slide Work In BIOLOGY BOTANY ZOOLOGY**

A special purchase for our microscope customers. The professional equipment in this complete kit is worth more than \$15. Made to the specifications required by researchers and biologists. Ten pieces in fitted hardwood case; two fine steel scalpels, two prof. dissecting instruments, one magnifying glass, one special scissors, one special tweezers, three blank slides. Perfect for universities, doctors, students. Postpaid \$4.95.

**IMPORTED 300 POWER MICROSCOPE \$14.95!**

**LABORATORY MODEL POSTPAID**

**Triple Revolving Turret Has 100, 200 and 300 Power Objective Lenses**

No frills, just excellent optical qualities, delicate adjustment and solid construction. Its quality and price astounded biology instructors. A lifetime bargain for students, schools, labs, research, amateurs. *Anyone can now own one!* (Performance cannot be duplicated for \$75.00.)

**FEATURES:** Fine micro adjustment, adjustable plano substage mirror. Dovetail hardwood case included free.

**USES:** Animal, plant and mineral research. Study plant cells, microscopic animal life, crystalline structure, etc. See the complex anatomy of tiny insects, larvae, eggs. 300 magnifications makes a fly look as large as a bird. If you are not amazed by the quality of this microscope, send it back in 10 days. Your money will be refunded immediately. \$5.00 deposit on C.O.D.'s. Send check, cash or money order for \$14.95.

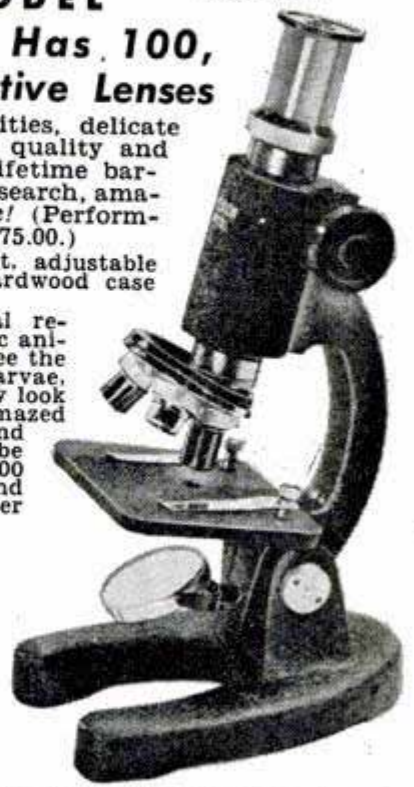

**"HUNTING WITH THE MICROSCOPE"**

Gaylord Johnson's intensely interesting 93 page book—how to hunt microscopic big game, micro detective work, how you see the oddities of the invisible world. Postpaid. . . . . **60c**



**HALF PRICE SALE — IMPORTED MAGNIFYING GLASSES**

2" dia. \$1.00    2 1/2" dia. \$1.35  
3" dia. \$1.95    3 1/2" dia. \$2.25  
4" dia. . . . . \$2.50 (all postpaid)

**NAVY TYPE MARK XX 20 POWER TELESCOPE**

\$30 value. Fine optically ground achromatic lenses, fully coated. Same power as standard artillery observers spotting scope. Precision all metal construction. Extends to 15 1/4 inches. Rust and salt-spray resistant. A valuable ship and boat owners possession now at a price everyone can afford! Shipped in fitted hardwood case. Postpaid \$9.95.



**8X COATED PENSCOPE \$4.95 ppd.**

Pocket Telescope fits in your pocket like a fountain pen, extends to form a powerful scope for spotting game, watching sports, etc. 8 power coated lens, more powerful than standard army binocular.

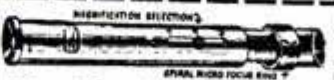

**20, 40, 60X POCKET MICROSCOPE**  
You select power, then focus with spiral ring. Finest optics, a new precision instrument for field use! Postpaid. . . . . **\$4.95**

**AKRON** 4400 SUNSET BLVD. LOS ANGELES 27, CALIF. OPTICAL DEPT. 3-P

Money-back 10 day guarantee on all items. Send check, cash or M.O. Free catalog on request or included with your order. Calif. residents add 3% state tax.

**Handy Mail Order List**

**Little Library of Useful INFORMATION**

Here at amazingly low cost is the practical help and information you have always wanted. Articles in previous issues of Popular Mechanics have been classified according to subject and are now available in these handy reprint booklets.

**5 for \$1.00**  
**12 for \$2.00**  
**25¢ Each**

- How to Use Measuring Tools—Micrometers, Calipers, etc.—106.
- Power Driven Saws—74.
- Drill Presses, Grinders, Etc.—79.
- Wood, Metal Turning—Lathes—81.
- Filing Machine, Hack Saw, Cutoff Wheel, Shaper—82.
- Lathe Tools You Can Make—101.
- Workbenches—Tool Cabinets—47.
- Spray Painting—94.
- From Pattern to Casting—91.
- Tool and Saw Sharpening—92.
- Sharpening Drills, Wood Bits—90.
- Successful Wood Turning—32.
- How to Read Blueprint—71.
- Metal Turning Lathe Kinks—99.
- Operating a Metal Lathe—100.
- Heat Treating, Hardening—102.
- Working With Glass—103.
- Servicing Elec. Motors—75.
- Electromagnets & Solenoids—44.
- Transformer Construction—41.
- The Boy Electrician—43.
- Soldering and Brazing—17.
- Arc and Spot Welders—5.
- Electroplating With Nickel, Chromium, Cadmium, Etc.—86.
- Plating Leather, Wood, etc.—87.
- Lower Your Fuel Costs—31.
- Curing Leaky Basements—45.
- Fitting Home Game Room—55.
- Indoor & Outdoor Fireplaces—88.
- Backyard Gardening—39.
- Lawn and Garden Novelties—72.
- Trellises, Pergolas, Fences—76.
- Lawn and Garden Furniture—77.
- Playground Equipment—73.
- How to Use Your Drill Press—125.
- Making Serving Trays—53.
- Knots and Ropework—105.
- Sanders—80.
- House Wiring—89.
- Hanging Wallpaper—38.
- Built-in Fixtures—78.
- Bird Houses—7.
- Magazine Racks—49.
- Clock Cases—50.
- Book Ends—52.
- Small Tables—54.
- Smoking Stands—56.
- Desks—58.
- Book Cases—59.
- Action Toys—66.
- High Flying Kites—67.
- Telescopes—20.
- Metal Craft—28.
- Small Looms—37.
- Gem Cutting—42.
- Photo Enlargers—1.
- Photo Kinks—98.
- Cleaning Formulas—11.
- Taxidermy—9.
- Photo Lighting—119.
- Training Dogs—35.
- Small Furnaces—36.
- Working With Plastics—61.
- Simple Home Improvements—104.
- Ridding Home of Insect Pests—107.
- Children's Room Furniture—51.
- Jigsawed Novelties—57.
- Doll House & Doll Furniture—60.
- 25 Shelves You Can Make—64.
- Novelties Turned on Lathe—62.
- Inlay Pictures—Veneering—63.
- Wood, Soap Carving—65.
- Windmills & Weather-vanes—68.
- Lamps from Wood, Metal—69.
- Plastic Furniture—18.
- Wood Finishing—40.
- How to Fix Electrical Appliances—111.
- Painting Your House—117.
- Build Your Own Relays—123.
- Rowboats, Small Dinghy—83.
- Small Sail Boats—84.
- Two Outboard Runabouts—85.
- Build Own Canoe, Kayak—30.
- Build Class-E Ice Yacht—22.
- Auto Kinks, Shortcuts—10.
- Lawn and Garden Equipment—124.
- Motor-Driven Midget Cars—34.
- Stop Auto Elect. Troubles—95.
- Photo Printers and Dryers—25.
- Photo Darkroom Equipment—96.
- Trick and Table Top Photos—97.
- Home Movie Equipment—118.
- Poultry Houses—108.
- Guns and Decoys—109.
- Re-Silvering Mirrors—70.
- Chemical Experiments—93.
- Log Cabins, Tourist Houses—14.
- Using Basic Tools—120.
- Farm and Garden Tractors—8.
- Building Extra Attic Rooms—23.
- Attractive Basement Rooms—24.



**NEW POPULAR MECHANICS MAGAZINE LIBRARY FILE**

**Brand New, Grand New Way to Preserve Each and Every Issue of Popular Mechanics**

Now you can preserve every treasured issue of Popular Mechanics in these ingenious, custom-built storage files. Constructed to look like an attractively bound book, Popular Mechanics Magazine Library Files afford neat, orderly, flick-of-the-finger convenience. Handy reference index printed on back records the exact location of selected articles, diagrams, etc. A "must" for every reader of Popular Mechanics Magazine. A sensational Popular Mechanics value scoop. Order yours today. Use the handy coupon.

**Only 70¢ PER SET OF 2**  
(Set holds 12 issues)  
**POSTAGE PAID**  
5 sets only **\$3.10**  
10 sets only **\$6.00**  
**POSTPAID**

**USE THIS COUPON...MAIL TODAY**

Popular Mechanics Magazine, Dept. PL 200 East Ontario Street, Chicago 11, Illinois P3-52

Please rush PREPAID \_\_\_\_\_ set Popular Mechanics Magazine Library Files. (QUANTITY)

Remittance for \$ \_\_\_\_\_ is enclosed. (AMOUNT)

Name \_\_\_\_\_

Address \_\_\_\_\_

City \_\_\_\_\_ Zone \_\_\_\_\_ State \_\_\_\_\_

Check Titles Wanted, Clip, Mail with Remittance to  
**POPULAR MECHANICS PRESS, Dept. 23, 200 E. Ontario, Chicago 11**



Bronson Presents

The finest reel  
money can buy!

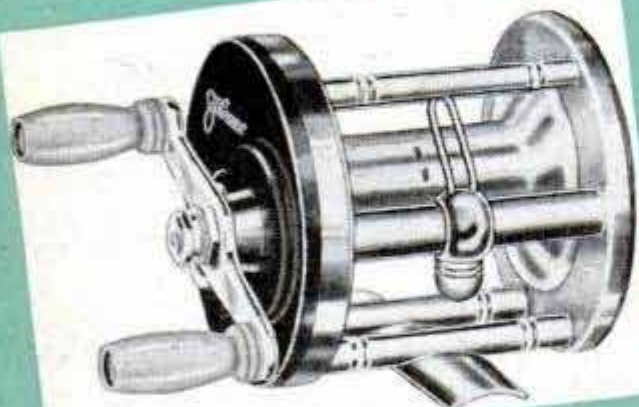

J. A. Coxo 25-C Coronet  
\$33.00  
... with the sensational  
one-piece spool



You'll agree it's the finest when you see this new Bronson-made automatic free-spool reel. Handles automatically disengage and do not turn on the cast. One-piece aluminum spool is the lightest yet, weighs only 33/64 oz. It's stronger, too—and machined inside and out for perfect balance. Spool revolves on a stationary shaft for perfect alignment. 10-second takedown without tools.

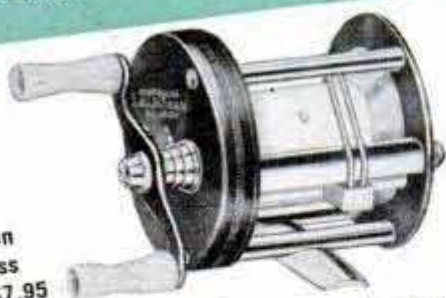

Bronson  
Lashless  
1710—\$7.95

For a lightweight reel at a medium price, choose the Bronson Lashless. Precision built, beautifully balanced, modern in every detail. Green anodized aluminum, weighs in at 4 3/4 oz. 3-piece takedown, snap-on plastic arbor. Famous Bronson Duo-Pawl doubles the life of the reel. Take a new Coxo or Bronson reel on your next fishing trip. \$2.95 to \$33.00.

# Bronson

WRITE FREE CATALOG Bronson Reel Co., Bronson, Michigan  
Dept. P (Division of Higbie Manufacturing Co.)

ESP card tests, PK dice experiments average well above chance. So do the scores on a weird gadget, hung on a swivel, in which chips, marked with a bull's-eye on one side and a plus sign on the other, cascade down a snaky chute to a flared bottom. Subjects try to influence one side of the chips to come up more often than the other.

To see if distance might affect their results, the group at Duke, and other parapsychology centers have tried their experiments by remote control. At distances up to hundreds of yards, Pearce, the perfect-score man, averaged eight hits per run during hundreds of tests with ESP cards. One woman hit 19, 16 and 16 on three successive days from a point 250 miles from Duke.

Men like Doctor Rhine are goaded in their search by an occasional performer who leaves them gasping—like the British photographer Basil Shackleton, who was being studied by English scientists. After Shackleton had run a series of terrible scores in GESP tests with a deck of cards, the experimenters suddenly discovered to their amazement that the man was naming not the card the experimenter was looking at, but the *next one*, which the experimenters hadn't even seen yet. His scores were consistently high. They checked him with cards depicting animal pictures, in which he'd name the animal. He did the same thing. They checked him in a separate room. He still did it.

Those who have been working in it know that ESP is a slippery business, which eludes time and space. But by probing deeper and deeper in the dark corridors of the subconscious mind, explorers such as Rhine hope to find exactly where human personality belongs in the scheme of things. If their premonitory hunch is right, they may well change our entire concept of the physical laws of the universe.

## Tougher Base For Movie Film

Home-movie fans will be happy to learn that a new base for motion-picture film promises to wear three or four times longer than present film. It also has twice the tear resistance of standard acetate or nitrate-base film. Developed by Du Pont research, the film base is a polyester and is chemically related to Dacron polyester fiber, the newest of Du Pont's synthetic fibers. Because of its toughness and stiffness, it is believed that the new film will make it possible to reduce the thickness of film by at least 20 percent, with a resultant increase in footage per reel. The new film will soon be produced on a pilot-plant basis by Du Pont.





## D.C. GENERATORS

Finest aircraft quality . . . heavy duty . . . lifetime grease-sealed ball bearings. Terrific for truck and marine use, for welders, plating, D. C. Appliances, lights, etc. Type P-1 Mfd. by Ford, General Electric, Westinghouse & Delco-Remy. Rated 200 Amps., 28 Volts; 2500 RPM., can be "revved" up to 300 Amps. Shpg. Wt. 53 lbs. Approx. Govt. Cost \$350 . . . New to you . . . **\$21.50**

## LOW VOLTAGE CIRCUIT TESTER

Made for U. S. Ordnance Dept. to rigid specifications. Portable steel hand carrying unit is a self-contained trouble shooting device for making a complete and rapid check of the generator battery circuit, including any circuit and voltage regulators. Battery voltage, regulators, cut-out settings and generator performance can be easily determined. A terrific testing unit for garages, mechanics, truck fleet owners, boat and marine mechanics. Can be used on any 6 or 12 volt system. Govt. cost approx. \$175. **NEW—complete with instruction book—only \$32.50.** Shipping weight, 20 lbs.



## WILLARD WET PLATE BATTERY

Extra-long life, rechargeable battery. 2 V., 20 Amps. Great for portable radios, mobile units, bell circuits, alarm systems, rural telephones, Strobe bulbs, etc. Only 5" high. Visible ball float hydrometer built in Lucite case. Shipped dry (wt. 3 1/2 lbs.) . . . any battery service will supply standard battery electrolyte. Used singly or in multiples. **ALL NEW! Now only \$1.95 ea.**



## PORTABLE WELDER



Will weld, broze, solder and cut all metals up to 3/16". No experience needed, full instructions included. Weld iron, steel, brass, aluminum and other metals. Plug into any 110 Volt A.C. or D.C. line. Save hundreds of hours and money doing repair work for yourself and others. A great item for any mechanic or hobbyist, etc. Not a toy. Comes complete with electrode and carbon holders and an ample supply of electrodes, carbons, flux and necessary components to do a thorough welding job of any type. This unit cannot be duplicated for many times its price. **NEW—price \$12.00.**

## "BALTIC" SWEDISH TOOLMAKERS VERNIER CALIPER



**ULTRA PRECISION—0.6" in .001 graduations.** Quick, accurate depth, inside, outside measurements, line engraving. Extra heavy rule, hand-fitted sliding head, no side play. Rockwell C.60, lapped measuring surfaces. For the extra particular mechanic who must have the best—used and recommended by most critical experimental & research machinists at Lockheed, Douglas, Bendix, GM, RCA, General Electric. Save 80%! A \$37.50 value—only **\$14.75**, leather case incl. Also a standard grade Mauser Design Caliper made in Germany. For the production machinist, 0.6" in thousandth, the most accurate caliper of this type on the market, 1000's of satisfied users. Only **\$10.95**, leather case incl. These Calipers are of acceptable quality for precision aircraft work. Both are guaranteed buys, money back if not entirely satisfied. Order now! New low price due to lower import duty!

## CUNO OIL FILTER, permanent type.



This is the maximum capacity unit (not the small type) that gives greatest protection to your pump, boat, midget racer or engine. It's the perfect filter to keep motor oil or hyd. fluid clean at all times. Just turn handle and element is clean. Inlet & outlet ports take 3/4" pipe. Accommodates 16 GPM at 30 PSI. Mtg. bracket. Wt. 4 lbs. Approx. Govt. cost \$35. Cost to you, **NEW, \$3.75.**

## FLEXIBLE SHAFT MAGNET

For picking up cotter pins, nuts, wrenches, etc. from inaccessible places. Removes Bobbie Pins, etc. from drains. Lifetime Magnetism Guarantee. Highly polished magnet and handle. **\$2.00 postpaid.**

## DRILL GRINDER Sharpens round, square or tapered drills up to 6" long.

Even an amateur mechanic can get a new, factory finish on a drill in 25 seconds. New protractor feature gives every drill sharpening angle, with 5 convenient angles already marked off. Usable with hand or power stone. A brand new development. All new **\$2.80 ea.** Postpaid in U.S.A.

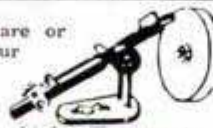

## HEAVY DUTY DROP-FORGED STEEL SHEARS



Inlaid Wolfram Vanadium duckbill blades cut straight, circular or irregular forms . . . guaranteed to hold edge under constant severe use on heavy gauge metals. Handy spring opening handles for better leverage. **NEW, 10" size, \$2.45 ea.—12" size, \$2.95 ea.**

## GAS OR FUEL STRAINER



This'll save you money because it protects fuel pump & carburetor . . . removes foreign particles, water, prevents sludge formation . . . for all cars, trucks, tractors & boats. Will handle aromatic fuels & light oils. Easy to connect to gas line in few minutes. Design allows for use either right or left-handed without changes. Stainless steel filter screen easy to remove to clean or replace. 3/4" pipe inlet & outlet ports. Quick opening drain cock. Capacity up to 60 GPH., 2 mtg ports. Wt. 2 3/4 lbs. Made to Air Corps specs. type C2C. Approx. Govt. Cost \$27.50. **NEW! Now only \$3.75.**

## MICROSWITCH



Type Z—2" x 1". Used open or closed. For automatic contacting . . . light, sound, model train systems, chimes, etc. **NEW! 5 for \$2.** Aluminum Spring Actuator to fit above Microswitch—5 for \$2.

## THOR PNEUMATIC SQUEEZE RIVETER



"C" Yoke Head. Size PRS-1. Model 4520. Shpg. Wt. 20 lbs. Approx. Govt. Cost \$250. Like new—guaranteed perfect! Just **\$35.00.**

## MICROMETERS

Chrome plated, precision engineered, carefully tooled to give long life. All new 0.1" capacity—**\$2.25 ea** 1.2" capacity—**\$3.50.**



## HIGH SPEED DRILLS



All new Fractional & numbered Orig value \$18 Nationally known brand. Assorted sizes. Set of 30, **\$3.50**

## WOODWORKERS DRILLS



From 1/8" to 1/2" with 1/4" shanks. A \$12.50 value—**NEW—just \$2.50** for complete set!

## HIGH SPEED STRAIGHT SHANK DRILLS

10 different size H.S. Straight Shank Jobber Length Drills, 1/4" to 1/2" (shank same diameter as drill) \$25 value. **NEW—\$3.50.**



## HIGH SPEED DRILLS

SET from 1/4" to 3/64", 5 sizes with 1/4" shanks—**NEW—get this, \$3.00** takes this set!

## FIRE EXTINGUISHER.

For safety's sake order now! Every home, garage, car, workshop should have this handy fire fighting wonder. It's fully charged (at 1,000 lbs. P.S.I. or more) with that miracle CO<sub>2</sub> (carbon dioxide) chemical that smothers oil, gasoline & electrical fires. Anyone can operate, in a hurry. Heavy ICC approved steel cylinder, valve and 3000 lb. gauge that shows available remaining pressure. REFILL costs very little. Hose included for emergency tire inflator or air blast. Wt. 4 lbs. Approx. Govt. Cost \$25. **NEW, complete with cloth carrying case, just \$6.50.**



## U. S. BAROMETRIC ALTIMETER



This U.S. Gauge Altimeter is terrific for auto or airplane. Tells ALTITUDE . . . accurately, guaranteed! It's **NEW!** Approx. Govt. Cost \$175. **NEW to you, only \$9.95.**

## HAND MITRE



Pays its way in just 1 day! Saves 100's of hrs., cuts any desired angle . . . just a "click" of the hand for precision mitre every time. Made of heavy gauge stainless steel . . . rugged construction. Handles hard and soft wood mouldings, plastic trim, base shoe, laminated materials. rubber extrusions, etc. Hand Mitre's a **MUST at \$9.95** ppd.

## MAGNETIC BASE INDICATOR HOLDER

For all types of dial indicators with guaranteed lifetime ALNICO magnets. V-slotted base has a 45 to 50 lbs. pull, permits immediate application without clamps or special attachments and mountings can be made on cylindrical surfaces. For machinists, tool-makers and inspectors. Base 3 1/2" long by 1 1/4" wide. **NEW. \$3.50 ea.**

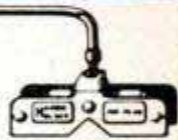

## RIGHT ANGLE ACTUATOR



Has worm gear drive in 6 to 1 ratio. Thrust shaft and 9/16" dia. and travels 12", forward or reverse on Acme Worm Thread. Drive shafts on either side of housing are 3/8" dia. with 16 splines. Overall length 25", width 4". Ideal for pushing, pulling or lifting. Sealed, self-lubricating chamber. Shpg. Wt. 5 lbs. Govt. Cost \$150. **NEW \$4.95 ea.**

NEW, BIG 1952 CATALOG BARGAINS FOR EVERYONE • SEND 25c FOR YOUR COPY TODAY! ORDER from ad NOW!

Send check, money order or cash. 25% deposit required on C.O.D. orders. All prices F.O.B. Culver City, Calif., unless otherwise stated. **AIRBORNE SALES CO., INC DEPT. PM 352 CULVER CITY, CALIF. SAVE \$\$\$**



## "Little Giant" Radio-Intercom System For Experimenters

(Continued from page 230)

required in remote locations. Many commercial loops have a second winding for this purpose and do not have the condenser network. Both types are suitable.

A standard wooden cabinet, the inside



dimensions of which are  $6\frac{7}{8} \times 7\frac{3}{8} \times 14\frac{3}{4}$  in., is necessary to house the completed unit. The cabinet used was number 98-929 listed in the Allied Radio catalogue. It is priced at \$5.69. Any similar-size wood cabinet may be used. The tuning dial is a "Croflex" type 231. It requires a cabinet cutout  $1\frac{7}{8}$  in. wide by  $4\frac{3}{8}$  in. long. Remember the cabinet holes for the dial face, the volume-control shaft and the tuning shaft must coincide exactly with the component as mounted on the chassis. Dial-cord-stringing directions are furnished with the dial.

The next step is the assembly of the switches and the parts to be fastened to the inside of the cabinet. The switch connections are clearly shown pictorially in Fig. 3. As no provision is made for the remote station to signal the master station if the set is not turned on and in the intercom position, No. 4, a separate buzzer circuit is employed. This is shown in Fig. 5. Ordinary bell wire can be used for this circuit between the two locations. Notice that some of the leads on the output transformer and the rotary switch are connected to components underneath the chassis base through holes drilled for this purpose. Make sure that these leads are long enough so that they need not be stretched tightly

(Continued to page 274)

# STOP THAT OIL EATER!

Now - Get New Car Performance with **PISTON SEAL** WITHOUT COSTLY OVERHAULING

● Piston Seal — the amazing compound that forms a self expanding, pliable lubricating seal around pistons that compensates for wear. Eliminates oil burning, restores power and compression. Can be applied in a few minutes without dismantling the engine. Guaranteed in writing not to harm the finest engine.

**GOOD FOR 10,000 MILES**



### READ WHAT SATISFIED USERS SAY ABOUT PISTON SEAL!

I installed a tube of Piston Seal in my 1940 Packard convertible which prior to the use of Piston Seal was using a quart of oil to every 65 to 75 miles. Now the same car is using oil at the rate of less than one quart every 800 miles.

Thanking you for saving us a great amount of time, effort and money.

N. E. P. — LYNN, MASSACHUSETTS

On October 22, 1950, I had a tube of Piston Seal installed in my 1941 Hudson. Prior to the installation of Piston Seal, my car was using a quart of oil every 100 miles. Now, after having driven 225 miles, my oil checks full.

H. G. J. — LYNN, MASSACHUSETTS

Have received one tube and it is doing a good job. Enclosed find check for another tube of Piston Seal.

S. C. S. — LAFAYETTE, RHODE ISLAND



Write Now for Complete Free Details

Write to

ATTENTION CANADIANS!  
Write TREGLOWN CO., INC.  
1269 Greene Avenue  
Montreal, Canada

**RICHIE DISTRIBUTING CO.**  
11916 MADISON AVE. • DEPT. C  
CLEVELAND 7, OHIO



# LOOK at the *Atlas* FENCE—TRY IT

*It's the Easiest to Use, Most Accurate Fence Ever Developed*

**Atlas 10" TILT ARBOR SAW**



**IT LIFTS OFF!**



Releases instantly for lifting off or positioning either side of blade. A great time saver.

**LOCKS AT BOTH ENDS!**



One movement of the lever locks both ends of fence to table. It's anchored in place — can't move to spoil your work.

**HAS VERNIER CONTROL!**



Fence slides smoothly to position you want — has Vernier control for exact setting.

**T**HE FENCE alone makes Atlas the saw to see before you buy, and in an Atlas you'll find a host of other advanced features that will be of great importance to you in your work. It has the capacity to build a garage, a house, or remodel a room — the accuracy for "factory-quality" work on fine cabinets and furniture, cupboards.

You'll like the big precision-ground grey-iron table; the smoothness and long-service of its large sealed-for-life ball bearings; the easy operating blade-height and angle controls. Blade cuts 3 1/4" deep — tilts to 45° — work is always flat. It's a big, rugged, fast, efficient saw — sure to make your shop and your work outstanding in the neighborhood.



SEE *Atlas* 8" SAWS, TOO!

Built with the same precision construction features — has the same exclusive Atlas fence — as the 10" saws.

**Atlas** DEPENDABLE QUALITY TOOLS SINCE 1911

**FREE — Woodworking Tool Catalog**

ATLAS PRESS CO., 343 N. Pitcher St., Kalamazoo, Mich.  
Please send your woodworking tool catalog.

NAME \_\_\_\_\_  
ADDRESS \_\_\_\_\_  
CITY, STATE \_\_\_\_\_



when the parts are mounted on the inside of the cabinet. The output transformer is mounted on the master-set speaker. It is difficult to mount the parts inside the cabinet with the chassis in place. Keep the chassis outside the cabinet, but close to it.

With all wiring completed, and the set chassis outside the cabinet, you are ready



to align the receiver. This can be done with the rotary switch in the No. 1 position as shown by the round four-position dial plate on top of the cabinet. The sound will come through the master-set speaker. The i.f. transformers are factory aligned and require only slight trimmer (tr.) adjustments. Allow the set to warm up, and then tune in a station and make these adjustments for maximum volume if necessary. In order to obtain proper tracking, close the tuning condenser completely, and then open it slowly until the first station is heard. Determine the frequency of the station and then position the tuning-dial pointer so that it coincides with this frequency on the tuning dial. Now tune in a station at the high end of the band. If the pointer does not indicate the correct frequency of this station, continue to rotate the tuning condenser until the pointer coincides with the frequency of the station just heard. (The station may not be heard at this point.) Then adjust the oscillator-section trimmer condenser across C4 until the same station is again heard. Finally adjust the trimmer on the r.f. section across C3 for maximum volume. Detailed student material list R-408 is available from Popular Mechanics Radio and Electronics department upon receipt of ordinary letter postage.

## UNCLE WALTER

### IT SMELLS GRAND



AROMA PROMISING SWEET RELEASE

### IT PACKS RIGHT



CUT TO PACK  
SO JOYS INCREASE

### IT SMOKES SWEET



MAKES EVERY PIPE  
A PIPE OF PEACE!

### IT CAN'T BITE!

SIR WALTER RALEIGH'S BLEND OF CHOICE KENTUCKY BURLEYS IS EXTRA-AGED TO GUARD AGAINST TONGUE BITE. STAYS LIT TO THE LAST PUFF. AND NEVER LEAVES A SOGGY HEEL IN YOUR PIPE.

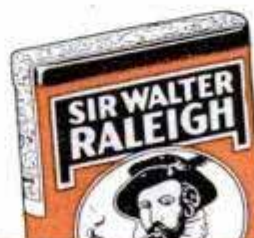

*It costs  
no more  
to get  
the best!*



**Amazing Automotive Gas Economy  
and Power Improvement**

# BRITISH WARTIME DISCOVERY MADE AVAILABLE IN THE U.S.

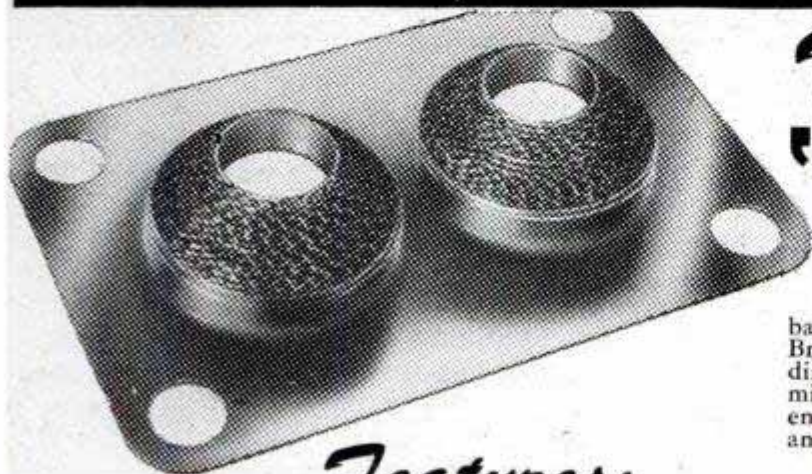

## Vokes "GASMASTER"

(Distribution Rectifier)

The principles of the sensational "Gasmaster" are based on those of the distribution rectifier designed by British engineers during the last war, to improve fuel distribution on internal combustion gasoline engines for military aircraft. The "Gasmaster" gives astonishing engine performance improvement, gasoline economy, and quicker starts.

### Features:

- ★ Improved Engine Performance
- ★ Gasoline Economy
- ★ Quick Starts

**OVER 250,000 NOW IN USE**

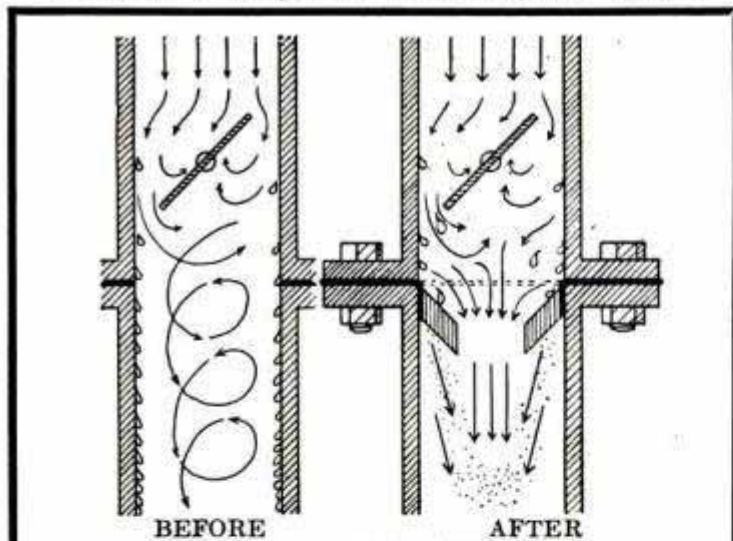

### HOW IT WORKS

When air passes through the carburetor it is mixed with fuel in a ratio fixed by the engine manufacturers, and then distributed to the cylinders. However, distribution of the air-gas mixture to the cylinders is imperfect in all engines, in fact, the gasoline engine with perfect distribution has yet to be made. After leaving the carburetor some of the mixture still contains liquid gasoline and is not of uniform consistency. The butterfly valve induces swirls and eddies and the shape of the intake and the number of cylinders also has an effect. In designing the "Gasmaster" all these factors were carefully

analyzed. Here's how the "Gasmaster" overcomes them as shown in the diagram on the right:

The swirls in the mixture are removed by the straightening effect of the mesh apertures. Vapourization is improved because the small droplets are broken down by the mesh, and scrubbed off by the mixture flow. By breaking down the droplets, fuel wastage is avoided and maximum power developed. The result is a more homogeneous fuel mixture which gives improved power, performance and gasoline economy. The "Gasmaster" lasts the life of your car.

### SOLD ON MONEY-BACK BASIS, IT'S GUARANTEED NOT TO BURN VALVES

Many "gas-savers" and similar products have been offered to the motoring public. Poorly engineered and unscientific, most of these "gadgets" did not live up to claims and many actually harmed the engines on which they were fitted. The "Gasmaster" is fully guaranteed. It does not change the air-gas ratio set by engine manufacturers and can therefore be unconditionally guaranteed not to burn valves. The "Gasmaster" is installed between the carburetor and the intake manifold in a matter of minutes, and goes into the line as easily as a gasket.

Provided with each "Gasmaster" are full instructions for installation. Each model of "Gasmaster" is custom-made for a specific model of car—all popular makes and models can be supplied. Each is provided with an extra gasket for an air-tight seal. The "Gasmaster" is produced by Vokes—manufacturers of the world's widest range of filtration equipment for ships, mines, aircraft, engines, air conditioning units etc.

**Price All  
Models \$4.95**

Postage—paid on Cash Enclosed Orders. C.O.D. orders—you pay postage and C.O.D. charges.



DEALER INQUIRIES ARE INVITED

Mailway (Gasmaster Division),  
514 Hudson Street,  
NEW YORK CITY, N.Y.

TPM-1

Check the method you wish to use:  
 (...) Please send me . . . . . Gasmaster(s) for which I enclose my cheque . . . . . or money order . . . . . for \$4.95 each. I understand my "Gasmaster" will be shipped postage pre-paid immediately.  
 (...) Please send me . . . . . Gasmaster(s) C.O.D. and I will pay postage and C.O.D. charges.  
 Name . . . . .  
 Address . . . . .  
 City . . . . . Zone . . . . . State . . . . .  
 Make of Car . . . . . Year . . . . .  
 Model . . . . . No. of Cylinders . . . . .  
 In Canada: Please address coupon to "Gasmaster"  
 3801 Dundas St., W., Toronto, Ont.





# CABINET LOCK

Put easy-to-install Corbin Cabinet Locks on *all* your cabinet work and you'll enjoy both pride of craftsmanship and real security!

These fine locks add that "finished" touch to desks, cabinets, drawers, chests, wardrobes — to *all* cabinet work.

They keep valuable papers secure . . . protect your guns and tools . . . keep children away from harmful medicines and caustics.

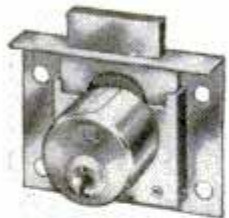

There's a Corbin cabinet lock or padlock for every purpose. Ask for them at better hardware stores everywhere!



**CORBIN**  
**LOCKS**

**Corbin Cabinet Lock Division**  
The American Hardware Corporation  
New Britain, Connecticut, U.S.A.

the air-filled balloon floats in it. We've found it to be an extremely effective fire-extinguishing agent, at least twice as effective as carbon tetrachloride, and many times more effective under winter conditions. The Army Engineer Corps reports that it is superior to all other fire extinguishers now in use. Another point is that many chemical fire extinguishers form toxic gases. For example, some actually produce phosgene, a war gas. Not this stuff. Its toxicity can scarcely be measured."

Doctor Bryce describes some of the other properties of the chemicals.

"Many of the liquids have extremely low surface tension, making them good wetting agents. They'll strike like lightning through cloth. You can imagine what they could do for a dye. This wetting ability of the fluorocarbons also may be important in the field of detergents. Water, on an arbitrary scale, has a wetting ability rated at around 75. The best soaps and detergents reduce this to about 30—they make the water more than twice as wet. A one-percent solution of fluorocarbon in water cuts even this figure in half, to around 15. You can see what this might mean to the cleaning industry."

The penetrating power of fluorocarbons probably will make them important in the medical field, too. Most medicines become effective only after they are absorbed into the body. Fluorocarbons, being nontoxic and having great penetrating power, could have startling effects on the body processes.

Here are just a few of the other possible uses for the magic compounds: Fireproof plastics; polishes that positively repel grease as well as water; paints and varnishes that resist weathering; cooling fluids and gases wherever high temperatures are produced; electrical insulations (fluorocarbons won't conduct electricity); nontoxic insecticides; better photofilms with unique optical qualities; refrigerants; permanent hydraulic fluids; crease-resistant clothing; anesthetics with no aftereffects. One chemist states there is a fluorochemical that destroys adhesion—eliminates it so effectively that it may be possible to treat airplane wings to prevent ice formation.

Even Taylor, Bryce and the other experts don't pretend to know how fluorocarbons will fit into the industrial pattern. All they know is that they've tweaked the tail of something big, and from here on the industrial chemists will take over. For that reason most of the current output is flowing to industrial laboratories all over the country. While Taylor and his associates turn out a growing flood of fluorocarbons, the second team is working to capitalize on the unique offspring of nature's most violent element.



**THE HANDIEST PAIR  
OF LEGS IN THE  
WORLD!**

**MAKE TABLES,  
TRAIN PLATFORMS,  
WORK BENCHES, etc.**

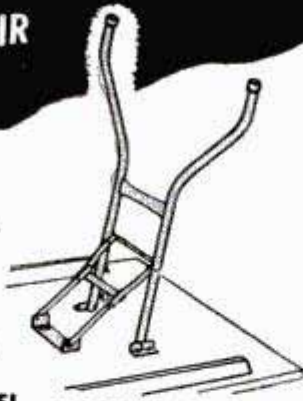

**Atlas STEEL FOLDING UTILITY LEGS**

For home, office or factory! It's easy to bolt or screw them to wood, masonite or other materials. Hold over 600 lbs., fold easily, lock into position for safety. Complete with bolts, folding mechanism. Money-back guarantee!



TABLES

TRAIN PLATFORMS



WORK BENCHES

please specify **\$8.95** pr. postpaid  
height desired (on C.O.D. orders  
26, 30 or 34" you pay postage  
3 sets, \$25)

**INSTITUTIONAL SALES CO.**

DEPT. A 4932 PORTICO ST. PHILA. 44, PA.

**BURKS  
SUPER TURBINE  
PUMPS  
LAST  
LONGER**

**ONLY PUMP  
WITH LIFE-LOK  
FEATURE**

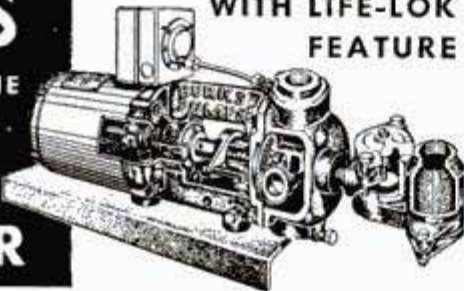

Thanks to the LIFE-LOK feature, the BURKS Super Turbine Water System lasts up to 40% longer than any other kind, delivers more gallons per minute and provides "like-new" performance and efficiency when other types would be worn out. It's completely automatic—self-priming.

**FREE BOOK PICTURES PUMP DETAILS**

Send today for "The Story of Burks"—a 32-page book giving detail drawings, graphs, etc. See why BURKS is finest engineered system . . . why it delivers more water per hour . . . why it's the finest water system you can buy. Write to—**DECATUR PUMP CO., 61 Elk St., Decatur 70, Ill.**

**You CAN Take It With You!**

**BECKER Self-Contained  
SPRAY GUN**

**NOTHING ELSE TO BUY**

TAKE IT ANYWHERE—the first completely portable spray gun. Needs no compressor, motor, or electrical outlet. Pressure-powered with an inexpensive CO2 cartridge that sprays up to 21 liquid ounces, depending on viscosity. Extra cartridges, 10 for \$1, postpaid, or buy from your dealer.

**PAINTS • VARNISHES • ENAMELS  
MOTH-PROOFS • INSECTICIDES**

Every home needs a Becker Spray Gun for dozens of jobs in the house, workshop, garden or garage. Complete instructions furnished for effective results. Order yours today for the season ahead.

**HOW TO ORDER**—If your dealer can't supply, send \$15.95 and we ship postpaid—or \$2 now and pay postman balance plus postage and fee. Money back if not delighted after 5 days' trial.

**SULLIVAN-BECKER CO.**  
Dept. 112-C, Kenosha, Wis.



**ONLY  
\$15.95  
with 3  
cartridges**



**PALMGREN  
HOBB-E TOOLS**

**ANGLE VISE**

Set up hard angle jobs in 5 seconds. Drill, grind, mill round, square or irregular pieces quickly and accurately. Save time, money and errors. PALMGREN "Hobb-E" ANGLE VISE has 1½" Jaws, 1 Plain 1 Grooved. Accurately machined and graduated. No. XI only

**\$4.95**

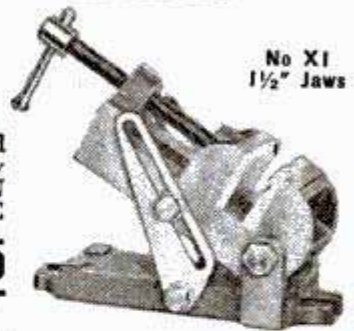

No XI  
1½" Jaws

**ROTARY INDEX MILLING TABLE**

Turn drill press into vertical miller. Mill, Grind, Index Rabbet, Mortise and Rout curved or straight PALMGREN "Hobb-E" ROTARY TABLE is a precision machine, accurately graduated. Bolts to table.

No. 83-8" Table 4"  
Cross Feeds, **\$54.50**  
360° Rotary Feed .....  
No. 82- Without Rotary Feed... **\$43.75**



No. 83

**ADJUSTABLE ANGLE PLATE**

Every Hobbyist should have one for jobs difficult to hold in vise. No delay, less spoilage on complicated angles in drilling, milling, grinding or layout work. No. 256 B has 6" x 6" surface plate, 8 bolt slots. Adjustable to full 90°. Accurate graduations. Swivel Base. Only .....

**\$14.35**



No. 256B

**BENCH DRILL PRESS VISE**

A fine "Hobb-E" tool. Base bolts to work bench for general work. Vise is dovetailed and removable for use on drill press by loosening thumb screw. Unit rotates 360° horizontally. Adapter has steel jib which locks vise in position. No. 12 Removable Jaws 2¼" wide. 1 Plain 1 Grooved. Only.....

**\$12.95**

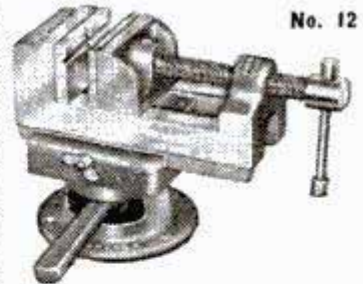

No. 12

**ALL PURPOSE ALUMINUM HAND VISE**

This "Hobb-E" tool grips small pieces for grinding, buffing and 101 other uses. Safe-guards hands and fingers. Small parts easier and faster to handle with better results. No. 15 Jaws 1½" accurately machined, can't mar work. Only.....

**\$2.15**

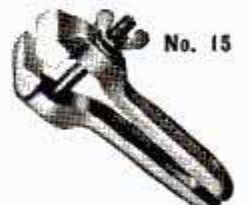

No. 15

**ORDER NOW! SEND COUPON TODAY!**

**CHICAGO TOOL & ENGINEERING CO.,**  
8376 South Chicago Ave., Chicago 17, Ill.

Enclosed find \_\_\_\_\_ for items checked below.  
 PALMGREN "Hobb-E" ANGLE VISE.  PALMGREN "Hobb-E" ANGLE PLATE.  PALMGREN "Hobb-E" MILLING TABLE.  PALMGREN "Hobb-E" HAND VISE.  PALMGREN "Hobb-E" BENCH DRILL PRESS VISE.  Send Circular.

NAME \_\_\_\_\_

ADDRESS \_\_\_\_\_

TOWN \_\_\_\_\_ ZONE \_\_\_\_\_ STATE \_\_\_\_\_





## Make every job easier...

### ...USE A SARGENT PARALLEL-ACTION PLIER

The one above, for example, is a PLIER, a CUTTER and a WRENCH with the NON-SLIP JAWS OF A VISE...

And here's what you get:

- **Extreme Gripping Power** developed through compound leverage... parallel jaws hold like the jaws of a vise.
- **Outside Cutter Blades**—even cut wire which lies tight against a flat surface.
- **Open Throat** allows wire to run between the parallel jaws from either end.

4½" size is the fisherman's favorite. In the larger sizes...5½", 6½", 8"...it's an ideal household and sportsman tool.

Ask your hardware dealer or write for full information. Dept. 20C. **Sargent & Company**  
New York • New Haven, Conn. • Chicago

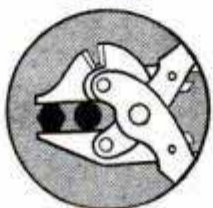
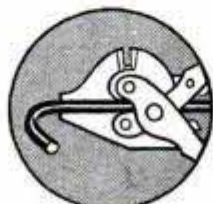

#### SARGENT TOOLS FOR EVERY PURPOSE



Diagonal  
Cutting Plier  
No. 177



End Cutting  
Nippers  
No. 165



Aviation  
Metal Snips  
No. 888

**SARGENT**  
of New Haven

The Tops in Tools  
The Latest in Locks

Builders Hardware and Fine Tools since 1864

## From Boot to Electronic Whiz-Kid

(Continued from page 126)

problem mathematically. The expert disappeared for several hours, then returned bearing a dazed look and seven sheets of paper covered with algebraic symbols representing the 87 steps necessary to solve the "simple" problem.

Aboard a battlegon or cruiser, elements of the fire-control system are scattered all over the ship. They consist of radar antennas, scopes and compact steel boxes which contain a bewildering array of glowing vacuum tubes and miles of fine wire. It's a scholastic miracle that a man with a high-school education, or less, can be trained to diagnose and repair the troubles that beset these mathematical monsters. Yet it's being done, and in 44 weeks, at the Fire Control Technicians School, Class A.

The officer in charge of the school is Lt. Comdr. B. E. Toon, a slight, soft-voiced man with a college major in education. Every four weeks 30 new students show up at his school to start the course.

The average age of these men is 18 years, and many have had no training in advanced mathematics. Take a Chicago seaman we'll call Millard P. Strom. He's 19 years old, and already has served 14 months in the Navy. He's had nothing beyond high-school algebra, but at the end of boot camp he decided he wanted to get into electronics—"Seemed the best thing, with television and all." After 39 weeks of training Strom stands at the top of his class.

"The school's tough, all right," says Strom, "but the surprising thing is, a guy with average intelligence can make the grade. I figure television will be a snap if I decide to go back into civvies."

Two things make it possible to give a man like Strom the ability to service a Mark 56 fire-control system, which costs about \$250,000.

The first factor is the equipment itself. All the latest electronic gear is designed in units. If anything goes haywire aboard ship, Strom will make a series of tests to isolate the unit causing the trouble. If there's a replacement unit aboard ship, he'll make the switch, similar to replacing an entire television chassis. If he has no replacement, he'll have to make further tests—within clearly defined limits—to determine exactly which of the tubes, condensers or wires is the villain.

The other factor is the training program, which Toon constantly revises to conquer ever more complicated pieces of equipment. Toon's training program navigates a course along basic lines—there's no need

(Continued to page 280)



# "Do-it-yourself" with New PABCO LINOLEUM TILE!



9-inch squares. Many lovely colors. 3 qualities. Starting at **12¢** per tile!

## ONLY PABCO gives you all these:

- New Exclusive "Calitone" design, related colors.
- Resilience—gives you quiet comfort underfoot.
- "Precision-Cut" 9-inch squares for instant laying.
- "Soil-Sealed" quality for easiest cleaning.
- Free Simple Instruction Sheets—at all dealers.



**PABCO PRODUCTS INC.**  
475 Brannan Street  
San Francisco, Calif.



Complete the picture with  
**"Do-it-yourself"**  
**WALL COVERING**  
in related colors...

## "PABCOWALL"

— pastes over any wall surface. Made in 54" rolls, 14 colors, 3 styles, with base & cap strips. Rivals expensive individual tile, but costs only about

**15¢** per sq. ft.

# NOW! Upper Cylinder Lubrication That Resists "RED HOT" Temperatures

Upper cylinder areas in today's engines operate under excessive heat because combustion chamber temperatures may reach 2,500°. Since ordinary oil breaks down at 550° or less, valves, rings and other parts may operate without lubrication. Result: Excessive wear . . . loss of power . . . eventual engine failure.

Miracle Power used in the gas assures upper cylinder lubrication because it deposits colloidal synthetic graphite on vital surfaces. This special graphite lubricates effectively at temperatures higher than ever found in any automotive engine.

And in your oil, Miracle Power prevents DRY STARTING damage to other engine parts. That means smoother performance . . . and more power with less gas.

Try Miracle Power next time you get gas.

Miracle Power Division  
**THE AP PARTS CORPORATION**  
756 AP BUILDING, TOLEDO 1, OHIO

At better service stations,  
garages and car dealers,  
use this coupon for intro-  
ductory offer.



**THE AP PARTS CORPORATION**  
756 AP BUILDING, TOLEDO 1, OHIO

Enclosed find \$.....for which please send me *postpaid*:

..... trial cans of Miracle Power at 75c each (1 for gas, 1 for oil)  
Please send me free literature on making my car last longer.

Name \_\_\_\_\_

Address \_\_\_\_\_

City \_\_\_\_\_ Zone \_\_\_\_\_ State \_\_\_\_\_



# MODERNIZE YOUR WALLS WITH BEAUTIFUL, THRIFTY

# CONGOWALL

TRADE-MARK ®



**Looks—cleans—feels like tile!**  
**Easy as A-B-C to apply!**

Why waste your time on wall treatments that will soon need refinishing? Gold Seal Congowall is not only easy to apply and inexpensive, but durable, too.

Congowall's baked enamel surface simulates ceramic tile, even to the mortar lines! . . . costs only about 15¢ a square foot . . . yet rivals the performance of wall materials costing several times as much.

Be sure you get the genuine—with the patented duplex backing that's proved successful in over 3,000,000 home installations! The Gold Seal *guarantees* you satisfaction or your money back!



Look for the back-marking that identifies the genuine Gold Seal Congowall!



Half the depth of the backing is moisture resistant—half will absorb the paste. Paste becomes part of Congowall, locks it to the wall!

## MAIL THIS COUPON!

Congoleum-Nairn Inc.  
Kearny 1, New Jersey

Please send me the free Congowall color guide and instruction folder.

Name .....

Address .....

City ..... Zone ..... State .....

© 1952, Congoleum-Nairn Inc.

for a man to understand the calculus involved in solving the surface-to-air problem as long as he understands enough mathematics to use his test instruments.

During his first 12 weeks at the school Strom waded through a course in basic electricity, electronics and radar fundamentals. He learned to build simple radio receivers (homemade radios are a dime a dozen on the base). He built involved circuits on practice panels. By the time he had survived the basic course he had absorbed the equivalent of a trade-school education.

Through the next eight weeks, Strom wrestled with his first fire-control system, the Mark 63, one of the least complicated. He pushed deep into radar, and studied the two automatic gunsights which permit the gunner to track the target visually.

All the latest computers, range keepers and electronic testing equipment are laid out and disassembled on workbenches so students can see how they tick. Strom learned to repair casualties to the equipment by watching experts do the work.

He spent two weeks on another system of gunfire control, mostly studying the differences between it and the basic Mark 63. Then came a three-week break in the electronic work, during which he analyzed the power drive, the whirring mechanical system which points the gun mounts. Another 15 weeks was allotted the Mark 37 system—including the mathematical computer, the basic fire-control mechanism, the radar and the stable element (the gyroscope instrument which calculates the roll and pitch of the ship and transmits a signal to the gun mount to overcome this movement).

To polish off the course, the students are subjected to a week of battery alignment—the system by which every gun on the ship can be simultaneously aimed at one target.

If he had faltered anywhere along the course, Strom would have been required to take two hours of extra instruction per day. A shipping student once marched into Toon's office, stood at rigid attention, and made the classic request that one of his shipmates take his extra instruction that night because he himself had a date.

Strom is the first to admit he doesn't understand how the gunfire-control system makes its lightning calculations. But he does have confidence he can maintain and help repair such a system once he reaches the fleet. If he goes to a battlewagon or cruiser, it's likely he'll be working as a striker (apprentice). On the other hand, he might land on a smaller ship where even the skipper would be at a loss if anything happened to the gunfire-control equipment. This gives Strom a feeling of being a vital cog in the world's best navy—which he is.





***It's a fact!—***

**THIS  
DELTA  
20-A  
RADIAL SAW**

***will Perform  
Most of the  
Operations  
in Your Shop***

Just look at the astonishing number of operations you can do with this one-saw shop . . .

- |                    |                     |                     |                         |
|--------------------|---------------------|---------------------|-------------------------|
| <b>circle rout</b> | <b>tenon</b>        | <b>groove</b>       | <b>grind</b>            |
| <b>bevel rip</b>   | <b>rafter notch</b> | <b>raise panels</b> | <b>radial drill</b>     |
| <b>sand</b>        | <b>mortise</b>      | <b>plough gain</b>  | <b>size and joint</b>   |
| <b>shape</b>       | <b>cove cut</b>     | <b>rabbet</b>       | <b>saw horizontally</b> |
- compound miter . . . and many others**

—in addition to regular cross-cutting, ripping, beveling and mitering.

It's compact, safe to operate. All its controls are right up front. You work from above—layout marks are easy to follow.

Check this remarkable saw against all-comers—and you'll know it as *the saw you want*.

Talk to your Delta dealer about it—or ask us for his name. Use the coupon.

**DELTA POWER TOOLS • Another  Product**  
53 Machines • 246 Models • More than 1300 accessories

**DELTA  
MILWAUKEE**

*Wood and Metal Working*  
**Power Tools** FOR HOME AND INDUSTRY

**DELTA POWER TOOL DIVISION**

**Rockwell** MANUFACTURING COMPANY

803C E. Vienna Avenue • Milwaukee 1, Wisconsin

Please send me the name of the nearest Delta dealer

Please send the new Delta Radial Saw "Idea Book"

Name \_\_\_\_\_

Address \_\_\_\_\_

City \_\_\_\_\_ Zone \_\_\_\_\_ State \_\_\_\_\_





"Stand by with the  
**'DUCO' CEMENT!**"

## Fix it for keeps WITH **DU PONT DUCO CEMENT**

REG. U.S. PAT. OFF.



**CHIPPED KEYS**  
strike a sour note  
in a piano's  
appearance. Mend  
broken keys with  
"Duco" Cement.



**TORN WALL-  
PAPER** needn't be  
a household  
catastrophe. Just  
mend it like new  
with "Duco" Cement.



**NAMEPLATES IN  
OVERSHOES**  
prevent mixups in  
the school coatroom.  
Put them in with  
"Duco" Cement.

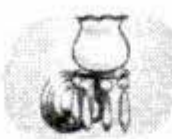

**REPAIR CHIPPED  
GLASS "Duco"**  
Cement's trans-  
parency makes the re-  
pair simple and neat  
—almost invisible.

**STRONG, TRANSPARENT  
FLEXIBLE, WATERPROOF**



REG. U.S. PAT. OFF.

**BETTER THINGS FOR BETTER LIVING  
... THROUGH CHEMISTRY**

## The Bottom of the Barrel

(Continued from page 117)

There is still a long way to go. We have yet, for instance, to learn how to extract and use economically more than a few of the minerals known to be locked in the coarse rocks called pegmatites. But efforts to solve such problems are going ahead, and there is no reason to suppose that the pattern of producing better and better end products from leaner and leaner ores, which has characterized our mineral industries from the very start, will not be continued.

Our mineral resources have also been vastly expanded by the development of new materials. Perhaps the most obvious example is aluminum, which was a rare metal half a century ago and which today is one of the mainstays of our defense program and of our peace-time industry. Equally striking are the alloy steels, which are so much stronger and better than the carbon steels of the turn of the century that the weight of metal required to serve a given purpose has been greatly reduced. Ductile titanium, just coming into commercial production, is a new structural metal of possibilities still unfathomed, which may stand now just where aluminum stood 50 years ago. Ductile zirconium, still in the demonstration-plant stage and very expensive, is another new structural metal which appears to have great possibilities in specialized uses.

Meanwhile, there has been a tremendous rise in the use of more familiar metals—particularly iron and steel. Fifty years ago, steel was relatively a luxury item, with production totaling only about 15 million tons a year. Today we produce close to 100 million tons annually, with an expansion in capacity under way. Our iron-ore production in 1901 was 29 million gross tons; in 1950, it was 98 million tons. In the last half century we have produced 2.9 billion tons of iron ore, of which the Lake Superior region supplied 2.6 million tons.

This, of course, has meant a tremendous drain on our reserves. Our country has by no means come close to exhausting these reserves, but it does threaten to exhaust the most easily obtained high-grade ores. Fortunately, much work has been done on the lower-grade ores, and the trend recently has been toward the liberation of finer iron particles from the gangue material. Intensive laboratory and pilot-plant experimentation has developed several methods of agglomerating the fine concentrates into a suitable physical structure, and large-scale investigation now seeks the most economic of these. Progress has been such that

(Continued to page 284)



CHOOSE THE MODEL BEST FOR YOU!

# Two DREMEL Electric SANDERS with STRAIGHT LINE Action for Guaranteed SCRATCH-FREE Surfaces

## OUTSTANDING PERFORMANCE FEATURES

(In both models) Only 2 moving parts; 14,400 strokes per min., easy one-hand operation; dustproof—foolproof; 10-second paper change; 110-120 V., 60 cycle A.C. PLUS mirror-smooth, straight-line sanding action.

### MODEL 2000 FOR HEAVY DUTY CRAFT AND WOODWORKING PROJECTS —

Fastest seller in the field for rugged power and smoothest finishes at lowest cost. Ample power for furniture and cabinet making, boat building or refinishing, resurfacing large areas. Great for building operations—woodwork, stairs, dry-wall joints, siding, etc. Does a superb polishing job! Weighs 5 lbs.; 21 sq. in. of sanding surface; overall size 3 1/8" x 4 1/2" x 7".

### MODEL "A" FOR HOBBIES, REFINISHING, REDECORATING—

Finest sander ever offered housewives, home-owners, hobbyists. A lighter-capacity model for woodwork, unfinished furniture, hobby shop projects, etc. Wonderful for polishing waxed surfaces. Also a soothing massager! Weighs only 2 1/2 lbs. Sanding pad 2 1/4" x 5 1/2".

### ONLY STRAIGHT-LINE ACTION SANDS WITH THE GRAIN NEVER MARS OR SCRATCHES —

Don't just take our word for it. Ask any professional woodworker about sanding action. He will tell you that only straight-line, with-the-grain sanding can produce a flaw-less finish.

### BEFORE YOU BUY ANY SANDER . . . COMPARE!

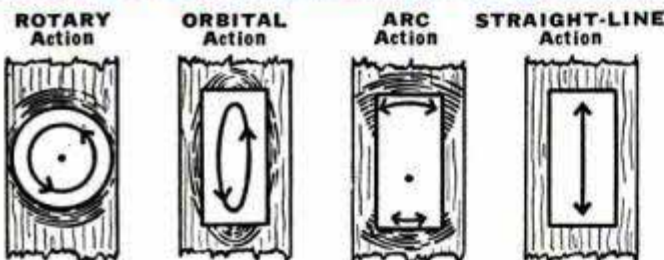

14,400  
SANDING STROKES  
PER MIN.



MODEL 2000  
**\$24.50**

Price includes all-steel storage case, 25 asstd. abrasives, and sheepskin pad.

MODEL "A"  
**\$14.85**

Price includes 6 sandpapers, 1 sheepskin, 1 felt pad.

## DREMEL Electric COPING SAW

CUTS SCROLLS LIKE MAGIC—SANDS AS IT SAWS



BLADE  
FACES  
4 WAYS

Only  
**\$5.85**  
with 3 saw blades

MAKE  
YOUR OWN  
JIG SAW  
PLANS FREE!

JUST  
GUIDE IT!

### SAFE! AS A HANDSAW

For home, hobby, repair work—no other tool pleases so much for so little cost. Works in any direction—delivers 7,200 strokes per minute smoothly, effortlessly. Saws through 3/4" medium-hard wood at a foot-a-minute speed. Touch-of-the-trigger, foolproof action. Only 2 moving parts, never needs oiling. Uses 110-120 V., A.C. Free plans, packed with each saw, for six useful woodworking projects and for making your own jig saw.

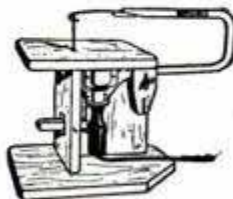

## GRINDS • CARVES • ENGRAVES DRILLS • ROUTS • SHARPENS DREMEL Electric MOTO-TOOL

FASTEST MOST POWERFUL TOOL  
in its class—Approx. 27,000 r.p.m.

Most practical tool a man can own—more powerful than any similar tool you can buy. Works well in wood, plastics, and metal. For home maintenance jobs you'll wonder how you got along without it. For model making it's a must. And for general shop operations it saves time and money. Compare it, try it, buy it. You be the judge!

### Check These Important Features

- Oilless sealed bearings
- Dynamically balanced armature
- Shockproof, Bakelite housing
- Dust-filtered air cooling system
- Sturdy 110-120 V., A.C.-D.C. motor
- Wt. only 13 oz.
- A precision tool widely used in industry for many years.



MOTO-TOOL No. 2  
(with 1 emery wheel point)

**\$16.50**

MOTO-TOOL KIT No. 2  
With 23 Accessories  
(High-Speed Steel Cutters,  
Grinding Wheels, Polishers)

**\$23.50**

YOU BE THE JUDGE OF DREMEL PRODUCTS—Our reputation has been built on results rather than sensational claims. We invite comparison of Dremel tools with any similar products made. Then you'll know why we guarantee the most for your money!



WHERE TO BUY—If your dealer doesn't carry, remit in full for postpaid shipment. Or send only \$2 now, pay postman balance plus postage and COD fee. Five-day trial, money-back guarantee!

DREMEL MFG. CO., Dept. 112-C, Racine, Wis.



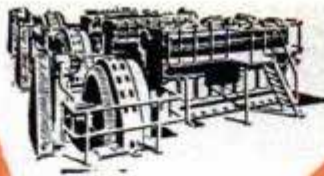

Great basic invention—the dynamo. Its power turns our wheels, operates our factories, provides the speed required to run our modern world.

**SPEED**



The Plumb Hammer is the pace-maker on any job. Scientific design and perfect balance make it much faster, easier to use.

The special analysis steel heads are scientifically tempered with four separate zones of hardness. Hard striking faces . . . Sturdy claws for prying . . . Hard-biting, long-wearing nail splits . . . Tough yielding mid-sections.

Handles are turned from resilient, second growth hickory.

Use a Plumb Hammer—it's the modern hand tool for modern craftsmen—first choice over all others.

The black head with the red handle — exclusively **PLUMB**

**Quality Comes FIRST**  
**PLUMB**  
**is FIRST in Quality**

**PLUMB**®

HAMMERS • HATCHETS • AXES • FILES

magnetic taconite, a hard rock occurring largely in Minnesota containing finely disseminated magnetic iron oxides, is expected eventually to become the source of 25 million tons of high-grade ore per year.

Facilities for treatment of this ore will require much time and money. Since our requirements for iron ore are expanding so rapidly, we will need large tonnages of imported ore. Canada promises to become a large supplier when the Quebec-Labrador deposits are developed—in which connection the prospective opening of the St. Lawrence Seaway is important.

It seems likely that aluminum will become the second-largest-tonnage metal in the future, next to iron. In 1900, aluminum was produced at a rate of less than 2000 tons a year; 1951 production will probably exceed one million tons, and by 1954 we should be producing more than 1.5 million tons. The limiting factor in determining capacity of aluminum is low-cost electric power; it is worth noticing that all of the reduction plants in the United States are in the Pacific Northwest, the Tennessee Valley, the Texas Gulf and other areas where electric power is relatively cheap.

Some of the greatest changes of the half century have been in the field of mineral fuels. Fifty years ago, coal was the unchallenged king, with petroleum useful chiefly as a source of kerosene and lubricants. Coal is still our most important single source of fuel energy, but in 1950 it provided only a fraction over 41 percent of the nation's total fuel energy, compared with 90 percent in 1900. To a large extent, this change reflects the rise in importance of petroleum.

Yet in the future the relative importance of coal is likely to rise. We possess enormous reserves of coal—the latest estimate is that about 2.4 trillion tons remain in the ground, half of it recoverable on the basis of historic mining losses—and we are finding new ways to use it. Although this country still produces more than half the world's output of oil, demand has outstripped domestic production and we are now a net importer. Hence it is fortunate that we are now in position to count on gasoline and oil made from coal as an economic source of liquid fuels in the near future. In addition, experimentation has shown that we shall be able to produce vast quantities of gasoline from oil shale, and it becomes evident that in the second half of this century we shall see the birth of a new liquid-fuels industry, based on coal and oil shale.

It should not be inferred from this that we have solved all of the problems which arise in connection with our minerals supply. In the main, the story of the last 50

(Continued to page 286)



## HIGH SPEED MORSE TAPER SHANK DRILLS



Reconditioned and sharpened—ready to go! Many drills with extra lengths of flute. Immediate delivery. These drills are priced as low as 25% of your present cost and shipped post paid to you.

Size in in.	Twist Lgth.	Price	Size in in.	Twist Lgth.	Price
37/64	6 1/4	\$1.00	1 1/8	8 1/2	\$4.00
37/64	20	4.00	1-5/32	6 1/2	3.76
19/32	4 1/4	1.00	1-11/64	7 3/4	3.95
39/64	6 1/4	1.06	1-3/16	7 1/2	3.95
21/32	6	1.19	1-7/32	8 1/2	4.14
11/16	4 1/2	1.31	1-15/64	7 1/2	4.51
23/32	5	1.44	1-21/64	8 1/2	5.38
47/64	5	1.57	1-11/32	9 1/2	5.38
31/32	5	1.87	1-15/32	7	6.13
49/64	4 1/2	1.84	1-19/32	7	7.16
51/64	5 1/2	1.85	1-9/16	10 1/2	7.50
13/16	4	1.82	1 5/8	10 1/2	8.50
13/16	22	8.00	1-11/16	12	9.13
27/32	5 1/2	1.91	1 3/4	5	6.00
55/64	4 1/2	2.02	1 7/8	9	11.56
7/8	5 1/4	2.02	1-15/16	11	12.95
57/64	5 1/4	2.12	2 1/8	10	15.00
15/16	5 1/4	2.20	2-7/32	11	16.50
15/16	9 3/4	4.00	2 1/4	10 3/4	17.50
61/64	4 1/4	2.42	2-9/32	7 1/4	18.00
31/32	4 3/4	2.42	2-5/16	7	18.25
63/64	5	2.50	2 3/8	9	18.00
1-1/32	6	2.76	2 3/4	24	27.50
1-3/64	8	2.82	2-7/16	11	21.50
1-1/16	7 1/4	2.82	2-15/32	13	23.50
1-5/64	7 3/4	3.33	2 1/2	11	25.00
1-3/32	6	3.33	2-13/16	14 1/2	27.50
1-7/64	9	4.00	3	10	30.00
1-7/64	18 1/2	8.50	4	9	34.50

Large quantities available in every size. 5% DISCOUNT ON PURCHASES OF \$50 OR MORE. 10% DISCOUNT ON PURCHASES OF \$100 OR MORE.

## COMPLETE H. S. TAPER SHANK DRILL SETS BY 64ths!

Never before offered at these ridiculous prices. Used drills, but all sharp and ready to go.

1/4" to 1/2" by 64ths: 17 drills. New cost approximately \$26.00. Only \$8.95 PPD  
 3/8" to 1" by 64ths: 32 drills. New cost approximately \$175.00. Only \$49.95 PPD  
 1" to 1 3/8" by 64ths: 25 drills. New cost approximately \$300.00. Only \$79.50 PPD

## HIGH SPEED HAND TAPS

**SET 1Y** 8 different size H. S. Standard Thread Hand Taps up to 5/8", including 2 Std. H. S. Pipe Taps. PPD ..... \$2.95

**SET 40Y** 16 same as above. PPD \$4.80



## HIGH SPEED DRILLS

1/4" to 1/2" with 1/4" Shanks  
 1/2" to 1" with 1/2" Shanks



For the first time at these low prices! HIGH SPEED DRILL BITS UP TO 1/2" FOR YOUR 1/4" DRILL AND HIGH SPEED DRILL BITS UP TO 1-3/16" FOR YOUR 1/2" DRILL. The Tungsten steel content of these drills means they will outlast carbon and regular steel drills many, many times! Drills are used surplus; have plenty of flute length, are sharpened and ready for your drill.

### DRILLS UP TO 1/2" FOR YOUR 1/4" DRILLS!

Will Fit Any Size Chuck 1/4" and Larger	SIZE	PRICE EA.	SIZE	PRICE EA.
1/4	\$0.30	25/64	\$0.50	
17/64	.45	13/32	.60	
9/32	.45	27/64	.65	
19/64	.48	7/16	.65	
5/16	.48	29/64	.73	
21/64	.50	15/32	.73	
11/32	.50	31/64	.75	
23/64	.55	33/64	.90	
3/8	.55	17/32	.90	

### DRILLS UP TO 1-3/16" FOR YOUR 1/2" DRILLS!

Will Fit Any Size Chuck 1/2" and Larger	SIZE	PRICE EA.	SIZE	PRICE EA.
33/64	\$0.91	55/64	\$2.25	
17/32	.91	7/8	2.25	
37/64	1.24	57/64	2.25	
19/32	1.24	59/64	2.40	
39/64	1.30	15/16	2.43	
41/64	1.43	31/32	2.50	
21/32	1.43	1-1/32	2.80	
43/64	1.55	1-1/16	3.05	
23/32	1.70	1-5/64	3.56	
47/64	1.80	1-3/32	3.60	
49/64	1.80	1-7/64	3.60	
3/4	1.80	1-1/8	3.98	
25/32	1.86	1-5/32	3.98	
51/64	2.05	1-11/64	3.98	
13/16	2.05	1-3/16	4.10	
53/64	2.15			

Large quantities available in every size with special discounts for quantities. We can furnish drills from 1" up, with any size shank. Write us your special needs. Post paid

## H. S. TAPER SHANK CHUCKING REAMERS



**SET 15** Different Size High Speed Morse Taper Shank Chucking Reamers up to 1 1/2" with No. 1 and 2 tapers. New and used. Priced at only ..... \$6.95

**SET 8** Different Size High Speed Morse Taper Shank Chucking Reamers from 1/4" to 1". New and used. Priced at only ..... \$4.95

**SET 10** Different Size High Speed Morse Taper Shank Chucking Reamers from 1/2" to 1 1/8". New and used. \$65.00 value. Priced at only ..... \$9.95

**SET 5** different size H. S. Morse Taper Shank Chucking Reamers from 1" to 2 3/4". New and used. Priced at only ..... \$11.95

## HIGH SPEED WOODRUFF KEY SEAT CUTTER

**SET 5** Different Size Cutters. Can be used as mounted milling 4Y cutter or circular saw. All with 3/8" and 1/2" shanks, widths up to 1 1/4", dia. up to 1". New and used. Priced at only ..... \$3.95 PPD



## 6 SLITTING SAWS WITH MANDREL

**SET 6** Different Size High Speed Slitting Saws, 2 3/4" dia. x 1" arbor. Thickness from .040 to .071. Cuts wood, aluminum, brass, steel, etc. PLUS SPECIAL MANDREL which enables use of saws in 1/4" or 1/2" elec. drill. \$25 Value. PPD. Only ..... \$4.95



7 selected, sharp H. S. Slitting Saws as above to use on your own mandrel or milling machine. New and used. PPD. A bargain at ..... \$4.95

**SEMI-H. S. SAW BLADES:** 5 3/4" x 1 3/32" x 1/2" arbor. Fine tooth. Fits above mandrel. 2 for ..... \$1.29 PPD  
 NOTE: Mandrel only ..... 30c

## NEW HIGH SPEED COMBINATION DRILL AND COUNTERSINKS

**SET 8** selected sizes from A1 to F2 (3/64" drill x 1 1/2" body to 3/16" drill x 7/16" body) 60° angle of countersink. New cost on these countersinks 75c to \$2.50 ea. Priced to you PPD at only ..... \$3.98



## Bargain Tool & Shop Mixes!—PPD

**SPRING MIX:** 300 new springs, compression, tension and torsion types up to 6" in length, only ..... \$1.79

**HAND REAMER MIX:** 8 different size hand reamers up to 5/8" including 3 taper pin reamers. Majority of reamers in new condition. .... \$3.69

**MILLING CUTTER MIX:** Assortment of 4 various size H. S. milling cutters, all with 1" arbors; up to 3" dia. only. .... \$3.98

**NEW ROTARY FILE MIX:** 7 different size H. S. files, 1/4" shanks. New cost as high as \$2.00 ea. Only ..... \$4.49

**DRILL BIT MIX:** Over 300 pcs. (2 lbs.) of used H. S. drill bits up to 1/4". Most require sharpening. Ideal for pin punches, drift pins, etc. Less than 1c ea. at ..... \$2.98

**FILE MIX—BRAND NEW:** Set of 12 different files, lengths 6, 8, 10, 12 in. Half rounds, bastards, knife, mills, etc. First line Nichols, Heller and other brands. .... \$3.49

**DOUBLE-END END MILL MIX:** 4 right hand twist H. S. 7/16" straight-shank end mills, size 5/16" to 7/16". New and used. .... \$3.95

## SURPRISE MIX!

Over 50 pcs. for your 1/4" electric drill including rotary files, drills, bits, reamers, grinding wheels and arbors for our customers who like pleasant surprises. Your money back if you aren't satisfied. .... \$2.98

Money Back Guarantee—All Mdse. Mixture of New and Reconditioned Unless Specified New. All Items (Except Those Specified Post Paid) Will Be Shipped F.O.B. Tulsa—Or, Add 10% and We Will Ship Your Mdse. PPD.

Write For Free Catalog Describing Thousands Of Bargain Cutting Tools.

## NEW 360° SWIVEL TYPE TOOL HOLDER AND BORING BAR



Here is a tool that will do the work of a left, right and straight tool holder, plus a boring bar, all for a fraction of its original cost. Post paid to you

**TOOL A** takes a 5/16" sq. bit or 5/16" dia. boring tool. Shank size 9/16"x1"x4 3/4". PPD. Only ..... \$3.29

**TOOL B** takes a 3/8" sq. bit or 3/8" dia. boring tool. Shank size 5/8"x1-3/16"x5 3/4". PPD. Only ..... \$3.95

**TOOL BIT SPECIAL:** 1 doz. H.S. 3/16" sq. x 2 1/2" new tool bits. PPD. \$2.95

## THREE-SPEED TRANSMISSION

Contains 7 assorted spur and beveled gears. Has auxiliary power take-off driven from main drive. Three separate gear ratios are 16:1, 12:1 and 3 1/2:1. Contains 10 1/2" dia. ring gear, 5", 2 1/2" and 1 1/2" dia. beveled gears; 3 1/4", 4" and 2 1/4" dia. spur gears. All mounted on precision ball-bearings. Main drive has throw-in hand clutch. Auxiliary drive can be engaged or disengaged. Excellent for transmission, winch and many other uses. Wt. 30 lbs. .... \$14.98



## 90° HEAVY DUTY GEAR BOX

Ball-bearing throughout with 1/2" drive spline. 1:1 gear ratio which can be changed by different size pulleys or gears. Wt. 5 1/4 lbs. Length 11". Beveled gears. Excellent for hot rods, power mowers, etc. Only ..... \$5.95

**10 TO 1 GEAR BOX:** Worm gear drive, throwout type clutch, ball-bearing throughout. 1/2" drive spline, 3/4" output gear. Wt. 6 lbs. Rated up to 6 H.P. Only ..... \$6.95

## BRAND NEW PUMP AND MOTOR

Pump has 1" connections, built-in relief valve, adjustable up to 1500 lbs. Max. capacity 6 GPM. 1 1/2 H.P., 24-volt motor, 4000 RPM. Can be used on 12 or 36 volts. 500 units available at quantity discounts. CLOSE OUT AT ..... \$9.98



## HYDRAULIC CYLINDER

Bore 2", shaft 7/8", stroke 12 1/2", double action, double-end shaft can be mounted stationary allowing cylinder to slide. Wt. 14 3/4 lbs. Post paid to you at only ..... \$12.95



## 1500-lb. Vickers Pump or Motor

Positive displacement, angle piston, 2 1/2 GPM at 3000 RPM at 1500 PSI. 1/2" drive spline, can be used as a hydraulic motor. Factory cost over \$200. Ppd. Only \$19.50



## NEW MASTER HYDRAULIC CONTROL VALVE

For controlling two single or double action cylinders separately or simultaneously. Valve is close center type. 1500 PSI rating, only ..... \$9.98

## HYDRAULIC HOSE

12-in. 250-lb. test with 7/16" tubing conn. 6 pcs. PPD. .... \$1.49  
 2-ft. 1000-lb. test, 7/16" tubing conn. 4 pcs. PPD. .... \$1.95  
 10-ft. 1500-lb. test, 1/4" female & 1/2" male pipe conn. PPD. .... \$3.49  
 15-ft. 1000-lb. test, 7/16" tubing conn. PPD. .... \$3.49



*Blow into your hardware store and meet a new friend!*



# SIMONDS SI-CLONE

...the new line of Popular-Priced, Top-Quality Saws for Home Workshops

Look for this bright red package ... and look at the precision cutting tool that's inside it! Now you can do smoother sawing and better work than ever. And it costs so little you'll be amazed. Yes, in many cases it costs less to buy a new Simonds SI-CLONE than to sharpen your old saw. And still you get famed Simonds quality ... special edge-holding steel, milled teeth, extra smooth finish ... fully guaranteed. All types, in all diameters to 12", with any type of centre-hole ... for use on any table, radial arm, or electric handsaw machine. So breeze into your hardware dealer today and tell him: "Let's see those new Simonds SI-CLONE Saws."



**SIMONDS  
SAW AND STEEL CO.**

FITCHBURG, MASS.

Factory Branches in Boston, Chicago, San Francisco, and Portland, Ore. Canadian Factory in Montreal, Que.

years is the story of the continuing struggle between the forces which deplete our mineral resources and those that replenish them. We have many problems yet to solve; in the case of some minerals, we shall undoubtedly have to rely increasingly on foreign supplies. Yet in the main we have plenty of reason for optimism.

With minerals as with other things, we have learned much about the proper way to use our resources while we conserve them. We can no longer afford to be prodigal or wasteful; we can see at last that neither we nor any other people have "inexhaustible" resources at our disposal. But we are beginning to see how to make a far better use of these resources than we have made in the past. Our progress has hardly more than begun. If the last 50 years have taught us anything—and I believe they have taught us much—they have shown that we can continue to develop an economy of abundance, with a constantly rising standard of living, provided that we go on making every effort to use our resources wisely, scientifically and economically.

## Report on the Foreign Cars

(Continued from page 110)

engineering and a favorite of many sports-car enthusiasts.

The Jowett Javelin is unique with its opposed four-cylinder air-cooled engine. The Lagonda, Lanchester, Lea-Francis, Morgan, Alvis, Riley, Rover, Allard, Singer, Sunbeam-Talbot, Triumph and Wolseley are other makes which suit the tastes of certain types of drivers. The new Vauxhall (G. M.'s British make) made a hit with new styling in the 35-horsepower Wyvern and 58-horsepower Velox models.

Next I flew to Copenhagen and Stockholm. Both Swedish automobile factories, Saab and Volvo, were closed for the holidays but I drove both makes. They are well built and suitable for Europe's buyers who like light, economical cars. From Stockholm I flew to Hamburg, where a driver from the Volkswagen Werke was waiting. He drove me 125 miles to Wolfsburg, Germany's largest producer of cars and the youngest town in Germany. The new Volkswagen plant seemed almost unbelievable in its operation. All of the profits are used for improvements. The company builds houses for its workers, which they can rent or buy. Eleven million marks (about \$2,750,000) have been spent for dwellings. The largest swimming pool in Germany is available for the use of workers and residents of the city. The plant also supplies gas for the city of Wolfsburg.

(Continued to page 288)



# THIS ONE-TWO PUNCH

adds power—pep—miles  
in auto performance!

- K.O.'s top-cylinder wear
- Frees sticky valves
- Defeats gum formations
- Provides ring seal

## 1 MARVEL INVERSE OILER

Tested and proven through years of scientific research. Now available in one quart model. Visible oil reservoir feeds oil automatically in proportion to engine needs direct to upper cylinder area. Install a Marvel Inverse Oiler for better motor performance, longer engine life . . . more engine-hours per dollar!

## 2 MARVEL MYSTERY OIL

A specially developed top cylinder oil for today's high compression engines. Ideal for use with hydraulic valves. Contains no ingredients or graphites harmful to engines. All-around lubricating action insures smoother, carefree driving . . . protects and adds years to the life of your car.

Be engine wise . . .  
Marvelize NOW!



For detailed information,  
ask your dealer or write:

**EMEROL**  
MANUFACTURING CO.

DEPT. 115, 242 West 69th St.,  
New York 23, N. Y.



# Save \$89.50

on this combination!

**STARTS**

as a ROUTER



Router Complete with base and motor—\$49.50



**BECOMES**

a PLANE



By adding Plane Attachment — \$25.00

**THEN**

a SHAPER



By adding Shaper Table — \$24.00



**Interchangeable Motor powers 3 tools . . . saves cost of 2 motors!**

## All 3 Tools for only \$98.50

For expert woodworking, build your home workshop around this Guild Tool combination — production tools used by Builders — and save \$89.50!

**As a ROUTER**—you can tongue, groove, rabbet, dovetail, do scrollwork, cut contours and beaded edges on wood, composition or plastic.

**As a PLANE**—you can shave off wood at high speed — taking cuts from  $\frac{1}{64}$ " to  $\frac{3}{32}$ " deep — without a wave or ripple! Attachment for sharpening right on the job.

**As a SHAPER**—you can edge irregular pieces; joint strips accurately, even narrow and short pieces; make hundreds of fancy cuts for cabinets, furniture, trim, toys, picture framing, molding, etc.

Purchased separately, all tools complete with motors would cost you \$188.00. But, with one Interchangeable Motor mounted in the proper attachments, you get all 3 tools for only \$98.50 — a saving of \$89.50!

See this great money-saving combination at your Guild dealer's. Or mail coupon today for full details.

PORTER-CABLE Machine Co.  
6163 N. Salina St., Syracuse 8, N. Y.  
Send me full information about Guild Router, Plane and Shaper Combination . . . also name of nearest Guild dealer.

Name \_\_\_\_\_

Address \_\_\_\_\_

City \_\_\_\_\_

State \_\_\_\_\_

**Manufacturers of SPEEDMATIC and GUILD Electric Tools**  
In Canada write: Strongridge, Ltd., London, Ont.

Eighty-four percent of Wolfsburg's adult population of 28,000 works for Volkswagen. A population of 50,000 is predicted for 1956. The factory is modern, with new machinery, and production-line capacity is 415 passenger cars and 35 delivery vans a day. It could produce 40 percent more cars but for shortages of rolled sheet steel and coal. The production is sold out for eight months in advance. The firm has 70,000 orders on its books, of which 8000 were taken at the Paris motor show. A German buyer must wait eight to ten months for delivery.

At present, 15,000 men work two shifts. There is no fixed time for lunch; workers may eat when they wish on company time. Two thousand women work in offices, machine shops and company kitchens. About 34 percent of Volkswagen production is for export.

Practically all units for the entire car, including all castings, are made in Volkswagen's own foundries. No Marshall Plan aid was needed by Volkswagen to resume car production.

The Volkswagen originally was designed for Hitler as the "People's Car" by the late Dr. Ferdinand Porsche, long a famous German engineer. The Hitler regime collected about 280,000,000 prewar marks from 300,000 Germans, promising each a People's Car. The one-story factory was planned to be three times its present size, which is about  $\frac{3}{4}$  of a mile long. The money paid in before the war by Germans desiring cars was on deposit in Berlin. When the Russians entered the city they seized the funds and never returned them. Thus 300,000 Germans were left holding paper receipts for their savings. All money appears to have been lost, although the case now is pending before the highest court in West Germany.

I rode from Hamburg to Wolfsburg and from Wolfsburg to Bremen, about 250 miles, in a Volkswagen. It is a sturdily built small car (1554 pounds) with a unique opposed four-cylinder air-cooled engine of 69.014 cubic inches mounted in the rear. Horsepower is 24 at 2400 revolutions per minute. Compression ratio is 8.5:1. It rides exceptionally well for a car of its size because of good weight distribution and independent rear-wheel suspension. The car runs about 35 miles on a gallon of low-grade gas. This makes it a popular car in Europe, where gas sells in various countries from 45 cents to \$1 a gallon. It is stable at top speed (65 to 85 miles per hour), has good hydraulic brakes, a four-speed gearbox, and it corners well. A duplicate of the Volkswagen, but somewhat larger, probably would sell well in the U. S.

(To be continued next month)





# Preferred at Famous Fishing Spots

**LAKE PEND OREILLE, IDAHO.** This famous fishing spot—produces rainbow trout which are literally out of this world. These rainbows reach the whopping weight of 37 lbs. (world record for rainbow trout, 1937). One of the largest rainbows from Lake Pend Oreille—33 pounds—was caught in 1949 on H-I tackle by Tom E. Kocher of Spokane, Washington.

In other famous fishing spots . . . everywhere and anywhere that fishermen fish and catch 'em—you'll find H-I tackle preferred for its quality, dependability and value. Buy H-I—the preferred line for every fisherman and every kind of fishing—at your dealer's. Horrocks-Ibbotson Company, Utica, N.Y. Manufacturers of the largest line of fishing tackle in the world.

Take your pick from a complete line of tubular and solid H-I POWER GLASS RODS for fly, bait casting, spinning and salt water. Compare their lithe, live action and "fishin' feel" with any rods—of any material—you've ever used. Compare them for VALUE, too.

# Power Glass Rods



### SPINNING RODS

**GOLDEN ROD**—2-piece, tubular, H-I Power Glass. Length: 6½'—Weight: 4½ oz. \$20.00. (Also available with fly rod reel seat below cork grip. \$21.50.)

**HUDSON**—1-piece, tubular, H-I Power Glass. Length: 6½'; Weight: 5½ oz. \$16.00.

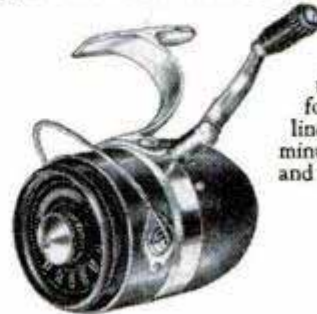

**BRADCO SPINNER**—Finest, strongest spinning reel on the market, with greatest capacity for holding 5 to 18 lb. test Nylon line. Anti-friction bearings. Aluminum body and spool for strength and lightness. \$17.00.

OLD HI SAYS—"As one fisherman to another, better buy H-I." Write for my free books: "Fishing for the Millions," "Salt Water Sports Fishing" or "Pacific Coastal Fishing." Horrocks-Ibbotson Co., Utica, New York, Dept. 23.



**HORROCKS-IBBOTSON CO., UTICA, N. Y.**

Buy the Mechanic's FIRST Choice

...EMPIRE LEVELS

For Home, Farm, all Trades



See Empire Levels at your dealer, or write for free booklet "Choice and Care of your Level."

Empire No. 151 Aluminum Level; Adjustable vial cases, twin levels, plumbs, 45° vials—24"—\$7.50.



EMPIRE LEVEL MFG. COMPANY

10930 West Potter Rd., Dept. PM., Milwaukee 13, Wis.

USE EASTER SEALS

## New MOTOR BARGAINS for Home, Farm & Industry



New Dayton 1/2 H.P. Induction Type 3450 RPM 110 V. 60 cy. 1 ph. A. C. Motor. #GEH-5. Fob. . . . . \$18.50

#DH-5-2. Same 220V Fob. Only . . . . . \$15.00

New General Electric 1/2 H.P. Cap/Ind. Ball Brg. 1750 RPM, double 1/2" shaft. 110 V. 60 cy. #GE-17. Fob. . . . . \$29.75

New General Electric 3/4 H.P. Cap/Ind. Ball Brg. 1750 RPM, double 1/2" shaft. 110 V. 60 Cy. 1 Ph. A. C. Motor. #GE-75. Fob. . . . . \$34.50

New Dayton 1 H.P. Heavy Duty, Cap or Repulsion Induction, 3450 RPM, 110/220 V. 60 Cy., 1 Ph. A. C. Motor. #EH-1. Fob. . . . . \$52.00

Same as above, 2 H.P. 220-V. 3450 RPM #EH-20. . . . . only . . . . . \$75.00

Same as above 3 H.P. 220-V. 3450 RPM, #EH-30. . . . . Only . . . . . \$97.00

Write for FAN CIRCULAR: listing Blades, Guards, Motors, All Sizes for building your own Attic Fan, Window Fan or Room Cooler.

C. MARSHALL SALES, 3546 W. Fullerton Ave., Dept. P-3, Chicago 47

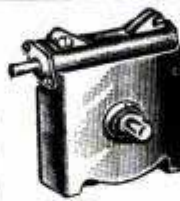

## 16 to 1 SPEED REDUCERS

For Display Table — Barbecue Spits — Toy Auto Gear Box — Experimental Uses, Etc. Gears Enclosed in Aluminum Housing. Bronze Gear, Hardened Worm, Input Shaft 1/4 in. Output Shaft 3/8 in. Speed Reducer #R 161 \$3.95 Post Paid

## General Utility Motors



Shaded Pole Motor, brushless, Non-Radio, T.V. Interfering. 110 V.-60 cy. A. C. Speed 1550 RPM for light machine duty, exhaust fans, furnace fans, blowers and many practical and experimental purposes. Handles fan blades from 12 to 20 inches.

- #UM-40 . . . 1/40th H.P. Postpaid . . . . . Only \$6.25
  - #UM-30 . . . 1/30th H.P. Postpaid . . . . . Only \$7.50
  - #UM-20 . . . 1/20th H.P. Postpaid . . . . . Only \$8.75
  - #UM-15 . . . 1/15th H.P. Postpaid . . . . . Only \$9.75
- FAN BLADES TO FIT THE ABOVE RESPECTIVELY
- 12 inch blade . . . . . Only \$1.50
  - 16 inch blade . . . . . Only \$2.75
  - 18 inch blade . . . . . Only \$3.75
  - 20 inch blade . . . . . Only \$4.75
- (all above blades are Postpaid)
- Three Speed Motor Control for above motors #1X-474. . . . . Postpaid . . . . . Only \$4.25

## Volume Blowers for Heating, Ventilating, Exhausting

Blowers for forced drafts, heating boosters, exhausters, coolers, dryers and dust collectors, 110 volt A.C., 50/60 cycle motors.

- #MBL-1 Midget Blower, 5 cu. ft. per minute, skeleton type motor, Postpaid . . . . . \$5.95
- #BL-50 Fifty cu. ft. per minute blower & motor, 3 in. diameter wheel, Postpaid . . . . . \$9.75
- #BL-75 Seventy-five cu. ft. per minute blower and motor, 4 in. dia. wheel, Postpaid . . . . . \$11.25
- #BL-150 Dust collector blower & hi-speed motor, 150 CFM, Postpaid . . . . . \$12.50

## JOHNSON'S FAIR

705 Glenwood Ave., Phila. 40, Pa.



**NOW... LUFKIN NEW X46F**  
**EXTENSION RULE Gives You**  
**Flat, Inside and Regular Readings**

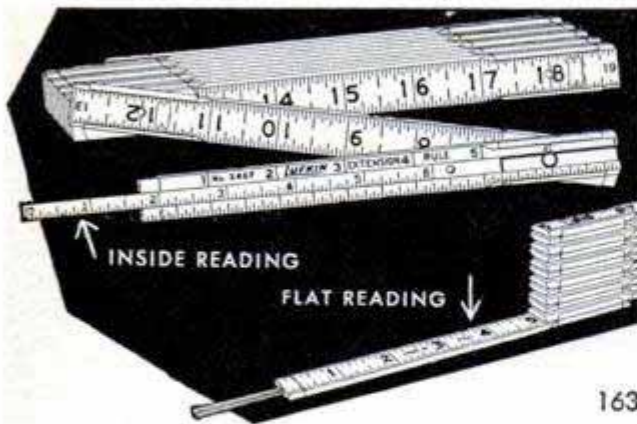

163

Measuring begins at extension end of rule on both sides of this new extension rule. One side allows rule to be used flat against work. The sliding brass extension permits accurate inside measurements. A sturdy, rigid, accurate rule. LUFKIN "RED END" quality throughout. See this new rule at your dealer's!

**BUY LUFKIN** Tapes • Rules • Precision Tools From Your Dealer

THE LUFKIN RULE CO., SAGINAW, MICHIGAN  
 132-138 Lafayette St., New York City • Barrie, Ontario

**SHARPEN**  
**hard-to-get-at**  
**edges...**



**It's easy with the right**  
**INDIA® OIL STONE**



Take, for example, a dull or nicked Countersink. A few strokes with a triangular INDIA Oilstone File will make it sharp again. You can restore the worn, nicked or burred edges of countless tools and machine parts with the right shaped INDIA file.

32-Page "How to Sharpen" Book

Gives full data on sharpening methods for all home and shop tools. Send 10c to Dept. PM-3.



**BEHR-MANNING**

® Division of Norton Co., Troy, N. Y.

Coated Abrasives • Sharpening Stones • Masking Tapes

**GARDEN TRACTORS**



**SPEEDEX**  
 YOUR CHOICE OF TWO TYPES  
**8 H.P. RIDING**  
**2½ H.P. WALKING**

**Exceptionally Low Prices Still in Effect**

New catalog gives you full details on the famous Speedex. Illustrates many labor-saving uses. Complete descriptions.

SEND POSTCARD FOR YOUR FREE COPY OF NEW CATALOG TODAY

**SPEEDEX GARDEN TRACTOR CO.**  
 Box 216-E1B RAVENNA, OHIO P-251-32

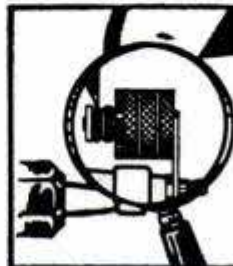

**SURE FIRE** SPARK PLUG INTENSIFIER

**NEW UNUSUAL MULTIPLIES HEAT OF SPARK**  
 Insures easier starting, smoother, more economical operation of Outboard Motors, Power Mowers, Generators, any 2 or 4 cycle gasoline engines. **NO MORE FOULED PLUGS.** SURE FIRE burns excess gas for more power - greater economy - keep plug points clean - lasts longer - pay for itself. Money back guarantee.

**SPECIAL INTRODUCTORY OFFER 50¢** each postpaid  
 Dealer inquiries invited Wahl Products, Inc. Eau Claire, Wis.  
 600-610 Randall St.



**LAWN ORNAMENT-NOVELTY PATTERNS**

28 Lawn Ornament Patterns, 25c. Other Patterns: 15-20" high; Dutch Girl, Dutch Boy, Pirate, Bull Terrier, Mexican Girl, Mexican Boy, Dwarf, Penguin, Flower Girl, 10c each. 25 Novelty Patterns, 30c. All 62 Full Size Patterns, \$1.00 Postpaid. Strother Pattern Service, Dept. CT-8, Box 129, Belington, W. Va.

**HIGH POWER TELESCOPE**  
**60 POWER—ALUMINUM TUBES—OPENS TO 33"**

Variable Power Adjustable to 15X, 30X, and 60X.

\$5.95



Leather Case Included

5 Sections, 4 Ground & Polished Lenses. Also used as 50X Microscope. Ready to use, only \$5.95. POSTPAID.

**CRITERION CO.**  
 DEPT. AP3

438 ASYLUM ST.  
 HARTFORD 3, CONN.



Unbreakable Fire-Safe Amber  
 Hammer Proof  
 Shock Proof  
 TOOL STEEL  
 PRICED FROM 5c TO \$1.00 EACH

Ask Your Hardware Store for  
**FULLER'S**  
**Unbreakable Amber Handle**  
**SCREW DRIVERS**

America's most popular line of moderately-priced screw drivers! Wide range of sizes. Fuller Tool Co., Inc., 915 Faile St., New York 59 World's largest makers of Amber-Handle Tools Export Sales Dept., John H. Graham Co., 105 Duane Street New York, U.S.A.

USE EASTER SEALS. HELP CRIPPLED CHILDREN

**Foley Filer Users—Attention!!**

Save on File Expense! Improve Your Workmanship!  
**Sharpen More Saws With Each File!**

"FLOATING ROLLERS" will solve these problems for you! "FLOATING ROLLERS" replace saw carrier clips and have a tension spring which holds the carrier snug to the lower rollers, eliminating irregular size teeth, carrier play, etc., which must be remedied before precision work can be accomplished. Many other features make the "FLOATING ROLLERS" a MUST investment for you. Easily attached in five minutes.

For Model F-16, F-24 or F-61 Foley Filer, equipped with carrier rollers. \$7.50 per set.

For Model F-5, F-16 or F-24 not equipped with carrier rollers. \$10.25 per set.

Order a set today for 30-days trial. If not satisfied in any way, return them and your money will be refunded. Save COD and postage charges by sending check or money order with order, or write for further information.

**STADICK MANUFACTURING CO.**  
 Box 73, New Ulm, Minnesota



# BRIKCRETE



## Local Manufacturers Have Broad Opportunities

Brikrete manufacturers operate compact, self-contained plants under franchise privileges in protected territories. Each is an independently owned unit in a country-wide chain, using local materials and local labor to supply the world's most modern masonry for local building needs.

Brikrete is rich in sales appeal because it is ahead in design, style, size, color, economy. Easily the preferred masonry. But because local production eliminates economic wastefulness,

Brikrete can be sold at a lower-than-lumber price. Yet still allow a generous profit margin.

Brikrete offers much to men looking for a community enterprise on a nominal investment. We supply complete equipment; easy terms when desired. Liberal cooperation. Write today for Brikrete Book No. 2—while territory is still open.

**BRIKCRETE ASSOCIATES, INC.**

4679 Division Avenue, S.  
Grand Rapids 8, Mich. 82



## NEW 1952 KING MIDGET AUTO

World's Lowest Priced 2 Passenger Car Drive it for 75c per week. Amazing performance. Surprising comfort. All steel construction. Full accessories, top and heater. Ready to run or assemble it with our bolt together parts. Rider agents wanted, earn your car free. Send 25c for detailed literature or \$1 (refunded first order) for actual assembly book and service manual filled with photos, drawings, specifications, etc.



**MIDGET MOTORS MFG. CO.**  
ATHENS, OHIO

## SET-UP - KNOCKDOWN SAWHORSE with *Jiffy* BRACKETS



No nails or bolts... use 2x4's for legs. 2x4 or wider for crossbar. Rugged, sturdy, easy to move, saves storage space. Sold by hardware and building material dealers, or order direct.

**GRAND HAVEN STAMPED PRODUCTS CO., Grand Haven, Mich.**

## FILE SAWS the RIGHT WAY

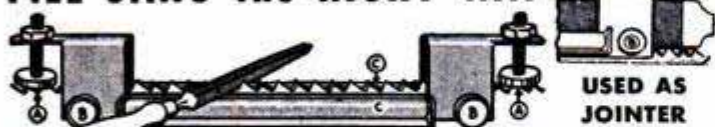

**USED AS JOINTER**

SO EASY with this new filing jig and jointer anyone can now sharpen any handsaw like new! When file hits hardened steel rollers teeth are finished and EXACTLY THE SAME HEIGHT. All teeth cut and saw runs true and smooth. Jig and instructions \$2.95 postpaid. FREE FOLDER.

## SHARPEN YOUR CIRCULAR SAWS

The RIGHT WAY on your own saw table. Sharpens rip, cutoff, hollow ground and combination blades—6" to 10". Saws stay round with correct bevel. Precision made, easy to use. GUARANTEED. Only \$8.95. Includes \$3.00 Grinding wheel.

"TRU-CIRCLE" saw set automatically sets teeth at 10° or more. \$2.95

**AT DEALERS OR POSTPAID**



A. D. McBurney, 317 E. 4th St., Los Angeles 14, Cal., Dept. A-15

# FREE



## 1952

## ALLIED RADIO & TV CATALOG

EVERYTHING IN RADIO AND TV AT LOWEST PRICES!

SEND FOR IT

**212 PAGES**  
Value-Packed

Everything for Experimenters, Builders, Amateurs, Servicemen, Engineers, Soundmen...

Save money on every Radio and TV need! Get the big 212-page 1952 ALLIED Catalog featuring the world's largest selections of top-quality electronic equipment at lowest, money-saving prices. See the latest in TV, home radios, Amateur equipment, P.A. systems and Hi-Fidelity custom sound, recorders, test instruments, builders' kits—plus thousands of parts, tools, books and diagrams. Get more for your money from the World's Largest Radio Supply House. Send today for your FREE 1952 ALLIED Catalog!

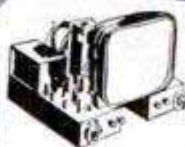

Save on Everything in Radio & TV



**FREE CATALOG**

SEND FOR IT TODAY

## ALLIED RADIO

ALLIED RADIO CORP., Dept. 5-CC-2  
833 W. Jackson Blvd., Chicago 7, Ill.

Rush FREE 1952 ALLIED 212-Page Catalog

Name \_\_\_\_\_

Address \_\_\_\_\_

City \_\_\_\_\_ Zone \_\_\_\_\_ State \_\_\_\_\_



**GIVE YOUR CAR  
A LIFETIME  
OF PROTECTION**

FOR  
LESS THAN  
**\$500<sup>00</sup>**

14' x 20'



Erect this all-aluminum 1½ car garage yourself in just one day!

Delivered complete with beautiful 6" embossed aluminum siding and roof. Overhead door, hardware and nails plus screened louvers. Factory-cut framing members of clean, white kilndried lumber. Fire-resistant, rodent, rust and weather proof. Acceptable for FHA financing.

Send for our circular on 1, 1½ and 2 car garages, cottages, farm and utility buildings.

**SWIFT HOMES, INC**  
CLAIRTON, PA.

SOME DEALERSHIPS  
STILL OPEN

# CONVERT HAND MOWERS to POWER MOWERS

**Takes less than 3 hours**

The Handy-Dandy Lawn Mower Kit fits any hand mower from the 16 to the 20 inch size. Complete with all necessary parts. Kits can be purchased separately, complete with engines or complete with Pennsylvania mower.



Also manufacturers of complete power mowers and garden cultivators.

**LE CLAIRE MFG. CO., Le Claire, Iowa, Dept. PM**

## LATEST MODELS HISTORY-MAKING TANKS by

*Authentic*  
Precision built tank miniatures  
... 75 models of 5 nations ...  
Cast in metal and hand assembled  
... Moveable turrets ... In-  
cluded are styles used in Korea.  
SEE THEM IN VOL. III - 35¢  
COMET METAL PRODUCTS CO., INC.  
91-04 132nd St Richmond Hill, N. Y.



3180 WALKER BULLDOG \$1.75

## POWER HACKSAW \$52.75

LESS MOTOR

F. O. B. Benton Harbor

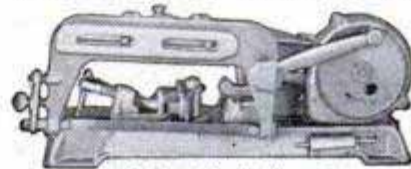

● Rugged cast iron construction. Wt. 56 lbs. bronze bearings. Draw cut. Auto. return lift. Auto. shut-off. Vise swivels 45°. Cap. 4"x4".

Send for full details and name of nearest dealer.

EXCEL MACHINE TOOLS Dept. PM-32 BENTON HARBOR, MICHIGAN

## Print Your Own

Cards, stationery, circulars, tags, labels, photo and movie titles, advertising, etc. Save money. **Print for Others, Good Profit!** easy rules sent. Raised Printing like Engraving, too. Sold direct from factory only. Write for free catalog of outfits and all details. **KELSEY PRESSES, M-37, Meriden, Conn.**



## BRONZE FOUNDRY

Schools and Home Workshops

Make your own castings of aluminum, copper, bronze, silver. Foundry sets are available in three sizes including 2400 Deg. F. blast Furnaces. \$22.50; \$29.50; and \$42.00. f.o.b. Kansas City. Free Circular.

KANSAS CITY SPECIALTIES CO. P. O. BOX 6022, DEPT. P-3 KANSAS CITY, MO.

## GREATEST SAVING EVER OFFERED!

U. S. GOV'T SURPLUS

## "BARGAIN BOOK"

SAVE ON WINTER NEEDS!

It's loaded with bargains in genuine Gov't Surplus for farm-home-industry. Save up to 85% on clothing, hardware, sporting goods, etc. The "Book of the Year". Send 10c for yours today.



500 BARGAINS  
• FARMS • SPORTS  
• HOME • SHOP

MAIL  
TODAY Only  
**10¢**

**FISLER SALES CO.**

723 WALNUT ST., DESK M-3, KANSAS CITY, MO.



## Send for this BIG NEW Hunt's WOODWORKERS CATALOG NO. 18

NEW LOW PRICES

ONLY  
**15¢**

Offers greatest selection of fine domestic and imported woods--and hundreds of woodworkers items at bargain prices!

You'll save time and money with this big, new catalog. Contains everything wood craftsman needs. Shows 32 rare and fancy woods in color...43 veneer designs...275 scroll patterns...multicolor inlays, overlays, bandings...all kinds of tools, machinery, cabinet hardware, ornaments, mouldings...and pages of valuable tips, ideas, information, instruction. Send for your copy NOW. Only 15¢



144 PAGES

QUICK  
DELIVERY

• on maple, poplar, oak, mahogany, red cedar, cherry, walnut, and many others—  
• all properly seasoned and kiln dried.

MAIL THIS COUPON--TODAY!

CRAFTSMAN WOOD SERVICE CO.

2729 S. Mary St., Dept. A-3  
Chicago 8, Illinois

Send me the big, new, money-saving Catalog No. 18. Enclosed is 15¢

Name \_\_\_\_\_

Address \_\_\_\_\_

City \_\_\_\_\_ Zone \_\_\_\_\_ State \_\_\_\_\_



# GOOD WOODWORKING



IS A CINCH  
WHEN YOU HAVE

## THESE PLANS

Save money by making your own furniture in your spare time. Rogers simplified project sheets will show you how step-by-step. Send only 15c for which we will send you a full-size jar of Rogers famous Gorilla Grip Glue and include these valuable plans free. Write to Rogers Isinglass & Glue Co., Gloucester, Mass. Ask for Rogers Glue at your local hardware store.



"A Ton of  
Strength in  
Every Drop"

### ROGERS

the best LIQUID FISH GLUE  
GLOUCESTER, MASS.



## MARCOT KEY MACHINE



MARCOT No. 8 KEY MACHINE, less motor . . . . . \$110.00  
Auto Code Book and Depth Keys . . . 12.50  
75 Dz. Popular Key Blanks . . . . . 60.00  
Set — Key File, Follow-Through Rods, Lock Picks, Bit Key Gauge, Thimble, Pins, Springs . . . . . 10.50  
"Locksmith Trade Books" . . . . . 6.75  
How to Open Locks without Keys or Picks; Secret of Locksmithing; How to Make Keys by the Impression Method; Master Key Systems.  
TOTAL COST . . . . . \$199.75

Immediate Delivery

A. J. MARCOTTE CO., 1200 N. Kedzie Ave., Dept. PM, Chicago 51, Ill.

## ACE TOOLS



Be permanently  
tooled-up for every operation  
on your Metal Cutting Lathe.

No. 8-A Ace Tool Set for 9" and 10" Swing Lathes—fits shank size 3/4" x 3/4". Includes Turning, Cutting-off, Boring, Knurling and Threading Tools with high speed cutters, blades and wrenches. 8 complete tools in fitted steel case—nothing else to buy. See your local dealer or order direct.

ARMSTRONG BROS. TOOL CO. \$26<sup>95</sup>  
5268 W. Armstrong Ave., Chicago 30, Ill.

## MAGNETS

OF ALL TYPES — 10c UP  
AMAZINGLY POWERFUL!  
1/2 lb. magnet lifts 25 lbs. \$1.95.  
Our Leader, 1 lb. magnet lifts 40 lbs. \$2.95. New alloy—will not weaken!  
Useful for lifting valuables from tanks, takes, or rivers easily! 7 small magnets \$1.25 with list of many shop and home uses. Satisfaction guaranteed.  
R. EYRICH, 1219 W. MEINECKE AVE., MILWAUKEE, WIS.

Give the handicapped a chance. Use Easter Seals

## ELECTRICITY Anywhere

FOR PORTABLE, EMERGENCY OR HOME USE

ONAN Electric Plants generate 110-volt, 60-cycle current for homes, farms, cabins and resorts beyond the highline. Lightweight, portable plants cut costs, speed work for contractors. Standby plants protect units against power failure. 400 to 55,000 watts. Gasoline or Diesel-powered. Priced from \$219.00.



WRITE FOR CATALOG

**D. W. ONAN & SONS INC.**  
5855 UNIVERSITY AVE., MINNEAPOLIS 14, MINN.

# Spare Time

\$3<sup>00</sup> AN  
PAYS 3 HOUR  
and MORE  
with



## UNIVERSAL Lawn Mower Grinder

Here is a business you can start in your own garage or basement. Sharpen hand and power mowers on the Universal Grinder and make \$3.00 to \$5.00 an hour.

G. Spurlock of Arkansas writes: "I have had my Universal Grinder only 2 months. Live 2 1/2 miles from town. Yet have already made \$227 net profit." J. L. Peterman of Pa. says: "I averaged \$100.00 a week in May, and made \$1,000.00 spare time this season."

**REMEMBER—Only on the UNIVERSAL GRINDER** can the inside face and edge of the stationary blade, as well as all of the reel blades, be ground to the proper clearance

### ALL IN ONE SET-UP

WITHOUT REMOVING ANY BLADE FROM THE MOWER  
Rogers Mfg. Co., Dept. PM-32, Lindsey, Ohio

## SEND THIS COUPON NOW

**ROGERS MFG. CO., Dept. PM-32, Lindsey, Ohio**  
Please send me full facts about the Universal Lawn Mower Grinder and its big money making opportunities.

NAME \_\_\_\_\_  
ADDRESS \_\_\_\_\_  
CITY \_\_\_\_\_ STATE \_\_\_\_\_

# NOW—40 different cuts with AMAZING, NEW

## Warren DADO SAWING WASHERS

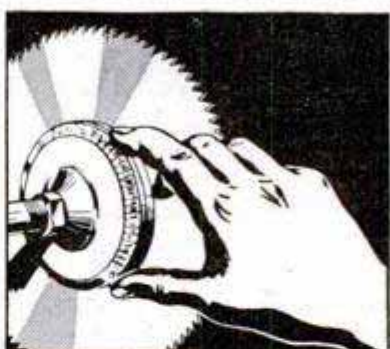

ON YOUR  
SAW BLADE!  
NO Warp...  
NO Wobble...  
NO Burning!

ONLY \$4<sup>95</sup> PER SET

## 4 Washers Mean Perfect Balance

Make clean, smooth parallel grooves at any angle—no chewing, no sanding. Just dial your cut—no trick screws, no vibration, strengthens blade for straight cuts. Warren Washers greatest improvement in 30 years—and most copied—look for the name on the box and washers. It costs no more to get the best—WARREN, IT'S GUARANTEED! At your dealer or order direct. Give arbor size—1/2", 3/4", 5/8", 1"—sent postpaid.

## WARREN DADO SAWING WASHERS CO.

Dept. 23 • Box 98 North End Station  
Detroit, Michigan



# CAMPBELL-HAUSFELD Spray Painting Outfits

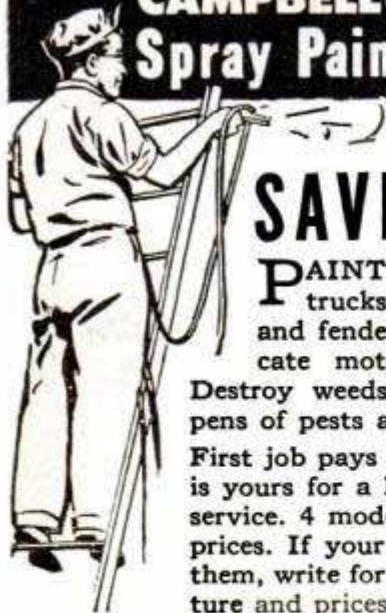

**SAVE** time, materials  
and money

**PAINT** buildings, tractors, trucks. Refinish furniture and fenders. Inflate tires; lubricate motors and implements.

Destroy weeds. Rid live stock and pens of pests and parasites

First job pays for the outfit. Then it is yours for a lifetime of trouble-free service. 4 models at 4 money-saving prices. If your dealer does not have them, write for literature and prices, giving his name.

pressure queen

The only 4 cylinder portable. Outperforms them all for spray painting without pulsation.

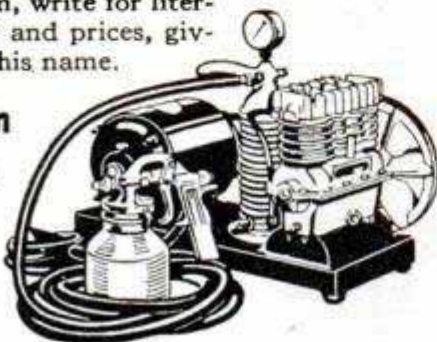

**THE CAMPBELL-HAUSFELD CO.**  
1046 RAILROAD AVE. HARRISON, OHIO



## GLIDE TO THE HAUNTS OF THE BIG ONES

• Smoothly and quietly you reach the best spots when your canoe is an easily handled Old Town. Strong yet light, Old Towns are built to give years and years of pleasurable, reliable service. Every canoe is backed by half a century of skilled experience in building water-wise craft.

**FREE CATALOG** shows all kinds of canoes for paddling, for sailing, for outboards. Also sailboats, outboard boats, dinghies, rowboats.

## OLD TOWN CANOES

Old Town Canoe Co., 843 Elm St., Old Town, Maine  
**PLEASE SEND ME FREE CATALOG**

Name \_\_\_\_\_

Address \_\_\_\_\_

City \_\_\_\_\_ State \_\_\_\_\_

## "WOVEN-Gards"

**BETTER HAND PROTECTION  
at Amazing Low Cost**

"Woven-Gards" are hand protectors, mitts, pads, sleeves and aprons made of a new long-wearing safety material. Provide flexibility, comfort, resistance to abrasion and cutting far beyond anything used before. Extremely oil-absorbent, excellent for handling oily, slippery sheets. Porous weave makes them one of the finest protectors for handling lower temperatures. Enthusiastic users say they have never seen values like "Woven-Gards." Excellent protection at lowest cost. Send now for descriptive folder and prices.



Steel Grip  
**INDUSTRIAL**  
Safety Apparel

**INDUSTRIAL GLOVES COMPANY**  
A Corporation

1200 Garfield St., Danville, Ill.  
(In Canada: Safety Supply Co., Toronto.)

To be Sure of the Genuine  
Demand This Trade Mark

## Clark EXPANSIVE BIT



**CUTS BETTER • COSTS LESS!**

Accurate, fast; cuts smooth holes in hard or soft wood. Chrome vanadium steel blades, all chrome body. No. 250, 1/2"-1 1/2", \$1.89; No. 251, 7/8"-3", \$2.19. **GUARANTEED.**

At your dealer or write Dept. PM-3

**ROBERT H. CLARK COMPANY • Beverly Hills, California**



## GIANT BALLOONS

Neoprene: Surplus Govt. Weather and Target Balloons. Terrific attention getters for Lodges, Civic Events, School Functions, Conventions, Exhibitions, Trade Shows. Advertise your special events in the Hollywood manner. Make any occasion a success. Great backyard fun. Marvelous for parties, dances, fairs, picnics, all festivities.

**3 Ft. Dia. 39c    6 Ft. Dia. 79c    13 Ft. Dia. \$1.39**  
Add 10% For Postage and Handling. Calif. Res. add sales tax.

**WAR ASSETS DIV. VOLUME SALES CO.**  
Dept. M-3-52, 3930 Sunset Blvd., Los Angeles 29, Calif.



Thousands  
In Use

**SMALL! POWERFUL!**

America's finest low cost tractor Ruggedly built. Easy to operate. No belts, no chains, Borg-Warner clutch, trans. and diff. 140 to 1 reduction. 40% more drawbar pull than ordinary tractors. 8-1/4 H.P. engine—gasoline or kerosene. 20 quick change implements. Write for complete details.

**ENGINEERING PRODUCTS CO.**  
915-K3 Niagara Ct.  
Waukesha, Wis.

## Ball-Bearing **SPEED WHEELS**



**JUVENILE WHEELS** (No bearing, solid tires)

4" . . . . .	40c	6" . . . . .	65c
5" . . . . .	45c	7" . . . . .	75c
(Semi-pneumatic tire, ball bearing)			
8 x 1.25 . . .	1.85	10 x 1.25 . . .	2.20
8 x 1.75 . . .	1.95	10 x 1.75 . . .	2.30
8 x 2 . . . . .	2.20	10 x 2 . . . . .	2.65
12 x 1.75 . . . . . 3.45			

**INDUSTRIAL WHEELS**

Lug Base, Semi-Pneumatic tire			
5 x 1.75 . . .	3.65	10 x 2.00 . . .	6.10
6 x 2 SW . . .	3.45	10 x 2.75 . . .	5.15
6 x 2.00 . . .	4.00	12 x 2.00 . . .	6.90
8 x 2.00 . . .	5.20	12 x 3.00 . . .	9.20
8 x 2.50 . . .	5.40	16 x 4.00 . . .	15.15
Smooth Base, Pneumatic tire and tube			
8 x 3.00 . . .	11.00	12 x 4.00 . . .	12.10
10 x 2.75 . . .	6.80	4.00 x 8 . . .	13.10
10 x 3.50 . . .	10.55	14 x 4.50 . . .	13.40

Dealers, Jobbers, and Manufacturers! Our new prices will interest you.

Available Now — **CASTERS**  
Write for circulars on all wheels.

No c.o.d. orders. Prices F.O.B. our plant.  
**JIM BROWN TOY COMPANY**  
1095 HOME AVENUE AKRON 10, OHIO



# 4 TOOLS IN 1

The Complete  
METAL WORK SHOP  
FOR HOME AND PLANT

Height 5"  
Width 8"  
Length 13"  
Weight 6 lbs.

IT FORMS  
SHEARS  
PUNCHES  
RIVETS

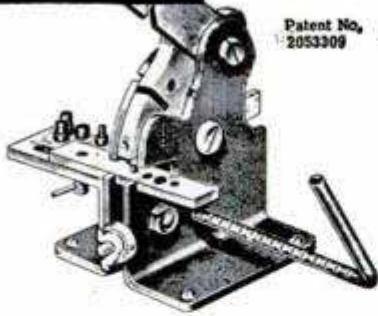

Patent No.  
2053309

Introductory  
Price  
ONLY  
**\$6.95**  
DELIVERED

Ideal for hobbyists, craftsmen, radio repair, metal shops, garages, bicycle repair shops, model manufacturers, experimental laboratories, etc. Check must accompany order. Money refunded if not fully satisfied.

**ALBERT J. TATU**

85 Columbia Dr. (Dept. 105) Williamsville, N. Y.

**BUILD FINE GRANDFATHER CLOCK NOW**  
The simple sensible Red-i-Kut way as thousands have — SAVE HALF. SHOP TESTED PLANS "SPIRIT OF THE CENTURY" Narrow waist 83" tall or stately straight side "SPIRIT OF AMERICA." EASY-TO-FOLLOW photopack PLANS tell all—plus BROCHURE of heavy brass weight Westminster, tube chime, movements, gorgeous dials, 3/4" solid mahogany case kits. Send \$1.00 today — Both plans \$1.50 NOW.

KUEMPEL CHIME CLOCK CO., #4 Kuempel Bldg., Minneapolis 16, Minn.

## NU-WAY HEAVY DUTY CUTTING UNIT

with Timken Roller Bearings

PRICE  
**\$16.50**  
WHY PAY MORE



Build your own rotary type lawn or weed cutter. Take the hard work out of weed cutting. Build yourself an up-to-date weed and lawn mower with the Nu-Way heavy duty unit.

Write for Free Circular—We Supply Cutting Unit Complete  
**TRACTOR-LITE MFG. CO., Spirit Lake, Iowa**

## MONEY MEN ALL FREE

THE PLASTEX Industry needs manufacturers on small scale and for big production of Lamp and Clock Stands, Art Goods and Novelties in Plastex and Marble imitation. Experience unnecessary. 1/2¢ material makes regular 10¢ store sellers. Rubber moulds furnished for speed production. Small investment brings good returns. We are now placing big Chain Store Orders with manufacturers. Ambitious men have chance for real prosperity. Our Free booklet will interest and benefit you.

**PLASTEX INDUSTRIES, Dept. A**  
3400 Third Ave. New York 56, N. Y.



The Modern PLASTIC  
for lasting Home Repairs

PERMANENTLY mends cracks or holes in wood, tile, stone or plaster. Sticks and stays put—Does not chip, shrink or fall out. Easy to use. Economical. Mold it, chisel it, polish or paint it. If unobtainable from your lumber, paint or hardware dealer, the big 4-lb. can will be sent you post-paid (in U.S.) for only \$1.25. Full money-back guarantee, order now.

**DONALD DURHAM CO.**  
Box 804-O, Des Moines, Iowa

# Arc Welding

pays big with the new  
**Hobart**



Hundreds of dollars  
extra profit monthly  
can be yours with this

← **LOW COST**  
250 amp. (full size)  
**ARC WELDER**

**HOBART ARC WELDERS  
ARE SIMPLIFIED**

**Be independent!** Set up your own welding shop and start earning big money. With a Hobart "Simplified" Welder, that is easy to use—a welder that will let you go out after the big pay jobs for farmers, contractors, factories, builders, etc.

Hobart Welders are rugged, dependable, economical — let you handle all types of work — assure low cost, high quality welds. That's why they're used in America's leading production plants. Hobart Welders give you 1000 combinations of welding heat—let you make fine welding adjustments right at your work, without returning to machine. Auxiliary power outlet lets you operate lights, tools, etc. Available in gas and electric models, portable and stationary. Check coupon for complete details.



**Complete Text and Lessons Book.** Covers all welding work. 544 pages, over 600 illus. ....\$3.00

**Lessons Book.** Complete operator's training course. 200 pages, fully illus. ....\$1.00

**Practical Design.** Hundreds of welding ideas in design form. 3 vols, 100 designs each.

Single vol....\$3.50  
Set of 3.....\$10

### Learn QUICKLY at the Hobart school



Earn big money doing all kinds of welding work. Learn quickly, easily, at low cost in modern non-profit Hobart Trade School. Complete or partial courses. Best equipment, thorough training, experienced instructors.

Check coupon and MAIL TODAY!

**HOBART BROTHERS CO., Box M-32, Troy, Ohio**  
"One of the world's largest builders of arc welders"

HOBART BROTHERS CO., Box M-32, TROY, OHIO

Send complete details on items checked.  
 Electric Drive Welders  Gas Drive Welders  
 Hobart Trade School  
Send books checked  Complete Text  
Practical Design:  Vol. 1  Vol. 2  
 Vol. 3  Set of 3 Vols.  
 Lessons Book  Cash encl.  C.O.D.

**FREE**

new booklet  
"Guide to Better Welding"

NAME \_\_\_\_\_  
ADDRESS \_\_\_\_\_  
CITY \_\_\_\_\_ STATE \_\_\_\_\_



The easy way to paint!

*Speedy Sprayer*

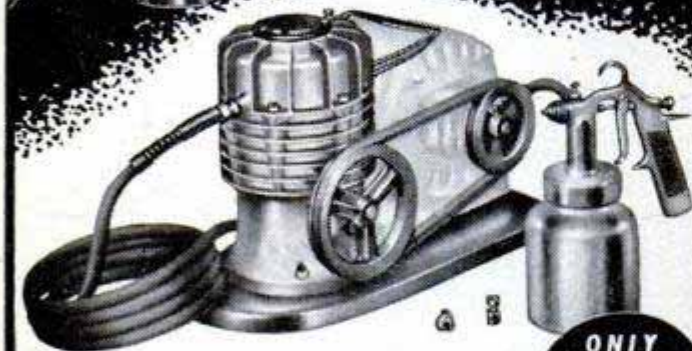

Favorite of home owners and craftsmen for 20 years! SPEEDY SPRAYER gives your work that professional paint finish everyone admires. Sprays paint, enamel, varnish, lacquer, etc. . . . 4 to 7 times faster than hand brushing! Lightweight, portable, uses any 1/4 H.P. motor. Improved diaphragm principle assures clean, oil-free air. You'll find dozens of time and money saving uses for SPEEDY SPRAYER, including spraying insecticides 2-4-D and DDT. Complete outfit, without motor, only \$32.50.

ONLY  
**\$32.50**  
LESS  
MOTOR

At leading hardware, lumber, and auto supply dealers.  
FREE—write for handy booklet "How to Spray."

**W. R. BROWN CORPORATION**  
2635 N. Normandy • Chicago 35, Ill.

BUILD AN

**IDEAL**

LAWNMOWER SHARPENER  
BUSINESS!

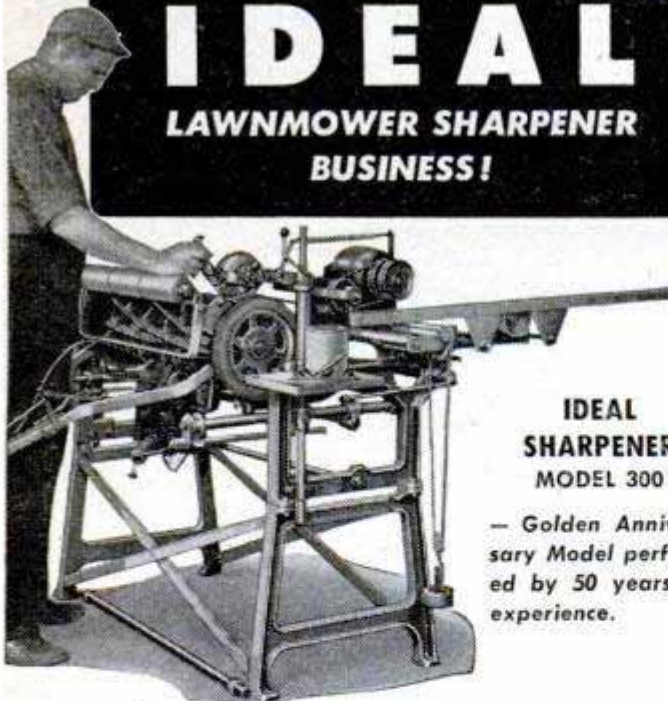

IDEAL  
SHARPENER  
MODEL 300

— Golden Anniversary Model perfected by 50 years of experience.

Build a profitable business of your own with the outstanding lawnmower sharpener — the IDEAL MODEL 300. Ruggedly built, easy to operate, sharpens all mowers without disassembling, handles all mowers. Get your share of profits; write for information today.

**THE FATE-ROOT-HEATH COMPANY**  
Dept. Q-3 — Plymouth, Ohio

TEST YOUR OWN RADIO AND TELEVISION TUBES AT HOME!!!



CONDUCTANCE  
**TUBE TESTER**

No tube manual or knowledge of tubes necessary — tests all tubes — 100% accurate for direct shorts, opens, burned out tubes. Buy it—Try it—If not satisfied, return in 5 days — Money cheerfully refunded.

ALSO AVAILABLE!  
**CONDENSER TESTER**  
CHECKS SHORTED,  
OPEN AND  
LEAKY  
CONDENSERS **6.98**

ONLY **\$4.98**  
SEND \$1.00 and pay BALANCE, plus charges on delivery. Send check, cash or money order & we pay postage.  
**E-Z TESTER CO. DEPT. P.M. MACON, GA.**

*Micromodels*

Show your friends something new Build a Miniature Museum • Tiny: Amazingly realistic three-dimensional volumetric models • Authentic in Detail • Locos of the world: Engineering: Famous Buildings: Galleons, Sailing: & Warships: Auto-moving Toys & other Models • Your skill gives challenging results • Cost only pence; sell for real money • Handy: you carry your workshop in a cigar-box! • Send \$1 bill for parcel of 10 Micromodels (or \$5 for wider range, carrying > paid) & illustrated List of 100 other Micromodels Ltd., 3 Racquet Court, Fleet Street, London, England.

SEND \$1

**SUMP PUMPS**

2,400 GALLON CAPACITY

1 1/4" outlet — No screen to clog — fool proof



The time tested Lokomona sump pump is absolutely automatic — has a special fool-proof trap at the intake—oilless bearing at the bottom. Made of aluminum castings, it's 42" high and carries a 1/4 H.P. 110 V. A.C. heavy duty motor. The pump is designed for continuous service. Enclosed switch. All parts always available. Order yours today. C.O.D. If cash with order, we pay postage.

**\$44.50**  
COMPLETE  
**\$26.00**  
LESS MOTOR  
**\$22.50**  
PUMP ONLY

LOKOMONA PUMP CO., P.O. BOX 86, ROYAL OAK 1, MICH.

**STARRETT "Tools and Rules" BOOK**

Describes and illustrates the precision methods skilled mechanics use. Only one dime. Write Dept. AP.

THE L. S. STARRETT CO., Athol, Mass., U. S. A.

**MAKE YOUR OWN!**  
WITH



**GRIFFIN LEATHERCRAFT KITS**  
Best assortment of tools, materials in U. S. A.! Send 25¢ for 116-page catalog. (money refunded first order)

**GRIFFIN CRAFT SUPPLIES**  
SINCE 1924  
5626-A Telegraph Ave., Oakland 9, Calif

**USE EASTER SEALS**

Regular Price of a Slide Rule \$4 and up

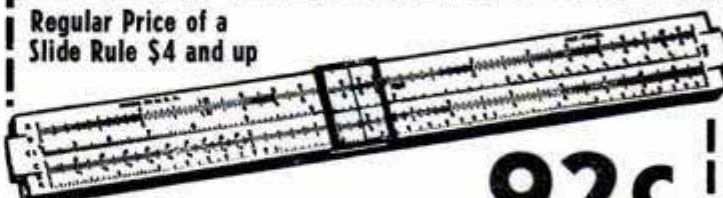

**Slide Rule**

**92c**

and this coupon  
Add 8c Postage

If you know how to use a pencil you can use a slide rule. For bookkeepers, accountants, salesmen (figuring commissions, cost, etc.), farmers, housewives, etc. For Armed Forces highly important. Men's most useful tool. Easy to calculate instantly. Multiplying, proportions, division, extracting roots, etc. "High Vision" Clear View Slide. Full 10" Rule. A, B, C, D, C1 and K scales. FREE 28-page instruction book on how to get correct answers instantly without pencil or paper.

**Gene Loewy, 545 5th Ave., N. Y. 17**  
Dept. 143-B Limit three rules to each coupon



a push...  
and you're through

"YANKEE" No. 41  
Automatic Drill

Drilling is an easy, one-hand job with the "Yankee" No. 41 Automatic Drill. Just push the handle and the drill point spins in. Return action spring clears chips. Magazine handle contains eight drill points, 1/8"-1 1/4". At your Stanley dealer's. North Bros. Mfg. Co., Dept. 4, 215 West Lehig Ave., Philadelphia 33, Pa.

"YANKEE" TOOLS  
NOW PART OF



THE TOOL BOX  
OF THE WORLD

NORTH BROS. MFG. CO., Philadelphia 33, Pa.

**POWER MOWERS & KITS**

**FREE PLANS**



3 & 4  
Wheel  
Model

4  
Wheel  
Direct  
Drive

Build your own quality mower with our LOW COST KITS, Parts, Engines. Free Plans guide you. 3 and 4 Wheel Kits, complete. Parts precision finished, ready to use. Write TODAY for Free Plans, Low Prices, Parts List and Guarantee.

3-WHEEL KIT NO. T-800



America's Finest Power Mowers completely assembled in 3 and 4 wheel models. Belt or direct drive, 18" and 20" sizes. Nationally known make engine. Latest improved features, sturdy construction and money back guarantee fully described in color folder. Write today.

TRIANGLE MANUFACTURING CO., Box M-11, Fort Scott, Kansas

For Prospectors, Miners, Oil Companies, Plumbers,  
Treasure hunters, etc.

**SCR 625 FAMOUS ARMY MINE-DETECTOR**

This unit is being offered now at a considerable reduction in price. Recently advertised at \$79.50 it is now available in the same brand new wrappings in suitcase carrying case (less batteries) at

**\$59.50 WHILE THEY LAST!** Used, like new, **\$39.50**

F.O.B. Chicago — 20% Dep. with order; Bal. C.O.D.  
ARROW SALES, INC. DEPT. PM-1, 1712 SO. MICHIGAN AVE.  
CHICAGO 16, ILLINOIS

Give the handicapped a chance. Use Easter Seals

**READY CUT HOMES**

**\$2150 AND UP**  
Freight paid. Save up to \$1000 on production method More compared with builders' prices. Anyone can assemble with simple plans furnished. Complete, including paint, hardware, roofing, glass, etc. Send 25c in coin for full color catalog, 57 modern low priced homes and floor plans, Complete building plans, ready for filling at low cost. Sold separately if desired. Five Easy Payment Plans including monthly payments.



**NEW COLOR CATALOG FOR ONLY 25c**

INTERNATIONAL MILL & TIMBER CO., Bay City, Mich., Dept. P.M. 32



**GOT THESE WHEN HORSESHOE LAKE BASS MET HULA DIVER**

"The largest weighed 7 and 8 lbs.," writes W. E. McEwen Jr. of Memphis, Tenn. "I got the best results around the deep knees of the cypress trees. I believe this was the first time your Hula Diver was ever fished at Horseshoe Lake (Ark.). Your Hawaiian Wigglers have been favorites of mine and I think this new bait will be as good." Hula Diver gives you perfect control both of the running depth and of the sensational new wiggling action that makes bass, walleyes, other game fish strike hard. Perfect for "problem" spots. Ideal for trolling.



DEEP  
RUNNER

PERFECT  
CONTROL

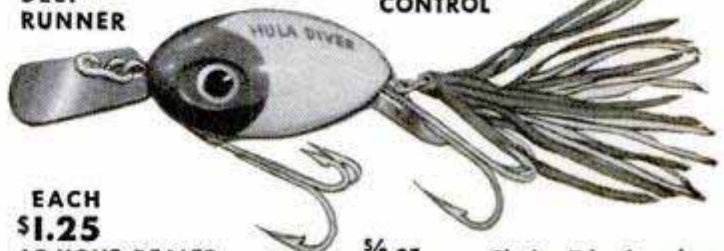

EACH  
\$1.25

AT YOUR DEALER

3/8 oz.

Choice 7 body colors

**FREE** WRITE TODAY FOR YOUR BIG FREE ARBOGAST COLOR CATALOG OF BAITS—FULL OF PICTURES OF CATCHES

**FRED ARBOGAST & CO., INC.**  
2263 WEST NORTH STREET • AKRON 3, OHIO

TAKE LESS THAN 1 MINUTE TO

Keep Paint Brushes  
Like **NEW!**

Store Them Dry.  
They Stay Soft  
and Flexible  
**READY FOR  
INSTANT USE!**

**PROCESS 33**

**INSTANT PAINT BRUSH CLEANER**

- Quickly cleans fresh paint from a paint brush or roller.
- You can paint instantly with another color—or store brush dry—it will stay soft.
- Economical—can be used again and again.
- Safe for all brushes and rollers.

Pint 59¢ Quart 98¢ Gallon \$3.25



**A GOOD START IS THE RIGHT FINISH**

**GLASS  
SMOOTH  
FINISH**



**WITH A  
GLORIOUS  
GLOW**

**CUTS REFINISHING TIME AND COSTS IN 1/2!**

BoatLIFE DURABLE PLASTIC FINISH is Guaranteed NOT TO CRACK, CHIP OR PEEL — It lasts and lasts . . . much longer than ordinary paints. BoatLIFE means absolute protection from harmful rot, mildew, salt water corrosion and decomposition. It's Waterproof! Use BoatLIFE from keel to mast, on metal or wood.

BoatLIFE is excellent for station wagons, furniture, floors, tables, all woodwork—thousands of uses—inside and out!

At marine dealers or order direct: Plasticlear (non-skinning varnish), Blue, Red, Green, Gray, Black, Flat White, Gloss White, Ivory, Metal Primer.

**\$3.85 Qt. — \$12.80 Gal.**  
Send Now For FREE Paint Color Folder —

**SAVE 50%  
BUILD IT YOURSELF  
CHOOSE THE RIGHT WOODS**

We sell only first class specialty and general imported and domestic boat and "all purpose" lumbers in all sizes and types. We have assisted thousands of craftsmen and boat owners in practical planning of lowest cost lumber specifications since 1912.

Send For FREE Folder:  
HOW TO  
SELECT BOAT LUMBER

**BoatLIFE**

**DURABLE PLASTIC FINISH**

M. L. CONDON CO., INC., 266 Ferris Avenue  
White Plains, N. Y.

**NEW! the  
GUARDSMAN**

**finest rule your  
money can buy...**

Will outlast, outperform, remain accurate longer than any wood rule on the market today. Completely new in design the Guardsman by Master Rule Manufacturing Company, Inc. is the result of 50 years of painstaking experimentation and rule making know-how. See it, try it today. Open and close the new "Safe Lock" joints. Listen to its smooth "click" action. If you do, you'll never be satisfied with less than a Guardsman.

Ask for #996, #996F (flat reading). Only ..... **\$1.50**

**MASTER**

MASTER RULE MFG. CO., INC. Middletown New York  
WOOD AND STEEL TAPE RULES

**HOLD-E-ZEE**

The Original  
**AUTOMATIC GRIP  
SCREWDRIVERS**

Hold, start and set up screws in unhandy places. Gripper instantly released by SPRING ACTION, sliding up out of way when not in use. Highest quality throughout.

New Models FOR RECESSED  
HEAD SCREWS



UPSON BROS., INC., ROCHESTER 4, N. Y.

At Leading Dealers Everywhere

Insert Installed



**LEAKY FAUCETS?**

**SUPERIOR FAUCET INSERTS** stop leaks permanently. Provide all new working parts. Make worn-out faucets better than new. Easily installed. Guaranteed. Two Million Satisfied Users. Brass Model 854, Chrome \$1.00. Specify "hot" or "cold." At hardware, plumbing dealers.

**SUPERIOR VALVE MFG. COMPANY**  
740 SUPERIOR, W., CLEVELAND 13, OHIO

**ONE-MAN SAWMILL** LOW \$50<sup>00</sup> AS... DOWN



Take BELSAW Portable Sawmill right to the trees—turn out valuable lumber for local yards—do "custom sawing" for neighbors. BELSAW lasts a lifetime. No crew needed. Power with old auto engine. Beginners get excellent results. Send postcard for FREE BOOK, "How To Make Lumber."

**BELSAW MACHINERY CO.**  
8116 Field Bldg., 315 Westport Rd., Kansas City 2, Mo.

**Black & Decker Utility Tools**  
for HOMES • FARMS • WORKSHOPS

**ELECTRIC WELDER**

AC or DC 110 Volts



"The Little Marvel" All-Metal welder. 5-year written guarantee. Welds 1/4" thick metal or money back. Repairs tanks, tools, fenders, machine parts, etc. Comes complete with everything—rods, unit, eye shield, and directions. We also make a welder for 16 to 22 gauge metal . . . \$3.95 complete.

plete. Transformer welder \$18.95. On C.O.D. postage extra.

ESSAY MFG. CO., Inc., Dept. 51, Quincy 69, Mass.

**\$645**  
Complete

**MORE JOBS  
EASIER  
QUICKER**

With Gear-Driven  
**"RED-E"  
GARDEN TRACTORS**



Buy Direct  
from  
Manufacturer  
and SAVE

**NO BELTS! NO CHAINS!**  
Proven For Over 29 Years  
**NEW 1952 MODELS**

Thousands of satisfied users say "RED-E" has solved their tractor problems. You too, will like its smooth, powerful, easy-to-operate, gear-driven action—with power turning clutch for 4 1/2 and 6 H.P. WALKING MODELS and automotive type differential for 7 1/2 H.P. RIDING MODEL. Our 2 and 3 H.P. Walking Models low as \$169.00. Attachments for plowing, sowing, cultivating, wood-sawing, snow-plowing, etc. **EASY TERMS** — Factory-To-You discount. Write TODAY for FREE Catalog.

**FREE CATALOG** Write TODAY for FREE Catalog.  
**RED-E TRACTOR CO. RICHFIELD 251, WISCONSIN**



**A HOLLOW GROUND Hand Saw**  
**World's First and Only Saw Blade**  
**That Has Maximum Clearance**  
**WHERE YOU NEED IT MOST!**

**The ONLY BLADE**  
 with full clearance in the  
**WORKING AREA**

Patent  
 Pending



For the easiest, fastest, smooth-  
 est sawing action known, get  
 a hollow ground saw!

**FREE** Valuable tips on easier  
 sawing, and hints on saw care.  
 New folder shows amazing ad-  
 vantages of *hollow ground*  
 saws over ordinary taper-ground  
 saws. Send for *free copy* today.

**THEY  
 COST  
 NO  
 MORE!**

Sold thru  
 dealers only

The **LARSAN Mfg. Co.** 23 South 11th St., Newark, Ohio



Ben Hardesty—for 4 straight years  
 U. S. Professional Casting Champion!

Use the Rod the Champ Uses...:

*Shakespeare*  
**WONDERRODS**

Now yours  
 for as little as

**\$7.95**

(A Full Length 5'2" Rod!)

Yes, now you can get the rod the  
 Champ uses for the same price as  
 many ordinary glass rods. We say  
 ordinary, because Shakespeare  
 Wonderrods are Howald Process  
 built—with hundreds of thousands  
 of *parallel* glass fibers *strung under  
 tension and double bonded*. And only  
 Wonderrods have 1-2-3 Zone Ac-  
 tion. (See illustration.)

1. ACTION ZONE. Fast tip action for bul-  
 let-like casts!

2. POWER ZONE. Power to set the hook!

3. ACCURACY ZONE. Accuracy made  
 easy with Tru-Aim double offset handles!

Also ask your dealer about the  
 new fly fishing, spinning and salt  
 water Wonderrods. Bait casting  
 Wonderrods are \$7.95 to \$27.00.

FREE! Write for 1952 Catalog, Fishing  
 Calendar and inside story of glass rods.

Dept. PM-3

*Shakespeare*

WONDERRODS • REELS • LINES • BAITS  
 Kalamazoo 2, Michigan

**DRIVING COMFORT at its best!**  
**The New Electric Throttle**  
**With Foot Control**

The Electric Throttle ("Speed-  
 selector") sets whatever speed you  
 choose electrically — releases in-  
 stantly at a touch on the toe-but-  
 ton, or by applying foot brake.  
 Banish foot and back strain for  
 good! Install it yourself. Price,  
 \$17.50 F.O.B. Check or C.O.D.  
 Salesmen, Dealer and Manufacturer  
 agent inquiries welcome. Give car,  
 make, and year.

WRITE FOR DETAILS

**D & M MFG. CORP., Anderson, Ind.**



**STANDARD GARDEN AND SMALL FARM TRACTORS**

Plow  
 Seed  
 Cultivate  
 Mow Hay  
 and Lawns

Powerful Gas Tractors for Small Farms,  
 Gardeners, Florists, Poultrymen,  
 Fruit Growers, Suburbanites.

1 & 2 Cylinders

High Wheels. Rubber or  
 Steel Tires. Walk or Ride.

Easy Terms — Free Catalog

**STANDARD ENGINE CO.**  
 MINNEAPOLIS, MINN.  
 3221 Como Avenue

NEW YORK, N. Y.  
 617 West 26th Street



USE EASTER SEALS. HELP CRIPPLED CHILDREN

**It's easy! MODERNIZE YOUR HOME**  
**THE MONEY-SAVING, "SLIDE-ALL" WAY!**

● Now... You can install your own  
 sliding doors... do the complete job  
 yourself... in just 15 minutes.

Buy any size door or hardware  
 either separately or in a prefabricated  
 package with no extras needed.

Hardware is overhead track with  
 ball bearing rollers. *Unconditionally  
 guaranteed* for smooth, silent per-  
 formance by America's largest man-  
 ufacturer of Sliding Doors.



GET THE FACTS TODAY! SEND COUPON  
 BELOW FOR FULL INFORMATION

**SLIDE-ALL COMPANY**

2084 First Ave., New York 29, N. Y.

PM-2

Please send me complete information on your  
 sliding doors and hardware for self-installation.

Name.....  
 (Please print)

Address.....

City.....Zone.....State.....



# BIGGEST SHOTGUN VALUE!

## 3-shot repeaters with C-LECT-CHOKE\*

Any choke desired, instantly, by a twist of the fingers. Settings are positive and visual, like a micrometer. NOT an "extra". You buy gun and C-LECT-CHOKE\* installed at these amazing prices—and there is no finer variable choke.



\* Pat. pending

**YOUR MOSSBERG DEALER WANTS TO SHOW YOU THESE**

Drop in and have a look. You'll be delighted with the beauty, quality and fine balance of the #185K and #190.

Send for **FREE** catalog. No sales at factory.

**No. 185K** 20 ga. **\$29<sup>95</sup>** **No. 190** 16 ga. **\$31<sup>95</sup>**  
 (\$30.95 W. of Rockies) (\$32.95 W. of Rockies)  
 Prices above are with C-LECT-CHOKE\* and ventilated barrel.

**HUNTER'S BEST FRIEND**

Best friend the hunter has is the property owner. Good hunters are careful and considerate of the property on which they hunt.

**O.F. Mossberg**  
E. SONS, INC.

29703 St. John St., New Haven 5, Conn.

# Your WHIZZER means FUN!

See, ride, own a 1952 "SPORTSMAN"

There's no thrill like riding your own Whizzer! Beautiful moderately-priced Whizzer "Sportsman" carries two at speeds up to 35 mph, up to 100 miles per gallon of gas. A complete motorbike, with 5" brake, kick starter, generator and lights. Dependable, trouble-free performance from 4 cycle, 3 h.p. motor. • Get in on the fun! Ride your own Sportsman this year! See your dealer or write direct for illustrated folder.



WHIZZER MOTOR CO., 300 S. Sanford, Pontiac, Mich.

# Don't stir paint

2-minute shake-up in your dealer's Red Devil Paint Conditioner makes paint ready to use—fresher than fresh. Buy where you see this machine.



## Red Devil Tools

IRVINGTON 11, N. J., U. S. A.

### BIG LEATHER & CRAFT CATALOG!

1000's of items for Leathercraft, Textile Painting, Copper Tooling, Kits, Projects, Tools, Supplies, Etc. Send 25c (refunded with 1st order) to:  
**RUSSO HANDICRAFT SUPPLIES** Dept. CD-9, 245 S. SPRING, LOS ANGELES 12, CALIF.

POSTPAID ANYWHERE IN U.S.A.

WE FURNISH ALL MACHINED METAL PARTS, EVERY SCREW, NUT, BOLT, WASHER, AND COMPLETE PLANS FOR THIS...



### BIG 10" POWER SAW

**\$10<sup>95</sup>** FULL REFUND IF LESS GUARD & WOOD NOT SATISFIED IN 10 DAYS

ASSEMBLE IT YOURSELF WITH SIMPLE HOUSEHOLD TOOLS!

COMPLETE PLANS 10c  
**MARCUS-POLLAK**  
 DEPT. N, ROYERSFORD, PA.



### NEW, IMPROVED CALCULATOR FOR WOODWORKERS only 25c

Instantly gives information on lumber, nails, concrete mixes, painting materials, etc. Convenient, simple to read. Just set dial for nail specifications, to convert linear to board feet, find bit sizes for screws, compare characteristics of woods. 6" diameter heavily varnished cardboard. Send 25c, no stamps, please to Greenlee Tool Co., 2103 Columbia Avenue, Rockford, Illinois.

### DADO HEAD BARGAIN

Complete 5 1/2" dado head, 2 outside cutters, 3 inside cutters. Your choice 1/2 or 5/8 arbor. Send cash, check or M. O. plus 25c for mailing. This set is made of finest quality special analysis saw steel.



**\$3<sup>95</sup>** Reg. Price \$8

E. G. HOWARD, 2240 S. W. 19th Terrace, Miami, Florida

### MODERN LAWN MOWER SHARPENER

FOR LAWN MOWER SHOPS  
 FIX-IT SHOPS  
 GOLF COURSES • PARKS  
 101 OTHER JOBS

Sharpens All Reel Type Mowers • Hand, Power or Gang • 10 to 20 Minutes • No Dismantling • No Extra Attachments Needed.

All reel type mowers, from 5-inch edgers to 36-inch power mowers, are quickly sharpened to extreme ends of both left and right twist blades.



PRICE **\$24<sup>50</sup>** less motor

**\$26<sup>300</sup>** with motor

**ORDER NOW**  
 Immediate Delivery

Handle, wheels, roller and motor remain in place when sharpening is in process. Bed knife is sharpened in same brackets. Grinding head rides on five ball bearing races. Easy to operate. Also sharpens chisels, jointer knives, planer blades. Big profit maker. Own your own business. Send Today for FREE Illustrated Bulletin No. 10-C. Prices Subject To Change Without Notice

**MODERN MFG. CO.** 160 N. FAIR OAKS AVE. PASADENA, CALIFORNIA



Assemble a

**Roberts**  
KIT-CRAFT  
**BOAT**



You can have a strong, fully guaranteed Roberts Kit-Craft Boat and save 50% by assembling it yourself. Finest marine materials. All brass screws. All parts prefabricated!

11 MODELS ☆ 8' to 14' ☆ FROM \$42.50

Prams ● Cartops ● Skiffs ● Rowboats  
Sailing Prams ● Speed Hulls ● Runabouts

Send for big colorful catalog with dozens of action photos . . . 25¢, deductible from first order.

**Roberts Industries, Inc.**  
1380 North Main St., Branford, Conn.

SAVE UP TO 80%  
ON  
CONSTRUCTION  
COSTS!

Don't be misled when doing construction! Contracting-Specialist will advise you on practical, short cut, MONEY-SAVING construction tips! Write for FREE information. No obligation.

**JOHN J. ROMANO**  
Home Construction Consultant  
414 Times Square Building,  
Seattle 1, Washington

**BATTERIES!—START**

—a factory at home and re-cast junk batteries into new; latest achievement. We supply complete instructions and everything needed. Large daily profits!

BATTERY LABORATORIES, Dept. PM, Minneapolis 4, Minn.



**VARIABLE SPEED**

HYDRAULIC POWER  
TRANSMISSION



It has Infinite Speeds 0 to 550. Reverse. Automatic Overload Protection; Adjustable Torque up to 180 inch pounds. 5/8" Input and Output Shafts. It will handle 1/2" to 1 1/2" H.P. Motor. Case measures 7 1/2" long, 7" high 6 1/2" wide. VALUE OVER \$300. Shipping Wt. 25#. On C.O.D. Orders we require a 10% only \$54.50 Fob. Chicago Deposit.

DIRZIUS MACHINE SHOP "L" 1423-25 So. 52nd Ave., Cicero 50, Ill.

Give the handicapped a chance. Use Easter Seals

**START A  
BUSINESS**  
this Quick Way



"I have taken in 100 mowers in 5 weeks since I got my Foley".  
says George C. Wise.

**FOLEY LAWN MOWER SHARPENER**

Start in spare time and make a quick CASH PROFIT. The Foley handles up to 3 or 4 mowers per hour—prices run \$1.50 to \$3.00 for hand mowers, \$5.00 to \$8.00 for power mowers. You make 99% profit!

FREE—Valuable illustrated Book shows how to sharpen all leading makes of power mowers. Foley prices are low—easy payments available. FREE PLAN tells how to start. Write today—no salesman will call.

FOLEY MFG. CO., 307-2 Foley Bldg., Mpls. 18, Minn.



No Pest  
Mosquitoes

Seventeen great lakes in Tennessee covering 600 thousand acres created by the giant dams of TVA and USA Engineers. One hundred docks and camps, thousands of boats and motors. Champion Bass and Walleye, prize strings of Crappie, Bream and Sauger.

Send for your free copy of Fishing Guide, 1952 edition, containing map showing location of docks, names and addresses of operators, facilities and digest of fishing laws. Send now — Early Spring fishing is best.

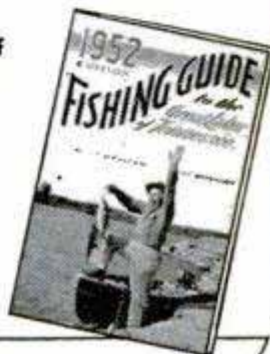

© 1952  
**Division of Information**  
652 State Office Bldg., Nashville 3, Tenn.  
A Division of the Department of Conservation

**INTERNATIONAL ROTARY**  
**HI-SPEED COPE-SAW DRILL-BIT**  
IT DRILLS IT SAWS IT REAMS

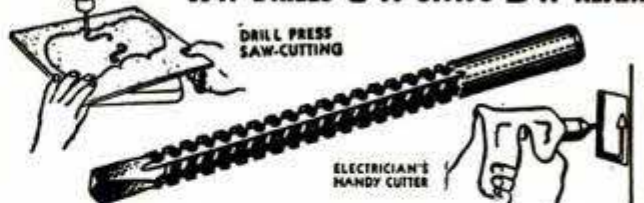

DRILL, SAW, REAM . . . metal, pipe, wood, plastic, Transite, etc. Use with any electric drill, slow drill press, lathe or milling machine. Drills own starting hole—upper part of bit is used to cut, saw or ream circles, ovals, squares or scrolls. Easy to operate. Ideal for carpenters, mechanics, electricians, plumbers, hobbyists, many others. Abrasive resistant, high speed steel. Flutes ground from solid. Will withstand severe continuous use without breaking. Resharpener at no charge. Takes place of up to \$50 in tools. 1/2" diameter, 2" cutting sections, total length 3 1/2". Also available specially designed for wood or metal and in 2 1/2" and 1 1/2" lengths. Write for details. Specify all-purpose bit. Shipped same day. Money-back guarantee. Dealer inquiries invited.

SEND CASH, CHECK OR MONEY ORDER  
Manufactured and distributed by:  
**INTERNATIONAL TWIST DRILL CORP.**  
624 Wyandotte, Rm. 639, Kansas City 6, Mo.

only  
**\$3.95**  
POST PAID



**KNOWN FOR THEIR FINER QUALITY**

**The Army Meets the Big "A"**

(Continued from page 120)



**GENSCO**

IMPORTED

**SWEDISH TOOLS**

**WOOD CHISELS**

Finest Swedish steel blades with unbreakable, machined plastic handles. Take and hold a better cutting edge. Sizes from 1/4" to 2" widths.

**MORA HUNTING KNIVES**

Seven models, all with leather sheaths. Hand forged, hand honed Swedish steel blades. Polished curly birch handles.

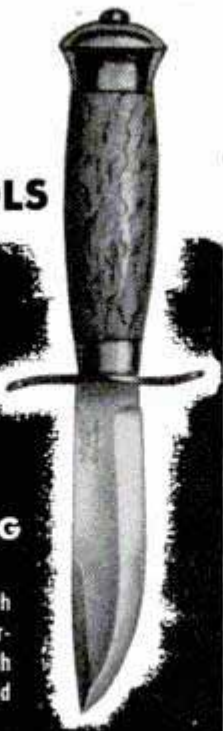

**BUSHMAN BOW SAWS**

Fastest cutting saw you can own for firewood and rough work. For campers, home owners, farmers, ranchers. 24", 30", 36", 42" sizes.

AT BETTER HARDWARE STORES EVERYWHERE

**GENSCO TOOL DIVISION**

GENERAL STEEL WAREHOUSE CO., INC.

1832 North Kostner Ave. • Chicago 39, Ill.

**DELCO MOTOR**

You can't beat this sensational buy! Triple Rubber Mounted DELCO Motor for fans, refrigeration, air-conditioning units, etc.

1/75 H.P. 115 Volt 50-60-Cy. A.C. 1500 R.P.M. Over-all Ht. 7 3/4". 1200 C.F.M. Tested! Guaranteed! Powerful! Quiet! Cool Running! Immediate delivery. ORDER NOW! Weight, 5 lbs. complete with blade. . . . . **\$5.25\***



**WALL CIRCULATOR**

Uses Any Type Gas, Natural or Manufactured. Easily installed between studding. Complete instructions with each circulator. Cool Air Baffling insures fire-proof wall. Room Air circulates through wall unit. Front is vitreous white enamel. Harmonious in design. Three heavy duty ceramic radiants for clean, odorless, dry heat. Width 13 3/4". Height 18". Depth 5 5/8". Wall Opening Size 12 1/4" x 16 1/4". B.T.U. 10,000. Shipping Wt. 28 lbs. No. H-1191. . . . . **\$14.00\***



**Bubble-Stream Shower Head**

Aerates every drop — to form a soothing, fluffy spray and an abundance of lathery suds with less soap. Also floods a wider area and flushes dirt and soap away faster—to save water, heat, soap and time. Finish is highly polished chromium plate. Ball joint provides instant adjustment of spray angle. Replaces any shower. Wt. 2 lbs. No. S.H.106. . . . . **\$3.39\***



**NO SPLASH SWING SPOUT FAUCET**

Heavy duty chrome plated brass swing faucet. Wall type — with soap dish. Fits any sink. Newest non-splash aerator flow attached. Wt. 3 1/2 lbs. No. S.P. 101. . . . . **\$7.95\***



**WASHER ASSORTMENT**

Handy washer assortment for all plumbing faucet needs. Don't be without it! Fibre & rubber washers. 75 pc. assorted. Wt. 1 lb. No. W104. . . . . **\$1.10\***



\*PLUS POSTAGE FREE! Send for large Electrical, Plumbing & Motor Catalogue MARKEL INDUSTRIES, INC. 4300 N. W. 2nd AVE. MIAMI, FLA.

Right now the Army thinks that the best time to drop a tactical bomb is when the wind happens to be blowing toward the enemy. If fall-out materials should blow back onto friendly territory, two things are important. First, troops should not remain in the area for periods longer than the safe times indicated by radiation meters. Second, personnel and equipment leaving the area should be decontaminated by washing to remove the fall-out materials. The area will remain contaminated for several days.

The cloud remains radioactive until it finally dissipates, although the degree of activity diminishes rapidly. In moist air, the cloud may become part of a rain-producing front, with the result that radioactive rain would fall from it.

Aside from the dangers of flying through such a cloud, the Air Force has the special problem of preventing flash-blindness in the air. Today the members of a flight crew wear dark glasses while they drop a bomb, a safety measure not practical in war. The Special Weapons Command is testing filter panels that screen out all excessive light. These could be used on all the windows of military aircraft if successful.

The A.E.C. detonations program is basically for pure science, providing information in many fields aside from the development of atomic artillery shells, guided missiles, atomic depth charges and new varieties of bombs. Precise measurements are made of blast, heat, light, radiation, seismic effects and other phenomena.

Several hundred technicians are busy for days ahead of time in preparation for a blast, preparing and installing instruments and cameras at points that in some cases are more than 100 miles away. About 99 percent of the instruments at the site itself are remotely controlled to minimize hazard to personnel. All instruments are placed in operation by master switches inside the nuclear-blast-control center, a windowless blockhouse that overlooks the principal test area and has superstrength-concrete walls and roof.

Picked groups of ground-force troops were indoctrinated in atomic warfare this past winter as part of the blast program. They became familiar with the effects of the new weapon. They laid out typical front-line emplacements before one blast at various distances from ground zero. The men set up machine-gun positions, dug fox holes, erected command posts, strung wire and parked vehicles at points where they might be stationed in actual combat. Ammunition,

(Continued to page 304)





● \$650,000.00 INVENTORY SALE

● WE PAY SHIPPING CHARGES

## WATER PUMPS and SYSTEMS

Save 60%. Expert advice on your problem. Pumps for wells, irrigation, basements, spraying, septic tanks, etc.

- Centrifugal Pumps. Cast iron case, bronze impeller, stainless shaft, ball bg. To 140 g.p.m. Pressures to 30 lb.  $\frac{3}{4}$ " \$18.90, 1", \$28.90,  $1\frac{1}{4}$ " \$35.60.
- Rotary Pumps. Low pressure: (to 25 lbs.) Self priming, Hv-Car impeller. To 20 g.p.m.  $\frac{1}{2}$ " \$12.75,  $\frac{3}{4}$ " \$16.95, 1" \$22.95. High pressure type: Positive displacement. Pressures to 150 lbs. To 20 g.p.m.  $\frac{1}{2}$ " \$14.50,  $\frac{3}{4}$ " \$20.95, 1" \$27.95.
- Motor Driven Sump. 110-v.  $\frac{1}{2}$  h.p. automatic. 2000 g.p.m., 1" disch. \$42.97
- Burdex Shallow Well Water System. 110-v.  $\frac{1}{4}$  h.p., 300 g.p.m. 40 lbs. pressure \$69.50
- Burdex Deep Well Jet System. 110-v.  $\frac{1}{4}$  h.p. 350 g.p.m. 40 lbs. 70 ft. lift \$109.95

Write for special Water Pump catalog-data

## POWER PLANTS and GENERATORS

- Kato Generators, 5KW, 115-v. 60-c. 1800 RPM, 1 ph., ball bg. with panel, pulley, base, etc. Cost \$550 \$259.60
- Burdex Generators, 115-v. 60-c. 1 ph. 3600 RPM with pulley and floating base. 500 watt. \$94.50. 1000-watt. \$134.90. 2000-watt. \$159.50
- Homelite Plant, 1.5 KW, 115-v. 60-c. 1 ph. Air cooled engine. Manual start. Portable. Cost over \$465 \$259.50
- Master Plant, 5 KW, 115/230 v. 60-c. 1 ph. 4 cyl. water-cooled engine. Manual start. Cost over \$1100 \$597.90
- Onan Plant, 5 KW, 115-v. 60-c. 1 ph. 4 cyl. eng. Push but. start. Cost \$1400 \$715.99

## PHONES — CITY and RURAL

- Rural Magneto. Compact oak case. Wall, (a) 3 bar, 1000-ohm, \$9.95 (b) 4-5 bar, 1600-ohm, \$13.90. City up-right desk, bells \$4.99

## WINCHES and HOISTS

- Boat, dock, utility hand winch, 1-4 gear ratio. 1500 lb. \$19.95
- Industrial light duty. Hand 1-3, 1-9 ratio. 2000 lb. \$29.95
- Cable  $\frac{1}{4}$ ", 50' with load hook \$8.95
- Contr. hvy. duty, hand, 10,000 lb. 1-5, 1-27 ratio \$89.95
- Heil Power Winch, 15,000 lbs. with 150'  $\frac{1}{2}$ " cable. Cost \$290 \$179.00
- Coffing Chain Hoist. Lever ratchet type, 3000 lbs. 100s of uses. \$19.95

## AIR COMPRESSOR UNITS

Paint, blow up tires, control termites, use in shop, etc. Build your own unit.

- Deluxe Kit. Build your own. Save 50%. Consists S.S. 12"x24" (400 lb. test) tank, 1-cyl. piston 3 c.f.m. compressor, valves, gauge, fittings, hose and excellent paint gun, dust gun, tire chuck, "How-to-Build" instructions \$45.90
- Quincy Portable Compressor, 110-v., 60-c., 100 lbs. pressure, 1-cyl. 2-wheel, with tank, gauge, hose and paint gun, tire chuck, etc. Ready to use. Special \$74.95
- Air Components. Piston compressors (a) 1-cyl. \$20.50, (b) 2-cyl. \$49.50. Adj. Auto Pressure Switch, (on 50 lb., off 75 lb.) \$4.95. Pres. Regulator, (0 to 250 lbs.) \$2.65. Gauges (60, 100, 160 lb.) \$1.89. Pressure tanks, 6"x24", \$5.49, 12"x24", \$11.95. Adj. Safety Valve, \$1.95. Air hose with fittings, 25' \$3.35. 50 ft. special \$5.95

Write for useful Air Data-Catalog

## MISCELLANEOUS BARGAINS

- Tachometer, Direct rd. 0-4000 r.p.m. \$6.79
- Compass, for Auto, Cost \$59. \$8.95
- Drawing Instruments, 13-pc. set \$9.89
- Chain Saw, Electric, 110-v., 8-amp. \$112.50
- Chain Saw, Gas, 4 h.p. 1-man. \$299.50
- Hand Saw, Electric,  $6\frac{1}{2}$ " 110-v. \$37.40
- Drill, Electric,  $\frac{1}{2}$ " cap. 110-v. \$26.95
- Drill, Electric,  $\frac{1}{4}$ " cap. 110-v. \$11.76
- Tap-Die Set,  $\frac{1}{4}$ " to  $\frac{1}{2}$ " \$19.49
- Clock Switch, 20 amp. 110-v. 60-c. \$4.72
- Engineers Sighting Level, precision \$5.84
- Gyro-Motor Unit, 12-24 volt. \$1.98
- City Desk Phone, upright type. \$1.99
- Burglar-Fire Alarm, magnetic unit. \$1.49
- Motors, Hi-Speed series, 6-12-v. \$2.88
- Hydraulic Cyl. 3"x31", 19" stroke \$18.49
- Fire Alarm Control \$1.99
- Abrasive Stones (10)  $\frac{1}{2}$ " bore \$3.98
- Heater Coils, 2 k.w. 110-v. \$1.99
- Simpson Multi-range Testers \$21.89
- Home Battery Chargers, 6-amp. 110-v. \$13.49
- Electric Table Stove, (2-plate 110-v.) \$6.94
- Pop-up Toaster, 110-v. Top Quality \$11.79
- W. E. Microphone, very compact \$1.79
- Cathode Ray Tubes, 5" experimental \$4.35
- Binoculars, 7x50 with case, Tx. Pd. \$45.95
- Barometer, Beautiful precision unit. \$5.95
- Bolt-Screw-Nut Mix, A buy! 6 lbs. \$1.99
- Hundreds other bargains in tools, electronic items, radio, etc.

## TRACTOR WEED SPRAY OUTFITS

- Winter Special (good to May 1 only.) 5-row all brass T-jet boom. P.T.O. bronze gear pump, hose, all fittings and controls. Universal mounting. Regular \$140.50 \$79.50

## ELECTRIC ARC WELDERS

- D-C, 0 to 250 amp. output, complete \$108.90
- D-C, 0 to 200 amp. Generator \$24.65
- A-C, 110-220-v., Welder-brazer \$54.70

## ELECTRIC DRILL ACCESSORIES

- Work on any  $\frac{1}{4}$ " drill. Leading make, top quality units. Do amazing work. Handiest tools made. Guaranteed.
- Item 10-A—Reciprocating Saw. Finest, most versatile unit made. Heavy rugged unit with case hardened parts. Use ordinary hack saw blade. Saws wood, metal, plastics, etc. Ideal electricians, furnace men, repair shops, body shops. \$50 value. Special \$16.49
- Item 10-B—Sander-Polisher. Use ordinary sandpaper. Heavy steel. Excellent mechanism. Has full  $\frac{1}{4}$ " reciprocating motion. Roller bearing. Many uses. A professional tool. \$20.00 value. Special \$8.49

ORDER FROM AD or Write for Free Catalog!

BURDEN'S 30-Year Policy: ● Everything guaranteed to satisfy. ● We pay all shipping charges in U.S.



## BURDEN SALES COMPANY

807 "O" ST.

LINCOLN, NEBR.

## HAUCK FLAME GUN KILLS WEEDS



KILL WEEDS, crab grass, Canada thistle—stalks, seeds and roots. Destroy brush, caterpillar nests, diseased trees, grasshoppers, chinch bugs, etc. Clear irrigation ditches, split rocks, burn tree stumps. Sterilize poultry houses, kennels, barns. Use as portable home forge. Melt ice, thaw pipes. Safe, inexpensive. Burns only 6% kerosene, 94% air! Thousands satisfied users. 7 models. Write for FREE CATALOG.

HAUCK MFG. CO., 77 Tenth St., Brooklyn 15, N.Y.

## More Local Plants Needed to Make Cement Drain Tile



Hundreds of local plants are selling millions of dollars' worth of cement drain tile every year. But demand is getting bigger, and opportunities are open for hundreds more.

Farm drainage, reclamation projects, highway construction—these and other sources are creating a large market. It can be most economically supplied by compact, local plants.

### Outstanding Manufacturing Opportunity

Champion drain tile machine is deliberately designed to supply compact, low-investment, tile-making equipment. Makes finest tile possible—dense, truly round, and shale proof. Better than clay tile, yet can sell for less because local production saves freight and distribution cost. But project possibilities are high. Business requires no previous experience—no skilled labor—no special building. Equipment available on easy terms. Full information on the cement tile business and equipment are given in the Drain Tile Book—free on request.



### Concrete Equipment Company

E3 522 Ottawa Ave., Holland, Michigan

## Paper Pattern Simplifies Building GARAGE DOOR



Save Money . . . Build Your Own Garage Door. With Easi-Bild\*—Build it Yourself Pattern No. 86 you can build either a single or double Garage Door for less than  $\frac{1}{2}$  present costs. Pattern tells what materials to buy, where and when each is used. No special tools or skill required. Even though you haven't used tools in years, you'll be amazed to see how easily and economically you can

build a professional looking door by following the simplified step-by-step procedure outlined in this pattern.

With "Stanley's" new Garage Door Set, you can install the Swing-Up Hardware using only hand tools. Ask your dealer for Simplified Directions for installing Stanley Swing-Up Hardware and Easi-Bild Garage Door Patterns— or send coupon below.

\*TRADE MARK REG. U. S. PAT. OFF.—Easi-Bild Pattern Co.

Easi-Bild Pattern Co., Dept. S-4, Pleasantville, N. Y.

Enclosed is 50c in Coin, Money Order, Check for Single and Double Garage Door Pattern No. 86.

Please send Simplified Directions for installing  
 Single  Double Garage Door Hardware.

Name.....

Address.....

City.....



# FREE!



## NEW BOOK for Fishermen

● Every angler needs the new '52 edition of "Fishing—What Tackle and When." Over 100 pages of fishing tips and instructions—Skish rules—fish pictures and records—new rods, reels, lines, lures. Write now. FREE!

### NEW! DIFFERENT!

**SPINCAST®  
REEL . . . . .**  
The simpler-to-use spinning reel!  
Fully enclosed.  
No backlashes.



Precision-built for perfect spin-fishing.  
No. 1100—\$27.50

**SOUTH BEND BAIT CO.**  
891 High Street  
South Bend 23, Indiana

## SOUTH BEND

*A Name Famous in Fishing*



field rations and other supplies were placed where they would be in combat.

Next, the A.E.C. installed measuring and recording instruments in and around the positions to measure actual effects. Instruments were placed outside and inside a tank to measure the amounts of heat and blast. The resulting information may contribute to new designs of tanks built to withstand atomic warfare.

The men were stationed five miles away from the blast and received instructions via loudspeakers.

"About face!" they were commanded. "Sit down!"

The voice told them that they could swing around for a look three seconds after the flash. They would be temporarily blinded by the light if they turned any earlier. Anyone who stood up too soon would be knocked down by the hot blast wave.

After the tremendous explosion, they returned to the emplacement area to find out what had happened to their weapons and equipment. They were preceded by monitors with radiation meters who marked off the "hot" areas and tested the radioactivity of guns and vehicles. Members of the monitoring teams wore coveralls, gloves, skull-caps and cloth wrappings around their shoes, as well as respirators. This protective clothing prevented radioactive dust from coming in contact with their bodies. Monitoring teams will be part of any military group in areas in which nuclear weapons are used.

When the men inspected their battle area, they found several surprising things. Nothing was left in the immediate vicinity, of course, yet experimental animals that had been placed in fox holes and deep dugouts no more than a mile from ground zero were dazed but unhurt. Shelter in the form of several feet of earth appeared to be good protection against heat, blast and radiation. Some of the men concluded that they would be safe in deep fox holes even though a tactical A-bomb blasted an enemy area no more than half a mile away.

This provides ample safety margin for atomic artillery of the type shown to Congress in January. No details were released on the weapon, but it is believed that the caliber and length of tube must be greater than in any existing Army weapon. Despite great progress in reducing the size of atomic explosives, it is doubtful that they are yet small enough for standard artillery tubes. The Army's largest mobile gun is a 240-mm. howitzer. That is a bore of slightly under 10 inches. Double this size and you still have a mobile weapon that could toss an atomic shell well beyond the required margin of safety.

## Handy Flexible SHAFT With 1/8 Inch Adjustable Chuck



**ONLY  
\$3.95**

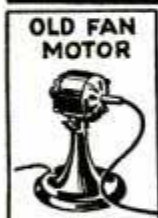

Converts any motor, drill press, electric drill, electric fan (10 inch or larger) into a handy rotary tool. Attach ROTA-SHAFT in a jiffy. Use for grinding, polishing, sharpening, cleaning, engraving, making tools, carving on metal, plastic, wood, leather, glass. Handles tools from zero to 1/8 inch diameter. 40-inch overall length. Complete with buff and sanding disc ready to use in a drill press chuck. ORDER TODAY!

**SEND NO MONEY!** Mail your order. Pay postman only \$3.95 plus postage on delivery. Try 10 days — if not delighted return for money back. For use on motor—35c extra for Special Coupling. Give exact size of motor shaft diameter.

**STRADER PRODUCTS CO., Dept. F-101**  
259 Strader Ave. Cincinnati 26, Ohio





# ELECTRIC MOTOR BARGAINS!



- 1/2 HP 3450 RPM 110 Volt 60 Cy. Cap. type, #333... **19.75**
- 1/2 HP Same as above, 220-Volt only, Rep. Ind., #050... **16.50**
- 1 HP 3450 RPM 110/220 Volt 60 Cy. Rep. Ind., #199... **39.00**
- 1 HP 1750 RPM 110/220 Volt 60 Cy. Cap. type, #E150... **52.00**
- 1 1/2 HP 3450 RPM 110/220 Volt 60 Cy. Rep. Ind., #226... **47.50**
- 2 HP as above 220V #126 **65.00**; 3 HP 220V #129 **77.50**

Every Motor Fully Guaranteed ALL PRICES F.O.B. Write for 32-volt Bargain List

## DOUBLE SHAFT MOTORS at 50% Saving

- 1/6 HP—\$10.00 1/4 HP—\$11.00
- 1750 RPM Split Phase — 1/2"x3" Shafts
- 1/3 HP—\$14.00
- 1750 RPM Split Phase — 5/8"x3" Shafts

These motors are new, shopworn, but all in perfect condition, and fully guaranteed. Resilient mounted for quiet operation on 110-volt, 60-cycle AC current. Ideal for Blowers, Grinders and Tool layouts.



Immediate Delivery

## 1/3 HP ROPER PUMP UNIT

Original cost \$133.00 **\$59.50**  
Our Price F.O.B. only

Will handle any liquid from water to heavy lubricating oils... For permanent installation or can be used as a portable unit for irrigation, weed spraying, etc. This is not to be confused with ordinary units sold for light duty and intermittent work. **ROPER IS THE NAME IN PUMPS.** Unit is powered by heavy duty Repulsion Induction—1/2 HP Leland—110-220 Volt—60 Cy.—Single Phase motor. Pump will handle up to 300 gallons per hour, 22" suction lift—20' head possible—60' head at 30 lb. pressure—self priming—1/2 inlet; 1/2 outlet; wt. 60 lbs. All new and fully guaranteed.

ROBERTS ELECTRIC CO., 849 W. Grand, Dept. 1, Chicago



## Fluorescent Lighting Adapter FOR YOUR

Workshop - Kitchen - Recreation Room

LOW COST BETTER LIGHT



REMOVE OLD BULB SCREW IN CIRCLINE ADAPTER

- Screw-in adapters Model 200G (Etched Glass) \$13.95
- Model 100C \$10.95 (Less Glass)



Floor Lamp Adapter Model 100F \$11.95 No installation cost. Workshop, Kitchen, Recreation Room or any room in your house can have marvelous Fluorescent lighting. Low initial cost, costs less to use, far better light. Send check or money order. Sent to you Parcel Post Prepaid. Money Back Satisfaction Guarantee.

Circline Sales Co P.O. Box 208, Omaha, Nebr.

# STOP Faucet Leaks for years!

## SNAP-IN

### SWIVEL WASHER

FEATURED IN READER'S DIGEST...

This amazing faucet washer lasts 10 to 20 times longer than ordinary washers. Patented swivel action allows washer to seat tightly without grinding—practically eliminates wear. Genuine Neoprene face disc. Snaps into faucet stem—no special tools needed. Ask your hardware dealer for Snap-in Swivel Washers. 3 for 69¢. Accept no substitute. If dealer cannot supply, send 69¢ and bibb washer size to Snap Products Corp., 123 E. Brighton Ave., Syracuse, N.Y.

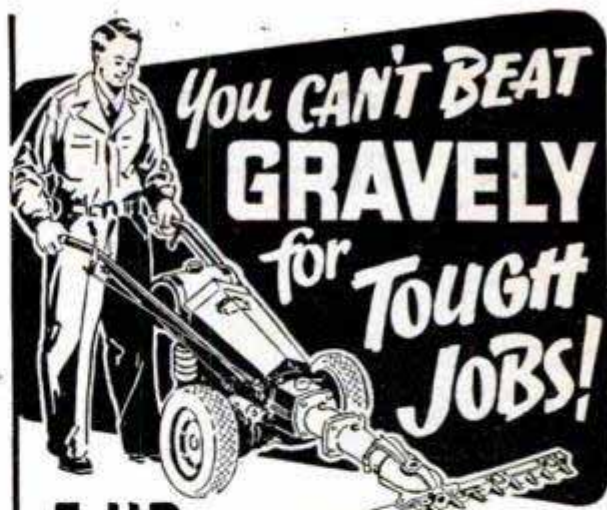

# You CAN'T BEAT GRAVELY for TOUGH JOBS!

## 5-HP GRAVELY Tractor

**Offers 20 Tools to Save You Work!**  
Rugged, dependable POWER for day-in and day-out plowing, mowing, cultivating—20 jobs in all! With the powerful 5-HP Gravely Tractor, metal muscles do your toughest jobs—better, faster... with less work!

All-gear drive, power reverse. Field tested for 31 years. Only the Gravely does so many jobs so well!

FREE!

"Power vs Drudgery" tells how to put POWER to work for you! Write today!



# GRAVELY

BOX 363 DUNBAR, W VA

FIELD-TESTED FOR 31 YEARS

Give the handicapped a chance. Use Easter Seals

EASY TIME PAY PLAN

What? POWER TOOLS only \$16 EACH!



5 POWER TOOLS IN ONE

FACTORY TO YOU \$79.95

SUPERSHOP offers you a precision-built complete power tool workshop. 100% ball bearing. RUGGED. Accurate. Big capacity. 15 day FREE trial. Money back guarantee. Mail postcard for FREE catalog. Buy on easy pay plan.

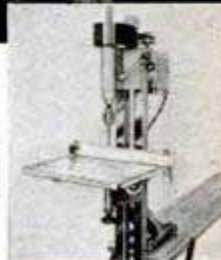

POWER TOOLS, INC.

133 YATES AVENUE BELOIT, WISCONSIN

VERTICAL DRILL PRESS



# Operate Your Own Business!



## Clean and Mothproof Rugs and Upholstery

- Nationally Advertised Services
- Big Profits
- Repeat Orders
- No Experience Needed

If you are dependable, honest and willing to work, send today for details on how to become financially independent in a profitable, growing business of your own. Choose an open territory anywhere in United States, Canada or foreign countries. Services rendered in homes, offices, clubs or public buildings.

**DURACLEAN** cleans by absorption. No scrubbing! No soaking or shrinkage. This modern safe cleaning process uses mild solvents. Dirt, grease and many unsightly spots vanish as if by magic. Wool fibers come to life . . . matted pile rises . . . colors revive. Upholstery and floor coverings last longer.

**DURAPROOF** is another year 'round service. Not only kills moths and carpet beetles but makes materials resistant to both. Protects furnishings, clothing and auto interiors. **DURAPROOF**, to our knowledge, is the only moth proof service backed by a National Money Back 4 YEAR WARRANTY.

Leading furniture and department stores recommend **DURACLEAN** Dealer's service. Almost every building in your territory houses a potential customer needing one or both of these Nationally Advertised services. Even auto dealers buy your service to revive upholstery in used cars.

Easy to learn. No shop needed. Operate from your own home. Alert dealers can average \$4.50 hourly gross profits on service they render, and \$3 on EACH of their servicemen at National Price Guide charges. Start full or part time. Territories are limited! Write immediately for **FREE** Booklet explaining details. Easy terms.

**Duraclean Co.** Dept. 2-163 DEERFIELD, ILL.

## Get Aboard and Get Growing!



8 h. p.

Write for Folder

A mechanic's dream in its rugged construction! Compact, perfectly balanced for easy turning; power-packed for thrilling performance; so economical to operate. Wheelbase 48"; length 74 1/4"; width 33"; plant clearance 19"; variable tread width 28" to 38"; auto-type steering, differential and transmission with 3 speeds forward; 1 reverse. Power take-off, too. And there's a full line of fine year-round attachments.

**New Appearance! Major Improvements!**



5 MODELS  
2 to 4 1/2 h. p.

All Big Values!



Only Garden-All has features like Instant Tool Attachment and Exclusive Depth Control. Get the best!

Garden-All Tractor, Inc., Dept. P, Liberty, Indiana

## Makes repainting

# EASIER!

**YOU DO A BETTER JOB, TOO**



Save time and labor on repainting—and get a professional looking finish! Just dampen a cloth with Wil-Bond and wipe over the old finish. All dirt and grease are instantly removed! At the same time, Wil-Bond dulls the gloss and makes the old finish slightly tacky so that the new finish will bond tightly without "crawling" or pulling away.

Wil-Bond is faster, easier than using sandpaper. Perfect, too, for removing wax from floors or grease from kitchen walls. At paint and hardware stores.

## WIL-BOND

Write for Informative leaflet

Wilson-Imperial Company, 128 Chestnut Street, Newark 5, N. J.

## HOBBYISTS-SEE HERE-

DENTAL INSTRUMENTS ALL 8 \$1.98 ONLY



IDEAL for working in plastic, wood, leather, clay, plaster, etc., or as scribers. Many other uses—overall length 6"—Government Surplus—all new!

150 Piece HOBBY MIX . . . a mere 98c

Parcel Post and Handling 25c for 1 item. 35c for 2 items. Write for FREE CATALOG of Government Surplus Bargains.



Dental Specialty & Sales Co., Dept. PM3, P.O. Box 692, Great Neck, N.Y.



## NEW SAW SHARPENER

Improved #64 Hand Gummer sharpens all types circular saws 4" to 20" diam. Ideal for saw shops. Self-Centering adjustment for quick, easy set-ups. Complete with 1/4 HP motor, 1 grinding wheel & cord. \$79.50 FOB Portland. Wt. 70#. SEND FOR FREE LITERATURE.

P. T. HOBBS MACHINERY  
8375 N. INTERSTATE AVE.  
Dept. P.M.-61, PORTLAND 17, OREGON

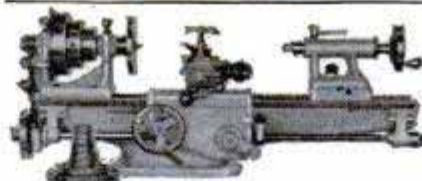

**BUILD YOUR OWN MACHINE TOOLS CASTINGS-DRAWINGS**

Catalog with complete construction drawings of this 8 inch Modelmaker screw cutting lathe with milling, grinding and hand shaper attachments, 25 cents postpaid, or send one dollar for drawings of three lathes, three milling machines and six inch crank shaper. Refund on castings order.

POOTATUCK CORPORATION, 100 Sammis Pl., Stratford, Conn.

## QUALITY AT LOW COST SHOP ACCESSORIES FULLY GUARANTEED

<p><b>Saw Blades</b> CHROME : NICKEL : MOLY STEEL 1/2-5/8-3/4" ARBOR</p>	<p><b>FLAT GROUND</b> RIP • CROSSCUT • REGULAR OR NOVELTY COMBINATION 6" dia. \$1.88 8" dia. \$2.39 7" dia. \$2.18 10" dia. \$3.18</p>	<p>You'll Want This Book SEND FOR IT TODAY! 32 PAGES on use of saws, dodos, moulding head, sanding discs, OVER 100 photographic illustrations. Only 50c</p>
<p><b>HOLLOW GROUND</b> MITER OR PLANNER BLADES 6" dia. \$2.75 8" dia. \$3.85 7" dia. \$3.19 10" dia. \$4.80</p>	<p><b>SHAPER HEADS</b> FOR YOUR TABLE SAW 1/2-5/8-3/4" ARBOR Only \$4.50</p>	<p><b>6 IN. DADO HEADS</b> CHROME : NICKEL : MOLY STEEL 1/2-5/8-3/4" ARBOR Cuts 1/8 to 13/16" in steps of 1/16" Only \$9.95 2 Hollow Ground Blades 5 Inside Chippers</p>
<p><b>8 IN. SANDING DISCS</b> FOR YOUR TABLE SAW 1/2-5/8-3/4" ARB. 1 coarse, 1 fine grit on each side Only \$4.95</p>	<p><b>EXTRA SANDPAPER</b> 5 grits 80c</p>	<p><b>SANDING DISC CEMENT</b> only 40c</p>

SEND CHECK OR M. O. All prices prepaid—WRITE FOR FREE CATALOG P-3

JAXON COMPANY • 369 ELLICOTT ST. • BUFFALO 3, N. Y.



**SAVE MONEY**

**on Home and Farm Repairs, Improvements**

Do brick, stone or cement work, plastering jobs yourself — and save. It's easy with these handy tools.

**Plastering Trowel** — perfectly tempered flexible steel blade; aluminum mounting; ten rivets secure blade to handle. 10 1/2" x 4 1/2" blade. Each, \$3.95.

**Brick Trowel** — perfectly tempered, tapered and polished; hardwood handle with fine steel ferrule assures maximum comfort. 11" x 4 3/4". Each, \$3.75.

**Level** — seamless aluminum level for bricklaying, plastering, and tile setting. Sides, edges, ends and corners always square, straight and smooth. 48" length. Each, \$10.45. Save money by ordering

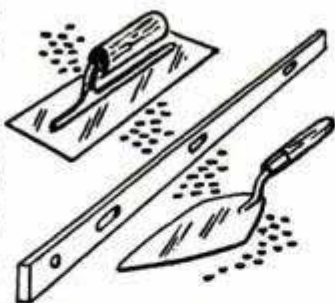

all three at special price of \$17.25.

Designed and made to professional standards. Materials and workmanship guaranteed. Money refunded if not completely satisfied. REED'S pays postage. Mail check or money order TODAY for immediate shipment.

**REED'S MAIL ORDER MART**

17 East 19th St.

Kansas City 8, Mo.

Hundreds of uses for this guaranteed line of power hand tools

You must be satisfied with the quality and performance of this Dumore tool or you get your money back. The DUMORE Company, Racine, Wisconsin. 1958 Schwanitz, President.

Dumore Duplex Grinder (1/14 hp) \$24.50  
Hobby-Flex shaft tool (1/20 hp) \$24.50  
Hobby Tool Hand Grinder (1/40 hp) \$19.50  
Amazing Dumore Router (1/16 hp) \$29.50  
Send check or money order. We pay postage.

**The DUMORE Company**  
1300 17th Street, Racine, Wisconsin

**RETAPE YOUR OWN VENETIAN BLINDS**  
Complete Kit \$1.00



Send \$1.00 per kit with order and kit will be postpaid or COD plus postage.

Each kit consists of 4 yds. of tape, 9 yds. of cord and 2 pull knobs. Enough to Retape any two tape blinds up to 72 inches in length. Natural off-white color.

**CADDO PRODUCTS CO.**

P. O. BOX 3296

SHREVEPORT, LA.

Genuine **WISE-GRIP** WRENCH



Jaws LOCK To Work with Ton-Grip — Leave Hands Free

Does jobs no other tool can do. Easily turns rusted or battered nuts, bolts, screws — makes ideal hand-vise — hundreds of other uses. LOCKS, CLAMPS, TWISTS, TURNS, PULLS, RATCHETS, HOLDS! With Cutter — No. 7W, 7", \$2.25; No. 10W, 10", \$2.60. Without Cutter — No. 7C, 7", \$1.95; No. 10C, 10", \$2.25. Straight Jaw model — No. 7, 7", \$1.85; No. 10, 10", \$2.15.

Order Genuine VISE-GRIP From Your Dealer.

**PETERSEN MFG. CO., Dept. P-3, DeWitt, Nebr.**

MARCH 1952

An all-around electrical trouble shooter  
**FOR REPAIRING ALL ELECTRICAL APPLIANCES-MOTORS**



- Measures AC/DC Voltages, Current — Resistances, etc.
- Measures current consumption while appliance under test is in operation. Appliance or utility plugs directly into front panel. Insulated clip-end leads included for motors, etc.
- A sensitive direct reading resistance range accurately measures all resistances in appliances, motors, etc. Enables continuity checks and tests for shorts and opens.
- Tests thermostats, radio tube filaments, bulbs, fuses, fluorescent, switches, condensers, circuit breakers, lighting systems, etc. Handsome bakelite case. Complete with test leads, instructions. . . . . **13.90**

**SOLD ON EASY PAYMENTS AT THE NET CASH PRICE**

No interest or carrying charges added. Simply remit \$3.90 with order, pay balance, \$2.00 per month for 5 months.

**SUPERIOR ELECTRONIC CO., INC.**  
Dept. B-57 • 227 FULTON STREET • NEW YORK 7, N.Y.

USE EASTER SEALS. HELP CRIPPLED CHILDREN

**Do 3 outboard jobs with a SINGLE KNOB**



EVERY SCOTT-ATWATER Shiftmotor has Single Knob Carburetor Control. (1) You simply push in this knob to choke the motor . . . (2) turn it to tune the carburetor . . . (3) close and push it to drain the carburetor for leak-proof motor-carrying. This convenient three-in-one control is on all four Scott-Atwater Shift outboards, 5, 7.5, 10, 16 HP—and nowhere else! Another reason why . . .



**You get MORE with SCOTT-ATWATER!**

SEND ME FREE CATALOG! Dept. 33, Scott-Atwater Mfg. Co., Inc., Minneapolis 13, Minn.

Name.....

Address.....

City.....State.....

Export Dept.—American Steel Export Co., 347 Madison Ave., N. Y. 17, N. Y.





# NEW! 10

**FORWARD SPEEDS**  
ALL AT MAXIMUM HORSEPOWER  
—PLUS REVERSE

## Bready GARDEN TRACTOR

with **SELECT-O-SPEED** Transmission

The most practical garden tractor ever built. You can instantly change tractor speed, while tractor is running, yet always have maximum power at the drawbar! You select the speed to suit the job. Other new features include Safety Reverse and Free Wheeling. Complete line of implements for year 'round use. Don't buy a tractor until you've seen the new Bready!

WRITE TODAY for free literature, name of dealer.

**The BREADY TRACTOR and  
IMPLEMENT Company**

Box 230

Solon, Ohio

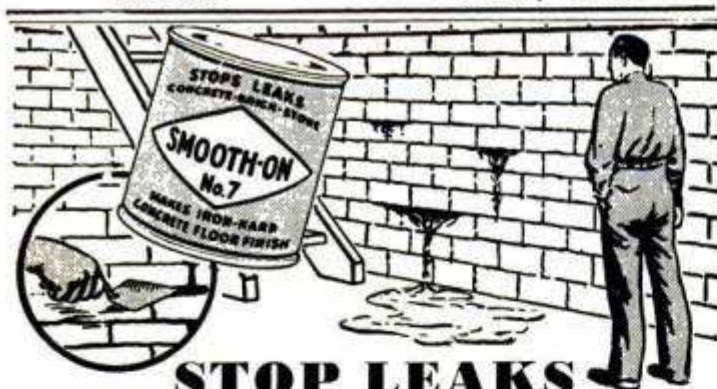

## STOP LEAKS IN CELLAR WALLS

Do it with Smooth-On No. 7 Cement! Apply with trowel or stiff brush to leaky cracks, holes, porous spots, seams or other leaks in concrete, brick or stone walls and floors. The leaking will stop and Smooth-On will "stay put", for it expands slightly as it hardens. May be applied to wet or dry surfaces, indoors or outside. Use Smooth-On No. 7, too, to seal openings around pipes passing through walls. Buy Smooth-On No. 7 by name and number in 1-, 5-, 20- or 100-lb. size. If your hardware store hasn't it, write us.

### FREE Leaflet and Handbook

We'll send you leaflet showing No. 7 uses, also the famous 40-page Smooth-On Repair Handbook describing other Smooth-On Cements and showing many helpful home repairs. 170 illustrations. Write today.

SMOOTH-ON MFG. CO., Dept. 37C  
570 Communipaw Ave., Jersey City 4, N. J.



Do it with  
**SMOOTH-ON**  
NO. 7 CEMENT

## BURN WATER IN YOUR CAR



With The **OCTA-GANE INJECTOR**

This amazing all bronze, "fog type", exhaust operated **PRESSURE INJECTOR** will burn water, alcohol or both. It is adjustable to burn up to one gallon of water with every 10 gallons of gasoline. U.S. Agricultural Dept. Scientists say: "The gasoline mileage of new high compression auto engines can be increased up to 30% with alcohol-water-gasoline fuels."



Complete with 1 1/2 gal. tank

**Only \$27.45 ppd.**

(Or send \$2, balance C.O.D.)

List car make, year, # cyl.

**DEALER INQUIRIES INVITED**

World's Largest Firm Specializing in Hi-Performance and Hi-Mileage Equipment for All Makes of Cars.  
**NEWHOUSE AUTOMOTIVE INDUSTRIES**  
Dept. OK-3, 5805 E. Beverly Blvd., Los Angeles 22, Calif.

WRITE FOR  
**FREE**  
ILLUSTRATED  
LITERATURE

## Make Your Own POWER LAWN MOWER

with this **DRIVE CUTTER ASSEMBLY**

Constructed for those who desire to build their own mower or to replace your old cutter assembly. Complete with 18" blade and double ball bearing drive, only . . . .

**\$12.95**

Add 50c to cover handling and shipping. No C.O.D.'s



**ATLAS KEEN MOWER**

229 S.W. BLVD.

Dept. **MP2**

KANSAS CITY, MO

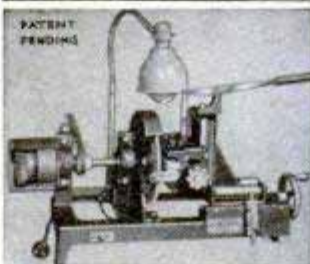

## Start a NEW BUSINESS!

or Add to your present  
*Repair Business*

**SHARPEN DULL PIPE WRENCHES**

PIPE TAPS & DIES

"GUM" CIRCULAR SAWS

Write for Information

**J. C. MOORE INDUSTRIES**  
BOX # 276 FREDONIA, PA.

LEARN FASCINATING

## Leathercraft

Make your own bags, belts, wallets, etc. Learn fascinating, profitable leathercraft in spare time. Send 25c for valuable Catalog, has over 200 photographs. (refunded first purchase).



**BURTONS LEATHERCRAFT**

Dept. PM-3, 1755 1/2 Glendale Boulevard, Los Angeles 26, Calif.

## Build your own JET ENGINE!



SEND  
NO  
MONEY

Order these plans today

1. JET PROPELLED BICYCLE. Assemble your own. Photo and instructions, \$1.00.
2. HOW TO MAKE EXPERIMENTAL JET ENGINES. Seven sheets drawings with information and instructions \$2.95.
3. BOTH OF ABOVE in one order \$3.75. SEND NO MONEY. Order both at once \$3.75 C.O.D. in USA plus c.o.d. postage. Send check or Money Order and we pay postage. Get other information too. Rush Order.

**J. HOUSTON MAUPIN, Dept. 55, Tipp City, Ohio**



**CUT BUILDING COSTS 1/3!**  
**Make Your Own Concrete  
BLOCKS and BRICKS**  
To Use or Sell

New superior moulds make absolutely square, true, easy-to-lay blocks which will pass any building code. Production is fast . . . easy. One durable \$30 machine will make four 5"x8"x12" blocks per minute—1,000 a day. Pays for itself in one day! Sell blocks for big profit . . . or save 1/3 building cost for yourself. **POST CARD BRINGS FREE FOLDER.**

**ECONOMY MFG. CO.**  
DEPT. P STONE MOUNTAIN, GA.



TUTHILL — SELF-PRIMING

BRONZE

# CENTRIFUGAL PUMP

240 GALLONS PER HOUR

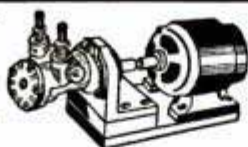

Ideal for Circulating Oils, Coolants, Draining Basements, Cisterns, Waters Livestock, Fuel Transfer, Irrigates Gardens, Lawns, etc. Pump has heavy cast bronze housing and highest quality precision-machined bronze impeller vanes. The mounting bracket is of cast aluminum. Shaft rotates on sealed Class A Fairair and New Departure ball bearings. Has 3/4" threaded intake and outlet, two plain end 1/2" reducer fittings furnished. Delivers 240 GPH at 100 lb. pressure. Direct drive, universal joint. Complete with 110V, AC, 60C, 1/4 HP motor, 1750 RPM. Pump is re-conditioned, guaranteed. Orig. cost, \$65.00. Shpg. wt., 38 lb. The greatest pump buy in **\$29.95** years! **NOW ONLY**

Pump without motor, but including 3" pulley for V-belt drive, Only **\$14.95**

## AVIATOR'S OXYGEN OUTFITS



Brand New! Bail out type. Consists of all metal tank, brass release valve, 0-3000 lb. gauge and breather hose, all enclosed in khaki colored canvas bag. Tanks are charged with breathing oxygen at 1800 lbs. pressure. Ideal emergency oxygen supply for airmen, mountaineers, firemen, paint shop workers, diving outfits, etc. Shipping weight, 4 lbs.

**\$5.95**

Aviator's Oxygen Mask—Demand type. Type A-14, 24" rubber tube. Brand New! Only **\$1.95**

## 6 VOLT LUCITE WET CELL BATTERY

Brand New! Made by Willard. Extra long life. Rechargeable. Ideal for radios, boats, autos, etc. 3 cells of 2 volts each. 1 1/2" high ball float hydrometers built-in each Lucite case. Shipped dry. Size, 7 1/2" x 2 1/2" x 6". Shpg. wt., 6 1/2 lb. **ONLY**



**\$6.75**

check, or money order. **MONEY BACK GUARANTEE!** Edw. Aguado Trdg. Co. 689-G Arcade Bldg. St. Louis 1, Mo.

## PURULATOR OIL FILTERS



Permanent Type

Brand New!

# G 159J-40.

The perfect filter to keep motor oil or hyd. fluid clean at all times. Protect your pump, engine, mid-g et racer or boat with this unit. Just turn handle and element is clean. Inlet and outlet ports take pipe or straight threads up to 3/4". Accommodates 16 GPM at 30 PSI. Mfg. bracket. Shpg. wt., 4 lb. #13 val. **\$3.95** ue. **NOW**

**FREE!** 2 male Reducer Connectors given with every Filter.

**ORDER FROM THIS AD!** Prices F.O.B. St. Louis, Mo. Include postage with cash.

# Buy the Best...WISS!

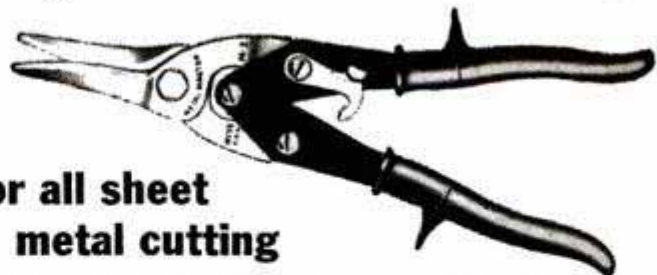

for all sheet metal cutting

## WISS Metal Master Compound Action Snips

#M-3. Easily cuts 18 gauge sheet metal. Cuts curves and circles as well as straight. Ideal for the home workshop. \$4.25. Rubber grips recommended, 60¢ extra.

## WISS Straight Cut Snips

#9. Crucible steel inlaid blades. The basic snips for straight metal cutting. Gun metal handles. Overall length 12 1/2". **\$5.25.**

## WISS Combination Snips

#V-13. Solid steel, with gray japanned handles. Cuts curves and irregular shapes with ease. Handy pocket size, 7" long. Accurately tempered jaws and strong bolts. **\$1.85.**



Prices slightly higher Denver and West



Quality for more than a Century

J. WISS & SONS CO. • NEWARK 7, N. J.

## NEW—Sensational! GEIGER COUNTER



"The SNOOPER"  
LOW PRICE ONLY **\$24.95**  
COMPLETE

Find a fortune in uranium with this new, super-sensitive Geiger Counter. Get one for atom bomb defense. So small it fits in the palm of the hand or in the hip pocket, and yet more sensitive than many large, expensive instruments. Weighs only 1 1/4 lbs. Uses flashlight battery. Low price includes earphone, radio active sample, instructions. Sold with ironclad moneyback guarantee.

**ORDER YOURS TODAY**—Send \$5.00 with order or payment in full to save C.O.D. Write for free catalog on treasure finders for gold, silver, etc. and larger, more elaborate Geiger Counters.

Dealer Inquiries Invited **PRECISION RADIATION INSTRUMENTS** 4113 PM W. Jefferson, L. A. 16, Calif.

## \$14 POST PAID PRECISION CALIPER

M.Z.B. Vernier Calipers guarantee highest accuracy for any kind of precision work. This chrome-steel, spring-tempered instrument measures inside, outside, thread and depth to .001" and 1/20mm (#30-64) or .001" and 1/128" (#30-61) 8" overall 6" graduation. Glass hard measuring surfaces. Either one also available in stainless steel at \$16.50 each. We also stock 12" Calipers with fine micrometer adjustment, and height gauges and 1" micrometers reading .0001".

Leather Cases \$1.00 extra. You pay postage on C.O.D. Money Back Guarantee. We are interested in contacting representatives for several territories.

Send for descriptive literature, also on our fine imported precision pliers.

**INTER-CONTINENTAL TRADING CORP.** 90 WEST STREET, NEW YORK 6, N. Y.



**WEAR?**  
I'LL SAY...BUT MAN!  
SO SOFT!

## WOLVERINE Pigskins

Dry Soft... Stay Soft

Here's a new high in work glove comfort. Enjoy it! You'll find that it doesn't cost a cent because Wolverine's famous secret process tans tough native pigskin soft as buckskin yet retains all its enormous resistance to wear. No other work gloves on earth made like 'em.

Try a pair and see!



## Free WOLVERITE PENCIL

A genuine Wolverine Mechanical Pencil sent FREE if you write for name of nearest Wolverine dealer. No obligation. Offer limited to Continental U.S. only.

## WOLVERINE

Dept. JG-3

Rockford, Michigan



THE  
**Ace** of  
LOW COST  
TRANSPORTATION

**Cushman**

- 75 miles per gallon
- 40 miles per hour



Cushman is the "Trump Ace" of speedy, convenient, low cost transportation. Ride it to work, ride it for pleasure, quick trips around town. Ideal in traffic, no parking problems. Eliminates the second car in the family. Operate your Cushman for less than one penny per mile! Over fifty years of engineering experience gives you maximum power, maximum economy. Go Cushman in '52!

Write today for FREE illustrated literature  
**CUSHMAN MOTOR WORKS, INC.**  
921 NO. 21 ST. • LINCOLN, NEBRASKA



**STOP BURNING OIL!  
RESTORE COMPRESSION!**

Fisher's Compression SEAL

**ONLY \$3.95 PPD**

Amazing Fisher's Compression SEAL will put new power & zip into your car. Because of friction, engines lose compression, become oil burners. A small amount of Fisher's Compression SEAL in each cylinder bore, expands 30 times; restores compression, stops piston slap, and reduces oil consumption accordingly. Old, tired engines may not need expensive overhauling.

**SATISFACTION GUARANTEED**

If after having driven 400 miles, you are not completely satisfied with the new performance and oil savings obtained from Fisher's Compression SEAL, return the used tube for a full refund. \$25,000 indemnity insurance policy is your assurance that it will not harm the finest engine. Only \$3.95 postpaid or at your dealer. Write for free folder. Easily installed, send cash, check or money order today.

**ADVANCED ENGINEERING** BOX 7013  
Los Angeles 37, Calif. Dept. PM-3

**DUST-O-VAC**  
FOR HOME WORKSHOP & INDUSTRY

FOR ALL MACHINES — Collects & Bags Wood & Plastic Chips, Wood & Metal Dust, Wood Shavings. 110 AC. DC. SEND FOR FREE LITERATURE. **\$19.95**

F.O.B. Yonkers

**HEAVY CAST ALUMINUM BLOWER — ONLY \$11.25**  
For workshop, lab., kitchen, cellar, app. 100 CFM. Send for circular.

**UNIVERSAL YONKERS CORP.,** 137 ALEXANDER ST., M-3, YONKERS 2, N. Y.

**NEW AMAZING LOW PRICE**

**SUPERIOR KIT ONLY  
CONVERTS HAND MOWER TO  
POWER MOWER \$20**



• Furnished complete—except engine. Differential drive. No reels to cut off—easier to mount. Send money order today or write for free information.

**CIZEK MFG. CO., DEPT. PM2, CLUTIER, IOWA**

**DELAYED ACTION LIGHT SWITCH**

It never leaves you in the dark. Provides FULL LIGHT FOR EXIT until vacuum cylinder turns light off approximately 3/4 minute after switch is turned off. Ideal for FRONT PORCHES, BEDROOMS, GARAGES, ETC. Tested and approved by UNDERWRITERS LABS. UNCONDITIONAL MONEY BACK GUARANTEE IF NOT SATISFIED. Enclose \$2.00.

**EDWILL CO., 1246 E. DICKINSON, GRAND RAPIDS 7, MICHIGAN**

**Always KNOW which way to GO!**

**DRIVE BY HULL AUTO COMPASS**

Write for local dealer's name and free literature

**HULL MFG. CO.** Beaconlite \$6.95  
P. O. BOX 246-D3, WARREN, O. Streamline \$4.95

**PAGE Garden Tractors**

**NEW 1952 MODELS! MORE FEATURES!**

Both riding and walking models 2 to 6 HP with complete gear drive and reverse... no chains, ratchets, or belts. Quick-hitch for easy changing. Over 50 attachments for all farm and home chores.

Also new, handy 1 wheel Page "Bantam."

**LOW PRICES, EASY TERMS**

26 years' experience behind every Page tractor. Every model guaranteed!

**PAGE FARM EQUIPMENT**

1904 S. 81st St., Milwaukee, Wis.

Write for Free Catalog

**Free to mechanics**

**DURO-CHROME TOOL CATALOG**

**NEW pocket-book of tool "best sellers"**

Send today for this Pocket-Size Catalog filled with pictures and descriptions of Duro-Chrome Quality regular and special tools, preferred by professional mechanics, and on sale at your dealer's. Also contains tool tips that help make you a better mechanic. All yours without cost or obligation.

also makers of nationally advertised **DURO POWER TOOLS**

"DOGGONE GOOD TOOLS"

clip this coupon now to get FREE copy  
**MAIL TO DURO METAL PRODUCTS COMPANY**  
2649 N. Kildare Ave. Chicago 39, Illinois.

Write your name and address in margin space



Your **ELECTRIC DRILL TRIMS**  
**HEDGES — SHRUBS — GRASS**  
 with **ROTO-TRIM**  
**DRILL ATTACHMENT**

FITS ANY  
 1/4" DRILL

Today's Greatest  
 Hedge Trimmer **VALUE \$10.95**  
 Yours, Postpaid, for only **\$10.95** (Less Drill)

Keep your whole yard neatly tailored . . . trim hedges, shrubs, and hard-to-reach grass easily and smoothly with this new, inexpensive drill attachment. ROTO-TRIM quickly converts any 1/4" drill into an easy handling, keen-cutting Hedge Trimmer.

**Quality Built throughout.** Rigid steel and aluminum construction with smooth-running hardened steel gears and cam in one-piece case. Cutting blades are 10" long, of high-carbon steel, heat-treated, precision ground and designed for maximum safety and efficiency.

**Easy to Use!** Quickly attached to drill—flats simplify chucking. Light weight and precision balance make ROTO-TRIM much easier to handle than more expensive trimmers. Handle turns blade to any angle.

**Order TODAY!** Don't miss this chance to get your ROTO-TRIM Hedge Trimmer Attachment while still available at today's low price of \$10.95.

**UNCONDITIONAL 10-DAY MONEY BACK GUARANTEE!** Send check, cash or M. O. and we'll ship postpaid — direct from factory to you.

Dept. 352 **ROTEX COMPANY** 837 WEST DAVIS DALLAS 8, TEXAS



**MANUFACTURE LEATHER LOUNGES FOR KITCHENS AND RESTAURANTS**

*Frames, springs, filling, construction simplified.*

Anyone handy with tools can build one.

Send \$5.00 for complete plans and instructions, or 10¢ for brochure.

**STEFAN GALENSKI**  
 Designer & Manufacturer

2221 BROADWAY BUFFALO 12, NEW YORK

**YOUR CAR HARD TO START?**  
 Use **WIRE DRY** to Protect Ignition Wires From Dampness, Snow & Rain

WIRE DRY puts a waterproof coating on ignition wires for quick starting in all weather. Order a bottle of WIRE DRY now. Send 50¢ to JOHNSON'S ENTERPRISE P.O. Box 5786 Chicago 80, Ill.

**Amazing Midget Wrist Radio**

**\$2.98**

Enjoy music, sports, programs with your own private, portable Wrist Radio! Use indoors or outdoors! Brings in local stations up to 50 miles! Worn like wrist watch, yet receives regular radio stations. Has super-sensitive crystal diode (worth \$1.95 alone!) & needs NO BATTERIES! NO TUBES! NO ELECTRICAL PLUG-INS! Lasts for years with NO EXPENSE! Built-in earphone. Complete with 2 clips. Just connect & set is ready for use. About 2 1/2-in. diameter, colorful plastic case, adjustable im. leather band. Only available at this low price while war-surplus diodes last so order now! **\$2.98** (2 for \$4.98) EACH COMPLETE POSTPAID ONLY.

JOHNSON SMITH & CO., Dept. 488, Detroit 7, Michigan

**DYNAMIC POWER TOOL COMBINATION**



INCLUDES: Cummins 1/4" Electric Drill; Cummins Saw Attachment; Combination Saw Blade; Set of Drills; Lambs Wool Bonnet; 6 Sanding Disks; Steel Arbor and Attachments; Cloth Buffing Wheels; Grinding Wheel; Wire Wheel Brush; Steel Point Mixer; Steel Bench Stand; Portable Steel Carrying Case.

Price of Dynamic Power Tool Combination complete is \$26.95

**SHIPPED ON APPROVAL**  
**NO MONEY WITH ORDER — NO C. O. D.**

Try it ten days before you buy. If completely satisfied then send \$2.95 and pay balance at rate of \$4.00 per month for 6 months—No Interest or Carrying Charges Added. If not completely satisfied, return to us, no explanation necessary.

KAPNER HARDWARE, INC.

Dept. A-29, 2248 Second Ave., N. Y. 29, N. Y.



**SpeedWay Speed Sander**

**\$34.50**



**Sands, Cleans, Smooths, Polishes Electrically**

Designed for industry, for professional work, this light, beautifully balanced, orbital-motion, SpeedSander is rapidly becoming a standard home appliance. With its powerful electric motor and all-ball-bearing construction, anyone can easily re-surface and refinish furniture, woodwork, metal surfaces or walls. It will quickly remove old paint, stain, or enamel down to the bare wood or metal; will sandpaper to a "piano finish"; remove rust and corrosion or "feather edge" a scraped fender. It will burnish pots and pans or with lambs wool bonnet, delicately polish fine furniture. It makes

tedious, tiresome jobs fun—saves hands! In design, convenience and efficiency it is today's finest sander regardless of price. Ask your local dealer to demonstrate it.

Write for Catalog

**SpeedWay MANUFACTURING CO.**

So. 52nd Ave., Cicero 50, Illinois

**Reload your own ammunition**



with **Lyman IDEAL TOOLS**

Reload a whole carton for the cost of a few rounds of factory ammunition. Shotgun shells, rifle and pistol cartridges can be reloaded safely and easily with an inexpensive set of famous IDEAL Reloading Tools. The ammunition you produce will be *more accurate* for your gun than any you can buy!

184 pg. Ideal Reloading Hand Book . . . 75¢. Free Folder.



The Lyman Gun Sight Corp.  
 MIDDLEFIELD, CONN.



**RELIEVES  
HEADACHE  
NEURALGIA  
NEURITIS PAIN**

**FAST**



**Here's Why...**

Anacin® is like a doctor's prescription. That is, Anacin contains not one but a combination of medically proved active ingredients. Anacin is specially compounded to give **FAST, LONG LASTING** relief. Don't wait. Buy Anacin today.

**DO IT EASIER --- FASTER --- BETTER**

with a

**SHAW  
DU-ALL**

**Walking or Riding Tractor**

Plow  
Plant  
Cultivate  
Mow  
Rake  
Cut Trees  
Saw Wood



1½, 2½, 3 and 5 H. P. walking tractors for all large and small gardening. 5, 8 and 12 H. P. riding models that will handle good sized farms. Quality built for 50 years. All wanted tools and attachments.

See the Shaw dealer. Write for **FREE CATALOGS**, low prices on complete Shaw line. Address

**SHAW MANUFACTURING CO.**  
4503 Front St., Galesburg, Kansas  
668-G N. 4th St., Columbus, Ohio

**DRIVE 3 TO 6 DAYS A MONTH**



**Gas Free!**

Users claim and exhaustive tests have proved that the **REMAR** AUTOMATIC GASOLINE INJECTOR saves up to 20% on gas, boosts power and pick up on all cars, light trucks and tractors. Install it easily and test for 30 days on your car. IF NOT COMPLETELY SATISFIED, RETURN FOR FULL REFUND. List your name, address, car make, year, model and no. of cylinders. Free Literature on Request. \$9.95 Postpaid. \$1 C.O.D. Deposit.

**FREE Economy Manual With Each Remarr Order**  
This famous economy manual sent Free to all who order a Remarr injector. Learn how to cut your auto operating cost in half... how to get more speed, power and better performance from any car. It also introduces many new economy products.  
G. B. SCHUYLER, Dept. 83, 2804 10th Street, Berkeley 2, California



**SAW WITH AMAZING  
SPEED & ACCURACY**

**EVERY ¼" ELECTRIC DRILL A PORTABLE SAW IN ONE MINUTE!**  
**FOR DEPTH & BEVEL CUTTING**

NO. 445 "ARCO-SAW" \$11.50 with DEPTH-BEVEL-RIP GAGE & 4" ARCO "HYCARBON" Crosscut Blade

"ARCO-SAW" is ideal for work around the house, shop, factory. Makes the handsaw obsolete. You whiz through wood, plastic, plywood, etc. without effort. And you'll be amazed at its smooth, square cuts.

**CUTS 1¼" or 2x4 by turning over CAN BE USED WITH ONE HAND!**

**LOOK AT THESE TERRIFIC FEATURES**

**THE ONLY SAW WITH PRECISION GRADUATED GAGES.**  
Depth gage: 0 to 1¼" depth, Bevel gage: 0 to 45° angle, Adjustable rip gage, Visual guide for accurate cuts, **RIGHT ANGLE GEAR DRIVE** eliminates clumsy dangerous direct drive, **Safety-yoke** for rigid connection and safety, **90-DAY FACTORY GUARANTEE.**

**No. 444 "ARCO-SAW"**. Has some expensive features as No. 445—less gages...STILL ONLY \$9.95

**Depth-Bevel-Rip Gage**. Quickly converts any No. 444 "ARCO-SAW" to a No. 445... \$1.95

**Lowest priced quality Replacement Blades.** "HYCARBON" 4" Crosscut or 4" Combination \$1.60

**TRY "ARCO-SAW" ON OUR UNCONDITIONAL 10-DAY MONEY BACK GUARANTEE.**

**ORDER TODAY!** Insist on "ARCO-SAW" at your dealer. If not available send us check or M.O. (Postpaid). C.O.D.'s—postage extra. Write for literature of other tools.

**ARROW METAL PRODUCTS CO.**  
Dept. PM-3, 140 West Broadway, N.Y. 13, N.Y.



**DEALERS:**  
Write for name of nearest wholesaler.

**V-PLEX AUTOMATIC CLUTCHES**

Get smooth pickup for your power mower, motor scooter or garden tractor... with only throttle control. Prevent stalling engine, cut belt wear, permit no-load idling. Easily installed on ½, ¾, ¾" gas engine shafts. Factory-tested. See dealer or write for folder.



V-PLEX CLUTCH DIVISION — Hagerstown, Indiana



**SEW SAW**

**NEW JIG SAW ATTACHMENT FOR YOUR SEWING MACHINE.**

ONLY \$1.95 post paid. On or off in a jiffy. Saws wood, plastics, etc. Make models, toys, puzzles, and hundreds of useful items. Attachment complete with table, dust bag, & 2 saw blades. Give name, etc. of your machine.

MASON MFG. CO., CLIFTON SPRINGS, N.Y.

**REVERSIBLE MOTOR**



**115 V., 60 CY. AC.**  
1/40 H. P. Ball-bearing, ¼" shaft, 3450 R.P.M. in Blast Proof Case. Needs only a capacitor for starting. Manufactured by GE., Delco, Diehl.  
**SPECIAL LOW PRICE... \$4.95**

Lots of Ten or More \$4.00 Ea. ALL BRAND NEW.  
**STARTING CAPACITOR For Above Motor... Ea. 69c**

**TAPE** { **CANNED FRICTION TAPE, ¾", 82½ Ft. 6 Rolls to the Can... \$1.25 per can**  
**INDIVIDUAL BOXES**  
RUBBER TAPE, ¾", 15 Ft. .... 15c per Roll  
SCOTCH TAPE, 1", 50 Yds. .... 35c per Can  
FRICTION TAPE, ¾", 82½ Ft. .... 15c per Roll  
MICA TAPE ..... 25c per Roll

Write for Free Booklet listing our stock and prices on Radio, Electronics, Tools, Hardware, Motors, Wire, Meters, Batteries, Aluminum Sheets, Etc. Minimum Order Filled, \$1.00. Please send cash with order. All items subject to prior sale.

STANDARD SURPLUS, Dept. M, 1230 Market St., San Francisco 3, Calif.



# WANTED!

## MEN AND WOMEN TO EARN SPARE TIME MONEY

Many Popular Mechanics neighborhood representatives are making extra cash for easy, after-hours work. A few more are needed. For details, write:

**POPULAR MECHANICS**  
ROOM 408  
200 E. ONTARIO STREET  
CHICAGO 11, ILLINOIS



**LIGHTWEIGHT**

**\$370.00**

(Fed. tax paid, at factory)

9.5 hp. 4-cycle. 3-speed. Foot-shift. Over 70 miles per gal. Over 60 m.p.h. Write for free circular.

**MUSTANG, Dept. PM**

635 W. Colorado, Glendale 4, Calif.



## Authentick! COLONIAL FURNITURE KITS

Make your own "antiques." These unfinished knocked-down furniture kits are exact museum reproductions. Easy to assemble and finish. Ideal for home or resale. Make 100% profit. Write for FREE folder today.  
**HAGERTY, 82 Ship St., Cohasset, Mass.**

GET UP TO 40% OFF!

**BUY IT WHOLESALE!**

**START A BUYING SERVICE** at home, spare time.

Get big-name merchandise for clients (and yourself) at up to 40% and more below the regular list price. Make fat commissions. Folks eagerly buy through you to get sizeable discounts. Send postcard for details.

**AMERICAN BUYERS' SERVICE, 631-P Linden Ave., Buffalo 16, N. Y.**



*Little Farmer*  
**POWERED CULTIVATOR**

**\$99.50**

F.O.B. ORRVILLE, OHIO

At last, an effective powered cultivator in the low-price field. The Little Farmer is ideal for city or farm garden use. Compact design and fine balance make it easy to operate. Just right for narrow rows where larger equipment may damage plants. See your dealer now, or write for information. Money-back guarantee.

**THE WILL-BURT CO.**

DEPT. PM, ORRVILLE, OHIO

## THE JUNIOR SUPER-METER For Radio & TV Repairs

D.C. Volts: 0-7.5/75/150/750/1500 Volts.  
A.C. Volts: 0-15/150/300/1500/3000 Volts.

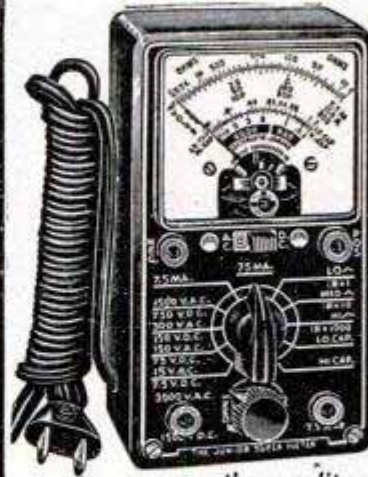

Resistance: 0-10,000/100,000 ohms, 0-10 Mgms.

D.C. Current: 0-7.5/75 Ma. 0-7.5 amps.

Capacity: .001 Mfd. -2 Mfd., .1 Mfd. -20 Mfd.

Decibels: -10 Db. to +18 Db., +10 Db. to +38 Db., +38 Db. to +58 Db.

Reactance: 15 ohms -25 K ohms, 15 K ohms -2.5 Megohms,

Inductance: .5 Henry -50 Henries, 30 Henries -10 K Henries.

Plus Good-Bad scale for checking the quality of electrolytic condensers.

Handsome round cornered molded bakelite case 3 1/8" x 5 7/8" x 2 1/4" complete with all test leads and instructions.

**\$21<sup>40</sup>**

**SOLD ON EASY PAYMENTS AT THE NET CASH PRICE**

No interest or carrying charges added. Simply remit \$5.40 with order, pay balance \$4.00 per month for four months.

**MOSS ELECTRONIC DIST. CO., INC.**

Dept. B-16 38 Murray St. New York 7, N. Y.

**PFLUEGER**

# TRUMP REEL

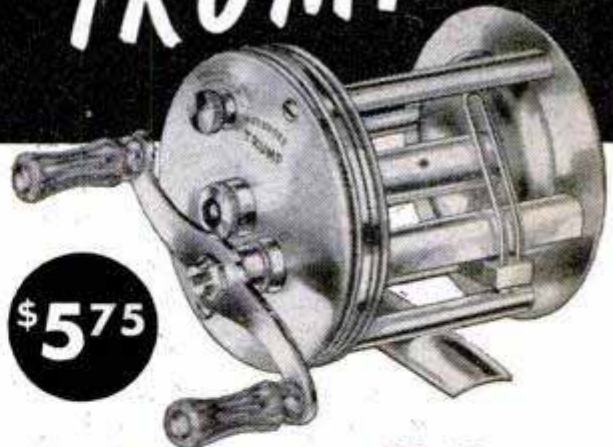

**\$5<sup>75</sup>**

**Casts Beautifully**

You'll be surprised at how well the Pfluegers make this smart looking reel. Its dependable gears and level-wind mechanism work smoothly - its anti-back lash has graduated tension to assure positive action. Its extra heavy chromium of finest quality resists corrosion. Here's the ideal reel as an extra in your tackle box or for regular fishing. Ask your dealer.

**THE ENTERPRISE MFG. CO., AKRON, OHIO**

88 years making fishing tackle

Everything for fresh or salt water fishing

**PFLUEGER**

(Pronounced FLEW-GER)

A GREAT NAME IN TACKLE



ALL-IN-ONE Multi-Purpose  
Car  
and  
General  
**UTILITY LIGHT**

Perfect For Your  
**CAR, SHOP, HOME,  
BOAT, etc.**

So easy to attach. Plugs into either cigarette lighter receptacle in car or into any wall outlet or socket. (Also specially made for battery use.)

Look at These Features  
All rubber, heavy duty 15 Ft. service cord, Easy Open Cage, Full Size Bulb, Non-Glare Reflector, 2 Tool Outlet Taps, Heavy Duty All Rubber Handle.

BE PREPARED for all emergencies. Avoid dangerous and costly accidents. Send check or M.O., postpaid, or order C.O.D. plus postage.

Only  
**\$3.98**  
ppd.

5 DAY  
MONEY  
BACK  
GUARANTEE

MADISON Electric Merchandiser Co.  
Box 759, 1474 BROADWAY, N. Y. 18

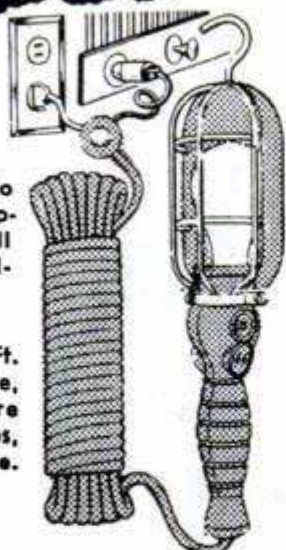

**DRILL PRESS OWNERS!**

HERE'S 1 TOOL WITH 5 DISTINCT USES



THE BARRON MULTI-PURPOSE  
ROTARY WOOD PLANER

PLANES & SURFACES • PANELS & BEADS  
ROUTS & GROOVES • RABBETS • TENONS **\$7.50** COMPLETE

Finest precision performance—certainty of skilled workmanship—time-saving, money saving short cuts—yours with world famous Barron Drill Press Tools. Fifteen important operations—all available on any standard drill press—with Barron Accessories. Equip your shop with these versatile exclusively designed tools—and save up to \$500. 200,000 Barron owners have bought on our liberal 10 day full money back guarantee. Order, or write for catalog.

BARRON TOOL CO. INC.

205 Architects Bldg., Detroit 1, Mich.

FREE  
Workshop  
Guide &  
Catalog

**AUTOMATIC RETOOTHER**

MAKES NEW  
PROFITS

for HAND SAWS

Cuts new teeth in 50 seconds—any size 4 to 16 points. Old teeth fall off as chips. Easy to operate. A perfect job.

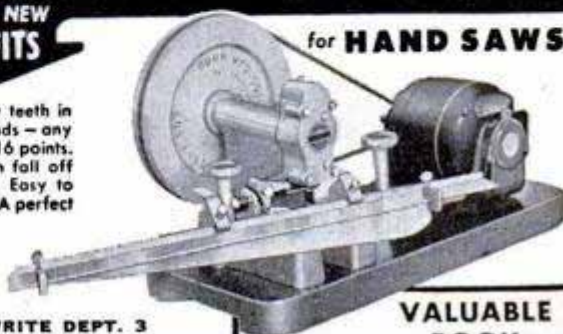

WRITE DEPT. 3

BURR MFG. CO.  
8933 VENICE BLVD.  
LOS ANGELES 34, CALIFORNIA

VALUABLE  
BOOK

25¢

Order Burr's Blue Book of Coast to Coast prices for saw shop services

Satisfies demands of the most exacting  
music fans...



**BELL**  
Custom HIGH FIDELITY AMPLIFIER  
with amazingly versatile Remote Control

For more enjoyable and relaxing listening, choose this Bell 2145 Amplifier. Expressly designed for music lovers. Can be used with any built-in or custom audio system. Assures finest reception at all sound levels, with naturally life-like tone and clarity from recordings, broadcasts, and telecasts. In addition, the small, neat remote unit lets you switch to and from AM, FM radio (or TV); or phono, for all domestic and foreign records, 78, 45, and 33 1/2 rpm; also adjust volume, bass, and treble. It can be table or console mounted at your favorite easy chair or some other convenient point. Amplifier can be tucked away anywhere, out of sight. The cost of this master touch to your home music system, phono, radio, or TV set is surprisingly low. Write for details.



**BELL Sound Systems, Inc.**

665 Marion Road, Columbus 7, Ohio

Specialists in custom components for home music systems

**SEND ME**



every month so I am sure to  
see each new issue. Here's

- \$3.50 for 1 year  
 \$8.00 for 3 years

name \_\_\_\_\_

address \_\_\_\_\_

city \_\_\_\_\_

zone \_\_\_\_\_

state \_\_\_\_\_

B-32

Hand this order to your newsdealer or send it to

**POPULAR MECHANICS**  
200 East Ontario St. Chicago 11, Ill.





# Refinish

without drudgery or danger



New no-wash, non-inflammable remover peels off paint, enamels, synthetics

IT'S FAST! IT'S CLEAN! Sold at leading paint, hardware and department stores.

Product of  
W. M. BARR & CO.

2360 S. Lauderdale • Memphis 2, Tenn.

## this ONE GOVERNOR



fits ALL popular farm & industrial gasoline engines

### PIERCE LONG RANGE Universal Governor

ONLY \$44.00

Includes Standard 5" Pulley. Send Check or Money Order. State Make, Model of Engine.

Write for Complete Information  
DEALERSHIPS AVAILABLE

THE PIERCE GOVERNOR CO., Inc.  
1600 Ohio Avenue, Box 1000  
Anderson, Indiana, U. S. A.

"World's Most Experienced Governor Manufacturer"

# SAVE OVER 50% ON THESE BRAND NEW WAR SURPLUS POWER UNITS



BE PREPARED for any emergency!  
LIGHT PLANT BUYERS in emergency telephone collect—unit shipped same day!

- 5 KW Plant, 120 volts, 60 cycle AC. List today \$1910.00. Used \$875.00. NEW. Your price only **\$895.00**
- 2500 Watt, AC, 110 volts, 60 cycle. Slightly used but reconditioned and fully guaranteed ONLY... \$295.00
- NEW, same as above... \$345.00
- Plants built in 1951... \$426.00
- 3000 Watt, 110-220 volts, with AUTOMATIC battery starter... \$465.00
- 300 Watt, Reg. \$145. Now... \$99.00
- 750-1000 Watt... NEW \$169.00
- 1000-1200 Watt... NEW \$194.00
- 1500 Watt AC... NEW \$275
- 2000-2500 Watt... NEW \$294.50
- 3000 Watt DC Contractor's PORTABLE. Rubber tired wheels. 5 to 7 HP gas engine. Used like new \$220. New... \$279.00
- 7500 Watt 4 cyl. engine; New \$995.00
- 10,000 Watt Used \$1195.00; New \$1495.00
- 25,000 Watt Used \$1995.00; New \$2495.00
- 35,000 Watt Diesel, Rebuilt \$2995.00
- 50,000 Watt Diesel, New. \$5990.00



**ELECTRIC BOOSTER FANS**  
Fit any 8", 9", 10" furnace pipe. 1500 rpm motor with 6" cord, mounting frame, 7" blade. Motor 110 v. 60 cycle, 1550 rpm. Easy to install. Silent operation. Warm those rooms with long runs. Regularly \$11.95. Your price... \$6.95  
10" Ball Bearing EXHAUST FAN, 13x13" Steel Frame... \$12.95



**HIGH VOLUME BLOWERS**  
Top performance for forced draft, ventilating, exhausting, cooling and drying. 110 v. AC. Intake 2 1/2", discharge 2 1/4". 75 cu. ft. per min. \$10.95. Intake 3 1/2", discharge 2 1/2", 150 cu. ft. per min. \$14.95

**BUILD YOUR OWN DUMB-WAITER ELEVATOR**  
We have all necessary parts—Steel Car—Guide Rails—Worm Gear—Limit Switches—Electrical Controls—Steel Cable. SEND 25c for completely diagrammed instructions with list of parts, kits, and prices.

### SENSATIONAL WINCH VALUES

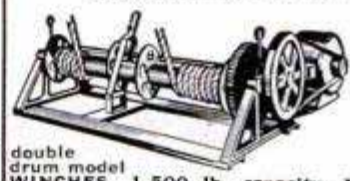

FOR — CONTRACTORS, BOATS, FARMERS, TRUCKS, LOGGERS, etc.  
**WINCHES**, 1,000 lb. capacity, Hand operated... \$9.95  
**WINCHES**, Hand operated ball bearing model, 1500 lb. cap. 3-1 ratio, hand brake, two speeds... \$39.50  
**WINCHES**, 6,000 lb. double drum, Hand operated... \$49.50  
**WINCHES**, 6,000 lb. capacity, Electric drive... \$108.00  
**CABLE**, 1/4" preformed stainless steel aircraft; 100 ft. or less, 17c per ft.; over 100 ft., 15c per ft.

SEND TODAY FREE CATALOG Thousands of \$\$ saving buys. These are a few of the many items at sensationally low prices!

- Air Tanks
- Drop Cords
- Fire Pumps
- Saws
- Pumps
- Grinders
- Clutches
- Generators

**C&H ELECTRIC MACHINE CO. Inc.**  
4340 W. Juneau Ave., Milwaukee 3, Wisconsin

### YOU'LL CATCH BIGGER FISH

and have more fun catching them after you read Popular Mechanics HOW TO TEMPT A FISH. Here is the experience of veteran guides and fishermen brought to you for hours of enjoyable reading. Many pages of brilliant full color kodachrome plates. Covers every phase and style of fishing—even tells where to find the big ones and what baits to use. Hundreds of kinks and tips to make every trip more enjoyable. Endorsed by leading sportsmen throughout the country. 128 pages. 525 illus.



POPULAR MECHANICS PRESS \$2.00  
200 E. Ontario Street, Chicago 11

### USE EASTER SEALS. HELP CRIPPLED CHILDREN

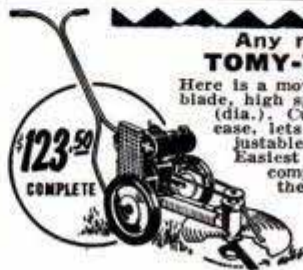

Any mowing job made easier!  
**TOMY-WESS POWER MOWER**  
Here is a mower with all the features you want. 18" blade, high speed 1 1/2 h.p. B and S motor, 12" wheel (dia.). Cuts the toughest grass and weeds with ease, lets you get next buildings, trees, etc. Adjustable handle, and semi pneumatic tires. Easiest guiding machine yet made. Light and compact. Order direct from this ad. We pay the postal charges. \$123.50 complete—Less motor \$63.50. Order today!  
**TOMY MOTOR WORKS,**  
Dept. M, Touhy, Nebraska



**Now** YOU CAN POWER BORE  
LARGE HOLES IN WOOD •  
PLASTIC • ALUMINUM  
*fast* AND  
WITHOUT EFFORT

INTERCHANGEABLE NEW!!

1" hole effortless  
in 5 seconds

marking, electrical,  
plumbing work

end grain, through  
nails, any angle

**Order Today - THIS BRAND NEW  
5-PIECE WOOD-BORING SET  
4 Blades and Shaft \$3.98  
Introductory Offer**

Bits are of BLUE SPRING STEEL  
Tempered - rugged - sharp cutting  
edges that bore clean, smooth,  
accurate holes. Extra Blades only  
75c each.

Shaft precisely designed of tem-  
pered steel to fit hand power drills  
and drill presses.

**FREE!** Handsome vest pocket size  
case—to hold complete set.

Another First by **TIME SAVER TOOLS-INC**  
MUNDELEIN • ILLINOIS

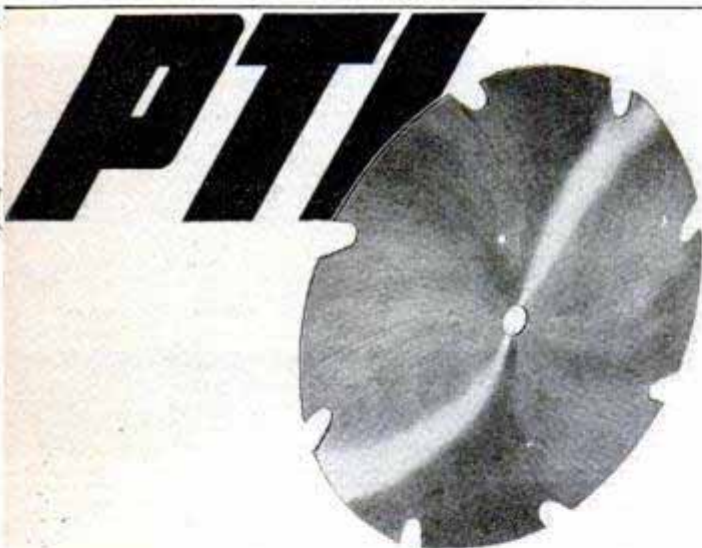

The original safety saw blade  
tested and approved by the  
world's leading laboratories

For a dependable safety saw blade that  
really minimizes danger and "kick-  
backs" from circular sawing—insist on  
the genuine PTI blade. (U.S. Patent  
No. 2,559,355).

Precision made of chrome vanadium  
steel by one of the world's leading saw  
blade manufacturers. Cuts cleaner,  
quieter, smoother—and requires 30% less  
power. Available in sizes from 7" to 16"  
and for standard makes of portable saws.

**NEW! PTI saw sharpener for safety blades**

Get franchise in your locality! WRITE FOR DETAILS.

**EXTRA BLADE BONUS SPECIAL**

with every PTI blade you buy at the regular  
price . . . you get an extra blade for only \$1  
more. Write for full particulars.

**INCORPORATED, 401 Broadway, New York 13**

**NEW!**  
**ALL ABOUT  
TELEVISION**

**Service Your TV Set Yourself and Save Hundreds  
of Dollars . . . Save on the Purchase of a New Set!**

Here's the brand new  
book that tells and shows  
you how 9 times out of 10  
you can service your TV  
set yourself and save the  
\$5 to \$25 fee charged by  
professional repairmen  
for service calls.

Here are famous step-by-  
step instructions by John  
Derby, famous television  
engineer, which make it  
possible for you to locate  
trouble quickly and re-  
pair it in the matter of  
minutes. Hundreds of  
"show-how" photos,  
drawings and diagrams  
actually show you just  
how to go about making  
most TV repairs.

A special illustrated sec-  
tion contains actual pho-  
tographs of imperfect TV  
pictures. By comparing  
the picture on your set  
with those in the book  
you immediately identify  
the trouble and then by  
following Derby's instruc-  
tions you make the ad-  
justment or repair which  
will give you perfect re-  
ception once again.

Find out how to install  
your own antenna at a  
savings of as much as \$20  
. . . how to replace burnt-  
out picture tubes . . . how  
to get the best reception  
in outlying areas . . . how  
to save money when buy-  
ing a new set . . . what to  
look for when you pur-  
chase a TV set.

Go with Derby into TV  
studios and see stars in  
action . . . see how tele-  
vision shows are produced  
and what goes on "be-  
hind the scenes."

No other TV book on the  
market is so compre-  
hensive and so chock-full of  
valuable information. No  
other book can save you  
so much money.

Send just \$3.00 for your  
copy of "All About Tele-  
vision." Read it for seven  
full days and unless you  
agree that it can save  
you hundreds of dollars  
and enable you to service  
your TV set yourself just  
slip it back in its wrap-  
per and return it to us  
for a full refund. Use the  
handy order blank today.

*Order on this Handy Coupon*

**POPULAR MECHANICS PRESS**

200 E. Ontario Street, Chicago 11, Ill.

Remittance for \$3.00 enclosed. Rush postpaid my copy of "All  
About Television." Unless it is entirely satisfactory I may re-  
turn it within seven days for a full refund.

NAME \_\_\_\_\_

ADDRESS \_\_\_\_\_

CITY \_\_\_\_\_ ZONE \_\_\_\_\_ STATE \_\_\_\_\_

Send C.O.D. (Postage extra)



# AMAZING NEW WOOD-TURNING TOOLS! Outlasts Steel Up to 50 to 1!



**SHARPEN ONCE IN 12-YEARS!  
(UNDER NORMAL USE)**

These remarkable tools tipped with TUNGSTEN CARBIDE will astound you with their performance. They work FREE HAND equally well in wood, plastic or soft metals—and at the same time hold their razor-like edge almost indefinitely. Tests show that they will turn wood or plastic for days and days CONTINUOUSLY without showing any signs of dulling. They are the finest tools available at any price. Beautifully finished 5" blade—flush ground, polished tip—finest brass tube ferrule—9" hardwood handle—over all length 14"—25 tools to choose from: round & square nose from 1/8" to 1 1/2";—1/8 and 3/16 cut off; 1/2"x30° skew, spear, r. & l. skews, turning and parting. Amazingly Low Prices! Write at once for free literature.

**JOHNS MFG. CO., DUNELLEN 16, N. J.**



## HAVE A BIGGER — MORE EFFICIENT HOME WORKSHOP

Popular Mechanics PLANNING YOUR HOME WORKSHOP shows you how to make use of every inch of space in your workshop; detailed floor plans, wiring layouts and power tool hookups plus actual photographs of famous home workshops you can use as models. Save money by building your own shop furniture. Special Where-to-Buy-It Guide, 450 Illustrations. Cloth Bound. Working Diagrams. Order your copy today from

**\$2.50**

POPULAR MECHANICS PRESS  
200 E. Ontario Street Chicago 11

## HELPFUL BOOKS

Send post card asking for FREE catalog

Popular Mechanics Press, 200 E. Ontario, Dept. 601, Chicago 11

Lend a hand



# PLEASE!

Easter Seals are an investment in hope for a crippled child. Easter Seals promise a normal life for the crippled through medical care, education and vocational training, and many other services. You can help. Won't you lend a hand?

## GIVE NOW!

THE NATIONAL SOCIETY FOR  
CRIPPLED CHILDREN AND ADULTS, INC.  
11 S. LASALLE STREET, CHICAGO 3, ILL.  
THE EASTER SEAL AGENCY

# THIS ALADDIN 5-ROOM HOUSE \$1974

FREIGHT PAID



## SAVE 4 PROFITS ON LUMBER, MILLWORK, HARDWARE & LABOR

The Aladdin Read-Cut System of Construction enables you to save 18% lumber waste and up to 30% labor costs, and guarantees you will receive the highest quality KILN DRY lumber and a COMPLETE house as specified. You can buy YOUR COMPLETE HOUSE, ALL IN ONE SHIPMENT, direct from our mills and save the in-between profits.

## BUILD IT YOURSELF—AND PAY YOURSELF THOSE HIGH WAGES

You get all the lumber cut to fit by fast machinery-production line methods—marked and numbered, ready to erect practically without the use of a saw; also siding, flooring, trim, all millwork, doors, windows, mouldings, glass, hardware, nails, roofing, paint and complete drawings with instructions. Many Aladdin home buyers erect their own houses.

## ALADDIN HOUSES ARE NOT PREFABRICATED



Aladdin new 1952 catalog in four colors contains 110 new and modern plans. Aladdin guarantee: Satisfaction or your money back. Send 25c for this beautiful book.

ASK FOR CATALOG No. RM-1.

IMMEDIATE DELIVERY

## THE ALADDIN CO. BAY CITY MICHIGAN



OVER 700%

# PROFIT!

WITH THE

## PDQ CHAMPION PHOTOMASTER

Makes finished pictures in 2 minutes.

Takes and finishes 30 to 40 everlasting, black and white or sepia photos an hour. No dark room. Guaranteed not to fade. Photos taken on "SUPER SPEED" direct positive paper. Picture size 2 1/2 x 3 1/2 in. Complete, easy-to-operate portable photo studio. Size 4 1/2 x 5 x 10. Wt. 6 lbs. 700% PROFIT. Write quick, get details about the great PDQ CHAMPION PHOTOMASTER.

P D Q CAMERA CO.

1161 N. CLEVELAND AVE. Dept. PM-3 CHICAGO 10, ILL.



# Why let your cellar pipes be eyesores?

Aluminum Krylon coating adds color, stops "sweating." Use wherever you'd use aluminum paint. Just spray it on!



If you prize it—**KRYLON-ize** it!

Aluminum Krylon Acrylic Spray is as different from paint as summer from winter! It covers more surface, is easier to apply, cleans easier, lasts much longer, waterproofs completely. Won't crack, peel, dry out, or change color. Krylon is an ACRYLIC coating that seals surfaces—protects, preserves, beautifies. Just press a button, spray Krylon on. Use aluminum Krylon wherever you'd use aluminum paint. At hardware and paint counters everywhere in 12 oz. aerosol spray cans.

KRYLON is also available in CRYSTAL CLEAR and WHITE. Spray on almost any metal, paper, leather or wood surface. Rustproofs metal. Dozens of uses in every home and workshop.

KRYLON, INC., 2601 N. Broad St., Philadelphia 32, Pa.

Get quick, sure...

## INSTANT STARTS for your cars and trucks!

*the Dependable*



**STEWART-WARNER Electric FUEL PUMP**

Get yours now! Get quick, sure starts every time—in any weather. A Stewart-Warner Electric Fuel Pump feeds a steady flow of fuel to your carburetor the second you turn on the ignition. Saves your battery. Saves you the trouble and expense of a car that won't start instantly, stalls in traffic, or dies at every stop.

Easy to install on any car or truck. Do it yourself or visit your local Service Garage.

**FREE Illustrated Booklet on Request**

Stewart-Warner Corp., Dept. N-32  
1840 Diversey Parkway, Chicago 14, Ill.

Please send FREE Illustrated Booklet on the dependable new Stewart-Warner Electric Fuel Pumps.

Name \_\_\_\_\_  
Address \_\_\_\_\_  
City \_\_\_\_\_ Zone \_\_\_\_\_ State \_\_\_\_\_  
 For Cars  For Trucks

## 2 DRILLS in 1

**\$11.95** post paid

Send check or Money Order • Satisfaction guaranteed • Order yours now

This attachment gives you two drills in one. It converts any 1/4 inch electric drill to 1/2 inch capacity. Reduction gears reduce the drill speed 5 to 1, the average speed of a 1/2 inch drill, and thereby increases the power. Absolutely indispensable for all shop work and home craftsmen.

**G. M. CO. MANUFACTURING, INC.**  
1308 43rd AVE.  
LONG ISLAND CITY 1, NEW YORK

## NEW! CHEAP! OIL BURNER SWEEPING THE COUNTRY!

**(SALESMEN BIG MONEY)**

SLIPS INTO ANY COAL RANGE, STOVE OR FURNACE

Amazing quick, intense heat. By finger-tip control. Cheaper than coal. No more shoveling coal or ashes. **SENT ON TRIAL.** Prove it pays for itself quickly by what it saves. \$1 bonus for testing. We'll let you try one in your own home for one month. Write for details today. **NORTHWEST MFG. CO., 360-C Main, Mitchell, S. Dak.**

## SPORTONE MUFFLERS

Ford & Chevrolet.....	\$ 4.45
All other popular cars.....	5.45
V-8 Dual Sets.....	15.95
Chromed Silentips.....	2.95

(Please state make & year of car on all orders.)

**SANDEE MUFFLER CO.**  
5643 Corryne Place • Culver City, California

## STEAM BOILER OWNERS?? DON'T TAKE CHANCES

INSTALL "AUTOMATIC WATER" FEED YOURSELF IN AN HOUR

Only wrench needed. **\$18.75 Complete**

Write: **A. FILANCIA, P. O. BOX #228-P, HARRISON, N. Y.**

## WARN HUB CAP MAKES 2 JEEPS OUT OF 1

Ends front wheel drag on 4-wheel drive Willys Station Wagons, Pick-ups and Jeeps

Saves gas up to 5 miles per gallon, tire wear, front axles, increases speed and power. Stops shimmy—front wheels coast out of gear! 4-wheel drive handles, performs, climbs like 2-wheel. Install or remove WARN HUB CAPS in 10 minutes. Polished aluminum, guaranteed. Rush check, M.O., or C.O.D. Write for circular.

**\$20.00** Prepaid U.S., Canada

**WARN MFG. CO., Dept. A, 1625-3rd Ave., Seattle 1, Wash.**

**Saves Digging, Pumping, Moving!**

## OUTDOOR TOILETS CESS POOLS • SEPTIC TANKS Cleaned — Deodorized

Banish offensive odor of disposal units with amazing new product! Just mix dry powder with water and pour into outdoor toilet, cess pool or septic tank. That's all! Absolutely safe—nontoxic, no poisons. Works like magic to reduce mass, to unclog walls and pipes... to facilitate free and easy drainage. One treatment lasts months and months.



**FREE!** Just send your name and address on a postcard and get exciting details BY RETURN MAIL. Discover how you can clean, deodorize and sanitize your disposal unit QUICKLY and EASILY... at amazing low cost. **LEARN HOW YOU CAN AVOID DIGGING, PUMPING AND MOVING.** Write TODAY for complete details sent FREE!

**BURSON LABORATORIES, 951 Willard Ct., Dept. 802, Chicago 22, Ill.**



## 65 KW. 225 Volt D. C. DIESEL ELECTRIC GENERATING UNIT



**RECONDITIONED**  
Equipped with 8 cyl. DRXC Hercules DIESEL engine, 4 5/8" bore, 5 1/4" stroke, 133 H.P. at 2000 R.P.M. Complete with injector, pump, nozzles and electrical equipment. Generator attached to engine. Complete as shown.

RADIATOR for above unit... \$89.50

Each \$1375.00  
Lots of 2 each... \$1295.00

Write for price on DIESEL ENGINE only.



### 1952 EDITION

It's NEW! Get the world's largest Auto Accessory & Parts Catalog & Save money. Over 50,000 items, including Hollywood Accessories, Hi-Speed Equipment,



### FOR GAS, OIL, WATER. NEW 5 GAL. CANS

- Self locking cap.
- Compact in size.
- Sturdily made.
- Floats when full.
- 3 bar strong handle.
- 18" High, 6 1/4" thick, 13" wide.

Ea. \$2.95 \$2.49  
Lots 5, or more ea.

Rebuilt Engines, all parts & accessories for all cars & trucks. We have that Hard-to-Get part. Completely illustrated. 100 pages. Send 25c (refundable)

SEND 25% CASH WITH ORDER, BALANCE C.O.D.

## J. C. WHITNEY & CO.

1917SP ARCHER AVE.

CHICAGO 16, ILL.

## WELD BRAZE, SOLDER, and CUT

ONLY \$1475 F.O.B. complete!



No experience needed. Follow simple instructions, weld on iron, steel, bronze, brass, aluminum, and other metals. Plugs into any properly wired 110 volt A.C. or D.C. line. Make or save time and money doing repair work for yourself and others. Repair men, farmers, tinsmiths, home and auto owners, hobbyists, etc., say FOUR-WAY pays for itself over and over. Order today or send for Free details.

Larger Equipment Available on Request  
**FOUR-WAY WELDER COMPANY, Dept. F2-CC**  
2326 S. Michigan Ave. • Chicago 16, Illinois

ORDER NOW 10 DAY TRIAL

## KINKADE GARDEN TRACTOR

and Power Lawnmower

A Practical Power Plow and Cultivator for Suburbanites, Gardeners, Florists, Estates, Fruit, Nursery & Poultrymen.

Easy Terms - Write Today

American Farm Machine Co.  
1058 33rd Ave. S. E. Minneapolis, Minn.



Catalog Free

## HANDEE® tool of 1001 Uses

- Handicraft Hobbies
  - Household Repairs
  - Auto Maintenance
- Everyone Needs a Handee!

Absolutely the finest in hand power tools. Cool running, controlled power for those countless small jobs. A whole toolbox in your hand... grinds, drills, engraves, cuts, polishes, saws, routs, sands... pays for itself quickly!

HANDEE with 51 accessories, in fitted steel case \$27.50

HANDEE with 7 basic accessories \$19.95

**MONEY BACK GUARANTEE!** Liberal 10-day free trial offer. Get HANDEE at your dealer's today, or order direct postpaid.



FREE!

New HANDEE Catalog... shows a host of practical applications. Write today!

CHICAGO  
**WHEEL & MFG. CO.**  
Dept. PM, 1101 West Monroe Street, Chicago 7, Ill.

# Last Year's Profit \$3,000!

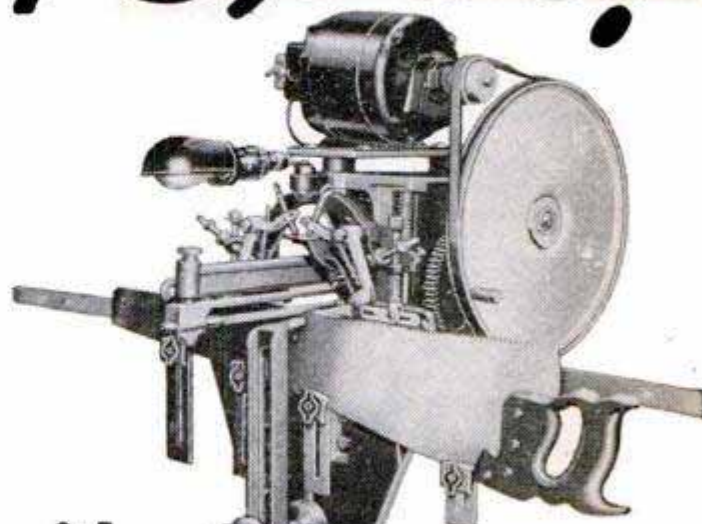

with a

## FOLEY automatic SAW FILER

"Last year's profit amounted to \$3,000. Not so bad for a one-man outfit" — from Chas. C. Hough. James B. Williams wrote us—"I made \$765 last year filing saws, and it sure comes in handy. I do this work in my spare time." Men in communities of all sizes make up to \$3 or \$4 an hour with the Foley Saw Filer working full time or part time.

It's no trick to take care of the saw filing for your neighborhood hardware or lumber dealer — plus looking after the saws for farmers, townspeople, manual training departments and factories. The Foley files all hand saws, also band and cross-cut circular saws. It's a cash business, no canvassing, no eyestrain and no experience needed.

### FREE BOOK Shows How to Start

"MONEY MAKING FACTS" shows just how you can start at home in your spare time working in your basement or garage. It's an immediate cash business that can develop into a full-time repair shop. Send coupon today — no salesman will call.



### Send Coupon for FREE BOOK

FOLEY MFG. CO., 316-2 Foley Bldg. Minneapolis 18, Minn.

Send me free book "MONEY MAKING FACTS"

Name \_\_\_\_\_

Address \_\_\_\_\_



# EAVESDROP...

behind the "IRON CURTAIN"  
hear Aircraft! Ships! Amateurs!

*Sensational*

**TABLE  
RADIO**  
SW-54  
**\$49.95**



**GUARANTEED RECEPTION  
ON 3 SHORTWAVE BANDS  
PLUS STANDARD BROADCAST**

Turn the knob and—presto!—Radio Moscow is pouring propaganda into your ears! Turn it again and hear music from Paris, or amateurs chatting, or an aircraft control operator! Thousands have discovered a whole new world of listening pleasure with the "Mighty Midget," by the makers of radio equipment for the famed Kon-Tiki Expedition. Write for details and name of nearest supplier.

**NATIONAL COMPANY, INC.**  
61 Sherman St., Malden, Mass.

send for **FREE CATALOG**



America's Foremost  
*money-making*  
**MECHANICS'  
TOOLS**

It's easy to own the same "pay-off" tools used and endorsed by America's top-earning mechanics throughout the automotive, aviation and industrial fields! Snap-on tools help you handle every repair job faster, easier, better. And they LAST... pay for themselves over and over again! Start building your own tool set now with basic Snap-on units—add others any time. Genuine Snap-on tools are never sold in stores—direct to users only. Mail coupon for free catalog.

**Snap-on Tools**  
THE HOME OF BETTER MECHANICS

**SNAP-ON TOOLS CORPORATION**  
8062-C 28th Ave., Kenosha, Wisconsin  
Send me free catalog of Snap-on tools.

Name \_\_\_\_\_  
Address \_\_\_\_\_  
City \_\_\_\_\_ Zone \_\_\_\_\_ State \_\_\_\_\_

## Most Sensational Luggage Hit In All Luggage History

"Army & Navy" **"B-4"** Type Utility Size



Measures full 18" x 12" made with a full 18" side pocket attached, making separate compartment. This bag of water-proof canvas contains two full zipper enclosures across. Has following uses: fishing, camping, traveling, bowling, hunting, picnicking, infants' use, gym and school use. Also used by soldiers on furlough. Satisfaction or money back guarantee. Price.....

**\$4.98**

Enclose Check or Money Order or order C.O.D. Tax included, Postage and C.O.D. Charge Prepaid

**BROADWAY SHOP, 826 Liberty Ave., Pittsburgh 22, Pa.**



**CAPE COD CHAIRS  
TRELLISES • ARBORS  
DUTCH WINDMILLS**

Chairs style B-C-A PLANS 50c Ea., all 3 only \$1.00. 12 different

ent trellis designs PLAN of all 12 only 50c. Authentic 40" high Dutch Windmill Detailed PLAN only 75c. Unique 40" high Light-house having copper lantern, ideal for garden or on lake shore of summer home. Large detailed PLAN 75c.

**SPECIAL ALL PLANS ABOVE \$3.00 VALUE ONLY \$2.50**

SEND 10c for catalogue of many fine projects.

**CRAFTSMAN'S MODEL CO. DEPT. P38 DELAFIELD, WISCONSIN**

make your own **Gems** 29<sup>50</sup> F.O.B.

All necessary lapidary equipment is furnished, including a super-charged diamond blade for sawing, and all wheels for grinding, shaping and polishing; also complete instructions. The complete equipment as shown, less motor and belt, for only \$29.50. f.o.b., Burlington, Wisconsin. Write today for information and literature.

**B & I MANUFACTURING CO.**  
Dept. S Burlington, Wis.



## Gerstner TOOL CHESTS

Provide Proper Care for the good tools of Toolmakers and Machinists. Free Catalog.

**GERSTNER TOOL CHESTS**  
452 Columbia St. Dayton 7, Ohio

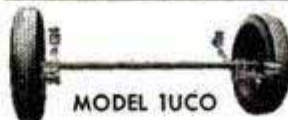

MODEL TUCO

## AXLE ASSEMBLIES

Ideal axles for farm implements, carts and trailers of all kinds

\$65.29 Less Tires  
F.O.B. Factory

Solid steel construction with springs and saddles—U-bolts and shackles—spring bolts and brackets—hubs and bearings and 15" or 16" Wheels—shipped complete, ready for use

**HAMMER BLOW TOOL COMPANY** Wausau 13C, Wisconsin



**WAR  
SURPLUS  
BARGAINS**

**\$500,000.00 INVENTORY  
for QUICK LIQUIDATION**

Surplus items—hundreds of them for home, shop, factory, farm and outdoor use. New items, used items, reconditioned items—all at tremendous savings—all priced for quick sale.

**Page After Page of Values**

This big catalog shows page after page of amazing money saving values. Write for your copy today. Send 10c to cover postage, mailing, etc. Write today!

SEND TODAY FOR YOUR COPY **10c**

**STARK'S** Dept. PMC 509 So. STATE STREET CHICAGO 5, ILLINOIS





**Portable LIGHT PLANT**

**PUSH BUTTON START**  
500-700 watts 110-120 v. - 60 cyc. A.C. Powered by a sturdy dependable, easy starting, air cooled 1 3/4 hp. gas engine. No wiring necessary, just plug in and operate. Plenty of current for any oil burner, freezer, brooder, pump, emergency lights, etc. which require up to 700 watts. Ideal for Civil Defense, Fire Depts; trailers & camps. Complete with Voltmeter and built-in winding to charge 6 v. auto batteries. Wt. 85 lbs. Fully guaranteed. Be prepared if war or storm knocks out power lines.

(Item 24) etc. which require up to 700 watts. Ideal for Civil Defense, Fire Depts; trailers & camps. Complete with Voltmeter and built-in winding to charge 6 v. auto batteries. Wt. 85 lbs. Fully guaranteed. Be prepared if war or storm knocks out power lines.  
Reg. \$275.00 value. **\$143.50**  
700-800 Watt Plant (Item 44) Same as above but greater output. **\$169.95**  
1000-1200 Watt Plant (Item 45) same as Item 24, but larger generator & engine. **\$199.50**

**GIANT 2000-2500 WATT PLANT**

110-120 V. 60 cyc., A.C. Absolutely the best made - exclusive dynamically balanced armature; heavy windings develop up to 5000 watt overload for motor starting. Skid-mounted - portable. Powered by easy starting Briggs or 6 hp. Wisconsin engine - complete with all accessories; engine easily disconnected for other uses. Big outlet box, voltmeter, no wiring necessary. Ample current for all purposes. Factory warranty and instructions included. Wt. 220 lbs. Reg. \$585.00. Special at... **\$299.50**  
With Electric Self Starter (Item 179) **\$359.50**  
**GENERATOR ONLY** and control box. **\$169.50**  
Drive it with your engine or tractor.  
**TRANSFORMERS** - Convert 110 v. A.C. to 220 v. Capacity 2 kva. Simple hook-up. Regularly \$55. Our price - when purchased with light plant... **\$27.50**  
Purchased separately \$34.50.

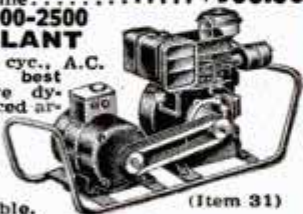

**HI-LINE 6000 WATT PLANT**

(Item 162) Push Button Start, 115-230 v. 60 cycle A.C. A brute of a power plant with a rugged 13 hp. Wisconsin engine. Plenty of electricity for ranges, water heaters, freezers, pumps, machinery, etc. Affords both 110 and 220 volts. Ideal where heavy current is needed. Wt. 590 lbs. Easily worth \$995.00. (with self starter) Factory special... **\$645.00**  
Same plant (with crank starter) (Item 168) Wt. 570 lbs. **\$585.00**  
Generator and control box only, belt driven. Use your engine or tractor. Wt. 240 lbs. **\$345.00**

**We Are World's Largest Direct Factory Distributors of Light Plants**

**You can pay more - but you can't buy better**

**D. C. GENERATOR** (Item 92) Model P1, 25 v. 250 amps, for marine, aircraft or truck duty. Make welders, light plants, etc. Has 7/8" splined shaft, can be turned down to 3/4" round if desired. War surplus, in guaranteed operating condition. Wt. 53 lbs. Cost govt. over \$300.00. Special... **\$22.50**

**32 pc. SOCKET SET**

32-pc. Socket Set (Item 59) Highest quality guar. non-breakable sockets made by Husky. Beautiful, matched chrome alloy, absolutely the best. Complete range of 21 sockets from 1/4" thru 7/16" in 1/4" drive and 7/16" thru 1-1/16" in 1/2" drive; 2 extensions, reversible ratchet, adaptor bit, slide head, all angle coupling, 2 end wrenches, 1/4" spreader handle and sturdy metal tool box. For prof. mechanics who want the best. Wt. 14 lbs. **\$16.95**  
Easily worth \$41.50. While they last.



**ELECTRIC HAND SAW**

(Item 36) Most perfectly balanced and smoothest running saw made. Advanced design provides max. power and light weight. Easily adjusted for all angles, depth and width of cut. Comes complete with 6 1/4" comb. blade, ripping guide and 10 ft. hvv. duty cord. Built-in saw-telescoping guard. 110-120 v. AC-DC. Depth of cut 2 3/4". 1 year written guar. Wt. 12 lbs. Drastically reduced... **\$39.95**



**IMMEDIATE DELIVERY - ALL ITEMS HEAVY DUTY D-C ARC WELDER**



Use as portable or shop welder. Up to 300 amps. Senior model. Made for years of trouble-free, continuous service. Will handle light or heavy jobs. Easily welds up to 3/4" plate using 1/4" rods. Built-in air-cooling system. Arc is easy to strike and hold because of specially designed arc stabilizer. Hi-lo switch and dial control gives wide range of welding heats. Run welder at 2600 rpm. with tractor, jeep or 15 hp. gas engine, or 7 hp. elec. motor. Complete with instructions, guar. and double V belt or flat pulley. You can pay more, but you can't buy a better welder. Wt. 110 lbs. **\$99.75**  
A \$400 value at...

**DUAL CONTROL MODEL** same as above but with built-in dual rheostat for low heat soldering, brazing and welding. **\$119.50**

**WELDING KIT**, Two 10 ft. leads, welding helmet, electrode holder, ground clamp. Sold only with welder at... **\$10.50**

**Variable Speed Selector**

Heavy duty, made by B. F. GOODRICH for industrial use. Provides instant speed changes for any drive. For machine tools, dryers, printing, conveyors, production lines, hoists - any operation requiring variable speed. Ideal for midgeet autos. Employs reliable "trouble free" planetary system. No hydraulic power losses or creeping. Infinite range, smooth operation, easy installation. 3 sizes: 1/2-1 hp. wt. 36 lbs.; 1-2 hp. wt. 55 lbs.; 2-3 hp. wt. 105 lbs. Reg. \$228, \$252 and \$352. Brand new in Goodrich boxes and guaranteed. Complete installation data included. Unprecedented surplus sacrifice **\$79.50, \$89.50 and \$114.50.**



**Automatic Electric WATER HEATER**

(Item 76) Immersion type 115 v. AC-1250 watts. Convert your present tank to modern automatic hot water heater. Long life Westinghouse or Chromalox element screws into std. 1 1/4 in. opening in tank. Adjustable thermostat keeps water at desired temp. Can also be used in washing machine or tub. Wt. 8 lbs. Heater element and thermostat regularly \$49.50. Special... **\$14.95**  
Heater only, for manual control. Wt. 3 lbs. **\$7.95**

**FIRE EXTINGUISHER**

(Item 39) Fully charged at 1,000 lbs. P. S. I. or more) with CO2 (carbon dioxide), the proven miracle fire fighting chemical that smother's oil, gasoline and electrical fires. Play safe, keep one in your car, garage and home. Heavy ICC approved steel cylinder, valve and 3000 lb. gauge that shows available remaining pressure. REFILLABLE at nominal cost. Hose included for emergency tire inflator or air blast. Wt. 4 lbs. **\$19.50** value. Special... **\$6.95**

**POTTERS WHEEL**

(Item 47) Complete, prof. equip. for making finest ceramics and pottery. Large dynamically balanced cast-aluminum reversible turntable with variable speed drive (38 to 140 rpm) controlled by foot-pedal. Built-in adjustable arm rests, water cup and wedging wire. 16x12" enclosed throwing table - ample area for largest pieces. Req. 1/4 hp. motor (not incl.). Can be set up on 20x24" table and stored on edge. Complete with pulleys, belts and instructions. Wt. 26 lbs. **\$145 value at... \$59.95**

**RUBBER HOSE**

New genuine Neoprene Hose - outlasts ordinary rubber 3 to 1. Reinforced with super tough cotton cord plies. Flexible. Easy Flo brass couplings with standard pipe threads for quick connections. Included. Pump water for irrigation, stock tanks, home, barn, fire fighting, etc. Pump Gas or Fuel Oil. Save more than 60%. (Inside Diam.) 1" 1 1/4" 1 1/2" 1 3/4" 2" Length 10 ft. 25 ft. 50 ft. 100 ft. 30 ft. Price 5.95 9.25 24.75 49.95 14.75 If specified we will send special hose for gas or oil at same prices.

**TERRIFIC VALUES!**

Included. Pump water for irrigation, stock tanks, home, barn, fire fighting, etc. Pump Gas or Fuel Oil. Save more than 60%. (Inside Diam.) 1" 1 1/4" 1 1/2" 1 3/4" 2" Length 10 ft. 25 ft. 50 ft. 100 ft. 30 ft. Price 5.95 9.25 24.75 49.95 14.75 If specified we will send special hose for gas or oil at same prices.

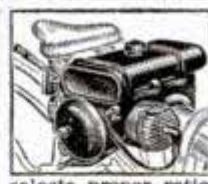

**COMMANDO BIKE MOTOR**

(Item 90) New, super-modern 1952 model. This job is the Cadillac of all bike motors. Sensational Auto-Clutch prevents killing motor at each stop. Also selects proper ratio on hills. Mounts behind and drives rear wheel with Dynatorq. Free Wheeling lever permits pedaling if desired. Rear mounting eliminates fumes, heat, dirt, and hard steering. Easily installed in 15 minutes with home tools. Sturdy, trouble-free, easy starting, light weight. Airplane type engine; up to 150 miles per gallon. Fully guar. Ride for fun or profit. Ideal for deliveries, paper routes, messenger service, etc. Ride to work and save. Dealer inquiries invited. The Commando Captain, 1 cylinder 1 1/2 hp. **\$99.75**  
The Commando General, 2 cylinder 3 hp. (Item 91)... **\$125.00**  
All Commandos shipped prepaid in U.S.

**TRENCH-LAY WIRE**

Cond. - for buried service to lights, etc. Absolutely impervious to soil or moisture. Each conductor consists of two #17 solid wires encased in tough Neoprene. Twist ends together for #14 cap. Min. order 100 ft., Wt. 7 lbs. Terrific bargain. 8c per ft.

**EXTENSION POWER CABLE # 1 2 - 2**

Cond. - stranded, flexible, rubber covered and shielded; with heavy duty plug and outlet; finest power cable made. 50 ft. (Wt. 8 lbs.) **\$6.95**; 100 ft. (Wt. 16 lbs.) **\$12.95**. #8-2 Cond. - rubber cov. - 50' lgth. **\$20.** #4-2 Cond. - rubber cov. - 50' lgth. **\$27.**

**EXTENSION CORD**

(Item 16) 40 ft. heavy duty, made of specially insulated No. 12 conductor wire. So tough that you can drive over it and yet flexible and easy to handle. Resists oil, grease or water. Extends electricity up to 400 ft. without voltage drop. Use indoors or out. Complete with heavy rubber plug and outlet. Wt. 2 1/2 lbs. Usually \$4.50 - Special 40 ft. **\$1.99** Comb: 2-40 ft. and 1-20 ft. (total 100 ft.) **\$4.95** 100 foot length (one piece)... **\$4.85**  
**WIRE ONLY (Item 50) No fittings, 100 ft. \$4.00**

**CARRY-AIR**

(Item 32) Corrosion-resistant steel tank - capacity 500 cu. in. at 400 lbs. press. complete with inlet and shutoff valves, press. gauge, detachable air hose, tire chuck. Fill at any service station. Carry air for tire inflation, blowing out lines, spray painting, insecticides, etc. One emergency pays back cost. Wt. 10 lbs. Worth \$20.00. Our price... **\$8.95**  
(Item 55) With big double tank (1000 cu. in.)... **\$11.95**

**A.C. ARC WELDER**

(Item 169) Master Hi-Line Welder - 20-100 amps. output. Fast, dependable welding, brazing, soldering and cutting. Handles 24 gauge to 1/4" metals. Will pay for itself in a few jobs. Easily controlled at any heat desired. Operates on 110-220 V. Portable and powerful. Handsome steel case 14" x 13" x 10". Wt. 65 lbs. Full instructions and guar. incl. Worth \$125.00. Factory price only... **\$64.95**  
Welding Kit (Item 181) incl. helmet, 2 leads, electrode holder, ground clamp, power cord and rods (sold only with welder) Wt. 12 lbs. **\$12.50**

**PORTABLE SPOT WELDER**

(Item 186) Cut costs drastically. Ten times faster than drilling holes and riveting or bolting. Makes high-strength welds instantly. Easily carried to the job. No skill required - a boy can operate it. Operates on 110 or 220 V. Built-in clamp holds and positions work quickly. Will pay for itself on any auto body or sheet metal operation. Wt. 23 lbs. Wholesale price... **\$98.00** 6" tongs - \$6.00 12" tongs - \$8.00

**HEATING & VENTILATING FAN**

(Item 10) Easily installed in furnace pipes. Forces even heat to all rooms. Over range, removes kitchen smoke and odors. Powerful continuous duty motor, 110-120 V. A.C. Quiet, super efficient fan moves huge volume of air (400 to 600 c.f.m.) 8" Fan, wt. 5 lb. **\$6.35**; 9" Fan, wt. 6 lbs. **\$7.45**; 10" Fan, wt. 7 lb. **\$8.45**; 12" Fan, wt. 8 lbs. **\$9.45.**

Send 10c for a Big War Surplus Catalog. Included Free with Every Order.



# BUILD YOUR OWN POWER TOOLS—TILT/ARBOR SAW

## Exclusive GIL-BILT Build-It-Yourself Features

- No machining—build easily with hand tools only
- No blueprint reading—step-by-step pictorial plans, full scale patterns, actual photographs
- Sturdy wood, aluminum, and steel construction
- Capacity and performance of commercial saws selling for \$60 and up

## BANDSAW

## BELT SANDER

SAVE \$50. OR MORE

## GIL-BILT 10-INCH TILTING ARBOR SAW



- 27x28 in. table, 131½ in. capacity in front of blade
- 10 in. blade cuts 3¼ in. deep, tilts full 45 degrees
- Floor model 34" high, table always stays level

- New Departure ball bearing arbor, ¾" precision shaft turned down for 5/8" bore blades, alum. housing, shipped ready to run
- Jackscrew and 4½ in. dia. handwheel lowers and raises blade
- Cast aluminum miter gauge and self-aligning rip fence guide

GIL-BILT Metal Parts Kit includes Plans, ball bearing arbor, miter gauge and bar, rip fence guide, dado insert, lock knobs, jack screw mechanism and handwheel, and all other metal parts (less blade).....\$20.95  
Same Kit with 10" Combination Blade \$24.90  
Same Kit with 8" Combination Blade \$23.90

## GIL-BILT 12-INCH BAND SAW

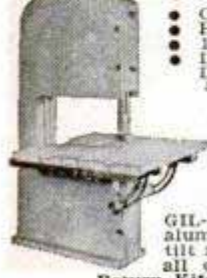

- Cuts to center of 24 inch circle
- Handles stock up to 6 inch thick
- 18x18 inch table tilts 45 degrees
- Lower wheel and drive pulley runs on sealed New Departure Ball Bearings; Upper wheel runs on two 3/8" bore Oilite Bronze bearings.
- Upper wheel tension and tilt mechanism of cast aluminum, completely assembled.
- Upper and lower blade guides. Each has ball thrust bearing, self-lub bronze jaws
- Rigid cast aluminum wheels fully machined ready-to-install. Heavy rubber tires.
- Uses standard 78 inch blades up to 3/8 in. wide.
- Fully enclosed mechanism for utmost safety.

GIL-BILT Metal Parts Kit includes Plans, rubber tires, aluminum wheels, ¼ in. blade, ball bearing spindle, tilt mechanism, blade guides, table tilt segments, and all other metal parts.....\$21.95  
Return Kits in 10 days for refund if not satisfied.  
(Prices include postage within 300 miles. Over 300 add 5%)

Also available—Plans and Parts Kit for Belt Sander and 8" Tilt/Table Saw. Order Plans at \$1.00 each—Send postpaid anywhere in the world or write for FREE descriptive catalog.

GILLIOM POWER TOOLS P.O. Box 1-PC, Lambert Field St. Louis 21, Missouri

## USE EASTER SEALS. HELP CRIPPLED CHILDREN

## LOCKS onto the work

"HOLDS ON after you let go"



AND THE "SNAP-LOCK" PLIER WRENCH HAS THESE FURTHER ADVANTAGES:

### USERS WRITE:

- "Most used tool I own."
- "Does the work of 7 different tools."
- "Couldn't be without it."

- 1 Swivel Jaw adjusts itself to the shape of the work, for better, surer grip.
- 2 Automatic Finger Tip Release. Tremendously powerful grip is released quickly, easily.
- 3 Jaw-size Adjustment. Calibration on upper handle enables you to pre-set jaws to proper size.

Don't be satisfied with anything less than the Seymour Smith "Snap-Lock"

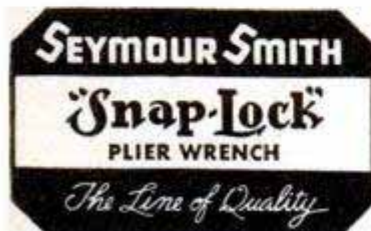

10"—\$2.50 7"—\$1.95  
Your hardware dealer has the "Snap-Lock" or can get it for you. Remember the name "Snap-Lock."  
**FREE!** Send for descriptive folder...  
SEYMOUR SMITH & SON, INC.  
21203 Main St. Oakville, Conn.

## STOPS LEAKS PERMANENTLY

Cut your fixture replacement, water and fuel bills with Economy Renewable Seats. Make economical, permanent repairs quickly and easily with the Junior Kit (illus.). Repair bathroom, kitchen and laundry fixtures. Everything you need included in steel box. This is a natural for the "Fixit" shops—get extra income from making permanent repairs on your customers' faucets.

Senior Muster Kit also available—repairs faucets and valves up to 1" pipe.

Write for illustrated circular.  
**JUNIOR KIT, only \$22.50**  
with 15 assorted Renewable Seats  
"Less than the cost of a set of kitchen sink fixtures."



## ECONOMY VALVE SEAT CO.

1430 N. Keating Ave. Chicago, Ill.

## ALNICO MAGNETS LIFT 175-lb.

AMAZING PERMANENT MAGNETS — WILL NOT WEAKEN! NON-ELECTRIC. Retrieve guns, tackle, tools and other steel items from lake, river, plating tanks, drains or other hard-to-reach spots. Recover drills, taps, etc. from floor sweepings. Clear alley of harmful tacks, nails. Many other uses listed. Pays for itself quickly. **GUARANTEED:** Try any magnet one week. Money refunded if you are not well-pleased. Cat. No. 675 (Has pull of 175 lbs. on a flat steel block).....\$10.50  
Cat. No. 650 (150 lb. pull) \$8.50 Cat. No. 530 (30 lb. pull) \$3.00  
Cat. No. 550 (50 lb. pull) \$4.00 Send M.O. or check. We pay postage.  
Cat. No. 30—Hobbyist assortment of six medium magnets.....\$1.50

MIAMI MAGNET CO.,

3240 N.W. 27th Ave., Aviation Bldg. No. 43, Miami, Florida

## \$ Free Course! Big Profits! \$



## Flocks & Sandblasts

Dual Purpose Spray Gun! Uses only 25 lbs. Air Pressure  
• Thousands of uses in Home, Shop, Industry: Makes Auto Interiors Clean & New, Lines drawers, Marproofs lamp bases, Refinishes any object. All in colorful Flock. Etch & Frost windows, glassware, etc. Removes Paint & Rust from Autos, Tools. Guaranteed! Send \$24.75 or write for free information. Flocking supplies!  
**BLASTO SPRAY GUN MFG.**  
Dept. PM-10, 7007 Haas Avenue, Los Angeles 47, Calif.

## SELL GOLD & SILVER WINDOW LETTERS

300% PROFIT! Fast, easy sales to stores, offices, doctors, lawyers, etc. Individual orders for merchants interested in saving \$\$\$ doing their own window lettering. Letters easily applied on glass, wood, metal with varnish-glue (not water). Won't wash off; withstands frost. Write for samples.  
**METALLIC SIGN CO., 430 N. Clark St., Chicago 10, Ill.**

## CASH IN YOUR SPARE TIME! BIG MONEY IN OWN BUSINESS

YOU CAN MAKE UP TO \$40 a DAY sharpening and setting circular saws for factories, builders, lumber yards—with **LIFE-TIME SECURITY YOUR OWN BUSINESS**  
**NEW BELSAW COMPLETE CIRCULAR SAW SHOP. Low Cost, only \$15 down, sharpens 4 to 5 saws an hour. No experience needed!** Instructions Furnished. Send Postcard Today for **FREE BOOK.**  
**BELSAW MACHINERY CO 3703 Field Bldg. Kansas City 2, Mo.**

## TREASURE! URANIUM!

GEIGER COUNTERS—METAL DETECTORS  
GEIGER COUNTERS for Uranium. METAL DETECTORS for gold, silver and buried treasure. 5 models from which to choose. We have one in your price range. No finer instruments available anywhere. **FREE ILLUSTRATED FOLDERS.**



THE *Detectron* CO. Model DG-7

5631 CAHUENGA, NO. HOLLYWOOD, CALIF.



**DO YOUR OWN WELDING  
EARN  
WHILE YOU SAVE ON REPAIRS!**

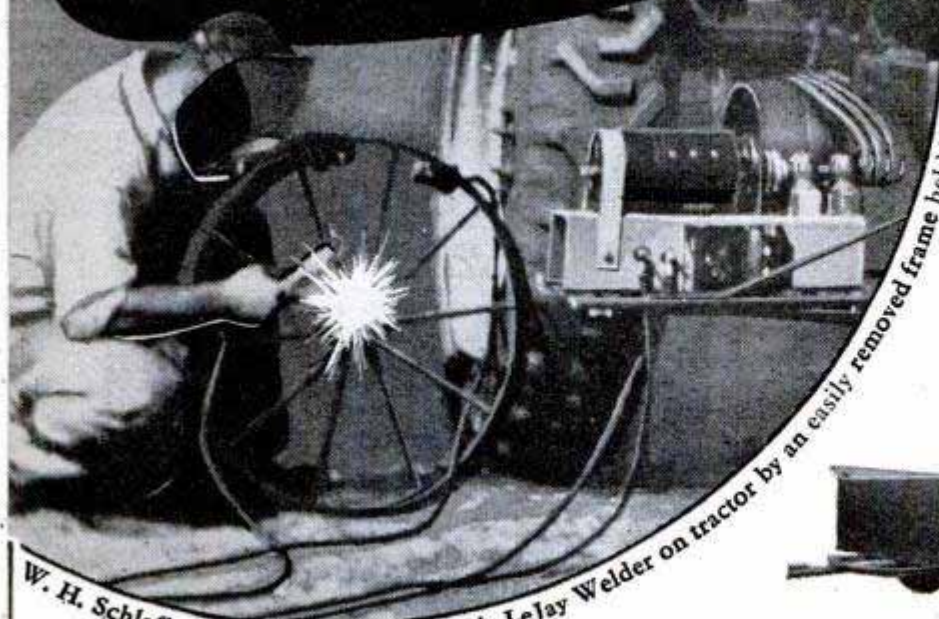

W. H. Schlafke, Jewell, Iowa, mounts his LeJay Welder on tractor by an easily removed frame held by set screws.

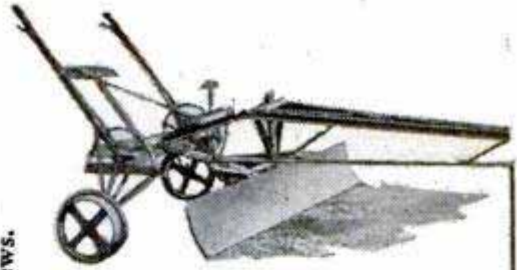

T. F. Waller, Circle, Mont., won first prize in our recent welders' contest with this grader and terracer made at "very low cost" with a Model 200 LeJay Welder.



Wilfrid Wassenberg, Marysville, Kansas, loads up to 240 bales hourly with this bale loader. His LeJay Welder is driven by a Model A Ford engine.



Robert Anderson, Winnebago, Minn., fabricated this steel trailer with his LeJay Welder. "I have welded car fenders, cast iron, steel, aluminum, bronze . . . have used it continuously all day . . . with very little amperage drop."

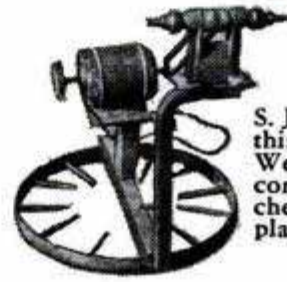

S. J. Sedlacek, Barnes, Kansas, built this portable grinder with his LeJay Welder for "on the job" use. According to Sedlacek, ". . . it's the cheapest piece of machinery on the place."

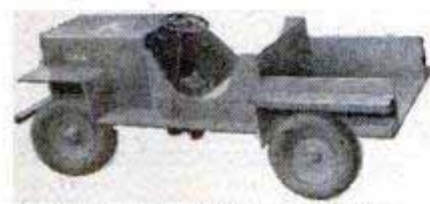

Ray Burton, Chicago Heights, Ill., built this Army "Jeep" with his portable LeJay Welder. A Clinton 2.9 H.P. motor propels it at 10 M.P.H. in third gear.

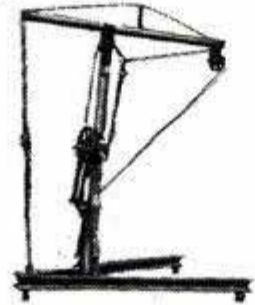

Heavy duty utility hoist also made by Wassenberg with his LeJay Welder. Capacity is 1500 lbs.

**COMPARE THIS!! 250 AMP. D.C. WELDER KIT—\$39.95 ASSEMBLE YOUR OWN...**

**PAY FOR YOUR WELDER...  
BY WELDING FOR OTHERS!**

**SAVE  
HALF!**

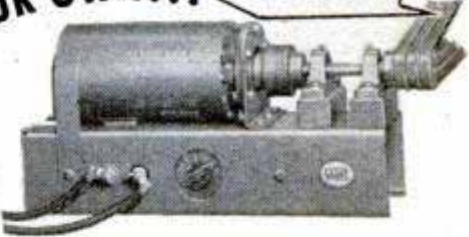

NOW, at a fraction of its original cost, you can make your own welder using any aircraft generator. You can not only save money, but a few repair jobs for your friends will quickly pay for your welder. Only a pair of pliers and a few minutes are needed to assemble this kit into a sturdy welder giving you many years of useful service—with satisfaction guaranteed.

**HERE'S WHAT YOU GET:**

- No. AW5-Kit includes these ten parts: (1) special hook-up leads (2) amperage control with leads (3) Hi-Lo switch (4) mounting plate (5) pillow bearings (6) bearing supports (7) shaft extension (8) flexible coupling splined to fit your generator (9) triple groove "B" type pulley (10) complete assembly plan. No. AW5-Kit Complete..... \$39.95
- No. AW6-Kit includes AW5-Kit above plus Arc Stabilizer..... \$49.95
- No. AW9-Kit includes AW6-Kit plus P-1-200 Amp. Generator (250 amp. short welding periods)..... \$67.90 (P-1-200 Amp. Generator Cost Govt. Approx. \$200.00)



**EXTRA! A \$15.95 Accessory Kit Complete for only \$12.95! Includes: (1) Welding Helmet (2) Electrode Holder (3) 5 Lbs. Ass't. Rods (4) Two 10-Ft. Welding Leads with Terminals and Ground Clip. Plus (5) Audel's Welding Guide.**

**SOLD WITH ANY WELDER KIT.....Special Price \$12.95**

**PLANS 35¢—LeJay's proven plan for building your own welder using aircraft generator. Catalog included.**

**FREE! BIG NEW CATALOG OF ELECTRICAL BARGAINS AND SURPLUS ITEMS—WRITE FOR IT!**



**LEJAY MFG. CO., INC.**

**647 LEJAY BUILDING  
MINNEAPOLIS 8, MINNESOTA**

**ORDER DIRECT FROM THIS AD**



# A JEWEL OF A TOOL FOR SPRING CLEAN-UP



SYNGRO POWER UNITS  
**GUARANTEED**  
AGAINST BURN-OUT DURING  
YOUR OWNERSHIP OR  
REPLACED FREE!

No. 504



STROKE  
ADJUSTER

60 Cycle,  
110-120  
Volt A C

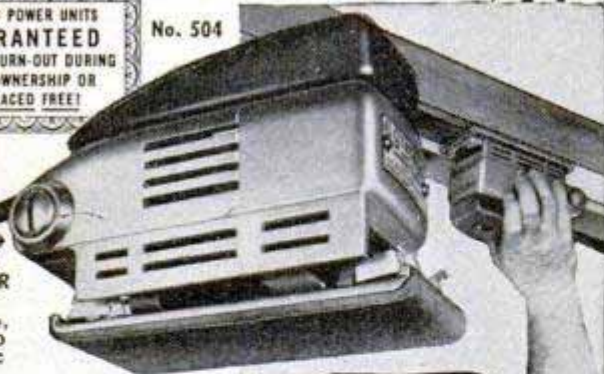

**DOUBLE ARC MOTION**  
*Doubles*  
**SANDING ACTION!**

ONLY

**SYNGRO**  
ELECTRIC

**SANDER HAS IT...**

For an easier, faster job of sanding, polishing around home this spring—get new "504" Syngro! Its exclusive Double Arc Motion **DOUBLES** sanding action—combines best of features of orbital, straight-line sanding. Powerful yet light for easy vertical or over-head work. Gives satin-smooth high-gloss finish. Sanding area approx. 14 sq. in.! **COMPLETE** with new Built-In Reactance Type Electric Motor, 10 sand-papers, lamb's wool and fabric polishing pads. Low cost. At dealers or write for **FREE CIRCULAR**. (Dealers, Jobbers—write!)



No. 504  
DeLuxe  
With  
Metal  
Case

SYNGRO CORPORATION, Dept. D-32, OXFORD, MICH., U.S.A.

## DOUBLE DUTY MIL-LATHE

Save 100% by assembling this new Mil-Lathe yourself. The Mil-Lathe is a vertical mill with protruding arm to hold bracket for center to turn the work on centers. All parts machined—easily assembled in 6 hours. Takes 1 1/2" 8 thread chuck. Price \$220.00 f.o.b. L.A. Does not include vise, motor or chuck. Write today for folder. Satisfaction guaranteed.



**TURNING LATHE**  
surface grinding, drilling,  
ing, etc.

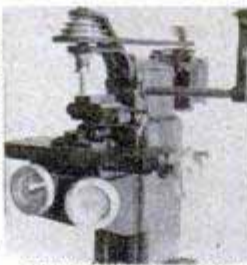

**VERTICAL MILL USE**

**J. C. GRANT**  
Machine Works  
5917 Lemona Av.,  
Dept. PM-11,  
Van Nuys, Calif.



**magnifiers**

Rugged, precision instruments with high power, quality lenses on cast-iron base... for model-making, fly-tying; detail or precision work. Indispensable for the collector. Lens in mounting removable for use without stand. \$2.95 model has 2" lens. \$4.95 model 2 1/2" lens. Double steel universal joints permit any adjustment. Money back immediately if not delighted! Check or money order to **ZORAN PRODUCTS**, Dept. M, 507 Fifth Ave., N. Y., N. Y.

\$2.95

\$4.95  
Extra  
Strong  
2 1/2"  
lens

# New POWER MOWER

**FREE** Building Instructions  
Write For Them

Amazing invention makes whirl-blade mower pull and steer itself as well as cut grass and weeds. Convert your mower or build a complete mower with screw-driver & pliers. Send name and address. A postcard will do.

**PULLS  
ITSELF,  
STEERS  
ITSELF**

Convert Your Mower  
Or Build A New One

T & H Mfg. Co., Dept. 017, 811 E. 31 St., Kans. City, Mo.



Spindle—Platform—Wheels—Fork—Handles—Driving & Steering Parts  
All parts available—Kit or separately.

Make Money  
SELLING  
Eshelman  
Tractors  
and doing  
GARDEN  
WORK

RAKES  
PLOW  
CULTIVATES  
HARROWS  
HAULS  
SPRAYS  
SAWS  
DOZER  
MOWS  
CUTS  
ROLLS  
TILLS  
SNOW PLOW

**ESHELMAN**

FOR BETTER  
LAWNS

and GARDENS  
also POWER MOWERS  
and RIDING TRACTORS  
Women can operate it.

Also Power Reverse  
Free Catalog. Write  
**ESHELMAN**, Dept. 307  
119 Light St., Balto 2, Md.



## YOU CAN BUILD A VIOLIN FOR PLEASURE OR PROFIT

Now you can build a rich toned mellow violin modeled after a famous "Strad." **YOU CAN MAKE A STRADIVARIUS VIOLIN** contains 8 full scale plans plus complete instructions. You work directly from the plans with no confusing scale of dimensions to translate. Detailed instructions for each step including varnishing and stringing—even shows how to build your own tools. Cloth bound. Order today from

**POPULAR MECHANICS PRESS . . . \$3.50**  
200 EAST ONTARIO STREET, CHICAGO 11, ILLINOIS

## Build Your Own Motorized Workshop

This Famous Book Shows How to DO IT!



NEW EDITION



## Easy-to-Make 40 Different Power Machines

Make them yourself—lathes, drill presses, sanding machines, shaper, circular, band and scroll saws and other power tools—from wood, pipe, and discarded parts that cost little or nothing. Get the new edition of "Forty Power Tools You Can Make" even though you have the older edition. This new book has 20 new tools. Make yourself up-to-date, efficient power machines that will save you hundreds of dollars. Send \$1.50 with order and save high C. O. D. charges. Your money back if not satisfied.

POPULAR MECHANICS PRESS, 200 E. Ontario St., Chicago 11, Ill.

## YES! SEND



directly  
to my door  
every month

I am enclosing

- \$3.50 for 1 year  
 \$8.00 for 3 years

name \_\_\_\_\_

address \_\_\_\_\_

city \_\_\_\_\_

zone \_\_\_\_\_

state \_\_\_\_\_

A-32

Hand this order to your newsdealer or send it to

**POPULAR MECHANICS**  
200 East Ontario St. Chicago 11, Ill.



# ADD-A-PAIR SHELF HANGERS

PAT. NO. 2,458,332

## NO MORE STORAGE PROBLEMS!

### For BASEMENT, ATTIC, GARAGE & SHOP

Shelves that grow for storing canned goods, tools, boxes, paints, rugs, awnings, pipe, lumber. Quick, easy installation; use large nails. Hangers 12 by 12 inches hold boards up to one foot wide, any length, support 500 pounds. All hangers identical. Can be added to without disturbing upper shelves. Rustproof high tensile steel. Millions in use all over America, in homes, farms, offices, garages, shops, factories, warehouses.

3 pairs \$2.50—per pair \$1—12 pairs \$9.50 10-DAY MONEY BACK GUARANTEE.

IF CHECK OR MONEY ORDER ACCOMPANIES ORDER, WE PAY POSTAGE.

BOSCHAN & BIRD—DEPT. P-3—10 S. 18th St., Phila. 3, Pa.

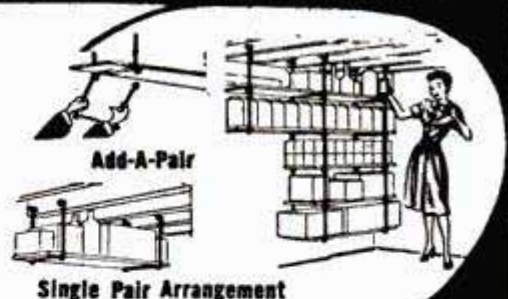

Single Pair Arrangement

## WELLWORTH BARGAINS — ALL NEW EQUIPMENT

### The BIG 3 Wellworth COMPRESSORS

#### ONE YEAR GUARANTEE

2 compression and one oil ring, aluminum alloy connecting rod. Stainless steel valves with brass seats and retainers. Cool-flo cylinder head, spray mist lubrication to every moving part. V groove fly wheel.

#### MODEL W3

2½"x2". 2.55 to 4.80 c.f.m. up to 150 lb. pressure. Operates with ¼-½-¾ HP motor. **\$27.95**  
Special Price...  
Shipping wt. 24 lbs.



#### MODEL W7

2 cylinder 2½"x2". 5.10 to 8.50 c.f.m. up to 150 lbs. pressure. Operates with ½-¾-1-1½ HP motor. **\$54.50**  
Special Price...  
Shipping wt. 45 lbs.

#### MODEL W800

2" bore, 1¾" stroke, 2 to 2.8 c.f.m. up to 150 lbs. pressure. Operates with ¼ or ½ h.p. motor **\$20.50**  
Shipping wt. 16 lbs.

### AIR REGULATOR and EXTRACTOR

¼" Air Regulator, Gauge and filter. Wt. 5 lbs. **\$8.95**  
New  
Regulator and Gauge only **\$5.95**  
½" Klidde Regulator & gauge. **\$12.50**  
\$18.00 List



### AIR TANK and Accessories

6"x24" tank, air gauge and chuck, 20 ft. hose, pop-off valve, copper tubing with 4 brass flared fittings, 4 way cross, 3 nipples  
PRICE **\$12.45**  
TANK ONLY **\$6.25**  
Same outfit as above furnished with 12" x 24" stainless steel tank. PRICE **\$19.75**  
TANK ONLY **\$14.50**



### WELLWORTH V-Belt CLUTCH

Ideal for lawn mowers, garden tractors, etc. Takes starting load off engine or motor. "A" belt 2.35" pitch diam., 3½" long, ¾" bore, ball bearing. Price. **\$7.50**  
Bushing for ½" shaft 15¢  
Same clutch with ¾" bore **\$8.50**



### MOTOR SPECIALS

1/12 h.p., Delco 110V, 60-cy. A.C. 1 phase 1750 r.p.m., 2 amps., will take 50% overload. Shaft 3/8"x1¼". Heavy duty, bronze sleeve bearing. Size 8" long, 5" high, net wt. 12 lbs. List \$21.00 Special. **\$13.50**  
1/10 h.p. 1/2" shaft **\$14.50**  
1/4 h.p. 3/2 volt **\$29.50**

### AUTOMATIC COMPRESSOR UNIT

½ H.P. heavy duty capacitor motor. AC 110/220 volt, 60 cycle, 2x1¼ inch piston type compressor, splash feed lubrication. 12x24 inch tank, automatic pressure switch. CFM 2.8 at 100 lb. pressure, or 150 lbs. pressure for intermittent duty. Check valve, safety valve, air regulator with gauge and filter, 20 ft. air hose with air chuck for inflating tires. V. belt drive. Mounted on 2 wheels, ball bearing, with 2"x10" semi-pneumatic tires. Portable with handle. Shipping wt. 90 lbs. With ½ h.p. motor **\$98.50** Less With 1½ h.p. Motor gas engine **\$124.50**

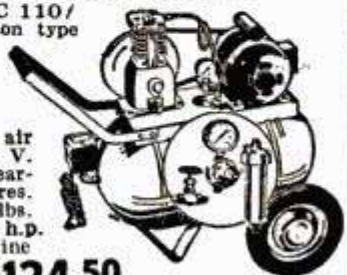

### 2000-2500 WATT LIGHT PLANT

Heavy duty windings  
110 v., 60 cy. A.C., takes starting overload up to 5000 watts. Floating Base for Automatic Belt Adjusting, 2-Groove Engine Pulleys, V-Belts, Bolts, etc. 5 H.P. Wisconsin or Briggs & Stratton Model 14 Engine. Voltmeter, 2 plug-in receptacles. Portable Tubular Steel Skid Type Carrier. Dim: L 34½" x W 17" x H 20". Wt. 180 lbs. **\$299.50**  
Generator only, with voltmeter, 2 plug-in receptacles. Shipp. Wt. 75 lbs. **\$169.50**  
500 WATT GENERATOR, wt. 55 lbs. **\$99.50**  
5000 to 6000 W. GENERATOR, 110/220V. Wt. 225 lbs. **\$325**  
5000 W. LIGHT PLANT, 110/220V. 60 cy. Wt. 575 lbs. **\$645**

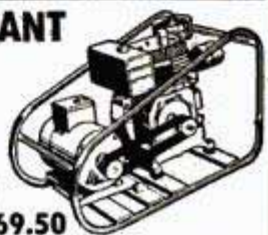

### PORTABLE SPRAY OUTFIT

½ H. P. HEAVY DUTY MOTOR  
EXTERNAL ATOMIZING GUN Paint Sprayer mounted on 6x24 inch tank, ½ H.P. 110 V. 60 cy. Heavy duty motor with overload relay, 10 ft. cord and plug, V belt drive. Piston type Compressor with 2 compression rings, 1 oil ring, 2 inch Bore, 1¾ inch stroke, displacement 2.86 C.F.M. at 60 lbs. pressure. Safety Valve, Gun external atomizing. Flat and round spray, quart cup; maintains 35 to 40 lbs. working pressure. Oil and water extractor, 1 air gauge, 20 ft. heavy duty two-braid air hose with leakproof fittings. Complete with carrying handle. Wt. 60 lbs.  
OUTFIT **\$52.00** SPRAY GUN AND 20 FT. HOSE **\$12.95** COMPLETE OUTFIT **\$67.50**



### "Wellworth" BLOWER BARGAIN

Quiet operating. Double wheel inlet; double width blower. For heating, ventilating, cooling, air washing, exhausting and forced draft. DIMENSIONS: 10" wheel; outlet 13¼"x11¾"; inlet 8¾". Height 19". Width 18". Depth 16½". C.F.M., ¼" S.P. 1600; outlet vel. 1575. Wt. 45 lbs. **\$27.50**  
BLOWER LESS MOTOR AND DRIVE **\$2.50** extra.  
Same blower, complete with ¼ h.p. motor, **\$47.50**



### LELAND GENERATOR

2500 to 3000 watts, 110 v. 60 cy. single phase 1800 r.p.m., self excited. Fungus treated for long life. 1951 model. Brand new, in original factory crate. Shipp. wt. 135 lbs. **\$225**  
List \$375. SPECIAL PRICE

PRICES F.O.B. CHICAGO. MONEY BACK GUARANTEE. SEND CHECK OR MONEY ORDER TODAY. PROMPT SHIPMENT. WRITE FOR NEW CATALOG. SEND 10c FOR POSTAGE.

WELLWORTH TRADING CO. 1832 S. Wabash Ave., Dept. D-352, Chicago 16, Ill.



# AMAZING TOOL BARGAINS!

ALL BRAND NEW MERCHANDISE

**112 PIECE ASSORTMENT \$3.95**  
**FOR ELECTRIC GRINDER**  
 \$10.00 VALUE — ONLY **Post-paid**



Here's what you get! Mounted Stones on 1/8" mandrel, Drum Sander, Sanding Sleeves for sander, Rotary Cutters, Wire Scratch Brush, Bristle Brushes, Circular Saw, Buffing Wheel, Grinding Wheel, Rubber Polishing Wheel, Cut-off Wheels, Rubber Cylinder, Mandrels to fit above tool, asst'd. Sanding Discs, Sharpening Stone, etc.

**SURPRISE VALUE**  
**100 Pieces \$1.00**  
**FOR ELECTRIC GRINDERS**  
**Post-paid**



Grinding Wheels, Cut-off Wheels, Sanding Discs, Mounted Stones, Sharpening and Honing Stones, Rotary Cutting Burs, Abrasive Cartridges, Mandrels, and many other items.

**12 MINIATURE CUTTERS \$1.00**  
**FOR CUTTING WOOD, PLASTIC, or METAL**  
**Post-paid**



Actual size, Asst. shapes on 3/32" shank. For die makers, home workshop, etc.

**20 ABRASIVE ROLLS, cloth, and 1/8" mandrel \$1.00**  
**FOR GRINDING, sanding, deburring metal, plastic, wood or rubber. ONLY....**  
**Post-paid**



**12 MOUNTED WHEELS and points on 1/8" Mandrel. \$2.95**  
**FOR grinding on plastic, wood soft and hard metals. Regular \$8.40 List Val.**  
**12 wheels on 1/4" Mandrel \$3.60**  
**Post-paid**



**18 MOUNTED POINTS ON 3/32" MANDREL \$2.50**  
**2 DRUM SANDERS \$1.50**  
 With 12 Bands in Assorted Grits. 1 1/2" dia. x 1" long on 1/8" arbor with 12 bands **Post-paid**  
**ONE DRUM, 1" DIA. x 1" LONG ON 1/4" ARBOR WITH 6 EXTRA SLEEVES \$1.00**  
**Post-paid**



**FLEXIBLE SHAFT — ONLY \$4.95**  
**Post-paid**



Fits all electric drills & hand power tools. 35 3/4" long. Oilite bearings. Core of specially wound, high carbon steel wire in flexible steel casing. Will accommodate tool shafts up to 1/8" dia. For lathes, electric drills, etc.

**2 CIRCULAR SAWS ON 2 MANDRELS — ALL AT ONE LOW PRICE \$1.50**  
**Post-paid**



1" diameter saws on 1/8" Mandrels. For cutting wood, plastic, or soft metals. Order at once! Send Check or Money Order.

**ADAPTER CHUCK \$1.50**  
 With 2 interchangeable coils, opening from 3/32" to 0, on 1/8" mandrel. Price each only. **Post-paid**

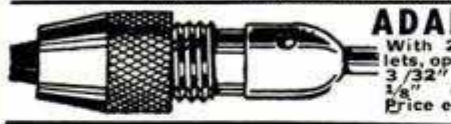

**7 HIGH SPEED TWIST DRILLS \$1.00**  
 15 DRILLS FOR ONLY \$2.00! Order Today! 7 Popular Sizes — up to 1/4". Brand new, ideal for home or shop use. Fits all standard chucks. **Post-paid**



**18 GRINDING WHEELS and rubber polishing wheels up to 1" dia. For grinding & polishing metals, plastic, wood. With one 3/32" mandrel. \$1.00**  
**10 CUT-OFF WHEELS 1 1/2" DIA. WITH 1/8" MANDREL. \$1.00**  
**Post-paid**



**18 ROTARY CUTTERS \$5.85**  
 Assorted sizes cutter on 1/4" or 3/32" shank. Will fit all hand grinders. Ideal for cutting wood, metal, or plastic. Brand new. Value **Post-paid**



**SCHUPACK SUPPLY CO.,** 7331 Cottage Grove, Dept. M-28 Chicago 19, Ill.  
 NEW 1952 Illustrated Catalog 10c

# PARTS FOR MILITARY TRUCKS

FOR JEEP, DODGE, CHEV., GMC, STUDEBAKER, 4 WHEEL DRIVE AND 6 WHEEL DRIVE. ALSO PARTS CATALOG. WRITE

**AXLES FOR TRAILERS**  
 (Surplus) Heavy Duty axles suitable for building of many types of trailers, farm wagons, etc. Standard width straight axle, 2 inch square and is complete with Hubs, Timken bearings, 6 Hole **\$69.50**  
 750x20 or 825x20 wheels, without brakes, only.....  
 Dual Wheels..... add \$15.00 extra



All prices quoted good 30 days FOB, Kansas City  
 25% DEPOSIT REQUIRED ON ALL ORDERS

**American AUTO PARTS CO. INC.**  
 1830 LOCUST — DEPT. PM  
 KANSAS CITY, MISSOURI



**ALL-PURPOSE TORCH FOR YOUR SHOP \$7.75**  
**Money with order Post-paid**



Adjustable Soldering-Brazing Torch for delicate or heavy work. Air and gas valves adjust flame from needle-point to pencil size. Torch uses air compressor or can be breath-blown. Ideal for silver soldering; light brazing; hardening drills and bushings. Excellent for radiator, electrical and sheet metal work. Lights instantly. Made for natural, artificial or bottled gas. Specify type of gas when ordering. Brass torch, 11 1/2" long, 10 day money-back guarantee.

**MASS COMPANY, 1123 W. 4 1/2 St., Davenport 3, Iowa**

**MAKE BIG MONEY!**



Be a floor surfacing contractor and sand both new and old floors. Sanders are easy to operate and better still, you're your own boss. Write for latest "tell-all" booklet entitled "Opportunities in Floor Surfacing", enclosing 25 cents in coin or stamps to cover handling.

**AMERICAN**  
 FLOOR SURFACING MACHINE CO.  
 535 So. St. Clair Street • Toledo 3, Ohio

**SHEET METAL BRAKES**  
 Forms angles, flanges and Pittsburgh locks. 26 gauge steel, heavier aluminum. Cam locking. Portable, can be bolted to bench, or clamped to edge of truck. All steel, reinforced. Shipped Exp. Coll. 30" size. Wt. 54 lbs., \$26.50. 36", Wt. 66 lbs. \$31.00. 48", Wt. 100 lbs. \$45.00. Floor mountings, portable, 32" high, 30 lbs. \$7.00 12" BRAKE. Fits in vise to form difficult compound bends, up to 20 gauge steel. Not illustrated..... \$12.50 PP.  
 24" CURVE FORMER, 2 roll, 16 gauge, 2" to 2' dia. .... \$10.00 P.P.  
 IRON BENDER. Forms hooks, angles, eyelets, etc. without heating. Capacity, 1/4x2", 5/16x1 1/2". 10 parts all steel. .... \$10.00 Pre. P.  
 Immediate Delivery. Order direct, cash or C.O.D. or send for folder.

**VYKE BRAKE CO., P-1116 So. 27th St., Omaha 5, Nebr.**



**DO MORE PLANING JOBS WITH LOW-COST BELSAW \$215.00**



**AMAZING 12 1/2-IN. PLANER Does All Ordinary Planing Mill Jobs.** Provides attachments for Jointing, Rabbeting, Tongue, Groove, Matching. 12 1/2 x 6-in. capacity, 3-knife solid round all-steel cutterhead. Power feeds at 24 feet per minute, 42 cuts per inch. Provides for full line of accessory attachments—Grind and Joint knives IN THE CUTTERHEAD WITHOUT REMOVING.

**BELSAW MACHINERY CO**  
 1018 Field Bldg., 315 Westport Rd., Kansas City 2, Mo.

**FREE BOOK**

**BLACK CLOUD only ELECTRIC WATER PUMP \$6.95**



For Fountains in Bird Baths. Have real running water in creeks for water falls and water wheels, etc. in Christmas displays.

Size 2 1/4" x 6"  
 Pumps approx. one gallon per min.

**PAUL MCFARLAND**  
 R. D. No. 1 ROYERSFORD, PA.



# FOAM RUBBER

**CORED** **SLAB STOCK** **TOPPER PAD**

Our tremendous carload purchases enable us to offer you **FOAM RUBBER** in an amazing selection of sizes and shapes for your every need. Cushions, mattresses, pillows, cored and slab stock at less than wholesale . . .

**WRITE FOR INFORMATION**  
Our **FABRICATING EXPERTS** will advise you. Foam rubber as low as 25¢ per square foot.

**HAND LINE**

Rat-proof, weather resistant, hard linen line. Originally used as hand line in fishing for tuna, marlin, etc. Also has many uses around farm, factory, etc.

**NEW IN 300 ft. lengths.** **169**

**CHEMISTRY SET**

Made for Chemical Warfare Division for testing, water, etc. A handy addition to the chemistry lab, or an exciting experiment for the amateur. Set includes test tubes, complete instructions, 15 different items. Packed in attractive lucite box with cover and dividers . . .

**189**

**NAVIGATORS LAMP**

A handy light for desk, workbench, chart table, engine room, etc. Can be used on 6-12-24 & 110 Volt by changing bulb. 3 ft. shaft has 4 joints to adjust position. . . . .

**329**

**TACHOMETER**

Operates on direct drive with a flex shaft from camshaft or at 2 to 1 reduction from crankshaft. Range is 0 to 4500 R.P.M. Ideal for planes, boats, autos, etc.

**475**

**7 PIECE DRAWING SET**

A Real Palley Bargain! Has a 4 1/2" compass, with pen & pencil part, a 4 1/2" divider, a 3 1/2" reverse bow compass for pencil & ink, a 4 1/2" ruling pen, capsule of extra leads. Complete in a velvet lined case. ONLY

**325**

**EYE LOUPES**

An indispensable aid in fine inspection work. Available in 2 1/2, 2 3/4, 3, 4 & 5 power. each

**99¢**

**EXACTOR HYDRAULIC REMOTE CONTROL**

**MASTER & SLAVE**

Consists of two units. Designed to operate controls on boats, machinery, engines, motors, etc. without need for rods, cables, pulleys, etc.

When connected with 1/4" tubing & filled with oil they act as a precision, remote controller. When Master handle is moved, Slave arm responds in exact motion. Range is 0 to 90 degrees.

Combination Master & Slave for **425**  
MASTER only - For an extra control . . . **215**

**NEW! 1952 CATALOG**

**OVER 230 PAGES COMPLETELY ILLUSTRATED**

Showing Thousands of items in **NEW** and **WAR SURPLUS!** Some at **SAVINGS** up to 85%!

Clothing, Household Items, Power and Hand Tools, Camping & Outdoor equip., Farm & Ranch supplies, Electrical and Pneumatic equip., & a huge stock of Hydraulic equip., including Cylinders, Valves, Pumps, Motors, Fittings, etc. Send only 50¢ for your copy TODAY!

# SAVE UP TO 85% IN WAR SURPLUS

**2 WAY INTERCOM**

Made by **DICTOGRAPH**. Designed for convenient 2-way conversation. Can be used anywhere, from room to room, house to house, office to stockroom, etc. Requires only a simple 2-wire hook-up, limited only by the length of wire used. Produces a strong, audible sound easily heard 500 feet away. Operates on two flashlight batteries.

Unit includes 2 Talkies & 25 ft. of wire. In original packages with complete instructions.

**BELL WIRE** - for use with above - 100 ft. \$3.98

**NEW 11.95**

**100% WOOL FILLED SLEEPING BAG**

The bag with everything you desire in comfort & convenience. Square box construction. Outer covering is vat dyed, Forest Green, combed Zelon treated, poplin, Waterproof - with plaid inner lining. Insulated with weather-strip. Has detachable head flap and side closing. 100" Talon zipper. Double mattress pocket. Two bags may be zipped together. Overall size 36" x 80".

**1995**

**NAVY Sealed Beam LAMP**

U.S. NAVY portable search-spot light. Has pistol grip and aiming sight. Makes an ideal search, spot or emergency light for auto, boat, etc.

12V. light - 4" lens . . . **429**  
24V. light - 4" lens . . . **479**

Set of 3 filters: red, green, amber (specify type lamp) . . . **99¢**

**Navy WADING SUIT**

Adds real pleasure to surf & deep stream fishing. Made of rubberized canvas. Vulcanized seams. Has inner air pockets, to give buoyancy & balance in deep water. Finest quality, rubber gloves & 1/2 length rubber boots attached to sleeves and pants legs . . . . .

**795**

SIZES: small; medium; large

**DOUBLE TRIGGER SIGNAL LAMP**

Has interchangeable, colored filters and controlled, directional beam. The 4" parabolic, Pyrex mirror reflector is movable by trigger in handle. Other trigger is off-on switch. Lamp housing is all metal with crackle finish. Kit comes complete with extra Red and Violet filters, 2 bulbs, 25 feet of cord, all in handy wooden carrying case. Operates on 12V-DC.

**595**

**HUNTING KNIVES**

**GENUINE G.I. EQUIPMENT.** Has a 6 inch, polished Vanadium blade & Handle made of leather and fibre discs. Complete with tanned leather sheath. Only

**198**

**7 x 35 BINOCULARS**

The Very **POPULAR CENTER FOCUS** Model with Coated, Achromatic Lenses. Combines higher resolving power with extreme image brightness and amazing clarity. An **IDEAL GLASS FOR ALL AROUND USE DAY or NIGHT!** Has Lightweight, Precision made, Aluminum housing. Field of view is approx., 375 feet at 1000 yds. Complete with Leather Carrying Case and Neck Straps.

**475** (PLUS FED.TAX)

**7 X 50 PRISM BINOCULARS**

Big, Powerful Lenses give maximum image brightness & needle-sharp vision. Individual eye focus, Wide field of view. With Leather Case and Straps.

**335** (plus Fed. Tax)

**ALNICO SPEAKER**

Model No. S10540-2. Permanent magnet type. Sturdy die-stamped steel frame with 4 hole mounting. Requires only two wire hook-up. Makes an ideal speaker for small radios, multiple communication systems, inter office systems, test equipment, etc. 4" dia.

**249**

**MICROPHONE**

Telephone type, highly sensitive with excellent, Clear tone. This was the Signal Corps favorite. An ideal instrument for the radio "ham" and professional recording studio, broadcasting, home recording, public address, etc. . . . .

Complete with cord & plug . . . **329**

A SENSATIONAL BUY!

**BRIDGE FRAME WINCH HOIST**

Certified for Safety! Has 4 to 1 power ratio. Lifts up to 1500 lbs., on 1 line or has 6000 lbs., cap., on 5 lines. Gears & ratchet are machine cut for precision & safety. Takes 135 ft of 1/4" or 100 ft 5/16" cable.

**1995**

**D.C. ARC WELDER**

**300 AMPS CONTINUOUS - 350-400 AMPS. INTERMITTENT**

For light or heavy duty work. Will easily handle welding up to 1/2" plate. Made to operate continuously, giving years of trouble free service. Built around that famous B-29(R-1) generator incorporating many features no other generator has. Unit includes pulley re-actor output controls. Hi-lo switches & rheostats. All assembled on heavy steel frame and easily adapted to mounting on jeep or tractor for portability & power supply. Can be run on 7 1/2 H.P. electric or 10 H.P. gas motor. Generator alone cost Gov't \$400!

**975**

**NOW ONLY**

**PALLEY SUPPLY CO.** 6321 SAN FERNANDO RD GLENDALE 1 CALIF.

**FISH GAFF**

Make sure you **'LAND THOSE BIG ONES** next time. Here is a gaff that grips your fish in spring loaded jaws. It's as sensitive as a mouse trap when "cocked". Snaps closed automatically upon contact. Corrosion resistant, steel jaws and spring. **NEW 149**

**NYLON FISHLINE**

**STRONG - LIGHTWEIGHT - NYLON FISHING LINE. ROT-PROOF AND WATERPROOF . . .**

1500 ft. 10 lb. Test **\$1.59**  
1000 ft. 25 lb. " **\$1.80**  
750 ft. 45 lb. " **\$3.29**  
750 ft. 50 lb. " **\$3.50**  
300 ft. 72 lb. Braided **\$3.79**

**SURPLUS WATERPROOF NON-SKID BOOTS**

Assures complete foot and shoe protection in the coldest weather. Specially designed to keep the feet warm and comfortable & the shoes dry. Has 9 inch leather boot top, rubber shoe & sole with felt inner sole. Reconditioned - in excellent condition.

**395**  
**NEW 495**

**16 POCKET VEST**

The ideal jacket for the Rifleman or Hunter . . . Has 14 individual, outside pockets for shells, glasses & other accessories. 2 large (11" x 8") inner pockets, a leather holder for knife, gun or tool. Sturdy, yet lightweight with tie-straps at back for adjustable fit . . . . .

**349**

**LENSATIC COMPASS**

Here is a precision compass of unusual accuracy & dependability. Has a prismatic, hair-line guide for sighting at distant object and at same time reading degree of setting. Needle is jewel mounted. Has luminous dial for night use and canvas carrying case. **NEW**

**395**

**17 Power Telescope**

A fine quality, **IMPORTED** instrument. Gives a bright, clear image with a wide field of view. An ideal telescope for all-around use.

**ONLY 795**

**Aviators (AN-6530) Windproof & Dustproof GOGGLES**

Chamois lined, rubber covered frames. Inter-changeable, **GROUND LENSES** in clear or green. Has non-fogging breathers in frame. Adj. nose bar. Ideal for flying, cycling, etc.

**229**  
**NEW 395**

**GO-1 GOGGLE KIT**

**NEW! U.S. NAVY**

Has soft sponge rubber frame. 4 Polaroid lenses, 2 green; 1 red; 1 clear. Perfect for racing, cycling, etc. . . . .

**SPECIAL 89¢**

**STOP WATCH**

Genuine 9 Jewel Waltham Watch. Large sweep sec. hand circles full dial in 10 sec. Smaller dial records up to five minutes total time. **NEW**

**ONLY 1795**

**ORDER FROM THIS AD.** All sales final. Prices F.O.B. Glendale. Pay by M.O. or Check, P.O.'s accepted from D & B. Firms. 1/2 deposit with C.O.D.'s.



# SOUTH BEND 10"-1" COLLET LATHE

puts  
*Professional  
Quality*  
in  
Your Work

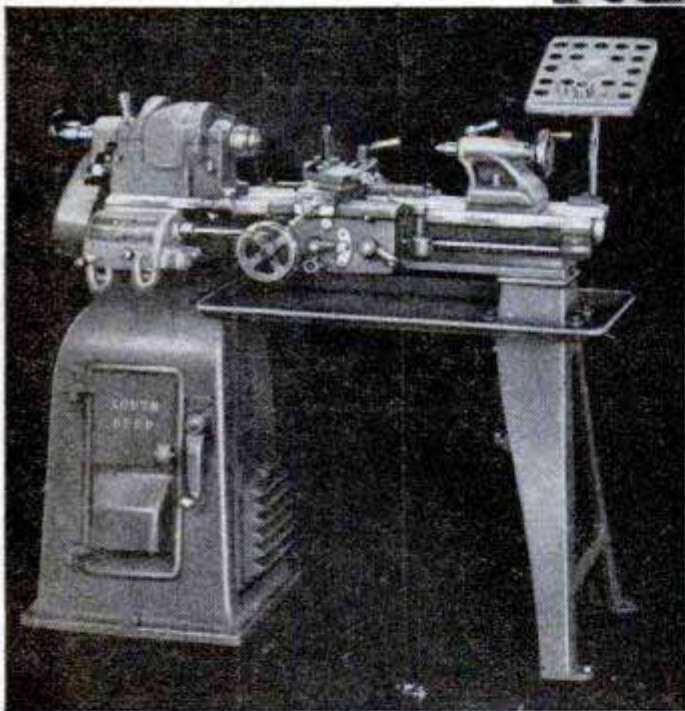

Built for exacting industrial work, the South Bend 10"-1" collet lathe satisfies the demands of any craftsman. Its accuracy simplifies precision jobs and permits work of the highest professional quality. This is the perfect tool for shop owners who want accuracy and versatility. Write for literature on the 10"-1" collet lathe and its many attachments.

SEND INFORMATION  
CHECKED:

 \_\_\_\_\_  
\_\_\_\_\_

9" and 10"  
BENCH LATHES



10" to 16-24"  
FLOOR LATHES



1/2" and 1" Collet  
TURRET LATHES



14"  
DRILL PRESSES



7"  
BENCH SHAPERS

Name \_\_\_\_\_ Company \_\_\_\_\_

Street \_\_\_\_\_ City & State \_\_\_\_\_

Building Better Tools Since 1906 • SOUTH BEND LATHE • South Bend 22, Indiana



Printed by Popular Mechanics Company, Chicago, Ill., U. S. A.



# HOW TO FIX ANY PART OF ANY CAR

USED BY U. S. ARMED FORCES

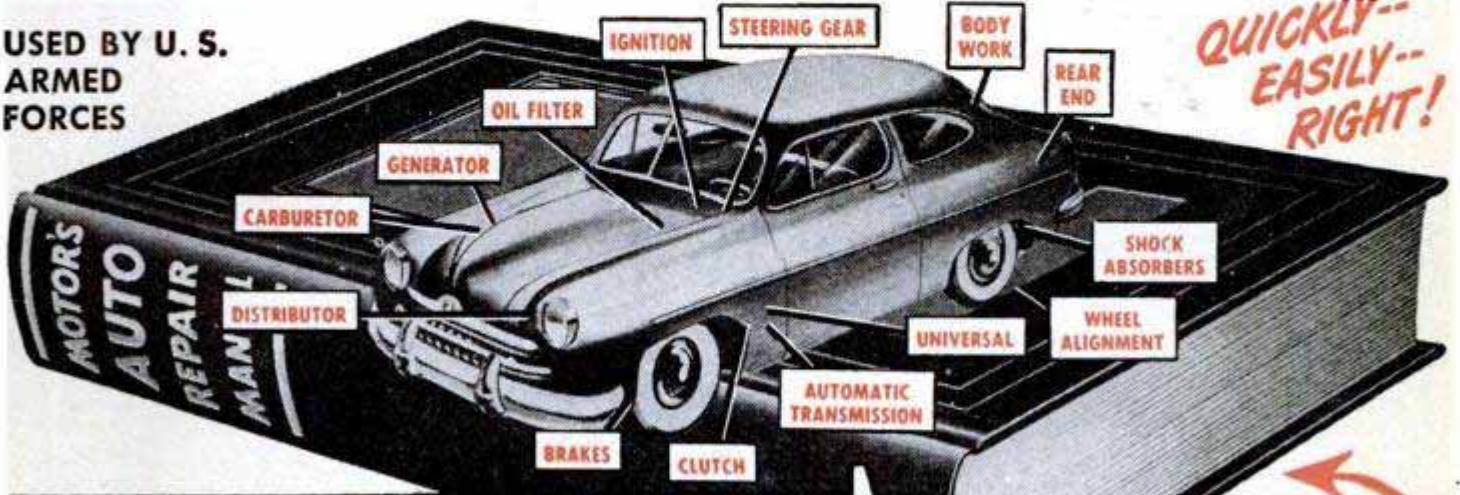

QUICKLY--EASILY--RIGHT!

**NOW**—Whether You're a Beginner or an Expert Mechanic —You Can "Breeze Through" ANY AUTO REPAIR JOB! MoToR's BIG BRAND-NEW AUTO REPAIR MANUAL Shows You HOW—With 2300 PICTURES AND SIMPLE STEP-BY-STEP INSTRUCTIONS.

**Free 7-DAY TRIAL**  
Return and Pay Nothing If Not Satisfied!

## COVERS EVERY JOB ON EVERY CAR BUILT FROM 1935 THRU 1951

**Y**ES, it's easy as A-B-C to do any "fix-it" job on any car whether it's a simple carburetor adjustment or a complete overhaul. Just look up the job in the index of MoToR's New AUTO REPAIR MANUAL. Turn to pages covering job. Follow the clear, illustrated step-by-step instructions. Presto—the job is done!

No guesswork! MoToR's Manual takes nothing for granted. Tells you where to start. What tools to use. Then it leads you easily and quickly through the entire operation!

**Same FREE Offer On MoToR's Truck and Tractor Manual**  
Covers EVERY job on EVERY popular make gasoline truck, tractor made from 1936 thru 1951. FREE 7-Day Trial. Check proper box in coupon.

short-cuts that will amaze you. No wonder this guide is used by the U. S. Army and Navy! No wonder hundreds of thousands of men call it the "Auto Repair Mans' Bible"!

### Meat of Over 150 Official Shop Manuals

Engineers from every automobile plant in America worked out these time-saving procedures for their own motor car line. Now the editors of MoToR have gathered together this wealth of "Know-How" from over 150 Official Factory Shop Manuals, "boiled it down" into crystal-clear terms in one handy indexed book!

- Covers 800 Models—All These Makes**
- |           |           |                                |
|-----------|-----------|--------------------------------|
| Buick     | Henry J.  | Nash Rambler                   |
| Cadillac  | Hudson    | Oldsmobile                     |
| Chevrolet | Kaiser    | Packard                        |
| Chrysler  | Lafayette | Plymouth                       |
| Crosley   | La Salle  | Pontiac                        |
| De Soto   | Lincoln   | Studebaker                     |
| Dodge     | Mercury   | Terraplane                     |
| Ford      | Nash      | Willys                         |
| Frazer    | ALSO      | tune-up adjustments for others |



Many Letters of Praise from Users  
"MoToR's Manual paid for itself on the first 2 jobs, and saved me valuable time by eliminating guesswork."  
—W. SCHROP, Ohio.

He Does Job in 30 Min.—Fixed motor another mechanic had worked on half a day. With your Manual I did it in 30 minutes.  
—C. AUBERRY, Tenn.



Over TWO THOUSAND Pictures! So Complete, So Simple, You CAN'T Go Wrong!

**LATEST REVISED Edition** covers everything you need to know to repair 800 car models. 769 giant pages, 2300 "This-Is-How" pictures. Over 200 "Quick-Check" charts—more than 38,000 essential repair specifications. Over 225,000 service and repair facts. Instructions and pictures are so clear you can't go wrong!

Even a green beginner mechanic can do a good job with this giant manual before him. And if you're a top-notch mechanic, you'll find

Try Book FREE 7 Days

**SEND NO MONEY!** Just mail coupon! When the postman brings book, pay him nothing. First, make it show you what it's got! Unless you agree this is the greatest time-saver and work-saver you've ever seen—return book in 7 days and pay nothing. Mail coupon today! Address: **MoToR Book Dept., Desk 1C, 250 West 55th St., New York 19, N. Y.**

## MAIL COUPON NOW FOR 7-DAY FREE TRIAL

**MoToR BOOK DEPT.**  
Desk 1C, 250 W. 55th St., New York 19, N. Y.

Rush to me at once (check box opposite book you want):

MoToR's New **AUTO REPAIR MANUAL**. If O.K., I will remit \$1 in 7 days (plus 35c delivery charges), \$2 monthly for 2 months and a final payment of 95c one month after that. Otherwise I will return the book postpaid in 7 days. (Foreign price, remit \$8 cash with order.)

MoToR's New **TRUCK & TRACTOR REPAIR MANUAL**. If O. K., I will remit \$2 in 7 days, and \$2 monthly for 3 months, plus 35c delivery charges with final payment. Otherwise I will return book postpaid in 7 days. (Foreign price, remit \$10 cash with order.)

Print Name.....Age.....

Address.....

City.....State.....

Check box and save 35c shipping charge by enclosing WITH coupon entire payment of \$5.95 for Auto Repair Manual (or \$8 for Truck and Tractor Repair Manual.) Same 7-day return-refund privilege applies.



# Why did you change to Camels, DENNIS O'KEEFE?



My cigarette must be kind to my throat and Camels agree with my throat — pack after pack! I've never enjoyed a cigarette so much as Camels!

*Dennis O'Keefe*  
POPULAR MOVIE STAR

NOTED THROAT SPECIALISTS REPORTED AFTER TESTS:

*Not one single case of throat irritation due to smoking **CAMELS***



THIS was the finding of noted throat specialists in a coast-to-coast test of hundreds of people with normal throats who smoked only Camels for thirty days!

Prove Camel mildness yourself! Make your own 30-day Camel test. Enjoy the rich, full flavor. See how mild Camels are, how well they agree with your throat — pack after pack. You'll know why...



Make your own sensible 30-day Camel mildness test in your "T-Zone" — T for Throat, T for Taste.

R. J. Reynolds Tobacco Co., Winston-Salem, N. C.

**CAMEL LEADS ALL OTHER BRANDS—BY BILLIONS!**